

FATEK®

P5/P2K Series

Connection Manual

www.nicsanat.com

021-87700210



Version	Date	Modification
V1.0.0	Janu 18,2015	First Draft
V1.0.1	MAR 7 2019	Increase Xinje
V1.0.2	MAR 15 2019	Increase Vigor

1.	HMI Model Serial Information	4
2.	PLC Connection	7
2.1	FATEK Automation Corp.	7
2.1.1	FBs/B1/B1z/HB1.....	7
2.1.2	FBe.....	11
2.1.3	FBs/B1/B1z/HB1 (TCP)	17
2.1.4	FBe (TCP)	20
2.1.5	FBs/B1/B1z/HB1 (UDP)	22
2.1.6.	Sflag series	25
2.2	Mitsubishi.....	31
2.2.1	FX2N CPU	31
2.2.2	FX2N-485BD	34
2.2.3	FX3U CPU	42
2.2.4	FX3U-485BD	46
2.2.5	FX3U Ethernet.....	53
2.2.6	FX5U-Serial.....	59
2.2.7	FX5U Ethernet.....	68
2.2.8	QSeries-Serial Communication(Link Port).....	75
2.2.9	QSeries-Serial Communication(CPU Port)	83
2.2.10	Q/L Series-ENET	88
2.2.11	iQ-R Series-ENET	92
2.3	Omron	96
2.3.1	Omron SYSMAC CP Series	96
2.3.2	Omron SYSMAC CP Series Ethernet	101
2.3.3	Omron SYSMAC CS/CJ Series	104
2.3.4	Omron SYSMAC CS/CJ Series Ethernet	109
2.3.5	Omron SYSMAC CPM Series.....	113
2.3.6	Omron SYSMAC NJ/NX Series(EtherNet/IP).....	117
2.3.7	Omron Ethernet	120
2.3.8	Sysmac NJ Series (FINS/TCP)	123
2.3.9	Sysmac NX/NJ Series (FINS/UDP).....	126

2.3.10	Omron SYSMAC CQM Series	129
2.4	Siemens.....	134
2.4.1	Siemens S7-200 SMART	134
2.4.2	Siemens S7-200 SMART Ethernet	140
2.4.3	Siemens S7-1200 Ethernet.....	145
2.4.4	Siemens S7-200.....	149
2.4.5	Siemens LOGO.....	156
2.5	Hitachi	159
2.5.1	EHV Series	159
2.5.2	EHV Series (Ethernet).....	162
2.6	Schneider	163
2.6.1	MODBUS RTU	163
2.6.2	MODBUS TCP	167
2.7	Allen-Bradley.....	169
2.7.1	CompactLogix/ControlLogix/FlexLogix Tag Series.....	169
2.7.2	SLC series (EtherNet/IP)	173
2.7.3	SLC Series	177
2.7.4	MicroLogix Series (EtherNet/IP).....	182
2.7.5	MicroLogix Series	186
2.8	Taiwan Instrument & Control Co., Ltd.....	191
2.8.1	FY Series	191
2.9	Delta	201
2.9.1	DVP Series	201
2.9.2	AH500 Series	204
2.10	Panasonic	211
2.10.1	FP Series	211
2.10.2	FP Series (Ethernet).....	215
2.11	YASKAWA.....	217
2.11.1	Extended MEMOBUS	217
2.11.2	MP Series Extension (Ethernet)	220
2.12	Keyence	223
2.12.1	KV-3000/5000/5500/7500(Ethernet)	223
2.12.2	KV-L21V/3000/5000/5500 (host link)	228
2.12.3	KV-Nano (host link)	237
2.13	Beckhoff Automation	241
2.13.1	Twincat(Ethernet)	241
2.14	Koyo.....	245
2.14.1	Direct.....	245

2.15	Yudian.....	252
2.15.1	Al	252
2.16	Xinje	255
2.16.1	XC series	255
2.16.2	XD series.....	259
2.17	Vigor.....	263
2.17.1	M/VB/VH Series	263
2.17.2	VS series	267
2.18	LS.....	272
2.18.1	LS XBC-cnet	273
2.18.2	LS XEC-Cnet	276
2.18.3	LS XBC-Fnet	280
2.18.4	LS XEC-Fnet.....	283

1. HMI Model Serial Information

P5043S/P5043N/P5070VS/P5102VS

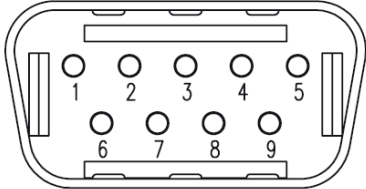
Serial Interface	COM1(RS-232[TXD,RXD]), COM2(RS-422/485), COM3(RS-485)					
Serial Layout	RS-232/ RS-422/ RS-485					
		PIN#	COM1	COM2 (RS-422)	COM2 (RS-485)	COM3
		1		TX+	DATA+	
		2	RX			
		3	TX			
		4		RX+		
		5	GND	GND	GND	GND
		6		TX-	DATA-	
		7				DATA+
		8				DATA-
	9		RX-			

P5070S/ P5070N/ P5070N1/ P5102S/ P5102N/ P5102N1

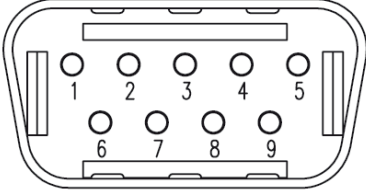
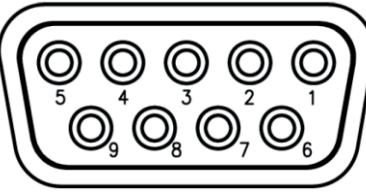
Serial Interface	COM1(RS-232[TXD,RXD,RTS,CTS]), COM3(RS-422/485), COM4(RS-485)																																											
Serial Layout	RS-232																																											
		<table border="1"> <thead> <tr> <th>PIN#</th> <th>COM1</th> </tr> </thead> <tbody> <tr><td>1</td><td></td></tr> <tr><td>2</td><td>RX</td></tr> <tr><td>3</td><td>TX</td></tr> <tr><td>4</td><td></td></tr> <tr><td>5</td><td>GND</td></tr> <tr><td>6</td><td></td></tr> <tr><td>7</td><td>RTS</td></tr> <tr><td>8</td><td>CTS</td></tr> <tr><td>9</td><td></td></tr> </tbody> </table>	PIN#	COM1	1		2	RX	3	TX	4		5	GND	6		7	RTS	8	CTS	9																							
		PIN#	COM1																																									
		1																																										
		2	RX																																									
		3	TX																																									
		4																																										
		5	GND																																									
		6																																										
		7	RTS																																									
	8	CTS																																										
	9																																											
		RX																																										
		TX																																										
			GND																																									
		RTS																																										
		CTS																																										
	RS-422/ 485	Old Model																																										
																																												
<table border="1"> <thead> <tr> <th>PIN#</th> <th>COM3 (RS-422)</th> <th>COM3 (RS-485)</th> <th>COM4</th> </tr> </thead> <tbody> <tr><td>1</td><td>TX-</td><td>DATA-</td><td></td></tr> <tr><td>2</td><td>TX+</td><td>DATA+</td><td></td></tr> <tr><td>3</td><td>RX-</td><td></td><td></td></tr> <tr><td>4</td><td>RX+</td><td></td><td></td></tr> <tr><td>5</td><td></td><td>ISO_GND</td><td></td></tr> <tr><td>6</td><td></td><td></td><td></td></tr> <tr><td>7</td><td></td><td></td><td>DATA-</td></tr> <tr><td>8</td><td></td><td></td><td>DATA+</td></tr> <tr><td>9</td><td></td><td></td><td></td></tr> </tbody> </table>		PIN#	COM3 (RS-422)	COM3 (RS-485)	COM4	1	TX-	DATA-		2	TX+	DATA+		3	RX-			4	RX+			5		ISO_GND		6				7			DATA-	8			DATA+	9						
PIN#		COM3 (RS-422)	COM3 (RS-485)	COM4																																								
1		TX-	DATA-																																									
2		TX+	DATA+																																									
3		RX-																																										
4		RX+																																										
5			ISO_GND																																									
6																																												
7			DATA-																																									
8			DATA+																																									
9																																												
	TX-	DATA-																																										
	TX+	DATA+																																										
	RX-																																											
	RX+																																											
		ISO_GND																																										
			DATA-																																									
			DATA+																																									

New Model			
			
PIN#	COM3 (RS-422)	COM3 (RS-485)	COM4
1			DATA+
2			DATA-
3	ISO_GND	ISO_GND	ISO_GND
4	RX+		
5	RX-		
6	TX+	DATA+	
7	TX-	DATA-	

P2K SERIES

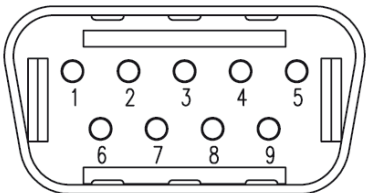
Serial Interface	COM1(RS-232[TXD,RXD]), COM2(RS-422/485)				
Serial Layout	RS-232/ RS-422/ RS-485				
		PIN#	COM1	COM2 (RS-422)	COM2 (RS-485)
		1		TX+	DATA+
		2	RX		
		3	TX		
		4		RX+	
		5	GND	GND	GND
		6		TX-	DATA-
		7			
		8			
9		RX-			

2. PLC Connection

2.1 FATEK Automation Corp.

2.1.1 FBs/B1/B1z/HB1

2.1.1.1 Communication Setting

Item	Default Setting	Remark
Signal Level	RS232	
Baud Rate	9600	
Data Length	7	
Stop Bit	1	
Parity	Even	
PLC Station No.	1	Must match PLC port setting
Communication Method	FATEK Communication Protocol	

2.1.1.2 Memory Resource Review

Device	Data Bits	Address Format	Min.	Max.	Description
X	1	DDDD	0	255	Input Discrete
Y	1	DDDD	0	255	Output Relay
M	1	DDDD	0	2001	Internal Relay
S	1	DDDD	0	999	Step Relay
T	1	DDDD	0	255	Timer Discrete
C	1	DDDD	0	255	Counter Discrete
WX	16	DDDD	0	255	Input Discrete
WY	16	DDDD	0	255	Output Relay
WM	16	DDDD	0	2001	Input Relay
WS	16	DDDD	0	999	Step Relay
RT	16	DDDD	0	255	Timer Register
RC	16	DDDD	0	199	Counter Register
DRC	32	DDDD	200	255	Counter Register
R	16	DDDD	0	8071	Data Register
D	16	DDDD	0	4095	Data Register
F	16	DDDD	0	8191	File Register

2.1.1.3 Connecting to PLC

Configuring the PLC

Use the application **WinProLadder** (ver. 3.25) to configure the serial port of the PLC. Connect the PLC to a computer. In the application, under the **PLC** tab, select the **On-Line** option. In the dialog, select **RS232** for the Connection Name and press 'Edit'. Within the edit dialog, select the port number the PLC is connected to. Press OK to confirm the settings.

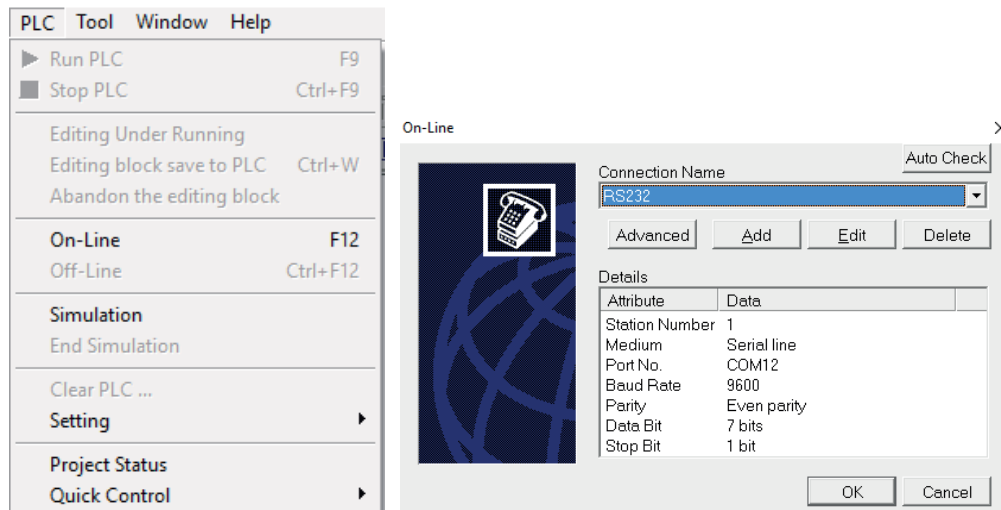

Under the **PLC** tab, select the **Setting** option and choose Port 0. Here, the Baud rate and other parameters of the serial port can be configured.

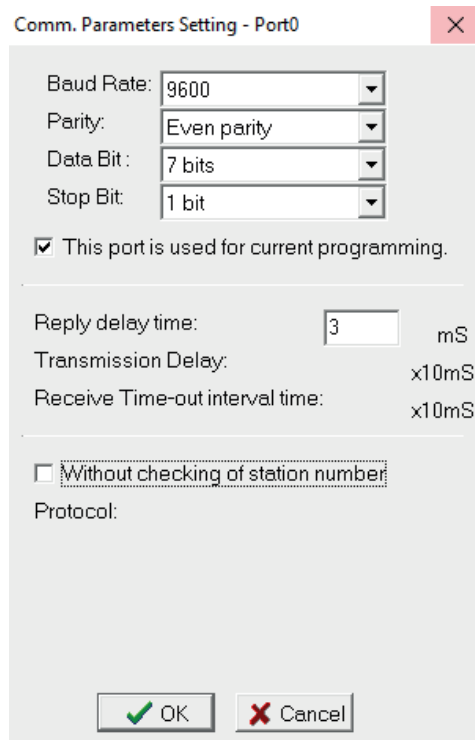

Note: For more detailed information please refer to the PLC manual.

Connecting PLC to HMI

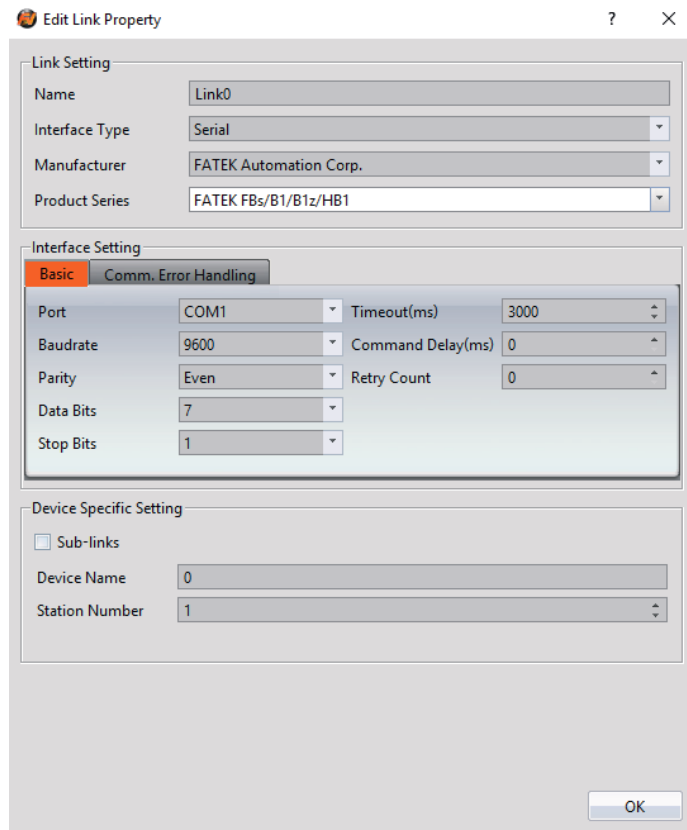

Within the **Link** configuration window in FvDesigner:

Under **Interface Type** select Serial

Under **Manufacturer** select FATEK Automation Corp

Under **Product Series** select FATEK FBs/B1/B1z/HB1

Under **Port** select COM1

Verify the other parameters are consistent with the settings on the PLC.

2.1.1.4 Wiring Diagrams

HMI COM1 Pinout

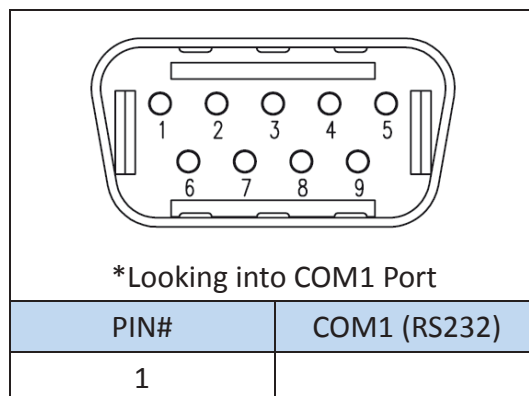

2	RX
3	TX
4	
5	GND
6	
7	RTS
8	CTS
9	

PLC RS232 Pinout

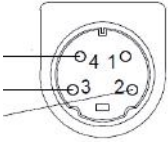
<p>Mini-DIN (PLC Site)</p>  <p>*Looking into PLC</p>	
PIN#	Signal
1	
2	GND
3	RX
4	TX

All P5 and P2K Series

HMI COM1	PLC RS232 Port
2 RX	4 TX
3 TX	3 RX
5 GND	2 GND

Wiring Diagrams: All P5 and P2K Series

HMI COM1

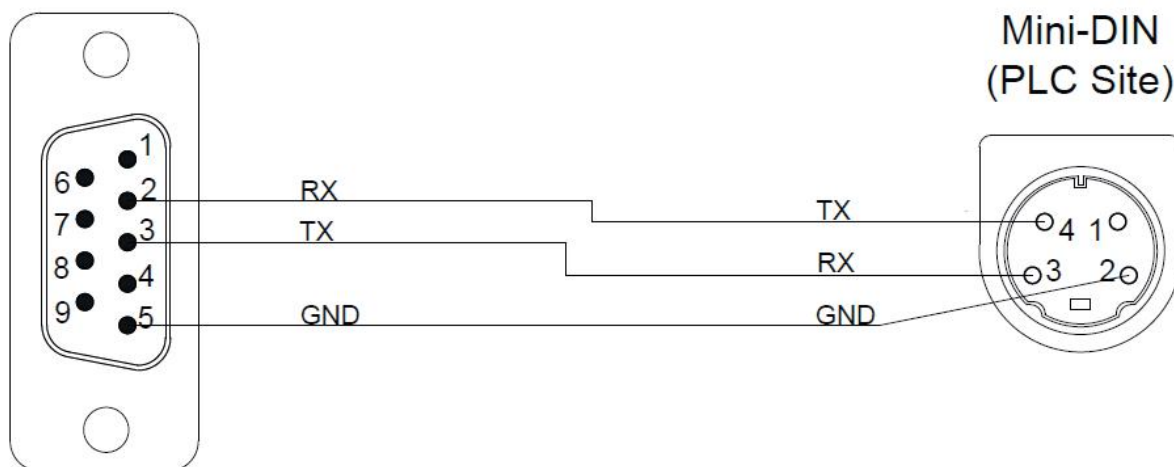

2.1.2 FBe

2.1.2.1 Communication Setting

Item	Default Setting	Remark
Signal Level	RS232 / RS485	
Baud Rate	9600	
Data Length	7	
Stop Bit	1	
Parity	Even	
PLC Station No.	1	Must match PLC port setting
Communication Method	FATEK Communication Protocol	

2.1.2.2 Memory Resource Review

Device	Data Bits	Address Format	Min.	Max.	Description
X	1	DDDD	0	255	Input Discrete
Y	1	DDDD	0	255	Output Relay
M	1	DDDD	0	2001	Internal Relay
S	1	DDDD	0	999	Step Relay
T	1	DDDD	0	255	Timer Discrete
C	1	DDDD	0	255	Counter Discrete

WX	16	DDDD	0	255	Input Discrete
WY	16	DDDD	0	255	Output Relay
WM	16	DDDD	0	2001	Input Relay
WS	16	DDDD	0	999	Step Relay
RT	16	DDDD	0	255	Timer Register
RC	16	DDDD	0	199	Counter Register
DRC	32	DDDD	200	255	Counter Register
R	16	DDDD	0	8071	Data Register
D	16	DDDD	0	4095	Data Register

2.1.2.3 Connecting to PLC

Configuring the PLC

Use the application **WinProLadder** (ver. 3.25) to configure the serial port of the PLC. Connect the PLC to a computer. In the application, under the **PLC** tab, select the **On-Line** option. In the dialog, select **RS232** for the Connection Name and press 'Edit'. Within the edit dialog, select the port number the PLC is connected to. Press OK to confirm the settings.

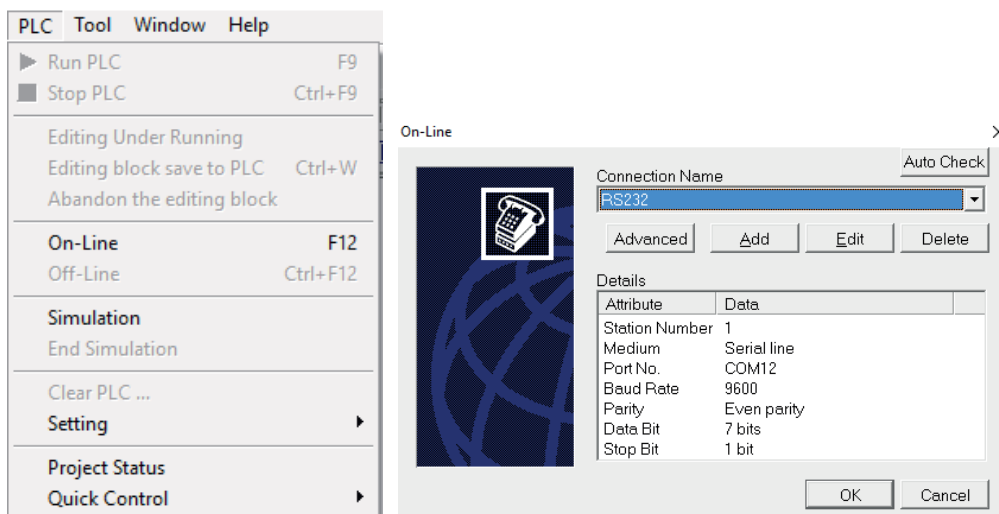

Under the **PLC** tab, select the **Setting** option and choose Port 0. Here, the Baud rate and other parameters of the serial port can be configured.

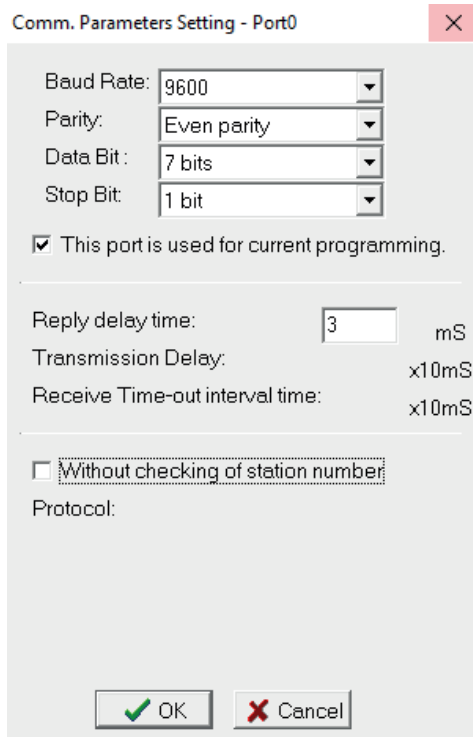

Note: For more detailed information please refer to the PLC manual.

Connecting PLC to HMI

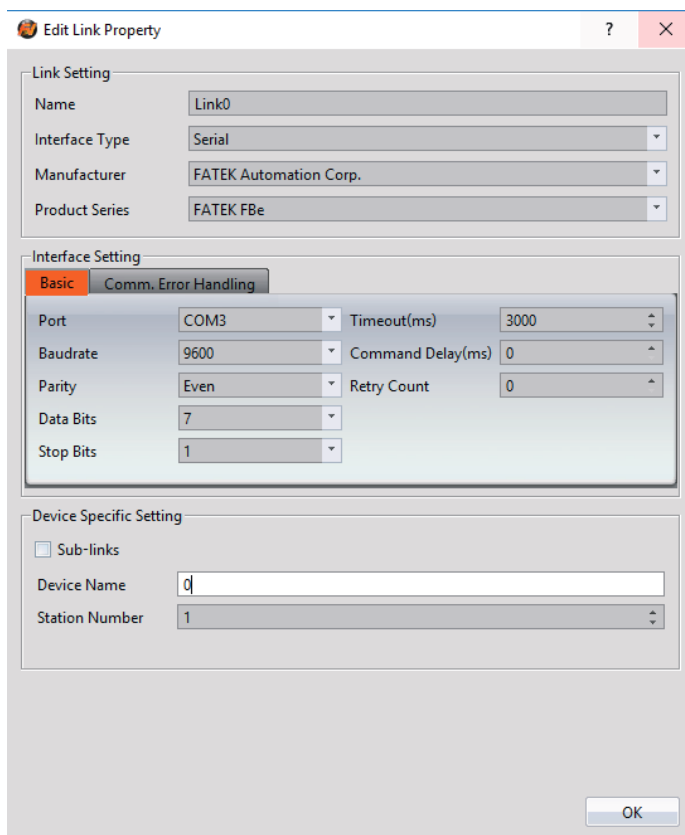

Within the **Link** configuration window in FvDesigner:

Under **Interface Type** select Serial

Under **Manufacturer** select FATEK Automation Corp.

Under **Product Series** select FATEK FBe

Under **Port** select the port corresponding to the connection to the PLC

Verify the other parameters are consistent with the settings on the PLC

2.1.2.4 Wiring Diagrams

Note: The connections were made between the HMI and the FB-DTBR-E module. The module provides ports for each connection type.

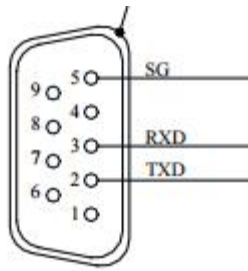
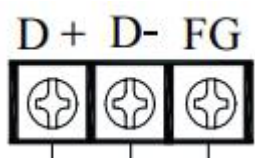
PLC RS232 Pinout		PLC RS485 Pinout
		
*Looking into port0		
PIN#	Port 0 (RS-232)	Port 2 (RS-485)
1		DATA+
2	TXD	DATA-
3	RXD	FG
4		
5	GND	
6		
7		
8		
9		

HMI COM1 Pinout

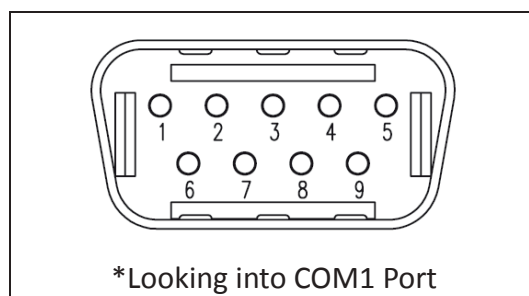

PIN#	COM1 (RS232)
1	
2	RX
3	TX
4	
5	GND
6	
7	RTS
8	CTS
9	

HMI COM3 Pinout

PIN#	COM3 (RS-422/RS-485)
1	
2	
3	ISO_GND
4	
5	
6	DATA+
7	DATA-

All P5 and P2K Series

HMI COM1	PLC RS232 Port
2 RX	2 TXD
3 TX	3 RXD
5 GND	5 GND

Wiring Diagrams: All P5 and P2K Series

HMI COM1

PLC RS232

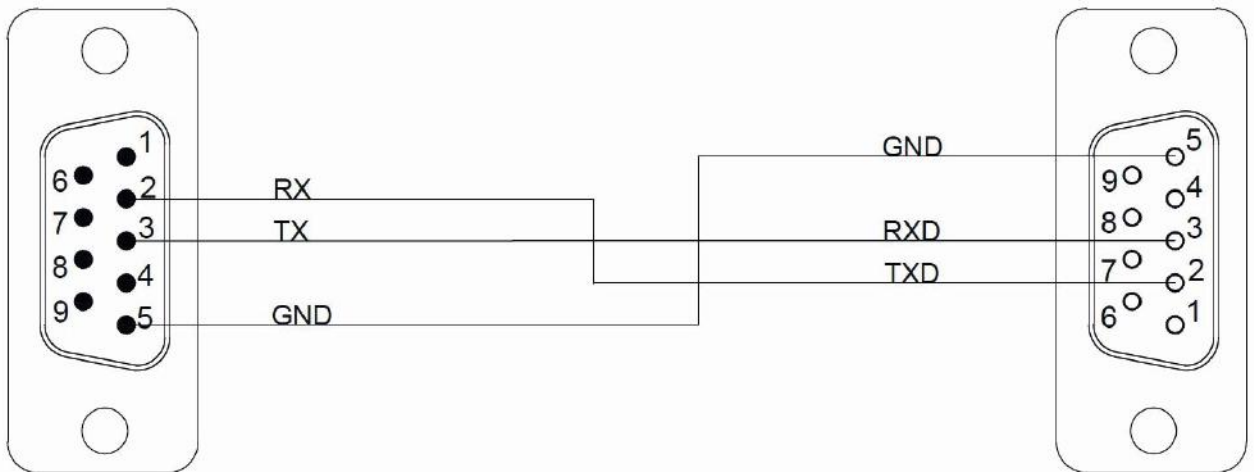

P5070S/ P5070N/ P5070N1/ P5102S/ P5102N/ P5102N1

HMI COM3	PLC RS485 Port
6 DATA+	DATA+
7 DATA-	DATA-

Wiring Diagrams: P5070S/ P5070N/ P5070N1/ P5102S/ P5102N/ P5102N1

HMI COM3

PLC RS485

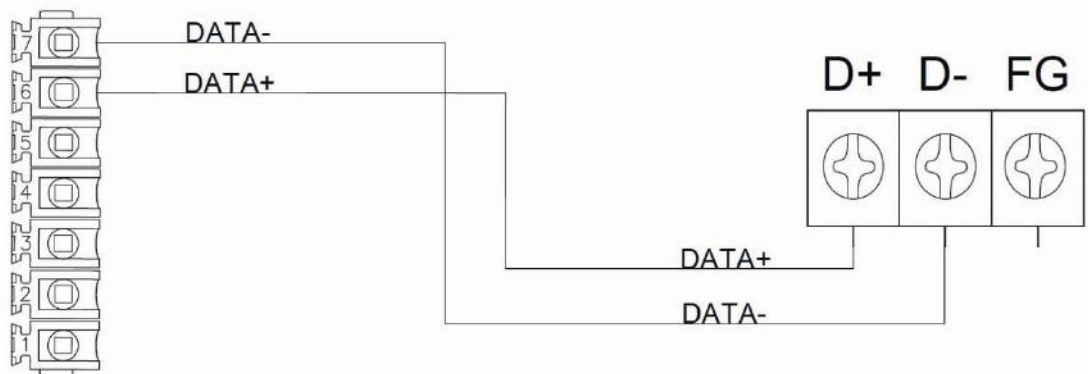

P5043S/P5043N/P5070VS/P5102VS/P2K SERIES

HMI COM2	PLC RS485 Port
1 DATA+	DATA+
6 DATA-	DATA-

HMI COM2

PLC RS485

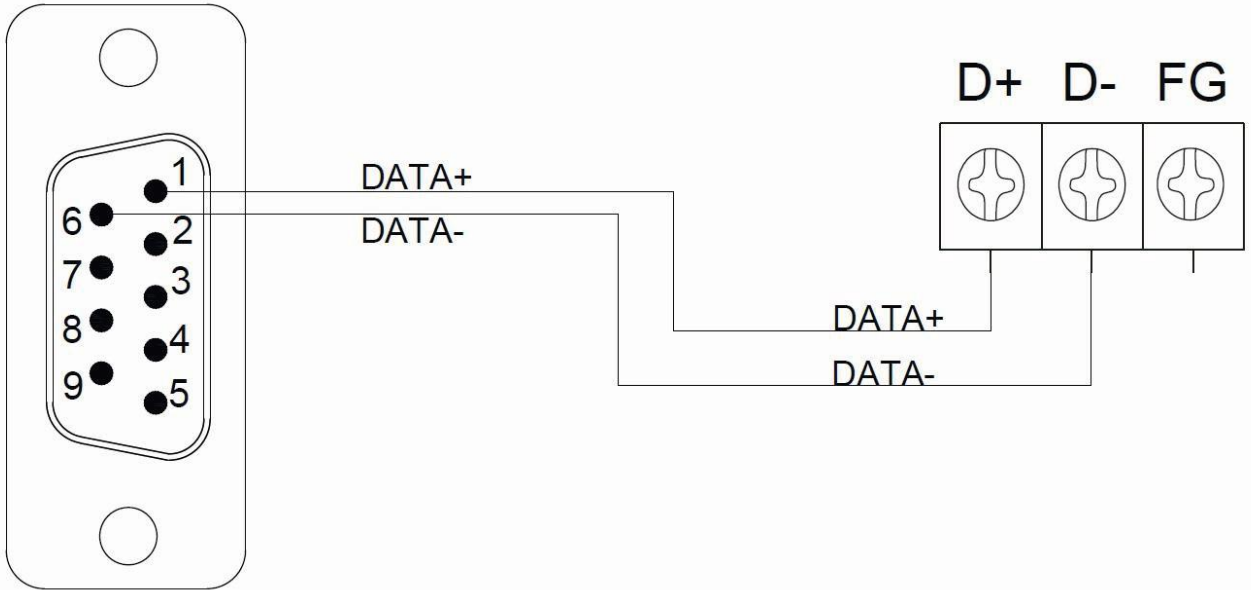

2.1.3 FBs/B1/B1z/HB1 (TCP)

2.1.3.1 Communication Setting

Item	Default Setting	Remark
Signal Level	Ethernet	
Internet Protocol	192.168.1.3	
Port	500	
PLC Station No.	0	
Communication Method	TCP	

2.1.3.2 Memory Resource Review

Device	Data Bits	Address Format	Min.	Max.	Description
X	1	DDDD	0	255	Input Discrete
Y	1	DDDD	0	255	Output Relay
M	1	DDDD	0	2001	Internal Relay
S	1	DDDD	0	999	Step Relay
T	1	DDDD	0	255	Timer Discrete
C	1	DDDD	0	255	Counter Discrete
WX	16	DDDD	0	255	Input Discrete
WY	16	DDDD	0	255	Output Relay

WM	16	DDDD	0	2001	Input Relay
WS	16	DDDD	0	999	Step Relay
RT	16	DDDD	0	255	Timer Register
RC	16	DDDD	0	199	Counter Register
DRC	32	DDDD	200	255	Counter Register
R	16	DDDD	0	8071	Data Register
D	16	DDDD	0	4095	Data Register
F	16	DDDD	0	8191	File Register

2.1.3.3 Connecting to HMI

Configuring IP Address on PLC

Use the application **FATEK Ethernet Module Configuration Tool** to configure the IP address of the PLC. Connect an Ethernet cable to the PLC. Under **Attached Media**, select LAN and press scan.

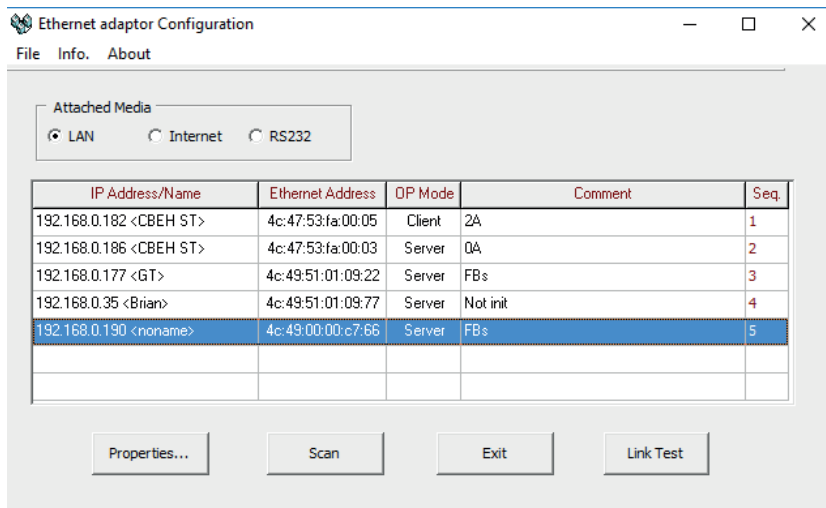

Select the PLC to connect to and right click or press Properties to change the IP.

Note: The default IP address for the PLC has 1 for its third octet. If the IP address of the computer has a different number at that position, the PLC will not show up in the scan. Configure network settings on the computer to be able to see the PLC in the local network.

In the dialog window, the IP address and other parameters of the PLC can be configured. In the **Service Ports** tab, the port number of the PLC can be changed.

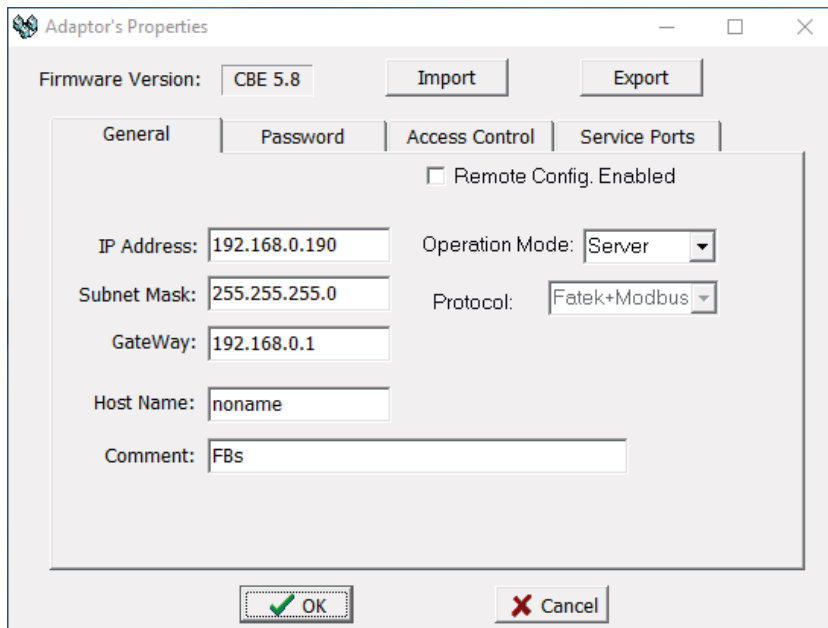

Note: For more detailed information please refer to the PLC manual.

Connecting PLC to HMI

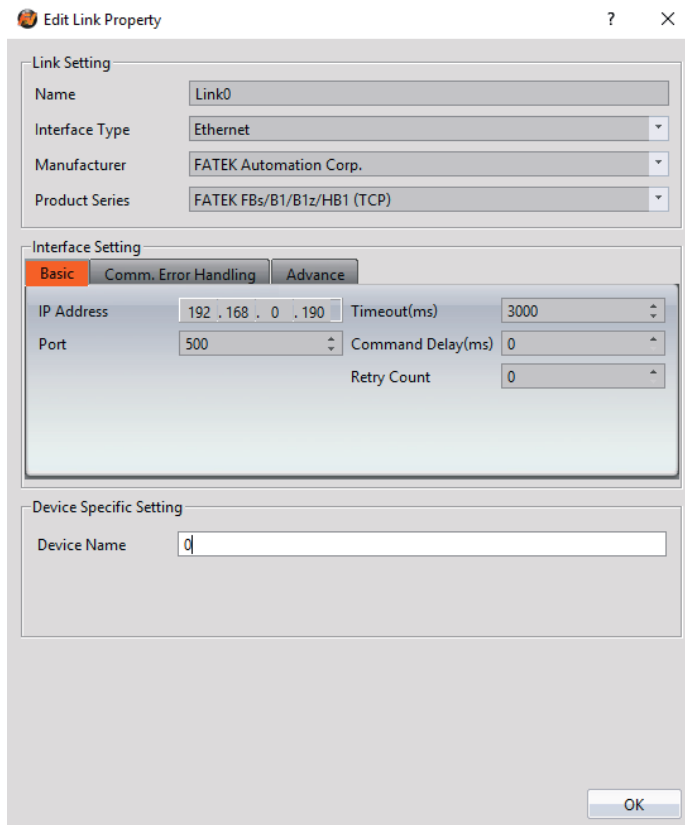

Within the **Link** configuration window in FvDesigner:
 Under **Interface Type** select Ethernet
 Under **Manufacturer** select FATEK Automation Corp
 Under **Product Series** select FATEK FBs/B1/B1z/HB1 (TCP)

Use the IP address and port number assigned on the PLC

2.1.4 FBe (TCP)

2.1.4.1 Communication Setting

Item	Default Setting	Remark
Signal Level	Ethernet	
Internet Protocol	192.168.1.3	
Port	500	
PLC Station No.	0	
Communication Method	TCP	

2.1.4.2 Memory Resource Review

Device	Data Bits	Address Format	Min.	Max.	Description
X	1	DDDD	0	255	Input Discrete
Y	1	DDDD	0	255	Output Relay
M	1	DDDD	0	2001	Internal Relay
S	1	DDDD	0	999	Step Relay
T	1	DDDD	0	255	Timer Discrete
C	1	DDDD	0	255	Counter Discrete
WX	16	DDDD	0	255	Input Discrete
WY	16	DDDD	0	255	Output Relay
WM	16	DDDD	0	2001	Input Relay
WS	16	DDDD	0	999	Step Relay
RT	16	DDDD	0	255	Timer Register
RC	16	DDDD	0	199	Counter Register
DRC	32	DDDD	200	255	Counter Register
R	16	DDDD	0	8071	Data Register
D	16	DDDD	0	4095	Data Register

2.1.4.3 Connecting to HMI

Configuring IP Address on PLC

Use the application **FATEK Ethernet Module Configuration Tool** to configure the IP address of the PLC. Connect an Ethernet cable to the PLC. Under **Attached Media**, select LAN and press scan.

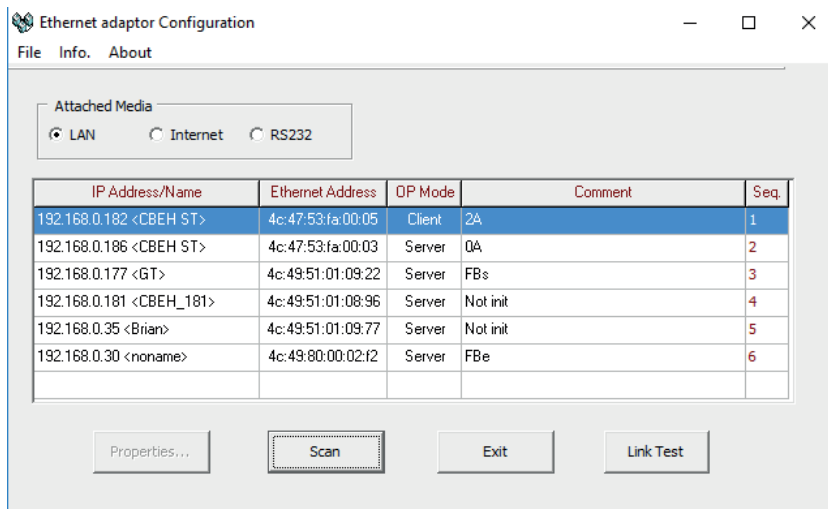

Select the PLC to connect to and right click or press Properties to change the IP.

Note: The default IP address for the PLC has 1 for its third octet. If the IP address of the computer has a different number at that position, the PLC will not show up in the scan. Configure network settings on the computer to be able to see the PLC in the local network.

In the dialog window, the IP address and other parameters of the PLC can be configured.

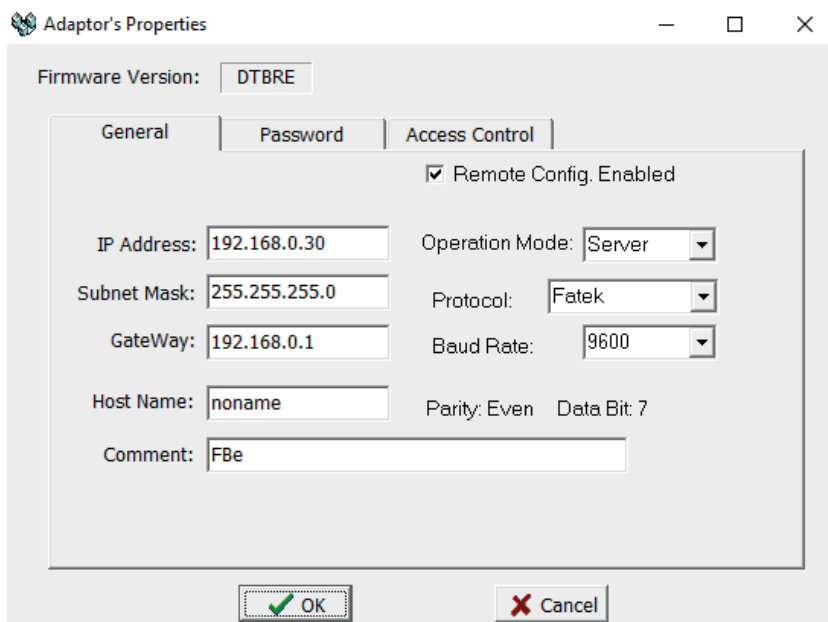

Note: For more detailed information please refer to the PLC manual.

Connecting PLC to HMI

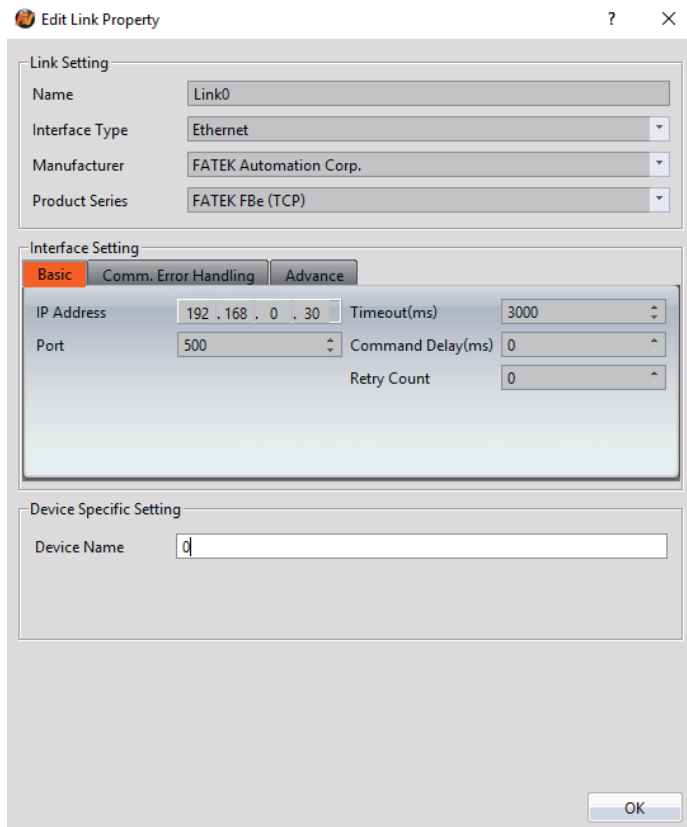

Within the **Link** configuration window in FvDesigner:

Under **Interface Type** select Ethernet

Under **Manufacturer** select FATEK Automation Corp

Under **Product Series** select FATEK FBe (TCP)

Use the IP address assigned on the PLC

Leave the Port at the default value

2.1.5 FBs/B1/B1z/HB1 (UDP)

2.1.5.1 Communication Setting

Item	Default Settings	Remark
Signal Level	Ethernet	
Internet Protocol	192.168.1.100	
Port	500	
PLC Station No.	0	
Communication Method	UDP	

2.1.5.2 Memory Resource Review

Device	Data Bits	Address Format	Min.	Max.	Description
X	1	DDDD	0	255	Input Discrete
Y	1	DDDD	0	255	Output Relay
M	1	DDDD	0	2001	Internal Relay
S	1	DDDD	0	999	Step Relay
T	1	DDDD	0	255	Timer Discrete
C	1	DDDD	0	255	Counter Discrete
WX	16	DDDD	0	255	Input Discrete
WY	16	DDDD	0	255	Output Relay
WM	16	DDDD	0	2001	Input Relay
WS	16	DDDD	0	999	Step Relay
RT	16	DDDD	0	255	Timer Register
RC	16	DDDD	0	199	Counter Register
DRC	32	DDDD	200	255	Counter Register
R	16	DDDD	0	8071	Data Register
D	16	DDDD	0	4095	Data Register
F	16	DDDD	0	8191	File Register

2.1.5.3 Connecting to HMI

Configuring IP Address on PLC

Use the application **FATEK Ethernet Module Configuration Tool** to configure the IP address of the PLC. Connect an Ethernet cable to the PLC. Under **Attached Media**, select LAN and press scan.

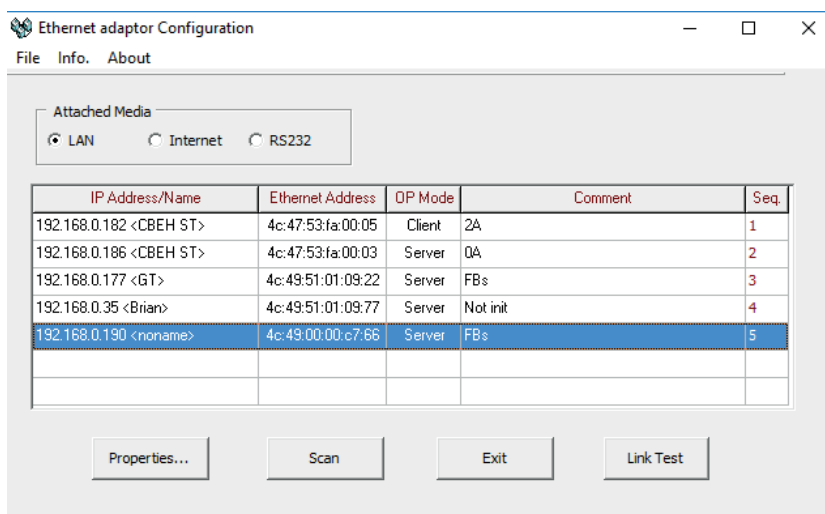

In the dialog window, the IP address and other parameters of the PLC can be

configured.

Adaptor's Properties

Firmware Version: CBE 5.8 Import Export

General Password Access Control Service Ports

Remote Config. Enabled

IP Address: 192.168.0.190 Operation Mode: Server

Subnet Mask: 255.255.255.0 Protocol: Fatek+Modbus

GateWay: 192.168.0.1

Host Name: noname

Comment: FBs

OK Cancel

Note: For more detailed information please refer to the PLC manual.

Connecting PLC to HMI

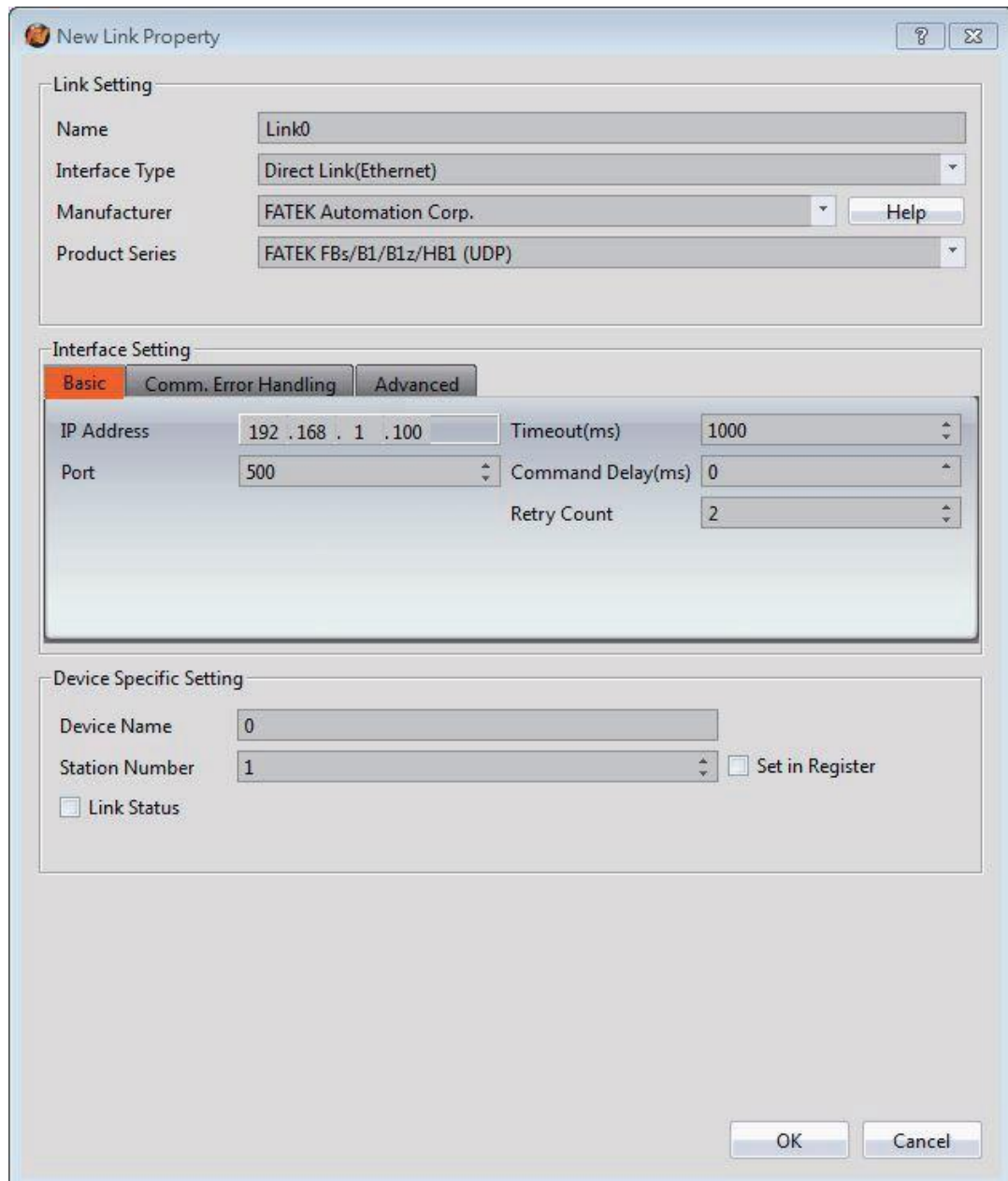

Within the **Link** configuration window in FvDesigner:

Under **Interface Type** select Ethernet

Under **Manufacturer** select FATEK Automation Corp

Under **Product Series** select FATEK FBe (UDP)

Use the IP address assigned on the PLC

Leave the Port at the default value

2.1.6. Sflag series

2.1.6.1. Communication Setting

ITEMS	SPEC
-------	------

Electrical specifications	Asynchronous serial communication half duplex
Baud rate	2400,4800,9600,19200,38400,57600bps
Data bit	8 bit
Parity bit	None even odd
Stop bit	1bit 2bit
Check sum	CRC16-CCITT
Data transfer	8 bit (binary)
Communication data length	32 bytes

2.1.6.2. Memory Resource Review

Bit/Word	Device Name	Register symbol	Input format	Start	End	Read/Write
B	Alarm Status	A	D	0	0	R
W	Parameter	P	DDDD	0	1029	R/W
	State	S	DDDD	0	1029	R
	Multi-Turn Data	MTD	D	0	0	R
	Alarm Status	A	D	0	0	R
DW	Parameter	DP	DDDD	0	1029	R/W
	State	DS	DDDD	0	1029	R
	Single-Turn Data	STD	D	0	0	R

2.1.6.3. Connecting to HMI

Sankyo Servo Parameter configuration



With the upper control device specifications, set the drive communication address and communication parameters. The following are the parameters that must be set for RS-485.

Parameter No.	parameter	Setting value
4.0	RS-485 communication address	1-32 Initial value 1.
6.0	RS-485 communication Baud rate	0 : 2,400bps 1 : 4,800bps 2 : 9,600bps 3 : 19,200bps 4 : 38,400bps 5 : 57,600bps (Initial value)

6.1	RS-485 communication STOP bit	0 : 1 bit (Initial value) 1 : 2 bit
6.2	RS-485 communication parity	0 : none (Initial value) 1 : EVEN 2 : ODD
8.0	RS-485 communication ON/OFF	0 : no use (Initial value) 1 : use
11.0	RS-485 Communication Minimum response time	0-255 Initial value 3 [ms] ◦

2.1.6.4. Wiring Diagrams

Parameter setting method (alternatively set the following parameters):

參數設定方法	
	Use the drive front panel settings.
	S-TUNE has been set for adjustment. Software needs to be installed on the computer.

Method1:

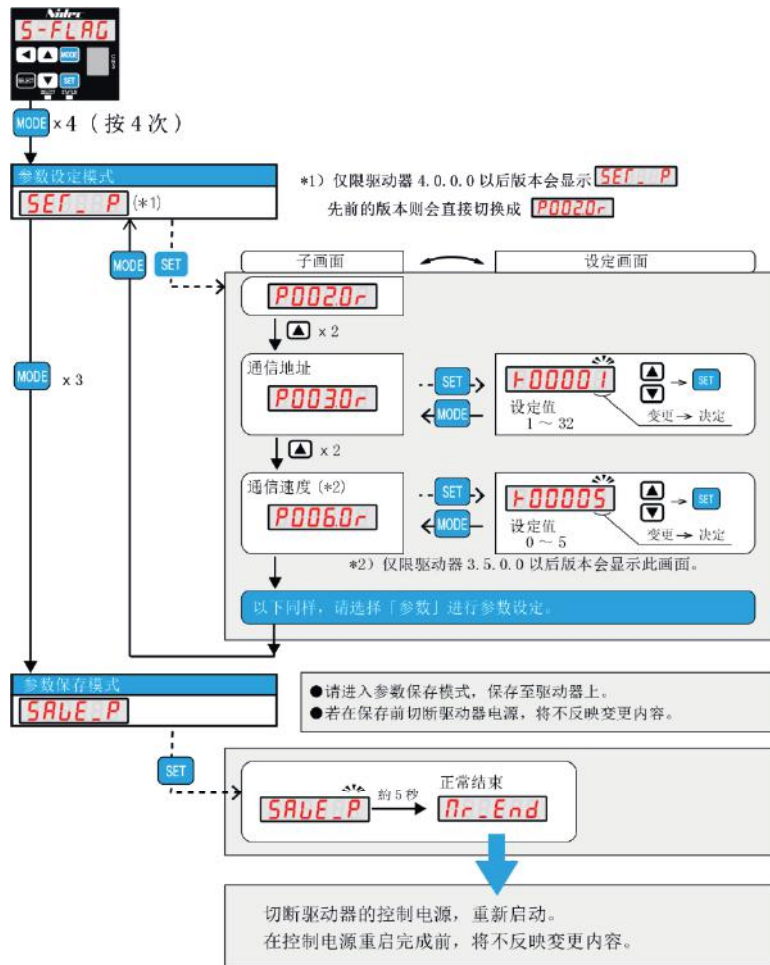

Method2:

Open Sankyo S-TUNE and use the mini USB cable to connect to the computer USB port, it will automatically connect



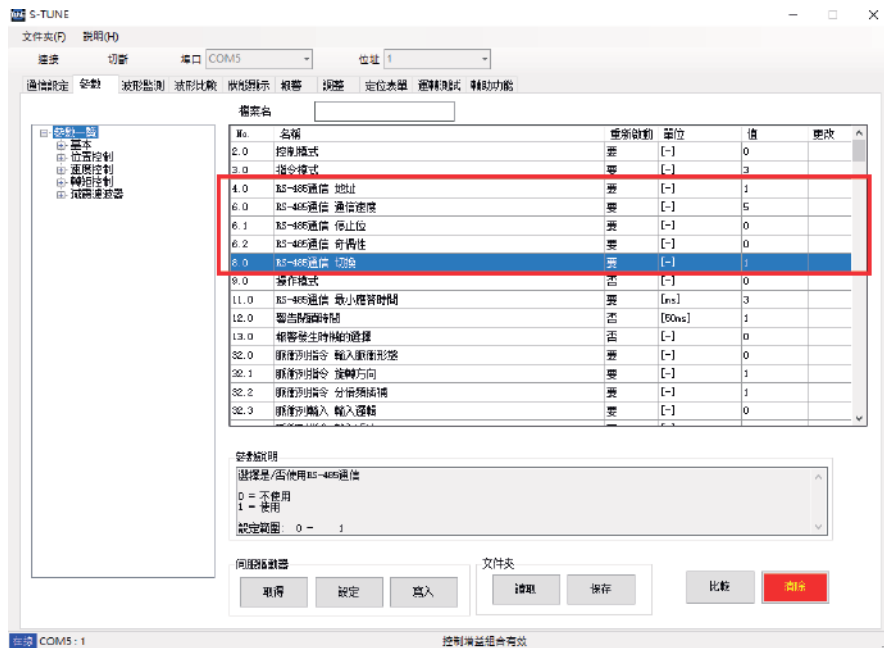

HMI 設定

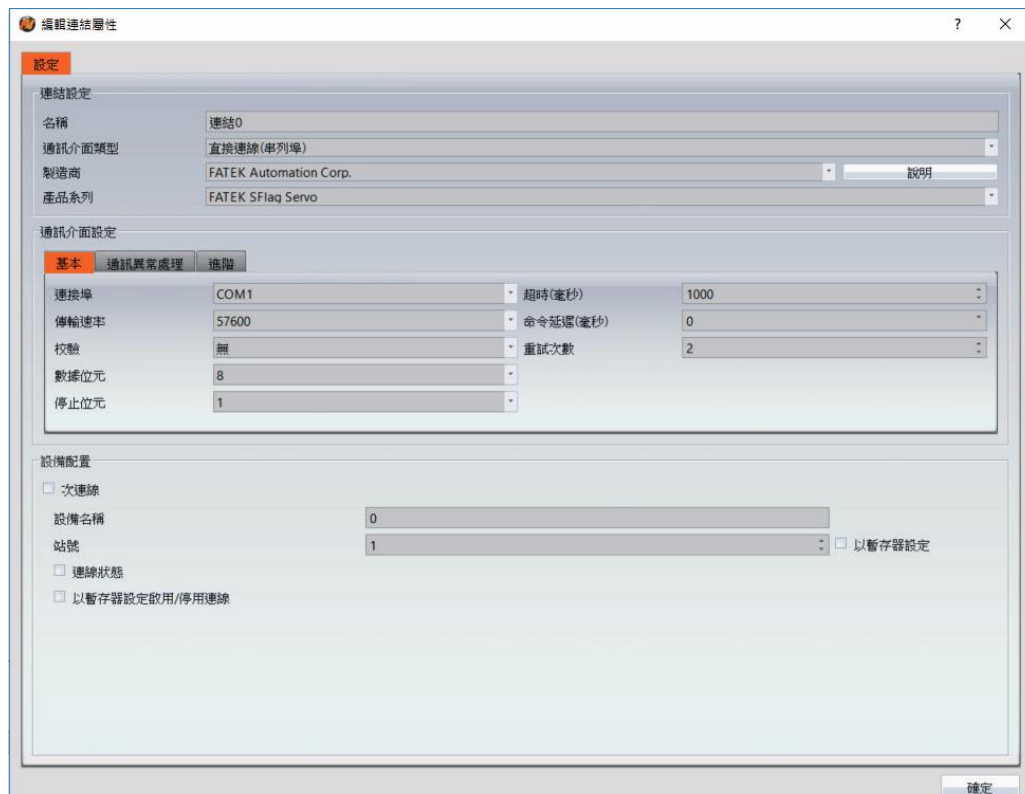

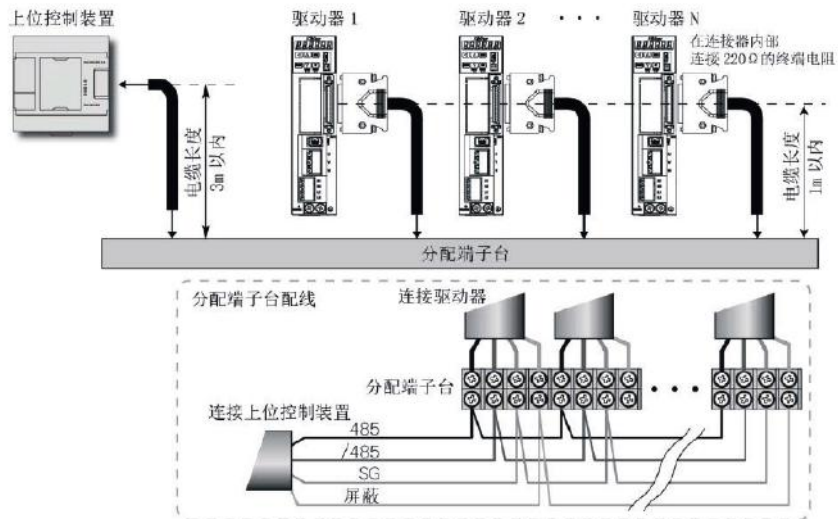

连接器配线复杂时，请以端子台进行信号分配。

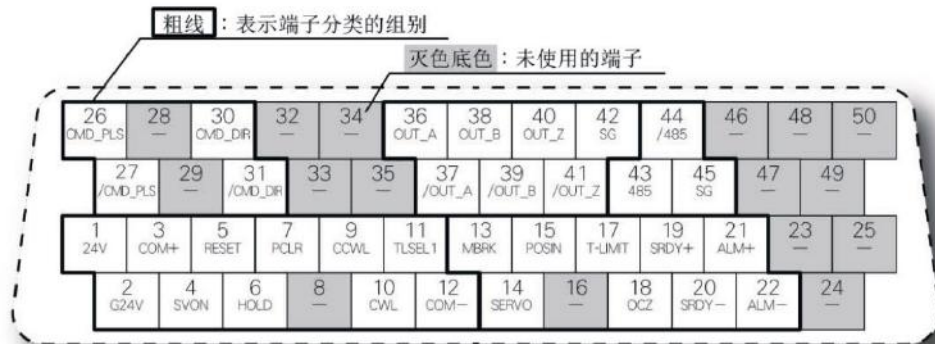

Sankyo Servo CN1 PIN脚位

HMI COM2

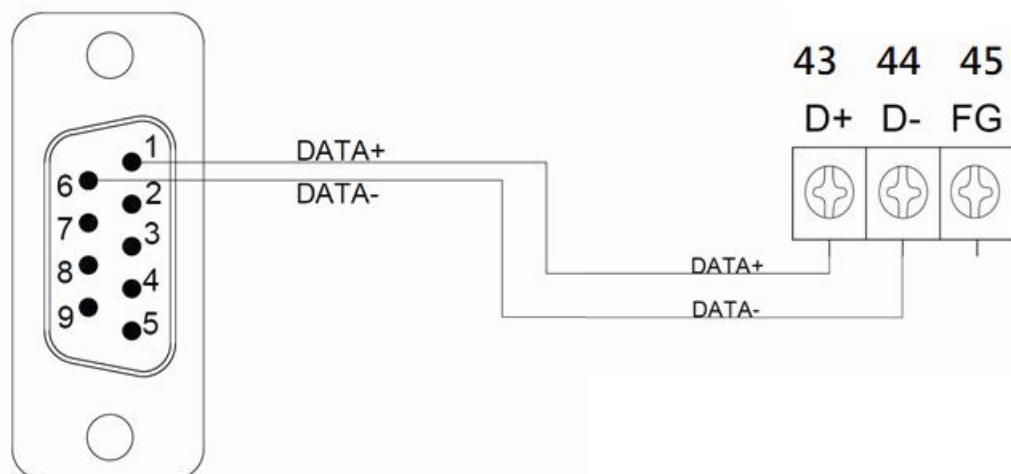

2.2 Mitsubishi

2.2.1 FX2N CPU

2.2.1.1 Communication Setting

Item	Default Setting	Remark
Signal Level	RS485 4W	
Baud Rate	9600	
Data Length	7	
Stop Bit	1	
Parity	Even	
PLC Station No.	0	
Communication Method	Programming Protocol	

2.2.1.2 Memory Resource Review

Device	Description	Data bit	Min.	Max.
X	Input Discrete	1	0	377
Y	Output Relay	1	0	377
M	Internal Relay	1	0	7999
SM	Special Relay	1	8000	8255
S	Step Relay	1	0	4095
TS	Timer Discrete	1	0	255
CS	Counter Discrete	1	0	255
WX	Input Discrete	16	0	360
WY	Output Relay	16	0	360
WM	Internal Relay	16	0	7984
WS	Step Relay	16	0	4080
TN	Timer Memory	16	0	255
CN	Counter Memory	16	0	199
D	Data Register	16	0	7999
SD	Special Data Register	16	8000	8255
DCN	Counter Memory	32	200	255

2.2.1.3 Connecting to HMI

Connecting PLC to HMI

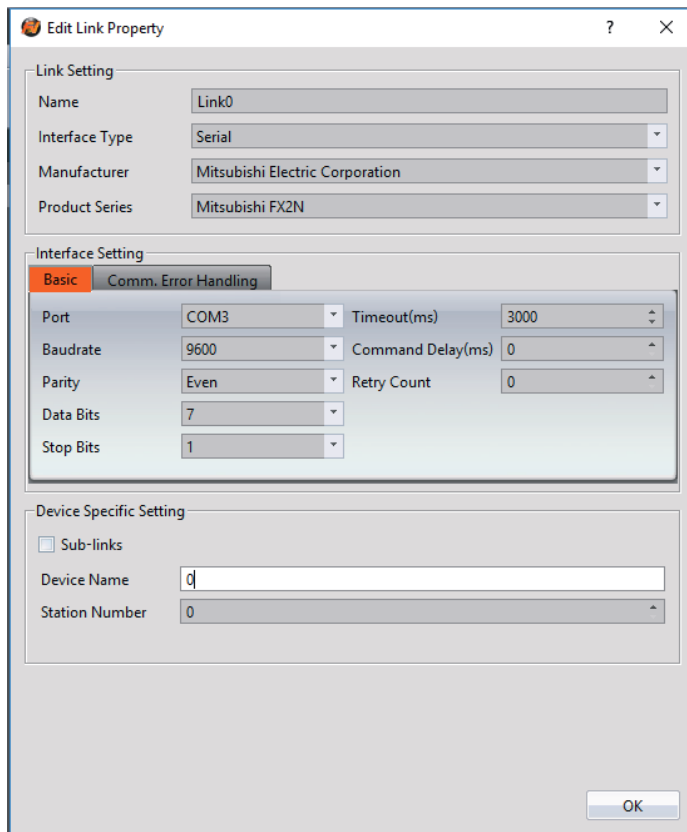

- Within the **Link** configuration window in FvDesigner:
- Under **Interface Type** select Serial
- Under **Manufacturer** select Mitsubishi Electric Corporation
- Under **Product Series** select Mitsubishi FX2N
- Under **Port** select COM3

2.2.1.4 Wiring Diagrams

PLC RS422 Pinout

*View from soldering point of the cable

PIN#	Signal
1	RX-
2	RX+
3	GND
4	TX-

5	
6	
7	TX+
8	

HMI COM3 Pinout

	
*Looking into HMI Device	
PIN#	COM3 (RS-422/RS-485)
1	
2	
3	ISO_GND
4	RX+
5	RX-
6	TX+
7	TX-

P5070S/P5070N/P5070N1/P5102N/P5102N1

HMI COM3	PLC RS422 Port
5 RX-	4 TX-
4 RX+	7 TX+
7 TX-	1 RX-
6 TX+	2 RX+
3 ISO_GND	3 GND

Wiring Diagrams: P5070S/P5070N/P5070N1/P5102N/P5102N1

HMI COM3

PLC RS422

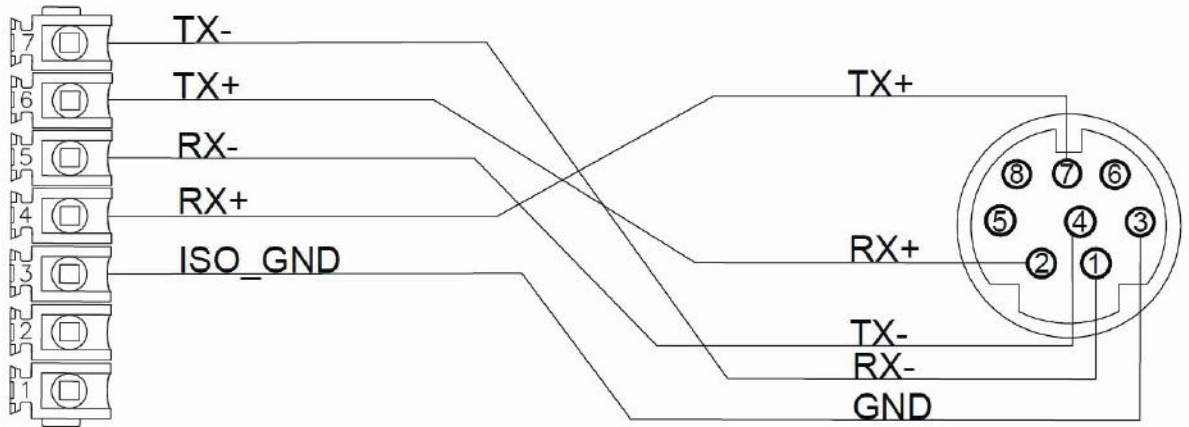

P5043S/P5043N/P5070VS/P5102VS/P2K SERIES

HMI COM2	PLC RS422 Port
9 RX-	4 TX-
4 RX+	7 TX+
6 TX-	1 RX-
1 TX+	2 RX+
5 GND	3 GND

Wiring Diagrams: P5043S/P5043N/P5070VS/P5102VS/P2K SERIES

HMI COM2

Mini-DIN (PLC Site)

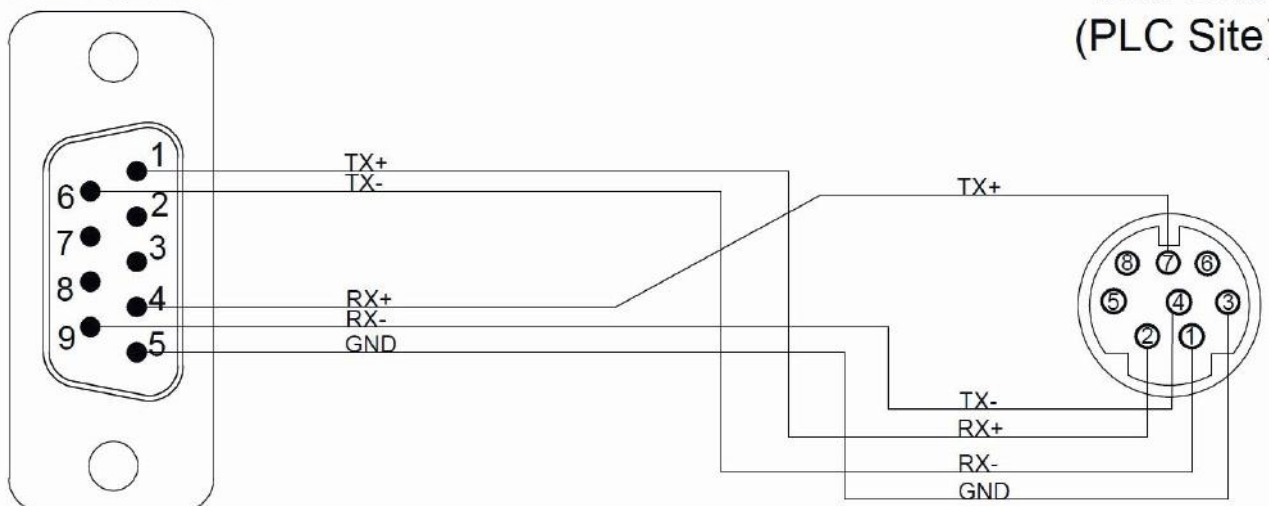

2.2.2 FX2N-485BD

2.2.2.1 Communication Setting

Item	Default Setting	Remark
Signal Level	RS485	
Baud Rate	19200	
Data Length	7	
Stop Bit	1	
Parity	Even	
PLC Station No.	1	
TX Control	Form1	Without CR,LF
Checksum	Yes	
Communication Method	Computer Link	

2.2.2.2 Memory Resource Review

Device	Description	Data bit	Min.	Max.
X	Input Discrete	1	0	377
Y	Output Relay	1	0	377
M	Internal Relay	1	0	3071
SM	Special Relay	1	8000	8255
S	Step Relay	1	0	999
TS	Timer Discrete	1	0	255
CS	Counter Discrete	1	0	199
WX	Input Discrete	16	0	360
WY	Output Relay	16	0	360
WM	Internal Relay	16	0	3056
WS	Step Relay	16	0	976
TN	Timer Memory	16	0	255
CN	Counter Memory	16	0	199
D	Data Register	16	0	7999
SD	Special Data Register	16	8000	8255
DCN	Counter Memory	32	200	255

2.2.2.3 Connecting to HMI

Configuring the PLC

Use **MELSOFT GX Works2** to configure the port of the PLC.

Under the **Online** menu option, select **Read from PLC**

Select the **FXCPU** PLC series.

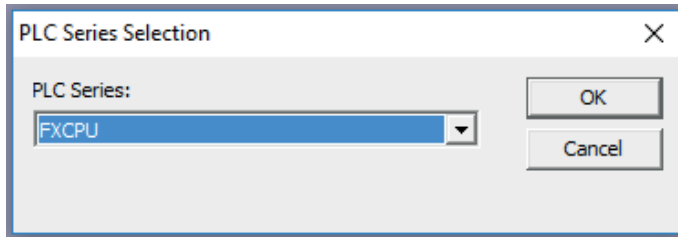

Select **Serial USB** in the Transfer Setup Communication window.

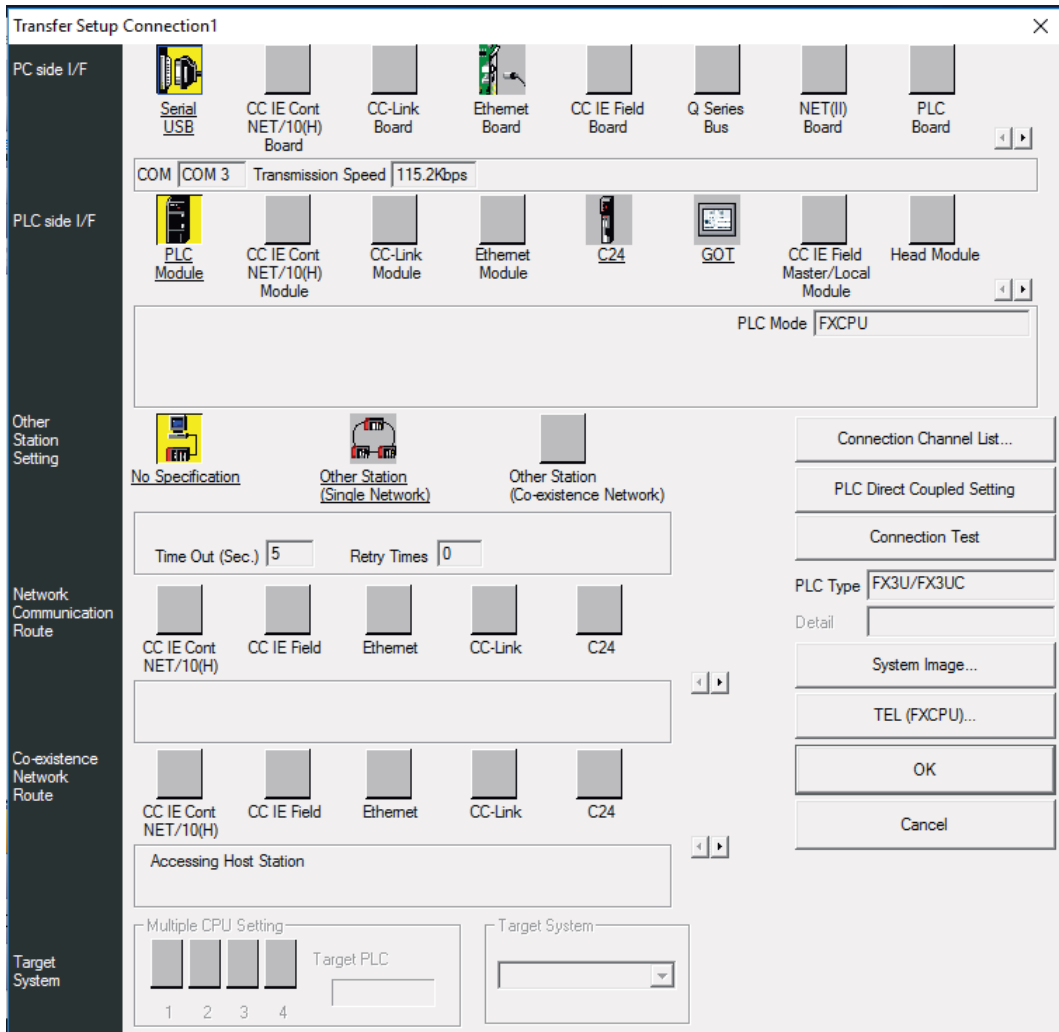

Select the **RS-232C** radio button and select the **COM Port** that the PLC is connected at. Click **Connection Test** to verify the connection and then press OK.

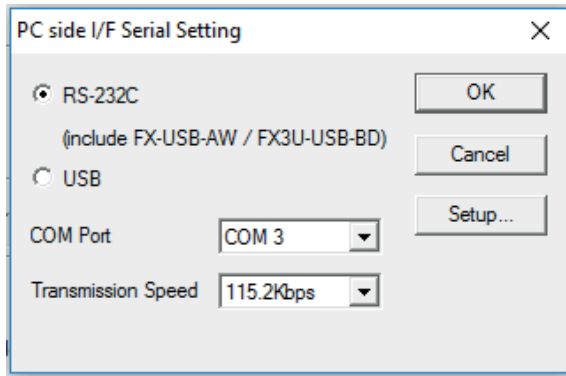

After confirming the **Parameter** option is checked, press **Execute** in the Online Data Operation window.

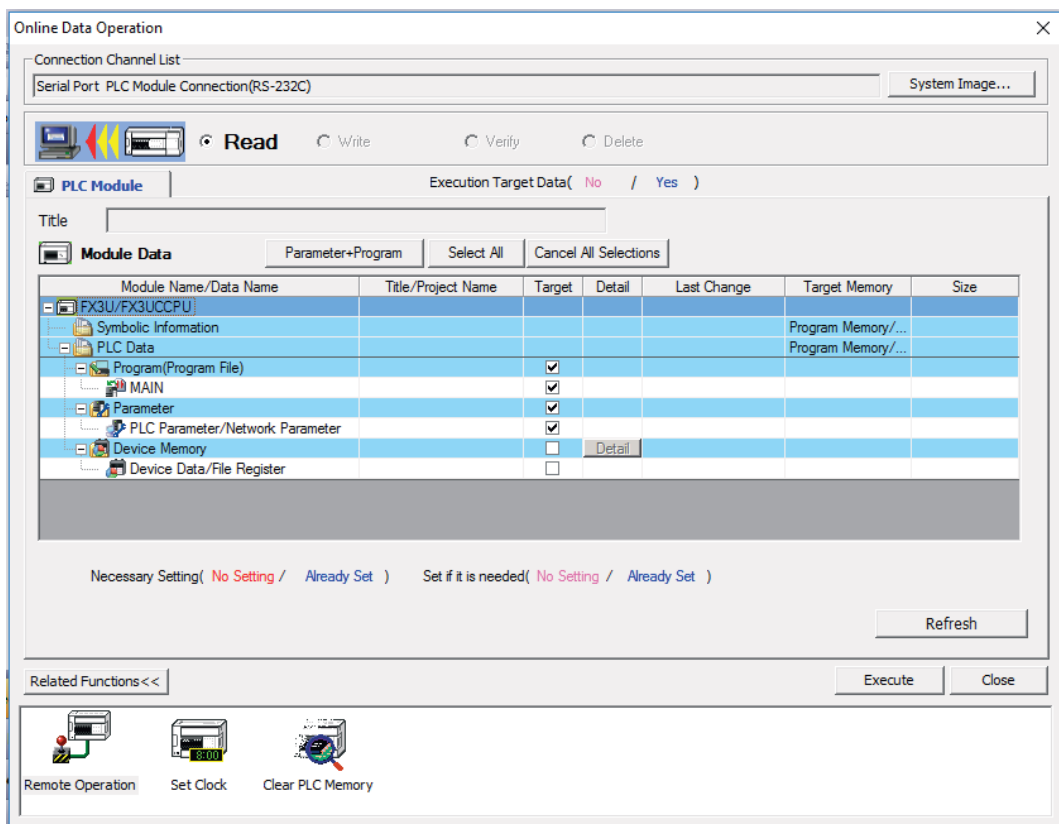

Under the Project Sidebar, expand **Parameter** and select **PLC Parameter**.

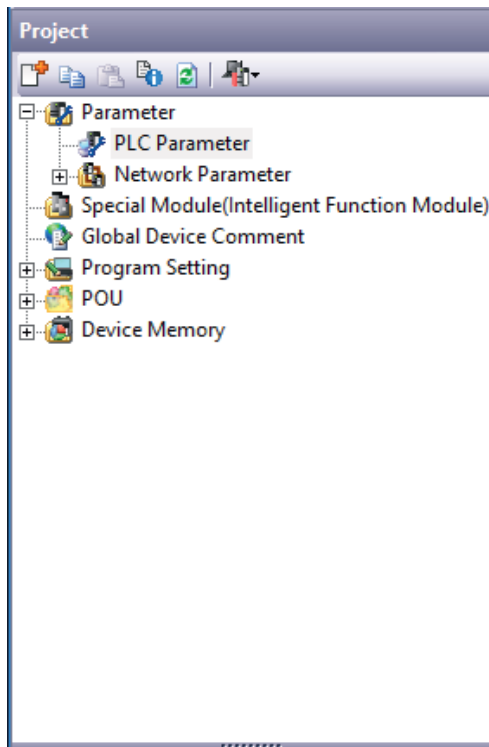

Navigate to the **PLC System(2)** tab and configure it to the settings detailed below.

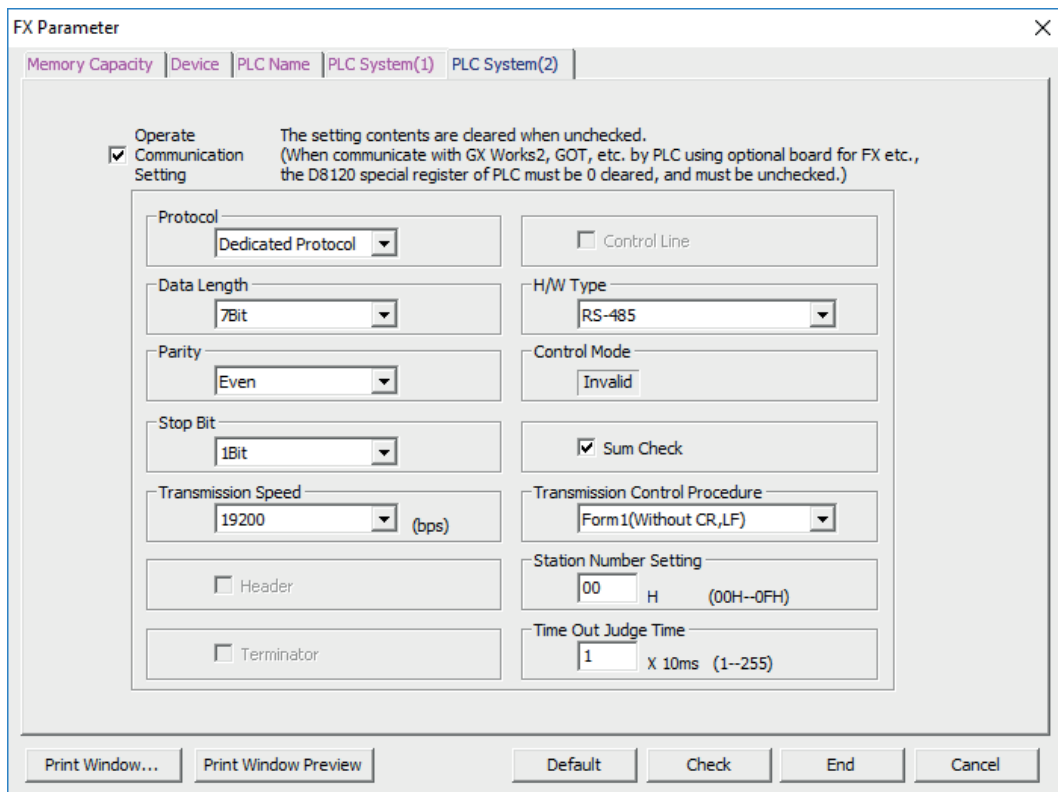

Check **Operate Communication Setting** to enable configuration

Set Protocol to **Dedicated Protocol**

Set Parity to **Even**

Set Transmission Speed to **19200**

Set H/W Type to **RS-485**

Check the **Sum Check** checkbox

Verify the Station Number is consistent with the one set in FvDesigner.

Note: For more detailed information please refer to the PLC manual.

Connecting PLC to HMI

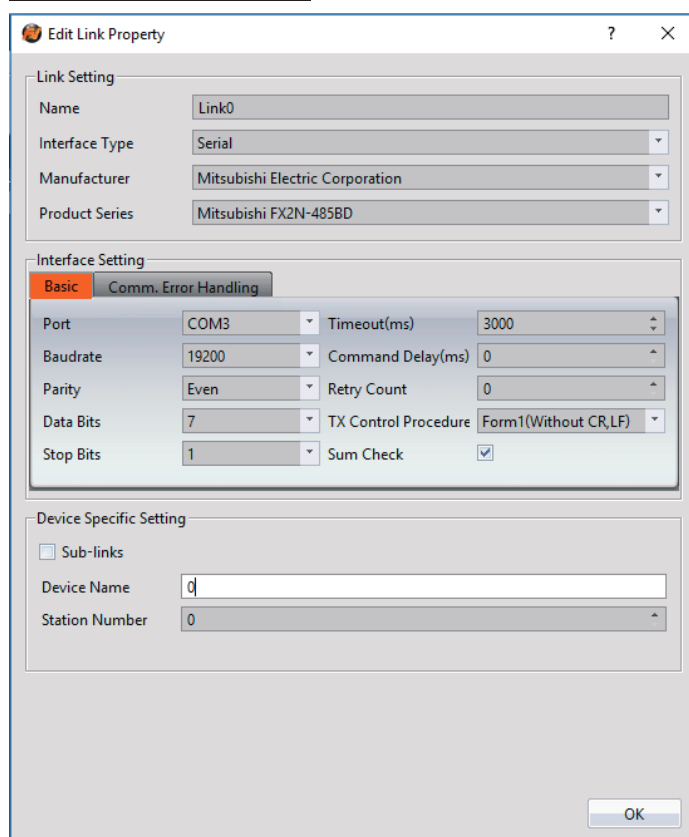

Within the **Link** configuration window in FvDesigner:

Under **Interface Type** select Serial

Under **Manufacturer** select Mitsubishi Electric Corporation

Under **Product Series** select Mitsubishi FX2N-485BD.

Under **Port** select COM3

2.2.2.4 Wiring Diagrams

PLC RS422 Pinout



HMI COM3 Pinout



*Looking into HMI Device

PIN#	COM3 (RS-422/RS-485)
1	
2	
3	ISO_GND
4	RX+
5	RX-
6	TX+
7	TX-

P5070S/P5070N/P5070N1/P5102N/P5102N1

HMI COM3	PLC RS422 Port
5 RX-	SDB
4 RX+	SDA
7 TX-	RDB
6 TX+	RDA
3 ISO_GND	SG

Wiring Diagrams: P5070S/P5070N/P5070N1/P5102N/P5102N1

HMI COM3

PLC RS422

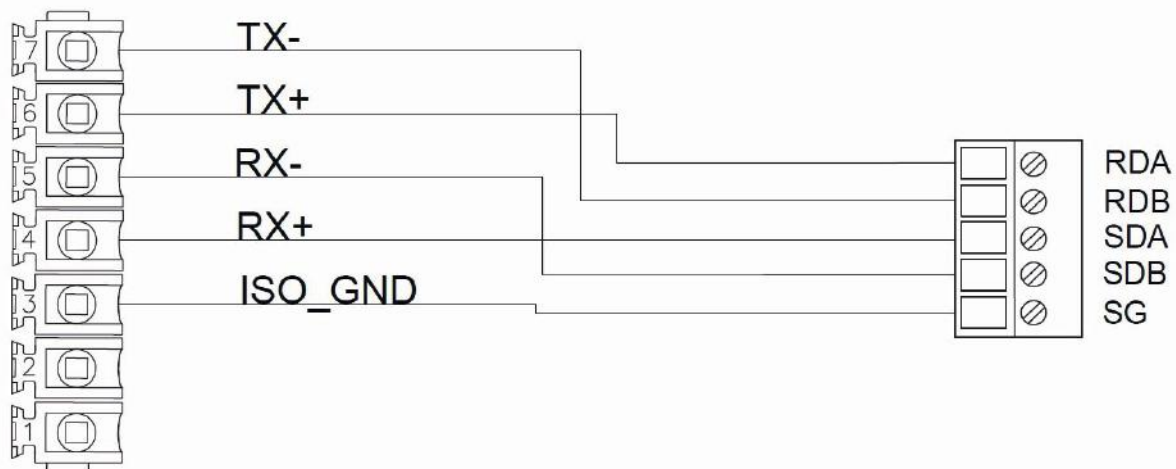

P5043S/P5043N/P5070VS/P5102VS/P2K SERIES

HMI COM2	PLC RS422 Port
9 RX-	SDB
4 RX+	SDA
6 TX-	RDB
1 TX+	RDA
5 GND	SG

Wiring Diagrams: P5043S/P5043N/P5070VS/P5102VS/P2K SERIES

HMI COM2

PLC RS422

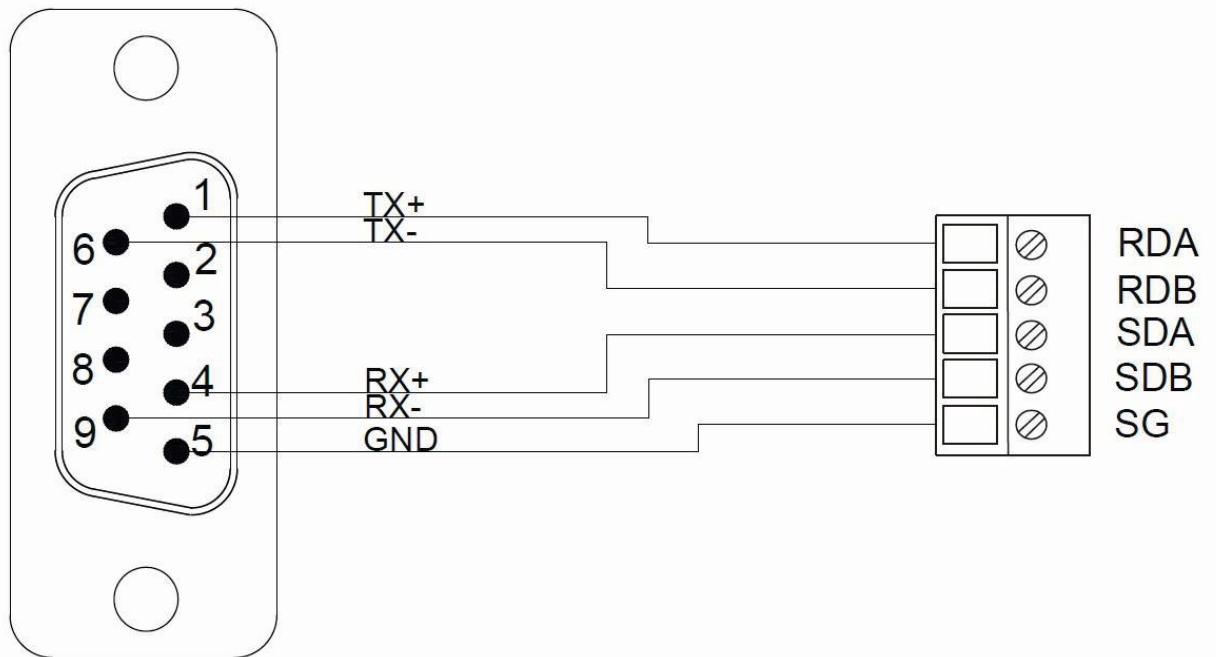

2.2.3 FX3U CPU

2.2.3.1 Communication Setting

Item	Default Setting	Remark
Signal Level	RS485 4W	
Baud Rate	9600	
Data Length	7	
Stop Bit	1	
Parity	Even	
PLC Station No.	0	
Communication Method	Programming Protocol	

2.2.3.2 Memory Resource Review

Device	Description	Data bit	Min.	Max.
X	Input Discrete	1	0	377
Y	Output Relay	1	0	377
M	Internal Relay	1	0	7999
SM	Special Relay	1	8000	8511
S	Step Relay	1	0	4095
TS	Timer Discrete	1	0	511

CS	Counter Discrete	1	0	199
WX	Input Discrete	16	0	360
WY	Output Relay	16	0	360
WM	Internal Relay	16	0	7664
WS	Step Relay	16	0	4080
TN	Timer Memory	16	0	511
CN	Counter Memory	16	0	199
D	Data Register	16	0	7999
SD	Special Data Register	16	8000	8511
R	Extended Register	16	0	32767
DCN	Counter Memory	32	200	255

2.2.3.3 Connecting to HMI

Connecting PLC to HMI

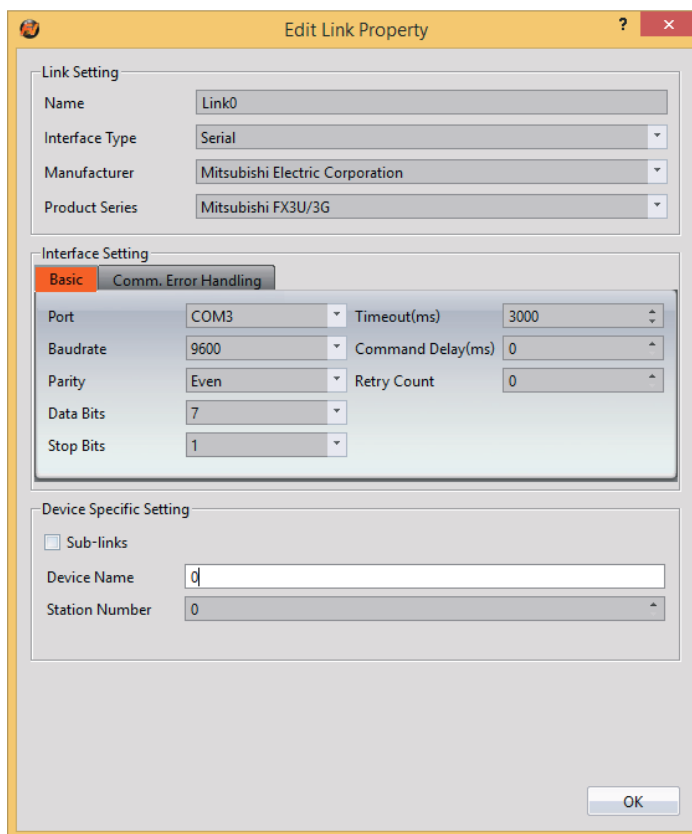

Within the **Link** configuration window in FvDesigner:

Under **Interface Type** select Serial

Under **Manufacturer** select Mitsubishi Electric Corporation

Under **Product Series** select Mitsubishi FX3U/3G

Under **Port** select COM3

2.2.3.4 Wiring Diagrams

PLC RS422 Pinout

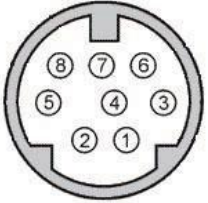
	
*View from soldering point of the cable	
PIN#	Signal
1	RX-
2	RX+
3	GND
4	TX-
5	
6	
7	TX+
8	

HMI COM3 Pinout

	
*Looking into HMI Device	
PIN#	COM3 (RS-422/RS-485)
1	
2	
3	ISO_GND
4	RX+
5	RX-
6	TX+
7	TX-

P5070S/P5070N/P5070N1/P5102N/P5102N1

HMI COM3	PLC RS422 Port
5 RX-	4 TX-
4 RX+	7 TX+
7 TX-	1 RX-
6 TX+	2 RX+
3 ISO_GND	3 GND

Wiring Diagrams: P5070S/P5070N/P5070N1/P5102N/P5102N1

HMI COM3

PLC RS422

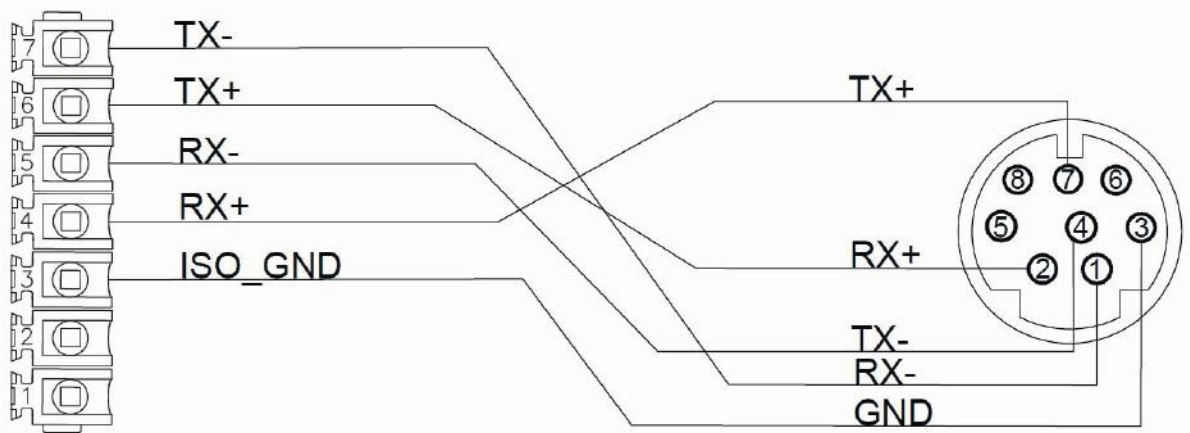

P5043S/P5043N/P5070VS/P5102VS/P2K SERIES

HMI COM2	PLC RS422 Port
9 RX-	4 TX-
4 RX+	7 TX+
6 TX-	1 RX-
1 TX+	2 RX+
5 GND	3 GND

Wiring Diagrams: P5043S/P5043N/P5070VS/P5102VS/P2K SERIES

HMI COM2

PLC RS422

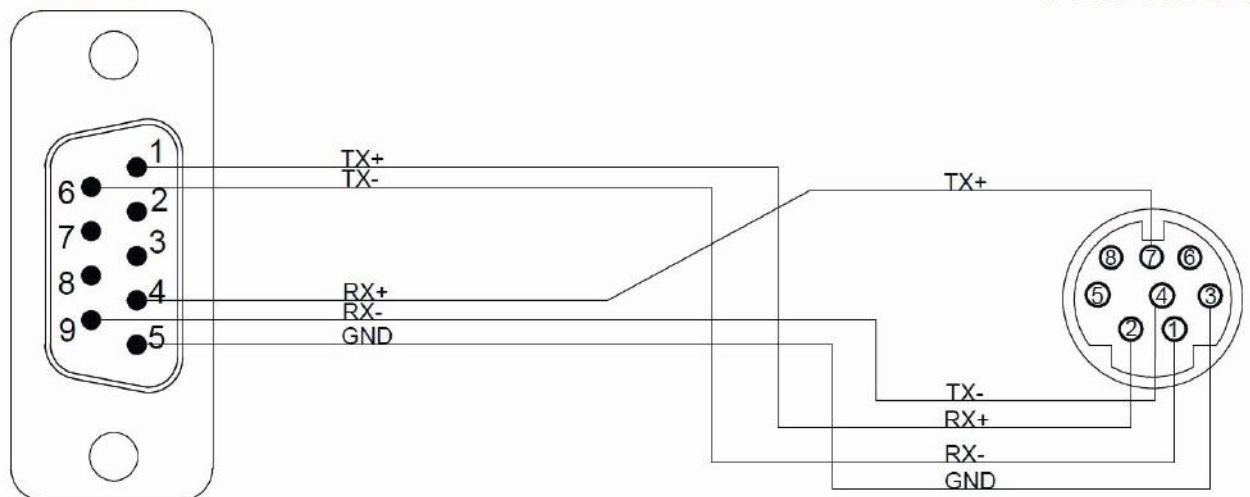

2.2.4 FX3U-485BD

2.2.4.1 Communication Setting

Item	Default Setting	Remark
Signal Level	RS485	
Baud Rate	19200	
Data Length	7	
Stop Bit	1	
Parity	Even	
PLC Station No.	1	
TX Control	Form1	Without CR,LF
Checksum	Yes	
Communication Method	Computer Link	

2.2.4.2 Memory Resource Review

Device	Description	Data bit	Min.	Max.
X	Input Discrete	1	0	377
Y	Output Relay	1	0	377
M	Internal Relay	1	0	7679
SM	Special Relay	1	8000	8511
S	Step Relay	1	0	4095
TS	Timer Discrete	1	0	511
CS	Counter Discrete	1	0	199
WX	Input Discrete	16	0	360
WY	Output Relay	16	0	360

WM	Internal Relay	16	0	7664
WS	Step Relay	16	0	4080
TN	Timer Memory	16	0	511
CN	Counter Memory	16	0	199
D	Data Register	16	0	7999
SD	Special Data Register	16	8000	8511
R	Extended Register	16	0	32767
DCN	Counter Memory	32	200	255

2.2.4.3 Connecting to HMI

Configuring the PLC

Use **MELSOFT GX Works2** to configure the port of the PLC.

Under the **Online** menu option, select **Read from PLC**

Select the **FXCPU** PLC series.

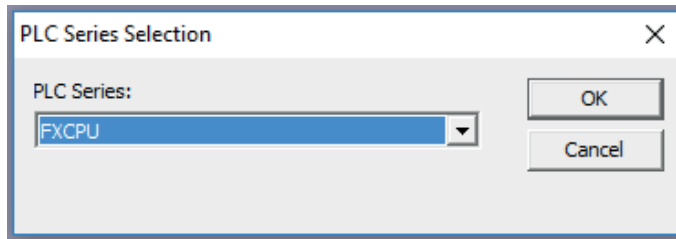

Select **Serial USB** in the Transfer Setup Communication window.

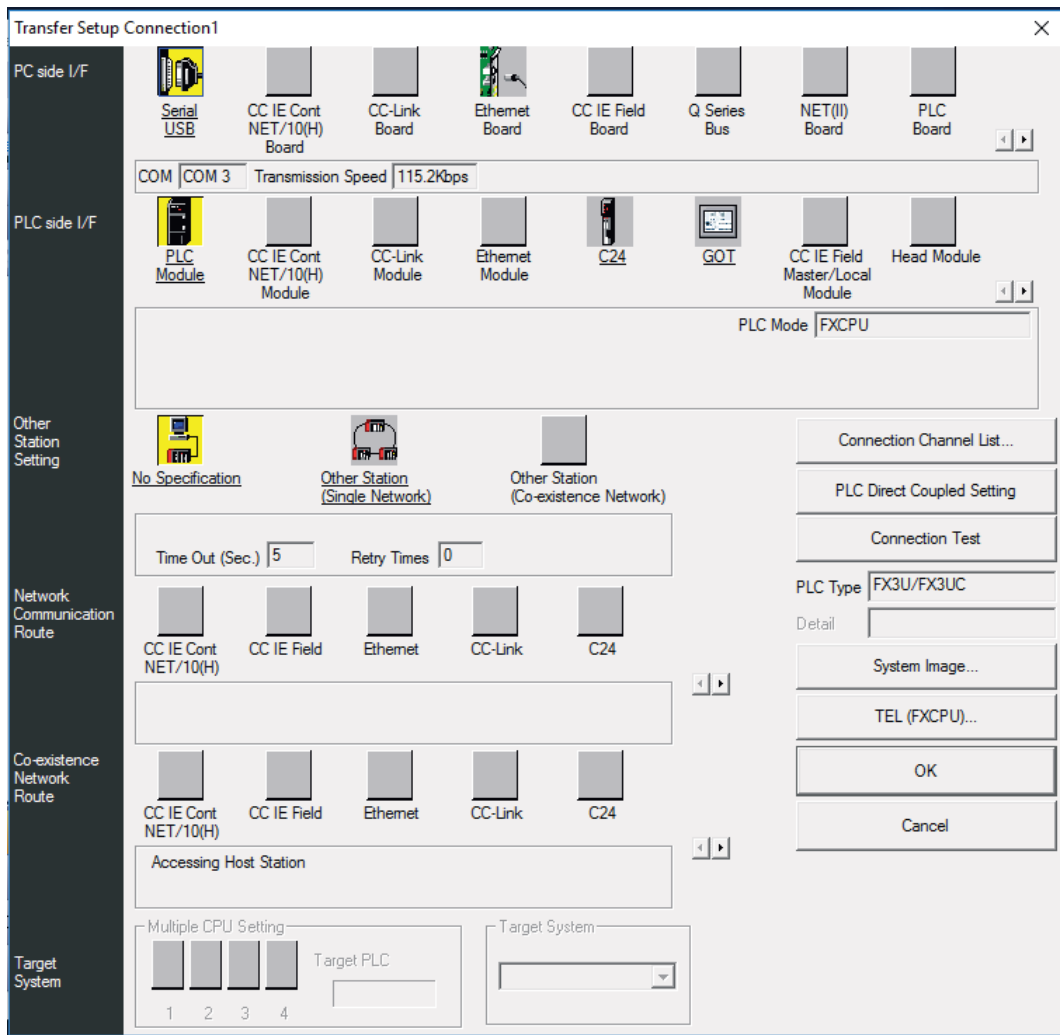

Select the **RS-232C** radio button and select the **COM Port** that the PLC is connected at. Click **Connection Test** to verify the connection and then press OK.

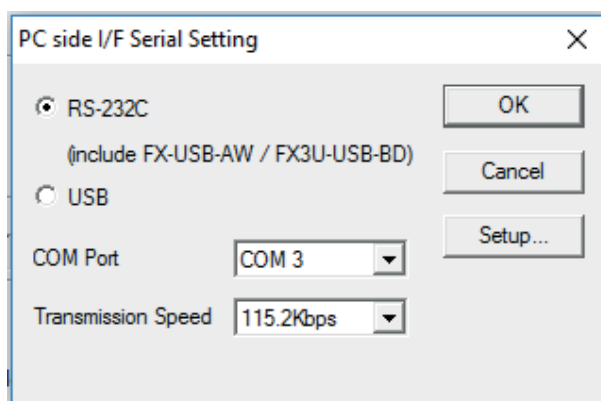

After confirming the **Parameter** option is checked, press **Execute** in the Online Data Operation window.

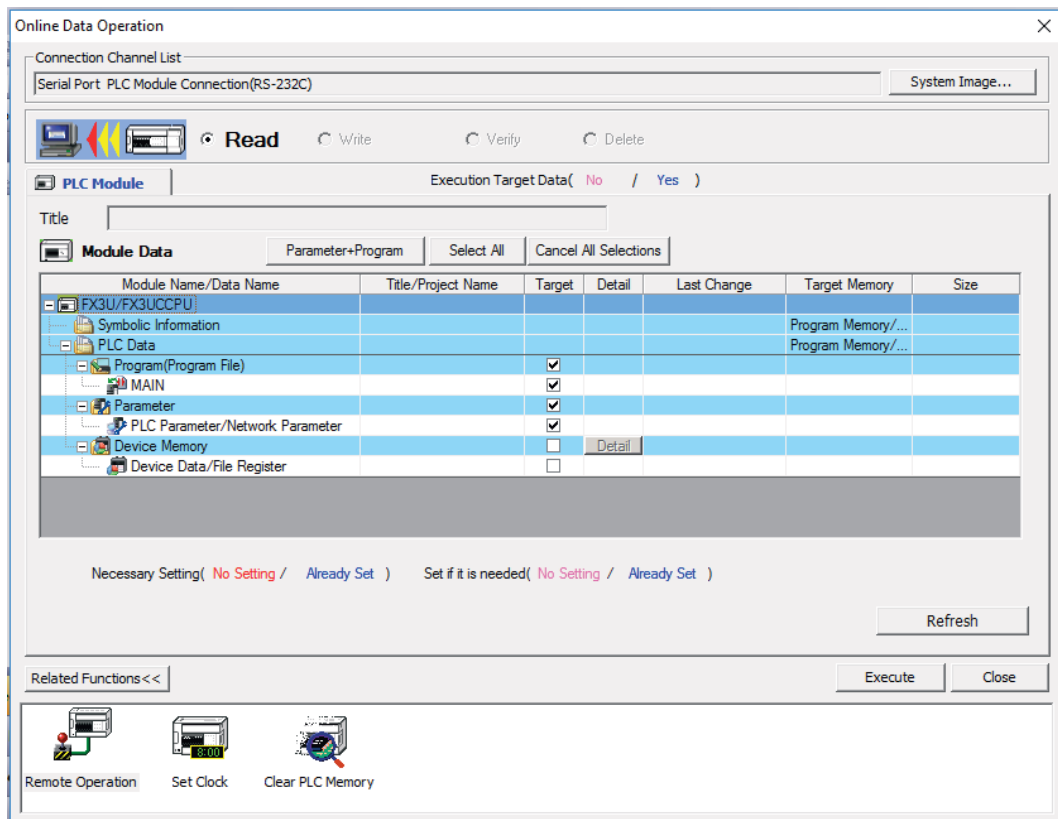

Under the Project Sidebar, expand **Parameter** and select **PLC Parameter**.

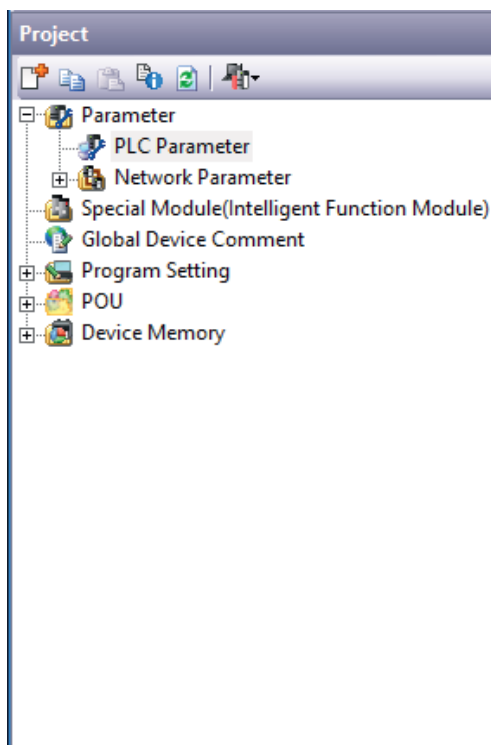

Navigate to the **PLC System(2)** tab and configure it to the settings detailed below.

FX Parameter

Memory Capacity | Device | PLC Name | PLC System(1) | PLC System(2) | Special Function Block | Positioning | Ethernet Port

CH1

Operate
 Communication Setting

The setting contents are cleared when unchecked.
(When communicate with GX Works2, GOT, etc. by PLC using optional board for FX etc., the D8120 special register of PLC must be 0 cleared, and must be unchecked.)

Protocol Dedicated Protocol	<input type="checkbox"/> Control Line
Data Length 7Bit	H/W Type RS-485
Parity Even	Control Mode Invalid
Stop Bit 1Bit	<input checked="" type="checkbox"/> Sum Check
Transmission Speed 19200 (bps)	Transmission Control Procedure Form1(Without CR,LF)
<input type="checkbox"/> Header	Station Number Setting 00 H (00H--0FH)
<input type="checkbox"/> Terminator	Time Out Judge Time 1 X 10ms (1--255)

Print Window... | Print Window Preview | Default | Check | End | Cancel

Check **Operate Communication Setting** to enable configuration

Set Protocol to **Dedicated Protocol**

Set Parity to **Even**

Set Transmission Speed to **19200**

Set H/W Type to **RS-485**

Check the **Sum Check** checkbox

Verify the Station Number is consistent with the one set in FvDesigner.

Note: For more detailed information please refer to the PLC manual.

Connecting PLC to HMI

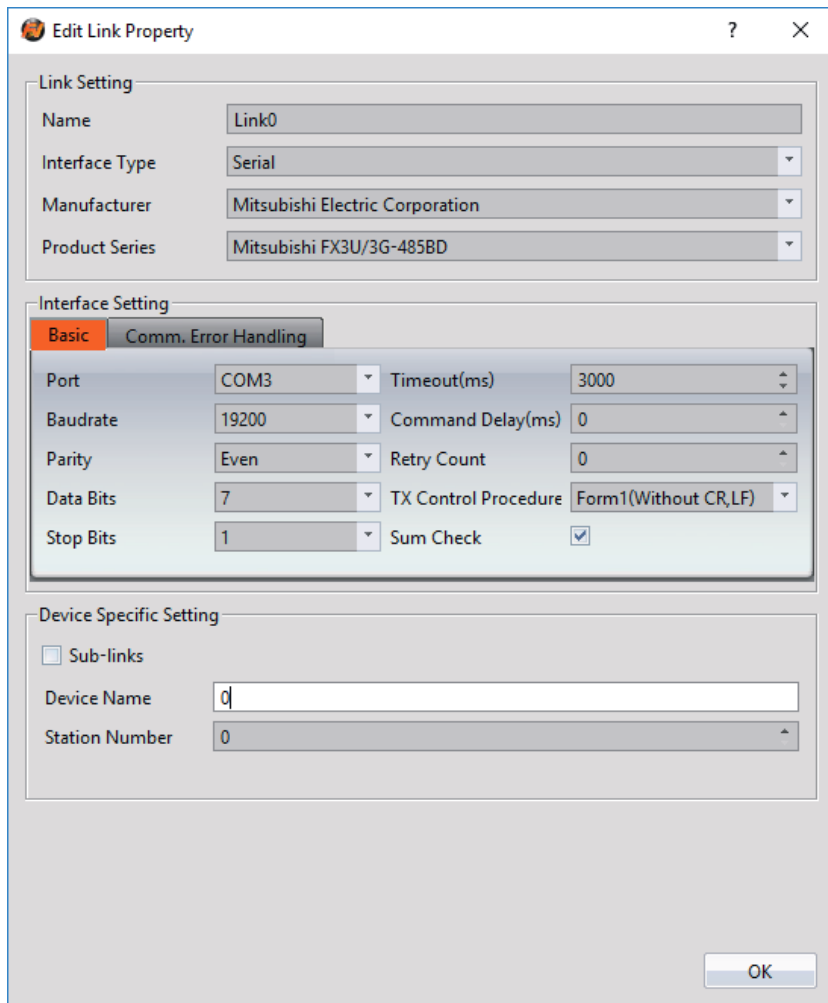

Within the **Link** configuration window in FvDesigner:
 Under **Interface Type** select Serial
 Under **Manufacturer** select Mitsubishi Electric Corporation
 Under **Product Series** select Mitsubishi FX3U/3G-485BD.
 Under **Port** select COM3

2.2.4.4 Wiring Diagrams

PLC RS422 Pinout



HMI COM3 Pinout



*Looking into HMI Device

PIN#	COM3 (RS-422/RS-485)
1	
2	
3	ISO_GND
4	RX+
5	RX-
6	TX+
7	TX-

P5070S/P5070N/P5070N1/P5102N/P5102N1

HMI COM3	PLC RS422 Port
5 RX-	SDB
4 RX+	SDA
7 TX-	RDB
6 TX+	RDA
3 ISO_GND	SG

Wiring Diagrams: P5070S/P5070N/P5070N1/P5102N/P5102N1

HMI COM3

PLC RS422

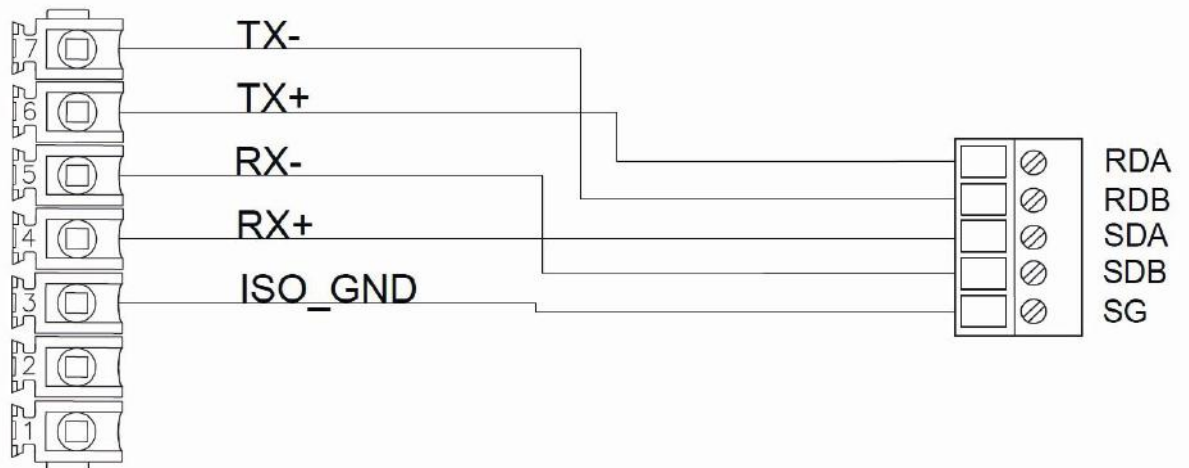

P5043S/P5043N/P5070VS/P5102VS/P2K SERIES

HMI COM2	PLC RS422 Port
9 RX-	SDB
4 RX+	SDA
6 TX-	RDB
1 TX+	RDA
5 GND	SG

Wiring Diagrams: P5043S/P5043N/P5070VS/P5102VS/P2K SERIES

HMI COM2

PLC RS422

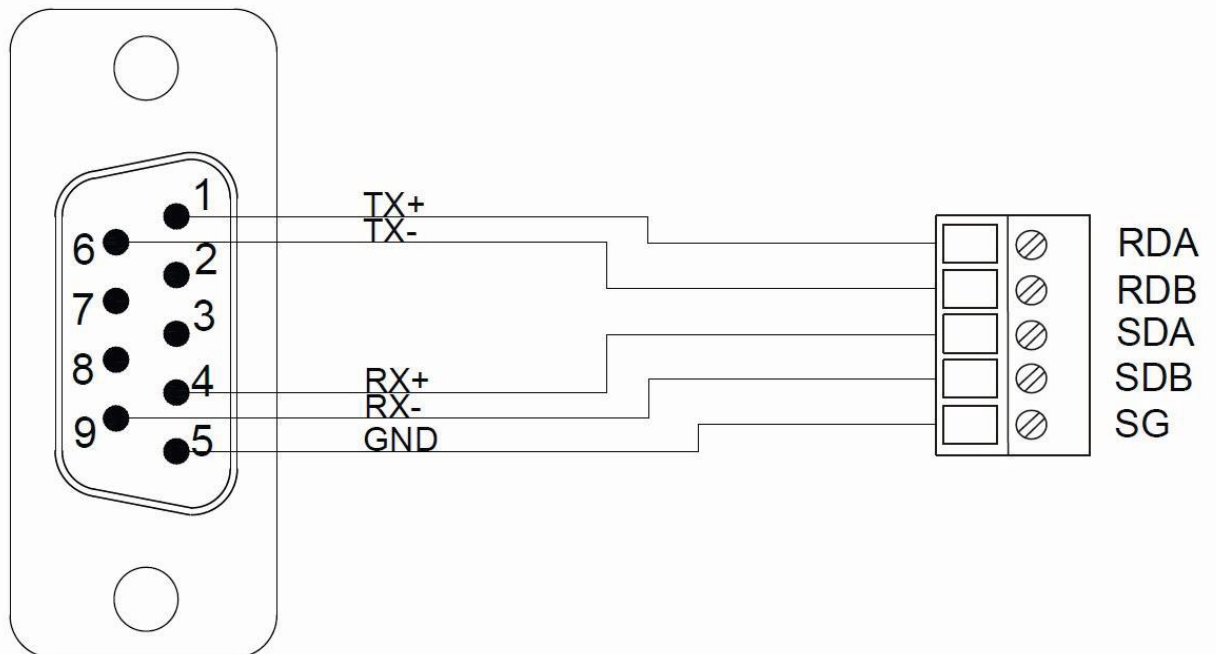

2.2.5 FX3U Ethernet

2.2.5.1 Communication Setting

Item	Default Setting	Remark
Signal Level	Ethernet	
Internet Protocol	0.0.0.0	
Port	5001	
PLC Station No.	0	
Communication Method	MC protocol	Binary/ASCII

2.2.5.2 Memory Resource Review

Device	Description	Data bit	Min.	Max.
X	Input Discrete	1	0	377
Y	Output Relay	1	0	377
M	Internal Relay	1	0	7679
SM	Special Relay	1	8000	8511
S	Step Relay	1	0	4095
TS	Timer Discrete	1	0	511
CS	Counter Discrete	1	0	199
WX	Input Discrete	16	0	360
WY	Output Relay	16	0	360
WM	Internal Relay	16	0	7664
WS	Step Relay	16	0	4080
TN	Timer Memory	16	0	511
CN	Counter Memory	16	0	199
D	Data Register	16	0	7999
SD	Special Data Register	16	8000	8511
R	Extended Register	16	0	32767
DCN	Counter Memory	32	200	255

2.2.5.3 Connecting to HMI

Configuring IP Address on PLC

Use **MELSOFT GX Works2** to configure the IP address of the PLC.

Under the **Online** menu option, select **Read from PLC**

Select the **FXCPU** PLC series.

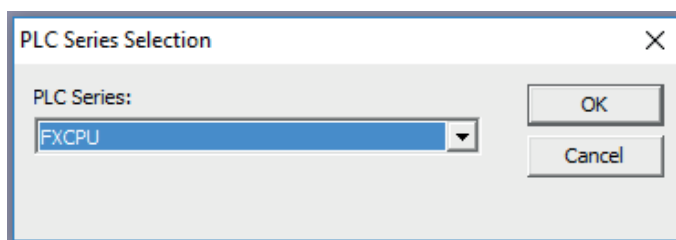

Select **Serial USB** in the Transfer Setup Communication window.

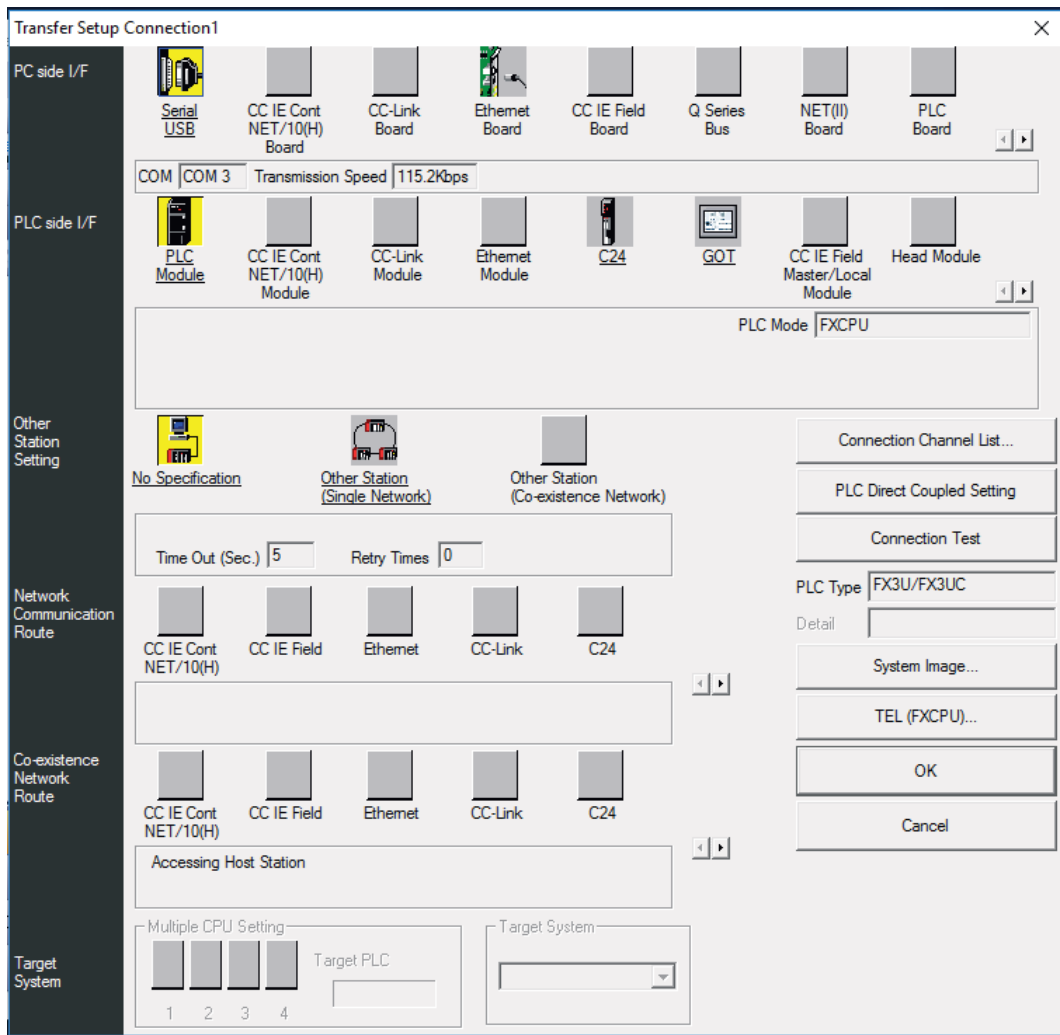

Select the **RS-232C** radio button and select the **COM Port** that the PLC is connected at. Click **Connection Test** to verify the connection and then press OK.

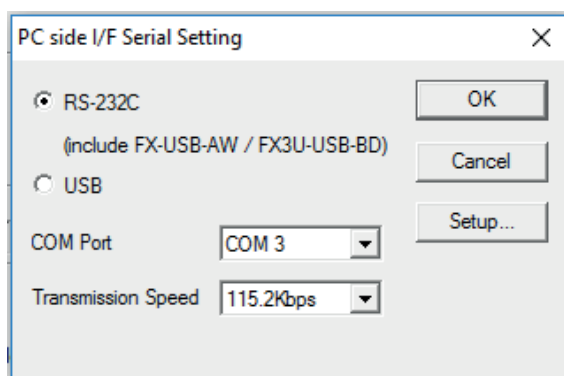

After confirming the **Parameter** option is checked, press **Execute** in the Online Data Operation window.

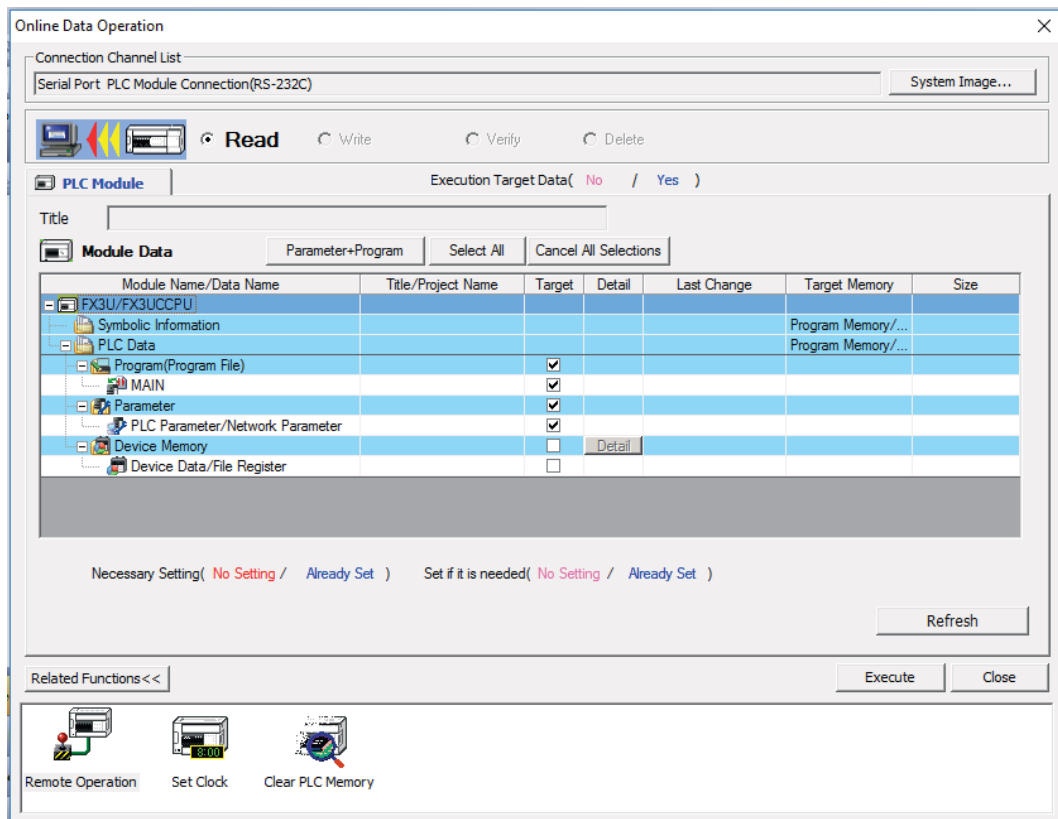

Under the Project Sidebar, expand **Parameter** and select **PLC Parameter**.

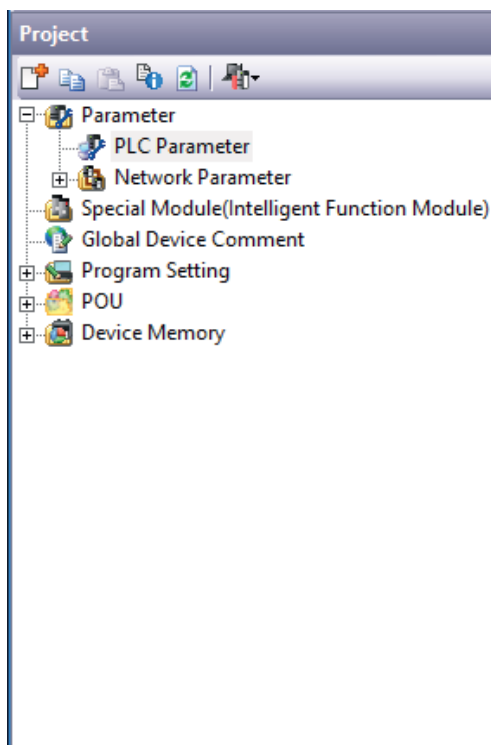

In the **Ethernet Port** tab, set an open IP address.

FX Parameter

Memory Capacity | Device | PLC Name | PLC System(1) | PLC System(2) | Special Function Block | Positioning | Ethernet Port

Channel: CH2

IP Address Setting

Input Format: DEC

IP Address: 192 | 168 | 0 | 30

Subnet Mask Pattern: | | | |

Default Router IP Address: | | | |

Open Setting

Time Setting

Log Record Setting

Optional Settings (Default / Changed)

Communication Data Code

Binary Code

ASCII Code

Disable direct connection to MELSOFT

Do not respond to search for CPU on network

Print Window... | Print Window Preview | Default | Check | End | Cancel

Click **Open Setting** and set the entire **Open System** column to **MC Protocol**. For the **Host Station Port No.**, set row 1 to 5001, row 2 to 5002 and so on.

Ethernet Port Open Setting

	Protocol	Open System	Host Station Port No.	Destination IP Address	Destination Port No.
1	TCP	MC Protocol	5001		
2	TCP	MC Protocol	5002		
3	TCP	MC Protocol	5003		
4	TCP	MC Protocol	5004		

Input decimal value for the Host Station Port No., Destination IP Address and Destination Port No..

End | Cancel

Under the **Online** menu option, select **Write to PLC** to save the settings to the PLC. Press **Execute** in the Online Data Operation window.

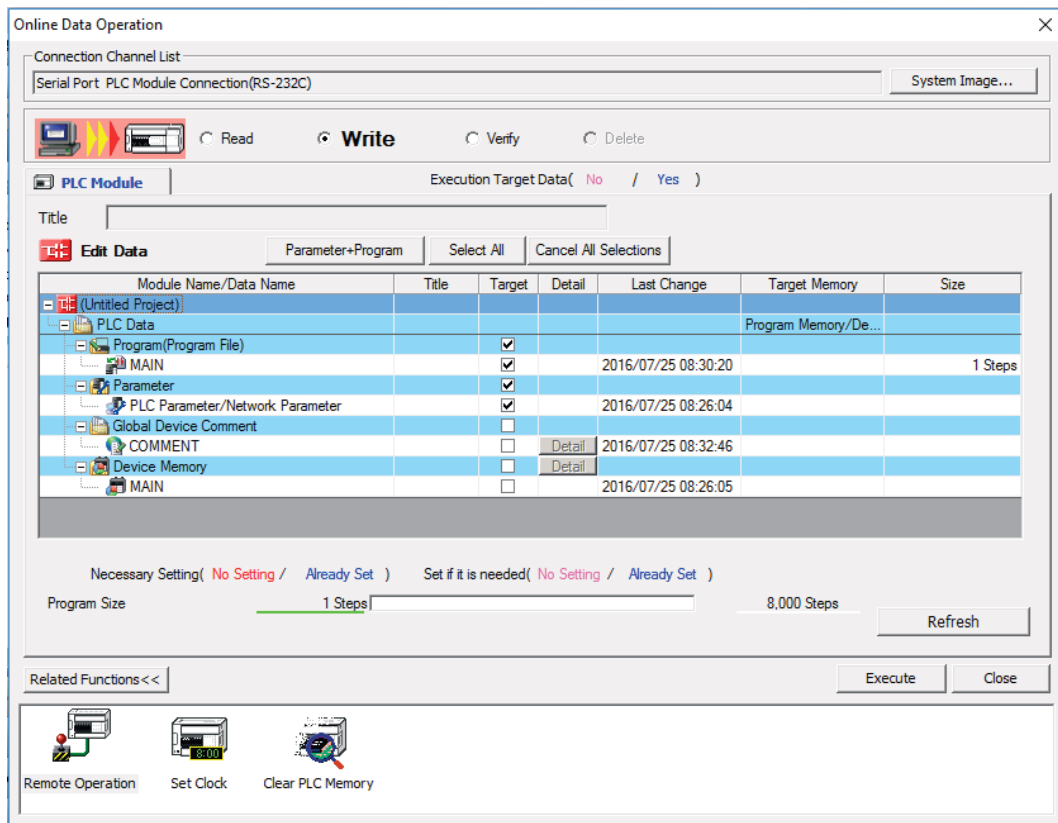

Note: For more detailed information please refer to the PLC manual.

Connecting PLC to HMI

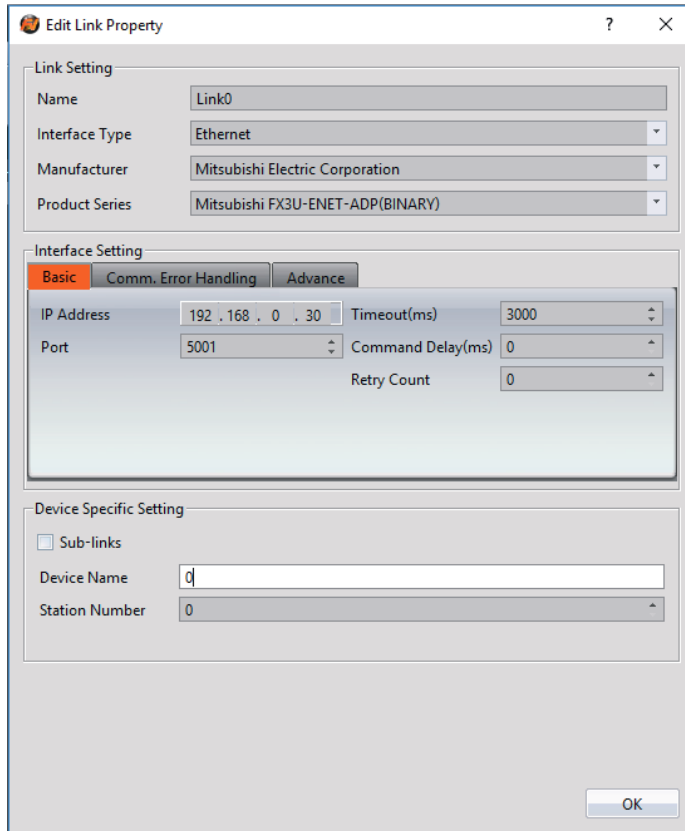

Within the **Link** configuration window in FvDesigner:

Under **Interface Type** select Ethernet

Under **Manufacturer** select Mitsubishi Electric Corporation

Under **Product Series** select one of the Mitsubishi FX3U-ENET-ADP options. The last part of the series name (BINARY or ASCII) should be consistent with the Connection Data Code set in the Ethernet Port for the PLC.

Enter the **IP Address** that was written into the PLC.

Enter 5001 for the Port.

2.2.6 FX5U-Serial

2.2.6.1 Communication Setting

Item	Default Setting	Remark
Signal Level	RS485	
Baud Rate	19200	
Data Length	8	
Stop Bit	1	
Parity	None	
PLC Station No.	0	

TX Control	Form1	Without CR,LF
Checksum	Yes	
Communication Method	MC Protocol 3C	

2.2.6.2 Memory Resource Review

Device	Description	Data bit	Input Format	Min.	Max.
X	Input Relay	1	OOOO	0	1777
Y	Output Relay	1	OOOO	0	1777
M	Internal Relay	1	DDDDD	0	32767
B	Link Relay	1	HHHH	0	7FFF
F	Annunciator	1	DDDDD	0	32767
SB	Link Special Relay	1	HHHH	0	7FFF
S	Step Relay	1	DDDD	0	4095
TS	Timer Contact	1	DDDD	0	1023
TC	Timer Coil	1	DDDD	0	1023
SS	Retentive Timer Contact	1	DDDD	0	1023
SC	Retentive Timer Coil	1	DDDD	0	1023
CS	Counter Contact	1	DDDD	0	1023
CC	Counter Coil	1	DDDD	0	1023
LCS* ¹	Long Counter Contact	1	DDDD	0	1023
LCC* ¹	Long Counter Coil	1	DDDD	0	1023
SM	Special Relay	1	DDDD	0	9999
WX* ²	Input Relay	16	OOOO	0	1760
WY* ²	Output Relay	16	OOOO	0	1760
WM* ³	Internal Relay	16	DDDDD	0	32752
B_Word* ³	Link Relay	16	HHHH	0	7FF0
F_Word* ³	Annunciator	16	DDDDD	0	32752
SB_Word* ³	Link Special Relay	16	HHHH	0	7FF0
WS* ³	Step Relay	16	DDDD	0	4080
TS_Word* ³	Timer Contact	16	DDDD	0	1008
TC_Word* ³	Timer Coil	16	DDDD	0	1008
SS_Word* ³	Retentive Timer Contact	16	DDDD	0	1008

SC_Word *3	Retentive Timer Coil	16	DDDD	0	1008
CS_Word *3	Counter Contact	16	DDDD	0	1008
CC_Word *3	Counter Coil	16	DDDD	0	1008
SM_Word *3	Special Relay	16	DDDD	0	9984
TN	Timer Current Value	16	DDDD	0	1023
SN	Retentive Timer Current Value	16	DDDD	0	1023
CN	Counter Current Value	16	DDDD	0	1023
D	Data Register	16	DDDD	0	7999
W	Link Register	16	HHHH	0	7FFF
SW	Link special Register	16	HHHH	0	7FFF
SD	Special Register	16	DDDDD	0	11999
R	File Register	16	DDDDD	0	32767
Z	Index Register	16	DD	0	23
LCN*1	Long Counter Current Value	32	DDDD	0	1023
LZ	Long Index Register	32	DD	0	11

*1 Binary mode support only

*2 Address increased by 0, 20, 40, 60...

*3 Address increased by 0, 20, 40, 60...

2.2.6.3 Connecting to HMI

Configuring the PLC

Connect the PLC using an Ethernet cable. The following setup uses an Ethernet Port Direct Connection to configure the PLC.

Use **MELSOFT GX Works3** to configure the port of the PLC.

Under the **Online** menu option, select **Read from PLC**.

Select the **FX5CPU** option for the Series.

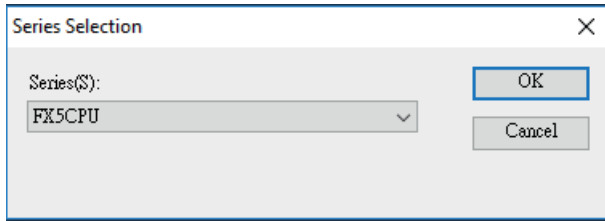

In the connection window, select **Ethernet Board**. Click **PLC Module** and in the dialog window, select the **Ethernet Port Direct Connection** radio button.

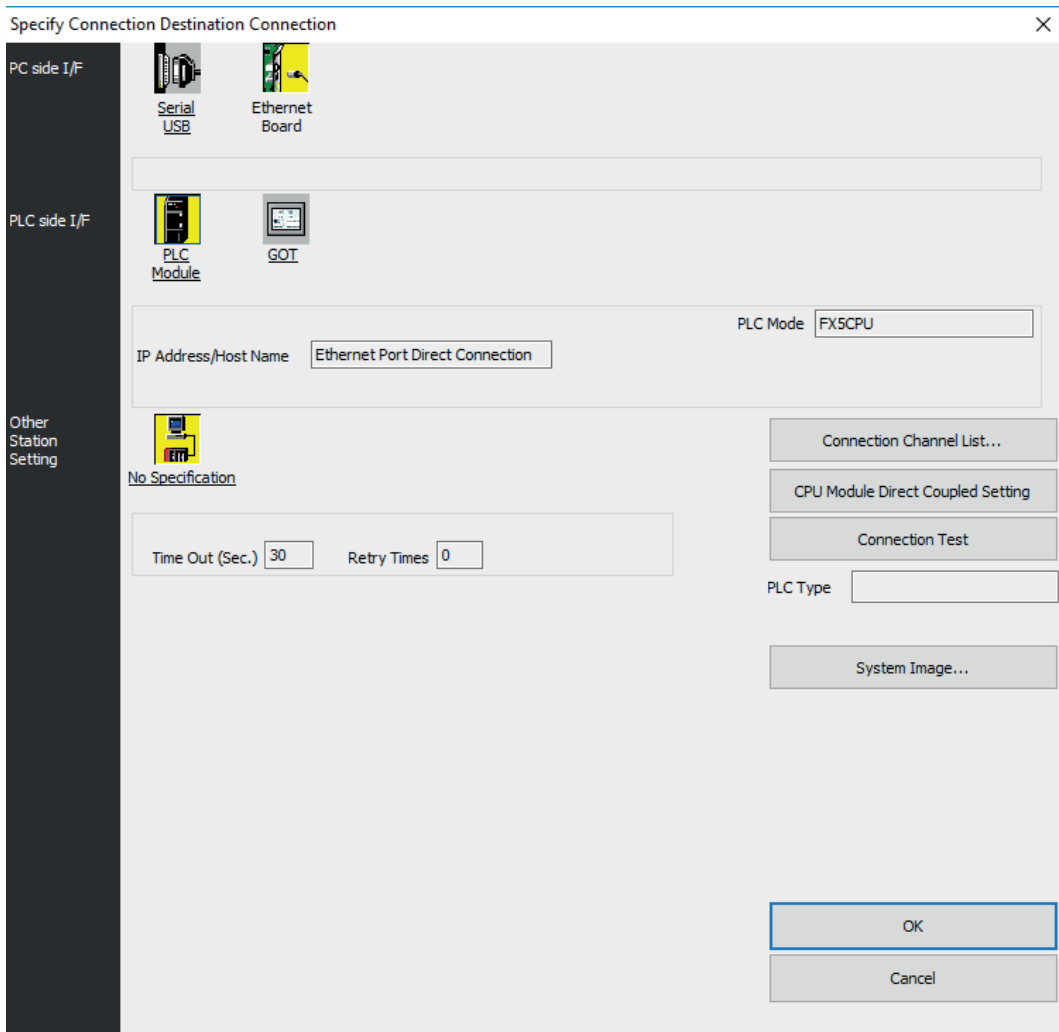

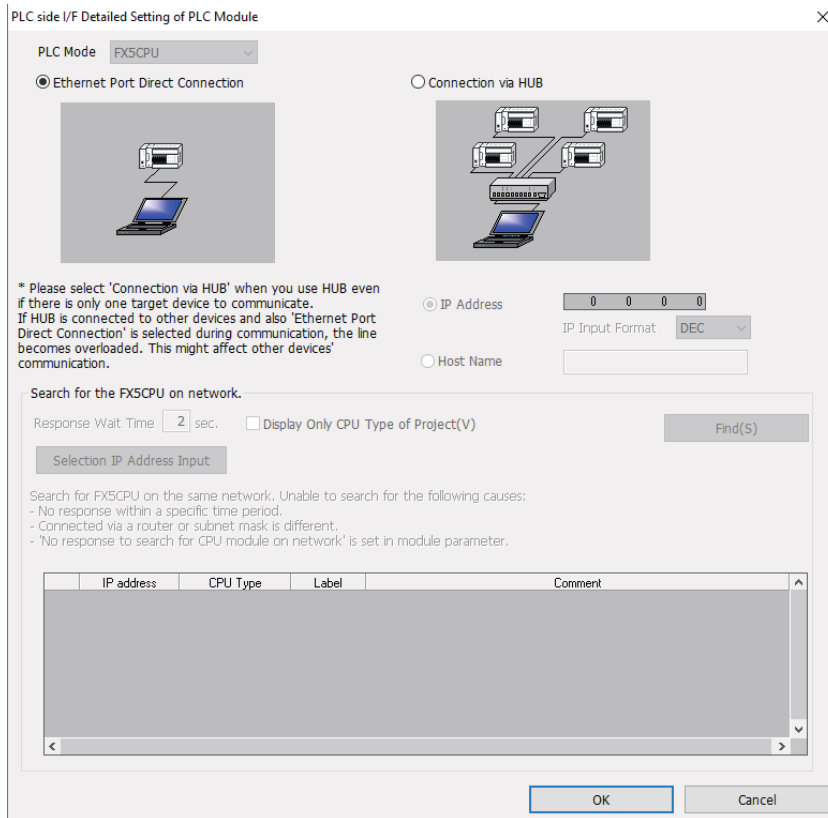

Click **Connection Test** to verify the connection and then press **OK**.

Click **Select All** in the Online Data Operation window and press **Execute**. Allow the read to finish.

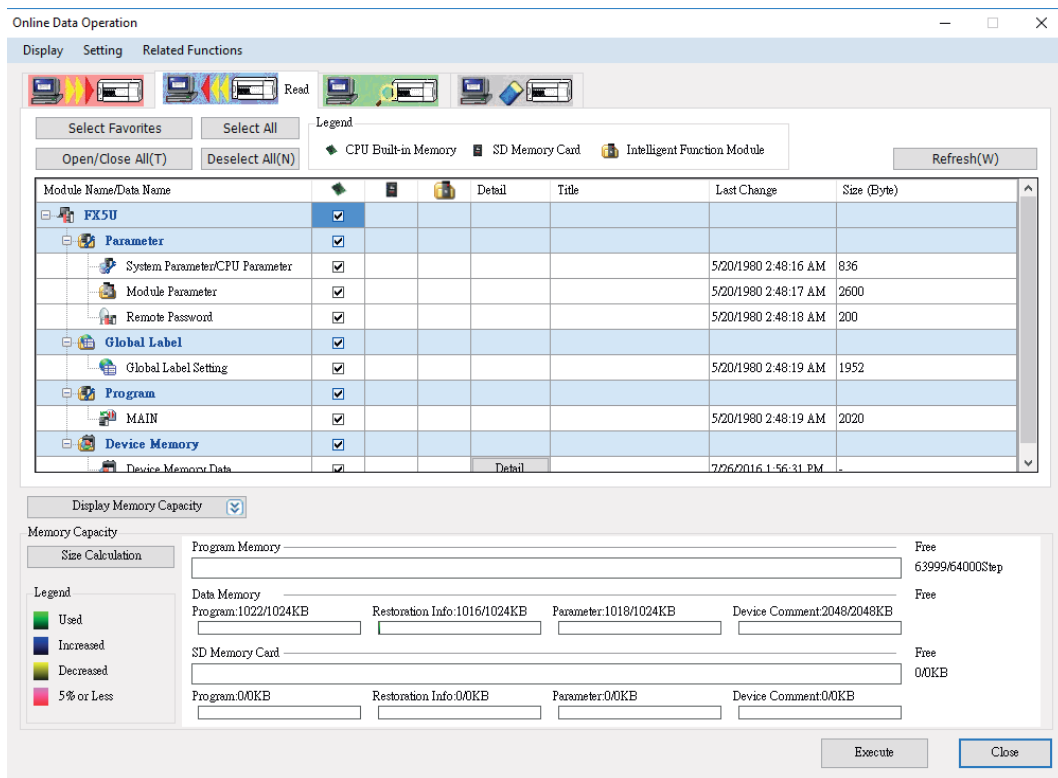

In the **Project** sidebar, expand **Parameter**, **FX5UCPU**, and **Module Parameter** and select **485 Serial Port**.

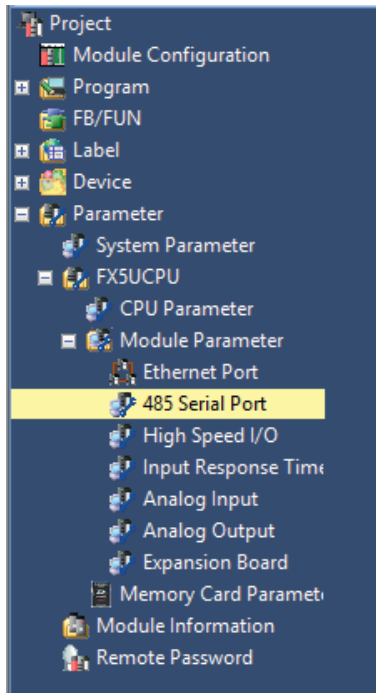

Under **Basic Settings**, change **Communication Protocol Type** to **MC Protocol**.

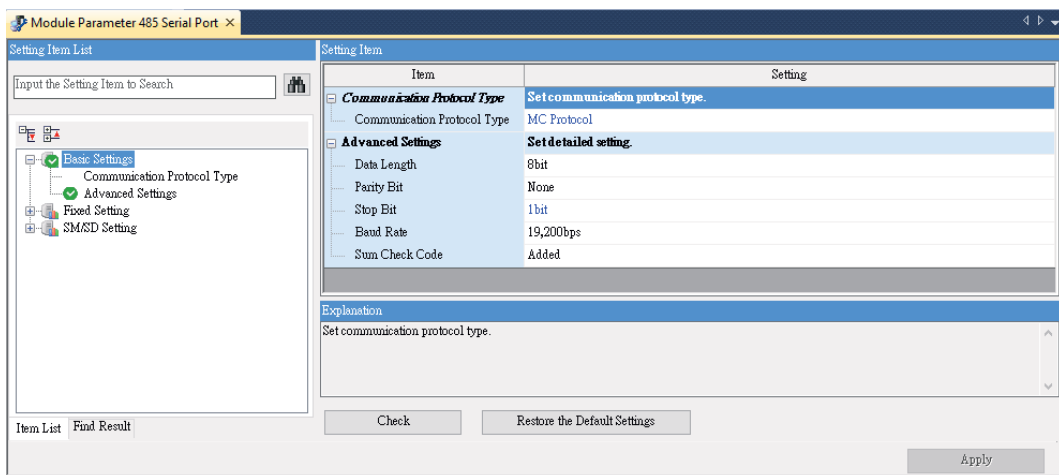

Under **Fixed Setting**, change **Message Pattern** to **Pattern 1** and verify the station number is consistent with the one set in FvDesigner.

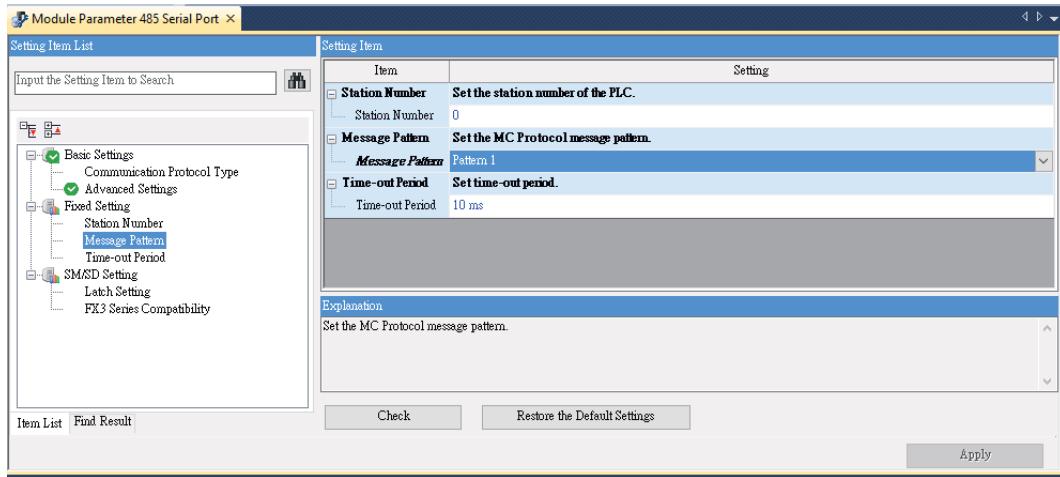

Under the **Online** menu option, select **Write to PLC** to save the settings to the PLC. Click **Select All** and press **Execute** in the Online Data Operation window.

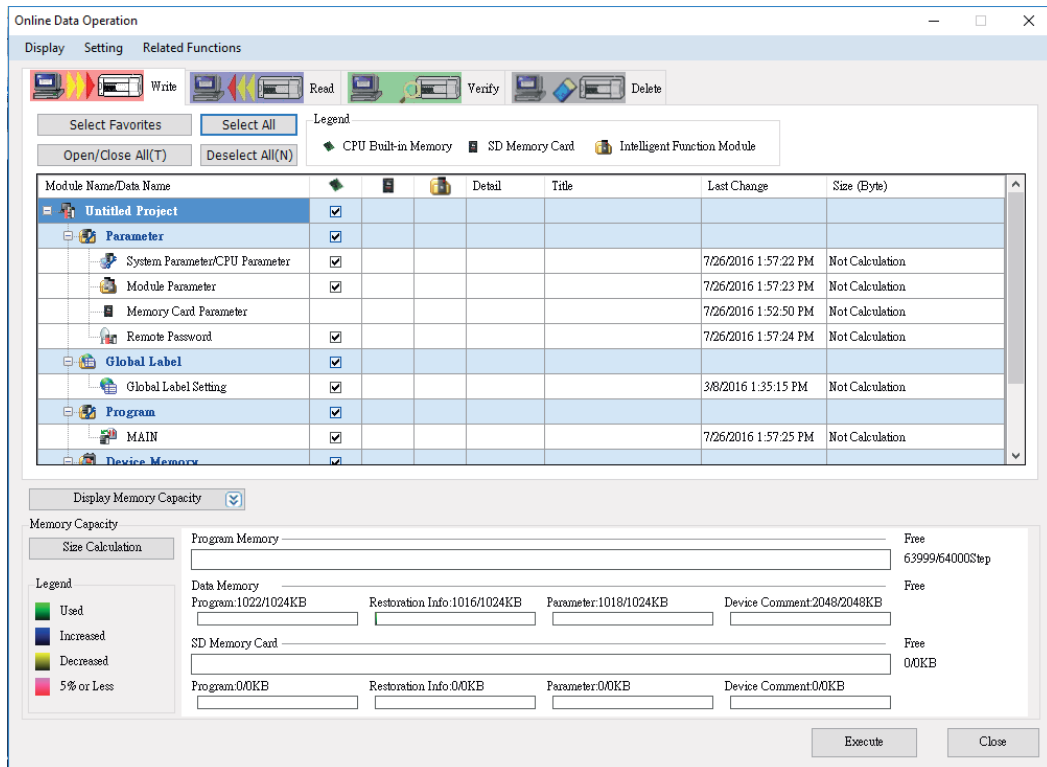

Note: For more detailed information please refer to the PLC manual.

Connecting PLC to HMI

Within the **Link** configuration window in FvDesigner:

Under **Interface Type** select Serial

Under **Manufacturer** select Mitsubishi Electric Corporation

Under **Product Series** select Mitsubishi FX5U-SERIAL.

Verify the parameters match the window above.

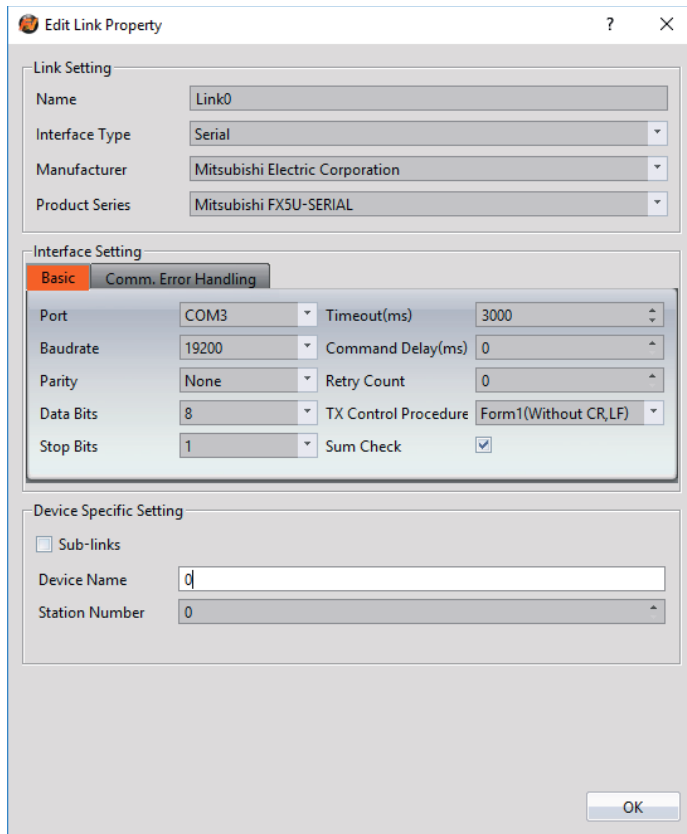

2.2.6.4 Wiring Diagrams

PLC RS422 Pinout

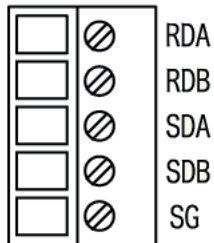

HMI COM3 Pinout

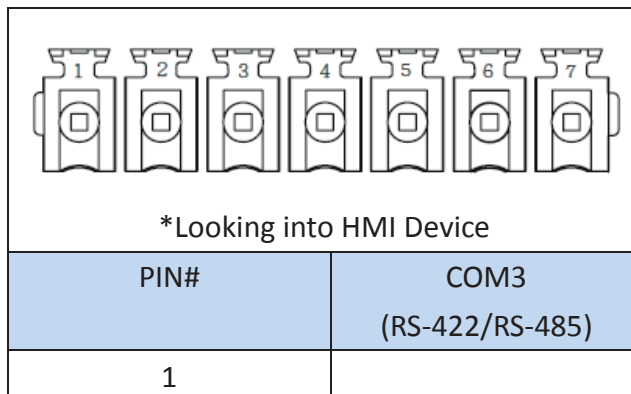

2	
3	ISO_GND
4	RX+
5	RX-
6	TX+
7	TX-

P5070S/P5070N/P5070N1/P5102N/P5102N1

HMI COM3	PLC RS422 Port
5 RX-	SDB
4 RX+	SDA
7 TX-	RDB
6 TX+	RDA
3 ISO_GND	SG

Wiring Diagrams: P5070S/P5070N/P5070N1/P5102N/P5102N1

HMI COM3

PLC RS422

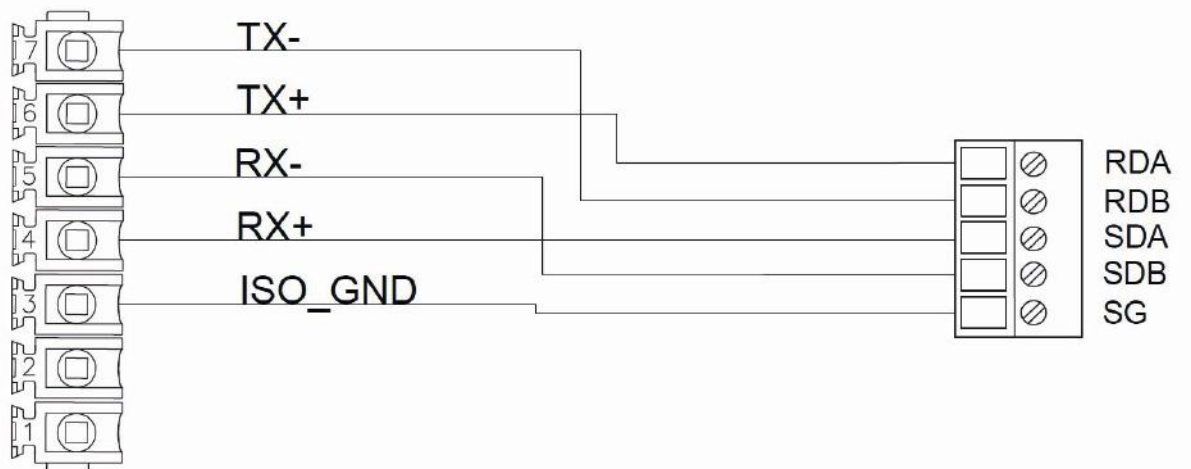

P5043S/P5043N/P5070VS/P5102VS/P2K SERIES

HMI COM2	PLC RS422 Port
9 RX-	SDB
4 RX+	SDA
6 TX-	RDB
1 TX+	RDA
5 GND	SG

HMI COM2

PLC RS422

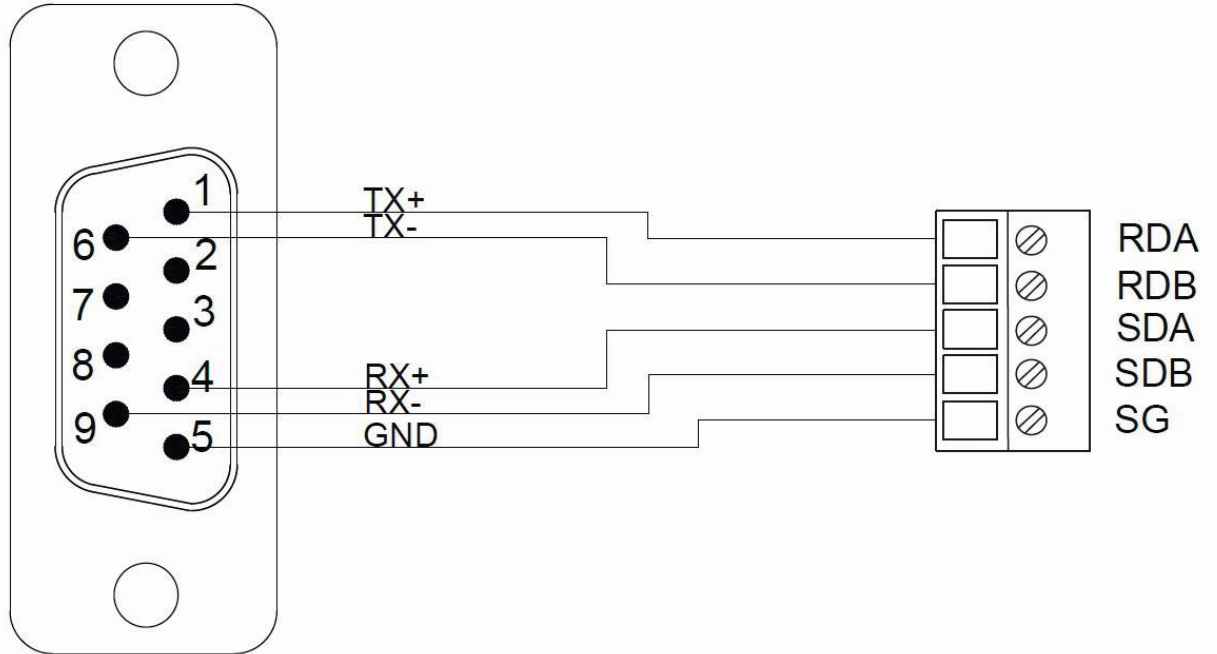

2.2.7 FX5U Ethernet

2.2.7.1 Communication Setting

Item	Default Setting	Remark
Signal Level	Ethernet	
Internet Protocol	0.0.0.0	
Port	1025	
PLC Station No.	0	
Communication Method	MC protocol 3E	Binary/ASCII

2.2.7.2 Memory Resource Review

Device	Description	Data bit	Input Format	Min.	Max.
X	Input Relay	1	OOOO	0	1777
Y	Output Relay	1	OOOO	0	1777
M	Internal Relay	1	DDDDD	0	32767
B	Link Relay	1	HHHH	0	7FFF
F	Annunciator	1	DDDDD	0	32767

SB	Link Special Relay	1	HHHH	0	7FFF
S	Step Relay	1	DDDD	0	4095
TS	Timer Contact	1	DDDD	0	1023
TC	Timer Coil	1	DDDD	0	1023
SS	Retentive Timer Contact	1	DDDD	0	1023
SC	Retentive Timer Coil	1	DDDD	0	1023
CS	Counter Contact	1	DDDD	0	1023
CC	Counter Coil	1	DDDD	0	1023
LCS* ¹	Long Counter Contact	1	DDDD	0	1023
LCC* ¹	Long Counter Coil	1	DDDD	0	1023
SM	Special Relay	1	DDDD	0	9999
WX* ²	Input Relay	16	OOOO	0	1760
WY* ²	Output Relay	16	OOOO	0	1760
WM* ³	Internal Relay	16	DDDDD	0	32752
B_Word * ³	Link Relay	16	HHHH	0	7FF0
F_Word * ³	Annunciator	16	DDDDD	0	32752
SB_Word * ³	Link Special Relay	16	HHHH	0	7FF0
WS* ³	Step Relay	16	DDDD	0	4080
TS_Word * ³	Timer Contact	16	DDDD	0	1008
TC_Word * ³	Timer Coil	16	DDDD	0	1008
SS_Word * ³	Retentive Timer Contact	16	DDDD	0	1008
SC_Word * ³	Retentive Timer Coil	16	DDDD	0	1008
CS_Word * ³	Counter Contact	16	DDDD	0	1008
CC_Word * ³	Counter Coil	16	DDDD	0	1008
SM_Word * ³	Special Relay	16	DDDD	0	9984
TN	Timer Current Value	16	DDDD	0	1023
SN	Retentive Timer Current Value	16	DDDD	0	1023
CN	Counter Current Value	16	DDDD	0	1023

D	Data Register	16	DDDD	0	7999
W	Link Register	16	HHHH	0	7FFF
SW	Link special Register	16	HHHH	0	7FFF
SD	Special Register	16	DDDDD	0	11999
R	File Register	16	DDDDD	0	32767
Z	Index Register	16	DD	0	23
LCN* ¹	Long Counter Current Value	32	DDDD	0	1023
LZ	Long Index Register	32	DD	0	11

*¹ Binary mode support only

*² Address increased by 0, 20, 40, 60...

*³ Address increased by 0, 20, 40, 60...

2.2.7.3 Connecting to HMI

Configuring IP Address on PLC

Connect the PLC using an Ethernet cable. The following setup uses an Ethernet Port Direct Connection to configure the PLC.

Use **MELSOFT GX Works3** to configure the port of the PLC.

Under the **Online** menu option, select **Read from PLC**.

Select the **FX5CPU** option for the Series.

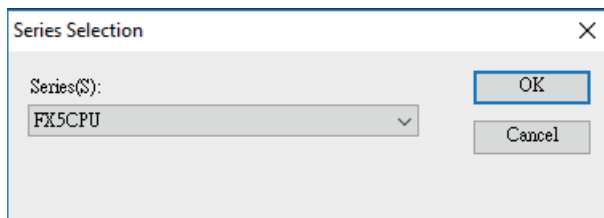

In the connection window, select **Ethernet Board**. Click **PLC Module** and in the dialog window, select the **Ethernet Port Direct Connection** radio button.

Specify Connection Destination Connection

PC side I/F

Serial USB Ethernet Board

PLC side I/F

PLC Module GOT

IP Address/Host Name Ethernet Port Direct Connection PLC Mode FX5CPU

Other Station Setting

No Specification

Time Out (Sec.) 30 Retry Times 0

Connection Channel List...

CPU Module Direct Coupled Setting

Connection Test

PLC Type

System Image...

OK

Cancel

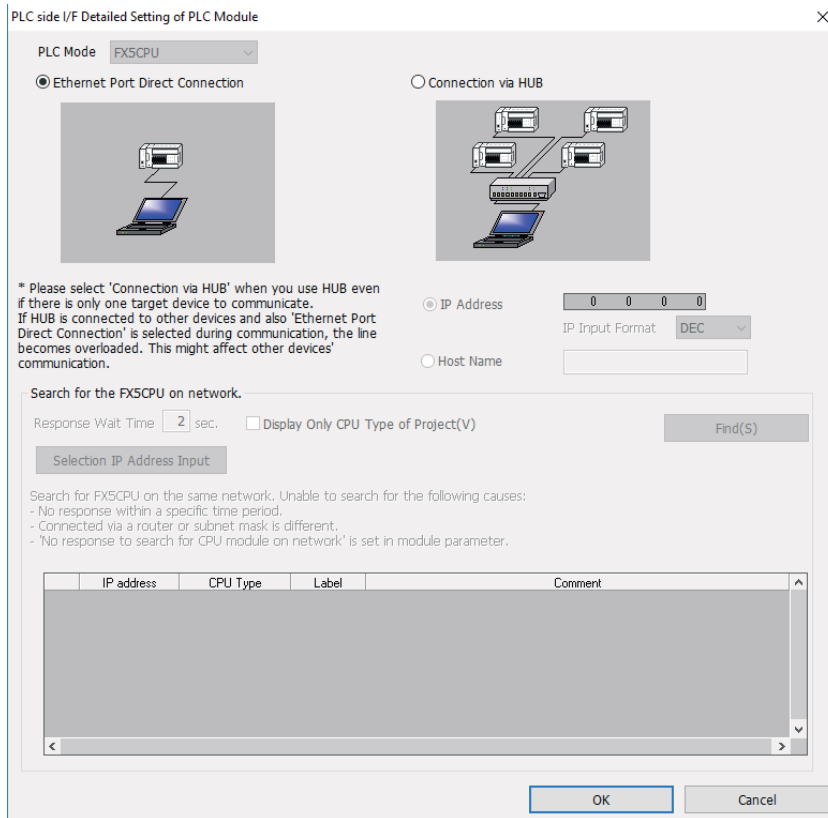

Click **Connection Test** to verify the connection and then press OK.

Click **Select All** in the Online Data Operation window and press **Execute**. Allow the read to finish.

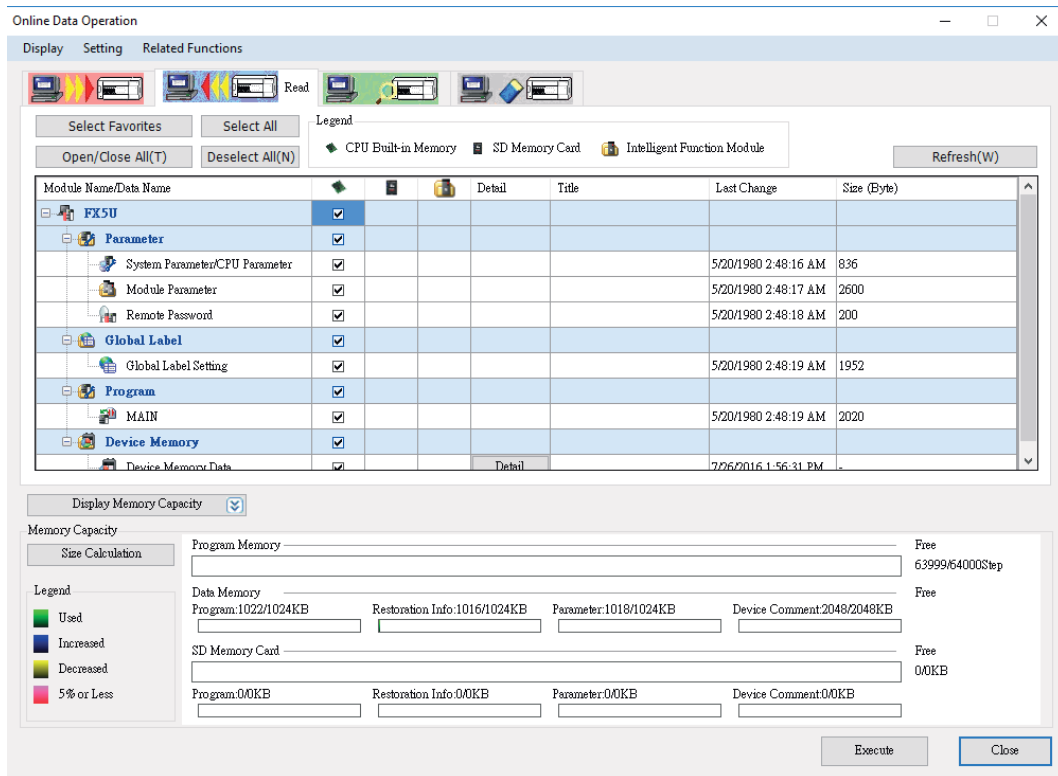

In the **Project** sidebar, expand **Parameter**, **FX5UCPU**, and **Module Parameter** and select **Ethernet Port**.

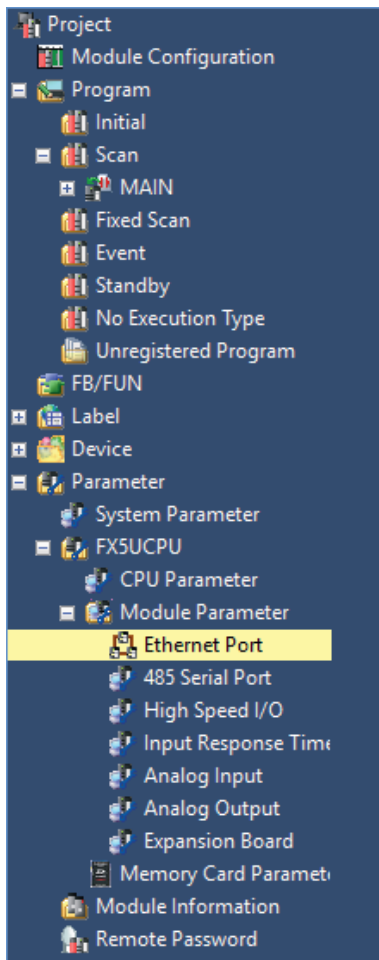

The **IP Address** of the PLC can be obtained here. Switch the **Communication Data Code** to the mode needed (Binary or ASCII). Double click “<Detailed Setting>” under **External Device Configuration** to get the port information. Verify the **Protocol** is TCP.

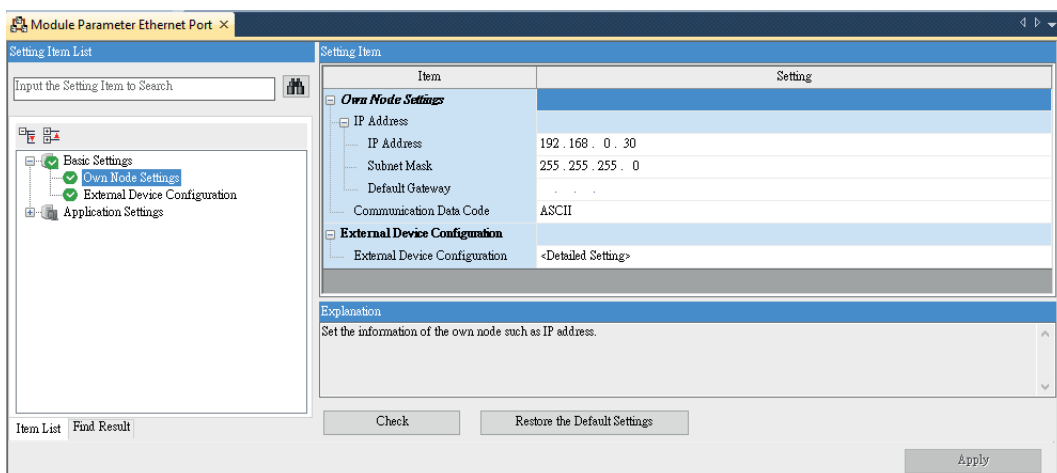

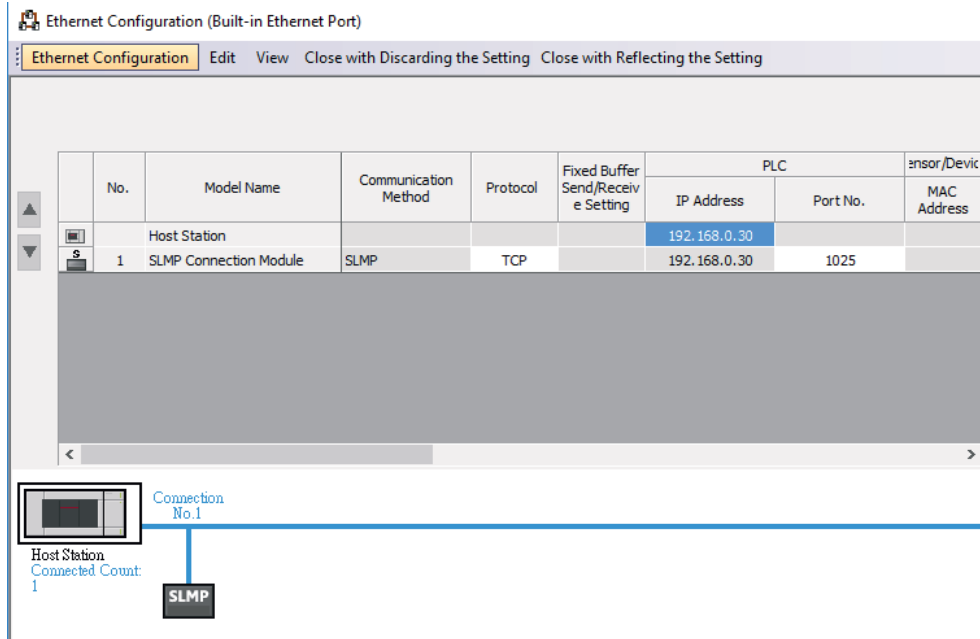

If the user needs to change the **IP Address**, edit the IP address under the **Own Node Settings**. Then enter the Detailed Settings and press **Close with Reflecting the Setting**. Under the **Online** menu option, select **Write to PLC** to save the settings to the PLC. Click **Select All** and press **Execute** in the Online Data Operation window.

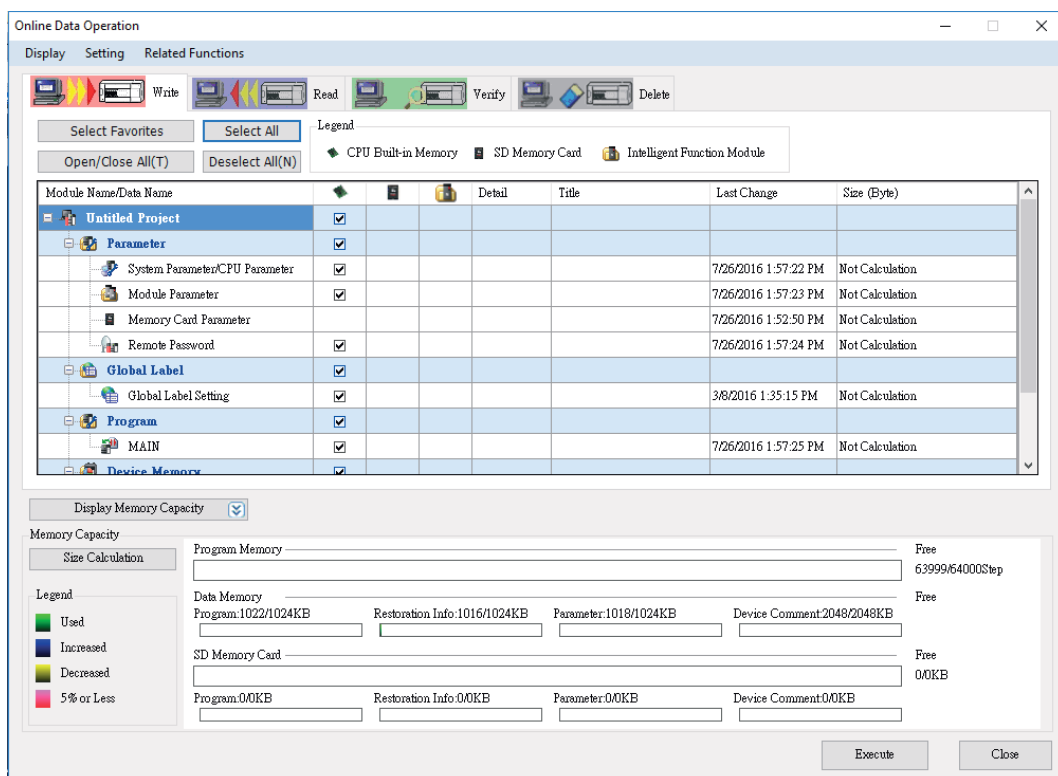

Note: For more detailed information please refer to the PLC manual.

Connecting PLC to HMI

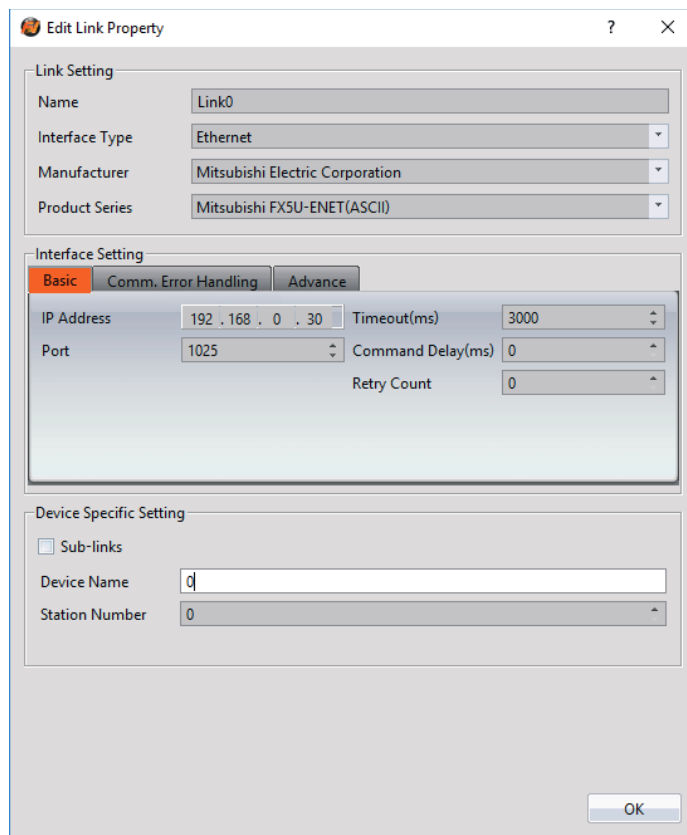

Within the **Link** configuration window in FvDesigner:

Under **Interface Type** select Ethernet

Under **Manufacturer** select Mitsubishi Electric Corporation

Under **Product Series** select one of the Mitsubishi FX5U-ENET options. The last part of the series name (BINARY or ASCII) should be consistent with the Connection Data Code set in the Ethernet Port for the PLC.

Enter the **IP Address** that was written into the PLC.

Enter 1025 for the Port.

2.2.8 QSeries-Serial Communication(Link Port)

2.2.8.1 Communication Setting

Item	Default Setting	Remark
Signal Level	RS232/RS422/RS485	QJ71C24N Module
Baud Rate	115200	
Data Length	7	
Stop Bit	1	
Parity	Odd	
PLC Station No.	0	

TX Control Procedure	Form4	Without CR,LF
Sum Check	Yes	
Communication Method	MC Protocol 3C	

2.2.8.2 Memory Resource Review

Device	Description	Data bit	Input format	Max.	Max.
X	Input Relay	1	HHHH	0	1fff
Y	Output Relay	1	HHHH	0	1fff
M	Internal Relay	1	DDDDD	0	61439
L	Latch Relay	1	DDDD	0	32767
B	Link Relay	1	HHHH	0	efff
F	Annunciator	1	DDDD	0	32767
V	Edge Relay	1	DDDD	0	32767
SB	Link Special Relay	1	HHH	0	7FFF
S	Step Relay	1	DDDD	0	16383
TS	Timer Contact	1	DDDD	0	32767
TC	Timer Coil	1	DDDD	0	32767
SS	Retentive Timer Contact	1	DDDD	0	32767
SC	Retentive Timer Coil	1	DDDD	0	32767
CS	Counter Contact	1	DDDD	0	32767
CC	Counter Coil	1	DDDD	0	32767
SM	Special Relay	1	DDDD	0	2047
DX	Direct Input	1	HHHH	0	1fff
DY	Direct Output	1	HHHH	0	1fff
WX	Input Relay	16	HHHH	0	1ff0
WY	Output Relay	16	HHHH	0	1ff0
WM	Internal Relay	16	DDDDD	0	61424
WL	Link Relay	16	DDDD		32752
B_Word	Link Relay	16	HHHH	0	eff0
F_Word	Annunciator	16	DDDDD	0	32752
WV	Edge relay	16	DDDDD	0	32752
SB_Word	Link Special Relay	16	HHH	0	7ff0
WS	Step Relay	16	DDDD	0	16368
TS_Word	Timer Contact	16	DDDD	0	32752

TC_Word	Timer Coil	16	DDDD	0	32752
SS_Word	Retentive Timer Contact	16	DDDD	0	32752
SC_Word	Retentive Timer Coil	16	DDDD	0	32752
CS_Word	Counter Contact	16	DDDD	0	32752
CC_Word	Counter Coil	16	DDDD	0	32752
SM_Word	Special Relay	16	DDDD	0	2032
TN	Timer Current Value	16	DDDD	0	32752
SN	Retentive Timer Current Value	16	DDDD	0	32752
CN	Counter Current Value	16	DDDD	0	32752
D	Data Register	16	DDDDD	0	39935
W	Link Register	16	HHHH	0	9bff
SW	Link special Register	16	HHH	0	7FFF
SD	Special Register	16	DDDD	0	2047
R	File Register	16	DDDDD	0	32767
Z	Index Register	16	DD	0	19
ZR	File Register	16	HHHHH	0	9fff

2.2.8.3 Connecting to HMI

Configuring the PLC

Use **MELSOFT GX Works2** to configure the port of the **QJ71C24N Module**.

Under the Project Sidebar, expand **Intelligent Function Module** and select **Switch Setting**.

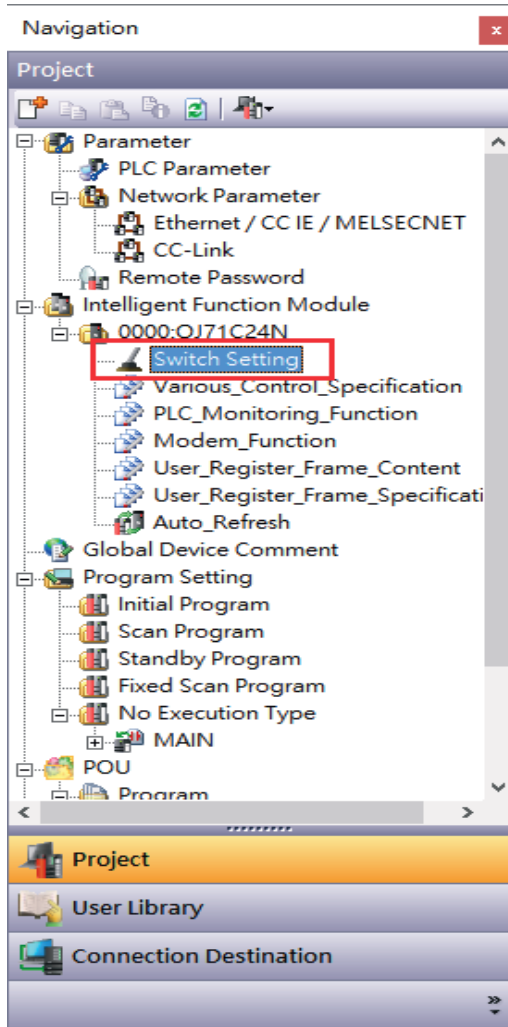

Configure it to the settings detailed below.

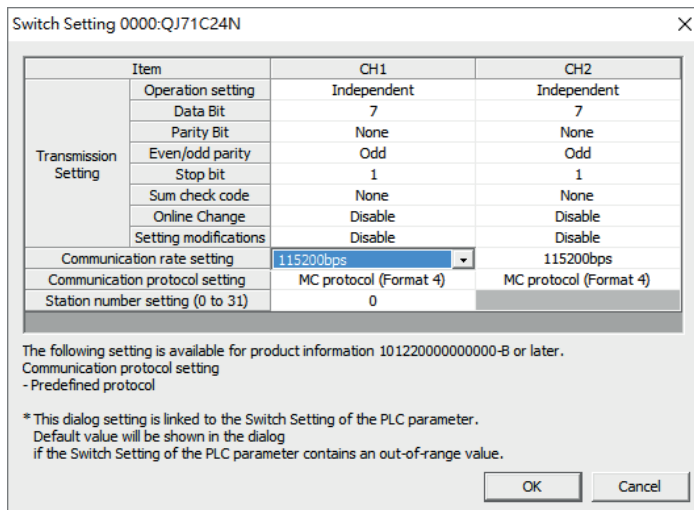

Note: For more detailed information please refer to the PLC manual.

Connecting PLC to HMI

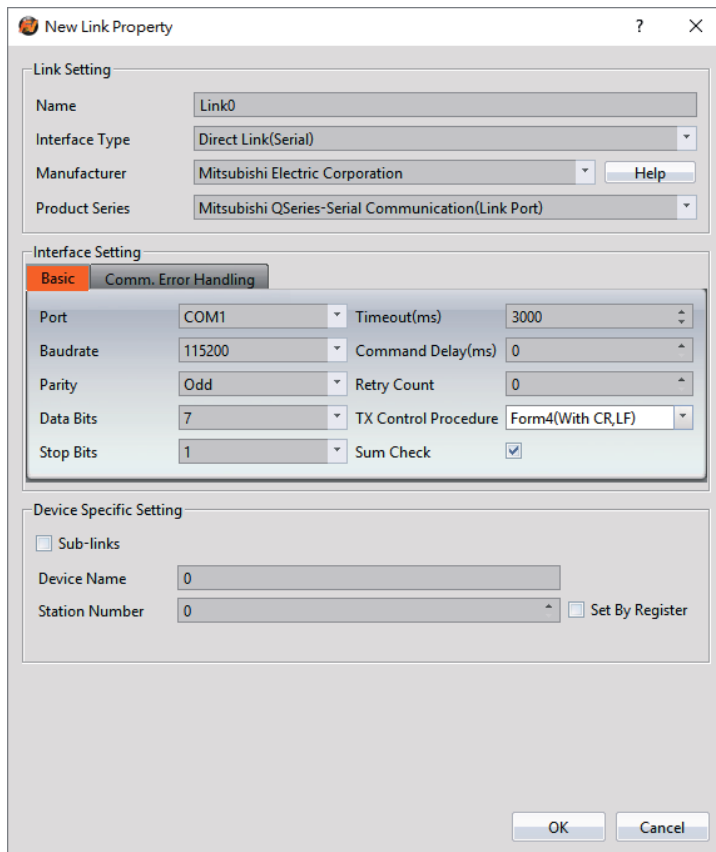

Within the **Link** configuration window in FvDesigner:

Under **Interface Type** select Serial

Under **Manufacturer** select Mitsubishi Electric Corporation

Under **Product Series** select Mitsubishi QSeries-Serial Communication(Link Port).

Verify the parameters match the window above.

The setting of Q series CPU setting if "Use serial communication" is checked, please use QSeries-Serial Communication (Link Port), and the transfer control program is set to Form 5 (Binary mode).

2.2.8.4 Wiring Diagrams

QJ71C24N RS232 Pinout



2	RXD
3	TXD
4	DTR
5	GND
6	DSR
7	RTS
8	CTS

QJ71C24N RS422/485 Pinout

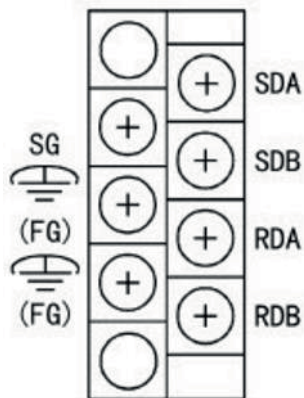

HMI COM1 pinout

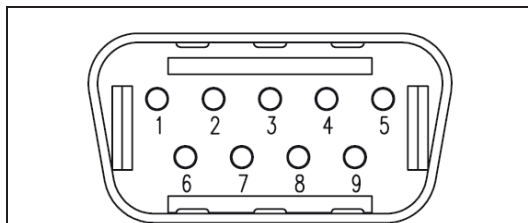

*Looking into COM1 Port

PIN#	COM1 (RS232)
1	
2	RX
3	TX
4	
5	GND
6	
7	RTS
8	CTS
9	

HMI COM3 pinout

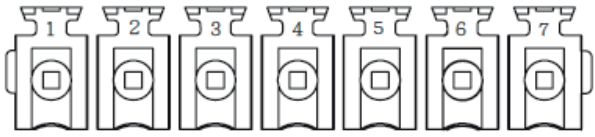

*Looking into HMI Device

PIN#	COM3 (RS-422/RS-485)
1	
2	
3	ISO_GND
4	RX+
5	RX-
6	TX+
7	TX-

All P5 and P2K Series

RS232

HMI COM1	QJ71 RS232 Port	
2 RX	3	TXD
3 TX	2	RXD
5 GND	5 GND	
	1 DCD	circuit
	4 DTR	
	6 DSR	
	7 RTS	circuit
	8 CTS	

Wiring Diagrams:RS232

HMI COM1

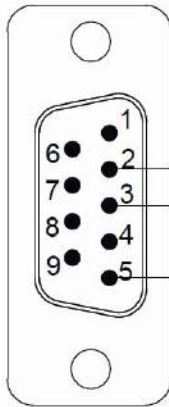

PLC RS232

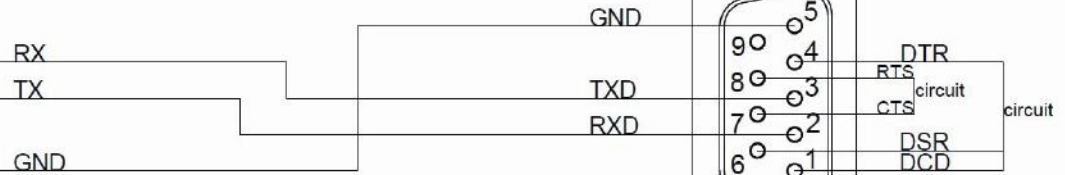
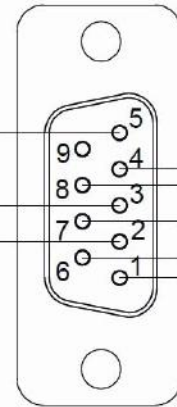

RS422

HMI COM3	QJ71 RS422/485 Port
4 RX+	SDA
5 RX-	SDB
6 TX+	RDA
7 TX-	RDB
3 GND	SG

Wiring Diagrams:RS422

HMI COM3



QJ71 RS422/485

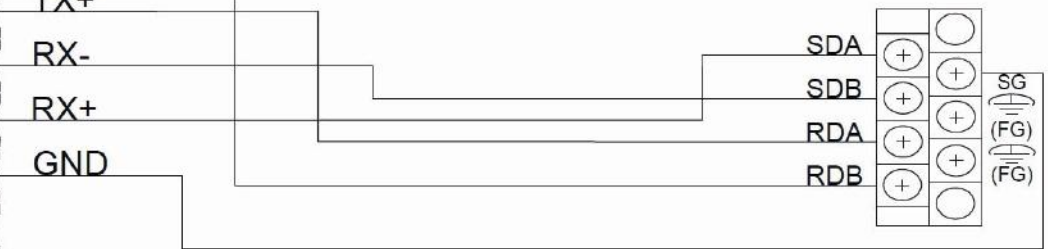

RS485

HMI COM3	QJ71 RS422/485 Port
6 TX+	SDA
	RDA
7 TX-	SDB

	RDB
3 GND	SG

Wiring Diagrams: RS485

HMI COM3

QJ71 RS422/485

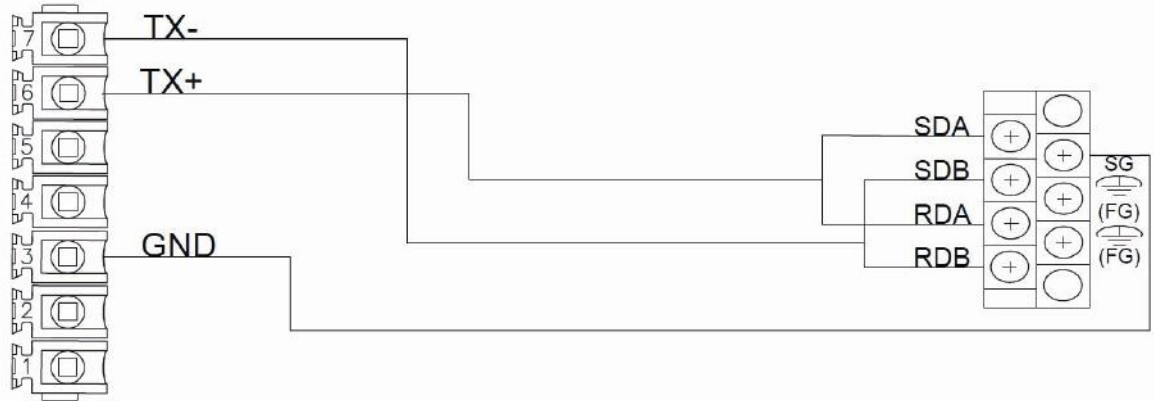

2.2.9 QSeries-Serial Communication(CPU Port)

2.2.9.1 Communication Setting

Item	Default Setting	Remark
Signal Level	RS232	
Baud Rate	19200	
Data Length	8	
Stop Bit	1	
Parity	Odd	
PLC Station No.	0	

2.2.9.2 Memory Resource Review

Device	Description	Data bit	Input format	Min.	Max.
X	Input Relay	1	HHHH	0	1fff
Y	Output Relay	1	HHHH	0	1fff
M	Internal Relay	1	DDDDD	0	61439
L	Latch Relay	1	DDDDD	0	32767
B	Link Relay	1	HHHH	0	Efff
F	Annunciator	1	DDDDD	0	32767
V	Edge Relay	1	DDDDD	0	32767
SB	Link Special Relay	1	HHHH	0	7fff

S	Step Relay	1	DDDDD	0	16383
TS	Timer Contact	1	DDDDD	0	32767
TC	Timer Coil	1	DDDDD	0	32767
SS	Retentive Timer Contact	1	DDDDD	0	32767
SC	Retentive Timer Coil	1	DDDDD	0	32767
CS	Counter Contact	1	DDDDD	0	32767
CC	Counter Coil	1	DDDDD	0	32767
SM	Special Relay	1	DDDD	0	2047
DX	Direct Input	1	HHHH	0	1fff
DY	Direct Output	1	HHHH	0	1fff
WX	Input Relay	16	HHHH	0	1ff0
WY	Output Relay	16	HHHH	0	1ff0
WM	Internal Relay	16	DDDDD	0	61424
WL	Latch Relay	16	DDDDD	0	32752
B_Word	Link Relay	16	HHHH	0	Eff0
F_Word	Annunciator	16	DDDDD	0	32752
WV	Edge Relay	16	DDDDD	0	32752
SB_Word	Link Special Relay	16	HHHH	0	7ff0
WS	Step Relay	16	DDDDD	0	16368
TS_Word	Timer Contact	16	DDDDD	0	32752
TC_Word	Timer Coil	16	DDDDD	0	32752
SS_Word	Retentive Timer Contact	16	DDDDD	0	32752
SC_Word	Retentive Timer Coil	16	DDDDD	0	32752
CS_Word	Counter Contact	16	DDDDD	0	32752
CC_Word	Counter Coil	16	DDDDD	0	32752
SM_Word	Special Relay	16	DDDD	0	2032
TN	Timer Current Value	16	DDDDD	0	32767
SN	Retentive Timer Current Value	16	DDDDD	0	32767
CN	Counter Current Value	16	DDDDD	0	32767
D	Data Register	16	DDDDD	0	39935
W	Link Register	16	HHHH	0	9bff
SW	Link Special Register	16	HHHH	0	7fff
SD	Special Register	16	DDDD	0	2047

R	File Register	16	DDDDD	0	32767
Z	Index Register	16	DD	0	19
ZR	File Register	16	HHHHH	0	9ffff

2.2.9.3 Connecting to HMI

Configuring IP Address on PLC

Use **MELSOFT GX Works2** to configure the port of the PLC.

In the **Project** sidebar, expand **Parameter** and expand **PLC Parameter**.

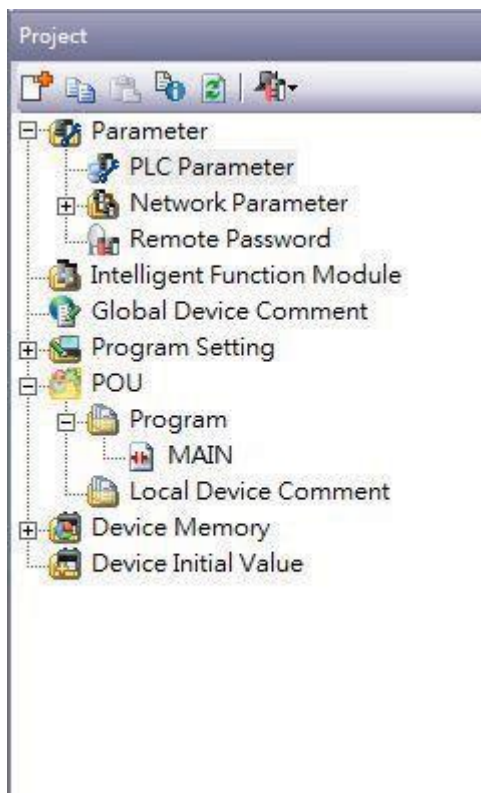

The setting of Q series CPU setting if "Use serial communication" is checked, please use QSeries-Serial Communication (Link Port).

Note: For more detailed information please refer to the PLC manual.

Connect PLC to HMI

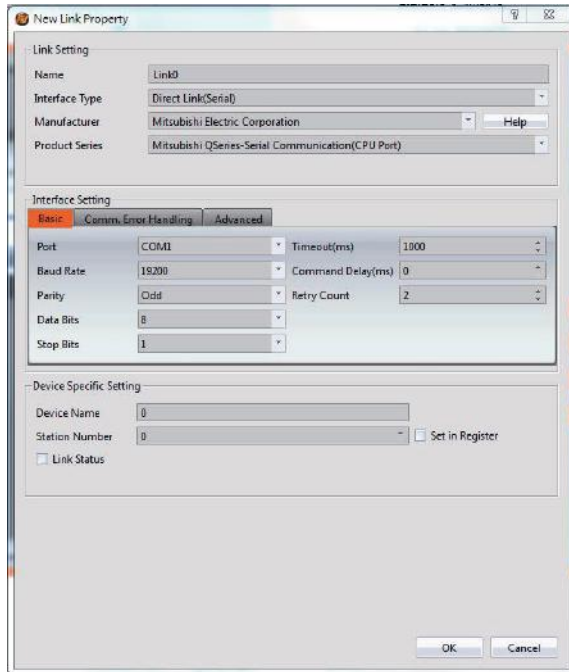

Within the **Link** configuration window in FvDesigner:

Under **Interface Type** select Direct Link(Serial)

Under **Manufacturer** select Mitsubishi Electric Corporation

Under **Product Series** select one of the Mitsubishi QSeries-Series Communication(CPU Port).

Verify the parameters match the window above.

2.2.9.4 Wiring Diagrams

PLC RS232 Pinout

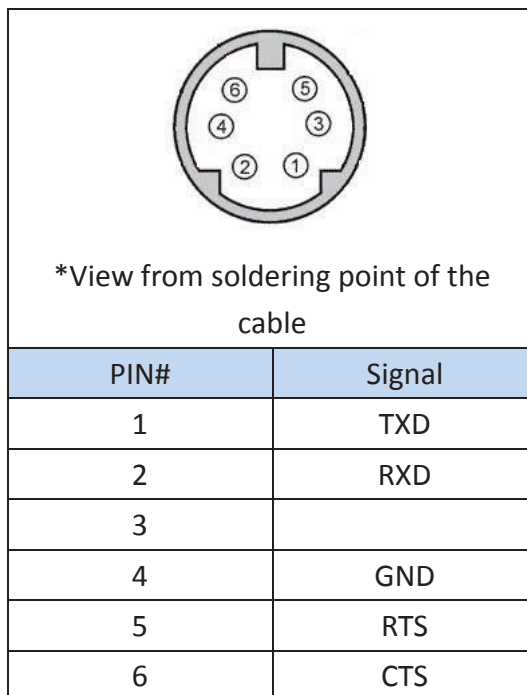

HMI COM1 Pinout

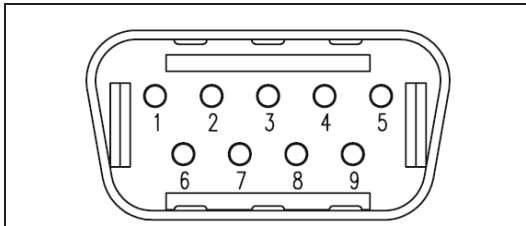

*Looking into COM1 Port

PIN#	COM1 (RS232)
1	
2	RX
3	TX
4	
5	GND
6	
7	RTS
8	CTS
9	

All P5 and P2K Series

HMI COM1	PLC RS232 Port	
2 RX	1 TXD	
3 TX	2 RXD	
5 GND	4 GND	
	5 RTS	circuit
	6 CTS	

Wiring Diagrams: All P5 and P2K Series

HMI COM1

PLC RS232

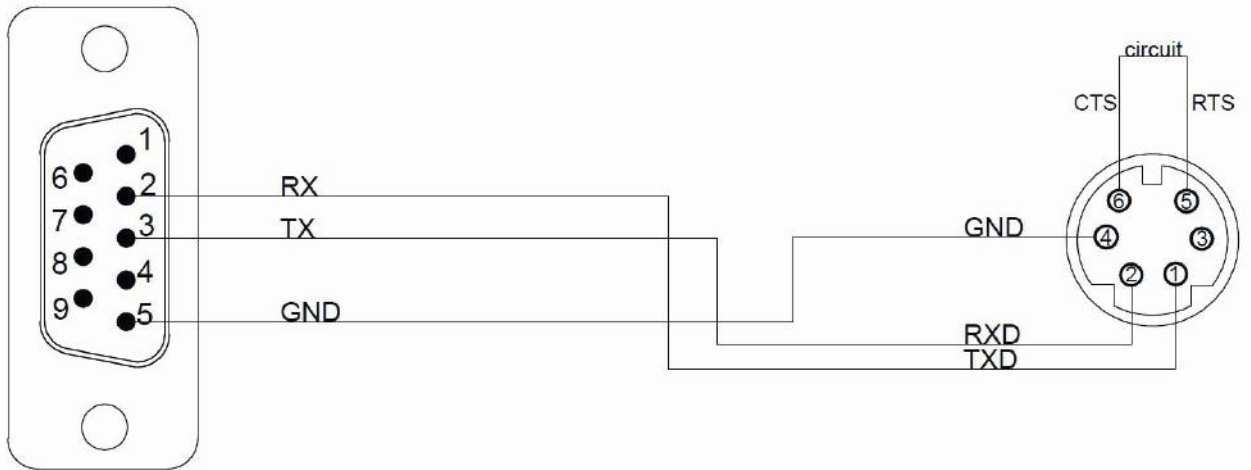

2.2.10 Q/L Series-ENET

2.2.10.1 Communication Setting

Item	Default Setting	Remark
Signal Level	Ethernet	
Internet Protocol	0.0.0.0	
Port	4999	
PLC Station No.	0	
Communication Method	MC protocol 3E	Binary/ASCII

2.2.10.2 Memory Resource Review

Device	Description	Data bit	Input Format	Min.	Max.
X	Input Relay	1	HHHH	0	1fff
Y	Output Relay	1	HHHH	0	1fff
M	Internal Relay	1	DDDDD	0	61439
L	Latch Relay	1	DDDD	0	32767
B	Link Relay	1	HHHH	0	efff
F	Annunciator	1	DDDD	0	32767
V	Edge Relay	1	DDDD	0	32767
SB	Link Special Relay	1	HHH	0	7FFF
S	Step Relay	1	DDDD	0	16383
TS	Timer Contact	1	DDDD	0	32767
TC	Timer Coil	1	DDDD	0	32767
SS	Retentive Timer	1	DDDD	0	32767

	Contact				
SC	Retentive Timer Coil	1	DDDD	0	32767
CS	Counter Contact	1	DDDD	0	32767
CC	Counter Coil	1	DDDD	0	32767
SM	Special Relay	1	DDDD	0	2047
DX	Direct Input	1	HHHH	0	1fff
DY	Direct Output	1	HHHH	0	1fff
WX* ¹	Input Relay	16	HHHH	0	1ff0
WY* ¹	Output Relay	16	HHHH	0	1ff0
WM* ¹	Internal Relay	16	DDDDD	0	61424
WL	Link Relay	16	DDDD		32752
B_Word * ¹	Link Relay	16	HHHH	0	eff0
F_Word * ¹	Annunciator	16	DDDDD	0	32752
WV	Edge relay	16	DDDDD	0	32752
SB_Word * ¹	Link Special Relay	16	HHH	0	7ff0
WS* ¹	Step Relay	16	DDDD	0	16368
TS_Word * ¹	Timer Contact	16	DDDD	0	32752
TC_Word * ¹	Timer Coil	16	DDDD	0	32752
SS_Word * ¹	Retentive Timer Contact	16	DDDD	0	32752
SC_Word * ¹	Retentive Timer Coil	16	DDDD	0	32752
CS_Word * ¹	Counter Contact	16	DDDD	0	32752
CC_Word * ¹	Counter Coil	16	DDDD	0	32752
SM_Word * ¹	Special Relay	16	DDDD	0	2032
TN	Timer Current Value	16	DDDD	0	32752
SN	Retentive Timer Current Value	16	DDDD	0	32752
CN	Counter Current	16	DDDD	0	32752

	Value				
D	Data Register	16	DDDDD	0	39935
W	Link Register	16	HHHH	0	9bff
SW	Link special Register	16	HHH	0	7FFF
SD	Special Register	16	DDDD	0	2047
R	File Register	16	DDDDD	0	32767
Z	Index Register	16	DD	0	19
ZR	File Register	16	HHHHH	0	9fff

*1 Address increased by 0, 20, 40, 60...

2.2.10.3 Connecting to HMI

Configuring IP Address on PLC

Use **MELSOFT GX Works2** to configure the port of the PLC.

In the **Project** sidebar, expand **Parameter** and expand **PLC Parameter**.

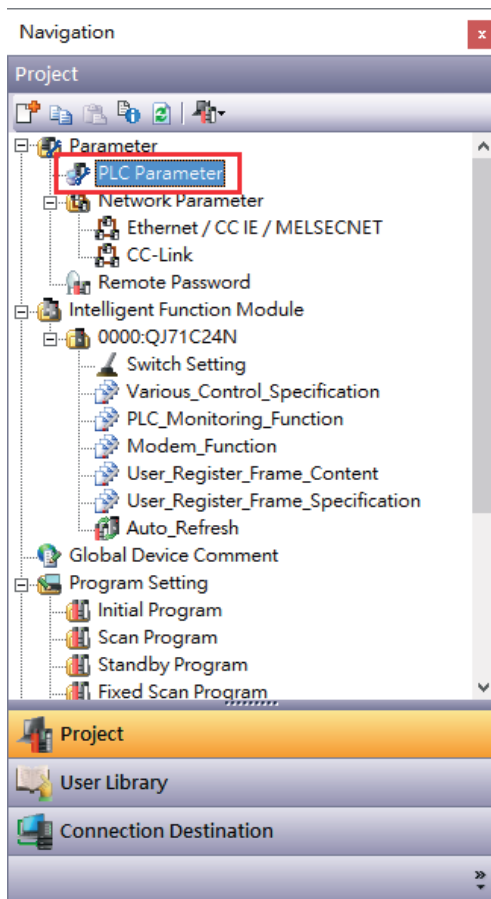

Navigate to **Built-in Ethernet Port Setting** tab, the IP address and other parameters can be set.

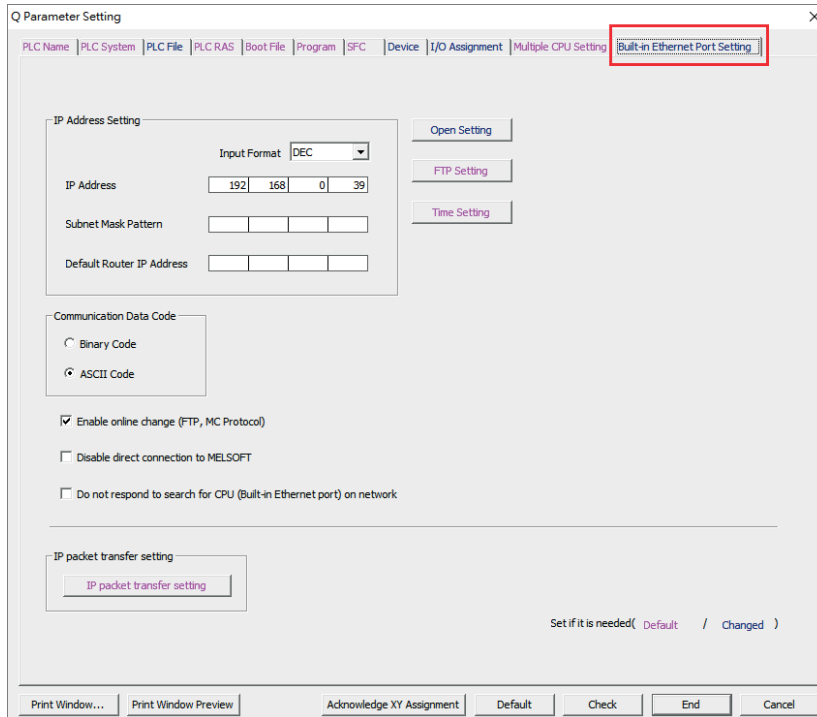

Click Open Setting and set the entire Open System column to MC Protocol. For the Host Station Port No 4999.

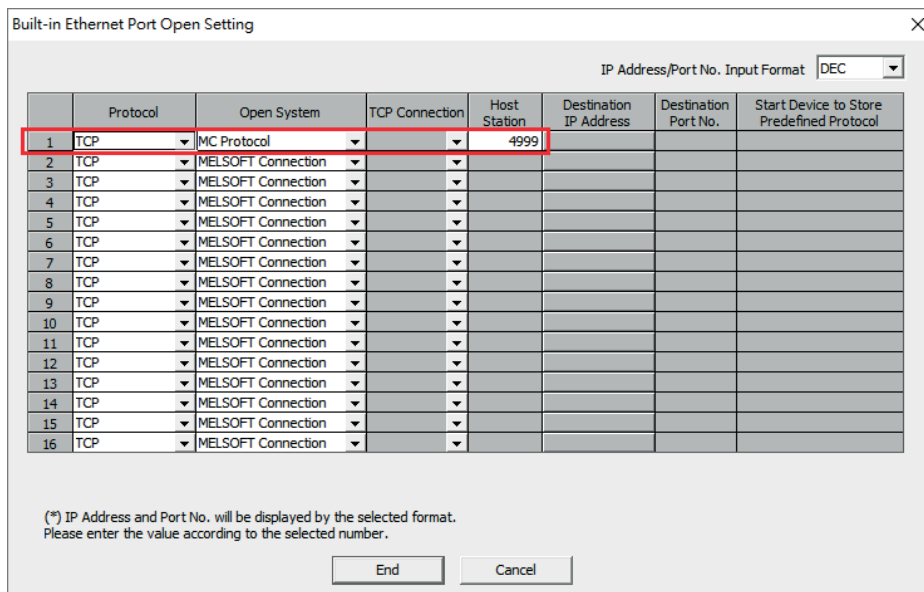

Note: For more detailed information please refer to the PLC manual.

Connect PLC to HMI

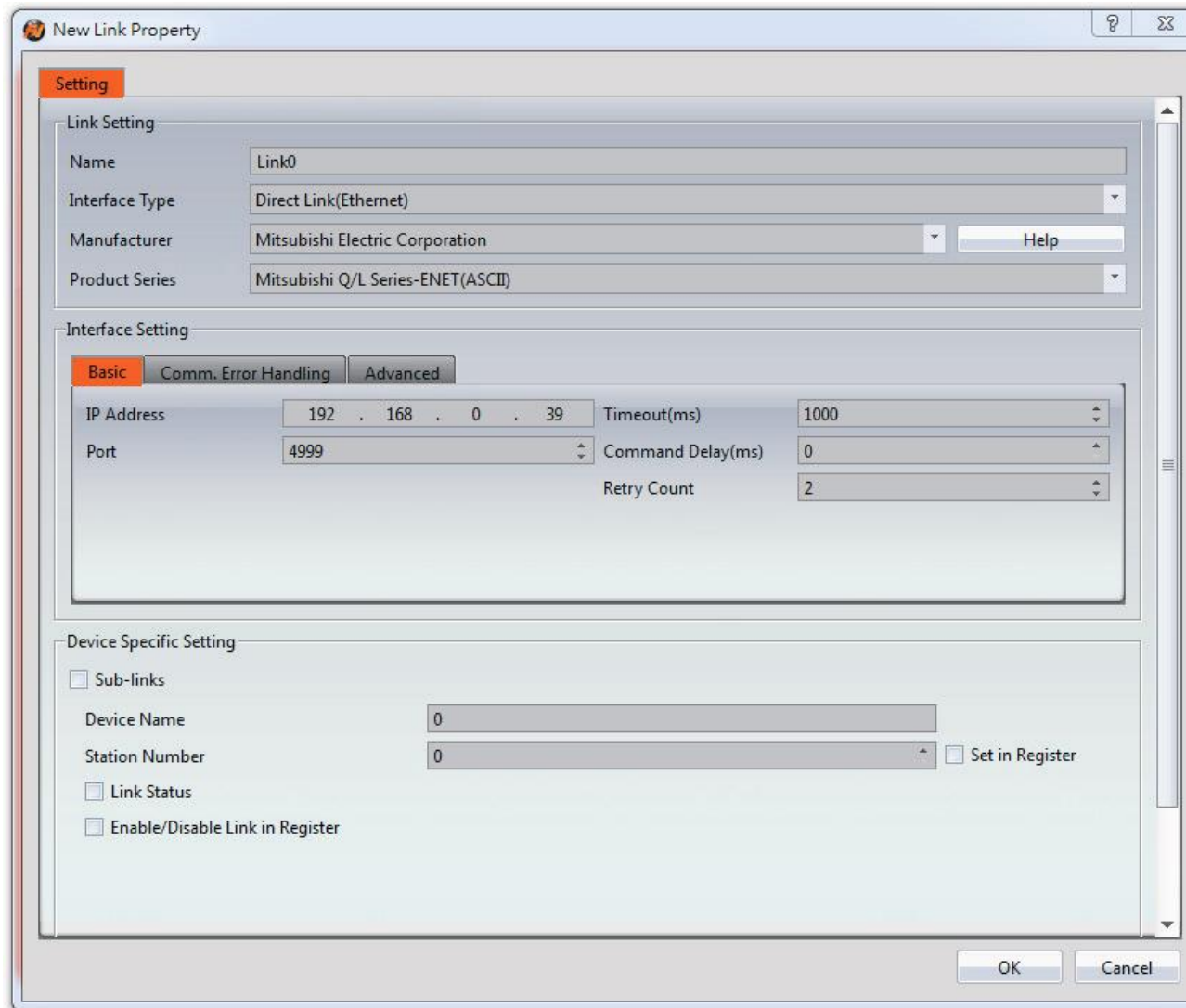

Within the **Link** configuration window in FvDesigner:

Under **Interface Type** select Ethernet

Under **Manufacturer** select Mitsubishi Electric Corporation

Under **Product Series** select one of the Mitsubishi Q/L Series-ENET(BINARY 或 ASCII).

The last part of the series name (BINARY or ASCII) should be consistent with the Connection Data Code set in the Ethernet Port for the PLC.

Enter the **IP Address** that was written into the PLC.

Verify the parameters match the window above.

2.2.11 iQ-R Series-ENET

2.2.11.1 Communication Setting

Item	Default Setting	Remark
------	-----------------	--------

Signal Level	Ethernet	
Internet Protocol	0.0.0.0	
Port	4999	
PLC Station No.	0	
Communication Method	MC protocol 3E	Binary/ASCII

2.2.11.2 Memory Resource Review

類型	資料位元	說明	地址格式	最小	最大
X	1	Input	HHHH	0	2fff
Y	1	Output	HHHH	0	2fff
M	1	Internal Relay	DDDDD	0	638975
SM	1	Special Relay	DDDD	0	4095
B	1	Link Relay	HHHHH	0	9bfff
SB	1	Link Special Relay	HHHHH	0	9bfff
F	1	Annunciator	DDDDD	0	32767
V	1	Edge Relay	DDDDD	0	32767
TS	1	Timer Contact	DDDDD	0	35487
TC	1	Timer Coil	DDDDD	0	35487
LTS	1	Long Timer Contact	DDDDD	0	35487
LTC	1	Long Timer Coil	DDDDD	0	35487
STS	1	Retentive Timer Contact	DDDDD	0	35487
STC	1	Retentive Timer Coil	DDDDD	0	35487
LSTS	1	Long Retentive Timer Contact	DDDDD	0	35487
LSTC	1	Long Retentive Timer Coil	DDDDD	0	35487
CS	1	Counter Contact	DDDDD	0	35487
CC	1	Counter Coil	DDDDD	0	35487
LCS	1	Long Counter Contact	DDDDD	0	35487
LCC	1	Long Counter Coil	DDDDD	0	35487
L	1	Latch Relay	DDDDD	0	32767
D	16	Data Register	DDDDD	0	39935
SD	16	Special Register	DDDD	0	4095
W	16	Link Register	HHHH	0	9bff
SW	16	Link Special Register	HHHH	0	9bff
TN	16	Timer Current Value	DDDDD	0	35487
STN	16	Retentive Timer	DDDDD	0	35487

		Current Value			
CN	16	Counter Current Value	DDDD	0	35487
Z	16	Index Register	DD	0	23
LTN	16	Long Timer Current Value	DDDD	0	35487
LSTN	16	Long Retentive Timer Current Value	DDDD	0	35487
LCN	16	Long Counter Current Value	DDDD	0	35487
LZ	16	Long Index Register	DD	0	11

2.2.11.3 Connecting to HMI

Configuring IP Address on PLC

Use **MELSOFT GX Works2** to configure the port of the PLC.

In the **Project** sidebar, expand **Parameter** and expand **PLC Parameter**.

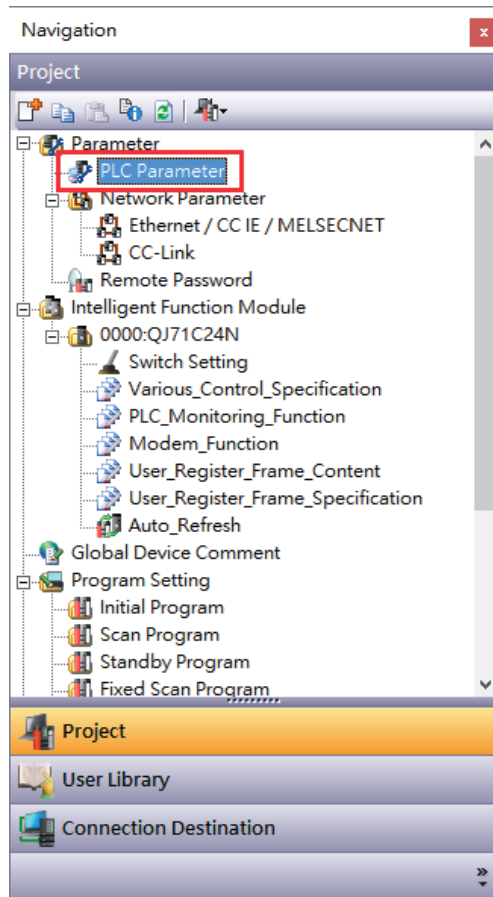

Navigate to **Built-in Ethernet Port Setting** tab, the IP address and other parameters can be set.

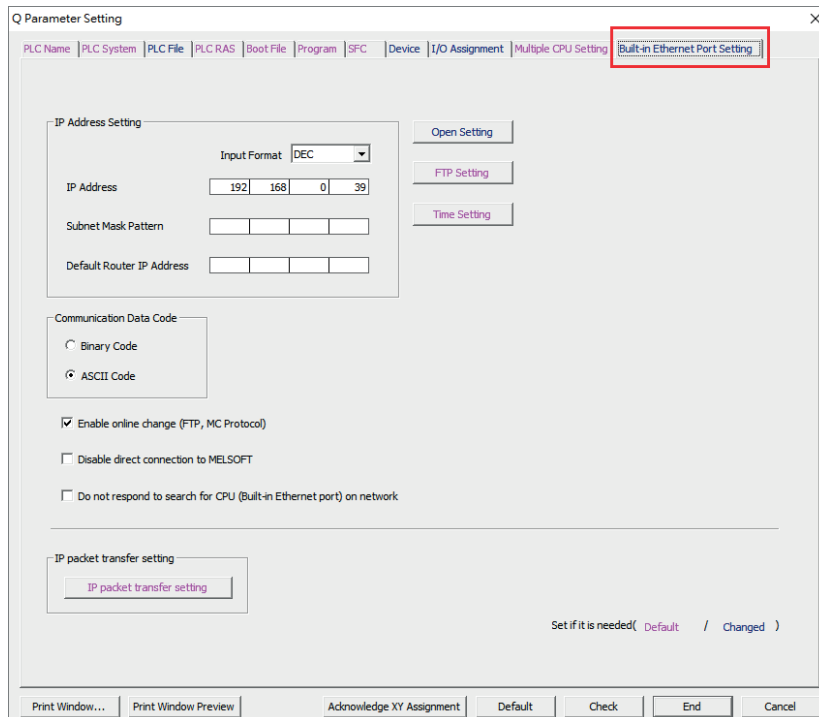

Click Open Setting and set the entire Open System column to MC Protocol. For the Host Station Port No 4999.

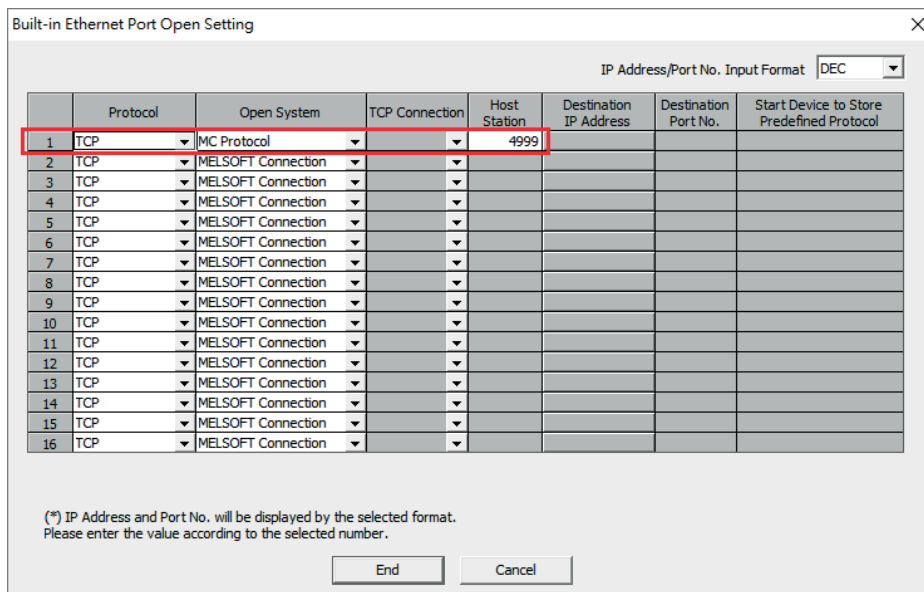

Note: For more detailed information please refer to the PLC manual.

Connect PLC to HMI

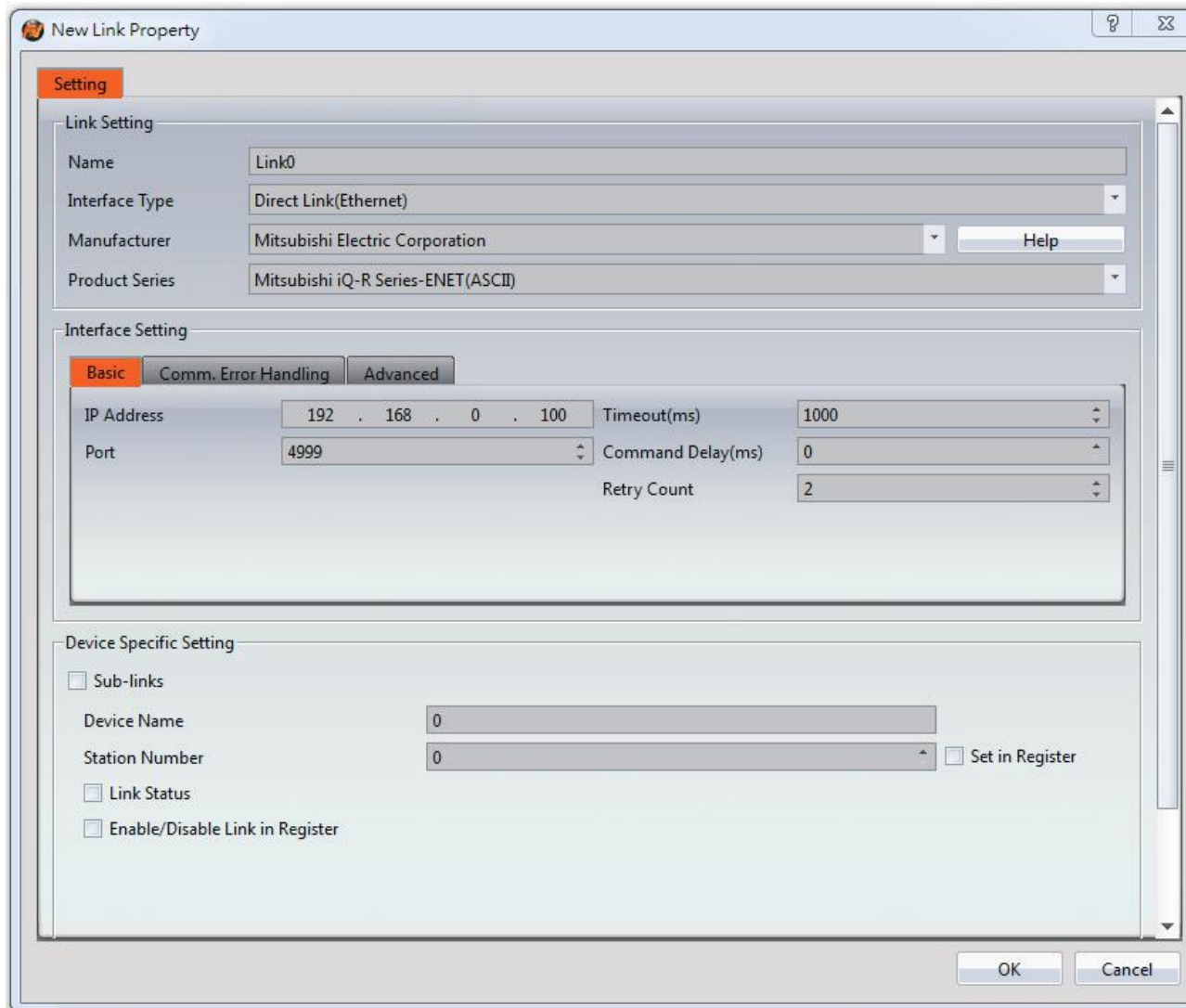

Within the **Link** configuration window in FvDesigner:

Under **Interface Type** select Ethernet

Under **Manufacturer** select Mitsubishi Electric Corporation

Under **Product Series** select one of the Mitsubishi iQ-R Series-ENET(BINARY 或 ASCII).

The last part of the series name (BINARY or ASCII) should be consistent with the Connection Data Code set in the Ethernet Port for the PLC.

Enter the **IP Address** that was written into the PLC.

Verify the parameters match the window above.

2.3 Omron

2.3.1 Omron SYSMAC CP Series

2.3.1.1 Communication Setting

Item	Default Setting	Remark
Signal Level	RS232	

Baud Rate	9600	
Data Length	7	
Stop Bit	2	
Parity	Even	
PLC Station No.	0	
Communication Method	FINS	

2.3.1.2 Memory Resource Review

Device	Description	Data bit	Min.	Max.
TIM	Timer Area	1	0	4095
CNT	Counter Area	1	0	4095
CIO	CIO Area	16	0	6143
W	Work Area	16	0	511
H	Holding Bit Area	16	0	511
A	Auxiliary Bit Area	16	0	959
T	Timer Area	16	0	4095
C	Counter Area	16	0	4095
D	DM Area	16	0	32767

2.3.1.3 Connecting to HMI

Configuring the PLC

Use **CX-Programmer** to configure the port of the PLC.

Under 專案 Task 工作區 Sidebar, expand 設定.

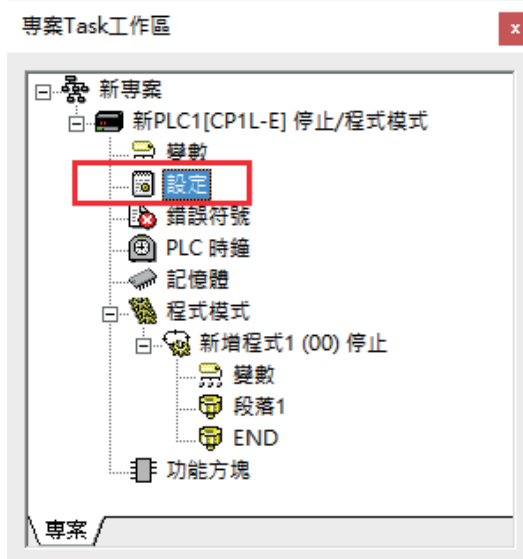

Navigate to 序列埠 1 tab and configure it to the settings detailed below.



After click 傳輸到 PLC to write in PLC.

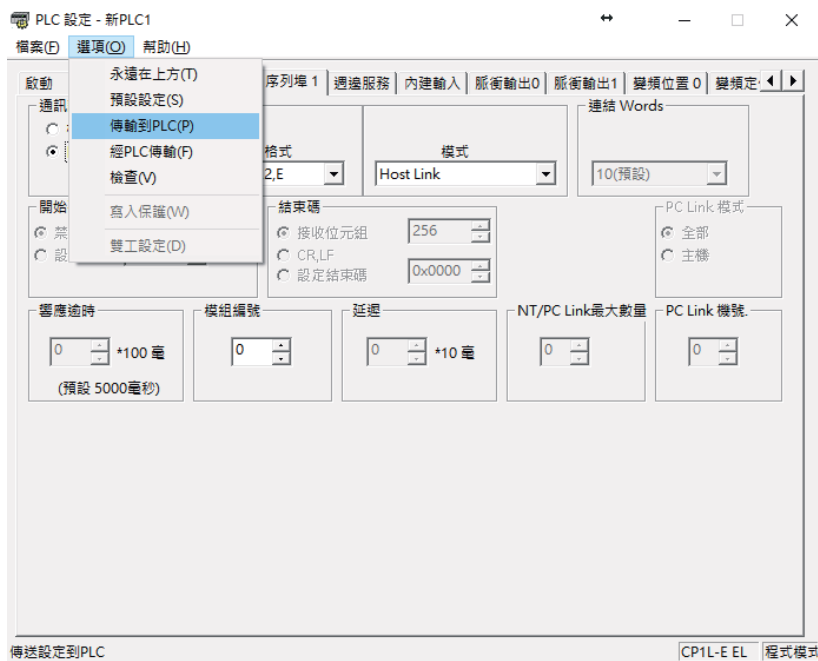

Note: For more detailed information please refer to the PLC manual.

Connecting PLC to HMI

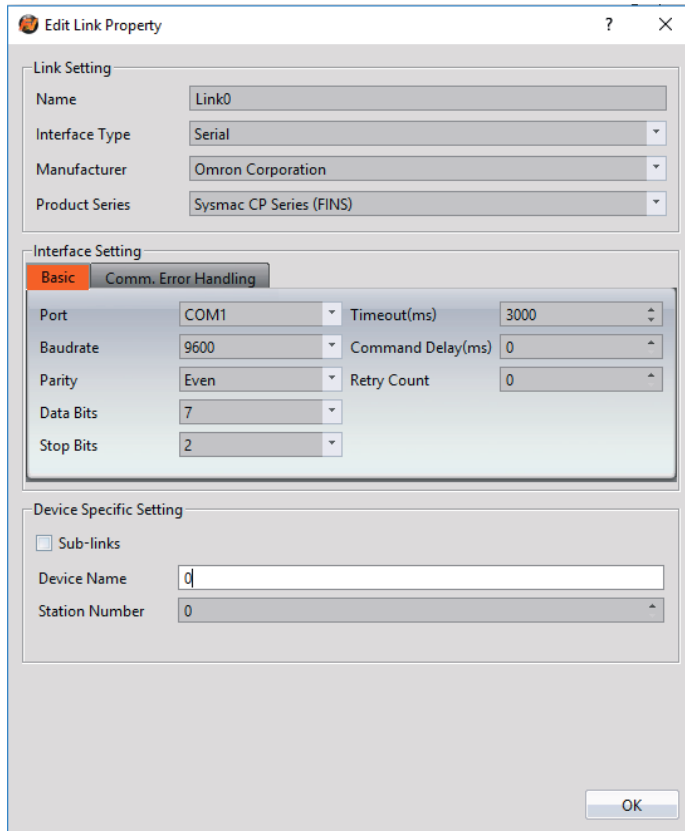

Within the **Link** configuration window in FvDesigner:

Under **Interface Type** select Serial

Under **Manufacturer** select Omron Corporation

Under **Product Series** select Sysmac CP Series (FINS)

Under **Port** select COM1

2.3.1.4 Wiring Diagrams

PLC RS232 Pinout

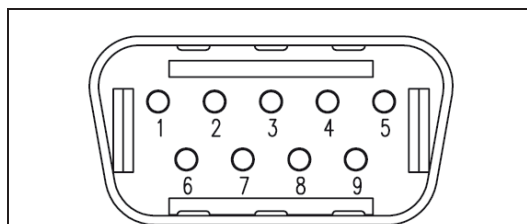

*Looking into male RS232 Cable

PIN#	Signal
1	
2	TX
3	RX
4	
5	

6	
7	
8	
9	GND

HMI COM1 Pinout

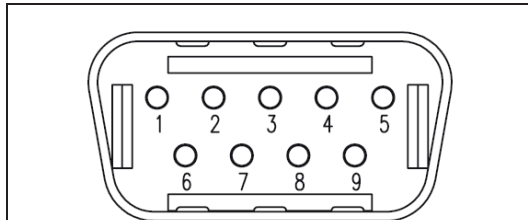

*Looking into COM1 Port

PIN#	COM1 (RS232)
1	
2	RX
3	TX
4	
5	GND
6	
7	RTS
8	CTS
9	

All P5 and P2K Series

HMI COM1	PLC RS232 Port
2 RX	2 TX
3 TX	3 RX
5 GND	9 GND

Wiring Diagrams: All P5 and P2K Series

HMI COM1

PLC RS232

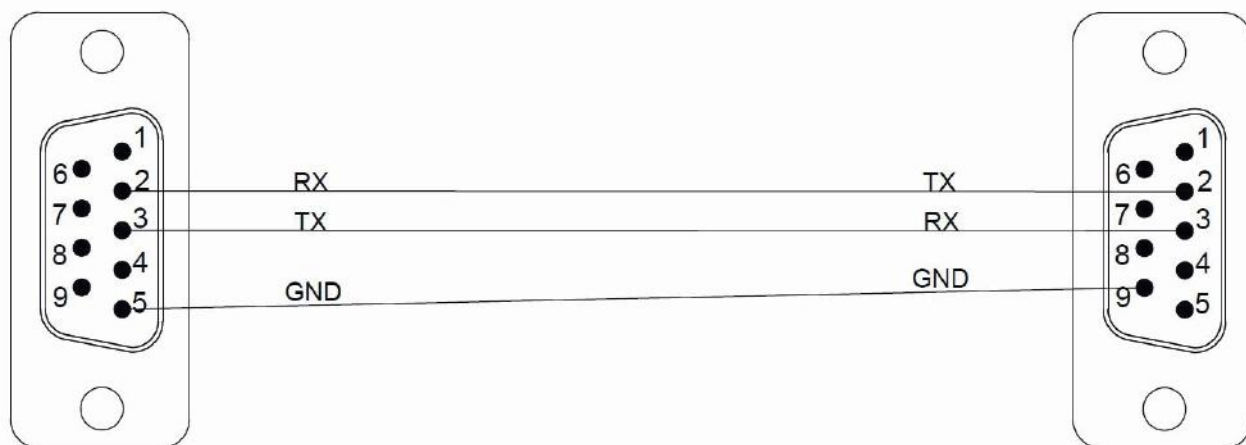

2.3.2 Omron SYSMAC CP Series Ethernet

2.3.2.1 Communication Setting

Item	Default Setting	Remark
Signal Level	Ethernet	
Internet Protocol	0.0.0.0	To be configured
Port	9600	
PLC Station No.	0	
Communication Method	FINS/TCP	

2.3.2.2 Memory Resource Review

Device	Description	Data bit	Min.	Max.
TK	Task Flag	1	0	31
TIM	Timer Area	1	0	4095
CNT	Counter Area	1	0	4095
CIO	CIO Area	16	0	6143
W	Work Area	16	0	511
H	Holding Area	16	0	511
A	Auxiliary Area	16	0	959
T	Timer Area	16	0	4095
C	Counter Area	16	0	4095
D	Data Memory Area	16	0	32767
IR	Index Register	32	0	15
DR	Data Register	16	0	15

2.3.2.3 Connecting to HMI

Configuring IP Address on PLC

Use **CX-Programmer** to configure the IP of the PLC.

In the **專案Task sidebar**, expand **設定**

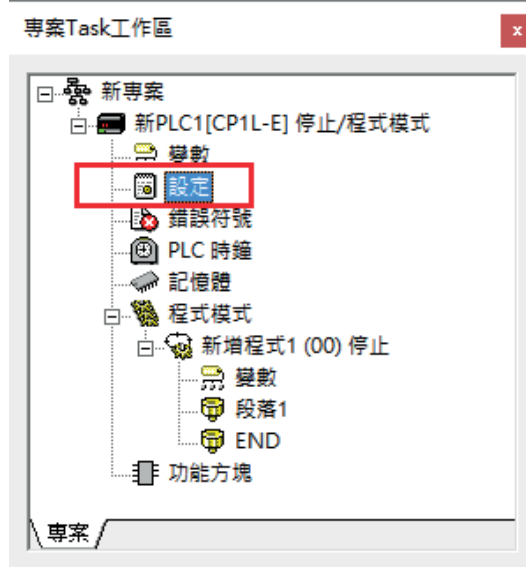

Navigate to **內置乙太網路 tab**, the IP address and other parameters can be set.



After click **傳輸到 PLC** to write in PLC.

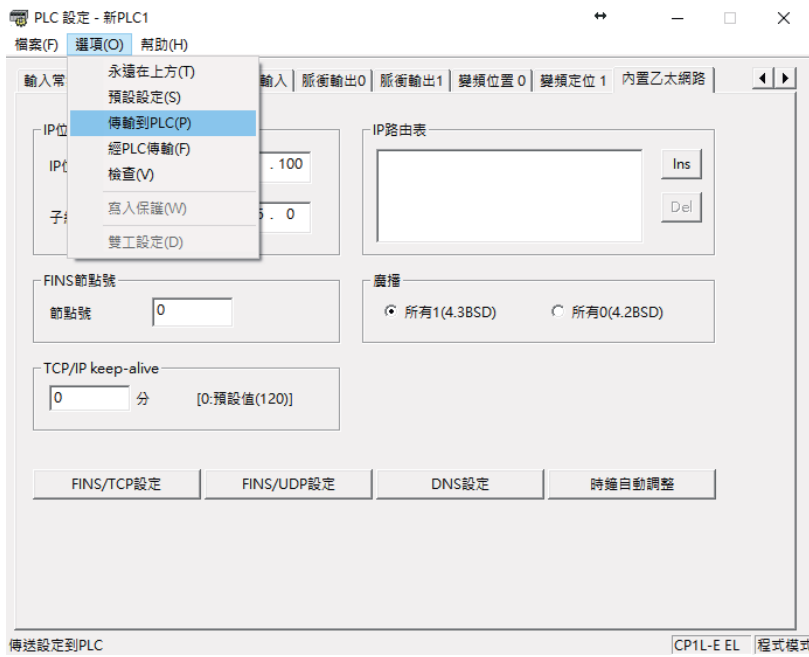

Note: For more detailed information please refer to the PLC manual.

HMI 設定

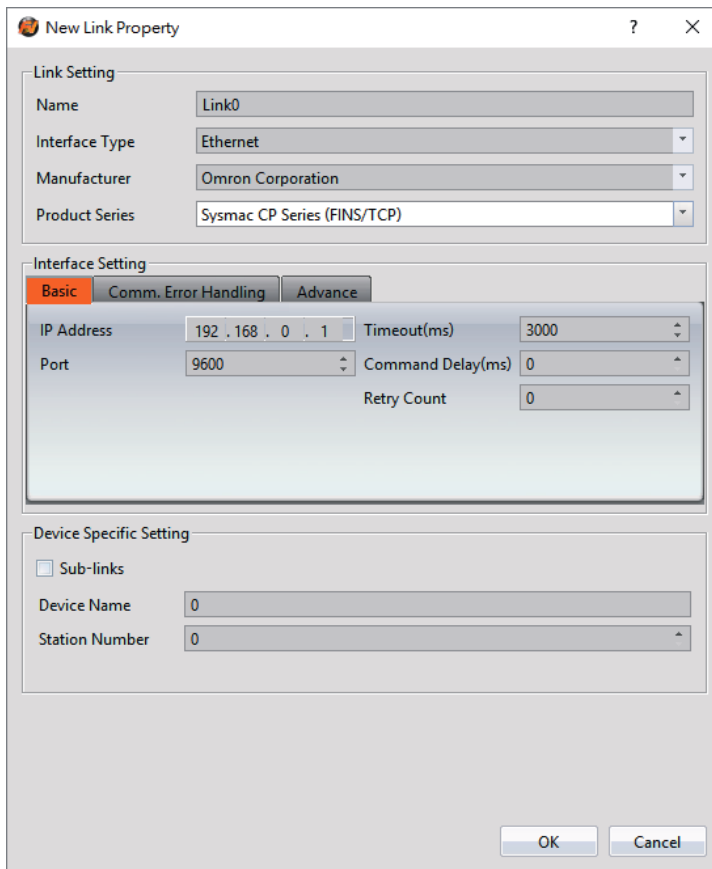

Within the **Link** configuration window in FvDesigner:

Under **Interface Type** select Ethernet

Under **Manufacturer** select Omron Corporation

Under **Product Series** select Sysmac CP Series (FINS/TCP)

Enter the **IP Address** that was written into the PLC

Enter 9600 for the Port

2.3.3 Omron SYSMAC CS/CJ Series

2.3.3.1 Communication Setting

Item	Default Setting	Remark
Signal Level	RS232/RS422	
Baud Rate	9600	
Data Length	7	
Stop Bit	2	
Parity	Even	
PLC Station No.	0	
Communication Method	FINS	

2.3.3.2 Memory Resource Review

Device	Description	Data bit	Min.	Max.
TK	Task Flag	1	0	127
TIM	Timer Area	1	0	4095
CNT	Counter Area	1	0	4095
CIO	CIO Area	16	0	6143
W	Work Area	16	0	511
H	Holding Bit Area	16	0	1535
A	Auxiliary Bit Area	16	0	11535
T	Timer Area	16	0	4095
C	Counter Area	16	0	4095
D	DM Area	16	0	32767
E0	EM Bank 0	16	0	32767
E1	EM Bank 1	16	0	32767
E2	EM Bank 2	16	0	32767
E3	EM Bank 3	16	0	32767
E4	EM Bank 4	16	0	32767

E5	EM Bank 5	16	0	32767
E6	EM Bank 6	16	0	32767
E7	EM Bank 7	16	0	32767
E8	EM Bank 8	16	0	32767
E9	EM Bank 9	16	0	32767
EA	EM Bank 10	16	0	32767
EB	EM Bank 11	16	0	32767
EC	EM Bank 12	16	0	32767
EM	Current EM Bank	16	0	32767
DR	Data Register	16	0	15
IR	Index Register	32	0	15

2.3.3.3 Connecting to HMI

Configuring the PLC

Use **CX-Programmer** to configure the port of the PLC.

Under **專案 Task 工作區 Sidebar**, expand **設定**.

After navigate to **Serial Prot** tab and configure it to the settings detailed below.

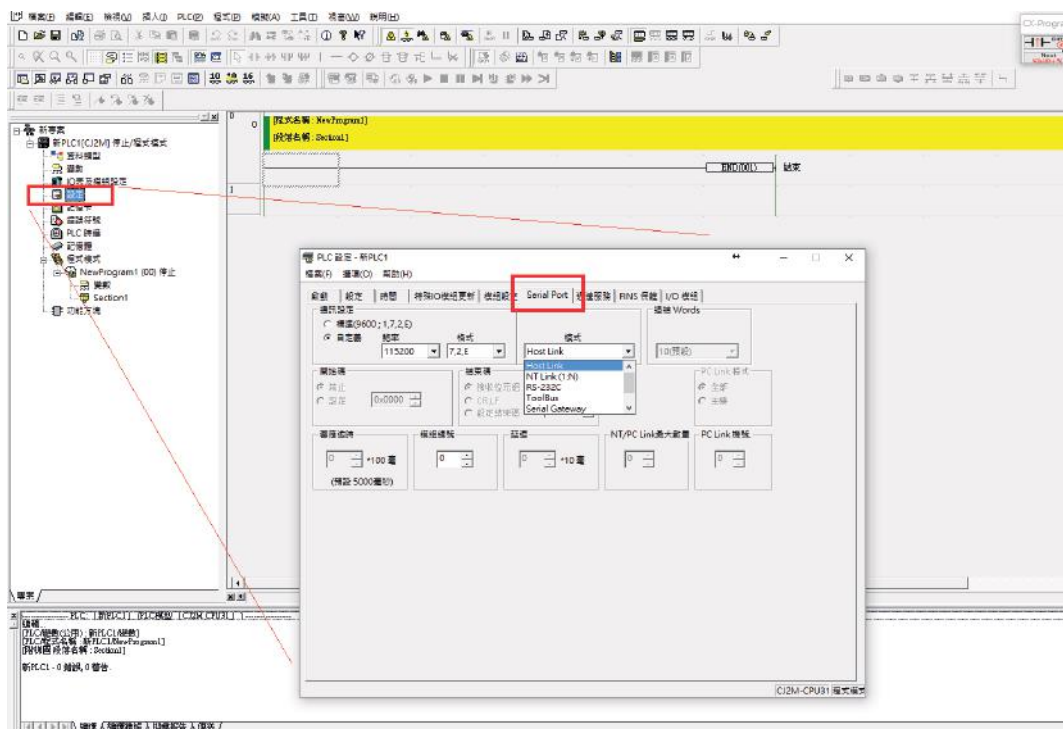

Note: For more detailed information please refer to the PLC manual.

Connecting PLC to HMI

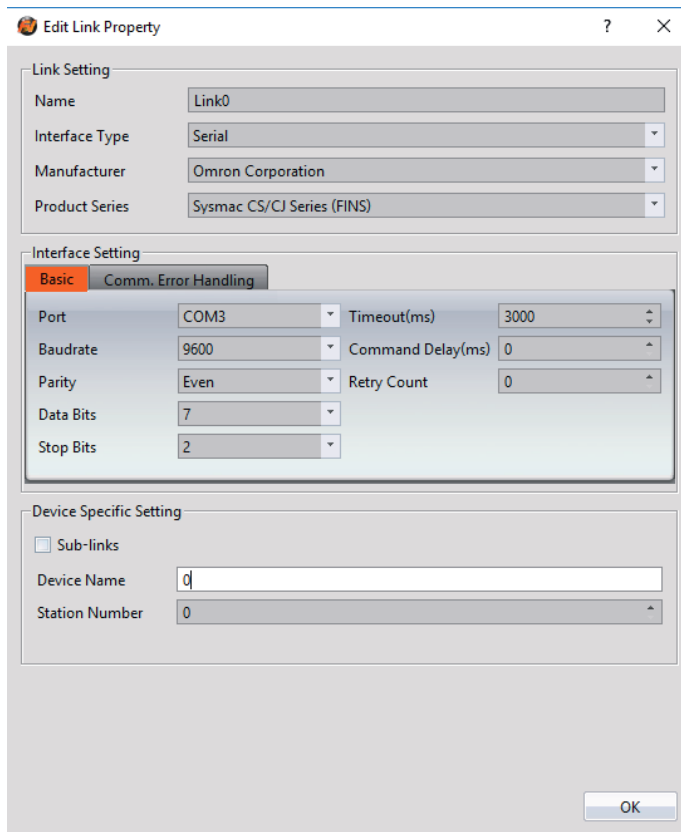

Within the **Link** configuration window in FvDesigner:

Under **Interface Type** select Serial

Under **Manufacturer** select Omron Corporation

Under **Product Series** select Sysmac CS/CJ Series (FINS)

Under **Port** select COM3

2.3.3.4 PLC Message

When the first 4 error codes are 200A, it means that the last 4 error codes are created by PLC.

Please refer to PLC manual <https://www.automationdirect.com/microsites/c-more/software-help/Content/476.htm>

2.3.3.5 Wiring Diagrams

CJ1W-CIF11 (RS422/485)

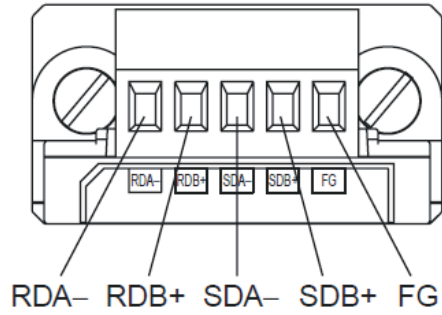

HMI COM3 Pinout

*Looking into HMI Device	
PIN#	COM3 (RS-422/RS-485)
1	
2	
3	ISO_GND
4	RX+
5	RX-
6	TX+
7	TX-

P5070S/P5070N/P5070N1/P5102N/P5102N1

HMI COM3	PLC RS422 Port
5 RX-	SDA-
4 RX+	SDB+
7 TX-	RDA-
6 TX+	RDB+
3 ISO_GND	FG

Wiring Diagrams: P5070S/P5070N/P5070N1/P5102N/P5102N1

HMI COM3

PLC RS485

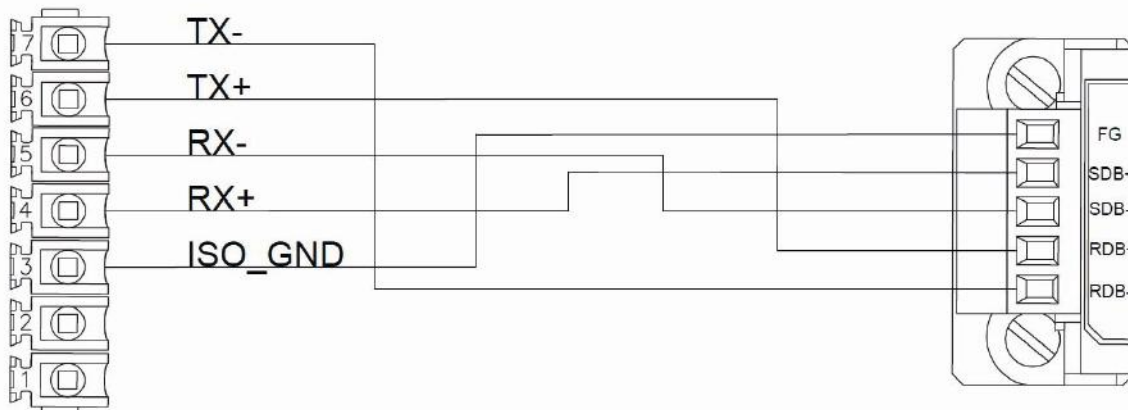

P5043S/P5043N/P5070VS/P5102VS/P2K SERIES

HMI COM2	PLC RS422 Port
9 RX-	SDA-
4 RX+	SDB+
6 TX-	RDA-
1 TX+	RDB+
5 GND	FG

Wiring Diagrams: P5043S/P5043N/P5070VS/P5102VS/P2K SERIES

HMI COM2

PLC RS485

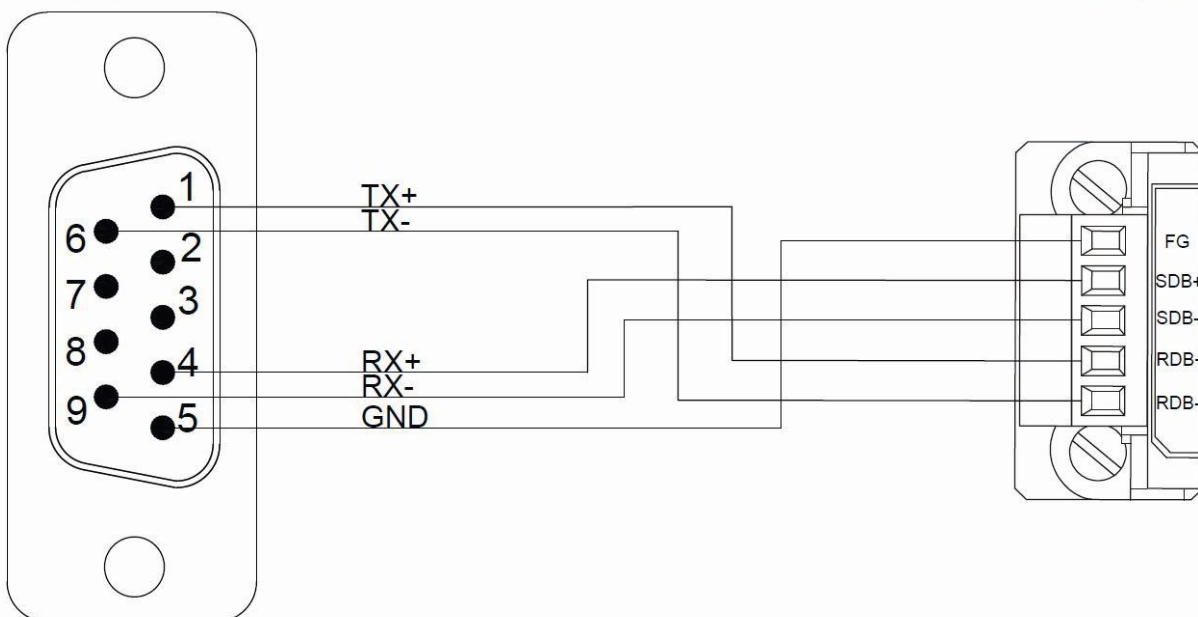

2.3.4 Omron SYSMAC CS/CJ Series Ethernet

2.3.4.1 Communication Setting

Item	Default Setting	Remark
Signal Level	Ethernet	
Internet Protocol	0.0.0.0	To be configured
Port	9600	
PLC Station No.	0	
Communication Method	FINS/TCP	

2.3.4.2 Memory Resource Review

Device	Description	Data bit	Min.	Max.
TK	Task Flag	1	0	127
TIM	Timer Area	1	0	4095
CNT	Counter Area	1	0	4095
CIO	CIO Area	16	0	6143
W	Work Area	16	0	511
H	Holding Bit Area	16	0	1535
A	Auxiliary Bit Area	16	0	11535
T	Timer Area	16	0	4095
C	Counter Area	16	0	4095
D	DM Area	16	0	32767
E0	EM Bank 0	16	0	32767
E1	EM Bank 1	16	0	32767
E2	EM Bank 2	16	0	32767
E3	EM Bank 3	16	0	32767
E4	EM Bank 4	16	0	32767
E5	EM Bank 5	16	0	32767
E6	EM Bank 6	16	0	32767
E7	EM Bank 7	16	0	32767
E8	EM Bank 8	16	0	32767
E9	EM Bank 9	16	0	32767
EA	EM Bank 10	16	0	32767
EB	EM Bank 11	16	0	32767
EC	EM Bank 12	16	0	32767
EM	Current EM Bank	16	0	32767
DR	Data Register	16	0	15

IR	Index Register	32	0	15
----	----------------	----	---	----

2.3.4.3 Connecting to HMI

Configuring the PLC

Use **CX-Programmer** to configure the IP of the PLC.

In the **專案 Task 工具區** sidebar, expand **IO 表及模組設定**.

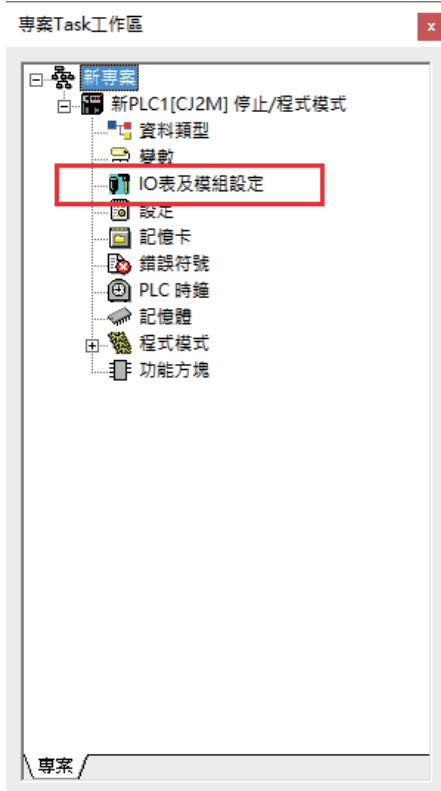

Expand **內建埠/嵌入板**, and expand **EtherNet/IP Port**

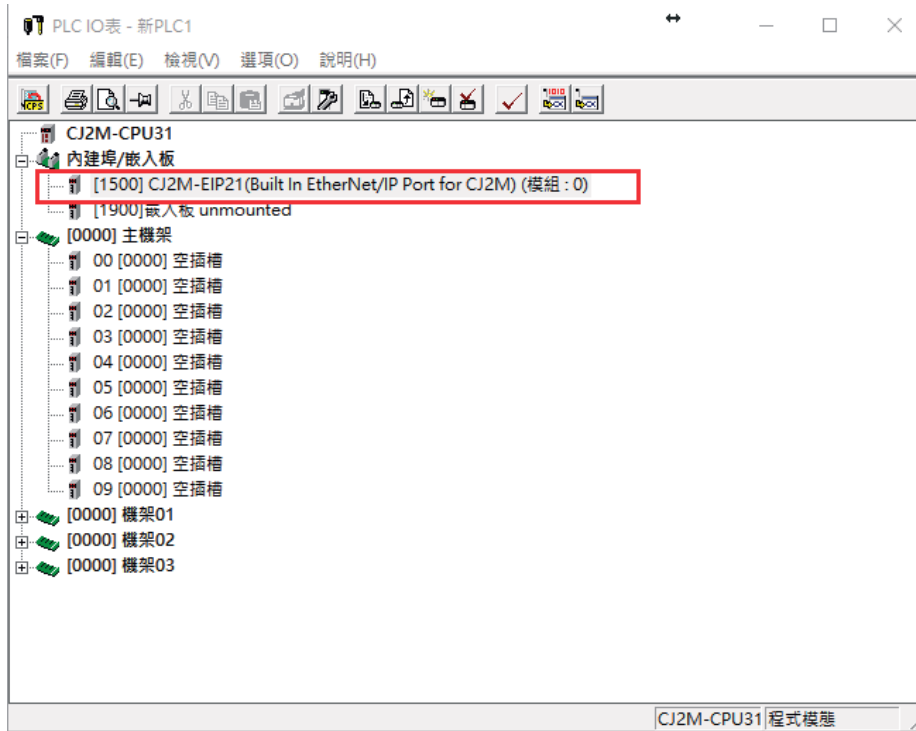

IP address and other parameters can be set.



Note: For more detailed information please refer to the PLC manual.

Connect PLC to HMI

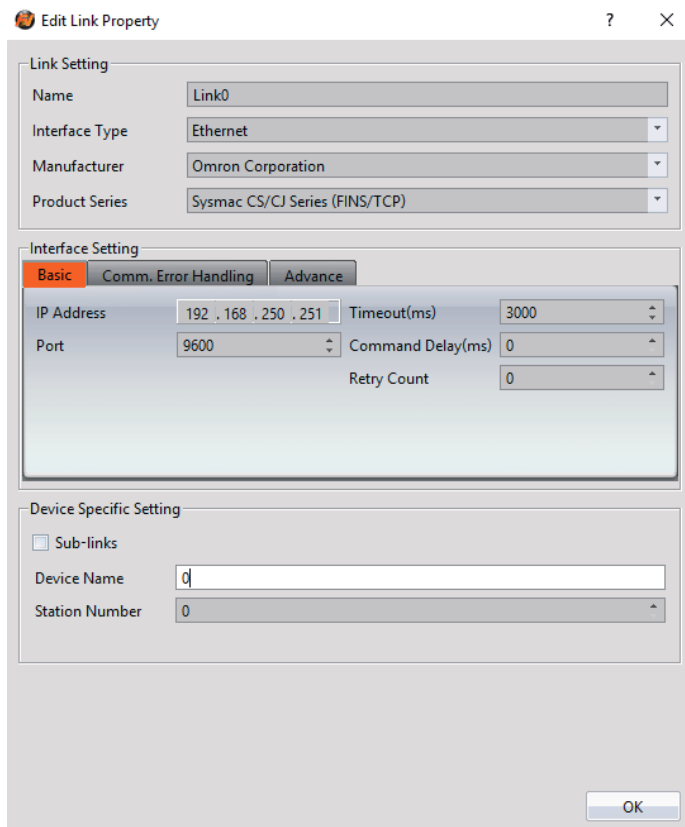

Within the **Link** configuration window in FvDesigner:
Under **Interface Type** select Ethernet
Under **Manufacturer** select Omron Corporation
Under **Product Series** select Sysmac CS/CJ Series (FINS/TCP)
Enter the **IP Address** that was written into the PLC
Enter 9600 for the Port

2.3.5 Omron SYSMAC CPM Series

2.3.5.1 Communication Setting

Item	Default Setting	Remark
Signal Level	RS232	
Baud Rate	9600	
Data Length	7	
Stop Bit	2	
Parity	Even	
PLC Station No.	0	
Communication Method	HOSTLINK	

2.3.5.2 Memory Resource Review

Device	Description	Data bit	Min.	Max.
TNB	Timer Area	1	0	255
CNB	Counter Area	1	0	255
IR	IR area	16	0	227
HR	HR area	16	0	19
AR	AR area	16	0	23
LR	LR area	16	0	15
TN	Timer area	16	0	255
CN	Counter area	16	0	255
DM	DM area	16	0	6655

2.3.5.3 Connecting to HMI

Configuring the PLC

Use **CX-Programmer** to configure the port of the PLC.

Under 專案 Task 工作區 Sidebar, expand 設定.

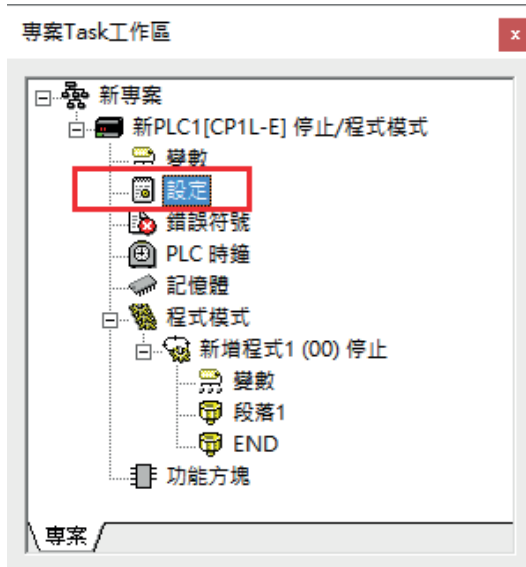

Navigate to **序列埠 1** tab and configure it to the settings detailed below.

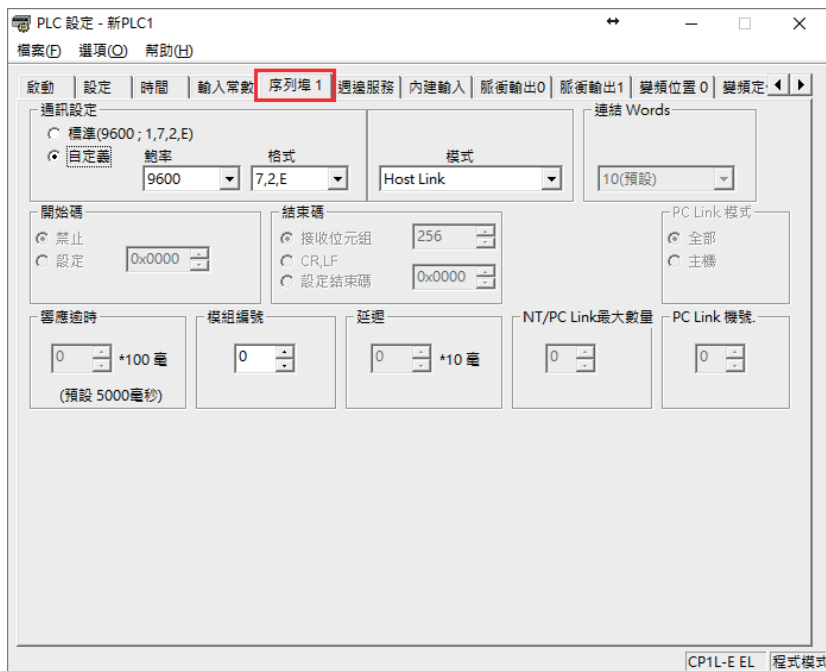

After click **傳輸到 PLC** to write in PLC.

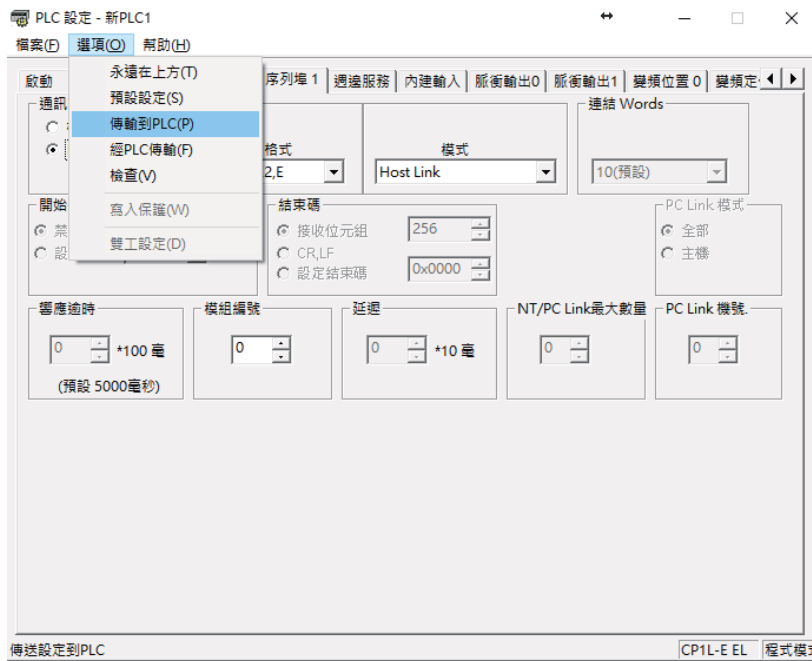

Note: For more detailed information please refer to the PLC manual.

Connecting PLC to HMI

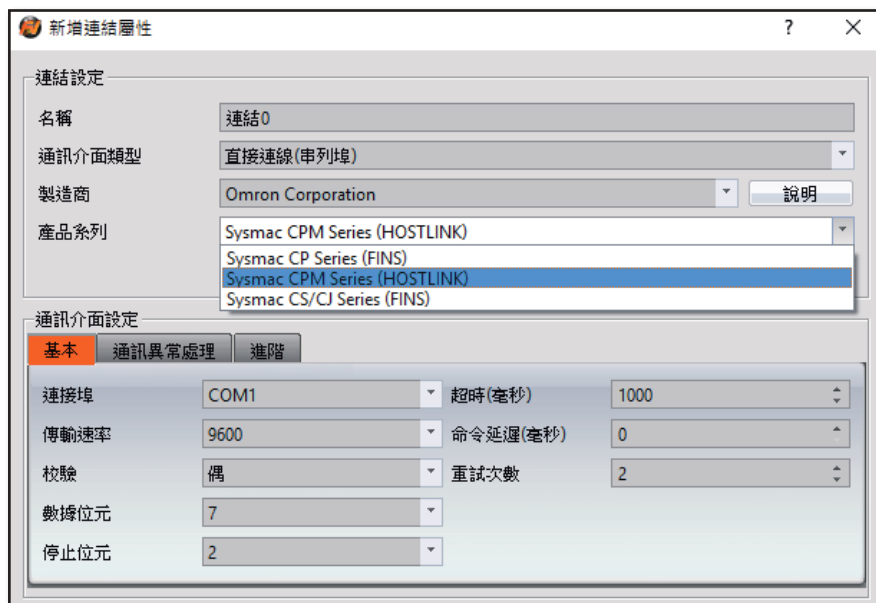

- Within the **Link** configuration window in FvDesigner:
- Under **Interface Type** select Serial
- Under **Manufacturer** select Omron Corporation
- Under **Product Series** select Sysmac CPM Series (HOSTLINK)
- Under **Port** select COM1

2.3.5.4 Wiring Diagrams

Omron PLC Pinout

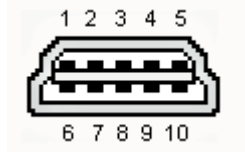

*Looking into Omron PLC Cable

PIN#	Signal
1	
2	
3	
4	RX
5	
6	
7	GND
8	TX
9	RTS
10	CTS

HMI COM1 Pinout

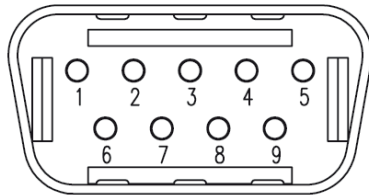

*Looking into COM1 Port

PIN#	COM1 (RS232)
1	
2	RX
3	TX
4	
5	GND
6	
7	RTS
8	CTS
9	

All P5 and P2K Series

HMI COM1	Omron PLC Port
2 RX	8 TX
3 TX	4 RX
5 GND	7 GND

Wiring Diagrams: All P5 and P2K Series

HMI COM1

Omron PLC

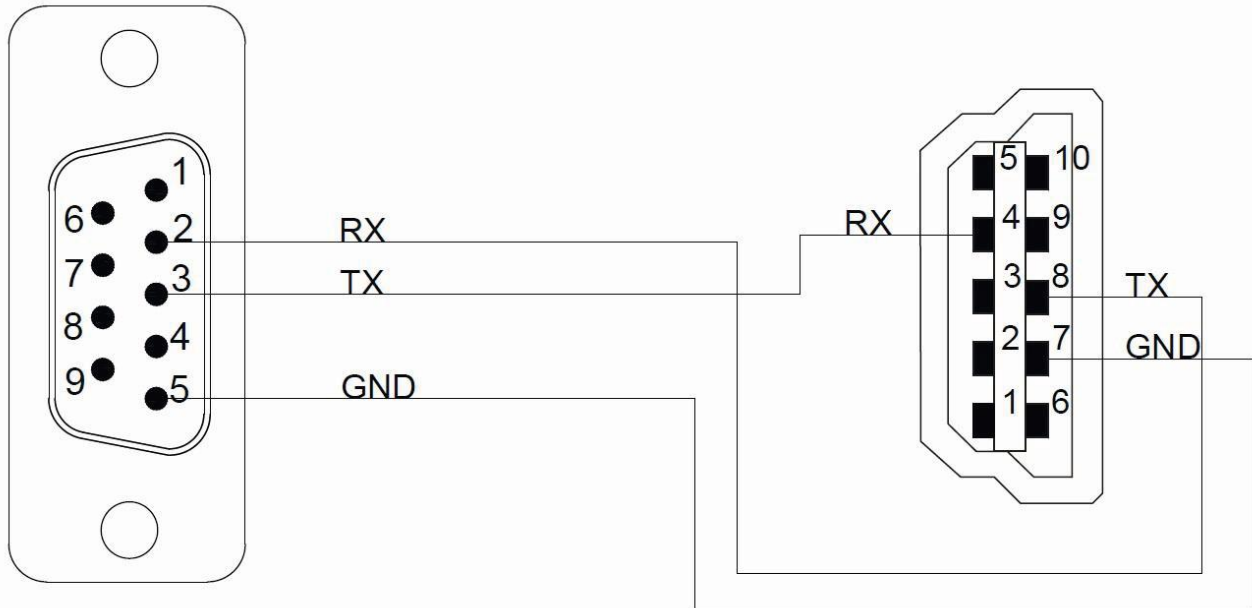

2.3.6 Omron SYSMAC NJ/NX Series(EtherNet/IP)

2.3.6.1 Communication Setting

Item	Default Setting	Remark
Signal Level	Ethernet	
Internet Protocol	192.168.250.1	
Port	44818	
PLC Station No.	1	
Communication Method	EtherNet/IP	

2.3.6.2 Memory Resource Review

Device	Data bit	Description
BOOL	1	boolean value
BYTE	8	byte value
SINT	8	short integer value
USINT	8	unsigned short integer value
INT	16	integer value

UINT	---	16	unsigned integer value
WORD	---	16	word value
DINT	---	32	double integer value
DWORD	---	32	double word value
REAL	---	32	float value
UDINT	---	32	unsigned double integer value
BOOL[]	BOOL	1*n	array of Boolean value
BYTE[]	BYTE	8*n	array of byte value
SINT[]	SINT	8*n	array of short integer value
USINT[]	USINT	8*n	array of unsigned short integer value
INT[]	INT	16*n	array of integer value
UINT[]	UINT	16*n	array of unsigned integer value
WORD[]	WORD	16*n	array of word value
DINT[]	DINT	32*n	array of Double integer value
DWORD[]	DWORD	32*n	array of double word value
REAL[]	REAL	32*n	array of float value
UDINT[]	UDINT	32*n	array of unsigned double integer value

2.3.6.3 Connecting to HMI

Configuring the PLC

Use **Sysmac Studio** to configure the port of the PLC.

Under 專案多檢視瀏覽器 Sidebar, select 設定和安裝>控制器設定>內置 EtherNet/IP 通訊設定 and configure it to the settings detailed below.

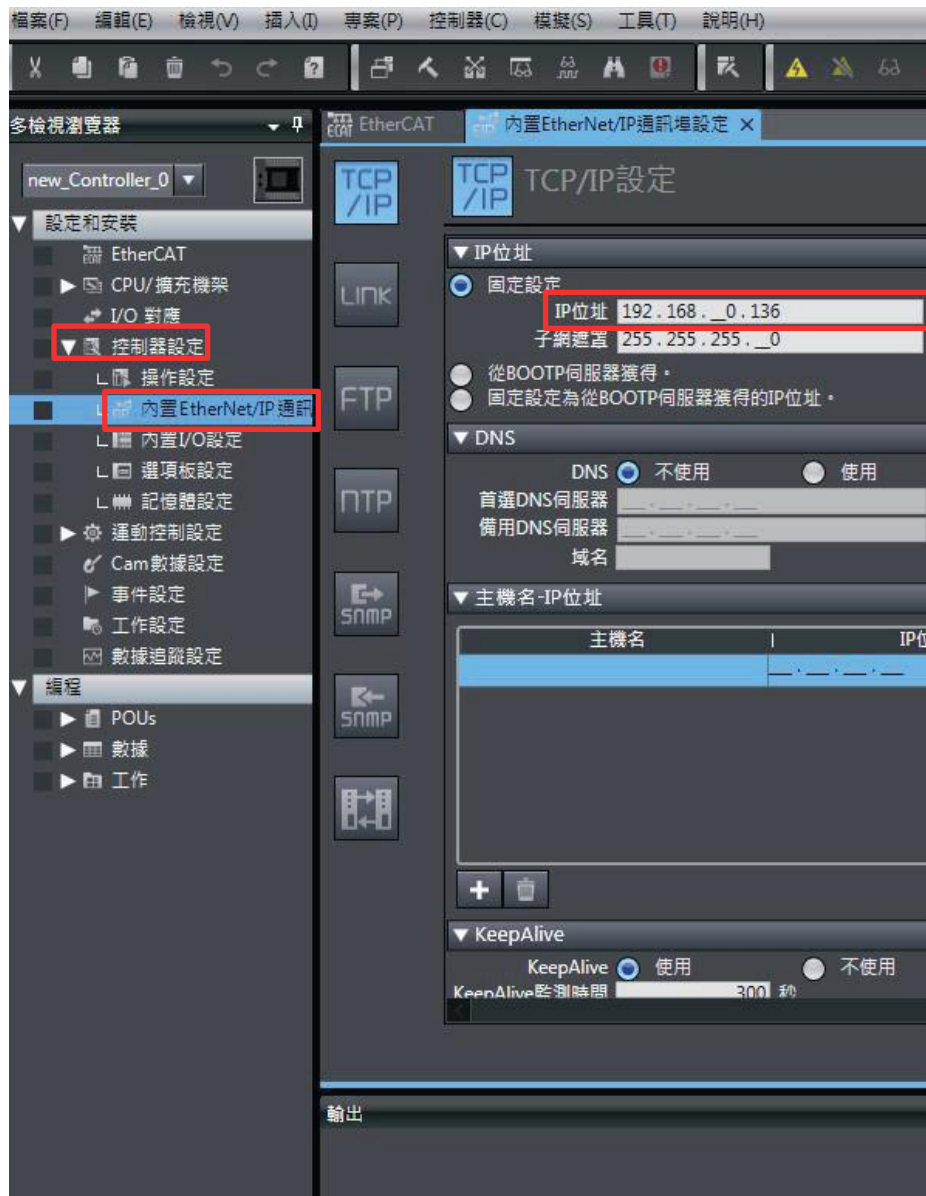

Note: For more detailed information please refer to the PLC manual.

Connecting PLC to HMI



Within the **Link** configuration window in FvDesigner:

Under **Interface Type** select Ethernet

Under **Manufacturer** select Omron Corporation

Under **Product Series** select SYSMAC NJ/NX Series(EtherNet/IP)

Enter the IP Address that was written into the PLC

Enter 44818 for the Port

2.3.7 Omron Ethernet

2.3.7.1 Communication Setting

Item	Default Setting	Remark
Signal Level	Ethernet	
Internet Protocol	192.168.250.1	
Port	9600	
PLC Station No.	0	
Communication Method	FINS/UDP	

2.3.7.2 Memory Resource Review

Device	Description	Data bit	Min	Max
TK	Task Flag	1	0	127
TIM	Timer Area	1	0	4095
CNT	Counter Area	1	0	4095
CIO	CIO Area	16	0	6143
W	Work Area	16	0	511
H	Holding Bit Area	16	0	1535

A	Auxiliary Bit Area	16	0	11535
T	Timer Area	16	0	4095
C	Counter Area	16	0	4095
D	DM Area	16	0	32767
E0_	EM Bank 0	16	0	32767
E1_	EM Bank 1	16	0	32767
E2_	EM Bank 2	16	0	32767
E3_	EM Bank 3	16	0	32767
E4_	EM Bank 4	16	0	32767
E5_	EM Bank 5	16	0	32767
E6_	EM Bank 6	16	0	32767
E7_	EM Bank 7	16	0	32767
E8_	EM Bank 8	16	0	32767
E9_	EM Bank 9	16	0	32767
EA_	EM Bank 10	16	0	32767
EB_	EM Bank 11	16	0	32767
EC_	EM Bank 12	16	0	32767
EM_	Current EM Bank	16	0	32767
DR	Data Register	16	0	15
IR	Index Register	32	0	15

2.3.7.3 Connecting to HMI

Configuring the PLC

Use **Sysmac Studio** to configure the port of the PLC.

Under 專案多檢視瀏覽器 Sidebar, select 設定和安裝>控制器設定>內置 **EtherNet/IP 通訊設定** and configure it to the settings detailed below.

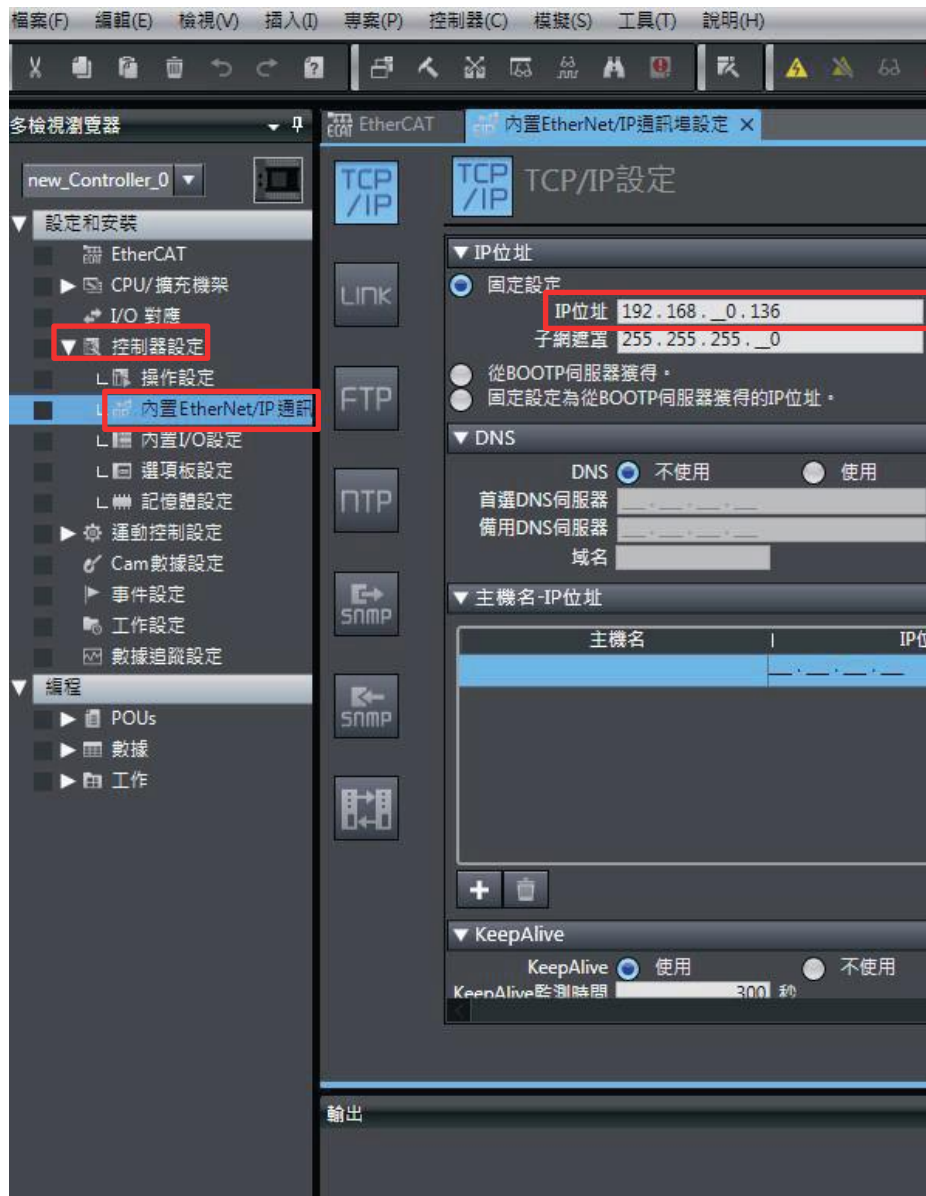

Note: For more detailed information please refer to the PLC manual.

Connecting PLC to HMI



Within the **Link** configuration window in FvDesigner:
 Under **Interface Type** select Ethernet
 Under **Manufacturer** select Omron Corporation
 Under **Product Series** select Sysmac Omron Ethernet
 Enter the **IP Address** that was written into the PLC
 Enter 9600 for the Port

2.3.8 Sysmac NJ Series (FINS/TCP)

2.3.8.1 Communication Setting

Item	Default Setting	Remark
Signal Level	Ethernet	
Internet Protocol	192.168.250.1	
Port	9600	
PLC Station No.	0	
Communication Method	FINS/TCP	

2.3.8.2 Memory Resource Review

Device	Description	Data bit	Min.	Max.
%	CIO Area	16	0	6143
%W	Work Area	16	0	511
%H	Holding Bit Area	16	0	1535

%D	DM Area	16	0	32767
%E0_	EM Bank 0	16	0	32767
%E1_	EM Bank 1	16	0	32767
%E2_	EM Bank 2	16	0	32767
%E3_	EM Bank 3	16	0	32767
%E4_	EM Bank 4	16	0	32767
%E5_	EM Bank 5	16	0	32767
%E6_	EM Bank 6	16	0	32767
%E7_	EM Bank 7	16	0	32767
%E8_	EM Bank 8	16	0	32767
%E9_	EM Bank 9	16	0	32767
%EA_	EM Bank 10	16	0	32767
%EB_	EM Bank 11	16	0	32767
%EC_	EM Bank 12	16	0	32767

2.3.8.3 Connecting to HMI

Configuring the PLC

Use Sysmac Studio to configure the port of the PLC.

Under 專案多檢視瀏覽器 Sidebar, select 設定和安裝>控制器設定>內置 EtherNet/IP 通訊設定 and configure it to the settings detailed below

Note: For more detailed information please refer to the PLC manual.

Connecting PLC to HMI

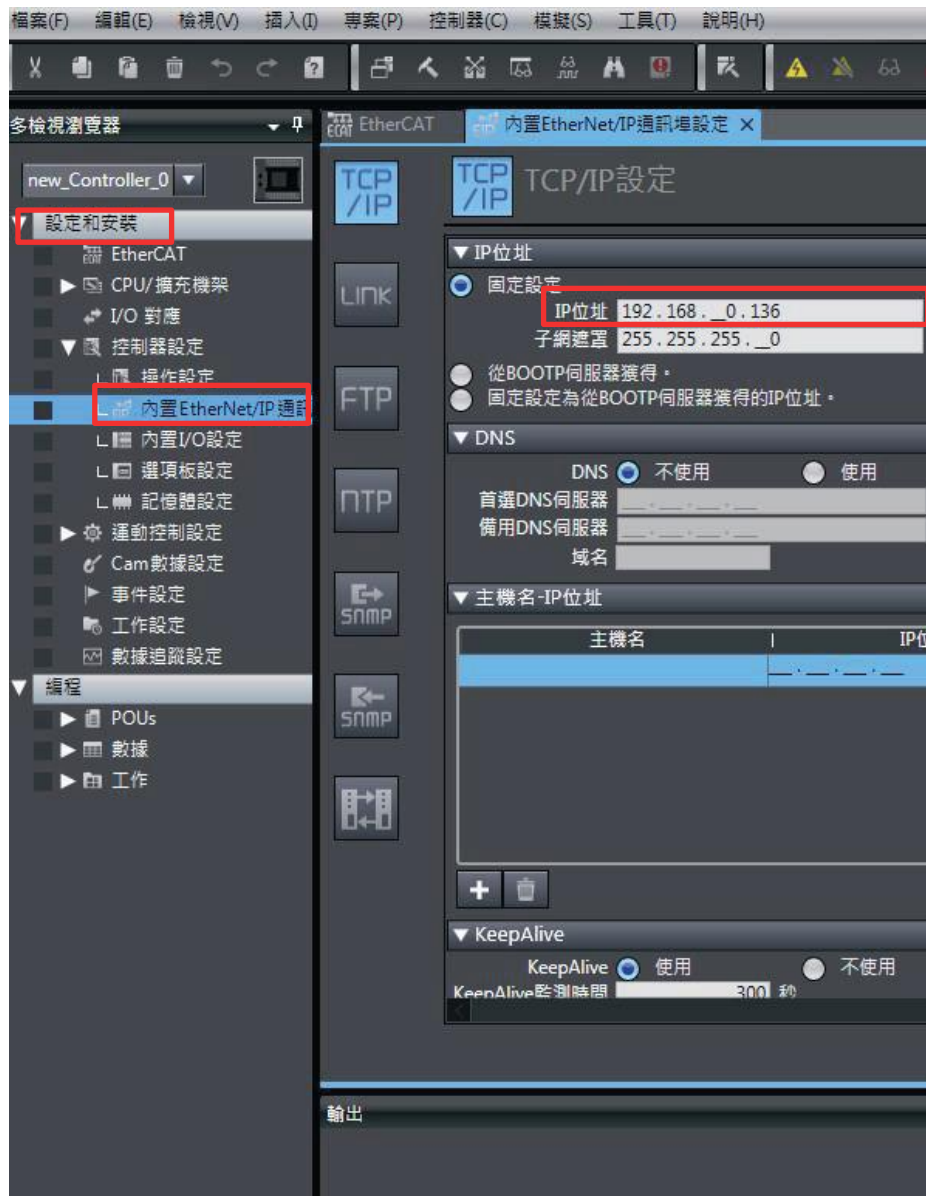



Within the **Link** configuration window in FvDesigner:

Under **Interface Type** select Ethernet

Under **Manufacturer** select Omron Corporation

Under **Product Series** select Sysmac NJ Series (FINS/TCP)

Enter the IP Address that was written into the PLC

Enter 9600 for the Port

2.3.9 Sysmac NX/NJ Series (FINS/UDP)

2.3.9.1 Communication Setting

Item	Default Setting	Remark
Signal Level	Ethernet	
Internet Protocol	192.168.250.1	
Port	9600	
PLC Station No.	0	
Communication Method	FINS/UDP	

2.3.9.2 Memory Resource Review

Device	Description	Data bit	Min.	Max.
%	CIO Area	16	0	6143
%W	Work Area	16	0	511
%H	Holding Bit Area	16	0	1535

%D	DM Area	16	0	32767
%E0_	EM Bank 0	16	0	32767
%E1_	EM Bank 1	16	0	32767
%E2_	EM Bank 2	16	0	32767
%E3_	EM Bank 3	16	0	32767
%E4_	EM Bank 4	16	0	32767
%E5_	EM Bank 5	16	0	32767
%E6_	EM Bank 6	16	0	32767
%E7_	EM Bank 7	16	0	32767
%E8_	EM Bank 8	16	0	32767
%E9_	EM Bank 9	16	0	32767
%EA_	EM Bank 10	16	0	32767
%EB_	EM Bank 11	16	0	32767
%EC_	EM Bank 12	16	0	32767

2.3.9.3 Connecting to HMI

Configuring the PLC

Use Sysmac Studio to configure the port of the PLC.

Under 專案多檢視瀏覽器 Sidebar, select 設定和安裝>控制器設定>內置 EtherNet/IP 通訊設定 and configure it to the settings detailed below.

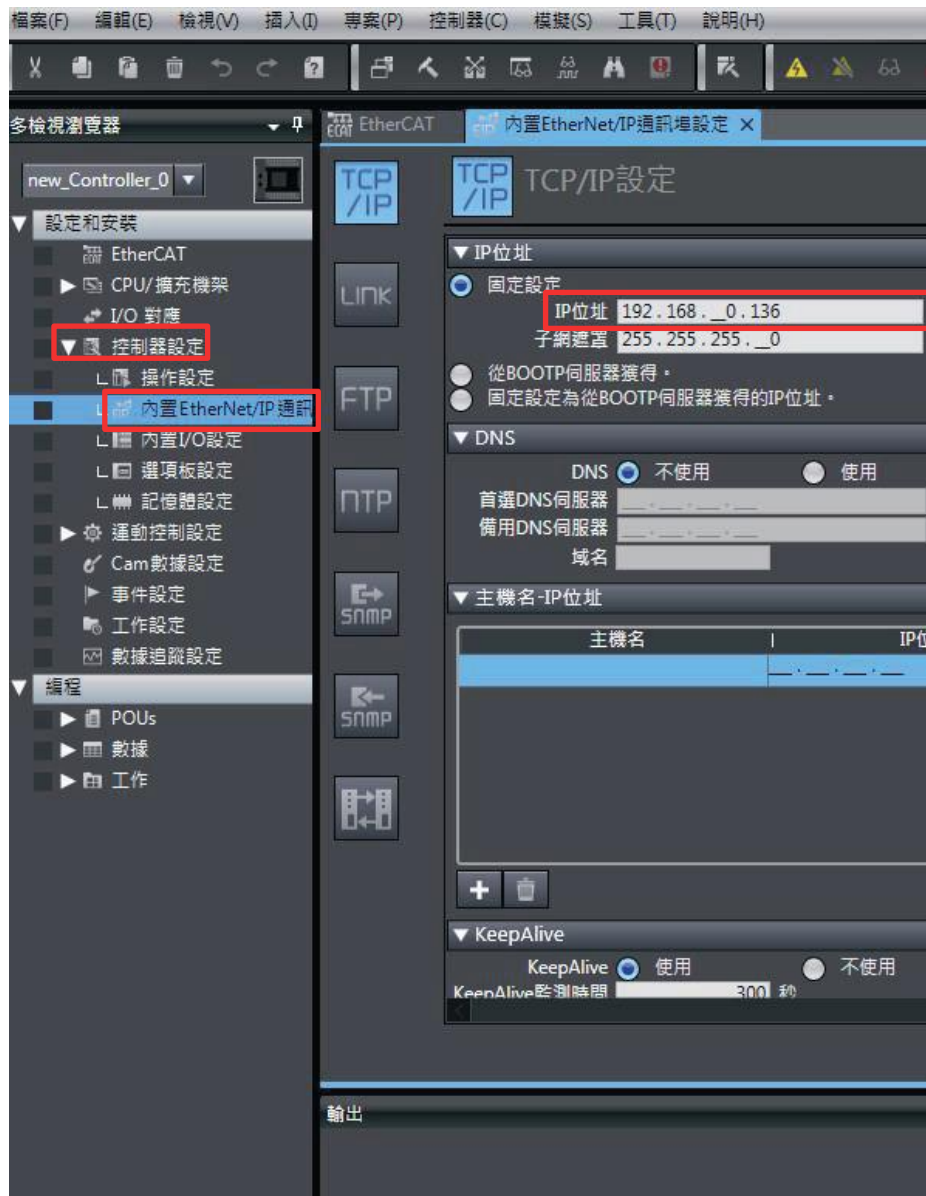

Note: For more detailed information please refer to the PLC manual.

Connecting PLC to HMI

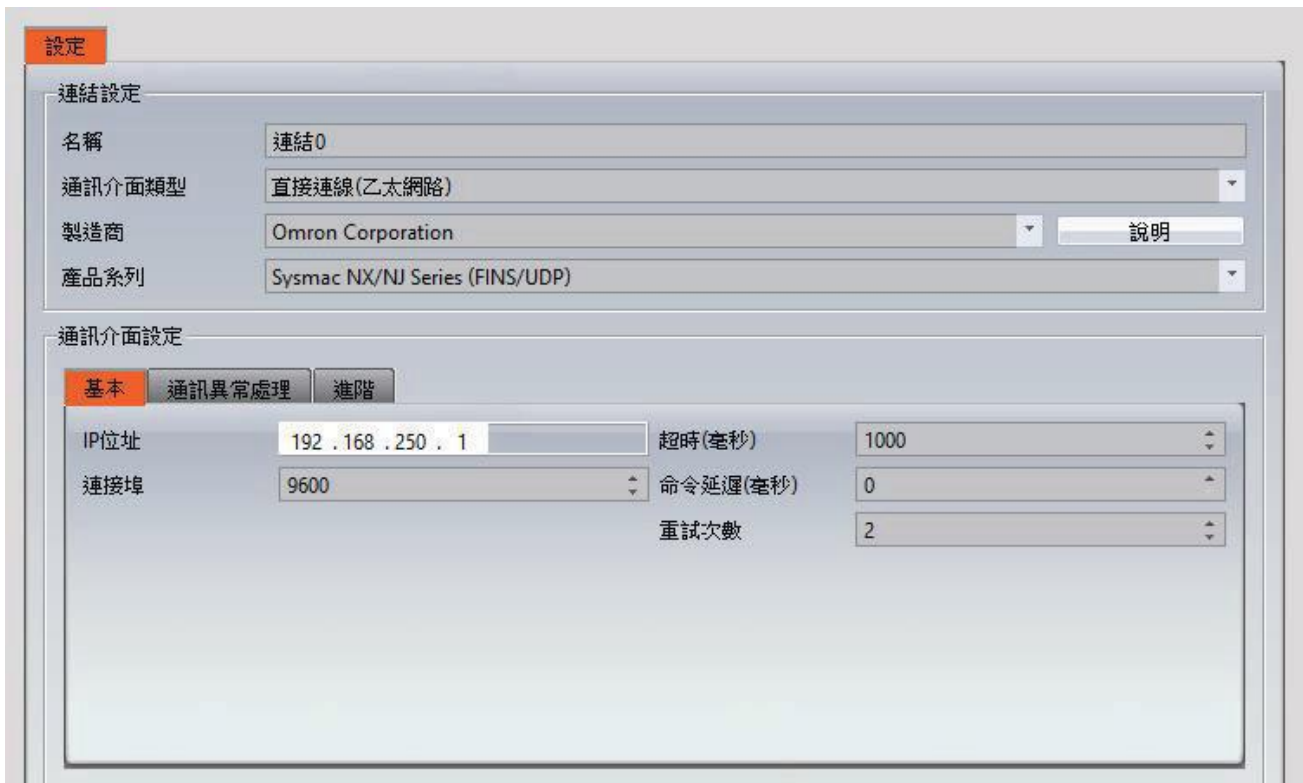

Within the **Link** configuration window in FvDesigner:

Under **Interface Type** select Ethernet

Under **Manufacturer** select Omron Corporation

Under **Product Series** select Sysmac NX/NJ Series (FINS/UDP)

Enter the IP Address that was written into the PLC

Enter 9600 for the Port

2.3.10 Omron SYSMAC CQM Series

2.3.10.1 Communication Setting

Item	Default Setting	Remark
Signal Level	RS232	
Baud Rate	9600	
Data Length	7	
Stop Bit	2	
Parity	Even	
PLC Station No.	0	
Communication Method	HOSTLINK	

2.3.10.2 Memory Resource Review

Device	Description	Data bit	Min.	Max.
TNB	Timer Area	1	0	255
CNB	Counter Area	1	0	255
IR	IR area	16	0	227
HR	HR area	16	0	19
AR	AR area	16	0	23
LR	LR area	16	0	15
TN	Timer area	16	0	255
CN	Counter area	16	0	255
DM	DM area	16	0	6655

2.3.10.3 Connecting to HMI

Configuring the PLC

Use **CX-Programmer** to configure the port of the PLC.

Under 專案 Task 工作區 Sidebar, expand 設定.

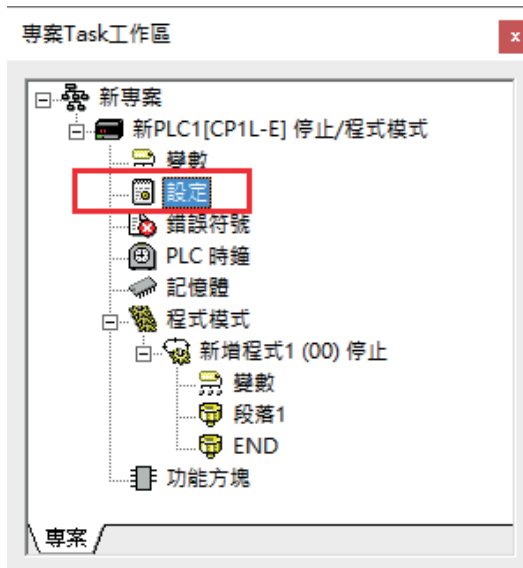

Navigate to 序列埠 1 tab and configure it to the settings detailed below.

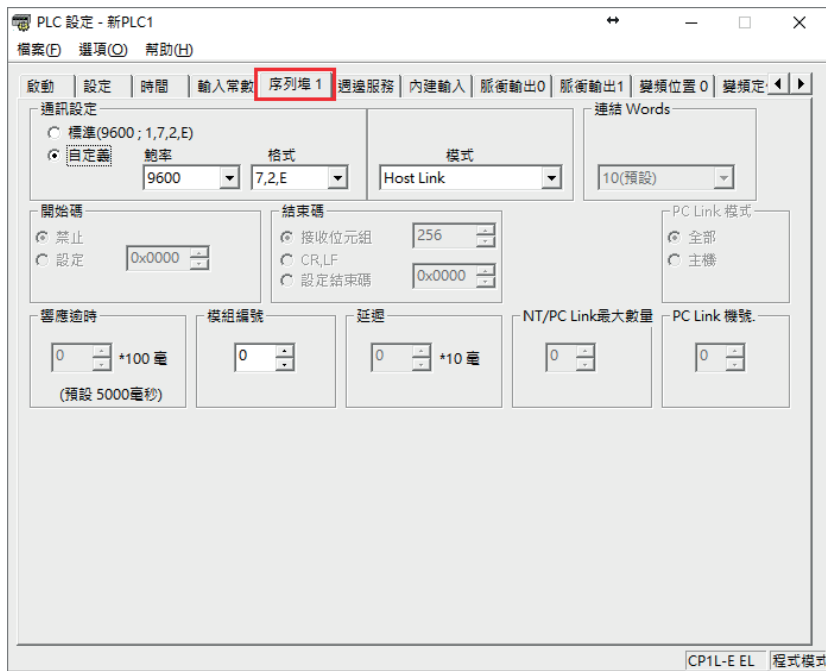

After click **傳輸到 PLC** to write in PLC.



Note: For more detailed information please refer to the PLC manual.

Connecting PLC to HMI

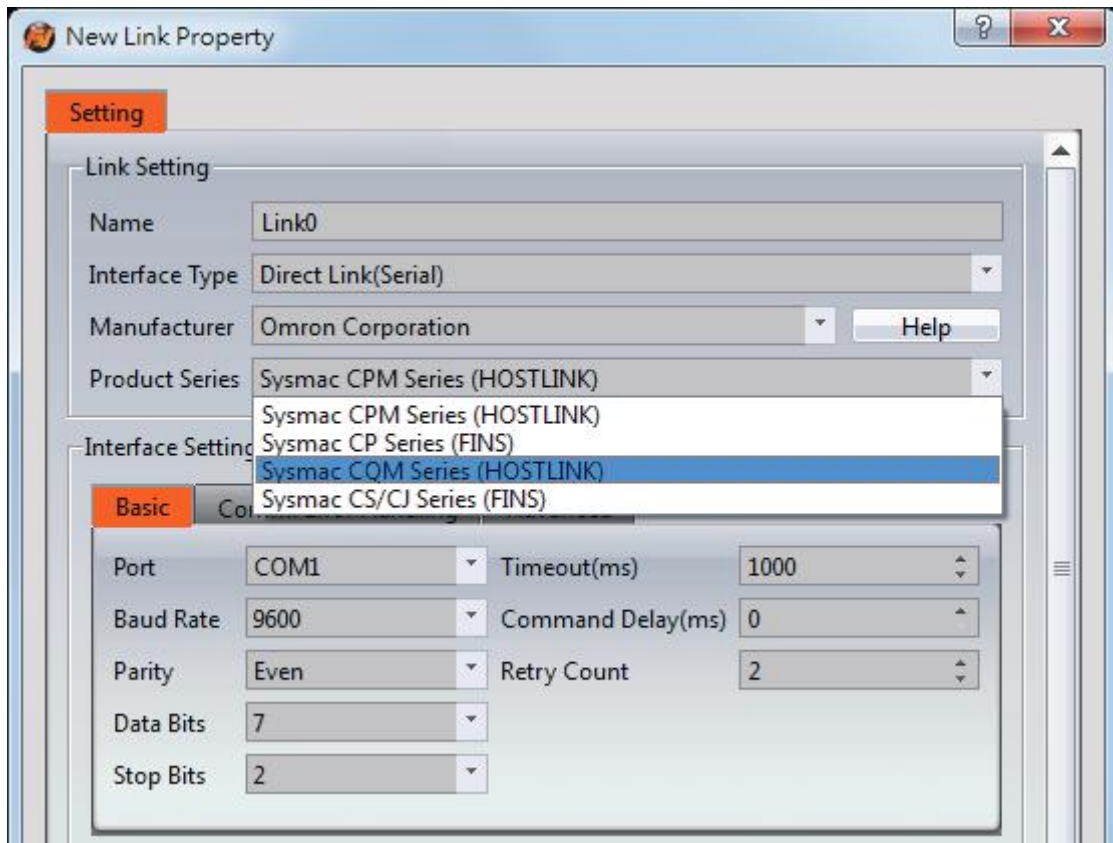

Within the **Link** configuration window in FvDesigner:

Under **Interface Type** select Serial

Under **Manufacturer** select Omron Corporation

Under **Product Series** select Sysmac CQM Series (HOSTLINK)

Under **Port** select COM1

2.3.10.4 Wiring Diagrams

Omron PLC Pinout

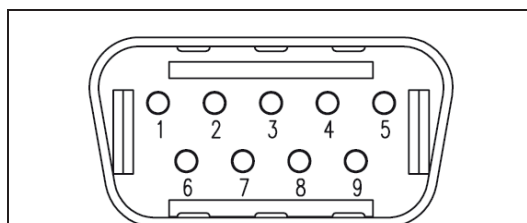

*Looking into PLC Port

PIN#	Signal
1	
2	SD
3	RD
4	RS
5	CS

6	
7	
8	
9	SG

HMI COM1 Pinout

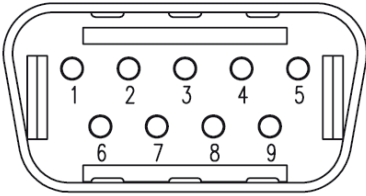
	
*Looking into COM1 Port	
PIN#	COM1 (RS232)
1	
2	RX
3	TX
4	
5	GND
6	
7	
8	
9	

All P5 and P2K Series

HMI COM1	Omron PLC Port	
2 RX	2 SD	
3 TX	3 RD	
5 GND	9 SG	
	4 RS	circuit
	5 CS	

Wiring Diagrams: All P5 and P2K Series

HMI COM1

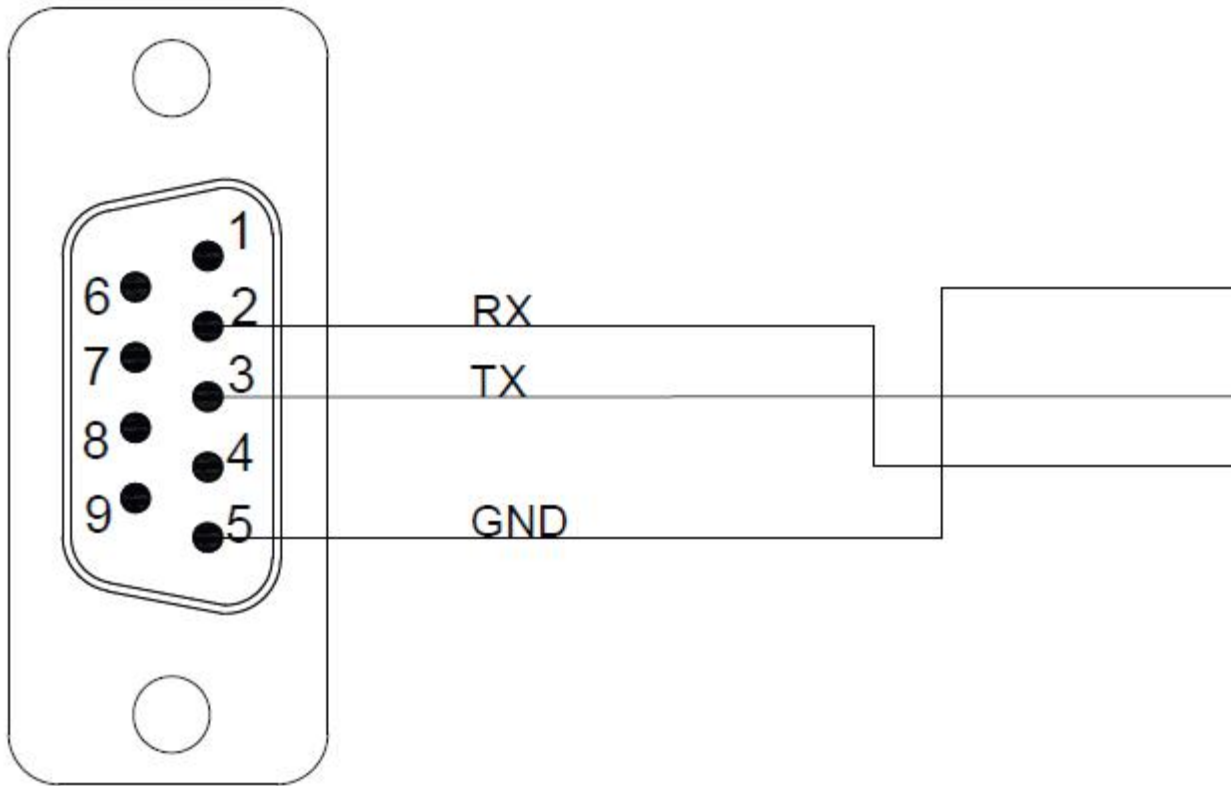

2.4 Siemens

2.4.1 Siemens S7-200 SMART

2.4.1.1 Communication Setting

Item	Default Setting	Remark
Signal Level	RS485 2W	
Baud Rate	9600	
Data Length	8	
Stop Bit	1	
Parity	Even	
PLC Station No.	2	
Communication Method	PPI	

2.4.1.2 Memory Resource Review

Device	Description	Data bit	Min.	Max.
I	Input	1	0	31
Q	Output	1	0	31

M	Bit Memory	1	0	31
V	Variable Memory	1	0	20479
C	Counter	1	0	255
T	Timer	1	0	255
S	Sequential Control Relays	1	0	31
SM	Special Memory Bit	1	0	1535
IW	Input	16	0	31
QW	Output	16	0	31
TW	Timer	16	0	255
CW	Counter	16	0	255
MW	Word Memory	16	0	31
SW	SCR	16	0	31
VW	V Memory	16	0	20479
SMW	Special Memory	16	0	1535
AIW	Analog Input	16	0	111
AQW	Analog Output	16	0	111

2.4.1.3 Connecting to HMI

Configuring the PLC

Use **Step7 microWIN smart** to configure the port of the PLC.

Under the Project Sidebar, expand **CPU model** and configure it to the settings detailed below.

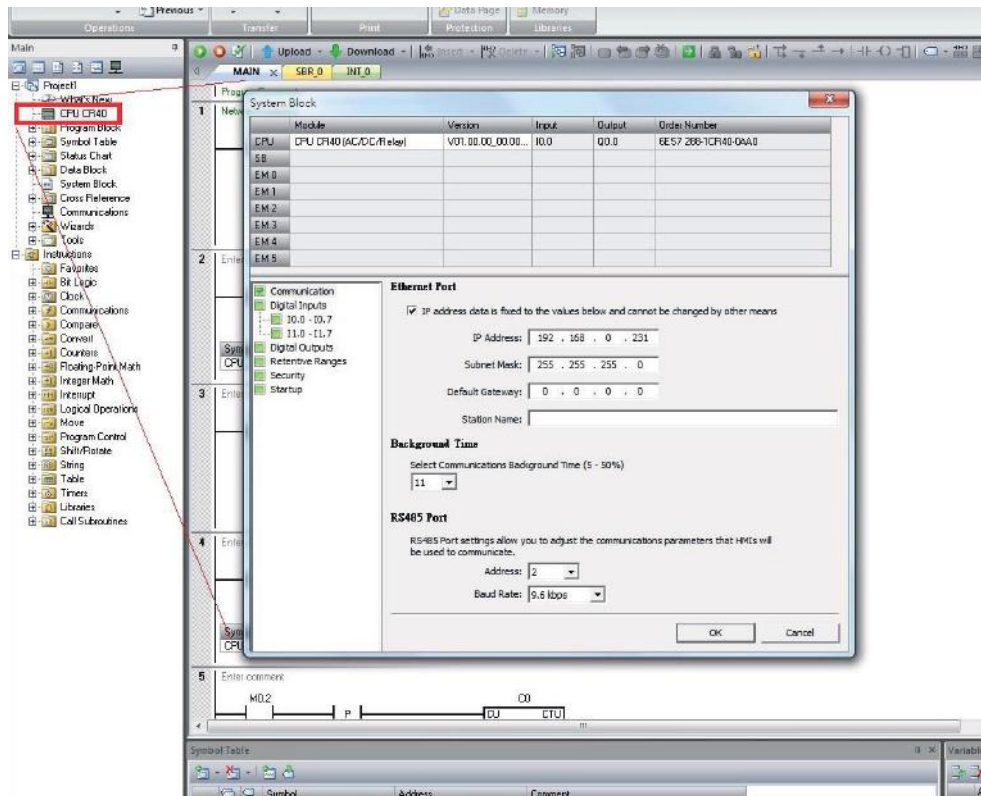

Note: For more detailed information please refer to the PLC manual.

Connecting PLC to HMI

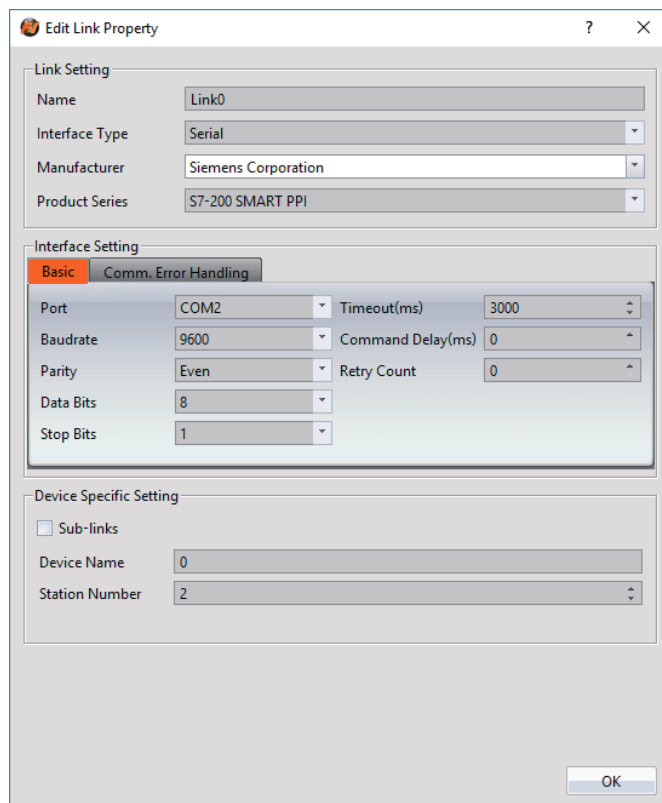

Within the **Link** configuration window in FvDesigner:

Under **Interface Type** select Serial

Under **Manufacturer** select Siemens Corporation

Under **Product Series** select S7-200 SMART PPI

Under **Port** select the port number that corresponds to the RS485 connection on the HMI.

2.4.1.4 Wiring Diagrams

PLC RS485 Port

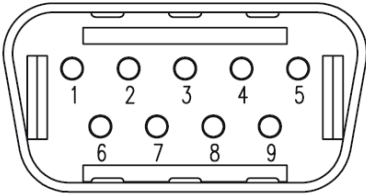

*Looking into male RS485 Cable

PIN#	Signal
1	
2	
3	DATA+
4	
5	GND
6	
7	
8	DATA-
9	

HMI (ex.P5043N) COM2 Pinout

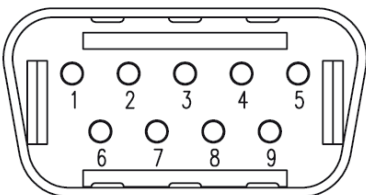

*Looking into HMI

PIN#	COM2 (RS485)
1	DATA+
2	
3	
4	

5	GND
6	DATA-
7	
8	
9	

HMI (ex.P5070N1) COM3 Pinout

	
*Looking into HMI Device	
PIN#	COM3 (RS-422/RS-485)
1	
2	
3	ISO_GND
4	
5	
6	DATA+
7	DATA-

P5070S/P5070N/P5070N1/P5102N/P5102N1

HMI COM3 Port	PLC RS485 Port
6 DATA+	3 DATA+
7 DATA-	8 DATA-
5 GND	5 GND

Wiring Diagrams: P5070S/P5070N/P5070N1/P5102N/P5102N1

HMI COM3

PLC RS485

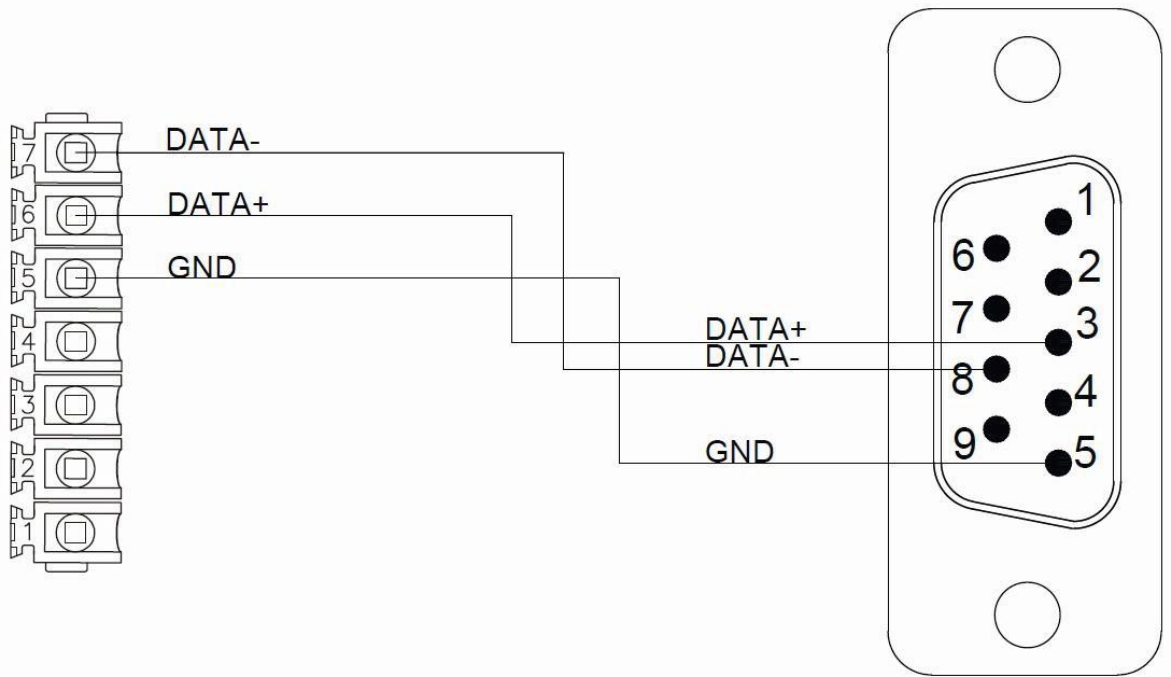

P5043S/P5043N/P5070VS/P5102VS/P2K SERIES

HMI COM3 Port	PLC RS485 Port
1 DATA+	3 DATA+
6 DATA-	8 DATA-
5 GND	5 GND

Wiring Diagrams: P5043S/P5043N/P5070VS/P5102VS/P2K SERIES

HMI COM2

PLC RS485

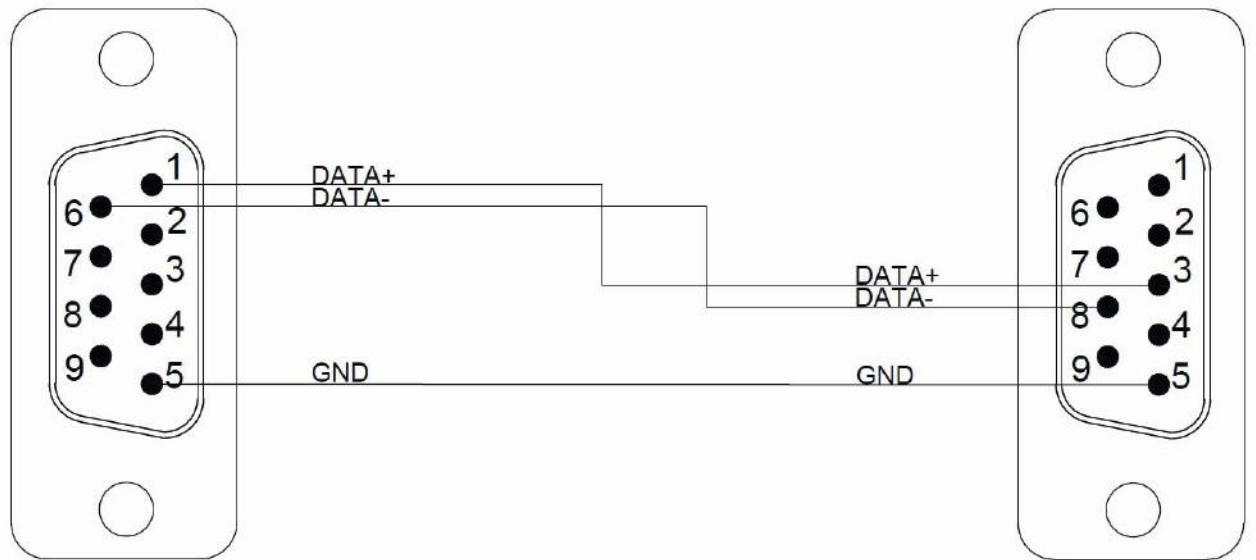

2.4.2 Siemens S7-200 SMART Ethernet

2.4.2.1 Communication Setting

Item	Default Setting	Remark
Signal Level	Ethernet	
Internet Protocol	0.0.0.0	To be configured
Port	102	
PLC Station No.	0	
Communication Method	ISO TCP	

2.4.2.2 Memory Resource Review

Device	Description	Data bit	Min.	Max.
I	Input	1	0	31.7
Q	Output	1	0	31.7
M	Bit Memory	1	0	31.7
V	Variable Memory	1	0	20479.7
C	Counter	1	0	255
T	Timer	1	0	255
S	Sequential Control Relays	1	0	31.7
SM	Special Memory Bit	1	0	1535.7
IW	Input	16	0	31
QW	Output	16	0	31
TW	Timer	16	0	255

CW	Counter	16	0	255
MW	Word Memory	16	0	31
SW	SCR	16	0	31
VW	V Memory	16	0	20479
SMW	Special Memory	16	0	1535
AIW	Analog Input	16	0	111
AQW	Analog Output	16	0	111

2.4.2.3 Connecting to HMI

Configuring IP Address on PLC

Use the application **STEP 7-MicroWIN SMART** to configure the IP address of the PLC. Under the **Project**, press the **Communications** option to connect to the PLC over the local network.

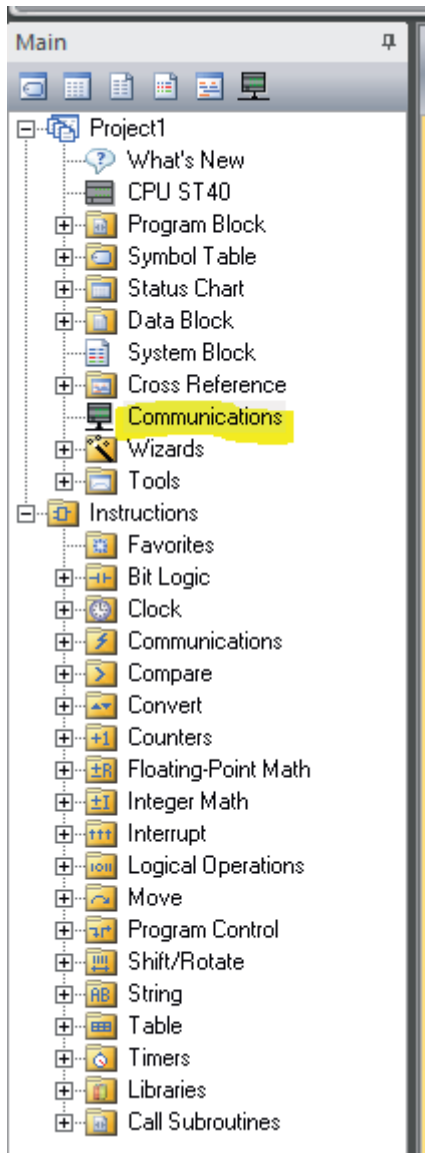

Under Network interface, select one of the options to scan the local network. The IP address of the PLC will show up. The MAC address can be verified with the one on the PLC.

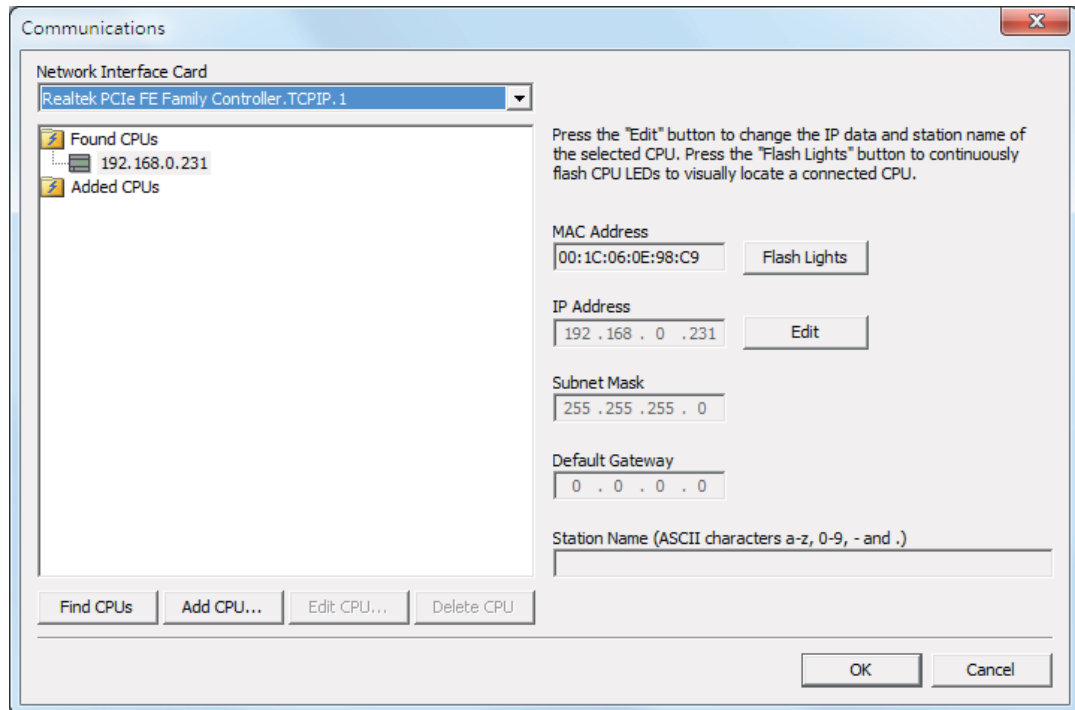

Navigate to the PLC tab and select to upload the PLC program onto the computer.

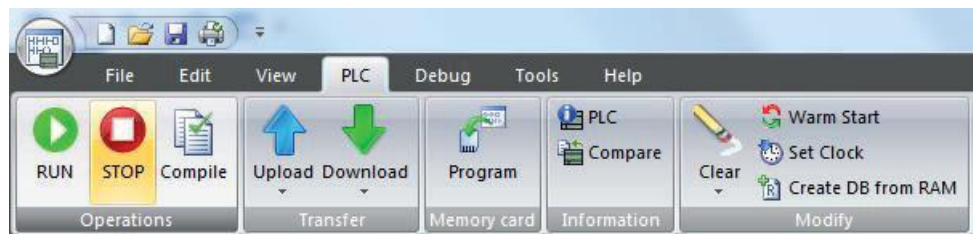

On the sidebar, right click CPU CR40 and select the first option. A dialog window will open up.

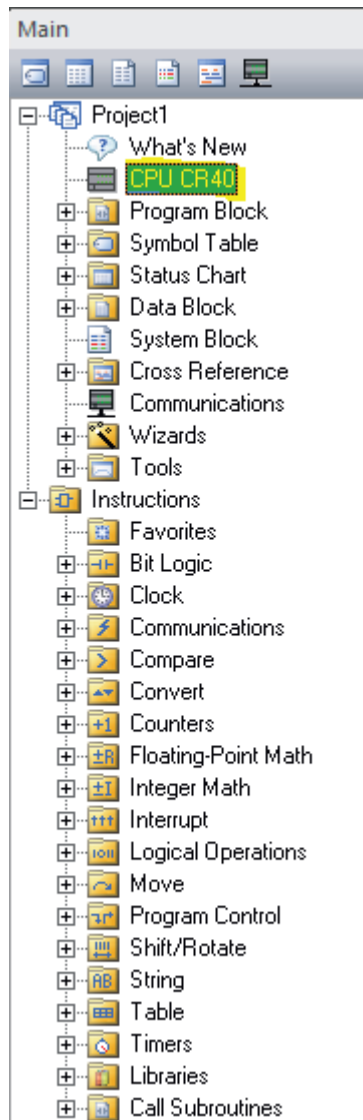

In the dialog window, the IP address can be changed. Press OK to confirm the setting.

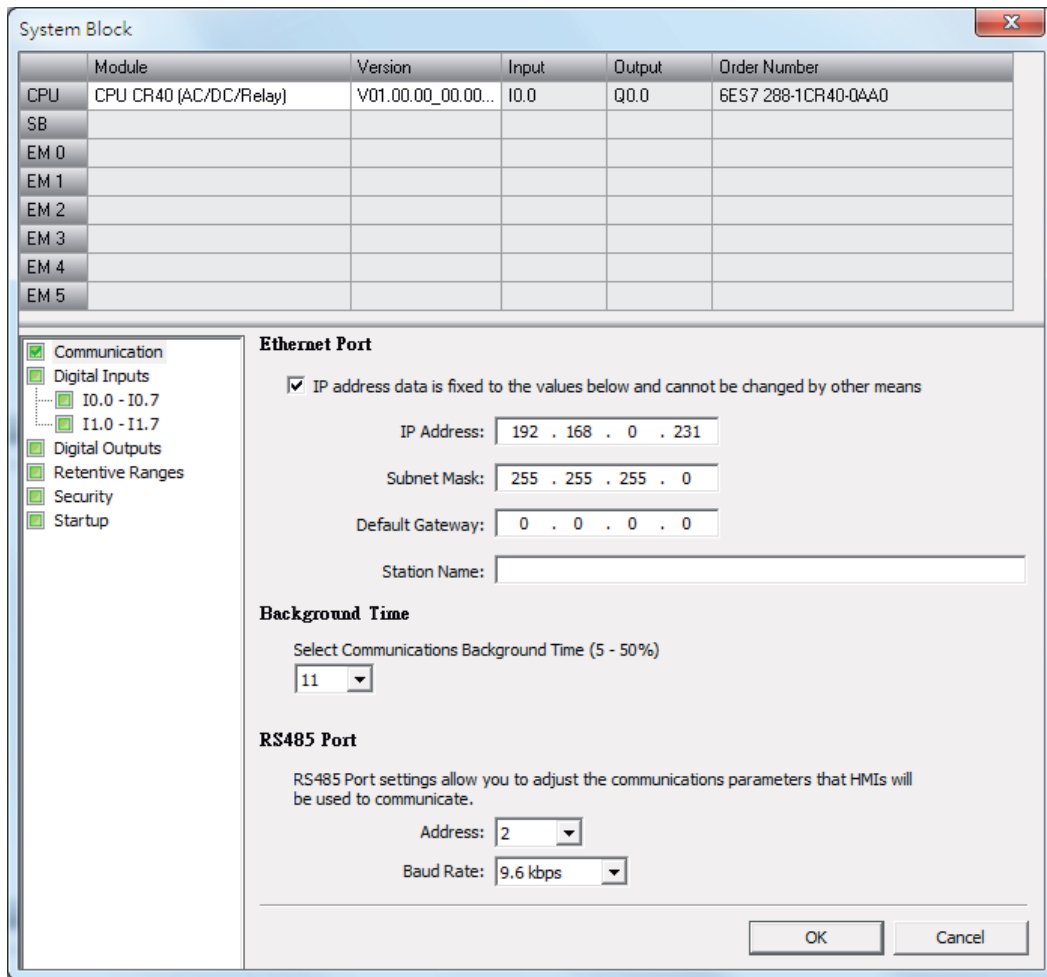

In the PLC tab, select to download the settings onto the PLC.

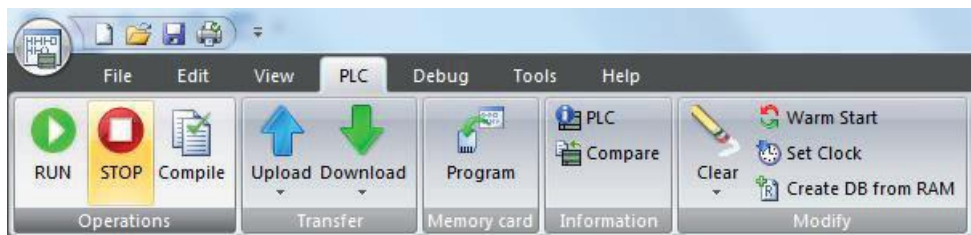

Note: For more detailed information please refer to the PLC manual.

Connecting PLC to HMI

Within the **Link** configuration window in FvDesigner:

Under **Interface Type** select Ethernet

Under **Manufacturer** select Siemens Corporation

Under **Product Series** select S7-200 SMART ISO TCP

Enter the **IP Address** that was written into the PLC.

Enter the **Port** number that was set on the PLC. The default is 102.

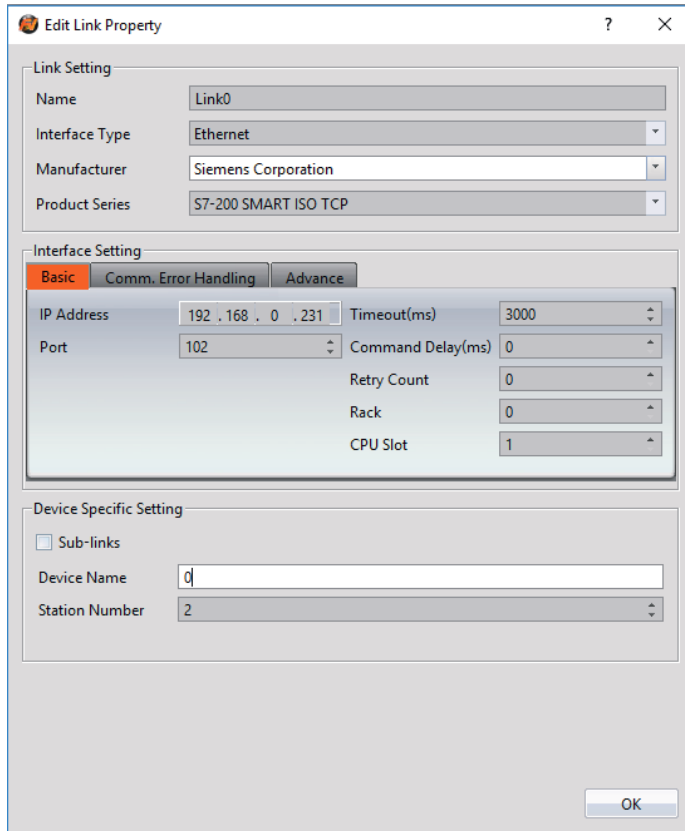

2.4.3 Siemens S7-1200 Ethernet

2.4.3.1 Communication Setting

Item	Default Setting	Remark
Signal Level	Ethernet	
Internet Protocol	0.0.0.0	To be configured
Port	102	
PLC Station No.	0	
Communication Method	ISO TCP	

2.4.3.2 Memory Resource Review

Device	Description	Data bit	Min.	Max.
I	Input	1	0	1022.7
Q	Output	1	0	1022.7
M	Bit Memory	1	0	1022.7
IW	Input	16	0	1022
QW	Output	16	0	1022
MW	Word Memory	16	0	1022

2.4.3.3 Support Data block type

Data block type	Size
Bool	Bit
Byte	8-bit
SInt	8-bit
USInt	8-bit
Word	16-bit
Int	16-bit
UInt	16-bit
DWord	32-bit
DInt	32-bit
UDInt	32-bit
Real	32-bit
String	Length = 254 byte

Please make sure that proper setting is in TIA:

- (1) [DB Properties]→[Attributes]→[Optimized block access] is unchecked
- (2) [PLC program Properties]→[Protection]→[Permit access with PUT/GET communication from remote partner (PLC,HMI,OPC,···)] is checked.

2.4.3.4 Connecting to HMI

Configuring IP Address on PLC

Use the application **TIA V13 Step Basic** to configure the IP address on the PLC.

Open a new project and add the device to be configured.

In the Project tree sidebar, select the device and navigate to the **Online** menu option.

Under the Online menu option, select **Extend Download to Device**. Select the appropriate network interfaces and check **Show all accessible devices**. The application will scan the network for the device. When the device shows up, select it.

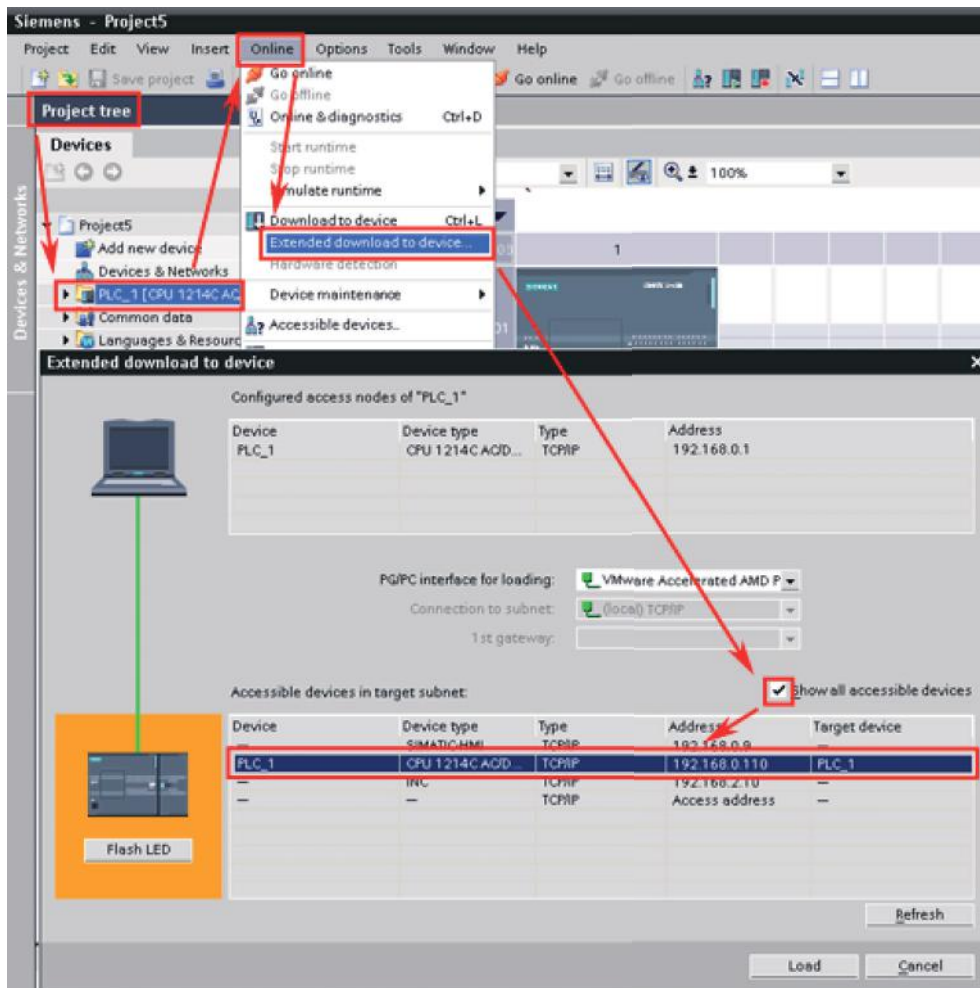

Under the device in the project tree, select **Device configuration** and click the Ethernet port on the device image. Under the **Ethernet addresses** menu option, the IP address can be configured.

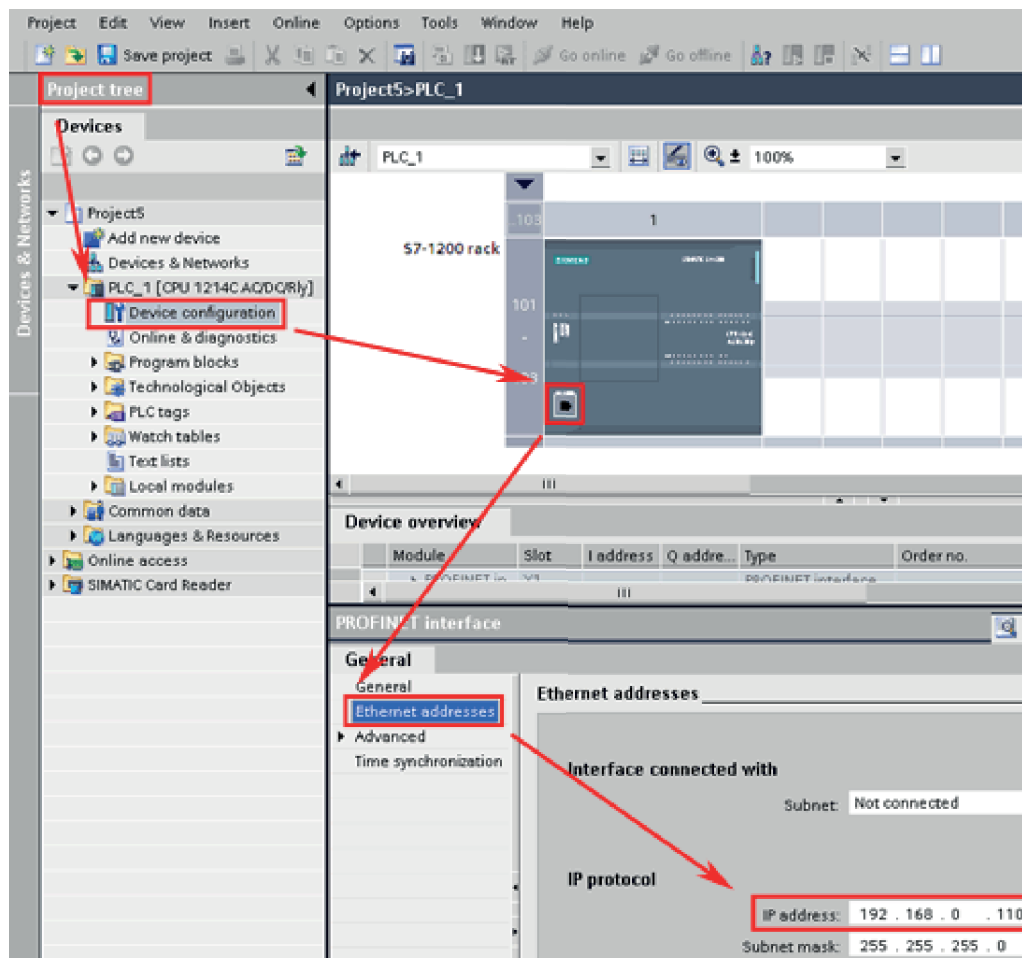

Note: For more detailed information please refer to the PLC manual.

Connecting PLC to HMI

Within the **Link** configuration window in FvDesigner:

Under **Interface Type** select Ethernet

Under **Manufacturer** select Siemens Corporation

Under **Product Series** select S7-1200

Enter the **IP Address** that was written into the PLC.

Enter the **Port** number that was set on the PLC. The default is 102.

Edit Link Property

Link Setting

Name: Link0

Interface Type: Ethernet

Manufacturer: Siemens Corporation

Product Series: S7-1200

Interface Setting

Basic | Comm. Error Handling | Advance

IP Address: 192 . 168 . 0 . 17 Timeout(ms): 3000

Port: 102 Command Delay(ms): 0

Retry Count: 0

Rack: 0

CPU Slot: 1

Device Specific Setting

Sub-links

Device Name: 0

Station Number: 1

Tags Import

OK

2.4.4 Siemens S7-200

2.4.4.1 Communication Setting

Item	Default Setting	Remark
Signal Level	RS485 2W	
Baud Rate	9600	
Data Length	8	
Stop Bit	1	
Parity	Even	
PLC Station No.	2	
Communication Method	PPI	

2.4.4.2 Memory Resource Review

Device	Description	Data Bit	Min.	Max.
I	Input	1	0	15
Q	Output	1	0	15
M	Bit Memory	1	0	31
V	Variable Memory	1	0	10239

C	Counter	1	0	255
T	Timer	1	0	255
S	Sequential Control Relays	1	0	31
SM	Special Memory Bit	1	0	549
IW	Input	16	0	14
QW	Output	16	0	14
TW	Timer	16	0	255
CW	Counter	16	0	255
MW	Word Memory	16	0	30
SW	SCR	16	0	30
VW	V Memory	16	0	10238
SMW	Special Memory	16	0	548
AIW	Analog Input	16	0	62
AQW	Analog Output	16	0	62
ID	Input	32	0	12
QD	Output	32	0	12
MD	Word Memory	32	0	28
SD	SCR	32	0	28
VD	V Memory	32	0	10236
SMD	Special Memory	32	0	546

2.4.4.3 Connecting to HMI

Configuring the PLC

Use Step7 MicroWIN SP9 to configure the port of the PLC.

After choose the PLC type, click communication in the view field, then double click the “double click to refresh” to connect.

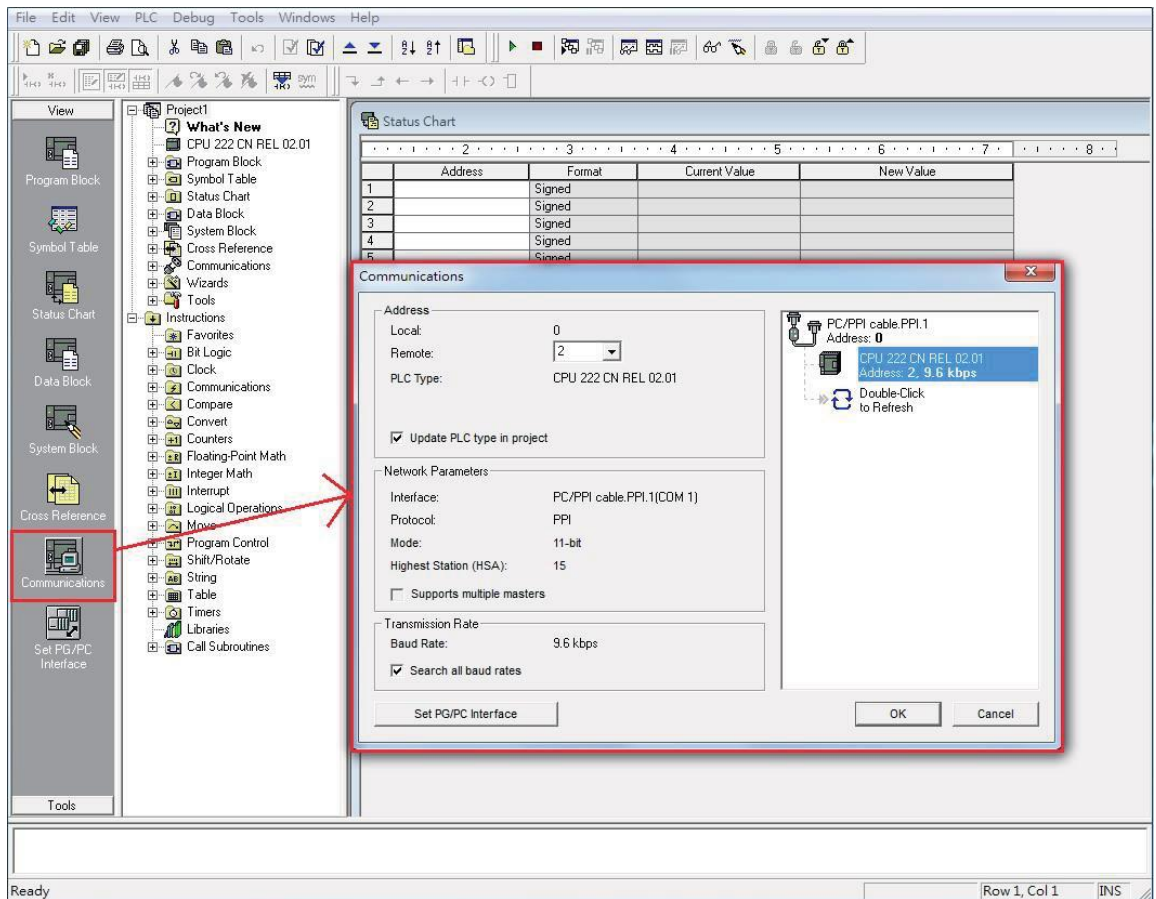

Note: For more detailed information please refer to the PLC manual.

Connecting PLC to HMI

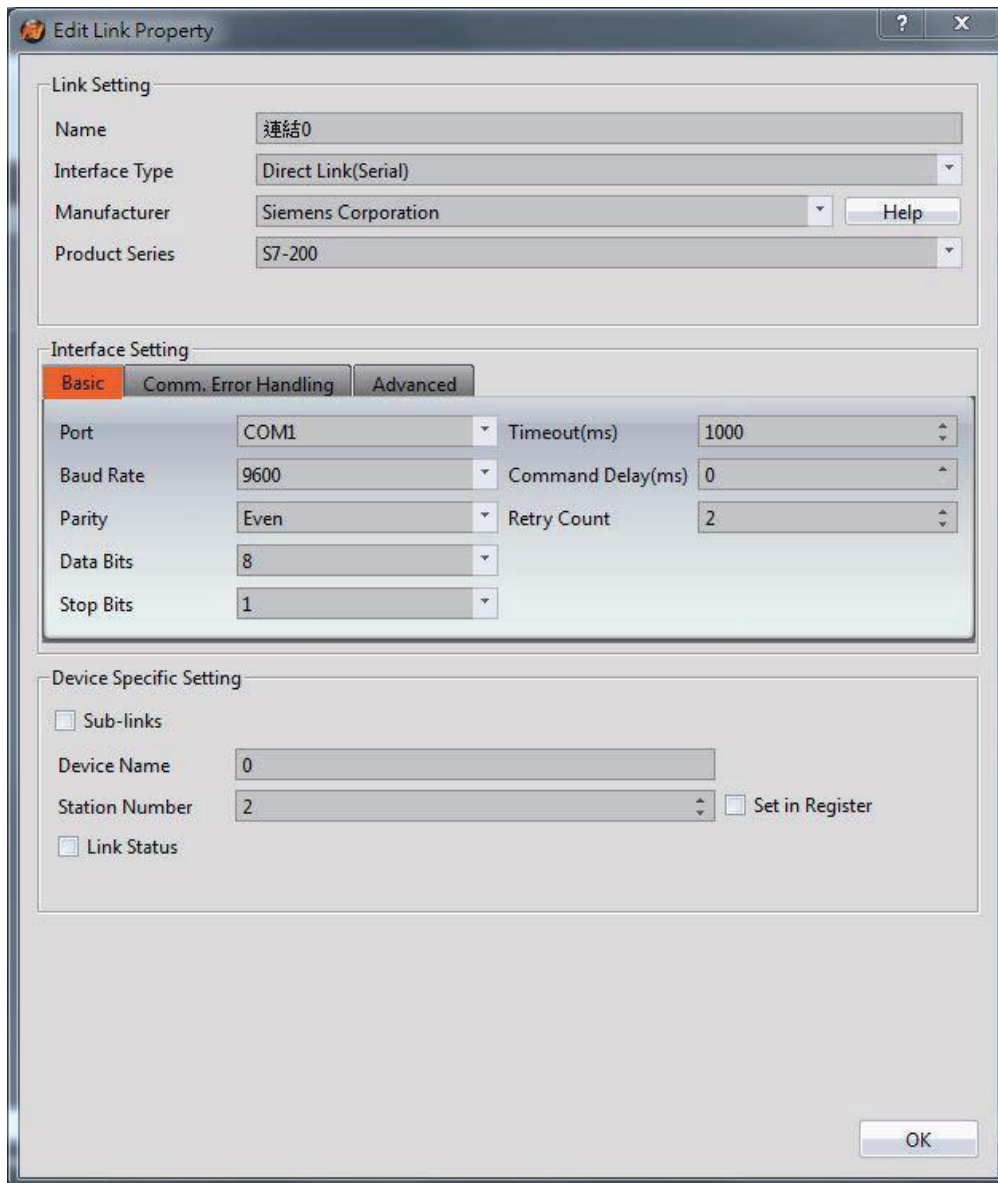

Within the **Link** configuration window in FvDesigner:

Under **Interface Type** select Serial

Under **Manufacturer** select Siemens Corporation

Under **Product Series** select S7-200

Under **Port** select the port number that corresponds to the RS485 connection on the HMI.

2.4.4.4 Wiring Diagrams

PLC RS485 Port

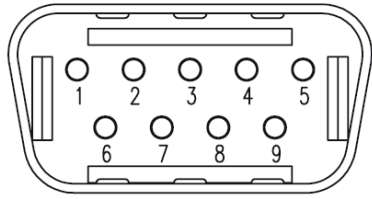

*Looking into male RS485 Cable

PIN#	Signal
1	
2	
3	DATA+
4	
5	GND
6	
7	
8	DATA-
9	

HMI (ex.P5043N) COM2 Pinout

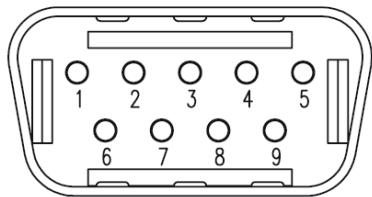

*Looking into HMI

PIN#	COM2 (RS485)
1	DATA+
2	
3	
4	
5	GND
6	DATA-
7	
8	
9	

HMI (ex.P5070N1) COM3 Pinout



*Looking into HMI Device

PIN#	COM3 (RS-422/RS-485)
1	
2	
3	ISO_GND
4	
5	
6	DATA+
7	DATA-

P5070S/P5070N/P5070N1/P5102N/P5102N1

HMI COM3 Port	PLC RS485 Port
6 DATA+	3 DATA+
7 DATA-	8 DATA-
5 GND	5 GND

Wiring Diagrams: P5070S/P5070N/P5070N1/P5102N/P5102N1

HMI COM3

PLC RS485

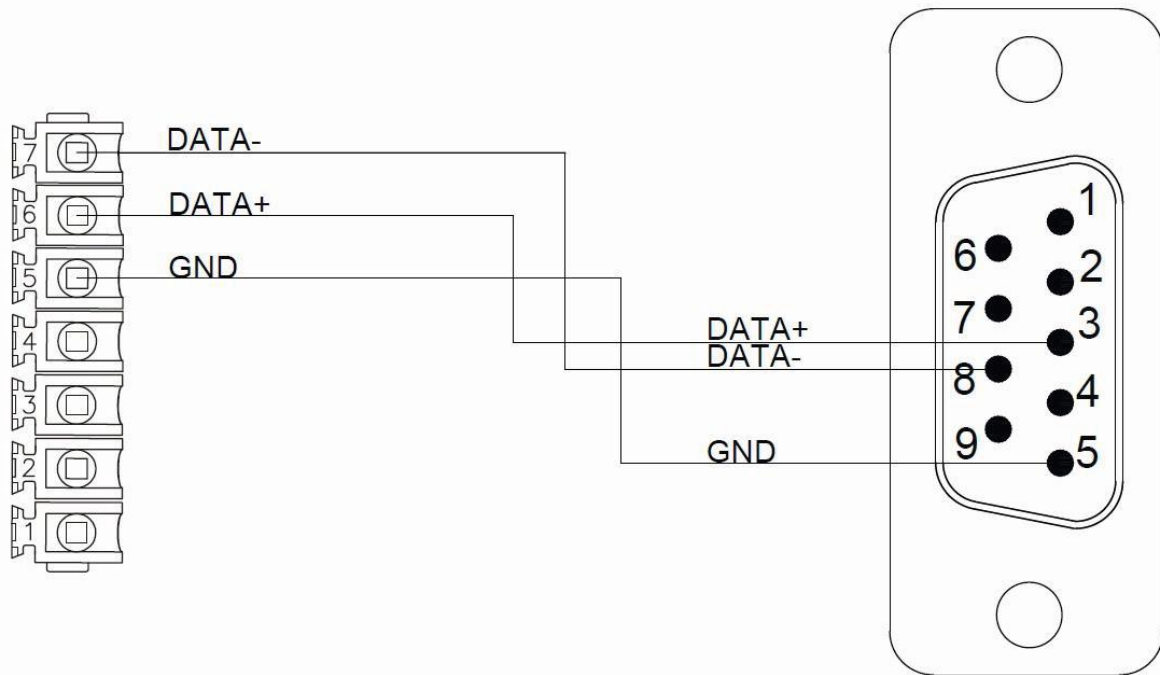

P5043S/P5043N/P5070VS/P5102VS/P2K SERIES

HMI COM3 Port	PLC RS485 Port
1 DATA+	3 DATA+
6 DATA-	8 DATA-
5 GND	5 GND

Wiring Diagrams: P5043S/P5043N/P5070VS/P5102VS/P2K SERIES

HMI COM2

PLC RS485

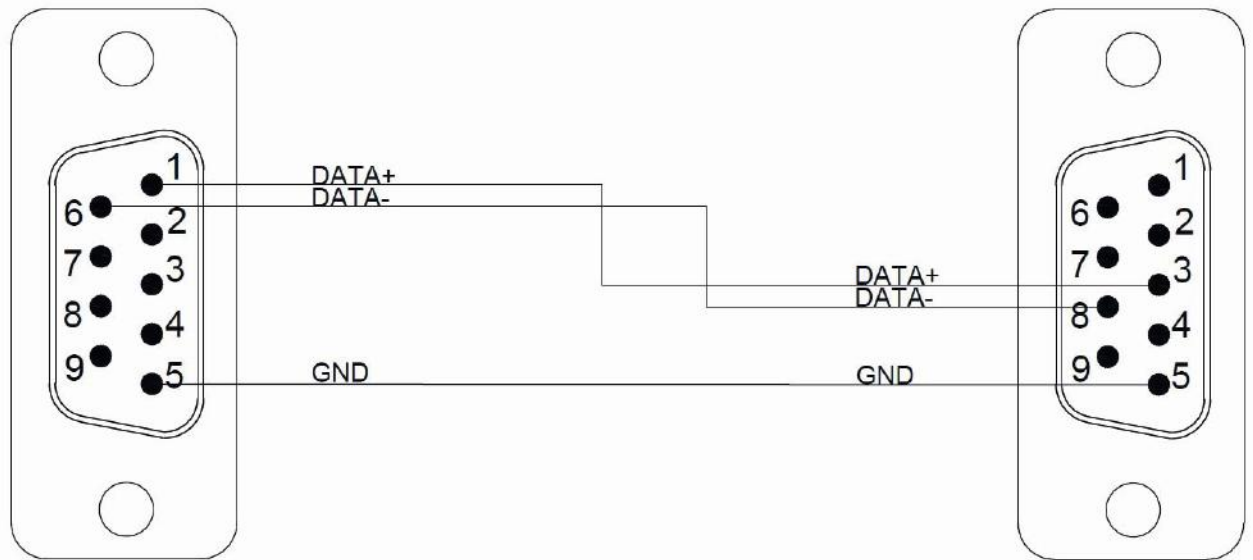

2.4.5 Siemens LOGO

2.4.5.1 Communication Setting

Item	Default Setting	Remark
Signal Level	Ethernet	
Internet Protocol	0.0.0.0	To be configured
Port	102	
PLC Station No.	0	
Communication Method	ISO TCP	
Model	0BA8	0BA7/0BA8
Local TSAP	1000	HEX
Remote TSAP	2100	HEX

2.4.5.2 Memory Resource Review

Device	Description	Data bit	Min.	Max.
I	Input	1	1	64
Q	Output	1	1	64
M	Bit Memory	1	1	112
V	Variable Memory	1	0.0	1469.7
AI	Analog Input	16	1	16
AQ	Analog Output	16	1	16
AM	Analog Memory	16	1	64
VW		16	0	1468

VD		32	0	1466
----	--	----	---	------

2.4.5.3 Connecting to HMI

Configuring IP Address on PLC

Use the application **LOGO!Soft Comfort V8.1** to configure the IP address of the PLC.

Under the **Online** menu option, select **Ethernet Connections**.

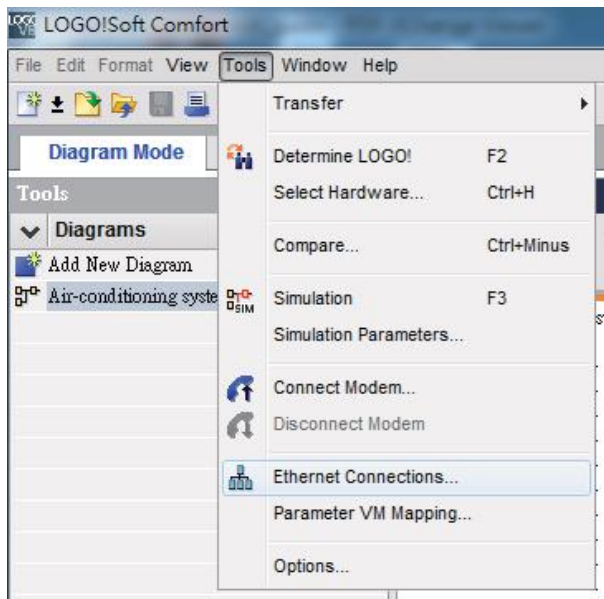

Right click **Ethernet Connections** and **Add server connections**.

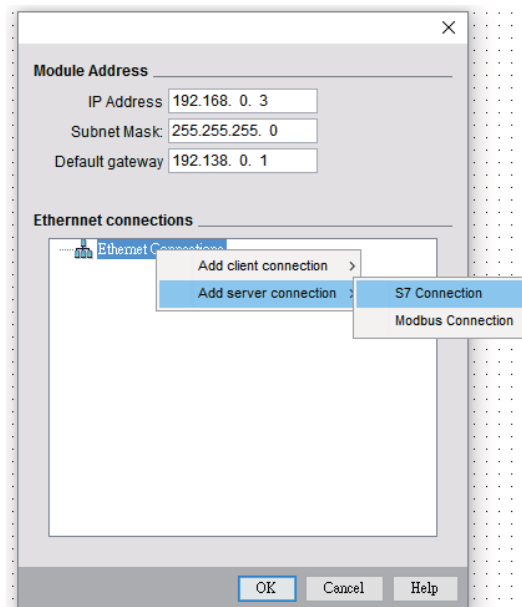

Enable **Accept all connection requests**, And setting TSAP for **Remote Properties(Client)**

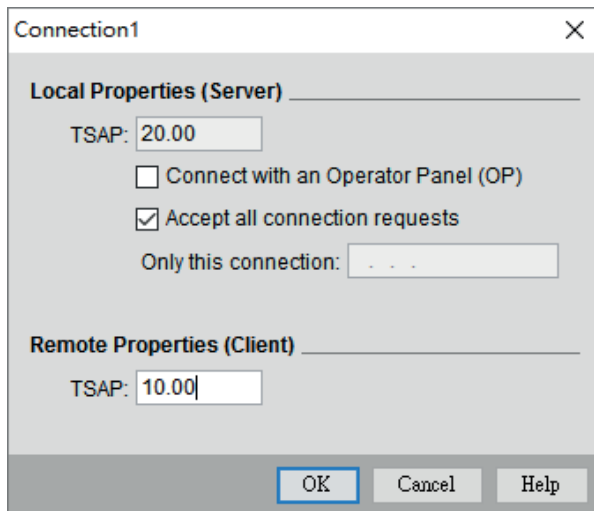

Note: For more detailed information please refer to the PLC manual.

Connecting PLC to HMI

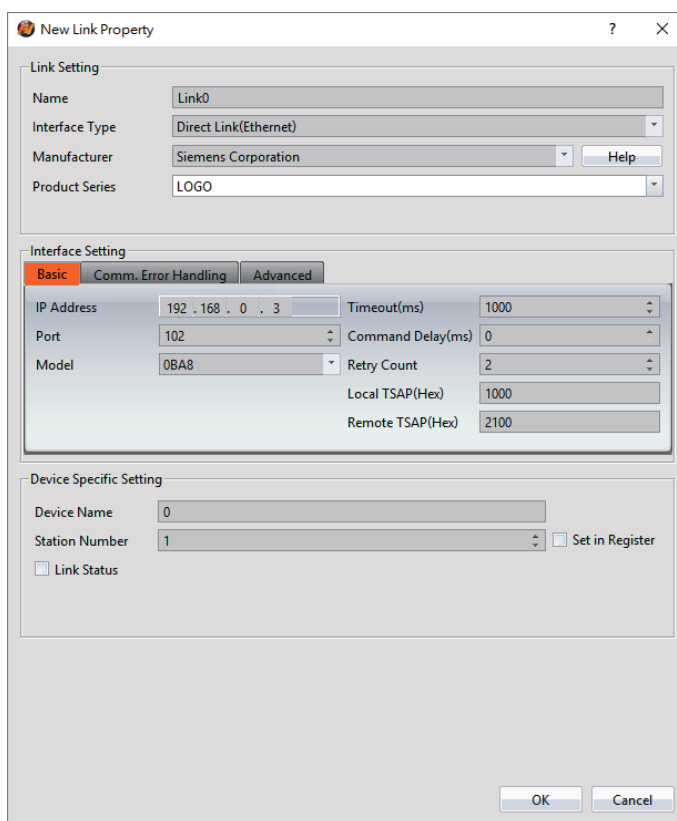

Within the **Link** configuration window in FvDesigner:

Under **Interface Type** select Ethernet

Under **Manufacturer** select Siemens Corporation

Under **Product Series** select LOGO

Enter the **IP Address** that was written into the PLC.

Enter the **Port** number that was set on the PLC. The default is 102.

2.5 Hitachi

2.5.1 EHV Series

2.5.1.1 Communication Setting

Item	Default Setting	Remark
Signal Level	RS232C	
Baud Rate	19200	
Data Length	7	
Stop Bit	1	
Parity	Even	
PLC Station No.	0	
Communication Method	h protocol	

2.5.1.2 Memory Resource Review

Device	Description	Data bit	Input format	Min.	Max.
X	Input bit	1	DDDDD	0	65535
Y	Output bit	1	DDDDD	0	65535
M	Memory bit	1	HHHH	0	FFFF
R	Internaloutput bit	1	HHH	0	FFF
L	Link bit	1	HHHH	0	3FFF
TD	Timer	1	DDDD	0	2559
CU	Counter	1	DDD	0	511
WX	Input word	16	DDDD	0	9999
WY	Output word	16	DDDD	0	9999
WM	Memory word	16	HHH	0	FFF
WR	Internaloutput word	16	HHHH	0	FFFF
WL	Link word	16	HHH	0	3FF
TC	Timer / Counter	16	DDDD	0	2559

2.5.1.3 Connecting to HMI

Connecting PLC to HMI

Within the **Link** configuration window in FvDesigner:

Under **Interface Type** select Serial

Under **Manufacturer** select Hitachi Ltd.

Under **Product Series** select EHV Series

Under **Port** select the port number that corresponds to the RS232 connection on the

HMI.

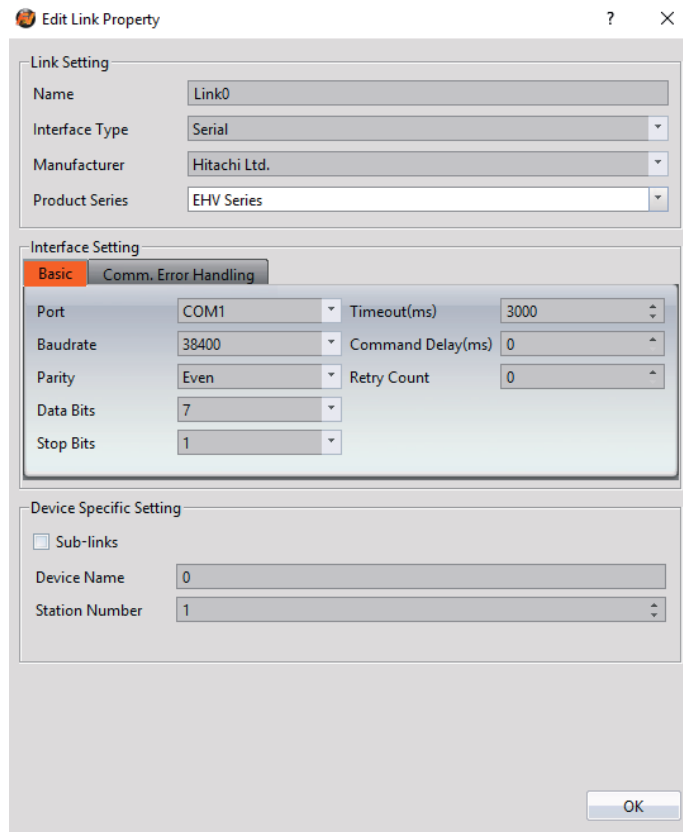

2.5.1.4 Wiring Diagrams

HMI COM1 Pinout

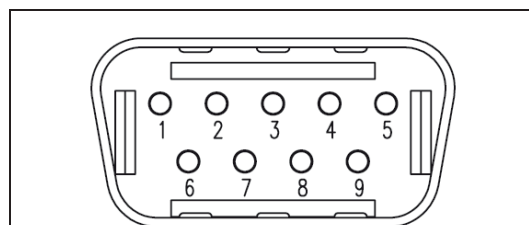

*Looking into COM1 Port

PIN#	COM1 (RS232)
1	
2	RX
3	TX
4	
5	GND
6	
7	RTS
8	CTS

9	
---	--

PLC RS232 Pinout

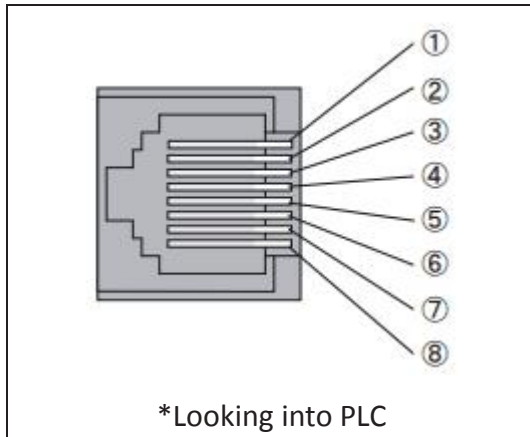

PIN#	Signal
1	SG
2	VCC
3	ER
4	
5	TxD
6	RxD
7	
8	RTS

All P5 and P2K Series

HMI COM1	PLC RS232 Port
2 RX	5 TxD
3 TX	6 RxD
5 GND	1 SG
8 CTS	8 RTS

Wiring Diagrams: All P5 and P2K Series

HMI COM1

PLC RS232

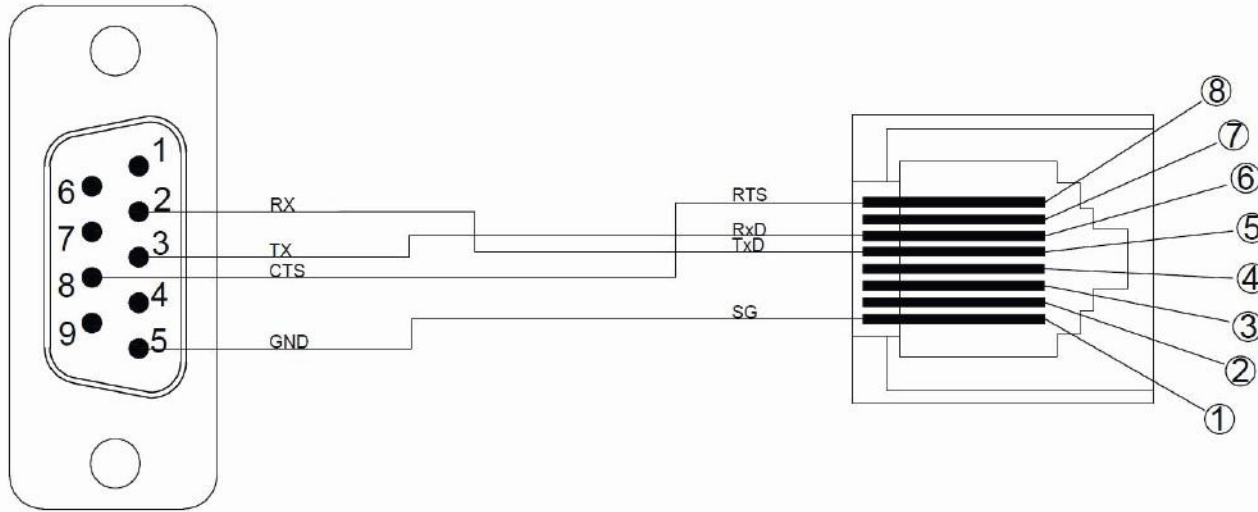

2.5.2 EHV Series (Ethernet)

2.5.2.1 Communication Setting

Item	Default Setting	Remark
Signal Level	Ethernet	
Internet Protocol	192.168.1.100	
Port	3004	
PLC Station No.	0	
Communication Method	h protocol (Ethernet)	

2.5.2.2 Memory Resource Review

Device	Description	Data bit	Input format	Min.	Max.
X	Input bit	1	DDDDD	0	65535
Y	Output bit	1	DDDDD	0	65535
M	Memory bit	1	HHHH	0	FFFF
R	Internal output bit	1	HHH	0	FFF
L	Link bit	1	HHHH	0	3FFF
TD	Timer	1	DDDD	0	2559
CU	Counter	1	DDD	0	511
WX	Input word	16	DDDD	0	9999
WY	Output word	16	DDDD	0	9999
WM	Memory word	16	HHH	0	FFF
WR	Internal output word	16	HHHH	0	FFFF

WL	Link word	16	HHH	0	3FF
TC	Timer / Counter	16	DDDD	0	2559

2.6 Schneider

2.6.1 MODBUS RTU

2.6.1.1 Communication Setting

Item	Default Setting	Remark
Signal Level	RS485 2W	
Baud Rate	19200	
Data Length	8	
Stop Bit	1	
Parity	None	
PLC Station No.	0	
Communication Method	MODBUS RTU(Zero-based)	

2.6.1.2 Memory Resource Review

Device	Description	Data bit	Input format	Min.	Max.
%M	Memory bit	1	DDDDD	0	65535
%MW	Memory word	16	DDDDD	0	65535

2.6.1.3 Connecting to HMI

Configuring the PLC

Use **TwidoSuite** to configure the port of the PLC.,
 expand **Describe** tab and creation Modbus setting,
 Click **MY NETWORK** and configure it to the settings detailed below.

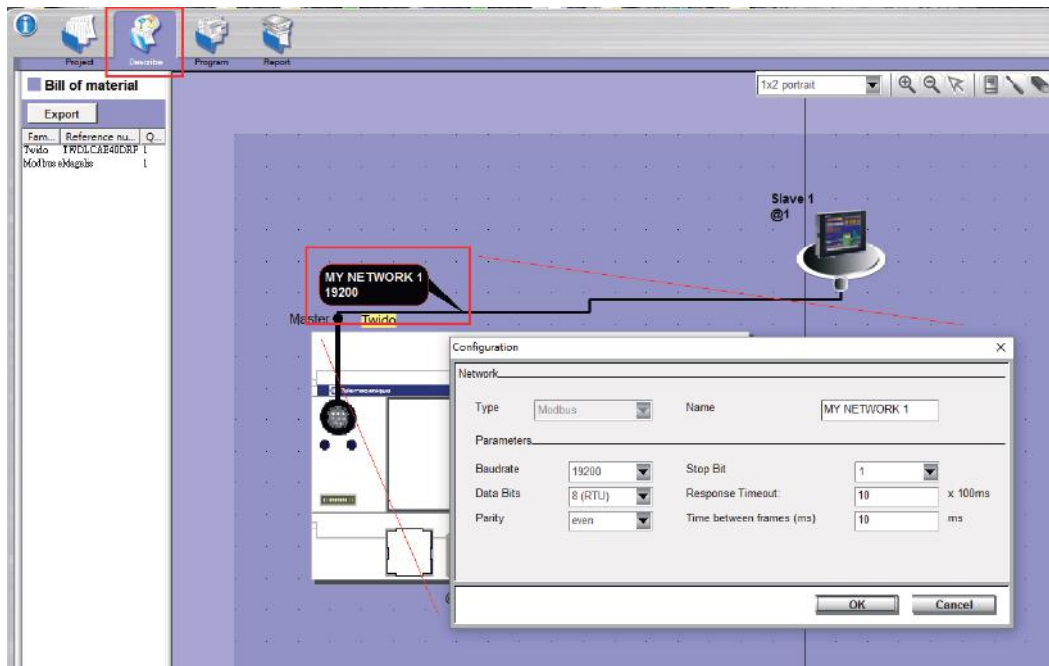

Note: For more detailed information please refer to the PLC manual.

Connecting PLC to HMI

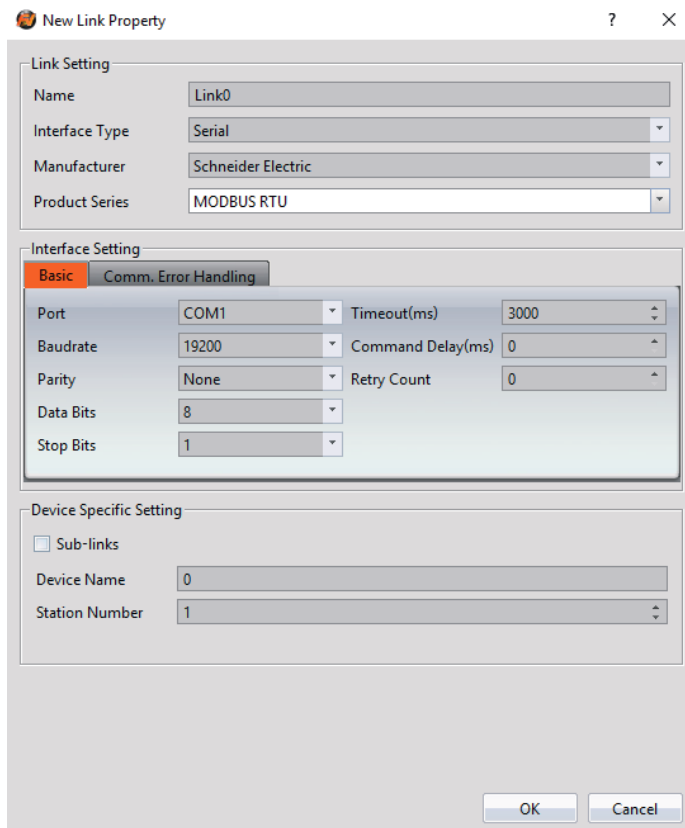

Within the **Link** configuration window in FvDesigner:
Under **Interface Type** select Serial

Under **Manufacturer** select Schneider
 Under **Product Series** select MODBUS RTU
 Enter the **IP Address** that was written into the PLC.

2.6.1.4 Wiring Diagrams

HMI (ex.P5043N) COM2 Pinout

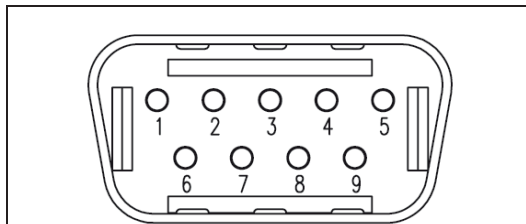

*Looking into HMI

PIN#	COM2 (RS485)
1	DATA+
2	
3	
4	
5	GND
6	DATA-
7	
8	
9	

HMI (ex.P5070N1) COM3 Pinout



*Looking into HMI Device

PIN#	COM3 (RS-422/RS-485)
1	
2	
3	ISO_GND
4	
5	

6	DATA+
7	DATA-

PLC RS485 Pinout

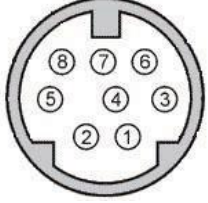
 <p>*Looking into PLC</p>	
PIN#	Signal
1	DATA+
2	DATA-
3	
4	
5	
6	
7	GND
8	

P5070S/P5070N/P5070N1/P5102N/P5102N1

HMI COM3 Port	PLC RS485 Port
6 DATA+	1 DATA+
7 DATA-	2 DATA-
5 GND	5 GND

Wiring Diagrams: P5070S/P5070N/P5070N1/P5102N/P5102N1

HMI COM3

PLC RS485

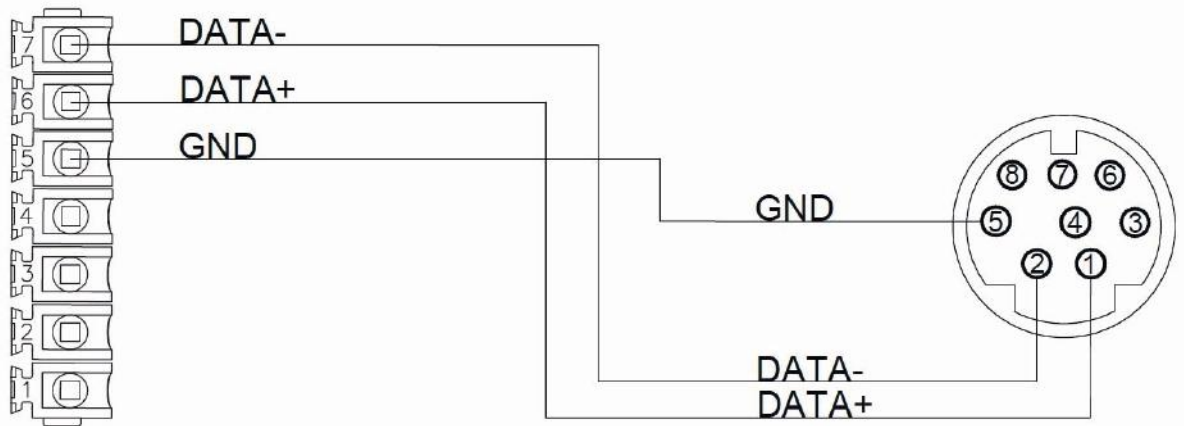

P5043S/P5043N/P5070VS/P5102VS/P2K SERIES

HMI COM2 Port	PLC RS485 Port
1 DATA+	1 DATA+
6 DATA-	2 DATA-
5 GND	5 GND

Wiring Diagrams: P5043S/P5043N/P5070VS/P5102VS/P2K SERIES

HMI COM2

PLC RS485

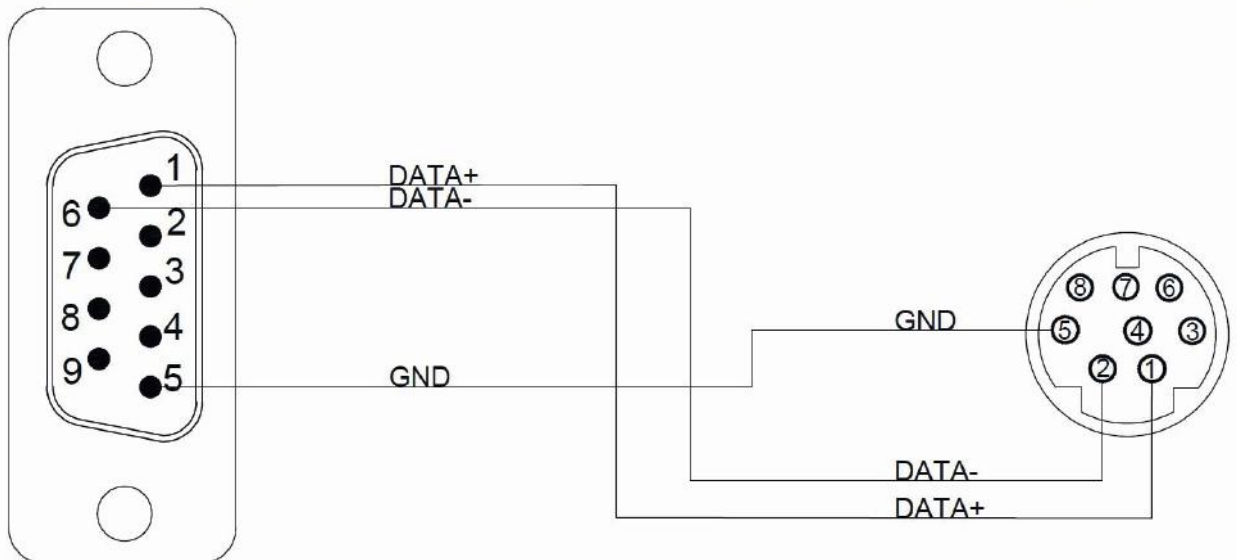

2.6.2 MODBUS TCP

2.6.2.1 Communication Setting

Item	Default Setting	Remark
------	-----------------	--------

Signal Level	Ethernet	
Internet Protocol	192.168.0.2	
Port	502	
PLC Station No.	0	
Communication Method	MODBUS TCP(Zero-based)	

2.6.2.2 Memory Resource Review

Device	Description	Data bit	Input format	Min.	Max.
%M	Memory bit	1	DDDDD	0	65535
%MW	Memory word	16	DDDDD	0	65535

2.6.2.3 Connecting to HMI

Configuring IP Address on PLC

Use **TwidoSuite** to configure the IP of the PLC.

Expand **Describe** tab, and click **Ethernet Port**,

The IP address and other parameters can be set.

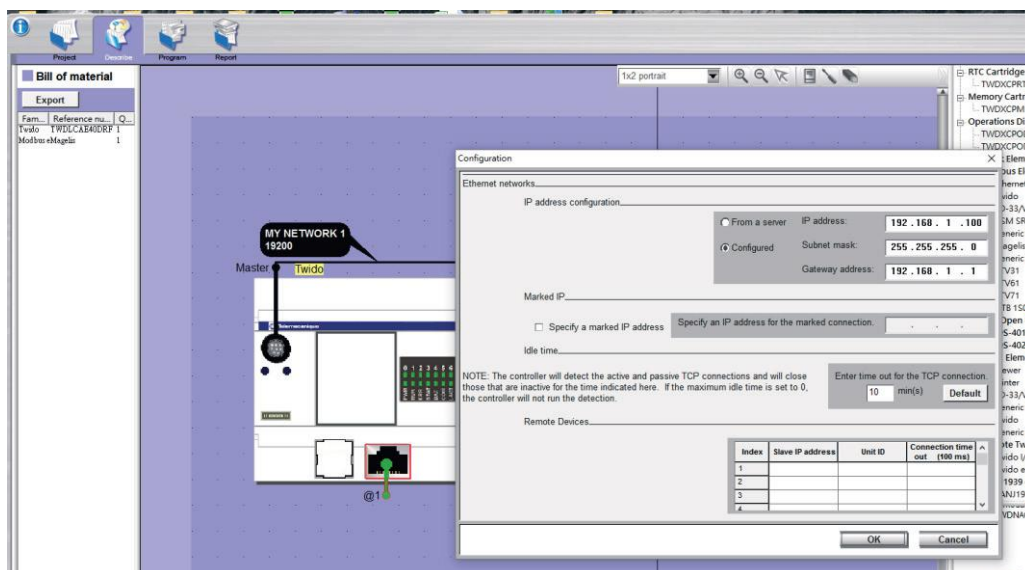

Note: For more detailed information please refer to the PLC manual.

Connect PLC to HMI

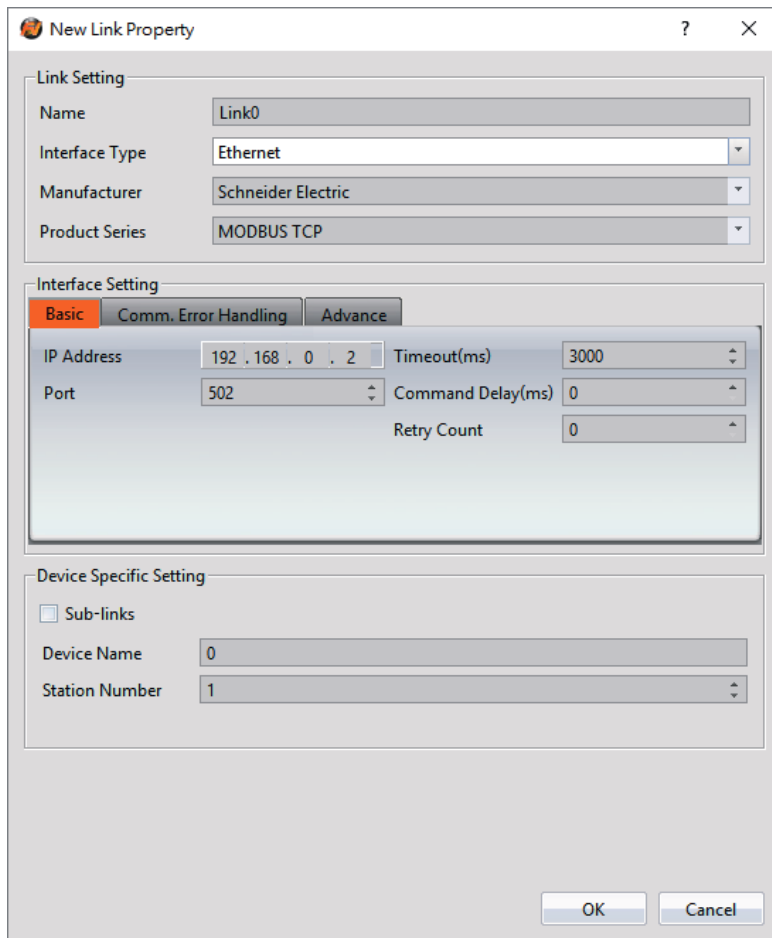

Within the **Link** configuration window in FvDesigner:

Under **Interface Type** select Ethernet

Under **Manufacturer** select Schneider Electric.

Under **Product Series** select Modbus TCP.

Enter the **IP Address** that was written into the PLC.

2.7 Allen-Bradley

2.7.1 CompactLogix/ControlLogix/FlexLogix Tag Series

2.7.1.1 Communication Setting

Item	Default Setting	Remark
Signal Level	Ethernet	
Internet Protocol	192.168.0.2	
Port	44818	
PLC Station No.	0	
Communication Method	EtherNet/IP	

2.7.1.2 PLC Resource Review

DataType		bits	Description
BOOL	---	1	Boolean
SINT	---	8	Single integer
INT	---	16	Integer
DINT	---	32	Double integer
REAL	---	32	Float number
STRING	LEN		Length of string
	DATA		Character data of string
COUNTER	PRE	32	Preset value
	ACC	32	Accumulatedvalue
	CU	1	Count up flag
	CD	1	Count down flag
	DN	1	Done flag
	OV	1	Overflowflag
	UN	1	Underflowflag
TIMER	PRE	32	Preset value
	ACC	32	Accumulatedvalue
	EN	1	Enable flag
	TT	1	Timing flag
	DN	1	Done Flag
AB:1769_DI16:I:0	Fault	32	
	Data	16	Data of DI16
AB:1769_DI32:I:0	Fault	32	
	Data	32	Data of DI32
AB:1769_DO16:O:0	Data	16	Data of DO16
AB:1769_DO32:O:0	Data	32	Data of DO32

2.7.1.3 Connecting to HMI

Configuring IP Address on PLC

The application **RSLinx Classic** (ver. 3.51) was used to configure the IP address on the device.

On the PLC device, make sure the switch on the main module is not set to the **RUN** setting.

Open RSLinx Classic and connect to the PLC either with a USB-Serial cable or through the local network. To connect to PLC via the local network, follow the steps below.

In the **Communications** menu tab, select **Configure Drivers**. Select **EtherNet/IP Driver** and press 'Add New'. Select "Your Network Interface Card" and press OK. Start the

Driver and close out of the dialog window.

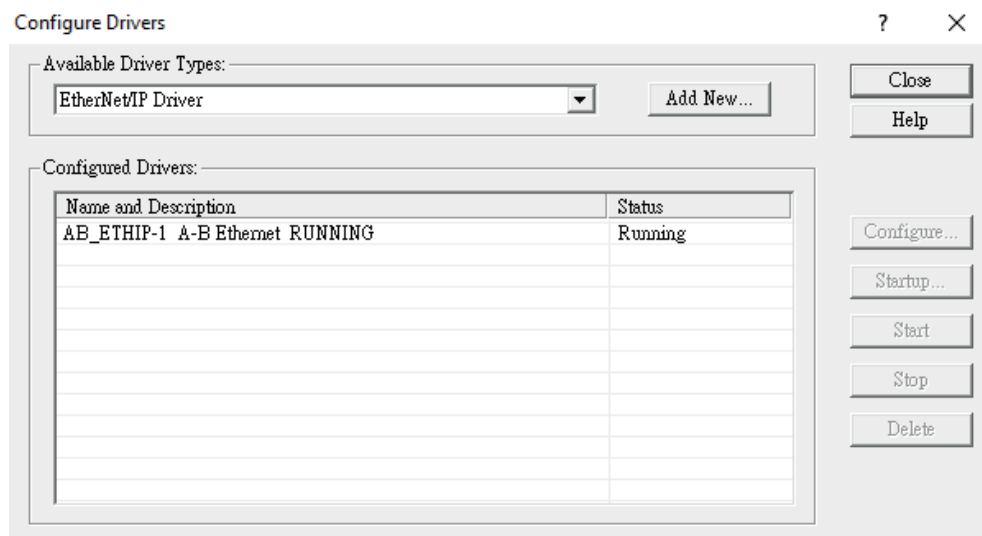

Under the new Ethernet driver, the PLC connected to the local network should be visible.

Right click the main module of the PLC and select **Module Configuration**.

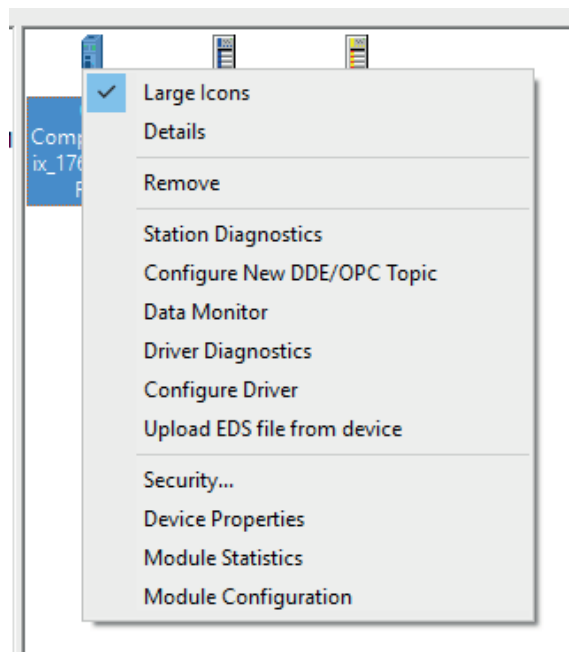

Navigate to the **Port Configuration** tab. Here, the IP address and other parameters can be set. Press OK to confirm the settings.

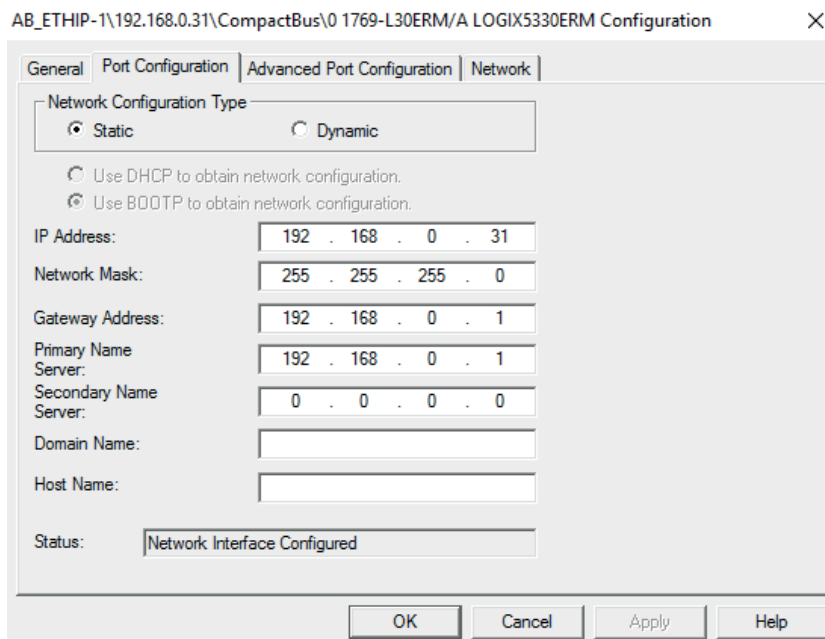

Note: For more detailed information please refer to the PLC manual.

Connect PLC to HMI

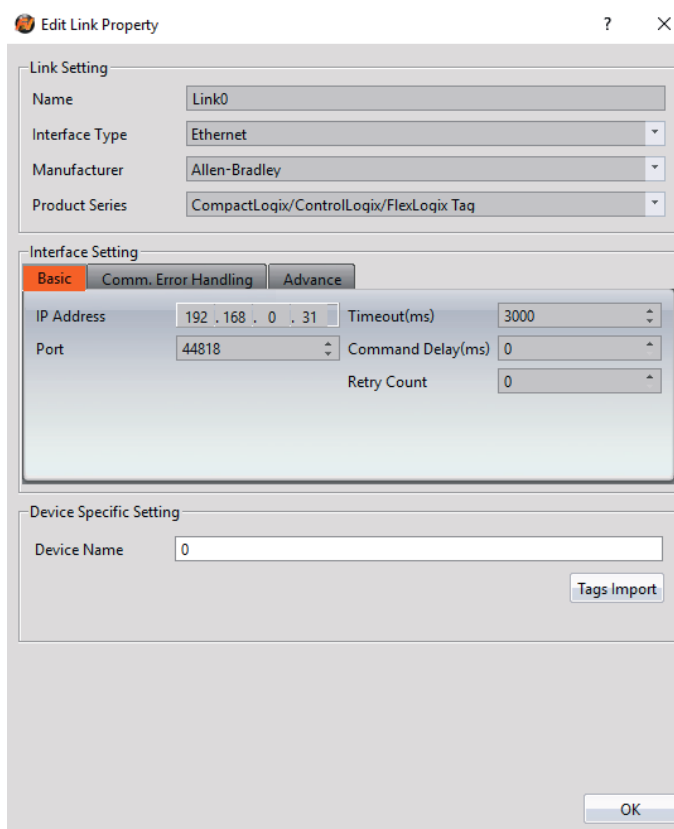

Within the **Link** configuration window in FvDesigner:

Under **Interface Type** select Ethernet

Under **Manufacturer** select Allen-Bradley.

Under **Product Series** select CompactLogix/ControlLogix/FlexLogix Tag.

Enter the **IP Address** that was written into the PLC.

To access variables in the program, tags will have to be imported. Tags are created in the program RSLogix 5000.

Right click 控制器标签(controller tag) in the controller sidebar and select 导出 (Export) Tag.

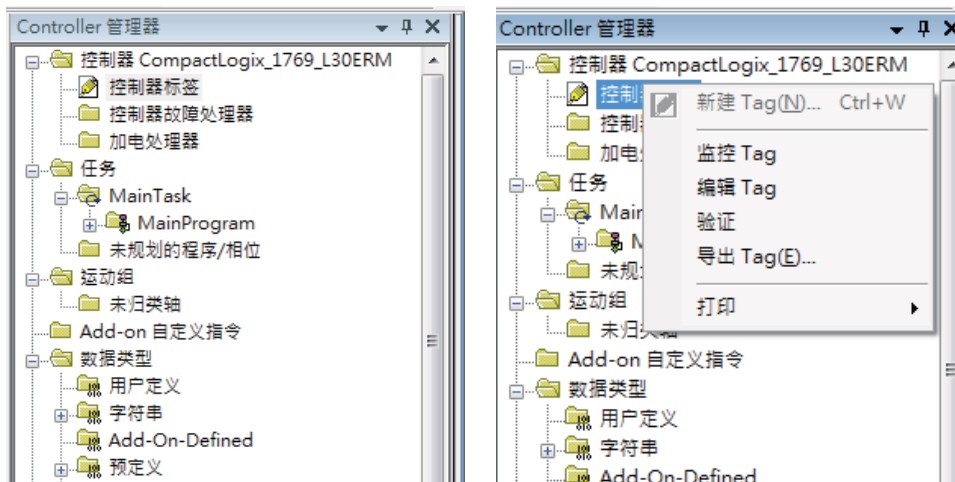

Select which tags to export. The register tags can now be imported into the HMI project.

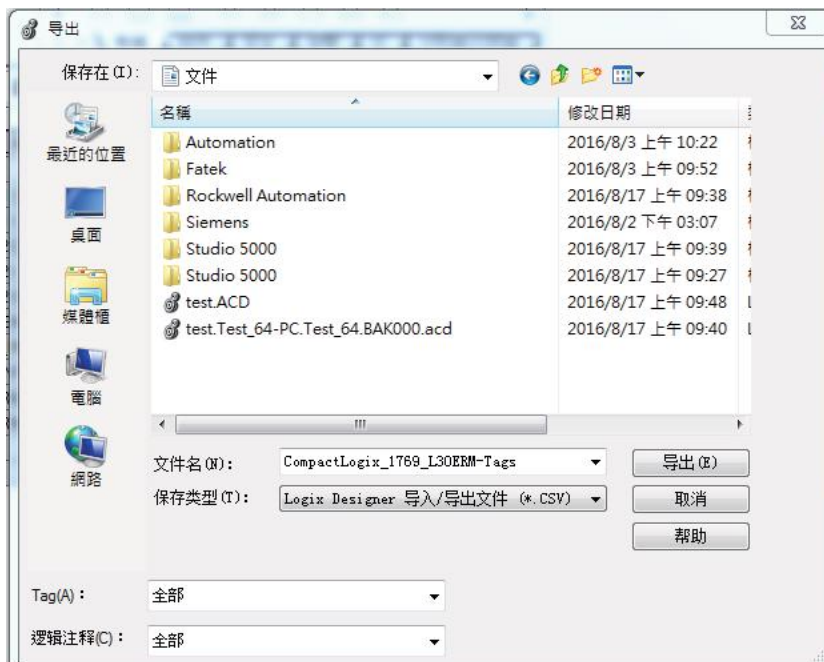

2.7.2 SLC series (EtherNet/IP)

2.7.2.1 Communication Setting

Item	Default Setting	Remark
Signal Level	Ethernet	
Internet Protocol	192.168.0.1	
Port	44818	
Communication Method	EtherNet/IP	

2.7.2.2 PLC Resource Review

Device	Description	Data bit	Input format	Min.	Max.
O	Output File	1/16	O F:S.D	O0:0.0	O0:30.255
I	Input File	1/16	I F:S.D	I1:0.0	I1:30.255
S	Status File	1/16	S F:E	S2:0	S2:163
B	Bit File	1/16	B F:E	B3:0	B255:255
T	Timer File	1/16	T F:E.D	T4:0.0	T255:255.2
C	Counter File	1/16	C F:E.D	C5:0.0	C255:255.2
R	Control File	1/16	R F:E.D	R6:0.0	R255:255.2
N	Integer File	1/16	N F:E	N7:0	N255:255
F	Floating File	32	F F:E	F8:0	F255:255
A	ASCII File	1/16	A F:E	A9:0	A255:255
ST	String File	1/16	ST F:E.D	ST9:0.0	ST255:255.41

2.7.2.3 Connecting to HMI

The SLC series PLC can be configured using the same procedure as the Micrologix series configuration. The figures refer to the Micrologix PLC but the procedure is the same.

Configuring IP Address on PLC

If the IP address needs to be configured, follow the steps below.

Use the applications **RSLinx Classic Lite** and **RSLogix 500** to configure the IP address of the PLC.

First open **RSLinx Classic Lite** to set up a connection between the computer and PLC.

An Ethernet cable needs to be connected to the PLC and the computer must be online.

In the **Communications** menu tab, select **Configure Drivers**. Select **EtherNet/IP Driver** and press 'Add New'. Select "Your Network Interface Card" and press OK. Start the Driver and close out of the dialog window.

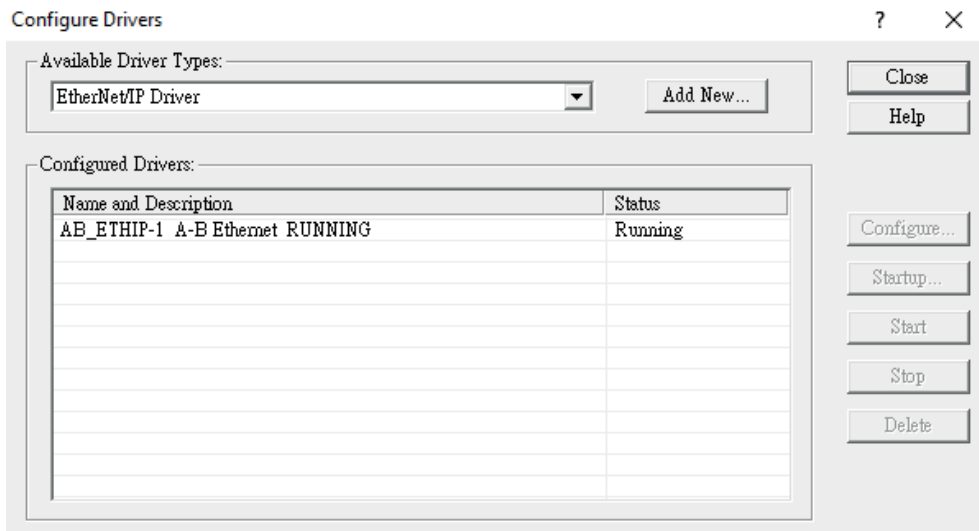

Under the new Ethernet driver, the PLC connected to the local network should be visible. If the status of the device is OK, open up **RSLogix 500**.

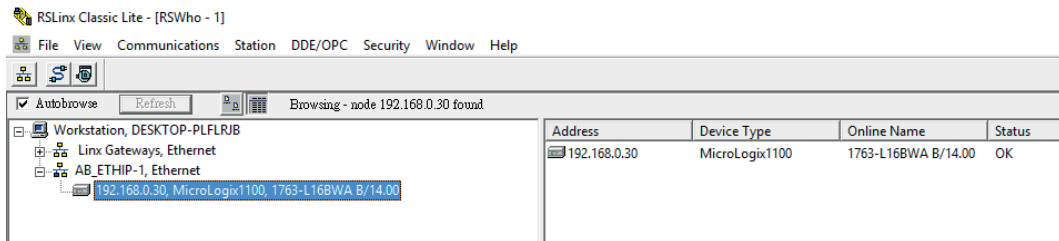

In **RSLogix 500**, under the **Comms** menu option, select **Who Active go Online**. In the dialog window that appears, select the PLC device connected through RSLinx.

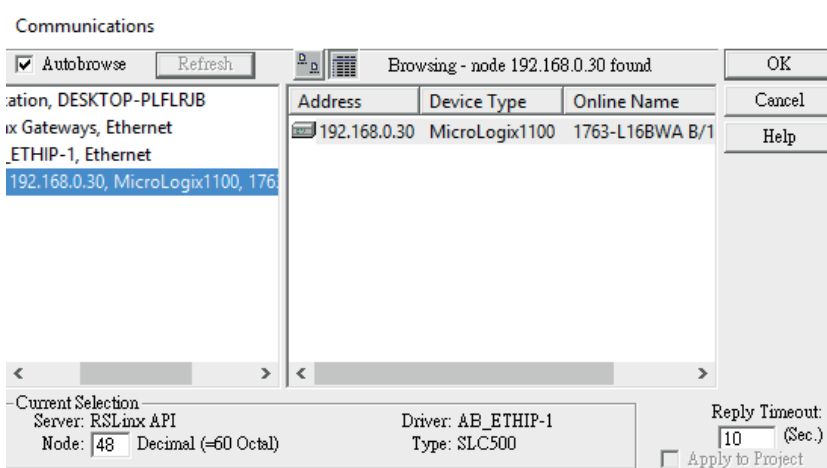

Press **Create New File** in the dialog window that appears after pressing OK.

On the left side of the program, double click **Channel Configuration** to access the PLC's Ethernet settings. Under the Channel 1 tab, the IP address can be changed.

Channel Configuration ×

General | Channel 0 | Channel 1

Driver: Ethernet

Hardware Address: 00:1D:9C:A1:62:93 Network Link ID: 0

IP Address: 192 . 168 . 0 . 30

Subnet Mask: 255 . 255 . 255 . 0

Gateway Address: 192 . 168 . 0 . 1

Default Domain Name:

Primary Name Server: 192 . 168 . 0 . 1

Secondary Name Server: 255 . 0 . 0 . 0

Protocol Control

BOOTP Enable DHCP Enable Msg Connection Timeout (x 1mS): 15000

SNMP Server Enable Msg Reply Timeout (x 1mS): 3000

HTTP Server Enable

Auto Negotiate

Port Setting: 10/100 Mbps Full Duplex/Half Duplex

Contact:

Location:

OK Cancel Apply Help

Note: For more detailed information please refer to the PLC manual.

Connect PLC to HMI

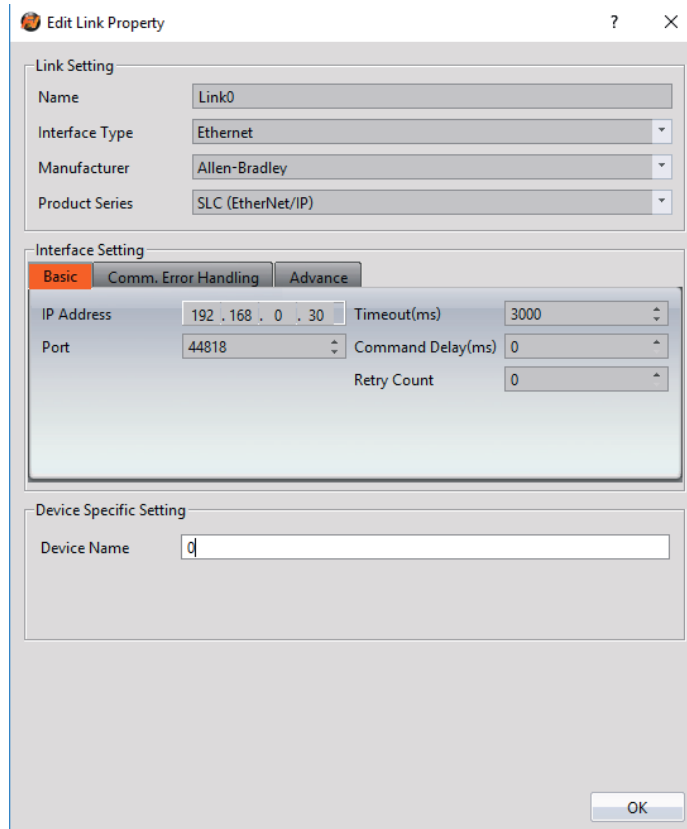

Within the **Link** configuration window in FvDesigner:
 Under **Interface Type** select Ethernet
 Under **Manufacturer** select Allen-Bradley
 Under **Product Series** select SLC (Ethernet/IP)
 Enter the **IP Address** that was written into the PLC.
 Keep the **Port** at the default setting.

2.7.3 SLC Series

2.7.3.1 Communication Setting

Item	Default Setting	Remark
Signal Level	RS232	
Baud Rate	19200	
Data Length	8	
Stop Bit	1	
Parity	None	
PLC Station No.	1	
TX Control	CRC	CRC/BCC

Communication Method	DF1	
----------------------	-----	--

2.7.3.2 PLC Resource Review

Device	Description	Data bit	Input format	Min.	Max.
O	Output File	1/16	O F:S.D	O0:0.0	O0:30.255
I	Input File	1/16	I F:S.D	I1:0.0	I1:30.255
S	Status File	1/16	S F:E	S2:0	S2:163
B	Bit File	1/16	B F:E	B3:0	B255:255
T	Timer File	1/16	T F:E.D	T4:0.0	T255:255.2
C	Counter File	1/16	C F:E.D	C5:0.0	C255:255.2
R	Control File	1/16	R F:E.D	R6:0.0	R255:255.2
N	Integer File	1/16	N F:E	N7:0	N255:255
F	Floating File	32	F F:E	F8:0	F255:255
A	ASCII File	1/16	A F:E	A9:0	A255:255
ST	String File	1/16	ST F:E.D	ST9:0.0	ST255:255.41

2.7.3.3 Connecting to HMI

Configuring the PLC

Use **RSLinx Classic Lite** and **RSLogix 500** to configure the port of the PLC.

Under the Project Sidebar, expand **Channel Configuration**. And expand **Channel 0** tab, Configure it to the settings detailed below.

Channel Configuration ×

General Channel 0 Channel 1

Driver DF1 Full Duplex Source ID 1 (decimal)

Baud 19200

Parity NONE

Protocol Control

Control Line No Handshaking ACK Timeout (x20 ms) 50

Error Detection CRC

Embedded Responses Auto Detect

Duplicate Packet Detect

NAK Retries 3

ENQ Retries 3

OK Cancel Apply Help

Note: For more detailed information please refer to the PLC manual.

Connecting PLC to HMI

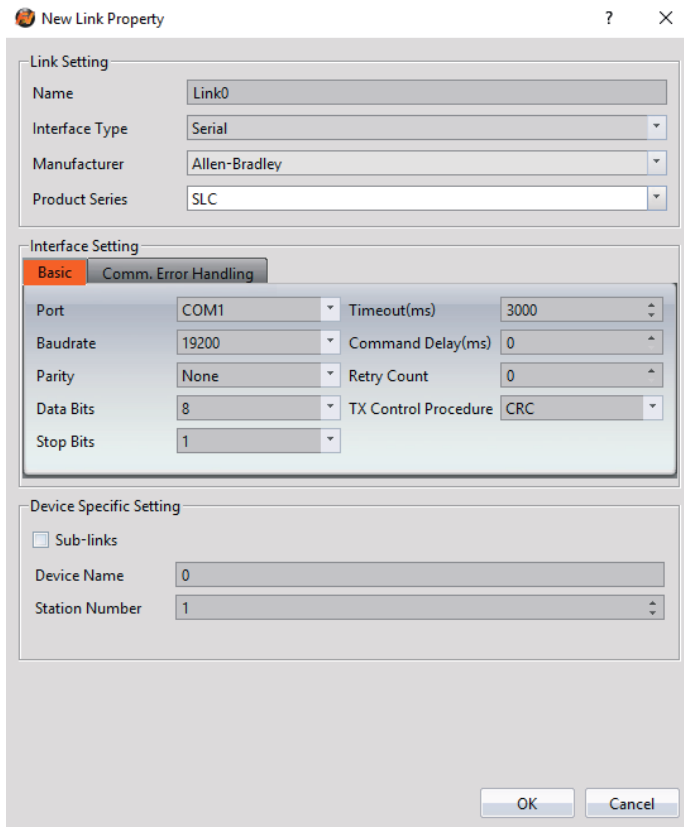

Within the **Link** configuration window in FvDesigner:

Under **Interface Type** select Serial

Under **Manufacturer** select Allen-Bradley

Under **Product Series** select SLC.

Verify the parameters match the window above.

2.7.3.4 Wiring Diagrams

HMI COM1 Pinout

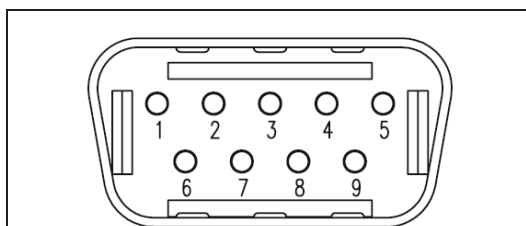

*Looking into COM1 Port

PIN#	COM1 (RS232)
1	
2	RX
3	TX
4	

5	GND
6	
7	RTS
8	CTS
9	

PLC RS232 Pinout

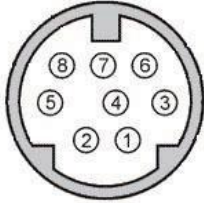
 <p>*Looking into PLC</p>	
PIN#	Signal
1	
2	GND
3	
4	RXD
5	
6	
7	TXD
8	

All P5 and P2K Series

HMI COM1	PLC RS232 Port
2 RX	7 TXD
3 TX	4 RXD
5 GND	2 GND

Wiring Diagrams: All P5 and P2K Series

HMI COM1

PLC RS232

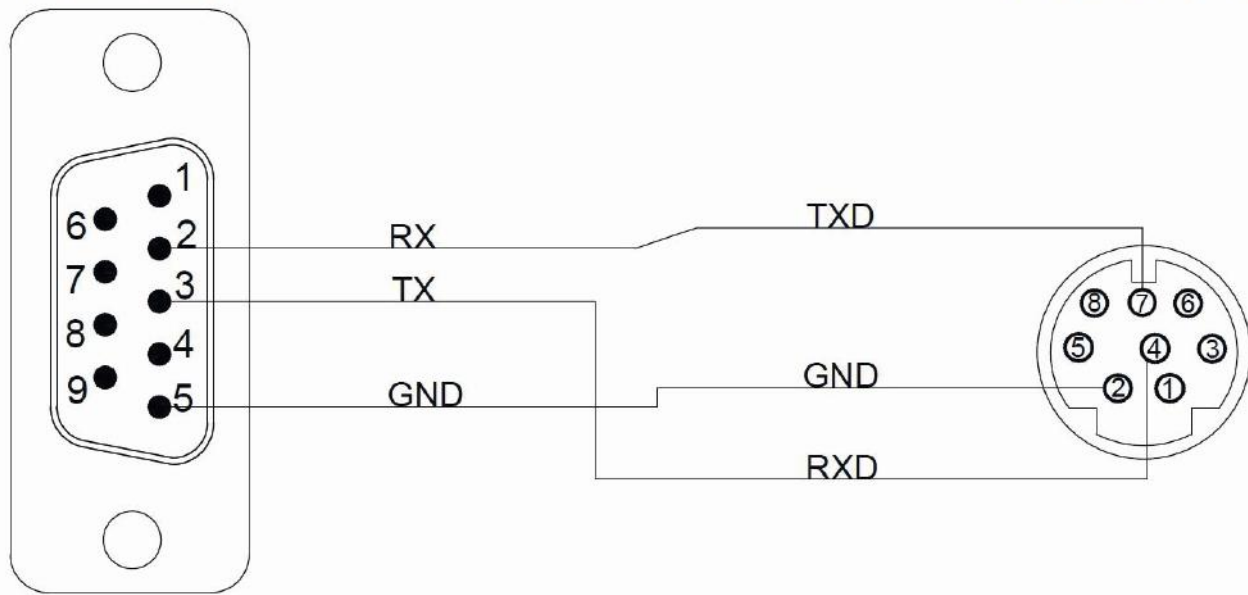

2.7.4 MicroLogix Series (EtherNet/IP)

2.7.4.1 Communication Setting

Item	Default Setting	Remark
Signal Level	Ethernet	
Internet Protocol	192.168.0.1	
Port	44818	
Communication Method	EtherNet/IP	

2.7.4.2 PLC Resource Review

Device	Description	Data bit	Input format	Min.	Max.
O	Output File	1/16	O F:S.D	O0:0.0	O0:30.255
I	Input File	1/16	I F:S.D	I1:0.0	I1:30.255
S	Status File	1/16	S F:E	S2:0	S2:163
B	Bit File	1/16	B F:E	B3:0	B255:255
T	Timer File	1/16	T F:E.D	T4:0.0	T255:255.2
C	Counter File	1/16	C F:E.D	C5:0.0	C255:255.2
R	Control File	1/16	R F:E.D	R6:0.0	R255:255.2
N	Integer File	1/16	N F:E	N7:0	N255:255
F	Floating File	32	F F:E	F8:0	F255:255
ST	String File	1/16	ST F:E.D	ST9:0.0	ST255:255.41
L	Long word	32	L F:E	L9:0	L255:255

	File				
--	------	--	--	--	--

2.7.4.3 Connecting to HMI

Configuring IP Address on PLC

If the IP address needs to be configured, follow the steps below.

Use the applications **RSLinx Classic Lite** and **RSLogix 500** to configure the IP address of the PLC.

First open **RSLinx Classic Lite** to set up a connection between the computer and PLC.

An Ethernet cable needs to be connected to the PLC and the computer must be online.

In the **Communications** menu tab, select **Configure Drivers**. Select **EtherNet/IP Driver** and press 'Add New'. Select "Your Network Interface Card" and press OK. Start the Driver and close out of the dialog window.

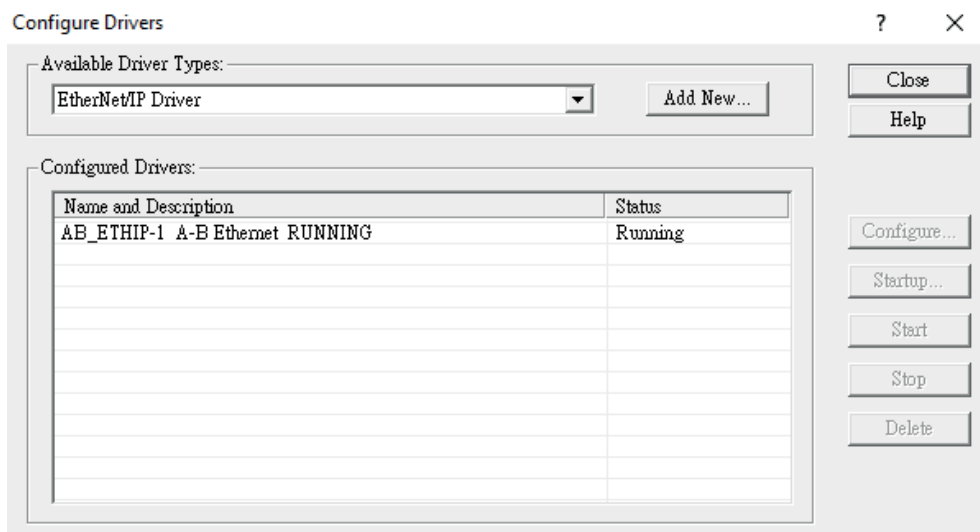

Under the new Ethernet driver, the PLC connected to the local network should be visible. If the status of the device is OK, open up **RSLogix 500**.

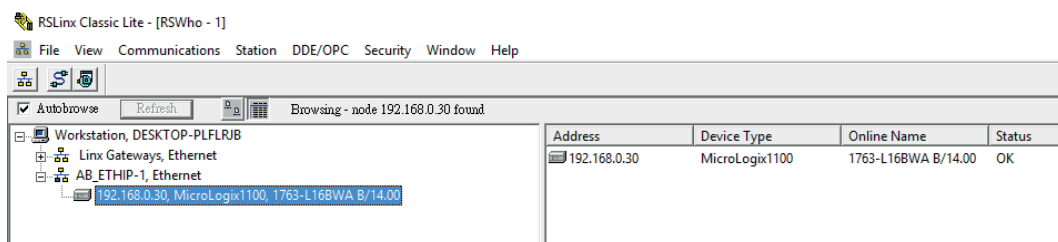

In **RSLogix 500**, under the **Comms** menu option, select **Who Active go Online**. In the dialog window that appears, select the PLC device connected through RSLinx.

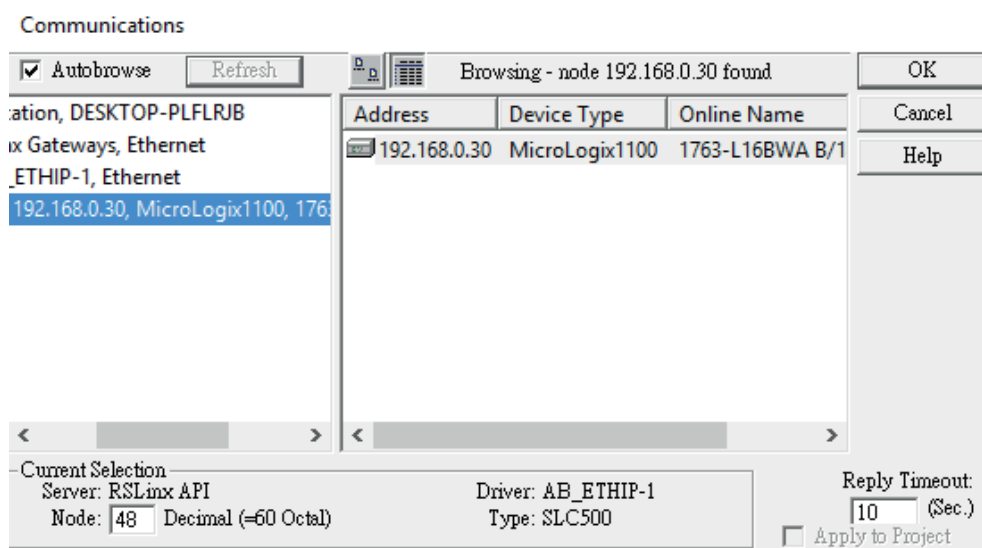

Press **Create New File** in the dialog window that appears after pressing OK.

On the left side of the program, double click **Channel Configuration** to access the PLC's Ethernet settings. Under the Channel 1 tab, the IP address can be changed.

Channel Configuration ×

General | Channel 0 | Channel 1

Driver: Ethernet

Hardware Address: 00:1D:9C:A1:62:93 Network Link ID: 0

IP Address: 192 . 168 . 0 . 30

Subnet Mask: 255 . 255 . 255 . 0

Gateway Address: 192 . 168 . 0 . 1

Default Domain Name:

Primary Name Server: 192 . 168 . 0 . 1

Secondary Name Server: 255 . 0 . 0 . 0

Protocol Control

BOOTP Enable DHCP Enable Msg Connection Timeout (x 1mS): 15000

SNMP Server Enable Msg Reply Timeout (x 1mS): 3000

HTTP Server Enable

Auto Negotiate

Port Setting: 10/100 Mbps Full Duplex/Half Duplex

Contact:

Location:

OK Cancel Apply Help

Note: For more detailed information please refer to the PLC manual.

Connect PLC to HMI

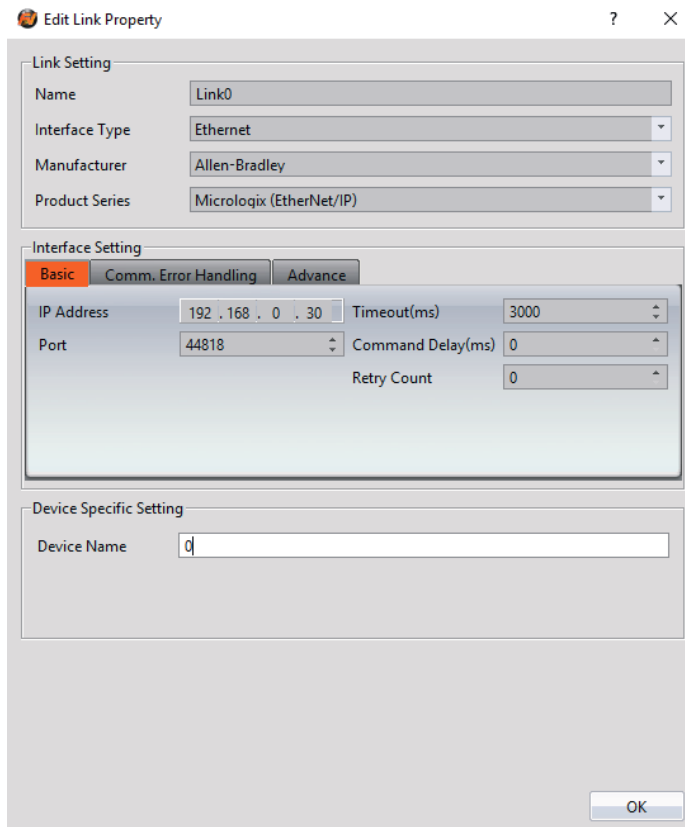

Within the **Link** configuration window in FvDesigner:
 Under **Interface Type** select Ethernet
 Under **Manufacturer** select Allen-Bradley
 Under **Product Series** select Micrologix (Ethernet/IP)
 Enter the **IP Address** that was written into the PLC.
 Keep the **Port** at the default setting.

2.7.5 MicroLogix Series

2.7.5.1 Communication Setting

Item	Default Setting	Remark
Signal Level	RS232	
Baud Rate	19200	
Data Length	8	
Stop Bit	1	
Parity	None	
PLC Station No.	1	
TX Control	CRC	CRC/BCC

Communication Method	DF1 Protocol	
----------------------	--------------	--

2.7.5.2 PLC Resource Review

Device	Description	Data bit	Input format	Min.	Max.
O	Output File	1/16	O F:S.D	O0:0.0	O0:30.255
I	Input File	1/16	I F:S.D	I1:0.0	I1:30.255
S	Status File	1/16	S F:E	S2:0	S2:163
B	Bit File	1/16	B F:E	B3:0	B255:255
T	Timer File	1/16	T F:E.D	T4:0.0	T255:255.2
C	Counter File	1/16	C F:E.D	C5:0.0	C255:255.2
R	Control File	1/16	R F:E.D	R6:0.0	R255:255.2
N	Integer File	1/16	N F:E	N7:0	N255:255
F	Floating File	32	F F:E	F8:0	F255:255
ST	String File	1/16	ST F:E.D	ST9:0.0	ST255:255.41
L	Long word File	32	L F:E	L9:0	L255:255

2.7.5.3 Connecting to HMI

Configuring the PLC

To connect the PLC to a computer, follow the same steps detailed in the previous chapter. Configuring the serial connection of the PLC is the same as configuring the IP address of the PLC.

Double click **Channel Configuration** and navigate to the Channel 0 tab. Here, the serial connection settings can be adjusted if needed.

Channel Configuration ×

General Channel 0 Channel 1

Driver: DF1 Full Duplex Source ID: 1 (decimal)

Baud: 19200

Parity: NONE

Protocol Control

Control Line: No Handshaking ACK Timeout (x20 ms): 50

Error Detection: CRC

Embedded Responses: Auto Detect

Duplicate Packet Detect

NAK Retries: 3

ENQ Retries: 3

OK Cancel Apply Help

Note: For more detailed information please refer to the PLC manual.

Connecting PLC to HMI

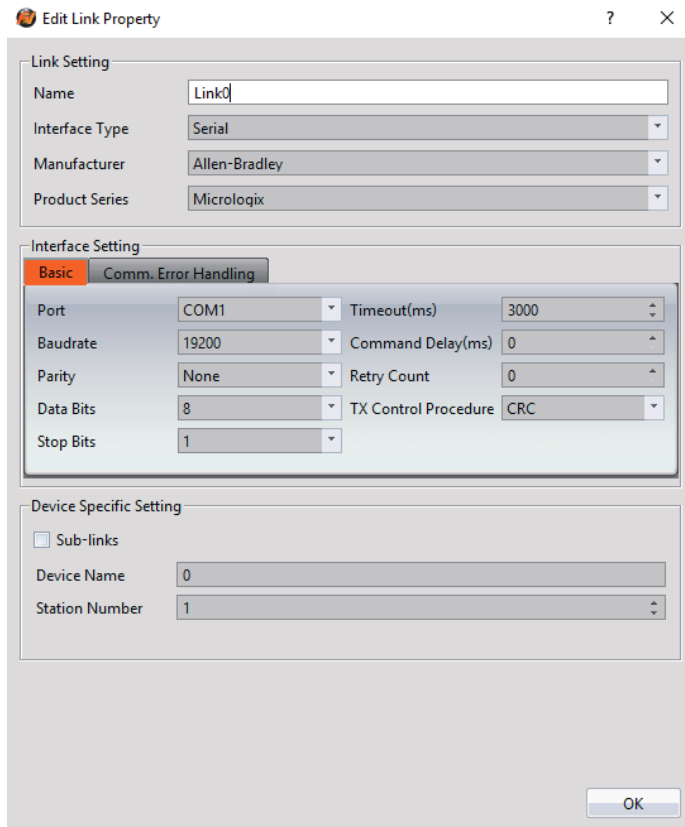

Within the **Link** configuration window in FvDesigner:

Under **Interface Type** select Serial

Under **Manufacturer** select Allen-Bradley

Under **Product Series** select Micrologix

Under **Port** select COM1

Verify the other parameters are consistent with the ones set on the PLC.

2.7.5.4 Wiring Diagrams

HMI COM1 Pinout

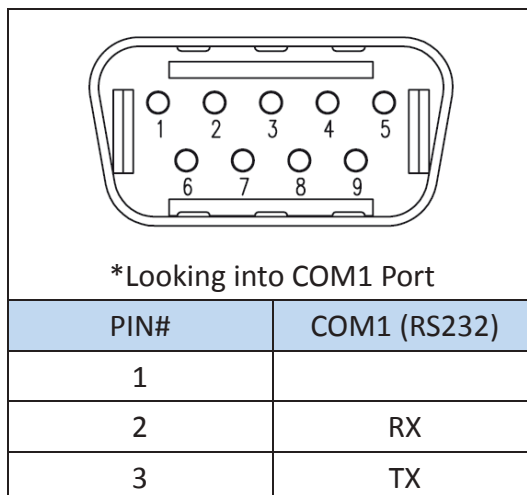

4	
5	GND
6	
7	RTS
8	CTS
9	

PLC RS232 Pinout

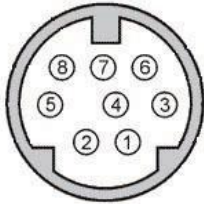
 <p>*Looking into PLC</p>	
PIN#	Signal
1	
2	GND
3	
4	RXD
5	
6	
7	TXD
8	

All P5 and P2K Series

HMI COM1	PLC RS232 Port
2 RX	7 TXD
3 TX	4 RXD
5 GND	2 GND

Wiring Diagrams: All P5 and P2K Series

HMI COM1

PLC RS232

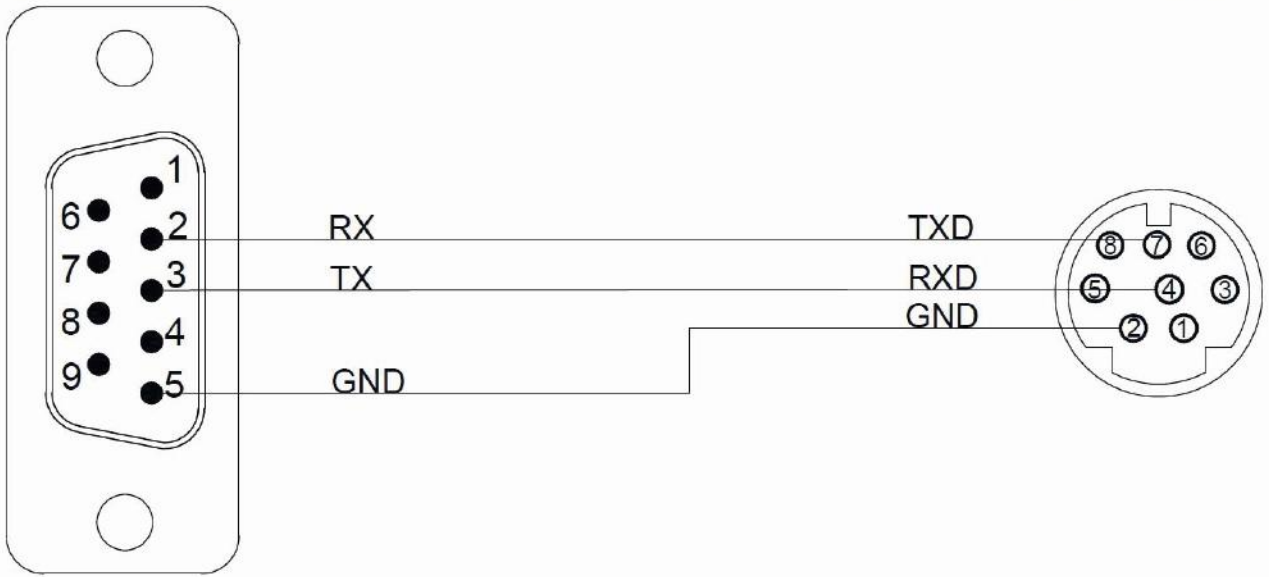

2.8 Taiwan Instrument & Control Co., Ltd.

2.8.1 FY Series

2.8.1.1 Communication Setting

Item	Default Setting	Remark
Signal Level	RS485 2W	
Baud Rate	38400	
Data Length	8	
Stop Bit	1	
Parity	Odd	
PLC Station No.	0	
Communication Method	MODBUS RTU	

2.8.1.2 Memory Resource Review

Device	Description	Data bit	Input format	Min.	Max.
SV	Set Point	16	D	0	0
OUTL	Output Limit	16	D	0	0
AT	Auto Tuning	16	D	0	0
AL1	Alarm 1 set value	16	D	0	0
AL2	Alarm 2 set value	16	D	0	0
AL3	Alarm 3 set value	16	D	0	0
PTN	Program Pattern	16	D	0	0

SEG	Program Segment Display	16	D	0	0
TIMR	Program Countdown Display	16	D	0	0
SV_1	Set Point of Seg.1(Pattern 1)	16	D	0	0
TM_1	Run Time of Seg.1(Pattern 1)	16	D	0	0
OUT1	Output Limit of Seg.1(Pattern 1)	16	D	0	0
SV_2	Set Point of Seg.2(Pattern 1)	16	D	0	0
TM_2	Run Time of Seg.2(Pattern 1)	16	D	0	0
OUT2	Output Limit of Seg.2(Pattern 1)	16	D	0	0
SV_3	Set Point of Seg.3(Pattern 1)	16	D	0	0
TM_3	Run Time of Seg.3(Pattern 1)	16	D	0	0
OUT3	Output Limit of Seg.3(Pattern 1)	16	D	0	0
SV_4	Set Point of Seg.4(Pattern 1)	16	D	0	0
TM_4	Run Time of Seg.4(Pattern 1)	16	D	0	0
OUT4	Output Limit of Seg.4(Pattern 1)	16	D	0	0
SV_5	Set Point of Seg.5(Pattern 1)	16	D	0	0
TM_5	Run Time of Seg.5(Pattern 1)	16	D	0	0
OUT5	Output Limit of Seg.5(Pattern 1)	16	D	0	0
SV_6	Set Point of Seg.6(Pattern 1)	16	D	0	0
TM_6	Run Time of	16	D	0	0

	Seg.6(Pattern 1)				
OUT6	Output Limit of Seg.6(Pattern 1)	16	D	0	0
SV_7	Set Point of Seg.7(Pattern 1)	16	D	0	0
TM_7	Run Time of Seg.7(Pattern 1)	16	D	0	0
OUT7	Output Limit of Seg.7(Pattern 1)	16	D	0	0
SV_8	Set Point of Seg.8(Pattern 1)	16	D	0	0
TM_8	Run Time of Seg.8(Pattern 1)	16	D	0	0
OUT8	Output Limit of Seg.8(Pattern 1)	16	D	0	0
SV_12	Set Point of Seg.1(Pattern 2)	16	D	0	0
TM_12	Run Time of Seg.1(Pattern 2)	16	D	0	0
OUT12	Output Limit of Seg.1(Pattern 2)	16	D	0	0
SV_22	Set Point of Seg.2(Pattern 2)	16	D	0	0
TM_22	Run Time of Seg.2(Pattern 2)	16	D	0	0
OUT22	Output Limit of Seg.2(Pattern 2)	16	D	0	0
SV_32	Set Point of Seg.3(Pattern 2)	16	D	0	0
TM_32	Run Time of Seg.3(Pattern 2)	16	D	0	0
OUT32	Output Limit of Seg.3(Pattern 2)	16	D	0	0
SV_42	Set Point of Seg.4(Pattern 2)	16	D	0	0
TM_42	Run Time of Seg.4(Pattern 2)	16	D	0	0

OUT42	Output Limit of Seg.4(Pattern 2)	16	D	0	0
SV_52	Set Point of Seg.5(Pattern 2)	16	D	0	0
TM_52	Run Time of Seg.5(Pattern 2)	16	D	0	0
OUT52	Output Limit of Seg.5(Pattern 2)	16	D	0	0
SV_62	Set Point of Seg.6(Pattern 2)	16	D	0	0
TM_62	Run Time of Seg.6(Pattern 2)	16	D	0	0
OUT62	Output Limit of Seg.6(Pattern 2)	16	D	0	0
SV_72	Set Point of Seg.7(Pattern 2)	16	D	0	0
TM_72	Run Time of Seg.7(Pattern 2)	16	D	0	0
OUT72	Output Limit of Seg.7(Pattern 2)	16	D	0	0
SV_82	Set Point of Seg.8(Pattern 2)	16	D	0	0
TM_82	Run Time of Seg.8(Pattern 2)	16	D	0	0
OUT82	Output Limit of Seg.8(Pattern 2)	16	D	0	0
P1	OUT1 Proportional Band	16	D	0	0
I1	OUT1 Integral Time	16	D	0	0
D1	OUT1 Derivative Time	16	D	0	0
DB1	Dead-band Time	16	D	0	0
ATVL	Auto Tuning Offset	16	D	0	0
CYT1	OUT1 Cycle Time	16	D	0	0
HYS1	OUT1 Hysteresis	16	D	0	0
P2	OUT2 Proportional Band	16	D	0	0



I2	OUT2 Integral Time	16	D	0	0
D2	OUT2 Derivative Time	16	D	0	0
CYT2	OUT2 Cycle Time	16	D	0	0
HYS2	OUT2 Hysteresis	16	D	0	0
GAP1	OUT1 Control Gap	16	D	0	0
GAP2	OUT2 Control Gap	16	D	0	0
LCK	Function Lock	16	D	0	0
INP1	Input Type Selection	16	D	0	0
ANL1	Linear Input Zero Calibration	16	D	0	0
ANH1	Linear Input Span Calibration	16	D	0	0
DP	Decimal Point Position	16	D	0	0
LSPL	Lower Set Point Limit	16	D	0	0
USPL	Upper Set Point Limit	16	D	0	0
ANL2	Remote Input Zero Calibration	16	D	0	0
ANH2	Linear Input Span Calibration	16	D	0	0
ALD1	Alarm mode for AL1	16	D	0	0
ALT1	Alarm time for AL1	16	D	0	0
ALD2	Alarm mode for AL2	16	D	0	0
ALT2	Alarm time for AL2	16	D	0	0
ALD3	Alarm mode for AL3	16	D	0	0
ALT3	Alarm time for AL3	16	D	0	0
HYSA	Hysteresis for all Alarms	16	D	0	0
CLO1	OUT1 Lower Calibration	16	D	0	0
CHO1	OUT1 Upper Calibration	16	D	0	0
CLO2	OUT1 Lower Calibration	16	D	0	0
CHO2	OUT1 Upper Calibration	16	D	0	0

CLO3	TRS Lower Calibration	16	D	0	0
CHO3	TRS Upper Calibration	16	D	0	0
RUCY	Full run time of motor valve	16	D	0	0
WAIT	Full run time of proportional motor valve	16	D	0	0
SETA		16	D	0	0
PSL	Protocol Selection	16	D	0	0
BITS	Communication Bits	16	D	0	0
IDNO	ID Number	16	D	0	0
BAUD	Baud rate	16	D	0	0
SVOS	SV Compensation	16	D	0	0
PVOS	PV Compensation	16	D	0	0
UNIT	Unit of PV and SV	16	D	0	0
PVFT	PV Filter	16	D	0	0
CASC		16	D	0	0
ODD	Heating / Cooling selection	16	D	0	0
OPAD	Control Algorithm	16	D	0	0
HZ	Power Frequency	16	D	0	0
SET1	Hide/ Display parameter	16	D	0	0
SET2	Hide/ Display parameter	16	D	0	0
SET3	Hide/ Display parameter	16	D	0	0
SET4	Hide/ Display parameter	16	D	0	0
SET5	Hide/ Display parameter	16	D	0	0
SET6	Hide/ Display parameter	16	D	0	0
SET7	Hide/ Display parameter	16	D	0	0

SET8	Hide/ Display parameter	16	D	0	0
SET9	Hide/ Display parameter	16	D	0	0
SET0	Hide/ Display parameter	16	D	0	0
INP2	Hide/ Display parameter	16	D	0	0
OUTY	Hide/ Display parameter	16	D	0	0
VER	Output mode selection	16	D	0	0
OUT%	Firmware Version	16	D	0	0
OBIT	Output percentage	16	D	0	0
CV	CT Current Value	16	D	0	0
PV	Process Value	16	D	0	0

2.8.1.3 Connecting to HMI

Configuring the PLC

Press  +  key 3 seconds to configure parameters in Level 3

Character	Name , Functions and Setting range	Default
<i>P S L</i>	Protocol Selection <i>r t U</i> : MODBUS RTU Protocol <i>A S C I</i> : MODBUS ASCII Protocol <i>t A I E</i> : TAIE Protocol	<i>r t U</i>
<i>b i t 5</i>	Communication Bits <i>O _ B 1</i> : Odd parity , Data bits = 8 , Stop Bit = 1 <i>O _ B 2</i> : Odd parity , Data bits = 8 , Stop Bit = 2 <i>E _ B 1</i> : Even parity , Data bits = 8 , Stop Bit = 1 <i>E _ B 2</i> : Even parity , Data bits = 8 , Stop Bit = 2	<i>O _ B 1</i>
<i>I d , N O</i>	ID Number Range : 0 ~ 255	1
<i>b A U d</i>	Communication Baud rate <i>2 4</i> : 2400 bps <i>4 8</i> : 4800 bps <i>9 6</i> : 9600 bps <i>1 9 2</i> : 19200 bps <i>3 8 4</i> : 38400 bps	384

- When parameter *b i t 5* or *b A U d* was changed, always turn on the power again. Otherwise, no communication is performed by using the changed value.

Note: For more detailed information please refer to the PLC manual.

Connecting PLC to HMI

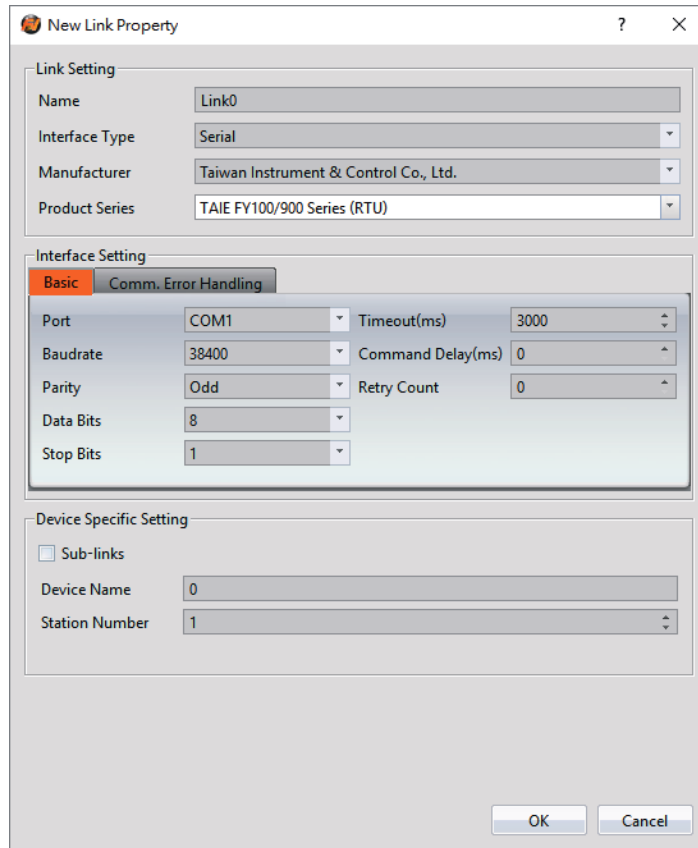

Within the **Link** configuration window in FvDesigner:

Under **Interface Type** select Serial

Under **Manufacturer** select Taiwan Instrument & Control Co.,Ltd.

Under **Product Series** select TAIE FY100/900 Series.

Verify the parameters match the window above.

2.8.1.4 Wiring diagrams

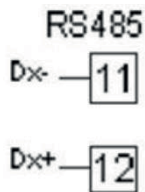

HMI (ex.P5043N) COM2 Pinout

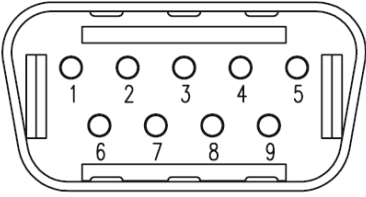

*Looking into HMI

PIN#	COM2 (RS485)
1	DATA+
2	
3	
4	
5	GND
6	DATA-
7	
8	
9	

HMI COM3 Pinout



*Looking into HMI Device

PIN#	COM3 (RS-422/RS-485)
1	
2	
3	ISO_GND
4	
5	
6	DATA+
7	DATA-

P5070S/P5070N/P5070N1/P5102N/P5102N1

HMI COM3 Port	PLC RS485 Port
6 DATA+	12 DATA+
7 DATA-	11 DATA-

3 ISO_GND	GND
-----------	-----

Wiring Diagrams: P5070S/P5070N/P5070N1/P5102N/P5102N1

HMI COM3

PLC RS485

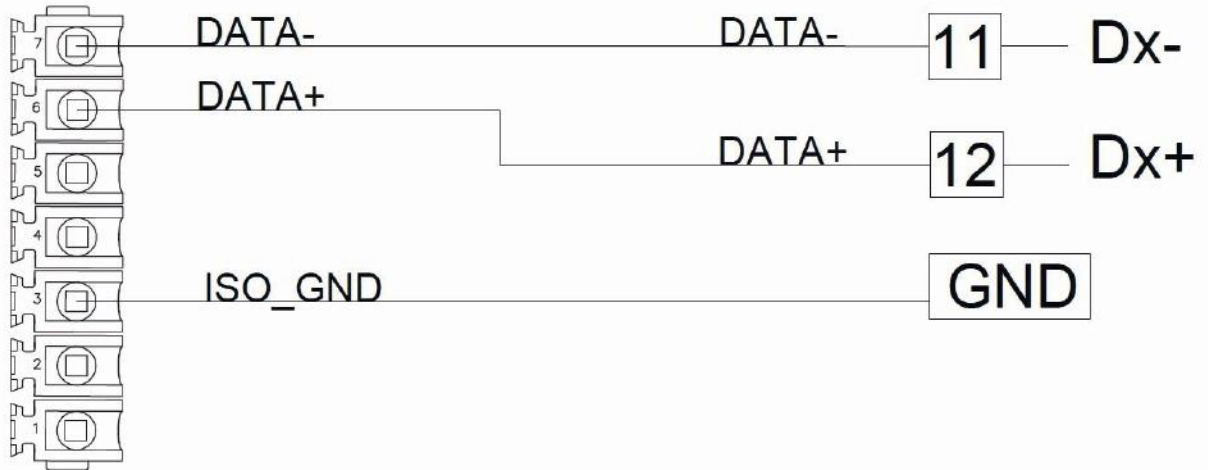

P5043S/P5043N/P5070VS/P5102VS/P2K SERIES

HMI COM2 Port	PLC RS485 Port
1 DATA+	12 DATA+
6 DATA-	11 DATA-
5 GND	GND

Wiring Diagrams: P5043S/P5043N/P5070VS/P5102VS/P2K SERIES

HMI COM2

PLC RS485

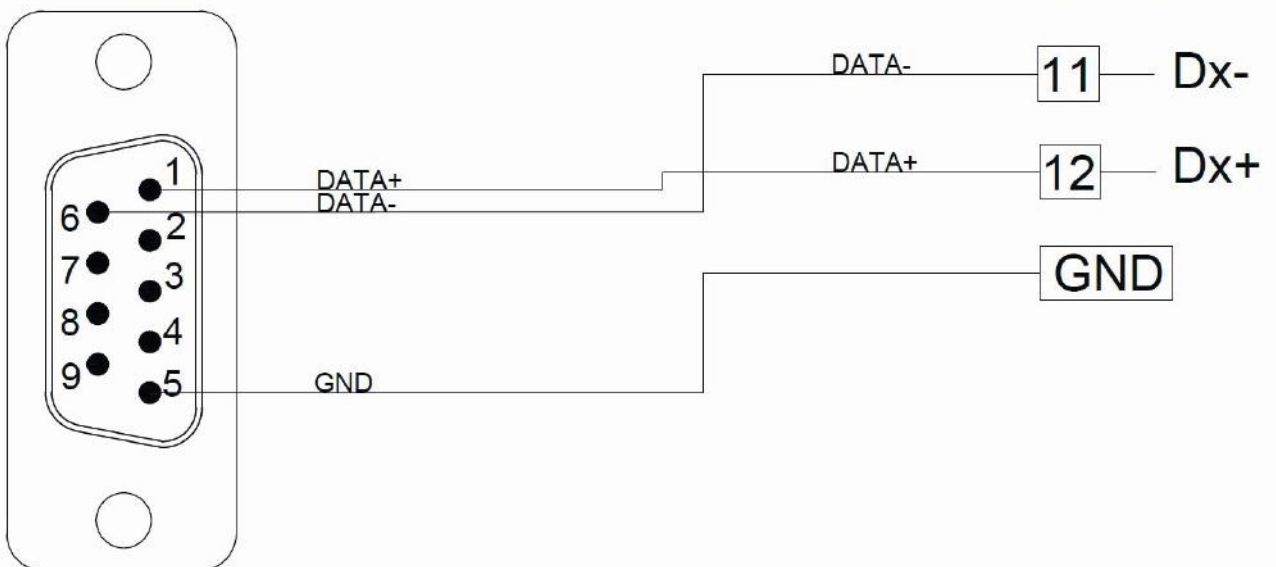

2.9 Delta

2.9.1 DVP Series

2.9.1.1 Communication Setting

Item	Default Setting	Remark
Signal Level	RS232C	
Baud Rate	9600	
Data Length	7	
Stop Bit	1	
Parity	Even	
PLC Station No.	0	
Communication Method	MODBUS ASCII	

2.9.1.2 Memory Resource Review

Device	Description	Data bit	Input format	Min.	Max.
X	Input relay	1	OOO	0	377
Y	Output relay	1	OOO	0	377
M	Auxiliary relay	1	DDDD	0	4095
S	Step	1	DDDD	0	1023
T	Timer	1	DDD	0	255
C	Counter	1	DDD	0	255
CV	Counter memory	16	DDD	0	199
TV	Timer memory	16	DDD	0	255
D	Data register	16	DDDDD	0	11999
SCV	Counter memory	32	DDD	200	255

2.9.1.3 Connecting to HMI

Configuring the PLC

Use ISPsoft to configure the port of the PLC.

But RS232 can't change setting.

Note: For more detailed information please refer to the PLC manual.

Connecting PLC to HMI

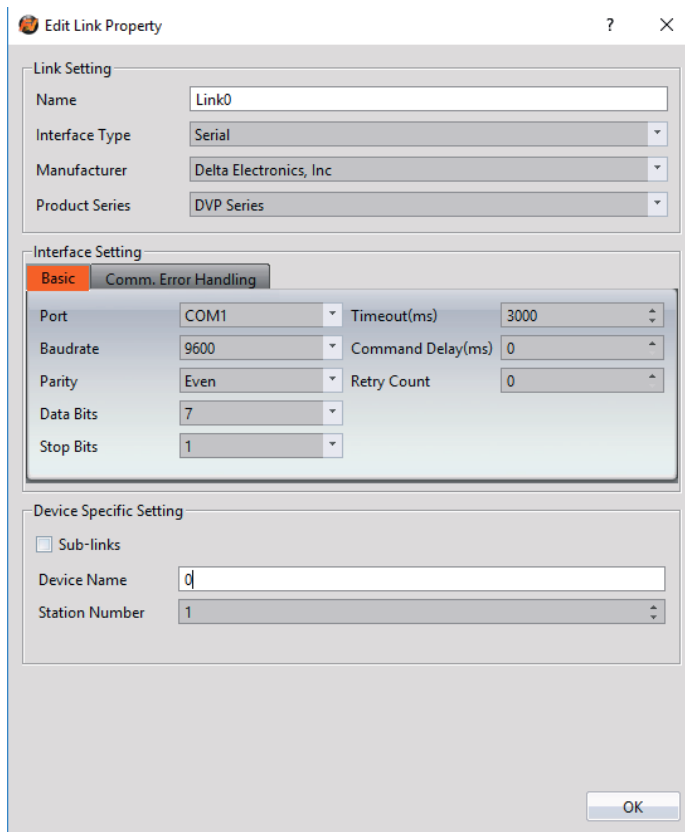

Within the **Link** configuration window in FvDesigner:

Under **Interface Type** select Serial

Under **Manufacturer** select Delta Electronics, Inc

Under **Product Series** select DVP Series

Make sure the other parameters are set at the values in the figure.

2.9.1.4 Wiring Diagrams

HMI COM1 Pinout

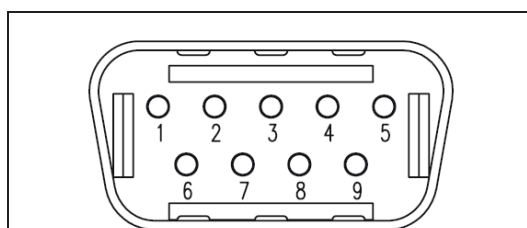

*Looking into COM1 Port

PIN#	COM1 (RS232)
1	
2	RX
3	TX
4	

5	GND
6	
7	RTS
8	CTS
9	

PLC RS232 Pinout

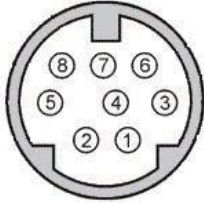
	
*Looking into PLC	
PIN#	Signal
1	
2	
3	
4	RXD
5	TXD
6	
7	
8	GND

All P5 and P2K Series

HMI COM1	PLC RS232 Port
2 RX	5 TXD
3 TX	4 RXD
5 GND	8 GND

Wiring Diagrams: All P5 and P2K Series

HMI COM1

PLC RS232

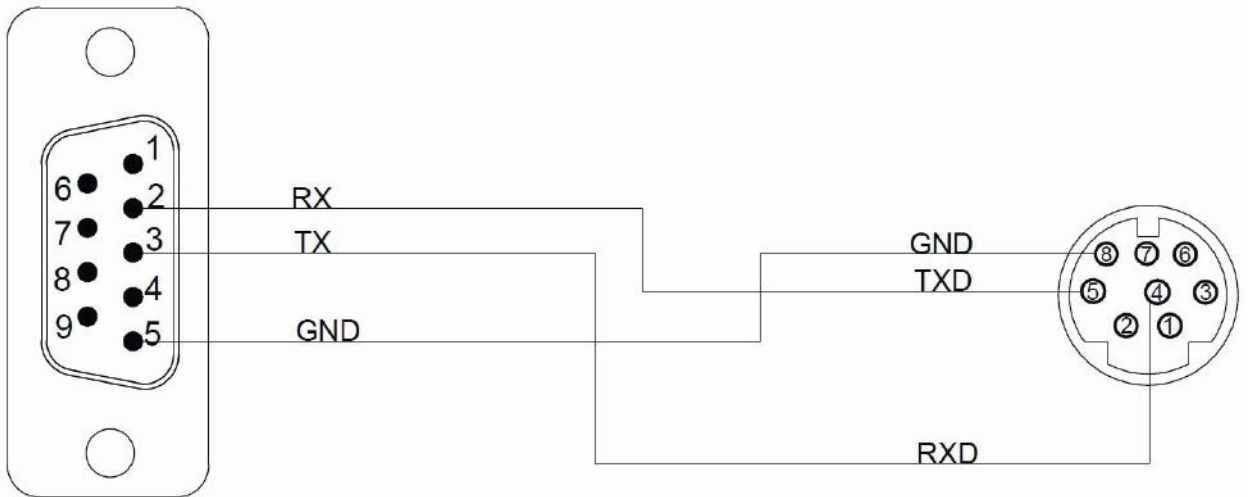

2.9.2 AH500 Series

2.9.2.1 Communication Setting

Item	Default Setting	Remark
Signal Level	RS232C	
Baud Rate	9600	
Data Length	7	
Stop Bit	1	
Parity	Even	
PLC Station No.	1	
Communication Method	MODBUS ASCII	

2.9.2.2 Memory Resource Review

Device	Description	Data bit	Input format	Min.	Max.
X	Input relay	1	DDD.D	0.0	511.15
		16	DDD	0	511
Y	Output relay	1	DDD.D	0.0	511.15
		16	DDD	0	511
D	Data register	1	DDDDD.D	0	65535.15
		16	DDDDD	0	65535
L	Link register	1	DDDDD.D	0	65535.15
		16	DDDDD	0	65535
M	Auxiliary relay	1	DDDD	0	8191
SM	Special Auxiliary	1	DDDD	0	2047

	Relay				
S	Stepping Relay	1	DDDD	0	2047
T	Timer	1	DDDD	0	2047
TV	Timer memory	16	DDDD	0	2047
C	Counter	1	DDDD	0	2047
CV	Counter memory	16	DDDD	0	2047
HC	32-bit Counter	1	DD	0	63
HCV	32-bit Counter memory	32	DD	0	63
SR	Special data register	16	DDDD	0	2047
E	Index register	16	DD	0	31

2.9.2.3 Connecting to HMI

Configuring the PLC

Use the application **ISPSOft** (Ver. 2.05) to configure the PLC. The application **COMMGR** is used to establish the connection between the PLC and the computer.

Open **COMMGR**. The application opens in the system tray. Double click the icon to open it.

In Device Manager, verify the port number the PLC is connected to. In COMMGR, press **Add** and for **Connection Setup**, select RS232/422/485 for type. Select the port number the PLC is connected to for the **COM Port** setting. Press **Auto-detect** and the application will automatically adjust the rest of the parameters.

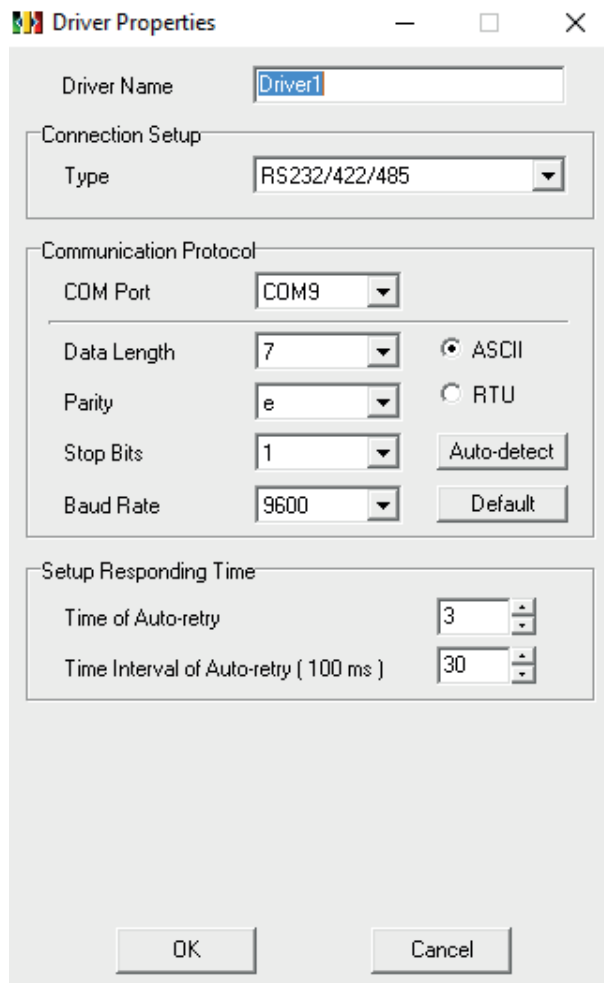

In **ISPSOft**, under the **Tools** menu option, select **Communication Settings**. Select the name of the connection configured in **COMMGR** and press **OK**.

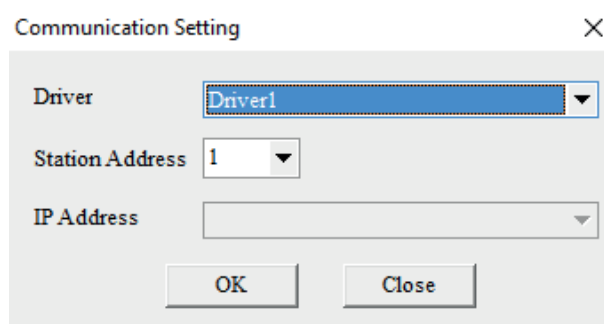

Under the **PLC** menu option, select **Transfer** and **Upload**. If there is a program on the PLC, it will be uploaded and the system settings can be configured. If there is no program present on the PLC one will have to be downloaded.

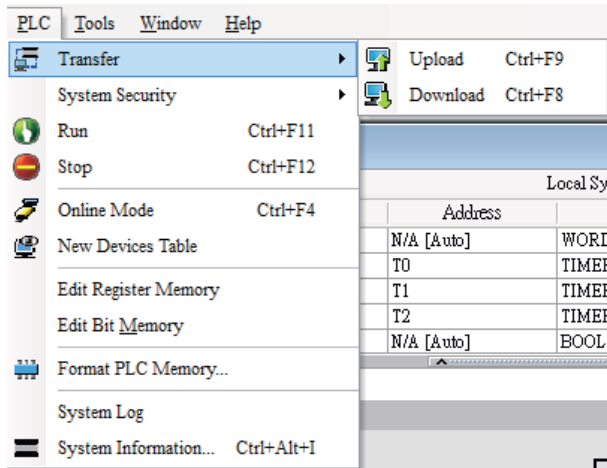

If program has to be downloaded onto the PLC, press open and select a program. In the active folder, there are example programs. The device associated with the example program may not be the same as the device connected. Under **Tools**, select **PLC Type** and select the device currently used. Once a program is opened, the PLC settings can be configured.

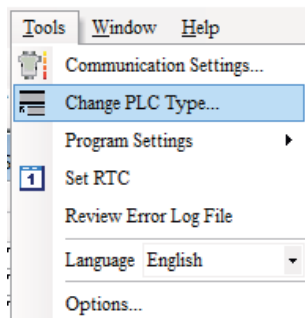

In the Project sidebar, double click **HWCONFIG**. Double click the **CPU** module and navigate to the **COM Port** tab in the settings dialog. Adjust communication parameters and press OK to confirm the settings.

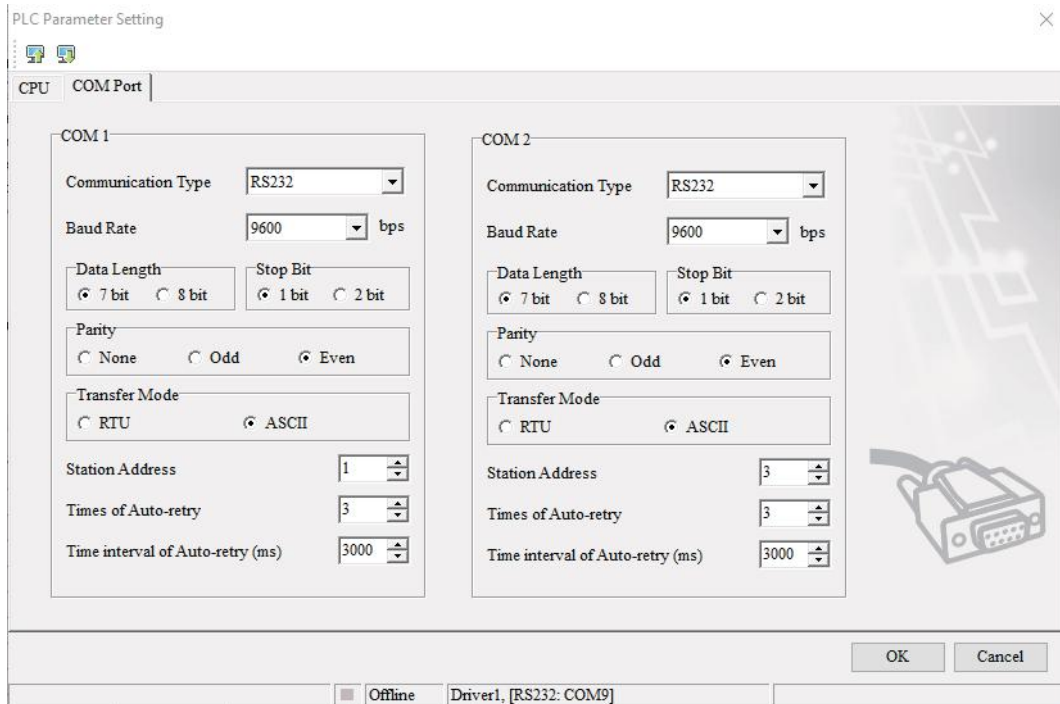

Under the **PLC** menu option, the program and PLC configurations can be downloaded onto the device.

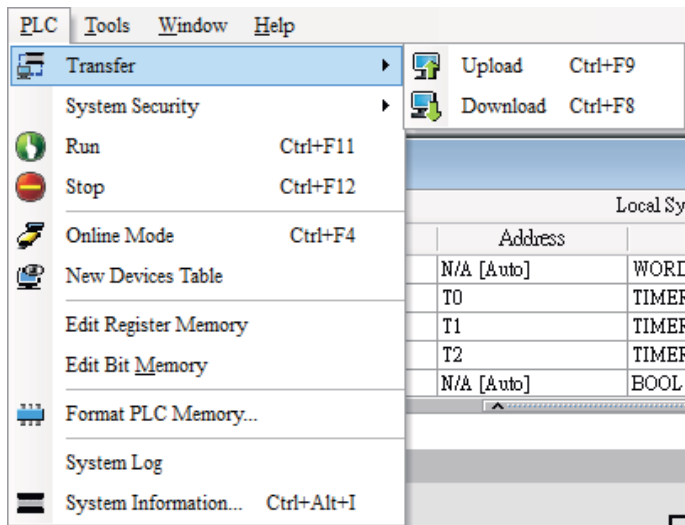

Note: For more detailed information please refer to the PLC manual.

Connecting PLC to HMI

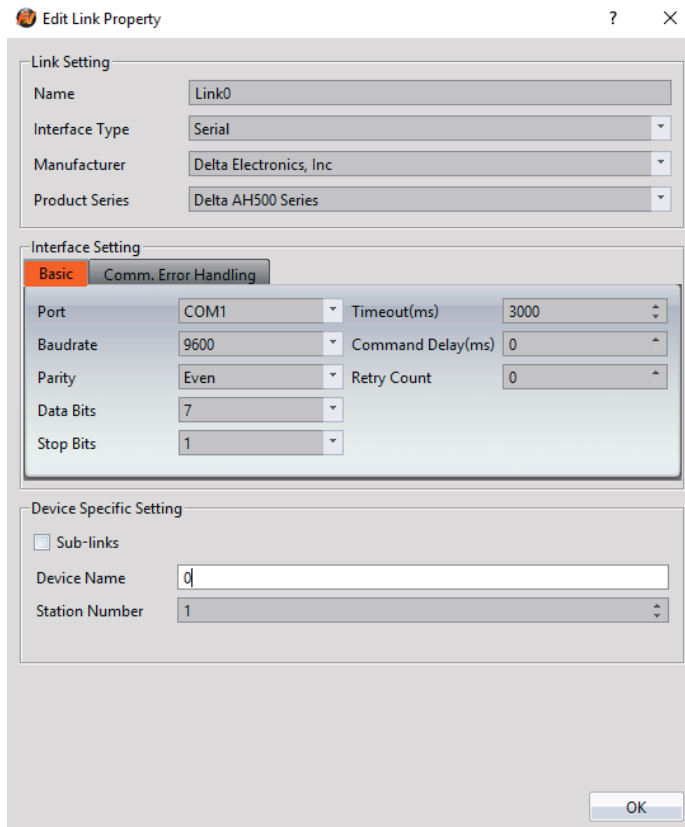

Within the **Link** configuration window in FvDesigner:
 Under **Interface Type** select Serial
 Under **Manufacturer** select Delta Electronics, Inc
 Under **Product Series** select Delta AH500 Series
 Select the appropriate **Port** to establish connection with the PLC.
 Verify the other parameters are configured correctly.

2.9.2.4 Wiring Diagrams

HMI COM1 Pinout

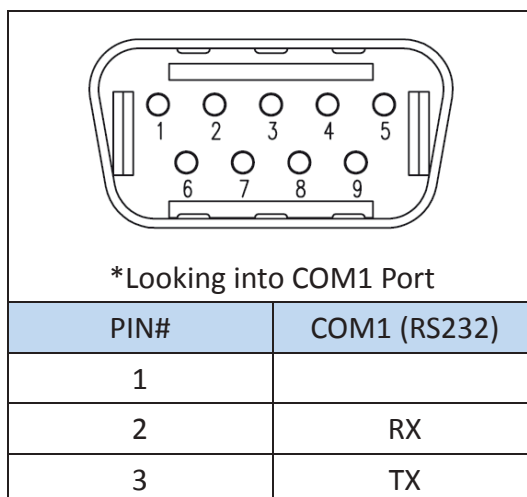

4	
5	GND
6	
7	RTS
8	CTS
9	

PLC COM1/COM2 Pinout

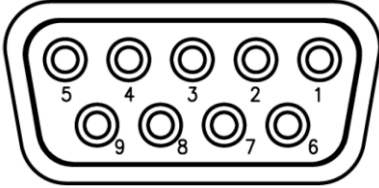
	
*Looking into PLC	
PIN#	Signal
1	
2	RXD
3	TXD
4	
5	GND
6	
7	
8	
9	

All P5 and P2K Series

HMI COM1	PLC RS232 Port
2 RX	3 TXD
3 TX	2 RXD
5 GND	5 GND

Wiring Diagrams: All P5 and P2K Series

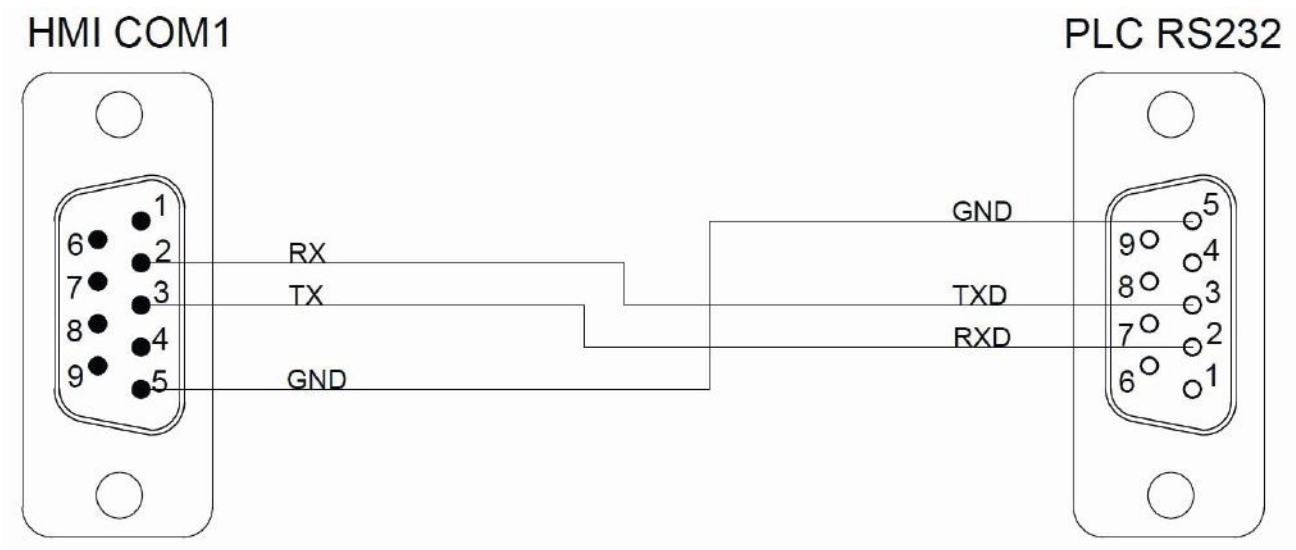

2.10 Panasonic

2.10.1 FP Series

2.10.1.1 Communication Setting

Item	Default Setting	Remark
Signal Level	RS232C	
Baud Rate	9600	
Data Length	8	
Stop Bit	1	
Parity	Odd	
PLC Station No.	1	
Communication Method	MEWTOCOL (computer link)	

2.10.1.2 Memory Resource Review

Device	Description	Data bit	Input format	Min.	Max.
X	External input relay	1	DDDD	0	8191
Y	External output relay	1	DDDD	0	8191
R	Internal relay	1	DDDDD	0	14191
L	Link Relay	1	DDDDD	0	10239
T	Timer	1	DDDD	0	3071
C	Counter	1	DDDD	0	3071
WX	External input relay	16	DDD	0	511
WY	External output relay	16	DDD	0	511

WR	Internal relay	16	DDD	0	886
WL	Link Relay	16	DDD	0	639
DT	Data register	16	DDDDD	0	99999
LD	Link data register	16	DDDD	0	8447
SV	Timer/Counter set value area	16	DDDD	0	3071
EV	Timer/Counter elapsed value area	16	DDDD	0	3071
FL	File register	16	DDDDD	0	99999

2.10.1.3 Connecting to HMI

Configuring the PLC

If the PLC does not connect based on the default communication settings, configuration of the PLC settings is needed.

Within **FPWIN GR**:

Connect the PLC to the computer via USB and navigate to the **Online** menu option and switch to **Online Editing Mode**.

Navigate to the **Option** menu option and select **PLC Configuration**.

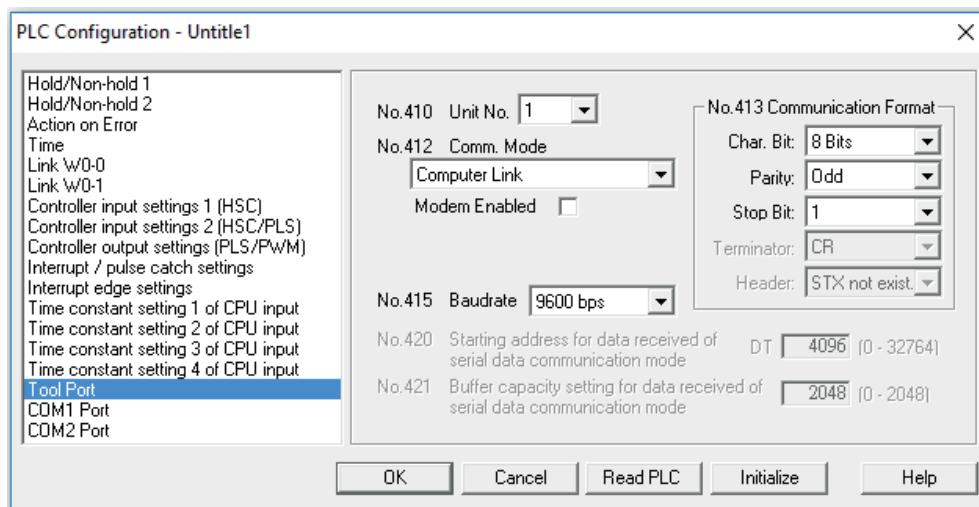

Go to the **Tool Port** option in the sidebar and select **Read PLC** to see the current PLC settings. Change the settings needed to be changed and press OK.

Navigate to the **File** menu option and select **Download to PLC** to save the settings to the PLC.

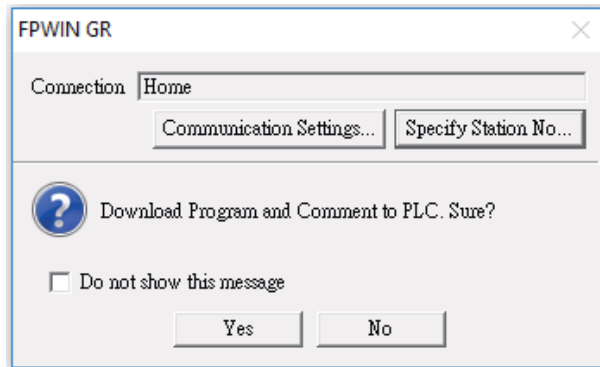

Note: For more detailed information please refer to the PLC manual.

Connecting PLC to HMI

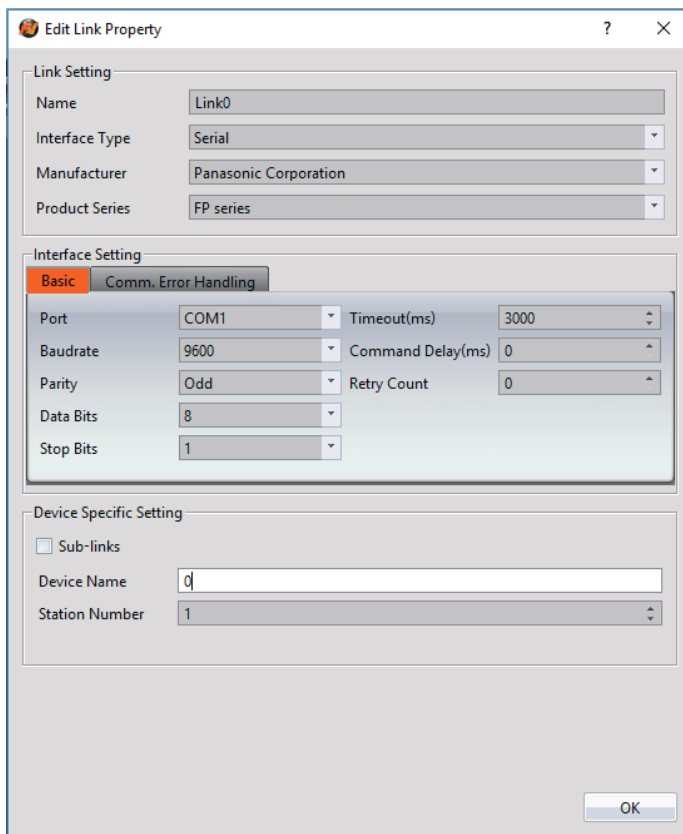

Within the **Link** configuration window in FvDesigner:

Under **Interface Type** select Serial

Under **Manufacturer** select Panasonic Corporation

Under **Product Series** select FP Series

Select **COM1** for the port

Select **1** for the station number

Verify the other settings are consistent with the settings on the PLC.

2.10.1.4 Wiring Diagrams

PLC RS232 Pinout

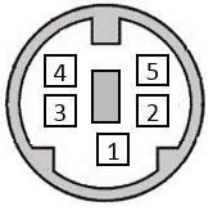

*View looking into PLC

PIN#	Signal
1	GND
2	TXD
3	RXD
4	
5	

HMI COM1 Pinout

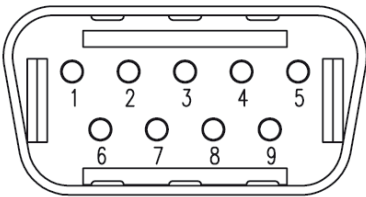

*Looking into COM1 Port

PIN#	COM1 (RS232)
1	
2	RX
3	TX
4	
5	GND
6	
7	RTS
8	CTS
9	

All P5 and P2K Series

HMI COM1	PLC RS232 Port
2 RX	2 TXD
3 TX	3 RXD

5 GND	1 GND
-------	-------

Wiring Diagrams: All P5 and P2K Series

HMI COM1

PLC RS232

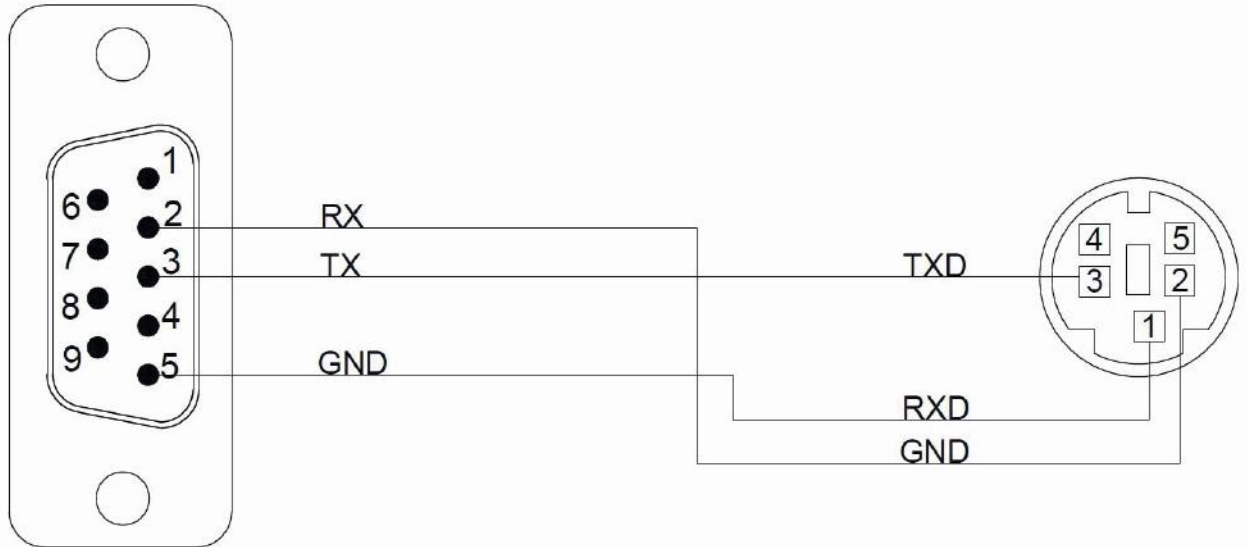

2.10.2 FP Series (Ethernet)

2.10.2.1 Communication Setting

Item	Default Setting	Remark
Signal Level	Ethernet	With AFPX-COM5
Internet Protocol	192.168.1.100	
Port	9094	
PLC Station No.	1	
Communication Method	MEWTOCOL (computer link)	

2.10.2.2 Memory Resource Review

Device	Description	Data bit	Input format	Min.	Max.
X	External input relay	1	DDDD	0	8191
Y	External output relay	1	DDDD	0	8191
R	Internal relay	1	DDDDD	0	14191
L	Link Relay	1	DDDDD	0	10239
T	Timer	1	DDDD	0	3071

C	Counter	1	DDDD	0	3071
WX	External input relay	16	DDD	0	511
WY	External output relay	16	DDD	0	511
WR	Internal relay	16	DDD	0	886
WL	Link Relay	16	DDD	0	639
DT	Data register	16	DDDDD	0	99999
LD	Link data register	16	DDDD	0	8447
SV	Timer/Counter set value area	16	DDDD	0	3071
EV	Timer/Counter elapsed value area	16	DDDD	0	3071
FL	File register	16	DDDDD	0	99999

2.10.2.3 Connecting to HMI

Configuring IP Address on PLC

Use the application Configurator WD to view/change the IP address on the PLC.

Press the **Search Unit** to search for the PLC on the local network. Right click the PLC and press **Setting IP Address** to change the IP address if needed.

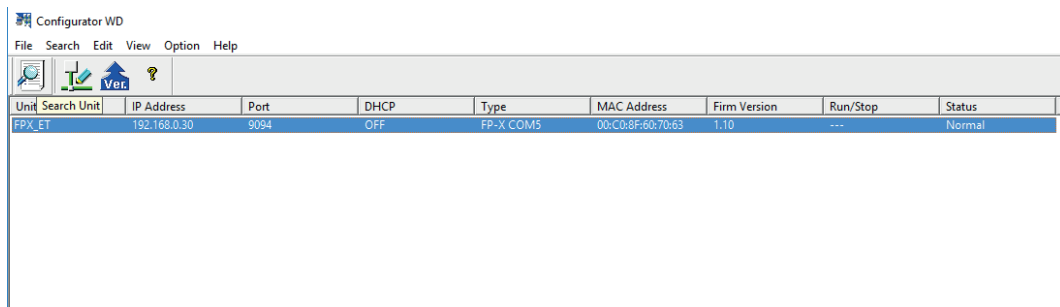

Right click the PLC and press **Communication Setting** to change the port if necessary.

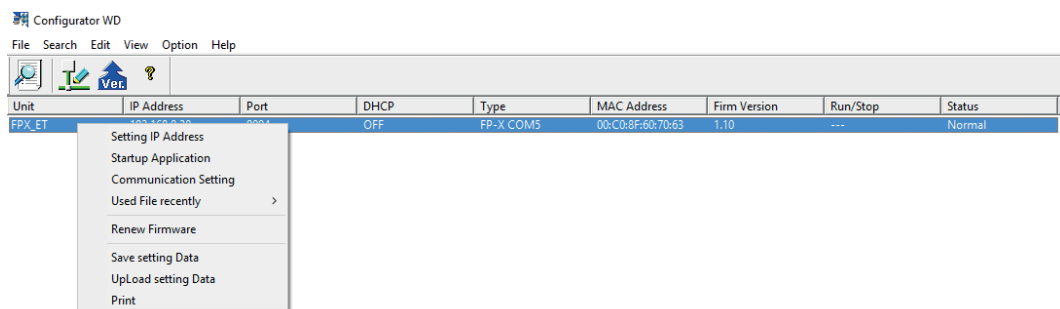

Note: For more detailed information please refer to the PLC manual.

Connecting PLC to HMI

Within the **Link** configuration window in FvDesigner:
 Under **Interface Type** select Ethernet
 Under **Manufacturer** select Panasonic Corporation
 Under **Product Series** select FP Series(Ethernet)
 Enter the **IP Address** that was written into the PLC.
 Enter the **Port** number that was set on the PLC.

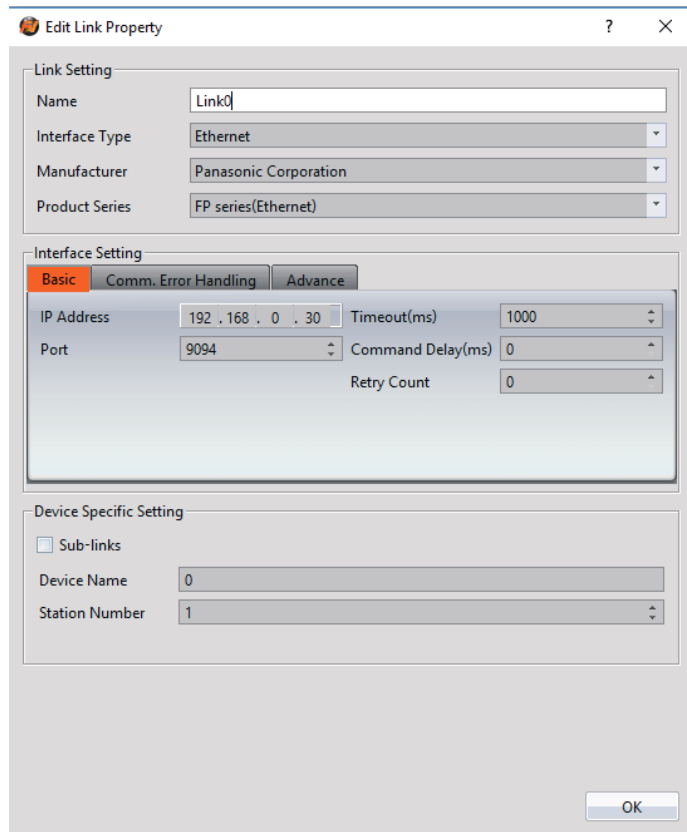

2.11 YASKAWA

2.11.1 Extended MEMOBUS

2.11.1.1 Communication Setting

Item	Default Setting	Remark
Signal Level	Ethernet	
Internet Protocol	192.168.1.1	
Port	502	
PLC Station No.	1	
Communication Method	Extended MEMOBUS	

2.11.1.2 Memory Resource Review

Device	Description	Data bit	Input format	Min.	Max.
IB	Input bits(Read only)	1	HHHHH	0	FFFF
MB	Data bits	1	DDDDDH	0	65534F
IW	Input registers(Read only)	16	HHHH	0	FFFF
MW	Data registers	16	DDDDD	0	65534
IL	Input registers (DWord / Read only)	32	HHHH	0	FFFF
ML	Data registers (Dword)	32	DDDDD	0	65533
IF	Input registers (Float / Read only)	32	HHHH	0	FFFF
MF	Data registers(Float)	32	DDDDD	0	65533

2.11.1.3 Connecting to HMI

Configuring IP Address on PLC

Use **MPE720 Ver.7** to configure the IP of the PLC.

Click **Module configuration** function

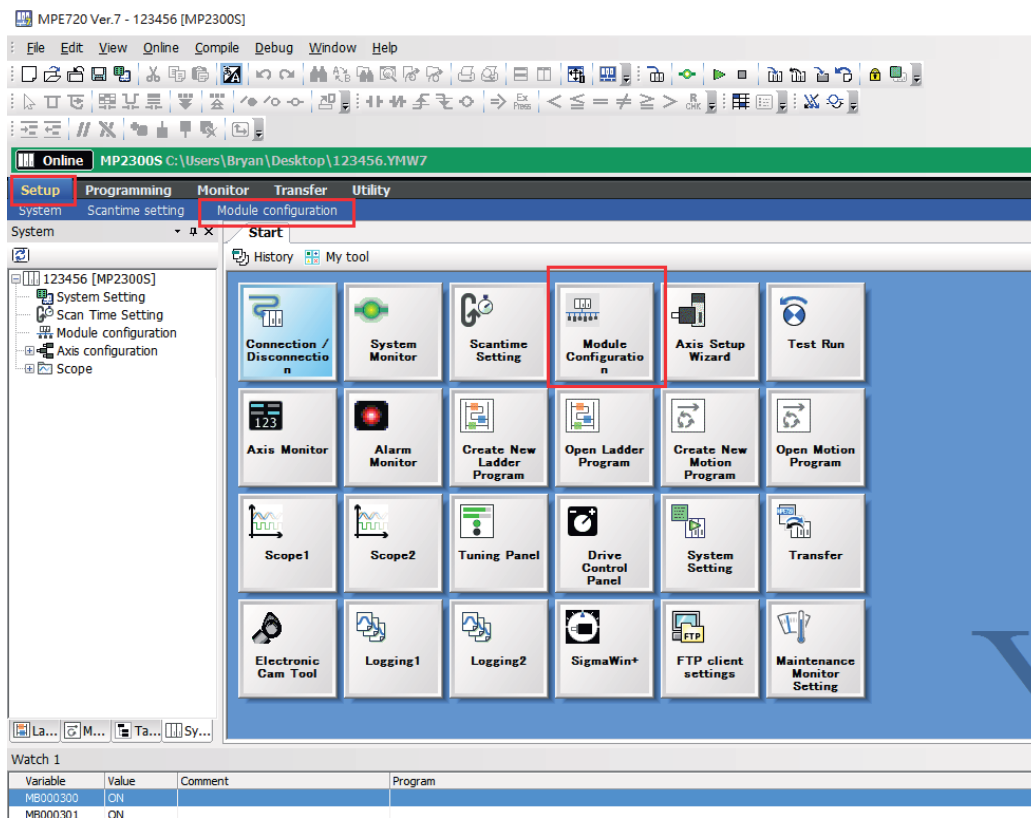

Double click 218IFA, or click 218IFA then click Edit-Setting

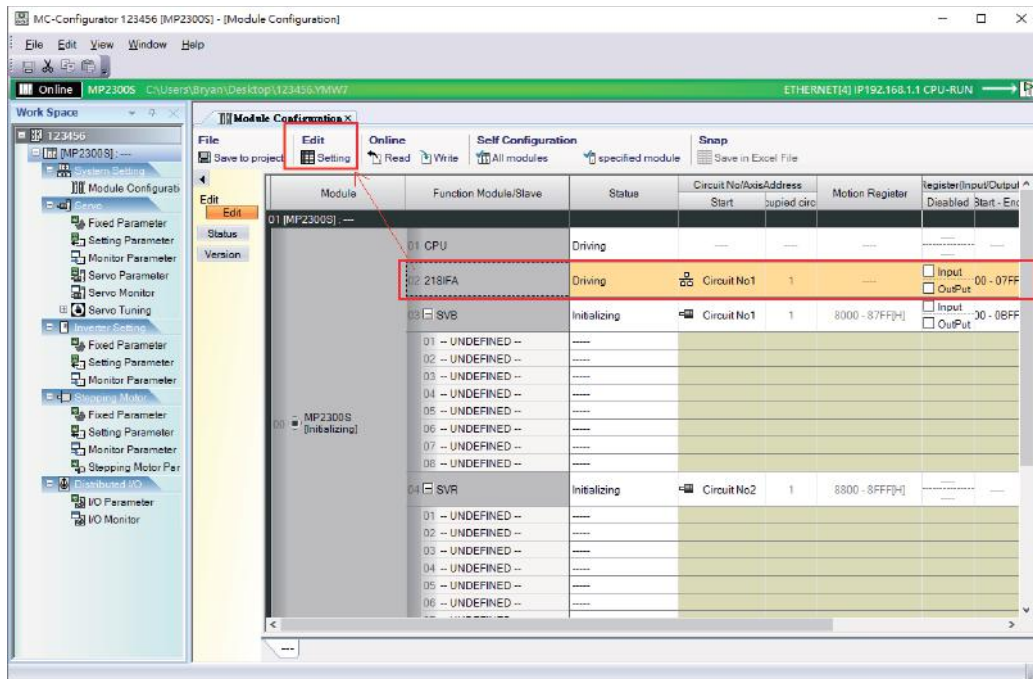

the IP address and other parameters can be set.

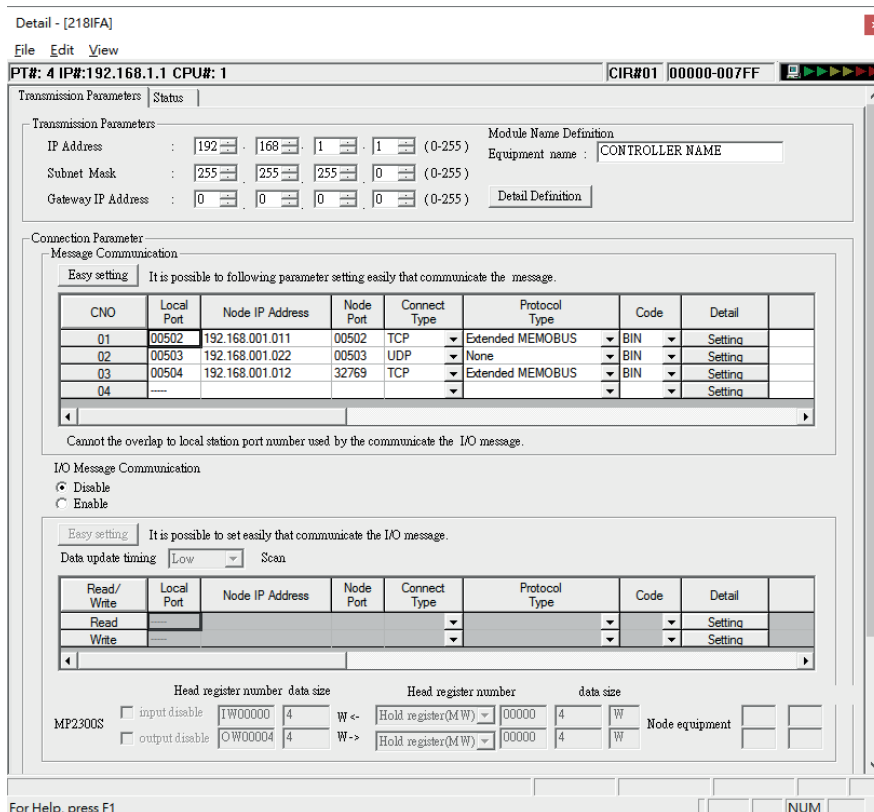

Note: For more detailed information please refer to the PLC manual.

Connect PLC to HMI

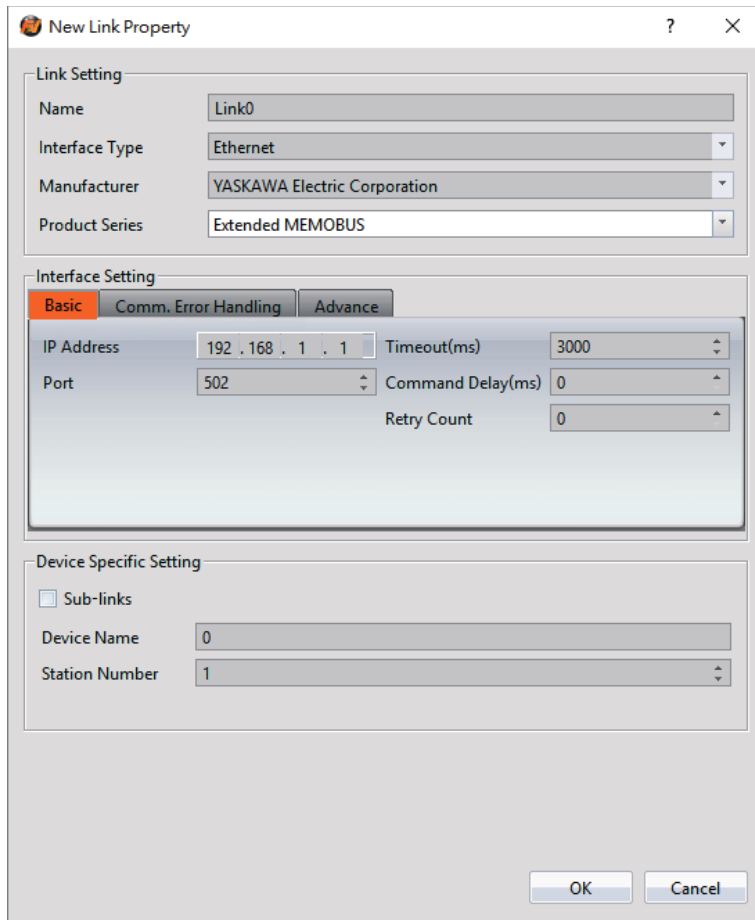

Within the **Link** configuration window in FvDesigner:

Under **Interface Type** select Ethernet

Under **Manufacturer** select YASKAWA Electric Corporation.

Under **Product Series** select Extended MEMOBUS.

Enter the **IP Address** that was written into the PLC.

Verify the parameters match the window above.

2.11.2 MP Series Extension (Ethernet)

2.11.2.1 Communication Setting

Item	Default Setting	Remark
Signal Level	Ethernet	UDP
Internet Protocol	192.168.1.1	
Port	10000	
PLC Station No.	1	
Communication Method	MP Series Extension (Ethernet)	

2.11.2.2 Memory Resource Review

Device	Description	Data bit	Input format	Min.	Max.
SB	System bits	1	DDDDH	0	8191F
MB	Data bits	1	DDDDH	0	65534F
IB	Input bits	1	HHHHH	0	FFFFFF
OB	Output bits	1	HHHHH	0	FFFFFF
SW	System registers	16	DDDD	0	8191
MW	Data registers	16	DDDD	0	65534
IW	Input registers	16	HHHH	0	FFFF
OW	Output registers	16	HHHH	0	FFFF
ML	Data registers(Dword)	32	DDDD	0	65533

2.11.2.3 Connecting to HMI

Configuring IP Address on PLC

Use **MPE720 Ver.7** to configure the IP of the PLC.

Click **Module configuration** function

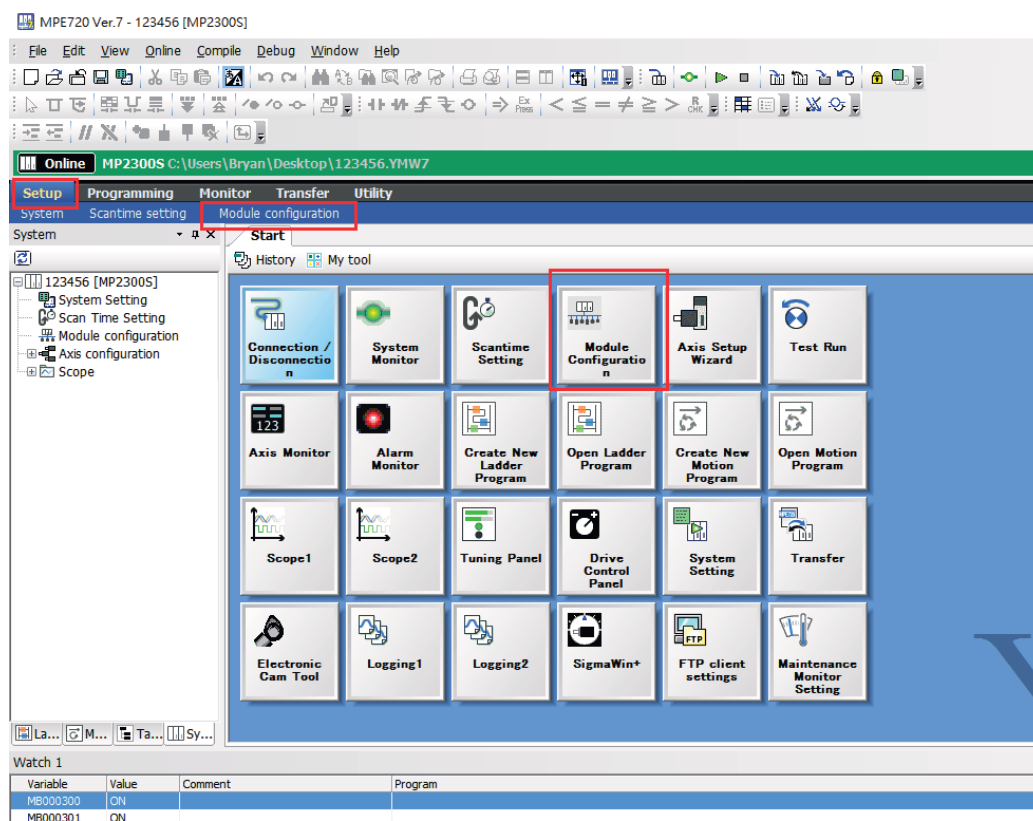

Double click 218IFA, or chick 218IFA then chick Edit-Setting

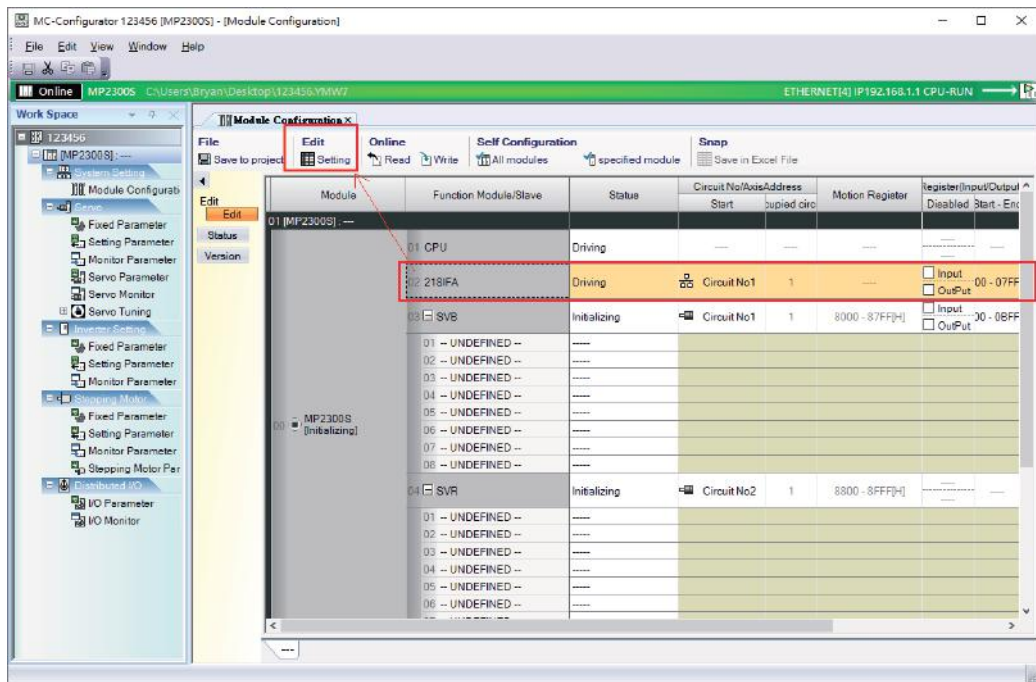

the IP address and other parameters can be set.

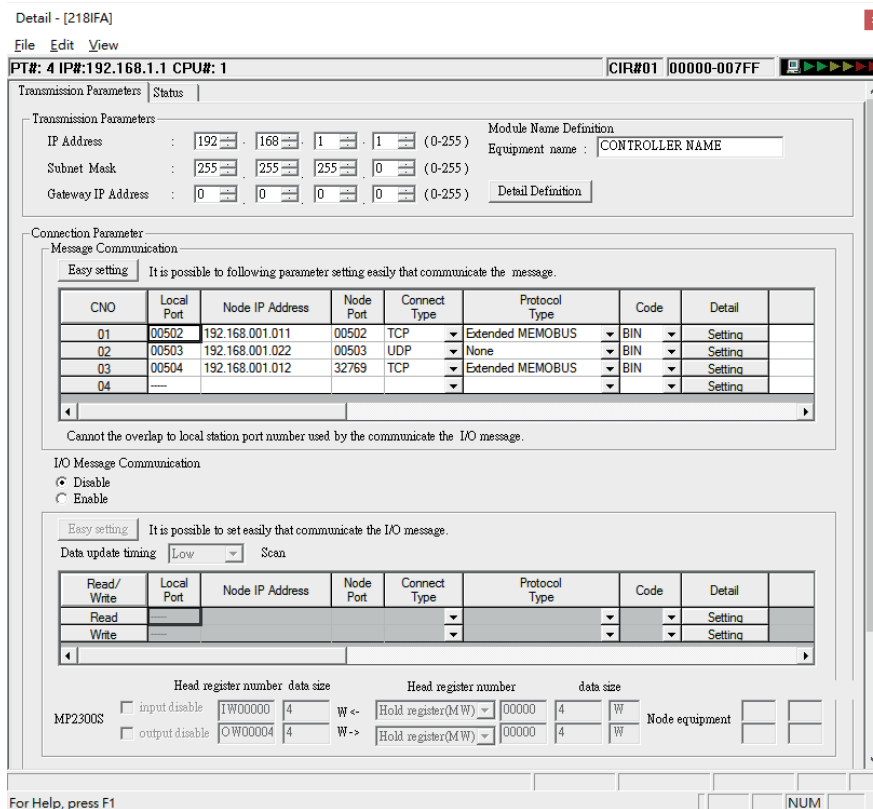

Note: For more detailed information please refer to the PLC manual.

Connect PLC to HMI

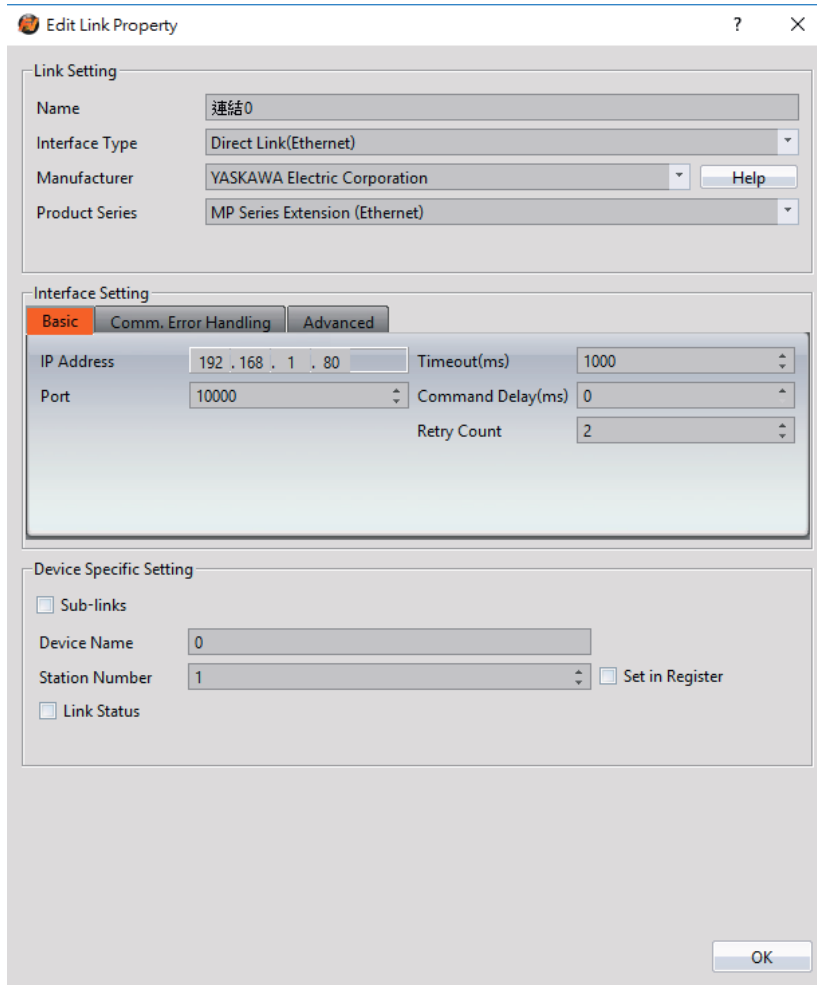

Within the **Link** configuration window in FvDesigner:

Under **Interface Type** select Ethernet

Under **Manufacturer** select YASKAWA Electric Corporation.

Under **Product Series** select MP Series Extension (Ethernet).

Enter the **IP Address** that was written into the PLC.

Verify the parameters match the window above.

2.12 Keyence

2.12.1 KV-3000/5000/5500/7500(Ethernet)

2.12.1.1 Communication Setting

Item	Default Setting	Remark
Signal Level	Ethernet	
Internet Protocol	0.0.0.0	
Port	8501	
PLC Station No.	0	
Communication Method	HOST-LINK	

	COMMUNICATION	
--	---------------	--

2.12.1.2 Memory Resource Review

Device	Description	Data bit	Input format	Min.	Max.
R	Relay	1	DDDdd	0	99915
B	Link relay	1	HHHH	0	7FFF
MR	Internal auxiliary relay	1	DDDDdd	0	399915
LR	Latch relay	1	DDDdd	0	99915
T	Timer	1	DDDD	0	3999
C	Counter	1	DDDD	0	3999
CTC_sts	High-speed counter comparator (contact)	1	D	0	7
CR	Control relay	1	DDdd	0	7915
VB	Work relay	1	HHHH	0	F9FF
DM	Data memory	16	DDDDD	0	65534
EM	Extended data memory	16	DDDDD	0	65534
FM	File register	16	DDDDD	0	32767
ZF	File register	16	DDDDDD	0	524287
W	Link register	16	HHHH	0	7FFFF
TM	Temporary data memory	16	DDD	0	511
CM	Control memory	16	DDDD	0	5999
VM	Work memory	16	DDDDD	0	50999
Z	Index register	32	D	1	12
TC	Timer (current value)	32	DDDD	0	3999
TS	Timer (set value)	32	DDDD	0	3999
CC	Counter (current value)	32	DDDD	0	3999
CS	Counter (set value)	32	DDDD	0	3999
CTH	High-speed counter (current value)	32	D	0	3
CTC	High-speed counter	32	D	0	7

	comparator (set value)				
TRM	Digital trimmer	32	D	0	7

2.12.1.3 Connecting to HMI

Configuring IP address on PLC

Use the application **KV Studio** to configure the IP address of the PLC.

Select the connection between the PLC and the computer. A USB connection was used in this case.

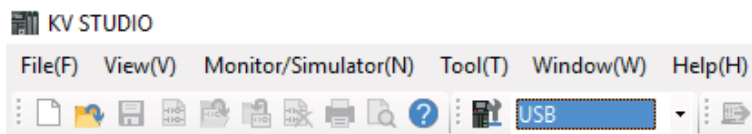

Under the **Monitor/Simulator** menu option, select **Read from PLC** and execute the operation.

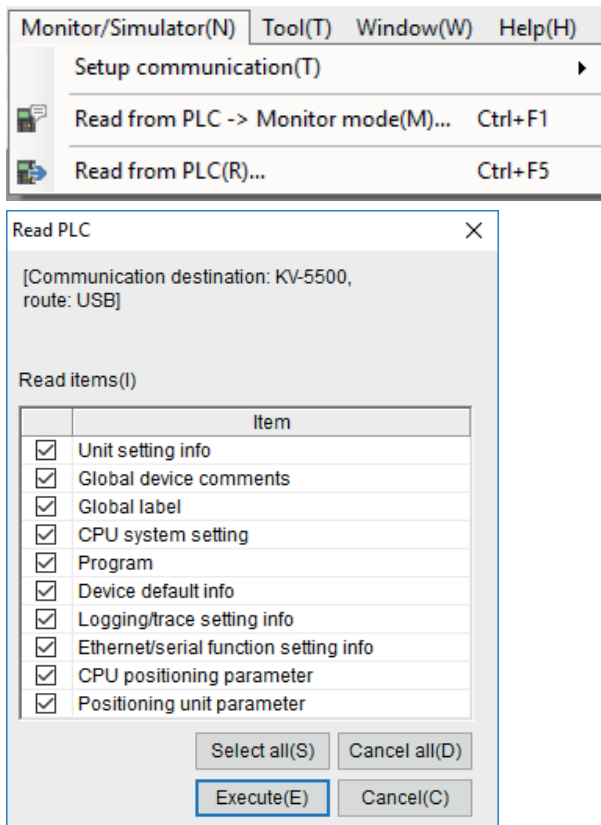

In the Workspace, right click the PLC model name and select **Unit Editor**.

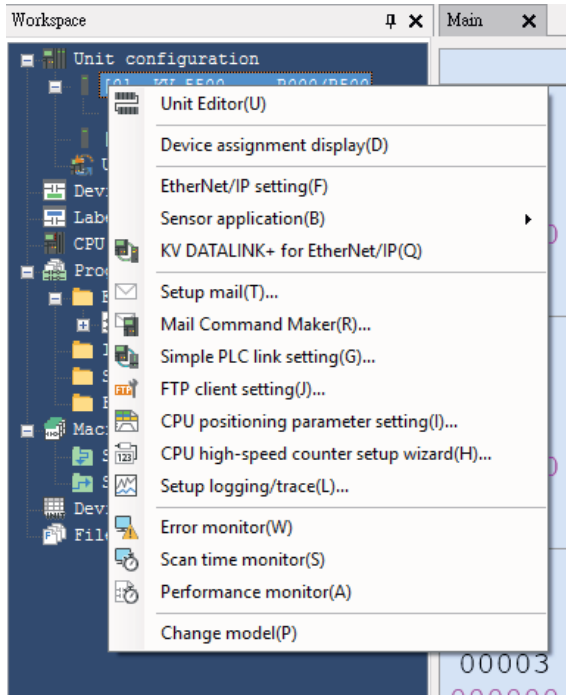

On the right side of the dialog window, the IP address and Port can be changed. When done, close out of the window and select 'Yes' to save the settings.

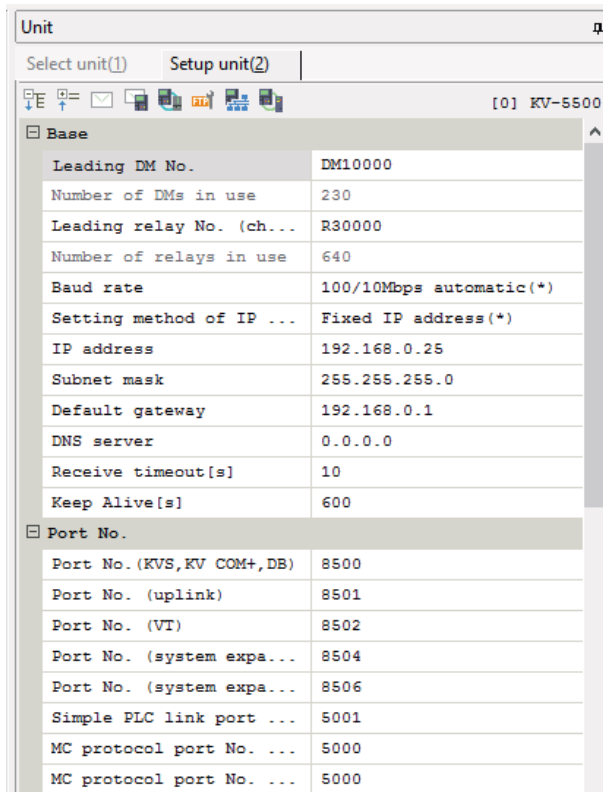

Under **Monitor/Simulator**, select **Transfer to PLC** to download the changes onto the PLC. Confirm the execution of the operation

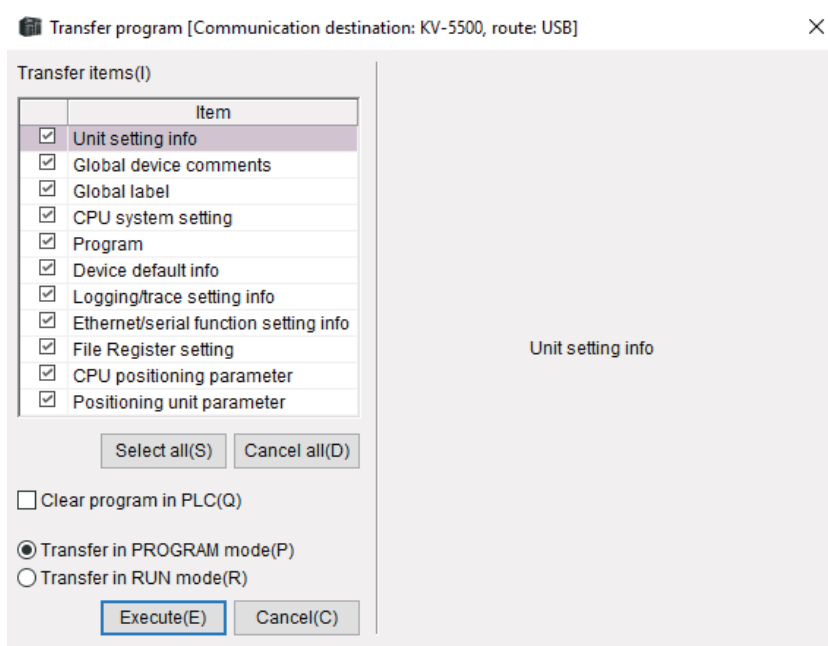
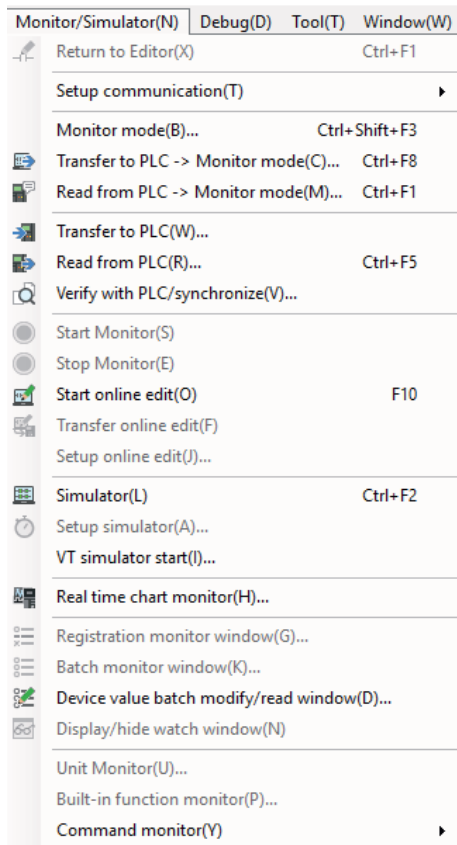

Note: For more detailed information please refer to the PLC manual.

Connecting PLC to HMI

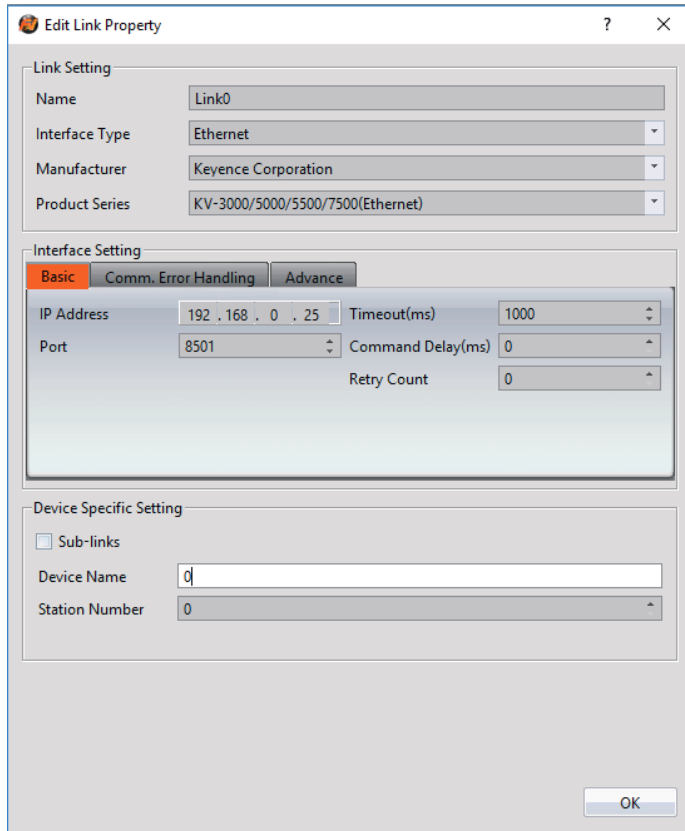

Within the **Link** configuration window in FvDesigner:
 Under **Interface Type** select Ethernet
 Under **Manufacturer** select Keyence Corporation
 Under **Product Series** select KV-3000/5000/5500/7500(Ethernet)
 Set the **IP address** and **Port** to the values configured on the PLC.

2.12.2 KV-L21V/3000/5000/5500 (host link)

2.12.2.1 Communication Setting

Item	Default Setting	Remark
Signal Level	RS232C	
Baud Rate	115200	
Data Length	8	
Stop Bit	1	
Parity	Even	
PLC Station No.	0	
Communication Method	HOST-LINK COMMUNICATION	

2.12.2.2 Memory Resource Review

Device	Description	Data bit	Input format	Min.	Max.
R	Relay	1	DDDdd	0	99915
B	Link relay	1	HHHH	0	7FFF
MR	Internal auxiliary relay	1	DDDDdd	0	399915
LR	Latch relay	1	DDDdd	0	99915
T	Timer	1	DDDD	0	3999
C	Counter	1	DDDD	0	3999
CTC_sts	High-speed counter comparator (contact)	1	D	0	7
CR	Control relay	1	DDdd	0	7915
VB	Work relay	1	HHHH	0	F9FF
DM	Data memory	16	DDDDD	0	65534
EM	Extended data memory	16	DDDDD	0	65534
FM	File register	16	DDDDD	0	32767
ZF	File register	16	DDDDDD	0	524287
W	Link register	16	HHHH	0	7FFFF
TM	Temporary data memory	16	DDD	0	511
CM	Control memory	16	DDDD	0	5999
VM	Work memory	16	DDDDD	0	50999
Z	Index register	32	D	1	12
TC	Timer (current value)	32	DDDD	0	3999
TS	Timer (set value)	32	DDDD	0	3999
CC	Counter (current value)	32	DDDD	0	3999
CS	Counter (set value)	32	DDDD	0	3999
CTH	High-speed counter (current value)	32	D	0	3
CTC	High-speed counter comparator (set	32	D	0	7

	value)				
TRM	Digital trimmer	32	D	0	7

2.12.2.3 Connecting to HMI

Configuring the PLC

Use the application **KV Studio** to configure the serial connection of the PLC.

Select the connection between the PLC and the computer. A USB connection was used in this case.

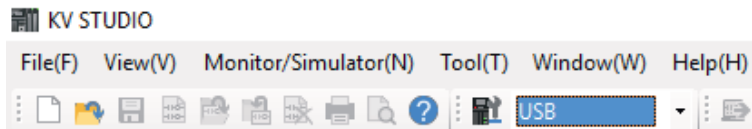

Under the **Monitor/Simulator** menu option, select **Read from PLC** and execute the operation.

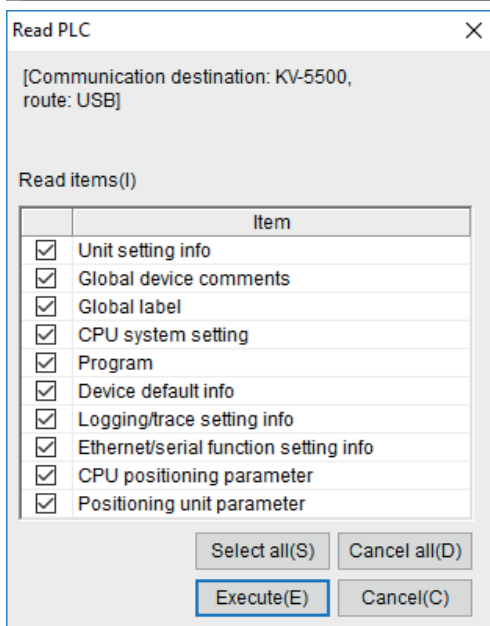
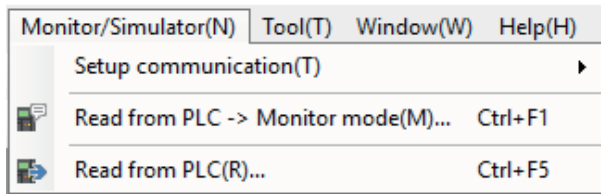

In the Workspace, right click the PLC model name and select **Unit Editor**.

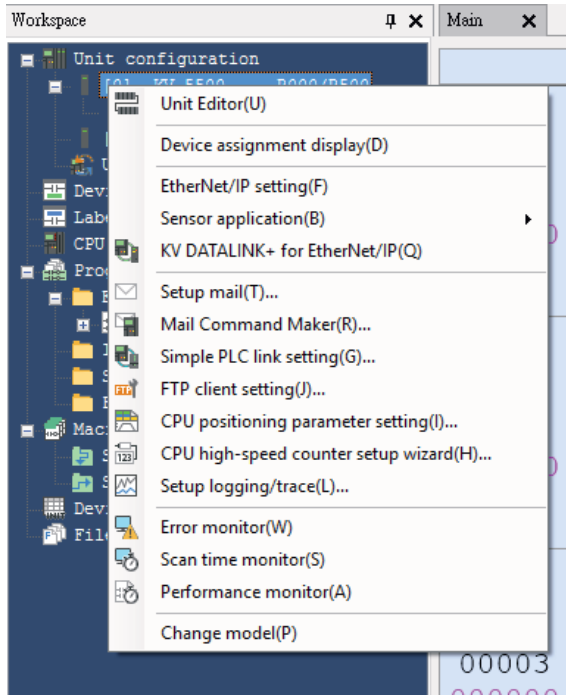

On the right side of the dialog window, verify the baud rate is **115200bps**. Close out of the window and select 'Yes' to save the settings.

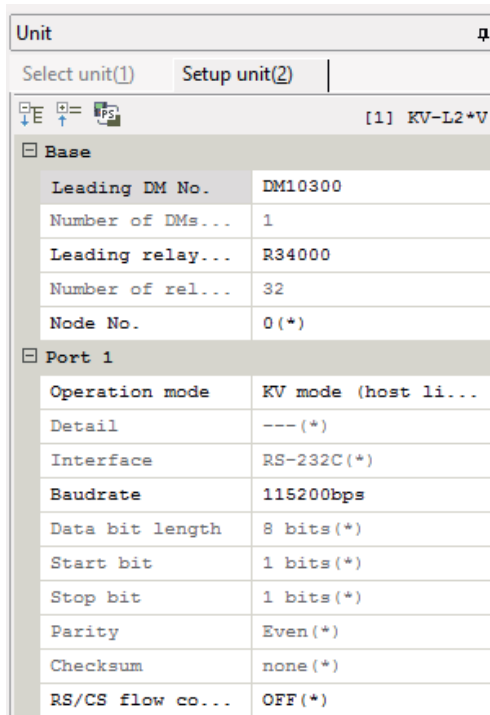

Under **Monitor/Simulator**, select **Transfer to PLC** to download the changes onto the PLC. Confirm the execution of the operation

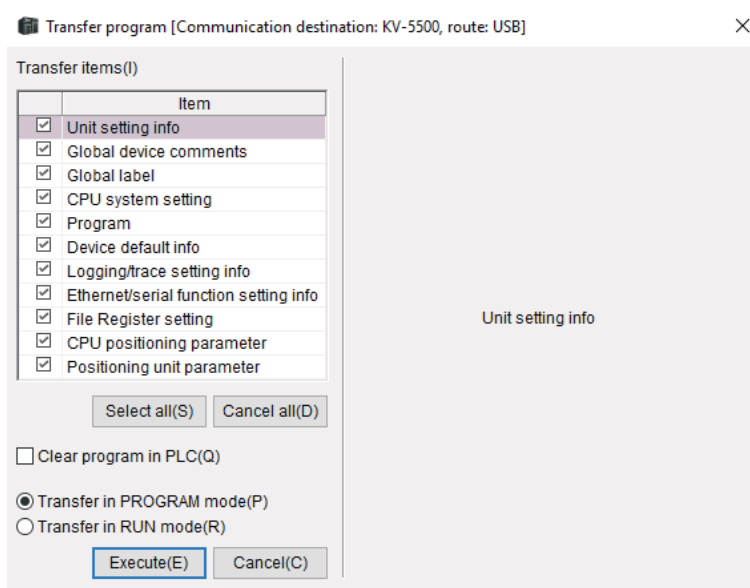
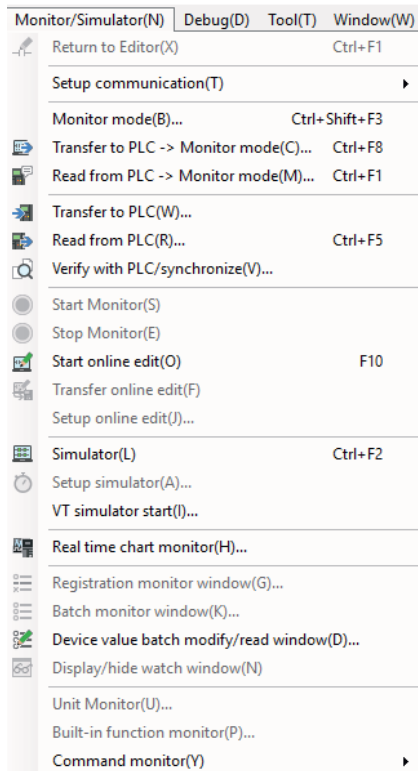

Note: Port 2 of the PLC can also be configured following the steps above. The parameters for Port 2 are under the parameters for Port 1 in the dialog window.

Note: For more detailed information please refer to the PLC manual.

Connecting PLC to HMI

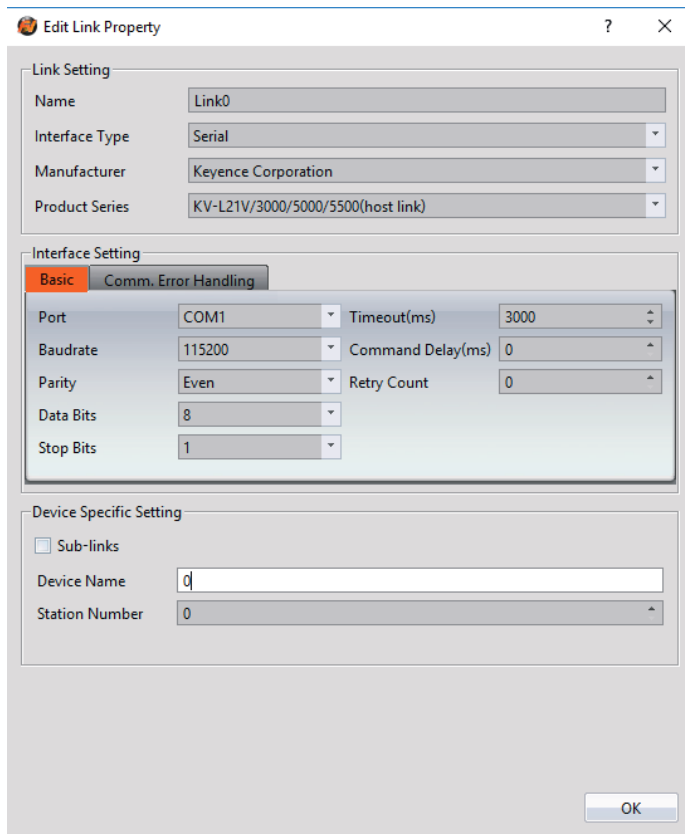

Within the **Link** configuration window in FvDesigner:

Under Interface Type select Serial

Under **Manufacturer** select Keyence Corporation

Under **Product Series** select KV-L21V/3000/5000/5500(host link)

Under **Port** select required COM port. Verify the baud rate is the same as the value set on the PLC.

2.12.2.4 Wiring Diagrams

Using Port 1

PLC RS232 Port (PORT1)

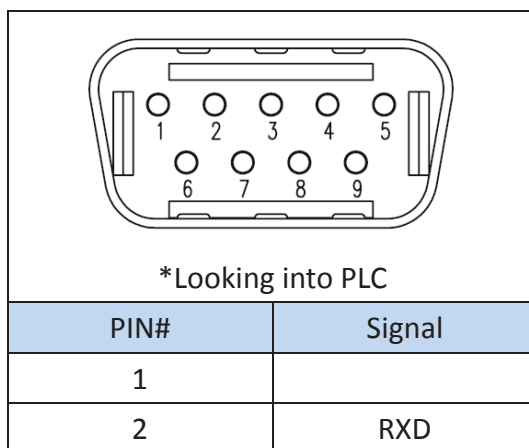

3	TXD
4	
5	GND
6	
7	
8	
9	

HMI COM1 Pinout

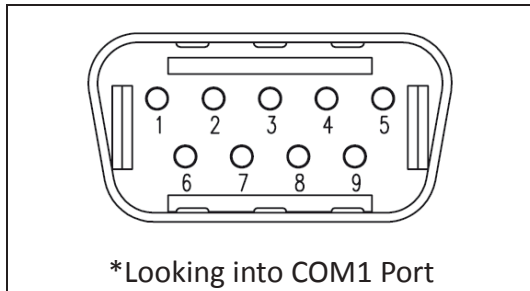

*Looking into COM1 Port

PIN#	COM1 (RS232)
1	
2	RX
3	TX
4	
5	GND
6	
7	RTS
8	CTS
9	

All P5 and P2K Series

HMI COM1	PLC RS232 Port
2 RX	3 TXD
3 TX	2 RXD
5 GND	5 GND

Wiring Diagrams: All P5 and P2K Series

HMI COM1

PLC RS232

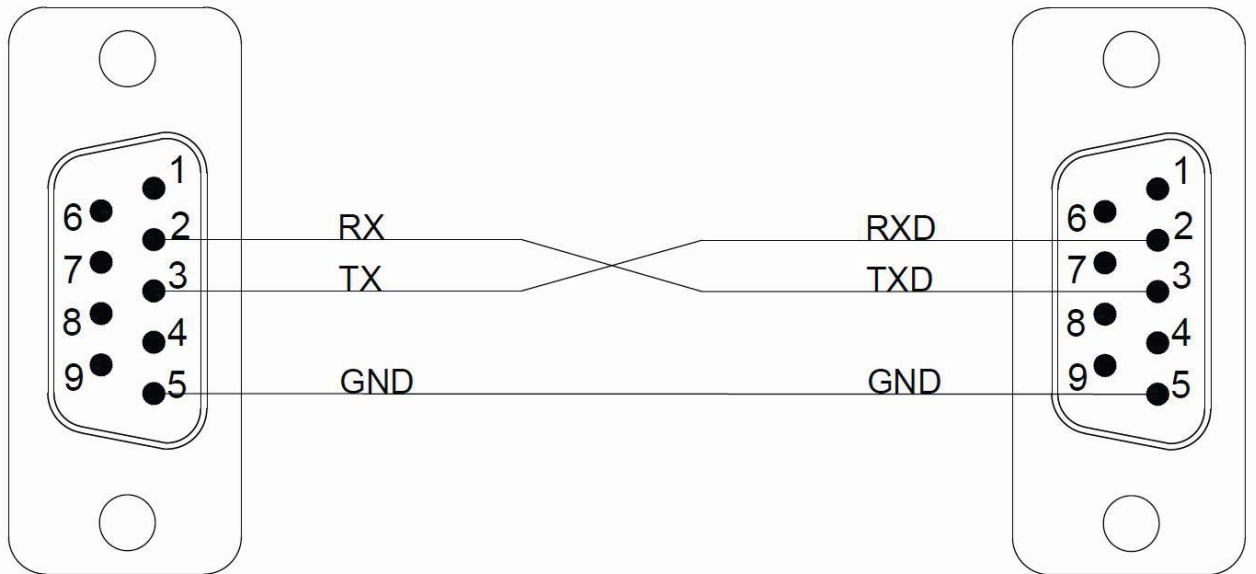

Using Port 2

HMI COM3 Pinout



*Looking into HMI Device

PIN#	COM3 (RS-422/RS-485)
1	
2	
3	ISO_GND
4	RX+
5	RX-
6	TX+
7	TX-

PLC RS485 Port (PORT2)

1	3	5
SG	SDA(-)	SDB(+)
	2	4

	RDA(-)	RDB(+)	
--	--------	--------	--

P5070S/P5070N/P5070N1/P5102N/P5102N1

HMI COM3	PLC RS485 Port
5 RX-	3 SDA(-)
4 RX+	5 SDB(+)
7 TX-	2 RDA(-)
6 TX+	4 RDA(+)
3 ISO_GND	1 SG

Wiring Diagrams:P5070S/P5070N/P5070N1/P5102N/P5102N1

HMI COM3

PLC RS485

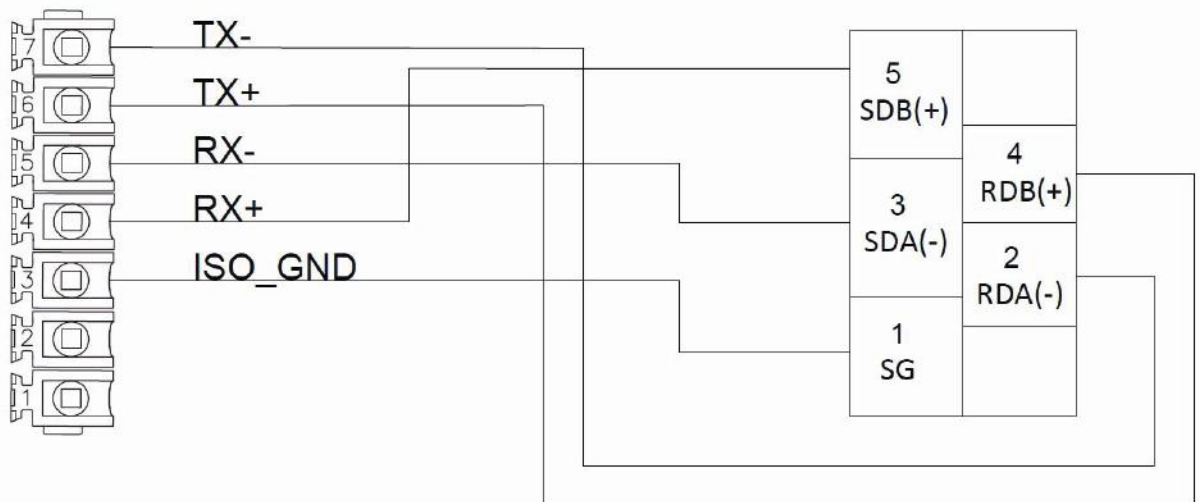

P5043S/P5043N/P5070VS/P5102VS/P2K SERIES

HMI COM2	PLC RS485 Port
9 RX-	3 SDA(-)
4 RX+	5 SDB(+)
6 TX-	2 RDA(-)
1 TX+	4 RDA(+)
5 GND	1 SG

Wiring Diagrams:P5043S/P5043N/P5070VS/P5102VS/P2K SERIES

HMI COM2

PLC RS485

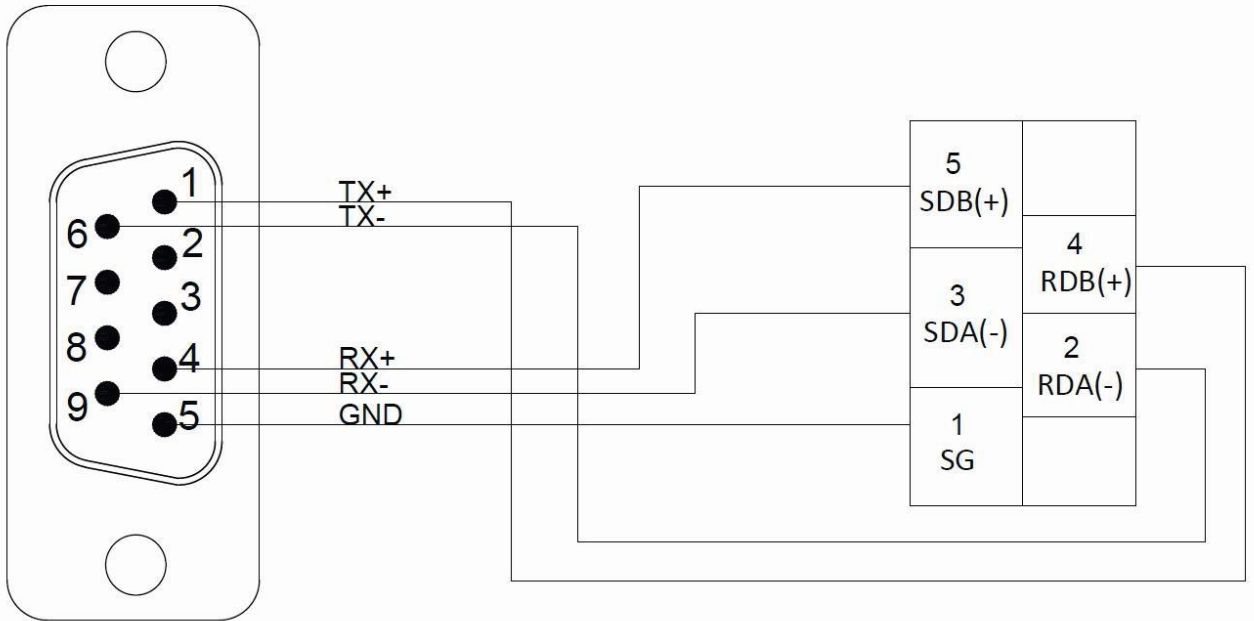

2.12.3 KV-Nano (host link)

2.12.3.1 Communication Setting

Item	Default Setting	Remark
Signal Level	RS232C	OP-26486
Baud Rate	115200	
Data Length	8	
Stop Bit	1	
Parity	Even	
PLC Station No.	0	
Communication Method	HOST-LINK COMMUNICATION	

2.12.3.2 Memory Resource Review

Device	Description	Data bit	Input format	Min.	Max.
R	Relay	1	DDDdd	0	59915
B	Link relay	1	HHHH	0	1FFF
MR	Internal auxiliary relay	1	DDDDdd	0	59915
LR	Latch relay	1	DDDdd	0	19915

T	Timer	1	DDDD	0	511
C	Counter	1	DDDD	0	255
CTC_sts	High-speed counter comparator (contact)	1	D	0	7
CR	Control relay	1	DDdd	0	8915
VB	Work relay	1	HHHH	0	1FFF
DM	Data memory	16	DDDDD	0	32767
W	Link register	16	HHHH	0	3FFF
TM	Temporary data memory	16	DDD	0	511
CM	Control memory	16	DDDD	0	8999
VM	Work memory	16	DDDDD	0	9999
Z	Index register	32	D	1	12
TC	Timer (current value)	32	DDDD	0	511
TS	Timer (set value)	32	DDDD	0	511
CC	Counter (current value)	32	DDDD	0	255
CS	Counter (set value)	32	DDDD	0	255
CTH	High-speed counter (current value)	32	D	0	3
CTC	High-speed counter comparator (set value)	32	D	0	7

2.12.3.3 Connecting to HMI

Configuring the PLC

Use the software KV Studio (ver. 9.02) to configure the PLC.

Right click the device in **Unit configuration** and select Unit Editor.

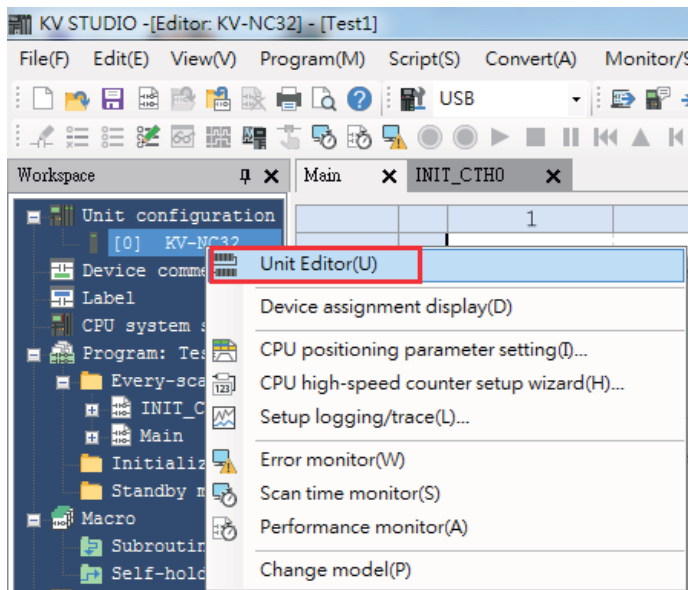

Choose **KV mode (Host Link)** and set the Baud rate to 115200.

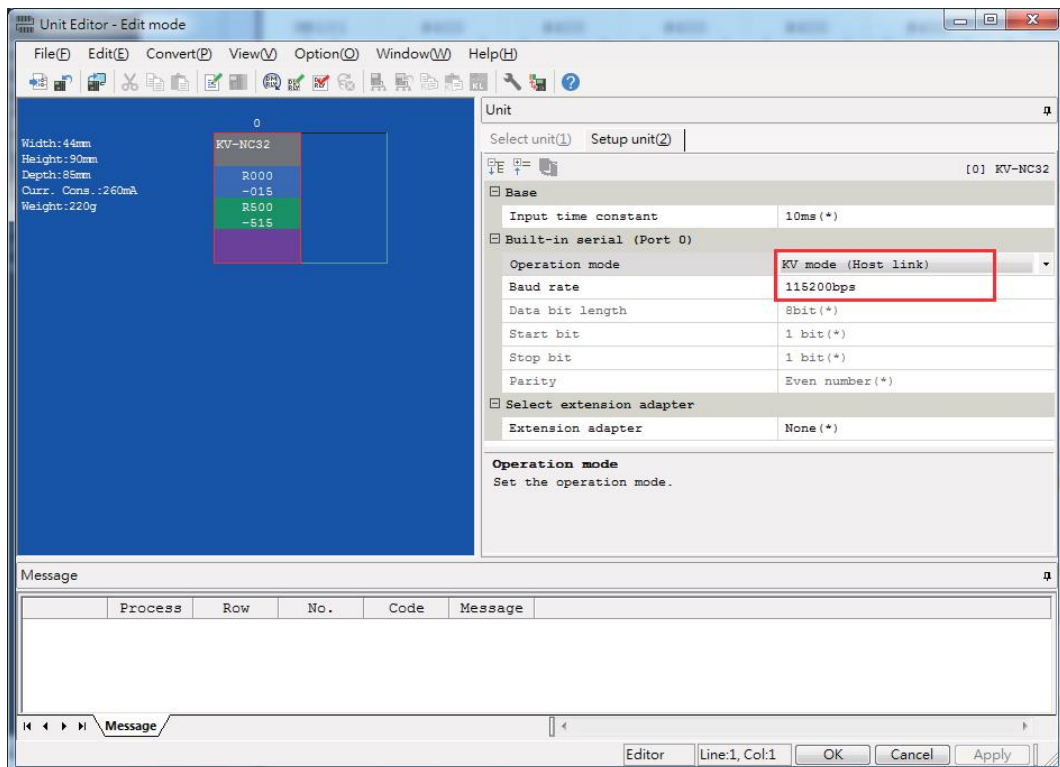

Download the settings back onto the PLC and reset it.

Required register ranges

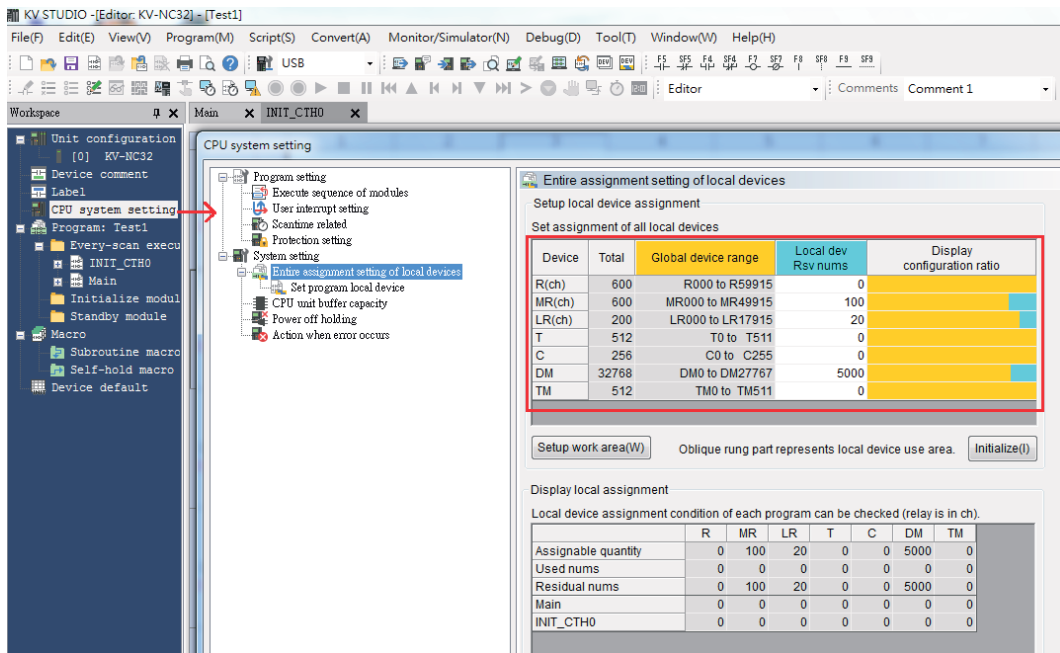

Note: For more detailed information please refer to the PLC manual.

Connecting PLC to HMI

Link settings screen to connect PLC to HMI

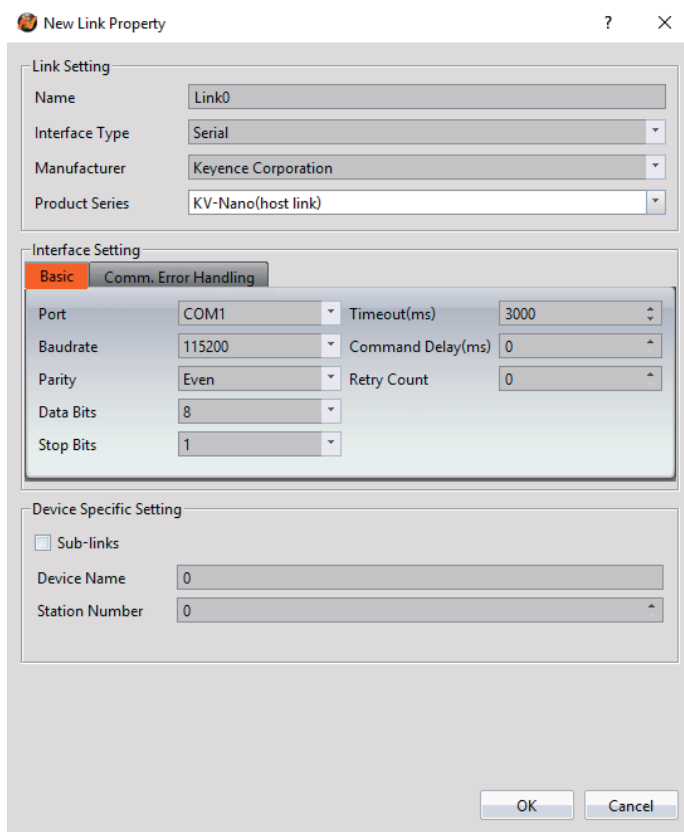

2.12.3.4 Wiring Diagrams

Port 1: RS232

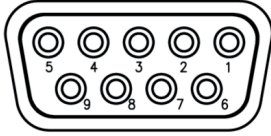
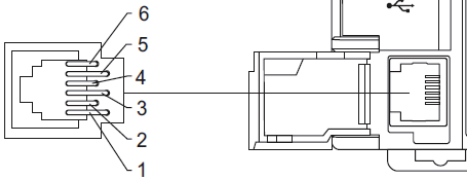
	HMI		PLC	
Serial Interface	COM1 RS-232 9 pin D-SUB Female		RS232 6 pin	
				
	PIN#	Signal	PIN#	Signal
	2	RX	5	SD
	3	TX	3	RD
	5	GND	4	SG

Wiring Diagrams:Port 1: RS232

HMI COM1

PLC RS232

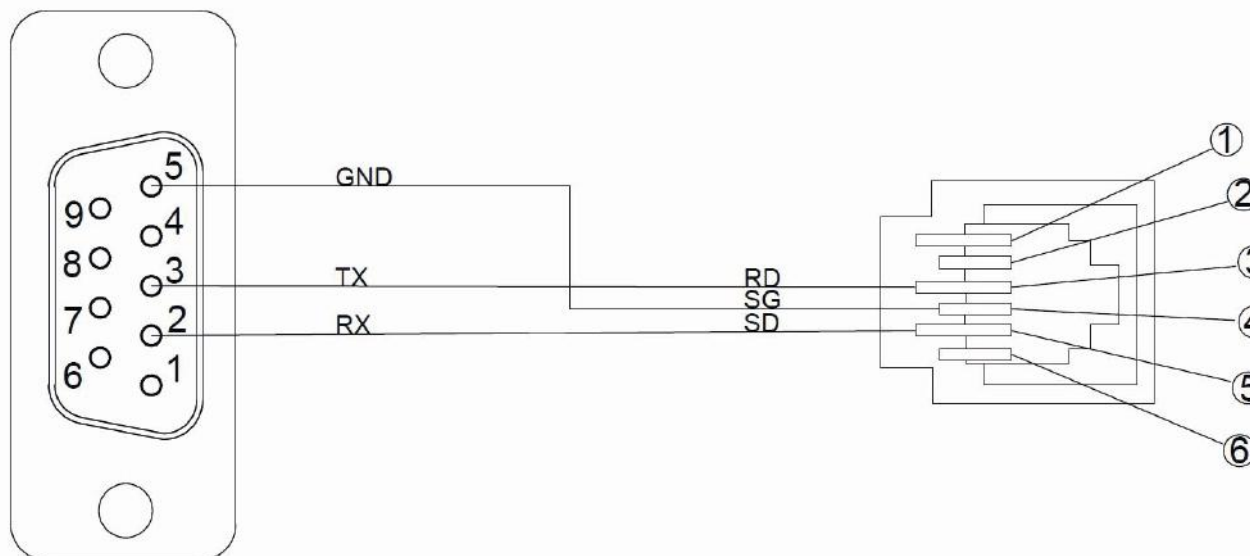

2.13 Beckhoff Automation

2.13.1 Twincat(Ethernet)

2.13.1.1 Communication Setting

Item	Default Setting	Remark
Signal Level	Ethernet	

IP	192.168.1.100	
Port	801	
PLC Station No.	1	
Communication Method	ADS	

2.13.1.2 Memory Resource Review

Device	Description	Data Bits	Address Format	Min.	Max.
IX	Input	1	DDDDD.O	0.0	27484.7
QX	Output	1	DDDDD.O	0.0	27484.7
MX	Bit Memory	1	DDDDD.O	0.0	27484.7
IW		16	DDDDD	0	65534
QW		16	DDDDD	0	65534
MW		16	DDDDD	0	65534
ID		32	DDDDD	0	65532
QD		32	DDDDD	0	65532
MD		32	DDDDD	0	65532

2.13.1.3 Connecting to PLC

Configuring the PLC

1. Set IP-Address connected with PC.

Open **TwinCAT System Control** , setting IP-Address of plc in TwinCAT System Properties

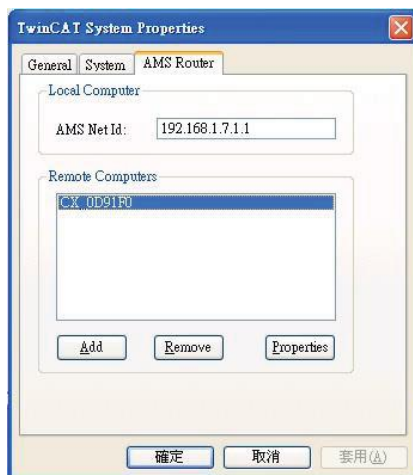

Open **TwinCAT system manager** build Route Table to ensure whether connecting success, if reopen plc, need to execute these steps.

Note: when connecting success, display''x''

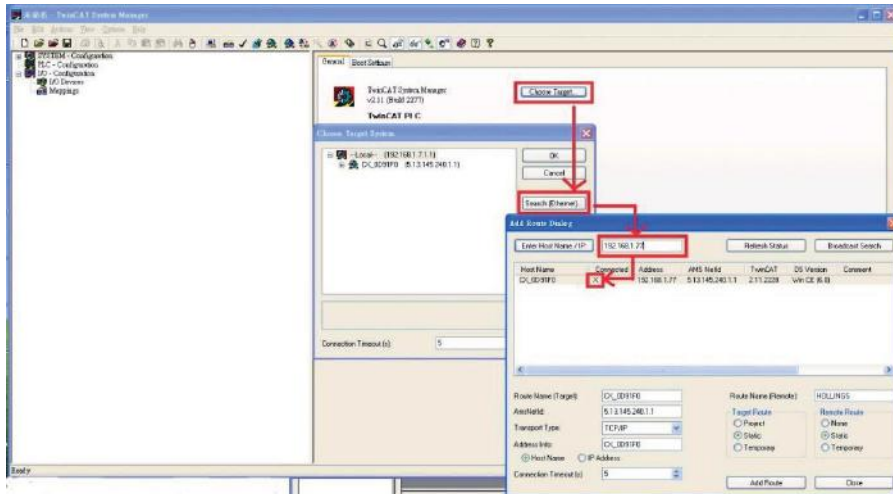

2. Use **CERHOST** to connect with plc, enter IP and Password of plc.

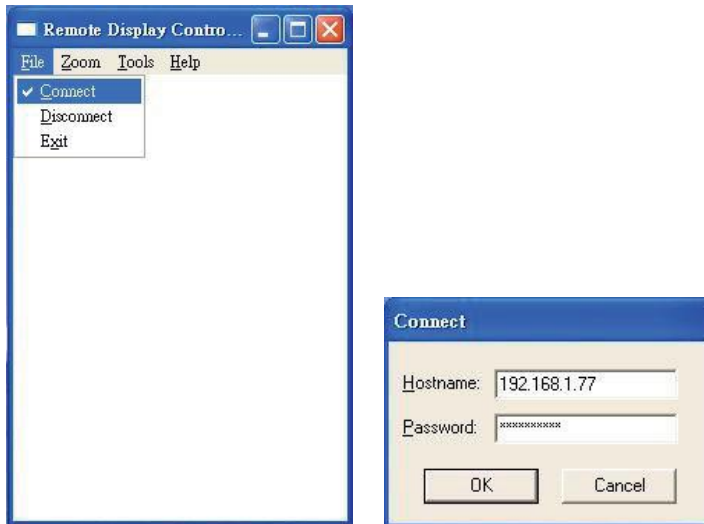

After connecting success with plc, click start → control panel

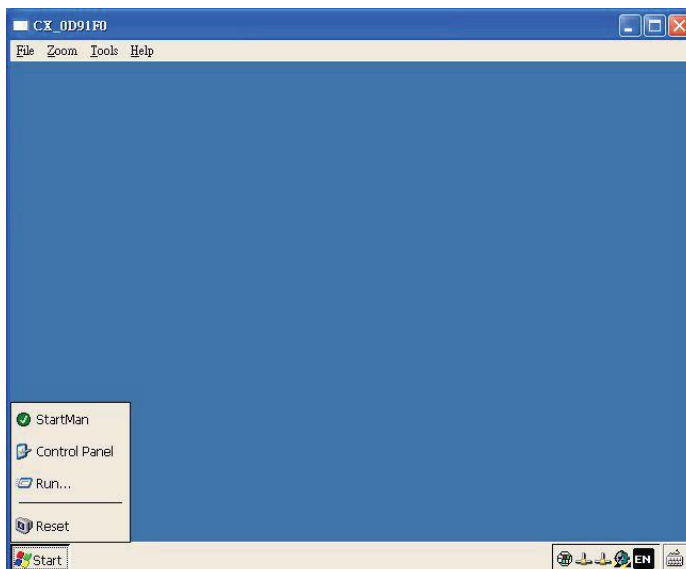

Click Network and Dial-up Connections, display information of plc, click plc to ensure the IP.

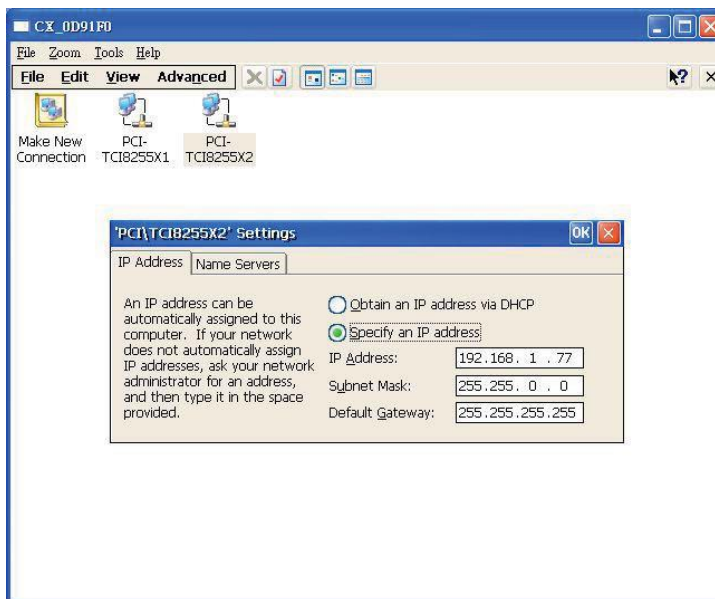
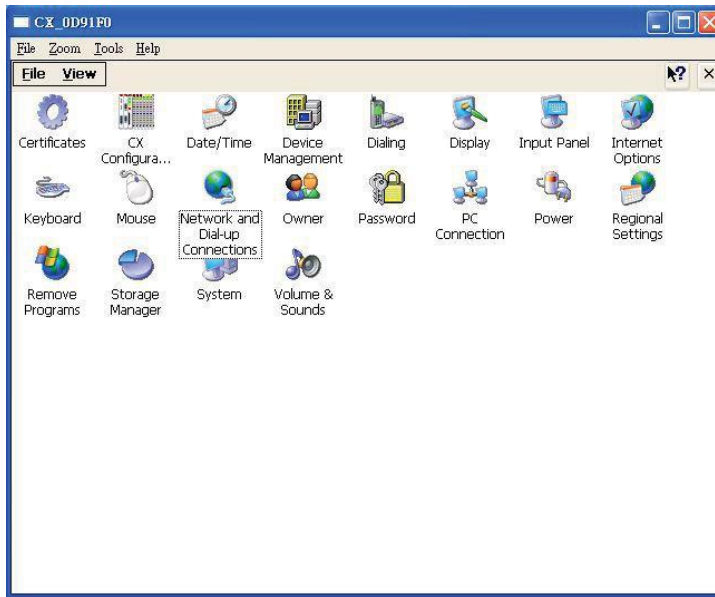

Note: For more detailed information please refer to the PLC manual.

Connecting PLC to HMI

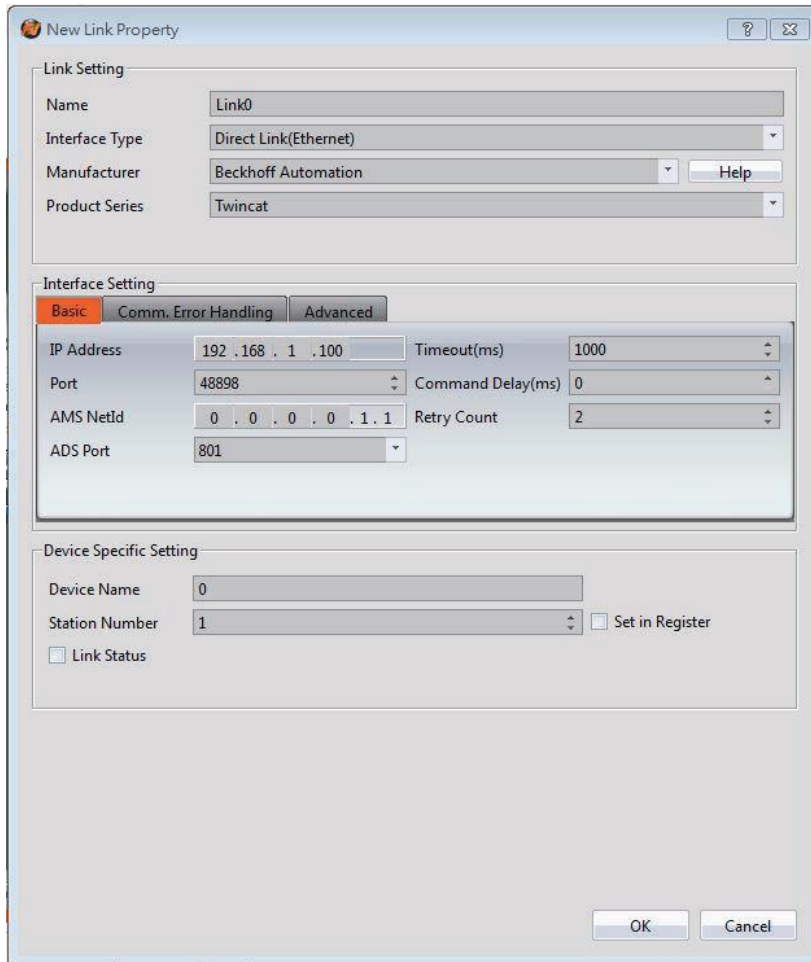

Within the **Link** configuration window in FvDesigner:

Under **Interface Type** select Serial

Under **Manufacturer** select FATEK Automation Corp.

Under **Product Series** select FATEK FBe

Under **Port** select the port corresponding to the connection to the PLC

Verify the other parameters are consistent with the settings on the PLC

2.14 Koyo

2.14.1 Direct

2.14.1.1 Communication Setting

Item	Default Setting	Remark
Signal Level	RS232	
Baud Rate	9600	or 19200,38400
Data Length	8	

Stop Bit	1	
Parity	Odd	or even, no
PLC Station No.	1	1-90 DirectNET, K sequence 1-247 Modbus RTU
Communication Method	K sequence (slave), DirectNET (master/slave), Modbus	

2.14.1.2 Memory Resource Review

Device	Data bit	Data format	Max.	Min.	Description
GX	1	0000	3777	0	Global Input Bits
GY	1	0000	3777	0	Global Output Bits
X	1	0000	1777	0	Input Bits
Y	1	0000	1777	0	Output Bits
C	1	0000	3777	0	Control Relays
S	1	0000	1777	0	Stage Status Bits
T	1	000	377	0	Timer Status Bits
CT	1	000	777	0	Counter Status Bits
SP	1	0000	1777	0	System Status Bits
V	16	00000	77777	0	V Memory

2.14.1.3 Connecting to HMI

Configuring the PLC

1. open **DSL** launch 5, click Applications → DirectSOFT 5 Programming on the left side.

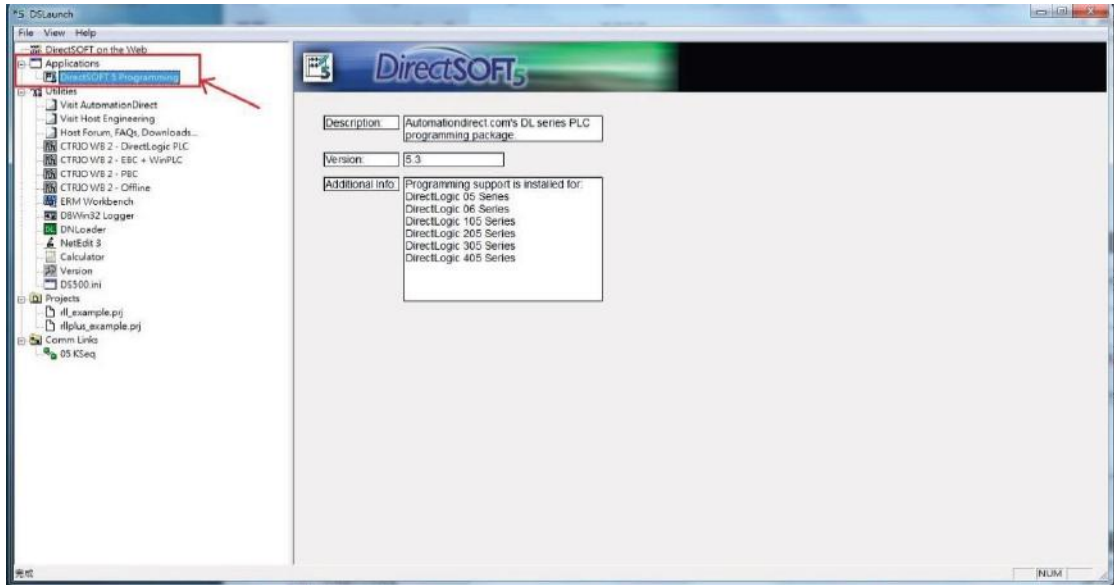

2. choose model and build project.

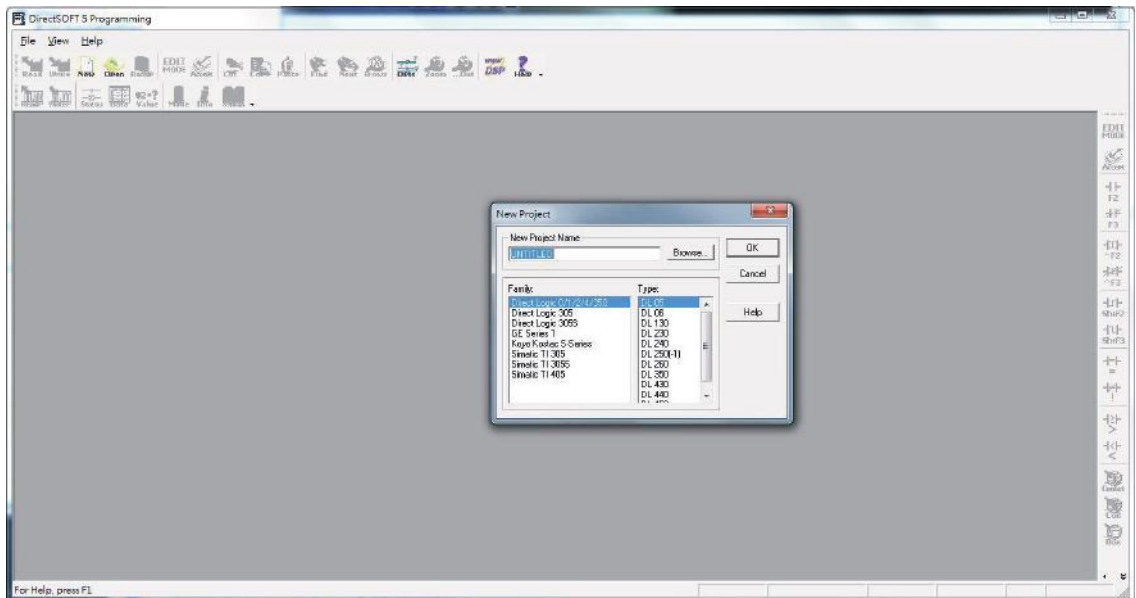

click PLC on the top, select "connect" to connect.

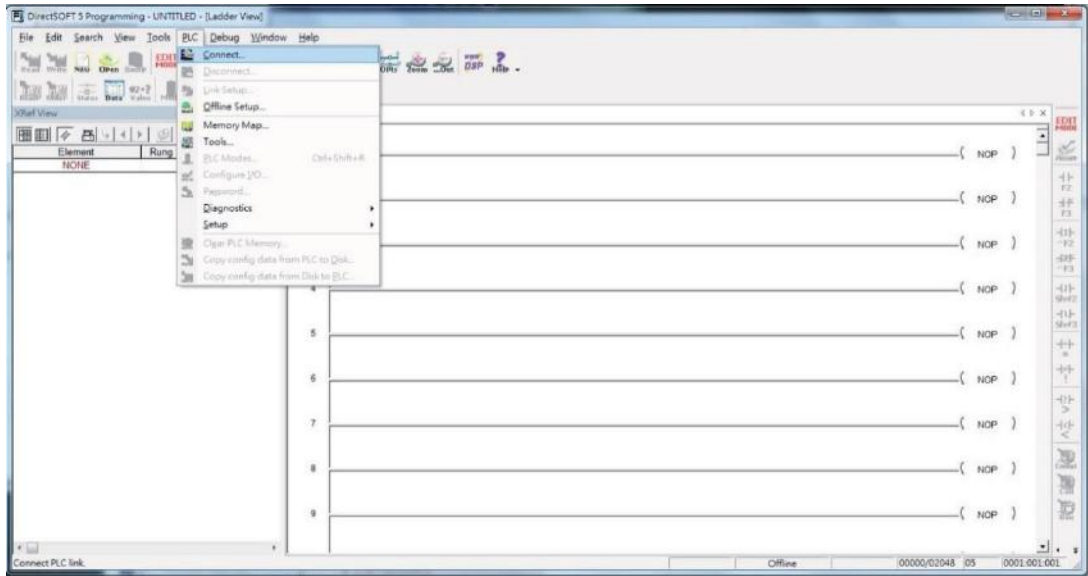

connect success, as shown below.

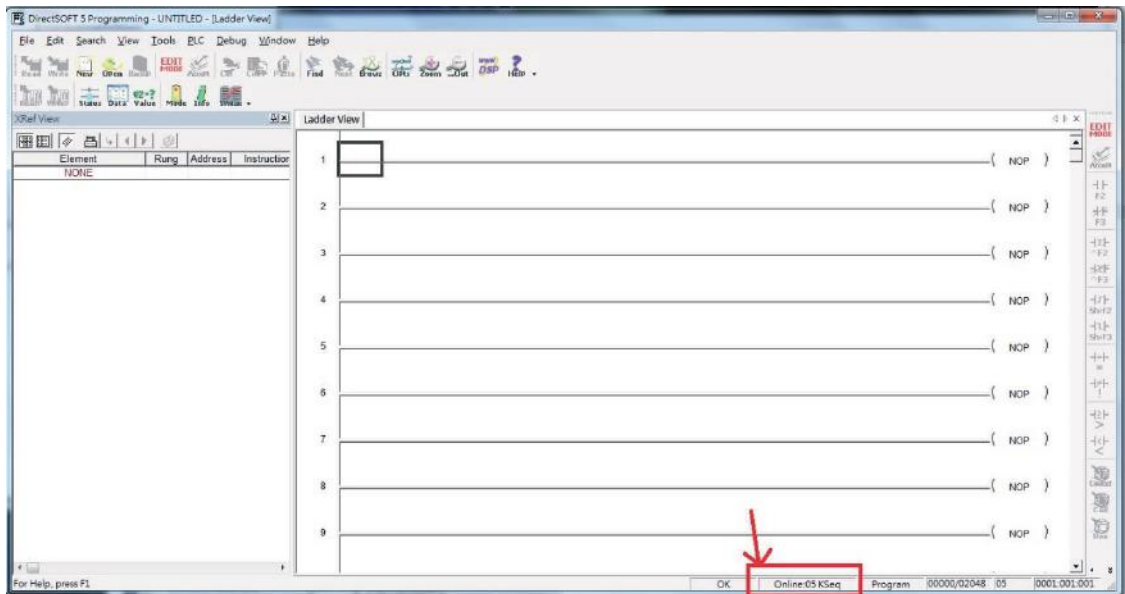

HMI Setting

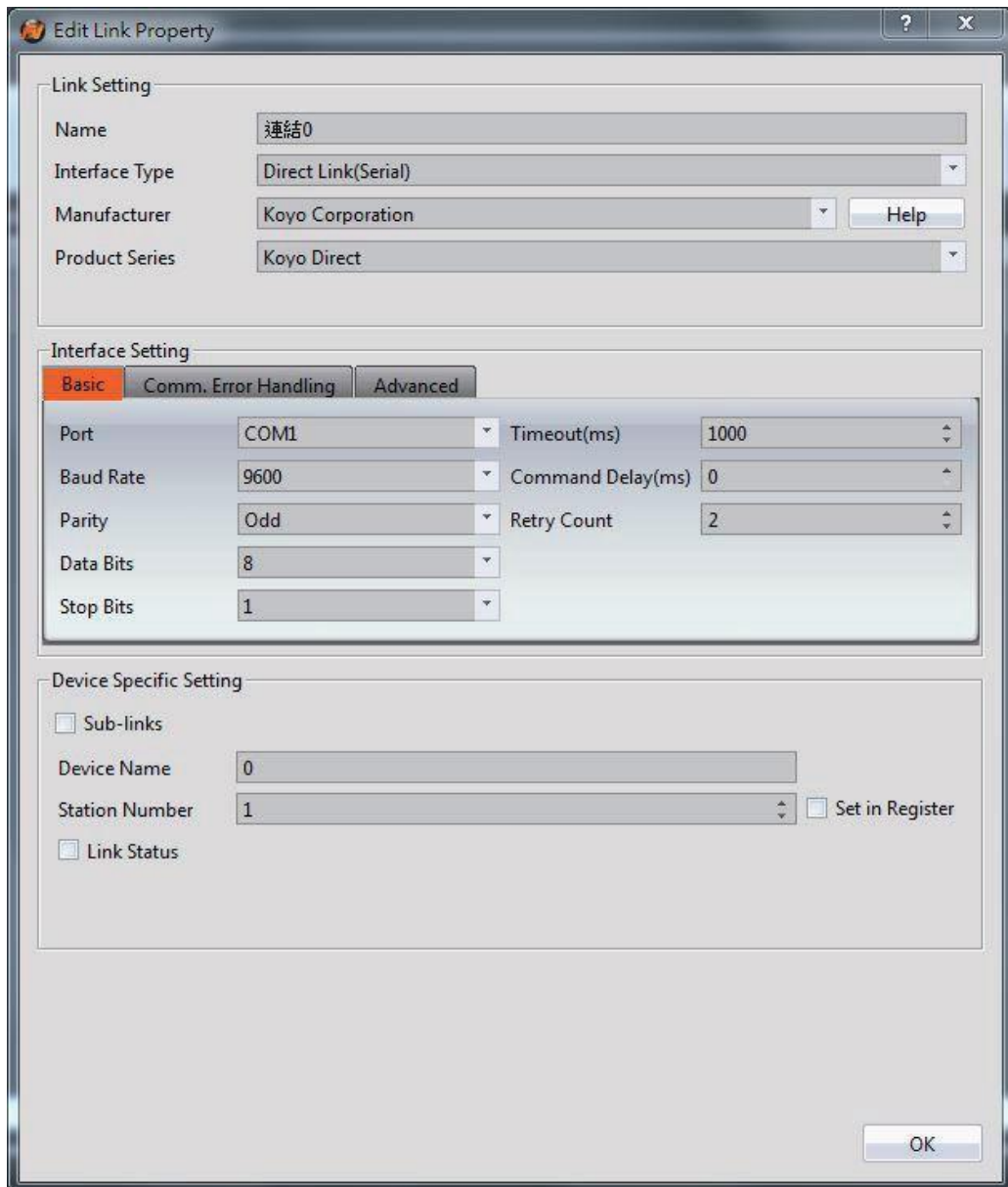

Within the **Link** configuration window in FvDesigner:

Under Interface Type select Serial

Under **Manufacturer** select Koyo Corporation

Under **Product Series** select Koyo Direct

Under **Port** select required COM port. Verify the baud rate is the same as the value set on the PLC.

2.14.1.4 Wiring Diagrams

PLC RS232 Pinout

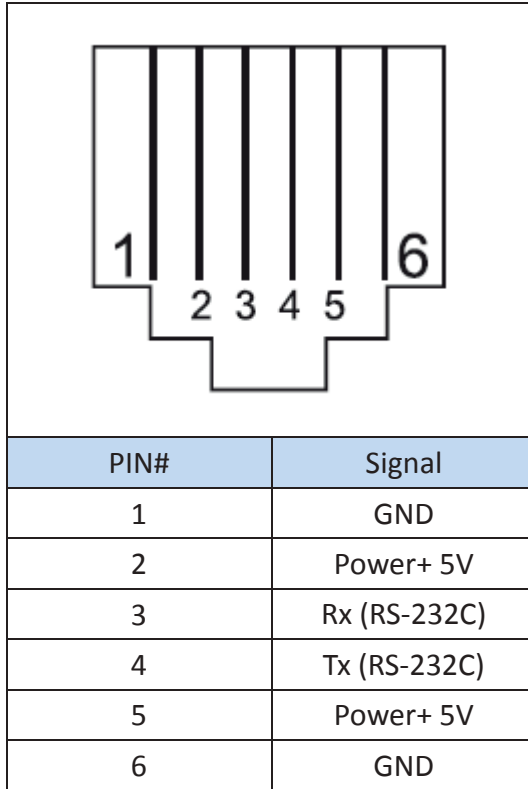

HMI COM1 Pinout

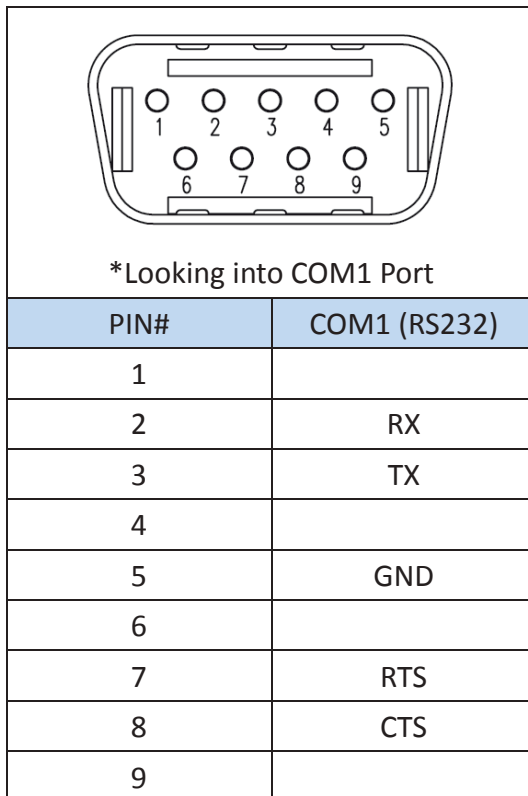

All P5 and P2K Series

HMI COM1	PLC Port
----------	----------

2 RX	4 Tx (RS-232C)
3 TX	3 Rx (RS-232C)
5 GND	1 GND

Wiring Diagrams: All P5 and P2K Series

HMI COM1

PLC RS232

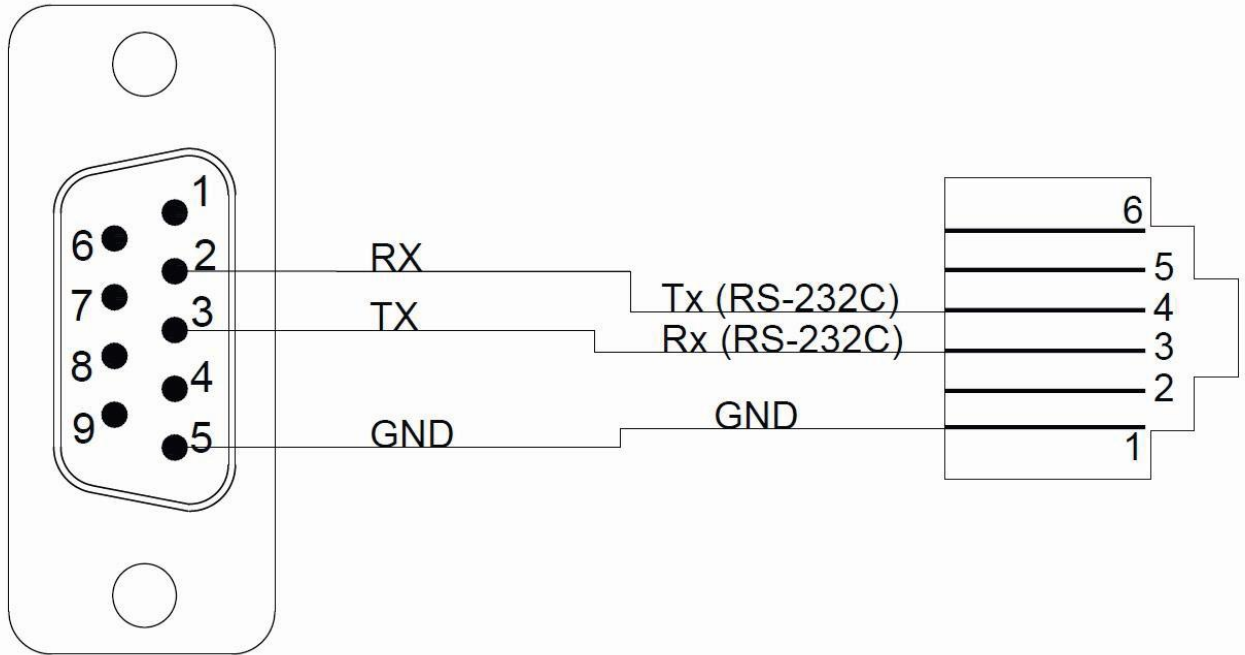

2.15 Yudian

2.15.1 AI

2.15.1.1 Communication Setting

Item	Default Setting	Remark
Signal Level	RS232/RS485	
Baud Rate	9600	or 4800,19200
Data Length	8	
Stop Bit	1	
Parity	NONE	
PLC Station No.	0	
Communication Method	Yudian Communication Protocol	

2.15.1.2 Memory Resource Review

Device	Data bit	Data format	Min.	Min.	Description
Parm	16	HH	0	B4	Parameter
SV	16	D	0	B4	Pre-set Value
PV	16	D	0	0	Measuring Value
MV	16	D	0	0	Manual Output Value
AL	16	D	0	0	Alarm Status

2.15.1.3 Connecting to HMI

Configuring the PLC

Press the control panel button on the device for 2 seconds, then let go of your finger after the "parameter settings" were displayed, the panel will display the parameters in sequence, bAud: communication baud rate, Addr: communication address.

Other detailed settings can refer to Yudian official website

<http://www.yudian.com/>

HMI Setting

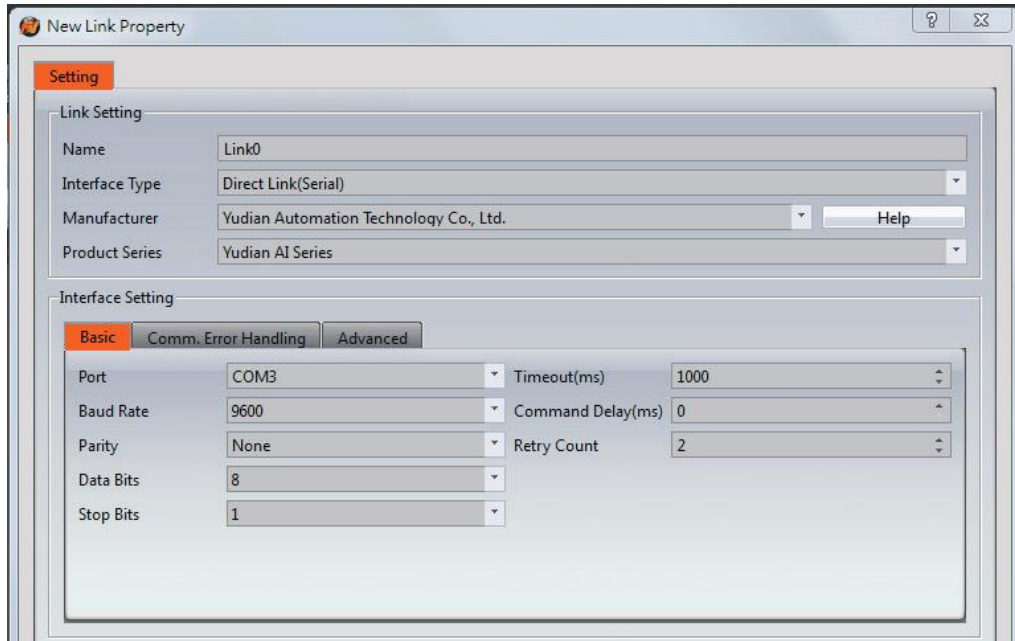

Within the **Link** configuration window in FvDesigner:

Under Interface Type select Serial

Under **Manufacturer** select Yudian Automation Technology Co, Ltd.

Under **Product Series** select Yudian AI Series

Under **Port** select required COM port. Verify the baud rate is the same as the value set on the PLC.

2.15.1.4 Wiring Diagrams

PLC RS485 Pinout

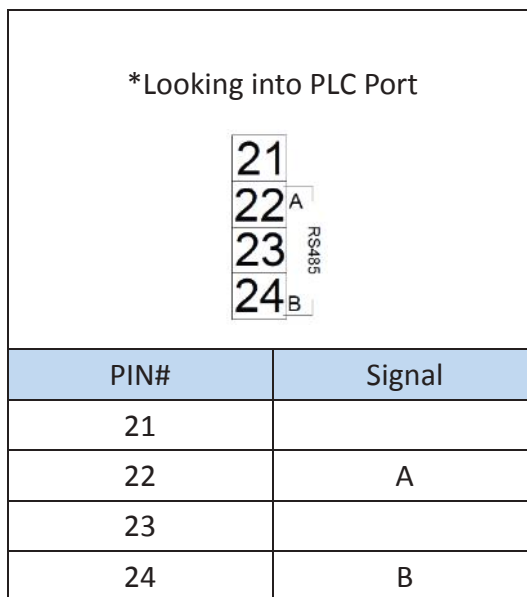

HMI COM3 腳位



*Looking into HMI Device

PIN#	COM3 (RS-422/RS-485)
1	
2	
3	ISO_GND
4	
5	
6	DATA+
7	DATA-

P5070S/P5070N/P5070N1/P5102N/P5102N1

HMI COM3	PLC RS485 Port
6 DTAT+	22 A
7 DATA-	24 B

Wiring Diagrams:P5070S/P5070N/P5070N1/P5102N/P5102N1

HMI COM3

PLC RS485

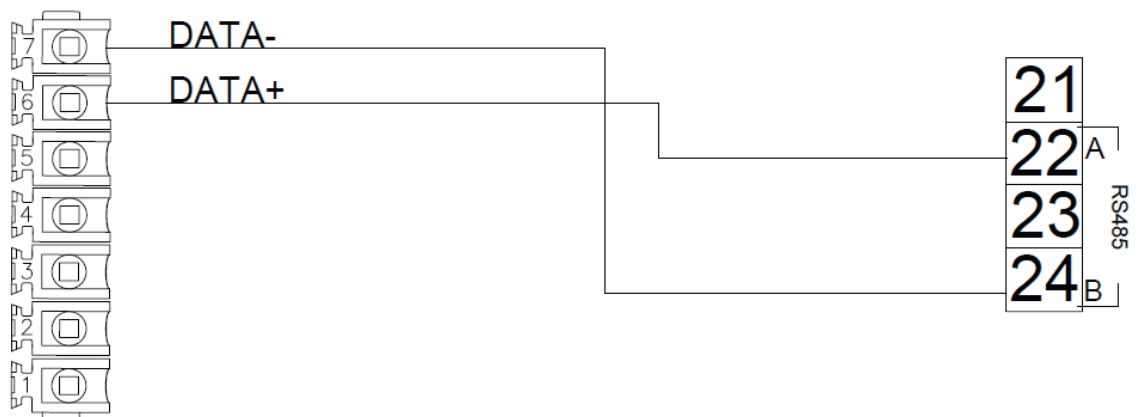

P5043S/P5043N/P5070VS/P5102VS/P2K SERIES

HMI COM2	PLC RS485 Port
1 DATA+	22 A

6 DATA-	24 B
---------	------

Wiring Diagrams:P5043S/P5043N/P5070VS/P5102VS/P2K SERIES

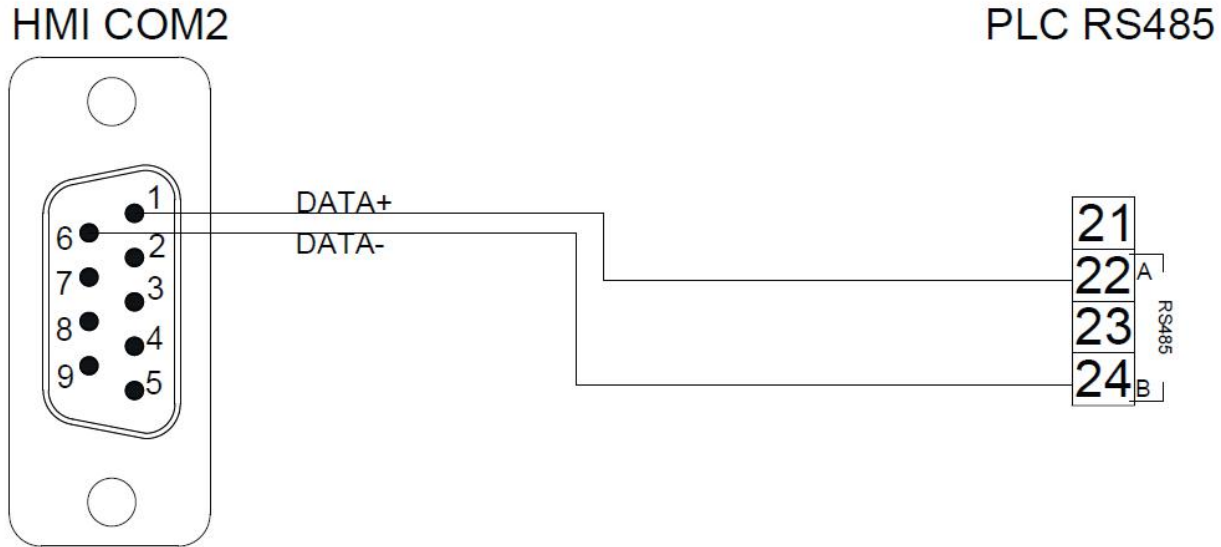

2.16 Xinje

2.16.1 XC series

2.16.1.1 Communication Setting

Item	Default Setting	Remark
Signal Level	RS232	
Baud Rate	19200	
Data Length	8	
Stop Bit	1	
Parity	NONE	
PLC Station No.	0	
Communication Method	HOST-LINK COMMUNICATION	

2.16.1.2 Memory Resource Review

Device	Data bit	Data format	Min.	Min.	Description
M	1	DDDD	0	8511	
X	1	O000	0	1037	
Y	1	O000	0	1037	
S	1	DDDD	0	1023	

T	1	DDD	0	618	
C	1	DDD	0	634	
D	16	DDDD	0	8511	
TD	16	DDD	0	618	
CD	16	DDD	0	634	
FD_1	16	DDDD	0	5000	
FD_2	16	DDDD	8000	8511	

2.16.1.3 Connecting to HMI

PLC Setting

Open XCPPro and use the official DVP cable to connect to the computer RS232 hole, the default will be use COM1 to connect automatically.

(Please do not modify the COM1 connection parameters, this will cause the PLC to be unable to connect to the PC)

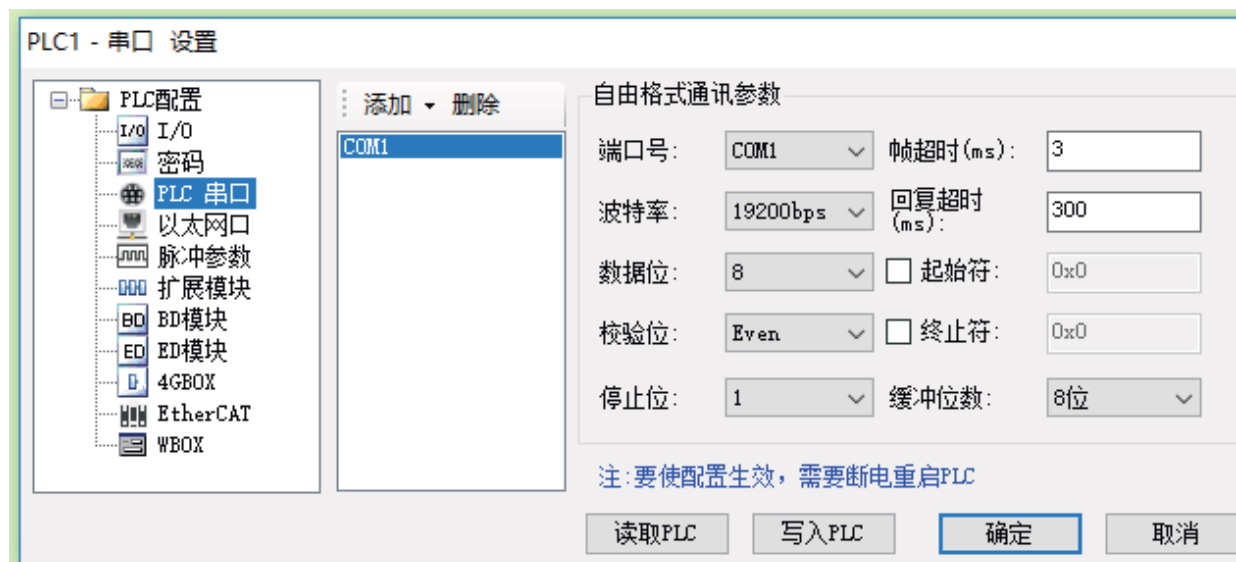

HMI Setting

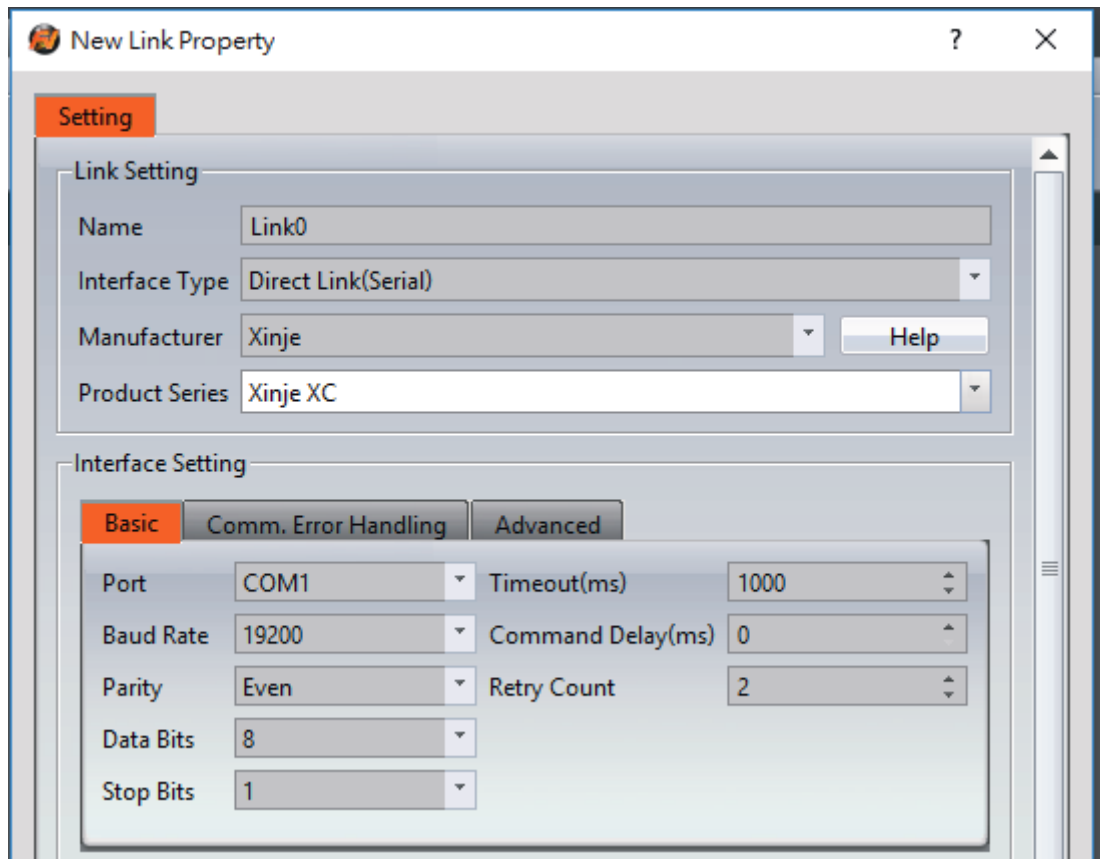

Within the Link configuration window in FvDesigner:

Under Interface Type select Serial

Under Manufacturer select Xinje

Under Product Series select XinjeXC Series

Under Port select required COM port. Verify the baud rate is the same as the value set on the PLC.

2.16.1.4 Wiring Diagrams

HMI COM1 Pinout

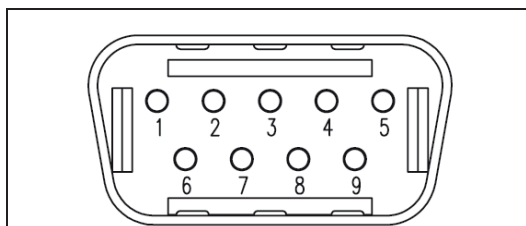

*Looking into COM1 Port

PIN#	COM1 (RS232)
1	
2	RX
3	TX
4	

5	GND
6	
7	
8	
9	

PLC RS232 Pinout

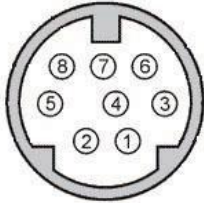
	
*Looking into PLC	
PIN#	Signal
1	
2	GND
3	
4	RXD
5	
6	
7	TXD
8	

All P5 and P2K Series

HMI COM1	PLC RS232 Port
2 RX	7 TXD
3 TX	4 RXD
5 GND	2 GND

Wiring Diagrams: All P5 and P2K Series

HMI COM1

PLC RS232

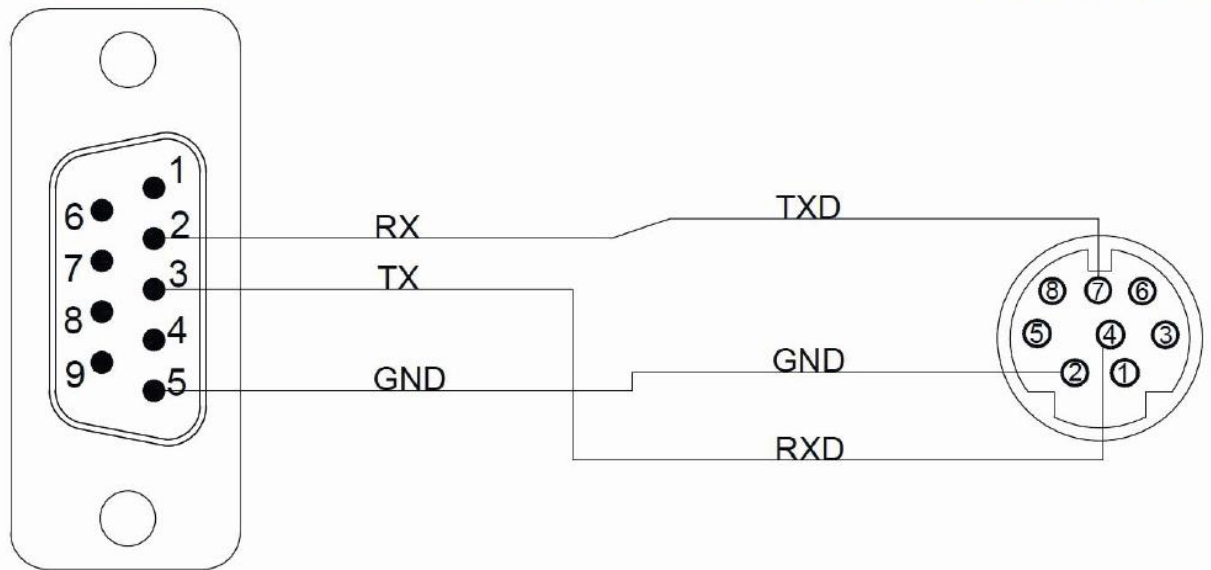

2.16.2 XD series

2.16.2.1 Communication Setting

Item	Default Setting	Remark
Signal Level	RS232	
Baud Rate	19200	
Data Length	8	
Stop Bit	1	
Parity	NONE	
PLC Station No.	0	
Communication Method	HOST-LINK COMMUNICATION	

2.16.2.2 Memory Resource Review

Device	Data bit	Data format	Min.	Min.	Description
M	1	DDDDD	0	20479	
X	1	OO	0	77	
Y	1	DD	0	77	
S	1	DDDD	0	7999	
SM	1	DDDD	0	4095	
T	1	DDDD	0	4095	
C	1	DDDD	0	4095	
ET	1	DD	0	39	
SEM	1	DDD	0	127	

HM	1	DDDD	0	6143	
HS	1	DDD	0	999	
HT	1	DDDD	0	1023	
HC	1	DDDD	0	1023	
HSC	1	DD	0	39	
X_Extension	1	OOOOO	10000	11777	
X_BD	1	OOOOO	20000	20100	
Y_Extension	1	OOOOO	10000	11777	
Y_BD	1	OOOOO	20000	20100	
D	16	DDDDD	0	20479	
ID	16	DD	0	99	
QD	16	DD	0	99	
SD	16	DDDD	0	4095	
TD	16	DDDD	0	4095	
CD	16	DDDD	0	4095	
ETD	16	DD	0	39	
HD	16	DDDD	0	6143	
HSD	16	DDDD	0	1023	
HTD	16	DDDD	0	1023	
HCD	16	DDDD	0	1023	
HSCD	16	DD	0	39	
FD	16	DDDD	0	8191	
SFD	16	DDDD	0	5999	
FS	16	DD	0	49	
ID_Extension	16	DDDDD	10000	11599	
ID_BD	16	DDDDD	20000	20099	
QD_Extension	16	DDDDD	10000	11599	
QD_BD	16	DDDDD	20000	20099	

2.16.2.3 Connecting to HMI

PLC Setting

Open XDPPor and use the official DVP cable to connect to the computer RS232 hole, the default will be use COM1 to connect automatically.

(Please do not modify the COM1 connection parameters, this will cause the PLC to be unable to connect to the PC)

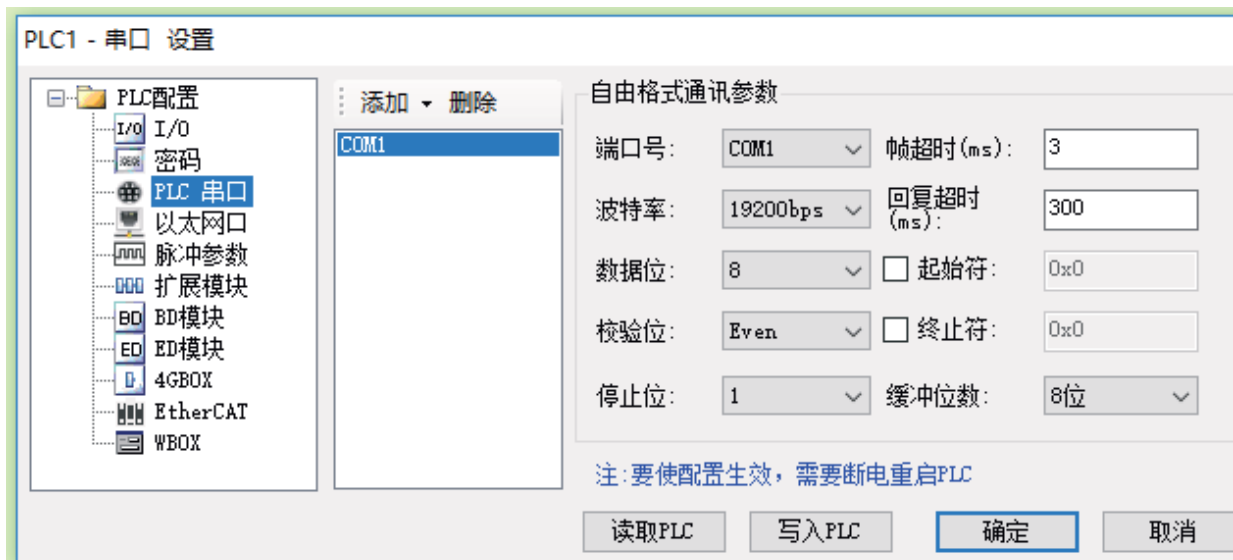

HMI Setting

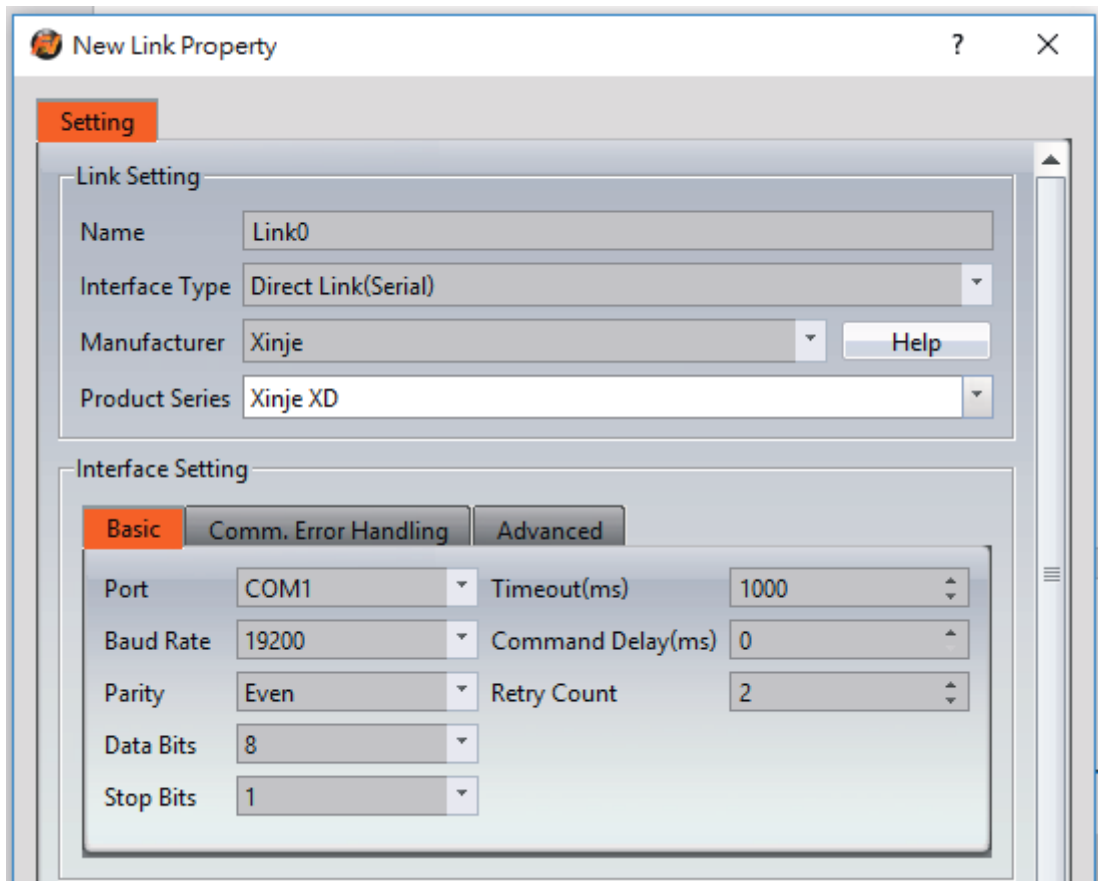

Within the Link configuration window in FvDesigner:

Under Interface Type select Serial

Under Manufacturer select Xinje

Under Product Series select XinjeXD Series

Under Port select required COM port. Verify the baud rate is the same as the value set on the PLC.

2.16.2.4 Wiring Diagrams

HMI COM1 Pinout

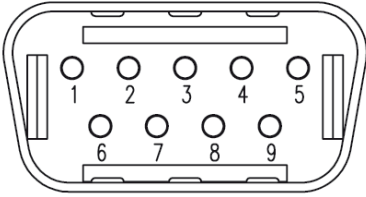

*Looking into COM1 Port

PIN#	COM1 (RS232)
1	
2	RX
3	TX
4	
5	GND
6	
7	
8	
9	

PLC RS232 Pinout



*Looking into PLC

PIN#	Signal
1	
2	GND
3	
4	RXD
5	
6	
7	TXD
8	

All P5 and P2K Series

HMI COM1	PLC RS232 Port
2 RX	7 TXD
3 TX	4 RXD
5 GND	2 GND

Wiring Diagrams: All P5 and P2K Series

HMI COM1

PLC RS232

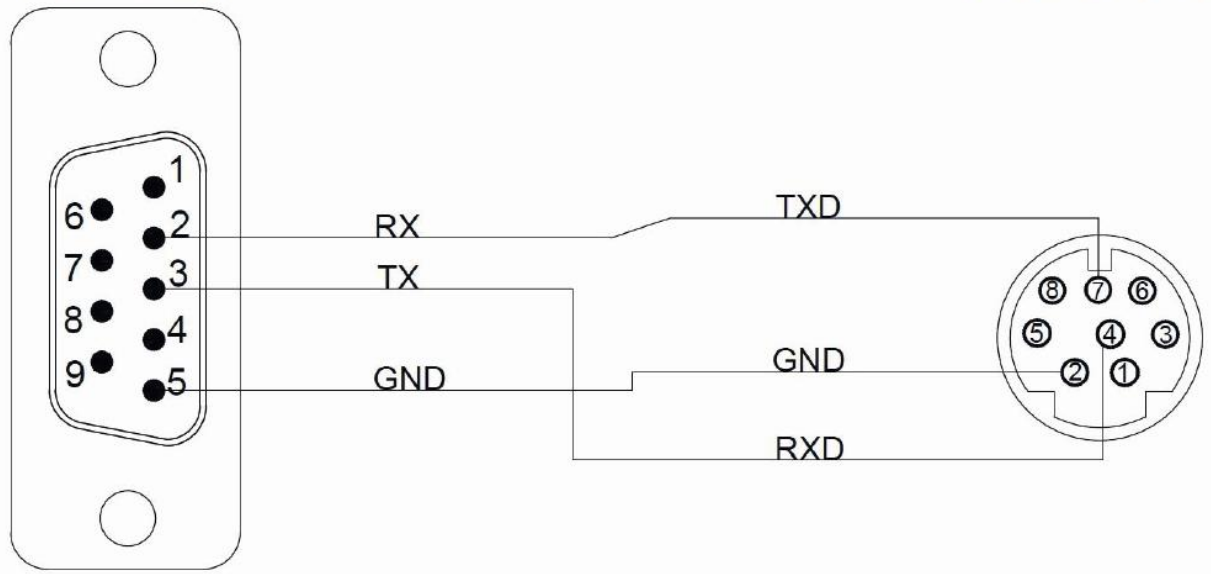

2.17 Vigor

2.17.1 M/VB/VH Series

2.17.1.1 Communication Setting

Item	Default Setting	Remark
Signal Level	RS485 2W	
Baud Rate	19200	
Data Length	8	
Stop Bit	1	
Parity	Even	
PLC Station No.	0	
Communication Method	Vigor M/VB/VH protocol	

2.17.1.2 Memory Resource Review

Device	Data bit	Data format	Min.	Min.	Description
X	1	OOO	0	777	External input relay
Y	1	OOO	0	777	External output relay
M	1	DDDD	0	7999	Internal relay
S	1	DDD	0	999	Step relay
SM	1	DDDD	9000	9255	Special relay
TC	1	DDD	0	255	Timer coil
CC	1	DDD	0	255	Counter coil
TS	1	DDD	0	255	Timer contact
CS	1	DDD	0	255	Counter contact
D	16	DDDD	0	8999	D data register
SD	16	DDD	9000	9255	Special data register
T	16	DDD	0	255	Timer
C	16	DDD	0	199	16 bits counter
CL	16	DDD	200	255	32 bits counter

2.17.1.3 Connecting to HMI

PLC Setting

Open Ladder Master and use the Vigor VBUSB-200 cable to connect to the computer USB port, it will automatically connect.

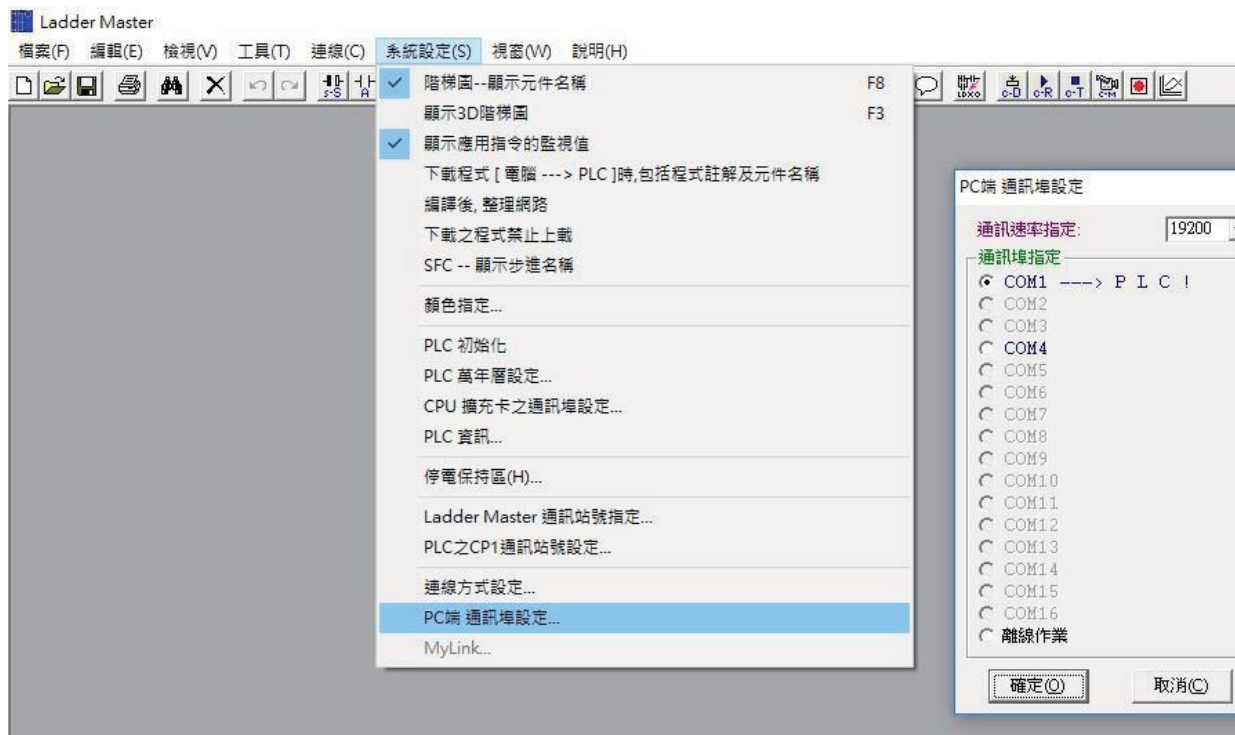

HMI Setting

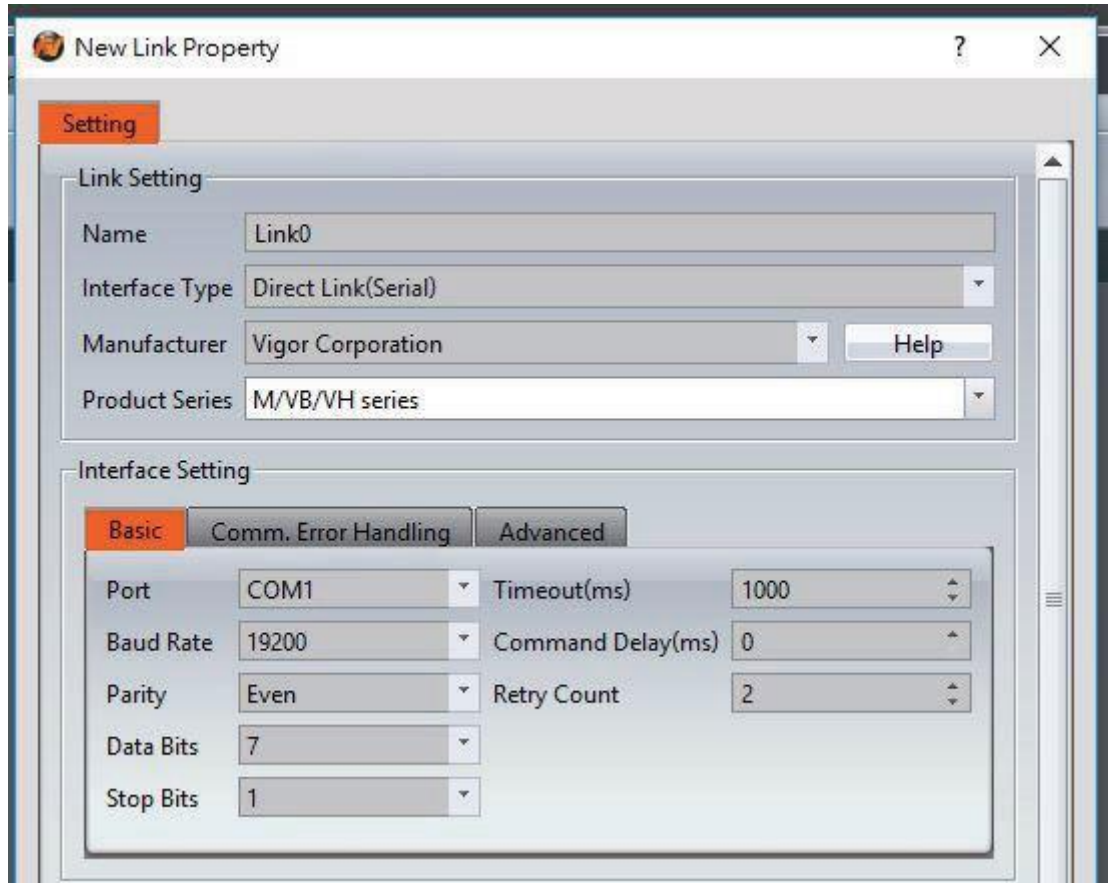

Within the Link configuration window in FvDesigner:

Under Interface Type select Serial

Under Manufacturer select Vigor Corporation

Under Product Series select VS Series

Under Port select required COM port. Verify the baud rate is the same as the value set on the PLC.

2.17.1.4 Wiring Diagrams

HMI COM1 Pinout

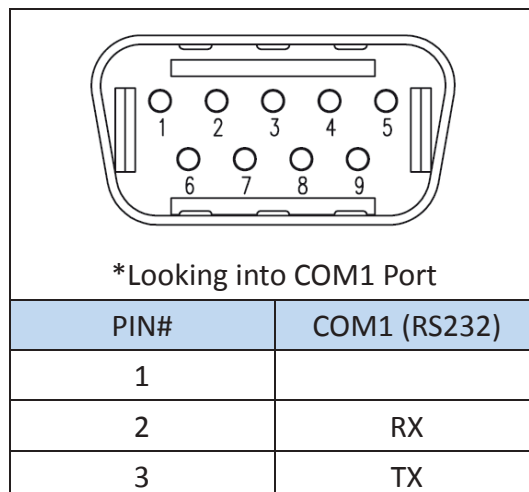

4	
5	GND
6	
7	
8	
9	

PLC USB Pinout

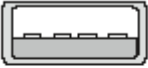
 4 3 2 1 USB Type A	
PIN#	Signal
1	
2	D-
3	D+
4	GND

All P5 and P2K Series

HMI COM1	PLC USB Port
2 RX	3 D+
3 TX	2 D-
5 GND	5 GND

Wiring Diagrams: All P5 and P2K Series

HMI COM1

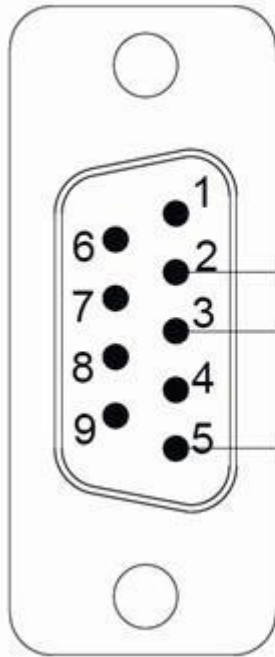

PLC USB Type A

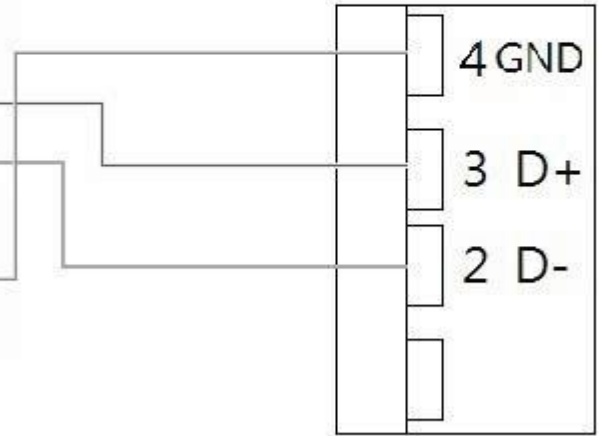

2.17.2 VS series

2.17.2.1 Communication Setting

Item	Default Setting	Remark
Signal Level	RS232	
Baud Rate	19200	
Data Length	8	
Stop Bit	1	
Parity	None	
PLC Station No.	0	
Communication Method	HOST-LINK COMMUNICATION	

2.17.2.2 Memory Resource Review

Device	Data bit	Data format	Min.	Min.	Description
X	1	OOO	0	377	External input relay
Y	1	OOO	0	377	External output relay
M	1	DDDD	0	8191	Internal relay
S	1	DDDD	0	4095	Step relay
SM	1	DDD	9000	9511	Special relay

DB	1	DDDD.H	0.0	8999.f	D data register bits
RB	1	DDDDD.H	0.0	25999.f	R data register bits
TC	1	DDD	0	511	Timer coil
CC	1	DDD	0	255	Counter coil
TS	1	DDD	0	511	Timer contact
CS	1	DDD	0	255	Counter contact
D	16	DDDD	0	8999	D data register
SD	16	DDD	9000	9511	Special data resgister
R	16	DDDDD	0	25999	R data resgister
T	16	DDD	0	511	Timer
C	16	DDD	0	199	16 bits counter
WX	16	OOO	0	377	External input relay
WY	16	OOO	0	377	External output relay
WM	16	DDDD	0	8191	Internal relay
WS	16	DDDD	0	4095	Step relay
CL	32	DDD	200	255	32 bits counter

2.17.2.3 Connecting to HMI

PLC Setting

Open Ladder Master and use the Vigor VBUSB-200 cable to connect to the computer USB port, it will automatically connect.

(Note: Mini-USB cable is required for programming, RS-485 is required for connection with human machine)

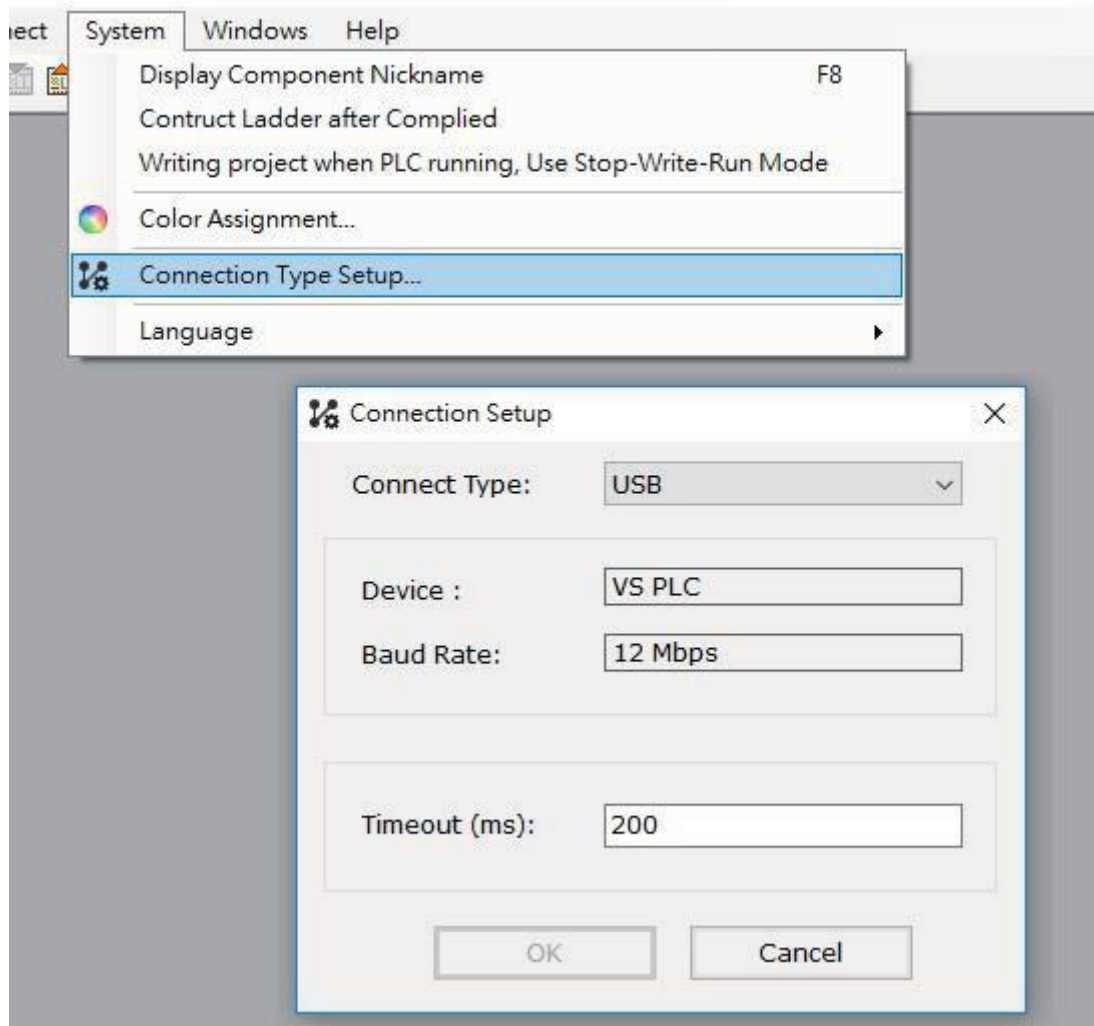

HMI Setting

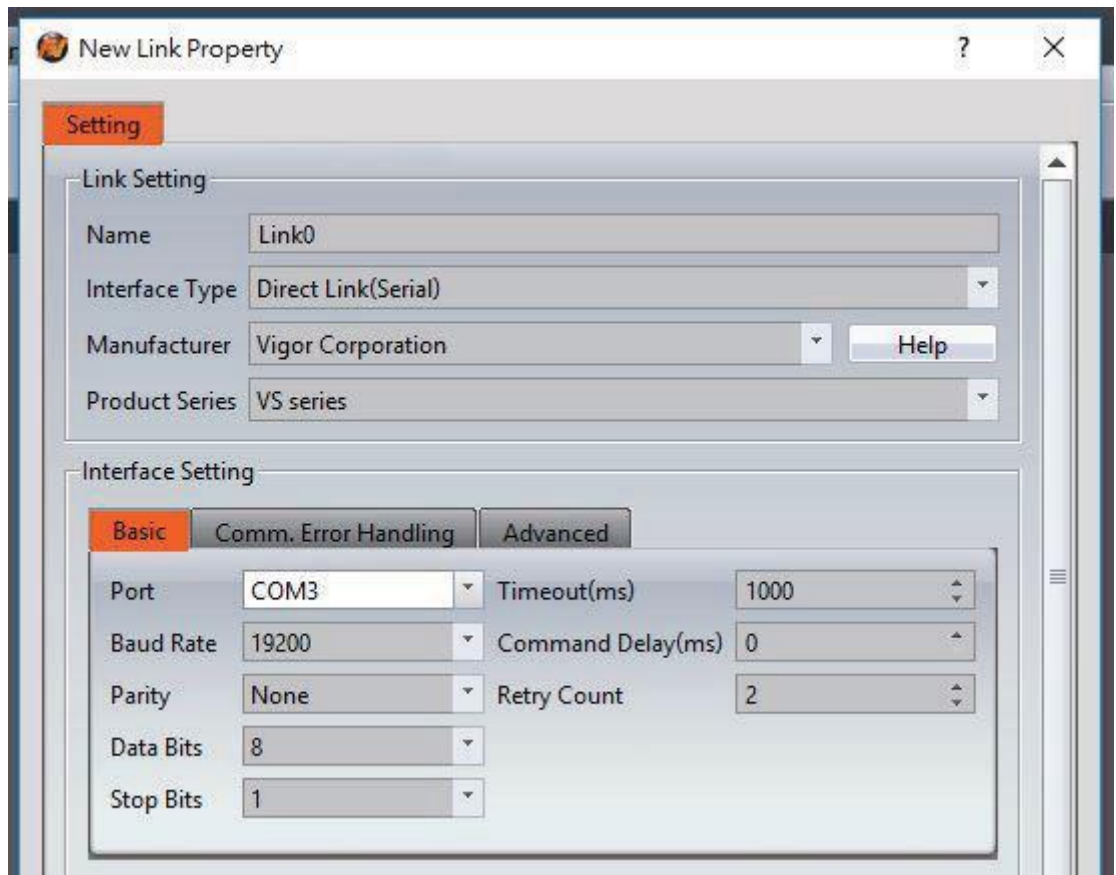

Within the Link configuration window in FvDesigner:

Under Interface Type select Serial

Under Manufacturer select Vigor Corporation

Under Product Series select VS Series

Under Port select required COM port. Verify the baud rate is the same as the value set on the PLC.

2.17.2.4 Wiring Diagrams

PLC RS485 Pinout

D-
D+
Signal
D-
D+

HMI COM3 Pinout: P5043S/P5043N/P5070VS/P5102VS/P2K

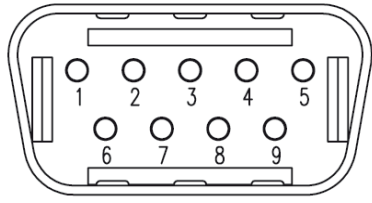

*Looking into COM3 Port

PIN#	COM3 (RS-485)
1	DATA+
2	
3	
4	
5	GND
6	DATA-
7	
8	
9	

P5043S/P5043N/P5070VS/P5102VS/P2K

HMI COM3	PLC RS485 Port
1 DATA+	D+
6 DATA-	D-

HMI COM3 Pinout:P5070S/ P5070N/ P5070N1/ P5102S/ P5102N/ P5102N1



*Looking into HMI Device

PIN#	COM3 (RS-485)
1	
2	
3	ISO_GND
4	
5	
6	DATA+
7	DATA-

P5070S/ P5070N/ P5070N1/ P5102S/ P5102N/ P5102N1

HMI COM3	PLC RS485 Port
6 DATA+	DATA+
7 DATA-	DATA-

Wiring Diagrams:P5043S/P5043N/P5070VS/P5102VS/P2K

HMI COM3

PLC RS485

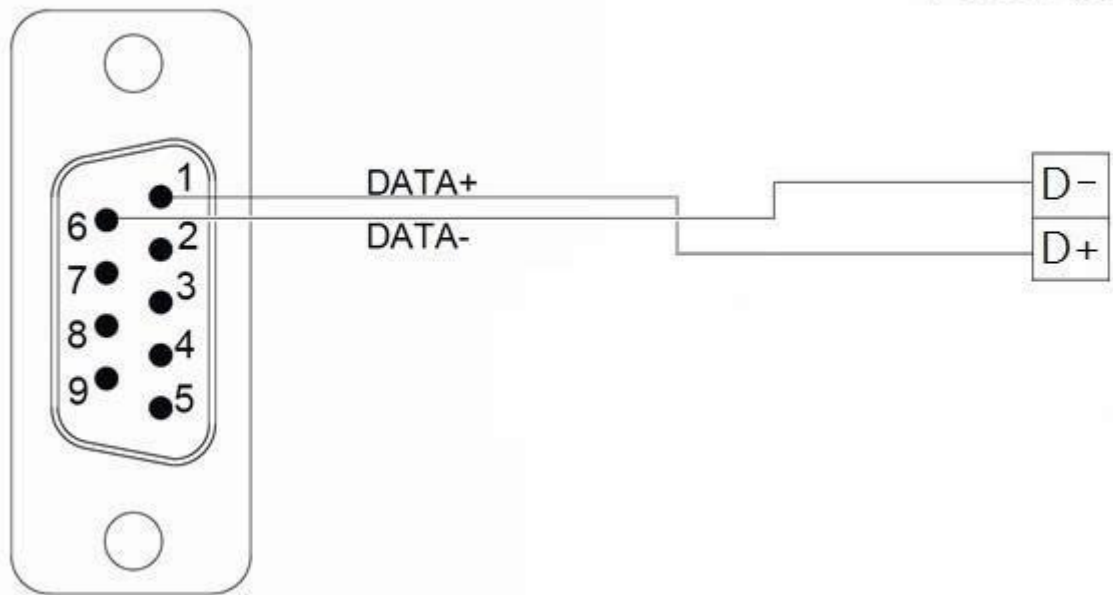

Wiring Diagrams:P5070S/ P5070N/ P5070N1/ P5102S/ P5102N/ P5102N1

HMI COM3

PLC RS485

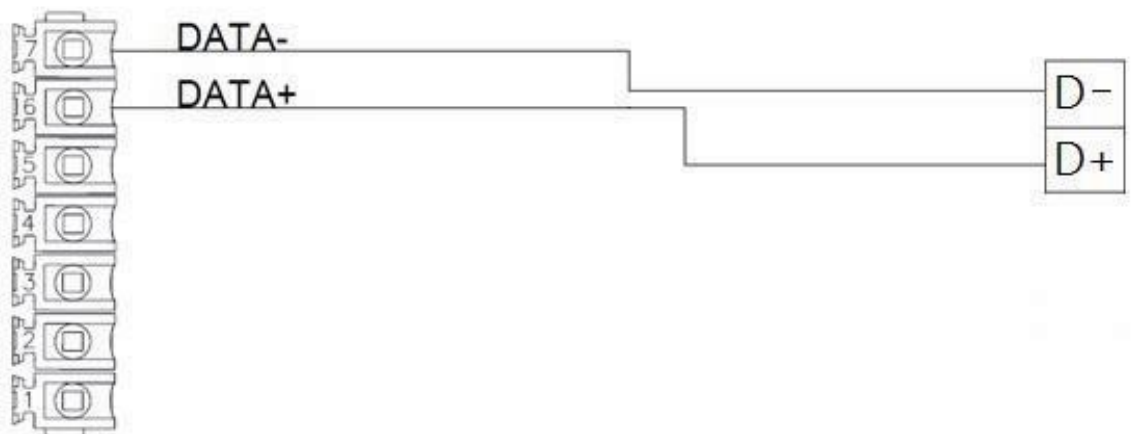

2.18 LS

2.18.1 LS XBC-cnet

2.18.1.1 Communication Setting

Item	Default Setting	Remark
Signal Level	RS-232/RS-485	
Baud Rate	115200	
Data Length	8	
Stop Bit	1	
Parity	None	
PLC Station No.	0	
Communication method	Serial	

2.18.1.2 Memory Resource Review

Bit/ Word	Device Type	Range	XBC
B	PX	0-2047F	0-1023F
	MX	0-2047F	0-1023F
	KX	0-2559F	0-2559F
	FX	0-2047F	0-1023F
	TX	0-2047	0-1023
	CX	0-2047	0-1023
	UX	0-3F.31F	0-A.31F
	SX	0-12799	0-12799
	L	0-4095	0-2047F
	D	0-32767	0-10239
	R	0-32767	0-2047
W	PW	0-2047	0-1023
	MW	0-2047	0-1023
	KW	0-2559	0-2559
	FW	0-2047	0-1023
	TW	0-2047	0-1023
	CW	0-2047	0-1023
	UW	0-3F.31	0-A.31
	SW	0-12799	0-12799
	ZW	0-127	0-127
	LW	0-4095	0-2047F
	DW	0-32767	0-10239

	RW	0-32767	0-10239
--	----	---------	---------

2.18.1.3 Connecting to HMI

HMI setting

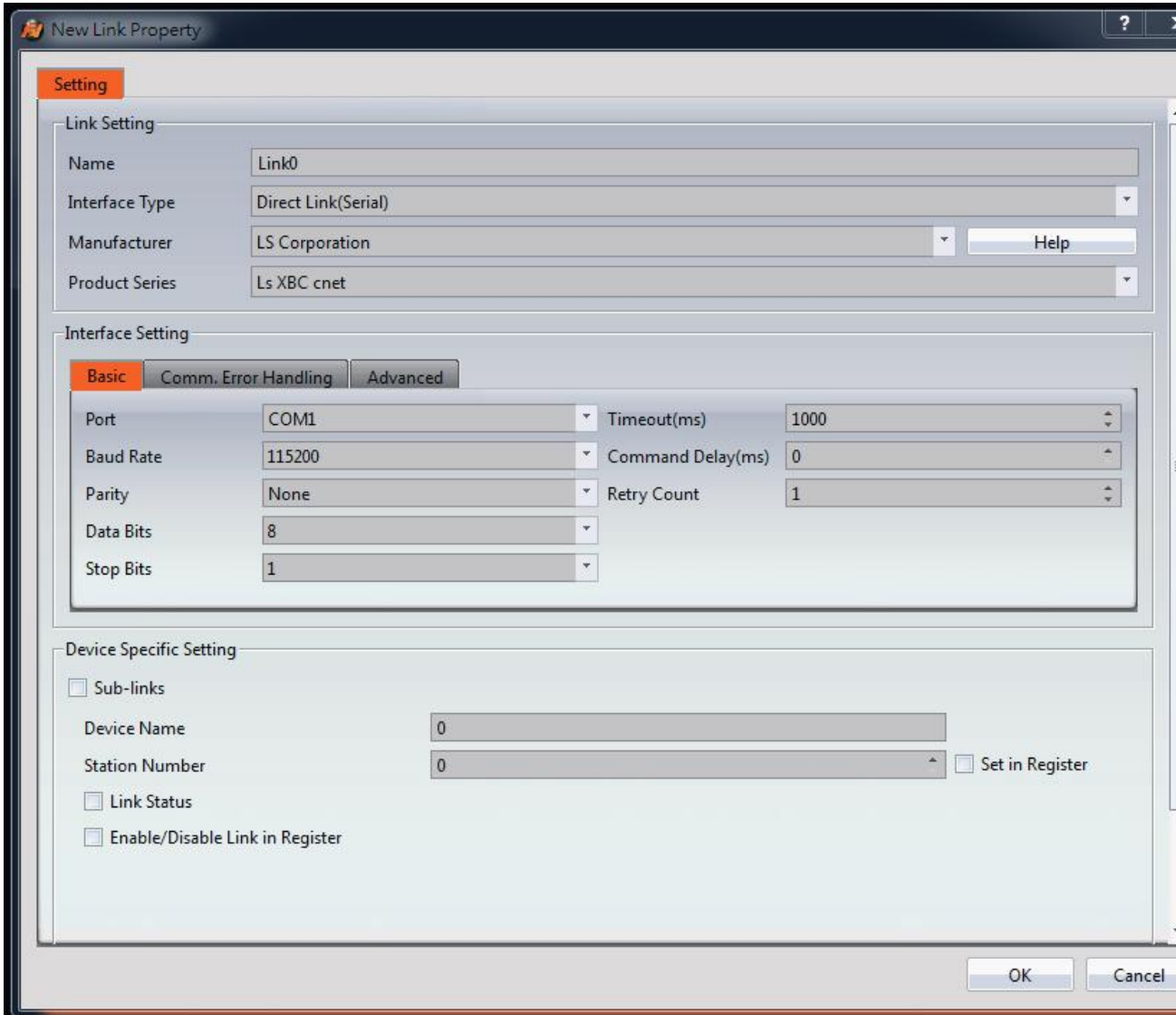

Within the Link configuration window in FvDesigner:

Under Interface Type select Serial

Under Manufacturer select LS Corporation

Under Product Series select LS XBC cnet

Under Port select COM1

2.18.1.4 Wiring Diagrams



XBC-Cnet Pinout

XBC-Cnet RS232 Pinout	XBC-Cnet RS485 Pinout
RX TX SG 	D+ D-
RS-232	RS-485
SG	DATA+(485+)
TX	DATA- (485-)
RX	

HMI COM1 Pinout

*Looking into COM1 Port

PIN	COM1 (RS232)
1	
2	RX
3	TX
4	
5	GND
6	

7	RTS
8	CTS
9	

All P5 and P2K Series

HMI COM1	XBC-Cnet RS232 Port
2 RX	TX
3 TX	RX
5 GND	SG

Wiring Diagrams : All P5 and P2K Series

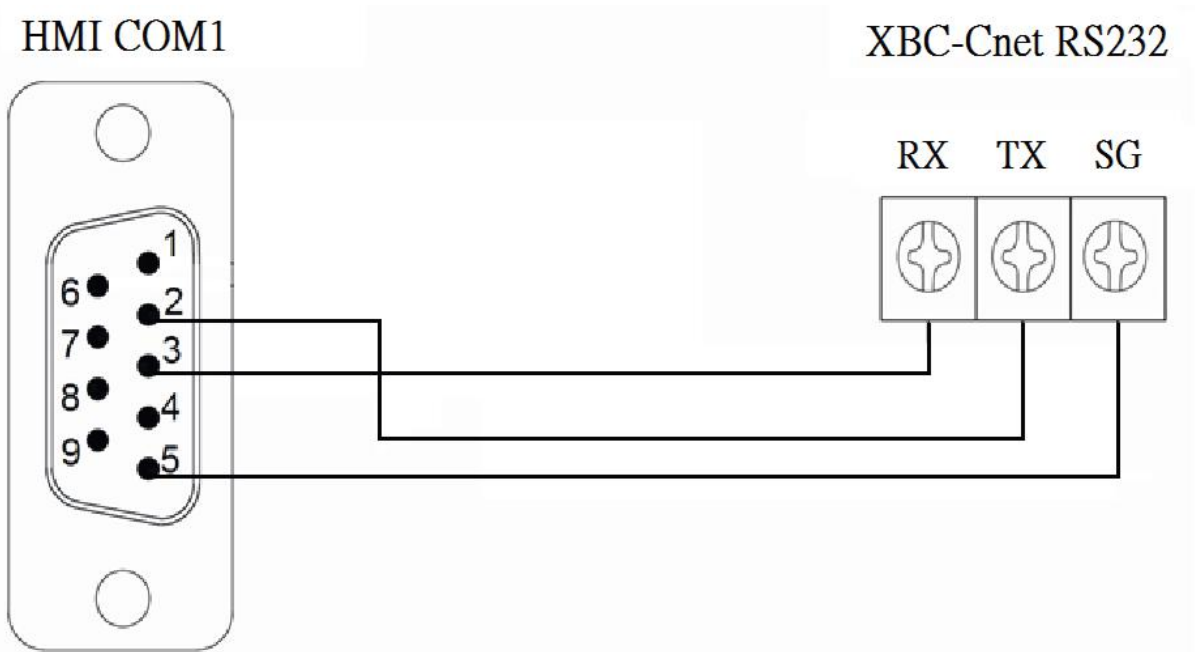

2.18.2 LS XEC-Cnet

2.18.2.1 Communication Setting

Item	Default Setting	Remark
Signal Level	RS-232/RS-485	
Baud Rate	115200	
Data Length	8	
Stop Bit	1	
Parity	None	
PLC Station No.	0	
Communication method	Serial	

2.18.2.2 Memory Resource Review

Bit/ Word	Device Type	Range	XEC
B	IX	0.0.0-15.15.63	0.0.0-15.15.63
	QX	0.0.0-15.15.63	0.0.0-15.15.63
	MX	0-262143	0-262143
	LX	0-65535	0-65535
	NX	0-163839	0-163839
	KX	0-131071	0-131071
	UX	0.0-11.511	0.0-11.511
	RX	0-262143	0-262143
	AX	0-524287	0-524287
	WX	0-524287	0-524287
	FX	0-32767	0-32767
W	I	0.0.0-15.15.3	0.0.0-15.15.3
	QW	0.0.0-15.15.3	0.0.0-15.15.3
	MW	0-16383	0-16383
	LW	0-4095	0-4095
	NW	0-10239	0-10239
	KW	0-8191	0-8191
	UW	0.0-11.31	0.0-11.31
	RW	0-16383	0-16383
	AW	0-32767	0-32767
	WW	0-32767	0-32767
	FW	0-2047	0-2047

2.18.2.3 Connecting to HMI

HMI setting

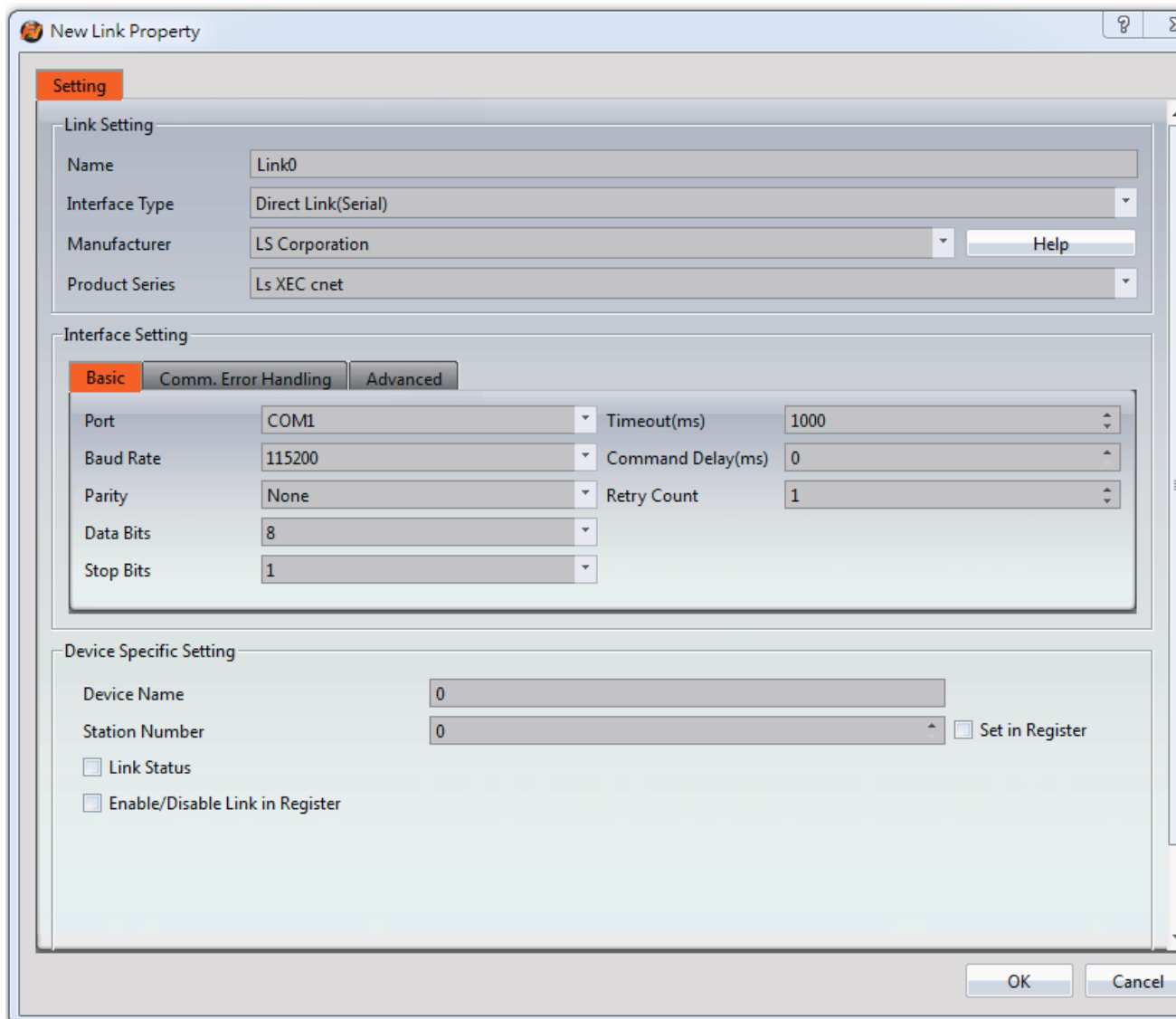

Within the Link configuration window in FvDesigner:

Under Interface Type select Serial

Under Manufacturer select LS Corporation

Under Product Series select LS XBC cnet

Under Port select COM1

2.18.2.4 Wiring Diagrams

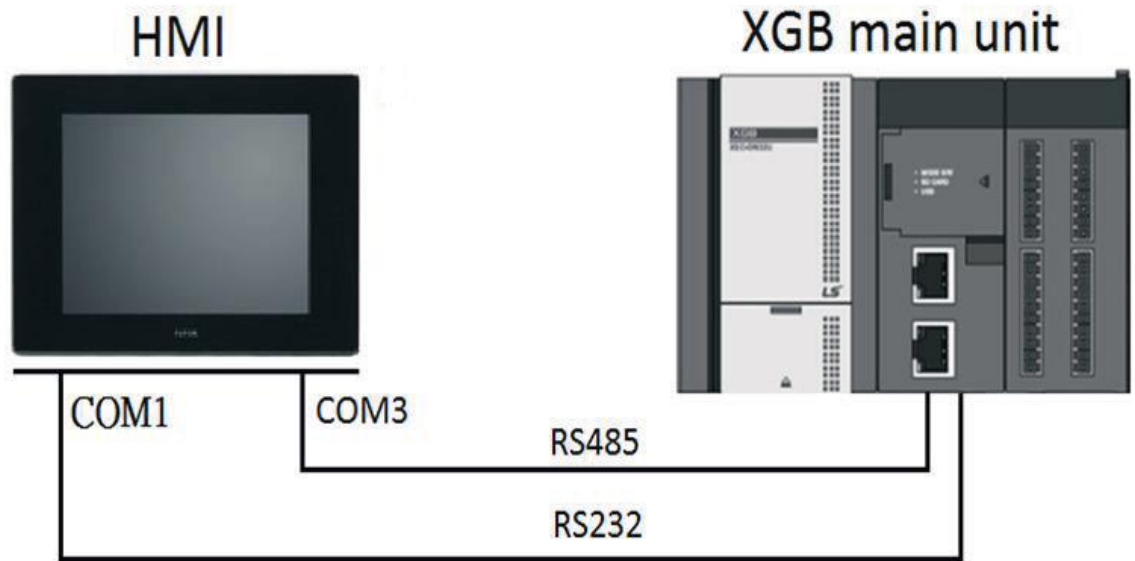

XBC-Cnet Pinout

RS-232	RS-485
SG	D- (485-)
TX	D+(485+)
RX	

HMI COM1 Pinout

*Looking into COM1 Port	
PIN	COM1 (RS232)
1	
2	RX

3	TX
4	
5	GND
6	
7	RTS
8	CTS
9	

All P5 and P2K Series

HMI COM1	XBC-Cnet RS232 Port
2 RX	TX
3 TX	RX
5 GND	SG

Wiring Diagrams : All P5 and P2K Series

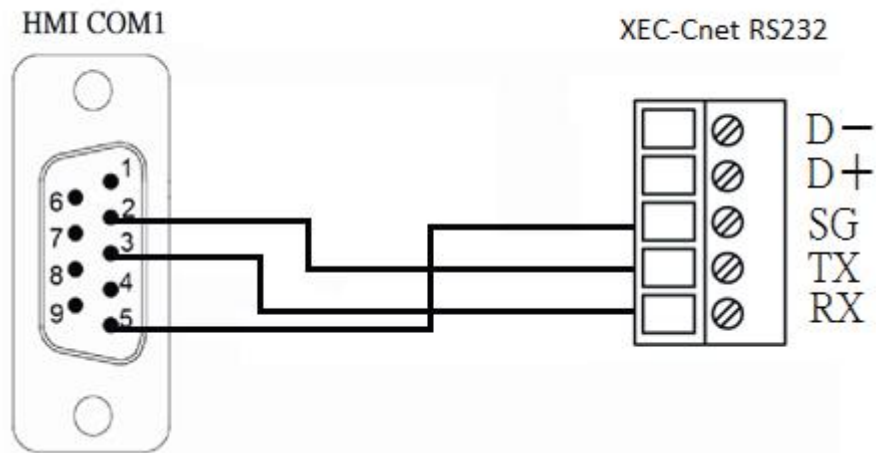

2.18.3 LS XBC-Fnet

2.18.3.1 Communication Setting

Item	Default Setting	Remark
Signal Level	Ethernet	
Internet Protocol	192.168.0.61	
Port	2004	
PLC Station No.	1	
Communication Method	TCP	

2.18.3.2 Memory Resource Review

類型	資料位元	地址格式	最小	最大	說明
PW	16	DDDD	0	2047	I/O relay
MW	16	DDDD	0	2047	Auxiliary relay
LW	16	DDDDD	0	4095	Link relay
KW	16	DDDD	0	2559	Keep relay
FW	16	DDDD	0	2047	Special relay
CW	16	DDDD	0	2047	Counter
TW	16	DDDD	0	2047	Timer
SW	16	DDD	0	12799	Step controller
DW	16	DDDDD	0	32767	Data register
UW	16	DH.DD	0	3F.31	Analog data register
RW	16	DDDDD	0	32767	File register
ZW	16	DDD	0	127	Index register
PX	1	DDDDH	0	2047F	Auxiliary relay
MX	1	DDDDH	0	2047F	Auxiliary relay
LX	1	DDDDDH	0	4095	Link relay
KX	1	DDDDH	0	2559F	Keep relay
FX	1	DDDDH	0	2047F	Special relay
DX	1	DDDDDH	0	32767	Data register
UX	1	DH.DD	0	3F.31F	Analog data register
RX	1	DDDDDH	0	32767	File register
SX	1	DDDDD	0	12799	Step controller
TX	1	DDDD	0	2047	Timer
CX	1	DDDD	0	2047	Counter

2.18.3.3 Connecting to HMI

PLC setting

Open XG5000.exe and use mini-USB to connect the USB port of the computer, it will connect automatically.

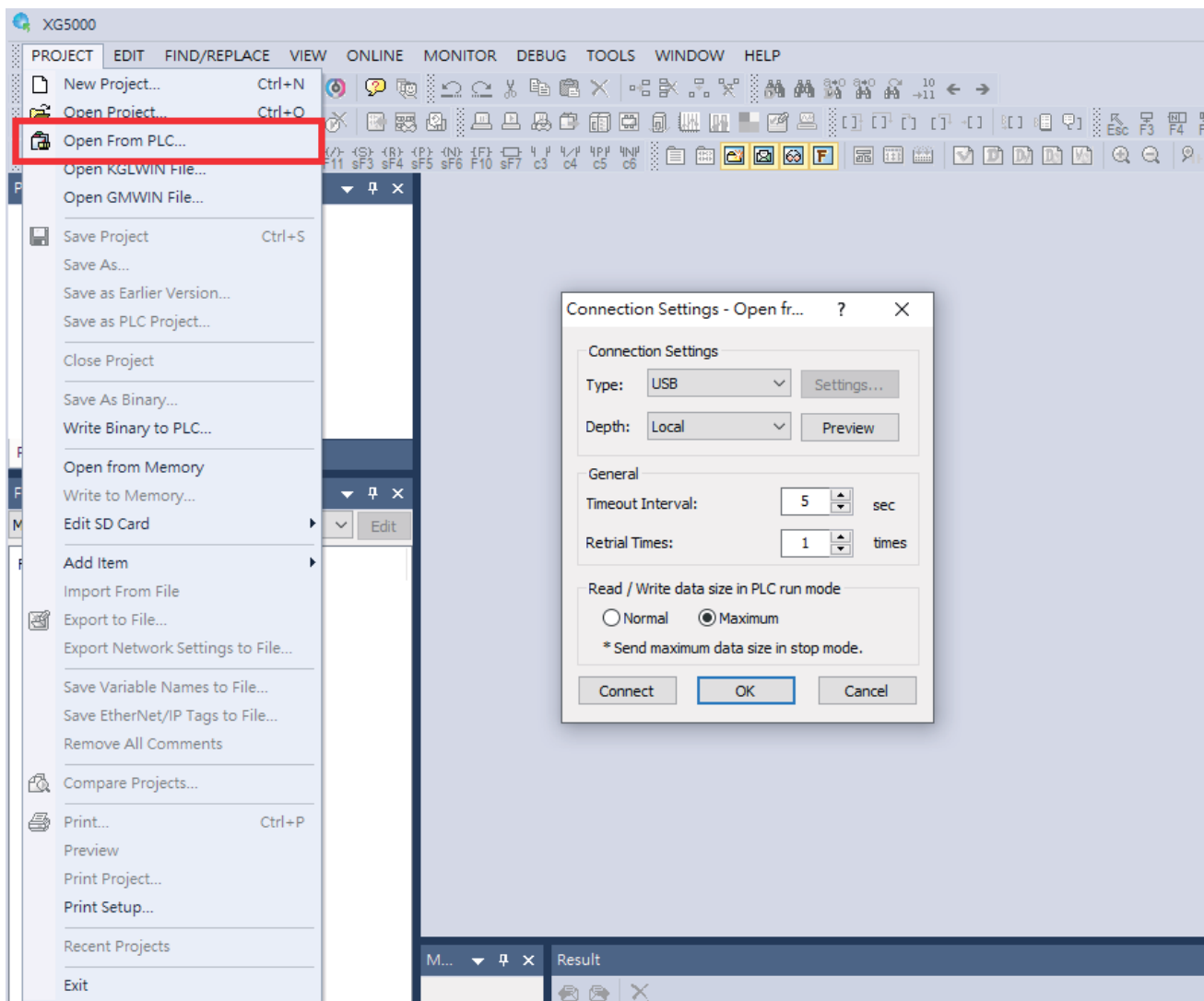

HMI setting

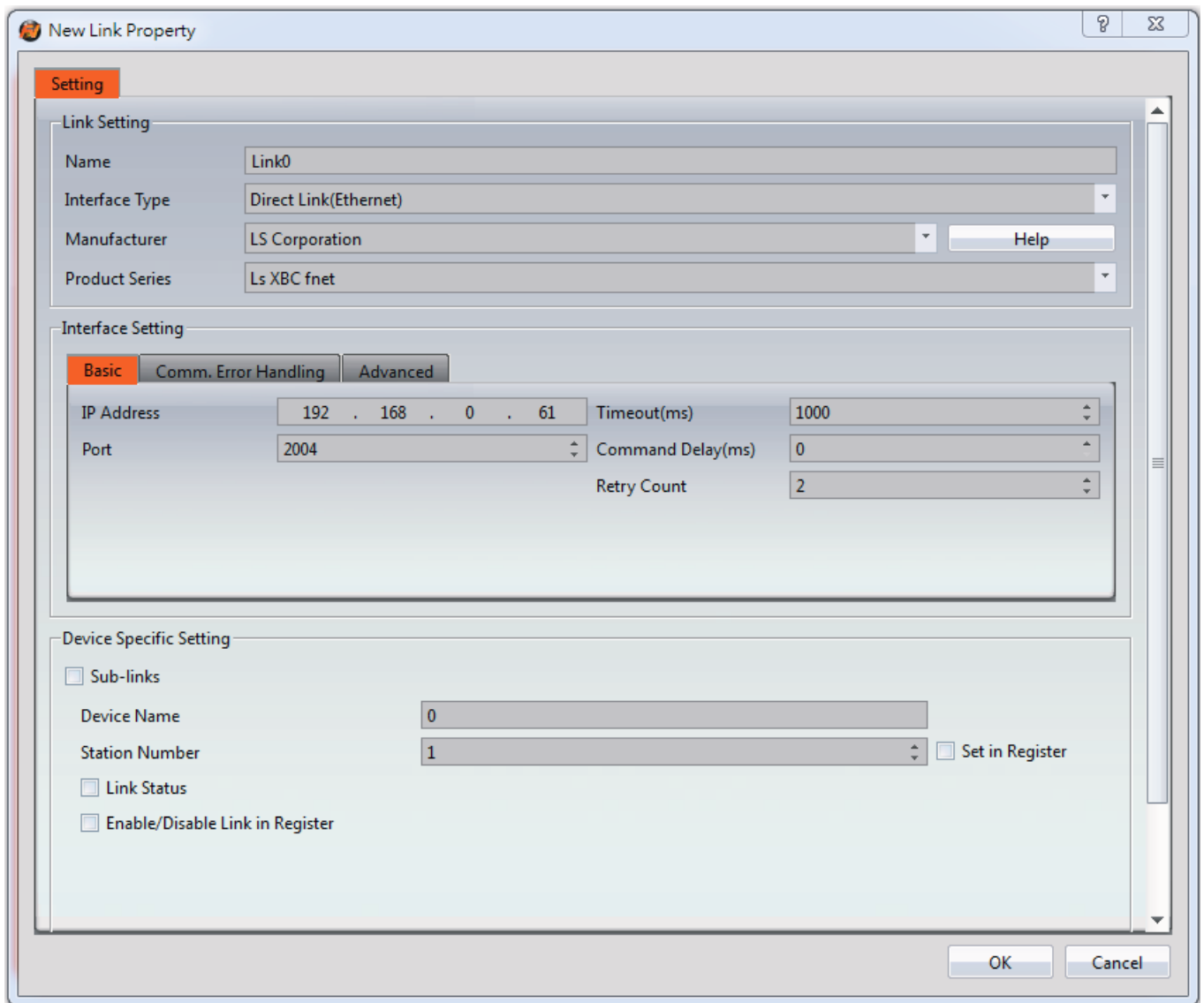

Within the Link configuration window in FvDesigner:

Under Interface Type select Ethernet

Under Manufacturer select LS Corporation

Under Product Series select LS XBC fnet

Please confirm that the HMI communication setting and the PLC setting are consistent

2.18.4 LS XEC-Fnet

2.18.4.1 Communication Setting

Item	Default Setting	Remark
Signal Level	Ethernet	
Internet Protocol	192.168.0.6	
Port	2004	
PLC Station No.	1	
Communication Method	TCP	

2.18.4.2 Memory Resource Review

Bit/ Word	Device Type	Range	XEC
B	IX	0.0.0-15.15.63	0.0.0-15.15.63
	QX	0.0.0-15.15.63	0.0.0-15.15.63
	MX	0-262143	0-262143
	LX	0-65535	0-65535
	NX	0-163839	0-163839
	KX	0-131071	0-131071
	UX	0.0-11.511	0.0-11.511
	RX	0-262143	0-262143
	AX	0-524287	0-524287
	WX	0-524287	0-524287
	FX	0-32767	0-32767
W	I	0.0.0-15.15.3	0.0.0-15.15.3
	QW	0.0.0-15.15.3	0.0.0-15.15.3
	MW	0-16383	0-16383
	LW	0-4095	0-4095
	NW	0-10239	0-10239
	KW	0-8191	0-8191
	UW	0.0-11.31	0.0-11.31
	RW	0-16383	0-16383
	AW	0-32767	0-32767
	WW	0-32767	0-32767
	FW	0-2047	0-2047

2.18.4.3 Connecting to HMI

PLC setting

Open XG5000.exe and use mini-USB to connect the USB port of the computer, it will connect automatically.

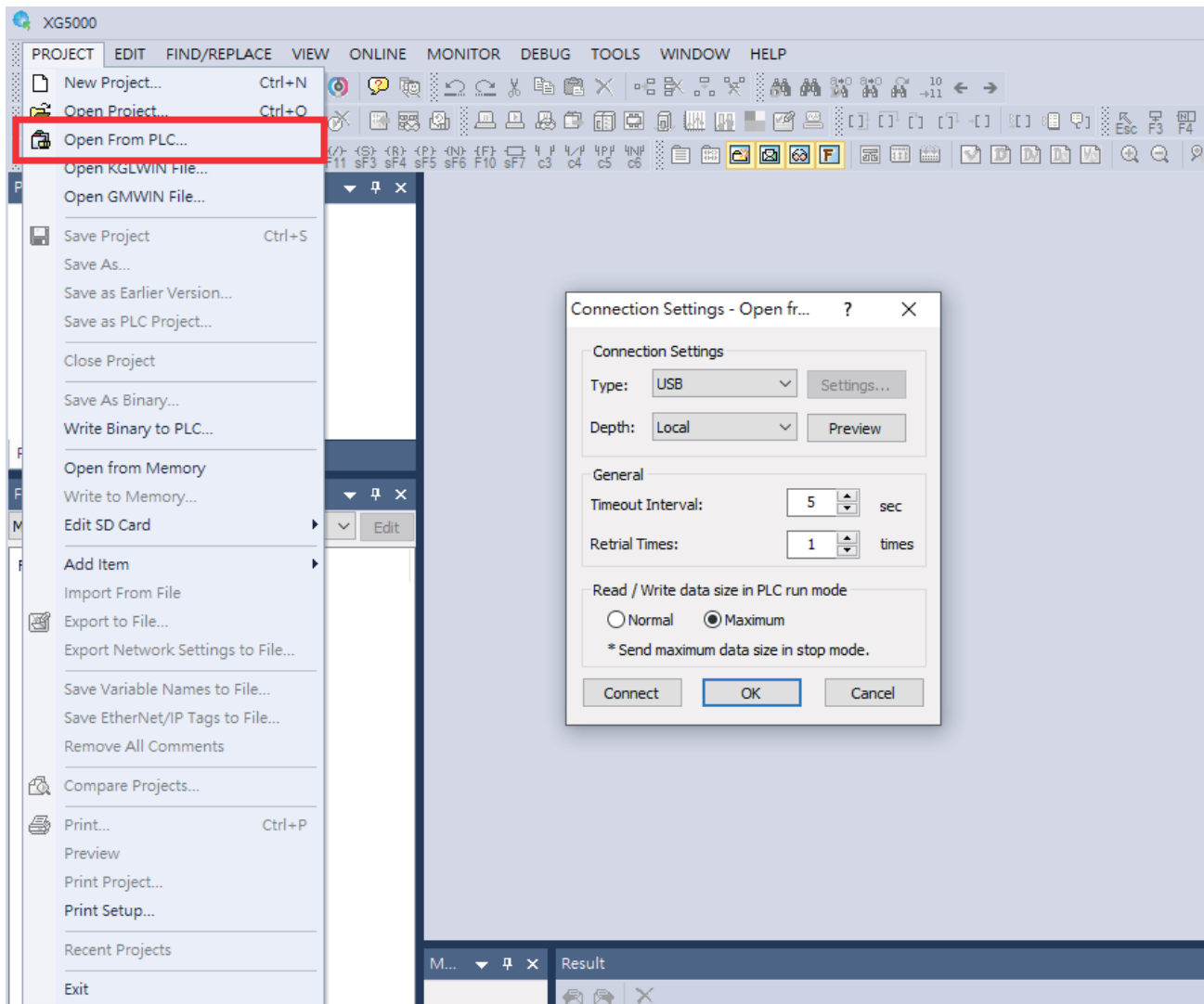

HMI setting

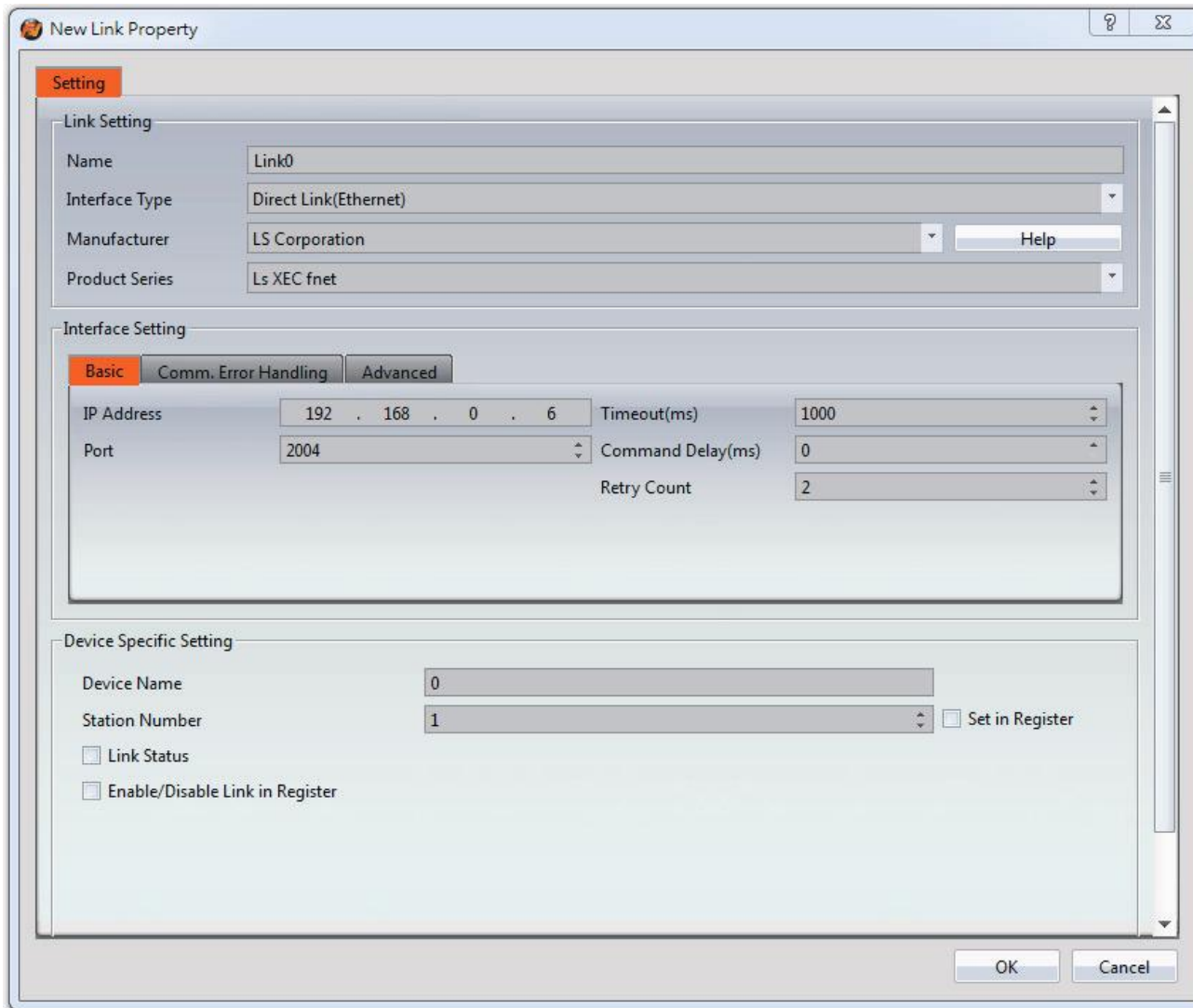

Within the Link configuration window in FvDesigner:

Under Interface Type select Ethernet

Under Manufacturer select LS Corporation

Under Product Series select LS XEC fnet

Please confirm that the HMI communication setting and the PLC setting are consistent