

ACS 500

# Programming Manual Including Application Macros

ACS 500 Adjustable Frequency  
AC Drives 1 to 400 HP, Series B

ACS 500-05C  
EFFECTIVE 9/1/94  
SUPERCEDES 6/1/94

[www.nicsanat.com](http://www.nicsanat.com)

021-87700210



ABB Drives



## Safety Instructions

---

### General Safety Instructions

Warnings in this manual appear in either of two ways:

- *Dangerous voltage warnings*, preceded by a Dangerous Voltage symbol, indicate the presence of voltages which may cause death or serious injury. These warnings describe procedures to avoid death or serious injury.
- *General warnings*, preceded by a General Warning symbol, indicate situations or conditions which may cause death or serious injury. These warnings describe procedures to avoid death or serious injury.

---

**CAUTIONS** inform you of situations or conditions which will damage machinery or cause additional motor-operation down-time if you do not take suggested steps to correct or address such situations or conditions.

---

*Note: Notes provide you with additional and useful information. Although less urgent than cautions and warnings, notes are important and should not be ignored.*

### Warning Symbols

For your own safety please pay special attention to instructions containing these symbols:



This warning symbol indicates the presence of dangerous voltage. This symbol informs you of high voltage conditions, situations, and locations that may cause death or serious injury if you do not follow precautions and proper steps.



This warning symbol indicates a general warning.



This warning symbol indicates an electrostatic discharge hazard.

## Warnings, Cautions, and Notes



**WARNING!** Your drive contains dangerous voltages when connected to the line power. Always check that the ACS 500 is safe, after disconnecting the power, by measuring the DC bus voltage and line input voltage. Failure to check voltages could cause death or serious injury. Only a qualified electrician should carry out the electrical installation.

---

Note that the Motor Control Card of the ACS 500 is at DC bus voltage potential.

The DC bus capacitors contain dangerous DC voltage levels ( $1.35 \times V_{IN}$ ). After disconnecting the supply, wait at least five minutes after the display readout on the control panel has disappeared before taking any measurements.

Dangerous external control voltages may be present on the relay outputs of the Control Interface Card and Option Cards.



---

**CAUTION:** Electrostatic Discharge (ESD) can damage electronic circuits. Do not handle any components without following the proper ESD precautions.

---

# Table of Contents

---

## Chapter 1 – Introduction

How To Use This Manual .....	1-1
Intended Audience .....	1-2
Conventions Used In This Manual .....	1-2
Control Panel Display .....	1-2
Control Panel Keys .....	1-3
Related Publications .....	1-3

## Chapter 2 – Overview of ACS 500 Programming

Overview of Application Macros .....	2-1
Application Macros Defined .....	2-1
Menu System of Parameters .....	2-2
Start-up Data Parameters .....	2-2
Operating Data Parameters .....	2-3
Menu Navigation .....	2-3

## Chapter 3 – Start-up Data

Start-up Data Parameters .....	3-1
Overview .....	3-1
Parameter Selection .....	3-2

## Chapter 4 – Control Operation

Operating Data Parameters .....	4-1
Overview .....	4-1
Parameter Selection .....	4-3
Motor Control Values .....	4-6
Keypad Control vs. External Control .....	4-7
Keypad Control .....	4-7
External Control .....	4-7
Keypad Reference 1 and Keypad PI .....	4-9
External Reference 1 and 2 .....	4-10
Password Protection (Parameter Lock) .....	4-10

## Chapter 5 – Standard Application Macro Programs

User Macro .....	5-1
Macro Applications and Access .....	5-2
Application 1 – Factory Macro .....	5-3
Operation Diagram .....	5-3
Input and Output Signals .....	5-3
Factory Macro External Connections .....	5-4
Factory Macro Parameter Settings .....	5-5

Application 2 – Hand/Auto Control .....	5-6
Operation Diagram .....	5-6
Input and Output Signals .....	5-6
Hand/Auto External Connections .....	5-7
Hand/Auto Parameter Settings .....	5-8
Application 3 – PI Control .....	5-9
Operation Diagram .....	5-9
Input and Output Signals .....	5-9
PI Control External Connections .....	5-10
PI Control Parameter Settings .....	5-11
Application 4 – Opt. Pack .....	5-12
Operation Diagram .....	5-12
Input and Output Signals .....	5-12
Opt. Pack External Connections .....	5-13
Opt. Pack Parameter Settings .....	5-14
Application 5 – Seq Ctrl .....	5-15
Operation Diagram .....	5-15
Input and Output Signals .....	5-15
Seq Ctrl External Connections .....	5-16
Seq Ctrl Parameter Settings .....	5-17
Application 6 – Pump and Fan .....	5-18
Operation Diagram .....	5-18
Input and Output Signals .....	5-18
Pump and Fan External Connections .....	5-19
Pump and Fan Parameter Settings .....	5-20

## Chapter 6 – Parameters

ACS 500 Parameter Menus .....	6-1
ACS 500 Parameters .....	6-1
Main 10 Control Connections .....	6-2
Group 10.1 Start/Stop/Direction .....	6-2
Group 10.2 Ext Reference Select .....	6-4
Group 10.3 Preset Speeds .....	6-7
Group 10.4 System Contr Inputs .....	6-9
Group 10.5 Analog Inputs .....	6-10
Group 10.6 Relay Outputs .....	6-12
Group 10.7 Analog Outputs .....	6-14
Group 10.8 Ext Communication .....	6-16
Main 20 Drive Parameters .....	6-16
Group 20.2 Start/Stop .....	6-17
Group 20.3 Accel/Decel .....	6-20
Group 20.4 Motor Control .....	6-22
Group 20.5 Crit Frequencies .....	6-28
Main 30 Protection Parameters .....	6-30
Group 30.1 Fault Function .....	6-30
Group 30.2 Automatic Reset .....	6-37
Group 30.3 Supervision .....	6-38
Group 30.4 Information .....	6-40

Main 40 Application Parameters .....	6-41
Group 40.1 PI-Controller .....	6-41
Group 40.2 Pump & Fan Control .....	6-45
<b>Appendix A – Complete Parameter Settings</b> .....	<b>A-1</b>
<b>Appendix B – Programming Digital Inputs</b> .....	<b>B-1</b>
<b>Index</b> .....	<b>I-1</b>

This page intentionally left blank.

## Chapter 1 – Introduction

---

### **How To Use This Manual**

This chapter describes the purpose and contents of this manual, describes the intended audience, explains conventions used in this manual, and lists related publications.

The purpose of this manual is to provide you with the information necessary to select, modify, and apply Application macros to the operation of your ACS 500 drive.

ACS 500 user documentation also includes either the *ACS 501 Installation & Start-up Manual* or the *ACS 502 Installation & Start-up Manual*, which is included with the drive.

*Chapter 1 – Introduction*, the chapter you are reading now, introduces you to the *ACS 500 Adjustable Frequency AC Drives Programming Manual Including Application Macros* and conventions used throughout the manual.

*Chapter 2 – Overview of ACS 500 Programming* provides an overview of Application macros and describes how to use the menu system of parameters to select and modify the macros.

*Chapter 3 – Start-up Data* lists and explains the Start-up Data parameters. This chapter also describes how to set the Start-up Data parameters.

*Chapter 4 – Control Operation* describes operating data parameters, keypad references, drive-mounted and external controls, setting parameters for your specific drive application, and protecting your drive parameters from unauthorized changes.

*Chapter 5 – Standard Application Macro Programs* defines Application macros in terms of parameter settings. This chapter also describes the operation and application suitability of six standard Application macros and the User macro.

*Chapter 6 – Parameters* lists the ACS 500 parameters and explains the functions of each parameter.

*Appendix A – Complete Parameter Settings* lists, in a table form, all parameter settings for the ACS 500.

*Appendix B – Programming Digital Inputs DI1 – DI6* lists, in table form, parameter values and digital I/O configurations.

*Index* helps you locate the page numbers of topics contained in this manual.



### Intended Audience

The audience for this manual has:

- Knowledge of standard electrical wiring practices, electronic components, and electrical schematic symbols.
- Minimal knowledge of ABB product names and terminology.
- No experience or training in installing, operating, or servicing the ACS 500.

### Conventions Used In This Manual

The following are illustrations and examples of Control Panel keys and Control Panel display formats.

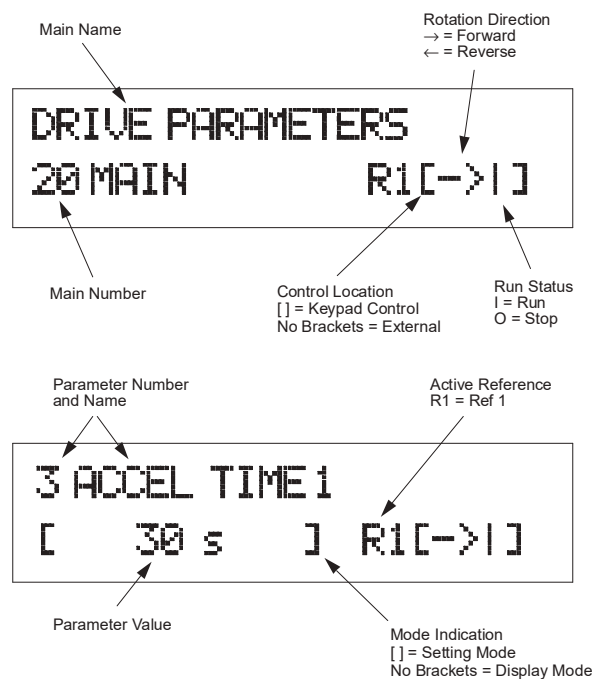
#### Control Panel Display

The Control Panel display is an LCD readout of drive functions, drive parameter selections, and other drive information. Letters or numbers appear in the display according to which Control Panel keys you press.

The operation information, parameters and fault indications are displayed in nine languages: English, German, Italian, Spanish, Dutch, French, Danish, Finnish, and Swedish. The language selection is made in Start-up Data Parameter A (Language).

Figure 1-1 shows control panel display indications.

Figure 1-1 Control Panel Displays










### Control Panel Keys

Control Panel keys are flat, labeled, pushbutton keys that allow you to monitor drive functions, select drive parameters, and change drive macros and settings.

Table 1-1 illustrates each Control Panel Key as it appears on the Control Panel Keypad. Table 1-1 also shows how the keys are represented in this manual's text and describes the function of each key.

Table 1-1 Control Panel Keys

Control Panel Key	Text Reference	Function
	[ * ]	Selects the Setting mode and saves the selected parameter value.
 	[Right Arrow]  [Left Arrow]	<b>Steps between levels.</b> Selects between Operating Data, Main, Group, and Parameter levels.  and  In Setting Mode, returns to the Display mode without changing the Parameter value.
 	[Up Arrow]  [Down Arrow]	<b>Steps through choices within a level.</b> In Display mode, selects the next/previous Main, Group, or Parameter.  and  In Setting mode, increases/decreases parameter value.
	[Fwd/Rev]	Changes the rotation direction in Keypad control (refer to parameter 10.1.3).
	[Start/Stop]	Starts and stops the motor in Keypad control. Resets faults, warnings, and supervision indications.

### Related Publications

For related information, refer to the *Installation & Start-up Manual*.

**This page intentionally left blank.**

## Chapter 2 – Overview of ACS 500 Programming

---

This chapter defines Application macros in terms of parameter settings and describes how to use the menu system of parameters to select and modify the macros.

### Overview of Application Macros

#### **Application Macros Defined**

Application macros are pre-programmed parameter sets. You'll use them to start the ACS 500 quickly and easily.

Application macros minimize the number of different parameters to be set during start-up. All parameters have factory-set default values. The Factory macro program is the factory-set default macro.

While starting up the ACS 500, you can specify a macro as the base setting for a drive. You can select any one of the following macros from Start-up Data Parameter B (Applications):

- Factory
- Hand/Auto Ctrl
- PI-Control
- Opt. Pack
- Seq Ctrl
- Pump and Fan

In addition to these application macros, there is a User macro. The User macro allows the user to save the existing parameter settings for recall at a later time.

Macro programs do not usually set all parameter values exactly as needed for a special application. Check frequency limits and acceleration/deceleration times and modify as required for your application.

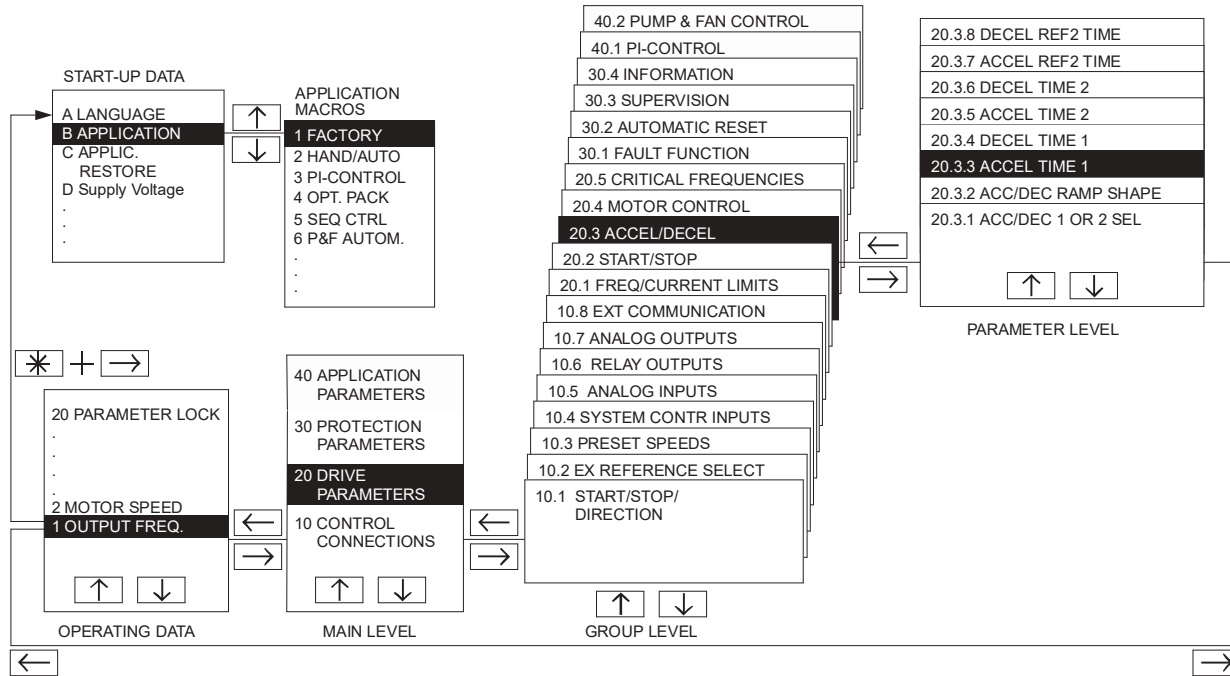
You may need to modify digital and analog inputs and/or outputs. The Parameter Settings tables in *Chapter 5 – Standard Application Macro Programs* indicate parameters you may have to modify. These parameters are indicated in the tables with an arrow (→) symbol.

## Menu System of Parameters

The parameters in the ACS 500 are organized via a system of menus. There are four levels of information, plus a start-up data menu. The four levels are: Operating Data, Main Level, Group Level, and Parameter Level. Each is described in this chapter.

Figure 2-1 shows how to select Start-up Data parameters, Operating Data parameters, Application macros, Main, Group, and Parameter levels using the Control Panel keypad.

Figure 2-1 Parameter Selection



### Start-up Data Parameters

The Start-up Data menu contains some basic settings needed to match the ACS 500 with your motor and to set the Control Panel display language. This menu also contains a list of pre-programmed Application macros. The Start-up Data menu is the first menu you modify to start-up your drive.

### ***Using the Start-up Data Menu***

The Start-up Data Menu provides access to parameters that should be set at start-up, and should not need to be changed. These parameters are Language, Application Macro, and Motor Information. Refer to *Chapter 3 – Start-up Data* for descriptions of each parameter.

To enter the Start-up Data menu:

1. Choose Operating Data Parameter 1 (Output Frequency).
2. Press and hold [ \* ], then press [Right Arrow].

To change a parameter:

1. Use the [Up Arrow] or [Down Arrow] to select a value.
2. Press [ \* ] to confirm the value and step to the next parameter.
3. Repeat Steps 1 and 2 for Parameters A through K.

To exit the Start-up Data menu, press [ \* ] to confirm the value for the last parameter, Parameter K. The program returns automatically to Operating Data Parameter 1 (Output Frequency).

### ***Operating Data Parameters***

The Operating Data menu contains 20 data values, status information, and three selection functions. There are eight additional Operating Data parameters that display when certain applications are selected. The selection functions are:

- Control Location Selection,
- External Reference Input Selection, and
- Parameter Lock locking/unlocking function.

Refer to *Chapter 4 – Control Operation* for a detailed discussion of the Operating Data parameters.

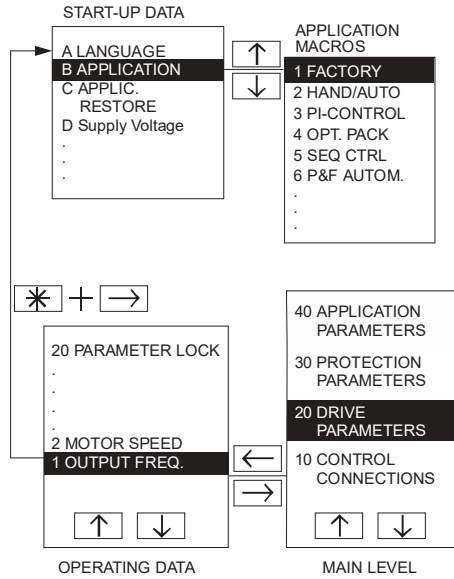
### ***Menu Navigation***

The [Right Arrow] and [Left Arrow] keys are used to move between the different levels (Operating Data, Main Level, Group Level, and Parameter Level).

The [Up Arrow] and [Down Arrow] keys are used to step through the choices within a level.

**Main Level** The Main Level organizes the parameters into four main functional areas. The ACS 500 has four Mains. Each Main allows you to access Groups within the Main. One of the Mains, *Application Parameters*, is only accessible when you select an Application macro that requires additional set-up parameters. Figure 2-2 shows how to select the Main level using the Control Panel Keypad.

Figure 2-2 Main Level Selection



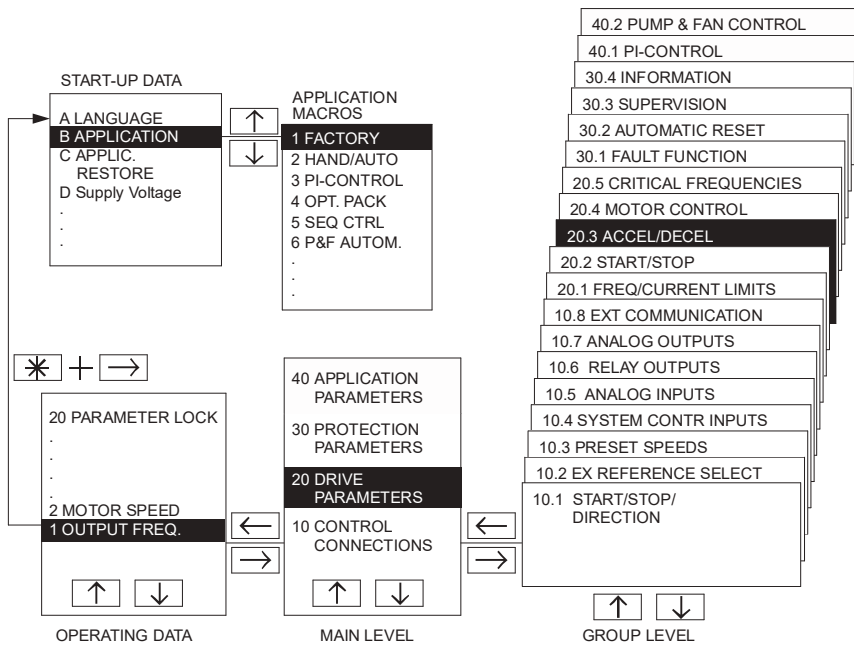
**Group Level** The Group Level groups the parameters by their functionality. Each Main provides access to several Groups. For example:

- CONTROL CONNECTIONS/10 MAIN contains Groups 10.1 – 10.8.
- DRIVE PARAMETERS/20 MAIN contains Groups 20.1 – 20.5.
- PROTECTION PARAMETER/30 MAIN contains Groups 30.1 – 30.4.
- APPLIC. PARAMETERS/40 MAIN contains Groups 40.1 – 40.2.

The groups in Main 40 can only be accessed if the appropriate macro has been selected.

Figure 2-3 shows how to select the group level using the Control Panel Keypad.

Figure 2-3 Group Level Selection





**Parameter Level** The Parameter Level is the programming level where the parameters are viewed and can be modified. Each Group contains several Parameters. Parameters allow you to change certain specifications or values to meet the needs of your particular application.

To change a Parameter value:

1. Use the arrow keys to select the parameter you would like to change.
2. Press [ \* ] to enter the Setting mode. This places square brackets around the value displayed in the lower left of the Display.
3. Press [Up Arrow] or [Down Arrow] to change the Parameter value.
4. Press [ \* ] to save the selected value and exit Setting mode, or [Right Arrow] or [Left Arrow] to cancel and return to previous value.

**Note:** Start-up Data and Operating Data are not Main or Group levels, but define certain Parameters. Procedures for changing Start-up Data Parameters A – K are not the same as those described above. Refer to Chapter 3 – Start-up Data for Start-up Data details.

Figure 2-4 shows how to select a Parameter using the Control Panel Keypad.

Figure 2-4 Parameter Level Selection

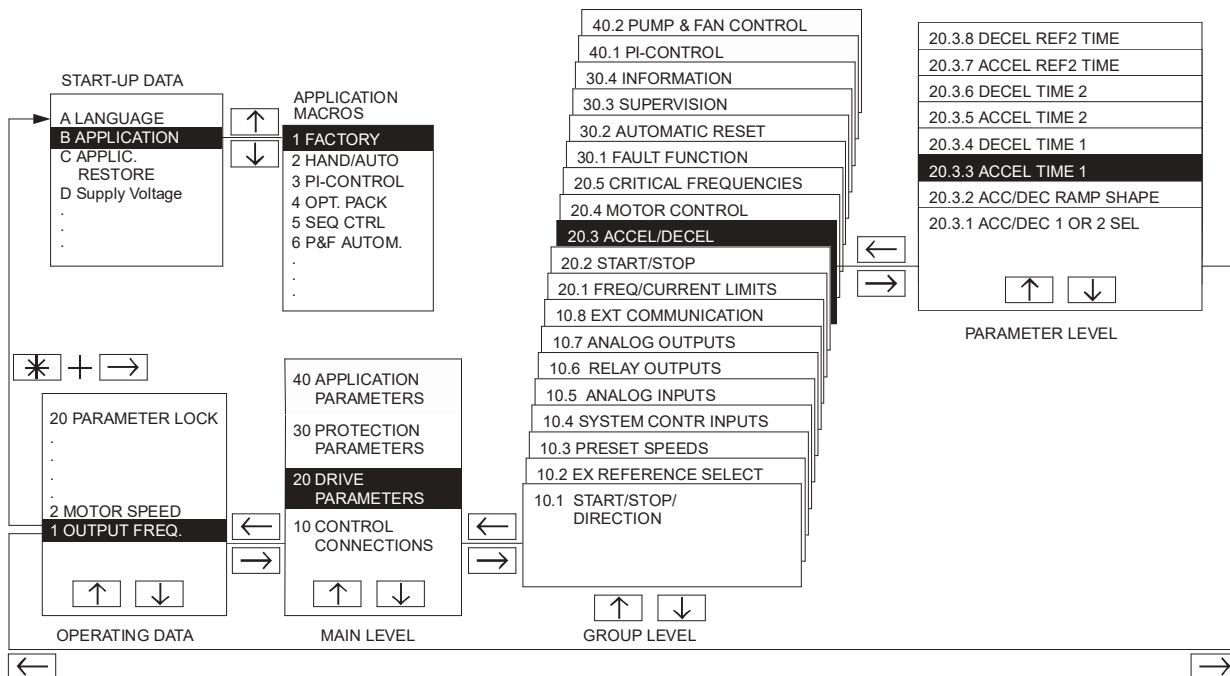
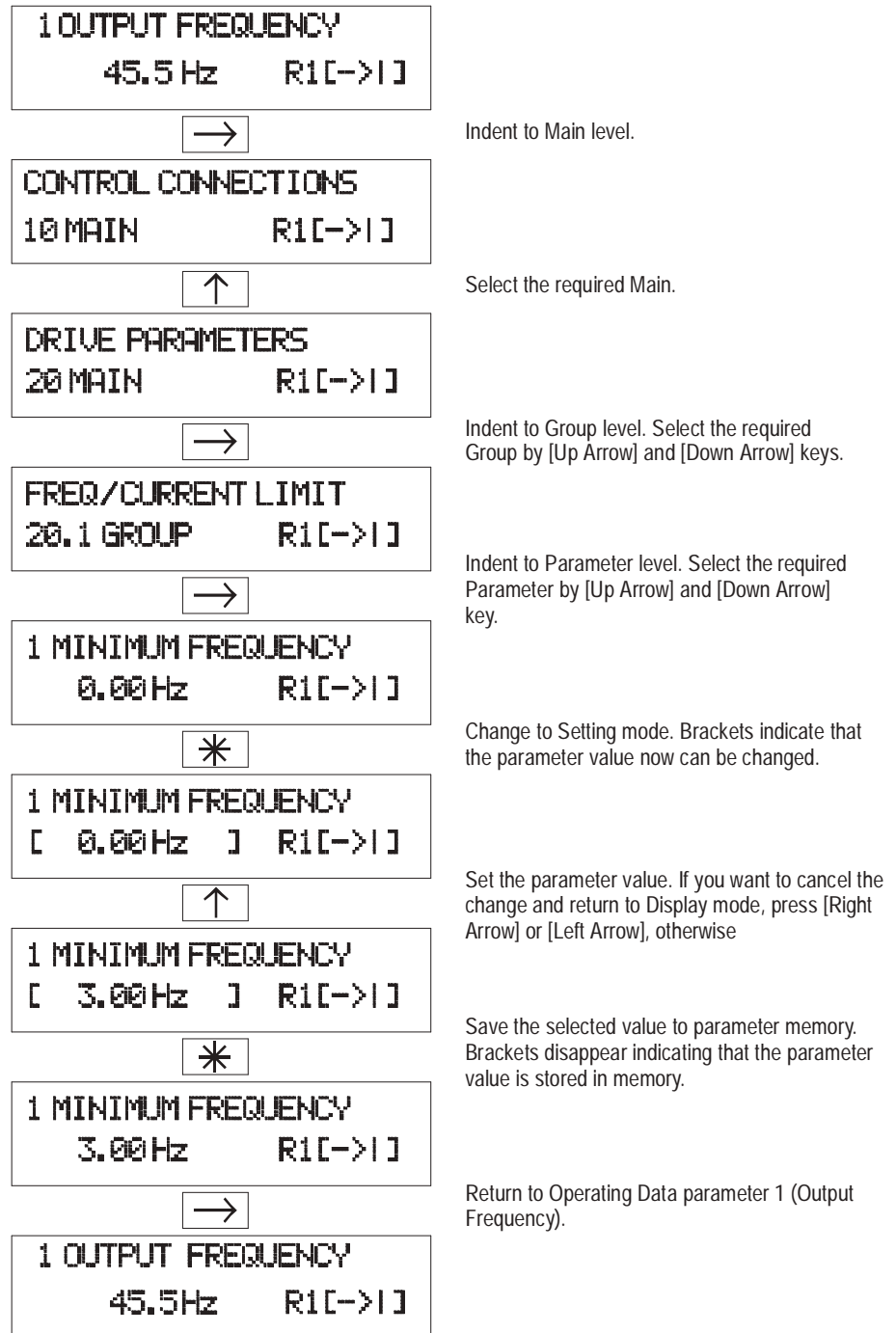


Figure 2-5 shows how to set Parameter 20.1.1 (Minimum Frequency) to 3 Hz starting from Operating Data Parameter 1 (Output Frequency).

*Note:* To accelerate the change of parameter value, press and hold the [Up Arrow] or [Down Arrow] button.

Figure 2-5 Parameter Settings



*Application Macros* Table 2-1 is an example of Factory macro parameters that you are most likely to modify if you are using the ACS 500 Factory macro to control your motor. The Factory macro default settings appear in the Default column.

Table 2-1 Factory Macro Parameters

Main	Group	Parameter	Default	
OPERATING DATA	OPERATING DATA	9 CONTROL LOCATION	KEYPAD R1	
		12 EXT REF 1 OR 2	REF 1	
		20 PARAMETER LOCK	OPEN xxx	
START-UP DATA	START-UP DATA	A LANGUAGE	ENGLISH	
		B APPLICATIONS	FACTORY	
		C APPLIC. RESTORE	NO	
		D SUPPLY VOLTAGE	480	
		E USER DISPLAY SCALE	0	
		F MOTOR CURRENT -FLA	(Current Rating)	
		G MOTOR POWER	(Power Rating)	
		H MOTOR POWER FACTOR	0.83	
10 CONTROL CONNECTIONS	10.1 START/ STOP/ DIRECTION	10.1.3 LOC/EXT DIRECTION	FORWARD	
		10.3 PRESET SPEEDS	10.3.2 PRESET SPEED 1	5 Hz
		10.3.3 PRESET SPEED 2	10 Hz	
		10.3.4 PRESET SPEED 3	15 Hz	
	10.5 ANALOG INPUTS	10.5.1 MINIMUM AI1	0 V/0 mA	
		10.5.2 MAXIMUM AI1	10 V/20 mA	
	10.7 ANALOG OUTPUTS	10.7.3 MINIMUM AO1	0 mA	
		10.7.8 MINIMUM AO2	0 mA	
	20 DRIVE PARAMETERS	20.1 FREQ / CURRENT LIMITS	20.1.1 MINIMUM FREQUENCY	0 Hz
			20.1.2 MAXIMUM FREQUENCY	60 Hz
20.1.4 CURRENT LIMIT			(1.5 x I <sub>N</sub> ) A	
20.3 ACCEL/ DECEL		20.3.3 ACCEL TIME 1	3s	
		20.3.4 DECEL TIME 1	3s	

Refer to *Chapter 5 – Standard Application Macro Programs* for a detailed discussion of the Application macros.

## Chapter 3 – Start-up Data

---

This chapter lists and explains the Start-up Data parameters and describes how to set these parameters. The Start-up Data parameters are a special set of parameters that allow you to set-up the drive and motor information.

Start-up Data parameters should only need to be set during start-up and should not need to be changed.

### **Start-up Data Parameters**

**Overview** To access the Start-up Data parameters, you must be at Operating Data Parameter 1 (Output Frequency). Press and Hold the [ \* ] key while pressing the [Right Arrow] key. This will bring you to Start-up Data Parameter A (Language).

The [Up Arrow] and [Down Arrow] keys are used to change the value or selection for the Start-up Data parameters. When a parameter is set to the value or selection you want, press the [ \* ] key to enter that value as the acceptable value and move to the next parameter.

To complete the Start-up Data parameters and return to the Operating Data parameters, continue to enter the information by pressing [ \* ] for each Start-up Data parameter.

The Range/Unit column in Table 3-1 shows parameter values. The text following the table explains parameter values in detail.

Table 3-1 Start-up Data Parameters

Parameter	Range/Unit	Description
A LANGUAGE	Available languages	Language selection.
B APPLICATIONS	Application macros	Application macro selection.
C APPLIC. RESTORE	No, Yes	Restores parameters to original values.
D SUPPLY VOLTAGE	Supply voltage selections	Sets the supply voltage.
E USER DISPLAY SCALE	0 – 10000	Scaling factor for speed.
F MOTOR CURRENT -FLA	0 A – 1000 A	Matches the ACS 500 to the rated motor current.
G MOTOR POWER hp (kW)	0.7 hp – 1340 hp (0.5 kW – 1000 kW)	Matches the motor rated power.
H MOTOR POWER FACTOR	0.1 – 1.0	Matches the motor power factor.
I MOTOR BASE FREQ.	30 Hz – 500 Hz	Sets the motor frequency.
J MOTOR BASE R.P.M.	200 rpm – sync. speed	Sets the nameplate speed.
K MOTOR NOM. VOLTAGE	110 V – 575 V	Sets the motor nameplate voltage.

**Parameter Selection**

The following is a list of the Start-up Data parameters with a description of each parameter.

**A LANGUAGE**

The ACS 500 displays all information in the language you select. The available languages are: English, German, Italian, Spanish, Dutch, French, Danish, Finnish, and Swedish.

**B APPLICATIONS**

This parameter is used to select the Application macro which will configure the ACS 500 for a particular application. Refer to *Chapter 6 – Parameters* for a list of available Application macros.

**C APPLIC. RESTORE**

This parameter restores all parameters of the current application to the original parameter values for that macro.

**D SUPPLY VOLTAGE**

This parameter is used to set the supply voltage to the ACS 500. The choices are 208, 220, 230, and 240 VAC for 230-volt units; 440, 460, 480, and 500 VAC for 480-volt units; 380, 400, and 415 VAC for 380-volt units; or 525, 550, 575, and 600 VAC for 600-volt units.

**E USER DISPLAY SCALE**

This parameter is used to set the scaling factor for Operating Data Parameter 2 (Speed). When set to 0, the speed display will show RPM. When set to 100, the speed display will show %. When set to any other value from 0 – 10000, the display will show this value (minus slip unless slip compensation is ON) when the output frequency is at the frequency set by Start-up Data Parameter I (Motor Base Frequency).

<b>F MOTOR CURRENT -FLA</b>	<p>This parameter matches the ACS 500 to the rated motor current, adjustable between 0 and 1000 amps. The drive uses this parameter for motor overload protection and current (amperage) information displays.</p> <p>If the accuracy of the current display (parameter O.3) is off by more than 10% due to long motor cables (ACS 501 units only), a software calculation can be installed by pressing and holding the [left arrow] until an exclamation point appears on the display. This will calculate the current based on the motor power and power factor. These parameters must be entered correctly for the calculation to be accurate.</p>
<b>G MOTOR POWER</b>	<p>This parameter matches the motor rated power, adjustable between 0.7 hp and 1340 hp. The drive uses this parameter for motor overload and kWh information displays. The left key switches the display between hp and kWh. To change the display, press and hold the left key for two seconds.</p>
<b>H MOTOR POWER FACTOR</b>	<p>This parameter matches the motor power factor (at rated speed and load on sinusoidal power), adjustable between 0.10 and 1.0. The drive uses this parameter for motor torque and power information displays.</p>
<b>I MOTOR BASE FREQUENCY</b>	<p>This parameter is used to set the designed frequency of the motor, adjustable from 30 Hz to 500 Hz in 10 Hz increments. Changing this value will automatically set the Field Weakening Point (FWP) to the same value.</p>
<b>J MOTOR BASE R.P.M.</b>	<p>This parameter is used to set the nameplate speed of the motor and is adjustable from 200 to the maximum 2 pole motor speed based on Start-up Data Parameter I (Motor Base Frequency).</p>
<b>K MOTOR NOM. VOLTAGE</b>	<p>This parameter is used to set the motor nameplate voltage. The default is 460 V for 480-volt units, 380 V for 380-volt units, and 230 V for 230-volt units. Changing this parameter automatically changes the Maximum Output Voltage.</p> <p><i>Note: If the motor rated voltage is lower than the supply voltage, make sure that the motor insulation is rated for the DC bus voltage level which is <math>V_{IN} \times 110\% \times 1.35 \times 1.3</math> minimum (input voltage <math>\times \pm 10\%</math> tolerance <math>\times</math> peak of rectified wave <math>\times</math> overvoltage limit).</i></p>

**This page intentionally left blank.**

## Chapter 4 – Control Operation

---

This chapter describes the Operating Data parameters and how to monitor and select them. It explains Keypad control and External control, and describes the Keypad Reference 1, Keypad PI, and External Reference 1 and 2 parameters.

### **Operating Data Parameters**

The Operating Data Parameter monitored values are updated five times a second.

Parameters 1 – 8 monitor drive functions and do not affect drive performance.

#### **Overview**

To monitor drive and motor activity, select Operating Data Parameters 1 – 8. These parameters display information about the ACS 500 and motor activity only. You cannot change the values of these parameters. Refer to *Motor Control Values* in this chapter for more information on the monitoring functions of Operating Data Parameters 1 – 8.

The Operating Data parameters begin with Parameter 1 (Output Frequency). Press [Up Arrow] or [Down Arrow] to move to the next Operating Data Parameter.

Figure 4-1 Operating Data Parameter 1

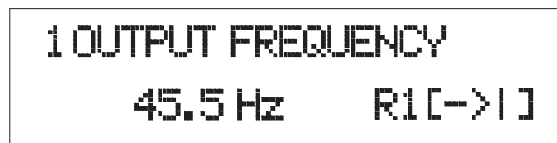


Table 4-1 lists the Operating Data Parameters, selected or monitored values, and functions.



Table 4-1 Operating Data Parameters

Parameter	Range/Unit	Description
1 OUTPUT FREQUENCY	Hz	Frequency to motor.
2 SPEED	rpm%/no units	Calculated speed, either motor RPM, %, or a scaled speed display. Displayed value is based on frequency minus slip.
3 MOTOR CURRENT	A	Motor current, (10% accuracy).
4 % RATED TORQUE	%	Calculated motor torque. 100 is the motor nominal torque rating, (15% accuracy).
5 % RATED POWER	%	Calculated motor power. 100 is the motor nominal power rating, (15% accuracy).
6 DC BUS VOLTAGE	V / %	Intermediate circuit DC voltage displayed in VDC and % of full voltage.
7 OUTPUT VOLTAGE	V	Calculated motor voltage, (5% accuracy).
8 DRIVE TEMPERATURE	degrees C and F	Temperature of the heatsink.
9 CONTROL LOCATION	KEYPAD R1/KEYPAD PI/ EXTERNAL	Control location selection (R1 = Referenced, PI = Closed loop controller).
10 KEYPAD REF 1	Hz	Frequency reference from Control Panel.
11 KEYPAD PI (REF 2)	%	Frequency reference (controller reference for PI) from Control Panel.
12 EXT REF 1 OR 2	REF1/REF2	External control place selection.
13 EXTERNAL REF 1	Hz	External frequency reference.
14 EXTERNAL REF 2	%	External controller reference.
15 RUN TIME	h/min	Elapsed time meter.
16 KILOWATT HOURS	kWh	kWh meter.
17 LAST-RECD FAULT	-	The latest fault and warning indication.
18 SECOND-RECD FAULT	-	The previous fault and warning indication.
19 FIRST-RECD FAULT	-	The oldest fault and warning indication.
20 PARAMETER LOCK	OPEN xxx/LOCKED xxx OPEN/LOCKED	Parameter software lock (xxx = 358 to unlock). Lock from Digital Inputs.

Parameter	Range/Unit	Description
21 APPL BLOCK OUTPUT *	Hz	PI-Controller output signal.
22 ACTUAL VALUE 1 *	%	Feedback signal for the PI-Controller.
23 ACTUAL VALUE 2 *	%	Feedback signal for the PI-Controller.
24 LAG MOTORS RUNNING **	0 – 3	Number of lag motors running in Pump and Fan Control.
25 CONTROLLER OUTPUT	%	PI-Controller output signal.
26 CONTROL DEVIATION	%	Difference between reference and actual signal.
27 ACT VALUE 1 (PFC)	Engineering Units	Actual (feedback) signal 1.
28 ACT VALUE 2 (PFC)	Engineering Units	Actual (feedback) signal 2.

\*) Visible only when PI-Control macro or P&F Autom. macro is selected.

\*\*\*) Visible only when P&F Autom. macro is selected.

You may change the values of some of the parameters to fit the needs of your application. For example, to control the ACS 500 from a control device other than the ACS 500 Control Panel keypad, follow these steps:

1. Press [left Arrow] or [Right Arrow] until the LCD Display displays any one of the Operating Data Parameters listed in Table 4-1.
2. Press [Up Arrow] or [Down Arrow] until 9 CONTROL LOCATION displays. KEYPAD R1 displays on the second line of the LCD Display.
3. Press [ \* ] to enter the Parameter Setting mode. This displays square brackets [ ] around the KEYPAD R1 display.
4. Press [Up Arrow] or [Down Arrow] to change the KEYPAD R1 display to EXTERNAL.
5. Press [ \* ] to save the selection and exit Setting mode.

This procedure allows you to operate the ACS 500 from a control device other than the ACS 500 Control Panel keypad.

### **Parameter Selection**

The following procedures describe the Operating Data parameters, how to change values, and how to advance through the parameters.

#### **1 OUTPUT FREQUENCY**

This parameter displays the ACS 500 frequency (Hz) to the motor. Press [Up Arrow] to move to the next parameter.

#### **2 SPEED**

This parameter displays a calculated speed based on load and slip compensation. With no slip compensation, motor speed decreases as load increases. As default, the speed is displayed in motor RPM. The scaling of this display is set by Start-up Data Parameter E (User Display Scale). The speed display can be scaled to show % or any other scaled value up to 10,000. This will allow the ACS 500 to display the process speed, i.e., cans per minute. Press [Up Arrow] to move to the next parameter.

#### **3 MOTOR CURRENT**

This parameter displays motor current. Long motor cables can cause an inaccurate current display. Press [Up Arrow] to move to the next parameter.

- 4 CALCULATED TORQUE** This parameter displays motor torque in percent of motor rating, as calculated by the drive. Press [Up Arrow] to move to the next parameter.
- 5 CALCULATED POWER** This parameter displays motor power in percent of motor rating, as calculated by the drive. Press [Up Arrow] to move to the next parameter.
- 6 DC BUS VOLTAGE** This parameter displays DC bus voltage, as measured in the drive. The voltage is displayed in volts DC and in % ( $100\% = 1.35 \times V_N$ ). Press [Up Arrow] to move to the next parameter.
- 7 OUTPUT VOLTAGE** This parameter displays motor voltage as calculated by the drive. Press [Up Arrow] to move to the next parameter.
- 8 DRIVE TEMPERATURE** This parameter displays the temperature of the drive heatsink in degrees Fahrenheit and degrees centigrade. Press [Up Arrow] to move to the next parameter.
- 9 CONTROL LOCATION** This parameter allows you to select the location of the drive controls for start/stop, speed reference, and rotation direction commands. Press [ \* ] to enter Setting mode. Press [Up Arrow] or [Down Arrow] to change the control location. Select:
- KEYPAD R1 to operate the drive from the Control Panel keypad.
  - EXTERNAL to operate the drive from an external control device connected to Terminal Block X50.
  - KEYPAD PI to use the Control Panel keypad to change the reference for a PI -Controller if using PI control.
- Press [ \* ] to save the setting.
- Press [Up Arrow] to move to the next parameter.
- 10 KEYPAD REF 1** This parameter displays the ACS 500 reference frequency (Hz) used when in Keypad R1. Press [ \* ] to enter Setting mode. Press [Up Arrow] or [Down Arrow] to change the value of the reference frequency. This parameter can be set while viewing any of the first eight Operating Data parameters. Press [ \* ] to save the setting. Press [Up Arrow] to move to the next parameter.
- 11 KEYPAD PI (REF 2)** This parameter displays the ACS 500 keypad reference used when in Keypad PI. Press [ \* ] to enter Setting mode. Press [Up Arrow] or [Down Arrow] to change the value of the reference. Press [ \* ] to save the setting. Press [Up Arrow] to move to the next parameter.
- 12 EXT REF 1 OR 2** This parameter allows you to select between two external control locations. Use this parameter when Parameter 10.2.1 (Ext 1/Ext 2 Select) is set to KEYPAD, otherwise the external control location is selected by a digital input. Press [ \* ] to enter Setting mode. Press [Up Arrow] or [Down Arrow] to change the external control location. Press [ \* ] to save the setting. Press [Up Arrow] to move to the next parameter.
- 13 EXTERNAL REF 1** This parameter is the external frequency reference (Hz) from control location R1. The signal source selection is made with Parameter 10.2.2 (External Ref1 Sel). Press [Up Arrow] to move to the next parameter.

- 14 EXTERNAL REF 2** This parameter is the external frequency reference from control location R2, displayed in percent. The signal source selection is made with Parameter 10.2.5 (External Ref2 Sel). Press [Up Arrow] to move to the next parameter.
- 15 RUN TIME** This parameter is an elapsed-time indicator. It counts time that a drive has an Enable signal and a Start command, and is not in a faulted state. Counted time cannot be reset. Press [Up Arrow] to move to the next parameter.
- 16 KILOWATT HOURS** This parameter counts kilowatt hours of drive operation. Press [Up Arrow] to move to the next parameter.
- 17 LAST-RECD FAULT** This parameter displays the name of the most recent fault/warning message. Refer to *Chapter 5 – Fault Tracing* in the *Installation & Start-up Manual* for information on resetting faults. Press [Up Arrow] to move to the next parameter.
- 18 SECOND-RECD FAULT** This parameter displays the name of the second most recent fault/warning message. Refer to *Chapter 5 – Fault Tracing* in the *Installation & Start-up Manual* for information on resetting faults. Press [Up Arrow] to move to the next parameter.
- 19 FIRST-RECD FAULT** This parameter displays the name of the third most recent fault/warning message. Refer to *Chapter 5 – Fault Tracing* in the *Installation & Start-up Manual* for information on resetting faults. Press [Up Arrow] to move to the next parameter.
- 20 PARAMETER LOCK** This parameter indicates if the parameters are locked or open. If LOCKED or OPEN are followed by xxx, then the parameter lock is from the Keypad, otherwise the parameter lock is from a digital input. The parameter lock allows you to lock all the ACS 500 parameters, protecting the parameters from unauthorized changes through parameter Setting mode. Parameter 10.4.3 (Param. Lock Sel) allows you to select the Parameter Lock control location. You may view locked parameters at any time.
- When Parameter Lock is from the Keypad:
- To lock: Press [ \* ] to enter Setting mode. Press [Up Arrow] or [Down Arrow] to change from OPEN xxx to LOCKED xxx. Press [ \* ] to save the setting. Press [Up Arrow] to move to the next parameter. To unlock the parameters:
1. Return to Operating Data Parameter 20 (Parameter Lock). The LCD Display shows LOCKED xxx.
  2. Press [ \* ] to enter Setting mode.
  3. Press and hold [Up Arrow] to change LOCKED xxx to LOCKED 358.
  4. Press [ \* ] to open the Parameter Lock. The LCD Display shows OPEN xxx.
- 21 APPL BLOCK OUTPUT** This parameter is the PI-Controller output signal. Refer to Figure 4-3 in the *External Control* section of this chapter. Press [Up Arrow] to move to the next parameter.
- 22 ACTUAL VALUE 1** This parameter is a feedback signal to the PI-Controller, displayed in percent. Press [Up Arrow] to move to the next parameter.

<i>23 ACTUAL VALUE 2</i>	This parameter is a feedback signal to the PI-Controller, displayed in percent. Press [Up Arrow] to move to the next parameter.
<i>24 LAG MOTRS RUNNING</i>	Number of lag motors running in Pump and Fan control.
<i>25 CONTROLLER OUTPUT</i>	Output value of the PI-Controller. Value is in percent of the regulation range.
<i>ACT VALUE 1 (PFC)</i>	Unscaled actual feedback signal number one. Displayed in the units set by Parameter 40.2.30 (Display Unit).
<i>ACT VALUE 2 (PFC)</i>	Unscaled actual feedback signal number two. Displayed in the units set by Parameter 40.2.31 (Displ Unit Scale).

### **Motor Control Values**

During motor operation, or when troubleshooting, you may need to check the vital statistics of the motor and drive. Operating Data Parameters 1 – 8 allow you to view motor and drive activity.

When controlling the drive from the keypad, you may adjust motor speed while displaying Operating Data Parameters 1 – 8. To do this while viewing these parameters:

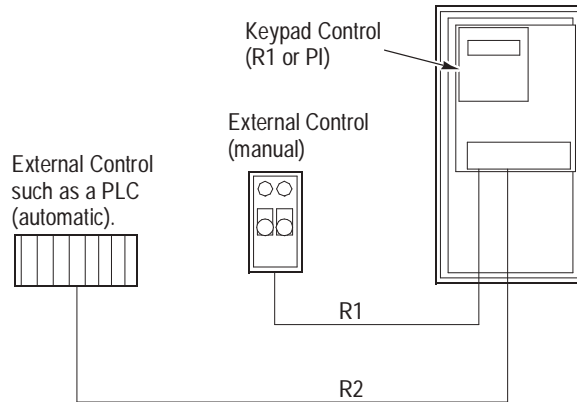
1. Press [ \* ] to enter the Setting mode.
2. Press [Up Arrow] to increase motor speed or [Down Arrow] to decrease motor speed.

When viewing Operating Data Parameters 1 (Output Frequency) and 2 (Speed), the LCD display changes to show Operating Data Parameter 10 (Keypad Ref 1) while pressing the [Up Arrow] or [Down Arrow].

## Keypad Control vs. External Control

The ACS 500 can be controlled from two external control locations or from the Control Panel keypad. Figure 4-2 shows all control locations.

Figure 4-2 Control Locations



Select Operating Data Parameter 9 (Control Location), then select KEYPAD R1 for keypad control or EXTERNAL for external control. The valid control location is indicated on the display. Square brackets around the Direction and Run indicators on the LCD Display mean Keypad control. No square brackets means External control. R1 on the LCD means Ref 1 and R2 means Ref 2.

### Keypad Control

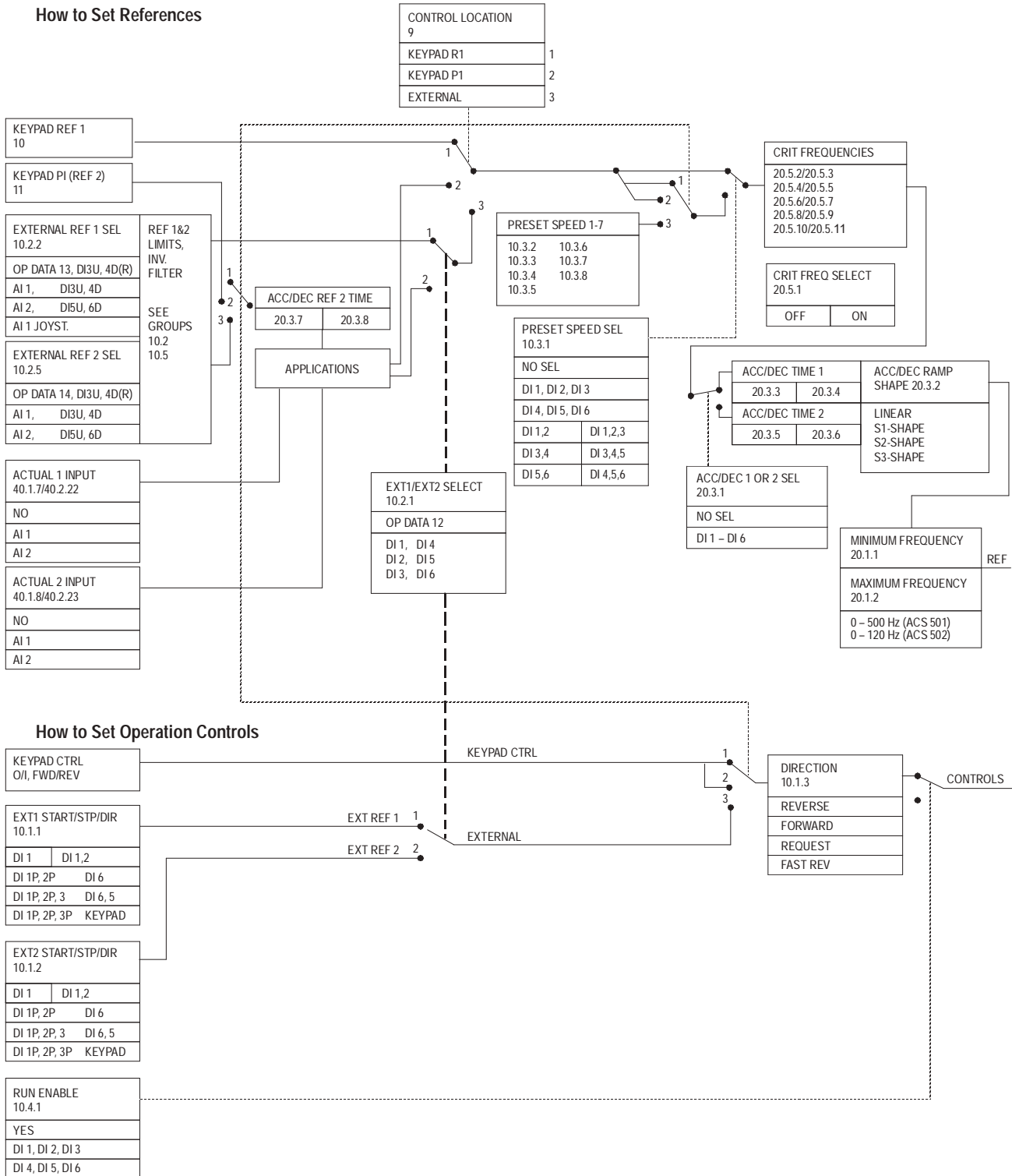
When you select KEYPAD R1 or KEYPAD PI from Operating Data Parameter 9, Keypad commands operate the ACS 500.

### External Control

External control locations Ref 1 and Ref 2 are selected with digital inputs 1 – 6 or Operating Data Parameter 12 (Ext Ref 1 or 2), depending on the setting of Parameter 10.2.1 (Ext 1/Ext 2 Select).

Figure 4-3 shows a signal flow diagram indicating the control signal selections.

Figure 4-3 Control Signal Selection



## Keypad Reference 1 and Keypad PI

### Keypad Reference 1

Operating Data Parameter 10 (Keypad Ref 1) is a direct frequency reference. To set the frequency reference, select Parameter 10 (Keypad Ref 1), press [ \* ], then press [Up Arrow] or [Down Arrow] keys to increase or decrease the keypad reference.

When in Keypad control using Reference 1, you can change the Keypad Reference value while monitoring any of the measured values 1 – 8. For example, you can monitor Operating Data Parameter 7 (Output Voltage) while changing the frequency. To do this, select the measured value you prefer, press [ \* ], then press [Up Arrow] or [Down Arrow] to increase or decrease the reference frequency. If Operating Data Parameters 1 (Output Frequency) or 2 (Speed) are selected, the display will switch to show Parameter 10 (Keypad Ref 1) while changing the reference and will automatically change back when the arrow key is released.

If the ACS 500 is running with an External Reference and the control location is changed to Keypad R1, it is possible to let the Keypad Ref 1 assume the current value of the External Reference.

Example: The ACS 500 is receiving frequency reference from a transducer via Terminal Block X50. You want to temporarily override the external frequency reference.

1. Set Operating Data Parameter 9 (Control Location) to KEYPAD R1.
2. Press and hold down [Start/Stop] and press [ \* ].

*Note: If external Start/Stop function is set to Keypad, the ACS 500 will stop, but will read the reference.*

The ACS 500 puts the value of External Reference into Operating Data Parameter 10 (Keypad Ref 1) which will make a smooth transition from External to Keypad possible. You may now control the drive manually by Keypad Ref 1.

If you enter Display mode by pressing [ \* ] after setting Operating Data Parameter 9 (Control Location) to KEYPAD R1, the value of Operating Data Parameter 10 (Keypad Ref 1) will be the set minimum frequency.

### Keypad PI (Ref 2)

Keypad PI goes through an application block, where it can be manipulated when the PI-Controller is selected. Keypad PI can be used as controller reference or it can be given its own acceleration/deceleration ramps. Refer to Parameters 20.3.7 (Accel Ref 2 Time) and 20.3.8 (Decel Ref 2 Time).



## **External Reference 1 and 2**

*External Reference 1* This is the external frequency reference from control location R1. The signal source selection is made with Parameter 10.2.2 (External Ref 1 Sel).

*External Reference 2* This is the external reference from control location R2. The signal source selection is made with Parameter 10.2.5 (External Ref 2 Sel). External Reference 2 goes through an application block, where it can be manipulated as Keypad Reference 2.

## **Password Protection (Parameter Lock)**

Parameter Lock prevents unauthorized persons from altering the parameters. If Parameter Lock is active through Operating Data Parameter 23 (Parameter Lock) or Parameter 10.4.3 (Param. Lock Sel) (Keypad, DI1 – DI6), it is not possible to select the Setting mode to change any ACS 500 parameters, but all parameters may be accessed and viewed.

The ACS 500 Parameter Lock can be controlled with Keypad (Operating Data Parameter 23 (Parameter Lock)) or a digital input. The control location is selected with Parameter 10.4.3 (Param. Lock Sel) (Keypad, DI1 – DI6). To activate the Parameter Lock, set Operating Data Parameter 23 (Parameter Lock) to LOCKED xxx (if the control location is the Keypad) or activate the selected digital input (if the control location is a DI setting).

The Parameter Lock control location is indicated in Operating Data Parameter 23 (Parameter Lock). Characters xxx after the parameter value (OPEN xxx, LOCKED xxx) indicate that the current control location is Keypad.

To open the Parameter Lock, you must enter the correct combination. The combination for all ACS 500 units is 358. When viewing Parameter Lock, enter setting mode and set the 358 code. Press [ \* ] to open the Parameter Lock.

## Chapter 5 – Standard Application Macro Programs

---

This chapter describes the operation and application suitability of six standard Application macros and the User macro.

The chapter begins with Table 5-1 which lists the macros, suitable applications for each, what each macro controls, and how to access each macro to modify its parameters.

The remainder of this chapter contains the following information for each macro:

- Operation
- Input and Output Signals
- External Connections
- Parameter Settings

### **User Macro**

The User macro allows the current parameter settings to be stored in memory.

To store your customized parameters:

1. Access the Start-up Data menu.
2. Change Parameter B (Application) to USER save.
3. Press [ \* ] to save.
4. Press [ \* ] for each of the remaining Start-up Data Parameters to get back to the Operating Data.

The current settings are now stored in the User macro. Changes can be made to the programming without losing the parameters saved to the User Macro.

To recall the last saved parameters or User macro:

1. Access the Start-up Data menu.
2. Change Parameter B (Application) to USER load.
3. Press [ \* ] to load.
4. Press [ \* ] for each of the remaining Start-up Data Parameters to get back to the Operating Data.

## Macro Applications and Access

Table 5-1 Macro Applications and Access

Macro	Suitable Applications	Controls	Select
Factory	<p>Conveyors and other constant torque industrial applications.</p> <p>Vibration endurance test benches needing variable speeds of vibrating motors.</p> <p>Testing of rotating machines.</p> <p>Drives to be run long periods with constant speed different from the nominal speed of the drive.</p> <p>All applications needing traditional external controls.</p>	Keypad, External	FACTORY
Hand/Auto	<p>Processes requiring motor speed control both automatically with PLC or other process automation and manually with a remote control panel. Active control location selection with digital input.</p> <p>Speed controls having one or two external control locations with reference setting and START/STOP control. Active reference selection with digital input.</p>	Ext1, Ext2	HAND/AUTO
PI-Control	<p>Intended for use with different closed loop control systems such as pressure control, level control, and flow control. For example:</p> <ul style="list-style-type: none"> <li>• Booster pumps of municipal water supply systems.</li> <li>• Automatic level control of water reservoirs.</li> <li>• Booster pumps of district heating systems.</li> <li>• Speed control of different types of material handling systems where material flow has to be regulated (use linear V/Hz-curve.)</li> </ul>	Process	PI-CONTROL
Option Pack	Fans and pumps when factory supplied option pack on ACS 501 units, or when Hand/Off/Auto or Bypass are supplied on ACS 502 units.	Enclosure Mounted Operator Devices, External Signals	OPT. PACK
Sequential Control	Processes requiring motor speed control in addition to the adjustable speed with 1 to 7 preset speeds and/or with two different acceleration/deceleration times automatically with PLC or other process automation or using manual speed selection switches.	Regulated Constant Speed	SEQ CTRL
Pump and Fan	<p>Closed loop control systems utilizing pumps or fans such as constant pressure control, level control, or flow control.</p> <ul style="list-style-type: none"> <li>• Booster pumps of municipal water supply systems.</li> <li>• Automatic level control of water reservoirs.</li> <li>• Pumps and fans of waste water treatment plants.</li> <li>• Cooling tower fan drives.</li> <li>• Combustion air and exhaust gas fans of power plants.</li> </ul>	Process	P & F AUTOM.
Speed Control	<p>Closed loop speed control for more precise control of motor speed.</p> <p><b>Requires SNAT 7610 BAC option card.</b> For a complete description and parameter listing, see the Users Manual for the SNAT 7610 BAC option board.</p>		SPEED CTRL

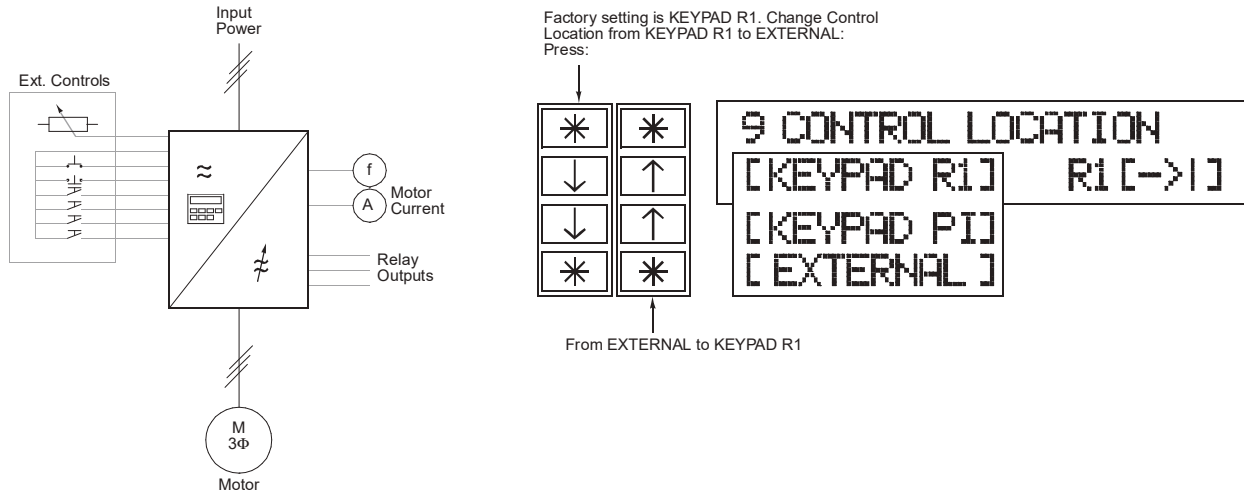
Refer to Appendix A – Complete Parameter Settings for the alternative settings for all parameters.

## Application 1 – Factory Macro

All drive commands, reference settings, and parameter settings can be undertaken from the local keypad or through the screw terminals (external). Select the control device with Parameter 9 (Control Location). Two analog and three relay output contact signals are available on Terminal Block X50.

### Operation Diagram

Figure 5-1 Operation Diagram



### Input and Output Signals

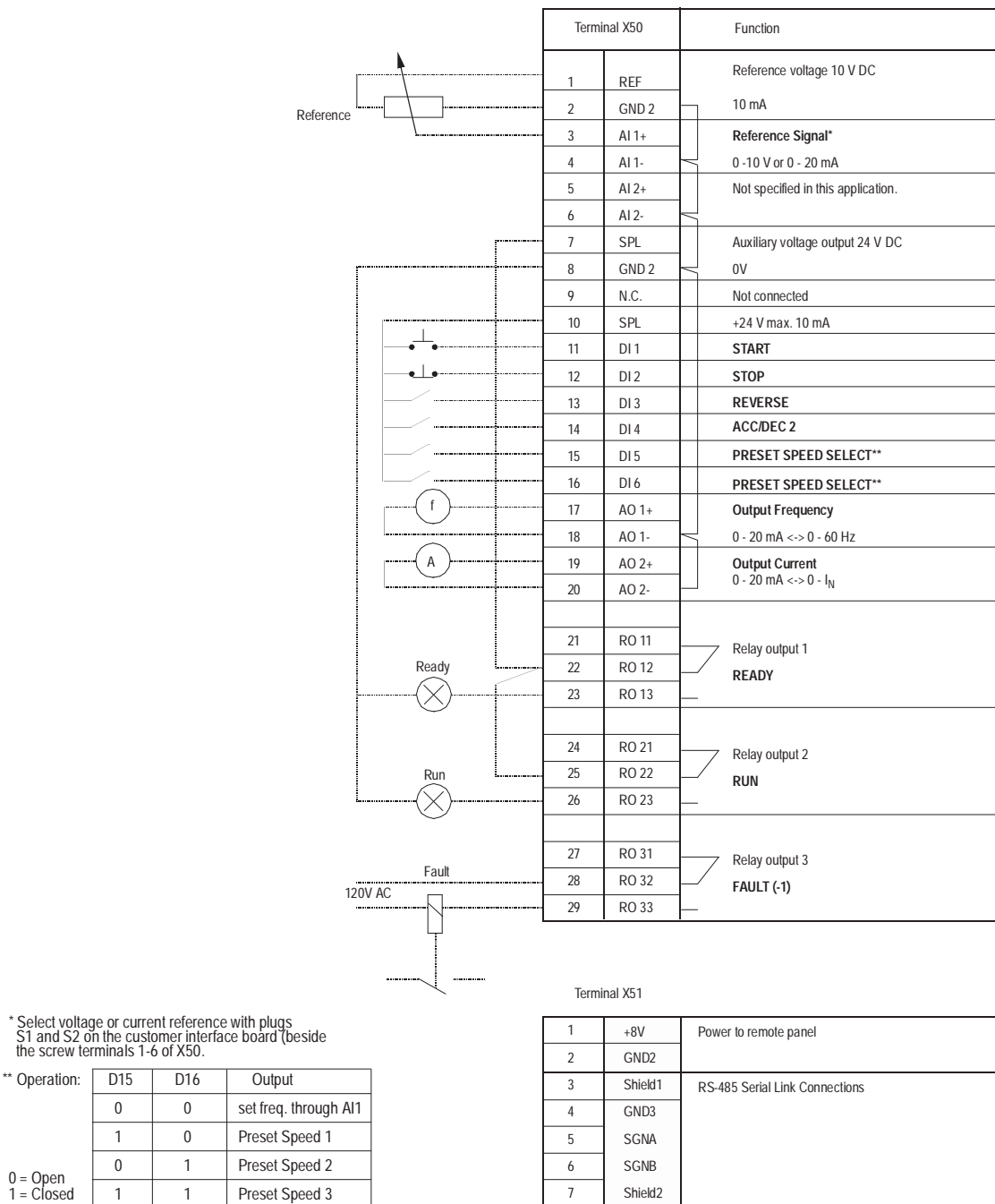
Table 5-2 Input and Output Signals

Input Signals	Output Signals
Start, Stop, Direction, ACC/DEC 1/2, and two Preset Speeds. One Analog Reference input.	Analog Output AO1: Output Frequency Analog Output AO2: Output Current Relay Output RO1: READY Relay Output RO2: RUN Relay Output RO3: FAULT (-1)

## Factory Macro External Connections

### Connection Example

Figure 5-2 Factory Macro Connection Example



## Factory Macro Parameter Settings

### START-UP DATA

A LANGUAGE	→ ENGLISH
B APPLICATIONS	→ FACTORY
C APPLIC. RESTORE	→ NO
D SUPPLY VOLTAGE	→ 480/230/380
E USER DISPLAY SCALE	→ 0
F MOTOR CURRENT -FLA	→ $I_N$ of drive
G MOTOR POWER (kW)	→ $P_N$ of drive
H MOTOR POWER FACTOR	→ 0.83
I MOTOR BASE FREQ.	→ 60
J MOTOR BASE R.P.M.	→ 1728
K MOTOR NOM. VOLTAGE	→ 460/230/380

### OPERATING DATA

1 OUTPUT	
2 SPEED	
3 MOTOR CURRENT	
4 % RATED TORQUE	
5 % RATED POWER	
6 DC BUS VOLTAGE	
7 OUTPUT VOLTAGE	
8 DRIVE TEMPERATURE	
9 CONTROL LOCATION	→ KEYPAD R1
10 KEYPAD REF 1	
11 KEYPAD PI (REF 2)	
12 EXT REF 1 OR 2	REF 1
13 EXTERNAL REF 1	
14 EXTERNAL REF 2	
15 RUN TIME	
16 KILOWATT HOURS	
17 LAST-RECD FAULT	
18 SECOND-RECD FAULT	
19 FIRST-RECD FAULT	
20 PARAMETER LOCK	OPEN

### 10 CONTROL CONNECTIONS

#### 10.1 START/STOP/DIRECTION

10.1.1 EXT 1 STRT/STP/DIR	DI1P,2P,3
10.1.2 EXT 2 STRT/STP/DIR	NOT SEL
10.1.3 LOC/EXT DIRECTION	→ FORWARD

#### 10.2 EX REFERENCE SELECT

10.2.1 EXT 1/EXT 2 SELECT	OP DATA 12
10.2.2 EXTERNAL REF1 SEL	AI1
10.2.3 EXT REF1 MINIMUM	0 Hz
10.2.4 EXT REF1 MAXIMUM	60 Hz
10.2.7 EXTERNAL REF2 SEL	OP DATA 14
10.2.8 EXT REF2 MINIMUM	0 Hz
10.2.9 EXT REF2 MAXIMUM	60 Hz

#### 10.3 PRESET SPEEDS

10.3.1 PRESET SPEED SEL	DI5,6
10.3.2 PRESET SPEED 1	→ 5 Hz
10.3.3 PRESET SPEED 2	→ 10 Hz
10.3.4 PRESET SPEED 3	→ 15 Hz

#### 10.4 SYSTEM CONTR INPUTS

10.4.1 RUN ENABLE	YES
10.4.2 FAULT RESET SELECT	NOT SEL
10.4.3 PARAM. LOCK SEL	OP DATA 20
10.4.4 EXTERNAL FAULT	NOT SEL

### 10.5 ANALOG INPUTS

10.5.1 MINIMUM AI1	→ 0 V/0 mA
10.5.2 MAXIMUM AI1	→ 10 V/20 mA
10.5.3 RC FILTER ON AI1	0.1s
10.5.4 INVERT AI1	NO
10.5.5 MINIMUM AI2	0 V/0 mA
10.5.6 MAXIMUM AI2	10 V/20 mA
10.5.7 RC FILTER ON AI2	0.1s
10.5.8 INVERT AI2	NO

### 10.6 RELAY OUTPUTS

10.6.1 RELAY RO1 OUTPUT	READY
10.6.2 RELAY RO2 OUTPUT	RUN
10.6.3 RELAY RO3 OUTPUT	FAULT (-1)

### 10.7 ANALOG OUTPUTS

10.7.1 ANALOG OUTPUT 1	OUT FREQ
10.7.2 SCALE AO1	100%
10.7.3 MINIMUM AO1	→ 0 mA
10.7.4 RC FILTER ON AO1	2s
10.7.5 INVERT AO1	NO
10.7.6 ANALOG OUTPUT 2	OUT CURR
10.7.7 SCALE AO2	100%
10.7.8 MINIMUM AO2	→ 0 mA
10.7.9 RC FILTER ON AO2	2s
10.7.10 INVERT AO2	NO

### 20 DRIVE PARAMETERS

#### 20.1 FREQ/CURRENT LIMITS

20.1.1 MINIMUM FREQUENCY	→ 0 Hz
20.1.2 MAXIMUM FREQUENCY	→ 60 Hz
20.1.3 FREQUENCY RANGE	0 – 120 Hz
20.1.4 CURRENT LIMIT	→ $1.5 \times I_N$

#### 20.2 START/STOP

20.2.1 START FUNCTION	RAMP
20.2.2 TORQUE BOOST CURR	$1.5 \times I_N$
20.2.3 STOP FUNCTION	COAST
20.2.4 BRAKE CHOPPER	NO
20.2.5 DC HOLD	OFF
20.2.6 DC HOLD VOLTAGE	$0.01 \times V_N$
20.2.7 DC BRAKE VOLTAGE	$0.01 \times V_N$
20.2.8 DC BRAKE TIME	0s

#### 20.3 ACCEL/DECCEL

20.3.1 ACC/DEC 1 OR 2 SEL	DI4
20.3.2 ACC/DEC RAMP SHAPE	LINEAR
20.3.3 ACCEL TIME 1	→ 3s
20.3.4 DECEL TIME 1	→ 3s
20.3.5 ACCEL TIME 2	60s
20.3.6 DECEL TIME 2	60s

#### 20.4 MOTOR CONTROL

20.4.1 SWITCHING FREQ	3 kHz
20.4.2 MAX OUTPUT VOLTAGE	460 V
20.4.3 V/HZ RATIO	LINEAR
20.4.4 FIELD WEAK POINT	60 Hz
20.4.5 IR COMPENSATION	NO
20.4.6 IR COMP VOLTAGE	$0.01 \times V_N$
20.4.7 IR COMP RANGE	0 Hz
20.4.8 SLIP COMPENSATION	OFF
20.4.9 NOMINAL SLIP	4%
20.4.10 VOLTAGE LIMIT	ON

### 20.5 CRIT FREQUENCIES

20.5.1 CRIT FREQ SELECT	OFF
20.5.2 CRIT FREQ 1 LOW	0 Hz
20.5.3 CRIT FREQ 1 HIGH	0 Hz
20.5.4 CRIT FREQ 2 LOW	0 Hz
20.5.5 CRIT FREQ 2 HIGH	0 Hz
20.5.6 CRIT FREQ 3 LOW	0 Hz
20.5.7 CRIT FREQ 3 HIGH	0 Hz
20.5.8 CRIT FREQ 4 LOW	0 Hz
20.5.9 CRIT FREQ 4 HIGH	0 Hz
20.5.10 CRIT FREQ 5 LOW	0 Hz
20.5.11 CRIT FREQ 5 HIGH	0 Hz

### 30 PROTECTION/INFORMAT

#### 30.1 FAULT FUNCTION

30.1.1 SERIAL FAULT FUNC	STOP
30.1.2 AI <MIN FUNCTION	NO
30.1.3 MOT TEMP FLT FUNC	→ FAULT
30.1.4 MOTOR THERM TIME	700s
30.1.5 MOTOR LOAD CURVE	100%
30.1.6 ZERO SPEED LOAD	40%
30.1.7 BREAK POINT	60 Hz
30.1.8 STALL FUNCTION	WARNING
30.1.9 STALL CURRENT	$1.2 \times I_N$
30.1.10 STALL TIME/FREQ	20s/25 Hz
30.1.11 UNDERLOAD FUNC	NO
30.1.12 UNDERLOAD TIME	600s
30.1.13 UNDERLOAD CURVE	1

#### 30.2 AUTOMATIC RESET

30.2.1 NUMBER OF RESETS	2
30.2.2 TIME WINDOW	30s
30.2.3 TIME BETW. RES ATT	0
30.2.4 OVERVOLTAGE	NO
30.2.5 UNDERVOLTAGE	YES
30.2.6 OVERCURRENT	NO
30.2.7 AI SIGNAL <MIN	NO

#### 30.3 SUPERVISION

30.3.1 OUTPUT FREQ 1 FUNC	NO
30.3.2 OUTPUT FREQ 1 LIM	0
30.3.3 OUTPUT FREQ 2 FUNC	NO
30.3.4 OUTPUT FREQ 2 LIM	0
30.3.5 CURRENT FUNCTION	NO
30.3.6 CURRENT LIMIT	$0 \times I_N$
30.3.7 REF1 FUNCTION	NO
30.3.8 REF1 LIMIT	0 Hz
30.3.9 REF2 FUNCTION	NO
30.3.10 REF2 LIMIT	0%
30.3.11 SUPERVIS MESSAGES	ON

#### 30.4 INFORMATION

30.4.11 CRI PROG VERSION	(version)
30.4.2 MC PROG VERSION	(version)
30.4.3 TEST DATE	(date)

→ = Typical parameter values to check during start-up. If needed, change values to meet the needs of your application. Complete parameter list provided in Appendix A.

## Application 2 – Hand/Auto Control

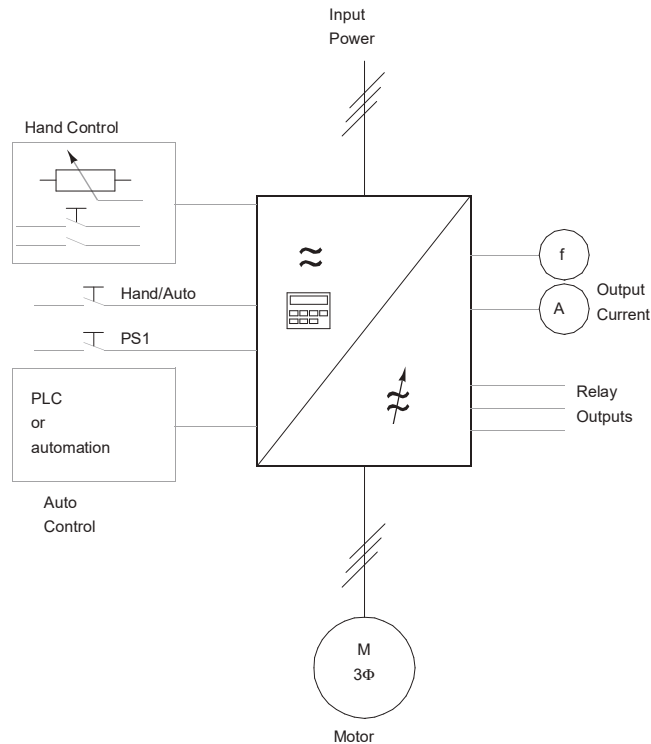
START/STOP and REVERSE commands and reference settings can be issued selectively from two different external control places, Ext1 and Ext2.

Control location selection is through digital input. Control is also possible with KEYPAD. One preset speed is available.

Two analog and three relay output contact signals are available on Terminal Block X50.

### Operation Diagram

Figure 5-3 Operation Diagram



### Input and Output Signals

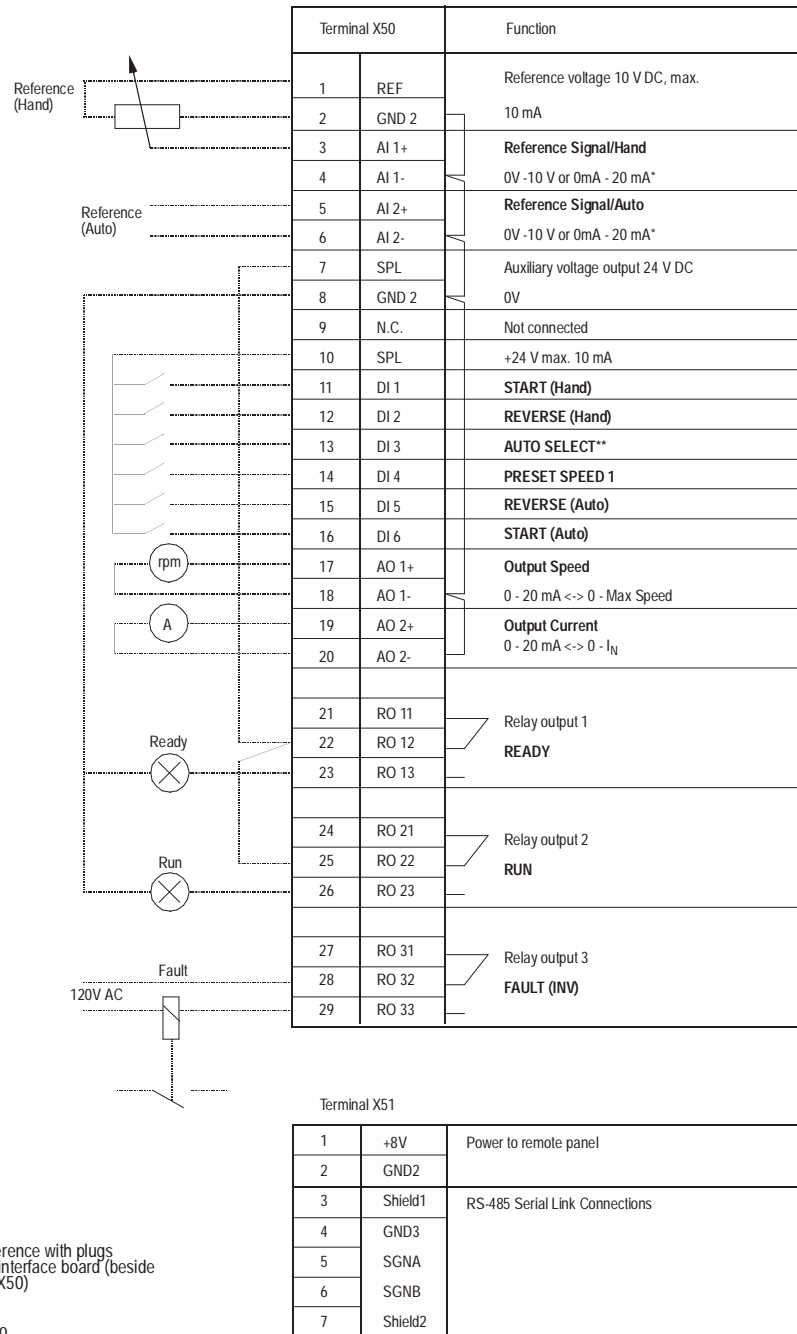
Table 5-3 Input and Output Signals

Input Signals	Output Signals
Two analog reference inputs, START/STOP and REVERSE-switch input for each control location. Control switch inputs for selection of the location and one preset speed.	Analog Output AO1: Output Frequency Analog Output AO2: Output Current Relay Output RO1: READY Relay Output RO2: RUN Relay Output RO3: FAULT (-1)

## Hand/Auto External Connections

### Connection Example

Figure 5-4 Connection Example





## Hand/Auto Parameter Settings

### START-UP DATA

A LANGUAGE	→ ENGLISH
B APPLICATIONS	→ HAND/AUTO CTRL
C APPLIC. RESTORE	→ NO
D SUPPLY VOLTAGE	→ 480/230/380
E USER DISPLAY SCALE	→ 0
F MOTOR CURRENT -FLA	→ I <sub>N</sub> of drive
G MOTOR POWER (kW)	→ P <sub>N</sub> of drive
H MOTOR POWER FACTOR	→ 0.83
I MOTOR BASE FREQ.	→ 60
J MOTOR BASE R.P.M.	→ 1728
K MOTOR NOM. VOLTAGE	→ 460/230/380

### OPERATING DATA

1 OUTPUT	
2 SPEED	
3 MOTOR CURRENT	
4 % RATED TORQUE	
5 % RATED POWER	
6 DC BUS VOLTAGE	
7 OUTPUT VOLTAGE	
8 DRIVE TEMPERATURE	
9 CONTROL LOCATION	→ EXTERNAL
10 KEYPAD REF 1	
11 KEYPAD PI (REF 2)	
12 EXT REF 1 OR 2	REF 1
13 EXTERNAL REF 1	
14 EXTERNAL REF 2	
15 RUN TIME	
16 KILOWATT HOURS	
17 LAST-RECD FAULT	
18 SECOND-RECD FAULT	
19 FIRST-RECD FAULT	
20 PARAMETER LOCK	OPEN

### 10 CONTROL CONNECTIONS

#### 10.1 START/STOP/DIRECTION

10.1.1 EXT 1 STRT/STP/DIR	DI1,2
10.1.2 EXT 2 STRT/STP/DIR	DI6,5
10.1.3 LOC/EXT DIRECTION	→ REQUEST

#### 10.2 EX REFERENCE SELECT

10.2.1 EXT 1/EXT 2 SELECT	DI3
10.2.2 EXTERNAL REF1 SEL	AI1
10.2.3 EXT REF1 MINIMUM	0 Hz
10.2.4 EXT REF1 MAXIMUM	60 Hz
10.2.7 EXTERNAL REF2 SEL	AI2
10.2.8 EXT REF2 MINIMUM	0 Hz
10.2.9 EXT REF2 MAXIMUM	60 Hz

#### 10.3 PRESET SPEEDS

10.3.1 PRESET SPEED SEL	DI4
10.3.2 PRESET SPEED 1	→ 5 Hz

#### 10.4 SYSTEM CONTR INPUTS

10.4.1 RUN ENABLE	YES
10.4.2 FAULT RESET SELECT	NOT SEL
10.4.3 PARAM. LOCK SEL	OP DATA 20
10.4.4 EXTERNAL FAULT	NOT SEL

### 10.5 ANALOG INPUTS

10.5.1 MINIMUM AI1	→ 0 V/0 mA
10.5.2 MAXIMUM AI1	→ 10 V/20 mA
10.5.3 RC FILTER ON AI1	0.1s
10.5.4 INVERT AI1	NO
10.5.5 MINIMUM AI2	0 V/0 mA
10.5.6 MAXIMUM AI2	10 V/20 mA
10.5.7 RC FILTER ON AI2	0.1s
10.5.8 INVERT AI2	NO

### 10.6 RELAY OUTPUTS

10.6.1 RELAY RO1 OUTPUT	READY
10.6.2 RELAY RO2 OUTPUT	RUN
10.6.3 RELAY RO3 OUTPUT	FAULT (-1)

### 10.7 ANALOG OUTPUTS

10.7.1 ANALOG OUTPUT 1	MOT SPEED
10.7.2 SCALE AO1	100%
10.7.3 MINIMUM AO1	→ 0 mA
10.7.4 RC FILTER ON AO1	2s
10.7.5 INVERT AO1	NO
10.7.6 ANALOG OUTPUT 2	OUT CURR
10.7.7 SCALE AO2	100%
10.7.8 MINIMUM AO2	→ 0 mA
10.7.9 RC FILTER ON AO2	2s
10.7.10 INVERT AO2	NO

### 20 DRIVE PARAMETERS

#### 20.1 FREQ/CURRENT LIMITS

20.1.1 MINIMUM FREQUENCY	→ 0 Hz
20.1.2 MAXIMUM FREQUENCY	→ 60 Hz
20.1.3 FREQUENCY RANGE	0 – 120 Hz
20.1.4 CURRENT LIMIT	→ 1.5 x I <sub>N</sub>

#### 20.2 START/STOP

20.2.1 START FUNCTION	RAMP
20.2.2 TORQUE BOOST CURR	1.5 x I <sub>N</sub>
20.2.3 STOP FUNCTION	COAST
20.2.4 BRAKE CHOPPER	NO
20.2.5 DC HOLD	OFF
20.2.6 DC HOLD VOLTAGE	0.01 x V <sub>N</sub>
20.2.7 DC BRAKE VOLTAGE	0.01 x V <sub>N</sub>
20.2.8 DC BRAKE TIME	0s

#### 20.3 ACCEL/DECEL

20.3.1 ACC/DEC 1 OR 2 SEL	NOT SEL
20.3.2 ACC/DEC RAMP SHAPE	LINEAR
20.3.3 ACCEL TIME 1	→ 3s
20.3.4 DECEL TIME 1	→ 3s
20.3.7 ACCEL REF2 TIME	→ 0.1s
20.3.8 DECEL REF2 TIME	→ 0.1s

#### 20.4 MOTOR CONTROL

20.4.1 SWITCHING FREQ	3 kHz
20.4.2 MAX OUTPUT VOLTAGE	460 V
20.4.3 V/Hz RATIO	LINEAR
20.4.4 FIELD WEAK POINT	60 Hz
20.4.5 IR COMPENSATION	NO
20.4.6 IR COMP VOLTAGE	0.01 x V <sub>N</sub>
20.4.7 IR COMP RANGE	0 Hz
20.4.8 SLIP COMPENSATION	OFF
20.4.9 NOMINAL SLIP	4%
20.4.10 VOLTAGE LIMIT	ON

### 20.5 CRIT FREQUENCIES

20.5.1 CRIT FREQ SELECT	OFF
20.5.2 CRIT FREQ 1 LOW	0 Hz
20.5.3 CRIT FREQ 1 HIGH	0 Hz
20.5.4 CRIT FREQ 2 LOW	0 Hz
20.5.5 CRIT FREQ 2 HIGH	0 Hz
20.5.6 CRIT FREQ 3 LOW	0 Hz
20.5.7 CRIT FREQ 3 HIGH	0 Hz
20.5.8 CRIT FREQ 4 LOW	0 Hz
20.5.9 CRIT FREQ 4 HIGH	0 Hz
20.5.10 CRIT FREQ 5 LOW	0 Hz
20.5.11 CRIT FREQ 5 HIGH	0 Hz

### 30 PROTECTION/INFORMAT

#### 30.1 FAULT FUNCTION

30.1.1 SERIAL FAULT FUNC	STOP
30.1.2 AI <MIN FUNCTION	NO
30.1.3 MOT TEMP FLT FUNC	→ FAULT
30.1.4 MOTOR THERM TIME	700s
30.1.5 MOTOR LOAD CURVE	100%
30.1.6 ZERO SPEED LOAD	40%
30.1.7 BREAK POINT	60 Hz
30.1.8 STALL FUNCTION	WARNING
30.1.9 STALL CURRENT	1.2 x I <sub>N</sub>
30.1.10 STALL TIME/FREQ	20s/25 Hz
30.1.11 UNDERLOAD FUNC	NO
30.1.12 UNDERLOAD TIME	600s
30.1.13 UNDERLOAD CURVE	1

#### 30.2 AUTOMATIC RESET

30.2.1 NUMBER OF RESETS	2
30.2.2 TIME WINDOW	30s
30.2.3 TIME BETW. RES ATT	0
30.2.4 OVERVOLTAGE	NO
30.2.5 UNDERVOLTAGE	YES
30.2.6 OVERCURRENT	NO
30.2.7 AI SIGNAL <MIN	NO

#### 30.3 SUPERVISION

30.3.1 OUTPUT FREQ 1 FUNC	NO
30.3.2 OUTPUT FREQ 1 LIM	0
30.3.3 OUTPUT FREQ 2 FUNC	NO
30.3.4 OUTPUT FREQ 2 LIM	0
30.3.5 CURRENT FUNCTION	NO
30.3.6 CURRENT LIMIT	0 x I <sub>N</sub>
30.3.7 REF1 FUNCTION	NO
30.3.8 REF1 LIMIT	0 Hz
30.3.9 REF2 FUNCTION	NO
30.3.10 REF2 LIMIT	0%
30.3.11 SUPERVIS MESSAGES	ON

#### 30.4 INFORMATION

30.4.11 CRI PROG VERSION	(version)
30.4.2 MC PROG VERSION	(version)
30.4.3 TEST DATE	(date)

→ = Typical parameter values to check during start-up. If needed, change values to meet the needs of your application. Complete parameter list provided in Appendix A.

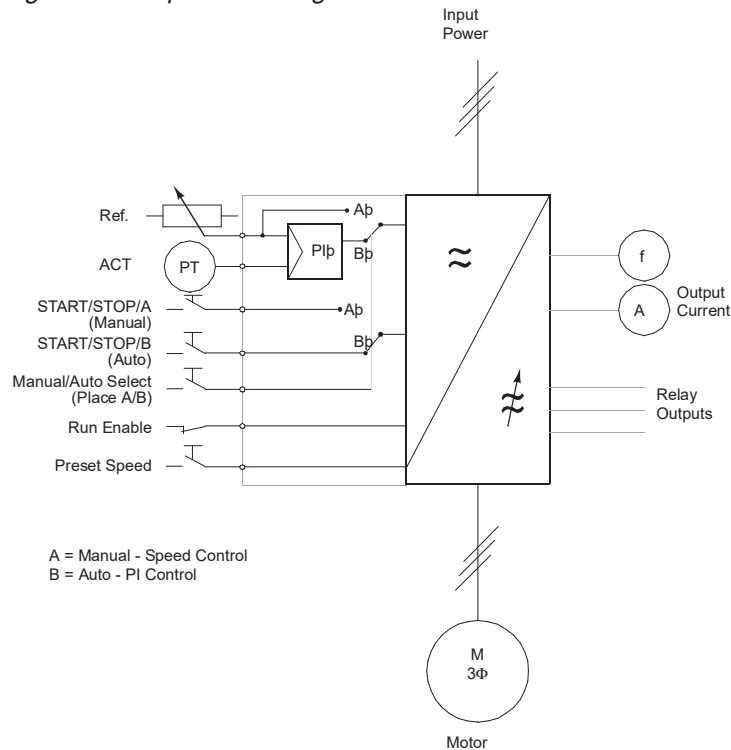
### Application 3 – PI Control

Start/Stop from two different places, Control Location selection, Run Enable selection, one Preset Speed selection, Reference setting and actual value feedback through screw terminal inputs. Reference setting also possible internally with the keypad.

Place A is intended for direct speed setting with a reference signal and Place B is intended for closed-loop speed control using the same reference as Place A. Preset speed overrides external analog settings.

### Operation Diagram

Figure 5-5 Operation Diagram



### Input and Output Signals

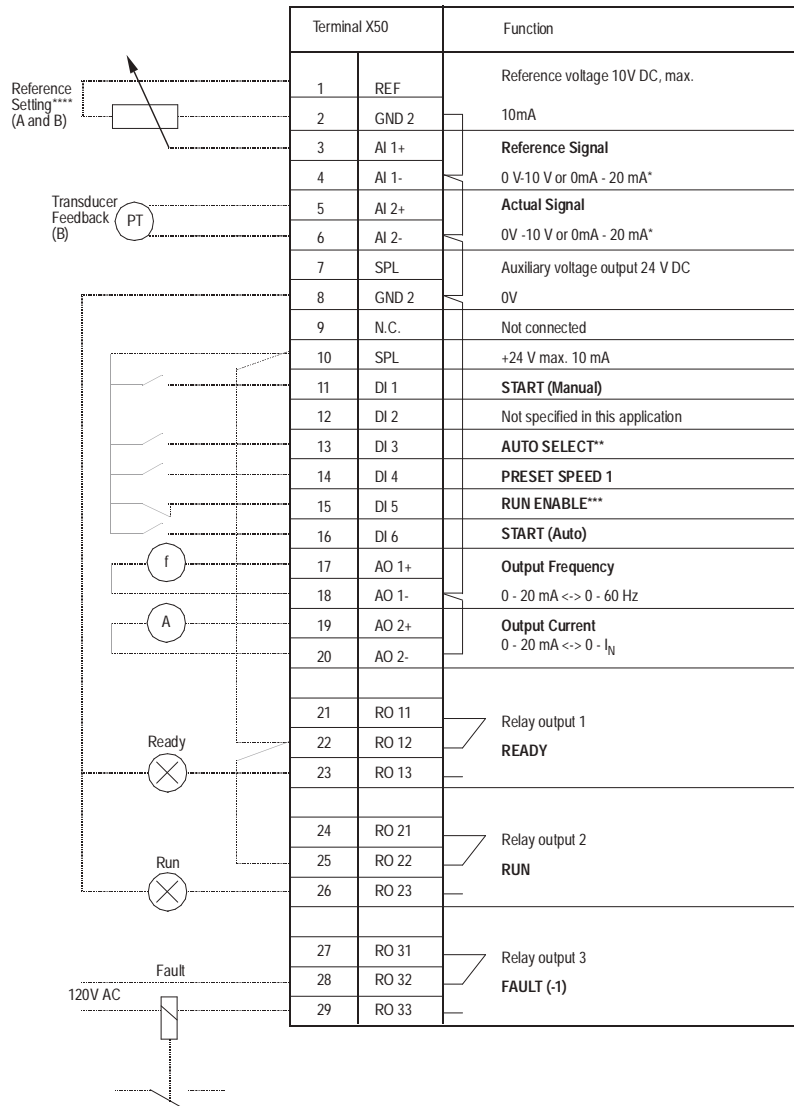
Table 5-4 Input and Output Signals

Input Signals	Output Signals
Reference Value 0 – V DC Actual Value 4 – 20 mA	Analog Output AO1: Output Frequency Analog Output AO2: Output Current Relay Output RO1: READY Relay Output RO2: RUN Relay Output RO3: FAULT (-1)

**PI Control External Connections**  
Process Control = Auto  
Direct Speed Control = Manual

Connection Example

Figure 5-6 Connection Example



\* Select voltage or current reference with plugs S1 and S2 on the customer interface board (beside the screw terminals 1 - 6 of X50)  
 \*\* Open Switch = Manual Control (direct speed setting)  
 close switch (+24V) = Auto Control (PI-control)  
 \*\*\* Run Enable switch:  
 Open switch = run disabled, also from the keypad  
 Closed switch = run enabled  
 \*\*\*\* Reference setting possible also internally with the keypad.

Terminal X51		
1	+8V	Power to remote panel
2	GND2	
3	Shield1	RS-485 Serial Link Connections
4	GND3	
5	SGNA	
6	SGNB	
7	Shield2	

## PI Control Parameter Settings

### START-UP DATA

A LANGUAGE	→ ENGLISH
B APPLICATIONS	→ PI-CONTROL
C APPLIC. RESTORE	→ NO
D SUPPLY VOLTAGE	→ 480/230/380
E USER DISPLAY SCALE	→ 0
F MOTOR CURRENT -FLA	→ I <sub>N</sub> of drive
G MOTOR POWER (kW)	→ P <sub>N</sub> of drive
H MOTOR POWER FACTOR	→ 0.83
I MOTOR BASE FREQ.	→ 60
J MOTOR BASE R.P.M.	→ 1728
K MOTOR NOM. VOLTAGE	→ 460/230/380

### OPERATING DATA

1 OUTPUT	
2 SPEED	
3 MOTOR CURRENT	
4 % RATED TORQUE	
5 % RATED POWER	
6 DC BUS VOLTAGE	
7 OUTPUT VOLTAGE	
8 DRIVE TEMPERATURE	
9 CONTROL LOCATION	→ EXTERNAL
10 KEYPAD REF 1	
11 KEYPAD PI (REF 2)	
12 EXT REF 1 OR 2	REF 1
13 EXTERNAL REF 1	
14 EXTERNAL REF 2	
15 RUN TIME	
16 KILOWATT HOURS	
17 LAST-RECD FAULT	
18 SECOND-RECD FAULT	
19 FIRST-RECD FAULT	
20 PARAMETER LOCK	OPEN
21 APPL BLOCK OUTPUT	
22 ACTUAL VALUE 1	
23 ACTUAL VALUE 2	

### 10 CONTROL CONNECTIONS

#### 10.1 START/STOP/DIRECTION

10.1.1 EXT 1 STRT/STP/DIR	DI1
10.1.2 EXT 2 STRT/STP/DIR	DI6

#### 10.2 EX REFERENCE SELECT

10.2.1 EXT 1/EXT 2 SELECT	DI3
10.2.2 EXTERNAL REF1 SEL	AI1
10.2.3 EXT REF1 MINIMUM	0 Hz
10.2.4 EXT REF1 MAXIMUM	60 Hz
10.2.7 EXTERNAL REF2 SEL	AI1

#### 10.3 PRESET SPEEDS

10.3.1 PRESET SPEED SEL	DI4
10.3.2 PRESET SPEED 1	→ 5 Hz

#### 10.4 SYSTEM CONTR INPUTS

10.4.1 RUN ENABLE	DI5
10.4.2 FAULT RESET SELECT	NOT SEL
10.4.3 PARAM. LOCK SEL	OP DATA 20
10.4.4 EXTERNAL FAULT	NOT SEL

### 10.5 ANALOG INPUTS

10.5.1 MINIMUM AI1	→ 0 V/0 mA
10.5.2 MAXIMUM AI1	→ 10 V/20 mA
10.5.3 RC FILTER ON AI1	0.1s
10.5.4 INVERT AI1	NO
10.5.5 MINIMUM AI2	→ 0 V/0 mA
10.5.6 MAXIMUM AI2	→ 10 V/20 mA
10.5.7 RC FILTER ON AI2	0.1s
10.5.8 INVERT AI2	NO

### 10.6 RELAY OUTPUTS

10.6.1 RELAY RO1 OUTPUT	READY
10.6.2 RELAY RO2 OUTPUT	RUN
10.6.3 RELAY RO3 OUTPUT	FAULT (-1)

### 10.7 ANALOG OUTPUTS

10.7.1 ANALOG OUTPUT 1	OUT FREQ
10.7.2 SCALE AO1	100%
10.7.3 MINIMUM AO1	→ 0 mA
10.7.4 RC FILTER ON AO1	2s
10.7.5 INVERT AO1	NO
10.7.6 ANALOG OUTPUT 2	OUT CURR
10.7.7 SCALE AO2	100%
10.7.8 MINIMUM AO2	→ 0 mA
10.7.9 RC FILTER ON AO2	2s
10.7.10 INVERT AO2	NO

### 20 DRIVE PARAMETERS

#### 20.1 FREQ/CURRENT LIMITS

20.1.1 MINIMUM FREQUENCY	→ 0 Hz
20.1.2 MAXIMUM FREQUENCY	→ 60 Hz
20.1.3 FREQUENCY RANGE	0 – 120 Hz
20.1.4 CURRENT LIMIT	→ 1.5 x I <sub>N</sub>

#### 20.2 START/STOP

20.2.1 START FUNCTION	RAMP
20.2.2 TORQUE BOOST CURR	1.5 x I <sub>N</sub>
20.2.3 STOP FUNCTION	COAST
20.2.4 BRAKE CHOPPER	NO
20.2.5 DC HOLD	OFF
20.2.6 DC HOLD VOLTAGE	0.01 x V <sub>N</sub>
20.2.7 DC BRAKE VOLTAGE	0.01 x V <sub>N</sub>
20.2.8 DC BRAKE TIME	0s

#### 20.3 ACCEL/DECEL

20.3.1 ACC/DEC 1 OR 2 SEL	NOT SEL
20.3.2 ACC/DEC RAMP SHAPE	LINEAR
20.3.3 ACCEL TIME 1	→ 1s
20.3.4 DECEL TIME 1	→ 1s
20.3.7 ACCEL REF2 TIME	→ 0.1s
20.3.8 DECEL REF2 TIME	→ 0.1s

#### 20.4 MOTOR CONTROL

20.4.1 SWITCHING FREQ	3 kHz
20.4.2 MAX OUTPUT VOLTAGE	460 V
20.4.3 V/Hz RATIO	LINEAR
20.4.4 FIELD WEAK POINT	60 Hz
20.4.5 IR COMPENSATION	NO
20.4.6 IR COMP VOLTAGE	0.01 x V <sub>N</sub>
20.4.7 IR COMP RANGE	0 Hz
20.4.8 SLIP COMPENSATION	OFF
20.4.9 NOMINAL SLIP	4%
20.4.10 VOLTAGE LIMIT	ON

#### 20.5 CRIT FREQUENCIES\*

20.5.1 CRIT FREQ SELECT	OFF
20.5.2 CRIT FREQ 1 LOW	0 Hz
20.5.3 CRIT FREQ 1 HIGH	0 Hz
20.5.4 CRIT FREQ 2 LOW	0 Hz
20.5.5 CRIT FREQ 2 HIGH	0 Hz
20.5.6 CRIT FREQ 3 LOW	0 Hz
20.5.7 CRIT FREQ 3 HIGH	0 Hz
20.5.8 CRIT FREQ 4 LOW	0 Hz
20.5.9 CRIT FREQ 4 HIGH	0 Hz
20.5.10 CRIT FREQ 5 LOW	0 Hz
20.5.11 CRIT FREQ 5 HIGH	0 Hz

### 30 PROTECTION/INFORMAT

#### 30.1 FAULT FUNCTION

30.1.1 SERIAL FAULT FUNC	STOP
30.1.2 AI <MIN FUNCTION	FAULT
30.1.3 MOT TEMP FLT FUNC	→ FAULT
30.1.4 MOTOR THERM TIME	700s
30.1.5 MOTOR LOAD CURVE	100%
30.1.6 ZERO SPEED LOAD	40%
30.1.7 BREAK POINT	60 Hz
30.1.8 STALL FUNCTION	WARNING
30.1.9 STALL CURRENT	1.2 x I <sub>N</sub>
30.1.10 STALL TIME/FREQ	20s/25 Hz
30.1.11 UNDERLOAD FUNC	NO
30.1.12 UNDERLOAD TIME	600s
30.1.13 UNDERLOAD CURVE	1

#### 30.2 AUTOMATIC RESET

30.2.1 NUMBER OF RESETS	2
30.2.2 TIME WINDOW	30s
30.2.3 TIME BETW. RES ATT	0
30.2.4 OVERVOLTAGE	NO
30.2.5 UNDERVOLTAGE	YES
30.2.6 OVERCURRENT	NO
30.2.7 AI SIGNAL <MIN	→ NO

#### 30.3 SUPERVISION

30.3.1 OUTPUT FREQ 1 FUNC	NO
30.3.2 OUTPUT FREQ 1 LIM	0
30.3.3 OUTPUT FREQ 2 FUNC	NO
30.3.4 OUTPUT FREQ 2 LIM	0
30.3.5 CURRENT FUNCTION	NO
30.3.6 CURRENT LIMIT	0 x I <sub>N</sub>
30.3.7 REF1 FUNCTION	NO
30.3.8 REF1 LIMIT	0 Hz
30.3.9 REF2 FUNCTION	NO
30.3.10 REF2 LIMIT	0%
30.3.11 SUPERVIS MESSAGES	ON

#### 30.4 INFORMATION

30.4.11 CRI PROG VERSION	(version)
30.4.2 MC PROG VERSION	(version)
30.4.3 TEST DATE	(date)

### 40 APPLICATION PARAMETERS

#### 40.1 PI-CONTROL

40.1.1 PI-CONT GAIN	100%
40.1.2 PI-CONT I-TIME	60s
40.1.3 PI-CONT MIN LIMIT	25 Hz
40.1.4 PI-CONT MAX LIMIT	60 Hz
40.1.5 ERROR VALUE INVERT	NO
40.1.6 ACTUAL VALUE SEL	ACT 1
40.1.7 ACTUAL 1 INPUT	AI2
40.1.8 ACTUAL 2 INPUT	NO
40.1.9 ACT 1 MIN SCALE	0
40.1.10 ACT 1 MAX SCALE	100
40.1.11 ACT 2 MIN SCALE	0
40.1.12 ACT 2 MAX SCALE	0

→ = Typical parameter values to check during start-up. If needed, change values to meet needs of your application. Complete parameter list in Appendix A.

\* - See Critical Frequencies in Chapter 6.

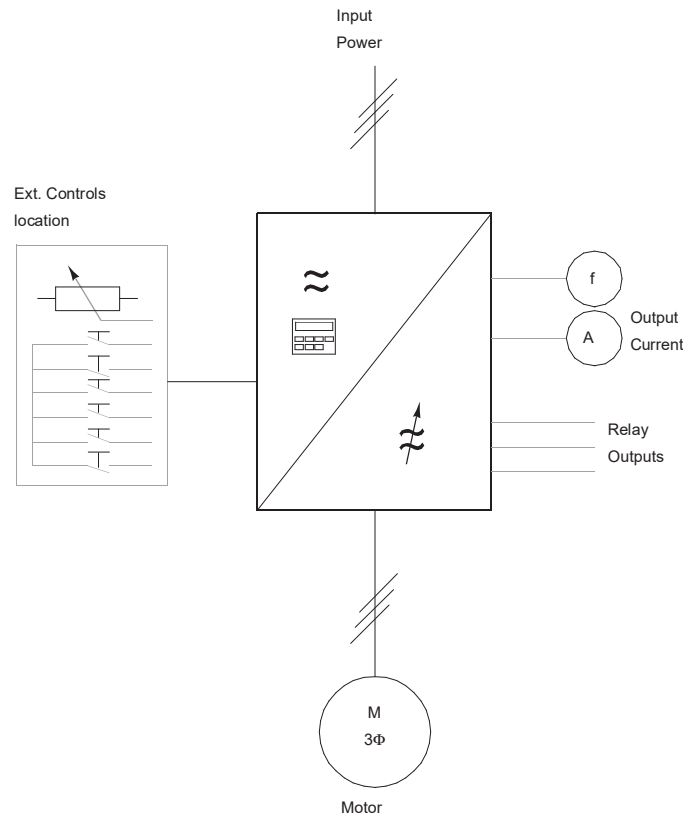
### Application 4 – Opt. Pack

This macro configures the terminals on X50 to interface with the Option Pack on the ACS 500, and with the extended terminal board supplied with the ACS 502 with Bypass or Hand/Off/Auto options. Refer to the appropriate option manual (ACS501-08 or ACS502-04) supplied with the drive for complete connection details.

Two analog and three relay contact output signals available through Terminal Block X50.

### Operation Diagram

Figure 5-7 Operation Diagram



### Input and Output Signals

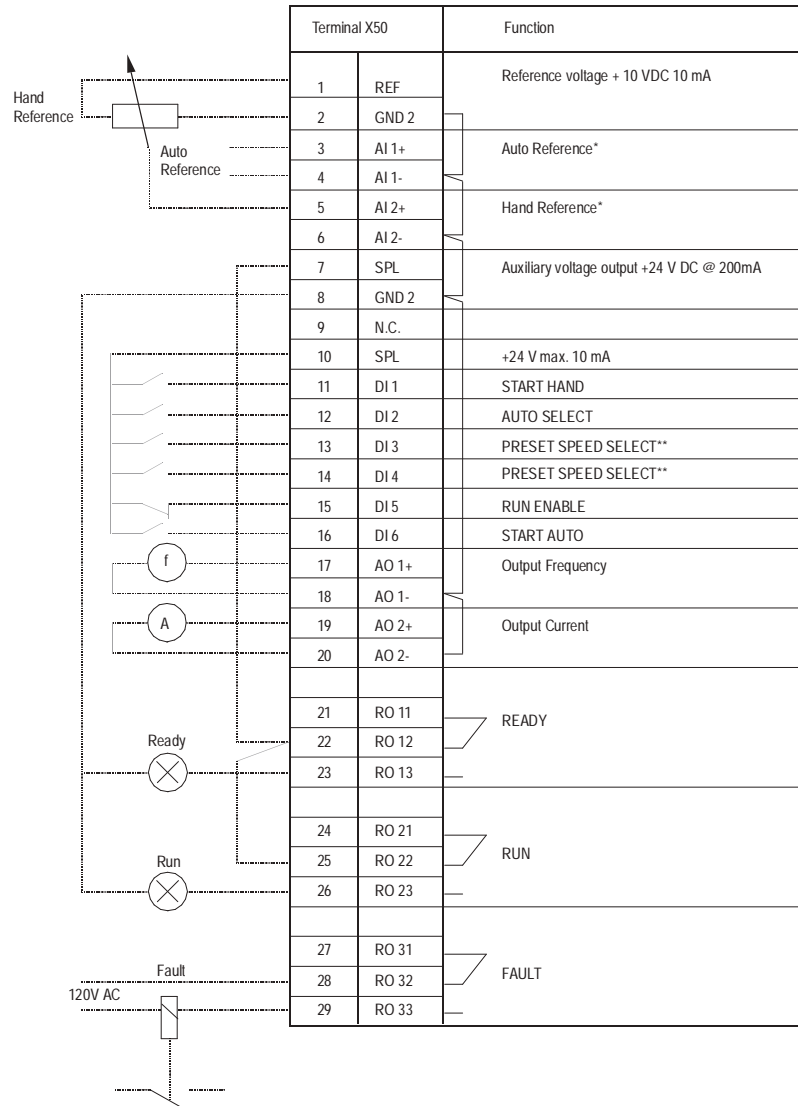
Table 5-5 Input and Output Signals

Input Signals	Output Signals
Two Analog Reference inputs. Six Digital Inputs: Start Hand, Start Auto, Preset Speed (2), Auto Select, and Run Enable.	Analog Output AO1: Output Frequency Analog Output AO2: Output Current Relay Output RO1: READY Relay Output RO2: RUN Relay Output RO3: FAULT

## Opt. Pack External Connections

### Connection Example

Figure 5-8 Connection Example



\* Select voltage or current reference with plugs S1 and S2 on the customer interface board (beside the screw terminals 1-6 of X50).

\*\* Operation:

D15	D16	Output
0	0	set freq. through AI1
1	0	Preset Speed 1
0	1	Preset Speed 2
1	1	Preset Speed 3

0 = Open  
1 = Closed

Terminal X51

1	+8V	Power to remote panel
2	GND2	
3	Shield1	RS-485 Serial Link Connections
4	GND3	
5	SGNA	
6	SGNB	
7	Shield2	

## Opt. Pack Parameter Settings

### START-UP DATA

A LANGUAGE	→ ENGLISH
B APPLICATIONS	→ OPT. PACK
C APPLIC. RESTORE	→ NO
D SUPPLY VOLTAGE	→ 480/230/380
E USER DISPLAY SCALE	→ 0
F MOTOR CURRENT -FLA	→ $I_N$ of drive
G MOTOR POWER (kW)	→ $P_N$ of drive
H MOTOR POWER FACTOR	→ 0.83
I MOTOR BASE FREQ.	→ 60
J MOTOR BASE R.P.M.	→ 1728
K MOTOR NOM. VOLTAGE	→ 460/230/380

### OPERATING DATA

1 OUTPUT	
2 SPEED	
3 MOTOR CURRENT	
4 % RATED TORQUE	
5 % RATED POWER	
6 DC BUS VOLTAGE	
7 OUTPUT VOLTAGE	
8 DRIVE TEMPERATURE	
9 CONTROL LOCATION	→ EXTERNAL
10 KEYPAD REF 1	
11 KEYPAD PI (REF 2)	
12 EXT REF 1 OR 2	REF 1
13 EXTERNAL REF 1	
14 EXTERNAL REF 2	
15 RUN TIME	
16 KILOWATT HOURS	
17 LAST-RECD FAULT	
18 SECOND-RECD FAULT	
19 FIRST-RECD FAULT	
20 PARAMETER LOCK	OPEN

### 10 CONTROL CONNECTIONS

#### 10.1 START/STOP/DIRECTION

10.1.1 EXT 1 STRT/STP/DIR	DI1
10.1.2 EXT 2 STRT/STP/DIR	DI6

#### 10.2 EX REFERENCE SELECT

10.2.1 EXT 1/EXT 2 SELECT	DI2
10.2.2 EXTERNAL REF1 SEL	AI2
10.2.3 EXT REF1 MINIMUM	0 Hz
10.2.4 EXT REF1 MAXIMUM	60 Hz
10.2.7 EXTERNAL REF2 SEL	AI1
10.2.8 EXT REF2 MINIMUM	0 Hz
10.2.9 EXT REF2 MAXIMUM	60 Hz

#### 10.3 PRESET SPEEDS

10.3.1 PRESET SPEED SEL	DI3,4
10.3.2 PRESET SPEED 1	→ 5 Hz
10.3.3 PRESET SPEED 2	→ 10 Hz
10.3.4 PRESET SPEED 3	→ 15 Hz

#### 10.4 SYSTEM CONTR INPUTS

10.4.1 RUN ENABLE	DI5
10.4.2 FAULT RESET SELECT	NOT SEL
10.4.3 PARAM. LOCK SEL	OP DATA 20
10.4.4 EXTERNAL FAULT	NOT SEL

### 10.5 ANALOG INPUTS

10.5.1 MINIMUM AI1	→ 0 V/0 mA
10.5.2 MAXIMUM AI1	→ 10 V/20 mA
10.5.3 RC FILTER ON AI1	0.1s
10.5.4 INVERT AI1	NO
10.5.5 MINIMUM AI2	0 V/0 mA
10.5.6 MAXIMUM AI2	10 V/20 mA
10.5.7 RC FILTER ON AI2	0.1s
10.5.8 INVERT AI2	NO

### 10.6 RELAY OUTPUTS

10.6.1 RELAY RO1 OUTPUT	READY
10.6.2 RELAY RO2 OUTPUT	RUN
10.6.3 RELAY RO3 OUTPUT	FAULT

### 10.7 ANALOG OUTPUTS

10.7.1 ANALOG OUTPUT 1	OUT FREQ
10.7.2 SCALE AO1	100%
10.7.3 MINIMUM AO1	→ 0 mA
10.7.4 RC FILTER ON AO1	2s
10.7.5 INVERT AO1	NO
10.7.6 ANALOG OUTPUT 2	OUT CURR
10.7.7 SCALE AO2	100%
10.7.8 MINIMUM AO2	→ 0 mA
10.7.9 RC FILTER ON AO2	2s
10.7.10 INVERT AO2	NO

### 20 DRIVE PARAMETERS

#### 20.1 FREQ/CURRENT LIMITS

20.1.1 MINIMUM FREQUENCY	→ 0 Hz
20.1.2 MAXIMUM FREQUENCY	→ 60 Hz
20.1.3 FREQUENCY RANGE	0 – 120 Hz
20.1.4 CURRENT LIMIT	→ $1.5 \times I_N$

#### 20.2 START/STOP

20.2.1 START FUNCTION	FLYING
20.2.2 TORQUE BOOST CURR	$1.5 \times I_N$
20.2.3 STOP FUNCTION	COAST
20.2.4 BRAKE CHOPPER	NO
20.2.5 DC HOLD	OFF
20.2.6 DC HOLD VOLTAGE	$0.01 \times V_N$
20.2.7 DC BRAKE VOLTAGE	$0.01 \times V_N$
20.2.8 DC BRAKE TIME	0s

#### 20.3 ACCEL/DECEL

20.3.1 ACC/DEC 1 OR 2 SEL	NOT SEL
20.3.2 ACC/DEC RAMP SHAPE	LINEAR
20.3.3 ACCEL TIME 1	→ 30s
20.3.4 DECEL TIME 1	→ 30s
20.3.5 ACCEL TIME 2	60s
20.3.6 DECEL TIME 2	60s
20.3.7 ACCEL REF2 TIME	0.1s
20.3.8 DECEL REF2 TIME	0.1s

#### 20.4 MOTOR CONTROL

20.4.1 SWITCHING FREQ	3 kHz
20.4.2 MAX OUTPUT VOLTAGE	460 V
20.4.3 V/Hz RATIO	→ SQUARED
20.4.4 FIELD WEAK POINT	60 Hz
20.4.5 IR COMPENSATION	NO
20.4.6 IR COMP VOLTAGE	$0.01 \times V_N$
20.4.7 IR COMP RANGE	0 Hz
20.4.8 SLIP COMPENSATION	OFF
20.4.9 NOMINAL SLIP	4%
20.4.10 VOLTAGE LIMIT	ON

### 20.5 CRIT FREQUENCIES

20.5.1 CRIT FREQ SELECT	OFF
20.5.2 CRIT FREQ 1 LOW	0 Hz
20.5.3 CRIT FREQ 1 HIGH	0 Hz
20.5.4 CRIT FREQ 2 LOW	0 Hz
20.5.5 CRIT FREQ 2 HIGH	0 Hz
20.5.6 CRIT FREQ 3 LOW	0 Hz
20.5.7 CRIT FREQ 3 HIGH	0 Hz
20.5.8 CRIT FREQ 4 LOW	0 Hz
20.5.9 CRIT FREQ 4 HIGH	0 Hz
20.5.10 CRIT FREQ 5 LOW	0 Hz
20.5.11 CRIT FREQ 5 HIGH	0 Hz

### 30 PROTECTION/INFORMAT

#### 30.1 FAULT FUNCTION

30.1.1 SERIAL FAULT FUNC	STOP
30.1.2 AI <MIN FUNCTION	NO
30.1.3 MOT TEMP FLT FUNC	→ FAULT
30.1.4 MOTOR THERM TIME	700s
30.1.5 MOTOR LOAD CURVE	100%
30.1.6 ZERO SPEED LOAD	40%
30.1.7 BREAK POINT	60 Hz
30.1.8 STALL FUNCTION	WARNING
30.1.9 STALL CURRENT	$1.5 \times I_N$
30.1.10 STALL TIME/FREQ	20s/25 Hz
30.1.11 UNDERLOAD FUNC	NO
30.1.12 UNDERLOAD TIME	600s
30.1.13 UNDERLOAD CURVE	1

#### 30.2 AUTOMATIC RESET

30.2.1 NUMBER OF RESETS	5
30.2.2 TIME WINDOW	30s
30.2.3 TIME BETW. RES ATT	0
30.2.4 OVERVOLTAGE	→ NO
30.2.5 UNDERVOLTAGE	YES
30.2.6 OVERCURRENT	→ NO
30.2.7 AI SIGNAL <MIN	NO

#### 30.3 SUPERVISION

30.3.1 OUTPUT FREQ 1 FUNC	→ NO
30.3.2 OUTPUT FREQ 1 LIM	→ 0
30.3.3 OUTPUT FREQ 2 FUNC	NO
30.3.4 OUTPUT FREQ 2 LIM	0
30.3.5 CURRENT FUNCTION	NO
30.3.6 CURRENT LIMIT	$0 \times I_N$
30.3.7 REF1 FUNCTION	NO
30.3.8 REF1 LIMIT	0 Hz
30.3.9 REF2 FUNCTION	NO
30.3.10 REF2 LIMIT	0%
30.3.11 SUPERVIS MESSAGES	ON

#### 30.4 INFORMATION

30.4.11 CRI PROG VERSION	(version)
30.4.2 MC PROG VERSION	(version)
30.4.3 TEST DATE	(date)

→ = Typical parameter values to check during start-up. If needed, change values to meet the needs of your application. Complete parameter list provided in Appendix A.

## Application 5 – Seq Ctrl

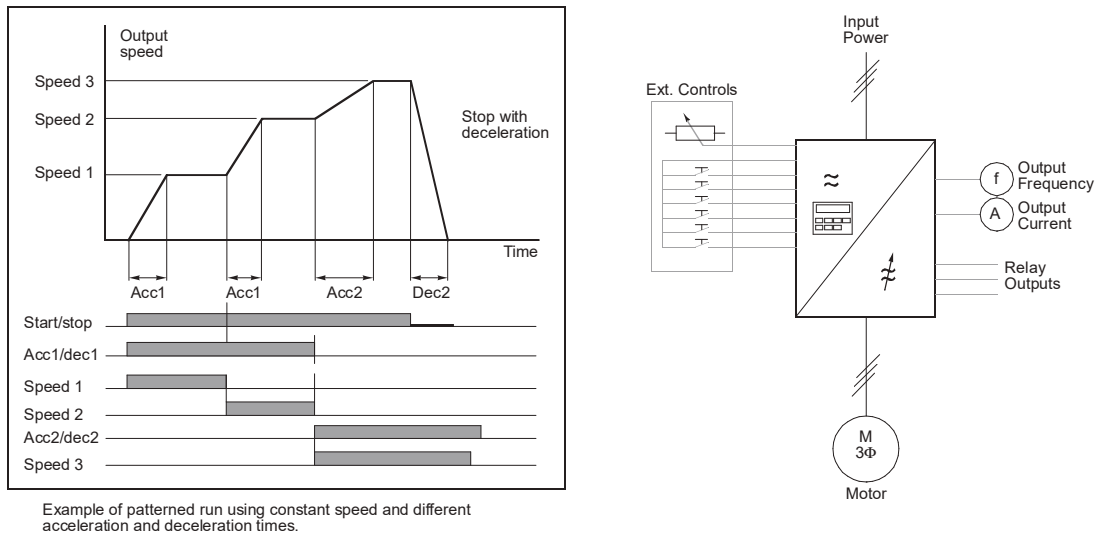
Start/Stop, Direction, Selection of 7 preset speeds, and Acc/Dec 1 or 2 selection commands and analog reference setting through screw terminals.

Control location selection and local control possible with the Keypad.

Two analog and three relay contact output signals available through Terminal Block X50.

### Operation Diagram

Figure 5-9 Operation Diagram



### Input and Output Signals

Table 5-6 Input and Output Signals

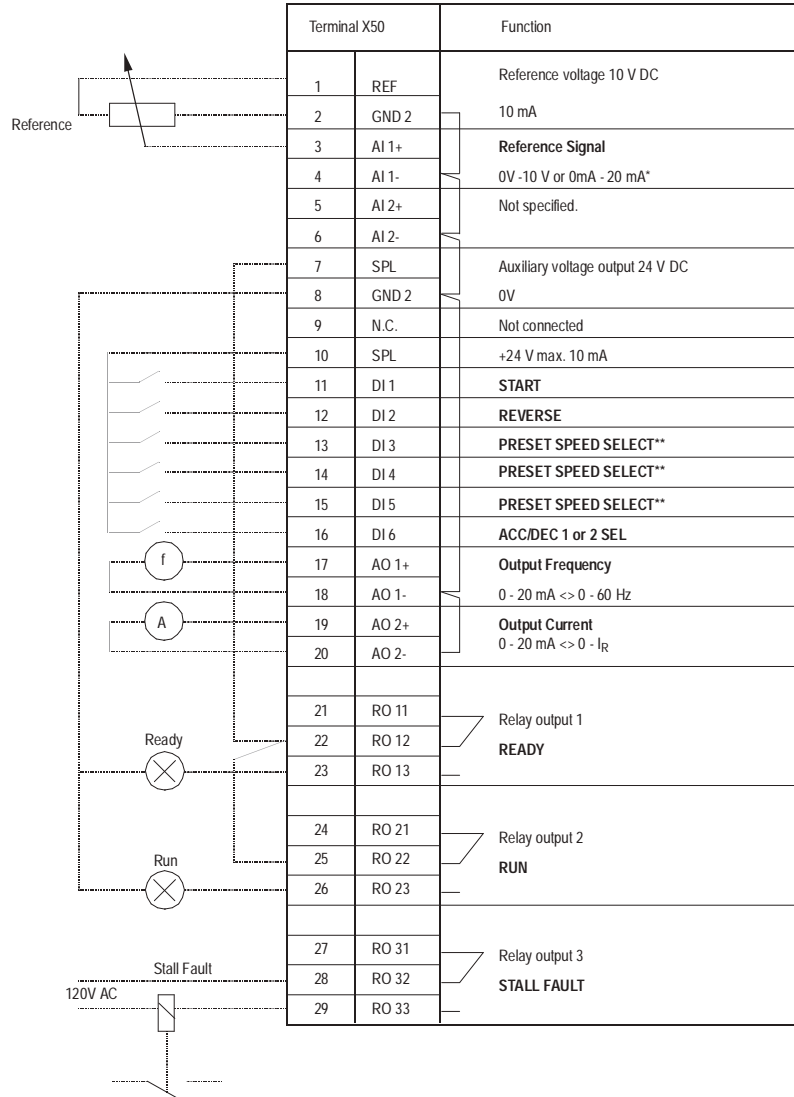
Input Signals	Output Signals
One Analog Reference input, Start/Stop switch, Direction switch, three switches for Preset Speed selection, and one input for selection of Acc/Dec 1 or Acc/Dec 2 time.	Analog Output AO1: Output Frequency Analog Output AO2: Output Current Relay Output RO1: READY Relay Output RO2: RUN Relay Output RO3: STALL FAULT



## Seq Ctrl External Connections

### Connection Example

Figure 5-10 Connection Example



\* Select voltage or current reference with plugs S1 and S2 on the customer interface board (beside the screw terminals 1-6 of X50).

\*\* Operation:

	D13	D14	D14	Output
	0	0	0	set freq. through AI1
	1	0	0	Preset Speed 1
	0	1	0	Preset Speed 2
	1	1	0	Preset Speed 3
	0	0	1	Preset Speed 4
	1	0	1	Preset Speed 5
	0	1	1	Preset Speed 6
	1	1	1	Preset Speed 7

0 = Open  
1 = Closed

Terminal X51		
1	+8V	Power to remote panel
2	GND2	
3	Shield1	RS-485 Serial Link Connections
4	GND3	
5	SGNA	
6	SGNB	
7	Shield2	

## Seq Ctrl Parameter Settings

### START-UP DATA

A LANGUAGE	→ ENGLISH
B APPLICATIONS	→ SEQ CTRL
C APPLIC. RESTORE	→ NO
D SUPPLY VOLTAGE	→ 480/230/380
E USER DISPLAY SCALE	→ 0
F MOTOR CURRENT -FLA	→ $I_N$ of drive
G MOTOR POWER (kW)	→ $P_N$ of drive
H MOTOR POWER FACTOR	→ 0.83
I MOTOR BASE FREQ.	→ 60
J MOTOR BASE R.P.M.	→ 1728
K MOTOR NOM. VOLTAGE	→ 460/230/380

### OPERATING DATA

1 OUTPUT	
2 SPEED	
3 MOTOR CURRENT	
4 % RATED TORQUE	
5 % RATED POWER	
6 DC BUS VOLTAGE	
7 OUTPUT VOLTAGE	
8 DRIVE TEMPERATURE	
9 CONTROL LOCATION	→ EXTERNAL
10 KEYPAD REF 1	
11 KEYPAD PI (REF 2)	
12 EXT REF 1 OR 2	REF 1
13 EXTERNAL REF 1	
14 EXTERNAL REF 2	
15 RUN TIME	
16 KILOWATT HOURS	
17 LAST-RECD FAULT	
18 SECOND-RECD FAULT	
19 FIRST-RECD FAULT	
20 PARAMETER LOCK	OPEN

### 10 CONTROL CONNECTIONS

#### 10.1 START/STOP/DIRECTION

10.1.1 EXT 1 STRT/STP/DIR	DI1,2
10.1.2 EXT 2 STRT/STP/DIR	NOT SEL
10.1.3 LOC/EXT DIRECTION	→ REQUEST

#### 10.2 EX REFERENCE SELECT

10.2.1 EXT 1/EXT 2 SELECT	OP DATA 12
10.2.2 EXTERNAL REF1 SEL	AI1
10.2.3 EXT REF1 MINIMUM	0 Hz
10.2.4 EXT REF1 MAXIMUM	60 Hz
10.2.7 EXTERNAL REF2 SEL	OP DATA 14
10.2.8 EXT REF2 MINIMUM	0 Hz
10.2.9 EXT REF2 MAXIMUM	60 Hz

#### 10.3 PRESET SPEEDS

10.3.1 PRESET SPEED SEL	DI3,4,5
10.3.2 PRESET SPEED 1	→ 5 Hz
10.3.3 PRESET SPEED 2	→ 25 Hz
10.3.4 PRESET SPEED 3	→ 50 Hz
10.3.4 PRESET SPEED 4	→ 20 Hz
10.3.4 PRESET SPEED 5	→ 25 Hz
10.3.4 PRESET SPEED 6	→ 40 Hz
10.3.4 PRESET SPEED 7	→ 50 Hz

#### 10.4 SYSTEM CONTR INPUTS

10.4.1 RUN ENABLE	YES
10.4.2 FAULT RESET SELECT	NOT SEL
10.4.3 PARAM. LOCK SEL	OP DATA 20
10.4.4 EXTERNAL FAULT	NOT SEL

### 10.5 ANALOG INPUTS

10.5.1 MINIMUM AI1	→ 0 V/0 mA
10.5.2 MAXIMUM AI1	→ 10 V/20 mA
10.5.3 RC FILTER ON AI1	0.1s
10.5.4 INVERT AI1	NO
10.5.5 MINIMUM AI2	0 V/0 mA
10.5.6 MAXIMUM AI2	10 V/20 mA
10.5.7 RC FILTER ON AI2	0.1s
10.5.8 INVERT AI2	NO

### 10.6 RELAY OUTPUTS

10.6.1 RELAY RO1 OUTPUT	READY
10.6.2 RELAY RO2 OUTPUT	RUN
10.6.3 RELAY RO3 OUTPUT	STALL FAULT

### 10.7 ANALOG OUTPUTS

10.7.1 ANALOG OUTPUT 1	OUT FREQ
10.7.2 SCALE AO1	100%
10.7.3 MINIMUM AO1	→ 0 mA
10.7.4 RC FILTER ON AO1	2s
10.7.5 INVERT AO1	NO
10.7.6 ANALOG OUTPUT 2	OUT CURR
10.7.7 SCALE AO2	100%
10.7.8 MINIMUM AO2	→ 0 mA
10.7.9 RC FILTER ON AO2	2s
10.7.10 INVERT AO2	NO

### 20 DRIVE PARAMETERS

#### 20.1 FREQ/CURRENT LIMITS

20.1.1 MINIMUM FREQUENCY	→ 0 Hz
20.1.2 MAXIMUM FREQUENCY	→ 60 Hz
20.1.3 FREQUENCY RANGE	0 – 120 Hz
20.1.4 CURRENT LIMIT	→ $1.5 \times I_N$

#### 20.2 START/STOP

20.2.1 START FUNCTION	RAMP
20.2.2 TORQUE BOOST CURR	$1.5 \times I_N$
20.2.3 STOP FUNCTION	RAMP
20.2.4 BRAKE CHOPPER	NO
20.2.5 DC HOLD	ON
20.2.6 DC HOLD VOLTAGE	$0.01 \times V_N$
20.2.7 DC BRAKE VOLTAGE	$0.01 \times V_N$
20.2.8 DC BRAKE TIME	2s

#### 20.3 ACCEL/DECEL

20.3.1 ACC/DEC 1 OR 2 SEL	DI6
20.3.2 ACC/DEC RAMP SHAPE	LINEAR
20.3.3 ACCEL TIME 1	→ 3s
20.3.4 DECEL TIME 1	→ 3s
20.3.5 ACCEL TIME 2	10s
20.3.6 DECEL TIME 2	10s

#### 20.4 MOTOR CONTROL

20.4.1 SWITCHING FREQ	3 kHz
20.4.2 MAX OUTPUT VOLTAGE	460 V
20.4.3 V/Hz RATIO	LINEAR
20.4.4 FIELD WEAK POINT	60 Hz
20.4.5 IR COMPENSATION	NO
20.4.6 IR COMP VOLTAGE	$0.01 \times V_N$
20.4.7 IR COMP RANGE	0 Hz
20.4.8 SLIP COMPENSATION	OFF
20.4.9 NOMINAL SLIP	4%
20.4.10 VOLTAGE LIMIT	ON

### 20.5 CRIT FREQUENCIES

20.5.1 CRIT FREQ SELECT	OFF
20.5.2 CRIT FREQ 1 LOW	0 Hz
20.5.3 CRIT FREQ 1 HIGH	0 Hz
20.5.4 CRIT FREQ 2 LOW	0 Hz
20.5.5 CRIT FREQ 2 HIGH	0 Hz
20.5.6 CRIT FREQ 3 LOW	0 Hz
20.5.7 CRIT FREQ 3 HIGH	0 Hz
20.5.8 CRIT FREQ 4 LOW	0 Hz
20.5.9 CRIT FREQ 4 HIGH	0 Hz
20.5.10 CRIT FREQ 5 LOW	0 Hz
20.5.11 CRIT FREQ 5 HIGH	0 Hz

### 30 PROTECTION/INFORMAT

#### 30.1 FAULT FUNCTION

30.1.1 SERIAL FAULT FUNC	STOP
30.1.2 AI <MIN FUNCTION	NO
30.1.3 MOT TEMP FLT FUNC	→ FAULT
30.1.4 MOTOR THERM TIME	700s
30.1.5 MOTOR LOAD CURVE	100%
30.1.6 ZERO SPEED LOAD	40%
30.1.7 BREAK POINT	60 Hz
30.1.8 STALL FUNCTION	WARNING
30.1.9 STALL CURRENT	$1.2 \times I_N$
30.1.10 STALL TIME/FREQ	20s/25 Hz
30.1.11 UNDERLOAD FUNC	NO
30.1.12 UNDERLOAD TIME	600s
30.1.13 UNDERLOAD CURVE	1

#### 30.2 AUTOMATIC RESET

30.2.1 NUMBER OF RESETS	2
30.2.2 TIME WINDOW	30s
30.2.3 TIME BETW. RES ATT	0
30.2.4 OVERVOLTAGE	NO
30.2.5 UNDERVOLTAGE	YES
30.2.6 OVERCURRENT	NO
30.2.7 AI SIGNAL <MIN	NO

#### 30.3 SUPERVISION

30.3.1 OUTPUT FREQ 1 FUNC	NO
30.3.2 OUTPUT FREQ 1 LIM	0
30.3.3 OUTPUT FREQ 2 FUNC	NO
30.3.4 OUTPUT FREQ 2 LIM	0
30.3.5 CURRENT FUNCTION	NO
30.3.6 CURRENT LIMIT	$0 \times I_N$
30.3.7 REF1 FUNCTION	NO
30.3.8 REF1 LIMIT	0 Hz
30.3.9 REF2 FUNCTION	NO
30.3.10 REF2 LIMIT	0%
30.3.11 SUPERVIS MESSAGES	ON

#### 30.4 INFORMATION

30.4.11 CRI PROG VERSION	(version)
30.4.2 MC PROG VERSION	(version)
30.4.3 TEST DATE	(date)

→ = Typical parameter values to check during start-up. If needed, change values to meet needs of your application. Complete parameter list in Appendix A.

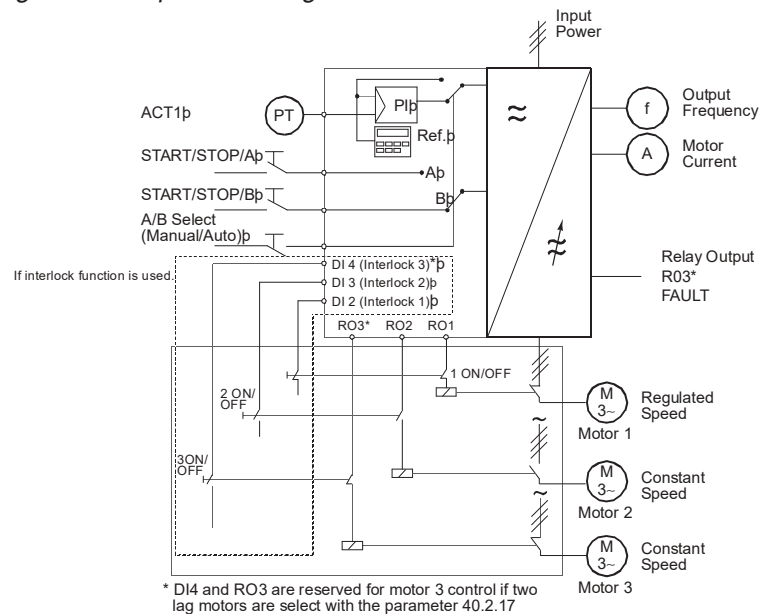
## Application 6 – Pump and Fan

The main application areas of Pump and Fan Control (PFC) are pumping and ventilation systems where speed regulation of a drive motor and automatic start/stop of a maximum of three constant speed motors are beneficial. PFC can easily be connected to a custom made automatic motor alternation system for controlled changing of drive motors. In this way, all the motors run equal duty times. This Application macro allows you to choose between manual and automatic control. A reference (setpoint) value can be given either internally through a LCD panel or externally through screw terminals. A maximum of two actual values can be connected through the screw terminals. Actual values can perform different mathematical operations (addition, subtraction, multiplication, minimum, maximum, and square root) to get a correct final actual value for the PI-controller.

The PI-controller can also be bypassed and actual value used as the speed reference.

### Operation Diagram

Figure 5-11 Operation Diagram



### Input and Output Signals

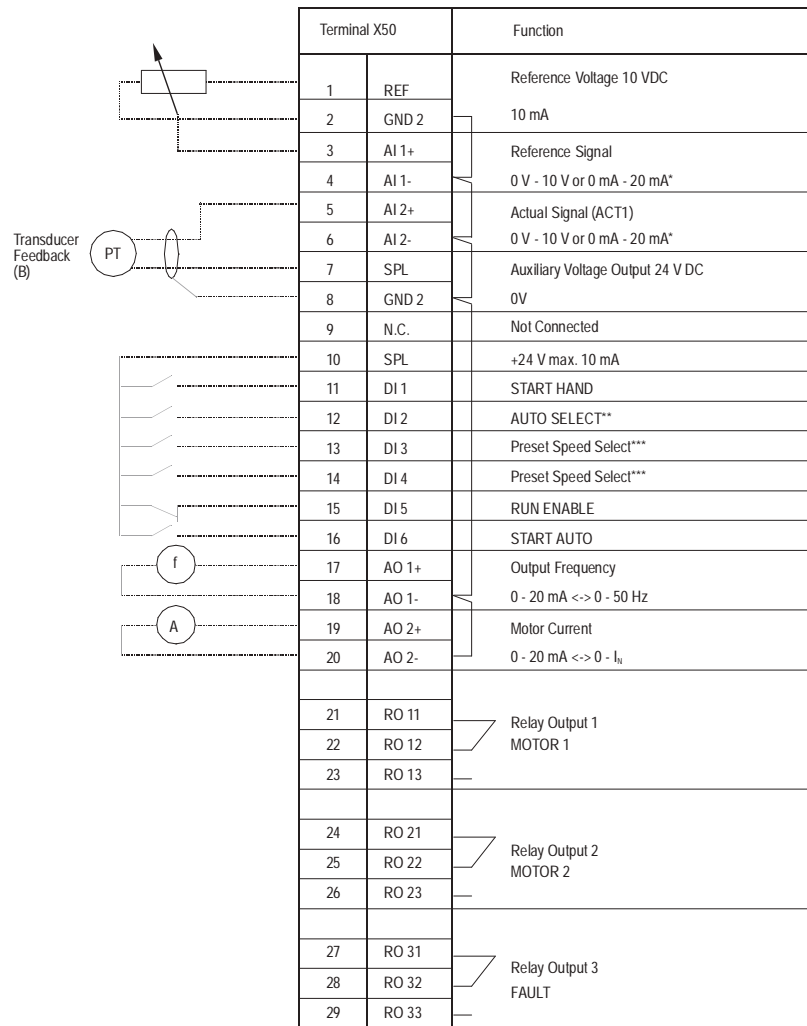
Table 5-7 Input and Output Signals

Input Signals	Output Signals
Actual value 4 – 20 mA	Analog Output AO1: Output Frequency Analog Output AO2: Motor Current Relay Output RO1: First Motor Control Relay Output RO2: Second Motor Control Relay Output RO3: FAULT

## Pump and Fan External Connections

### Connection Example

Figure 5-12 Connection Example



\* Select voltage or current reference with plugs S1 and S2 on the customer interface board (beside the screw terminals 1-6 of X50).

\*\* Open switch = Manual (direct speed setting)  
Closed switch (+24V) = Automatic (PFC)

\*\*\* Operation:

D13	D14	Output
0	0	set freq. through AI1
1	0	Preset Speed 1
0	1	Preset Speed 2
1	1	Preset Speed 3

0 = Open  
1 = Closed

Terminal X51

1	+8V	Power to Remote Panel
2	GND2	
3	Shield1	RS485 Serial Link Connections
4	GND3	
5	SGNA	
6	SGNB	
7	Shield2	

## Pump and Fan Parameter Settings

### START-UP DATA

A LANGUAGE	→ ENGLISH
B APPLICATIONS	→ P&F AUTOM.
C APPLIC. RESTORE	→ NO
D SUPPLY VOLTAGE	→ 480/230/380
E USER DISPLAY SCALE	→ 0
F MOTOR CURRENT -FLA	→ I <sub>N</sub> of drive
G MOTOR POWER (kW)	→ P <sub>N</sub> of drive
H MOTOR POWER FACTOR	→ 0.83
I MOTOR BASE FREQ.	→ 60
J MOTOR BASE R.P.M.	→ 1728
K MOTOR NOM. VOLTAGE	→ 460/230/380

### OPERATING DATA

1 OUTPUT	
2 SPEED	
3 MOTOR CURRENT	
4 % RATED TORQUE	
5 % RATED POWER	
6 DC BUS VOLTAGE	
7 OUTPUT VOLTAGE	
8 DRIVE TEMPERATURE	
9 CONTROL LOCATION	EXTERNAL
10 KEYPAD REF 1	
11 KEYPAD PI (REF 2)	
12 EXT REF 1 OR 2	REF 1
13 EXTERNAL REF 1	
14 EXTERNAL REF 2	
15 RUN TIME	
16 KILOWATT HOURS	
17 LAST-RECD FAULT	
18 SECOND-RECD FAULT	
19 FIRST-RECD FAULT	
20 PARAMETER LOCK	→ OPEN
21 APPL BLOCK OUTPUT	
22 ACTUAL VALUE 1	
23 ACTUAL VALUE 2	
24 AUX MOTRS RUNNING	
25 CONTROLLER OUTPUT	
26 CONTROL ERROR	
27 ACT VALUE 1 (PFC)	
28 ACT VALUE 2 (PFC)	

### 10 CONTROL CONNECTIONS

#### 10.1 START/STOP/DIRECTION

10.1.1 EXT 1 STRT/STP/DIR	→ DI1
10.1.2 EXT 2 STRT/STP/DIR	→ DI6
10.1.3 LOC/EXT DIRECTION	→ FORWARD

#### 10.2 EX REFERENCE SELECT

10.2.1 EXT 1/EXT 2 SELECT	→ DI2
10.2.2 EXTERNAL REF1 SEL	→ OP DATA 13
10.2.3 EXT REF1 MINIMUM	0 Hz
10.2.4 EXT REF1 MAXIMUM	60 Hz
10.2.7 EXTERNAL REF2 SEL	→ OP DATA 14

#### 10.3 PRESET SPEEDS

10.3.1 PRESET SPEED SEL	DI3,4
10.3.2 PRESET SPEED 1	→ 5 Hz
10.3.3 PRESET SPEED 2	→ 10 Hz
10.3.4 PRESET SPEED 3	→ 15 Hz

#### 10.4 SYSTEM CONTR INPUTS

10.4.1 RUN ENABLE	DI5
10.4.2 FAULT RESET SELECT	→ ON STOP
10.4.3 PARAM. LOCK SEL	→ KEYPAD
10.4.4 EXTERNAL FAULT	NOT SEL

#### 10.5 ANALOG INPUTS

10.5.1 MINIMUM AI1	→ 0 V/0 mA
10.5.2 MAXIMUM AI1	→ 10 V/20 mA
10.5.3 RC FILTER ON AI1	0.1s
10.5.4 INVERT AI1	NO
10.5.5 MINIMUM AI2	→ 2 V/4 mA
10.5.6 MAXIMUM AI2	10 V/20 mA

10.5.7 RC FILTER ON AI2	0.1s
10.5.8 INVERT AI2	NO

#### 10.6 RELAY OUTPUTS

10.6.1 RELAY RO1 OUTPUT	PFC AUTOM
10.6.2 RELAY RO2 OUTPUT	PFC AUTOM
10.6.3 RELAY RO3 OUTPUT	FAULT

#### 10.7 ANALOG OUTPUTS

10.7.1 ANALOG OUTPUT 1	OUT FREQ
10.7.2 SCALE AO1	100%
10.7.3 MINIMUM AO1	→ 0 mA
10.7.4 RC FILTER ON AO1	2s
10.7.5 INVERT AO1	NO
10.7.6 ANALOG OUTPUT 2	OUT CURR
10.7.7 SCALE AO2	100%
10.7.8 MINIMUM AO2	→ 0 mA
10.7.9 RC FILTER ON AO2	2s
10.7.10 INVERT AO2	NO

### 20 DRIVE PARAMETERS

#### 20.1 FREQ/CURRENT LIMITS

20.1.1 MINIMUM FREQUENCY	→ 25 Hz
20.1.2 MAXIMUM FREQUENCY	→ 60 Hz
20.1.3 FREQUENCY RANGE	120 Hz
20.1.4 CURRENT LIMIT	→ 1.5 x I <sub>N</sub>

#### 20.2 START/STOP

20.2.1 START FUNCTION	RAMP
20.2.2 TORQUE BOOST CURR	1.5 x I <sub>N</sub>
20.2.3 STOP FUNCTION	COAST
20.2.4 BRAKE CHOPPER	NO
20.2.5 DC HOLD	OFF
20.2.6 DC HOLD VOLTAGE	0.01 x V <sub>N</sub>
20.2.7 DC BRAKE VOLTAGE	0.01 x V <sub>N</sub>
20.2.8 DC BRAKE TIME	0s

#### 20.3 ACCEL/DECEL

20.3.1 ACC/DEC 1 OR 2 SEL	NOT SEL
20.3.2 ACC/DEC RAMP SHAPE	LINEAR
20.3.3 ACCEL TIME 1	→ 1s
20.3.4 DECEL TIME 1	→ 1s
20.3.5 ACCEL TIME 2	60s
20.3.6 DECEL TIME 2	60s
20.3.7 ACCEL REF2 TIME	0.1s
20.3.8 DECEL REF2 TIME	0.1s

#### 20.4 MOTOR CONTROL

20.4.1 SWITCHING FREQ	3 kHz
20.4.2 MAX OUTPUT VOLTAGE	100% X V <sub>N</sub>
20.4.3 V/HZ RATIO	→ LINEAR
20.4.4 FIELD WEAK POINT	60 Hz
20.4.5 IR COMPENSATION	NO
20.4.6 IR COMP VOLTAGE	0.01 x V <sub>N</sub>
20.4.7 IR COMP RANGE	0 Hz
20.4.8 SLIP COMPENSATION	OFF
20.4.9 NOMINAL SLIP	4%
20.4.10 VOLTAGE LIMIT	ON

#### 20.5 CRIT FREQUENCIES\*

20.5.1 CRIT FREQ SELECT	OFF
20.5.2 CRIT FREQ 1 LOW	0 Hz
20.5.3 CRIT FREQ 1 HIGH	0 Hz
20.5.4 CRIT FREQ 2 LOW	0 Hz
20.5.5 CRIT FREQ 2 HIGH	0 Hz
20.5.6 CRIT FREQ 3 LOW	0 Hz
20.5.7 CRIT FREQ 3 HIGH	0 Hz
20.5.8 CRIT FREQ 4 LOW	0 Hz
20.5.9 CRIT FREQ 4 HIGH	0 Hz
20.5.10 CRIT FREQ 5 LOW	0 Hz
20.5.11 CRIT FREQ 5 HIGH	0 Hz

### 30 PROTECTION/INFORMAT

#### 30.1 FAULT FUNCTION

30.1.1 SERIAL FAULT FUNC	STOP
30.1.2 AI <MIN FUNCTION	FAULT
30.1.3 MOT TEMP FLT FUNC	→ FAULT
30.1.4 MOTOR THERM TIME	700s
30.1.5 MOTOR LOAD CURVE	100%
30.1.6 ZERO SPEED LOAD	40%

30.1.7 BREAK POINT	60 Hz
30.1.8 STALL FUNCTION	FAULT
30.1.9 STALL CURRENT	.75 x I <sub>N</sub>
30.1.10 STALL TIME/FREQ	20s/25 Hz
30.1.11 UNDERLOAD FUNC	NO
30.1.12 UNDERLOAD TIME	600s
30.1.13 UNDERLOAD CURVE	1

#### 30.2 AUTOMATIC RESET

30.2.1 NUMBER OF RESETS	2
30.2.2 TIME WINDOW	30s
30.2.3 TIME BETW. RES ATT	0
30.2.4 OVERVOLTAGE	YES
30.2.5 UNDERVOLTAGE	YES
30.2.6 OVERCURRENT	YES
30.2.7 AI SIGNAL <MIN	→ NO

#### 30.3 SUPERVISION

30.3.1 OUTPUT FREQ 1 FUNC	NO
30.3.2 OUTPUT FREQ 1 LIM	0
30.3.3 OUTPUT FREQ 2 FUNC	NO
30.3.4 OUTPUT FREQ 2 LIM	0
30.3.5 CURRENT FUNCTION	NO
30.3.6 CURRENT LIMIT	0 x I <sub>N</sub>
30.3.7 REF1 FUNCTION	NO
30.3.8 REF1 LIMIT	0 Hz
30.3.9 REF2 FUNCTION	NO
30.3.10 REF2 LIMIT	0%
30.3.11 SUPERVIS MESSAGES	OFF

#### 30.4 INFORMATION

30.4.11 CRI PROG VERSION	(version)
30.4.2 MC PROG VERSION	(version)
30.4.3 TEST DATE	(date)

### 40 APPLICATION PARAMETERS

40.2 P&F AUTOM	
40.2.1 PI-CONT GAIN	→ 250.0%
40.2.2 PI-CONT I-TIME	→ 3s
40.2.3 REFERENCE STEP 1	→ 0%
40.2.4 REFERENCE STEP 2	→ 0%
40.2.5 REFERENCE STEP 3	0%
40.2.6 SLEEP DELAY	→ 60s
40.2.7 SLEEP LEVEL	→ 24.00 Hz
40.2.8 WAKE UP LEVEL	→ 35.0%
40.2.9 START FREQ 1	→ 57.00 Hz
40.2.10 START FREQ 2	→ 57.00 Hz
40.2.11 START FREQ 3	57.00 Hz
40.2.12 LOW FREQ 1	→ 27.00 Hz
40.2.13 LOW FREQ 2	→ 27.00 Hz
40.2.14 LOW FREQ 3	27.00 Hz
40.2.15 AUX MOT START DLY	→ 5s
40.2.16 AUX MOT STOP DLY	→ 3s
40.2.17 NBR OF AUX MOTORS	→ 1
40.2.18 AUTOCHANGE INTERV	→ 72 h 00 min
40.2.19 AUTOCHANGE LEVEL	→ 45.0%
40.2.20 INTERLOCKS	→ OFF
40.2.21 ERROR VALUE INV	→ NO
40.2.22 ACTUAL 1 INPUT	AI2
40.2.23 ACTUAL 2 INPUT	NO
40.2.24 ACTUAL VALUE SEL	→ ACT 1
40.2.25 ACT 1 MIN SCALE	→ 0%
40.2.26 ACT 1 MAX SCALE	→ +100%
40.2.27 ACT 2 MIN SCALE	0%
40.2.28 ACT 2 MAX SCALE	0%
40.2.29 REGUL BYPASS	→ NO
40.2.30 DISPLAY UNIT	→ psi
40.2.31 DISPL UNIT SCALE	→ 1000
40.2.32 NBR OF DECIMALS	→ 2

→ = Typical parameter values to check during start-up. If needed, change values to meet the needs of your application. Complete parameter list provided in Appendix A.

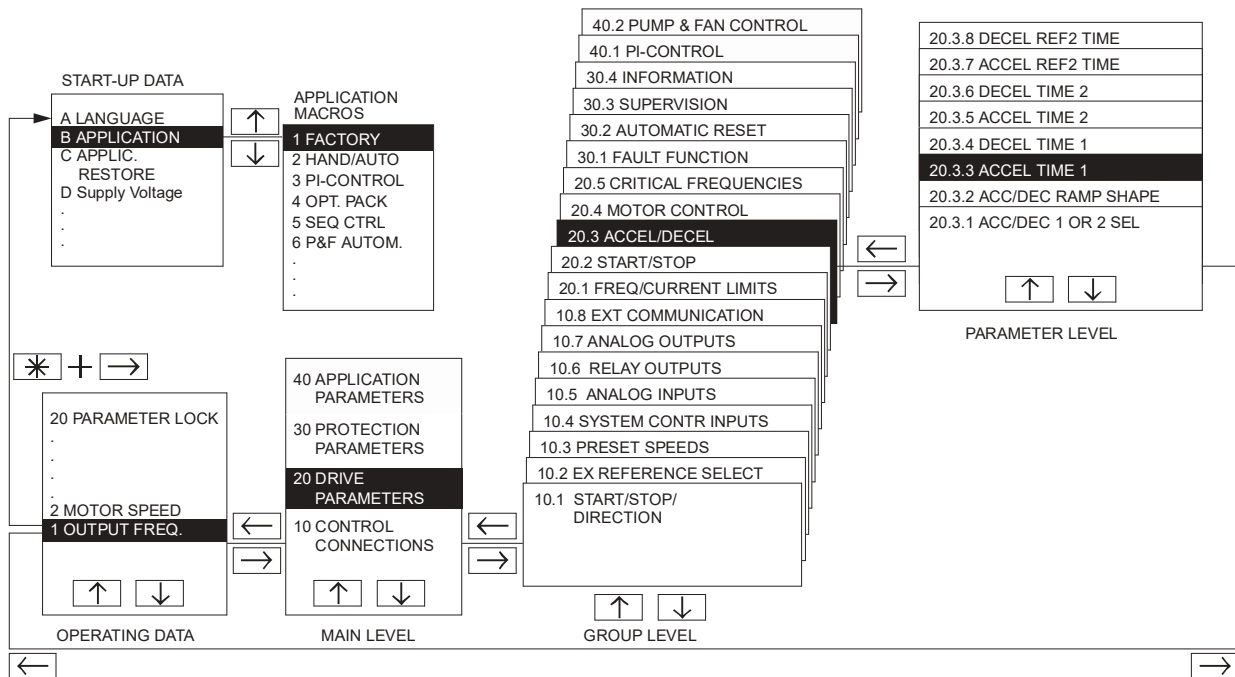
\* - See Critical Frequencies in Chapter 6.

## Chapter 6 – Parameters

### ACS 500 Parameter Menus

This chapter explains the function of each parameter in the ACS 500, and the valid selections for each parameter. Figure 6-1 shows the process of accessing the ACS 500 Parameter Menus.

Figure 6-1 Parameter Menu Selection



### ACS 500 Parameters

The ACS 500 parameters are divided according to function into four Mains and 19 Groups. Operating Data parameters and Start-up Data parameters are not accessed through Mains or Groups. Refer to *Chapter 3 – Start-up Data* and *Chapter 4 – Control Operations* in this manual for more information on Operating Data parameters.

## Main 10 Control Connections

### Group 10.1 Start/Stop/Direction

These parameter values can only be altered with the ACS 500 stopped. The Range/Unit column in Table 6-1 shows parameter values. The text following the table explains parameter values in detail.

Table 6-1 Group 10.1

Parameter	Range/Unit	Description
1 EXT 1 STRT/STP/DIR	Not Sel/Digital Inputs	External control reference R1 start/ stop and direction input.
2 EXT 2 STRT/STP/DIR	Not Sel/Digital Inputs	External control reference R2 Start/ stop and direction input.
3 DIRECTION	Reverse/Forward/ Request/Fast Rev	Rotation direction lock.

#### 1 EXT 1 STRT/STP/DIR

This parameter selects the Digital Inputs used for Start/Stop and Reverse commands.

#### NOT SEL

No Digital Input selected.

#### DI1

*Two-wire start/stop.*

0 V DC = Stop and 24 V DC = Start. Rotation direction is fixed.

#### DI1,2

*Two-wire start/stop and direction.*

Start/Stop is connected to DI1 and Reverse to DI2. 0 V DC on DI2 = Forward and 24 V DC = Reverse.

#### DI1P,2P

*Three-wire start/stop.*

Start/Stop commands are from momentary push-buttons. The stop push-button is normally closed, and connected to DI2. The start push-button is normally open, and connected to DI1. Multiple start push-buttons are connected in parallel, and stop push-buttons in series.

#### DI1P,2P,3

*Three-wire start/stop and direction.*

Refer to DI1P,2P. Reverse is connected to DI3. 0 V DC = Forward, 24 V DC = Reverse.

### **DI1P,2P,3P**

*Start forward, start reverse, and stop.*

Start and direction commands are given simultaneously with two separate momentary push-buttons. The stop push-button is normally closed, and connected to DI3. The start forward push-button is normally open, and connected to DI1. The start reverse push-button is normally open, and connected to DI2. Multiple start push-buttons are connected in parallel, and stop push-buttons in series.

### **DI6**

*Two-wire start/stop.*

0 V DC = Stop and 24 V DC = Start. Rotation direction is fixed.

### **DI6,5**

*Two-wire start/stop and direction.*

Start/Stop is connected to DI6 and Reverse is connected to DI5. 0 V DC on DI5 = Forward.

### **KEYPAD**

Start/Stop command and Direction command are from the Keypad for Ext 1.

#### **2 EXT 2 STRT/STP/DIR**

This parameter selects the Digital Inputs used for Start/Stop and Reverse commands. The choices are the same as Parameter 10.1.1 (Ext 1 Strt/Stp/Dir).

#### **3 DIRECTION**

This parameter allows you to fix rotation direction to FORWARD or REVERSE. If you select REQUEST, the rotation direction is selected by Digital Inputs as defined in Parameters 10.1.1 (Ext 1 Strt/Stp/Dir) and 10.1.2 (Ext 2 Strt/Stp/Dir) or by keypad push-button. If FAST REV is selected, and Parameter 20.2.3 (Stop Function) is set to COAST, the modulator starts to operate in a reverse direction immediately when REVERSE is requested. This procedure results in fast reversing.



**Group 10.2 Ext  
Reference Select**

These parameter values can be altered with the ACS 500 running, except those marked with (O). The Range/Unit column in Table 6-2 shows parameter values. The text following the table explains parameter values in detail.

Table 6-2 Group 10.2

Parameter	Range/Unit	Description
1 EXT 1/EXT 2 SELECT (O)	OP DATA 12/ DI1–DI6/	External control location selection input.
2 EXTERNAL REF1 SEL (O)	OP DATA 13/Analog and Digital Inputs	External reference 1 input.
3 EXT REF1 MINIMUM	0 – 500 Hz (ACS 501) 0 – 120 Hz (ACS 502)	External reference 1 minimum value.
4 EXT REF1 MAXIMUM	0 – 500 Hz (ACS 501) 0 – 120 Hz (ACS 502)	External reference 1 maximum value.
5 EXT REF1 OFFSET	-30 - 30 Hz	Offset for scaling external reference 1
6 EXT REF1 GAIN	-100 - 100%	Gain for scaling external reference 1
7 EXTERNAL REF2 SEL (O)	OP DATA 14/Analog and Digital Inputs	External reference 2 input.
8 EXT REF2 MINIMUM	0 – 500 Hz (ACS 501) 0 – 120 Hz (ACS 502)	External reference 2 minimum value.
9 EXT REF2 MAXIMUM	0 – 500 Hz (ACS 501) 0 – 120 Hz (ACS 502)	External reference 2 maximum value.
10 EXT REF2 OFFSET	-30 - 30 Hz	Offset for scaling external reference 2
11 EXT REF2 GAIN	-100 - 100%	Gain for scaling external reference 2

Parameters 10.2.8 - 10.2.11 are not available in PI, PFC, or Speed Control.

**1 EXT 1/EXT 2 SELECT**

This parameter defines how to select the external control location (Ext Ref 1/ Ext Ref 2). If you choose OP DATA 12, the selection is made with Operating Data Parameter 12 (Ext Ref 1 or 2). If you choose a Digital Input (DI1 – DI6), 0 V DC = Ext Ref 1 and 24 V DC = Ext Ref 2.

**2 EXTERNAL REF1 SEL**

This parameter selects the signal source of External Reference 1.

**OP DATA 13**

Reference is given from the Keypad, Operating Data Parameter 13.

**AI1**

Reference from analog input 1.

**AI2**

Reference from analog input 2.

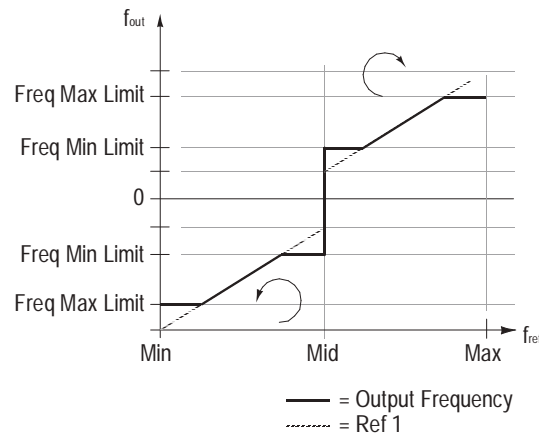
## AI1/JOYST

Reference from analog input 1 configured for a joystick. Analog input minimum signal is full speed reverse, and analog input maximum signal is full speed forward. The mid point between minimum and maximum is zero speed.

**CAUTION:** Minimum reference for joystick must be 0.3 V/0.6 mA or greater. If a 0 – 10 V or 0 – 20 mA signal is used, the drive will run at fmax to Reverse if the control signal is lost. Set Parameter 10.5.1 (Minimum AI1) to 2 V/4 mA or to a value 0.3 V/0.6 mA or greater, and Parameter 30.1.2 (AI < Min Function) to Fault, and the drive will stop in case of lost control signal.

Figure 6-2 shows Joystick control.

Figure 6-2 Joystick Control



## DI3U,4D(R)

Speed reference via digital inputs as Floating Point Control, or Motor Operated Potentiometer Control. DI3 increases speed, and DI4 decreases speed. (R) indicates that the reference will reset to minimum frequency when stop command is given. The rate of change of the reference signal is controlled by parameter 20.3.5, ACCEL TIME 2.

## DI3U,4D

Same as above except speed reference does not reset to zero on stop command.

## DI5U,6D

Same as above.

3 EXT REF1 MINIMUM 0 Hz – 500 Hz (ACS 501)

0 Hz – 120 Hz (ACS 502)

This parameter sets the frequency corresponding to the minimum reference. When Parameter 20.1.1 (Minimum Frequency) is changed, this parameter is automatically set to the same value.

**4 EXT REF1 MAXIMUM**    **0 Hz – 500 Hz (ACS 501)**

**0 Hz – 120 Hz (ACS 502)**

This parameter sets the frequency corresponding to the maximum reference. When Parameter 20.1.2 (Maximum Frequency) is changed, this parameter is automatically set to the same value.

**5 EXT REF1 OFFSET**    This parameter with the **EXT REF1 GAIN** are used for scaling the incoming serial reference. The **EXT REF1 OFFSET** is added to the received serial reference.

**6 EXT REF1 GAIN**    This parameter with the **EXT REF1 OFFSET** are used for scaling the incoming serial reference. The **EXT REF1 GAIN** specifies what percentage of the received serial reference is added to the received serial reference.

The External Reference Offset and Gain are used to scale also the reference sources AI1, AI2, and AI1/JOYST.

Example: The reference is 20 Hz, EXT REF1 OFFSET is 5Hz, and EXT REF1 GAIN is 10%. The drive reference is now  $20\text{Hz} + 5\text{Hz} + 0.1 * 20\text{Hz} = 27\text{Hz}$ .

**7 EXTERNAL REF2 SEL**    **OP DATA 14**

This parameter selects the signal source for External Reference 2.

Reference is given from the Keypad, Operating Data Parameter 14.

**AI1**

Reference from analog input 1.

**AI2**

Reference from analog input 2

**DI3U,4D(R)**

Speed reference via digital inputs as Floating Point Control, or Motor Operated Potentiometer Control. DI3 increases speed, and DI4 decreases speed. (R) indicates that the reference will reset to zero when stop command is given.

**DI3U,4D**

Same as above except speed reference does not reset to zero on stop command.

**DI5U,6D**

Same as above.

**8 EXT REF2 MINIMUM**    **0 Hz – 500 Hz (ACS 501)**

**0 Hz – 120 Hz (ACS 502)**

This parameter sets the frequency corresponding to the minimum reference. When Parameter 20.1.1 (Minimum Frequency) is changed, this parameter is automatically set to the same value.

9 EXT REF2 MAXIMUM 0 Hz – 500 Hz (ACS 501)

0 Hz – 120 Hz (ACS 502)

This parameter sets the frequency corresponding to the maximum reference. When Parameter 20.1.2 (Maximum Frequency) is changed, this parameter is automatically set to the same value.

10 EXT REF2 OFFSET Same as parameter 10.2.5.

11 EXT REF2 GAIN Same as parameter 10.2.6.

**Group 10.3  
Preset Speeds**

These parameter values can be altered with the ACS 500 running, except those marked with (O). The Range/Unit column in Table 6-3 shows parameter values. The text following the table explains parameter values in detail.

Table 6-3 Group 10.3

Parameter	Range/Unit	Description
1 PRESET SPEED SEL (O)	Digital Inputs	Preset speed selection.
2 PRESET SPEED 1	0 – 500 Hz (ACS 501) 0 – 120 Hz (ACS 502)	Override frequency 1.
3 PRESET SPEED 2	0 – 500 Hz (ACS 501) 0 – 120 Hz (ACS 502)	Override frequency 2.
4 PRESET SPEED 3	0 – 500 Hz (ACS 501) 0 – 120 Hz (ACS 502)	Override frequency 3.
5 PRESET SPEED 4	0 – 500 Hz (ACS 501) 0 – 120 Hz (ACS 502)	Override frequency 4.
6 PRESET SPEED 5	0 – 500 Hz (ACS 501) 0 – 120 Hz (ACS 502)	Override frequency 5.
7 PRESET SPEED 6	0 – 500 Hz (ACS 501) 0 – 120 Hz (ACS 502)	Override frequency 6.
8 PRESET SPEED 7	0 – 500 Hz (ACS 501) 0 – 120 Hz (ACS 502)	Override frequency 7/Fault Frequency (Refer to Parameters 30.1.1 and 30.1.2).

This Group has seven programmable preset speeds, ranging from 0.0 Hz to 500 Hz (ACS 501) or 0.0 Hz to 120 Hz (ACS 502), with a 0.01 Hz step.

When in External Control mode, preset speeds override any other reference. Preset speeds are activated with Digital Input(s) selected through Parameter 10.3.1 (Preset Speed Sel).

**Note:** Parameter 10.3.8 (Preset Speed 7) is a fault frequency, which may be activated in case of a serial communication fault or a loss of analog input fault. Refer to Parameter 30.1.1 (Serial Fault Func) and 30.1.2 (AI < Min Func) when in external mode.

**1 PRESET SPEED SEL** This parameter defines which Digital Inputs are used to select Preset Speeds.

**NOT SEL**

**DI1 – DI6**

Preset speed number 1 selected by the Digital Input. 24 V DC = Preset Speed activated.

**DI1,2**

Three Preset Speeds (1 – 3) are selected with two Digital Inputs.

*Table 6-4 Digital Inputs DI1,2*

DI1	DI2	Function
0	0	No Preset Speed.
1	0	Preset Speed 1.
0	1	Preset Speed 2.
1	1	Preset Speed 3.

**DI3,4**

Three Preset Speeds (1 – 3) are selected with two Digital Inputs as in DI1,2.

**DI5,6**

Three Preset Speeds (1 – 3) are selected with two Digital Inputs as in DI1,2.

**DI1,2,3**

Seven Preset Speeds (1 – 7) are selected with three Digital Inputs.

*Table 6-5 Digital Inputs DI1,2,3*

DI1	DI2	DI3	Function
0	0	0	No Preset Speed.
1	0	0	Preset Speed 1.
0	1	0	Preset Speed 2.
1	1	0	Preset Speed 3.
0	0	1	Preset Speed 4.
1	0	1	Preset Speed 5.
0	1	1	Preset Speed 6.
1	1	1	Preset Speed 7.

**DI3,4,5**

Refer to DI1,2,3.

### DI4,5,6

Refer to DI1,2,3.

### Group 10.4 System Contr Inputs

These parameter values can only be altered with the ACS 500 stopped. The Range/Unit column in Table 6-6 shows parameter values. The text following the table explains parameter values in detail.

Table 6-6 Group 10.4

Parameter	Range/Unit	Description
1 RUN ENABLE	Yes/DI1–DI6	Run enable input.
2 FAULT RESET SELECT	Not Sel/DI1–DI6/ On Stop	Fault/Warning/Supervision reset input.
3 PARAM LOCK SEL	Op Data 20/ DI1–DI6	Parameter lock input.
4 EXTERNAL FAULT	Not Sel/DI1–DI6	External fault input.

#### 1 RUN ENABLE

This parameter selects the source of the Run Enable signal.

#### YES

Run Enable signal active. Drive is ready to start without an external Run Enable signal.

#### DI1 – DI6

To activate the Run Enable signal, the selected Digital Input must be connected to +24 V DC. If the Digital Input goes to 0 V DC, the drive will coast to stop.

#### 2 FAULT RESET SELECT

#### NOT SEL/DI1 – DI6/ON STOP

If you select NOT SEL, fault reset is done from the Keypad. If a digital input is selected, fault reset is done from an external switch or from the keypad. Reset is activated by opening a normally closed contact (negative edge on digital input). If ON STOP is selected, a fault is reset by giving a stop command from the active STOP signal, or from the Keypad.

#### 3 PARAM. LOCK SEL

This parameter selects the control location for Parameter Lock.

If you select OP DATA 20, Parameter Lock is controlled with Operating Data Parameter 20 (Parameter Lock). If you select a Digital Input (1 – 6), 0 V DC equals Open and 24 V DC equals Locked.

#### 4 EXTERNAL FAULT

#### NOT SEL

#### DI1 – DI6

Input for external fault device such as a motor overload relay or fire alarm. The device should have a normally closed contact. The digital input must be connected to +24 VDC. If the digital input goes to 0 VDC, the drive will coast to stop and a fault message will display.

### Group 10.5 Analog Inputs

These parameter values can be altered with the ACS 500 running. The Range/Unit column in Table 6-7 shows parameter values. The text following the table explains parameter values in detail.

Table 6-7 Group 10.5

Parameter	Range/Unit	Description
1 MINIMUM AI1	V/mA	Minimum value of AI1. Value to correspond to minimum reference.
2 MAXIMUM AI1	V/mA	Maximum value of AI1. Value to correspond to maximum reference.
3 RC FILTER ON AI1	0.01 – 10s	Filter time constant for AI1.
4 INVERT AI1	No/Yes	Analog Input signal 1 inversion.
5 MINIMUM AI2	V/mA	Minimum value of AI2. Value to correspond to minimum reference.
6 MAXIMUM AI2	V/mA	Maximum value of AI2. Value to correspond to maximum reference.
7 RC FILTER ON AI2	0.01 – 10s	Filter time constant for AI2.
8 INVERT AI2	No/Yes	Analog Input signal 2 inversion.

#### 1 MINIMUM AI1 **0V/0mA; 2V/4mA; READ INPUT**

This parameter sets the minimum value of the signal to be applied to AI1. This value will then correspond to zero speed. Typical minimum values are 0 V/0 mA or 2 V/4 mA.

When input minimum is not 0 or 2 V for a voltage signal, or 0 or 4 mA for a current signal, the drive can read the minimum from this third display by applying the minimum signal to the analog input, and pressing [ \* ]. This value then becomes the minimum. The range is 0 – 10 V, and 0 – 20 mA.

The ACS 500 has a “living zero” function which allows the protection and supervision circuits to detect a loss of signal. For this feature to be functional, the minimum input signal must be greater than 0.3 V/0.6 mA. When the minimum is set less than this level, the “/” between the volts and milliamps will disappear, indicating the “living zero” is not active even if it has been programmed.

#### 2 MAXIMUM AI1 **10V/20mA; READ INPUT**

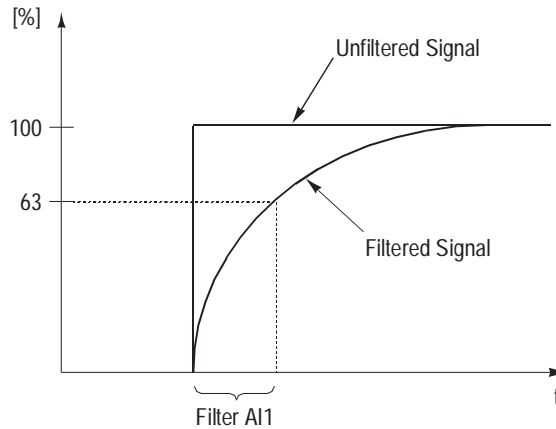
When the maximum reference is less than 10 V or 20 mA, this parameter will set what the maximum reference is, so the drive will run at full speed when this reference is applied. By going into this parameter and applying the maximum reference, pressing [ \* ] will store the applied reference, and the ACS 500 will consider this value to be maximum.

**3 RC FILTER ON AI1** Filter time constant for Analog Input 1.

As the Analog Input value changes, 63 percent of the change takes place within the time period given by this parameter. If you select the minimum value 0.01s, the signal is not filtered.

Figure 6-3 shows filter time constant.

Figure 6-3 Filter +Time Constant



**4 INVERT AI1** **NO/YES**

If this parameter is set to YES, maximum reference gives minimum frequency and minimum reference gives maximum frequency.

**5 MINIMUM AI2** Refer to Parameter 10.5.1.

**6 MAXIMUM AI2** Refer to Parameter 10.5.2.

**7 RC FILTER ON AI2** Refer to Parameter 10.5.3.

**8 INVERT AI2** Refer to Parameter 10.5.4.



**Group 10.6  
Relay Outputs**

These parameter values can only be altered when the ACS 500 is not running. The text following Table 6-8 explains parameter values in detail.

Table 6-8 Group 10.6

Parameter	Range/Unit	Description
1 RELAY RO1 OUTPUT	Refer to the text below for the available selections.	Relay Output 1 content.
2 RELAY RO2 OUTPUT		Relay Output 2 content.
3 RELAY RO3 OUTPUT		Relay Output 3 content.

**1 RELAY RO1 OUTPUT**

This parameter allows you to select which information is indicated with Relay Output 1.

**READY**

The ACS 500 is ready to function. The relay is energized unless no run enable is present or a fault exists.

**RUN**

The drive has been started, has an enable signal, and is not in a fault trip.

**FAULT**

Any fault occurs. Refer to *Chapter 5 – Fault Tracing* in the *Installation & Start-up Manual* for more details.

**FAULT (-1)**

Relay energizes when power is applied, and de-energizes upon a fault trip.

**FAULT(RST)**

The ACS 500 is in a fault condition, but will reset after the programmed autoreset delay.

**STALL FLT**

Stall protection has tripped.

**MOT OT FLT**

Motor overload ( $I^2t$ ) protection has tripped.

**OT FAULT**

The ACS 500 overheat protection has tripped. The tripping level is 158°F (70°C) for ACS 501 and 185°F (85°C) for ACS 502.

**FAULT/WARN**

Any fault or warning has occurred.

**WARNING**

Any warning has occurred.

**OT WARNING**

The heatsink temperature has exceeded the warning level 149°F (65°C).

**REVERSED**

Reverse is selected.

**EXT. CTRL**

External control selected.

**REF 2 SEL**

Reference 2 selected.

**PRESET SPD**

A Preset Speed (1 – 7) selected.

**DC BUS LIM**

Voltage regulator is activated.

**FREQ1 LIM**

Output frequency has exceeded the Supervision Limit 1. Refer to Parameter 30.3.1 (Output Freq 1 Func).

**FREQ2 LIM**

Output frequency has exceeded the Supervision Limit 2. Refer to Parameter 30.3.4 (Output Freq 2 Lim).

**CURRENT LIMIT**

Motor current has exceeded the set Current Supervision Limit. Refer to Parameter 30.3.6 (Current Limit).

**REF 1 LIMIT**

Reference 1 has exceeded the set Supervision Limit. Refer to Parameter 30.3.8 (Ref 1 Limit).

**REF 2 LIMIT**

Reference 2 has exceeded the set Supervision Limit. Refer to Parameter 30.3.10 (Ref 2 Limit).

**AT SPEED**

The output frequency is equal to the set frequency (+/- .25 Hz of set frequency).

**HIGH TEMP**

High heatsink temperature indication with hysteresis. Relay activates at 60°C (140°F), and opens at 40°C (104°F).

**P&F AUTOM**

When Pump and Fan macro is selected, some relays are automatically reserved for the lag pumps. When a relay is reserved for Pump and Fan sequencing, P&F AUTOM will appear in this parameter.

**2 RELAY RO2 OUTPUT** Refer to Parameter 10.6.1 (Relay RO1 Output).

**3 RELAY RO3 OUTPUT** Refer to Parameter 10.6.1 (Relay RO1 Output).

### Group 10.7 Analog Outputs

These parameter values can be altered with the ACS 500 running, except those marked with (O). The Range/Unit column in Table 6-9 shows parameter values. The text following the table explains parameter values in detail.

Table 6-9 Group 10.7

Parameter	Range/Unit	Description
1 ANALOG OUTPUT 1 (O)	Refer to the text below for the available selections.	Analog Output 1 content.
2 SCALE AO1	10 – 1000%	Analog Output signal 1 scaling factor.
3 MINIMUM AO1	0 mA/4 mA	Analog Output signal 1 minimum.
4 RC FILTER ON AO1	0.01 – 10s	Filter time constant for AO1.
5 INVERT AO1	NO/YES	Analog Output signal 1 inversion.
6 ANALOG OUTPUT 2 (O)	Refer to the text below for the available selections.	Analog Output 2 content.
7 SCALE AO2	10 – 1000%	Analog Output signal 2 scaling factor.
8 MINIMUM AO2	0 mA/4 mA	Analog Output signal 2 minimum.
9 RC FILTER ON AO2	0.01 – 10s	Filter time constant for AO2.
10 INVERT AO2	NO/YES	Analog Output signal 2 inversion.

#### 1 ANALOG OUTPUT 1

This Parameter allows you to select which output signal is connected to Analog Output 1 (current signal). The following list shows the full scale reading with Parameters 10.7.2 (Scale AO1) and 10.7.7 (Scale AO2) set to 100%.

#### NOT USED

#### OUT FREQ

Output frequency. 20 mA = 60 Hz.

#### MOT SPEED

Motor speed. 20 mA = motor speed at 60 Hz.

#### OUT CURR

Output current. 20 mA = motor nominal current.

#### MOT TORQ

Motor torque. 20 mA = 100% of motor nominal rating.

#### MOT POWER

Motor power. 20 mA = 100% of motor nominal rating.

### V/DC BUS

DC bus voltage. 20 mA = 100% of Nominal DC Bus Voltage ( $V_N \times 1.35$ ).

### MOTOR VOLT

Motor voltage. 20 mA = Supply Voltage.

### REFERENCE

Active reference that the ACS 500 is currently following. 20 mA = 100% of the active reference.

The following can only be seen when the Pump & Fan macro is selected.

### ERROR VAL

Scaled difference of ACT and REF values.

### PICON OUTP

PI regulator output.

### ACTUAL 1

Unscaled actual value 1.

### ACTUAL 2

Unscaled actual value 2.

### PICON REF

Reference of PI-Controller.

<i>2 SCALE AO1</i>	This parameter is the scaling factor for the Analog Output 1 signal. If you select 100%, the nominal value of the output signal corresponds to 20 mA. If the maximum is less than full scale, increase the value of this parameter.
<i>3 MINIMUM AO1</i>	The minimum value of the Analog Output signal can be set to either 0 mA or 4 mA.
<i>4 RC FILTER ON AO1</i>	Filter time constant for Analog Output 1.  As Analog Output value changes, 63 percent of the change takes place within the time period given by this parameter. If you select the minimum value 0.01s, the signal is not filtered. (See Figure 6-3 for Parameter 10.7.4).
<i>5 INVERT AO1</i>	If you select YES, the Analog Output 1 signal is inverted.
<i>6 ANALOG OUTPUT 2</i>	Refer to Parameter 10.7.1.
<i>7 SCALE AO2</i>	Refer to Parameter 10.7.2.
<i>8 MINIMUM AO2</i>	Refer to Parameter 10.7.3.
<i>9 RC FILTER ON AO2</i>	Refer to Parameter 10.7.4.
<i>10 INVERT AO2</i>	Refer to Parameter 10.7.5.

**Group 10.8 Ext  
Communication**

For external communication parameter settings, refer to the *Remote Panel Manual* (SAGS700PAN-04) or the *DMT 500 PC Manual* (DMT500PC-US-04) for information on the GS protocol parameters, or the *ACS 500 Modbus Manual* (ACS500MODBUS-US-04) for information on the Modbus protocol parameters.

**Main 20  
Drive Parameters**

**Group 20.1  
Freq/Current Limits**

These parameter values can be altered with the ACS 500 running, except those marked with (O). The Range/Unit column in Table 6-10 shows parameter values. The text following the table explains parameter values in detail.

Table 6-10 Group 20.1

Parameter	Range/Unit	Description
1 MINIMUM FREQUENCY	0 – 500 Hz (ACS 501) 0 – 120 Hz (ACS 502)	Operating range minimum frequency.
2 MAXIMUM FREQUENCY	0 – 500 Hz (ACS 501) 0 – 120 Hz (ACS 502)	Operating range maximum frequency.
3 FREQUENCY RANGE (O)	0 – 500 Hz or 0 – 120 Hz	Frequency Range. (ACS 501 only)
4 CURRENT LIMIT	0.5 – 2.0 times ACS 500 current ( $I_N$ )	Output current limit.

**1 MINIMUM FREQUENCY** Represents the minimum output frequency.

**2 MAXIMUM FREQUENCY** Represents the maximum output frequency.

**3 FREQUENCY RANGE** To use the ACS 501 for frequencies higher than 120 Hz, you must first change this parameter.

This parameter sets the range for all frequency parameters.

**0 – 120 Hz**

Default frequency range. Output frequency display to 0.01 Hz.

**0 – 500 Hz**

Extended frequency range. Available for ACS 501 only. Output frequency display to 0.1 Hz.

---

**CAUTION:** Special application considerations must be taken into account for high frequency operation.

---

#### 4 CURRENT LIMIT

This setting is the output current limit the ACS 500 will supply to the motor. If the rated current of the motor is lower than the rated current of the ACS 500, set the current limit in accordance with the motor rating in standard applications.

*Note: Current limitation time is not supervised. Too long a period of overcurrent may cause the ACS 500 to shut down due to overtemperature.*

#### Group 20.2 Start/Stop

These parameter values can only be altered with the ACS 500 stopped, except those marked with (I). The Range/Unit column in Table 6-11 shows parameter values. The text following the table explains parameters values in detail.

Table 6-11 Group 20.2

Parameter	Range/Unit	Description
1 START FUNCTION	RAMP/FLYING/ TORQ BOOST/ FLYING+TQB	Conditions during motor acceleration.
2 TORQUE BOOST CURR	0.5 – 2.0 times drive output current	Torque Boost current level selection.
3 STOP FUNCTION (I)	COAST/RAMP/ DC BRAKE	Conditions during motor deceleration.
4 BRAKE CHOPPER (I)	NO/YES	Dynamic Braking Device activation.
5 DC HOLD	OFF/ON	Enable DC Hold.
6 DC HOLD VOLTAGE	0.01 – 0.1 times drive output voltage	Voltage set for DC Hold.
7 DC BRAKE VOLTAGE	0.01 – 0.1 times drive output voltage	Voltage set for DC injection braking.
8 DC BRAKE TIME	0 – 250s	Duration of DC injection braking.

#### 1 START FUNCTION

##### **RAMP**

Ramp acceleration as set in Group 20.3.

##### **FLYING**

Use this setting to start the motor if it is already rotating, such as in a fan drive. The drive will start smoothly at the current frequency instead of starting at 0 Hz.

*Note: Flying Start searches for the running speed by applying a small voltage to the load at the maximum frequency and decreasing the output frequency until the load speed is found. If the motor is not coupled to a load or the load has low inertia, the shaft speed can follow this search program.*

## TORQ BOOST

Automatic start current boost, which may be necessary in applications requiring high starting torque. Automatic torque boost is active only from 0 Hz to 20 Hz or until the reference speed is reached. Torque boost is not activated if the output frequency falls below 20 Hz while running.

Refer to IR Compensation in Group 20.4 for added torque at low speeds while running.

## FLYING + TQB

Both Flying Start and Torque Boost functions are active.

### 2 TORQUE BOOST CUR

Sets the current that will be allowed when Torque Boost start is selected. Keep the boost current as low as possible for the application. Setting is in actual amps, 0.5 – 2.0 x I<sub>N</sub>, 1% step.

### 3 STOP FUNCTION

#### COAST

The ACS 500 AC drive stops supplying voltage immediately after stop command is received and the motor coasts to a stop.

#### RAMP

Ramp deceleration as set in Group 20.3.

#### DC BRAKE

DC injection braking stops the motor by applying DC to the stator windings. By using DC braking, the motor can be stopped in the shortest possible time, outside of using a dynamic braking device.

*Note: If the Run Enable input is deactivated, the ACS 500 will stop by coasting, regardless of the Stop Function setting.*

### 4 BRAKE CHOPPER

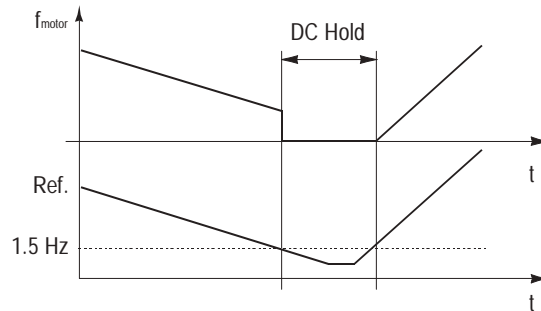
If a dynamic braking device is used, the Decel Limit level (voltage regulator upper limit) can be increased by selecting YES for this parameter. Decel Limit level is raised to within five percent of the Overvoltage Trip point, essentially eliminating the Decel Limit.

### 5 DC HOLD

If this parameter is set to YES, the DC Hold feature is enabled.

Figure 6-4 shows DC Hold.

Figure 6-4 DC Hold



When both reference and output frequencies drop below 1.5 Hz, the drive will stop generating sinusoidal current and inject DC into the motor. The voltage value is the voltage set in the DC Hold Voltage. When the reference frequency goes above 1.5 Hz, the DC will be removed and normal drive function resumes.

DC Hold has no effect if the Start signal is deactivated.

*Note: Injecting DC voltage into the motor causes the motor to heat up. In applications where long DC Hold times are required, externally ventilated motors should be used. In a long DC Hold period, the DC Hold cannot keep the motor shaft from rotating if a constant load is applied to the motor.*

#### 6 DC HOLD VOLTAGE

Sets the voltage level applied to the motor when DC Hold is activated. Range is from 0.01 to 0.1 times the nominal voltage.

#### 7 DC-BRAKE VOLTAGE

When the stop function is set to DC BRAKE, this parameter sets the voltage injected into the motor. The factory setting is suitable for a nominal size motor. If braking is too sudden, decrease this value. If braking is not sufficient, increase this value.

#### 8 DC-BRAKE TIME

When the stop function is set to DC BRAKE, this parameter sets the DC injection time in seconds. If the braking time is too short, the drive stops by coasting after the DC-Brake Time has elapsed.



**Group 20.3  
Accel/Decel**

These parameter values can be altered with the ACS 500 running, except those marked with (O). The Range/Unit column in Table 6-12 shows parameter values. The text following the table explains parameter values in detail.

Table 6-12 Group 20.3

Parameter	Range/Unit	Description
1 ACC/DEC 1OR2 SEL (O)	Not Sel/ DI1–DI6	Acceleration/Deceleration ramp selection.
2 ACC/DEC RAMP SHAPE	Linear/S1 – S3	Accel./Decel. ramp shape selection.
3 ACCEL TIME 1	0.1 – 1800s	Time for output frequency min. to max. acceleration ramp 1.
4 DECEL TIME 1	0.1 – 1800s	Time for output frequency max. to min. deceleration ramp 1.
5 ACCEL TIME 2	0.1 – 1800s	Time for output frequency min. to max. acceleration ramp 2.
6 DECEL TIME 2	0.1 – 1800s	Time for output frequency max. to min. deceleration ramp 2.
7 ACCEL REF2 TIME	0.1 – 1800s	Ref2 acceleration ramp time for 0 – 100%.
8 DECEL REF2 TIME	0.1 – 1800s	Ref2 deceleration ramp time for 100 – 0%.

**1 ACC/DEC 1OR2 SEL**

This parameter defines which Digital Input (1 – 6) is used to select the Acceleration/Deceleration Ramp used. 0 V DC equals Acc/Dec Time 1, 24 V DC equals Acc/Dec Time 2.

**2 ACC/DEC  
RAMP SHAPE**

This parameter allows you to select the shape of the acceleration/deceleration ramp. The available options are:

**LINEAR**

Suitable for drives requiring steady acceleration/deceleration and/or slow ramps.

**S1 SHAPE**

Suitable for ramp times less than one second.

**S2 SHAPE**

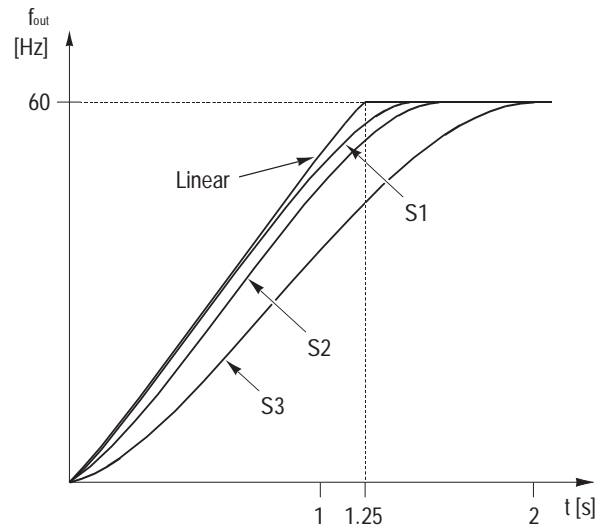
Suitable for ramp times less than 1.5 seconds.

**S3 SHAPE**

Suitable for ramp times up to 15 seconds.

Figure 6-5 shows acceleration and deceleration ramp shapes.

Figure 6-5 Acceleration and Deceleration Ramp Shapes



### 3 ACCEL TIME 1

The time required for the output frequency to change from minimum to maximum frequency. Regardless of the settings, the maximum acceleration/ deceleration is 120 Hz/0.1s and the minimum is 120 Hz/1800s. The time required for the acceleration from zero to minimum frequency depends on the Accel Time (acceleration equals  $f_{\max} - f_{\min} / \text{acceleration time}$ ).

**Note:** The ACS 500 incorporates a bus controller that prevents overcurrent and overvoltage trips caused by too quick acceleration and deceleration settings for a given system (by increasing the acceleration/deceleration).

If a small number is entered for acceleration time in a system with high inertia, the acceleration time will be limited by Parameter 20.1.4 (Current Limit). Conversely, if a small number is entered for deceleration time in such a system, the deceleration time will be limited by the DC bus regulator. In some cases, the motor will take a long time to come to a stop. If a short deceleration time is critical to your application, we suggest you add a dynamic braking device to your system.

The maximum/minimum recommended acceleration/deceleration for the nominal size motor is 40 Hz in one second. If the motor rating is less than the maximum power of the ACS 500, smaller settings can be used.

If the reference signal changes at a rate slower than the acceleration or deceleration time, the output frequency change will follow the reference signal. If the reference signal changes faster than the acceleration or deceleration time, the output frequency change will be limited by the parameters.

### 4 DECEL TIME 1

The time required for output frequency to change from maximum to minimum. Refer to Parameter 20.3.3.

### 5 ACCEL TIME 2

Refer to Parameter 20.3.3.

- 6 DECEL TIME 2 Refer to Parameter 20.3.4.
- 7 ACCEL REF2 TIME Corresponds to the time required for the reference to change from 0 to 100 percent and vice versa, if the PI-Controller is not used.
- 8 DECEL REF2 TIME Refer to Parameter 20.3.7.

**Group 20.4  
Motor Control**

These parameter values can only be altered with the ACS 500 stopped, except those marked with (I). The Range/Unit column in Table 6-13 shows parameter values. The text following the table explains parameter values in detail.

Table 6-13 Group 20.4

Parameter	Range/Unit	Description
1 SWITCHING FREQ	1.0 – 12.0 kHz (ACS 501) 1.0 – 5.0 kHz (600 V - ACS 501) 3.0 kHz (ACS 502)	Carrier frequency selection.
2 MAX OUT VOLTAGE	0.15 – 1.05 times drive output voltage	Maximum motor voltage selection.
3 V/Hz RATIO	LINEAR/SQUARED/AUTOMATIC	Voltage to frequency relationship in region below Field Weakening Point.
4 FIELD WEAK POINT	30 – 500 Hz	Threshold for nominal voltage.
5 IR COMPENSATION	NO/MANUAL/AUTOMATIC	Low speed torque boost function.
6 IR COMP VOLTAGE	0.01 – 0.15 times drive output voltage	Voltage level in manual IR Compensation.
7 IR COMP RANGE	0 Hz – FWP	Zero point in manual IR Compensation.
8 SLIP COMPENSATION (I)	OFF/ON	Automatic slip reduction.
9 NOMINAL SLIP (I)	0.1 – 10%	Nominal slip of the motor.
10 VOLTAGE LIMIT (I)	OFF/ON	Over-/Undervoltage Controller.

### 1 SWITCHING FREQ

Motor noise can be minimized by adjusting the switching frequency to a value that does not create resonances in the motor and load. The optimum switching frequency is the lowest frequency where the noise is acceptable.

As the switching frequency goes up, the inverter efficiency goes down, so it is best to use as low a switching frequency as possible relative to acceptable noise levels for the particular application.

*Note: Consult factory for derating information for increased switching frequency above 3 kHz.*

### 2 MAX OUTPUT VOLTAGE

Maximum voltage that the drive will output at and above the Field Weakening point. This parameter is automatically set to the same value as Start-up Data Parameter K (Motor Nom. Voltage) when that parameter is changed. Set in actual volts, step equals 1% of  $V_N$ . Range is  $0.15 - 1.05 \times V_N$ .

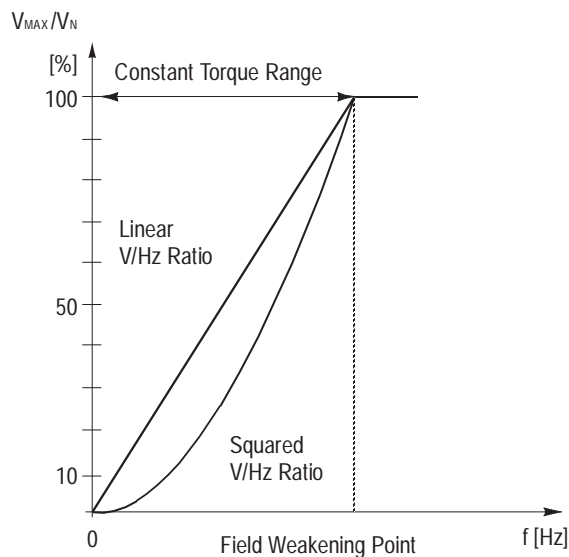
### 3 V/Hz RATIO

#### LINEAR

The voltage of the motor changes linearly with frequency in the constant torque area. Linear V/Hz ratio is normally used in Torque control mode, or where the torque characteristics of the load is constant with speed.

Figure 6-6 shows V/Hz ratios.

Figure 6-6 V/Hz Ratios



#### SQUARED

A squared V/Hz ratio undermagnetizes the motor, reducing noise and motor losses. Squared V/Hz ratio is normally used in applications where the load torque characteristic is proportional to the square of the speed, such as centrifugal pumps, fans and compressor drives.

## AUTOMATIC

The motor voltage is automatically controlled to minimize the motor losses and noise. This setting is suitable for a motor which has a slowly changing load torque and which operates mainly below nominal load. This feature should not be used with undersized motors (motor hp below drive rated hp).

**Note:** If Parameter 20.4.3 (V/Hz Ratio) is set to SQUARED or AUTOMATIC, Parameter 20.4.5 (IR Compensation) must be set to NO.

### 4 FIELD WEAK POINT

The Field Weakening Point is the frequency where the output voltage reaches the maximum output voltage. Above this frequency, the voltage remains at the maximum motor voltage value.

Figure 6-7 shows various field weakening points.

Figure 6-7 Field Weakening Points

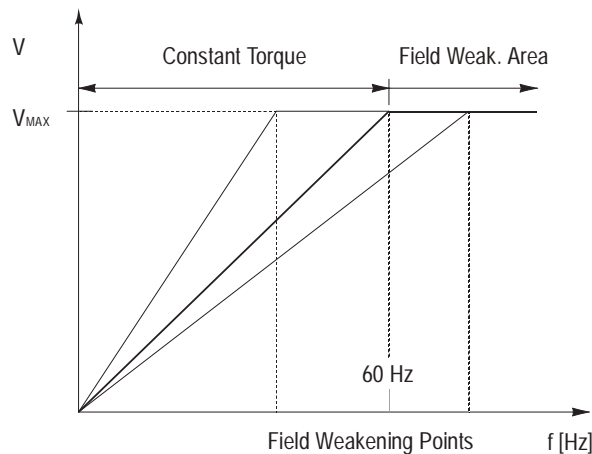
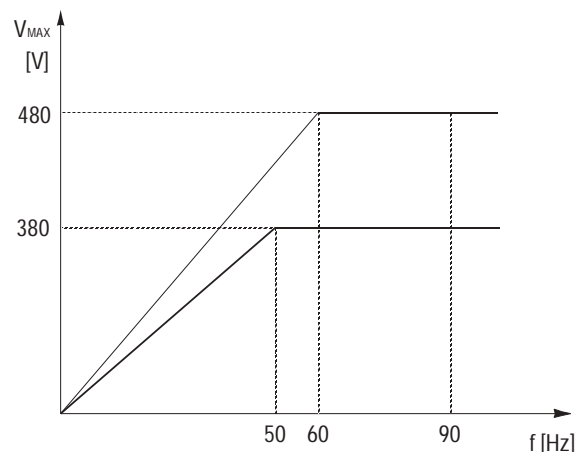


Figure 6-8 shows Parameters 20.4.2 and 20.4.4 adjusted to run a motor not of rated voltage.

Figure 6-8 Motor Not of Rated Voltage



## 5 IR COMPENSATION

This parameter allows extra torque at speeds between 0.1 Hz and the set field weakening point. This parameter differs from the Torq Boost option of the Start Function in that it is always valid in the above mentioned speed range.

When using IR Compensation, always set Parameter 20.4.3 (V/Hz Ratio) to LINEAR.

### NO

No compensation wanted.

### MANUAL

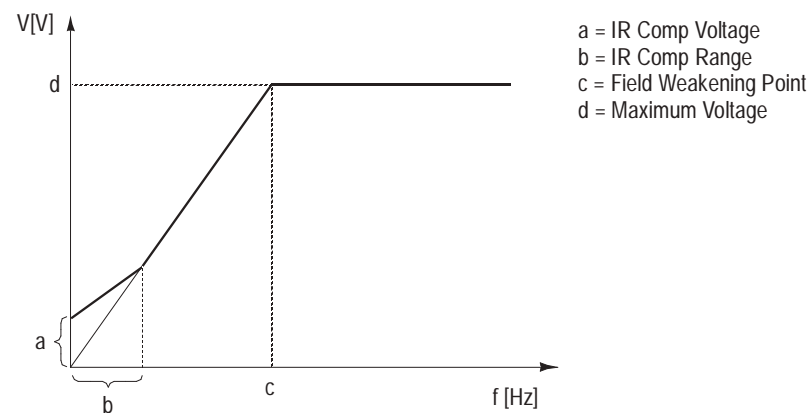
The user sets the compensation voltage and range (Parameters 20.4.6 and 20.4.7).

### AUTOMATIC

The IR-Compensation voltage is automatically controlled as a function of effective motor current. This setting is suitable when the need for IR Compensation changes or manual optimization of the compensation voltage is difficult.

Figure 6-9 shows IR-Compensation applying extra voltage to a motor.

Figure 6-9 IR Compensation



Changing the motor base frequency automatically changes this value if it is set higher than the motor base frequency.

### 6 IR-COMP VOLTAGE

This parameter sets the compensation voltage level in Manual IR Compensation. Keep the boost voltage as low as possible for the application, as the motor will overheat rapidly or an overcurrent fault may occur if a high level of compensation is applied.

Small motors can take higher compensation than larger motors because the winding resistance is higher in small motors. If the motor must drive a load with a high starting torque, use Torq Boost to start. If the load torque is high below the set field weakening point, and you run continuously below the field weakening point, use just enough IR-Compensation to drive the load. If you have trouble with the motor overheating, use a lower speed motor, and run at a higher frequency. Set in actual volts, step equals 1% of  $V_N$ ,  $0.01 - 0.15 \times V_N$ , voltage level at 0.1 Hz.

### 7 IR-COMP RANGE

This parameter defines the frequency at which the Manual IR Compensation reduces to zero. The compensation voltage reduces linearly when the frequency increases.

If Start-Up Data Parameter I (Motor Base Frequency) or Parameter 20.4.4 (Field Weak Point) is changed to a value lower than Parameter 20.4.7 (IR Comp Range), that value will automatically be copied to Parameter 20.4.7 (IR-Comp Range).

### 8 SLIP COMPENSATION

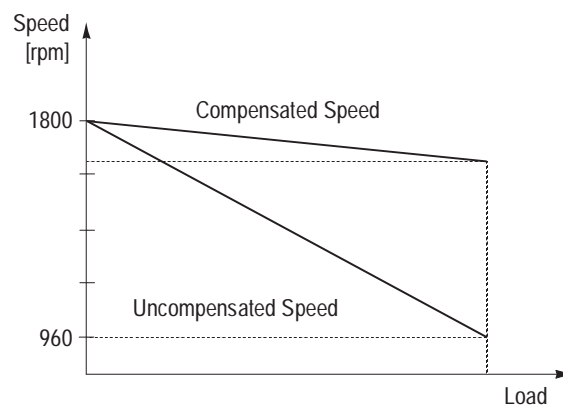
A squirrel-cage motor will slip when loaded. The ACS 500 can compensate for this slip by increasing the frequency as the current increases. With this parameter ON, the slip will be reduced down to approximately 10 percent of the original value.

You must set this function to OFF when using synchronous motors.

This parameter is automatically set to a value based on Start-Up Data Parameters I (Motor Base Freq.) and J (Motor Base R.P.M.). You can adjust the slip compensation after start-up.

Figure 6-10 shows how slip compensation reduces slip in a 4-pole motor under load.

Figure 6-10 Slip Reduction



### 9 NOMINAL SLIP

For the precise operation of the Slip Compensation function, the ACS 500 must know the nominal slip of the motor. Set the nominal slip as a percentage of the nominal motor speed with a range of 0.1 – 10.0%, 0.1% step.

$$\text{Slip} = \left( 1 - \frac{\text{nameplate speed}}{\text{synchronous speed}} \right) \times 100$$

### 10 VOLTAGE LIMIT

This parameter allows you to deactivate the Over and Undervoltage Controllers.

The overvoltage controller will increase the output frequency if the DC bus voltage exceeds the high DC bus voltage limit level, typically from an overhauling load, to prevent an overvoltage trip.

The undervoltage controller will decrease the output frequency if the DC bus voltage drops below the low DC bus voltage limit, caused by a loss of input power. By decreasing the output frequency, the inertia of the load will cause regeneration back into the drive, keeping the DC bus charged, and preventing an undervoltage trip. This will increase power loss ride through on systems with a high inertia, such as a centrifuge or fan.



**Group 20.5  
Crit Frequencies**

These parameter values can be altered with the ACS 500 running. The Range/Unit column in Table 6-14 shows parameter values. The text following the table explains parameter values in detail.

Table 6-14 Group 20.5

Parameter	Range/Unit	Description
1 CRIT FREQ SELECT	OFF/ON	Critical frequency jump over logic.
2 CRIT FREQ 1 LOW	0 – 500 Hz (ACS 501) 0 – 120 Hz (ACS 502)	Critical frequency 1 start.
3 CRIT FREQ 1 HIGH	0 – 500 Hz (ACS 501) 0 – 120 Hz (ACS 502)	Critical frequency 1 end.
4 CRIT FREQ 2 LOW	0 – 500 Hz (ACS 501) 0 – 120 Hz (ACS 502)	Critical frequency 2 start.
5 CRIT FREQ 2 HIGH	0 – 500 Hz (ACS 501) 0 – 120 Hz (ACS 502)	Critical frequency 2 end.
6 CRIT FREQ 3 LOW	0 – 500 Hz (ACS 501) 0 – 120 Hz (ACS 502)	Critical frequency 3 start.
7 CRIT FREQ 3 HIGH	0 – 500 Hz (ACS 501) 0 – 120 Hz (ACS 502)	Critical frequency 3 end.
8 CRIT FREQ 4 LOW	0 – 500 Hz (ACS 501) 0 – 120 Hz (ACS 502)	Critical frequency 4 start.
9 CRIT FREQ 4 HIGH	0 – 500 Hz (ACS 501) 0 – 120 Hz (ACS 502)	Critical frequency 4 end.
10 CRIT FREQ 5 LOW	0 – 500 Hz (ACS 501) 0 – 120 Hz (ACS 502)	Critical frequency 5 start.
11 CRIT FREQ 5 HIGH	0 – 500 Hz (ACS 501) 0 – 120 Hz (ACS 502)	Critical frequency 5 end.

**Note:** Using the critical frequency lockout function in a closed loop application (such as PI Control or Pump & Fan Control) will cause the system to oscillate if the output frequency required is within the critical frequency band.

In some mechanical systems, certain frequency ranges can cause resonance problems. With this Group, it is possible to set up to five different frequency ranges that the ACS 500 will skip over. For example, it is not necessary that Parameter 20.5.4 (Crit Freq 2 Low) be greater than Parameter 20.5.3 (Crit Freq 1 High), just as long as the Low parameter of any one set is lower than the High parameter of the same set. Sets may overlap, but the skip will be from the lower Low value to the higher High value.

To activate the Critical Frequency settings, select Parameter 20.5.1 (Crit Freq Select) YES.

*Note: Set unused Critical Frequencies to 0 Hz.*

Example: Fan system with bad vibration from 18 Hz to 23 Hz and from 46 Hz to 52 Hz. Running speed set to 60 Hz with reference. Set the parameters as follows:

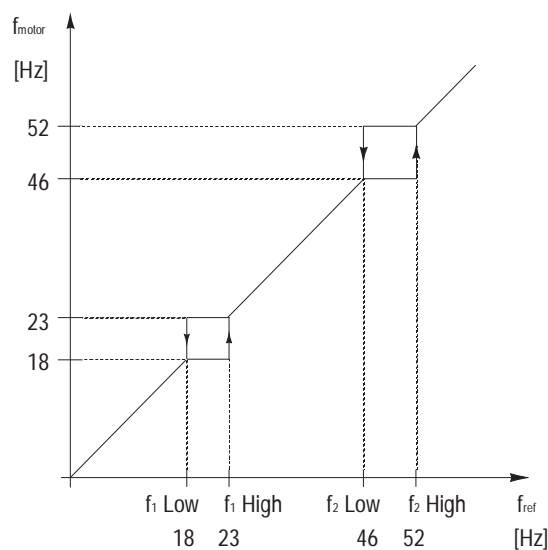
- 2 CRIT FREQ 1 LOW 18 Hz
- 3 CRIT FREQ 1 HIGH 23 Hz
- 4 CRIT FREQ 2 LOW 46 Hz
- 5 CRIT FREQ 2 HIGH 52 Hz

If, due to bearing wear, another resonance occurs at 34 – 36 Hz, the critical frequency table can be added to as follows:

- 6 CRIT FREQ 3 LOW 34 Hz
- 7 CRIT FREQ 3 HIGH 36 Hz

Figure 6-11 shows the critical frequencies settings for fan vibration ranges 18 – 23 Hz and 46 – 52 Hz.

Figure 6-11 Critical Frequency Settings



## Main 30 Protection Parameters

### Group 30.1 Fault Function

These parameter values can be altered with the ACS 500 running. The Range/Unit column in Table 6-15 shows parameter values. The text following the table explains parameter values in detail.

Table 6-15 Group 30.1

Parameter	Range/Unit	Description
1 SERIAL FAULT FUNC	STOP/ PRE SPEED7	Operation in case of Serial Communication fault.
2 AI < MIN FUNCTION	NO/WARNING/ FAULT/ PRE SPEED7/ LAST SPEED	Operation in case of AI <Minimum fault.
3 MOT TEMP FLT FUNC	NO/WARNING/ FAULT	Operation in case of motor overtemp.
4 MOTOR THERM TIME	20 – 10000s	Time for 63% temperature rise.
5 MOTOR LOAD CURVE	50 – 150%	Motor current maximum limit.
6 ZERO SPEED LOAD	40% - MOTOR LOAD CURVE	Motor load curve point at zero speed.
7 BREAK POINT	1 Hz – 500 Hz	Break point of motor load curve.
8 STALL FUNCTION	NO/WARNING/ FAULT	Operation in case of motor stall.
9 STALL CURRENT	0 – 1.5 times drive current rating.	Current limit for Stall protection logic.
10 STALL TIME/FREQ	10s/15Hz or 20s/ 25Hz or 30s/35Hz	Time/Freq limit for Stall protection logic.
11 UNDERLOAD FUNC	NO/WARNING/ FAULT	Operation in case of Underload fault.
12 UNDERLOAD TIME	0 – 600s	Time limit for Underload logic.
13 UNDERLOAD CURVE	1 – 5	Torque limit for Underload logic.

#### 1 SERIAL FAULT FUNC

This parameter allows you to select the preferred operation in case of a malfunction in serial communication between Control Interface and Motor Control Cards.

#### STOP

The ACS 500 stops according to the setting of Parameter 20.2.3 (Stop Function).

### PRE SPEED7

The ACS 500 drives the motor at a preset speed selected with Parameter 10.3.8 (Preset Speed 7) when in external mode.

*Note: If the selected control location is Keypad, the ACS 500 stops in case of serial communication fault.*

### 2 AI < MIN FUNCTION

This parameter allows you to select the preferred operation in case Analog Input (1 or 2) (whichever is being used at that time) signal drops below the minimum setting, provided the minimum is set at 0.3 V/0.6 mA or above (“living zero”).

#### NO

No activity wanted.

#### WARNING

Warning indication on display.

#### FAULT

Fault indication on display and the drive stops according to the setting of Parameter 20.2.3 (Stop Function).

### PRE SPEED7

Fault indication on display and the output frequency goes to the value set by Parameter 10.3.8 (Preset Speed 7).

### LAST SPEED

Fault indication on display and the output frequency goes to the last speed (average over the last 10 seconds).

### 3 MOT TEMP FLT FUNC

This parameter defines the operation of the motor thermal protection function.

#### NO

No activity wanted.

#### WARNING

Warning indication is displayed when the motor temperature reaches the warning level (95 percent of the nominal value).

#### FAULT

Displays a warning indication at warning level. Displays a fault indication and stops the ACS 500 when the motor temperature reaches 100 percent level.

The motor connected to the ACS 500 can be protected from overheating by motor thermal protection. The ACS 500 calculates the temperature rise of the motor using the following assumptions:

- The ambient temperature is 104°F (40°C).
- The motor is at ambient when power is applied to the ACS 500.
- When stopped, the motor cooling time is four times the cooling time when running.

Motor heating is calculated assuming a load curve. The load curve is defined by the Motor Load Curve, Zero Speed Load, and Break Point parameters. If Motor Load Curve is set to 100%, the Motor Thermal Protection allows the motor to be loaded to 100% of the current set by Start-up Data Parameter F (Motor Current -FLA). The load curve level should be adjusted if the ambient temperature differs from the nominal value.

The motor will heat above nominal temperature if it operates in the region above the curve, and cool if operated below the curve. The rate of heating and cooling is set by Motor Therm Time. Motor Therm Time is the time period within which the motor temperature reaches 63 percent of the final temperature rise. As a rule of thumb, Motor Thermal Time equals 35 times  $t_6$  ( $t_6$  in seconds is the safe operating time at locked rotor current given by the motor manufacturer).

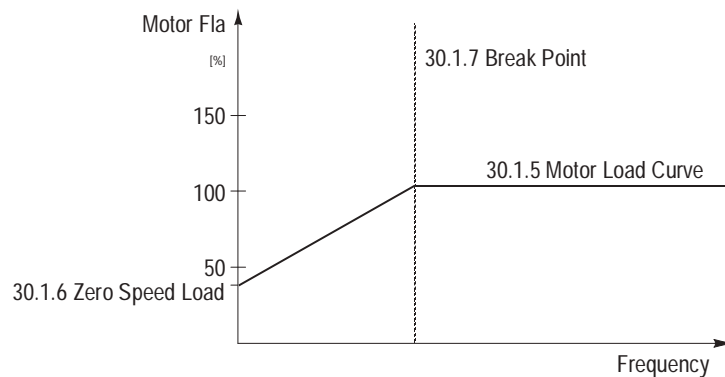
Because of the simple thermal model used for calculating temperature rise, this technique of thermal protection may cause undesirable trips if the motor is run continuously at low frequencies. If your application requires continuous running at frequencies lower than 25 Hz, you may need to provide external cooling.

---

**CAUTION:** Motor thermal protection will not protect the motor if the cooling efficiency of the motor is reduced due to dust and dirt.

---

Figure 6-12 Motor Load Curve



**4 MOTOR THERM TIME**

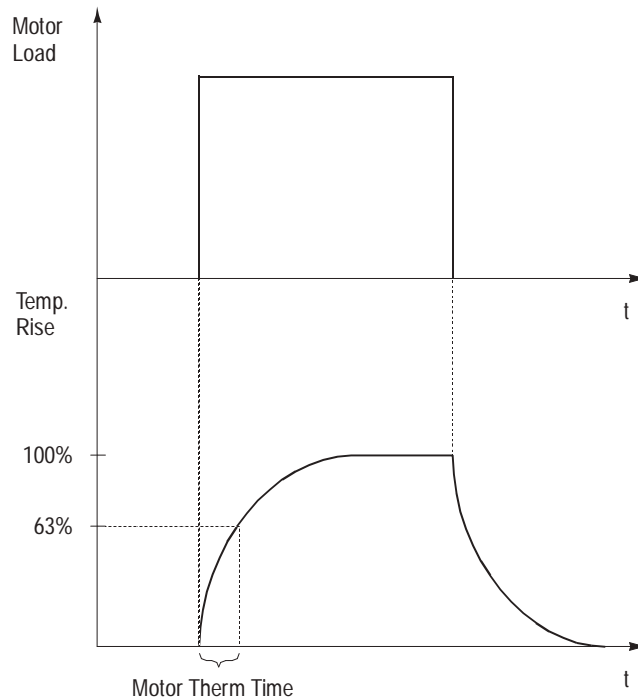
The time period within which the motor temperature reaches 63 percent of the final temperature rise. As a rule of thumb, Motor Thermal Time equals 35times t6 (t6 in seconds is the time that the motor can safely operate at six times its rated current, given by the motor manufacturer). Table 6-16 shows some motor thermal times measured by ABB. The default value is set to 700s, which is the value for a Class 20 trip curve. This has been tested and is UL Listed as motor overload protection. The time for a Class 10 trip curve is 350s and for a Class 30 trip curve is 1050s.

Table 6-16 Motor Thermal Times

P <sub>N</sub> [HP]	Number of Poles		
	2	4	6
	t [s]	t [s]	t [s]
3	660	1020	1440
5	780	1140	1740
7.5	900	1260	1760
10	970	1380	1860
15	1140	1560	2040
20	1200	1740	2340
25	1260	1860	2340
30	1380	2040	2760
40	1680	2220	2940
50	1860	2460	3180
60	2040	2640	3420
75	2220	2820	3660
100	2400	3120	3960
125	2640	3300	4320
150	2820	3600	4680
200	3120	3960	5100
250	3420	4320	5700
300	3780	4740	6420
350	3780	4740	6420
400	3780	4740	6420

Figure 6-13 shows motor thermal time.

Figure 6-13 Motor Thermal Time



#### 5 MOTOR LOAD CURVE

The Motor Load Curve sets the maximum allowable operating load of the motor. The load is adjustable from 50% to 150%. Refer to Figure 6-12 for an example of motor load curve.

When set to 100%, the maximum allowable load is equal to the value of Start-up Data Parameter F (Motor Current -FLA).

#### 6 ZERO SPEED LOAD

This parameter defines the maximum allowable current at zero speed to define the Motor Load Curve. Refer to Figure 6-12 for an illustration of the Motor Load Curve.

The current is adjustable from 40% to the Motor Load Curve set by Parameter 30.1.5 (Motor Load Curve).

#### 7 BREAK POINT

This parameter defines the point at which the motor load curve begins to decrease from the maximum value set by Parameter 30.1.5 (Motor Load Curve) to the Zero Speed Load (Parameter 30.1.6). The value is adjustable from 1 Hz to 500 Hz. Refer to Figure 6-12 for an example of motor load curve.

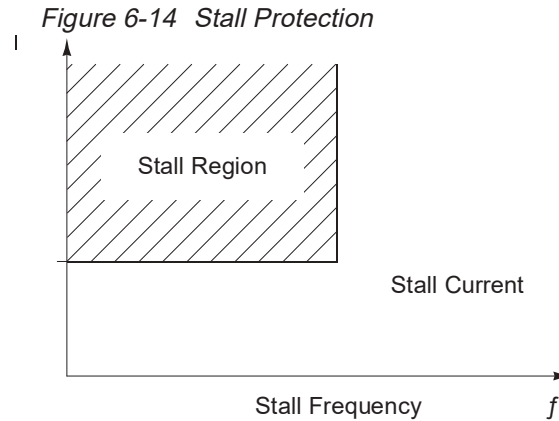
#### 8 STALL FUNCTION

This parameter defines the operation (NO/WARNING/FAULT) of the Stall Protection. The protection is activated if:

- The motor current exceeds the limit set in Parameter 30.1.9 (Stall Current),
- The output frequency is below the level set in Parameter 30.1.10 (Stall Time/Freq), and

- This condition has lasted longer than the period set in Parameter 30.1.10 (Stall Time/Freq).

Figure 6-14 shows stall protection.

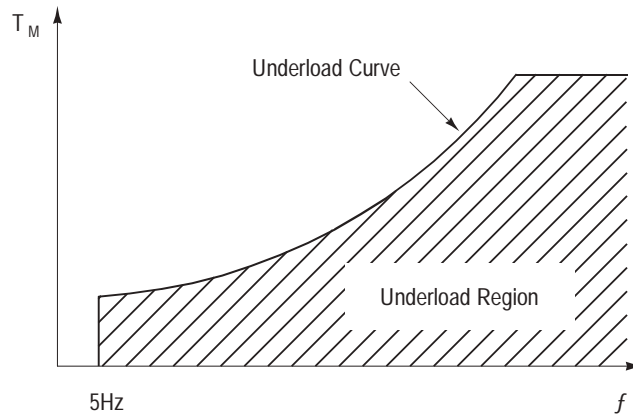


- 9 STALL CURRENT** This parameter sets the current level that must be exceeded for the stall protection to activate. Setting in actual amps, step is 1% of  $I_N$ , 0 – 1.5 x  $I_N$ .
- 10 STALL TIME/FREQ** **10s/15Hz**  
**20s/25Hz**  
**30s/35Hz**  
This parameter sets the time and frequency values for the stall function.
- 11 UNDERLOAD FUNC** Removal of motor load may indicate a process malfunction. The protection is activated if:
- The motor torque drops below the load curve selected in Parameter 30.1.13 (Underload Curve),
  - This condition has lasted longer than the time set in Parameter 30.1.12 (Underload Time), and
  - Output frequency is more than 5 Hz.
- Select NO/WARNING/FAULT according to the activity you prefer.
- 12 UNDERLOAD TIME** **0 – 600s**, 1s step.  
Time limit for underload logic.



Figure 6-15 shows underload protection.

Figure 6-15 Underload Protection



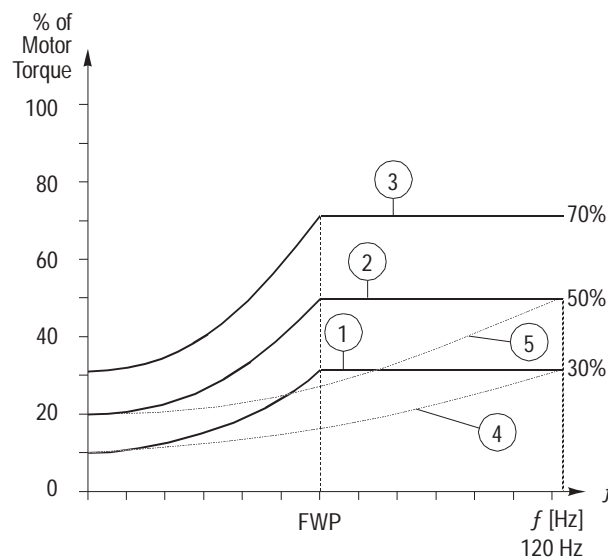
### 13 UNDERLOAD CURVE

This parameter provides you with five selectable curves.

Torque limit for underload logic.

Figure 6-16 shows five available Underload Curve types. If the load drops below the set curve for a longer time than the time set by Parameter 30.1.12, the underload protection will activate. Curves 1 – 3 reach maximum at the Field Weakening Point set by Parameter 20.4.4 (Field Weak Point).

Figure 6-16 Underload Curve Types



**Group 30.2  
Automatic Reset**

These parameter values can be altered with the ACS 500 running. The Range/Unit column in Table 6-17 shows parameter values. The text following the table explains parameter values in detail.

Table 6-17 Group 30.2

Parameter	Range/Unit	Description
1 NUMBER OF RESETS	0 – 5	Number of faults limit for Autoreset logic.
2 TIME WINDOW	1s – 180s	Time limit for Autoreset logic.
3 TIME BETW. RESET ATTEMPTS	0s– 120s	Time delay between reset attempts.
4 OVERVOLTAGE	NO/YES	Enable automatic fault reset.
5 UNDERVOLTAGE	NO/YES	Enable automatic fault reset when bus voltage returns to normal.
6 OVERCURRENT	NO/YES	Enable automatic fault reset.
7 AI SIGNAL < MIN	NO/YES	Enable automatic fault reset when AI is greater than 0.25V.

**1 NUMBER OF RESETS**

Sets the number of resets the ACS 500 will attempt before staying shut down and indicating a fault.

**2 TIME WINDOW**

The maximum number of faults per time period to keep the Automatic Fault Reset System active is given with Parameters 30.2.1 (Number of Resets) and 30.2.2 (Time Window).

If more faults occur or a fault persists longer than Trial Time, the drive stops.

The Automatic Fault Reset System resets the faults selected with Parameters 30.2.4 (Overvoltage), 30.2.5 (Undervoltage), 30.2.6 (Overcurrent), and 30.2.7 (AI Signal < Min).

**3 TIME BETW.  
RESET ATTEMPTS**

**0 – 120s**

This parameter sets the time that the ACS 500 will wait after a fault occurs before attempting to reset. If set to zero, the ACS 500 will reset immediately making the fault transparent to the user. If set to a value greater than zero, the drive will wait before resetting and will count down the time until reset on the digital display. For AI Signal < Min Fault, the ACS 500 will start immediately when the signal returns.

**4 OVERVOLTAGE**

If you select YES, the ACS 500 resumes operation when the DC bus voltage returns to normal level.

**5 UNDERVOLTAGE** If you select YES, the ACS 500 resumes operation when the DC bus voltage returns to normal level. If the number of reset attempts is set to 0 and this parameter is set to YES, the drive will always reset in an undervoltage condition. If the number of reset attempts is greater than 0, the drive counts the number of undervoltage faults.

**6 OVERCURRENT** If you select YES, the fault resets automatically and the ACS 500 resumes normal operation.

**7 AI SIGNAL < MIN** If you select YES, the drive resets when the analog input signal returns to a level above the minimum.

**Group 30.3  
Supervision**

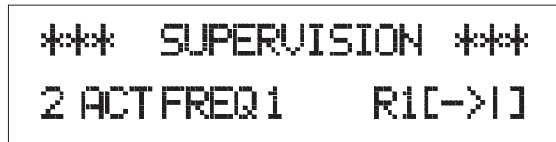
These parameter values can be altered with the ACS 500 running. The Range/Unit column in Table 6-18 shows parameter values. The text following the table explains parameter values in detail.

Table 6-18 Group 30.3

Parameter	Range/Unit	Description
1 OUTPUT FREQ 1 FUNC	NO/LOW LIMIT/ HIGH LIMIT	Output Frequency 1 supervision.
2 OUTPUT FREQ 1 LIM	0 – 500 Hz (ACS 501) 0 – 120 Hz (ACS 502)	Output Frequency 1 supervision limit.
3 OUTPUT FREQ 2 FUNC	NO/LOW LIMIT/ HIGH LIMIT	Output Frequency 2 supervision.
4 OUTPUT FREQ 2 LIM	0 – 500 Hz (ACS 501) 0 – 120 Hz (ACS 502)	Output Frequency 2 supervision limit.
5 CURRENT FUNCTION	NO/LOW LIMIT/ HIGH LIMIT	Motor Current supervision.
6 CURRENT LIMIT	0 – 2 times drive output current	Motor Current supervision limit.
7 REF1 FUNCTION	NO/LOW LIMIT/ HIGH LIMIT	Reference 1 supervision.
8 REF1 LIMIT	0 – 500 Hz (ACS 501) 0 – 120 Hz (ACS 502)	Reference 1 supervision limit.
9 REF2 FUNCTION	NO/LOW LIMIT/ HIGH LIMIT	Reference 2 supervision.
10 REF2 LIMIT	0 – 100%	Reference 2 supervision limit.
11 SUPERVIS MESSAGES	ON/OFF	Turn off display of supervision messages.

Figure 6-17 shows an example of a supervision indication.

Figure 6-17 Supervision Indication



<p>1 OUTPUT FREQ 1 FUNC</p>	<p>This parameter allows you to activate an output frequency supervision function. Relay outputs such as Parameters 10.6.1 (Relay RO1 Output), 10.6.2 (Relay RO2 Output), and 10.6.3 (Relay RO3 Output) and displays are used to indicate that the output frequency drops below (LOW LIMIT) or exceeds (HIGH LIMIT) the supervision limit.</p> <p><b>NO</b></p> <p>Supervision not used.</p> <p><b>LOW LIMIT</b></p> <p>Supervision will activate if value is below the limit set.</p> <p><b>HIGH LIMIT</b></p> <p>Supervision will activate if value is above the limit set.</p>
<p>2 OUTPUT FREQ 1 LIMIT</p>	<p>Output frequency supervision limit adjustable from 0 – 500 Hz (ACS 501) or 0 – 120 Hz (ACS 502), 0.1 Hz step.</p>
<p>3 OUTPUT FREQ 2 FUNC</p>	<p>Refer to Parameter 30.3.1.</p>
<p>4 OUTPUT FREQ 2 LIMIT</p>	<p>A second output frequency supervision limit adjustable from 0 – 500 Hz (ACS 501) or 0 – 120 Hz (ACS 502), 0.1 Hz step.</p>
<p>5 CURRENT FUNCTION</p>	<p>Motor Current supervision. Operates the same as Parameter 30.3.1.</p>
<p>6 CURRENT LIMIT</p>	<p>Motor current supervision limit. Setting in actual amps, step is 1% of <math>I_R</math>, adjustable from 0 – 2.0 x <math>I_R</math>.</p>
<p>7 REF1 FUNCTION</p>	<p>Reference 1 supervision. Operates the same as Parameter 30.3.1.</p>
<p>8 REF1 LIMIT</p>	<p>Reference 1 supervision limit adjustable from 0 – 120 Hz, 0.1 Hz step.</p>
<p>9 REF2 FUNCTION</p>	<p>Reference 2 supervision. Operates the same as Parameter 30.3.1.</p>
<p>10 REF2 LIMIT</p>	<p>Reference 2 supervision limit adjustable from 0 – 120 Hz, 0.1 Hz step.</p>
<p>11 SUPERVIS MESSAGES</p>	<p>This parameter controls the display of supervision messages. If set to OFF, the supervision messages will not display on the digital display.</p>

**Group 30.4  
Information**

You cannot alter these parameter values. The Range/Unit column in Table 6-19 shows parameter values. The text following the table explains parameter values in detail.

Table 6-19 Group 30.4

Parameter	Range/Unit	Description
1 CRI PROG VERSION	CRUxxy	Control Interface Card program version.
2 MC PROG VERSION	MCRxxy/CNTxxy	Motor Control Card program version.
3 TEST DATE	YY.MM.DD	Test date (year,month,day).

**1 CRI PROG VERSION** This parameter displays the Control Interface Card version installed in your ACS 500.

**2 MC PROG VERSION** This parameter displays the Motor Control Card version installed in your ACS 500.

**3 TEST DATE** This parameter displays the test date of the ACS 500.

**Group 30.5  
I/O Status**

You cannot alter these parameter values. The Range/Unit column in Table 6-20 shows parameter values. The text following the table explains parameter values in detail. The parameters in this group show the status of the I/O.

Table 6-20 Group 30.5

Parameter	Range/Unit	Description
1 DI1-6 STATUS	000000	Indication of the status of the six digital inputs. 0=Open; 1=Closed
2 AI1 V/mA	0.00/ 0.00	Signal at Analog Input 1 in volts and milliamps
3 AI2 V/mA	0.00/ 0.00	Signal at Analog Input 2 in volts and milliamps
4 RO1-3 STATUS	000	Indication of the status of the three relay outputs. 0=Open; 1=Closed
5 AO1 mA/%	0.00/ 0%	Signal at Analog Output 1 in milliamps and percent.
6 AO2 mA/%	0.00/ 0%	Signal at Analog Output 2 in milliamps and percent.

## Main 40 Application Parameters

### Group 40.1 PI-Controller

These parameters can only be seen when you select the PI-Control macro.

These parameter values can be altered with the ACS 500 running, except those marked with (O). The Range/Unit column in Table 6-21 shows parameter values. The text following the table explains parameter values in detail.

Table 6-21 Group 40.1

Parameter	Range/Unit	Description
1 PI-CONT GAIN	3 – 800%	PI-Controller Gain selection.
2 PI-CONT I-TIME	0.02 – 320.00s	PI-Controller I-time selection.
3 PI-CONT MIN LIMIT	0 – 120 Hz	PI-Controller output freq. minimum limit.
4 PI-CONT MAX LIMIT	0 – 120 Hz	PI-Controller output freq. maximum limit.
5 ERROR VALUE INVERT	NO/YES	PI-Controller error value inversion.
6 ACTUAL VALUE SEL (O)	ACT1/ACT1 - ACT2/ ACT+ACT2/ ACT1*ACT2	PI-Controller output signal selection.
7 ACTUAL 1 INPUT (O)	AI1/AI2	Actual 1 signal input selection.
8 ACTUAL 2 INPUT (O)	AI1/AI2	Actual 2 signal input selection.
9 ACT 1 MIN SCALE	-1600.0 – +1600.0%	Minimum scaling factor of the Actual 1.
10 ACT 1 MAX SCALE	-1600.0 – +1600.0%	Maximum scaling factor of the Actual 1.
11 ACT 2 MIN SCALE	-1600.0 – +1600.0%	Minimum scaling factor of the Actual 2.
12 ACT 2 MAX SCALE	-1600.0 – +1600.0%	Maximum scaling factor of the Actual 2.

The PI Controller allows the ACS 500 to take a reference signal (setpoint) and an actual signal (feedback), and automatically adjust the output frequency of the drive to match the actual signal to the reference.

#### 1 PI-CONT GAIN

This parameter defines the gain of the PI-Controller included in the Application macros of the ACS 500. Setting range is 3 – 800%. If you select 100%, a 10% change in error value causes controller output to change by 1.5 Hz.

If the parameter value is set to 3.0%, the PI-Controller operates as an I-Controller.

Table 6-22 lists a few examples of gain settings, and the resulting output frequency change to a 10% change in error and a 50% change in error.

Table 6-22 Gain Settings

PI-Cont Gain	Output Frequency Change for a 10% Change in Error	Output Frequency Change for a 50% Change in Error
50%	0.75 Hz	3.75 Hz
100%	1.5 Hz	7.5 Hz
300%	4.5 Hz	22.5 Hz

**2 PI-CONT I-TIME**

If the parameter value is set to 320.00s, the PI-Controller operates as a P-Controller. Time range is 0.02s – 320.00s, 0.01s step.

**3 PI-CONT MIN LIMIT**

The minimum value of the PI-Controller frequency output. The limit cannot be set less than 20.1.1 (Minimum Frequency). Range is 0 – 120 Hz, 0.01 Hz step.

**4 PI-CONT MAX LIMIT**

The maximum value of the PI-Controller frequency output. The limit cannot be set greater than 20.1.2 (Maximum Frequency). Range is 0 – 120 Hz, 0.01 Hz Step.

**5 ERROR VALUE  
INVERT**

This parameter allows you to invert the Error Value (and thus the operation of the PI-Controller). Normally, a decrease in Actual Signal (Feedback) causes an increase in drive speed. If a decrease in Actual should cause a decrease in speed, set Error Value Invert to YES.

**6 ACTUAL VALUE**

The Actual Value for the PI Controller can be a single signal, or two signals combined by subtraction, addition or multiplication. The choices are as follows.

**ACT1**

**ACT1-ACT2**

**ACT1+ACT2**

**ACT1\*ACT2**

**7 ACTUAL 1 INPUT**

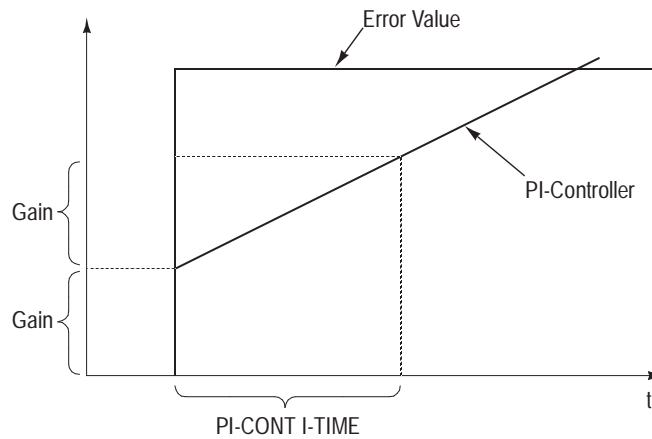
**AI1 OR AI2**

**8 ACTUAL 2 INPUT**

**AI1 OR AI2**

Figure 6-18 shows PI-Controller Gain, I-Time, and Error Value.

Figure 6-18 PI-Controller Gain, I-Time, and Error Value



**9 ACT 1 MIN SCALE**

Minimum scaling factor of the Actual Value 1. Setting range is -1600 to + 1600%.

**0%**

The minimum Actual Value corresponds to the minimum scaled Actual Value.

**100%**

The maximum Actual Value corresponds to the minimum scaled Actual Value.

**10 ACT 1 MAX SCALE**

Maximum scaling factor of the Actual Value 1. Setting range is -1600 to +1600%.

**0%**

The minimum Actual Value corresponds to the maximum scaled Actual Value.

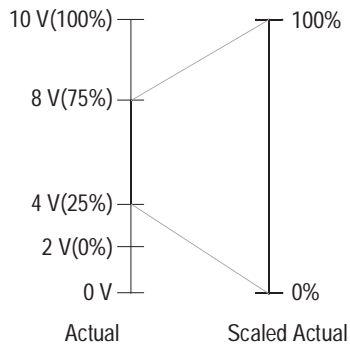
**100%**

The maximum Actual Value corresponds to the maximum scaled Actual Value.

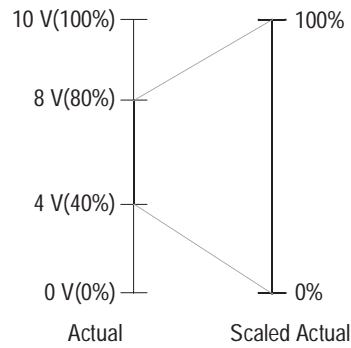


Figure 6-19 show three examples of actual value scaling.

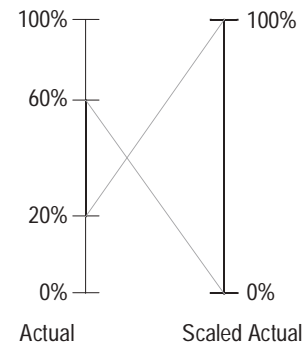
Figure 6-19 Actual Value Scaling



Minimum AI 2V/4mA  
Act 1 Max Scale 75%  
Act 1 Min Scale 25%



Minimum AI 0V/0mA  
Act 1 Max Scale 80%  
Act 1 Min Scale 40%



Act 1 Max Scale = 20%  
Act 1 Min Scale = 60%

11 ACT 2 MIN SCALE Refer to Parameter 40.1.9.

12 ACT 2 MAX SCALE Refer to Parameter 40.1.10.

**Group 40.2 Pump & Fan Control**

These parameters can only be seen when you select the P&F Autom. macro.

These parameter values can be altered with the ACS 500 running, except those marked with (O). The Range/Unit column in Table 6-23 shows parameter values.

Table 6-23 Group 40.2

Parameter	Range/Unit	Description
1 PI-CONT GAIN	3% – 800%	PI-Controller Gain selection.
2 PI-CONT I-TIME	0, 1s – 320s	PI-Controller I-time selection.
3 REFERENCE STEP 1	0% – 100%	Reference increase 1.
4 REFERENCE STEP 2	0% – 100%	Reference increase 2.
5 REFERENCE STEP 3	0% – 100%	Reference increase 3.
6 SLEEP DELAY	0s – 3600s	Time delay for sleep function.
7 SLEEP LEVEL	0 – 500 Hz (ACS 501) 0 – 120 Hz (ACS 502)	Level for activation of sleep function.
8 WAKE UP LEVEL	0% – 100%	Level for deactivation of sleep function.
9 START FREQ 1	0 – 500 Hz (ACS 501) 0 – 120 Hz (ACS 502)	Start frequency for first lag motor.
10 START FREQ 2	0 – 500 Hz (ACS 501) 0 – 120 Hz (ACS 502)	Start frequency for second lag motor.
11 START FREQ 2	0 – 500 Hz (ACS 501) 0 – 120 Hz (ACS 502)	Start frequency for third lag motor.
12 LOW FREQ 1	0 – 500 Hz (ACS 501) 0 – 120 Hz (ACS 502)	Output frequency after first lag motor starts.
13 LOW FREQ 2	0 – 500 Hz (ACS 501) 0 – 120 Hz (ACS 502)	Output frequency after second lag motor starts.
14 LOW FREQ 3	0 – 500 Hz (ACS 501) 0 – 120 Hz (ACS 502)	Output frequency after third lag motor starts.
15 LAG MOT START DLY	0s – 3600s	Lag motor start delay.
16 LAG MOT STOP DLY	0s – 3600s	Lag motor stop delay.
17 NBR OF LAG MOTORS	0 – 3	Number of lag motors.
18 ALTERNATION INTERV.	0h – 168h	Lag motor alternation interval.
19 ALTERNATION LEVEL	0% – 100%	Low level threshold for alternation.
20 INTERLOCKS	OFF/ON	Lag motor interlocks.

Parameter	Range/Unit	Description
21 ERROR VALUE INVERT	NO/YES	PI-Controller error value inversion.
22 ACTUAL 1 INPUT (O)	NO/AI1/AI2	Actual 1 signal input selection.
23 ACTUAL 2 INPUT (O)	NO/AI1/AI2	Actual 2 signal input selection.
24 ACTUAL VALUE SEL (O)	ACT1/ACT1 - ACT2/ ACT+ACT2/ ACT1*ACT2/ min(A1,A2)/ max(A1,A2)/sqrt(ACT1)/ sqA1+sqA2	PI-Controller output signal selection.
25 ACT 1 MIN SCALE	-1600.0 – +1600.0%	Minimum scaling factor of the Actual 1.
26 ACT 1 MAX SCALE	-1600.0 – +1600.0%	Maximum scaling factor of the Actual 1.
27 ACT 2 MIN SCALE	-1600.0 – +1600.0%	Minimum scaling factor of the Actual 2.
28 ACT 2 MAX SCALE	-1600.0 – +1600.0%	Maximum scaling factor of the Actual 2.
29 REGUL. BYPASS	OFF/ON	Bypass PI Regulator.
30 DISPLAY UNIT	NO UNIT; bar; %; m/s; C; F; diff temp; kPa; 1/min; m <sup>3</sup> /min; gpm; psi; dpsi; cFm; ft; in.; inHg	Units of ACT1 and ACT2 on the display.
31 DISPL UNIT SCALE	0 – 50000	Scaling factor for display.
32 NBR OF DECIMALS	0 – 5	Number of decimal digits.

The Pump and Fan Control (PFC) is a special type of PI-Control that will allow the ACS 500 to sequence on additional or lag motors when the demand exceeds the capabilities of one motor. As in the PI-Control macro, the ACS 500 is given two signals: a setpoint (or reference) and a feedback (or actual). The output frequency of the ACS 500 will adjust automatically to maintain the feedback at the same value as the setpoint. If the feedback and setpoint are not equal, the output frequency will increase or decrease.

An additional feature of the PFC is that if the output frequency reaches a high limit without making the feedback equal to the setpoint, a second motor will be started and the output frequency of the drive will decrease. Up to three lag motors can be connected.

An example of Pump and Fan Control use is provided after the following description of the parameters.

### 1 PI-CONT GAIN

This parameter defines the gain of the PI-Controller included in the Application macros of the ACS 500. Setting range is 3 – 800%. If you select 100%, a 10% change in error value causes controller output to change by 1.5 Hz.

If the parameter value is set to 3.0%, the PI-Controller operates as an I-Controller.

Table 6-22 lists a few examples of gain settings, and the resulting output frequency change to a 10% change in error and a 50% change in error.

Table 6-24 Gain Settings

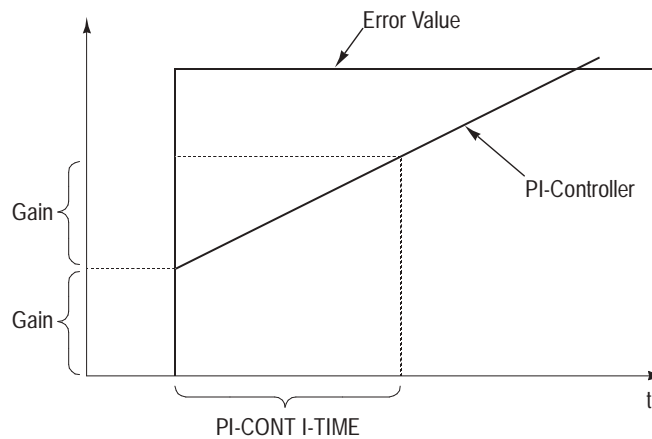
PI-Cont Gain	Output Frequency Change for a 10% Change in Error	Output Frequency Change for a 50% Change in Error
50%	0.75 Hz	3.75 Hz
100%	1.5 Hz	7.5 Hz
300%	4.5 Hz	22.5 Hz

### 2 PI-CONT I-TIME

If the parameter value is set to 320.00s, the PI-Controller operates as a P-Controller. Time range is 0.02s – 320.00s, 0.01s step.

Figure 6-20 shows PI-Controller Gain, I-Time, and Error Value.

Figure 6-20 PI-Controller Gain, I-Time, and Error Value



### 3 REFERENCE STEP 1 0 – 100%

Value that the setpoint (reference) is increased when the first lag motor is started.

**4 REFERENCE STEP 2 0 – 100%**

Value that the setpoint (reference) is increased when the second lag motor is started.

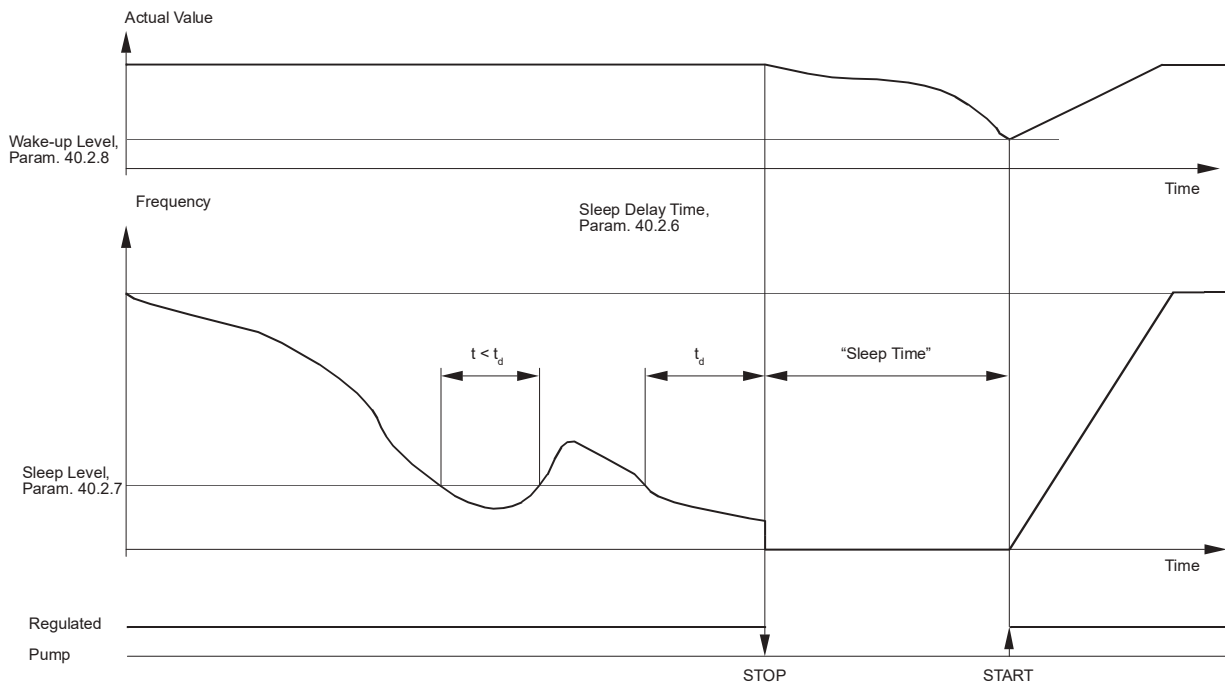
**5 REFERENCE STEP 3 0 – 100%**

Value that the setpoint (reference) is increased when the third lag motor is started.

**Sleep Function**

Sleep function is a special energy savings facility. This function can be used in pumping stations, for example, to minimize energy consumption by stopping the regulated pump automatically if demand stays very low longer than the preset time. Usually water consumption at night is almost zero and the regulated pump runs at the set minimum speed, which normally means that flow through the pump is zero. The sleep level (Parameter 40.2.7) and sleep delay (Parameter 40.2.8) parameters define when PFC stops the regulated pump. The wake-up level (Parameter 40.2.8) defines the start level which the actual signal has to reach to restart the regulated pump. Figure 6-21 shows an example of a sleep function.

Figure 6-21 Sleep Function Example



**6 SLEEP DELAY 0 – 3600s**

If the output frequency remains below the set sleep level longer than the Sleep Delay, the ACS 500 is stopped automatically. If Sleep Delay is set to 0, the sleep function is disabled.

**7 SLEEP LEVEL 0 – 500 Hz (ACS 501)**

**0 – 120 Hz (ACS 502)**

Level to start sleep delay counter.

**8 WAKE UP LEVEL 0 – 100%**

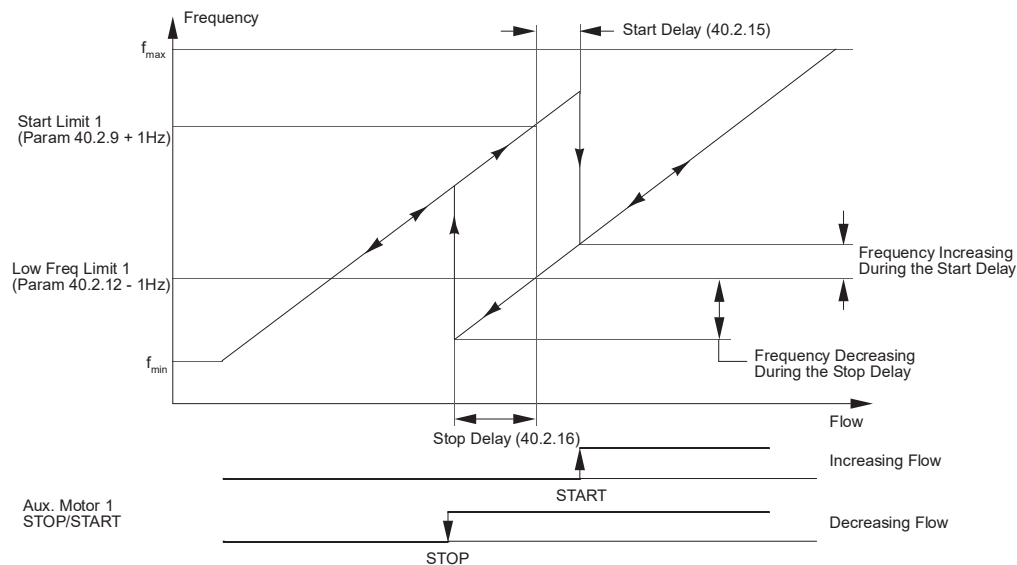
Level in % of the set reference range. This parameter determines the level of the actual value at which the ACS 500 will restart.

**9 START FREQ 1 0 – 500 Hz (ACS 501)**

**0 – 120 Hz (ACS 502)**

Output frequency at which the first lag motor will start. The start frequency has a fixed 1 Hz hysteresis.

Figure 6-22 Pump Automation Example



**10 START FREQ 2** Same functionality as Parameter 40.2.9 (Start Freq 1) except for second lag motor.

**11 START FREQ 2** Same functionality as Parameter 40.2.9 (Start Freq 1) except for third lag motor.

**12 LOW FREQ 1 0 – 500 Hz (ACS 501)**

**0 – 120 Hz (ACS 502)**

Output frequency that the ACS 500 will go to after the first lag motor is started. If the output frequency goes below this limit by 1 Hz, the lag motor will stop.

**13 LOW FREQ 2**    **0 – 500 Hz (ACS 501)**  
**0 – 120 Hz (ACS 502)**

Output frequency that the ACS 500 will go to after the second lag motor is started. If the output frequency goes below this limit by 1 Hz, the lag motor will stop.

**14 LOW FREQ 3**    **0 – 500 Hz (ACS 501)**  
**0 – 120 Hz (ACS 502)**

Output frequency that the ACS 500 will go to after the third lag motor is started. If the output frequency goes below this limit by 1 Hz, the lag motor will stop.

**15 LAG MOT START DLY**    **0 – 3600s**

Start delay for lag motors to prevent the lag motor from starting due to a momentary crossing of the start limit. The frequency must remain above the start limit for the period of time set by this parameter before the lag motor will start.

**16 LAG MOT STOP DLY**    **0 – 3600s**

Stop delay for lag motors to prevent the lag motor from stopping due to a momentary crossing of the stop limit. The frequency must remain below the stop limit for the period of time set by this parameter before the lag motor will stop.

**17 NBR OF LAG  
MOTORS**    **0 – 3**

Number of lag motors in the system. Requires I/O Extension Board to use third motor.

**18 ALTERNATION  
INTERV.**    **0 min – 168 hrs**

Time interval for changing the sequencing order of the motors. Alternation only occurs when the actual signal goes below the level set by Parameter 40.2.19 (Alternation Level). Setting the value to 00h 00min disables the alternation function. This must be done with the drive stopped. The interval time only counts the time that the ACS 500 is commanded to run.

**19 ALTERNATION  
LEVEL**    **0 – 100%**

Actual value level below which the alternation takes place. When the time set by Parameter 40.2.18 (Alternation Interv.) is exceeded and the level goes below the level set by this parameter, the order of the lag motors will change.

With this parameter set to 0, automatic alternation only takes place when the ACS 500 is stopped (normal or “sleep”).

The alternation level is in relation to the set maximum frequency and to the capacity of the system such that, if a value of the parameter is 45% and the system has only two motors, the automatic exchange takes place at the frequency of  $0.45/50 \times f_{max}$ .

If there are more motors connected, the percentage value corresponding to the set maximum frequency is:

1+1 motors	50.0%
1+2 motors	33.3%
1+3 motors	25.0%

For example: if the values of the parameters are:

Nbr of lag motors (40.2.17) = 2

Alternation level (40.2.19) = 25%

Max frequency (20.1.2) = 51 Hz

the alternation takes place at 38.3 Hz (25%/33.3% x 51 Hz) if the following conditions are true:

- Alternation interval time has elapsed,
- Actual value is below the set alternation level,
- Minimum one lag motor is not running, and
- The ACS 500 is not running at a preset speed (DI/param., Group 10.3).

When all the conditions are valid, PFC stops all motors, changes the order of the motors, and starts the motors using the new start order. The starting order cannot be changed externally.

The start order and the elapsed run time remain in the ACS 500 memory during a power interruption.

*Note: If only the regulated pump is used, cancel the alternation operation by setting Parameter 40.2.18 (Alternation Interv.) to 00 h 00 min. This releases relay outputs RO1 to RO4 for other use.*

## 20 INTERLOCKS ON/OFF

Digital inputs can be used as interlocks for the connected motors. A contact from the disconnect at each motor is brought to a digital input. If a motor is taken out of service, the ACS 500 will skip that motor when it is needed and select the next available pump. If this parameter is set to ON, DI2 DI3, and DI4 are reserved for the interlocks. The I/O extension board must be ordered to use this function. If this function is set to OFF, the digital inputs are available for other functions.

If an interlocking function is in use and one of the interlocking signals disappears while the motors are running, the ACS 500 will stop and a corresponding output relay (RO1 to RO4) will release and stop the respective motor. If other motors are available, PFC connects one of those instead and starts the ACS 500 again.

## 21 ERROR VALUE INV. NO/YES

This parameter allows you to invert the Error Value (and thus the operation of the PI-Controller). Normally, a decrease in Actual Signal (Feedback) causes an increase in drive speed. If a decrease in Actual should cause a decrease in speed, set Error Value Invert to YES.

## 22 ACTUAL 1 INPUT AI1 OR AI2



**23 ACTUAL 2 INPUT**

**AI1 OR AI2**

**24 ACTUAL VALUE SEL**

The Actual Value for the PI Controller can be a single signal, or two signals combined by subtraction, addition or multiplication. The choices are as follows.

**ACT1**

**ACT1-ACT2**

**ACT1+ACT2**

**ACT1\*ACT2**

**min(A1,A2)**

Actual value is ACT1 or ACT2, whichever is lower.

**max(A1,A2)**

Actual value is ACT1 or ACT2, whichever is higher.

**sqrt(ACT1)**

Square root of ACT1.

**sqA1+sqA2**

Square root of ACT1 + square root of ACT2.

**25 ACT 1 MIN SCALE**

Minimum scaling factor of the Actual Value 1. Setting range is -1600 to +1600%.

**0%**

The minimum Actual Value corresponds to the minimum scaled Actual Value.

**100%**

The maximum Actual Value corresponds to the minimum scaled Actual Value.

**26 ACT 1 MAX SCALE**

Maximum scaling factor of the Actual Value 1. Setting range is -1600 to +1600%.

**0%**

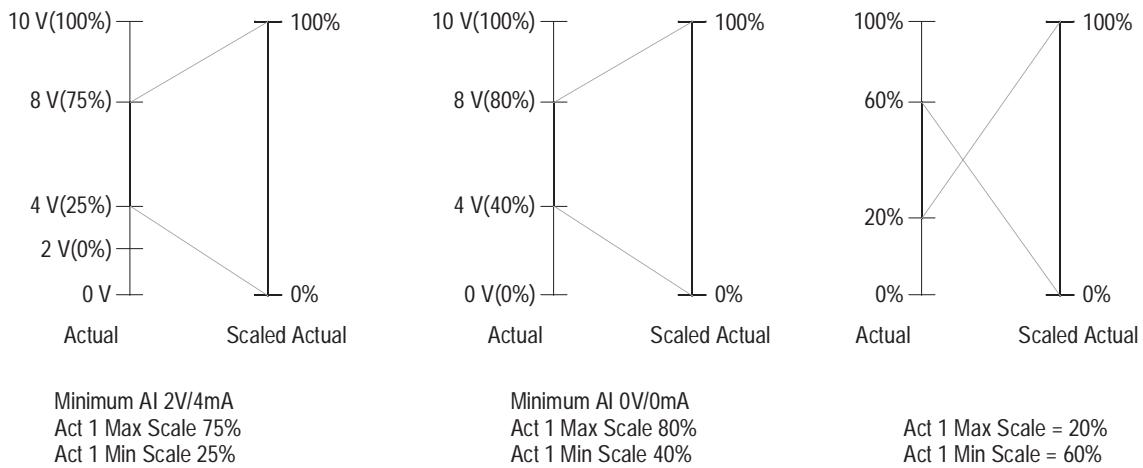
The minimum Actual Value corresponds to the maximum scaled Actual Value.

**100%**

The maximum Actual Value corresponds to the maximum scaled Actual Value.

Figure 6-23 show three examples of actual value scaling.

Figure 6-23 Actual Value Scaling



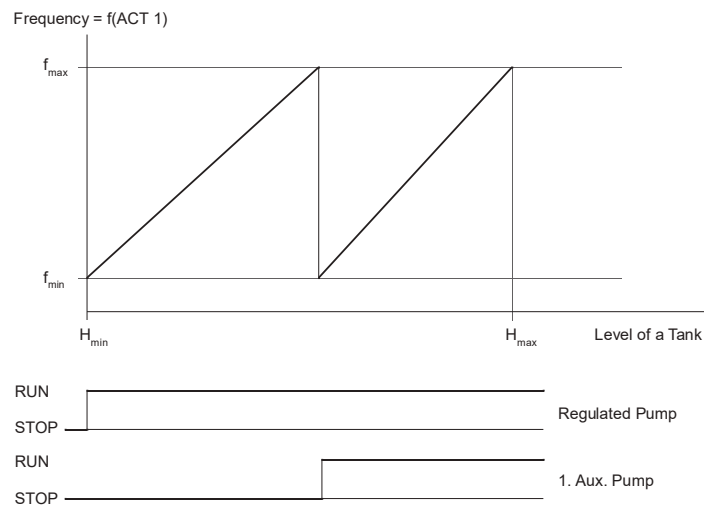
**27 ACT 2 MIN SCALE** Refer to Parameter 40.2.25.

**28 ACT 2 MAX SCALE** Refer to Parameter 40.2.26.

**29 BYPASS CONTROL** NO/YES

The PI regulator of the PFC can be bypassed if the value of Parameter 40.2.29 is set to YES. When the regulator is bypassed, the actual value signal replaces the output of the PI regulator as a final speed reference. The automatic start and stop of constant speed motors is referred to the actual value signal instead of the output of the PI regulator. Refer to Figure 6-24 for an example of the PI regulator bypass function. This function is useful in flow control of precipitation tanks.

Figure 6-24 PI Regulator Bypass Function



**30 DISPLAY UNIT** NO UNIT; bar; %; m/s; °C; °F; diff temp; kPa; 1/min; m<sup>3</sup>/min; gpm; psi; dps; cFm; ft; in.; inHg

Unit of ACT1 and ACT2 indicated on the display.

**31 DISPL UNIT SCALE** 0 – 50000

Scaling factor for display unit.

**32 NBR OF DECIMALS** 0 – 5

Number of decimal places in the displayed actual values.

**Sample PFC Application**

One example of automatic Pump and Fan Control application is fresh water constant pressure control with two pumps.

In this example a pump station has two pumps used to maintain constant pressure at different flow situations. One of the pumps is speed regulated with an ACS 500 and the other is a constant speed pump ON/OFF controlled with the PFC macro.

*Note: The other pump could also be controlled by an ACS 500.*

When water consumption is less than the nominal output of the pump, PFC controls the speed of the regulated pump downwards so that production of the pump equals the demand. If water consumption increases, the PFC regulator speed of the pump increases equally until the start limit of the constant speed pump is reached (start limit = set value of Parameter 40.2.9 (Start Freq 1) + 1 Hz). Start occurs after the set start delay (set value of Parameter 40.2.15) if demand remains above the start limit for longer than the start delay. When the constant speed pump starts, the speed of the regulated pump will automatically regulate to the set low frequency 1 value (Parameter 40.2.12).

If the demand increases further, the speed of the regulated pump regulates upwards, maintaining equal pressure in the system.

If demand decreases, the speed of the regulated pump first regulates downwards until the stop limit (stop limit = set value of Parameter 40.2.12 (Low Freq 1) - 1 Hz) of the constant speed pump is reached. The constant speed pump is stopped after the set stop delay (Parameter 40.2.16) if demand remains below the stop limit for longer than the stop delay. When the constant speed pump stops, the speed of the regulated pump will increase to meet the demand. Refer to Figure 6-22 for an example of pump automation.

If a start limit of an auxiliary pump has been set higher than the maximum frequency of the ACS 500, the lag pump starts at the defined start limit because the output of the PI regulator has not been limited by the maximum frequency of the ACS 500.

If a stop limit is set lower than the minimum frequency of the ACS 500, a lag pump will stop at the defined stop limit because the output of the PI regulator has not been limited by the minimum frequency of the ACS 500.

As long as the output of the regulator remains above the maximum frequency or below the minimum frequency, the regulated pump runs at the corresponding frequency limit.

## Appendix A – Complete Parameter Settings

The tables in this appendix list all the parameters and alternative settings for the ACS 500. Use these tables as reference guides when you are customizing macros for your ACS 500 application. A signal flow diagram is included at the end of this appendix.

Table A-1 Parameter Settings

Parameter	Alternative Settings	Custom Setting
<b>START-UP DATA</b>		
A LANGUAGE	ENGLISH; GERMAN; ITALIAN; SPANISH; DUTCH; FRENCH; DANISH; FINNISH; SWEDISH	
B APPLICATIONS	FACTORY; HAND/AUTO; PI-CONTROL; OPT. PACK; SEQ CTRL; P&F AUTOM; USER load; USER save	
C APPLIC. RESTORE	NO; YES	
D SUPPLY VOLTAGE	208/220/230/240; 380/400/415; 440/460/480/500	
E USER DISPLAY SCALE	0 – 10000	
F MOTOR CURRENT -FLA	0 A – 1000 A (printed on the motor nameplate)	
G MOTOR POWER hp (kW)	0.7 hp – 1340 hp (0.5 kW – 1000 kW) (printed on the motor nameplate)	
H MOTOR POWER FACTOR	0.1 – 1.0 (printed on the motor nameplate)	
I MOTOR BASE FREQ.	30 Hz – 500 Hz (printed on the motor nameplate)	
J MOTOR BASE R.P.M.	200 RPM – SYNC. SPEED (printed on the motor nameplate)	
K MOTOR NOM. VOLTAGE	110 V – 575 V (printed on the motor nameplate)	

Parameter	Alternative Settings	Custom Setting
<b>OPERATING DATA</b>		
1 OUTPUT FREQUENCY	Hz	
2 SPEED	RPM; %; USER SCALING	
3 MOTOR CURRENT	A	
4 % RATED TORQUE	%	
5 % RATED POWER	%	
6 DC BUS VOLTAGE	V; % OF RATED NOMINAL	
7 OUTPUT VOLTAGE	V	
8 DRIVE TEMPERATURE	degrees C and F	
9 CONTROL LOCATION	KEYPAD R1; KEYPAD PI; EXTERNAL	
10 KEYPAD REF 1	Hz	
11 KEYPAD PI (REF 2)	%	
12 EXT REF 1 OR 2	REF1/REF2	
13 EXTERNAL REF 1	Hz	
14 EXTERNAL REF 2	%	
15 RUN TIME	h/min	
16 KILOWATT HOURS	kWh	
17 LAST-RECD FAULT	FAULT; WARNING	
18 SECOND-RECD FAULT	FAULT; WARNING	
19 FIRST-RECD FAULT	FAULT; WARNING	
20 PARAMETER LOCK	OPEN xxx; LOCKED xxx; OPEN; LOCKED	
21 APPL BLOCK OUTPUT	%	
22 ACTUAL VALUE 1	%	
23 ACTUAL VALUE 2	%	
24 AUX MOTORS RUNNING	0 – 3	
25 CONTROLLER OUTPUT	%	
26 CONTROL ERROR	%	
27 ACT VALUE 1 (PFC)	Engineering Units	
28 ACT VALUE 2 (PFC)	Engineering Units	

Parameter	Alternative Settings	Custom Setting
<b>10 CONTROL CONNECTIONS</b>		
10.1 START/STOP/DIRECTION		
10.1.1 EXT 1 STRT/STP/DIR	NOT SEL; DI1; DI1,2; DI1P,2P; DI 1P, 2P, 3; DI1P,2P,3P; DI6; DI6,5; KEYPAD	
10.1.2 EXT 2 STRT/STP/DIR	NOT SEL; DI6; DI6,5; DI1; DI1,2; DI1P,2P; DI 1P, 2P, 3; DI1P,2P,3P; KEYPAD	
10.1.3 LOC/EXT DIRECTION	REVERSE; FORWARD; REQUEST; FAST REV	
10.2 EX REFERENCE SELECT		
10.2.1 EXT 1/EXT 2 SELECT	OP DATA 12; DI1; DI2; DI3; DI4; DI5; DI6	
10.2.2 EXTERNAL REF1 SEL	OP DATA 13; AI1; AI2; AI1/JOYST; DI3U,4D; DI3U,4D(R); DI5U,6D	
10.2.3 EXT REF1 MINIMUM	0 Hz – 500 Hz (ACS 501); 0 Hz – 120 Hz (ACS 502)	
10.2.4 EXT REF1 MAXIMUM	0 Hz – 500 Hz (ACS 501); 0 Hz – 120 Hz (ACS 502)	
10.2.5 EXT REF1 OFFSET	-30 Hz – 30 Hz	
10.2.6 EXT REF1 GAIN	-100% – 100 %	
10.2.7 EXTERNAL REF2 SEL	OP DATA 14; AI1; AI2; DI3U,4D; DI3U,4D(R); DI5U,6D	
10.2.8 EXT REF2 MINIMUM	0 Hz – 500 Hz (ACS 501); 0 Hz – 120 Hz (ACS 502)	
10.2.9 EXT REF2 MAXIMUM	0 Hz – 500 Hz (ACS 501); 0 Hz – 120 Hz (ACS 502)	
10.2.10 EXT REF2 OFFSET	-30 Hz – 30 Hz	
10.2.11 EXT REF2 GAIN	-100% – 100 %	
10.3 PRESET SPEEDS		
10.3.1 PRESET SPEED SEL	NOT SEL; DI1 – DI6; DI1,2; DI3,4; DI5, 6; DI1,2,3; DI3,4,5; DI4,5,6	
10.3.2 PRESET SPEED 1	0 Hz – 500 Hz (ACS 501); 0 Hz – 120 Hz (ACS 502)	
10.3.3 PRESET SPEED 2	0 Hz – 500 Hz (ACS 501); 0 Hz – 120 Hz (ACS 502)	
10.3.4 PRESET SPEED 3	0 Hz – 500 Hz (ACS 501); 0 Hz – 120 Hz (ACS 502)	
10.3.5 PRESET SPEED 4	0 Hz – 500 Hz (ACS 501); 0 Hz – 120 Hz (ACS 502)	
10.3.6 PRESET SPEED 5	0 Hz – 500 Hz (ACS 501); 0 Hz – 120 Hz (ACS 502)	
10.3.7 PRESET SPEED 6	0 Hz – 500 Hz (ACS 501); 0 Hz – 120 Hz (ACS 502)	
10.3.8 PRESET SPEED 7	0 Hz – 500 Hz (ACS 501); 0 Hz – 120 Hz (ACS 502)	
10.4 SYSTEM CONTR INPUTS		
10.4.1 RUN ENABLE	YES; DI1; DI2; DI3; DI4; DI5; DI6	

Parameter	Alternative Settings	Custom Setting
10.4.2 FAULT RESET SELECT	NOT SEL; DI1; DI2; DI3; DI4; DI5; DI6; ON STOP	
10.4.3 PARAM. LOCK SEL	OP DATA 20; DI1; DI2; DI3; DI4; DI5; DI6	
10.4.4 EXTERNAL FAULT	NOT SEL; DI1; DI2; DI3; DI4; DI5; DI6	
10.5 ANALOG INPUTS		
10.5.1 MINIMUM AI1	0 V/0 mA; 2 V/4 mA; READ INPUT	
10.5.2 MAXIMUM AI1	10 V/20 mA; READ INPUT	
10.5.3 RC FILTER ON AI1	0.1s – 10s	
10.5.4 INVERT AI1	NO; YES	
10.5.5 MINIMUM AI2	0 V/0 mA; 2 V/4 mA; READ INPUT	
10.5.6 MAXIMUM AI2	10 V/20 mA; READ INPUT	
10.5.7 RC FILTER ON AI2	0.1s – 10s	
10.5.8 INVERT AI2	NO; YES	
10.6 RELAY OUTPUTS		
10.6.1 RELAY RO1 OUTPUT	NOT USED; READY; RUN; FAULT; FAULT(-1); FAULT(RST) STALL FLT; MOT OT FLT; OT FAULT; FAULT/WARN; WARNING OT WARNING; REVERSED; EXT. CTRL; REF 2 SEL; PRESET SPD; DC BUS LIM; FREQ 1 LIM; FREQ 2 LIM; CURR LIMIT; REF 1 LIMIT; REF 2 LIMIT; AT SPEED; HIGH TEMP; (P&F AUTOM)	
10.6.2 RELAY RO2 OUTPUT		
10.6.3 RELAY RO3 OUTPUT		
10.7 ANALOG OUTPUTS		
10.7.1 ANALOG OUTPUT 1	NOT USED; OUT FREQ; MOT SPEED; OUT CURR; MOT TORQ; MOT POWER; V/DC BUS; MOTOR VOLT; REFERENCE; ERROR VAL; PICON OUTP; ACTUAL 1; ACTUAL 2; PICON REF	
10.7.2 SCALE AO1	10% – 1000%	
10.7.3 MINIMUM AO1	0 mA; 4mA	
10.7.4 RC FILTER ON AO1	0.01s – 10s	
10.7.5 INVERT AO1	NO; YES	
10.7.6 ANALOG OUTPUT 2	NOT USED; OUT FREQ; MOT SPEED; OUT CURR; MOT TORQ; MOT POWER; V/DC BUS; MOTOR VOLT; REFERENCE; ERROR VAL; PICON OUTP; ACTUAL 1; ACTUAL 2; PICON REF	
10.7.7 SCALE AO2	10% – 1000%	
10.7.8 MINIMUM AO2	0 mA; 4 mA	
10.7.9 RC FILTER ON AO2	0.01s – 10s	
10.7.10 INVERT AO2	NO; YES	

Parameter	Alternative Settings	Custom Setting
10.8 EXT COMMUNICATION		
10.8.1 DRIVE ID-NUMBER	1 - 247	
10.8.2 PROTOCOL	MODBUS; GS-BUS	
10.8.3 BIT RATE SELECT	0:1200; 1:2400; 3:4800; 4:9600	
10.8.4 PARITY	0:NONE; 1:FAULT; 2:FAULT+STOP	
10.8.5 COMMS FAULT FUNCT	0:NONE; 1:FAULT; 2:FAULT+STOP	
10.8.6 BAD MESSAGES COUNTER	0 – 65535	
10.8.7 GOOD MESSAGES COUNTER	0 - 65535	
<b>20 DRIVE PARAMETERS</b>		
20.1 FREQ/CURRENT LIMITS		
20.1.1 MINIMUM FREQUENCY	0 Hz – MAX. FREQ.	
20.1.2 MAXIMUM FREQUENCY	0 Hz – 500 Hz (ACS 501); 0 Hz – 120 Hz (ACS 502)	
20.1.3 FREQUENCY RANGE	0 Hz – 120 Hz; 0 Hz – 500 Hz (ACS 501 only)	
20.1.4 CURRENT LIMIT	0.5 – 2.0 x I <sub>N</sub> (ACS 500)	
20.2 START/STOP		
20.2.1 START FUNCTION	RAMP; FLYING; TORQ BOOST; FLYING+TQB	
20.2.2 TORQUE BOOST CURR	0.5 – 2.0 x I <sub>N</sub> (ACS 500)	
20.2.3 STOP FUNCTION	COAST; RAMP; DC BRAKE	
20.2.4 BRAKE CHOPPER	NO; YES	
20.2.5 DC HOLD	OFF; ON	
20.2.6 DC HOLD VOLTAGE	0.01 – 0.1 x V <sub>N</sub>	
20.2.7 DC BRAKE VOLTAGE	0.01 – 0.1 x V <sub>N</sub>	
20.2.8 DC BRAKE TIME	0s – 250s	
20.3 ACCEL/DECEL		
20.3.1 ACC/DEC 1 OR 2 SEL	NOT SEL; DI1; DI2; DI3; DI4; DI5; DI6	
20.3.2 ACC/DEC RAMP SHAPE	LINEAR; S1; S2; S3	
20.3.3 ACCEL TIME 1	0.1s – 1800s	



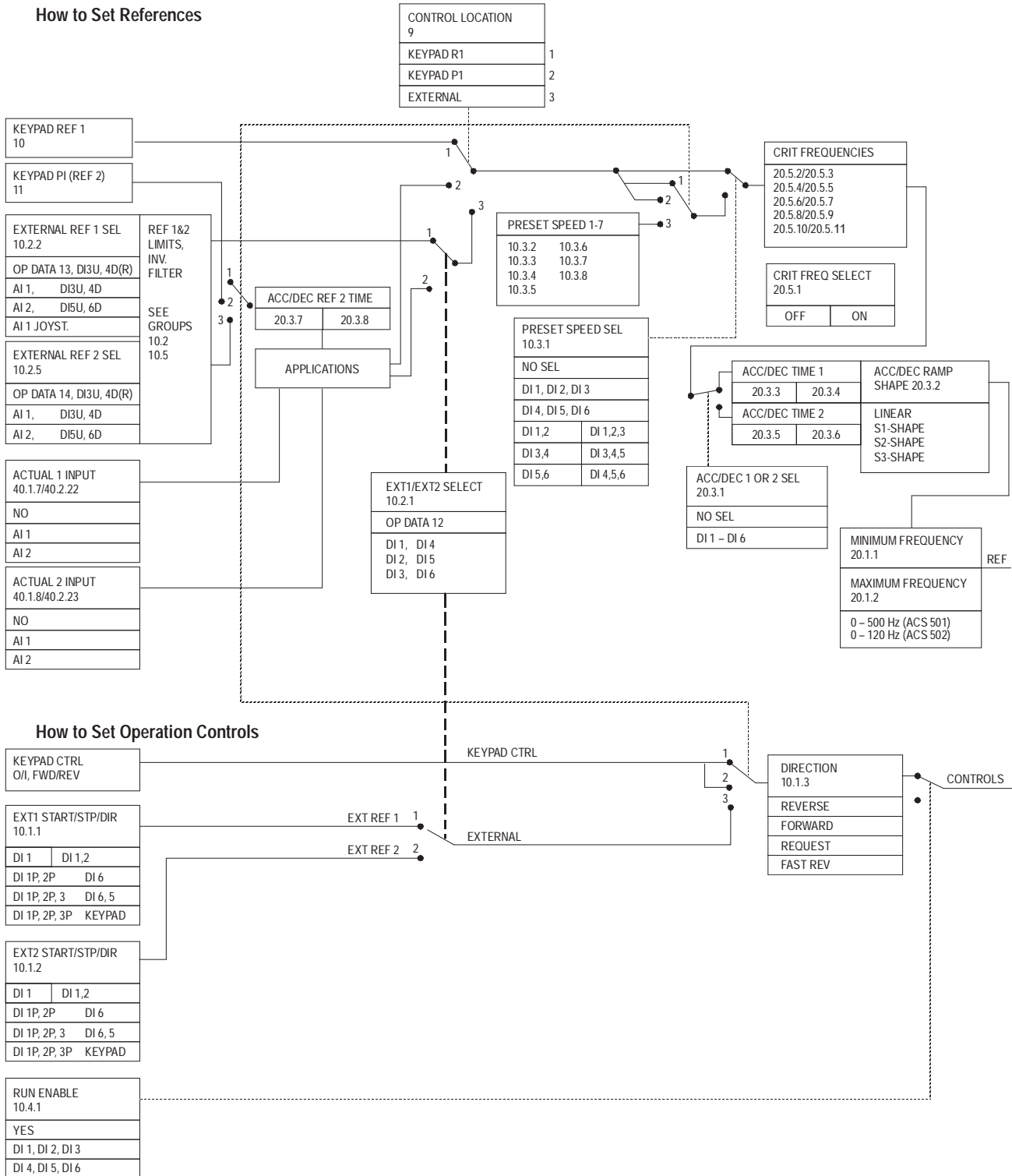
Parameter	Alternative Settings	Custom Setting
20.3.4 DECEL TIME 1	0.1s – 1800s	
20.3.5 ACCEL TIME 2	0.1s – 1800s	
20.3.6 DECEL TIME 2	0.1s – 1800s	
20.3.7 ACCEL REF2 TIME	0.1s – 1800s	
20.3.8 DECEL REF2 TIME	0.1s – 1800s	
20.4 MOTOR CONTROL		
20.4.1 SWITCHING FREQ	1.0 kHz – 12.0 kHz (ACS 501); 3.0 kHz (ACS 502)	
20.4.2 MAX OUTPUT VOLTAGE	0.15 – 1.05 x $V_N$	
20.4.3 V/HZ RATIO	LINEAR; SQUARED; AUTOMATIC	
20.4.4 FIELD WEAK POINT	30 Hz – 500 Hz	
20.4.5 IR COMPENSATION	NO; MANUAL; AUTOMATIC	
20.4.6 IR COMP VOLTAGE	0.01 – 0.15 x $V_N$	
20.4.7 IR COMP RANGE	0 Hz – FWP	
20.4.8 SLIP COMPENSATION	OFF; ON	
20.4.9 NOMINAL SLIP	0.1% – 10%	
20.4.10 VOLTAGE LIMIT	OFF; ON	
20.5 CRITICAL FREQUENCIES		
20.5.1 CRIT FREQ SELECT	OFF; ON	
20.5.2 CRIT FREQ 1 LOW	0 Hz – 500 Hz (ACS 501); 0 Hz – 120 Hz (ACS 502)	
20.5.3 CRIT FREQ 1 HIGH	0 Hz – 500 Hz (ACS 501); 0 Hz – 120 Hz (ACS 502)	
20.5.4 CRIT FREQ 2 LOW	0 Hz – 500 Hz (ACS 501); 0 Hz – 120 Hz (ACS 502)	
20.5.5 CRIT FREQ 2 HIGH	0 Hz – 500 Hz (ACS 501); 0 Hz – 120 Hz (ACS 502)	
20.5.6 CRIT FREQ 3 LOW	0 Hz – 500 Hz (ACS 501); 0 Hz – 120 Hz (ACS 502)	
20.5.7 CRIT FREQ 3 HIGH	0 Hz – 500 Hz (ACS 501); 0 Hz – 120 Hz (ACS 502)	
20.5.8 CRIT FREQ 4 LOW	0 Hz – 500 Hz (ACS 501); 0 Hz – 120 Hz (ACS 502)	
20.5.9 CRIT FREQ 4 HIGH	0 Hz – 500 Hz (ACS 501); 0 Hz – 120 Hz (ACS 502)	
20.5.10 CRIT FREQ 5 LOW	0 Hz – 500 Hz (ACS 501); 0 Hz – 120 Hz (ACS 502)	
20.5.11 CRIT FREQ 5 HIGH	0 Hz – 500 Hz (ACS 501); 0 Hz – 120 Hz (ACS 502)	

Parameter	Alternative Settings	Custom Setting
<b>30 PROTECTION/INFORMAT</b>		
30.1 FAULT FUNCTION		
30.1.1 SERIAL FAULT FUNC	STOP; PRE SPEED7	
30.1.2 AI <MIN FUNCTION	NO; WARNING; FAULT; PRE SPEED7; LAST SPEED	
30.1.3 MOT TEMP FLT FUNC	NO; WARNING; FAULT	
30.1.4 MOTOR THERM TIME	300s – 10000s	
30.1.5 MOTOR LOAD CURVE	50% – 150%	
30.1.6 ZERO SPEED LOAD	40% – MOTOR LOAD CURVE	
30.1.7 BREAK POINT	1 Hz – 500 Hz	
30.1.8 STALL FUNCTION	NO; WARNING; FAULT	
30.1.9 STALL CURRENT	0 – 1.5 x I <sub>N</sub>	
30.1.10 STALL TIME/FREQ	10s/15 Hz; 20s/25 Hz; 30s/35 Hz	
30.1.11 UNDERLOAD FUNC	NO; WARNING FAULT	
30.1.12 UNDERLOAD TIME	0 – 600s	
30.1.13 UNDERLOAD CURVE	1 – 5	
30.2 AUTOMATIC RESET		
30.2.1 NUMBER OF RESETS	0 – 5	
30.2.2 TIME WINDOW	1s – 180s	
30.2.3 TIME BETW. RESET ATTEMPTS	0s – 120s	
30.2.4 OVERVOLTAGE	NO; YES	
30.2.5 UNDERVOLTAGE	NO; YES	
30.2.6 OVERCURRENT	NO; YES	
30.2.7 AI SIGNAL <MIN	NO; YES	

Parameter	Alternative Settings	Custom Setting
30.3 SUPERVISION		
30.3.1 OUTPUT FREQ 1 FUNC	NO; LOW LIMIT; HIGH LIMIT	
30.3.2 OUTPUT FREQ 1 LIM	0 Hz – 500 Hz (ACS 501); 0 Hz – 120 Hz (ACS 502)	
30.3.3 OUTPUT FREQ 2 FUNC	NO; LOW LIMIT; HIGH LIMIT	
30.3.4 OUTPUT FREQ 2 LIM	0 Hz – 500 Hz (ACS 501); 0 Hz – 120 Hz (ACS 502)	
30.3.5 CURRENT FUNCTION	NO; LOW LIMIT; HIGH LIMIT	
30.3.6 CURRENT LIMIT	0 – 2 x I <sub>N</sub> (ACS 500)	
30.3.7 REF1 FUNCTION	NO; LOW LIMIT; HIGH LIMIT	
30.3.8 REF1 LIMIT	0 Hz – 500 Hz (ACS 501); 0 Hz – 120 Hz (ACS 502)	
30.3.9 REF2 FUNCTION	NO; LOW LIMIT; HIGH LIMIT	
30.3.10 REF2 LIMIT	0% – 100%	
30.3.11 SUPERVIS MESSAGES	OFF; ON	
30.4 INFORMATION		
30.4.11 CRI PROG VERSION	(Version in Drive)	
30.4.2 MC PROG VERSION	(Version in Drive)	
30.4.3 TEST DATE	(Date Tested)	
<b>40 APPLICATION PARAMETERS</b>	(CAN BE SEEN ONLY WITH APPLICATION MACROS)	
40.1 PI-CONTROL	(CAN BE SEEN ONLY WITH PI-CONTROL MACRO)	
40.1.1 PI-CONT GAIN	3% – 800%	
40.1.2 PI-CONT I-TIME	0.02s – 320s	
40.1.3 PI-CONT MIN LIMIT	0 Hz – PI-CONT MAX LIMIT	
40.1.4 PI-CONT MAX LIMIT	0 Hz – 500 Hz (ACS 501); 0 Hz – 120 Hz (ACS 502)	
40.1.5 ERROR VALUE INVERT	NO; YES	
40.1.6 ACTUAL VALUE SEL	ACT1; ACT1-ACT2; ACT1+ACT2; ACT1*ACT2	
40.1.7 ACTUAL 1 INPUT	AI1; AI2	
40.1.8 ACTUAL 2 INPUT	AI1; AI2	
40.1.9 ACT 1 MIN SCALE	-1600.0% – 1600.0%	
40.1.10 ACT 1 MAX SCALE	-1600.0% – 1600.0%	
40.1.11 ACT 2 MIN SCALE	-1600.0% – 1600.0%	
40.1.12 ACT 2 MAX SCALE	-1600.0% – 1600.0%	

Parameter	Alternative Settings	Custom Setting
40.2 PUMP & FAN CONTROL	(CAN BE SEEN ONLY WITH P&F AUTOM MACRO)	
40.2.1 PI-CONT GAIN	3% – 800%	
40.2.2 PI-CONT I-TIME	0.1s – 320s	
40.2.3 REFERENCE STEP 1	0% – 100%	
40.2.4 REFERENCE STEP 2	0% – 100%	
40.2.5 REFERENCE STEP 3	0% – 100%	
40.2.6 SLEEP DELAY	0s – 3600s	
40.2.7 SLEEP LEVEL	0 Hz – 500 Hz (ACS 501); 0 Hz – 120 Hz (ACS 502)	
40.2.8 WAKE UP LEVEL	0% – 100%	
40.2.9 START FREQ 1	0 Hz – 500 Hz (ACS 501); 0 Hz – 120 Hz (ACS 502)	
40.2.10 START FREQ 2	0 Hz – 500 Hz (ACS 501); 0 Hz – 120 Hz (ACS 502)	
40.2.11 START FREQ 3	0 Hz – 500 Hz (ACS 501); 0 Hz – 120 Hz (ACS 502)	
40.2.12 LOW FREQ 1	0 Hz – 500 Hz (ACS 501); 0 Hz – 120 Hz (ACS 502)	
40.2.13 LOW FREQ 2	0 Hz – 500 Hz (ACS 501); 0 Hz – 120 Hz (ACS 502)	
40.2.14 LOW FREQ 3	0 Hz – 500 Hz (ACS 501); 0 Hz – 120 Hz (ACS 502)	
40.2.15 LAG MOT START DLY	0s – 3600s	
40.2.16 LAG MOT STOP DLY	0s – 3600s	
40.2.17 NBR OF LAG MOTORS	0 – 3	
40.2.18 ALTERNATION INTERV	0h – 168h	
40.2.19 ALTERNATION LEVEL	0% – 100%	
40.2.20 INTERLOCKS	OFF; ON	
40.2.21 ERROR VALUE INV	NO; YES	
40.2.22 ACTUAL 1 INPUT	NO; AI1; AI2	
40.2.23 ACTUAL 2 INPUT	NO; AI1; AI2	
40.2.24 ACTUAL VALUE SEL	ACT1; ACT1-ACT2; ACT1+ACT2; ACT1*ACT2; min(A1,A2); max(A1,A2); sqrt(ACT1); sqA1+sqA2	
40.2.25 ACT 1 MIN SCALE	-1600.0% – 1600.0%	
40.2.26 ACT 1 MAX SCALE	-1600.0% – 1600.0%	
40.2.27 ACT 2 MIN SCALE	-1600.0% – 1600.0%	
40.2.28 ACT 2 MAX SCALE	-1600.0% – 1600.0%	
40.2.29 REGUL BYPASS	OFF; ON	
40.2.30 DISPLAY UNIT	NO UNIT; bar; %; m/s; C; Pa; 1/min; m <sup>3</sup> /min; gpm;psi	
40.2.31 DISPL UNIT SCALE	0 – 50000	
40.2.32 NBR OF DECIMALS	0 – 5	

Figure A-1 Signal Diagram



## Appendix B – Programming Digital Inputs

Table B-1 shows the available digital inputs and how these digital inputs can be applied to different tasks.

Table B-1 Digital Inputs

Name/Task of Parameter	Parameter Value	Digital I/O Configuration								
		DI1	DI2	DI3	DI4	DI5	DI6	DI7	DI8	DI9
10.1.1 EXT 1 STRT/STOP/DIR RUN/STOP 0 = Stop, 1 = Run RUN/STOP, REVERSE 0 = Forward, 1 = Reverse RUN FWD -pulse, STOP-pulse RUN-pulse, STOP-pulse, REVERSE 0 = Forward, 1 = Reverse RUN FWD-pulse, RUN REV-pulse, STOP-pulse	DI1; DI6 DI1,2; DI6,5 DI1P,2P DI1P,2P,3 DI1P,2P,3P	DI1 DI1 DI1 DI1 DI1					DI6 DI6 DI6 DI6 DI6			
10.1.2 EXT 2 STRT/STOP/DIR RUN/STOP 0 = Stop, 1 = Run RUN/STOP, REVERSE 0 = Forward, 1 = Reverse RUN FWD -pulse, STOP-pulse RUN-pulse, STOP-pulse, REVERSE 0 = Forward, 1 = Reverse RUN FWD-pulse, RUN REV-pulse, STOP-pulse	DI1; DI6 DI1,2; DI6,5 DI1P,2P DI1P,2P,3 DI1P,2P,3P	DI1 DI1 DI1 DI1 DI1					DI6 DI6 DI6 DI6 DI6			
10.2.1 EXT 1/EXT 2 SELECT 0 = EXT 1 (R1), 1 = EXT 2 (R2)	DIx	DI1	DI2	DI3	DI4	DI5	DI6	DI7	DI8	DI9
10.2.2 EXTERNAL REF 1 SEL DI3, DI5 = Increase reference DI4, DI6 = Decrease reference	DI3U,4D (R)** D3U,4D D5U,6D			DI3 DI3	DI4 DI4		DI5 DI6			
10.2.5 EXTERNAL REF 2 SEL DI3, DI5 = Increase reference DI4, DI6 = Decrease reference	DI3U,4D (R)** DI3U,4D DI5U,6D			DI3 DI3	DI4 DI4		DI5 DI6			

Name/Task of Parameter	Parameter Value	Digital I/O Configuration								
		DI1	DI2	DI3	DI4	DI5	DI6	DI7	DI8	DI9
10.3 PRESET SPEED SEL										
Single speed:	DIx*	DI1	DI2	DI3	DI4	DI5	DI6	DI7	DI8	DI9
Three speeds:	DI1,2	DI1	DI2							
0 0 No Preset Speed	DI3,4			DI3	DI4					
1 0 Preset Speed 1	DI5,6					DI5	DI6			
0 1 Preset Speed 2										
1 1 Preset Speed 3										
Seven speeds:	DI1,2,3	DI1	DI2	DI3						
0 0 0 No Preset Speed	DI3,4,5			DI3	DI4	DI5				
1 0 0 Preset Speed 1	DI4,5,6				DI4	DI5	DI6			
0 1 0 Preset Speed 2										
1 1 0 Preset Speed 3										
0 0 1 Preset Speed 4										
1 0 1 Preset Speed 5										
0 1 1 Preset Speed 6										
1 1 1 Preset Speed 7										
10.4.1 RUN ENABLE 0 = Disabled, 1 = Run enabled	DIx*	DI1	DI2	DI3	DI4	DI5	DI6	DI7	DI8	DI9
10.4.2 FAULT RESET SEL	DIx	DI1	DI2	DI3	DI4	DI5	DI6	DI7	DI8	DI9
10.4.3 PARAM LOCK SEL	DIx	DI1	DI2	DI3	DI4	DI5	DI6	DI7	DI8	DI9
20.3.1 ACC/DEC 1 OR 2 SEL	DIx	DI1	DI2	DI3	DI4	DI5	DI6	DI7	DI8	DI9

\* DIx = Any free DI input.

\*\* This selection resets reference value to 0 V if supply voltage is interrupted.

Input function:

0 = open input.

1 = +24 V applied to the input.

<b>A</b>		<b>B</b>	
ACC/DEC 1OR2 SEL	6-20	Boost	6-18
ACC/DEC RAMP SHAPE	6-20	BRAKE CHOPPER	6-18
ACCEL REF2 TIME	6-22	BREAK POINT	6-34
ACCEL TIME 1	6-21	BYPASS CONTROL	6-53
ACCEL TIME 2	6-21		
Accel/decel	6-20	<b>C</b>	
Acceleration time	6-20	Carrier frequency	6-23
ACT 1 MAX SCALE	6-43, 6-52	Cautions, definition	iii
ACT 1 MIN SCALE	6-43, 6-52	Coast stop	6-18
ACT 2 MAX SCALE	6-44, 6-53	Control connection parameters	6-2
ACT 2 MIN SCALE	6-44, 6-53	Control interface card, ESD warning	iv
ACTUAL 1 INPUT	6-42, 6-51	CONTROL LOCATION	4-3, 4-4
ACTUAL 2 INPUT	6-42, 6-52	Control operations	
ACTUAL VALUE	6-42	external	4-7
ACTUAL VALUE SEL	6-52	keypad	4-7
AI MIN FUNCTION	6-31	Control panel	
AI SIGNAL	6-38	display illustrated	1-2
ALTERNATION INTERV.	6-50	keypad menu navigation	2-3
ALTERNATION LEVEL	6-50	keys illustrated	1-3
Analog input		Conventions used in this manual	1-2
filtering	6-10	CRI PROG VERSION	6-40
scaling	6-10	Critical frequencies	6-28
Analog inputs	6-4, 6-10	CURRENT FUNCTION	6-39
ANALOG OUTPUT	6-14	CURRENT LIMIT	6-17, 6-39
Analog output			
filtering	6-15	<b>D</b>	
scaling	6-15	DC BRAKE TIME	6-19
ANALOG OUTPUT 2	6-15	DC BRAKE VOLTAGE	6-19
Analog outputs	6-14, 6-15	DC bus capacitors	iv
APPLIC. RESTORE	3-2	DC HOLD	6-18
Application macros	5-1	DC HOLD VOLTAGE	6-19
factory	5-3	DC Injection braking	6-18, 6-19
factory defaults	2-8	DECEL REF2 TIME	6-22
hand/auto control	5-6	DECEL TIME 1	6-21
opt. pack	5-12	DECEL TIME 2	6-22
overview	2-8	Deceleration time	6-20
PI control	5-9	Digital inputs, programming	B-1
pump and fan	5-18	Digital outputs	6-12
seq ctrl	5-15	DIRECTION	6-3
Application macros, defined	2-1	Direction	6-2, 6-3, 6-8
APPLICATIONS	3-2	DISPL UNIT SCALE	6-54
Audience, intended	1-2	DISPLAY UNIT	6-54
Automatic reset	6-37		
Automatic V/Hz	6-24		



<b>E</b>		Group 30.3 supervision	6-38
		Group 30.4 information	6-40
Eprom version	6-40	Group 40.1 PI-controller	6-41
ERROR VALUE INV.	6-51	Group 40.2 pump and fan control	6-45
ERROR VALUE INVERT	6-42	Group level	
ESD warning	iv	access	2-5
EXT 1/EXT 2 SELECT	6-4	defined	2-5
Ext communication	6-16	illustrated	2-5
EXT REF1 MAXIMUM	6-6	<b>H</b>	
EXT REF1 MINIMUM	6-6	Hand/auto control macro	5-6
EXT REF2 MAXIMUM	6-6	external connections	5-7
EXT REF2 MINIMUM	6-6	parameter settings	5-8
EXT1 STRT/STP/DIR	6-2	<b>I</b>	
EXT2 STRT/STP/DIR	6-3	I <sup>2</sup> t	6-31
External control	4-7	Information	6-40
EXTERNAL FAULT	6-9	INTERLOCKS	6-51
EXTERNAL REF1 SEL	6-4	INVERT AI1	6-11
EXTERNAL REF2 SEL	6-6	INVERT AI2	6-11
External reference 1	4-10	INVERT AO1	6-15
External reference 2	4-10	INVERT AO2	6-15
<b>F</b>		IR COMPENSATION	6-25
Factory macro	5-3	IR-COMP RANGE	6-26
external connections	5-4	IR-COMP VOLTAGE	6-26
parameter settings	5-5	<b>K</b>	
Fault functions	6-30	Keypad control	4-7
FAULT RESET SELECT	6-9	Keypad PI	4-9
Field weakening point	6-24	Keypad reference 1	4-9
Flying start	6-17	<b>L</b>	
Forward	6-2, 6-3, 6-8	LAG MOT START DLY	6-50
Freq/current limits	6-16	LAG MOT STOP DLY	6-50
FREQUENCY RANGE	6-16	LANGUAGE	3-2
<b>G</b>		Living zero	6-10, 6-31
Group 10.1 start/stop/direction	6-2	LOW FREQ 1	6-49
Group 10.2 reference select	6-4	LOW FREQ 2	6-50
Group 10.3 preset speeds	6-7	LOW FREQ 3	6-50
Group 10.4 system contr inputs	6-9	<b>M</b>	
Group 10.5 analog inputs	6-10	Macros	
Group 10.6 relay outputs	6-12	access	5-2
Group 10.7 analog outputs	6-14	applications	5-2
Group 10.8 ext communication	6-16	Macros, defined	2-1
Group 20.1 freq/current limits	6-16	Main 10 control connection parameters	6-2
Group 20.2 start/stop	6-17	Main 20 drive parameters	6-16
Group 20.3 accel/decel	6-20		
Group 20.4 motor control	6-22		
Group 20.5 crit frequencies	6-28		
Group 30.1 fault functions	6-30		
Group 30.2 automatic reset	6-37		

Main 30 protection parameters	6-30	<b>O</b>	
Main 40 application parameters	6-41		
Main level		Operating data	
access	2-4	access	4-3
defined	2-4	functions	4-1
illustrated	2-4	overview	2-3
Manual		parameter selection	4-3
conventions	1-2	parameters defined	4-1
how to use	1-1	parameters listed	4-2
MAX OUTPUT VOLTAGE	6-23	Opt. pack macro	5-12
MAXIMUM AI1	6-10	external connections	5-13
MAXIMUM AI2	6-11	parameter settings	5-14
MAXIMUM FREQUENCY	6-16	OUTPUT FREQ 1 FUNC	6-39
MC PROG VERSION	6-40	OUTPUT FREQ 1 LIMIT	6-39
Menu system		OUTPUT FREQ 2 FUNC	6-39
described	2-2	OUTPUT FREQ 2 LIMIT	6-39
illustrated	2-2	OVERCURRENT	6-38
navigation	2-3	OVERVOLTAGE	6-37
MINIMUM AI1	6-10		
MINIMUM AI2	6-11	<b>P</b>	
MINIMUM AO1	6-15	PARAM. LOCK SEL	6-9
MINIMUM AO2	6-15	Parameter	
MINIMUM FREQUENCY	6-16	menus	6-1
MOT TEMP FLT FUNC	6-31	selection illustrated	2-7
MOTOR BASE FREQUENCY	3-3	Parameter level	
MOTOR BASE R.P.M.	3-3	access	2-6
Motor control	6-22	changing values	2-6
Motor control card		defined	2-6
ESD warning	iv	illustrated	2-6
Motor control values	4-6	Parameter lock	4-5, 4-10, 6-9
MOTOR CURRENT -FLA	3-3	Parameters	
MOTOR LOAD CURVE	6-34	alternate settings	A-1
MOTOR NOM. VOLTAGE	3-3	listed	A-1
Motor overload protection	6-31	motor control values	4-6
MOTOR POWER	3-3	operating data	4-1
MOTOR POWER FACTOR	3-3	overview	6-1
MOTOR THERM TIME	6-33	Parameters, menu system	2-2
		defined	2-2
		illustrated	2-2, 6-1
		navigation	2-3
		start-up data	2-2
		PI control macro	5-9
		external connections	5-10
		parameter settings	5-11
		PI -CONT GAIN	6-41, 6-47
		PI -CONT I -TIME	6-42, 6-47
		PI -CONT MAX LIMIT	6-42
		PI -CONT MIN LIMIT	6-42
		PI-Controller	6-41
<b>N</b>			
NBR OF DECIMALS	6-54		
NBR OF LAG MOTORS	6-50		
NOMINAL SLIP	6-27		
Notes, definition	iii		
NUMBER OF RESETS	6-37		

PRESET SPEED SEL	6-8	STALL CURRENT	6-35
Preset speeds	6-7	STALL FUNCTION	6-34
Programming digital inputs	B-1	STALL TIME/FREQ	6-35
Protection parameters	6-30	START FREQ 1	6-49
Pump and fan control	6-45	START FREQ 2	6-49
Pump and fan macro	5-18	START FUNCTION	6-17
external connections	5-19	Start/stop	6-17
parameter settings	5-20	Start/stop/direction	6-2
sample application	6-54	Start-up	
		parameters	3-1
		Start-up data	
		described	2-2
		using the menu	2-3
		Start-up data parameters	3-1
		STOP FUNCTION	6-18
		SUPERVIS MESSAGES	6-39
		Supervision	6-38
		SUPPLY VOLTAGE	3-2
		SWITCHING FREQ	6-23, 6-24
		System contr inputs	6-9
		<b>T</b>	
		TEST DATE	6-40
		TIME BETW. RESET ATTEMPTS	6-37
		TIME WINDOW	6-37
		TORQUE BOOST CUR	6-18
		<b>U</b>	
		UNDERLOAD CURVE	6-36
		UNDERLOAD FUNCTION	6-35
		UNDERLOAD TIME	6-35
		UNDERVOLTAGE	6-38
		USER DISPLAY SCALE	3-2
		User macro	5-1
		<b>V</b>	
		V/Hz RATIO	6-23
		V/Hz2	6-23
		VOLTAGE LIMIT	6-27
		Voltage regulators	6-27
		<b>W</b>	
		WAKE UP LEVEL	6-49
		<b>Z</b>	
		ZERO SPEED LOAD	6-34

**R**

**S**

**T**

**U**

**V**

**W**

**Z**