



Low voltage AC drives

ABB industrial drives ACS880, drive modules 0.75 to 4250 hp (0.55 to 3200 kW) Catalog

www.nicsanat.com

021-87700210



Power and productivity
for a better world™



ACS880 series drives

Uncompromised productivity

Contents

4	Simplifying your world without limiting your possibilities
6	What does all-compatible mean for you?
8	Cost and time savings with drive-based functional safety
9	Drive-based application programming
10	Save time, ease troubleshooting and improve drive performance with ABB smartphone apps
12	Technical data and how to select a drive
13	Single drive modules, ACS880-01 with option +P940
14-15	Ratings, types and voltages, ACS880-01
16	Single drive modules, ACS880-04
17	High power single drive module packages, ACS880-04
18	Ratings, types and voltages, ACS880-04, -04XT
19	Ratings, types and voltages, nxR8i
20	Regenerative single drive module packages, ACS880-14
21	Ratings, types and voltages, ACS880-14
22	Ultra-low harmonic single drive module packages, ACS880-34
23	Ratings, types and voltages, ACS880-34
24-25	Multidrive modules, ACS880-X04
26-30	Ratings, types and voltages, inverter modules and supply units
31	Standard interface and extensions for comprehensive connectivity
32	Standard software for scalable control and functionality
33-34	Application control programs
35	Designed to control virtually any type of AC motor
36	Intuitive human-machine interface
36	PC tool for easy startup and maintenance
37	Integrated safety simplifies configuration
38	Drive application programming based on IEC standard 61131-3
39	Flexible connectivity to automation networks
40	Input/output extension modules for increased connectivity
40	Speed feedback interfaces for precise process control
40	I/O option extension adapter
40	DDCS communication option modules
40	Remote monitoring access worldwide
41	EMC – electromagnetic compatibility
42	Sine filters, ACS880-01, ACS880-07 and ACS880-17/-37
43	Brake options
43	Brake options, ACS880-01
44	Brake options, ACS880-04 -X04
45	Brake options, ACS880-604
47	DC-DC converter
49-50	du/dt filters
51	Dimensioning tool for selecting the optimal drive
52-55	Summary of features and options
56-59	Drive services



When your electric motor-driven application requires dependable capability and scalability to meet your exact requirements for variable speed operation, you need our ACS880 industrial drives. Our drives are built to truly understand and refine your business and cover every possible application. We make your opportunities work with our strong drives series that covers all your process control needs no matter what your industry. These are our ACS880 industrial drives, our benchmark of uncompromising productivity, serving you locally on a global scale.

Simplifying your world without limiting your possibilities

Drive modules

The all-compatible drives are designed to provide customers across industries and applications with unprecedented levels of compatibility and flexibility. The ACS880 drive modules are customized to meet the precise needs of industries such as metals, oil and gas, mining, marine, material handling, pulp and paper. They control a wide range of applications such as cranes, conveyors, pumps and fans.

Direct torque control (DTC)

ABB's signature motor control technology provides precise speed and torque control for all applications and virtually any type of AC motor.

See page 33

Application control programs

A range of ready-made programs to optimize productivity and usability in applications such as cranes, winches and artificial lifting.

See page 34

Removable memory unit

Stores all the software and parameter configurations in an easily replaceable and simple-to-install module.

See page 33



Energy efficiency

The drive provides features such as an energy optimizer and energy efficiency information that help you monitor and save the energy used in the processes.

See page 33

Remote monitoring

With a built-in Web server, NETA-21 makes worldwide access easy for industry applications.

See page 41



Drive-to-drive link

Allows fast communication between drives including master-follower configurations as standard.

See page 41



Wide range of safety features

Safe torque off is built-in as standard. An optional safety functions module provides extended safety functions, simplifying the configuration and reducing installation space.

[See page 38](#)



Drive application programming

Customizable to meet the precise application needs based on IEC 61131-3. Uses the same programming environment and is also easy to integrate with other ABB components such as PLCs and HMIs.

[See page 39](#)



Drives going mobile

We offer several smartphone applications to ease and enhance the use of ABB drives. These tools provide a user-friendly and easy-to-use approach for the commissioning, servicing and use of ABB drives.

[See page 10](#)



Intuitive human-machine interface

Intuitive, high-contrast and high-resolution display enabling easy navigation in multiple languages.

[See page 37](#)

Startup and maintenance tool

Drive composer PC tool for drive startup, configuration and daily use and process tuning. PC tool is connected to the drive via Ethernet or USB interface.

[See page 37](#)

Communication with all major automation networks

Fieldbus adapters enable connectivity with all major automation networks.

[See page 40](#)



Flexible product configurations

Drives are built to order with a wide range of options such as braking options and different enclosure variants.

[See product variant pages](#)

Extended connectivity

In addition to the standard interfaces, the drive has three built-in slots for additional input/output extension modules and speed feedback interfaces.

[See page 41](#)



What does all-compatible mean for you?

Business all-compatible

The all-compatible drives are not just equipment – they are part of your business strategy. Providing better control over your processes, our drives mean lower energy consumption, improved productivity, flexibility and ease of use. In addition to drives, we offer a wide range of products and services to support your business. With offices in over 90 countries and a global technical partner network, we are in a good position to offer technical advice and local support, worldwide.

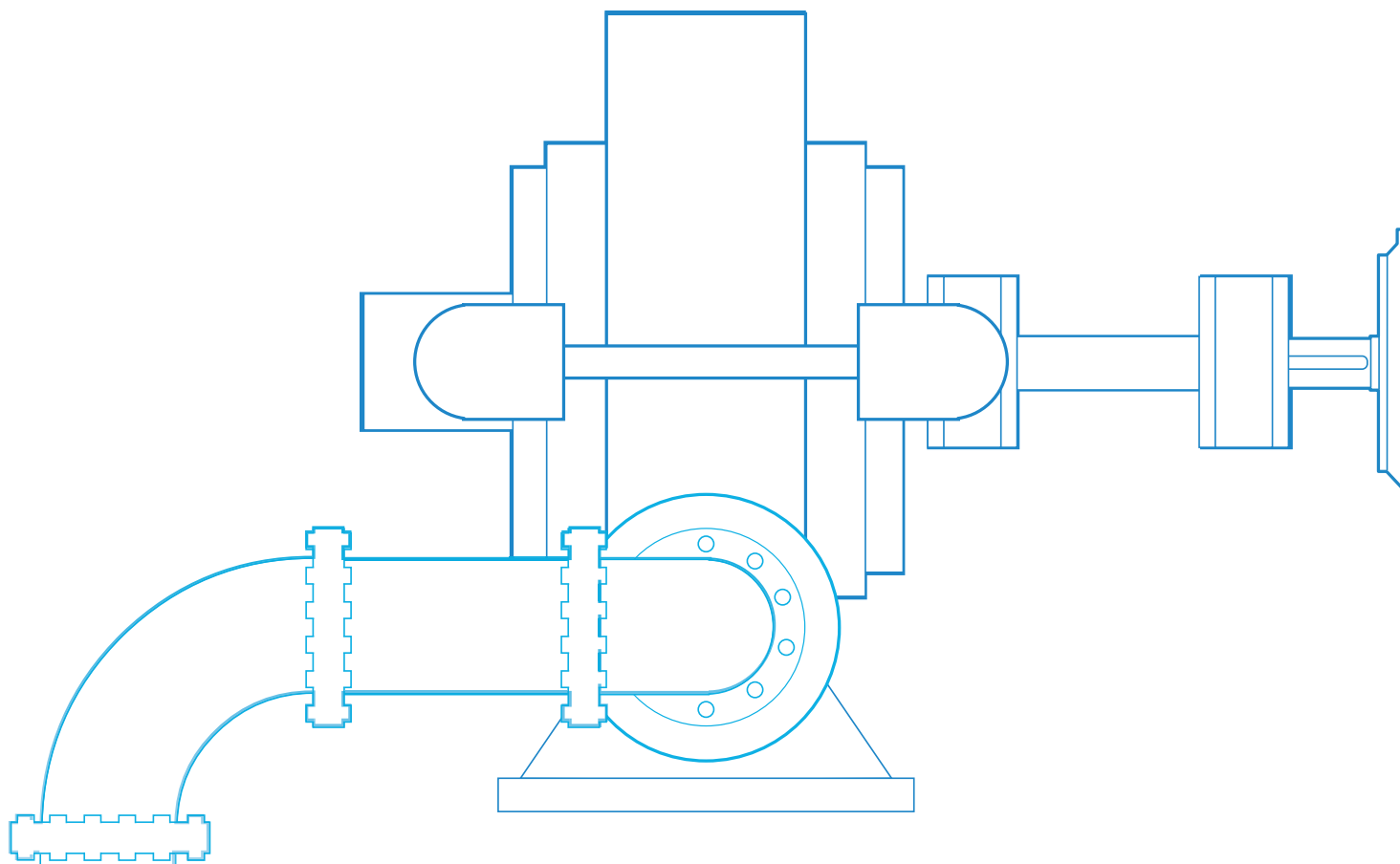

Process all-compatible

The drives are compatible with all kinds of processes. They control virtually any type of AC motor, provide extensive input/output connectivity and support all major fieldbus protocols. The drives cover a wide voltage and power range. Control performance is scalable from basic to demanding applications, delivered by direct torque control (DTC). The flexibility and scalability of the drives enable one drive platform to control virtually any application or process, making your drive selection easy.

Environment all-compatible

There is increased demand for industries to reduce their impact on the environment. Our drives can help you reduce energy consumption in a wide range of applications. Our drives have an energy optimizer feature that ensures maximum torque per ampere, reducing energy drawn from the supply. The built-in energy efficiency calculators help you to analyze and optimize your processes. We can help you to investigate the energy-saving potential of selected applications with our six-step energy appraisal.

Our wall-mounted ACS880 industrial drives fulfill the highest IE2 drive (EN 50598-2) energy efficiency class, further reducing environmental impact. In addition, all ACS880 industrial drives are compatible with high-efficiency IE4 motors.

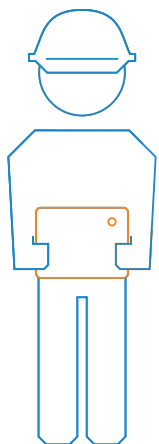
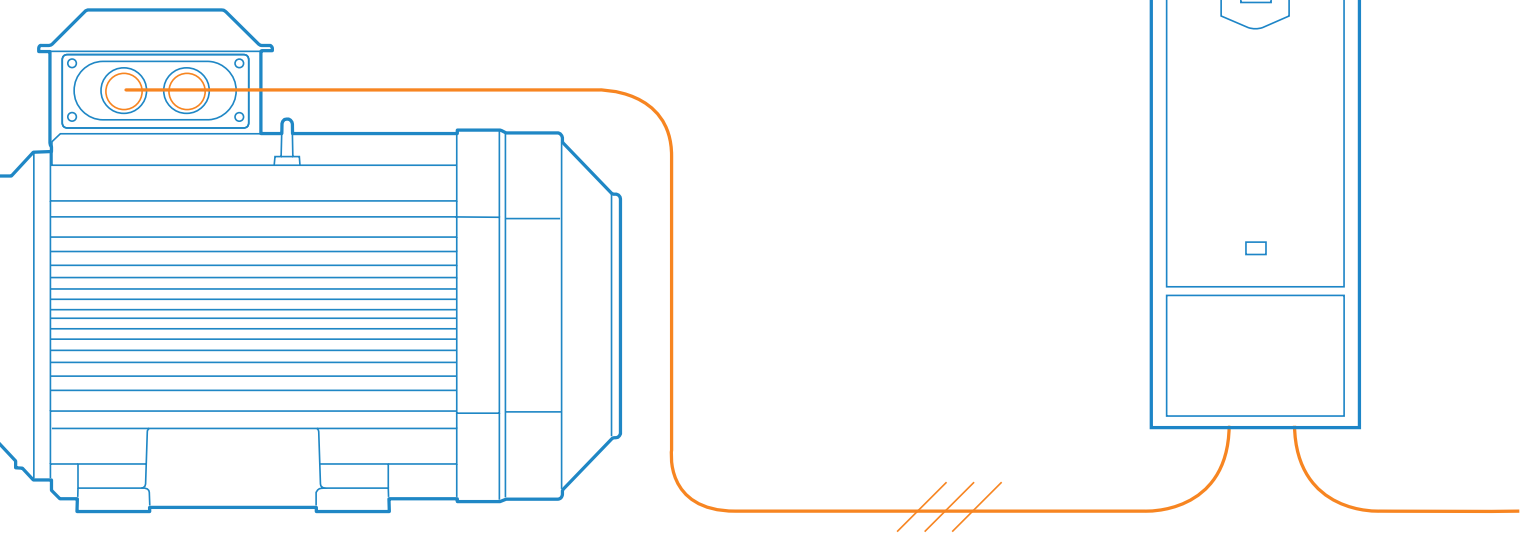

Human all-compatible

All our drives share easy-to-use interfaces, saving you time during drive commissioning and maintenance. When you have learned it once, you can use it with all the drives in our all-compatible drives portfolio.

The control panel supports over 20 languages. With the PC tool, you get extensive drive monitoring capabilities and quick access to the drive settings. Integrated and certified safety features provide safety for machine operators.

To further improve the user experience, we have developed mobile apps that can be utilized in interacting with the drive. These apps give you an easy graphical interface for management, maintenance and service of your drives.

Cost and time savings with drive-based functional safety

With our ACS880 drive, you can achieve SIL 3/PL e safety level with certified safety functions modules. The safety module is easy to integrate inside the drive and offers you several safety functions. Integration with automation systems is quick and reliable using PROFI-safe connectivity. ACS880 drives have a safe torque off (STO) function as a standard.

Scalable safety with PROFI-safe and Safety PLC

The safety functionality can be scaled to your needs. From a safety module integrated into a single relay to a complete safety system with a PROFI-safe and a safety PLC, eg, AC500-S.

Safely limited speed without encoders

The SIL 3/PL e certified safely-limited speed (SLS) function prevents the motor from exceeding a defined speed limit with no encoders. This allows machine interaction to be performed at a safe speed without stopping the process.

TÜV-certified safety design tool

Functional safety design tool (FSDT-01) is used for machinery safety. It helps to increase the safety of users in the vicinity of machines. You can perform functional safety modeling, design, calculations and verification for machine functional safety.



Drive-based application programming

The built in PLC capability of the ACS880 provides you a possibility to customize the drive for your application without the cost of extra hardware. As programming is based on the IEC 61131-3 standard used in AC500 PLCs and by many other PLC vendors, you do not need to retrain your staff. By decentralizing your machine control closer to the process, you achieve better control performance.

Adaptive programming

Adaptive programming is ideal for creating simple control programs for various applications. It does not require expertise in programming and is offered as a standard in All-compatible drives.

Application programming

Application programming makes it possible for system integrators and machine builders to integrate their desired functionality and know-how directly into the drive. It utilizes standard IEC 61131-3 programming used by many PLCs like the AC500. This means that programs can be easily moved from the drive to a PLC and extended into a larger system.

Automation builder

Automation Builder is a software suite for automation engineering, which makes programming industry devices such as drives, PLCs, robots and human-machine interfaces (HMIs) easy using one integrated engineering suite. Automation builder is used both for engineering devices and entire automation projects.

Save time, ease troubleshooting and improve drive performance with ABB smartphone apps

Better connectivity and user experience with Drivetune

Easy and fast access to product information and support

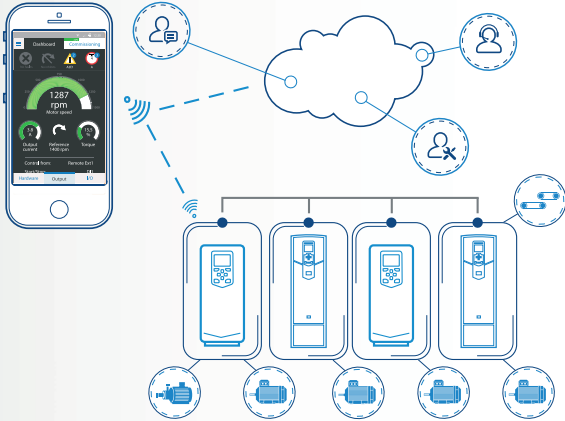

Manage your drives and the process lines and machines they control

Easy access to cloud-based drive and process information from anywhere via an online connection



Start up, commission and tune your drive and application



Simplified user guidance with instant access to drive status and configuration



Performance optimization via drive troubleshooting features and fast support



Services and support on the go with Drivebase

Search for support documents and contacts



Maintain and service all your installed drives on one or multiple sites

Get 6 months extra warranty for free by registering your drive with the Drivebase app

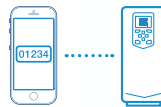

Access your product and service information in the cloud from anywhere



Access your drive's diagnostics data



Push notifications for critical product and service updates



Access information anywhere

Download the apps using the QR codes below or directly from the app stores

Drivetune for commissioning and managing drives



Drivebase for ensured reliability and reduced downtime on production sites

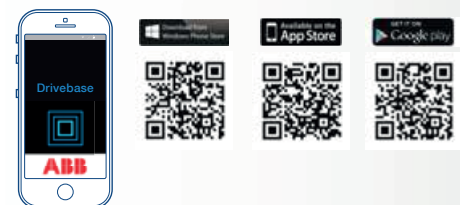



Technical data and how to select a drive

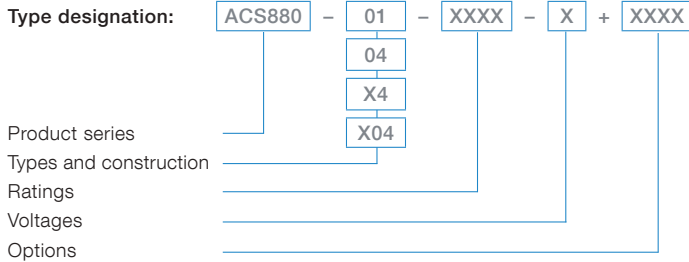

To choose the right drive for your application, please refer to the rating tables on pages 12, 13, 16, 17, 19, 21, 24, 25, 26, 27, 28 and 29 or use ABB's DriveSize (page 48) dimensioning tool. The selected drive has a unique type designation, which identifies the drive by construction, power and voltage range. The options are added to the type designation with a "plus" code. Build up your own ordering code using the type designation key or contact your local ABB drives sales office and let them know your needs/requirements.

Mains connection

Voltage and power range	3-phase, $U_{N2} = 208$ to 240 V, +10/-15% (-01) 3-phase, $U_{N5} = 380$ to 500 V, +10/-15% (-01, -04) 3-phase, $U_{N7} = 525$ to 690 V, +10/-15% (-01, -04) 3-phase, $U_{N5} = 380$ to 500 V, $\pm 10\%$ (-x04, -04 ³⁾ , -x4 ³⁾ 3-phase, $U_{N7} = 525$ to 690 V, $\pm 10\%$ (-x04, -04 ³⁾ , -x4 ³⁾ 0.75 to 4250 hp Diode supply unit (DSU) 55 to 5445 kVA IGBT supply unit (ISU) 5.5 to 3679 kVA Regenerative rectifier unit (RRU) 400 to 4135 kVA
Frequency	50/60 Hz $\pm 5\%$
Power factor	ISU: $\cos\phi = 1$ (fundamental) $\cos\phi = 0.99$ (total) DSU and RRU: $\cos\phi = 0.98$ (fundamental) $\cos\phi = 0.93$ to 0.95 (total)
Efficiency (at nominal power)	98% with DSU and RRU 97% with ISU

Motor connection

Voltage	3-phase output voltage 0 to $U_{N2}/U_{N3}/U_{N5}/U_{N7}$
Frequency	0 to ± 500 Hz ¹⁾⁴⁾
Motor control	Direct torque control (DTC)
Torque control:	Torque step rise time: Open loop Closed loop
Open loop	<5 ms with nominal torque
Closed loop	<5 ms with nominal torque
	Non-linearity:
Open loop	$\pm 4\%$ with nominal torque
Closed loop	$\pm 3\%$ with nominal torque
Speed control:	Static accuracy: Open loop Closed loop
Open loop	10% of motor slip
Closed loop	0.01% of nominal speed
	Dynamic accuracy:
Open loop	0.3 to 0.4% seconds with 100% torque step
Closed loop	0.1 to 0.2% seconds with 100% torque step

Product compliance

- CE
- Low Voltage Directive 2006/95/EC
- Machinery Directive 2006/42/EC
- EMC Directive 2004/108/EC
- Quality assurance system ISO 9001 and Environmental system ISO 14001
- RoHS
- UL, cUL, UL508C and CSA, C22.2 NO.14-10, EAC/GOST R ⁵⁾, C-Tick
- Functional safety: STO, TÜV Nord certificate
- ATEX-certified Safe Disconnection Function, Ex II (2) GD

EMC according to EN 61800-3 (2004)

- Category C2 with internal option (-01)
1st environment category C2 included as option (-x4 ³⁾
2nd environment category C3 included as standard (-x04, -x4 ³⁾
2nd environment category C3 included as option (-01, -04)
2nd environment category C4 included as standard

Environmental limits

Ambient temperature	Transport Storage Operation (air-cooled)	-40 to +70 °C -40 to +70 °C -15 to +40 °C as standard (-04) 0 to +40 °C as standard (-x04, -04 ³⁾ , -x4 ³⁾ +40 to +55 °C with derating of 1%/1 °C (-04 /-01 ⁴⁾ +40 to +50 °C with derating of 1%/1 °C (-x04, -04 ³⁾)
Cooling method	Air-cooled	Dry clean air
Altitude	0 to 1,000 m 1,000 to 4,000 m	Without derating With derating 1%/100 m ⁷⁾
Relative humidity		5 to 95%, no condensation allowed
Degree of protection	IP00 IP20	(-04, -04 ³⁾ , -x4 ³⁾ , -x04) (-01, -04)
Paint color		RAL 9017, RAL 9002
Contamination levels		No conductive dust allowed
Storage		IEC 60721-3-1, Class 1C2 (chemical gases), Class 1S2 (solid particles)
Transportation		IEC 60721-3-2, Class 2C2 or 3C2 (chemical gases), Class 2S2 (solid particles without air inlet filters)
Operation		IEC 60721-3-3, Class 3C2 (chemical gases), Class 3S2 (solid particles)
Functional safety	Standard Internal safety option, the Safety functions module	Safe torque off (STO according EN/IEC 61800-5-2) IEC 61508 ed2: SIL 3, IEC 61511: SIL 3, EN/IEC 62061: SIL CL 3, EN ISO 13849-1: PL e Safe stop 1 (SS1), safely-limited speed (SLS), safe stop emergency (SSE), safe brake control, (SBC) and safe maximum speed (SMS), prevention of unexpected startup (POUS), Safe direction (SDI), Safe speed monitor (SSM) EN/IEC 61800-5-2, IEC 61508 ed2: SIL 3, IEC 61511: SIL 3, EN/IEC 62061: SIL CL 3, EN ISO 13849-1: PL e TÜV Nord certified ⁶⁾

C = Chemically active substances

S = Mechanically active substances

¹⁾ For higher operational output frequencies please contact your local ABB office

²⁾ Please check availability per drive type

³⁾ Single drive module packages

⁴⁾ Operation above 120 Hz might require type specific derating, please contact your local ABB office

⁵⁾ EAC has replaced GOST R

⁶⁾ Pending (except for -01 and -04 single drive modules)

⁷⁾ Derating reduced by lower than 40 °C ambient temperature

Single drive modules, ACS880-01 with option +P940

Our all-compatible ACS880-01 single drives support easy and cost efficient cabinet installation with option +P940. The optimized module design makes cabinet installation easy and minimizes the need for cabinet space, while providing all-compatible features in one compact drive module. The power range is from 0.75 to 4250 hp and the voltage range is from 230 to 690 V. The enclosure class is IP20 as standard.

These single drive modules are customized to the precise needs of industries such as oil and gas, mining, metals, chemicals, cement, power plants, material handling, pulp and paper, sawmills and marine. They are designed to control a wide range of applications including cranes, extruders, winches, winders, conveyors, mixers, compressors, pumps and fans.

Optimized for cabinet assembly

All our modules (frame sizes R1 to R9) are built-on ABB's common drives architecture for easy commissioning and use. At the heart of the drive is direct torque control (DTC), ABB's premier motor control technology. To optimize the use of cabinet space, the ACS880-01 modules can be mounted side by side inside the cabinet. Because the drive module has built-in EMC filter, choke and braking chopper, design effort is reduced and installation is made easy. The extensive range of built-in and external options include EMC filters, encoders, resolvers, du/dt filters, sine filters, chokes and brake resistors, as well as application-specific software. Built-in safety features, such as safe torque off (STO), reduce the need for external safety components. Multiple drives can be daisy-chained for synchronized drive-to-drive communication. With the panelbus feature, several drive modules inside a cabinet can be accessed and operated using one common control panel. Our offering also covers an option for flange mounting with IP55 back side protection. In flange mounting the control electronics are separated from the cooling airflow for better thermal management.

ABB provides an extensive selection of support documentation for planning including dimension drawings in different formats, EPLAN P8 macros and line apparatus selection tool for selecting external components on the line side and motor side of the drive.

Main features

- Optimized for easy and cost efficient cabinet installation
- Enclosure class IP20
- Compact design for easy installation, commissioning and maintenance
- Side-by-side mounting
- Built-in EMC filter (as option), choke (as standard) and braking chopper (as option for frame sizes R5 to R9) will reduce design effort and makes installation easy
- Direct torque control (DTC) as standard, for high performance motor control
- Integrated safety including safe torque off (STO) as standard and the optional safety functions module, FSO-12 (TÜV Nord certified)
- Supports various motor types including synchronous reluctance motors
- Intuitive control panel with USB connection
- Removable memory unit for easy maintenance
- Drive composer PC tool for commissioning and configuration
- Primary control program - common software used throughout the ACS880 drive series
- Control unit supporting a wide range of fieldbuses, feedback devices and input/output options
- Coated boards as standard
- Controllable cooling fan
- Incoming air temperature measurement for protecting the drive from different temperature related failure mechanisms
- du/dt filter option for motor protection



Flange mounted ACS880-01, frame size R8, IP20



ACS880-01, frame sizes R1, R8 and R5, IP20

Ratings, types and voltages

Wall-mounted drives, ACS880-01

$U_N = 230$ V (range 208 to 240 V). The power ratings are valid at nominal voltage 230 V (0.55 to 75 kW).

Nominal ratings						Noise level	Heat dissipation	Air flow	Type designation	Frame size
Light-duty use			Heavy-duty use							
I_{Ld}	P_{Ld}		I_{2Hd}	P_{Hd}						
A	hp	kW	A	hp	kW	dB(A)	W	cfm		
4.4	1	0.75	3.7	0.75	0.55	46	73	26	ACS880-01-04A6-2	R1
6.3	1.5	1.1	4.6	1	0.75	46	94	26	ACS880-01-06A6-2	R1
7.1	2	1.5	6.6	1.5	1.1	46	122	26	ACS880-01-07A5-2	R1
10.1	3	2.2	7.5	2	1.5	46	172	26	ACS880-01-10A6-2	R1
16	5	4	10.6	3	3	51	232	52	ACS880-01-16A8-2	R2
23.1	7.5	5.5	16.8	5	4	51	337	52	ACS880-01-24A3-2	R2
29.3	10	7.5	24.3	7.5	5.5	57	457	79	ACS880-01-031A-2	R3
44	15	11	38	10	7.5	62	500	79	ACS880-01-046A-2	R4
58	20	15	45	15	11	62	630	165	ACS880-01-061A-2	R4
71	25	18.5	61	20	15	62	680	165	ACS880-01-075A-2	R5
83	30	22	72	25	18.5	62	730	165	ACS880-01-087A-2	R5
109	40	30	87	30	22	67	840	256	ACS880-01-115A-2	R6
138	50	37	105	40	30	67	940	256	ACS880-01-145A-2	R6
162	60	45	145	50	37	67	1260	265	ACS880-01-170A-2	R7
196	75	55	169	60	45	67	1500	265	ACS880-01-206A-2	R7
260	100	75	213	75	55	65	2100	324	ACS880-01-274A-2 ³	R8

Frame size	Height (H2)		Width (W)		Depth (D)		Weight	
	UL type 1	IP21	UL type 1	IP21	UL type open	IP20	UL type 1	IP21
	(in)	(mm)	(in)	(mm)	(in)	(mm)	(lbs)	(kg)
R1	14.6	370	6.1	155	8.9	226	13	6
R2	14.6	370	6.1	155	9.8	249	18	8
R3	16.5	420	6.7	172	10.1	256	22	10
R4	18.2	462	8.2	203	13.1	333	41	18.5
R5	23.5	596	8.2	203	13.1	333	51	23
R6	21.6	548	9.9	252	14.1	357	99	70
R7	23.6	600	11.2	284	14.4	365	121	55
R8	26.8	680	11.8	300	15.2	386	155	70
R9	26.7	680	15.0	380	16.3	413	216	98

Light-duty use

I_{Ld} Continuous current allowing 10% I_{Ld} for 1 min/5 min at 40 °C.

P_{Ld} Typical motor power in light-overload use.

Heavy-duty use

I_{Hd} Continuous current allowing 50% I_{Hd} for 1 min/5 min at 40 °C.

P_{Hd} Typical motor power in heavy-duty use.

The ratings apply at 40 °C ambient temperature. At higher temperatures (up to 55 °C) the derating is 1%/1 °C.

¹⁾ 30% overload

²⁾ 25% overload

³⁾ Comes with main power clamp

Ratings, types and voltages

Wall-mounted drives, ACS880-01

$U_N = 500 \text{ V}$ (range 380 to 500 V). The power ratings are valid at nominal voltage 500 V (0.55 to 250 kW).

Nominal ratings						Noise level	Heat dissipation	Air flow	Type designation	Frame size
Light-duty use			Heavy-duty use							
I_{Ld}	P_{Ld}		I_{2Hd}	P_{Hd}						
A	hp	kW	A	hp	kW	dB(A)	W	cfm		
2.1	1	0.75	1.7	0.75	0.55	46	30	26	ACS880-01-02A1-5	R1
3	1.5	1.1	2.1	1	0.75	46	40	26	ACS880-01-03A0-5	R1
3.4	2	1.5	3	1.5	1.1	46	52	26	ACS880-01-03A4-5	R1
4.8	3	2.2	3.4	2	1.5	46	73	26	ACS880-01-04A8-5	R1
7.6	5	4	5.2	3	3	46	122	26	ACS880-01-07A6-5	R1
11	7.5	5.5	7.6	5	4	46	172	26	ACS880-01-11A0-5	R1
14	10	7.5	11	7.5	5.5	51	232	52	ACS880-01-014A-5	R2
21	15	11	14	10	7.5	51	337	52	ACS880-01-021A-5	R2
27	20	15	21	15	11	57	457	79	ACS880-01-027A-5	R3
34	25	18.5	27	20	15	57	562	79	ACS880-01-034A-5	R3
40	30	22	34	25	18.5	62	667	79	ACS880-01-040A-5	R4
52	40	30	40	30	22	62	907	165	ACS880-01-052A-5	R4
65	50	37	52	40	30	62	1117	165	ACS880-01-065A-5	R5
77	60	45	65	50	37	62	1120	165	ACS880-01-077A-5	R5
96	75	55	77	60	45	67	1295	256	ACS880-01-096A-5	R6
124	100	75	96	75	55	67	1440	256	ACS880-01-124A-5	R6
156	125	90	124	100	75	67	1940	265	ACS880-01-156A-5	R7
180	150	110	156	125	90	67	2310	265	ACS880-01-180A-5	R7
240	200	132	180	150	110	65	3300	324	ACS880-01-240A-5 ⁴	R8
302	250	187.5	260	200	132	68	4200	677	ACS880-01-302A-5 ³	R9
361	300	200	302	250	188	68	4800	677	ACS880-01-361A-5 ⁶	R9
414*	350	250	361**	300	200	68	6000	677	ACS880-01-414A-5 ⁵	R9

$U_N = 690 \text{ V}$ (range 525 to 690 V). The power ratings are valid at nominal voltage 690 V (4 to 250 kW).

Nominal ratings						Noise level	Heat dissipation	Air flow	Type designation	Frame size
Light-duty use			Heavy-duty use							
I_{Ld}	P_{Ld}		I_{2Hd}	P_{Hd}						
A	hp	kW	A	hp	kW	dB(A)	W	cfm		
9	7.5	5.5	6.1	5	4	62	217	165	ACS880-01-07A3-7	R5
11	10	7.5	9	7.5	5.5	62	284	165	ACS880-01-07A3-7	R5
17	15	11	11	10	7.5	62	399	165	ACS880-01-14A2-7	R5
22	20	15	17	15	11	62	490	165	ACS880-01-018A-7	R5
27	25	18.5	22	20	15	62	578	165	ACS880-01-022A-7	R5
32	30	22	27	25	18.5	62	660	165	ACS880-01-026A-7	R5
41	40	30	32	30	22	62	864	165	ACS880-01-035A-7	R5
52	50	37	41	40	30	62	998	165	ACS880-01-042A-7	R5
52	50	37	41	40	30	62	1120	165	ACS880-01-049A-7	R5
62	60	45	52	50	37	67	1295	256	ACS880-01-061A-7	R6
77	75	55	62	60	45	67	1440	256	ACS880-01-084A-7	R6
99	100	75	77	75	55	67	1940	265	ACS880-01-098A-7	R7
125	125	90	99	100	75	67	2310	265	ACS880-01-119A-7	R7
144	150	110	125	125	90	65	3300	324	ACS880-01-142A-7	R8
180	200	132	144	150	110	65	3900	324	ACS880-01-174A-7 ³	R8
242	250	160	192	200	132	68	4200	677	ACS880-01-210A-7 ⁷	R9
271	250	200	242 ¹	250	160	68	4800	677	ACS880-01-271A-7 ⁵	R9

Frame size	Height (H2)		Width (W)		Depth (D)		Weight	
	UL type 1	IP21	UL type 1	IP21	UL type open	IP20	UL type 1	IP21
	(in)	(mm)	(in)	(mm)	(in)	(mm)	(lbs)	(kg)
R1	14.6	370	6.1	155	8.9	226	13	6
R2	14.6	370	6.1	155	9.8	249	18	8
R3	16.5	420	6.7	172	10.1	256	22	10
R4	18.2	462	8.2	203	13.1	333	41	18.5
R5	23.5	596	8.2	203	13.1	333	51	23
R6	21.6	548	9.9	252	14.1	357	99	70
R7	23.6	600	11.2	284	14.4	365	121	55
R8	26.8	680	11.8	300	15.2	386	155	70
R9	26.7	680	15.0	380	16.3	413	216	98

Light-duty use

I_{Ld} Continuous current allowing 10% I_{Ld} for 1 min/5 min at 40 °C.

P_{Ld} Typical motor power in light-overload use.

Heavy-duty use

I_{Hd} Continuous current allowing 50% I_{Hd} for 1 min/5 min at 40 °C.

P_{Hd} Typical motor power in heavy-duty use.

The ratings apply at 40 °C ambient temperature. At higher temperatures (up to 55 °C) the derating is 1%/1 °C.

¹ 30% overload

² 25% overload

³ Comes with main power clamp

Single drive modules, ACS880-04

Our ACS880-04 single drive modules are optimized for easy and cost efficient cabinet assembly. With a compact and robust cabinet design, they save a lot of floor space and are easy to maintain and service. Being part of the all-compatible ACS880 industrial drives series, the single drive modules are easy to integrate into other systems and they provide great control performance with versatile drive features. This power intensive drive module is compatible with a wide range of industries including oil and gas, mining, metals, chemicals, cement, power plants, material handling, pulp and paper and woodworking. Applications range from cranes, extruders, conveyors, compressors to pumps and fans.

Easy and cost efficient cabinet assembly

The module is designed with all the necessary components for making engineering, cabling and cabinet assembly easier. The module comes as a bookshelf and flat variant. It has a pedestal with wheels and a ramp for pushing the module inside the cabinet and connecting it to the optional cable panel. For optimized cabinet usage, features include power input connections on the top of the module and power output on the bottom. The control unit can be either installed inside or outside of the module, enabling free location of input/output terminals.

The built-in features include direct torque control (DTC), ABB's premier motor control technology, chokes for harmonic reduction, safe torque off (STO) and drive-to-drive communication as standard. Additional built-in options include EMC filters, braking chopper and common mode filters, several inputs/outputs terminals, fieldbus connectivity, integrated safety including several safety functions and option slots for speed feedback. The drive comes with IP20 enclosure class as standard, reducing engineering time and cabinet assembly costs.

ABB provides an extensive selection of support documentation for planning including dimension drawings in different formats,

EPLAN P8 macros and line apparatus selection tool for selecting external components on the line side and motor side of the drive.

Main features

- Enclosure class IP20 as standard
- Power supply coming from the top part of the module and out from the lower part of the cabinet, enabling more optimal cabinet design
- Possibility for flat mounting enables cabinet assembly even into cabinets with limited depth
- Easy installation, commissioning and maintenance with pedestal on wheels, ramp and optional cable panel (+H381)
- Direct torque control (DTC) as standard, for high performance motor control
- Integrated safety including safe torque off (STO) as standard and the optional safety functions module (TÜV Nord certified)
- Supports various motor types including synchronous reluctance motors
- Intuitive control panel with USB connection
- Removable memory unit for easy maintenance
- Drive composer PC tool for commissioning and configuration
- Control unit with three option slots, that can be installed either inside the module or in different parts of the cabinet, supporting a wide range of fieldbuses, feedback devices and input/output options
- Coated boards as standard
- Built-in choke as standard for input harmonics reduction
- Built-in braking chopper (option)
- EMC filter option
- Power terminals are available as standard on the left side of the module. The power terminals can also be cabled on the right side of the module as option
- ACS880-04XT, frame sizes R10 or R11 single drive modules can be parallel connected for higher powers.
- ACS880-04XT can be connected as 6-pulse or as 12-pulse



Single drive modules, ACS880-04, frame sizes R10 (with external control unit) and R11 (with internal control unit and control panel integrated in the module), bookshelf mounting



Single drive modules, ACS880-04, flat mounting



Optional cable panel installed inside the cabinet. ACS880-04 is pushed into the cabinet using a ramp and pedestal on wheels.

nxDxT supply units and nXR8i inverter units

The ACS880-04 high power single drives module packages include the parallel connected R8i inverter module and D8T half controlled diode bridge with thyristor charging. The power range is from 700 to 2450 hp, and the voltage range is from 380 to 690 V.

These compact multidrive modules come as bookshelf variants. They have been optimized for assembly into customer's own cabinets. Installing and transporting them is easy, as they come equipped with wheels. Connecting the modules to the motor cables inside the cabinet is quick as the modules come with quick connectors as standard. The modules can also be quickly pulled out from a cabinet without any need for disconnecting the motor cables. This is done simply by disconnecting a couple of bolts. The R8i inverter module comes equipped with a removable fan pedestal, which makes motor cabling easy.

The control unit and the input/output connections can be located in the most optimal part inside the cabinet. The circuit boards in the modules are in a sealed compartment, keeping them clean and cool during operation. The cooling fans in the module are speed controlled as a standard, helping to lower the noise level of the module and making it more energy efficient. The fans also make the temperature for the semiconductors more stable.

Main features

- Optimized design for easy cabinet assembly (comes with wheels)
- Compact bookshelf design
- Easy access to power terminals
- Side-by-side mounting
- Direct torque control (DTC) as standard, for high precision motor control
- Long lifetime cooling fan and capacitors
- Built-in redundancy with parallel connected modules
- Extensive, programmable inputs/output with galvanically isolated inputs
- Integrated safety including safe torque off (STO) as standard and the optional safety functions module (TÜV Nord certified)
- Supports various motor types including synchronous reluctance motors
- Removable memory unit for easy maintenance
- Drive composer PC tool for commissioning and configuration
- Control unit BCU-X2 is used with all parallel connected modules, such as nXR8i and DxT. It has three option slots, and a slot for DDCS optical communication
- The control unit can be installed in different parts of the cabinet, and it supports a wide range of fieldbuses, feedback devices and input/output options
- Coated boards come as standard
- Speed controlled cooling fans, or DOL as an option for certain frames
- Large power terminals allowing the use of a wide range of cable sizes
- Complete cabinet design for Rittal TS8 cabinets



ACS880-04 single drive module package with 1xD8T and 2xR8i

Ratings, types and voltages

ACS880-04, -04XT

$U_N = 480$ V (range 380 to 500 V). The power ratings are valid at nominal voltage 480 V.

Light-duty use			Heavy-duty use			Noise level	Heat dissipation	Air flow	Type designation	Frame size
I_{Ld} A	P_{Ld} hp	P_{Ld} kW	I_{Hd} A	P_{Hd} hp	P_{Hd} kW	dB(A)	W	cfm		
483	400	315	361	300	250	72	5602	710	ACS880-04-503A-5	R10
573	450	400	414	350	250	72	6409	710	ACS880-04-583A-5	R10
623	500	450	477	400	315	72	8122	710	ACS880-04-635A-5	R10
705	600	500	566	450	400	72	8764	710	ACS880-04-715A-5	R11
807	700	560	625	500	450	71	9862	835	ACS880-04-820A-5	R11
857	700	560	697 ²⁾	500	500	71	11078	835	ACS880-04-880A-5	R11

6 or 12-pulse

1146	1000	800	878	700	630	75	16244	1415	ACS880-04XT-1160A-5	2xR10
1570	1000	1000	1274 ²⁾	1000	900	74	21156	1670	ACS880-04XT-1610A-5	2xR11

$U_N = 575$ V (range 525 to 690 V). The power ratings are valid at nominal voltage 575 V.

Light-duty use			Heavy-duty use			Noise level	Heat dissipation	Air flow	Type designation	Frame size
I_{Ld} A	P_{Ld} hp	P_{Ld} kW	I_{Hd} A	P_{Hd} hp	P_{Hd} kW	dB(A)	W	cfm		
320	300	315	255	250	250	72	4403	710	ACS880-04-330A-7	R10
360	350	355	325	300	315	72	5602	710	ACS880-04-370A-7	R10
420	450	450	360 ¹⁾	415	350	72	6409	710	ACS880-04-430A-7	R10
455	450	450	415	450	400	72	8122	710	ACS880-04-470A-7	R11
505	500	500	455	450	450	72	8764	710	ACS880-04-522A-7	R11
571	600	560	505	500	500	71	9862	710	ACS880-04-590A-7	R11
630	700	630	571 ³⁾	600	560	71	10578	835	ACS880-04-650A-7	R11
705	700	630	571 ³⁾	600	560	71	10578	835	ACS880-04-721A-7	R11

6 or 12-pulse

791	800	710	678 ¹⁾	700	630	75	12818	1415	ACS880-04XT-0810A-7	2xR10
1051	1000	1000	929	1000	900	75	19724	1415	ACS880-04XT-1080A-7	2xR11
1297	1250	1200	1051 ³⁾	1000	1000	74	21156	1670	ACS880-04XT-1320A-7	2xR11

Dimensions

Frame size	Height (H)		Width (W)		Depth (D)		Weight	
	(in)	(mm)	(in)	(mm)	(in)	(mm)	(lbs)	(kg)
R10	60.7	1541 ¹⁾	13.8	350 ¹⁾	19.9	506	355	161
R11	68.5	1741 ¹⁾	13.8	350 ¹⁾	19.9	506	439	199

¹⁾ = 40 % overload

²⁾ = 45 % overload

³⁾ = 44 % overload

Light-duty use

I_{Ld} Continuous current allowing 10% I_{Ld} for 1 min/5 min at 40 °C.

P_{Ld} Typical motor power in light-overload use.

Heavy-duty use

I_{Hd} Continuous current allowing 50% I_{Hd} for 1 min/5 min at 40 °C.

P_{Hd} Typical motor power in heavy-duty use.

The ratings apply at 40 °C ambient temperature. At higher temperatures (up to 50 °C²⁾ or up to 55 °C³⁾) the derating is 1%/1 °C.

¹⁾ Without pedestal (+0H354) and without IP20 shrouds and full-size terminals (+0B051+0H371) height is 179 mm less and width 45 mm less. More information from HW manual.

²⁾ ACS880-04 high power single drive package.

³⁾ ACS880-04 single drive module.

Ratings, types and voltages

ACS880-04 nxR8i

$U_N = 500$ V (range 380 to 500 V). The power ratings are valid at nominal voltage 500 V (560 to 1400 kW).

Light-duty use			Heavy-duty use			Noise level	Heat dissipation	Air flow	Type designation	Frame size
I_{Ld} A	P_{Ld} hp	P_{Ld} kW	I_{Hd} A	P_{Hd} hp	P_{Hd} kW	dB(A)	W	cfm		

6-pulse

1027	950	710	800	700	560	73	18000	2525	ACS880-04-1070A-5	D8T+2xR8i
1267	1100	900	987	850	710	74	22000	3370	ACS880-04-1320A-5	2xD8T+2xR8i
1392	1200	900	1085	900	710	74	27000	3370	ACS880-04-1450A-5	2xD8T+2xR8i
1517	1350	1000	1182	1000	800	74	32000	3370	ACS880-04-1580A-5	2xD8T+2xR8i
1728	1500	1200	1346	1200	900	75	36000	4210	ACS880-04-1800A-5	2xD8T+3xR8i
1901	1700	1300	1481	1350	1000	75	44500	4210	ACS880-04-1980A-5	2xD8T+3xR8i

12-pulse

950	800	630	741	600	500	73	16000	3370	ACS880-04-0990A-5+A004	2xD7T+2xR8i
1267	1100	900	987	850	710	74	22000	3370	ACS880-04-1320A-5+A004	2xD8T+2xR8i
1392	1200	900	1085	900	710	74	25000	3370	ACS880-04-1450A-5+A004	2xD8T+2xR8i
1517	1300	1000	1182	1000	800	74	27000	3370	ACS880-04-1580A-5+A004	2xD8T+2xR8i
1728	1500	1200	1346	1200	900	75	32000	4210	ACS880-04-1800A-5+A004	2xD8T+3xR8i
1901	1700	1300	1481	1300	1000	75	36000	4210	ACS880-04-1980A-5+A004	2xD8T+3xR8i

$U_N = 690$ V (range 525 to 690 V). The power ratings are valid at nominal voltage 690 V (560 to 2200 kW).

Light-duty use			Heavy-duty use			Noise level	Heat dissipation	Air flow	Type designation	Frame size
I_{Ld} A	P_{Ld} hp	P_{Ld} kW	I_{Hd} A	P_{Hd} hp	P_{Hd} kW	dB(A)	W	cfm		

6-pulse

768	850	710	598	650	560	73	16000	2525	ACS880-04-0800A-7	D8T+2xR8i
864	1000	800	673	775	630	74	20000	2525	ACS880-04-0900A-7	D8T+2xR8i
1114	1200	1100	868	950	800	74	26000	3370	ACS880-04-1160A-7	2xD8T+2xR8i
1392	1500	1250	1085	1200	1000	75	32000	4210	ACS880-04-1450A-7	2xD8T+3xR8i
1584	1750	1500	1234	1350	1200	75	36500	4210	ACS880-04-1650A-7	2xD8T+3xR8i
2208	2450	2000	1720	1900	1600	76	52000		ACS880-04-2300A-7	3xD8T+4xR8i

12-pulse

768	850	710	598	650	560	73	16000	3370	ACS880-04-0800A-7+A004	2xD7T+2xR8i
912	1000	800	711	775	630	74	20000	3370	ACS880-04-0950A-7+A004	2xD8T+2xR8i
1114	1200	1100	868	950	800	74	26000	3370	ACS880-04-1160A-7+A004	2xD8T+2xR8i
1392	1500	1250	1085	1200	1000	75	32000	4210	ACS880-04-1450A-7+A004	2xD8T+3xR8i
1584	1750	1500	1234	1350	1200	75	36500	4210	ACS880-04-1650A-7+A004	2xD8T+3xR8i
2208	2450	2000	1720	1900	1600	77	52000	6735	ACS880-04-2300A-7+A004	4xD8T+4xR8i

Dimensions

Frame size	Height (H)		Width (W)		Depth (D)		Weight	
	(in)	(mm)	(in)	(mm)	(in)	(mm)	(lbs)	(kg)
R8i	55.0	1397	9.5	240	23.0	583	276	125
D7T	46.4	1178	6.7	170	16.4	417	176	80
D8T	55.0	1397	9.5	240	23.0	583	375	170

This single drive module package is a compact regenerative drive module solution. The package consists of R8i multidrive modules and a LCL line filter optimized for easy cabinet assembly. The ACS880-14 captures and utilizes energy which results in cost savings for the user.

With regenerative functionality, the braking energy of the motor is returned back to the drive and distributed forward to the supply network. This ensures that braking energy is not wasted as heat. In comparison with other braking methods, such as mechanical and resistor braking, the ACS880-14 brings much more energy savings. The module package is compatible with a broad range of industries including automotive, food and beverage, oil and gas, chemical, mining and metals. The drive is suitable for applications such as centrifuges, test benches conveyors, winches, elevators, pumps and fans.

High performance drives

The drive features direct torque control (DTC) as standard, enabling fast transition between motoring and generating mode in applications such as test benches and elevators. The drives active supply unit is able to boost output voltage, which guarantees full motor voltage even when the supply voltage is below nominal. The ACS880-14 reaches unity power factor.

Clear energy savings

Handling of waste heat may be a problem if the braking power is significant. The ACS880-14 does not need external braking devices, which makes drive installation simple as less need for cabinet space is required.



Simplified installation and connection

Installation of multidrive modules into cabinets is simplified with the use of mechanical and electrical accessories. These accessories are available giving full design to install the modules into Rittal TS8 cabinets. In addition, generic kits offer great help for installation of the modules into any other cabinet types that are available. Alternatively, ABB authorized and registered machine builders, system integrators and panel builders can manufacture their own accessory kits by accessing the online engineering support website which features detailed kit drawings. Cabinet assembly accessories help shorten engineering and assembly time as well as helping to reduce the risk of errors.

Main features

- Compact design for easy cabinet assembly and maintenance
- Optional air inlet and outlet kits available for enclosure classes IP20, IP42 and IP54
- LCL line filter
- Integrated safety including safe torque off (STO) as standard and the optional safety functions module (TÜV Nord certificate)
- Supports various motor types including synchronous reluctance motors
- Drive composer PC tool for commissioning and configuration
- Intuitive and easy to operate control panel with USB connection
- Device panel for optional switches and pilot lights
- Primary control program – common software used throughout the ACS880 drive series
- Control unit supporting a wide range of fieldbuses, feedback devices and input/output options
- Removable memory unit for easy maintenance
- Coated boards as standard
- Extensive, programmable digital and analog inputs and outputs
- Long lifetime capacitors
- Cooling fans with speed control or on-off control
- du/dt and common mode filter options for motor protection

Ratings, types and voltages

ACS880-14

$U_N = 500\text{ V}$ (range 380 to 500 V). The power ratings are valid at nominal voltage 500 V (200 to 1600 kW).

Light-duty use			Heavy-duty use			Noise level dB(A)	Heat dissipation W	Air flow		Type designation	Frame size
I_{Ld} A	P_{Ld} hp	P_{Ld} kW	I_{Hd} A	P_{Hd} hp	P_{Hd} kW			cfm	m ³ /hr		
403	300	250	314	250	200	75	13000	2213	3760	ACS880-14-0420A-5	R8i + BLCL-13-5 + R8i
547	475	355	426	300	250	75	17000	2213	3760	ACS880-14-0570A-5	R8i + BLCL-13-5 + R8i
749	650	500	583	500	400	75	25000	2213	3760	ACS880-14-0780A-5	R8i + BLCL-15-5 + R8i
1066	950	710	830	750	560	77	32000	4249	7220	ACS880-14-1110A-5	2xR8i + BLCL-24-5 + 2xR8i
1469	1300	1000	1144	1050	800	77	46000	4249	7220	ACS880-14-1530A-5	2xR8i + BLCL-25-5 + 2xR8i
1901	1750	1300	1481	1250	1000	78	59000	6815	11580	ACS880-14-1980A-5	3xR8i + BLCL-24-5 + 3xR8i
2179	2000	1500	1698	1600	1200	78	69000	6815	11580	ACS880-14-2270A-5	3xR8i + BLCL-24-5 + 3xR8i

$U_N = 690\text{ V}$ (range 525 to 690 V). The power ratings are valid at nominal voltage 690 V (200 to 2200 kW)

Light-duty use			Heavy-duty use			Noise level dB(A)	Heat dissipation W	Air flow		Type designation	Frame size
I_{Ld} A	P_{Ld} hp	P_{Ld} kW	I_{Hd} A	P_{Hd} hp	P_{Hd} kW			cfm	m ³ /hr		
307	300	250	239	250	200	75	16000	2213	3760	ACS880-14-0320A-7	R8i + BLCL-13-7 + R8i
374	475	355	292	300	250	75	19000	2213	3760	ACS880-14-0390A-7	R8i + BLCL-13-7 + R8i
557	650	500	434	500	400	75	26000	2213	3760	ACS880-14-0580A-7	R8i + BLCL-15-7 + R8i
739	950	710	576	750	560	77	34000	4249	7220	ACS880-14-0770A-7	2xR8i + BLCL-24-7 + 2xR8i
912	1050	800	711	950	710	77	40000	4249	7220	ACS880-14-0950A-7	2xR8i + BLCL-25-7 + 2xR8i
1085	1300	1000	845	1050	800	77	48000	4249	7220	ACS880-14-1130A-7	3xR8i + BLCL-25-7 + 3xR8i
1392	1700	1300	1085	1300	1000	78	63000	6815	11580	ACS880-14-1450A-7	4xR8i + BLCL-24-7 + 4xR8i
1613	2000	1500	1257	1550	1200	78	74000	6815	11580	ACS880-14-1680A-7	3xR8i + 2xBLCL-24-7 + 3xR8i
2141	2700	2000	1668	2100	1600	79	95000	8500	14440	ACS880-14-2230A-7	4xR8i + 2xBLCL-25-7 + 4xR8i

Dimensions

Frame size	Height (H)		Width (W)		Depth (D)		Weight	
	(in)	(mm)	(in)	(mm)	(in)	(mm)	(lbs)	(kg)
R8i	55.0	1397	9.5	240	23.0	585	275	125.0
BLCL-13-5	53.4	1355	9.5	240	19.9	505	398	180.7
BLCL-15-5	53.4	1355	9.5	240	19.9	505	492	223.5
BLCL-24-5	55.0	1397	9.5	240	22.9	581	704	320.0
BLCL-25-5	55.0	1397	9.5	240	22.9	581	713	324.0
BLCL-13-7	53.4	1355	9.5	240	19.9	505	391	177.7
BLCL-15-7	53.4	1355	9.5	240	19.9	505	479	217.5
BLCL-25-7	55.0	1397	9.5	240	22.9	581	682	310.0
BLCL-24-7	55.0	1397	9.5	240	22.9	581	662	301.0

Ultra-low harmonic single drives module package, ACS880-34

This single drive module package creates less harmonics compared to drives that offer standard diode supply solutions. The package consists of R8i multidrive modules and a LCL line filter optimized for easy cabinet assembly. The ACS880-34 produces exceptionally low harmonic content in the drives input. This is achieved without external filters or multi-pulse transformers. By managing and controlling harmonics, the drive reaches unity power factor. The active supply unit in the drive is able to boost output voltage, which guarantees full motor voltage even when the supply voltage is below nominal.

The ACS880-34 is compatible with a broad range of industries including oil and gas, chemical, mining, water and wastewater, cement and metals. The drive is suitable for applications such as pumps and fans, extruders, conveyors and compressors.

Improved harmonic performance

When compared to multi-pulse transformer solutions, the ACS800-34 does not require a dedicated transformer. For this reason, the cabinet-built low harmonic drive is simpler in terms of cabling arrangements and requires less floor space. Harmonic performance is also better when compared with 12- and 18-pulse solutions, handling online imbalance or other shortcomings in the supply network. Passive or active external filtering devices are avoided with the ACS800-34, making the solution compact and simple.

Simplified installation and connection

Installation of multidrive modules into cabinets is simplified with the use of mechanical and electrical accessories. These accessories are available giving full design to install the modules into Rittal TS8 cabinets. In addition, generic kits offer great help for installing the modules into any other cabinet types that are

available. Alternatively, ABB authorized and registered machine builders, system integrators and panel builders can manufacture their own accessory kits by accessing the online engineering support website which features detailed kit drawings. Cabinet assembly accessories help shorten engineering and assembly time as well as helping to reduce the risk of errors.

Main features

- Compact design for easy cabinet assembly and maintenance
- Optional air inlet and outlet kits available for enclosure classes IP20, IP42 and IP54
- LCL line filter
- Optional main switch and fuses
- Integrated safety including safe torque off (STO) as standard and the optional safety functions module (TÜV Nord certificate)
- Supports various motor types including synchronous reluctance motors
- Drive composer PC tool for commissioning and configuration
- Intuitive and easy to operate control panel with USB connection
- Device panel for optional switches and pilot lights
- Primary control program – common software used throughout the ACS880 drive series
- Control unit supporting a wide range of fieldbuses, feedback devices and input/output options
- Removable memory unit for easy maintenance
- Coated boards as standard
- Extensive, programmable digital and analog inputs and outputs
- Long lifetime capacitors
- Cooling fans with speed control or on-off control
- du/dt and common mode filter options for motor protection



Ratings, types and voltages

ACS880-34

$U_N = 500$ V (range 380 to 500 V). The power ratings are valid at nominal voltage 500 V (200 to 1600 kW).

Light-duty use			Heavy-duty use			Noise level dB(A)	Heat dissipation W	Air flow		Type designation	Frame size
I_{Ld} A	P_{Ld} hp	P_{Ld} kW	I_{Hd} A	P_{Hd} hp	P_{Hd} kW			cfm	m ³ /hr		
403	300	250	314	250	200	75	13000	2213	3760	ACS880-34-0420A-5	R8i + BLCL-13-5 + R8i
547	475	355	426	300	250	75	17000	2213	3760	ACS880-34-0570A-5	R8i + BLCL-13-5 + R8i
749	650	500	583	500	400	75	25000	2213	3760	ACS880-34-0780A-5	R8i + BLCL-15-5 + R8i
1066	950	710	830	750	560	77	32000	4249	7220	ACS880-34-1110A-5	2xR8i + BLCL-24-5 + 2xR8i
1469	1300	1000	1144	1050	800	77	46000	4249	7220	ACS880-34-1530A-5	2xR8i + BLCL-25-5 + 2xR8i
1901	1750	1300	1481	1250	1000	78	59000	6815	11580	ACS880-34-1980A-5	3xR8i + 2xBLCL-24-5 + 3xR8i
2179	2000	1500	1698	1600	1200	78	69000	6815	11580	ACS880-34-2270A-5	3xR8i + BLCL-24-5 + 3xR8i

$U_N = 690$ V (range 525 to 690 V). The power ratings are valid at nominal voltage 690 V (200 to 2200 kW).

Light-duty use			Heavy-duty use			Noise level dB(A)	Heat dissipation W	Air flow		Type designation	Frame size
I_{Ld} A	P_{Ld} hp	P_{Ld} kW	I_{Hd} A	P_{Hd} hp	P_{Hd} kW			cfm	m ³ /hr		
307	300	250	239	250	200	75	16000	2213	3760	ACS880-34-0320A-7	R8i + BLCL-13-7 + R8i
374	475	355	292	300	250	75	19000	2213	3760	ACS880-34-0390A-7	R8i + BLCL-13-7 + R8i
557	650	500	434	500	400	75	26000	2213	3760	ACS880-34-0580A-7	R8i + BLCL-15-7 + R8i
739	950	710	576	750	560	77	34000	4249	7220	ACS880-34-0770A-7	2xR8i + BLCL-24-7 + 2xR8i
912	1050	800	711	950	710	77	40000	4249	7220	ACS880-34-1130A-7	2xR8i + BLCL-25-7 + 2xR8i
1085	1300	1000	845	1050	800	77	48000	4249	7220	ACS880-34-1680A-7	2xR8i + BLCL-25-7 + 2xR8i
1392	1700	1300	1085	1300	1000	78	63000	6815	11580	ACS880-34-2230A-7	3xR8i + BLCL-24-7 + 3xR8i
1613	2000	1500	1257	1550	1200	78	74000	6815	11580	ACS880-34-1680A-7	3xR8i + BLCL-24-7 + 3xR8i
2141	2700	2000	1668	2100	1600	79	95000	8500	14440	ACS880-34-2230A-7	4xR8i + BLCL-25-7 + 4xR8i

Dimensions

Frame size	Height (H)		Width (W)		Depth (D)		Weight	
	(in)	(mm)	(in)	(mm)	(in)	(mm)	(lbs)	(kg)
R8i	55.0	1397	9.5	240	23.0	585	275	125.0
BLCL-13-5	53.4	1355	9.5	240	19.9	505	398	180.7
BLCL-15-5	53.4	1355	9.5	240	19.9	505	492	223.5
BLCL-24-5	55.0	1397	9.5	240	22.9	581	704	320.0
BLCL-25-5	55.0	1397	9.5	240	22.9	581	713	324.0
BLCL-13-7	53.4	1355	9.5	240	19.9	505	391	177.7
BLCL-15-7	53.4	1355	9.5	240	19.9	505	479	217.5
BLCL-25-7	55.0	1397	9.5	240	22.9	581	682	310.0
BLCL-24-7	55.0	1397	9.5	240	22.9	581	662	301.0

Our ACS880 multidrive modules are designed to be built into a customers' own cabinets by machine builders and system integrators. The power of the inverter modules is available up to 3200 kW. The diode supply unit (DSU) is available up to 5445 kVA. The IGBT supply unit (ISU) is available up to 3679 kVA. The regenerative rectifier unit (RRU) is available up to 4135 kVA. All supply units offer supply voltages from 380 to 690 V. Multidrive modules are used for building multidrive configurations. The modules are used in industries such as metals, oil and gas, mining, marine, offshore, material handling machines, pulp and paper, automotive, food and beverage, cement, power, water and wastewater. They control a wide range of applications such as cranes, profile and flat rolling, conveyors, winches, test benches, processing lines, paper machines, pumps and fans. The multidrive modules are built using ABB's common drives architecture and are available in several frame sizes.

Rectifiers, inverters, brake options, filters, inputs and outputs options, communication option, documentation and everything else required for a complete drive is available. The drive can control motors in either open loop or closed loop through its high precision motor control platform, direct torque control (DTC). Built-in safety features reduce the need for external safety components.

Main features

- Compact design for easy cabinet assembly and maintenance
- Diode bridge that is highly reliable with high power density
- IGBT supply modules for regenerative drive systems with low harmonic distortion
- Regenerative rectifier unit (RRU) enables higher powers of the same power module
- Integrated safety including safe torque off (STO) as standard with several safety functions as options
- Drive composer PC tool for commissioning and configuration
- Intuitive control panel with USB connection
- Primary control program - common software used throughout the ACS880 drive series
- Control unit ZCU for inverter modules (frame sizes R1i to R7i and diode supply modules DxX and IGBT supply modules R1i to R6i) comes with three option slots for extension option modules

- IGBT supply modules (frame size n×R8i), inverter modules (n×R8i), diode supply modules (n×DxT) and Regenerative rectifier unit (n×R8i) uses the BCU control unit that comes with integrated branching unit, power stage link data logger with detachable memory card, embedded Ethernet and three option slots with an additional slot for DDCS communication option
- Supports various motor types including synchronous reluctance motors
- Removable memory unit for easy maintenance
- Coated boards as standard
- Braking options
- Cabinet accessory kits
- Optional installation frames for mounting multidrive modules
- Detailed documentation for cabinet assembly

Simplified installation and connection

Installation of multidrive modules into cabinets is simplified with the use of mechanical and electrical accessories. These accessories are available giving full design to install the modules into Rittal TS8 cabinets. In addition, generic kits offer great help to install the modules into any other cabinet types that are available. Alternatively, ABB authorized and registered machine builders, system integrators and panel builders can manufacture their own accessory kits by accessing the online engineering support website which features detailed kit drawings. Cabinet assembly accessories help shorten engineering and assembly time as well as reduce the risk of errors.

Using our cabinet assembly accessories and part drawings enables easy and efficient installation, making sourcing the mechanical components more flexible. Other benefits that reduce time required for mechanical engineering include dimensional and assembly drawings with accessories drawings available as 3D models, EPLAN electric P8 macros, module circuit diagrams and installation example videos and animations for cabinets. Training material for cabinet assembly of drives is also available.



Multidrive modules, ACS880-X04

The modules have a side-by-side mounting on the assembly plate situated in the cabinet, making module installation faster and easier. Modules with bigger frame sizes are equipped with wheels so they can easily be moved in or out of the cabinet for maintenance purposes. This concept also allows pre-installation of the power cables inside the empty cabinet. Besides the compact design, the new ACS880 inverter and rectifier units include an extensive selection of options.

The multidrive construction simplifies the total installation and provides many advantages such as:

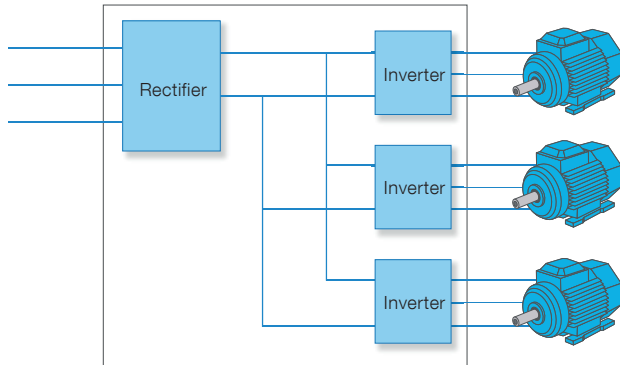

- Savings in cabling, installation and maintenance costs
- Space savings
- Reduced component count and increased reliability
- Reduced line currents and simpler braking arrangements
- Energy circulation over the common DC busbar, which can be used for motor-to-motor braking without the need for a braking chopper or regenerative supply unit
- Optimized and simple cabinet

Inverter units (INU)

Inverter units come in 8 different frame sizes. Frame sizes R1i to n×R8i start from 1.5 to 3200 kW. The voltage ranges from 380 to 690 V. Inverter units have built-in capacitors for smoothing the voltage of the DC busbars. The electrical connection to the common DC busbar is fuse protected. An optional switch can be selected to disconnect the whole drive unit from the DC bus. Each inverter unit comes with safe torque off (STO) as standard and has a control unit (ZCU/BCU) which has slots to place different option adapters, such as input/output extension modules, speed feedback modules and fieldbus adapter modules.

Diode supply units (DSU)

A diode supply unit is used in non-regenerative drive systems to convert three-phase AC voltage to DC voltage. Multidrives have two different diode supply unit types. One of these is a diode supply unit (D6D to D8D) for power range 60 to 850 kVA that has no charging circuit. The charging is built into the drive units (R1i to R7i). This diode supply unit is controlled by the ZCU control unit.

The other one is a diode supply unit (D7T and D8T) for power range 340 to 5445 kVA, built with 1 to 6 parallel units. This half controlled diode supply unit has thyristor charging, BCU control unit and 6-pulse and 12-pulse versions available.



Frame sizes R1i to R8i

Frame sizes D6D to D8D and D8T

IGBT supply units (ISU)

IGBT supply units are used in regenerative drives to convert three-phase AC voltage to DC voltage. These units are available from R1i to R4i, R6i and n×R8i frame size with LCL line filter in a power range from 5.5 to 6131 kVA. With regard to power control, it gives the same firm but gentle performance as direct torque control (DTC) gives in motor control. The IGBT module is hardware compatible with drive modules and it can operate in both motoring and generating modes.

The DC voltage is constant and the line current is sinusoidal. The control also provides a near unity power factor. The module can also boost DC voltages eg, when line voltage is low. Harmonic content remains extremely low due to DTC control and LCL line filtering.

Regenerative rectifier unit (RRU)

This supply unit is used in regenerative drive systems to convert three-phase AC voltage to DC voltage. The RRU is made of n×R8i inverter units and L filters. The IGBTs' are switched conducting only once during each network voltage cycle. This reduces switching losses and enables higher powers of the same power module. Operation of RRU is also reliable during supply network voltage variations.

Brake unit

Brake unit handles the energy generated by decelerating motors such as emergency stopping. During resistor braking, whenever the voltage in the intermediate circuit of a drive exceeds a certain limit, a braking chopper connects the circuit to a braking resistor.

Offering includes 1-phase brake unit and 3-phase dynamic brake unit (DBU) which utilizes R8i modules.

DC-DC converter (DDC)

DC-DC converter transfers energy from a common DC link of an multidrives into an external energy storage. From there it discharges energy back to the DC link. Energy storages can be batteries or super capacitors. Typical applications can be in marine (heave and peak load compensation) and automotive (battery simulators in test benches and electric car charging systems) industries.

Ratings, types and voltages Inverter modules

Inverter modules (INU), ACS880-104

$U_N = 500 \text{ V}$ (range 380 to 500 V). The power ratings are valid at nominal voltage 500 V (2 to 3750 hp) (1.5 to 2800 kw).

Light-duty use			Heavy-duty use			Noise level	Heat dissipation	Air flow	Type designation	Frame size
I_{Ld} A	P_{Ld} hp	P_{Ld} kW	I_{Hd} A	P_{Hd} hp	P_{Hd} kW	dB(A)	W	cfm		
3.4	1.5	1.5	3	1.5	1.5	47	60	14	ACS880-104-003A6-5	R1i
4.5	2	2.2	4	2	2.2	47	70	14	ACS880-104-004A8-5	R1i
5.5	3	3	5	3	2.2	47	80	14	ACS880-104-006A0-5	R1i
7.6	5	4	6	3	3	47	90	14	ACS880-104-008A0-5	R1i
9.7	5	5.5	9	5	4	39	130	28	ACS880-104-0011A-5	R2i
13	7.5	7.5	11	7.5	5.5	39	150	28	ACS880-104-0014A-5	R2i
16.8	10	7.5	14	10	7.5	39	180	28	ACS880-104-0018A-5	R2i
23	15	11	19	10	11	63	230	84	ACS880-104-0025A-5	R3i
28	20	15	24	15	15	63	280	84	ACS880-104-0030A-5	R3i
32	20	18.5	29	20	18.5	63	320	84	ACS880-104-0035A-5	R3i
46	30	30	44	30	30	71	480	118	ACS880-104-0050A-5	R3i
57	40	37	52	40	30	70	550	171	ACS880-104-0061A-5	R4i
74	50	45	69	50	45	70	650	171	ACS880-104-0078A-5	R4i
90	60	55	75	50	45	70	800	171	ACS880-104-0094A-5	R4i
108	75	75	85	60	55	71	1000	318	ACS880-104-0110A-5	R6i
131	100	90	102	75	55	71	1200	318	ACS880-104-0140A-5	R6i
158	125	110	123	100	75	71	1500	318	ACS880-104-0170A-5	R6i
189	150	132	147	125	90	71	1800	318	ACS880-104-0200A-5	R6i
230	200	160	180	150	110	71	2200	318	ACS880-104-0240A-5	R6i
290	250	200	226	200	132	72	2700	600	ACS880-104-0300A-5	R7i
326	250	250	254	200	160	72	3200	600	ACS880-104-0340A-5	R7i
422	300	250	329	250	200	72	4700	1300	ACS880-104-0440A-5	1xR8i
566	475	355	441	300	250	72	6300	1300	ACS880-104-0590A-5	1xR8i
710	600	450	554	475	355	72	8100	1300	ACS880-104-0740A-5	1xR8i
778	650	500	606	500	400	72	9300	1300	ACS880-104-0810A-5	1xR8i
1104	950	710	860	750	560	74	12000	2600	ACS880-104-1150A-5	2xR8i
1392	1200	900	1085	950	710	74	16000	2600	ACS880-104-1450A-5	2xR8i
1517	1300	1000	1182	1050	800	74	18000	2600	ACS880-104-1580A-5	2xR8i
2064	1850	1400	1608	1450	1100	76	24000	3900	ACS880-104-2150A-5	3xR8i
2256	2000	1500	1758	1600	1200	76	27000	3900	ACS880-104-2350A-5	3xR8i
2986	2650	2000	2326	2100	1600	76	36000	5200	ACS880-104-3110A-5	4xR8i
3706	3200	2400	2887	2650	2000	77	44000	6500	ACS880-104-3860A-5	5xR8i
4426	3750	2800	3448	3200	2400	78	53000	7800	ACS880-104-4610A-5	6xR8i

NOTE: Hp ratings are based on 2 or 4 pole motors and NEMA MG-1 Table 12-11 motor full load efficiencies of EPA Act Efficient Electric Motors

Dimensions

Frame size	Height (H)		Width (W)		Depth (D)		Weight	
	(in)	(mm)	(in)	(mm)	(in)	(mm)	(lbs)	(kg)
R1i	14.3	364	3.5	90	9.2	234	9	4
R2i	15.0	380	3.9	100	12.3	312	13	6
R3i	18.4	467	6.6	168	12.3	313	24	11
R4i	18.4	467	8.8	223	15.0	382	40	18
R6i	35.0	890	6.7	170	18.0	456	86	39
R7i	35.0	890	6.7	170	18.0	456	84	38
R8i	55.0	1397	9.4	240	23.0	583	275	125

With module covers and without strain relief clamps (R1i to R4i)

Light-overload use

I_{Ld} Continuous current allowing 10% I_{Ld} for 1 min/5 min at 40 °C.

P_{Ld} Power in light-overload use.

Heavy-duty use

I_{Hd} Continuous current allowing 50% I_{Hd} for 1 min/5 min at 40 °C.

P_{Hd} Power in heavy-duty use.

The ratings apply at 40 °C ambient temperature. At higher temperatures (up to 50 °C) the derating is 1%/1 °C.

- ¹⁾ +A003 Uncontrolled diode bridge
+A018 Half-controlled diode bridge
+A004 12-pulse DSU

Ratings, types and voltages Supply units

IGBT supply modules (ISU), ACS880-204

$U_N = 500$ V (range 380 to 500 V). The power ratings are valid at nominal voltage 500 V.

Nominal ratings		No-over-load use	Light-duty use		Heavy-duty use		Noise level	Heat dissipation	Air flow	Type designation	Frame size
I_N A (AC)	I_N A (DC)	P_N kW (DC)	I_{Ld} A (DC)	P_{Ld} kW (DC)	I_{Hd} A (DC)	P_{Hd} kW (DC)	dB(A)	W	cfm		
6.6	8	6	7.7	5.4	6	4.2	47	220	24	ACS880-204-006A6-5	R1i+WFU-01
15	18	13	17	12.3	14	9.6	39	500	48	ACS880-204-0015A-5	R2i+WFU-02
29	35	25	34	23.9	26	18.6	63	970	63	ACS880-204-0029A-5	R3i+WFU-11
41	50	35	48	33.7	37	26.3	71	1390	200	ACS880-204-0041A-5	R3i+WFU-21
77	93	66	90	63.4	70	49.4	70	2580	290	ACS880-204-0077A-5	R4i+WFU-22
210	255	180	244	173	190	135	72	4200	1150	ACS880-204-0210A-5	R6i+ALCL-05-5
396	480	340	461	326	359	254	72	9200	1300	ACS880-204-0400A-5	R8i+BLCL-13-5
531	644	455	618	437	482	341	72	11500	1300	ACS880-204-0530A-5	R8i+BLCL-13-5
729	884	625	849	600	661	468	72	16700	1300	ACS880-204-0730A-5	R8i+BLCL-15-5
1035	1255	887	1205	852	939	664	74	20800	2600	ACS880-204-1040A-5	2xR8i+BLCL-24-5
1422	1724	1219	1655	1170	1290	912	74	29400	2600	ACS880-204-1420A-5	2xR8i+BLCL-25-5
2115	2564	1813	2462	1741	1918	1356	76	43900	3900	ACS880-204-2120A-5	3xR8i+2xBLCL-24-5
2799	3394	2400	3258	2304	2539	1795	76	58500	5200	ACS880-204-2800A-5	4xR8i+2xBLCL-25-5
4149	5031	3557	4829	3415	3763	2661	78	87600	7800	ACS880-204-4150A-5	6xR8i+3xBLCL-25-5

Regenerative rectifier units (RRU), ACS880-904

$U_N = 500$ V (range 230 to 525 V). The power ratings are valid at nominal voltage 500 V (520 to 2996 kVA).

600	735	496	705	476	550	371	72	8550	1295	ACS880-904-0600A-5	1xR8i + BL-15-5
900	1102	744	1058	714	824	556	72	13000	1295	ACS880-904-0900A-5	1xR8i + BL-15-5
1180	1445	976	1387	936	1081	730	74	16100	2415	ACS880-904-1180A-5	2xR8i + BL-25-5
1770	2168	1463	2081	1405	1622	1095	74	25600	2415	ACS880-904-1770A-5	2xR8i + BL-25-5
2310	2829	1910	2716	1833	2116	1428	76	32200	4825	ACS880-904-2310A-5	4xR8i + 2xBL-25-5
3460	4238	2860	4068	2746	3170	2140	76	51100	4825	ACS880-904-3460A-5	4xR8i + 2xBL-25-5

Diode supply modules (DSU), ACS880-304

$U_N = 500$ V (range 380 to 500 V). The power ratings are valid at nominal voltage 500 V.

Nominal ratings		No-over-load use	Light-duty use		Heavy-duty use		Noise level	Heat dissipation	Air flow	Type designation ¹⁾	Frame size
I_N A (AC)	I_N A (DC)	P_N kW (DC)	I_{Ld} A (DC)	P_{Ld} kW (DC)	I_{Hd} A (DC)	P_{Hd} kW (DC)	dB(A)	kW	cfm		
6-pulse diode											
80	98	66	94	63	78	53	62	800	218	ACS880-304-0080A-5+A003	D6D
173	212	143	203	137	170	114	62	1300	218	ACS880-304-0170A-5+A003	D6D
327	400	270	384	260	320	216	62	2000	424	ACS880-304-0330A-5+A003	D7D
490	600	405	576	389	480	324	62	3000	424	ACS880-304-0490A-5+A003	D7D
653	800	540	768	518	640	432	65	3500	530	ACS880-304-0650A-5+A003	D8D
980	1200	810	1152	778	960	648	65	6000	530	ACS880-304-0980A-5+A003	D8D
653	800	540	768	518	598	404	72	5000	1300	ACS880-304-0650A-5+A018	D8T
980	1200	810	1152	778	898	606	72	7000	1300	ACS880-304-0980A-5+A018	D8T
1215	1488	1004	1428	964	1113	751	74	9000	2600	ACS880-304-1210A-5+A018	2xD8T
1822	2232	1507	2143	1446	1670	1127	74	13000	2600	ACS880-304-1820A-5+A018	2xD8T
2734	3348	2260	3214	2170	2504	1690	76	20000	3900	ACS880-304-2730A-5+A018	3xD8T
3645	4464	3013	4285	2893	3339	2254	76	27000	5200	ACS880-304-3640A-5+A018	4xD8T
4556	5580	3767	5357	3616	4174	2817	77	33000	6500	ACS880-304-4560A-5+A018	5xD8T
5467	6696	4520	6428	4339	5009	3381	78	40000	7800	ACS880-304-5470A-5+A018	6xD8T
12-pulse diode											
911	1116	753	1071	723	835	563	74	8000	1800	ACS880-304-0910A-5+A004+A018	2xD7T
1215	1488	1004	1428	964	1113	751	74	9000	2600	ACS880-304-1210A-5+A004+A018	2xD8T
1822	2232	1507	2143	1446	1670	1127	74	13000	2600	ACS880-304-1820A-5+A004+A018	2xD8T
2430	2976	2009	2857	1928	2226	1503	76	18000	5200	ACS880-304-2430A-5+A004+A018	4xD8T
3645	4464	3013	4285	2893	3339	2254	76	27000	5200	ACS880-304-3640A-5+A004+A018	4xD8T
5467	6696	4520	6428	4339	5009	3381	78	40000	7800	ACS880-304-5470A-5+A004+A018	6xD8T

Ratings, types and voltages

Supply units

Dimensions

Frame size	Height (H)		Width (W)		Depth (D)		Weight	
	(in)	(mm)	(in)	(mm)	(in)	(mm)	(lbs)	(kg)
IGBT Supply Module (ISU)								
R1i	14.3	364	3.5	90	9.2	234	9	4
R2i	15.0	380	4.0	100	12.3	312	13	6
R3i	18.4	467	6.5	165	12.3	313	24	11
R4i	18.4	467	6.5	165	12.3	313	40	18
R6i	18.4	467	8.7	220	18.0	456	84	38
R8i	55.0	1397	9.5	240	23.0	583	275	125
LCL-line filter for IGBT supply Modules (ISU)								
WFU-01	12.4	315	8.4	213	8.6	218	24	11
WFU-02	12.4	315	8.4	213	8.6	218	24	11
WFU-11	15.2	386	11.3	288	10.1	256	75	34
WFU-21	16.0	406	12.5	318	11.8	299	99	45
WFU-22	16.0	406	12.5	318	11.8	299	112	51
ALCL-05-5	33.3	845	14.9	378	12.0	305	220	100
BLCL-13-5	53.3	1355	9.5	240	19.9	505	398	181
BLCL-15-5	53.3	1355	9.5	240	19.9	505	493	224
BLCL-24-5	55.0	1397	9.5	240	22.9	581	704	320
BLCL-25-5	55.0	1397	9.5	240	22.9	581	713	324

Frame size	Height (H)		Width (W)		Depth (D)		Weight	
	(in)	(mm)	(in)	(mm)	(in)	(mm)	(lbs)	(kg)
Regenerative Rectifier unit (RRU)								
R8i	55.0	1397	9.4	240	23.0	585	275	125
BL-15-5	53.3	1355	9.4	240	19.9	505	341	155
BL-25-5	55.0	1397	9.4	240	22.9	581	473	215
Diode Supply Modules (DSU)								
D6D	32.1	815	6.7	170	16.3	415	81	37
D7D	41.5	1054	6.7	170	16.4	417	161	73
D8D	55.0	1397	9.4	240	23.2	589	381	173
D7T	41.5	1054	6.7	170	16.4	417	176	80
D8T	55.0	1397	9.4	240	23.2	589	396	180

Ratings, types and voltages Inverter modules

$U_N = 690$ V (range 525 to 690 V). The power ratings are valid at nominal voltage 690 V (4 to 3200 kW).

Light-duty use			Heavy-duty use			Noise level	Heat dissipation	Air flow	Type designation	Frame size
I_{Ld} A	P_{Ld} hp	P_{Ld} kW	I_{Hd} A	P_{Hd} hp	P_{Hd} kW	dB(A)	W	cfm		
6.9	5	5.5	5.6	5	4	62	220	280	ACS880-104-007A3-7	R5i
9.3	7.5	7.5	7.3	7.5	5.5	62	280	280	ACS880-104-009A8-7	R5i
13.5	15	11	9.8	10	7.5	62	400	280	ACS880-104-014A2-7	R5i
17.1	20	15	14.2	10	11	62	490	280	ACS880-104-0018A-7	R5i
20.9	20	18.5	18	15	15	62	580	280	ACS880-104-0022A-7	R5i
25.7	30	22	22	20	18.5	62	660	280	ACS880-104-0027A-7	R5i
33.3	30	30	27	30	22	62	860	280	ACS880-104-0035A-7	R5i
39.9	40	37	35	30	30	62	1000	280	ACS880-104-0042A-7	R5i
49.4	50	45	42	40	37	62	1120	280	ACS880-104-0052A-7	R5i
60	60	55	46	50	45	71	800	650	ACS880-104-0062A-7	R6i
79	75	75	61	60	55	71	1100	650	ACS880-104-0082A-7	R6i
95	100	90	74	75	75	71	1300	650	ACS880-104-0100A-7	R6i
120	125	110	94	75	75	71	1500	650	ACS880-104-0130A-7	R6i
138	150	132	108	100	90	71	1800	650	ACS880-104-0140A-7	R6i
184	200	160	144	150	132	71	2500	650	ACS880-104-0190A-7	R6i
208	250	200	162	200	160	72	2800	940	ACS880-104-0220A-7	R7i
259	250	250	202	250	200	72	3300	940	ACS880-104-0270A-7	R7i
326	250	250	254	250	200	72	5200	1300	ACS880-104-0340A-7	1×R8i
394	475	355	307	250	250	72	6100	1300	ACS880-104-0410A-7	1×R8i
509	600	450	396	475	355	72	7900	1300	ACS880-104-0530A-7	1×R8i
576	750	560	449	500	400	72	9000	1300	ACS880-104-0600A-7	1×R8i
768	950	710	598	750	560	74	12000	2600	ACS880-104-0800A-7	2×R8i
989	1200	900	770	950	710	74	15000	2600	ACS880-104-1030A-7	2×R8i
1123	1300	1000	875	1050	800	74	18000	2600	ACS880-104-1170A-7	2×R8i
1478	1850	1400	1152	1450	1100	76	23000	3900	ACS880-104-1540A-7	3×R8i
1670	2100	1600	1302	1600	1200	76	26000	3900	ACS880-104-1740A-7	3×R8i
2208	2650	2000	1720	2100	1600	76	35000	5200	ACS880-104-2300A-7	4×R8i
2746	3200	2400	2139	2650	2000	77	43000	6500	ACS880-104-2860A-7	5×R8i
3283	4250	3200	2558	3200	2400	78	52000	7800	ACS880-104-3420A-7	6×R8i

Dimensions

Frame size	Height (H)		Width (W)		Depth (D)		Weight	
	(in)	(mm)	(in)	(mm)	(in)	(mm)	(lbs)	(kg)
R5i	23.5	596	8.0	203	9.5	240	31	14
R6i	35.0	890	6.7	170	18.0	456	86	39
R7i	35.0	890	6.7	170	18.0	456	84	38
R8i	55.0	1397	9.4	240	23.0	583	275	125

With module covers (R5i)

Light-duty use

I_{Ld} Continuous current allowing 10% I_{Ld} for 1 min/5 min at 40 °C.

P_{Ld} Power in light-overload use.

Heavy-duty use

I_{Hd} Continuous current allowing 50% I_{Hd} for 1 min/5 min at 40 °C.

P_{Hd} Power in heavy-duty use.

The ratings apply at 40 °C ambient temperature. At higher temperatures (up to 50 °C) the derating is 1%/1 °C.

¹⁾ +A018 Half-controlled diode bridge
+A004 12-pulse DSU

Ratings, types and voltages

Supply units

IGBT supply modules (ISU), ACS880-204

$U_N = 690$ V (range 525 to 690 V). The power ratings are valid at nominal voltage 690 V.

Nominal ratings		No-over-load use	Light-duty use		Heavy-duty use		Noise level	Heat dissipation	Air flow	Type designation	Frame size
I_N A (AC)	I_N A (DC)	P_N kW (DC)	I_{Ld} A (DC)	P_{Ld} kW (DC)	I_{Hd} A (DC)	P_{Hd} kW (DC)	dB(A)	W	cfm		
306	371	362	356	348	278	271	72	11800	1300	ACS880-204-0310A-7	R8i+BLCL-13-7
369	447	437	430	419	335	327	72	13500	1300	ACS880-204-0370A-7	R8i+BLCL-13-7
540	655	639	629	613	490	478	72	17600	1300	ACS880-204-0540A-7	R8i+BLCL-15-7
720	873	852	838	818	653	637	74	23200	2600	ACS880-204-0720A-7	2xR8i+BLCL-24-7
1053	1277	1246	1226	1196	955	932	74	31700	2600	ACS880-204-1050A-7	2xR8i+BLCL-25-7
1566	1899	1853	1823	1779	1420	1386	76	49600	3900	ACS880-204-1570A-7	3xR8i+2xBLCL-24-7
2070	2510	2449	2409	2351	1877	1832	76	63000	5200	ACS880-204-2070A-7	4xR8i+2xBLCL-25-7
3078	3732	3642	3583	3496	2792	2724	78	94400	7800	ACS880-204-3080A-7	6xR8i+3xBLCL-25-7
4104	4976	4856	4777	4661	3722	3632	79	125900	10400	ACS880-204-4100A-7	8xR8i+4xBLCL-25-7
5130	6220	6070	5971	5827	4653	4540	79	156300	13000	ACS880-204-5130A-7	10xR8i+5xBLCL-25-7

Regenerative rectifier units (RRU), ACS880-904

$U_N = 690$ V (range 525 to 690 V). The power ratings are valid at nominal voltage 690 V.

Nominal ratings		No-over-load use	Light-duty use		Heavy-duty use		Noise level	Heat dissipation	Air flow	Type designation	Frame size
I_N A (AC)	I_N A (DC)	P_N kW (DC)	I_{Ld} A (DC)	P_{Ld} kW (DC)	I_{Hd} A (DC)	P_{Hd} kW (DC)	dB(A)	W	cfm		
600	735	685	705	657	550	512	72	9800	1295	ACS880-904-0600A-5	1xR8i + BL-15-5
900	1102	1027	1058	986	824	768	72	14300	1295	ACS880-904-0900A-5	1xR8i + BL-15-5
1180	1445	1346	1387	1292	1081	1007	74	18500	2415	ACS880-904-1180A-5	2xR8i + BL-25-5
1770	2168	2019	2081	1939	1622	1510	74	28100	2415	ACS880-904-1770A-5	2xR8i + BL-25-5
2310	2829	2635	2716	2530	2116	1971	76	37100	4825	ACS880-904-2310A-5	4xR8i + 2xBL-25-5
3460	4238	3947	4068	3789	3170	2953	76	56200	4825	ACS880-904-3460A-5	4xR8i + 2xBL-25-5

Diode supply modules

$U_N = 690$ V (range 525 to 690 V). The power ratings are valid at nominal voltage 690 V.

Nominal ratings		No-over-load use	Light-duty use		Heavy-duty use		Noise level	Heat dissipation	Air flow	Type designation	Frame size
I_N A (AC)	I_N A (DC)	P_N kW (DC)	I_{Ld} A (DC)	P_{Ld} kW (DC)	I_{Hd} A (DC)	P_{Hd} kW (DC)	dB(A)	W	cfm		
6-pulse diode											
572	700	652	672	626	524	488	72	5000	1300	ACS880-304-0570A-7+A018	D8T
816	1000	932	960	894	748	697	72	6000	1300	ACS880-304-0820A-7+A018	D8T
1063	1302	1213	1250	1164	974	907	74	9000	2600	ACS880-304-1060A-7+A018	2xD8T
1519	1860	1733	1786	1663	1391	1296	74	13000	2600	ACS880-304-1520A-7+A018	2xD8T
2278	2790	2599	2678	2495	2087	1944	76	19000	3900	ACS880-304-2280A-7+A018	3xD8T
3037	3720	3465	3571	3327	2783	2592	76	26000	5200	ACS880-304-3040A-7+A018	4xD8T
3797	4650	4331	4464	4158	3478	3240	77	32000	6500	ACS880-304-3800A-7+A018	5xD8T
4556	5580	5198	5357	4990	4174	3888	78	38000	7800	ACS880-304-4560A-7+A018	6xD8T
12-pulse diode											
759	930	866	893	832	696	648	74	8000	1800	ACS880-304-0760A-7+A004+A018	2xD7T
1063	1302	1213	1250	1164	974	907	74	9000	2600	ACS880-304-1060A-7+A004+A018	2xD8T
1519	1860	1733	1786	1663	1391	1296	74	13000	2600	ACS880-304-1520A-7+A004+A018	2xD8T
2126	2604	2426	2500	2329	1948	1814	76	18000	5200	ACS880-304-2130A-7+A004+A018	4xD8T
3037	3720	3465	3571	3327	2783	2592	76	26000	5200	ACS880-304-3040A-7+A004+A018	4xD8T
4556	5580	5198	5357	4990	4174	3888	78	38000	7800	ACS880-304-4560A-7+A004+A018	6xD8T

Dimensions

Frame size	Height (H)		Width (W)		Depth (D)		Weight	
	(in)	(mm)	(in)	(mm)	(in)	(mm)	(lbs)	(kg)

LCL-Line filter for IGBT supply Modules (ISU)

BLCL-13-7	53.4	1355	9.5	240	19.9	505	392	178
BLCL-15-7	53.4	1355	9.5	240	19.9	505	480	218
BLCL-24-7	55.0	1397	9.5	240	22.9	581	662	301
BLCL-25-7	55.0	1397	9.5	240	22.9	581	682	310

Regenerative Rectifier Units (RRU)

R8i	55.00	1397	9.5	240	23.0	585	275	125
BL-15-5	53.35	1355	9.5	240	19.9	505	341	155
BL-25-5	55.00	1397	9.5	240	22.9	581	473	215

Frame size	Height (H)		Width (W)		Depth (D)		Weight	
	(in)	(mm)	(in)	(mm)	(in)	(mm)	(lbs)	(kg)

Diode Supply Modules (DSU)

D7T	41.5	1054	6.7	170	16.4	417	176	80
D8T	55.0	1397	9.5	240	23.2	589	396	180

Standard interface and extensions for comprehensive connectivity

The ACS880 drive modules offer a wide range of standard interfaces. In addition the drive has three option slots that can be used for extensions including fieldbus adapter modules, input/

output extension modules, feedback modules and a safety functions module.

Control connections	Description
2 analog inputs (XAI)	Current input: -20 to 20 mA, R_{in} : 100 ohm Voltage input: -10 to 10 V, R_{in} > 200 kohm Resolution: 11 bit + sign bit
2 analog outputs (XAO)	0 to 20 mA, R_{load} < 500 ohm Frequency range: 0 to 300 Hz Resolution: 11 bit + sign bit
6 digital inputs (XDI)	Input type: NPN/PNP (DI1 to DI5), NPN (DI6) DI6 can alternatively be used as an input for a PTC thermistor.
Digital input interlock (DIIL)	Input type: NPN/PNP
2 digital inputs/outputs (XDIO)	As input: 24 V logic levels: "0" < 5 V, "1" > 15 V R_{in} : 2.0 kohm Filtering: 0.25 ms As output: Total output current from 24 V DC is limited to 200 mA Can be set as pulse train input and output
3 relay outputs (XRO1, XRO2, XRO3)	250 V AC/30 V DC, 2 A
Safe torque off (XSTO)	For the drive to start, both connections must be closed
Drive-to-drive link (XD2D)	Physical layer: EIA-485
Built-in Modbus	EIA-4285
Assistant control panel/PC tool connection	Connector: RJ-45



Control unit ZCU

Example of a typical drive modules input/output connection diagram. Variations may be possible (please see HW manual for more information).

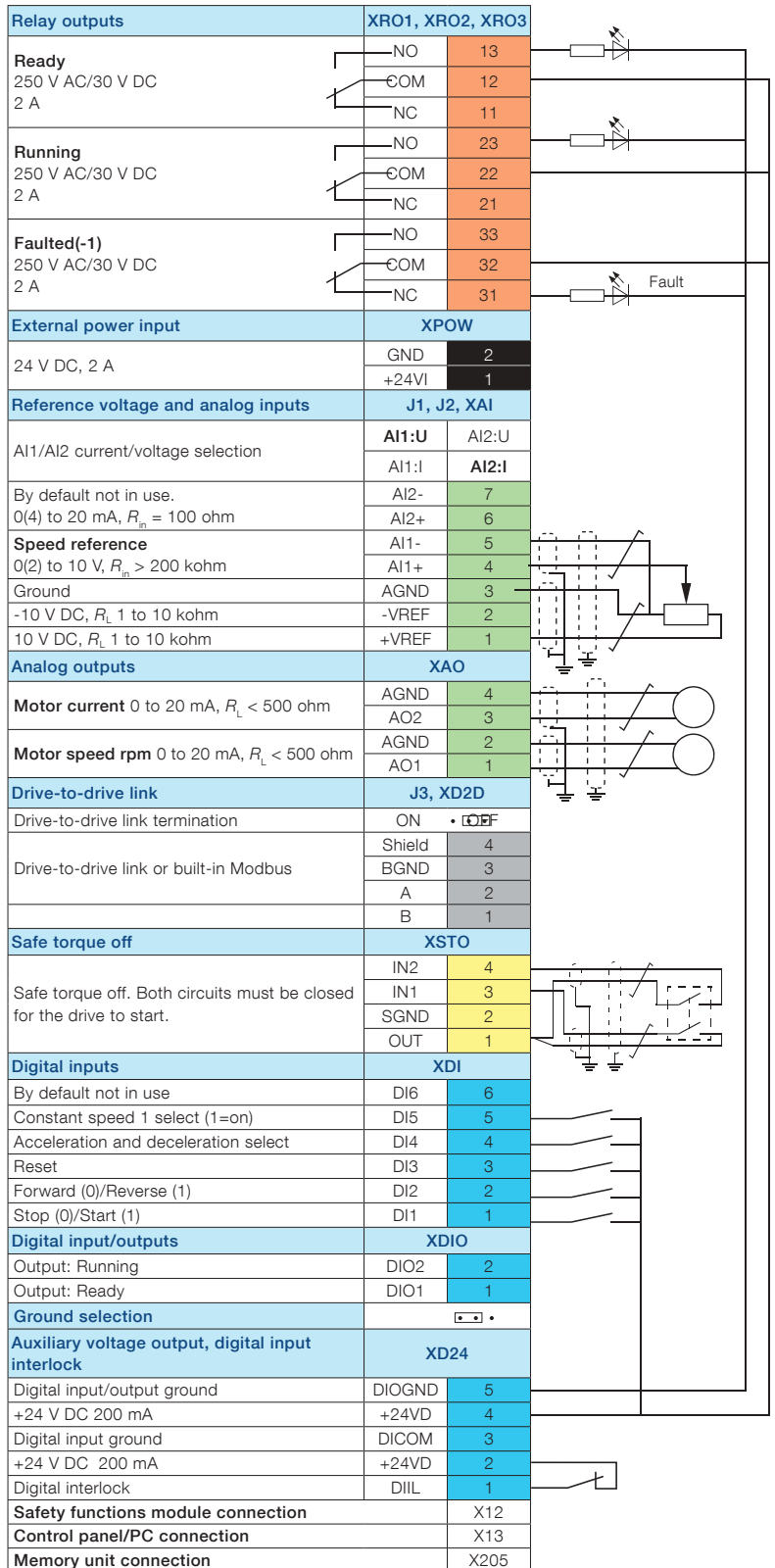

Standard software for scalable control and functionality

The same software, the primary control program, is used across the whole ACS880 series. Features such as built-in pre-programmed application macros save time during configuration and drive commissioning. The application macros help set parameters for various functions including:

- Basic setup for input/output control and fieldbus control
- Hand/auto control for local and remote operation
- PID control for closed loop processes
- Sequential control for repetitive cycles
- Torque control
- Four user defined sets, for own parameter settings

Direct torque control (DTC)

The drives are equipped with direct torque control (DTC), ABB's signature motor control platform which supports motors such as induction motors, permanent magnet motors, servo motors and the new synchronous reluctance motor. DTC helps control the motor from standstill to maximum torque and speed without the necessity of position sensors or encoders. DTC allows high overloadability, gives high starting torque and reduces stress on mechanics.

Energy efficiency information

The drives come with built-in energy efficiency information that helps the user fine-tune processes to ensure optimum energy use. The energy optimizer mode ensures the maximum torque per ampere, reducing energy drawn from the supply. The load profile feature collects drive values with three loggers: two amplitude loggers and one peak value logger. Calculators provide essential energy efficiency information: used and saved electrical energy, CO₂ reduction and money saved.

Additional software features include:

- Access levels
- Adaptive programming
- Automatic reset
- Automatic start
- Constant speeds
- Critical speeds and frequencies
- DC hold
- DC magnetizing
- Diagnostics
- Drive-to-drive link for master-follower control
- Flux braking
- Jogging
- Maintenance timer and counters
- Mechanical brake control
- Motor potentiometer
- Output phase order selection, switches rotation direction of the motor
- Oscillation damping
- Power loss ride-through
- Process PID control with trim function
- Programmable and pre-programmed protection functions
- Programmable inputs and outputs
- Scalar control with IR compensation
- Speed controller with auto tuning
- Startup assistants
- User adjustable load supervision/limitation
- User selectable acceleration and deceleration ramps
- Variable slope

Removable memory unit

The removable memory unit stores the standard software that includes user settings, parameter settings and motor data. Situated on the control unit, the memory unit can easily be removed for maintenance, update or replacement purposes. This common type of memory unit is used throughout the ACS880 series.





Our application control programs are developed by working closely with our customers over many years. This results in application programs that include the lessons learned from many customers, and that are designed to give you the flexibility to adapt the programs to your specific needs. These programs enhance application usability and lower energy consumption. They increase safe operation of the applications and reduce the need for a PLC. Other benefits include protection of machinery and optimization of application productivity. The programs also optimize time usage and lower operational costs.

The ACS880 application control programs come with adaptive programming features. This makes fine tuning of the ready-made application control program functionalities easy. Additionally, we understand that you may need to use different configurations in your process. That's why each of our control programs comes with the ability to configure up to four different configurations, or "user sets." The ACS880 drives offer integrated safety with safe torque off (STO) functionality as standard. The optional safety functions module comes with several safety functions including safe brake control (SBC).

Control program for cranes

This control program is dedicated for industrial, harbor, tower and marine deck cranes. It is possible to control crane movements in hoist and trolley and travel motions using the same software. The control program comes with integrated

mechanical brake control to assure safe opening and closing of the mechanical disc or drum brakes. Standalone and master-follower functionality is supported along with synchro control of multimotors. The synchro control for common operation of the load functionality makes it possible to lift and lower loads, such as containers, in a smooth and balanced way during transportation. The load speed control function maximizes the hoist speed for the given load and ensures that there is sufficient motor torque in the field weakening area. This minimizes operation time and optimizes crane capacity. Fieldbus and conventional I/O control is supported. The antisway function is designed for indoor cranes to prevent unnecessary swaying of the load.

Control program for winder

This control program makes sure that the unwinding and winding of a roll of web material, such as textile, plastic and paper is performed optimally. The control program observes the diameter of rolls and tension of the web material and makes sure that the drives controlling different parts of the winder are in sync. Based on the feedback from the dancer or tension measurement of the web, the speed or torque of the drive is adjusted appropriately. The result is a straightforward, cost-effective solution in web handling. Another feature is the mechanics ID run function that calculates automatically the inertia and friction of the roll. This speeds up the commissioning of the drive.



Control program for artificial oil lifting

This control program increases oil production for PCP (progressive cavity pumps), ESP (electro submersible pumps) or rod pumps. The program does not require any feedback encoder to work, which saves costs and increases reliability. The software also reduces stress on the complete pump system when optimizing fluid production. Backspin functionality is especially suitable for PCP and ESP pumps, which minimizes failure and makes oil pumping safe. Various startup ramp functions are also available. The sensorless control function (pump off control) helps to optimize oil pumping productivity by keeping the energy usage on a predetermined level. The efficiency of PCP pumps is significantly increased when using ACS880 drives together with SynRM motors.

Control program for centrifuge/decanter

This control program is designed to perform practical programmable sequences for conventional centrifuges. The program optimizes the separation of solids from the liquids in centrifuges, separators or decanter centrifuges. The speed difference of the decanter bowl and the scroll in the decanter centrifuge is controlled by the drive-to-drive functionality available in ACS880 drives.

Control program for cooling tower

This program is used in ACS880 drives to control high-torque and slow-speed synchronous RPM-AC permanent magnet motors in cooling tower applications. The control program is the basis for a drive-motor package where the cooling tower direct drive motor (CTDD) and the ACS880 drive is installed directly to the fans without any need for gearboxes, drive shafts or couplings. This provides high torque that is required for cooling tower applications without additional drivetrain components. The result is energy savings, reduced maintenance risk and costs, and direct-on-load startup current peaks. The control program for cooling tower is easy to commission and use. The ACS880 drives offer a streamlined parameter set that is focused on the typical cooling tower direct drive configurations where only necessary parameters are visible. Other cooling tower features in the drive include trickle current for keeping the motor warm and dry, a de-icing function to prevent ice build-up on the fan blades and an anti-windmill function to prevent rotation of the fan during standby.

Designed to control virtually any type of AC motor

www.nicsanat.com
021-87700210



Our ACS880 drives control virtually any type of AC motor including induction, permanent magnet, servo and synchronous reluctance motors. Motor control is optimized with direct torque control (DTC), ABB's premium motor control, built-in as a standard feature in our ACS880 drives. Our robust industrial drives ensure an energy efficient and reliable motor controller with significant cost savings for the user.

Direct torque control (DTC) for optimal control of motors

To ensure optimal control of an motor, our ACS880 drives offer direct torque control (DTC) as a built-in standard feature. In majority of applications, the DTC reduces the need for an expensive speed feedback encoder. Direct torque control provides fast reaction to load changes in the motor shaft as well as reference changes on speed or torque made by the user. It makes the motor run optimally which lowers energy consumption and wear of the application.

ACS880 and induction motors form a reliable combination

Induction motors are used throughout the industry in several types of industry applications which demand robust and high enclosure motor and drive solutions. The ACS880 drives fit perfectly together with this type of motor, used in a wide range of industrial environments. The drives fit into environments that require high degree of protection and offer narrow facilities. ACS880 drives come with DTC as standard, which ensures high speed accuracy.

Because they are ATEX certified, our drives can be combined with ABB motors for explosive atmospheres.

ACS880 and permanent magnet motors for smooth operation

Permanent magnet technology is often used for improved motor characteristics such as energy efficiency, compactness and control performance. This technology is particularly well suited for low speed control industry applications, as they eliminate the need to use gear boxes. Actual characteristics between different permanent magnet motors can vary considerably. ACS880 drives with DTC can control ABB and most other permanent magnet motors without speed or rotor position sensors.

ACS880 and IE4 synchronous reluctance motors for a package with high efficiency

Combining the ACS880's control technology with our synchronous reluctance (SynRM) motors provides an IE4 motor and drive package that gives you great energy savings benefits. The key is in the rotor design. The synchronous reluctance rotor replaces the traditional induction rotor and requires no permanent magnets. ABB has tested our SynRM motor and drive packages and produced manufacturer's statements providing verified system (drive and motor) efficiency.

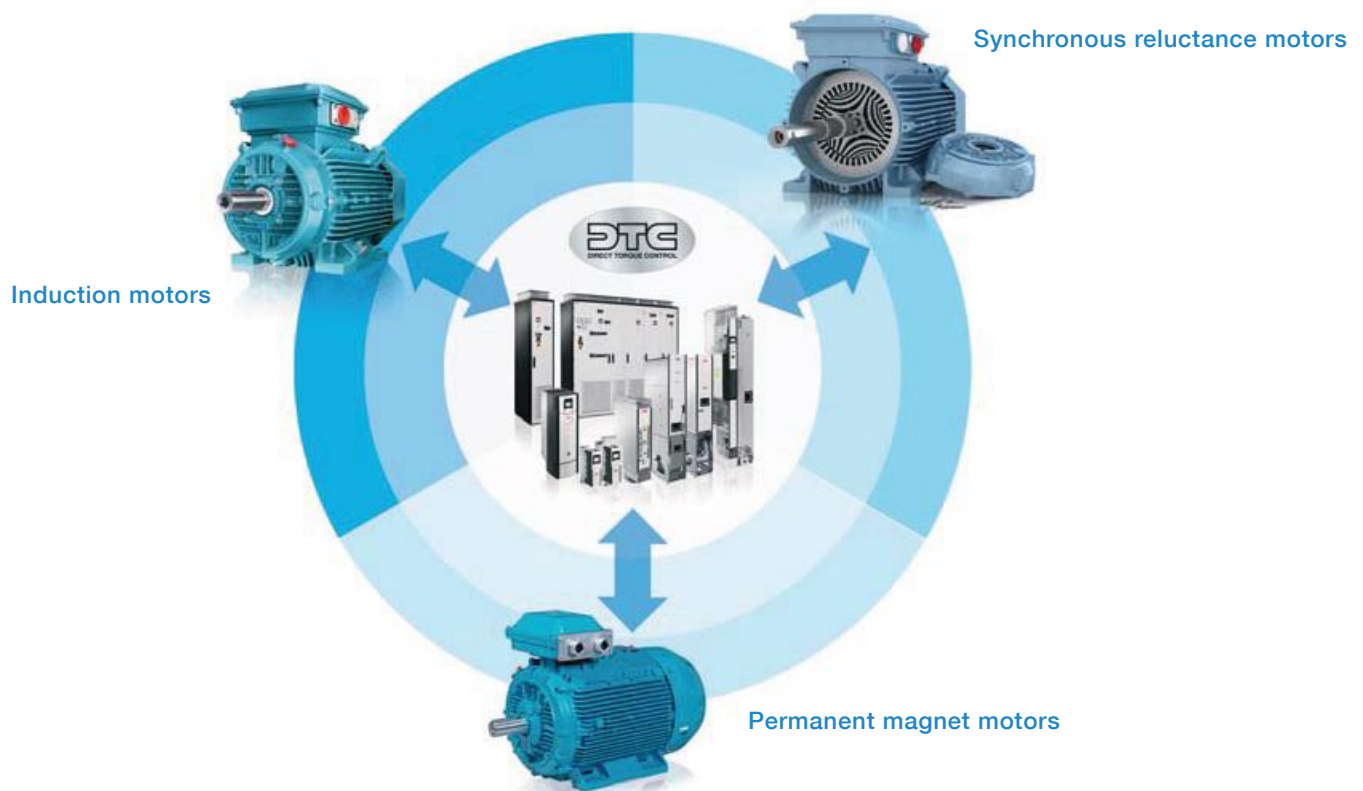

Intuitive human-machine interface

The assistant control panel features intuitive use and easy navigation. High resolution display enables visual guidance. The panel saves on commissioning and learning time by means of different assistants, making the drive simple to set up and use.

It is possible to organize parameters in different ways and store essential parameters for different configurations for any specialized application needed. The menus and messages can be customized for specific terminology so that each application can be set up and configured to its optimum performance. This makes the drive easier to use with information that is familiar to users. With the panel's text editor, users can also add information, customize text and label the drive. Powerful backup and restore functions are supported as well as different language versions. The help key provides context sensitive guidance. Faults or warnings can be resolved quickly since the help key provides troubleshooting instructions.

One control panel can be connected to several drives simultaneously using the panel network feature. The user can also select the drive to operate in the panel network. The PC tool can be easily connected to the drive through the

USB connector on the control panel. There is also the assistant control panel mounting platform, DPMP-01 IP55 kit available for cabinet door flush mounting.



PC tool for easy startup and maintenance

The Drive composer PC tool offers fast and harmonized setup, commissioning and monitoring for the whole drives portfolio. The free version of the tool provides startup and maintenance capabilities, while the professional version provides additional features such as custom parameter windows, control diagrams of the drive's configuration and safety settings.

The Drive composer tool is connected to the drive using an Ethernet connection or through the USB connection on the assistant control panel. All drive information such as parameter loggers, faults, backups and event lists are gathered into a support diagnostics file with a single mouse click. This provides faster fault tracking, shortens downtime and minimizes operational and maintenance costs.

Drive composer pro

Drive composer pro provides basic functionality, including parameter settings, downloading and uploading files and search parameters. Advanced features such as graphical control diagrams and various displays are also available. The control diagrams save users from browsing long lists of parameters and help to set the drive's logic quickly and easily. The tool

has fast monitoring capabilities of multiple signals from several drives in a PC tool network. Full backup and restore functions are also included. Safety settings can be configured with Drive composer pro.



Integrated safety reduces the need for external safety components, simplifying configuration and reducing installation space. The safety functionality is a built-in feature of the ACS880, with safe torque off (STO) as standard. Additional safety functions can be commissioned with the optional and compact safety functions module. ACS880 drives offer encoderless safety. The drives' functional safety is designed in accordance with EN/IEC 61800-5-2 and complies with the requirements of the European Union Machinery Directive 2006/42/EC.

Safe torque off as standard

Safe torque off (STO) is used to prevent unexpected startup and in stopping-related functions, enabling safe machine maintenance and operation. With safe torque off activated, the drive will not provide a rotational field. This prevents the motor from generating torque on the shaft. This function corresponds to an uncontrolled stop in accordance with stop category 0 of EN 60204-1.

The safety functions module

The easy to connect and configure safety functions module (FSO-12 and -21) offers a wide range of safety functions and a self diagnostic function that meets current safety requirements and standards, all in one compact module. Compared to using external safety components, the safety functions module comes with the supported functions seamlessly integrated with the drive functionality, reducing the implementation of safety function connections and configuration. Installation of the module results in less need for cabling and provides a cost-effective solution.

Commissioning and configuration of the safety functions module is done with the Drive composer pro PC tool. Larger safety systems can be built using PROFIsafe over Profinet connection between a safety PLC (such as AC500-S) and the ACS880 drive. The connection is achieved using the FENA-21 fieldbus adapter module and the safety functions module.



ACS880 drive with FSO-12

ACS880 cabinet-built drive with FSO-12

The safety functions module can also be ordered as a spare part kit and installed afterwards to the drive. The kit includes most common assembly accessories for ACS880 drives.

The module supports the following safety functions (which achieve up to SIL 3 or PL e (Cat. 3) safety level):

- **Safe stop 1 (SS1)** brings the machine to a stop (STO) using a monitored deceleration ramp. It is typically used in applications where the machinery motion needs to be brought to a stop (stop category 1) in a controlled way before switching over to the no-torque state.
- **Safe stop emergency (SSE)** can be configured to, upon request, either activate STO instantly (category 0 stop), or first initiate motor deceleration and then, once the motor has stopped, activate the STO (category 1 stop).
- **Safe brake control (SBC)** provides a safe output for controlling the motor's external (mechanical) brakes, together with STO.
- **Safely-limited speed (SLS)** ensures that the specified speed limit of the motor is not exceeded. This allows machine interaction to be performed at slow speed without stopping the drive. The safety function module comes with four individual SLS settings for speed monitoring. The safety functions module also provides a variable SLS function with PROFIsafe connection. This allows the user to change the speed limit of the SLS on the fly through a safety fieldbus communication.
- **Safe maximum speed (SMS)** monitors that the speed of the motor does not exceed the configured speed limit.
- **Prevention of unexpected startup (POUS)** ensures that the machine remains stopped when people are in a danger area.
- **Safe direction (SDI)** ensures that rotation is allowed only to the selected direction. Available only with FSO-21 and FSE-31.
- **Safe speed monitor (SSM)** provides information that speed is within the configured limits. Available only with FSO-21

The safety functions module enables safety functions without an encoder. If the application requires a safe encoder feedback it can be established with the safety certified pulse encoder interface module FSE-31. The module provides safe encoder data to the safety functions module and can simultaneously be used as a feedback device for the drive.

Safety functions module

Option	Ordering code
FSO-12	+Q973
FSO-21+FSE-31	+Q972+L521 ¹⁾

¹⁾ For availability please check with your local ABB

Drive application programming based on IEC standard 61131-3

Automation Builder, ABB's new software suite for automation engineering, makes programming of industry devices such as drives, PLC's, robots and human machine interfaces (HMI) easy using one integrated engineering suite. The Automation Builder is used both for engineering individual industry devices and for putting together entire automation projects. It is based on a widely used software environment that fulfills many different requirements of industrial automation projects, according to the IEC standard 61131-3. As a single tool, the Automation Builder reduces time typically needed for system configuration and programming. It also reduces the need for installing and maintaining separate programs simultaneously. Automation Builder enables the possibility to do online diagnostic checking of multiple tasks performed by different industrial devices such as ACS880 drives.

Drive application programming

Automation Builder makes it possible for system integrators and machine builders to integrate their desired functionality and know-how directly into ACS880 drives. This is possible as ACS880 drives come with programming capability embedded inside the drive. Designing an application program in the drive makes the end user application run more efficiently, even without a separate programmable controller. It also brings higher end-product quality and requires less need for installation space and wiring.

Automation Builder lets you extend the standard functionality of parameter functions for ACS880 drives. This makes the ACS880 drives very flexible to meet exact requirements set for end user applications. The library management functionality in Automation Builder shortens engineering time as reuse of existing program code is possible. Additional features include the ability to select and use one of five different programming languages, effective program debugging and user password protection.

Integrated engineering suite for operating several industry components together

Using the Drive manager tool embedded in Automation Builder together with ABB's AC500 PLC gives the user online connection to all drives in a fieldbus network. This speeds up commissioning and makes diagnostic of the entire automation system easy. Automation Builder saves all the configuration data of industry devices, including drive parameter settings, and program code to the same project archive. This makes engineering work more consistent and manageable.

Drive application programmability

Option	Option code
License key	+N8010

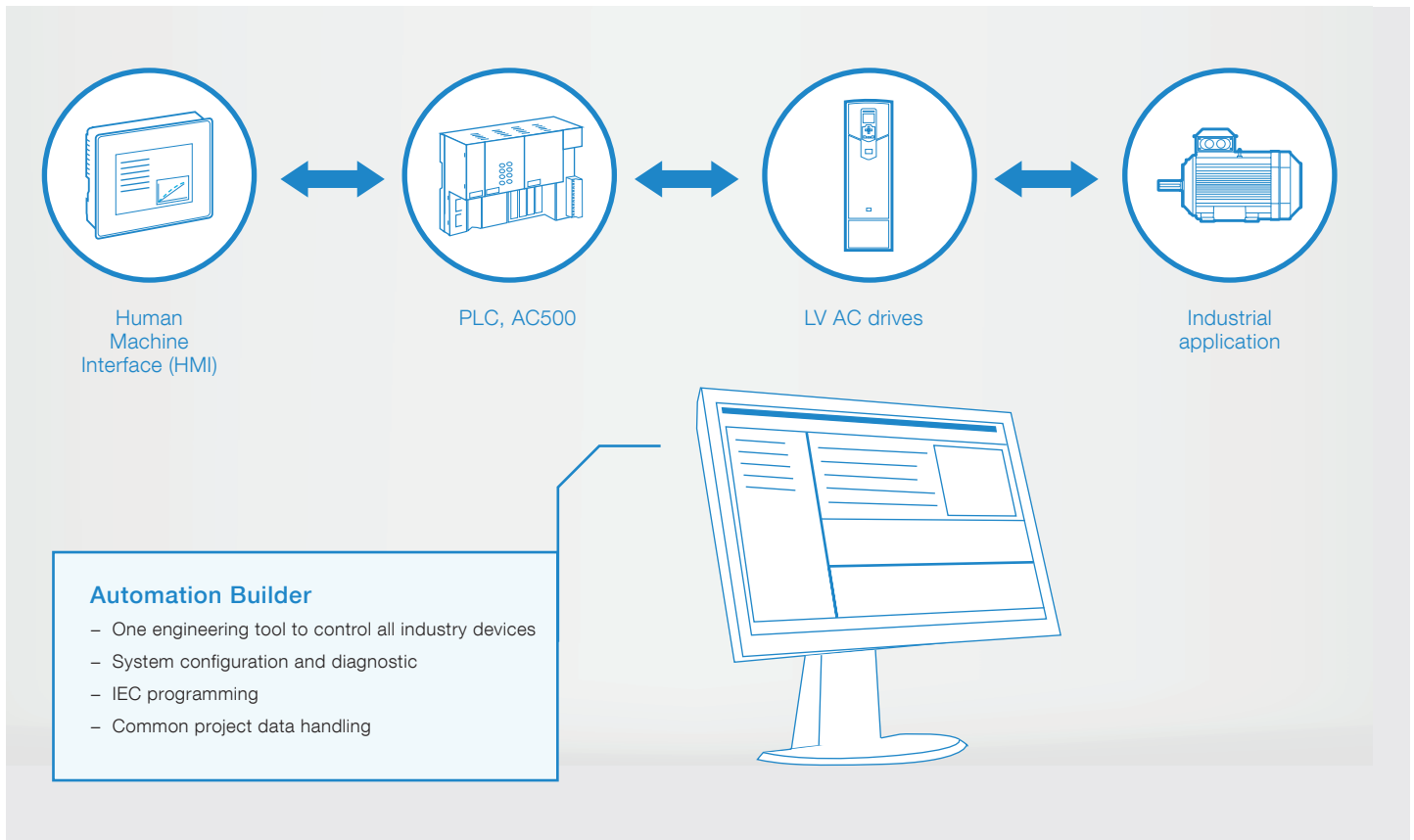

Our fieldbus adapter modules enable communication between drives, systems, devices and software. Our industrial drives are compatible with a wide range of fieldbus protocols.

The plug-in fieldbus adapter module can easily be mounted inside the drive. Other benefits include reduced wiring costs when compared with traditional input/output connections. Fieldbus systems are also less complex than conventional systems, resulting in less overall maintenance.

Multiple fieldbus connections for flexible control

ACS880 supports two fieldbus connections simultaneously. The user has flexibility of choice for control modes by being able to select one protocol for control and one for monitoring. Fieldbus adapters using the same protocol.

Drive monitoring

A set of drive parameters and/or actual signals, such as torque, speed, current, etc., can be selected for cyclic data transfer, providing fast data access.

Drive diagnostics

Accurate and reliable diagnostic information can be obtained through the alarm, limit and fault words.

Drive parameter handling

The Ethernet fieldbus adapter module allows users to build an Ethernet network for drive monitoring and diagnostic and parameter handling purposes.



Cabling

Substituting the large amount of conventional drive control cabling and wiring with a single cable reduces costs and increases system reliability and flexibility.

Design

The use of fieldbus control reduces engineering time at installation due to the modular structure of the hardware and software and the simplicity of the connections to the drives.

Commissioning and assembly

The modular machine configuration allows pre-commissioning of single machine sections and provides easy and fast assembly of the complete installation.

Universal communication with ABB fieldbus adapters

The ACS880 supports the following fieldbus protocols:

Fieldbus adapter modules

Option	Option code	Fieldbus protocol
FPBA-01	+K454	PROFIBUS DP, DPV0/DPV1
FCAN-01	+K457	CANopen®
FDNA-01	+K451	DeviceNet™
FENA-11	+K473	1 port EtherNet/IP™, Modbus TCP, PROFINET IO, PROFI-safe 1)
FENA-21	+K475	2 port EtherNet/IP™, Modbus TCP, PROFINET IO, PROFI-safe 1)
FECA-01	+K469	EtherCAT®
FSCA-01	+K458	Modbus RTU
FEPL-02	+K470	PowerLink
FCNA-01	+K462	ControlNet™

¹⁾ For the PROFI-safe to work PROFINET fieldbus adapter module (FENA-21) and the safety functions module (FSO-12/-21) are required.



Input/output extension modules for increased connectivity

Standard input and output can be extended by using optional analog and digital input/output extension modules. The modules are easily installed in the extension slots located on the control unit.

Analog and digital input/output extension modules

Option	Option code	Connections
FIO-01	+L501	4×DI/O, 2×RO
FIO-11	+L500	3×AI (mA/V), 1×AO (mA), 2×DI/O
FAIO-01	+L525	2×AI (mA/V), 2×AO (mA)

Speed feedback interfaces for precise process control

ACS880 drives can be connected to various feedback devices, such as HTL pulse encoder, TTL pulse encoder, absolute encoder and resolver. The optional feedback module is installed in the option slot on the drive. It is possible to use two feedback modules at the same time, either of the same type or different type.

Feedback interface modules

Option	Option code	Connections
FEN-01	+L517	2 inputs (TTL pulse encoder), 1 output
FEN-11	+L518	2 inputs (SinCos absolute, TTL pulse encoder), 1 output
FEN-21	+L516	2 inputs (Resolver, TTL pulse encoder), 1 output
FEN-31	+L502	1 input (HTL pulse encoder), 1 output

I/O option extension adapter

For additional I/O option slots the FEA-03 is suitable for this use. An analog and digital input/output extension and speed feedback interface can be installed on the FEA-03. Two extension modules can be installed on each I/O extension slot. The connection to the control unit is via a fiber optic link and the adapter can be mounted on a DIN rail (35 x 7.5 mm).

I/O extension adapter

Option	Option code	Connections
FEA-03	+L515	2×F-type option extension slots

DDCS communication option modules

The FDCO-0X (used in the ZCU control unit) and RDCO-0X (used in the BCU control unit) optical DDCS communication options are add-on modules on the ACS880 industrial drives control board. The modules include connectors for two fiber optic DDCS channels. The FDCO-0X modules make it possible to perform master-follower and AC800 M communication.

Option	Option code	Connections
FDCO-01	+L503	Optical DDCS (10 Mbd/10 Mbd)
FDCO-02	+L508	Optical DDCS (5 Mbd/10 Mbd)
RDCO-04	+L509	Optical DDCS (10 Mbd/10 Mbd/10 Mbd/10 Mbd)

Remote monitoring access worldwide

The remote monitoring tool, NETA-21, gives easy access to the drive via the Internet or local Ethernet network. NETA-21 comes with a built-in web server. Being compatible with standard web browsers, it ensures easy access to a web-based user interface. Through the interface the user can configure drive parameters, monitor drive log data, and follow up load levels, run time, energy consumption, I/O data and bearing temperature of the motor connected to the drive.

The user can access the remote monitoring tool web page using 3G modem from anywhere with a standard PC, tablet or a mobile phone. The remote monitoring tool helps to reduce cost when personnel are able to monitor or perform maintenance for unmanned or manned applications in a range of industries. It is also very useful when more than one user wants to access the drive from several locations.

Enhanced monitoring functions

The remote monitoring tool supports process and drive data logging. Values of process variables or drives actual values can be logged to NETA-21's SD memory card which is situated in the remote monitoring tool or sent forward to a centralized database. NETA-21 does not need an external database as the remote monitoring tool is able to store valuable data of the drive during its entire lifetime.

Unmanned monitoring of processes or devices is ensured by the built-in alarm functions that notify maintenance personnel if a safety level is reached. Alarm history with true time stamps are stored internally to the memory card as well as technical data, which is provided by the drive for troubleshooting purposes. True time stamps are also used with drives that do not have a real time clock as standard for ensuring events of all connected drives.



NETA-21

EMC standards

The EMC product standard (EN 61800-3 (2004)) covers the specific EMC requirements stated for drives (tested with motor and cable) within the EU. EMC standards such as EN 55011 or EN 61000-6-3/4 are applicable to industrial and domestic equipment and systems including components inside the drive. Drive units complying with the requirements of EN 61800-3 are compliant with comparable categories in EN 55011 and EN 61000-6-3/4, but not necessarily vice versa. EN 55011 and EN 61000-6-3/4 do not specify cable length or require a motor to be connected as a load. The emission limits are comparable to EMC standards according to the table below.

1st environment versus 2nd environment

1st environment includes domestic premises. It also includes establishments directly connected without an intermediate transformer to a low voltage power supply network that supplies buildings used for domestic purposes.

2nd environment includes all establishments other than those directly connected to a low voltage power supply network that supplies buildings used for domestic purposes.

EMC standards

EMC according to EN 61800-3 (2004) product standard	EN 61800-3 product standard	EN 55011, product family standard for industrial, scientific and medical (ISM) equipment	EN 61000-6-4, generic emission standard for industrial environments	EN 61000-6-3, generic emission standard for residential, commercial and light-industrial environment
1 st environment, restricted distribution	Category C2	Group 1, Class A	Applicable	Not applicable
2 nd environment, unrestricted distribution	Category C3	Group 2, Class A	Not applicable	Not applicable
2 nd environment, restricted distribution	Category C4	Not applicable	Not applicable	Not applicable

Selecting an EMC filter

The following table gives the correct filter selection.

Type	Voltage	Frame sizes	1 st environment, restricted distribution, C2, grounded network (TN) Option code	2 nd environment, C3, grounded network (TN) Option code	2 nd environment, C3, ungrounded network (IT) Option code	2 nd environment, C3, grounded/ ungrounded network (TN/IT) Option code
ACS880-01	380 to 500 V	R1 to R9	+E202	+E200	+E201 (R6 to R9 frame size)	–
ACS880-01	690 V	R5 to R9	–	+E200	+E201 (R7 to R9 frame size)	–
ACS880-04	380 to 690 V	R10, R11	+E202 (not for 690 V)	–	–	+E210
ACS880-04	380 to 690 V	nxD8T + nxR8i	Not for 690V. Only for 1xD8T	–	–	As standard ¹⁾
ACS880-14	380 to 690 V	nxR8i	Not for 690V. Only for 1xR8i	–	–	As standard ¹⁾
ACS880-34	380 to 690 V	nxR8i	Not for 690V. Only for 1xR8i	–	–	As standard ¹⁾
ACS880-204	380 to 690 V	R1i-R4i, R6i, nxR8i	Not for 690V. Only for R6i, 1xR8i	–	–	As standard ¹⁾
ACS880-304	380 to 690 V	DxD, nxDxT	Not for 690V. Only for 1xD8T	–	–	As standard ¹⁾

¹⁾For Category C3 no optional equipment is needed, but the drive must be installed according to the instructions given in the manuals.

Sine filters

Together with a sine filter, ACS880 drives offer smooth motor operation. The sine filter suppresses high frequency components of the motors output voltage, creating almost a sinusoidal voltage wave form for the motor. The filter offers optimized LC design that takes into account switching frequency, voltage drop and filtering characteristics.

The ACS880 drive and sine filter solution can be used together with a variety of requirements for products and components:

- For motors which don't have adequate insulation for the drives duty
- Where the total motor cable length is long as a result of a number of parallel motors
- For step-up applications eg where medium voltage motor needs to be driven
- For submersible pumps with long motor cables eg in the oil industry
- When the motor noise needs to be reduced
- When there are industry specific requirements for peak voltage level and voltage rise time

I_N A	P_N kW	Inverter Type designation	Filter size	Height		Width		Depth		Weight		Degree of protection	Frame size
				(in)	(mm)	(in)	(mm)	(in)	(mm)	(lbs)	(kg)		
$U_N = 500$ V (range 380 to 500 V). The power ratings are valid at nominal voltage 500 V.													
430	250	ACS880-04-460A-5	NSIN900-6	83.5	2120	39.4	1000	23.6	600	1518	690	IP00	R10
470	315	ACS880-04-503A-5	NSIN900-6	83.5	2120	39.4	1000	23.6	600	1518	690	IP00	R10
514	355	ACS880-04-583A-5	NSIN900-6	83.5	2120	39.4	1000	23.6	600	1518	690	IP00	R10
560	400	ACS880-04-635A-5	NSIN900-6	83.5	2120	39.4	1000	23.6	600	1518	690	IP00	R10
637	450	ACS880-04-715A-5	NSIN900-6	83.5	2120	39.4	1000	23.6	600	1518	690	IP00	R11
730	500	ACS880-04-820A-5	NSIN900-6	83.5	2120	39.4	1000	23.6	600	1518	690	IP00	R11
730	500	ACS880-04-880A-5	NSIN900-6	83.5	2120	39.4	1000	23.6	600	1518	690	IP00	R11

$U_N = 690$ V (range 525 to 690 V). The power ratings are valid at nominal voltage 690 V.													
330	315	ACS880-04-330A-7	NSIN485-6	81.1	2060	15.8	400	23.6	600	551	250	IP00	R10
340	315	ACS880-04-370A-7	NSIN485-6	81.1	2060	15.8	400	23.6	600	551	250	IP00	R10
360	355	ACS880-04-430A-7	NSIN485-6	81.1	2060	15.8	400	23.6	600	551	250	IP00	R10
*	*	ACS880-04-425A-7	NSIN485-6	81.1	2060	15.8	400	23.6	600	551	250	IP00	R11
*	*	ACS880-04-470A-7	NSIN900-6	83.5	2120	39.4	1000	23.6	600	1522	690	IP00	R11
*	*	ACS880-04-522A-7	NSIN900-6	83.5	2120	39.4	1000	23.6	600	1522	690	IP00	R11
530	500	ACS880-04-590A-7	NSIN900-6	83.5	2120	39.4	1000	23.6	600	1522	690	IP00	R11
550	560	ACS880-04-650A-7	NSIN900-6	83.5	2120	39.4	1000	23.6	600	1522	690	IP00	R11
550	630	ACS880-04-721A-7	NSIN900-6	83.5	2120	39.4	1000	23.6	600	1522	690	IP00	R11

* For further information please contact your local ABB

Note: Noise level is a combined value for the drive and the filter. Heat dissipation is a combined value for the drive and the filter.

Nominal ratings

I_N	Rated current of the drive-filter combination available continuously without overload at 40 °C.
P_N	Typical motor power

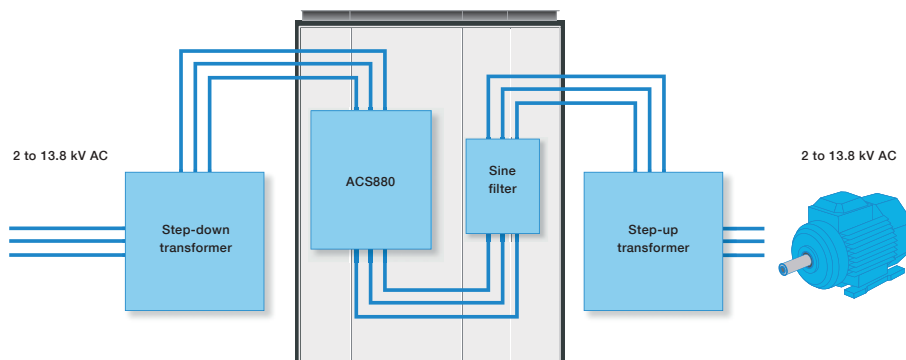

For step-up applications eg, where medium voltage motor needs to be driven

Brake options, ACS880-01

Brake chopper

The brake chopper is built-in as standard for the ACS880-01 frame sizes R1 to R4. For other ACS880-01 frames, a brake chopper is a selectable internal option. The air-cooled brake chopper for other single and multidrive module unit includes an NBRA brake chopper module or two parallel-connected NBRA brake chopper modules. The brake chopper handles the energy generated by a decelerating motor. The chopper connects the brake resistor to the intermediate DC circuit whenever the voltage in the circuit exceeds the limit defined by the control program. Energy consumption by the resistor losses lowers the voltage until the resistor can be disconnected.

Brake resistor

The brake resistors (JBR, SACE, SAFUR) are separately available for ACS880 drive modules. Resistors other than the standard option resistors may be used, provided that the specified resistance value is not decreased and that the heat dissipation capacity of the resistor is sufficient for the drive application.



NBRA659 brake chopper

ACS880-01 brakes

$U_N = 230 \text{ V}$ (range 208 to 240 V)

Braking power		Brake resistor(s)			Type designation	Frame size
P_{brcont} [kW]	R_{min} ohm	R [Ohm]	E_r [kJ]	P_{rcont} [kW]		
0.75	65	80	40	0.14	ACS880-01-04A6-2	R1
1.1	65	80	40	0.14	ACS880-01-06A6-2	R1
1.5	65	80	40	0.14	ACS880-01-07A5-2	R1
2.2	65	80	40	0.14	ACS880-01-10A6-2	R1
4	18	22	420	2	ACS880-01-16A8-2	R2
5.5	18	22	420	2	ACS880-01-24A3-2	R2
7.5	13	13	435	2	ACS880-01-031A-2	R3
11	12	13	435	2	ACS880-01-046A-2	R4
11	12	13	435	2	ACS880-01-061A-2	R4
18.5	6	8	1800	4.5	ACS880-01-075A-2+D150	R5
22	6	8	1800	4.5	ACS880-01-087A-2+D150	R5
30	3.5	4	3600	9	ACS880-01-115A-2+D150	R6
37	3.5	4	3600	9	ACS880-01-145A-2+D150	R6
45	2.4	2.7	5400	13.5	ACS880-01-170A-2+D150	R7
55	2.4	2.7	5400	13.5	ACS880-01-206A-2+D150	R7
75	1.8	2.7	5400	13.5	ACS880-01-274A-2+D150	R8

All brake resistors are to be installed outside the converter module.
The SACE brake resistors are built-in to an IP21 metal housing.
The SAFUR brake resistors are built-in to an IP00 metal frame.

Brake options, ACS880-04, ACS880-X04

ACS880-04 brakes

$U_N = 500 \text{ V}$ (range 380 to 500 V)

Braking power		Brake resistor(s)			Type designation	Frame size
P_{brcont} [kW]	R_{min} ohm	R [Ohm]	E_r [kJ]	P_{rcont} [kW]		
250	2.0	2.00	7200	18	ACS880-04-460A-5	R10
250	2.0	2.00	7200	18	ACS880-04-503A-5	R10
315	1.3	1.35	10800	27	ACS880-04-583A-5	R10
315	1.3	1.35	10800	27	ACS880-04-635A-5	R10
400	0.7	0.90	16200	40	ACS880-04-715A-5	R11
400	0.7	0.90	16200	40	ACS880-04-820A-5	R11
400	0.7	0.90	16200	40	ACS880-04-880A-5	R11

$U_N = 690 \text{ V}$ (range 525 to 690 V)

Braking power		Brake resistor(s)			Type designation	Frame size
P_{brcont} [kW]	R_{min} ohm	R [Ohm]	E_r [kJ]	P_{rcont} [kW]		
285	2.2	2.7	3600	13	ACS880-04-330A-7	R10
285	2.2	2.7	3600	13	ACS880-04-370A-7	R10
285	2.2	2.7	3600	13	ACS880-04-430A-7	R10
350	2.0	2.0	7200	18	ACS880-04-425A-7	R11
350	2.0	2.0	7200	18	ACS880-04-470A-7	R11
350	2.0	2.0	7200	18	ACS880-04-522A-7	R11
400	1.8	2.0	7200	18	ACS880-04-590A-7	R11
400	1.8	2.0	7200	18	ACS880-04-650A-7	R11
400	1.8	2.0	7200	18	ACS880-04-721A-7	R11

Brake options, ACS880-604

ACS880-604 brake chopper

$U_N = 500 \text{ V}$ (range 380 to 500 V)

Nominal ratings					Duty cycle (1min/5min)		Duty cycle (10s/60s)		Noise dB(A)	Air flow m ³ /h	Type designation	Module type
$P_{br,max}$ kW	R_{min} ohm	I_{max} A	I_{rms} A	$P_{cont.}$ kW	$P_{br.}$ kW	I_{rms} A	$P_{br.}$ kW	I_{rms} A				

Brake chopper without brake resistor

268	2.15	380	101	81	268	331	268	331	64	660	ACS880-604-0260-5	NBRA658
403	1.43	571	136	109	317	391	403	498	64	660	ACS880-604-0400-5	NBRA659
806	2×1.43	1142	272	218	634	782	806	996	67	1320	ACS880-604-0800-5	2×NBRA659
1208	0.45	1713	408	327	951	1173	1209	1494	68	1980	ACS880-604-1200-5	3×NBRA659
1611	0.3575	2284	544	436	1268	1564	1612	1992	69	2640	ACS880-604-1600-5	4×NBRA659
2014	0.286	2855	680	545	1585	1955	2015	2490	70	3300	ACS880-604-2000-5	5×NBRA659
2417	0.225	3426	816	654	1902	2346	2418	2988	71	3960	ACS880-604-2400-5	6×NBRA659

$U_N = 690 \text{ V}$ (range 525 to 690 V)

Nominal ratings					Duty cycle (1min/5min)		Duty cycle (10s/60s)		Noise dB(A)	Air flow m ³ /h	Type designation	Module type
$P_{br,max}$ kW	R_{min} ohm	I_{max} A	I_{rms} A	$P_{cont.}$ kW	$P_{br.}$ kW	I_{rms} A	$P_{br.}$ kW	I_{rms} A				

Brake chopper without brake resistor

404	2.72	414	107	119	298	267	404	361	64	660	ACS880-604-0400-7	NBRA669
807	1.36	828	214	238	596	534	808	722	64	660	ACS880-604-0800-7	2×NBRA669
1211	0.9066	1242	321	357	894	801	1212	1083	64	1320	ACS880-604-1200-7	3×NBRA669
1615	0.68	1656	428	476	1192	1068	1616	1444	64	1980	ACS880-604-1600-7	4×NBRA669
2019	0.544	2070	535	595	1490	1335	2020	1805	64	2640	ACS880-604-2000-7	5×NBRA669
2422	0.2383	2484	642	714	1788	1602	2424	2166	64	3300	ACS880-604-2400-7	6×NBRA669

Heat loss of braking chopper is 1% of braking power

Heat loss of section with braking resistors is the same as braking power

Maximum braking power of the ACS880 equipped with the standard chopper and the standard resistor

$P_{br,max}$	Maximum short time braking power.
R	Recommended braking resistor resistance. Also nominal resistance of corresponding SAFUR resistor.
I_{max}	Maximum peak current per chopper during braking. Current is achieved with recommended resistor resistance.
$P_{cont.}$	Maximum continuous braking power. Continuous power (heat) dissipation of the resistor when placed correctly. Energy E_r dissipates in 400 seconds.
E_r	SAFUR resistor nominal braking capacity without forced cooling. Energy pulse that the resistor assembly will withstand (400 s duty cycle). This energy will heat the resistor element from 40 °C to the maximum allowable temperature.
$P_{br.}$	Braking power during corresponding cycle load: 1min/5min = 1 minute braking with power $P_{br.}$ and 4 minutes unload. 10 s/60 s = 10 second braking with power $P_{br.}$ and 50 seconds unload.
I_{rms}	Corresponding rms current per chopper during load cycle.
R_{min}	Minimum allowable resistance value for the brake resistor.

Dimensions Choppers

Brake chopper	Height		Width		Depth		Weight	
	(in)	(mm)	(in)	(mm)	(in)	(mm)	(lbs)	(kg)
NBRA658	23.0	584	13.2	334	9.4	240	57	26
NBRA659	23.0	584	13.2	334	9.4	240	57	26
NBRA669	23.0	584	13.2	334	9.4	240	57	26

ACS880-604 3-phase dynamic brake units

ACS880-04 brakes

$U_N = 500 \text{ V}$ (range 380 to 500 V)

Resistor values		Ratings R_{min}								Ratings R_{max}							Type designation	Frame size
		No-overload use				Cycle load (1min/5min)				No-overload use				Cycle load (1min/5min)				
R_{min} ohm	R_{max} ohm	I_{dc} A DC	I_{rms} A DC	P_{rcont} kW	I_{max} A DC	I_{dc} A DC	$I_{rms}-R_{min}$ A DC	$P_{br}-R_{min}$ kW	I_{dc} A DC	I_{rms} A DC	$P_{contmax}$ kW	I_{max} A DC	I_{dc} A DC	$I_{rms}-R_{max}$ A DC	$P_{br}-R_{max}$ kW			
2.2	2.6	781	310	630	370	999	351	800	781	284	630	312	835	293	670	ACS880-604-0630-5	R8i	
1.4	1.7	1171	465	940	555	1499	527	1210	1171	430	940	468	1277	449	1030	ACS880-604-0940-5	R8i	
2.2	2.6	1562	621	1260	740	1998	702	1610	1562	568	1260	625	1671	587	1340	ACS880-604-1260-5	2xR8i	
1.4	1.7	2342	931	1880	1110	2997	1053	2410	2342	860	1880	937	2555	898	2060	ACS880-604-1880-5	2xR8i	
1.4	1.7	3514	1396	2830	1665	4496	1580	3620	3514	1289	2830	1405	3832	1347	3080	ACS880-604-2830-5	3xR8i	
1.4	1.7	4685	1862	3770	2220	5994	2106	4820	4685	1719	3770	1874	5110	1795	4110	ACS880-604-3770-5	4xR8i	
1.4	1.7	5856	2327	4710	2775	7493	2633	6030	5856	2149	4710	2342	6387	2244	5140	ACS880-604-4710-5	5xR8i	

$U_N = 690 \text{ V}$ (range 525 to 690 V)

Resistor values		Ratings R_{min}								Ratings R_{max}							Type designation	Frame size
		No-overload use				Cycle load (1min/5min)				No-overload use				Cycle load (1min/5min)				
R_{min} ohm	R_{max} ohm	I_{dc} A DC	I_{rms} A DC	P_{rcont} kW	I_{max} A DC	I_{dc} A DC	$I_{rms}-R_{min}$ A DC	$P_{br}-R_{min}$ kW	I_{dc} A DC	I_{rms} A DC	$P_{contmax}$ kW	I_{max} A DC	I_{dc} A DC	$I_{rms}-R_{max}$ A DC	$P_{br}-R_{max}$ kW			
3.0	3.6	781	310	870	370	999	351	1110	781	283	870	312	833	293	920	ACS880-604-0870-7	R8i	
2.0	2.4	1171	465	1300	555	1499	527	1660	1171	425	1300	468	1249	439	1390	ACS880-604-1300-7	R8i	
3.0	3.6	1562	621	1730	740	1998	702	2220	1562	567	1730	625	1665	585	1850	ACS880-604-1730-7	2xR8i	
2.0	2.4	2342	931	2600	1110	2997	1053	3330	2342	850	2600	937	2498	878	2770	ACS880-604-2600-7	2xR8i	
2.0	2.4	3514	1396	3900	1665	4496	1580	4990	3514	1275	3900	1405	3746	1316	4160	ACS880-604-3900-7	3xR8i	
2.0	2.4	4685	1862	5200	2220	5994	2106	6650	4685	1700	5200	1874	4995	1755	5540	ACS880-604-5200-7	4xR8i	
2.0	2.4	5856	2327	6500	2775	7493	2633	8320	5856	2125	6500	2342	6244	2194	6930	ACS880-604-6500-7	5xR8i	

Dimensions

Frame size	Height		Width		Depth		Weight	
	(in)	(mm)	(in)	(mm)	(in)	(mm)	(lbs)	(kg)
R8i	55.0	1397	9.5	240	23.0	585	275	125

Resistor

R_{min}	Minimum allowed resistance value of the brake resistor for one phase of the brake module.
R_{max}	Resistance value of the brake resistor for one phase of the brake module corresponding to the maximum achieved continuous braking power.

Note: Connect one resistor per brake module phase. For example, a brake unit of frame size 2xR8i including two brake modules → 2 x 3 resistors are needed.

Typical ratings for no-overload use

I_{dc}	Total input DC current of brake unit.
I_{rms}	Total rms DC output phase current of brake unit.
I_{max}	Peak brake current (DC) per chopper module phase.
$P_{cont,max}$	Maximum continuous braking power per brake unit.

Cyclic load (1 min/5 min)

I_{dc}	Total input DC current of brake unit during a period of 1 minute with braking power P_{br} .
I_{rms}	Total rms DC current per brake unit phase during a period of 1 minute with braking power P_{br} .
P_{br}	Short term braking power

DC-DC converter

ACS880-1604

$U_N = 500V$ (range 380 to 415 V). The power ratings are valid at nominal voltage 500 V.

No overload use					Fast overload cycle (10 s/60 s)		Heavy overload cycle (1 min/60 s)		Noise level	Heat dissipation	Air flow	Filter type	Type designation	Frame size
I_{dc} Input A (DC)	I_{rms} output A (DC)	P_N kW	I_{max} output A (DC)	I_{p2p} A	I_{fast} A	P_{fast} kW	I_{Hd} A	P_{Hd} kW	dBA	kW	m ³ /h			
600	600	382	900	27	450	286	510	324	74	6	2200	BDCL-14-5	ACS880-1604-0600A-5	R8i
900	900	573	1350	41	675	429	765	487	74	9.1	2200	BDCL-15-5	ACS880-1604-0900A-5	R8i
1200	1200	764	1800	55	899	572	1020	649	76	12.1	4400	2xBDCL-14-5	ACS880-1604-1200A-5	2xR8i
1800	1800	1146	2700	82	1349	859	1529	973	76	18.8	4400	2xBDCL-15-5	ACS880-1604-1800A-5	2xR8i
2700	2700	1718	4050	123	2024	1288	2294	1460	78	28.9	6600	3xBDCL-15-5	ACS880-1604-2700A-5	3xR8i
3600	3600	2291	5400	164	2698	1717	3059	1947	78	39.6	8800	4xBDCL-15-5	ACS880-1604-3600A-5	4xR8i
4500	4500	2864	6750	205	3373	2147	3824	2433	79	50.8	11000	5xBDCL-15-5	ACS880-1604-4500A-5	5xR8i

$U_N = 690 V$ (range 380 to 415 V). The power ratings are valid at nominal voltage 690 V.

No overload use					Fast overload cycle (10 s/60 s)		Heavy overload cycle (1 min/60 s)		Noise level	Heat dissipation	Air flow	Filter type	Type designation	Frame size
I_{dc} Input A (DC)	I_{rms} output A (DC)	P_N kW	I_{max} output A (DC)	I_{p2p} A	I_{fast} A	P_{fast} kW	I_{Hd} A	P_{Hd} kW	dBA	kW	m ³ /h			
400	400	351	600	38	300	263	340	298	74	6.4	2200	BDCL-14-7	ACS880-1604-0400A-7	R8i
600	600	527	900	56	450	395	510	448	74	10.6	2200	BDCL-15-7	ACS880-1604-0600A-7	R8i
800	800	703	1200	75	600	527	680	597	76	12.8	4400	2xBDCL-14-7	ACS880-1604-0800A-7	2xR8i
1200	1200	1054	1800	113	899	790	1020	895	76	21.5	4400	2xBDCL-15-7	ACS880-1604-1200A-7	2xR8i
1800	1800	1581	2700	169	1349	1185	1529	1343	78	32.6	6600	3xBDCL-15-7	ACS880-1604-1800A-7	3xR8i
2400	2400	2108	3600	226	1799	1580	2039	1791	78	43.9	8800	4xBDCL-15-7	ACS880-1604-2400A-7	4xR8i
3000	3000	2635	4500	282	2249	1975	2549	2239	79	55.4	11000	5xBDCL-15-7	ACS880-1604-3000A-7	5xR8i

Dimensions

Frame size	Height		Width		Depth		Weight	
	(in)	(mm)	(in)	(mm)	(in)	(mm)	(lbs)	(kg)
R8i	55	1397	9.5	240	23	583	275	125
BDCL-14-5	55	1397	9.5	240	23	444	429	195
BDCL-14-7	55	1397	9.5	240	23	444	429	195
BDCL-15-5	55	1397	9.5	240	23	444	561	255
BDCL-15-7	55	1397	9.5	240	23	444	561	255

No overload use

I_{dc} Input	Maximum continuous input DC current
I_{rms} output	Maximum continuous output current
P_N	Maximum continuous output power
I_{max} output	Maximum instantaneous output current
I_{p2p}	Maximum output ripple current

Fast/heavy load cycle

I_{fast}	Continuous output current allowing 10 s of I_{max} every 60 seconds
P_{fast}	Continuous output power allowing 10 s of I_{max} every 60 seconds
I_{Ld}	Continuous output current allowing overload of 150% I_{Hd} for 1 min every 5 min
P_{Ld}	Continuous output power allowing 150% I_{Hd} for 1 min every 5 min



du/dt filtering suppresses inverter output voltage spikes and rapid voltage changes that stress motor insulation. Additionally, du/dt filtering reduces capacitive leakage currents and high frequency emission of the motor cable as well as high frequency losses and bearing currents in the motor. The need for du/dt filtering depends on the motor insulation. For information on the construction of the motor insulation, consult the manufacturer.

If the motor does not fulfill the following requirements, the lifetime of the motor might decrease. Insulated N-end (non-driven end) bearings and/or common mode filters are also required for motor bearing currents with motors bigger than 100 kW. For more information, please see the ACS880 hardware manuals.

Please see below about how to select a filter according to the motor.

Filter selection table for ACS880

Motor type	Nominal AC supply voltage	Requirements for		
		Motor insulation system	ABB du/dt and common mode filters, insulated N-end motor bearings	
			$P_N < 100 \text{ kW}$ and frame size < IEC 315	$100 \text{ kW} \leq P_N < 350 \text{ kW}$ or IEC 315 \leq frame size < IEC 400
			$P_N < 134 \text{ hp}$ and frame size < NEMA 500	$134 \text{ hp} \leq P_N < 469 \text{ hp}$ or NEMA 500 \leq frame size \leq NEMA 580
ABB motors				
Random-wound M2__, M3__ and M4__	$U_N \leq 500 \text{ V}$	Standard	-	+ N
	$500 \text{ V} < U_N \leq 600 \text{ V}$	Standard	+ du/dt	+ du/dt + N
		or Reinforced	-	+ N
	$600 \text{ V} < U_N \leq 690 \text{ V}$ (cable length $\leq 150 \text{ m}$)	Reinforced	+ du/dt	+ du/dt + N
$600 \text{ V} < U_N \leq 690 \text{ V}$ (cable length > 150 m)	Reinforced	-	+ N	
Form-wound HX__ and AM__	$380 \text{ V} < U_N \leq 690 \text{ V}$	Standard	n/a	+ N + CMF
Old ¹⁾ form-wound HX__ and modular	$380 \text{ V} < U_N \leq 690 \text{ V}$	Check with the motor manufacturer	+ du/dt with voltages over 500 V + N + CMF	
Random-wound HX__ and AM__ ²⁾	$0 \text{ V} < U_N \leq 500 \text{ V}$	Embedded wire with fiber glass taping	+ N + CMF	
	$500 \text{ V} < U_N \leq 690 \text{ V}$		+ du/dt + N + CMF	
HDP	Consult the motor manufacturer.			
Non-ABB motors				
Random-wound and form-wound	$U_N \leq 420 \text{ V}$	Standard $\hat{U}_{LL} = 1300 \text{ V}$	-	+ N or CMF
		Standard $\hat{U}_{LL} = 1300 \text{ V}$	+ du/dt	+ du/dt + N or + du/dt + CMF
	$420 \text{ V} < U_N \leq 500 \text{ V}$	or Reinforced: $\hat{U}_{LL} = 1600 \text{ V}$, 0.2 microsecond rise time	-	+ N or CMF
		Reinforced: $\hat{U}_{LL} = 1600 \text{ V}$	+ du/dt	+ du/dt + N or + du/dt + CMF
	$500 \text{ V} < U_N \leq 600 \text{ V}$	or Reinforced: $\hat{U}_{LL} = 1800 \text{ V}$	-	+ N or CMF
		Reinforced: $\hat{U}_{LL} = 1800 \text{ V}$	+ du/dt	+ du/dt + N
$600 \text{ V} < U_N \leq 690 \text{ V}$	Reinforced: $\hat{U}_{LL} = 2000 \text{ V}$, 0.3 microsecond rise time	-	+ N or CMF	

¹⁾ Manufactured before 1.1.1998. ²⁾ For motors manufactured before 1.1.1998, check for additional instructions with the motor manufacturer.

The abbreviations used in the table are defined below

Abbr.	Definition
U_N	Nominal AC line voltage.
\hat{U}_{LL}	Peak line-to-line voltage at motor terminals which the motor insulation must withstand.
P_N	Motor nominal power.
du/dt	du/dt filter at the output of the drive. Available both as standard and as an optional add-on kit from ABB.
CMF	Common mode filter. Depending on the drive type, CMF is available from ABB as a factory-installed option (+E208) or as an optional add-on kit.
N	N-end bearing: insulated motor non-drive end bearing.
n/a	Motors of this power range are not available as standard units. Consult the motor manufacturer.

du/dt filters

Applicability

Separate du/dt filters are available for ACS880-01/-04. Unprotected IP00 filters must be placed into an enclosure that provides an adequate degree of protection. ACS880-104 parallel connected R8i modules ranging from 380 to 690 V have du/dt filters built-in as standard. du/dt filters are also available as standard for 1xR8i, 690 V.

		du/dt filter type (3 filters included in kits marked*)															
		Unprotected (IP00)				Protected to IP22				Protected to IP54							
500 V	690 V	NOCH0016-60	NOCH0030-60	NOCH0070-60	NOCH0120-60*)	FOCH0260-70	FOCH0320-50	NOCH0016-62	NOCH0030-62	NOCH0070-62	NOCH0120-62	FOCH0260-72	FOCH0320-52	NOCH0016-65	NOCH0030-65	NOCH0070-65	NOCH0120-65
02A1-5		x					x						x				
03A0-5		x					x						x				
03A4-5		x					x						x				
04A8-5		x					x						x				
05A2-5		x					x						x				
07A6-5	07A3-7	x					x						x				
	09A8-7	x					x						x				
11A0-5		x					x						x				
	14A2-7	x					x						x				
014A-5			x					x						x			
021A-5	018A-7		x					x						x			
	022A-7		x					x						x			
	026A-7		x					x						x			
027A-5				x						x							x
034A-5	035A-7			x						x							x
040A-5	042A-7			x						x							x
052A-5	049A-7			x						x							x
065A-5	061A-7				x					x							x
077A-5				x						x							x
	084A-7			x						x							x
096A-5	098A-7			x						x							x
124A-5	119A-7				x							x					
156A-5	142A-7				x							x					
180A-5	174A-7				x							x					
240A-5	210A-7				x							x					
260A-5	271A-7				x							x					
361A-5						x							x				
414A-5						x							x				

External du/dt filters for ACS880-04

ACS880-04		Unprotected (IP00)	
500 V	690 V	FOCH0610-70	FOCH0875-70
	330A-7	x	
	370A-7	x	
460A-5	425A-7	x	
	430A-7	x	
503A-5	470A-7	x	
583A-5	522A-7	x	
635A-5	590A-7	x	
715A-5	650A-7		x
820A-5	721A-7		x
880A-5			x

ACS880-104		Unprotected (IP00)			
500 V	690 V	BOCH-0350A-7	NOCH0016-60	NOCH0030-60	NOCH0070-60
0110A-5	0062A-7	x			
0140A-5	0082A-7	x			
0170A-5	0100A-7	x			
0200A-5	0130A-7	x			
0240A-5	0140A-7	x			
0300A-5	0190A-7	x			
0340A-5	0220A-7	x			
	0270A-7	x			
003A6-5	007A3-7		x		
004A8-5	009A8-7		x		
006A0-5	14A2-7		x		
008A0-5			x		
0011A-5			x		
0014A-5			x		
0018A-5			x		
0025A-5	0018A-7			x	
	0022A-7			x	
0035A-5	0027A-7			x	
	0035A-7				x
0050A-5	0042A-7				x
0061A-5	0052A-7				x
0078A-5					x
0094A-5					x

Dimensions and weights of the du/dt filters

du/dt filter	Height		Width		Depth		Weight	
	(in)	(mm)	(in)	(mm)	(in)	(mm)	(lbs)	(kg)
BOCH-0350A-7 ¹⁾	12.1	310	13.5	347	10.0	256	35	16
NOCH0016-60	7.6	195	5.5	140	4.5	115	5	2.4
NOCH0016-62/65	12.6	323	7.8	199	6.0	154	13	6
NOCH0030-60	8.4	215	6.4	165	5.1	130	10	4.7
NOCH0030-62/65	13.6	348	9.7	249	6.7	172	20	9
NOCH0070-60	10.2	261	7.0	180	5.9	150	21	9.5
NOCH0070-62/65	16.9	433	10.9	279	7.9	202	34	15.5
NOCH0120-60 ²⁾	7.8	200	6.0	154	4.1	106	15	7
NOCH0120-62/65	29.8	765	12.0	308	10.0	256	99	45
NOCH0260-60 ²⁾	14.9	383	7.2	185	4.3	111	26	12
FOCH0260-70	14.9	382	13.3	340	9.9	254	104	47
FOCH0260-72	35.1	900	12.2	314	15.0	384	161	73
FOCH0320-50	25.8	662	12.4	319	11.4	293	143	65
FOCH0320-52	42.6	1092	15.4	396	16.1	413	220	100
FOCH0610-70	25.8	662	12.4	319	11.4	293	143	65
FOCH0875-70	25.8	662	12.4	319	11.4	293	143	65

¹⁾ Values are for three single-phase filters.

²⁾ 3 filters included, dimensions apply for one filter.

Dimensioning tool for selecting the optimal drive

www.nicsanat.com
021-87700210



DriveSize is designed to help select the optimal drive, motor or transformer for the application. Based on data supplied by the user, the tool calculates and suggests which drive and motors to use. DriveSize uses technical specifications found in our technical catalogs and manuals. It provides default values which can be changed by the user.

Easy to access and use

DriveSize is a free software and can be used either online or downloaded for PC from www.abb.com/drives.

DriveSize creates documents for drive and motor dimensioning based on the load, network and cooling data provided by the user. Dimensioning results can be viewed graphically and numerically in the tool.

The tool can be used to calculate currents and network harmonics for a single supply unit or a whole system. The user can import a user-defined motor database by using a separate template that comes with the installation package. DriveSize is easy to use and has shortcut keys to make navigation quicker.



Summary of features and options

Power and voltage range	Ordering code	ACS880-01	ACS880-04	ACS880-04XT	ACS880-04	ACS880-14	ACS880-34
		Single drive modules with option +P940	Single drive modules	Single drive modules	Single drive module packages (6- and 12- pulse)	Regenerative single drive module packages	Low harmonic single drive module packages
		Frame sizes R1 to R9	Frame sizes R10 to R11	Frame sizes 2xR10 to 2xR11	Frame sizes nxDxT+ n×R8i	Frame sizes n×R8i	Frame sizes n×R8i
		hp	hp	hp	hp	hp	hp
230 V		0.75 to 100	300 to 700	700 to 1250	700 to 1700	250 to 2000	250 to 2000
500 V		0.75 to 350	300 to 700	700 to 1250	700 to 1700	250 to 2000	250 to 2000
690 V		0.5 to 250	250 to 700	700 to 1250	650 to 2450	250 to 2900	250 to 2900
Mounting							
For cabinet mounting	+P940	<input type="checkbox"/>	<input checked="" type="checkbox"/>	<input checked="" type="checkbox"/>	<input checked="" type="checkbox"/>	<input checked="" type="checkbox"/>	<input checked="" type="checkbox"/>
Mounting direction - bookshelf		<input checked="" type="checkbox"/>	<input checked="" type="checkbox"/>	<input checked="" type="checkbox"/>	<input checked="" type="checkbox"/>	<input checked="" type="checkbox"/>	<input checked="" type="checkbox"/>
Mounting direction - flat (= sideways)	+C173	<input type="checkbox"/>	<input type="checkbox"/>	<input type="checkbox"/>	<input type="checkbox"/>	<input type="checkbox"/>	<input type="checkbox"/>
Flange mounting	+C135	<input type="checkbox"/>	<input type="checkbox"/>	<input type="checkbox"/>	<input type="checkbox"/>	<input type="checkbox"/>	<input type="checkbox"/>
Side by side mounting		<input checked="" type="checkbox"/>	<input checked="" type="checkbox"/>	<input checked="" type="checkbox"/>	<input checked="" type="checkbox"/>	<input checked="" type="checkbox"/>	<input checked="" type="checkbox"/>
External drive control unit		<input type="checkbox"/>	<input checked="" type="checkbox"/>	<input checked="" type="checkbox"/>	<input checked="" type="checkbox"/>	<input checked="" type="checkbox"/>	<input checked="" type="checkbox"/>
Integrated drive control unit	+P905	<input checked="" type="checkbox"/>	<input type="checkbox"/>	<input type="checkbox"/>	<input type="checkbox"/>	<input type="checkbox"/>	<input type="checkbox"/>
Installation frames for drive modules		<input type="checkbox"/>	<input type="checkbox"/>	<input type="checkbox"/>	<input checked="" style="font-size: small;" type="checkbox"/> 1)	<input checked="" style="font-size: small;" type="checkbox"/> 1)	<input checked="" style="font-size: small;" type="checkbox"/> 1)
Wheels for easy maneuvering of the module		<input type="checkbox"/>	<input checked="" type="checkbox"/>	<input checked="" type="checkbox"/>	<input checked="" type="checkbox"/>	<input checked="" type="checkbox"/>	<input checked="" type="checkbox"/>
Cabling							
Supply bottom entry (module terminals)		<input checked="" type="checkbox"/>	<input type="checkbox"/>	<input type="checkbox"/>	<input checked="" type="checkbox"/>	<input checked="" type="checkbox"/>	<input checked="" type="checkbox"/>
Supply top entry (module terminals)		<input type="checkbox"/>	<input checked="" type="checkbox"/>	<input checked="" type="checkbox"/>	<input type="checkbox"/>	<input type="checkbox"/>	<input type="checkbox"/>
Inverter bottom exit (module terminals)		<input checked="" type="checkbox"/>	<input checked="" type="checkbox"/>	<input checked="" type="checkbox"/>	<input checked="" type="checkbox"/>	<input checked="" type="checkbox"/>	<input checked="" type="checkbox"/>
DC connection bus bars/terminals	+H356	<input checked="" type="checkbox"/>	<input type="checkbox"/>	<input type="checkbox"/>	<input checked="" type="checkbox"/>	<input checked="" type="checkbox"/>	<input checked="" type="checkbox"/>
Cabling panel for quick module installation/removal	+H381	<input type="checkbox"/>	<input type="checkbox"/>	<input type="checkbox"/>	<input type="checkbox"/>	<input type="checkbox"/>	<input type="checkbox"/>
Right hand side terminals (180 degrees turn)	+H391	<input type="checkbox"/>	<input type="checkbox"/>	<input type="checkbox"/>	<input type="checkbox"/>	<input type="checkbox"/>	<input type="checkbox"/>
Degree of protection							
IP00 (UL open type)	+0B051	<input type="checkbox"/>	<input type="checkbox"/>	<input type="checkbox"/>	<input checked="" type="checkbox"/>	<input checked="" type="checkbox"/>	<input checked="" type="checkbox"/>
IP20 (UL open type)		<input checked="" type="checkbox"/>	<input checked="" type="checkbox"/>	<input checked="" type="checkbox"/>	<input type="checkbox"/>	<input type="checkbox"/>	<input type="checkbox"/>
Motor control							
DTC (direct torque control)		<input checked="" type="checkbox"/>	<input checked="" type="checkbox"/>	<input checked="" type="checkbox"/>	<input checked="" type="checkbox"/>	<input checked="" type="checkbox"/>	<input checked="" type="checkbox"/>
Software							
Primary control program		<input checked="" type="checkbox"/>	<input checked="" type="checkbox"/>	<input checked="" type="checkbox"/>	<input checked="" type="checkbox"/>	<input checked="" type="checkbox"/>	<input checked="" type="checkbox"/>
Drive application programming based on IEC 61131-3 using Automation Builder	+N8010	<input type="checkbox"/>	<input type="checkbox"/>	<input type="checkbox"/>	<input type="checkbox"/>	<input type="checkbox"/>	<input type="checkbox"/>
Application control program for crane	+N5050	<input type="checkbox"/>	<input type="checkbox"/>	<input type="checkbox"/>	<input type="checkbox"/>	<input type="checkbox"/>	<input type="checkbox"/>
Application control program for winch	+N5100	<input type="checkbox"/>	<input type="checkbox"/>	<input type="checkbox"/>	<input type="checkbox"/>	<input type="checkbox"/>	<input type="checkbox"/>
Application control program for winder	+N5000	<input type="checkbox"/>	<input type="checkbox"/>	<input type="checkbox"/>	<input type="checkbox"/>	<input type="checkbox"/>	<input type="checkbox"/>
Application control program for PCP/ESP pump	+N5200	<input type="checkbox"/>	<input type="checkbox"/>	<input type="checkbox"/>	<input type="checkbox"/>	<input type="checkbox"/>	<input type="checkbox"/>
Application control program for Rod pump	+N5250	<input type="checkbox"/>	<input type="checkbox"/>	<input type="checkbox"/>	<input type="checkbox"/>	<input type="checkbox"/>	<input type="checkbox"/>
Application control program for centrifuge/decanter	+N5150	<input type="checkbox"/>	<input type="checkbox"/>	<input type="checkbox"/>	<input type="checkbox"/>	<input type="checkbox"/>	<input type="checkbox"/>
Application control program for test bench	+N5300	<input type="checkbox"/>	<input type="checkbox"/>	<input type="checkbox"/>	<input type="checkbox"/>	<input type="checkbox"/>	<input type="checkbox"/>
Support for asynchronous motor		<input checked="" type="checkbox"/>	<input checked="" type="checkbox"/>	<input checked="" type="checkbox"/>	<input checked="" type="checkbox"/>	<input checked="" type="checkbox"/>	<input checked="" type="checkbox"/>
Support for permanent magnet motor		<input checked="" type="checkbox"/>	<input checked="" type="checkbox"/>	<input checked="" type="checkbox"/>	<input checked="" type="checkbox"/>	<input checked="" type="checkbox"/>	<input checked="" type="checkbox"/>
Support for synchronous reluctance motor (SynRM)	+N7502	<input type="checkbox"/>	<input type="checkbox"/>	<input style="font-size: small;" type="checkbox"/> 2)	<input style="font-size: small;" type="checkbox"/> 2)	<input style="font-size: small;" type="checkbox"/> 2)	<input style="font-size: small;" type="checkbox"/> 2)
Control panel							
Intuitive control panel		<input checked="" type="checkbox"/>	<input checked="" type="checkbox"/>	<input checked="" type="checkbox"/>	<input type="checkbox"/>	<input type="checkbox"/>	<input type="checkbox"/>
Integrated control panel holder in the drive	+J414	<input checked="" type="checkbox"/>	<input type="checkbox"/>	<input type="checkbox"/>	<input type="checkbox"/>	<input type="checkbox"/>	<input type="checkbox"/>
Control panel mounting platform (flush), DPMP-01	+J410	<input checked="" type="checkbox"/>	<input type="checkbox"/>	<input type="checkbox"/>	<input type="checkbox"/>	<input type="checkbox"/>	<input type="checkbox"/>
Control connections (I/O) and communications							
2 pcs analog inputs, programmable, galvanically isolated		<input checked="" type="checkbox"/>	<input checked="" type="checkbox"/>	<input checked="" type="checkbox"/>	<input checked="" type="checkbox"/>	<input checked="" type="checkbox"/>	<input checked="" type="checkbox"/>
2 pcs analog outputs, programmable		<input checked="" type="checkbox"/>	<input checked="" type="checkbox"/>	<input checked="" type="checkbox"/>	<input checked="" type="checkbox"/>	<input checked="" type="checkbox"/>	<input checked="" type="checkbox"/>
6 pcs digital inputs, programmable, galvanically isolated - can be divided into two groups		<input checked="" type="checkbox"/>	<input checked="" type="checkbox"/>	<input checked="" type="checkbox"/>	<input checked="" type="checkbox"/>	<input checked="" type="checkbox"/>	<input checked="" type="checkbox"/>
2 pcs digital inputs/outputs		<input checked="" type="checkbox"/>	<input checked="" type="checkbox"/>	<input checked="" type="checkbox"/>	<input checked="" type="checkbox"/>	<input checked="" type="checkbox"/>	<input checked="" type="checkbox"/>
1 pcs digital input interlock		<input checked="" type="checkbox"/>	<input checked="" type="checkbox"/>	<input checked="" type="checkbox"/>	<input checked="" type="checkbox"/>	<input checked="" type="checkbox"/>	<input checked="" type="checkbox"/>
3 pcs relay outputs programmable		<input checked="" type="checkbox"/>	<input checked="" type="checkbox"/>	<input checked="" type="checkbox"/>	<input checked="" type="checkbox"/>	<input checked="" type="checkbox"/>	<input checked="" type="checkbox"/>
Safe torque off (STO)		<input checked="" type="checkbox"/>	<input checked="" type="checkbox"/>	<input checked="" type="checkbox"/>	<input checked="" type="checkbox"/>	<input checked="" type="checkbox"/>	<input checked="" type="checkbox"/>
Drive-to-drive link/Built-in Modbus		<input checked="" type="checkbox"/>	<input checked="" type="checkbox"/>	<input checked="" type="checkbox"/>	<input checked="" type="checkbox"/>	<input checked="" type="checkbox"/>	<input checked="" type="checkbox"/>
Assistant control panel/PC tool connection		<input checked="" type="checkbox"/>	<input checked="" type="checkbox"/>	<input checked="" type="checkbox"/>	<input checked="" type="checkbox"/>	<input checked="" type="checkbox"/>	<input checked="" type="checkbox"/>
Possibility for external power supply for control unit		<input checked="" type="checkbox"/>	<input checked="" type="checkbox"/>	<input checked="" type="checkbox"/>	<input checked="" type="checkbox"/>	<input checked="" type="checkbox"/>	<input checked="" type="checkbox"/>
Built-in I/O extension and speed feedback modules: for more details see sections: "Input/output extension modules for increased connectivity", "Speed feedback interfaces for precise process control" and "DDCS communication option modules"		<input type="checkbox"/>	<input type="checkbox"/>	<input type="checkbox"/>	<input type="checkbox"/>	<input type="checkbox"/>	<input type="checkbox"/>
Built-in adapters for several fieldbuses: for more details see section "Flexible connectivity to automation networks"		<input type="checkbox"/>	<input type="checkbox"/>	<input type="checkbox"/>	<input type="checkbox"/>	<input type="checkbox"/>	<input type="checkbox"/>

Summary of features and options

Power and voltage range	Ordering code	ACS880-01	ACS880-04	ACS880-04XT	ACS880-04	ACS880-14	ACS880-34
		Single drive modules with option +P940	Single drive modules	Single drive modules	Single drive module packages (6- and 12- pulse)	Regenerative single drive module packages	Low harmonic single drive module packages
		Frame sizes R1 to R9	Frame sizes R10 to R11	Frame sizes 2xR10 to 2xR11	Frame sizes nxDxT+ n×R8i	Frame sizes n×R8i	Frame sizes n×R8i
230 V		hp	hp	hp	hp	hp	hp
500 V		0.75 to 100	300 to 700	700 to 1250	700 to 1700	250 to 2000	250 to 2000
690 V		0.5 to 250	250 to 700	700 to 1250	650 to 2450	250 to 2900	250 to 2900

EMC filters							
EMC 1 st environment, restricted distribution, C2, grounded network (TN)	+E202	<input type="checkbox"/> ³⁾	<input type="checkbox"/> ⁴⁾	<input type="checkbox"/> ⁴⁾	<input checked="" type="checkbox"/> ⁴⁾	<input checked="" type="checkbox"/> ⁴⁾	<input checked="" type="checkbox"/> ⁴⁾
EMC 2 nd environment, C3, grounded network (TN)	+E200	<input type="checkbox"/> ⁵⁾	<input type="checkbox"/> ⁶⁾	<input type="checkbox"/> ⁶⁾	-	-	-
EMC 2 nd environment, C3, ungrounded network (IT)	+E201	<input type="checkbox"/> ⁷⁾	<input type="checkbox"/> ⁶⁾	<input type="checkbox"/> ⁶⁾	-	-	-
EMC 2 nd environment, C3, grounded (TN) and ungrounded (IT)	+E210	-	<input type="checkbox"/> ⁴⁾	<input type="checkbox"/> ⁴⁾	<input checked="" type="checkbox"/>	<input checked="" type="checkbox"/>	<input checked="" type="checkbox"/>
Line filter							
AC or DC choke		<input checked="" type="checkbox"/>	<input checked="" type="checkbox"/>	<input checked="" type="checkbox"/>	<input checked="" type="checkbox"/>	-	-
LCL		-	-	-	-	<input checked="" type="checkbox"/>	<input checked="" type="checkbox"/>
Output filters							
Common mode filter	+E208	<input type="checkbox"/>	<input type="checkbox"/>	<input type="checkbox"/>	<input checked="" type="checkbox"/>	<input checked="" type="checkbox"/>	<input checked="" type="checkbox"/>
du/dt filters		<input checked="" type="checkbox"/>	<input checked="" type="checkbox"/>	<input checked="" type="checkbox"/>	<input checked="" type="checkbox"/>	<input checked="" type="checkbox"/>	<input checked="" type="checkbox"/>
Braking (see braking unit table)							
Brake chopper	+D150	<input type="checkbox"/> ⁸⁾	<input type="checkbox"/>	<input type="checkbox"/>	<input checked="" type="checkbox"/>	<input checked="" type="checkbox"/>	<input checked="" type="checkbox"/>
Brake resistor		<input checked="" type="checkbox"/>	<input checked="" type="checkbox"/>	<input checked="" type="checkbox"/>	<input checked="" type="checkbox"/>	<input checked="" type="checkbox"/>	<input checked="" type="checkbox"/>
Regenerative braking		-	-	-	-	<input checked="" type="checkbox"/>	-
Safety functions							
Safe torque off (STO)		<input checked="" type="checkbox"/>	<input checked="" type="checkbox"/>	<input checked="" type="checkbox"/>	<input checked="" type="checkbox"/>	<input checked="" type="checkbox"/>	<input checked="" type="checkbox"/>
Safety functions module, FSO-12, without encoder, programmable functions:	+Q973	<input type="checkbox"/>	<input type="checkbox"/>	<input type="checkbox"/>	<input type="checkbox"/>	<input type="checkbox"/>	<input type="checkbox"/>
Safe stop 1 (SS1)		<input checked="" type="checkbox"/>	<input checked="" type="checkbox"/>	<input checked="" type="checkbox"/>	<input checked="" type="checkbox"/>	<input checked="" type="checkbox"/>	<input checked="" type="checkbox"/>
Safely-limited speed (SLS)		<input checked="" type="checkbox"/>	<input checked="" type="checkbox"/>	<input checked="" type="checkbox"/>	<input checked="" type="checkbox"/>	<input checked="" type="checkbox"/>	<input checked="" type="checkbox"/>
Safe brake control (SBC)		<input checked="" type="checkbox"/>	<input checked="" type="checkbox"/>	<input checked="" type="checkbox"/>	<input checked="" type="checkbox"/>	<input checked="" type="checkbox"/>	<input checked="" type="checkbox"/>
Safe maximum speed (SMS)		<input checked="" type="checkbox"/>	<input checked="" type="checkbox"/>	<input checked="" type="checkbox"/>	<input checked="" type="checkbox"/>	<input checked="" type="checkbox"/>	<input checked="" type="checkbox"/>
Safe stop emergency (SSE)		<input checked="" type="checkbox"/>	<input checked="" type="checkbox"/>	<input checked="" type="checkbox"/>	<input checked="" type="checkbox"/>	<input checked="" type="checkbox"/>	<input checked="" type="checkbox"/>
Prevention of unexpected startup (POUS)		<input checked="" type="checkbox"/>	<input checked="" type="checkbox"/>	<input checked="" type="checkbox"/>	<input checked="" type="checkbox"/>	<input checked="" type="checkbox"/>	<input checked="" type="checkbox"/>
Safety functions module, FSO-21, with encoder, programmable functions:	+Q972 ¹⁰⁾	<input type="checkbox"/>	<input type="checkbox"/>	<input type="checkbox"/>	<input type="checkbox"/>	<input type="checkbox"/>	<input type="checkbox"/>
Safe stop 1 (SS1)		<input checked="" type="checkbox"/>	<input checked="" type="checkbox"/>	<input checked="" type="checkbox"/>	<input checked="" type="checkbox"/>	<input checked="" type="checkbox"/>	<input checked="" type="checkbox"/>
Safely-limited speed (SLS)		<input checked="" type="checkbox"/>	<input checked="" type="checkbox"/>	<input checked="" type="checkbox"/>	<input checked="" type="checkbox"/>	<input checked="" type="checkbox"/>	<input checked="" type="checkbox"/>
Safe brake control (SBC)		<input checked="" type="checkbox"/>	<input checked="" type="checkbox"/>	<input checked="" type="checkbox"/>	<input checked="" type="checkbox"/>	<input checked="" type="checkbox"/>	<input checked="" type="checkbox"/>
Safe maximum speed (SMS)		<input checked="" type="checkbox"/>	<input checked="" type="checkbox"/>	<input checked="" type="checkbox"/>	<input checked="" type="checkbox"/>	<input checked="" type="checkbox"/>	<input checked="" type="checkbox"/>
Safe stop emergency (SSE)		<input checked="" type="checkbox"/>	<input checked="" type="checkbox"/>	<input checked="" type="checkbox"/>	<input checked="" type="checkbox"/>	<input checked="" type="checkbox"/>	<input checked="" type="checkbox"/>
Prevention of unexpected startup (POUS)		<input checked="" type="checkbox"/>	<input checked="" type="checkbox"/>	<input checked="" type="checkbox"/>	<input checked="" type="checkbox"/>	<input checked="" type="checkbox"/>	<input checked="" type="checkbox"/>
Safe direction (SDI), requires encoder feedback, FSE-31		<input checked="" type="checkbox"/>	<input checked="" type="checkbox"/>	<input checked="" type="checkbox"/>	<input checked="" type="checkbox"/>	<input checked="" type="checkbox"/>	<input checked="" type="checkbox"/>
Safe speed monitoring (SSM), requires encoder feedback, FSE-31		<input checked="" type="checkbox"/>	<input checked="" type="checkbox"/>	<input checked="" type="checkbox"/>	<input checked="" type="checkbox"/>	<input checked="" type="checkbox"/>	<input checked="" type="checkbox"/>
Pulse encoder interface module, FSE-31	+L521 ¹⁰⁾	<input type="checkbox"/>	<input type="checkbox"/>	<input type="checkbox"/>	<input type="checkbox"/>	<input type="checkbox"/>	<input type="checkbox"/>
Earth fault monitoring, earthed mains		<input checked="" type="checkbox"/>	<input checked="" type="checkbox"/>	<input checked="" type="checkbox"/>	<input checked="" type="checkbox"/>	<input type="checkbox"/>	<input type="checkbox"/>
Earth fault monitoring, unearthed mains	+Q954	-	<input type="checkbox"/>	<input type="checkbox"/>	<input type="checkbox"/>	<input type="checkbox"/>	<input type="checkbox"/>
Auxiliary option kits							
Fuses, fuse base		-	-	-	<input checked="" type="checkbox"/>	<input checked="" type="checkbox"/>	<input checked="" type="checkbox"/>
DC-fuse switch		-	-	-	<input checked="" type="checkbox"/>	<input checked="" type="checkbox"/>	<input checked="" type="checkbox"/>
Assembly kits for Rittal TS8 cabinets		-	-	-	<input checked="" type="checkbox"/>	<input checked="" type="checkbox"/>	<input checked="" type="checkbox"/>
IP20, IP42 and IP54 door and roof kits		-	<input checked="" type="checkbox"/>	<input checked="" type="checkbox"/>	<input checked="" type="checkbox"/>	<input checked="" type="checkbox"/>	<input checked="" type="checkbox"/>
Approvals							
CE		<input checked="" type="checkbox"/>	<input checked="" type="checkbox"/>	<input checked="" type="checkbox"/>	<input checked="" type="checkbox"/>	<input checked="" type="checkbox"/>	<input checked="" type="checkbox"/>
UL, cUL, CSA		<input checked="" type="checkbox"/>	<input checked="" type="checkbox"/>	<input checked="" type="checkbox"/>	<input checked="" type="checkbox"/>	<input checked="" type="checkbox"/>	<input checked="" type="checkbox"/>
EAC (EAC has replaced GOST R)		<input checked="" type="checkbox"/>	<input checked="" type="checkbox"/>	<input checked="" type="checkbox"/>	<input checked="" type="checkbox"/>	<input checked="" type="checkbox"/>	<input checked="" type="checkbox"/>
RoHS		<input checked="" type="checkbox"/>	<input checked="" type="checkbox"/>	<input checked="" type="checkbox"/>	<input checked="" type="checkbox"/>	<input checked="" type="checkbox"/>	<input checked="" type="checkbox"/>
C-Tick		<input checked="" type="checkbox"/>	<input checked="" type="checkbox"/>	<input checked="" type="checkbox"/>	<input checked="" type="checkbox"/>	<input checked="" type="checkbox"/>	<input checked="" type="checkbox"/>
Marine type approvals	+C132	<input type="checkbox"/> ⁹⁾	-	-	-	-	-
TUV Nord certificate for safety functions	+Q973	<input checked="" type="checkbox"/>	<input checked="" type="checkbox"/>	<input checked="" type="checkbox"/>	<input checked="" type="checkbox"/>	<input checked="" type="checkbox"/>	<input checked="" type="checkbox"/>
VTT ATEX protective device certificate	+Q973	<input type="checkbox"/>	<input type="checkbox"/>	<input type="checkbox"/>	<input type="checkbox"/>	<input type="checkbox"/>	<input type="checkbox"/>

- Standard
- Selectable option, with plus code
- Selectable option, external, no plus code
- Not available

Notes

- ¹⁾ Only for 6-pulse D8T module
- ²⁾ Pending
- ³⁾ Earthed network, frame sizes R1 to R9, 380 to 500 V
- ⁴⁾ For 380 to 500 V
- ⁵⁾ Earthed network, frame sizes R6 to R9, 380 to 500 V

⁶⁾ For 525 to 690 V

⁷⁾ Unearthed network, frame sizes R6 to R9 380 to 500 V, frame sizes R7 to R9, 690 V

⁸⁾ Frame sizes R1 to R4 built-in and R5 to R9 as selectable option

⁹⁾ Contact ABB to check all approved bodies

¹⁰⁾ For availability please check with your local ABB

Summary of features and options

Power and voltage range	Ordering code	ACS880-104	ACS880-204	ACS880-304	ACS880-304	ACS880-904	ACS880-604	ACS880-1604
		inverter modules	ISU (IGBT supply unit)	DSU (diode supply unit)	DSU (diode supply unit)	RRU (regenerative rectifier unit)	Brake units	DC-DC converter
		Frame sizes R11 to n×R8i	Frame sizes R11 to R4i, R6i and n×R8i	Frame sizes D6D to D8D	Frame sizes 2×D7T and n×D8T	Frame sizes n×R8i	Frame sizes n×R8i	Frame sizes n×R8i
		kW	kVA	kVA	kVA	kVA	kVA	kVA
230 V		0.75 to 100	300 to 700	700 to 1250	700 to 1700	250 to 2000	250 to 2000	
500 V		0.75 to 350	250 to 700	700 to 1250	650 to 2450	250 to 2900	250 to 2900	
690 V		0.5 to 250						
Mounting								
For cabinet mounting	+P940	●	●	●	●	●	●	●
Mounting direction - bookshelf		□	● ¹⁾	●	●	●	●	●
Mounting direction - flat (= sideways)	+C173	-	-	-	-	-	-	-
Flange mounting	+C135	-	-	-	-	-	-	-
Side by side mounting		●	●	●	●	●	●	●
External drive control unit		● ²⁾	● ²⁾	●	●	●	●	●
Integrated drive control unit	+P905	● ³⁾	-	-	-	-	-	-
Installation frames for drive modules		■ ⁴⁾	-	-	■ ⁵⁾	-	-	-
Wheels for easy maneuvering of the module		● ⁶⁾	●	●	●	●	●	●
Cabling								
Supply bottom entry (module terminals)		-	●	●	●	●	●	●
Supply top entry (module terminals)		-	-	-	-	-	-	-
Inverter bottom exit (module terminals)		●	-	-	-	-	●	●
DC connection bus bars/terminals	+H356	●	□	□	□	□	□	□
Cabling panel for quick module installation/removal	+H381	-	-	-	-	-	-	-
Right hand side terminals (180 degrees turn)	+H391	-	-	-	-	-	-	-
Degree of protection								
IP00 (UL open type)	+0B051	●	●	●	●	●	●	●
IP20 (UL open type)		-	-	-	-	-	-	-
Motor control								
DTC (direct torque control)		●	-	-	-	-	-	-
Software								
Primary control program		●	●	-	-	-	-	-
Drive application programming based on IEC 61131-3 using Automation Builder	+N8010	□	□	-	-	-	-	□
Application control program for crane	+N5050	□	-	-	-	-	-	-
Application control program for winder	+N5000	□	-	-	-	-	-	-
Application control program for PCP/ESP pump	+N5200	□	-	-	-	-	-	-
Application control program for Rod pump	+N5250	□	-	-	-	-	-	-
Application control program for centrifuge/decanter	+N5150	□	-	-	-	-	-	-
Support for asynchronous motor		●	-	-	-	-	-	-
Support for permanent magnet motor		●	-	-	-	-	-	-
Support for synchronous reluctance motor (SynRM)	+N7502	□	-	-	-	-	-	-
Control panel								
Intuitive control panel		□	□	□	□	□	□ ¹³⁾	□
Integrated control panel holder in the drive	+J414	- ⁸⁾	-	-	-	-	-	-
Control panel mounting platform (flush), DPMP-01	+J410	□	□	□	□	□	□ ¹³⁾	□
Control connections (I/O) and communications								
2 pcs analog inputs, programmable, galvanically isolated		●	●	●	●	●	● ¹³⁾	●
2 pcs analog outputs, programmable		●	●	●	●	●	● ¹³⁾	●
6 pcs digital inputs, programmable, galvanically isolated - can be divided into two groups		●	●	●	●	●	● ¹³⁾	●
2 pcs digital inputs/outputs		●	●	●	●	●	● ¹³⁾	●
1 pcs digital input interlock		●	●	●	●	●	● ¹³⁾	●
3 pcs relay outputs programmable		●	●	●	●	●	● ¹³⁾	●
Safe torque off (STO)		●	-	-	-	-	-	-
Drive-to-drive link/Built-in Modbus		●	●	●	●	●	● ¹³⁾	●
Assistant control panel/PC tool connection		●	●	●	●	●	● ⁹⁾	●
Possibility for external power supply for control unit		●	●	●	●	●	●	●
Built-in I/O extension and speed feedback modules:		□	□	□	□	□	□	□
for more details see sections:								
"Input/output extension modules for increased connectivity",								
"Speed feedback interfaces for precise process control" and								
"DDCS communication option modules"								
Built-in adapters for several fieldbuses: for more details see section "Flexible connectivity to automation networks"		□	□	□	□	□	□	□

Summary of features and options

Power and voltage range	Ordering code	ACS880-104 inverter modules	ACS880-204 ISU (IGBT supply unit)	ACS880-304 DSU (diode supply unit) DxT (6-pulse)	ACS880-304 DSU (diode supply unit) DxT (6- and 12-pulse)	ACS880-904 RRU (regenerative rectifier unit) (6-pulse)	ACS880-604 Brake units	ACS880-1604 DC-DC converter
		Frame sizes R11 to n×R8i	Frame sizes R11 to R4i, R6i and n×R8i	Frame sizes D6D to D8D	Frame sizes 2×D7T and n×D8T	Frame sizes n×R8i	Frame sizes n×R8i	Frame sizes n×R8i
		kW	kVA	kVA	kVA	kVA	kVA	kVA
		230 V 500 V 690 V	0.75 to 100 0.75 to 350 0.5 to 250	300 to 700 250 to 700	700 to 1250 700 to 1250	700 to 1700 650 to 2450	250 to 2000 250 to 2900	250 to 2000 250 to 2900

EMC filters								
EMC 1 st environment, restricted distribution, C2, grounded network (TN)	+E202	-	■	-	■	-	-	-
EMC 2 nd environment, C3, grounded network (TN)	+E200	-	-	-	-	-	-	-
EMC 2 nd environment, C3, ungrounded network (IT)	+E201	-	-	-	-	-	-	-
EMC 2 nd environment, C3, grounded (TN) and ungrounded (IT)	+E210	●	●	●	●	●	●	●
Line filter								
AC or DC choke		-	-	●	●	-	-	-
LCL or L		-	●	-	-	●	-	-
Output filters								
Common mode filter	+E208	●	- ⁹⁾	-	-	●	●	●
du/dt filters		● ¹⁰⁾	● ⁴⁾	-	-	● ⁴⁾	● ⁴⁾	● ⁴⁾
Braking (see braking unit table)								
Brake chopper	+D150	■	-	-	-	-	●	-
Brake resistor		■	-	-	-	-	■	-
Regenerative braking		-	●	-	-	●	-	-
Safety functions								
Safe torque off (STO)		●	-	-	-	-	-	-
Safety functions module, FSO-12, without encoder, programmable functions:	+Q973	□	-	-	-	-	-	-
Safe stop 1 (SS1)								
Safely-limited speed (SLS)								
Safe brake control (SBC)								
Safe maximum speed (SMS)								
Safe stop emergency (SSE)								
Prevention of unexpected startup (POUS)								
Safety functions module, FSO-21, with encoder, programmable functions:	+Q972 ¹²⁾	□	-	-	-	-	-	-
Safe stop 1 (SS1)								
Safely-limited speed (SLS)								
Safe brake control (SBC)								
Safe maximum speed (SMS)								
Safe stop emergency (SSE)								
Prevention of unexpected startup (POUS)								
Safe direction (SDI), requires encoder feedback, FSE-31								
Safe speed monitoring (SSM), requires encoder feedback, FSE-31								
Pulse encoder interface module, FSE-31	+L521 ¹²⁾	□	-	-	-	-	-	-
Earth fault monitoring, earthed mains		●	●	-	●	●	-	-
Earth fault monitoring, unearthed mains	+Q954	-	-	-	-	-	-	-
Auxiliary option kits								
Fuses, fuse base		■	■	■	■	■	■	■
DC-fuse switch		■	-	-	-	-	■	■
Assembly kits for Rittal TS8 cabinets		■	■	■	■	■	■	■
IP22 to IP54 door and roof kits		■	■	■	■	■	■	■
Approvals								
CE		●	●	●	●	●	●	●
UL, cUL, CSA		●	●	●	●	●	●	●
EAC (EAC has replaced GOST R)		●	●	●	●	●	●	●
RoHS		●	●	●	●	●	●	●
C-Tick		●	●	●	●	●	●	●
Marine type approvals	+C132	-	-	-	-	-	-	-
TUV Nord certificate for safety functions	+Q973	● ¹¹⁾	-	-	-	-	-	-
VTT ATEX protective device certificate	+Q973	□	-	-	-	-	-	-

● Standard	Notes	⁵⁾ Only for 6-pulse D8T module	¹⁰⁾ Optional in frame sizes R11 to R8i and 400 V/500 V
□ Selectable option, with plus code	¹⁾ Internal with R11 to R4i	⁶⁾ R11 to R7i without wheels	¹¹⁾ For availability contact your local ABB representative
■ Selectable option, external, no plus code	²⁾ R11 to R7i on the module	⁷⁾ Pending	¹²⁾ For availability please check with your local ABB
- Not available	³⁾ R8i as external	⁸⁾ R11 to R5i as standard	¹³⁾ Not available for 1-pulse brake unit
	⁴⁾ Only for R8i module	⁹⁾ Available for R8i and R6i	

Drives service

Your choice, your future

The future of your drives depends on the service you choose.

Whatever you choose, it should be a well-informed decision. No guesswork. We have the expertise and experience to help you find and implement the right service for your drive equipment. You can start by asking yourself these two critical questions:

- Why should my drive be serviced?
- What would my optimal service options be?

From here, you have our guidance and full support along the course you take, throughout the entire lifetime of your drives.

Your choice, your business efficiency

ABB Drive Care agreement lets you focus on your core business. A selection of predefined service options matching your needs provides optimal, more reliable performance, extended drive lifetime and improved cost control. So you can reduce the risk of unplanned downtime and find it easier to budget for maintenance.

We can help you more by knowing where you are!

Register your drive at www.abb.com/drivereg for extended warranty options and other benefits.



Service to match your needs

Your service needs depend on your operation, life cycle of your equipment and business priorities. We have identified our customers' four most common needs and defined service options to satisfy them. What is your choice to keep your drives at peak performance?

Is uptime your priority?

Keep your drives running with precisely planned and executed maintenance.

Example services include:

- ✓ Life Cycle Assessment
- ✓ Installation and Commissioning
- ✓ Spare Parts
- ✓ Preventive Maintenance
- ✓ Reconditioning
- ✓ ABB Drive Care agreement
- ✓ Drive Exchange

Is rapid response a key consideration?

If your drives require immediate action, our global network is at your service.

Example services include:

- ✓ Technical Support
- ✓ On-site Repair
- ✓ Remote Support
- ✓ Response time agreements
- ✓ Training

Need to extend your assets' lifetime?

Maximize your drive's lifetime with our services.

Example services include:

- ✓ Life Cycle Assessment
- ✓ Upgrades, Retrofits and Modernization
- ✓ Replacement, Disposal and Recycling

Is performance most critical to your operation?

Get optimal performance out of your machinery and systems.

Example services include:

- ✓ Advanced services
- ✓ Engineering and Consulting
- ✓ Inspection and Diagnostics
- ✓ Upgrades, Retrofits and Modernization
- ✓ Workshop Repair
- ✓ Tailored services



Drives service

A lifetime of peak performance

You're in control of every life cycle phase of your drives. At the heart of drive services is a four-phase product life cycle management model. This model defines the services recommended and available throughout drives lifespan.

Now it's easy for you to see the exact service and maintenance available for your drives.

ABB drives life cycle phases explained:

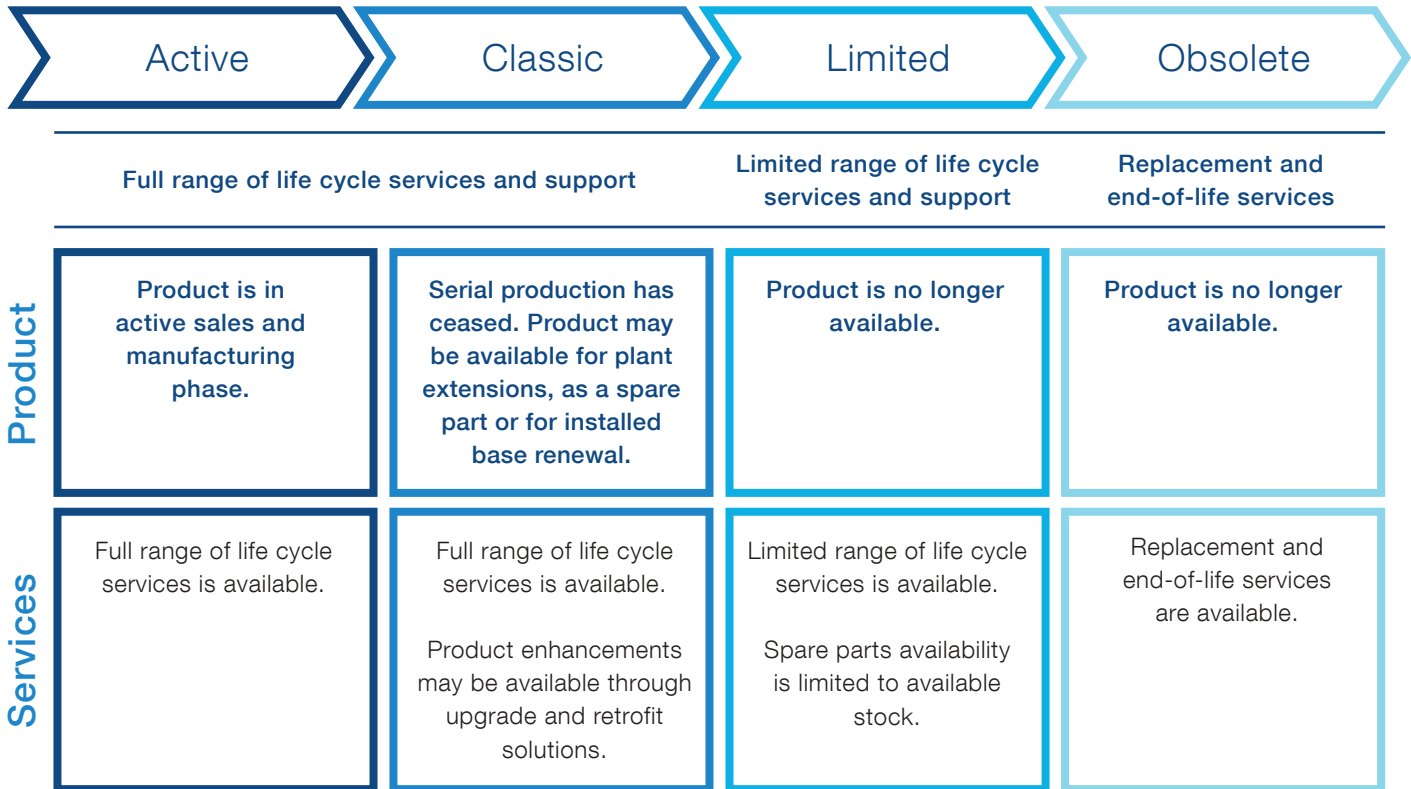

Keeping you informed

We notify you every step of the way using life cycle status statements and announcements.

Your benefit is clear information about your drives' status and precise services available. It helps you plan the preferred service actions ahead of time and make sure that continuous support is always available.

Step 1 Life Cycle Status Announcement

Provides early information about the upcoming life cycle phase change and how it affects the availability of services.

Step 2 Life Cycle Status Statement

Provides information about the drive's current life cycle status, availability of product and services, life cycle plan and recommended actions.



A series of horizontal dotted lines for writing notes.

A series of horizontal dotted lines for writing notes.

Contact us

For more information please contact your local ABB representative or visit:

www.abb.com/drives

© Copyright 2016 ABB. All rights reserved.
Specifications subject to change without notice.



ACS880 drive
modules web page

3AUJA0000164773 REV H US 9.6.2016

www.nicsanat.com

021-87700210



Power and productivity
for a better world™

