



## Technical Data

# PowerFlex® 4 and PowerFlex® 40 AC Drives



[www.nicsanat.com](http://www.nicsanat.com)

021-87700210



## PowerFlex® 4 and PowerFlex® 40 AC Drives Technical Data

Providing users with powerful motor speed control in a compact, space saving design, the Allen-Bradley **PowerFlex 4** and **40** AC drives are the smallest and most cost-effective members of the PowerFlex family of drives. Available in power ratings from 0.2 to 11 kW (0.25 to 15 HP) and in voltage classes of 120, 240, 480 and 600 volts, PowerFlex 4 and 40 are designed to meet global OEM and end-user demands for flexibility, space savings, ease of use and are cost-effective alternatives for speed control of applications such as machine tools, fans, pumps and conveyors and material handling systems.

### Table of Contents

Description	Page
PowerFlex 4 and 40 Common Attributes . . . . .	3
Performance . . . . .	4
PowerFlex 40 Advanced Features . . . . .	5
Communication & Software . . . . .	6
Feature Comparison . . . . .	7
Catalog Number Explanation . . . . .	8
Product Selection . . . . .	9
User Installed Options . . . . .	12
Installation Considerations . . . . .	13
Control Wiring . . . . .	14
Specifications . . . . .	17
Parameter Descriptions . . . . .	20
Approximate Dimensions . . . . .	23



*Shaded areas are applicable to PowerFlex 40 only.*

## PowerFlex 4-Class Common Attributes

### Packaging and Mounting

- Installation can be a virtual snap using the **DIN rail mounting** feature on A and B frame drives. Panel mounting is also available, providing added flexibility.
- **Flange mount** drives are available to reduce overall enclosure size.
- **Zero Stacking™** is allowable for ambient temperatures up to 40°C, saving valuable panel space. 50°C ambient temperatures are permitted with minimal spacing between drives.
- **Integral filtering** is available on all 230V single phase ratings, providing a cost-effective means of meeting EN55011, Class A and B EMC requirements. External filters provide compliance to Class A and B requirements for all PowerFlex 4 and 40 ratings.
- An optional **IP30 (NEMA 1) conduit box** is easily adapted to the standard IP20 (NEMA Type Open) product, providing increased environmental ratings.



### Start Up, Programming and Operation

- An **integral keypad** provides out of the box operation using the local potentiometer and control keys.
- The 10 most common application parameters are contained in the **Basic Program Group**, making programming fast and easy.
- The **programming keys** have the same function as all other PowerFlex drives, so if you can program one PowerFlex drive, you can program them all.
- **4 digit display** with 10 additional LED indicators provides an intuitive display of drive status and information.
- Integral **RS-485 communications** can be used for programming from a PC. It can also be used in a multi-drop network configuration. A serial converter module provides connectivity to any controller with a DF1 port.
- A **NEMA Type 4X** remote and **NEMA Type 1 hand-held LCD keypad** provide additional programming and control flexibility, both featuring the popular CopyCat function.



### Optimized Performance

- **Removable MOV** to ground provides trouble-free operation when used on ungrounded distribution systems.
- A **relay pre-charge** limits inrush current.
- **Integral brake transistor**, available on all ratings (except no brake version), provides dynamic braking capability with simple low cost brake resistors.
- DIP switch-settable **24V DC sink or source control** for control wiring flexibility.
- 150% overload for 60 seconds or 200% overload for 3 seconds provides **robust overload protection**.
- **Adjustable PWM frequency up to 16 kHz** ensures quiet operation.



## Performance

### Sensorless Vector Performance

#### PowerFlex 4

- Drive automatically provides auto boost (IR compensation) and slip compensation.
- Provides excellent speed regulation and high levels of torque across the entire speed range of the drive, and improved speed regulation even as loading increases.

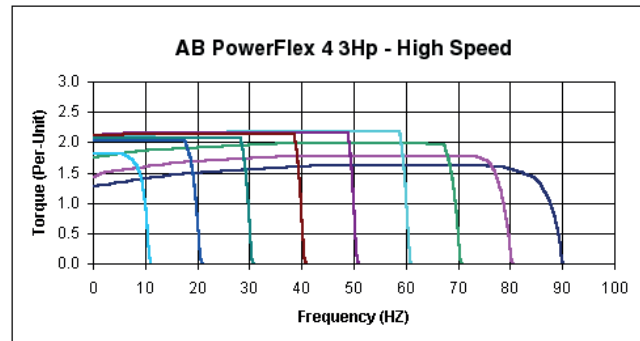

### Sensorless Vector Control

#### PowerFlex 40

- Sensorless Vector Control provides exceptional speed regulation and very high levels of torque across the entire speed range of the drive.
- The Autotune feature allows the PowerFlex 40 to adapt to individual motor characteristics.

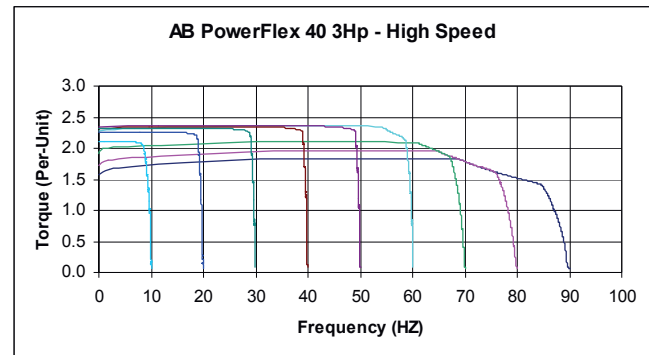

## Performance

- This graph depicts the ability of a PowerFlex 40 drive to accelerate into at least 150% load. A PowerFlex 4 will perform similarly, but with a slightly higher acceleration time.
- At 100% motor load, the drive will run the motor at synchronous speed.
- Excellent current regulation.
- Linear acceleration.
- Best in class digital input response time and repeatability.

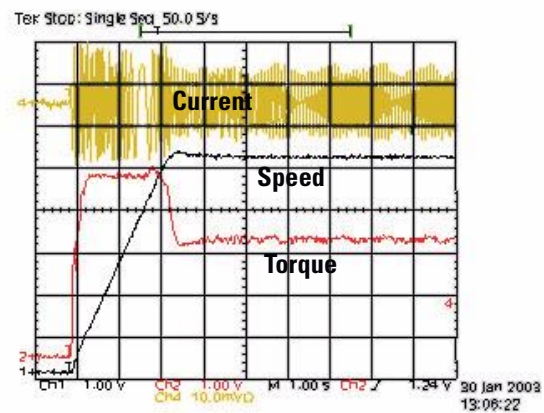

## PowerFlex 40 Advanced Features

### Performance

- **Sensorless Vector Control** develops high torque over a wide speed range and adapts to individual motor characteristics.
- **Variable PWM** allows the drive to output more current at low frequencies.
- Integral **PID** functionality enhances application flexibility.
- **Timer, Counter, Basic Logic and StepLogic™ functions** can reduce hardware design costs and simplify control schemes.
  - **Timer function:** Relay or opto outputs controlled by drive performing timer function. Timer is initiated by activating a digital input programmed as "Timer Start."
  - **Counter function:** Relay or opto outputs controlled by drive performing counter function. Counter function is activated by a digital input programmed as "Counter Input."
  - **Basic Logic:** Relay or opto outputs controlled by status of digital inputs programmed as "Logic Inputs." Performs basic Boolean logic.
  - **StepLogic:** Logic-based steps using preset speed settings. Each step can be programmed for a specific speed, direction and accel/decel profile. Drive outputs can be used to indicate which step is being performed.



### I/O

- **Two (2) Analog Inputs** (one unipolar and one bipolar) are independently isolated from the rest of the drive I/O. These inputs can be toggled between via a digital input.
- **Three (3) fixed and four (4) fully programmable Digital Inputs** provide application versatility.
- **One (1) Analog Output** is DIP switch selectable for either 0-10V or 0-20mA. This scalable, 10-bit output is suitable for metering or as a speed reference for another drive.
- **Two (2) Opto Outputs** and one (1) form C relay output can be used to indicate various drive, motor or logic conditions.

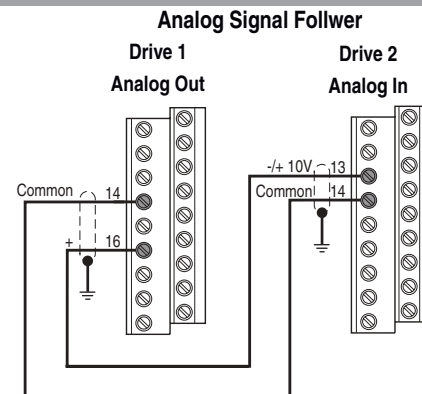

### Communications

- Integral communication cards such as **DeviceNet™, EtherNet/IP** and **Profibus** can improve machine performance.
- **Field installed option** allows for future addition of stand-alone drives to a network.
- **Online EDS file creation** with RS NetWorx providing ease of set-up on a network.



**Versatile Programming and Network Solutions**

- PowerFlex 4 and PowerFlex 40 are compatible with any device that acts as a RTU Master and supports standard 03 and 06 RTU commands.
- A network can be configured using PowerFlex 40 drives with optional communication cards for high performance and flexible configuration capabilities.
  - DeviceNet
  - EtherNet/IP
  - Profibus
- A multi-drive solution can be reached using a single PowerFlex 40 DeviceNet option, with the ability for up to five (5) drives to reside on one (1) node.
- Integral RS485 communications enable the drives to be used in a multi-drop network configuration. A serial converter module (SCM) provides connectivity to any controller with a DF1 port. The SCM can be eliminated if the controller acts as a RTU Master.

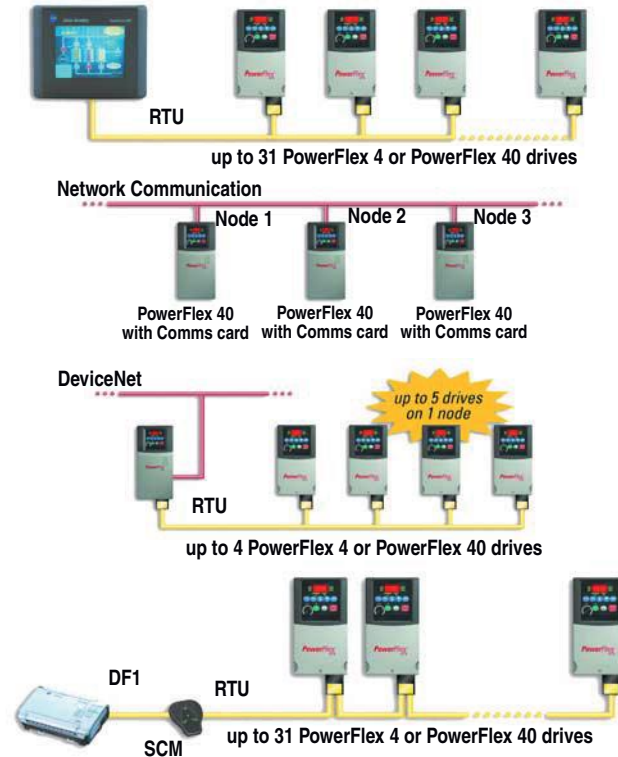

**PC Programming Software**

Through the use of a Serial Converter Module and DriveExplorer™ or DriveTools™ SP software, programming can be greatly simplified.

**DriveExplorer Software**

- View and modify drive and adapter parameters in a method similar to the file management capability of Microsoft Windows Explorer.
- Operate the drive via an on-screen Control Bar, which is a tool that allows you to start, stop, and change the speed reference of the drive.
- Save, restore and print parameter information.
- Compare current parameters with factory defaults or previously saved parameter values.
- Edit, upload and download parameters.

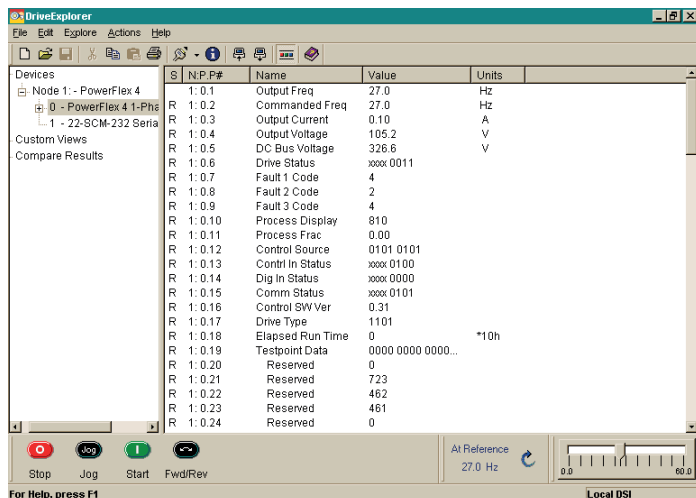

**DriveTools SP Software**

- Online and offline programming capability
- In-grid and dialog-based parameter editing
- Immediate visual indication of drive and communication status when viewing online drive
- Integrated HTML Help architecture

## Feature Comparison

Use the chart below to assist in determining which product is most appropriate for an application.

Feature	<b>PowerFlex® 4</b>	<b>PowerFlex® 40</b>
Catalog Reference	22A...	22B...
Maximum (kW)HP Rating/Input Voltage	(1.1) 1.5 HP/115V, 1ø (2.2) 3 HP/230V, 1ø (3.7) 5 HP/230V, 3ø (3.7) 5 HP/460V, 3ø	(1.1) 1.5 HP/115V, 1ø (2.2) 3 HP/230V, 1ø (7.5) 10 HP/230V, 3ø (11.0) 15 HP/460V, 3ø (11.0) 15 HP/600V, 3ø
Overload Capacity	150% for 60 seconds 200% for 3 seconds	150% for 60 seconds 200% for 3 seconds
NEMA 1/IP30 Option	●	●
EMC Filtering	Internal - 1ø, 230V External - All 1ø, 115V and 3ø Ratings	Internal - 1ø, 230V External - All 1ø, 115V and 3ø Ratings
DIN Rail Mounting Standard	●	● (Through 5 HP)
Integral Keypad with Speed Pot	●	●
Keypad - Remote LCD	●	●
Keypad CopyCat Function	●	●
Control Type	V/Hz	Sensorless Vector & V/Hz
Internal DB Transistor	● Not available on no brake models.	●
Preset Speeds	4	8
Carrier Frequency	2-16 kHz	2-16 kHz
Skip Frequency		●
Process Control Loop		● (PID)
StepLogic Functionality		●
Timer/Counter Functions		●
Control Voltage	24V sink/source	24V sink/source
Discrete Inputs	3 fixed for START/STOP/REV 2 fully programmable	3 fixed for START/STOP/REV 4 fully programmable
Analog Input - Unipolar	1 (0-10V or 4-20 mA)	2 (0-10V and 4-20 mA)
Analog Input - Bipolar		1 (+/- 10V) ❶
Analog Response	2 Hz (500 ms)	100 Hz (10 ms)
Relay Output	1 - N.O./N.C. dry contact	1 - N.O./N.C. dry contact
Digital/Optocoupler Output		2
Analog Output		● (0-10V or 4-20 mA)
Integral RS485	●	●
RS232 (Requires use of Serial Converter Module)	●	●
DeviceNet		●
EtherNet/IP		●
Profibus		●

❶ When using bipolar input, the 0-10V unipolar input cannot be used.

## Catalog Number Explanation

Position								
1-3	4	5	6-8	9	10	11	12(1)	13-14
<b>22A</b>	<b>-</b>	<b>A</b>	<b>1P5</b>	<b>N</b>	<b>1</b>	<b>1</b>	<b>4</b>	<b>AA</b>
Drive	Dash	Voltage Rating	Rating	Enclosure	HIM	Emission Class	Version	Optional

### Code

22A PowerFlex 4  
22B PowerFlex 40

### Code Version

3 No Brake IGBT  
4 Standard

### Code Voltage Ph.

V 120V AC 1  
A 240V AC 1  
B 240V AC 3  
D 480V AC 3  
E 600V AC 3

### Code Rating

0 Not Filtered  
1 Filtered

### Code Interface Module

1 Fixed Keypad

### Code Purpose

AA Reserved for  
Thru custom firmware  
ZZ

### Code Enclosure

N Panel Mount - IP 20 (NEMA Type Open)  
F Flange Mount - IP 20 (NEMA Type Open)  
H Replacement Plate Drive - IP 20 (NEMA Type Open)  
- Contact factory for ordering information.

### Output Current @ 100-120V Input

Code	Amps	kW (HP)
1P5	1.5	0.2 (0.25)
2P3	2.3	0.4 (0.5)
4P5	4.5	0.75 (1.0)
5P0	5.0	0.75 (1.0)
6P0	6.0	1.1 (1.5)

### Output Current @ 200-240 Input, NO BRAKE (2)

Code	Amps	kW (HP)
1P4	1.4	0.2 (0.25)
2P1	2.1	0.4 (0.5)
3P6	3.6	0.75 (1.0)
6P8	6.8	1.5 (2.0)
9P6	9.6	2.2 (3.0)

### Output Current @ 200-240V Input

Code	Amps	kW (HP)
1P5	1.5	0.2 (0.25)
2P3	2.3	0.4 (0.5)
4P5	4.5	0.75 (1.0)
5P0	5.0	0.75 (1.0)
8P0	8.0	1.5 (2.0)
012	12.0	2.2 (3.0)
017	17.5	3.7 (5.0)
024	24.0	5.5 (7.5)
033	33.0	7.5 (10.0)

### Output Current @ 380-480V Input

Code	Amps	kW (HP)
1P4	1.4	0.4 (0.5)
2P3	2.3	0.75 (1.0)
4P0	4.0	1.5 (2.0)
6P0	6.0	2.2 (3.0)
8P7	8.7	3.7 (5.0)
010	10.5	4.0 (5.0)
012	12.0	5.5 (7.5)
017	17.0	7.5 (10.0)
024	24.0	11.0 (15.0)

### Output Current @ 460-600V Input

Code	Amps	kW (HP)
1P7	1.7	0.75 (1.0)
3P0	3.0	1.5 (2.0)
4P2	4.2	2.2 (3.0)
6P6	6.6	4.0 (5.0)
9P9	9.9	5.5 (7.5)
012	12.0	7.5 (10.0)
019	19.0	11.0 (15.0)

(1) Position 12 of the Catalog Number now indicates drive version. All PowerFlex 4 and 40 drives are equipped with RS485 communication.  
(2) PowerFlex 4 option only.



## Product Selection

Drive Ratings			PowerFlex 4			IP 20 Flange Mount	PowerFlex 40			IP 20 Flange Mount
Input Voltage	KW	HP	Output Current	Catalog Number	Frame Size	Catalog Number	Output Current	Catalog Number	Frame Size	Catalog Number
120V 50/60 Hz 1-Phase No Filter	0.2	0.25	1.5A	22A-V1P5N104	A	22A-V1P5F104	—	—	—	—
	0.4	0.5	2.3A	22A-V2P3N104	A	22A-V2P3F104	2.3A	22B-V2P3N104	B	22B-V2P3F104
	0.75	1.0	4.5A	22A-V4P5N104	B	22A-V4P5F104	5.0A	22B-V5P0N104	B	22B-V5P0F104
	1.1	1.5	6.0A	22A-V6P0N104	B	22A-V6P0F104	6.0A	22B-V6P0N104	B	22B-V6P0F104
240V 50/60 Hz 1-Phase NO BRAKE No Filter	0.2	0.25	1.4A	22A-A1P4N103	A	—	—	—	—	—
	0.4	0.5	2.1A	22A-A2P1N103	A	—	—	—	—	—
	0.75	1.0	3.6A	22A-A3P6N103	A	—	—	—	—	—
	1.5	2.0	6.8A	22A-A6P8N103	B	—	—	—	—	—
240V 50/60 Hz 1-Phase NO BRAKE With Integral "S Type" EMC Filter ❶	2.2	3.0	9.6	22A-A9P6N103	B	—	—	—	—	—
	0.2	0.25	1.4A	22A-A1P4N113	A	—	—	—	—	—
	0.4	0.5	2.1A	22A-A2P1N113	A	—	—	—	—	—
	0.75	1.0	3.6A	22A-A3P6N113	A	—	—	—	—	—
240V 50/60 Hz 1-Phase With Integral "S Type" EMC Filter ❶	1.5	2.0	6.8A	22A-A6P8N113	B	—	—	—	—	—
	2.2	3.0	9.6	22A-A9P6N113	B	—	—	—	—	—
	0.2	0.25	1.5A	22A-A1P5N114	A	—	—	—	—	—
	0.4	0.5	2.3A	22A-A2P3N114	A	—	2.3A	22B-A2P3N114	B	—
240V 50/60 Hz 1-Phase With Integral "S Type" EMC Filter ❶	0.75	1.0	4.5A	22A-A4P5N114	A	—	5.0A	22B-A5P0N114	B	—
	1.5	2.0	8.0A	22A-A8P0N114	B	—	8.0A	22B-A8P0N114	B	—
	2.2	3.0	—	—	—	—	12.0A	22B-A012N114	C	—
	0.2	0.25	1.5A	22A-A1P5N104	A	22A-A1P5F104	—	—	—	—
240V 50/60 Hz 1-Phase No Filter	0.4	0.5	2.3A	22A-A2P3N104	A	22A-A2P3F104	2.3A	22B-A2P3N104	B	22B-A2P3F104
	0.75	1.0	4.5A	22A-A4P5N104	A	22A-A4P5F104	5.0A	22B-A5P0N104	B	22B-A5P0F104
	1.5	2.0	8.0A	22A-A8P0N104	B	22A-A8P0F104	8.0A	22B-A8P0N104	B	22B-A8P0F104
	2.2	3.0	—	—	—	—	12.0A	22B-A012N104	C	22B-A012F104
240V 50/60 Hz 3-Phase No Filter	0.2	0.25	1.5A	22A-B1P5N104	A	22A-B1P5F104	—	—	—	—
	0.4	0.5	2.3A	22A-B2P3N104	A	22A-B2P3F104	2.3A	22B-B2P3N104	B	22B-B2P3F104
	0.75	1.0	4.5A	22A-B4P5N104	A	22A-B4P5F104	5.0A	22B-B5P0N104	B	22B-B5P0F104
	1.5	2.0	8.0A	22A-B8P0N104	A	22A-B8P0F104	8.0A	22B-B8P0N104	B	22B-B8P0F104
	2.2	3.0	12.0A	22A-B012N104	B	22A-B012F104	12.0A	22B-B012N104	B	22B-B012F104
	3.7	5.0	17.5A	22A-B017N104	B	22A-B017F104	17.5A	22B-B017N104	B	22B-B017F104
	5.5	7.5	—	—	—	—	24.0A	22B-B024N104	C	22B-B024F104
480V 50/60 Hz 3-Phase No Filter	7.5	11	—	—	—	—	33.0A	22B-B033N104	C	22B-B033F104
	0.4	0.5	1.4A	22A-D1P4N104	A	22A-D1P4F104	1.4A	22B-D1P4N104	B	22B-D1P4F104
	0.75	1.0	2.3A	22A-D2P3N104	A	22A-D2P3F104	2.3A	22B-D2P3N104	B	22B-D2P3F104
	1.5	2.0	4.0A	22A-D4P0N104	A	22A-D4P0F104	4.0A	22B-D4P0N104	B	22B-D4P0F104
	2.2	3.0	6.0A	22A-D6P0N104	B	22A-D6P0F104	6.0A	22B-D6P0N104	B	22B-D6P0F104
	3.7	5.0	8.7A	22A-D8P7N104	B	22A-D8P7F104	—	—	—	—
	4.0	5.0	—	—	—	—	10.5A	22B-D010N104	B	22B-D010F104
	5.5	7.5	—	—	—	—	12.0A	22B-D012N104	C	22B-D012F104
	7.5	10.0	—	—	—	—	17.0A	22B-D017N104	C	22B-D017F104
	11.0	15.0	—	—	—	—	24.0A	22B-D024N104	C	22B-D024F104
600V 50/60 Hz 3-Phase No Filter	0.75	1.0	—	—	—	—	1.7A	22B-E1P7N104	B	22B-E1P7F104
	1.5	2.0	—	—	—	—	3.0A	22B-E3P0N104	B	22B-E3P0F104
	2.2	3.0	—	—	—	—	4.2A	22B-E4P2N104	B	22B-E4P2F104
	4.0	5.0	—	—	—	—	6.6A	22B-E6P6N104	B	22B-E6P6F104
	5.5	7.5	—	—	—	—	9.9A	22B-E9P9N104	C	22B-E9P9F104
	7.5	10.0	—	—	—	—	12.0A	22B-E012N104	C	22B-E012F104
	11.0	15.0	—	—	—	—	19.0A	22B-E019N104	C	22B-E019F104

❶ This filter is suitable for use with a cable length of at least 10 meters for Class A and 1 meter for Class B environments.

## User Installed Options

### IP30/NEMA 1/UL Type 1 Conversion Kit

Item	Description	Drive Frame	PowerFlex 4 Catalog Number ②	PowerFlex 40 Catalog Number ②
IP30/NEMA 1/UL Type 1 Kit	Field installed kit. Converts drive to IP30/NEMA 1/UL Type 1 enclosure. Includes conduit box with mounting screws and plastic top panel.	A	22-JBAA	–
		B	22-JBAB	22-JBAB
		C	–	22-JBAC
IP30/NEMA 1/UL Type 1 Kit with Communication Option	Field installed kit. Converts drive to IP30/NEMA 1/UL Type 1 enclosure. Includes communication option conduit box with mounting screws and plastic top panel.	B	–	22-JBCB
		C	–	22-JBCC

### Human Interface Module Option Kits and Accessories

Item	Description	Catalog Number ②
Remote Human Interface Modules (HIMs)	LCD Display, Remote Panel Mount, Digital Speed Control, Full Numeric Keypad, CopyCat capable, IP66 (NEMA Type 4X/12) indoor use only, Includes 2.9 meter cable.	22-HIM-C2S ① 22-HIM-C2
	LCD Display, Remote Handheld, Digital Speed Control, Full Numeric Keypad, CopyCat capable, IP30 (NEMA Type 1), Includes 1.0 meter cable, Panel Mount with optional Bezel Kit.	22-HIM-A3
Bezel Kit	Panel Mount for LCD Display, Remote Handheld unit, IP30 (NEMA Type 1), Includes a 22-RJ45CBL-C20 cable.	22-HIM-B1
DSI HIM Cable	DSI HIM Cable (DSI HIM to RJ45 cable) 1.0 Meter (3.3 Feet) 2.9 Meter (9.51 Feet)	22-HIM-H10
		22-HIM-H30

### Communication Option Kits

Item	Description	Catalog Number ②
Serial Converter Module (RS485 to RS232)	Provides serial communication via DF1 protocol for use with DriveExplorer™ and DriveExecutive™ software. Smart Self-powered Serial Converter (RS-232) includes: DSI to RS232 serial converter DriveExplorer Lite Version 3.01 or later 1203-SFC and 22-RJ45CBL-C20 Cables	22-SCM-232
DSI Cable	2.0 meter RJ45 to RJ45 cable, male to male connectors.	22-RJ45CBL-C20
Communication Adapters	Embedded communication option for use with the PowerFlex family of drives. Requires a Communication Adapter Cover (Ordered Separately). DeviceNet EtherNet/IP Profibus	22-COMM-D 22-COMM-E 22-COMM-P
Communication Adapter Covers	Houses the optional communication adapters. These covers add 25 mm (0.98 in.) to the overall depth of the drive. PowerFlex 40 Drive Frame B PowerFlex 40 Drive Frame C	22B-CCB 22B-CCC
Serial Cable	2.0 meter serial cable with a locking low profile connector to connect to the serial converter and a 9-pin sub-miniature D female connector to connect to a computer.	1203-SFC
Null Cable Converter	For use when connecting the serial converter to DriveExplorer on a handheld PC.	1203-SNM
Splitter Cable	RJ45 one to two port splitter cable.	AK-U0-RJ45-SC1
Terminating Resistors	RJ45 120 Ohm resistor (2 pieces).	AK-U0-RJ45-TR1
Terminal Block	RJ45 Two position terminal block (5 pieces).	AK-U0-RJ45-TB2P

### PC Programming Software

Item	Description	Catalog Number
DriveTools SP Software, Version 2.02 or later	"Windows" based software package that provides an intuitive means for monitoring or configuring Allen-Bradley drives and communications adapters online and offline. Compatibility: Windows 98, ME, NT, 4.0 (Service Pack 3 or later), 2000 and XP. ③	9303-4DTE01ENE
DriveExplorer™ Software, Version 4.02 or later	"Windows" based software package that provides an intuitive means for monitoring or configuring Allen-Bradley drives and communications adapters online and offline. Compatibility: Windows 98, ME, NT, 4.0 (Service Pack 3 or later), 2000 and XP. ③	9306-4EXP01ENE

① The 22-HIM-C2S is smaller than the 22-HIM-C2 and cannot be used as a direct replacement.

② For pricing information, refer to the PowerFlex 4 and 40 AC Drives Price List, publication 22-PL001x-EN-P.

③ See [www.ab.com/drive/](http://www.ab.com/drive/) for support devices.

## User Installed Options

### DC Bus Inductors

Input Voltage	kW	HP	Amps	Inductance mh	MTE Catalog Number
240V 50/60 Hz 3-Phase	5.5	7.5	32	0.85	32RB001
	7.5	10.0	40	0.5	40RB001
480V 50/60 Hz 3-Phase	5.5	7.5	18	3.75	18RB004
	7.5	10.0	25	4.0	25RB005
	11.0	15.0	32	2.68	32RB003
600V 50/60 Hz 3-Phase	5.5	7.5	12	6.0	12RB004
	7.5	10.0	18	6.0	18RB005
	11.0	15.0	25	4.0	25RB005

### Dynamic Brake Resistors

Drive Ratings			PowerFlex 4	PowerFlex 40
Input Voltage	kW	HP	Catalog Number ❶	Catalog Number ❶
120V 50/60 Hz 1-Phase	0.2	0.25	AK-R2-091P500	–
	0.4	0.5	AK-R2-091P500	–
	0.75	1.0	AK-R2-091P500	–
	1.1	1.5	AK-R2-091P500	–
240V 50/60 Hz 1-Phase	0.2	0.25	AK-R2-091P500	–
	0.4	0.5	AK-R2-091P500	–
	0.75	1.0	AK-R2-091P500	–
	1.5	2.0	AK-R2-091P500	–
	2.2	3.0	–	AK-R2-047P500
240V 50/60 Hz 3-Phase	0.2	0.25	AK-R2-091P500	–
	0.4	0.5	AK-R2-091P500	–
	0.75	1.0	AK-R2-091P500	–
	1.5	2.0	AK-R2-091P500	–
	2.2	3.0	AK-R2-047P500	–
	3.7	5.0	AK-R2-047P500	–
	5.5	7.5	–	AK-R2-030P1K2
7.5	10.0	–	AK-R2-030P1K2	
480V 50/60 Hz 3-Phase	0.4	0.5	AK-R2-360P500	–
	0.75	1.0	AK-R2-360P500	–
	1.5	2.0	AK-R2-360P500	–
	2.2	3.0	AK-R2-120P1K2	–
	4.0	5.0	AK-R2-120P1K2	–
	5.5	7.5	–	AK-R2-120P1K2
	7.5	10.0	–	AK-R2-120P1K2
600V 50/60 Hz 3-Phase No Filter	0.75	1.0	–	AK-R2-360P500
	1.5	2.0	–	AK-R2-360P500
	2.2	3.0	–	AK-R2-120P1K2
	4.0	5.0	–	AK-R2-120P1K2
	5.5	7.5	–	AK-R2-120P1K2
	7.5	10.0	–	AK-R2-120P1K2
	11.0	15.0	–	AK-R2-120P1K2❷

❶ Resistors listed in this table are rated for a minimum 5% duty cycle. See publication no. PFLEX-AT001x-EN-P for additional information.

❷ Requires two resistors wired in parallel.

### 3% Line Reactors

Input Voltage	kW	HP	Fundamental Amps	Max Continuous Amps	Inductance mh	Watts Loss	Catalog Number ❶	
240V 50/60 Hz 3-Phase	0.2	0.25	2	3	12.0	7.5 W	1321-3R2-A	
	0.4	0.5	4	6	12.0	21 W	1321-3R4-D	
	0.75	1.0	8	12	3.0	29 W	1321-3R8-B	
	1.5	2.0	8	12	1.5	19.5 W	1321-3R8-A	
	2.2	3.0	12	18	1.25	26 W	1321-3R12-A	
	3.7	5.0	18	27	0.8	36 W	1321-3R18-A	
	5.5	7.5	25	37.5	0.5	48 W	1321-3R25-A	
	7.5	10.0	35	52.5	0.4	49 W	1321-3R35-A	
	480V 50/60 Hz 3-Phase	0.4	0.5	2	3	20.0	11.3 W	1321-3R2-B
	0.75	1.0	4	6	9.0	20 W	1321-3R4-C	
1.5	2.0	4	6	6.5	20 W	1321-3R4-B		
2.2	3.0	8	12	5.0	25.3 W	1321-3R8-C		
3.7	5.0	8	12	3.0	29 W	1321-3R8-B		
4.0	5.0	12	18	2.5	31 W	1321-3R12-B		
5.5	7.5	12	18	2.5	31 W	1321-3R12-B		
7.5	10.0	18	27	1.5	43 W	1321-3R18-B		
11.0	15.0	25	37.5	1.2	52 W	1321-3R25-B		
600V 50/60 Hz 3-Phase No Filter	0.75	1.0	2	3	20.0	11.3 W	1321-3R2-B	
	1.5	2.0	4	6	6.5	20 W	1321-3R4-B	
	2.2	3.0	4	6	6.5	20 W	1321-3R4-B	
	4.0	5.0	8	12	5.0	25.3 W	1321-3R8-C	
	5.5	7.5	12	18	2.5	31 W	1321-3R12-B	
	7.5	10.0	12	18	2.5	31 W	1321-3R12-B	
	11.0	15.0	18	27	1.5	43 W	1321-3R18-B	

❶ Catalog numbers listed are for 3% impedance open style units. NEMA Type 1 and 5% impedance reactor types are also available. Refer to publication 1321-TD001x-EN-P.

## User Installed Options

### PowerFlex 4 EMC Filters

Drive Ratings			S Type Filter	L Type Filter
Input Voltage	kW	HP	Catalog Number ❶	Catalog Number ❷
120V 50/60 Hz 1-Phase	0.2	0.25	–	22-RF010-AL
	0.4	0.5	–	22-RF010-AL
	0.75	1.0	–	22-RF018-BL
240V 50/60 Hz 1-Phase	0.2	0.25	❸	22-RF010-AL
	0.4	0.5	❸	22-RF010-AL
	0.75	1.0	❸	22-RF010-AL
	1.5	2.0	❸	22-RF018-BL
240V 50/60 Hz 3-Phase	0.2	0.25	22-RF9P5-AS	22-RF9P5-AL
	0.4	0.5	22-RF9P5-AS	22-RF9P5-AL
	0.75	1.0	22-RF9P5-AS	22-RF9P5-AL
	1.5	2.0	22-RF9P5-AS	22-RF9P5-AL
	2.2	3.0	22-RF021-BS	22-RF021-BL
	3.7	5.0	22-RF021-BS	22-RF021-BL
480V 50/60 Hz 3-Phase	0.4	0.5	22-RF5P7-AS	22-RF5P7-AL
	0.75	1.0	22-RF5P7-AS	22-RF5P7-AL
	1.5	2.0	22-RF5P7-AS	22-RF5P7-AL
	2.2	3.0	22-RF012-BS	22-RF012-BL
	4.0	5.0	22-RF012-BS	22-RF012-BL

### PowerFlex 40 EMC Filters

Drive Ratings			S Type Filter	L Type Filter	
Input Voltage	kW	HP	Catalog Number ❶	Catalog Number ❷	
120V 50/60 Hz 1-Phase	0.4	0.5	–	22-RF018-BL	
	0.75	1.0	–	22-RF018-BL	
	1.1	1.5	–	22-RF018-BL	
240V 50/60 Hz 1-Phase	0.4	0.5	❸	22-RF018-BL	
	0.75	1.0	❸	22-RF018-BL	
	1.5	2.0	❸	22-RF018-BL	
	2.2	3.0	❸	22-RF025-CL	
240V 50/60 Hz 3-Phase	0.4	0.5	22-RF021-BS ❹	22-RF021-BL	
	0.75	1.0	22-RF021-BS ❹	22-RF021-BL	
	1.5	2.0	22-RF021-BS ❹	22-RF021-BL	
	2.2	3.0	22-RF021-BS ❹	22-RF021-BL	
	3.7	5.0	22-RF021-BS ❹	22-RF021-BL	
	5.5	7.5	22-RF034-CS	22-RF034-CL	
	7.5	10.0	22-RF034-CS	22-RF034-CL	
	11.0	15.0	22-RF026-CS	22-RF026-CL	
480V 50/60 Hz 3-Phase	0.4	0.5	22-RF012-BS	22-RF012-BL	
	0.75	1.0	22-RF012-BS	22-RF012-BL	
	1.5	2.0	22-RF012-BS	22-RF012-BL	
	2.2	3.0	22-RF012-BS	22-RF012-BL	
	4.0	5.0	22-RF012-BS	22-RF012-BL	
	5.5	7.5	22-RF018-CS	22-RF018-CL	
	7.5	10.0	22-RF018-CS	22-RF018-CL	
	11.0	15.0	22-RF026-CS	22-RF026-CL	
	600V 50/60 Hz 3-Phase	0.75	1.0	–	22-RF008-BL
		1.5	2.0	–	22-RF008-BL
2.2		3.0	–	22-RF008-BL	
4.0		5.0	–	22-RF008-BL	
5.5		7.5	–	22-RF015-CL	
7.5		10.0	–	22-RF015-CL	
11.0		15.0	–	22-RF024-CL	

- ❶ This filter is suitable for use with a cable length up to 10 meters for Class A and 1 meter for Class B environments.
- ❷ This filter is suitable for use with a cable length up to 100 meters for Class A and 5 meters for Class B environments.
- ❸ Drives are available in these ratings with internal "S Type" filters.
- ❹ Filter must be Series B or later.

## Installation Considerations

PowerFlex 4 and 40 drives have the following built in protective features to help simplify installation.

- Ground fault protection while starting and running ensures reliable operation
- Electronic motor overload protection increases motor life
- Removable MOV to ground ensures compatibility with ungrounded systems
- 6kV transient protection provides increased robustness for 380-480V system voltages

There are many other factors that must be considered for optimal performance in any given application. The block diagram below highlights the primary installation considerations. Consult the PowerFlex 4 or PowerFlex 40 *User Manual*, Publications 22A-UM001... or 22B-UM001... available online at [www.ab.com/manuals/dr](http://www.ab.com/manuals/dr), for detailed recommendations on input power conditioning, CE conformance (EMC filtering), dynamic braking, reflected wave protection, motor cable types and motor cable distances.

### Block Diagram

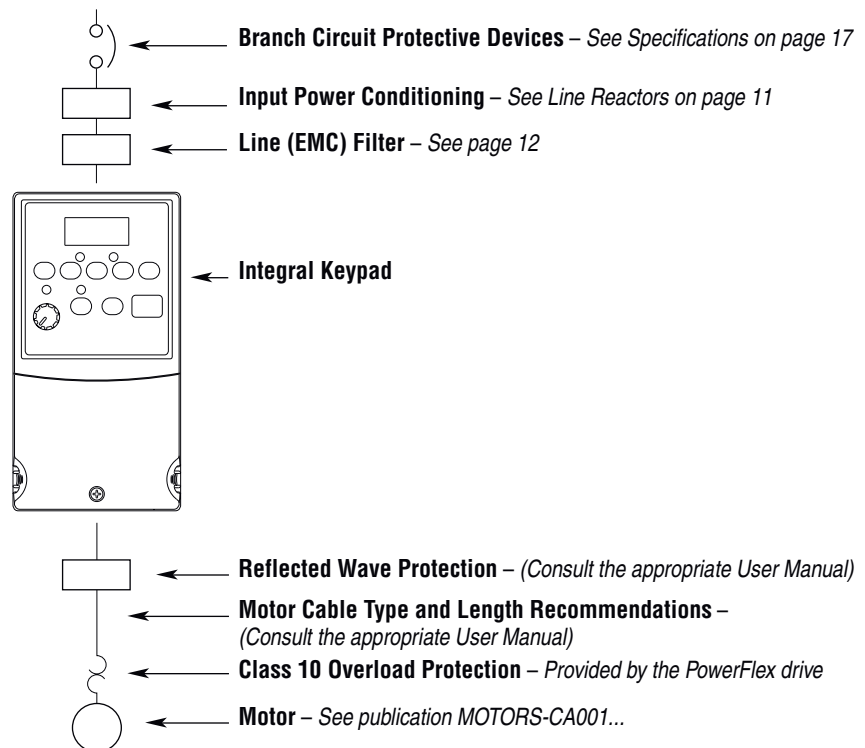

## Control Wiring

### PowerFlex 4

- The control logic is 24V DC and can be set for either Sink or Source control via a DIP switch setting.
- Control terminal screws are sized for a conventional blade screw driver.
- I/O Terminals 1, 2 and 3 are dedicated for Stop, Start and Reverse operation respectively. These I/O Terminals can be programmed for 2- or 3-Wire operation to meet application requirements.
- I/O Terminals 4 and 5 are programmable and provide added flexibility. Programmable functions include:
  - Local Control
  - Jog
  - Second Accel/Decel
  - Clear Fault
  - Preset Frequencies
  - RS485 Control
  - Auxiliary Fault
- Speed can be controlled via a 0-10V input or 4-20 mA input. Both are electrically isolated from the drive.
- One form C relay can be programmed to provide the status of a wide variety of drive conditions.
- The drive is shipped with a jumper installed between I/O Terminals 01 and 11 to allow out of box operation from the keypad.

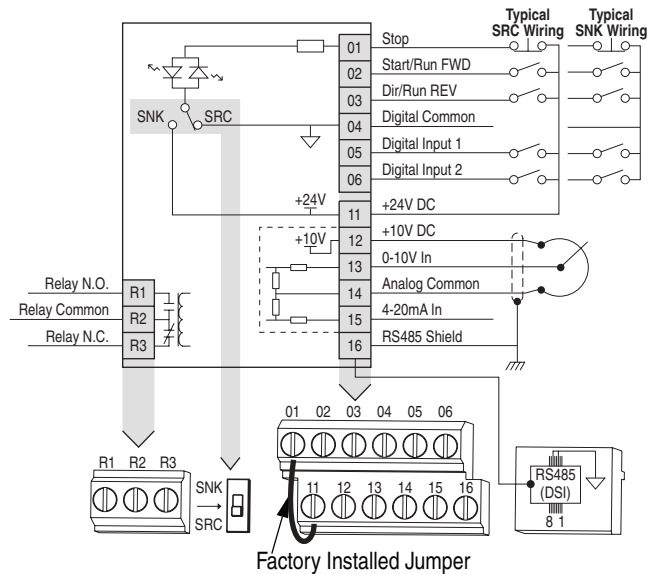

No.	Signal	Default	Description
R1	Relay N.O.	Fault	Normally open contact for output relay.
R2	Relay Common	–	Common for output relay.
R3	Relay N.C.	Fault	Normally closed contact for output relay.

	30V DC	125V AC	240V AC
Resistive	3.0 A	3.0 A	3.0 A
Inductive	0.5 A	0.5 A	0.5 A

Sink/Source DIP Switch	Source (SRC)	Inputs can be wired as Sink (SNK) or Source (SRC) via DIP Switch setting.	
01	Stop <sup>(1)</sup>	Coast	The factory installed jumper or a normally closed input must be present for the drive to start.
02	Start/Run FWD	Not Active	Command comes from the integral keypad by default. To disable reverse operation, see A095 [Reverse Disable].
03	Direction/Run REV	Not Active	
04	Digital Common	–	For digital inputs. Electronically isolated with digital inputs from analog I/O.
05	Digital Input 1	Preset Freq	Program with A051 [Digital In1 Sel].
06	Digital Input 2	Preset Freq	Program with A052 [Digital In2 Sel].
11	+24V DC	–	Drive supplied power for digital inputs. Maximum output current is 100mA.
12	+10V DC	–	Drive supplied power for 0-10V external potentiometer. Maximum output current is 15mA.
13	0-10V In <sup>(1)</sup>	Not Active	For external 0-10V input supply (input impedance = 100k ohm) or potentiometer wiper.
14	Analog Common	–	For 0-10V In or 4-20mA In. Electronically isolated with analog inputs from digital I/O.
15	4-20mA In <sup>(1)</sup>	Not Active	For external 4-20mA input supply (input impedance = 250 ohm).
16	RS485 (DSI) Shield	–	Terminal should be connected to safety ground - PE when using the RS485 (DSI) communications port.

<sup>(1)</sup> Only one analog frequency source may be connected at a time. If more than one reference is connected at the same time, an undetermined frequency reference will result.

## Control Wiring

### PowerFlex 40

- The control logic is 24V DC and can be set for either Sink or Source control via a DIP switch setting.
- Control terminal screws are sized for a conventional blade screw driver.
- I/O Terminals 1, 2 and 3 are dedicated for Stop, Start and Reverse operation respectively. These I/O Terminals can be programmed for 2- or 3-Wire operation to meet application requirements.
- I/O Terminals 5, 6, 7 and 8 are programmable and provide added flexibility. Programmable functions include Local Control, Jog, Second Accel/Decel, Clear Fault, Preset Frequencies, RS485 Control and Auxiliary Fault.
- Speed can be controlled via a 0-10V input and/or 4-20 mA input. Both inputs are independently isolated from the rest of the drive and can be used for applications such as PID. Voltage input can be programmed for bipolar operation.
- The drive is shipped with a jumper installed between I/O Terminals 01 and 11 to allow out of box operation from the keypad.

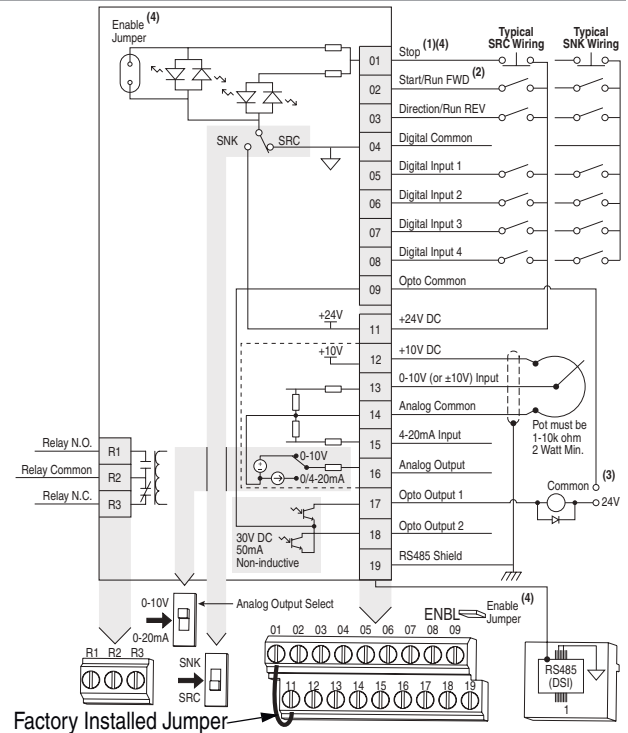

No.	Signal	Default	Description
R1	Relay N.O.	Fault	Normally open contact for output relay.
R2	Relay Common	-	Common for output relay.
R3	Relay N.C.	Fault	Normally closed contact for output relay.
Analog Output Select DIP Switch		0-10V	Sets analog output to either voltage or current. Setting must match A065 [Analog Out Sel].
Sink/Source DIP Switch		Source (SRC)	Inputs can be wired as Sink (SNK) or Source (SRC) via DIP Switch setting.
01	Stop	Coast	The factory installed jumper or a normally closed input must be present for the drive to start.
02	Start/Run FWD	Not Active	Command comes from the integral keypad by default. To disable reverse operation, see A095 [Reverse Disable].
03	Direction/Run REV	Not Active	
04	Digital Common	-	
05	Digital Input 1	Preset Freq	Program with A051 [Digital In1 Sel].
06	Digital Input 2	Preset Freq	Program with A052 [Digital In2 Sel].
07	Digital Input 3	Local	Program with A053 [Digital In3 Sel].
08	Digital Input 4	Jog Forward	Program with A054 [Digital In4 Sel].
09	Opto Common	-	For opto-coupled outputs. Electronically isolated with opto outputs from analog I/O and digital inputs.
11	+24V DC	-	Referenced to Digital Common. Drive supplied power for digital inputs. Maximum output current is 100mA.
12	+10V DC	-	Referenced to Analog Common. Drive supplied power for 0-10V external potentiometer. Maximum output current is 15mA.
13	±10V In (1)	Not Active	For external 0-10V (unipolar) or ±10V (bipolar) input supply (input impedance = 100k ohm) or potentiometer wiper.
14	Analog Common	-	For 0-10V In or 4-20mA In. Electronically isolated with analog inputs and outputs from digital I/O and opto outputs.

## Control Wiring

No.	Signal	Default	Description
15	4-20mA In (1)	Not Active	For external 4-20mA input supply (input impedance = 250 ohm).
16	Analog Output	OutFreq 0-10	The default analog output is 0-10V. To covert to a current value, change the Analog Output Select DIP Switch to 0-20mA. Program with A065 [Analog Out Sel]. Max analog value can be scaled with A066 [Analog Out High]. Maximum Load:4-20mA = 525 ohm (10.5V) 0-10V = 1k ohm (10mA)
17	Opto Output 1	MotorRunning	Program with A058 [Opto Out1 Sel]
18	Opto Output 2	At Frequency	Program with A061 [Opto Out2 Sel]
19	RS485 (DSI) Shield	-	Terminal should be connected to safety ground - PE when using the RS485 (DSI) communications port.

(1) 0-10V In and 4-20mA In are distinct input channels and may be connected simultaneously. Inputs may be used independently for speed control or jointly when operating in PID mode.



## Specifications

### Drive Ratings — PowerFlex 4

Catalog Number	Output Ratings		Input Ratings			Branch Circuit Protection			Power Dissipation	
	kW (HP)	Amps	Voltage Range	kVA	Amps	Fuses ❶	140M Motor Protectors ❷	Contactors	Internal	Total
<b>100 - 120V AC – 1-Phase Input, 0 - 230V 3-Phase Output</b>										
22A-V1P5N104	0.2 (0.25)	1.5	90-126	0.75	6.0	10	140M-C2E-C10	100-C09	10	25
22A-V2P3N104	0.4 (0.5)	2.3	90-126	1.15	9.0	15	140M-C2E-C16	100-C12	9	30
22A-V4P5N104	0.75 (1.0)	4.5	90-126	2.25	18.0	30	140M-D8E-C20	100-C23	12	50
22A-V6P0N104	1.1 (1.5)	6.0	90-126	3.00	24.0	40	140M-D8E-C32	100-C37	12	70
<b>200 - 240V AC – 1-Phase Input, 0 - 230V 3-Phase Output (No Brake) ❸</b>										
22A-A1P4N103	0.2 (0.25)	1.4	180-265	0.7	3.2	6	140M-C2E-B40	100-C09	10	25
22A-A2P1N103	0.4 (0.5)	2.1	180-265	1.05	5.3	10	140M-C2E-B63	100-C09	9	30
22A-A3P6N103	0.75 (1.0)	3.6	180-265	1.8	9.2	15	140M-C2E-C16	100-C12	12	50
22A-A6P8N103	1.5 (2.0)	6.8	180-265	3.4	14.2	25	140M-C2E-C16	100-C16	16	80
22A-A9P6N103	2.2 (3.0)	9.6	180-265	4.8	19.6	30	140M-D8E-C25	100-C23	11	110
<b>200 - 240V AC – 1-Phase Input, 0 - 230V 3-Phase Output ❸</b>										
22A-A1P5N104	0.2 (0.25)	1.5	180-265	0.75	5.0	10	140M-C2E-B63	100-C09	10	25
22A-A2P3N104	0.4 (0.5)	2.3	180-265	1.15	6.0	10	140M-C2E-B63	100-C09	9	30
22A-A4P5N104	0.75 (1.0)	4.5	180-265	2.25	10.0	15	140M-C2E-C16	100-C12	12	50
22A-A8P0N104	1.5 (2.0)	8.0	180-265	4.0	18.0	30	140M-D8E-C20	100-C23	16	80
<b>200 - 240V AC – 3-Phase Input, 0 - 230V 3-Phase Output</b>										
22A-B1P5N104	0.2 (0.25)	1.5	180-265	0.75	1.8	3	140M-C2E-B25	100-C09	10	25
22A-B2P3N104	0.4 (0.5)	2.3	180-265	1.15	2.5	6	140M-C2E-B40	100-C09	9	30
22A-B4P5N104	0.75 (1.0)	4.5	180-265	2.25	5.2	10	140M-C2E-C10	100-C09	12	50
22A-B8P0N104	1.5 (2.0)	8.0	180-265	4.0	9.5	15	140M-C2E-C16	100-C12	16	80
22A-B012N104	2.2 (3.0)	12.0	180-265	5.5	15.5	25	140M-C2E-C16	100-C16	16	115
22A-B017N104	3.7 (5.0)	17.5	180-265	8.6	21.0	35	140M-F8E-C25	100-C23	16	165
<b>380 - 480V AC – 3-Phase Input, 0 - 460V 3-Phase Output</b>										
22A-D1P4N104	0.4 (0.5)	1.4	340-528	1.4	1.8	3	140M-C2E-B25	100-C09	15	30
22A-D2P3N104	0.75 (1.0)	2.3	340-528	2.3	3.2	6	140M-C2E-B40	100-C09	13	40
22A-D4P0N104	1.5 (2.0)	4.0	340-528	4.0	5.7	10	140M-C2E-B63	100-C09	13	60
22A-D6P0N104	2.2 (3.0)	6.0	340-528	5.9	7.5	15	140M-C2E-C10	100-C09	17	90
22A-D8P7N104	3.7 (5.0)	8.7	340-528	8.6	9.0	15	140M-C2E-C16	100-C16	14	145

❶ Recommended Fuse Type: UL Class J, CC, T or Type BS88; 600V (550V) or equivalent.

❷ Refer to Bulletin 140M Motor Protectors Selection Guide, publication 140-SG001... to determine the frame and breaking capacity required for your application.

❸ 200-240V AC - 1-Phase drives are also available with an integral EMC filter. Catalog suffix changes from N104 to N114 or N103 to N113.

## Specifications

### Drive Ratings — PowerFlex 40

Catalog Number	Output Ratings		Input Ratings			Branch Circuit Protection			Power Dissipation	
	kW (HP)	Amps	Voltage Range	kVA	Amps	Fuses ①	140M Motor Protectors ②	Contactors	Internal	Total
<b>100 - 120V AC – 1-Phase Input, 0 - 230V 3-Phase Output</b>										
22B-V2P3N104	0.4 (0.5)	2.3	90-132	1.15	9.0	15	140M-C2E-C16	100-C12	9	30
22B-V5P0N104	0.75 (1.0)	5.0	90-132	2.45	20.3	35	140M-D8E-C20	100-C23	12	55
22B-V6P0N104	1.1 (1.5)	6.0	90-132	3.0	24.0	40	140M-F8E-C32	100-C37	12	70
<b>200 - 240V AC – 1-Phase Input, 0 - 230V 3-Phase Output ③</b>										
22B-A2P3N104	0.4 (0.5)	2.3	180-264	1.15	6.0	10	140M-C2E-B63	100-C09	9	30
22B-A5P0N104	0.75 (1.0)	5.0	180-264	2.45	12.0	20	140M-C2E-C16	100-C12	12	55
22B-A8P0N104	1.5 (2.0)	8.0	180-264	4.0	18.0	30	140M-D8E-C20	100-C23	16	80
22B-A012N104	2.2 (3.0)	12.0	180-264	5.5	25.0	40	140M-F8E-C32	100-C37	11	110
<b>200 - 240V AC – 3-Phase Input, 0 - 230V 3-Phase Output</b>										
22B-B2P3N104	0.4 (0.5)	2.3	180-264	1.15	2.5	6	140M-C2E-B40	100-C07	9	30
22B-B5P0N104	0.75 (1.0)	5.0	180-264	2.45	5.7	10	140M-C2E-C10	100-C09	12	55
22B-B8P0N104	1.5 (2.0)	8.0	180-264	4.0	9.5	15	140M-C2E-C16	100-C12	16	80
22B-B012N104	2.2 (3.0)	12.0	180-264	5.5	15.5	25	140M-C2E-C16	100-C23	16	115
22B-B017N104	3.7 (5.0)	17.5	180-264	8.6	21.0	35	140M-F8E-C25	100-C23	16	165
22B-B024N104	5.5 (7.5)	24.0	180-264	11.8	26.1	40	140M-F8E-C32	100-C37	28	225
22B-B033N104	7.5 (10.0)	33.0	180-264	16.3	34.6	60	140M-G8E-C45	100-C60	28	290
<b>380 - 480V AC – 3-Phase Input, 0 - 460V 3-Phase Output</b>										
22B-D1P4N104	0.4 (0.5)	1.4	342-528	1.4	1.8	3	140M-C2E-B25	100-C07	15	30
22B-D2P3N104	0.75 (1.0)	2.3	342-528	2.3	3.2	6	140M-C2E-B40	100-C07	13	40
22B-D4P0N104	1.5 (2.0)	4.0	342-528	4.0	5.7	10	140M-C2E-B63	100-C09	13	60
22B-D6P0N104	2.2 (3.0)	6.0	342-528	5.9	7.5	15	140M-C2E-C10	100-C09	17	90
22B-D010N104	4.0 (5.0)	10.5	342-528	10.3	13.0	20	140M-C2E-C16	100-C23	14	150
22B-D012N104	5.5 (7.5)	12.0	342-528	11.8	14.2	25	140M-D8E-C20	100-C23	23	160
22B-D017N104	7.5 (10.0)	17.0	342-528	16.8	18.4	30	140M-D8E-C20	100-C23	24	200
22B-D024N104	11.0 (15.0)	24.0	342-528	23.4	26.0	50	140M-F8E-C32	100-C43	25	285
<b>460 - 600V AC – 3-Phase Input, 0 - 575V 3-Phase Output</b>										
22B-E1P7N104	0.75 (1.0)	1.7	414-660	2.1	2.3	6	140M-C2E-B25	100-C09	13	40
22B-E3P0N104	1.5 (2.0)	3.0	414-660	3.65	3.8	6	140M-C2E-B40	100-C09	13	60
22B-E4P2N104	2.2 (3.0)	4.2	414-660	5.2	5.3	10	140M-C2E-B63	100-C09	17	90
22B-E6P6N104	4.0 (5.0)	6.6	414-660	8.1	8.3	15	140M-C2E-C10	100-C09	14	150
22B-E9P9N104	5.5 (7.5)	9.9	414-660	12.1	11.2	20	140M-C2E-C16	100-C16	23	160
22B-E012N104	7.5 (10.0)	12.2	414-660	14.9	13.7	25	140M-C2E-C16	100-C23	24	200
22B-E019N104	11.0 (15.0)	19.0	414-660	23.1	24.1	40	140M-D8E-C25	100-C30	25	285

① Recommended Fuse Type: UL Class J, CC, T or Type BS88; 600V (550V) or equivalent.

② Refer to Bulletin 140M Motor Protectors Selection Guide, publication 140-SG001... to determine the frame and breaking capacity required for your application.

③ 200-240V AC - 1-Phase drives are also available with an integral EMC filter. Catalog suffix changes from N104 to N114 or N103 to N113.

## Specifications

<b>Input/Output Ratings</b>		<b>Approvals</b>	
Output Frequency: 0-240 Hz (Programmable) Efficiency: 97.5% (Typical)		0-400 Hz (Programmable)	
<b>Digital Control Inputs (Input Current = 6mA)</b>		<b>Analog Control Inputs</b>	
SRC (Source) Mode: 18-24V = ON 0-6V = OFF		SNK (Sink) Mode: 0-6V = ON 18-24V = OFF	
<b>Control Output</b>		<b>Opto Outputs</b>	
Programmable Output (form C relay) Resistive Rating: 3.0A at 30V DC, 3.0A at 125V AC, 3.0A at 240V AC Inductive Rating: 0.5A at 30V DC, 0.5A at 125V AC, 0.5A at 240V AC		30V DC, 50 mA Non-inductive	
<b>Fuses and Circuit Breakers</b>		<b>Analog Output (10-bit)</b>	
Recommended Fuse Type: UL Class J, CC, T or Type BS88; 600V (550V) or equivalent. Recommended Circuit Breakers: HMCP circuit breaker or equivalent.		0-10V, 1k ohm Min. 4-20 mA, 525 ohm Max.	
<b>Protective Features</b>			
Motor Protection: I <sup>2</sup> t overload protection - 150% for 60 Secs, 200% for 3 Secs (Provides Class 10 protection)			
Overcurrent: 200% hardware limit, 300% instantaneous fault			
Over Voltage: 100-120V AC Input – Trip occurs at 405V DC bus voltage (equivalent to 150V AC incoming line) 200-240V AC Input – Trip occurs at 405V DC bus voltage (equivalent to 290V AC incoming line) 380-480V AC Input – Trip occurs at 810V DC bus voltage (equivalent to 575V AC incoming line) 460-600V AC Input – Trip occurs at 1005V DC bus voltage (equivalent to 711V AC incoming line)			
Under Voltage: 100-120V AC Input – Trip occurs at 210V DC bus voltage (equivalent to 75V AC incoming line) 200-240V AC Input – Trip occurs at 210V DC bus voltage (equivalent to 150V AC incoming line) 380-480V AC Input – Trip occurs at 390V DC bus voltage (equivalent to 275V AC incoming line) 460-600V AC Input – If P042 = 1 “High Voltage” trip occurs at 487V DC bus voltage (344V AC incoming line); If P042 = 0 “Low Voltage” trip occurs at 390V DC bus voltage (275V AC incoming line)			
Control Ride Through: Minimum ride through is 0.5 Secs - typical value 2 Secs			
Faultless Power Ride Through: 100 milliseconds			
<b>Dynamic Braking</b>			
Internal brake IGBT included with all ratings except No Brake drives (Cat. Nos. 22A-AxPxN103 or 22A-AxPxN113). Refer to page 11 for ordering information.			
<b>Environment</b>			
Altitude:		1000 m (3300 ft) max. without derating	
Ambient Operating Temperature			
IP20:		-10 to 50 degrees C (14 to 122 degrees F)	
NEMA 1:		-10 to 40 degrees C (14 to 104 degrees F)	
Cooling Method Fan:		All drive ratings	
Storage Temperature:		-40 to 85 degrees C (-40 to 185 degrees F)	
Atmosphere:		<b>Important:</b> Drive <b>must not</b> be installed in an area where the ambient atmosphere contains volatile or corrosive gas, vapors or dust. If the drive is not going to be installed for a period of time, it must be stored in an area where it will not be exposed to a corrosive atmosphere.	
Relative Humidity:		0 to 95% non-condensing	
Shock (operating):		15G peak for 11ms duration (±1.0ms)	
Vibration (operating):		1G peak, 5 to 2000 Hz	
<b>Control</b>			
Carrier Frequency		2-16 kHz. Drive rating based on 4 kHz.	
Frequency Accuracy			
Digital Input:		Within ±0.05% of set output frequency.	
Analog Input:		Within 0.5% of maximum output frequency.	
Analog Output:		±2% of full scale, 10-bit resolution	
Speed Regulation - Open Loop with Slip Compensation:		±2% of base speed across a 40:1 speed range. 1% of base speed across a 60:1 speed range.	
Stop Modes:		Multiple programmable stop modes including - Ramp, Coast, DC-Brake, Ramp-to-Hold and S Curve.	
Accel/Decel:		Two independently programmable accel and decel times. Each time may be programmed from 0 - 600 seconds in 0.1 second increments.	
Intermittent Overload:		150% Overload capability for up to 1 minute 200% Overload capability for up to 3 seconds	
Electronic Motor Overload Protection		Class 10 protection with speed sensitive response.	

## Parameter Descriptions

Parameter Number	Parameter Name	Description	Factory Default
<i>Display Group</i>			
d001	Output Freq	Output frequency present at T1, T2 & T3 (U, V & W)	Read Only
d002	Commanded Freq	Value of the active frequency command	Read Only
d003	Output Current	Output current present at T1, T2 & T3 (U, V & W)	Read Only
d004	Output Voltage	Output voltage present at T1, T2 & T3 (U, V & W)	Read Only
d005	DC Bus Voltage	Present DC bus voltage level	Read Only
d006	Drive Status	Present operating condition of the drive	Read Only
d007-d009	Fault x Code	A code that represents a drive fault	Read Only
d010	Process Display	The output frequency scaled by parameter A099 [Process Factor]	Read Only
d012	Control Source	Displays the source of the Start Command and Speed Reference	Read Only
d013	Contrl In Status	Status of the control terminal block control inputs	Read Only
d014	Dig In Status	Status of the control terminal block digital inputs	Read Only
d015	Comm Status	Status of the communications ports	Read Only
d016	Control SW Ver	Main Control Board software version	Read Only
d017	Drive Type	Used by Rockwell Automation field service personnel	Read Only
d018	Elapsed Run Time	Accumulated time drive is outputting power	Read Only
d019	Testpoint Data	The present value of the function selected in parameter A102 [Testpoint Sel]	Read Only
d020	Analog In 0-10V	The present value of the voltage at I/O Terminal 13 (100.0% = 10 volts)	Read Only
d021	Analog In 4-20mA	The present value of the current at I/O Terminal 15 (0.0% = 4 mA, 100.0% = 20 mA)	Read Only
d022	Output Power	Output power present at T1, T2 & T3 (U, V & W)	Read Only
d023	Output Power Fctr	The angle in electrical degrees between motor voltage and motor current	Read Only
d024	Drive Temp	Present operating temperature of the drive power section	Read Only
d025	Counter Status	The current value of the counter when counter is enabled	Read Only
d026	Timer Status	The current value of the timer when timer is enabled	Read Only
d028	Stp Logic Status	When P038 [Speed Reference] is set to 6 "Stp Logic", this parameter will display the current step logic profile as defined by parameters A140-A147 [Stp Logic x]	Read Only
d29	Torque Current	Displays the current value of the motor torque current as measured by the drive	Read Only
<i>Basic Program Group</i>			
P031	Motor NP Volts	20 to drive rated volts	Based on Drive Rating
P032	Motor NP Hertz	10 to 240 Hz	60 Hz
		15 to 400 Hz	60 Hz
P033	Motor OL Current	0.0 Amps to (Drive Rated Amps x 2) in units of 0.1 Amps	Based on Drive Rating
P034	Minimum Freq	0.0 to 240.0 Hz	0.0 Hz
		0.0 to 400.0 Hz	0.0 Hz
P035	Maximum Freq	0.0 to 240.0 Hz	60.0 Hz
		0.0 to 400.0 Hz	60.0 Hz
P036	Start Source	6 settings; Keypad, 3-Wire, 2-Wire, 2-Wire Level Sensitive, 2-Wire High Speed, Comm Port	Keypad
		7 settings; Keypad, 3-Wire, 2-Wire, 2-Wire Level Sensitive, 2-Wire High Speed, Comm Port, Momentary FWD/REV	Keypad
P037	Stop Mode	8 settings; Ramp-Clear Fault, Coast-Clear Fault, DC Brake-Clear Fault, DC Brake w/Shutoff-Clear Fault, Ramp, Coast, DC Brake, DC Brake w/Shutoff	Ramp, CF (Clear Fault)
		10 settings; Ramp-Clear Fault, Coast-Clear Fault, DC Brake-Clear Fault, DC Brake w/Shutoff-Clear Fault, Ramp, Coast, DC Brake, DC Brake w/Shutoff, Ramp Stop w/EM Brake Control-Clear Fault, Ramp Stop w/EM Brake Control	Ramp, CF (Clear Fault)
P038	Speed Reference	6 settings; Drive Potentiometer, Internal Freq, 0-10V Input/Remote Potentiometer, 4-20 mA Input, Preset Freq 0-3, Communications Port	Drive Pot
		8 settings; Drive Potentiometer, Internal Freq, 0-10V Input/Remote Potentiometer, 4-20 mA Input, Preset Freq 0-7, Communications Port, Step Logic, Analog In Mult	Drive Pot
P039	Accel Time 1	0.0 to 600.0 seconds	10.0 Secs
P040	Decel Time 1	0.1 to 600.0 seconds	10.0 Secs
P041	Reset To Defaults	Used to reset drive to factory default settings	Ready/Idle
P042	Voltage Class	Sets the voltage class of 600V drives, Low Voltage (460/480V) or High Voltage (575/600V)	High Voltage (575/600V)
<i>Advanced Program Group</i>			
A051	Digital In1 Sel	16 settings; Not Used, Accel 2 & Decel 2, Jog, Auxiliary Fault, Preset Frequencies, Local, Comm Port, Clear Fault, Ramp Stop Clear Fault, Coast Stop Clear Fault, DC Brake Clear Fault, Jog Forward, Jog Reverse, 10V In Control, 20 mA In Control, Analog Invert	Preset Freq
A052	Digital In2 Sel		
		27 settings; Not Used, Accel 2 & Decel 2, Jog, Auxiliary Fault, Preset Frequencies, Local, Comm Port, Clear Fault, Ramp Stop - Clear Fault, Coast Stop - Clear Fault, DC Brake - Clear Fault, Jog Forward, Jog Reverse, 10V In Control, 20 mA In Control, PID Disable, MOP Up, MOP Down, Timer Start, Counter In, Reset Timer, Reset Counter, Reset Timer and Counter, Logic In1, Logic In2, Current Limit2, Analog Invert	

## Parameter Descriptions

Parameter Number	Parameter Name	Description	Factory Default
A053	Digital In3 Sel	27 settings; Not Used, Accel 2 & Decel 2, Jog, Auxiliary Fault, Preset Frequencies, Local, Comm Port, Clear Fault, Ramp Stop - Clear Fault, Coast Stop - Clear Fault, DC Brake - Clear Fault, Jog Forward, Jog Reverse, 10V In Control, 20 mA In Control, PID Disable, MOP Up, MOP Down, Timer Start, Counter In, Reset Timer, Reset Counter, Reset Timer and Counter, Logic In1, Logic In2, Current Limit2, Analog Invert	Local
A054	Digital In4 Sel		Jog Forward
A055	Relay Out Sel	13 different settings for a variety of drive status conditions	Ready/Fault
		23 different settings for a variety of drive status conditions	Ready/Fault
A056	Relay Out Level	0.0 to 9999	0.0
A058	Opto Out1 Sel	23 settings; Ready/Fault, At Frequency, Motor Running, Reverse, Motor Overload, Ramp Regulator, Above Frequency, Above Current, Above DC Voltage, Retries Exceeded, Above Analog Voltage, Logic In1, Logic In2, Logic 1 & 2, Logic 1 or 2, Step Logic Out, Timer Out, Counter Out, Above PF Angle, Analog Input Loss, Param Control, Non-Recoverable Fault, EM Brake Control	MotorRunning
A059	Opto Out1 Level	0.0 to 9999	0.0
A061	Opto Out2 Sel	23 settings; Ready/Fault, At Frequency, Motor Running, Reverse, Motor Overload, Ramp Regulator, Above Frequency, Above Current, Above DC Voltage, Retries Exceeded, Above Analog Voltage, Logic In1, Logic In2, Logic 1 & 2, Logic 1 or 2, Step Logic Out, Timer Out, Counter Out, Above PF Angle, Analog Input Loss, Param Control, Non-Recoverable Fault, EM Brake Control	At Frequency
A062	Opto Out2 Level	0.0 to 9999	0.0
A064	Opto Out Logic	Determines the logic (NO or NC) of the opto outputs, 4 settings - NO/NO, NC/NO, NO/NC, NC/NC	NO/NO
A065	Analog Out Sel	Sets the analog output signal mode, various settings	Output Freq 0-10, 0V=0Hz
A066	Analog Out High	0 to 800%	100%
A067	Accel Time 2	0.0 to 600.0 seconds	20.0 Secs
A068	Decel Time 2	0.1 to 600.0 seconds	20.0 Secs
A069	Internal Freq	0.0 to 240.0 Hz	60.0 Hz
		0.0 to 400.0 Hz	60.0 Hz
A070	Preset Freq 0	0.0 to 240.0 Hz	0.0 Hz
		0.0 to 400.0 Hz	0.0 Hz
A071	Preset Freq 1	0.0 to 240.0 Hz	5.0 Hz
		0.0 to 400.0 Hz	5.0 Hz
A072	Preset Freq 2	0.0 to 240.0 Hz	10.0 Hz
		0.0 to 400.0 Hz	10.0 Hz
A073	Preset Freq 3	0.0 to 240.0 Hz	20.0 Hz
		0.0 to 400.0 Hz	20.0 Hz
A074	Preset Freq 4	0.0 to 400.0 Hz	30.0 Hz
A075	Preset Freq 5	0.0 to 400.0 Hz	40.0 Hz
A076	Preset Freq 6	0.0 to 400.0 Hz	50.0 Hz
A077	Preset Freq 7	0.0 to 400.0 Hz	60.0 Hz
A078	Jog Frequency	0.0 to (Value set in P035 [Maximum Freq])	10.0 Hz
A079	Jog Accel/Decel	0.1 to 600.0 seconds	10.0 Secs
A080	DC Brake Time	0.0 to 90.0 seconds	0.0 Secs
		0.0 to 99.9 seconds	0.0 Secs
A081	DC Brake Level	0.0 to (Drive Rated Amps x 1.8)	Drive Rated Amps x 0.05
A082	DB Resistor Sel	Used to set percent duty cycle for external dynamic braking	Disabled
A083	S Curve %	0 to 100%	0% (Disabled)
A084	Boost Select	14 boost settings (in % of P031 [Motor NP Volts]), redefines the Volts per Hertz curve	5.0 (2.5 for 5 HP drives)
		15 boost settings (in % of P031 [Motor NP Volts]), redefines the Volts per Hertz curve	5.0, CT (2.5 CT for 5-15 HP drives)
A085	Start Boost	0.0 to 25.0%	2.5%
A086	Break Voltage	0.0 to 100.0%	25.0%
A087	Break Frequency	0.0 to 400.0 Hz	15.0 Hz
A088	Maximum Voltage	20 to Drive Rated Volts	Drive Rated Volts
A089	Current Limit 1	0.1 to (Drive Rated Amps x 1.8)	Drive Rated Amps x 1.5
A090	Motor OL Select	3 settings; No Derate, Minimum Derate, Maximum Derate	No Derate
A091	PWM Frequency	2.0 to 16.0 kHz	4.0 kHz
A092	Auto Rstrt Tries	0 to 9	0
A093	Auto Rstrt Delay	0.0 to 300.0 seconds	1.0 Secs
A094	Start At PowerUp	2 settings; Disabled, Enabled	Disabled
A095	Reverse Disable	2 settings; Reverse Enabled, Reverse Disabled	Rev Enabled

## Parameter Descriptions

Parameter Number	Parameter Name	Description	Factory Default
<i>Advanced Program Group, Continued</i>			
A096	Flying Start En	2 settings; Disabled, Enabled	Disabled
A097	Compensation	4 settings; Disabled, Electrical, Mechanical, Both	Electrical
A098	SW Current Trip	Software instantaneous trip, 0.0 to (Drive Rated Amps x 2)	0.0 (Disabled)
A099	Process Factor	0.1 to 999.9	30.0
A100	Fault Clear	Resets a fault and clears the fault queue	Ready/Idle
A101	Program Lock	Protects parameters against change by unauthorized personnel	Unlocked
A102	Testpoint Sel	Used by Rockwell Automation field service personnel	400
A103	Comm Data Rate	6 settings; 1200, 2400, 4800, 9600, 19.2K, 38.4K	9600
A104	Comm Node Addr	1 to 247	100
A105	Comm Loss Action	4 settings; Fault, Coast to Stop, Stop, Continue Last Speed	Fault
A106	Comm Loss Time	0.1 to 60.0 seconds	5.0 Secs
A107	Comm Format	6 settings; RTU 8-N-1, RTU 8-E-1, RTU 8-O-1, RTU 8-N-2, RTU 8-E-2, RTU 8-O-2	RTU 8-N-1
A108	Language	11 settings; English, Francais, Espanol, Italiano, Deutsch, Reserved, Portugues, Reserved, Reserved, Nederlands	English
A109	Anlg Out Setpt	0.0/100.0%	100.0%
A110	Anlg In 0-10V Lo	0.0 to 100.0%	0.0%
A111	Anlg In 0-10V Hi	0.0 to 100.0%	100.0%
A112	Anlg In4-20mA Lo	0.0 to 100.0%	0.0%
A113	Anlg In4-20mA Hi	0.0 to 100.0%	100.0%
A114	Slip Hertz @ FLA	0.0 to 10.0 Hz	2.0 Hz
A115	Process Time Lo	0.00 to 99.99	0.00
A116	Process Time Hi	0.00 to 99.99	0.00
A117	Bus Reg Mode	0/1	Disabled
A118	Current Limit 2	0.1 to (Drive Rated Amps x 1.8)	Drive Rated Amps x 1.5
A119	Skip Frequency	0 to 400 Hz	0 Hz
A120	Skip Freq Band	0.0 to 30.0 Hz	0.0 Hz
A121	Stall Fault Time	6 settings; 60 Seconds, 120 Seconds, 240 Seconds, 360 Seconds, 480 Seconds, Fit Disabled	60 Seconds
A122	Analog In Loss	7 settings; Disabled, Fault (F29), Stop, Zero Ref, Min Freq Ref, Max Freq Ref, Int Freq Ref	Disabled
A123	10V Bipolar Enbl	2 settings; Uni-Polar In, Bi-Polar In	Uni-Polar In
A124	Var PWM Disable	2 settings; Enabled, Disabled	Enabled
A125	Torque Perf Mode	2 settings; V/Hz, Sensorless Vector	Sensrls Vect
A126	Motor NP FLA	Drive Rated Amps x 0.1/2	Drive Rated Amps
A127	Autotune	3 settings; Ready/Idle, Static Tune, Rotate Tune	Ready/Idle
A128	IR Voltage Drop	0.0 to 230.0 VAC	Based on Drive Rating
A129	Flux Current Ref	0.00 to Motor NP Volts	Based on Drive Rating
A130	PID Trim Hi	0.0 to 400.0	60.0
A131	PID Trim Lo	0.0 to 400.0	0.1
A132	PID Ref Sel	9 settings; PID Disabled, PID Setpoint, 0-10V Input, 4-20mA Input, Comm Port, Setpoint - Trim, 0-10V - Trim, 4-20mA - Trim, Comm - Trim	PID Disabled
A133	PID Feedback Sel	3 settings; 0-10V Input, 4-20mA Input, Comm Port	0-10V Input
A134	PID Prop Gain	0.00 to 99.99	0.01
A135	PID Integ Time	0.0 to 999.9 Seconds	0.1
A136	PID Diff Rate	0.00 to 99.99 (1/Secs)	0.01
A137	PID Setpoint	0.0 to 100.0%	0.0%
A138	PID Deadband	0.0 to 10.0%	0.0%
A139	PID Preload	0.0 to 400.0 Hz	0.0
A140-A147	Stp Logic 0-7	0001 to BAFF	00F1
A150-157	Stp Logic Time 0-7	0.0 to 999.9 Seconds	30.0
A160	EM Brk Off Delay	0.01/10.00 Secs	2.0 Secs
A161	EM Brk On Delay	0.01/10.00 Secs	2.0 Secs
A162	MOP Reset Sel	2 settings; Zero MOP Ref, Save MOP Ref	Zero MOP Ref

## Dimensions

### Approximate Dimensions

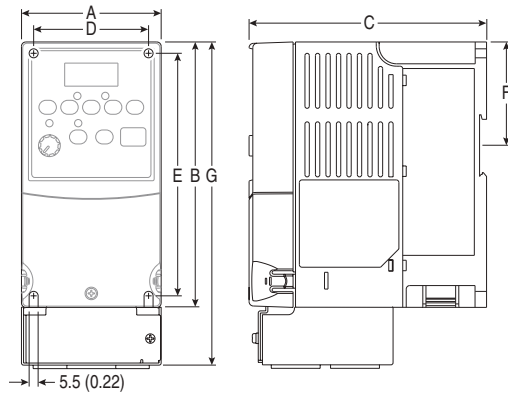

Dimensions are in millimeters and (inches). Weights are in kilograms and (pounds).

Frame	A	B ❶	C	D	E	F	G ❷	Shipping Weight
A	80 (3.15)	152 (5.98)	136 (5.35)	67 (2.64)	140 (5.51)	59.3 (2.33)	185 (7.28)	1.4 (3.1)
B	100 (3.94)	180 (7.09)	136 (5.35)	87 (3.43)	168 (6.61)	87.4 (3.44)	213 (8.39)	2.2 (4.9)
C	130 (5.1)	260 (10.2)	180 (7.1)	116 (4.57)	246 (9.7)	–	320 (12.6)	4.3 (9.5)

- ❶ Overall height of standard IP 20/Open Type Drive.
- ❷ Overall height of drive with IP 30/NEMA 1/UL Type 1 option kit installed.

Ratings are in kW and (HP).

PowerFlex 4 — Frame	120V AC – 1-Phase	240V AC – 1-Phase	240V AC – 3-Phase	480V AC – 3-Phase
A	0.2 (0.25) 0.4 (0.5)	0.2 (0.25) 0.4 (0.5) 0.75 (1.0)	0.2 (0.25) 0.4 (0.5) 0.75 (1.0) 1.5 (2.0)	0.4 (0.5) 0.75 (1.0) 1.5 (2.0)
B	0.75 (1.0) 1.1 (1.5)	1.5 (2.0)	2.2 (3.0) 3.7 (5.0)	2.2 (3.0) 3.7 (5.0)

PowerFlex 40 — Frame	120V AC – 1-Phase	240V AC – 1-Phase	240V AC – 3-Phase	480V AC – 3-Phase	600V AC – 3-Phase
B	0.4 (0.5) 0.75 (1.0) 1.1 (1.5)	0.4 (0.5) 0.75 (1.0) 1.5 (2.0)	0.4 (0.5) 0.75 (1.0) 1.5 (2.0) 2.2 (3.0) 3.7 (5.0)	0.4 (0.5) 0.75 (1.0) 1.5 (2.0) 2.2 (3.0) 4.0 (5.0)	0.75 (1.0) 1.5 (2.0) 2.2 (3.0) 4.0 (5.0)
C		2.2 (3.0)	5.5 (7.5) 7.5 (10.0)	5.5 (7.5) 7.5 (10.0) 11.0 (15.0)	5.5 (7.5) 7.5 (10.0) 11.0 (15.0)

# Dimensions

## Flange Mount Drive

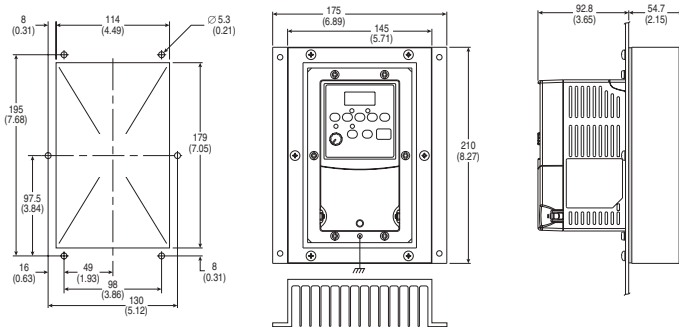

Frame A — PowerFlex 4 only

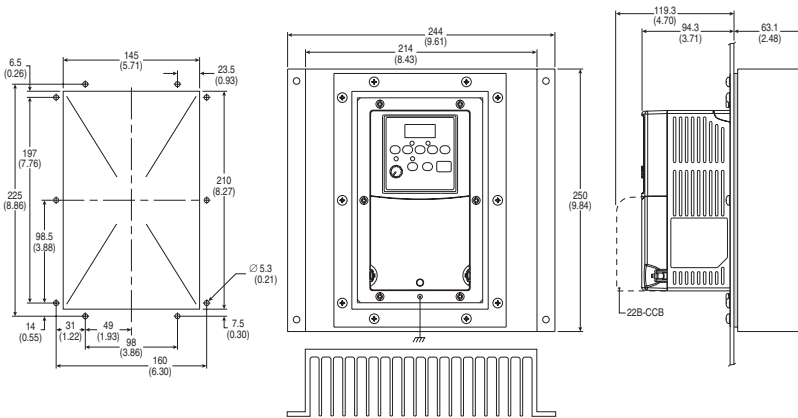

Frame B— PowerFlex 4 and PowerFlex 40

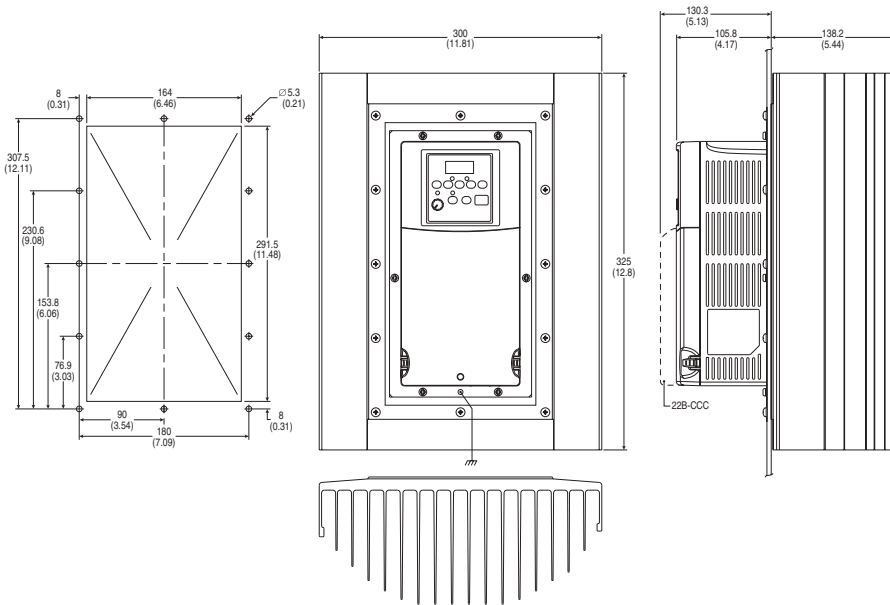

Frame C—PowerFlex 40 only



## Dimensions

### IP 30/NEMA Type 1/UL Type 1 Option Kit without Communication Options

PowerFlex 4 uses Frames A & B. PowerFlex 40 uses Frames B & C.

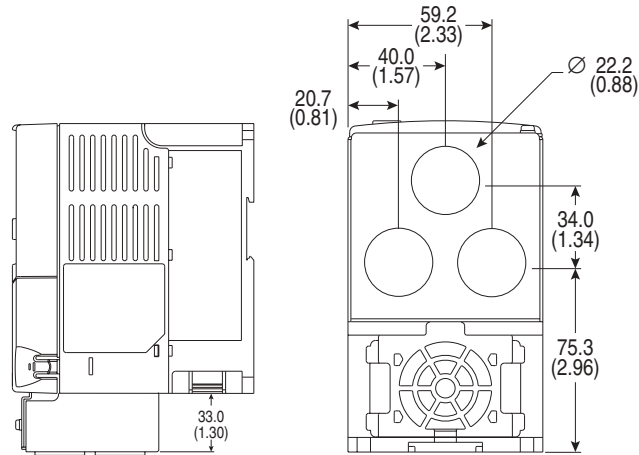

Frame A — 22-JBAA

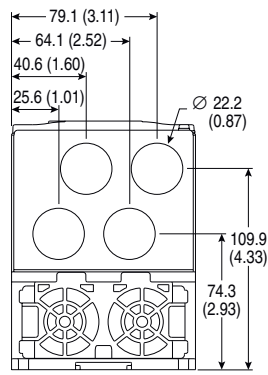
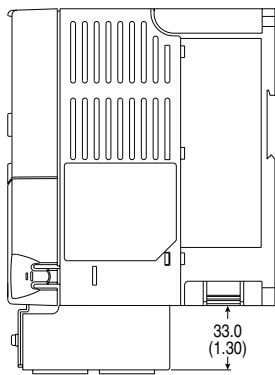

Frame B — 22-JBAB

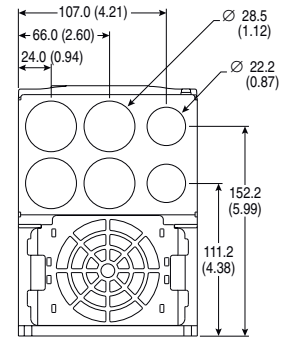
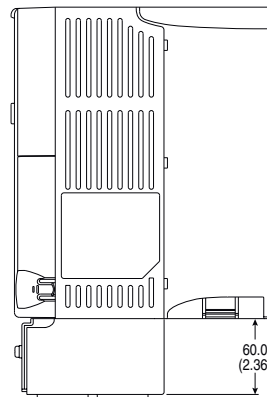

Frame C — 22-JBAC

### PowerFlex 40 IP 30/NEMA 1/UL Type 1 Option Kit with Communication Option

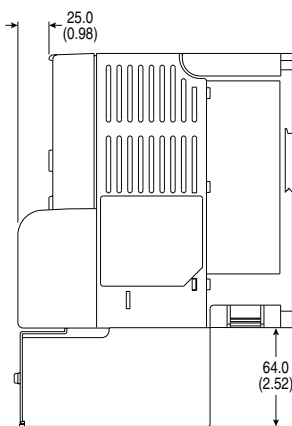

Frame B — 22-JBCB

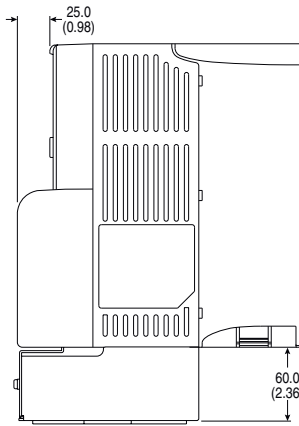
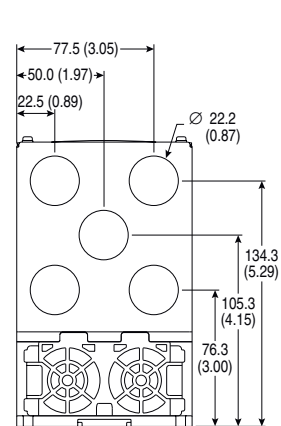

Frame C — 22-JBCC

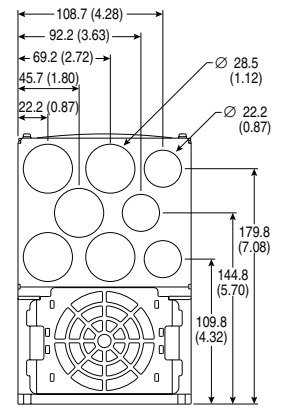

## Dimensions

### Dynamic Brake Resistors

Dimensions are in millimeters and (inches)

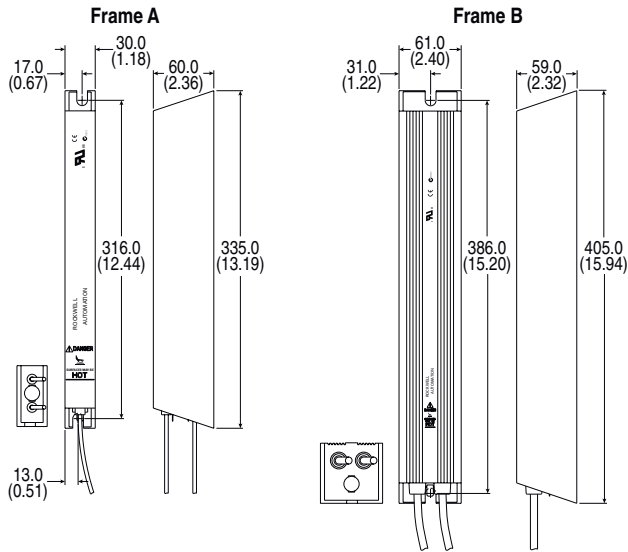

Frame	Catalog Number
A	AK-R2-091P500, AK-R2-047P500, AK-R2-360P500
B	AK-R2-030P1K2, AK-R2-120P1K2

### Bulletin 1321-3R Series Line Reactors

Dimensions are in millimeters and (inches). Weights are in kilograms and (pounds).

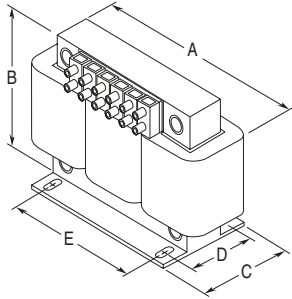

Catalog Number	A	B	C	D	E	Weight
1321-3R2-A	112 (4.40)	104 (4.10)	70 (2.75)	50 (1.98)	37 (1.44)	1.8 (4)
1321-3R2-B	112 (4.40)	104 (4.10)	70 (2.75)	50 (1.98)	37 (1.44)	1.8 (4)
1321-3R4-A	112 (4.40)	104 (4.10)	76 (3.00)	50 (1.98)	37 (1.44)	1.8 (4)
1321-3R4-B	112 (4.40)	104 (4.10)	76 (3.00)	50 (1.98)	37 (1.44)	1.8 (4)
1321-3R4-C	112 (4.40)	104 (4.10)	86 (3.38)	60 (2.35)	37 (1.44)	2.3 (5)
1321-3R8-A	152 (6.00)	127 (5.00)	76 (3.00)	53 (2.10)	51 (2.00)	3.1 (7)
1321-3R8-B	152 (6.00)	127 (5.00)	76 (3.00)	53 (2.10)	51 (2.00)	3.6 (8)
1321-3R8-C	152 (6.00)	127 (5.00)	85 (3.35)	63 (2.48)	51 (2.00)	4.9 (11)
1321-3R12-A	152 (6.00)	127 (5.00)	76 (3.00)	53 (2.10)	51 (2.00)	4.1 (9)
1321-3R12-B	152 (6.00)	127 (5.00)	76 (3.00)	53 (2.10)	51 (2.00)	4.5 (10)
1321-3R18-A	152 (6.00)	133 (5.25)	79 (3.10)	54 (2.13)	51 (2.00)	4.1 (9)
1321-3R18-B	152 (6.00)	133 (5.25)	86 (3.40)	63 (2.48)	51 (2.00)	5.4 (12)
1321-3R25-A	183 (7.20)	146 (5.76)	85 (3.35)	60 (2.35)	76 (3.00)	4.9 (11)
1321-3R35-A	193 (7.60)	146 (5.76)	91 (3.60)	66 (2.60)	76 (3.00)	6.3 (14)

## Dimensions

### EMC Line Filters

**Frame A EMC Line Filters** – Dimensions are in millimeters and (inches)  
 Catalog Numbers: 22-RF5P7-AS, -AL; 22-RF9P5-AS, -AL; 22-RF010-AL

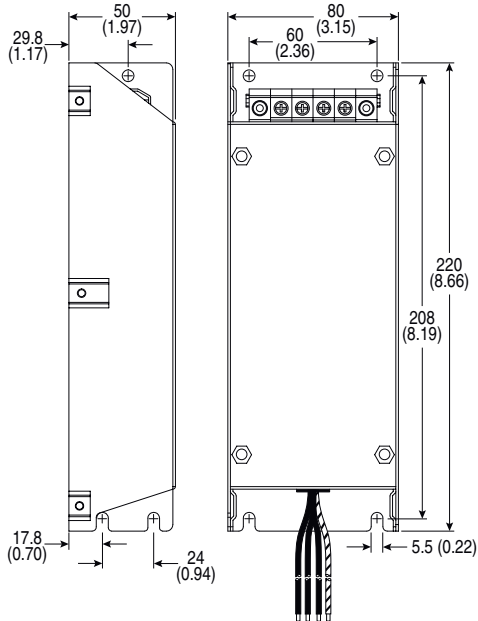

**Frame B EMC Line Filters** – Dimensions are in millimeters and (inches)  
 Catalog Numbers: 22-RF012-BS, -BL; 22-RF018-BS; 22-RF021-BS, -BL

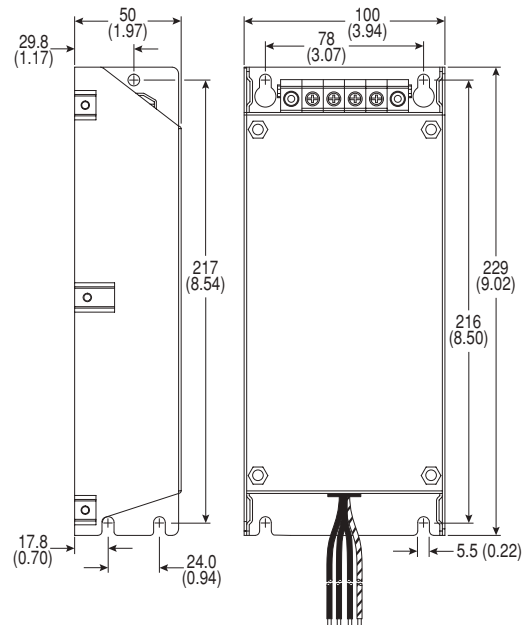

**Frame C EMC Line Filters** – Dimensions are in millimeters and (inches)  
 Catalog Numbers: 22-RF015-CL; 22-RF018-CS, -CL; 22-RF024-CL; 22-RF025-CL; 22-RF026-CS, -CL; 22RF034-CS, -CL

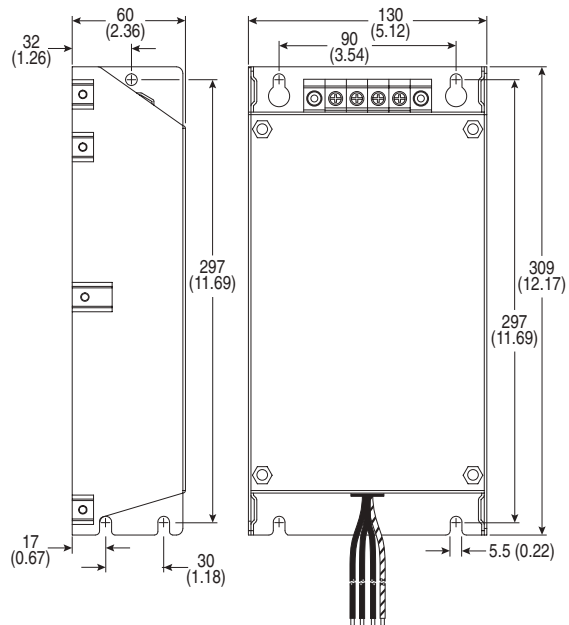

# Dimensions

## Human Interface Module (HIM) Dimensions

**NEMA Type 1 Bezel** – Dimensions are in millimeters and (inches)  
Catalog Number: 22-HIM-B1

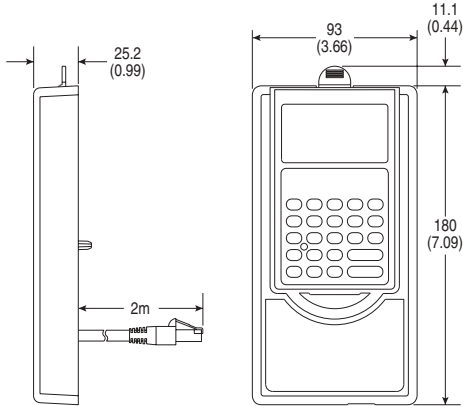

**NEMA Type 4X/12 Remote (Panel Mount) Small HIM**  
– Dimensions are in millimeters and (inches)  
Catalog Number: 22-HIM-C2S

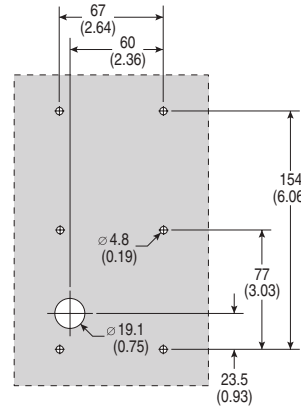
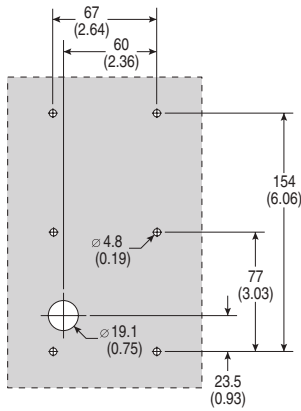
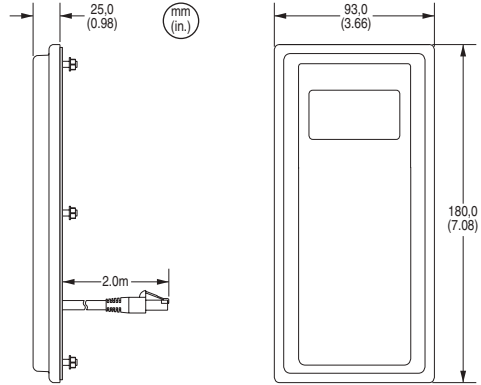

**NEMA Type 4X/12 Remote (Panel Mount) HIM** – Dimensions are in millimeters and (inches)  
Catalog Number: 22-HIM-C2

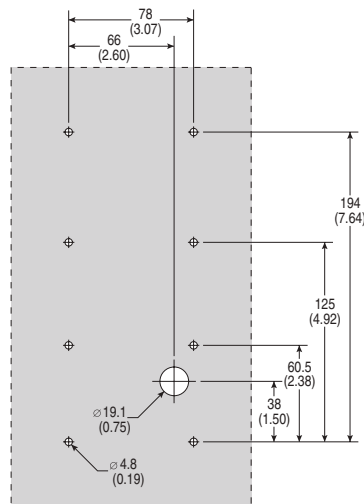
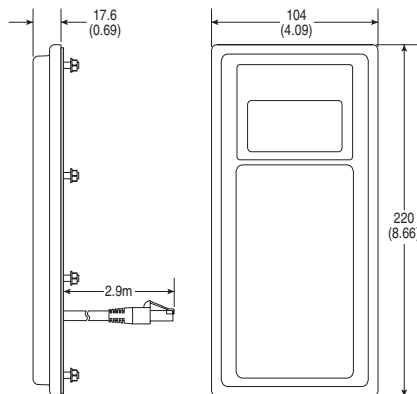



[www.nicsanat.com](http://www.nicsanat.com)  
021-87700210







[www.nicsanat.com](http://www.nicsanat.com)  
021-87700210



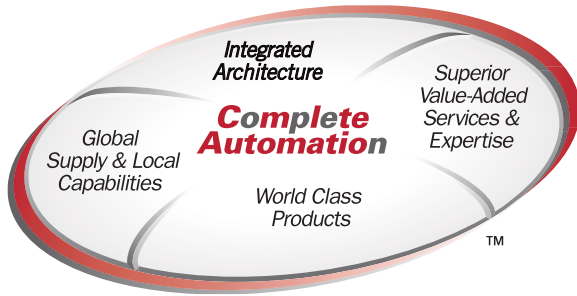

The Allen-Bradley PowerFlex family of AC drives provides a single-source solution for virtually any drive application requirement ranging from 0.2 to 3,000 kW (0.25 to 4,000 hp). Significant commonality across multiple platforms including networks, operator interface, programming and hardware make PowerFlex drives easy to start up, operate and maintain. Multi-lingual programming, operator interface text and voltage-sensitive defaults in PowerFlex drives will help global OEMs and end-users save time and money during set-up, integration and maintenance of virtually any automation system.

Rockwell Automation supports drive users whenever and wherever needed, providing drive specialists and manufacturing expertise for unmatched service and support around the globe. In fact, one of every five Rockwell Automation employees is in the field with users every day. Rockwell Automation also offers a full spectrum of value-added services and expertise to help simplify maintenance and enhance productivity.

Rockwell Automation is committed to helping its customers meet ever-changing demands. PowerFlex drives illustrate our commitment to user productivity through timely delivery of world-class products and continued backward compatibility to minimize life-cycle costs. Count on Rockwell Automation to be your Complete Automation™ partner – now and in the future.

For further information on PowerFlex drives visit our web site at: [www.abpowerflex.com](http://www.abpowerflex.com)

PowerFlex, Zero Stacking, DriveExplorer, DriveTools SP and Complete Automation are trademarks of Rockwell Automation.

DeviceNet is a trademark of the Open DeviceNet Vendor Association.

[www.rockwellautomation.com](http://www.rockwellautomation.com)

**Corporate Headquarters**

Rockwell Automation, 777 East Wisconsin Avenue, Suite 1400, Milwaukee, WI, 53202-5302 USA, Tel: (1) 414.212.5200, Fax: (1) 414.212.5201

**Headquarters for Allen-Bradley Products, Rockwell Software Products and Global Manufacturing Solutions**

Americas: Rockwell Automation, 1201 South Second Street, Milwaukee, WI 53204-2496 USA, Tel: (1) 414.382.2000, Fax: (1) 414.382.4444  
 Europe: Rockwell Automation SA/NV, Vorstlaan/Boulevard du Souverain 36-BP 3A/B, 1170 Brussels, Belgium, Tel: (32) 2 663 0600, Fax: (32) 2 663 0640  
 Asia Pacific: Rockwell Automation, 27/F Citicorp Centre, 18 Whitfield Road, Causeway Bay, Hong Kong, Tel: (852) 2887 4788, Fax: (852) 2508 1846

**Headquarters for Dodge and Reliance Electric Products**

Americas: Rockwell Automation, 6040 Ponders Court, Greenville, SC 29615-4617 USA, Tel: (1) 864.297.4800, Fax: (1) 864.281.2433  
 Europe: Rockwell Automation, Brühlstraße 22, D-74834 Elztal-Dallau, Germany, Tel: (49) 6261 9410, Fax: (49) 6261 1774  
 Asia Pacific: Rockwell Automation, 55 Newton Road, #11-01/02 Revenue House, Singapore 307987, Tel: (65) 351 6723, Fax: (65) 355 1733

**U.S. Allen-Bradley Drives Technical Support**

Tel: (1) 262.512.8176, Fax: (1) 262.512.2222, Email: [support@drives.ra.rockwell.com](mailto:support@drives.ra.rockwell.com), Online: [www.ab.com/s](http://www.ab.com/s)

Publication 22-TD  
 Supersedes 22-TD001A

[www.nicsanat.com](http://www.nicsanat.com)  
 021-87700210



USA.