

www.nicsanat.com

021-87700210



Danfoss

Operating Instructions VLT[®] HVAC Drive FC 102

1.1-90 kW



www.danfoss.com/drives

VLT[®]
THE REAL DRIVE

Contents

1 Introduction	3
1.1 Purpose of the Manual	3
1.2 Additional Resources	3
1.3 Document and Software Version	3
1.4 Intended Use	3
1.5 Block Diagram of the Frequency Converter	4
1.6 Enclosure Types and Power Ratings	4
1.7 Approvals and Certifications	4
1.8 Disposal Instruction	4
2 Safety	5
2.1 Safety Symbols	5
2.2 Qualified Personnel	5
2.3 Safety Precautions	5
3 Mechanical Installation	7
3.1 Unpacking	7
3.2 Installation Environments	10
3.3 Mounting	10
4 Electrical Installation	11
4.1 Safety Instructions	11
4.2 EMC Compliant Installation	11
4.3 Grounding	11
4.4 Wiring Schematic	12
4.5 Access	14
4.6 Motor Connection	14
4.7 AC Mains Connection	15
4.8 Control Wiring	16
4.8.1 Control Terminal Types	16
4.8.2 Wiring to Control Terminals	17
4.8.3 Enabling Motor Operation (Terminal 27)	18
4.8.4 Voltage/Current Input Selection (Switches)	18
4.8.5 Safe Torque Off (STO)	18
4.8.6 RS-485 Serial Communication	19
4.9 Installation Check List	20
5 Commissioning	21
5.1 Safety Instructions	21
5.2 Applying Power	21

5.3 Local Control Panel Operation	21
5.4 Basic Programming	24
5.4.1 Commissioning with SmartStart	24
5.4.2 Commissioning via [Main Menu]	24
5.4.3 Asynchronous Motor Setup	25
5.4.4 Permanent Magnet Motor Setup	25
5.4.5 Automatic Energy Optimization (AEO)	26
5.4.6 Automatic Motor Adaptation (AMA)	26
5.5 Checking Motor Rotation	27
5.6 Local-control Test	27
5.7 System Start-up	27
5.8 Maintenance	27
6 Application Set-up Examples	28
7 Diagnostics and Troubleshooting	32
7.1 Status Messages	32
7.2 Warning and Alarm Types	34
7.3 List of Warnings and Alarms	35
7.4 Troubleshooting	41
8 Specifications	43
8.1 Electrical Data	43
8.1.1 Mains Supply 3x200-240 V AC	43
8.1.2 Mains Supply 3x380-480 V AC	45
8.1.3 Mains Supply 3x525-600 V AC	47
8.1.4 Mains Supply 3x525-690 V AC	49
8.2 Mains Supply	51
8.3 Motor Output and Motor Data	51
8.4 Ambient Conditions	51
8.5 Cable Specifications	52
8.6 Control Input/Output and Control Data	52
8.7 Connection Tightening Torques	55
8.8 Fuse Specifications	56
8.9 Power Ratings, Weight and Dimensions	62
9 Appendix	63
9.1 Symbols and Abbreviations	63
9.2 Parameter Menu Structure	63
Index	68

1 Introduction

1.1 Purpose of the Manual

These operating instructions provide information for safe installation and commissioning of the frequency converter.

The operating instructions are intended for use by qualified personnel.

Read and follow the operating instructions in order to use the frequency converter safely and professionally, and pay particular attention to the safety instructions and general warnings. Keep these operating instructions available with the frequency converter at all times.

1.2 Additional Resources

Other resources are available to understand advanced frequency converter functions and programming.

- The *VLT® Programming Guide* provides greater detail on working with parameters and many application examples.
- The *VLT® Design Guide* provides detailed information about capabilities and functionality to design motor control systems.
- Instructions for operation with optional equipment.

Supplementary publications and manuals are available from Danfoss. See www.danfoss.com/BusinessAreas/DrivesSolutions/Documentations/VLT+Technical+Documentation.htm for listings.

Disclosure, duplication and sale of this document, as well as communication of its content, are prohibited unless explicitly permitted. Infringement of this prohibition incurs liability for damages. All rights reserved with regard to patents, utility patents and registered designs. VLT® is a registered trademark.

1.3 Document and Software Version

This manual is regularly reviewed and updated. All suggestions for improvement are welcome. *Table 1.1* shows the document version and the corresponding software version.

Edition	Remarks	Software version
MG11AJxx	Replaces MG11Alxx	3.92

Table 1.1 Document and Software Version

1.4 Intended Use

The frequency converter is an electronic motor controller that

- regulates motor speed in response to system feedback or to remote commands from external controllers. A power drive system consists of the frequency converter, the motor and equipment driven by the motor.
- monitors aspects of system and motor status.
- can be used for motor protection.

Depending on configuration, the frequency converter can be used in standalone applications or form part of a larger appliance or installation.

The frequency converter is intended for use in residential, industrial and commercial environments in accordance with local laws and standards. Do not use the frequency converter in applications that do not comply with specified designated operating conditions and environments.

NOTICE

In a residential environment this product may cause radio interference, in which case supplementary mitigation measures may be required.

1.5 Block Diagram of the Frequency Converter

Illustration 1.1 is a block diagram of the frequency converter's internal components. See Table 1.2 for their functions.

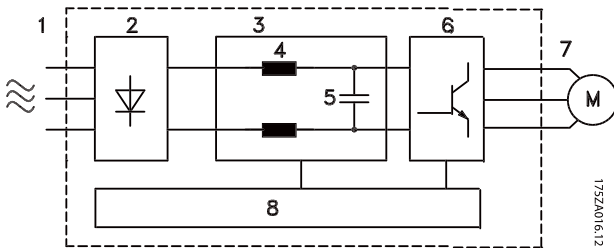

Illustration 1.1 Frequency Converter Block Diagram

Area	Title	Functions
1	Mains input	<ul style="list-style-type: none"> 3-phase AC mains power supply to the frequency converter
2	Rectifier	<ul style="list-style-type: none"> The rectifier bridge converts the AC input to DC current to supply inverter power
3	DC bus	<ul style="list-style-type: none"> Intermediate DC-bus circuit handles the DC current
4	DC reactors	<ul style="list-style-type: none"> Filter the intermediate DC circuit voltage Provide line transient protection Reduce RMS current Raise the power factor reflected back to the line Reduce harmonics on the AC input
5	Capacitor bank	<ul style="list-style-type: none"> Stores the DC power Provides ride-through protection for short power losses
6	Inverter	<ul style="list-style-type: none"> Converts the DC into a controlled PWM AC waveform for a controlled variable output to the motor
7	Output to motor	<ul style="list-style-type: none"> Regulated 3-phase output power to the motor

Area	Title	Functions
8	Control circuitry	<ul style="list-style-type: none"> Input power, internal processing, output, and motor current are monitored to provide efficient operation and control User interface and external commands are monitored and performed Status output and control can be provided

Table 1.2 Legend to Illustration 1.1

1.6 Enclosure Types and Power Ratings

For enclosure types and power ratings of the frequency converters, refer to 8.9 Power Ratings, Weight and Dimensions.

1.7 Approvals and Certifications



Table 1.3 Approvals and Certifications

More approvals and certifications are available. Contact local Danfoss partner. The T7 (525-690 V) frequency converters are not certified for UL.

The frequency converter complies with UL508C thermal memory retention requirements. For more information refer to the section *Motor Thermal Protection* in the *Design Guide*.

For compliance with the European Agreement concerning International Carriage of Dangerous Goods by Inland Waterways (ADN), refer to *ADN-compliant Installation* in the *Design Guide*.

1.8 Disposal Instruction

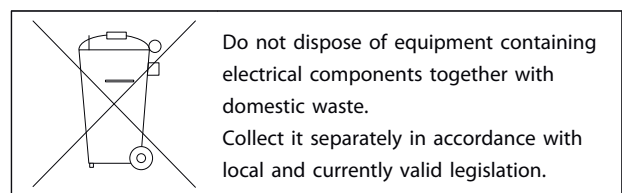

Table 1.4 Disposal Instruction

2 Safety

2.1 Safety Symbols

The following symbols are used in this document.

⚠ WARNING

Indicates a potentially hazardous situation which could result in death or serious injury.

⚠ CAUTION

Indicates a potentially hazardous situation which could result in minor or moderate injury. It may also be used to alert against unsafe practices.

NOTICE

Indicates important information, including situations that may result in damage to equipment or property.

2.2 Qualified Personnel

Correct and reliable transport, storage, installation, operation and maintenance are required for the trouble-free and safe operation of the frequency converter. Only qualified personnel is allowed to install or operate this equipment.

Qualified personnel is defined as trained staff, who are authorised to install, commission, and maintain equipment, systems and circuits in accordance with pertinent laws and regulations. Additionally, the personnel must be familiar with the instructions and safety measures described in this document.

2.3 Safety Precautions

⚠ WARNING

HIGH VOLTAGE!

Frequency converters contain high voltage when connected to AC mains input power. Installation, start-up, and maintenance must be performed by qualified personnel only. Failure to perform installation, start-up, and maintenance by qualified personnel could result in death or serious injury.

⚠ WARNING

UNINTENDED START!

When the frequency converter is connected to AC mains, the motor may start at any time. The frequency converter, motor, and any driven equipment must be in operational readiness. Failure to be in operational readiness when the frequency converter is connected to AC mains could result in death, serious injury, equipment or property damage.

⚠ WARNING

DISCHARGE TIME!

Frequency converters contain DC-link capacitors that can remain charged even when the frequency converter is not powered. To avoid electrical hazards, disconnect AC mains, any permanent magnet type motors, and any remote DC-link power supplies, including battery backups, UPS and DC-link connections to other frequency converters. Wait for the capacitors to discharge completely before performing any service or repair work. The amount of waiting time is listed in *Table 2.1*. Failure to wait the specified time after power has been removed before doing service or repair could result in death or serious injury.

Voltage [V]	Minimum waiting time [minutes]		
	4	7	15
200-240	1.1-3.7 kW		5.5-45 kW
380-480	1.1-7.5 kW		11-90 kW
525-600	1.1-7.5 kW		11-90 kW
525-690		1.1-7.5 kW	11-90 kW
High voltage may be present even when the warning LED indicator lights are off.			

Table 2.1 Discharge Time

⚠ WARNING

LEAKAGE CURRENT HAZARD!

Leakage currents are higher than 3.5 mA. It is the responsibility of the user or certified electrical installer to ensure correct grounding of the equipment. Failure to ground the frequency converter properly could result in death or serious injury.

2

⚠ WARNING

EQUIPMENT HAZARD!

Rotating shafts and electrical equipment can be hazardous. All electrical work must conform to national and local electrical codes. Installation, start-up, and maintenance are performed only by trained and qualified personnel. Failure to follow these guidelines could result in death or serious injury.

⚠ WARNING

WINDMILLING!

Unintended rotation of permanent magnet motors causes a risk of personal injury and equipment damage. Ensure permanent magnet motors are blocked to prevent unintended rotation.

⚠ CAUTION

POTENTIAL HAZARD IN THE EVENT OF INTERNAL FAILURE!

Risk of personal injury when the frequency converter is not properly closed. Before applying power, ensure all safety covers are in place and securely fastened.

3 Mechanical Installation

3.1 Unpacking

3.1.1 Items Supplied

- Check the packaging and the frequency converter visually for damage caused by inappropriate handling during shipment. File any claim for damage with the carrier. Retain damaged parts for clarification.
- Make sure the items supplied and the information on the nameplate correspond to the order confirmation.

1	Type code
2	Order number
3	Power rating
4	Input voltage, frequency and current (at low/high voltages)
5	Output voltage, frequency and current (at low/high voltages)
6	Enclosure type and IP rating
7	Maximum ambient temperature
8	Certifications
9	Discharge time (Warning)
10	Serial number

Table 3.1 Legend to Illustration 3.1

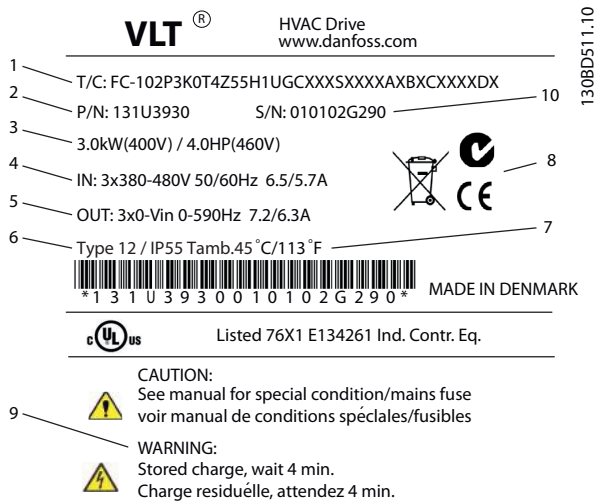

NOTICE

Do not remove the nameplate from the frequency converter (loss of warranty).

3.1.2 Storage

Ensure that requirements for storage are fulfilled. Refer to 8.4 Ambient Conditions for further details.

Illustration 3.1 Product Nameplate (Example)

3.1.3 Product Overview

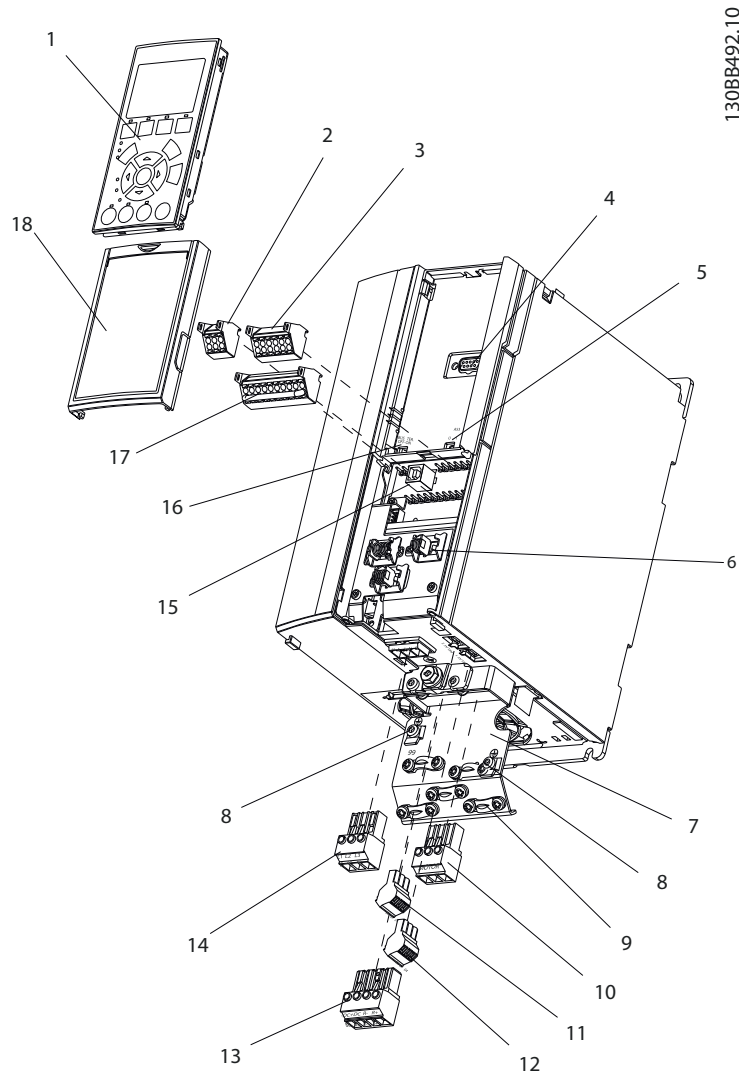

Illustration 3.2 Exploded View Enclosure Type A, IP20

1	Local control panel (LCP)	10	Motor output terminals 96 (U), 97 (V), 98 (W)
2	RS-485 serial bus connector (+68, -69)	11	Relay 2 (01, 02, 03)
3	Analog I/O connector	12	Relay 1 (04, 05, 06)
4	LCP input plug	13	Brake (-81, +82) and load sharing (-88, +89) terminals
5	Analog switches (A53), (A54)	14	Mains input terminals 91 (L1), 92 (L2), 93 (L3)
6	Cable screen connector	15	USB connector
7	Decoupling plate	16	Serial bus terminal switch
8	Grounding clamp (PE)	17	Digital I/O and 24 V power supply
9	Shielded cable grounding clamp and strain relief	18	Cover

Table 3.2 Legend to *Illustration 3.2*

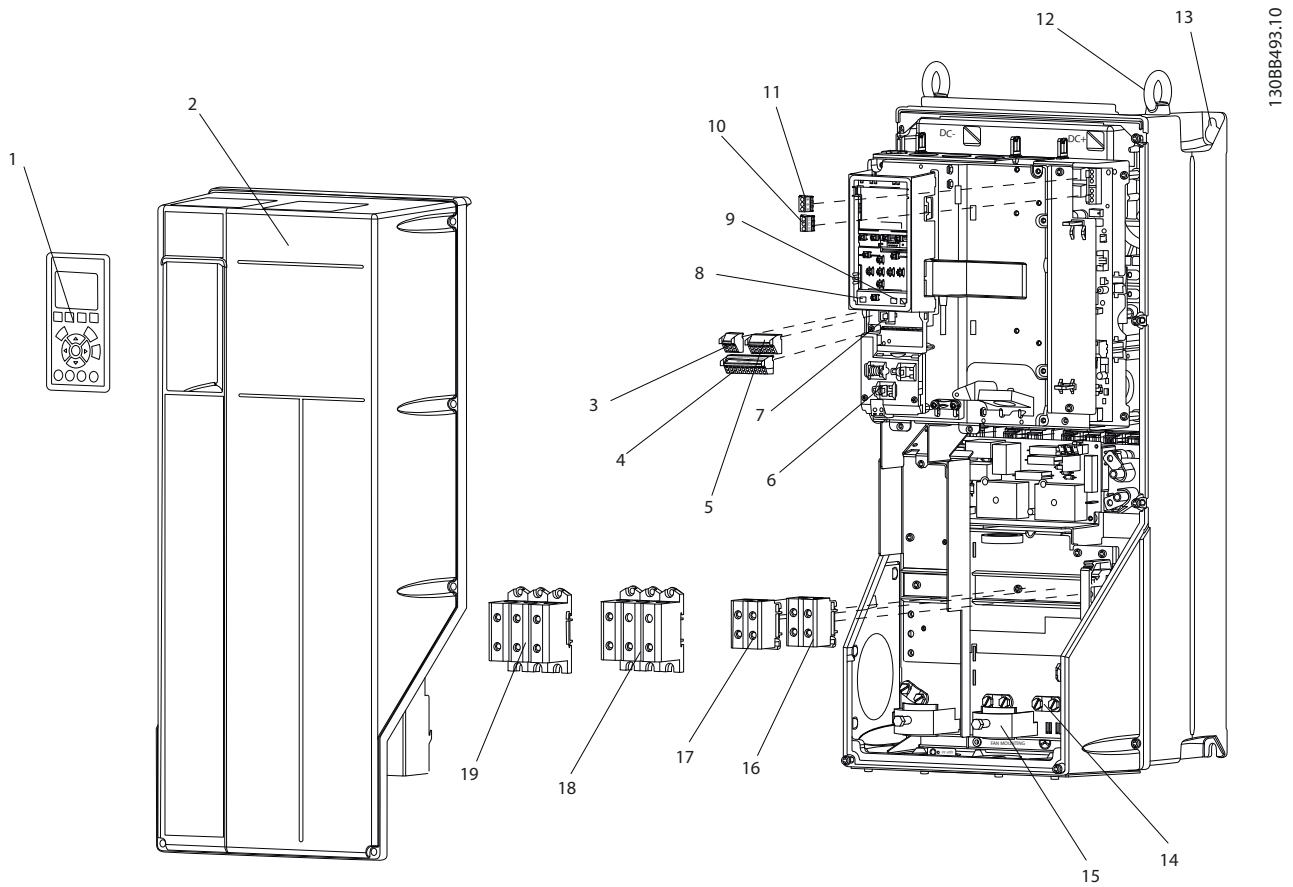

Illustration 3.3 Exploded View Enclosure Types B and C, IP55 and IP66

1	Local control panel (LCP)	11	Relay 2 (04, 05, 06)
2	Cover	12	Lifting ring
3	RS-485 serial bus connector	13	Mounting slot
4	Digital I/O and 24 V power supply	14	Grounding clamp (PE)
5	Analog I/O connector	15	Cable screen connector
6	Cable screen connector	16	Brake terminal (-81, +82)
7	USB connector	17	Load sharing terminal (DC bus) (-88, +89)
8	Serial bus terminal switch	18	Motor output terminals 96 (U), 97 (V), 98 (W)
9	Analog switches (A53), (A54)	19	Mains input terminals 91 (L1), 92 (L2), 93 (L3)
10	Relay 1 (01, 02, 03)		

Table 3.3 Legend to Illustration 3.3

3.2 Installation Environments

NOTICE

In environments with airborne liquids, particles, or corrosive gases, ensure that the IP/Type rating of the equipment matches the installation environment. Failure to meet requirements for ambient conditions can reduce lifetime of the frequency converter. Ensure that requirements for air humidity, temperature and altitude are met.

Vibration and Shock

The frequency converter complies with requirements for units mounted on the walls and floors of production premises, as well as in panels bolted to walls or floors.

For detailed ambient conditions specifications, refer to 8.4 Ambient Conditions.

3.3 Mounting

NOTICE

Improper mounting can result in overheating and reduced performance.

Cooling

- Ensure that top and bottom clearance for air cooling is provided. See *Illustration 3.4* for clearance requirements.

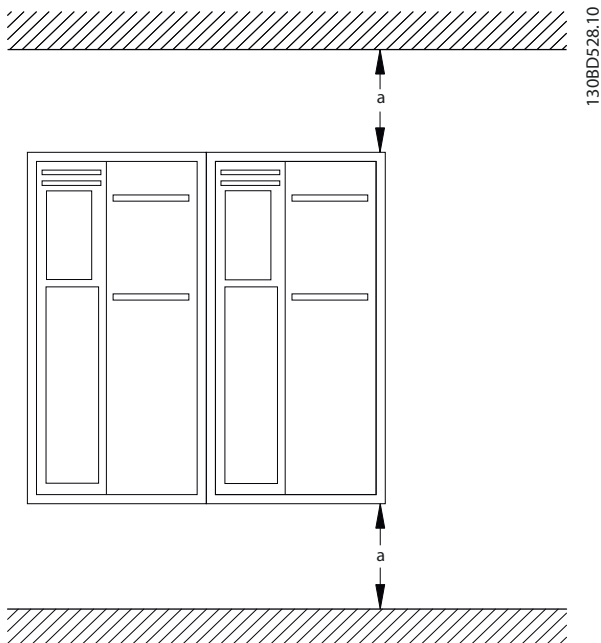

Illustration 3.4 Top and Bottom Cooling Clearance

Enclosure	A2-A5	B1-B4	C1, C3	C2, C4
a (mm)	100	200	200	225

Table 3.4 Minimum Airflow Clearance Requirements

Lifting

- To determine a safe lifting method, check the weight of the unit, see 8.9 Power Ratings, Weight and Dimensions.
- Ensure that the lifting device is suitable for the task.
- If necessary, plan for a hoist, crane, or forklift with the appropriate rating to move the unit.
- For lifting, use hoist rings on the unit, when provided.

Mounting

1. Ensure that the strength of the mounting location supports the unit weight. The frequency converter allows side-by-side installation.
2. Mount the unit vertically on a solid flat surface or on the optional back plate.
3. Use the slotted mounting holes on the unit for wall mounting, when provided.

Mounting with back plate and railings

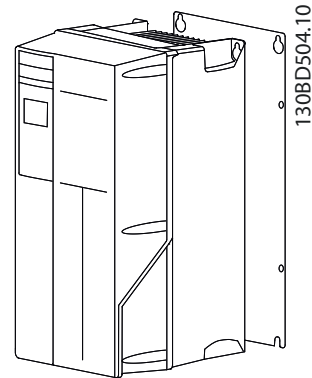

Illustration 3.5 Proper Mounting with Back Plate

NOTICE

Back plate is required when mounted on railings.

4 Electrical Installation

4.1 Safety Instructions

See 2 *Safety* for general safety instructions.

⚠ WARNING

INDUCED VOLTAGE!

Induced voltage from output motor cables that run together can charge equipment capacitors even with the equipment turned off and locked out. Failure to run output motor cables separately or use screened cables could result in death or serious injury.

⚠ CAUTION

DC CURRENT HAZARD!

A DC current in the protective grounding conductor can be caused by the frequency converters. When a residual current-operated protective or monitoring device (RCD/RCM) is used for protection, only an RCD or RCM of Type B is allowed.

Over-current Protection

- Additional protective equipment such as short-circuit protection or motor thermal protection between frequency converter and motor is required for applications with multiple motors.
- Input fusing is required to provide short-circuit and over-current protection. If not factory-supplied, fuses must be provided by the installer. See maximum fuse ratings in *8.8 Fuse Specifications*.

Wire Type and Ratings

- All wiring must comply with local and national regulations regarding cross-section and ambient temperature requirements.
- Power connection wire recommendation: minimum 75 °C rated copper wire.

See *8.1 Electrical Data* and *8.5 Cable Specifications* for recommended wire sizes and types.

4.2 EMC Compliant Installation

To obtain an EMC compliant installation, follow the instructions provided in *4.3 Grounding*, *4.4 Wiring Schematic*, *4.6 Motor Connection* and *4.8 Control Wiring*.

4.3 Grounding

⚠ WARNING

LEAKAGE CURRENT HAZARD!

Leakage currents are higher than 3.5 mA. It is the responsibility of the user or certified electrical installer to ensure correct grounding of the equipment. Failure to ground the frequency converter properly could result in death or serious injury.

For electrical safety

- Ground the frequency converter properly in accordance with applicable standards and directives.
- Use a dedicated ground wire for input power, motor power and control wiring.
- Do not ground one frequency converter to another in a “daisy chain” fashion.
- Keep the ground wire connections as short as possible.
- Do not use pigtails.
- Follow motor manufacturer wiring requirements.
- Minimum cable cross-section: 10 mm² (or 2 rated earth wires terminated separately).

For EMC compliant installation

- Establish electrical contact between cable shield and frequency converter enclosure by using metal cable glands or by using the clamps provided on the equipment.
- Use high-strand wire to reduce electrical interference.

NOTICE

POTENTIAL EQUALISATION!

Electrical interference risks disturbing the entire installation, when the ground potential between the frequency converter and the system is different. To avoid electrical interference, install equalising cables between the system components. Recommended cable cross-section: 16 mm².

4.4 Wiring Schematic

4

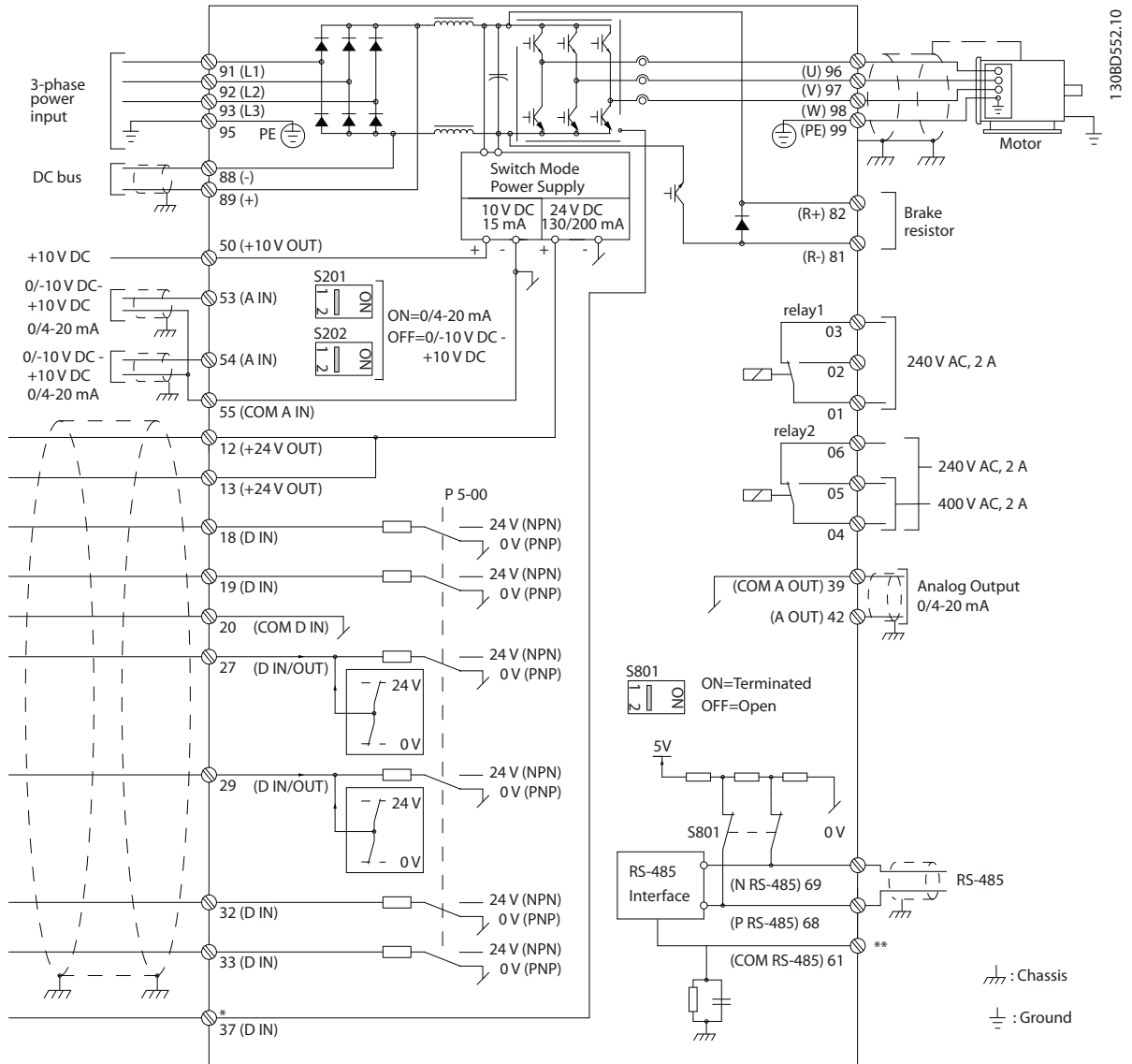
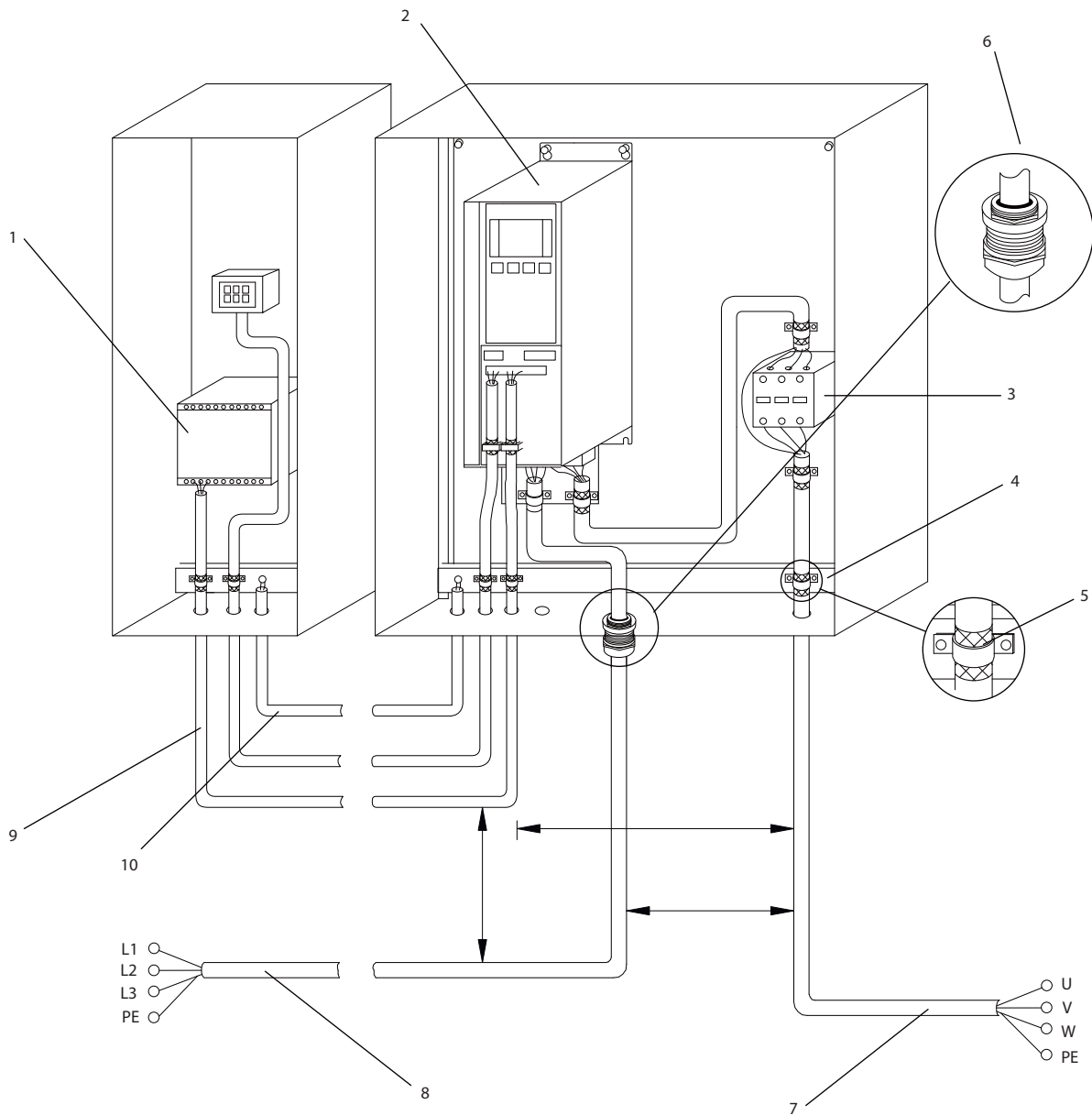

Illustration 4.1 Basic Wiring Schematic

A=Analog, D=Digital

*Terminal 37 (optional) is used for Safe Torque Off. For Safe Torque Off installation instructions, refer to the *Safe Torque Off Operating Instructions for Danfoss VLT® Frequency Converters*.

**Do not connect cable screen.



1308D529.10

4

Illustration 4.2 EMC-correct Electrical Connection

1	PLC	6	Shielded cable
2	Frequency converter	7	Motor, 3-phase and PE
3	Output contactor	8	Mains, 3-phase and reinforced PE
4	Grounding rail (PE)	9	Control wiring
5	Cable insulation (stripped)	10	Equalising min. 16 mm ² (0.025 in)

Table 4.1 Legend to *Illustration 4.2*

NOTICE

EMC INTERFERENCE!

Use separated shielded cables for input power, motor wiring and control wiring, or run cables in 3 separate metallic conduits. Failure to isolate power, motor and control wiring can result in unintended behaviour or reduced performance. Minimum 200 mm (7.9 in) clearance between control cables, motor and mains.

4.5 Access

- Remove cover with a screw driver (See *Illustration 4.3*) or by loosening attaching screws (See *Illustration 4.4*).

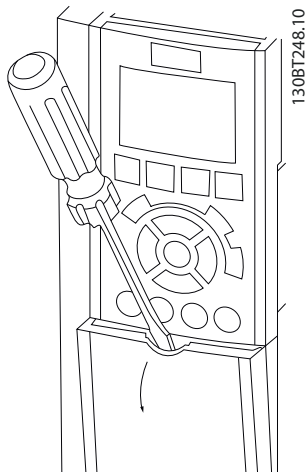

Illustration 4.3 Access to Wiring for IP20 and IP21 Enclosures

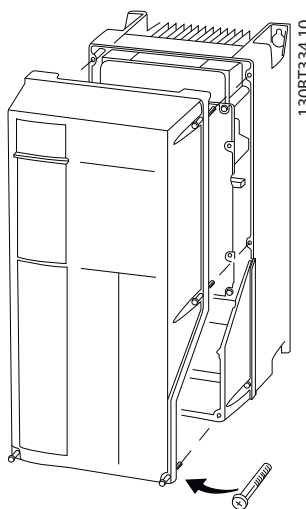

Illustration 4.4 Access to Wiring for IP55 and IP66 Enclosures

See *Table 4.2* before tightening the covers.

Enclosure	IP55	IP66
A4/A5	2	2
B1/B2	2.2	2.2
C1/C2	2.2	2.2
No screws to tighten for A2/A3/B3/B4/C3/C4.		

Table 4.2 Tightening Torques for Covers [Nm]

4.6 Motor Connection

WARNING

INDUCED VOLTAGE!

Induced voltage from output motor cables that run together can charge equipment capacitors even with the equipment turned off and locked out. Failure to run output motor cables separately or use screened cables could result in death or serious injury.

- Comply with local and national electrical codes for cable sizes. For maximum wire sizes see *8.1 Electrical Data*.
- Follow motor manufacturer wiring requirements.
- Motor wiring knockouts or access panels are provided at the base of IP21 (NEMA1/12) and higher units.
- Do not wire a starting or pole-changing device (e.g. Dahlander motor or slip ring induction motor) between the frequency converter and the motor.

Procedure

- Strip a section of the outer cable insulation.
- Position the stripped wire under the cable clamp to establish mechanical fixation and electrical contact between cable shield and ground.
- Connect ground wire to the nearest grounding terminal in accordance with grounding instructions provided in *4.3 Grounding*, see *Illustration 4.5*.
- Connect the 3-phase motor wiring to terminals 96 (U), 97 (V), and 98 (W), see *Illustration 4.5*.
- Tighten terminals in accordance with the information provided in *8.7 Connection Tightening Torques*.

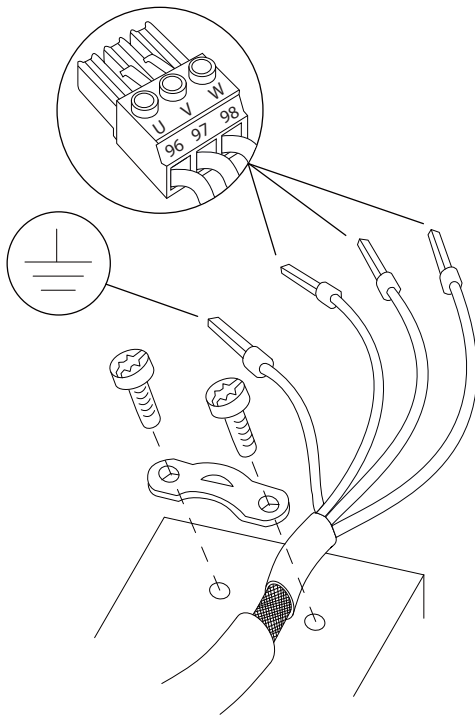

Illustration 4.5 Motor Connection

Illustration 4.6, Illustration 4.7 and Illustration 4.8 represent mains input, motor, and grounding for basic frequency converters. Actual configurations vary with unit types and optional equipment.

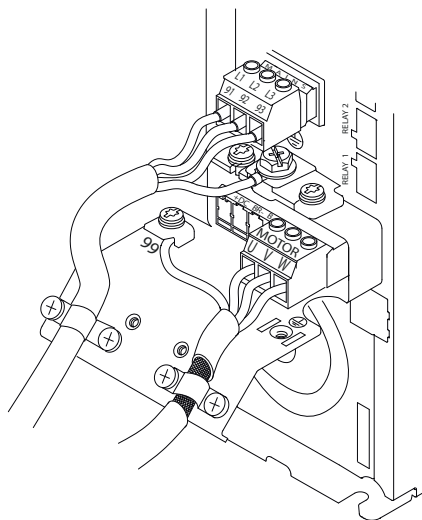

Illustration 4.6 Motor, Mains and Ground Wiring for Enclosure Types A2 and A3

1308D531.10

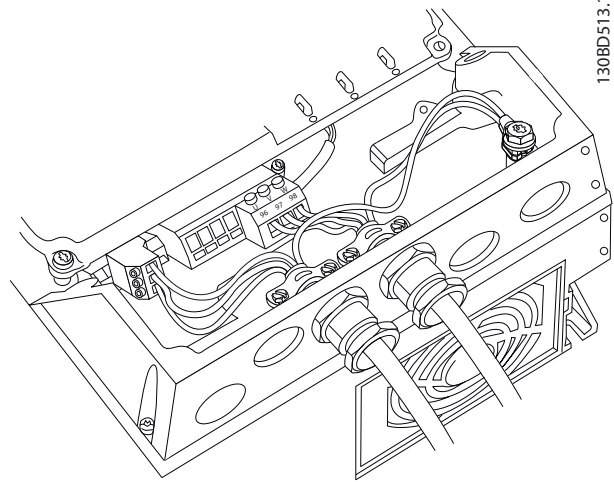

Illustration 4.7 Motor, Mains and Ground Wiring for Enclosure Types A4 and A5

1308D513.10

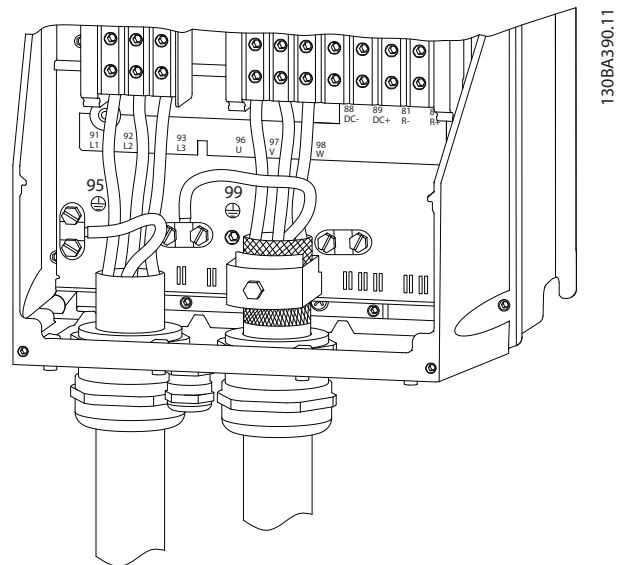

Illustration 4.8 Motor, Mains and Ground Wiring for Enclosure Types B and C Using Shielded Cable

130BA390.11

1308D577.10

4.7 AC Mains Connection

- Size wiring based upon the input current of the frequency converter. For maximum wire sizes see 8.1 *Electrical Data*.
- Comply with local and national electrical codes for cable sizes.

Procedure

1. Connect 3-phase AC input power wiring to terminals L1, L2, and L3 (see *Illustration 4.9*).
2. Depending on the configuration of the equipment, input power will be connected to the mains input terminals or the input disconnect.

3. Ground the cable in accordance with grounding instructions provided in 4.3 *Grounding*.
4. When supplied from an isolated mains source (IT mains or floating delta) or TT/TN-S mains with a grounded leg (grounded delta), ensure that 14-50 RFI Filter is set to OFF to avoid damage to the intermediate circuit and to reduce earth capacity currents in accordance with IEC 61800-3.

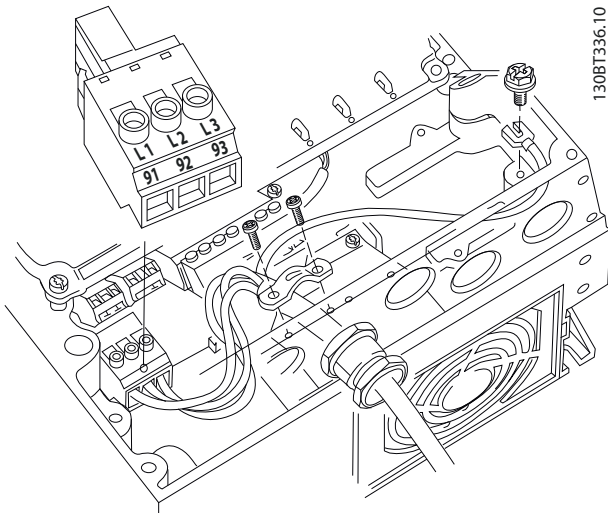

Illustration 4.9 Connecting to AC Mains

4.8 Control Wiring

- Isolate control wiring from high power components in the frequency converter.
- When the frequency converter is connected to a thermistor, ensure that the thermistor control wiring is screened and reinforced/double insulated. A 24 V DC supply voltage is recommended.

4.8.1 Control Terminal Types

Illustration 4.10 shows the removable frequency converter connectors. Terminal functions and default settings are summarised in Table 4.3.

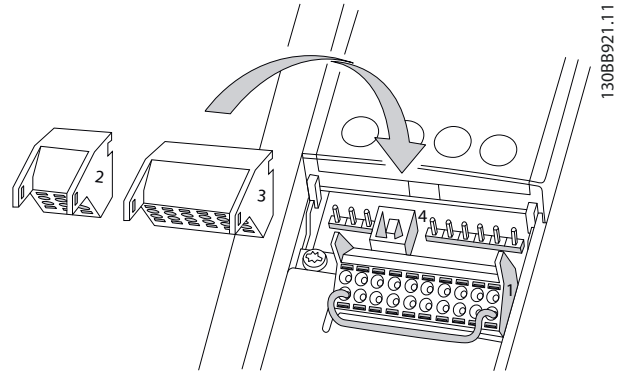

Illustration 4.10 Control Terminal Locations

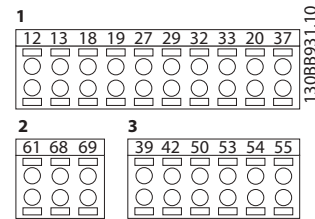

Illustration 4.11 Terminal Numbers

- **Connector 1** provides four programmable digital inputs terminals, two additional digital terminals programmable as either input or output, a 24 V DC terminal supply voltage, and a common for optional customer supplied 24 V DC voltage.
- **Connector 2** terminals (+)68 and (-)69 are for an RS-485 serial communications connection
- **Connector 3** provides two analog inputs, one analog output, 10 V DC supply voltage, and commons for the inputs and output
- **Connector 4** is a USB port available for use with the MCT 10 Set-up Software

Terminal description			
Terminal	Parameter	Default Setting	Description
Digital Inputs/Outputs			
12, 13	-	+24 V DC	24 V DC supply voltage. Maximum output current is 200 mA total for all 24 V loads. Usable for digital inputs and external transducers.
18	5-10	[8] Start	Digital inputs.
19	5-11	[0] No operation	
32	5-14	[0] No operation	
33	5-15	[0] No operation	
27	5-12	[2] Coast inverse	Selectable for digital input and output.
29	5-13	[14] JOG	Default setting is input.
20	-		Common for digital inputs and 0 V potential for 24 V supply.
37	-	Safe Torque Off (STO)	Safe input (optional). Used for STO.
Analog Inputs/Outputs			
39	-		Common for analog output
42	6-50	Speed 0 - High Limit	Programmable analog output. The analog signal is 0-20 mA or 4-20 mA at a maximum of 500 Ω
50	-	+10 V DC	10 V DC analog supply voltage. 15 mA maximum commonly used for potentiometer or thermistor.
53	6-1	Reference	Analog input.
54	6-2	Feedback	Selectable for voltage or current. Switches A53 and A54 select mA or V.
55	-		Common for analog input
Serial Communication			
61	-		Integrated RC-Filter for cable screen. ONLY for connecting the screen when experiencing EMC problems.

68 (+)	8-3		RS-485 Interface. A control card switch is provided for termination resistance.
69 (-)	8-3		
Relays			
01, 02, 03	5-40 [0]	[0] Alarm	Form C relay output. Usable for AC or DC voltage and resistive or inductive loads.
04, 05, 06	5-40 [1]	[0] Running	

Table 4.3 Terminal Description

Additional terminals:

- 2 form C relay outputs. Location of the outputs depends on frequency converter configuration.
- Terminals located on built-in optional equipment. See the manual provided with the equipment option.

4.8.2 Wiring to Control Terminals

Control terminal connectors can be unplugged from the frequency converter for ease of installation, as shown in *Illustration 4.10*.

NOTICE

Keep control wires as short as possible and separate from high power cables to minimise interference.

1. Open the contact by inserting a small screw driver into the slot above the contact and push the screw driver slightly upwards.

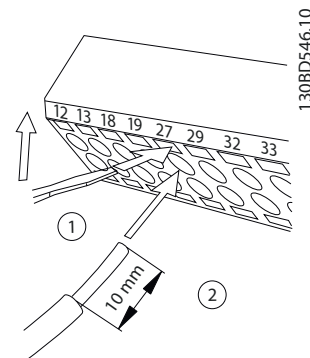

Illustration 4.12 Connecting Control Wires

2. Insert the bared control wire into the contact.
3. Remove the screw driver to fasten the control wire into the contact.
4. Ensure the contact is firmly established and not loose. Loose control wiring can be the source of equipment faults or less than optimal operation.

See 8.5 *Cable Specifications* for control terminal wiring sizes and 6 *Application Set-up Examples* for typical control wiring connections.

4.8.3 Enabling Motor Operation (Terminal 27)

A jumper wire may be required between terminal 12 (or 13) and terminal 27 for the frequency converter to operate when using factory default programming values.

- Digital input terminal 27 is designed to receive an 24 V DC external interlock command. In many applications, the user wires an external interlock device to terminal 27
- When no interlock device is used, wire a jumper between control terminal 12 (recommended) or 13 to terminal 27. This provides an internal 24 V signal on terminal 27
- No signal present prevents the unit from operating
- When the status line at the bottom of the LCP reads AUTO REMOTE COAST, this indicates that the unit is ready to operate but is missing an input signal on terminal 27.
- When factory installed optional equipment is wired to terminal 27, do not remove that wiring

NOTICE

The frequency converter cannot operate without a signal on terminal 27 unless terminal 27 is re-programmed.

4.8.4 Voltage/Current Input Selection (Switches)

The analog input terminals 53 and 54 allow setting of input signal to voltage (0-10 V) or current (0/4-20 mA).

Default parameter settings:

- Terminal 53: speed reference signal in open loop (see 16-61 *Terminal 53 Switch Setting*).
- Terminal 54: feedback signal in closed loop (see 16-63 *Terminal 54 Switch Setting*).

NOTICE

Remove power to the frequency converter before changing switch positions.

1. Remove the local control panel (see *Illustration 4.13*).
2. Remove any optional equipment covering the switches.
3. Set switches A53 and A54 to select the signal type. U selects voltage, I selects current.

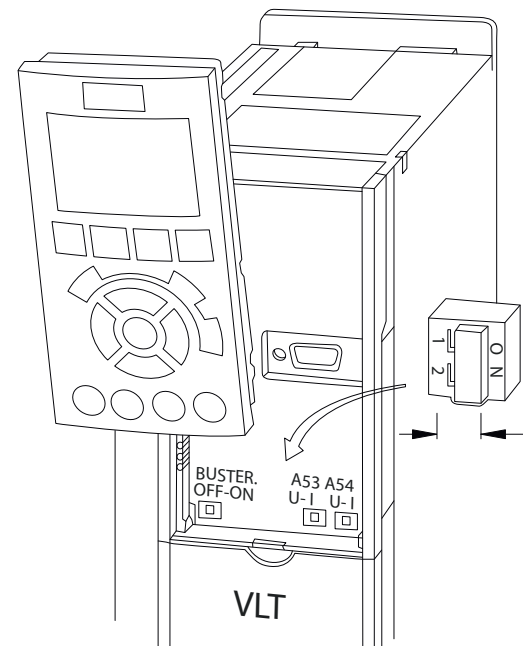

130BD530.10

Illustration 4.13 Location of Terminals 53 and 54 Switches

4.8.5 Safe Torque Off (STO)

To run Safe Torque Off, additional wiring for the frequency converter is required, refer to *Safe Torque Off Operating Instructions for Danfoss VLT® Frequency Converters* for further information.

4.8.6 RS-485 Serial Communication

Up to 32 nodes can be connected as a bus, or via drop cables from a common trunk line to 1 network segment. Repeaters can divide network segments. Each repeater functions as a node within the segment in which it is installed. Each node connected within a given network must have a unique node address, across all segments.

- Connect RS-485 serial communication wiring to terminals (+)68 and (-)69.
- Terminate each segment at both ends, using either the termination switch (bus term on/off, see *Illustration 4.13*) on the frequency converters, or a biased termination resistor network.
- Connect a large surface of the screen to ground, for example with a cable clamp or a conductive cable gland.
- Apply potential-equalising cables to maintain the same ground potential throughout the network.
- Use the same type of cable throughout the entire network to prevent impedance mismatch.

Cable	Screened twisted pair (STP)
Impedance	120 Ω
Max. cable length [m]	1200 (including drop lines) 500 station-to-station

Table 4.4 Cable Information

4.9 Installation Check List

Before completing installation of the unit, inspect the entire installation as detailed in *Table 4.5*. Check and mark the items when completed.

4

Inspect for	Description	<input checked="" type="checkbox"/>
Auxiliary equipment	<ul style="list-style-type: none"> Look for auxiliary equipment, switches, disconnects, or input fuses/circuit breakers that may reside on the input power side of the frequency converter or output side to the motor. Ensure that they are ready for full-speed operation Check function and installation of any sensors used for feedback to the frequency converter Remove any power factor correction caps on motor(s) Adjust any power factor correction caps on the mains side and ensure that they are dampened 	
Cable routing	<ul style="list-style-type: none"> Ensure that motor wiring and control wiring are separated or screened or in 3 separate metallic conduits for high-frequency interference isolation 	
Control wiring	<ul style="list-style-type: none"> Check for broken or damaged wires and loose connections Check that control wiring is isolated from power and motor wiring for noise immunity Check the voltage source of the signals, if necessary The use of shielded cable or twisted pair is recommended. Ensure that the shield is terminated correctly 	
Cooling clearance	<ul style="list-style-type: none"> Measure that top and bottom clearance is adequate to ensure proper air flow for cooling, see <i>3.3 Mounting</i> 	
Ambient conditions	<ul style="list-style-type: none"> Check that requirements for ambient conditions are met 	
Fusing and circuit breakers	<ul style="list-style-type: none"> Check for proper fusing or circuit breakers Check that all fuses are inserted firmly and are in operational condition and that all circuit breakers are in the open position 	
Grounding	<ul style="list-style-type: none"> Check for good ground connections that are tight and free of oxidation Grounding to conduit, or mounting the back panel to a metal surface, is not a suitable grounding 	
Input and output power wiring	<ul style="list-style-type: none"> Check for loose connections Check that motor and mains are in separate conduit or separated screened cables 	
Panel interior	<ul style="list-style-type: none"> Inspect that the unit interior is free of dirt, metal chips, moisture, and corrosion Check that the unit is mounted on an unpainted, metal surface 	
Switches	<ul style="list-style-type: none"> Ensure that all switch and disconnect settings are in the proper positions 	
Vibration	<ul style="list-style-type: none"> Check that the unit is mounted solidly, or that shock mounts are used, as necessary Check for an unusual amount of vibration 	

Table 4.5 Installation Check List

CAUTION

POTENTIAL HAZARD IN THE EVENT OF INTERNAL FAILURE!

Risk of personal injury when the frequency converter is not properly closed. Before applying power, ensure all safety covers are in place and securely fastened.

5 Commissioning

5.1 Safety Instructions

See 2 *Safety* for general safety instructions.

⚠ WARNING

HIGH VOLTAGE!

Frequency converters contain high voltage when connected to AC mains input power. Installation, start-up, and maintenance must be performed by qualified personnel only. Failure to perform installation, start-up, and maintenance by qualified personnel could result in death or serious injury.

Before applying power:

1. Close cover properly.
2. Check that all cable glands are firmly tightened.
3. Ensure that input power to the unit is OFF and locked out. Do not rely on the frequency converter disconnect switches for input power isolation.
4. Verify that there is no voltage on input terminals L1 (91), L2 (92), and L3 (93), phase-to-phase and phase-to-ground.
5. Verify that there is no voltage on output terminals 96 (U), 97 (V), and 98 (W), phase-to-phase and phase-to-ground.
6. Confirm continuity of the motor by measuring ohm values on U-V (96-97), V-W (97-98), and W-U (98-96).
7. Check for proper grounding of the frequency converter as well as the motor.
8. Inspect the frequency converter for loose connections on terminals.
9. Confirm that the supply voltage matches voltage of frequency converter and motor.

5.2 Applying Power

⚠ WARNING

UNINTENDED START!

When the frequency converter is connected to AC mains, the motor may start at any time. The frequency converter, motor, and any driven equipment must be in operational readiness. Failure to be in operational readiness when the frequency converter is connected to AC mains could result in death, serious injury, equipment or property damage.

1. Confirm that the input voltage is balanced within 3%. If not, correct input voltage imbalance before proceeding. Repeat this procedure after the voltage correction.
2. Ensure that optional equipment wiring, if present, matches the installation application.
3. Ensure that all operator devices are in the OFF position. Panel doors must be closed or cover mounted.
4. Apply power to the unit. DO NOT start the frequency converter at this time. For units with a disconnect switch, turn to the ON position to apply power to the frequency converter.

NOTICE

If the status line at the bottom of the LCP reads **AUTO REMOTE COASTING** or **Alarm 60 External Interlock** is displayed, this indicates that the unit is ready to operate but is missing an input signal on terminal 27. See 4.8.3 *Enabling Motor Operation (Terminal 27)* for details.

5.3 Local Control Panel Operation

5.3.1 Local Control Panel

The local control panel (LCP) is the combined display and keypad on the front of the unit.

The LCP has several user functions:

- Start, stop, and control speed when in local control
- Display operational data, status, warnings and cautions
- Programming frequency converter functions
- Manually reset the frequency converter after a fault when auto-reset is inactive

An optional numeric LCP (NLCP) is also available. The NLCP operates in a manner similar to the LCP. See the *Programming Guide* for details on use of the NLCP.

NOTICE

For commissioning via PC, install MCT 10 Set-up Software. The software is available for downloading at www.danfoss.com/BusinessAreas/DrivesSolutions/software-download (basic version) or for ordering (advanced version, order number 130B1000).

5.3.2 LCP Layout

The LCP is divided into 4 functional groups (see *Illustration 5.1*).

- A. Display area
- B. Display menu keys
- C. Navigation keys and indicator lights (LEDs)
- D. Operation keys and reset

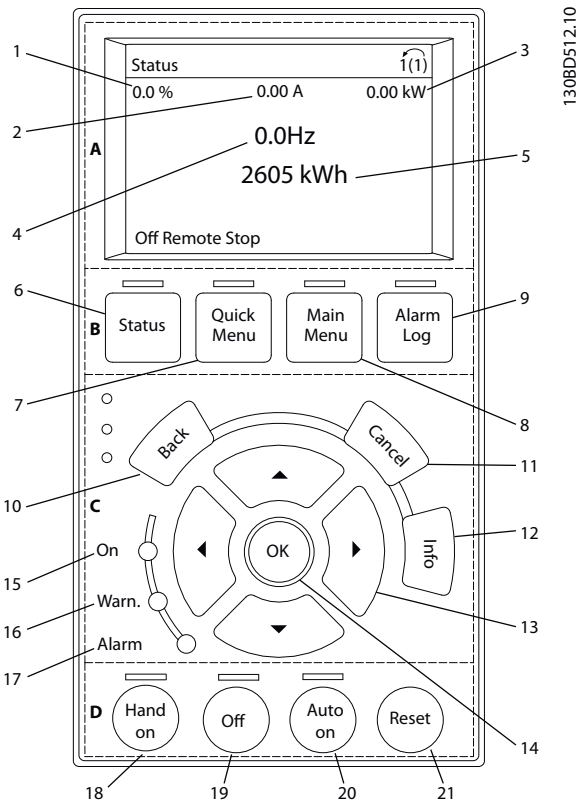

Illustration 5.1 Local Control Panel (LCP)

A. Display Area

The display area is activated when the frequency converter receives power from mains voltage, a DC bus terminal, or an external 24 V DC supply.

The information displayed on the LCP can be customized for user application. Select options in the Quick Menu Q3-13 *Display Settings*.

Display	Parameter number	Default setting
1	0-20	Reference %
2	0-21	Motor current
3	0-22	Power [kW]
4	0-23	Frequency
5	0-24	kWh counter

Table 5.1 Legend to *Illustration 5.1*, Display Area

B. Display Menu Keys

Menu keys are used for menu access for parameter set-up, toggling through status display modes during normal operation, and viewing fault log data.

	Key	Function
6	Status	Shows operational information.
7	Quick Menu	Allows access to programming parameters for initial set-up instructions and many detailed application instructions.
8	Main Menu	Allows access to all programming parameters.
9	Alarm Log	Displays a list of current warnings, the last 10 alarms, and the maintenance log.

Table 5.2 Legend to *Illustration 5.1*, Display Menu Keys

C. Navigation Keys and Indicator Lights (LEDs)

Navigation keys are used for programming functions and moving the display cursor. The navigation keys also provide speed control in local (hand) operation. There are also 3 frequency converter status indicator lights in this area.

	Key	Function
10	Back	Reverts to the previous step or list in the menu structure.
11	Cancel	Cancels the last change or command as long as the display mode has not changed.
12	Info	Press for a definition of the function being displayed.
13	Navigation Keys	Use the 4 navigation keys to move between items in the menu.
14	OK	Use to access parameter groups or to enable a choice.

Table 5.3 Legend to *Illustration 5.1*, Navigation Keys

	Indicator	Light	Function
15	ON	Green	The ON light activates when the frequency converter receives power from mains voltage, a DC bus terminal, or an external 24 V supply.
16	WARN	Yellow	When warning conditions are met, the yellow WARN light comes on and text appears in the display area identifying the problem.
17	ALARM	Red	A fault condition causes the red alarm light to flash and an alarm text is displayed.

Table 5.4 Legend to *Illustration 5.1*, Indicator Lights (LEDs)

D. Operation Keys and Reset

Operation keys are located at the bottom of the LCP.

	Key	Function
18	Hand On	Starts the frequency converter in local control. <ul style="list-style-type: none"> An external stop signal by control input or serial communication overrides the local hand on
19	Off	Stops the motor but does not remove power to the frequency converter.
20	Auto On	Puts the system in remote operational mode. <ul style="list-style-type: none"> Responds to an external start command by control terminals or serial communication
21	Reset	Resets the frequency converter manually after a fault has been cleared.

Table 5.5 Legend to Illustration 5.1, Operation Keys and Reset

NOTICE

The display contrast can be adjusted by pressing [Status] and [▲]/[▼] keys.

5.3.3 Parameter Settings

Establishing the correct programming for applications often requires setting functions in several related parameters. Details for parameters are provided in 9.2 Parameter Menu Structure.

Programming data are stored internally in the frequency converter.

- For backup, upload data into the LCP memory
- To download data to another frequency converter, connect the LCP to that unit and download the stored settings
- Restoring factory default settings does not change data stored in the LCP memory

5.3.4 Uploading/Downloading Data to/from the LCP

- Press [Off] to stop the motor before uploading or downloading data.
- Go to [Main Menu] 0-50 LCP Copy and Press [OK].
- Select *All to LCP* to upload data to LCP or select *All from LCP* to download data from the LCP.
- Press [OK]. A progress bar shows the uploading or downloading process.
- Press [Hand On] or [Auto On] to return to normal operation.

5.3.5 Changing Parameter Settings

View Changes

Quick Menu Q5 - Changes Made lists all parameters changed from default settings.

- The list shows only parameters which have been changed in the current edit-setup.
- Parameters which have been reset to default values are not listed.
- The message 'Empty' indicates that no parameters have been changed.

Changing Settings

Parameter settings can be accessed and changed from the [Quick Menu] or from the [Main Menu]. The [Quick Menu] only gives access to a limited number of parameters.

- Press [Quick Menu] or [Main Menu] on the LCP.
- Press [▲] [▼] to browse through the parameter groups, press [OK] to select a parameter group.
- Press [▲] [▼] to browse through the parameters, press [OK] to select a parameter.
- Press [▲] [▼] to change the value of a parameter setting.
- Press [◀] [▶] to shift digit when a decimal parameter is in the editing state.
- Press [OK] to accept the change.
- Press either [Back] twice to enter "Status", or press [Main Menu] once to enter "Main Menu".

5.3.6 Restoring Default Settings

NOTICE

Initialisation restores the unit to factory default settings. Any programming, motor data, localisation, and monitoring records will be lost. Uploading data to the LCP provides a backup before initialisation.

Restoring the frequency converter parameter settings back to default values is done by initialisation of the frequency converter. Initialisation can be carried out through 14-22 Operation Mode (recommended) or manually.

- Initialisation using 14-22 Operation Mode does not reset frequency converter settings such as operating hours, serial communication selections, personal menu settings, fault log, alarm log, and other monitoring functions.
- Manual initialisation erases all motor, programming, localization, and monitoring data and restores factory default settings.

Recommended Initialisation Procedure, via 14-22 Operation Mode

1. Press [Main Menu] twice to access parameters.
2. Scroll to 14-22 Operation Mode and press [OK].
3. Scroll to Initialisation and press [OK].
4. Remove power to the unit and wait for the display to turn off.
5. Apply power to the unit.

Default parameter settings are restored during start-up. This may take slightly longer than normal.

6. Alarm 80 is displayed.
7. Press [Reset] to return to operation mode.

Manual Initialisation Procedure

1. Remove power to the unit and wait for the display to turn off.
2. Press and hold [Status], [Main Menu], and [OK] at the same time while applying power to the unit (approximately 5 s or until audible click and fan starts).

Factory default parameter settings are restored during start-up. This may take slightly longer than normal.

Manual initialisation does not reset the following frequency converter information

- 15-00 Operating hours
- 15-03 Power Up's
- 15-04 Over Temp's
- 15-05 Over Volt's

5.4 Basic Programming

5.4.1 Commissioning with SmartStart

The SmartStart wizard enables fast configuration of basic motor and application parameters.

- At first power up or after initialisation of the frequency converter, SmartStart starts by itself.
- Follow on-screen instructions to complete commissioning of the frequency converter. SmartStart can always be re-activated by selecting *Quick Menu Q4 - SmartStart*.
- For commissioning without use of the SmartStart wizard, refer to 5.4.2 Commissioning via [Main Menu] or the Programming Guide.

NOTICE

Motor data are required for the SmartStart setup. The required data are normally available on the motor nameplate.

5.4.2 Commissioning via [Main Menu]

Recommended parameter settings are intended for start-up and checkout purposes. Application settings may vary.

Enter data with power ON, but before operating the frequency converter.

1. Press [Main Menu] on the LCP.
2. Use the navigation keys to scroll to parameter group 0-** Operation/Display and press [OK].

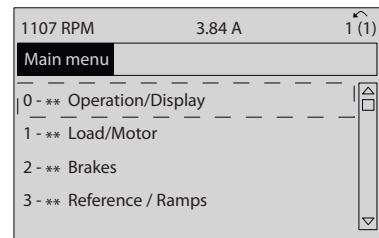

130BP066.10

Illustration 5.2 Main Menu

3. Use navigation keys to scroll to parameter group 0-0* Basic Settings and press [OK].

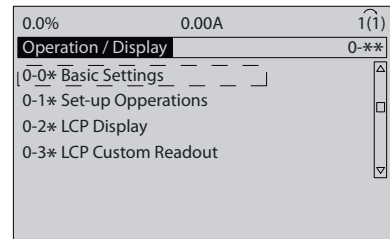

130BP087.10

Illustration 5.3 Operation/Display

4. Use navigation keys to scroll to 0-03 Regional Settings and press [OK].

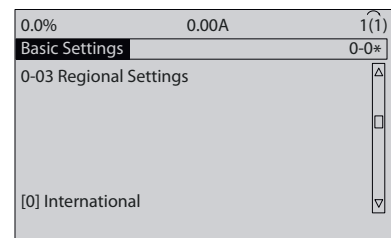

130BP088.10

Illustration 5.4 Basic Settings

5. Use navigation keys to select [0] International or [1] North America as appropriate and press [OK]. (This changes the default settings for a number of basic parameters).
6. Press [Main Menu] on the LCP.

7. Use the navigation keys to scroll to *0-01 Language*.
8. Select language and press [OK].
9. If a jumper wire is in place between control terminals 12 and 27, leave *5-12 Terminal 27 Digital Input* at factory default. Otherwise, *No Operation* should be selected in *5-12 Terminal 27 Digital Input*. For frequency converters with an optional bypass, no jumper wire is required between control terminals 12 and 27.
10. *3-02 Minimum Reference*
11. *3-03 Maximum Reference*
12. *3-41 Ramp 1 Ramp Up Time*
13. *3-42 Ramp 1 Ramp Down Time*
14. *3-13 Reference Site*. Linked to Hand/Auto Local Remote.

5.4.3 Asynchronous Motor Setup

Enter the motor data in parameters 1-20 or 1-21 to 1-25. The information can be found on the motor nameplate.

1. *1-20 Motor Power [kW] or 1-21 Motor Power [HP]*
2. *1-22 Motor Voltage*
3. *1-23 Motor Frequency*
4. *1-24 Motor Current*
5. *1-25 Motor Nominal Speed*

5.4.4 Permanent Magnet Motor Setup

NOTICE

Only use permanent magnet (PM) motor with fans and pumps.

Initial Programming Steps

1. Activate PM motor operation *1-10 Motor Construction*, select (1) PM, non salient SPM
2. Set *0-02 Motor Speed Unit* to [0] RPM

Programming motor data

After selecting PM motor in *1-10 Motor Construction*, the PM motor-related parameters in parameter groups *1-2* Motor Data*, *1-3* Adv. Motor Data* and *1-4** are active. The necessary data can be found on the motor nameplate and in the motor data sheet. Program the following parameters in the listed order

1. *1-24 Motor Current*
2. *1-26 Motor Cont. Rated Torque*
3. *1-25 Motor Nominal Speed*
4. *1-39 Motor Poles*

5. *1-30 Stator Resistance (Rs)*
Enter line to common stator winding resistance (Rs). If only line-line data are available, divide the line-line value with 2 to achieve the line to common (starpoint) value.
It is also possible to measure the value with an ohmmeter, which will also take the resistance of the cable into account. Divide the measured value by 2 and enter the result.
6. *1-37 d-axis Inductance (Ld)*
Enter line to common direct axis inductance of the PM motor.
If only line-line data are available, divide the line-line value with 2 to achieve the line-common (starpoint) value.
It is also possible to measure the value with an inductancemeter, which will also take the inductance of the cable into account. Divide the measured value by 2 and enter the result.
7. *1-40 Back EMF at 1000 RPM*
Enter line to line back EMF of PM Motor at 1000 RPM mechanical speed (RMS value). Back EMF is the voltage generated by a PM motor when no drive is connected and the shaft is turned externally. Back EMF is normally specified for nominal motor speed or for 1000 RPM measured between two lines. If the value is not available for a motor speed of 1000 RPM, calculate the correct value as follows: If back EMF is e.g. 320 V at 1800 RPM, it can be calculated at 1000 RPM as follows:
Back EMF = (Voltage / RPM)*1000 =
(320/1800)*1000 = 178. This is the value that must be programmed for *1-40 Back EMF at 1000 RPM*.

Test Motor Operation

1. Start the motor at low speed (100 to 200 RPM). If the motor does not turn, check installation, general programming and motor data.
2. Check if start function in *1-70 PM Start Mode* fits the application requirements.

Rotor detection

This function is the recommended choice for applications where the motor starts from standstill, e.g. pumps or conveyors. On some motors, an acoustic sound is heard when the impulse is sent out. This does not harm the motor.

Parking

This function is the recommended choice for applications where the motor is rotating at slow speed e.g. windmilling in fan applications. *2-06 Parking Current* and *2-07 Parking Time* can be adjusted. Increase the factory setting of these parameters for applications with high inertia.

Start the motor at nominal speed. If the application does not run well, check the VVC^{plus} PM settings. Recommendations in different applications can be seen in *Table 5.6*.

Application	Settings
Low inertia applications $I_{Load}/I_{Motor} < 5$	<p>1-17 <i>Voltage filter time const.</i> to be increased by factor 5 to 10</p> <p>1-14 <i>Damping Gain</i> should be reduced</p> <p>1-66 <i>Min. Current at Low Speed</i> should be reduced (<100%)</p>
Low inertia applications $50 > I_{Load}/I_{Motor} > 5$	Keep calculated values
High inertia applications $I_{Load}/I_{Motor} > 50$	<p>1-14 <i>Damping Gain</i>, 1-15 <i>Low Speed Filter Time Const.</i> and 1-16 <i>High Speed Filter Time Const.</i> should be increased</p>
High load at low speed <30% (rated speed)	<p>1-17 <i>Voltage filter time const.</i> should be increased</p> <p>1-66 <i>Min. Current at Low Speed</i> should be increased (>100% for a prolonged time can overheat the motor)</p>

Table 5.6 Recommendations in Different Applications

If the motor starts oscillating at a certain speed, increase 1-14 *Damping Gain*. Increase the value in small steps. Depending on the motor, a good value for this parameter can be 10% or 100% higher than the default value.

Starting torque can be adjusted in 1-66 *Min. Current at Low Speed*. 100% provides nominal torque as starting torque.

5.4.5 Automatic Energy Optimization (AEO)

NOTICE

AEO is not relevant for permanent magnet motors.

Automatic Energy Optimization (AEO) is recommended for

- Automatic compensation for oversized motors
- Automatic compensation for slow system load change
- Automatic compensation for seasonal changes
- Automatic compensation for low motor loading
- Reduced energy consumption
- Reduced motor heating
- Reduced motor noise

To activate AEO, set parameter 1-03 *Torque Characteristics* to [2] *Auto Energy Optim. CT* or [3] *Auto Energy Optim. VT*.

5.4.6 Automatic Motor Adaptation (AMA)

NOTICE

AMA is not relevant for permanent magnet motors.

Automatic motor adaptation (AMA) is a procedure that optimizes compatibility between the frequency converter and the motor.

- The frequency converter builds a mathematical model of the motor for regulating output motor current. The procedure also tests the input phase balance of electrical power. It compares the motor characteristics with the data entered in parameters 1-20 to 1-25
- The motor shaft does not turn and no harm is done to the motor while running the AMA
- Some motors may be unable to run the complete version of the test. In that case, select [2] *Enable reduced AMA*
- If an output filter is connected to the motor, select *Enable reduced AMA*
- If warnings or alarms occur, see 7.3 *List of Warnings and Alarms*
- Run this procedure on a cold motor for best results

To run AMA

1. Press [Main Menu] to access parameters.
2. Scroll to parameter group 1-** *Load and Motor* and press [OK].
3. Scroll to parameter group 1-2* *Motor Data* and press [OK].
4. Scroll to 1-29 *Automatic Motor Adaptation (AMA)* and press [OK].
5. Select [1] *Enable complete AMA* and press [OK].
6. Follow on-screen instructions.
7. The test will run automatically and indicate when it is complete.

5.5 Checking Motor Rotation

⚠ WARNING

MOTOR START!

Ensure that the motor, system, and any attached equipment are ready for start. It is the responsibility of the user to ensure safe operation under any condition. Failure to ensure that the motor, system, and any attached equipment is ready for start could result in personal injury or equipment damage.

NOTICE

Risk of damage to pumps/compressors caused by motor running in wrong direction. Before running the frequency converter, check the motor rotation.

The motor will run briefly at 5 Hz or the minimum frequency set in 4-12 *Motor Speed Low Limit* [Hz].

1. Press [Main Menu].
2. Scroll to 1-28 *Motor Rotation Check* and press [OK].
3. Scroll to [1] *Enable*.

The following text will appear: *Note! Motor may run in wrong direction.*

4. Press [OK].
5. Follow the on-screen instructions.

NOTICE

To change the direction of rotation, remove power to the frequency converter and wait for power to discharge. Reverse the connection of any 2 of the 3 motor wires on the motor or frequency converter side of the connection.

5.6 Local-control Test

⚠ WARNING

MOTOR START!

Ensure that the motor, system, and any attached equipment are ready for start. It is the responsibility of the user to ensure safe operation under any condition. Failure to ensure that the motor, system, and any attached equipment is ready for start could result in personal injury or equipment damage.

1. Press [Hand On] to provide a local start command to the frequency converter.
2. Accelerate the frequency converter by pressing [▲] to full speed. Moving the cursor left of the decimal point provides quicker input changes.
3. Note any acceleration problems.

4. Press [Off]. Note any deceleration problems.

In the event of acceleration or deceleration problems, see 7.4 *Troubleshooting*. See 7.3 *List of Warnings and Alarms* for resetting the frequency converter after a trip.

5.7 System Start-up

The procedure in this section requires user-wiring and application programming to be completed. The following procedure is recommended after application set-up is completed.

⚠ WARNING

MOTOR START!

Ensure that the motor, system, and any attached equipment are ready for start. It is the responsibility of the user to ensure safe operation under any condition. Failure to ensure that the motor, system, and any attached equipment is ready for start could result in personal injury or equipment damage.

1. Press [Auto On].
2. Apply an external run command.
3. Adjust the speed reference throughout the speed range.
4. Remove the external run command.
5. Check sound and vibration level of the motor to ensure that the system is working as intended.

If warnings or alarms occur, see 7.3 *List of Warnings and Alarms*.

5.8 Maintenance

Under normal operating conditions and load profiles, the frequency converter is maintenance-free throughout its designed lifetime. To prevent breakdown, danger, and damage, examine the frequency converter at regular intervals depending on the operating conditions. Replace worn or damaged parts with original spare parts or standard parts. For service and support, refer to www.danfoss.com/contact/sales_and_services/.

⚠ CAUTION

Risk of personal injury or equipment damage exists. Repair and service must be carried out by Danfoss authorized personnel only.

6 Application Set-up Examples

The examples in this section are intended as a quick reference for common applications.

- Parameter settings are the regional default values unless otherwise indicated (selected in 0-03 Regional Settings)
- Parameters associated with the terminals and their settings are shown next to the drawings
- Where switch settings for analog terminals A53 or A54 are required, these are also shown

6

NOTICE

When the optional Safe Torque Off feature is used, a jumper wire may be required between terminal 12 (or 13) and terminal 37 for the frequency converter to operate when using factory default programming values.

6.1 Application Examples

6.1.1 Speed

		Parameters	
FC		Function	Setting
+24 V	12		
+24 V	13	6-12 Terminal 53	4 mA*
D IN	18	Low Current	
D IN	19	6-13 Terminal 53	20 mA*
COM	20	High Current	
D IN	27	6-14 Terminal 53	0 Hz
D IN	29	Low Ref./Feedb. Value	
D IN	32	6-15 Terminal 53	50 Hz
D IN	33	High Ref./Feedb. Value	
D IN	37		
+10 V	50	* = Default Value	
A IN	53	Notes/comments: D IN 37 is an option.	
A IN	54		
COM	55		
A OUT	42		
COM	39		

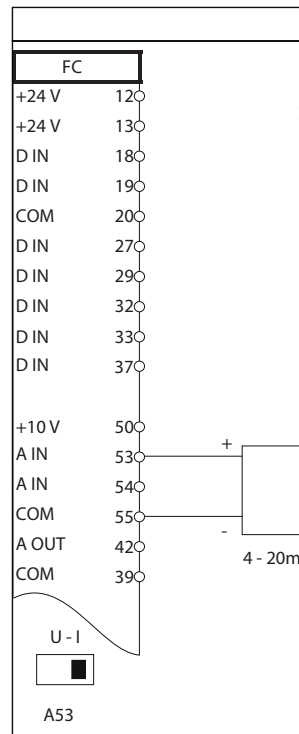

Table 6.2 Analog Speed Reference (Current)

		Parameters	
FC		Function	Setting
+24 V	12		
+24 V	13	6-10 Terminal 53	
D IN	18	Low Voltage	0.07 V*
D IN	19	6-11 Terminal 53	10 V*
COM	20	High Voltage	
D IN	27	6-14 Terminal 53	0 Hz
D IN	29	Low Ref./Feedb. Value	
D IN	32	6-15 Terminal 53	50 Hz
D IN	33	High Ref./Feedb. Value	
D IN	37		
+10 V	50	* = Default Value	
A IN	53	Notes/comments: D IN 37 is an option.	
A IN	54		
COM	55		
A OUT	42		
COM	39		

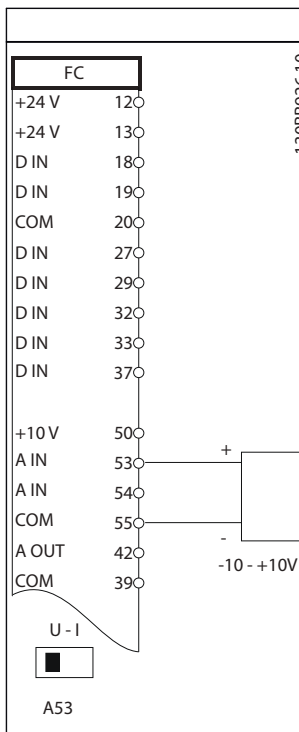

Table 6.1 Analog Speed Reference (Voltage)

		Parameters	
FC		Function	Setting
+24 V	12		
+24 V	13	6-10 Terminal 53	
D IN	18	Low Voltage	0.07 V*
D IN	19	6-11 Terminal 53	10 V*
COM	20	High Voltage	
D IN	27	6-14 Terminal 53	0 Hz
D IN	29	Low Ref./Feedb. Value	
D IN	32	6-15 Terminal 53	1500 Hz
D IN	33	High Ref./Feedb. Value	
D IN	37		
+10 V	50	* = Default Value	
A IN	53	Notes/comments: D IN 37 is an option.	
A IN	54		
COM	55		
A OUT	42		
COM	39		

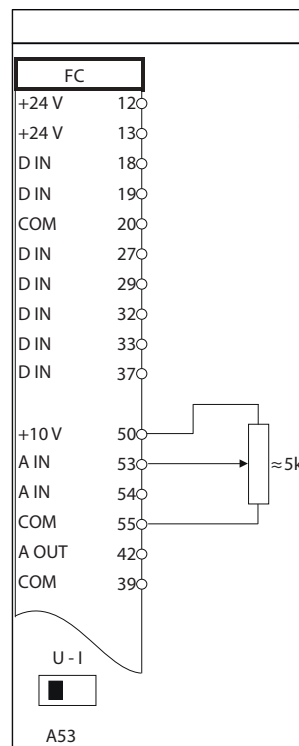

Table 6.3 Speed Reference (Using a Manual Potentiometer)

		Parameters	
FC		Function	Setting
+24 V	12	5-10 Terminal 18 Digital Input	[8] Start*
+24 V	13		
D IN	18	5-12 Terminal 27 Digital Input	[19] Freeze Reference
D IN	19		
COM	20	5-13 Terminal 29 Digital Input	[21] Speed Up
D IN	27		
D IN	29	5-14 Terminal 32 Digital Input	[22] Speed Down
D IN	32		
D IN	33		
D IN	37		
* = Default Value			
Notes/comments: D IN 37 is an option.			

Table 6.4 Speed Up/Down

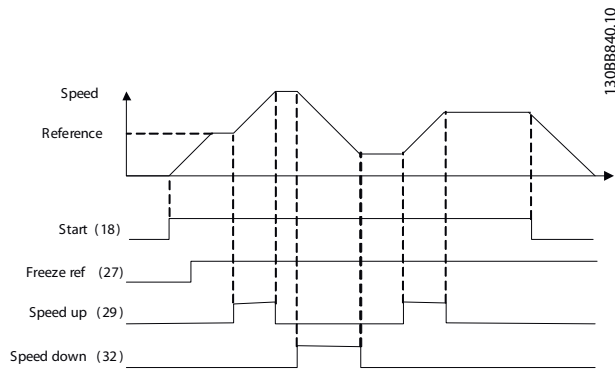

Illustration 6.1 Speed Up/Down

6.1.2 Start/Stop

		Parameters	
FC		Function	Setting
+24 V	12	5-10 Terminal 18 Digital Input	[8] Start*
+24 V	13		
D IN	18	5-12 Terminal 27 Digital Input	[0] No operation
D IN	19		
COM	20	5-19 Terminal 37 Safe Stop	[1] Safe Stop Alarm
D IN	27		
D IN	29		
D IN	32		
D IN	33		
D IN	37		
* = Default Value			
Notes/comments: If 5-12 Terminal 27 Digital Input is set to [0] No operation, a jumper wire to terminal 27 is not needed. D IN 37 is an option.			

Table 6.5 Start/Stop Command with Safe Stop Option

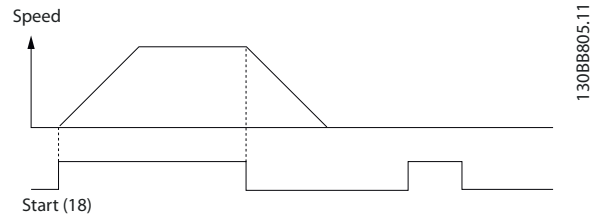

Illustration 6.2 Start/Stop Command with Safe Stop

FC		Parameters	
		Function	Setting
+24 V	12	5-10 Terminal 18 Digital Input	[9] Latched Start
+24 V	13		
D IN	18	5-12 Terminal 27 Digital Input	[6] Stop Inverse
D IN	19		
COM	20	* = Default Value	
D IN	27	Notes/comments: If 5-12 Terminal 27 Digital Input is set to [0] No operation, a jumper wire to terminal 27 is not needed. D IN 37 is an option.	
D IN	29		
D IN	32		
D IN	33		
D IN	37		
+10 V	50		
A IN	53		
A IN	54		
COM	55		
A OUT	42		
COM	39		

Table 6.6 Pulse Start/Stop

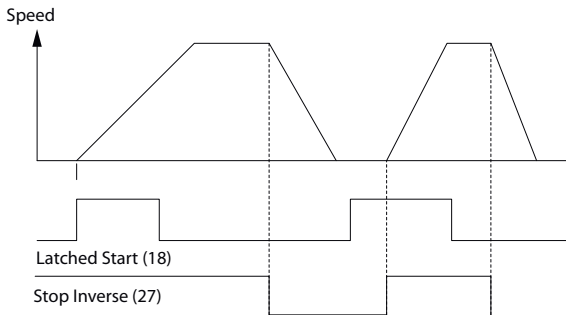

Illustration 6.3 Latched Start/Stop Inverse

FC		Parameters	
		Function	Setting
+24 V	12	5-10 Terminal 18 Digital Input	[8] Start
+24 V	13		
D IN	18	5-11 Terminal 19 Digital Input	[10] Reversing*
D IN	19		
COM	20	* = Default Value	
D IN	27	5-12 Terminal 27 Digital Input	[0] No operation
D IN	29		
D IN	32	5-14 Terminal 32 Digital Input	[16] Preset ref bit 0
D IN	33		
D IN	37	5-15 Terminal 33 Digital Input	[17] Preset ref bit 1
D IN	37		
+10 V	50	3-10 Preset Reference Preset ref. 0 25% Preset ref. 1 50% Preset ref. 2 75% Preset ref. 3 100%	
A IN	53		
A IN	54		
COM	55		
A OUT	42		
COM	39	* = Default Value	
		Notes/comments: D IN 37 is an option.	

Table 6.7 Start/Stop with Reversing and 4 Preset Speeds

6.1.3 External Alarm Reset

FC		Parameters	
		Function	Setting
+24 V	12	5-11 Terminal 19 Digital Input	[1] Reset
+24 V	13		
D IN	18	* = Default Value	
D IN	19	Notes/comments: D IN 37 is an option.	
COM	20		
D IN	27		
D IN	29		
D IN	32		
D IN	33		
D IN	37		
+10 V	50		
A IN	53		
A IN	54		
COM	55		
A OUT	42		
COM	39		

Table 6.8 External Alarm Reset

6.1.4 RS-485

		Parameters	
FC		Function	Setting
+24 V	12		
+24 V	13	8-30 Protocol	FC*
D IN	18	8-31 Address	1*
D IN	19	8-32 Baud Rate	9600*
COM	20	* = Default Value	
D IN	27	Notes/comments:	
D IN	29	Select protocol, address and baud rate in the above mentioned parameters.	
D IN	32	D IN 37 is an option.	
D IN	33		
D IN	37		
+10 V	50		
A IN	53		
A IN	54		
COM	55		
A OUT	42		
COM	39		
R1	01		
	02		
	03		
R2	04		
	05		
	06		
	61		
	68		
	69		

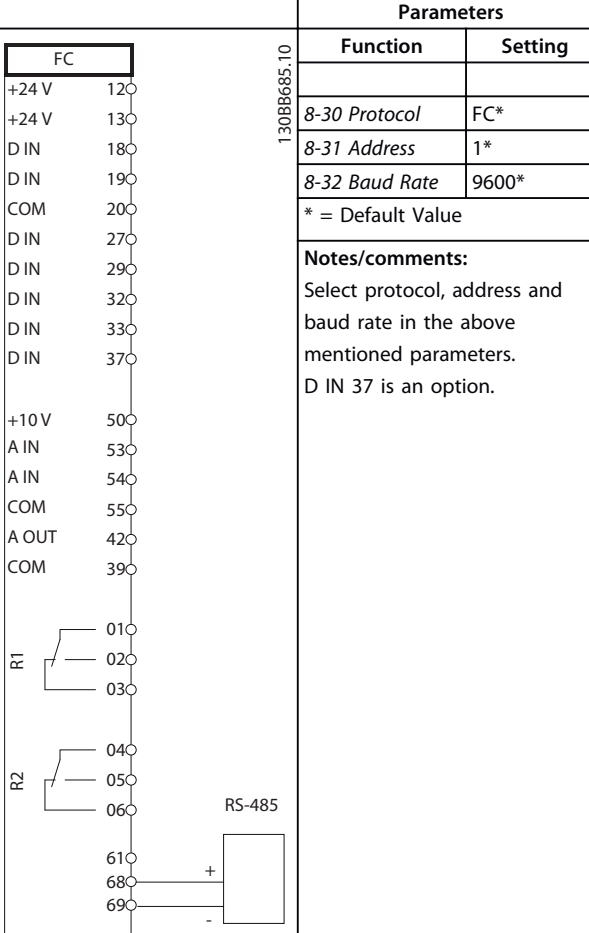

The diagram shows a terminal block with 39 pins. Pins 12, 13, 18, 19, 20, 27, 29, 32, 33, 37, 50, 53, 54, 55, 42, and 39 are labeled. Pins 01, 02, 03, 04, 05, and 06 are grouped under R1 and R2. Pins 61, 68, and 69 are connected to an RS-485 module. A vertical label '130BB685.10' is on the right side of the terminal block.

Table 6.9 RS-485 Network Connection

6.1.5 Motor Thermistor

CAUTION

Use only thermistors with reinforced or double insulation to meet PELV insulation requirements.

		Parameters	
VLT		Function	Setting
+24 V	12		
+24 V	13	1-90 Motor Thermal Protection	[2] Thermistor trip
D IN	18		
D IN	19	1-93 Thermistor Source	[1] Analog input 53
COM	20	* = Default Value	
D IN	27	Notes/comments:	
D IN	29	If only a warning is desired, 1-90 Motor Thermal Protection should be set to [1] Thermistor warning.	
D IN	32	D IN 37 is an option.	
D IN	33		
D IN	37		
+10 V	50		
A IN	53		
A IN	54		
COM	55		
A OUT	42		
COM	39		
		U - I	
		A53	

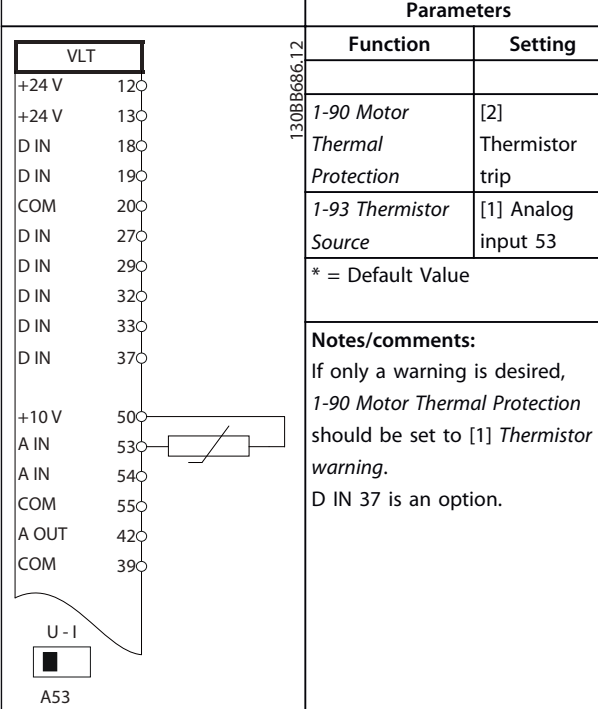

The diagram shows a terminal block with 39 pins. Pins 12, 13, 18, 19, 20, 27, 29, 32, 33, 37, 50, 53, 54, 55, 42, and 39 are labeled. A thermistor is connected between pins 53 and 54. A vertical label '130BB686.12' is on the right side of the terminal block. A component labeled 'U - I' and 'A53' is shown at the bottom.

Table 6.10 Motor Thermistor

7 Diagnostics and Troubleshooting

This chapter describes the status messages, warnings and alarms and basic troubleshooting.

7.1 Status Messages

When the frequency converter is in status mode, status messages are generated automatically and appear in the bottom line of the display (see *Illustration 7.1*).

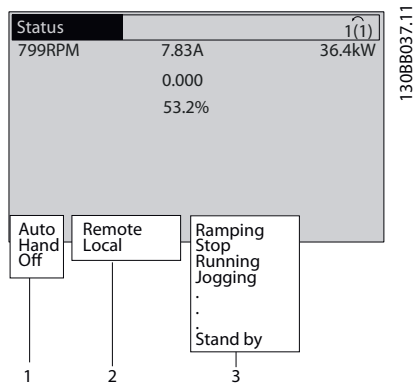

Illustration 7.1 Status Display

1	Operation Mode (see <i>Table 7.2</i>)
2	Reference Site (see <i>Table 7.3</i>)
3	Operation Status (see <i>Table 7.4</i>)

Table 7.1 Legend to *Illustration 7.1*

Table 7.2 to *Table 7.4* describe the displayed status messages.

Off	The frequency converter does not react to any control signal until [Auto On] or [Hand On] is pressed.
Auto On	The frequency converter is controlled from the control terminals and/or the serial communication.
Hand On	The frequency converter can be controlled by the navigation keys on the LCP. Stop commands, reset, reversing, DC brake, and other signals applied to the control terminals can override local control.

Table 7.2 Operation Mode

Remote	The speed reference is given from external signals, serial communication, or internal preset references.
Local	The frequency converter uses [Hand On] control or reference values from the LCP.

Table 7.3 Reference Site

AC Brake	AC Brake was selected in <i>2-10 Brake Function</i> . The AC brake over-magnetizes the motor to achieve a controlled slow-down.
AMA finish OK	Automatic motor adaptation (AMA) was carried out successfully.
AMA ready	AMA is ready to start. Press [Hand On] to start.
AMA running	AMA process is in progress.
Braking	The brake chopper is in operation. Generative energy is absorbed by the brake resistor.
Braking max.	The brake chopper is in operation. The power limit for the brake resistor defined in <i>2-12 Brake Power Limit (kW)</i> has been reached.
Coast	<ul style="list-style-type: none"> Coast inverse was selected as a function for a digital input (parameter group <i>5-1* Digital Inputs</i>). The corresponding terminal is not connected. Coast activated by serial communication
Ctrl. Ramp-down	Control Ramp-down was selected in <i>14-10 Mains Failure</i> . <ul style="list-style-type: none"> The mains voltage is below the value set in <i>14-11 Mains Voltage at Mains Fault</i> at mains fault The frequency converter ramps down the motor using a controlled ramp down
Current High	The frequency converter output current is above the limit set in <i>4-51 Warning Current High</i> .
Current Low	The frequency converter output current is below the limit set in <i>4-52 Warning Speed Low</i>
DC Hold	DC hold is selected in <i>1-80 Function at Stop</i> and a stop command is active. The motor is held by a DC current set in <i>2-00 DC Hold/Preheat Current</i> .

DC Stop	<p>The motor is held with a DC current (2-01 DC Brake Current) for a specified time (2-02 DC Braking Time).</p> <ul style="list-style-type: none"> DC Brake is activated in 2-03 DC Brake Cut In Speed [RPM] and a stop command is active. DC Brake (inverse) is selected as a function for a digital input (parameter group 5-1* Digital Inputs). The corresponding terminal is not active. The DC Brake is activated via serial communication.
Feedback high	The sum of all active feedbacks is above the feedback limit set in 4-57 Warning Feedback High.
Feedback low	The sum of all active feedbacks is below the feedback limit set in 4-56 Warning Feedback Low.
Freeze output	<p>The remote reference is active, which holds the present speed.</p> <ul style="list-style-type: none"> Freeze output was selected as a function for a digital input (parameter group 5-1* Digital Inputs). The corresponding terminal is active. Speed control is only possible via the terminal functions Speed Up and Speed Down. Hold ramp is activated via serial communication.
Freeze output request	A freeze output command has been given, but the motor will remain stopped until a run permissive signal is received.
Freeze ref.	Freeze Reference was chosen as a function for a digital input (parameter group 5-1* Digital Inputs). The corresponding terminal is active. The frequency converter saves the actual reference. Changing the reference is now only possible via terminal functions Speed Up and Speed Down.
Jog request	A jog command has been given, but the motor remains stopped until a run permissive signal is received via a digital input.
Jogging	<p>The motor is running as programmed in 3-19 Jog Speed [RPM].</p> <ul style="list-style-type: none"> Jog was selected as function for a digital input (parameter group 5-1* Digital Inputs). The corresponding terminal (e.g. Terminal 29) is active. The Jog function is activated via the serial communication. The Jog function was selected as a reaction for a monitoring function (e.g. No signal). The monitoring function is active.

Motor check	In 1-80 Function at Stop, Motor Check was selected. A stop command is active. To ensure that a motor is connected to the frequency converter, a permanent test current is applied to the motor.
OVC control	Overvoltage control was activated in 2-17 Overvoltage Control, [2] Enabled. The connected motor is supplying the frequency converter with generative energy. The overvoltage control adjusts the V/Hz ratio to run the motor in controlled mode and to prevent the frequency converter from tripping.
PowerUnit Off	(Only frequency converters with an external 24 V power supply installed). Mains supply to the frequency converter is removed, but the control card is supplied by the external 24 V.
Protection md	<p>Protection mode is active. The unit has detected a critical status (an overcurrent or overvoltage).</p> <ul style="list-style-type: none"> To avoid tripping, switching frequency is reduced to 4 kHz. If possible, protection mode ends after approximately 10 s Protection mode can be restricted in 14-26 Trip Delay at Inverter Fault
QStop	<p>The motor is decelerating using 3-81 Quick Stop Ramp Time.</p> <ul style="list-style-type: none"> Quick stop inverse was chosen as a function for a digital input (parameter group 5-1* Digital Inputs). The corresponding terminal is not active. The quick stop function was activated via serial communication.
Ramping	The motor is accelerating/decelerating using the active Ramp Up/Down. The reference, a limit value, or a standstill is not yet reached.
Ref. high	The sum of all active references is above the reference limit set in 4-55 Warning Reference High.
Ref. low	The sum of all active references is below the reference limit set in 4-54 Warning Reference Low.
Run on ref.	The frequency converter is running in the reference range. The feedback value matches the setpoint value.
Run request	A start command has been given, but the motor is stopped until a run permissive signal is received via digital input.
Running	The motor is driven by the frequency converter.

Sleep Mode	The energy-saving function is enabled. This means that at present the motor has stopped, but it will restart automatically when required.
Speed high	Motor speed is above the value set in 4-53 <i>Warning Speed High</i> .
Speed low	Motor speed is below the value set in 4-52 <i>Warning Speed Low</i> .
Standby	In Auto On mode, the frequency converter will start the motor with a start signal from a digital input or serial communication.
Start delay	In 1-71 <i>Start Delay</i> , a delay starting time was set. A start command is activated and the motor will start after the start delay time expires.
Start fwd/rev	Start forward and start reverse were selected as functions for 2 different digital inputs (parameter group 5-1* <i>Digital Inputs</i>). The motor will start in forward or reverse depending on which corresponding terminal is activated.
Stop	The frequency converter has received a stop command from the LCP, digital input or serial communication.
Trip	An alarm occurred and the motor is stopped. Once the cause of the alarm is cleared, the frequency converter can be reset manually by pressing [Reset] or remotely by control terminals or serial communication.
Trip lock	An alarm occurred and the motor is stopped. Once the cause of the alarm is cleared, power must be cycled to the frequency converter. The frequency converter can then be reset manually by pressing [Reset] or remotely by control terminals or serial communication.

Table 7.4 Operation Status

NOTICE

In auto/remote mode, the frequency converter requires external commands to execute functions.

7.2 Warning and Alarm Types

Warnings

A warning is issued when an alarm condition is impending or when an abnormal operating condition is present and may result in the frequency converter issuing an alarm. A warning clears by itself when the abnormal condition is removed.

Alarms

Trip

An alarm is issued when the frequency converter is tripped, which means that the frequency converter suspends operation to prevent frequency converter or system damage. The motor will coast to a stop. The frequency converter logic will continue to operate and monitor the frequency converter status. After the fault

condition is remedied, the frequency converter can be reset. It will then be ready to start operation again.

Resetting the frequency converter after trip/trip lock

A trip can be reset in any of 4 ways:

- Press [Reset] on the LCP
- Digital reset input command
- Serial communication reset input command
- Auto reset

Trip lock

Input power is cycled. The motor coasts to a stop. The frequency converter continues to monitor the frequency converter status. Remove input power to the frequency converter, correct the cause of the fault, and reset the frequency converter.

Warning and Alarm Displays

- A warning is displayed in the LCP along with the warning number.
- An alarm flashes along with the alarm number.

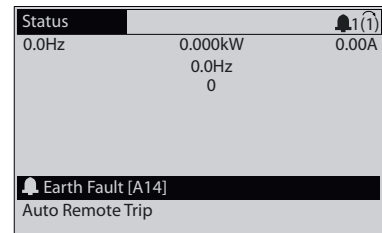

130BP086.11

Illustration 7.2 Alarm Display Example

In addition to the text and alarm code on the LCP of the frequency converter, there are 3 status indicator lights.

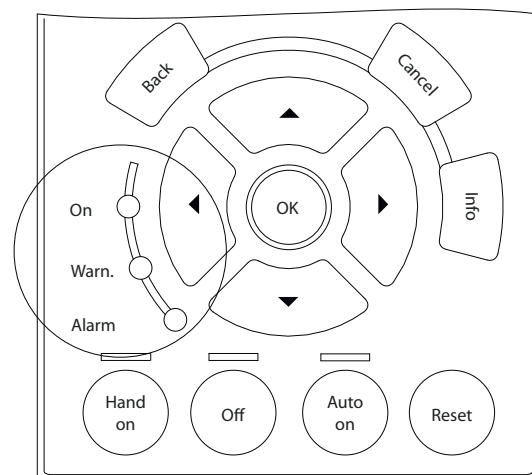

130BB467.10

Illustration 7.3 Status Indicator Lights

	Warning LED	Alarm LED
Warning	On	Off
Alarm	Off	On (Flashing)
Trip-Lock	On	On (Flashing)

Table 7.5 Status Indicator Lights Explanations

7.3 List of Warnings and Alarms

The warning/alarm information below defines each warning/alarm condition, provides the probable cause for the condition, and details a remedy or troubleshooting procedure.

WARNING 1, 10 Volts low

The control card voltage is below 10 V from terminal 50. Remove some of the load from terminal 50, as the 10 V supply is overloaded. Max. 15 mA or minimum 590 Ω.

A short circuit in a connected potentiometer or improper wiring of the potentiometer can cause this condition.

Troubleshooting

Remove the wiring from terminal 50. If the warning clears, the problem is with the wiring. If the warning does not clear, replace the control card.

WARNING/ALARM 2, Live zero error

This warning or alarm only appears if programmed in *6-01 Live Zero Timeout Function*. The signal on one of the analog inputs is less than 50% of the minimum value programmed for that input. Broken wiring or faulty device sending the signal can cause this condition.

Troubleshooting

Check connections on all the analog input terminals. Control card terminals 53 and 54 for signals, terminal 55 common. MCB 101 terminals 11 and 12 for signals, terminal 10 common. MCB 109 terminals 1, 3, 5 for signals, terminals 2, 4, 6 common).

Check that the frequency converter programming and switch settings match the analog signal type.

Perform Input Terminal Signal Test.

WARNING/ALARM 4, Mains phase loss

A phase is missing on the supply side, or the mains voltage imbalance is too high. This message also appears for a fault in the input rectifier on the frequency converter. Options are programmed at *14-12 Function at Mains Imbalance*.

Troubleshooting

Check the supply voltage and supply currents to the frequency converter.

WARNING 5, DC link voltage high

The intermediate circuit voltage (DC) is higher than the high-voltage warning limit. The limit is dependent on the frequency converter voltage rating. The unit is still active.

WARNING 6, DC link voltage low

The intermediate circuit voltage (DC) is lower than the low-voltage warning limit. The limit is dependent on the frequency converter voltage rating. The unit is still active.

WARNING/ALARM 7, DC overvoltage

If the intermediate circuit voltage exceeds the limit, the frequency converter trips after a time.

Troubleshooting

Connect a brake resistor

Extend the ramp time

Change the ramp type

Activate the functions in *2-10 Brake Function*

Increase *14-26 Trip Delay at Inverter Fault*

If the alarm/warning occurs during a power sag, use kinetic back-up (*14-10 Mains Failure*)

WARNING/ALARM 8, DC under voltage

If the intermediate circuit voltage (DC link) drops below the under voltage limit, the frequency converter checks if a 24 V DC back-up supply is connected. If no 24 V DC back-up supply is connected, the frequency converter trips after a fixed time delay. The time delay varies with unit size.

Troubleshooting

Check that the supply voltage matches the frequency converter voltage.

Perform input voltage test.

Perform soft charge circuit test.

WARNING/ALARM 9, Inverter overload

The frequency converter is about to cut out because of an overload (too high current for too long). The counter for electronic, thermal inverter protection issues a warning at 98% and trips at 100%, while giving an alarm. The frequency converter *cannot* be reset until the counter is below 90%.

The fault is that the frequency converter has run with more than 100% overload for too long.

Troubleshooting

Compare the output current shown on the LCP with the frequency converter rated current.

Compare the output current shown on the LCP with measured motor current.

Display the Thermal Drive Load on the LCP and monitor the value. When running above the frequency converter continuous current rating, the counter increases. When running below the frequency converter continuous current rating, the counter decreases.

WARNING/ALARM 10, Motor overload temperature

According to the electronic thermal protection (ETR), the motor is too hot. Select whether the frequency converter issues a warning or an alarm when the counter reaches 100% in *1-90 Motor Thermal Protection*. The fault occurs when the motor runs with more than 100% overload for too long.

Troubleshooting

- Check for motor overheating.
- Check if the motor is mechanically overloaded
- Check that the motor current set in *1-24 Motor Current* is correct.
- Ensure that Motor data in parameters 1-20 to 1-25 are set correctly.
- If an external fan is in use, check in *1-91 Motor External Fan* that it is selected.
- Running AMA in *1-29 Automatic Motor Adaptation (AMA)* tunes the frequency converter to the motor more accurately and reduces thermal loading.

WARNING/ALARM 11, Motor thermistor over temp

Check whether the thermistor is disconnected. Select whether the frequency converter issues a warning or an alarm in *1-90 Motor Thermal Protection*.

Troubleshooting

- Check for motor overheating.
- Check if the motor is mechanically overloaded.
- When using terminal 53 or 54, check that the thermistor is connected correctly between either terminal 53 or 54 (analog voltage input) and terminal 50 (+10 V supply). Also check that the terminal switch for 53 or 54 is set for voltage. Check *1-93 Thermistor Source* selects terminal 53 or 54.
- When using digital inputs 18 or 19, check that the thermistor is connected correctly between either terminal 18 or 19 (digital input PNP only) and terminal 50. Check *1-93 Thermistor Source* selects terminal 18 or 19.

WARNING/ALARM 12, Torque limit

The torque has exceeded the value in *4-16 Torque Limit Motor Mode* or the value in *4-17 Torque Limit Generator Mode*. *14-25 Trip Delay at Torque Limit* can change this warning from a warning-only condition to a warning followed by an alarm.

Troubleshooting

- If the motor torque limit is exceeded during ramp up, extend the ramp up time.
- If the generator torque limit is exceeded during ramp down, extend the ramp down time.

If torque limit occurs while running, possibly increase the torque limit. Make sure that the system can operate safely at a higher torque.

Check the application for excessive current draw on the motor.

WARNING/ALARM 13, Over current

The inverter peak current limit (approximately 200% of the rated current) is exceeded. The warning lasts about 1.5 s, then the frequency converter trips and issues an alarm. Shock loading or quick acceleration with high inertia loads can cause this fault. It can also appear after kinetic back-up, if the acceleration during ramp up is quick. If extended mechanical brake control is selected, trip can be reset externally.

Troubleshooting

- Remove power and check if the motor shaft can be turned.
- Check that the motor size matches the frequency converter.
- Check parameters 1-20 to 1-25 for correct motor data.

ALARM 14, Earth (ground) fault

There is current from the output phases to earth, either in the cable between the frequency converter and the motor or in the motor itself.

Troubleshooting

- Remove power to the frequency converter and repair the earth fault.
- Check for earth faults in the motor by measuring the resistance to ground of the motor leads and the motor with a megohmmeter.

ALARM 15, Hardware mismatch

A fitted option is not operational with the present control board hardware or software.

Record the value of the following parameters and contact your Danfoss supplier:

- 15-40 FC Type*
- 15-41 Power Section*
- 15-42 Voltage*
- 15-43 Software Version*
- 15-45 Actual Typecode String*
- 15-49 SW ID Control Card*
- 15-50 SW ID Power Card*
- 15-60 Option Mounted*
- 15-61 Option SW Version* (for each option slot)

ALARM 16, Short circuit

There is short-circuiting in the motor or motor wiring.

Remove power to the frequency converter and repair the short circuit.

WARNING/ALARM 17, Control word timeout

There is no communication to the frequency converter. The warning is only active when *8-04 Control Word Timeout Function* is NOT set to [0] Off.

If *8-04 Control Word Timeout Function* is set to [5] Stop and Trip, a warning appears and the frequency converter ramps down until it stops then displays an alarm.

Troubleshooting

Check connections on the serial communication cable.

Increase *8-03 Control Word Timeout Time*

Check the operation of the communication equipment.

Verify a proper installation based on EMC requirements.

ALARM 18, Start failed

The speed has not been able to exceed *1-77 Compressor Start Max Speed [RPM]* during start within the allowed time. (set in *1-79 Compressor Start Max Time to Trip*). This may be caused by a blocked motor.

WARNING 23, Internal fan fault

The fan warning function is an extra protective function that checks if the fan is running/mounted. The fan warning can be disabled in *14-53 Fan Monitor ([0] Disabled)*.

For the D, E, and F Frame filters, the regulated voltage to the fans is monitored.

Troubleshooting

Check for proper fan operation.

Cycle power to the frequency converter and check that the fan operates briefly at start-up.

Check the sensors on the heatsink and control card.

WARNING 24, External fan fault

The fan warning function is an extra protective function that checks if the fan is running/mounted. The fan warning can be disabled in *14-53 Fan Monitor ([0] Disabled)*.

Troubleshooting

Check for proper fan operation.

Cycle power to the frequency converter and check that the fan operates briefly at start-up.

Check the sensors on the heatsink and control card.

WARNING 25, Brake resistor short circuit

The brake resistor is monitored during operation. If a short circuit occurs, the brake function is disabled and the warning appears. The frequency converter is still operational but without the brake function. Remove power to the frequency converter and replace the brake resistor (see *2-15 Brake Check*).

WARNING/ALARM 26, Brake resistor power limit

The power transmitted to the brake resistor is calculated as a mean value over the last 120 seconds of run time. The calculation is based on the intermediate circuit voltage and the brake resistance value set in *2-16 AC brake Max. Current*. The warning is active when the dissipated braking power is higher than 90% of the brake resistance power. If [2] Trip is selected in *2-13 Brake Power Monitoring*, the frequency converter trips when the dissipated braking power reaches 100%.

WARNING/ALARM 27, Brake chopper fault

The brake transistor is monitored during operation and if a short circuit occurs, the brake function is disabled and a warning is issued. The frequency converter is still operational but, since the brake transistor has short-circuited, substantial power is transmitted to the brake resistor, even if it is inactive.

Remove power to the frequency converter and remove the brake resistor.

WARNING/ALARM 28, Brake check failed

The brake resistor is not connected or not working. Check *2-15 Brake Check*.

ALARM 29, Heatsink temp

The maximum temperature of the heatsink has been exceeded. The temperature fault will not reset until the temperature falls below a defined heatsink temperature. The trip and reset points are different based on the frequency converter power size.

Troubleshooting

Check for the following conditions.

Ambient temperature too high.

Motor cable too long.

Incorrect airflow clearance above and below the frequency converter.

Blocked airflow around the frequency converter.

Damaged heatsink fan.

Dirty heatsink.

ALARM 30, Motor phase U missing

Motor phase U between the frequency converter and the motor is missing.

Remove power from the frequency converter and check motor phase U.

ALARM 31, Motor phase V missing

Motor phase V between the frequency converter and the motor is missing.

Remove power from the frequency converter and check motor phase V.

ALARM 32, Motor phase W missing

Motor phase W between the frequency converter and the motor is missing.

Remove power from the frequency converter and check motor phase W.

ALARM 33, Inrush fault

Too many power-ups have occurred within a short time period. Let the unit cool to operating temperature.

WARNING/ALARM 34, Fieldbus communication fault

The fieldbus on the communication option card is not working.

WARNING/ALARM 36, Mains failure

This warning/alarm is only active if the supply voltage to the frequency converter is lost and *14-10 Mains Failure* is NOT set to [0] *No Function*. Check the fuses to the frequency converter and mains supply to the unit.

ALARM 38, Internal fault

When an internal fault occurs, a code number defined in *Table 7.6* is displayed.

Troubleshooting

- Cycle power
- Check that the option is properly installed
- Check for loose or missing wiring

It may be necessary to contact your Danfoss supplier or service department. Note the code number for further troubleshooting directions.

No.	Text
0	Serial port cannot be initialised. Contact your Danfoss supplier or Danfoss Service Department.
256-258	Power EEPROM data is defective or too old. Replace power card.
512-519	Internal fault. Contact your Danfoss supplier or Danfoss Service Department.
783	Parameter value outside of min/max limits
1024-1284	Internal fault. Contact your Danfoss supplier or the Danfoss Service Department.
1299	Option SW in slot A is too old
1300	Option SW in slot B is too old
1315	Option SW in slot A is not supported (not allowed)
1316	Option SW in slot B is not supported (not allowed)
1379-2819	Internal fault. Contact your Danfoss supplier or Danfoss Service Department.
2561	Replace control card
2820	LCP stack overflow
2821	Serial port overflow
2822	USB port overflow
3072-5122	Parameter value is outside its limits
5123	Option in slot A: Hardware incompatible with control board hardware
5124	Option in slot B: Hardware incompatible with control board hardware
5376-6231	Internal fault. Contact your Danfoss supplier or Danfoss Service Department.

Table 7.6 Internal Fault Codes

ALARM 39, Heatsink sensor

No feedback from the heatsink temperature sensor.

The signal from the IGBT thermal sensor is not available on the power card. The problem could be on the power card, on the gate drive card, or the ribbon cable between the power card and gate drive card.

WARNING 40, Overload of digital output terminal 27

Check the load connected to terminal 27 or remove short-circuit connection. Check *5-00 Digital I/O Mode* and *5-01 Terminal 27 Mode*.

WARNING 41, Overload of digital output terminal 29

Check the load connected to terminal 29 or remove short-circuit connection. Check *5-00 Digital I/O Mode* and *5-02 Terminal 29 Mode*.

WARNING 42, Overload of digital output on X30/6 or overload of digital output on X30/7

For X30/6, check the load connected to X30/6 or remove the short-circuit connection. Check *5-32 Term X30/6 Digi Out (MCB 101)*.

For X30/7, check the load connected to X30/7 or remove the short-circuit connection. Check *5-33 Term X30/7 Digi Out (MCB 101)*.

ALARM 45, Earth fault 2

Earth (ground) fault on start-up.

Troubleshooting

- Check for proper earthing (grounding) and loose connections.
- Check for proper wire size.
- Check motor cables for short-circuits or leakage currents.

ALARM 46, Power card supply

The supply on the power card is out of range.

There are three power supplies generated by the switch mode power supply (SMPS) on the power card: 24 V, 5 V, ±18 V. When powered with 24 V DC with the MCB 107 option, only the 24 V and 5 V supplies are monitored. When powered with three phase mains voltage, all three supplies are monitored.

Troubleshooting

- Check for a defective power card.
- Check for a defective control card.
- Check for a defective option card.
- If a 24 V DC power supply is used, verify proper supply power.

WARNING 47, 24 V supply low

The 24 V DC is measured on the control card. The external 24 V DC back-up power supply may be overloaded, otherwise contact the Danfoss supplier.

WARNING 48, 1.8 V supply low

The 1.8 V DC supply used on the control card is outside of allowable limits. The power supply is measured on the control card. Check for a defective control card. If an option card is present, check for an overvoltage condition.

WARNING 49, Speed limit

When the speed is not within the specified range in 4-11 *Motor Speed Low Limit [RPM]* and 4-13 *Motor Speed High Limit [RPM]*, the frequency converter shows a warning. When the speed is below the specified limit in 1-86 *Trip Speed Low [RPM]* (except when starting or stopping), the frequency converter trips.

ALARM 50, AMA calibration failed

Contact your Danfoss supplier or Danfoss Service Department.

ALARM 51, AMA check U_{nom} and I_{nom}

The settings for motor voltage, motor current and motor power are wrong. Check the settings in parameters 1-20 to 1-25.

ALARM 52, AMA low I_{nom}

The motor current is too low. Check the settings.

ALARM 53, AMA motor too big

The motor is too big for the AMA to operate.

ALARM 54, AMA motor too small

The motor is too small for the AMA to operate.

ALARM 55, AMA parameter out of range

The parameter values of the motor are outside of the acceptable range. AMA cannot run.

ALARM 56, AMA interrupted by user

The user has interrupted the AMA.

ALARM 57, AMA internal fault

Try to restart AMA again. Repeated restarts can over heat the motor.

ALARM 58, AMA Internal fault

Contact your Danfoss supplier.

WARNING 59, Current limit

The current is higher than the value in 4-18 *Current Limit*. Ensure that Motor data in parameters 1-20 to 1-25 are set correctly. Possibly increase the current limit. Be sure that the system can operate safely at a higher limit.

WARNING 60, External interlock

A digital input signal is indicating a fault condition external to the frequency converter. An external interlock has commanded the frequency converter to trip. Clear the external fault condition. To resume normal operation, apply 24 V DC to the terminal programmed for external interlock. Reset the frequency converter.

WARNING 62, Output frequency at maximum limit

The output frequency has reached the value set in 4-19 *Max Output Frequency*. Check the application to determine the cause. Possibly increase the output

frequency limit. Be sure the system can operate safely at a higher output frequency. The warning will clear when the output drops below the maximum limit.

WARNING/ALARM 65, Control card over temperature

The cut-out temperature of the control card is 80 °C.

Troubleshooting

- Check that the ambient operating temperature is within limits
- Check for clogged filters
- Check fan operation
- Check the control card

WARNING 66, Heatsink temperature low

The frequency converter is too cold to operate. This warning is based on the temperature sensor in the IGBT module.

Increase the ambient temperature of the unit. Also, a trickle amount of current can be supplied to the frequency converter whenever the motor is stopped by setting 2-00 *DC Hold/Preheat Current* at 5% and 1-80 *Function at Stop*

ALARM 67, Option module configuration has changed

One or more options have either been added or removed since the last power-down. Check that the configuration change is intentional and reset the unit.

ALARM 68, Safe Stop activated

Safe stop has been activated. To resume normal operation, apply 24 V DC to terminal 37, then send a reset signal (via Bus, Digital I/O, or by pressing the reset key).

ALARM 69, Power card temperature

The temperature sensor on the power card is either too hot or too cold.

Troubleshooting

- Check that the ambient operating temperature is within limits.
- Check for clogged filters.
- Check fan operation.
- Check the power card.

ALARM 70, Illegal FC configuration

The control card and power card are incompatible. To check compatibility, contact your supplier with the type code of the unit from the nameplate and the part numbers of the cards.

ALARM 80, Drive initialised to default value

Parameter settings are initialised to default settings after a manual reset. To clear the alarm, reset the unit.

ALARM 92, No flow

A no-flow condition has been detected in the system. 22-23 *No-Flow Function* is set for alarm. Troubleshoot the system and reset the frequency converter after the fault has been cleared.

ALARM 93, Dry pump

A no-flow condition in the system with the frequency converter operating at high speed may indicate a dry pump. *22-26 Dry Pump Function* is set for alarm. Troubleshoot the system and reset the frequency converter after the fault has been cleared.

ALARM 94, End of curve

Feedback is lower than the set point. This may indicate leakage in the system. *22-50 End of Curve Function* is set for alarm. Troubleshoot the system and reset the frequency converter after the fault has been cleared.

ALARM 95, Broken belt

Torque is below the torque level set for no load, indicating a broken belt. *22-60 Broken Belt Function* is set for alarm. Troubleshoot the system and reset the frequency converter after the fault has been cleared.

ALARM 96, Start delayed

Motor start has been delayed due to short-cycle protection. *22-76 Interval between Starts* is enabled. Troubleshoot the system and reset the frequency converter after the fault has been cleared.

WARNING 97, Stop delayed

Stopping the motor has been delayed due to short cycle protection. *22-76 Interval between Starts* is enabled. Troubleshoot the system and reset the frequency converter after the fault has been cleared.

WARNING 98, Clock fault

Time is not set or the RTC clock has failed. Reset the clock in *0-70 Date and Time*.

WARNING 200, Fire mode

This warning indicates the frequency converter is operating in fire mode. The warning clears when fire mode is removed. See the fire mode data in the alarm log.

WARNING 201, Fire mode was active

This indicates the frequency converter had entered fire mode. Cycle power to the unit to remove the warning. See the fire mode data in the alarm log.

WARNING 202, Fire mode limits exceeded

While operating in fire mode one or more alarm conditions have been ignored which would normally trip the unit. Operating in this condition voids unit warranty. Cycle power to the unit to remove the warning. See the fire mode data in the alarm log.

WARNING 203, Missing motor

With a frequency converter operating multi-motors, an under-load condition was detected. This could indicate a missing motor. Inspect the system for proper operation.

WARNING 204, Locked rotor

With a frequency converter operating multi-motors, an overload condition was detected. This could indicate a locked rotor. Inspect the motor for proper operation.

WARNING 250, New spare part

A component in the frequency converter has been replaced. Reset the frequency converter for normal operation.

WARNING 251, New typecode

The power card or other components have been replaced and the typecode changed. Reset to remove the warning and resume normal operation.

7.4 Troubleshooting

Symptom	Possible cause	Test	Solution
Display dark/No function	Missing input power	See <i>Table 4.5</i>	Check the input power source.
	Missing or open fuses or circuit breaker tripped	See open fuses and tripped circuit breaker in this table for possible causes	Follow the recommendations provided.
	No power to the LCP	Check the LCP cable for proper connection or damage	Replace the faulty LCP or connection cable.
	Shortcut on control voltage (terminal 12 or 50) or at control terminals	Check the 24 V control voltage supply for terminals 12/13 to 20-39 or 10 V supply for terminals 50 to 55	Wire the terminals properly.
	Wrong LCP (LCP from VLT® 2800 or 5000/6000/8000/ FCD or FCM)		Use only LCP 101 (P/N 130B1124) or LCP 102 (P/N 130B1107).
	Wrong contrast setting		Press [Status] + [▲]/[▼] to adjust the contrast.
	Display (LCP) is defective	Test using a different LCP	Replace the faulty LCP or connection cable.
	Internal voltage supply fault or SMPS is defective		Contact supplier.
Intermittent display	Overloaded power supply (SMPS) due to improper control wiring or a fault within the frequency converter	To rule out a problem in the control wiring, disconnect all control wiring by removing the terminal blocks.	If the display stays lit, then the problem is in the control wiring. Check the wiring for short circuits or incorrect connections. If the display continues to cut out, follow the procedure for display dark.
Motor not running	Service switch open or missing motor connection	Check if the motor is connected and the connection is not interrupted (by a service switch or other device).	Connect the motor and check the service switch.
	No mains power with 24 V DC option card	If the display is functioning but no output, check that mains power is applied to the frequency converter.	Apply mains power to run the unit.
	LCP Stop	Check if [Off] has been pressed	Press [Auto On] or [Hand On] (depending on operation mode) to run the motor.
	Missing start signal (Standby)	Check <i>5-10 Terminal 18 Digital Input</i> for correct setting for terminal 18 (use default setting)	Apply a valid start signal to start the motor.
	Motor coast signal active (Coasting)	Check <i>5-12 Coast inv.</i> for correct setting for terminal 27 (use default setting)..	Apply 24 V on terminal 27 or program this terminal to <i>No operation</i> .
	Wrong reference signal source	Check reference signal: Local, remote or bus reference? Preset reference active? Terminal connection correct? Scaling of terminals correct? Reference signal available?	Program correct settings. Check <i>3-13 Reference Site</i> . Set preset reference active in parameter group <i>3-1* References</i> . Check for correct wiring. Check scaling of terminals. Check reference signal.
Motor running in wrong direction	Motor rotation limit	Check that <i>4-10 Motor Speed Direction</i> is programmed correctly.	Program correct settings.
	Active reversing signal	Check if a reversing command is programmed for the terminal in parameter group <i>5-1* Digital inputs</i> ..	Deactivate reversing signal.
	Wrong motor phase connection		See <i>5.5 Checking Motor Rotation</i> .
Motor is not reaching maximum speed	Frequency limits set wrong	Check output limits in <i>4-13 Motor Speed High Limit [RPM]</i> , <i>4-14 Motor Speed High Limit [Hz]</i> and <i>4-19 Max Output Frequency</i> .	Program correct limits.
	Reference input signal not scaled correctly	Check reference input signal scaling in <i>6-0* Analog I/O Mode</i> and parameter group <i>3-1* References</i> . Reference limits in parameter group <i>3-0* Reference Limit</i> .	Program correct settings.

Symptom	Possible cause	Test	Solution
Motor speed unstable	Possible incorrect parameter settings	Check the settings of all motor parameters, including all motor compensation settings. For closed-loop operation, check PID settings.	Check settings in parameter group 1-6* <i>Analog I/O mode</i> . For closed-loop operation, check settings in parameter group 20-0* <i>Feedback</i> .
Motor runs rough	Possible over-magnetisation	Check for incorrect motor settings in all motor parameters	Check motor settings in parameter groups 1-2* <i>Motor Data</i> , 1-3* <i>Adv Motor Data</i> , and 1-5* <i>Load Indep. Setting</i> .
Motor will not brake	Possible incorrect settings in the brake parameters. Possible too short ramp-down times	Check brake parameters. Check ramp-time settings	Check parameter group 2-0* <i>DC Brake</i> and 3-0* <i>Reference Limits</i> .
Open power fuses or circuit breaker trip	Phase to phase short	Motor or panel has a short phase to phase. Check motor and panel phase for shorts	Eliminate any short circuits detected.
	Motor overload	Motor is overloaded for the application	Perform startup test and verify motor current is within specifications. If motor current is exceeding nameplate full load current, motor may run only with reduced load. Review the specifications for the application.
	Loose connections	Perform pre-startup check for loose connections	Tighten loose connections.
Mains current imbalance greater than 3%	Problem with mains power (See <i>Alarm 4 Mains phase loss</i> description)	Rotate input power leads into the frequency converter 1 position: A to B, B to C, C to A.	If imbalanced leg follows the wire, it is a power problem. Check mains power supply.
	Problem with the frequency converter	Rotate input power leads into the frequency converter 1 position: A to B, B to C, C to A.	If imbalance leg stays on same input terminal, it is a problem with the unit. Contact the supplier.
Motor current imbalance greater than 3%	Problem with motor or motor wiring	Rotate output motor leads 1 position: U to V, V to W, W to U.	If imbalanced leg follows the wire, the problem is in the motor or motor wiring. Check motor and motor wiring.
	Problem with the frequency converters	Rotate output motor leads 1 position: U to V, V to W, W to U.	If imbalance leg stays on same output terminal, it is a problem with the unit. Contact the supplier.
Frequency converter acceleration problems	Motor data are entered incorrectly	If warnings or alarms occur, see 7.3 <i>List of Warnings and Alarms</i> Check that motor data are entered correctly	Increase the ramp-up time in 3-41 <i>Ramp 1 Ramp Up Time</i> . Increase current limit in 4-18 <i>Current Limit</i> . Increase torque limit in 4-16 <i>Torque Limit Motor Mode</i> .
Frequency converter deceleration problems	Motor data are entered incorrectly	If warnings or alarms occur, see 7.3 <i>List of Warnings and Alarms</i> Check that motor data are entered correctly	Increase the ramp-down time in 3-42 <i>Ramp 1 Ramp Down Time</i> . Enable overvoltage control in 2-17 <i>Over-voltage Control</i> .
Acoustic noise or vibration (e.g. a fan blade is making noise or vibrations at certain frequencies)	Resonances, e.g. in the motor/fan system	Bypass critical frequencies by using parameters in parameter group 4-6* <i>Speed Bypass</i>	Check if noise and/or vibration have been reduced to an acceptable limit.
		Turn off over-modulation in 14-03 <i>Overmodulation</i>	
		Change switching pattern and frequency in parameter group 14-0* <i>Inverter Switching</i>	
		Increase Resonance Dampening in 1-64 <i>Resonance Dampening</i>	

Table 7.7 Troubleshooting

8 Specifications

8.1 Electrical Data

8.1.1 Mains Supply 3x200-240 V AC

Type Designation	P1K1	P1K5	P2K2	P3K0	P3K7
Typical Shaft Output [kW]	1.1	1.5	2.2	3.0	3.7
Typical Shaft Output [HP] at 208 V	1.5	2.0	2.9	4.0	4.9
IP20/Chassis ⁶⁾	A2	A2	A2	A3	A3
IP55/Type 12	A4/A5	A4/A5	A4/A5	A5	A5
IP66/NEMA 4X	A4/A5	A4/A5	A4/A5	A5	A5
Output current					
Continuous (3x200-240 V) [A]	6.6	7.5	10.6	12.5	16.7
Intermittent (3x200-240 V) [A]	7.3	8.3	11.7	13.8	18.4
Continuous kVA (208 V AC) [kVA]	2.38	2.70	3.82	4.50	6.00
Max. input current					
Continuous (3x200-240 V) [A]	5.9	6.8	9.5	11.3	15.0
Intermittent (3x200-240 V) [A]	6.5	7.5	10.5	12.4	16.5
Additional specifications					
Estimated power loss at rated max. load [W] ⁴⁾	63	82	116	155	185
IP20, IP21 max. cable cross-section (mains, motor, brake and load sharing) [mm ² /(AWG)]	4, 4, 4 (12, 12, 12) (min. 0.2 (24))				
IP55, IP66 max. cable cross-section (mains, motor, brake and load sharing) [mm ² /(AWG)]	4, 4, 4 (12, 12, 12)				
Max. cable cross-section with disconnect	6, 4, 4 (10, 12, 12)				
Efficiency ³⁾	0.96	0.96	0.96	0.96	0.96

8

Table 8.1 Mains Supply 3x200-240 V AC - Normal overload 110% for 1 minute, P1K1-P3K7

Type Designation	P5K5	P7K5	P11K	P15K	P18K	P22K	P30K	P37K	P45K
Typical Shaft Output [kW]	5.5	7.5	11	15	18.5	22	30	37	45
Typical Shaft Output [HP] at 208 V	7.5	10	15	20	25	30	40	50	60
IP20/Chassis ⁷⁾	B3	B3	B3	B4	B4	C3	C3	C4	C4
IP21/NEMA 1	B1	B1	B1	B2	C1	C1	C1	C2	C2
IP55/Type 12	B1	B1	B1	B2	C1	C1	C1	C2	C2
IP66/NEMA 4X	B1	B1	B1	B2	C1	C1	C1	C2	C2
Output current									
Continuous (3x200-240 V) [A]	24.2	30.8	46.2	59.4	74.8	88.0	115	143	170
Intermittent (3x200-240 V) [A]	26.6	33.9	50.8	65.3	82.3	96.8	127	157	187
Continuous kVA (208 V AC) [kVA]	8.7	11.1	16.6	21.4	26.9	31.7	41.4	51.5	61.2
Max. input current									
Continuous (3x200-240 V) [A]	22.0	28.0	42.0	54.0	68.0	80.0	104.0	130.0	154.0
Intermittent (3x200-240 V) [A]	24.2	30.8	46.2	59.4	74.8	88.0	114.0	143.0	169.0
Additional Specifications									
Estimated power loss at rated max. load [W] ⁴⁾	269	310	447	602	737	845	1140	1353	1636
IP20 max. cable cross-section (mains, brake, motor and load sharing)	10, 10 (8,8,-)		35,-,-(2,-,-)	35 (2)	50 (1)			150 (300MCM)	
IP21, IP55, IP66 max. cable cross-section (mains, motor) [mm ² /(AWG)]	10, 10 (8,8,-)		35, 25, 25 (2, 4, 4)	50 (1)				150 (300MCM)	
IP21, IP55, IP66 max. cable cross-section (brake, load sharing) [mm ² /(AWG)]	16, 10, 16 (6, 8, 6)		35,-,-(2,-,-)	50 (1)				95 (3/0)	
Efficiency ³⁾	0.96	0.96	0.96	0.96	0.96	0.97	0.97	0.97	0.97

Table 8.2 Mains Supply 3x200-240 V AC - Normal overload 110% for 1 minute, P5K5-P45K

8.1.2 Mains Supply 3x380-480 V AC

Type Designation	P1K1	P1K5	P2K2	P3K0	P4K0	P5K5	P7K5
Typical Shaft Output [kW]	1.1	1.5	2.2	3.0	4.0	5.5	7.5
Typical Shaft Output [HP] at 460 V	1.5	2.0	2.9	4.0	5.0	7.5	10
IP20/Chassis ⁶⁾	A2	A2	A2	A2	A2	A3	A3
IP55/Type 12	A4/A5	A4/A5	A4/A5	A4/A5	A4/A5	A5	A5
IP66/NEMA 4X	A4/A5	A4/A5	A4/A5	A4/A5	A4/A5	A5	A5
Output current							
Continuous (3x380-440 V) [A]	3	4.1	5.6	7.2	10	13	16
Intermittent (3x380-440 V) [A]	3.3	4.5	6.2	7.9	11	14.3	17.6
Continuous (3x441-480 V) [A]	2.7	3.4	4.8	6.3	8.2	11	14.5
Intermittent (3x441-480 V) [A]	3.0	3.7	5.3	6.9	9.0	12.1	15.4
Continuous kVA (400 V AC) [kVA]	2.1	2.8	3.9	5.0	6.9	9.0	11.0
Continuous kVA (460 V AC) [kVA]	2.4	2.7	3.8	5.0	6.5	8.8	11.6
Max. input current							
Continuous (3x380-440 V) [A]	2.7	3.7	5.0	6.5	9.0	11.7	14.4
Intermittent (3x380-440 V) [A]	3.0	4.1	5.5	7.2	9.9	12.9	15.8
Continuous (3x441-480 V) [A]	2.7	3.1	4.3	5.7	7.4	9.9	13.0
Intermittent (3x441-480 V) [A]	3.0	3.4	4.7	6.3	8.1	10.9	14.3
Additional specifications							
Estimated power loss at rated max. load [W] ⁴⁾	58	62	88	116	124	187	255
IP20, IP21 max. cable cross-section (mains, motor, brake and load sharing) [mm ² /(AWG)] ²⁾	4, 4, 4 (12, 12, 12) (min. 0.2 (24))						
IP55, IP66 max. cable cross-section (mains, motor, brake and load sharing) [mm ² /(AWG)] ²⁾	4, 4, 4 (12, 12, 12)						
Max. cable cross-section with disconnect	6, 4, 4 (10, 12, 12)						
Efficiency ³⁾	0.96	0.97	0.97	0.97	0.97	0.97	0.97

8

Table 8.3 Mains Supply 3x380-480 V AC - Normal overload 110% for 1 minute, P1K1-P7K5

Type Designation	P11K	P15K	P18K	P22K	P30K	P37K	P45K	P55K	P75K	P90K
Typical Shaft Output [kW]	11	15	18.5	22	30	37	45	55	75	90
Typical Shaft Output [HP] at 460 V	15	20	25	30	40	50	60	75	100	125
IP20/Chassis ⁷⁾	B3	B3	B3	B4	B4	B4	C3	C3	C4	C4
IP21/NEMA 1	B1	B1	B1	B2	B2	C1	C1	C1	C2	C2
IP55/Type 12	B1	B1	B1	B2	B2	C1	C1	C1	C2	C2
IP66/NEMA 4X	B1	B1	B1	B2	B2	C1	C1	C1	C2	C2
Output current										
Continuous (3x380-439 V) [A]	24	32	37.5	44	61	73	90	106	147	177
Intermittent (3x380-439 V) [A]	26.4	35.2	41.3	48.4	67.1	80.3	99	117	162	195
Continuous (3x440-480 V) [A]	21	27	34	40	52	65	80	105	130	160
Intermittent (3x440-480 V) [A]	23.1	29.7	37.4	44	61.6	71.5	88	116	143	176
Continuous kVA (400 V AC) [kVA]	16.6	22.2	26	30.5	42.3	50.6	62.4	73.4	102	123
Continuous kVA (460 V AC) [kVA]	16.7	21.5	27.1	31.9	41.4	51.8	63.7	83.7	104	128
Max. input current										
Continuous (3x380-439 V) [A]	22	29	34	40	55	66	82	96	133	161
Intermittent (3x380-439 V) [A]	24.2	31.9	37.4	44	60.5	72.6	90.2	106	146	177
Continuous (3x440-480 V) [A]	19	25	31	36	47	59	73	95	118	145
Intermittent (3x440-480 V) [A]	20.9	27.5	34.1	39.6	51.7	64.9	80.3	105	130	160
Additional specifications										
Estimated power loss at rated max. load [W] ⁴⁾	278	392	465	525	698	739	843	1083	1384	1474
IP20 max. cable cross-section (mains, brake, motor and load sharing)	16, 10, - (8, 8, -)		35, -, - (2, -, -)		35 (2)		50 (1)		150 (300 MCM)	
IP21, IP55, IP66 max. cable cross-section (mains, motor) [mm ² /(AWG)]	10, 10, 16 (6, 8, 6)		35, 25, 25 (2, 4, 4)		50 (1)		150 (300 MCM)			
IP21, IP55, IP66 max. cable cross-section (brake, load sharing) [mm ² /(AWG)]	10, 10, - (8, 8, -)		35, -, - (2, -, -)		50 (1)		95 (3/0)			
With mains disconnect switch included: Efficiency ³⁾	0.98	0.98	0.98	0.98	0.98	0.98	0.98	0.98	0.98	0.99

Table 8.4 Mains Supply 3x380-480 V AC - Normal overload 110% for 1 minute, P11K-P90K

8.1.3 Mains Supply 3x525-600 V AC

Type Designation	P1K1	P1K5	P2K2	P3K0	P3K7	P4K0	P5K5	P7K5
Typical Shaft Output [kW]	1.1	1.5	2.2	3.0	3.7	4.0	5.5	7.5
IP20/Chassis	A3	A3	A3	A3	A2	A3	A3	A3
IP21/NEMA 1	A3	A3	A3	A3	A2	A3	A3	A3
IP55/Type 12	A5	A5	A5	A5	A5	A5	A5	A5
IP66/NEMA 4X	A5	A5	A5	A5	A5	A5	A5	A5
Output current								
Continuous (3x525-550 V) [A]	2.6	2.9	4.1	5.2	-	6.4	9.5	11.5
Intermittent (3x525-550 V) [A]	2.9	3.2	4.5	5.7	-	7.0	10.5	12.7
Continuous (3x525-600 V) [A]	2.4	2.7	3.9	4.9	-	6.1	9.0	11.0
Intermittent (3x525-600 V) [A]	2.6	3.0	4.3	5.4	-	6.7	9.9	12.1
Continuous kVA (525 V AC) [kVA]	2.5	2.8	3.9	5.0	-	6.1	9.0	11.0
Continuous kVA (575 V AC) [kVA]	2.4	2.7	3.9	4.9	-	6.1	9.0	11.0
Max. input current								
Continuous (3x525-600 V) [A]	2.4	2.7	4.1	5.2	-	5.8	8.6	10.4
Intermittent (3x525-600 V) [A]	2.7	3.0	4.5	5.7	-	6.4	9.5	11.5
Additional specifications								
Estimated power loss at rated max. load [W] ⁴⁾	50	65	92	122	-	145	195	261
IP20 max. cable cross-section ⁵⁾ (mains, motor, brake and load sharing) [mm ² /(AWG)]	4, 4, 4 (12, 12, 12) (min. 0.2 (24))							
IP55, IP 66 max. cable cross-section ⁵⁾ (mains, motor, brake and load sharing) [mm ² /(AWG)]	4, 4, 4 (12, 12, 12) (min. 0.2 (24))							
Max. cable cross-section with disconnect	6, 4, 4 (12, 12, 12)							
Mains disconnect switch included:	4/12							
Efficiency ³⁾	0.97	0.97	0.97	0.97	-	0.97	0.97	0.97

8

Table 8.5 Mains Supply 3x525-600 V AC - Normal overload 110% for 1 minute, P1K1-P7K5

Specifications

VLT® HVAC Drive Operating Instructions

88

Type Designation	P11K1	P15K	P18K	P22K	P30K	P37K	P45K	P55K	P75K	P90K
Typical Shaft Output [kW]	11	15	18.5	22	30	37	45	55	75	90
IP20/Chassis	B3	B3	B3	B4	B4	B4	C3	C3	C4	C4
IP21/NEMA 1	B1	B1	B1	B2	B2	C1	C1	C1	C2	C2
IP55/Type 12	B1	B1	B1	B2	B2	C1	C1	C1	C2	C2
IP66/NEMA 4X	B1	B1	B1	B2	B2	C1	C1	C1	C2	C2
Output current										
Continuous (3x525-550 V) [A]	19	23	28	36	43	54	65	87	105	137
Intermittent (3x525-550 V) [A]	21	25	31	40	47	59	72	96	116	151
Continuous (3x525-600 V) [A]	18	22	27	34	41	52	62	83	100	131
Intermittent (3x525-600 V) [A]	20	24	30	37	45	57	68	91	110	144
Continuous kVA (525 V AC) [kVA]	18.1	21.9	26.7	34.3	41	51.4	61.9	82.9	100	130.5
Continuous kVA (575 V AC) [kVA]	17.9	21.9	26.9	33.9	40.8	51.8	61.7	82.7	99.6	130.5
Max. input current										
Continuous (3x525-600 V) [A]	17.2	20.9	25.4	32.7	39	49	59	78.9	95.3	124.3
Intermittent (3x525-600 V) [A]	19	23	28	36	43	54	65	87	105	137
Additional specifications										
Estimated power loss at rated max. load [W] ⁴⁾	300	400	475	525	700	750	850	1100	1400	1500
IP21, IP55, IP66 max. cable cross-section (mains, brake and load sharing) [mm ² /(AWG)]	16, 10, 10 (6, 8, 8)		35, 25, 25 (2, 2, 2)		50, 35, 35 (1, 1, 1)				95 (4/0)	
IP21, IP55, IP66 max. cable cross-section (motor) [mm ² /(AWG)]	10, 10, - (8, 8, -)		35, 25, 25 (2, 4, 4)		50, 35, 35 (1, 1, 1)				150 (300 MCM)	
IP20 max. cable cross-section (mains, brake and load sharing) [mm ² /(AWG)]	10, 10, - (8, 8, -)		35, -, - (2, -, -)		50, 35, 35 (1, 2, 2)		50, 35, 35 (1, 1, 1)		150 (300 MCM)	
Max. cable cross-section with disconnect	16, 10, 10 (6, 8, 8)				50, 35, 35 (1, 2, 2)			95, 70, 70 (3/0, 2/0, 2/0)	185, 150, 120 (350 MCM, 300 MCM, 4/0)	
Mains disconnect switch included:			16/6				35/2		70/3/0	185/kcmil350
Efficiency ³⁾	0.98	0.98	0.98	0.98	0.98	0.98	0.98	0.98	0.98	0.98

Table 8.6 Mains supply 3x525-600 V AC - Normal overload 110% for 1 minute, P11K-P90K

8.1.4 Mains Supply 3x525-690 V AC

Type Designation	P1K1	P1K5	P2K2	P3K0	P4K0	P5K5	P7K5
Typical Shaft Output [kW]	1.1	1.5	2.2	3.0	4.0	5.5	7.5
Enclosure IP20 (only)	A3	A3	A3	A3	A3	A3	A3
Output current							
Continuous (3x525-550 V) [A]	2.1	2.7	3.9	4.9	6.1	9.0	11
Intermittent (3x525-550 V) [A]	3.4	4.3	6.2	7.8	9.8	14.4	17.6
Continuous kVA (3x551-690 V) [A]	1.6	2.2	3.2	4.5	5.5	7.5	10
Intermittent kVA (3x551-690 V) [A]	2.6	3.5	5.1	7.2	8.8	12	16
Continuous kVA 525 V AC	1.9	2.5	3.5	4.5	5.5	8.2	10
Continuous kVA 690 V AC	1.9	2.6	3.8	5.4	6.6	9.0	12
Max. input current							
Continuous (3x525-550 V) [A]	1.9	2.4	3.5	4.4	5.5	8.0	10
Intermittent (3x525-550 V) [A]	3.0	3.9	5.6	7.1	8.8	13	16
Continuous kVA (3x551-690 V) [A]	1.4	2.0	2.9	4.0	4.9	6.7	9.0
Intermittent kVA (3x551-690 V) [A]	2.3	3.2	4.6	6.5	7.9	10.8	14.4
Additional specifications							
Estimated power loss at rated max. load [W] ⁴⁾	44	60	88	120	160	220	300
Max. cable cross section ⁵⁾ (mains, motor, brake and load sharing) [mm ²]/(AWG)	6, 4, 4 (10, 12, 12) (min. 0.2 (24))						
Max. cable cross-section with disconnect	6, 4, 4 (10, 12, 12)						
Efficiency ³⁾	0.96	0.96	0.96	0.96	0.96	0.96	0.96

Table 8.7 Mains Supply 3x525-690 V AC - Normal overload 110% for 1 minute, P1K1-P7K5

Type Designation	P11K	P15K	P18K	P22K	P30K
High/Normal Load	NO	NO	NO	NO	NO
Typical Shaft Output at 550 V [kW]	7.5	11	15	18.5	22
Typical Shaft Output at 690 V [kW]	11	15	18.5	22	30
IP20/Chassis	B4	B4	B4	B4	B4
IP21/NEMA 1	B2	B2	B2	B2	B2
IP55/NEMA 12	B2	B2	B2	B2	B2
Output current					
Continuous (3 x 525-550 V) [A]	14	19	23	28	36
Intermittent (60 s overload) (3 x 525-550 V) [A]	22.4	20.9	25.3	30.8	39.6
Continuous (3 x 551-690 V) [A]	13	18	22	27	34
Intermittent (60 s overload) (3 x 551-690 V) [A]	20.8	19.8	24.2	29.7	37.4
Continuous kVA (550 V AC) [kVA]	13.3	18.1	21.9	26.7	34.3
Continuous kVA (690 V AC) [kVA]	15.5	21.5	26.3	32.3	40.6
Max. input current					
Continuous (at 550 V) [A]	15	19.5	24	29	36
Intermittent (60 s overload) (at 550 V) [A]	23.2	21.5	26.4	31.9	39.6
Continuous (at 690 V) [A]	14.5	19.5	24	29	36
Intermittent (60 s overload) (at 690 V) [A]	23.2	21.5	26.4	31.9	39.6
Max. pre-fuses ¹⁾ [A]	63	63	63	80	100
Additional specifications					
Estimated power loss at rated max. load [W] ⁴⁾	150	220	300	370	440
Max. cable cross-section (mains/motor, load sharing and brake) [mm ²]/(AWG) ²⁾	35, 25, 25 (2, 4, 4)				
Max. cable size with mains disconnect [mm ²]/(AWG) ²⁾	16, 10, 10 (6, 8, 8)				
Efficiency ³⁾	0.98	0.98	0.98	0.98	0.98

Table 8.8 Mains Supply 3 x 525-690 V AC - Normal overload 110% for 1 minute, P11K-P30K

Specifications

VLT® HVAC Drive Operating Instructions

Type Designation	P37K	P45K	P55K	P75K	P90K
High/Normal Load	NO	NO	NO	NO	NO
Typical Shaft Output at 550 V [kW]	30	37	45	55	75
Typical Shaft Output at 690 V [kW]	37	45	55	75	90
IP20/Chassis	B4	C3	C3	D3h	D3h
IP21/NEMA 1	C2	C2	C2	C2	C2
IP55/NEMA 12	C2	C2	C2	C2	C2
Output current					
Continuous (3 x 525-550 V) [A]	43	54	65	87	105
Intermittent (60 s overload) (3 x 525-550 V) [A]	47.3	59.4	71.5	95.7	115.5
Continuous (3 x 551-690 V) [A]	41	52	62	83	100
Intermittent (60 s overload) (3 x 551-690 V) [A]	45.1	57.2	68.2	91.3	110
Continuous kVA (550 V AC) [kVA]	41	51.4	61.9	82.9	100
Continuous kVA (690 V AC) [kVA]	49	62.1	74.1	99.2	119.5
Max. input current					
Continuous (at 550 V) [A]	49	59	71	87	99
Intermittent (60 s overload) (at 550 V) [A]	53.9	64.9	78.1	95.7	108.9
Continuous (at 690 V) [A]	48	58	70	86	94.3
Intermittent (60 s overload) (at 690 V) [A]	52.8	63.8	77	94.6	112.7
Max. pre-fuses ¹⁾ [A]	125	160	160	160	-
Additional specifications					
Estimated power loss at rated max. load [W] ⁴⁾	740	900	1100	1500	1800
Max. cable cross-section (mains and motor) [mm ²]/(AWG) ²⁾	150 (300 MCM)				
Max. cable cross-section (load sharing and brake) [mm ²]/(AWG) ²⁾	95 (3/0)				
Max. cable size with mains disconnect [mm ²]/(AWG) ²⁾	95, 70, 70 (3/0, 2/0, 2/0)			185, 150, 120 (350 MCM, 300 MCM, 4/0)	
Efficiency ³⁾	0.98	0.98	0.98	0.98	0.98

Table 8.9 Mains Supply 3 x 525-690 V - Normal overload 110% for 1 minute, P37K-P90K

¹⁾ For type of fuse see 8.8 Fuse Specifications.

²⁾ American Wire Gauge.

³⁾ Measured using 5 m screened motor cables at rated load and rated frequency.

⁴⁾ The typical power loss is at normal load conditions and expected to be within $\pm 15\%$ (tolerance relates to variety in voltage and cable conditions).

Values are based on a typical motor efficiency. Lower efficiency motors will also add to the power loss in the frequency converter and vice versa. If the switching frequency is raised from nominal, the power losses may rise significantly.

LCP and typical control card power consumptions are included. Further options and customer load may add up to 30 W to the losses. (Though typically only 4 W extra for a fully-loaded control card or options for slot A or slot B, each).

Although measurements are made with state-of-the-art equipment, some measurement inaccuracy must be allowed for ($\pm 5\%$).

⁵⁾ The three values for the max. cable cross section are for single core, flexible wire and flexible wire with sleeve, respectively. Motor and mains cable: 300 MCM/150 mm².

⁶⁾ A2+A3 may be converted to IP21 using a conversion kit. See also Mechanical mounting and IP21/Type 1 Enclosure kit in the Design Guide.

⁷⁾ B3+4 and C3+4 may be converted to IP21 using a conversion kit. See also Mechanical mounting and IP21/Type 1 Enclosure kit in the Design Guide.

8.2 Mains Supply

Mains supply

Supply Terminals	L1, L2, L3
Supply voltage	200-240 V ±10%
Supply voltage	380-480 V/525-600 V ±10%
Supply voltage	525-690 V ±10%

Mains voltage low/mains drop-out:

During low mains voltage or a mains drop-out, the frequency converter continues until the intermediate circuit voltage drops below the minimum stop level, which corresponds typically to 15% below the frequency converter's lowest rated supply voltage. Power-up and full torque cannot be expected at mains voltage lower than 10% below the frequency converter's lowest rated supply voltage.

Supply frequency	50/60 Hz ±5%
Max. imbalance temporary between mains phases	3.0 % of rated supply voltage
True Power Factor (λ)	≥ 0.9 nominal at rated load
Displacement Power Factor ($\cos \phi$)	near unity (> 0.98)
Switching on input supply L1, L2, L3 (power-ups) ≤ 7.5 kW	maximum 2 times/min.
Switching on input supply L1, L2, L3 (power-ups) 11-90 kW	maximum 1 time/min.
Environment according to EN60664-1	overvoltage category III/pollution degree 2

The unit is suitable for use on a circuit capable of delivering not more than 100,000 RMS symmetrical Amperes, 240/500/600/690 V maximum.

8

8.3 Motor Output and Motor Data

Motor output (U, V, W)

Output voltage	0 - 100% of supply voltage
Output frequency (1.1-90 kW)	0-590 ¹⁾ Hz
Switching on output	Unlimited
Ramp times	1-3600 s

¹⁾ From software version 3.92 the output frequency of the frequency converter is limited to 590 Hz. Contact local Danfoss partner for further information.

Torque characteristics

Starting torque (Constant torque)	maximum 110% for 60 s ¹⁾
Starting torque	maximum 135% up to 0.5 s ¹⁾
Overload torque (Constant torque)	maximum 110% for 60 s ¹⁾
Starting torque (Variable torque)	maximum 110% for 60 s ¹⁾
Overload torque (Variable torque)	maximum 110% for 60 s
Torque rise time in VVC ^{plus} (independent of fsw)	10 ms

¹⁾ Percentage relates to the nominal torque.

²⁾ The torque response time depends on application and load but as a general rule, the torque step from 0 to reference is 4-5 x torque rise time.

8.4 Ambient Conditions

Environment

IP rating	IP00/Chassis, IP20 ¹⁾ /Chassis, IP21 ²⁾ /Type 1, IP54/Type 12, IP55/Type 12, IP66/Type 4X
Vibration test	1.0 g
Max. relative humidity	5% - 93% (IEC 721-3-3; Class 3K3 (non-condensing) during operation
Aggressive environment (IEC 60068-2-43) H ₂ S test	class Kd

Specifications

VLT® HVAC Drive Operating Instructions

Ambient temperature ³⁾	Max. 50 °C (24-hour average maximum 45 °C)
Minimum ambient temperature during full-scale operation	0 °C
Minimum ambient temperature at reduced performance	- 10 °C
Temperature during storage/transport	-25 to +65/70 °C
Maximum altitude above sea level without derating	1000 m

Derating for high altitude, see special conditions in the Design Guide

EMC standards, Emission	EN 61800-3, EN 61000-6-3/4, EN 55011
EMC standards, Immunity	EN 61800-3, EN 61000-6-1/2, EN 61000-4-2, EN 61000-4-3, EN 61000-4-4, EN 61000-4-5, EN 61000-4-6

See section on special conditions in the Design Guide.

¹⁾ Only for ≤ 3.7 kW (200-240 V), ≤ 7.5 kW (400-480 V)

²⁾ As enclosure kit for ≤ 3.7 kW (200-240 V), ≤ 7.5 kW (400-480 V)

³⁾ Derating for high ambient temperature, see special conditions in the Design Guide

8.5 Cable Specifications

Cable lengths and cross-sections for control cables¹⁾

Max. motor cable length, screened	150 m
Max. motor cable length, unscreened	300 m
Maximum cross section to control terminals, flexible/ rigid wire without cable end sleeves	1.5 mm ² /16 AWG
Maximum cross section to control terminals, flexible wire with cable end sleeves	1 mm ² /18 AWG
Maximum cross section to control terminals, flexible wire with cable end sleeves with collar	0.5 mm ² /20 AWG
Minimum cross section to control terminals	0.25 mm ² /24AWG

¹⁾For power cables, see electrical data tables in 8.1 Electrical Data.

8.6 Control Input/Output and Control Data

Digital inputs

Programmable digital inputs	4 (6) ¹⁾
Terminal number	18, 19, 27 ¹⁾ , 29 ¹⁾ , 32, 33,
Logic	PNP or NPN
Voltage level	0-24 V DC
Voltage level, logic '0' PNP	<5 V DC
Voltage level, logic '1' PNP	>10 V DC
Voltage level, logic '0' NPN ²⁾	>19 V DC
Voltage level, logic '1' NPN ²⁾	<14 V DC
Maximum voltage on input	28 V DC
Pulse frequency range	0-110 kHz
(Duty cycle) Min. pulse width	4.5 ms
Input resistance, R _i	approx. 4 kΩ

Safe Torque Off Terminal 37^{3, 4)} (Terminal 37 is fixed PNP logic)

Voltage level	0-24 V DC
Voltage level, logic '0' PNP	<4 V DC
Voltage level, logic '1' PNP	>20 V DC
Maximum voltage on input	28 V DC
Typical input current at 24 V	50 mA rms
Typical input current at 20 V	60 mA rms
Input capacitance	400 nF

All digital inputs are galvanically isolated from the supply voltage (PELV) and other high-voltage terminals.

¹⁾ Terminals 27 and 29 can also be programmed as output.

Specifications

VLT® HVAC Drive Operating Instructions

- 2) Except Safe Torque Off input Terminal 37.
- 3) See for further information about terminal 37 and Safe Torque Off.
- 4) When using a contactor with a DC coil inside in combination with Safe Torque Off, it is important to make a return way for the current from the coil when turning it off. This can be done by using a freewheel diode (or, alternatively, a 30 or 50 V MOV for quicker response time) across the coil. Typical contactors can be bought with this diode.

Analog inputs

Number of analog inputs	2
Terminal number	53, 54
Modes	Voltage or current
Mode select	Switch S201 and switch S202
Voltage mode	Switch S201/switch S202 = OFF (U)
Voltage level	-10 to +10 V (scalable)
Input resistance, R_i	approx. 10 k Ω
Max. voltage	± 20 V
Current mode	Switch S201/switch S202 = ON (I)
Current level	0/4 to 20 mA (scalable)
Input resistance, R_i	approx. 200 Ω
Max. current	30 mA
Resolution for analog inputs	10 bit (+ sign)
Accuracy of analog inputs	Max. error 0.5% of full scale
Bandwidth	20 Hz/100 Hz

The analog inputs are galvanically isolated from the supply voltage (PELV) and other high-voltage terminals.

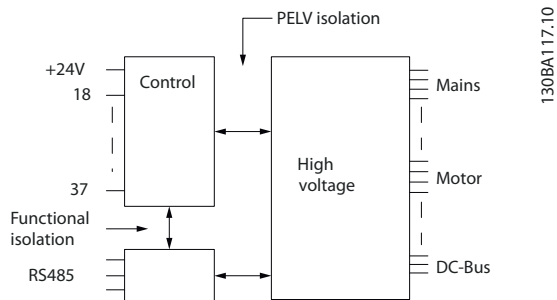

Illustration 8.1 PELV Isolation

Pulse

Programmable pulse	2/1
Terminal number pulse	29 ¹⁾ , 33 ²⁾ / 33 ³⁾
Max. frequency at terminal 29, 33	110 kHz (Push-pull driven)
Max. frequency at terminal 29, 33	5 kHz (open collector)
Min. frequency at terminal 29, 33	4 Hz
Voltage level	see 8.6.1 Digital Inputs
Maximum voltage on input	28 V DC
Input resistance, R_i	approx. 4 k Ω
Pulse input accuracy (0.1-1 kHz)	Max. error: 0.1% of full scale
Encoder input accuracy (1-11 kHz)	Max. error: 0.05 % of full scale

The pulse and encoder inputs (terminals 29, 32, 33) are galvanically isolated from the supply voltage (PELV) and other high-voltage terminals.

- 1) FC 302 only
- 2) Pulse inputs are 29 and 33

Analog output

Number of programmable analog outputs	1
Terminal number	42
Current range at analog output	0/4-20 mA

Specifications

VLT® HVAC Drive Operating Instructions

Max. load GND - analog output	500 Ω
Accuracy on analog output	Max. error: 0.5% of full scale
Resolution on analog output	12 bit

The analog output is galvanically isolated from the supply voltage (PELV) and other high-voltage terminals.

Control card, RS-485 serial communication

Terminal number	68 (P,TX+, RX+), 69 (N,TX-, RX-)
Terminal number 61	Common for terminals 68 and 69

The RS-485 serial communication circuit is functionally separated from other central circuits and galvanically isolated from the supply voltage (PELV).

Digital output

Programmable digital/pulse outputs	2
Terminal number	27, 29 ¹⁾
Voltage level at digital/frequency output	0-24 V
Max. output current (sink or source)	40 mA
Max. load at frequency output	1 kΩ
Max. capacitive load at frequency output	10 nF
Minimum output frequency at frequency output	0 Hz
Maximum output frequency at frequency output	32 kHz
Accuracy of frequency output	Max. error: 0.1 % of full scale
Resolution of frequency outputs	12 bit

¹⁾ Terminal 27 and 29 can also be programmed as input.

The digital output is galvanically isolated from the supply voltage (PELV) and other high-voltage terminals.

Control card, 24 V DC output

Terminal number	12, 13
Output voltage	24 V +1, -3 V
Max. load	200 mA

The 24 V DC supply is galvanically isolated from the supply voltage (PELV), but has the same potential as the analog and digital inputs and outputs.

Relay outputs

Programmable relay outputs	2
Relay 01 Terminal number	1-3 (break), 1-2 (make)
Max. terminal load (AC-1) ¹⁾ on 1-3 (NC), 1-2 (NO) (Resistive load)	240 V AC, 2 A
Max. terminal load (AC-15) ¹⁾ (Inductive load @ cosφ 0.4)	240 V AC, 0.2 A
Max. terminal load (DC-1) ¹⁾ on 1-2 (NO), 1-3 (NC) (Resistive load)	60 V DC, 1 A
Max. terminal load (DC-13) ¹⁾ (Inductive load)	24 V DC, 0.1 A
Relay 02 (FC 302 only) Terminal number	4-6 (break), 4-5 (make)
Max. terminal load (AC-1) ¹⁾ on 4-5 (NO) (Resistive load) ²⁾³⁾ Overvoltage cat. II	400 V AC, 2 A
Max. terminal load (AC-15) ¹⁾ on 4-5 (NO) (Inductive load @ cosφ 0.4)	240 V AC, 0.2 A
Max. terminal load (DC-1) ¹⁾ on 4-5 (NO) (Resistive load)	80 V DC, 2 A
Max. terminal load (DC-13) ¹⁾ on 4-5 (NO) (Inductive load)	24 V DC, 0.1 A
Max. terminal load (AC-1) ¹⁾ on 4-6 (NC) (Resistive load)	240 V AC, 2 A
Max. terminal load (AC-15) ¹⁾ on 4-6 (NC) (Inductive load @ cosφ 0.4)	240 V AC, 0.2 A
Max. terminal load (DC-1) ¹⁾ on 4-6 (NC) (Resistive load)	50 V DC, 2 A
Max. terminal load (DC-13) ¹⁾ on 4-6 (NC) (Inductive load)	24 V DC, 0.1 A
Min. terminal load on 1-3 (NC), 1-2 (NO), 4-6 (NC), 4-5 (NO)	24 V DC 10 mA, 24 V AC 20 mA
Environment according to EN 60664-1	overvoltage category III/pollution degree 2

¹⁾ IEC 60947 part 4 and 5

The relay contacts are galvanically isolated from the rest of the circuit by reinforced isolation (PELV).

²⁾ Overvoltage Category II

³⁾ UL applications 300 V AC 2A

Specifications

VLT® HVAC Drive Operating Instructions

Control card, 10 V DC output

Terminal number	50
Output voltage	10.5 V \pm 0.5 V
Max. load	15 mA

The 10 V DC supply is galvanically isolated from the supply voltage (PELV) and other high-voltage terminals.

Control characteristics

Resolution of output frequency at 0-590 Hz	\pm 0.003 Hz
Repeat accuracy of <i>Precise start/stop</i> (terminals 18, 19)	\leq \pm 0.1 ms
System response time (terminals 18, 19, 27, 29, 32, 33)	\leq 2 ms
Speed control range (open loop)	1:100 of synchronous speed
Speed control range (closed loop)	1:1000 of synchronous speed
Speed accuracy (open loop)	30-4000 rpm: error \pm 8 rpm
Speed accuracy (closed loop), depending on resolution of feedback device	0-6000 rpm: error \pm 0.15 rpm

All control characteristics are based on a 4-pole asynchronous motor

Control card performance

Scan interval	1 ms
---------------	------

Control card, USB serial communication

USB standard	1.1 (Full speed)
USB plug	USB type B "device" plug

Connection to PC is carried out via a standard host/device USB cable.

The USB connection is galvanically isolated from the supply voltage (PELV) and other high-voltage terminals.

The USB ground connection is not galvanically isolated from protection earth. Use only an isolated laptop as PC connection to the USB connector on the frequency converter.

8.7 Connection Tightening Torques

Enclosure	Power [kW]				Torque [Nm]					
	200-240 V	380-480/500 V	525-600 V	525-690 V	Mains	Motor	DC connection	Brake	Earth	Relay
A2	1.1-2.2	1.1-4.0			0.6	0.6	0.6	1.8	3	0.6
A3	3.0-3.7	5.5-7.5	1.1-7.5	1.1-7.5	0.6	0.6	0.6	1.8	3	0.6
A4	1.1-2.2	1.1-4.0			0.6	0.6	0.6	1.8	3	0.6
A5	1.1-3.7	1.1-7.5	1.1-7.5		0.6	0.6	0.6	1.8	3	0.6
B1	5.5-11	11-18	11-18		1.8	1.8	1.5	1.5	3	0.6
B2	15	22-30	22-30	11-30	4.5	4.5	3.7	3.7	3	0.6
B3	5.5 -11	11-18	11-18		1.8	1.8	1.8	1.8	3	0.6
B4	15-18	22-37	22-37	11-37	4.5	4.5	4.5	4.5	3	0.6
C1	18-30	37-55	37-55		10	10	10	10	3	0.6
C2	37-45	75-90	75-90	37-90	14/24 ¹⁾	14/24 ¹⁾	14	14	3	0.6
C3	22-30	45-55	45-55	45-55	10	10	10	10	3	0.6
C4	37-45	75-90	75-90		14/24 ¹⁾	14/24 ¹⁾	14	14	3	0.6

Table 8.10 Tightening of Terminals

¹⁾ For different cable dimensions x/y, where $x \leq 95 \text{ mm}^2$ and $y \geq 95 \text{ mm}^2$.

8.8 Fuse Specifications

It is recommended to use fuses and/or circuit breakers on the supply side as protection in case of component break-down inside the frequency converter (first fault).

NOTICE

This is mandatory in order to ensure compliance with IEC 60364 for CE or NEC 2009 for UL.

The fuses below are suitable for use on a circuit capable of delivering 100,000 Arms (symmetrical), depending on the frequency converter voltage rating. With the proper fusing the frequency converter Short Circuit Current Rating (SCCR) is 100,000 Arms.

8.8.1 CE Compliance

200-240 V

Enclosure type	Power [kW]	Recommended fuse size	Recommended Max. fuse size	Recommended circuit breaker (Moeller)	Max. trip level [A]
A2	1.1-2.2	gG-10 (1.1-1.5) gG-16 (2.2)	gG-25	PKZM0-25	25
A3	3.0-3.7	gG-16 (3) gG-20 (3.7)	gG-32	PKZM0-25	25
B3	5.5-11	gG-25 (5.5-7.5) gG-32 (11)	gG-63	PKZM4-50	50
B4	15-18	gG-50 (15) gG-63 (18)	gG-125	NZMB1-A100	100
C3	22-30	gG-80 (22) aR-125 (30)	gG-150 (22) aR-160 (30)	NZMB2-A200	150
C4	37-45	aR-160 (37) aR-200 (45)	aR-200 (37) aR-250 (45)	NZMB2-A250	250
A4	1.1-2.2	gG-10 (1.1-1.5) gG-16 (2.2)	gG-32	PKZM0-25	25
A5	0.25-3.7	gG-10 (0.25-1.5) gG-16 (2.2-3) gG-20 (3.7)	gG-32	PKZM0-25	25
B1	5.5-11	gG-25 (5.5) gG-32 (7.5-11)	gG-80	PKZM4-63	63
B2	15	gG-50	gG-100	NZMB1-A100	100
C1	18-30	gG-63 (18.5) gG-80 (22) gG-100 (30)	gG-160 (18.5-22) aR-160 (30)	NZMB2-A200	160
C2	37-45	aR-160 (37) aR-200 (45)	aR-200 (37) aR-250 (45)	NZMB2-A250	250

Table 8.11 200-240 V, Enclosure Types A, B and C

Specifications

VLT® HVAC Drive Operating Instructions

380-480 V

Enclosure type	Power [kW]	Recommended fuse size	Recommended Max. fuse size	Recommended circuit breaker (Moeller)	Max. trip level [A]
A2	1.1-4.0	gG-10 (1.1-3) gG-16 (4)	gG-25	PKZM0-25	25
A3	5.5-7.5	gG-16	gG-32	PKZM0-25	25
B3	11-18	gG-40	gG-63	PKZM4-50	50
B4	22-37	gG-50 (22) gG-63 (30) gG-80 (37)	gG-125	NZMB1-A100	100
C3	45-55	gG-100 (45) gG-160 (55)	gG-150 (45) gG-160 (55)	NZMB2-A200	150
C4	75-90	aR-200 (75) aR-250 (90)	aR-250	NZMB2-A250	250
A4	1.1-4	gG-10 (1.1-3) gG-16 (4)	gG-32	PKZM0-25	25
A5	1.1-7.5	gG-10 (1.1-3) gG-16 (4-7.5)	gG-32	PKZM0-25	25
B1	11-18.5	gG-40	gG-80	PKZM4-63	63
B2	22-30	gG-50 (22) gG-63 (30)	gG-100	NZMB1-A100	100
C1	37-55	gG-80 (37) gG-100 (45) gG-160 (55)	gG-160	NZMB2-A200	160
C2	75-90	aR-200 (75) aR-250 (90)	aR-250	NZMB2-A250	250

8

Table 8.12 380-480 V, Enclosure Types A, B and C

525-600 V

Enclosure type	Power [kW]	Recommended fuse size	Recommended Max. fuse size	Recommended circuit breaker (Moeller)	Max. trip level [A]
A3	5.5-7.5	gG-10 (5.5) gG-16 (7.5)	gG-32	PKZM0-25	25
B3	11-18	gG-25 (11) gG-32 (15-18)	gG-63	PKZM4-50	50
B4	22-37	gG-40 (22) gG-50 (30) gG-63 (37)	gG-125	NZMB1-A100	100
C3	45-55	gG-63 (45) gG-100 (55)	gG-150	NZMB2-A200	150
C4	75-90	aR-160 (75) aR-200 (90)	aR-250	NZMB2-A250	250
A5	1.1-7.5	gG-10 (1.1-5.5) gG-16 (7.5)	gG-32	PKZM0-25	25
B1	11-18	gG-25 (11) gG-32 (15) gG-40 (18.5)	gG-80	PKZM4-63	63
B2	22-30	gG-50 (22) gG-63 (30)	gG-100	NZMB1-A100	100
C1	37-55	gG-63 (37) gG-100 (45) aR-160 (55)	gG-160 (37-45) aR-250 (55)	NZMB2-A200	160
C2	75-90	aR-200 (75-90)	aR-250	NZMB2-A250	250

Table 8.13 525-600 V, Enclosure Types A, B and C

Specifications

VLT® HVAC Drive Operating Instructions

525-690 V

Enclosure type	Power [kW]	Recommended fuse size	Recommended Max. fuse size	Recommended circuit breaker (Moeller)	Max. trip level [A]
A3	1.1	gG-6	gG-25	-	-
	1.5	gG-6	gG-25	-	-
	2.2	gG-6	gG-25	-	-
	3	gG-10	gG-25	-	-
	4	gG-10	gG-25	-	-
	5.5	gG-16	gG-25	-	-
	7.5	gG-16	gG-25	-	-
B2/B4	11	gG-25 (11)	gG-63	-	-
	15	gG-32 (15)		-	-
	18	gG-32 (18)		-	-
	22	gG-40 (22)		-	-
B4/C2	30	gG-63 (30)	gG-80 (30)		
C2/C3	37	gG-63 (37)	gG-100 (37)	-	-
	45	gG-80 (45)	gG-125 (45)	-	-
C2	55	gG-100 (55)	gG-160 (55-75)	-	-
	75	gG-125 (75)		-	-

Table 8.14 525-690 V, Enclosure Types A, B and C

8

8.8.2 UL Compliance

3x200-240 V

Power [kW]	Recommended max. fuse					
	Bussmann Type RK1 ¹⁾	Bussmann Type J	Bussmann Type T	Bussmann Type CC	Bussmann Type CC	Bussmann Type CC
1.1	KTN-R-10	JKS-10	JJN-10	FNQ-R-10	KTK-R-10	LP-CC-10
1.5	KTN-R-15	JKS-15	JJN-15	FNQ-R-15	KTK-R-15	LP-CC-15
2.2	KTN-R-20	JKS-20	JJN-20	FNQ-R-20	KTK-R-20	LP-CC-20
3.0	KTN-R-25	JKS-25	JJN-25	FNQ-R-25	KTK-R-25	LP-CC-25
3.7	KTN-R-30	JKS-30	JJN-30	FNQ-R-30	KTK-R-30	LP-CC-30
5.5	KTN-R-50	KS-50	JJN-50	-	-	-
7.5	KTN-R-60	JKS-60	JJN-60	-	-	-
11	KTN-R-80	JKS-80	JJN-80	-	-	-
15-18.5	KTN-R-125	JKS-125	JJN-125	-	-	-
22	KTN-R-150	JKS-150	JJN-150	-	-	-
30	KTN-R-200	JKS-200	JJN-200	-	-	-
37	KTN-R-250	JKS-250	JJN-250	-	-	-

Table 8.15 3x200-240 V, Enclosure Types A, B and C

Power [kW]	Recommended max. fuse							
	SIBA Type RK1	Littel fuse Type RK1	Ferraz-Shawmut Type CC	Ferraz-Shawmut Type RK1 ³⁾	Bussmann Type JFHR2 ²⁾	Littel fuse JFHR2	Ferraz-Shawmut JFHR2 ⁴⁾	Ferraz-Shawmut J
1.1	5017906-010	KLN-R-10	ATM-R-10	A2K-10-R	FWX-10	-	-	HSJ-10
1.5	5017906-016	KLN-R-15	ATM-R-15	A2K-15-R	FWX-15	-	-	HSJ-15
2.2	5017906-020	KLN-R-20	ATM-R-20	A2K-20-R	FWX-20	-	-	HSJ-20
3.0	5017906-025	KLN-R-25	ATM-R-25	A2K-25-R	FWX-25	-	-	HSJ-25
3.7	5012406-032	KLN-R-30	ATM-R-30	A2K-30-R	FWX-30	-	-	HSJ-30
5.5	5014006-050	KLN-R-50	-	A2K-50-R	FWX-50	-	-	HSJ-50
7.5	5014006-063	KLN-R-60	-	A2K-60-R	FWX-60	-	-	HSJ-60
11	5014006-080	KLN-R-80	-	A2K-80-R	FWX-80	-	-	HSJ-80
15-18.5	2028220-125	KLN-R-125	-	A2K-125-R	FWX-125	-	-	HSJ-125
22	2028220-150	KLN-R-150	-	A2K-150-R	FWX-150	L25S-150	A25X-150	HSJ-150
30	2028220-200	KLN-R-200	-	A2K-200-R	FWX-200	L25S-200	A25X-200	HSJ-200
37	2028220-250	KLN-R-250	-	A2K-250-R	FWX-250	L25S-250	A25X-250	HSJ-250

Table 8.16 3x200-240 V, Enclosure Types A, B and C

- 1) KTS-fuses from Bussmann may substitute KTN for 240 V frequency converters.
- 2) FWH-fuses from Bussmann may substitute FWX for 240 V frequency converters.
- 3) A6KR fuses from FERRAZ SHAWMUT may substitute A2KR for 240 V frequency converters.
- 4) A50X fuses from FERRAZ SHAWMUT may substitute A25X for 240 V frequency converters.

8

3x380-480 V

Power [kW]	Recommended max. fuse					
	Bussmann Type RK1	Bussmann Type J	Bussmann Type T	Bussmann Type CC	Bussmann Type CC	Bussmann Type CC
1.1	KTS-R-6	JKS-6	JJS-6	FNQ-R-6	KTK-R-6	LP-CC-6
1.5-2.2	KTS-R-10	JKS-10	JJS-10	FNQ-R-10	KTK-R-10	LP-CC-10
3	KTS-R-15	JKS-15	JJS-15	FNQ-R-15	KTK-R-15	LP-CC-15
4	KTS-R-20	JKS-20	JJS-20	FNQ-R-20	KTK-R-20	LP-CC-20
5.5	KTS-R-25	JKS-25	JJS-25	FNQ-R-25	KTK-R-25	LP-CC-25
7.5	KTS-R-30	JKS-30	JJS-30	FNQ-R-30	KTK-R-30	LP-CC-30
11	KTS-R-40	JKS-40	JJS-40	-	-	-
15	KTS-R-50	JKS-50	JJS-50	-	-	-
18	KTS-R-60	JKS-60	JJS-60	-	-	-
22	KTS-R-80	JKS-80	JJS-80	-	-	-
30	KTS-R-100	JKS-100	JJS-100	-	-	-
37	KTS-R-125	JKS-125	JJS-125	-	-	-
45	KTS-R-150	JKS-150	JJS-150	-	-	-
55	KTS-R-200	JKS-200	JJS-200	-	-	-
75-90	KTS-R-250	JKS-250	JJS-250	-	-	-

Table 8.17 3x380-480 V, Enclosure Types A, B and C

Specifications

VLT® HVAC Drive Operating Instructions

Power [kW]	Recommended max. fuse							
	SIBA Type RK1	Littel fuse Type RK1	Ferraz-Shawmut Type CC	Ferraz-Shawmut Type RK1	Bussmann JFHR2	Ferraz-Shawmut J	Ferraz-Shawmut JFHR2 ¹⁾	Littel fuse JFHR2
1.1	5017906-006	KLS-R-6	ATM-R-6	A6K-6-R	FWH-6	HSJ-6	-	-
1.5-2.2	5017906-010	KLS-R-10	ATM-R-10	A6K-10-R	FWH-10	HSJ-10	-	-
3	5017906-016	KLS-R-15	ATM-R-15	A6K-15-R	FWH-15	HSJ-15	-	-
4	5017906-020	KLS-R-20	ATM-R-20	A6K-20-R	FWH-20	HSJ-20	-	-
5.5	5017906-025	KLS-R-25	ATM-R-25	A6K-25-R	FWH-25	HSJ-25	-	-
7.5	5012406-032	KLS-R-30	ATM-R-30	A6K-30-R	FWH-30	HSJ-30	-	-
11	5014006-040	KLS-R-40	-	A6K-40-R	FWH-40	HSJ-40	-	-
15	5014006-050	KLS-R-50	-	A6K-50-R	FWH-50	HSJ-50	-	-
18	5014006-063	KLS-R-60	-	A6K-60-R	FWH-60	HSJ-60	-	-
22	2028220-100	KLS-R-80	-	A6K-80-R	FWH-80	HSJ-80	-	-
30	2028220-125	KLS-R-100	-	A6K-100-R	FWH-100	HSJ-100	-	-
37	2028220-125	KLS-R-125	-	A6K-125-R	FWH-125	HSJ-125	-	-
45	2028220-160	KLS-R-150	-	A6K-150-R	FWH-150	HSJ-150	-	-
55	2028220-200	KLS-R-200	-	A6K-200-R	FWH-200	HSJ-200	A50-P-225	L50-S-225
75-90	2028220-250	KLS-R-250	-	A6K-250-R	FWH-250	HSJ-250	A50-P-250	L50-S-250

Table 8.18 3x380-480 V, Enclosure Types A, B and C

1) Ferraz-Shawmut A50QS fuses may substitute A50P fuses.

3x525-600 V

Power [kW]	Recommended max. fuse									
	Bussmann Type RK1	Bussmann Type J	Bussmann Type T	Bussmann Type CC	Bussmann Type CC	Bussmann Type CC	SIBA Type RK1	Littel fuse Type RK1	Ferraz-Shawmut Type RK1	Ferraz-Shawmut J
1.1	KTS-R-5	JKS-5	JJS-6	FNQ-R-5	KTK-R-5	LP-CC-5	5017906-005	KLS-R-005	A6K-5-R	HSJ-6
1.5-2.2	KTS-R-10	JKS-10	JJS-10	FNQ-R-10	KTK-R-10	LP-CC-10	5017906-010	KLS-R-010	A6K-10-R	HSJ-10
3	KTS-R-15	JKS-15	JJS-15	FNQ-R-15	KTK-R-15	LP-CC-15	5017906-016	KLS-R-015	A6K-15-R	HSJ-15
4	KTS-R-20	JKS-20	JJS-20	FNQ-R-20	KTK-R-20	LP-CC-20	5017906-020	KLS-R-020	A6K-20-R	HSJ-20
5.5	KTS-R-25	JKS-25	JJS-25	FNQ-R-25	KTK-R-25	LP-CC-25	5017906-025	KLS-R-025	A6K-25-R	HSJ-25
7.5	KTS-R-30	JKS-30	JJS-30	FNQ-R-30	KTK-R-30	LP-CC-30	5017906-030	KLS-R-030	A6K-30-R	HSJ-30
11	KTS-R-35	JKS-35	JJS-35	-	-	-	5014006-040	KLS-R-035	A6K-35-R	HSJ-35
15	KTS-R-45	JKS-45	JJS-45	-	-	-	5014006-050	KLS-R-045	A6K-45-R	HSJ-45
18	KTS-R-50	JKS-50	JJS-50	-	-	-	5014006-050	KLS-R-050	A6K-50-R	HSJ-50
22	KTS-R-60	JKS-60	JJS-60	-	-	-	5014006-063	KLS-R-060	A6K-60-R	HSJ-60
30	KTS-R-80	JKS-80	JJS-80	-	-	-	5014006-080	KLS-R-075	A6K-80-R	HSJ-80
37	KTS-R-100	JKS-100	JJS-100	-	-	-	5014006-100	KLS-R-100	A6K-100-R	HSJ-100
45	KTS-R-125	JKS-125	JJS-125	-	-	-	2028220-125	KLS-R-125	A6K-125-R	HSJ-125
55	KTS-R-150	JKS-150	JJS-150	-	-	-	2028220-150	KLS-R-150	A6K-150-R	HSJ-150
75-90	KTS-R-175	JKS-175	JJS-175	-	-	-	2028220-200	KLS-R-175	A6K-175-R	HSJ-175

Table 8.19 3x525-600 V, Enclosure Types A, B and C

Specifications

VLT® HVAC Drive Operating Instructions

3x525-690 V

Power [kW]	Recommended max. fuse					
	Bussmann Type RK1	Bussmann Type J	Bussmann Type T	Bussmann Type CC	Bussmann Type CC	Bussmann Type CC
1.1	KTS-R-5	JKS-5	JJS-6	FNQ-R-5	KTK-R-5	LP-CC-5
1.5-2.2	KTS-R-10	JKS-10	JJS-10	FNQ-R-10	KTK-R-10	LP-CC-10
3	KTS-R-15	JKS-15	JJS-15	FNQ-R-15	KTK-R-15	LP-CC-15
4	KTS-R-20	JKS-20	JJS-20	FNQ-R-20	KTK-R-20	LP-CC-20
5.5	KTS-R-25	JKS-25	JJS-25	FNQ-R-25	KTK-R-25	LP-CC-25
7.5	KTS-R-30	JKS-30	JJS-30	FNQ-R-30	KTK-R-30	LP-CC-30
11	KTS-R-35	JKS-35	JJS-35	-	-	-
15	KTS-R-45	JKS-45	JJS-45	-	-	-
18	KTS-R-50	JKS-50	JJS-50	-	-	-
22	KTS-R-60	JKS-60	JJS-60	-	-	-
30	KTS-R-80	JKS-80	JJS-80	-	-	-
37	KTS-R-100	JKS-100	JJS-100	-	-	-
45	KTS-R-125	JKS-125	JJS-125	-	-	-
55	KTS-R-150	JKS-150	JJS-150	-	-	-
75-90	KTS-R-175	JKS-175	JJS-175	-	-	-

Table 8.20 3x525-690 V, Enclosure Types A, B and C

Power [kW]	Max. prefuse	Recommended max. fuse						
		Bussmann E52273 RK1/JDDZ	Bussmann E4273 J/JDDZ	Bussmann E4273 T/JDDZ	SIBA E180276 RK1/JDDZ	Littelfuse E81895 RK1/JDDZ	Ferraz-Shawmut E163267/E2137 RK1/JDDZ	Ferraz-Shawmut E2137 J/HSJ
11	30 A	KTS-R-30	JKS-30	JKJS-30	5017906-030	KLS-R-030	A6K-30-R	HST-30
15-18.5	45 A	KTS-R-45	JKS-45	JJS-45	5014006-050	KLS-R-045	A6K-45-R	HST-45
22	60 A	KTS-R-60	JKS-60	JJS-60	5014006-063	KLS-R-060	A6K-60-R	HST-60
30	80 A	KTS-R-80	JKS-80	JJS-80	5014006-080	KLS-R-075	A6K-80-R	HST-80
37	90 A	KTS-R-90	JKS-90	JJS-90	5014006-100	KLS-R-090	A6K-90-R	HST-90
45	100 A	KTS-R-100	JKS-100	JJS-100	5014006-100	KLS-R-100	A6K-100-R	HST-100
55	125 A	KTS-R-125	JKS-125	JJS-125	2028220-125	KLS-150	A6K-125-R	HST-125
75-90	150 A	KTS-R-150	JKS-150	JJS-150	2028220-150	KLS-175	A6K-150-R	HST-150

Table 8.21 3x525-690 V, Enclosure Types B and C

8

8.9 Power Ratings, Weight and Dimensions

Enclosure Type	A2	A3	A4	A5	B1	B2	B3	B4	C1	C2	C3	C4
Rated Power [kW]	200-240V	3.0-3.7	1.1-2.2	1.1-3.7	5.5-11	15	5.5-11	15-18	18-30	37-45	22-30	37-45
	380-480/500V	5.5-7.5	1.1-4.0	1.1-7.5	11-18	22-30	11-18	22-37	37-55	75-90	45-55	75-90
IP NEMA	525-600V	1.1-7.5		1.1-7.5	11-18	22-30	11-18	22-37	37-55	75-90	45-55	75-90
	525-690V	1.1-7.5		55/66 Type 12	21/ 55/66 Type 1/ Type 12	11-30			21/55/66 Type 1/ Type 12	37-90	45-55	
Height [mm]	20 Chassis	20 Chassis	55/66 Type 12	55/66 Type 12	21/ 55/66 Type 1/ Type 12	21/55/66 Type 1/ Type 12	20 Chassis	20 Chassis	21/55/66 Type 1/ Type 12	21/55/66 Type 1/ Type 12	20 Chassis	20 Chassis
Height of back plate	A 268	268	390	420	480	650	399	520	680	770	550	660
Height with de-coupling plate for Fieldbus cables	A 374	374	-	-	-	-	420	595			630	800
Distance between mounting holes	a 257	257	401	402	454	624	380	495	648	739	521	631
Width [mm]												
Width of back plate	B 90	130	200	242	242	242	165	230	308	370	308	370
Width of back plate with one C option	B 130	170	242	242	242	242	205	230	308	370	308	370
Width of back plate with two C options [mm]	B 150	190	242	242	242	242	225	230	308	370	308	370
Distance between mounting holes	b 70	110	171	215	210	210	140	200	272	334	270	330
Depth [mm]												
Depth without option A/B	C 205	205	175	200	260	260	249	242	310	335	333	333
With option A/B	C 220	220	175	200	260	260	262	242	310	335	333	333
Screw holes [mm]												
	c 8.0	8.0	8.25	8.25	12	12	8		12.5	12.5		
	d ø11	ø11	ø12	ø12	ø19	ø19	12		ø19	ø19		
	e ø5.5	ø5.5	ø6.5	ø6.5	ø9	ø9	6.8	8.5	ø9	ø9	8.5	8.5
	f 9	9	6	9	9	9	7.9	15	9.8	9.8	17	17
Max. weight [kg]	4.9	5.3	9.7	13.5/14.2	23	27	12	23.5	45	65	35	50
Front cover tightening torque [Nm]												
Plastic cover (low IP)	Click	Click	-	-	Click	Click	Click	Click	Click	Click	2.0	2.0
Metal cover (IP55/66)	-	-	1.5	1.5	2.2	2.2	-	-	2.2	2.2	2.0	2.0

Table 8.22 Power Ratings, Weight and Dimensions

9 Appendix

9.1 Symbols and Abbreviations

AC	Alternating Current
AEO	Automatic Energy Optimization
AWG	American Wire Gauge
AMA	Automatic Motor Adaptation
°C	Degrees Celsius
DC	Direct Current
EMC	Electro Magnetic Compatibility
ETR	Electronic Thermal Relay
FC	Frequency Converter
LCP	Local Control Panel
MCT	Motion Control Tool
IP	Ingress Protection
$I_{M,N}$	Nominal Motor Current
$f_{M,N}$	Nominal Motor Frequency
$P_{M,N}$	Nominal Motor Power
$U_{M,N}$	Nominal Motor Voltage
PM Motor	Permanent Magnet Motor
PELV	Protective Extra Low Voltage
PCB	Printed Circuit Board
I_{LIM}	Current Limit
I_{INV}	Rated Inverter Output Current
RPM	Revolutions Per Minute
Regen	Regenerative Terminals
n_s	Synchronous Motor Speed
T_{LIM}	Torque Limit
$I_{VLT,MAX}$	The Maximum Output Current
$I_{VLT,N}$	The Rated Output Current Supplied by the Frequency Converter

Table 9.1 Symbols and Abbreviations

9.2 Parameter Menu Structure



Appendix VLT® HVAC Drive Operating Instructions

0-0*	Operation / Display	Torque Characteristics	Thermistor Source	Max Output Frequency	5-68	Pulse Output Max Freq #X30/6
0-0*	Basic Settings	Clockwise Direction	2-** Brakes	4-5* Adj. Warnings	5-8*	I/O Options
0-01	Language	1-03 Motor Selection	2-0* DC-Brake	4-50 Warning Current Low	5-80	AHF Cap Reconnect Delay
0-02	Motor Speed Unit	1-10 Motor Construction	2-00 DC Hold/Preheat Current	4-51 Warning Current High	5-9*	Bus Controlled
0-03	Regional Settings	1-1* VVC+ PM	2-01 DC Brake Current	4-52 Warning Speed Low	5-90	Digital & Relay Bus Control
0-04	Operating State at Power-up	1-14 Damping Gain	2-02 DC Braking Time	4-53 Warning Speed High	5-93	Pulse Out #27 Bus Control
0-05	Local Mode Unit	1-15 Low Speed Filter Time Const.	2-03 DC Brake Cut In Speed [RPM]	4-54 Warning Reference Low	5-94	Pulse Out #27 Timeout Preset
0-1*	Set-up Operations	1-16 High Speed Filter Time Const.	2-04 DC Brake Cut In Speed [Hz]	4-55 Warning Reference High	5-95	Pulse Out #29 Bus Control
0-10	Active Set-up	1-17 Voltage filter time const.	2-06 Parking Current	4-56 Warning Feedback Low	5-96	Pulse Out #29 Timeout Preset
0-11	Programming Set-up	1-2* Motor Data	2-07 Parking Time	4-57 Warning Feedback High	5-97	Pulse Out #X30/6 Bus Control
0-12	This Set-up Linked to	1-20 Motor Power [kW]	2-1* Brake Energy Funct.	4-58 Missing Motor Phase Function	5-98	Pulse Out #X30/6 Timeout Preset
0-13	Readout: Linked Set-ups	1-21 Motor Power [HP]	2-10 Brake Function	4-6* Speed Bypass	6-**	Analog In/Out
0-14	Readout: Prog. Set-ups / Channel	1-22 Motor Voltage	2-11 Brake Resistor (ohm)	6-00 Bypass Speed From [RPM]	6-0*	Analog I/O Mode
0-2*	LCP Display	1-23 Motor Frequency	2-12 Brake Power Limit (kW)	4-61 Bypass Speed From [Hz]	6-00	Live Zero Timeout Time
0-20	Display Line 1.1 Small	1-24 Motor Current	2-13 Brake Power Monitoring	4-62 Bypass Speed To [RPM]	6-01	Live Zero Timeout Function
0-21	Display Line 1.2 Small	1-25 Motor Nominal Speed	2-15 Brake Check	4-63 Bypass Speed To [Hz]	6-02	Fire Mode Live Zero Timeout Function
0-22	Display Line 1.3 Small	1-26 Motor Cont. Rated Torque	2-16 AC brake Max. Current	4-64 Semi-Auto Bypass Set-up	6-1*	Analog Input 53
0-23	Display Line 2 Large	1-28 Motor Rotation Check	2-17 Over-voltage Control	5-** Digital In/Out	6-10	Terminal 53 Low Voltage
0-24	Display Line 3 Large	1-29 Automatic Motor Adaptation (AMA)	3-** Reference / Ramps	5-0* Digital I/O mode	6-11	Terminal 53 High Voltage
0-25	My Personal Menu	1-3* Adv. Motor Data	3-0* Reference Limits	5-00 Digital I/O Mode	6-12	Terminal 53 Low Current
0-3*	LCP Custom Readout	1-30 Stator Resistance (Rs)	3-02 Minimum Reference	5-01 Terminal 27 Mode	6-13	Terminal 53 High Current
0-30	Custom Readout Unit	1-31 Rotor Resistance (Rr)	3-03 Maximum Reference	5-02 Terminal 29 Mode	6-14	Terminal 53 Low Ref./Feedb. Value
0-31	Custom Readout Min Value	1-35 Main Reactance (Xh)	3-04 Reference Function	5-1* Digital Inputs	6-15	Terminal 53 High Ref./Feedb. Value
0-32	Custom Readout Max Value	1-36 Iron Loss Resistance (Rfe)	3-1* References	5-10 Terminal 18 Digital Input	6-16	Terminal 53 Filter Time Constant
0-37	Display Text 1	1-37 d-axis Inductance (Ld)	3-10 Preset Reference	5-11 Terminal 19 Digital Input	6-17	Terminal 53 Live Zero
0-38	Display Text 2	1-39 Motor Poles	3-11 Jog Speed [Hz]	5-12 Terminal 27 Digital Input	6-2*	Analog Input 54
0-39	Display Text 3	1-40 Back EMF at 1000 RPM	3-13 Reference Site	5-13 Terminal 29 Digital Input	6-20	Terminal 54 Low Voltage
0-4*	LCP keypad	1-46 Position Detection Gain	3-14 Preset Relative Reference	5-14 Terminal 32 Digital Input	6-21	Terminal 54 High Voltage
0-40	[HAnd on] Key on LCP	1-5* Load indep. Setting	3-15 Reference 1 Source	5-15 Terminal 33 Digital Input	6-22	Terminal 54 Low Current
0-41	[Off] Key on LCP	1-50 Motor Magnetisation at Zero Speed	3-16 Reference 2 Source	5-16 Terminal X30/2 Digital Input	6-23	Terminal 54 High Current
0-42	[Auto on] Key on LCP	1-51 Min Speed Normal Magnetising [RPM]	3-17 Reference 3 Source	5-17 Terminal X30/3 Digital Input	6-24	Terminal 54 Low Ref./Feedb. Value
0-43	[Reset] Key on LCP	1-52 Min Speed Normal Magnetising [Hz]	3-19 Jog Speed [RPM]	5-18 Terminal X30/4 Digital Input	6-25	Terminal 54 High Ref./Feedb. Value
0-44	[Off/Reset] Key on LCP	1-58 Flystart Test Pulses Current	3-4* Ramp 1	5-19 Terminal 37 Safe Stop	6-26	Terminal 54 Filter Time Constant
0-45	[Drive Bypass] Key on LCP	1-59 Flystart Test Pulses Frequency	3-41 Ramp 1 Ramp Up Time	5-3* Digital Outputs	6-27	Terminal 54 Live Zero
0-5*	Copy/Save	1-6* Load Depen. Setting	3-42 Ramp 1 Ramp Down Time	5-30 Terminal 27 Digital Output	6-3*	Analog Input X30/11
0-50	LCP Copy	1-60 Low Speed Load Compensation	3-5* Ramp 2	5-31 Terminal 29 Digital Output	6-30	Terminal X30/11 Low Voltage
0-51	Set-up Copy	1-61 High Speed Load Compensation	3-51 Ramp 2 Ramp Up Time	5-32 Term X30/6 Digi Out (MCB 101)	6-31	Terminal X30/11 High Voltage
0-6*	Password	1-62 Slip Compensation	3-52 Ramp 2 Ramp Down Time	5-33 Term X30/7 Digi Out (MCB 101)	6-34	Term. X30/11 Low Ref./Feedb. Value
0-60	Main Menu Password	1-63 Slip Compensation Time Constant	3-8* Other Ramps	5-4* Relays	6-35	Term. X30/11 High Ref./Feedb. Value
0-61	Access to Main Menu w/o Password	1-64 Resonance Dampening	3-80 Jog Ramp Time	5-40 Function Relay	6-36	Term. X30/11 Filter Time Constant
0-65	Personal Menu Password	1-65 Resonance Dampening Time Constant	3-81 Quick Stop Ramp Time	5-41 On Delay, Relay	6-37	Term. X30/11 Live Zero
0-66	Access to Personal Menu w/o Password	1-66 Min. Current at Low Speed	3-82 Starting Ramp Up Time	5-42 Off Delay, Relay	6-4*	Analog Input X30/12
0-67	Bus Access Password	1-7* Start Adjustments	3-9* Digital Pot.Meter	5-5* Pulse Input	6-40	Terminal X30/12 Low Voltage
0-7*	Clock Settings	1-70 PM Start Mode	3-90 Step Size	5-50 Term. 29 Low Frequency	6-41	Terminal X30/12 High Voltage
0-70	Date and Time	1-71 Start Delay	3-91 Ramp Time	5-51 Term. 29 High Frequency	6-44	Term. X30/12 Low Ref./Feedb. Value
0-71	Date Format	1-72 Start Function	3-92 Power Restore	5-52 Term. 29 Low Ref./Feedb. Value	6-45	Term. X30/12 High Ref./Feedb. Value
0-72	Time Format	1-73 Flying Start	3-93 Maximum Limit	5-53 Term. 29 High Ref./Feedb. Value	6-46	Term. X30/12 Filter Time Constant
0-74	DST/Summerime	1-77 Compressor Start Max Speed [RPM]	3-94 Minimum Limit	5-54 Pulse Filter Time Constant #29	6-47	Term. X30/12 Live Zero
0-76	DST/Summerime Start	1-78 Compressor Start Max Speed [Hz]	3-95 Ramp Delay	5-55 Term. 33 Low Frequency	6-5*	Analog Output 42
0-77	DST/Summerime End	1-79 Compressor Start Max Time to Trip	4-** Limits / Warnings	5-56 Term. 33 High Frequency	6-50	Terminal 42 Output
0-79	Clock Fault	1-8* Stop Adjustments	4-1* Motor Limits	5-57 Term. 33 Low Ref./Feedb. Value	6-51	Terminal 42 Output Min Scale
0-81	Working Days	1-80 Function at Stop	4-10 Motor Speed Direction	5-58 Term. 33 High Ref./Feedb. Value	6-52	Terminal 42 Output Max Scale
0-82	Additional Working Days	1-81 Min Speed for Function at Stop [RPM]	4-11 Motor Speed Low Limit [RPM]	5-59 Pulse Filter Time Constant #33	6-53	Terminal 42 Output Bus Control
0-83	Additional Non-Working Days	1-82 Min Speed for Function at Stop [Hz]	4-12 Motor Speed Low Limit [Hz]	5-6* Pulse Output	6-54	Terminal 42 Output Timeout Preset
0-89	Date and Time Readout	1-86 Trip Speed Low [RPM]	4-13 Motor Speed High Limit [RPM]	5-60 Terminal 27 Pulse Output Variable	6-55	Analog Output Filter
1-0*	Load and Motor	1-87 Trip Speed Low [Hz]	4-14 Motor Speed High Limit [Hz]	5-62 Pulse Output Max Freq #27	6-6*	Analog Output X30/8
1-0*	General Settings	1-87* Motor Temperature	4-16 Torque Limit Motor Mode	5-63 Terminal 29 Pulse Output Variable	6-60	Terminal X30/8 Output
1-00	Configuration Mode	1-90 Motor Thermal Protection	4-17 Torque Limit Generator Mode	5-65 Pulse Output Max Freq #29	6-61	Terminal X30/8 Min. Scale
		1-91 Motor External Fan	4-18 Current Limit	5-66 Terminal X30/6 Pulse Output Variable	6-62	Terminal X30/8 Max. Scale

Appendix

VLT® HVAC Drive Operating Instructions

6-63	Terminal X30/8 Output Bus Control	9-15	PCD Write Configuration	12-2*	Process Data	14-01	Switching Frequency	15-23	Historic log: Date and Time
6-64	Terminal X30/8 Output Timeout Preset	9-16	PCD Read Configuration	12-20	Control Instance	14-03	Overmodulation	15-3*	Alarm Log
8-0*	Comm. and Options	9-18	Node Address	12-21	Process Data Config Write	14-04	PWM Random	15-30	Alarm Log: Error Code
8-01	Control Site	9-22	Telegram Selection	12-22	Process Data Config Read	14-1*	Mains On/Off	15-31	Alarm Log: Value
8-02	Control Source	9-27	Parameters for Signals	12-27	Primary Master	14-10*	Mains Failure	15-32	Alarm Log: Time
8-03	Control Timeout Time	9-28	Parameter Edit	12-28	Store Data Values	14-11	Mains Voltage at Mains Fault	15-33	Alarm Log: Date and Time
8-04	Control Timeout Function	9-44	Process Control	12-29	Store Always	14-12	Function at Mains Imbalance	15-4*	Drive Identification
8-05	End-of-Timeout Function	9-45	Fault Message Counter	12-3*	EtherNet/IP	14-2*	Reset Functions	15-40	FC Type
8-06	Reset Control Timeout	9-47	Fault Code	12-30	Warning Parameter	14-20	Reset Mode	15-41	Power Section
8-07	Diagnosis Trigger	9-52	Fault Number	12-31	Net Reference	14-21	Automatic Restart Time	15-42	Voltage
8-08	Readout Filtering	9-53	Fault Situation Counter	12-32	Net Control	14-22	Operation Mode	15-43	Software Version
8-09	Communication Charset	9-63	Profibus Warning Word	12-33	CIP Revision	14-23	Typecode Setting	15-44	Ordered Typecode String
8-1*	Control Settings	9-64	Actual Baud Rate	12-34	CIP Product Code	14-25	Trip Delay at Torque Limit	15-45	Actual Typecode String
8-10	Control Profile	9-65	Device Identification	12-35	EDS Parameter	14-26	Trip Delay at Inverter Fault	15-46	Frequency Converter Ordering No
8-13	Configurable Status Word STW	9-67	Profile Number	12-37	COS Inhibit Timer	14-28	Production Settings	15-47	Power Card Ordering No
8-3*	FC Port Settings	9-68	Control Word 1	12-38	COS Filter	14-29	Service Code	15-48	LCP Id No
8-30	Protocol	9-71	Status Word 1	12-4*	Modbus TCP	14-3*	Current Limit Ctrl.	15-49	SW ID Control Card
8-31	Address	9-72	Profibus Save Data Values	12-40	Status Parameter	14-30	Current Lim Ctrl, Proportional Gain	15-50	SW ID Power Card
8-32	Baud Rate	9-75	ProfibusDriveReset	12-41	Slave Message Count	14-31	Current Lim Ctrl, Integration Time	15-51	Frequency Converter Serial Number
8-33	Parity / Stop Bits	9-80	DO Identification	12-42	Slave Exception Message Count	14-32	Current Lim Ctrl, Filter Time	15-53	Power Card Serial Number
8-34	Estimated cycle time	9-81	Defined Parameters (1)	12-8*	Other Ethernet Services	14-4*	Energy Optimising	15-55	Vendor URL
8-35	Minimum Response Delay	9-82	Defined Parameters (2)	12-80	FTP Server	14-40	VT Level	15-56	Vendor Name
8-36	Maximum Response Delay	9-83	Defined Parameters (3)	12-81	HTTP Server	14-41	AEO Minimum Magnetisation	15-59	CSV Filename
8-37	Maximum Inter-Char Delay	9-84	Defined Parameters (4)	12-82	SMTP Service	14-42	Minimum AEO Frequency	15-6*	Option Ident
8-4*	FC telegram set	9-90	Defined Parameters (5)	12-89	Transparent Socket Channel Port	14-43	Motor Cosphi	15-60	Option Mounted
8-40	Telegram Selection	9-91	Changed Parameters (1)	12-9*	Advanced Ethernet Services	14-5*	Environment	15-61	Option SW Version
8-42	PCD Write Configuration	9-92	Changed Parameters (2)	12-90	Cable Diagnostic	14-50	RFI Filter	15-62	Option Ordering No
8-43	PCD Read Configuration	9-93	Changed Parameters (3)	12-91	Auto Cross Over	14-51	DC Link Compensation	15-63	Option Serial No
8-5*	Digital/Bus	9-94	Changed Parameters (4)	12-92	IGMP Snooping	14-52	Fan Control	15-70	Option in Slot A
8-50	Coasting Select	9-99	Changed Parameters (5)	12-93	Cable Error Length	14-53	Fan Monitor	15-71	Slot A Option SW Version
8-52	DC Brake Select	11-0*	LonWorks	12-94	Broadcast Storm Protection	14-55	Output Filter	15-72	Option in Slot B
8-53	Start Select	11-0*	LonWorks ID	12-95	Broadcast Storm Filter	14-59	Actual Number of Inverter Units	15-73	Slot B Option SW Version
8-54	Reversing Select	11-0*	Neuron ID	12-96	Port Config	14-6*	Auto Derate	15-8*	Operating Data II
8-55	Set-up Select	11-1*	Lon Functions	12-99	Interface Counters	14-60	Function at Over Temperature	15-80	Fan Running Hours
8-56	Preset Reference Select	11-15	Lon Warning Word	12-99	Media Counters	14-61	Function at Inverter Overload	15-81	Preset Fan Running Hours
8-7*	BACnet	11-17	XIF Revision	13-0*	Smart Logic	14-62	Inv. Overload Derate Current	15-9*	Parameter Info
8-70	BACnet Device Instance	11-18	LonWorks Revision	13-0*	SLC Settings	14-9*	Fault Settings	15-92	Defined Parameters
8-72	M5/TP Max Masters	11-21	Lon Param. Access	13-00	SL Controller Mode	14-90	Fault Level	15-93	Modified Parameters
8-73	M5/TP Max Info Frames	11-21	Store Data Values	13-01	Start Event	15-0*	Drive Information	15-98	Drive Identification
8-74	"I-Am" Service	11-21	Store Data Values	13-02	Stop Event	15-0*	Operating Data	15-99	Parameter Metadata
8-75	Initialisation Password	12-0*	Ethernet	13-03	Reset SLC	15-00	Operating hours	16-0*	Data Readouts
8-8*	FC Port Diagnostics	12-0*	IP Settings	13-1*	Comparators	15-01	Running hours	16-0*	General Status
8-80	Bus Message Count	12-00	IP Address Assignment	13-10	Comparator Operand	15-02	kWh Counter	16-00	Control Word
8-81	Bus Error Count	12-01	IP Address	13-11	Comparator Operator	15-03	Power Up's	16-01	Reference [Unit]
8-82	Slave Messages Rcvd	12-02	Subnet Mask	13-12	Comparator Value	15-04	Over Temp's	16-02	Reference [%]
8-83	Slave Error Count	12-03	Default Gateway	13-2*	Timers	15-05	Over Volt's	16-03	Status Word
8-84	Slave Messages Sent	12-04	DHCP Server	13-4*	SLC Rules	15-06	Reset kWh Counter	16-05	Main Actual Value [%]
8-85	Slave Timeout Errors	12-05	Lease Expires	13-40	Logic Rule Boolean 1	15-08	Reset Running Hours Counter	16-09	Custom Readout
8-89	Diagnostics Count	12-06	Name Servers	13-41	Logic Rule Operator 1	15-1*	Data Log Settings	16-1*	Motor Status
8-9*	Bus Jog / Feedback	12-07	Domain Name	13-42	Logic Rule Operator 2	15-10	Logging Source	16-10	Power [kW]
8-90	Bus Jog 1 Speed	12-08	Host Name	13-43	Logic Rule Operator 2	15-11	Logging Interval	16-11	Power [hp]
8-91	Bus Jog 2 Speed	12-09	Physical Address	13-44	Logic Rule Boolean 3	15-12	Trigger Event	16-12	Motor Voltage
8-94	Bus Feedback 1	12-10	Link Status	13-5*	States	15-13	Logging Mode	16-13	Frequency
8-95	Bus Feedback 2	12-11	Link Duration	13-51	SL Controller Event	15-14	Samples Before Trigger	16-14	Motor current
8-96	Bus Feedback 3	12-12	Auto Negotiation	13-52	SL Controller Action	15-2*	Historic Log	16-15	Frequency [%]
9-00	Setpoint	12-13	Link Speed	14-0*	Special Functions	15-20	Historic Log: Event	16-16	Torque [Nm]
9-07	Actual Value	12-14	Link Duplex	14-00	Inverter Switching	15-21	Historic Log: Value	16-17	Speed [RPM]
						15-22	Historic Log: Time	16-18	Motor Thermal
								16-20	Motor Angle

Appendix

VL^T® HVAC Drive Operating Instructions

16-22	Torque [%]	18-00	Maintenance Log: Item	20-79	PID Autotuning	21-57	Ext. 3 Reference [Unit]	22-85	Speed at Design Point [RPM]
16-26	Power Filtered [kW]	18-01	Maintenance Log: Action	20-8*	PID Basic Settings	21-58	Ext. 3 Feedback [Unit]	22-86	Speed at Design Point [Hz]
16-27	Power Filtered [hp]	18-02	Maintenance Log: Time	20-81	PID Normal/ Inverse Control	21-59	Ext. 3 Output [%]	22-87	Pressure at No-Flow Speed
16-3*	Drive Status	18-03	Maintenance Log: Date and Time	20-82	PID Start Speed [RPM]	21-6*	Ext. CL 3 PID	22-88	Pressure at Rated Speed
16-30	DC Link Voltage	18-1*	Fire Mode Log	20-83	PID Start Speed [Hz]	21-60	Ext. 3 Normal/Inverse Control	22-89	Flow at Design Point
16-32	Brake Energy /s	18-10	FireMode Log:Event	20-84	On Reference Bandwidth	21-61	Ext. 3 Proportional Gain	22-90	Flow at Rated Speed
16-33	Brake Energy /2 min	18-11	Fire Mode Log: Time	20-91	PID Controller	21-62	Ext. 3 Integral Time	23-*	Time-based Functions
16-34	Heatsink Temp.	18-12	Fire Mode Log: Date and Time	20-92	PID Anti Windup	21-63	Ext. 3 Differentiation Time	23-0*	Timed Actions
16-35	Inverter Thermal	18-3*	Inputs & Outputs	20-93	PID Proportional Gain	21-64	Ext. 3 Dif. Gain Limit	23-00	ON Time
16-36	Inv. Nom. Current	18-30	Analog Input X42/1	20-94	PID Integral Time	22-*	Appl. Functions	23-01	ON Action
16-37	Inv. Max. Current	18-31	Analog Input X42/3	20-95	PID Differentiation Time	22-0*	Miscellaneous	23-02	OFF Time
16-38	SL Controller State	18-32	Analog Input X42/5	20-96	PID Diff. Gain Limit	22-00	External Interlock Delay	23-03	OFF Action
16-39	Control Card Temp.	21-*	Ext. Closed Loop	21-0*	Ext. CL Autotuning	22-01	Power Filter Time	23-04	Occurrence
16-40	Logging Buffer Full	18-33	Analog Out X42/7 [V]	21-00	Closed Loop Type	22-2*	No-Flow Detection	23-0*	Timed Actions Settings
16-41	Logging Buffer Full	18-34	Analog Out X42/9 [V]	21-01	Low Power Auto Set-up	22-20	Low Power Auto Set-up	23-08	Timed Actions Mode
16-43	Timed Actions Status	18-35	Analog Out X42/11 [V]	21-02	PID Performance	22-21	Low Speed Detection	23-09	Timed Actions Reactivation
16-49	Current Fault Source	18-37	Temp. Input X48/4	21-03	PID Output Change	22-22	Low Speed Detection	23-1*	Maintenance
16-5*	Ref. & Feeds.	18-38	Temp. Input X48/7	21-03	Minimum Feedback Level	22-23	No-Flow Function	23-10	Maintenance Item
16-50	External Reference	18-39	Temp. Input X48/10	21-04	Maximum Feedback Level	22-24	No-Flow Delay	23-11	Maintenance Action
16-52	Feedback[Unit]	18-5*	Ref. & Feeds.	21-09	PID Autotuning	22-26	Dry Pump Function	23-12	Maintenance Time Base
16-53	Digi Pot Reference	18-50	Sensorless Readout [unit]	21-1*	Ext. CL 1 Ref./Fb.	22-27	Dry Pump Delay	23-13	Maintenance Time Interval
16-54	Feedback 1 [Unit]	20-*	Drive Closed Loop	21-10	Ext. 1 Ref./Feedback Unit	22-3*	No-Flow Power Tuning	23-14	Maintenance Date and Time
16-55	Feedback 2 [Unit]	20-00	Feedback 1 Source	21-11	Ext. 1 Minimum Reference	22-30	No-Flow Power	23-1*	Maintenance Reset
16-56	Feedback 3 [Unit]	20-01	Feedback 1 Conversion	21-12	Ext. 1 Maximum Reference	22-31	Power Correction Factor	23-15	Reset Maintenance Word
16-6*	Inputs & Outputs	20-02	Feedback 2 Source Unit	21-13	Ext. 1 Reference Source	22-32	Low Speed [RPM]	23-16	Maintenance Text
16-60	Digital Input	20-03	Feedback 2 Source	21-14	Ext. 1 Feedback Source	22-33	Low Speed [Hz]	23-5*	Energy Log
16-61	Terminal 53 Switch Setting	20-04	Feedback 2 Conversion	21-15	Ext. 1 Setpoint	22-34	Low Speed Power [kW]	23-50	Energy Log Resolution
16-62	Analog Input 53	20-05	Feedback 3 Conversion	21-17	Ext. 1 Reference [Unit]	22-35	Low Speed Power [HP]	23-51	Period Start
16-63	Terminal 54 Switch Setting	20-06	Feedback 3 Source	21-18	Ext. 1 Feedback [Unit]	22-36	High Speed [RPM]	23-53	Energy Log
16-64	Analog Input 54	20-07	Feedback 3 Source Unit	21-19	Ext. 1 Output [%]	22-37	High Speed [Hz]	23-54	Reset Energy Log
16-65	Analog Output 42 [mA]	20-08	Feedback 3 Source Unit	21-2*	Ext. CL 1 PID	22-38	High Speed Power [kW]	23-6*	Trending
16-66	Digital Output [bin]	20-12	Reference/Feedback Unit	21-20	Ext. 1 Normal/Inverse Control	22-39	High Speed Power [HP]	23-60	Trend Variable
16-67	Pulse Input #29 [Hz]	20-13	Minimum Reference/Feedb.	21-21	Ext. 1 Proportional Gain	22-4*	Sleep Mode	23-61	Continuous Bin Data
16-68	Pulse Input #33 [Hz]	20-14	Maximum Reference/Feedb.	21-22	Ext. 1 Integral Time	22-40	Minimum Run Time	23-62	Timed Bin Data
16-69	Pulse Output #27 [Hz]	20-2*	Feedback/Setpoint	21-23	Ext. 1 Differentiation Time	22-41	Minimum Sleep Time	23-63	Timed Period Start
16-70	Pulse Output #29 [Hz]	20-20	Feedback Function	21-24	Ext. 1 Dif. Gain Limit	22-42	Wake-up Speed [RPM]	23-64	Timed Period Stop
16-71	Relay Output [bin]	20-21	Setpoint 1	21-3*	Ext. CL 2 Ref./Fb.	22-43	Wake-up Speed [Hz]	23-65	Minimum Bin Value
16-72	Counter A	20-22	Setpoint 2	21-30	Ext. 2 Ref./Feedback Unit	22-44	Wake-up Ref./FB Difference	23-66	Reset Continuous Bin Data
16-73	Counter B	20-23	Setpoint 3	21-31	Ext. 2 Minimum Reference	22-45	Setpoint Boost	23-67	Reset Timed Bin Data
16-75	Analog In X30/11	20-3*	Feeds. Adv. Conv.	21-32	Ext. 2 Maximum Reference	22-5*	End of Curve	23-8*	Payback Counter
16-76	Analog In X30/12	20-30	Refrigerant	21-33	Ext. 2 Reference Source	22-50	End of Curve Function	23-80	Power Reference Factor
16-77	Analog Out X30/8 [mA]	20-31	User Defined Refrigerant A1	21-34	Ext. 2 Feedback Source	22-50	End of Curve Delay	23-81	Energy Cost
16-8*	Fieldbus & FC Port	20-32	User Defined Refrigerant A2	21-35	Ext. 2 Setpoint	22-51	End of Curve Delay	23-82	Investment
16-80	Fieldbus CTW 1	20-33	User Defined Refrigerant A3	21-37	Ext. 2 Reference [Unit]	22-6*	Broken Belt Detection	23-83	Energy Savings
16-82	Fieldbus REF 1	20-34	Duct 1 Area [m2]	21-38	Ext. 2 Feedback [Unit]	22-60	Broken Belt Function	23-84	Cost Savings
16-84	Comm. Option STW	20-35	Duct 2 Area [m2]	21-39	Ext. 2 Output [%]	22-61	Broken Belt Torque	24-*	Appl. Functions 2
16-85	FC Port CTW 1	20-36	Duct 2 Area [m2]	21-4*	Ext. CL 2 PID	22-62	Broken Belt Delay	24-0*	Fire Mode
16-86	FC Port REF 1	20-37	Duct 2 Area [m2]	21-40	Ext. 2 Normal/Inverse Control	22-7*	Short Cycle Protection	24-00	Fire Mode Function
16-9*	Diagnosis Readouts	20-38	Air Density Factor [%]	21-41	Ext. 2 Proportional Gain	22-75	Short Cycle Protection	24-01	Fire Mode Configuration
16-90	Alarm Word	20-6*	Sensorless	21-42	Ext. 2 Integral Time	22-76	Interval between Starts	24-02	Fire Mode Unit
16-91	Alarm Word 2	20-60	Sensorless Unit	21-43	Ext. 2 Differentiation Time	22-77	Minimum Run Time	24-03	Fire Mode Min Reference
16-92	Warning Word	20-69	Sensorless Information	21-44	Ext. 2 Dif. Gain Limit	22-78	Minimum Run Time Override	24-04	Fire Mode Max Reference
16-93	Warning Word 2	20-7*	PID Autotuning	21-5*	Ext. CL 3 Ref./Fb.	22-79	Minimum Run Time Override Value	24-05	Fire Mode Preset Reference
16-94	Ext. Status Word	20-70	Closed Loop Type	21-50	Ext. 3 Ref./Feedback Unit	22-8*	Flow Compensation	24-06	Fire Mode Reference Source
16-95	Ext. Status Word 2	20-71	PID Performance	21-51	Ext. 3 Minimum Reference	22-80	Flow Compensation	24-07	Fire Mode Feedback Source
16-96	Maintenance Word	20-72	PID Output Change	21-52	Ext. 3 Maximum Reference	22-81	Square-linear Curve Approximation	24-09	Fire Mode Alarm Handling
18-*	Info & Readouts	20-73	Minimum Feedback Level	21-54	Ext. 3 Reference Source	22-82	Work Point Calculation	24-1*	Drive Bypass
18-0*	Maintenance Log	20-74	Maximum Feedback Level	21-55	Ext. 3 Setpoint	22-83	Speed at No-Flow [RPM]	24-10	Drive Bypass Function
						22-84	Speed at No-Flow [Hz]	24-11	Drive Bypass Delay Time

24-9*	Multi-Motor Funct.	25-91	Manual Alternation	35-00	Term. X48/4 Temperature Unit	99-2*	Platform Readouts
24-90	Missing Motor Function	26-6*	Analog I/O Option	35-01	Term. X48/4 Input Type	99-29	Platform Version
24-91	Missing Motor Coefficient 1	26-0*	Analog I/O Mode	35-02	Term. X48/7 Temperature Unit	99-4*	Software Control
24-92	Missing Motor Coefficient 2	26-00	Terminal X42/1 Mode	35-03	Term. X48/7 Input Type	99-40	Startup Wizard State
24-93	Missing Motor Coefficient 3	26-01	Terminal X42/3 Mode	35-04	Term. X48/10 Temperature Unit	99-5*	PC Debug
24-94	Missing Motor Coefficient 4	26-02	Terminal X42/5 Mode	35-05	Term. X48/10 Input Type	99-50	PC Debug Selection
24-95	Locked Rotor Function	26-1*	Analog Input X42/1	35-06	Temperature Sensor Alarm Function	99-51	PC Debug 0
24-96	Locked Rotor Coefficient 1	26-10	Terminal X42/1 Low Voltage	35-1*	Temp. Input X48/4	99-52	PC Debug 1
24-97	Locked Rotor Coefficient 2	26-11	Terminal X42/1 High Voltage	35-14	Term. X48/4 Filter Time Constant	99-53	PC Debug 2
24-98	Locked Rotor Coefficient 3	26-14	Term. X42/1 Low Ref./Feedb. Value	35-15	Term. X48/4 Temp. Monitor	99-54	PC Debug 3
24-99	Locked Rotor Coefficient 4	26-15	Term. X42/1 High Ref./Feedb. Value	35-16	Term. X48/4 Low Temp. Limit	99-55	PC Debug 4
25-0*	Cascade Controller	26-16	Term. X42/1 Filter Time Constant	35-17	Term. X48/4 High Temp. Limit	99-56	Fan 1 Feedback
25-00	System Settings	26-17	Term. X42/1 Live Zero	35-2*	Temp. Input X48/7	99-57	Fan 2 Feedback
25-00	Cascade Controller	26-2*	Analog Input X42/3	35-24	Term. X48/7 Filter Time Constant	99-58	PC Auxiliary Temp
25-02	Motor Start	26-20	Terminal X42/3 Low Voltage	35-25	Term. X48/7 Temp. Monitor	99-59	Power Card Temp.
25-04	Pump Cycling	26-21	Terminal X42/3 High Voltage	35-26	Term. X48/7 Low Temp. Limit	99-90	Internal Values
25-05	Fixed Lead Pump	26-24	Term. X42/3 Low Ref./Feedb. Value	35-27	Term. X48/7 High Temp. Limit	99-90	Options present
25-06	Number of Pumps	26-25	Term. X42/3 High Ref./Feedb. Value	35-3*	Temp. Input X48/10	99-91	Motor Power Internal
25-2*	Bandwidth Settings	26-26	Term. X42/3 Filter Time Constant	35-34	Term. X48/10 Filter Time Constant	99-92	Motor Voltage Internal
25-20	Staging Bandwidth	26-27	Term. X42/3 Live Zero	35-35	Term. X48/10 Temp. Monitor	99-93	Motor Frequency Internal
25-21	Override Bandwidth	26-3*	Analog Input X42/5	35-36	Term. X48/10 Low Temp. Limit	99-94	Imbalance derate [%]
25-22	Fixed Speed Bandwidth	26-30	Terminal X42/5 Low Voltage	35-37	Term. X48/10 High Temp. Limit	99-95	Temperature derate [%]
25-23	SBW Staging Delay	26-31	Terminal X42/5 High Voltage	35-4*	Analog Input X48/2	99-96	Overload derate [%]
25-24	SBW Destaging Delay	26-34	Term. X42/5 Low Ref./Feedb. Value	35-42	Term. X48/2 Low Current		
25-25	OBW Time	26-35	Term. X42/5 High Ref./Feedb. Value	35-43	Term. X48/2 High Current		
25-26	Destage At No-Flow	26-36	Term. X42/5 Filter Time Constant	35-44	Term. X48/2 Low Ref./Feedb. Value		
25-27	Stage Function	26-37	Term. X42/5 Live Zero	35-45	Term. X48/2 High Ref./Feedb. Value		
25-28	Stage Function Time	26-4*	Analog Out X42/7	35-46	Term. X48/2 Filter Time Constant		
25-29	Destage Function	26-40	Terminal X42/7 Output	35-47	Term. X48/2 Live Zero		
25-30	Destage Function Time	26-41	Terminal X42/7 Min. Scale	99-9*	Devcl support		
25-4*	Staging Settings	26-42	Terminal X42/7 Max. Scale	99-0*	DSP Debug		
25-40	Ramp Down Delay	26-43	Terminal X42/7 Bus Control	99-00	DAC 1 selection		
25-41	Ramp Up Delay	26-44	Terminal X42/7 Timeout Preset	99-01	DAC 2 selection		
25-42	Staging Threshold	26-5*	Analog Out X42/9	99-02	DAC 3 selection		
25-43	Destaging Threshold	26-50	Terminal X42/9 Output	99-03	DAC 4 selection		
25-44	Staging Speed [RPM]	26-51	Terminal X42/9 Min. Scale	99-04	DAC 1 scale		
25-45	Staging Speed [Hz]	26-52	Terminal X42/9 Max. Scale	99-05	DAC 2 scale		
25-46	Destaging Speed [RPM]	26-53	Terminal X42/9 Bus Control	99-06	DAC 3 scale		
25-47	Destaging Speed [Hz]	26-54	Terminal X42/9 Timeout Preset	99-07	DAC 4 scale		
25-5*	Alternation Settings	26-6*	Analog Out X42/11	99-08	Test param 1		
25-50	Lead Pump Alternation	26-60	Terminal X42/11 Output	99-09	Test param 2		
25-51	Alternation Event	26-61	Terminal X42/11 Min. Scale	99-10	DAC Option Slot		
25-52	Alternation Time Interval	26-62	Terminal X42/11 Max. Scale	99-1*	Hardware Control		
25-53	Alternation Timer Value	26-63	Terminal X42/11 Bus Control	99-11	RFI 2		
25-54	Alternation Predefined Time	26-64	Terminal X42/11 Timeout Preset	99-12	Fan		
25-55	Alternate if Load < 50%	30-3*	Special Features	99-1*	Software Readouts		
25-56	Staging Mode at Alternation	30-2*	Adv. Start Adjust	99-13	Idle time		
25-58	Run Next Pump Delay	30-22	Locked Rotor Detection	99-14	Paramdb requests in queue		
25-59	Run on Mains Delay	30-23	Locked Rotor Detection Time [s]	99-15	Secondary Timer at Inverter Fault		
25-8*	Status	31-1*	Bypass Option	99-16	No of Current Sensors		
25-80	Cascade Status	31-00	Bypass Mode	99-2*	Heatsink Readouts		
25-81	Pump Status	31-01	Bypass Start Time Delay	99-20	HS Temp. (PC1)		
25-82	Lead Pump	31-02	Bypass Trip Time Delay	99-21	HS Temp. (PC2)		
25-83	Relay Status	31-03	Test Mode Activation	99-22	HS Temp. (PC3)		
25-84	Pump ON Time	31-10	Bypass Status Word	99-23	HS Temp. (PC4)		
25-85	Relay ON Time	31-11	Bypass Running Hours	99-24	HS Temp. (PC5)		
25-86	Reset Relay Counters	31-19	Remote Bypass Activation	99-25	HS Temp. (PC6)		
25-9*	Service	35-9*	Sensor Input Option	99-26	HS Temp. (PC7)		
25-90	Pump Interlock	35-0*	Temp. Input Mode	99-27	HS Temp. (PC8)		

Index

A		Default Settings	23
Abbreviations	63	Digital Input	17, 33, 36, 18
AC		Dimensions	62
Input.....	4, 15	Discharge Time	5
Mains.....	4, 15	Disconnect Switch	21
Waveform.....	4	Disposal Instruction	4
Additional Resources	3	E	
AEO	26	Earth Wire	11
Alarm Log	22	Electrical Interference	11
Alarms	34	EMC	
AMA	26, 32, 36, 39	EMC.....	11
Ambient Conditions	51	Interference.....	13
Analog		Exploded View	8
Input.....	16, 17, 35	External	
Output.....	16, 17	Alarm Reset.....	30
Signal.....	35	Commands.....	4, 34
Speed Reference.....	28	Controllers.....	3
Approvals	4	Interlock.....	18
Auto On	23, 27, 32, 34	F	
Auto-reset	21	Fault Log	22
B		Feedback	18, 20, 38, 33, 40
Back Plate	10	Floating Delta	16
Braking	37, 32	Front Cover Tightening Torque	62
C		Fuses	11, 20, 38, 41
Certifications	4	G	
Circuit Breakers	20	Ground	
Clearance Requirements	10	Connections.....	20
Closed Loop	18	Wire.....	11
Communication Option	38	Grounded Delta	16
Conduit	20	Grounding	14, 16, 21, 20
Control		H	
Card.....	35	Hand On	23, 27, 32
Card, USB Serial Communication.....	55	Harmonics	4
Signal.....	32	High Voltage	5
Terminals.....	25, 32, 34, 23	I	
Wiring.....	11, 13, 18, 20	IEC 61800-3	16
Cooling		Initialisation	24
Cooling.....	10	Input	
Clearance.....	20	Current.....	15
Current		Disconnect.....	15
Limit.....	42	Power.....	11, 13, 15, 20, 21, 34, 41, 4
Rating.....	35	Signal.....	18
D		Terminal.....	15, 18, 21, 35
DC		Voltage.....	21
Current.....	4, 32		
Link.....	35		

Installation		Output	
Installation.....	17, 20	Current.....	32, 35
Environments.....	10	Terminal.....	21
Intended Use	3	Over-current Protection	11
Interference Isolation	20	Overvoltage	42, 33
Isolated Mains	16		
Items Supplied	7	P	
		Parameter Menu Structure	64
J		PELV	31
Jumper.....	18	Phase Loss	35
		Potential Equalisation	11
L		Power	
Leakage Current.....	5	Connection.....	11
Lifting	10	Factor.....	4, 20
Local		Ratings.....	62
Control.....	21, 32, 23	Programming	18, 23, 35, 21, 22
Control Panel.....	21	Pulse Start/stop	30
Start.....	27		
		Q	
M		Qualified Personnel	5
Main Menu.....	22	Quick Menu	22
Mains Voltage.....	22, 32		
Maintenance.....	27	R	
Manual Initialisation.....	24	Ramp-down Time	42
Menu		Ramp-up Time	42
Keys.....	22	Reference	28, 32, 33, 22
Structure.....	22	Relays	17
Motor		Remote	
Cables.....	11, 14	Commands.....	3
Current.....	4, 26, 39, 22	Reference.....	33
Data.....	25, 36, 42, 39, 26	Reset	21, 34, 35, 39, 22, 23, 24
Output.....	51	RFI Filter	16
Power.....	11, 39, 22	RMS Current	4
Protection.....	3	RS-485	
Rotation.....	27	RS-485.....	19
Speeds.....	24	Network Connection.....	31
Status.....	3	Run	
Thermistor.....	31	Command.....	27
Wiring.....	13, 20	Permissive.....	33
Mounting	10, 20		
Multiple Frequency Converters	11, 14	S	
		Safe Torque Off	18
N		Screened Twisted Pair (STP)	19
Nameplate.....	7	Serial Communication	16, 17, 32, 33, 34, 23
Navigation Keys.....	24, 32, 22	Setpoint	33
		Set-up	27, 22
O		Shielded Cable	13, 20
Open Loop.....	18	Shock	10
Operation Keys.....	22	Short Circuit	36
Optional Equipment.....	18, 21		

Sleep Mode.....	34
Speed Reference.....	18, 27, 28, 32
Start Up.....	24
Start/stop Command.....	29
Status Mode.....	32
Storage.....	7
Supply Voltage.....	16, 17, 21, 38
Switching Frequency.....	33
Symbols.....	63
System Feedback.....	3

T

Terminal

53.....	18
54.....	18

Thermal Protection.....	4
-------------------------	---

Thermistor

Thermistor.....	16, 31
Control Wiring.....	16

Tightening Of Terminals.....	55
------------------------------	----

Torque Limit.....	42
-------------------	----

Transient Protection.....	4
---------------------------	---

Trip

Trip.....	34
Lock.....	34

U

Unintended Start.....	5
-----------------------	---

V

Vibration.....	10
----------------	----

Voltage

Imbalance.....	35
Level.....	52

VVCplus.....	26
--------------	----

W

Warnings.....	34
---------------	----

Weight.....	62
-------------	----

Windmilling.....	6
------------------	---

Wire Sizes.....	11, 14
-----------------	--------

Wiring Schematic.....	12
-----------------------	----



www.danfoss.com/drives

Danfoss Power Electronics A/S
Ulsnaes 1
6300 Graasten
Denmark
www.danfoss.com

Danfoss can accept no responsibility for possible errors in catalogues, brochures and other printed material. Danfoss reserves the right to alter its products without notice. This also applies to products already on order provided that such alterations can be made without subsequential changes being necessary in specifications already agreed. All trademarks in this material are property of the respective companies. Danfoss and the Danfoss logotype are trademarks of Danfoss A/S. All rights reserved.

