

Total Power Quality Solutions for System Reliability

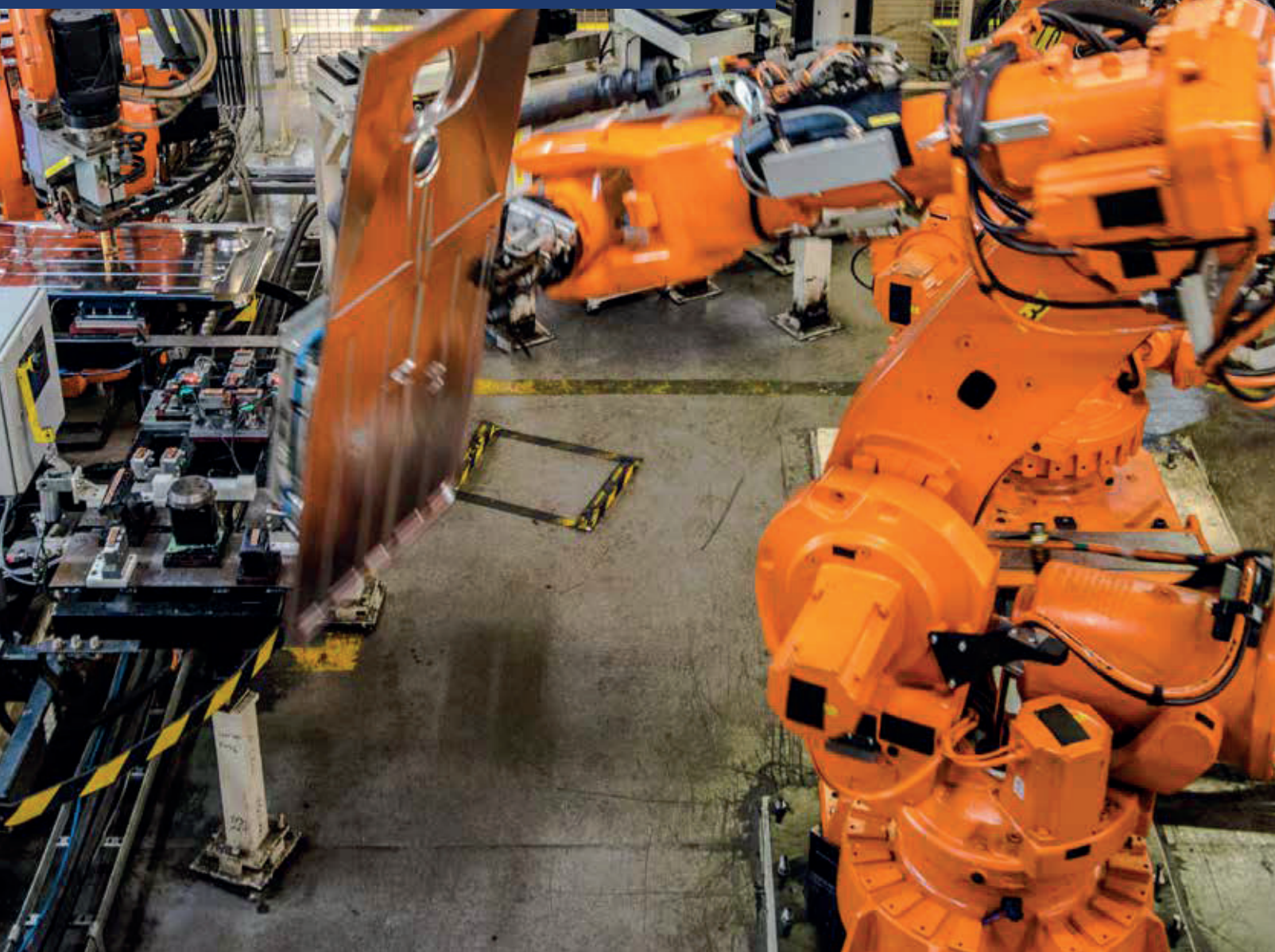

www.nicsanat.com

021-87700210



www.nicsanat.com

021-87700210



Catalog Index.....	2-3
Introduction.....	4-9
Power Solutions Flow Charts.....	10-11
Glossary of Terms.....	12-16
Power Quality Solutions	
1: Power Conditioning and Surge Protection (Single and Three Phase up to 1400A)	18
2: Uninterruptible Power Supplies (UPS) (350 to 20 kVA).....	57
Control Power Solutions	
3: Power Supplies (Single and Three Phase from 14.4 Watts to 4920 Watts)	118
4: Industrial Control Transformers (50 VA to 5 KVA)	169
Power Distribution Solutions	
5: Dry Type Distribution Transformers	190
6: Buck-Boost Transformers (100 VA to 10 kVA)	235

1EWPS1K Series -----	114	E2H--S Series Transformers -----	202	S4K2U Series UPS -----	73
1EWPS3K Series -----	114	E2H--SCU Series Transformers ----	202	S4K2U48BAT UPS Battery -----	79
1EWPS4K Series -----	114	E2HB Series Transformers -----	207	S4K2U96BAT UPS Battery -----	79
23-13- Series Power Conditioners ---	42	E2HF Series Transformers -----	208	S4K4U Series UPS -----	84
23-22-112-2 Power Conditioners ----	42	E3H Series Transformers-----	201	S4K5U Series UPS -----	94
23-23 Series Power Conditioners ----	42	E5H Series Transformers-----	199	S4K6U Series UPS -----	84
23-28- Series Power Conditioners ----	42	E5HB Series Transformers -----	207	S4KPAD Series UPS Accessory-----	89
3EWPS1K Series -----	114	E5HF Series Transformers -----	208	S5KC Series UPS Module -----	101
3EWPS3K Series -----	114	E6H Series Transformers-----	201	S5KREPOKIT UPS Option -----	90
3EWPS4K Series -----	114	E79H Transformers -----	202	SBE Series Transformers-----	178
K4E2H Series -----	211	E81H Series Transformers -----	200	SBEDIN Cover Kit-----	177
K13E2H Series-----	211	E84H Series Transformers -----	200	SCD Series Power Supplies -----	151
K13E2H Series-----	211	E85H Series Transformers -----	201	SCP Series Power Supplies -----	149
63-13- Series-----	48	FB2 Cover Kit -----	177	SCP-X Series Power Supplies-----	153
63-23- Series-----	44	FB2X Cover Kit-----	177	SHP Series Power Supplies -----	146
63-28- Series-----	44	FBP Cover Kit -----	177	SDN-C Series Power Supplies -----	122
63-29- Series-----	45	FBPC1 Cover Kit-----	177	SDN-C Redundancy Series Power Supplies-----	143
63-31- Series-----	45	HS1B Series Transformers-----	218	SDN-P Series Power Supplies-----	130
63-32- Series-----	45	HS1F Series Transformers -----	218	SDP Series Power Supplies -----	135
63TAA Series -----	55	HS10B Series Transformers -----	218	SDU-A AC Series UPS -----	65
63TCA Series-----	55	HS10F Series Transformers-----	218	SDU DC Series UPS-----	60
63TCC Series -----	55	HS12F Series Transformers-----	219	SDU UPS Accessories -----	61
63TDA Series-----	55	HS14F Series Transformers-----	218	SL Series Power Supplies-----	165
30HWBP2U -----	90	HS5F Series Transformers -----	218	ISUNITYDP UPS Option-----	90
DT631 Series Power Conditioner --	230	HSS1F Series Transformers -----	218	SRS1832 UPS Option-----	90
DT651 Series Power Conditioner --	230	HSS10F Series Transformers -----	218	STC Series Power Protection-----	36
DT661 Series Power Conditioner --	230	HSS5F Transformer-----	218	STF Series Power Protection -----	27
E---Series Transformers -----	174	HSZ Series Transformers-----	185	STFE Elite Power Protection -----	33
E---D Series Transformers -----	176	HT1F Series Transformers -----	220	STFV Plus Series Power Protection --	30
E---E Series Transformers-----	174	HT5F Series Transformers -----	220	STV 25K - Series Surge Protective Devices -----	
E---EW Series Transformers -----	174	HT6F Series Transformers -----	220	25-- STV 100K- Series Surge Protective Devices -----	23
E---EWA Series Transformers -----	174	HT7F Series Transformers -----	221	STV 200/400K - Series Surge Protective Devices -----	20
E--- EWB Series Transformers-----	174	HT79 Series Transformers -----	221	T----Series Transformers -----	179
E---JL Series Transformers -----	176	HT84 Series Transformers -----	221	W Transformer Accessory-----	177
E---JN Series Transformers -----	176	HT85 Series Transformers -----	221	WA Transformer Accessory -----	177
E--- TC Series Transformers -----	181	HTS1F Series Transformers-----	220	WB Transformer Accessory-----	177
E--- TE Series Transformers -----	181	HTS5F Series Transformers-----	220	WS Series Weather Shields-----	196
E--- TF Series Transformers -----	182	ICE Transformers-----	183	Y Series -----	178
E--- TH Series Transformers -----	182	IP20 Cover Kit-----	177		
E---W Series Transformers-----	175	MS5 Service Program -----	116		
E---WA Series Transformers -----	175	IS-RELAY UPS Accessory -----	90		
E---WB Series Transformers -----	175	S1K Series UPS-----	69		
ES12H Series Transformers-----	198	S3K Series UPS-----	71		
ES5H Series Transformers -----	198	S4K144BAT UPS Battery -----	88		
ES5HB Series Transformers -----	206	S4K144INTBAT UPS Battery -----	87		
ES5HF Series Transformers-----	208	S4K288BAT UPS Battery -----	88		
		S4K240BAT UPS Battery -----	98		

Anywhere in your facility from the service entrance to the most critical production equipment, Emerson can power your process control applications with our power conversion and power quality products.

Our SolaHD™ products are engineered to meet the most demanding applications worldwide.

- Factory automation
- Inspection, test and instrumentation equipment
- Laboratory and non-patient medical
- High efficiency applications (Energy Star®)
- UL508 environments such as waste water treatment
- Harsh environment and remote site locations
- Building automation
- Service automation
- Process control



Automotive/Industrial Control

We offer many products suited for harsh environments including our encapsulated power supplies and transformers. We also offer a wide range of Class I, Division 2 products.

When Power Is Money

Power is a dynamic aspect in production and automation. Companies lose billions of dollars every year due to voltage sags and power outages.

Conditioning your incoming power keeps productivity high and costs down. Using compatible power conversion components ensures your system reliability.

Power Is Our Only Business

Our industrial power specialists are serious about your system performance. Our SolaHD brand has been a trusted name in power conversion and power quality since 1915. We provide innovative and reliable products with proven technologies to help control your equipment or facility's efficiency, productivity, and longevity. Our products meet strict global requirements and new efficiency standards. Emerson delivers total power quality solutions to drive your system reliability, your return on investment (ROI) and your customer satisfaction.



Power Products (14.4 watts to 500 kVA)

Consider the Entire Picture

We draw upon 100 years of global experience in developing innovative solutions to optimize operational performance, improve efficiencies, preserve data and increase equipment longevity. Our comprehensive line of products stretch from entrances to load points to communications networks throughout facilities, making our total power quality solutions indispensable to today's industries.

Total power quality involves both power protection and power conversion. Power conversion choices made upstream can impact the type of power protection required downstream. Only our SolaHD products and expertise can save you time, money and space with combined power protection and conversion solutions that are right for your facility.

Power Supplies

Power Supplies and Uninterruptible Power Supplies (UPS) provide clean, consistent power. Both products safeguard equipment from power anomalies, such as fluctuations through complete power failures. Power Supply and UPS systems can also offer power conditioning benefits by filtering noise, harmonics and dangerous frequency variations.

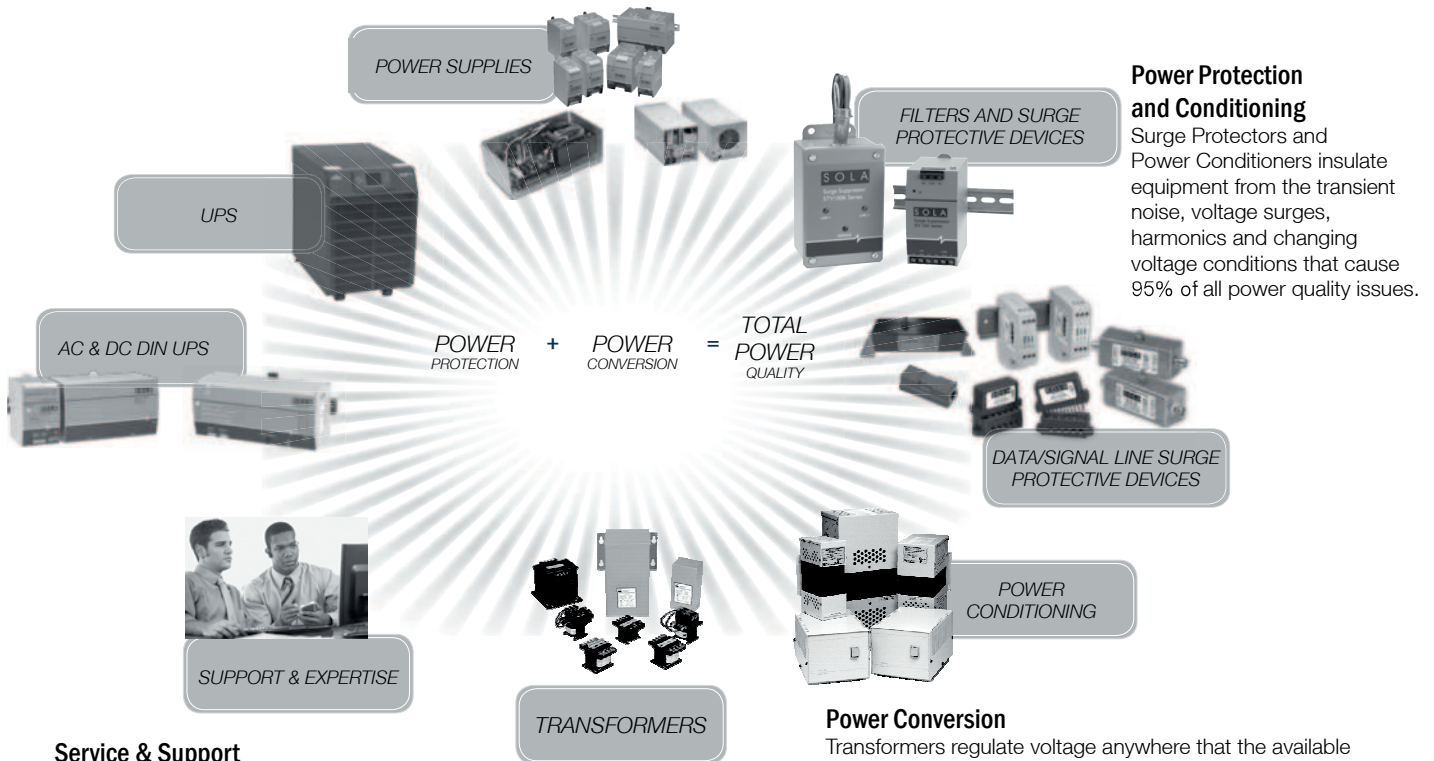

Power Protection and Conditioning

Surge Protectors and Power Conditioners insulate equipment from the transient noise, voltage surges, harmonics and changing voltage conditions that cause 95% of all power quality issues.

Service & Support

Selecting the proper power quality solution for your application can be tricky. Experienced and dedicated sales representatives, along with award-winning online tools, help you make the right choice, every time. Representatives are available around the world for stock and support help.

Power Conversion

Transformers regulate voltage anywhere that the available voltage must be changed to accommodate electrical circuit or equipment requirements. Transformers are designed and built in a vast range of configurations to meet requirements for variables, such as size, heat, voltage capacity and environmental conditions.

Emerson is at work for you on the facility floor, branch panel, power distribution points and point-of-use applications.

Our SolaHD products power the most demanding applications and environments and can be used in conjunction or alone to ensure controlled, reliable power at any part of the factory floor or machinery.

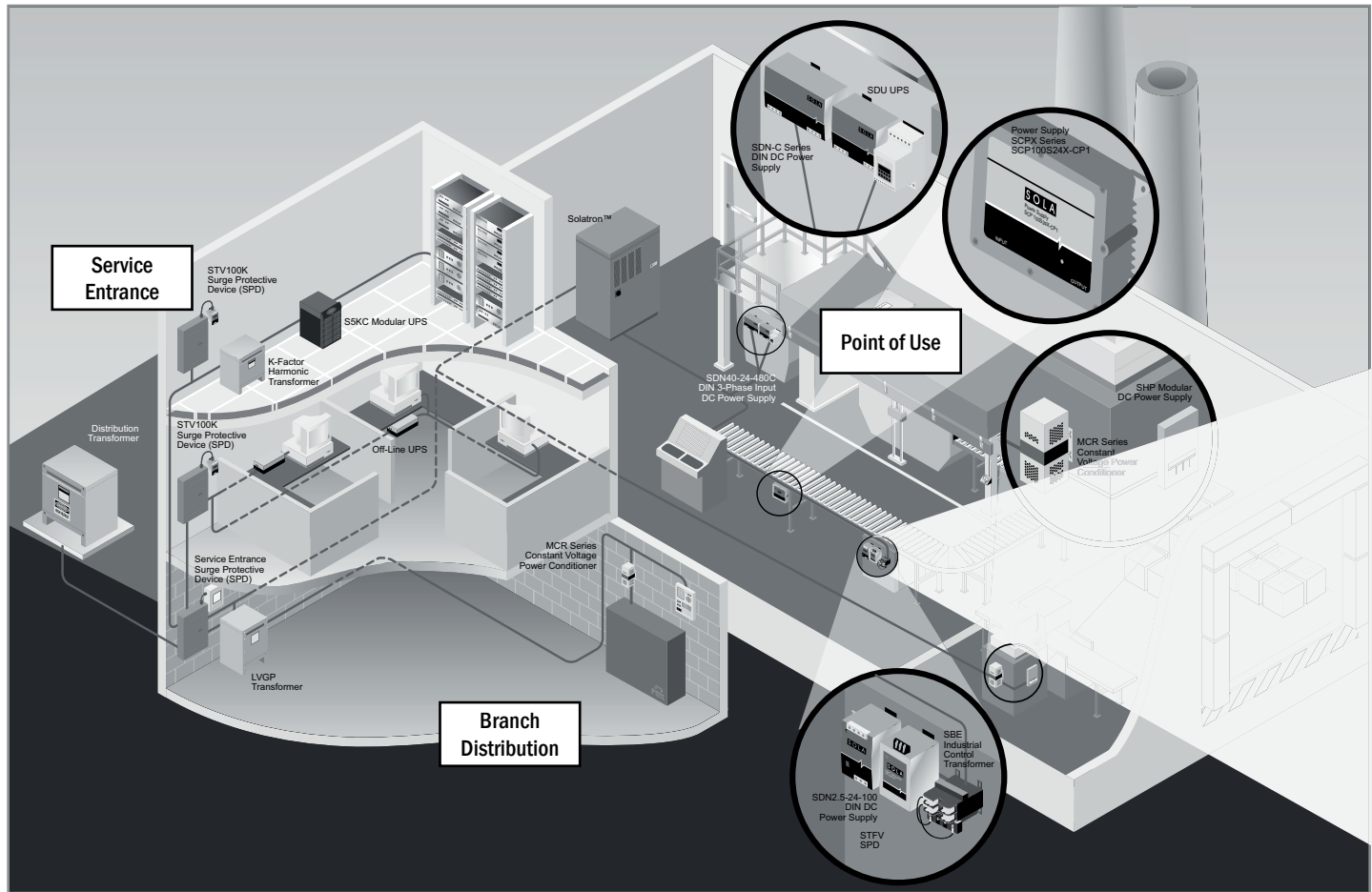

	Industrial Power Conversion and Protection Solutions				
	Power Conditioning	SPD/Filters	Transformers	Power Supplies	UPS
Service Entrance		X	X		
Branch Panels		X	X		X
Networks	X	X		X	X
Large Machinery	X	X	X	X	X
Process Rooms	X	X		X	X
PLC's & Industrial PC's	X	X	X	X	X
Ethernet & Communications		X		X	X
DeviceNet™		X		X	X
Motion Control		X		X	X
Drives	X	X	X		X
Analog I/O		X		X	X

Impulse (Transient/Spike)

Definition	Narrow, high voltage or current impulse superimposed on the AC
Causes	Utility grid switching
	Contactor opening or closing
	Heavy industrial equipment starting
	Lightning
Effects	Equipment failure or damage
	System lock-up
	Data corruption/loss
	Component stress that can lead to breakdown
Solution	Surge Protective Devices and Active Tracking® Filters Power Conditioner



Active Tracking® Filters and Surge Protection

Electrical Noise

Definition	Low amplitude, low current, high frequency disturbances
Causes	Non-linear loads
	Other loads
	Improper grounding
	Loose wiring
	Electromagnetic interference
Effects	Perceived software errors
	System lock-up
Solution	Isolation Transformer Active Tracking® Filters Power Conditioner UPS



Isolation Transformers

Sag

Definition	Temporary drop in RMS voltage, may last for several cycles
Causes	Large load start-up (ex. motors, air conditioner)
	Utility switching
Effects	Hardware crashes (ex. PLCs)
	Occasional equipment failure
	Reduced efficiency and life span of electrical equipment
Solution	UPS Power Conditioner Voltage Regulator Power Supplies with sag immunity



UPS

Surge (Swell)

Definition	Temporary rise in RMS voltage, may last for several cycles
Causes	Large load turning off (ex. motors, air conditioner)
	Utility shedding loads
Effects	Hardware damage
	Bright light
Solution	Power Conditioner UPS Voltage Regulator



Solatron™ Power Conditioner

Brownout

Definition	Temporary drop in RMS voltage, may last for several hours
Causes	High demand on utility grid
	Service located at the end of grid
Effects	Hardware crashes
	Occasional equipment failure
	Reduced efficiency and life span of electrical equipment, particularly motors
Solution	Voltage Regulator



MCR Voltage Regulator

Harmonics

Definition	Distortion to the sine wave
Causes	Switch mode power supplies
	Non-linear loads
	Variable frequency drives
Effects	High neutral current
	Overheated neutral conductors and transformers
	Voltage distortion
	Breaker tripping
	Loss of system capacity
Solution	K-Factor Transformers UPS Power Conditioner



K-Factor Transformers

We have provided some quick charts below to help you migrate through our SolaHD product catalog. Your specific application and environment will always determine the most suitable product. The following is a guide to help you determine the type of application you have.

Our solutions can be divided into two main categories:

- Power Conversion - Manipulating AC or DC power to another state.
- Power Quality - Regulate, isolate, filter, protect or backup AC or DC power.

Power Quality

Emerson provides a broad array of power quality products to fit your application and your budget. Our most relied upon industrial power quality solution, the voltage regulating power conditioner, is complemented by many surge, filter, UPS (Standby) and UPS (Online) options.

Whether you are protecting your expensive equipment, backing up power for outages or sags, or delivering clean, safe power to your sensitive devices for maximum productivity, Emerson can provide the solution. Many of these SolaHD products can be used in combination in your system or across your facility to provide a complete solution.

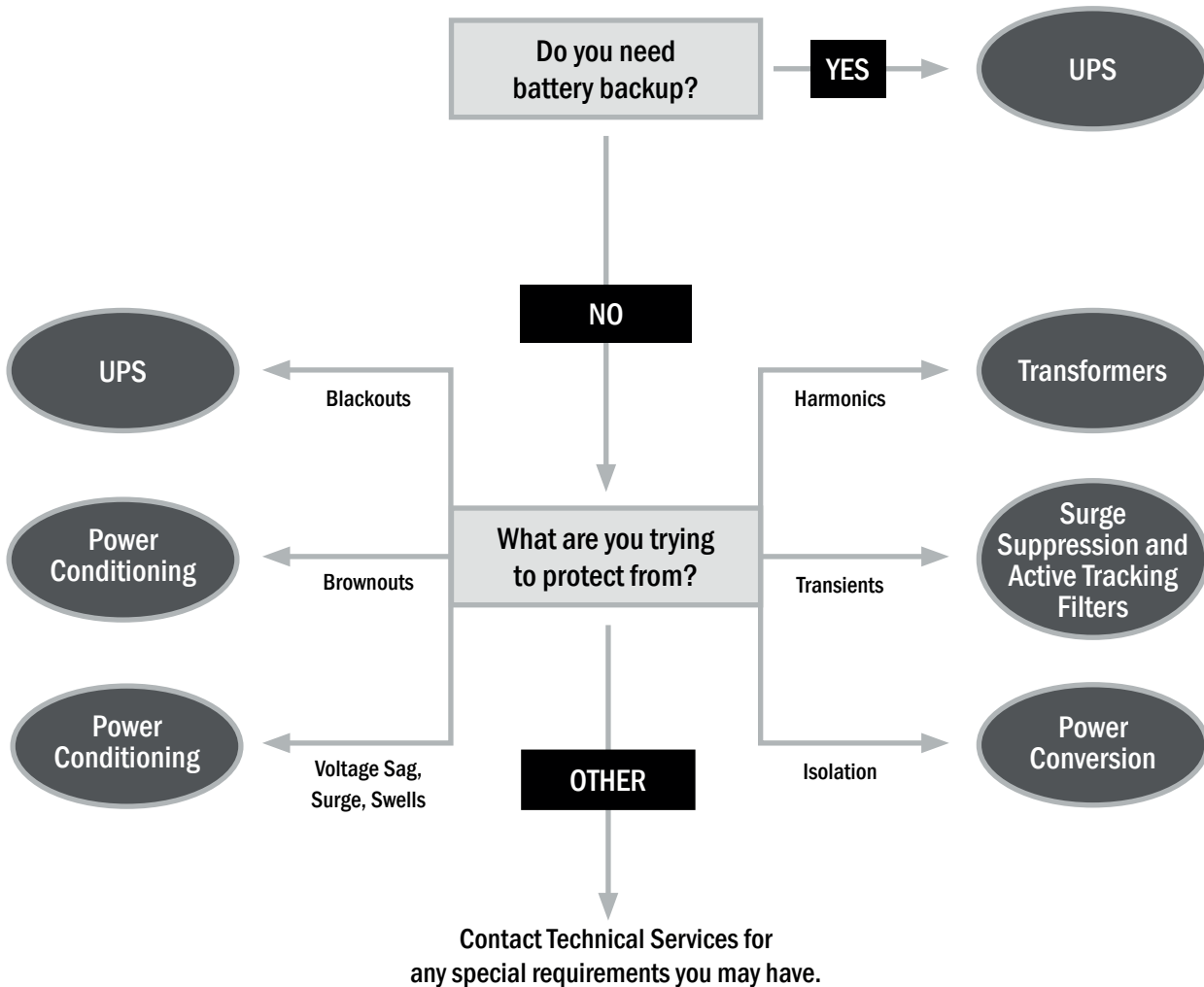

Power Conversion

We offer a broad range of standard SolaHD products to meet almost all of your industrial AC-AC, AC-DC, and DC-DC needs. DIN Mount, chassis and rackmount products are offered in many conversion topologies to meet your exact mounting and performance requirements.

SolaHD products are differentiated by industrial performance ratings such as wide temperature ratings, high MTBF, lack of fans in designs, continuous short circuit capabilities, high densities, and rugged packaging. Global specifications and high efficiency designs make industrial system design easy.

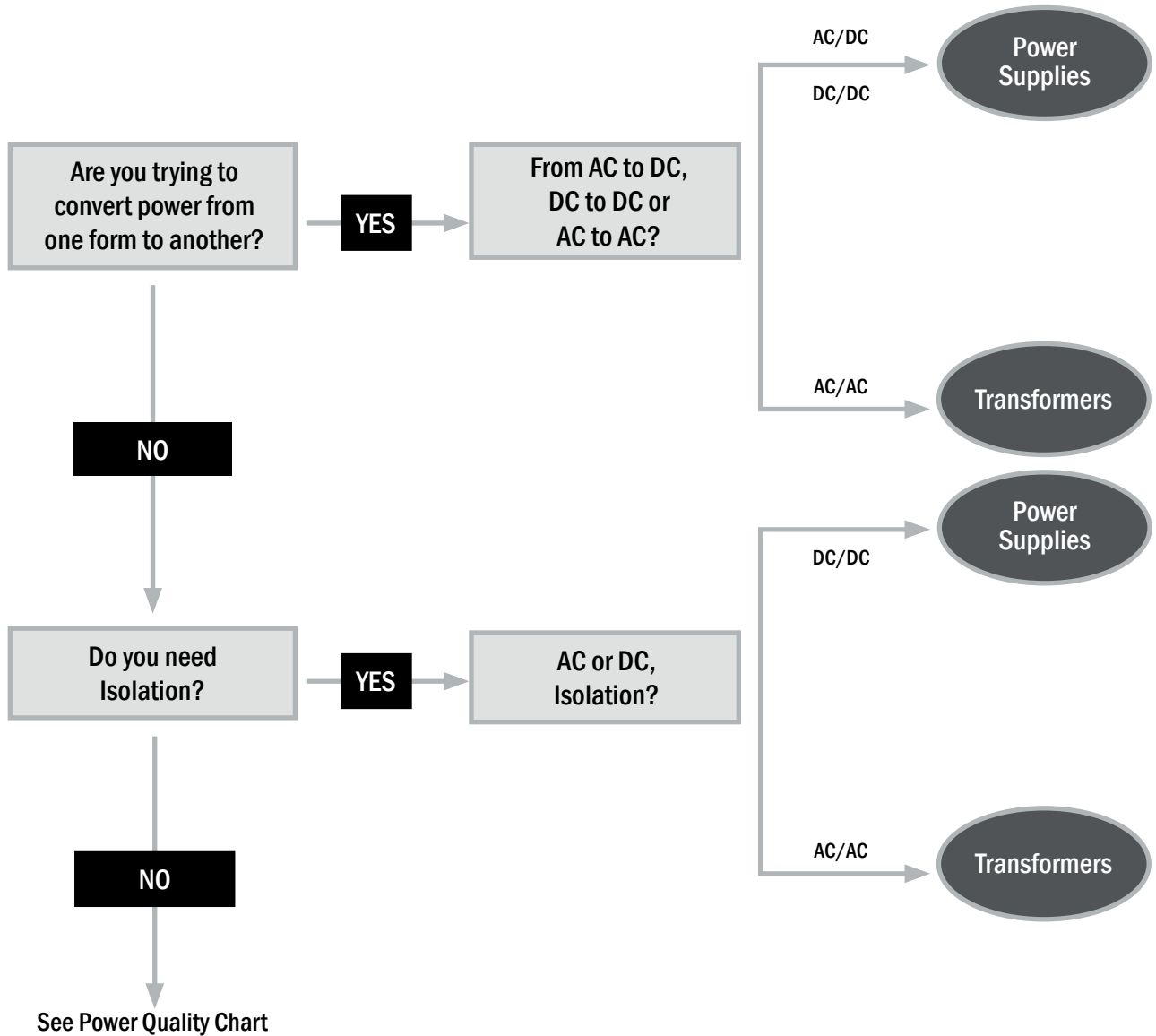

2/50 Voltage Wave

Voltage surge with a virtual front time of 1.2 ms and a time to half-value of 50 ms delivered across an open circuit.

8/20 Current Wave

Current surge with a virtual front time of 8 μ s and a time to half-value of 20 μ s delivered into a short circuit.

AC (Alternating Current)

Current that reverses direction in response to voltage that is changing polarity.

AC Power Interface

The electrical points where an SPD is electrically connected to the AC power system.

Active Tracking® Filter

A Surge Suppressor/Electrical Noise filter device, that suppresses both transient and low voltage electrical noise found on the AC line.

Active Tracking® Filter Plus:

A device that both divert or clamp high amplitude transients, and attenuate low-energy, high frequency noise.

Air-Cooled

A product cooled by the natural circulation of air.

Ambient Noise Level

The sound level of the area measured in decibels.

Ambient Temperature

The temperature of the air surrounding a product.

Ampacity

The current-carrying capacity of an electrical conductor or device.

Ampere

The practical unit of electric current.

Attenuation

Decrease in signal voltage or power.

Autotransformer

A transformer in which part of one winding is common to both the primary and secondary circuits associated with that winding.

Banked

Two or more transformers connected together to increase kVA.

Basic Impulse Level (BIL)

A measure of the ability of the insulation system to withstand very high voltage surges. For example, a 600-volt class transformer has a 10 kV BIL rating.

Battery Run Time

The amount of time (in minutes) a battery system can support a load.

Blackout

Slang term for the total loss of electrical power for more than one minute.

Breakdown Voltage

The maximum AC or DC voltage which may be applied from input to output and/or chassis of a power supply. *See Hi-Pot Testing.*

Brownout

Slang term for an extended voltage reduction (more than a few cycles) of more than 10%.

Bypass

A mechanical or electronic switch to provide an alternate path for the line current.

CBEMA

An acronym for Computer and Business Equipment Manufacturers Association. Replaced by the Information Technology Industry Council (ITIC).

CE Mark

(Conformité Européenne) - A marking that shows the product meets the fundamental safety, health, environmental and consumer protection requirements of the European Community.

Chassis

The metal framework or case in which an electrical circuit or system is constructed.

Combination Wave

Also called combination surge. A surge delivered by a generator which has the inherent capability of applying a 1.2/50 ms voltage wave across an open circuit and delivering an 8/20 ms current wave into a short circuit. The exact wave that is delivered is determined by the generator's fictive impedance.

Common-Mode Noise

Noise that occurs between the current carrying conductors and ground.

Compensated Transformer

A transformer with a turn's ratio which provides a higher rated voltage at no-load and rated voltage at rated load. Normally used on units rated 2 kVA or smaller.

Constant Current Power Supply

A power supply that regulates its output current for changes in line, load, ambient temperature, and time.

Constant Voltage Power Supply

A power supply that regulates its output voltages for changes in line, load, ambient temperature and time.

Constant Voltage Transformer (CVT)

A power conditioner that provides a stable and regulated sine wave output voltage.

Continuous Duty

The service requirement that demands operation at a constant load for an indefinite period of time.

Control Transformer

Usually referred to as an Industrial Control transformer. Designed for good voltage regulation characteristics when low power factor and /or large inrush currents are drawn (5 to 15 times normal).

Conductor Losses

Losses in the transformer winding that are incidental to the carrying of the load. These losses include those due to resistance as well as to stray and eddy currents.

Core

The steel that carries the magnetic flux in a transformer.

Core Loss

Losses caused by a magnetization of the core.

Crest Factor

The ratio of the peak value and RMS value of a voltage or current waveform.

Cross-Regulation

In a multiple output power supply, the percent voltage change at one output caused by the load change on another output.

Crowbar

An overvoltage protection circuit which rapidly places a low resistance shunt across the power supply output terminals if a predetermined voltage is exceeded.

CSA

Canadian Standard Association

Current Limiting

See *Output Current Limiting*.

DC

(Direct Current) Current that flows in only one direction.

Decibel (db)

A unit used to express the magnitude of a change in signal or sound level, either an increase or decrease.

Delta Connection

A method used for connecting the three windings of a three phase transformer (or three single phase transformers). The windings are connected in series, the three phase supply being taken from or supplied to the junctions.

Delta-Wye

The method of connection for both primary and secondary windings of a three phase transformer bank.

Derating

The specified reduction in an operating parameter to improve reliability.

Differential Mode Noise

Noise that occurs between the current carrying conductors.

DIN Rail

A standard rail (typically 35 mm wide) that mounts to the chassis and allows other electrical components to be installed and replaced easily.

Distribution Transformer

Any transformer rated between 3 and 500 kVA and a primary voltage of 601 volts or less.

Double Conversion UPS

See *On-line UPS*

Double Wound Transformer

A transformer with double wound coils on both the primary and secondary.

Drift

The change in output voltage of a power supply over a specified period of time, following a warm-up period, with all other operating parameters such as line, load, and ambient temperature held constant.

Drive Isolation Transformer

A transformer designed to withstand the additional heat and mechanical stress caused by DC drives.

Dry Type Transformer

A transformer cooled by a medium other than a liquid, usually through the circulation of air.

Dual Wound Coils

Two part windings that can be connected in series or parallel to adjust the voltage or current.

Dynamic Load Regulation

The ratio of change in output voltage to change in load current.

Eddy Currents

Additional currents caused by a magnetic field.

Efficiency

A measure of energy loss in a circuit.

Electronic Tap Changing Regulator

An electronic switching system used to adjust for changes in line voltage to maintain the output voltage within acceptable levels.

Electrostatic Shield

A grounded conductor placed between the primary and secondary winding to greatly reduce or eliminate line-to-line or line-to-ground noise. Often referred to as a "Faraday shield".

EMC

(Electromagnetic Compatibility) A directive necessary to get the CE Mark, which shows the electrical device will not create high levels of EMI and will not fail due to normal levels of EMI.

EMI

See *Noise/Electrical Noise*.

Encapsulated

A method of sealing a device with epoxy to resist environmental effects.

ESR

Equivalent Series Resistance. The amount of resistance in series with an ideal capacitor which exactly duplicates the performance of a real capacitor.

Excitation Current

The steady rate current that keeps the transformer energized after the inrush has dissipated, with all other windings open-circuited. Also called "magnetizing" or "no-load current."

Faraday Shield

See *Electrostatic Shield*.

FCAN and FCBN Taps

Acronyms for Full Capacity Above Normal and Full Capacity Below Normal.

Ferroresonance

A method of producing a constant voltage by use of a special saturated transformer. Invented and patented by Joseph Sola in 1938.

Ferroresonant Power Supply

A stabilized power supply (CVDC) driven by a constant voltage transformer.

Filter

A device that reduces unwanted electrical noise.

FL

Acronym for full-load

Flyback Converter

A power supply switching circuit which normally uses a single transistor. During the first half of the switching period the transistor is on and energy is stored in a transformer primary; during the second half period this energy is transferred to the transformer secondary and the load.

Foldback Current Limiting

A power supply output protection circuit whereby the output current decreases with increasing overload, reaching a minimum at short circuit.

Force Air Cooled

A means of accelerating heat dissipation to lower the temperature rise of an electrical device.

Forward Converter

A power supply switching circuit in which energy is transferred to the transformer secondary when the switching transistor is on. In this circuit minimal energy is stored in the transformer.

Frequency (Hertz)

Cycles per second.

Full Bridge Rectifier

A power switching circuit in which four diodes are connected in a bridge configuration.

Ground Loop

The condition of having two or more ground references in a common system.

Half Bridge Rectifier

A power switching circuit similar to the full bridge converter except that only two diodes are used.

Harmonics Distortion

The distortion of the AC waveform due to the addition of sinewaves of different frequencies being added to the AC voltage.

Hi-Pot Test

High Potential Test. A test to determine if the breakdown voltage of a transformer or power supply exceeds the minimum requirement.

Holdup Time

The length of time a power supply's output voltage remains within specifications following the loss of input power.

Impulse

A high amplitude, short duration spike (milliseconds) superimposed on the normal voltage or current.

Input Line Filter

A low-pass or band-reject filter at the input of a power supply which reduces line noise fed to the supply. This filter may be external to the device.

Input Voltage Range

The high and low input voltage limits within which a device meets its specifications.

Inrush Current

The peak instantaneous input current drawn by a device at turn-on.

Inrush Current Limiting

A circuit which limits the inrush current during turn-on of a device.

Inverter

A power converter that changes DC input power into AC output power.

Isolation Transformer

A transformer in which the input winding and the output winding are not electrically connected.

Isolation

The electrical separation between input and output of a circuit.

Isolation Voltage

The rated AC or DC voltage which may be continuously applied from input to output and/or chassis of a device. See *Hi-Pot*.

kVA Rating

A measurement of apparent power. 1 kVA = 1000 VA.

KW Rating (kilowatts)

A measurement of real power delivered to a load $1 \text{ KW} = 1000 \text{ VA} \times \text{Power Factor}$

Leakage Current

The AC or DC current flowing from input to output and/or chassis of an isolated device at a specified voltage.

Line Regulation

The change in output voltage due to a variation in input voltage.

Linear Power Supply

A power supply that uses a control device, like a transistor, in series (or parallel) with the load. The control device adjusts the effective resistance to give a constant voltage output.

Linear Regulator

See *Linear Power Supply*.

Load Regulation

The change in output voltage due to a variation in load.

Local Sensing

Using the power supply output voltage terminals as the sense points to provide feedback to the voltage regulator.

Low Voltage Transients

High frequency noise.

LVD

Acronym for Low Voltage Directive. A European Community directive which shows the device is not a shock or fire hazard.

Maximum Continuous Operating Voltage (MCOV)

The maximum designated root-mean-square (rms) value of the power frequency voltage that may be continuously applied to the mode of protection of an SPD.

Modes of Protection

Electrical paths where the SPD offers defense against transient overvoltages. Examples include Line to Neutral (L-N), Line to Ground (L-G), Line to Line (L-L) and Neutral to Ground (N-G).

MOV

Acronym for Metal-Oxide-Varistor. A voltage sensitive device used to limit overvoltage conditions on AC power and data lines.

MTBF

Acronym for Mean Time Between Failure. The statistical failure rate of a device.

Noise/Electrical Noise

Also called electromagnetic interference, or EMI. Unwanted electrical signals that produce undesirable effects and otherwise disrupt the control system circuits.

Nominal Value

The stated or objective value for a quantity.

Normal Mode Noise

See *Differential Mode Noise*.

Off-Line UPS

A UPS where the inverter is normally off until there is a power failure. Also known as a Standby UPS.

On-Line UPS

A UPS where the inverter is always powering the load. AC is converted to DC to charge the battery then DC is converted to AC to power the load. On-Line UPS are often referred to as a "Double Conversion UPS".

Output Current Limiting

An output protection feature which limits the output current to a predetermined value in order to prevent damage to the device under overload conditions.

Output Voltage

The nominal value of the voltage at the output terminals of a device.

Overload Protection

See *Output Current Limiting*.

Overshoot

A transient change in output voltage, in excess of specified output accuracy limits, which can occur when a power supply is turned on or off, or when there is a step change in line or load.

OVP

Acronym for Overvoltage Protection. A power supply feature which shuts down the supply, or crowbars or clamps the output, when its voltage exceeds a preset level.

Parallel Operation

The connection of the outputs of two or more identical devices to obtain a higher output power.

PARD

Acronym for Periodic and Random Deviation. A term used for the sum of all ripple and noise components measured over a specified band width and stated in either peak-to-peak or RMS value.

PE

Acronym for Protective Earthing. The incoming earthing conductor provided by the utility.

PI Filter

A commonly used filter at the input of a switching supply or DC/DC converter to reduce reflected ripple current. The filter usually consists of two parallel capacitors separated by a series inductance and is generally built into the supply.

Post Regulator

A linear regulator used on the output of a switching power supply to improve line and load regulation and reduce output ripple voltage.

Power Boost™

Describes the advanced overload capability of the SDN™ and SDP™ power supplies to power high inrush loads without oversizing.

Power Factor

The ratio of true power (Watts) to apparent power (VA).

Power Fail Detection

A power supply option which monitors the input voltage and provides an isolated logic output signal when there is loss of line voltage.

Pre-regulation

The regulation at the front-end of a power supply, generally by a type of switching regulator, this is followed by output regulation, either by a linear or switching type regulator.

PWM Inverter

Acronym for Pulse Width Modulation. An efficient method of creating sinewave power.

Push-Pull Converter

A power switching circuit which uses a center-tapped transformer and two power switches which are driven on and off alternately. This circuit does not provide regulation by itself.

Rated Output Current

The continuous load current that a device was designed to provide.

Rectification

The conversion of alternating current to direct current.

Redundancy

The addition of extra devices to provide a backup in the event of the loss of one of those devices.

Remote Sensing

The ability for a power supply to sample the load voltage located a distance away, and adjust for the resulting voltage drop.

Return

The name for the common terminal of the output of a power supply; it carries the return current for the outputs.

Reverse Voltage Protection

A feature which protects a power supply against a reverse voltage applied at the input or output terminals.

Ripple

A small AC voltage on the DC output of a power supply that remains after filtering.

Ripple and Noise Perturbations

Small AC voltage on the output of a DC power supply at a specified bandwidth. This is the result of feed through of the rectified line frequency, internal switching transients and other random noise.

Sag

A temporary drop in the RMS voltage, which may last from one cycle to a few seconds.

Short-Circuit Protection

A feature which protects the device from a short-circuit so that the device will not be damaged.

SNMP

Acronym for Simple Network Management Protocol. A standard for LAN management messaging and control of network devices and their functions.

Soft Start

A feature which limits the start-up switching currents of a switching supply and causes the output voltage to rise gradually to its final value.

SPD

Surge Protective Device. Divert or clamp high amplitude transients.

Standby UPS

See *Off-Line UPS*.

Static UPS

See *On-Line UPS*.

Step-Up/Step-Down Transformers

A transformer that either increases or decreases the input voltage.

Swell

A temporary increase in the RMS voltage, which may last from a half cycle to a few seconds.

Switching Frequency

The rate at which the voltage is switched in a DC-DC converter or switching power supply.

Switching Regulator

A high efficiency circuit used to regulate output voltages.

Switchmode Power Supplies (SMPS)

A power supply that uses a switching regulator.

Temperature Coefficient

The average percent change in output voltage per degree Centigrade change in ambient temperature over a specified temperature range.

Temperature Range, Operating

The ambient temperature range within which a device may be safely operated and meets its specifications.

Temperature Range, Storage

The ambient temperature range within which a device may be safely stored, non-operating, with no degradation in its subsequent operation.

Thermal Protection

An internal safeguard circuit that shuts down the unit in the event of excess internal temperatures.

THD

Acronym for Total Harmonic Distortion. The ratio of the harmonic content to the fundamental frequency expressed as a percent of the fundamental.

Transfer Time

The amount of time a device takes to switch from one mode of operation to another.

Transformer

An electrical device that changes AC voltage from one level to another.

Transformer Turns Ratio

The ratio of primary turns to secondary turns.

Transient

A high amplitude, short duration (milliseconds) spike superimposed on the normal voltage or current. Sometimes called a **spike** or a **surge**.

Transient Recovery Time

The time required for the output voltage of a device to settle within specified output accuracy limits following a step change in output load current or a step change in input voltage.

Transverse Mode Noise

See *Differential Mode Noise*.

TVSS

Transient Voltage Surge Suppressor. Also known as SPD

UL

Acronym for Underwriters Laboratories tested.

UL Recognized

Designation given to components that when used properly in an end product are deemed to be safe.

UL Listed

Designation given to products ready for end use.

Undervoltage

See **Brownout**.

UPS

Acronym for Uninterruptible Power Supply. A device which supplies power to the critical load when the existing AC line voltage is not within normal operating values, or fails completely.

VA

Acronym for Voltamp. A measure of power. 1000 VA = 1 kVA.

VFD

Variable Frequency Drive.

Voltage Balance

The difference in magnitude, in percent, between the two output voltages of a dual output power supply where the voltages have equal nominal values with opposite polarities.

Warm-Up Drift

The initial change in output voltages of a device from turn-on until it reaches thermal equilibrium.

Warm-Up Time

The time required, after initial turn-on, for a device to meet its performance specifications.

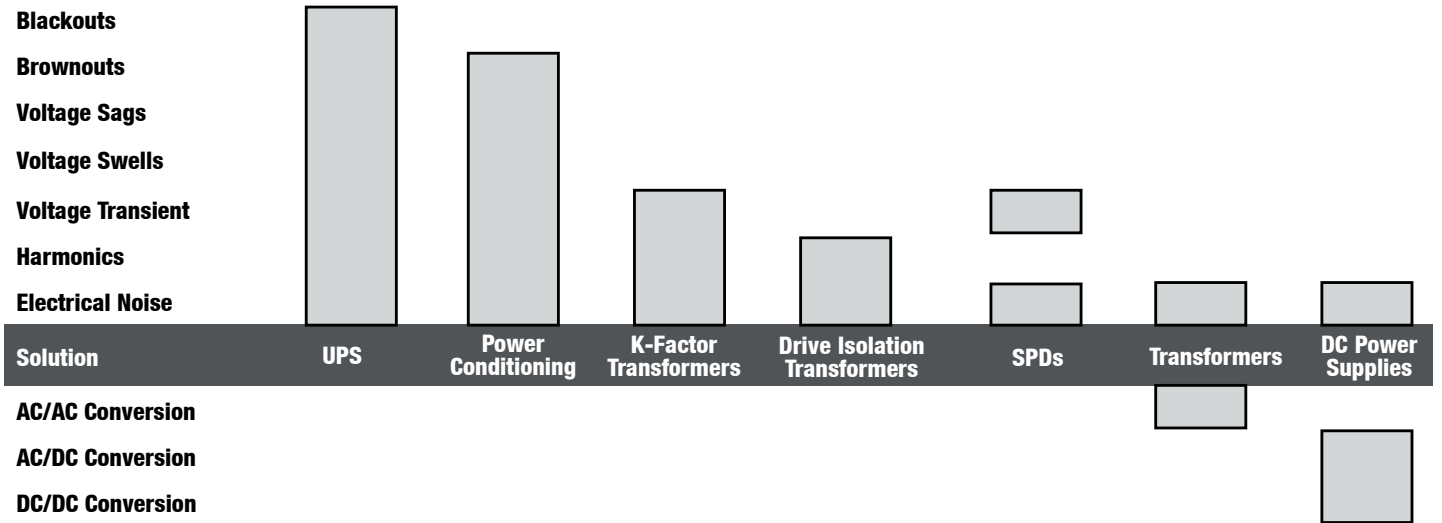
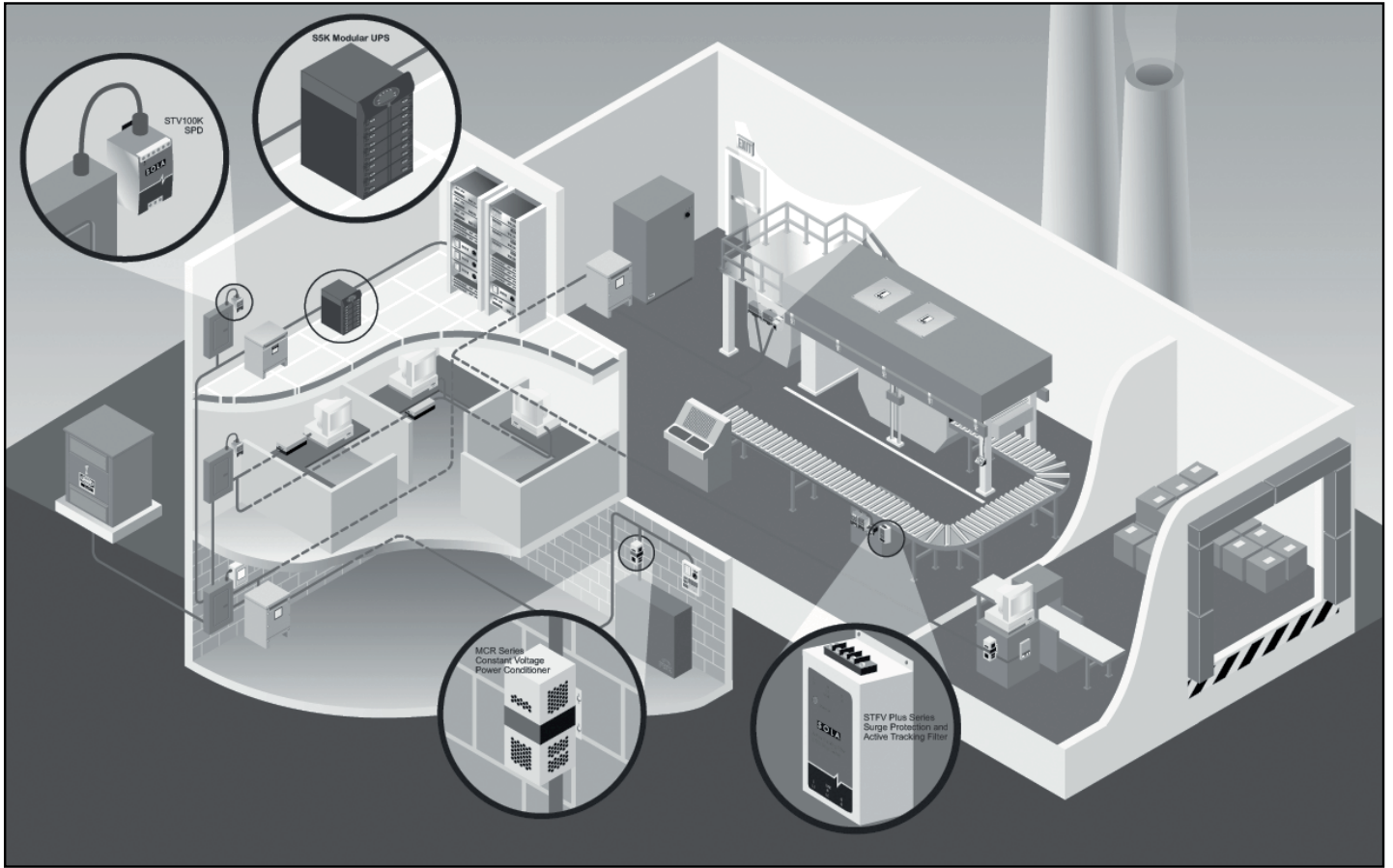



Surge Protection and Active Tracking® Filtering

Introduction19

STV200/400K Three Phase Series.....20

STV100K Single and Three Phase Series.....23

STV25K DIN Rail Mount Series.....25

STF Series Three Phase Active Tracking® Filters27

STFV Plus Series Active Tracking® Filters with Surge Protection.....30

STFE Elite Series Active Tracking® Filters with Surge Protection.....33

STC Series of Data/Signal Line Surge Protection36



Power Conditioning

CVS Hardwired ($\pm 1\%$ Output Regulation)42

MCR Hardwired ($\pm 3\%$ Output Regulation).....44

Hardwired CVS and MCR Connection Diagrams46

MCR Portable ($\pm 3\%$ Output Regulation)48

CVS and MCR Model Comparison/BTU Output Chart50

CVS and MCR Operating Characteristics51

SOLATRON™ Plus Three Phase Power Conditioners54

Surge Protective Devices and Active Tracking® Filtering

Today's industries depend on their telecommunication, networking, computing and production equipment for optimized manufacturing performance. Emerson's proven SolaHD surge protection and filtering devices protect these critical operations across facilities from the continuous threat of transient spikes, noise and harmonic distortion.

Employing an entire facility protection strategy will safeguard the electrical system against most transients. Multi-stage protection involves clamping the initial high energy surge, filtering any remaining noise or transients to the protected sensitive equipment and finally, protecting the data/signal lines entering or leaving the control panel or the factory floor. This coordination of devices provides the lowest possible let through voltage to the equipment to ensure maximum productivity.

Surge Protective Devices

High-energy transients either externally or internally generated pose an immediate threat to the reliability and performance of your sensitive electronic equipment. We recommend placing high-energy STAT Surge Protective Devices (SPDs) on key panels throughout your facility. Within your facility, motors, inductive loads and various equipment load switching can cause damage or costly downtime.

Our surge protective devices focus on limiting high-voltage spikes to a level that is acceptable to most electronic equipment. Plus, they're a great first line of defense, using components that are placed in parallel with the line and serve as clamping mechanisms for high-energy impulses. Protection at this level is referred to in the industry as Sine Wave Tracking or electronic grade. Surge protective devices are typically installed at service entrances, on larger distribution panels and at the point of use.

Active Tracking® Filtering with Surge Protection

Low-energy transients and high-frequency noise are the primary causes for system disruption and long-term degradation of microprocessor-based equipment within your facility. For more than 30 years, our SolaHD Active Tracking Filters have proven to be the most effective solution in critical equipment protection within harsh industrial environments. Active tracking filters are built upon a unique multi-stage hybrid design. This design creates a foundation for a family of products that attenuate impulses that would normally go untouched by standard, parallel clamping devices. Changing technology and dependence on total automation



processes within modern facilities create a critical need for clean AC power at the equipment level. Active tracking filters are a perfect solution for your microprocessor-based products, including industrial PLCs, OEM applications and motion control systems.

Data/Signal Line Surge Protection

The rapid development of automated controls, telecommunications and fire/alarm/security systems make it imperative to have properly coordinated low-voltage surge protection. Modern networked industrial facilities require error-free transmission of information for maximum productivity and integrity of data, but these areas are often overlooked when it comes to power protection.

The need to protect all susceptible low-voltage cable routes entering a facility and at key points within the building is as critical as protecting the equipment from high-energy impulses. The importance of protecting at this level grows as your facility's reliance on sensitive instrumentation, networked automation, and uncorrupted data transmission increases. Our SolaHD Data/Signal Line products utilize high-speed, high-energy components that come in a variety of voltage levels and unique packaging configurations.

STV200/400K Series - Surge Protective Devices

SolaHD STV200/400K Series offers continuous protection from damaging voltage transients and electrical noise commonly found at the service entrance or distribution panel. The modular design of the STV200/400K allows for installation flexibility and its' robust design allows for installation in the most severe exposure locations. They are capable of handling the high-impulse, potentially damaging transients commonly found at the service entrance or distribution panels. The modular design of the STV200/400K allows for installation flexibility. Its robust design allows for placement in the most severe exposure locations.

The STV200/400K utilizes circuitry to monitor the status of all protection modes, including neutral to ground. Should protection be unavailable in any mode, the Green LED will be extinguished, and the Red LED will be illuminated. In addition, high isolation form C dry contacts provide remote monitoring of protection system failure, under voltage, phase and power loss. The STV200/400K protection integrity monitoring indicates failure for both shorted or opened protection components.

These devices are built to meet your unique requirements, and are available in hardwire, three phase configuration. They are designed for years of trouble free operation and require little or no operator intervention after installation.

Applications

The STV200/400K Series can be a facility-wide product family and may be installed from service entrances to distribution panels to branch panels.

- Industrial Plants
- Commercial Buildings
- Institutional Facilities
- Any facility that has an environment with electronics based equipment



Features

- Modular design allows for flexibility
- Surge current capacity of 200 to 400 kA per phase
- All modes transient protection (L-N, L-G, and N-G)
- form C dry contacts and audible alarm status indications
- Internal/external monitoring, including neutral to ground
- EMI/RFI Filtering
- Five year limited warranty



- Custom options (contact technical support)
 - NEMA 12 enclosure, NEMA 3R, 4, and 4X
 - Optional rotary disconnect and transient counter

Certifications and Compliances

-  Listed
 - UL 1449, Type 1 locations
 - UL rated 200 kA with component level fusing for safe operation
 -  Listed/NEMA type 12 enclosure; 3R, 4, 4X available
- ANSI/IEEE C62.11, C62.41, C62.45 Categories A, B, and C3 tested
- Tested to Third Party Witness Tested (former NEMALS1), ISO 9001

Related Products

- Power Conditioners
- Uninterruptible Power System
- Transformers
- STV25K, STV100K, STF, STFV and STC Series

Selection Table

Catalog Number	Input Voltage	
STV400K-10Y	120/208 V	Three Phase Wye, 4 wire + Ground
STV200K-10Y	208Y/120 V	Three Phase Wye, 4 wire + Ground
STV400K-27Y	480Y/277 V	Three Phase Wye, 4 wire + Ground
STV200K-27Y	480Y/277 V	Three Phase Wye, 4 wire + Ground
STV400K-48D	480 V	Three Phase Δ, 3 wire + Ground
STV200K-48D	480 V	Three Phase Δ, 3 wire + Ground

STV200/400K Specifications

Parameters	Catalog Number					
	STV200K-10Y	STV200K-27Y	STV200K-48D	STV400K-10Y	STV400K-27Y	STV400K-48D
Input Voltage	208Y/120 V	480Y/277 V	480 V	208Y/120 V	480Y/277 V	480 V
	3Ph Wye, 4 W + G	3Ph Wye, 4 W + G	3Ph Delta, 3 W + G	3Ph Wye, 4 W + G	3Ph Wye, 4 W + G	3Ph Delta, 3 W + G
Maximum Continuous Operating Voltage (MCOV)	125% of the nominal level for 120 V; 115% for all other voltages					
Line Frequency	47-63 Hz					
Response Time	< 0.5 ns					
Enclosure	Metal, UL Listed /NEMA type 12 (3R, 4, 4X also available)					
Mounting Type	Wall Mounted (mounting hardware ¼ in.)					
Connection	Internally connected					
Status Indication	Red and green LED status indicators, audible alarm, summary alarm contacts					
Operating Temperature	-40°C to +50°C					
Operating Humidity	0% to 95% non-condensing					
Noise Attenuation	50 dB maximum					
Modes of Protection	All Modes: L-N, L-L, L-G, N-G *					
Short Circuit Current Rating (SCCR)	200 kA					
Nominal Discharge Current Rating (I _n)	20 kA					
Warranty	5 year limited warranty					
UL 1449, Type 1 Voltage Protection Ratings (VPRs)						
Line to Neutral	800 V	1200 V	N/A	700 V	1200 V	N/A
Line to Line	1200 V	2000 V	2000 V	1200 V	1800 V	2000 V
Line to Ground	900 V	1200 V	1800 V	800 V	1200 V	1800 V
Neutral to Ground	700 V	1000 V	N/A	700 V	1000 V	N/A
Peak Surge Current Capability						
Per Phase	200 kA	200 kA	200 kA	400 kA	400 kA	400 kA
Line to Neutral	100 kA	100 kA	N/A	200 kA	200 kA	N/A
Line to Line	100 kA	100 kA	100 kA	200 kA	200 kA	200 kA
Line to Ground	100 kA	100 kA	100 kA	200 kA	200 kA	200 kA
Neutral to Ground	100 kA	100 kA	N/A	200 kA	200 kA	N/A

* Delta Model does not offer N-G mode of protection

Dimensional Diagram - in. (mm)

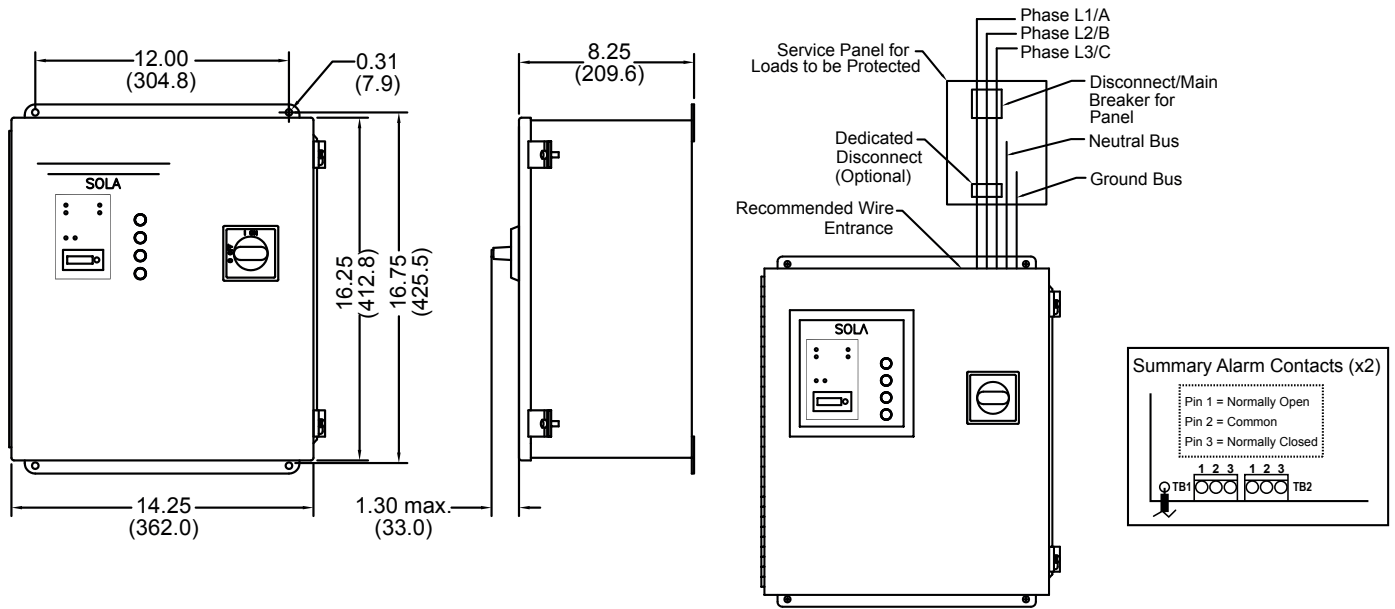

Installation Specifications

STV200/400K Series						
Model	Weight lbs (kg)	Dimensions D x W x H – in. (mm)	Suggested Breaker Size	Suggested Wire Size AWG	Allowable Breaker Range	Allowable Wire Range
STV200K	35.0 (15.88)	8.25 x 14.25 x 16.25 (209.6 x 362.0 x 412.8)	40 A	#8	15–100 A	#14–2
STV400K	42.0 (19.05)	8.25 x 14.25 x 16.25 (209.6 x 362.0 x 412.8)	100 A	#2	15–100 A	#14–2

Units with Rotary Disconnect						
Model	Weight lbs (kg)	Dimensions D x W x H – in. (mm)	Suggested Breaker Size	Suggested Wire Size AWG	Allowable Breaker Range	Allowable Wire Range
STV200K	38.0 (17.23)	8.25 x 14.25 x 16.25 (209.6 x 362.0 x 412.8)	40 A	#8	15–175 A	#14–2/0
STV400K	45.0 (20.41)	8.25 x 14.25 x 16.25 (209.6 x 362.0 x 412.8)	100 A	#2	15–175 A	#14–2/0

The STV100K Series - Surge Protective Devices

SolaHD STV100K Series hardwired surge protective devices are designed for installation at the service entrance, branch panel or a dedicated sensitive electronic load. These units feature all mode protection, LED and audible alarm status indication, sinewave tracking and form C dry contacts. The STV100K Series also contains the highest levels of safety built into the product including thermal fusing and a short circuit current protection rating of 100kA.

Applications

- Distribution Panels (<1200 A)
- Branch, Lighting and Control Panels
- Factory Automation Installations
- Dedicated Industrial Equipment

Features

- 100,000 amp peak current rating provides all mode protection against severe transients
- Low clamping levels for more effective protection
- LED status and audible alarms
- Compact, rugged metal

Certifications and Compliances

- cULus Listed
 - UL 1449, type 2 locations
- UL Listed/NEMA type 12 enclosure
 - CSA C22.2 No. 8, CSA TI I-IIB, TI A-24
- ABS Type Approved
- RoHS Compliant

Related Products

- Power Conditioners
- UPS
- Drive Isolation and K-Factor Transformers



Selection Table

Catalog Number	Input Voltage	
STV100K-10S	120/240 V	Single Phase 3 wire + Ground
STV100K-10Y	208Y/120 V	Three Phase Wye 4 wire + Ground
STV100K-10N	120 V	Single Phase 2 wire + Ground
STV100K-24L	240 V	Single Phase 2 wire + Ground
STV100K-23Y	400Y/230 V	Three Phase Wye 4 wire + Ground
STV100K-27Y	480Y/277 V	Three Phase Wye 4 wire + Ground
STV100K-24D	240 V	Three Phase Δ 3 wire + Ground
STV100K-48D	480 V	Three Phase Δ 3 wire + Ground
STV100K-10D4	240/120 CT	Three Phase Δ 4 wire + Ground
STV100K-24D4	480/240 CT	Three Phase Δ 4 wire + Ground

Dimensional Diagram - in. (mm)

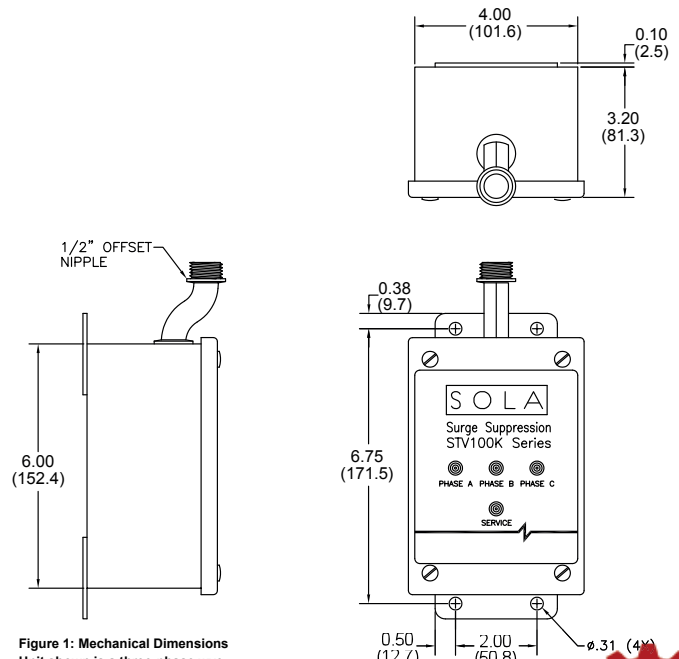

Figure 1: Mechanical Dimensions

www.nicsanat.com
021-87700210



STV100K Specifications

Description	Catalog Number									
	STV100K-10S	STV100K-10N	STV100K-24L	STV100K-10Y	STV100K-23Y	STV100K-27Y	STV100K-24D	STV100K-48D	STV100K-10D4	STV100K-24D4
Nominal Input Vac	120/240 V	120 V	240 V	208Y/120 V	400Y/230 V	480Y/277 V	240 V	480 V	240 D/120 V	480 D/240 V
System Configuration	Single Phase 3 wire + Ground	Single Phase 2 wire + Ground		Three Phase Wye 4 wire + Ground			Three Phase Delta 3 wire + Ground		Three Phase Delta High Leg 4 wire + Ground	
Maximum Continuous Operating Voltage (MCOV)	125% of the nominal level for 120 V; 115% for all other voltages									
Line Frequency	47-63 Hz									
Response Time	< 0.5 nsec									
Short Circuit Current Rating (SCCR)	100kA									
Fusing	Thermal and Fault Current									
Nominal Discharge Current Rating	20 kA									
Modes of Protection	All Mode: L - N, L - L, L - G, N - G									
Operating Temperature	-40°C to +60°C									
Operating Humidity	0% to 95% Non-condensing									
Noise Attenuation	40 dB max.									
Dimensions – W x D x H – in. (mm)	6.00 x 4.00 x 3.20 (152.4 x 101.6 x 81.3)									
Net Weight – lbs (kg)	8.0 (3.63) max.									
Enclosure	Metal, UL Listed/NEMA Type 12 Enclosure									
Connection/ Mounting Type	Parallel/Flange									
Status Indication	Red and green LED status indicators, audible alarm, form C contacts									
Warranty	10 year limited warranty									
UL 1449, Type 2 Voltage Protection Ratings (VPRs) Vpeak										
Line to Neutral	600 V	600 V	N/A	600 V	1200 V	1200 V	N/A	N/A	600 V	1200 V
Line to Line	1000 V	N/A	1000 V	1000 V	1800 V	1800 V	1000 V	2000 V	1000 V	1800 V
Line to Ground	700 V	700 V	1200 V	700 V	1200 V	1200 V	1200 V	1800 V	700 V	1200 V
Neutral to Ground	600 V	600 V	N/A	600 V	1200 V	1000 V	N/A	N/A	600 V	1200 V
High Leg to Neutral	N/A	N/A	N/A	N/A	N/A	N/A	N/A	N/A	1200 V	1800 V
High Leg to Line	N/A	N/A	N/A	N/A	N/A	N/A	N/A	N/A	1200 V	1800 V
High Leg to Ground	N/A	N/A	N/A	N/A	N/A	N/A	N/A	N/A	1800 V	3000 V
Peak Surge Current Capability										
Per Phase	100 kA	100 kA	100 kA	100 kA	100 kA	100 kA	100 kA	100 kA	100 kA	100 kA
Line to Neutral	50 kA	50 kA	N/A	50 kA	50 kA	50 kA	N/A	N/A	50 kA	50 kA
Line to Line	50 kA	N/A	50 kA	50 kA	50 kA	50 kA	50 kA	50 kA	50 kA	50 kA
Line to Ground	50 kA	50 kA	50 kA	50 kA	50 kA	50 kA	50 kA	50 kA	50 kA	50 kA
Neutral to Ground	50 kA	50 kA	N/A	50 kA	50 kA	50 kA	N/A	N/A	50 kA	50 kA

The STV25K DIN Rail Series - Surge Protective Devices

SolaHD sTV25K Series provides point-of-use protection, at the dedicated equipment level, against damaging transients. Ideal for installation in electronic control cabinets found in harsh industrial environments such as the factory floor or at remote location. These devices provide 25,000 amps of surge protection, sinewave tracking, LED status indication and form C dry contacts. This DIN rail series also provides protection on all electrical paths and comes with a standard ten year product warranty.

Applications (20 Amp Max)

- Control Cabinets for Industrial Automation
- Point-of-Use Industrial/Service Equipment
- Remote Commercial or Industrial Equipment
- Instrumentation and Large Test Equipment
- Commercial and Building Automation Systems

Features

- Compact and narrow design maximizes panel space.
- Low clamping levels for more effective protection.
- Easy access terminal screws for quick mounting and installation.
- 25,000 amps of surge protection.
- Sine wave tracking and all mode protection provide consistent and reliable protection on all electrical paths.
- Thermal fusing prevents MOV overheating caused by excessive current levels.

Certifications and Compliances

-  UL Recognized Component
 - UL 1449, type 2CA
 - UL 1283
- ABS Type Approved
- RoHS Compliant

Related Products

- DIN Rail Power Supplies
- DIN Rail AC UPS
- Industrial Control Transformers
- Active Tracking® Filters



Selection Table

Catalog Number	Input Voltage	
STV25K-10S	120 V	Single Phase (L - N)
STV25K-24S	240 V	Single Phase (L1 - L2)

Dimensional Diagram - in. (mm)

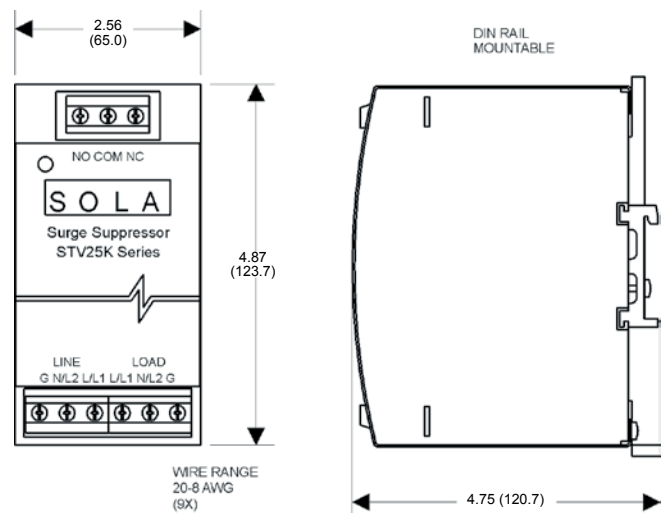

STV25K Specifications

Description	Catalog Number	
	STV25K-10S	STV25K-24S
Input Voltage	120 Vac, Single Phase 0-135 Vrms	240 Vac, Single Phase 0-260 Vrms
Maximum Continuous Operating Voltage (MCOV)	150 Vrms	300 Vrms
Line Frequency	47-63 Hz	
Connection/Mounting Type	DIN Rail Mount (Chassis Mount Bracket Optional order SDN-PMBRK2) with screw terminals for #12 AWG.	
Input Current Rating	20 amps	
Phase Configuration	2 wire + GND	
Short Circuit Current Rating (SCCR)	5kA	
Nominal Discharge Current (In)	3kA	
Weight – lbs (kg)	3.0 (1.36)	
Dimensions H x W x D – in (mm)	4.87 x 2.56 x 4.75 (123.7 x 65.0 x 120.7) includes mounting bracket	
Modes of Protection	All Mode: L - N, L - L, L - G, N-G	
Status Indication	Green LED, form C Contacts	
Packaging	Metal DIN Rail Mount Enclosure, IP20	
Response Time	< 0.5 nsec	
Operating Temperature	-40°C to +60°C	
Operating Humidity	0% to 95% Non-condensing	
	Noise Attenuation	
Normal Mode	50 dB Min.	
Common Mode	40 dB Min.	
	UL 1449, Type 4 Voltage Protection Ratings (VPRs) Vpeak	
L – N	500	–
L – L	–	900
L – G	500	900
N – G	500	–
	Peak Surge Current Capability	
Warranty	10 year limited warranty	

STF Series – Active Tracking® Filters

Low voltage/high frequency noise is caused by everyday events such as turning on machinery, motors, or equipment. Although noise is less dramatic than high voltage transients, the long term effects of these frequent disturbances can be as damaging. Filtering systems such as SolaHD Active Tracking® Filters provide clean AC power by eliminating lower voltage noise.

The SolaHD STF Series offers our original active tracking technology to guard against commonly occurring but very damaging, lower energy transients. Offering excellent noise reduction, the filter continuously tracks the input AC power line and responds instantly upon detecting extraneous high frequency noise.

The STF Series eliminates low voltage/high frequency noise via a low-pass or L-C filter. These filters are used for low energy, high frequency noise reduction and consist of a series of inductors, capacitors and resistors. STFs are load dependent which means that the series inductors located on each phase and neutral conductors are sized to handle the maximum current draw on the line. These inductors together with the capacitors and resistors form a circuit capable of absorbing a large bandwidth of noise.

These devices are designed to meet UL 1283, and CSA C22.2 No. 8 for Electromagnetic Interference Filters. STFs attenuate or reduce the amplitude of noise to a minimum of 40 dB that occurs in a frequency range of 50 kHz to 50 MHz. They also provide the industry's best IEEE Category "A" protection, typically reducing normal mode transients to +/- 5 volts.

Built to meet your unique requirements, these filters are available in a multitude of voltage configurations. They are hardwired and designed for years of trouble free operation requiring little or no operator intervention after installation.

Active Tracking® Filters are one part Emerson's a total power quality solution. They can be used alone or in conjunction with other SolaHD products to solve more complex power quality problems.

Applications

- Branch and Control Panels
- Factory Automation Installations
- Point of Use Industrial Service Equipment
- Dedicated Industrial and Machine Tools Equipment
- Telecommunications Equipment



Features

- Non degrading, series filter technology for total durability
- High frequency noise filter, RLC low-pass filter
- Three phase applications up to 200 amp
- Attenuates noise to 40 dB in frequency range of 50 kHz to 50 MHz
- Operating temperature from -40°C to +45°C
- Hardwired connection
- MTBF greater than 100,000 hours, Mil Std. 217F
- Ten year limited warranty

Certifications and Compliances

-  Listed
- UL 1283
- CSA C22.2 No. 8
- RoHS Compliant

Related Products

- Power Conditioners
- Uninterruptible Power System
- Power Supplies

Selection Table

Catalog Number	Amps	Min. Wire Size (AWG Suggested)	Fuse/Circuit Breaker Ampacity		Case Dim. in (mm) – A x B x C	Mounting Flange Dim. in (mm) – D x E x F	Weight lbs (kg)	Design Style
			Suggest	Max				
Three phase Models (120/208 Vac wye) *								
STF0150-10Y	15.0	14	15A	18.75A	14.00 x 12.00 x 6.00 (355.6 x 304.8 x 152.4)	14.75 x 10.0 x 15.5 (374.7 x 254.0 x 393.7)	35.0 (19.90)	4
STF0300-10Y	30.0	10	30 A	37.5A	14.00 x 12.00 x 6.00 (355.6 x 304.8 x 152.4)	14.75 x 10.0 x 15.5 (374.7 x 254.0 x 393.7)	35.0 (19.90)	4
STF0500-10Y	50.0	4	50A	62.5A	16.00 x 14.00 x 8.00 (406.4 x 355.6 x 203.2)	16.75 x 12.00 x 18.5 (425.4 x 304.8 x 469.9)	45.0 (20.41)	2
STF1000-10Y	100.0	2	100A	125 A	20.00 x 16.00 x 10.00 (508 x 406.4 x 254)	21.25 x 10.0 x 22.5 (539.8 x 254.0 x 571.5)	65.0 (29.48)	2
STF2000-10Y	200.0	3/0	200A	250A	24.00 x 20.00 x 10.00 (609.6 x 508 x 254)	25.25 x 14.0 x 26.5 (641.4 x 355.6 x 673.1)	115.0 (52.16)	2
Three phase Models (240 V Delta) *								
STF0150-24D	15.0	14	15A	18.75A	14.00 x 12.00 x 6.00 (355.6 x 304.8 x 152.4)	14.75 x 10.0 x 15.5 (374.7 x 254.0 x 393.7)	35.0 (19.90)	4
STF0300-24D	30.0	10	30 A	37.5A	14.00 x 12.00 x 6.00 (355.6 x 304.8 x 152.4)	14.75 x 10.0 x 15.5 (374.7 x 254.0 x 393.7)	35.0 (19.90)	4
STF0500-24D	50.0	4	50A	62.5A	16.00 x 14.00 x 8.00 (406.4 x 355.6 x 203.2)	16.75 x 12.00 x 18.5 (425.4 x 304.8 x 469.9)	45.0 (20.41)	2
STF1000-24D	100.0	2	100A	125 A	20.00 x 16.00 x 10.00 (508 x 406.4 x 254)	21.25 x 10.0 x 22.5 (539.8 x 254.0 x 571.5)	65.0 (29.48)	2
STF2000-24D	200.0	3/0	200A	250A	24.00 x 20.00 x 10.00 (609.6 x 508 x 254)	25.25 x 14.0 x 26.5 (641.4 x 355.6 x 673.1)	115.0 (52.16)	2
Three phase Models (277/480 V wye) *								
STF0150-27Y	15.0	14	15A	18.75A	14.00 x 12.00 x 6.00 (355.6 x 304.8 x 152.4)	14.75 x 10.0 x 15.5 (374.7 x 254.0 x 393.7)	35.0 (19.90)	4
STF0300-27Y	30.0	10	30 A	37.5A	14.00 x 12.00 x 6.00 (355.6 x 304.8 x 152.4)	14.75 x 10.0 x 15.5 (374.7 x 254.0 x 393.7)	35.0 (19.90)	4
STF0500-27Y	50.0	4	50A	62.5A	16.00 x 14.00 x 8.00 (406.4 x 355.6 x 203.2)	16.75 x 12.00 x 18.5 (425.4 x 304.8 x 469.9)	45.0 (20.41)	2
STF1000-27Y	100.0	2	100A	125 A	20.00 x 16.00 x 10.00 (508 x 406.4 x 254)	21.25 x 10.0 x 22.5 (539.8 x 254.0 x 571.5)	65.0 (29.48)	2
STF2000-27Y	200.0	3/0	200A	250A	24.00 x 20.00 x 10.00 (609.6 x 508 x 254)	25.25 x 14.0 x 26.5 (641.4 x 355.6 x 673.1)	115.0 (52.16)	2
Three phase Models (480 V Delta) *								
STF0150-48D	15.0	14	15A	18.75A	14.00 x 12.00 x 6.00 (355.6 x 304.8 x 152.4)	14.75 x 10.0 x 15.5 (374.6 x 254.0 x 393.7)	35.0 (19.90)	4
STF0300-48D	30.0	10	30 A	37.5A	20.0 x 16.0 x 10.0 (508.0 x 406.4 x 254.0)	21.25 x 10.0 x 21.5 (539.75 x 254.0 x 546.1)	35.0 (19.90)	4
STF0500-48D	50.0	4	50A	62.5A	20.0 x 16.0 x 10.0 (508.0 x 406.4 x 254.0)	21.25 x 10.0 x 21.5 (539.75 x 254.0 x 546.1)	45.0 (20.41)	4
STF1000-48D	100.0	2	100A	125 A	20.00 x 16.00 x 10.00 (508 x 406.4 x 254)	21.25 x 10.0 x 21.5 (539.8 x 254.0 x 546.1)	65.0 (29.48)	2
STF2000-48D	200.0	3/0	200A	250A	24.00 x 20.00 x 10.00 (609.6 x 508 x 254)	25.25 x 14.0 x 25.5 (641.4 x 355.6 x 647.7)	115.0 (52.16)	2

* Units are standard in NEMA 12 hinged enclosures.

STF Specifications

Description	120/208 Vac Models	277/480 Vac Models	480 Vac Models
Input Voltage	0-150/240 Vrms	0-320/520 Vrms	0-520 Vrms
Line Frequency	50/60 Hz		
Transient Attenuation Response Time	Instantaneous		
Mean Time Between Failure (MTBF)	> 100,000 Hours (Mil Std. 217F)		
Packaging	Single phase < 30 amps housed in black, high impact plastic case, vacuum impregnated magnetics, epoxy encapsulated. Single phase > 30 amps, 480 Vac, and three phase units housed in NEMA 12 enclosures.		
Operating Temperature	-40°C to +45°C; Derate Linearly to 60% at +70°C		
Load Surge Current Rating	10m sec: 5 x Nominal		
	1 sec : 3 x Nominal		
	5 sec: 2 x Nominal		
Transient Reduction	Minimum of 40 dB from 50 kHz through 50 MHz. Attenuation is greater than 50 dB to the surge withstand capability Ringwave test IEEE C62.41, Category "A" (IEEE Category A Ringwave 6 kV, 200A, 100 kHz) and "B" (IEEE Category B Ringwave 6 kV, 500 A, 100 kHz).		
Warranty	10 year limited warranty		

Dimensional Drawings See Selection Table for dimensions (in. and mm.)

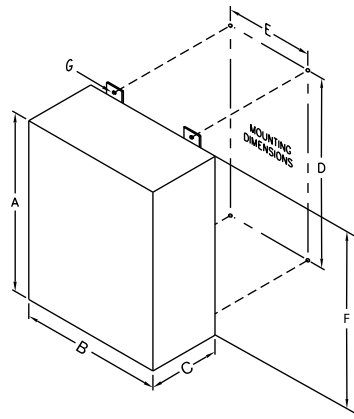

Design Style 2

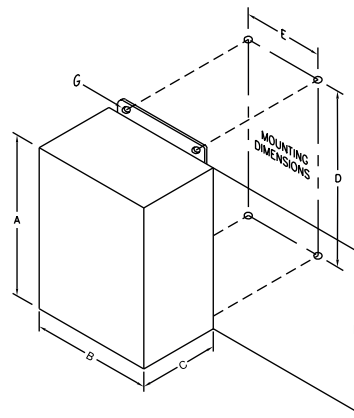

Design Style 4

STFV Plus Series – Active Tracking® Filtering with Surge Protection

The SolaHD STFV Plus Series combines Active Tracking® filtration for low energy noise and surge protection for high energy transients. It continuously tracks the input AC power line responding instantly into action upon detecting extraneous high frequency noise and high voltage transients caused by everyday events such as turning on machinery, motors, or equipment.

These devices are designed to meet UL 1283 for Electromagnetic Interference Filters. STFV Plus attenuates or reduces the amplitude of high frequency noise to a maximum of 90 dB that occurs in a range of 100 kHz to 50 MHz. STFV Plus provides the industry's best IEEE C62.41 Category "A & B" Ringwave protection.

They are built to meet your unique requirements, and are available in hardwired, single phase configuration. They are designed for years of trouble free operation and require little or no operator intervention after installation.

Active Tracking® Filters Plus is one part of Emerson's total power quality solution. They can be used alone or in conjunction with other SolaHD products to solve more complex power quality problems.

Applications



- Branch and Control Panels
- Factory Automation Installations
- Point of Use Industrial Service Equipment
- Programmable Logic Controllers
- Dedicated Industrial and Machine Tools
- Telecommunications and IT Equipment

Features

- Non degrading, series filter/TVSS technology for total durability
- UL surge current capacity – 25,000 amps
- High impact plastic case, epoxy encapsulated enclosure
- Transient protection in all modes (L-N, L-G, and N-G)
- Single phase applications up to 30 amp
- Operating temperature from -40°C to +60°C
- Hardwired connection
- LED power indication
- Ten year limited warranty



Certifications and Compliances

-  Certified
 - CSA C22.2 No. 8
-  UL Recognized Component
 - UL 1283
- RoHS Compliant

Related Products

- Power Conditioners
- Uninterruptible Power Supplies
- Power Supplies

Selection Table

Catalog Number	Amps	Case Dim. in (mm) – A x B x C	Mounting Flange Dim. in (mm) – D x E x F x G	Number Min. Wire Size (AWG Suggested)	Screw Size	Fuse/Circuit Breaker Ampacity		Weight lbs (kg)
						Suggest	Max	
Single phase Models (120 Vac)								
STFV025-10N	2.5	4.00 x 2.88 x 1.81 (101.6 x 73.2 x 46.0)	4.38 x 2.12 x 5.31 x 0.19 (111.3 x 53.8 x 134.9 x 4.8)	26	#6	2.5	3.125	1.0 (.45)
STFV050-10N	5.0	4.00 x 2.88 x 1.81 (101.6 x 73.2 x 46.0)	4.38 x 2.12 x 5.31 x 0.19 (111.3 x 53.8 x 134.9 x 4.8)	22	#6	5	6.25	1.3 (.59)
STFV075-10N	7.5	4.75 x 4.75 x 2.35 (120.7 x 120.7 x 59.7)	5.25 x 3.50 x 6.25 x 0.19 (133.4 x 88.9 x 158.8 x 4.8)	18	#6	7.5	9.375	2.0 (.91)
STFV150-10N	15.0	6.25 x 4.75 x 2.35 (158.8 x 120.7 x 59.7)	6.75 x 3.50 x 7.75 x 0.19 (171.5 x 88.9 x 196.9 x 4.8)	14	#8	15	18.75	3.5 (1.59)
STFV300-10N	30.0	7.75 x 4.75 x 2.35 (196.9 x 120.7 x 59.7)	8.25 x 3.50 x 9.00 x 0.19 (209.6 x 88.9 x 228.6 x 4.8)	10	#8	30	37.5	6.0 (2.72)
Single phase Models (240 Vac)								
STFV025-24L	2.5	4.00 x 2.88 x 1.81 (101.6 x 73.2 x 46.0)	4.38 x 2.12 x 5.31 x 0.19 (111.3 x 53.8 x 134.9 x 4.8)	26	#6	2.5	3.125	1.3 (.59)
STFV050-24L	5.0	4.75 x 4.75 x 2.35 (120.7 x 120.7 x 59.7)	5.25 x 3.50 x 6.25 x 0.19 (133.4 x 88.9 x 158.8 x 4.8)	22	#6	5	6.25	2.0 (.91)
STFV075-24L	7.5	6.25 x 4.75 x 2.35 (158.8 x 120.7 x 59.7)	6.75 x 3.50 x 7.75 x 0.19 (171.5 x 88.9 x 196.9 x 4.8)	18	#6	7.5	9.375	3.5 (1.59)
STFV150-24L	15.0	7.75 x 4.75 x 2.35 (196.9 x 120.7 x 59.7)	8.25 x 3.50 x 9.00 x 0.19 (209.6 x 88.9 x 228.6 x 4.8)	14	#8	15	18.75	5.8 (2.63)
STFV300-24L	30.0	7.75 x 4.75 x 2.35 (196.9 x 120.7 x 59.7)	8.25 x 3.50 x 9.00 x 0.19 (209.6 x 88.9 x 228.6 x 4.8)	10	#8	30	37.5	6.0 (2.72)

Dimensional Diagram

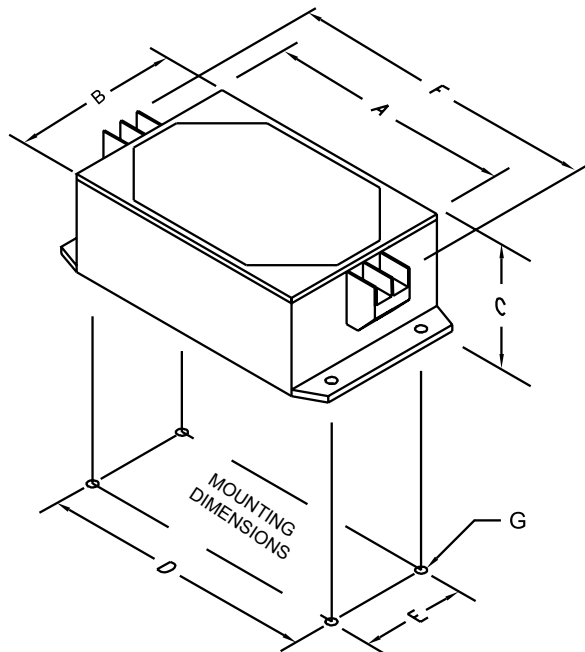

System Design

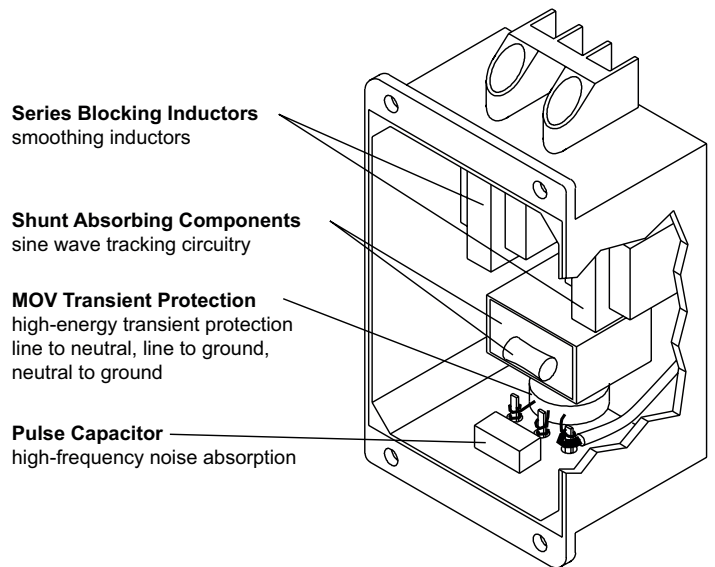

STFV Specifications

Description	Value	
Input Voltage	120 Vac Models	0-150 Vrms
	240 Vac Models	0-275 Vrms
Line Frequency	50/60 Hz	
Configuration	Single Phase (2 wire + ground)	
Response Time	< 5 ns	
Enclosure	High impact plastic case, 94V-0, Vacuum impregnated magnetics, epoxy encapsulated	
Fusing	External	
Status Indication	Green LED	
Connection/Mounting Type	Series/Panel Mount	
Operating Temperature	-40°C to +60°C at full load Derate Linearly to 60% at +70°C	
Operating Humidity	0% to 95% Non-condensing	
Mean Time Between Failure (MTBF)	Greater than 100,000 hours (Mil. Std. 217F)	
Packaging	High impact plastic case, vacuum impregnated magnetics, epoxy encapsulated	
Peak Surge Current Capability (8 x 20 μs)	Per Phase	25,000 amps
	Line to Neutral	12,500 amps
	Line to Ground	12,500 amps
	Neutral to Ground	12,500 amps
Load Surge Current Rating	10m sec	5 x Nominal
	1 sec	3 x Nominal
	10 sec	2 x Nominal
Frequency Response (Forward Reverse)	100 kHz to 50 MHz	90 dB Max
Transient Reduction * (IEEE C62.41)	Typical Category A Ringwave (6 kV, 200A, 100 kHz)	< 10 volts peak
	Typical Category B Ringwave (6 kV, 500A, 100 kHz)	< 50 volts peak
Warranty	10 year limited warranty	

* All measurements in volts. IEEE test results with no AC applied.

STFE Elite Series - Active Tracking® Filters with Surge Protection

The SolaHD STF Elite DIN Rail Mount Series combines Active Tracking® technology with UL Listed surge protection to protect against the full spectrum of voltage transients and surges. It continuously tracks the input AC power line responding instantly into action upon detecting extraneous high frequency noise and high voltage transients caused by everyday events such as turning on machinery, motors, or equipment.

The STFE Series attenuates or reduces the amplitude of normal mode noise to a minimum of 90 dB that occurs in a frequency range of 100 kHz to 50 MHz, and common mode noise to a minimum of 60 dB that occurs in a frequency range of 5 MHz to 50 MHz. STFE provides the industry’s best IEEE C62.41 Category “A & B” Ringwave protection.

They are built to meet your unique requirements, and are available in hardwired DIN Rail mount, single phase configuration. They are designed for years of trouble free operation and require little or no operator intervention after installation.

Applications

- Control Panels
- Factory Automation Installations
- Point of Use Industrial Equipment
- Programmable Logic Controllers
- Dedicated Industrial and Machine Tools Equipment

Features

- Series connected DIN rail mounted filter
- Durable metal mount clip
- UL Listed surge current capacity – 45,000 amps
- Transient protection in all modes (L-N, L-G, and N-G)
- Single phase applications up to 20 Amp
- Operating temperature from -40°C to +50°C
- Screw terminal connections
 - Reliable and convenient screw clamp connections
 - Accept 10-16 AWG wire
 - Meet IP20 specifications for ingress protection
- LED status indication
- Form C contact for remote monitoring
- Five year limited warranty



Certifications and Compliances

- **UL US** UL Recognized Component
 - UL 1449, Type 4 locations
 - UL 1283
 - CSA C22.2 No. 8
- **CE** - EN 61643-11:2002
- **ABS** Type Approved
- RoHS Compliant

Related Products

- Power Conditioners
- Uninterruptible Power System
- Power Supplies

Selection Table

Catalog Number	Input Voltage	
	120 V	240 V
STFE030-10N	Single Phase 2 Wire + Ground	Single Phase 2 Wire + Ground
STFE050-10N	Single Phase 2 Wire + Ground	Single Phase 2 Wire + Ground
STFE100-10N	Single Phase 2 Wire + Ground	Single Phase 2 Wire + Ground
STFE200-10N	Single Phase 2 Wire + Ground	Single Phase 2 Wire + Ground
STFE030-24L	Single Phase 2 Wire + Ground	Single Phase 2 Wire + Ground
STFE050-24L	Single Phase 2 Wire + Ground	Single Phase 2 Wire + Ground
STFE100-24L	Single Phase 2 Wire + Ground	Single Phase 2 Wire + Ground
STFE200-24L	Single Phase 2 Wire + Ground	Single Phase 2 Wire + Ground

STFE Specifications

Description	STFEXX-10N	STFEXX-24L
Input Voltage	120 V (0-150 Vrms)	240 V (0-275 Vrms)
Line Frequency	47 - 63 Hz	
Response Time	< .5 ns normal mode, <5 ns common mode	
Enclosure	Fully Enclosed Metal Housing	
Fusing	Reference Fuse/Circuit Breaker Chart	
Status Indication	Green LED "OK"/form C Contact/10 amps @ 250 Vac or 5 amps @ 100 Vdc	
Connection/Mounting Type	DIN Rail Mount	
Operating Temperature	-40°C to +50°C at full load Derate Linearly to 60% at +70°C	
Weight – lbs (kg)	1.7 (0.70)	
Dimensions – in (mm) (H x W x D)	4.88 x 2.56 x 4.56 (124.0 x 65.0 x 116.0)	
Operating Humidity	0% to 95% Non-condensing	
Peak Surge Current Capability	Per Phase	30,000 amps
	Line to Neutral	20,000 amps
	Line to Ground	10,000 amps
	Neutral to Ground	10,000 amps
Load Surge Current Rating	10m sec	5 x Nominal
	1 sec	3 x Nominal
	10 sec	2 x Nominal
Frequency Response		
Normal Mode (Forward–Reverse)	100 kHz to 50 MHz	90 dB Max
Common Mode (Forward–Reverse)	5 MHz to 50 MHz	60 dB Max
Transient Reduction (IEEE C62.41)	Typical Category A Ringwave (6 kV, 200A, 100 kHz)	< 60 V Peak
	Typical Category B Ringwave (6 kV, 500A, 100 kHz)	<100 V Peak UL 1449
Warranty	5 year limited warranty	

Connection Diagram

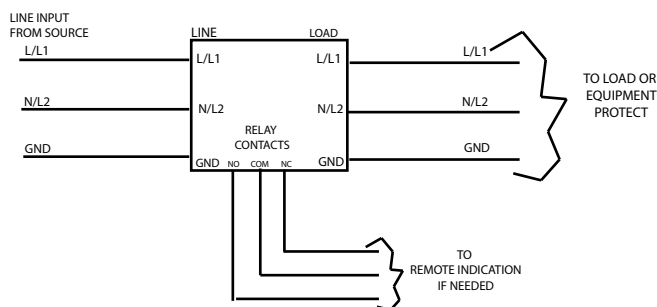

Dimensional Diagram - in. (mm)

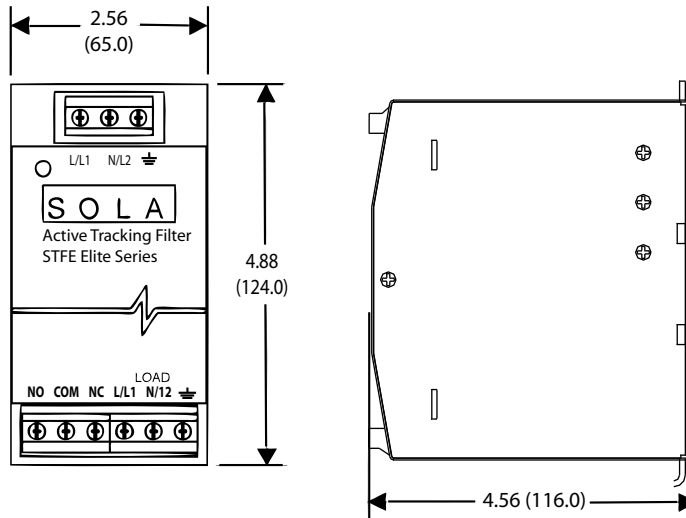

Wiring Specifications

Catalog Number	Amps	Min Wire Size * (AWG Suggested)	Fuse/Circuit Breaker Ampacity	
			Suggest	Max
Single phase Models (120 Vac)				
STFE030-10N	3.0	24	3A	3.75A
STFE050-10N	5.0	22	5A	6.25 A
STFE100-10N	10.0	20	10 A	12.5A
STFE200-10N	20.0	12	20A	25 A
Single phase Models (240 Vac)				
STFE030-24L	3.0	24	3A	3.75A
STFE050-24L	5.0	22	5A	6.25 A
STFE100-24L	10.0	20	10 A	12.5A
STFE200-24L	20.0	12	20A	25 A

* 16 AWG wire or larger may be required by code dependent upon the application.

Internal Diagram

Rear View

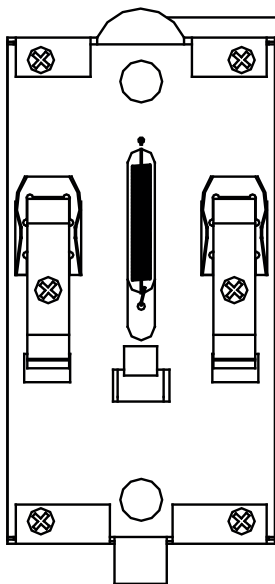

Internal View of Components

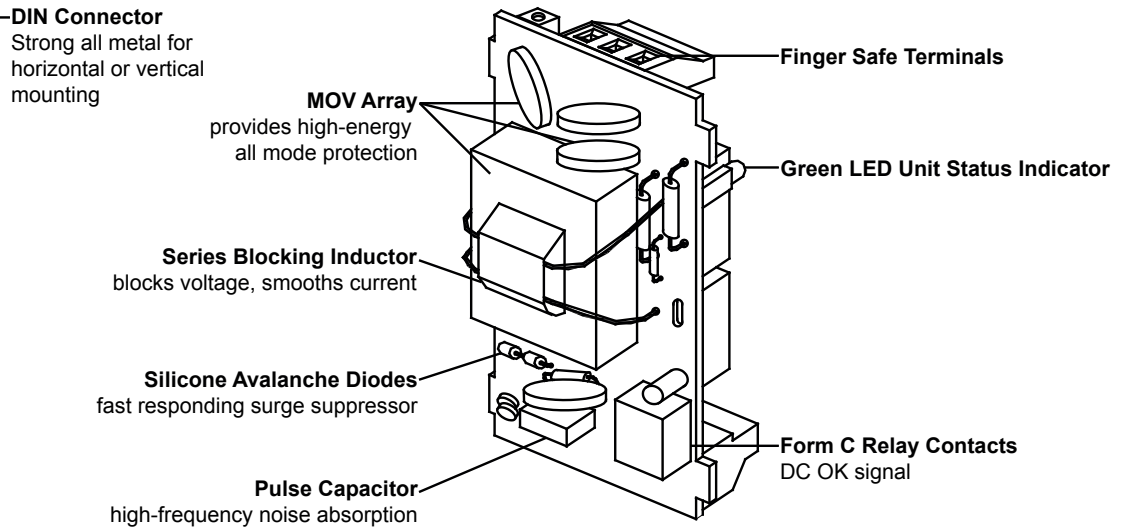

STC Series – Data/Signal Line Surge Protection Devices for Transient Data

The rapid development of automated controls, telecommunications and fire/security systems has made it imperative to have properly coordinated low-voltage protection. Modern networked industrial facilities require error free transmission of information for maximum productivity and integrity of data.

The SolaHD STC Series protects all susceptible low-voltage cable routes entering a facility and at key points within the building. These devices can be used as part of a multi-stage protection strategy which involves clamping the initial high-energy impulse, filtering any remaining noise or transients to the PLC or sensitive equipment and finally, protecting the Data/Signal lines entering and leaving the control panel. Modern, networked industrial facilities require error free transmission of information for maximum productivity and data integrity.

The hybrid design of these Data/Signal Line surge suppressors allows them to respond quickly with high energy absorption. These units are available in a variety of application specific voltage levels and packaging configurations. The STC Series is used to protect network signal lines entering or leaving control panels including PLCs, universal remote I/O, DeviceNet™ and Data Highway Plus.



Select Models E175287

Related Products

- Single and Three Phase Power Conditioners
- Uninterruptible Power System
- Transient Voltage Surge Protective Devices
- Active Tracking® Filters
- Power Supplies

Low Voltage - Data/Signal, STC Series

Series	Application
STC-POE	Power-over-Ethernet, Category 5 and Category 6
STC-DRS	DIN Rail mountable, single pair surge protection
STC-642	Two-Pair Data/Signal Protection
STC-CCTV	High-Frequency Coaxial protection for head and camera ends

STC-PoE Series, Category 5 and 6 Power-over-Ethernet Applications

The SolaHD STC Power-over-Ethernet (PoE) Series is designed to work on Category 5 PoE transmission lines as well as Category 6 applications. They feature both female to female and male to female RJ-45 connection options for ease of installation.



Power-over-Ethernet is a technology for wired Ethernet LANs (Local Area Networks) that allows the electrical current to be carried by the data cables rather than power cords. This minimizes the number of wires that must be strung in order to install the network. The result is lower cost, less downtime, easier maintenance and greater installation flexibility than with traditional wiring.

PoE allows users to power devices over Ethernet cabling. Power and networking is provided over a single cable. PoE has tremendous advantages in industrial applications. The ease of combining signal and power in a single Ethernet cable connection is contributing to the already rapid evolution of Ethernet-based industrial control systems. Category 5e and Category 6 commonly known as Cat5e and Cat6 are the most widely used Ethernet connectivity methods on the market today. Cat5e and Cat6 are defined in ANSI/TIA/EIA 568-B standard for Unshielded Twisted Pair Cabling.

The STC PoE Series is ideally suited to protect expensive equipment and critical communication/data transfer from internally generated transients and noise.

Features

- Exceeds CAT 5 PoE & 6 transmission values
- Applications up to 60 Vdc @ 300 mA
- Three year limited warranty

STC-PoE-65FF

Features

- Single use design
- 60 Vdc @ 300 mA continuous
- Cost effective protection

STC-CAT6-PoE-I

Features

- Hybrid PTC (positive temperature coefficient) resettable fuse - up to 5,000 times
- 60 Vdc @ 750 mA continuous
- Isolated ground available
- 10kA peak surge current
- Premium protection

Selection Table

Catalog Number	Description
STC-POE-65FF	Female to Female Connector
STC-CAT6-POE-I	Female to Female Connector with isolated ground

Specifications

Description	STC-POE-65FF	STC-CAT6-POE-I
Mode of Protection	Normal Mode (L-L) All Lines (1-8) Protected	All Lines (1-8) Protected (L-L) and (L-G) Signal High-Low; High-Ground; Low-Ground
DC Breakover Voltage	60 Vdc	
Insertion Loss	< .1 dB	
Certified Transmission Speeds	10baseT, 100baseT, 1000baseT	
Peak Surge Energy	300 Watt	750 Watt
Response Time	<1 ns	
Connectors	RJ-45 (Female - Female)	
Dimensions – in (mm)	2.30 x 1.00 x .80 (58.4 x 25.4 x 20.3)	5.40 x 1.60 x 1.70 (137.2 x 40.7 x 43.2)
Warranty	3 year limited warranty	5 year limited warranty

STC-DRS Series, DIN Rail Protection

Using three-stage hybrid technology, the SolahD STC-DRS Series DIN rail mountable, single pair, surge protection device attenuates over-voltage transients with gas tubes and silicon avalanche components while resettable fuses (PTCs) mitigate sneak currents. The PTC increases resistance by several orders of magnitude when over-currents exceed safe levels. A normal state resumes when over-currents are removed. The ability to self-restore in this manner significantly increases performance and survivability.

The STC-DRS Series mounts onto a standard 35 mm industrial DIN rail. There are three Field Side and three Electronics Side screw terminals. One is reserved for a shield. Three electrically tied ground terminals are provided for grounding the unit to building-approved ground. The shield is isolated from ground.

Application

- Intended for indoor use on communication loop circuits which have been isolated from the Public Switch Telephone Network.

Features

- Low-Voltage data surge protection
- Three-Stage hybrid technology
- Sneak/Fault current protection with resettable fuses (PTCs)
- Low profile packaging
- Easy installation
- Fits standard 35 mm DIN Rail
- Fast response time <1 nanosecond
- Five year limited warranty

Certifications and Compliances

-  Listed
- UL 497B
- RoHS Compliant

Selection Table

Catalog Number	Max Peak Signal Voltage	Nominal Breakdown Voltage	Max Current 1p 10X1000 ms (Occurrences)	Peak Current 8X20 ms	Typ. Cap (PF)	Max Continuous Current	Nominal Series Resistance
STC-DRS-232	15	22	>100	10KA	1500	150ma	5 Ω
STC-DRS-036	30	36	>100	10KA	1500	150ma	5 Ω
STC-DRS-060	52	60	>100	10KA	1500	150ma	5 Ω



Dimensional Diagram - in. (mm)

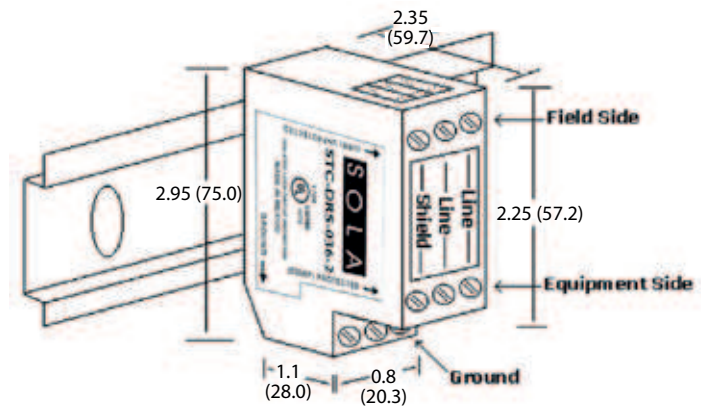

Note:

The communication loop circuits shall not be exposed to accidental contact with the electric light or power conductors. The protectors shall be installed per the applicable requirements of the National Electric Code, ANSI/NFPA 70.

STC-642 Series, Data/Signal Line Protection

The SolaHD STC-642 series of surge suppressors are dual pair (four wire) modules using three-stage hybrid technology. This module addresses over voltage transients with gas tubes and silicon avalanche components. In addition, sneak and fault currents are mitigated with resettable fuses (PTCs). The PTCs increase resistance several orders of magnitude when over currents exceed safe levels. A normal state resumes when over currents are removed. The ability to self restore in this manner significantly increases suppressor performance and survivability.

The STC-642 card edge module is gold-plated, double sided and is designed to mate with the STC-642 gold-plated female terminal connector (sold separately). When snapped together, the data circuits pass thru the protector in a serial fashion from the four Field Side terminals to the four Electronics Side terminals. Terminals 1 or 10 of the STC-PCB1B must be attached to building approved ground.

Application

- Intended for indoor use on communication loop circuits which have been isolated from the Public Switch Telephone Network.
- RS232 applications used with STC642-020 and STC-PCB1B
- 4-20 ma signal applications used with STC642-036 and STC-PCB1B
- For use in service capable of supplying less than 150 milliamperes continuously.

Features

- Lightning protection for low voltage data
- Signal lines
- Three-stage protection
- Sneak/fault current protection
- Resettable solid-state fuses - PTCs
- Low capacitance option for high speed data
- Plug-in module / Requires STC-PCB1B base
- Hybrid design of includes series resistance
- Fast response time
- Five year limited warranty

Certifications and Compliances

-  Listed
- UL 497B
- RoHS Compliant



Selection Table

Catalog Number	Description
STC642-020	20 Volt Clamp
STC642-036	36 Volt Clamp
STC-PCB1B	Base for all STC-642 models. Designed to accommodate up to 10 AWG wire. It offers Flat/Phillips screws and can be mounted using 2 #6 size screws. Must be ordered separately.
STC-FM4-DRC	Optional DIN Rail Mounting Clip for STC-PCB1B

Specifications

Description	STC642-020 *	STC642-036 *
Peak Surge Current (10 times)	8x20 s .. 10kA 10x700 s 500A per line	
Life Expectancy	8x20 s (2000A) .. >100 occurrences 10x700 s (400A)	
Response Time	<1ns	
Voltage Clamp	20	36
Technology	SAD Hybrid	
Resistance	5 (typical)	
Capacitance (typical)	1500pf	
Operating Temperature	-40°C to +85°C	
Weight	2 oz.	
Dimensions H x W x L – in (mm) STC-642 & PCB1B	2.05 x 1.00 x 2.40 (52.1 x 25.4 x 61.0)	
Warranty	5 year limited warranty	

* Part number STC-PCBIB sold separately

STC-642 Series, Data/Signal Line Protection

Wiring Diagram (PIN Assignments)

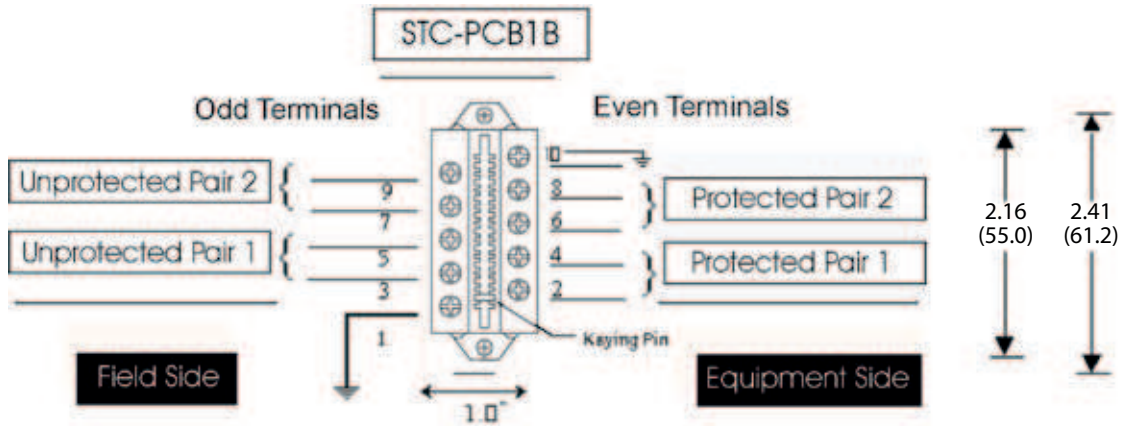

Ground Terminal 1 or 10 (internally tied together) to building approved ground. The STC-PCB1B accommodates 24 to 10 AWG wire.

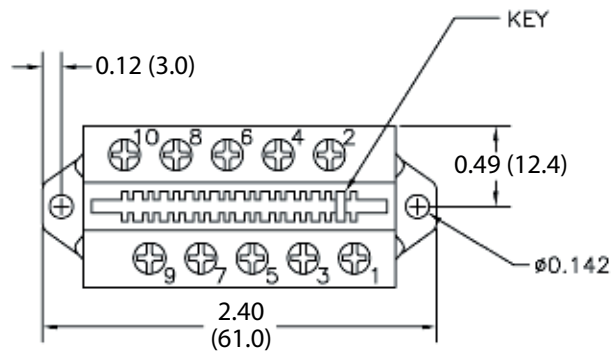

Top View

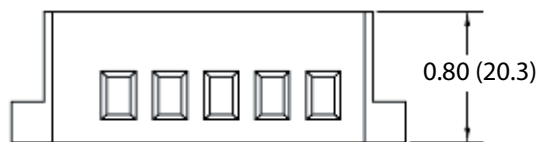

Side View

STC-CCTV Coax Series

The SolaHD STC-CCTV Series is tailored specifically to CCTV, data, audio and cable applications. These units are single Coax Surge Protective Devices implementing three-stage hybrid technology. They address overvoltage transients with a primary gas tube, and secondary silicon avalanche components. Over-currents (e.g. sneak and fault currents) are mitigated with solid-state resettable fuses (PTCs). The STC-CCTV units are designed in accordance with NFPA 780 (2004 Edition) requirements, with up to 20kA of surge current capability. The STC-CCTV-75I model has an isolated ground and is recommended for use at the camera end.

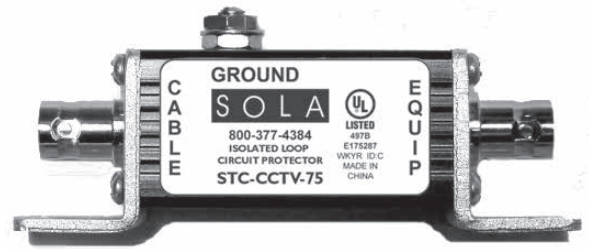

Applications

- CCTV Head End
- CCTV Camera End

Features

- Hybrid, three-stage technology
- Sneak/fault current protection
- Low insertion loss
- Shielded case
- Five year limited warranty

Certifications and Compliances

- Listed
- UL 497B
- RoHS Compliant
- NFPA 780 (2004) Compliant for Communication Protectors

Selection Table

Catalog Number	Description
STC-CCTV-75	Without isolated ground
STC-CCTV-75I	With isolated ground

Specifications

Description	STC-CCTV-75	STC-CCTV-75I
Operating Voltage	5	
Clamping Voltage	6	
Frequency Range	0 to 20 MHz	
Equipment Location	IEEE Category C, and Category B	
Rated Load Current	0.35 amperes	
Topology	2-port Series	
STC Technology	Primary Stage: Gas Tubes, Secondary Stage: Silicon Avalanche Components Third Stage: resettable fuses (PTCs)	
Modes of Protection	Signal to Ground	
Nominal Discharge Current per Mode	10.0 kA	
Maximum Discharge Current per Mode	20.0 kA	
EMI Attenuation	< 0.1 dB at 20 MHz	
VSWR	< 1.2	
Continuous Power	0.72 Watts	
Operating Humidity	0-95 % Non-condensing	
Operating & Storage Temperature	-40°C to +85°C	
Input & Output Connection Type	BNC, 50/75 Ohm	
Mounting	Flange	
Enclosure Type	Metal	
Warranty	5 year limited warranty	

CVS Hardwired Series – Constant Voltage Transformers

Superior voltage regulation of $\pm 1\%$ sets the SolaHD CVS Series apart from other power conditioning technologies on the market. Extremely tight regulation is accomplished by our ferroresonant transformer technology. The CVS recreates a well regulated sinusoidal waveform that is well isolated from input disturbances including:

- Impulses
- Swells
- Brownouts
- Sags
- Severe waveform distortion

No other power conditioning technology provides as complete a solution against these power quality disturbances. The CVS series is ideal for applications where even a small change in voltage level can lead to unscheduled downtime, misoperation, incorrect data or scrapped production.

Applications

- Industrial automation and control equipment PLCs
- Analytical laboratory and factory automating equipment
- Photo processing equipment
- Sound/recording systems
- Photographic enlargers
- Broadcast equipment

Features

- Superior voltage regulation of $\pm 1\%$
- Surge protection tested to ANSI/IEEE C62.41, Class A & B waveform
- Harmonic filtering
- Hardwired



- Acts as a step-up/step-down transformer
- Galvanic isolation provides exceptional circuit protection
- 25 year typical mean time between failure
- No maintenance required

Certifications and Compliances

-  Listed
 - UL 1012
 - CSA C22.2 No. 107.1
- RoHS Compliant

Related Products

- On-line UPS (S4K Industrial)
- Surge Protection
- Three Phase Power Conditioners
- Active Tracking® Filters

Selection Tables: Single Phase

Group 1 – CVS Series, 60 Hz

VA	Catalog Number	Voltage Input	Voltage Output	Height in (mm)	Width in (mm)	Depth in (mm)	Ship Weight lbs (kg)	Design Style	Elec Conn
120	23-22-112-2	120, 240	120	8.00 (203.2)	4.00 (101.6)	5.00 (127.0)	13.0 (5.90)	1	J
250	23-23-125-8	120, 240, 480	120	11.00 (279.4)	6.00 (152.4)	8.00 (203.2)	29.0 (13.15)	1	G
500	23-23-150-8	120, 208, 240, 480	120, 240	13.00 (330.2)	9.00 (228.6)	7.00 (177.8)	42.0 (19.05)	1	H
1000	23-23-210-8	120, 208, 240, 480	120, 240	17.00 (431.8)	9.00 (228.6)	7.00 (177.8)	65.0 (29.48)	1	H
2000	23-23-220-8	120, 208, 240, 480	120, 240	18.00 (457.2)	13.00 (330.2)	10.00 (254.0)	111.0 (50.35)	1	H
3000	23-23-230-8	120, 208, 240, 480	120, 240	19.00 (482.6)	13.00 (330.2)	10.00 (254.0)	142.0 (64.41)	1	H
5000	23-23-250-8	120, 208, 240, 480	120, 240	28.00 (711.2)	13.00 (330.2)	10.00 (254.0)	222.0 (100.70)	1	H
7500 *	23-28-275-6	240, 480	120, 240	27.00 (685.8)	25.00 (635.0)	9.00 (228.6)	365.0 (165.56)	2	J

* This unit is UL Listed only.

Specifications

Parameter	Condition	Value
Input		
Voltage	Continuous at full load (lower input voltage possible at lighter load)	+10% to -20% of nominal
	For temporary surge or sags	+20% to -35% of nominal
Current ¹	at Full Load & 80% of nominal input voltage	$I_{in} \cong (VA/.87)/(V_{in} \times 80\%)$
Frequency	See Operating Characteristics section for details.	60 Hz
Output ²		
Line Regulation	$V_{in} >80\%$ and $<110\%$ of nominal	±1%
Overload Protection	At Nominal Input Voltage	Current limited at 1.65 times rated current
Output Harmonic Distortion	At Full Load within Input Range	3% total RMS content
Noise Attenuation	-Common Mode	40 dB
	-Transverse Mode	40 dB
General		
Efficiency	At Full Load	Up to 92%
Storage Temperature	Humidity <95% non-condensing	-20° to 80°C
Operating Temperature	Humidity <95% non-condensing	-20° to 50°C
Audible Noise	Full Resistive Noise	32 dBA to 65 dBA
Warranty	10 year limited warranty	

Notes:

- 1 - Consult user manual for fuse sizing.
- 2 - It is recommended that the unit run at a minimum of 40-50% load.
See the Operating Characteristics section for more details.

Design Styles (CVS and MCR Hardwired)

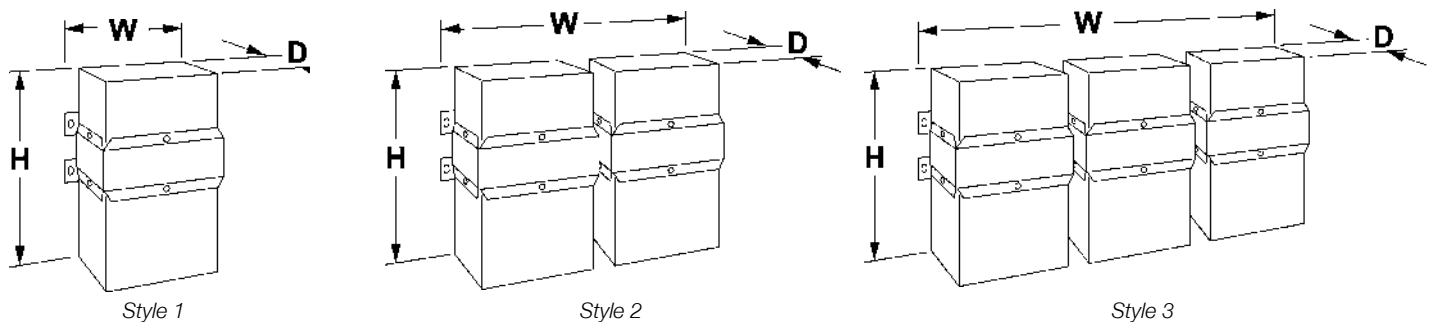

These styles are single phase only.

MCR Hardwired Series – Power Line Conditioning with Voltage Regulation

The SolaHD MCR Hardwired Series provides excellent noise filtering and surge protection to safeguard connected equipment from damage, degradation or misoperation. Combined with the excellent voltage regulation inherent to our ferroresonant design, the MCR can increase the actual Mean Time Between Failure (MTBF) of protected equipment. The MCR is a perfect choice where dirty power, caused by impulses, swell, sags, brownouts and waveform distortion can lead to costly downtime because of damaged equipment.



Applications

- Industrial automation and control equipment PLCs
- Machine tools
- Computer loads and electronic equipment
- Robotics
- Semiconductor fabrication equipment

Features

- ±3% output voltage regulation
- Noise attenuation
 - 120 dB common mode
 - 60 dB transverse mode
- Surge protection tested to ANSI/IEEE C62.41 Class A & B Waveform:
 - <10 V let through typical
- Acts as a step-up or step-down transformer
- Harmonic filtering
- Hardwired
- Galvanic isolation provides exceptional circuit protection
- 25 year typical MTBF
- No maintenance required

Selection Tables: Single Phase

Group 2 – MCR Series, 60 Hz Only

VA	Catalog Number	Voltage Input	Voltage Output	Height in (mm)	Width in (mm)	Depth in (mm)	Ship Weight lbs (kg)	Design Style	Elec Conn
120	63-23-112-4	120, 208, 240, 480	120	9 (229)	4 (102)	5 (127)	15 (7)	1	D
250	63-23-125-4	120, 208, 240, 480	120	10 (254)	6 (152)	8 (203)	27 (12)	1	D
500	63-23-150-8	120, 208, 240, 480	120, 208, 240	13 (330)	9 (229)	7 (178)	37 (17)	1	E
750	63-23-175-8	120, 208, 240, 480	120, 208, 240	14 (356)	9 (229)	7 (178)	52 (24)	1	E
1000 *	63-23-210-8	120, 208, 240, 480	120, 208, 240	17 (432)	9 (229)	7 (178)	62 (28)	1	E
1500 *	63-23-215-8	120, 208, 240, 480	120, 208, 240	17 (432)	13 (330)	9 (229)	95 (43)	1	E
2000 *	63-23-220-8	120, 208, 240, 480	120, 208, 240	18 (457)	13 (330)	9 (229)	109 (49)	1	E
3000 *	63-23-230-8	120, 208, 240, 480	120, 208, 240	19 (483)	13 (330)	9 (229)	142 (64)	1	E
5000 *	63-23-250-8	120, 208, 240, 480	120, 208, 240	28 (711)	13 (330)	9 (229)	222 (101)	1	E
7500	63-28-275-8	208, 240, 480	120, 208, 240	27 (686)	26 (660)	9 (229)	362 (164)	2	F
10000	63-28-310-8	208, 240, 480	120, 208, 240	28 (711)	26 (660)	9 (229)	446 (202)	2	F
15000	63-28-315-8	208, 240, 480	120, 208, 240	28 (711)	38 (965)	10 (254)	710 (322)	3	F

Certifications and Compliances

All Models

- RoHS Compliant

Selection Table: Group 2

- cULus Listed (120 VA-750 VA Units) (1-5kVa ("-C8" Units)
 - UL 1012, CSA C22.2 No. 107.1

- UL Listed (7.5kVA-15kVA Units) (1-5kVa ("-8" Units)
 - UL 1012

Selection Table: Group 3

- cULus Listed (500 VA-3kVA Units)
 - UL 1012, CSA C22.2 No. 107.1

- SF Certified (5kVA-15kVA Units)
 - CSA C22.2 No. 66

Selection Table: Group 4

- cULus Listed
 - UL 1012, CSA C22.2 No. 107.1

Related Products

- On-line UPS (S4K Industrial)
- Surge Protection
- Three Phase Power Conditioners
- Active Tracking® Filters

* Canadian option: cULus units must be ordered by changing "-8" (UL only) to "-C8" Dimensions are approximate. See user manual for exact dimensions.



Selection Tables: Single Phase

Group 3 – MCR Series, 60 Hz Only

VA	Catalog Number	Voltage Input	Voltage Output	Height in (mm)	Width in (mm)	Depth in (mm)	Ship Weight lbs (kg)	Design Style	Elec Conn
500	63-31-150-8	600	120, 208, 240	13 (330)	9 (229)	7 (178)	38 (17)	1	B
1000	63-32-210-8	600	120, 208, 240	17 (432)	9 (229)	7 (178)	62 (28)	1	B
2000	63-32-220-8	600	120, 208, 240	18 (457)	13 (330)	10 (254)	109 (49)	1	B
3000	63-32-230-8	600	120, 208, 240	19 (483)	13 (330)	10 (254)	142 (64)	1	B
5000	63-29-250-8	208, 240, 480, 600	120, 208, 240	28 (711)	13 (330)	10 (254)	221 (100)	1	A
7500	63-29-275-8	208, 240, 480, 600	120, 208, 240	27 (686)	25 (635)	10 (254)	360 (163)	2	A
10000	63-29-310-8	208, 240, 480, 600	120, 208, 240	28 (711)	25 (635)	10 (254)	441 (200)	2	A
15000	63-29-315-8	208, 240, 480, 600	120, 208, 240	28 (711)	38 (965)	10 (254)	706 (320)	3	A

Group 4 – MCR Series, 50 Hz Only ($\pm 5\%$ output voltage regulation)

VA	Catalog Number	Voltage Input	Voltage Output	Height in (mm)	Width in (mm)	Depth in (mm)	Ship Weight lbs (kg)	Design Style	Elec Conn
120	63-23-612-8	110, 120, 220, 240, 380, 415	110, 120, 220, 240	9 (229)	6 (152)	8 (203)	24 (11)	1	C
250	63-23-625-8	110, 120, 220, 240, 380, 415	110, 120, 220, 240	11 (279)	6 (152)	8 (203)	27 (12)	1	C
500	63-23-650-8	110, 120, 220, 240, 380, 415	110, 120, 220, 240	13 (330)	9 (229)	7 (178)	40 (18)	1	C
1000	63-23-710-8	110, 120, 220, 240, 380, 415	110, 120, 220, 240	18 (457)	9 (229)	7 (178)	64 (29)	1	C
2000	63-23-720-8	110, 120, 220, 240, 380, 415	110, 120, 220, 240	18 (457)	13 (330)	10 (254)	113 (51)	1	C
3000	63-23-730-8	110, 120, 220, 240, 380, 415	110, 120, 220, 240	27 (686)	13 (330)	10 (254)	162 (73)	1	C
5000	63-23-750-8	110, 120, 220, 240, 380, 415	110, 120, 220, 240	30 (762)	13 (330)	10 (254)	266 (121)	1	C
7500	63-28-775-8	220, 240, 380, 415	110, 120, 220, 240	28 (711)	26 (660)	10 (254)	393 (178)	2	C1
10000	63-28-810-8	220, 240, 380, 415	110, 120, 220, 240	30 (762)	26 (660)	10 (254)	490 (222)	2	C2
15000	63-28-815-8	220, 240, 380, 415	110, 120, 220, 240	30 (762)	38 (965)	10 (254)	776 (352)	3	C2

Specifications

Parameter	Condition	Value
Input		
Voltage	Continuous at full load (lower input voltage possible at lighter load)	+10% to -20% of nominal
	For temporary surge or sags	+20% to -35% of nominal
Current ¹	at Full Load & 80% of nominal input voltage	$I_n \cong (VA/.89)/(V_n \times 80\%)$
Frequency	See Operating Characteristics section for details.	50 Hz or 60 Hz depending on model
Output ²		
Line Regulation	$V_n > 80\%$ and $< 110\%$ of nominal	$\pm 5\%$ for 50 Hz units, $\pm 3\%$ for 60 Hz units
Overload Protection	At Nominal Input Voltage	Current limited at 1.65 times rated current
Output Harmonic Distortion	At full load within input range	3% total RMS content
Noise Attenuation	Common Mode	120 dB
	Transverse Mode	60 dB
General		
Efficiency	At Full Load	Up to 92%
Storage Temperature	Humidity $< 95\%$ non-condensing	-20° to $+85^\circ\text{C}$
Operating Temperature	Humidity $< 95\%$ non-condensing	-20° to 50°C
Audible Noise	Full Resistive Noise	35 dBA to 65 dBA
Warranty	10 + 2 year limited warranty	

Notes: 1 - Consult user manual for fuse sizing.

2 - It is recommended that the unit run at a minimum of 40-50% load.

Dimensions are approximate. See user manual for exact dimensions.

Electrical Connections

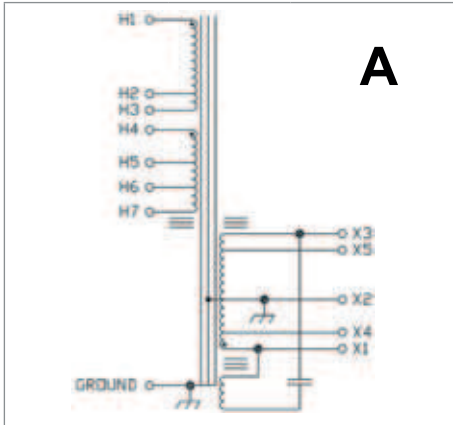

A

Primary Voltage	Interconnect	Connect Lines To
208	H1 to H4 H2 to H5	H1 & H5
240	H1 to H4 H3 to H6	H1 & H6
480	H3 to H4	H1 & H6
600	H3 to H4	H1 & H7
Secondary Voltage	Interconnect	Connect Lines To
120		X1 & X2 or X3 & X2
208		X4 & X5
240		X1 & X3

MCR 60 Hz 5000–15000 VA

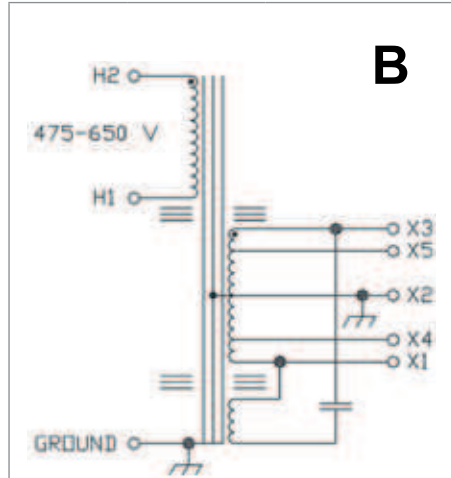

B

Primary Voltage	Interconnect	Connect Lines To
600		H1 & H2
Secondary Voltage	Interconnect	Connect Lines To
120		X1 & X2 or X3 & X2
208		X4 & X5
240		X1 & X3

MCR 60 Hz 500–3000 VA

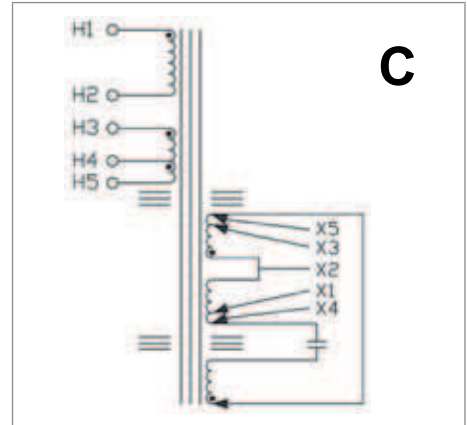

C

Primary Voltage	Interconnect	Connect Lines To
110-120	H1 to H3 H2 to H4	H1 & H4
220-240	H2 to H3	H1 & H4
380-415	H2 to H3	H1 & H5
Secondary Voltage	Interconnect	Connect Lines To
110		X1 & X2 or X3 & X2
120		X4 & X2 or X5 & X2
220		X1 & X3
240		X4 & X5

MCR 50 Hz 120–5000 VA

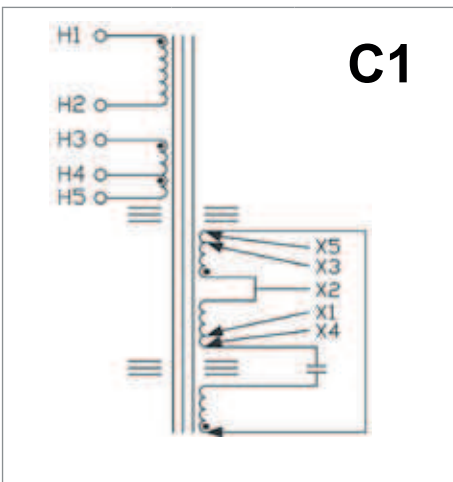

C1

Primary Voltage	Interconnect	Connect Lines To
220-240	H1 to H3 H2 to H5	H1 & H5
380-415	H2 to H3	H1 & H4
Secondary Voltage	Interconnect	Connect Lines To
110		X1 & X2 or X2 & X3
120		X4 & X2 or X5 & X2
220		X1 & X3
240		X4 & X5

MCR 50 Hz 7500 VA

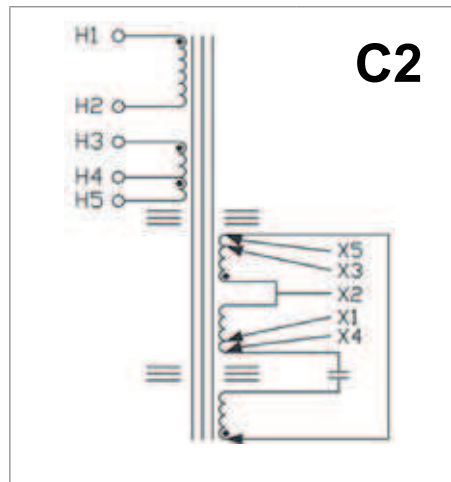

C2

Primary Voltage	Interconnect	Connect Lines To
220-240	H2 to H3	H1 & H4
380-415	H2 to H3	H1 & H5
Secondary Voltage	Interconnect	Connect Lines To
110		X1 & X2 or X3 & X2
120		X4 & X2 or X5 & X2
220		X1 & X3
240		X4 & X5

MCR 50 Hz 10000–15000 VA

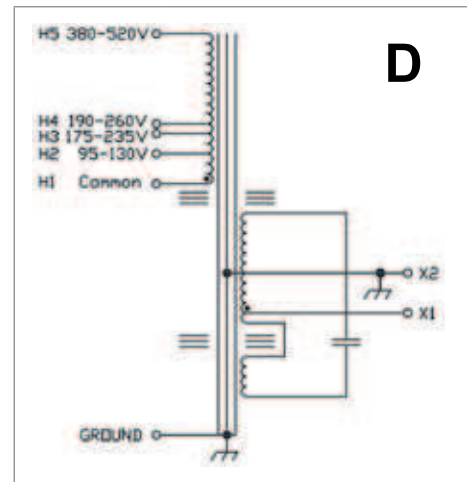

D

Primary Voltage	Interconnect	Connect Lines To
120		H1 & H2
208		H1 & H3
240		H1 & H4
480		H1 & H5
Secondary Voltage	Interconnect	Connect Lines To
120		X1 & X2

MCR 60 Hz 120–250 VA

Electrical Connections

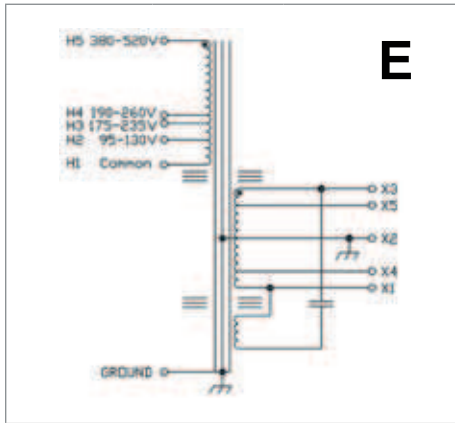

Primary Voltage	Interconnect	Connect Lines To
120		H1 & H2
208		H1 & H3
240		H1 & H4
480		H1 & H5
Secondary Voltage	Interconnect	Connect Lines To
120		X1 & X2 or X3 & X2
208		X4 & X5
240		X1 & X3

MCR 60 Hz 500-5000 VA

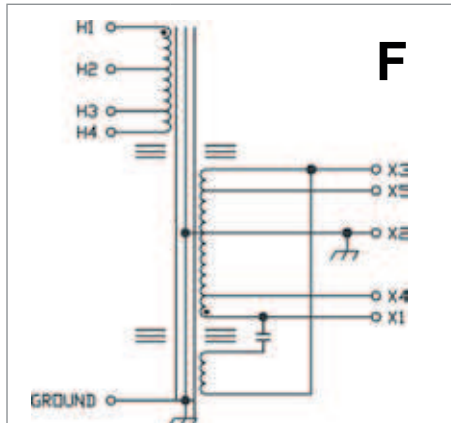

Primary Voltage	Interconnect	Connect Lines To
208		H2 & H3
240		H2 & H4
480		H1 & H4
Secondary Voltage	Interconnect	Connect Lines To
120		X1 & X2 or X3 & X2
208		X4 & X5
240		X1 & X3

MCR 60 Hz 7500, 10000 and 15000 VA

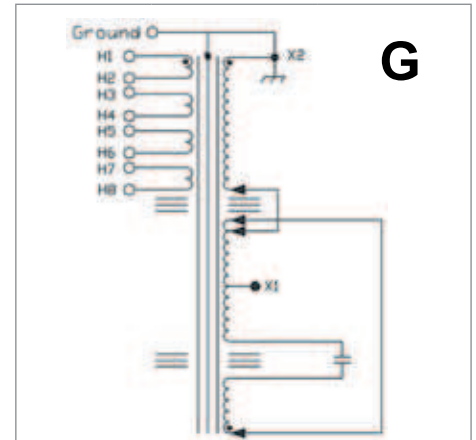

Primary Voltage	Interconnect	Connect Lines To
120	H1 to H3 to H5 to H7 H2 to H4 to H6 to H8	H1 & H2
240	H2 to H3 H6 to H7 H1 to H5 H4 to H8	H1 & H4
480	H2 to H3 H4 to H5 H6 to H7	H1 & H8
Secondary Voltage	Interconnect	Connect Lines To
120		X1 & X2

CVS 60 Hz 250 VA only

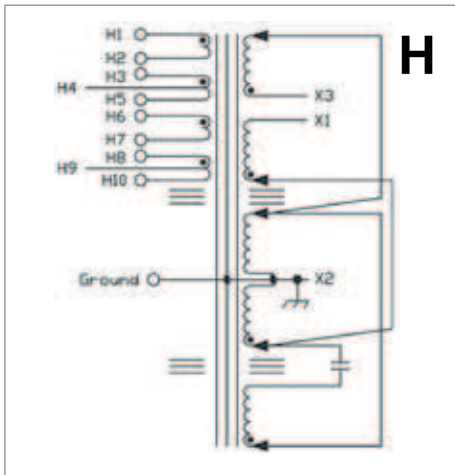

Primary Voltage	Interconnect	Connect Lines To
120	H1 to H3 to H6 to H8 H2 to H5 to H7 to H10	H1 & H2
208	H2 to H3 H7 to H8 H1 to H6 H4 to H9	H1 & H4
240	H2 to H3 H7 to H8 H1 to H6 H5 to H10	H1 & H5
480	H2 to H3 H5 to H6 H7 to H8	H1 & H10
Secondary Voltage	Interconnect	Connect Lines To
120		X1 & X2 or X3 & X2
240		X1 & X3

CVS 60 Hz 500-5000 VA

Series-Multiple Primary with Tap for two input voltages J

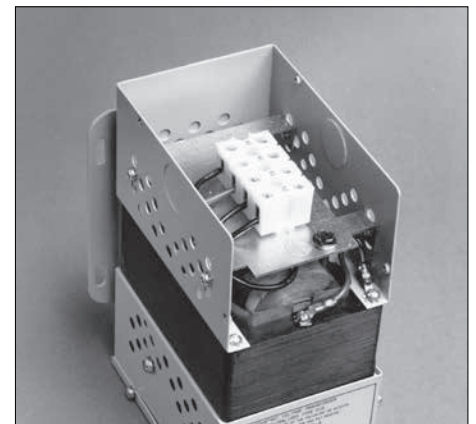
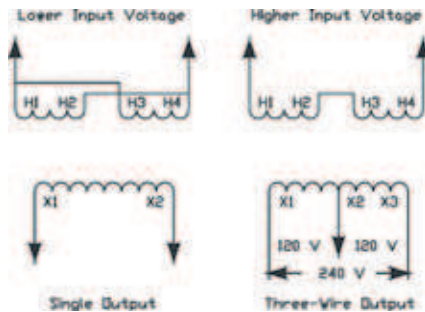

Open MCR/ CVS terminal

30 & 60 VA Primary Voltage	120 VA Primary Voltage	7500 VA Primary Voltage	Interconnect	Connect Lines To
120	N/A	N/A	Note: H3 & H4 are not used	H1 & H2
N/A	120	240	H1 to H3 H2 to H4	H1 & H4
N/A	240	480	H2 to H3	H1 & H4
30 & 60 VA Secondary Voltage	120 VA Secondary Voltage	7500 VA Secondary Voltage	Interconnect	Connect Lines To
120	120	N/A		X1 & X2
N/A	N/A	120		X1 & X2 or X3 & X2
N/A	N/A	240		X1 & X3

Note: Secondaries are not grounded. Ground X₂ per Code.

CVS 60 Hz 30-120 VA & 7500 VA

MCR Portable Series – Power Line Conditioning with Voltage Regulation

The SolaHD MCR Series provides excellent noise filtering and surge protection to protect connected equipment from damage, degradation or misoperation. Combined with the excellent voltage regulation inherent to our ferroresonant design, they can increase the actual Mean Time Between Failure (MTBF) of protected equipment. These units are a perfect choice where dirty power caused by impulses, swell, sags, brownouts and waveform distortion can lead to costly downtime because of damaged equipment.



Applications

- Computers/ Printers
- Telephone/FAX systems
- POS terminals
- Security systems
- Laboratory equipment
- LAN networks

Features

- ±3% output voltage regulation
- Noise attenuation
 - 120 dB common mode
 - 60 dB transverse mode
- Surge protection tested to ANSI/IEEE C62.41 Class A & B waveform (<10 V let-through typical)
- Harmonic filtering
- Galvanic isolation provides exceptional circuit protection.
- Point-of-use protection (cord & plug connected)
 - Easy & Flexible Installation
- 25 year typical MTBF
- No maintenance required

Certifications and Compliances

All Models

- RoHS Compliant
- Listed
 - UL 1012

Select Models

- Listed (1500 VA Units)
 - UL 1012, CSA C22.2 No. 66
- Certified (70 VA-1kVA Units)
 - CSA C22.2 No. 66

Related Products

- DIN Rail AC UPS (SDU)
- Off-Line UPS (S1K Mini-Tower)
- Line-Interactive UPS (S3K Mini-Tower)

Selection Tables: Single Phase

Group A – MCR Portable Series, 60 Hz

VA	Catalog Number	Voltage Input/Output	Height in (mm)	Width in (mm)	Depth in (mm)	Ship Weight lbs (kg)	Receptacle (No.) Type (NEMA)	Plug (NEMA)
70	63-13-070-6	120	6.00 (152.4)	7.00 (177.8)	9.00 (228.6)	18.0 (8.16)	(4) 5-15R	5-15P
150	63-13-115-6	120	6.00 (152.4)	7.00 (177.8)	9.00 (228.6)	21.0 (9.53)	(4) 5-15R	5-15P
250	63-13-125-6	120	6.00 (152.4)	7.00 (177.8)	9.00 (228.6)	26.0 (11.79)	(4) 5-15R	5-15P
500	63-13-150-6	120	9.00 (228.6)	9.00 (228.6)	16.00 (406.4)	32.0 (14.51)	(4) 5-15R	5-15P
750	63-13-175-6	120	9.00 (228.6)	9.00 (228.6)	16.00 (406.4)	64.0 (29.03)	(4) 5-15R	5-15P
1000	63-13-210-6	120	9.00 (228.6)	9.00 (228.6)	16.00 (406.4)	69.0 (31.30)	(4) 5-15R	5-15P
1500*	63-13-215-6	120	11.00 (279.4)	11.00 (279.4)	17.00 (431.8)	95.0 (43.09)	(6) 5-15R	5-20P
2000	63-13-220-6	120	11.00 (279.4)	11.00 (279.4)	17.00 (431.8)	115.0 (52.16)	(4) 5-15R, (1) L5-30R	L5-30P
3000*	63-13-230-6	120	11.00 (279.4)	11.00 (279.4)	17.00 (431.8)	143.0 (64.86)	(4) 5-15R, (1) L5-30R	5-50P

* cULus

* UL Only

Specifications

Parameter	Condition	Value
Input		
Voltage	Continuous at full load (lower input voltage possible at lighter load)	+10% to -20% of nominal
	For temporary surge or sags	+20% to -35% of nominal
Current ¹	At Full Load & 80% of nominal input voltage	$I_{in} \cong (VA/.89)/(V_{in} \times 80\%)$
Frequency	See Operating Characteristics section for details.	60 Hz depending on model
Output ¹		
Line Regulation	$V_{in} >80\%$ and $<110\%$ of nominal	$\pm 3\%$ for 60 Hz units
Overload Protection	At Nominal Input Voltage	Current limited at 1.65 times rated current
Output Harmonic Distortion	At full load within input range	3% total RMS content
Noise Attenuation	-Common Mode	120 dB
	-Transverse Mode	60 dB
Let-Through	ANSI/IEEE C62.41 Class A & B Waveform	<10 V typical
General		
Efficiency	At Full Load	92% Typical
Storage Temperature	Humidity $<95\%$ non-condensing	-20° to $+85^{\circ}\text{C}$
Operating Temperature	Humidity $<95\%$ non-condensing	-20° to 40°C
Audible Noise	Full Resistive Noise	35 dBA to 65 dBA
Warranty	10 + 2 year limited warranty	

Notes:

1 - It is recommended that the unit run at a minimum of 40-50% load.

Back Panels



60 Hz, 70 – 1000 VA,
(4) 5-15R Receptacles



60 Hz, 2000–3000 VA,
(4) 5-15R and
(1) L5-30R Receptacle

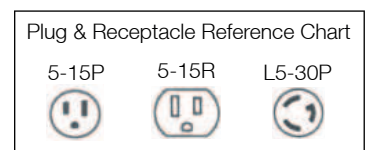

Model Comparison

Description	Hardwired CVS	Hardwired MCR	Portable MCR
VA Ratings	30 to 7500 VA	120 to 15000 VA	70 to 3000 VA
Input Voltage Range	+10/-20% of nominal		
Voltage Regulation	±1% for an input line variation of +10/-20%. No loss of output for line loss of 3 msec.	±3% for an input line variation of +10/-20% (50 Hz hardwired units ±5%). No loss of output for complete line loss of 3 msec.	
Overload	Limits output current to 1.65 x rated current at nominal input.		
Output Harmonic Distortion	3% total RMS content at full load.		
Noise Isolation	40 dB common and normal code.	120 dB common mode and 60 dB normal mode.	
Surge Protection	Up to 6000 Volt surges are suppressed to a let through of less than 1% per ANSI/IEEE C62.41 Class A & B waveforms.	ANSI/IEEE C62.41 Class A & B 6000 waveforms are suppressed to a let-through of less than 0.2%.	
Efficiency	Up to 92% at full load		Up to 90% at full load
Operating Temperature	-20°C to 50°C		-20°C to 40°C
Audible Noise	32 dB to 65 dB	35 dB to 65 dB	34 dB to 49 dB
Warranty	10 year limited warranty		

Note: All values are typical and may vary based on VA ratings of actual units.

BTU Output Chart for CVS and MCR Series

VA Ratings	120	250	500	750	1000	1500	2000	3000	5000	7500	10000	15000
Total BTUs	136	225	280	444	519	686	1229	1331	2117	2407	3209	4813

Note: Ratings are for a 40°C ambient temperature.

Operating Characteristics of the CVS & MCR Series

Except as noted, all characteristics of Solahd CVS products also apply to the MCR series.

Regulation

Solahd CVS Series power conditioners will hold output voltages to $\pm 1.0\%$ or less with input variations as great as $\pm 15\%$ (115 V $\pm 15\%$ or 120 V $+10\%/-20\%$). Units operated at less than rated load will maintain approximately $\pm 1\%$ regulation over a wider input line voltage variation. Output meets NEMA voltage specifications even when input voltage drops to 65% of nominal. The output versus input voltage relationship for a typical CVS is show in Figure A.

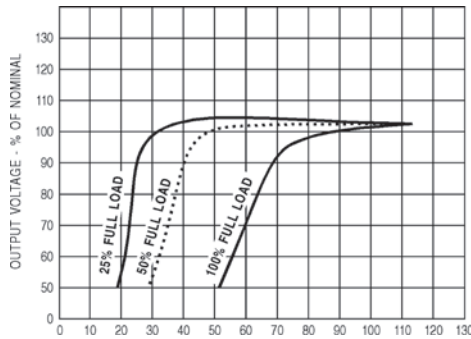

Figure A: Load Variation

Note: Solahd MCR Series line regulations: $\pm 3\%$ for 60 Hz; $\pm 5\%$ for 50 Hz. The typical performances shown in Figure B indicate that most of the residual changes take place near the lower (95 V) and upper (130 V) ends of the input range. It is possible to improve output regulation if line variations remain within a restricted range near the center of the name-plate range (for example, 100-120 V).

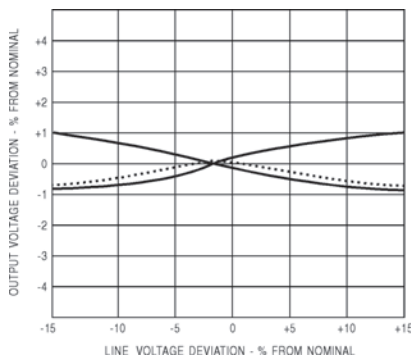

Figure B: Line Regulation

Normally, the output voltage will rise as the load is decreased. Typical percentages for changes in resistive load from full to zero load as shown below.

CVS Conditioner Rating – VA	Increase in Output Voltage due to Load Removal
30	3%
60 & 120	2%
250 & over	1%

Input Characteristics

Solahd power conditioners include a resonant circuit that is energized whether or not it is serving load. The input current at no load or light load may run 50% or more of the full primary current. As a result, the temperature of the unit may rise to substantially full-load level, even at light or no load. Input power factor will average 90-100% at full load, but may drop to about 75% at half load and 25% at no load. In any case, the current is always leading. The input no load watts are about 12.5% of the VA rating.

Frequency

Output voltage varies linearly with a change of frequency of the input voltage. This change is about 1.5% of the output voltage for each 1% change in input frequency and in the same direction as the frequency change.

Operating Characteristics of the CVS & MCR Series

Except as noted, all characteristics of SolaHD CVS products also apply to the MCR series.

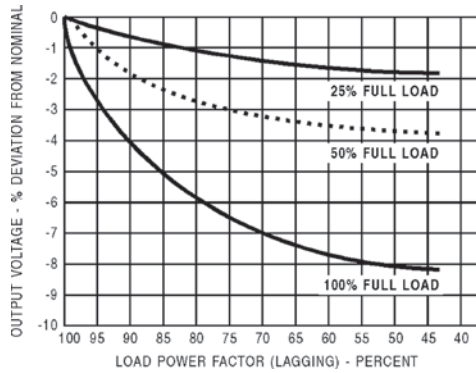

Figure C: Power Factor

Power Factor

SolaHD power conditioners regulate any power factor load. Output voltage is a function of load current and load power factor (see Figure C). If lower voltage under lagging power factor is objectionable, correction may be made with capacitors at the load. “Median” value of output voltage will vary from the nameplate rating if the load has a power factor other than that for which the transformer was designed. Load regulation will also be relatively greater as the inductive load power factor is decreased (see Figure C). However, the resulting median values of output voltage will be regulated against supply line changes at any reasonable load or load power factor.

Efficiency

The copper magnet wire and lamination material used in our ferroresonant products are selected to achieve efficiencies of 90% or higher. Whether or not an external load is being served, current will be drawn from the line whenever the primary is energized, since the capacitor remains connected in the circuit.

Overload and Short Circuits

When the load is increased beyond the regulator’s rated value, a point is reached where the output voltage suddenly collapses and will not regain its normal value until the load is partially released. Under direct short circuit, the load current is limited to approximately 150-200% of the rated full load value and the input watts to less than 10% of normal.

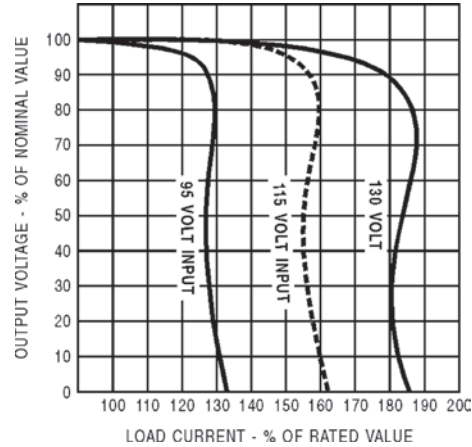

Figure D: Overload Performance

A constant voltage regulator will protect both itself and its load against damage from excessive fault currents. Fusing of load currents may not be necessary. The actual value of short-circuit current varies with the specific design and rating. Units may be operated indefinitely at short-circuit. This characteristic protects the unit itself as well as the load and load circuit being served. Typical overload performance is shown in Figure D.

Motor Loads

Because of the fast response time of the SolaHD circuit, any current-limiting characteristic must be taken into account for transient overloads such as motor starting and solenoid operation. In general, the SolaHD constant voltage regulator must have a capacity nearly equal to the maximum demand made on it, even for an instant. To determine the power rating of the regulator, peak motor-starting current or solenoid inrush current should be measured or power factor correcting capacitors should be used to reduce the starting VA of the load.

Response Time

An important advantage of our SolaHD ferroresonant transformer is its fast response time compared with other types of AC regulators. Transient changes in supply voltage are usually corrected within 1½ cycles or less; the output voltage will not fluctuate more than a few percent, even during this interval.

Operating Characteristics of the CVS & MCR Series

Except as noted, all characteristics of SolaHD CVS products also apply to the MCR series.

Temperature

Our SolaHD ferroresonant power conditioners are very stable with respect to temperature. The change in output voltage is only 0.025%/°C. Units are factory adjusted to +2%/-0% of nominal, with full load and nominal input voltage. This adjustment to the high side of nominal is to compensate for the natural temperature drift of about 1% that takes place during initial turn-on or warm-up. When the unit warms up to operating temperature, the voltage typically falls about 1%.

At a stable operating temperature, the output voltage will change slightly with varying ambient temperatures. This shift is equal to approximately 1% for each 40°C of temperature change. The normal maximum temperature rise of a SolaHD power conditioner may fall anywhere in the range of +40°C to +110°C depending on the type and rating. The nominal design ambient range is between -20°C and +50°C (-20°C to +40°C for 70 - 1000 VA, 60 Hz portable models).

External Magnetic Field

In almost all applications, this effect may be disregarded. Our exclusive SolaHD “wide outside leg” construction reduces stray magnetic fields to a practical minimum. On critical applications, care should be taken in orientation of the core with respect to critical circuits to minimize the effect of the field.

Phase Shift

The phase difference which exists between input and output voltages is in the range of 120 degrees to 140 degrees at full load. This phase difference varies with the magnitude and power factor of the load, and to a lesser extent, with changes in line voltage and load power factor.

Transient Protection

Our ferroresonant power conditioners protect input transients (caused by lightning and load switching) from damaging the sensitive electronic load. A typical surge protective device (SPD) tries to “clamp” a transient by diverting it to ground. A ferroresonant power conditioner “blocks” the transient. This ‘blocking’ action is achieved by total physical separation from input (primary) to output (secondary). Because of this difference in operation, it is difficult to apply the same specifications to a ferroresonant power conditioner. Some parallels can be made however.

One, is that under load, the let-through voltage of a ferroresonant power conditioner (SPD refers to “clamping voltage”) is less than 10 V above the point where the sine wave would normally be at any given time. The ferroresonant power conditioner is an “active tracking” suppressor with several advantages. The Ferro power conditioner will not shunt the transient to the ground line as SPD devices typically do. Shunting the transient to ground can cause the disturbance to be transmitted to other sensitive loads within a facility. This can pose serious problems with electronic or microprocessor-based equipment, especially if there is poor grounding within a facility. Other advantages provided by ferroresonant power conditioners include noise filtering, filtering of harmonic distortion and protection against voltage fluctuations such as sags or swells. These features are not provided by standard surge protection devices but are often misrepresented or misused by SPD manufacturers trying to market their product as a “Do All” power quality device.

SOLATRON™ Plus Series - Three Phase Power Conditioners

Applications

- Automatic Packaging Machinery
- Large Machine Tool Equipment
- UPS Bypass Circuits
- Retail Store
- Process Equipment

Features

- Rugged, industrial construction
- High overload capability
- High MTBF - No fans used
- No power factor restriction on loads
- Tight regulation for protection against sag (-25%) and swell (+10%) conditions
- No load current interruption for auto-bypass mode
- Status indicating lights
- Shielded, copper wound isolation transformer
- Surge protection to ANSI/IEEE and IEC Standards
- High efficiency (96%) microprocessor controlled on-load tap changer
- Automatic over and under voltage regulation. Auto restart upon power loss and return
- Two year limited warranty

Certifications and Compliances

-  Listed
 - UL 1012
 - CSA C22.2 No.125
- FCC Rules: complies with Part 15 Subpart J for a Class A computing device

Input Surge Suppressor

- UL 1449

Related Products

- STV100K
- Isolation Transformers



Selection Table

Output kVA	Catalog Number	Vac Input	Vac Output	Ship Weight lbs (kg)
208 Vac Input, 208Y/120 Vac Output, 60Hz				
30	63TAA330	208	208Y/120	750.0 (341.00)
50	63TAA350	208	208Y/120	950.0 (432.00)
75	63TAA375	208	208Y/120	1200.0 (545.00)
480 Vac Input, 208Y/120 Vac Output, 60 Hz				
20	63TCA320	480	208Y/120	600.0 (273.00)
30	63TCA330	480	208Y/120	750.0 (341.00)
50	63TCA350	480	208Y/120	950.0 (432.00)
75	63TCA375	480	208Y/120	1200.0 (545.00)
480 Vac Input, 480Y/277 Vac Output, 60 Hz				
20	63TCC320	480	480Y/277	600.0 (273.00)
30	63TCC330	480	480Y/277	750.0 (341.00)
50	63TCC350	480	480Y/277	950.0 (432.00)
75	63TCC375	480	480Y/277	1200.0 (545.00)
100	63TCC410	480	480Y/277	1600 (726.00)
150	63TCC415	480	480Y/277	2000 (907.00)
200	63TCC420	480	480Y/277	2300 (1043.00)
600 Vac Input, 208Y/120 Vac Output, 60 Hz				
20	63TDA320	600	208Y/120	600.0 (273.00)
30	63TDA330	600	208Y/120	750.0 (341.00)
50	63TDA350	600	208Y/120	950.0 (432.00)
75	63TDA375	600	208Y/120	1200.0 (545.00)
Contact Technical Services for custom voltages, kVA sizes. LCD display or power monitoring options.				

Protection Specifications

Under Voltage	Output voltage will switch to bypass mode when input is less than 50% of nominal. Regulated output voltage will be re-established once input voltage is with specifications.
Short Circuit Protection	Input circuit breaker
Over Temperature Protection	Amber lamp indication of over temperature at approximately 180°C. Unit switches to by-pass mode until internal temperature is reduced to specified values.

Noise Suppression Performance Specifications

Common Mode Noise Attenuation	150 dB at 100 kHz
Normal Mode Noise Attenuation	65 dB at 100 kHz
Surge Protection	Tested to ANSI/IEEE standard C62.41 A&B

Electrical Specifications

Power Ratings	20, 30, 50, 75 kVA, Three Phase *
Nominal Voltages	See Selection Table
Input Voltage Range	-25% to +10% of nominal rated voltage
Output Voltage Range	Regulated to $\pm 3\%$ of nominal voltage with an input voltage range of -25% to +10%.
Response Time	Responds to any line variation in <1.5 cycles typical.
Technology	Enhance Voltage Regulation (EVR), Microprocessor controlled electronic tap switching. 6 steps, switched independent of waveform zero cross, with no load interruption. Regulation is RMS based.
Operating Frequency	57-63 Hz
Load Power Factor	No Restriction
Insulation Resistance	100 megohms from winding to core measured at 500 Vdc
Efficiency	96% typical
Overload Capability	1000% of rated load for 1 second 200% of rated load for 1 minute
EMI	Less than 0.2 gauss at a distance of 3 ft.

* Contact Technical Services for other ratings.

Mechanical Specifications

Power Rating: 20–75 kVA, Three Phase

Indicators	Indicating Lamps: 2 amber (over temperature and bypass mode), 1 green (regulated output present)			
Connections	Field wired, terminal blocks			
Size		H	W	D
	in	43	28	26
	mm	1093	712	661

Power Rating: 100–200 kVA, Three Phase

Indicators	LCD Status Display, 4 x 20 Character, 3-Button Interface			
Connections	Field wired, terminal blocks			
Size		H	W	D
	in	65	44	33
	mm	1651	1118	838

Environmental Specifications

Audible Noise	Less than 65 dBA at 1 meter
Ambient Temperature	0° to 40°C Operating, 0° to 80°C Storage
Operating Altitude	10,000 feet without derating
Operating Humidity	95% relative (non-condensing)

Design Style

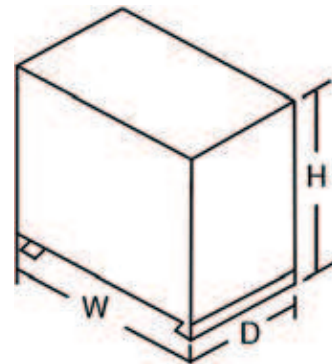



Selecting a UPS 58

SDU Direct Current (DC) DIN Rail UPS..... 60

SDU AC - A Series (500 VA & 850 VA) Off-line DIN Rail UPS.. 65

S1K (320 VA to 1.5 kVA) Off-line UPS 69

S3K (700 VA to 1.4 kVA) Line-Interactive UPS 71

S4K2U-C, 2U-5C (Industrial) On-Line UPS 73

S4K4U-C 6 kVA On-Line UPS 84

S4K6U-C 10 kVA On-Line UPS 84

S4K5U-5C 6 kVA International On-Line UPS 92

S5KC Modular Series On-Line UPS 101

UPS Extended Warranty for UPS up to 6 kVA..... 114

Field Service Programs for UPS 6 kVA and higher 115

Selection Table

Feature	Benefits	DC	Off-Line		Line-Interactive	On-Line	
		SDU DC	SDU AC-A	S1K	S3K	S4K-C	S5KC
Power Rating	—	240-480 VA DC	500-850 VA	320-1500 VA	700-1440 VA	700 VA - 10 kVA	5KVA - 20KVA
Battery Back-up	Stop power interruptions from destroying data and work in progress	•	•	•	•	•	•
Surge Protection & Filtering	Prevent surges, spikes and noise from damaging your hardware		•	•	•	•	•
Voltage Regulation	Keep working during power sags, brownouts and high line voltage without draining your battery.			• (on 320, 520 & 1500 VA models only)	•	•	•
Sinewave Output	More compatible with sensitive loads				•	•	•
Extended Battery Option	Work through the longest black-outs with the extended battery option	•				•	•
Hardwired Input & Output Possible	Easy, permanent installation with less chance of “accidental” misuse.	•	•			•	•
On-Line “Zero Transfer Time” Performance	Mission-critical work requires on-line premium power protection.	•				•	•
Page Number		60	65	69	71	73	101

SDU Series, Direct Current Uninterruptible Power Supply (DC UPS) System

The SolaHD SDU DIN Rail DC UPS is an advanced 24 Vdc uninterruptible power system that combines an industry leading design with a wide operational temperature range and unique installation options. The SDU DC UPS is a powerful, microprocessor controlled UPS that provides protection from power interruptions. With an input voltage range of 22.5 to 30.0 Vdc, the DC UPS is the ideal power back-up solution for your critical connected loads.

These units were designed specifically for use with our popular SolaHD SDN Series of power supplies. There is an external battery module that is the only one on the market that allows you to seal the electronics in the panel and maintain safety by placing the battery outside of a non-ventilated enclosure.

These units include easy to wire screw terminations for critical devices needing battery back-up. The SDU DC UPS includes an automatic self-test feature that checks the UPS and battery functions. Battery charging occurs automatically when input DC power is applied. When power fails, the DC UPS will switch to battery back-up. If the battery is no longer useful, the UPS will sound an alarm and an LED indicator will illuminate.

Back-up power protection in modern industrial applications depends mainly on AC UPS. AC is converted to DC, and converted back to AC in the AC UPS, then converted back to DC in the protected equipment power supply. By applying the SolaHD SDU DIN Rail DC UPS, you avoid the inefficiencies of all these conversions. This design maximizes system up-time flexibility, and optimizes reliability assurance.

Applications

- Industrial/Machine Control
- Automation Process Control
- Computer-based Control Systems
- Conveying Equipment
- Material Handling
- Packaging Machines
- Semiconductor fabrication equipment
- DeviceNet™
- Amusement Park Equipment
- Pharmaceutical Applications
- Control Rooms

Features

- Modular, rugged industrial grade design
- Microprocessor based controls
- Automatic self-test feature for UPS function and battery



- management check
- Power module wide operation temperature range (-20 to +50°C)
- Flexible batteries back-up expansion capabilities
- Overload protection in normal and battery modes
- User replaceable batteries
- IP20 rated input and output screw terminals
- No internal fan, no extra cooling required
- Sturdy, reliable all metal DIN rail mounting connector
- LED status indicators
- Universal dry contact relay terminals provide remote signaling
- Monitoring, diagnostics, and remote turn-on and shut-off capabilities
- Two year limited warranty

Certifications and Compliances

All Models

- Listed, Ind. Control Equipment, E61379
- UL 508, CSA C22.2 No. 107.1
- UL Recognized Component, ITE, E137632
- UL 60950-1/CSA C22.2 No. 60950-1
- - IEC/EN60950-1
- RoHS Compliant

Related Products

- SDN-P Series DIN Rail Power Supplies
- SDN-C Series DIN Rail Power Supplies
- STV 25K Series Surge Protective Devices

Selection Table

Catalog Number	Description	Approx. Ship Weight lbs (kg)
UPS		
SDU 10-24	240 VA, 24 V/10 A DIN Rail DC UPS power module, battery module is required	1.7 (0.77)
SDU 20-24	480 VA, 24 V/20 A DIN Rail DC UPS power module, battery module is required	1.7 (0.77)
Battery		
SDU 24-BAT	24 V DIN Rail/Panel Mount Battery Module (cable included)	12.0 (5.33)
SDU 24-BATEM	24 V External Mount Battery Module (cable included)	16.0 (7.11)
Accessories		
SDU 24EXTBC6	Optional 6 ft. Battery Module cable to 24 V DC UPS	0.5 (0.22)
SDU 24-DB9	Optional interface kit to convert relay contacts signals to DB9 signals	1.0 (0.45)
SDU-PMBRK	Optional chassis mount brackets to secure UPS to wall, panel, or enclosure	0.5 (0.22)

There are three individual hardware products when putting an SDU DC UPS system into operation:

1. 24 Vdc Power Supply (Recommended SolaHD SDN Series)
2. 24 Vdc SDU DC UPS Power Module
3. 24 Vdc SDU DC UPS Battery Module; or 24 Vdc SDU DC UPS External Battery Module

There are two models of the SDU DC UPS Power Module:

1. SDU 10-24, 24 Vdc/10 Amp (battery modules are required)
2. SDU 20-24, 24 Vdc/20amp (battery modules are required)

There are two models * of the SDU DC UPS Battery Modules:

1. SDU 24-BAT, DIN Rail/Panel mount for installation in ventilated enclosure, up to 4 battery modules can be connected to the SDU DC UPS.
2. SDU 24-BATEM, Panel mount, alternate battery module for external installation of non-ventilated enclosures, only 1 battery module can be connected to the SDU DC UPS.

* Cannot use a combination of both models of the battery modules, only one model of the battery module can be connected to the SDU DC UPS.

DIN Rail Mounted Battery Option

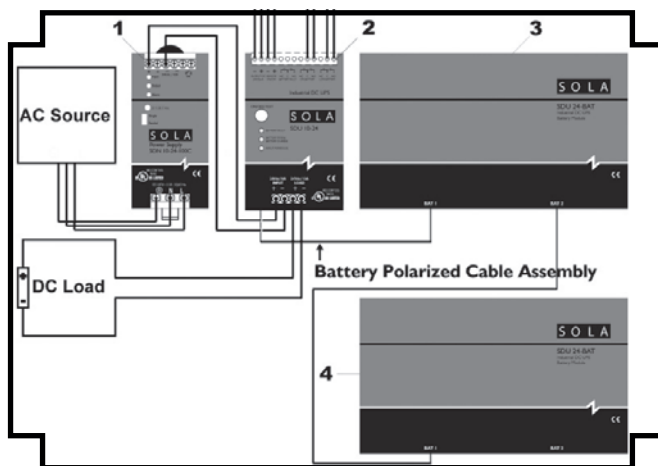

- 1) AC/DC Power Supply
- 2) Power Module: SDU 10-24 or SDU 20-24
- 3) Battery Module: SDU 24-BAT
- 4) Optional battery module for extended Back-up.

External Battery Option

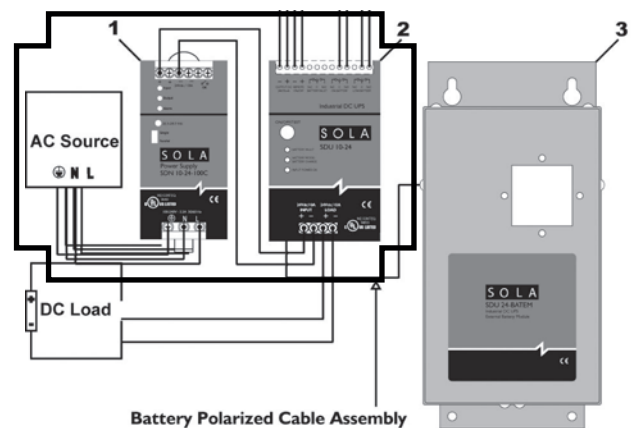

- 1) AC/DC Power Supply
- 2) Power Module: SDU 10-24 or SDU 20-24
- 3) Battery Module: SDU 24-BATEM

SDU DC UPS Power Modules Specifications

Specification	SDU 10-24	SDU 20-24
Input		
Nominal Input Voltage	24 Vdc	
Input Voltage Range	22.5 - 30 Vdc	
Input Fuse	DC Fuse 30 A	
Output		
Nominal Output Voltage	24 Vdc	
Output Voltage Range	22.5 - 30 Vdc	
Output Current	10 A	20 A
Current Limit	12 A	22 A
Protection		
Input Protection	Fuse for overload & short circuit protection	
Overload Protection	Electrical Circuit Protection	
Short Circuit	UPS output cut off immediately	
Battery Module		
Type	Sealed, maintenance-free lead acid batteries.	
Charging Current	0.5 A	
Typical Recharge Time (to 90% of full capacity)	8 Hours for 1 Battery Module 24 Hours for 2 Battery Module 12 Hours for each additional Battery Module	
Back-up Time (full load) ¹	14 minutes	4 minutes
Protection	UPS Shutdown when battery voltage drops below 22V, to prevent the complete depletion of the battery, short circuit protection by a 30 A fuse.	
Physical		
Net Weight – lbs (kg)	1.7 (0.77)	
Dimensions H x W x D – in. (mm)	4.88 x 3.02 x 4.55 (124.0 x 77.0 x 116.0)	
Alarm		
Battery Low	Rapid Audible Indicator every 1 second	
Overload	Continuous Audible Indicator	
Environment		
Audible Noise	<40 dBA (1 meter from surface)	
Power Module Operating Temperature	-20°C to +50°C	
Storage Temperature	-20°C to +70°C	
Humidity	0-95%	
Max Elevation	3500 meters (11,483 feet)	
Shock & Vibration	According to ISTA 2A	
DC UPS System ²		
EMC	FCC Part 15, Subpart B, Class A Directive 2004/108/EC: EN 62040-2 Category C2 EN 55022 Class A + A1 + A2, CISPR 22 Class A (2005), IEC 61000-3-2, IEC 61000-4-2, IEC 61000-4-3, IEC 61000-4-4, IEC 61000-4-5, IEC 61000-4-6 + A1, IEC 61000-4-8, IEC 61000-2-2	
General		
MTBF	> 200,000 Hours, MIL-STD 217F	
Installation		
Output	Outputs are capable of providing high currents for short periods of time for inductive load start-up or switching. Fusing may be required for wire/loads if 2x Nominal O/P current rating cannot be tolerated. Continuous current overload allows for reliable fuse tripping	
Mounting	Simple snap-on system for DIN Rail TS35/7.5 or TS35/15 or chassis-mounted, optional screw mounting set SDU-PMBRK.	
Connections	Input & Output: IP20-rated screw terminals, connector size range: 16-12 AWG (0.5-4 mm ²) for copper conductors rated 90°, Torque 4.3 lb-in. (0.49 Nm).	
Relay Contact Terminal Connections	IP20 screw terminals; connector size range: 24-16 AWG (0.34-4mm ²)	
Case	Fully enclosed metal housing with ventilation grid to keep out small particles.	
Free Space	20 mm above, 35 mm below, 20 mm left/right, 10 mm in front	

Notes:

- See Battery Back-up Times on next page.
- DC UPS System includes one power module (SDU 10-24 or SDU 20-24) and one or more battery modules (SDU 24-BAT or SDU 24BATEM)

SDU DC UPS Battery Module Specifications

Parameter	SDU 24-BAT	SDU 24-BATEM
Nominal Voltage	24 Vdc	
Protection	Fuse: 30 A	Circuit Breaker: 24 V, 25 A
Charging Current	0.5 A	0.8 A
Enclosure Dimension in. (mm)	4.88 x 8.27 x 4.55 (124.0 x 210.0 x 116.0)	11.5 x 5.57 x 4.57 (292.0 x 142.0 x 116.0)
Enclosure Type	IP20	NEMA 1
Terminal Connector Type	Polarized Powerpole Connectors	
Batteries	Replaceable Batteries	
Accessories	1 ft. polarized battery cable	6 ft. polarized battery cable
Operating Temperature	-20° to +50°C	
Storage Temperature	-20° to +40°C	
Humidity	95% no condensation	
Weight – lbs (kg)	12.0 (5.33)	16.0 (7.11)
Mounting	Simple snap-on system for DIN Rail TS35/7.5 or TS35/15 or chassis-mounted, optional screw mounting set SDU-PMBRK .	Wall/Chassis Mounting

SDU DC UPS Back-Up Times (Typical)

SDU 10–24 with SDU 24–BAT					
Load	20% (2A)	40% (4A)	60% (6A)	80% (8A)	100% (10 A)
1 unit	113	45	30	21	14
2 units	247	114	74	48	38
3 units	396	178	117	80	58
4 units	531	233	148	111	81
SDU 10–24 with SDU 24–BATEM					
1 EBP	135	52	28	19	14
SDU 20–24 with SDU 24–BAT					
Load	20% (4A)	40% (8A)	60% (12A)	80% (16A)	100% (20A)
1 unit	46	21	10	06	04
2 units	116	50	28	17	10
3 units	178	80	46	31	20
4 units	237	113	65	43	31
SDU 20–24 with SDU 24–BATEM					
1 EBP	48	17	9	6	4

Note: Run times in this table are approximate. They are based upon new, fully charged standard battery modules at a temperature of 25°C (77°F) with 100% resistive UPS loading. Run times listed above can vary by +/-5% due to manufacturing variances of the individual batteries

SDU AC -A Series, DIN Rail UPS

The SolaHD SDU AC - A Series DIN Rail UPS combines an industry leading compact design with a wide operation temperature range, enhanced communication and unique installation options. The SDU Series provides economical protection from damaging impulses and power interruptions. These units include easy to wire screw terminations for critical devices needing battery back up such as computer based control systems.

Applications

- Programmable Logic Controllers
- Factory Automation
- Robotics
- Conveying Equipment
- Computer based Control Systems

Features

- Lightweight, compact industrial design
- Communications port for optional Industrial Ethernet protocols or discrete communication card
- Wide operation temperature range (0°C to 50°C)
- Cold start capability
- Software and cable included for easy installation
- Simulated sinewave output
- USB communication port
- Remote turn-on and shutdown capabilities
- Two year limited warranty
- Panel/wall mounting brackets (optional)

Certifications and Compliances

- - Low Voltage Directive: EN62040-1
 - EMC Directive: EN62040-2

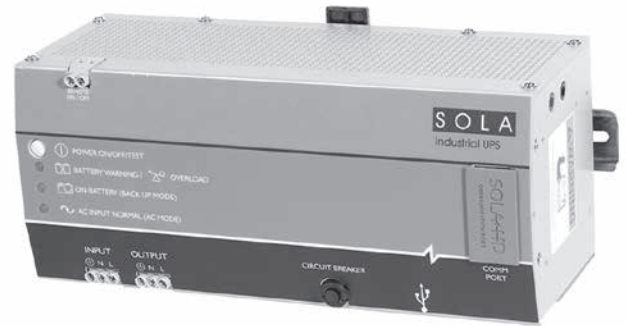

- UL Recognized Component, UPS Equipment, E179213
 - UL 1778 5th Ed., CSA C22.2 No. 107.3
 - Suitable for UL 508 at full load output (no derating) and Ind. Control Equipment Applications Overvoltage Cat III, Pollution Degree III
- UL Recognized Component, Hazardous Locations E491259
 - ANSI ISA 12.12.01/CSA 213
 - Class I, Division 2, Groups A, B, C, D, T3
- ODVA Compliant
 - EtherNet/IP™ SDUENETIPCARD has been tested and approved for conformance by the ODVA. More information about EtherNet/IP™ and the ODVA can be obtained from the following website: www.odva.org.
- RoHS Compliant

Related Products

- Portable MCR Power Conditioners
- STV Surge Protective Devices
- SDN DIN Rail Power Supplies
- STFV Plus Active Tracking® Filters

Selection Table

Catalog Number	Capacity (VA/W)	Volts, Frequency In/Out	Typical Back-Up Time (minutes) At full load/half load.	Input/Output Connections	Approx. Ship Weight – lbs (kg)
SDU 500A	500/300	120 Vac, 50/60 Hz	4/18	IP20 touch proof, screw terminals. Wire range: 10 ~ 18 AWG.	10.6 (4.8)
SDU 850A	850/510		2/10		11.5 (5.2)
SDU 500A-5	500/300	230 Vac, 50/60 Hz	4/18		10.6 (4.8)
SDU 850A-5	850/510		2/10		11.5 (5.2)

Note: Run times in this table are approximate. They are based upon new, fully charged standard battery modules at a temperature of 25°C (77°F) with 100% resistive UPS loading. Run times listed above can vary by +/-5% due to manufacturing variances of the individual batteries

Specifications

Catalog Number	SDU 500A	SDU 850A	SDU 500A-5	SDU 850A-5
Capacity (VA/Watts)	500/300	850/510	500/300	850/510
Load Power Factor	0.6			
Dimensions – inches (mm)				
Unit (H x W x D) – in. (mm)	4.87 x 11.1 x 4.81 (123.7 x 281.9 x 122.3)			
Weight – lbs (kg)	10.6 (4.8)	11.5 (5.2)	10.6 (4.8)	11.5 (5.2)
Input Parameters				
Voltage	120 V (+10%, -20%)		230 V (+/- 15%)	
Frequency	50 +/- 5 Hz or 60 Hz +/- 6 Hz (auto sensing)			
Output AC Parameters				
Voltage (Battery Mode)	Simulated sinewave +/- 5%			
Frequency (On Battery)	50 or 60 Hz +/- 0.3 Hz			
Overload Protection	UPS automatic shutdown if overload exceeds: 105% of nominal at 20 seconds, 120% of nominal at 10 seconds, 130% of nominal at 3 seconds			
Short Circuit	UPS shutdown, auto-recovery			
Battery Parameters				
Battery Type	Sealed, non-spillable, maintenance-free lead acid batteries			
Transfer Time	Typical <8 ms			
Back-Up Time (minutes) Full Load/Half Load	4/18	2/10	4/18	2/10
Recharge Time	8 hours to 90% capacity of full discharge			
Environmental				
Operating Temperature	0°C to 50°C			
Storage Temperature	-15°C to 60°C			
Relative Humidity	0 to 95%, non-condensing			
Ambient Operation	0-95% humidity non-condensing, 0-50°C up to 6,600 ft. (2000m)			
Audible Noise	< 40 dBA (1 meter from surface)			
Standards				
EMC	FCC Part 15, Subpart B, Class A Level 4; EMC: EN62040-2; EN55032; CISPR22; EN61000-3-2; IEC61000-4-2, -4-3, -4-4, -4-5, -4-6, -4-8, -2-2			
Elevation	5000 ft. without derating			
Surge Protection	Meets IEEE C62.41, Category A			
Shock	Operating - IEC60068-2-27, Half Sine Wave: 10G for a duration of 11ms, shock for 1 direction (X axis) Non-operating - IEC60068-2-27, Half Sine Wave : 30G for duration of 11ms, 3 shocks for all 3 axes			
Vibration	Operating - IEC60068-2-6, Sine Wave: 10Hz to 500Hz @19.6m/S ² , displacement of 0.35mm, 60 min per axis for all X, Y, Z direction. Non-operating - IEC60068-2-6, Random : 5hz to 500Hz (2.09Grms); 20 min per axis for all X,Y,Z			
Mounting	To be mounted on DIN TS35/7.5 or TS35/15 rail system. Chassis mounting permissible via optional brackets (SDU-PMBRK).			

Comm Card Accessories



Active - (Industrial Ethernet)



Passive

Catalog Number	Description	Approx. Ship Weight – oz. (g)
Active - (Industrial Ethernet)		
SDUENETPCARD	2 Port EtherNet/IP™ COMM CARD	1.0 (28.4)
SDUECATCARD	2 Port EtherCAT COMM CARD	1.0 (28.4)
SDUMBUSCARD	2 Port Modbus® - TCP COMM CARD	1.0 (28.4)
SDUPNETCARD	2 Port Profinet Industrial Protocol COMM CARD	1.0 (28.4)
Passive		
SDUCFRELAYCARD	SDU CF Dry Contact I/O RELAY CARD	1.0 (28.4)

SDU CF Relay Card Connection Diagram

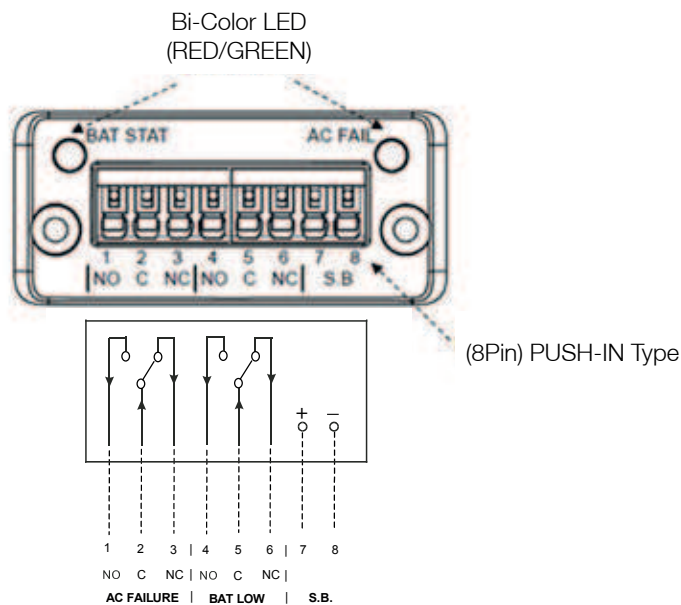

SDU Accessories

Catalog Number	Description	Approx. Ship Weight – oz. (g)
SDU-PMBRK	Mounting brackets to secure UPS to wall, back of panel or enclosure.	16.0 (454.0)
SDUEDC	Enhanced DIN Clip to secure UPS to DIN rail	1.6 (45.3)

Comm Card Specifications

Description	Catalog Number	
	SDUCFRELAYCARD	Active Cards (Example: SDUENETIPCARD)
Input		
Nominal Voltage	+3.3 V \pm 5 %	
Standby Signal	Active low via normally open momentary switch	
Frequency	50/60 Hz	
Output		
LED Diagnostics	Refer to diagram	Refer to diagram NS = Network Status, MS=Module Status
Relay Logic Signals	Refer to diagram	—
Relay Contact Ratings	60 V peak, 1A	—
Case/Enclosure Material	Housing: LCP(Liquid Crystal Polymer) Color: Natural, Thermoplastic,UL 94 V-0	
Weight & Dimensions		
H x W x D, in. (mm)	0.91 x 2.0 x 2.2 (23 x 50 x 55) approximate	
Net Weight, oz. (g)	1.0 (28.4) approximate	
EMC		
Immunity/Emissions	Emission EN 61000-6-4 EN55016-2-3 Radiated emission EN55022 Conducted emission Immunity EN 61000-6-2 EN61000-4-2 Electrostatic discharge, EN61000-4-3 Radiated immunity. EN61000-4-4 Fast transients/burst, EN61000-4-6 Conducted immunity	
Temperature °F (°C)	Storage: -40 to +185 (-40 to +85) Operating: -40 to +158 (-40 to +70) Convection cooling; no forced air required.	
Vibration	Operating: IEC60068-2-6, Sine Wave: 10Hz to 500Hz @19.6m/S ² , displacement of 0.35mm, 60 min per axis for all X, Y, Z direction. Non-Operating: IEC60068-2-6, Random : 5hz to 500Hz (2.09Grms); 20 min per axis for all X,Y,Z direction.	
Shock	Operating: IEC60068-2-27, Half Sine Wave: 10G for a duration of 11ms, shock for 1 direction (X axis). Non-Operating: IEC60068-2-27, Half Sine Wave : 50G for duration of 11ms, 3 shocks for each 3 directions.	
Humidity	0% to 90% RH, noncondensing; IEC 60068-2-2, 60068-2-3	
Warranty	2 Years	
MTBF (bellcore)	1,968,800 Hours	
General Protection	Protected against Continuous short -circuit, Continuous overload, Continuous open circuit. Galvanic Isolation: I/P to O/P: 3 KVac, I/P to GND: 1.5 KVac, O/P to GND: 0.5 KVac	

S1K Mini-Tower Off-line UPS

The SolaHD S1K Series provides economical protection from damaging impulses and power interruptions. These units include two types of outlets; three for critical devices needing battery back-up and surge protection such as the CPU and one surge protected only outlet for non-critical devices like printers and fax machines. The S1K is ideal for point of sale and office applications.



Applications

- PCs
- Workstations
- Computer Terminals

Features

- Lightweight, compact design
- 4 NEMA 5-15R outlets, (3 Battery, 1 Surge)
- Data-line surge protection for phone or network included on every unit
- DB9 communications Interface
- Software and cable included
- Step sinewave output
- Two year limited warranty

Certifications and Compliances

- cUL US Listed, UPS Equipment
- UL 1778, CSA C22.2 No. 107.3
- RoHS Compliant

Related Products

- Surge Protective Devices
- Active Tracking® Filters
- Portable MCR Power Conditioners

Selection Table

Capacity (VA/W)	Catalog Number	Volts, Frequency In/Out	Typical Back-up Time * (minutes)	Input Plug/ Output Receptacle	Approx. Ship Weight lbs (kg)
320/240	S1K320	115 Vac, 50 or 60 Hz	10	5-15P / 5-15R (3) Battery (1) Surge	8.8 (4.00)
520/340	S1K520		15		11.6 (5.30)
650/390	S1K650		15		8.1 (3.70)
850/600	S1K850		25		10.8 (4.90)
1200/720	S1K1200		30		10.8 (4.90)
1500/900	S1K1500		70	5-15P / 5-15R (4) Battery	30.0 (13.60)

* For a typical PC with a 15" monitor.

Note: Run times in this table are approximate. They are based upon new, fully charged standard battery modules at a temperature of 25°C (77°F) with 100% resistive UPS loading. Run times listed above can vary by +/-5% due to manufacturing variances of the individual batteries

S1K Accessories

Catalog Number	Description	Approx. Ship Weight lbs (kg)
S1K-PMBRK **	Wall/panel mount bracket kit for S1K (320 VA~1200 VA) UPS	1.0 (0.45)
UPSMON-USB	RS232 to USB Adapter Cable	1.0 (0.45)

** Not applicable to S1K1500 and S1K650

Specifications

Catalog Number	S1K320	S1K520	S1K650	S1K850	S1K1200	S1K1500
Capacity (VA/Watts)	320/240	520/340	650/390	850/600	1200/720	1440/900
Dimensions – inches (mm)						
Unit (H x W x D) – in. (mm)	5.30 x 3.80 x 12.6 (135.0 x 97.0 x 320.0)	5.30 x 3.80 x 12.60 (135.0 x 97.0 x 320.0)	5.30 x 3.80 x 10.40 (135.0 x 97.0 x 264.0)	5.30 x 3.80 x 12.60 (135.0 x 97.0 x 320.0)	7.50 x 5.11 x 15.00 (191.0 x 130.0 x 381.0)	
Weight – lbs (kg)	8.8 (4.00)	11.6 (5.30)	8.1 (3.70)	10.8 (4.90)		30.0 (13.60)
Input Parameters						
Voltage	115 V + 20% / -25%		115 V +/-15%		115 V +/-25%	
Frequency	50 or 60 Hz ± 10% (auto sensing)					
Input Power Cord	6 ft. with NEMA 5-15P					
Output AC Parameters						
Voltage (Battery Mode)	Step sinewave at 115 V					
	±10%		±5%			
Frequency (On Battery)	50 or 60 Hz					
	±1 Hz		±0.3 Hz		±1 Hz	
Auto Voltage Regulation (AVR function under Normal Mode)	AVR automatically increases output voltage 15% above input voltage if 91% to 75% of nominal. AVR decrease output voltage 13% below input voltage if 109% to 125% of nominal		N/A		AVR (See first column for definition)	
Overload Protection	UPS automatic shutdown if overload exceeds 105% of nominal at 20 seconds, 120% at 10 seconds, 130% at 3 seconds				UPS automatic shutdown if overload exceeds 110% of nominal at 60 seconds, 130% at 3 seconds	
Short Circuit	UPS output cut off immediately					
Battery Parameters						
Battery Type	Sealed, maintenance-free lead acid batteries					
Transfer Time	4 milliseconds, Typical					
Back-up Time* (minutes)	10-20	15-25	15-30	25-40	30-45	70-80
Recharge Time	4 hours		6 hours			
Environmental						
Operating Temperature	0°C to 40°C					
Storage Temperature	-15°C to 50°C					
Relative Humidity	0% to 90%, non-condensing					
Ambient Operation	0-95% humidity non-condensing, 0-40°C up to 10,000 ft. (3000m)					
Audible Noise	< 40 dBA (1 meter from surface)					
Standards						
EMC	FCC Part 15, Subpart B, Class A					
Surge Protection	Meets IEEE C62.41, Category A					

* For a typical PC with a 15" monitor.

S3K Mini-Tower Line-Interactive UPS

The SolaHD S3K Series is an economical choice for those applications requiring the performance of a sinewave output, line interactive UPS with the mini-tower shape for cabinet installations. The S3K Series protects against most severe power disturbances through state-of-the-art, line-interactive technology. Most power disturbance corrections are accomplished without transferring to the internal battery. Utility power is continually protected by the S3K Series UPS and internal battery life is optimized.

This UPS has built in protection for under and over voltage conditions including low-energy lightning surges introduced on the input power source. All S3K Series UPS are provided with an input circuit protector and surge protected data line connectors. The S3K Series UPS is provided with a battery test function. Should the battery fail this test, the UPS will display a warning to indicate that the battery needs to be replaced.

Applications

- Workstations
- PLCs
- Robotics and Process Control
- Industrial Automation Systems
- Automatic Service & Dispensing Equipment

Features

- Mini-Tower design for control cabinet installation
- Automatic voltage regulation (AVR) topology saves battery power for deep voltage sag situations
- Sine wave output
- User replaceable, "hot swappable" batteries (downtime for battery replacement not required)
- RS-232 communications port
- Built-in surge protection
- Cold start capability (DC power on)
- Telephone/modem spike protection
- Power management software is included (UPSMON).
- 50/60 Hz auto sensing
- Fully digitized, microprocessor controlled
- Protects against most adverse power conditions including:
 - Frequency variations
 - Surge
 - Sags
 - Spike
 - Blackouts
 - Over and under voltages
- Two year limited warranty



Certifications and Compliances

- cUL US Listed, UPS Equipment - UL 1778, CSA C22.2 No. 107.3
- IEC 60801-2, Level 4 / IEC 60801-4, Level 4 / ANSI C62.41 Category A & B
- RoHS Compliant

Related Products

- Portable MCR Power Conditioners
- Surge Protective Devices
- Active Tracking® Filters

Battery Back-up Times Chart

Model	S3K-700	S3K-1000	S3K-1600
Load (%)	Run-Time (minutes)		
20%	48	34	36
40%	21	14	15
50%	15	11	11
70%	9	7	7
100%	5	4	3

Note: Run times in this table are approximate. They are based upon new, fully charged standard battery modules at a temperature of 25°C (77°F) with 100% resistive UPS loading. Run times listed above can vary by +/-5% due to manufacturing variances of the individual batteries.

Selection Table

Capacity (VA/W)	Catalog Number	Volts, Frequency (In/Out)	Typical Back-up Time (minutes)*	Input Plug/Output Receptacle	Approx. Ship Weight lbs (kg)
700/480	S3K700	120/120, 50/60 Hz	5/15	(Detached) 5-15P / (4)5-15R	34.1 (15.50)
1000/750	S3K1000	120/120, 50/60 Hz	4/11	(Detached) 5-15P / (4)5-15R	37.0 (16.80)
1440/1200	S3K1600	120/120, 50/60 Hz	3/11	(Attached) 5-15P / (6)5-15R	70.4 (32.00)

* Full/Half Load (in minutes).

Specifications

Catalog Number	S3K700	S3K1000	S3K1600
Power Rating (VA/Watts)	700/480	1000/750	1440 */1200
Dimensions – inches (mm)			
Unit (H x W x D)	8.30 x 5.50 x 17.20 (210.0 x 140.0 x 436.0)		8.90 x 6.70 x 17.70 (226.0 x 170.0 x 450.0)
Shipping (H x W x D)	11.75 x 10.50 x 19.20 (300.0 x 265.0 x 492.0)		14.00 x 12.00 x 22.25 (358.0 x 307.0 x 581.0)
Approx. Shipping Weight – lbs (kg)	34.1 (15.50)	37.0 (16.80)	70.4 (32.00)
Input AC Parameters			
Voltage Range	103-132 Vac		
Plug	6 ft. detachable with NEMA 5-15P		Attached 5-15P
Line to Boost Transfer	Maintains output to 120 Vac; -14%, when input is 120 Vac, -25%		
Line to Buck Transfer	Maintains output to 120 Vac; +10%, when input is 120 Vac, +23%		
Frequency	45-55 Hz or 55-65 Hz; auto sensing		
Output AC Parameters			
Voltage	103 Vac to 132 Vac		
Receptacles	(4) NEMA 5-15R		(6) NEMA 5-15R
Frequency	50 Hz or 60 Hz ±0.5%		
Waveform	Sine wave		
Overload Warning	100-110% Nominal		
Overload Shutdown	200% Nominal		
Battery Parameters			
Type	Valve-regulated, non-spillable, lead acid		
Battery Time (mins) (FL/HL)	5/15	4/11	3/11
Qty. x Voltage x Rating	2 x 12 V x 7 AH		4 x 12 V x 7 AH
Transfer Time	2-4 ms typical		
Back-up Time	See Battery Back-up Times Charts		
Recharge Time	4 Hours to 90% rated capacity, after full discharge into resistive load		
Environmental			
Operating Temperature	0°C to +40°C		
Storage Temperature	-15°C to +50°C		
Relative Humidity	0% to 95%, non-condensing		
Operating Elevation	Up to 10,000 ft. (3000 m) at 35°C without derating		
Audible Noise	<40 dBA, (beyond 1 m)		<45 dBA, (beyond 1 m)
Standards			
EMC	FCC Part 15, Subpart B, Class A		

* Note: 1200W at 0.75 power factor equals 1600 VA. Line cord limits total load to 1440 VA (max).

S4K2U-C and S4K2U-5C Industrial On-Line UPS

The SolaHD S4KC Series is a single phase, on-line (doubleconversion) UPS system available in 700-3000 VA, 120 V and 230 V. On-Line design means zero transfer time from external to internal power. When utility power fails, your critical load remains supported by a seamless flow of power. Rack or tower configurable, the S4KC Series UPS offers customers a higher power factor, longer battery life, higher reliability and reduced cost of ownership. Housed in a slim 2U package, the SolaHD S4KC protects equipment from virtually all power disturbances due to blackouts, brownouts, sags, surges or noise interference. The UPS includes internal batteries. Optional, matching external battery cabinets, also in a slim 2U (3.5") size, offer extended battery runtime.

The LED display indicates battery capacity, percentage of UPS load, battery operation, bypass operation and UPS fault condition.

The rack-tower models are also supplied with securing flanges and rack slide mounting hardware is available separately, if required. Units can be easily hardwired by removing the attached line cord and receptacle plate. All units include a conduit knockout cover in the box.

Applications

- Industrial Automation Systems
- Critical Microprocessors and PC Based Systems
- Robotics and Process Control
- Programmable Logic Controllers (PLC)
- Mission Critical and High Speed Networks
- Enterprise Telecommunication Systems
- Pharmaceutical and Medical Diagnosis Equipment
- Printing and Publishing Machinery

Features

- Hardwire capability for permanent installation
- Small 2U height maximizes available space
- Input and output noise suppression
- Higher output power factor of 0.90
- PWM (pulse-width modulation) inverter reduces output voltage distortion
- Add on batteries for extended back-ups
- Integral sealed non-spillable batteries
- Hot swappable user replaceable battery
- Automatic restart

Note: The securing flanges do not support the weight of the UPS. Rack slides or shelves are required (sold separately). EAC applies only to certain CE models.



- Automatic and manual battery test
- Rack-mount or stand-alone tower mounting
- Units are field configurable with a PC as a frequency converter (bypass will be disabled)
- Select S4KC models use an average of 35% less energy than their standard counterparts
- Select S4KC models provide continuous uptime for the connected equipment, with capacity and battery back-up delivered in cabinets that use 2U of rack space
- Integral dynamic bypass reduces shutdowns
- Compatible with most standby generators
- Two year limited warranty

Certifications and Compliances

All Models

- ABS Type Approved
- RoHS Compliant
- ISTA Procedure 1A

S4K2U-C, S4K2U3000-5C:

- cUL US Listed, UPS Equipment
 - UL 1778
 - CSA C22.2 No. 107.3

S4K2U-C:

- ENERGY STAR certified:
 - 700, 1000, 1500, 2000, 3000 VA 120 V input

S4K2U-5C:

- CE : EC/EN/AS 62040-1-1:2008
- EAC: TR CU 004/2011 - Technical Regulation of Custom Union "On the safety of low-voltage equipment"

Selection Table - S4K2U-C & S4K2U-5C Tower/Rack-Mount Models

Capacity (VA/W)	Catalog Number	Typical Back-up Times * (minutes)	Input Plug/Output Receptacle	Approx. Ship Weight – lbs (kg)
120 Vac, 50/60 Hz Models				
700/630	S4K2U700C	11/27	5-15P / (6) 5-15R	52.9 (24.00)
1000/900	S4K2U1000C	7/17	5-15P / (6) 5-15R	
1500/1350	S4K2U1500C	4/11	5-15P / (6) 5-15R	57.3 (26.00)
2000/1800	S4K2U2000C	3/11	5-20P / (6)5-20R (15/20 amp type)	61.7 (28.00)
3000/2700	S4K2U3000C	3/11	L5-30P / (5)5-20R (15/20 amp type); (1) L5-30R	70.5 (32.00)
230 Vac, 50/60 Hz International Models				
1000/900	S4K2U10005C	6/17	IEC 320-C14 / (6) IEC 320-C13	44.0 (20.00)
2000/1800	S4K2U20005C	3/11	IEC 320-C20 / (6) IEC 320-C13	61.7 (28.00)
3000/2700	S4K2U30005C	3/11	IEC 320-C20 / (6) IEC 320-C13 (1) IEC 320-C19	70.5 (32.00)

* Full/Half Load (in minutes) at rated wattage.

S4K2U-C, 120 Vac, 50/60 Hz Tower/Rack-Mount Models Specifications

Catalog Number	S4K2U700C	S4K2U1000C	S4K2U1500C	S4K2U2000C	S4K2U3000C
Dimensions – D x W x H, in. (mm)					
Unit	19.70 x 16.90 x 3.40 (500.4 x 430.0 x 86.4)				23.70 x 16.90 x 3.40 (602.0 x 430.0 x 86.4)
Shipping	25.50 x 23.90 x 10.60 (648.0 x 607.1 x 270.0)				29.40 x 23.40 x 10.60 (747.0 x 594.4 x 270.0)
Weight – lbs. (kg)					
Unit	37.0 (16.80)		51.1 (23.20)	51.1 (23.20)	71.4 (32.40)
Shipping	44.1 (20.00)		57.3 (26.00)	57.3 (26.00)	79.4 (36.00)
Input AC Parameters					
Voltage Range (typical)	120 Vac nominal; variable based on output load				
90% to 100% Loading	90 Vac/140 Vac		102 Vac/140 Vac		
70% to 90% Loading	86 Vac/140 Vac		96 Vac/140 Vac		
30% to 70% Loading	77 Vac/140 Vac		84 Vac/140 Vac		
0% to 30% Loading	60 Vac/140 Vac		60 Vac/140 Vac		
Power Factor	0.99				
Frequency	40 Hz to 70 Hz; auto sensing				
Input Power Cord *	10 ft. attached with NEMA 5-15P plug			10 ft. attached with NEMA 5-20P plug	10 ft. attached with NEMA L5-30P plug
Output AC Parameters					
Output Receptacles *	5-15R x 6			5-20R x 6	L5-30R x 1 + 5-20R x 6
Voltage	110/115/120/127 Vac (user-configurable) ±3%				
Waveform	Sine wave				
Utility (Vac) Mode Overload	200% for 2 seconds; 150% for 50 seconds with transfer to bypass				
Power Factor	0.90				
Battery					
Type	Valve-regulated, non-spillable, lead acid				
Qty x V x Rating	4 x 12 V x 5.0 Ah		4 x 12 V x 7.2 Ah	4 x 12 V x 9.0 Ah	6 x 12 V x 9.0 Ah
Battery Mfr./Part Number	YUASA/NPH5-12; CSB/HR 1221W		Panasonic/UP- RW1245; CSB/UPS12460F2	Panasonic/UP-RW1245; CSB/UPS12460F2	
Recharge Time	3 hours to 90% capacity after full discharge with 100% load until UPS auto shutdown (internal batteries only)				
Environmental Requirements					
Operating Temperature	0°C to +40°C; See Operating Temperature Parameters				
Storage Temperature	-15°C to +50°C				
Relative Humidity	0% to 95%, non-condensing				
Operating Elevation	Up to 10,000 ft. (3,000 m)				
Storage Elevation	50,000 ft. (15,000 m) max.				

Notes:

* Input power cord and output receptacles can be removed for hardwired applications.

S4K2U-C, 120 Vac, 50/60 Hz Tower/Rack-Mount Models Specifications - continued

Catalog Number	S4K2U700C	S4K2U1000C	S4K2U1500C	S4K2U2000C	S4K2U3000C
Audible Noise	<43 dBA max. @ 3 ft. (1 m) front & sides; <46 dBA max. @ 3 ft. (1 m) rear	<45 dBA max. @ 3 ft. (1 m) front & sides; <50 dBA max. @ 3 ft. (1 m) rear	<46 dBA max. @ 3 ft. (1 m) front & sides; <45 dBA max. @ 3 ft. (1 m) rear	<48 dBA max. @ 3 ft. (1 m) front & sides; <48 dBA max. @ 3 ft. (1 m) rear	
Standards					
EMC	FCC Part 15, Class A				

Operating Temperature Parameters			
Ambient Temperature	+25°C to +30°C	+30°C to +35°C	+35°C to +40°C
Maximum output power factor derating at maximum load	100% to 93%	93% to 86%	86% to 79%

S4K2U-5C, 230 Vac, 50/60 Hz Tower/Rack-Mount Models Specifications

Catalog Number	S4K2U1000-5C	S4K2U2000-5C	S4K2U3000-5C
Dimensions – D x W x H, in. (mm)			
Unit	19.60 x 16.90 x 3.30 (497.0 x 430.0 x 85.0)		23.70 x 16.90 x 3.30 (602.0 x 430.0 x 85.0)
Shipping	28.20 x 22.40 x 10.30 (717.0 x 570.0 x 262.0)		28.20 x 22.40 x 10.30 (717.0 x 570.0 x 262.0)
Weight – lbs. (kg)			
Unit	37.0 (16.80)	51.1 (23.20)	71.4 (32.40)
Shipping	44.1 (20.00)	57.3 (26.00)	79.4 (36.00)
Input AC Parameters			
Voltage Range (typical)	230 Vac nominal; variable based on output load		
90% to 100% Loading	177 Vac/280 Vac		196 Vac/280 Vac
70% to 90% Loading	168 Vac/280 Vac		184 Vac/280 Vac
30% to 70% Loading	150 Vac/280 Vac		161 Vac/280 Vac
0% to 30% Loading	115 Vac/280 Vac		115 Vac/280 Vac
Power Factor	0.99		
Frequency	40 Hz to 70 Hz; auto sensing		
Input Power Receptacle *	IEC 320 C14	IEC 320 C20	
Output AC Parameters			
Output Receptacles *	IEC 320 C13 x 6		IEC 320 C13 x 6; IEC 320 C19 x 1
Voltage	208/220/230/240 Vac (user-configurable**) ±3%		
Frequency	50 Hz or 60 Hz		
Waveform	Sine wave		
Overload	200% for 2 seconds; 150% for 1 minute with transfer to bypass	200% for 2 seconds; 150% for 50 seconds with transfer to bypass	200% for 2 seconds; 150% for 55 seconds with transfer to bypass
Power Factor	0.90		
Battery			
Type	Valve-regulated, non-spillable, lead acid		
Qty x V x Rating	4 x 12 V x 5.0 Ah	4 x 12 V x 9.0 Ah	6 x 12 V x 9.0 Ah
Battery Mfr./Part Number	YUASA/NPH5-12; CSB/HR 1221W	Panasonic/UP-RW1245; CSB/UPS12460F2	
Recharge Time	3 hours to 90% capacity after full discharge with 100% load until UPS auto shutdown (internal batteries only)		
Environmental Requirements			
Operating Temperature	0°C to +40°C; See Operating Temperature Parameters		
Storage Temperatures	-15°C to +50°C		
Relative Humidity	0% to 95%, non-condensing		
Operating Elevation	Up to 3,000 m (10,000 ft.)		
Storage Elevation	15,000 m (50,000 ft.) max.		

Notes:

* Input power cord and output receptacles can be removed for hardwired applications.

**Contact Technical Support on any derating.

S4K2U-5C, 230 Vac, 50/60 Hz Tower/Rack-Mount Models Specifications

Catalog Number	S4K2U1000-5C	S4K2U2000-5C	S4K2U3000-5C
Audible Noise	<43 dBA max. @ 1 m (3 ft.) front & sides; <46 dBA max. @ 1 m (3 ft.) rear	<48 dBA max. @ 1 m (3 ft.) front & sides; <48 dBA max. @ 1 m (3 ft.) rear	
Standards			
EMC	IEC/EN/AS 62040-2 2 nd Edition = CISPR22 Class A; IEC62040-2 2 nd Edition		

Operating Temperature Parameters			
Ambient temperature	+25°C to +30°C	+30°C to +35°C	+35°C to +40°C
Maximum output power factor derating at maximum load	100% to 93%	93% to 86%	86% to 79%

External Battery Cabinets Specifications

Catalog Numbers	S4K2U48BATC	S4K2U96BATC
Used with UPS models	S4K2U700C, S4K2U1000C (-5), S4K2U1500C, S4K2U2000C (-5)	S4K2U3000C (-5)
Dimensions – D x W x H, in. (mm)		
Unit	19.70 x 16.90 x 3.40 (500.4 x 430.0 x 86.4)	23.70 x 16.90 x 3.40 (602.0 x 430.0 x 86.4)
Shipping	24.30 x 22.40 x 10.30 (617.2 x 570.0 x 262.0)	28.20 x 22.40 x 10.30 (717.0 x 570.0 x 262.0)
Weight – lbs. (kg)		
Unit	70.5 (32.00)	93.5 (42.40)
Shipping	77.2 (35.00)	101.4 (46.00)
Battery		
Type	Valve-regulated, non-spillable, lead acid	
Qty x V x Rating	2 x 4 x 12 V x 9.0 Ah	2 x 6 x 12 V x 9.0 Ah
Battery Mfr./Part Number	Panasonic/UP-RW1245; GSB/UPS12460F2	
Back-up Time	Battery Back-up Times Chart	
Environmental Requirements		
Operating Temperature	0°C to +40°C	
Storage Temperatures	-15°C to +50°C; High ambient temperatures will reduce battery life	
Relative Humidity	0% to 95%, non-condensing	
Operating Elevation	Up to 10,000 ft. (3,000 m)	
Storage Elevation	50,000 ft. (15,000 m) max.	

S4K2U-C Battery Back-up Times

Number of Batteries/Cabinets	Load % of Capacity	Model Rating				
		700 VA	1000 VA	1500 VA	2000 VA	3000 VA
		Back-up Time in Minutes				
Internal battery	10%	105	90	123	92	82
	20%	61	37	52	38	38
	30%	37	30	34	23	23
	40%	32	23	23	16	16
	50%	27	17	18	12	12
	60%	22	14	14	9	9
	70%	18	11	11	7	7
	80%	15	9	9	5	5
	90%	13	8	7	4	4
Internal battery + 1 external battery cabinet	10%	426	332	335	303	224
	20%	302	165	162	140	137
	30%	163	137	129	96	95
	40%	144	108	96	66	66
	50%	125	92	72	49	49
	60%	106	74	54	38	41
	70%	94	61	46	33	34
	80%	78	49	38	28	27
	90%	69	40	34	23	23
Internal battery + 2 external battery cabinets	10%	480	456	451	431	427
	20%	433	331	318	207	202
	30%	327	222	187	150	149
	40%	265	166	151	124	124
	50%	201	152	131	97	98
	60%	164	137	107	75	76
	70%	153	122	91	61	62
	80%	142	105	74	50	50
	90%	131	95	64	41	45
Internal battery + 3 external battery cabinets	10%	480	480	480	455	452
	20%	461	441	426	326	323
	30%	438	336	312	197	196
	40%	344	305	198	155	155
	50%	322	209	160	136	136
	60%	300	167	145	111	112
	70%	213	157	130	96	98
	80%	189	146	111	78	79
	90%	163	135	99	68	70
100%	155	124	83	56	60	

Note: Run times in this table are approximate. They are based upon new, fully charged standard battery modules at a temperature of 25°C (77°F) with 100% resistive UPS loading. Run times listed above can vary by +/-5% due to manufacturing variances of the individual batteries

S4K2U-C Battery Back-up Times - continued

Number of Batteries/Cabinets	Load % of Capacity	Model Rating				
		700 VA	1000 VA	1500 VA	2000 VA	3000 VA
		Back-up Time in Minutes				
Internal battery + 4 external battery cabinets	10%	480	480	480	480	466
	20%	480	459	446	424	421
	30%	457	435	341	308	307
	40%	441	339	309	192	192
	50%	424	316	204	157	158
	60%	336	221	164	142	143
	70%	318	199	153	126	128
	80%	301	166	141	107	109
	90%	213	158	130	95	97
	100%	197	149	112	79	81
Internal battery + 5 external battery cabinets	10%	480	480	480	480	480
	20%	480	466	458	441	439
	30%	464	446	432	333	332
	40%	451	427	333	225	225
	50%	438	341	306	188	190
	60%	424	322	207	158	159
	70%	343	303	167	145	147
	80%	329	212	158	133	135
	90%	315	193	148	120	122
	100%	300	166	139	104	107
Internal battery + 6 external battery cabinets	10%	480	480	480	480	480
	20%	480	480	467	452	450
	30%	480	458	445	422	421
	40%	462	442	422	319	319
	50%	451	426	327	216	218
	60%	440	342	304	185	188
	70%	428	326	208	159	160
	80%	370	309	184	148	149
	90%	336	221	161	137	139
	100%	324	204	153	126	129

Note: Run times in this table are approximate. They are based upon new, fully charged standard battery modules at a temperature of 25°C (77°F) with 100% resistive UPS loading. Run times listed above can vary by +/-5% due to manufacturing variances of the individual batteries

S4K2U-5C Battery Back-up Times

Number of Batteries/Cabinets	Load % of Capacity	Model Rating		
		1000 VA	2000 VA	3000 VA
		Back-up Time in Minutes		
Internal battery	10%	91	81	91
	20%	38	37	39
	30%	31	23	23
	40%	23	16	16
	50%	17	12	12
	60%	14	9	9
	70%	11	7	7
	80%	9	5	5
	90%	8	4	4
Internal battery + 1 external battery cabinet	10%	334	222	302
	20%	166	137	139
	30%	138	94	95
	40%	108	66	66
	50%	92	49	48
	60%	72	39	41
	70%	56	34	34
	80%	48	28	27
	90%	40	23	23
Internal battery + 2 external battery cabinets	10%	457	426	431
	20%	333	201	205
	30%	224	149	150
	40%	166	124	124
	50%	151	97	97
	60%	135	75	76
	70%	113	61	63
	80%	103	50	50
	90%	92	41	45
Internal battery + 3 external battery cabinets	10%	480	451	455
	20%	442	322	325
	30%	337	195	196
	40%	305	154	155
	50%	208	136	136
	60%	166	111	112
	70%	155	96	98
	80%	144	78	79
	90%	132	68	70
	100%	122	56	60

Note: S4K2U-5C models are not available in 700 VA or 1500 VA.

Run times in this table are approximate. They are based upon new, fully charged standard battery modules at a temperature of 25°C (77°F) with 100% resistive UPS loading. Run times listed above can vary by +/-5% due to manufacturing variances of the individual batteries

S4K2U-5C Battery Back-up Times - continued

Number of Batteries/Cabinets	Load % of Capacity	Model Rating		
		1000 VA	2000 VA	3000 VA
		Back-up Time in Minutes		
Internal battery + 4 external battery cabinets	10%	480	466	480
	20%	460	421	423
	30%	436	306	307
	40%	340	192	192
	50%	315	157	157
	60%	218	142	143
	70%	195	127	128
	80%	165	107	109
	90%	156	95	97
	100%	147	80	81
Internal battery + 5 external battery cabinets	10%	480	480	480
	20%	467	438	440
	30%	447	331	332
	40%	428	224	225
	50%	341	189	189
	60%	320	158	159
	70%	227	146	147
	80%	208	133	135
	90%	189	120	122
	100%	164	104	106
Internal battery + 6 external battery cabinets	10%	480	480	480
	20%	480	450	452
	30%	458	420	421
	40%	442	319	319
	50%	426	217	217
	60%	341	186	187
	70%	323	159	160
	80%	306	148	150
	90%	217	137	139
	100%	201	126	128

Note: S4K2U-5C models are not available in 700 VA or 1500 VA.

Run times in this table are approximate. They are based upon new, fully charged standard battery modules at a temperature of 25°C (77°F) with 100% resistive UPS loading. Run times listed above can vary by +/-5% due to manufacturing variances of the individual batteries

S4K4U-C 6 kVA and S4K6U-C 10 kVA Industrial On-Line UPS

The SolaHD S4K4U6000C and S4K6U10KC Industrial UPS Series are the first true On-Line industrial UPS that provides higher output power factor, higher efficiency, flexible output voltage, an integrated maintenance bypass switch and internal batteries all in slim 4U (7.0") and 6U (10.5") enclosures respectively.

The S4K4UC and S4K6UC features true On-Line (double conversion) topology providing the ultimate in protection against a wide range of potential power problems. The S4K4UC design of two 3 kVA, 120 V inverters allow flexible output voltage to meet mixed load voltage requirements. The UPS automatically configures the output voltage to match the input configuration without requiring tap selections. Self diagnostics simplify maintenance and troubleshooting. The standard maintenance bypass switch provides an additional level of protection.

The S4K4UC and S4K6UC also feature a wide input voltage window to support the critical load without having to transfer to the battery. This extends system availability when back-up is truly needed.

Applications

- Industrial Computers
- Robotics and Process Controls
- Industrial Automation Systems
- Network Servers
- Enterprise Telecommunication Systems
- Printing and Publishing Machinery
- Pharmaceutical and Medical Diagnosis Equipment
- Industrial and Commercial Machinery
- Micro-processor Controlled Equipment
- Mission Critical Devices

Features

- True double conversion topology
- Higher power factor of 0.80 (6kVA) and 0.90 (10kVA)
- Both models offer 208/120 V or 240/120 V
- Configurable as a tower or rack mounting
- Highest density, 6 kVA in only 4U and 10 kVA in only 6U of rack space
- Easily installed in 18" to 32" deep rack using rack mount kit # SRS1832
- User replaceable, hot-swappable internal battery module
- Extended battery cabinets
- Includes both automatic and manual maintenance bypass switch



- Automatic frequency detection (60 or 50 Hz)
- Power factor correction
- Self-diagnostics simplify maintenance and troubleshooting
- Remote emergency Power Off (REPO)
- Intellislot™ USB and terminal block communication ports
- Compatible with most standby generators
- Uses an average of 35% less energy than their standard counterparts
- Provides continuous uptime for the connected equipment, with capacity and battery back-up delivered in cabinets that use 4U to 6U of rack space
- Two year limited warranty

Certifications and Compliances

- cUL US Listed, UPS Equipment
 - UL 1778
 - CSA C22.2 No. 107.3
- IEEE/ANSI C62.41 Category A & B
- ISTA Procedure 1A
- ABS Type Approved
- RoHS Compliant
- ENERGY STAR® certified



Related Products

- Portable MCR Power Conditioners
- Surge Protective Devices
- Active Tracking® Filters

S4K 6 and 10 kVA Specifications

Table 1: UPS Specifications

Parameters	Model Number	
	S4K4U6000C	S4K6U10KC
Rating	4800 W/6000 VA	9000 W/10000 VA
Dimensions – W x D x H, in. (mm)		
Unit	6.80 x 26.10 x 16.90 (173.0 x 662.0 x 430.0)	10.30 x 26.50 x 16.90 (261.0 x 672.0 x 430.0)
Shipping	13.20 x 33.10 x 26.10 (336.0 x 842.0 x 662.0)	16.70 x 32.80 x 24.10 (424.0 x 832.0 x 612.0)
Weight – lbs. (kg)		
Unit	56.2 (25.50)	78.3 (35.50)
Shipping	70.5 (32.00)	92.6 (42.00)
Input AC Parameters		
Nominal Operating Frequency	50 or 60 Hz (Factory default is 60 Hz)	
Factory Default Vac	120/208 Vac @ 120°	
L1–L2 Factory Default Input Phase Angle	120°C	
Allowable Input Phase Angle	120, 180, 240 degrees; auto-sensing on application of alternating current (Restrictions for L–N voltage other than 120 Vac)	
Factory Default L1–N, L2–N Vac	120 Vac nominal	
User Configurable L1–N, L2–N Vac	100/110/115/120/127 Vac (Can be modified with configuration program)	
Input Frequency w/o Battery Operation	40–70 Hz	
Input Power Connection	Hardwire terminal block 3W + G (L–L–N–G)	
L1–N, L2–N Maximum Allowable Vac	150 Vac	
Output AC Parameters		
Factory Default Vac	120/208 Vac @ 120°C	
L1–L2 Factory Default Output Phase Angle	120°C	
Allowable Output Phase Angle	120, 180, 240 degrees; auto-sensing on initial application of input alternating current	
Factory Default L1–N, L2–N Vac	120 Vac nominal	
User Configurable L1–N, L2–N Vac	100/110/115/120/127 Vac, ±2%	
L1–N, L2–N Overload Rating		
105% to 130%	1 minute	
131% to 150%	10 seconds	
151% to 200%	1 second	
>200% (impact load)	At least 5 cycles	

S4K 6 and 10 kVA Specifications - continued

Table 2: UPS Specifications

Parameters	Model Number	
	S4K4U6000C	S4K6U10KC
Bypass Protection Limits		
Disable Bypass Operation	If input voltage exceeds $\pm 15\%$ of the nominal voltage	
Re-enable Bypass Operation	If input voltage returns to within $\pm 10\%$ of nominal output voltage	
Disable Bypass Operation	When the input frequency prevents synchronous operation	
Environmental Requirements		
Operating Temperature	0°C to +40°C; see Table 11 for operating temperature parameters	
Storage Temperature	-15°C to +50°C	
Relative Humidity	0% to 95%, non-condensing	
Operating Elevation	Up to 10,000 ft. (3,000 m)	
Audible Noise	<55 dBA @ 3.2 ft. (1 m) rear; <50 dBA @ 3.2 ft. (1 m) front & sides	
Standards		
EMC	FCC Part 15, Subpart B, Class A, FCC Class A	

Table 3: Operating Temperature Parameters

Ambient Temperature	Model Number	
	S4K4U6000C	S4K6U10KC
pf @ 30°C $\pm 3^\circ\text{C}$	0.8 pf	0.9 pf
pf @ 40°C $\pm 3^\circ\text{C}$	0.8 pf	0.8 pf

Table 4: Internal Battery Specifications

Parameters	Model Number	
	S4K144INTBATC	S4K288INTBATC
Used with UPS Models	S4K4U6000C	S4K6U10KC
Dimensions – W x D x H, in. (mm)		
Unit	2.80 x 19.30 x 8.10 (70.0 x 490.0 x 206.0)	5.30 x 19.70 x 8.10 (135.0 x 500.0 x 207.0)
Shipping	12.20 x 23.70 x 10.30 (310.0 x 602.0 x 262.0)	12.20 x 23.90 x 9.50 (310.0 x 607.0 x 242.0)
Weight – lbs. (kg)		
Unit	75.8 (34.40)	71.1 (32.30)
Shipping	81.1 (36.80)	76.4 (34.70)
Battery Parameters		
Type	Valve-regulated, non-spillable, flame retardant, lead acid	
Qty x V x Rating	2 x 6 x 12 V x 9.0 Ah	2 x 12 x 12 V x 9.0 Ah
Battery Mfr./Part Number	CSB type UPS12460F2	
Back-up Time	See Table 8	
Recharge Time	3 hours to 90% capacity after full discharge into 100% load	
Environmental Requirements		
Operating Temperature	0°C to +40°C	
Storage Temperature	-15°C to +50°C	
Relative Humidity	0% to 95%, non-condensing	
Operating Elevation	Up to 10,000 ft. (3,000 m) at +40°C without derating	

Table 5: External Battery Cabinet Specifications

Parameters	Model Number	
	S4K144BATC	S4K288BATC
Used with UPS Models	S4K4U6000C	S4K6U10KC
Dimensions – W x D x H, in. (mm)		
Unit (with bezel)	3.30 x 26.10 x 16.90 (85.0 x 662.0 x 430.0)	6.80 x 26.50 x 16.90 (173.0 x 672.0 x 430.0)
Shipping	25.80 x 34.30 x 12.30 (655.0 x 872.0 x 312.0)	13.20 x 33.10 x 24.50 (336.0 x 842.0 x 622.0)
Weight – lbs. (kg)		
Unit	99.9 (45.30)	29.8 (13.50)
Shipping	110.2 (50.00)	44.1 (20.00)
Battery Parameters		
Type	Valve-regulated, non-spillable, flame retardant, lead acid	
Qty x V x Rating	2 x 6 x 12 V x 9.0 Ah	2 x 12 x 12 V x 9.0 Ah
Battery Mfr./Part Number	CSB type UPS12460F2	
Back-up Time	See Table 8	
Environmental Requirements		
Operating Temperature	0°C to +40°C	
Storage Temperature	-15°C to +50°C	
Relative Humidity	0% to 95%, non-condensing	
Operating Elevation	Up to 10,000 ft. (3,000 m) at +40°C without derating	

Table 6: Power Distribution Specifications for S4K4U6000C

Parameters	Model Number					
	S4KPAD2-001C	S4KPAD2-002C	S4KPAD2-003C	S4KPAD2-004C	S4KPAD2-005C	S4KPAD2-006C
Dimensions – W x D x H, in. (mm)						
Unit	5.20 x 15.50 x 3.50 (132.0 x 393.0 x 88.0)					
Shipping	9.50 x 20.70 x 9.10 (242.0 x 527.0 x 230.0)					
Weight – lbs. (kg)						
Unit	8.8 (4.00)	8.6 (3.90)	8.6 (3.90)	9.9 (4.50)	10.6 (4.80)	9.5 (4.30)
Shipping	11.0 (5.00)	10.8 (4.90)	10.8 (4.90)	12.1 (5.50)	12.8 (5.80)	11.7 (5.30)
Electrical Specifications						
Amp Rating	30 A 2-pole input breaker					
Input Power Connections	(1) L14-30R on a 300 mm cord					
Output Power Connections	(4) 5-20R (1) L14-30R (1) L6-30R	(2) 5-20R (2) L6-20R	(4) 5-20R (2) L6-30R	(4) L5-20R (2) L5-30R	(4) L5-20R (2) L6-30R	(4) L6-20R

Table 7: Battery Back-up Times

Number of Batteries/Cabinets	Load % of Capacity	Model Rating	
		6000 VA	10000 VA
		Back-up Time in Minutes	
Internal battery	10%	106	112
	20%	46	48
	30%	27	30
	40%	19	21
	50%	14	16
	60%	11	12
	70%	9	10
	80%	7	8
	90%	5	6
	100%	5	5
Internal battery + 1 external battery cabinet	10%	188	201
	20%	108	120
	30%	67	73
	40%	46	49
	50%	37	40
	60%	28	31
	70%	23	26
	80%	19	21
	90%	16	18
	100%	14	16
Internal battery + 2 external battery cabinets	10%	321	330
	20%	152	157
	30%	109	121
	40%	77	82
	50%	53	64
	60%	47	49
	70%	40	43
	80%	33	37
	90%	27	31
	100%	25	27
Internal battery + 3 external battery cabinets	10%	424	430
	20%	192	204
	30%	143	149
	40%	109	122
	50%	82	95
	60%	68	73
	70%	51	60
	80%	46	49
	90%	41	44
	100%	36	40

The factory default is programmed for internal batteries only. Table 7 shows the estimated battery back-up times at different loads. The user may specify the number of external battery cabinets attached to the UPS.

Note: Run times in this table are approximate. They are based upon new, fully charged standard battery modules at a temperature of 25°C (77°F) with 100% resistive UPS loading. Run times listed above can vary by +/-5% due to manufacturing variances of the individual batteries

Table 7: Battery Back-up Times continued

Number of Batteries/Cabinets	Load % of Capacity	Model Rating	
		6000 VA	10000 VA
		Back-up Time in Minutes	
Internal battery + 4 external battery cabinets	10%	442	447
	20%	300	310
	30%	161	165
	40%	138	144
	50%	110	122
	60%	92	99
	70%	74	79
	80%	62	68
	90%	50	53
Internal Battery + 5 external battery cabinets	10%	454	459
	20%	324	332
	30%	194	206
	40%	153	158
	50%	134	140
	60%	110	122
	70%	95	102
	80%	77	82
	90%	67	73
Internal Battery + 6 external battery cabinets	10%	463	467
	20%	341	420
	30%	219	301
	40%	164	183
	50%	148	153
	60%	131	138
	70%	110	122
	80%	97	104
	90%	80	92
	100%	71	77

The factory default is programmed for internal batteries only. Table 7 shows the estimated battery back-up times at different loads. The user may specify the number of external battery cabinets attached to the UPS.

Note: Run times in this table are approximate. They are based upon new, fully charged standard battery modules at a temperature of 25°C (77°F) with 100% resistive UPS loading. Run times listed above can vary by +/-5% due to manufacturing variances of the individual batteries

S4K5U-5C 6 kVA International On-Line UPS

The SolaHD S4K5U6K5C Industrial On-Line UPS Series is designed for international usage and provides flexible output voltage, an integrated maintenance bypass switch and internal batteries all in a slim 5U (8.7") enclosure. The S4K5U-5C features true On-Line (double conversion) topology providing the ultimate in protection against a wide range of potential power problems. Flexible output voltages (220/230/240 Volt) are available through the configuration program to allow for international use. One of the three Line-to-Neutral (L-N) output voltages is selected to match the local voltage. Self diagnostics simplify maintenance and troubleshooting, and the UPS can be serviced by the customer. The standard maintenance bypass switch provides an additional level of protection.



The S4K5U-5C also features a wide input voltage window to support the critical load without having to transfer to the battery. This extends system availability when back-up is truly needed.



Applications

- Industrial Computers
- Robotics and Process Controls
- Industrial Automation Systems
- Network Servers
- Enterprise Telecommunication Systems
- Printing and Publishing Machinery
- Industrial and Commercial Machinery
- Pharmaceutical and Medical Diagnosis Equipment

Features

- True double conversion topology
- Higher power factor of 0.80
- Flexible L-N output voltage (220/230/240 V)
- Configurable as a tower or rack mount model
- High density, 6 kVA in only 5U of rack space
- Easily installed in 18" to 32" deep rack using rack mount kit # SRS1832
- User replaceable, hot-swappable internal battery module
- Matching 3U extended battery cabinets
- Includes both automatic and manual maintenance bypass switch
- Automatic frequency detection of either 60 or 50 Hz
- Power factor correction
- Self-diagnostics simplify maintenance and troubleshooting

- Remote Emergency Power Off (REPO)
- Intellislot™, USB, and terminal block communication ports
- Compatible with most standby generators
- Two year limited warranty

Certifications and Compliances

- **CE**
- IEC62040-1
- EAC: TR CU 004/2011 - Technical Regulation of Custom Union "On the safety of low-voltage equipment"
- ISTA Procedure 1A
- ABS Type Approved

Related Products

- Portable MCR Power Conditioners
- Surge Protective Devices
- Active Tracking® Filters

Table 8: UPS Specifications

Parameters	Model Number: S4K5U6K5C
Rating	6000 VA/4800 W
Dimensions – D x W x H, in. (mm)	
Unit	22.40 x 16.90 x 8.70 (570.0 x 430.0 x 220.0)
Shipping	29.30 x 20.90 x 20.30 (745.0 x 530.0 x 516.0)
Weight – lbs. (kg)	
Unit	132.2 (60.00)
Shipping	156.5 (71.00)
Input AC Parameters	
Nominal Operating Frequency	50 or 60 Hz (Factory default is 50 Hz)
Factory Default Vac	230 Vac
User-configurable Vac	208/220/230/240 Vac (Can be modified using included configuration program)
Operating Voltage Range without Battery Operation	176–280 Vac
Maximum Allowable Vac	280 Vac
Input Frequency without Battery Operation	40–70 Hz
Input Power Connection	S4KPAD2-CEHWMBSC Standard (See “3.3 Removable Power Distribution Box”)
Output AC Parameters	
Factory Default Vac	230 Vac
Output Connections	S4KPAD2-CEHWMBSC Standard (See “3.3 Removable Power Distribution Box”)
Frequency	50 or 60 Hz, nominal
Wave form	Sine wave
Main Mode Overload	>200% for 5 cycles; 151– 200% for 1 second; 131–150% for 10 seconds; 105–130% for 1 minute
Bypass Protection Limits	
Disable Bypass Operation	If input voltage exceeds $\pm 15\%$ of the nominal voltage
Re-enable Bypass Operation	If input voltage returns to within $\pm 10\%$ of nominal output voltage
Disable Bypass Operation	When the input frequency prevents synchronous operation
Environmental Requirements	
Operating Temperature	0°C to +40°C; See Table 12 for Derating Parameters
Storage Temperature	-15°C to +50°C
Relative Humidity	0% to 95%, non-condensing
Operating Elevation	Up to 1,000 m (3,281 ft.) at +30°C without derating
Audible Noise	<55 dBA @ 1 m (3.2 ft.) rear; <50 dBA @ 1 m (3.2 ft.) front & sides
Standards	
EMC	IEC/EN/AS 62040-2 2 nd Edition (Cat 2 – Table 6); EN61000-4-2, Level 4, Criteria A, EN61000-4-3, Level 3, Criteria A, EN61000-4-4, Level 4, Criteria A, EN61000-4-5, Level 3, Criteria A

Table 9: UPS Specifications

Parameters	Model Number: S4K5U6K5C
Agency	
Safety	IEC62040-1:2008 Version
EMI/EMC	IEC/EN/AS 62040-2 2 nd Edition (Cat 2— Table 6)
ESD	EN61000-4-2, Level 4, Criteria A
Radiated Susceptibility	EN61000-4-3, Level 3, Criteria A
Electrical Fast Transient	EN61000-4-4, Level 4, Criteria A
Surge Immunity	EN61000-4-5, Level 3, Criteria A
Transportation	ISTA Procedure 1A

Table 10: Operating Temperature Parameters

Ambient Temperature	Model Number: S4K5U6K5C
pf @ 30°C ±3°C	0.8 pf
pf @ 40°C ±3°C	0.8 pf

Table 11: Power Distribution Specifications

Parameters	Model Number: S4KPAD2-CEHWBSC
Used with UPS Model	S4K5U6K5C
Power Distribution Box Includes:	Two (2) IEC320 C19 16 A/250 V Sockets Six (6) C13 10 A/250 V Sockets Manual bypass switch with indicator lamp
Ampere Rating	32 A
Input/Output Power Connections	3-wire hard wired, 6–10 mm ² (8–10 AWG)
User-supplied Input Branch Circuit Breaker	32 A

Table 12: Internal Battery Specifications

Parameters	Model Number: S4K240INTBATC
Used with UPS Model	S4K5U6K5C
Dimensions – D x W x H, in. (mm)	
Unit	15.40 x 4.40 x 7.20 (390.0 x 113.0 x 184.0)
Shipping	18.40 x 7.00 x 10.30 (467.0 x 178.0 x 262.0)
Weight – lbs. (kg)	
Unit	45.1 (20.46)
Shipping	50.7 (23.00)
Battery Parameters	
Type	Valve-regulated, non-spillable, lead acid
Qty x V x Rating	20 x 12 V x 9.0 Ah
Battery Mfr./Part Number	CSB/HR1221WF2 / Yuasa NPH5-12
Back-up Time	See Table 15
Recharge Time	3 hours to 90% capacity after full discharge into 100% load
Environmental Requirements	
Operating Temperature	0°C to +40°C; see Table 9
Storage Temperature	-15°C to +50°C
Relative Humidity	0% to 95%, non-condensing
Operating Elevation	Up to 3,000 m (10,000 ft.) at +40°C without derating

Table 13: External Battery Cabinet Specifications

Parameters	Model Number: S4K240BATC
Used with UPS Model	S4K5U6K5C
Dimensions – D x W x H, in. (mm)	
Unit (with bezel)	22.40 x 16.90 x 5.80 (570.0 x 430.0 x 148.0)
Shipping	29.30 x 20.80 x 16.00 (745.0 x 530.0 x 407.0)
Weight – lbs. (kg)	
Unit	111.0 (50.40)
Shipping	119.0 (54.00)
Battery Parameters	
Type	Valve-regulated, non-spillable, lead acid
Qty x V	1 x 20 x 12 V
Battery Mfr./Part Number	CSB/HR1221WF2 / Yuasa NPH5-12
Back-up Time	See Table 15
Environmental Requirements	
Operating Temperature	0°C to +40°C
Storage Temperature	-15°C to +50°C
Relative Humidity	0% to 95%, non-condensing
Operating Elevation	Up to 1,000 m (3,281 ft.) at +40°C

Table 14: Battery Back-up Times

Number of Batteries/Cabinets	Load % of Capacity	Model Rating
		6 kVA
		Back-up Time in Minutes
Internal battery	10%	97
	20%	47
	30%	33
	40%	22
	50%	17
	60%	14
	70%	11
	80%	9
	90%	8
	100%	6
Internal battery + 1 external battery cabinets	10%	158
	20%	97
	30%	65
	40%	48
	50%	40
	60%	33
	70%	26
	80%	22
	90%	19
	100%	17
Internal battery + 2 external battery cabinets	10%	205
	20%	123
	30%	97
	40%	74
	50%	53
	60%	48
	70%	43
	80%	38
	90%	33
	100%	28
Internal battery + 3 external battery cabinets	10%	223
	20%	158
	30%	110
	40%	97
	50%	78
	60%	66
	70%	52
	80%	48
	90%	44
	100%	41

The factory default is programmed for internal batteries only. Table 14 shows the estimated battery back-up times at different loads. The user may specify the number of external battery cabinets attached to the UPS.

Note: Run times in this table are approximate. They are based upon new, fully charged standard battery modules at a temperature of 25°C (77°F) with 100% resistive UPS loading. Run times listed above can vary by +/-5% due to manufacturing variances of the individual batteries.

Table 14: Battery Back-up Times continued

Number of Batteries/Cabinets	Load % of Capacity	Model Rating
		6 kVA
		Back-up Time in Minutes
Internal battery + 4 external battery cabinets	10%	360
	20%	191
	30%	138
	40%	108
	50%	97
	60%	81
	70%	71
	80%	61
	90%	51
	100%	48
Internal battery + 5 external battery cabinets	10%	400
	20%	205
	30%	159
	40%	124
	50%	106
	60%	98
	70%	83
	80%	74
	90%	66
	100%	53
Internal battery + 6 external battery cabinets	10%	420
	20%	215
	30%	186
	40%	144
	50%	112
	60%	105
	70%	98
	80%	90
	90%	77
	100%	70

The factory default is programmed for internal batteries only. Table 14 shows the estimated battery back-up times at different loads. The user may specify the number of external battery cabinets attached to the UPS.

Note: Run times in this table are approximate. They are based upon new, fully charged standard battery modules at a temperature of 25°C (77°F) with 100% resistive UPS loading. Run times listed above can vary by +/-5% due to manufacturing variances of the individual batteries.

S4KC Accessories

30HWBP2U Power A/C Distribution (PAD)

The SolaHD 30HWBP2U provides an isolated path of power for the UPS system for preventive maintenance or service.



Certifications and Compliances

- Listed
 - UL 1778
 - CSA C22.2 No. 107.3
-
- IEC 62040-1
- ISTA Procedure 1A
- ABS Type Approved
- EAC: TR CU 004/2011 - Technical Regulation of Custom Union "On the safety of low-voltage equipment"



Catalog Number	Description	Series
30HWBP2U	120/208/230 Volt, 2U sized, Hardwired for use up to 30 Amp Input	S4K2U-C (120 Vac) and S4K2U-5C (230 Vac) (700-3000 VA Models were applicable) & S4K5U6K5C 6000 VA / 230 Vac

Hardware for Rack Mount (order part number separately)

Catalog Number	Description	Approx. Ship Weight lbs (kg)
Rack Slide Kits		
SRS1832	Rack slide kit for racks with 18-32" deep support rails.	8 (3.6)

Optional Equipment

Catalog Number	Description
Communications Options	
IS-RELAY	Relay contact board, 2 relay contact signals each independently configured for "On Battery", "Low Battery", "On Bypass", "On UPS", "Summary Alarm" and "UPS Fault" (rated at 24 V @ 1 Amp AC or DC).
IS-UNITY-DP	UNITY card Web, SNMP, Modbus, BACnet (S4KC and S5KC compatible). Protocols: HTTP, HTTPS, Emerson, Remote service Delivery, Email, SMS, SNMP (v1,v2c, v3), BACnet IP / BACnet MSTP and Modbus TCP / Modbus RTU

Note: Additional PADs available on the following page. PADs can only be used with units having matching receptacles for the line cords provided.

S4KC Accessories

Power A/C Distribution (PAD)

SolaHD PADs provide output distribution, input connection and a rotary maintenance bypass switch. The PAD is field installed by the customer and allows the UPS to be removed without interrupting power to the load.

Catalog Number	Description	Series
A2D115HW	120 Volt, Hardwired for use with 15 Amp Input	S4K2U-C (700 - 1500 VA Models)
A2D120HW	120 Volt, Hardwired for use with 20 Amp Input	S4K2U-C (2000 VA Model)
A2D130HW	120 Volt, Hardwired for use with 30 Amp input	S4K2U-C (3000 VA Model)
S4KPAD2-001C	208/120 V or 240/120 V, Plug-n-Play L14-30P, (4)5-20 (1) L14-30 (1) L6-30R	S4K4U6000C
S4KPAD2-002C	208/120 V or 240/120 V, Plug-n-Play L14-30P, (2) 5-20R, (2) L6-20R	S4K4U6000C
S4KPAD2-003C	208/120 V or 240/120 V, Plug-n-Play L14-30P, (4) 5-20R, (2) L6-30	S4K4U6000C
S4KPAD2-004C	208/120 V or 240/120 V, Plug-n-Play L14-30P, (4) L5-20R, (2) L5-30R	S4K4U6000C
S4KPAD2-005C	208/120 V or 240/120 V, Plug-n-Play L14-30P, (4) L5-20R, (2) L6-30R	S4K4U6000C
S4KPAD2-006C	208/120 V or 240/120 V, Plug-n-Play L14-30P, (4) L6-20R	S4K4U6000C
S4KPAD2-101C	208/120 V or 240/120 V, Output Distribution, (2) L6-30 (8) 5-20R	S4K6U10KC
S4KPAD2-102C	208/120 V or 240/120 V, Output Distribution, (4) L6-20R, (4) 5-20R	S4K6U10KC
S4KPAD2-103C	208/120 V or 240/120 V, Output Distribution, (4) 5-20R, (4) L6-30R	S4K6U10KC
S4KPAD2-104C	208/120 V or 240/120 V, Output Distribution, (4) 5-20R, (2) L6-30R, (2) L6-20R	S4K6U10KC
S4KPAD2-105C	208/120 V or 240/120 V, Output Distribution, (4) 5-20R, (2) L5-30R, (2) L5-20R	S4K6U10KC
S4KPAD2-106C	208/120 V or 240/120 V, Output Distribution, (4) L6-20R, (4) L5-20R	S4K6U10KC

Note: PADs can only be used with units having matching receptacles for the line cords provided.

S5KC Modular Series On-Line Uninterruptible Power Systems (UPS)

The SolahD S5KC Modular On-Line UPS Series is scalable from 5 to 20 kVA, offering many flexible options by adding a few standard modules. Designed to be fully configured, tested and shipped in the configuration you need, the S5KC Modular UPS also has the ability to be easily upgraded in the field to either higher VA ratings (up to 20 kVA maximum), longer back-ups time or to add N+x parallel redundancy. Configurations can be cost-effectively upgraded keeping your S5KC Modular UPS current without a large reinvestment in a new system.

The optional N+x redundancy provides a fault-tolerant group of power modules and controls. The modular design is easy to upgrade so the UPS can grow with the needs of the system that is being protected.

Each of the modular components, including 5 kVA power modules, LCD display, battery modules and system control modules, can be hot-swapped making it easy to increase power, extend your back-up time or add redundancy while still providing power protection to the load.

This fault-tolerant system uses intelligent power and battery modules which take themselves off-line if there is a problem without interrupting power to the load. Self-diagnostic capabilities simplify maintenance and troubleshooting. Each unit incorporates an internal automatic bypass.

Applications

With multiple standard options in a smaller footprint, providing more flexibility for capacity and communication both pre- and post-installation, the S5KC delivers the power protection needs in applications such as

- Oil and Gas (Pure OEMs)
- Pharmaceutical
- Automotive
- Food & Beverage

Features

- Module level redundancy provides multiple layers of protection to ensure your machine has the power it needs to run safely with no single point of failure, critical loads continue to run on conditioned battery power even if a system component malfunctions.
- An industry leading 0.9 power factor keeps machines performing flawlessly when running on battery power.
- Superior overload capabilities deliver conditioned power during temporary power anomalies without unnecessarily transferring to and from bypass power.



- Independently controlled maintenance bypass is designed to provide maximum system availability to critical equipment by allowing transfer of connected equipment to an alternate power path. The UPS can then be turned Off and removed from service with no interruption of power to connected equipment.
- True on-line double conversion with a large input voltage range (low line transfer down to 110 Vac) isolates sensitive equipment from power fluctuations while minimizing transfers to increase battery life.
- ENERGY STAR® qualified UPS models – UPS products meeting the EPA's requirements use an average of 35% less energy than their standard counterparts.
- To enhance the availability and trouble-free operation, every pre-configured S5KC UPS arrives standard with one IS-UNITY-DP communications card installed. This enables you to take advantage of the remote monitoring and diagnostic service available with your system during your initial standard warranty period.
- Start-up services available, contact your local sales representative for details.

Certifications and Compliances

All Models

- Energy Star models: S5KC-A, S5KC-B, S5KC-C (except 5 kVA), S5KC-D (except 5 kVA), S5KC-E, S5KC-F:
- Listed, UPS Equipment
 - UL 1778, Fourth Edition
 - CSA C22.2 No. 107.3
- ABS Type Approved
- RoHS Compliant

Series S5KCA, S5KCB, S5KCC, S5KCD

- (Low Voltage and EMC Directive)
 - EN62040-1, EN62040-2
- EAC: TR CU 004/2011 - Technical Regulation of Custom Union "On the safety of low-voltage equipment"

Chassis Selection

The SolaHD S5KC Modular UPS system has multiple chassis available to build on:

Select the proper chassis based on your applications current and future need for expansion. Also consider if redundancy will be required for your application then consider your application power and location wiring needs. To help with selecting the appropriate chassis series, we have provided a useful selection flow chart to guide you to an appropriate chassis series to meet your requirements.

Steps to Selection

1. Determine the maximum kVA you will need for future expansion.
2. Determine the kVA and run time value for your immediate need.
3. Using the flow chart to the right, determine the voltage, phase configuration and chassis requirements.
4. Determine if you need redundancy. If the exact run time is critical and you are not sure which unit is appropriate, please contact our technical support team to aid in selection.
5. Select the unit that meets both your immediate requirements, and is expandable to your future needs. Each chassis will have a "Maximum Upgrade" capacity. The Maximum Upgrade is the highest kVA expansion that particular configuration is capable of without removing any of the battery modules from the original configuration.
6. External Battery Cabinets (EBC). Depending on extended run-times desired or your location's spacing requirements, you may be able to add an optional EBC to extend your run-time.
7. Optional External Maintenance Bypass (EMB) or other available accessories. Review your application's current and future needs and consider all functional options including filters and spare modules if desired.

Which Product Do I Select?

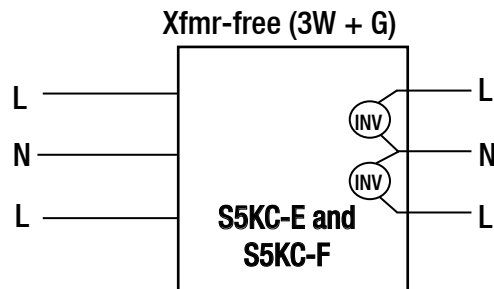
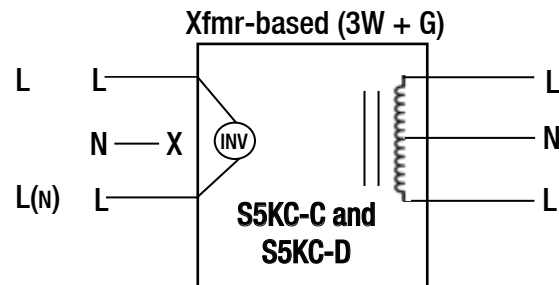
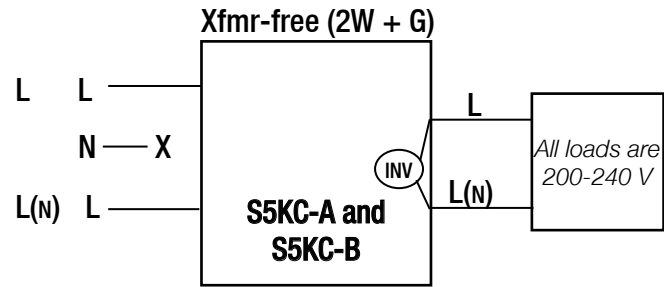
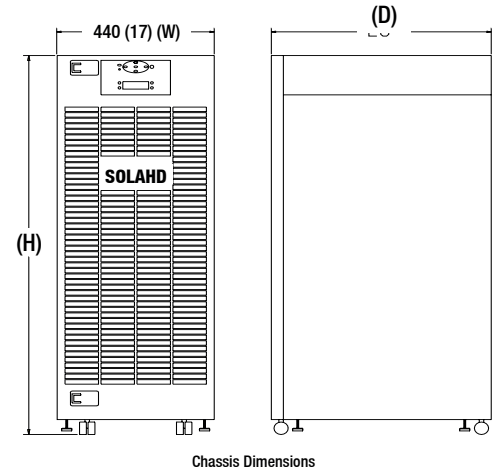

Table 15: Specifications

	10 Bay (A)	16 Bay (B)	12 Bay (C)	16 Bay (D)	10 Bay (E)	16 Bay (F)	
	Xfmr-free		Xfmr-based		Xfmr-free dual inverter		
Capacity	15 kVA	20 kVA	15 kVA	20 kVA	15 kVA	20 kVA	
	13.5 kW	18 kW	13.5 kW	18 kW	13.5 kW	18 kW	
General and Environment							
Conducted and radiated EMC levels	IEC/EN/AS 62040-2 Cat 2, CISPR22 Class A, FCC Part 15 Class A						
Compliant immunity standards	IEC/EN/AS 61000-4-2, 3, 4, 5, 6						
Environmental	WEEE and ROHS2 (6 by 6), REACH Compliant						
ENERGY STAR® qualified	Yes All Models	Yes All Models	Yes 10, 15, 20 kVA	Yes 10, 15, 20 kVA	Yes All Models	Yes All Models	
Dimensions — mm (in) & Weight kg (lbs)							
Width	440 (17)	440 (17)	440 (17)	440 (17)	440 (17)	440 (17)	
Depth	800 (32)	850 (34)	800 (32)	850 (34)	800 (32)	850 (34)	
Height	695 (27)	970 (38)	1060 (42)	1240 (49)	695 (27)	970 (38)	
Weight (frame rating populated)	Unit Weight	256 (565)	318 (700)	361 (795)	417 (920)	256 (565)	318 (700)
	Shipping Weight	274 (605)	336 (740)	379 (835)	435 (960)	274 (605)	336 (740)
Environmental							
Operating temperature	0°C - 40°C (32 °F - 104 °F)						
Relative humidity	0 - 95%, non-condensing						
Altitude	3000 m (10000 ft) @ 25°C (77°F)						
Efficiency (AC-AC)	91.8-92.0%	91.6-92.0%	88.5-89.9%	88.6-89.7%	90.4-91.0%	90.0-91.0%	
Heat dissipation	4208 BTU / Hr	5747 BTU / Hr	5528 BTU / Hr	7965 BTU / Hr	4904 BTU / Hr	6768 BTU / Hr	
Input Data							
Nominal input voltage	200/208/220/230/240 Vac; Single Phase			200/100, 208/120, 220/110, 230/115, 240/120 Vac; Single Phase			
	380/400/415 Vac; 3 Phase		Not Applicable				
Input Voltage Range	The input voltage range based on the output loading, refer to User Manual						
Power Factor	Single phase input, > 0.99 Cos; three phase input, > 0.95 Cos		Single phase input, > 0.99 Cos				
Input Frequency Range	40 Hz to 70 Hz auto-sensing						
Battery Module							
Battery capacity	36W @ 15min-rate to 1.67V per cell @ 25°C (77°F)						
Battery Back-up Time (full load)	5 minutes (for non-redundant system which has equal number of battery strings and power modules)						
Maximum Charge current (full load)	Power module internal charger: 1.8A / Charger module: 10 A						
Nominal Voltage	144 VDC						
Recharge time	< 5 hours to 90% capacity (PM internal charger with 1:1 ratio of PM to Battery Strings)						
Output Data							
Output voltage	200/208/220/230/240 Vac; Single Phase		100/100/173/200,110/110/ 190/220, 115/115/199/230, 120/120/208/240 Vac; Single Phase		200/100, 208/120, 220/110, 230/115, 240/120 Vac; Single Phase		
Voltage regulation	±3%						
Voltage stability (100% step load)	±7%						
Voltage Recovery time	≤ 60 minutes						
Voltage distortion	≤ 3%, linear load						
	≤ 5%, non-linear load		≤ 7%, non-linear load		≤ 5%, non-linear load		
Output frequency	50/60 Hz						
Output overload capability	< 104% continuous						
	105% - 130% for 1 min						
	131% - 150% for 10 sec						
	151% - 200% for 1 sec > 201% for 250 msec						

Table 16: Mechanical Description

Chassis	Dimension mm (In)	
	Height (H)	Depth (D)
S5KC-A SERIES	695 (27)	800 (32)
S5KC-B SERIES	970 (38)	850 (34)
S5KC-C SERIES	1060 (42)	800 (32)
S5KC-D SERIES	1240 (49)	850 (34)
S5KC-E SERIES	695 (27)	800 (32)
S5KC-F SERIES	970 (38)	850 (34)



Chassis Designation	Number of Bays	Description
S5KC-A	10 Bay	5-15 kVA, 1PH, Xfmr-free, 200-240 Vac input/output
S5KC-B	16 Bay	5-20 kVA, 1PH, Xfmr-free, 200-240 Vac input/output
S5KC-C	12 Bay	5-15 kVA, 1PH, Xfmr-based, 200-240 Vac input - 200/100-240/120 Vac output
S5KC-D	16 Bay	5-20 kVA, 1PH, Xfmr-based, 200-240 Vac input - 200/100-240/120 Vac output
S5KC-E	10 Bay	5-15 kVA, 2PH, Xfmr-free, 200/100-240/120 Vac input/output
S5KC-F	16 Bay	5-20 kVA, 2PH, Xfmr-free, 200/100-240/120 Vac input/output

S5KC Operating Modes

The S5KC UPS is a true online double-conversion system, having the following operating modes:

- Normal Mode
- Back-up Mode
- Auto Restart Mode
- Bypass Mode

Normal Mode

The power module rectifiers derive power from a utility AC source and supply regulated DC power to the inverter. The module's inverter regenerates precise AC power to supply the connected equipment. The battery charger is in the power module and maintains a float-charge on the batteries of the UPS; additionally, the optional charger module (S5KCCHRGMOD) can also charge the batteries to maintain a quicker recharge time for long back-up time applications.

Back-up Mode

When AC utility fails, the connected equipment is supplied power by the inverter, which obtains energy from the battery modules. The output power will not be interrupted during the failure or restoration of the AC utility/mains source.

Auto Restart Mode

After a power outage and complete battery discharge, and once AC utility is restored, the UPS will automatically restart and resume supplying power to connected equipment. This feature is enabled at the factory, but can be disabled by the user. The user can also program two auto restart delay settings from the LCD:

- Battery capacity level (%)
- Countdown timer

Bypass Mode

The bypass provides an alternate path for power to the connected equipment and operates in the following manner:

- **Automatic:** In the event of an internal fault or should the inverter overload capacity be exceeded, the UPS performs an automatic transfer of the connected equipment from the inverter to the bypass source.
- **Manual:** Should the UPS need to be taken out of service for limited maintenance or repair, manual activation of the bypass will cause an immediate transfer of the equipment from the inverter to the bypass source.

S5KC-A & S5KC-B Frames:

Xfmr-Free

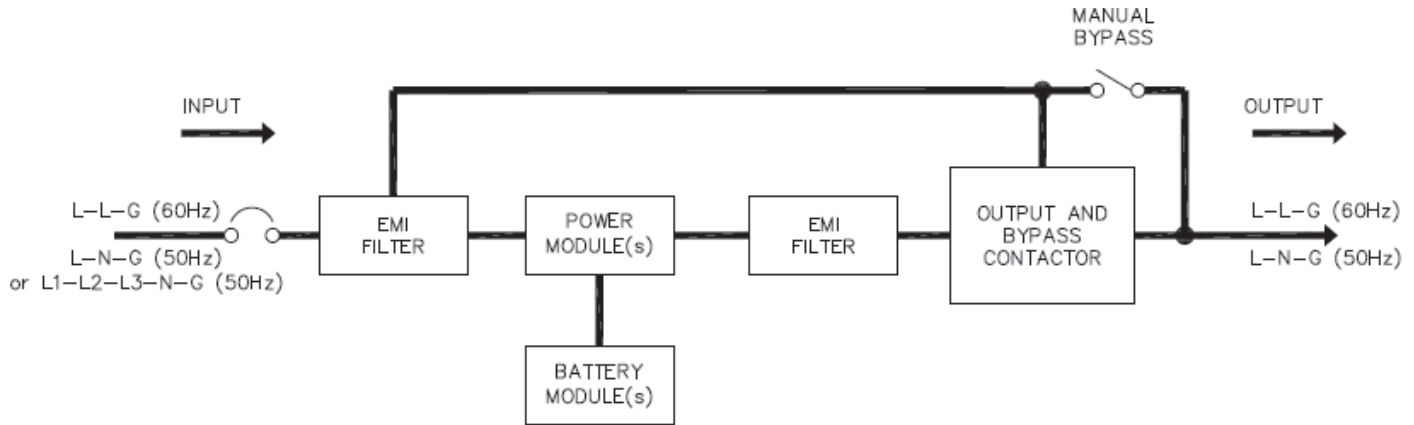

S5KC-C & S5KC-D Frames:

Xfmr-Based

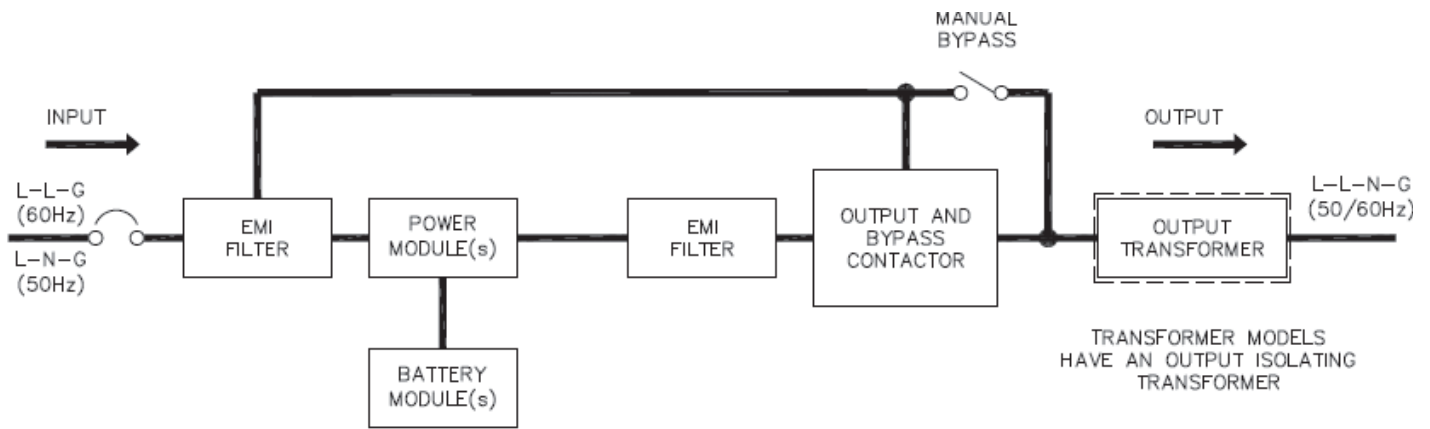

S5KC-E & S5KC-F Frames:

Xfmr-Free

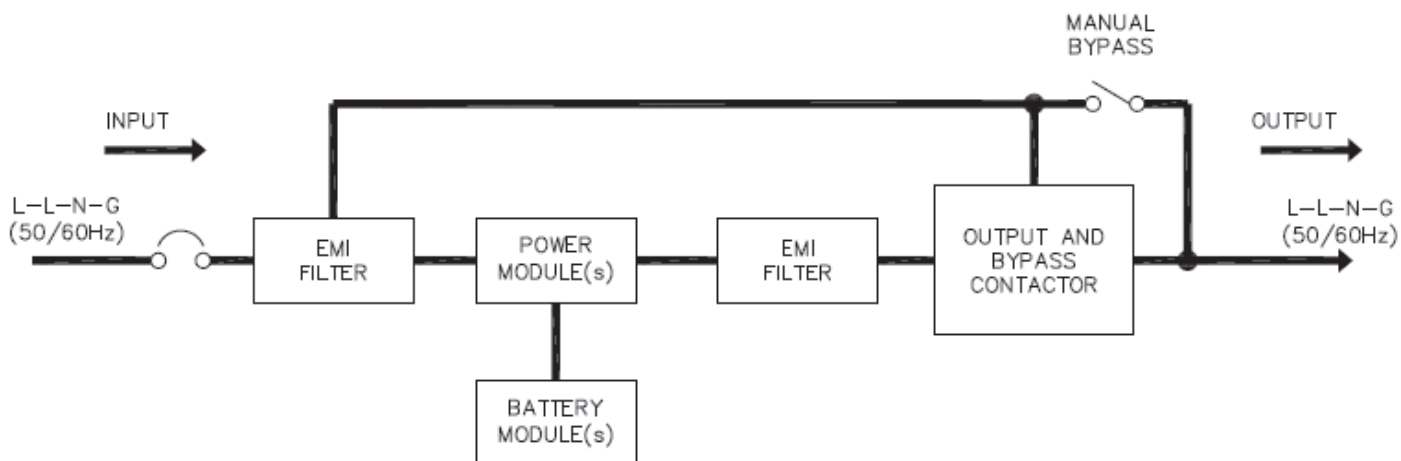

Table 17: Part Number Configuration

The S5KC modular is available in many combinations. Use the part number template below to identify the description of any given part number.

	Frame Configuration Type	System kVA / kW	Number of Charger Modules	System Type	Battery Type and Number Strings
Series Designation	A = 10 Bay, Xfmr Free, 1PH, cULus Listed, GS/CE/C-tick Marked	05A = 5 kVA / 4.5 kW 10 A = 10 kVA / 9 kW	N = No charger module A = 1 charger module	N = Non-redundant R = Redundant Power and Controls F = Redundant Power, Controls, and Battery	NN = None (allows for empty replacement frames to be shipped) C1 = 1 String, CSB UPS 12460 F2 FR C2 = 2 Strings, CSB UPS 12460 F2 FR C3 = 3 Strings, CSB UPS 12460 F2 FR C4 = 4 Strings, CSB UPS 12460 F2 FR C5 = 5 Strings, CSB UPS 12460 F2 FR C6 = 6 Strings, CSB UPS 12460 F2 FR C7 = 7 Strings, CSB UPS 12460 F2 FR
	B = 16 Bay, Xfmr Free, 1PH, cULus Listed, GS/CE/C-tick Marked	15A = 15 kVA / 13.5 kW 20A = 20 kVA / 18 kW			
	C = 12 Bay Xfmr Based, 1PH, cULus Listed, GS/CE/C-tick Marked				
	D = 16 Bay Xfmr Based, 1PH, cULus Listed, GS/CE/C-tick Marked				
	E = 10 Bay, Xfmr Free, 2PH, cULus Listed				
	F = 16 Bay Xfmr Free, 2PH, cULus Listed				

Example: 10 Bay, 1PH, 10 kVA/9 kW, No Charger Module, Non-Redundant, 2 strings, 208V, 60 Hz, L-L-G, No Distribution Slots, Standard Product

S5K	A	10 A	A	N	C2
-----	---	------	---	---	----

Configuration Notes:

1. Every pre-configured S5KC UPS arrives standard with one IS-UNITY-DP communications card installed. This allows you to take advantage of the monitoring included with your system during your initial standard warranty period. Start-up services available, contact your local sales representative for details.
2. "Maximum Upgrade" capacity considerations. The Maximum Upgrade is the highest kVA expansion each configuration will provide without removing any of the battery modules from the original configuration. Please consider your future expansion and redundancy needs.

Output Voltage/Frequency/Wiring	Distribution Slot 1	Distribution Slot 2	Product Type
A = 200 V, 60Hz, L-L-G	N = None	N = None	C = Standard product
B = 220 V, 60Hz, L-L-G	1 = (2) L6-30R, (8) 5-15/20R [PD2-101]	1 = (2) L6-30R, (8) 5-15/20R [PD2-101]	
C = 208V, 60Hz, L-L-G	2 = (4) L6-20R, (4) 5-15/20R [PD2-102]	2 = (4) L6-20R, (4) 5-15/20R [PD2-102]	
D = 240 V, 60Hz, L-L-G	3 = (4) L6-30R, (4) 5-15/20R [PD2-103]	3 = (4) L6-30R, (4) 5-15/20R [PD2-103]	
E = 200/100 V, 60Hz, L-L-N-G	4 = (2) L6-30R, (2) L6-20R, (4) 5-15/20R [PD2-104]	4 = (2) L6-30R, (2) L6-20R, (4) 5-15/20R [PD2-104]	
F = 220/110 V, 60Hz, L-L-N-G	5 = (2) L5-30R, (2) L5-20R, (4) 5-15/20R [PD2-105]	5 = (2) L5-30R, (2) L5-20R, (4) 5-15/20R [PD2-105]	
G = 208/120 V, 60Hz, L-L-N-G	6 = (4) L6-20R, (4) L5-20R [PD2-106]	6 = (4) L6-20R, (4) L5-20R [PD2-106]	
H = 240/120 V, 60Hz, L-L-N-G	7 = (4) L5-20R, (4) 5-15/20R [PD2-107]	7 = (4) L5-20R, (4) 5-15/20R [PD2-107]	
J = 220/127V, 60Hz, L-L-N-G	8 = (2) L6-30R, (2) L6-20R [PD2-108]	8 = (2) L6-30R, (2) L6-20R [PD2-108]	
K = 200 V, 50Hz, L-L-PE	9 = (2) L14-30R [PD2-109]	9 = (2) L14-30R [PD2-109]	
L = 220 V, 50Hz, L-N-PE	A = (4) IEC320-C19, (4) IEC320-C13 [PD2-200]	A = (4) IEC320-C19, (4) IEC320-C13 [PD2-200]	
M = 230 V, 50Hz, L-N-PE	B = (2) IEC320-C19, (8) IEC320-C13 [PD2-201]	B = (2) IEC320-C19, (8) IEC320-C13 [PD2-201]	
N = 240 V, 50Hz, L-N-PE	C = (12) IEC320-C13 [PD2-202]	C = (12) IEC320-C13 [PD2-202]	
P = 208V, 50Hz, L-L-PE	D = (2) IEC309-32A, (4) IEC320-C13 [PD2-204]	D = (2) IEC309-32A, (4) IEC320-C13 [PD2-204]	
Q = 200/100 V, 50Hz, L-L-N-PE			
R = 208/120 V, 50Hz, L-L-N-PE			
S = 220/110 V, 50Hz, L-L-N-PE			
T = 230/115 V, 50Hz, L-L-N-PE			
U = 240/120 V, 50Hz, L-L-N-PE			
W = 220/127V, 50Hz, L-L-N-PE			

C	N	N	C
----------	----------	----------	----------

Table 18: Basic Recommended Part Numbers (scalable for your application needs)

Back-up time: 5 minutes minimum at full load with 1-battery string per 5 kVA ①

kVA/kW	Non-Redundant Catalog Number	Available Expansion Bays (Total/Power)	Redundant Catalog Number	Available Expansion Bays (Total/Power)
S5KA Xfmr-Free (2W + G)				
5/4.5	S5KA05ANNC1GNNC	7/2	S5KA05ANRC1GNNC	6/2
10/9	S5KA10 ANNC2GNNC	5/1	S5KA10 ANRC2GNNC	3/1
15/13.5	S5KA15ANNC3GNNC	1/0	S5KA15ANRC3GNNC	0/0
S5KB Xfmr-Free (2W + G)				
5/4.5	S5KB05ANNC1GNNC	13/3	S5KB05ANRC1GNNC	12/3
10/9	S5KB10 ANNC2GNNC	10/2	S5KB10 ANRC2GNNC	9/2
15/13.5	S5KB15ANNC3GNNC	7/1	S5KB15ANRC3GNNC	6/1
20/18	S5KB20ANNC4GNNC	4/0	S5KB20ANRC4GNNC	3/0
S5KC Xfmr-Based (Input: 2W + G, Output: 3W + G)				
5/4.5	S5KC05ANNC1GNNC	9/2	S5KC05ANRC1GNNC	8/2
10/9	S5KC10 ANNC2GNNC	6/1	S5KC10 ANRC2GNNC	5/1
15/13.5	S5KC15ANNC3GNNC	3/0	S5KC15ANRC3GNNC	2/0
S5KD Xfmr-Based (Input: 2W + G, Output: 3W + G)				
5/4.5	S5KD05ANNC1GNNC	13/3	S5KD05ANRC1GNNC	12/3
10/9	S5KD10 ANNC2GNNC	10/2	S5KD10 ANRC2GNNC	9/2
15/13.5	S5KD15ANNC3GNNC	7/1	S5KD15ANRC3GNNC	6/1
20/18	S5KD20ANNC4GNNC	4/0	S5KD20ANRC4GNNC	3/0
S5KE Xfmr-Free (3W + G)				
5/4.5	S5KE05ANNC1GNNC	7/2	S5KE05ANRC1GNNC	6/2
10/9	S5KE10 ANNC2GNNC	5/1	S5KE10 ANRC2GNNC	3/1
15/13.5	S5KE15ANNC3GNNC	1/0	S5KE15ANRC3GNNC	0/0
S5KF Xfmr-Free (3W + G)				
5/4.5	S5KF05ANNC1GNNC	13/3	S5KF05ANRC1GNNC	12/3
10/9	S5KF10 ANNC2GNNC	10/2	S5KF10 ANRC2GNNC	9/2
15/13.5	S5KF15ANNC3GNNC	7/1	S5KF15ANRC3GNNC	6/1
20/18	S5KF20ANNC4GNNC	4/0	S5KF20ANRC4GNNC	3/0

Configuration Notes:

- Voltage Options: Additional Output Voltage Configurations are available. Refer to Table 16 and 18, part number configuration template table.
Example: D = 240 V, 60Hz, L-L-G ; S5KC05ANN1DNNC is a 240 V configuration.
- Every pre-configured S5KC UPS arrives standard with one IS-UNITY-DP communications card installed. This allows you to take advantage of the monitoring included with your system during your initial standard warranty period. Start-up services available, contact your local sales representative for details.
- Available Expansion Bays (Total/Power) equals the TOTAL available expansion bays still available and POWER is the number of bays that can be used for remaining POWER modules up to the maximum allowed for that configuration. For example: S5KA05ANNC1GNNC, has 7 total, 2 power so you can add either 6 battery modules, 1 charging module or 6 battery modules and 2 power modules.
- Do you require an EBC or MBC? Please refer to configuration table 20 and 21 to build an appropriate part.

① Configurations with run-times in excess of 5 minutes are available, contact Technical Services.

Table 19: External Battery Cabinet (EBC) Part Number Configuration

The SolaHD S5KC Modular UPS includes internal batteries. Optional, matching external battery cabinets, offer extended battery runtime. Use the part number template below to identify the description of any given part number.

Specifications

Mechanical	
Conducted and Radiated EMC Levels	IEC/EN/AS 62040-2—Class A, FCC Part 15 (Class A)
Safety Standards	IEC/EN/AS 62040-1:2008, UL 1778 4th Ed and CSA 22.2 No. 107.3
Immunity Standards	IEC/EN/AS 61000-4-2, 3, 4, 5, 6 (C-tick)
Transportation	ISTA-1E
Dimensions – WxDxH in (mm)	17 x 28 x 38 (440 x 712 x 970)
Unit Weight – lbs (kg)	170 (77.1)
Shipping Weight – lbs (kg)	210 (129.3)
Environmental	
Operating Temperature °F (°C)	32 to 104 (0 to 40)
Storage Temperature, °F (°C)	Without battery: -4 to 140 (-20 to 60) With battery: 5 to 104 (-15 to 40)
Relative Humidity, %	0 - 95%, non-condensing
Altitude, ft. (m)	10000 (3000)



Series Designation	Frame Configuration Type	Number of Battery Strings	Battery Manufacturer	Battery Model	Overcurrent Protection	Product Type
		1 = 1 String	C = CSB	XX = CSB UPS 12460 F2 FR	B = Circuit Breaker	C = Standard product
		2 = 2 Strings	N = None (allows for empty replacement frames to be shipped)	NN = None (allows for empty replacement frames to be shipped)		
		3 = 3 Strings				
		4 = 4 Strings				
		5 = 5 Strings				
		6 = 6 Strings				
		7 = 7 Strings				
		N = None (allows for empty replacement frames to be shipped)				
Example: 4 String, CSB, CSB UPS 12460 F2 FR, Circuit Breaker, Standard Product						
S5K	EBC	4	C	XX	B	C

Table 20: Maintenance Bypass Options

The S5KC Modular Series Maintenance Bypass provides maximum system availability to business critical equipment by allowing transfer of connected equipment to an alternate power path allowing full isolation of the UPS for maintenance. The UPS can then be turned Off and removed from service with no interruption of power to connected equipment.



Specifications

Mechanical	
Dimensions – W x D x H, mm (In)	440 x 862 355 (17.3 x 33.9 x 14.3)
Safety Standards	IEC/EN/AS 62040-1:2008, UL 1778 4th Ed and CSA 22.2 No. 107.3
Transportation	ISTA Procedure 1A
Weight – kg (lbs)	30 (66.1)
Environmental	
Operating Ambient Temperature	0°C to +40°C (32°F to 104°F)
Storage Ambient Temperature	-20°C to +60°C (-4°F to +140°F)
Humidity	0 to 95% non-condensing

Series Designation	Frame Configuration Type	Mounting	Rating	Voltage/Frequency/Wiring	Agency	Distribution Slot 1	Distribution Slot 2	Product Type
		R = Rackmount	1 = 15 kVA, 100A 2 = 20 kVA, 125 A	A = 200 V, 60Hz, L-L-G B = 220 V, 60Hz, L-L-G C = 208V, 60Hz, L-L-G D = 240 V, 60Hz, L-L-G E = 200/100 V, 60Hz, L-L-N-G F = 220/110 V, 60Hz, L-L-N-G G = 208/120 V, 60Hz, L-L-N-G H = 240/120 V, 60Hz, L-L-N-G J = 220/127V, 60Hz, L-L-N-G	U = cULus	N = None 1 = (2) L6-30R, (8) 5-15/20R [PD2-101] 2 = (4) L6-20R, (4) 5-15/20R [PD2-102] 3 = (4) L6-30R, (4) 5-15/20R [PD2-103] 4 = (2) L6-30R, (2) L6-20R, (4) 5-15/20R [PD2-104] 5 = (2) L5-30R, (2) L5-20R, (4) 5-15/20R [PD2-105] 6 = (4) L6-20R, (4) L5-20R [PD2-106] 7 = (4) L5-20R, (4) 5-15/20R [PD2-107] 8 = (2) L6-30R, (2) L6-20R [PD2-108] 9 = (2) L14-30R [PD2-109] A = (4) IEC320-C19, (4) IEC320-C13 [PD2-200] B = (2) IEC320-C19, (8) IEC320-C13 [PD2-201] C = (12) IEC320-C13 [PD2-202] D = (2) IEC309-32A, (4) IEC320-C13 [PD2-204]	N = None 1 = (2) L6-30R, (8) 5-15/20R [PD2-101] 2 = (4) L6-20R, (4) 5-15/20R [PD2-102] 3 = (4) L6-30R, (4) 5-15/20R [PD2-103] 4 = (2) L6-30R, (2) L6-20R, (4) 5-15/20R [PD2-104] 5 = (2) L5-30R, (2) L5-20R, (4) 5-15/20R [PD2-105] 6 = (4) L6-20R, (4) L5-20R [PD2-106] 7 = (4) L5-20R, (4) 5-15/20R [PD2-107] 8 = (2) L6-30R, (2) L6-20R [PD2-108] 9 = (2) L14-30R [PD2-109] A = (4) IEC320-C19, (4) IEC320-C13 [PD2-200] B = (2) IEC320-C19, (8) IEC320-C13 [PD2-201] C = (12) IEC320-C13 [PD2-202] D = (2) IEC309-32A, (4) IEC320-C13 [PD2-204]	C = Standard product
Example: Rackmount, 15 kVA, 100A, 208V, 60Hz, L-L-G,					UL, cUL Listed, No Distribution Slots, Standard Product			
S5K	MBC	R	1	C	U	N	N	C

NOTES:

RM-MBC (Rack Mount - Maintenance By-Pass Cabinet)

Optional Equipment

Catalog Number	Description
Communication Options	
IS-UNITY-DP	IS Communications Card for multiple protocols: BACnet, Modbus, SNMP, Web, YDN23
IS-RELAY	Relay contact board, relay contact signals for "On Battery", "Low Battery", "On Bypass", "On UPS", "Summary Alarm" and "UPS Fault".
S5KREPOKIT	Remote Emergency Power Off Kit includes 50' length of cable with connector to UPS and external push button switch.

Optional Equipment

Model Number	Description
S5KCRACKKIT	Rackmount Kit
S5KCEBCCBL1M	EBC Cable 1 meter
S5KCEBCCBL3M	EBC Cable 3 meters
S5KCEBCCBL5M	EBC Cable 5 meters
S5KCLRTCONNKIT	LRT Connector Kit
S5KCLRTTEMPKIT	LRT Temperature Sensor Kit
S5KCHRGRMOD	Charger Module, 10 amps
S5KCEBCCARD	EBC Communication Card
S5KCBATMODCU	Expansion Battery to increase run time. Note: Each kit includes one string (2 modules)

Spare Equipment Parts

Model Number	Description
S5K5KPWRMOD1	Power Module (PM1), 208/120 Vac, 5 kVA / 4.5kW (E & F Chassis)
S5K5KPWRMOD2	Power Module (PM2), 230, 208 Vac, 5 kVA / 4.5kW (A, B, C & D Chassis)
S5KCBATMODCU	Replacement Battery Note: Each kit includes one string (2 modules)
S5KCBYDPSMOD	Bypass DSP Module
S5KCBYPMCUMOD	Bypass MCU Module
S5KCLCDMOD	LCD module
S5KCAFLTRKIT	Air Filter Kit
S5KCAFLTRKIT-FD	Fine Dust Air Filter Kit
S5KCEZELHMI	Metal HMI Bezel with Display Opening and Filter
S5KCEZEL	Metal Bezel for Module Bays and Filter

S5KCHRGRMOD, Charger Module

In AC mains mode, the charger module charges the system battery modules or external battery cabinet. Each charger module is rated to deliver 10 A charging current. The charger module has an independent control function and maintains real-time communication with the system and the battery modules to ensure stable charging and fault protection.

The charger module may be added or replaced on-line with no interruption or danger to the user, connected battery system or connected equipment.

Example: 10-Bay Configuration
(S5KC Chassis E and F)

S5K5KPWRMOD1	(P, B, C) *
(P, B, C) *	(P, B, C) *
S5KCBATMODCU = 2 Modules or 1 string	
B **	B **
B **	B **

P = Power module

B = Battery module

C = Charger module

* Where you have an empty spot you can add a power, battery or charger.

** Battery module only.

UPS Extended Warranty Offering for the SolaHD S1K, S3K and S4K Series

S1K

Catalog Number	Description
1–Year Extended Warranty	
1EWPS1K320	1-year extended warranty for S1K320
1EWPS1K520	1-year extended warranty for S1K520
1EWPS1K650	1-year extended warranty for S1K650
1EWPS1K850	1-year extended warranty for S1K850
1EWPS1K1200	1-year extended warranty for S1K1200
1EWPS1K1500	1-year extended warranty for S1K1500
3–Year Extended Warranty	
3EWPS1K320	3-year extended warranty for S1K320
3EWPS1K520	3-year extended warranty for S1K520
3EWPS1K650	3-year extended warranty for S1K650
3EWPS1K850	3-year extended warranty for S1K850
3EWPS1K1200	3-year extended warranty for S1K1200
3EWPS1K1500	3-year extended warranty for S1K1500

S3K

Catalog Number	Description
1–Year Extended Warranty	
1EWPS3K700	1-year extended warranty for S3K700
1EWPS3K1000	1-year extended warranty for S3K1000
1EWPS3K1600	1-year extended warranty for S3K1600
3–Year Extended Warranty	
3EWPS3K700	3-year extended warranty for S3K700
3EWPS3K1000	3-year extended warranty for S3K1000
3EWPS3K1600	3-year extended warranty for S3K1600

S4K4UC AND S4K6UC – Maintenance Bypass Switch

Catalog Number	Description
1–Year Extended Warranty	
1EWPS4K06KPAD	1-year extended warranty for S4K4UC PADs
1EWPS4K10KPAD	1-year extended warranty for S4K6UC PADs
3–Year Extended Warranty	
3EWPS4K06KPAD	3-year extended warranty for S4K4UC PADs
3EWPS4K10KPAD	3-year extended warranty for S4K6UC PADs

S4KC Industrial – UPS Models

The extended warranty program extends the standard two-year product warranty by the term of the extension purchased, 1-year or 3 years. This results in warranty terms of 3 or 5 years (depending on the extension selected) from the date of purchase. We will repair or replace the SolaHD unit at any point during the extension period, subject to the same conditions as the standard warranty. The warranty extension is not transferable.

Catalog Number	Description
1–Year Extended Warranty	
1EWPS4K2U700C	1-year extended warranty for S4K2U700C
1EWPS4K2U1000C	1-year extended warranty for S4K2U1000C
1EWPS4K2U1500C	1-year extended warranty for S4K2U1500C
1EWPS4K2U2000C	1-year extended warranty for S4K2U2000C
1EWPS4K2U3000C	1-year extended warranty for S4K2U3000C
1EWPS4K4U6000C	1-year extended warranty for S4K4U6000C
1EWPS4K6U10KC	1-year extended warranty for S4K6U10KC
3–Year Extended Warranty	
3EWPS4K2U700C	3-year extended warranty for S4K2U700C
3EWPS4K2U1000C	3-year extended warranty for S4K2U1000C
3EWPS4K2U1500C	3-year extended warranty for S4K2U1500C
3EWPS4K2U2000C	3-year extended warranty for S4K2U2000C
3EWPS4K2U3000C	3-year extended warranty for S4K2U3000C
3EWPS4K4U6000C	3-year extended warranty for S4K4U6000C
3EWPS4K6U10KC	3-year extended warranty for S4K6U10KC

Note: Warranty on S4K4U6000 covers electronics and internal battery.

S4KC Industrial – Battery Cabinets

Catalog Number	Description
1–Year Extended Warranty	
1EWPS4K2U48BATC	1-year extended warranty for S4K2U48BATC
1EWPS4K2U96BATC	1-year extended warranty for S4K2U96BATC
1EWPS4K144BATC	1-year extended warranty for S4K144BATC
1EWPS4K288BATC	1-year extended warranty for S4K288BATC
3–Year Extended Warranty	
3EWPS4K2U48BATC	3-year extended warranty for S4K2U48BATC
3EWPS4K2U96BATC	3-year extended warranty for S4K2U96BATC
3EWPS4K144BATC	3-year extended warranty for S4K144BATC
3EWPS4K288BATC	3-year extended warranty for S4K288BATC

Field Service Programs for the S5KC Series

These programs are for Domestic coverage (valid only within the continental United States and Canada); additional travel expenses may be billed to customers with site locations more than 150 miles from a major metropolitan area.

S5KC Modular Start-Up Programs

Start-up services should be ordered as a separate line item at the time of purchase. S5KC Series UPS sold with start-up Services are provided with a 2 year parts and labor warranty. Please refer to the following information for a menu of start-up options and please choose the appropriate start-up service required. If start-up is not ordered and performed, please note that this will reduce your warranty period to two years of parts and, 90 days labor.

A separate Preventative Maintenance Only plan is available in addition to the standard Start-Up plan.

Service Programs - S5KC Series

Preferred service level options include 6-hour on-site response, 24x7 within 150 miles of nearest service centers. 24x7 emergency service includes parts (including internal batteries), labor, and travel. Also includes one (1) Preventive Maintenance (PM) visit per year, scheduled at the customer's convenience (24x7).

Essential service level options include 6-hour on-site response, 24x7 within 150 miles of nearest service centers. 24x7 emergency service includes parts (including internal batteries), labor, and travel. Also includes one (1) Preventive Maintenance (PM) visit per year, scheduled by the customer for M-F 8AM-5PM.

Basic service level options include 6-hour on-site response, 24x7 within 150 miles of nearest service centers. 24x7 emergency service includes parts (excluding internal batteries), labor, and travel. Preventive Maintenance (PM) not included and is not available if the Basic Service plan is selected.

Field Service Programs for the S5KC Series

Catalog Number	Equipment
SUS5KCXXMF	S5KC Start-Up Monday-Friday 8-5
SUS5KCXX24	S5KC Start-Up 7x24
SUPS5KCXXMF	S5KC Start-Up Plus M-F 8-5 w/1PM over initial warranty period
SUPS5KCXX24	S5KC Start-Up Plus 7x24 w/1PM over initial warranty period

PM = Preventative Maintenance

S5KC Modular Service Programs

Contact Technical Services to obtain the catalog number for any of the Preferred, Essential or Basic Services (catalog number depends on the S5KC configuration).

X = Number of Power/Charger Modules (#1 through #6)

YY = Number of Battery Modules (#01 through #07)

Catalog Number	Service Program
MUUS5KCXPYY	Preferred Service
MUUS5KCXESYY	Essential Service
MUUS5KCXBAYY	Basic Service
MS5KC1PM24	PM Only (7-Days/Week, 24 Hrs/Day) for all configurations

Note: Service programs are valid for one year.

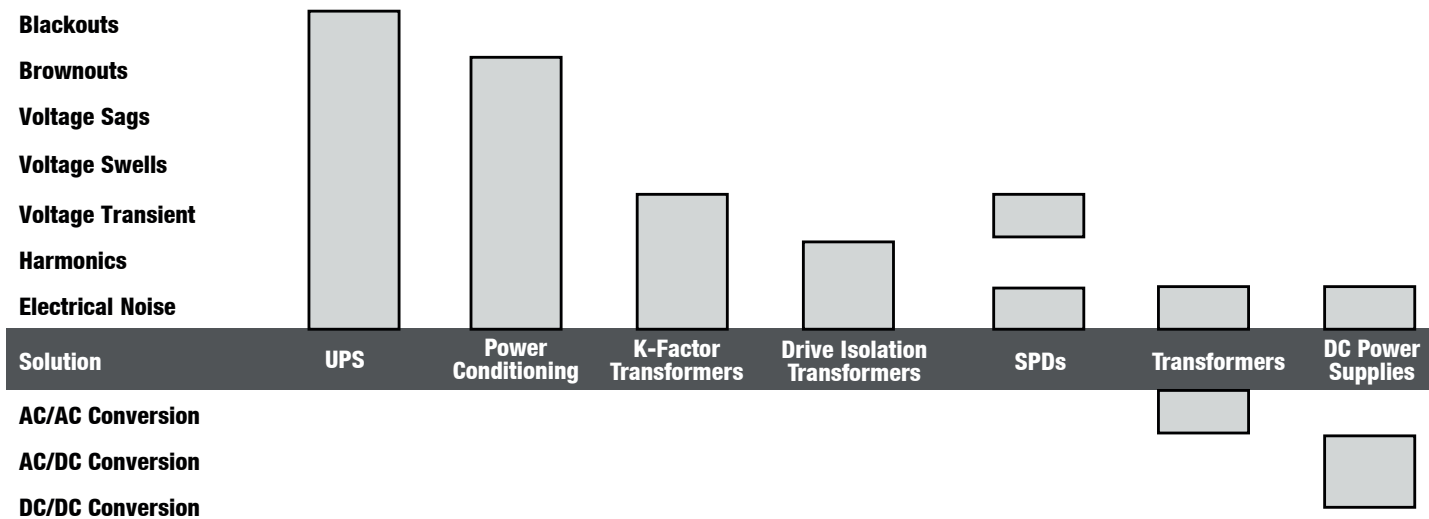
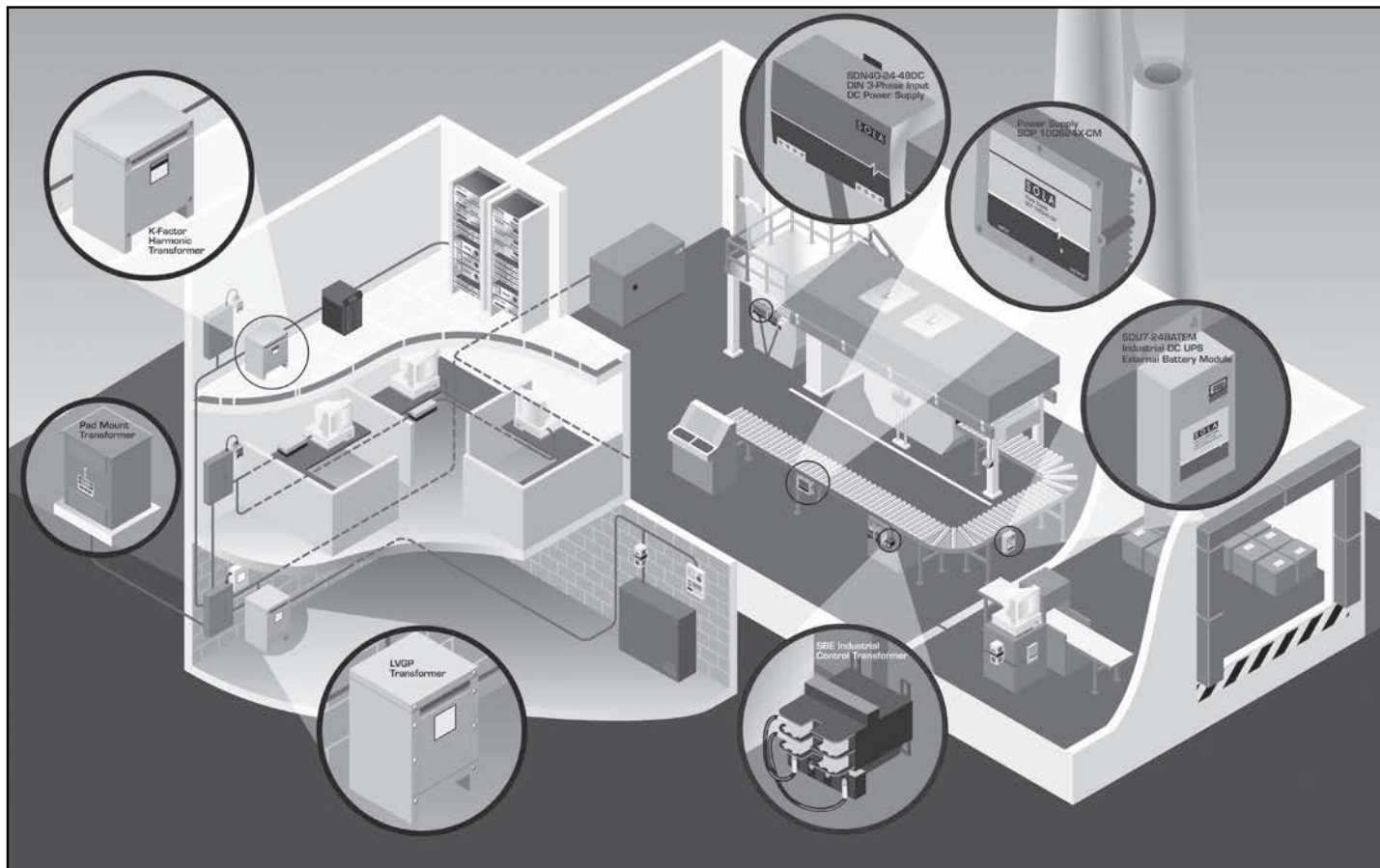

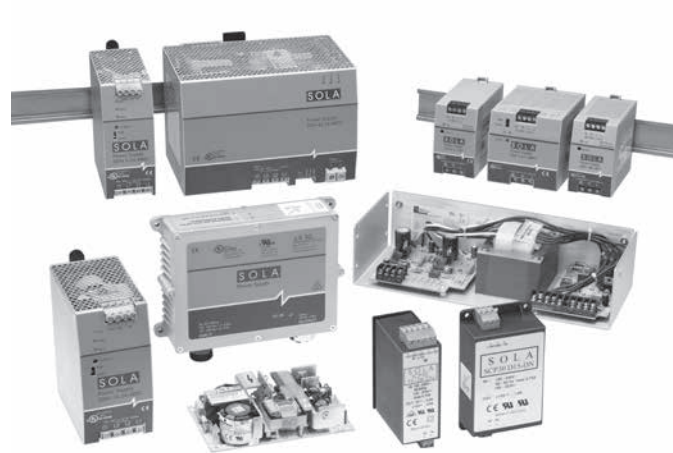

Power Supply Overview

Power Supply Overview 119
 Power Supply Selection Worksheet..... 120
 Power Supply Selection Tables 121

Power Supplies

SDN-C High Performance DIN Rail Power Supplies 122
 SDN-P Core DIN Rail Power Supplies 130
 SDP™ Low Power DIN Rail Power Supplies 135
 SVL Essential DIN Rail Power Supplies 138
 SDN-C Redundancy Modules Din Rail Power Supplies 143
 IP67 SCP-X Extreme Environment Power Supplies 146
 SCP 30 Watt Power Supplies (Single, Dual and Triple) 149
 SCD Encapsolated DC-DC Converters 151
 SHP High Power Modular Power Supplies 153
 SL Silver Line Linear Power Supplies 165

Emerson has a broad range of SolaHD power supplies to suit almost any application. Three tiers of DIN rail power supplies, from high reliability in the harshest of environments, to applications with extremely economical requirements. IP67-rated power supplies, conveniently mounted as a standalone device without an enclosure. Very compact power supplies and DC-to-DC converters for low wattage applications. High capacity modular power supplies for unusual custom application needs. Traditional linear power supplies for applications where modern switching design power supplies are not suitable.



SDN-C: Highest performance specifications and extensive international certifications ensure that SDN-C High Performance DIN Rail Power Supplies are suitable for the most extreme environments, including hazardous locations and off-shore applications. Wide operating temperature range and PowerBoost™ capability ensure reliable operation in the harshest industrial environments. Parallel operation, extensive LED diagnostics, and universal AC or DC input voltage simplify installation and maintenance. Available with 12 or 24 Vdc output; currents up to 40 A; with single phase AC, 3-phase AC, or DC input.

SDN-P: Providing industry leading performance at a reasonable cost, the SDN-P Core DIN Rail Power Supplies feature sag immunity, transient suppression, power factor correction, and wide operation temperature range. Available in output currents 2.5 A to 9 A; 12, 24, and 48 Vdc outputs; with 1-phase AC or DC input.

SDP: An extension of the Core Series, the SDP Low Power DIN Rail Power Supplies fill out the mid-range with low power options. The compact, lightweight power supplies come in output voltages from 5 to 48 Vdc and power ratings up to 100 Watts.

SVL: The cost effective SVL Essential DIN Rail Power Supplies are perfect for high volume, controlled environment applications, ranging from 15 to 480 Watts in 5, 12, 24 and 48 Volt combinations.

Power Supply Redundancy Modules: For an additional level of system reliability, our DIN Rail Redundancy Modules are used to support redundant power supply operation. The Redundancy Module continually monitors the condition of two power supplies connected to a single load. If one power supply fails, the Redundancy Module automatically changes over to the other power supply. It also provides important diagnostic information, and helps to balance the load between the two power supplies during normal operation. The Redundancy Modules have extensive international certifications required for harsh industrial environments and hazardous locations. The module works with SolaHD SDN-C, SDN-P, and most other power supplies capable of parallel operation.

SCP-X: No enclosure required! IP67-rated standalone SCP-X Extreme Environment IP67 Power Supplies deliver reliable field power to distributed and remote machine controls. Mounts directly on the machine or production line, eliminating the complexity and cost of unnecessary enclosures and excess wiring. Quick change connectors simplify connectivity to I/O devices. Class II rated, 24 Vdc output in single and dual 100 Watt models. Perfect for automotive, packaging and automated distribution applications.

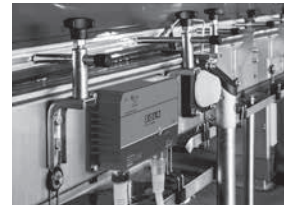

SCP: The convenience of a very compact design in either DIN rail or chassis mount configuration, the SCP 30 Watt Power Supplies are available with Single, Dual and Triple output configurations.

SCD: Similar to the SCP Series, the very compact SCD 30 Watt DC-DC Converters provide DC to DC conversion in either DIN rail or chassis mounting configuration. Single, Dual and Triple output configurations.

SHP: The high power, modular design of SHP High Power Modular Power Supplies allow extremely flexible design of single or multiple output configurations up to 4920 Watts. Intelligent design option provides I2C or CANBUS/RS485 interface to monitor and control power supply attributes.

SL: Although linear design power supplies are generally considered to be old technology, the SL Silver Line Linear Power Supplies still provide some advantages over modern switching power supplies. Often preferred for applications where very tight regulation, very clean DC output, or very fast transient response is more important than the large, heavy, inefficient, heat producing operation inherent to linear-based power supply design.

DC Power Supply Selection Worksheet

Power supplies can be selected by following the directions below. Enter your power requirements and a list of matching power supplies will list. You can also manually select a power supply by following the directions below:

- 1) Gather the required information.
 - Input voltage and frequency?
 - Wattage needed?
 - Number of outputs?
 - Voltage of each output?
 - Amperage of each output?
 - Don't forget to take into account the peak loading of each output.
 - Battery Back-up?

- 2) Calculate the power (wattage) of the DC power supply you need. If more than one output is required, do the following calculation:
 - Multiply the Voltage times the Amperage of each output to calculate the Wattage of each output. Next, add together the Wattage of each output to get the total Wattage for the supply.

- 3) Determine which models from the Power Supply Selection Chart (on the next page) meet all of the required specifications.

- 4) Reference www.solahd.com for the latest specifications sheets.

- 5) Check the mounting style, connections and physical size of the power supply to ensure its suitability for the intended application.

- 6) Check for applicable safety approvals for the country and application the power supply will be used in.

Selection Worksheet

Output:

- _____ Vdc x _____ Amps = _____ Watts
- _____ Vdc x _____ Amps = _____ Watts
- _____ Vdc x _____ Amps = _____ Watts
- _____ Vdc x _____ Amps = _____ Watts
- _____ Vdc x _____ Amps = _____ Watts
- _____ Vdc x _____ Amps = _____ Watts
- _____ Vdc x _____ Amps = _____ Watts

Add Watts from each output to calculate

Total Watts = _____

Physical Dimensions:

_____ H x _____ W x _____ D

Mounting:

- _____ DIN Rail
- _____ Chassis
- _____ Other

Other required features or options:

If you have filled out this form and cannot find the appropriate power supply, e-mail this information to the Technical Services group:
solahd.technicalservices@emerson.com

Power Supply Selection Table

This chart is intended only as a guide for selecting a series of DC power supply, some of the Series listed may not work in all applications.

Series	Input Voltage			Output Voltage						Power Range (Total Watts)	Number of Outputs				Page
	DC	1Ø AC	3Ø AC	3.3 V	5 V	12V	15 V	24 V	48V		Single	Dual	Triple	>4	
SDN-C High Performance, DIN Rail	X	X	X			X		X		120 – 960	X				124
SDN-P Core, DIN Rail	X	X				X		X	X	60 – 240	X				132
SDP Low Power, DIN Rail	X	X			X	X	X	X	X	15 – 100	X				144
SVL Essential, DIN Rail	X	X			X	X		X	X	15 – 480	X				147
Redundancy Modules, DIN Rail	X					X	X	X		Up to 1920	X				141
SCP-X Extreme Environment IP67	X	X						X		100, 2 X 100	X				160
SCP 30 Watt Multi-output	X	X		X	X	X	X	X	X	30	X	X	X		152
SCD 30 Watt DC-DC Converter	X				X	X	X	X	X	30	X	X			154
SHP High Power Modular	X	X		X	X	X	X	X	X	36 – 4920	X	X	X	X	171
SL Silver Line Linear		X			X	X	X	X		15 – 244	X	X	X		156

DIN Rail Selection Guide

		Output Voltages										
		48	24	15	12	10	5	±15	±12	5/24	5/12/12	
AMPS	1	SDP 1-48-100T	SDP 06-24-100T SDP 1-24-100T SVL 1-24-100	SCP 30S15-DN							SCP 30D524-DN SCP30S524B-DN	SCP 30T512-DN
	2.5	SVL 2-48-100	SDN 2.5-24-100P SDP 2-24-100T SVL 2-24-100		SDP 2-12-100T SCP 30S12B-DN			SCP 30D15-DN	SCP 30D12-DN			
	3			SDP 3-15-100T	SDP 3-15-100T	SDP2-12-100T	SVL 3-5-100					
	3.8		SDN 4-24-100LP SDP 4-24-100LT									
	4		SDP 4-24-100RT SVL 4-24-100		SVL 4-12-100							
	5	SDN 5-48-100P	SVL 5-24-100 SDN 5-24-100C SDN 5-24-100P SDN 5-24-480C (3Ø)				SDP 5-5-100T					
	6						SCP 30S5B-DN SVL 6-5-100					
	9				SDN 9-12-100P							
	10		SVL 10-24-100 SDN 10-24-100C SDN 10-24-100P SDN 10-24-480C (3Ø)									
	16				SDN 16-12-100C							
	20		SVL-20-24-100 SDN 20-24-100C SDN 20-24-480CD (3Ø)									
	40		SDN 40-24-480C (3Ø)									

SDN-C Performance DIN Rail Series

High performance specifications and extensive international certifications ensure that the SolaHD SDN-C is suitable for the most extreme environments, including hazardous locations and off-shore applications. Features like wide operating temperature range, power boost capability, and adjustable output voltage ensure reliable operation in the harshest industrial environments. Parallel operation, extensive LED diagnostics, and universal AC or DC input voltage simplify installation and maintenance. For added reliability, the SDN-C power supplies can be used with the SolaHD Redundancy modules to provide redundant power supply operation.

Applications

- Industrial Automation
- Process Control
- Material Handling and Conveyors
- Hazardous Locations
- Marine Applications

Features

- Extensive international hazardous location certifications, including Class I, Zone 2, ATEX, IECEx, ExEAC. Hazardous location temperature code (T-Code) rating of T4.
- International off-shore certifications, including ABS and DNV-GL
- PowerBoost™ enables short duration overload capability, to start loads with high inrush current
- Three LEDs provide extensive diagnostics
- Dual output terminals for convenience in wiring
- DC OK relay to provide diagnostic information to a PLC, controller, or monitoring system
- Universal AC and DC input voltages to accommodate global requirements
- Wide operating temperature range accommodates both extreme hot and extreme cold environments
- Active Power Factor Correction on most models
- Parallel operation capability standard
- Supports redundant power supply operation using optional SDN™ Redundancy modules
- 5-year limited warranty

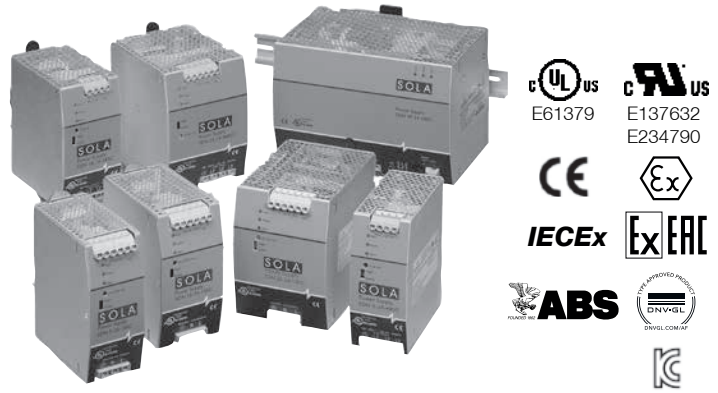

Certifications and Compliances *

All Models

- Listed, Ind. Control Equipment, E61379
 - UL 508, CSA C22.2 No. 107.1
- UL Recognized Component, ITE, E137632
 - UL 60950-1/CSA C22.2 No. 60950-1, 2nd Edition
- UL Recognized Component, Class I, Div 2; Class I Zone 2; T4 E234790
- - Low Voltage Directive
 - IEC/EN60950-1, 2nd Edition
- RoHS Compliant

Models SDN 5-24-100C, SDN 10-24-100C, SDN 16-12-100C, SDN 20-24-100C, SDN 40-24-100C, SDN 5-24-480C, SDN 10-24-480C, SDN 20-24-480CD

- UL Recognized Component, Haz. Loc., E234790
 - UL60079-0/CSA E60079-0, UL 60079-15, CSA E60079-15
 - Class I, Zone 2, AEx nA nC IIC, Ex nA nC IIC
- ATEX Directive
 - EN60079-0, EN60079-7, EN60079-15
 - II 3 G, Ex ec nC IIC Gc
- **IECEx** Certified
 - IEC 60079-0, IEC 60079-7, IEC 60079-15
 - Ex ec nC IIC Gc

Models SDN 5-24-100C, SDN 10-24-100C, SDN 16-12-100C, SDN 20-24-100C, SDN 40-24-100C, SDN 5-24-480C, SDN 10-24-480C

- TR CU 012/2011 Safety of Equipment intended for Explosive Atmospheres
- Type Approval

Models SDN 5-24-100C, SDN 10-24-100C, SDN 16-12-100C, SDN 20-24-100C, SDN 40-24-100C

- Type Approved

Models SDN 5-24-100C, SDN 10-24-100C, SDN 20-24-100C, SDN 40-24-100C

- Certified

* Refer to user manual for installation requirements when used in hazardous locations.

Related Products

- SDN-C Redundancy Modules
- IP67 SCP-X Extreme Environment Series
- SDU UPS

Accessories

- Chassis Mount Brackets

The SolaHD Difference

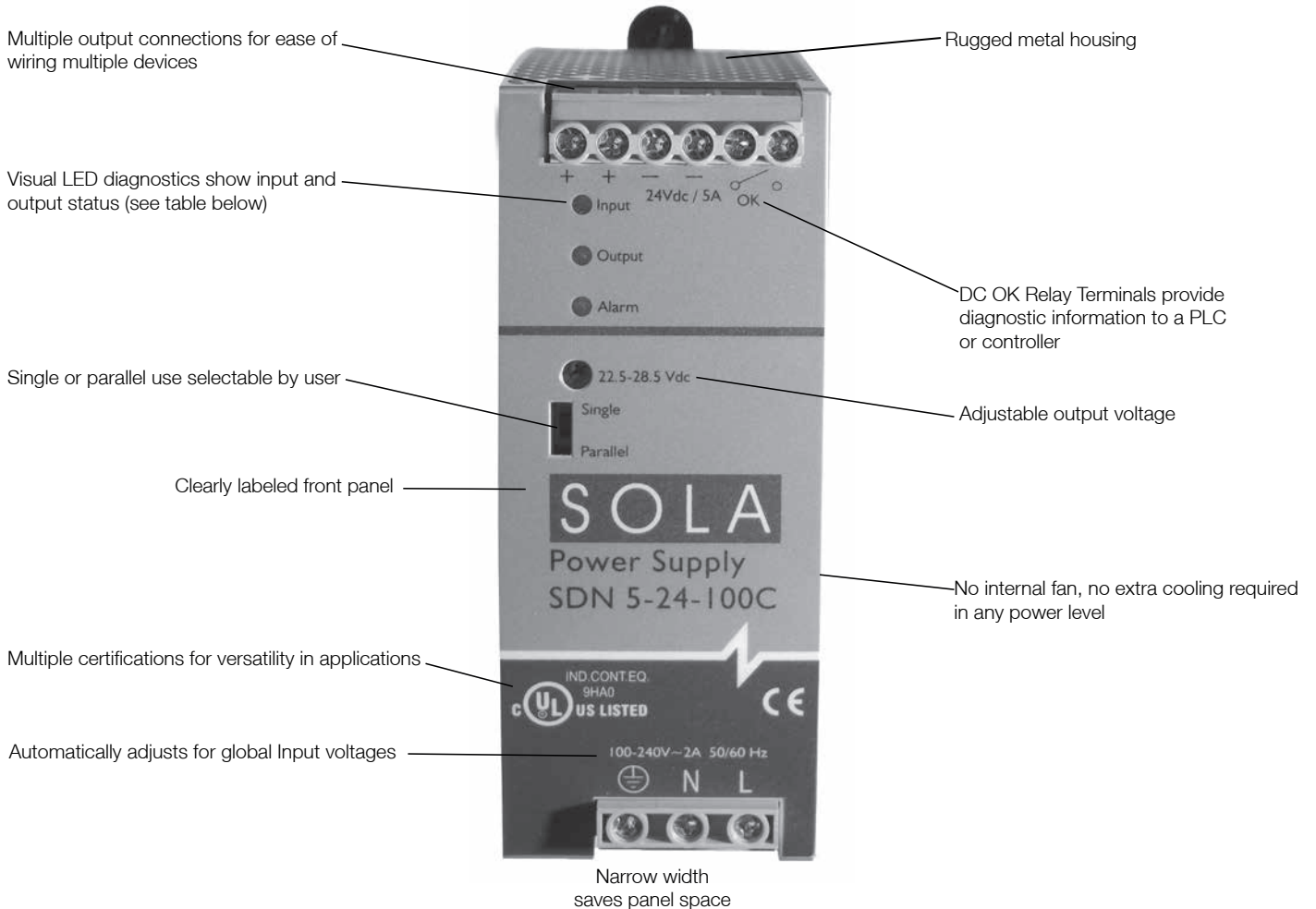

LED Light Status Conditions

	Normal	AC Power Loss	AC Input Low	No DC	High Load	Overload	Hot	Too Hot
Input	Green	-	Amber	Green	Green	Green	Green	Green
Output	Green	-	Green	-	Amber	Amber	Green	-
Alarm	-	-	-	Red	Amber	Red	Amber	Amber

SDN-C Specifications (Single Phase)

Description	Catalog Number				
	SDN 16-12-100C	SDN 5-24-100C	SDN 10-24-100C	SDN 20-24-100C	SDN 40-24-100C
Input					
Nominal AC Voltage (Range)	100 - 240 Vac (85-264 Vac)				
Nominal DC Voltage (range)	100-340 Vdc (90-375 Vdc)			100-250 Vdc (90-275 Vdc)	120-340 Vdc (108-375 Vdc)
Frequency	43 - 67 Hz				
Nominal Current ¹	1.77 – 0.9 A	1.65 - 0.55 A	3.2 - 1.0 A	6 - 3 A	12 - 4 A
-Inrush current	Typ. <5.8A at 120 Vac, <12.7A at 230 Vac, measured at 25°C	Typ. <3.7A at 120 Vac, <7.4A at 230 Vac, measured at 25°C	Typ. <12.7A at 120 Vac, <24.8A at 230 Vac, measured at 25°C	Typ. <5.8A at 120 Vac, <11.5A at 230 Vac, measured at 25°C	Typ. <5.8A at 120 Vac, <11.5A at 230 Vac, measured at 25°C
Efficiency (Losses ²)	> 86.5% typ. (24 W)	> 88% typ. (14 W)	> 90% typ. (24 W)	> 92% (38 W)	> 93 % (67 W)
Power Factor Correction	Active power factor correction typ. 0.98 @ 115 Vac/ 0.92 @ 230 Vac				
Output					
Nominal Voltage	12 V (12-15 Vdc Adj.)	24 V (23.5-28.5 Vdc Adj.)			
Initial Voltage Setting	12.5 V ± 1%	24.5 V ± 1%			
-Tolerance	< ±2 % overall (combination Line, load, time and temperature related changes)				
-Ripple ³	< 100 mVpp	< 50 mVpp		< 100 mVpp	
PAR (Periodic and Random Deviation)	100 mVpp max				
Nominal Current (Rated Power at +60°C)	16 A (192 W)	5 A (120 W)	10 A (240 W)	20 A (480 W)	40 A (960 W)
Parallel Operation ⁴	Single or Parallel operation selectable via front switch.				Active Paralleling.
Turn On Time	< 1 s after AC is applied to input at full resistive load (T _{amb} =+25°C). <1.5 ms with capacitive load 7000µF				
Holdup Time	>40ms (Full load, 100 Vac Input @ T _{amb} =+25°C) to 95% output voltage	>20 ms (Full load, 100 Vac Input @ T _{amb} =+25°C) to 95% output voltage			
Voltage Fall Time	<150 mS from 95% to 10% rated voltage @ full load (T _{amb} =+25°C)				
Protection					
-Short Circuit	Output automatically goes to near zero and output is protected from continuous short circuit. Auto-recovery.				
-Peak Current ⁵	1.5 × Nominal Current for > 4 seconds minimum while holding voltage > 20 Vdc (> 10 Vdc for SDN 16-12-100C)				
-Overcurrent Protection	PowerBoost™				
Back EMF Immunity	< 18 V No damage, auto-recovery	< 35 V No damage, auto-recovery			
Overvoltage Protection	> 18 but < 20 Vdc, auto-recovery	> 30.5 but < 33 Vdc, auto-recovery			
Overtemperature Protection	LED Alarm and Output shutdown , auto-recovery				
Environmental Data					
Emissions	EN61000-6-3, EN61000-6-4, Class B EN55011, EN61000-3-2 Class A, Class B EN 55032, EN 61326-1 Class B, EN 61000-3-3				
Immunity	EN 55024, EN 61000-6-1, EN 61000-6-2, EN 61326-1, SEMI F47				
General Protection/ Safety	Protected against continuous short circuit, continuous overload, continuous open circuit. IEC 60950-1: Class I Earthed, Output is SELV (Safety Extra Low Voltage), Environmental Rating: Pollution Degree 2 IEC 60529 Ingress Protection Rating: IP20				
Temperature ⁶	Storage: -40°C to +85°C, Operation -40°C to +60°C full power, with linear derating to 75% power from +60°C to 70°C (Convection cooling). Operation up to 50% load with sideways or front-side-up mounting orientation.				
Humidity	5 to 95 % RH Non-condensing; IEC 60068-2-2, IEC 60068-2-3				
Vibration	2.5g RMS, 10-2000 Hz (random); three axes for 20 minutes each - IEC 60068-2-6				
Shock	10(g) RMS, three axes, 11mseconds for each axis - IEC 60068-2-27				
Altitude	0 to 6000 meters (0 to 20,000 feet) per MIL-STD-810F				

1. Input current ratings are conservatively specified with low AC input, worst case efficiency and power factor.
2. Losses are heat dissipation in watts at full load, nominal AC input line.
3. Ripple/noise is stated as typical values when measured with a 20 MHz, bandwidth scope and 50 Ohm resistor.
4. All models are capable of paralleling. For redundant operation, please use external Redundancy module. Only the 40A uses Active paralleling scheme. Please refer to user manual for details.
5. Peak current is calculated at nominal voltage levels.
6. Contact tech support for operation at -40°C.

SDN-C Specifications (Single Phase) continued

Description		Catalog Number				
		SDN 16-12-100C	SDN 5-24-100C	SDN 10-24-100C	SDN 20-24-100C	SDN 40-24-100C
Reliability						
MTBF	Telcordia SR-332 Issue 2 Method 1 Case 3 @ 25°C	>2,088,000 hours @ 115 Vac >2,133,000 hours @ 230 Vac	>1,800,000 hours @ 115 Vac >2,100,000 hours @ 230 Vac	> 550,000 hours @ 115 Vac >650,000 hours @ 230 Vac	>800,000 hours @ 115 Vac >850,000 hours @ 230 Vac	>550,000 hours @ 115 Vac >570,000 hours @ 230 Vac
	Telcordia SR-332 Issue 2 Method 1 Case 3 @ 40°C	>1,112,000 hours @ 115 Vac >1,170,000 hours @ 230 Vac	>1,000,000 hours @ 115 Vac >1,100,000 hours @ 230 Vac	>300,000 hours @ 115 Vac >400,000 hours @ 230 Vac	>500,000 hours @ 115 Vac >570,000 hours @ 230 Vac	>360,000 hours @ 115 Vac >370,000 hours @ 230 Vac
Installation						
Fusing –Input		Input Branch fuse or circuit breaker should be provided by customer. See manual for details.				
–Output		Outputs are capable of providing high currents for short periods of time for inductive load startup or switching. Fusing may be required for wire/loads if 2x Nominal O/P current rating cannot be tolerated. Continuous current overload allows for reliable fuse tripping.				
Mounting		Simple snap-on to DIN TS35/7.5 or TS35/15 rail system.				
Connections ^{7,8} (Screw Type)	Input	16-10 AWG (1.5-6 mm ²) solid or stranded conductors. Screw torque: 4.4-6.5 lb-inch (50-73 N-cm).			13-10 AWG (3-6 mm ²) solid/stranded conductors. Screw Torque: 4.4 lb-inch (50 N-cm).	
	Output (dual output terminals)	16-10 AWG (1.5-6 mm ²) for solid or stranded conductors. Screw torque: 4.4-6.5 lb-inch (50-73 N-cm).			7-6 AWG (10.6-13 mm ²) solid/stranded conductors. Screw Torque: 15.6 lb-inch (176 N-cm)	
–Free Space	Above & Below	0.98 in (25 mm)		1.6 in (40 mm)		0.98in (25mm)
	Left & Right	0.39 in (10mm)				0.59in (15mm)
	Front	0.59 (15)				
Dimensions – WxDxH in (mm)		4.85 × 2.36 × 4.36 (123.0 × 60.0 × 110.0)	4.85 × 1.97 × 4.36 (123.0 × 50.0 × 110.0)	4.85 × 2.36 × 4.36 (123.0 × 60.0 × 110.0)	4.85 × 3.42 × 4.98 (123.0 × 87.0 × 127.0)	4.85 × 7.09 × 4.81 (123.0 × 180.0 × 122.0)
Weight – lbs (kg)		1.76 (0.80)	1.3 (0.6)	1.7 (0.8)	3.0 (1.4)	6.0 (2.8)
General						
Case		Fully enclosed metal housing with fine ventilation grid to keep out small parts. IP20 touch proof				
Status Indicators		Visual: 3 status LEDs (Input, Output, Alarm) Relay: N.O. contact rated 200mA/50 Vdc Signal Active when Vout > 18.5 Vdc +/-5% (Vout > 10.8 Vdc for SDN 16-12-100C)				
Warranty		5 Year Limited Warranty				

7. Screw terminals. Use only one copper wire per terminal. Non-ratcheting torque driver recommended.

8. SDN 40-24-100C only — Provided with Signal Mode terminal block which includes the following features: DC OK, Ground signal, PS ON, I_share connection. Refer to Signals Manual for terminal connection details..

SDN-C Specifications (Three Phase)

Description	Catalog Number			
	SDN 5-24-480C	SDN 10-24-480C	SDN 20-24-480CD	SDN 40-24-480C
Input				
Nominal AC Voltage (Range)	380 - 480 Vac (320 - 540 Vac), 3-phase			
Two-phase input ¹	Yes			
Nominal DC Voltage (Range)	600 Vdc (+/- 50 Vdc)			
Frequency	50/60 Hz			
Nominal Current ²	3 x 0.5 A	3 x 0.8 A	3 x 0.9A	3 x 1.6A
-Inrush current max.	Typ. < 25 A		Negligible	
Efficiency (Losses ³)	> 85% (18 W)	91% (24W)	93% (42 W)	94% (78 W)
Power Factor Correction	Meets EN61000-3-2 Class A		Active Power Factor Correction > 0.92	
Output				
Nominal Voltage ⁴	24 V (23.5 – 28.5 Vdc Adj.)			
Initial Voltage Setting	24.5 V ± 1%			
-Tolerance	< ±2 % overall (combination Line, load, time and temperature related changes)			
-Ripple ⁵	< 50 mVpp		< 100 mVpp	
PARD (Periodic and Random Deviation)	100 mVpp max		200 mVpp max	
Nominal Current (Rated Power)	5 A (120 W)	10 A (240 W)	20 A (480 W)	40 A (960 W)
Parallel Operation ⁶	Single or Parallel operation selectable via front switch.			Active Paralleling.
Turn On Time	< 1 s after AC is applied to input at full resistive load (Tamb=+25°C). <1.5 s With capacitive load 7000µF			
Holdup Time (Full load, 100 Vac Input @ T = +25°C)	20 ms			15 ms
Voltage Fall Time	<150 mS from 95% to 10% rated voltage @ full load (T =+25°C)			
Protection				
-Short Circuit Current	Voltage output automatically goes to near zero and output is protected from continuous short circuit. Auto-recovery.			
-Peak Current ⁷	1.5 x Nominal Current for > 4 seconds minimum while holding voltage > 20 Vdc			
-Current Limit	PowerBoost™			
Back EMF Immunity	< 35 V No damage, auto-recovery			
Overvoltage Protection	> 30.5 but < 33 Vdc, auto-recovery			
Over Temperature Protection	LED Alarm and Output shutdown , auto-recovery			
Environmental Data				
Emissions	EN 61000-6-3, EN 55011 Class B, EN 55022 Class B, EN 61326-1, EN 61000-3-2, EN 61000-3-3	EN 61000-6-3, EN 55011 Class B, EN 55032 Class B, EN 61326-1, EN 61000-3-2, EN 61000-3-3	EN 55011 Class B, EN 55022 Class B, EN 61000-3-2, EN 61000-3-3	
Immunity	EN 55024, EN 61326-1, EN 61000-6-1, EN 61000-6-2, SEMI F47	EN 55024, EN 61326-1, EN 61000-6-1, EN 61000-6-2, SEMI F47	EN 61000-4-2, EN 61000-4-4, EN 61000-4-5, SEMI F47	
General Protection/ Safety	Protected against continuous short circuit, continuous overload, continuous open circuit. IEC 60950-1: Class I Earthed, Output is SELV (Safety Extra Low Voltage), Environmental Rating: Pollution Degree 2 IEC 60529 Ingress Protection Rating: IP20			
Temperature ⁸	Storage: -40°C to + 85°C, Operation -40°C to +60°C full power, with linear derating to 75% power from 60 to 70°C (Convection cooling, no forced air required). Operation up to 50% load permissible with sideways or front-side-up mounting orientation.			
Humidity	5 to 95 % RH Non-condensing, IEC 60068-2-2, IEC 60068-2-3			
Vibration	2.5g RMS, 10-2000 Hz (random); three axes for 20 minutes each - IEC 60068-2-6			
Shock	10g RMS, three axes, 11mseconds for each axis - IEC 60068-2-27			
Altitude	0 to 3000 meters (0 to 10,000 feet)			

1. In the event of a phase loss, the power supply will continue to operate normally. However, the resulting lower rectified RMS voltage can cause excessive heat build up, which may eventually cause the unit to shut down if maximum operating temperature is exceeded.
2. Input current ratings are specified with low AC 3-phase input, line conditions, worst case efficiency values and power factor spikes. Input current at nominal AC 3-phase input will typically be half these values.
3. Losses are heat dissipation in watts at full load, nominal line.
4. 24-28 Vdc adjustable guaranteed at full load.
5. Ripple/noise is stated as typical values when measured with a 20 MHz, bandwidth scope and 50 Ohm resistor
6. All models are capable of paralleling. For redundant operation, please use external Redundancy module. Only the 40A uses active paralleling scheme. Please refer to user manual for details.
7. SDN 20 and SDN 40 are capable of delivering 150% load for approximately 4s before the unit will go to HICCUP mode. SDN 5 and 10 will maintain minimum 4s to deliver 150% load then drops to almost zero Vout. The output voltage will immediately drop to almost zero when load rises above 150%.
8. Contact Tech Support for operation -40°C.

SDN-C Specifications (Three Phase)

Description		Catalog Number			
		SDN 5–24–480C	SDN 10–24–480C	SDN 20–24–480CD	SDN 40–24–480C
Reliability					
MTBF	Telcordia SR–332 Issue 2 Method 1 Case 3 @ 25°C	>1,100,000 hours @ 380 Vac >900,000 hours @ 480 Vac	>1,400,000 hours @ 380 Vac >900,000 hours @ 480 Vac	>630,000 hours @ 380 Vac >630,000 hours @ 480 Vac	>600,000 hours @ 380 Vac >550,000 hours @ 480 Vac
	Telcordia SR–332 Issue 2 Method 1 Case 3 @ 40°C	>600,000 hours @ 380 Vac >500,000 hours @ 480 Vac	>910,000 hours @ 380 Vac >600,000 hours @ 480 Vac	>460,000 hours @ 380 Vac >450,000 hours @ 480 Vac SDN 20-24-480CR	>380,000 hours @ 380 Vac >360,000 hours @ 480 Vac
Status Indicators		Visual: 3 status LEDs (Input, Output, Alarm) Relay: N.O. contact rated 200mA/50 Vdc, Signal Active when Vout> 18.5 Vdc +/-5%			
Installation					
Fusing –Input		Input Branch fuse or circuit breaker should be provided by customer. See manual for details.			
–Output		Outputs are capable of providing high currents for short periods of time for inductive load startup or switching. Fusing may be required for wire/loads if 2x Nominal O/P current rating cannot be tolerated. Continuous current overload allows for reliable fuse tripping.			
Mounting		Simple snap-on to DIN TS35/7.5 or TS35/15 rail system.			
Connections ^{9,10} (Screw Type)	Input	16-10 AWG (1.5-6 mm ²) for solid conductors. Screw Torque: 4.4 lb-in (~ 50 N-cm).			
	Output	16-10 AWG (1.5-6 mm ²) for solid conductors. Screw Torque: 7 lb-inch (~ 80 N-cm)			7–6 AWG (10.6–13 mm ²) solid or stranded conductors. Screw Torque: 15.6 lb-inch (176 N-cm)
–Free Space	Above & Below	0.98 in (25 mm)		1.6 in (40 mm)	2.80 in (70mm)
	Left & Right	0.98in (25mm)			
	Front	0.59 in. (15 mm)			
Dimensions – WxDxH in (mm)		4.85 × 1.97 × 4.36 (123.0 × 50.0 × 110.0)	4.85 × 2.36 × 4.36 (123.0 × 60.0 × 110.0)	4.85 × 3.42 × 4.98 (123.0 × 87.0 × 127.0)	4.85 × 7.09 × 4.66 (123.0 × 180.0 × 119.0)
Weight – lbs (kg)		1.2 (0.5)	1.5 (0.7)	2.7 (1.2)	5.3 (2.4)
General					
Case		Fully enclosed metal housing with fine ventilation grid to keep out small parts. IP20 touch proof			
Status Indicators		Visual: 3 status LEDs (Input, Output, Alarm) Relay: N.O. contact rated 200mA/50 Vdc, Signal Active when Vout> 18.5 Vdc +/-5%			
Warranty		5 Year Limited Warranty			

9. Screw terminals. Use only one copper wire per terminal. Non-ratcheting torque driver recommended.

10. SDN 40-24-480C only: Output signaling terminal block features (Shut down, Power Good, Current Monitor, Current Balance, signal GND). Please refer to Signals Manual for details.

SDN-C Series Dimensions

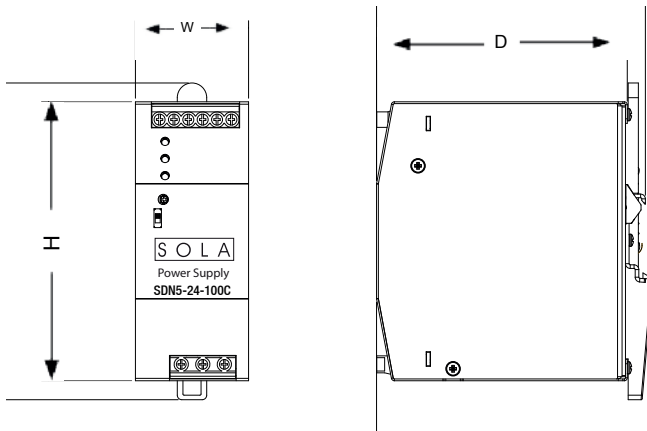

Catalog Number	Dimensions – inches (mm)		
	H	W	D
SDN 5–24–100C	4.85 (123.0)	1.97 (50.0)	4.36 (111.0)
SDN 10–24–100C	4.85 (123.0)	2.36 (60.0)	4.36 (111.0)
SDN 16–12–100C	4.85 (123.0)	2.36 (60.0)	4.36 (111.0)
SDN 20–24–100C	4.85 (123.0)	3.42 (87.0)	4.98 (127.0)
SDN 5–24–480C	4.85 (123.0)	1.97 (50.0)	4.36 (111.0)
SDN 10–24–480C	4.85 (123.0)	2.36 (60.0)	4.36 (111.0)
SDN 20–24–480CD	4.85 (123.0)	3.42 (87.0)	4.98 (127.0)

SDN 40-24-480C Dimensions

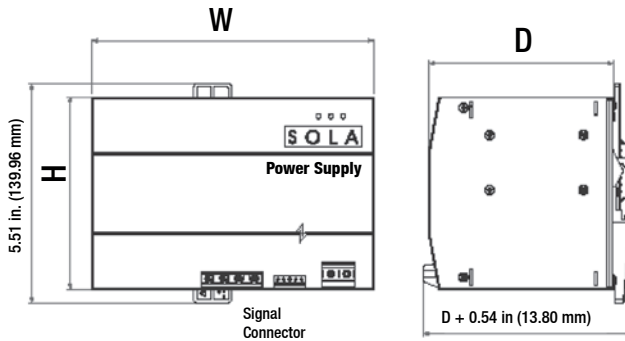

SDN 40-24-100C Dimensions

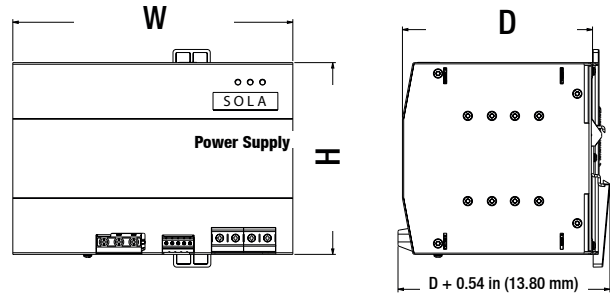

Voltage adjustment potentiometer located on top of power supply

Catalog Number	Dimensions – inches (mm)		
	H	W	D
SDN 40–24–100C	4.85 (123.0)	7.09 (180.0)	4.81 (122.0)
SDN 40–24–480C	4.85 (123.0)	7.09 (180.0)	4.66 (119.0)

SDN 40-24-100C and SDN 40-24-480C output signaling terminal block features: Shut Down, Power Good, Current Monitor, Current Balance, GND, and active current sharing through I_SHARE connectors (See Signals Manual for connection information).

SDN-C Series Mounting

SolaHD SDN-C power supplies are designed to be easily and reliably mounted to DIN rail. For applications requiring mounting the power supply directly to the panel, optional Panel Mount Adapter Brackets are available.

DIN Rail Mounting

Snap on the DIN rail:

1. Tilt unit slightly backwards. Put it onto the DIN rail
3. Push downwards until stopped
4. Push at the lower front edge to lock
5. Shake the unit slightly to ensure that the retainer has locked

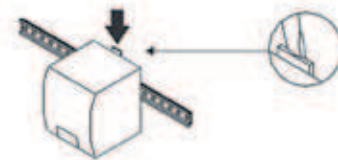

Detachment from DIN Rail:

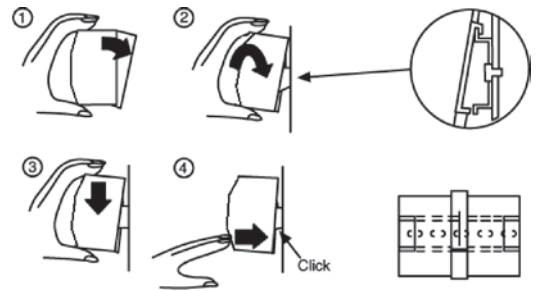

Alternative Panel Mount: Using the optional SDN-PMBRK3 accessory, the unit can be screw mounted to a panel.

Panel Mounting

Panel mounting of SDN-C power supplies is simplified by using an optional Panel Mounting Bracket kit. Each kit comes with two brackets for modifying one power supply. Choose the appropriate bracket kit based on the power supply model in the tables below. Note that the Panel Mount bracket will add approximately 2-4mm in depth, compared to DIN rail mounting. Refer to the manual that comes with the bracket kit for detailed instructions on assembly and mounting.

SDN-PMBRK3

Power Supply
SDN 16-12-100C
SDN 5-24-100C
SDN 10-24-100C
SDN 20-24-100C
SDN 40-24-100C
SDN 10-24-480C
SDN 20-24-480CD

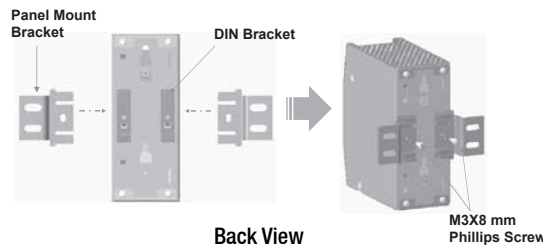

Dimensions - in. (mm)

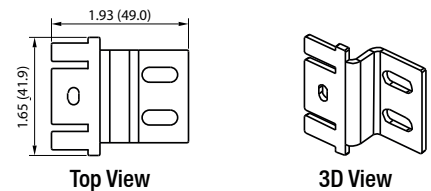

SDN-PMBRK2

Power Supply
SDN 5-24-480C
SDN 40-24-480C

Dimensions - in. (mm)

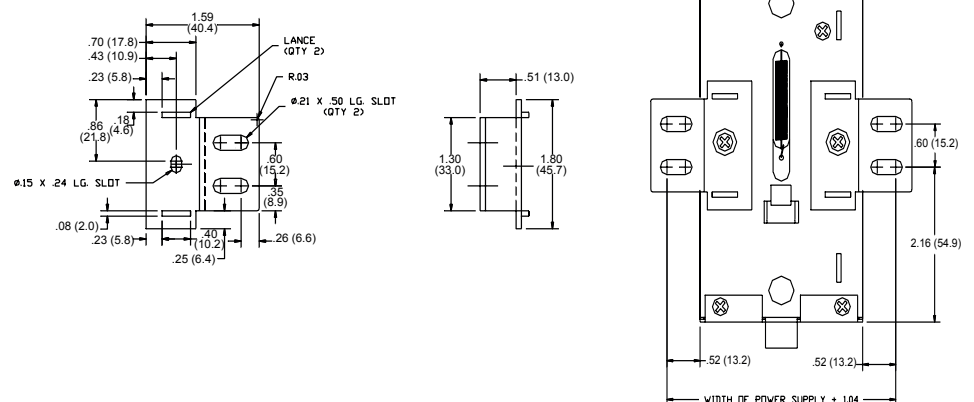

SDN-P™ DIN Rail Series

The SolaHD SDN-P DIN Rail Series power supplies provide industry leading performance. Sag Immunity, transient suppression and noise tolerant, the SDN-P Series ensures compatibility in demanding applications. Power factor correction to meet European directives, hazardous location approvals and optional redundant accessories allow the SDN-P series to be used in a wide variety of applications. Wide operation temperature range, high tolerance to shock and vibration and reliable design make the SDN-P series the preferred choice of users.



Applications

- Industrial/Machine Control
- Process Control
- Conveying Equipment
- Material Handling
- Vending Machines
- Packaging Equipment
- DeviceNet™
- Amusement Park Equipment
- Semiconductor Fabrication Equipment

Features

- Power Factor Correction (per EN61000-3-2)
- Auto Select 115/230 Vac, 50/60 Hz Input
- Improved metal mounting clip
- DC OK Signal
- Adjustable Voltage
- Parallel Capability standard on all units
- Industrial grade design
 - -10°C to 60°C operation without derating. Indefinite short circuit, overvoltage and overtemperature protection.
 - Powers high inrush loads without shutdown or foldback
 - Rugged metal case and DIN connector
- Narrow width on rail for space critical applications
- User-friendly front panel
 - Large, rugged, accessible, multiple connection screw terminations
 - Easy installation
- 12 Vdc and 48 Vdc single phase models available
- Highly efficient >90% switching technology
- High MTBF and reliability

Accessories

- SDN-C Redundant Modules
- Chassis Mount Bracket (SDN-PMBRK2)

Certifications and Compliances *

All Models

- UL US Listed, Ind. Control Equipment, E61379
 - UL 508, CSA C22.2 No. 107.1
- UL US UL Recognized Component, ITE, E137632
 - UL 60950-1/CSA C22.2 No. 60950-1, 2nd Edition
- UL US UL Recognized Component, Haz. Loc., E234790
 - ISA 12.12.01, CSA C22.2 No. 213
 - Class I, Division 2, Groups A, B, C, D
- CE - Low Voltage Directive
 - IEC/EN60950-1, 2nd Edition
- Sag Immunity: SEMI F47
- RoHS Compliant

Models SDN 2.5-24-100P, SDN 4-24-100LP

- Class II per UL 1310, CSA C22.2 No. 223

Related Products

- SVL Series
- SDP™ Series
- SCP Series
- SCL Series
- SDU UPS

* Refer to user manual for installation requirements when used in hazardous locations.

SDN-P Specifications (Single Phase), 24 Vdc Output

Description	Catalog Number			
	SDN 2.5–24–100P	SDN 4–24–100LP	SDN 5–24–100P	SDN 10–24–100P
Input				
Nominal Voltage	115/230 Vac, Auto select			
–AC Range	85-264 Vac	85-132/176-264 Vac		
–DC Range ¹	90 - 375 Vdc	210 - 375 Vdc		
–Frequency	47 - 63 Hz			
Nominal Current ²	1.3 / 0.7 A	2.1 / 1.0 A	2.2 / 1.0 A	5 / 2 A typ.
–Inrush current max.	typ. < 25 A	typ. < 20 A		typ. < 40 A
Efficiency (Losses ³)	> 87.5% typ. (8.6 W)	> 88% typ. (13.1 W)	> 88% typ. (16.4 W)	> 88% typ. (32.7 W)
Power Factor Correction	Units Fulfill EN61000-3-2			
Output				
Nominal Voltage	24 Vdc (22.5 - 28.5 Vdc adj.)	24 Vdc (22.5 - 25.7 Vdc adj.)	24 Vdc (22.5 - 28.5 Vdc adj.)	
–Tolerance	< ±2% overall (combination Line, load, time and temperature related changes)			
–Ripple ⁴	< 50 mVpp			
Overvoltage Protection	< 33 Vdc	< 27 Vdc	< 33 Vdc	
Nominal Current	2.5 A (60 W)	3.8 A (92 W)	5 A (120 W)	10 A (240 W)
–Current Limit	Fold Forward (Current rises, voltage drops to maintain constant power during overload up to max peak current)			
Holdup Time ⁵	> 20 ms @ full load			
Parallel Operation	Single or Parallel use is selectable via Front Panel Switch (SDN 2.5, 4 should not be used in parallel as Class II rating would be violated.)			
General				
EMC: –Emissions	EN61000-6-3, -4; Class B EN55011, EN55022 Radiated and Conducted including Annex A. EN61000-3-2			
–Immunity	EN61000-6-1, -2; EN61000-4-2 Level 4, EN61000-4-3 Level 3; EN61000-4-6 Level 3; EN61000-4-4 Level 4 input and Level 3 output; EN61000-4-5 Isolation Class 4, EN61000-4-11;			
Temperature	Storage: -25°C...+85°C Operation. -10°-60°C full power with operation to 70°C possible with a linear derating to half power from 60°C to 70°C (Convection cooling, no forced air required). Operation up to 50% load permissible with sideways or front-side-up mounting orientation.			
Humidity	The relative humidity is < 90% RH, noncondensing; IEC 68-2-2, 68-2-3.			
MTBF:	> 820,000 hours	> 640,000 hours		> 600,000 hours
– Standard	Bellcore Issue 6 Method 1 Case 3 @ 40°C			
Warranty	5 year limited warranty			
General Protection/Safety	Protected against continuous short-circuit, overload, open-circuit. Protection Class I (IEC536), degree of protection IP20 (IEC 529) Safe low voltage: SELV (acc. EN60950)			
Status Indicators	Green LED and DC OK signal (N.O. Solid State Contact rated 200 mA / 60 Vdc)			
Installation				
Fusing –Input	Internally fused. External 10 A slow acting fusing for the input is recommended to protect input wiring.			
–Output	Outputs are capable of providing high currents for short periods of time for inductive load startup or switching. Fusing may be required for wire/ loads if 2x Nominal O/P current rating cannot be tolerated. Continuous current overload allows for reliable fuse tripping.			
Mounting	Simple snap-on system for DIN Rail TS35/7.5 or TS35/15 or chassis-mounted (optional screw mounting set SDN-PMBRK2 required).			
Connections	Input: IP20-rated screw terminals, connector size range: 16-10 AWG (1.5-6 mm ²) for solid conductors. 16-12 AWG (0.5-4 mm ²) for flexible conductors. Output: Two connectors per output, connector size range: 16-10 AWG (1.5 - 6 mm ²) for solid conductors.			
Case	Fully enclosed metal housing with fine ventilation grid to keep out small parts.			
–Free Space	25 mm above and below, 25 mm left and right, 10 mm in front	25 mm above and below, 25 mm left and right, 15 mm in front	70 mm above and below, 25 mm left and right, 15 mm in front	
Dimensions – WxDxH in (mm)	4.88. x 1.97 x 4.55 (124.0 x 50.0 x 116.0)	4.88 x 2.56 x 4.55 (124.0 x 65.0 x 116.0)		4.88 x 3.26 x 4.55 (124.0 x 83.0 x 116.0)
Weight – lbs (kg)	1.6 (.73)	2.4 (1.10)		3.3 (1.50)

- Not UL listed for DC input.
- Input current ratings are conservatively specified with low input, worst case efficiency and power factor.
- Losses are heat dissipation in watts at full load, nominal input line.

- Ripple/noise is stated as typical values when measured with a 20 MHz, bandwidth scope and 50 Ohm resistor.
- Full load, 100 Vac Input @ T_{amb} = +25°C

SDN-P Specifications (Single Phase), 12 Vdc and 48 Vdc Output

Description	Catalog Number	
	SDN 9-12-100P	SDN 5-48-100P
Input		
Nominal Voltage	115/230 Vac auto select	
-AC Range	85-132/176-264 Vac; 210 - 375 Vdc	
-DC Range ¹	210 - 375 Vdc	
-Frequency	47 - 63 Hz	
Nominal Current ²	2.0 A / 1.5 A	4 A / 2.3 A
-Inrush current max.	Typ. < 20 A	typ. < 40 A
Efficiency (Losses ³)	> 84% typ. (17.28 W)	> 88% typ. (28.8 W)
Power Factor Correction	Units fulfill EN61000-3-2	
Output		
Nominal Voltage	12 V (11.6-15.2 Vdc Adj.)	48 V (35.8 - 52 Vdc Adj.)
Tolerance	< ±2 % overall (combination Line, load, time and temperature related changes)	
-Line Regulation	< 0.5%	
-Load Regulation	< 0.5%	
-Time & Temp. Drift	< 1%	
Ripple ⁴	< 50 mVpp	
Overvoltage Protection	< 16 Vdc with auto-recovery	< 60 Vdc with auto-recovery
Nominal Current	9 A (108 W)	5 A (240 W)
-Current Limit	110% of nominal - Fold Forward (Current rises, voltage drops to maintain constant power during overload up to max peak current)	
Holdup Time ⁵	>20 ms @ full load	
Parallel Operation	Supplies will not be damaged with parallel operation	
Power Back Immunity	16 Vdc	60 Vdc
General		
EMC: -Emissions	EN61000-6-3, EN61204-3, EN55022 Class B, EN61000-3-2, EN61000-3-3	
-Immunity	EN61000-6-2, EN61204-3, EN55024, IEC61000-4-2, IEC61000-4-3, IEC61000-4-4, IEC61000-4-5, IEC61000-4-6, IEC61000-4-8, IEC61000-4-11	
Temperature	Storage: -25 to +85°C, Operation -10 to +60°C full power; with linear derating to half power from 60 to 70°C (Convection cooling, no forced air required). Operation up to 50% load permissible with sideways or front-side-up mounting orientation.	
Humidity	< 90% RH, non-condensing; IEC 68-2-2, 68-2-3	
MTBF:	>500,000 hrs	
- Standard	Telcordia/Bellcore, Issue Case 3 @ 25°C	
Warranty	5 year limited warranty	
General Protection/Safety	Protected against continuous short -circuit, continuous overload, continuous open circuit. Protection Class I (IEC536), Degree of Protection IP20 (IEC 529) Safe low voltage: SELV (acc. EN60950)	
Status Indicators (Visual)	Green LED on when $V_{out} > 75%$ (with ± 5% tolerance) of nominal output voltage	
Status Indicators (Relay)	Normally Open solid state relay - signal active when $V_{out} > 70%$ of nominal output voltage (rated up to 200 mA, 60 Vdc)	
Installation		
Fusing -Input	Internally fused	
-Output	Outputs are capable of providing high currents for short periods of time for inductive load startup or switching. Fusing may be required if Nominal O/P current rating cannot be tolerated. Continuous current overload allows for reliable fuse tripping.	
Mounting	Simple snap-on to DIN TS35/7.5 or TS35/15 rail system. Unit should handle normal shock and vibration of industrial use and transportation without falling off the rail.	
Connections	Input: Screw terminals, connector size range: 16-10 AWG (1.5-6 mm ²) for solid conductors. Output: Two terminals per output, connector size range: 16-10 AWG (1.5-6 mm ²) for solid conductors.	
Case	Fully enclosed metal housing with fine ventilation grid to keep out small parts.	
-Free Space	70 mm above and below, 25 mm left and right, 15 mm in front	
Dimensions - WxDxH in (mm)	4.88 × 2.56 × 4.55 (124.0 × 65.0 × 116.0)	4.88 × 3.23 × 4.55 (124.0 × 83.0 × 116.0)
Weight - lbs (kg)	2.4 (1.10)	3.3 (1.50)

1. Not UL listed for DC input.

2. Input current ratings are conservatively specified with low input, worst case efficiency and power factor.

3. Losses are heat dissipation in watts at full load, nominal input line.

4. Ripple/noise is stated as typical values when measured with a 20 MHz, bandwidth scope and 50 Ohm resistor.

5. Full load, 100 Vac Input @ $T_{amb} = +25^{\circ}\text{C}$

SDN-P Series Dimensions

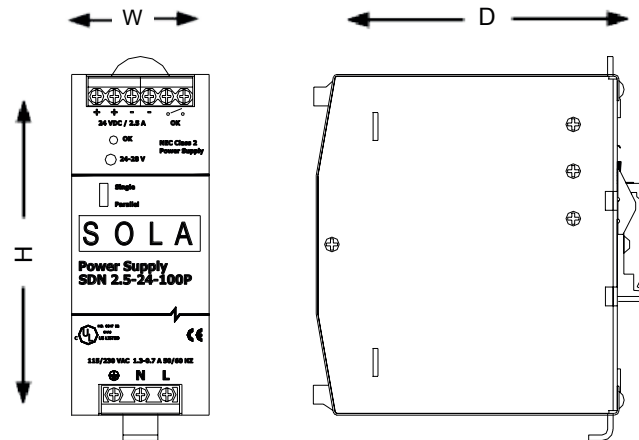

Catalog Number	Dimensions – inches (mm)		
	H	W	D
12 Vdc			
SDN 9-12-100P	4.88 (124.0)	2.56 (65.0)	4.55 (116.0)
SDN 16-12-100P	4.88 (124.0)	3.23 (83.0)	4.55 (116.0)
24 Vdc			
SDN 2.5-24-100P	4.88 (124.0)	1.97 (50.0)	4.55 (116.0)
SDN 4-24-100LP	4.88 (124.0)	2.56 (65.0)	4.55 (116.0)
SDN 5-24-100P	4.88 (124.0)	2.56 (65.0)	4.55 (116.0)
SDN 10-24-100P	4.88 (124.0)	3.26 (83.0)	4.55 (116.0)
48 Vdc			
SDN 5-48-100P	4.88 (124.0)	3.23 (83.0)	4.55 (116.0)

SDN-P Series Mounting

DIN Rail Mounting

Snap on the DIN Rail:

1. Tilt unit slightly backwards
2. Put it onto the DIN Rail
3. Push downwards until stopped
4. Push at the lower front edge to lock
5. Shake the unit slightly to ensure that the retainer has locked

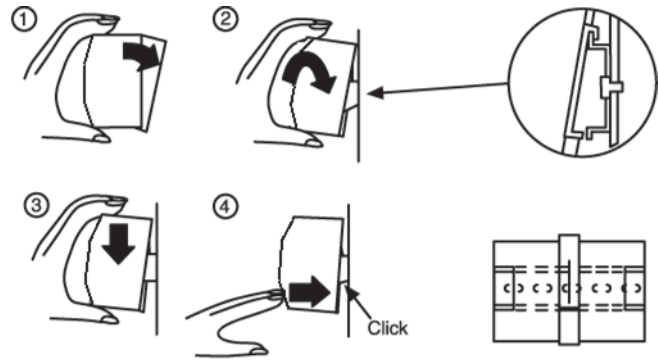

Alternative Panel Mount: Using the optional SDN-PMBRK2 accessory, the unit can be screw mounted to a panel.

Detachment from DIN Rail:

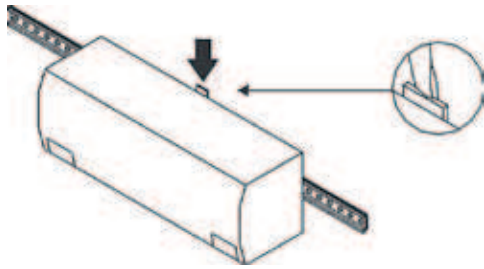

Chassis Mounting

Instead of snapping a SolaHD SDN unit on the DIN Rail, you can also attach it using the screw mounting set SDN-PMBRK2.

This set consists of two metal brackets, which replace the existing two aluminum profiles.

Dimensions - in. (mm)

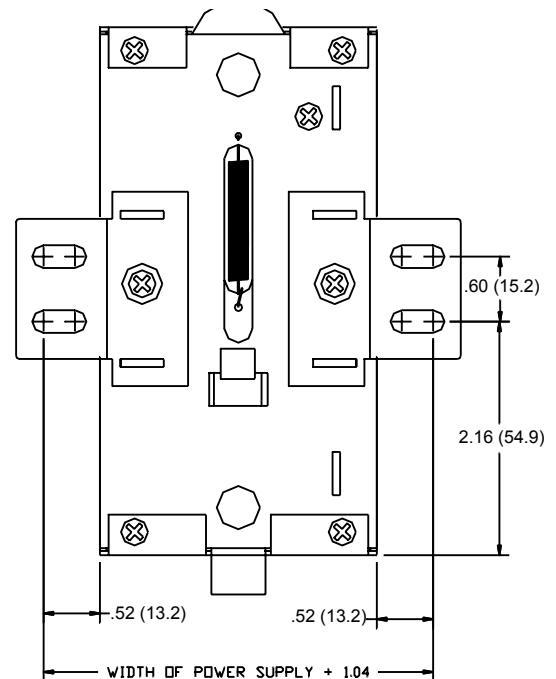
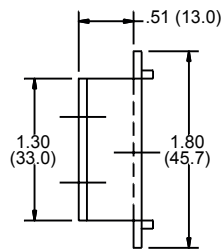
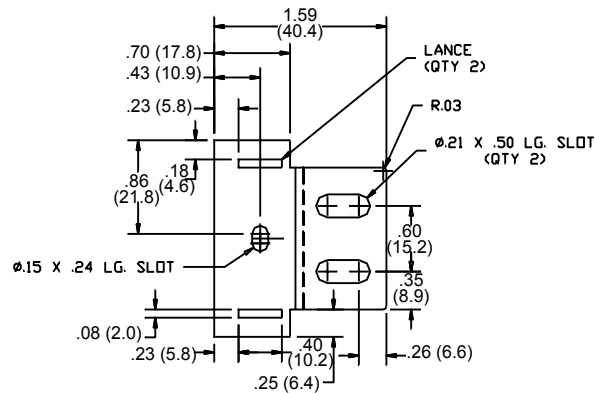

SDP Low Power DIN Rail Series

The compact, lightweight SolaHD SDP DIN rail power supplies come in output voltages from 5 to 48 Vdc and power ratings of up to 100 Watts. These extra small, efficient units are designed specifically for the industrial environment. Each unit is rated from -10°C to 70°C, with no derating necessary until above 60°C.

Many extra “industrial” features are standard for the SDP PowerBoost™ overload circuitry can start up industrial loads (i.e. motors, relays, solenoids and DC-DC converters), that can cause ordinary power supplies to foldback or shutdown. Each unit contains a DC indicator and front panel adjustment potentiometer. With the SDP Series, you can count on a high grade design.

Applications

- Industrial Control
- Machine Control
- Building Automation
- Instrumentation

Features

- Adjustable output
- PowerBoost™ industrial overload design
- Overvoltage, short circuit protection
- Continuous short circuit protection
- Low output noise
- Screw terminal connections
- Three year limited warranty



Certifications and Compliances

- UL US Listed, Industrial Control Equipment, E61379
- UL 508, CSA C22.2 No. 107.1
- IEC US Recognized Component, ITE, E137632
- UL 60950-1/CSA C22.2 No. 60950-1, 2nd Edition
- IEC US Recognized Component, Haz. Loc., E234790
- ISA 12.12.01, CSA C22.2 No. 213
- Class I, Division 2, Groups A, B, C, D
- CE
- IEC/EN60950-1, 2nd Edition
- RoHS Compliant
- NEC Class II power supply except Model SDP 4-24-100RT

Related Products

- SDN Series
- SCP Series

Catalog Number	DC Output Voltage	Output Current	Ripple / Noise	Size (H x W x D) – in. (mm)
SDP 5-5-100T	5 - 6 V	5 A	<50 mVpp	2.95 in x 1.77 in x 3.58 in (75.0 mm x 45.0 mm x 91.0 mm)
SDP 2-12-100T	10 - 12 V	3 - 2.5 A		
SDP 3-15-100T	12 - 15 V	4.2 - 3.4 A		
SDP 1-48-100T	48 - 56 V	1 A		2.95 in x 0.9 in x 3.8 in (75.0 mm x 22.8 mm x 96.7 mm)
SDP 06-24-100T	24-28 Vdc	0.6 A		
SDP 1-24-100T		1.3 A		
SDP 2-24-100T		2.1 A		
SDP 4-24-100LT		3.8 A		
SDP 4-24-100RT *		4.2 A	2.95 in x 2.85 in x 3.8 in (75.0 mm x 72.5 mm x 96.7 mm)	

* NEC Class I

SDP Series Specifications (24 V models)

Description	Catalog Number				
	SDP 06–24–100T	SDP 1–24–100T	SDP 2–24–100T	SDP 4–24–100LT	SDP 4–24–100RT
Input					
Input Voltage ¹	85-264 Vac, 90-375 Vdc			85-132 / 176-264 Vac, 210-375 Vdc	
Input Frequency	47-63 Hz				
Input Current	0.4 A / 0.25 A	0.7 A / 0.4 A	1.1 A / 0.7 A	1.8 A / 1.0 A	2.2 A / 1.2 A
External Fusing	Not required. Unit provides internal fuse (T3A, not accessible)				
Hold-Up Time	> 25 ms				
Efficiency	> 80% typ.	> 83% typ.	> 86% typ.	> 88% typ.	
Losses	< 3.75 W typ.	< 6.1 W typ.	< 8.1 W typ.	< 12 W typ.	
Output					
Output Voltage	24 V (22.5 - 28.5 Vdc Adj.)			24 V (24 - 25.7 Vdc Adj.)	24 V (22.5 - 28.5 Vdc Adj.)
Voltage Regulation	Static 0.5% V _{out} , dynamic + 2% V _{out} overall\				
Ripple/Noise ²	< 50 mVpp				
Oversvoltage Protection (OVP)	> 30 Vdc, but < 33 Vdc, auto-recovery			> 26 Vdc, but < 27.2 Vdc, auto-recovery	> 30 Vdc, but < 33 Vdc, auto-recovery
Output Noise Suppression	Radiated EMI values below EN61000-6-2				
Rated Continuous Loading	0.63 A @ 24 Vdc / 0.54 A @ 28 Vdc	1.3 A @ 24 Vdc / 1.1 A @ 28 Vdc	2.1 A @ 24 Vdc / 1.8 A @ 28 Vdc	3.8 A @ 24.5 Vdc	4.2 A @ 24.5 Vdc / 3.6 A @ 28 Vdc
Overload Behavior	Continuous operation at overload/short-circuit: up to 1.5 x Nominal Current Continuous				
Protection	Unit is continuously protected against short-circuit, overload and open-circuit.				
Power Back Immunity	35 V				
Installation					
Status Indicators	Green LED on, when V _{out} "OK".				
Case & Mounting	Molded plastic housing using UL 94 approved flameproof material rating 94V-2. Simple snap-on to DIN TS35/7.5 or TS35/15 rail system.				
Dimensions					
H x W x D – inches (mm)	2.95 x 0.90 x 3.80 (75.0 x 22.8 x 96.7)	2.95 x 1.77 x 3.58 (75.0 x 45.0 x 91.0)	2.95 x 2.85 x 3.80 (75.0 x 72.5 x 96.7)		
Weight – lbs (kg)	0.4 (0.18)	0.5 (0.23)	0.7 (0.32)		
Mounting Orientation	Standard: Vertical; Optional: Horizontal or on top (Contact Technical Services).				
Ventilation/Cooling •Free space for cooling	Normal convection, no fan required; Above/below: 25 mm recommended.				
Connection •Connector size range	Input: screw terminals, connector size range: 20-12AWG (1.5 - 6 mm ²) for solid or stranded conductors.				
General					
Electromagnetic Emissions (EMC)	EN61000-6-3 (Includes EN61000-6-4) Class B (EN 55022) incl. Annex A				
Electromagnetic Immunity (EMI)	EN61000-6-2 (Includes EN61000-6-1) (EN55024) Criterion A: no derogation of performance				
Temperature	Storage: -25°C to +85°C Operation: -10° to +60°C full power with linear derating to half power from 60°C to 70°C. (Convection cooling, no forced air required).				
MTBF	> 500,000 hours according to Telcordia/Bellcore Document SR-332, Issue 1				
Humidity	Up to 90% RH, noncondensing; IEC 68-2-2, 68-2-3				
Safe Low Voltage	SELV (acc. EN60950)				
Protection Class/Voltage	IP20 (IEC529), Protection Class I (IEC536)				
Warranty	3 year limited warranty				

Notes:

1. Not UL listed for DC input.
2. Ripple/noise is stated as typical values when measured with a 20 MHz, bandwidth scope and 50 ohm resistor.

SDP Series Specifications (Other Voltages)

Description	Catalog Number			
	SDP 5-5-100T	SDP 2-12-100T	SDP 3-15-100T	SDP 1-48-100T
Input				
Input Voltage ¹	85-264 Vac, 90-375 Vdc			
Input Frequency	47 - 63 Hz			
Input Current	0.6 A @ 102 Vac; 0.33 A @196 Vac		1.0 A @ 102 Vac; 0.6 A @ 196 Vac	<1.0 A @ 100 Vac; <0.6 A @ 196 Vac
External Fusing	Not required. Unit provides internal fuse (T3A, not accessible)			
Hold-Up Time	> 25 ms			
Efficiency	> 80% typ.		> 86% typ.	> 90% typ.
Losses	7.5 W typ.	8.1 W typ.	< 8.1 W typ.	
Output				
Output Voltage	5 - 5.5 Vdc (5 - 6 min adj.)	12 Vdc (9.9 - 12.1 min adj.)	15 Vdc (11.9 - 15.1 min adj.)	48 Vdc (48 - 56 min adj.)
Voltage Regulation	< 2% Dynamic; < 0.5% Static			
Ripple/Noise ²	< 50 mVpp			
Overvoltage Protection (OVP)	> 6.7 Vdc	> 18 Vdc	> 20 Vdc	> 56 Vdc
Output Noise Suppression	Radiated EMI values below EN61000-6-2			
Rated Continuous Loading	$I_{out} = 5A @ V_{out} = 5.1V$	3A @ 10 Vdc 2.5A @12 Vdc	4.2A @ 12 Vdc 3.4A @ 15 Vdc	Up to 1.05A @ 48 V 0.9A @ 56 V
Overload Behavior	Continuous operation at overload/short-circuit: up to 1.5 x Nominal Current Continuous			
Protection	Unit is continuously protected against short-circuit, overload and open-circuit.			
Power Back Immunity	10 V	22 V		80 V
Installation				
Status Indicators	Green LED on, when V_{out} "OK".			
Case & Mounting	Molded plastic housing using UL 94 approved flameproof material rating 94V-2. Simple snap-on to DIN TS35/7.5 or TS35/15 rail system.			
Dimensions				
(H x W x D) (in/mm)	2.95 x 1.77 x 3.58 (75.0 x 45.0 x 91.0)			
Weight – lbs (kg)	0.5 (0.23)			
Mounting Orientation	Standard: Vertical; Optional: Horizontal or On Top (Contact Technical Services).			
Ventilation/Cooling •Free space for cooling	Normal convection, no fan required; Above/below: 25 mm recommended.			
Connection •Connector size range	Input: screw terminals, connector size range: 20-12 AWG (1.5 - 6 mm ²) for solid or stranded conductors.			
General				
Temperature	Storage: -25°C to +85°C Operation: -10°C to +60°C full power with linear derating to half power from +60°C to +70°C. (Convection cooling, no forced air required).			
MTBF	> 500,000 hours according to Telcordia/Bellcore Document SR-332, Issue 1.			
Humidity	Up to 90% RH, noncondensing; IEC 68-2-2, 68-2-3			
Electromagnetic Emissions (EMC)	EN61000-6-3 (Includes EN61000-6-4) Class B (EN 55022) incl. Annex A			
Electromagnetic Immunity (EMI)	EN61000-6-2 (Includes EN61000-6-1) (EN55024) Criterion A: no degradation of performance			
Safe Low Voltage	SELV (acc. EN60950)			
Protection Class/Voltage	IP20 (IEC529), Protection Class I (IEC536)			
Warranty	3 year limited warranty			

Notes:

1. Not UL listed for DC input.
2. Ripple/noise is stated as typical values when measured with a 20 MHz, bandwidth scope and 50 Ohm resistor.

SVL Essential DIN Rail Series

The SolaHD SVL Series power supplies are perfect for high volume, controlled environment applications where essential features are the only requirement. When space inside an enclosure is at a premium, their small footprint makes these power supplies an excellent alternative to embedded open frame switchers. The DIN rail mounting capability provides quicker and easier installation while allowing for design flexibility. These power supplies range from 15 to 480 Watts in 5, 12, 24 and 48 Volt combinations.



Applications

- Test and Measure Equipment
- Scanners
- Instrumentation
- Printers Peripheral
- ATM Machines
- Semiconductor Fabrication Equipment
- Vending Machines

Features

- Universal Input
- Protection
 - Short Circuit
 - Over Voltage
 - Overload
 - Over Temperature
- Power Factor Correction
- Convection Cooling
- Blinking OCP Diagnostic
- DC OK LED
- DC OK Relay for >120 Watts models
- Two year limited warranty



Certifications and Compliances

All Models

- Listed, Ind. Control Equipment, E61379
 - UL 508, CSA C22.2 No. 107.1
- Recognized Component, ITE, E137632
 - UL 60950-1/CSA C22.2 No. 60950-1, 2nd Edition
- - IEC/EN60950-1, 2nd Edition
 - Model SVL 1-24-100, SVL 3-5-100, SVL 4-12-100, SVL 2-24-100 were evaluated for NEC Class II outputs
- RoHS Compliant

Related Products

- SDN-C Series
- SDN-P™ Series
- SDP™ Series

SVL Specifications <120W

Description	Catalog Number		
	SVL 3–5–100	SVL 1–24–100	SVL 6–5–100
Input			
Input Voltage Range	85-264 Vac		
– AC Range	100–240 Vac		
– DC Range ¹	120-375 Vdc		
– Frequency	50/60 Hz		
Nominal Current	0.5 A @ 115 Vac 0.3 A @ 230 Vac	0.8 A @ 115 Vac 0.4 A @ 230 Vac	0.9 A @ 115 Vac 0.5 A @ 230 Vac
– Inrush Current max,	35 A @ 115 Vac 65 A @ 230 Vac	35 A @ 115 Vac 60 A @ 230 Vac	
Efficiency	79% typ	88% typ	80% typ
Leakage Current	<1 mA @ 240 Vac		
Power Factor Correction	Meets EN61000-3-2 Class A		
Output			
Nominal Voltage	5 V	24 V	5 V
– Tolerance	+/-2%		
Voltage Adjustable Range	5-5.5 V	24-28 V	5-5.5 V
– Ripple (25°C)	<75 mVp-p		
PARC (25°C)	<75 mVp-p		
Nominal Current	3 A	1.25 A	6 A
Max. Power	15 W	30 W	
Holdup Time at full load (25°C)	20 ms typ. @ 115 Vac 100 ms typ. @ 230 Vac		
Rise Time at full load (25°C)	<100 ms		
Start Up at full load (25°C)	<3000 ms @ 115 Vac, <1500 ms @ 230 Vac		
Regulation	<0.5% Line and <1% Load		
Environmental Data			
Operating Temperature	-20°C to +70°C		
Relative Humidity	5 to 95% RH Non-condensing		
Storage temp	-40°C to +85°C		
Power Derating ²	See derating tables.		
Shock	IEC60068-2-27: half sine wave 10 G, single axis for a duration of 11 ms operational and 50 G three axes for duration of 11 ms each non-operational		
Vibration	IEC60068-2-6: sine wave; 10 Hz to 500 Hz at 2 g, 0.35 mm displacement, three axes for 60 min each operational and 5 Hz to 500 Hz at 2.09 grms, three axes for 20 min each non-operational		
Protections			
Overvoltage Protection	6.3-7.4 V, Latching	30-34.8 V, Latching	6.3-7.4 V, Latching
Overload Protection	Hiccup		
Over Temperature Protection	No component damage, latch mode		
Short Circuit	Hiccup mode, non-latching (auto-recovery when the fault is removed)		
Reliability			
MTBF	>350 khrs (115 Vac/230 Vac @ 25°C) acc. to Telcordia SR-332 issue 3		
EMC			
Galvanic Isolation	I/P to O/P: 3 K Vac; I/P to GND: 1.5 K Vac; O/P to GND: 0.5 K Vac		
Emissions	EN55022 (CISPR22) Class B, EN55011 Class B, EN61000-6-3, EN61000-6-4, EN61000-3-3, EN61204-3, EN61000-3-2 Class A		
Immunity	EN55024, EN61000-6-1, EN61000-6-2 (EN61000-4-2, 3, 4, 5, 6, 8, 11, 12) Level 3, Performance Criteria A		
General			
Housing	Plastic		
H x W x D – in (mm)	2.95 x 0.82 x 3.52 (75.0 x 21.0 x 89.5)		2.95 x 1.18 x 3.52 (75.0 x 30.0 x 89.5)
Unit Weight – lbs (g)	0.242 (110)		0.368 (167)
Shipping Weight – lbs (g)	0.309 (140)		0.419 (190)
LED Signals	GREEN light = DC OK , OCP = blinking		
DC OK Relay Contact	No		
Warranty	2 year		

1. DC input range is not listed in safety file it is only to confirm product functional performance.

SVL Specifications 120W and Above

Description	Catalog Number		
	SVL 4-12-100	SVL 2-24-100	SVL 4-24-100
Input			
Input Voltage Range	85-264 Vac		
- AC Range	100-240 Vac		
- DC Range ¹	120-375 Vdc		
- Frequency	50/60 Hz		
Nominal Current	1.0 A @ 115 Vac 0.6 A @ 230 Vac	1.0 A @ 115 Vac 0.6 A @ 230 Vac	1.2 A @ 115 Vac 0.6 A @ 230 Vac
- Inrush Current max.	35 A @ 115 Vac 60 A @ 230 Vac		
Efficiency	88% typ		89% typ
Leakage Current	<1 mA @ 240 Vac		
Power Factor Correction	Meets EN61000-3-2 Class A		Active PFC >0.9
Output			
Nominal Voltage	12 V	24 V	
- Tolerance	+/-2%		
Voltage Adjustable Range	12-15 V	24-28 V	
- Ripple (25°C)	<75 mVp-p		
PAR (25°C)	<75 mVp-p		
Nominal Current	4 A	2.1 A	4 A
Max. Power	48 W	50 W	96 W
Holdup Time at full load (25°C)	20 ms typ. @ 115 Vac 90 ms typ. @ 230 Vac		25 ms typ. @ 115 Vac 50 ms typ. @ 230 Vac
Rise Time at full load (25°C)	<100 ms		
Start Up at full load (25°C)	<3000 ms @ 115 Vac, <1500 ms @ 230 Vac		
Regulation	<0.5% Line and <1% Load		
Environmental Data			
Operating Temperature	-20°C to +70°C		
Relative Humidity	5 to 95% RH Non-condensing		
Storage temp	-40°C to +85°C		
Power Derating ²	See SVL derating tables.		
Shock	IEC60068-2-27: half sine wave 10 G, single axis for a duration of 11 ms operational and 50 G three axes for duration of 11 ms each non-operational		
Vibration	IEC60068-2-6: 10 Hz to 500 Hz at 2 g, 0.35mm displacement, three axes for 60 min each operational and 5 Hz to 500 Hz at 2.09 grms, three axes for 20 min each non-operational		
Protections			
Overvoltage Protection	16-18.7 V, Latching	30-34.8 V, Latching	
Overload Protection	Current foldforward and then hiccup		
Over Temperature Protection	No component damage, latch mode		
Short Circuit	Hiccup mode, non-latching (auto-recovery when the fault is removed)		
Reliability			
MTBF	>350 khrs (115 Vac/230 Vac @ 25°C) as per Telcordia SR-332 issue 3 Jan 2011.		
EMC			
Galvanic Isolation	I/P to O/P: 3 K Vac; I/P to GND: 1.5 K Vac; O/P to GND: 0.5 K Vac		
Emissions	EN55022 (CISPR22) Class B, EN55011 Class B, EN61000-6-3, EN61000-6-4, EN61000-3-3, EN61204-3, EN61000-3-2 Class A		
Immunity	EN55024, EN61000-6-1, EN61000-6-2 (EN61000-4-2, 3, 4, 5, 6, 8, 11, 12) Level 3, Performance Criteria A		
General			
Housing	Metal Encased		
H x W x D – in (mm)	2.95 x 1.18 x 3.52 (75.0 x 30.0 x 89.5)		2.95 x 1.77 x 3.93 (75.0 x 45.0 x 100.0)
Unit Weight – lbs (g)	0.390 (177)		0.698 (317)
Shipping Weight – lbs (g)	0.478 (217)		0.816 (370)
LED Signals	GREEN light = DC OK , OCP = blinking		
DC OK Relay Contact	No		
Warranty	2 year		

1. DC input range is not listed in safety file it is only to confirm product functional performance.

SVL Specifications <120W

Description	Catalog Number			
	SVL 2-48-100	SVL 5-24-100	SVL 10-24-100	SVL 20-24-100
Input				
Input Voltage Range	85-264 Vac			
- AC Range	100-240 Vac			
- DC Range ¹	120-375 Vdc			
- Frequency	50/60 Hz			
Nominal Current	2.20 A @ 115 Vac 1.40 A @ 230 Vac		2.8 A @ 115 Vac 1.4 A @ 230 Vac	5.4 A @ 115 Vac 2.7 A @ 230 Vac
- Inrush Current max.	20 A typ.@ 115 Vac 40 A typ.@ 230 Vac			40A typ.@ 115 Vac 80A typ.@ 230 Vac
Efficiency	88% typ			
Leakage Current	<1 mA @ 240 Vac			
Power Factor Correction	Meets EN61000-3-2 Class A		Active PFC >0.95	
Output				
Nominal Voltage	48V		24 V	
- Tolerance	+/-2%			
Voltage Adjustable Range	44-56 V		22-28 V	
- Ripple (25°C)	<120 mVp-p		<100 mVp-p	
PARD (25°C)	<150 mVp-p		<120 mVp-p	
Nominal Current	2.5 A	5 A	10 A	20 A
Max. Power	120 W		240 W	480 W
Holdup Time at full load (25°C)	10 ms typ.@ 115 Vac 16 ms typ @ 230 Vac			
Rise Time at full load (25°C)	<100 ms			
Start Up at full load (25°C)	<1000 ms @ 115 Vac & 230 Vac			
Regulation	<0.5% Line and <1% Load			
Environmental Data				
Operating Temperature	-20°C to +70°C			
Relative Humidity	5 to 95% RH Non-condensing			
Storage temp	-40°C to +85°C			
Power Derating ²	See derating tables.			
Shock	IEC60068-2-27: half sine wave 10 G, single axis for a duration of 11 ms operational and 50 G three axes for duration of 11 ms each non-operational			
Vibration	IEC60068-2-6: sine wave; 10 Hz to 500 Hz at 2 g, 0.35 mm displacement, three axes for 60 min each operational and 5 Hz to 500 Hz at 2.09 grms, three axes for 20 min each non-operational			
Protections				
Overvoltage Protection	56-67.2 V, Latching, re-power to recover	28.8-35.2 V, latching, re-power to recover		
Overload Protection	105- 50% of rated load; constant current at >20 V output and hiccup at <20 V output. SVL 2-48-100: constant current at >40 V output and hiccup at <40 V output, auto-recovery			
Over Temperature Protection	No component damage, latch mode, re-power to recover			
Short Circuit	Hiccup mode, non-latching (auto-recovery when the fault is removed)			
Reliability				
MTBF	>700 khrs (115 Vac & 230 Vac @ 25°C) as per Telcordia SR-332 issue 3 Jan 2011.			
EMC				
Galvanic Isolation	I/P to O/P: 3 K Vac; I/P to GND: 2 K Vac; O/P to GND: 0.5 K Vac			
Emissions	EN55022 (CISPR22) Class B, EN55011 Class B, EN61000-6-3, EN61000-6-4, EN61000-3-3, EN61204-3, EN61000-3-2 Class A			
Immunity	EN55024, EN61000-6-1, EN61000-6-2 (EN61000-4-2, 3, 4, 5, 6, 8, 11, 12) Level 3, Performance Criteria A, SEMI F47 @ 200 Vac			
General				
Housing	Plastic			
H x W x D – in (mm)	4.84 x 1.57 x 4.63 (123.6 x 40.0 x 117.6)		4.87 x 2.36 x 4.63 (123.6 x 60.0 x 117.6)	4.87 x 3.37 x 5.06 (123.6 x 85.5 x 128.5)
Unit Weight – lbs (g)	1.19 (540)		1.76 (800)	2.87 (1300)
Shipping Weight – lbs (g)	1.46 (660)		2.09 (950)	3.20 (1452)
LED Signals	GREEN light = DC OK , OCP = blinking			
DC OK Relay Contact	Yes			
Warranty	2 year			

1. DC input range is not listed in safety file it is only to confirm product functional performance.

SVL Derating Tables

15 Watt – 96 Watt Models

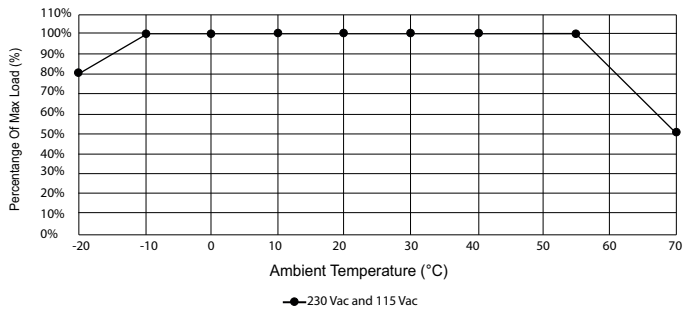

240 Watt Models

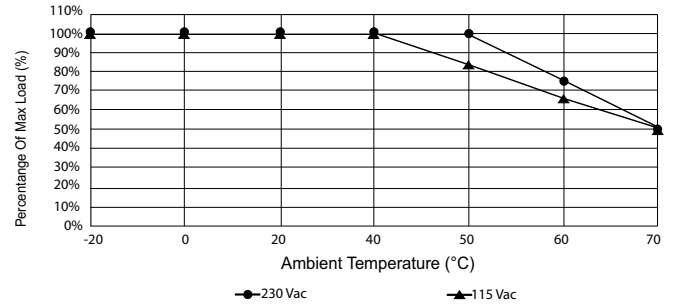

120 Watt and 480 Watt Models

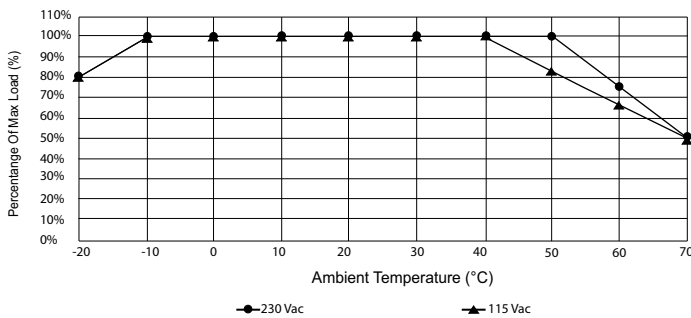

120 Watt – 480 Watt Models

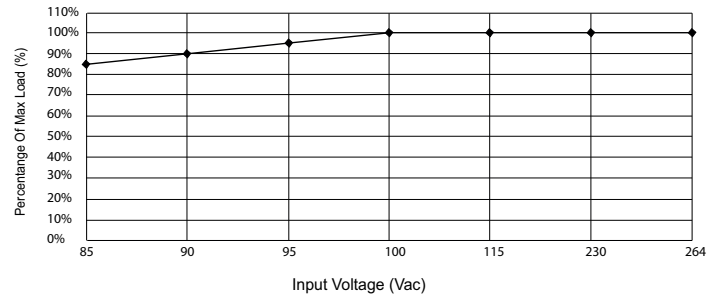

SVL Series Dimensions

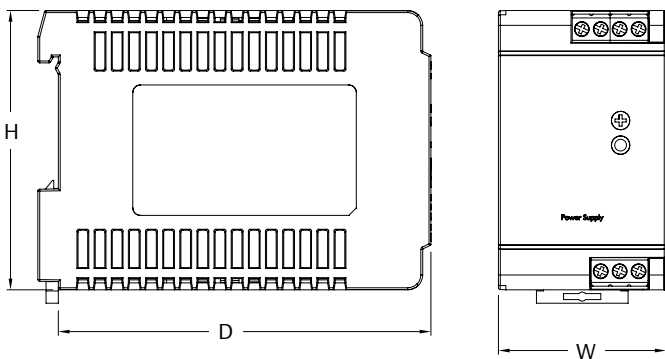

Catalog Number	Dimensions – inches (mm)		
	H	W	D
SVL 3–5–100	2.95 (75.0)	0.82 (21.0)	3.52 (89.5)
SVL 1–24–100	2.95 (75.0)	0.82 (21.0)	3.52 (89.5)
SVL 6–5–100	2.95 (75.0)	1.18 (30.0)	3.52 (89.5)
SVL 4–12–100	2.95 (75.0)	1.18 (30.0)	3.52 (89.5)
SVL 2–24–100	2.95 (75.0)	1.18 (30.0)	3.52 (89.5)
SVL 4–24–100	2.95 (75.0)	1.77 (45.0)	3.93 (100.0)
SVL 2–48–100	4.84 (123.6)	1.57 (40.0)	4.63 (117.6)
SVL 5–24–100	4.84 (123.6)	1.57 (40.0)	4.63 (117.6)
SVL 10–24–100	4.87 (123.6)	2.36 (60.0)	4.63 (117.6)
SVL 20–24–100	4.87 (123.6)	3.37 (85.5)	5.06 (128.5)

SDN-C Redundancy Modules

The SolaHD SDN-C Redundancy (RED) Modules support redundant power supply operation. The RED module continually monitors the condition of two power supplies connected to a single load. If one power supply fails, the RED module automatically changes over to the other power supply.

The MOSFET design of the RED modules generate less heat than traditional diode-based designs. Less heat translates to longer life of the components that are housed in the same enclosure as the RED module, and a more compact design of the RED module itself, saving on panel space.

Diagnostic LEDs assist in balancing the load between the two power supplies during normal operation, extending the life of both power supplies. Output status information can be easily provided to a PLC or other control equipment, using the RED module's relay output contact.

Extensive certifications mean the RED modules are suitable internationally, for harsh industrial environments and even hazardous locations.

The RED module works with SolaHD SDN-C and SDN-P Series power supplies, as well as most power supplies capable of parallel operation. Three models are available. Choose the model that most closely matches your application requirements, per the Selection Table. For non-redundant operation, please contact SolaHD Technical Services for additional information.

Applications

- Hazardous Locations
- Process Control
- Critical Production
- Remote Location

Features

- Redundant power supply operation with true isolation
- Compact size saves panel space
- Extensive diagnostics
- Load balancing support extends power supply life
- Use in hazardous locations, with T4 temperature rating
- Works with a wide variety of power supplies

Related Products

- SDN-C Series power supplies
- SDN-P Series power supplies



Certifications and Compliances

- **UL US** Listed, Ind. Control Equipment, E61379
- UL 508, CSA C22.2 No. 107.1
- **UL US** UL Recognized Component, ITE, E137632
- UL 60950-1/CSA C22.2 No. 60950-1, 2nd Edition
- **UL US** UL Recognized Component, Haz. Loc., E234790
- UL 60079-15/CSA E60079-15
- Class I, Zone 2, AEx nA nC IIC, Ex nA nC IIC
- **CE** - Low Voltage Directive
- IEC/EN60950-1, 2nd Edition
- **Ex** ATEX Directive
- EN60079-0, EN60079-7, EN60079-15
- **Ex** II 3 G, Ex ec nC IIC Gc
- **IECEx** Certified
- IEC 60079-0, IEC 60079-7, IEC 60079-15
- Ex ec nC IIC Gc
- **Ex EAC** TR CU 012/2011 Safety of Equipment intended for Explosive Atmospheres
- **ABS** Type Approved
- **DNV-GL** Certified
- RoHS Compliant

Selection Table

Part Number	Max Current (Redundant)	Max Current (Non-redundant)
SDN 2X10RED	10 A	20A
SDN 2X20RED	20A	40A
SDN 2X40RED	40A	80A

SDN-C Redundancy Modules Specifications

Catalog Number	SDN 2X10RED	SDN 2X20RED	SDN 2X40RED
Input			
Input Voltage Range	10.8-30.8 V DC (SELV)		
– Nominal Voltage	12-28 Vdc		
– Maximum Voltage	30.8 Vdc		
Maximum Current	2 x 10 A, 1 x 20A (-40°C to +70°C) 2 x 12A, 1 x 24A (-40°C to +60°C) 2 x 12.5A, 1 x 25 A (-40°C to +50°C) 2 x 13A, 1 x 26A (-40°C to +40°C)	2 x 20A, 1 x 40A (-40°C to +70°C) 2 x 24A, 1 x 48A (-40°C to +60°C) 2 x 25 A, 1 x 50A (-40°C to +50°C) 2 x 26A, 1 x 52A (-40°C to +40°C)	2 x 35A, 1 x 70A (-40°C to +70°C) 2 x 40A, 1 x 80A (-40°C to +60°C) 2 x 42A, 1 x 85A (-40°C to +50°C) 2 x 45A, 1 x 90A (-40°C to +40°C)
Type of Protection	Protect against static surge voltages >30 V		
Output			
Nominal Voltage	12-28 Vdc		
Voltage Drop (input–output)	0.2V Typical		
Nominal Output Current	10 A (Redundant) 20A (Non-Redundant)	20A (Redundant) 40A (Non-Redundant)	40A (Redundant) 80A (Non-Redundant)
Current Handling Capacity (Power Boost)	50A for 5 seconds	65A for 5 seconds	120A for 5 seconds
Inverse Polarity Protection	Yes		
Installation			
Mounting	DIN TS35/7.5 or TS35/15 rail system.		
Connection			
– Input	10–12 AWG (5.3–3.3 mm ²) for solid/stranded conductors. Torque: 7 lb-inch (79.1 N-cm).		6–8AWG (13.3–8.4 mm ²) for solid/stranded conductors. Torque: 15.6 lb-inch (176.3 N-cm)
– Output	6–8AWG (13.3–8.4 mm ²) for solid/stranded conductors. Torque: 15.6 lb-inch (176.3 N-cm)		2–6AWG (33.6–13.3 mm ²) for solid/stranded conductors. Torque: 15.6 lb-inch (176.3 N-cm).
– Contact Relay	12-22 AWG (3.3-0.33 mm ²) for solid/stranded conductors. Torque: 4.4 lb-inch (49.7 N-cm)		
Dimensions – H x W x D in (mm)	4.85 (123.2) x 1.38 (35.0) x 4.46 (113.3)		4.85 (123.2) x 1.81 (46.0) x 4.61 (117.0)
Weight – lb. (kg)	0.8 (0.36)		1.1 (0.48)
Environmental Data			
Ambient Temperature	Storage/Shipment: -40°C to +85°C Full Nominal Load: -40°C to +70°C		
Relative Humidity	0 to 95% RH, non-condensing		
Altitude	0 to 6,000 meters (0 to 20,000 feet) per MIL-STD-810F		
Degree of Protection	IP20		
Minimum Required Free Space for Cooling	0.39 in. (10.0 mm) above/below, 0.39 in. (10.0 mm) left/right. Do not obstruct air flow.		
Warranty	5 years		
EMC	EN 61326-1; EN 55022 +AC: Class B; EN 55011 + A1: Group 1 Class B; EN 61000-3-2; EN 61000-3-3; EN 55024; EN 61000-6-1; EN 61000-6-2:2005; EN 61000-6-3:2007+A1; EN 61000-6-4:2007+A1; IEC/EN 61000-4 SERIES REGULATIONS		
MTBF Telecordia SR–322 Issue 2	>1.3M h (25°C)		>1.2M h (25°C)
General			
Emissions/Immunity	According generic standards: EN 61000-6-1, EN 61000-6-2, EN 61000-6-3, EN 61000-6-4		
Status Indicators	(3) two-color LEDs (V_{in1} , V_{in2} , V_{out}) Normally Open “V _{out} OK” Relay Contact (60 Vdc, 1A maximum)		

Wiring Diagram

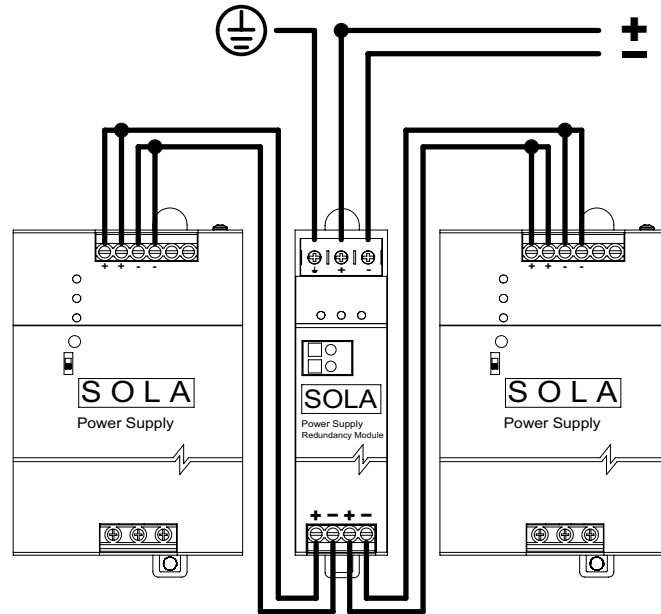

Diagnostics

Condition		LED Indicators			Contact Status
PSU 1	PSU 2	V _{in1}	V _{out}	V _{in2}	V _{out} OK
On	On	Green	Green	Green	Closed
Off	Off	Off	Off	Off	Open
On	Off	Green	Green	Off	Closed
Off	On	Off	Green	Green	Closed
$V_{in1} > V_{in2}$		Red	Green	Green	Closed
$V_{in2} > V_{in1}$		Green	Green	Red	Closed
No Output		Green	Red	Green	Open

IP67 SCP-X Extreme Environment Series

The SolaHD IP67 SCP-X power supplies provide the versatility and cost-efficiency to deliver reliable distributed and remote field power to machine controls. Mounts directly on the machine or production line eliminating the complexity and cost of unnecessary enclosures and excess wiring. Quick change connectors simplify connectivity for distributed I/O devices on industrial machinery. These Class II Listed, 24 Vdc power supplies are available in single and dual 100 Watt models and are perfect for automotive, packaging and automated distribution applications.

Control Output Models

Designed for Control Power applications where a grounded power supply output is required.

- Input connector: 3-PIN IP67 molded plug externally threaded with 7/8"-16 UN mounting thread.
- Output connector: 4-PIN IP67 molded receptacle internally threaded with 7/8"-16 UN mounting thread.

Isolated Output Models

Designed for application where an isolated output from ground is required such as DeviceNet™.

- Input connector: 3-PIN IP67 molded plug externally threaded with 7/8"-16 UN mounting thread.
- Output connector: 4-PIN IP67 molded receptacle internally threaded with 7/8"-16 UN mounting thread.

Features

- IP66/67 rated versatile enclosure
- 24 Vdc, 100-240 Vac, up to four outputs at 3.8A Nominal Current (per pair for dual models)
- Class II Listed power supply for stand alone applications
- Can be mounted in any orientation without limitation

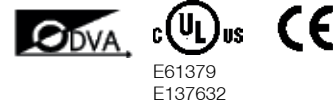

- Safety approved for AC and DC universal input
- Reliable operation from -40°C to 60°C without derating
- DC OK Green LED
- Worldwide approvals
- Five year limited warranty

Certifications and Compliances

- US Listed, Inc. Control Equipment, E61379, ITE, E137632
 - UL 508, CSA C22.2 No. 107.1
 - UL 60950-1/CSA C22.2 No. 60950-1, 2nd Edition
- - Low Voltage Directive
 - IEC/EN60950-1, 2nd Edition
- RoHS Compliant

Related Products

- SDN Series

Selection Table

Catalog Number	Output Current	Output Voltage	Output Power
SCP 100S24X-CP1	3.8 A	24 Vdc	100 W
SCP 100S24X-DVN1			
SCP 102D24X-C02	7.6 A total (3.8 A max. per pair)		2 x 100 W
SCP 102D24X-D02			

Recommended Electrical Connections/Cordsets¹

Input 3-PIN Connections	Output 4-PIN Connections
Daniel Woodhead P/N 103000A01FXX0 ⁽²⁾ or Harting P/N 21 04 516 23XX ⁽⁴⁾	Turck P/N RSM46*M ⁽³⁾ or Harting P/N 21 04 516 14XX ⁽⁴⁾

1. Connections to be provided by the user.
2. XX is the length of the cordset in feet.
3. * is the length of the cordset in meters
4. XX is the length of the cordset in meters.

SCP100S24X-CP1 and SCP100S24X-DVN1 Mechanical Diagrams

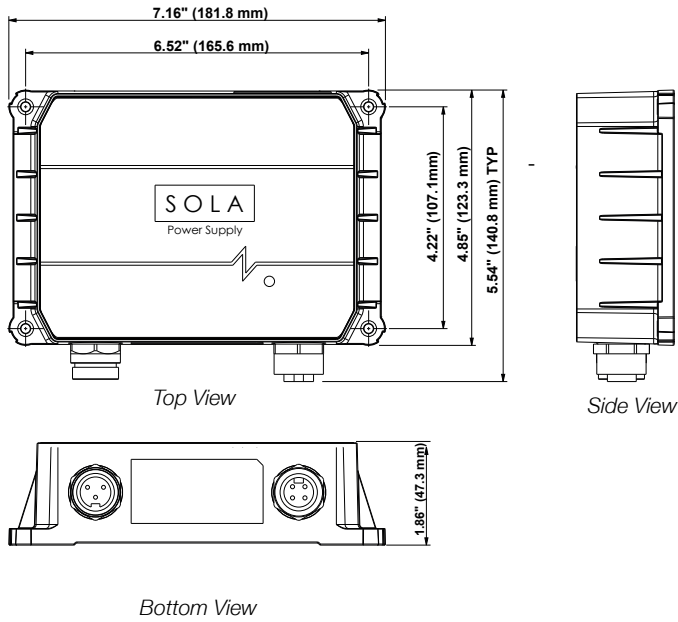

Electrical Connections

Input		Output	
50/60/400 Hz 100-240 V ac 100-353 V dc, 0.7-1.6 A		24 V dc, 3.8 A, Class II	
SCP 100S24X-CP1			
1 = Ground 2 = Power 3 = Neutral		1 = +24 V dc 2 = +24 V dc 3 = 0 V dc ⁽¹⁾ 4 = 0 V dc ⁽¹⁾	
SCP 100S24X-DVN1			
1 = Ground 2 = Power 3 = Neutral		1 = +24 V dc 2 = +24 V dc 3 = Ground ⁽²⁾ 4 = -V dc ⁽³⁾	

NOTES:

- 0 Vdc connections are internally bonded to ground.
- Ground is isolated from V-.
- Vdc is isolated from ground. -Vdc is a separately derived source, so it is permissible to bond to ground if required in the application.

SCP102D24X-C02 and SCP102D24X-D02 Mechanical Diagrams

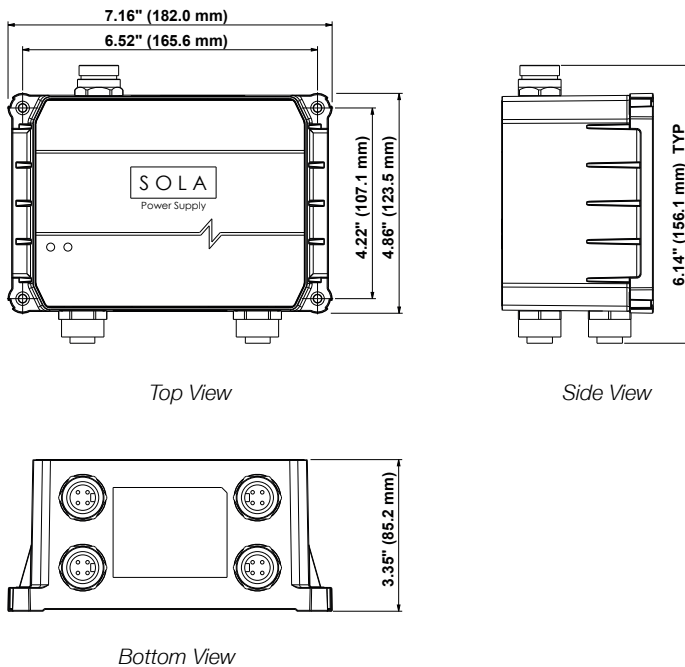

Electrical Connections

Input		Output	
50/60/400 Hz 100-240 Vac / 2.4 - 1.4A 100-353 Vdc / 2.4 - 0.7A		24 Vdc, 3.8 A (x2), Class II	
SCP 102D24X-C02			
1 = Ground 2 = Power 3 = Neutral		1 = +24 Vdc 2 = +24 Vdc 3 = 0 Vdc 4 = 0 Vdc DC 1	
		1 = +24 Vdc 2 = +24 Vdc 3 = GROUND 4 = -Vdc DC 2	
SCP 102D24X-D02			
1 = Ground 2 = Power 3 = Neutral		1 = +24 Vdc 2 = +24 Vdc 3 = GROUND 4 = -Vdc DC 1	
		1 = +24 Vdc 2 = +24 Vdc 3 = GROUND 4 = -Vdc DC 2	

IP67 SCP-X Specifications

Descriptions	Catalog Number	
	SCP 100S24X-CP1 SCP 100S24X-DVN1	SCP 102D24X-C02 SCP 102D24X-D02
Input		
Nominal Voltage	Any voltage from 100 to 240 Vac Input	
-AC Range	85 - 264 Vac Universal Input	
-DC Range	100 - 353 Vdc	
Nominal Current ¹	1.6 A / 0.7 A	2.4 - 1.4 A / 2.4 - 0.7 A
-Inrush current max.	Typ. <30 A	
Power Factor Correction ²	0.95	
Frequency	50/60/400 Hz	
Output		
Power Back Immunity	35 V	
Overvoltage Protection	25-25.5 Vdc, autorecovery	
Nominal Voltage	24 Vdc	
Tolerance	< +/-2% overall	
- Line Regulation	< 0.5%	
- Load Regulation	< 0.5%	
- Time & Temp. Drift	< 1%	
Input Voltage Setting	24.5 V +/-1%	
Ripple ³	< 50 mVpp	
Total Nominal Current	3.8 A	7.6 A Total (3.8 A max. per pair)
Holdup Time	> 50 ms (Full load, 100 Vac Input @ T _{amb} = +25°C) to 95% output voltage	
General		
Emissions ⁴	EN61000-6-3, EN61000-6-4, EN55011 Group 1, Class B, EN55022 Class B, EN61000-3-2, EN61000-3-3	
Immunity ⁴	EN61000-6-1, EN61000-6-2, EN55024, IEC61000-4-2, IEC61000-4-3, IEC61000-4-4, IEC61000-4-5, IEC61000-4-6, IEC61000-4-8, IEC61000-4-11, SEMI F47 Sag Immunity	
Temperature	Storage: -40° to +85°C, Operation: -40° to +60°C full power with linear derating to half power from +60° to +70°C. No forced air required. Operation up to 100% load permissible with sideways or front-side-up mounting orientation.	Storage: -40° to +85°C, Operation: -25° to +60°C full power with linear derating to half power from +60° to +70°C. No forced air required. Operation up to 100% load permissible with sideways or front-side-up mounting orientation.
Humidity	Up to 100% RH with condensation	
Altitude	0 to 3,000 m (0 to 10,000 ft.)	
Vibration	1 g non-operating swept sine over 10–500 Hz (IEC 60068-2-6). Non-operating random vibration test: 1.87 g over 10–500 Hz (IEC 60068-2-64). Operating random vibration test: 0.15 g over 5–100 Hz (IEC 60068-2-64)	
Shock	Non-operating: 30 g peak, 18 ms half-sine pulse (IEC 68-2-27). Operating: 4 g peak, 22 ms half-sine pulse (IEC 68-2-27)	
Warranty	5 Year Limited Warranty	
MTBF	>800,000 hours according to Telcoredia/Bellcore SR-332 Issue 1, (Vin 120 Vac, Tamb = 40°C)	>800,000 hr. according to Telcoredia/Bellcore SR-332 Issue 3, (Vin 120 Vac, ambient temp. = 40°C)
General Protection/Safety	Protected against continuous short-circuit, continuous overload, and continuous open circuit. Protection NEC Class II (IEC536), degree of protection IP66/IP67 versatile (IEC60529). Safety extra low voltage circuits: SELV (acc. EN60950-1).	Protected against continuous short-circuit, continuous overload, continuous open circuit. Protection Class I. Safety extra low voltage circuits: SELV (acc. EN60950).
Status Indicators – Visual	DC OK LED	
Installation		
Fusing –Input	Internally fused, fuses not replaceable	
-Output	Electronically current limited to meet NEC Class II per UL1310	
Mounting	Chassis mounted using integral mounting tabs. Recommended Screw Size: M4 x 0.7. Tightening Torque: 1N-m	
Connections	An accessible disconnect device shall be installed external to the equipment. Input: 3-PIN IP67 molded plug (quick disconnect). Output: 4-PIN IP67 molded receptacle (quick disconnect). Use UL 758 wire rated min. 24 V, WW-1/FT-1, max. 3.05 m.	
Case	IP66/67 versatile ingress protection; also meets UL50 Type 4X enclosure	
Min. Required Free Space	0.39 in. (10 mm) all sides but base	1 in. (25 mm) all sides but base
H x W x D – in (mm)	4.73 x 7.00 x 1.80 (120.1 x 177.8 x 45.7)	4.73 x 7.00 x 3.27 (120.1 x 177.8 x 83.0)
Weight – lbs (kg)	2.2 (1.0)	3.3 (1.5)

1. Input current ratings are specified with low input, line conditions, worst case efficiency values and power factor.
2. Power Factor Correction at 50/60 Hz only.
3. Ripple/noise is stated as typical AC values when measured with a 20 MHz bandwidth scope and 50 Ohm termination.
4. Emissions and immunity are met by individual power supply modules.

SCP Series, 30 Watt; Single, Dual and Triple

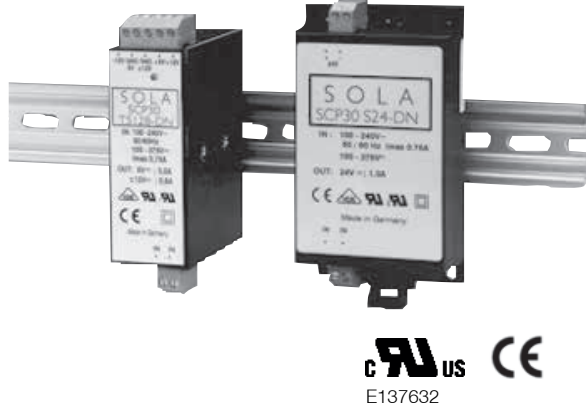

The SolaHD SCP switchers are compact, rugged power supplies designed to power many of your industrial control and instrumentation devices and equipment, with high reliability and tight regulation through the most difficult factory floor conditions around the globe. “User friendly” applies to these unique power supplies that feature easy-to-install DIN rail and chassis mounting. Terminations are also easy to access (AC and DC terminations are well separated) and simple to wire. Safety is another aspect where the SCP distinguishes itself. The encapsulated design meets IP20 specifications, and the wide range of voltages will reliably support almost any low power device in your cabinet or system for years to come.

Features

- International approvals for global use
- DIN Rail or Chassis Mount
- Rugged, encapsulated design to resist environment
- IP20 protection
- Many output voltages, 3.3-48 Volts; single, dual, triple
- Five year limited warranty

Packaging and Mounting Specifications

- Simple snap-on for DIN Rail TS35/7.5 or TS35/15
- M3 screw clamp terminations
- Chassis mounting possible on -DN Low Profile versions by removing DIN clips (simply unscrew at the back of the unit).

Selection Table

Low Profile Catalog Number	Description	Output Voltages						Min Load V1 A	Efficiency %
		V1		V2		V3			
		Vdc	A	Vdc	A	Vdc	A		
SCP 30S3.3-DN	3.3 V	3.3	6.0	-	-	-	-	0	≥ 62
SCP 30S5-DN	5 V	5	6.0	-	-	-	-	0	≥ 70
SCP 30S12-DN	12 V	12	2.5	-	-	-	-	0	≥ 75
SCP 30S15-DN	15 V	15	2.0	-	-	-	-	0	≥ 75
SCP 30S24-DN	24 V	24	1.3	-	-	-	-	0	≥ 77
SCP 30S48-DN	48 V	48	0.6	-	-	-	-	0	≥ 77
SCP 30D12-DN	Dual O/P +/- 12 V	12	1.2	-12	1.2	-	-	0.12	≥ 68
SCP 30D15-DN	Dual O/P +/- 15 V	15	1.0	-15	1.0	-	-	0.15	≥ 68
SCP 30D512-DN	Dual O/P 5 V & 12 V	5	3.0	12	1.2	-	-	0.3	≥ 68
SCP 30D524-DN	Dual O/P 5 V & 24 V	5	3.0	24	0.6	-	-	0.3	≥ 68
SCP 30T512-DN	Triple O/P 5/12/12 V	5	3.0	-12	0.6	12	0.6	0.3	≥ 68
SCP 30T515-DN	Triple O/P 5/15/15 V	5	3.0	-15	0.5	15	0.5	0.3	≥ 68

Please order using the following model number suffixes:

-DN: Low Profile – DIN Rail or Chassis Mount (ie: SCP30S3.3-DN).

B-DN: Slim Line – DIN Rail Mount Availability Only (ie: SCP30S3.3B-DN).

Note: Slim line version not available on SCP30D512-DN

Options and Accessories

- SCP-MDC – Pair of metal DIN clips
- SCP-PDC – 1 plastic DIN clip with lever for removal from rail

Certifications and Compliances

- UL Recognized Component, ITE, E137632
- - IEC/EN 60950-1, 2nd Edition
- IP20
- RoHS Compliant

Specifications

Parameter	Condition	Value
Input		
AC Input Voltage	—	85 - 264 Vac
DC Input Voltage	—	100 - 375 Vdc
Input Frequency	—	50/60 HZ
Filtering EMI/RFI	—	EN 55011/B, 55022/B
Switching Frequency	—	Typ. 100 kHz
Input Fusing Required	—	Use 2.0 A Slow Fuse
Output		
Output Voltage Accuracy	$V_{in} = 230 V, I_{out} = \text{max}, 25^{\circ}C$	$V1 \leq \pm 1\%, V2/3 \leq \pm 3\%$
Ripple	$V_{in} = \text{min}, I_{out} = \text{max}, 25^{\circ}C$	$\leq 1\%, V_{out}$
Noise	$V_{in} = \text{min}, I_{out} = \text{max}, 25^{\circ}C$	$\leq 2\%, V_{out}$
Line Regulation	$V_{in} = \text{min/max } 25^{\circ}C$ $I_{out} = \text{max}, 25^{\circ}C$	$\leq \pm 0.5\%, V_{out}$
Load Regulation	$I_{out} = 10 \text{ to } 90 \text{ to } 10\%$, $25^{\circ}C V_{in} = 230 \text{ Vac}, 25^{\circ}C$	$\leq \pm 0.5\%, V_{out}$
Overcurrent Protection	—	105 to 130% I_{nom}
Load Regulation Timing	10 to 90 to 10%, $25^{\circ}C$	<4 ms
Temperature Coefficient	$T_{amb} = -25 \text{ to } +65^{\circ}C$	0.01%/K
Overload/Short Circuit	Continuous	
Derating Single/Dual/Triple	$T_{amb} > 50^{\circ}C$	2/3/5%/K max
General		
Holdup Time	$V_{in} = 230 \text{ Vac}$	>50 ms
Operating Temperature	—	-25 to +65°C
Storage Temperature	$T_{amb} = 25^{\circ}C$	45 to +85°C
Case Temperature Rise at Full Load	—	45 K max
MTBF at 25°C (input/output)	acc. MIL-HDBK-217F	800,000 hrs
Transient Protection	—	EN61000-4-2, 3, 4, 5
Cooling	—	Convection
Weight – lbs (kg)	0.7 (.34)	0.8 (.38)
Case Material/Potting	—	UL94-VO
Protection	—	IP20
Visual Indicators	—	Green LED indicates DC OK for B-DN Slim Line versions only

Dimensions (H x W x D)

- Low Profile “–DN”**
 4.72 x 2.55 x 1.29 in (120.0 x 65.0 x 33.0 mm)
 (Takes up 2.55 in or 65.0 mm on DIN rail)
- Slim Line “B–DN”**
 4.72 x 1.29 x 2.68 in (120.0 x 33.0 x 68.0 mm)
 (Takes up 1.29 in or 33.0 mm on DIN rail)

Dimensional Diagram – in (mm)

Low Profile DIN Rail (–DN) or Chassis Mount *

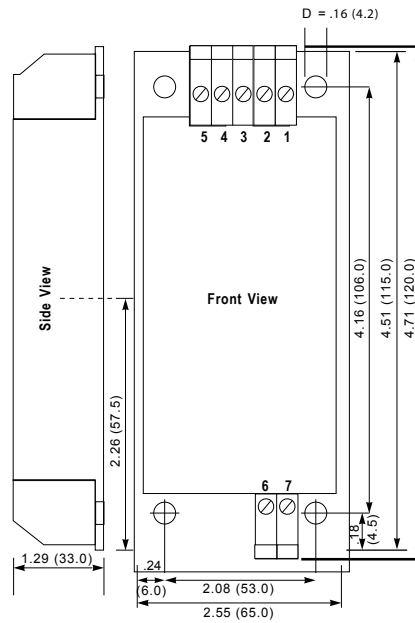

* Unscrew DIN connector for chassis mounting.

Slim Line DIN Rail Mount only (B–DN)

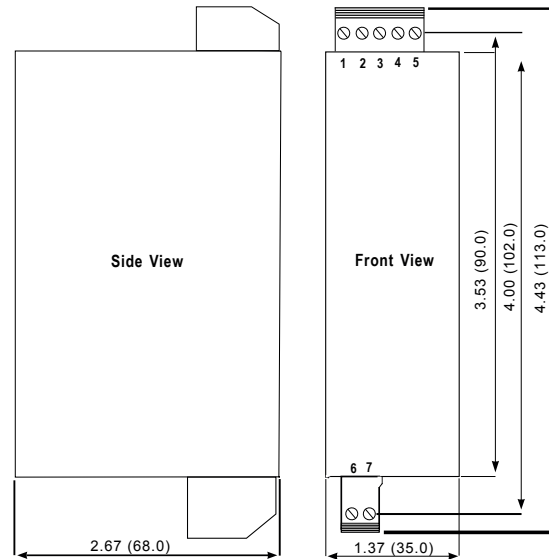

Pin-Out

SCP 30	1	2	3	4	5	6	7
Single				RETURN	+V1	IN	IN
Dual sym			-V2	COM	+V1	IN	IN
Dual asym		COM (V1)	+V1	COM V3	+V3	IN	IN
Triple	-V2	COM (V1)	COM (V2/3)	+V1	+V3	IN	IN

SCD Series, Encapsulated, Industrial DC to DC Converter

The SolahD SCD Series compact, rugged DC to DC converters are power supplies designed to power industrial control instrumentation devices and equipment where AC power is not convenient or accessible. With high reliability and wide input range, these units can operate through the most difficult factory floor conditions around the globe. "User friendly" applies to these unique power supplies that feature easy-to-install DIN rail and chassis mounting. Terminations are also easy to access and simple to wire. Encapsulated design meets IP20 specifications for use in harsh environments.

Applications

These units regulate voltage for sensitive electronic equipment run from battery power. For example, a 24 Vdc battery system where the battery voltage can be 30 volts, sometimes higher during charging, and dip below 22 volts under heavy load. The SCD can be used to stabilize the voltage for those devices not designed to handle wider voltage swings.

They are also a convenient and inexpensive alternative to running AC power through a large industrial machine. The SCD can use 24 Vdc commonly available on many parts of the machine to create other voltages needed to run sensors, transducers and other devices that the machine requires to work properly.

- Industrial
 - Encoders, special sensors, communications and instrumentation
- Telecommunications systems
- Remote Site/Harsh Environment

Features

- DIN Rail or Chassis Mount by removing DIN clips
- Rugged, encapsulated design to resist environment
- IP20 protection
- Wide 20 to 72 Vdc input range
- M3 screw clamp terminations
- Simple snap-on for DIN Rail TS35/7.5 or TS35/15
- Galvanic isolation
- Five year limited warranty

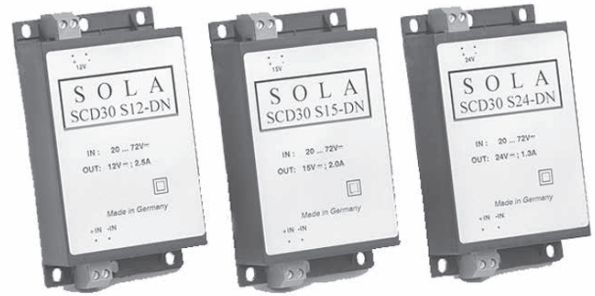

Options and Accessories

- SCP-MDC – Pair of metal DIN clips
- SCP-PDC – 1 plastic DIN clip with lever for removal from rail

Certifications and Compliances

- cUL US Listed, Ind. Control Equip., E61379
 - UL 508/CSA C22.2 No. 107.1
- cUL US Recognized Component, ITE, E137632
 - UL 60950/CSA C22.2 No. 234-M90
- CE -IEC/EN60950-1
- IP20
- RoHS Compliant

SCD Series, Encapsulated, Industrial DC to DC Converter

Selection Table

Low Profile Catalog Number	Description	Output Voltages				Min Load V1 A
		V1		V2		
		Vdc	A	Vdc	A	
30 Watts; Switching DC Power Supply						
SCD 30S5-DN	5 V	5	5	-	-	0
SCD 30S12-DN	12 V	12	2.5	-	-	0
SCD 30S15-DN	15 V	15	2	-	-	0
SCD 30S24-DN	24 V	24	1.3	-	-	0
SCD 30S48-DN	48 V	48	0.6	-	-	0
SCD 30D15-DN	Dual O/P+15 V	15	0.8	-15	0.8	0.15

Dimensions - in (mm)

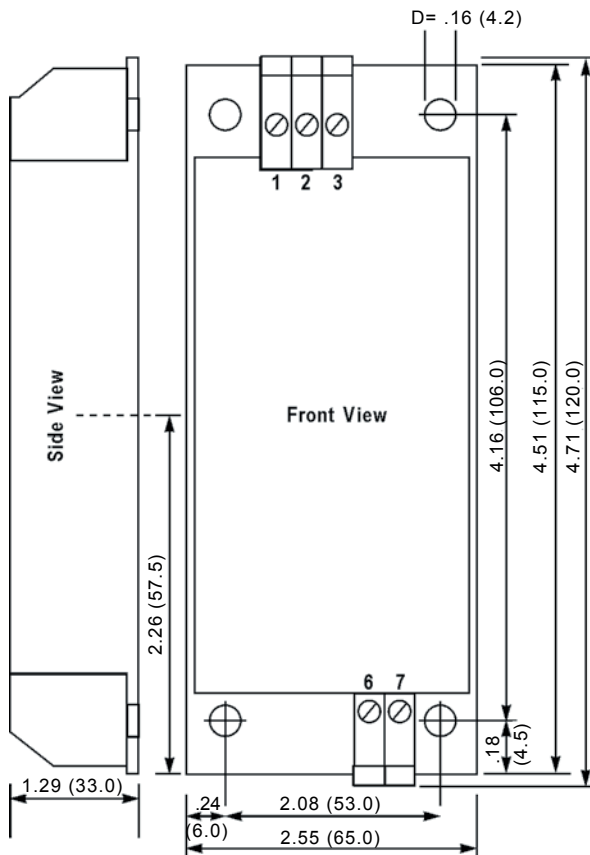

Pin-Out

SCD 30	1	2	3	6	7
Single	+V1	-V1		+IN	-IN
Dual	V1	COM	V2	+IN	-IN

Specifications

Parameter	Condition	Value
Input		
Input Voltage	-	20 - 72 Vdc
Filtering EMI/RFI	-	EN 55011/B, 55022/B
Switching Frequency	-	Typ. 100 kHz
Output		
Output Voltage Accuracy	$V_{in} = 48V$, $I_{out} = \text{max}$, 25°C	$V1 \leq \pm 1\%$, $V2 \leq \pm 4\%$
Ripple	$V_{in} = \text{min}$, $I_{out} = \text{max}$, 25°C	$\leq 1\%$, V_{out}
Noise	$V_{in} = \text{min}$, $I_{out} = \text{max}$, 25°C	$\leq 2\%$, V_{out}
Line Regulation	$V_{in} = \text{min/max}$ 25°C $I_{out} = \text{max}$, 25°C	$\leq +0.5\%$, V_{out}
Load Regulation	$I_{out} = 10$ to 90 to 10%, 25°C, $V_{in} = 48 V$, 25°C	$\leq +0.5\%$, V_{out}
Overcurrent Protection		105 to 130% I_{nom}
Load Regulation Timing	10 to 90 to 10%, 25°C	<4 ms
Temperature Coefficient	$T_A = -25$ to +65°C	0.01%/K
Overload/Short Circuit		Continuous
Derating Single/Dual/Triple	$T_A > 50^\circ C$	5%/K max
General		
Holdup Time	$V_{in} = 48 V$	>10 ms
Operating Temperature		-25 to +65°C
Storage Temperature	$T_A = 25^\circ C$	45 to +85°C
Case Temperature Rise at Full Load	-	45 K max
MTBF at 25°C (input/output)	acc. MIL-STD-217F	800,000 hrs
Transient Protection	-	EN61000-4-2, 3, 4, 5
Cooling	-	Convection
Weight - lbs (kg)	-	0.8 (.39)
Case Material/Potting	-	UL94-VO
Protection	-	IP20

Note: No input protection against reverse voltage.

SHP Series: Heavy Duty Modular Power Supplies

The SolaHD SHP Series high power, intelligent modular power supplies, range from 1500 through 4920 watts and were designed for optimum flexibility. The modular design makes these units easy to customize for unusual voltage and power combinations, and the intelligent modules allow the use of I²C or CANBUS/RS485 communication to monitor and control many attributes of the power supply.

All units have power factor corrected inputs, an end mounted fan for cooling and a variety of built-in signals and controls. High reliability and a flexible design make these power supplies an excellent choice for process control and semiconductor fabrication applications.

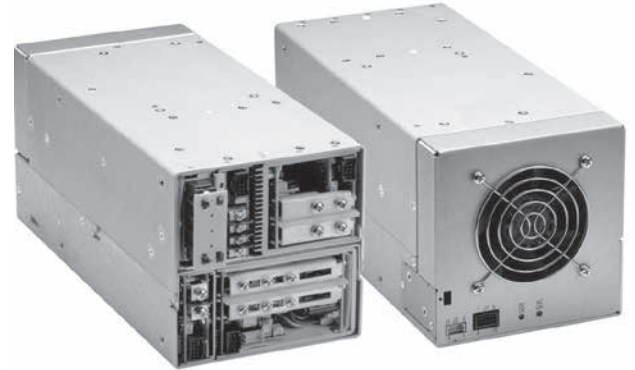

Applications

- Process Controls
- Semi-Conductor Fabrication
- Automated Service Equipment

Features

- Available in intelligent and non-intelligent models
- Single, dual and triple output modules configurable in combinations up to 24 different outputs
- Single phase and three phase inputs
- I²C control in intelligent modules
- End mounted intelligent fan (speed control/fault status)
- Voltage adjustment on all outputs (manual or I²C)
- CANBUS and RS-485 optional interface
- Overload protection on all outputs
- Power factor correction (.99 typ.)
- Configurable output UP/DOWN sequencing
- Modular Construction
- Configurable input and output OK signals and indicators
- Programmable voltage, current limit, inhibit/enable through I²C
- Three year limited warranty

Certifications and Compliances

- UL Recognized Component, ITE, E137632
- UL 60950-1/CSA C22.2 No. 60950-1, 2nd Edition
- - Low Voltage Directive
- IEC/EN 60950-1, 2nd Edition
- RoHS Compliant

Related Products

- Surge Protective Devices
- SCD DC to DC Converters
- Active Tracking® Filters

Standard Offering Selection Table

Catalog Number	Output Voltage	Output Current	Watts
SH30-4LS-0Z	12 V	125 A	1500
SH30-4NS-0Z	15 V	100 A	1500
SH30-4QS-0Z	24 V	62 A	1500
SH30-4RS-0Z	28 V	53 A	1500
SH30-4WS-0Z	48 V	31 A	1500
SH45-4QS-3QS-4Z	24 V	92 A	2000

Accessories Table

Catalog Number	Description
73-769-001	USB to I ² C adapter
70-841-004	Mating Connector Kit for Control & Signals (J1 Connector)
70-841-023	Mating Connector Kit for I ² C Interface (J2 Connector)

Specifications

Description	SH30	SH45	S3H3	S3H5
Input				
Input voltage range	90–264 Vac; 120–300 Vdc; Single phase		170-264 Vac; Three phase	
Frequency	47–63 Hz			
Inrush current	40 A peak maximum (soft start)			
Efficiency	Up to 85% at full load			
Power factor	0.99 typical			
Turn–on time	AC on 1.5 s typical, inhibit/enable 150 ms typical, configurable through I ² C; 50 ms internal turn-on delay (dual output only)			
Hold–up time	10 ms minimum			
AC OK	>5 ms early warning before outputs lose regulation, full cycle ride through at 50 Hz, configurable through I ² C			
Output				
Output voltage range	±10% minimum for all outputs, user-adjustable pot, full adjustment range using I ² C			
Factory set point accuracy	0.01			
I ² C output program accuracy	±5%			
Margining	±4–6% nominal analog (single output module only)			
Line/load regulation	0.4% or 20 mV maximum (1% maximum for 1500 W module)			
Ripple	RMS: 0.1% or 10 mV maximum; Pk-Pk: 1.0% or 50 mV maximum; bandwidth limited to 20 MHz			
Dynamic response	<2% or 100 mv with 25% load step			
Recovery time	Within 1% in <300 μs			
Overcurrent protection	Single output module and main output of the dual output module 105–120% of rated output current. Aux output of dual output module 105–140% of rated output current. Special programmable OCP delay on 1500 W module from 100 ms to 25.5 s with shutdown features. Configurable through I ² C with load calibration required (except for 1500 W module).			
Short–circuit protection	Protected for continuous short-circuit; recovery is automatic upon removal of short. Shutdown mode available on the 1500 W module.			
Overvoltage protection	Single output module: 2–5.5 V, 122–134%; 6–60 V, 110–120%; Dual output module: 2–6 V, 122–134%; 8–28 V, 110–120% Triple output module: No overvoltage protection provided; Configurable through I ² C			
Thermal protection	All outputs are disabled when the internal temperature exceeds the safe operating range; configurable through I ² C			
Remote sense	Up to 0.5 V drop (not available on triple output module)			
Single wire parallel	Current share to within 2% of total rated current			
DC OK	±5% of nominal; configurable through I ² C			
Minimum load	Not required			
Housekeeping bias voltage	5 V dc @ 1.0 A maximum present whenever ac input is applied			
Module inhibit	Configured and controlled through I ² C			
Output/output isolation	>1 MΩ, 500 V			
Global inhibit/enable	TTL, Logic “1” and Logic “0”; configurable through I ² C			
Environmental				
Operating temperature	–40°C to +70°C ambient; derate each output 2.5% per degree from 50°C to 70°C			
Storage temperature	–40°C to +85°C			
Humidity	10% to 95% RH, non-condensing			
Vibration	IEC68-2-6 to the levels of IEC721-3-2			
MTBF demonstrated	>550,000 hr. @ full load, 220 V ac, 25°C ambient			
Safety				
Electromagnetic susceptibility	EN61000-4-2, EN61000-4-4, EN61000-4-5 Level 3			
EMI filter	CISPR 22/EN55022 Level B when installed in a properly grounded and shielded metal enclosure			
Radiated EMI	CISPR 22/EN55022 Level B when installed in a properly grounded and shielded metal enclosure			
General				
Case dimensions H x W x D – in (mm)	5 x 5 x 11 (127.0 x 127.0 x 279.4)	5 x 8 x 11 (127.0 x 203.2 x 279.4)	5 x 5 x 11 (127.0 x 127.0 x 279.4)	5 x 8 x 11 (127.0 x 203.2 x 279.4)
Case weight – lbs (kg)	6.2 (2.81)	9.0 (4.08)	6.2 (2.81)	9.0 (4.08)
Slots available per case	9	14	9	14
Limited warranty	3 years			

Output Module Specification Overview

Intelligent Module Code	1	2	3	4	5		6
Module Type	Single	Single	Single	Single	Dual		Triple
Max output power ¹	210 W	360 W	750 W	1500 W	144 W		36 W
Max output current ²	35 A	60 A	150 A	140 A	10 A		2 A
Output voltages available	2-60 V	2-60 V	2-60 V	6-60 V	8-15, 24-28; 8-15, 8-15; 8-15, 2-6; 2-6, 2-6; 24-28, 24-28; 24-28, 2-6		8-15, 8-15, 2-6; 8-15, 8-15; 8-15, 8-15, 18-28; 8-15, 18-28, 2-6
Standard voltage increments	25	25	25	18	16		18
Remote sense	Yes	Yes	Yes	Yes	Yes	Yes	No
Remote margin	Yes	Yes	Yes	Yes	No	No	No
V-Program – I ² C control	Yes	Yes	Yes	Yes	Yes	Yes	No
Active current share	Yes	Yes	Yes	Yes	Yes	No	No
Module inhibit – I ² C control	Yes	Yes	Yes	Yes	Yes	Yes	Yes
Module inhibit – Analog	Yes	Yes	Yes	Yes	No	No	No
Overvoltage/Overcurrent protection	Yes	Yes	Yes	Yes	Yes	Yes	Yes
Minimum load required	No	No	No	No	No	No	No
Slots occupied in any SHP case	1	2	3	4	1		1
Weight – lbs (kg)	0.6 (0.27)	1.0 (0.45)	1.6 (0.73)	2.0 (0.91)	0.6 (0.27)		0.5 (0.23)

Non-Intelligent Module Code	1	2	3	-	5		6
Module Type	Single	Single	Single	-	Dual		Triple
Max output power	210 W	360 W	600 W	-	144 W		36 W
Max output current	35 A	60 A	120 A	-	10 A		2 A
Output voltages available	2-60 V	2-60 V	2-60 V	-	2-28 V		2-28 V
Standard voltage increments	25	25	25	-	19		18
Remote sense	Yes	Yes	Yes	-	Yes	Yes	No
Remote margin/V-Program	Yes	Yes	Yes	-	No	No	No
Module inhibit – isolated	Yes	Yes	Yes	-	-	-	-
Single wire active current share	Yes	Yes	Yes	-	Yes	No	-
Overvoltage/Overcurrent protection	Yes	Yes	Yes	-	Yes	Yes	Overcurrent
Minimum load required	No	No	No	-	Yes (10% of load)	No	No
Slots occupied in any SHP case	1	2	3	-	1		1
Weight ³ – lbs (kg)	0.6 (0.27)	1.0 (0.45)	2.0 (0.91)	-	0.6 (0.27)		0.5 (0.23)

Notes:

- 1) For dual & triple output modules: the max output power is the total amount of power for the module.
- 2) For dual & triple output modules: the max output current is the total max current for each output.
- 3) To calculate the total weight of the power supply: sum up the weight for each module and add it to the weight of the case given under the Specifications Table.

Catalog Numbering Selection

Intelligent Model

Example: 4500 W case with: a 1500 W module set at 24 V @ 62.5 A and a 750 W module set at 24 V @ 30 A connected in parallel for a total of 24 V @ 92.5 A single output.

SH45-4QS-3QS-4Z







Case Size	Module Codes	Case Options
<p>Single Phase Input SH30 = 1500 W - 3210 W, 9 Slots SH45 = 1800 W - 4500 W, 14 Slots</p> <p>Three Phase Input S3H3 = 3120 W, 9 Slots S3H5 = 4920 W, 14 Slots</p>	<p>1 = 210 W single O/P (1 slot) 2 = 360 W single O/P (2 slot) 3 = 750 W single O/P (3 slot) 4 = 1500 W single O/P (4 Slot) 5 = 144 W dual O/P (1 slot) 6 = 36 W triple O/P (1 slot) X = Extra 30mS hold-up (1 slot) ¹</p> <p>Output Voltage Codes See Output Module Voltage/Current Table for Intelligent Modules</p> <p>Module Option Codes S = Standard T = Module enable U = Constant current V = T & U combined W = Shutdown mode for 1500 W Y = T & W combined</p>	<p>Paralleling Options 0 = No Parallel Option 1-19 = See Parallel Code Table</p> <p>Special Options Z = No Options R = Reverse air N = Not used G = Global enable F = Fan Idle w/inhibit H = Opt R + Opt G I = Opt R + Opt F J = Opt G + Opt F K = Opt R + G + F C = CANBUS/RS485 (73-544-001) B = USB (73-546-001)</p>

Output Voltage/Current Table for Intelligent Modules ²

Voltage	Voltage Code	Single Output			Dual Output ³		Triple Output			PC Adjustment Ranges ⁴	
		Module Code									
		1	2	3	4	5	6	6	6		
2 V	A	35 A	60 A	150 A	-	10 A	10 A	-	-	2 A	1.8 - 2.2 V
2.2 V	B	35 A	60 A	150 A	-	10 A	10 A	-	-	2 A	2.0 - 2.4 V
3 V	C	35 A	60 A	150 A	-	10 A	10 A	-	-	2 A	2.7 - 3.3 V
3.3 V	D	35 A	60 A	150 A	-	10 A	10 A	-	-	2 A	3.0 - 3.6 V
5 V	E	35 A	60 A	150 A	-	10 A	10 A	-	-	2 A	4.5 - 5.5 V
5.2 V	F	35 A	60 A	144 A	-	10 A	10 A	-	-	2 A	4.7 - 5.7 V
5.5 V	G	34 A	58 A	136 A	-	10 A	10 A	-	-	2 A	5.0 - 6.1 V
6.0 V	H	23 A	42 A	97.5 A	140 A	10 A	10 A	-	-	2 A	5.4 - 6.6 V
8.0 V	I	20 A	36 A	84.4 A	140 A	10 A	4 A	1 A	1 A	1 A	7.2 - 8.8 V
10 V	J	18 A	32 A	75 A	140 A	10 A	4 A	1 A	1 A	1 A	9.0 - 11.0 V
11 V	K	17 A	31 A	68 A	136.3 A	10 A	4 A	1 A	1 A	1 A	9.9 - 12.1 V
12 V	L	17 A	30 A	62.5 A	125 A	10 A	4 A	1 A	1 A	1 A	10.8 - 13.2 V
14 V	M	14 A	21 A	53.5 A	107 A	9 A	4 A	1 A	1 A	1 A	12.6 - 15.4 V
15 V	N	14 A	20 A	50 A	100 A	8 A	4 A	1 A	1 A	1 A	13.5 - 16.5 V
18 V	O	11 A	19 A	41.6 A	83.3 A	-	-	-	0.5 A	0.5 A	16.2 - 19.8 V
20 V	P	10.5 A	18 A	37.5 A	75 A	-	-	-	0.5 A	0.5 A	18.0 - 22.0 V
24 V	Q	8.5 A	15 A	30 A	62.5 A	4 A	2 A	-	0.5 A	0.5 A	21.6 - 26.4 V
28 V	R	6.7 A	11 A	26.8 A	53.5 A	3 A	2 A	-	0.5 A	0.5 A	25.2 - 30.8 V
30 V	S	6.5 A	11 A	25 A	50 A	-	-	-	-	-	27.0 - 33.0 V
33 V	T	6.2 A	10.9 A	22.7 A	35.8 A	-	-	-	-	-	29.7 - 36.3 V
36 V	U	5.8 A	10 A	20.8 A	35.8 A	-	-	-	-	-	32.4 - 39.6 V
42 V	V	4.2 A	7.5 A	16 A	35.7 A	-	-	-	-	-	37.8 - 46.2 V
48 V	W	4.0 A	7.5 A	15.6 A	31.2 A	-	-	-	-	-	43.2 - 52.8 V
54 V	X	3.7 A	6.0 A	13.9 A	27.7 A	-	-	-	-	-	48.6 - 59.4 V
60 V	Y	3.5 A	6.0 A	12.5 A	25 A	-	-	-	-	-	54.0 - 66.0 V

Notes:

- 1) Certifications pending.
- 2) Increments of current not shown can be achieved by paralleling modules. See Parallel Code Table.
- 3) Total output power on dual and triple modules must not exceed the max output power rating for the module.
- 4) PC Adjustment Ranges apply to single output modules only.

SHP Series: Intelligent Modules	
Single	
 210 W	 750 W
 360 W	 1500 W
Dual	
 144 W	 36 W

Catalog Numbering Selection

Non-Intelligent Model

Example: 3210 W case with: a 36 W triple output module set at 11 V @ 1A, 24 V @ 0.5 A, 5 V @ 2 A and a 600 W module set at 24 V @ 23.5 A.

SH30-6KQE-3Q-0Z

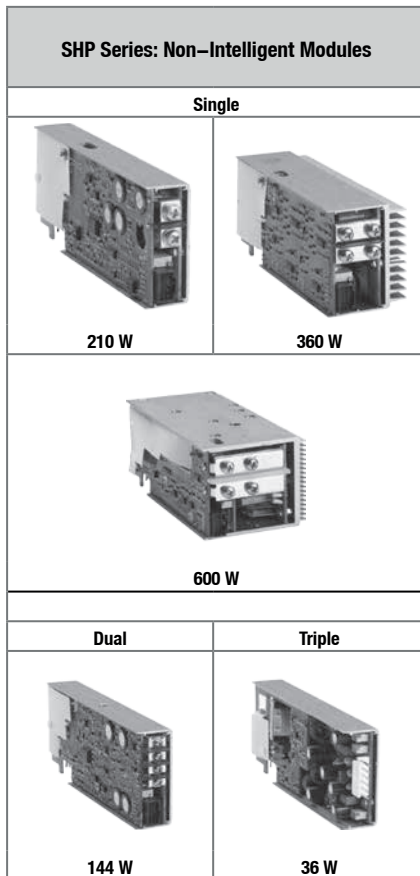
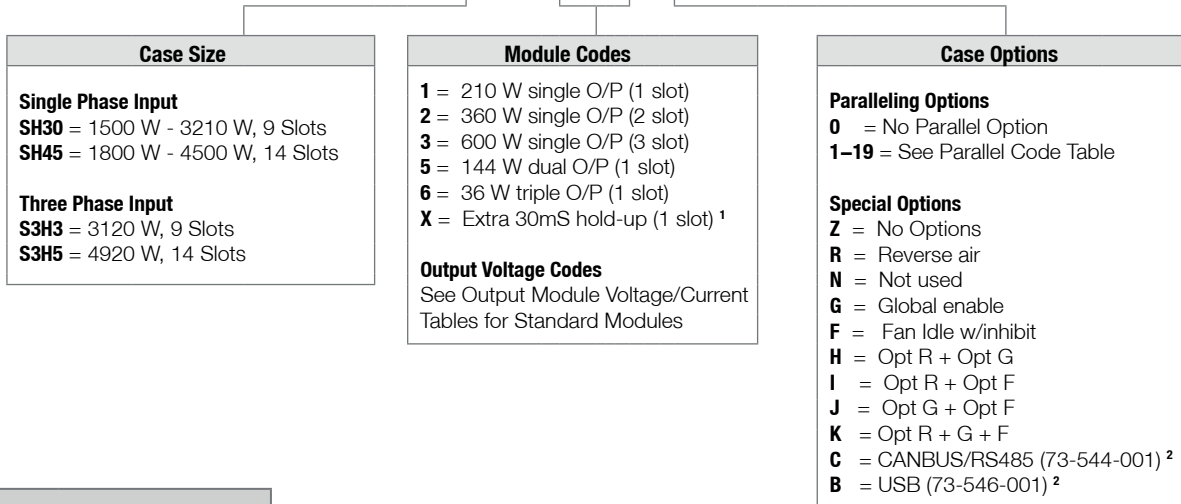

Output Voltage/Current Table for Non-Intelligent Modules ³

Voltage	Voltage Code	Single Output			Dual Output ⁴		Triple Output		
		1	2	3	5	6	6	6	
Module Code									
	Module Code	1	2	3	5	5	6	6	6
2 V	A	35 A	60 A	120 A	-	10 A	-	-	2 A
2.2 V	B	35 A	60 A	120 A	-	10 A	-	-	2 A
3 V	C	35 A	60 A	120 A	-	10 A	-	-	2 A
3.3 V	D	35 A	60 A	120 A	-	10 A	-	-	2 A
5 V	E	35 A	60 A	120 A	10 A	10 A	-	-	2 A
5.2 V	F	35 A	60 A	115 A	-	10 A	-	-	2 A
5.5 V	G	34 A	58 A	109 A	-	10 A	-	-	2 A
6.0 V	H	23 A	42 A	78 A	-	10 A	-	-	2 A
8.0 V	I	20 A	36 A	68 A	-	-	1 A	1 A	1 A
10 V	J	18 A	32 A	60 A	-	-	1 A	1 A	1 A
11 V	K	17 A	31 A	54.5 A	-	-	1 A	1 A	1 A
12 V	L	17 A	30 A	50 A	10 A	4 A	1 A	1 A	1 A
14 V	M	14 A	21 A	40.5 A	9 A	4 A	1 A	1 A	1 A
15 V	N	14 A	20 A	39 A	8 A	4 A	1 A	1 A	1 A
18 V	O	11 A	19 A	33.3 A	-	-	-	0.5 A	0.5 A
20 V	P	10.5 A	18 A	30 A	-	-	-	0.5 A	0.5 A
24 V	Q	8.5 A	15 A	23.5 A	4 A	2 A	-	0.5 A	0.5 A
28 V	R	6.7 A	12.8 A	21.4 A	3 A	2 A	-	0.5 A	0.5 A
30 V	S	6.5 A	12 A	20 A	-	-	-	-	-
33 V	T	6.2 A	10.9 A	18.2 A	-	-	-	-	-
36 V	U	5.8 A	10 A	16.6 A	-	-	-	-	-
42 V	V	4.2 A	7.5 A	12.5 A	-	-	-	-	-
48 V	W	4.0 A	7.5 A	12.5 A	-	-	-	-	-
54 V	X	3.7 A	6.0 A	11 A	-	-	-	-	-
60 V	Y	3.5 A	6.0 A	10 A	-	-	-	-	-

Notes:

- 1) Certifications pending.
- 2) Only the input parameters will have communications capabilities with these options. Non-intelligent modules do not provide communication capabilities on the output side.
- 3) Increments of current not shown can be achieved by paralleling modules. See Parallel Code Table.
- 4) Total output power on dual and triple modules must not exceed the max output power rating for the module.

Parallel Code Table

Parallel Code		SH30 & S3H3	SH45 & S3H5
Slot No.	Possible Configurations (Modules in Watts)	Slot No.	Possible Configurations (Modules in Watts)
1	1 & 2 AC 9 8 7 6 5 4 3 2 1 210-210; 210-144; 144-144	1 & 2 AC 14 13 12 11 10 9 8 7 6 5 4 3 2 1 210-210; 210-144; 144-144	
2	2 & 3 AC 9 8 7 6 5 4 3 2 1 360-360; 360-210; 360-144; + above	2 & 3 AC 14 13 12 11 10 9 8 7 6 5 4 3 2 1 360-360; 360-210; 360-144; + above	
3	3 & 4 AC 9 8 7 6 5 4 3 2 1 750-360; 750-210; 750-144; 210-210; 210-144; 144-144	3 & 4 AC 14 13 12 11 10 9 8 7 6 5 4 3 2 1 750-750; 750-360; 750-210; 750-144; 210-210; 210-144; 144-144	
4	4 & 5 AC 9 8 7 6 5 4 3 2 1 1500-210; 1500-144; 210-210; 210-144; 144-144; 360-210; 360-144	4 & 5 AC 14 13 12 11 10 9 8 7 6 5 4 3 2 1 1500-1500; 1500-750; 1500-360; 1500-210; 1500-144; 210-210; 210-144; 144-144; 360-360; 360-210; 360-144	
5	3, 4, & 5 AC 9 8 7 6 5 4 3 2 1 750-210-210; 750-210-144; 750-144-144	3, 4, & 5 AC 14 13 12 11 10 9 8 7 6 5 4 3 2 1 750-210-210; 750-210-144; 750-144-144	
6	4 & 6 AC 9 8 7 6 5 4 3 2 1 1500-1500; 1500-750	—	
7	4, 5, & 6 AC 9 8 7 6 5 4 3 2 1 1500-210-210; 1500-210-144; 1500-144-144	4, 5, & 6 AC 14 13 12 11 10 9 8 7 6 5 4 3 2 1 1500-210-210; 1500-210-144; 1500-144-144	
8	3 & 6 AC 9 8 7 6 5 4 3 2 1 750-750	4, 5, & 9 AC 14 13 12 11 10 9 8 7 6 5 4 3 2 1 1500-1500-1500; 1500-1500-750; 1500-1500-360; 1500-1500-210; 1500-1500-144	
9	1 & 6 AC 9 8 7 6 5 4 3 2 1 1500-1500; 1500-360; 1500-144	4, 5 & 9; 12 & 13 AC 14 13 12 11 10 9 8 7 6 5 4 3 2 1 1500-1500-1500-360; 1500-1500-1500-210; 1500-1500-1500-144	
10	3 & 4; 8 & 9 AC 9 8 7 6 5 4 3 2 1 750-210 & 750-210	4 & 5; 11 & 12 AC 14 13 12 11 10 9 8 7 6 5 4 3 2 1 1500-1500 & 750-750	
11	3, 4 & 6 AC 9 8 7 6 5 4 3 2 1 750-360-750	6 & 7; 3, 4, 11 & 12 AC 14 13 12 11 10 9 8 7 6 5 4 3 2 1 750, 750, 360, 750, 750	
12	3, 4, 6; 8 & 9 AC 9 8 7 6 5 4 3 2 1 750, 360, 750, 210	3, 4, 11, & 12 AC 14 13 12 11 10 9 8 7 6 5 4 3 2 1 750, 750, 750, 750	
13	7 & 8 AC 9 8 7 6 5 4 3 2 1 360-360	3 & 4; 11 & 12 AC 14 13 12 11 10 9 8 7 6 5 4 3 2 1 750-360 & 750-210; 750-750 & 750-750	
14	—	3,4 & 9 AC 14 13 12 11 10 9 8 7 6 5 4 3 2 1 750-750-750	
15	—	11 & 12 AC 14 13 12 11 10 9 8 7 6 5 4 3 2 1 750-750	
16	—	4 & 5; 9 & 10 AC 14 13 12 11 10 9 8 7 6 5 4 3 2 1 1500-210 & 210-1500	
17	—	1 & 9; 5 & 12 AC 14 13 12 11 10 9 8 7 6 5 4 3 2 1 1500-750 & 1500-750	
18	—	3 & 4; 7 & 8; 9 & 10 AC 14 13 12 11 10 9 8 7 6 5 4 3 2 1 750-210 & 750-210 & 210-1500	
19	—	3, 4 & 9; 6 & 7 AC 14 13 12 11 10 9 8 7 6 5 4 3 2 1 750, 750, 360, 750	

Connector Tables

Table 1: AC Input			
PIN #	FUNCTION		FUNCTION
	SH30 & SH45	S3H3 & S3H5	
1	AC neutral (DC -)	L1	L1
2	AC line (DC +)	L2	L2
3	Chassis (earth) ground	L3	L3
4	—	Chassis (earth) ground	⊕

BARRIER TYPE
 SH30: THREE #6-32 BH SCREWS, 6 in.-lbs. (0.67 N-m) TORQUE
 SH45: THREE M4 SCREWS, 7 in.-lbs. (0.79 N-m) TORQUE
 S3H3: FOUR M3 SCREWS, 6 in.-lbs. (0.67 N-m) TORQUE
 S3H5: THREE M3.5 SCREWS, 6 in.-lbs. (0.67 N-m) TORQUE

Table 2: PFC Input Connector (Control & Signals)		
PIN #	FUNCTION	
1	Input ac OK (emitter)	
2	Input ac OK (collector)	
3	Global dc OK (emitter)	
4	Global dc OK (collector)	
5	No connection	
6	Global inhibit/optional enable logic "0"	
7	Global inhibit/optional enable logic "1"	
8	Global inhibit/optional enable return	
9	+5 VSB housekeeping (1A max)	
10	+5 VSB housekeeping return	

MATES WITH:
 MOLEX 90142-0010 HOUSING
 MOLEX 90119-2110 TERMINAL
CONNECTOR KIT P/N 70-841-004

Table 3: I ² C Bus Output Connector		
PIN #	FUNCTION	
1	No connection	
2	No connection	
3	No connection	
4	Serial clock signal (SCL)	
5	Serial data signal (SDA)	
6	Address bit 0 (A0)	
7	Address bit 1 (A1)	
8	Address bit 2 (A2)	
9	Secondary return (GND)	
10	5 Vcc external bus (1A max)	

MATES WITH:
 JST PHDR-10 VS HOUSING
 JST SPHD-002T-P0.5 TERMINAL (FOR 24-28 AWG WIRE)
 JST SPHD-001T-P0.5 TERMINAL (FOR 24-28 AWG WIRE) OR
 LAND WIN 2050S1000 HOUSING
 LAND WIN 2053T011P TERMINAL
CONNECTOR KIT P/N 70-841-023

Table 4: DC Output Connector (Located on output modules)		
PIN #	FUNCTION	
1	+ Remote sense (single or dual o/p main)	
2	Remote margin/V. program (single o/p)	
3	Margin high (single o/p)	
4	- Remote sense/margin low (single or dual o/p main)	
5	Spare	
6	Module isolated inhibit (single or dual o/p)	
7	Module inhibit return (single or dual o/p)	
8	Current share (SWP) (single or dual o/p main)	
9	+ Remote sense V2 (dual o/p, single is spare)	
10	- Remote sense V2 (dual o/p, single is spare)	

MATES WITH:
 MOLEX 90142-0010 HOUSING
 MOLEX 90119-2110 TERMINAL
CONNECTOR KIT P/N 70-841-004

Notes:

Output Module Connections: M4 x 8 mm screws for all single output modules; maximum torque is 10 in.-lb. (1.13 N-m).

M3 x 8 mm screws for dual output module; maximum torque is 5 in.-lb. (0.57 N-m).

36 W triple output module connector mates with Molex 09-91-0600 housing and Molex 26-60-5060 terminals.

Case Specifications

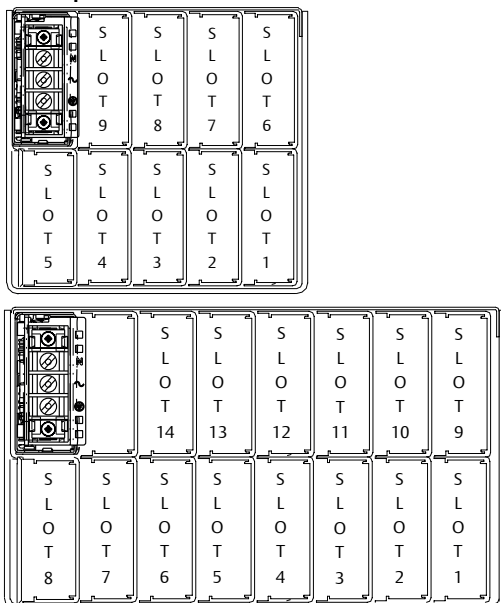

Case Dimensions	Input	
SH30 = 5" x 5" x 11" (127 x 127 x 279.4 mm) 9 available slots, Single phase	90-264 Vac 1500 W max.	170-264 Vac 3210 W max.
S3H3 = 5" x 5" x 11" (127 x 127 x 279.4 mm) 9 available slots, Three phase	N/A	170-264 Vac 3210 W max.
SH45 = 5" x 8" x 11" (127 x 203.2 x 279.4 mm) 14 available slots, Single phase	90-264 Vac 1800 W max.	170-264 Vac 4500 W max.
S3H5 = 5" x 8" x 11" (127 x 203.2 x 279.4 mm) 14 available slots, Three phase	N/A	170-264 Vac 4920 W max.

SH30 and S3H3 Dimensional Drawings – in. (mm)

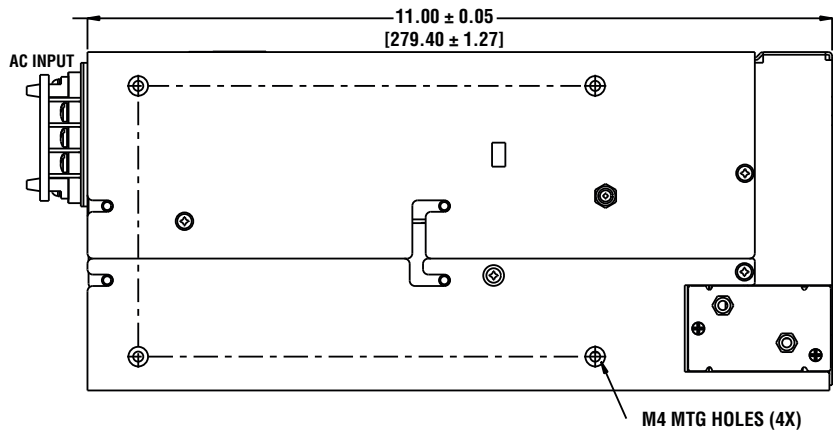
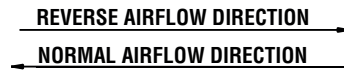
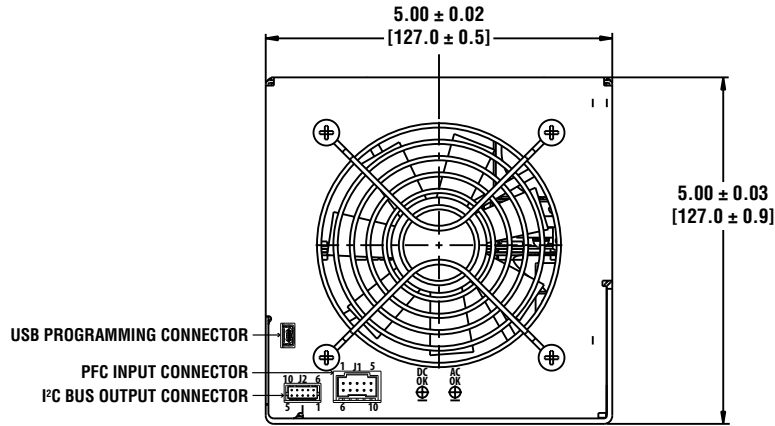

Notes:

1. See Connectors Table 1 for screw types.
2. Chassis material: aluminum with chemical film coating (conductive).
3. All dimensions are in millimeters and inches, and are typical.
4. Customer mounting - 3 sides M4, bottom also includes 8-32 mounting holes. Max. penetration is 0.155" (4.0 mm). Max. torque: 5in-lbs. (0.57 N-m).

SH45 and S3H5 Dimensional Drawings – in. (mm)

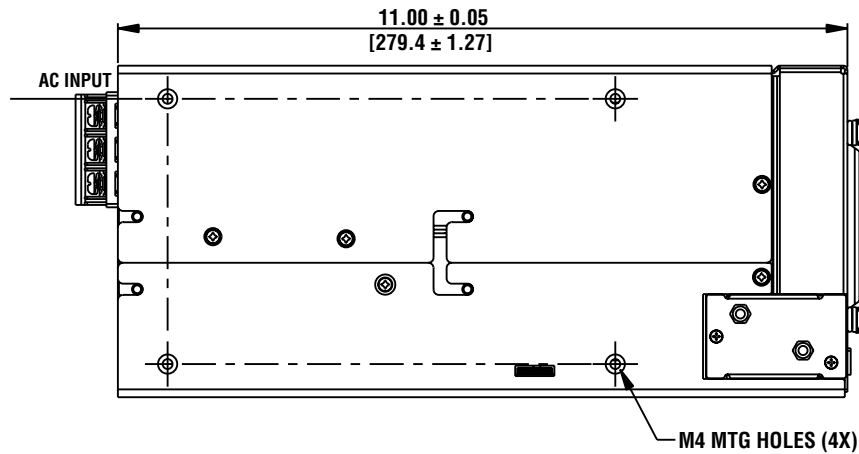
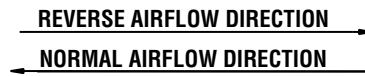
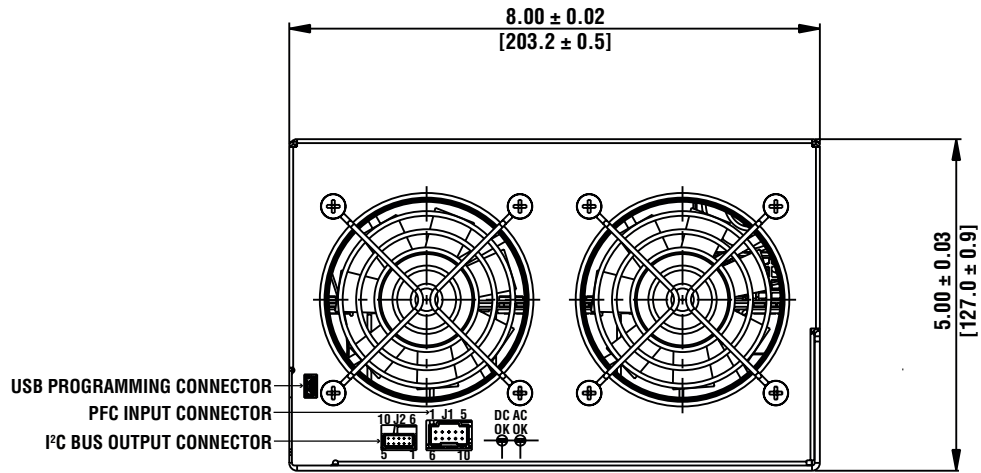

Notes:

1. See Connectors Table 1 for screw types.
2. Chassis material: aluminum with chemical film coating (conductive).
3. All dimensions are in millimeters and inches, and are typical.
4. Customer mounting - 3 sides M4, bottom also includes 8-32 mounting holes. Max. penetration is 0.155" (4.0 mm). Max. torque: 5 in-lbs. (0.57 N-m).

Intelligent Modules Dimensional Drawings – in. (mm)

Single 210 Watt

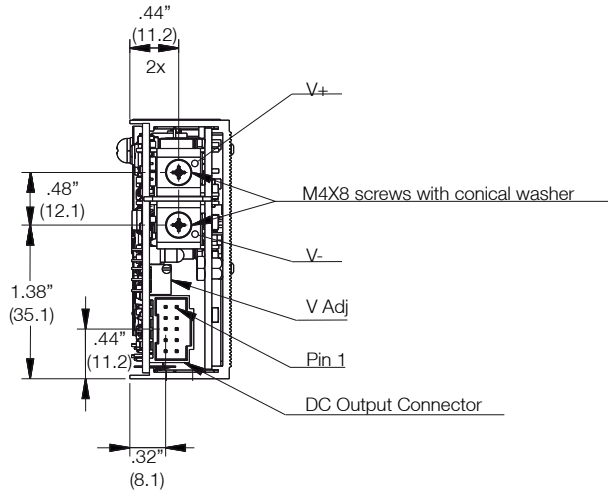

Single 360 Watt

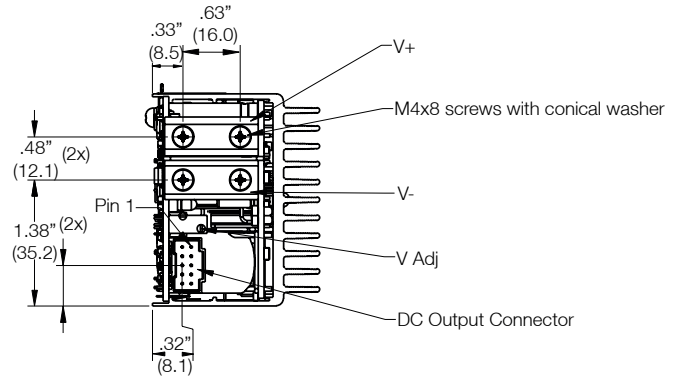

Single 750 Watt

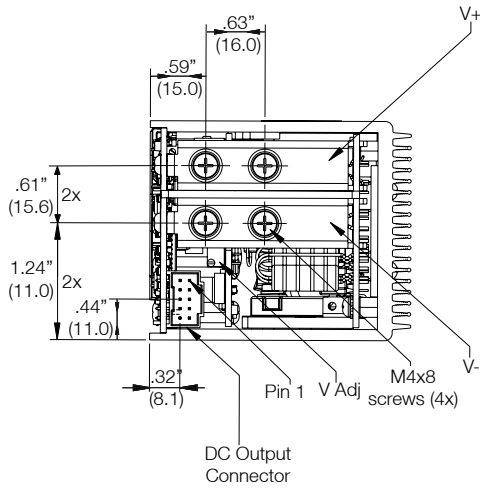

Single 1500 Watt

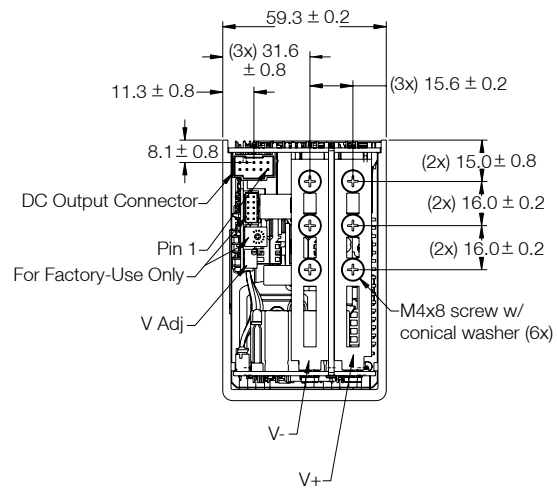

Dual 144 Watt

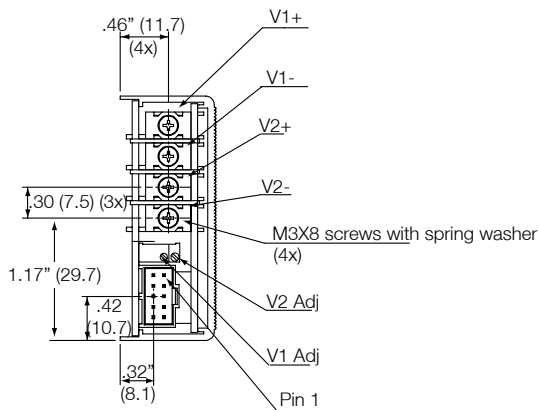

Triple 36 Watt

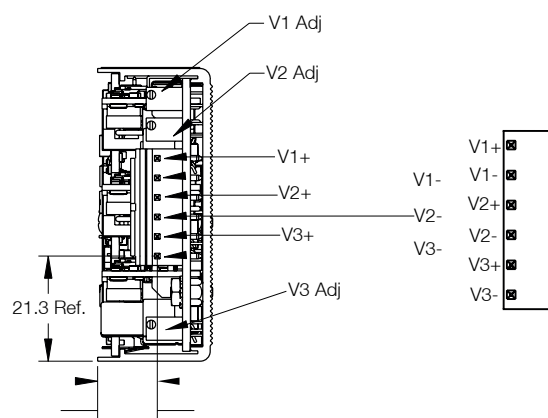

- Notes:
1. Output Module Connections: All single O/P modules are M4 x 8 mm screws. Maximum torque: 10 in.-lbs. (1.13 N-m).
Dual O/P module is M3 x 8 mm screws. Maximum torque: 5 in.-lbs. (0.57 N-m).
 2. All output modules have a green DC OK LED, (except for 36 W module).
 3. See Connectors Table 4 for mating connector kits.

Non-Intelligent Modules Dimensional Drawings – in. (mm)

Single 210 Watt

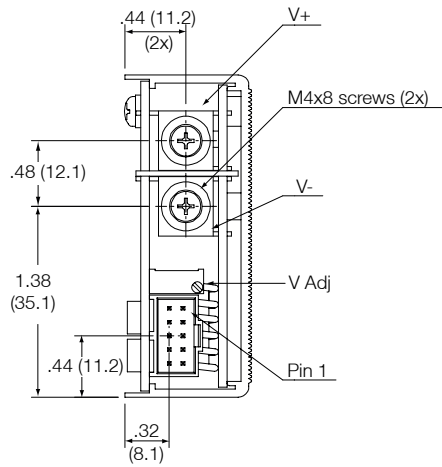

Single 360 Watt

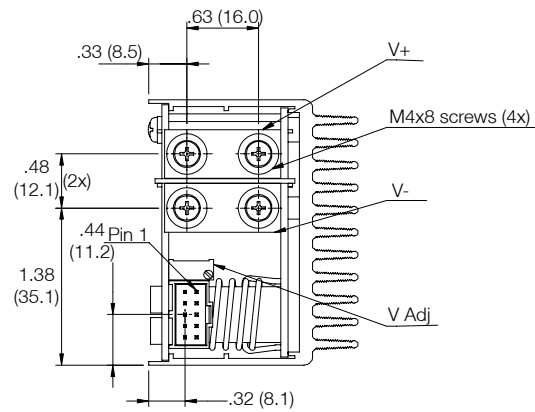

Notes:

1. Output Module Connections: All single O/P modules are M4 x 8 mm screws. Maximum torque: 10 in.-lbs. (1.13 N-m).
Dual O/P module is M3 x 8 mm screws. Maximum torque: 5 in.-lbs. (0.57 N-m).
2. All output modules have a green DC OK LED, (except for 36 W module).
3. See Connectors Table 4 for mating connector kits.

Non-Intelligent Modules Dimensional Drawings – in. (mm)

Single 600 Watt

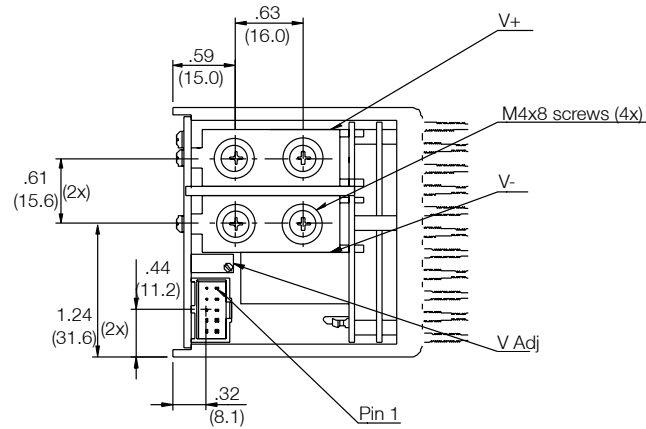

Dual 144 Watt

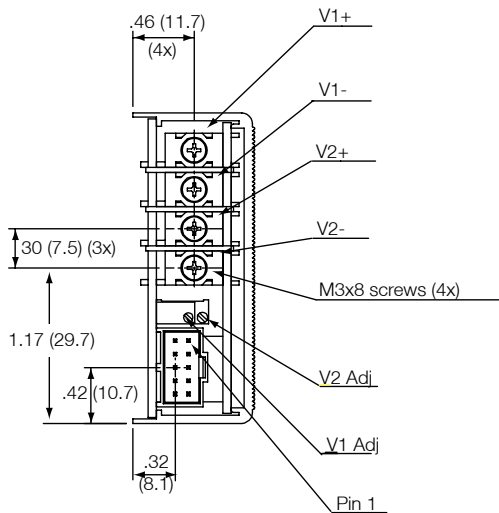

Triple 36 Watt

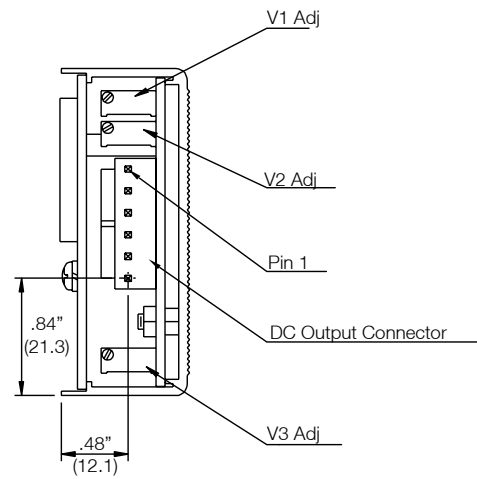

☒	V1+
☒	V1-
☒	V2+
☒	V2-
☒	V3+
☒	V3-

Notes:

1. Output Module Connections: All single O/P modules are M4 x 8 mm screws. Maximum torque: 10 in.-lbs. (1.13 N-m).
Dual O/P module is M3 x 8 mm screws. Maximum torque: 5 in.-lbs. (0.57 N-m).
2. All output modules have a green DC OK LED, (except for 36 W module).
3. See Connectors Table 4 for mating connector kits.

Silver Line Series – Single & Multi-Output Linears

The SolaHD Silver Line Series follows the industry accepted footprint for open frame, linear power supplies. Standard screw terminal connections and optional covers are offered for safety considerations.

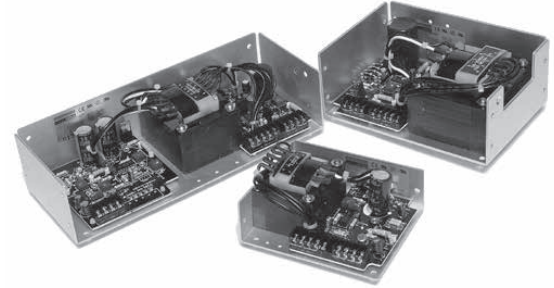

Applications

- Industrial Control Circuits and Components
- Instrumentation
- Drives
- CNC Machinery
- Equipment for food industry
- Microprocessor Circuits
- Analog Circuits
- Noise sensitive Circuitry and Sensors

Features

- Easy-to-install screw terminal connections
- Cover options
- Industry standard footprint
- Universal input and approvals (115/230 Vac)
- Low noise, extremely quiet DC output. For noise sensitive or analog circuitry.
- Fast transient response. Ideal for test applications.
- Built-in OVP on 5 V models and optional on 12, 15 and 24 V models
- Automatic resetting overload protection
- Short circuit protected
- Two year limited warranty

Certifications and Compliances

-  Recognized Component, ITE
 - UL 60950-1
-  Certified, ITE
 - CSA C22.2 CSA 60950-1
- 
 - IEC60950-1
- RoHS Compliant

Specifications

Parameter	Condition	Limit
Input		
Input Voltage		100/120/220/230/240 Vac Selectable
Input Frequency		47-63 Hz
Output		
Line Regulation	for 10% change	0.05%
Load Regulation	for 50% change	0.05%
Ripple		3.0 mV maximum Peak-to-Peak
DC Output Adjustment Range		±5% Minimum
Overvoltage Protection		All 5-Volt outputs include build-in OVP as standard (setting is 6.2 V ±0.4 V) OVP is optionally available on other types
Transient Response Time	at 50% Load Changes	50 msec.
Overload Protection		Automatic current limit foldback
Remote Sensing	Available to compensate for output voltage drop on selected models.	0.5 Vdc
General		
Operating Temperature Range	Derate to 40% at +70°C	0 to +50°C
Storage Temperature Range		-25°C to +85°C
Temperature Coefficient (Typical)		0.01% 0°C
Stability	After warm-up	±.5%
EMI/RFI	Linear power supplies have inherently low conducted and radiate noise levels	For most system applications they will meet requirements of FCC Class B and VDE 0871 for Class B
Cover Option	Derate power by an additional 15%	
Cooling	Forced air. 20 CFM required for full rating Derate 30% without cooling	

Specifications are typical. Load Regulation on outputs without Remote Sense, .1% typical.

SL Series Selection Table

Catalog Number	Output 1	Output 2	Output 3	Case
SLS-05-030-1T	5 V @ 3 A *2	-	-	A
SLS-05-060-1T	5 V @ 6 A *2	-	-	B1
SLS-05-090-1T	5 V @ 9 A *2	-	-	C
SLS-05-120-1T	5 V @ 12 A *2	-	-	I2
SLS-12-017T 1	12 V @ 1.7 A 2 or 15 V @ 1.5 A	-	-	A
SLS-12-034T	12 V @ 3.4 A 2	-	-	B1
SLS-12-051T	12 V @ 5.1 A 2	-	-	C
SLS-12-068T	12 V @ 6.8 A 2	-	-	I2
SLS-15-045T	15 V @ 4.5 A 2	-	-	C
SLS-15-060T	15 V @ 6 A 2	-	-	I2
SLS-24-012T	24 V @ 1.2 A v	-	-	A
SLS-24-024T	24 V @ 2.4 A 2	-	-	B2
SLS-24-036T	24 V @ 3.6 A 2	-	-	C
SLS-24-048T	24 V @ 4.8 A 2	-	-	I2
SLS-24-072T	24 V @ 7.2 A 2	-	-	K
SLS-24-120T	24 V @ 12.0 A 2	-	-	L
SLD-12-1010-12T 1	12 V @ 1 A or 15 V @ .8 A	-12 V @ 1 A or -15 V @ .8	-	H1
SLD-12-1818-12T 1	12 V @ 1.8 A or 15 V @ 1.5 A	-12 V @ 1.8 A or -15 V @ 1.5 A	-	D
SLD-12-3434-12T	12 V @ 3.4 A 2	-12 V @ 3.4 A 2	-	I3
SLD-15-3030-15T	15 V @ 3 A 2	-15 V @ 3 A 2	-	I3
SLD-12-6034-05T	5 V @ 6 A *2	12 V @ 3.4 A 2	-	I1
SLD-12-3015-05T	5 V @ 3 A *2	12 V @ 1.5 A	-	C1
SLT 12-20404-12T 1	5 V @ 2 A *2	12 V @ .4 A or 15 V @ .4 A	-12 V @ .4 A or -15 V @ .4 A	H2
SLT 12-31010-12T 1	5 V @ 3 A *2	12 V @ 1 A 2 or 15 V @ .8 A	-12 V @ 1 A 2 or -15 V @ .8 A	F
SLT 12-61818-12T 1	5 V @ 6 A *2	12 V @ 1.8 A or 15 V @ 1.5 A	-12 V @ 1.8 A or -15 V @ 1.5 A	G2
Over Voltage Protector (OVP)				
SLO-12-000-1	6.2 V to 34 V Adjustable @ 8 A	For Cases B through K		J1
SLO-12-000-TB	6.2 V to 34 V Adjustable @ 8 A	For Case A or Cases B through K (when used with a cover)		J2

Notes:

* With Built-In OVP

1. 12/15 Volt models are factory set for 12 Volt operation. 15 Volt operation is field adjustable.

2. With Remote Sense (R.S.)

Dimensions - inches (mm)

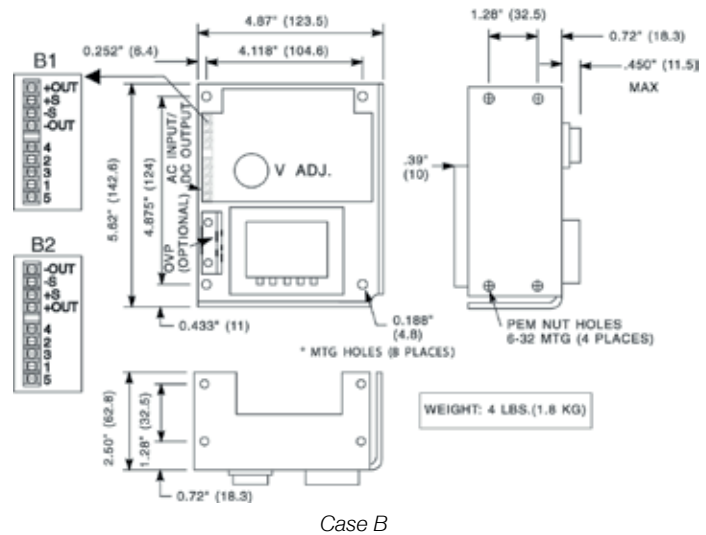
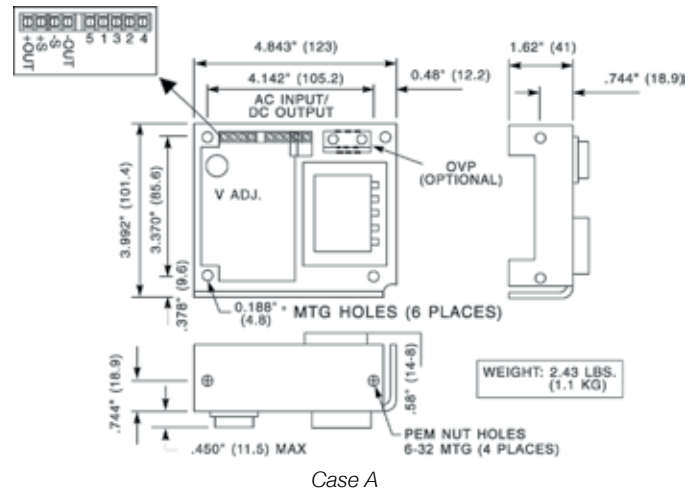

Cover Options

Catalog Number	Description	Catalog Number	Description
SLCASA-CVR	Cover for Case A	SLCASI-CVR	Cover for Cases I1, I2, & I3
SLCASB-CVR	Cover for Case B	SLCASK-CVR	Cover for Case K
SLCASC-CVR	Cover for Case C	SLCASL-CVR	Cover for Case L

Note:

Covers are sold separately. When used, derate the power supply by 15% of its rated value.

Silver Line Dimensions (inches/mm)

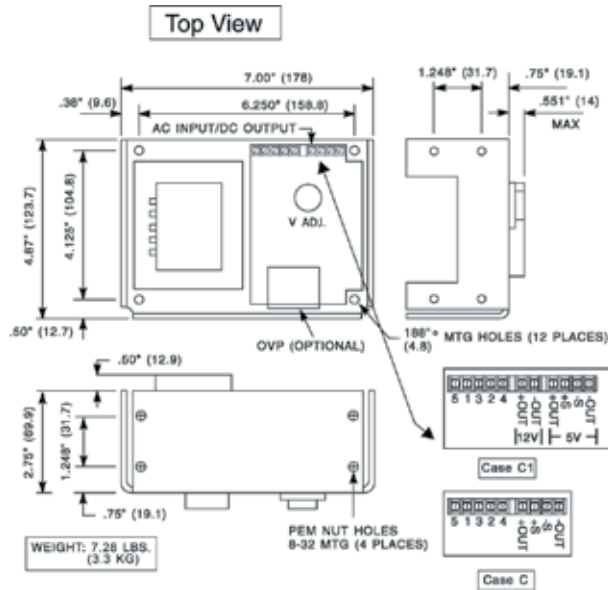

Cases C and C1

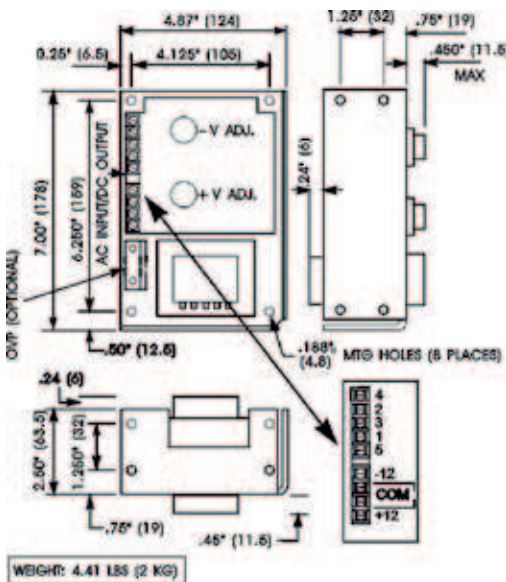

Case D

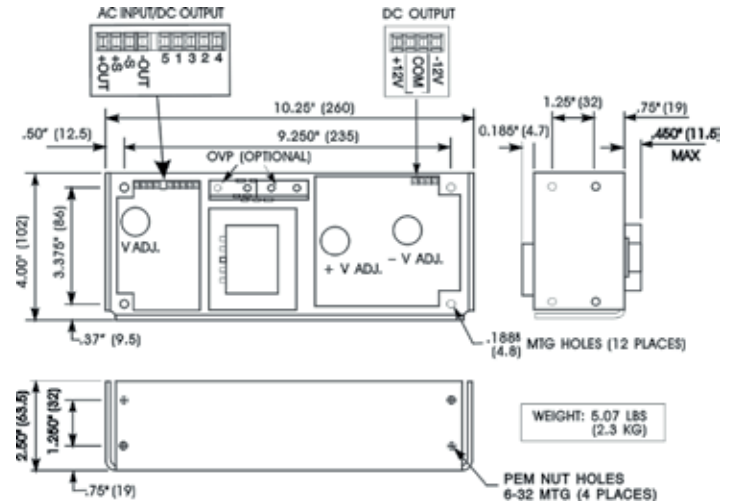

Case F

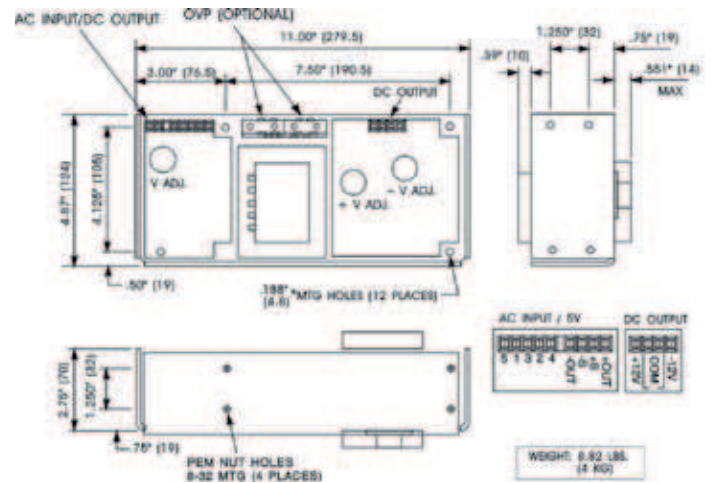

Case G2

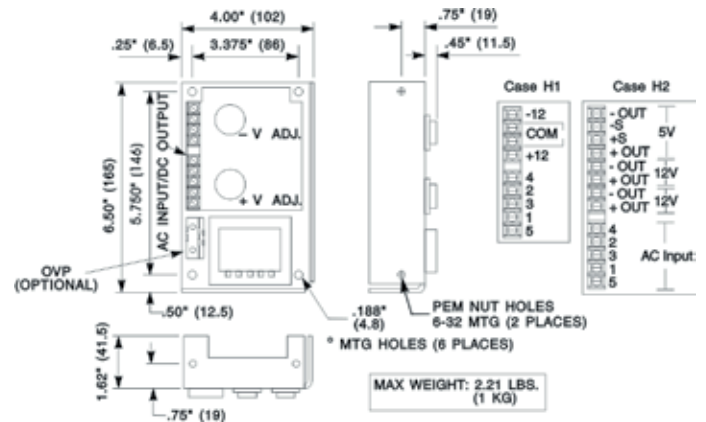

Cases H1 and H2

AC Input Jumper Connections

For use at:	100 Vac	120 Vac	220 Vac	230/240 Vac
Connect:	1-3, 2-4	1-3, 2-4	2-3	2-3
Apply AC:	1 & 5	1 & 4	1 & 5	1 & 4

Silver Line Dimensions (inches/mm)

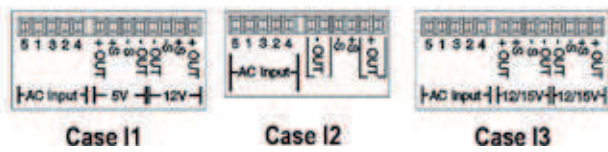
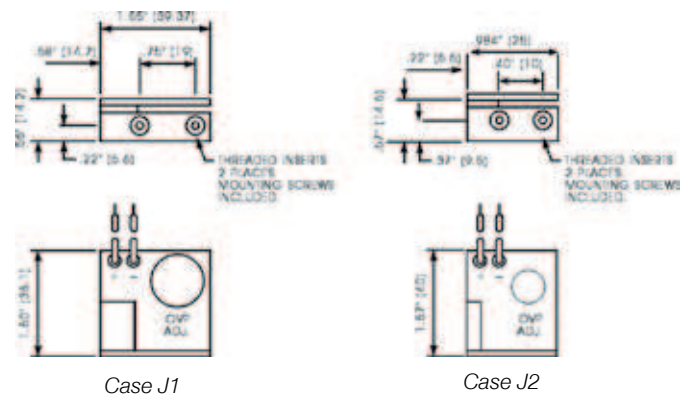
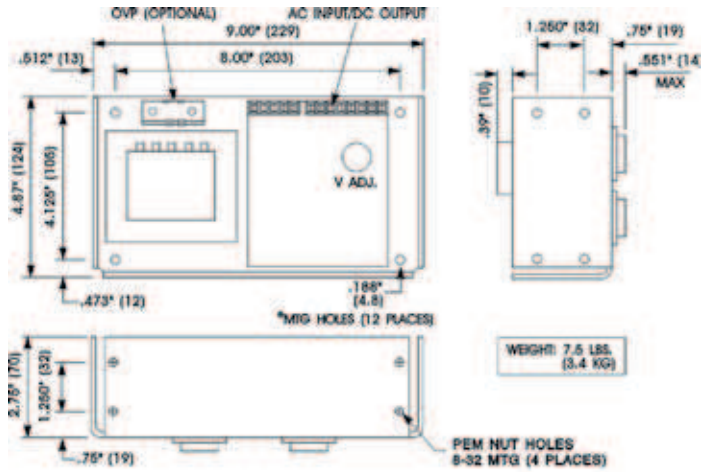

Cases I1, I2 and I3

Notes:

All dimensions in inches (mm). Dimensions may change and should not be used for construction purposes.

Be sure to specify the complete part number when ordering. Orders may be placed with your local Solahd distributor.

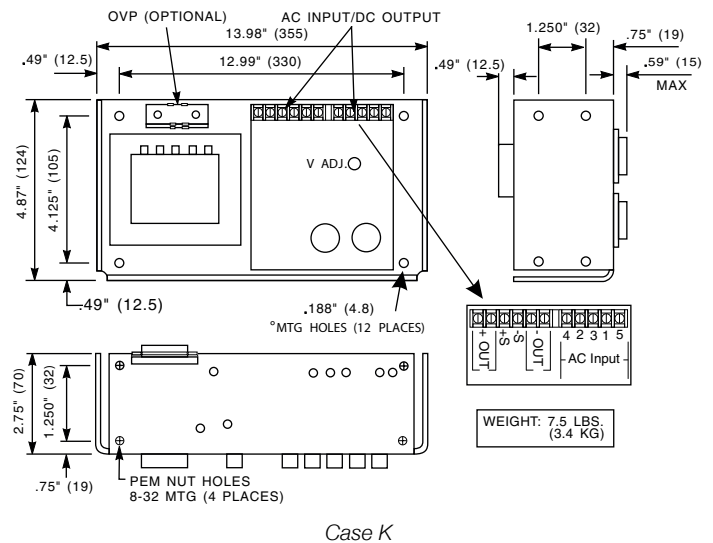

Case K

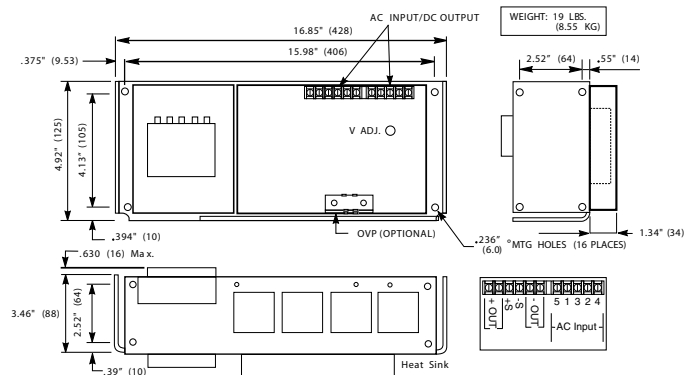

Case L

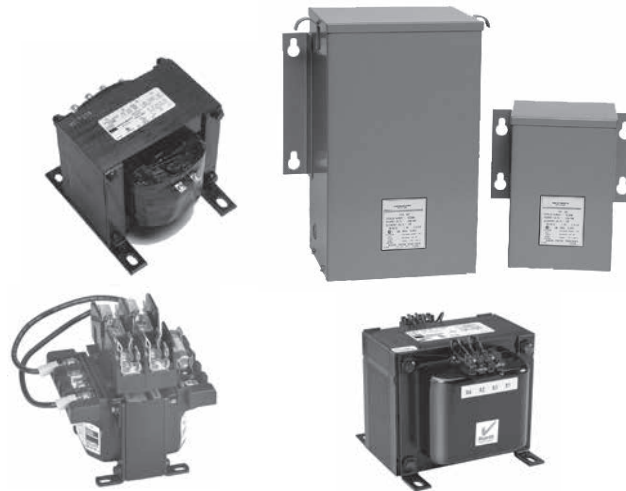

Industrial Control Transformer Overview

Industrial Control Transformer Overview 170
 Industrial Control Transformer Selection Tables 172

Industrial Control Transformers

SBE Encapsulated, 55C rise, copper wound,
 50 – 1000 VA 173
 SBE Open Style, 55C rise, copper wound,
 1500 – 5000 VA..... 178
 SMT Open Style, 115C rise, aluminum wound,
 1000 – 5000 VA..... 179
 SBE International Encapsulated, 55C rise, copper wound,
 50 – 750 VA..... 180
 ICE International Encapsulated, 80C rise, copper wound,
 750 – 2000 VA..... 183
 HSZ Enclosed (NEMA 3R, 4, 12), 80C rise, copper wound,
 1 – 10 kVA 185

Other

Fuse Recommendation 188

Design Choices

Emerson offers a broad range of SolaHD industrial control solutions for the most demanding industrial applications. Our products exceed NEMA ratings for inrush and regulation to ensure control systems are powered correctly. Electromagnetic control components demand inrush currents up to 10 times the transformer's nominal rating. While this inrush is occurring, the output side of the transformer must not fall below 85% of nominal as specified by NEMA ST-1, Part 4. Using a transformer that does not meet these ratings may cause erroneous shutdowns of downstream processes.

To meet your complete control needs, our four SolaHD Series of control transformers, exceed the NEMA standards. The Selection Chart can be used to identify the appropriate transformer for your application.

The **SBE Series** is available from 50 - 5000 VA, 55°C rise and features copper windings and encapsulation (through 1000 VA) for longer life and protection from the environment. This low temperature performance can mean smaller cabinet size or longer life for any electronic components that may be nearby.

The **SMT Series** are 115°C rise and aluminum wound for applications where good voltage regulation and higher power capacities (1000-5000 VA) are required.

The **ICE International Series** meets IEC requirements and IP20 (touch proof covers ordered separately for E models) for European applications.

The **HSZ Series** rounds out our line with an enclosed series of control transformers from 1 - 10 kVA that feature either a UL Listed Type 3R, 4, 4X or 12 enclosure. This unique design, featuring copper windings and encapsulated construction, can help system designers meet harsher environmental standards or design for a safer installation outside of a control cabinet. The HSZ Series is for applications where cost or heat issues make mounting the transformer outside the control panel necessary.

Emerson is pleased to offer SolaHD custom transformers 1 kVA and larger. If you can't find what you are looking for here, we are happy to provide a quote on a custom transformer if available. Contact your local sales representative for more information.

Sizing an Industrial Control Transformer

For proper transformer selection, three characteristics of the load circuit must be determined in addition to the minimum voltage required to operate the circuit. These are total steady state (sealed) VA, total inrush VA, and inrush load power factor.

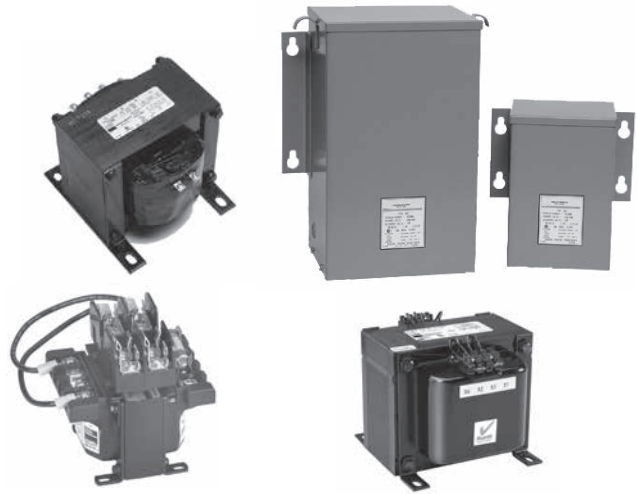

- A. Sealed VA** – Total steady state sealed VA is the Volt-Amperes that the transformer must deliver to the load circuit for an extended period of time.
- B. Inrush VA** – Total inrush VA is the Volt-Amperes that the transformer must deliver upon initial energization of the control circuit. Energization of electromagnetic devices takes 30-50 milliseconds. During this inrush period the electromagnetic control devices draw many times normal current – 3-10 times normal is typical.
- C. Inrush Load Power Factor** is difficult to determine without detailed vector analysis of all the load components. Generally such an analysis is not feasible, therefore, a safe assumption is 40% power factor (PF). Until recently 20% PF was commonly used for transformer calculations, however, tests conducted on major brands of control devices indicate that 40% PF is a safer default assumption.

Selection Steps

1. Determine the Supply and Load Voltages. The Supply Voltage is the available voltage to the control transformer. The Load Voltage is the operating voltage of the devices that will be connected to the transformer output.
2. Calculate the total sealed VA by adding the VA requirements of all components that will be energized together (timers, contactors, relays, solenoids, pilot lamps, etc.). Sealed VA data is available from the control device manufacturer.
3. Add the inrush VA of all components that will be energized together. Be sure to include the sealed VA of components that do not have an inrush, (lamps, timers, etc.) as they present a load to the transformer during maximum inrush.

4. Calculate selection inrush VA in one of the following two ways:

A. Selection inrush VA =

$$\sqrt{(VA \text{ sealed})^2 + (VA \text{ inrush})^2}$$

Alternative Method

B. VA sealed + VA inrush = Selection inrush

Method B will result in a slightly oversized transformer.

5. If your line voltage varies 10% or more, contact Technical Services for assistance.
6. Utilizing the regulation data chart below, select the transformer VA needed for your application from the "Transformer VA Rating" column. Check to be sure that the nameplate VA rating exceeds the sealed VA of the control circuit calculated in Step 1. If it does not, select a larger transformer VA that exceeds the circuit sealed VA.

By following the above procedure, the secondary voltage delivered by the transformer will be 90% of the nameplate secondary voltage under maximum inrush conditions at rated input voltage.

Now refer to the selection tables on the following pages for the style you have chosen. Select your transformer according to your required voltage and VA capacity.

Regulation Data – Inrush VA at 20% and 40% Power Factor

Selection Inrush VA ¹				Transformer VA Rating
Type SBE		Type SMT		
20% PF ²	40% PF ²	20% PF ²	40% PF ²	
294	207	N/A	N/A	50
515	363	N/A	N/A	75
696	490	N/A	N/A	100
1362	959	N/A	N/A	150
2131	1501	N/A	N/A	200
2883	2031	N/A	N/A	250
3608	2541	N/A	N/A	300
4777	3364	N/A	N/A	350
7601	5353	N/A	N/A	500
12939	9112	N/A	N/A	750
18703	13171	8277	5829	1000
23814	16066	17182	12100	1500
34586	24356	22834	16080	2000
45633	32770	34506	24300	3000
158000	111000	71284	50200	5000

¹ Assuming the transformer is to deliver a minimum of 90% secondary voltage during inrush conditions.

² See C. Inrush Load Power Factor on page previous page.

Chart A: Voltage Code Chart

Voltage Code	Primary Voltage	Secondary Voltage	Hertz
None	240 x 480	120	60
	230 x 460	115	50/60
	220 x 440	110	50/60
A	240/480/600	120/99	50/60
	230/460/575	115/95	
D	240 x 480	24	60
E	120 x 240	24	60
JL	208/240/277	120/24	60
JN	208/240/480/600	120/24	60
	200/230/460/575	115/23	
R	480	240	50/60
TC	208/240/—	120/ — /24	60
	200/230/400	115/24/23	50/60
	—/220/380	110/23/ —	50/60
TE	208/240/—	24	60
	—/277/480	24	60
	200/230/400	24	50/60
—/220/380	23	50/60	
TF	208/240/—/480/*600	120	60
	200/230/400/460/*575	115	50/60
	220/*277/380	110	50/60
TH	240/—/480	120/240	60
	230/400/460	115/230	50/60
	220/380/440	110/220	50/60
MH	208/240/—/480/600	120/240	60
	200/230/400/460/575	115/230	50/60
	—/220/380/440/550	110/220	50/60
MC	208/240/—/480/600	120/ — /24	60
	200/230/400/460/575	115/24/23	50/60
	—/220/380/440/550	110/23/ —	50/60

Note: "—" indicated tap not used.

* 60 Hz only at 277, 575 or 600 V.

Choosing the Correct Series

The **SBE Series** of industrial control transformers provide voltage regulation which exceeds NEMA standards. They have a 55°C rise and have copper windings and are 50/60 Hz rated. The SBE series can handle significant inrush with a minimal drop in output voltage.

The **SMT Series** are 115°C rise and aluminum wound for applications where good voltage regulation and higher power capacities are required.

The **ICE International Series** have multiple voltage taps for easy application. These units also meet IEC 61558-1, 61558-2-2 and are CE marked for easy export to European countries.

The **HSZ Series** is for applications where cost or heat issues make mounting the transformer outside the control panel necessary. This Series has 80°C rise and has copper winding for industrial applications. These units are enclosed with UL Listed/NEMA Type 3R enclosures. Also available in UL Listed/NEMA Type 4, 4X and 12.

Selection Chart

VA	SBE ENCAPSULATED					SBE OPEN (SZO)	SMT OPEN	HSZ * TYPE 3R		
	--	D	E	JL	JN	--	--	--	A	R
Temp	55°C						115°C	80°C		
50	E050	E050D	E050E	E050JL	E050JN					
75	E075		E075E							
100	E100	E100D	E100E	E100JL	E100JN					
150	E150		E150E		E150JN					
200	E200		E200E							
250	E250	E250D	E250E	E250JL	E250JN					
300	E300		E300E							
350	E350		E350E							
500	E500	E500D	E500E	E500JL	E500JN					
750	E750		E750E							
1000	E1000						T1000	HZ1000	HZ1000A	HZ1000R
1500						Y1500	T1500	HZ1500	HZ1500A	HZ1500R
2000						Y2000	T2000	HZ2000	HZ2000A	HZ2000R
3000						Y3000	T3000	HZ3000	HZ3000A	HZ3000R
5000						Y5000	T5000	HZ5000	HZ5000A	HZ5000R
7500								HZ75000	HZ75000A	HZ75000R
10000								HZ10000	HZ10000A	HZ10000R

* Change HZxxxx to HZ12xxxx for Type 12 or 4 applications or HZ4Xxxxx for Type 4X applications.

Selection Chart - International Series

VA	INTERNATIONAL SBE SERIES ENCAPSULATED				INTERNATIONAL SFP SERIES ENCAPSULATED		
	TC	TE	TF	TH	TH	MH	MC
Temp	55°C				80°C		
50	E050TC	E050TE	E050TF	E050TH			
100	E100TC	E100TE	E100TF	E100TH			
150	E150TC	E150TE	E150TF	E150TH			
250	E250TC	E250TE	E250TF	E250TH			
500	E500TC	E500TE	E500TF	E500TH			
750			E750TF	E750TH			CE750MC
1000					CE1000TH	CE1000MH	CE1000MC
1500					CE1500TH	CE1500MH	CE1500MC
2000					CE2000TH	CE2000MH	

The SBE - Encapsulated, Copper Wound Series

The SolahD SBE Encapsulated industrial control transformers are epoxy encapsulated to seal the transformer windings against moisture, dirt and industrial contaminants. Extra deep, molded terminal barriers reduce the chance of electrical failure as the result of arcing or frayed lead wires. The rugged construction and proven reliability of the SBE design is uniquely suited for all industrial environments.



Features

- 50 - 1000 VA, 50/60 Hz – suitable for worldwide applications
- Interleaved copper windings reduce I²R losses and maximize efficiency
- 55°C Rise, 105°C insulation system to minimize heat
- Epoxy encapsulated to protect cores and coils against moisture, dirt, and other contaminants
- Meets or exceeds NEMA Standard ST-1 and ANSI C89.1 for load inrush capability
- Integrally molded, flame retardant (IEC 707/ISO Class I210) Terminal Blocks provide greater terminal contact area and improved conductivity
- Heavy gauge steel mounting plate
- Mounting dimensions are compatible with similar control transformers
- Secondary fuse holders (FB2X) included for 13/32 x 1 1/2 cartridges (fuses not included)
- Factory-installed fuse holders are available (See W, WA & WB options)
- Ten year limited warranty



Mounting Profiles

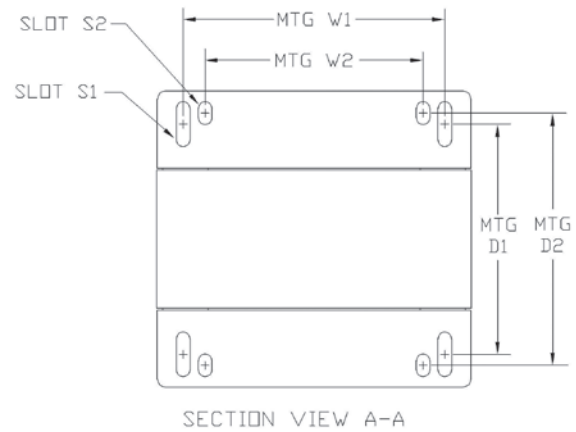

Certifications and Compliances

- Listed: E77014 - Type SBE
 - UL 5085-1, UL 5085-2
 - CSA C22.2 No. 66.1, No. 66.2
- RoHS Compliant

Related Products

- Linear Power Supplies
- DIN Rail DC Power Supplies
- Constant Voltage Transformers
- See SBE Accessories

Design Style

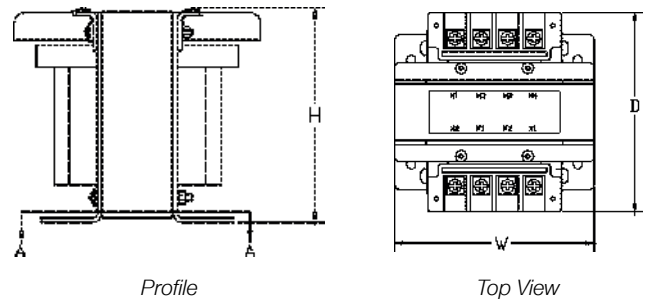

SBE Encapsulated Series Selection Tables

Group 1 – 120 x 240 Volt Primary, 24 Volt Secondary, 60 Hz

VA	Catalog Number	Height in (mm)	Width in (mm)	Depth in (mm)	Mtg Width W1 / W2 – in (mm)	Mtg Depth D1 / D2 – in (mm)	Slot Size S1 / S2 – in (mm)	Approx. Ship Weight lbs (kg)
50	E050E	2.72 (69.1)	3.01 (76.5)	3.99 (101.3)	2.51 / N/A (63.8 / N/A)	2.02 / N/A (51.3 / N/A)	.20 x .33 / .20 x .33 (5.1 x 8.4 / 5.1 x 8.4)	3.0 (1.36)
75	E075E	2.96 (75.2)	3.39 (86.1)	4.36 (110.7)	2.81 / 2.50 (71.4 / 63.5)	2.10 / N/A (53.3 / N/A)	.20 x .50 / .20 x .50 (5.1 x 12.7 / 5.1 x 12.7)	4.0 (1.82)
100	E100E	2.96 (75.2)	3.39 (86.1)	4.61 (117.1)	2.81 / 2.50 (71.4 / 63.5)	2.37 / N/A (60.2 / N/A)	.20 x .50 / .20 x .50 (5.1 x 12.7 / 5.1 x 12.7)	5.0 (2.27)
150	E150E	3.89 (98.8)	4.50 (114.3)	4.48 (113.8)	3.74 / 3.12 (95.0 / 79.3)	2.56 / 2.87 (65.0 / 72.9)	.20 x .65 / .20 x .33 (5.1 x 16.5 / 5.1 x 8.4)	8.0 (3.64)
200	E200E	3.89 (98.8)	4.50 (114.3)	4.79 (121.7)	3.74 / 3.12 (95.0 / 79.3)	2.87 / 3.18 (72.9 / 80.8)	.20 x .65 / .20 x .33 (5.1 x 16.5 / 5.1 x 8.4)	10.0 (4.55)
250	E250E	3.89 (98.8)	4.50 (114.3)	5.21 (132.3)	3.74 / 3.12 (95.0 / 79.3)	3.29 / 3.61 (83.6 / 91.7)	.20 x .65 / .20 x .33 (5.1 x 16.5 / 5.1 x 8.4)	11.0 (5.00)
300	E300E	4.53 (115.1)	5.25 (133.4)	4.66 (118.4)	4.38 / 3.75 (111.3 / 95.3)	3.10 / N/A (78.7 / N/A)	.31 x .71 / .31 x .71 (7.9 x 18.0 / 7.9 x 18.0)	12.0 (5.45)
350	E350E	4.53 (115.1)	5.25 (133.4)	5.07 (128.8)	4.38 / 3.75 (111.3 / 95.3)	3.54 / N/A (89.9 / N/A)	.31 x .71 / .31 x .71 (7.9 x 18.0 / 7.9 x 18.0)	15.0 (6.82)
500	E500E	4.53 (115.1)	5.25 (133.4)	5.75 (146.1)	4.38 / 3.75 (111.3 / 95.3)	4.33 / N/A (110.0 / N/A)	.31 x .85 / .31 x .85 (7.9 x 21.6 / 7.9 x 21.6)	19.0 (8.64)
750	E750E	5.56 (141.2)	6.38 (162.1)	6.93 (176.0)	5.32 / 4.37 (135.1 / 111.0)	4.25 / 5.75 (108.0 / 146.1)	.31 x .85 / .31 x .85 (7.9 x 21.6 / 7.9 x 21.6)	31.0 (14.09)

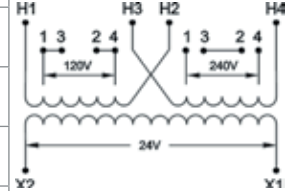

Note: Includes FB2X Secondary fuse holder.

Group 1A – Factory Installed Primary Fuse Holder Class "CC" and:

W – Secondary Fuse Holder (Midget Cartridge, 13/32" x 1 1/2" fuse) supplied, no covers

WA – Secondary Fuse Holder (Glass or Ceramic – Type 3AG, 1/4" x 1 1/4" fuse type); WB – Secondary Fuse Holder (Midget Cartridge, 13/32" x 1 1/2" fuse)

VA	Primary Fuse Holder Class "CC"			Dimensions						
	W Option – Midget Type Catalog Number	WA Option – Type 3AG w/ Covers Catalog Number	WB Option – Midget Type w/ Covers Catalog Number	Height in (mm)	Width in (mm)	Depth in (mm)	Mtg Width W1 / W2 in (mm)	Mtg Depth D1 / D2 in (mm)	Slot Size S1 / S2 in (mm)	Approx. Ship Weight lbs (kg)
50	E050EW	E050EWA	E050EWB	4.18 (106.2)	3.01 (76.5)	3.99 (101.3)	2.51 / N/A (63.8 / N/A)	2.02 / N/A (51.3 / N/A)	.20 x .33 / .20 x .33 (5.1 x 8.4 / 5.1 x 8.4)	3.0 (1.36)
75	E075EW	E075EWA	E075EWB	4.41 (112.0)	3.39 (86.1)	4.36 (110.7)	2.81 / 2.50 (71.4 / 63.5)	2.10 / N/A (53.3 / N/A)	.20 x .50 / .20 x .50 (5.1 x 12.7 / 5.1 x 12.7)	4.0 (1.82)
100	E100EW	E100EWA	E100EWB	4.41 (112.0)	3.39 (86.1)	4.61 (117.1)	2.81 / 2.50 (71.4 / 63.5)	2.37 / N/A (60.2 / N/A)	.20 x .50 / .20 x .50 (5.1 x 12.7 / 5.1 x 12.7)	5.0 (2.27)
150	E150EW	E150EWA	E150EWB	5.36 (136.1)	4.50 (114.3)	4.48 (113.8)	3.74 / 3.12 (95.0 / 79.3)	2.56 / 2.87 (65.0 / 72.9)	.20 x .65 / .20 x .33 (5.1 x 16.5 / 5.1 x 8.4)	8.0 (3.64)
200	E200EW	E200EWA	E200EWB	5.36 (136.1)	4.50 (114.3)	4.79 (121.7)	3.74 / 3.12 (95.0 / 79.3)	2.87 / 3.18 (72.9 / 80.8)	.20 x .65 / .20 x .33 (5.1 x 16.5 / 5.1 x 8.4)	10.0 (4.55)
250	E250EW	E250EWA	E250EWB	5.36 (136.1)	4.50 (114.3)	5.21 (132.3)	3.74 / 3.12 (95.0 / 79.3)	3.29 / 3.61 (83.6 / 91.7)	.20 x .65 / .20 x .33 (5.1 x 16.5 / 5.1 x 8.4)	11.0 (5.00)
300	E300EW	E300EWA	E300EWB	5.99 (152.1)	5.25 (133.4)	4.66 (118.4)	4.38 / 3.75 (111.3 / 95.3)	3.10 / N/A (78.7 / N/A)	.31 x .71 / .31 x .71 (7.9 x 18.0 / 7.9 x 18.0)	12.0 (5.45)
350	E350EW	E350EWA	E350EWB	5.99 (152.1)	5.25 (133.4)	5.07 (128.8)	4.38 / 3.75 (111.3 / 95.3)	3.54 / N/A (89.9 / N/A)	.31 x .71 / .31 x .71 (7.9 x 18.0 / 7.9 x 18.0)	15.0 (6.82)
500	E500EW	NA	E500EWB	5.99 (152.1)	5.25 (133.4)	5.75 (146.1)	4.38 / 3.75 (111.3 / 95.3)	4.33 / N/A (110.0 / N/A)	.31 x .85 / .31 x .85 (7.9 x 21.6 / 7.9 x 21.6)	19.0 (8.64)
750	E750EW	NA	E750EWB	7.01 (178.1)	6.38 (162.1)	6.93 (176.0)	5.32 / 4.37 (135.1 / 111.0)	4.25 / 5.75 (108.0 / 146.1)	.31 x .85 / .31 x .85 (7.9 x 21.6 / 7.9 x 21.6)	31.0 (14.09)

Notes: WA and WB suffix include finger safe covers. Fuses not included. FB2 sold separately for W option. Secondary fusing assembly required.

SBE Encapsulated Series Selection Tables

Group 2 – 220 x 440 Volt Primary, 110 Volt Secondary, 50/60 Hz, 230 x 460 Volt Primary, 115 Volt Secondary, 50/60 Hz
240 x 480 Volt Primary, 120 Volt Secondary, 60 Hz

VA	Catalog Number	Height in (mm)	Width in (mm)	Depth in (mm)	Mtg		Slot Size S1 / S2 – in (mm)	Approx. Ship Weight lbs (kg)
					W1 / W2 – in (mm)	D1 / D2 – in (mm)		
50	E050	2.72 (69.1)	3.01 (76.5)	3.99 (101.3)	2.51 / N/A (63.8 / N/A)	2.02 / N/A (51.3 / N/A)	.20 x .33 / .20 x .33 (5.1 x 8.4 / 5.1 x 8.4)	3.0 (1.36)
75	E075	2.96 (75.2)	3.39 (86.1)	4.36 (110.7)	2.81 / 2.50 (71.4 / 63.5)	2.10 / N/A (53.3 / N/A)	.20 x .50 / .20 x .50 (5.1 x 12.7 / 5.1 x 12.7)	4.0 (1.82)
100	E100	2.96 (75.2)	3.39 (86.1)	4.61 (117.1)	2.81 / 2.50 (71.4 / 63.5)	2.37 / N/A (60.2 / N/A)	.20 x .50 / .20 x .50 (5.1 x 12.7 / 5.1 x 12.7)	5.0 (2.27)
150	E150	3.89 (98.8)	4.50 (114.3)	4.48 (113.8)	3.74 / 3.12 (95.0 / 79.3)	2.56 / 2.87 (65.0 / 72.9)	.20 x .65 / .20 x .33 (5.1 x 16.5 / 5.1 x 8.4)	8.0 (3.64)
200	E200	3.89 (98.8)	4.50 (114.3)	4.79 (121.7)	3.74 / 3.12 (95.0 / 79.3)	2.87 / 3.18 (72.9 / 80.8)	.20 x .65 / .20 x .33 (5.1 x 16.5 / 5.1 x 8.4)	10.0 (4.55)
250	E250	3.89 (98.8)	4.50 (114.3)	5.21 (132.3)	3.74 / 3.12 (95.0 / 79.3)	3.29 / 3.61 (83.6 / 91.7)	.20 x .65 / .20 x .33 (5.1 x 16.5 / 5.1 x 8.4)	11.0 (5.00)
300	E300	4.53 (115.1)	5.25 (133.4)	4.66 (118.4)	4.38 / 3.75 (111.3 / 95.3)	3.10 / N/A (78.7 / N/A)	.31 x .71 / .31 x .71 (7.9 x 18.0 / 7.9 x 18.0)	12.0 (5.45)
350	E350	4.53 (115.1)	5.25 (133.4)	5.07 (128.8)	4.38 / 3.75 (111.3 / 95.3)	3.54 / N/A (89.9 / N/A)	.31 x .71 / .31 x .71 (7.9 x 18.0 / 7.9 x 18.0)	15.0 (6.82)
500	E500	4.53 (115.1)	5.25 (133.4)	5.75 (146.1)	4.38 / 3.75 (111.3 / 95.3)	4.33 / N/A (110.0 / N/A)	.31 x .85 / .31 x .85 (7.9 x 21.6 / 7.9 x 21.6)	19.0 (8.64)
750	E750	5.56 (141.2)	6.38 (162.1)	6.93 (176.0)	5.32 / 4.37 (135.1 / 111.0)	4.25 / 5.75 (108.0 / 146.1)	.31 x .85 / .31 x .85 (7.9 x 21.6 / 7.9 x 21.6)	31.0 (14.09)
1000	E1000	5.56 (141.2)	6.38 (162.1)	7.36 (186.9)	5.32 / 4.37 (135.1 / 111.0)	4.68 / 6.18 (118.9 / 157.0)	.31 x .85 / .31 x .85 (7.9 x 21.6 / 7.9 x 21.6)	36.0 (16.36)

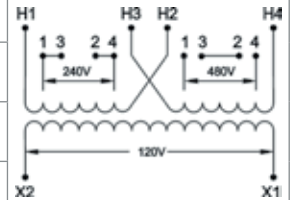

Note: Includes FB2X Secondary fuse holder.

Group 2A – Factory Installed Primary Fuse Holder Class "CC" and: W – Secondary Fuse Holder (Midget Cartridge, 13/32" x 1 1/2" fuse) supplied, no covers; WA – Secondary Fuse Holder (Glass or Ceramic – Type 3AG, 1/4" x 1 1/4" fuse type); WB – Secondary Fuse Holder (Midget Cartridge, 13/32" x 1 1/2" fuse)

VA	Primary Fuse Holder Class "CC"			Dimensions						
	W Option – Midget Type Catalog Number	WA Option – Type 3AG w/ Covers Catalog Number	WB Option – Midget Type w/ Covers Catalog Number	Height in (mm)	Width in (mm)	Depth in (mm)	Mtg Width W1 / W2 in (mm)	Mtg Depth D1 / D2 in (mm)	Slot Size S1 / S2 in (mm)	Approx. Ship Weight lbs (kg)
50	E050W	E050WA	E050WB	4.18 (106.2)	3.01 (76.5)	3.99 (101.3)	2.51 / N/A (63.8 / N/A)	2.02 / N/A (51.3 / N/A)	.20 x .33 / .20 x .33 (5.1 x 8.4 / 5.1 x 8.4)	3.0 (1.36)
75	E075W	E075WA	E075WB	4.41 (112.0)	3.39 (86.1)	4.36 (110.7)	2.81 / 2.50 (71.4 / 63.5)	2.10 / N/A (53.3 / N/A)	.20 x .50 / .20 x .50 (5.1 x 12.7 / 5.1 x 12.7)	4.0 (1.82)
100	E100W	E100WA	E100WB	4.41 (112.0)	3.39 (86.1)	4.61 (117.1)	2.81 / 2.50 (71.4 / 63.5)	2.37 / N/A (60.2 / N/A)	.20 x .50 / .20 x .50 (5.1 x 12.7 / 5.1 x 12.7)	5.0 (2.27)
150	E150W	E150WA	E150WB	5.36 (136.1)	4.50 (114.3)	4.48 (113.8)	3.74 / 3.12 (95.0 / 79.3)	2.56 / 2.87 (65.0 / 72.9)	.20 x .65 / .20 x .33 (5.1 x 16.5 / 5.1 x 8.4)	8.0 (3.64)
200	E200W	E200WA	E200WB	5.36 (136.1)	4.50 (114.3)	4.79 (121.7)	3.74 / 3.12 (95.0 / 79.3)	2.87 / 3.18 (72.9 / 80.8)	.20 x .65 / .20 x .33 (5.1 x 16.5 / 5.1 x 8.4)	10.0 (4.55)
250	E250W	E250WA	E250WB	5.36 (136.1)	4.50 (114.3)	5.21 (132.3)	3.74 / 3.12 (95.0 / 79.3)	3.29 / 3.61 (83.6 / 91.7)	.20 x .65 / .20 x .33 (5.1 x 16.5 / 5.1 x 8.4)	11.0 (5.00)
300	E300W	E300WA	E300WB	5.99 (152.1)	5.25 (133.4)	4.66 (118.4)	4.38 / 3.75 (111.3 / 95.3)	3.10 / N/A (78.7 / N/A)	.31 x .71 / .31 x .71 (7.9 x 18.0 / 7.9 x 18.0)	12.0 (5.45)
350	E350W	E350WA	E350WB	5.99 (152.1)	5.25 (133.4)	5.07 (128.8)	4.38 / 3.75 (111.3 / 95.3)	3.54 / N/A (89.9 / N/A)	.31 x .71 / .31 x .71 (7.9 x 18.0 / 7.9 x 18.0)	15.0 (6.82)
500	E500W	E500WA	E500WB	5.99 (152.1)	5.25 (133.4)	5.75 (146.1)	4.38 / 3.75 (111.3 / 95.3)	4.33 / N/A (110.0 / N/A)	.31 x .85 / .31 x .85 (7.9 x 21.6 / 7.9 x 21.6)	19.0 (8.64)
750	E750W	E750WA	E750WB	7.01 (178.1)	6.38 (162.1)	6.93 (176.0)	5.32 / 4.37 (135.1 / 111.0)	4.25 / 5.75 (108.0 / 146.1)	.31 x .85 / .31 x .85 (7.9 x 21.6 / 7.9 x 21.6)	31.0 (14.09)
1000	E1000W	E1000WA	E1000WB	7.01 (178.1)	6.38 (162.1)	7.36 (186.9)	5.32 / 4.37 (135.1 / 111.0)	4.68 / 6.18 (118.9 / 157.0)	.31 x .85 / .31 x .85 (7.9 x 21.6 / 7.9 x 21.6)	36.0 (16.36)

Notes: WA and WB suffix include finger safe covers. Fuses not included. W option for secondary fusing requires assembly (FB2 sold separately).

SBE Series Selection Tables - continued

Group 3 – 240 x 480 Volt Primary, 24 Volt Secondary, 60 Hz

VA	Catalog Number	Height in (mm)	Width in (mm)	Depth in (mm)	Mtg Width W1 / W2 in (mm)	Mtg Depth D1 / D2 in (mm)	Slot Size in (mm)	Approx. Ship Weight lbs (kg)	
50	E050D	2.72 (69.1)	3.01 (76.5)	3.99 (101.3)	2.51 / N/A (63.8 / N/A)	2.02 / N/A (51.3 / N/A)	.20 x .33 (5.1 x 8.4)	3.0 (1.36)	
100	E100D	2.96 (75.2)	3.39 (86.1)	4.61 (117.1)	2.81 / 2.50 (71.4 / 63.5)	2.37 / N/A (60.2 / N/A)	.20 x .50 (5.1 x 12.7)	5.0 (2.27)	
250	E250D	3.89 (98.8)	4.50 (114.3)	5.21 (132.3)	3.74 / 3.12 (95.0 / 79.3)	3.29 / 3.61 (83.6 / 91.7)	.20 x .65 (5.1 x 16.5)	11.0 (5.00)	
500	E500D	4.53 (115.1)	5.25 (133.4)	5.75 (146.1)	4.38 / 3.75 (111.3 / 95.3)	4.33 / N/A (110.0 / N/A)	.31 x .71 (7.9 x 18.0)	19.0 (8.64)	

Note: Includes FB2X secondary fuse holder.

Group 4 – 208/240/277 Volt Primary, 120/24 Volt Secondary, 60 Hz

VA	Catalog Number	Height in (mm)	Width in (mm)	Depth in (mm)	Mtg Width W1 / W2 in (mm)	Mtg Depth D1 / D2 in (mm)	Slot Size in (mm)	Approx. Ship Weight lbs (kg)	
50	E050JL	2.72 (69.1)	3.01 (76.5)	3.99 (101.3)	2.51 / N/A (63.8 / N/A)	2.02 / N/A (51.3 / N/A)	.20 x .33 (5.1 x 8.4)	3.0 (1.36)	
100	E100JL	2.96 (75.2)	3.39 (86.1)	4.61 (117.1)	2.81 / 2.50 (71.4 / 63.5)	2.37 / N/A (60.2 / N/A)	.20 x .50 (5.1 x 12.7)	5.0 (2.27)	
250	E250JL	3.89 (98.8)	4.50 (114.3)	5.21 (132.3)	3.74 / 3.12 (95.0 / 79.3)	3.29 / 3.61 (83.6 / 91.7)	.20 x .65 (5.1 x 16.5)	11.0 (5.00)	
500	E500JL	4.53 (115.1)	5.25 (133.4)	5.75 (146.1)	4.38 / 3.75 (111.3 / 95.3)	4.33 / N/A (110.0 / N/A)	.31 x .71 (7.9 x 18.0)	19.0 (8.64)	

Note: Will only accept one FB2 secondary fuse holder. Will not accept FB2X secondary fuse holder.

Group 5 – 208/240/480/600 Volt Primary, 120/24 Volt Secondary, 60 Hz
200/230/460/575 Volt Primary, 115/23 Volt Secondary, 60 Hz







VA	Catalog Number	Height in (mm)	Width in (mm)	Depth in (mm)	Mtg Width W1 / W2 in (mm)	Mtg Depth D1 / D2 in (mm)	Slot Size in (mm)	Approx. Ship Weight lbs (kg)	
50	E050JN	2.96 (75.2)	3.39 (86.1)	4.36 (110.7)	2.81 / 2.50 (71.4 / 63.5)	2.10 / N/A (53.3 / N/A)	.20 x .50 (5.1 x 12.7)	4.0 (1.81)	
100	E100JN	3.89 (98.8)	4.50 (114.3)	4.48 (113.8)	3.74 / 3.12 (95.0 / 79.3)	2.56 / 2.87 (65.0 / 72.9)	.20 x .65 (5.1 x 16.5)	8.0 (3.67)	
150	E150JN	3.89 (98.8)	4.50 (114.3)	5.21 (132.3)	3.74 / 3.12 (95.0 / 79.3)	3.29 / 3.61 (83.6 / 91.7)	.20 x .65 (5.1 x 16.5)	11.0 (5.00)	
250	E250JN	4.53 (115.1)	5.25 (133.4)	5.07 (128.8)	4.38 / 3.75 (111.3 / 95.3)	3.54 / N/A (89.9 / N/A)	.31 x .71 (7.9 x 18.0)	15.0 (6.82)	
500	E500JN	5.56 (141.2)	6.38 (162.1)	6.93 (176.0)	5.32 / 4.37 (135.1 / 111.0)	4.25 / 5.75 (108.0 / 146.1)	.31 x .85 (7.9 x 21.6)	30.0 (13.64)	

Note: Will only accept one FB2 secondary fuse holder. Will not accept FB2X secondary fuse holder.



SBE Accessories

FIELD INSTALLED OPTIONS	ACCESSORIES INCLUDED			FACTORY INSTALLED OPTIONS
Accessory Catalog Number	Primary Fuse (Class "CC" Rejection Type)	Secondary Fuse	IP20 Covers	Suffix Codes
FB2	—	Type 3AG	—	N/A
FB2 + FBPC1	Yes	Type 3AG	Yes	WA (i.e. E500WA)
FBPC1	Yes	Midget Type	Yes	WB (i.e. E500WB)
FB2X *	Yes	Midget Type	—	W (i.e. E500W)
FBP	Yes	Midget Type	—	N/A

* Supplied with applicable SBE models. Refer to the note at the bottom of the product selection tables.

CATALOG NUMBER	FIELD INSTALLED OPTIONS DESCRIPTIONS	CATALOG NUMBER	FIELD INSTALLED OPTIONS DESCRIPTIONS
FB2	 <p>Fuse Block – Secondary Side Field installed secondary fuse holder kit designed to accommodate one glass or ceramic, 1/4" x 1 1/4" fuse.</p>	FBP	 <p>Fuse Block – Primary Side Field installed primary fuse holder kit designed to accommodate two class "CC" rejection type fuse. Finger safe covers not available.</p>
FBPC1	 <p>Fuse Block and Finger Safe Cover Kit Field installed primary fuse holder designed to accommodate two class "CC" rejection type fuses with primary and secondary. Finger safe covers kit.</p>	SBEDIN	 <p>DIN Circuit Breaker Mounting DIN Rail adapter kit for mounting IEC circuit breaker.</p>
FB2X	 <p>Fuse Block – Secondary Side Field installed secondary fuse holder designed to accommodate one 13/32" x 1-1/2" (Midget type) cartridge fuse (included with applicable transformer purchase only).</p>	IP20	 <p>Terminal Covers (Two Covers Per Kit) Field installed primary and secondary IEC Touch Proof Cover Kit.</p>

FACTORY INSTALLED OPTIONS			
 <p>SBE Control Transformer without Covers - W Option (FB2X not installed)</p>	<table border="1"> <tr> <th>Option</th> </tr> <tr> <td>W</td> </tr> </table>	Option	W
Option			
W			

FACTORY INSTALLED OPTIONS			
 <p>SBE Control Transformer with Covers - WA & WB Option</p>	Option	Secondary Fusing	
	WA	Glass/Ceramic - Type 3AG (FB2 kit not installed)	
WB	Midget Type (FB2X installed)		

SBE - Open Style, Copper Wound - SBE performance in larger VA (1500 - 5000) sizes

The open style Solahd SBE Series provides voltage regulation in excess of NEMA recommendations without exceeding 55°C rise. These higher power capacity transformers are the best choice when 80% or more of the load components are electromagnetic devices.



Features

- Interleaved copper windings reduce I²R losses and maximize efficiency
- Ratings 60 Hz unless noted 50/60 Hz
- Meets or exceeds electrical requirements of NEMA, ANSI, NMTBA and JIC
- 55°C rise, 105°C insulation system
- High quality silicon steel core



Certifications and Compliances

- Listed: E77014 - Type SZO
- UL 5085-1, UL 5085-2
- Certified LR14328-4
- CSA C22.2 No. 66.1, No. 66.2
- RoHS Compliant

Related Products

- Linear Power Supplies
- DIN Rail DC Power Supplies
- Constant Voltage Transformers

Design Style

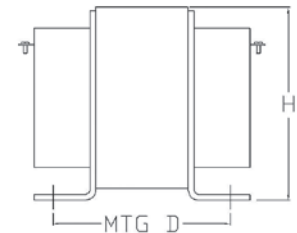
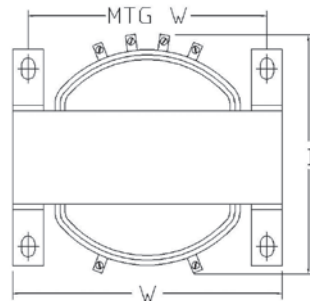

Selection Table

Group 1 – 240 X 480 Volt Primary, 120 Volt Secondary 60 Hz
230 X 460 Volt Primary, 115 Volt Secondary 50/60 Hz
220 X 440 Volt Primary, 110 Volt Secondary 50/60 Hz

VA	Catalog Number	Height in (mm)	Width in (mm)	Depth in (mm)	Mtg Width in (mm)	Mtg Depth in (mm)	Slot Size in (mm)	Approx. Ship Weight lbs (kg)
1500	Y1500	6.25 (158.8)	6.75 (171.5)	8.75 (222.3)	5.75 (146.1)	6.38 (162.1)	.44 x .69 (11.2 x 17.5)	43.0 (19.55)
2000	Y2000	6.25 (158.8)	6.75 (171.5)	10.00 (254.0)	5.75 (146.1)	7.75 (196.9)	.44 x .69 (11.2 x 17.5)	55.0 (25.00)
3000	Y3000	8.00 (203.2)	9.00 (228.6)	9.63 (244.6)	8.00 (203.2)	6.00 (152.4)	.44 x .69 (11.2 x 17.5)	74.0 (33.64)
5000	Y5000	8.00 (203.2)	9.00 (228.6)	12.00 (304.8)	8.00 (203.2)	8.75 (222.3)	.44 x .69 (11.2 x 17.5)	120.0 (54.55)

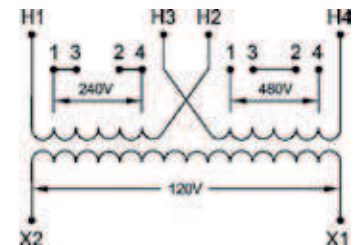

Note: Fuse holders are not available for this voltage configuration.

SMT Series - Open Style, Aluminum Wound



The SolaHD SMT Series is economical and compact with traditional open wound varnished coils. Ratings are from 1 kVA through 5 kVA with Class 180°C insulation system and 115°C rise under full load. SMT transformers provide excellent cost benefits with NEMA regulation characteristics and electrical performance specifications.

Features

- Available from 1000–5000 VA, 60 Hz unless noted
- Meets or exceeds electrical requirements of NEMA, ANSI, NMTBA and JIC



Certifications and Compliances

-  Listed: E77014 - Type SMT
- UL 5085-1, UL 5085-2
-  Certified LR14328-4
- CSA C22.2 No. 66.1, No. 66.2
- RoHS Compliant



Related Products

- Linear Power Supplies
- DIN Rail DC Power Supplies
- Constant Voltage Transformers

Design Style

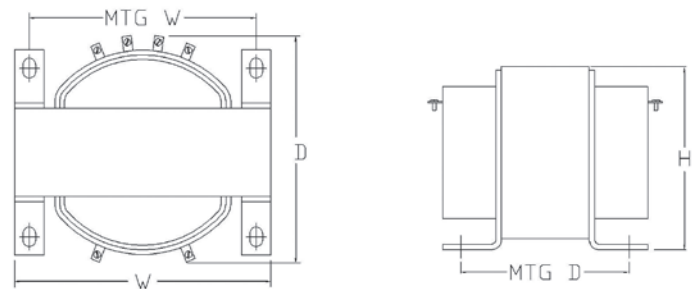

Selection Table

Group 1 – 240 X 480 Volt Primary, 120 Volt Secondary 60 Hz
230 X 460 Volt Primary, 115 Volt Secondary 50/60 Hz
220 X 440 Volt Primary, 110 Volt Secondary 50/60 Hz

VA	Catalog Number	Height in (mm)	Width in (mm)	Depth in (mm)	Mtg Width in (mm)	Mtg Depth in (mm)	Slot Size in (mm)	Approx. Ship Weight lbs (kg)	
1000	T1000	5.63 (143.0)	6.38 (162.1)	6.38 (162.1)	5.31 (134.9)	4.25 (108.0)	.31 x .69 (7.9 x 17.5)	22 (10.00)	
1500	T1500	6.25 (158.8)	6.75 (171.5)	8.25 (209.6)	5.75 (146.1)	6.38 (162.1)	.44 x .69 (11.2 x 17.5)	28.3 (12.86)	
2000	T2000	6.25 (158.8)	6.75 (171.5)	9.13 (231.9)	5.75 (146.1)	6.63 (168.4)	.44 x .69 (11.2 x 17.5)	38.5 (17.5)	
3000	T3000	8.00 (203.2)	9.00 (228.6)	9.30 (236.2)	8.00 (203.2)	5.81 (147.6)	.44 x .69 (11.2 x 17.5)	55 (25.00)	
5000	T5000	8.00 (203.2)	9.00 (228.6)	11.3 (287.0)	8.00 (203.2)	7.50 (190.5)	.44 x .69 (11.2 x 17.5)	91 (41.36)	

Note: Fuse holders are not available for this voltage configuration.

SBE International Series Control Transformers: 50 - 750 VA



Electromagnetic control components demand inrush currents up to 10 times the transformers nominal rating without sacrificing secondary voltage stability beyond practical limits. The SolaHD SBE International Series transformers fully comply with IEC and NEMA standards and are available with IEC touchproof covers (IP20).

Features

- Epoxy encapsulated for cooler operation
- Interleaved copper windings to reduce impedance
- 50/60 Hz
- 55°C Rise, 105°C insulation system for harsh, heavy duty applications
- Exceeds IEC, NEMA, ANSI, NMTBA, JIC and automotive standards





Certifications and Compliances

-  Listed: E77014 - Type SBE
 - UL 5085-1, UL 5085-2
 - CSA C22.2 No. 66.1, No. 66.2
-  - IEC/EN 61558-1, IEC/EN 61558-2-2
- RoHS Compliant

Related Products

- DIN Rail Power Supplies
- 63 Series Power Conditioners
- Surge Protective Devices

CATALOG NUMBER		FIELD INSTALLED OPTIONS DESCRIPTIONS
SBEDIN		DIN Circuit Breaker Mounting DIN Rail adapter kit for mounting IEC circuit breaker.
IP20		Terminal Covers (Two Covers Per Kit) Field installed primary and secondary IEC Touch Proof Cover Kit.

Selection Tables: International Series

Group 1 – –/220/380 V Primary, 110/23 V Secondary, 50/60 Hz
208/240/415 V Primary, 120/24 V Secondary, 50/60 Hz
200/230/400 V Primary, 115/24 V Secondary, 50/60 Hz

Continuous VA	Instantaneous VA	Catalog Number	Height in (mm)	Width in (mm)	Depth in (mm)	Mtg Width W1 / W2 – in (mm)	Mtg Depth D1 / D2 – in (mm)	Slot Size S1/S2 – in (mm)	Approx. Ship Weight lbs (kg)
50	105	E050TC	2.96 (75.2)	3.39 (86.1)	4.36 (110.7)	2.81 / 2.50 (71.4 / 63.5)	2.10 / N/A (53.3 / N/A)	.20 x .50 / .20 x .50 (5.1 x 12.7 / 5.1 x 12.7)	4.0 (1.82)
100	230	E100TC	3.89 (98.8)	4.50 (114.3)	4.48 (113.8)	3.74 / 3.12 (95.0 / 79.3)	2.56 / 2.87 (65.0 / 72.9)	.20 x .65 / .20 x .33 (5.1 x 16.5 / 5.1 x 8.4)	8.0 (3.67)
150	420	E150TC	3.89 (98.8)	4.50 (114.3)	5.21 (132.3)	3.74 / 3.12 (95.0 / 79.3)	3.29 / 3.61 (83.6 / 91.7)	.20 x .65 / .20 x .33 (5.1 x 16.5 / 5.1 x 8.4)	11.0 (5.00)
250	675	E250TC	4.53 (115.1)	5.25 (133.4)	5.07 (128.8)	4.38 / 3.75 (111.3 / 95.3)	3.54 / N/A (89.9 / N/A)	.31 x .85 / .31 x .85 (7.9 x 21.6 / 7.87 x 21.6)	15.0 (6.82)
500	1550	E500TC	5.56 (141.2)	6.38 (162.1)	6.93 (176.0)	5.32 / 4.37 (135.1 / 111.0)	4.25 / 5.75 (108.0 / 146.1)	.31 x .03 / .31 x .85 (7.9 x .85 / 7.9 x 21.6)	30.0 (13.64)

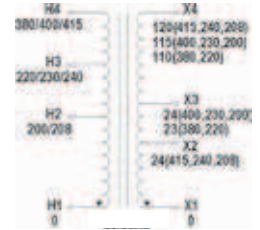

Group 2 – 208/240/415 V Primary, 24 V Secondary, 50/60 Hz
277/480 V Primary, 24 V Secondary, 60 Hz
200/230/400 V Primary, 24 V Secondary, 50/60 Hz
220/380 V Primary, 23 V Secondary, 50/60 Hz

Continuous VA	Instantaneous VA	Catalog Number	Height in (mm)	Width in (mm)	Depth in (mm)	Mtg Width W1 / W2 in (mm)	Mtg Depth D1 / D2 in (mm)	Slot Size S1/S2 – in (mm)	Approx. Ship Weight lbs (kg)
50	105	E050TE	2.96 (75.2)	3.39 (86.1)	4.36 (110.7)	2.81 / 2.50 (71.4 / 63.5)	2.10 / N/A (53.3 / N/A)	.20 x .50 / .20 x .50 (5.1 x 12.7 / 5.1 x 12.7)	4.0 (1.82)
100	230	E100TE	3.89 (98.8)	4.50 (114.3)	4.48 (113.8)	3.74 / 3.12 (95.0 / 79.3)	2.56 / 2.87 (65.0 / 72.9)	.20 x .03 / .20 x .01 (5.1 x .65 / 5.1 x .33)	8.0 (3.67)
150	420	E150TE	3.89 (98.8)	4.50 (114.3)	5.21 (132.3)	3.74 / 3.12 (95.0 / 79.3)	3.29 / 3.61 (83.6 / 91.7)	.20 x .03 / .20 x .01 (5.1 x .65 / 5.1 x .33)	11.0 (5.00)
250	700	E250TE	4.53 (115.1)	5.25 (133.4)	5.07 (128.8)	4.38 / 3.75 (111.3 / 95.3)	3.54 / N/A (89.9 / N/A)	.30 x .71 / .30 x .71 (7.9 x 18.0 / 7.9 x 18.0)	15.0 (6.82)
500	1550	E500TE	5.56 (141.2)	6.38 (162.1)	6.93 (176.0)	5.32 / 4.37 (135.1 / 111.0)	4.25 / 5.75 (108.0 / 146.1)	.30 x .85 / .30 x .85 (7.9 x 21.6 / 7.9 x 21.6)	30.0 (13.64)

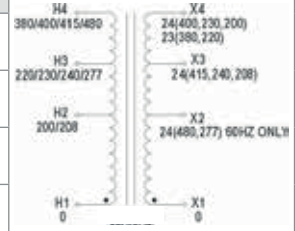

Note: Instantaneous VA calculated at At 50% PF (Power Factor), 95% Nominal Secondary Voltage.

Design Style

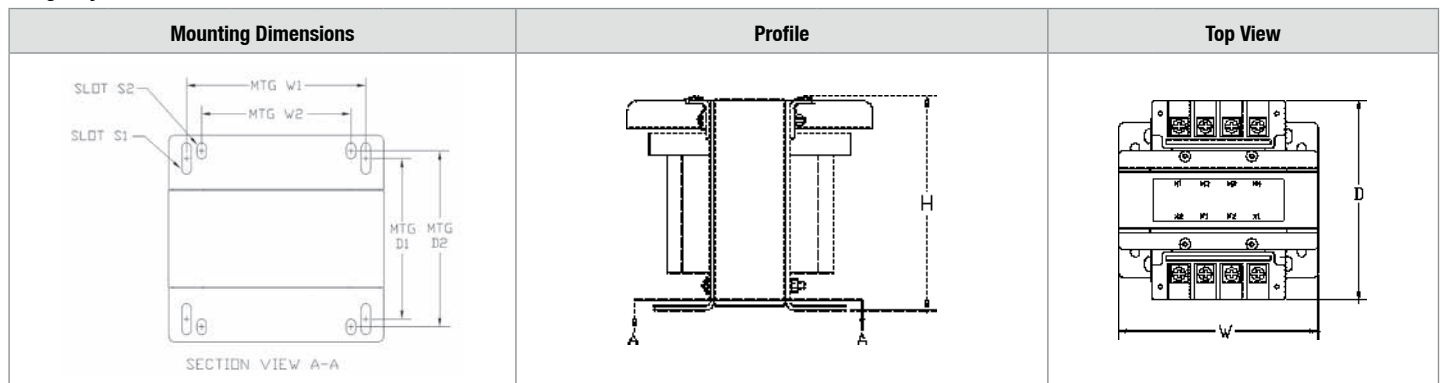

Selection Tables: International Series - continued

Group 3 – 208/240/415/480/600 V Primary, 120 V Secondary, 50/60 Hz 200/230/400/460/575 V Primary, 115 V Secondary, 50/60 Hz 220/277 /380 V Primary, 110 V Secondary, 50/60 Hz

Note: 277V, 575 V, 600 V taps are 60Hz only.

Continuous VA	Instantaneous VA	Catalog Number	Height in (mm)	Width in (mm)	Depth in (mm)	Mtg Width W1 / W2 – in (mm)	Mtg Depth D1 / D2 – in (mm)	Slot Size S1/S2 – in (mm)	Approx. Ship Weight lbs (kg)
50	93	E050TF	2.96 (75.2)	3.39 (86.1)	4.36 (110.7)	2.81 / 2.50 (71.4 / 63.5)	2.10 / N/A (53.3 / N/A)	.20 x .50 / .20 x .50 (5.1 x 12.7 / 5.1 x 12.7)	4.0 (1.82)
100	205	E100TF	3.89 (98.8)	4.50 (114.3)	4.48 (113.8)	3.74 / 3.12 (95.0 / 79.3)	2.56 / 2.87 (65.0 / 73.0)	.20 x .65 / .20 x .33 (5.1 x 16.5 / 5.1 x 8.4)	8.0 (3.67)
150	390	E150TF	3.89 (98.8)	4.50 (114.3)	5.21 (132.3)	3.74 / 3.12 (95.0 / 79.3)	3.29 / 3.61 (83.6 / 91.7)	.20 x .65 / .20 x .33 (5.1 x 16.5 / 5.1 x 8.4)	11.0 (5.00)
250	630	E250TF	4.53 (115.1)	5.25 (133.4)	5.07 (128.8)	4.38 / 3.75 (111.3 / 95.3)	3.54 / N/A (89.9 / N/A)	.31 x .71 / .31 x .71 (7.9 x 18.0 / 7.9 x 18.0)	15.0 (6.82)
500	1200	E500TF	5.56 (141.2)	6.38 (162.1)	6.93 (176.0)	5.32 / 4.37 (135.1 / 111.0)	4.25 / 5.75 (108.0 / 146.1)	.31 x .85 / .31 x .85 (7.9 x 21.6 / 7.9 x 21.6)	30.0 (13.64)
750	2290	E750TF	5.56 (141.2)	6.38 (162.1)	7.36 (187.0)	5.32 / 4.37 (135.1 / 111.0)	4.68 / 6.18 (118.9 / 157.0)	.31 x .85 / .31 x .85 (7.9 x 21.6 / 7.9 x 21.6)	34.0 (15.45)

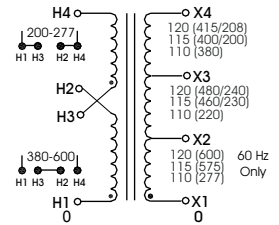

Group 4 – 240/415/480 V Primary, 120/240 V Secondary, 50/60 Hz 230/400/460 V Primary, 115/230 V Secondary, 50/60 Hz 220/380/440 V Primary, 110/220 V Secondary, 50/60 Hz

Continuous VA	Instantaneous VA	Catalog Number	Height in (mm)	Width in (mm)	Depth in (mm)	Mtg Width W1 / W2 in (mm)	Mtg Depth D1 / D2 in (mm)	Slot Size S1/S2 – in (mm)	Approx. Ship Weight lbs (kg)
50	110	E050TH	2.96 (75.2)	3.39 (86.1)	4.36 (110.7)	2.81 / 2.50 (71.4 / 63.5)	2.10 / N/A (53.3 / N/A)	.20 x .50 / .20 x .50 (5.1 x 12.7 / 5.1 x 12.7)	4.0 (1.82)
100	235	E100TH	3.89 (98.8)	4.50 (114.3)	4.48 (113.8)	3.74 / 3.12 (95.0 / 79.3)	2.56 / 2.87 (65.0 / 73.0)	.20 x .65 / .20 x .33 (5.1 x 16.5 / 5.1 x 8.4)	8.0 (3.67)
150	470	E150TH	3.89 (98.8)	4.50 (114.3)	5.21 (132.3)	3.74 / 3.12 (95.0 / 79.3)	3.29 / 3.61 (83.6 / 91.7)	.20 x .65 / .20 x .33 (5.1 x 16.5 / 5.1 x 8.4)	11.0 (5.00)
250	730	E250TH	4.53 (115.1)	5.25 (133.4)	5.07 (128.8)	4.38 / 3.75 (111.3 / 95.3)	3.54 / N/A (89.9 / N/A)	.31 x .81 / .31 x .85 (7.9 x 20.6 / 7.9 x 18.0)	15.0 (6.82)
500	1550	E500TH	5.56 (141.2)	6.38 (162.1)	6.93 (176.0)	5.32 / 4.37 (135.1 / 111.0)	4.25 / 5.75 (108.0 / 146.1)	.31 x .85 / .31 x .85 (7.9 x 21.6 / 7.9 x 21.6)	30.0 (13.64)
750	2250	E750TH	5.56 (141.2)	6.38 (162.1)	7.36 (187.0)	5.32 / 4.37 (135.1 / 111.0)	4.68 / 6.18 (118.9 / 157.0)	.31 x .85 / .31 x .85 (7.9 x 21.6 / 7.9 x 21.6)	34.0 (15.45)

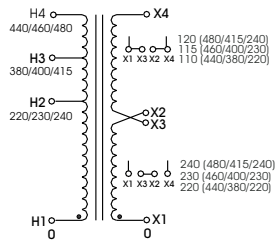

Note: Instantaneous VA calculated at At 50% PF (Power Factor), 95% Nominal Secondary Voltage.

International Series - Fuse Recommendations

Primary Fusing: Consult local electrical code. Secondary Fusing: per IEC/EN61558-2-2.

VA	Maximum Current Rating of Fuse		
	24 Vac	115 Vac	230 Vac
50	2	0.5	0.25
100	4	1	0.5
150	6	1.6	0.8
250	10	2.5	1.25
500	20	5	2.5
750	20	6.3	3.15

ICE International Series: 750 - 2000 VA

SolaHD ICE International Series CE marked transformers include IP20 touchproof terminations and copper windings in an encapsulated design. These units range from 750 to 2000 VA with 80°C temperature rise. The design is highly flexible due to the use of the standardized primary coil for multiple worldwide voltage combinations. CE Marked and cULus approval make the ICE International Series the perfect choice for OEM export equipment.

Features

- IP20 Touch-Proof terminals
- Copper windings
- Epoxy encapsulated for cooler operation and increased reliability
- 80°C rise temp, 130°C insulation system for harsh, heavy-duty standards
- 50/60 Hz Frequency
- Meets or exceeds electrical requirements of NEMA, ANSI and IEC

Certifications and Compliances

-  Listed: E77014 - Type SFP
 - UL 5085-1, UL 5085-2
 - CSA C22.2 No. 66.1, No. 66.2
-  -IEC 61558-1, IEC 61558-2-2
- RoHS Compliant

Related Products

- DIN Rail Power Supplies
- 63 Series Power Conditioners
- Surge Protective Devices



Design Style

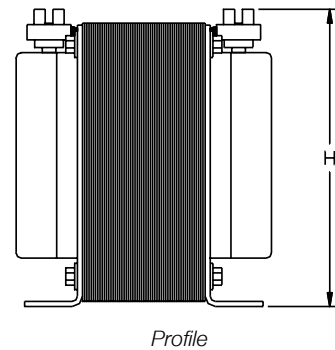
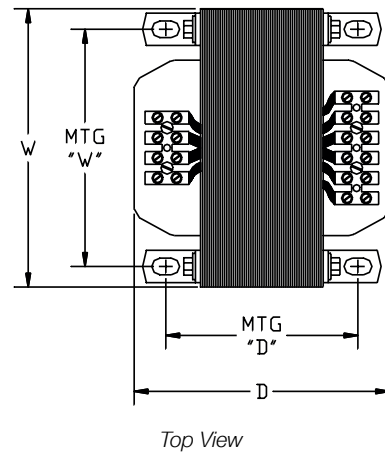

Selection Tables: International Series

Group 5 – 240/415/480 Volt Primary, 120/240 Volt Secondary, 60 Hz 230/400/460 Volt Primary, 115/230 Volt Secondary, 50/60 Hz 220/380/440 Volt Primary, 110/220 Volt Secondary, 50/60 Hz

Continuous VA	Instantaneous VA	Catalog Number	Height in (mm)	Width in (mm)	Depth in (mm)	Mtg Width "W"	Mtg Depth "D"	Slot Size – inches (mm)	Approx. Ship Weight lbs (kg)
1000	2500	CE1000TH	5.63 (143.0)	6.38 (162.1)	6.00 (152.4)	5.31 (135.0)	4.25 (108.0)	.31 x .69 (7.9 x 17.5)	25 (11.36)
1500	4200	CE1500TH	5.63 (143.0)	6.38 (162.1)	6.75 (171.5)	5.31 (135.0)	5.00 (127.0)	.31 x .69 (7.9 x 17.5)	32 (14.55)
2000	5500	CE2000TH	5.63 (143.0)	6.38 (162.1)	7.75 (196.9)	5.31 (135.0)	6.00 (152.4)	.31 x .69 (7.9 x 17.5)	37 (16.82)

Group 6 – 208/240/415/480/600 Volt Primary, 120/240 Volt Secondary, 60 Hz 200/230/400/460/575 Volt Primary, 115/230 Volt Secondary, 50/60 Hz – /220/380/440/550 Volt Primary, 110/220 Volt Secondary, 50/60 Hz

Continuous VA	Instantaneous VA	Catalog Number	Height in (mm)	Width in (mm)	Depth in (mm)	Mtg Width "W" in (mm)	Mtg Depth "D" in (mm)	Slot Size in (mm)	Approx. Ship Weight lbs (kg)
1000	2500	CE1000MH	5.63 (143.0)	6.38 (162.1)	6.00 (152.4)	5.31 (135.0)	4.25 (108.0)	.31 x .69 (7.9 x 17.5)	25.0 (11.36)
1500	4200	CE1500MH	5.63 (143.0)	6.38 (162.1)	6.75 (171.5)	5.31 (135.0)	5.00 (127.0)	.31 x .69 (7.9 x 17.5)	32.0 (14.55)
2000	5500	CE2000MH	5.63 (143.0)	6.38 (162.1)	7.75 (196.9)	5.31 (135.0)	6.00 (152.4)	.31 x .69 (7.9 x 17.5)	37.0 (16.82)

Group 7 – 208/240/415/480/600 Volt Primary, 120/ – /24 Volt Secondary, 60 Hz 200/230/400/460/575 Volt Primary, 115/24/23 Volt Secondary, 50/60 Hz – /220/380/440/550 Volt Primary, 110/23/– Volt Secondary, 50/60 Hz

Continuous VA	Instantaneous VA *	Catalog Number	Height in (mm)	Width in (mm)	Depth in (mm)	Mtg Width "W" in (mm)	Mtg Depth "D" in (mm)	Slot Size in (mm)	Approx. Ship Weight lbs (kg)
750	1875	CE750MC	5.63 (143.0)	6.38 (162.1)	6.00 (152.4)	5.31 (135.0)	4.25 (108.0)	.31 x .69 (7.9 x 17.5)	25 (11.36)
1000	3000	CE1000MC	5.63 (143.0)	6.38 (162.1)	6.75 (171.5)	5.31 (135.0)	5.00 (127.0)	.31 x .69 (7.9 x 17.5)	32 (14.55)
1500	4500	CE1500MC	5.63 (143.0)	6.38 (162.1)	7.75 (196.9)	5.31 (135.0)	6.00 (152.4)	.31 x .69 (7.9 x 17.5)	37 (16.82)

Notes: At 50% PF (Power Factor), 95% Nominal Secondary Voltage.

International Series - Fuse Recommendations

Primary Fusing: Consult local electrical code. Secondary Fusing: per IEC/EN61558-2-2.

VA	Maximum Current Rating of Fuse			Maximum VA Rating for 110/220 Vac Output *
	24 Vac	115 Vac	230 Vac	
750	20	6	-	720
1000	20	8	4	960
1500	20	12	6	1440
2000	-	16	8	1920

* For 110 Vac and 220 Vac output taps only, de-rate the output by 4% so the fuse is not loaded more than 1.1 times its rating per IEC 615558.

HSZ Series Industrial Control Transformers

The SolaHD HSZ Series is for applications where cost or heat issues make mounting the transformer outside the control panel necessary. This series has 80°C rise and have copper winding for industrial applications.

Features

- UL Class 180°C insulation system, 80°C temperature rise under full load
- Meets or exceeds NEMA regulation standards
- Copper windings
- Encapsulated
- Standard enclosure styles available:
 - UL Listed/NEMA Type 3R (rain proof)
 - UL Listed/NEMA Type 4 (wash down and dust proof)
 - UL Listed/NEMA Type 4X (corrosion proof, painted stainless steel)



Optional Styles

- Other UL Listed/NEMA Type 4X (corrosion proof) enclosure styles available (contact Technical Support for details):
 - Passivated Stainless Steel
 - 316 Stainless Steel

Certifications and Compliances

-  Listed: E77014 - Type HSZ
 - UL 5085-1, UL 5085-2
 - CSA C22.2 No. 66.1, No. 66.2
- RoHS Compliant

Related Products

- DIN Rail DC Power Supplies
- Constant Voltage Transformers

Design Style 1 - Type 3R

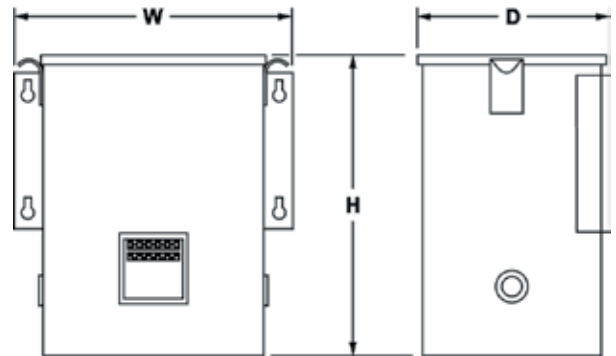

Design Style 2 - Type 4, Type 4X, Type 12

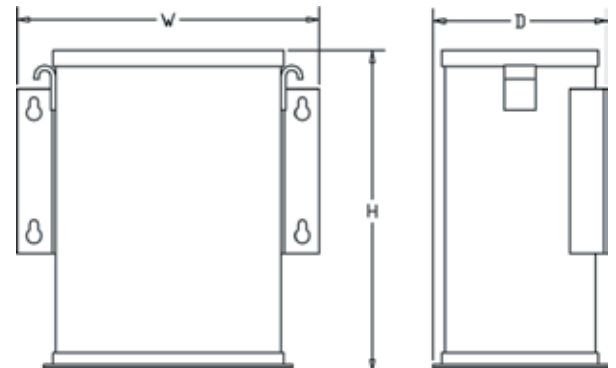

HSZ Series Selection Tables and Electrical Connections

Group 1 – 240/480, 230/460, 220/440 Volt Primary, 120/115/110 Volt Secondary, 50/60 Hz

kVA	Catalog Number Type-3R	Catalog Number Type-4/12	Catalog Number Type-4X	Height in (mm)	Width in (mm)	Depth in (mm)	Approx. Ship Weight lbs (kg)
1	HZ1000	HZ12-1000	HZP4X-1000	12.00 (304.8)	10.00 (254.0)	7.00 (177.8)	43.0 (19.55)
1.5	HZ1500	HZ12-1500	HZP4X-1500	12.00 (304.8)	10.00 (254.0)	7.00 (177.8)	55.0 (25.00)
2	HZ2000	HZ12-2000	HZP4X-2000	12.00 (304.8)	10.00 (254.0)	7.00 (177.8)	68.0 (30.91)
3	HZ3000	HZ12-3000	HZP4X-3000	17.00 (431.8)	14.00 (355.6)	9.00 (228.6)	108.0 (49.09)
5	HZ5000	HZ12-5000	HZP4X-5000	17.00 (431.8)	14.00 (355.6)	9.00 (228.6)	138.0 (62.73)
7.5	HZ7500	HZ12-7500	HZP4X-7500	17.00 (431.8)	14.00 (355.6)	9.00 (228.6)	173.0 (78.64)
10	HZ10000	HZ12-10000	HZP4X-10000	17.00 (431.8)	17.00 (431.8)	12.00 (304.8)	210.0 (95.45)

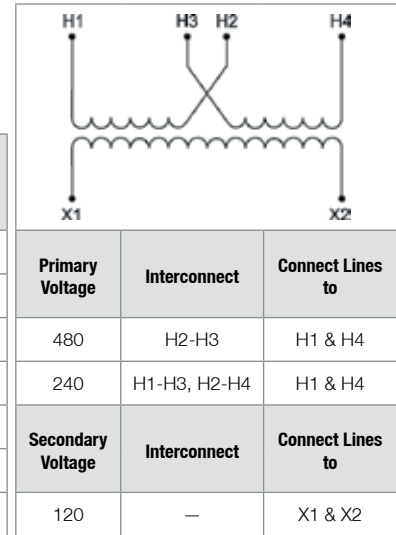

Group 2 – 230/460/575 Volt Primary, 115/95 Volt Secondary, 50/60 Hz

kVA	Catalog Number Type-3R	Catalog Number Type-4/12	Catalog Number Type-4X	Height in (mm)	Width in (mm)	Depth in (mm)	Approx. Ship Weight lbs (kg)
1	HZ1000A	HZ12-1000A	HZP4X-1000A	12.00 (304.8)	10.00 (254.0)	7.00 (177.8)	43.0 (19.55)
1.5	HZ1500A	HZ12-1500A	HZP4X-1500A	12.00 (304.8)	10.00 (254.0)	7.00 (177.8)	55.0 (25.00)
2	HZ2000A	HZ12-2000A	HZP4X-2000A	12.00 (304.8)	10.00 (254.0)	7.00 (177.8)	68.0 (30.91)
3	HZ3000A	HZ12-3000A	HZP4X-3000A	17.00 (431.8)	14.00 (355.6)	9.00 (228.6)	108.0 (49.09)
5	HZ5000A	HZ12-5000A	HZP4X-5000A	17.00 (431.8)	14.00 (355.6)	9.00 (228.6)	138.0 (62.73)
7.5	HZ7500A	HZ12-7500A	HZP4X-7500A	17.00 (431.8)	14.00 (355.6)	9.00 (228.6)	173.0 (78.64)
10	HZ10000A	HZ12-10000A	HZP4X-10000A	17.00 (431.8)	17.00 (431.8)	12.00 (304.8)	210.0 (95.45)

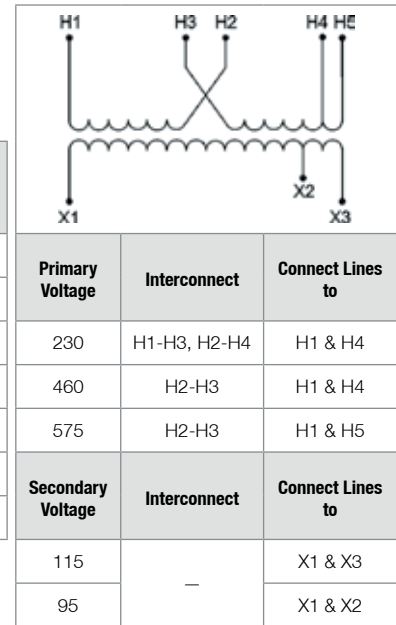

Note: Contact Technical Services for lead times, or for other enclosure types.

HSZ Series Selection Tables and Electrical Connections

Group 3 – 480 Volt Primary, 240 Volt Secondary, 50/60 Hz

kVA	Catalog Number Type-3R	Catalog Number Type-4/12	Catalog Number Type-4X	Height in (mm)	Width in (mm)	Depth in (mm)	Approx. Ship Weight lbs (kg)
1	HZ1000R	HZ12-1000R	HZP4X-1000R	12.00 (304.8)	10.00 (254.0)	7.00 (177.8)	43 (19.55)
1.5	HZ1500R	HZ12-1500R	HZP4X-1500R	12.00 (304.8)	10.00 (254.0)	7.00 (177.8)	55 (25.00)
2	HZ2000R	HZ12-2000R	HZP4X-2000R	12.00 (304.8)	10.00 (254.0)	7.00 (177.8)	68 (30.91)
3	HZ3000R	HZ12-3000R	HZP4X-3000R	17.00 (431.8)	14.00 (355.6)	9.00 (228.6)	108 (49.09)
5	HZ5000R	HZ12-5000R	HZP4X-5000R	17.00 (431.8)	14.00 (355.6)	9.00 (228.6)	138 (62.73)
7.5	HZ7500R	HZ12-7500R	HZP4X-7500R	17.00 (431.8)	14.00 (355.6)	9.00 (228.6)	173 (78.64)
10	HZ10000R	HZ12-10000R	HZP4X-10000R	17.00 (431.8)	17.00 (431.8)	12.00 (304.8)	210 (95.45)

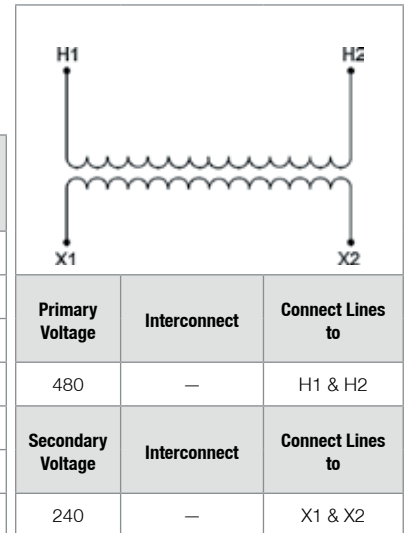

Primary Fuse Recommendations

Primary Voltage													
V _m	120	200	208	220	230	240	277	440	460	480	550	575	600
VA													
50	1.25 (2)	.75 (1.25)	.6 (1.13)	.6 (1.13)	.6 (1)	.6 (1)	.5 (.8)	.3 (.5)	.3 (.5)	.3 (.5)	.25 (.4)	.25 (.4)	.25 (.4)
75	1.8 (3)	1.13 (1.8)	1 (1.8)	1 (1.6)	.8 (1.6)	.8 (1.5)	.8 (1.25)	.5 (.8)	.4 (.8)	.4 (.75)	.4 (.6)	.3 (.6)	.3 (.6)
100	2.5 (4)	1.5 (2.5)	1.4 (2.25)	1.25 (2.25)	1.25 (2)	1.25 (2)	1 (1.8)	.6 (1.13)	.6 (1)	.6 (1)	.5 (.8)	.5 (.8)	.5 (.8)
150	3.5 (6.25)	2.25 (3.5)	2 (3.5)	2 (3.2)	1.8 (3.2)	1.8 (3)	1.6 (2.5)	1 (1.6)	.8 (1.6)	.8 (1.5)	.8 (1.25)	.75 (1.25)	.75 (1.25)
200	5 (8)	3 (5)	2.8 (4.5)	2.5 (4.5)	2.5 (4)	2.5 (4)	2 (3.5)	1.25 (2.25)	1.25 (2)	1.25 (2)	1 (1.8)	1 (1.5)	1 (1.6)
250	3 (5)	3.5 (6.25)	3.5 (6)	3.2 (5.6)	3.2 (5)	3 (5)	2.5 (4.5)	1.6 (2.8)	1.6 (2.5)	1.5 (2.5)	1.25 (2.25)	1.25 (2)	1.25 (2)
300	4 (6.25)	4.5 (7.5)	4 (7)	4 (6.25)	3.5 (6.25)	3.5 (6.25)	3.2 (5)	2 (3.2)	1.8 (3.2)	1.8 (3)	1.6 (2.5)	1.5 (2.5)	1.5 (2.5)
350	4.5 (7)	5 (8)	5 (8)	4.5 (7.5)	4.5 (7.5)	4 (7)	3.5 (6.25)	2.25 (3.5)	2.25 (3.5)	2 (3.5)	1.8 (3)	1.8 (3)	1.75 (2.5)
500	6.25 (10)	4 (6.25)	4 (6)	3.5 (5.6)	3.5 (5)	3 (5)	5 (9)	3.2 (5.6)	3.2 (5)	3 (5)	2.5 (4.5)	2.5 (4)	2.5 (4)
750	10 (15)	6.25 (9)	6 (9)	5.6 (8)	5 (8)	5 (7.5)	8 (12)	5 (8)	4.5 (8)	4.5 (7.5)	4 (6.25)	3.5 (6.25)	3.5 (6.25)
1000	12 (20)	8 (12)	8 (12)	7.5 (10)	7 (10)	6.25 (10)	10 (17.5)	3.5 (5.6)	3.6 (5)	3 (5)	5 (9)	5 (8)	5 (8)
1500	17.5 (30)	12 (15)	12 (15)	10 (15)	10 (15)	10 (15)	15 (25)	5.6 (8)	5 (8)	5 (7.5)	4.5 (6.25)	4.5 (6.25)	4.5 (6.25)
2000	25 (40)	15 (25)	15 (20)	15 (20)	12 (20)	12 (20)	20 (35)	7.5 (10)	7 (10)	6.25 (10)	6 (9)	5.6 (8)	5 (8)
3000	35 (60)	20 (35)	20 (35)	17.5 (30)	17.5 (30)	20 (30)	35 (50)	10 (15)	10 (15)	10 (15)	9 (12)	8 (12)	8 (12)
5000	60 (100)	35 (60)	30 (60)	30 (50)	30 (50)	30 (50)	60 (90)	15 (25)	15 (25)	15 (25)	12 (20)	12 (20)	12 (20)
7500	80 (150)	50 (90)	45 (90)	45 (80)	45 (80)	40 (70)	90 (125)	25 (40)	25 (40)	20 (35)	20 (30)		
10K	110 (200)	70 (125)	60 (110)	60 (110)	60 (110)	60 (100)	110 (175)	30 (50)	30 (50)	30 (50)	25 (45)		
15K	175 (300)	100 (175)	90 (175)	90 (150)	90 (150)	80 (150)	175 (250)	45 (80)	45 (80)	40 (70)	35 (60)		
25K	300 (500)	175 (300)	150 (300)	150 (250)	150 (250)	150 (250)	90 (250)	60 (70)	70 (125)	70 (125)	60 (110)		
37K						200 (350)				100 (175)			80 (150)
50K						300 (500)				150 (250)			110 (200)
75K						400 (750)				200 (350)			175 (300)
100K						600 (1000)				300 (500)			225 (400)
167K						900 (1600)				450 (850)			350 (650)

Fuse = I times 300% next size smaller if primary current is less than 2 amp. No secondary fusing required.
 (Fuse) = (I*500%) next size smaller if used for a motor control circuit per NEC 430.72 (C) (4).

Fuse = I times 167% next size smaller if primary current is less than 9 amp. No secondary fusing required.
 (Fuse) = (I times 250%) next size smaller if primary current is less than 9 Amps. Secondary fusing is required see chart for size.

Fuse = I times 125% next size higher if primary current is 9 amp. or higher. No secondary fusing required.
 (Fuse) = (I times 250%) next size smaller if primary current is 9 Amps. or higher. Secondary fusing is required see chart for size.

Recommended fuse sizes per UL 508 and NEC 450.3 (B), NEC 430.72 and commercially available type fuses.

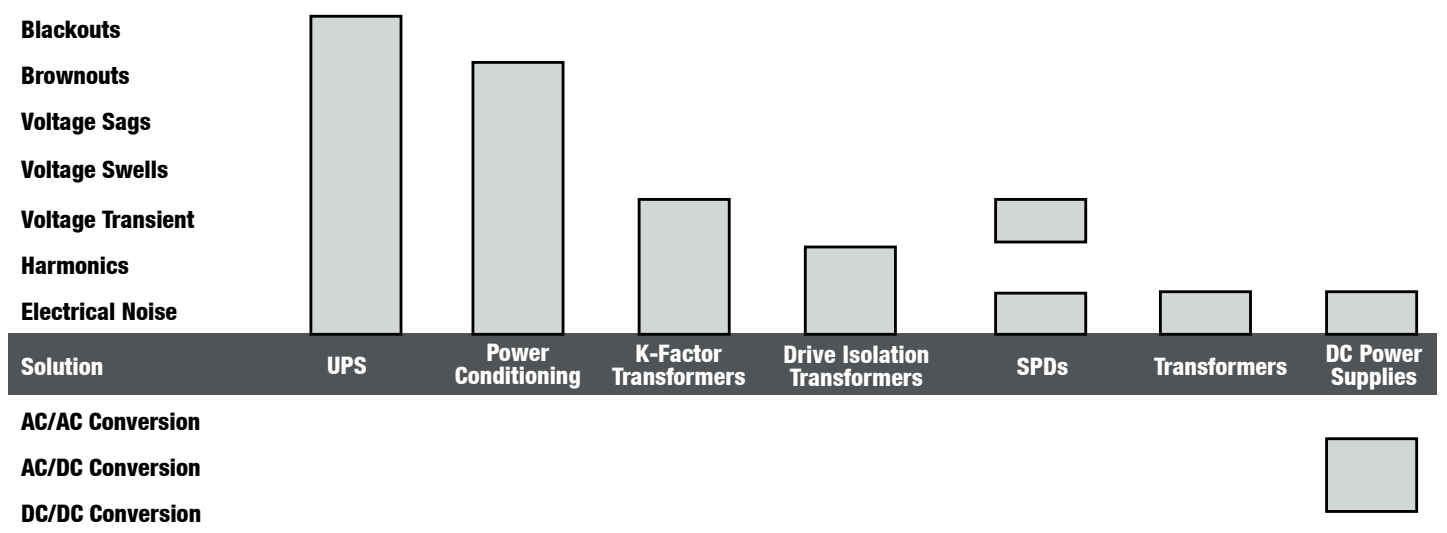
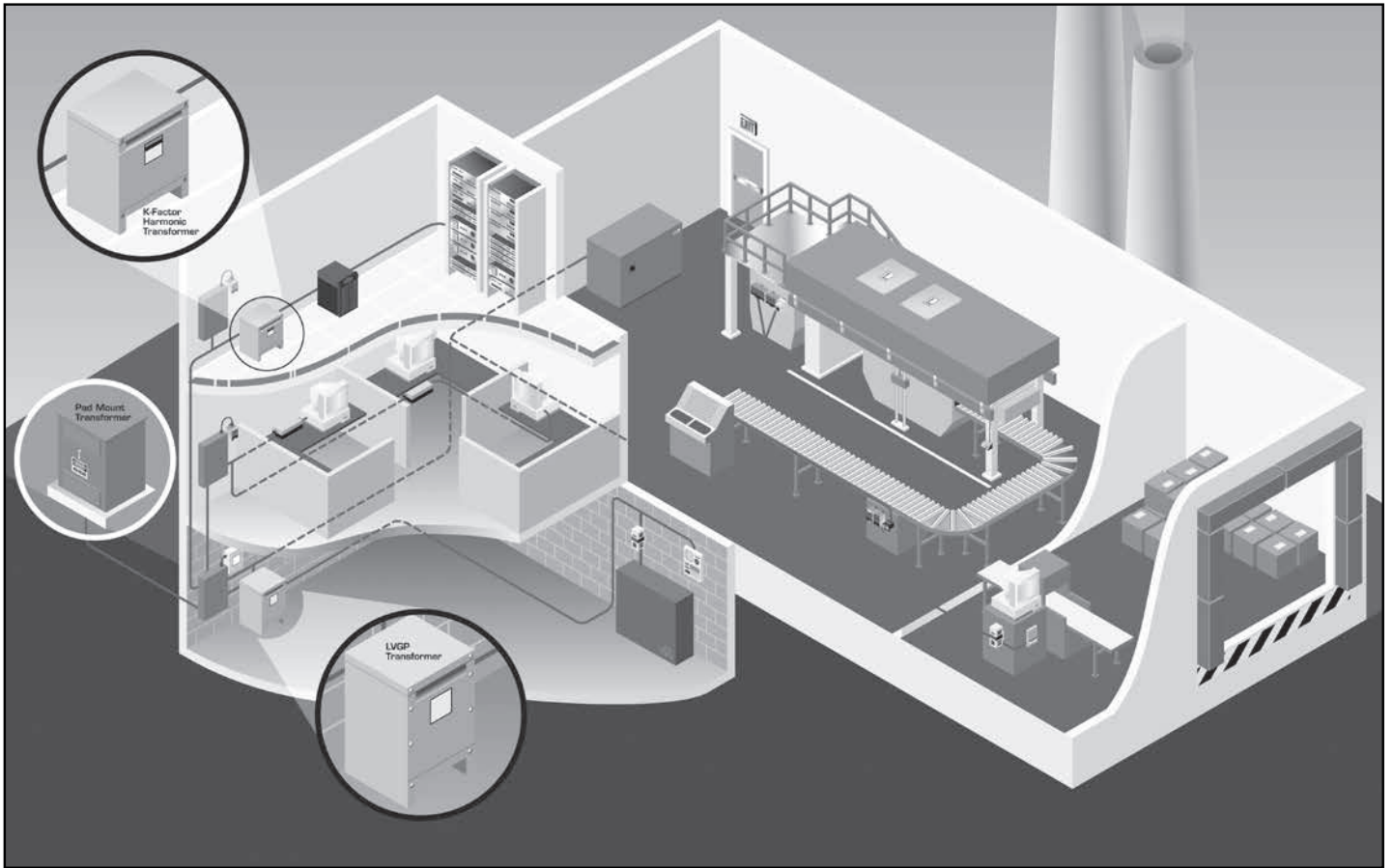



Introduction	191
Selection Steps.....	192
Overcurrent Protection.....	194
Fuse Recommendations.....	195
Distribution Transformers	
15 kVA to 500 kVA DOE 2016 Compliant, Ventilated	197
General Purpose.....	198
Low Temperature Rise	206
K-Factor	212
Automation Transformers	
50 VA to 45 kVA Non-Ventilated.....	217
 Drive Isolation Transformers.....	 229

SolaHD Family of Transformers

Our broad range of SolaHD transformers are designed to meet many applications. These dry-type transformers are offered encapsulated, ventilated or non-ventilated, 600 Volt Class, isolation type, single and three phase, through 500 kVA. Indoor and outdoor models are available.

Applications

Transformers are useful where the available voltage must be changed to accommodate the voltage required by the load. For many electrical circuits, the National Electrical Code (NEC) requires a separately derived neutral secondary connection provided by Delta-Wye connected transformers. Typical applications include:

- Hospitals
- Industrial Plants
- Commercial Buildings
- Apartment Buildings
- Institutional Buildings
- Office Buildings
- Schools
- Shopping Centers
- High Rise Buildings

General purpose transformers can be located close to the load. No vaults are required for installation and no long, expensive feeder lines are needed. Common applications include inductive and resistive loads such as motors, lighting and heating.

Our SolaHD general purpose transformers are manufactured to meet applicable industry standards, are Listed in accordance with UL 5058 and UL 1561 specifications and are classified as isolation transformers. The family of transformers includes:

Distribution Transformers - Ventilated 15 kVA to 500 kVA

General Purpose

These industry workhorses feature dry type construction and are classified as isolation transformers.

Low Temperature Rise

Lower thermal stress on transformer insulation increases useful life.

K-Factor

Designed to reduce the heating effects of harmonic currents created by solid state loads.

Copper Wound

General purpose transformers have standard aluminum coil windings. As an option, copper windings are available.



Automation Transformers - Non-Ventilated 50 VA to 45 kVA, Drive Isolation 7.5 kVA to 440 kVA and Industrial Control 50 VA to 10 kVA

General Purpose

Dry-type transformers, 600 Volt Class, isolation type, single and three phase. Indoor and outdoor models available.

Hazardous Location (Encapsulated)

Comply with Article 500 of the NEC for Class I, Division 2, Group A, B, C and D locations.

Buck-Boost

Used for outdoor or designer low voltage lighting. When connected properly, these transformers can be used to raise or lower the supply voltage to match the needs of the load.

Drive Isolation

Designed to handle the mechanical stresses, voltage demands and harmonics associated with SCR applications.

Industrial Control

The units supply inrush current demands of electromagnetic loads and control applications.

Selection Steps

- A. Use the following steps below to manually select a transformer.
- B. Find the electrical load requirements. These are:
 1. Load operating voltage.
 2. Load frequency (expressed in Hz).
 3. Determine load size - usually expressed in kVA, amperage or horsepower.
 4. Is the load designed to operate on single phase or three phase power?

This information is available from the equipment manufacturer and is typically listed on the nameplate of the equipment.

- C. Know the supply voltage conditions:
 1. Available source voltage.
 2. Available source frequency (a transformer will not change frequency. The frequency of the supply voltage and the needed load voltage must be equal).
 3. Number of phases on power source.
- D. Determine the transformer kVA rating:
 1. If the load is expressed in kVA, select the appropriate transformer from the following selection charts (make sure the selected transformer's kVA rating is equal to or greater than the required load kVA).
 2. If the load is expressed in amperage, use either the appropriate kVA formula listed below or the appropriate sizing chart on the next page.

$$\text{kVA (1}\phi\text{)} = \frac{\text{Volts} \times \text{amps}}{1000}$$

$$\text{kVA (3}\phi\text{)} = \frac{\text{Volts} \times \text{amps} \times 1.732}{1000}$$



3. If the load is expressed in wattage, either utilize the formula below to convert to kVA or refer to the equipment nameplate to obtain amperage requirement.

$$\text{kVA} = \frac{\text{Wattage}}{(1000 \times \text{Power Factor of the load})}$$

4. If the load is a motor and expressed in horsepower, refer to the motor horsepower charts on the next page.

Some sizes may require an optional weather shield (order separately) for outdoor use.

Always size the transformer to the load requirements.

Single Phase: Full Load Current Chart

kVA Rating	120 V	208 V	240 V	277 V	480 V	600 V
Amperes						
0.05	0.42	0.24	0.21	0.18	0.1	0.08
0.075	0.63	0.36	0.31	0.27	0.16	0.13
0.1	0.83	0.48	0.42	0.36	0.21	0.17
0.15	1.3	0.72	0.63	0.54	0.31	0.25
0.25	2.1	1.2	1	0.9	0.52	0.42
0.5	4.2	2.4	2.1	1.8	1.4	0.83
0.75	6.3	3.6	3.1	2.7	1.6	1.3
1	8.3	4.8	4.2	3.6	2.1	1.7
1.5	12.5	7.2	6.3	5.4	3.1	2.5
2	16.7	9.6	8.3	7.2	4.2	3.3
3	25	14.4	12.5	10.8	6.3	5
5	41.7	24	20.8	18.1	10.4	8.3
7.5	62.5	36.1	31.3	27.1	15.6	12.5
10	83.3	48.1	41.7	36.1	20.8	16.7
15	125	72.1	62.5	54.2	31.3	25.0
25	208.3	120.2	104.2	90.3	52.1	41.7
37.5	312.5	180.3	156.3	135.4	78.1	62.5
50	416.7	240.4	208.3	180.5	104.2	83.3
75	625	361	313	271	156	125.0
100	833	481	417	361	208	167.0
167	1392	803	696	603	348	278.0
200	1667	962	833	722	417	333.0
250	2083	1202	1042	903	521	417.0

Three Phase: Full Load Current Chart

kVA Rating	208 V	240 V	480 V	600 V
Amperes				
3	8.3	7.2	3.6	2.9
6	16.7	14.4	7.2	5.8
9	25	21.7	10.8	8.7
15	41.6	36.1	18	14.4
30	83.3	72.2	36.1	28.9
45	125	108.3	54.1	43.3
75	208.2	180.4	90.2	72.2
112.5	312	271	135	108.0
150	416	361	180	144.0
225	625	541	271	217.0
300	833	722	361	289.0
500	1388	1203	601	481.0

Single Phase Motor Chart: AC, Motor Horsepower Amperage

Horse Power	115 V	208 V	230 V	460 V	575 V	Mini Tfr. kVA	Std. NEMA kVA Size
1/6	4.4	2.4	2.2	1.1	0.9	0.53	0.75
¼	5.8	3.2	2.9	1.4	1.2	0.7	0.75
1/3	7.2	4	3.6	1.8	1.4	0.87	1
½	9.8	5.4	4.9	2.5	2	1.2	1.5
¾	13.8	7.6	6.9	3.5	2.8	1.7	2
1	16	8.8	8	4	3.2	1.9	2
1½	20	11	10	5	4	2.4	3
2	24	13.2	12	6	4.8	2.9	3
3	34	18.7	17	8.5	6.8	4.1	5
5	56	30.8	28	14	11.2	6.7	7.5
7.5	80	44	40	21	16	9.6	10
10	100	55	50	26	20	12	15

Three Phase Motor Chart: AC, Motor Horsepower Amperage

Horse Power	208 V	230 V	460 V	575 V	Mini Tfr. kVA	Std. NEMA kVA Size
½	2.2	2	1	0.8	0.9	3.0
¾	3.1	2.8	1.4	1.1	1.2	3.0
1	4	3.6	1.8	1.4	1.5	3.0
1½	5.7	5.2	2.6	2.1	2.1	3.0
2	7.5	6.8	3.4	2.7	2.7	3.0
3	10.7	9.6	4.8	3.9	3.8	6.0
5	16.7	15.2	7.6	6.1	6.3	9.0
7½	24	22	11	9	9.2	15.0
10	31	28	14	11	11.2	15.0
15	46	42	21	17	16.6	30.0
20	59	54	27	22	21.6	30.0
25	75	68	34	27	26.6	30.0
30	88	80	40	32	32.4	45.0
40	114	104	52	41	43.2	45.0
50	143	130	65	52	52	75.0
60	170	154	77	62	64	75.0
75	211	192	96	77	80	112.5
100	273	248	124	99	103	112.5
125	342	312	156	125	130	150.0
150	396	360	180	144	150	150.0
200	528	480	240	192	200	225.0

Three things to keep in mind:

1. Motor horsepower charts are based on 1800 RPM squirrel cage induction motors. If using another type of motor, check running amperage against the chart and adjust as necessary.
2. Increase required transformer kVA by 20% if motors are started more than once per hour.
3. If your motor service factor is greater than 1, proportionally increase full load amperage. (i.e. – if service factor is 1.10, increase full load amperage by 10%).

Are there any special application considerations?

- A. **For ambient conditions over 40°C**, derate the transformer nameplate kVA by 8% for each 10°C above 40°C.
- B. **For high altitude applications**, derate the transformer nameplate kVA by 0.3% for every 330 feet over 3300 feet above sea level. This assures proper transformer convection cooling.
- C. Some applications may require a transformer design that limits the BTU output of the unit at full load or a design to withstand and mitigate specific electrical anomalies.

Overcurrent Protection

Fusing and circuit breaker protection. How to overcurrent protect 600 Volt class transformers and associated wiring per NEC 450.3 (B), NEC 240.3 and NEC 240.6 (A).

1. Primary protection only is required if the transformer is single phase and the secondary has only two wires. Overcurrent protection rating and location are shown in Diagram A.

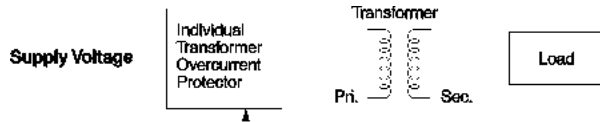

Primary Current	Overcurrent Protection Rating
Less than 2 amps	300% maximum
2 to 9 amps	167% maximum
9 amps or more	125% of rated primary current (or next highest standard rating)

Diagram A

2. If the branch circuit feeding the transformer has overcurrent protection to meet the individual protection requirements in Example 1, then individual transformer protection is **not** required.

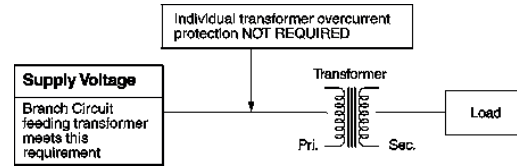

Primary Current	Overcurrent Protection Rating
Less than 2 amps	300% maximum
2 to 9 amps	167% maximum
9 amps or more	125% of rated primary current (or next highest standard rating)

Diagram B

3. Primary and secondary protection is required if the transformer has more than two wires on the secondary circuit.

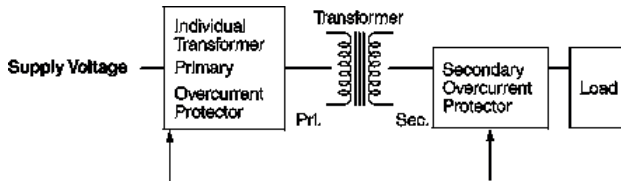

Primary Current	Secondary Current	Overcurrent Protection Rating
250% primary current	Less than 9 amps	167% maximum
Not more than 250%	9 amps or more	125% (or next higher standard rating)

Diagram C

4. If the branch circuit feeding the transformer has overcurrent protection to meet the individual primary overcurrent protection requirements in Example 3, then individual primary protection is **not** required. Secondary OCP is required as shown below.

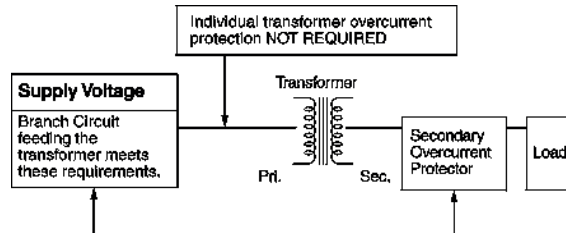

Primary Current	Secondary Current	Overcurrent Protection Rating
250% primary current	Less than 9 amps	167% maximum
Not more than 250%	9 amps or more	125% (or next higher standard rating)

Diagram D

Primary Fuse Recommendations

Primary Voltage													
V _{in}	120	200	208	220	230	240	277	440	460	480	550	575	600
VA													
50	1.25 (2)	.75 (1.25)	.6 (1.13)	.6 (1.13)	.6 (1)	.6 (1)	.5 (.8)	.3 (.5)	.3 (.5)	.3 (.5)	.25 (.4)	.25 (.4)	.25 (.4)
75	1.8 (3)	1.13 (1.8)	1 (1.8)	1 (1.6)	.8 (1.6)	.8 (1.5)	.8 (1.25)	.5 (.8)	.4 (.8)	.4 (.75)	.4 (.6)	.3 (.6)	.3 (.6)
100	2.5 (4)	1.5 (2.5)	1.4 (2.25)	1.25 (2.25)	1.25 (2)	1.25 (2)	1 (1.8)	.6 (1.13)	.6 (1)	.6 (1)	.5 (.8)	.5 (.8)	.5 (.8)
150	3.5 (6.25)	2.25 (3.5)	2 (3.5)	2 (3.2)	1.8 (3.2)	1.8 (3)	1.6 (2.5)	1 (1.6)	.8 (1.6)	.8 (1.5)	.8 (1.25)	.75 (1.25)	.75 (1.25)
200	5 (8)	3 (5)	2.8 (4.5)	2.5 (4.5)	2.5 (4)	2.5 (4)	2 (3.5)	1.25 (2.25)	1.25 (2)	1.25 (2)	1 (1.8)	1 (1.5)	1 (1.6)
250	3 (5)	3.5 (6.25)	3.5 (6)	3.2 (5.6)	3.2 (5)	3 (5)	2.5 (4.5)	1.6 (2.8)	1.6 (2.5)	1.5 (2.5)	1.25 (2.25)	1.25 (2)	1.25 (2)
300	4 (6.25)	4.5 (7.5)	4 (7)	4 (6.25)	3.5 (6.25)	3.5 (6.25)	3.2 (5)	2 (3.2)	1.8 (3.2)	1.8 (3)	1.6 (2.5)	1.5 (2.5)	1.5 (2.5)
350	4.5 (7)	5 (8)	5 (8)	4.5 (7.5)	4.5 (7.5)	4 (7)	3.5 (6.25)	2.25 (3.5)	2.25 (3.5)	2 (3.5)	1.8 (3)	1.8 (3)	1.75 (2.5)
500	6.25 (10)	4 (6.25)	4 (6)	3.5 (5.6)	3.5 (5)	3 (5)	5 (9)	3.2 (5.6)	3.2 (5)	3 (5)	2.5 (4.5)	2.5 (4)	2.5 (4)
750	10 (15)	6.25 (9)	6 (9)	5.6 (8)	5 (8)	5 (7.5)	8 (12)	5 (8)	4.5 (8)	4.5 (7.5)	4 (6.25)	3.5 (6.25)	3.5 (6.25)
1000	12 (20)	8 (12)	8 (12)	7.5 (10)	7 (10)	6.25 (10)	10 (17.5)	3.5 (5.6)	3.6 (5)	3 (5)	5 (9)	5 (8)	5 (8)
1500	17.5 (30)	12 (15)	12 (15)	10 (15)	10 (15)	10 (15)	15 (25)	5.6 (8)	5 (8)	5 (7.5)	4.5 (6.25)	4.5 (6.25)	4.5 (6.25)
2000	25 (40)	15 (25)	15 (20)	15 (20)	12 (20)	12 (20)	20 (35)	7.5 (10)	7 (10)	6.25 (10)	6 (9)	5.6 (8)	5 (8)
3000	35 (60)	20 (35)	20 (35)	17.5 (30)	17.5 (30)	20 (30)	35 (50)	10 (15)	10 (15)	10 (15)	9 (12)	8 (12)	8 (12)
5000	60 (100)	35 (60)	30 (60)	30 (50)	30 (50)	30 (50)	60 (90)	15 (25)	15 (25)	15 (25)	12 (20)	12 (20)	12 (20)
7500	80 (150)	50 (90)	45 (90)	45 (80)	45 (80)	40 (70)	90 (125)	25 (40)	25 (40)	20 (35)	20 (30)		
10K	110 (200)	70 (125)	60 (110)	60 (110)	60 (110)	60 (100)	110 (175)	30 (50)	30 (50)	30 (50)	25 (45)		
15K	175 (300)	100 (175)	90 (175)	90 (150)	90 (150)	80 (150)	175 (250)	45 (80)	45 (80)	40 (70)	35 (60)		
25K	300 (500)	175 (300)	150 (300)	150 (250)	150 (250)	150 (250)	90 (250)	60 (70)	70 (125)	70 (125)	60 (110)		
37K						200 (350)				100 (175)			80 (150)
50K						300 (500)				150 (250)			110 (200)
75K						400 (750)				200 (350)			175 (300)
100K						600 (1000)				300 (500)			225 (400)
167K						900 (1600)				450 (850)			350 (650)

Fuse = I times 300% next size smaller if primary current is less than 2 amp. No secondary fusing required.
 (Fuse) = (I*500%) next size smaller if used for a motor control circuit per NEC 430.72 (C) (4).

Fuse = I times 167% next size smaller if primary current is less than 9 amp. No secondary fusing required.
 (Fuse) = (I times 250%) next size smaller if primary current is less than 9 Amps. Secondary fusing is required see chart for size.

Fuse = I times 125% next size higher if primary current is 9 amp. or higher. No secondary fusing required.
 (Fuse) = (I times 250%) next size smaller if primary current is 9 Amps. or higher. Secondary fusing is required see chart for size.

Recommended fuse sizes per UL 508 and NEC 450.3 (B), NEC 430.72 and commercially available type fuses.

Primary Overcurrent Protection

A transformer has all the same component parts as a motor, and like a motor, exhibits an inrush when energized. This inrush current is dependent upon where in the sine wave the transformer was last turned off in relation to the point of the sinewave you are when you energize the transformer. Although transformer inrush could run up to 30 to 35 times full load current under no load, it typically is the same as a motor, about 6 to 8 times normal running current. For this reason it is important to use a dual element slow blow type fuse, the same type of fuse you would use with a motor. If using a circuit breaker, select a breaker with a time delay, again the same type you would use with a motor. If the time delay is not sufficient, you may experience “nuisance tripping” – a condition where the breaker trips when energizing the transformer but it functions properly after it is re-started.

Secondary Overcurrent Protection

Overcurrent devices are used between the output terminals of the transformer and the load for three reasons:

1. Protect the transformer from load electrical anomalies.
2. Since short circuit current is minimized, a smaller gauge wire may be used between the transformer and the load.
3. Per NEC, a larger primary fuse may be used to reduce nuisance tripping.

Capacity of Center Tap in Center Tap Delta Transformers

This is one of the most common transformer application questions. If the transformer is a SolaHD E5H Series the tap is full capacity, but we must define what full capacity means on one phase of a three phase transformer. A SolaHD three phase transformer, built by Emerson in a ventilated enclosure (standard construction on 15 kVA and above) has a per phase capacity equal to 1/3 of the nameplate rating. Therefore, the tapped phase of a E5H30S has a total capacity of 10 kVA (1/3 of 30 kVA). The 120 volt tap is at the center of this 240 volt winding so the capacity is 5 kVA on either side of the tap (X1 to X6 and X3 to X6).

To determine the available capacity of the center tap, you must know the three phase load applied to the 240 delta. Each phase will supply 1/3 of the kVA to the three phase load. If the E5H30 has a 21 kVA, 3 phase load connected to it, each phase is loaded at 7 kVA. Therefore, the tapped phase has 3 kVA available (10 kVA - 7 kVA = 3 kVA). The center tap can be loaded to 3 kVA without over loading the transformer, but the load must be split so that no more than 1.5 kVA (1/2 the available capacity) is connected to either side of the tap (X1 to X6 and X3 to X6).

The general formula is:

$$\frac{\text{Transformer kVA} - 3\text{Ø Load kVA}}{6} = \text{kVA of each Center Tap Circuit}$$

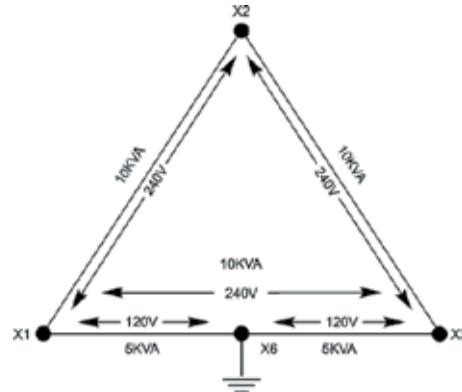

Note: All SolaHD 480 delta to 240 delta transformers stocked by Emerson are equipped with a center tap.

Secondary Fuse Recommendations

Secondary Voltage							
V _{OUT}	24	110	115	120	220	230	240
VA	Secondary Time Delay Dual Element Slow-Blow Fuse						
50	3.2	0.75	0.6	0.6	0.3	0.3	0.3
75	5	1.125	1	1	0.5	0.5	0.5
100	6.25	1.5	1.4	1.25	0.75	0.6	0.6
150	10	2.25	2	2	1.13	1	1
200	12	3	2.8	2.5	1.5	1.4	1.25
250	15	3.5	3.5	3.2	1.8	1.8	1.6
300	20	4.5	4	4	2.25	2	2
350	20	5	5	4.5	2.5	2.5	2.25
500	30	7.5	7	6.25	3.5	3.5	3.2
750	40	10	10	10	5.6	5	5
1000		12	12	12	7	7	6.25
1500		17.5	17.5	17.5	10	10	10
2000		25	25	25	12	12	12
3000		35	35	35	17.5	17.5	17.5
5000		60	60	60	30	30	30
7500		90	90	80	45	45	40
10K		125	110	110	60	60	60
15K		175	175	175	90	90	80
25K		300	300	300	150	150	150
37.5K				400			200
50K				600			300
75K				800			400
100K				1200			600
167K				1800			900

Fuse = 1 times 167% next size smaller if secondary current is less than 9 amp.

Fuse = 1 times 125% next size smaller if secondary current is 9 amp. or higher.

Distribution Transformers manufactured after January 1, 2016 must meet specific energy efficiency requirements. U.S. Department of Energy defines the term “distribution transformers” as any transformer which:

- Has an input voltage of 34.5 kV or less
- Has an output voltage of 600 V or less
- Is rated for operation at a frequency of 60 Hz
- Has a capacity of 10 kVA to 2500 kVA for liquid-immersed units and 15 kVA to 2500 kVA for dry-type units

The following special purpose transformers are excluded from the definition of “distribution transformers” and are, therefore, not required to meet the energy efficiency standards at this time:

- Autotransformers
- Drive (isolation) transformers
- Grounding transformers
- Machine-tool (control) transformers
- Non-ventilated transformers
- Rectifier and Regulating transformers
- Sealed transformers
- Special-impedance transformers
- Testing transformers
- Transformer with tap range of 20% or more
- Uninterruptible power supply transformers
- Welding transformers

Benefiting from Higher Energy Efficiencies

Increasing the energy efficiency of a transformer allows the unit to operate at the same level of power with less energy being wasted in the process. Decreasing usage through reduced waste by just .03% over the next 20 years cuts the need for new power generation in the United States by 60 to 66 million kw.

We have been engineering and producing energy efficient transformers for over a decade. The SolaHD energy efficient transformers are optimized to meet DOE’s CFR (Code of Federal Regulations) title 10, part 431 (also known as DOE 10 CFR p431 or referred to as DOE 2016) limits for load losses calculated to 35% of the name plate rating, yet are the same compact size and footprint as its’ conventional 150°C rise units.

The example pictured in Figure 1 shows the differences in efficiency for the old standard model compared to the compliant model. At 35% load, the absolute difference in efficiency is only 1.7%. However, that represents a 52% reduction in wasted energy. Taking that 52% reduction in

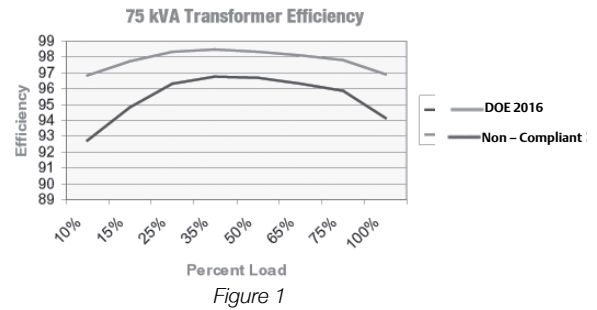

wasted energy and multiplying it across all the energy consumed results in substantial savings.

Emerson offers the following family of SolaHD transformers that meet the strict efficiency standards. The efficiencies of these transformers are optimized for the load losses calculated at 35% of the name plate rating. This 35% represents an industry average load of most LVGP transformers.

Applications

Any situation where the available voltage must be changed to accommodate the voltage required by the specific electrical circuit or connected equipment. For many electrical circuits, the National Electrical Code (NEC) requires a separately derived neutral secondary connection provided by Delta-Wye connected transformers.

Distribution transformers can be located close to the load. No vaults are required for installation and no long, expensive feeder lines are needed. Common applications include inductive and resistive loads such as motors, lighting and heating.

General Purpose Transformers

Transformers designed to meet the high energy efficiencies required by DOE 2016.

Low Temperature Rise Transformers

Transformers designed to limit the temperature rise of the core and coil assembly to either 80°C or 115°C above a 40°C ambient. Reduction in temperature rise increases reliability.

K-Factor Transformers

Transformers designed to withstand the electrical anomalies associated with solid state equipment and DC power supplies (excluding SCR variable speed motor drives) without derating the nameplate kVA.

Copper Wound Transformers

SolaHD general purpose transformers have standard aluminum coil windings. As an option, we offer a selection with copper windings.

General Purpose

Energy efficient dry-type SolaHD General Purpose Transformers 600 Volt Class, isolation type, single and three phase, 15 kVA through 500 kVA. Indoor and outdoor models available. For catalog numbers outside of the standard Selection Tables, fill out the *Custom Transformer Quotation Request* at the end of this section.



Accessories and Optional Design Styles

- Electrostatic shield for quality power
- Wall mounting brackets (500 lbs maximum) (Item WB1C)
- Weather Shields (UL Listed/NEMA Type 3R)
- Stainless Steel Enclosures
- Totally enclosed non-ventilated designs (TENV) (Non UL) *
- Open core and coil designs (UL Recognized)
- Copper Wound designs
- Low temperature designs

Features

- Energy Efficient Compliant to DOE 2016 ¹
- UL Listed/NEMA Type 3R ventilated outdoor enclosures when used with optional weather shields (order separately)
- UL Class II 20°C insulation system, 150°C temperature rise under full load
- Quiet operation with sound levels 3-6 dB below the NEMA ST-20 requirements

- Terminal board connections and spacious wiring compartment
- Panel enclosure design reduces labor time. Wiring diagram on inside front cover.
- High efficiency for low cost operation
- Single and three phase availability
- Fast delivery
- Meets transit test requirements for ISTA (International Safe Transit Association) – Test Procedure 1E for packaged-product
- 10 year limited warranty

Selection Tables: Single Phase

Group 1: 240 x 480 Volt Primary, 120/240 Secondary, 60 Hz

kVA	Catalog Number	Type 3R Weather Shield ²	Height in (mm)	Width in (mm)	Depth in (mm)	Approx. Ship Weight lbs (kg)	Design Style ³	Elec Conn ³	Primary Amps	Secondary Amps
15	ES5H15S	WS-15	28 (711)	16 (406)	16 (406)	210 (95)	1	1	62.5/31.3	125/62.5
25	ES5H25S	WS-15	28 (711)	16 (406)	16 (406)	245 (111)	1	1	104/52.1	208/104
37.5	ES5H37S	WS-17	31 (787)	18 (457)	18 (457)	340 (154)	1	1	156/78	313/156
50	ES5H50S	WS-17	31 (787)	18 (457)	18 (457)	415 (188)	1	1	208/104	416/208
75	ES5H75S	WS-09	44 (1118)	23 (584)	21 (533)	610 (277)	1	1	313/156	625/313
100	ES5H100S	WS-09	44 (1118)	23 (584)	21 (533)	705 (320)	1	1	417/208	833/417
167	ES5H167S	WS-16	46 (1168)	26 (660)	24 (610)	980 (445)	1	1	695/348	1392/695

Group 2 – 120/208/240/277 Volt Primary, 120/240 Secondary, 60 Hz

kVA	Catalog Number	Type 3R Weather Shield ²	Height in (mm)	Width in (mm)	Depth in (mm)	Approx. Ship Weight lbs (kg)	Design Style ³	Elec Conn ³	Primary Amps @ 277 V	Secondary Amps
15	ES12H15S	WS-15	28 (711)	16 (406)	16 (406)	215 (98)	1	2	54.2	125/62.5
25	ES12H25S	WS-15	28 (711)	16 (406)	16 (406)	250 (113)	1	2	90.3	208/104

Notes:

1. DOE 2016 refers to Department of Energy CFR (Code of Federal Regulations) title 10, part 431.196).
2. Weather shields (set of two) must be ordered separately.
3. Design Styles and Electrical Connections can be found at the end of the Ventilated Distribution Transformers section.

* Not all optional designs are listed. Contact Technical Services.

Certifications and Compliances

- Listed: E25872
- UL 1561

Selection Tables: Three Phase

Group A: 480 Volt Δ Primary, 208Y/120 Secondary, 60 Hz

kVA	Catalog Number	Type 3R Weather Shield ¹	Height in (mm)	Width in (mm)	Depth in (mm)	Approx. Ship Weight lbs (kg)	Design Style ²	Elec Conn ²	Primary Amps	Secondary Amps
15	E2H15 ³	WS-02	23 (584)	18 (457)	14 (356)	221 (100)	1	5	18.1	41.7
	E2H15S									
30	E2H30 ³	WS-14	28 (711)	23 (584)	16 (406)	310 (141)	1	5	36.1	83.4
	E2H30S									
45	E2H45 ³	WS-14	28 (711)	23 (584)	16 (406)	387 (176)	1	5	54.2	125
	E2H45S									
75	E2H75 ³	WS-30	34 (864)	28 (711)	22 (559)	678 (308)	1	5	90.3	208
	E2H75S									
112.5	E2H112S	WS-30	34 (864)	28 (711)	22 (559)	794 (360)	1	5	135	313
150	E2H150S	WS-10	44 (1118)	33 (838)	21 (533)	1005 (456)	1	5	181	417
225	E2H225S	WS-11	46 (1168)	36 (914)	24 (610)	1368 (621)	1	5	271	625
300	E2H300S	WS-11	46 (1168)	36 (914)	24 (6010)	1479 (671)	1	5	361	834
500	E2H500S	WS-12	65 (1651)	45 (1143)	35 (889)	2457 (1114)	1	5	602	1390

Group B: 480 Volt Δ Primary, 240 Volt Δ Secondary with 120 V reduced capacity center tap ⁴, 60 Hz

kVA	Catalog Number	Type 3R Weather Shield ¹	Height in (mm)	Width in (mm)	Depth in (mm)	Approx. Ship Weight lbs (kg)	Design Style ²	Elec Conn ²	Primary Amps	Secondary Amps
15	E5H15 ³	WS-02	23 (584)	18 (457)	14 (356)	221 (100)	1	6	18.1	36.1
	E5H15S									
30	E5H30 ³	WS-14	28 (711)	23 (584)	16 (406)	322 (146)	1	6	36.1	72.3
	E5H30S									
45	E5H45 ³	WS-14	28 (711)	23 (584)	16 (406)	387 (176)	1	6	54.2	108
	E5H45S									
75	E5H75 ³	WS-30	34 (864)	28 (711)	22 (559)	678 (308)	1	6	90.3	181
	E5H75S									
112.5	E5H112S	WS-30	34 (864)	28 (711)	22 (559)	792 (359)	1	6	135	271
150	E5H150S	WS-10	44 (1118)	33 (838)	21 (533)	1009 (458)	1	6	181	361
225	E5H225S	WS-11	46 (1168)	36 (914)	24 (610)	1367 (620)	1	6	271	542
300	E5H300S	WS-11	46 (1168)	36 (914)	24 (610)	1478 (670)	1	6	361	723
500	E5H500S	WS-12	65 (1651)	45 (1143)	35 (889)	2457 (1114)	1	6	602	1204

Notes:

- Weather shields (set of two) must be ordered separately.
- Design Styles and Electrical Connections can be found at the end of the Ventilated Distribution Transformers section.
- Unshielded model.
- Refer to *Capacity of Center Tap in Center Tap Delta Transformers* at the beginning of this section.

Selection Tables: Three Phase

Group C: 480 Volt Δ Primary, 480Y/277 Secondary, 60 Hz

kVA	Catalog Number	Type 3R Weather Shield ¹	Height in (mm)	Width in (mm)	Depth in (mm)	Approx. Ship Weight lbs (kg)	Design Style ²	Elec Conn ²	Primary Amps	Secondary Amps
15	E81H15S	WS-02	23 (584)	18 (457)	14 (356)	220 (100)	1	8	18.1	18.1
30	E81H30S	WS-14	28 (711)	23 (584)	16 (406)	322 (146)	1	8	36.1	36.1
45	E81H45S	WS-14	28 (711)	23 (584)	16 (406)	387 (176)	1	8	54.2	54.2
75	E81H75S	WS-30	34 (864)	28 (711)	22 (559)	679 (308)	1	8	90.3	90.3
112.5	E81H112S	WS-30	34 (864)	28 (711)	22 (559)	791 (359)	1	8	135	135
150	E81H150S	WS-10	44 (1118)	33 (838)	21 (533)	1001 (454)	1	8	181	181
225	E81H225S	WS-11	46 (1168)	36 (914)	24 (610)	1377 (625)	1	8	271	271
300	E81H300S	WS-11	46 (1168)	36 (914)	24 (610)	1497 (679)	1	8	361	361
500	E81H500S	WS-12	65 (1651)	45 (1143)	35 (889)	2456 (1114)	1	8	602	602

Group D: 208 Volt Δ Primary, 480Y/277 Secondary, 60 Hz

kVA	Catalog Number	Type 3R Weather Shield ¹	Height in (mm)	Width in (mm)	Depth in (mm)	Approx. Ship Weight lbs (kg)	Design Style ²	Elec Conn ²	Primary Amps	Secondary Amps
15	E84H15S	WS-02	23 (584)	18 (457)	14 (356)	220 (100)	1	10	41.7	18.1
30	E84H30S	WS-14	28 (711)	23 (584)	16 (406)	320 (145)	1	10	83.4	36.1
45	E84H45S	WS-14	28 (711)	23 (584)	16 (406)	390 (177)	1	10	125	54.2
75	E84H75S	WS-30	34 (864)	28 (711)	22 (559)	680 (308)	1	10	208	90.3
112.5	E84H112S	WS-30	34 (864)	28 (711)	22 (559)	799 (362)	1	10	313	135
150	E84H150S	WS-10	44 (1118)	33 (838)	21 (533)	1000 (454)	1	10	417	181

Notes:

1. Weather shields (set of two) must be ordered separately.
2. Design Styles and Electrical Connections can be found at the end of the Ventilated Distribution Transformers section.

Selection Tables: Three Phase

Group E: 208 Volt Δ Primary, 208Y/120 Secondary, 60 Hz

kVA	Catalog Number	Type 3R Weather Shield ¹	Height in (mm)	Width in (mm)	Depth in (mm)	Approx. Ship Weight lbs (kg)	Design Style ²	Elec Conn ²	Primary Amps	Secondary Amps
15	E3H15S	WS-02	23 (584)	18 (457)	14 (356)	222 (101)	1	9	41.7	41.7
30	E3H30S	WS-14	28 (711)	23 (584)	16 (406)	320 (145)	1	9	83.4	83.4
45	E3H45S	WS-14	28 (711)	23 (584)	16 (406)	390 (177)	1	9	125	125
75	E3H75S	WS-30	34 (864)	28 (711)	22 (559)	679 (308)	1	9	208	208
112.5	E3H112S	WS-30	34 (864)	28 (711)	22 (559)	801 (363)	1	9	313	313
150	E3H150S	WS-10	44 (1118)	33 (838)	21 (533)	1004 (455)	1	9	416	416

Group F: 240 Volt Δ Primary, 208Y/120 Secondary, 60 Hz

kVA	Catalog Number	Type 3R Weather Shield ¹	Height in (mm)	Width in (mm)	Depth in (mm)	Approx. Ship Weight lbs (kg)	Design Style ²	Elec Conn ²	Primary Amps	Secondary Amps
15	E6H15S	WS-02	23 (584)	18 (457)	14 (356)	220 (100)	1	11	36.1	41.7
30	E6H30S	WS-14	28 (711)	23 (584)	16 (406)	311 (141)	1	11	72.3	83.4
45	E6H45S	WS-14	28 (711)	23 (584)	16 (406)	392 (178)	1	11	108	125
75	E6H75S	WS-30	34 (864)	28 (711)	22 (559)	678 (308)	1	11	181	208
112.5	E6H112S	WS-30	34 (864)	28 (711)	22 (559)	799 (362)	1	11	271	313
150	E6H150S	WS-10	44 (1118)	33 (838)	21 (533)	1005 (456)	1	11	361	417

Group G: 240 Volt Δ Primary, 480Y/277 Secondary, 60 Hz

kVA	Catalog Number	Type 3R Weather Shield ¹	Height in (mm)	Width in (mm)	Depth in (mm)	Approx. Ship Weight lbs (kg)	Design Style ²	Elec Conn ²	Primary Amps	Secondary Amps
15	E85H15S	WS-02	23 (584)	18 (457)	14 (356)	221 (100)	1	12	36.1	18.1
30	E85H30S	WS-14	28 (711)	23 (584)	16 (406)	322 (146)	1	12	72.3	36.1
45	E85H45S	WS-14	28 (711)	23 (584)	16 (406)	392 (178)	1	12	108	54.2
75	E85H75S	WS-30	34 (864)	28 (711)	22 (559)	682 (309)	1	12	181	90.3
112.5	E85H112S	WS-30	34 (864)	28 (711)	22 (559)	798 (362)	1	12	271	135
150	E85H150S	WS-10	44 (1118)	33 (838)	21 (533)	1001 (454)	1	12	361	181

Notes:

1. Weather shields (set of two) must be ordered separately.
2. Design Styles and Electrical Connections can be found at the end of the Ventilated Distribution Transformers section.

Selection Tables: Three Phase

Group J: 480 Volt Δ Primary, 380Y/220 Secondary, 60 Hz

kVA	Catalog Number	Type 3R Weather Shield ¹	Height in (mm)	Width in (mm)	Depth in (mm)	Approx. Ship Weight lbs (kg)	Design Style ²	Elec Conn ²	Primary Amps	Secondary Amps
15	E79H15S	WS-02	23 (584)	18 (457)	14 (356)	220 (100)	1	7	18.1	22.8
30	E79H30S	WS-14	28 (711)	23 (584)	16 (406)	320 (145)	1	7	36.1	45.6
45	E79H45S	WS-14	28 (711)	23 (584)	16 (406)	387 (176)	1	7	54.2	68.4
75	E79H75S	WS-30	34 (864)	28 (711)	22 (559)	678 (308)	1	7	90.3	114
112.5	E79H112S	WS-30	34 (864)	28 (711)	22 (559)	797 (362)	1	7	135.3	170.9
150	E79H150S	WS-10	44 (1118)	33 (838)	21 (533)	1011 (459)	1	7	180.4	227.9

Group K: 480 Volt Δ Primary, 208Y/120 Secondary, 60 Hz, Copper-Wound

kVA	Catalog Number	Type 3R Weather Shield ¹	Height in (mm)	Width in (mm)	Depth in (mm)	Approx. Ship Weight lbs (kg)	Design Style ²	Elec Conn ²	Primary Amps	Secondary Amps
15	E2H15SCU	WS-02	23 (584)	18 (457)	14 (356)	255 (116)	1	5	18.1	41.7
30	E2H30SCU	WS-14	28 (711)	23 (584)	16 (406)	349 (158)	1	5	36.1	83.4
45	E2H45SCU	WS-14	28 (711)	23 (584)	16 (406)	455 (206)	1	5	54.2	125
75	E2H75SCU	WS-30	34 (864)	28 (711)	22 (559)	781 (354)	1	5	90.3	208
112.5	E2H112SCU	WS-30	34 (864)	28 (711)	22 (559)	923 (419)	1	5	135	313
150	E2H150SCU	WS-10	44 (1118)	33 (838)	21 (533)	1154 (523)	1	5	181	417
225	E2H225SCU	WS-11	46 (1168)	36 (914)	24 (610)	1539 (698)	1	5	271	625
300	E2H300SCU	WS-11	46 (1168)	36 (914)	24 (610)	1662 (754)	1	5	361	834
500	E2H500SCU	WS-12	65 (1651)	45 (1143)	35 (889)	2457 (1114)	1	5	602	1390

Notes:

1. Weather shields (set of two) must be ordered separately.
2. Design Styles and Electrical Connections can be found at the end of the Ventilated Distribution Transformers section.

Electrical Connections (Single Phase)

1

240 x 480 Volt Primary,
120/240 Volt Secondary
Taps: 2, 2½% FCAN; 4, 2½% FCBN

Primary Voltage	Interconnect	Connect Lines To
504	1 to 2	H1 & H2
492	2 to 3	H1 & H2
480	3 to 4	H1 & H2
468	4 to 5	H1 & H2
456	5 to 6	H1 & H2
444	6 to 7	H1 & H2
432	7 to 8	H1 & H2
252	H1 to 2 H2 to 1	H1 & H2
240	H1 to 4 H2 to 3	H1 & H2
228	H1 to 6 H2 to 5	H1 & H2
216	H1 to 8 H2 to 7	H1 & H2
Secondary Voltage	Interconnect	Connect Lines To
240	X2 to X3	X1 & X4
120-0-120	X2 to X3 X2 to \perp	X1-X2-X4
120	X1 to X3 X2 to X4	X1 & X4

ES5 Series

2

120/208/240/277 Volt Primary,
120/240 Volt Secondary
Taps: None

Primary Voltage	Interconnect	Connect Lines To
277	1 to 2	H1 & H2
240	3 to 4	H1 & H2
208	5 to 6	H1 & H2
120	H1 to 4 H2 to 3	H1 & H2
Secondary Voltage	Interconnect	Connect Lines To
240	X2 to X3	X1 & X4
120-0-120	X2 to X3 X2 to \perp	X1-X2-X4
120	X1 to X3 X2 to X4	X1 & X4

ES12 Series

Design Style

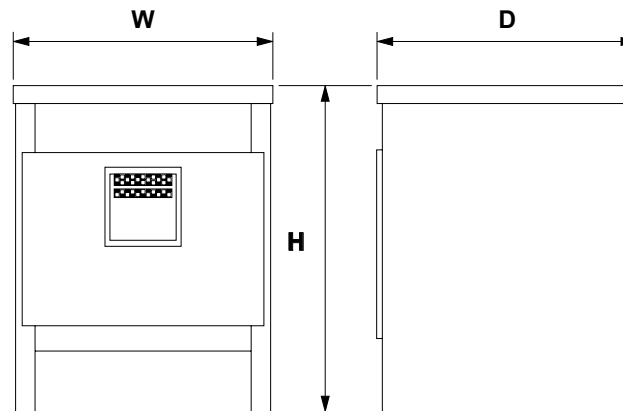

Style 1 - Ventilated

Electrical Connections (Three Phase)

480 Δ Volt Primary,
208Y/120 Volt Secondary
Taps: 2, 2½% FCAN; 4, 2½% FCBN **5**

Primary H1-H2-H3		Secondary Voltage	
@ Tap	Voltage	X1, X2, X3	X0- X1, X2, X3
1	504	208	120
2	492		
3	480		
4	468		
5	456		
6	444		
7	432		

E2 and 3H Series

** Shield available in electrostatically shielded units only.*

480 Δ Volt Primary,
240 Δ W/120 CT Volt Secondary
Taps: 2, 2½% FCAN; 4, 2½% FCBN **6**

Primary H1-H2-H3		Secondary Voltage	
@ Tap	Voltage	X1, X2, X3	X6-X1, X6-X3
1	504	240	120
2	492		
3	480		
4	468		
5	456		
6	444		
7	432		

E5 Series

** Shield available in electrostatically shielded units only.*

480 Δ Volt Primary
380Y/220 Volt Secondary
Taps: 2, 2½% FCAN; 4, 2½% FCBN **7**

Primary H1-H2-H3		Secondary Voltage	
@ Tap	Voltage	X1, X2, X3	X0- X1, X2, X3
1	504	380	220
2	492		
3	480		
4	468		
5	456		
6	444		
7	432		

E79 Series

480 Δ Volt Primary
480Y/277 Volt Secondary
Taps: 2, 2½% FCAN; 4, 2½% FCBN **8**

Primary H1-H2-H3		Secondary Voltage	
@ Tap	Voltage	X1, X2, X3	X0- X1, X2, X3
1	504	480	277
2	492		
3	480		
4	468		
5	456		
6	444		
7	432		

E81 Series

208 Δ Volt Primary
208Y/120 Volt Secondary
Taps: 2, 2½% FCAN; 4, 2½% FCBN **9**

Primary H1-H2-H3		Secondary Voltage	
@ Tap	Voltage	X1, X2, X3	X0- X1, X2, X3
1	218	208	120
2	213		
3	208		
4	203		
5	198		
6	192		
7	187		

E3 Series

Electrical Connections (Three Phase) cont.

10

208 Δ Volt Primary
480Y/277 Volt Secondary
Taps: 2, 2½% FCAN; 4, 2½% FCBN

Primary X1-X2-X3		Secondary Voltage	
@ Tap	Voltage	H1-H2-H3	H0-H1, H2, H3
1	218	480	277
2	213		
3	208		
4	203		
5	198		
6	192		
7	187		

E84 Series

11

240 Δ Volt Primary
208Y/120 Volt Secondary
Taps: 2, 2½% FCAN; 4, 2½% FCBN

Primary H1-H2-H3		Secondary Voltage	
@ Tap	Voltage	X1, X2, X3	X0- X1, X2, X3
1	252	208	120
2	246		
3	240		
4	234		
5	228		
6	222		
7	216		

E6 Series

12

240 Δ Volt Primary
480Y/277 Volt Secondary
Taps: 2, 2½% FCAN; 4, 2½% FCBN

Primary X1-X2-X3		Secondary Voltage	
@ Tap	Voltage	H1, H2, H3	H0- H1, H2, H3
1	252	480	277
2	246		
3	240		
4	234		
5	228		
6	222		
7	216		

E85 Series

Low Temperature Rise

SolaHD Low Temperature Rise transformers feature a 220°C insulation system and temperature rise of only 80°C or 115°C under full nameplate load. Reduction in temperature rise increases reliability.

The 35°C thermal reserve on 115°C rise units and 70°C reserve on 80°C rise units definitely mean higher reliability. The extra benefit is being able to operate either of these transformers as a 150°C rise unit and have a short term overload capacity of 15-30% *without* compromising normal life expectancy (See Figure 2).

Low temperature rise transformers are designed for any critical application requiring extra overload capability and cooler operating temperatures. All are available with either a 115°C or 80°C thermal rise and a Class 220°C insulation system.



Features

- Energy Efficient Compliant to DOE 2016 ¹
- Extra thermal reserve
- Meets transit test requirements for ISTA (International Safe Transit Association) – Test Procedure 1E for packaged-product
- Quiet operation with sound levels 3-6 dB below the NEMA ST-20 requirements

Accessories and Optional Design Styles

- Wall mounting brackets (500 lbs maximum) (Item WB1C)
- Weather Shields (UL Listed/NEMA Type 3R)
- Stainless Steel Enclosures
- Totally enclosed non-ventilated designs (TENV) (Non UL) *
- Open core and coil designs (UL Recognized)
- Copper Wound designs

Certifications and Compliances

- Listed: E25872
- UL 1561

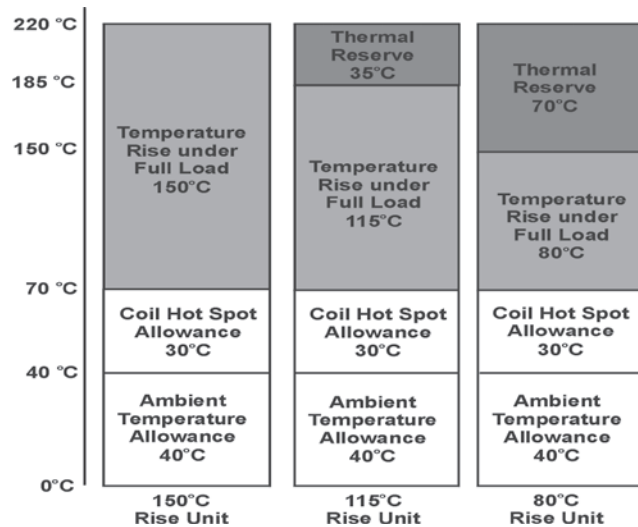

Figure 2

Selection Tables: Low Temperature Rise, Single Phase, 80°C Rise

Group 1: 240 x 480 Volt Primary, 120/240 Secondary, 60 Hz, 80°C Rise

kVA	Catalog Number 80°C Rise	Type 3R Weather Shield ²	Height in (mm)	Width in (mm)	Depth in (mm)	Approx. Ship Weight lbs (kg)	Design Style ³	Elec Conn ³	Primary Amps	Secondary Amps
15	ES5HB15S	WS-15	28 (711)	16 (406)	16 (406)	265 (120)	1	1	62.5/31.3	125/62.5
25	ES5HB25S	WS-17	31 (787)	18 (457)	18 (457)	340 (154)	1	1	104/52.1	208/104
37.5	ES5HB37S	WS-17	31 (787)	18 (457)	18 (457)	425 (193)	1	1	156/78	313/156
50	ES5HB50S	WS-09	44 (1118)	23 (584)	21 (533)	655 (297)	1	1	208/104	416/208
75	ES5HB75S	WS-09	44 (1118)	23 (584)	21 (533)	750 (340)	1	1	313/156	625/313
100	ES5HB100S	WS-16	46 (1168)	26 (660)	24 (610)	980 (445)	1	1	417/208	833/417

Notes:

1. DOE 2016 refers to Department of Energy CFR (Code of Federal Regulations) title 10, part 431.196).
 2. Weather shields (set of two) must be ordered separately.
 3. Design Styles and Electrical Connections can be found at the end of the Ventilated Distribution Transformers section.
- * Not all optional designs are UL listed. Contact Technical Services.

Selection Tables: Low Temperature Rise, Three Phase, **80°C Rise**

Group A: 480 Δ Primary, 208Y/120 Secondary, 60 Hz, 80°C Rise

kVA	Catalog Number 80°C Rise	Type 3R Weather Shield ¹	Height in (mm)	Width in (mm)	Depth in (mm)	Approx. Ship Weight lbs (kg)	Design Style ²	Elec Conn ²	Primary Amps	Secondary Amps
15	E2HB15S	WS-14	28 (711)	23 (584)	16 (406)	310 (141)	1	5	18.1	41.7
30	E2HB30S	WS-14	28 (711)	23 (584)	16 (406)	387 (176)	1	5	36.1	83.4
45	E2HB45S	WS-30	34 (864)	28 (711)	22 (559)	678 (308)	1	5	54.2	125
75	E2HB75S	WS-30	34 (864)	28 (711)	22 (559)	794 (360)	1	5	90.3	208
112.5	E2HB112S	WS-10	44 (1118)	33 (838)	21 (533)	1005 (456)	1	5	135	313
150	E2HB150S	WS-11	46 (1168)	36 (914)	24 (610)	1368 (621)	1	5	181	417
225	E2HB225S	WS-11	46 (1168)	36 (914)	24 (610)	1479 (671)	1	5	271	625
300	E2HB300S	WS-12	65 (1651)	45 (1143)	35 (889)	2457 (1114)	1	5	361	834

Group B: 480 Δ Primary, 240 Δ Secondary with 120 V Reduced Capacity Center Tap ³, 80°C Rise

kVA	Catalog Number 80°C Rise	Type 3R Weather Shield ¹	Height in (mm)	Width in (mm)	Depth in (mm)	Approx. Ship Weight lbs (kg)	Design Style ²	Elec Conn ²	Primary Amps	Secondary Amps
15	E5HB15S	WS-14	28 (711)	23 (584)	16 (406)	322 (146)	1	6	18.1	36.1
30	E5HB30S	WS-14	28 (711)	23 (584)	16 (406)	387 (176)	1	6	36.1	72.3
45	E5HB45S	WS-30	34 (864)	28 (711)	22 (559)	678 (308)	1	6	54.2	108
75	E5HB75S	WS-30	34 (864)	28 (711)	22 (559)	792 (359)	1	6	90.3	181
112.5	E5HB112S	WS-10	44 (1118)	33 (838)	21 (533)	1009 (458)	1	6	135	271
150	E5HB150S	WS-11	46 (1168)	36 (914)	24 (610)	1367 (620)	1	6	181	361
225	E5HB225S	WS-11	46 (1168)	36 (914)	24 (610)	1478 (670)	1	6	271	542
300	E5HB300S	WS-12	65 (1651)	45 (1143)	35 (889)	2457 (1114)	1	6	361	723

Notes:

- Weather shields (set of two) must be ordered separately.
- Design Styles and Electrical Connections can be found at the end of the Ventilated Distribution Transformers section.
- Refer to *Capacity of Center Tap in Center Tap Delta Transformers* at the beginning of this section.

Selection Tables: Low Temperature Rise, Single Phase, **115°C Rise**

Group 1: 240 x 480 Volt Primary, 120/240 Secondary, 60 Hz, **115°C Rise**

kVA	Catalog Number 115°C Rise	Type 3R Weather Shield ¹	Height in (mm)	Width in (mm)	Depth in (mm)	Approx. Ship Weight lbs (kg)	Design Style ²	Elec Conn ²	Primary Amps	Secondary Amps
15	ES5HF15S	WS-15	28 (711)	16 (406)	16 (406)	210 (95)	1	1	62.5/31.3	125/62.5
25	ES5HF25S	WS-15	28 (711)	16 (406)	16 (406)	245 (111)	1	1	104/52.1	208/104
37.5	ES5HF37S	WS-17	31 (787)	18 (457)	18 (457)	340 (154)	1	1	156/78	313/156
50	ES5HF50S	WS-17	31(787)	18(457)	18 (457)	425 (193)	1	1	208/104	416/208
75	ES5HF75S	WS-09	44 (1118)	23 (584)	21 (533)	610 (277)	1	1	313/156	625/313
100	ES5HF100S	WS-09	44 (1118)	23 (584)	21 (533)	750 (340)	1	1	417/208	833/417

Selection Tables: Low Temperature Rise, Three Phase, **115°C Rise**

Group A: 480 Δ Primary, 208Y/120 Secondary, 60 Hz, **115°C Rise**

kVA	Catalog Number 115°C Rise	Type 3R Weather Shield ¹	Height in (mm)	Width in (mm)	Depth in (mm)	Approx. Ship Weight lbs (kg)	Design Style ²	Elec Conn ²	Primary Amps	Secondary Amps
15	E2HF15S	WS-02	23 (584)	18 (457)	14 (356)	222 (101)	1	5	18.1	41.7
30	E2HF30S	WS-14	28 (711)	23 (584)	16 (406)	307 (139)	1	5	36.1	83.4
45	E2HF45S	WS-14	28 (711)	23 (584)	16 (406)	378 (171)	1	5	54.2	125
75	E2HF75S	WS-30	34 (864)	28 (711)	22 (559)	672 (305)	1	5	90.3	208
112.5	E2HF112S	WS-30	34 (864)	28 (711)	22 (559)	794 (360)	1	5	135	313
150	E2HF150S	WS-10	44 (1118)	33 (838)	21 (533)	1002 (454)	1	5	181	417
225	E2HF225S	WS-11	46 (1168)	36 (914)	24 (610)	1393 (632)	1	5	271	625
300	E2HF300S	WS-11	46 (1168)	36 (914)	24 (610)	1519 (689)	1	5	361	834

Group B: 480 Volt Δ Primary, 240 Volt Δ Secondary with 120 V reduced capacity center tap ⁴, 60 Hz, **115°C Rise**

kVA	Catalog Number	Type 3R Weather Shield ¹	Height in (mm)	Width in (mm)	Depth in (mm)	Approx. Ship Weight lbs (kg)	Design Style ²	Elec Conn ²	Primary Amps	Secondary Amps
15	E5HF15S	WS-02	23 (584)	18 (457)	14 (356)	224 (102)	1	6	18.1	36.1
30	E5HF30S	WS-14	28 (711)	23 (584)	16 (406)	307 (139)	1	6	36.1	72.3
45	E5HF45S	WS-14	28 (711)	23 (584)	16 (406)	378 (171)	1	6	54.2	108
75	E5HF75S	WS-30	34 (864)	28 (711)	22 (559)	668 (303)	1	6	90.3	181
112.5	E5HF112S	WS-30	34 (864)	28 (711)	22 (559)	794 (360)	1	6	135	271
150	E5HF150S	WS-10	44 (1118)	33 (838)	21 (533)	1002 (454)	1	6	181	361
225	E5HF225S	WS-11	46 (1168)	36 (914)	24 (610)	1393 (632)	1	6	271	542
300	E5HF300S	WS-11	46 (1168)	36 (914)	24 (610)	1519 (689)	1	6	361	723

Notes:

- Weather shields (set of two) must be ordered separately.
- Design Styles and Electrical Connections can be found at the end of the Ventilated Distribution Transformers section.

Electrical Connections (Single Phase)

1

240 x 480 Volt Primary,
120/240 Volt Secondary
Taps: 2, 2½% FCAN; 4, 2½% FCBN

Primary Voltage	Interconnect	Connect Lines To
504	1 to 2	H1 & H2
492	2 to 3	H1 & H2
480	3 to 4	H1 & H2
468	4 to 5	H1 & H2
456	5 to 6	H1 & H2
444	6 to 7	H1 & H2
432	7 to 8	H1 & H2
252	H1 to 2 H2 to 1	H1 & H2
240	H1 to 4 H2 to 3	H1 & H2
228	H1 to 6 H2 to 5	H1 & H2
216	H1 to 8 H2 to 7	H1 & H2
Secondary Voltage	Interconnect	Connect Lines To
240	X2 to X3	X1 & X4
120-0-120	X2 to X3 X2 to $\frac{1}{2}$	X1-X2-X4
120	X1 to X3 X2 to X4	X1 & X4

ES5 Series

2

120/208/240/277 Volt Primary,
120/240 Volt Secondary
Taps: None

Primary Voltage	Interconnect	Connect Lines To
277	1 to 2	H1 & H2
240	3 to 4	H1 & H2
208	5 to 6	H1 & H2
120	H1 to 4 H2 to 3	H1 & H2
Secondary Voltage	Interconnect	Connect Lines To
240	X2 to X3	X1 & X4
120-0-120	X2 to X3 X2 to $\frac{1}{2}$	X1-X2-X4
120	X1 to X3 X2 to X4	X1 & X4

ES12 Series

Design Style

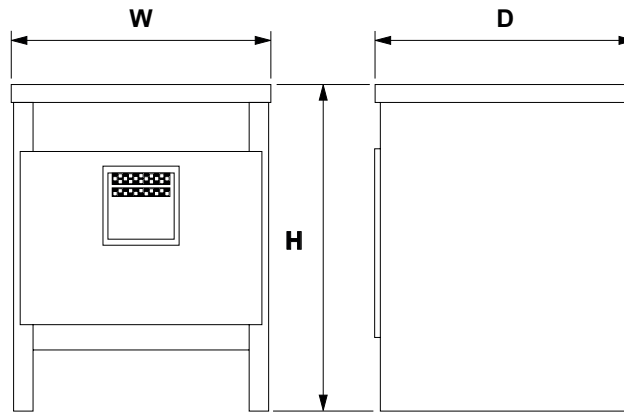

Style 1 - Ventilated

Electrical Connections (Three Phase)

5

480 Δ Volt Primary,
208Y/120 Volt Secondary
Taps: 2, 2½% FCAN; 4, 2½% FCBN

Primary H1-H2-H3		Secondary Voltage	
@ Tap	Voltage	X1, X2, X3	X0- X1, X2, X3
1	504	208	120
2	492		
3	480		
4	468		
5	456		
6	444		
7	432		

E2 and 3H Series

** Shield available in electrostatically shielded units only.*

6

480 Δ Volt Primary,
240 Δ W/120 CT Volt Secondary
Taps: 2, 2½% FCAN; 4, 2½% FCBN

Primary H1-H2-H3		Secondary Voltage	
@ Tap	Voltage	X1, X2, X3	X6-X1, X6-X3
1	504	240	120
2	492		
3	480		
4	468		
5	456		
6	444		
7	432		

E5 Series

** Shield available in electrostatically shielded units only.*

7

480 Δ Volt Primary
380Y/220 Volt Secondary
Taps: 2, 2½% FCAN; 4, 2½% FCBN

Primary H1-H2-H3		Secondary Voltage	
@ Tap	Voltage	X1, X2, X3	X0- X1, X2, X3
1	504	380	220
2	492		
3	480		
4	468		
5	456		
6	444		
7	432		

E79 Series

8

480 Δ Volt Primary
480Y/277 Volt Secondary
Taps: 2, 2½% FCAN; 4, 2½% FCBN

Primary H1-H2-H3		Secondary Voltage	
@ Tap	Voltage	X1, X2, X3	X0- X1, X2, X3
1	504	480	277
2	492		
3	480		
4	468		
5	456		
6	444		
7	432		

E81 Series

9

208 Δ Volt Primary
208Y/120 Volt Secondary
Taps: 2, 2½% FCAN; 4, 2½% FCBN

Primary H1-H2-H3		Secondary Voltage	
@ Tap	Voltage	X1, X2, X3	X0- X1, X2, X3
1	218	208	120
2	213		
3	208		
4	203		
5	198		
6	192		
7	187		

E3 Series

Electrical Connections (Three Phase) cont.

208 Δ Volt Primary
480Y/277 Volt Secondary
Taps: 2, 2½% FCAN; 4, 2½% FCBN

10

Primary X1-X2-X3		Secondary Voltage	
@ Tap	Voltage	H1-H2-H3	H0-H1, H2, H3
1	218	480	277
2	213		
3	208		
4	203		
5	198		
6	192		
7	187		

E84 Series

240 Δ Volt Primary
208Y/120 Volt Secondary
Taps: 2, 2½% FCAN; 4, 2½% FCBN

11

Primary H1-H2-H3		Secondary Voltage	
@ Tap	Voltage	X1, X2, X3	X0- X1, X2, X3
1	252	208	120
2	246		
3	240		
4	234		
5	228		
6	222		
7	216		

E6 Series

240 Δ Volt Primary
480Y/277 Volt Secondary
Taps: 2, 2½% FCAN; 4, 2½% FCBN

12

Primary X1-X2-X3		Secondary Voltage	
@ Tap	Voltage	H1, H2, H3	H0- H1, H2, H3
1	252	480	277
2	246		
3	240		
4	234		
5	228		
6	222		
7	216		

E85 Series

K-Factor Transformers

SolaHD K-Factor transformers are designed to reduce the heating effects of harmonic currents created by loads like those shown in Chart A. The K-Factor rating is an index of the transformer's ability to withstand harmonic content while operating within the temperature limits of its insulating system. Our K-Factor transformers have UL ratings of K-4, K-13, and K-20.

The SolaHD K-Factor design is a specialized transformer that offers these benefits:

- Conductors capable of carrying the harmonic currents of non-linear loads without exceeding the temperature rating of the insulation system.
- A transformer design that takes into account the increase in naturally occurring "stray" losses caused by non-linear loads. These losses cause standard transformers to dramatically overheat and substantially shorten design life.
- A core and coil design that manages the DC flux caused by triplen harmonics. As these harmonics increase, they cause additional current to circulate in the delta winding. This produces a DC flux in the core which leads to core saturation, voltage instability and overheating.

Features

- Energy Efficient Compliant to DOE 2016 ¹
- Conductors to carry harmonics of a K-rated load without exceeding insulation temperature ratings
- UL 1561 Listed up to K-20 rated protection
- Rated temperature rise of 150°C, 220°C insulation
- Shielded for quality power
- Basic design takes "stray losses" into account and functions within safe operating temperatures
- Core and coil design engineered to manage the zero sequence flux caused by triplen harmonics
- Provides 100% rated current without overheating the windings or saturating the core
- Meets transit test requirements for ISTA (International Safe Transit Association) – Test Procedure 1E for packaged-product
- Quiet operation with sound levels 3-6 dB below the NEMA ST-20 requirements



Accessories and Optional Design Styles

- Wall mounting brackets (500 lbs maximum) (Item WB1C)
- Weather Shields (UL Listed/NEMA Type 3R)
- Totally enclosed non-ventilated designs (TENV) (Non UL) *
- Low temperature rise units available
- Open core and coil designs (UL Recognized)
- Copper Wound designs
- Alternate voltages

Certifications and Compliances

- Listed: E25872
- UL 1561

Chart A: Typical Load K-Factors

Load	K-Factor
Electric discharge lighting	K-4
UPS with optional input filter	K-4
Welders	K-4
Induction heating equipment	K-4
PLCs and solid state controls	K-4
Telecommunications equipment (e.g., PBX)	K-13
UPS without input filtering.....	K-13
Multiwire receptacle circuits in general care areas of health care facilities and classrooms of schools, etc.	K-13
Multi-wire receptacle circuits supplying inspection or testing equipment on an assembly or production line.....	K-13
Mainframe computer loads	K-20
Solid state motor drives (variable speed drives).....	K-20

REPRINTED WITH PERMISSION FROM EDI MAGAZINE

* Not all optional designs are UL Listed. Contact Technical Services.

1. DOE 2016 refers to Department of Energy CFR (Code of Federal Regulations) title 10, part 431.196).

Selection Tables: Three Phase

Group A: K-4 Rated 480 Δ Primary, 208Y/120 Secondary, 60 Hz

kVA	Catalog Number	Type 3R Weather Shield ¹	Height in (mm)	Width in (mm)	Depth in (mm)	Approx. Ship Weight lbs (kg)	Design Style ²	Elec Conn ²	Primary Amps	Secondary Amps
15	K4E2H15S	WS-02	23 (584)	18 (457)	14 (356)	221 (100)	1	5	18.1	41.7
30	K4E2H30S	WS-14	28 (711)	23 (584)	16 (406)	310 (141)	1	5	36.1	83.4
45	K4E2H45S	WS-14	28 (711)	23 (584)	16 (406)	387 (176)	1	5	54.2	125
75	K4E2H75S	WS-30	34 (864)	28 (711)	22 (559)	678 (308)	1	5	90.3	208
112.5	K4E2H112S	WS-30	34 (864)	28 (711)	22 (559)	794 (360)	1	5	135	313
150	K4E2H150S	WS-10	44 (1118)	33 (838)	21 (533)	1005 (456)	1	5	181	417
225	K4E2H225S	WS-11	46 (1168)	36 (914)	24 (610)	1368 (621)	1	5	271	625
300	K4E2H300S	WS-11	46 (1168)	36 (914)	24 (610)	1479 (671)	1	5	361	834
500	K4E2H500S	WS-12	65 (1651)	45 (1143)	35 (889)	2457 (1114)	1	5	602	1390

Group B: K-13 Rated 480 Δ Primary, 208Y/120 Secondary, 60 Hz

kVA	Catalog Number	Type 3R Weather Shield ¹	Height in (mm)	Width in (mm)	Depth in (mm)	Approx. Ship Weight lbs (kg)	Design Style ²	Elec Conn ²	Primary Amps	Secondary Amps
15	K13E2H15S	WS-14	28 (711)	23 (584)	16 (406)	310 (141)	1	5	18.1	41.7
30	K13E2H30S	WS-14	28 (711)	23 (584)	16 (406)	387 (176)	1	5	36.1	83.4
45	K13E2H45S	WS-30	34 (864)	28 (711)	22 (559)	678 (308)	1	5	54.2	125
75	K13E2H75S	WS-30	34 (864)	28 (711)	22 (559)	794 (360)	1	5	90.3	208
112.5	K13E2H112S	WS-10	44 (1118)	33 (838)	21 (533)	1005 (456)	1	5	135	313
150	K13E2H150S	WS-11	46 (1168)	36 (914)	24 (610)	1368 (621)	1	5	181	417
225	K13E2H225S	WS-11	46 (1168)	36 (914)	24 (610)	1479 (671)	1	5	271	625
300	K13E2H300S	WS-12	65 (1651)	45 (1143)	35 (889)	2457 (1114)	1	5	361	834

Group C: K-20 Rated 480 Δ Primary, 208Y/120 Secondary, 60 Hz

kVA	Catalog Number	Type 3R Weather Shield ¹	Height in (mm)	Width in (mm)	Depth in (mm)	Approx. Ship Weight lbs (kg)	Design Style ²	Elec Conn ²	Primary Amps	Secondary Amps
15	K20E2H15S	WS-14	28 (711)	23 (584)	16 (406)	310 (141)	1	5	18.1	41.7
30	K20E2H30S	WS-14	28 (711)	23 (584)	16 (406)	387 (176)	1	5	36.1	83.4
45	K20E2H45S	WS-30	34 (864)	28 (711)	22 (559)	678 (308)	1	5	54.2	125
75	K20E2H75S	WS-30	34 (864)	28 (711)	22 (559)	794 (360)	1	5	90.3	208
112.5	K20E2H112S	WS-10	44 (1118)	33 (838)	21 (533)	1005 (456)	1	5	135	313
150	K20E2H150S	WS-11	46 (1168)	36 (914)	24 (610)	1368 (621)	1	5	181	417
225	K20E2H225S	WS-11	46 (1168)	36 (914)	24 (610)	1479 (671)	1	5	271	625
300	K20E2H300S	WS-12	65 (1651)	45 (1143)	35 (889)	2457 (1114)	1	5	361	834

Notes:

- Weather shields (set of two) must be ordered separately.
- Design Styles and Electrical Connections can be found at the end of the Ventilated Distribution Transformers section.

Electrical Connections (Single Phase)

1
 240 x 480 Volt Primary,
 120/240 Volt Secondary
 Taps: 2, 2½% FCAN; 4, 2½% FCBN

Primary Voltage	Interconnect	Connect Lines To
504	1 to 2	H1 & H2
492	2 to 3	H1 & H2
480	3 to 4	H1 & H2
468	4 to 5	H1 & H2
456	5 to 6	H1 & H2
444	6 to 7	H1 & H2
432	7 to 8	H1 & H2
252	H1 to 2 H2 to 1	H1 & H2
240	H1 to 4 H2 to 3	H1 & H2
228	H1 to 6 H2 to 5	H1 & H2
216	H1 to 8 H2 to 7	H1 & H2
Secondary Voltage	Interconnect	Connect Lines To
240	X2 to X3	X1 & X4
120-0-120	X2 to X3 X2 to \perp	X1-X2-X4
120	X1 to X3 X2 to X4	X1 & X4

ES5 Series

2
 120/208/240/277 Volt Primary,
 120/240 Volt Secondary
 Taps: None

Primary Voltage	Interconnect	Connect Lines To
277	1 to 2	H1 & H2
240	3 to 4	H1 & H2
208	5 to 6	H1 & H2
120	H1 to 4 H2 to 3	H1 & H2
Secondary Voltage	Interconnect	Connect Lines To
240	X2 to X3	X1 & X4
120-0-120	X2 to X3 X2 to \perp	X1-X2-X4
120	X1 to X3 X2 to X4	X1 & X4

ES12 Series

Design Style

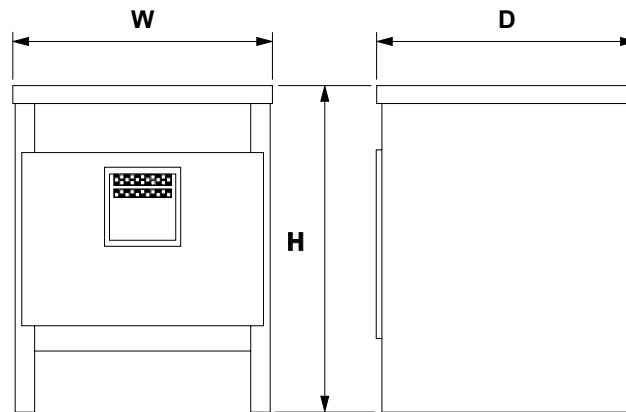

Style 1 - Ventilated

Electrical Connections (Three Phase)

480 Δ Volt Primary,
208Y/120 Volt Secondary
Taps: 2, 2½% FCAN; 4, 2½% FCBN

5

Primary H1-H2-H3		Secondary Voltage	
@ Tap	Voltage	X1, X2, X3	X0- X1, X2, X3
1	504	208	120
2	492		
3	480		
4	468		
5	456		
6	444		
7	432		

E2 and 3H Series

** Shield available in electrostatically shielded units only.*

480 Δ Volt Primary,
240 Δ W/120 CT Volt Secondary
Taps: 2, 2½% FCAN; 4, 2½% FCBN

6

Primary H1-H2-H3		Secondary Voltage	
@ Tap	Voltage	X1, X2, X3	X6-X1, X6-X3
1	504	240	120
2	492		
3	480		
4	468		
5	456		
6	444		
7	432		

E5 Series

** Shield available in electrostatically shielded units only.*

480 Δ Volt Primary
380Y/220 Volt Secondary
Taps: 2, 2½% FCAN; 4, 2½% FCBN

7

Primary H1-H2-H3		Secondary Voltage	
@ Tap	Voltage	X1, X2, X3	X0- X1, X2, X3
1	504	380	220
2	492		
3	480		
4	468		
5	456		
6	444		
7	432		

E79 Series

480 Δ Volt Primary
480Y/277 Volt Secondary
Taps: 2, 2½% FCAN; 4, 2½% FCBN

8

Primary H1-H2-H3		Secondary Voltage	
@ Tap	Voltage	X1, X2, X3	X0- X1, X2, X3
1	504	480	277
2	492		
3	480		
4	468		
5	456		
6	444		
7	432		

E81 Series

208 Δ Volt Primary
208Y/120 Volt Secondary
Taps: 2, 2½% FCAN; 4, 2½% FCBN

9

Primary H1-H2-H3		Secondary Voltage	
@ Tap	Voltage	X1, X2, X3	X0- X1, X2, X3
1	218	208	120
2	213		
3	208		
4	203		
5	198		
6	192		
7	187		

E3 Series

Electrical Connections (Three Phase) cont.

10

208 Δ Volt Primary
480Y/277 Volt Secondary
Taps: 2, 2½% FCAN; 4, 2½% FCBN

Primary X1-X2-X3		Secondary Voltage	
@ Tap	Voltage	H1-H2-H3	H0-H1, H2, H3
1	218	480	277
2	213		
3	208		
4	203		
5	198		
6	192		
7	187		

E84 Series

11

240 Δ Volt Primary
208Y/120 Volt Secondary
Taps: 2, 2½% FCAN; 4, 2½% FCBN

Primary H1-H2-H3		Secondary Voltage	
@ Tap	Voltage	X1, X2, X3	X0- X1, X2, X3
1	252	208	120
2	246		
3	240		
4	234		
5	228		
6	222		
7	216		

E6 Series

12

240 Δ Volt Primary
480Y/277 Volt Secondary
Taps: 2, 2½% FCAN; 4, 2½% FCBN

Primary X1-X2-X3		Secondary Voltage	
@ Tap	Voltage	H1, H2, H3	H0- H1, H2, H3
1	252	480	277
2	246		
3	240		
4	234		
5	228		
6	222		
7	216		

E85 Series

Automation Transformers - Non-Ventilated 50 VA to 45 kVA

SolaHD encapsulated transformers are rated for hazardous locations as well as harsh industrial environments. Encapsulation and rugged UL Listed/NEMA Type 3R enclosures protect the transformer from dust, moisture, and provides extra shock and vibration resistance. SolaHD transformers fully comply with the latest edition of the National Electrical Code for Class I, Division 2, Group A, B, C and D locations when installed in compliance with NEC 501.100 (B).

Features

Single Phase: .05 – .250 kVA

- UL Listed/NEMA Type 3R non encapsulated enclosure for indoor and outdoor service
- Low temperature rise, UL Class I30 °C insulation system, 80 °C temperature rise under full load
- Conduit knockouts for side entry into wiring compartment
- Copper lead wire terminations

Single Phase: 0.500 – 25 kVA

Three Phase: 3 – 45 kVA

- Available as standard in Cold Rolled Steel or Painted Stainless Steel
- UL Listed/NEMA Type 3R encapsulated enclosure for indoor and outdoor service
- Electrostatically shielded for quality power on sizes 1 kVA and larger
- UL Class 200°C insulation system, 115°C temperature rise under full load
- Conduit knockouts for side entry into wiring compartment (Type 3R versions only)
- Copper lead wire terminations
- .500 - 45 kVA units are encapsulated with electrical grade silica and epoxy for industrial applications

Related Products

- Some SolaHD DC power supplies are available with Class I, Division 2 ratings or encapsulation.
- Surge Protective Devices



Certifications and Compliances

All Models

- cULus Listed: E25872, E77014
 - UL 1561 or UL 5085-1, UL 5085-2
 - CSA C22.2 No. 47 or No. 66
 - RoHS Compliant

Group 5, Export Models

- CE Low Voltage Directive
 - IEC 61558-1, IEC 61558-2-4

Accessories and Optional Design Styles

- Other enclosure styles available (contact Technical Support for details):
 - 316 Stainless Steel
 - Copper Wound designs
- UL Listed/NEMA Type 4/12 or 4X Encapsulated Enclosures
- Low temperature designs available
- cULus Listed E361435 transformers for Class I, Division 2/Zone 2 hazardous locations are available as custom designs.

Note: Weights and dimensions may change and should not be used for construction purposes.

Selection Table: Single Phase

Group 1: 240 x 480 Primary, 120/240 Secondary, 60 Hz

kVA	Catalog Number Group I Rolled Steel	Catalog Number Group II Stainless Steel ²	Height in (mm)	Width in (mm)	Depth in (mm)	Approx. Ship Weight lbs (kg)	Design Style ¹	Elec Conn ¹	Primary Amps	Secondary Amps
Non-Encapsulated										
.050	HS1B50	N/A	6.00 (152.4)	4.00 (101.6)	3.00 (76.2)	3.00 (1.36)	2	15	.208/.104	0.416/0.208
.075	HS1B75		6.00 (152.4)	4.00 (101.6)	3.00 (76.2)	3.00 (1.36)	2	15	.312/.156	0.625/0.312
.100	HS1B100		6.00 (152.4)	4.00 (101.6)	3.00 (76.2)	4.00 (1.81)	2	15	.417/.208	0.833/0.417
.150	HS1B150		8.00 (203.2)	4.00 (101.6)	4.00 (101.6)	5.00 (2.27)	2	15	.625/.313	1.25/.625
.250	HS1B250		8.00 (203.2)	4.00 (101.6)	4.00 (101.6)	8.00 (3.63)	2	15	1.04/.512	2.08/1.04
Encapsulated										
0.5	HS1F500B	HSP1F500B	10.00 (254.0)	6.00 (152.4)	5.00 (127.0)	22.0 (9.98)	3	15	2.08/1.04	4.16/2.08
0.75	HS1F750B	HSP1F750B	10.00 (254.0)	6.00 (152.4)	5.00 (127.0)	27.0 (12.25)	3	15	3.13/1.56	6.25/3.13
1	HS1F1BS	HSP1F1BS	10.00 (254.0)	6.00 (152.4)	5.00 (127.0)	28.0 (12.70)	3	16	4.17/2.08	8.33/4.17
1.5	HS1F1.5AS	HSP1F1.5AS	12.00 (304.8)	10.00 (254.0)	7.00 (177.8)	38.0 (17.24)	4	16	6.25/3.13	12.5/6.25
2	HS1F2AS	HSP1F2AS	12.00 (304.8)	10.00 (254.0)	7.00 (177.8)	45.0 (20.42)	4	16	8.33/4.17	16.7/8.33
3	HS5F3AS	HSP5F3AS	12.00 (304.8)	10.00 (254.0)	7.00 (177.8)	55.0 (24.95)	4	17	12.5/6.25	25.0/12.5
5	HS5F5AS	HSP5F5AS	17.00 (431.8)	14.00 (355.6)	9.00 (228.6)	131.0 (59.42)	4	17	20.8/10.4	41.6/20.8
7.5	HS5F7.5AS	HSP5F7.5AS	17.00 (431.8)	14.00 (355.6)	9.00 (228.6)	156.0 (70.76)	4	18	31.3/15.6	62.5/31.3
10	HS5F10 AS	HSP5F10 AS	17.00 (431.8)	14.00 (355.6)	9.00 (228.6)	156.0 (70.76)	4	18	41.7/20.8	83.3/41.7
15	HS5F15AS	HSP5F15AS	30.00 (762.0)	29.00 (736.6)	12.00 (304.8)	549.0 (249.02)	4	18	62.5/31.2	125.0/62.5
25	HS5F25 AS	HSP5F25 AS	30.00 (762.0)	29.00 (736.6)	12.00 (304.8)	637.0 (288.94)	4	18	104.0/52.0	208.0/104.0

Group 2: 600 Volt Primary, 120/240 Secondary, 60 Hz

kVA	Catalog Number Group I Rolled Steel	Catalog Number Group II Stainless Steel ²	Height in (mm)	Width in (mm)	Depth in (mm)	Approx. Ship Weight lbs (kg)	Design Style ¹	Elec Conn ¹	Primary Amps	Secondary Amps
Non-Encapsulated										
.100	HS10B100	N/A	6.00 (152.4)	4.00 (101.6)	3.00 (76.2)	4.00 (1.81)	2	21	0.167	.833/.417
.150	HS10B150		8.00 (203.2)	4.00 (101.6)	4.00 (101.6)	5.00 (2.27)	2	21	0.25	1.25/.625
.250	HS10B250		8.00 (203.2)	4.00 (101.6)	4.00 (101.6)	8.00 (3.63)	2	21	0.417	2.08/1.04
Encapsulated										
.500	HS10F500B	HSP10F500B	10.00 (254.0)	6.00 (152.4)	5.00 (127.0)	22.0 (9.98)	3	21	0.833	4.16/2.08
.750	HS10F750B	HSP10F750B	10.00 (254.0)	6.00 (152.4)	5.00 (127.0)	23.0 (10.43)	3	21	1.25	6.25/3.13
1	HS10F1BS	HSP10F1BS	10.00 (254.0)	6.00 (152.4)	5.00 (127.0)	28.0 (12.70)	3	21	1.67	8.33/4.17
1.5	HS10F1.5AS	HSP10F1.5AS	12.00 (304.8)	10.00 (254.0)	7.00 (177.8)	38.0 (17.24)	4	21	2.5	12.5/6.25
2	HS10F2AS	HSP10F2AS	12.00 (304.8)	10.00 (254.0)	7.00 (177.8)	60.0 (27.22)	4	21	3.33	16.7/8.33
3	HS10F3AS	HSP10F3AS	12.00 (304.8)	10.00 (254.0)	7.00 (177.8)	66.0 (29.94)	4	22	5.0	25.0/12.5
5	HS10F5AS	HSP10F5AS	17.00 (431.8)	14.00 (355.6)	9.00 (228.6)	100.0 (45.36)	4	22	8.3	41.6/20.8
7.5	HS10F7.5AS	HSP10F7.5AS	17.00 (431.8)	14.00 (355.6)	9.00 (228.6)	135.0 (61.23)	4	22	12.5	62.5/31.3
10	HS10F10 AS	HSP10F10 AS	17.00 (431.8)	14.00 (355.6)	9.00 (228.6)	150.0 (68.04)	4	22	16.7	83.3/41.7

Notes:

1. Design Styles and Electrical Connections can be found at the end of the Non-Ventilated Distribution Transformers section.
2. Contact Technical Services for other enclosure types.

Selection Table: Single Phase

Group 3: 120/208/240/277 Volt Primary, 120/240 Secondary, 60 Hz

kVA	Catalog Number Group 1 Rolled Steel	Catalog Number Group 2 Stainless Steel ³	Height in (mm)	Width in (mm)	Depth in (mm)	Approx. Ship Weight lbs (kg)	Design Style ¹	Elec Conn ¹	Primary Amps @ 277 V	Secondary Amps
Encapsulated										
1	HS12F1BS	HSP12F1BS	10.00 (254.0)	6.00 (152.4)	5.00 (127.0)	29.0 (13.15)	3	19	3.6	8.33/4.17
1.5	HS12F1.5AS	HSP12F1.5AS	12.00 (304.8)	10.00 (254.0)	7.00 (177.8)	40.0 (18.14)	4	20	5.4	12.5/6.25
2	HS12F2AS	HSP12F2AS	12.00 (304.8)	10.00 (254.0)	7.00 (177.8)	60.0 (27.22)	4	20	7.2	16.7/8.33
3	HS12F3AS	HSP12F3AS	12.00 (304.8)	10.00 (254.0)	7.00 (177.8)	66.0 (29.94)	4	20	10.8	25.0/12.5
5	HS12F5AS	HSP12F5AS	17.00 (431.8)	14.00 (355.6)	9.00 (228.6)	104.0 (47.17)	4	20	18.0	41.6/20.8
7.5	HS12F7.5AS	HSP12F7.5AS	17.00 (431.8)	14.00 (355.6)	9.00 (228.6)	135.0 (61.23)	4	20	27.1	62.5/31.3
10	HS12F10 AS	HSP12F10 AS	17.00 (431.8)	14.00 (355.6)	9.00 (228.6)	156.0 (70.76)	4	20	36.1	83.3/41.7

Group 4: 190/200/208/220/380/400/415/440 Volt Primary, 110/220 Secondary, 50/60 Hz Copper wound 200/208/230/400/415/460 Volt Primary, 115/230 Secondary, 50/60 Hz Copper wound 208/240/415/480 Volt Primary, 120/240 Secondary, 60 Hz only Copper wound

kVA	Catalog Number Group 1 Rolled Steel	Catalog Number Group 2 Stainless Steel ³	Height in (mm)	Width in (mm)	Depth in (mm)	Approx. Ship Weight lbs (kg)	Design Style ¹	Elec Conn ¹	Primary Amps ²	Secondary Amps
Encapsulated, Copper Wound										
1	HS14F1BS	HSP14F1BS	10.00 (254.0)	6.00 (152.4)	5.00 (127.0)	34.0 (15.42)	3	23	4.5/2.3	9.1/4.5
1.5	HS14F1.5BS	HSP14F1.5BS	12.00 (304.8)	10.00 (254.0)	7.00 (177.8)	40.0 (18.13)	4	24	6.8/3.4	13.6/6.8
2	HS14F2BS	HSP14F2BS	12.00 (304.8)	10.00 (254.0)	7.00 (177.8)	60.0 (27.21)	4	24	9.1/4.5	18.2/9.1
3	HS14F3BS	HSP14F3BS	12.00 (304.8)	10.00 (254.0)	7.00 (177.8)	73.0 (33.11)	4	24	13.6/6.8	27.3/13.6
5	HS14F5BS	HSP14F5BS	17.00 (431.8)	14.00 (355.6)	9.00 (228.6)	100.0 (45.36)	4	24	22.7/11.4	45.5/22.7
7.5	HS14F7.5BS	HSP14F7.5BS	17.00 (431.8)	14.00 (355.6)	9.00 (228.6)	140.0 (63.50)	4	24	34.1/17.0	68.2/34.1
10	HS14F10BS	HSP14F10BS	17.00 (431.8)	14.00 (355.6)	9.00 (228.6)	175.0 (79.38)	4	24	45.5/22.7	90.9/45.5

Group 5: Export 190/200/208/220/380/400/415/440 Volt Primary, 110/220 Secondary, 50/60 Hz Copper wound Export 200/208/230/400/415/460 Volt Primary, 115/230 Secondary, 50/60 Hz Copper wound Export 208/240/415/480 Volt Primary, 120/240 Secondary, 60 Hz only Copper wound



kVA	Catalog Number Group 1 Rolled Steel	Catalog Number Group 2 Stainless Steel ³	Height in (mm)	Width in (mm)	Depth in (mm)	Approx. Ship Weight lbs (kg)	Design Style ¹	Elec Conn ¹	Primary Amps ²	Secondary Amps
Encapsulated, Copper Wound										
1	HS14F1CS-CE	HSP14F1CS-CE	12.00 (304.8)	10.00 (254.0)	7.00 (177.8)	52.0 (23.6)	4	24	4.5/2.3	9.1/4.5
1.5	HS14F1.5CS-CE	HSP14F1.5CS-CE	12.00 (304.8)	10.00 (254.0)	7.00 (177.8)	55.0 (25.0)	4	24	6.8/3.4	13.6/6.8
2	HS14F2CS-CE	HSP14F2CS-CE	12.00 (304.8)	10.00 (254.0)	7.00 (177.8)	62.0 (28.1)	4	24	9.1/4.5	18.2/9.1
3	HS14F3CS-CE	HSP14F3CS-CE	17.00 (431.8)	14.00 (355.6)	9.00 (228.6)	142.0 (64.4)	4	24	13.6/6.8	27.3/13.6
5	HS14F5CS-CE	HSP14F5CS-CE	17.00 (431.8)	14.00 (355.6)	9.00 (228.6)	146.0 (66.2)	4	24	22.7/11.4	45.5/22.7
7.5	HS14F7.5CS-CE	HSP14F7.5CS-CE	17.00 (431.8)	14.00 (355.6)	9.00 (228.6)	175.0 (79.4)	4	24	34.1/17.0	68.2/34.1

Notes:

- Design Styles and Electrical Connections can be found at the end of the Non-Ventilated Distribution Transformers section.
- Amperage calculated at 220/440 Volts on primary. UL Listed. 240 and 480 V not available at 50 Hz.
- Contact Technical Services for other enclosure types.

Selection Tables: Three Phase

Group A: 480 Volt Δ Primary, 208Y/120 Secondary, 60 Hz

kVA	Catalog Number Group I Rolled Steel	Catalog Number Group II Stainless Steel ³	Height in (mm)	Width in (mm)	Depth in (mm)	Approx. Ship Weight lbs (kg)	Design Style ¹	Elec Conn ¹	Primary Amps	Secondary Amps
3	HT1F3AS	HTP1F3AS	13.00 (330.2)	16.00 (406.4)	9.00 (228.6)	105.0 (47.63)	4	27	3.6	8.3
6	HT1F6AS	HTP1F6AS	13.00 (330.2)	16.00 (406.4)	9.00 (228.6)	150.0 (68.03)	4	27	7.2	16.6
9	HT1F9AS	HTP1F9AS	17.00 (431.8)	20.00 (508.0)	11.00 (279.4)	250.0 (113.40)	4	27	10.8	25.0
15	HT1F15AS	HTP1F15AS	17.00 (431.8)	20.00 (508.0)	11.00 (279.4)	261.0 (118.39)	4	27	18.1	41.7
30	HT1F30 AS	HTP1F30 AS	30.00 (762.0)	29.00 (736.6)	12.00 (304.8)	696.0 (315.70)	4	27	36.1	83.4
45	HT1F45AS	HTP1F45AS	30.00 (762.0)	29.00 (736.6)	12.00 (304.8)	844.0 (382.83)	4	27	54.2	125.0

Group B: 208 Volt Δ Primary, 208Y/120 Secondary, 60 Hz

kVA	Catalog Number Group I Rolled Steel	Catalog Number Group II Stainless Steel ³	Height in (mm)	Width in (mm)	Depth in (mm)	Approx. Ship Weight lbs (kg)	Design Style ¹	Elec Conn ¹	Primary Amps	Secondary Amps
3	HT3F3AS	HTP3F3AS	13.00 (330.2)	16.00 (406.4)	9.00 (228.6)	97.0 (44.00)	4	26	7.2	8.3
6	HT3F6AS	HTP3F6AS	13.00 (330.2)	16.00 (406.4)	9.00 (228.6)	150.0 (68.03)	4	26	14.4	16.6
9	HT3F9AS	HTP3F9AS	17.00 (431.8)	20.00 (508.0)	11.00 (279.4)	256.0 (116.12)	4	26	21.7	25.0

Group C: 480 Volt Δ Primary, 240 Volt Δ Secondary with 120 V reduced capacity center tap, 60 Hz ²

kVA	Catalog Number Group I Rolled Steel	Catalog Number Group II Stainless Steel ³	Height in (mm)	Width in (mm)	Depth in (mm)	Approx. Ship Weight lbs (kg)	Design Style ¹	Elec Conn ¹	Primary Amps	Secondary Amps
3	HT5F3AS	HTP5F3AS	13.00 (330.2)	16.00 (406.4)	9.00 (228.6)	105.0 (47.63)	4	28	3.6	7.2
6	HT5F6AS	HTP5F6AS	13.00 (330.2)	16.00 (406.4)	9.00 (228.6)	150.0 (68.03)	4	28	7.2	14.4
9	HT5F9AS	HTP5F9AS	17.00 (431.8)	20.00 (508.0)	11.00 (279.4)	250.0 (113.40)	4	28	10.8	21.7
15	HT5F15AS	HTP5F15AS	17.00 (431.8)	20.00 (508.0)	11.00 (279.4)	305.0 (138.35)	4	28	18.1	36.1
30	HT5F30 AS	HTP5F30 AS	30.00 (762.0)	29.00 (736.6)	12.00 (304.8)	698.0 (316.61)	4	28	36.1	72.2
45	HT5F45AS	HTP5F45AS	30.00 (762.0)	29.00 (736.6)	12.00 (304.8)	876.0 (397.35)	4	28	54.2	108.3

Group D: 240 Volt Δ Primary, 208Y/120 Secondary, 60 Hz

kVA	Catalog Number Group I Rolled Steel	Catalog Number Group II Stainless Steel ³	Height in (mm)	Width in (mm)	Depth in (mm)	Approx. Ship Weight lbs (kg)	Design Style ¹	Elec Conn ¹	Primary Amps	Secondary Amps
3	HT6F3AS	HTP6F3AS	13.00 (330.2)	16.00 (406.4)	9.00 (228.6)	97.0 (44.00)	4	25	7.2	8.3
6	HT6F6AS	HTP6F6AS	13.00 (330.2)	16.00 (406.4)	9.00 (228.6)	150.0 (68.03)	4	25	14.4	16.6
9	HT6F9AS	HTP6F9AS	17.00 (431.8)	20.00 (508.0)	11.00 (279.4)	256.0 (116.12)	4	25	21.7	25.0

Notes:

1. Design Styles and Electrical Connections can be found at the end of the Non-Ventilated Distribution Transformers section.
2. Refer to *Capacity of Center Tap in Center Tap Delta Transformers* at the beginning of this section.
3. Contact Technical Services for other enclosure types.

Selection Tables: Three Phase

Group E: 480 Volt Δ Primary, 380Y/220 Secondary, 60 Hz

kVA	Catalog Number Group I Rolled Steel	Catalog Number Group II Stainless Steel ²	Height in (mm)	Width in (mm)	Depth in (mm)	Approx. Ship Weight lbs (kg)	Design Style ¹	Elec Conn ¹	Primary Amps	Secondary Amps
3	HT79F3AS	HTP79F3AS	13.00 (330.2)	16.00 (406.4)	9.00 (228.6)	121.0 (54.88)	4	29	3.6	4.6
6	HT79F6AS	HTP79F6AS	13.00 (330.2)	16.00 (406.4)	9.00 (228.6)	150.0 (68.03)	4	29	7.2	9.1
9	HT79F9AS	HTP79F9AS	17.00 (431.8)	20.00 (508.0)	11.00 (279.4)	255.0 (115.7)	4	29	10.8	13.6

Group F: 600 Volt Δ Primary, 208Y/120 Secondary, 60 Hz

kVA	Catalog Number Group I Rolled Steel	Catalog Number Group II Stainless Steel ²	Height in (mm)	Width in (mm)	Depth in (mm)	Approx. Ship Weight lbs (kg)	Design Style ¹	Elec Conn ¹	Primary Amps	Secondary Amps
3	HT7F3AS	HTP7F3AS	13.00 (330.2)	16.00 (406.4)	9.00 (228.6)	116.0 (52.62)	4	30	2.9	8.3
6	HT7F6AS	HTP7F6AS	13.00 (330.2)	16.00 (406.4)	9.00 (228.6)	150.0 (68.03)	4	30	5.8	16.6
9	HT7F9AS	HTP7F9AS	17.00 (431.8)	20.00 (508.0)	11.00 (279.4)	225.0 (115.67)	4	30	8.7	25.0

Group G: 208 Volt Δ Primary, 480Y/277 Secondary, 60 Hz

kVA	Catalog Number Group I Rolled Steel	Catalog Number Group II Stainless Steel ²	Height in (mm)	Width in (mm)	Depth in (mm)	Approx. Ship Weight lbs (kg)	Design Style ¹	Elec Conn ¹	Primary Amps	Secondary Amps
3	HT84F3AS	HTP84F3AS	13.00 (330.2)	16.00 (406.4)	9.00 (228.6)	97.0 (44.00)	4	31	8.3	3.6
6	HT84F6AS	HTP84F6AS	13.00 (330.2)	16.00 (406.4)	9.00 (228.6)	150.0 (68.03)	4	31	16.6	7.2
9	HT84F9AS	HTP84F9AS	17.00 (431.8)	20.00 (508.0)	11.00 (279.4)	256.0 (116.12)	4	31	25.0	10.8

Group H: 240 Volt Δ Primary, 480Y/277 Secondary, 60 Hz

kVA	Catalog Number Group I Rolled Steel	Catalog Number Group II Stainless Steel ²	Height in (mm)	Width in (mm)	Depth in (mm)	Approx. Ship Weight lbs (kg)	Design Style ¹	Elec Conn ¹	Primary Amps	Secondary Amps
3	HT85F3AS	HTP85F3AS	13.00 (330.2)	16.00 (406.4)	9.00 (228.6)	97.0 (44.00)	4	32	7.2	3.6
6	HT85F6AS	HTP85F6AS	13.00 (330.2)	16.00 (406.4)	9.00 (228.6)	150.0 (68.03)	4	32	14.4	7.2
9	HT85F9AS	HTP85F9AS	17.00 (431.8)	20.00 (508.0)	11.00 (279.4)	256.0 (116.12)	4	32	21.6	10.8

Group J: 480 Volt Δ Primary, 480Y/277 Secondary, 60 Hz

kVA	Catalog Number Group I Rolled Steel	Catalog Number Group II Stainless Steel ²	Height in (mm)	Width in (mm)	Depth in (mm)	Approx. Ship Weight lbs (kg)	Design Style ¹	Elec Conn ¹	Primary Amps	Secondary Amps
3	HT81F3AS	HTP81F3AS	13.00 (330.2)	16.00 (406.4)	9.00 (228.6)	121.0 (54.88)	4	29	3.6	3.6
6	HT81F6AS	HTP81F6AS	13.00 (330.2)	16.00 (406.4)	9.00 (228.6)	150.0 (68.03)	4	29	7.2	7.2
9	HT81F9AS	HTP81F9AS	17.00 (431.8)	20.00 (508.0)	11.00 (279.4)	255.0 (115.7)	4	29	10.8	10.8
15	HT81F15AS	HTP81F15AS	17.00 (431.8)	20.00 (508.0)	11.00 (279.4)	261.0 (118.39)	4	29	18.1	18.1
30	HT81F30 AS	HTP81F30 AS	30.00 (762.0)	29.00 (736.6)	12.00 (304.8)	696.0 (315.70)	4	29	36.1	36.1
45	HT81F45AS	HTP81F45AS	30.00 (762.0)	29.00 (736.6)	12.00 (304.8)	844.0 (382.83)	4	29	54.2	54.2

Notes:

1. Design Styles and Electrical Connections can be found at the end of the Non-Ventilated Distribution Transformers section.
2. Contact Technical Services for other enclosure types.

Design Styles

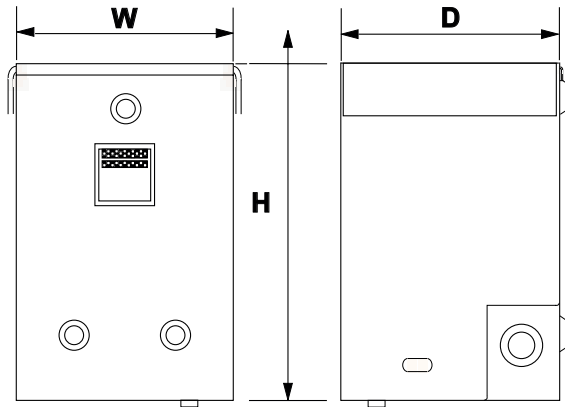

Style 2 - Non-Encapsulated

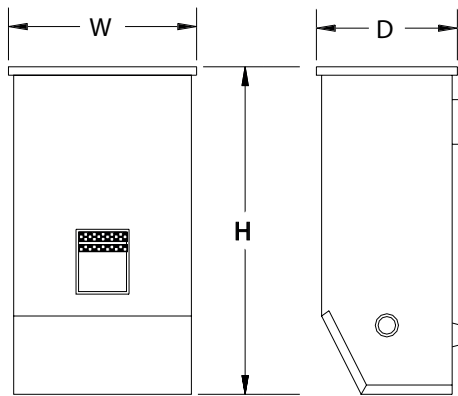

Style 3 - Encapsulated

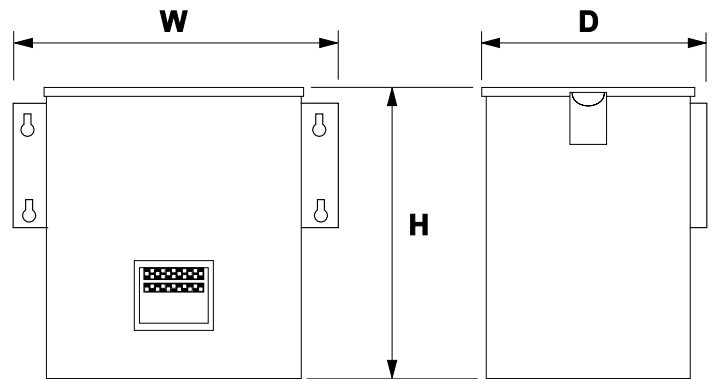

Style 4 - Encapsulated

Customized Enclosures - Contact Technical Services

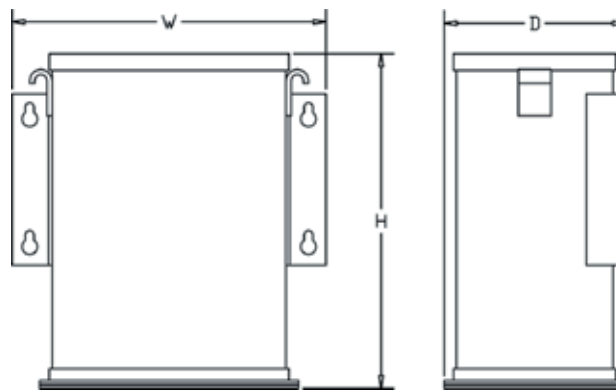

Style 5 - Encapsulated

Available for all encapsulated kVA sizes (For Type 4, 12 and 4X)

Electrical Connections (Single Phase)

240 X 480 Volt Primary
120/240 Volt Secondary
Taps: None

15

Primary Voltage	Interconnect	Connect Lines to
480	H2 to H3	H1 & H4
240	H1 to H3 H2 to H4	H1 & H4
Secondary Voltage	Interconnect	Connect Lines to
240	X2 to X3	X1 & X4
120-0-120	X2 to X3 X2 to \perp	X1-X2-X4
120	X1 to X3 X2 to X4	X1 & X4

HS1 Series

240 X 480 Volt Primary
120/240 Volt Secondary
Taps: None

16

Primary Voltage	Interconnect	Connect Lines to
480	H2 to H3	H1 & H4
240	H1 to H3 H2 to H4	H1 & H4
Secondary Voltage	Interconnect	Connect Lines to
240	X2 to X3	X1 & X4
120-0-120	X2 to X3 X2 to \perp	X1-X2-X4
120	X1 to X3 X2 to X4	X1 & X4

HS1 Series

240 X 480 Volt Primary
120/240 Volt Secondary
Taps: 2, 2½% FCAN & FCBN

17

Primary Voltage	Interconnect	Connect Lines to
504	H4 to H5	H1 & H8
492	H3 to H5	H1 & H8
480	H3 to H6	H1 & H8
468	H2 to H6	H1 & H8
456	H2 to H7	H1 & H8
252	H1 to H5 H4 to H8	H1 & H8
240	H1 to H6 H3 to H8	H1 & H8
228	H1 to H7 H2 to H8	H1 & H8
Secondary Voltage	Interconnect	Connect Lines to
240	X2 to X3	X1 & X4
120-0-120	X2 to X3 X2 to \perp	X1-X2-X4
120	X1 to X3 X2 to X4	X1 & X4

HS5 Series

240 X 480 Volt Primary,
120/240 Volt Secondary
Taps: 2, 2½% FCAN; 4, 2½% FCBN

18

Primary Voltage	Interconnect	Connect Lines to
504	H5 to H6	H1 & H10
492	H4 to H6	H1 & H10
480	H4 to H7	H1 & H10
468	H3 to H7	H1 & H10
456	H3 to H8	H1 & H10
444	H2 to H8	H1 & H10
432	H2 to H9	H1 & H10
252	H1 to H6 H5 to H10	H1 & H10
240	H1 to H7 H4 to H10	H1 & H10
228	H1 to H8 H3 to H10	H1 & H10
216	H1 to H9 H2 to H10	H1 & H10
Secondary Voltage	Interconnect	Connect Lines to
240	X2 to X3	X1 & X4
120-0-120	X2 to X3 X2 to \perp	X1-X2-X4
120	X1 to X3 X2 to X4	X1 & X4

HS5 Series

120/208/240/277 Volt Primary
120/240 Volt Secondary
Taps: None

19

Primary Voltage	Interconnect	Connect Lines to
277	H2 to H3	H1 & H6
240	H2 to H3	H1 & H5
208	H2 to H3	H1 & H4
120	H1 to H3 H2 to H5	H1 & H5
Secondary Voltage	Interconnect	Connect Lines to
240	X2 to X3	X1 & X4
120-0-120	X2 to X3 X2 to \perp	X1-X2-X4
120	X1 to X3 X2 to X4	X1 & X4

HS12 Series (1 kVA only)

\perp = Earth Ground

120/208/240/277 Volt Primary
120/240 Volt Secondary
Taps: None

20

Primary Voltage	Interconnect	Connect Lines to
277	H4 to H5	H1 & H8
240	H3 to H6	H1 & H8
208	H2 to H7	H1 & H8
120	H1 to H6 H3 to H8	H1 & H8
Secondary Voltage	Interconnect	Connect Lines to
240	X2 to X3	X1 & X4
120-0-120	X2 to X3 X2 to \perp	X1-X2-X4
120	X1 to X3 X2 to X4	X1 & X4

HS12 Series

Note:

Connect the electrostatic shield to the equipment ground (green) or to both the equipment ground and the system ground (white). Specifications are subject to change without notice.

Electrical Connections (Single Phase)

600 Volt Primary,
120/240 Volt Secondary
Taps: None

21

Primary Voltage	Interconnect	Connect Lines to
600		H1 & H2
Secondary Voltage	Interconnect	Connect Lines to
240	X2 to X3	X1 & X4
120-0-120	X2 to X3 X2 to \perp	X1, X2 & X4
120	X1 to X3 X2 to X4	X1 & X4

HS10 Series

Note: 1 through 2 kVA units have electrostatic shielding.

190/200/208/220/380/400/415/440 Volt Pri.
110/220 Volt Secondary
Taps: None

24

Primary Voltage	Interconnect	Connect Lines to
440/460/480	H5 to H6	H1 & H10
415	H4 to H7	H1 & H10
400/415	H3 to H8	H1 & H10
380/400	H2 to H9	H1 & H10
220/230/240	H1 to H6, H5 to H10	H1 & H10
208	H1 to H7, H4 to H10	H1 & H10
200/208	H1 to H8, H3 to H10	H1 & H10
190/200/208	H1 to H9 H2 to H10	H1 & H10
Secondary Voltage	Interconnect	Connect Lines to
220/230/240	X2 to X3	X1 & X4
110,220/115, 230/120,240	X2 to X3 X2 to \perp	X1, X2 & X4
110/115/120	X1 to X3 X2 to X4	X1 & X4

HS14 Series

600 Volt Primary
120/240 Volt Secondary
Taps: 2, 5% FCBN

22

Primary Voltage	Interconnect	Connect Lines to
600	H3 to H4	H1 & H6
570	H2 to H4	H1 & H6
540	H2 to H5	H1 & H6
Secondary Voltage	Interconnect	Connect Lines to
240	X2 to X3	X1 & X4
120-0-120	X2 to X3 X2 to \perp	X1-X2-X4
120	X1 to X3 X2 to X4	X1 & X4

HS10 Series

190/200/208/220/380/400/415/440 Volt Pri.
110/220 Volt Secondary
Taps: None

23

Primary Voltage	Interconnect	Connect Lines to
440/460/480	H5 to H6	H1 & H10
415	H4 to H6	H1 & H9
400/415	H3 to H6	H1 & H8
380/400	H2 to H6	H1 & H7
220/230/240	H1 to H6 H5 to H10	H1 & H10
208	H1 to H6 H4 to H9	H1 & H9
200/208	H1 to H6 H3 to H8	H1 & H8
190/200/208	H1 to H6 H2 to H7	H1 & H7
Secondary Voltage	Interconnect	Connect Lines to
220/230/240	X2 to X3	X1 & X4
110,220/115, 230/120,240	X2 to X3 X2 to \perp	X1, X2 & X4
110/115/120	X1 to X3 X2 to X4	X1 & X4

HS14F1BS

\perp = Earth Ground

Note:

Connect the electrostatic shield to the equipment ground (green) or to both the equipment ground and the system ground (white). Specifications are subject to change without notice.

Electrical Connections (Three Phase)

25
 240 Δ Volt Primary
 208Y/120 Volt Secondary
 Taps: 2, 5% FCBN

Primary Voltage	Connect Taps	Connect Lines To
240	1-H1 & 2-H2 & 3-H3	H1, H2, H3
228	4-H1 & 5-H2 & 6-H3	H1, H2, H3
216	7-H1 & 8-H2 & 9-H3	H1, H2, H3
Secondary Voltage		Connect Lines To
208		X1, X2, & X3
120		X0, X1, X2, X3

HT6 Series

26
 208 Δ Volt Primary
 208Y/120 Volt Secondary
 Taps: 2, 5% FCBN

Primary Voltage	Connect Taps	Connect Lines To
208	1-H1 & 2-H2 & 3-H3	H1, H2, H3
198	4-H1 & 5-H2 & 6-H3	H1, H2, H3
187	7-H1 & 8-H2 & 9-H3	H1, H2, H3
Secondary Voltage		Connect Lines To
208		X1, X2, & X3
120		X0, X1, X2, X3

HT3 Series

27
 480 Δ Volt Primary
 208Y/120 Volt Secondary
 Taps: 2, 5% FCBN

Primary Voltage	Interconnect	Connect Lines to
480	1-H1 & 2-H2 & 3-H3	H1, H2, H3
456	4-H1 & 5-H2 & 6-H3	H1, H2, H3
432	7-H1 & 8-H2 & 9-H3	H1, H2, H3
Secondary Voltage		Connect Lines to
208		X1, X2, & X3
120		X0, X1, X2, X3

HT1 Series

28
 480 Δ Volt Primary
 240 Δ w/120 CT Volt Secondary
 Taps: 2, 5% FCBN

Primary Voltage	Connect Taps	Connect Lines To
480	1-H1 & 2-H2 & 3-H3	H1, H2, H3
456	4-H1 & 5-H2 & 6-H3	H1, H2, H3
432	7-H1 & 8-H2 & 9-H3	H1, H2, H3
Secondary Voltage	Interconnect	Connect Lines To
240		X1, X2, X3
120-0-120	X6 to	X1-X6-X3

HT5 Series

29
 480 Δ Volt Primary
 380Y/220 Volt Secondary
 Taps: 2, 5% FCBN

Primary Voltage	Interconnect	Connect Lines to
480	1-H1 & 2-H2 & 3-H3	H1, H2 & H3
456	4-H1 & 5-H2 & 6-H3	H1, H2 & H3
432	7-H1 & 8-H2 & 9-H3	H1, H2 & H3
Secondary Voltage	Interconnect	Connect Lines to
380		X1, X2, X3
220		X0, X1, X2, X3

HT9 Series

= Earth Ground

Notes:

Connect the electrostatic shield to the equipment ground (green) or to both the equipment ground and the system ground (white). Specifications are subject to change without notice.

Electrical Connections (Three Phase)

30

600 Δ Volt Primary
208Y/120 Volt Secondary
Taps: 2, 5% FCBN

Primary Voltage	Connect Taps	Line Leads
600	1-H1 & 2-H2 & 3-H3	H1, H2, H3
570	4-H1 & 5-H2 & 6-H3	H1, H2, H3
540	7-H1 & 8-H2 & 9-H3	H1, H2, H3
Secondary Voltage		Line Leads
208		X1, X2, X3
120		X0, X1, X2, X3

HT7 Series

31

208 Δ Volt Primary
480Y/277 Volt Secondary
Taps: 2, 5% FCBN

Primary Voltage	Connect Taps	Line Leads
208	1-X1 & 2-X2 & 3-X3	X1, X2, X3
198	4-X1 & 5-X2 & 6-X3	X1, X2, X3
187	7-X1 & 8-X2 & 9-X3	X1, X2, X3
Secondary Voltage		Line Leads
480		H1, H2, H3
277		H0, H1, H2, H3

HT84 Series

32

240 Δ Volt Primary
480Y/277 Volt Secondary
Taps: 2, 5% FCBN

Primary Voltage	Connect Taps	Line Leads
240	1-X1 & 2-X2 & 3-X3	X1, X2, X3
228	4-X1 & 5-X2 & 6-X3	X1, X2, X3
216	7-X1 & 8-X2 & 9-X3	X1, X2, X3
Secondary Voltage		Line Leads
480		H1, H2, H3
277		H0, H1, H2, H3

HT85 Series

33

480 Δ Volt Primary
480Y/277 Volt Secondary
Taps: 2, 5% FCBN

Primary Voltage	Interconnect	Connect Lines to
480	1-H1 & 2-H2 & 3-H3	H1, H2 & H3
456	4-H1 & 5-H2 & 6-H3	H1, H2 & H3
432	7-H1 & 8-H2 & 9-H3	H1, H2 & H3
Secondary Voltage	Interconnect	Connect Lines to
480		X1, X2, X3
277		X0, X1, X2, X3

HT81 Series

Notes:

Connect the electrostatic shield to the equipment ground (green) or to both the equipment ground and the system ground (white). Specifications are subject to change without notice.

Automation Transformers - Floor Mount - Non-Ventilated 15 kVA to 150 kVA

SolaHD encapsulated transformers are rated for hazardous locations as well as harsh industrial environments. Encapsulation and rugged enclosures protect the transformer from dust, moisture, and provide extra shock and vibration resistance. SolaHD transformers fully comply with the latest edition of the National Electrical Code.



Features

- cULus Listed for Class I, Division 2/Zone 2 hazardous locations temperature classification T3 or T3C
- UL Listed/NEMA Type 1, 2, 3R, 4, and 12 encapsulated enclosure for indoor and outdoor service
- Electrostatically shielded for quality power
- UL Class 200°C insulation system, 115°C (40°C Ambient) temperature rise under full load
- Gland plates standard for ease of conduit entry
- Copper terminations on all units
- Encapsulated with electrical grade silica and epoxy for industrial applications

Related Products

- Some SolaHD DC power supplies are available with Class I, Division 2 ratings or encapsulation.
- Surge Protective Devices

Certifications and Compliances

All Models

- cULus Listed: E361435
 - UL 1561 or UL 5085-1, UL 5085-2
 - CSA C22.2 No. 47 or No. 66
 - RoHS Compliant

Accessories and Optional Design Styles

- NEMA 4X Stainless Steel Enclosures
- 50°C Ambient temperature and other temperature classifications (T4, T4A or T3B) available
- Additional copper, K-Factor and low temperature designs available
- 15, 30 and 45 kVA transformer designs are available contact technical support

Selection Tables: Floor Mount – Three Phase

Group A: 480 Volt Δ Primary, 208Y/120 Secondary, 60 Hz

kVA	Catalog Number Group I Rolled Steel	Height in (mm)	Width in (mm)	Depth in (mm)	Approx. Ship Weight lbs (kg)	Design Style ¹	Elec Conn ¹	Primary Amps	Secondary Amps
45	F2F45S	32.38 (822.5)	27.51 (698.8)	17.01 (432.1)	1400 (635)	6	34	54.1	124.9
75	F2F75SCU	32.38 (822.5)	27.51 (698.8)	17.01 (432.1)	1500 (680)	6	34	90.2	208.2
75	F2F75S	40.88 (1038.4)	31.51 (800.1)	17.01 (432.1)	1700 (771)	6	34	90.2	208.2
112.5	F2F112S	40.88 (1038.4)	31.51 (800.1)	17.01 (432.1)	1800 (816)	6	34	135.3	312.3
150	F2F150SCU	40.88 (1038.4)	31.51 (800.1)	17.01 (432.1)	2200 (998)	6	34	180.4	416.4

Group B: 480 Volt Δ Primary, 480Y/277 Secondary, 60 Hz

kVA	Catalog Number Group I Rolled Steel	Height in (mm)	Width in (mm)	Depth in (mm)	Approx. Ship Weight lbs (kg)	Design Style ¹	Elec Conn ¹	Primary Amps	Secondary Amps
45	F81F45S	32.38 (822.5)	27.51 (698.8)	17.01 (432.1)	1400 (635)	6	35	54.1	54.1
75	F81F75SCU	32.38 (822.5)	27.51 (698.8)	17.01 (432.1)	1500 (680)	6	35	90.2	90.2
75	F81F75S	40.88 (1038.4)	31.51 (800.1)	17.01 (432.1)	1700 (771)	6	35	90.2	90.2
112.5	F81F112S	40.88 (1038.4)	31.51 (800.1)	17.01 (432.1)	1800 (816)	6	35	135.3	135.3
150	F81F150SCU	40.88 (1038.4)	31.51 (800.1)	17.01 (432.1)	2200 (998)	6	35	180.4	180.4

Notes:

Weights and dimensions may change and should not be used for construction purposes.

1. Design Styles and Electrical Connections can be found at the end of the Non-Ventilated Distribution Transformers section.

Design Styles

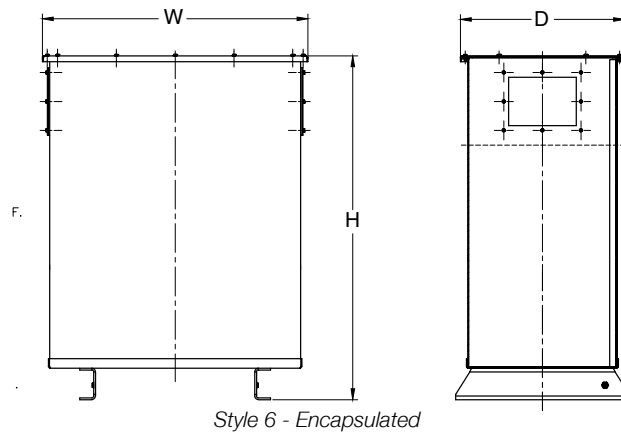

Electrical Connections (Three Phase)

480 Δ Volt Primary
208Y/120 Volt Secondary
Taps: 1, 2.5% FCAN; 1, 2.5% FCBN

34

Primary Voltage	Interconnect	Connect Lines to
492	1-H1 & 2-H2 & 3-H3	H1, H2, H3
480	4-H1 & 5-H2 & 6-H3	H1, H2, H3
468	7-H1 & 8-H2 & 9-H3	H1, H2, H3
Secondary Voltage		Connect Lines to
208		X1, X2, X3
120		X0-X1, X2, X3

F2 Series

480 Δ Volt Primary
480Y/277 Volt Secondary
Taps: 1, 2.5% FCAN; 1, 2.5% FCBN

35

Primary Voltage	Interconnect	Connect Lines to
492	1-H1 & 2-H2 & 3-H3	H1, H2, H3
480	4-H1 & 5-H2 & 6-H3	H1, H2, H3
468	7-H1 & 8-H2 & 9-H3	H1, H2, H3
Secondary Voltage	Interconnect	Connect Lines to
480		X1, X2, X3
277		X0-X1, X2, X3

F81 Series

= Earth Ground

Notes:

Connect the electrostatic shield to the equipment ground (green) or to both the equipment ground and the system ground (white). Specifications are subject to change without notice.

Drive Isolation Transformers: 7.5–440 kVA, Three Phase

Special Voltages and kVA Sizes for Drive Applications

For SCR (Silicon Control Rectifier) variable speed motor drive applications, a transformer is needed to magnetically isolate the incoming line from the motor drive. The transformer must also provide a voltage change to match the required voltage of the SCR Drive. Standard designs are delta primary and wye secondary to match the common power sources required in most three phase rectifier circuits.

SolaHD Drive Isolation Transformers are specifically designed to handle the mechanical stresses, voltage demands and harmonics associated with SCR applications.

Applications

- SCR Variable Speed Drives

Features

- Available from 7.5 thru 440 kVA, 3 Phase, 60 Hz
- Isolation minimizes load disturbances caused by the SCR drive
- UL Listed/NEMA Type 3R enclosures when used with optional weather shield
- Taps on all units for adjustments to incoming source voltage. Full capacity secondary neutral as required by the National Electric Code
- Shielding attenuates line to ground noise
- 10 year limited warranty

Certifications and Compliances

All Models

- Listed
 - E25872 (UL 1561) or E77014 (UL 5085)
 - RoHS Compliant

Selection Table 1: Three Phase

- Listed (7.5kVA Models only)
- Certified (11 and 14kVA Models only)

Related Products

- Surge Protective Devices
- K-13 Rated Transformers for Variable Frequency Drives

Accessories

- Weather Shields



Design Styles

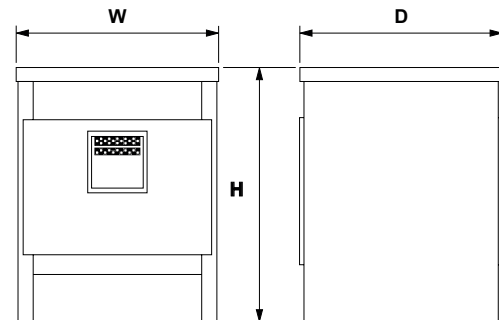

Style 1 - Ventilated

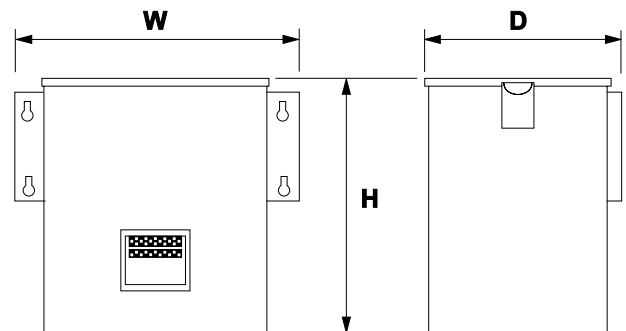

Style 4 - Encapsulated

Selection Table 1: Three Phase

kVA	Drive Horse Power	Group I Catalog Number	Group II Catalog Number	Group III Catalog Number	NEMA 3R Weather Shield ⁽¹⁾	Dimensions			Approx. Ship Weight lbs (kg)	Design Style
		460 Δ Primary 460Y/266 Secondary 60 Hz	460 Δ Primary 230Y/133 Secondary 60 Hz	575 Δ Primary 230Y/133 Secondary 60 Hz		Height in (mm)	Width in (mm)	Depth in (mm)		
7.5 ²	5	DT651F7.5S	DT661F7.5S	DT631F7.5S	N/A ⁽²⁾	17.00 (431.8)	20.00 (508.0)	10.00 (254.0)	236.0 (107.00)	4
11 ³	7.5	DT651H11S	DT661H11S	DT631H11S	WS-02	23.00 (584.2)	18.00 (457.2)	14.00 (355.6)	166.0 (72.00)	1
14 ³	10	DT651H14S	DT661H14S	DT631H14S	WS-02	23.00 (584.2)	18.00 (457.2)	14.00 (355.6)	180.0 (82.00)	1
20	15	DT651H20S	DT661H20S	DT631H20S	WS-02	23.00 (584.2)	18.00 (457.2)	14.00 (355.6)	210.0 (95.00)	1
27	20	DT651H27S	DT661H27S	DT631H27S	WS-14	28.00 (711.2)	23.00 (584.2)	16.00 (406.4)	277.0 (126.00)	1
34	25	DT651H34S	DT661H34S	DT631H34S	WS-14	28.00 (711.2)	23.00 (584.2)	16.00 (406.4)	309.0 (140.00)	1
40	30	DT651H40S	DT661H40S	DT631H40S	WS-14	28.00 (711.2)	23.00 (584.2)	16.00 (406.4)	329.0 (149.00)	1
51	40	DT651H51S	DT661H51S	DT631H51S	WS-14	28.00 (711.2)	23.00 (584.2)	16.00 (406.4)	372.0 (169.00)	1
63	50	DT651H63S	DT661H63S	DT631H63S	WS-30	34.00 (863.6)	28.00 (711.2)	22.00 (558.8)	479.0 (217.00)	1
75	60	DT651H75S	DT661H75S	DT631H75S	WS-30	34.00 (863.6)	28.00 (711.2)	22.00 (558.8)	510.0 (231.00)	1
93	75	DT651H93S	DT661H93S	DT631H93S	WS-30	34.00 (863.6)	28.00 (711.2)	22.00 (558.8)	637.0 (289.00)	1
118	100	DT651H118S	DT661H118S	DT631H118S	WS-10	44.00 (1117.6)	33.00 (838.2)	21.00 (533.4)	910.0 (413.00)	1
145	125	DT651H145S	DT661H145S	DT631H145S	WS-10	44.00 (1117.6)	33.00 (838.2)	21.00 (533.4)	920.0 (417.00)	1
175	150	DT651H175S	DT661H175S	DT631H175S	WS-11	46.00 (1168.4)	36.00 (914.4)	24.00 (609.6)	1150.0 (522.00)	1
220	200	DT651H220S	DT661H220S	DT631H220S	WS-11	46.00 (1168.4)	36.00 (914.4)	24.00 (609.6)	1280.0 (581.00)	1
275	250	DT651H275S	DT661H275S	DT631H275S	WS-11	46.00 (1168.4)	36.00 (914.4)	24.00 (609.6)	1415.0 (642.00)	1
330	300	DT651H330S	DT661H330S	DT631H330S	WS-11	46.00 (1168.4)	36.00 (914.4)	24.00 (609.6)	1525.0 (692.00)	1
440	400	DT651H440S	DT661H440S	DT631H440S	WS-12	65.00 (1651.0)	45.00 (1143.0)	35.00 (889.0)	2450.0 (1111.00)	1

Notes:

1. Weather shields come in a set of two and must be ordered separately.
2. Encapsulated. No weather shield required. cULus E77014.
3. Units are CSA marked.

Electrical Connection Key

Group	Electrical Connection Number
Group I	
7.5 kVA	1
11-440 kVA	4
Group II	
7.5 kVA	2
11-440 kVA	5
Group III	
7.5 kVA	3
11-440 kVA	6

Electrical Connections

460 Δ Primary, 460Y/266 Volt Secondary
Taps: 1,5% FCAN; 1,5% FCBN **1**

Primary Voltage	Connect	Line Leads
483	1-H1 & 2-H2 & 3-H3	H1, H2, H3
460	4-H1 & 5-H2 & 6-H3	H1, H2, H3
437	7-H1 & 8-H2 & 9-H3	H1, H2, H3
Secondary Voltage		Line Leads
460		X1, X2, X3
266		X0-X1, X2, X3

460 Δ Primary, 230Y/133 Volt Secondary
Taps: 1,5% FCAN; 1,5% FCBN **2**

Primary Voltage	Connect Taps	Line Leads
483	1-H1 & 2-H2 & 3-H3	H1, H2, H3
460	4-H1 & 5-H2 & 6-H3	H1, H2, H3
437	7-H1 & 8-H2 & 9-H3	H1, H2, H3
Secondary Voltage		Line Leads
230		X1, X2, X3
133		X0-X1, X2, X3

575 Δ Primary, 230Y/133 Volt Secondary
Taps: 1,5% FCAN; 1,5% FCBN **3**

Primary Voltage	Connect Taps	Line Leads
604	1-H1 & 2-H2 & 3-H3	H1, H2, H3
575	4-H1 & 5-H2 & 6-H3	H1, H2, H3
546	7-H1 & 8-H2 & 9-H3	H1, H2, H3
Secondary Voltage		Line Leads
230		X1, X2, X3
133		X0-X1, X2, X3

Electrical Connections

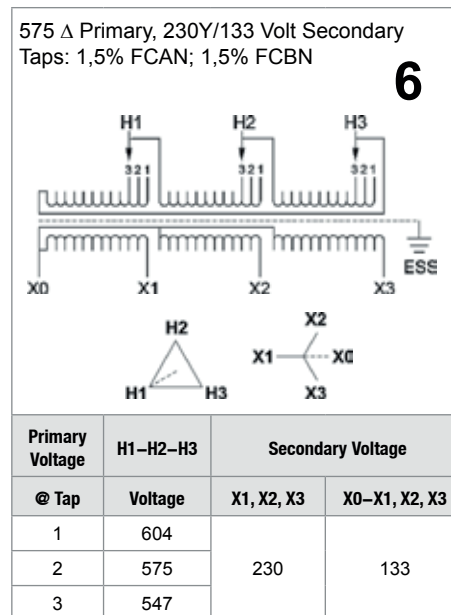
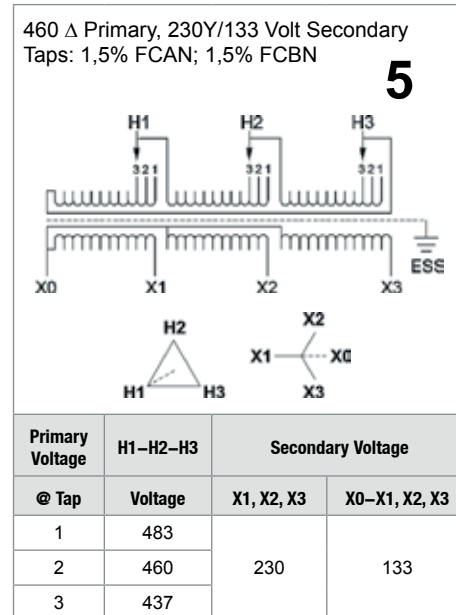
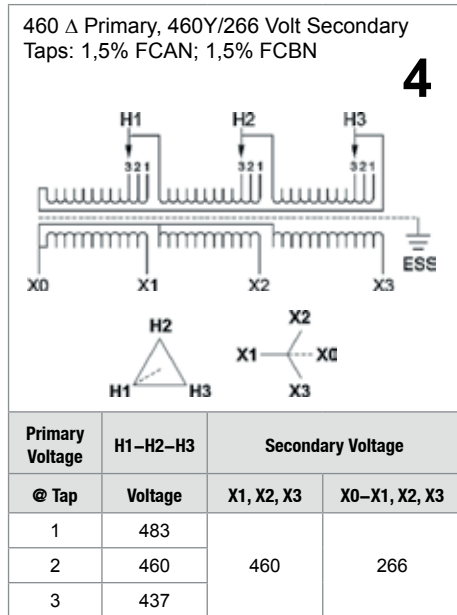

CUSTOM SOLAHD TRANSFORMER QUOTATION REQUEST

Information is required prior to quotation being issued | Email this form to solahd.technicalservices@emerson.com or fax to (800) 538-6545.

Emerson is pleased to offer the broadest range of transformers on the market including many custom designs. If you can't find what you are looking for, please fill out the information below and submit it to our Technical Services Group at solahd.technicalservices@emerson.com. We are happy to provide a quote on a custom transformer if available.

Information in bold is REQUIRED prior to quotation being issued.						Date: _____											
Customer Information																	
Distributor: _____						Representative: _____											
Contact: _____						Contact: _____											
Account Number: _____						Phone: _____											
Phone: _____						Fax: _____											
Fax: _____						Email: _____											
Email: _____						Job/Project Name: _____											
City/State: _____																	
1: Specifications																	
1A: Size																	
<input type="checkbox"/> 15	<input type="checkbox"/> 25	<input type="checkbox"/> 30	<input type="checkbox"/> 37.5	<input type="checkbox"/> 45	<input type="checkbox"/> 50	<input type="checkbox"/> 75	<input type="checkbox"/> 100	<input type="checkbox"/> 112.5	<input type="checkbox"/> 150	<input type="checkbox"/> 167	<input type="checkbox"/> 225	<input type="checkbox"/> 300	<input type="checkbox"/> 500				
<input type="checkbox"/> kVA	<input type="checkbox"/> VA	<input type="checkbox"/> Other															
1B: Quantity																	
_____ Number of Units				<input type="checkbox"/> One Time Buy				<input type="checkbox"/> Annual Usage				_____ Frequency of Purchase					
1C: Temperature Rise (Check One)																	
<input type="checkbox"/> 80°C			<input type="checkbox"/> 115°C			<input type="checkbox"/> 150°C											
1C: Check all that apply																	
<input type="checkbox"/> Three Phase			<input type="checkbox"/> Single Phase			<input type="checkbox"/> LVGP			<input type="checkbox"/> DOE 2016 (≥15kVA ventilated distribution transformers only)								
<input type="checkbox"/> 50 Hz			<input type="checkbox"/> 60 Hz (Standard)			<input type="checkbox"/> K-Factor 13											
<input type="checkbox"/> Copper Windings			<input type="checkbox"/> Aluminum Windings (Standard)			<input type="checkbox"/> K-Factor 20			<input type="checkbox"/> SCR Drive Isolation								
<input type="checkbox"/> No Electrostatic Shield			<input type="checkbox"/> Other: _____														
1D: Enclosure Type — Check all that apply																	
VENTILATED:			<input type="checkbox"/> Open Coil (<i>Top Terminated Standard (UL Recognized)</i>)			<input type="checkbox"/> NEMA 1			<input type="checkbox"/> NEMA 1 (SS)			<input type="checkbox"/> NEMA 3R (WSXX)			<input type="checkbox"/> NEMA 3R (SS)		
ENCLOSED (NON-UL):			<input type="checkbox"/> TENV			<input type="checkbox"/> TENV (SS)											
ENCAPSULATED:			<input type="checkbox"/> NEMA 3R			<input type="checkbox"/> NEMA 3R (SS)			<input type="checkbox"/> NEMA 4/12 (SS)			<input type="checkbox"/> NEMA 4X (SS)					
(SS) Stainless Steel Grade:			<input type="checkbox"/> Standard (304)			<input type="checkbox"/> Optional (316)											
Hazardous Location Class I, Division 2:				<input type="checkbox"/> No		<input type="checkbox"/> Yes (UL Certified)											
1E: Other																	
Please specify _____																	
3: Industrial Control Transformers																	
<input type="checkbox"/> ICE			<input type="checkbox"/> HSZ Series			<input type="checkbox"/> Other: _____											
4: Primary Voltage						5: Secondary Voltage											
<input type="checkbox"/> 120	<input type="checkbox"/> 208	<input type="checkbox"/> 240	<input type="checkbox"/> 480	<input type="checkbox"/> 600	<input type="checkbox"/> Other: _____	<input type="checkbox"/> 120	<input type="checkbox"/> 208	<input type="checkbox"/> 240	<input type="checkbox"/> 480	<input type="checkbox"/> 600	<input type="checkbox"/> Other: _____						
Taps:		<input type="checkbox"/> Standard: _____			<input type="checkbox"/> Other: _____			If Three phase:		<input type="checkbox"/> Delta			<input type="checkbox"/> Wye (Standard)				
If Three phase:		<input type="checkbox"/> Delta (Standard)															
6: Agency Certification																	
<input type="checkbox"/> UL			<input type="checkbox"/> CSA or cULus			<input type="checkbox"/> CE			<input type="checkbox"/> Other: _____								
7: Additional Information																	
Please quote a Catalog or Design Number :				<input type="checkbox"/> Similar to (must note changes above): _____				<input type="checkbox"/> Exactly Like: _____									
Does this request pertain to a bid specification?:				<input type="checkbox"/> No		<input type="checkbox"/> Yes											
8: Competitive Data — Must be completed for special pricing considerations																	
End User/Contractor: _____						Competition: _____											
Competitor's Part Number : _____						Competitor's Price : _____											
Target End User's Price : _____						Distributor Margin: _____											



Specification Guide for Low Voltage, General Purpose, Dry Type Transformers (600 Volt Class) - .05 kVA to 500 kVA

General

Single and three phase distribution transformers (600 Volt and below). 60 Hz, ventilated transformers above 15kVA need to meet DOE 2016 requirements.

- Provide and install, as referenced on the electrical plans, enclosed dry type SolaHD transformers as manufactured by Emerson.

Standards

- Transformers must be listed by Underwriters Laboratories, evaluated to CSA standards and designed, constructed and rated in accordance with NEMA ST 20 and applicable IEEE & OSHA specifications.

Construction

Cores

- All transformer cores shall be constructed of low loss, high quality, electrical grade laminate steel. By design, the flux density is to be kept well below the saturation level to reduce audible sound level and minimize core losses. The core volume shall allow operation at 10% above rated primary voltage at no load without exceeding the temperature rise of the unit.

Coils

- Coil conductors shall be either aluminum or copper and must be continuous. The entire core and coil assembly shall be impregnated with a thermal setting varnish and cured to reduce hot spots in the coils and seal out moisture. Coils with exposed magnet wire will not be acceptable. Transformers shall have common core construction.
- All transformers 1 kVA or larger shall incorporate a faraday (electrostatic) shield between primary and secondary windings for the attenuation of voltage spikes, line noise and voltage transients.
- General purpose transformers are classified as isolation transformers.

Electrostatic Shield

- For power conditioning purposes, it is recommended that isolation transformers be equipped with electrostatic shielding between the primary and secondary windings. An electrostatic shield provides a conducting path to ground that reduces the effect of coupling between primary and secondary windings and improves the isolation transformer's ability to isolate its' load from the common-mode noise present on the input power source. Electrostatic shields significantly reduce or eliminate electrical disturbances on the line from being transmitted to the sensitive load.

Enclosures

- Transformer enclosures shall be constructed of heavy gauge sheet steel and coated with a grey powder paint finish (ANSI 61). Enclosures shall be UL Listed/NEMA Type 1 and 3R rated for outdoor use. This information must be listed on the transformer nameplate.
- Maximum transformer enclosure temperature will not exceed 65°C rise above a 40°C ambient under full load.
- The transformer enclosure must be grounded by the installer in accordance with the latest edition of the National Electric Code and any local codes or ordinances.

Performance

- Audible sound levels will not exceed limits established in NEMA ST20:

Less than 10 kVA	40 db
10 to 50 kVA	45 db
51 to 150 kVA	50 db
151 to 300 kVA	55 db
301 to 500 kVA	60 db

- Transformers shall incorporate a UL Recognized insulation system.

Limited Warranty

- Transformers are warranted against material, performance and workmanship defects for a period of ten (10) years from date of manufacture with the provision for an additional two (2) years. Custom transformers come with a one (1) year warranty.

Approval

- Typical performance and dimensional data on similar units must be submitted on all transformers for approval. Factory testing must have been conducted in accordance with NEMA ST20. Submitted performance and dimensional data must include, but is not limited to the following:
 - A. Height, width, depth, mounting dimensions, conduit entry locations and lifting provisions
 - B. Weight
 - C. Transformer losses
 - D. Potential tests both applied and induced
 - E. Temperature - ambient and rise under full load
 - F. Insulation class
 - G. % excitation current
 - H. Electrical schematic including taps
 - I. Polarity and phase rotation
 - J. kVA, frequency and voltage rating
 - K. IR, IX, and IZ percentages at reference temperature
 - L. Audible sound level



Introduction236

Selection Steps236

Fusing237

Using the Selection Tables.....237

Specification Tables238

Connection Diagrams for Low Voltage Applications240

Design Styles.....241

Selection Tables: Single Phase242

Selection Tables: Three Phase248

Connection Diagrams for Buck-Boost Applications.....254

Application Note258

SolaHD Buck-Boost Transformers are small, single phase, dry type distribution transformers designed and shipped as insulating/isolating transformers. They have a dual voltage primary and a dual voltage secondary. These transformers can be connected for a wide range of voltage combinations. The most common use is to buck (lower) or boost (raise) the supply voltage a small amount, usually 5 to 27%. Buck-boost transformers are in compliance with NEC Article 210.9, Exception 1 when field connected as an autotransformer.

The major advantages of buck-boost transformers are their low cost, compact size and light weight. They are also more efficient and cost less than equivalent isolation transformers. When connected as an autotransformer, they can handle loads up to 20 times the nameplate rating. A buck-boost transformer is the ideal solution for changing line voltage by small amounts.

When a buck-boost has the primary and secondary windings connected, per recommended instructions, it becomes an autotransformer. Now, only the secondary windings are transforming voltage and current. The majority of the kVA load passes directly from the supply to the load. This is the reason buck-boost transformers can supply a load with a much larger kVA rating than the nameplate indicates.

Low voltage lighting control applications

SolaHD Buck-Boost Transformers are designed to supply power to low voltage lighting circuits, control panels or other systems requiring 12, 16, 24, 32, or 48 Volts. When connected as an insulating transformer (by following the wiring diagram located after the specification tables on the inside of the transformer case), the transformer's capacity matches the nameplate kVA rating.

SolaHD Buck-Boost Transformers are also suited for low voltage landscape lighting. They are UL Listed for outdoor service and their compact size makes them the perfect solution for providing power to accent lighting applications. Electrical connection diagrams are shown at the end of this section.

Use dimmers on the output of the transformer that are designed and rated for use with magnetic loads. We strongly recommend contacting the dimmer manufacturer for advice on your specific lighting application.

Certifications and Compliances

-  Listed
 - UL 506
 - CSA C22.2 No. 66



Accessories

- Surge Protective Devices
- Active Tracking® Filters

Selection Steps

1. Input Line Voltage

Measure the supply voltage with a voltmeter.

2. Voltage Required for the Load

Check the load equipment to determine the voltage requirement.

3. kVA or Ampere Rating of the Load

Find either the load kVA or the load amperage requirements. This information is listed on the nameplate of the load equipment.

4. Frequency

Either 50 or 60 Hz. The frequency of the transformer must match the frequency of the load.

5. Number of Phases

Single or three phase line and load must match (a transformer cannot convert single to three phase.) A common application is to make a single phase connection from a three phase supply by using one phase of the three phase supply circuit. Be careful not to overload that phase of the three phase supply. For buck-boost applications the supply must provide load kVA – not just the nameplate rating of the buck-boost. Refer to the Selection Tables on the following pages.

Three phase, buck-boost applications require two or three transformers. Check the “Quantity Required” column of the Three Phase Selection Tables for the exact quantity.

Fusing Buck-Boost Transformers

For determining the correct size of breaker or fuse for a given range of input or output ampere ratings, refer to Section 450.4, of the National Electric Code (NEC).

Where an overcurrent protection device is required, the electrical connections and selection tables will reference appropriately.

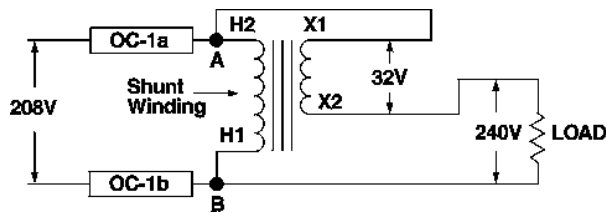

Overcurrent devices OC-1a and OC-1b are shown correctly installed in accordance with NEC 450.4. Locating an overcurrent device in series with the shunt winding anywhere between A and B is not permitted. The shunt winding is the winding common to both the input and the output circuits.

Using the Selection Tables

1. Determine if you are trying to Boost (raise) or Buck (lower) your voltage. Select an input/output voltage combination that comes closest to matching your application from the appropriate single or three phase charts on the following pages.
2. Move across your selected input/output voltage row to the amperage or kVA rating closest to, but greater than the rating required by your load.
3. Reading the top of the column will give you the catalog number of the exact buck-boost transformer you need. See the Specification Tables on the next page.
4. Connect the transformers according to the diagram indicated. See the Electrical Connections section at the end of this section. Connection diagrams are packed with each transformer.

Specification Tables

Group 1 – 120 x 240 Volt Primary, 12/24 Volt Secondary

KVA	Catalog Number	Maximum Secondary Amperage		Height in (mm)	Width in (mm)	Depth in (mm)	Approx. Ship Weight lbs (kg)	Design Style	Elec Conn
		12 V	24 V						
Non-Encapsulated – 50/60 Hz, Single Phase									
0.05	HS19B50	4.16	2.08	6.00 (152.4)	4.00 (101.6)	3.00 (76.2)	2.0 (0.91)	2	1
0.1	HS19B100	8.33	4.16	6.00 (152.4)	4.00 (101.6)	3.00 (76.2)	4.0 (1.82)	2	1
0.15	HS19B150	12.5	6.25	7.50 (190.5)	4.00 (101.6)	4.00 (101.6)	5.0 (2.27)	2	1
0.25	HS19B250	20.8	10.4	7.50 (190.5)	4.00 (101.6)	4.00 (101.6)	8.0 (3.64)	2	1
Encapsulated – 60 Hz, Single Phase									
0.5	HS19F500B	41.6	20.8	10.00 (254.0)	6.00 (152.4)	5.00 (127.0)	22.0 (10.00)	3	1
0.75	HS19F750B	62.5	31.2	10.00 (254.0)	6.00 (152.4)	5.00 (127.0)	27.0 (12.27)	3	1
1	HS19F1B	83.3	41.6	10.00 (254.0)	6.00 (152.4)	5.00 (127.0)	28.0 (12.73)	3	1
1.5	HS19F1.5A	125	62.5	12.00 (304.8)	10.00 (254.0)	7.00 (177.8)	38.0 (17.27)	4	1
2	HS19F2A	166.6	83.3	12.00 (304.8)	10.00 (254.0)	7.00 (177.8)	45.0 (20.45)	4	1
3	HS19F3A	250	125	12.00 (304.8)	10.00 (254.0)	7.00 (177.8)	55.0 (25.00)	4	1
5	HS19F5A	416.5	208.3	17.00 (431.8)	14.00 (355.6)	9.00 (228.6)	100.0 (45.45)	4	1
7.5	HS19F7.5A	625	312.5	17.00 (431.8)	14.00 (355.6)	9.00 (228.6)	135.0 (61.36)	4	1

Group 2 – 120 x 240 Volt Primary, 16/32 Volt Secondary

KVA	Catalog Number	Maximum Secondary Amperage		Height in (mm)	Width in (mm)	Depth in (mm)	Approx. Ship Weight lbs (kg)	Design Style	Elec Conn
		16 V	32 V						
Non-Encapsulated – 50/60 Hz, Single Phase									
0.15	HS20B150	9.38	4.69	8.00 (203.2)	4.00 (101.6)	4.00 (101.6)	6.0 (2.73)	2	2
0.25	HS20B250	15.6	7.81	8.00 (203.2)	4.00 (101.6)	4.00 (101.6)	8.0 (3.64)	2	2
Encapsulated – 60 Hz, Single Phase									
0.5	HS20F500B	31.2	15.6	10.00 (254.0)	6.00 (152.4)	5.00 (127.0)	22.0 (10.00)	3	2
0.75	HS20F750B	46.8	23.4	10.00 (254.0)	6.00 (152.4)	5.00 (127.0)	27.0 (12.27)	3	2
1	HS20F1B	62.5	31.2	10.00 (254.0)	6.00 (152.4)	5.00 (127.0)	28.0 (12.73)	3	2
1.5	HS20F1.5A	93.7	46.8	12.00 (304.8)	10.00 (254.0)	7.00 (177.8)	38.0 (17.27)	4	2
2	HS20F2A	125	62.5	12.00 (304.8)	10.00 (254.0)	7.00 (177.8)	45.0 (20.45)	4	2
3	HS20F3A	187.5	93.7	12.00 (304.8)	10.00 (254.0)	7.00 (177.8)	55.0 (25.00)	4	2
5	HS20F5A	312	156	17.00 (431.8)	14.00 (355.6)	9.00 (228.6)	100.0 (45.45)	4	2
7.5	HS20F7.5A	468	234	17.00 (431.8)	14.00 (355.6)	9.00 (228.6)	135.0 (61.36)	4	2

Note: Weights and dimensions may change and should not be used for construction purposes.

Specification Tables – continued

Group 3 – 240 x 480 Volt Primary, 24/48 Volt Secondary

KVA	Catalog Number	Maximum Secondary Amperage		Height in (mm)	Width in (mm)	Depth in (mm)	Approx. Ship Weight lbs (kg)	Design Style	Elec Conn
		24 V	48 V						
Non-Encapsulated – 50/60 Hz, Single Phase									
0.15	HS22B150	6.25	3.13	8.00 (203.2)	4.00 (101.6)	3.00 (76.2)	5.0 (2.27)	2	3
0.25	HS22B250	10.4	5.2	8.00 (203.2)	4.00 (101.6)	3.00 (76.2)	8.0 (3.64)	2	3
Encapsulated – 60 Hz, Single Phase									
0.5	HS22F500B	20.8	10.4	8.00 (203.2)	6.00 (152.4)	5.00 (127.0)	22.0 (10.00)	3	3
0.75	HS22F750B	31.2	15.6	10.00 (254.0)	6.00 (152.4)	5.00 (127.0)	27.0 (12.27)	3	3
1	HS22F1B	41.6	20.8	10.00 (254.0)	6.00 (152.4)	5.00 (127.0)	28.0 (12.73)	3	3
1.5	HS22F1.5A	62.5	31.2	12.00 (304.8)	10.00 (254.0)	7.00 (177.8)	38.0 (17.27)	4	3
2	HS22F2A	83.3	41.6	12.00 (304.8)	10.00 (254.0)	7.00 (177.8)	45.0 (20.45)	4	3
3	HS22F3A	125	62.5	12.00 (304.8)	10.00 (254.0)	7.00 (177.8)	55.0 (25.00)	4	3
5	HS22F5A	208	104	17.00 (431.8)	14.00 (355.6)	9.00 (228.6)	100.0 (45.45)	4	3
7.5	HS22F7.5A	312	156	17.00 (431.8)	14.00 (355.6)	9.00 (228.6)	135.0 (61.36)	4	3

Note: Weights and dimensions may change and should not be used for construction purposes.

Electrical Connections for Low Voltage Applications

 = Earth Ground

120 X 240 Volt Primary,
12/24 Volt Secondary
Taps: None

1

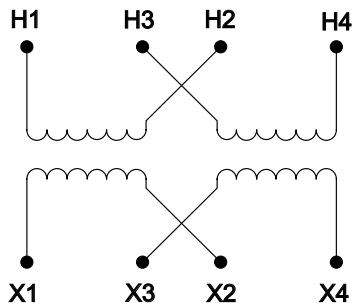



Primary Voltage	Interconnect	Connect Lines To
240	H2 to H3	H1 & H4
120	H1 to H3 H2 to H4	H1 & H4
Secondary Voltage	Interconnect	Connect Lines To
24	X2 to X3	X1 & X4
12-0-12	X2 to X3 X2 to 	X1-X2-X4
12	X1 to X3 X2 to X4	X1 & X4

HS19 and S19 Series

120 X 240 Volt Primary,
16/32 Volt Secondary
Taps: None

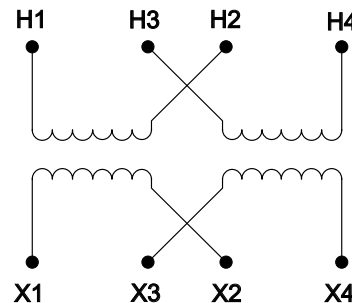
2





Primary Voltage	Interconnect	Connect Lines To
240	H2 to H3	H1 & H4
120	H1 to H3 H2 to H4	H1 & H4
Secondary Voltage	Interconnect	Connect Lines To
32	X2 to X3	X1 & X4
16-0-16	X2 to X3 X2 to 	X1-X2-X4
16	X1 to X3 X2 to X4	X1 & X4

HS20 and S20 Series

240 X 480 Volt Primary,
24/48 Volt Secondary
Taps: None

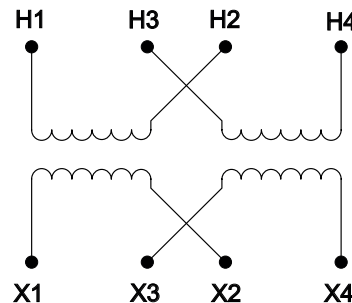
3



Primary Voltage	Interconnect	Connect Lines To
480	H2 to H3	H1 & H4
240	H1 to H3 H2 to H4	H1 & H4
Secondary Voltage	Interconnect	Connect Lines To
48	X2 to X3	X1 & X4
24-0-24	X2 to X3 X2 to 	X1-X2-X4
24	X1 to X3 X2 to X4	X1 & X4

HS22 and S22 Series

Design Styles

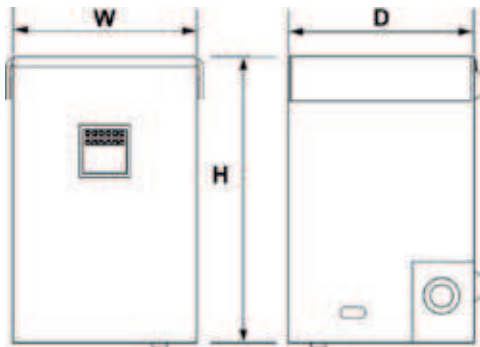

Style 2 - Non-Encapsulated

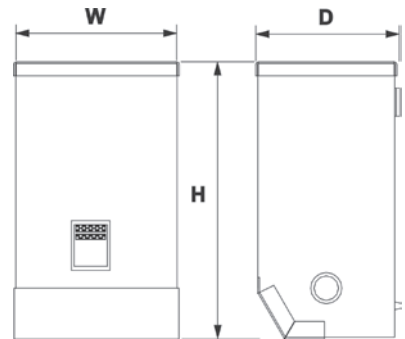

Style 3 - Encapsulated

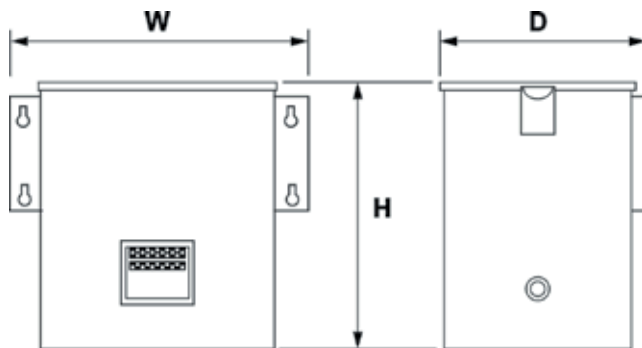

Style 4 - Encapsulated

Custom Design Styles

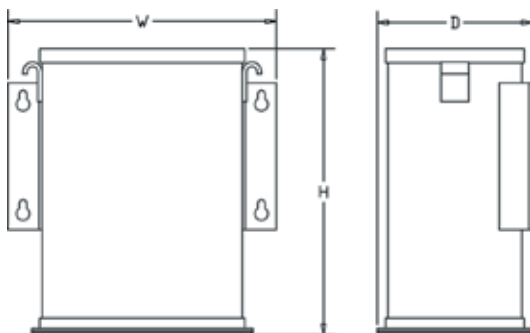

Style 5 - Encapsulated

Available for all encapsulated kVA sizes (For Type 4, 12 and 4X)

Selection Tables: Single Phase

Table 1: Using Group 1 (120 x 240 V Primary, 12/24 V Secondary) Transformers

Input Voltage	Output Voltage	Quantity Req'd	Connection Diagram *	Application Data	Catalog Number						
					HS19B50	HS19B100	HS19B150	HS19B250	HS19F500B	HS19F750B	HS19F1B
BOOSTING											
100	120	1	B1	kVA	0.25	0.5	0.75	1.25	2.5	3.75	5.0
				Load amps	2.08	4.16	6.25	10.4	20.8	31.2	41.6
				Fuse Size	6.0	10.0	15.0	25.0	35.0	50.0	70.0
109	120	1	A1	kVA	0.5	1.0	1.5	2.5	5.0	7.5	10.0
				Load amps	4.16	8.33	12.5	20.8	41.6	62.5	83.3
				Fuse Size	10.0	15.0	20.0	30.0	60.0	90.0	125.0
189	208	1	D1	kVA	0.43	0.87	1.3	2.16	4.33	6.49	8.65
				Load amps	2.08	4.16	6.25	10.4	20.8	31.2	41.6
				Fuse Size	6.0	10.0	15.0	15.0	30.0	45.0	60.0
197	208	1	C1	kVA	0.87	1.73	2.6	4.33	8.65	13.0	17.3
				Load amps	4.16	8.33	12.5	20.8	41.6	62.5	83.3
				Fuse Size	6.0	15.0	20.0	30.0	60.0	90.0	110.0
208	229	1	D1	kVA	0.48	0.95	1.43	2.38	4.77	7.15	9.54
				Load amps	2.08	4.16	6.25	10.4	20.8	31.2	41.6
				Fuse Size	6.0	10.0	15.0	15.0	30.0	45.0	60.0
218 **	240	1	D1	kVA	0.5	1.0	1.5	2.5	5.0	7.5	10.0
				Load amps	2.08	4.16	6.25	10.4	20.8	31.2	41.6
				Fuse Size	6.0	10.0	15.0	15.0	30.0	45.0	60.0
229	240	1	C1	kVA	1.0	2.0	3.0	5.0	10.0	15.0	20.0
				Load amps	4.16	8.33	12.5	20.8	41.6	62.5	83.3
				Fuse Size	6.0	15.0	20.0	30.0	60.0	90.0	110.0
BUCKING											
132 **	120	1	A2	kVA	0.55	1.1	1.65	2.75	5.5	8.25	11.0
				Load amps	4.58	9.16	13.75	22.9	45.8	68.7	91.6
				Fuse Size	10.0	15.0	20.0	30.0	60.0	80	110
144 **	120	1	B2	kVA	0.3	0.6	0.9	1.5	3.0	4.5	6.0
				Load amps	2.5	5.0	7.5	12.5	25	37.5	50.0
				Fuse Size	6.0	10.0	15.0	15.0	30.0	40.0	60.0
229	208	1	D2	kVA	0.48	0.95	1.43	2.38	4.77	7.15	9.54
				Load amps	2.29	4.58	6.88	11.4	22.9	34.4	45.8
				Fuse Size	6.0	10.0	15.0	15.0	30.0	40.0	60.0
252 **	240	1	C2	kVA	1.04	2.1	3.15	5.25	10.5	15.7	21.0
				Load amps	4.34	8.75	13.13	21.8	43.7	65.6	87.5
				Fuse Size	10.0	15.0	15.0	30.0	60.0	80.0	110.0
264 **	240	1	D2	kVA	0.55	1.1	1.65	2.75	5.5	8.25	11.0
				Load amps	2.29	4.58	6.88	11.4	22.9	34.3	45.8
				Fuse Size	6.0	10.0	15.0	15.0	30.0	40.0	60.0

* For alternate electrical connection diagrams, refer to the section immediately following the selection tables.

** Shaded items are 60 Hz only (All other ratings shown are 50/60 Hz).

Selection Tables: Single Phase

Table 1: Using Group 1 (120 x 240 V Primary, 12/24 V Secondary) Transformers

Input Voltage	Output Voltage	Quantity Req'd	Connection Diagram *	Application Data	Catalog Number				
					HS19F1.5A	HS19F2A	HS19F3A	HS19F5A	HS19F7.5A
BOOSTING									
100	120	1	B1	kVA	7.5	10.0	15.0	25.0	37.5
				Load amps	62.5	83.3	125.0	208.0	312.0
				Fuse Size	100.0	125.0	200.0	350.0	500.0
109	120	1	A1	kVA	15.0	20.0	30.0	49.9	75.0
				Load amps	125.0	167.0	250.0	416.0	625.0
				Fuse Size	175.0	250.0	350.0	600.0	1000.0
189	208	1	D1	kVA	13.0	17.3	26.0	43.3	64.9
				Load amps	62.5	83.3	125.0	208.0	312.0
				Fuse Size	90.0	125.0	175.0	300.0	450.0
197	208	1	C1	kVA	26.0	34.7	52.0	86.5	130.0
				Load amps	125.0	167.0	250.0	416.0	625.0
				Fuse Size	175.0	225.0	350.0	600.0	1000.0
208	229	1	D1	kVA	14.3	19.1	28.6	47.6	71.4
				Load amps	62.5	83.3	125.0	208.0	312.0
				Fuse Size	90.0	125.0	175.0	300.0	450.0
218 **	240	1	D1	kVA	15.0	20.0	30.0	49.9	74.9
				Load amps	62.5	83.3	125.0	208.0	312.0
				Fuse Size	90.0	125.0	175.0	300.0	450.0
229	240	1	C1	kVA	30.0	40.1	60.0	99.8	150.0
				Load amps	125.0	167.0	250.0	416.0	625.0
				Fuse Size	175.0	225.0	350.0	600.0	1000.0
BUCKING									
132 **	120	1	A2	kVA	16.5	22.0	33.0	54.9	82.5
				Load amps	137.5	183.3	275.0	457.6	687.5
				Fuse Size	175.0	225.0	350.0	600.0	800.0
144 **	120	1	B2	kVA	9.0	12.0	18.0	30.0	44.9
				Load amps	75.0	100.0	150.0	249.6	374.4
				Fuse Size	80.0	110.0	175.0	300.0	400.0
229	208	1	D2	kVA	14.3	19.1	28.6	47.6	71.4
				Load amps	68.8	91.6	137.5	228.8	343.2
				Fuse Size	80.0	110.0	175.0	300.0	400.0
252 **	240	1	C2	kVA	31.5	42.0	63.0	104.8	157.5
				Load amps	131.3	174.9	262.5	436.8	656.3
				Fuse Size	175.0	225.0	350.0	600.0	800.0
264 **	240	1	D2	kVA	16.5	22.0	33.0	54.9	78.6
				Load amps	68.8	91.6	137.5	228.8	343.2
				Fuse Size	80.0	110.0	175.0	300.0	400.0

* For alternate electrical connection diagrams, refer to the section immediately following the selection tables.

** Shaded items are 60 Hz only (All other ratings shown are 50/60 Hz).

Selection Tables: Single Phase

Table 2: Using Group 2 (120 x 240 V Primary, 16/32 V Secondary) Transformers

Input Voltage	Output Voltage	Quantity Req'd	Connection Diagram *	Application Data	Catalog Number				
					HS20B150	HS20B250	HS20F500B	HS20F750B	HS20F1B
BOOSTING									
95	120	1	B1	kVA	0.6	0.9	1.9	2.8	3.8
				Load amps	4.7	7.8	15.6	23.4	31.2
				Fuse Size	10.0	15.0	25.0	40.0	50.0
106	120	1	A1	kVA	1.1	1.9	3.7	5.6	7.5
				Load amps	9.4	15.6	31.2	46.8	62.5
				Fuse Size	15.0	25.0	45.0	70.0	90.0
183	208	1	D1	kVA	1.0	1.6	3.2	4.9	6.5
				Load amps	4.7	7.8	15.6	23.4	31.2
				Fuse Size	10.0	15.0	25.0	35.0	45.0
195	208	1	C1	kVA	2.0	3.2	6.5	9.7	13.0
				Load amps	9.4	15.6	31.2	46.8	62.5
				Fuse Size	15.0	25.0	45.0	70.0	90.0
208	236	1	D1	kVA	1.1	1.8	3.7	5.5	7.4
				Load amps	4.7	7.8	15.6	23.4	31.2
				Fuse Size	10.0	15.0	25.0	40.0	50.0
225	240	1	C1	kVA	2.3	3.7	7.5	11.2	15.0
				Load amps	9.4	15.6	31.2	46.8	62.5
				Fuse Size	15.0	25.0	45.0	70.0	90.0
240 **	272	1	D1	kVA	1.3	2.1	4.2	6.4	8.5
				Load amps	4.7	7.8	15.6	23.4	31.2
				Fuse Size	10.0	15.0	25.0	35.0	45.0
BUCKING									
136 **	120	1	A2	kVA	1.3	2.1	4.2	6.4	8.5
				Load amps	10.6	17.7	35.4	53.2	70.8
				Fuse Size	15.0	20.0	40.0	60.0	80.0
152 **	120	1	B2	kVA	0.7	1.2	2.4	3.6	4.7
				Load amps	6.0	9.9	19.8	29.6	39.5
				Fuse Size	10.0	15.0	20.0	30.0	40.0
236	208	1	D2	kVA	1.1	1.8	3.7	5.5	7.4
				Load amps	5.3	8.9	17.7	26.5	35.4
				Fuse Size	6.0	15.0	20.0	30.0	40.0
256 **	240	1	C2	kVA	2.4	4.0	8.0	12.0	16.0
				Load amps	10.0	16.6	33.3	50.0	66.7
				Fuse Size	15.0	20.0	40.0	60.0	80.0
272 **	240	1	D2	kVA	1.3	2.1	4.2	6.4	8.5
				Load amps	5.3	8.8	17.7	26.5	35.4
				Fuse Size	10.0	15.0	20.0	30.0	40.0

* For alternate electrical connection diagrams, refer to the section immediately following the selection tables.

** Shaded items are 60 Hz only (All other ratings shown are 50/60 Hz).

Selection Tables: Single Phase

Table 2: Using Group 2 (120 x 240 V Primary, 16/32 V Secondary) Transformers

Input Voltage	Output Voltage	Quantity Req'd	Connection Diagram *	Application Data	Catalog Number				
					HS20F1.5A	HS20F2A	HS20F3A	HS20F5A	HS20F7.5A
BOOSTING									
95	120	1	B1	kVA	5.6	7.5	11.2	18.7	28.0
				Load amps	46.8	62.5	93.7	156.0	234.0
				Fuse Size	80.0	100.0	150.0	250.0	400.0
106	120	1	A1	kVA	11.2	15.0	22.5	37.4	56.2
				Load amps	93.7	125.0	187.5	312.0	468.0
				Fuse Size	150.0	200.0	300.0	450.0	700.0
183	208	1	D1	kVA	9.7	13.0	19.5	32.4	48.6
				Load amps	46.8	62.5	93.7	156.0	234.0
				Fuse Size	70.0	90.0	150.0	225.0	350.0
195	208	1	C1	kVA	19.5	26.0	39.0	64.9	97.3
				Load amps	93.7	125.0	187.5	312.0	468.0
				Fuse Size	125.0	175.0	250.0	450.0	700.0
208	236	1	D1	kVA	11.0	14.7	22.0	36.8	55.2
				Load amps	46.8	62.5	93.7	156.0	234.0
				Fuse Size	70.0	90.0	150.0	225.0	350.0
225	240	1	C1	kVA	22.5	30.0	45.0	74.8	112.3
				Load amps	93.7	125.0	187.5	312.0	468.0
				Fuse Size	125.0	175.0	250.0	450.0	700.0
240 **	272	1	D1	kVA	12.7	17.0	25.5	42.4	63.6
				Load amps	46.8	62.5	93.7	156.0	234.0
				Fuse Size	70.0	90.0	150.0	225.0	350.0
BUCKING									
136 **	120	1	A2	kVA	12.7	17.0	25.5	42.4	63.6
				Load amps	106.2	141.7	212.5	353.6	530.4
				Fuse Size	125.0	175.0	250.0	400.0	600.0
152 **	120	1	B2	kVA	7.1	9.5	14.3	23.7	35.6
				Load amps	59.4	79.2	118.8	197.6	296.4
				Fuse Size	60.0	80.0	125.0	200.0	300.0
236	208	1	D2	kVA	11.1	14.8	22.1	36.8	55.2
				Load amps	53.2	70.9	106.4	177.0	265.5
				Fuse Size	60.0	80.0	125.0	200.0	300.0
256 **	240	1	C2	kVA	24.0	32.0	48.0	79.9	119.8
				Load amps	99.9	133.3	200.0	332.8	499.2
				Fuse Size	125.0	175.0	250.0	400.0	600.0
272 **	240	1	D2	kVA	12.8	17.0	25.5	42.4	63.6
				Load amps	53.2	70.8	106.3	176.8	265.2
				Fuse Size	60.0	80.0	125.0	200.0	300.0

* For alternate electrical connection diagrams, refer to the section immediately following the selection tables.

** Shaded items are 60 Hz only (All other ratings shown are 50/60 Hz).

Selection Tables: Single Phase

Table 3: Using Group 3 (240 x 480 V Primary, 24/48 V Secondary) Transformers

Input Voltage	Output Voltage	Quantity Req'd	Connection Diagram *	Application Data	Catalog Number				
					HS22B150	HS22B250	HS22F500B	HS22F750B	HS22F1B
BOOSTING									
200	240	1	B1	kVA	0.75	1.25	2.50	3.74	4.99
				Load amps	3.10	5.20	10.40	15.60	20.80
				Fuse Size	6.00	10.00	15.00	20.00	30.00
230 **	277	1	B1	kVA	0.87	1.44	2.88	4.22	5.76
				Load amps	3.10	5.20	10.40	15.60	20.80
				Fuse Size	10.00	15.00	20.00	25.00	35.00
346	380	1	D1	kVA	1.20	1.98	3.95	5.93	7.90
				Load amps	3.10	5.20	10.40	15.60	20.80
				Fuse Size	6.00	10.00	15.00	20.00	30.00
362	380	1	C1	kVA	2.40	3.95	7.90	11.86	15.81
				Load amps	6.30	10.40	20.80	31.20	41.60
				Fuse Size	10.00	15.00	30.00	40.00	60.00
378	416	1	D1	kVA	1.30	2.16	4.33	6.49	8.65
				Load amps	3.10	5.20	10.40	15.60	20.80
				Fuse Size	6.00	10.00	15.00	25.00	30.00
436	480	1	D1	kVA	1.50	2.50	4.99	7.49	9.98
				Load amps	3.10	5.20	10.40	15.60	20.80
				Fuse Size	6.00	10.00	15.00	25.00	30.00
458 **	480	1	C1	kVA	3.00	4.99	9.98	14.98	19.97
				Load amps	6.30	10.40	20.80	31.20	41.60
				Fuse Size	15.00	15.00	30.00	45.00	60.00
BUCKING									
277 **	230	1	B2	kVA	0.86	1.44	2.88	4.33	5.76
				Load amps	3.80	6.26	12.53	18.79	25.05
				Fuse Size	6.00	10.00	15.00	20.00	30.00
398	380	1	C2	kVA	2.50	4.14	8.28	12.40	16.60
				Load amps	6.50	10.89	21.79	32.70	43.60
				Fuse Size	10.00	15.00	30.00	40.00	60.00
418 **	380	1	D2	kVA	1.30	2.18	4.35	6.52	8.69
				Load amps	3.40	5.72	11.40	17.20	22.90
				Fuse Size	6.00	10.00	15.00	20.00	30.00
504 **	480	1	C2	kVA	3.10	5.24	10.50	15.70	21.00
				Load amps	6.60	10.40	21.80	32.80	43.70
				Fuse Size	15.00	15.00	30.00	45.00	60.00
528 **	480	1	D2	kVA	1.65	2.75	5.49	8.24	11.00
				Load amps	3.40	5.72	11.44	17.16	22.88
				Fuse Size	6.00	10.00	15.00	20.00	30.00

* For alternate electrical connection diagrams, refer to the section immediately following the selection tables.

** Shaded items are 60 Hz only (All other ratings shown are 50/60 Hz).

Selection Tables: Single Phase

Table 3: Using Group 3 (240 x 480 V Primary, 24/48 V Secondary) Transformers

Input Voltage	Output Voltage	Quantity Req'd	Connection Diagram *	Application Data	Catalog Number				
					HS22F1.5A	HS22F2A	HS22F3A	HS22F5A	HS22F7.5A
BOOSTING									
200	240	1	B1	kVA	7.49	9.98	15.0	24.96	37.44
				Load amps	31.2	41.6	62.5	104.0	156.0
				Fuse Size	50.0	70.0	90.0	150.0	225.0
230 **	277	1	B1	kVA	8.64	11.52	17.31	28.81	43.21
				Load amps	31.2	41.6	62.5	104.0	156.0
				Fuse Size	50.0	70.0	100.0	175.0	250.0
346	380	1	D1	kVA	11.86	15.81	23.75	39.52	59.28
				Load amps	31.2	41.6	62.5	104.0	156.0
				Fuse Size	45.0	60.0	90.0	150.0	225.0
362	380	1	C1	kVA	23.75	31.65	47.5	79.04	118.56
				Load amps	62.5	83.3	125	208	312.0
				Fuse Size	90.0	110.0	175.0	300.0	450.0
378	416	1	D1	kVA	12.98	17.31	26.0	43.26	64.9
				Load amps	31.2	41.6	62.5	104.0	156.0
				Fuse Size	50.0	60.0	90.0	150.0	225.0
436	480	1	D1	kVA	14.98	19.97	30.0	49.92	74.88
				Load amps	31.2	41.6	62.5	104.0	156.0
				Fuse Size	45.0	60.0	90.0	150.0	225.0
458 **	480	1	C1	kVA	30.0	39.98	60.0	99.84	149.76
				Load amps	62.5	83.3	125.0	208.0	312.0
				Fuse Size	90.0	110.0	175.0	300.0	450.0
BUCKING									
277 **	230	1	B2	kVA	8.64	11.5	17.3	28.8	43.2
				Load amps	37.6	50.1	75.3	125.3	187.9
				Fuse Size	40.0	60.0	80.0	150.0	200.0
398	380	1	C2	kVA	24.8	33.1	49.8	82.8	124.2
				Load amps	65.4	87.1	130.9	217.9	326.8
				Fuse Size	80.0	110.0	175.0	300.0	400.0
418 *	380	1	D2	kVA	13.0	17.4	26.1	43.5	65.2
				Load amps	34.3	45.8	68.8	114.4	171.6
				Fuse Size	40.0	60.0	80.0	150.0	200.0
504 **	480	1	C2	kVA	31.4	41.9	63.0	104.8	157.2
				Load amps	65.5	87.4	131.3	218.4	327.6
				Fuse Size	90.0	110.0	175.0	300.0	450.0
528 **	480	1	D2	kVA	16.5	22.0	33.0	54.9	82.4
				Load amps	34.3	45.8	68.8	114.4	171.6
				Fuse Size	40.0	60.0	80.0	150.0	200.0

* For alternate electrical connection diagrams, refer to the section immediately following the selection tables.

** Shaded items are 60 Hz only (All other ratings shown are 50/60 Hz).

Selection Tables: Three Phase

Table 4: Using Group 1 (120 x 240 V Primary, 12/24 V Secondary) Transformers

Input Voltage	Output Voltage	Quantity Req'd	Connection Diagram *	Application Data	Catalog Number						
					HS19B50	HS19B100	HS19B150	HS19B250	HS19F500B	HS19F750B	HS19F1B
BOOSTING											
188	208	2	F1	kVA	0.749	1.5	2.25	3.75	7.51	11.3	15.0
				Load amps	2.08	4.16	6.25	10.4	20.8	31.25	41.6
				Fuse Size	6.0	10.0	15.0	15.0	30.0	45.0	60.0
198	208	2	E1	kVA	1.5	3.0	4.5	7.51	15.0	22.5	30.0
				Load amps	4.16	8.32	12.5	20.8	41.6	62.5	83.3
				Fuse Size	6.0	15.0	25.0	30.0	60.0	90.0	110.0
208	229	2	F1	kVA	0.825	1.65	2.48	4.13	8.26	12.4	16.5
				Load amps	2.08	4.16	6.25	10.4	20.8	31.25	41.6
				Fuse Size	6.0	10.0	15.0	15.0	30.0	45.0	60.0
208	229	3	J1	kVA	1.65	3.3	4.96	8.26	16.5	24.8	33.1
				Load amps	4.16	8.32	12.5	20.8	41.6	62.5	83.3
				Fuse Size	10.0	15.0	20.0	30.0	60.0	90.0	125.0
228 **	240	2	E1	kVA	1.73	3.46	5.2	8.68	17.3	26	34.6
				Load amps	4.16	8.32	12.5	20.8	41.6	62.5	83.3
				Fuse Size	6.0	15.0	20.0	30.0	60.0	90.0	110.0
416	436	3	L1	kVA	3.15	6.29	9.44	15.8	31.5	47.2	62.9
				Load amps	4.16	8.32	12.5	20.8	41.6	62.5	83.3
				Fuse Size	6.0	15.0	20.0	30.0	60.0	90.0	110.0
416	458	3	M1	kVA	1.65	3.31	4.96	8.27	16.5	24.8	33
				Load amps	2.08	4.16	6.25	10.4	20.8	31.25	41.6
				Fuse Size	3.0	6.0	10.0	15.0	30.0	45.0	60.0
BUCKING											
218	208	2	E2	kVA	1.57	3.14	4.73	7.85	15.7	23.6	31.4
				Load amps	4.36	8.72	13.1	21.8	43.6	65.5	87.2
				Fuse Size	10.0	15.0	20.0	30.0	60.0	80.0	110.0
229	208	2	F2	kVA	0.824	1.65	2.48	4.12	8.25	12.4	16.5
				Load amps	2.29	4.58	6.88	11.4	22.9	34.4	45.8
				Fuse Size	6.0	10.0	15.0	15.0	30.0	40.0	60.0
252 **	240	2	E2	kVA	1.82	3.63	5.46	9.08	18.2	27.3	36.3
				Load amps	4.37	8.74	13.1	21.8	43.7	65.6	87.4
				Fuse Size	6.00	10.00	15.00	30.00	60.00	80.00	110.00
264 **	240	2	F2	kVA	0.951	1.9	2.86	4.76	9.51	14.3	19.00
				Load amps	2.29	4.58	6.88	11.44	22.9	34.4	45.8
				Fuse Size	6.0	6.0	10.0	15.0	30.0	40.0	60.0
418	378	3	M2	kVA	1.5	3.0	4.5	7.49	15.0	22.5	30.0
				Load amps	2.29	4.58	6.88	11.44	22.9	34.4	45.8
				Fuse Size	6.0	6.0	10.0	15.0	30.0	40.0	60.0

* For alternate electrical connection diagrams, refer to the section immediately following the selection tables.

** Shaded items are 60 Hz only (All other ratings shown are 50/60 Hz).

Selection Tables: Three Phase

Table 4: Using Group 1 (120 x 240 V Primary, 12/24 V Secondary) Transformers

Input Voltage	Output Voltage	Quantity Req'd	Connection Diagram *	Application Data	Catalog Number				
					HS19F1.5A	HS19F2A	HS19F3A	HS19F5A	HS19F7.5A
BOOSTING									
188	208	2	F1	kVA	22.5	30.0	45.0	75.1	112.5
				Load amps	62.5	83.3	125.0	208.3	312.5
				Fuse Size	90.0	125.0	175.0	300.0	450.0
198	208	2	E1	kVA	45.0	60.0	90.1	150.1	225.2
				Load amps	125.0	166.6	250.0	416.6	625.0
				Fuse Size	175.0	225.0	350.0	600.0	1000.0
208	229	2	F1	kVA	24.8	33.1	49.6	82.6	123.9
				Load amps	62.5	83.3	125.0	208.3	312.5
				Fuse Size	90.0	125.0	175.0	300.0	450.0
208	229	3	J1	kVA	49.6	66.1	99.2	165.3	247.9
				Load amps	125.0	166.6	250.0	416.6	625.0
				Fuse Size	175.0	250.0	350.0	600.0	1000.0
228 **	240	2	E1	kVA	52.0	69.3	103.9	173.2	259.8
				Load amps	125.0	166.6	250.0	416.6	625.0
				Fuse Size	175.0	250.0	350.0	600.0	1000.0
416	436	3	L1	kVA	94.4	125.8	188.79	314.6	472.0
				Load amps	125.0	166.6	250.0	416.6	625.0
				Fuse Size	175.0	250.0	350.0	600.0	1000.0
416	458	3	M1	kVA	49.6	66.1	99.2	165.3	247.9
				Load amps	62.5	83.3	125.0	208.3	312.5
				Fuse Size	90.0	125.0	175.0	300.0	450.0
BUCKING									
218	208	2	E2	kVA	47.2	62.7	94.4	157.3	236.0
				Load amps	131.0	174.0	262.0	436.6	655.0
				Fuse Size	175.0	225.0	350.0	600.0	800.0
229	208	2	F2	kVA	24.8	33.0	49.6	82.5	123.9
				Load amps	68.8	91.6	137.6	229.0	344.1
				Fuse Size	80.0	110.0	175.0	300.0	400.0
252 **	240	2	E2	kVA	54.6	72.5	109.1	181.8	272.8
				Load amps	131.3	174.3	262.5	437.4	656.3
				Fuse Size	175.0	225.0	350.0	600.0	800.0
264 **	240	2	F2	kVA	28.6	38.0	57.2	95.1	142.9
				Load amps	68.8	91.5	137.5	228.8	343.8
				Fuse Size	80.0	110.0	175.0	300.0	400.0
418	378	3	M2	kVA	45.0	59.9	90.1	149.9	225.2
				Load amps	68.8	91.6	137.6	228.9	343.9
				Fuse Size	80.0	110.0	175.0	300.0	400.0

* For alternate electrical connection diagrams, refer to the section immediately following the selection tables.

** Shaded items are 60 Hz only (All other ratings shown are 50/60 Hz).

Selection Tables: Three Phase

Table 5: Using Group 2 (120 x 240 V Primary, 16/32 V Secondary) Transformers

Input Voltage	Output Voltage	Quantity Req'd	Connection Diagram *	Application Data	Catalog Number				
					HS20B150	HS20B250	HS20F500B	HS20F750B	HS20F1B
BOOSTING									
184	208	2	F1	kVA	1.69	2.81	5.63	8.44	11.3
				Load amps	4.69	7.8	15.6	23.4	31.2
				Fuse Size	10.0	15.0	25.0	35.0	45.0
195	208	2	E1	kVA	3.38	5.63	11.3	16.9	22.5
				Load amps	9.38	15.6	31.2	46.9	62.5
				Fuse Size	15.0	25.0	45.0	70.0	90.0
208	236	2	F1	kVA	1.92	3.19	6.39	9.58	12.8
				Load amps	4.69	7.8	15.6	23.4	31.2
				Fuse Size	10.0	15.0	25.0	35.0	45.0
208	236	3	J1	kVA	3.83	6.38	12.8	19.2	25.6
				Load amps	9.38	15.6	31.2	46.9	62.5
				Fuse Size	15.0	25.0	45.0	70.0	90.0
225	240	2	E1	kVA	3.9	6.5	13.0	19.5	26.0
				Load amps	9.38	15.6	31.2	46.9	62.5
				Fuse Size	15.0	25.0	45.0	70.0	90.0
416	443	3	L1	kVA	7.2	12.0	24.0	36.0	48.0
				Load amps	9.38	15.6	31.2	46.9	62.5
				Fuse Size	15.0	25.0	45.0	70.0	90.0
416	471	3	M1	kVA	3.83	6.37	12.8	19.1	25.5
				Load amps	4.69	7.8	15.6	23.4	31.2
				Fuse Size	10.0	15.0	25.0	35.0	45.0
BUCKING									
222	208	2	E2	kVA	3.61	6.0	12.0	18.0	24.0
				Load amps	10.0	16.6	33.3	50.1	66.7
				Fuse Size	15.0	20.0	40.0	60.0	80.0
236	208	2	F2	kVA	1.92	3.19	6.38	9.56	12.8
				Load amps	5.32	8.85	17.7	26.5	35.4
				Fuse Size	10.0	10.0	20.0	30.0	40.0
256 **	240	2	E2	kVA	4.16	6.92	13.8	20.8	27.7
				Load amps	10.1	16.6	33.3	50.0	66.7
				Fuse Size	15.0	20.0	40.0	60.0	80.0
272 **	240	2	F2	kVA	2.21	3.67	7.35	11.0	14.7
				Load amps	5.32	8.84	17.7	26.5	35.4
				Fuse Size	10.0	15.0	20.0	30.0	40.0
432	380	3	M2	kVA	3.51	5.84	11.7	17.5	23.3
				Load amps	5.33	8.87	17.7	26.6	35.5
				Fuse Size	10.0	10.0	20.0	30.0	40.0

* For alternate electrical connection diagrams, refer to the section immediately following the selection tables.

** Shaded items are 60 Hz only (All other ratings shown are 50/60 Hz).

Selection Tables: Three Phase

Table 5: Using Group 2 (120 x 240 V Primary, 16/32 V Secondary) Transformers

Input Voltage	Output Voltage	Quantity Req'd	Connection Diagram *	Application Data	Catalog Number				
					HS20F1.5A	HS20F2A	HS20F3A	HS20F5A	HS20F7.5A
BOOSTING									
184	208	2	F1	kVA	16.9	22.5	33.8	56.3	84.4
				Load amps	46.9	62.5	93.8	156.0	234.0
				Fuse Size	60.0	90.0	150.0	225.0	350.0
195	208	2	E1	kVA	33.8	45.0	67.6	112.6	168.9
				Load amps	93.7	125.0	187.5	312.0	468.0
				Fuse Size	125.0	175.0	250.0	450.0	700.0
208	236	2	F1	kVA	19.2	25.6	38.2	63.9	95.8
				Load amps	46.9	62.5	93.7	156.0	234.0
				Fuse Size	70.0	90.0	150.0	225.0	350.0
208	236	3	J1	kVA	38.2	51.1	76.6	127.7	191.6
				Load amps	93.7	125.0	187.5	312.0	468.0
				Fuse Size	150.0	200.0	300.0	450.0	700.0
225	240	2	E1	kVA	71.9	52.0	77.9	129.9	194.0
				Load amps	93.7	125.0	187.5	312.0	468.0
				Fuse Size	125.0	175.0	250.0	450.0	700.0
416	443	3	L1	kVA	71.9	95.9	143.9	239.8	359.7
				Load amps	93.7	125	187.5	312.0	468.0
				Fuse Size	125.0	175.0	250.0	450.0	700.0
416	471	3	M1	kVA	38.2	51.0	76.5	127.5	191.2
				Load amps	46.9	62.5	93.8	156.0	234.0
				Fuse Size	70.0	90.0	150.0	225.0	350.0
BUCKING									
222	208	2	E2	kVA	36.0	48.1	72.1	120.0	179.9
				Load amps	100.0	133.4	200.1	333.0	499.5
				Fuse Size	125.0	175.0	250.0	400.0	600.0
236	208	2	F2	kVA	19.2	25.5	38.8	63.8	95.6
				Load amps	53.2	70.9	106.4	177.0	265.5
				Fuse Size	60.0	80.0	125.0	200.0	300.0
256 **	240	2	E2	kVA	41.5	55.4	83.1	138.3	207.5
				Load amps	99.9	133.3	200.0	332.8	499.2
				Fuse Size	125.0	175.0	250.0	400.0	600.0
272 **	240	2	F2	kVA	22.1	29.4	44.2	73.5	110.2
				Load amps	53.2	70.8	106.3	176.8	265.2
				Fuse Size	60.0	80.0	125.0	200.0	300.0
432	380	3	M2	kVA	35.1	46.8	70.2	116.7	175.1
				Load amps	53.3	71.1	106.6	177.3	266.0
				Fuse Size	60.0	80.0	125.0	200.0	300.0

* For alternate electrical connection diagrams, refer to the section immediately following the selection tables.

** Shaded items are 60 Hz only (All other ratings shown are 50/60 Hz).

Selection Tables: Three Phase

Table 6: Using Group 3 (240 x 480 V Primary, 24/48 V Secondary) Transformers

Input Voltage	Output Voltage	Quantity Req'd	Connection Diagram *	Application Data	Catalog Number				
					HS22B150	HS22B250	HS22F500B	HS22F750B	HS22F1B
BOOSTING									
173	208	2	G1	kVA	1.12	1.88	3.75	5.63	7.5
				Load amps	3.12	5.2	10.4	15.6	20.8
				Fuse Size	6.0	10.0	20.0	25.0	35.0
200	240	2	G1	kVA	1.3	2.16	4.33	6.5	8.66
				Load amps	3.12	5.2	10.4	15.6	20.8
				Fuse Size	6.0	10.0	20.0	25.0	35.0
362	380	2	E1	kVA	3.91	6.52	13	19.6	26.1
				Load amps	6.24	10.4	20.8	31.2	41.6
				Fuse Size	10.0	15.0	30.0	45.0	60.0
346	416	3	K1	kVA	2.25	3.75	7.5	11.3	15.0
				Load amps	3.12	5.2	10.4	15.6	20.8
				Fuse Size	6.0	10.0	20.0	25.0	35.0
400	480	3	K1	kVA	2.59	4.33	8.65	13.0	17.3
				Load amps	3.12	5.2	10.4	15.6	20.8
				Fuse Size	10.0	15.0	20.0	25.0	35.0
436	480	2	F1	kVA	2.59	4.33	8.65	13	17.3
				Load amps	3.12	5.2	10.4	15.6	20.8
				Fuse Size	6.0	10.0	15.0	25.0	30.0
468	492	2	E1	kVA	5.2	8.66	17.3	26.0	34.6
				Load amps	6.24	10.4	20.8	31.2	41.6
				Fuse Size	15.0	15.0	30.0	45.0	60.0
BUCKING									
250	208	2	G2	kVA	1.35	2.25	4.5	6.75	9.01
				Load amps	3.75	6.25	12.5	18.7	25.0
				Fuse Size	6.0	10.0	15.0	20.0	30.0
457	380	3	K2	kVA	2.47	4.12	8.23	12.3	16.5
				Load amps	3.75	6.25	12.5	18.8	25.0
				Fuse Size	6.0	10.0	15.0	20.0	30.0
499	416	3	K2	kVA	2.7	4.49	8.99	13.5	18.0
				Load amps	3.74	6.24	12.5	18.7	24.9
				Fuse Size	6.0	10.0	15.0	20.0	30.0
504 **	480	2	E2	kVA	5.45	9.08	18.2	27.2	36.3
				Load amps	6.56	10.9	21.8	32.8	43.7
				Fuse Size	15.0	15.0	30.0	40.0	60.0
528 **	480	2	F2	kVA	2.85	4.76	9.51	14.3	19.0
				Load amps	3.43	5.72	11.4	17.2	22.9
				Fuse Size	6.0	10.0	15.0	20.0	30.0

* For alternate electrical connection diagrams, refer to the section immediately following the selection tables.

** Shaded items are 60 Hz only (All other ratings shown are 50/60 Hz).

Selection Tables: Three Phase

Table 6: Using Group 3 (240 x 480 V Primary, 24/48 V Secondary) Transformers

Input Voltage	Output Voltage	Quantity Req'd	Connection Diagram *	Application Data	Catalog Number				
					HS22F1.5A	HS22F2A	HS22F3A	HS22F5A	HS22F7.5A
BOOSTING									
173	208	2	G1	kVA	11.3	15	22.5	37.5	56.3
				Load amps	31.2	41.6	62.5	104.0	156.0
				Fuse Size	50.0	70.0	100.0	175.0	250.0
200	240	2	G1	kVA	13.0	17.3	26.0	43.3	65.0
				Load amps	31.2	41.6	62.5	104.0	156.0
				Fuse Size	50.0	70.0	100.0	175.0	250.0
362	380	2	E1	kVA	39.1	52.2	78.4	130.4	195.6
				Load amps	62.4	83.2	125	208.0	312.0
				Fuse Size	90.0	125.0	175.0	300.0	450.0
346	416	3	K1	kVA	22.5	30.0	45.0	75.1	112.6
				Load amps	31.2	41.6	62.5	104.0	156.0
				Fuse Size	50.0	70.0	100.0	175.0	250.0
400	480	3	K1	kVA	26.0	34.6	52.0	86.6	129.9
				Load amps	31.2	41.6	62.5	104.0	156.0
				Fuse Size	50.0	70.0	100.0	175.0	250.0
436	480	2	F1	kVA	26.0	34.6	52.0	86.6	129.9
				Load amps	31.2	41.6	62.5	104.0	156.0
				Fuse Size	45.0	60.0	90.0	150.0	225.0
468	492	2	E1	kVA	52.0	69.3	103.9	173.2	259.8
				Load amps	62.4	83.2	125.0	208.0	312.0
				Fuse Size	90.0	110.0	175.0	300.0	450.0
BUCKING									
250	208	2	G2	kVA	13.5	18.0	27.1	45.0	67.5
				Load amps	37.5	50.0	75.1	125.0	187.5
				Fuse Size	40.0	60.0	80.0	150.0	200.0
457	380	3	K2	kVA	24.7	32.9	49.5	82.3	123.5
				Load amps	37.5	50.0	75.2	125.1	187.6
				Fuse Size	40.0	60.0	80.0	150.0	200.0
499	416	3	K2	kVA	27.0	36.0	54.0	89.9	134.8
				Load amps	37.4	49.9	75.0	124.7	187.1
				Fuse Size	40.0	60.0	80.0	150.0	200.0
504 **	480	2	E2	kVA	54.5	72.6	109.1	181.6	272.4
				Load amps	65.5	87.4	131.3	218.4	327.6
				Fuse Size	80.0	110.0	175.0	300.0	400.0
528 **	480	2	F2	kVA	28.5	38.0	57.2	95.1	142.7
				Load amps	34.3	45.8	68.8	114.4	171.6
				Fuse Size	40.0	60.0	80.0	150.0	200.0

* For alternate electrical connection diagrams, refer to the section immediately following the selection tables.

** Shaded items are 60 Hz only (All other ratings shown are 50/60 Hz).

Alternate Electrical Connections for Buck-Boost Applications

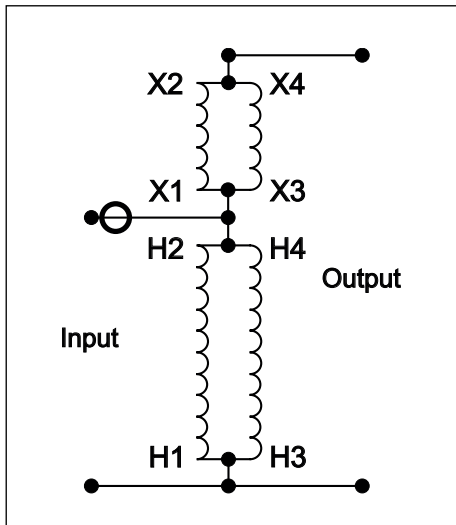

Diagram A1 – Boosting

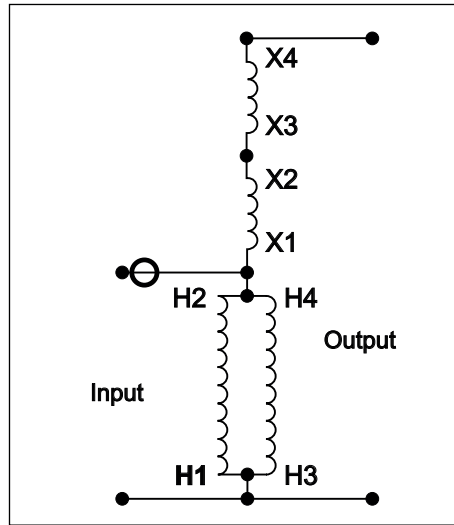

Diagram B1 – Boosting

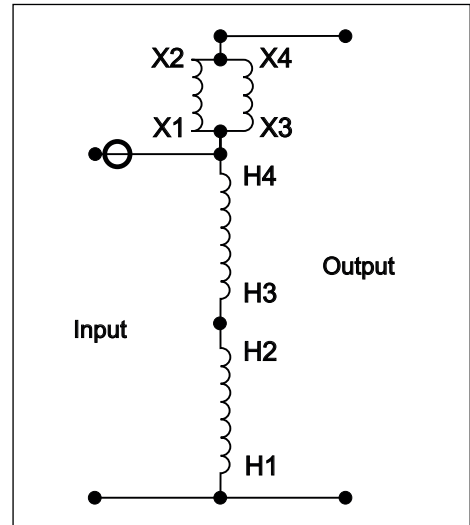

Diagram C1 – Boosting

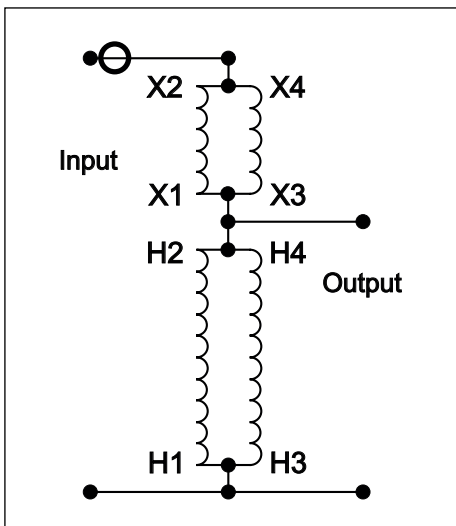

Diagram A2 – Bucking

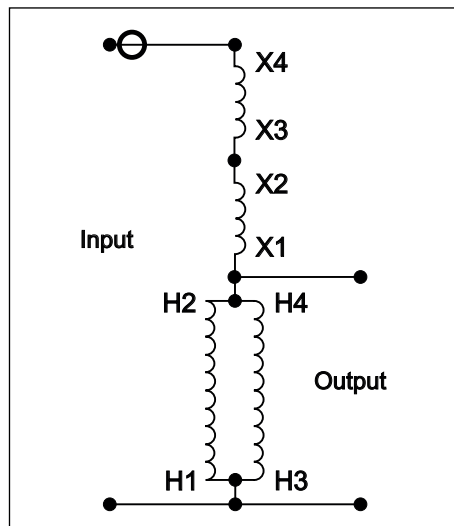

Diagram B2 – Bucking

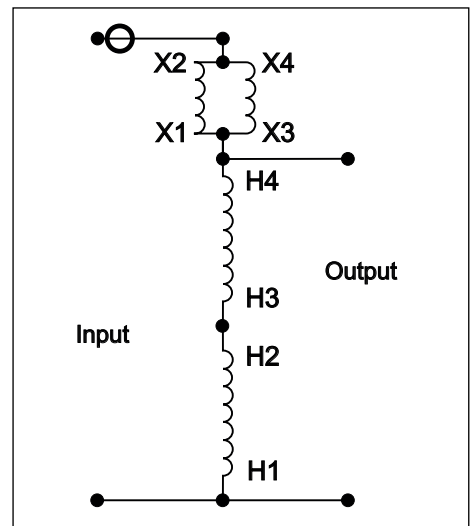

Diagram C2 – Bucking

The \ominus symbol shown on these connection diagrams indicates where fuses or breakers should be field installed for line to neutral applications. For line to line applications, fuses or breakers should be installed on both lines.

Application Note: On all auto-wye connections, the source neutral must be present and connected to the transformer bank. If source neutral is not present, do not use an auto-wye connection.

Alternate Electrical Connections for Buck-Boost Applications

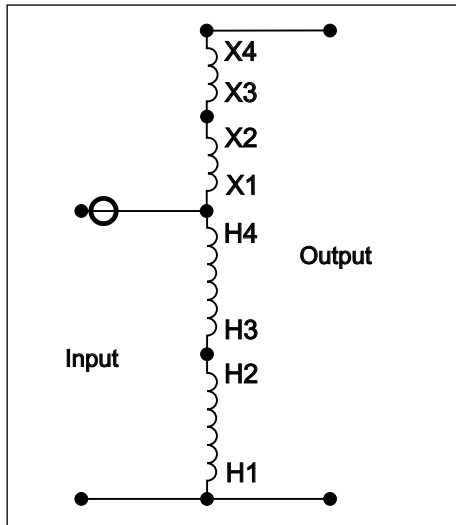

Diagram D1 – Boosting

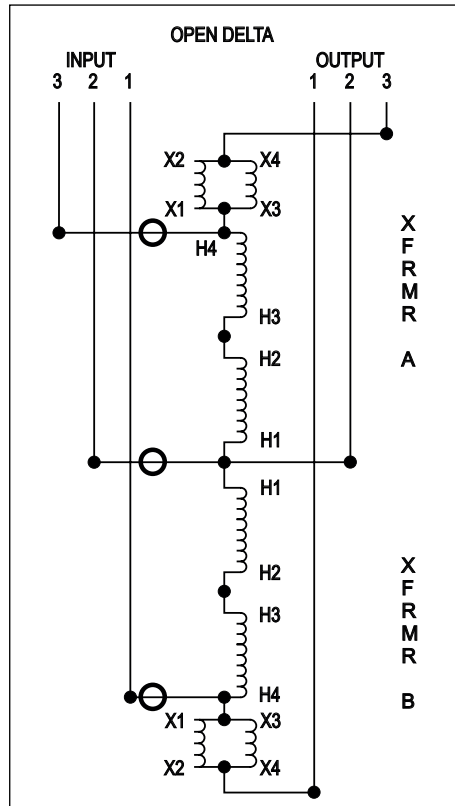

Diagram E1 – Boosting

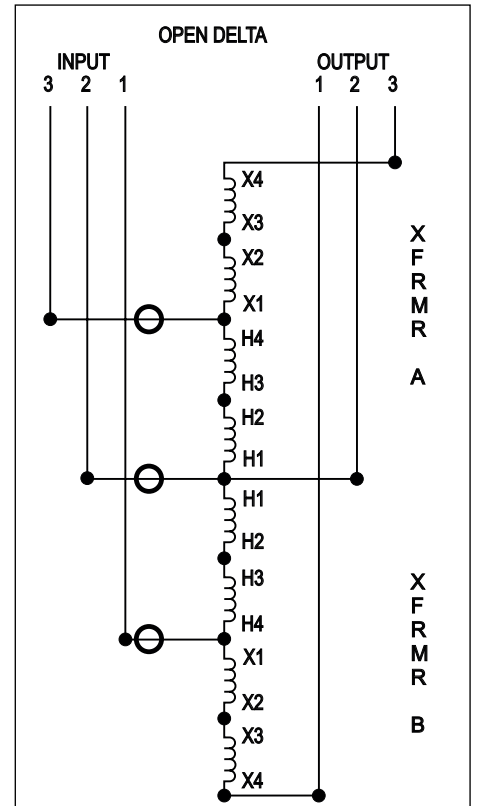

Diagram F1 – Boosting

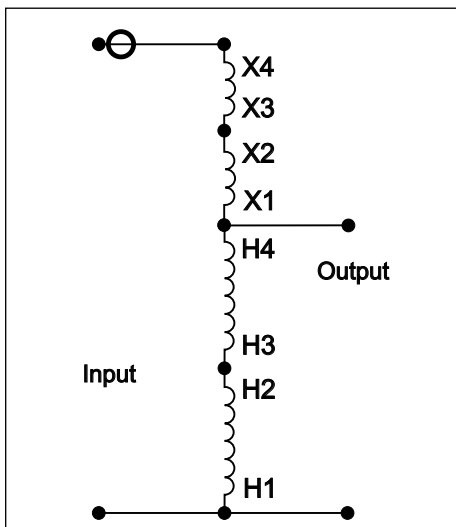

Diagram D2 – Bucking

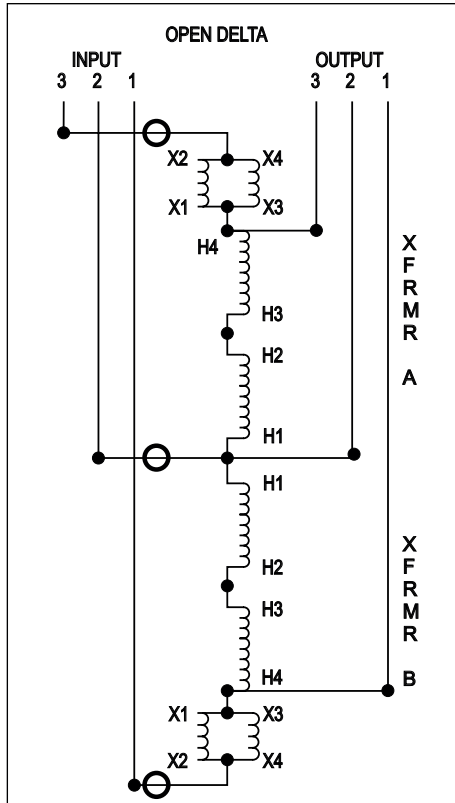

Diagram E2 – Bucking

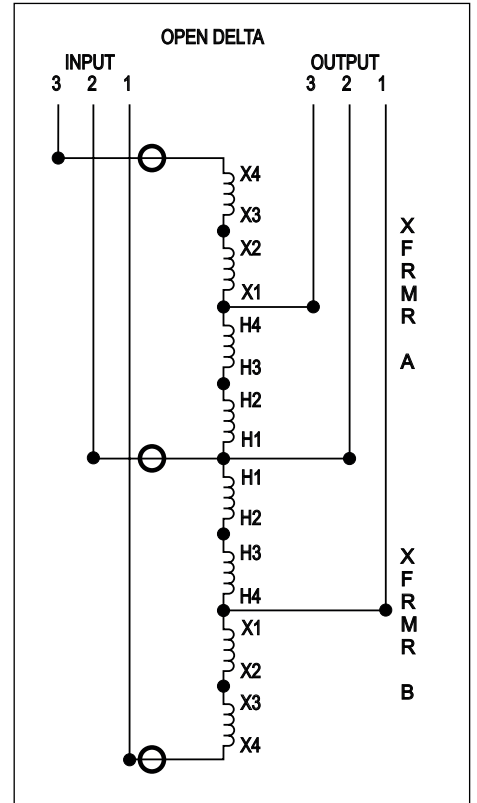

Diagram F2 – Bucking

Alternate Electrical Connections for Buck-Boost Applications

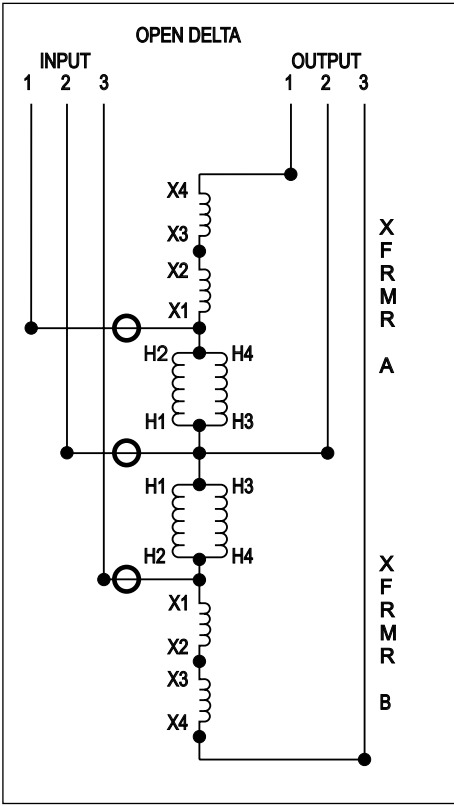

Diagram G1 – Boosting

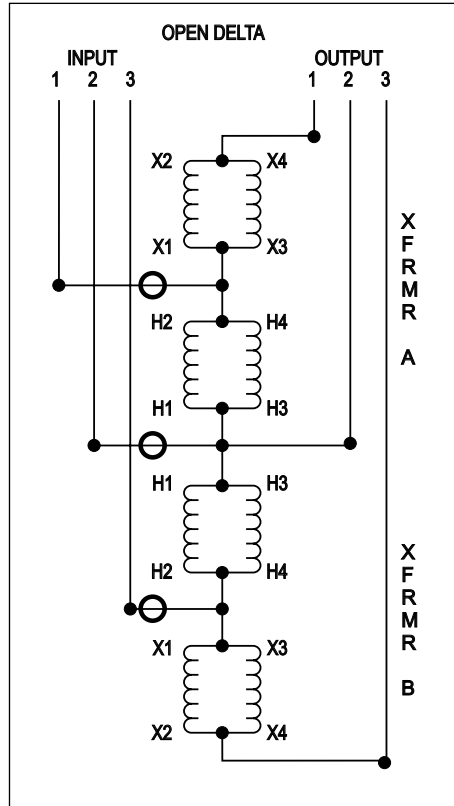

Diagram H1 – Boosting

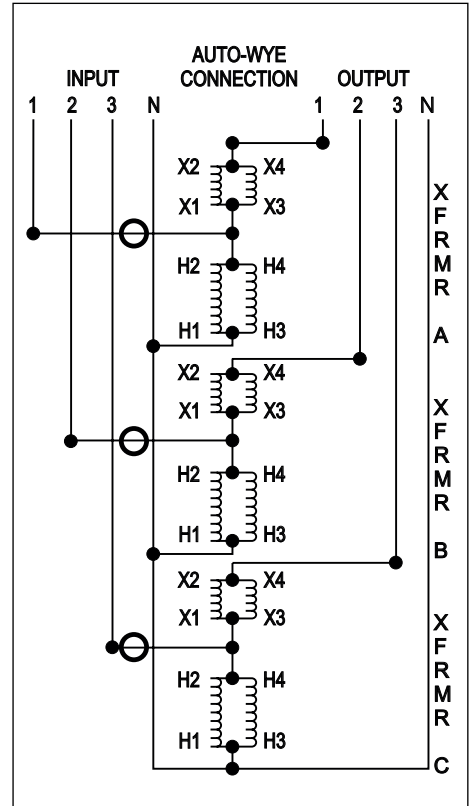

Diagram J1 – Boosting

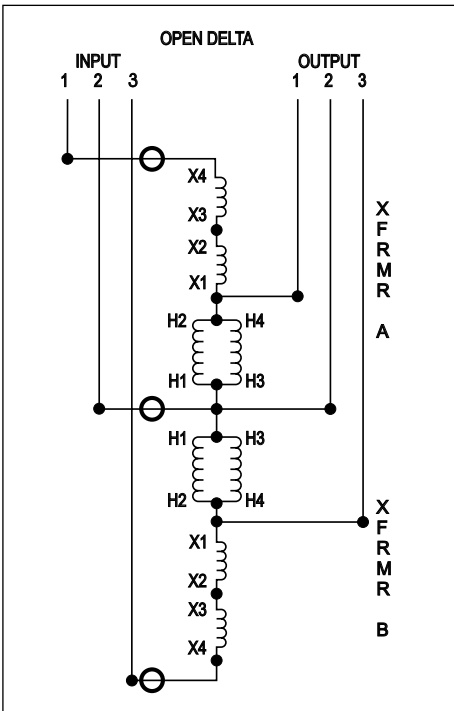

Diagram G2 – Bucking

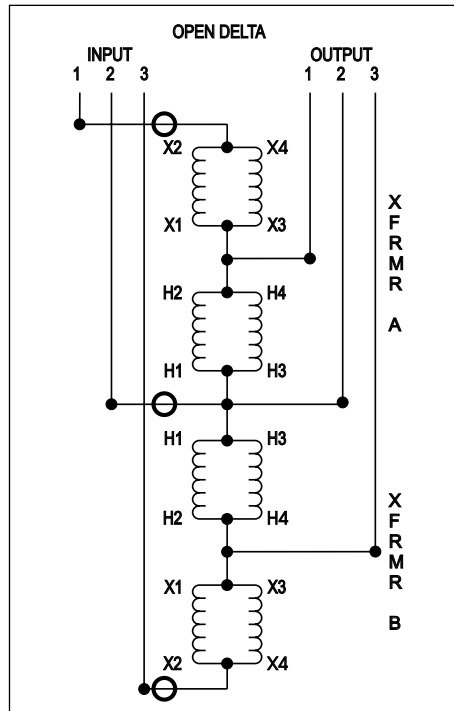

Diagram H2 – Bucking

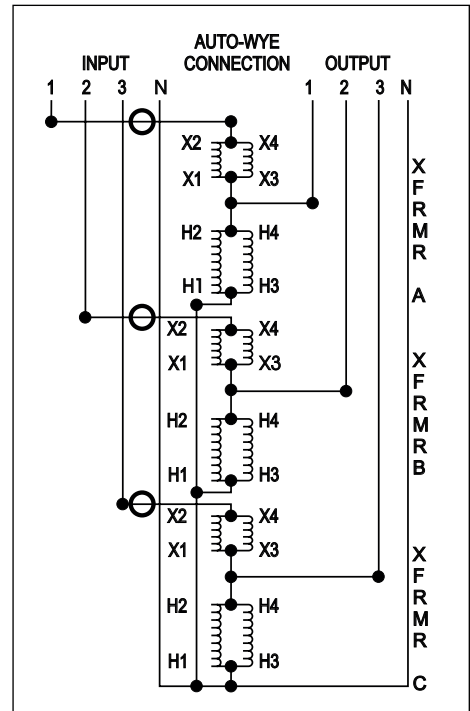

Diagram J2 – Bucking

Alternate Electrical Connections for Buck-Boost Applications

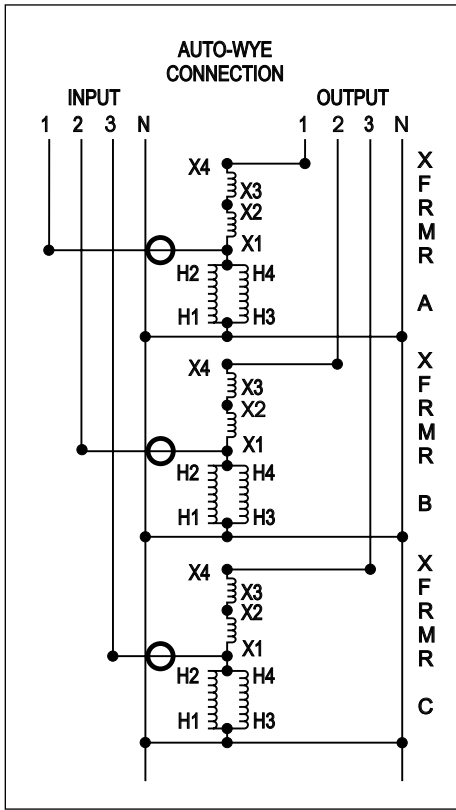

Diagram K1 – Boosting

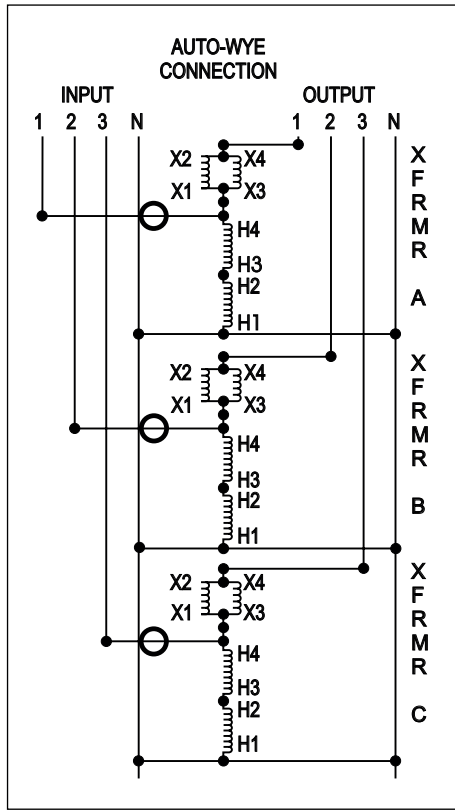

Diagram L1 – Boosting

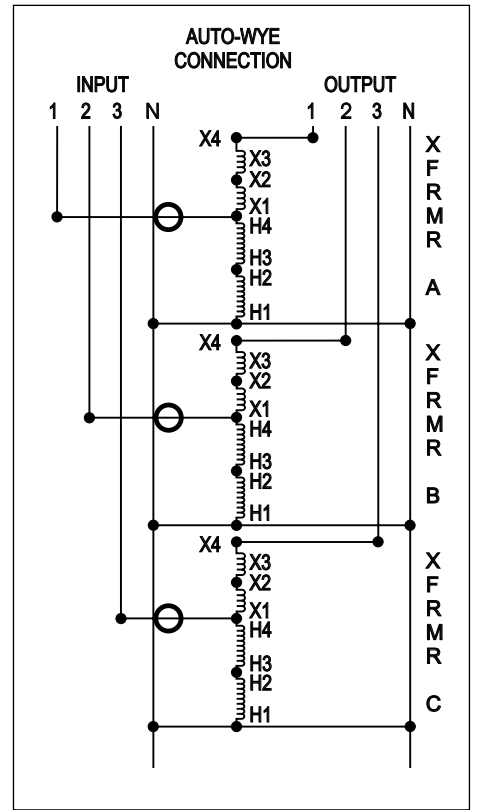

Diagram M1 – Boosting

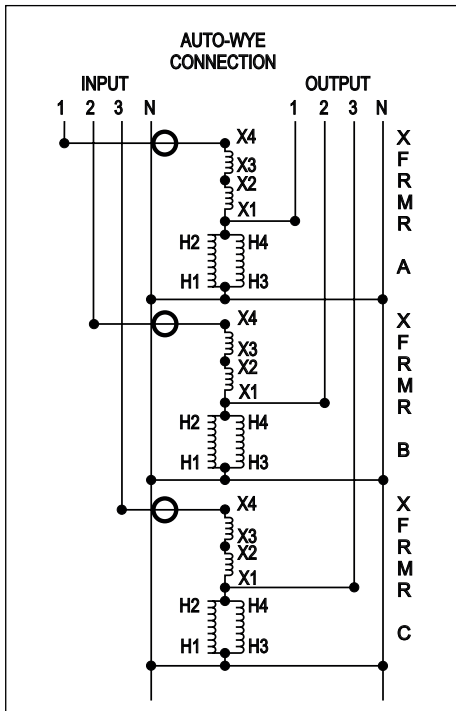

Diagram K2 – Bucking

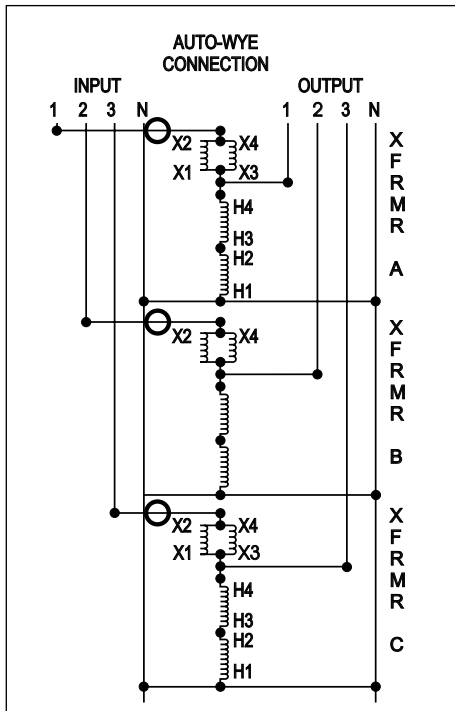

Diagram L2 – Bucking

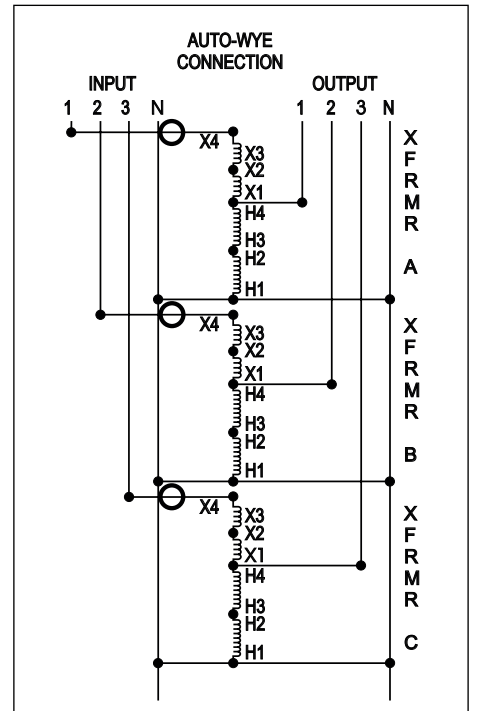

Diagram M2 – Bucking

Application Note

Application limitations with buck-boost transformers

- 1. A Buck-boost transformer cannot be used to develop a three phase, four wire wye circuit from a three phase, three wire delta circuit.**

A delta to wye connection does not supply enough current carrying capability to provide for unbalanced currents flowing in the neutral wire of the four wire circuit. The neutral created is not stable and under load will not deliver desired line to neutral voltages. This connection would also be in violation of the National Electric Code, Article 210.9.

- 2. Buck-boost transformers cannot be used in a closed delta connection.**

A closed delta requires more kVA capacity than a wye or an open delta connection, plus phase shifting comes into play on the output side.

- 3. Buck-boost transformers should not be used to correct for voltage drop on a long circuit run where the load fluctuates.**

Voltage drop varies with the load and buck-boost transformers are connected for a specific voltage change. If a buck-boost transformer was used to correct voltage drop during peak loading conditions, high voltages may result under light load conditions. This could be equally detrimental to the load and possibly pose safety hazards.

- 4. Buck-boost transformers cannot be used to create a 240/120 Volt, single phase service from a 208Y/120 Volt three phase supply.**

Two problems that would occur:

- A. Two neutrals would exist on the same circuit. Since neutrals must be grounded according to the National Electric Code, a short circuit would be created.
- B. Unbalanced line to output neutral voltages would be created; one line would read 120 Volts, the other 130+ Volts.

What is a buck-boost transformer and why is it used?

Isolation transformers have separate primary and secondary windings, electrically insulated and isolated from one another. With a relatively high voltage primary (typically 120, 240 or 480 Volts) and a relatively low voltage secondary (typically 12, 16, 24, 32 or 48 Volts), buck-boost transformers are designed to be field connected as autotransformers. These are transformers with one continuous winding, a portion of which is jointly shared between the input and the output. No electrical isolation is present in an autotransformer.

Buck-boost transformers have two major uses:

1. When field connected as an autotransformer, they can be used to Buck (lower) or Boost (raise) available line voltage in the range of 5 to 27% and at a kVA rating many times that listed on the transformer nameplate.
2. When left as an isolation transformer, they can be used to supply power to low voltage circuits at the nameplate rating listed.

The importance of altering available line voltage.

Electrical equipment is designed to operate at maximum efficiency at a specific standard supply voltage. Your voltage may not be at the standard supply voltage level. Causes can be proximity to a large utility transformer, losses in the line voltage due to loads on that circuit, or a difference between the standard supply voltage available and the standard supply voltage needed to run the equipment.

Normally the problem is having low voltage available. Low voltage on a circuit, even as little as 5% lower can cause a decrease in incandescent light output, and a decrease in resistive heat output. With motors low voltage can cause a decrease in motor torque, an increase in motor amperage requirements, an increase in motor temperature and decrease in motor life expectancy.

www.nicsanat.com
021-87700210



Innovative solutions to optimize operational performance, improve efficiencies, preserve data and increase equipment longevity.



SolaHD is the cornerstone brands of Emerson's Electrical Apparatus and Lighting business; trusted worldwide to power your process control applications in the most demanding applications worldwide.

**United States
(Headquarters)**

Appleton Grp LLC
9377 W. Higgins Road
Rosemont, IL 60018
United States
T +1 800 621 1506

Europe

ATX SAS
Espace Industriel Nord
35, rue André Durouchez,
CS 98017
80084 Amiens Cedex 2, France
T +33 3 2254 1390

Canada

EGS Electrical Group Canada Ltd.
99 Union Street
Elmira ON, N3B 3L7
Canada
T +1 888 765 2226

Asia Pacific

EGS Private Ltd.
Block 4008, Ang Mo Kio Ave 10,
#04-16 TechPlace 1,
Singapore 569625
T +65 6556 1100

Latin America

EGS Comercializadora Mexico S
de RL de CV
Calle 10 N°145 Piso 3
Col. San Pedro de los Pinos
Del. Álvaro Obregon
Ciudad de México. 01180
T +52 55 5809 5049

Australia Sales Office

Bayswater, Victoria
T +61 3 9721 0348

China Sales Office

Shanghai
T +86 21 3338 7000

Middle East Sales Office

Dammam, Saudi Arabia
T +966 13 510 3702

Chile Sales Office

Las Condes
T +56 2928 4819

India Sales Office

Chennai
T +91 44 3919 7300

Korea Sales Office

Seoul
T +82 2 3483 1555

Jebel Ali- Dubai Office

Emerson, Building A
Appleton Group
Jebel Ali Free Zone- South
T +971 4 811 81 00



Emerson.com



LinkedIn.com/company/emerson

The Emerson logo is a trademark and service mark of Emerson Electric Co. SolaHD is a registered trademark of Appleton Grp LLC. All other marks are the property of their respective owners. © 2018 Emerson Electric Co. All rights reserved.



EMERSON™

www.nicsanat.com

021-87700210

NIC SANAT

انیک صنعت

