

INVERTER SYSTEM & POWER SUPPLY UNIT

SIEIDrive ADV200 Drive Family

GEFRAN





Gefran is a leading manufacturer
of automation components



Forty-five years of experience, an extensive know-how, a structure precisely geared to our customers' requirements and continued investment in R&D, make Gefran a leader in the field of components for automation and industrial process control systems.

Customers know they can always depend on Gefran to provide the best solution for all their needs in terms of sensors, components, automation and motion control.

www.nicsanat.com
021-87700210





By working in partnership with **qualified Research Centres and Universities** and continuously **investing in R&D**, the Gefran Group is at the forefront of technology, developing products that anticipate its customers' needs.



Gefran is based in Italy, where it has three engineering and production facilities. The Group has some 800 employees. It is directly present in 12 countries with 7 production plants and a global sales network with more than 70 authorised dealers around the world.

Gefran Spa has been listed on the Milan Stock Exchange since 1998 and has been traded on the Star segment of high requirement shares since 2002.



The **Gefran Drive & Motion Control Unit**, based in Gerezano (Varese, Italy), designs, develops and manufactures **electric drives and power regeneration systems** used to control motors and application systems in the main industrial sectors, including: plastics, civil lift engineering, water treatment and ventilation, as well as control architectures for renewable energy systems.

The **ADV and AFE200 series of drives**, a complete range of solutions dedicated to the most advanced industrial automation systems, are the fruit of this experience.

The GEFRAN "SYSTEM DRIVE" range

The new generation of energy efficiency

With the new series of **ADV vector inverters** and **AFE200 "Active Front End" regenerative power supply units**, the GEFRAN "SYSTEM DRIVE" range meets the demands of systems integrators and machine builders, for solutions at the forefront of technology featuring high-level configurations.

A wide range with power ratings from **0.75kW up to 1.65MW** and compatibility with all **230Vac - 400Vac - 460Vac and 690Vac** power supplies or systems on a common DC Bus, make it possible to engineer and develop practically any kind of application architecture.

Thanks to the modular mechanical structure, compact modules and integration of accessories such as EMC filters and input chokes, the system takes up **significantly less space, wiring costs are optimised** and flexibility is assured.

Available in 7 stand alone and "parallel" configurations, the **ADV200** and **AFE200** are drives of innovative design, stemming from continuous technological research and the experience that GEFRAN has acquired in working alongside leading operators in the sector.

The **32-bit microprocessor** and **innovative control algorithms**, guarantee excellent performance, both in terms of the dynamics and precision of motor control and in terms of their advanced clean power control in power regeneration systems.

The man/machine interface is totally intuitive and "open", thanks to the powerful programming platform.

Customised menus and dedicated application software programs provide complete machine management at all levels, with the availability of specific functions and integration of the IEC61131-3 programming environment.



- » **Certified quality**
(Quality Management System complies with the requirements of ISO 9001:2008)
- » **Italian Technology**
- » **User Friendly Performance up to 1.65 MW**
- » **All in One design with integrated EMC filters and choke**
- » **"Clean Power" platform for energy efficiency of automation systems**



www.nicsanat.com
021-87700210



Overview of the "ADV - AFE200 System Drive" range

Models	Power (kW)																																			
	0,37	0,55	0,75	1,5	2,2	3,0	4,0	5,5	7,5	11	15	18,5	22	30	37	45	55	75	90	110	132	160	200	250	315	355	400	500	630	710	900	1000	1350	1650		
ADV200-4			Size 1			Size 2			Size 3			Size 4			Size 5			Size 6			Size 7			Parallel size 7 (*)												
ADV200-DC												Size 3			Size 4			Size 5			Size 6			Size 7			Parallel size 7 (*)									
ADV200-6																			T.5	Size 6			Size 7			Parallel size 7 (*)										
ADV100						Size 1		Size 2		Size 3			Size 4			Size 5																				
ADV80	Size 1		Size 2					Size 3																												
AFE200-4													S.3			S.4			S.5		S.6	Size 7			Parallel size 7 (*)											
AFE200-6																						Size 7			Parallel size 7 (*)											



(*) ADV200 and AFE200 starting from 400 kW basically consists of one MASTER unit and one or more SLAVE units.

ADV200-4 • Alimentazione 400...460 Vac

Introduction 8
 General Characteristics 9
 Standard connections 10
 Weights and dimensions 11
 Choosing the Inverter 18

Input Data 18
 Output Data 19
 Cooling 24
 Order codes 25

ADV200-DC • DC bus power supply

Introduction 30
 General Characteristics 31
 Standard connections 32
 Weights and dimensions 34
 Choosing the Inverter 38

Input Data 38
 Output Data 39
 Cooling 43
 Order codes 44

ADV200-6 • 690Vac Power Supply

Introduction 50
 General Characteristics 51
 Standard connections 52
 Weights and dimensions 53
 Choosing the Inverter 57

Input Data 57
 Output Data 58
 Cooling 61
 Order codes 62

ADV100 • 230...480 Vac Power Supply

Introduction 66
 General Characteristics 67
 Standard connections 68
 Weights and dimensions 69
 Choosing the Inverter 72

Input Data 72
 Output Data 73
 Cooling 75
 Order codes 76

ADV80 • 400...480 Vac Power supply

Introduction 80
 General Characteristics 81
 Standard connections 82
 Weights and dimensions 83
 Choosing the Inverter 85

Input Data 85
 Output Data 86
 Cooling 87
 Order codes 88

AFE200 • Active Front End Regenerative Power Supply Unit

Introduction 90
 General Characteristics 91
 Standard connections 92
 Weights and dimensions 95
 Choosing the power supply unit and drive 100

Input Data 102
 Output Data 104
 Cooling 105
 Order codes 106

Programming

"GF_eXpress" PC Configuration Tool 110
 Programming Keypad 111
 Softscope 111
 "MDPlc" advanced development environment 112

Accessories

Fuses 114
 Chokes 122
 External EMC filters 131
 LCL Filters 135
 Braking resistors 137

Options

Encoder expansion cards 139
 I/O expansion cards 139
 Fieldbus expansion cards 140
 Bus bar for parallel connection 141
 Pre-charge kit (mandatory) 141
 External Braking Unit 142
 AC/DC power supply units 142
 Connection via serial line 143
 Various 143

Gefran Service

Calendar of courses and education days 148
 After-sales Service 150
 Inverter Warranty 152
 Solutions 154



ADV200 - 4



ADV200-DC



ADV200 - 6



ADV100



ADV80



AFE200



PROGRAM.

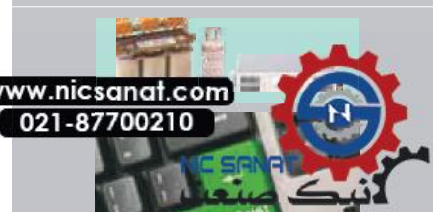

APPENDIX

www.nicsanat.com
 021-87700210

1. ADV200-4 • Alimentazione 400...460 VAc

1.1 Introduction



ADV200 - 4 Vector Inverters offer technologically advanced solutions for automation systems with stand-alone drives.

The range features power ratings from **0.75 kW up to 1.2 MW** for **three-phase power supplies of 380 VAc to 500 VAc**. Integrated accessories such as the filter and mains choke enhance long-term reliability, reduce overall dimensions and lower wiring costs.

Flexible Modular Technology

The ADV200-4 is based on a fully modular hardware with power structures that can be installed side by side. Designed to facilitate installation and guarantee ease of use, project flexibility, optimisation of space and reduction of wiring costs.

The ADV200-4 is available in 7 hardware sizes

- from 0.75kW to 355kW in the stand-alone configuration
- from 400kW to 1.2MW in "parallel" configurations

Integrated reliability

The ADV200-4 features high-quality engineering solutions that guarantee long-term reliability. Up to size 71320, the integrated input choke on the DC side reduces THD by up to 40% and the mains filter ensures compliance with EMC EN61800-3.

Total ease of use

Designed with the user in mind. The mechanical structure guarantees simple and fast product management, regardless of installation and assembly conditions. All operations are simple and immediate, from accessing the extractable terminal strips to rack-mounting of options. The dedicated accessories guarantee simple wiring and cable shielding to achieve immediate, EMC-compliant start-ups.

Serial line

The RS485 serial line is incorporated as standard across the range to enable peer-to-peer or multidrop connections using Modbus RTU protocol.

Management of optional cards

The ADV200-4 uses an intelligent rack system that allows 3 optional cards to be installed at the same time.

- Fieldbus interface card
- I/O expansion card
- Interface card for feedback with single or multiple encoders (up to 3).

Back-up power supply

The ADV200-4 is compatible with a separate +24VDC external power supply. This solution makes it possible to maintain all display and drive configuration functions and manage the connected fieldbuses in the event of a power failure.

Safety Card – SIL3 Level

ADV200-4+SI models integrate the **EXP-SFTy-ADV** Safety Card (standard in parallel master drives).

The card:

- performs the STO (Safe Torque Off) function, to prevent torque on the motor by blocking IGBT commands;
- can diagnose 99% of internal faults;
- meets the latest legal requirements with the integrated "Safe Torque Off" function:
 - safety integrity level SIL 3 according to EN 61508 and EN61800-5-2 (maximum available for drives)
 - PL d according to EN13849-1

The integrated **EXP-SFTy-ADV** safety card in the ADV200-4+SI series of drives achieves "Prevention of unexpected start-up", according to EN 1037:1995 + A1 ADV: 2008 on safety of machinery.

Drives provided with the safety card are just one element in an STO safety control system, which is the system level function. All system parts and components must be chosen, applied and integrated correctly to achieve the required level of safety.

The safety function may be used to perform an "emergency stop" with the drive still connected to the power supply (stop category 0 according to EN 60204-1).

The integrated safety function replaces the external safety components. The integrated "STO" function may be used to replace the motor contactors for controlling unexpected start-ups, if covered by risk-assessment. The use of the integrated safety function depends on the type of application and applicable standards.

Ideal Sizing

The ADV200-4 offers a choice of technical features so that you can choose the drive that represents the best technical and most cost-effective solution depending on the type of application and characteristics of the motor.

- Two overload modes for "heavy duty" with duty cycle of 150% of In for 1 minute every 5 minutes or for "light duty" (variable and/or quadratic torque) with duty cycle of 110% of In for 1 minute every 5 minutes
- Optimisation of **modulation dynamics**, according to the type of "duty" and drive temperature during duty cycles.
- In addition to the control capabilities for asynchronous motors, the standard software also incorporates the control algorithm for closed-loop brushless motor control (FOC-CL = Field Oriented Control with feedback) and open-loop control without feedback (FOC-OL = Open Loop).

1.2 General Characteristics

- Power supply: 3 x 380V_{AC} -15% ... 500V_{AC} +5%, 50/60Hz ±2%
- Power ratings: from 0.75kW to 1.2MW
- Max output voltage 0.98 x V_{in}
- Control mode:
 - Open-loop vector control (Asynchronous and Synchronous)
 - Vector control with feedback (Asynchronous and Synchronous)
 - Open loop V/f and V/f with feedback (Asynchronous)
- Light or heavy overload control
- Integration of up to 3 options onboard the drive
- "Safety" card compliant with machine safety directives (for ADV200-...+SI models)
- GF-eXpress multi-language programming SW (5 languages)
- PLC with advanced IEC61131-3 programming environment
- IP20-rated protection (IPOO size 7 and parallel)
- ADV200-...-EH models: from 18.5 to 90kW, with external heatsink and IP54 protection.

Fieldbus management



Performance

The ADV200 offers state-of-the-art control technology based on the use of a powerful 32-bit microprocessor able to guarantee maximum precision and performance of the motor as well as sophisticated management of the most advanced application systems.

Precision

Control mode	Speed control precision (*)	Control range
Asynchronous		
FOC with feedback	± 0.01% motor speed rating	1 : 1000
Open-loop FOC	± 30% motor slip rating	1 : 100
V/F	± 60% motor slip rating	1 : 30
Synchronous		
FOC with feedback	± 0.01% motor speed rating	1 : 1500
Open-loop FOC	± 0.1% motor speed rating	1 : 20

(*) for standard 4-pole motor

Standard supply configuration

- Integrated KB_ADV programming keypad
- Regulation:
 - 2 bipolar analog inputs (Voltage/Current)
 - 2 bipolar analog outputs (1: Voltage/Current, 1: Voltage)
 - 6 digital inputs (PNP/NPN)
 - 2 digital outputs (PNP/NPN)
 - 2 relay outputs, single contact
 - RS485 serial line (Modbus RTU)
- Power:
 - Integrated choke DC side (up to 132 kW)
 - Integrated mains filter
 - Integrated dynamic braking module (up to 55kW)
- Reference resolution: Digital = 15bit + sign
Analog input = 11-bit + sign
Analog output = 11-bit + sign

Conformity

- Immunity/Emissions: EEC - EN 61800-3
- Programming: according to IEC 61131-3
- Safety standards: STO (Safe Torque Off): IEC 61508 SIL 3, EN 954-1 Cat. 3
EN 61508 and EN 61800-5-2

Environmental conditions

- Ambient temperature: -10°C ... +40°C (+14°F ...+104°F), +40°C ...+50°C (+104°F...+122°F) with derating
- Altitude: Max 2000 m.(up to 1000 m without derating)

Markings

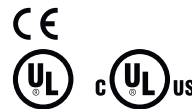

Complies with the EEC directive concerning low voltage equipment

Complies with directives for the American and Canadian markets.

1.3 Standard connections

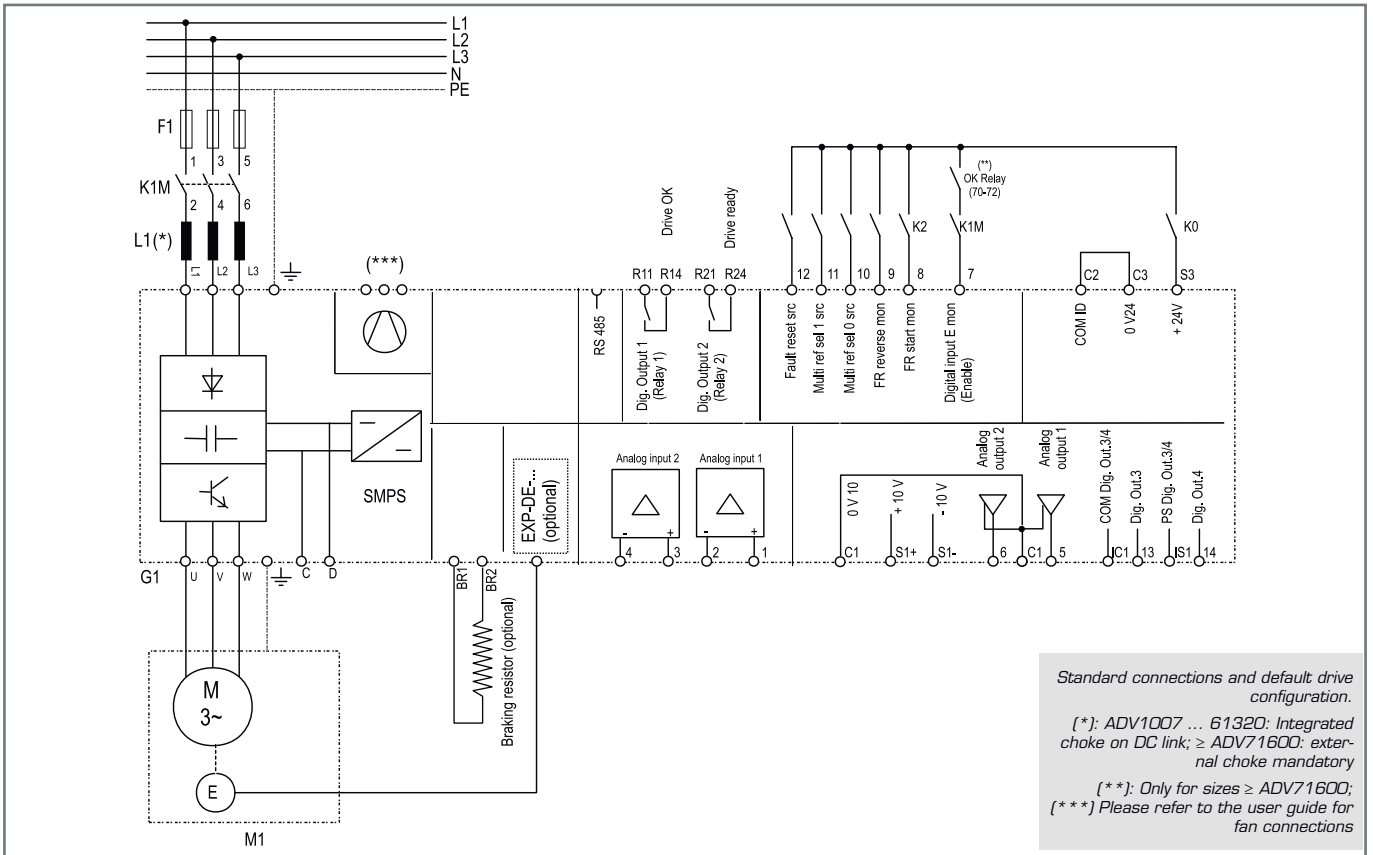

Standard connections and default drive configuration.

[*]: ADV1007 ... 61320: Integrated choke on DC link; ≥ ADV71600: external choke mandatory

[**]: Only for sizes ≥ ADV71600;

[***] Please refer to the user guide for fan connections

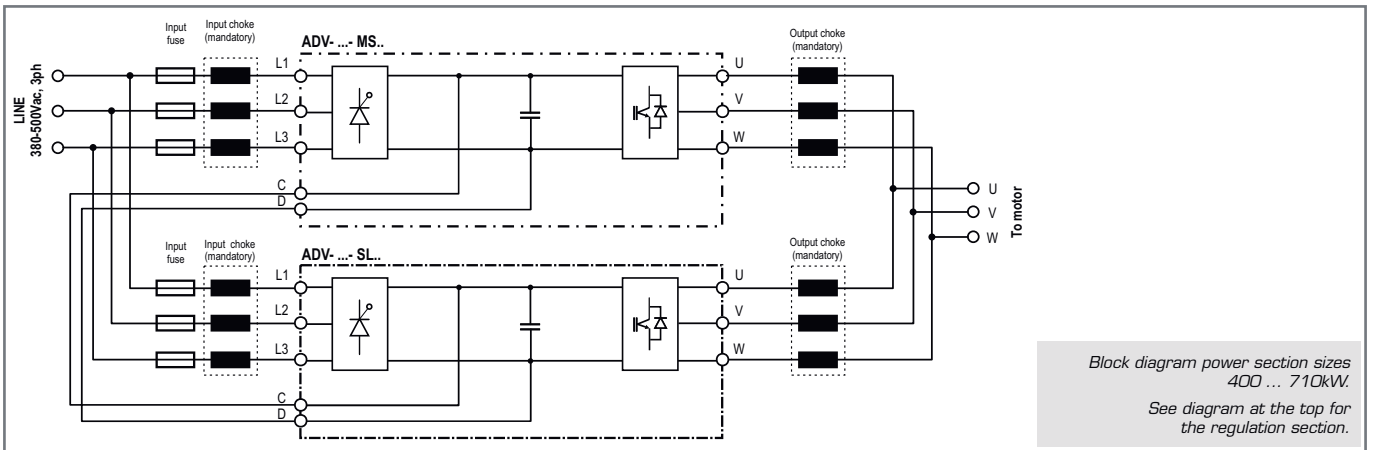

Block diagram power section sizes 400 ... 710kW.

See diagram at the top for the regulation section.

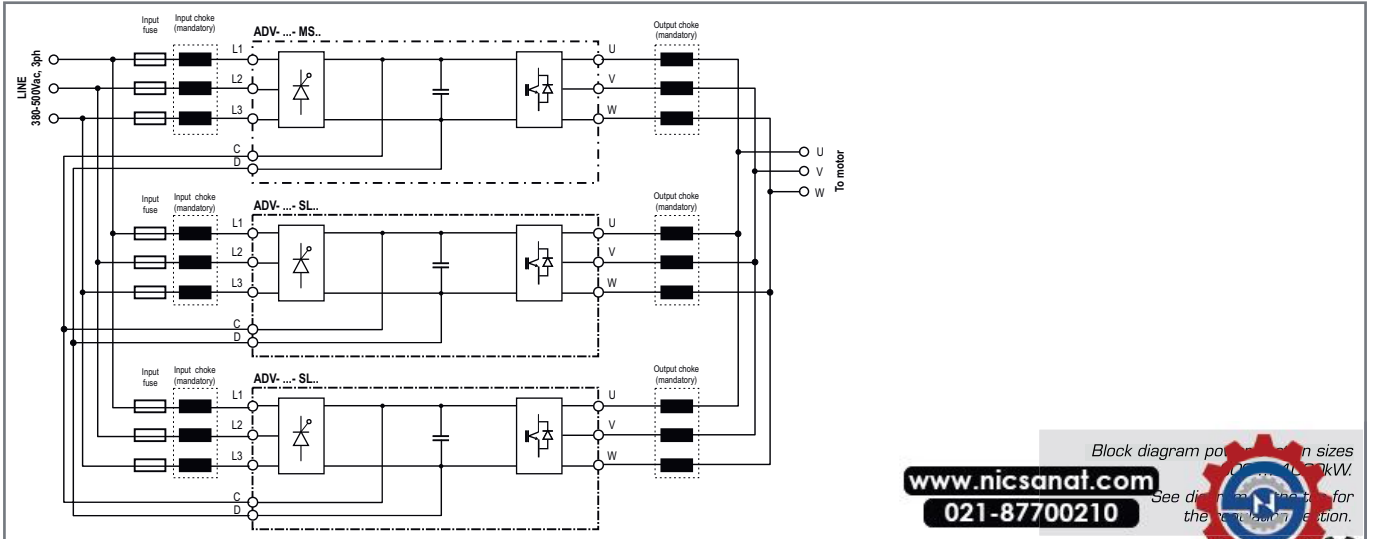

Block diagram power section sizes 400 ... 710kW.

See diagram at the top for the regulation section.

www.nicsanat.com
021-87700210



1.4 Weights and dimensions

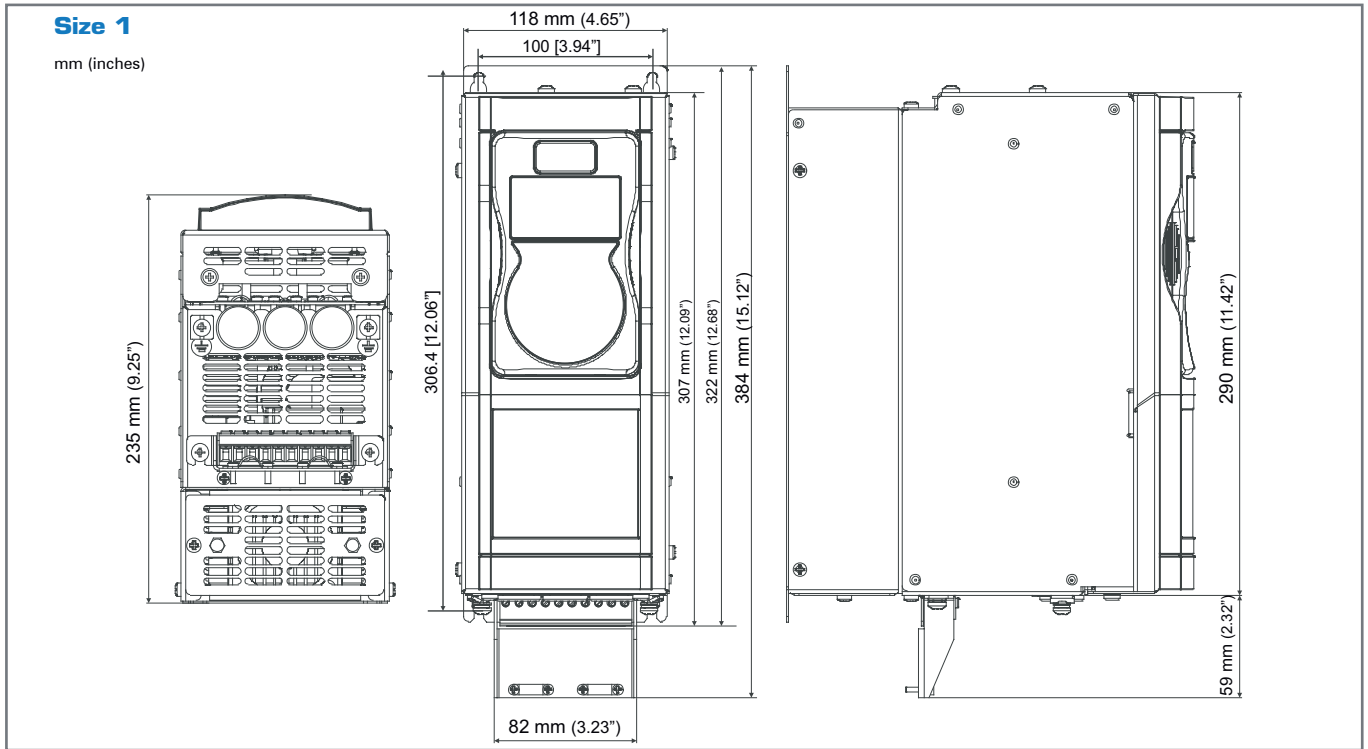

Size ADV200-4	Dimensions: Width x Height x Depth		Weight	
	mm	inches	kg	lbs
1007...1040	118 x 322 x 235	4.65 x 12.7 x 9.25	5.8	12.8

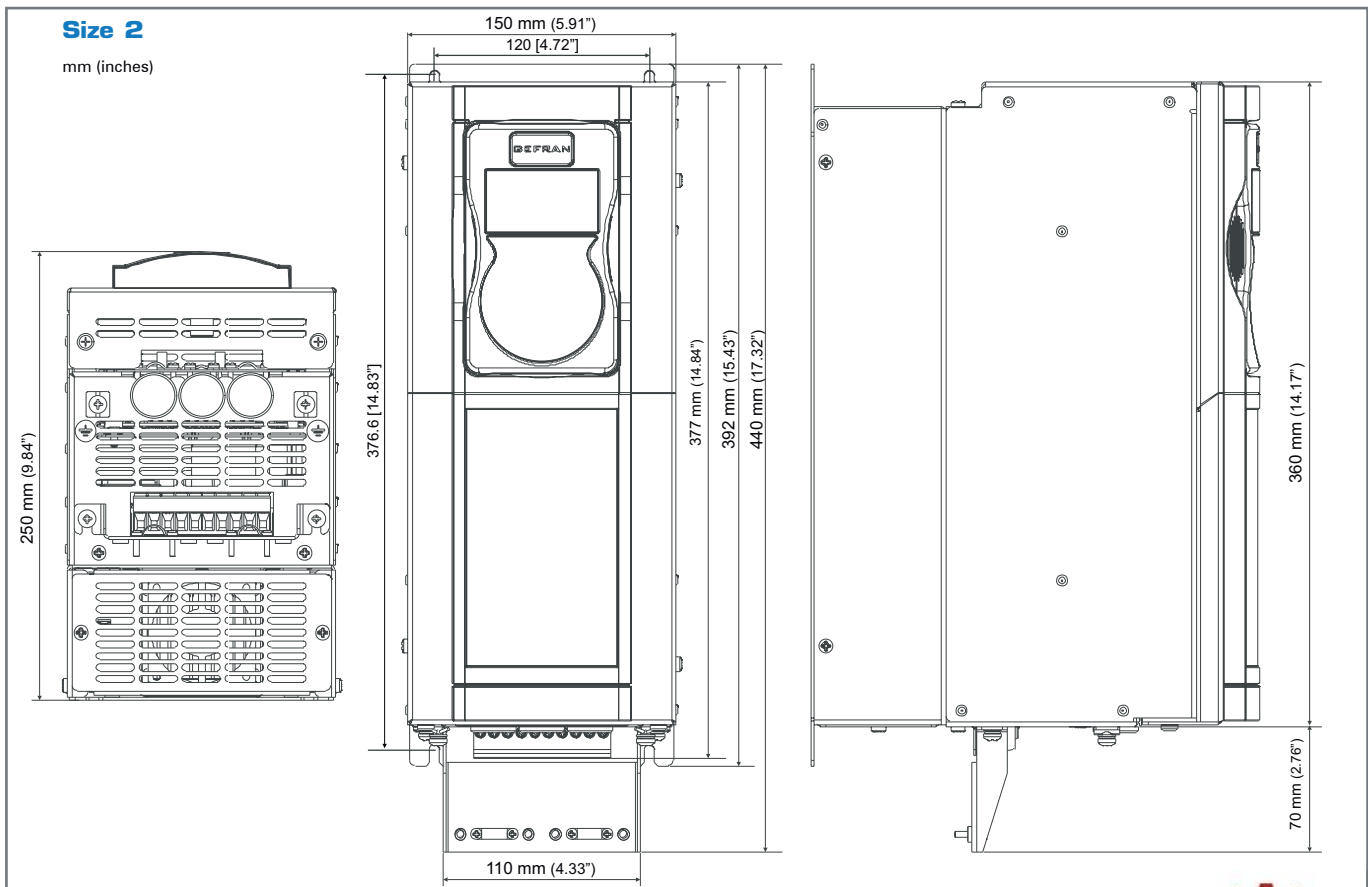

Size ADV200-4	Dimensions: Width x Height x Depth		Weight	
	mm	inches	kg	lbs
2055 ... 2110	150 x 392 x 250	5.91 x 15.43 x 9.84		

www.nicsanat.com
021-87700210



Size 3

mm (inches)

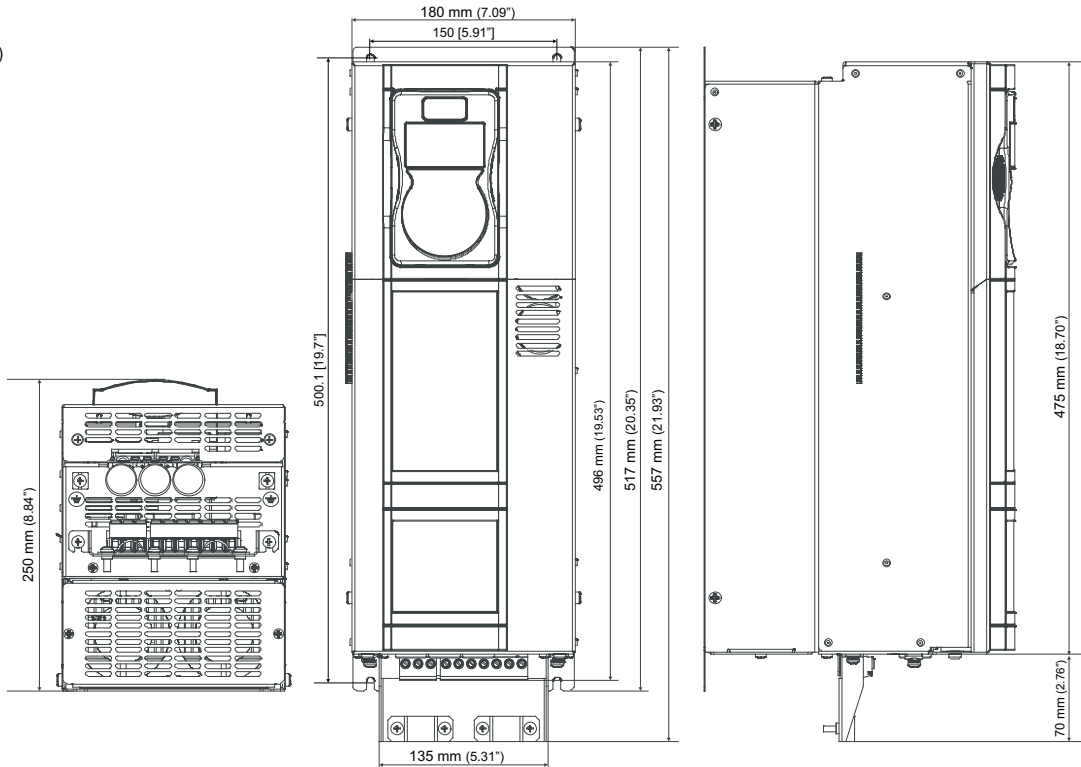

Size ADV200-4	Dimensions: Width x Height x Depth		Weight	
	mm	inches	kg	lbs
3150...3185	180 x 517 x 250	7.09 x 20.35 x 9.84	16.4	36.2
3220			22	48.5

Size 4

mm (inches)

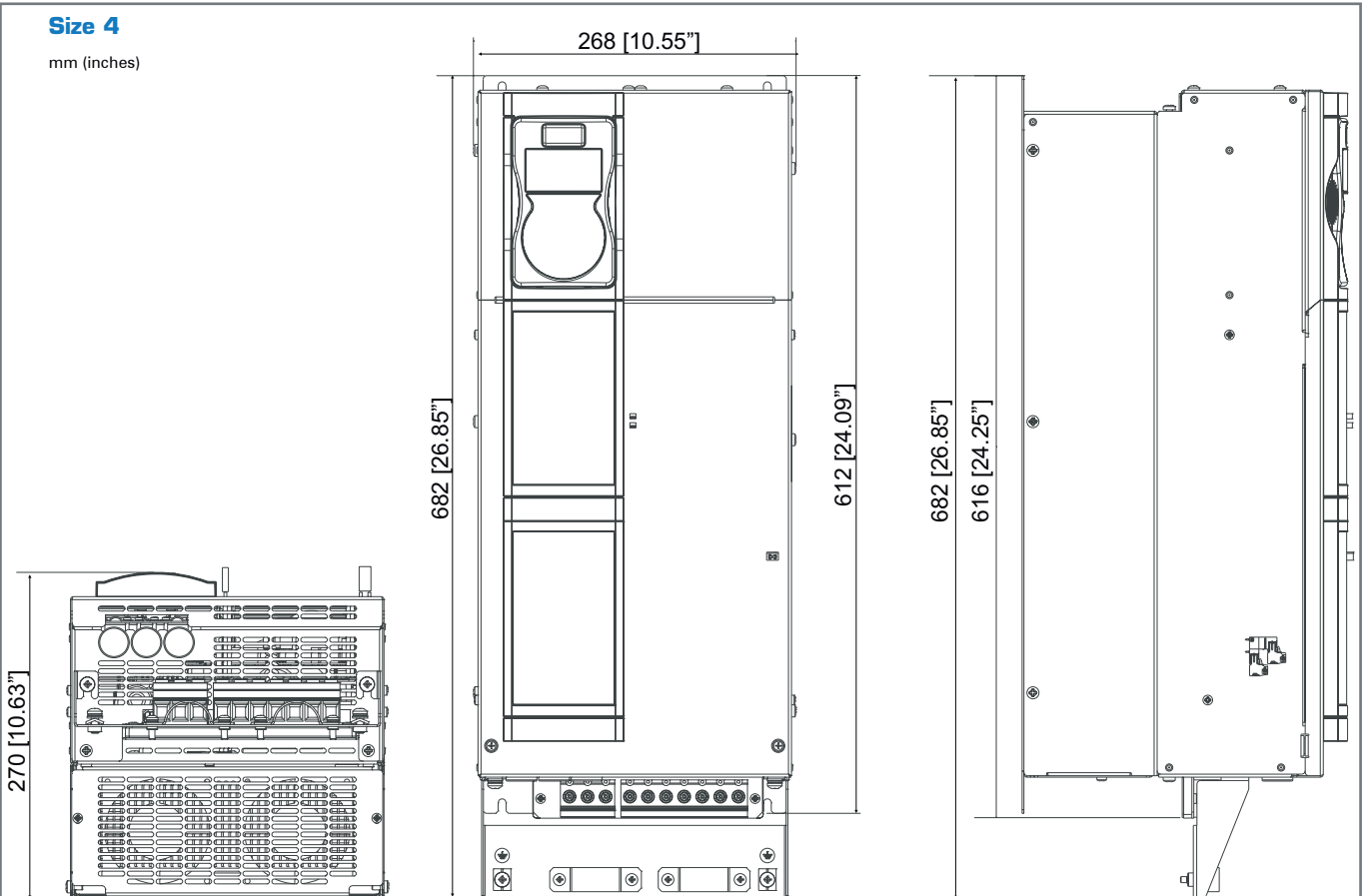

Size ADV200-4	Dimensions: Width x Height x Depth		Weight	
	mm	inches	kg	lbs
4300...4450	268 x 616 x 270	10.55 x 24.25 x 10.63		

www.nicsanat.com
021-87700210



Size 5

mm (inches)

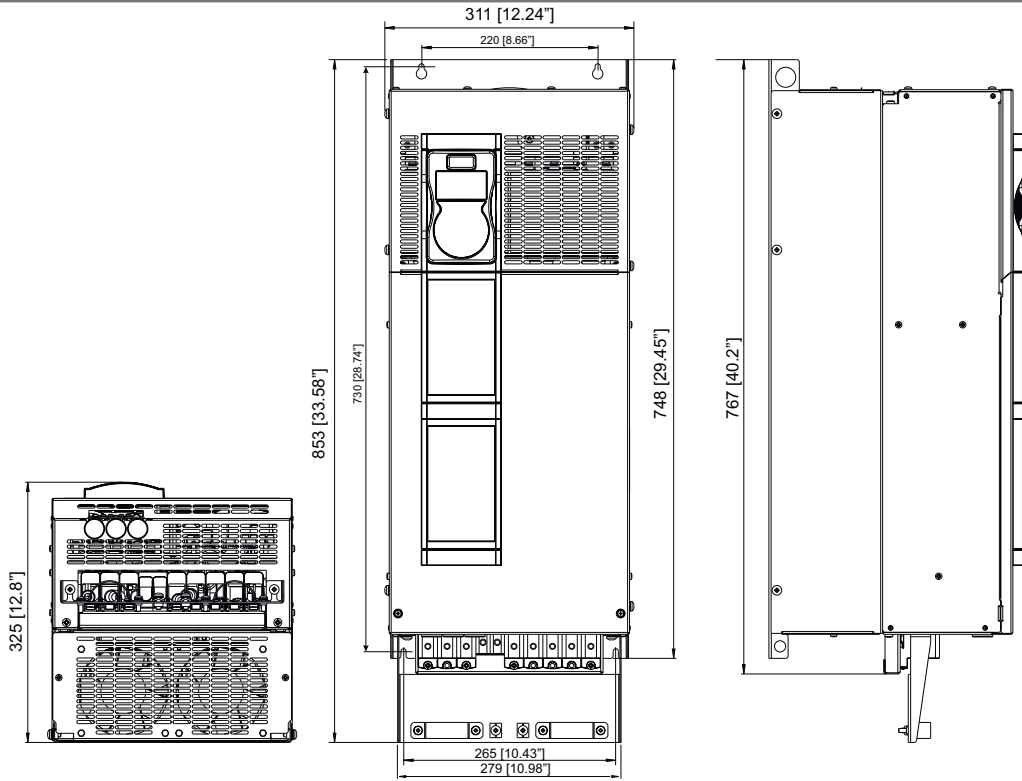

Size ADV200-4	Dimensions: Width x Height x Depth		Weight	
	mm	inches	kg	lbs
5550...5900	311 x 767 x 325	12.24 x 40.2 x 12.8	60	132.3

Size 6

mm (inches)

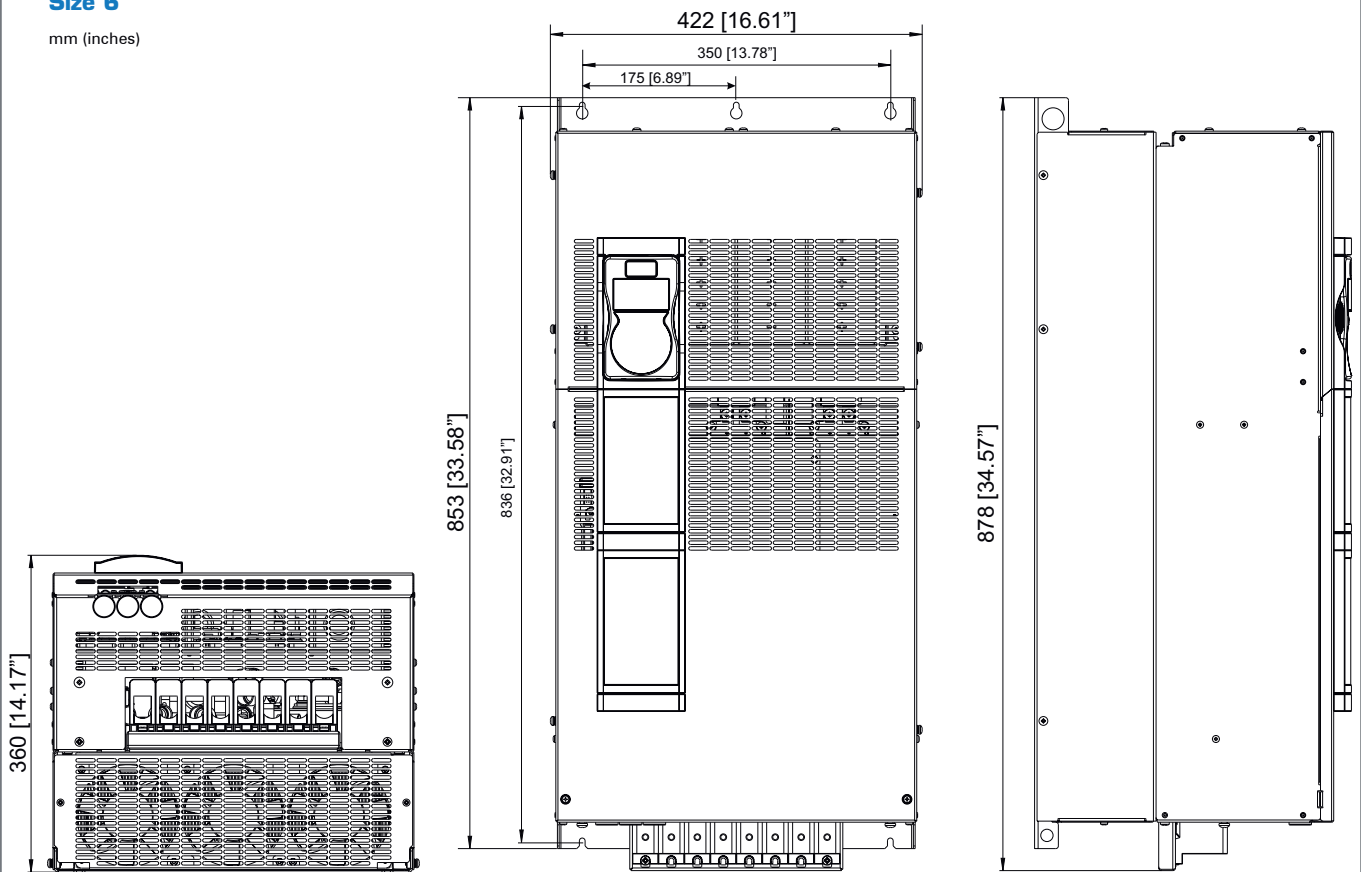

Size ADV200-4	Dimensions: Width x Height x Depth		Weight	
	mm	inches	kg	lbs
61100 ... 61320	422 x 878 x 360	16.61 x 34.6 x 14.2	60	132.3

www.nicsanat.com
021-87700210



Size 7

mm (inches)

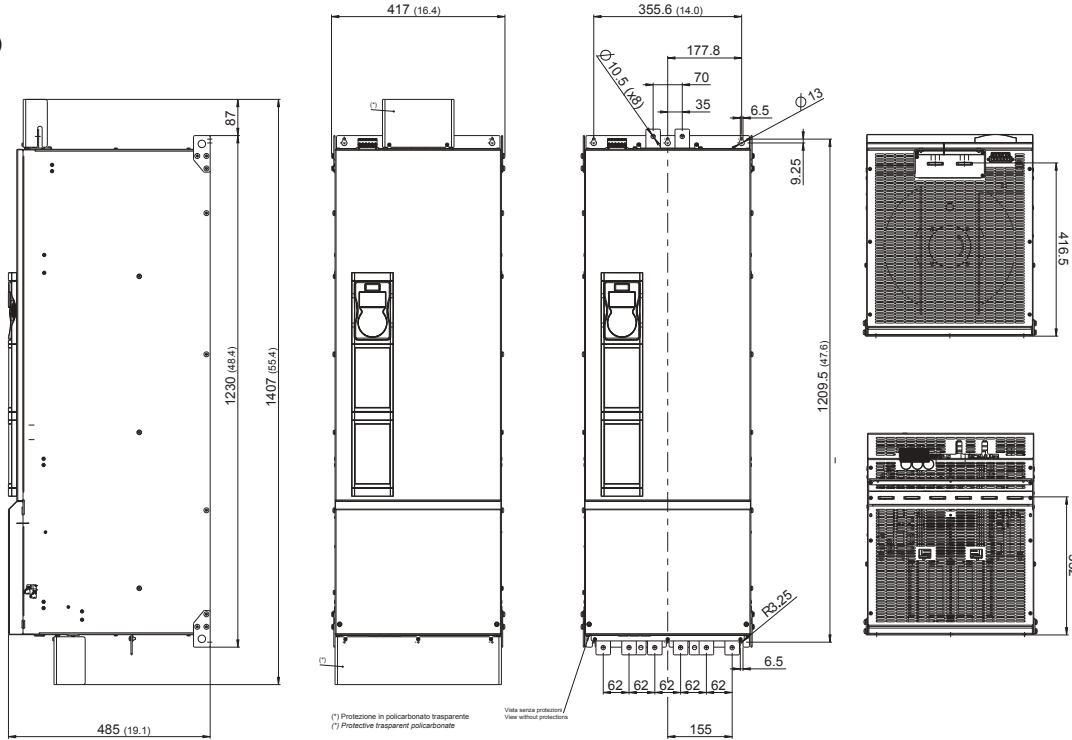

Size ADV200-4	Dimensions: Width x Height x Depth		Weight	
	mm	inches	kg	lbs
71600...72000	417 x 1407 x 485	16.42 x 55.4 x 19.1	130	286.6
72500			140	308.7
73150 ... 73550			150	330.7

Sizes 400 ... 710 kW

mm (inches)

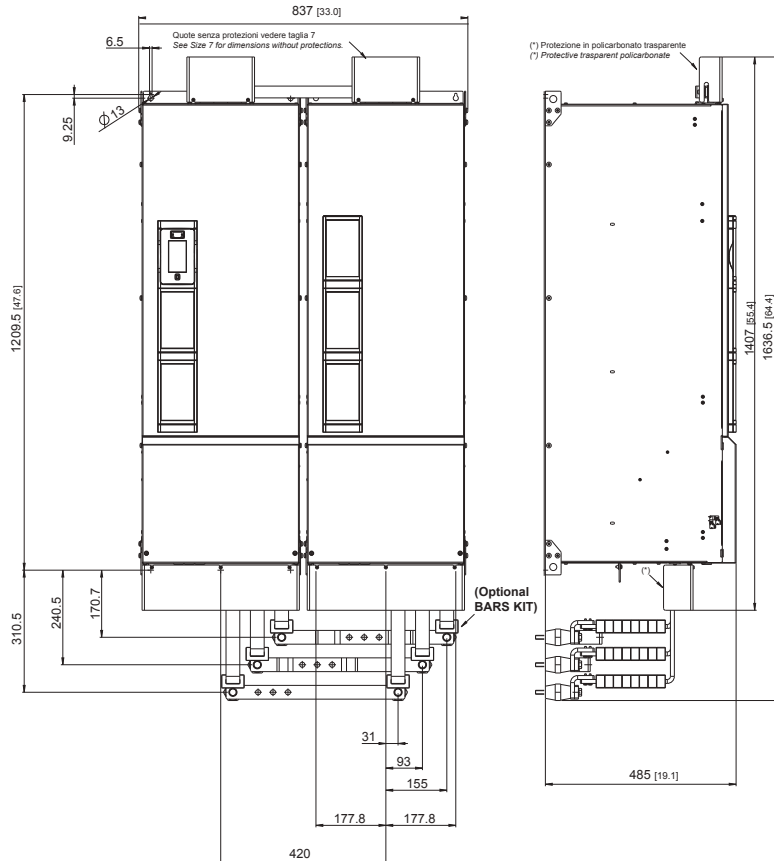

Size ADV200-4	Dimensions: Width x Height x Depth		Weight	
	mm	inches	kg	lbs
400kW	837 x 1407 x 485	33.0 x 55.4 x 19.1	www.nicsanat.com 021-87700210 450	
500kW				
630 - 710kW				



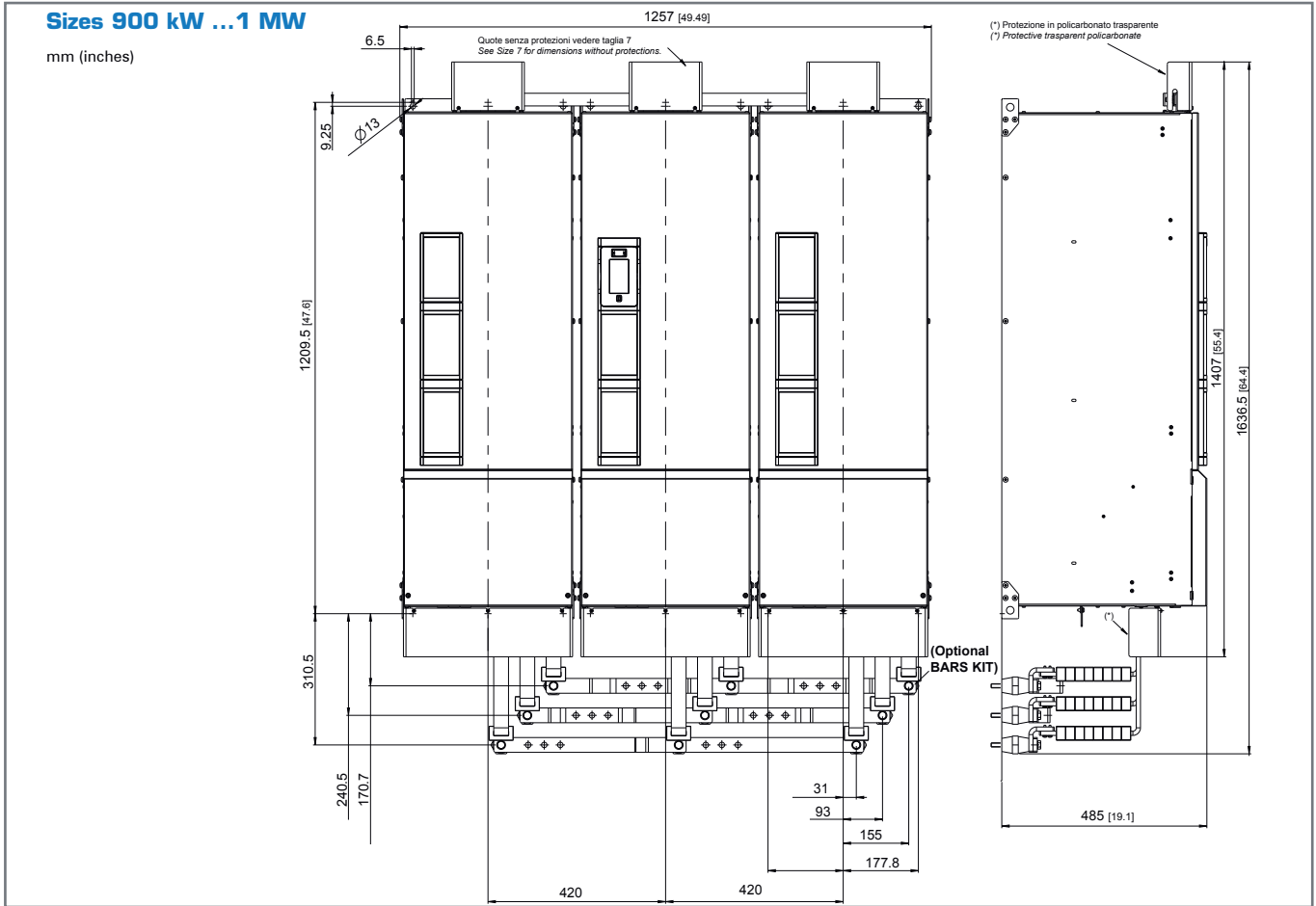

Size ADV200-4	Dimensions: Width x Height x Depth		Weight	
	mm	inches	kg	lbs
900 kW - 1 MW	1257 x 1407 x 485	49.5 x 55.4 x 19.1	450	992.1

ADV200 - 4

ADV200-DC

ADV200 - 6

ADV100

ADV80

AFE200

PROGRAM.

APPENDIX

Sizes 2 (Models -EH)

mm (inches)

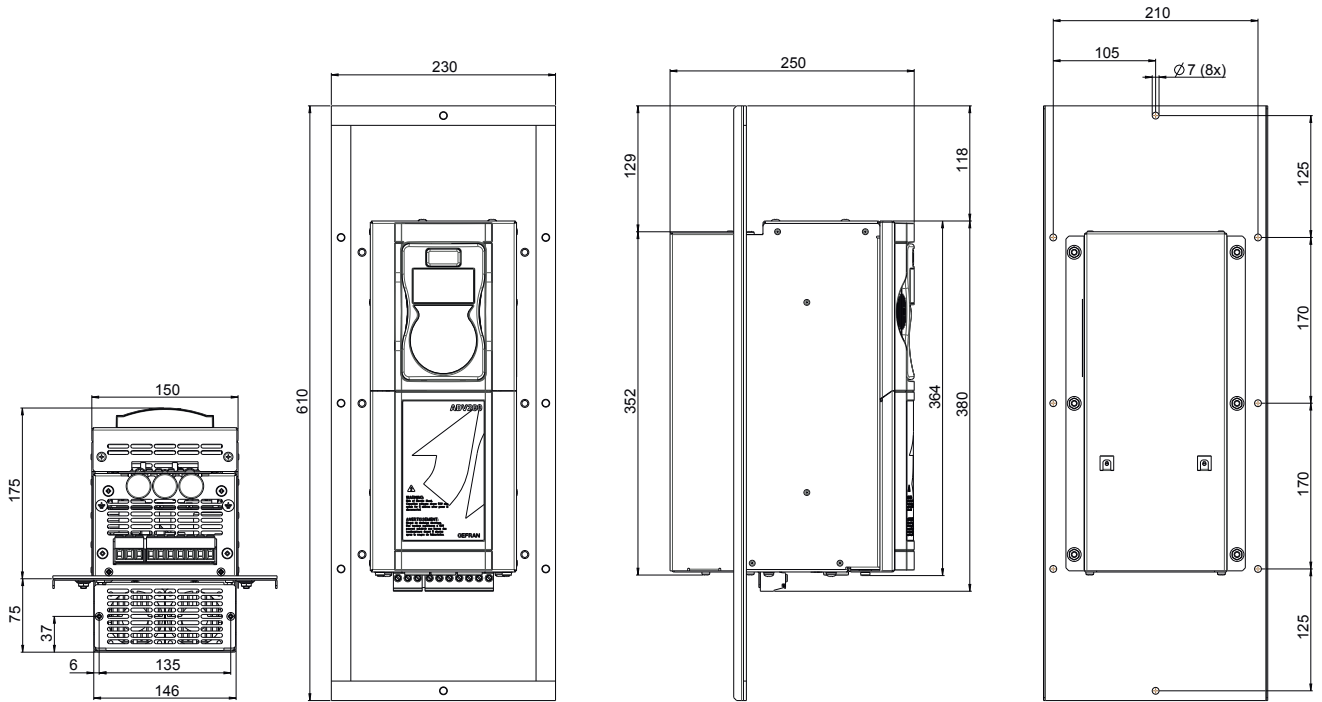

Size ADV200-...-EH	Dimensions: Width x Height x Depth		Weight	
	mm	inches	kg	lbs
2075 - 2110	230 x 610 x 250	9.1 x 24 x 9.8	10.2	22.5

Sizes 3 (Models -EH)

mm (inches)

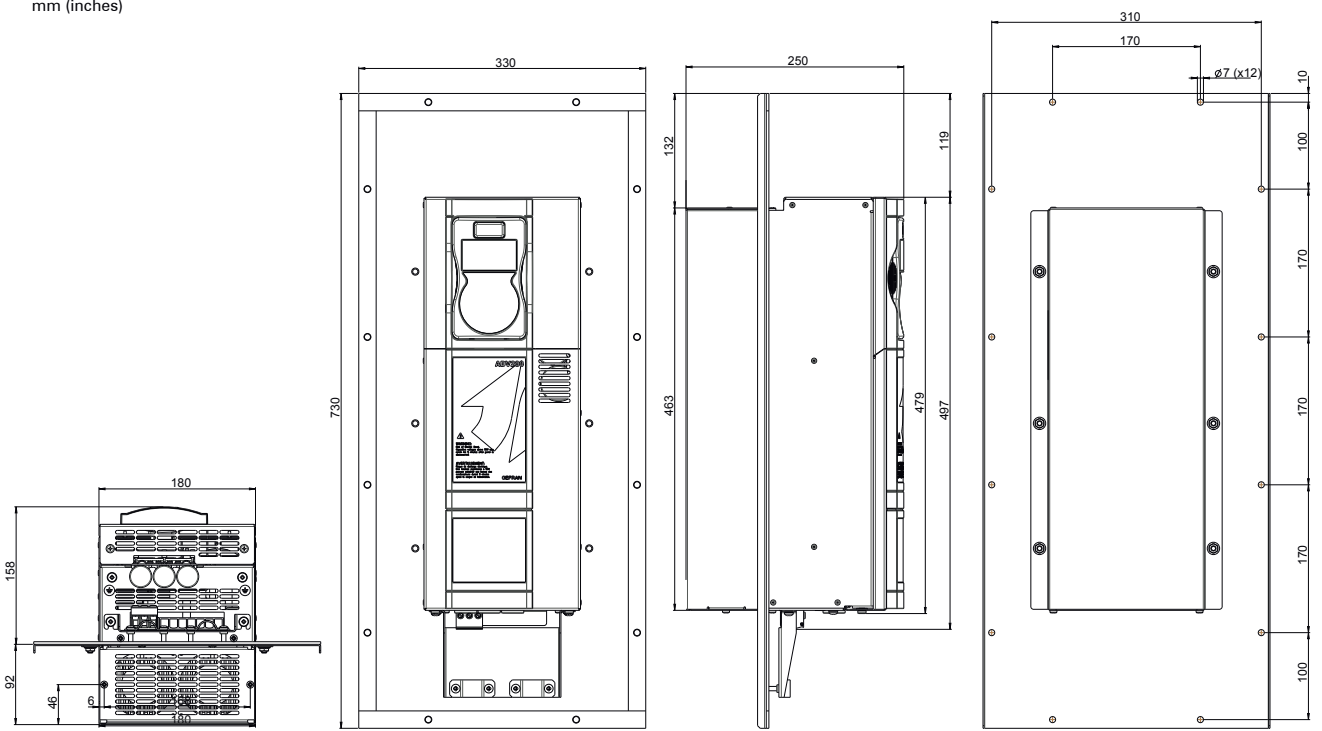

Size ADV200-...-EH	Dimensions: Width x Height x Depth		Weight	
	mm	inches	kg	lbs
3150 ... 3220	330 x 730 x 250	13 x 28.7 x 9.8	10.2	22.5

www.nicsanaf.com
021-87700210



Sizes 4 (Models -EH)

mm (inches)

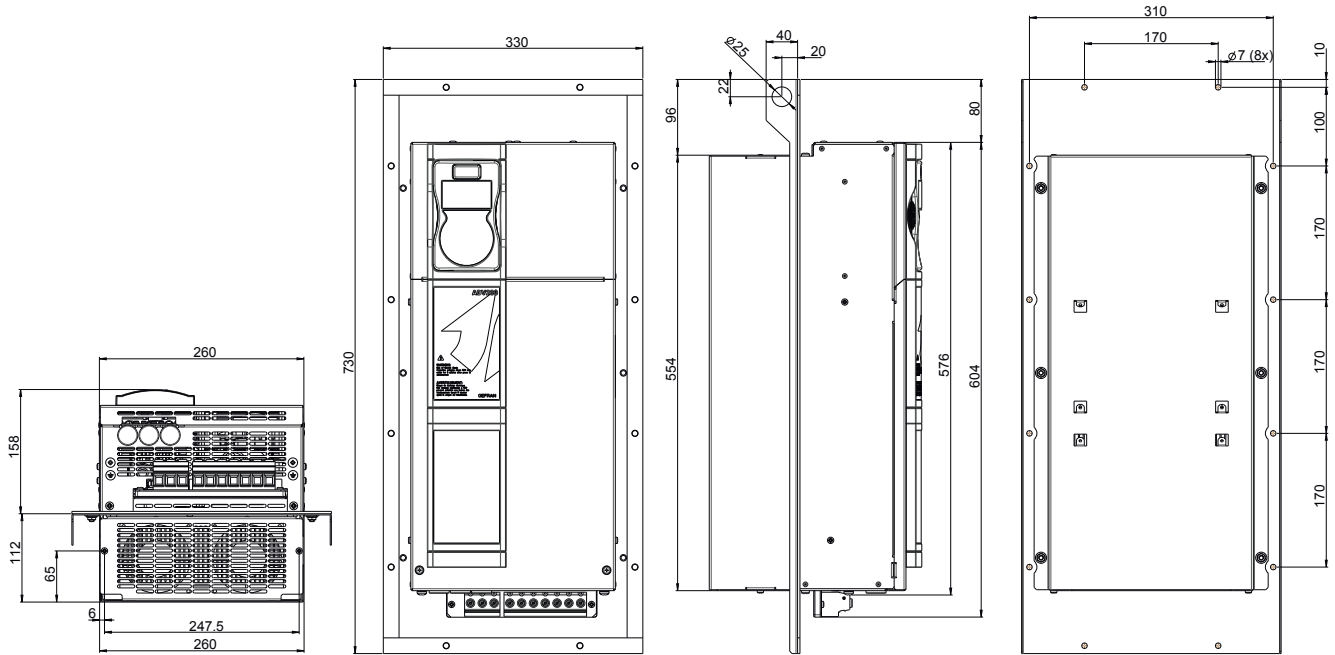

Size ADV200-...-EH	Dimensions: Width x Height x Depth		Weight	
	mm	inches	kg	lbs
4300 ... 4450	330 x 730 x 270	13 x 28.7 x 10.6	32	70.6

Sizes 5 (Models -EH)

mm (inches)

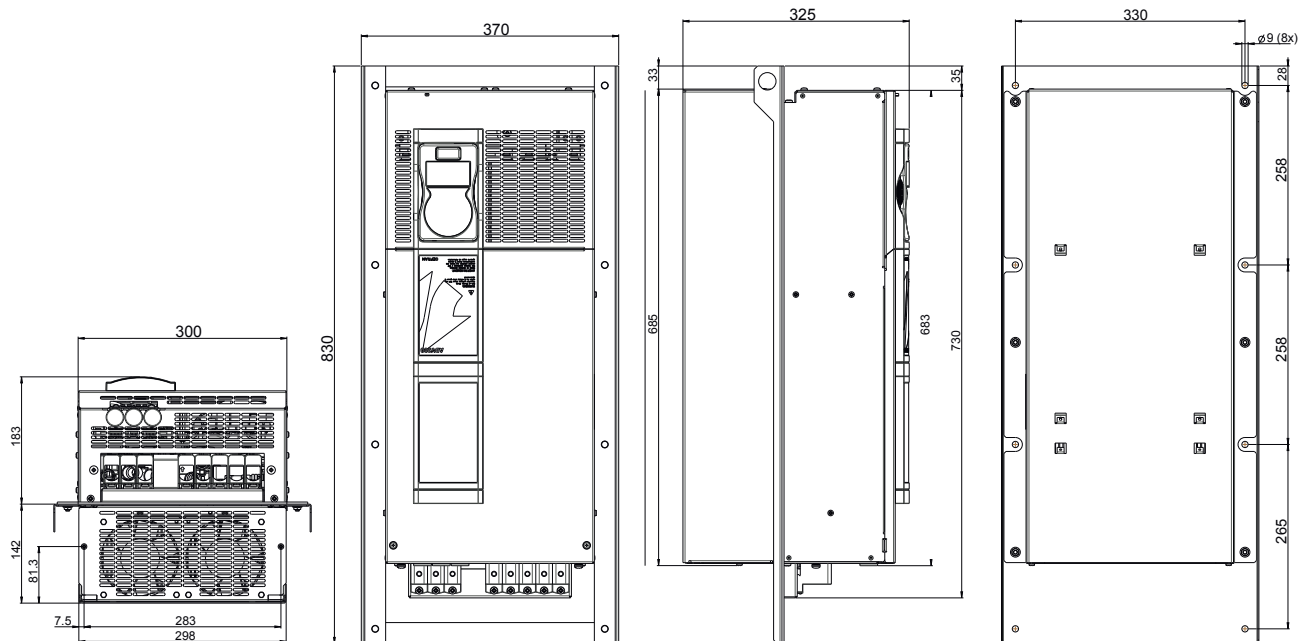

Size ADV200-...-EH	Dimensions: Width x Height x Depth		Weight	
	mm	inches	kg	lbs
5550 ... 5900	370 x 830 x 325	14.6 x 32.7 x 12.8		

www.nicsanaf.com
021-87700210



1.5 Choosing the Inverter

The combinations of motor power ratings and inverters listed in the table envisage the use of motors in which the voltage rating is equal to that of the mains power.

For motors with different voltage ratings the inverter must be chosen according to the current rating of the motor. The combinations listed in the table thus show the current that can be delivered by the drive during continuous operation and overload conditions, according to the mains voltage.

The same engineering criteria apply for operations with additional derating factors:

- KV Power supply voltage
- KT Ambient temperature
- Kf Switching frequency
- KALT Altitude of installation

1.6 Input Data

Sizes ADV200	Input voltage U _{LN} [VAC]	Input frequency [Hz]	Overvoltage threshold (Overvoltage) [V _{DC}]	Undervoltage threshold (Undervoltage) [V _{DC}]	DC-Link Capacity [μF]	Total harmonic distortion [THD] %	AC input current for continuous operation I _N	
							Heavy Duty (150% overload) @ 400 VAC [Arms]	Light Duty (110% overload) @ 400 VAC [Arms]
1007	Three- phase mains 380 VAC -15% ... 500 VAC +5%	50/60 Hz, ± 2%	820	380	235	40% Light Duty 50% Heavy Duty (at rated current)	2.1	3.7
1015					235		3.7	4.9
1022					340		4.9	6.5
1030					340		6.5	8.1
1040					340		8.1	11.1
2055					680		11.1	14.0
2075					680		14.0	19.6
2110					830		19.6	26.4
3150					1500		26.4	32.3
3185					1500		32.3	39
3220					1500		39	53
4300					2350		53	64
4370					2800		64	74
4450					3400		74	100
5550					4700		100	143
5750					5600		143	171
5900					6800		171	200
61100					11200		200	238
61320					13600		238	285
71600					16800		300	350
72000					16800		350	420
72500					25200		420	580
73150					25200		580	640
73550					25200		640	710
400 kW	2 * 16800	665	800					
500 kW	2 * 25200	800	1100					
630 kW	2 * 25200	1100	1215					
710 kW	2 * 25200	1215	1350					
900 kW	3 * 25200	1650	1800					
1 MW	3 * 25200	1800	2020					

1.7 Output Data

Sizes ADV200	Inverter Output		Pn mot (Recommended asynchronous motor rating, fsw = default)				Maximum output voltage U2 [V]	Output frequency f2 [Hz]	IGBT braking unit
	Heavy Duty [kVA]	Light Duty [kVA]	Heavy Duty (150% overload)		Light Duty (110% overload)				
			@400 VAC [kW]	@460 VAC [Hp]	@400 VAC [kW]	@460 VAC [Hp]			
1007	1.7	3.0	0.75	1	1.5	2	0.98 x UIn (UIn = AC input voltage)	Internal (with external resistor); braking torque 150 % MAX	
1015	3.0	4.0	1.5	2	2.2	3			
1022	4.0	5.3	2.2	3	3	5			
1030	5.3	6.6	3.0	5	4	5			
1040	6.6	9	4.0	5	5.5	7,5			
2055	9	11.4	5.5	7.5	7.5	10			
2075	11.4	15.9	7.5	10	11	15			
2110	15.9	21.5	11	15	15	20			
3150	21.5	26.3	15	20	18.5	25			
3185	26.3	32	18.5	25	22	30			
3220	32	43	22	30	30	40			
4300	43	52	30	40	37	50			
4370	52	60	37	50	45	60			
4450	60	73	45	60	55	75			
5550	73	104	55	75	75	100			
5750	104	125	75	100	90	125			
5900	125	145	90	125	110	150			
61100	145	173	110	150	132	175			
61320	173	208	132	175	160	200			
71600	208	267	160	200	200	250			
72000	267	319	200	250	250	300			
72500	319	409	250	300	315	400			
73150	409	450	315	400	355	450			
73550	450	506	355	450	400	500			
400 kW	506	603	400	500	500	650			
500 kW	603	776	500	650	630	850			
630 kW	776	852	630	850	710	950			
710 kW	852	956	710	950	800	1100			
900 kW	1108	1247	900	1200	1000	1300			
1 MW	1247	1420	1000	1300	1200	1600			

ADV200 - 4
ADV200-DC
ADV200 - 6
ADV100
ADV80
AFE200
PROGRAM.
APPENDIX

(*) For Brushless motors:
 MAX: FVCL/ FVOL = 280 Hz, min: 10% of rated frequency
 FVCL = Flux vector CL (Field Oriented Control with feedback); FVOL=Flux vector OL (Open Loop Field Oriented Control).

www.nicsanat.com
 021-87700210

Sizes ADV200	Rated output current In (fsw = default)							
	Heavy Duty				Light Duty			
	For Asynchronous motors (150% overload)		For Synchronous motors (160% overload)		For Asynchronous motors (110% overload)		For Synchronous motors (110% overload)	
	@400 VAC [A]	@460 VAC [A]	@400 VAC [A]	@460 VAC [A]	@400 VAC [A]	@460 VAC [A]	@400 VAC [A]	@460 VAC [A]
1007	2.5	2.3	2.3	2.1	4.3	3.9	3.9	3.5
1015	4.3	3.9	3.9	3.5	5.8	5.2	5.2	4.7
1022	5.8	5.2	5.2	4.7	7.6	6.8	6.8	6.1
1030	7.6	6.8	6.8	6.1	9.5	8.6	8.6	7.7
1040	9.5	8.6	8.6	7.7	13	11.7	11.7	10.5
2055	13	11.7	11.7	10.5	16.5	14.9	15	13.5
2075	16.5	14.9	15	13.5	23	20.7	21	18.9
2110	23	20.7	21	18.9	31	27.9	28	25.2
3150	31	27.9	28	25.2	38	34.2	34	30.6
3185	38	34.2	34	30.6	46	41.4	41	36.9
3220	46	41.4	41	36.9	62	55.8	56	50.4
4300	62	55.8	56	50.4	75	67.5	68	61.2
4370	75	67.5	68	61.2	87	78.3	78	70.2
4450	87	78	78	70.2	105	94.5	95	85.5
5550	105	94.5	95	85.5	150	135	135	121.5
5750	150	135	135	122	180	162	162	146
5900	180	162	162	146	210	189	189	170
61100	210	189	189	170	250	225	225	203
61320	250	225	225	203	300	270	270	243
71600	300	270	270	243	385	347	347	312
72000	385	347	347	312	460	414	414	373
72500	460	414	414	373	590	531	521	469
73150	590	531	521	469	650	585	585	527
73550	650	585	585	527	730	657	657	591
400 kW	730	657	657	591	870	783	783	705
500 kW	870	783	783	705	1120	1008	1008	907
630 kW	1120	1008	1008	907	1230	1107	1107	996
710 kW	1230	1107	1107	996	1380	1242	1242	1118
900 kW	1600	1440	1440	1296	1800	1620	1620	1458
1 MW	1800	1620	1620	1458	2050	1845	1845	1661

Sizes ADV200	Switching frequency fsw		Reduction factor									
	Default	Higher	Kv		KT (2)	KALT (3) %	Kf (4)					
			@400Vac (1)	@460Vac and from AFE200 (1)			2 kHz	4 kHz	6 kHz	8 kHz	10 kHz	12 kHz
1007	8	10, 12				1.2	1	1	1	1	0.85	0.7
1015	8	10, 12				1.2	1	1	1	1	0.85	0.7
1022	4	6, 8, 10, 12				1.2	1	1	0.85	0.7	0.55	0.4
1030	4	6, 8, 10, 12				1.2	1	1	0.85	0.7	0.55	0.4
1040	4	6, 8, 10, 12				1.2	1	1	0.85	0.7	0.6	0.5
2055	4	6, 8, 10, 12				1.2	1	1	0.85	0.7	0.6	0.5
2075	4	6, 8, 10, 12				1.2	1	1	0.85	0.7	0.6	0.5
2110	4	6, 8, 10, 12				1.2	1	1	0.85	0.7	0.6	0.5
3150	4	6, 8, 10, 12				1.2	1	1	0.85	0.7	0.6	0.5
3185	4	6, 8, 10, 12				1.2	1	1	0.85	0.7	0.6	0.5
3220	4	6, 8, 10, 12				1.2	1	1	0.85	0.7	0.6	0.5
4300	4	6, 8, 10, 12				1.2	1	1	0.85	0.7	0.6	0.5
4370	4	6, 8, 10, 12	Tamb 40°C = 1	Tamb ≤ 30°C = 1		1.2	1	1	0.85	0.7	0.6	0.5
4450	4	6, 8		Tamb 40°C = 0,9		1.2	1	1	0.85	0.7	0	0
5550	4	6, 8	from AFE200: Tamb ≤ 30°C = 1	from AFE200: Tamb ≤ 30°C = 0.9	HD: 0.9	1.2	1	1	0.85	0.7	0	0
5750	4	6, 8			LD: 0.8	1.2	1	1	0.85	0.7	0	0
5900	4	6, 8	from AFE200: Tamb 31 ... 40°C = 0.9	from AFE200: Tamb 31 ... 40°C = 0.81		1.2	1	1	0.85	0.7	0	0
61100	4	6, 8				1.2	1	1	0.85	0.7	0	0
61320	4	6, 8				1.2	1	1	0.85	0.7	0	0
71600	4	-				1.2	1	1	0	0	0	0
72000	4	-				1.2	1	1	0	0	0	0
72500	2	4				1.2	1	0.85	0	0	0	0
73150	2	-				1.2	1	0	0	0	0	0
73550	2	-				1.2	1	0	0	0	0	0
400 kW	4 (5)	-				1.2	1	1 (5)	0	0	0	0
500 kW	2	4 (5)				1.2	1	0.85 (5)	0	0	0	0
630 kW	2	-				1.2	1	0	0	0	0	0
710 kW	2	-				1.2	1	0	0	0	0	0
900 kW	2	-				1.2	1	0	0	0	0	0
1 MW	2	-				1.2	1	0	0	0	0	0

(1) Kv : Derating factor for mains voltage at 460Vac or AFE200 power supply.
 (2) KT : Derating factor for ambient temperature of 50°C (1% every °C over 40°C with HD and 2% every °C over 40°C with LD)
 (3) KALT : Derating factor for installation at altitudes above 1000 meters a.s.l. (up to a maximum of 2000 m). Value to be applied = 1.2% each 100 meters.
 For example: Altitude 2000 m, Kalt = 1.2% * 10 = 12% derating; In derated = (100 - 12) % = 88 % In
 (4) Kf : Derating factor for higher switching frequency
 (5) Derating factor from fw 6.03.

www.nicsanat.com
021-87700210



ADV200 - 4

ADV200-DC

ADV200 - 6

ADV100

ADV80

AFE200

PROGRAM.

APPENDIX

Sizes ADV200	Asynchronous motor control													
	Overload			Derating according to switching frequency (HD)						Overload according to output frequency				
	HD 150 % x In (1' each 5')	HD 180 % x In (for 0,5")	LD 110 % x In (1' each 5')	2 kHz	4 kHz	6 kHz	8 kHz	10 kHz	12 kHz	Heavy Duty			Light Duty	
	[A]	[A]	[A]	[A]	[A]	[A]	[A]	[A]	[A]	K1 HD [%]	K2 HD [%]	K3 HD [Hz]	K1 LD [%]	K2 LD [Hz]
1007	3.7	4.5	4.7	2.5	2.5	2.5	2.5	2.1	1.8	100	3	4.8	100	3
1015	6.5	7.7	6.4	4.3	4.3	4.3	4.3	3.7	3	100	3	4.8	75	3
1022	8.7	10.4	8.4	5.8	5.8	4.9	4.1	3.7	3	100	3	4.8	75	3
1030	11.4	13.7	10.5	7.6	7.6	6.5	5.3	4.2	3	100	3	4.8	80	3
1040	14.3	17.1	14.3	9.5	9.5	8.1	6.7	5.7	4.75	100	3	4.8	100	3
2055	19.5	23.4	18.1	13	13	11.1	9.1	7.8	6.5	100	3	4.8	100	3
2075	24.7	29.7	25.3	16.5	16.5	14.0	11.6	9.9	8.25	100	3	4.8	75	3
2110	34.5	41.4	34.1	23	23	19.6	16.1	13.8	11.5	100	3	4.8	75	5
3150	46.5	55.8	41.8	31	31	26.4	21.7	18.6	15.5	100	5	8	75	7
3185	57	68.4	50.6	38	38	32.3	26.6	22.8	19	100	5	8	85	5
3220	69	82.8	68.2	46	46	39.1	32.2	27.6	23	100	3	4.8	80	5
4300	93	111.6	82.5	62	62	52.7	43.4	37.2	31	100	3	4.8	80	3
4370	113	135	95.7	75	75	63.8	52.5	45	37.5	100	3	4.8	80	3
4450	131	157	116	87	87	74	60.9	n.a.	n.a.	100	3	4.8	80	3
5550	157	189	165	105	105	89	74	n.a.	n.a.	100	3	4.8	85	5
5750	225	270	198	150	150	128	105	n.a.	n.a.	100	5	8	85	5
5900	270	324	231	180	180	153	126	n.a.	n.a.	100	5	8	85	5
61100	315	378	275	210	210	179	147	n.a.	n.a.	100	3	4.8	100	3
61320	375	540	330	250	250	213	175	n.a.	n.a.	100	3	4.8	100	3
71600	450	540	424	300	300	n.a.	n.a.	n.a.	n.a.	100	3	4.8	80	3
72000	578	693	506	385	385	n.a.	n.a.	n.a.	n.a.	100	3	4.8	100	3
72500	690	828	649	460	n.a.	n.a.	n.a.	n.a.	n.a.	100	3	4.8	75	5
73150	885	1062	715	590	n.a.	n.a.	n.a.	n.a.	n.a.	100	3	4.8	100	3
73550	975	1170	803	650	n.a.	n.a.	n.a.	n.a.	n.a.	90	5	7.5	90	5
400 kW	1095	1314	957	730	n.a.	n.a.	n.a.	n.a.	n.a.	100	3	4.8	100	3
500 kW	1305	1566	1232	870	n.a.	n.a.	n.a.	n.a.	n.a.	100	3	4.8	75	5
630 kW	1680	2016	1353	1120	n.a.	n.a.	n.a.	n.a.	n.a.	100	3	4.8	100	3
710 kW	1845	2214	1518	1230	n.a.	n.a.	n.a.	n.a.	n.a.	90	5	7.5	90	5
900 kW	2400	2880	1980	1600	n.a.	n.a.	n.a.	n.a.	n.a.	100	3	4.8	100	3
1 MW	2700	3240	2255	1900	n.a.	n.a.	n.a.	n.a.	n.a.	90	5	7.5	90	5

- In Light Duty mode the switching frequency is fixed at 4 kHz, and no derating factor is applied.
- If, in the Heavy Duty mode, the factory setting of Mod freq commutaz, (Switch freq. mode) PAR: 568 is changed from 0=Fixed to 1=Variable, the switching frequency is controlled by the temperature of the drive heat sink and the output frequency. For further information see the ADV200 Functions and Parameters manual, menu 4.9.

Overload according to output frequency (Asynchronous motor control)

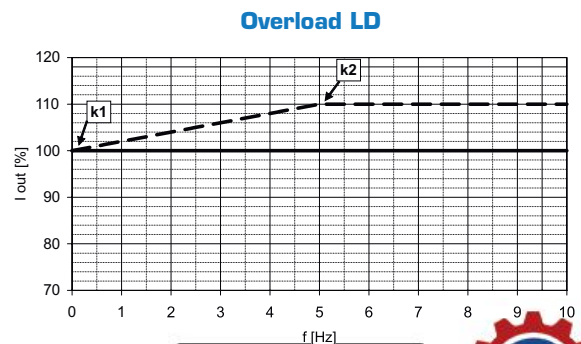
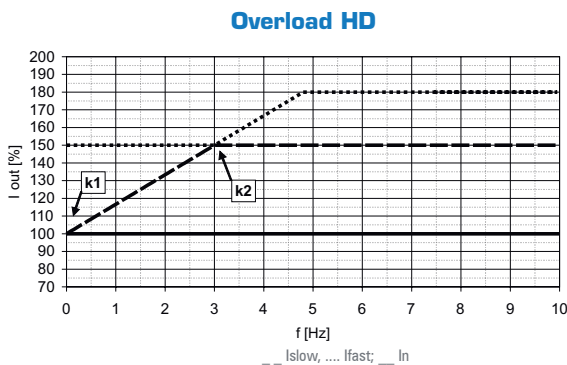

Sizes ADV200	Synchronous motor control													
	Overload			Derating according to switching frequency (HD)						Overload according to output frequency				
	HD 160% x In (1' each 5')	HD 200% x In (for 3')	LD 110% x In (1' each 5')	2 kHz	4 kHz	6 kHz	8 kHz	10 kHz	12 kHz	Heavy Duty			Light Duty	
	[A]	[A]	[A]	[A]	[A]	[A]	[A]	[A]	[A]	K1 HD [%]	K2 HD [%]	K3 HD [Hz]	K1 LD [%]	K2 LD [Hz]
1007	3.7	4.6	4,3	2.3	2.3	2.3	2.3	2.0	1.6	100	3	5	100	3
1015	6.2	7.8	5,7	3.9	3.9	3.9	3.9	3.3	2.7	100	3	5	75	3
1022	8.3	10.4	7,5	5.2	5.2	4.4	3.6	2.9	2.1	100	3	5	75	3
1030	10.9	13.6	9,5	6.8	6.8	5.8	4.8	3.7	2.7	100	3	5	80	3
1040	13.8	17.2	12,9	8.6	8.6	7.3	6.0	5.2	4.3	100	3	5	100	3
2055	18.7	23.4	16,5	11.7	11.7	9.9	8.2	7.0	5.9	100	3	5	100	3
2075	24	30	23,1	15	15	12.8	10.5	9	7.5	100	3	5	75	3
2110	33.6	42	30,8	21	21	17.9	14.7	12.6	10.5	100	3	5	75	5
3150	44.8	56	37,4	28	28	23.8	19.6	16.8	14	100	5	8.3	75	7
3185	54.4	68	45,1	34	34	28.9	23.8	20.4	17	100	5	8.3	85	5
3220	65.6	82	61,6	41	41	34.9	28.7	24.6	20.5	100	3	5	80	5
4300	89.6	112	74,8	56	56	47.6	39.2	33.6	28	100	3	5	80	3
4370	108.8	136	85,8	68	68	57.8	47.6	40.8	34	100	3	5	80	3
4450	124.8	156	104,5	78	78	66.3	54.6	n.a.	n.a.	100	3	5	80	3
5550	152	190	148,5	95	95	80.8	66.5	n.a.	n.a.	100	3	5	85	5
5750	216	270	178,2	135	135	114.8	94.5	n.a.	n.a.	100	5	8.3	85	5
5900	259.2	324	207,9	162	162	137.7	113.4	n.a.	n.a.	100	5	8.3	85	5
61100	302.4	378	247,5	189	189	160.7	132.3	n.a.	n.a.	100	3	5	100	3
61320	360	450	297,0	225	225	191.3	157.5	n.a.	n.a.	100	3	5	100	3
71600	432	540	381,7	270	270	n.a.	n.a.	n.a.	n.a.	100	3	5	80	3
72000	555.2	694	455,4	347	347	n.a.	n.a.	n.a.	n.a.	100	3	5	100	3
72500	662.4	828	573,1	414	351.9	n.a.	n.a.	n.a.	n.a.	100	3	5	75	5
73150	833.6	1042	643,5	521	n.a.	n.a.	n.a.	n.a.	n.a.	100	3	5	100	3
73550	936	1170	722,7	585	n.a.	n.a.	n.a.	n.a.	n.a.	90	5	7.9	90	5
400 kW	1051.2	1314	861,3	657	657 (1)	n.a.	n.a.	n.a.	n.a.	100	3	5	100	3
500 kW	1252.8	1566	1108,8	783	665.6 (1)	n.a.	n.a.	n.a.	n.a.	100	3	5	75	5
630 kW	1612.8	2016	1217,7	1008	n.a.	n.a.	n.a.	n.a.	n.a.	100	3	5	100	3
710 kW	1771.2	2214	1366,2	1107	n.a.	n.a.	n.a.	n.a.	n.a.	90	5	7.9	90	5
900 kW	2304	2880	1782,0	1440	n.a.	n.a.	n.a.	n.a.	n.a.	100	3	5	100	3
1 MW	2592	3240	2029,5	1620	n.a.	n.a.	n.a.	n.a.	n.a.	90	5	7.9	90	5

- In Light Duty mode the switching frequency is fixed at 4 kHz, and no derating factor is applied.
 - In the Heavy Duty mode, consider the derating values if PAR 568 Switch freq. mode is set [0] Fixed. If PAR 568 Switch freq. mode is set [1] Variable, the switching frequency is controlled by the temperature of the drive heat sink and the output frequency. For further information see the ADV200 Functions and Parameters manual, menu 4.9.
- (1) from fw 6.03.

Overload according to output frequency (Synchronous motor control)

Overload HD

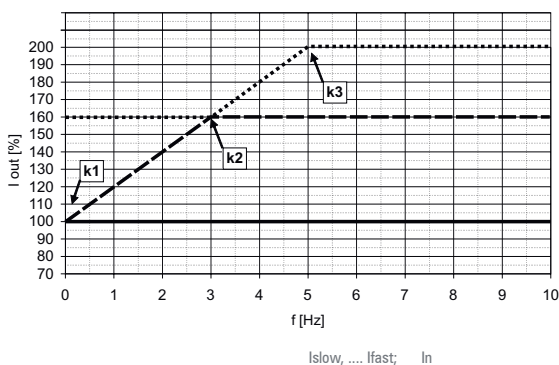

Overload LD

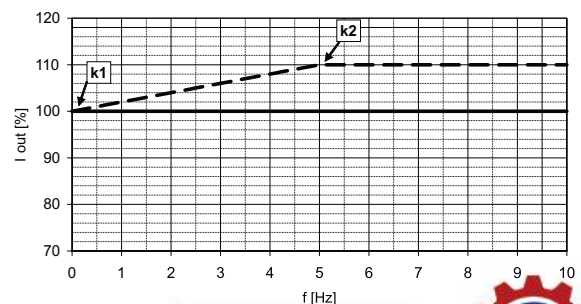

www.nicsanat.com
021-87700210



1.8 Cooling

All inverters are equipped with internal fans (excluding ADV200-...-EH models).

Size	Dissipated power [W]	Fan capacity	
		Dissipator [m ³ /h]	Internal [m ³ /h]
ADV-1007	60	32	26
ADV-1015	90	32	32
ADV-1022	100	32	32
ADV-1030	120	32	32
ADV-1040	160	32	32
ADV-2055	200	32	32
ADV-2075	250	56 x 2	32
ADV-2110	300	56 x 2	32
ADV-3150	380	80 x 2	32
ADV-3185	460	80 x 2	32
ADV-3220	600	80 x 2	32
ADV-4300	900	2 x 250	2 x 50
ADV-4370	1000	2 x 250	2 x 50
ADV-4450	1290	2 x 250	2 x 50
ADV-5550	1760	2 x 285	1 x 170
ADV-5750	2150	2 x 355	2 x 170
ADV-5900	2400	2 x 355	2 x 170
ADV-61100	2850	3 x 310	2 x 170
ADV-61320	3600	3 x 310	2 x 170
ADV-71600	3900	1500	-
ADV-72000	4000	1500	-
ADV-72500	5200	1500	-
ADV-73150	6000	2000	-
ADV-73550	6500	2000	-
400 kW	ADV-72000-KXX-4-MS 04	4000	-
	ADV-72000-XXX-4-SL	4000	-
500 kW	ADV-72500-KXX-4-MS 05	5200	-
	ADV-72500-XXX-4-SL	5200	-
630 kW	ADV-73150-KXX-4-MS 06	6000	-
	ADV-73150-XXX-4-SL	6000	-
710 kW	ADV-73150-KXX-4-MS 07	6500	-
	ADV-73150-XXX-4-SL	6500	-
900 kW	ADV-73150-KXX-4-MS 09	6000	-
	ADV-73150-XXX-4-SL	6000	-
1 MW	ADV-73150-KXX-4-MS 10	6500	-
	ADV-73150-XXX-4-SL	6500	-
	ADV-73150-XXX-4-SL	6500	2000

Size	Dissipated power (*) [W]
ADV-2075-...-EH	107.5
ADV-2110-...-EH	118
ADV-3150-...-EH	130
ADV-3220-...-EH	151
ADV-4300-...-EH	218
ADV-4370-...-EH	235
ADV-4450-...-EH	255
ADV-5550-...-EH	293
ADV-5750-...-EH	430
ADV-5900-...-EH	520

(*) Drives section installed in the control cabinet.

1.9 Order codes

Product identification

ADV - X XXX - X X X - Y - XX YY - SI			
EXP-SFTy-ADV safety card	SI = included	[empty] = not included	
Models with external heatsink IP54 protection.	XX = EH		
Only for parallel versions:	XX :	YY : Inverter power in kW	
	MS = MASTER	04 = 400.0 kW	
	SL = SLAVE	05 = 500.0 kW	
		06 = 630.0 kW	
		07 = 710.0 kW	
		09 = 900.0 kW	
		10 = 1000.0 kW	
Rated voltage (factory setting):	4 = 400 VAC / 50 Hz	4A = 460 VAC / 60 Hz	
Software:	X = standard		
Braking unit:	X = not included	B = included	
Keypad:	X = not included	K = included	
Inverter power in kW:			
007 = 0.75 kW	150 = 15.0 kW	900 = 90.0 kW	
015 = 1.5 kW	185 = 18.5 kW	1100 = 110.0 kW	
022 = 2.2 kW	220 = 22.0 kW	1320 = 132.0 kW	
030 = 3.0 kW	300 = 30.0 kW	1600 = 160.0 kW	
040 = 4.0 kW	370 = 37.0 kW	2000 = 200.0 kW	
055 = 5.5 kW	450 = 45.0 kW	2500 = 250.0 kW	
075 = 7.5 kW	550 = 55.0 kW	3150 = 315.0 kW	
110 = 11.0 kW	750 = 75.0 kW	3550 = 355.0 kW	
Mechanical dimensions of the drive:			
1 = size 1	4 = size 4	7 = size 7	
2 = size 2	5 = size 5		
3 = size 3	6 = size 6		
Inverter, ADV200 series			

Example:

ADV - 1 040 - K B X - 4 - SI			
EXP-SFTy-ADV safety card	SI = included		
Rated voltage (factory setting):	4 = 400 VAC		
Software:	X = standard		
Braking unit:	B = included		
Keypad:	K = included		
Inverter power in kW:	040 = 4.0 kW		
Mechanical dimensions of the drive:	1 = size 1		
Inverter, ADV200 series			

ADV200 - 4

ADV200-DC

ADV200 - 6

ADV100

ADV80

AFE200

PROGRAM.

APPENDIX

ADV200 - Standard Version

- Field-Orientated Vector Inverter
- "KB-ADV" Programming Keypad
- Power Supply 3 x 400VAC (-4) - 3 x 460VAC (-4A)
- HD = Heavy Duty (Overload 150%), LD = Light Duty (Overload 110%)

CODE	PRODUCT IDENTIFICATION	PN @ 400Vac (Asynchronous motors)		CONFIGURATION
		HD	LD	
S9001	ADV-1007-KBX-4	0.75kW	1.1kW	Integrated Braking - Integrated Filter - Integrated Choke
S9002	ADV-1015-KBX-4	1.5kW	2.2kW	Integrated Braking - Integrated Filter - Integrated Choke
S9003	ADV-1022-KBX-4	2.2kW	3kW	Integrated Braking - Integrated Filter - Integrated Choke
S9004	ADV-1030-KBX-4	3kW	4kW	Integrated Braking - Integrated Filter - Integrated Choke
S9005	ADV-1040-KBX-4	4kW	5.5kW	Integrated Braking - Integrated Filter - Integrated Choke
S9006	ADV-2055-KBX-4	5.5kW	7.5kW	Integrated Braking - Integrated Filter - Integrated Choke
S9007	ADV-2075-KBX-4	7.5kW	11kW	Integrated Braking - Integrated Filter - Integrated Choke
S9008	ADV-2110-KBX-4	11kW	15kW	Integrated Braking - Integrated Filter - Integrated Choke
S9009	ADV-3150-KBX-4	15kW	18.5kW	Integrated Braking - Integrated Filter - Integrated Choke
S9010	ADV-3185-KBX-4	18.5kW	22kW	Integrated Braking - Integrated Filter - Integrated Choke
S9011	ADV-3220-KBX-4	22kW	30kW	Integrated Braking - Integrated Filter - Integrated Choke
S9013	ADV-4300-KBX-4	30kW	37kW	Integrated Braking - Integrated Filter - Integrated Choke
S9015	ADV-4370-KBX-4	37kW	45kW	Integrated Braking - Integrated Filter - Integrated Choke
S9017	ADV-4450-KBX-4	45kW	55kW	Integrated Braking - Integrated Filter - Integrated Choke
S9019	ADV-5550-KBX-4	55kW	75kW	Integrated Braking - Integrated Filter - Integrated Choke
S9012	ADV-4300-KXX-4	30kW	37kW	Integrated Filter - Integrated Choke
S9014	ADV-4370-KXX-4	37kW	45kW	Integrated Filter - Integrated Choke
S9016	ADV-4450-KXX-4	45kW	55kW	Integrated Filter - Integrated Choke
S9018	ADV-5550-KXX-4	55kW	75kW	Integrated Filter - Integrated Choke
S9020	ADV-5750-KXX-4	75kW	90kW	Integrated Filter - Integrated Choke
S9021	ADV-5900-KXX-4	90kW	110kW	Integrated Filter - Integrated Choke
S9022	ADV-61100-KXX-4	110kW	132kW	Integrated Filter - Integrated Choke
S9023	ADV-61320-KXX-4	132kW	160kW	Integrated Filter - Integrated Choke
S9024	ADV-71600-KXX-4	160kW	200kW	Integrated Filter
S9025	ADV-72000-KXX-4	200kW	250kW	Integrated Filter
S9026	ADV-72500-KXX-4	250kW	315kW	Integrated Filter
S9027	ADV-73150-KXX-4	315kW	355kW	Integrated Filter (No UL Mark) - Fan power supply 400VAC / 50Hz.
S9028	ADV-73550-KXX-4	355kW	400kW	Integrated Filter (No UL Mark) - Fan power supply 400VAC / 50Hz.
S9029	ADV-73150-KXX-4A	315kW	355kW	Integrated Filter - Fan power supply 460VAC / 60Hz
S9030	ADV-73550-KXX-4A	355kW	400kW	Integrated Filter - Fan power supply 460VAC / 60Hz

ADV200 - Standard Version + SIL3 Safety Card

- Field-Orientated Vector Inverter
- "KB-ADV" Programming Keypad
- Power Supply 3 x 400VAC (-4) - 3 x 460VAC (-4A)
- HD = Heavy Duty (Overload 150%), LD = Light Duty (Overload 110%)

CODE	PRODUCT IDENTIFICATION	PN @ 400Vac (Asynchronous motors)		CONFIGURATION
		HD	LD	
S9001SI	ADV-1007-KBX-4+SI	0.75kW	1.1kW	Integrated Braking - Integrated Filter - Integrated Choke + Safety Card
S9002SI	ADV-1015-KBX-4+SI	1.5kW	2.2kW	Integrated Braking - Integrated Filter - Integrated Choke + Safety Card
S9003SI	ADV-1022-KBX-4+SI	2.2kW	3kW	Integrated Braking - Integrated Filter - Integrated Choke + Safety Card
S9004SI	ADV-1030-KBX-4+SI	3kW	4kW	Integrated Braking - Integrated Filter - Integrated Choke + Safety Card
S9005SI	ADV-1040-KBX-4+SI	4kW	5.5kW	Integrated Braking - Integrated Filter - Integrated Choke + Safety Card
S9006SI	ADV-2055-KBX-4+SI	5.5kW	7.5kW	Integrated Braking - Integrated Filter - Integrated Choke + Safety Card
S9007SI	ADV-2075-KBX-4+SI	7.5kW	11kW	Integrated Braking - Integrated Filter - Integrated Choke + Safety Card
S9008SI	ADV-2110-KBX-4+SI	11kW	15kW	Integrated Braking - Integrated Filter - Integrated Choke + Safety Card
S9009SI	ADV-3150-KBX-4+SI	15kW	18.5kW	Integrated Braking - Integrated Filter - Integrated Choke + Safety Card
S9010SI	ADV-3185-KBX-4+SI	18.5kW	22kW	Integrated Braking - Integrated Filter - Integrated Choke + Safety Card
S9011SI	ADV-3220-KBX-4+SI	22kW	30kW	Integrated Braking - Integrated Filter - Integrated Choke + Safety Card
S9013SI	ADV-4300-KBX-4+SI	30kW	37kW	Integrated Braking - Integrated Filter - Integrated Choke + Safety Card
S9015SI	ADV-4370-KBX-4+SI	37kW	45kW	Integrated Braking - Integrated Filter - Integrated Choke + Safety Card
S9017SI	ADV-4450-KBX-4+SI	45kW	55kW	Integrated Braking - Integrated Filter - Integrated Choke + Safety Card
S9019SI	ADV-5550-KBX-4+SI	55kW	75kW	Integrated Braking - Integrated Filter - Integrated Choke + Safety Card
S9012SI	ADV-4300-KXX-4+SI	30kW	37kW	Integrated Filter - Integrated Choke + Safety Card
S9014SI	ADV-4370-KXX-4+SI	37kW	45kW	Integrated Filter - Integrated Choke + Safety Card
S9016SI	ADV-4450-KXX-4+SI	45kW	55kW	Integrated Filter - Integrated Choke + Safety Card
S9018SI	ADV-5550-KXX-4+SI	55kW	75kW	Integrated Filter - Integrated Choke + Safety Card
S9020SI	ADV-5750-KXX-4+SI	75kW	90kW	Integrated Filter - Integrated Choke + Safety Card
S9021SI	ADV-5900-KXX-4+SI	90kW	110kW	Integrated Filter - Integrated Choke + Safety Card
S9022SI	ADV-61100-KXX-4+SI	110kW	132kW	Integrated Filter - Integrated Choke + Safety Card
S9023SI	ADV-61320-KXX-4+SI	132kW	160kW	Integrated Filter - Integrated Choke + Safety Card
S9024SI	ADV-71600-KXX-4+SI	160kW	200kW	Integrated Filter + Safety Card
S9025SI	ADV-72000-KXX-4+SI	200kW	250kW	Integrated Filter + Safety Card
S9026SI	ADV-72500-KXX-4+SI	250kW	315kW	Integrated Filter + Safety Card
S9027SI	ADV-73150-KXX-4+SI	315kW	355kW	Integrated Filter (No UL Mark) + Safety Card - Fan power supply 400Vac / 50Hz
S9028SI	ADV-73550-KXX-4+SI	355kW	400kW	Integrated Filter (No UL Mark) + Safety Card - Fan power supply 400Vac / 50Hz
S9029SI	ADV-73150-KXX-4A+SI	315kW	355kW	Integrated Filter + Safety Card - Power Supply 460 Vac Fan power supply 460Vac / 60Hz
S9030SI	ADV-73550-KXX-4A+SI	355kW	400kW	Integrated Filter + Safety Card - Power Supply 460 Vac Fan power supply 460Vac / 60Hz

ADV200 - Parallel Configurations + SIL3 Safety Card

- Field-Orientated Vector Inverter
- "KB-ADV" Programming Keypad
- Power Supply 3 x 400VAC (-4) - 3 x 460VAC (-4A)
- HD = Heavy Duty (Overload 150%), LD = Light Duty (Overload 110%)

CODE	PRODUCT IDENTIFICATION	PN @ 400Vac (Asynchronous motors)		CONFIGURATION
		HD	LD	
S9025M	ADV-72000-KXX-4-MS 04 -SI	400kW	500kW	Integrated EMC Filter + Integrated Safety Card
S9025S	ADV-72000-XXX-4-SL			
S9026M	ADV-72500-KXX-4-MS 05 -SI	500kW	630kW	Integrated EMC Filter + Integrated Safety Card
S9026S	ADV-72500-XXX-4-SL			
S9027M	ADV-73150-KXX-4-MS 06 -SI	630kW	710kW	Integrated EMC Filter - Integrated Safety Card (No UL Mark) Fan power supply 400Vac / 50Hz.
S9027S	ADV-73150-XXX-4-SL			
S9028M	ADV-73550-KXX-4-MS 07 -SI	710kW	800kW	Integrated EMC Filter - Integrated Safety Card (No UL Mark) Fan power supply 400Vac / 50Hz.
S9028S	ADV-73550-XXX-4-SL			
S9027M1	ADV-73150-KXX-4-MS 09 -SI	900kW	1MW	Integrated EMC Filter - Integrated Safety Card (No UL Mark) Fan power supply 400Vac / 50Hz.
S9027S	ADV-73150-XXX-4-SL			
S9027S	ADV-73150-XXX-4-SL			
S9028M1	ADV-73550-KXX-4-MS 10-SI	1MW	1.2MW	Integrated EMC Filter - Integrated Safety Card (No UL Mark) Fan power supply 400Vac / 50Hz.
S9028S	ADV-73550-XXX-4-SL			
S9028S	ADV-73550-XXX-4-SL			
S9029M	ADV-73150-KXX-4A-MS 06-SI	630kW	710kW	Integrated EMC Filter + Integrated Safety Card - Power Supply 460 Vac Fan power supply 460Vac / 50Hz.
S9029S	ADV-73150KXX-4A -SL			
S9030M	ADV-73550-KXX-4A- MS 07-SI	710kW	800kW	Integrated EMC Filter + Integrated Safety Card - Power Supply 460 Vac Fan power supply 460Vac / 60Hz.
S9030S	ADV-73550-KXX-4A- SL			
S9029M1	ADV-73150-KXX-4A-MS 09-SI	900kW	1MW	Integrated EMC Filter + Integrated Safety Card - Power Supply 460 Vac Fan power supply 460Vac / 60Hz.
S9029S	ADV-73150-KXX-4A -SL			
S9029S	ADV-73150-KXX-4A -SL			
S9030M1	ADV-73550-KXX-4A- MS 10-SI	1MW	1.2MW	Integrated EMC Filter + Integrated Safety Card - Power Supply 460 Vac Fan power supply 460Vac / 60Hz.
S9030S	ADV-73550-KXX-4A- SL			
S9030S	ADV-73550-KXX-4A- SL			

ADV200 - Version with external heatsink dissipator

- Field-Orientated Vector Inverter
- "KB-ADV" Programming Keypad
- Power Supply 3 x 400VAC
- HD = Heavy Duty (Overload 150%), LD = Light Duty (Overload 110%)

CODE	PRODUCT IDENTIFICATION	P _N @ 400Vac (Asynchronous motors)		CONFIGURATION
		HD	LD	
S9007H	ADV2075-KBX-4-EH	7,5kW	11kW	Integrated Braking - Integrated EMC Filter - Integrated Choke - (No UL Mark)
S9008H	ADV2110-KBX-4-EH	11kW	15kW	Integrated Braking - Integrated EMC Filter - Integrated Choke - (No UL Mark)
S9009H	ADV3150-KBX-4-EH	15kW	18,5kW	Integrated Braking - Integrated EMC Filter - Integrated Choke - (No UL Mark)
S9011H	ADV3220-KBX-4-EH	22kW	30kW	Integrated Braking - Integrated EMC Filter - Integrated Choke - (No UL Mark)
S9013H	ADV4300-KBX-4-EH	30kW	37kW	Integrated Braking - Integrated EMC Filter - Integrated Choke - (No UL Mark)
S9015H	ADV4370-KBX-4-EH	37kW	45kW	Integrated Braking - Integrated EMC Filter - Integrated Choke - (No UL Mark)
S9017H	ADV4450-KBX-4-EH	45kW	55kW	Integrated Braking - Integrated EMC Filter - Integrated Choke - (No UL Mark)
S9019H	ADV5550-KBX-4-EH	55kW	75kW	Integrated Braking - Integrated EMC Filter - Integrated Choke - (No UL Mark)
S9018H	ADV5550-KXX-4-EH	55kW	75kW	Integrated Filter - Integrated Choke - (No UL Mark)
S9020H	ADV5750-KXX-4-EH	75kW	90kW	Integrated Filter - Integrated Choke - (No UL Mark)
S9021H	ADV5900-KXX-4-EH	90kW	110kW	Integrated Filter - Integrated Choke - (No UL Mark)

2. ADV200-DC • DC bus power supply

2.1 Introduction



Flexible Modular Technology

The ADV200-DC is based on a fully modular hardware and power structures that can be installed side by side. Designed to facilitate installation and guarantee ease of use, project flexibility, optimisation of space and reduction of wiring costs.

- The ADV200-DC is available in various hardware sizes
- from 18.5kW to 355kW in the stand-alone configuration
 - from 400kW to 1.65MW in "parallel" configurations

Total ease of use

Designed with the user in mind. The mechanical structure guarantees simple and fast product management, regardless of installation and assembly conditions. All operations are simple and immediate, from accessing the extractable terminal strips to rack-mounting of options. The dedicated accessories guarantee simple wiring and cable shielding to achieve immediate, EMC-compliant start-ups.

For size 7 only, DC side fuses can be internally integrated on request

Serial line

The RS485 serial line is incorporated as standard across the range to enable peer-to-peer or multidrop connections using Modbus RTU protocol.

Management of optional cards

The ADV200-DC uses an intelligent rack system that allows up to 3 optional cards to be installed at the same time.

- Fieldbus interface card
- I/O expansion card
- Interface card for feedback with single or multiple encoders (up to 3).

Back-up power supply

The ADV200-DC is compatible with a separate +24VDC external power supply. This solution makes it possible to maintain all display and drive configuration functions and manage the connected fieldbuses in the event of a power failure.

ADV200-DC Vector Inverters are optimised for multi-drive or single-drive system configurations on a common DC Bus, supplied by conventional AC/DC power supply units or "Active Front End" regenerative units like the AFE200.

Power ratings range from **18.5kW to 1.65MW for three-phase external power supplies of 400 VAC...690 VAC.**

Factory-set to achieve the best technical and economic performance, compared to the basic version, the ADV200-DC range does not integrate the three-phase power supply input components:

- AC/DC input rectifier stage
- EMC filter
- choke on DC side

Safety Card

ADV200-DC+SI models integrate the **EXP-SFTy-ADV** Safety Card (standard in parallel master drives).

The card:

- performs the STO (Safe Torque Off) function, to prevent torque on the motor by blocking IGBT commands.
- can diagnose 99% of internal faults.
- meets the latest legal requirements with the integrated "Safe Torque Off" function:
 - safety integrity level SIL 3 according to EN 61508 and EN61800-5-2 (maximum available for drives)
 - PL d according to EN13849-1

The integrated **EXP-SFTy-ADV** safety card in the ADV200-DC+SI series of drives is used to achieve "Prevention of unexpected start-up", according to EN 1037:1995 + A1 ADV: 2008 on safety of machinery. Drives provided with the safety card are just one element in an STO safety control system, which is the system level function. All system parts and components must be chosen, applied and integrated correctly to achieve the required level of safety.

The safety function may be used to perform an "emergency stop" with the drive still connected to the power supply (stop category 0, according to EN 60204-1).

The integrated safety function replaces the external safety components. The integrated "STO" function may be used to replace the motor contactors for controlling unexpected start-ups, if covered by risk-assessment. The use of the integrated safety function depends on the type of application and applicable standards.

Ideal Sizing

The ADV200-DC offers a choice of technical features so that you can choose the drive that represents the best technical and most cost-effective solution depending on the type of application and characteristics of the motor.

- Two overload modes for "heavy duty" with duty cycle of 150% of In for 1 minute every 5 minutes or for "light duty" (variable and/or quadratic torque) with duty cycle of 110% of In for 1 minute every 5 minutes
- Optimisation of **modulation dynamics**, according to the type of "duty" and drive temperature during duty cycles.
- In addition to the control capabilities for asynchronous motors, the standard software also incorporates the control algorithm for closed-loop brushless motor control (FOC-CL = Field Oriented Control with feedback) and open-loop control without feedback (FOC-OL = Open Loop).

2.2 General Characteristics

→ Power supply:

- ADV200-4/4A-DC: **450...750Vcc**;
- ADV200-6/6A-DC: **840 ... 1120Vcc** (5750 ... 61320);
- ADV200-6/6A-DC: **600 ... 1120Vcc** (≥ 71600).

→ Power ratings: from 18.5kW to 1.65MW

→ Control mode:

- Open-loop vector control (Asynchronous and Synchronous)
- Vector control with feedback (Asynchronous and Synchronous)
- Open loop V/f and V/f with feedback (Asynchronous)

→ Light or heavy overload control

→ Integration of up to 3 options onboard the drive

→ "Safety" card compliant with machine safety directives (for ADV200-...+SI models)

→ GF-eXpress multi-language programming SW (5 languages)

→ PLC with advanced IEC61131-3 programming environment

→ IP20-rated protection (IPOO size 7 and parallel)

Fieldbus management



Performance

The ADV200-DC offers state-of-the-art control technology based on the use of a powerful 32-bit microprocessor able to guarantee maximum precision and performance of the motor as well as sophisticated management of the most advanced application systems.

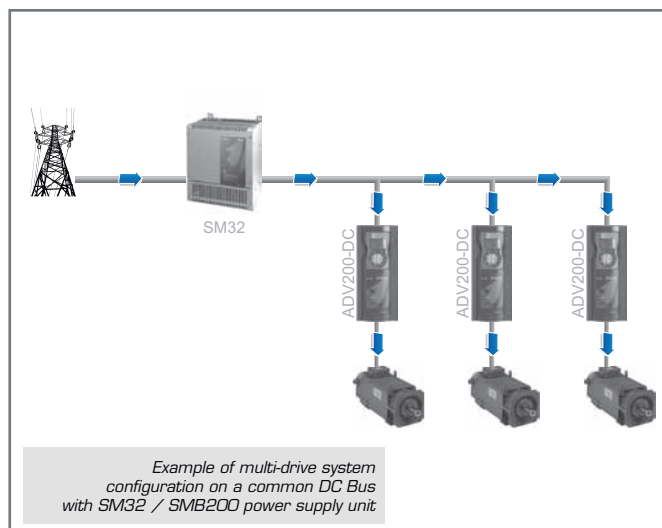

Precision

Control mode	Speed control precision (*)	Control range
Asynchronous		
FOC with feedback	$\pm 0.01\%$ motor speed rating	1 : 1000
Open-loop FOC	$\pm 30\%$ motor slip rating	1 : 100
V/F	$\pm 60\%$ motor slip rating	1 : 30
Synchronous		
FOC with feedback	$\pm 0.01\%$ motor speed rating	1 : 1500
Open-loop FOC	$\pm 0.1\%$ motor speed rating	1 : 20

(*) for standard 4-pole motor

Standard supply configuration

→ Integrated KB_ADV programming keypad

→ Regulation:

- 2 bipolar analog inputs (Voltage/Current)
- 2 bipolar analog outputs (1: Voltage/Current, 1: Voltage)
- 6 digital inputs (PNP/NPN)
- 2 digital outputs (PNP/NPN)
- 2 relay outputs, single contact
- RS485 serial line (Modbus RTU)

→ Reference resolution: Digital = 15-bit + sign
Analog input = 11-bit + sign
Analog output = 11-bit + sign

Conformity

→ Immunity/Emissions: EEC - EN 61800-3

→ Programming: according to IEC 61131-3

→ Safety standards: STO (Safe Torque Off): IEC 61508
SIL 3, EN 954-1 Cat. 3
EN 61508 and EN 61800-5-2

Environmental conditions

→ Ambient temperature: $-10^{\circ}\text{C} \dots +40^{\circ}\text{C}$ ($+14^{\circ}\text{F} \dots +104^{\circ}\text{F}$),
 $+40^{\circ}\text{C} \dots +50^{\circ}\text{C}$ ($+104^{\circ}\text{F} \dots +122^{\circ}\text{F}$)
with derating

→ Altitude: Max 2000 m. (up to 1000 m without derating)

Markings



Complies with the EEC directive concerning low voltage equipment



Complies with directives for the American and Canadian markets (sizes ADV200-4/4A-DC).

www.nicsanat.com
021-87700210



2.3 Standard connections

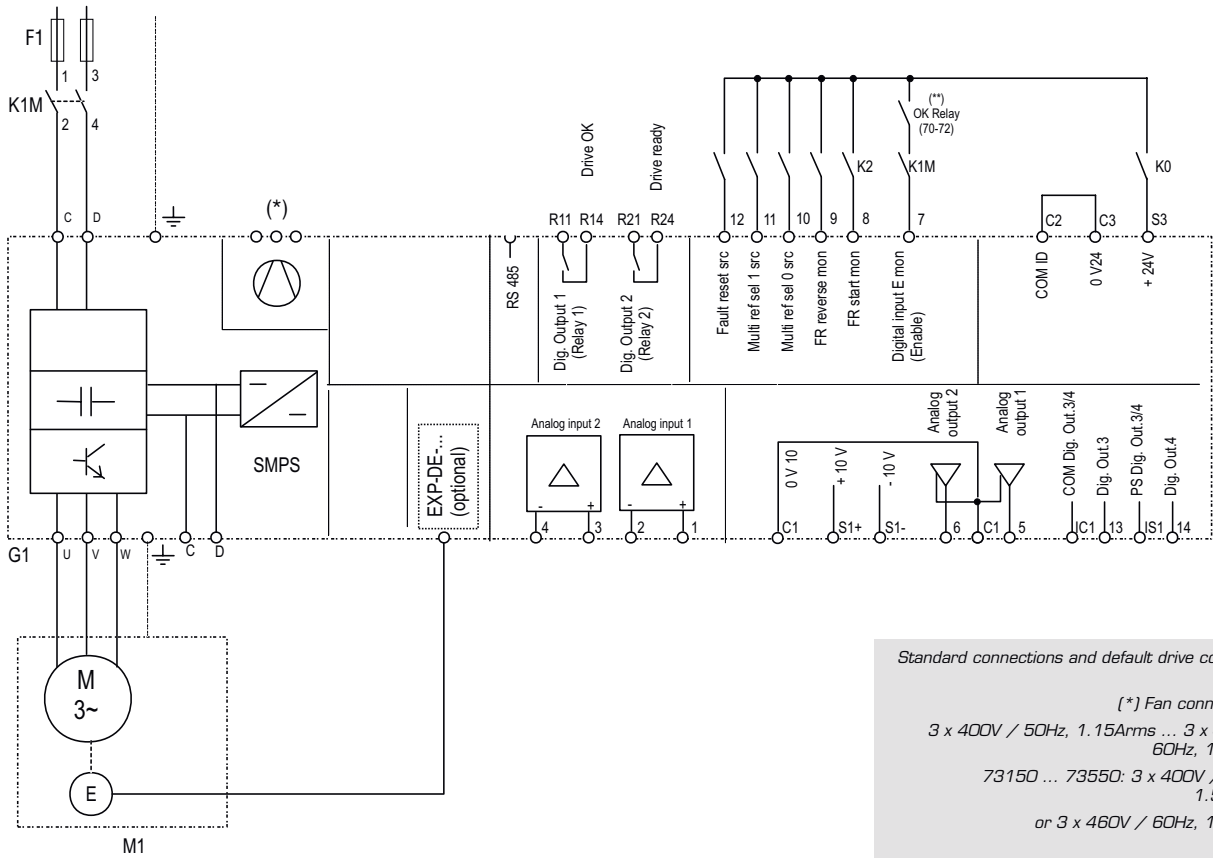

Standard connections and default drive configuration.

[*] Fan connections:

3 x 400V / 50Hz, 1.15Arms ... 3 x 460V / 60Hz, 1.4Arms

73150 ... 73550: 3 x 400V / 50Hz, 1.55Arms

or 3 x 460V / 60Hz, 1.7Arms

[**]: Only for sizes ≥ ADV71600.

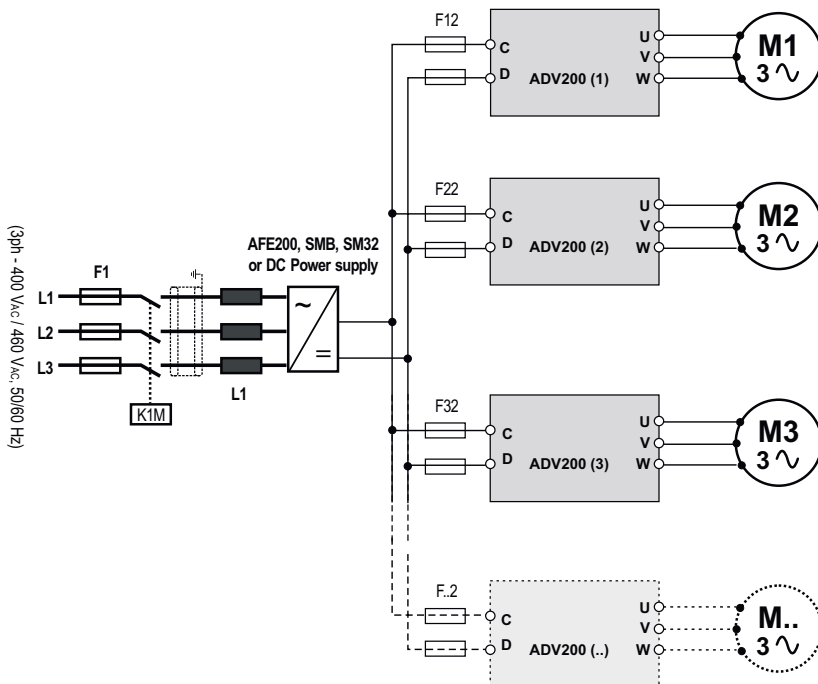

Connection of multi-drive on common DC bus with AC/DC power supply unit (with pre-load).

For size 7 only, Adaptation for internal mounting of "F...2-F..." fuses (DC side) on request

Caution: To avoid to damage the internal EMI filter, regenerative converters may not supply the DC power supply to standard ADV drives, version ADV...-DC or ADV...-IT must be used.

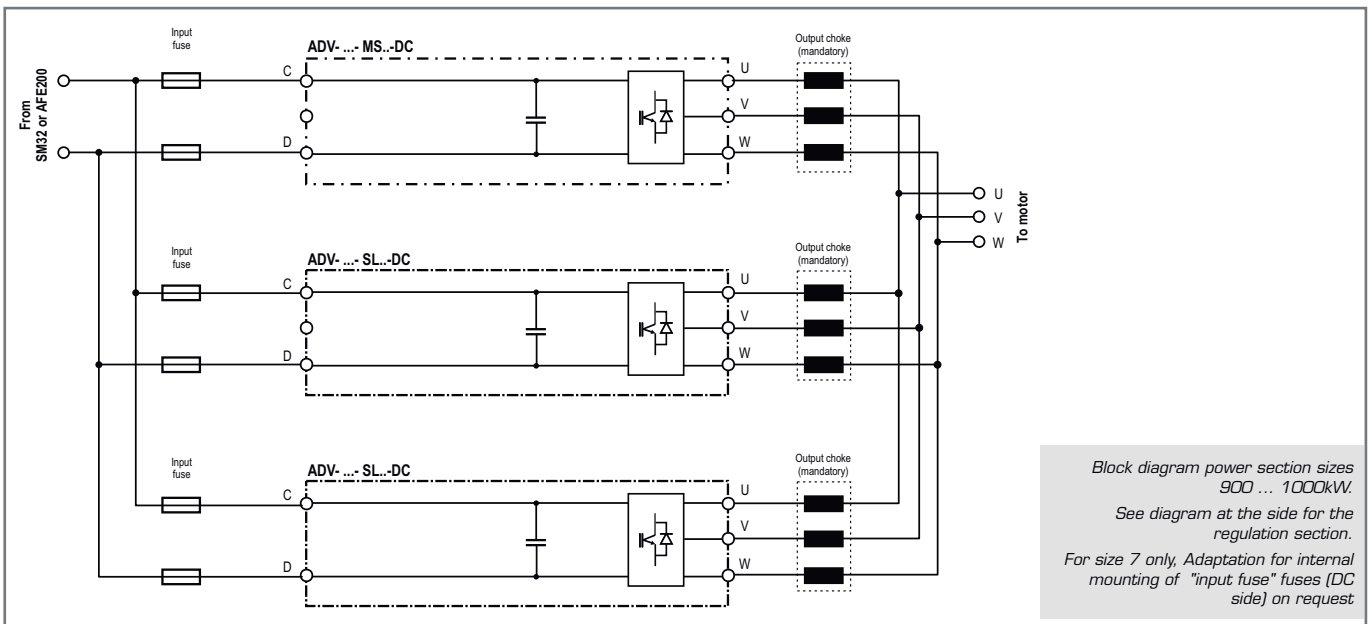
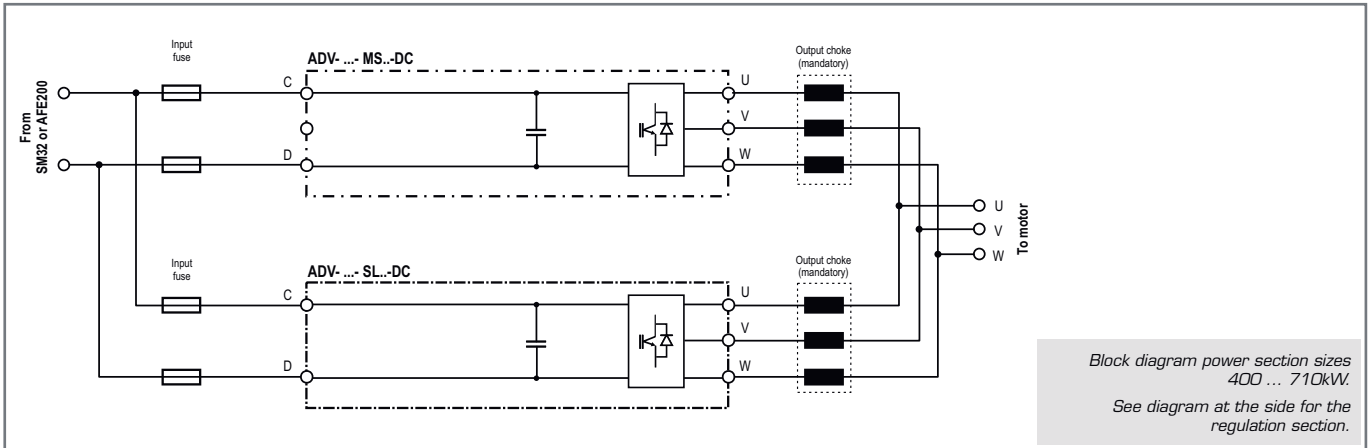

2.4 Weights and dimensions

Size 3

mm (inches)

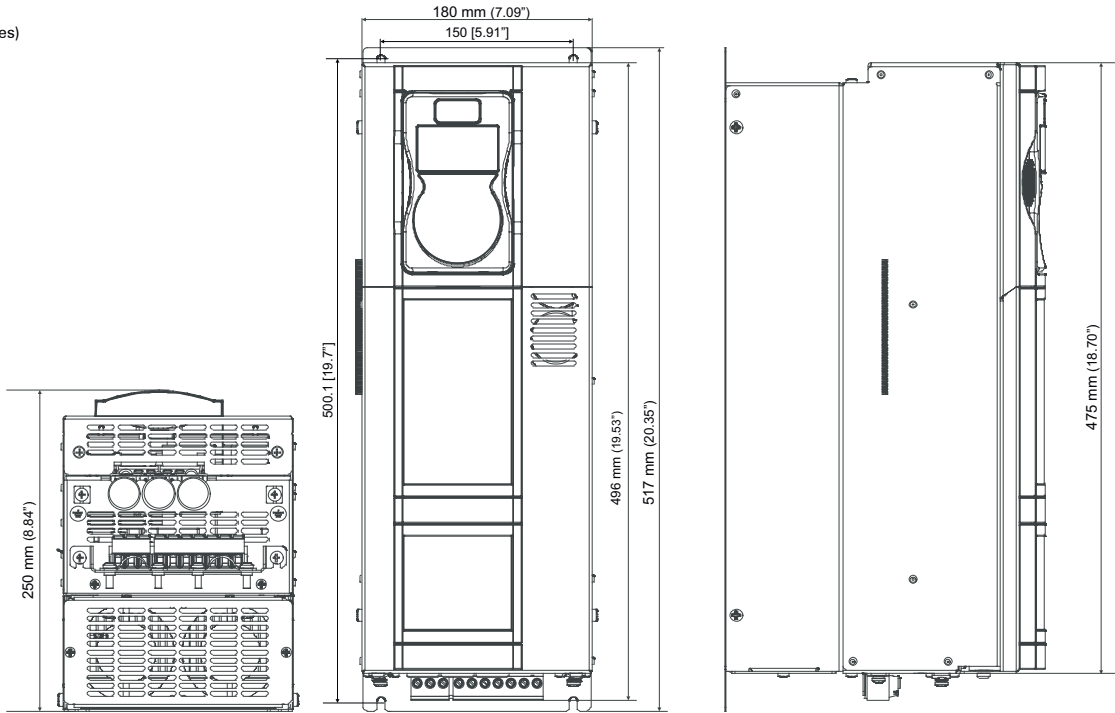

Size ADV200-DC	Dimensions: Width x Height x Depth		Weight	
	mm	inches	kg	lbs
3185	180 x 517 x 250.1	7.09 x 20.35 x 9.85	12	26,5
3220			18	39,7

Size 4

mm (inches)

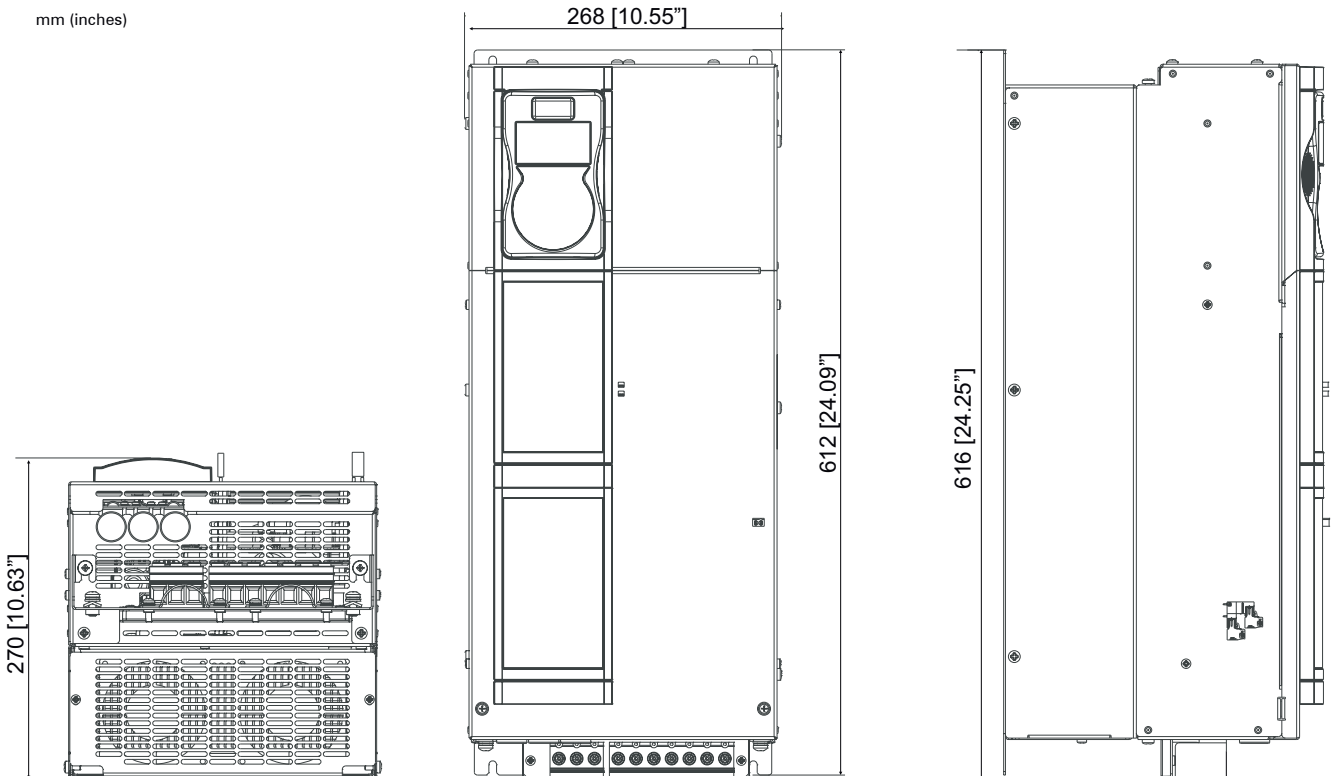

Size ADV200-DC	Dimensions: Width x Height x Depth		Weight	
	mm	inches	kg	lbs
4300...4450	268 x 616 x 270	10.55 x 24.25 x 10.63		

www.nicsanat.com
021-87700210



Size 5

mm (inches)

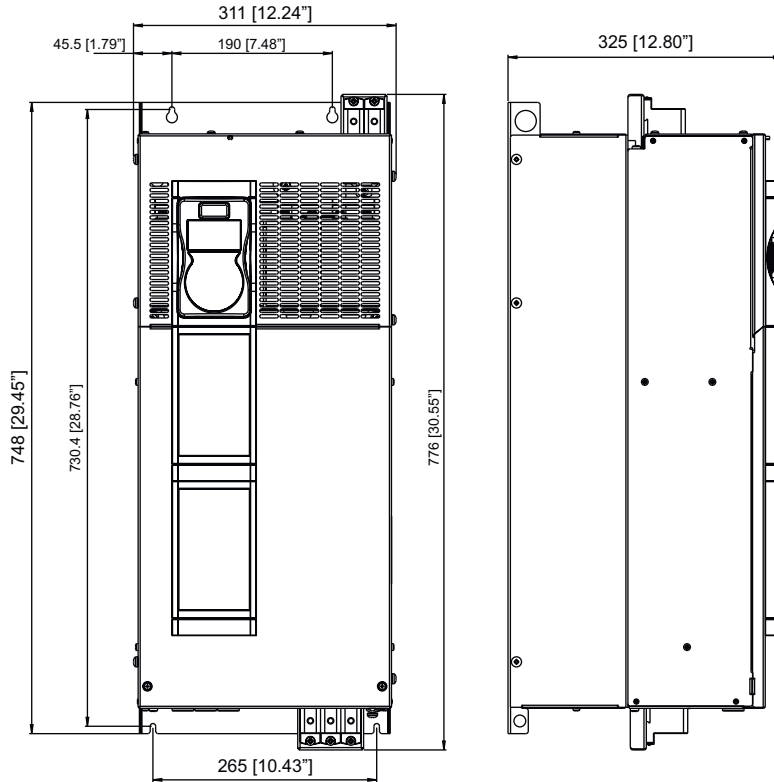

Size ADV200-DC

Dimensions: Width x Height x Depth

Weight

mm	inches
311 x 776 x 325	12.24 x 30.55 x 12.8

kg	lbs
40	88.2

5550 ... 5900

Size 61100

mm (inches)

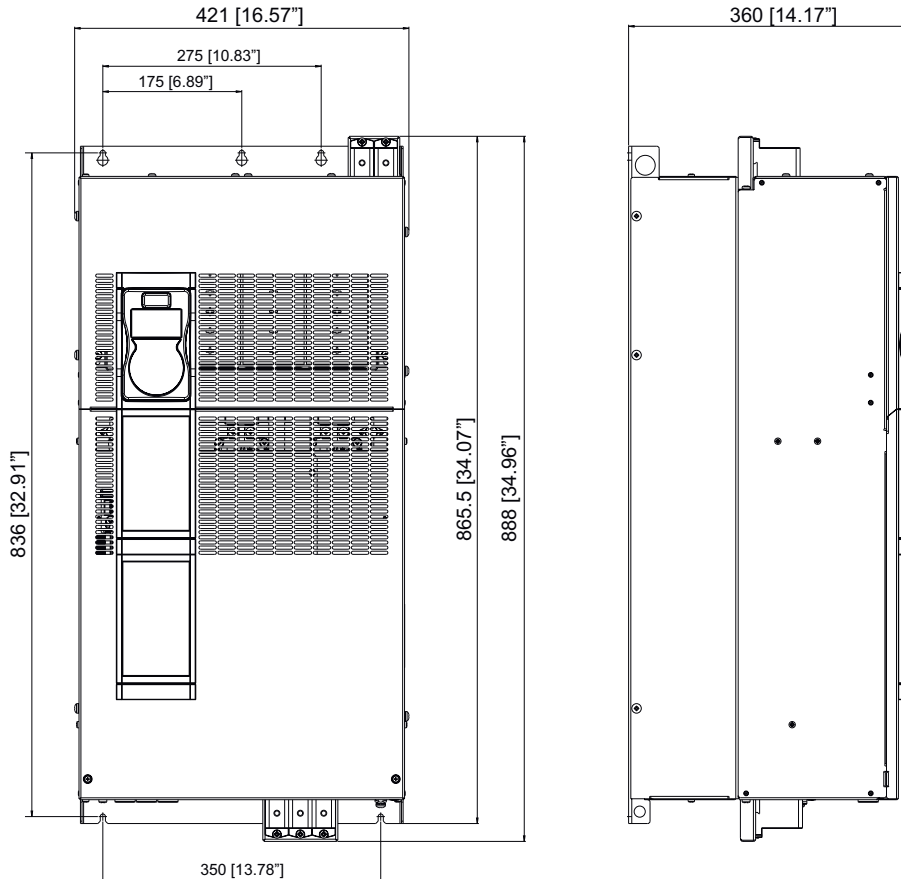

Size ADV200-DC

Dimensions: Width x Height x Depth

Weight

mm	inches
421 x 924.5 x 360	16.57 x 36.4 x 14.17

www.nicsanat.com
021-87700210



Size 61320

mm (inches)

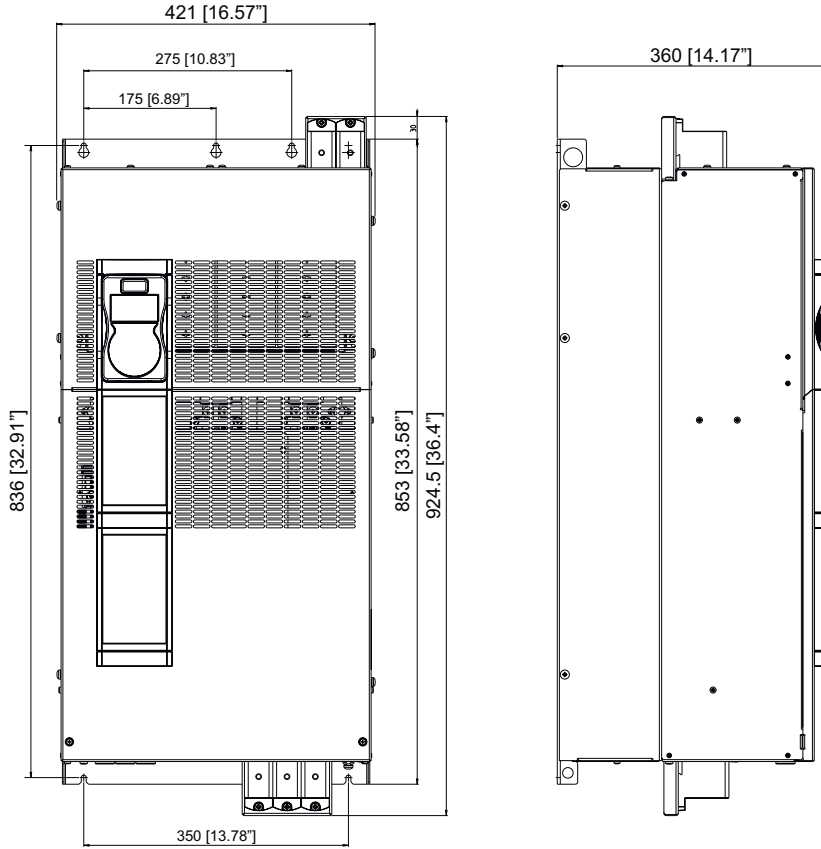

Size ADV200-DC	Dimensions: Width x Height x Depth		Weight	
	mm	inches	kg	lbs
61320	421 x 924.5 x 360	16.57 x 36.4 x 14.17	68	149.9

Size 7

mm (inches)

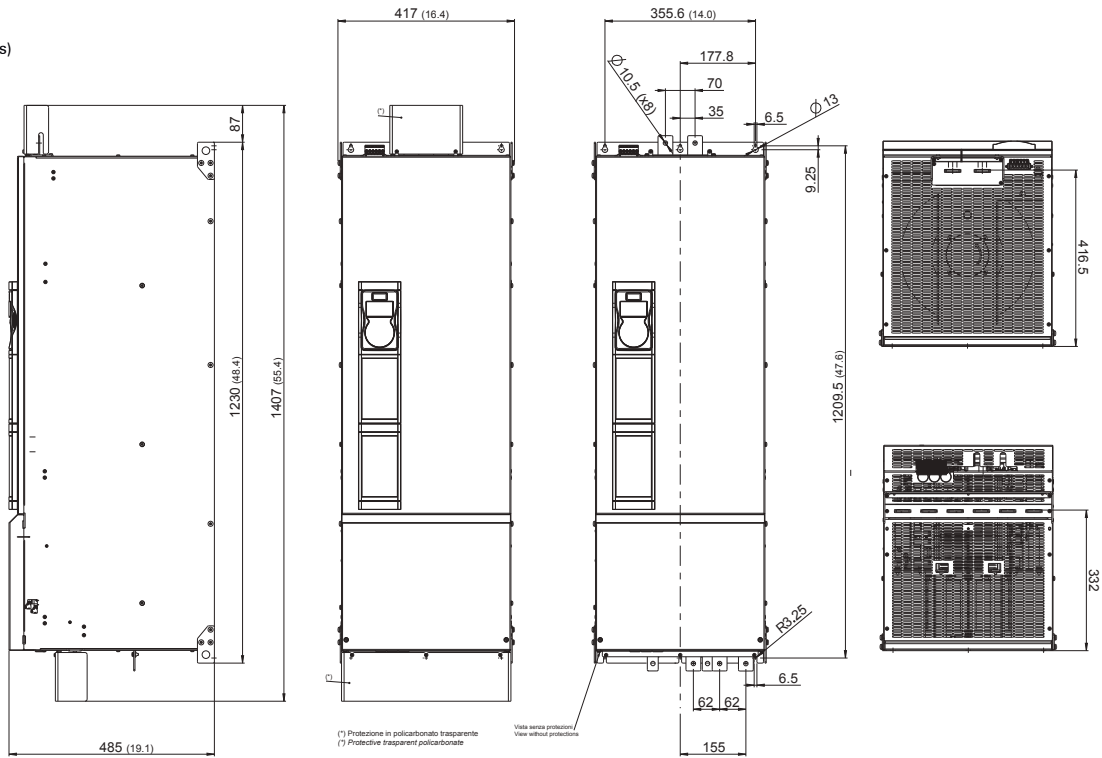

Sizes ADV200-DC	Dimensions: Width x Height x Depth		Weight (ADV200...-4-DC)		Weight (ADV200...-6-DC)	
	mm	inches	kg	lbs	kg	lbs
71600...72000	417 x 1407 x 485	16.42 x 55.4 x 19.1	120	267	135	298
72500			www.nicsanat.com		145	
73150 ... 73550			140	309	155	



Sizes 400 ... 710 kW

mm (inches)

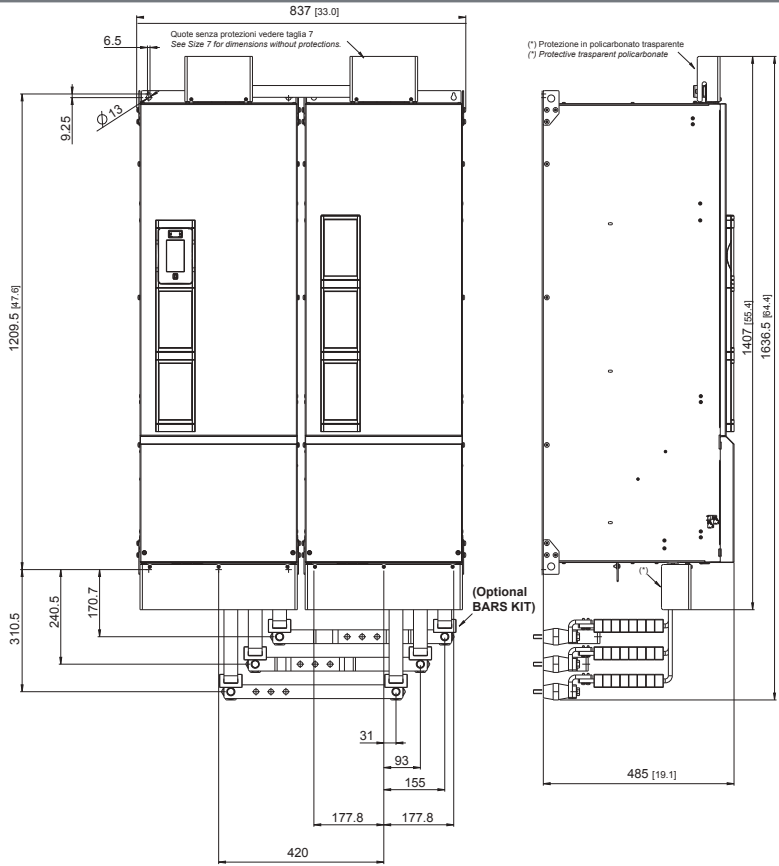

Sizes ADV200-DC	Dimensions: Width x Height x Depth		Weight (ADV200-...-4-DC)		Weight (ADV200-...-6-DC)	
	mm	inches	kg	lbs	kg	lbs
400kW	837 x 1407 x 485	33.0 x 55.4 x 19.1	240	529	270	595
500kW			260	573	290	639
630 - 710kW			420	926	310	683

Sizes 900 kW ...1 MW

mm (inches)

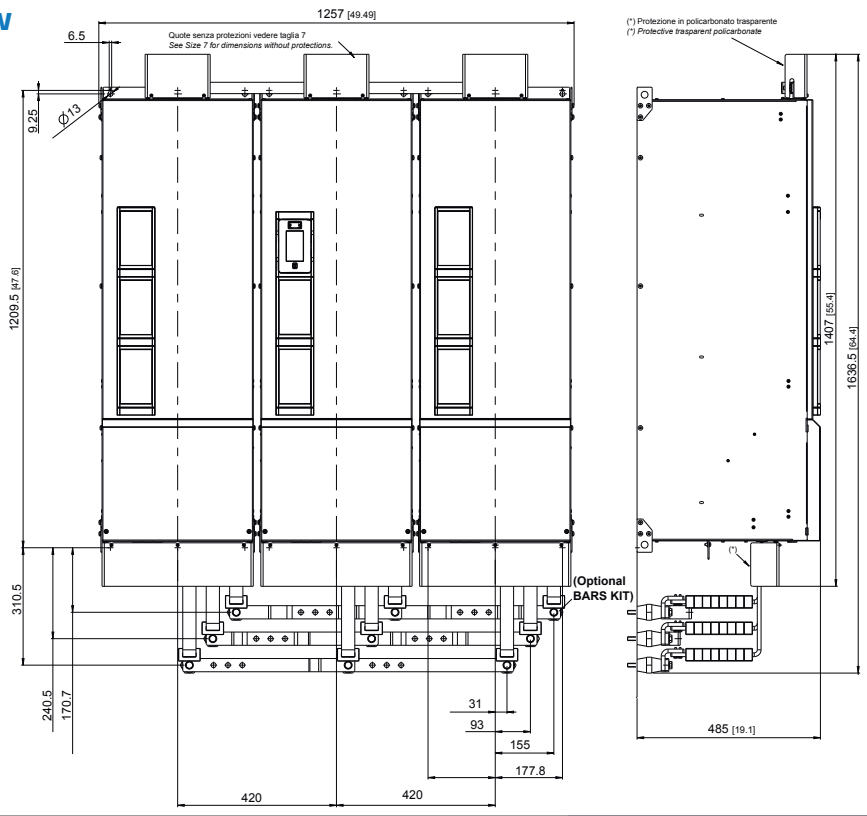

Size ADV200-DC	Dimensions: Width x Height x Depth		Weight (ADV200-...-4-DC)		Weight (ADV200-...-6-DC)	
	mm	inches	kg	lbs	kg	lbs
900 kW - 1 MW	1257 x 1407 x 485	49.5 x 55.4 x 19.1	420	926	465	1025

www.nicsanat.com
 021-87700210



2.5 Choosing the Inverter

The combinations of motor power ratings and inverters listed in the table envisage the use of motors in which the voltage rating is equal to that of the mains power.
For motors with different voltage ratings the inverter must be chosen according to the current rating of the motor. The combinations listed in the table thus show the current that can be delivered by the drive during continuous operation and overload conditions, according to the mains voltage.

The same engineering criteria apply for operations with additional derating factors:

- KV Power supply voltage
- KT Ambient temperature
- Kf Switching frequency
- KALT Altitude of installation

2.6 Input Data

Sizes ADV200-DC	Input voltage U _{dc}		Overvoltage threshold		Undervoltage threshold		DC input current (*)				DC-Link Capacity	
	-4/4A [Vdc]	-6/6A [Vdc]	(Overvoltage)		(Undervoltage)		Heavy Duty (150% overload)		Light Duty (110% overload)			
			-4/4A [Vdc]	-6/6A [Vdc]	-4/4A [Vdc]	-6/6A [Vdc]	-4/4A @ 540 [Vdc] [Arms]	-6/6A @ 930 [Vdc] [Arms]	-4/4A @ 540 [Vdc] [Arms]	-6/6A @ 930 [Vdc] [Arms]		
3185	450 ... 750 [Vdc]	-	820	-	380	-	39	-	48	-	1500	
3220		-		-		-	48	-	65	-	1500	
4300		-		-		-	65	-	80	-	2350	
4370		-		-		-	80	-	90	-	2800	
4450		-		-		-	90	-	125	-	3400	
5550		-		-		-	125	-	175	-	4700	
5750		-		-		-	175	-	210	-	5600	
5900		-		-		-	210	-	240	-	6800	
61100		-		-		-	240	-	290	-	11200	
61320		-		-		-	290	-	350	-	13600	
71600		600 ... 1120 [Vdc]		-		1192	676	370	211	430	257	16800
72000								430	262	510	322	16800
72500								510	322	710	405	25200
73150								710	412	780	468	25200
73550	780		468		850			514	25200			
400 kW	860		514		1020			637	2 x 16800			
500 kW	1020		653		1420			797	2 x 25200			
630 kW	1420		814		1560			925	2 x 25200			
710 kW	1560		926		1700			1032	2 x 25200			
900 kW	2130		1236		2610			1445	3 x 25200			
1 MW	2340	1445	2550	1542	3 x 25200							
1,35 MW	-	-	-	-	-	1684	-	1855	4 x 25200			
1,65 MW	-	-	-	-	-	-	2058	-	2254	5 x 25200		

(*) RMS input current in case of power from 6 impulse bridge.

2.7 Output Data

Sizes ADV200-DC	Inverter Output		Pn mot (Recommended asynchronous motor rating, fsw = default)						Maximum output voltage U2 [V]	Maximum output frequency f2		IGBT braking unit
	Heavy Duty @ 400V [kVA]	Light Duty @ 400V [kVA]	Heavy Duty (150% overload)			Light Duty (110% overload)				-4/4A [Hz]	-6/6A [Hz]	
			(1) [kW]	(2) [Hp]	(3) [kW]	(1) [kW]	(2) [Hp]	(3) [kW]				
3185	26,3	32	18,5	25	-	22	30	-	ADV200-...- 4/4A-DC: 0.98 x ULN	500 (6)	-	External optional (BUy series)
3220	32	43	22	30	-	30	40	-				
4300	43	52	30	40	-	37	50	-				
4370	52	60	37	50	-	45	60	-				
4450	60	73	45	60	-	55	75	-				
5550	73	104	55	75	-	75	100	-				
5750	104	125	75	100	75	90	125	-				
5900	125	145	90	125	90	110	150	-				
61100	145	173	110	150	110	132	175	-				
61320	173	208	132	175	132	160	200	-				
71600	208	267	160	200	160	200	250	200				
72000	267	319	200	250	200	250	300	250				
72500	319	409	250	300	250	315	400	315				
73150	409	450	315	400	315	355	450	355				
73550	450	506	355	450	355	400	500	400				
400 kW	506	603	400	500	400	500	650	500				
500 kW	603	776	500	650	500	630	850	630				
630 kW	776	852	630	850	630	710	950	710				
710 kW	852	956	710	950	710	800	1100	800				
900 kW	1108	1247	900	1200	900	1000	1300	1000				
1 MW	1247	1420	1000	1300	1000	1200	1600	1150				
1.35 MW	-	-	-	-	1350	-	-	1500				
1.65 MW	-	-	-	-	1650	-	-	18000				

(1) ADV200-...-4/4A-DC = @400 Vca; (2) ADV200-...-4/4A-DC = @460 Vca; (3) ADV200-...-6/6A-DC = @690 Vca. (6) See page 40 for details.

Sizes ADV200-DC	Rated output current In (fsw = default)															
	Heavy Duty				Light Duty (110% overload)				Light Duty (110% overload)				Light Duty (110% overload)			
	150% overload (For Asynchronous motors)				160% overload (For Synchronous motors)				For Asynchronous motors				For Synchronous motors			
	@540 Vdc (-4/4A) [A]	@650 Vdc (-4/4A) [A]	@930 Vdc (-6/6A) [A]	@1120Vdc (-6/6A) [A]	@540 Vdc (-4/4A) [A]	@650 Vdc (-4/4A) [A]	@930 Vdc (-6/6A) [A]	@1120Vdc (-6/6A) [A]	@540 Vdc (-4/4A) [A]	@650 Vdc (-4/4A) [A]	@930 Vdc (-6/6A) [A]	@1120Vdc (-6/6A) [A]	@540 Vdc (-4/4A) [A]	@650 Vdc (-4/4A) [A]	@930 Vdc (-6/6A) [A]	@1120Vdc (-6/6A) [A]
3185	38	34.2	-	-	34	30.6	-	-	46	41.4	-	-	41	36.9	-	-
3220	46	41.4	-	-	41	36.9	-	-	62	55.8	-	-	56	50.4	-	-
4300	62	55.8	-	-	56	50.4	-	-	75	67.5	-	-	68	61.2	-	-
4370	75	67.5	-	-	68	61.2	-	-	87	78.3	-	-	78	70.2	-	-
4450	87	78	-	-	78	70.2	-	-	105	94.5	-	-	95	85.5	-	-
5550	105	94.5	-	-	95	85.5	-	-	150	135	-	-	135	121.5	-	-
5750	150	135	-	-	135	122	-	-	180	162	-	-	162	146	-	-
5900	180	162	-	-	162	146	-	-	210	189	-	-	189	170	-	-
61100	210	189	-	-	189	170	-	-	250	225	-	-	225	203	-	-
61320	250	225	-	-	225	203	-	-	300	270	-	-	270	243	-	-
71600	300	270	170	148 (6)	270	243	153	182 (6)	385	347	210	133	347	312	189	164
72000	385	347	210	210	347	312	189	265	460	414	265	189	414	373	238	238
72500	460	414	265	233	414	373	238	290	590	531	330	209	521	469	297	261
73150	590	531	330	291	521	469	297	330	650	585	375	261	585	527	337	296
73550	650	585	375 (5)	330 (5)	585	527	337	260 (5)	730	657	415 (5)	296	657	591	373	328
400 kW	730	657	400	400	657	591	360	500	870	783	500	360	783	705	450	450
500 kW	870	783	500	440	783	705	450	554	1120	1008	630	396	1008	907	567	499
630 kW	1120	1008	630	554	1008	907	567	625	1230	1107	710	499	1107	996	639	562
710 kW	1230	1107	710 (5)	625 (5)	1107	996	639	695 (5)	1380	1242	790 (5)	562	1242	1118	711	625
900 kW	1600	1440	900	792	1440	1296	810	880	1800	1620	1000	712	1620	1458	900	792
1 MW	1800	1620	1000 (5)	880 (5)	1620	1458	900	1012 (5)	2050	1845	1150 (5)	792	1845	1661	1035	911
1.35 MW	-	-	1300 (3)	1144 (3)	-	-	1170 (3)	1276	-	-	1450	1029	-	-	1305	1148
1.65 MW	-	-	1600	1408	-	-	1440	1557	-	-	1770	1267	-	-	1593	1402

(1) Kv : Derating factor for DC-link voltage at 650 Vdc
 (2) Kt : Derating factor with an ambient temperature of 50°C (1% every °C over 40°C with HD and 2% every °C over 40°C with LD)
 (3) Kf : Derating factor for higher switching frequency
 (4) Kalt : Derating factor with an ambient temperature of 50°C (1% every °C over 40°C with HD and 2% every °C over 40°C with LD). Value to be applied = 1.2% each 100 m increase above 1000 m. For example: Altitude 2000 m, Kalt = 1.2% * 10 = 12% derating; In derated = (100 - 12) % = 88 % In

(5) Current values with an ambient temperature of 35°C.
 (6) If F switching = 2KHz, see column @930Vdc.
 Note "@1120Vdc" column:
 Derating value applied only at Ambient Temperature > 30°C (If Ambient Temperature <= 30°C please select data in column @930Vdc)

www.nicsanaf.com
021-87700210



ADV200 - 4
ADV200-DC
ADV200 - 6
ADV100
ADV80
AFE200
PROGRAM.
APPENDIX

Sizes ADV200-DC-4/4A	Switching frequency fsw		Reduction factor								
	Default	Higher	Kv (1) from AFE200	Kt (2)	KALT % (3)	Kf (4)					
						2 kHz	4 kHz	6 kHz	8 kHz	10 kHz	12 kHz
3185 ... 4370	4 kHz	6, 8, 10, 12 kHz	Tamb ≤ 30°C = 0.9 Tamb 31 ... 40°C = 0.81	HD=0.9 LD=0.8	1.2	1	1	0.85	0.7	0.6	0.5
4450 ... 61320	4 kHz	6, 8 kHz				1	1	0.85	0.7	0	0
71600 ... 72000	4 kHz	-				1	1	0	0	0	0
72500 ... 73150	2 kHz	72500=4 kHz ≥73150= -				1	0	0	0	0	0
400 kW	4 kHz (10)	-				1	0	0	0	0	0
500 kW	2 kHz	4 kHz (5)				1	0	0	0	0	0
400 kW ... 1 MW	2 kHz	-	1	0	0	0	0	0			

- (1) Kv : Derating factor for DC-link voltage at 650 Vdc
- (2) Kt : Derating factor with an ambient temperature of 50°C (1% every °C over 40°C with HD and 2% every °C over 40°C with LD)
- (3) KALT : Derating factor for installation at altitudes above 1000 meters a.s.l. (up to a maximum of 2000 m). Value to be applied = 1.2% each 100 m increase above 1000 m. For example: Altitude 2000 m, Kalt = 1.2% * 10 = 12% derating; In derated = (100 - 12) % = 88 % In
- (4) Kf : Derating factor for higher switching frequency
- (10) From fw 6.03

Sizes ADV200-DC-6/6A	Switching frequency fsw		Reduction factor			
	Maximum (default)	Minimum	Kv (5)		Kt (6)	KALT % (7)
			Tamb ≤ 30°C	Tamb 31 ... 40°C		
71600	2 kHz / 4 kHz (9)	2 kHz	1	0.87 (8)	HD=0,9 (0,85 for sizes 73550, 710kW and 1000kW)	1,2
72000	2 kHz / 4 kHz (9)	2 kHz	1	1		
72500 ... 73550	2 kHz	2 kHz	1	0.88		
400 kW	2 kHz	2 kHz	1	1		
500 kW ... 1,65 MW	2 kHz	2 kHz	1	0.88	LD=0,8	

- (5) Kv: Derating factor for DC power supply from AFE200 (1120 Vdc), only applied with ambient temperatures of more than 30°C.
- (6) Kf: Derating factor with an ambient temperature of 50°C (1% every °C over 40°C with HD and 2% every °C over 40°C with LD), >35°C for sizes 73550, 710 kW and ≥ 1 MW.
- (7) KALT: Derating factor for installation at altitudes above 1000 meters a.s.l. Value to be applied = 1.2% each 100 m increase above 1000 m (up to a maximum of 2000 m). If the ambient temperature is ≤ 30°C and the application provides for the use of Kv derating, Kalt derating can be avoided. E.g.: Altitude 2000 m, Kalt = 1.2% * 10 = 12% derating; In derated = (100 - 12) % = 88 % In.
- (8) Kv = 1, with fixed switching frequency set to 2 kHz (default = 4 kHz).
- (9) 4 kHz in "variable frequency" mode (PAR 658 Switch freq. mode = 1).

Sizes ADV200-DC 4/4A	Asynchronous motor control													
	Overload			Derating according to switching frequency (HD)						Overload according to output frequency				
	HD 150 % x In (1' every 5')	HD 180 % x In (for 0.5'')	LD 110 % x In (1' every 5')	2 kHz	4 kHz	6 kHz	8 kHz	10 kHz	12 kHz	Heavy Duty			Light Duty	
	[A]	[A]	[A]	[A]	[A]	[A]	[A]	[A]	[A]	K1 HD [%]	K2 HD [Hz]	K3 HD [Hz]	K1 LD [%]	K2 LD [Hz]
3185	57	68.4	50.6	38	38	32.3	26.6	22.8	19	100	5	8	85	5
3220	69	82.8	68.2	46	46	39.1	32.2	27.6	23	100	3	4.8	80	5
4300	93	111.6	82.5	62	62	52.7	43.4	37.2	31	100	3	4.8	80	3
4370	113	135	95.7	75	75	63.8	52.5	45	37.5	100	3	4.8	80	3
4450	131	157	116	87	87	74	60.9	n.a.	n.a.	100	3	4.8	80	3
5550	157	189	165	105	105	89	74	n.a.	n.a.	100	3	4.8	85	5
5750	225	270	198	150	150	128	105	n.a.	n.a.	100	5	8	85	5
5900	270	324	231	180	180	153	126	n.a.	n.a.	100	5	8	85	5
61100	315	378	275	210	210	179	147	n.a.	n.a.	100	3	4.8	100	3
61320	375	540	330	250	250	213	175	n.a.	n.a.	100	3	4.8	100	3
71600	450	540	424	300	300	n.a.	n.a.	n.a.	n.a.	100	3	4.8	80	3
72000	578	693	506	385	385	n.a.	n.a.	n.a.	n.a.	100	3	4.8	100	3
72500	690	828	649	460	391	n.a.	n.a.	n.a.	n.a.	100	3	4.8	75	5
73150	885	1062	715	590	n.a.	n.a.	n.a.	n.a.	n.a.	100	3	4.8	100	3
73550	975	1170	803	650	n.a.	n.a.	n.a.	n.a.	n.a.	90	5	7.5	90	5
400 kW	1095	1314	957	730	730	n.a.	n.a.	n.a.	n.a.	100	3	4.8	100	3
500 kW	1305	1566	1232	870	739	n.a.	n.a.	n.a.	n.a.	100	3	4.8	75	5
630 kW	1680	2016	1353	1120	n.a.	n.a.	n.a.	n.a.	n.a.	100	3	4.8	100	3
710 kW	1845	2214	1518	1230	n.a.	n.a.	n.a.	n.a.	n.a.	90	5	7.5	90	5
900 kW	2400	2880	1980	1600	n.a.	n.a.	n.a.	n.a.	n.a.	100	3	4.8	100	3
1 MW	2700	3240	2255	1900	n.a.	n.a.	n.a.	n.a.	n.a.	90	5	7.5	90	5

- In Light Duty mode the switching frequency is fixed at 4 kHz, and no derating factor is applied.
- f, in the Heavy Duty mode, the factory setting of Mod freq commutaz, (Switch freq. mode) PAR: 568 is changed from 0=Fixed to 1=Variable, the switching frequency and temperature derating factor sink and the output frequency. For further information see the ADV200 Functions and Parameters manual, menu 4.9.

www.nicsanat.com
021-87700210



Overload according to output frequency (Asynchronous motor control)

Overload HD (ADV200-...-DC-4/4A)

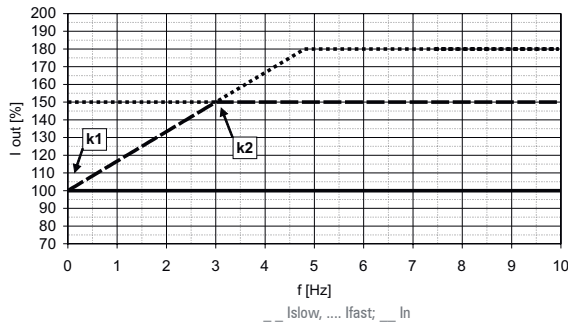

Overload LD (ADV200-...-DC-4/4A)

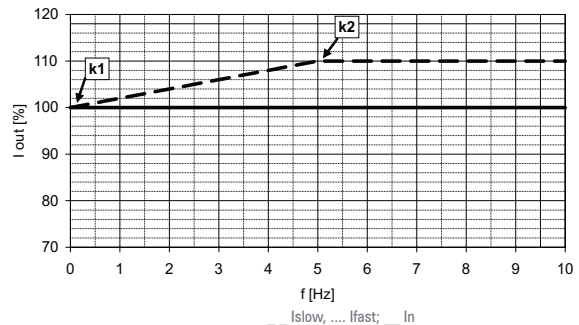

Overload HD (ADV200-...-DC-6/6A)

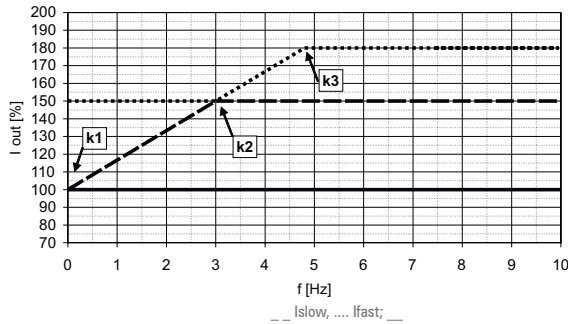

Overload LD (ADV200-...-DC-6/6A)

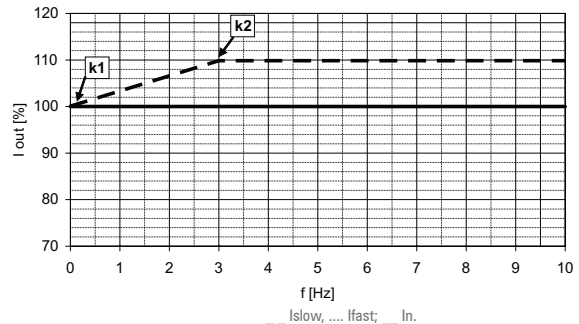

Sizes ADV200-DC 4/4A	Synchronous motor control													
	Overload			Derating according to switching frequency (HD)						Overload according to output frequency				
	HD 160 % x I _n (1' every 5')	HD 200 % x I _n (for 3'')	LD 110 % x I _n (1' every 5')	2 kHz	4 kHz	6 kHz	8 kHz	10 kHz	12 kHz	Heavy Duty			Light Duty	
	[A]	[A]	[A]	[A]	[A]	[A]	[A]	[A]	[A]	K1 HD [%]	K2 HD [Hz]	K3 HD [Hz]	K1 LD [%]	K2 LD [Hz]
3185	54.4	68	50.6	34	34	28.9	23.8	20.4	17	100	5	8.3	85	5
3220	65.6	82	68.2	41	41	34.9	28.7	24.6	20.5	100	3	5	80	5
4300	89.6	112	82.5	56	56	47.6	39.2	33.6	28	100	3	5	80	3
4370	108.8	136	95.7	68	68	57.8	47.6	40.8	34	100	3	5	80	3
4450	124.8	156	115.5	78	78	66.3	54.6	n.a.	n.a.	100	3	5	80	3
5550	152	190	165	95	95	80.8	66.5	n.a.	n.a.	100	3	5	85	5
5750	216	270	198	135	135	114.8	94.5	n.a.	n.a.	100	5	8.3	85	5
5900	259.2	324	231	162	162	137.7	113.4	n.a.	n.a.	100	5	8.3	85	5
61100	302.4	378	275	189	189	160.7	132.3	n.a.	n.a.	100	3	5	100	3
61320	360	450	330	225	225	191.3	157.5	n.a.	n.a.	100	3	5	100	3
71600	432	540	423.5	270	270	n.a.	n.a.	n.a.	n.a.	100	3	5	80	3
72000	555.2	694	506	347	347	n.a.	n.a.	n.a.	n.a.	100	3	5	100	3
72500	662.4	828	649	414	351.9	n.a.	n.a.	n.a.	n.a.	100	3	5	75	5
73150	833.6	1042	715	521	n.a.	n.a.	n.a.	n.a.	n.a.	100	3	5	100	3
73550	936	1170	803	585	n.a.	n.a.	n.a.	n.a.	n.a.	90	5	7.9	90	5
400 kW	1051.2	1314	957	657	657 (1)	n.a.	n.a.	n.a.	n.a.	100	3	5	100	3
500 kW	1252.8	1566	1232	783	665.6 (1)	n.a.	n.a.	n.a.	n.a.	100	3	5	75	5
630 kW	1612.8	2016	1353	1008	n.a.	n.a.	n.a.	n.a.	n.a.	100	3	5	100	3
710 kW	1771.2	2214	1518	1107	n.a.	n.a.	n.a.	n.a.	n.a.	90	5	7.9	90	5
900 kW	2304	2880	1980	1440	n.a.	n.a.	n.a.	n.a.	n.a.	100	3	5	100	3
1 MW	2592	3240	2255	1620	n.a.	n.a.	n.a.	n.a.	n.a.	90	5	7.9	90	5

(1) from fw 6.03.



Overload according to output frequency (Synchronous motor control)

Overload HD (ADV200-...-DC-4/4A)

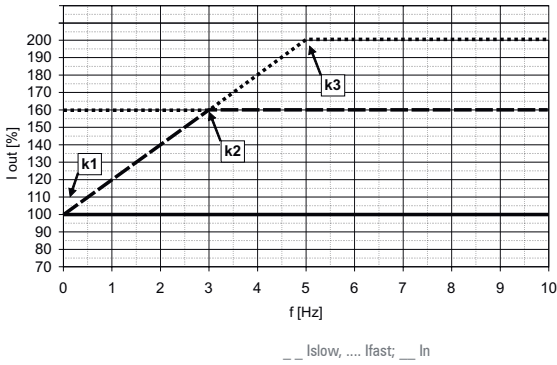

Overload LD (ADV200-...-DC-4/4A)

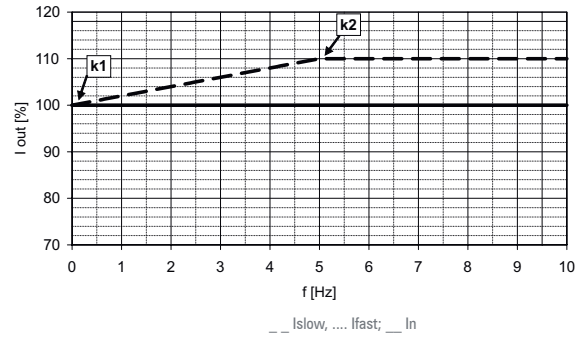

Overload HD (ADV200-...-DC-6/6A)

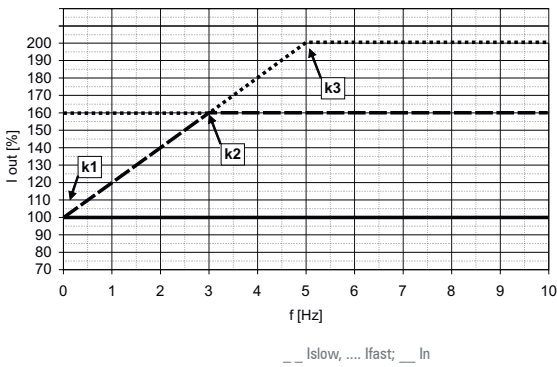

Overload LD (ADV200-...-DC-6/6A)

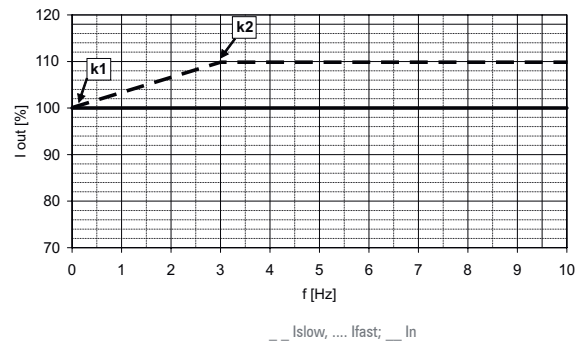

Output frequency f2

Sizes ADV200-...-DC	Maximum frequency			Minimum frequency		
	FVCL	FVOL	VF	FVCL	FVOL	VF
1007 ... 72000	300 Hz	150 Hz	500 Hz	0 Hz	0.5 Hz	1 Hz
72500 ... 1 MW	200 Hz	150 Hz	200 Hz			

(*) For Brushless motors:
MAX: FVCL/ FVOL = 280 Hz, min: 10% of rated frequency

2.8 Cooling

All inverters include internal fans.

Size	Dissipated power		Fan capacity		
	(-4/4A) [W]	(-6/6A)	Dissipator [m ³ /h]	Internal [m ³ /h]	
ADV-3185	460	-	80 x 2	32	
ADV-3220	600	-	80 x 2	32	
ADV-4300	900	-	2 x 250	2 x 50	
ADV-4370	1000	-	2 x 250	2 x 50	
ADV-4450	1290	-	2 x 250	2 x 50	
ADV-5550	1760	-	2 x 285	1 x 170	
ADV-5750	2150	-	2 x 355	2 x 170	
ADV-5900	2400	-	2 x 355	2 x 170	
ADV-61100	2850	-	3 x 310	2 x 170	
ADV-61320	3600	-	3 x 310	2 x 170	
ADV-71600	3900	3800	1500	-	
ADV-72000	4000	4200	1500	-	
ADV-72500	5200	4500	1500	-	
ADV-73150	6000	5200	2000	-	
ADV-73550	6500	5700	2000	-	
400 kW	ADV-72000-KXX-4-MS 04-DC	4000	4200	1500	-
	ADV-72000-XXX-4-SL-DC	4000	4200	1500	-
500 kW	ADV-72500-KXX-4-MS 05-DC	5200	4500	1500	-
	ADV-72500-XXX-4-SL-DC	5200	4500	1500	-
630 kW	ADV-73150-KXX-4-MS 06-DC	6000	5200	2000	-
	ADV-73150-XXX-4-SL-DC	6000	5200	2000	-
710 kW	ADV-73150-KXX-4-MS 07-DC	6500	5700	2000	-
	ADV-73150-XXX-4-SL-DC	6500	5700	2000	-
900 kW	ADV-73150-KXX-4-MS 09-DC	6000	5700	2000	-
	ADV-73150-XXX-4-SL-DC-DC	6000	5700	2000	-
	ADV-73150-XXX-4-SL-DC-DC	6000	5700	2000	-
1 MW	ADV-73150-KXX-4-MS 10-DC	6500	5700	2000	-
	ADV-73150-XXX-4-SL-DC	6500	5700	2000	-
	ADV-73150-XXX-4-SL-DC	6500	5700	2000	-

ADV200 - 4

ADV200-DC

ADV200 - 6

ADV100

ADV80

AFE200

PROGRAM.

APPENDIX

2.9 Order codes

Product identification

ADV - X XXX - X X X - Y - XX YY -DC - SI

EXP-SFTy-ADV safety card	SI = included	[empty] = not included
DC link power supply versions		
Only for parallel versions:	XX :	YY : Inverter power in kW
	MS = MASTER	04 = 400.0 kW
	SL = SLAVE with	05 = 500.0 kW
	MS/SL cable 1m	06 = 630.0 kW
	length	07 = 710.0 kW
	SL2 = SLAVE with	09 = 900.0 kW
	MS/SL cable 2m	10 = 1 MW
	length	14 = 1.35 MW
		17 = 1.65 MW
Rated voltage from external power supply (factory setting):	4 = 400 V _{AC} / 50 Hz 6 = 690 V _{AC} / 50 Hz	4A = 460 V _{AC} / 60 Hz 6A = 690 V _{AC} / 60Hz,
Software:	X = standard	
Braking unit:	X = not included	B = included
Keypad:	X = not included	K = included
Inverter power in kW:	185 = 18.5 kW 220 = 22.0 kW 300 = 30.0 kW 370 = 37.0 kW 450 = 45.0 kW 550 = 55.0 kW 750 = 75.0 kW	900 = 90.0 kW 1100 = 110.0 kW 1320 = 132.0 kW 1600 = 160.0 kW 2000 = 200.0 kW 2500 = 250.0 kW 3150 = 315.0 kW 3550 = 355.0 kW
Mechanical dimensions of the drive:	4 = size 4 5 = size 5	6 = size 6 7 = size 7
Inverter, ADV200 series		

Example:

ADV - 3 185 - K B X - 4-DC

DC link power supply versions		
Rated voltage from external power supply (factory setting):	4 = 400 V _{AC} / 50 Hz	
Software:	X = standard	
Braking unit:	B = included	
Keypad:	K = included	
Inverter power in kW:	185 = 18.5 kW	
Mechanical dimensions of the drive:	3 = size 3	
Inverter, ADV200 series		

ADV200-4/4A-DC - Common DC bus power supply

- Field-Orientated Vector Inverter
- Model with "KB-ADV" Programming Keypad
- HD = Heavy Duty (Overload 150%), LD = Light Duty (Overload 110%)

CODE	PRODUCT IDENTIFICATION	P _N @ 400Vac		CONFIGURATION
		HD	LD	
S9010DC	ADV-3185-KXX-4-DC	18.5kW	22kW	Configuration without rectifier, choke and filter
S9011DC	ADV-3220-KXX-4-DC	22kW	30kW	Configuration without rectifier, choke and filter
S9012DC	ADV-4300-KXX-4-DC	30kW	37kW	Configuration without rectifier, choke and filter
S9013DC	ADV-4370-KXX-4-DC	37kW	45kW	Configuration without rectifier, choke and filter
S9014DC	ADV-4450-KXX-4-DC	45kW	55kW	Configuration without rectifier, choke and filter
S9015DC	ADV-5550-KXX-4-DC	55kW	75kW	Configuration without rectifier, choke and filter
S9016DC	ADV-5750-KXX-4-DC	75kW	90kW	Configuration without rectifier, choke and filter
S9017DC	ADV-5900-KXX-4-DC	90kW	110kW	Configuration without rectifier, choke and filter
S9018DC	ADV-61100-KXX-4-DC	110kW	132kW	Configuration without rectifier, choke and filter
S9019DC	ADV-61320-KXX-4-DC	132kW	160kW	Configuration without rectifier, choke and filter
S9020DC	ADV-71600-KXX-4-DC	160kW	200kW	Configuration without rectifier, choke and filter
S9021DC	ADV-72000-KXX-4-DC	200kW	250kW	Configuration without rectifier, choke and filter
S9022DC	ADV-72500-KXX-4-DC	250kW	315kW	Configuration without rectifier, choke and filter
S9023DC	ADV-73150-KXX-4-DC	315kW	355kW	Configuration without rectifier, choke and filter (No UL Mark)
S9024DC	ADV-73550-KXX-4-DC	355kW	400kW	Configuration without rectifier, choke and filter (No UL Mark)
S9025DC	ADV-73150-KXX-4A-DC	315kW	355kW	Conf. without rectifier, choke and filter - 460Vac/60Hz fan power supply
S9026DC	ADV-73550-KXX-4A-DC	355kW	400kW	Conf. without rectifier, choke and filter - 460Vac/60Hz fan power supply

ADV200-4/4A-DC +SI - Power supply for Common DC Bus + SIL 3 Safety Card

- Field-Orientated Vector Inverter
- Model with "KB-ADV" Programming Keypad
- Integrated safety card
- HD = Heavy Duty (Overload 150%), LD = Light Duty (Overload 110%)

CODE	PRODUCT IDENTIFICATION	P _N @ 400Vac		CONFIGURATION
		HD	LD	
S9010DS	ADV-3185-KXX-4-DC+SI	18.5kW	22kW	Configuration without rectifier, choke and filter
S9011DS	ADV-3220-KXX-4-DC+SI	22kW	30kW	Configuration without rectifier, choke and filter
S9012DS	ADV-4300-KXX-4-DC+SI	30kW	37kW	Configuration without rectifier, choke and filter
S9013DS	ADV-4370-KXX-4-DC+SI	37kW	45kW	Configuration without rectifier, choke and filter
S9014DS	ADV-4450-KXX-4-DC+SI	45kW	55kW	Configuration without rectifier, choke and filter
S9015DS	ADV-5550-KXX-4-DC+SI	55kW	75kW	Configuration without rectifier, choke and filter
S9016DS	ADV-5750-KXX-4-DC+SI	75kW	90kW	Configuration without rectifier, choke and filter
S9017DS	ADV-5900-KXX-4-DC+SI	90kW	110kW	Configuration without rectifier, choke and filter
S9018DS	ADV-61100-KXX-4-DC+SI	110kW	132kW	Configuration without rectifier, choke and filter
S9019DS	ADV-61320-KXX-4-DC+SI	132kW	160kW	Configuration without rectifier, choke and filter

www.nicsanat.com
021-87700210



CODE	PRODUCT IDENTIFICATION	Pn @ 400Vac		CONFIGURATION
		HD	LD	
S9020DS	ADV-71600-KXX-4-DC+SI	160kW	200kW	Configuration without rectifier, choke and filter
S9021DS	ADV-72000-KXX-4-DC+SI	200kW	250kW	Configuration without rectifier, choke and filter
S9022DS	ADV-72500-KXX-4-DC+SI	250kW	315kW	Configuration without rectifier, choke and filter
S9023DS	ADV-73150-KXX-4-DC+SI	315kW	355kW	Configuration without rectifier, choke and filter (No UL Mark)
S9024DS	ADV-73550-KXX-4-DC+SI	355kW	400kW	Configuration without rectifier, choke and filter (No UL Mark)
S9025DS	ADV-73150-KXX-4A-DC+SI	315kW	355kW	Conf. without rectifier, choke and filter - 460VAc/60Hz fan power supply
S9026DS	ADV-73550-KXX-4A-DC+SI	355kW	400kW	Conf. without rectifier, choke and filter - 460VAc/60Hz fan power supply

ADV200-4/4A-DC - Parallel Configurations + SIL3 Safety Card

- Field-Orientated Vector Inverter
- "KB-ADV" Programming Keypad in the Master version (MS)
- Power supply for Common DC Bus
- Integrated safety card
- HD = Heavy Duty (Overload 150%), LD = Light Duty (Overload 110%)

CODE	PRODUCT IDENTIFICATION	Pn @ 400Vac		CONFIGURATION
		HD	LD	
S9025MC	ADV-72000-KXX-4- MS 04-DC- SI	400kW	500kW	Without rectifier - choke - filter + Integrated Safety Card
S9025SC	ADV-72000-KXX-4- SL-DC			
S9026MC	ADV-72500-KXX-4-MS 05-DC-SI	500kW	630kW	Without rectifier - choke - filter + Integrated Safety Card
S9026SC	ADV-72500-KXX-4-SL-DC			
S9025MC	ADV-72000-KXX-4- MS 04-DC- SI	500kW	630kW	Without rectifier - choke - filter + Integrated Safety Card
S9025SC	ADV-72000-KXX-4- SL-DC			
S9027MC	ADV-73150-KXX-4 -MS 06-DC-SI	630kW	710kW	Without rectifier - choke - filter + Integrated Safety Card (No UL Mark) 400VAc/50Hz fan power supply
S9027SC	ADV-73150-KXX-4 -SL-DC			
S9028MC	ADV-73550-KXX-4- MS 07-DC-SI	710kW	800kW	Without rectifier - choke - filter + Integrated Safety Card (No UL Mark) 400VAc/50Hz fan power supply
S9028SC	ADV-73550-KXX-4- SL-DC			
S9027M2	ADV-73150-KXX-4 -MS 09-DC-SI	900kW	1MW	Without rectifier - choke - filter + Integrated Safety Card (No UL Mark) 400VAc/50Hz fan power supply
S9027SC	ADV-73150-KXX-4 -SL-DC			
S9027SC	ADV-73150-KXX-4 -SL-DC			
S9028M2	ADV-73550-KXX-4- MS 10-DC-SI	1MW	1.2MW	Without rectifier - choke - filter - Integrated Safety Card (No UL Mark) 400VAc/50Hz fan power supply
S9028SC	ADV-73550-KXX-4- SL-DC			
S9028SC	ADV-73550-KXX-4- SL-DC			
S9029MC	ADV-73150-KXX-4A-MS 06-DC-SI	630kW	710kW	Without rectifier - choke - filter + Integrated Safety Card 460VAc/60Hz fan power supply
S9029SC	ADV-73150-KXX-4A -SL-DC			
S9030MC	ADV-73550-KXX-4A- MS 07-DC-SI	710kW	800kW	Without rectifier - choke - filter + Integrated Safety Card 460VAc/60Hz fan power supply
S9030SC	ADV-73550-KXX-4A- SL-DC			
S9029M2	ADV-73150-KXX-4A-MS 09-DC-SI	900kW	1MW	Without rectifier - choke - filter + Integrated Safety Card 460VAc/60Hz fan power supply
S9029SC	ADV-73150-KXX-4A -SL-DC			
S9029SC	ADV-73150-KXX-4A -SL-DC			
S9030M2	ADV-73550-KXX-4A- MS 10-DC-SI	1MW	1.2MW	Without rectifier - choke - filter + Integrated Safety Card 460VAc/60Hz fan power supply
S9030SC	ADV-73550-KXX-4A- SL-DC			
S9030SC	ADV-73550-KXX-4A- SL-DC			

ADV200 - 4

ADV200-DC

ADV200 - 6

ADV100

ADV80

AFE200

PROGRAM.

APPENDIX

ADV200-6/6A-DC

- Field-Orientated Vector Inverter
- Model with "KB-ADV" Programming Keypad
- Power supply for Common DC Bus
- HD = Heavy Duty (Overload 150%), LD = Light Duty (Overload 110%)

CODE	PRODUCT IDENTIFICATION	Pn @ 690Vac		CONFIGURATION
		HD	LD	
S9082	ADV-71600-KXX-6-DC	160kW	200kW	Without rectifier - choke - filter
S9083	ADV-72000-KXX-6-DC	200kW	250kW	Without rectifier - choke - filter
S9084	ADV-72500-KXX-6-DC	250kW	315kW	Without rectifier - choke - filter
S9085	ADV-73150-KXX-6-DC	315kW	355kW	Without rectifier - choke - filter - 400Vac/50Hz fan power supply
S9086	ADV-73550-KXX-6-DC	355kW	400kW	Without rectifier - choke - filter - 400Vac/50Hz fan power supply
S9087	ADV-73150-KXX-6A-DC	315kW	355kW	Without rectifier - choke - filter - 460Vac/60Hz fan power supply
S9088	ADV-73550-KXX-6A-DC	355kW	400kW	Without rectifier - choke - filter - 460Vac/60Hz fan power supply

ADV200-6/6A-DC +SI - Power supply for Common DC Bus + SIL 3 Safety Card

- Field-Orientated Vector Inverter
- Model with "KB-ADV" Programming Keypad
- Power supply for Common DC Bus
- Integrated safety card
- HD = Heavy Duty (Overload 150%), LD = Light Duty (Overload 110%)

CODE	PRODUCT IDENTIFICATION	Pn @ 690Vac		CONFIGURATION
		HD	LD	
S9082SI	ADV-71600-KXX-6-DC+SI	160kW	200kW	Without rectifier - choke - filter
S9083SI	ADV-72000-KXX-6-DC+SI	200kW	250kW	Without rectifier - choke - filter
S9084SI	ADV-72500-KXX-6-DC+SI	250kW	315kW	Without rectifier - choke - filter
S9085SI	ADV-73150-KXX-6-DC+SI	315kW	355kW	Without rectifier - choke - filter - 400Vac/50Hz fan power supply
S9086SI	ADV-73550-KXX-6-DC+SI	355kW	400kW	Without rectifier - choke - filter - 400Vac/50Hz fan power supply
S9087SI	ADV-73150-KXX-6A-DC+SI	315kW	355kW	Without rectifier - choke - filter - 460Vac/60Hz fan power supply
S9088SI	ADV-73550-KXX-6A-DC+SI	355kW	400kW	Without rectifier - choke - filter - 460Vac/60Hz fan power supply

ADV200-6/6A-DC +SI - Parallel Configurations + SIL3 Safety Card

- Field-Orientated Vector Inverter
- "KB-ADV" Programming Keypad in the Master version (MS)
- Power supply for Common DC Bus
- Integrated safety card
- HD = Heavy Duty (Overload 150%), LD = Light Duty (Overload 110%)

CODE	PRODUCT IDENTIFICATION	Pn @ 690Vac		CONFIGURATION
		HD	LD	
S9076MC	ADV-72000-KXX-6- MS 04-DC- SI	400kW	500kW	Without rectifier - choke - filter (No UL Mark)
S9076SC	ADV-72000-KXX-6- SL-DC			
S9077MC	ADV-72500-KXX-6-MS 05-DC-SI	500kW	630kW	Without rectifier - choke - filter (No UL Mark)
S9077SC	ADV-72500-KXX-6-SL-DC			
S9078MC	ADV-73150-KXX-6 -MS 06-DC-SI	630kW	710kW	Without rectifier - choke - filter - 400Vac/50Hz fan power supply (No UL Mark)
S9078SC	ADV-73150-KXX-6 -SL-DC			
S9079MC	ADV-73550-KXX-6- MS 07-DC-SI	710kW	800kW	Without rectifier - choke - filter - 400Vac/50Hz fan power supply (No UL Mark)
S9079SC	ADV-73550-KXX-6- SL-DC			
S9078M1C	ADV-73150-KXX-6 -MS 09-DC-SI	900kW	1MW	Without rectifier - choke - filter - 400Vac/50Hz fan power supply (No UL Mark)
S9078SC	ADV-73150-KXX-6 -SL-DC			
S9078SC	ADV-73150-KXX-6 -SL-DC			
S9079M1C	ADV-73550-KXX-6- MS 10-DC-SI	1MW	1.15MW	Without rectifier - choke - filter - 400Vac/50Hz fan power supply (No UL Mark)
S9079SC	ADV-73550-KXX-6- SL-DC			
S9079SC	ADV-73550-KXX-6- SL-DC			
S9079M2C	ADV-73550-KXX-6- MS 14-DC-SI	1.35MW	1,5MW	Without rectifier - choke - filter - 400Vac/50Hz fan power supply (No UL Mark)
S9079SC	ADV-73550-KXX-6- SL-DC			
S9079SC	ADV-73550-KXX-6- SL-DC			
S9079SC1	ADV-73550-KXX-6-SL2-DC			
S9079M3C	ADV-73550-KXX-6- MS 17-DC-SI	1.65MW	1,8MW	Without rectifier - choke - filter - 400Vac/50Hz fan power supply (No UL Mark)
S9079SC	ADV-73550-KXX-6- SL-DC			
S9079SC	ADV-73550-KXX-6- SL-DC			
S9079SC1	ADV-73550-KXX-6-SL2-DC			
S9079SC1	ADV-73550-KXX-6-SL2-DC			
S9080M	ADV-73150-KXX-6A-MS 06-DC-SI	630kW	710kW	Without rectifier - choke - filter - 460Vac/60Hz fan power supply (No UL Mark)
S9080S	ADV-73150-KXX-6A -SL-DC			
S9081M	ADV-73550-KXX-6A- MS 07-DC-SI	710kW	800kW	Without rectifier - choke - filter - 460Vac/60Hz fan power supply (No UL Mark)
S9081S	ADV-73550-KXX-6A- SL-DC			
S9080M1	ADV-73150-KXX-6A-MS 09-DC-SI	900kW	1MW	Without rectifier - choke - filter - 460Vac/60Hz fan power supply (No UL Mark)
S9080S	ADV-73150-KXX-6A -SL-DC			
S9080S	ADV-73150-KXX-6A -SL-DC			
S9081M1	ADV-73550-KXX-6A- MS 10-DC-SI	1MW	1.15MW	Without rectifier - choke - filter - 460Vac/60Hz fan power supply (No UL Mark)
S9081S	ADV-73550-KXX-6A- SL-DC			
S9081S	ADV-73550-KXX-6A- SL-DC			

3. ADV200-6 • 690Vac Power Supply

3.1 Introduction



ADV200-6 Vector Inverters offer the best system solutions for drives with stand-alone configuration or common DC Bus power supply.

The range features power ratings from **75kW** for **three-phase power supplies of 690 Vac**. Integrated accessories such as the mains choke enhance long-term reliability, reduce overall dimensions and lower wiring costs.

Flexible Modular Technology

The ADV200-6 range reflects the philosophy of the entire ADV range and is based on a fully modular hardware with power structures that have been optimised for modern automation systems.

Designed to facilitate installation and guarantee ease of use, project flexibility, optimisation of space and reduction of wiring costs.

In addition to the control capabilities for asynchronous motors, the standard software also incorporates the control algorithm for closed-loop brushless motor control (FOC-CL = Field Oriented Control with feedback) and open-loop control without feedback (FOC-OL = Open Loop).

The ADV200-6 is available in various hardware sizes:

- up to 355kW in the stand-alone configuration complete with rectifier stage
- from 400kW to 1.65MW in "parallel" configurations.

Integrated reliability

The ADV200-6 features high-quality engineering solutions that guarantee long-term reliability. The integrated input choke on the DC side reduces THD by up to 40% (up to size ADV-61320)

Total ease of use

Designed with the user in mind. The mechanical structure ensures simple and fast product management, regardless of installation and assembly conditions. All operations are simple and immediate, from accessing the extractable terminal strips to rack-mounting of options.

The dedicated accessories guarantee simple wiring and cable shielding to achieve immediate, EMC-compliant start-ups.

Serial line

The RS485 serial line is incorporated as standard across the range to enable peer-to-peer or multidrop connections using Modbus RTU protocol.

Management of optional cards

The ADV200-6 uses an intelligent rack system that allows 3 optional cards to be installed at the same time.

- Fieldbus interface card
- I/O expansion card
- Interface card for feedback with single or multiple encoders (up to 3).

Back-up power supply

The ADV200-6 is compatible with a separate +24Vdc external power supply. This solution makes it possible to maintain all display and drive configuration functions and manage the connected fieldbuses in the event of a power failure.

3.2 General Characteristics

- Power supply: 3 x 690VAc ±10%; 50-60 Hz ± 5%
- Power ratings: from 75kW to 1.65MW
- Max output voltage 0.98 x Vin
- Control mode:
 - Open-loop vector control (Asynchronous and Synchronous)
 - Vector control with feedback (Asynchronous and Synchronous)
 - Open loop V/f and V/f with feedback (Asynchronous)
- Heavy/light overload control
- Integration of up to 3 options onboard the drive
- GF-eXpress multi-language programming SW (5 languages)
- PLC with advanced IEC61131-3 programming environment
- IP20-rated protection (IPOO size 7 and parallel)

Fieldbus management



CANopen®

Modbus

EtherCAT®



Performance

The ADV200-6 offers state-of-the-art control technology based on the use of a powerful 32-bit microprocessor able to guarantee maximum precision and performance of the motor as well as sophisticated management of the most advanced application systems.

Precision

Control mode	Speed control precision (*)	Control range
Asynchronous		
FOC with feedback	± 0.01% motor speed rating	1 : 1000
Open-loop FOC	± 30% motor slip rating	1 : 100
V/F	± 60% motor slip rating	1 : 30
Synchronous		
FOC with feedback	± 0.01% motor speed rating	1 : 1500
Open-loop FOC	± 0.1% motor speed rating	1 : 20

(*)for standard 4-pole motor

Standard supply configuration

- Integrated KB_ADV programming keypad
- Regulation:
 - 2 bipolar analog inputs (Voltage/Current)
 - 2 bipolar analog outputs (1: Voltage/Current, 1: Voltage)
 - 6 digital inputs (PNP/NPN)
 - 2 digital outputs (PNP/NPN)
 - 2 relay outputs, single contact
 - RS485 serial line (Modbus RTU)
- Reference resolution: Digital = 15-bit + sign
Analog input = 11-bit + sign
Analog output = 11-bit + sign

Conformity

- Immunity/Emissions: EEC - EN 61800-3
- Programming: according to IEC 61131-3
- Electrical safety: EN 50178, EN 61800-5-1

Environmental conditions

- Ambient temperature: 0 ...+40°C (sizes 5750 ... 61320)
-10...+40°C (sizes 71600 ... 73150)
-10...+35°C (sizes 73550)
+40°C...+50°C with derating
- Altitude: Max 2000 m.(up to 1000 m without derating)

Markings



Complies with the EEC directive concerning low voltage equipment

3.3 Standard connections

ADV200-6 • 690V power supply

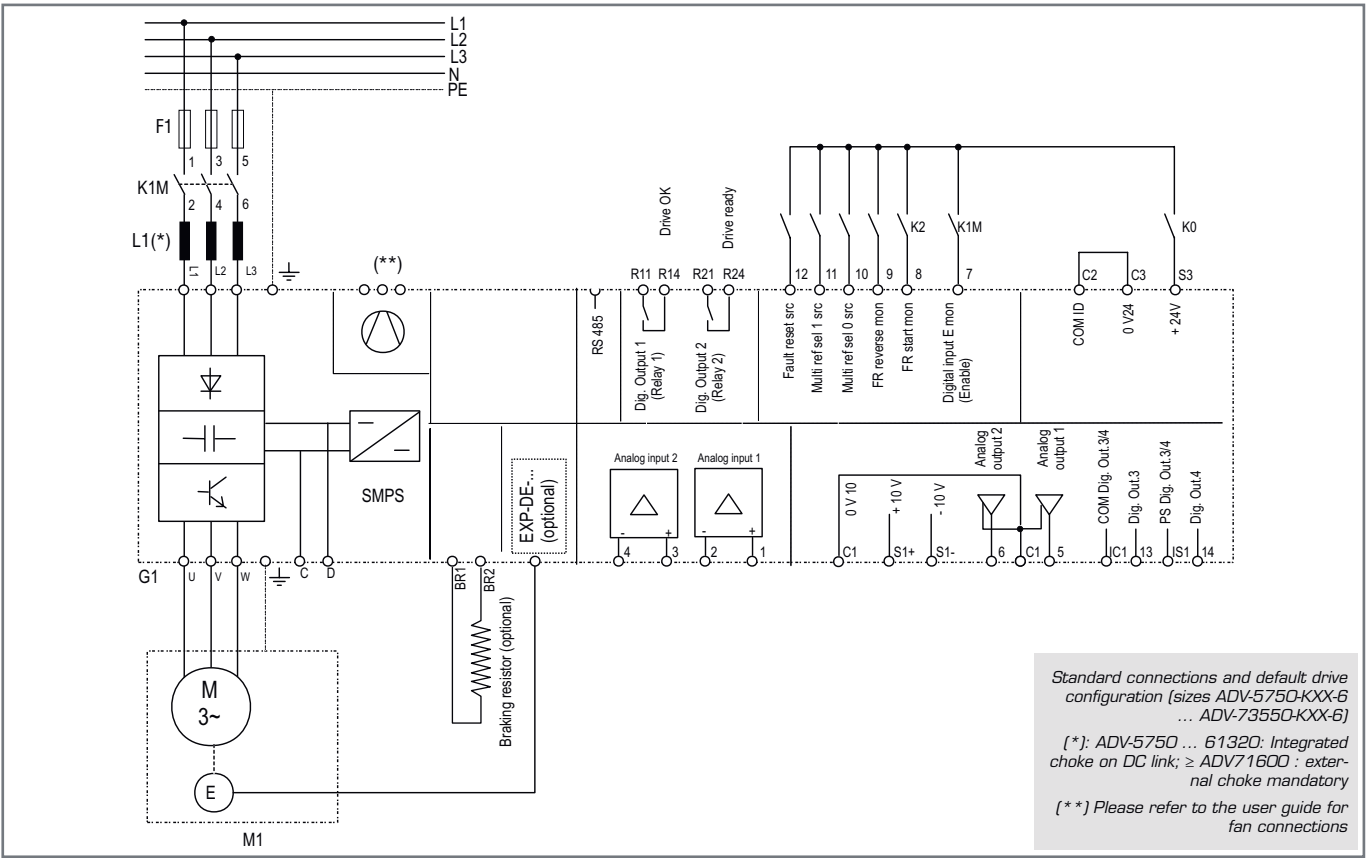

Standard connections and default drive configuration (sizes ADV-5750-KXX-6 ... ADV-73550-KXX-6)

[*]: ADV-5750 ... 61320: Integrated choke on DC link; ≥ ADV71600 : external choke mandatory

[**] Please refer to the user guide for fan connections

3.4 Weights and dimensions

Size 6 - IP20

mm (inches)

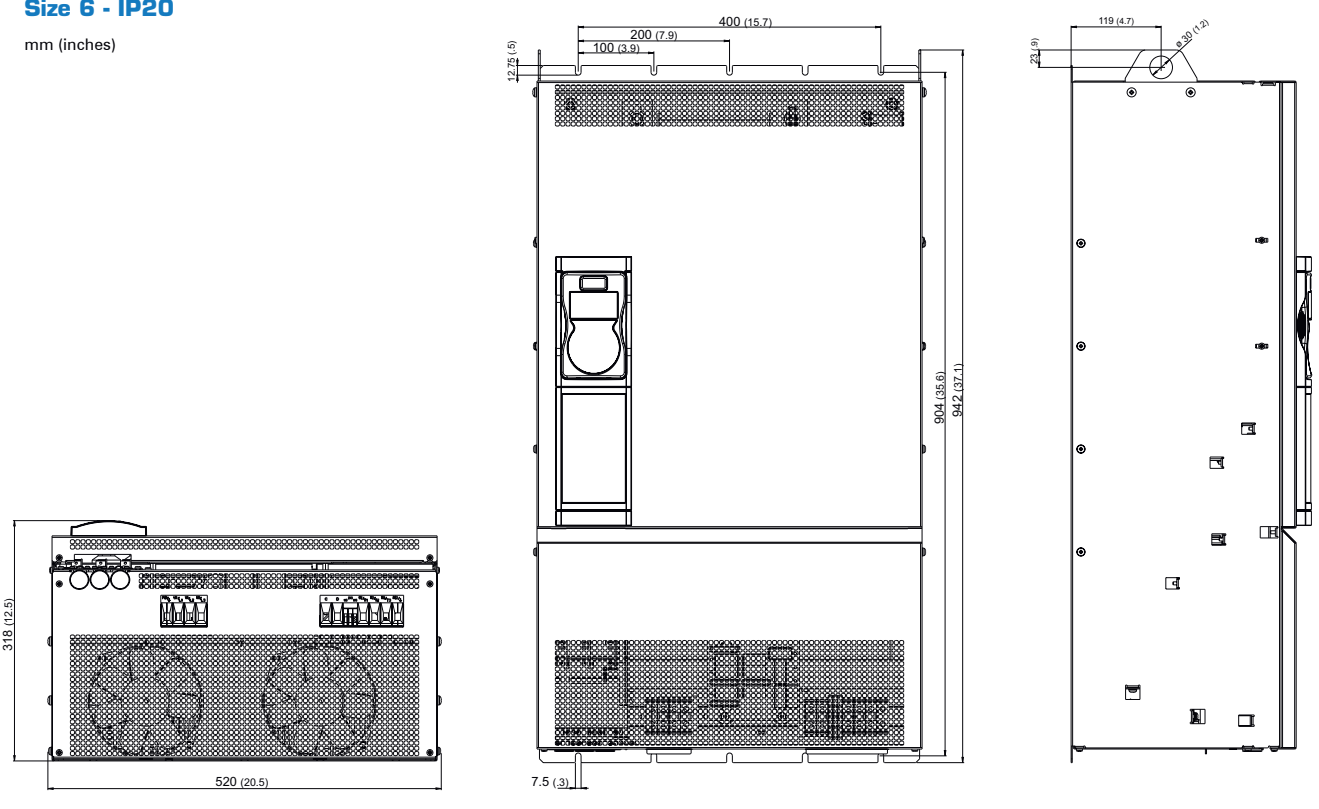

Sizes ADV200-6	Dimensions: Width x Height x Depth		Weight	
	mm	inches	kg	lbs
5750	520 x 942 x 318	20.5 x 37.1 x 12.5		

Size 7 - IP20

mm (inches)

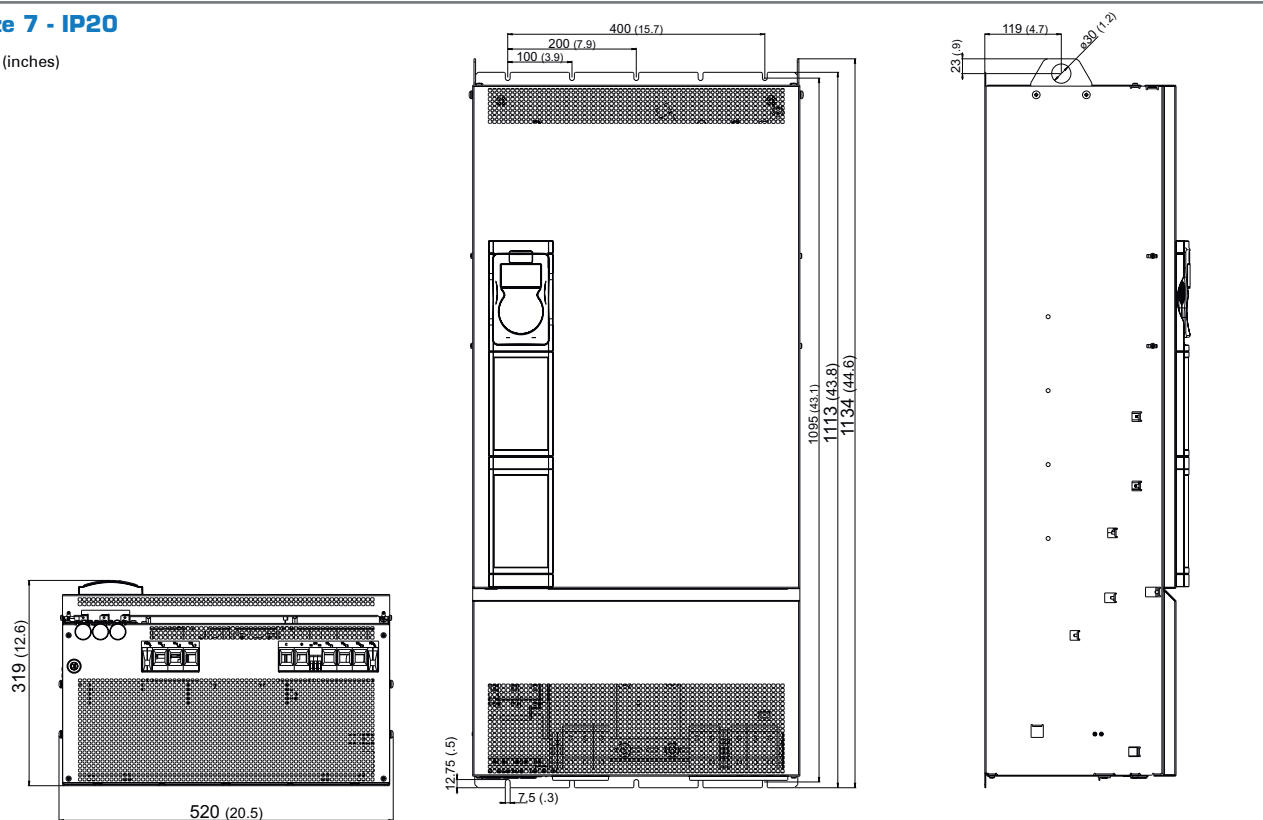

Sizes ADV200-6	Dimensions: Width x Height x Depth		Weight	
	mm	inches	kg	lbs
6900 - 61100 - 61320	520 x 1134 x 319	20.5 x 44.6 x 12.6		

ADV200 - 4

ADV200-DC

ADV200 - 6

ADV100

ADV80

AFE200

PROGRAM.

APPENDIX

Size 7

mm (inches)

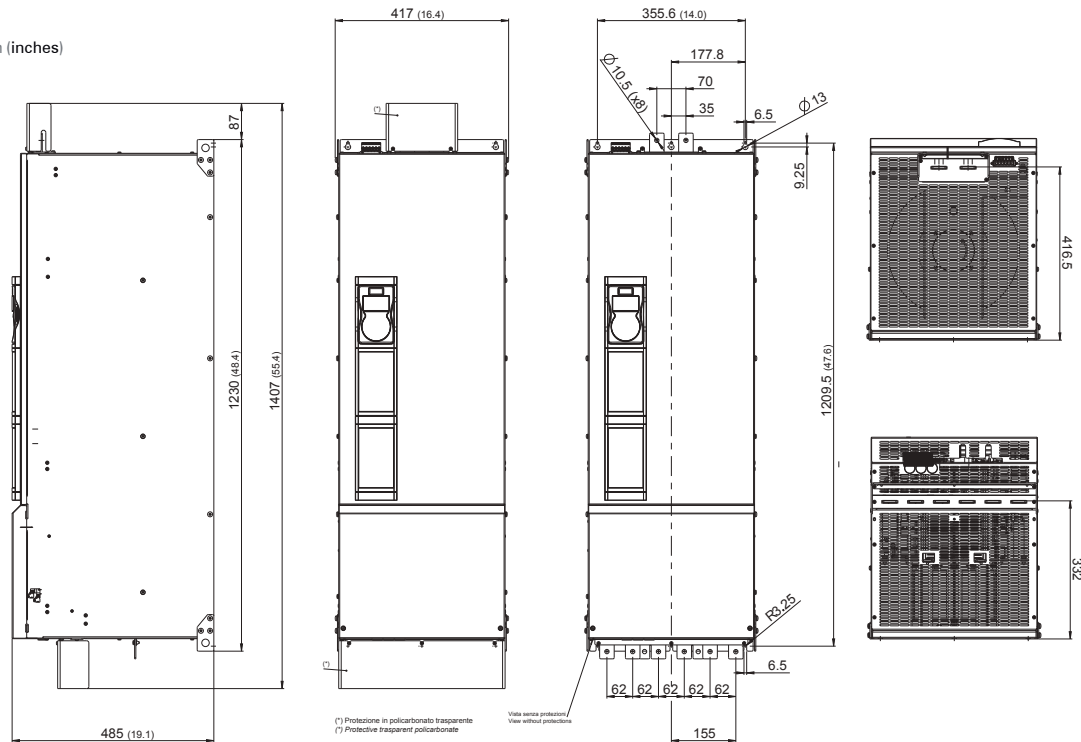

Size ADV200-6	Dimensions: Width x Height x Depth		Weight	
	mm	inches	kg	lbs
71600...72000	417 x 1407 x 485	16.42 x 55.4 x 19.1	135	298
72500			145	320
73150 ... 73550			155	342

Sizes 400 ... 710 kW

mm (inches)

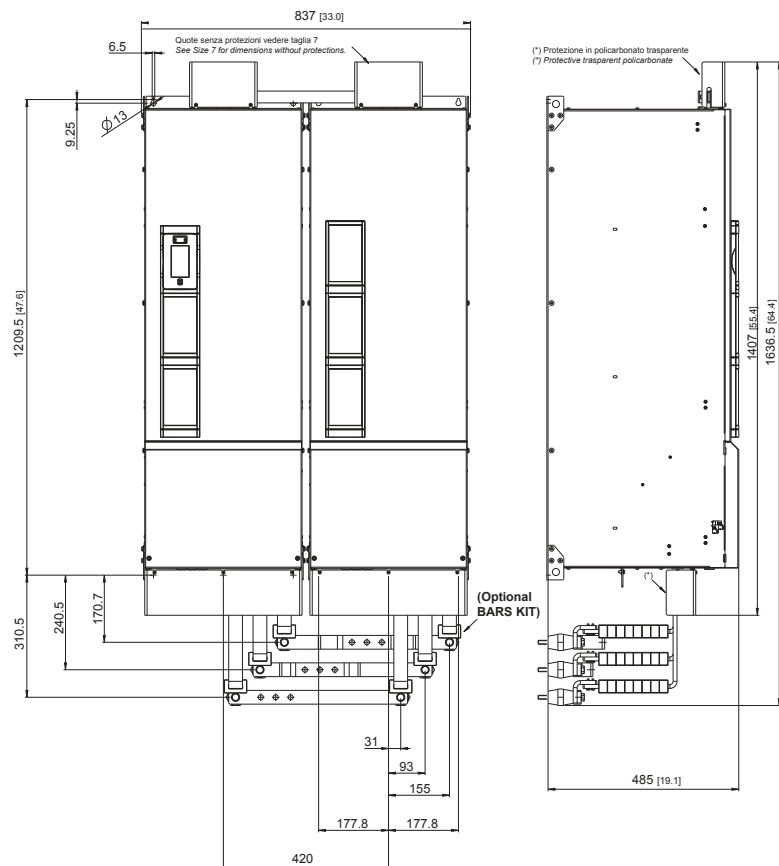

Size ADV200-6	Dimensions: Width x Height x Depth		Weight	
	mm	inches	kg	lbs
400kW	837 x 1407 x 485	33.0 x 55.4 x 19.1	270	595
500kW			290	639
630 - 710kW			310	683

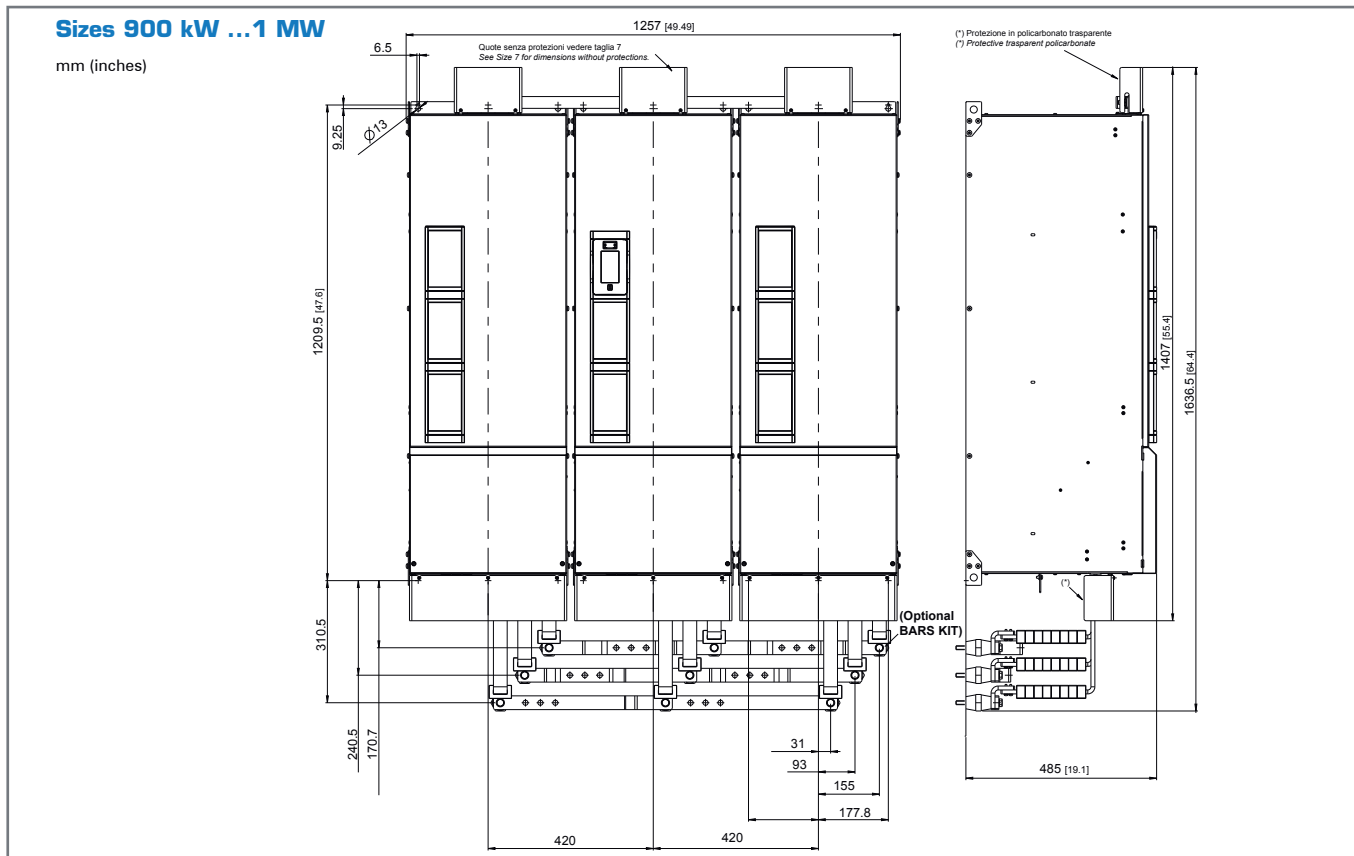

Size ADV200-6	Dimensions: Width x Height x Depth		Weight	
	mm	inches	kg	lbs
900 kW - 1 MW	1257 x 1407 x 485	49.5 x 55.4 x 19.1	465	1025

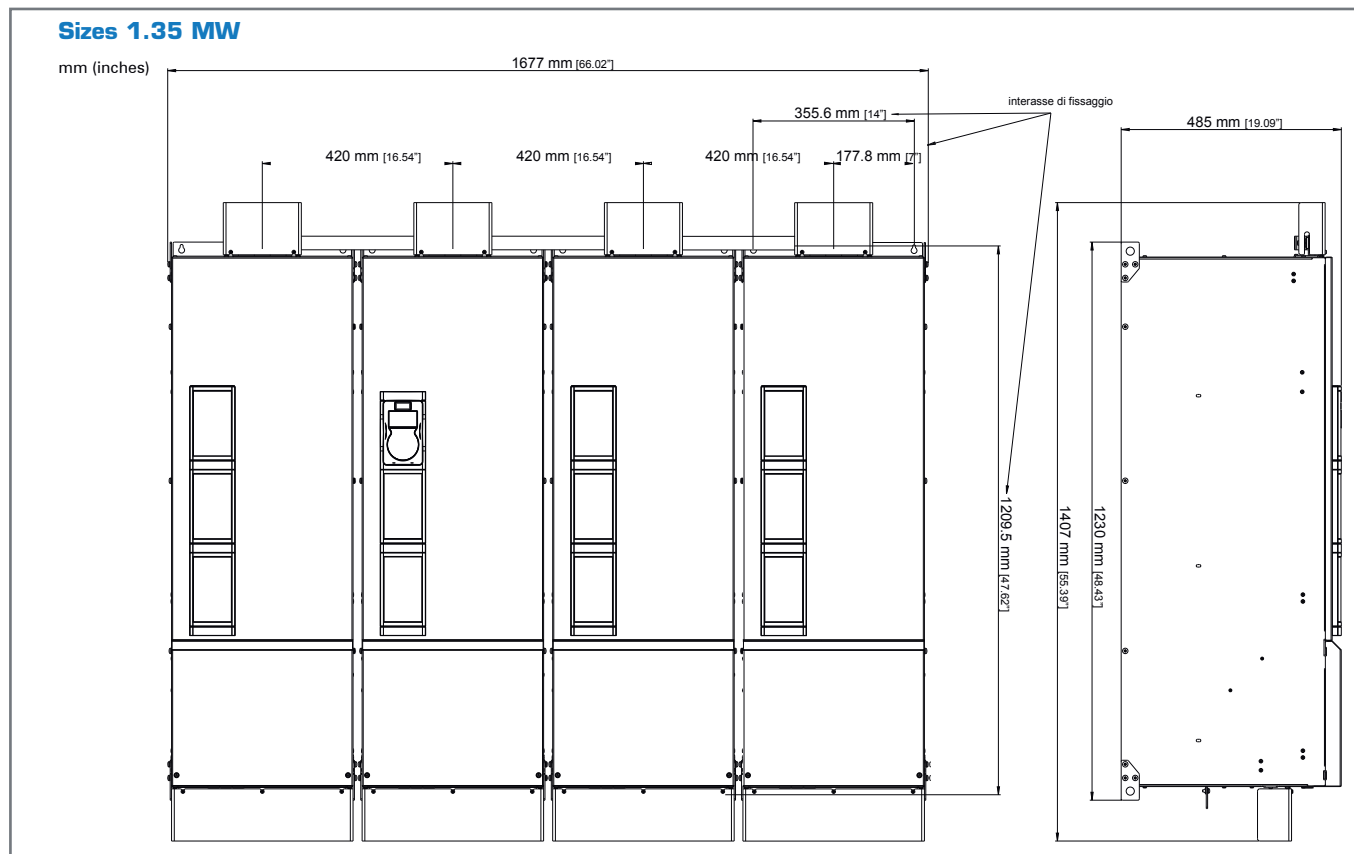

Size ADV200-6	Dimensions: Width x Height x Depth		Weight	
	mm	inches	kg	lbs
1.35 MW	1677 x 1407 x 485	66.02 x 55.4 x 19.1	600	1322.7

ADV200 - 4

ADV200-DC

ADV200 - 6

ADV100

ADV80

AFE200

PROGRAM.

APPENDIX

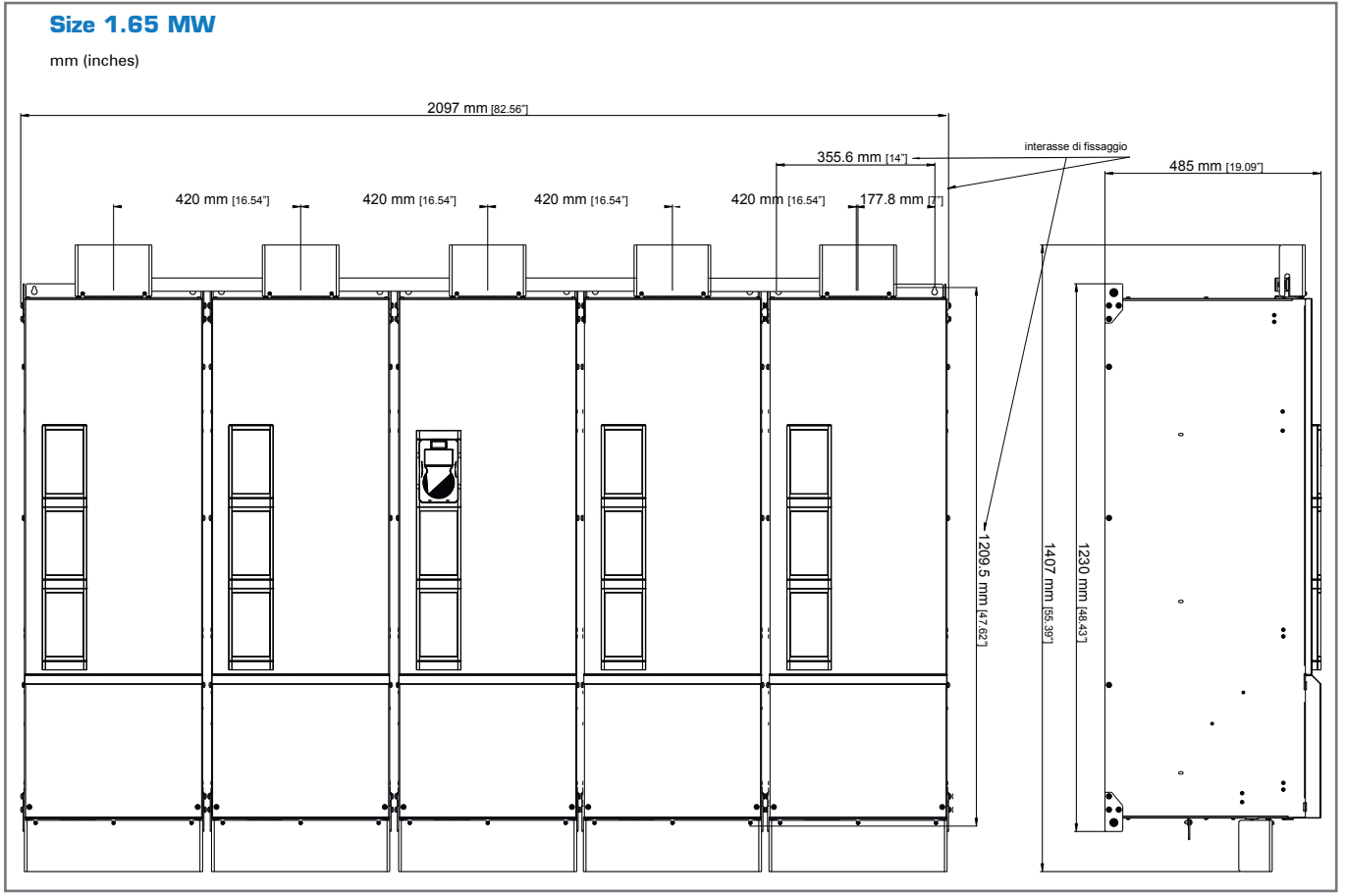

Size ADV200-6	Dimensions: Width x Height x Depth		Weight	
	mm	inches	kg	lbs
1.65 MW	2097 x 1407 x 485	82,56 x 55,4 x 19,1	750	1653

3.5 Choosing the Inverter

The combinations of motor power ratings and inverters listed in the table envisage the use of motors in which the voltage rating is equal to that of the mains power.

For motors with different voltage ratings the inverter must be chosen according to the current rating of the motor. The combinations listed in the table thus show the current that can be delivered by the drive during continuous operation and overload conditions, according to the mains voltage.

The same engineering criteria apply for operations with additional derating factors:

- Kt Ambient temperature
- K_F Switching frequency
- Kalt Altitude of installation
- Kv Derating factor for power supply type

3.6 Input Data

Sizes ADV200-6	Input voltage U _{LN} [VAC]	Overvoltage threshold (Overvoltage) [Vdc]	Undervoltage threshold (Undervoltage) [Vdc]	DC-Link Capacity [μF]	Total harmonic distortion [THD] %	AC input current	
						Heavy Duty @ 690 Vac [Arms]	Light Duty @ 690 Vac [Arms]
5750	Three-phase mains 690 Vac ±10%, 50/60 Hz, ± 2%	1192	676 (@690 Vac)	4700	40% Light duty, 50% Heavy duty (at rated current)	90	-
6900				6270		109	-
61100				6270		129	-
61320				6270		157	-
71600	Three-phase mains 500 Vac -10% ... 690 Vac +10%, 50/60 Hz ± 2%			11200		172	210
72000				11200		214	263
72500				11200		263	336
73150				11200		336	382
73550				11200		382	420
400 kW				22400		420	520
500 kW				22400		533	651
630 kW				22400		665	755
710 kW				22400		756	843
900 kW				33600		1009	1180
1 MW				33600		1180	1259
1.35 MW				44800		1375	1515
1.65 MW	56000	1680	1840				

3.7 Output Data

ADV200-6 • 690V power supply

Sizes ADV200-6	Pn mot (Recommended asynchronous motor rating, fsw = default)				Maximum output voltage U2 [V]	Maximum output frequency f2		IGBT braking unit
	Heavy Duty		Light Duty			Maximum [Hz]	Minimum [Hz]	
	@690 VAC [kW]	@575 VAC [Hp]	@690 VAC [kW]	@575 VAC [Hp]				
5750	75	-	-	-	0.95 x U _{LN} (U _{LN} = AC voltage input)	FVCL=300 Hz FVOL=150 Hz VF=400 Hz	External optional (BUy...-6 series)	
6900	90	-	-	-		FVCL=200 Hz FVOL=150 Hz VF=300 Hz		
61100	110	-	-	-		FVCL=200 Hz FVOL=150 Hz VF=500 Hz		
61320	132	-	-	-		FVCL=200 Hz FVOL=150 Hz VF=200 Hz		
71600	160	150	200	200				
72000	200	200	250	250				
72500	250	250	315	350				
73150	315	350	355	400				
73550	355	400	400	450				
400 kW	400	450	500	500				
500 kW	500	550	630	700				
630 kW	630	700	710	800				
710 kW	710	800	800	900				
900 kW	900	1000	1000	1100				
1 MW	1000	1100	1150	1300				
1,35 MW	1350	1500	1500	1600				
1,65 MW	1650	1800	1800	2000				

FVCL = Flux vector CL (Field Oriented Control with feedback); FVOL=Flux vector OL (Open Loop Field Oriented Control).

Sizes ADV200-6	Rated output current I _n (for Asynchronous motor) (fsw = default)		Rated output current I _n (For Synchronous motors) (fsw = default)	
	Heavy Duty	Light Duty	Heavy Duty	Light Duty
	[A]	[A]	[A]	[A]
5750	92	-	75	-
6900	110	-	90	-
61100	133	-	110	-
61320	159	-	130	-
71600	170	210	153	189
72000	210	265	189	238
72500	265	330	238	297
73150	330	375	297	337
73550	375 (1)	415	337	373
400 kW	400	500	360	450
500 kW	500	630	450	567
630 kW	630	710	567	639
710 kW	710 (1)	790	639	711
900 kW	900	1000	810	900
1 MW	1000 (1)	1150	900 (1)	1035
1,35 MW	1300 (1)	1450	1170 (1)	1305
1,65 MW	1600	1770	1440	1590

(1) Current values with an ambient temperature of 35°C.



The derating factors shown in the table below are applied to the rated DC output by the user. They are not automatically implemented by the drive:

$$I_{drive} = I_n \times K_{ALT} \times K_T \times K_v$$

Sizes ADV200-6	Reduction factor				
	K _v (2)		K _T (3)		K _{ALT} %
	T _{amb} ≤ 30°C	T _{amb} 31 ... 40°C	HD	LD	(4)
5750	1	0.9	0.8	-	1.2
6900	1	0.9	0.8	-	1.2
61100	1	0.9	0.8	-	1.2
61320	1	0.9	0.8	-	1.2
71600	1	0.87 (5)	0.9	0.8	1.2
72000	1	1	0.9	0.8	1.2
72500	1	0.88	0.9	0.8	1.2
73150	1	0.88	0.9	0.8	1.2
73550	1	0.88	0.85	0.8	1.2
400 kW	1	1	0.9	0.8	1.2
500 kW	1	0.88	0.9	0.8	1.2
630 kW	1	0.88	0.9	0.8	1.2
710 kW	1	0.88	0.85	0.8	1.2
900 kW	1	0.88	0.9	0.8	1.2
1 MW	1	0.88	0.85	0.8	1.2
1.35 MW	1	0.88	0.85	0.8	1.2
1.65 MW	1	0.88	0.85	0.8	1.2

- (2) K_v : Derating factor for DC power supply from AFE200 (1120 Vdc), only applied with ambient temperatures of more than 30°C.
- (3) K_T : Derating factor with an ambient temperature of 50°C (1% every °C over 40°C with HD and 2% every °C over 40°C with LD), > 35°C for sizes 73550, 710 kW and 1000 kW.
- (4) K_{ALT} : Derating factor for installation at altitudes above 1000 meters a.s.l. Value to be applied = 1.2% each 100 m increase above 1000 m (up to a maximum of 2000 m). If the ambient temperature is ≤ 30°C and the application provides for the use of K_v derating, K_{alt} derating can be avoided.
E.g.: Altitude 2000 m, K_{alt} = 1.2% * 10 = 12% derating; I_n derated = (100 - 12) % = 88 % I_n.
- (5) K_v = 1, , with fixed switching frequency set to 2 kHz (default = 4 kHz).

Sizes ADV200-6	Asynchronous motor control								
	Overload (For Asynchronous motors)		Switching frequency "Fixed frequency" mode (PAR 658 Switch freq. mode = 0, default)		Overload according to output frequency				
	Heavy Duty	Light Duty	Maximum (default)	Minimum	Heavy Duty			Light Duty	
	[A]	[A]	(kHz)	(kHz)	K1 HD [%]	K2 HD [Hz]	K3 HD [Hz]	K1 LD [%]	K2 LD [Hz]
5750	136% 60 sec, 183% 0.5 sec.	n.a.	4	2	100	3	4.8	100	3
6900			4	2	100	3	4.8	100	3
61100			2	2	100	3	4.8	100	3
61320			2	2	100	3	4.8	100	3
71600	150% 60 sec, 180% 0.5 sec.	110% 60 sec.	4	2	100	3	4.8	100	3
72000			2	2	100	3	4.8	100	3
72500			2	2	100	3	4.8	100	3
73150			2	2	100	3	4.8	100	3
73550			2	2	100	3	4.8	100	3
400 kW			2	2	100	3	4.8	100	3
500 kW			2	2	100	3	4.8	100	3
630 kW			2	2	100	3	4.8	100	3
710 kW			2	2	100	3	4.8	100	3
900 kW			2	2	100	3	4.8	100	3
1 MW			2	2	100	3	4.8	100	3
1.35 MW			2	2	2	2	4.8	3	3
1.65 MW	2	2	2	2	4.8	3	3	3	

www.nicsanat.com
021-87700210



Overload according to output frequency (Asynchronous motor control)

- Sizes ≤ 61320

Overload SP

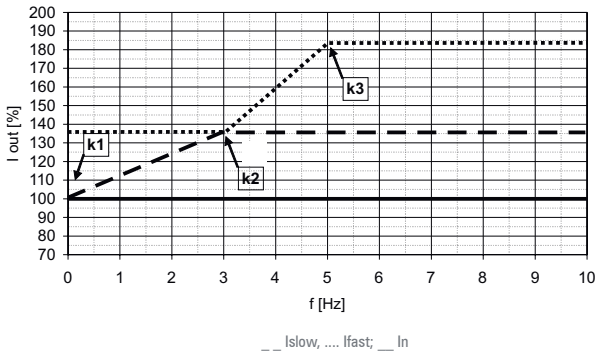

- Sizes ≥ 71600

Overload HD

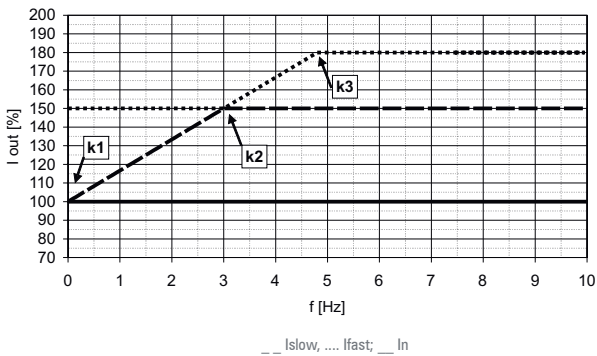

Overload LD

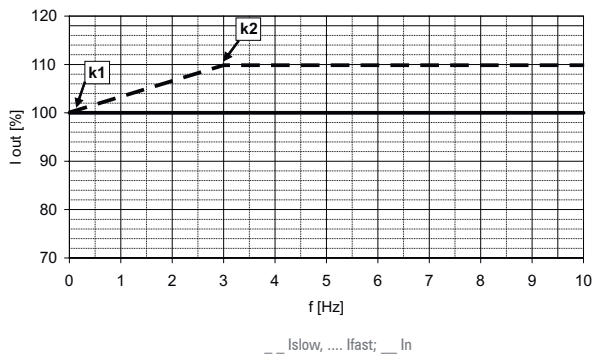

Sizes ADV200-6	Overload (For Synchronous motors)		Asynchronous motor control Switching frequency "Fixed frequency" mode (PAR 658 Switch freq. mode = 0, default)		Overload according to output frequency				
	Heavy Duty	Light Duty	Maximum (default)	Minimum	Heavy Duty			Light Duty	
	[A]	[A]	(kHz)	(kHz)	K1 HD [%]	K2 HD [Hz]	K3 HD [Hz]	K1 LD [%]	K2 LD [Hz]
5750	150% 60 sec. every 300 sec., 200% 3 sec.	n.a.	4	2	100	3	5	100	3
6900			4	2	100	3	5	100	3
61100			2	2	100	3	5	100	3
61320			2	2	100	3	5	100	3
71600	160% 60 sec. every 300 sec., 200% 3 sec.	110% 60 sec.	4	2	100	3	5	100	3
72000			2	2	100	3	5	100	3
72500			2	2	100	3	5	100	3
73150			2	2	100	3	5	100	3
73550			2	2	100	3	5	100	3
400 kW			2	2	100	3	5	100	3
500 kW			2	2	100	3	5	100	3
630 kW			2	2	100	3	5	100	3
710 kW			2	2	100	3	5	100	3
900 kW			2	2	100	3	5	100	3
1 MW	2	2	100	3	5	100	3		
1.35 MW	2	2	100	3	5	3	5	3	
1.65 MW	2	2	2	2	5	5	5	5	

www.nicsanat.com
021-87700210



Overload according to output frequency (Synchronous motor control)

- Sizes ≤ 61320

Overload SP

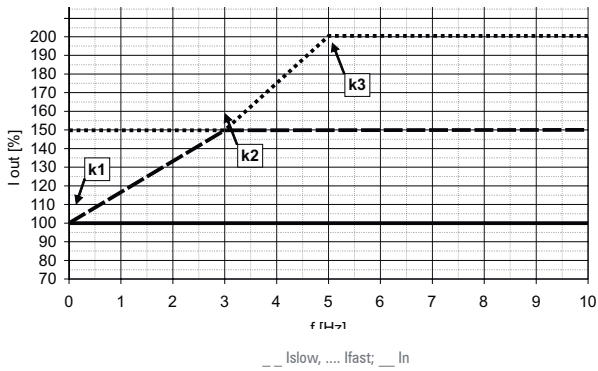

- Sizes ≥ 71600

Overload HD

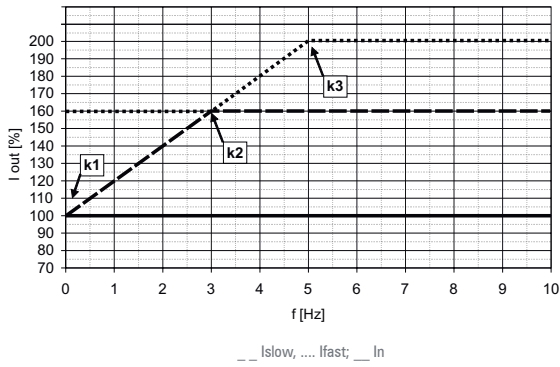

Overload LD

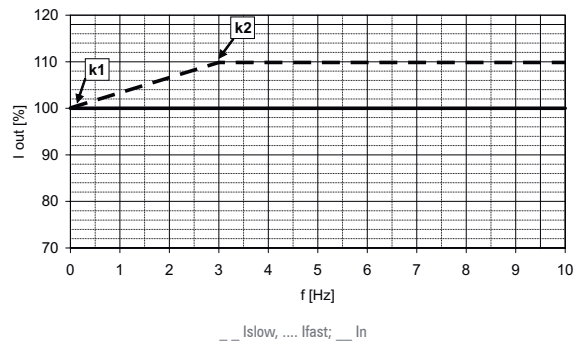

3.8 Cooling

All inverters include internal fans with external power supply.

Sizes ADV200-6	Max dissipated power	Fan capacity
	[W]	Dissipator [m ³ /h]
5750	1500	2 x 325
6900	2000	3 x 325
61100	2000	3 x 325
61320	2400	3 x 325
71600	3800	1500
72000	4200	1500
72500	4500	1500
73150	5200	2000
73550	5700	2000
400 kW	4200 (x 2)	1500 (x 2)
500 kW	4500 (x 2)	1500 (x 2)
630 kW	5200 (x 2)	2000 (x 2)
710 kW	5700 (x 2)	2000 (x 2)
900 kW	5700 (x 3)	2000 (x 3)
1 MW	5700 (x 3)	2000 (x 3)
1.35 MW	5700 (x 4)	2000 (x 4)
1.65 MW	5700 (x 5)	2000 (x 5)

3.9 Order codes

Product identification

ADV - X XXX - X X X - 6 - XX YY -DC - SI

	EXP-SFTy-ADV safety card	SI = included	[empty] = not included
	DC link power supply versions		
	Only for parallel versions:	XX :	YY : Inverter power in kW
		MS = MASTER	04 = 400.0 kW
		SL = SLAVE with	05 = 500.0 kW
		MS/SL cable 1m	06 = 630.0 kW
		length	07 = 710.0 kW
		SL2 = SLAVE with	09 = 900.0 kW
		MS/SL cable 2m	10 = 1 MW
		length	14 = 1.35 MW
			17 = 1.65 MW
	Rated voltage: (factory setting):	6 = 3ph 690 V _{ac} / 50 Hz	6A = 3ph 690 V _{ac} / 60Hz
	Software:	X = standard	
	Braking unit:	X = not included	B = included
	Keypad:	X = not included	K = included
	Potenza inverter in kW:		
		750 = 75,0 kW	1600 = 160.0 kW
		900 = 90,0 kW	2000 = 200.0 kW
		1100 = 110,0 kW	2500 = 250.0 kW
		1320 = 132,0 kW	3150 = 315.0 kW
			3550 = 355.0 kW
	Mechanical dimensions of the drive:	5 = size 5	
		6 = size 6	
		7 = size 7	
	Inverter, ADV200 series		

Example:

ADV - 5 750 - K X X - 6

	Rated voltage: (factory setting):	6 = 690 V _{ac}
	Software:	X = standard
	Braking unit:	X = not included
	Keypad:	K = included
	Inverter power in kW:	750 = 75,0 kW
	Mechanical dimensions of the drive:	5 = size 5
	Inverter, ADV200 series	

ADV200-6

- Field-Orientated Vector Inverter
- Model with "KB-ADV" Programming Keypad
- 3 x 690 VAC power supply
- HD = Heavy Duty (Overload 150%)

CODE	PRODUCT IDENTIFICATION	Pn @ 690Vac (Asynchronous motors)		CONFIGURATION
		HD	LD	
S9060	ADV-5750-KXX-6	75kW		Integrated DC choke - Integrated Filter
S9061	ADV-5900-KXX-6	90kW		Integrated DC choke - Integrated Filter
S9062	ADV-61100-KXX-6	110kW		Integrated DC choke - Integrated Filter
S9063	ADV-61320-KXX-6	132kW		Integrated DC choke - Integrated Filter

ADV200-6/6A

- Field-Orientated Vector Inverter
- Model with "KB-ADV" Programming Keypad
- Power supply 3 x 690 VAC - 3 x 500/575 VAC
- HD = Heavy Duty (Overload 150%), LD = Light Duty (Overload 110%)

CODE	PRODUCT IDENTIFICATION	Pn @ 690Vac (Asynchronous motors)		CONFIGURATION
		HD	LD	
S9075	ADV-71600-KXX-6	160kW	200kW	Integrated Filter
S9076	ADV-72000-KXX-6	200kW	250kW	Integrated Filter
S9077	ADV-72500-KXX-6	250kW	315kW	Integrated Filter
S9078	ADV-73150-KXX-6	315kW	355kW	Integrated filter – Fan power supply 400 Vac/50 Hz
S9079	ADV-73550-KXX-6	355kW	400kW	Integrated filter – Fan power supply 400 Vac/50 Hz
S9080	ADV-73150-KXX-6A	315kW	355kW	Integrated filter – Fan power supply 460 Vac/60 Hz
S9081	ADV-73550-KXX-6A	355kW	400kW	Integrated filter – Fan power supply 460 Vac/60 Hz

ADV200-6/6A +SI - Power supply for Common DC Bus + SIL 3 Safety Card

- Field-Orientated Vector Inverter
- Model with "KB-ADV" Programming Keypad
- Power supply 3 x 690 VAC - 3 x 500/575 VAC
- Integrated safety card
- HD = Heavy Duty (Overload 150%), LD = Light Duty (Overload 110%)

CODE	PRODUCT IDENTIFICATION	Pn @ 690Vac (Asynchronous motors)		CONFIGURATION
		HD	LD	
S9075SI	ADV-71600-KXX-6+SI	160kW	200kW	Integrated Filter - Integrated safety card (No UL Mark)
S9076SI	ADV-72000-KXX-6+SI	200kW	250kW	Integrated Filter - Integrated safety card (No UL Mark)
S9077SI	ADV-72500-KXX-6+SI	250kW	315kW	Integrated Filter - Integrated safety card (No UL Mark)
S9078SI	ADV-73150-KXX-6+SI	315kW	355kW	Integrated filter – Fan power supply 400 Vac/50 Hz - Integrated safety card (No UL Mark)
S9079SI	ADV-73550-KXX-6+SI	355kW	400kW	Integrated filter – Fan power supply 400 Vac/50 Hz - Integrated safety card (No UL Mark)
S9080SI	ADV-73150-KXX-6A+SI	315kW	355kW	Integrated filter – Fan power supply 460 Vac/60 Hz - Integrated safety card (No UL Mark)
S9081SI	ADV-73550-KXX-6A+SI	355kW	400kW	Integrated filter – Fan power supply 460 Vac/60 Hz - Integrated safety card (No UL Mark)

ADV200-6/6A +SI - Parallel Configurations + SIL3 Safety Card

- Field-Orientated Vector Inverter
- "KB-ADV" Programming Keypad in the Master version (MS)
- Power supply 3 x 690 VAC - 3 x 500/575 VAC
- Integrated safety card
- HD = Heavy Duty (Overload 150%), LD = Light Duty (Overload 110%)

CODE	PRODUCT IDENTIFICATION	PN @ 690Vac (Asynchronous motors)		CONFIGURATION
		HD	LD	
S9076M S9076S	ADV-72000-KXX-6-MS 04 -SI ADV-72000-KXX-6-SL	400kW	500kW	Integrated Filter - Integrated safety card - (No UL Mark)
S9077M S9077S	ADV-72500-KXX-6-MS 05 -SI ADV-72500-KXX-6-SL	500kW	630kW	Integrated Filter - Integrated safety card - (No UL Mark)
S9078M S9078S	ADV-73150-KXX-6-MS 06 -SI ADV-73150-KXX-6-SL	630kW	710kW	Integrated filter - Integrated safety card - (No UL Mark) Fan power supply 400 Vac/50 Hz
S9079M S9079S	ADV-73550-KXX-6-MS 07 -SI ADV-73550-KXX-6-SL	710kW	800kW	Integrated filter - Integrated safety card - (No UL Mark) Fan power supply 400 Vac/50 Hz
S9078M1 S9078S S9078S	ADV-73150-KXX-6-MS 09 -SI ADV-73150-KXX-6-SL ADV-73150-KXX-6-SL	900kW	1MW	Integrated filter - Integrated safety card - (No UL Mark) Fan power supply 400 Vac/50 Hz
S9079M1 S9079S S9079S	ADV-73550-KXX-6-MS 10-SI ADV-73550-KXX-6-SL ADV-73550-KXX-6-SL	1MW	1.15MW	Integrated filter - Integrated safety card - (No UL Mark) Fan power supply 400 Vac/50 Hz
S9079M2 S9079S S9079S S9079S1	ADV-73550-KXX-6-MS 14-SI ADV-73550-KXX-6-SL ADV-73550-KXX-6-SL ADV-73550-KXX-6-SL2	1.35MW	1.5MW	Integrated filter - Integrated safety card - (No UL Mark) Fan power supply 400 Vac/50 Hz
S9079M3 S9079S S9079S S9079S1 S9079S1	ADV-73550-KXX-6-MS 17-SI ADV-73550-KXX-6-SL ADV-73550-KXX-6-SL ADV-73550-KXX-6-SL2 ADV-73550-KXX-6-SL2	1.65MW	1.8MW	Integrated filter - Integrated safety card - (No UL Mark) Fan power supply 400 Vac/50 Hz
S9080M S9080S	ADV-73150-KXX-6A-MS 06-SI ADV-73150-KXX-6A -SL	630kW	710kW	Integrated filter - Integrated safety card - (No UL Mark) Fan power supply 460 Vac/60 Hz
S9081M S9081S	ADV-73550-KXX-6A- MS 07-SI ADV-73550-KXX-6A- SL	710kW	800kW	Integrated filter - Integrated safety card - (No UL Mark) Fan power supply 460 Vac/60 Hz
S9080M1 S9080S S9080S	ADV-73150-KXX-6A-MS 09-SI ADV-73150-KXX-6A -SL ADV-73150-KXX-6A -SL	900kW	1MW	Integrated filter - Integrated safety card - (No UL Mark) Fan power supply 460 Vac/60 Hz
S9081M1 S9081S S9081S	ADV-73550-KXX-6A- MS 10-SI ADV-73550-KXX-6A- SL ADV-73550-KXX-6A- SL	1MW	1.15MW	Integrated filter - Integrated safety card - (No UL Mark) Fan power supply 460 Vac/60 Hz
S9081M2 S9081S S9081S S9081S1	ADV-73550-KXX-6A-MS 14-SI ADV-73550-KXX-6A-SL ADV-73550-KXX-6A-SL ADV-73550-KXX-6A-SL2	1.35MW	1.5MW	Integrated filter - Integrated safety card - (No UL Mark) Fan power supply 460 Vac/60 Hz

4. ADV100 • 230...480 VAc Power Supply

4.1 Introduction



The GEFran range of ADV100 inverters is specifically designed to give the utmost **flexibility of application** to modern automation systems and ensure **ease of use**, while guaranteeing advanced control capabilities for all asynchronous motors.

Flexible Modular Technology

The ADV100 is based on a fully modular structure with a choice of standard configurations, optional cards and integrated accessories such as EMC filters and mains chokes. All these elements offer real advantages in terms of product optimisation and savings in panel space and wiring costs, bringing considerable economic benefits.

Two self-tuning modes

Self-tuning of motor parameters:

- "Reduced" for faster start-up
- "Complete" to obtain maximum efficiency.

Energy Saving

The ADV100 has a dedicated function that decreases the voltage applied at the motor terminals, and thus current absorption, in reduced load conditions.

PID Control

The ADV100 integrates a complete, easy-to-program, smart PID controller, with value settings in engineering units, leakage function and programmable stand-by.

Brake Control

The ADV100 can control an electromechanical parking brake mounted on the motor.

Serial line

Integrated standard RS232 serial line with Modbus RTU protocol, for peer-to-peer connections

Encoder

The ADV100 interfaces with incremental digital encoders (DE) for field-oriented vector control (FOC) of asynchronous motors.

SD Card port

The SD memory card (standard on ADV120-...-C models) makes saving and loading data and configurations with the ADV100 very simple.

4.2 General Characteristics

- Power supply: 3 x 230V_{AC} -15% ... 500V_{AC} +5%,
50/60Hz ±2%
- Power ratings: from 4kW to 90kW
- Max output voltage 0.98 x V_{in}
- Asynchronous motors control mode:
 - Open-loop vector control
 - Vector control with feedback
 - Open loop V/f and V/f with feedback
- Overload:
 - 150% I_n for 60 seconds every 5 minutes
 - 180% I_n for 0.5 seconds every 5 minutes
- Integration of up to 2 options onboard the drive
- GF-eXpress multi-language programming SW (5 languages)
- IP20-rated protection
- Reference resolution: Digital = 15bit + sign
Analog input = 11bit + sign
Analog output = 11bit + sign

Fieldbus management

CANopen / DeviceNet communication (integrated into ADV120...-C models)



CANopen®

Modbus

Precision

Control mode	Speed control precision (*)	Control range
FOC with feedback	± 0.01% motor speed rating	1 : 1000
Open-loop FOC	± 30% motor slip rating	1 : 100
V/F	± 60% motor slip rating	1 : 30

(*) for standard 4-pole motor

Standard supply configuration

- Regulation:
 - 2 bipolar analog inputs (Voltage/Current)
 - 2 bipolar analog outputs (1: Voltage/Current, 1: Voltage)
 - 6 digital inputs (PNP/NPN)
 - 2 relay outputs, single contact
 - RS232 serial line (Modbus RTU)
- Power:
 - Integrated choke DC side (from size 4300)
 - Integrated mains filter (≥ size 4300)
 - Integrated dynamic braking module (up to size 5550)

Options

- Multilingual programming keypad with LCD screen (5 lines x 20 characters) and memory for 5 parameter sets
- Input choke
- Output chokes
- Braking resistors
- Incremental digital encoder feedback card (EXP-DE-I1-ADL)
- I/O expansion cards
- CANopen / DeviceNet communication (integrated in ADV120...-C models)
- External EMC filter (4...45 kW: C2 Category / 1st Environment / Motor cable length 30m; ≥ 55kW: C3 Category / 2nd Environment / Motor cable length 100m)..

Conformity

- Immunity/Emissions: CEE - EN 61800-3

Environmental conditions

- Ambient temperature: -10°C ... +40°C (+14°F ...+104°F),
+40°C...+50°C (+104°F...+122°F)
with derating
- Altitude: Max 2000 m. (up to 1000 m without derating)

Markings



Complies with the EEC directive concerning low voltage equipment

Complies with directives for the American and Canadian markets.

www.nicsanat.com
021-87700210



4.3 Standard connections

ADV100 • 230V...480V Power supply

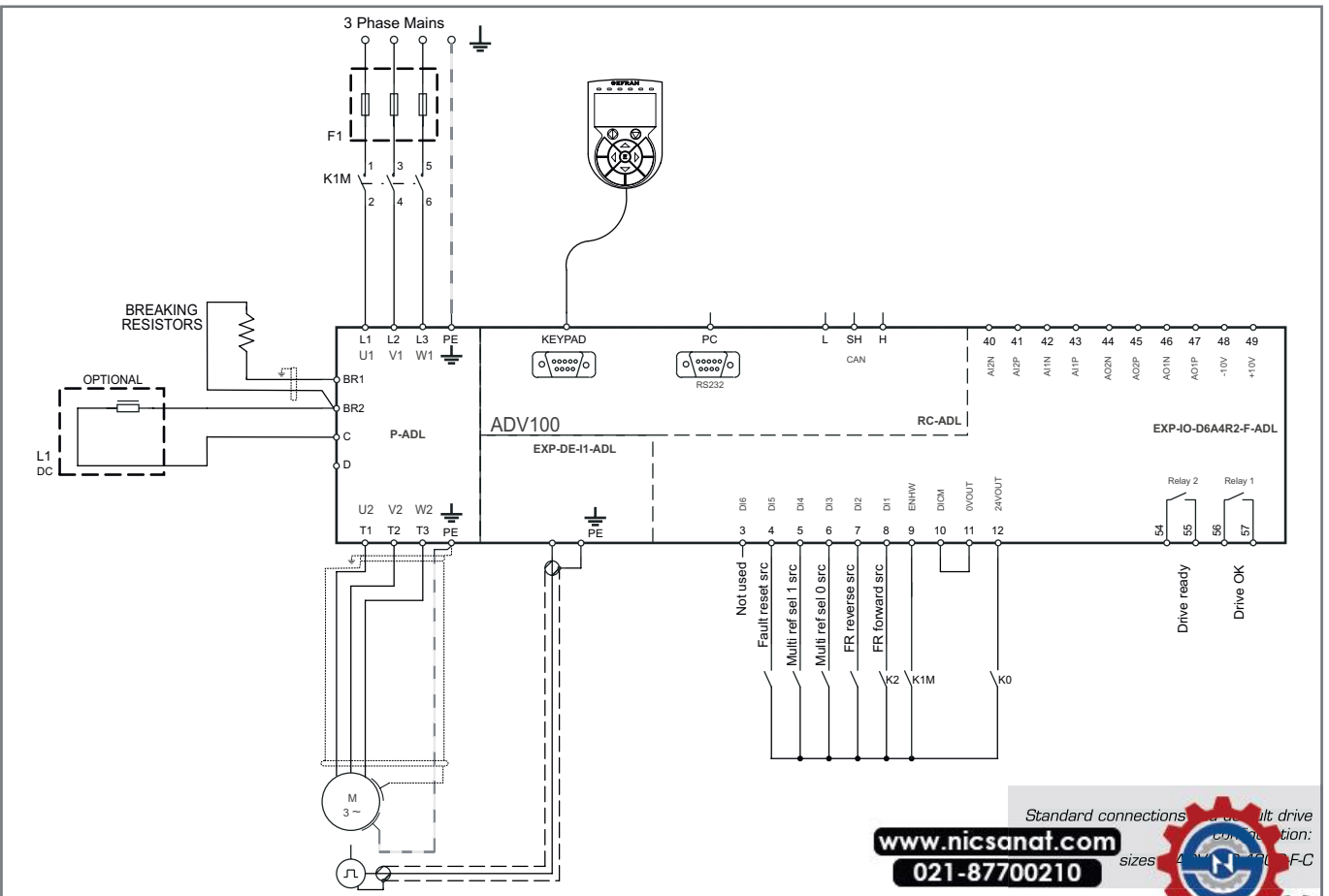
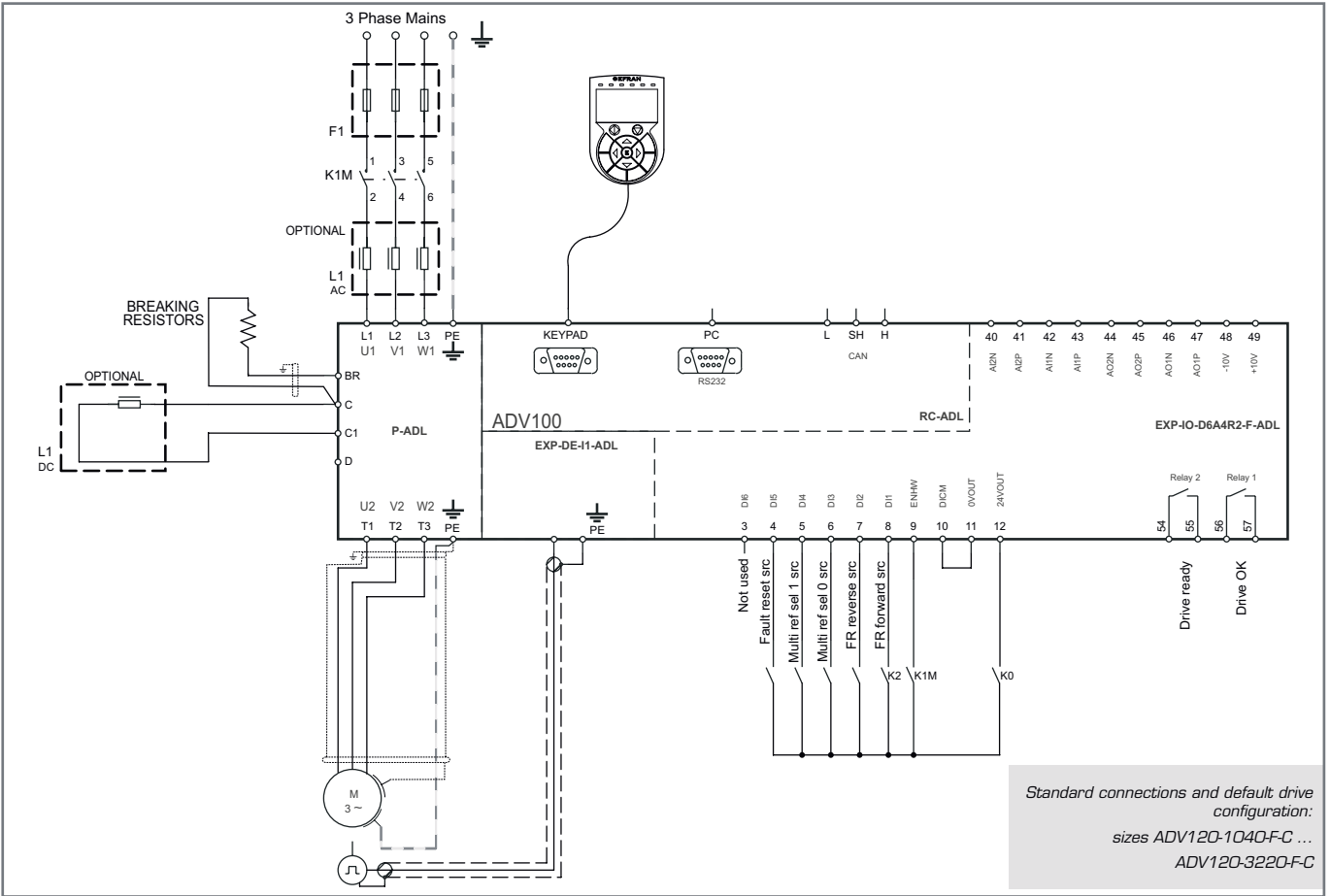

4.4 Weights and dimensions

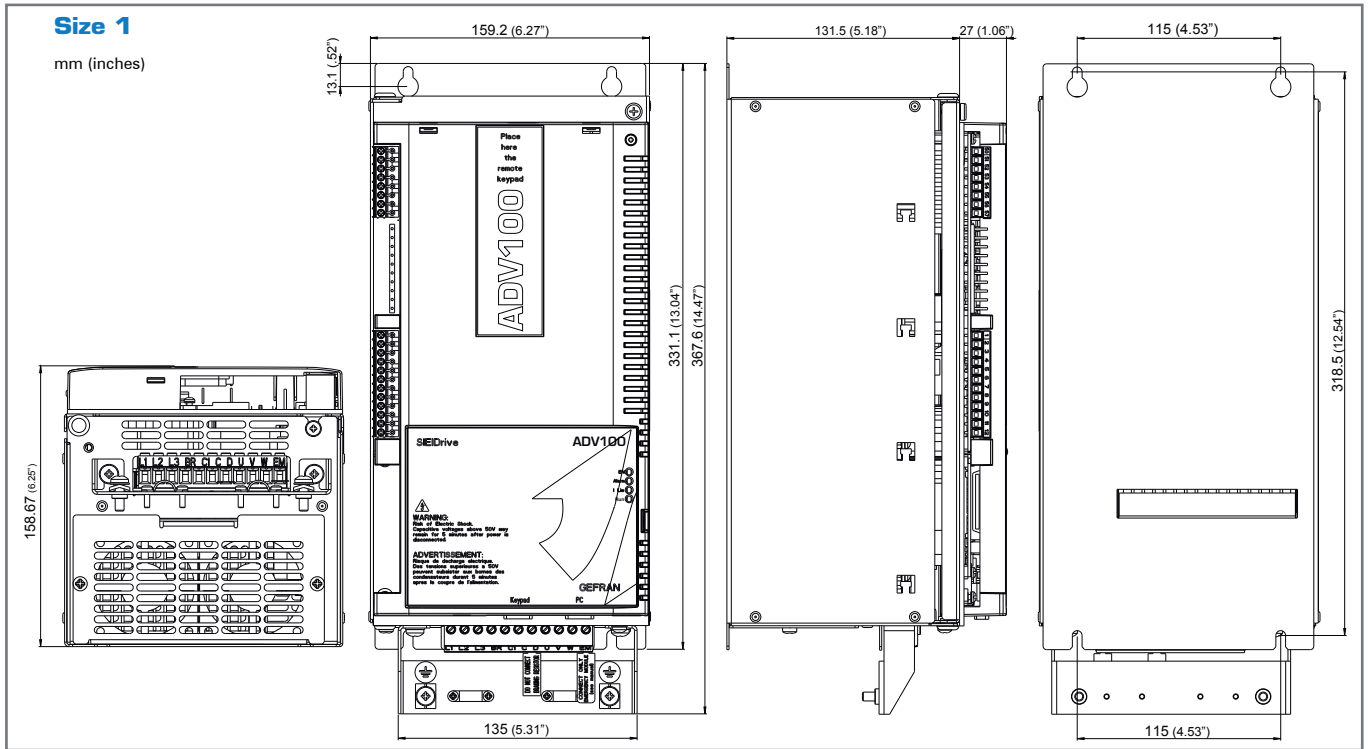

Size ADV100	Dimensions: Width x Height x Depth		Weight	
	mm	inches	kg	lbs
1040 - 1055	159.2 x 331.1 x 158.7	6.27 x 13.04 x 6.25	5.8	12.8

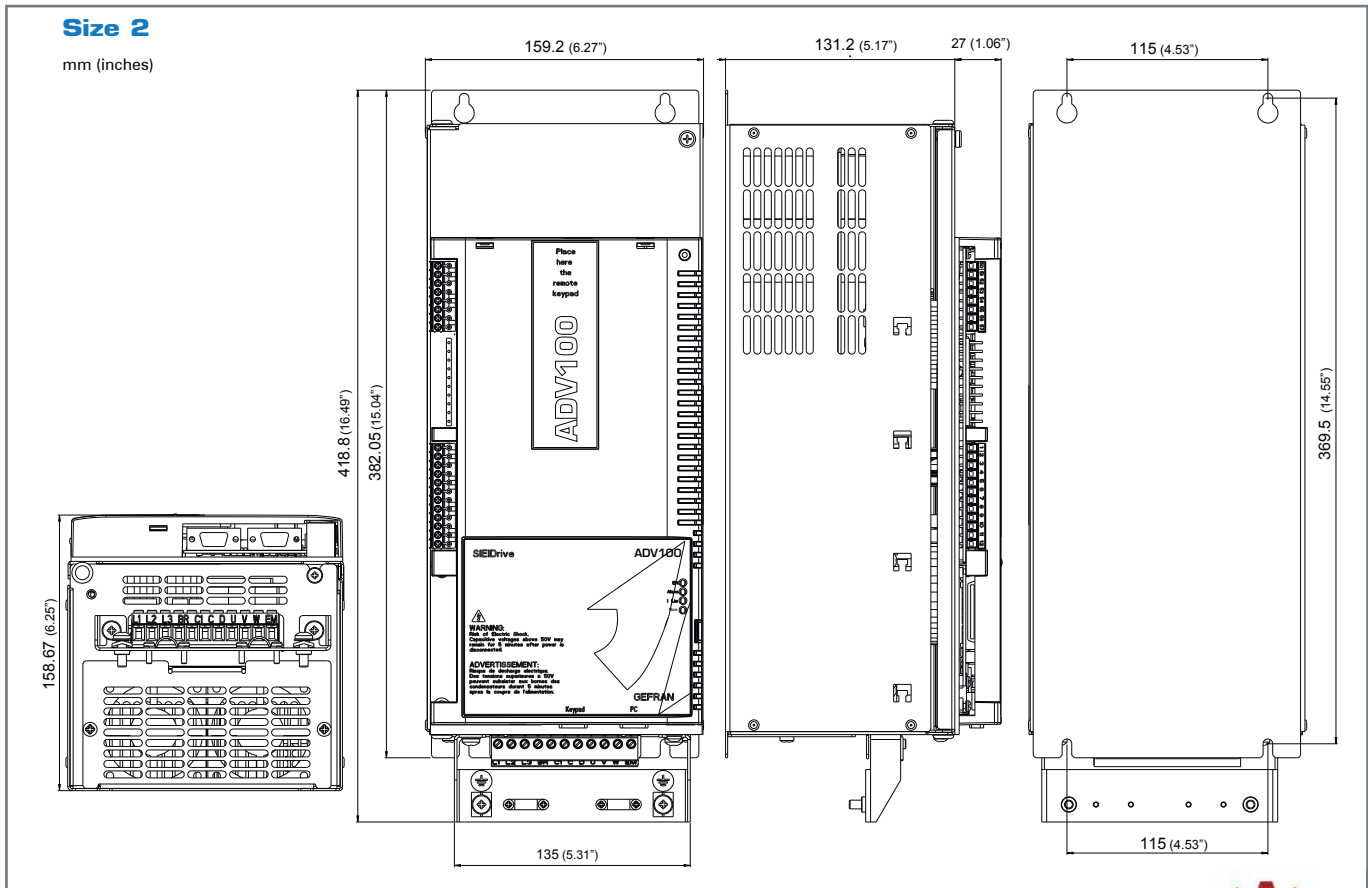

Size ADV100	Dimensions: Width x Height x Depth		Weight	
	mm	inches	kg	lbs
2075 - 2110	159.2 x 382.1 x 158.7	6.27 x 15.04 x 6.25		

www.nicsanat.com
021-87700210



Size 3

mm (inches)

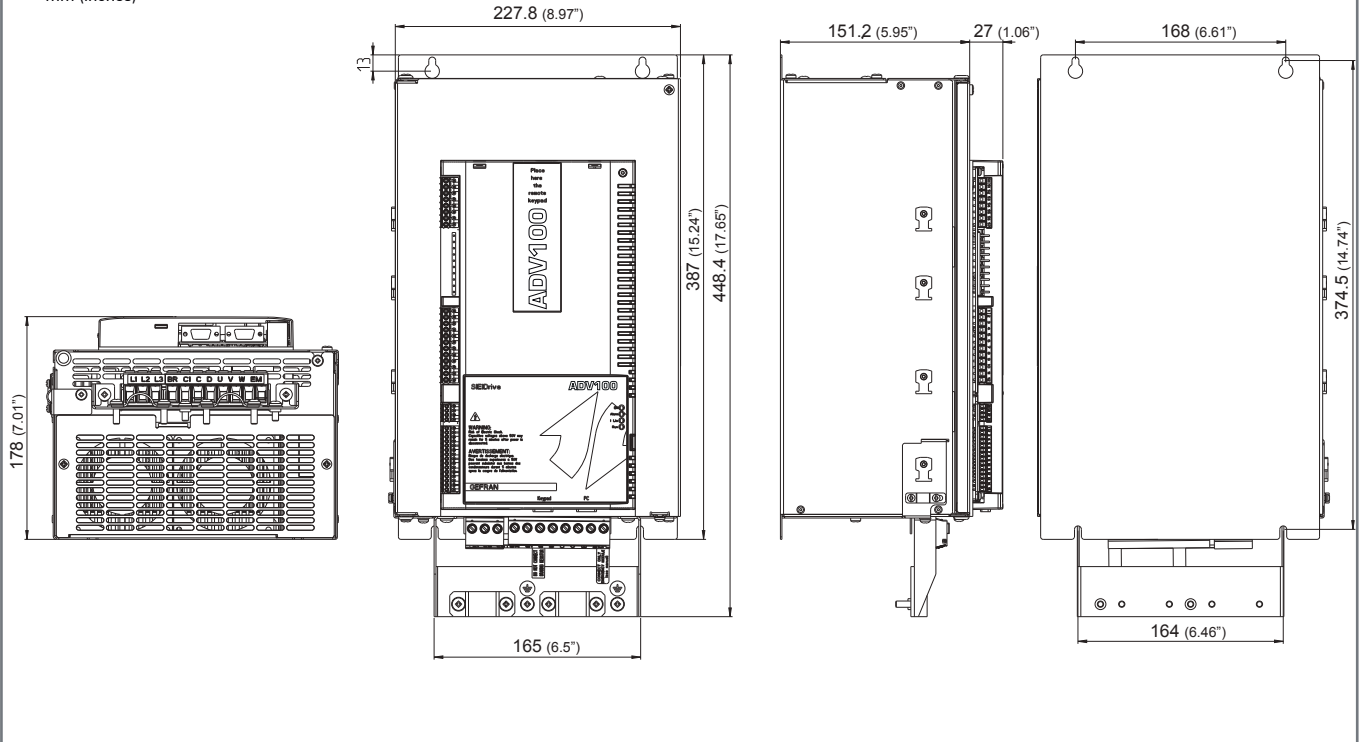

Size ADV100	Dimensions: Width x Height x Depth		Weight	
	mm	inches	kg	lbs
3150 ... 3220	227.8 x 387 x 178	8.97 x 15.24 x 7.01	10.5	23.15

Size 4

mm (inches)

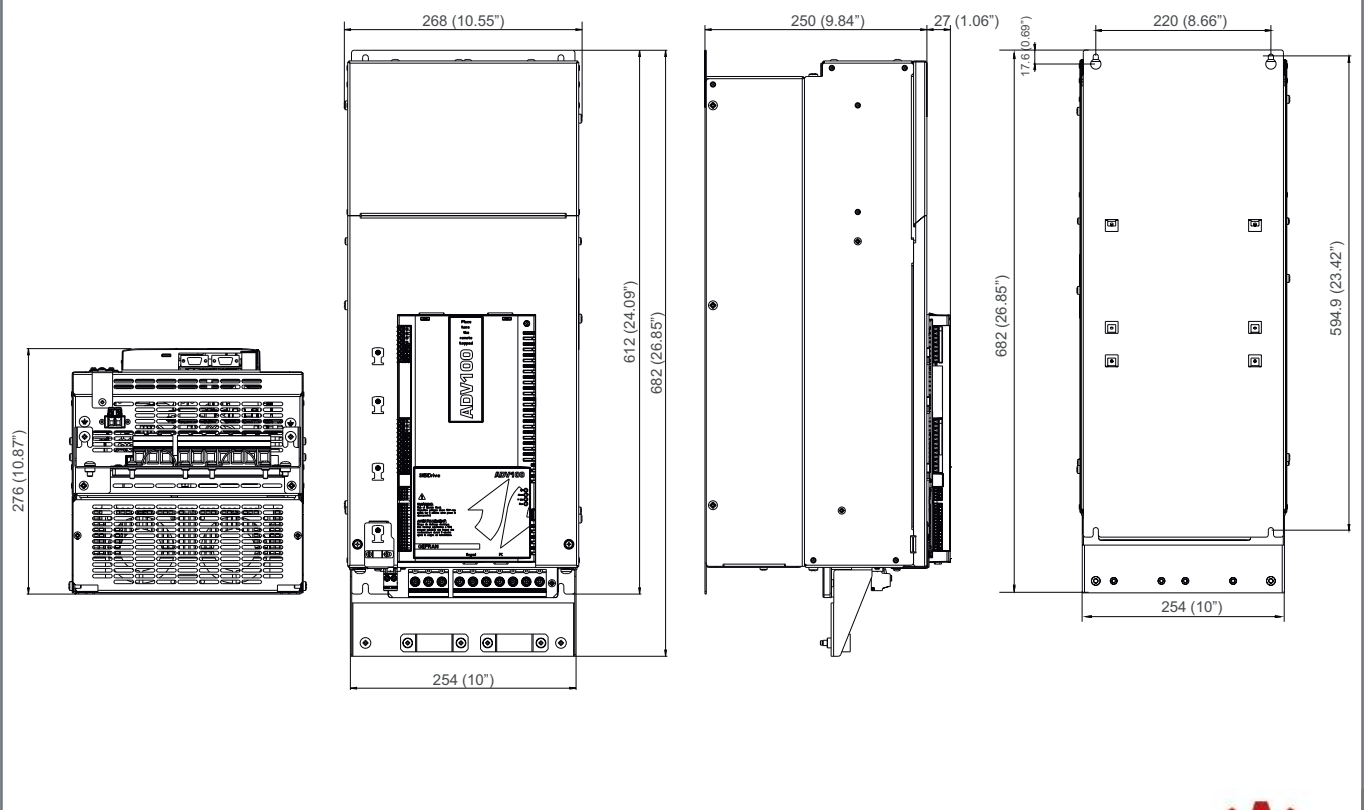

Size ADV100	Dimensions: Width x Height x Depth		Weight	
	mm	inches	kg	lbs
4300 ... 4450	268 x 612 x 276	10.55 x 24.09 x 10.87		

www.nicsanat.com
021-87700210



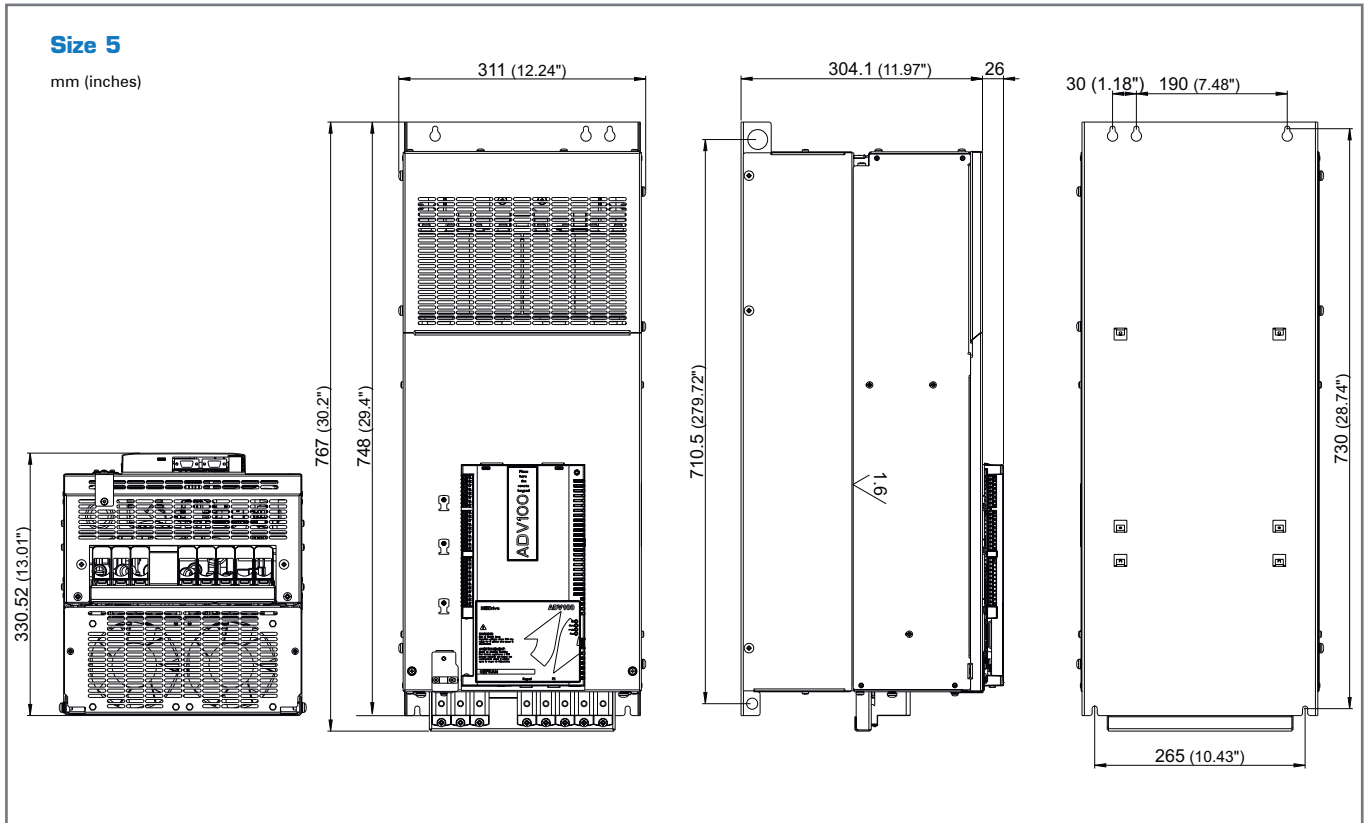

Size ADV100	Dimensions: Width x Height x Depth		Weight	
	mm	inches	kg	lbs
5550...5900	311 x 748 x 330.5	12.24 x 29.4 x 123.01	60	132.3

ADV200 - 4

ADV200-DC

ADV200 - 6

ADV100

ADV80

AFE200

PROGRAM.

APPENDIX

4.5 Choosing the Inverter

The combinations of motor power ratings and inverters listed in the table envisage the use of motors in which the voltage rating is equal to that of the mains power.

For motors with different voltage ratings the inverter must be chosen according to the current rating of the motor. The combinations listed in the table thus show the current that can be delivered by the drive during continuous operation and overload conditions, according to the mains voltage.

The same engineering criteria apply for operations with additional derating factors:

- K_V Power supply voltage
- K_T Ambient temperature
- K_f Switching frequency
- K_{ALT} Altitude of installation

4.6 Input Data

Sizes ADV100	Input voltage U_{LN} [V _{AC}]	Input frequency [Hz]	Overvoltage threshold (Overvoltage) [V _{DC}]	Undervoltage threshold (Undervoltage) [V _{DC}]	Total harmonic distortion [THD] %	AC input current I_n (@ I_{2n})	
						@ 230-400 V _{AC} [A]	@ 480 V _{AC} [A]
1040	Three-phase mains 230 V _{AC} -15% ... 500 V _{AC} +5%	50/60 Hz, ± 2%	820	@ 480V = 470V _{DC} ; @ 400V = 390V _{DC} ; @ 230V = 225V _{DC}	> 100 % (without choke) < 50 % (with external choke)	11	10
1055						16	14
2075						20	18
2110						28	26
3150						40	38
3185						47	44
3220					53	49	
4300					53	50	
4370					64	60	
4450					74	71	
5550					100	92	
5750					143	135	
5900					171	165	

4.7 Output Data

Sizes ADV100	Inverter Output for continuous duty [kVA]	Pn mot (Recommended motor rating, fsw = default)		I2n (Rated output current)		Maximum output voltage U2 [V]	Maximum output frequency f2 [Hz]	IGBT braking unit
		@400 VAc [kW]	@460 VAc [Hp]	@400 Vac [A]	@460 Vac [A]			
1040	7.6	4	5	9.5	8.6	0.98 x ULN 0.98 x ULN (ULN = AC input voltage)	500	Internal (with external resistor); braking torque 150 % MAX
1055	11.1	5.5	7.5	13	11.7			
2075	13.9	7.5	10	16.5	14.9			
2110	19.4	11	15	23	20.7			
3150	27.7	15	20	31	27.9			
3185	32.6	18.5	25	38	34.2			
3220	36.7	22	30	46	41.4			
4300	36.7	30	40	62	55.8			
4370	44.3	37	50	75	67.5			
4450	51.3	45	60	87	78			
5550	69.3	55	75	105	94.5			
5750	99.1	75	100	150	135			External optional (BUy series)
5900	118.5	90	125	180	162			

Sizes ADV100	Switching frequency fsw				F out [Hz]	T [°C]	Reduction factor			
	Default (5) [KHz]	Higher (5) [KHz]	lswf (6) [KHz]	hswf (6) [KHz]			Kv (1)	Kt (2)	Kf (3)	KALT % (4)
1040	4	6. 8. 10. 12	4	8	3	70	0.9	0.9	0.85; 0.7; 0.6; 0.5	1.2
1055	4	6. 8. 10. 12	4	8	3	75	0.9	0.9	0.85; 0.7; 0.6; 0.5	1.2
2075	4	6. 8. 10. 12	4	8	3	70	0.9	0.9	0.85; 0.7; 0.6; 0.5	1.2
2110	4	6. 8. 10. 12	4	8	3	70	0.9	0.9	0.85; 0.7; 0.6; 0.5	1.2
3150	4	6. 8. 10. 12	4	8	3	70	0.9	0.9	0.85; 0.7; 0.6; 0.5	1.2
3185	4	6. 8. 10. 12	4	8	3	75	0.9	0.9	0.85; 0.7; 0.6; 0.5	1.2
3220	4	6. 8. 10. 12	4	8	3	75	0.9	0.9	0.85; 0.7; 0.6; 0.5	1.2
4300	4	6. 8. 10. 12	4	8	3	65	0.9	0.9	0.85; 0.7; 0.6; 0.5	1.2
4370	4	6. 8. 10. 12	4	8	3	70	0.9	0.9	0.85; 0.7; 0.6; 0.5	1.2
4450	4	6. 8	4	8	3	75	0.9	0.9	0.85; 0.7	1.2
5550	4	6. 8	4	8	3	70	0.9	0.9	0.85; 0.7	1.2
5750	4	6. 8	4	8	5	65	0.9	0.9	0.85; 0.7	1.2
5900	4	6. 8	4	8	5	65	0.9	0.9	0.85; 0.7	1.2

(2) Kt : Derating factor for ambient temperature of 50°C (1% every °C above 40°C)

(3) Kf : Derating factor for higher switching frequency

(4) KALT : Derating factor for installation at altitudes above 1000 meters a.s.l.

Value to be applied = 1.2% each 100 m increase above 1000 m.

For example: Altitude 2000 m, KALT = 1.2% * 10 = 12% derating; In derated = (100 - 12) % = 88 % In

5) PAR 568 Switching freq mode = [0] Constant

6) PAR 568 Switching freq mode = [1] Variable

The switching frequency is variable between two levels (hswf and lswf) which are defined by the heatsink temperature and output frequency (hswf = Default switching frequency, lswf = Switching frequency when Fout or T reach the values showed in table).

Sizes ADV100	Overload		In [A]	K1 [%]	K2 [%]	OT [°C]
	150 % x In (1' each 5')	180 % x In (0,5' each 5')				
	[A]	[A]				
1040	14.3	17.1	9.5	100	3	78
1055	19.5	23.4	13	100	3	80
2075	24.8	29.7	16.5	100	3	80
2110	34.5	41.4	23	100	3	85
3150	46.5	55.8	31	100	5	92
3185	57	68.4	38	100	5	85
3220	69	82.8	46	100	3	87
4300	93	111.6	62	100	3	87
4370	112.5	135	75	100	3	88
4450	130.5	156.6	87	100	3	90
5550	157.5	189	105	100	3	85
5750	225	270	150	100	5	90
5900	270	324	180	100	5	93

Current limits positions according to output frequency

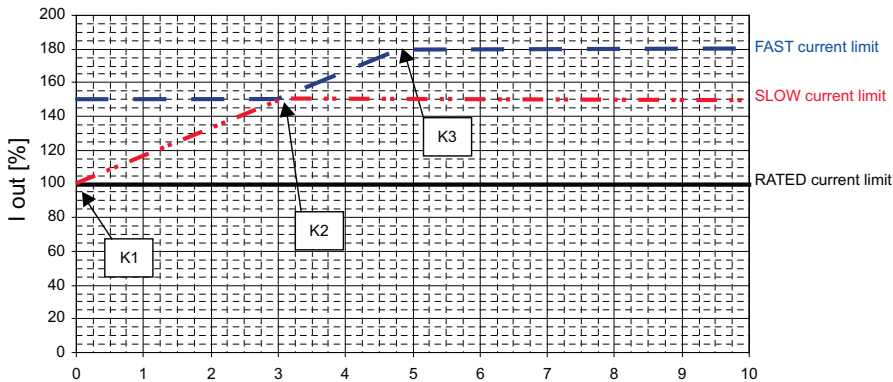

__ lslow, lfast; __ In

- k1 indicates the direct current (as a percentage with respect to the rated current) that the drive can deliver at a frequency of 0 Hz.
- k2 indicates the frequency at which the drive can deliver the 150% limit. Between 0 Hz and k2 the limit follows a linear pattern and thus also determines the k3 frequency at which the drive can deliver the 180% limit.
- OT (Drive overload temperature limit) below this temperature the 150% FAST current limit is also enabled for frequencies lower than k2; above this temperature only the slow current limit is enabled and this varies according to the output frequency and the ambient temperature (max 50°C).

The active current limit is always FAST; if fast I2t is loaded, the active current limit is SLOW. If SLOW I2t is loaded the active current limit is RATED.

4.8 Cooling

All inverters are fitted with internal fans (+ 24V) and threshold control (ON @ 55°C and OFF @ 45°C).

Size	P _v (*) (Heat dissipation) [W]	Fan capacity	
		Heat sink [m ³ /h]	Internal [m ³ /h]
1040	120	32	-
1055	160	2 x 56	-
2075	200	2 x 56	-
2110	250	2 x 32	-
3150	300	2 x 80	32
3185	380	2 x 80	32
3220	460	2 x 80	32
4300	600	2 x 250	2 x 50
4370	900	2 x 250	2 x 50
4450	1000	2 x 250	2 x 50
5550	1290	2 x 285	1 x 170
5750	1760	2 x 355	2 x 170
5900	2150	2 x 355	2 x 170

(*) : @U_{ln}=400..460Vac, values that refer to operation at default switching frequency.

ADV200 - 4

ADV200-DC

ADV200 - 6

ADV100

ADV80

AFE200

PROGRAM.

APPENDIX

4.9 Order codes

Product identification

ADV 1X0 -X XXX -X X X -Y -4 -C

CANbus:	[empty] = not included	C = included
Rated voltage: (factory setting):	4 = 400Vac	
EMI Filter:	X = not included	F = included
Software:	X = standard	
Braking unit:	X = not included	B = included
Keypad:	X = not included	K = included
Inverter power in kW:		
040 = 4.0 kW	185 = 18.5 kW	550 = 55.0 kW
055 = 5.5 kW	220 = 22.0 kW	750 = 75.0 kW
075 = 7.5 kW	300 = 30.0 kW	900 = 90.0 kW
110 = 11.0 kW	370 = 37.0 kW	
150 = 15.0 kW	450 = 45.0 kW	
Mechanical dimensions of the drive:		
	1 = size 1	4 = size 4
	2 = size 2	5 = size 5
	3 = size 3	
Regulation mode:	110 = FOC Sensorless	
	120 = FOC Closed loop	
Inverter, ADV100 series		

Example:

ADV 120 -1 040 -X X X -F -4 -C

CANbus:	C = included
Rated voltage: (factory setting):	4 = 400Vac
EMI Filter:	F = included
Software:	X = standard
Braking unit:	X = not included
Keypad:	X = not included
Inverter power in kW:	040 = 4.0 kW
Mechanical dimensions of the drive:	1 = size 1
Regulation mode:	120 = FOC Closed loop
Inverter, ADV100 series	

ADV110

- Field-Orientated Vector Inverter
- [Control for asynchronous motors in open loop](#)
- Power Supply 3 x 230VAC - 400VAC - 480VAC
- Optional Programming Keypad

CODE	PRODUCT IDENTIFICATION	PN @ 400Vac	CONFIGURATION
S9ADV01	ADV110-1040-XBX-4	4kW	Integrated Braking - Without encoder feedback
S9ADV11	ADV110-1055-XBX-4	5.5kW	Integrated Braking - Without encoder feedback
S9ADV21	ADV110-2075-XBX-4	7.5kW	Integrated Braking - Without encoder feedback
S9ADV31	ADV110-2110-XBX-4	11kW	Integrated Braking - Without encoder feedback
S9ADV41	ADV110-3150-XBX-4	15kW	Integrated Braking - Without encoder feedback
S9ADV51	ADV110-3185-XBX-4	18.5kW	Integrated Braking - Without encoder feedback
S9ADV61	ADV110-3220-XBX-4	22kW	Integrated Braking - Without encoder feedback
S9ADV72	ADV110-4300-XBX-F-4	30kW	Integrated Braking - Integrated Filter - Integrated Choke - Without encoder feedback
S9ADV82	ADV110-4370-XBX-F-4	37kW	Integrated Braking - Integrated Filter - Integrated Choke - Without encoder feedback
S9ADV92	ADV110-4450-XBX-F-4	45kW	Integrated Braking - Integrated Filter - Integrated Choke - Without encoder feedback
S9ADV102	ADV110-5550-XBX-F-4	55kW	Integrated Braking - Integrated Filter - Integrated Choke - Without encoder feedback
S9ADV71	ADV110-4300-XXX-F-4	30kW	Integrated Filter - Integrated Choke - Without encoder feedback
S9ADV81	ADV110-4370-XXX-F-4	37kW	Integrated Filter - Integrated Choke - Without encoder feedback
S9ADV91	ADV110-4450-XXX-F-4	45kW	Integrated Filter - Integrated Choke - Without encoder feedback
S9ADV101	ADV110-5550-XXX-F-4	55kW	Integrated Filter - Integrated Choke - Without encoder feedback
S9ADV111	ADV110-5750-XXX-F-4	75kW	Integrated Filter - Integrated Choke - Without encoder feedback
S9ADV121	ADV110-5900-XXX-F-4	90kW	Integrated Filter - Integrated Choke - Without encoder feedback

ADV120

- Field-Orientated Vector Inverter
- [Control for asynchronous motors in closed loop](#)
- Power Supply 3 x 230VAC - 400VAC - 480VAC
- Optional Programming Keypad

CODE	PRODUCT IDENTIFICATION	PN @ 400Vac	CONFIGURATION
S9ADV03	ADV120-1040-XBX-4	4kW	Integrated Braking - Digital encoder 2 Channels Card
S9ADV13	ADV120-1055-XBX-4	5.5kW	Integrated Braking - Digital encoder 2 Channels Card
S9ADV23	ADV120-2075-XBX-4	7.5kW	Integrated Braking - Digital encoder 2 Channels Card
S9ADV33	ADV120-2110-XBX-4	11kW	Integrated Braking - Digital encoder 2 Channels Card
S9ADV43	ADV120-3150-XBX-4	15kW	Integrated Braking - Digital encoder 2 Channels Card
S9ADV53	ADV120-3185-XBX-4	18.5kW	Integrated Braking - Digital encoder 2 Channels Card
S9ADV63	ADV120-3220-XBX-4	22kW	Integrated Braking - Digital encoder 2 Channels Card
S9ADV74	ADV120-4300-XBX-F-4	30kW	Integrated Braking - Integrated Filter - Integrated Choke - Digital encoder 2 Channels Card
S9ADV84	ADV120-4370-XBX-F-4	37kW	Integrated Braking - Integrated Filter - Digital encoder 2 Channels Card
S9ADV94	ADV120-4450-XBX-F-4	45kW	Integrated Braking - Integrated Filter - Digital encoder 2 Channels Card
S9ADV104	ADV120-5550-XBX-F-4	55kW	Integrated Braking - Integrated Filter - Digital encoder 2 Channels Card
S9ADV73	ADV120-4300-XXX-F-4	30kW	Integrated Filter - Integrated Choke - Digital encoder 2 Channels Card
S9ADV83	ADV120-4370-XXX-F-4	37kW	Integrated Filter - Digital encoder 2 Channels Card
S9ADV93	ADV120-4450-XXX-F-4	45kW	Integrated Filter - Digital encoder 2 Channels Card
S9ADV103	ADV120-5550-XXX-F-4	55kW	Integrated Filter - Digital encoder 2 Channels Card
S9ADV113	ADV120-5750-XXX-F-4	75kW	Integrated Filter - Digital encoder 2 Channels Card
S9ADV123	ADV120-5900-XXX-F-4	90kW	Integrated Filter - Digital encoder 2 Channels Card

ADV120-C

- Field-Orientated Vector Inverter
- Control for asynchronous motors in closed loop
- Power Supply 3 x 230V_{AC} - 400V_{AC} - 480V_{AC}
- Optional Programming Keypad
- [Integrated CAN](#)

CODE	PRODUCT IDENTIFICATION	PN @ 400Vac	CONFIGURATION
S9CDV05	ADV120-1040-XBX-4-C	4kW	Integrated Braking - Digital encoder 2 Channels Card
S9CDV15	ADV120-1055-XBX-4-C	5.5kW	Integrated Braking - Digital encoder 2 Channels Card
S9CDV25	ADV120-2075-XBX-4-C	7.5kW	Integrated Braking - Digital encoder 2 Channels Card
S9CDV35	ADV120-2110-XBX-4-C	11kW	Integrated Braking - Digital encoder 2 Channels Card
S9CDV45	ADV120-3150-XBX-4-C	15kW	Integrated Braking - Digital encoder 2 Channels Card
S9CDV55	ADV120-3185-XBX-4-C	18.5kW	Integrated Braking - Digital encoder 2 Channels Card
S9CDV65	ADV120-3220-XBX-4-C	22kW	Integrated Braking - Digital encoder 2 Channels Card
S9ADV76	ADV120-4300-XBX-F-4-C	30kW	Integrated Braking - Integrated Filter - Integrated Choke - Digital encoder 2 Channels Card
S9ADV86	ADV120-4370-XBX-F-4-C	37kW	Integrated Braking - Integrated Filter - Integrated Choke - Digital encoder 2 Channels Card
S9ADV96	ADV120-4450-XBX-F-4-C	45kW	Integrated Braking - Integrated Filter - Integrated Choke - Digital encoder 2 Channels Card
S9ADV106	ADV120-5550-XBX-F-4-C	55kW	Integrated Braking - Integrated Filter - Integrated Choke - Digital encoder 2 Channels Card
S9ADV75	ADV120-4300-XXX-F-4-C	30kW	Integrated Filter - Integrated Choke - Digital encoder 2 Channels Card
S9ADV85	ADV120-4370-XXX-F-4-C	37kW	Integrated Filter - Integrated Choke - Digital encoder 2 Channels Card
S9ADV95	ADV120-4450-XXX-F-4-C	45kW	Integrated Filter - Integrated Choke - Digital encoder 2 Channels Card
S9ADV105	ADV120-5550-XXX-F-4-C	55kW	Integrated Filter - Integrated Choke - Digital encoder 2 Channels Card
S9ADV115	ADV120-5750-XXX-F-4-C	75kW	Integrated Filter - Integrated Choke - Digital encoder 2 Channels Card
S9ADV125	ADV120-5900-XXX-F-4-C	90kW	Integrated Filter - Integrated Choke - Digital encoder 2 Channels Card

5. ADV80 • 400...480 Vac Power supply

5.1 Introduction



The ADV80 series brings together in a single product all the characteristics required by modern industrial processes, to meet the demands of installers and system integrators who require forefront, practical solutions that are, above all, advantageous in terms of space and cost.

Versatile and reliable

ADV80 inverters embody the latest technology to deliver high dynamic performance and excellent regulation accuracy, in all control situations where small AC motors are used.

Versatile and functional

With a choice of standard inputs/outputs and PNP or NPN settings, the ADV80 can be used in advanced application systems previously requiring the use of much more complex drives. An area with programmable logic can be used to create simple functions.

Energy Saving

The dedicated energy-saving function enables optimisation of the power and current absorbed by the motor to achieve even better energy efficiency than normally possible with inverters in general.

Start-Up menu

Simple and intuitive programming and a dedicated startup menu allow for fast drive configuration and immediate start-up.

PID control

The ADV80 incorporates an improved PID controller which allows simple, intuitive programming.

Multi Speed

With a wide choice of digital inputs, there are 16 speed settings and 4 completely independent ramps.

Serial & Fieldbus communication interfaces

The RS485 serial line with Modbus protocol is standard on the ADV80. The device can also be connected to the most advanced networks, including Profibus, CANbus and DeviceNet.

5.2 General Characteristics

- Power supply: 3 x 400VAC -15% ... 480VAC +10%, 50/60Hz ±5%
- Power ratings: from 0,37kW to 22kW
- Max output voltage: 0,94 x Vin
- Output frequency: 500Hz
- Asynchronous motors control mode:
 - Open-loop V/f and V/f with feedback
- Overload:
 - 150% In for 60 seconds every 5 minutes according to IEC146-1-1 Class 2
- GF-eXpress programming software
- Standard protection rating IP20
- Reference resolution: Digital = 0.1 Hz
Analog input = 10-bit + sign
Analog output = 8 bit

Fieldbus management

Interfacing with the most commonly-used fieldbus systems:



CANopen®



CANopen ® and DeviceNet interfaces incorporated in the ADV80-....-C version.

Standard supply configuration

- Regulation:
 - Integrated programming keypad
 - 2 differential analog inputs ±10 V (or current)
 - 2 analog outputs (voltage or current)
 - 5 digital inputs (PNP/NPN)
 - 2 digital outputs: 1 static and 1 relay (PNP/NPN)
 - RS485 serial line (Modbus protocol)
- Power:
 - Integrated dynamic braking module.

Options

- Input choke
- Output choke
- Braking resistors
- I/O expansion card: EXP_D6A1R1_ADV80
- Profibus interface: SBI_PDP_ADV80
- CANopen ®/DeviceNet interfaces (incorporated in the ADV80-....-C version)
- EMC filter for external mounting.

Conformity

- General: EN 61800-1, IEC 143-1-1
- Vibration: EN 60068-2-6, test Fc.
- Immunity/Emissions: EN61800-3 (with the use of dedicated filters)

Environmental conditions

- Ambient temperature: -10 ... 40°C,
+40°C...+50°C with derating
- Altitude: Max 2000 m.(up to 1000 m without derating).

Markings



Complies with the EEC directive concerning low voltage equipment.



Complies with directives for the American and Canadian market (sizes 3 only).

5.3 Standard connections

ADV80 • 400V...480V Power supply

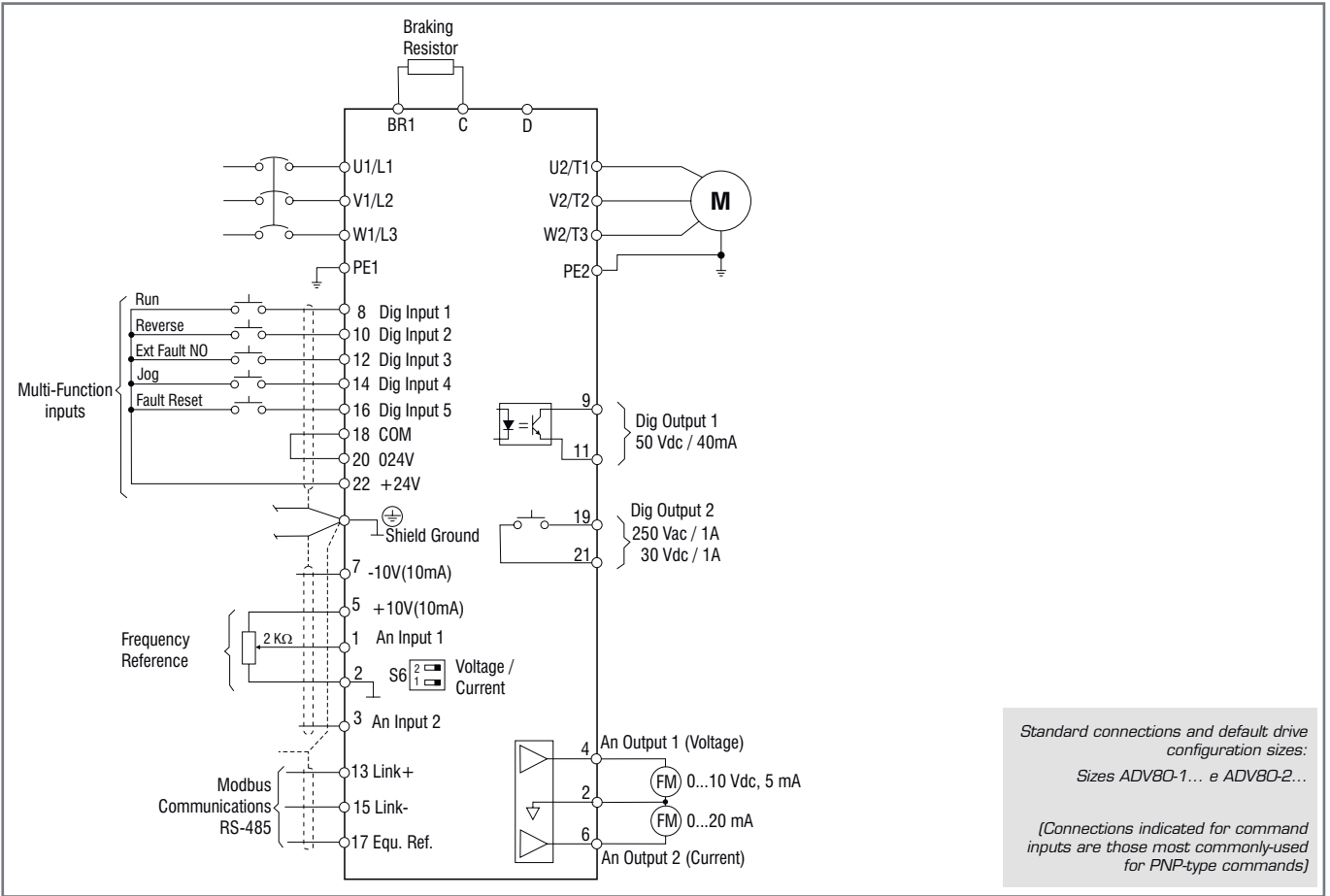

Standard connections and default drive configuration sizes:
 Sizes ADV80-1... e ADV80-2...
 (Connections indicated for command inputs are those most commonly-used for PNP-type commands)

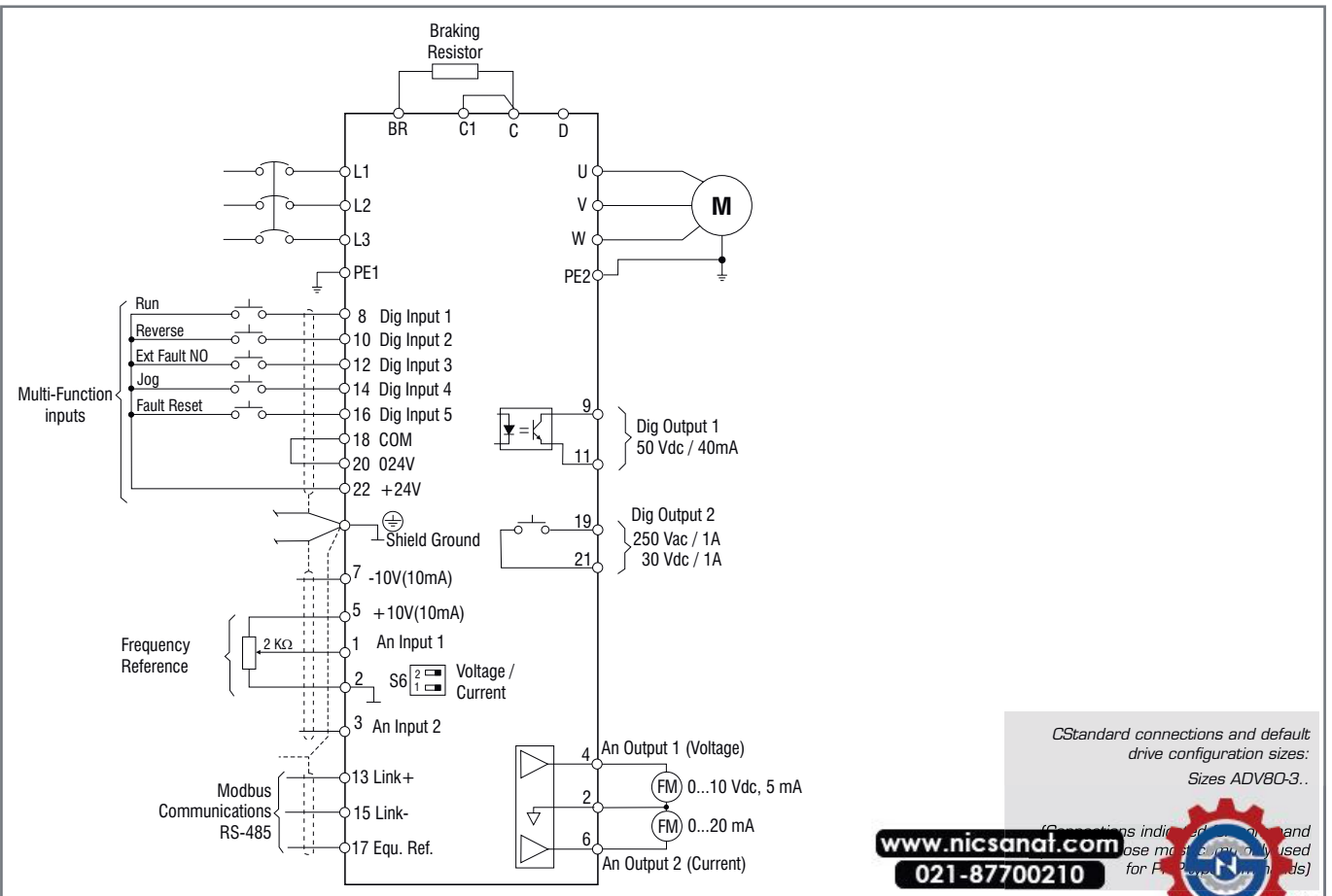

Standard connections and default drive configuration sizes:
 Sizes ADV80-3...
 (Connections indicated for command inputs are those most commonly-used for PNP-type commands)

5.4 Weights and dimensions

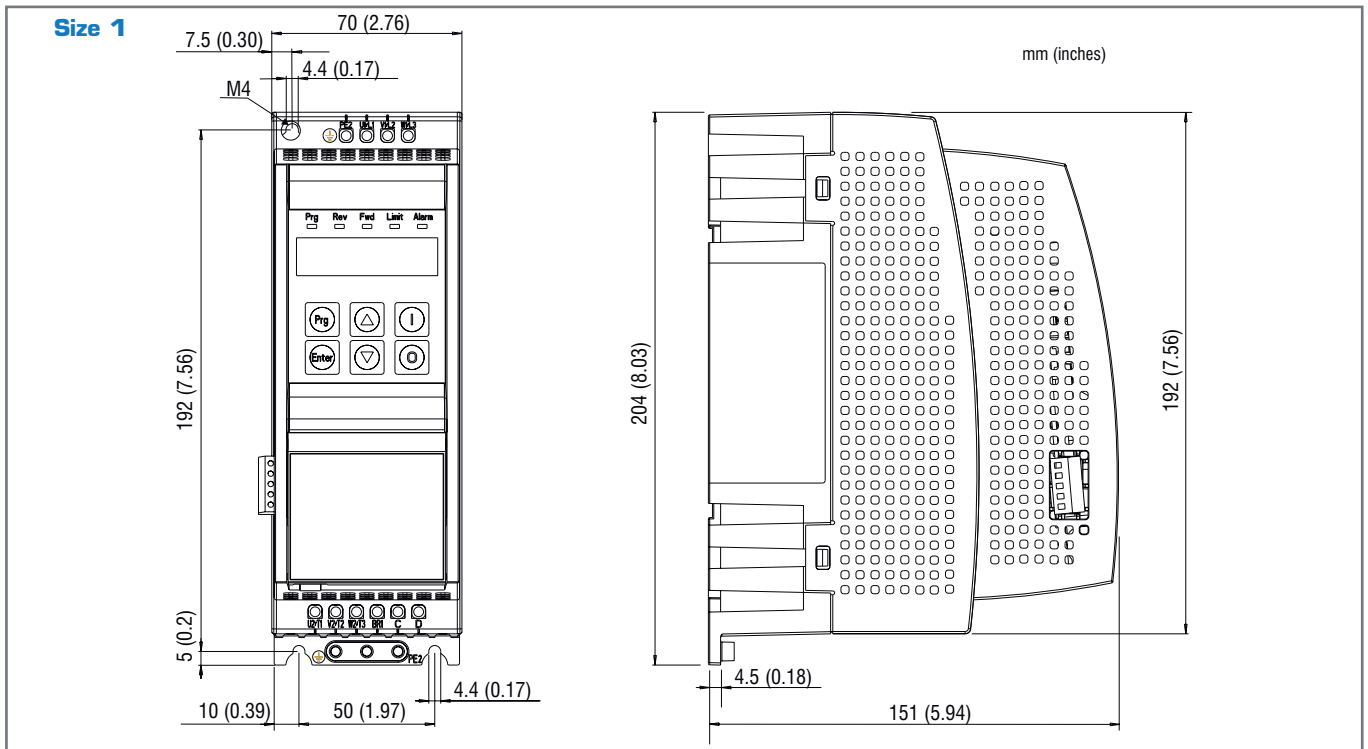

Sizes ADV80	Dimensions: Width x Height x Depth		Weight	
	mm	inches	kg	lbs
1004...1015	70 x 204 x 151	2.76 x 8.03 x 5.94	1.31	2.89

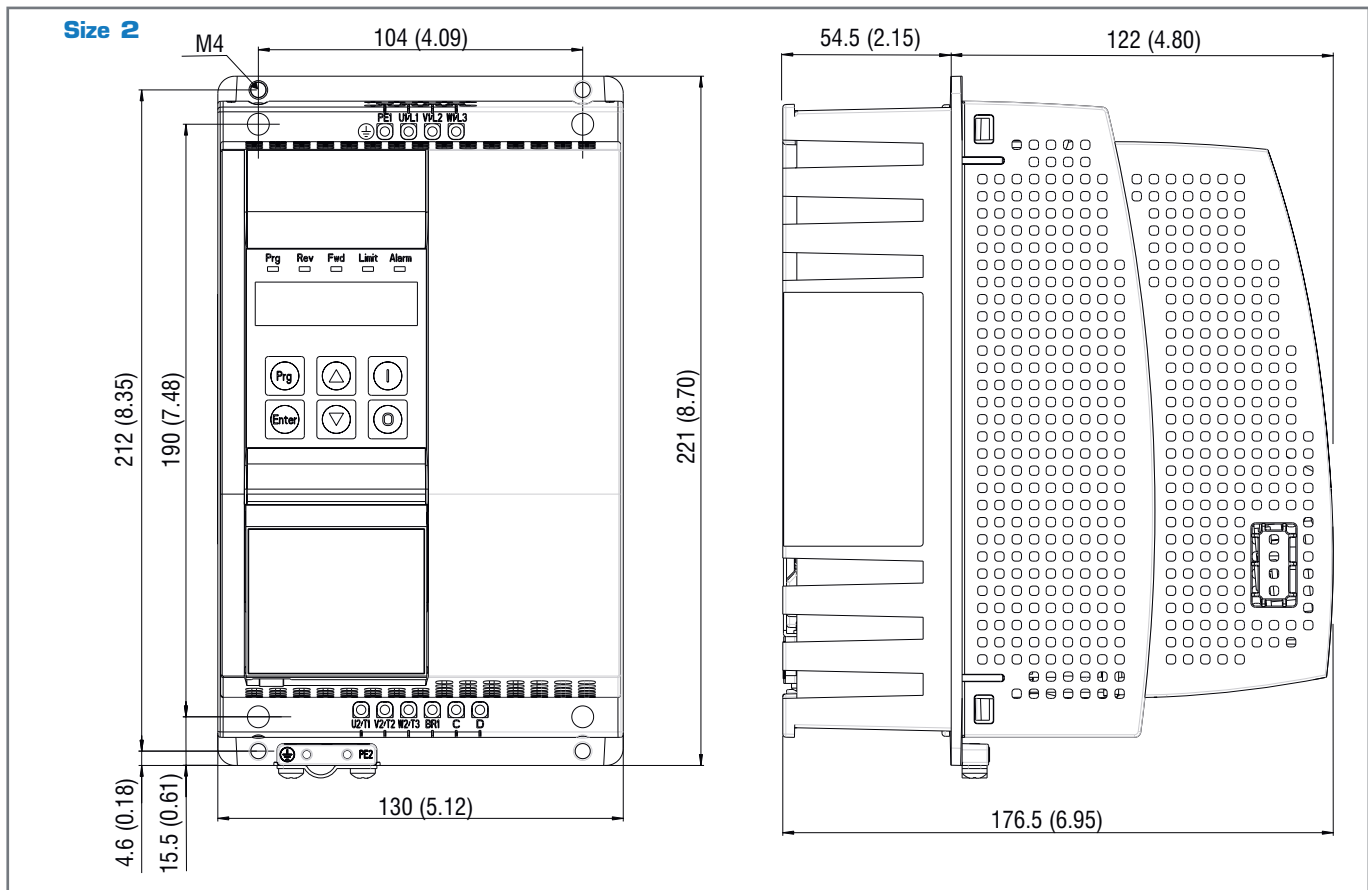

Sizes ADV80	Dimensions: Width x Height x Depth		Weight	
	mm	inches	kg	lbs
2022...2110	130 x 221 x 176.5	5.12 x 8.7 x 6.95		

www.nicsanaf.com
021-87700210



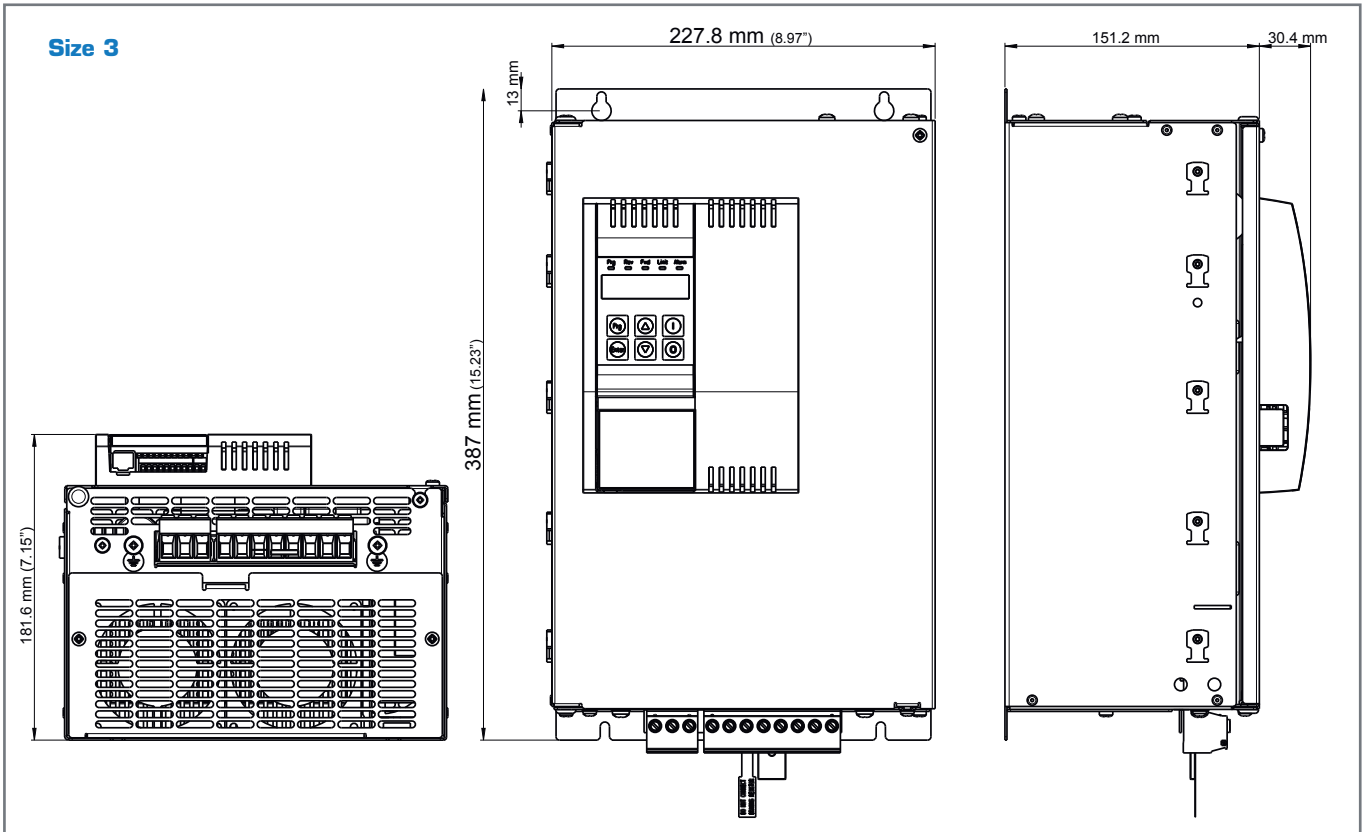

Sizes ADV80	Dimensions: Width x Height x Depth		Weight	
	mm	inches	kg	lbs
3150 ... 3220	227.8 x 387 x 181.6	8.97 x 15.23 x 7.15	10.5	23.15

5.5 Choosing the Inverter

The combinations of motor power ratings and inverters listed in the table envisage the use of motors in which the voltage rating is equal to that of the mains power.
For motors with different voltage ratings the inverter must be chosen according to the current rating of the motor.
The combinations listed in the table thus show the current that can be delivered by the drive during continuous operation and overload conditions, according to the mains voltage.

The same engineering criteria apply for operations with additional derating factors:

- K_T Ambient temperature
- K_f Switching frequency
- K_{ALT} Altitude of installation

5.6 Input Data

Sizes ADV80	Input voltage U_{LN} [VAC]	Input frequency [Hz]	Overtoltage threshold (Overtoltage) [Vdc]	Undervoltage threshold (Undervoltage) [Vdc]	Total harmonic distortion [THD] %
1004	Three-phase mains 400 VAC -15% ... 480 VAC +10%	50/60 Hz, \pm 5%	800	380 Vcc (for 380, 400VAC), 400 Vcc (for 420, 440 VAC), 415 Vcc (for 460, 480 VAC)	> 100 % (without mains choke) < 50 % (with optional mains choke)
1005					
1007					
1015					
2022					
2030					
2040					
2055					
2075					
2110					
3150					
3185					
3220					

Sizes ADV80	AC input current for continuous operation I_n (@ I_{2n})				Max. short circuit power without input choke ($Z_{min}=1\%$) [kVA]
	Connections with three-phase input choke		Connections without three-phase input choke		
	@ 400 VAC [A]	@ 480 VAC [A]	@ 400 VAC [A]	@ 480 VAC [A]	
1004	1.3	1.1	2.1	1.7	85
1005	1.6	1.3	2.6	2	115
1007	2.1	2	3.4	3.1	160
1015	4	3.6	5.9	5.3	270
2022	5.6	5	8.1	7.2	380
2030	7.1	6.5	10.2	9.1	500
2040	9.6	8.8	13	12	650
2055	10.8	9.1	17	14.5	850
2075	16	14.3	19	17	1115
2110	23	21	28	26	1600
3150	33	31	40	38	2200
3185	38	36	47	44	2700
3220	43	40	53	49	3200

5.7 Output Data

Sizes ADV80	Inverter Output (IEC146 class 2), 150% overload 60s [kVA]	Pn mot (Recommended rated power of motor, fsw = default)		I2n (Rated output current)		Maximum output voltage U2 [V]	Maximum output frequency f2 [Hz]	IGBT braking unit	Overload
		@400 VAC [kW]	@480 VAC [Hp]	@400 Vac [A]	@480 Vac [A]				
1004	0.8	0.37	0.5	1.1	1	0,94 x ULN (ULN = AC input voltage)	500	Internal (with external resistor); braking torque MAX 150%	Max. overload allowed: ≙ 150% x I2N cl.2. I2N indicates the values of the rated current for the most common service profiles (ambient temperature = 40°C, standard switching frequency). A similar criterion applies for operations with additional derating factors.
1005	1	0.55	0.75	1.5	1.4				
1007	1.4	0.75	1	2	1.8				
1015	2.6	1.5	1.5	3.7	3.2				
2022	3.6	2.2	2	5.2	4.5				
2030	4.7	3	4	6.8	5.9				
2040	6.4	4	5	9.2	7.6				
2055	8.2	5.5	7.5	11.8	9.7				
2075	11.2	7.5	10	16.1	13.2				
2110	15.9	11	15	23	20.7				
3150	21.5	15	20	31	27.9				
3185	26.3	18.5	25	38	34.2				
3220	31.8	22	30	46	41.4				

Sizes ADV80	Switching frequency fsw		Kt (1)	Kf (2)	KALT % (3)
	Default [KHz]	Higher [KHz]			
1004	8	12	0.8	0.7 for higher fsw values	1.2
1005	8	12	0.8	0.7 for higher fsw values	1.2
1007	8	12	0.8	0.7 for higher fsw values	1.2
1015	8	12	0.8	0.7 for higher fsw values	1.2
2022	8	12	0.8	0.7 for higher fsw values	1.2
2030	8	12	0.8	0.7 for higher fsw values	1.2
2040	8	12	0.8	0.7 for higher fsw values	1.2
2055	8	12	0.8	0.7 for higher fsw values	1.2
2075	8	12	0.8	0.7 for higher fsw values	1.2
2110	6	8	0.8	0.7 for higher fsw values	1.2
3150	8	12	0.8	0.7 for higher fsw values	1.2
3185	8	12	0.8	0.7 for higher fsw values	1.2
3220	8	12	0.8	0.7 for higher fsw values	1.2

(1) Kt : Derating factor with an ambient temperature of 50°C (1% every °C above 40°C)
 (2) Kf : Derating factor for higher switching frequency

(3) KALT : Derating factor for altitude
 Value to be applied for altitudes above 1000 m.
 E.g.: Altitude 2000 m
 In derated = (100 - 12) % = 88 % In



5.8 Cooling

Size	Pv (*) (Heat dissipation)		Fan capacity		Min. cooling vents in cabinet	
	@ ULN=400Vac [W]	@ ULN=480Vac [W]	Dissipator [m ³ /h]	Internal [m ³ /h]	Dissipator cm ²	Regulation cm ²
ADV80-1004	24	23	-	-	36	31
ADV80-1005	24	30	-	-		
ADV80-1007	38	37	-	-		
ADV80-1015	101	95	-	11	72	31
ADV80-2022	124	122	20	11		
ADV80-2030	147	146	2 x 20	11		
ADV80-2040	183	180	2 x 20	11		
ADV80-2055	205	213	2 x 20	11		
ADV80-2075	256	266	2 x 20	11		
ADV80-2110	214	202	2 x 25	25	70	90
ADV80-3150	300	300	2 x 80	32	328	
ADV80-3185	380	380	2 x 80	32	328	
ADV80-3220	460	460	2 x 80	32	328	

(*) : values refer to switching frequency with default conditions.

ADV200 - 4

ADV200-DC

ADV200 - 6

ADV100

ADV80

AFE200

PROGRAM.

APPENDIX

5.9 Order codes

Product identification

ADV80 -X XXX - K B X - C

CANopen/DeviceNet:	[empty] = not included	C = included
Software:	X = standard	
Braking unit:		B = included
Keypad:		K = included
Inverter power in kW:		
004 = 0.37 kW	030 = 3.0 kW	185 = 18.5 kW
005 = 0.55 kW	040 = 4.0 kW	220 = 22.0 kW
007 = 0.75 kW	055 = 5.5 kW	
015 = 1.5 kW	075 = 7.5 kW	
022 = 2.2 kW	110 = 11.0 kW	
Mechanical dimensions of the drive:	1 = size 1	3 = size 3
	2 = size 2	
Inverter, ADV80 series		

Example:

ADV80 -2 040 - K B X - C

CANopen/DeviceNet:	C = included
Software:	X = standard
Braking unit:	B = included
Keypad:	K = included
Inverter power in kW:	040 = 4,0 kW
Mechanical dimensions of the drive:	2 = size 2
Inverter, ADV80 series	

ADV80

- Control for asynchronous motors in open loop mode
- Power supply 3 x 400 V_{AC} - 480 V_{AC}
- Integrated programming keypad

CODE	PRODUCT IDENTIFICATION	P _N @ 400V _{AC}	CONFIGURATION
S9AGV1	ADV80-1004-KBX	0,4kW	Integrated braking unit
S9AGV2	ADV80-1005-KBX	0,55kW	Integrated braking unit
S9AGV3	ADV80-1007-KBX	0,75kW	Integrated braking unit
S9AGV18	ADV80-1015-KBX	1,5kW	Integrated braking unit
S9AGV5	ADV80-2022-KBX	2,2kW	Integrated braking unit
S9AGV6	ADV80-2030-KBX	3kW	Integrated braking unit
S9AGV7	ADV80-2040-KBX	4kW	Integrated braking unit
S9AGV8	ADV80-2055-KBX	5,5kW	Integrated braking unit
S9AGV9	ADV80-2075-KBX	7,5kW	Integrated braking unit
S9AGV14	ADV80-2110-KBX	11kW	Integrated braking unit
S9AGV11	ADV80-3150-KBX	15kW	Integrated braking unit
S9AGV12	ADV80-3185-KBX	18,5kW	Integrated braking unit
S9AGV13	ADV80-3220-KBX	22kW	Integrated braking unit

ADV80-...-C

- Control for asynchronous motors in open loop mode
- Power supply 3 x 400 V_{AC} - 480 V_{AC}
- Integrated programming keypad
- Integrated CAN

CODE	PRODUCT IDENTIFICATION	P _N @ 400V _{AC}	CONFIGURATION
S9AGV38	ADV80-1015-KBX-C	1,5kW	Integrated braking unit - Integrated CAN/DeviceNet
S9AGV25	ADV80-2022-KBX-C	2,2kW	Integrated braking unit - Integrated CAN/DeviceNet
S9AGV26	ADV80-2030-KBX-C	3kW	Integrated braking unit - Integrated CAN/DeviceNet
S9AGV27	ADV80-2040-KBX-C	4kW	Integrated braking unit - Integrated CAN/DeviceNet
S9AGV28	ADV80-2055-KBX-C	5,5kW	Integrated braking unit - Integrated CAN/DeviceNet
S9AGV29	ADV80-2075-KBX-C	7,5kW	Integrated braking unit - Integrated CAN/DeviceNet
S9AGV34	ADV80-2110-KBX-C	11kW	Integrated braking unit - Integrated CAN/DeviceNet
S9AGV31	ADV80-3150-KBX-C	15kW	Integrated braking unit - Integrated CAN/DeviceNet
S9AGV32	ADV80-3185-KBX-C	18,5kW	Integrated braking unit - Integrated CAN/DeviceNet
S9AGV33	ADV80-3220-KBX-C	22kW	Integrated braking unit - Integrated CAN/DeviceNet

6. AFE200 • Active Front End Regenerative Power Supply Unit

6.1 Introduction



AFE200 is the range of **regenerative power supply units** incorporating **Active Front End** technology.

Ideal for powering the batteries of drives connected on the same DC Bus or even for managing single-drive configurations.

The AFE200 offers a number of advantages:

- "Clean Power" thanks to the unit power factor and reduced harmonic distortion ($\leq 3\%$)
- Enhanced system dynamics during drive and regeneration
- Considerable energy savings during regeneration transients
- Improved stability of the DC Bus circuit under load changes
- Significant cost-effectiveness with the single power supply system
- Elimination of uneconomical conventional braking systems and braking resistors

The AFE200 range has power ratings of **22kW to 1.65MW** for three-phase power supplies of **400VAC to 690VAC**. Ease of use and intuitive programming make it possible for users of any level to exploit the high-level performance of Active Front End technology for a broad range of applications where there is a need for real energy saving.

Flexible Modular Technology

The AFE200 is also based on a fully modular hardware with power structures that can be installed side by side. Designed to facilitate installation and guarantee ease of use, project flexibility, optimisation of space and reduction of wiring costs.

The AFE200 is available in 5 hardware sizes

- from 22kW to 355kW in the stand-alone configuration
- from 400kW to 1.65MW in "parallel" configurations.

Pre-load system

External management of the intermediate circuit pre-load is a feature of the entire range. The dedicated AFE PRE-CHARGE KITS are supplied complete with pre-wired resistors and contactors.

Total ease of use

The AFE200 is designed to enable simple, quick, economical connections to the system to be powered. All structures are extremely easy to handle and the terminal strips and optional card racks are readily accessible. The dedicated accessories guarantee simple wiring and cable shielding to achieve immediate, EMC-compliant start-ups.

Serial line

The RS485 serial line is incorporated as standard across the range to enable peer-to-peer or multidrop connections using Modbus RTU protocol.

Management of optional cards

The AFE200 uses an intelligent rack system that allows the following optional cards to be installed at the same time:

- Fieldbus interface card
- I/O expansion card

Back-up power supply

The AFE200 is compatible with a separate +24Vdc external power supply. This solution makes it possible to maintain all display and drive configuration functions and manage the connected fieldbuses in the event of a power failure.

Ideal Sizing

The AFE200 offers a choice of technical features so that you can choose the drive best suited to the loads of the system to be controlled and specific operating conditions.

- Two overload modes for "heavy duty" with duty cycle of 150% of I_n for 1 minute every 5 minutes or for "light duty" (variable and/or quadratic torque) with duty cycle of 110% of I_n for 1 minute every 5 minutes.

6.2 General Characteristics

- Power supply: 380V_{AC} -15% ...500V_{AC} +5%, 50/60Hz (versions -4 and -4A)
500V_{AC} -10% ...690V_{AC} +10%, 50/60Hz (-6 and -6A versions)
- Power ratings: from 22kW to 1.65MW
- Cosphi ≥ 0.99
- THD ≤ 3% (Considering a network with voltage THD of less than 2%).
- Overload 150% for 60 sec every 5 minutes (Heavy duty) or 110% for 60 sec every 5 minutes (Light duty)
- Integration of up to 2 options onboard the drive
- GF-eXpress multi-language programming SW (5 languages)
- IP20-rated protection (IPOO size 7 and parallel)
- Reference resolution: Digital = 15-bit + sign
Analog input = 11-bit + sign
Analog output = 11-bit + sign

Fieldbus management



Modbus



CANopen®

EtherCAT®



Standard supply configuration

- Integrated KB_ADV programming keypad
- Regulation:
 - 2 bipolar analog inputs (Voltage/Current)
 - 2 bipolar analog outputs (1: Voltage/Current, 1: Voltage)
 - 6 digital inputs (PNP/NPN)
 - 2 digital outputs (PNP/NPN)
 - 2 relay outputs, single contact
 - RS485 serial line (Modbus RTU)

Options

- LCL type line input filter, is composed by one Input choke and one LC filter (mandatory)
- Pre-charge kit, includes fuses, resistors and pre-charge contactor (mandatory)
- External EMI mains filter

Conformity

- Climatic conditions EN 60721-3-3
- Electrical safety EN 50178, EN 61800-5-1, UL508C, UL840 pollution level 2
- Vibrations EN 60068-2-6, test Fc.
- EMC EN61800-3

Environmental conditions

- Ambient temperature: -10°C ... +40°C (+14°F ...+104°F), +40°C...+50°C (+104°F...+122°F) with derating
- Altitude: Max 2000 m.

Markings



Complies with the EEC directive concerning low voltage equipment



Complies with directives for the American and Canadian market.

(Sizes AFE200...-6/6A with 690 V power supply are not UL-marked..)

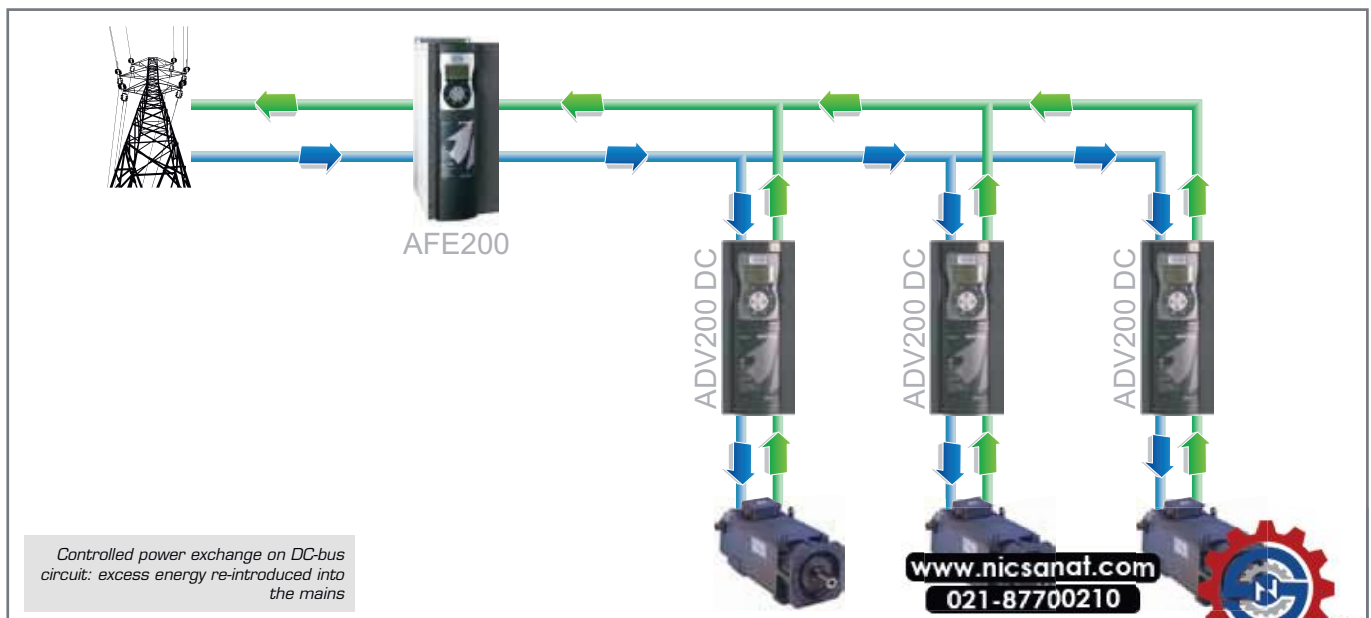

For parallel sizes:
AFE200 400kW ... 1.65MW

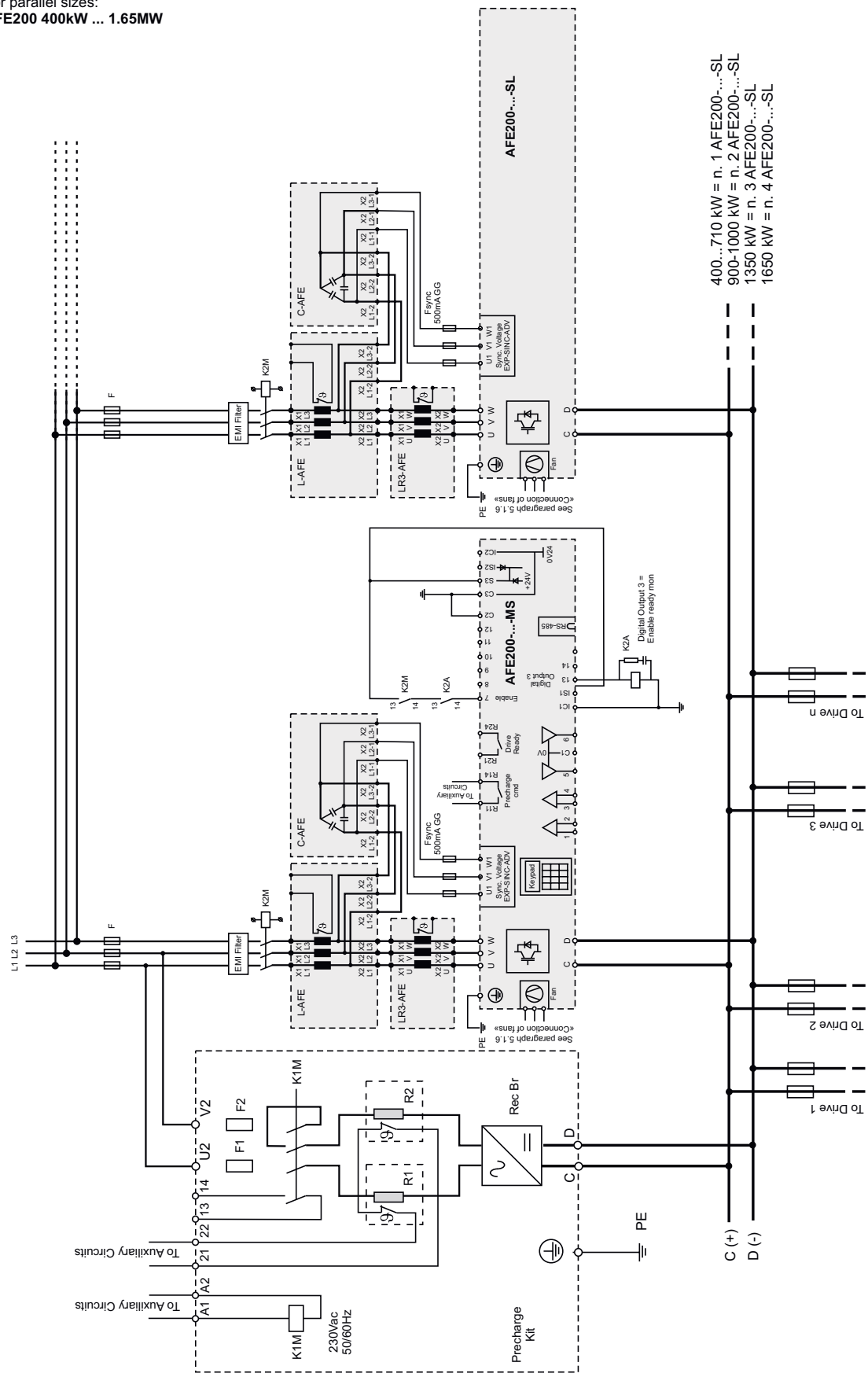

400...710 kW = n. 1 AFE200-...-SL
900-1000 kW = n. 2 AFE200-...-SL
1350 kW = n. 3 AFE200-...-SL
1650 kW = n. 4 AFE200-...-SL

Standard connections and default drive configuration (parallel versions).

Rev.	Date	Modification Description	Des/Sch	Appv'd	Name:	Nr.:	Date:	Rev.
					AFE Parallele Connection		29-1-2014	00
					Loc.			
					Des. BRI	Sch.	Appr. CNL	
					GEFRAN			Page over
					GEFran S.p.A. - Foto di Gerenzano (PV) - Via Via Carducci, 24 - Gerenzano (PV) - Italy			1
								1

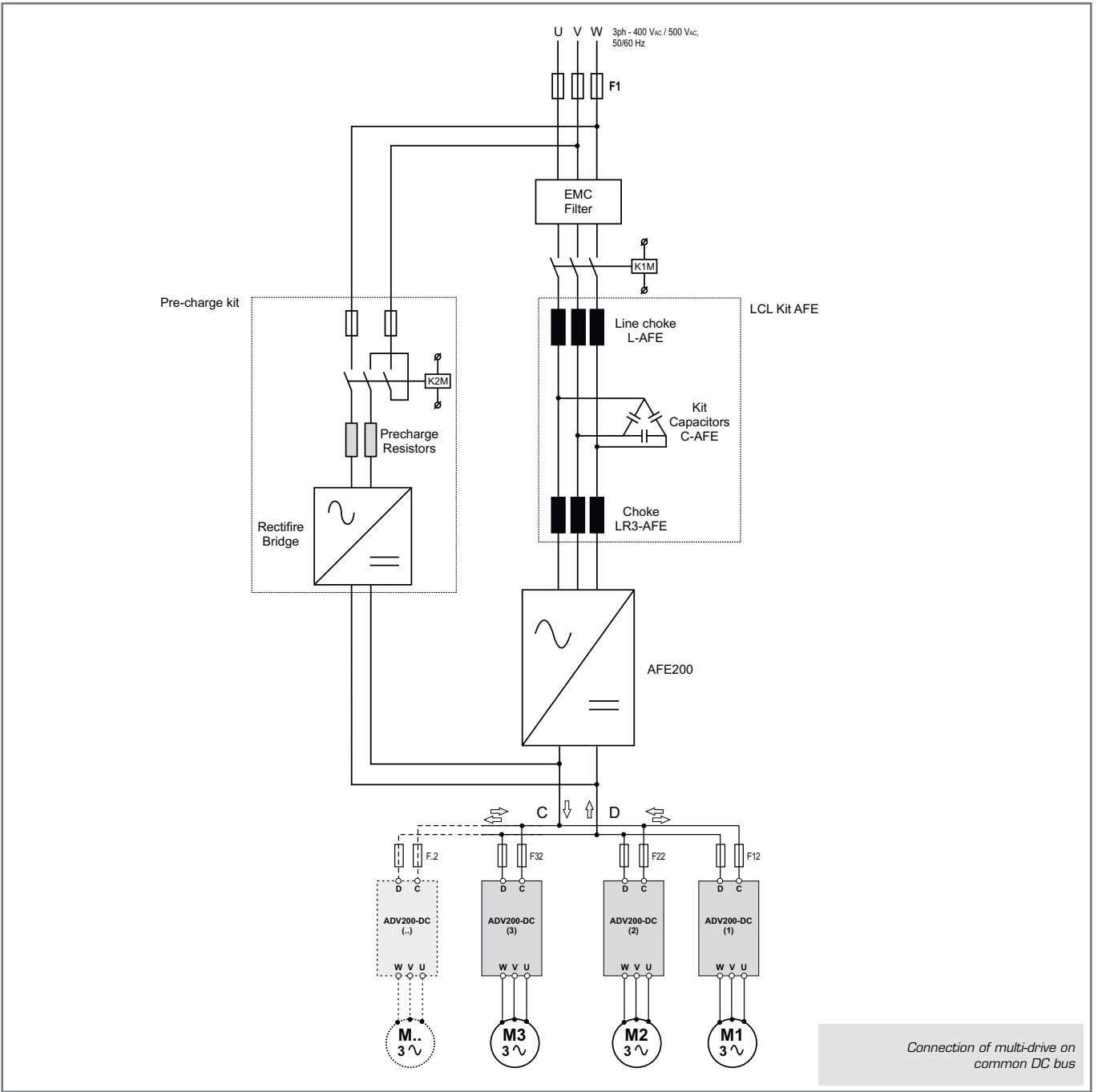

Connection of multi-drive on common DC bus

Generator mode
 Motor mode

6.4 Weights and dimensions

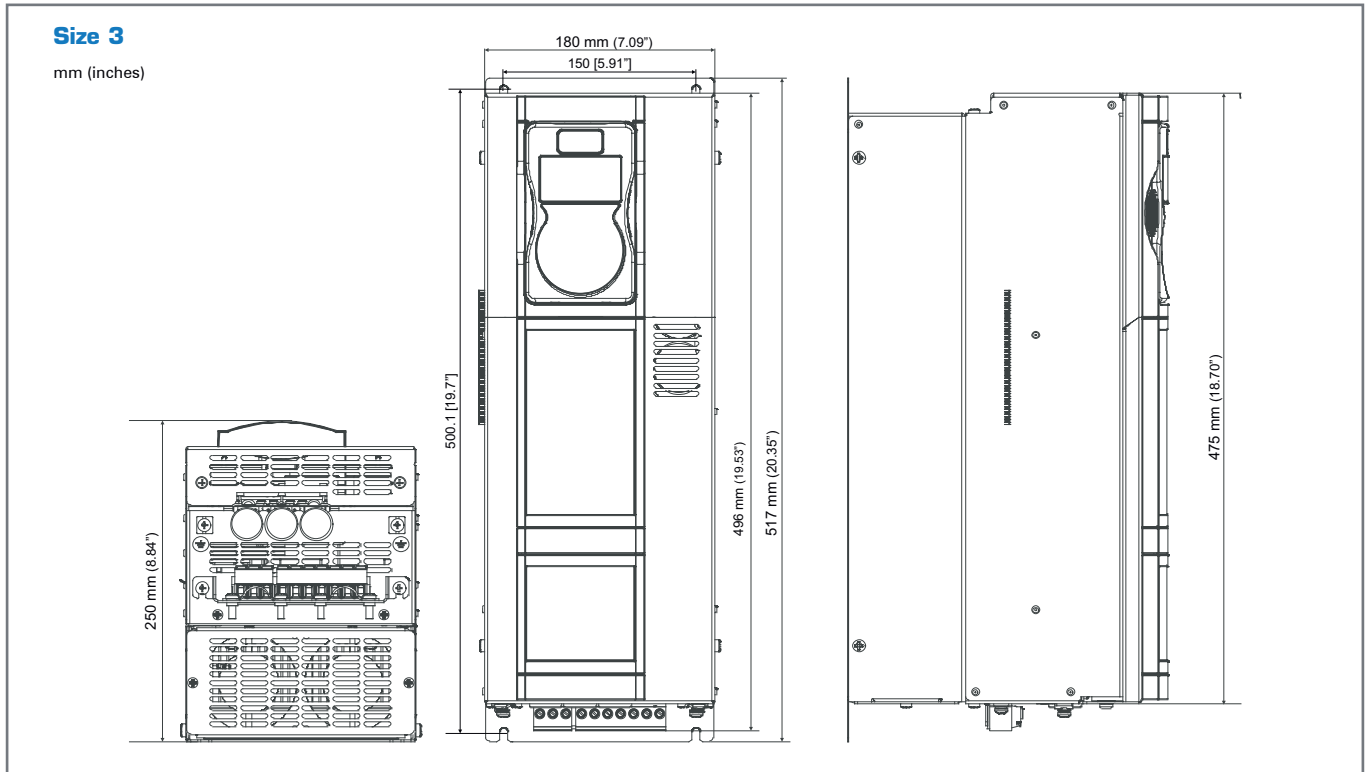

Sizes AFE200	Dimensions: Width x Height x Depth		Weight	
	mm	inches	kg	lbs
3220	180 x 517 x 250.1	7.09 x 20.35 x 9.85	18	39.7

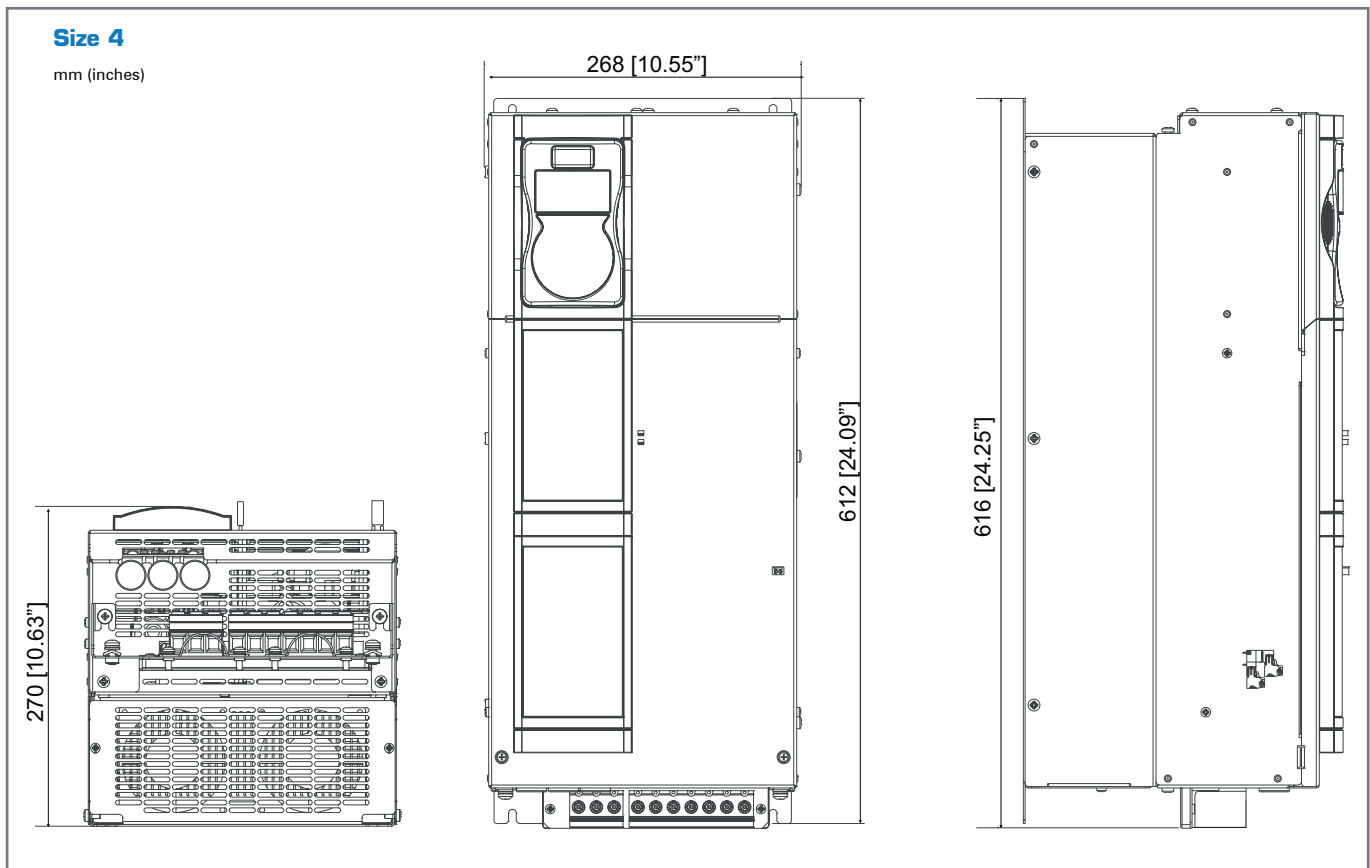

Sizes AFE200	Dimensions: Width x Height x Depth		Weight	
	mm	inches	kg	lbs
4450	268 x 616 x 270	10.55 x 24.25 x 10.63	24	52.9

Size 5

mm (inches)

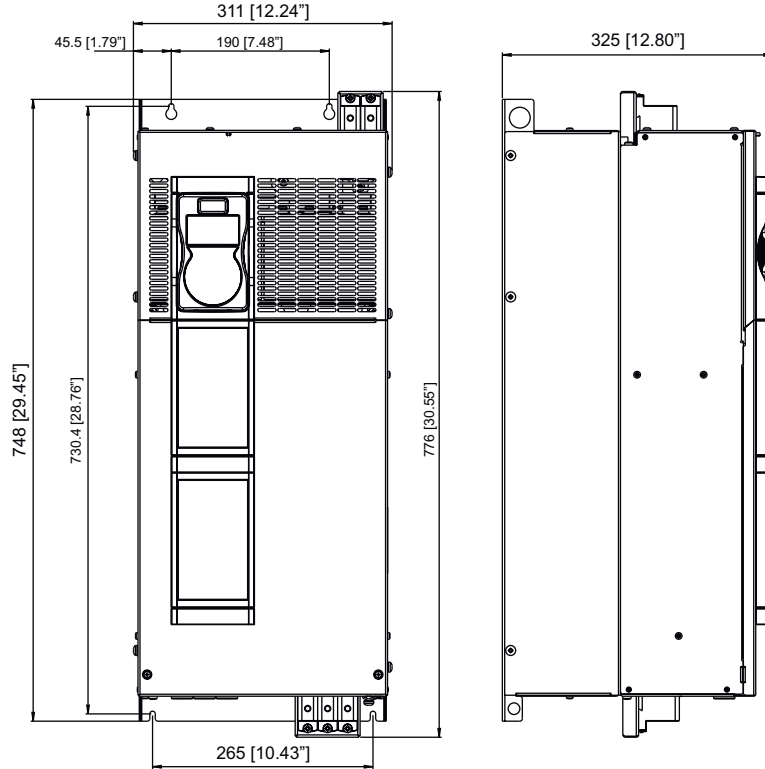

Sizes AFE200	Dimensions: Width x Height x Depth		Weight	
	mm	inches	kg	lbs
5900	311 x 776 x 325	12.24 x 30.55 x 12.8	40	88.2

Size 6

mm (inches)

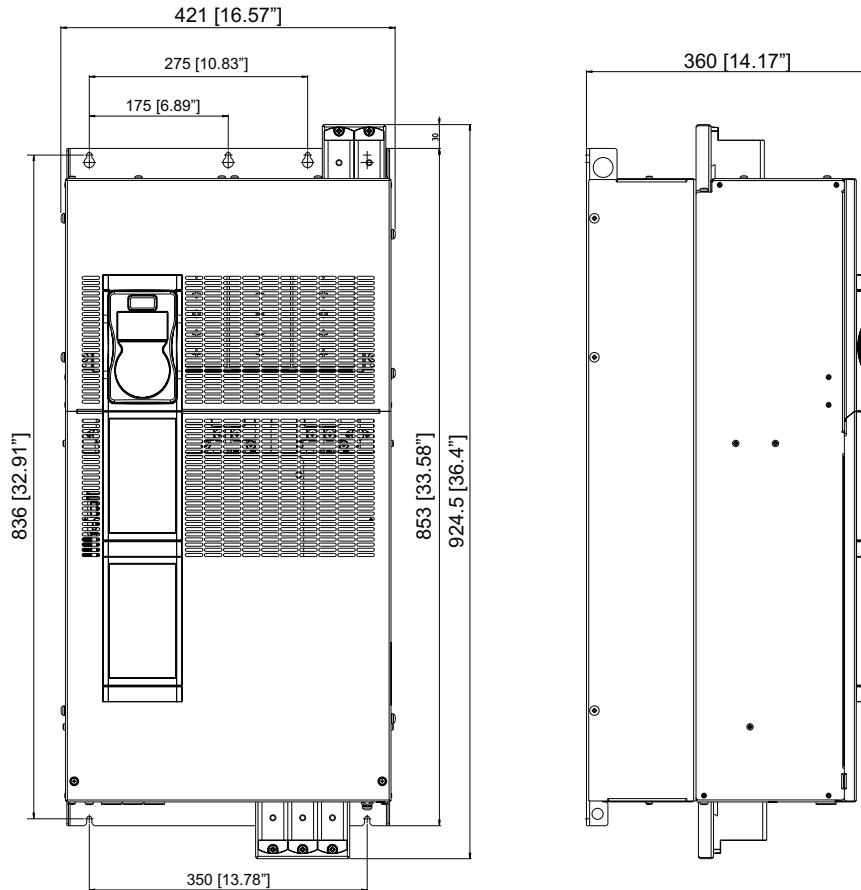

Sizes AFE200	Dimensions: Width x Height x Depth		Weight	
	mm	inches	kg	lbs
61320	421 x 924,5 x 360	16.57 x 36.4 x 14.17	68	149.9

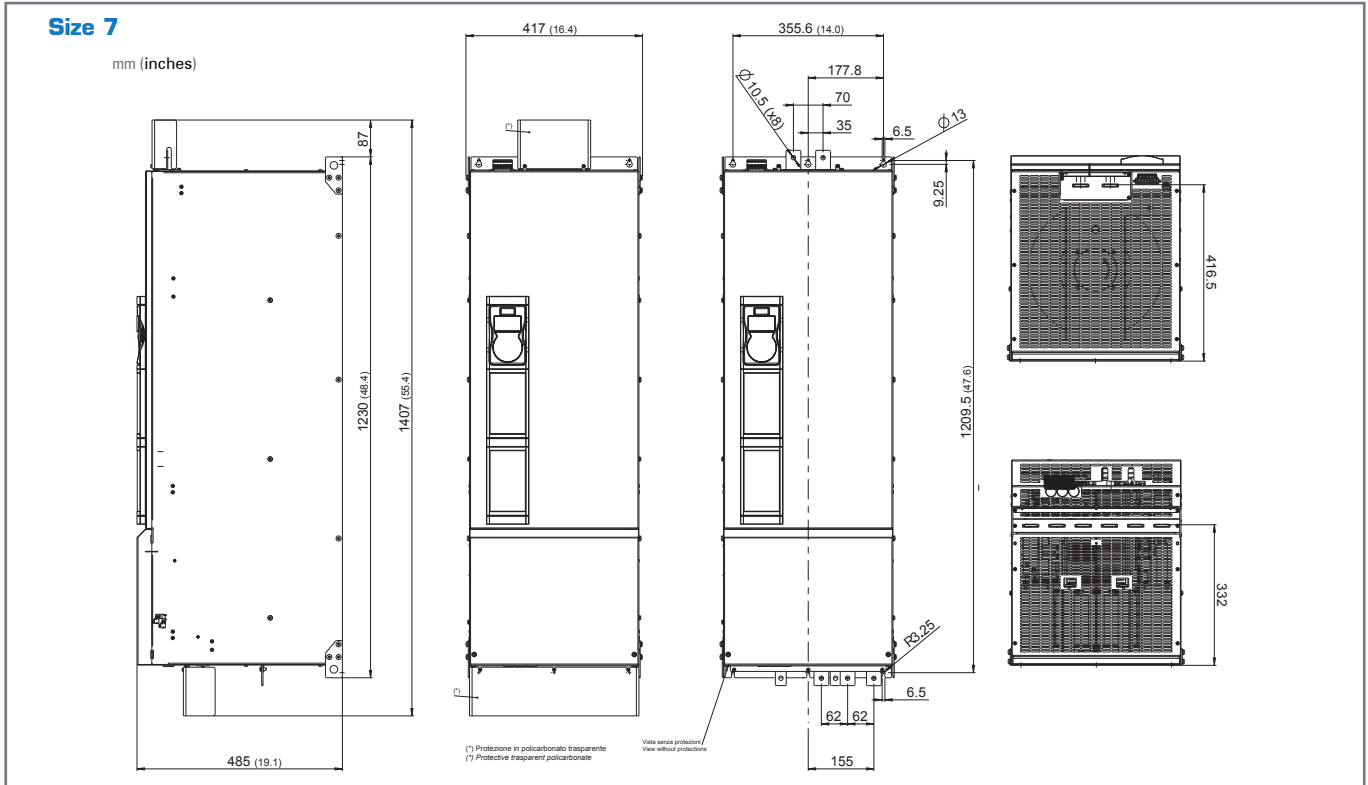

Sizes AFE200	Dimensions: Width x Height x Depth		Weight	
	mm	inches	kg	lbs
71600...72000	417 x 1407 x 485	16.42 x 55.4 x 19.1	120	264.6
72500			130	286.6
73150 ... 73550			140	308.6

ADV200 - 4

ADV200-DC

ADV200 - 6

ADV100

ADV80

AFE200

PROGRAM.

APPENDIX

Sizes 400 ... 710 kW

mm (inches)

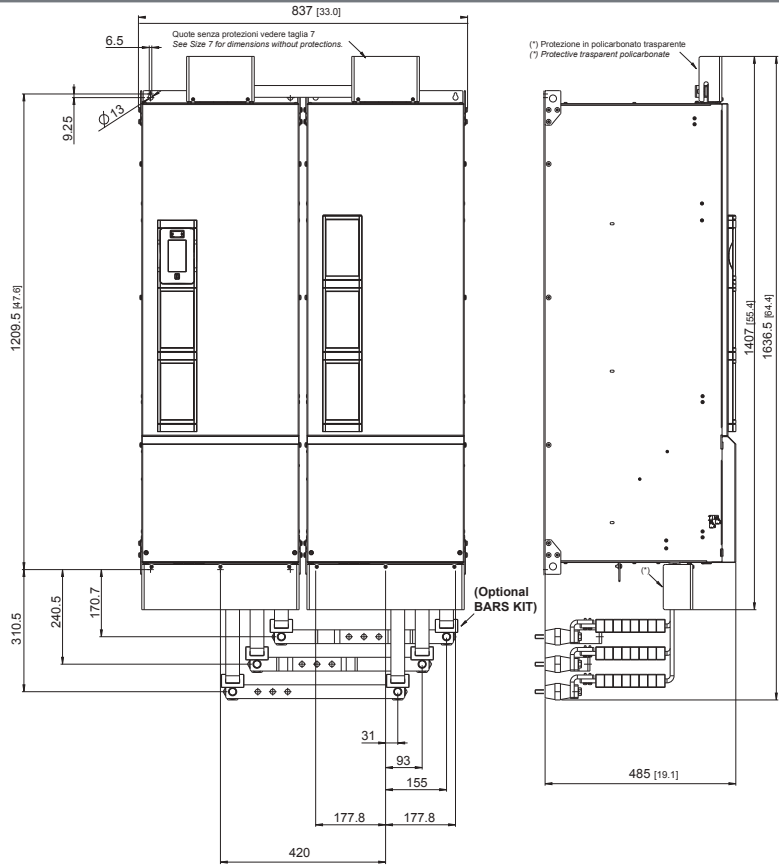

Sizes AFE200	Dimensions: Width x Height x Depth		Weight	
	mm	inches	kg	lbs
400kW	837 x 1407 x 485	33.0 x 55.4 x 19.1	260	573.2
500kW			280	617.4
630 - 710kW			300	661.4

Sizes 900 kW ...1 MW

mm (inches)

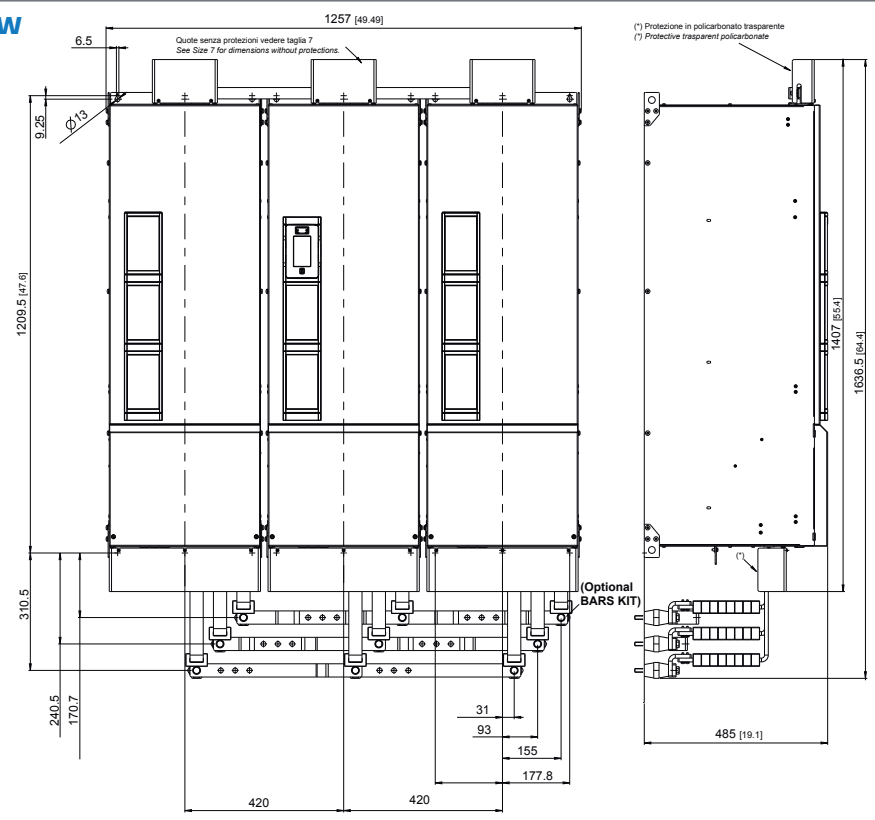

Sizes AFE200	Dimensions: Width x Height x Depth		Weight	
	mm	inches	kg	lbs
900 kW - 1 MW	1257 x 1407 x 485	49.5 x 55.4 x 19.1	450	992.1

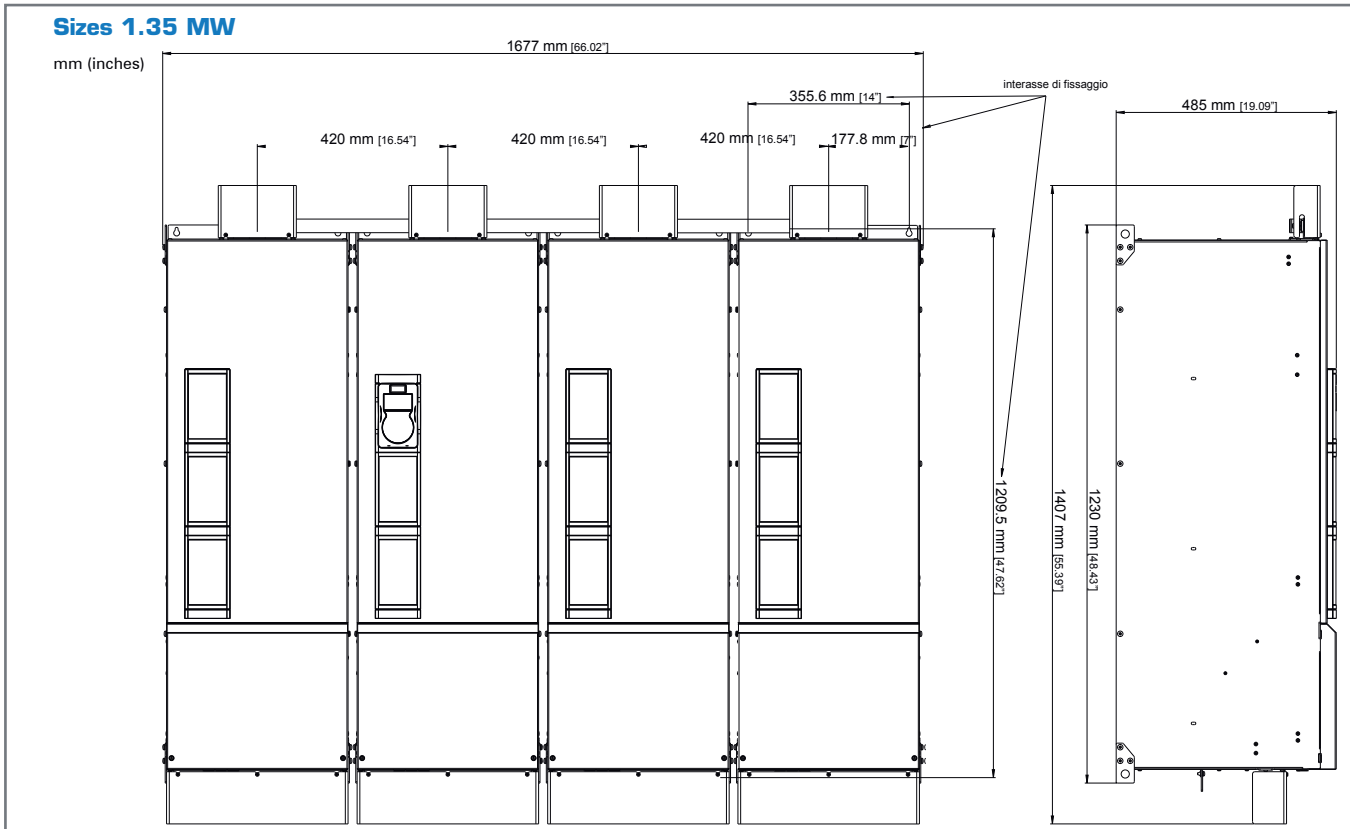

Sizes AFE200	Dimensions: Width x Height x Depth		Weight	
	mm	inches	kg	lbs
1.35 MW	1677 x 1407 x 485	66.02 x 55.4 x 19.1	560	1234.6

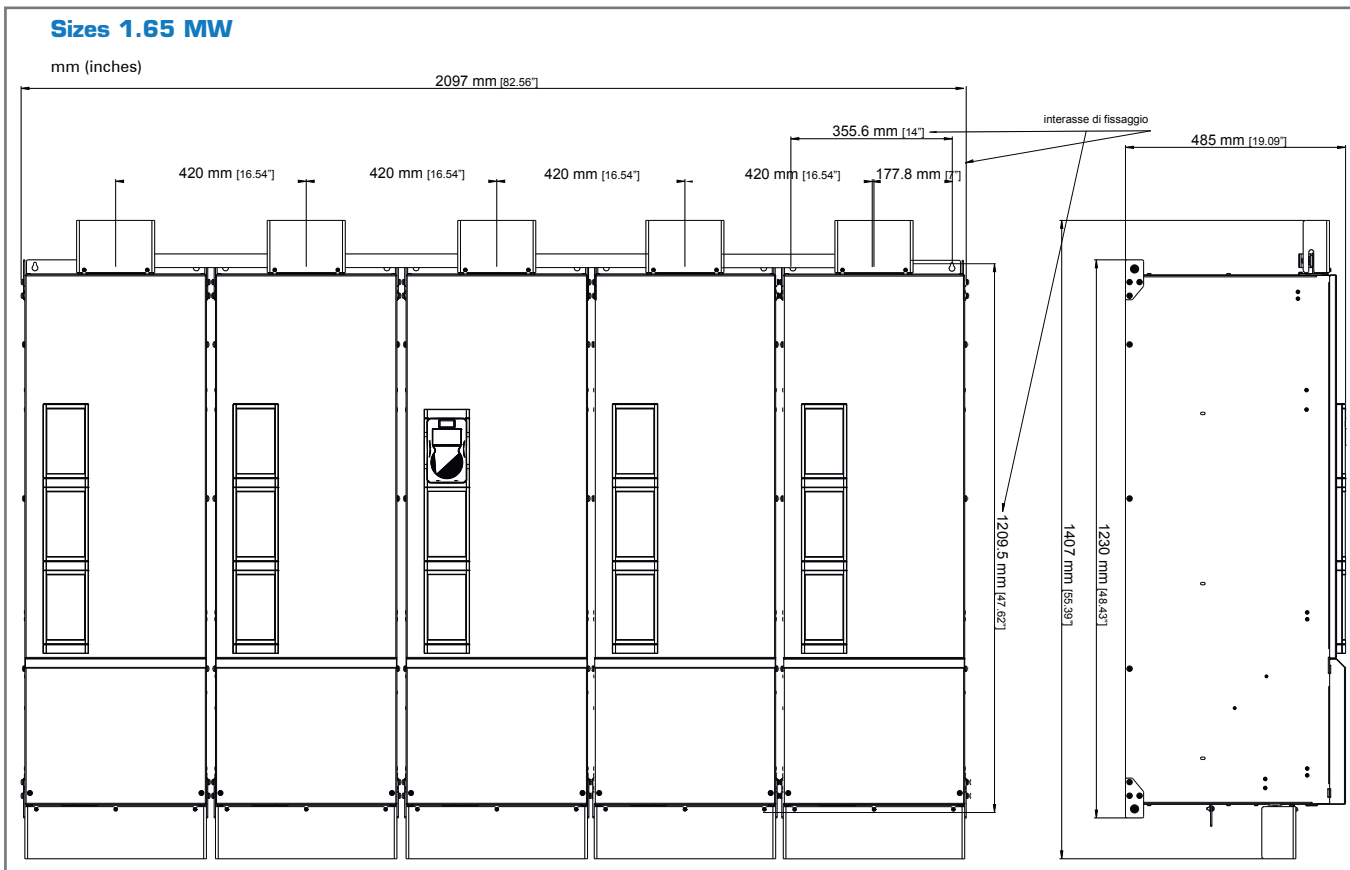

Sizes AFE200	Dimensions: Width x Height x Depth		Weight	
	mm	inches	kg	lbs
1.65 MW	2097 x 1407 x 485	82.56 x 55.4 x 19.1	700	1543.2

6.5 Choosing the power supply unit and drive

Design

AFE200 drives are normally used in applications that require the re-introduction of power into the mains. They can also be used when regeneration is not required, to achieve unitary cos phi or low total harmonic distortion values (which standard inverters do not guarantee, even with a DC or line choke). This section provides some examples of design, from the simplest, single-motor configuration to more complex ones.

As a general rule, the AFE2000 should be at least the same size as the drive, which is usually an ADV200-DC.

In certain cases the size can be chosen according to the work cycles and load profiles of each drive, in both motor or generator mode.

Another calculation to be performed is the sum of the loads connected to the DC-LINK, obtained from the total of the parallel connections.

The sum of the loads of each drive must be less than the maximum value specified in the AFE200 user guide in order to guarantee correct pre-load circuit operation.

Precharge kit must be selected according to AFE size and the capacity connected to the DC-Link (see AFE manual, chapter "5.5 Precharge Kit").

LCL Filter must be selected considering the use of the AFE: Heavy Duty or Low Duty overload (see AFE manual chapter "5.6 LCL Filters").

Key to symbols

P_{OUTM}	Motor output power (continuous operation)
V_{OUTM}	Motor rated voltage
V_{MAINS}	Rated voltage of the AC power supply
P_{OUTD}	Drive output power (light or heavy overload)
η_M	Typical motor efficiency
η_D	Typical drive efficiency (0.97)
P_{DC}	Power requested by the DC - Link
I_M	Motor rated current
V_{DCLINK}	DC-link rated voltage
	650V _{cc} at 400V _{Ac}
	750V _{cc} at 460V _{Ac}
	930V _{cc} at 575V _{Ac}
	1120V _{cc} at 690V _{Ac}

Note! For special applications please contact techno-help@gefran.com.

• Single-motor calculation based on motor output power

Mains: V_{MAINS} = three-phase 400V_{AC}

Motor: P_{OUTM} = 132kW
V_{OUTM} = 400V_{AC}
η_M = 0.95;
I_M = 236A

Application: Requires 100% of motor power
Requested overload = 150%

> Calculation of the current required on the DC-link:

$$I_{DC} = \frac{P_{OUTM} [\text{kW}] \cdot 1000}{V_{DCLINK} \cdot \eta_M \cdot \eta_D} = \frac{132 \cdot 1000}{650 \cdot 0.95 \cdot 0.97} = 220 \text{ A}$$

> Choosing the power supply unit:

The AFE200 must be capable of delivering a current of ≥ 220 A. Choose the size with the appropriate characteristics from the catalogue (section **AFE200** "2.7 Output Data" on page 39): **AFE200-61320**.

> Choosing the drive:

Choose the size with the rated current required by the motor (≥ 236A) from the catalogue (section **ADV200-DC** "2.7 Output Data" on page 39):

With a 650 V_{dc} drive:

ADV-71600-...-DC (I_n = 270A, OK).

Drive	Description	Code	Q.ty
ADV200-DC	ADV-61320-KXX-4-DC	S9019DC	1

AFE + components	Description	Code	Q.ty
AFE regenerative	AFE200-61320-KXX-4	S9AF04	1
Pre-charge kit	PRE CHARGE KIT- AFE-90/132-4	S728281	1
Kit LCL (required Heavy Duty overload)	LCL-Kit-AFE-4-132-HD	S7LC03	1
EMI filter	EMI FN3120 -480V-230A	S74EE	1
Fuses mains side connection	S1üf1/110/315A/690V	F4G30	3

Checking total DC-link capacity:

AFE200-61320 with ADV-71600-...-4-DC = 13600 + 16800 = 30400 μF ≤ 43000 μF (OK). See table on page 104

• Calculation for multi-motor system

Consider a system comprising:

Mains: $V_{MAINS} = \text{three-phase } 400V_{AC}$

Motor 1: $P_{OUTM} = 18.5kW$
 $V_{OUTM} = 400V_{AC}$
 $\eta_M = 0.95$
 $I_M = 37A$
 Application: continuous load, $P_{CONT} = 85\%$
 Requested overload = 130%

Motor 2: $P_{OUTM} = 18.5kW$
 $V_{OUTM} = 400V_{AC}$
 $\eta_M = 0.95$
 $I_M = 37A$
 Application: continuous load, $P_{CONT} = 90\%$
 Requested overload = 130%

Motor 3: $P_{OUTM} = 22kW$
 $V_{OUTM} = 400V_{AC}$
 $\eta_M = 0.96$
 $I_M = 43A$
 Application: continuous load, $P_{CONT} = 80\%$
 Requested overload = 130%

> Total electrical power absorbed:

$$P_{TOT} = \frac{(P_{OUTM} * P_{CONT})}{\eta_M}$$

$$P_{TOT} = \frac{(18.5 * 0.85)}{0.95} + \frac{(18.5 * 0.9)}{0.95} + \frac{(22 * 0.8)}{0.96} = 52.4 \text{ kW}$$

> Total power requested by the DC-link side:

$$P_{DC} = \frac{P_{TOT}}{\eta_D} + \frac{52.4}{0.97} = 54 \text{ kW}$$

400 Vac mains, corresponding DC-link value = 650Vcc

$$I_{TOT} = \frac{P_{DC} * 1000}{V_{DC-LINK}} + \frac{54000}{650} = 83 \text{ A}$$

$$I_{MAX} = \frac{(P_{OUTM} * I_{OVL})}{\eta_M} = \frac{(18.5 * 1.3)}{0.95} + \frac{(18.5 * 1.3)}{0.95} + \frac{(22 * 1.3)}{0.96} = 123 \text{ A}$$

The AFE200 must be capable of delivering a current of $\geq 83A$ with an overload current value of $\geq 123A$.

Choose the size with the appropriate characteristics from the catalogue (section **AFE200** "6.7 Output Data" on page 104):
AFE200 - 4450.

LCL filter selection

The AFE200 chosen will be used with "High Duty" overload, the appropriate LCL filter is selected according to table on page 135: **LCL-Kit-AFE-4-45-HD.**

> Choosing the drive:

Since the motors are used at below the rated power, the following inverters are suitable:

Motor 1 : $I_{M1} = 37A * 85\% = 31.4A$

Choose the size with the rated current required by the motor ($\geq 31.4A$) from the catalogue (section **ADV200-DC** "2.7 Output Data" on page 39).

With a 650 Vdc drive:
ADV-3185-...-DC ($I_n = 34.2A$, OK).

Motor 2 : $I_{M2} = 37A * 90\% = 33.3A$

Choose the size with the rated current required by the motor ($\geq 33.3A$) from the catalogue (section **ADV200-DC** "2.7 Output Data" on page 39).

With a 650 Vdc drive:
ADV-3185-...-DC ($I_n = 34.2A$, OK).

Motor 3 : $I_{M3} = 43A * 80\% = 34.4A$

Choose the size with the rated current required by the motor ($\geq 34.4A$) from the catalogue (section **ADV200-DC** "2.7 Output Data" on page 39).

With a 650 Vdc drive:
ADV-3220-...-DC ($I_n = 41.4A$, OK).

Drive	Description	Code	Q.ty
ADV200-DC	ADV-3185-KXX-4-DC	S9O10DC	2
ADV200-DC	ADV-3220-KXX-4-DC	S9O11DC	1
Fuses for connection DC side	S00C+üf1/80/80A/690V	F4EAF	6

AFE + components	Description	Code	Q.ty
AFE regenerative	AFE200-4450-KXX-4	S9AF02	1
Pre-charge kit	PRE CHARGE KIT-AFE-22/45-4	S72828	1
Kit LCL	LCL-Kit-AFE-4-45-HD	S7LC01	1
EMI filter	EMI FN3120-480-80	S73EE	1
Fuses mains side connection	S00C+üf1/80/125A/690V	F4EAJ	3

Precharge kit size

DC-Link total capacity:

(ADV-3185-KXX-4-DC * 2) 1500*2 + (ADV-3220-KXX-4-DC) 1500 + (AFE200-4450-KXX-4) 3400 = 7900 μF

The standard precharge kit for AFE200-4450-KXX-4 is PRE-CHARGE KITAFE-22/45-4.

As per the table on page 104, the maximum controllable capacity is 21500 μF :

7900 $\mu F \leq 21500 \mu F$ (OK).

www.nicsanat.com
 021-87700210



6.6 Input Data

Sizes AFE200	Input voltage U _{LN}		Overvoltage threshold (Overvoltage)		Undervoltage threshold (Undervoltage)		Input current THD	Cosphi
	AFE200...-4/4A [VAc]	AFE200...-6/6A [VAc]	AFE200...-4/4A [Vdc]	AFE200...-6/6A [Vdc]	AFE200...-4/4A [Vdc]	AFE200...-6/6A [Vdc]		
3220	380 - 15% ... 500 V _{Ac} + 5% 50/60 Hz ± 2%	500 - 10% ... 690 V _{Ac} + 10% 50/60 Hz ± 2%	820 Vdc	1192 Vdc	380 Vdc (@ 400 Vca)	676 Vdc (@ 690 VAc) 563 Vdc (@ 575 VAc)	≤ 3% (Considering a network with voltage THD of less than 2%).	≥ 0.99
4450								
5900								
61320								
71600								
72000								
72500								
73150								
73550								
400 kW								
500 kW								
630 kW								
710 kW								
900 kW								
1 MW								
1.35 MW	-	-	-	-	-	-	-	-
1.65 MW	-	-	-	-	-	-	-	-

Input current THD

"Clean Power" Technology. The AFE200 integrates cutting-edge energy recovery and energy efficiency technology.

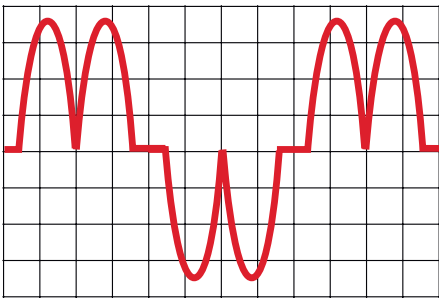

From AC inverter

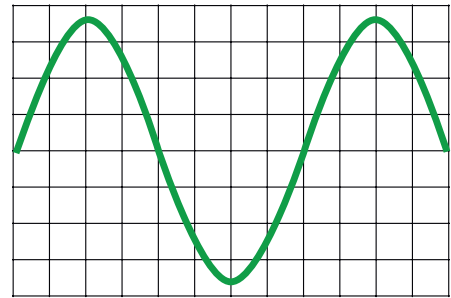

From AFE200 power supply unit

Mains input power factor

The AFE200 uses advanced control algorithms to maintain the input current in phase with voltage.

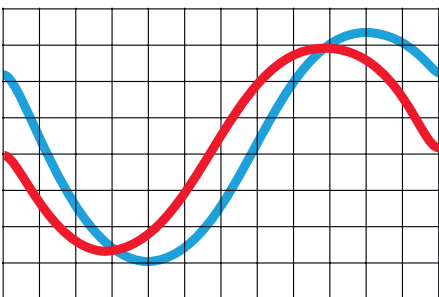

From AC inverter

— Mains voltage
— Mains current

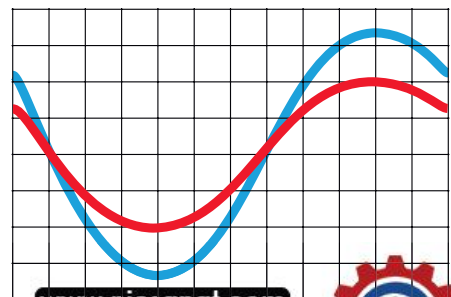

www.nicsanat.com

021-87700210 supply unit



Sizes AFE200-..-4	AC Input current for continuous operation I _N		Switching frequency fsw		Reduction factor			
	HD	LD	Default	Higher	Kv	K _T	K _F (@ 8 kHz)	K _{ALT} %
	@400 V _{AC} [A]	@400 V _{AC} [A]			(1)	(2)	(3)	(4)
3220	40	60	8	-	0.9	HD: 0.9 LD: 0.8	-	1.2
4450	80	100	8	-	0.9		-	1.2
5900	160	200	4	6.8	0.9		0,7	1.2
61320	230	280	4	6.8	0.9		0,7	1.2
71600	280	340	4	-	0.9		-	1.2
72000	340	400	2	4	0.9		-	1.2
72500	400	500	2	4	0.9		-	1.2
73150	500	560	2	-	0.9		-	1.2
73550	560	600	2	-	0.9		-	1.2
400 kW	600	760	2	-	0.9		-	1.2
500 kW	760	950	2	-	0.9		-	1.2
630 kW	950	1060	2	-	0.9		-	1.2
710 kW	1060	1050	2	-	0.9		-	1.2
900 kW	1400	1500	2	-	0.9		-	1.2
1 MW	1500	1730	2	-	0.9		-	1.2

Sizes AFE200-..-6	AC Input current for continuous operation I _N		Switching frequency fsw		Reduction factor			
	HD	LD	Default	Higher	KV	K _T (7)		K _{ALT} %
	@690 V _{AC} [A]	@690 V _{AC} [A]			(6)	HD	LD	(4)
71600	150	190	4	-	1	0.9	0.8	1.2
72000	190	240	2	-	1			1.2
72500	240	300	2	-	1			1.2
73150	300	340	2	-	1			1.2
73550	340 (5)	380	2	-	1	0.85	0.8	1.2
400 kW	360	455	2	-	1	0.9	0.8	1.2
500 kW	455	570	2	-	1			1.2
630 kW	570	645	2	-	1			1.2
710 kW	645 (5)	720	2	-	1			0.85
900 kW	850	920	2	-	1	0.9	0.8	1.2
1 MW	920 (5)	1150	2	-	1	0.85	0.8	1.2
1.35 MW	1200 (1)	1350	2	-	1	0.85	0.8	1.2
1.65 MW	1470 (1)	1645	2	-	1	0.85	0.8	1.2

HD: Heavy Duty (150% overload)
LD: Light Duty (110% overload)

- (1) Kv : Derating factor for mains voltage at 460Vac
- (2) K_t : Derating factor for ambient temperature of 50°C (1% every °C over 40°C with HD and 2% every °C over 40°C with LD)
- (3) K_f : Derating factor for higher switching frequency
- (4) K_{alt} : Derating factor for installation at altitudes above 1000 meters a.s.l. Value to be applied = 1.2% each 100 m increase above 1000 m.
For example: Altitude 2000 m, K_{alt} = 1.2% * 10 = 12% derating; I_n derated = (100 - 12) % = 88 % I_n
- (5) Current values with an ambient temperature of 35°C.
- (6) Kv : Derating factor for DC power supply (690 V)
- (7) K_t : Derating factor for ambient temperature of 50°C (1% every °C over 40°C with HD and 2% every °C over 40°C with LD)
For sizes 73550, 710 kW and 1000 kW: Derating factor for ambient temperatures of > 40°C up to 50°C (1% every °C over 35°C with HD and 2% every °C over 35°C with LD)

www.nicsanat.com
021-87700210



ADV200 - 4

ADV200-DC

ADV200 - 6

ADV100

ADV80

AFE200

PROGRAM.

APPENDIX



Sizes AFE200	Overload		Sizes AFE200	DC Link Capacity (AFE200-...-4)				DC Link Capacity (AFE200-...-6)			
	Heavy Duty	Light Duty		Internal [μ F]	Maximum capacity DC-LINK (AFE + Drive)			Internal [μ F]	Maximum capacity DC-LINK (AFE + Drive)		
					PRE-CHARGE KIT-AFE-	@ 480V [μ F]	@ 400V [μ F]		PRE-CHARGE KIT-AFE-	@ 690V [μ F]	
3220	150% 60 sec every 300 sec, 180% 0.5 sec.	110% 60 sec every 300 sec..	3220	1500	22/45-4	15000	21500	-	160/710-6	89700	
4450			3400	15000		21500	-	89700			
5900			6800	90/132-4	29900	43000	-	89700			
61320			13600		29900	43000	-	89700			
71600			16800	160/710-4	185300	266900	11200	89700			
72000			16800		185300	266900	11200	89700			
72500			25200		185300	266900	11200	89700			
73150			25200		185300	266900	11200	89700			
73550			25200		185300	266900	11200	89700			
400 kW			2 x 16800		185300	266900	2 x 11200	185300			
500 kW			2 x 25200		185300	266900	2 x 11200	185300			
630 kW			2 x 25200		185300	266900	2 x 11200	185300			
710 kW			2 x 25200	185300	266900	2 x 11200	185300				
900 kW			3 x 25200	900/1650-4	370600	533800	3 x 11200	370600			
1 MW			3 x 25200		370600	533800	3 x 11200	370600			
1.35 MW			-	-	-	-	4 x 11200	900/1650-6		370600	
1.65 MW	-	-	-	-	5 x 11200	370600					

6.7 Output Data

Sizes AFE200-...-4	Output				Output current rating In (DC) (fsw = default)				DC-link voltage rating [Vcc]
	Heavy Duty		Light Duty		Heavy Duty		Light Duty		
	@ 400 VAC [kW]	@ 460 VAC [kW]	@ 400 VAC [kW]	@ 460 VAC [kW]	650 Vdc [A]	750 Vdc [A]	650 Vdc [A]	750 Vdc [A]	
3220	28	29	42	43	43	39	64	57	650...780 Vdc
4450	55	57	69	72	85	76	107	96	
5900	110	115	139	143	171	153	213	191	
61320	159	165	194	201	245	220	298	268	
71600	194	201	236	244	298	268	363	325	
72000	236	244	277	287	363	325	426	383	
72500	277	287	346	358	426	383	532	477	
73150	346	358	388	402	532	477	597	536	
73550	388	402	416	430	597	536	640	573	
400 kW	416	430	527	545	640	551	811	699	
500 kW	527	545	658	681	811	699	1012	873	
630 kW	658	681	734	760	1012	873	1129	974	
710 kW	734	760	797	825	1129	974	1226	1058	
900 kW	970	1004	1039	1075	1492	1287	1598	1378	
1 MW	1039	1075	1200	1242	1598	1378	1846	1592	

Sizes AFE200...-6	Output		Output current rating In (DC) (fsw = default)		DC-link voltage rating [Vcc]
	Heavy Duty @ 690 V _{AC} [kW]	Light Duty @ 690 V _{AC} [kW]	Heavy Duty [A]	Light Duty [A]	
71600	179	227	298	363	820...1120 Vcc
72000	227	287	363	426	
72500	287	358	426	532	
73150	358	406	532	597	
73550	406	454	597	640	
400 kW	430	544	640	811	
500 kW	544	681	811	1012	
630 kW	681	771	1012	1129	
710 kW	771	860	1129	1226	
900 kW	1015	1100	1492	1598	
1 MW	1100	1255	1012	1155	
1.35 MW	1434	1613	1320	1485	
1.65 MW	1757	1966	1615	1810	

6.8 Cooling

All regenerative power supply units are equipped with internal fans.

Sizes AFE200	Max dissipated power [W]	Fan capacity	
		Dissipator [m ³ /h]	Internal [m ³ /h]
3220	400	80 x 2	32
4450	770	2 x 250	2 x 50
5900	1420	2 x 355	2 x 170
61320	2000	3 x 310	2 x 170
71600	2700	1500	-
72000	3200	1500	-
72500	3600	1500	-
73150	3900	2000	-
73550	4200	2000	-
400 kW	3200 (x 2)	1500 (x 2)	-
500 kW	3600 (x 2)	1500 (x 2)	-
630 kW	3900 (x 2)	2000 (x 2)	-
710 kW	4200 (x 2)	2000 (x 2)	-
900 kW	3900 (x 3)	2000 (x 3)	-
1 MW	4200 (x 3)	2000 (x 3)	-
1.35 MW	4200 (x 4)	2000 (x 4)	-
1.65 MW	4200 (x 5)	2000 (x 5)	-

6.9 Order codes

Product identification

AFE200 - X XXX - X X X - Y - XX YY

Only for parallel versions:	XX :	YY : Inverter power in kW
	MS = MASTER	04 = 400.0 kW
	SL = SLAVE with MS/SL cable 1m length	05 = 500.0 kW
	SL2 = SLAVE with MS/SL cable 2m length	06 = 630.0 kW
		07 = 710.0 kW
		09 = 900.0 kW
		10 = 1 MW
		14 = 1.35 MW
		17 = 1.65 MW
Rated voltage (factory setting):	4 = 400 V _{AC} / 50Hz	4A = 460 V _{AC} / 60Hz
	6 = 500...690 V _{AC} / 50Hz	6A = 690 V _{AC} / 60Hz
Software:	X = standard	
Braking unit:	X = not included	
Keypad:	X = not included	K = included
Inverter power in kW:	220 = 22.0 kW	1600 = 160.0 kW
	450 = 45.0 kW	2000 = 200.0 kW
	900 = 90.0 kW	2500 = 250.0 kW
	1100 = 110.0 kW	3150 = 315.0 kW
	1320 = 132.0 kW	3550 = 355.0 kW
Mechanical dimensions of the drive:	3 = size 3	6 = size 6
	4 = size 4	7 = size 7
	5 = size 5	
Regenerative power supply unit Active Front End		

Example:

AFE200 - 3 220 - K X X - 4

Rated voltage (factory setting):	4 = 400 V _{AC} / 50Hz
Software:	X = standard
Braking unit:	X = not included
Keypad:	K = included
Inverter power in kW:	220 = 22.0 kW
Mechanical dimensions of the drive:	3 = size 3
Regenerative power supply unit, serie AFE200	

AFE200-...-4

- Active Front End regenerative power supply
- Model with "KB-ADV" Programming Keypad
- Power supply, factory setting: 3 x 400VAC (3 x 460VAC)
- HD = Heavy Duty (Overload 150%), LD = Light Duty (Overload 110%)

CODE	PRODUCT IDENTIFICATION	Pn @ 400Vac		CONFIGURATION
		HD	LD	
S9AF01	AFE200-3220-KXX-4	22kW	30kW	Without choke - filter
S9AF02	AFE200-4450-KXX-4	45kW	55kW	Without choke - filter
S9AF03	AFE200-5900-KXX-4	90kW	110kW	Without choke - filter
S9AF04	AFE200-61320-KXX-4	132kW	160kW	Without choke - filter
S9AF05	AFE200-71600-KXX-4	160kW	200kW	Without choke - filter
S9AF06	AFE200-72000-KXX-4	200kW	250kW	Without choke - filter
S9AF07	AFE200-72500-KXX-4	250kW	315kW	Without choke - filter
S9AF08	AFE200-73150-KXX-4	315kW	355kW	Without choke - filter
S9AF09	AFE200-73550-KXX-4	355kW	400kW	Without choke - filter

AFE200-...-4/4A - Parallel configurations

- Active Front End regenerative power supply
- Model with "KB-ADV" Programming Keypad
- Power supply, factory setting: 3 x 400VAC (-4) - 3 x 460VAC (-4A)
- HD = Heavy Duty (Overload 150%), LD = Light Duty (Overload 110%)

CODE	PRODUCT IDENTIFICATION	Pn @ 400Vac		CONFIGURATION
		HD	LD	
S9AF21M	AFE200-72000-KXX-4-MS 04	400kW	500kW	Without choke - filter
S9AF21S	AFE200-72000-XXX-4-SL			
S9AF22M	AFE200-72500-KXX-4-MS 05	500kW	630kW	Without choke - filter
S9AF22S	AFE200-72500-XXX-4-SL			
S9AF23M	AFE200-73150-KXX-4-MS 06	630kW	710kW	Without choke - filter (No UL Mark) Fan power supply 400Vac / 50Hz.
S9AF23S	AFE200-73150-XXX-4-SL			
S9AF24M	AFE200-73550-KXX-4-MS 07	710kW	800kW	Without choke - filter (No UL Mark) Fan power supply 400Vac / 50Hz.
S9AF24S	AFE200-73550-XXX-4-SL			
S9AF231	AFE200-73150-KXX-4-MS 09	900kW	1MW	Without choke - filter (No UL Mark) Fan power supply 400Vac / 50Hz.
S9AF23S	AFE200-73150-XXX-4-SL			
S9AF23S	AFE200-73150-XXX-4-SL			
S9AF241	AFE200-73550-KXX-4-MS 10	1MW	1,2MW	Without choke - filter (No UL Mark) Fan power supply 400Vac / 50Hz.
S9AF24S	AFE200-73550-XXX-4-SL			
S9AF24S	AFE200-73550-XXX-4-SL			
On request	AFE200-73150-KXX-4A-MS 06	630kW	710kW	Without choke - filter Fan power supply 460Vac / 60Hz
On request	AFE200-73150-XXX-4A-SL			
On request	AFE200-73550-KXX-4A-MS 07	710kW	800kW	Without choke - filter Fan power supply 460Vac / 60Hz
On request	AFE200-73550-XXX-4A-SL			

(Contd)

CODE	PRODUCT IDENTIFICATION	Pn @ 400Vac		CONFIGURATION
		HD	LD	
On request	AFE200-73150-KXX-4A-MS 09			
On request	AFE200-73150-XXX-4A-SL	900kW	1MW	Without choke - filter Fan power supply 460Vac / 60Hz
On request	AFE200-73150-XXX-4A-SL			
On request	AFE200-73550-KXX-4A-MS 10			
On request	AFE200-73550-XXX-4A-SL	1MW	1,2MW	Without choke - filter Fan power supply 460Vac / 60Hz
On request	AFE200-73550-XXX-4A-SL			

AFE200-...-6

- Active Front End regenerative power supply
- Model with "KB-ADV" Programming Keypad
- Power supply, factory setting: 3 x 690VAC (3 x 500VAC...575VAC)
- HD = Heavy Duty (Overload 150%), LD = Light Duty (Overload 110%)

CODE	PRODUCT IDENTIFICATION	Pn @ 690Vac		CONFIGURATION
		HD	LD	
S9AF50	AFE200-71600-KXX-6	160kW	200kW	Without choke - filter - (No UL Mark)
S9AF51	AFE200-72000-KXX-6	200kW	250kW	Without choke - filter - (No UL Mark)
S9AF52	AFE200-72500-KXX-6	250kW	315kW	Without choke - filter - (No UL Mark)
S9AF53	AFE200-73150-KXX-6	315kW	355kW	Without choke - filter - (No UL Mark)
S9AF54	AFE200-73550-KXX-6	355kW	400kW	Without choke - filter - (No UL Mark)

AFE200-...-6/6A - Parallel configurations

- Active Front End regenerative power supply
- Model with "KB-ADV" Programming Keypad
- Power supply, factory setting: 3 x 690VAC (3 x 500VAC...575VAC)
- HD = Heavy Duty (Overload 150%), LD = Light Duty (Overload 110%)

CODE	PRODUCT IDENTIFICATION	Pn @ 690Vac		CONFIGURATION
		HD	LD	
S9AF51M	AFE200-72000-KXX-6-MS 04			
S9AF51S	AFE200-72000-XXX-6-SL	400kW	500kW	Without choke - filter - (No UL Mark)
S9AF52M	AFE200-72500-KXX-6-MS 05			
S9AF52S	AFE200-72500-XXX-6-SL	500kW	630kW	Without choke - filter - (No UL Mark)
S9AF53M	AFE200-73150-KXX-6-MS 06			
S9AF53S	AFE200-73150-XXX-6-SL	630kW	710kW	Without choke - filter - (No UL Mark) Fan power supply 400VAc/50Hz
S9AF54M	AFE200-73550-KXX-6-MS 07			
S9AF54S	AFE200-73550-XXX-6-SL	710kW	800kW	Without choke - filter - (No UL Mark) Fan power supply 400VAc/50Hz
S9AF53M1	AFE200-73150-KXX-6-MS 09			
S9AF53S	AFE200-73150-XXX-6-SL	900kW	1MW	Without choke - filter - (No UL Mark) Fan power supply 400VAc/50Hz
S9AF53S	AFE200-73150-XXX-6-SL			

(Contd)

CODE	PRODUCT IDENTIFICATION	Pn @ 690Vac		CONFIGURATION
		HD	LD	
S9AF54M1	AFE200-73550-KXX-6-MS 10			
S9AF54S	AFE200-73550-XXX-6-SL	1MW	1.2MW	Without choke - filter - (No UL Mark) Fan power supply 400Vac/50Hz
S9AF54S	AFE200-73550-XXX-6-SL			
S9AF54M4	AFE200-73550-KXX-6-MS 14			
S9AF54S	AFE200-73550-XXX-6-SL	1.35MW	1.5MW	Without choke - filter - (No UL Mark) Fan power supply 400Vac/50Hz
S9AF54S	AFE200-73550-XXX-6-SL			
S9AF54S2	AFE200-73550-XXX-6-SL2			
S9AF54M5	AFE200-73550-KXX-6-MS 17			
S9AF54S	AFE200-73550-XXX-6-SL	1.65MW	1.8MW	Without choke - filter - (No UL Mark) Fan power supply 400Vac/50Hz
S9AF54S	AFE200-73550-XXX-6-SL			
S9AF54S2	AFE200-73550-XXX-6-SL2			
S9AF54S2	AFE200-73550-XXX-6-SL2			
S9AF53M2	AFE200-73150-KXX-6A-MS 06	630kW	710kW	Without choke - filter - (No UL Mark) Fan power supply 460Vac/60Hz
S9AF53S1	AFE200-73150-XXX-6A-SL			
S9AF54M2	AFE200-73550-KXX-6A-MS 07	710kW	800kW	Without choke - filter - (No UL Mark) Fan power supply 460Vac/60Hz
S9AF54S1	AFE200-73550-XXX-6A-SL			
S9AF53M3	AFE200-73150-KXX-6A-MS 09	900kW	1MW	Without choke - filter - (No UL Mark) Fan power supply 460Vac/60Hz
S9AF53S1	AFE200-73150-XXX-6A-SL			
S9AF53S1	AFE200-73150-XXX-6A-SL			
S9AF54M3	AFE200-73550-KXX-6A-MS 10	1MW	1.2MW	Without choke - filter - (No UL Mark) Fan power supply 460Vac/60Hz
S9AF54S1	AFE200-73550-XXX-6A-SL			
S9AF54S1	AFE200-73550-XXX-6A-SL			

ADV200 - 4

ADV200-DC

ADV200 - 6

ADV100

ADV80

AFE200

PROGRAM.

APPENDIX

www.nicsanat.com
021-87700210



7. Programming

7.1 "GF_eXpress" PC Configuration Tool

Applications

- Parameter configuration of Gefran devices (Instruments, Drives, Sensors)
- Tuning of control parameters with on-line tests and trends
- Management of parameter archive for multiple configuration

Features

- Guided product selection
- Simplified settings
- Multiple languages
- Parameter printout
- Creation and storing of recipes
- Network autoscan



GF_eXpress is the software used to configure the parameters of the automation components, drives and sensors in the Gefran catalogue.

The procedures for selecting and configuring parameters are easy and intuitive, thanks to the graphic interface and devices are grouped according to product type and functions.

Product searches are performed by means of a context search and a visual selection from among actual images of the products.

This makes it possible to have a single library of devices for all Gefran products.

All details for configuration of each single device are set out in XML format to facilitate expansion of the catalogue and parameters.

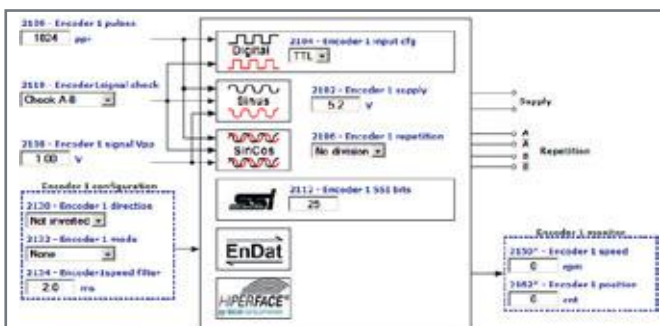
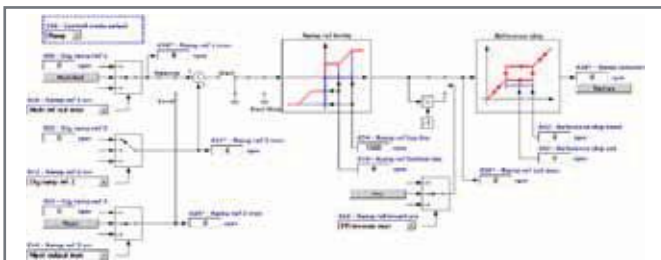

The selected product can be configured as follows:

- using a sub-set of predefined parameters
- using a guided graphic interface with context menus

The creation of custom parameter menus with a limited sub-set of data is envisaged, to enable better and more effective device configuration.

GF_eXpress is based on HTML technology. The graphic layout and content are intuitive and easy to use.

The interface and descriptions of the configuration parameters are available in multi-language format.

The use and support of UNICODE format, for multi-language management, enables the inclusion of languages that use special characters (Chinese, Korean, Russian, etc.).

GF_eXpress also offers the following functions:

• Autoscan

Device connection parameters can be configured manually or using the Autoscan function.

The Autoscan function automatically searches for the device connected to the development PC, sending serial commands to identify the type and parameters of communication.

• Monitor Window

When the device is connected, the configuration pages display the value of the single parameter in real-time.

Besides displaying the value the Monitor Window also enables parameters to be modified in real-time.

• Recipes

Saving and archiving a list of parameters. This function is used to manage same configurations on different devices or the transfer of configurations between different users.

• Oscilloscope

Simultaneous monitoring of up to 8 curves. The reference value for the curve being displayed can be selected from among all the variables that are available for the selected device.

• Print

Prints the variables that are displayed or selected. The Print function also includes the preview.

• Technical data

Operating systems:

- Windows ® 2000, XP, Vista, 7.

Minimum PC requirements:

- Pentium class CPU
- 512 MB of RAM
- Free space of > 200MB
- Graphic card min. VGA (1024x768)
- 1 RS232 or USB serial port
- 1 Ethernet port (for other Gefran devices, e.g. Geflex)
- CD-ROM drive

Communication protocols supported:

- Serial communication with the device (Modbus)
- Ethernet communication with TCP Modbus devices

7.2 Programming Keypad

ADV200-... and AFE200

The KB_ADV programming keypad (supplied as standard) makes the man-machine interface simple, immediate and highly functional. The programming software is available in 2 modes, Easy and Expert, suitable for users of any level and all programming requirements, however complex.

The powerful platform also features a menu/parameter structure that is easy to interpret and is facilitated by the keypad functions and display.

The "Wizard" tool ensures totally user-friendly **immediate start-up functions**. Standard features of the **ADV200AFE** include programming in **10 languages** (English, Italian, French, German, Spanish, Polish, Romanian, Russian, Turkish and Portuguese).



- 4 line x 21 character display
- Alphanumeric plaintext
- Complete information regarding each parameter
- Fast navigation keys
- Key for displaying the last 10 parameters that have been changed
- DISP key for rapid display of operating parameters
- Uploading-Downloading and saving of 5 complete sets of drive parameters
- Remote control from a distance of up to 10 metres.



ADV80

The integrated programming keypad allows fast programming and immediate start-up.



- 1-line x 4-character alphanumerical LED display with sign
- Drive START and STOP keys
- Simple parameter modification
- Menu displayed in text format, individual parameters in numerical format
- Fast navigation keys
- Alarm codes displayed
- Resetting of alarms from keypad.

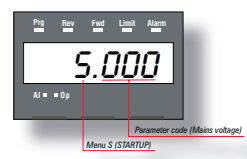

ADV100

The optional K-ADV100 programming keypad featuring full display of parameters and variables in 5 languages makes the ADV100 extremely intuitive and easy to use.

It has a strip of magnetic material on the back so that it can be attached to the front of the drive or other metal surface (e.g. door of the electrical panel).



- 5 line x 21 character display
- Alphanumeric plaintext
- Complete information regarding each parameter
- Fast navigation keys
- Key for displaying the last 10 parameters that have been changed
- DISP key for rapid display of operating parameters
- Uploading-Downloading and saving of 5 complete sets of drive parameters
- Remote control from a distance of up to 15 metres (a 70 cm-long connection cable is supplied as standard).

7.3 Softscope

SoftScope is a software oscilloscope with synchronous sampling (buffered with a minimum sampling time of 1ms). Using SoftScope the user can easily display in a fast way some specific variables, for example commissioning variables, variables to test performance levels achieved or to tune the control loops.

SoftScope allows the definition of the following parameters:

- Trigger conditions (e.g. climbing leading edge of a specific signal)
- Recording quality (a multiple of the basic clock at 1ms)
- Recording duration period
- System sizes to be recorded.

The curves can be displayed with different colours and they can be enabled/disabled. The zoom function allows enlargement of the details. The cursor allows detection of the signal peaks and duration.

The recorded data are displayed as time-based curves and therefore can be analysed. The displayed curves can be printed and stored in ASCII format and can be used with the most common data processing tools (for example Excel, Matlab).



Speed cycle
Start, ramp reference 1500 rpm, ramp output reaches 1500 rpm, Stop, ramp reference 0 rpm, ramp output reaches 0 rpm.

- 1) start command
- 2) ramp input speed reference
- 3) ramp output



Zoom
Ramp output phase from 0 rpm to 1500 rpm of the previous cycle.

- 1) start command
- 2) ramp input speed reference
- 3) ramp output

• Debug tools



MDPIc integrates a series of diagnostic tools supporting the application debug, its setting and optimisation. MDPIc allows the display, both numerically and graphically, and in suitable windows of all drive and application variables which have been con-

figured via the drag-and drop mode. The graphic curves are displayed with different colours for clarity; the different colours can be connected to configurable events and conditions (trigger). Because the synchronous acquisitions are buffered at 1ms, the variables are used with high accuracy so as to give a precise analysis of their condition.

During the application development and testing, it is possible to insert some triggers into pre-defined code points, which can be configured via a suitable window. The variables, which are read in a synchronous way with each trigger, can be displayed as numbers, as diagrams or tables. The MDPIc environment supports the application debug by highlighting any programming errors, which are then displayed in a suitable window during the compiling process. The highlighted error is displayed together with its position and error cause showing a direct link to the program section to be analysed.

• Instruction List (IL)



Instruction List is a low-level language, with a structure similar to a simple machine assembler language. It is ideal for solving small straightforward problems where there are few decision points and a limited number of changes in the program execution flow.

IL can be used when the execution time is critical, for example in the MDPIc Fast Task at 1ms.

• Structured Text (ST)



Structured text is a high-level language. It has a syntax that on first appearance is very similar to Pascal language. An ST program is usually organised as continuous text. This is divided and structured into paragraphs, which represent the logic units of

the ST program.

The wide range of basic commands satisfies the needs of the data management, computation functions, complex arithmetic calculations and control structure. ST has a comprehensive range of constructs to assign values to variables, to call functions and function blocks, to create expressions, to evaluate conditions (IF, CASE) and to implement iterations and loops (WHILE, REPEAT UNTIL).

ST is recommended in the MDPIc Fast Task at 1 ms, where the execution time is critical.

• Ladder Diagram (LD)



The representation of logical sequences in the form of the ladder diagram originates from the area of electrical plant engineering.

LD is based on the methods used to design relay logic. This form of representation is particularly suitable for implementing relay switching operations in PLC programs.

• Function Block Diagram (FBD)



The basic idea behind PLC programming with the function block diagram is that the program is structured in function-oriented logical sequence cascades (networks). FBD derives from the graphic representation of flow diagrams, hence its ease of use.

FBD is based on viewing a system in terms of the flow of signals, represented in the form of electronic circuit diagrams. Within one network, the execution direction is always from left to right. All input values must always be computed and available before the execution of a function block. The execution and evaluation of a network is not completed until the output values of all elements have been calculated.

• Sequential Flow Chart (SFC)



Sequential Function Chart is a powerful graphical language for the description of the sequential behaviour of a program in terms of states and transitions

SFC describes the sequential aspects of a program and it can be used to divide a control problem

so that only relevant aspects to a specific phase are considered.

SFC can be useful for the development of programs with a well-defined "top-down" or "bottom-up" structure. Usually SFC can include functions, function blocks and programs, and also actions and transitions written with languages such as FBD, IL, LD or ST, which are more suitable for descriptions of specific parts of the program and not of the sequential flow, implemented with the SFC program.J

8. Accessories

8.1 Fuses



8.1.1. External network side fuses (F1)

Size	Europe		America		ADV200-4	ADV200-6	ADV100	ADV80	AFE200
	Model	Code	Model	Code					
ADV200-4									
ADV-1007	GRD2/10	F4D13	A70P10	S7G49	●				
ADV-1015	GRD2/10	F4D13	A70P10	S7G49	●				
ADV-1022	GRD2/10	F4D13	A70P10	S7G49	●				
ADV-1030	GRD2/10	F4D13	A70P10	S7G49	●				
ADV-1040	GRD2/16	F4D14	A70P20-1	S7G48	●				
ADV-2055	GRD2/16	F4D14	A70P20-1	S7G48	●				
ADV-2075	GRD2/25	F4D16	A70P40	S7G52	●				
ADV-2110	GRD3/35	F4D20	A70P40	S7G52	●				
ADV-3150	GRD3/50	F4D21	A70P50	S7G53	●				
ADV-3185	GRD3/50	F4D21	A70P50	S7G53	●				
ADV-3220	S00C + /üf1/80/80A/690V	F4EAF	A70P80	S7G54	●				
ADV-4300	S00C + /üf1/80/80A/690V	F4EAF	A70P80	S7G54	●				
ADV-4370	S00C + /üf1/80/100A/690V	F4G18	A70P100	S7G55	●				
ADV-4450	S00C + /üf1/80/125A/690V	F4EAJ	A70P150	S7G56	●				
ADV-5550	S00/üf1/80/200A/690V	F4G23	A70P200	S7G58	●				
ADV-5750	S00/üf1/80/200A/690V	F4G23	A70P200	S7G58	●				
ADV-5900	S1üf1/110/250A/690V	F4G28	A70P250	S7G59	●				
ADV-61100	S1üf1/110/315A/690V	F4G30	A70P350	S7G61	●				
ADV-61320	S2üf1/110/400A/690V	F4G34	A70P400	S7G62	●				
ADV-71600	S2üf1/110/500A/690V	F4E30	A70P500	S7G63	●				
ADV-72000	S2üf1/110/630A/690V	F4E31	A70P600	S7G65	●				
ADV-72500	S2üf1/110/630A/690V	F4E31	A70P600	S7G65	●				
ADV-73150	S2üf1/110/800A/690V	F4G87	A70P800	S7813	●				
ADV-73550	S2üf1/110/800A/690V	F4G87	A70P800	S7813	●				
400 kW	ADV-72000-KXX-4-MS 04	S2üf1/110/630A/690V	F4E31	A70P600	S7G65	●			
	ADV-72000-XXX-4-SL	S2üf1/110/630A/690V	F4E31	A70P600	S7G65	●			
500 kW	ADV-72500-KXX-4-MS 05	S2üf1/110/630A/690V	F4E31	A70P600	S7G65	●			
	ADV-72500-XXX-4-SL	S2üf1/110/630A/690V	F4E31	A70P600	S7G65	●			
630 kW	ADV-73150-KXX-4-MS 06	S2üf1/110/800A/690V	F4G87	A70P800	S7813	●			
	ADV-73150-XXX-4-SL	S2üf1/110/800A/690V	F4G87	A70P800	S7813	●			
710 kW	ADV-73150-KXX-4-MS 07	S2üf1/110/800A/690V	F4G87	A70P800	S7813	●			
	ADV-73150-XXX-4-SL	S2üf1/110/800A/690V	F4G87	A70P800	S7813	●			
900 kW	ADV-73150-KXX-4-MS 09	S2üf1/110/800A/690V	F4G87	A70P800	S7813	●			
	ADV-73150-XXX-4-SL	S2üf1/110/800A/690V	F4G87	A70P800	S7813	●			
	ADV-73150-XXX-4-SL	S2üf1/110/800A/690V	F4G87	A70P800	S7813	●			
1 MW	ADV-73150-KXX-4-MS 10	S2üf1/110/800A/690V	F4G87	A70P800	S7813	●			
	ADV-73150-XXX-4-SL	S2üf1/110/800A/690V	F4G87	A70P800	S7813	●			
	ADV-73150-XXX-4-SL	S2üf1/110/800A/690V	F4G87	A70P800	S7813	●			
ADV200-6									
ADV-5750	S00C + /üf1/80/160A/690V	F4EAL	A70P175	S7G57		●			
ADV-6900	S00C + /üf1/80/160A/690V	F4EAL	A70P175	S7G57		●			
ADV-61100	S00C + /üf1/80/200A/690V	F4G23	A70P200	S7G58		●			
ADV-61320	S1üf1/110/250A/690V	F4G28	A70P300	S7G60		●			
ADV-71600	aR 315A/690V IEC/700V UL	S85C20	aR 315A/690V IEC/700V UL	S85C20		●			
ADV-72000	aR 400A/690V IEC/700V UL	S85C21	aR 400A/690V IEC/700V UL	S85C21		●			
ADV-72500	aR 500A/690V IEC/700V UL	S8B21BF	aR 500A/690V IEC/700V UL	S8B21BF		●			
ADV-73150	aR 630A/690V IEC/700V UL	S8B22BF	aR 630A/690V IEC/700V UL	S8B22BF		●			
ADV-73550	aR 630A/690V IEC/700V UL	S8B22BF	aR 630A/690V IEC/700V UL	S8B22BF		●			
400 kW	ADV-72000-KXX-6-MS 04	aR 400A/690V IEC/700V UL	S85C21	aR 400A/690V IEC/700V UL	S85C21		●		
	ADV-72000-XXX-6-SL	aR 400A/690V IEC/700V UL	S85C21	aR 400A/690V IEC/700V UL	S85C21		●		
500 kW	ADV-72500-KXX-6-MS 05	aR 500A/690V IEC/700V UL	S8B21BF	aR 500A/690V IEC/700V UL	S8B21BF		●		
	ADV-72500-XXX-6-SL	aR 500A/690V IEC/700V UL	S8B21BF	aR 500A/690V IEC/700V UL	S8B21BF		●		

Size	Europe		America		ADV200-4	ADV200-6	ADV100	ADV80	AFE200
	Model	Code	Model	Code					
630 kW	ADV-73150-KXX-6-MS 06	aR 630A/690V IEC/700V UL	S8B22BF	aR 630A/690V IEC/700V UL	S8B22BF		●		
	ADV-73150-XXX-6-SL	aR 630A/690V IEC/700V UL	S8B22BF	aR 630A/690V IEC/700V UL	S8B22BF				
710 kW	ADV-73150-KXX-6-MS 07	aR 630A/690V IEC/700V UL	S8B22BF	aR 630A/690V IEC/700V UL	S8B22BF		●		
	ADV-73150-XXX-6-SL	aR 630A/690V IEC/700V UL	S8B22BF	aR 630A/690V IEC/700V UL	S8B22BF				
900 kW	ADV-73150-KXX-6-MS 09	aR 630A/690V IEC/700V UL	S8B22BF	aR 630A/690V IEC/700V UL	S8B22BF		●		
	ADV-73150-XXX-6-SL	aR 630A/690V IEC/700V UL	S8B22BF	aR 630A/690V IEC/700V UL	S8B22BF				
	ADV-73150-XXX-6-SL	aR 630A/690V IEC/700V UL	S8B22BF	aR 630A/690V IEC/700V UL	S8B22BF				
1 MW	ADV-73150-KXX-6-MS 10	aR 630A/690V IEC/700V UL	S8B22BF	aR 630A/690V IEC/700V UL	S8B22BF		●		
	ADV-73150-XXX-6-SL	aR 630A/690V IEC/700V UL	S8B22BF	aR 630A/690V IEC/700V UL	S8B22BF				
	ADV-73150-XXX-6-SL	aR 630A/690V IEC/700V UL	S8B22BF	aR 630A/690V IEC/700V UL	S8B22BF				
1,35 MW	ADV-73550-KXX-6-MS 14	aR 630A/690V IEC/700V UL	S8B22BF	aR 630A/690V IEC/700V UL	S8B22BF		●		
	ADV-73550-XXX-6-SL	aR 630A/690V IEC/700V UL	S8B22BF	aR 630A/690V IEC/700V UL	S8B22BF				
	ADV-73550-XXX-6-SL	aR 630A/690V IEC/700V UL	S8B22BF	aR 630A/690V IEC/700V UL	S8B22BF				
	ADV-73550-XXX-6-SL2	aR 630A/690V IEC/700V UL	S8B22BF	aR 630A/690V IEC/700V UL	S8B22BF				
1,65 MW	ADV-73550-KXX-6-MS 17	aR 630A/690V IEC/700V UL	S8B22BF	aR 630A/690V IEC/700V UL	S8B22BF		●		
	ADV-73550-XXX-6-SL	aR 630A/690V IEC/700V UL	S8B22BF	aR 630A/690V IEC/700V UL	S8B22BF				
	ADV-73550-XXX-6-SL	aR 630A/690V IEC/700V UL	S8B22BF	aR 630A/690V IEC/700V UL	S8B22BF				
	ADV-73550-XXX-6-SL2	aR 630A/690V IEC/700V UL	S8B22BF	aR 630A/690V IEC/700V UL	S8B22BF				
ADV-73550-XXX-6-SL2	aR 630A/690V IEC/700V UL	S8B22BF	aR 630A/690V IEC/700V UL	S8B22BF		●			
ADV-73550-XXX-6-SL2	aR 630A/690V IEC/700V UL	S8B22BF	aR 630A/690V IEC/700V UL	S8B22BF					
ADV100									
1040		GRD2/20	F4D15	A70P20	S7G48			●	
1055		GRD2/25	F4D16	A70P25	S7G51			●	
2075		GRD2/25	F4D16	A70P25	S7G51			●	
2110		GRD3/35	F4D20	A70P40	S7G52			●	
3150		Z22GR63	F4M17	A70P60-4	S7I34			●	
3185		Z22GR63	F4M17	A70P60-4	S7I34			●	
3220		Z22GR80	F4M19	A70P80	S7G54			●	
4300		S00C + /üf1/80/80A/690V	F4EAF	A70P80	S7G54			●	
4370		S00C + /üf1/80/80A/690V	F4EAF	A70P80	S7G54			●	
4450		S00C + /üf1/80/100A/690V	F4G18	A70P100	S7G55			●	
5550		S00C + /üf1/80/125A/690V	F4EAJ	A70P150	S7G56			●	
5750		S00/üf1/80/160A/690V	F4EAL	A70P150	S7G56			●	
5900		S00/üf1/80/200A/690V	F4G23	A70P200	S7G58			●	
AFE200-4/4A									
AFE200-3220		S00C + /üf1/80/80A/690V	F4EAF	A70P80	S7G54				●
AFE200-4450		S00C + /üf1/80/125A/690V	F4EAJ	A70P150	S7G56				●
AFE200-5900		S1üf1/110/250A/690V	F4G28	A70P250	S7G59				●
AFE200-61320		S1üf1/110/315A/690V	F4G30	A70P350	S7G61				●
AFE200-71600		S2üf2/110/400A/690V	F4G34	A70P400	S7G62				●
AFE200-72000		S2üf2/110/500A/690V	F4E30	A70P500	S7G63				●
AFE200-72500		S3üf1/110/630A/690V	F4E31	A70P600	S7G65				●
AFE200-73150		S3üf1/110/800A/690V	F4H02	A70P800	S7813				●
AFE200-73550		S3üf1/110/800A/690V	F4H02	A70P800	S7813				●
400 kW	AFE200-72000-4-MS	S2üf2/110/500A/690V	F4E30	A70P500	S7G63				●
	AFE200-72000-4-SL	S2üf2/110/500A/690V	F4E30	A70P500	S7G63				●
500 kW	AFE200-72500-4-MS	S3üf1/110/630A/690V	F4E31	A70P600	S7G65				●
	AFE200-72500-4-SL	S3üf1/110/630A/690V	F4E31	A70P600	S7G65				●
630 kW	AFE200-73150-4/4A-MS	S3üf1/110/800A/690V	F4H02	A70P800	S7813				●
	AFE200-73150-4/4A-SL	S3üf1/110/800A/690V	F4H02	A70P800	S7813				●
710 kW	AFE200-73550-4/4A-MS	S3üf1/110/800A/690V	F4H02	A70P800	S7813				●
	AFE200-73550-4/4A-SL	S3üf1/110/800A/690V	F4H02	A70P800	S7813				●
900 kW	AFE200-73150-4/4A-MS	S3üf1/110/800A/690V	F4H02	A70P800	S7813				●
	AFE200-73150-4/4A-SL	S3üf1/110/800A/690V	F4H02	A70P800	S7813				●
	AFE200-73150-4/4A-SL	S3üf1/110/800A/690V	F4H02	A70P800	S7813				●



Size		Europe		America		ADV200-4	ADV200-6	ADV100	ADV80	AFE200
		Model	Code	Model	Code					
1 MW	AFE200-73550-4/4A-MS	S3üf1/110/800A/690V	F4H02	A70P800	S7813					●
	AFE200-73550-4/4A-SL	S3üf1/110/800A/690V	F4H02	A70P800	S7813					●
	AFE200-73550-4/4A-SL	S3üf1/110/800A/690V	F4H02	A70P800	S7813					●
AFE200-6/6A										
AFE200-71600-6		aR 315A/690V IEC/700V UL	S85C20	aR 315A/690V IEC/700V UL	S85C20					●
AFE200-72000-6		aR 400A/690V IEC/700V UL	S85C21	aR 400A/690V IEC/700V UL	S85C21					●
AFE200-72500-6		aR 500A/690V IEC/700V UL	S8B21BF	aR 500A/690V IEC/700V UL	S8B21BF					●
AFE200-73150-6/6A		aR 630A/690V IEC/700V UL	S8B22BF	aR 630A/690V IEC/700V UL	S8B22BF					●
AFE200-73550-6/6A		aR 630A/690V IEC/700V UL	S8B22BF	aR 630A/690V IEC/700V UL	S8B22BF					●
400 kW	AFE200-72000-KXX-6-MS 04	aR 400A/690V IEC/700V UL	S85C21	aR 400A/690V IEC/700V UL	S85C21					●
	AFE200-72000-XXX-6-SL	aR 400A/690V IEC/700V UL	S85C21	aR 400A/690V IEC/700V UL	S85C21					●
500 kW	AFE200-72500-KXX-6-MS 05	aR 500A/690V IEC/700V UL	S8B21BF	aR 500A/690V IEC/700V UL	S8B21BF					●
	AFE200-72500-XXX-6-SL	aR 500A/690V IEC/700V UL	S8B21BF	aR 500A/690V IEC/700V UL	S8B21BF					●
630 kW	AFE200-73150-KXX-6/6A-MS 06	aR 630A/690V IEC/700V UL	S8B22BF	aR 630A/690V IEC/700V UL	S8B22BF					●
	AFE200-73150-XXX-6/6A-SL	aR 630A/690V IEC/700V UL	S8B22BF	aR 630A/690V IEC/700V UL	S8B22BF					●
710 kW	AFE200-73550-KXX-6/6A-MS 07	aR 630A/690V IEC/700V UL	S8B22BF	aR 630A/690V IEC/700V UL	S8B22BF					●
	AFE200-73550-XXX-6/6A-SL	aR 630A/690V IEC/700V UL	S8B22BF	aR 630A/690V IEC/700V UL	S8B22BF					●
900 kW	AFE200-73150-KXX-6/6A-MS 09	aR 630A/690V IEC/700V UL	S8B22BF	aR 630A/690V IEC/700V UL	S8B22BF					●
	AFE200-73150-XXX-6/6A-SL	aR 630A/690V IEC/700V UL	S8B22BF	aR 630A/690V IEC/700V UL	S8B22BF					●
	AFE200-73150-XXX-6/6A-SL	aR 630A/690V IEC/700V UL	S8B22BF	aR 630A/690V IEC/700V UL	S8B22BF					●
1 MW	AFE200-73550-KXX-6/6A-MS 10	aR 630A/690V IEC/700V UL	S8B22BF	aR 630A/690V IEC/700V UL	S8B22BF					●
	AFE200-73550-XXX-6/6A-SL	aR 630A/690V IEC/700V UL	S8B22BF	aR 630A/690V IEC/700V UL	S8B22BF					●
	AFE200-73550-XXX-6/6A-SL	aR 630A/690V IEC/700V UL	S8B22BF	aR 630A/690V IEC/700V UL	S8B22BF					●
1.35MW	73550-KXX-6/6A-MS 14	aR 630A/690V IEC/700V UL	S8B22BF	aR 630A/690V IEC/700V UL	S8B22BF					●
	73550-XXX-6/6A-SL2	aR 630A/690V IEC/700V UL	S8B22BF	aR 630A/690V IEC/700V UL	S8B22BF					●
	73550-XXX-6/6A-SL	aR 630A/690V IEC/700V UL	S8B22BF	aR 630A/690V IEC/700V UL	S8B22BF					●
	73550-XXX-6/6A-SL	aR 630A/690V IEC/700V UL	S8B22BF	aR 630A/690V IEC/700V UL	S8B22BF					●
1.65MW	73550-KXX-6/6A-MS 17	aR 630A/690V IEC/700V UL	S8B22BF	aR 630A/690V IEC/700V UL	S8B22BF					●
	73550-XXX-6/6A-SL2	aR 630A/690V IEC/700V UL	S8B22BF	aR 630A/690V IEC/700V UL	S8B22BF					●
	73550-XXX-6/6A-SL2	aR 630A/690V IEC/700V UL	S8B22BF	aR 630A/690V IEC/700V UL	S8B22BF					●
	73550-XXX-6/6A-SL	aR 630A/690V IEC/700V UL	S8B22BF	aR 630A/690V IEC/700V UL	S8B22BF					●
	73550-XXX-6/6A-SL	aR 630A/690V IEC/700V UL	S8B22BF	aR 630A/690V IEC/700V UL	S8B22BF					●
ADV80 (Connections without CA input choke)										
ADV80-1004		Z14GR10	F4M03	A70P10	S7G49					●
ADV80-1005		Z14GR10	F4M03	A70P10	S7G49					●
ADV80-1007		Z14GR10	F4M03	A70P10	S7G49					●
ADV80-1015		Z14GR10	F4M03	A70P10	S7G49					●
ADV80-2022		Z14GR16	F4M05	A70P20	S7G48					●
ADV80-2030		Z14GR16	F4M05	A70P20	S7G48					●
ADV80-2040		Z14GR20	F4M07	A70P20	S7G48					●
ADV80-2055		Z14GR25	F4M09	A70P25	S7G51					●
ADV80-2075		Z14GR25	F4M09	A70P30	S7I50					●
ADV80-2110		GRD3/35	F4D20	A70P40	S7G52					●
ADV80-3150		Z22GR63	F4M17	A70P60-4	S7I34					●
ADV80-3185		Z22GR63	F4M17	A70P60-4	S7I34					●
ADV80-3220		Z22GR80	F4M19	A70P80	S7G54					●
ADV80 (Connections with CA input choke)										
ADV80-1004		Z14GR10	F4M03	A70P10	S7G49					●
ADV80-1005		Z14GR10	F4M03	A70P10	S7G49					●
ADV80-1007		Z14GR10	F4M03	A70P10	S7G49					●
ADV80-1015		Z14GR10	F4M03	A70P10	S7G49					●
ADV80-2022		Z14GR10	F4M03	A70P10	S7G49					●
ADV80-2030		Z14GR16	F4M05	A70P20	S7G48					●
ADV80-2040		Z14GR16	F4M05	A70P20	S7G48					●
ADV80-2055		Z14GR20	F4M07	A70P20	S7G48					●
ADV80-2075		Z14GR20	F4M07	A70P25	S7G51					●
ADV80-2110		GRD3/35	F4D20	A70P40	S7G52					●

Size	Europe		America		ADV200-4	ADV200-6	ADV100	ADV80	AFE200
	Model	Code	Model	Code					
ADV80-3150	Z22GR63	F4M17	A70P60-4	S7I34				●	
ADV80-3185	Z22GR63	F4M17	A70P60-4	S7I34				●	
ADV80-3220	Z22GR80	F4M19	A70P80	S7G54				●	

Technical data for fuses, including dimensions, weights, dissipated power, fuse blocks, etc. can be found in the manufacturers' catalogues:

Type M... (blade fuse), GRD..., Z22... , S... Jean Müller, Eltville
 A70... Ferraz
 FWP... Bussmann
 aR ... Square body DIN 43653 110 mm stuf mount high speed FUSE

ADV200 - 4

ADV200-DC

ADV200 - 6

ADV100

ADV80

AFE200

PROGRAM.

APPENDIX

www.nicsanat.com
 021-87700210



8.1.2. Fuses for the DC connection (F2)

Size	Europe		America		ADV200-4-DC	ADV200-6-DC	ADV100
	Model	Code	Model	Code			
ADV200-4 / ADV200-4-DC							
ADV-1007 ... ADV-1022	GRD2/10	F4D13	A70P10	S7G49	●		
ADV-1030	GRD2/16	F4D14	A70P20-1	S7G48	●		
ADV-1040	GRD2/20	F4D15	A70P20-1	S7G48	●		
ADV-2055	GRD2/20	F4D15	A70P30-1	S7I50	●		
ADV-2075	GRD3/35	F4D20	A70P40	S7G52	●		
ADV-2110	GRD3/50	F4D21	A70P50	S7G53	●		
ADV-3150 ... ADV-3220	S00C+/uf1/80/80A/690V	F4EAF	A70P80	S7G54	●		
ADV-4300	S00C+/uf1/80/100A/690V	F4G18	A70P100	S7G55	●		
ADV-4370	S00C+/uf1/80/125A/690V	F4EAJ	A70P150	S7G56	●		
ADV-4450	S00C+/uf1/80/160A/690V	F4EAL	A70P150	S7G56	●		
ADV-5550	S00/uf1/80/200A/690V	F4G23	A70P200	S7G58	●		
ADV-5750	S1uf1/110/250A/690V	F4G28	A70P250	S7G59	●		
ADV-5900	S1uf1/110/315A/690V	F4G30	A70P350	S7G61	●		
ADV-61100	S2uf1/110/400A/690V	F4G34	A70P400	S7G62	●		
ADV-61320 - ADV-71600	S2uf1/110/500A/690V	F4E30	A70P500	S7G63	●		
ADV-72000	S2uf1/110/630A/690V	F4E31	A70P600	S7G65	●		
ADV-72500	S3uf1/110/800A/690V	F4H02	A70P800	S7813	●		
ADV-73150 - ADV-73550	S3uf1/110/1000A/690V	F4H03	A70P1000	S7812	●		
400 kW	ADV-72000-KXX-4-MS 04	S2uf1/110/630A/690V	F4E31	A70P600	S7G65	●	
	ADV-72000-XXX-4-SL	S2uf1/110/630A/690V	F4E31	A70P600	S7G65	●	
500 kW	ADV-72500-KXX-4-MS 05	S3uf1/110/800A/690V	F4H02	A70P800	S7813	●	
	ADV-72500-XXX-4-SL	S3uf1/110/800A/690V	F4H02	A70P800	S7813	●	
630 kW	ADV-73150-KXX-4-MS 06	S3uf1/110/1000A/690V	F4H03	A70P1000	S7812	●	
	ADV-73150-XXX-4-SL	S3uf1/110/1000A/690V	F4H03	A70P1000	S7812	●	
710 kW	ADV-73150-KXX-4-MS 07	S3uf1/110/1000A/690V	F4H03	A70P1000	S7812	●	
	ADV-73150-XXX-4-SL	S3uf1/110/1000A/690V	F4H03	A70P1000	S7812	●	
900 kW	ADV-73150-KXX-4-MS 09	S3uf1/110/1000A/690V	F4H03	A70P1000	S7812	●	
	ADV-73150-XXX-4-SL	S3uf1/110/1000A/690V	F4H03	A70P1000	S7812	●	
	ADV-73150-XXX-4-SL	S3uf1/110/1000A/690V	F4H03	A70P1000	S7812	●	
1 MW	ADV-73150-KXX-4-MS 10	S3uf1/110/1000A/690V	F4H03	A70P1000	S7812	●	
	ADV-73150-XXX-4-SL	S3uf1/110/1000A/690V	F4H03	A70P1000	S7812	●	
	ADV-73150-XXX-4-SL	S3uf1/110/1000A/690V	F4H03	A70P1000	S7812	●	
ADV200-4-DC (Internal mounting fuses)							
ADV-71600	PWR-XC-500A-690V	S8B21BF	PWR-XC-500A-690V	S8B21BF	●		
ADV-72000	PWR-XC-630A-690V	S8B22BF	PWR-XC-630A-690V	S8B22BF	●		
ADV-72500	PWR-XC-800A-690V	S8B23BF	PWR-XC-800A-690V	S8B23BF	●		
ADV-73150 - ADV-73550	PWR-XC-1000A-690V	S8B24BF	PWR-XC-1000A-690V	S8B24BF	●		
ADV100							
1040	GRD2/20	F4D15	A70P20	S7G48		●	
1055	GRD2/25	F4D16	A70P25	S7G51		●	
2075	GRD3/35	F4D20	A70P40	S7G52		●	
2110	GRD3/50	F4D21	A70P50	S7G53		●	
3150	Z22GR63	F4M17	A70P60-4	S7I34		●	
3185 ... 4300	Z22GR80	F4M19	A70P80	S7G54		●	
4370	S00C+/uf1/80/100A/690V	F4G18	A70P100	S7G55		●	
4450	S00C+/uf1/80/125A/690V	F4EAJ	A70P150	S7G56		●	
5550	S00C+/uf1/80/160A/690V	F4EAL	A70P150	S7G56		●	
5750	S00/uf1/80/200A/690V	F4G23	A70P200	S7G58		●	
5900	S00/uf1/80/250A/690V	F4G28	A70P250	S7G59		●	
ADV200-6 / ADV200-6-DC							
ADV-5750	S00/uf1/80/200A/690V	F4G23	A70P200		●		

Size	Europe		America		ADV200-4-DC	ADV200-6-DC	ADV100		
	Model	Code	Model	Code					
ADV-6900	S1üf1/110/250A/690V	F4G28	A70P250	S7G59		●			
ADV-61100	S1üf1/110/315A/690V	F4G30	A70P350	S7G61		●			
ADV-61320	S2üf1/110/400A/690V	F4G34	A70P400	S7G62		●			
ADV-71600	aR 400A/1250V IEC/1300V UL	S85C13	aR 400A/1250V IEC/1300V UL	S85C13		●			
ADV-72000	aR 500A/1250V IEC/1300V UL	S85C14	aR 500A/1250V IEC/1300V UL	S85C14		●			
ADV-72500	aR 630A/1250V IEC/1300V UL	S85C15	aR 630A/1250V IEC/1300V UL	S85C15		●			
ADV-73150	aR 700A/1250V IEC/1300V UL	S85C16	aR 700A/1250V IEC/1300V UL	S85C16		●			
ADV-73550	aR 800A/1250V IEC/1300V UL	S85C17	aR 800A/1250V IEC/1300V UL	S85C17		●			
400 kW	ADV-72000-KXX-6-MS 04	aR 500A/1250V IEC/1300V UL	S85C14	aR 500A/1250V IEC/1300V UL	S85C14	●			
	ADV-72000-XXX-6-SL	aR 500A/1250V IEC/1300V UL	S85C14	aR 500A/1250V IEC/1300V UL	S85C14	●			
500 kW	ADV-72500-KXX-6-MS 05	aR 630A/1250V IEC/1300V UL	S85C15	aR 630A/1250V IEC/1300V UL	S85C15	●			
	ADV-72500-XXX-6-SL	aR 630A/1250V IEC/1300V UL	S85C15	aR 630A/1250V IEC/1300V UL	S85C15	●			
630 kW	ADV-73150-KXX-6-MS 06	aR 700A/1250V IEC/1300V UL	S85C16	aR 700A/1250V IEC/1300V UL	S85C16	●			
	ADV-73150-XXX-6-SL	aR 700A/1250V IEC/1300V UL	S85C16	aR 700A/1250V IEC/1300V UL	S85C16	●			
710 kW	ADV-73150-KXX-6-MS 07	aR 800A/1250V IEC/1300V UL	S85C17	aR 800A/1250V IEC/1300V UL	S85C17	●			
	ADV-73150-XXX-6-SL	aR 800A/1250V IEC/1300V UL	S85C17	aR 800A/1250V IEC/1300V UL	S85C17	●			
900 kW	ADV-73150-KXX-6-MS 09	aR 700A/1250V IEC/1300V UL	S85C16	aR 700A/1250V IEC/1300V UL	S85C16	●			
	ADV-73150-XXX-6-SL	aR 700A/1250V IEC/1300V UL	S85C16	aR 700A/1250V IEC/1300V UL	S85C16	●			
1 MW	ADV-73150-KXX-6-MS 10	aR 800A/1250V IEC/1300V UL	S85C17	aR 800A/1250V IEC/1300V UL	S85C17	●			
	ADV-73150-XXX-6-SL	aR 800A/1250V IEC/1300V UL	S85C17	aR 800A/1250V IEC/1300V UL	S85C17	●			
1,35 MW	ADV-73550-KXX-6-MS 14	aR 800A/1250V IEC/1300V UL	S85C17	aR 800A/1250V IEC/1300V UL	S85C17	●			
	ADV-73550-XXX-6-SL	aR 800A/1250V IEC/1300V UL	S85C17	aR 800A/1250V IEC/1300V UL	S85C17	●			
	ADV-73550-XXX-6-SL	aR 800A/1250V IEC/1300V UL	S85C17	aR 800A/1250V IEC/1300V UL	S85C17	●			
	ADV-73550-XXX-6-SL2	aR 800A/1250V IEC/1300V UL	S85C17	aR 800A/1250V IEC/1300V UL	S85C17	●			
1,65 MW	ADV-73550-KXX-6-MS 17	aR 800A/1250V IEC/1300V UL	S85C17	aR 800A/1250V IEC/1300V UL	S85C17	●			
	ADV-73550-XXX-6-SL	aR 800A/1250V IEC/1300V UL	S85C17	aR 800A/1250V IEC/1300V UL	S85C17	●			
	ADV-73550-XXX-6-SL	aR 800A/1250V IEC/1300V UL	S85C17	aR 800A/1250V IEC/1300V UL	S85C17	●			
	ADV-73550-XXX-6-SL2	aR 800A/1250V IEC/1300V UL	S85C17	aR 800A/1250V IEC/1300V UL	S85C17	●			
ADV200-6-DC (Internal mounting fuses)									
ADV-71600	PWR-XC-400A-1250V	S85C13	PWR-XC-400A-1250V	S85C13		●			
ADV-72000	PWR-XC-500A-1250V	S85C14	PWR-XC-500A-1250V	S85C14		●			
ADV-72500	PWR-XC-630A-1250V	S85C15	PWR-XC-630A-1250V	S85C15		●			
ADV-73150	PWR-XC-700A-1250V	S85C16	PWR-XC-700A-1250V	S85C16		●			
ADV-73550	PWR-XC-800A-1250V	S85C17	PWR-XC-800A-1250V	S85C17		●			

Technical data for fuses, including dimensions, weights, dissipated power, fuse blocks, etc. can be found in the manufacturers' catalogues:

- GRD... , Z22... Jean Müller, Eltville
- A70... Ferraz
- FWP... Bussmann
- aR .. Square body DIN 43653 110 mm stuf mount high speed FUSE
- PWR Siba or Bussmann or Ferraz

Size	Europe		America		ADV80	AFE200			
	Model	Code	Model	Code					
AFE200-4/4A									
AFE-3220	-	-	-	-		●			
AFE-4450	-	-	-	-		●			
AFE-5900	-	-	-	-		●			
AFE-61320	-	-	-	-		●			
AFE-71600	-	-	-	-		●			
AFE-72000	-	-	-	-		●			
AFE-72500	-	-	-	-		●			
AFE-73150	-	-	-	-		●			
AFE-73550	-	-	-	-		●			
400 kW	AFE-72000-4-MS	aR 630A/690V IEC/700V UL	S8B22BF	aR 630A/690V IEC/700V UL	S8B22BF	●			
	AFE-72000-4-SL	aR 630A/690V IEC/700V UL	S8B22BF	aR 630A/690V IEC/700V UL	S8B22BF	●			
500 kW	AFE-72500-4-MS	aR 800A/690V IEC/700V UL	S8B23BF	aR 800A/690V IEC/700V UL	S8B23BF	●			
	AFE-72500-4-SL	aR 800A/690V IEC/700V UL	S8B23BF	aR 800A/690V IEC/700V UL	S8B23BF	●			
630 kW	AFE-73150-4/4A-MS	aR 1000A/690V IEC/700V UL	S8B24BF	aR 1000A/690V IEC/700V UL	S8B24BF	●			
	AFE-73150-4/4A-SL	aR 1000A/690V IEC/700V UL	S8B24BF	aR 1000A/690V IEC/700V UL	S8B24BF	●			
710 kW	AFE-73550-4/4A-MS	aR 1000A/690V IEC/700V UL	S8B24BF	aR 1000A/690V IEC/700V UL	S8B24BF	●			
	AFE-73550-4/4A-SL	aR 1000A/690V IEC/700V UL	S8B24BF	aR 1000A/690V IEC/700V UL	S8B24BF	●			
900 kW	AFE-73150-4/4A-MS	aR 1000A/690V IEC/700V UL	S8B24BF	aR 1000A/690V IEC/700V UL	S8B24BF	●			
	AFE-73150-4/4A-SL	aR 1000A/690V IEC/700V UL	S8B24BF	aR 1000A/690V IEC/700V UL	S8B24BF	●			
	AFE-73150-4/4A-SL	aR 1000A/690V IEC/700V UL	S8B24BF	aR 1000A/690V IEC/700V UL	S8B24BF	●			
1 MW	AFE-73550-4/4A-MS	aR 1000A/690V IEC/700V UL	S8B24BF	aR 1000A/690V IEC/700V UL	S8B24BF	●			
	AFE-73550-4/4A-SL	aR 1000A/690V IEC/700V UL	S8B24BF	aR 1000A/690V IEC/700V UL	S8B24BF	●			
	AFE-73550-4/4A-SL	aR 1000A/690V IEC/700V UL	S8B24BF	aR 1000A/690V IEC/700V UL	S8B24BF	●			
AFE200-6/6A									
AFE200-71600-6	-	-	-	-		●			
AFE200-72000-6	-	-	-	-		●			
AFE200-72500-6	-	-	-	-		●			
AFE200-73150-6/6A	-	-	-	-		●			
AFE200-73550-6/6A	-	-	-	-		●			
400 kW	AFE200-72000-KXX-6-MS 04	aR 500A/1250V IEC/1300V UL	S85C14	aR 500A/1250V IEC/1300V UL	S85C14	●			
	AFE200-72000-XXX-6-SL	aR 500A/1250V IEC/1300V UL	S85C14	aR 500A/1250V IEC/1300V UL	S85C14	●			
500 kW	AFE200-72500-KXX-6-MS 05	aR 630A/1250V IEC/1300V UL	S85C15	aR 630A/1250V IEC/1300V UL	S85C15	●			
	AFE200-72500-XXX-6-SL	aR 630A/1250V IEC/1300V UL	S85C15	aR 630A/1250V IEC/1300V UL	S85C15	●			
630 kW	AFE200-73150-KXX-6/6A-MS 06	aR 700A/1250V IEC/1300V UL	S85C16	aR 700A/1250V IEC/1300V UL	S85C16	●			
	AFE200-73150-XXX-6/6A-SL	aR 700A/1250V IEC/1300V UL	S85C16	aR 700A/1250V IEC/1300V UL	S85C16	●			
710 kW	AFE200-73550-KXX-6/6A-MS 07	aR 800A/1250V IEC/1300V UL	S85C17	aR 800A/1250V IEC/1300V UL	S85C17	●			
	AFE200-73550-XXX-6/6A-SL	aR 800A/1250V IEC/1300V UL	S85C17	aR 800A/1250V IEC/1300V UL	S85C17	●			
900 kW	AFE200-73150-KXX-6/6A-MS 09	aR 700A/1250V IEC/1300V UL	S85C16	aR 700A/1250V IEC/1300V UL	S85C16	●			
	AFE200-73150-XXX-6/6A-SL	aR 700A/1250V IEC/1300V UL	S85C16	aR 700A/1250V IEC/1300V UL	S85C16	●			
	AFE200-73150-XXX-6/6A-SL	aR 700A/1250V IEC/1300V UL	S85C16	aR 700A/1250V IEC/1300V UL	S85C16	●			
1 MW	AFE200-73550-KXX-6/6A-MS 10	aR 800A/1250V IEC/1300V UL	S85C17	aR 800A/1250V IEC/1300V UL	S85C17	●			
	AFE200-73550-XXX-6/6A-SL	aR 800A/1250V IEC/1300V UL	S85C17	aR 800A/1250V IEC/1300V UL	S85C17	●			
	AFE200-73550-XXX-6/6A-SL	aR 800A/1250V IEC/1300V UL	S85C17	aR 800A/1250V IEC/1300V UL	S85C17	●			
1.35MW	AFE200-73550-KXX-6/6A-MS 14	aR 800A/1250V IEC/1300V UL	S85C17	aR 800A/1250V IEC/1300V UL	S85C17	●			
	AFE200-73550-XXX-6/6A-SL2	aR 800A/1250V IEC/1300V UL	S85C17	aR 800A/1250V IEC/1300V UL	S85C17	●			
	AFE200-73550-XXX-6/6A-SL	aR 800A/1250V IEC/1300V UL	S85C17	aR 800A/1250V IEC/1300V UL	S85C17	●			
1.65MW	AFE200-73550-KXX-6/6A-MS 17	aR 800A/1250V IEC/1300V UL	S85C17	aR 800A/1250V IEC/1300V UL	S85C17	●			
	AFE200-73550-XXX-6/6A-SL2	aR 800A/1250V IEC/1300V UL	S85C17	aR 800A/1250V IEC/1300V UL	S85C17	●			
	AFE200-73550-XXX-6/6A-SL2	aR 800A/1250V IEC/1300V UL	S85C17	aR 800A/1250V IEC/1300V UL	S85C17	●			
	AFE200-73550-XXX-6/6A-SL	aR 800A/1250V IEC/1300V UL	S85C17	aR 800A/1250V IEC/1300V UL	S85C17	●			
AFE200-73550-XXX-6/6A-SL	aR 800A/1250V IEC/1300V UL	S85C17	aR 800A/1250V IEC/1300V UL	S85C17	●				
ADV80									
ADV80-1004		Z14GR6	F4M01	A70P10	S7G49	●			
ADV80-1005		Z14GR6	F4M01	A70P10	S7G49	●			

Size	Europe		America		ADV80	AFE200			
	Model	Code	Model	Code					
ADV80-1007	Z14GR6	F4M01	A70P10	S7G49	●				
ADV80-1015	Z14GR10	F4M03	A70P10	S7G49	●				
ADV80-2022	Z14GR10	F4M03	A70P10	S7G49	●				
ADV80-2030	Z14GR16	F4M05	A70P20-1	S7G48	●				
ADV80-2040	Z14GR16	F4M05	A70P20-1	S7G48	●				
ADV80-2055	Z14GR20	F4M07	A70P20-1	S7G48	●				
ADV80-2075	GR2/25	F4D16	A70P30-1	S7I50	●				
ADV80-2110	GRD3/50	F4D21	A70P50	S7G53	●				
ADV80-3150	Z22GR63	F4M17	A70P60-4	S7I34	●				
ADV80-3185	Z22GR80	F4M19	A70P80	S7G54	●				
ADV80-3220	Z22GR80	F4M19	A70P80	S7G54	●				

Technical data for fuses, including dimensions, weights, dissipated power, fuse blocks, etc. can be found in the manufacturers' catalogues:

- S Jean Müller, Eltville
- A70... Ferraz
- aR .. Square body DIN 43653 110 mm stud mount high speed FUSE

ADV200 - 4

ADV200-DC

ADV200 - 6

ADV100

ADV80

AFE200

PROGRAM.

APPENDIX

www.nicsanat.com
021-87700210



8.2 Chokes



8.2.1. Input choke (L1 - CA)

A three-phase mains choke is mandatory for sizes of ≥ 160 kW.

Size	Output inverter	Choke rating [mH]	Current rating [A]	Current saturation [A]	Model	Code	Dimensions (WxHxd, mm) and weight	ADV200-4	ADV200-6	ADV100	ADV80	AFE200
ADV200-4												
ADV-1007 ... ADV-61320	HD / LD							(1)				
ADV-71600	HD	0.085	309	618	LR3-160	S7D40	300 x 270 x 260; 44kg	●				
	LD	0.085	420	710	LR3-200	S7AE9	300 x 270 x 355; 54kg	●				
ADV-72000	HD / LD	0.085	420	710	LR3-200	S7AE9		●				
ADV-72500	HD / LD	0.06	550	1050	LR3-315	S7D28	375 x 545 x 255; 110kg	●				
ADV-73150	HD / LD	0.04	700	900	LR3-ADV-355	S7LR01	390 x 400 x 290; 83kg	●				
ADV-73550	HD / LD	0.04	700	900	LR3-ADV-355	S7LR01		●				
400 kW	HD / LD	ADV-72000-KXX-4-MS 04	0.085	420	710	LR3-200	S7AE9	300 x 270 x 355; 54kg	●			
		ADV-72000-XXX-4-SL	0.085	420	710	LR3-200	S7AE9		●			
500 kW	HD / LD	ADV-72500-KXX-4-MS 05	0.06	550	1050	LR3-315	S7D28	375 x 545 x 255; 110kg	●			
		ADV-72500-XXX-4-SL	0.06	550	1050	LR3-315	S7D28		●			
630 kW	HD / LD	ADV-73150-KXX-4-MS 06	0.04	700	900	LR3-ADV-355	S7LR01	390 x 400 x 290; 83kg	●			
		ADV-73150-XXX-4-SL	0.04	700	900	LR3-ADV-355	S7LR01		●			
710 kW	HD / LD	ADV-73150-KXX-4-MS 07	0.04	700	900	LR3-ADV-355	S7LR01		●			
		ADV-73150-XXX-4-SL	0.04	700	900	LR3-ADV-355	S7LR01		●			
900 kW	HD / LD	ADV-73150-KXX-4-MS 09	0.04	700	900	LR3-ADV-355	S7LR01		●			
		ADV-73150-XXX-4-SL	0.04	700	900	LR3-ADV-355	S7LR01		●			
		ADV-73150-XXX-4-SL	0.04	700	900	LR3-ADV-355	S7LR01		●			
1 MW	HD / LD	ADV-73150-KXX-4-MS 10	0.04	700	900	LR3-ADV-355	S7LR01		●			
		ADV-73150-XXX-4-SL	0.04	700	900	LR3-ADV-355	S7LR01		●			
		ADV-73150-XXX-4-SL	0.04	700	900	LR3-ADV-355	S7LR01		●			
ADV200-6												
ADV-5750 ... ADV-61320	HD / LD							(1)				
ADV-71600	HD / LD	0.20	206	398	LR3-6-160-ADV	S7AL07	350 x 420 x 250; 54kg	●				
ADV-72000	HD / LD	0.16	260	493	LR3-6-200-ADV	S7AL08	350 x 360 x 250; 64kg	●				
ADV-72500	HD / LD	0.135	335	600	LR3-6-ADV-250	S7AD6	390 x 380 x 255; 75kg	●				
ADV-73150	HD / LD	0.11	405	852	LR3-6-315-355-ADV	S7AL09	380 x 450 x 270; 95kg	●				
ADV-73550	HD / LD	0.11	405	852	LR3-6-315-355-ADV	S7AL09		●				
400 kW	HD / LD	ADV-72000-KXX-6-MS 04	0.16	260	493	LR3-6-200-ADV	S7AL08	350 x 360 x 250; 64kg	●			
		ADV-72000-XXX-6-SL	0.16	260	493	LR3-6-200-ADV	S7AL08		●			
500 kW	HD / LD	ADV-72500-KXX-6-MS 05	0.135	335	600	LR3-6-ADV-250	S7AD6	390 x 380 x 255; 75kg	●			
		ADV-72500-XXX-6-SL	0.135	335	600	LR3-6-ADV-250	S7AD6		●			
630 kW	HD / LD	ADV-73150-KXX-6-MS 06	0.11	405	852	LR3-6-315-355-ADV	S7AL09	380 x 450 x 270; 95kg	●			
		ADV-73150-XXX-6-SL	0.11	405	852	LR3-6-315-355-ADV	S7AL09		●			
710 kW	HD / LD	ADV-73150-KXX-6-MS 07	0.11	405	852	LR3-6-315-355-ADV	S7AL09		●			
		ADV-73150-XXX-6-SL	0.11	405	852	LR3-6-315-355-ADV	S7AL09		●			
900 kW	HD / LD	ADV-73150-KXX-6-MS 09	0.11	405	852	LR3-6-315-355-ADV	S7AL09		●			
		ADV-73150-XXX-6-SL	0.11	405	852	LR3-6-315-355-ADV	S7AL09		●			
		ADV-73150-XXX-6-SL	0.11	405	852	LR3-6-315-355-ADV	S7AL09		●			
1 MW	HD / LD	ADV-73150-KXX-6-MS 10	0.11	405	852	LR3-6-315-355-ADV	S7AL09		●			
		ADV-73150-XXX-6-SL	0.11	405	852	LR3-6-315-355-ADV	S7AL09		●			
		ADV-73150-XXX-6-SL	0.11	405	852	LR3-6-315-355-ADV	S7AL09		●			

www.nicsanat.com
021-87700210



Size	Output inverter	Choke rating [mH]	Current rating [A]	Current saturation [A]	Model	Code	Dimensions (WxWxd, mm) and weight	ADV200-4	ADV200-6	ADV100	ADV80	AFE200
ADV100 (THD < 70 %:)												
1040				9 (*)	LR3y-2040	S7AAG	120 x 125 x 65; 2 kg			●		
1055				13 (*)	LR3y-2055	S7AB5	120 x 125 x 75; 2,2 kg			●		
2075				16 (*)	LR3y-2075	S7AB6	150 x 155 x 79; 4,9 kg			●		
2110				22 (*)	LR3y-3110	S7AB7	150 x 155 x 79; 5 kg			●		
3150				30 (*)	LR3y-3150	S7AB8	150 x 169 x 85; 5,5 kg			●		
3185				38 (*)	LR3-022	S7FF4	180 x 182 x 130; 7,8 kg			●		
3220				45 (*)	LR3-022	S7FF4				●		
ADV100 (THD < 35 %) : (2)												
1040				8 (*)	LDC-004	S7AI10	99 x 96 x 93; 2,4 kg			●		
1055				12 (*)	LDC-005	S7AI11	125 x 112 x 98; 4,1 kg			●		
2075				15 (*)	LDC-007	S7AI12	125 x 127 x 122; 4,9 kg			●		
2110				20 (*)	LDC-011	S7AI13	125 x 127 x 142; 6,6 kg			●		
3150				28 (*)	LDC-015	S7AI14	125 x 127 x 152; 8 kg			●		
3185				35 (*)	LDC-022	S7AI15	155 x 160 x 148; 8,5 kg			●		
3220				40 (*)	LDC-022	S7AI15				●		
ADV80												
ADV80-1004		6.1	2.5	5	LR3y-1007	S7AAD	120 x 125 x 65; 1,8 kg			●		
ADV80-1005		6.1	2.5	5	LR3y-1007	S7AAD				●		
ADV80-1007		6.1	2.5	5	LR3y-1007	S7AAD				●		
ADV80-2015		3.69	3.7	7.4	LR3y-1015	S7AAE	120 x 125 x 65; 1,8 kg			●		
ADV80-2022		2.71	5.5	11	LR3y-1022	S7AAF	120 x 125 x 65; 1,9 kg			●		
ADV80-2030		2.3	7.1	16	LR3y-1030	S7AB3	120 x 125 x 65; 1,9 kg			●		
ADV80-2040		1.63	9.6	22	LR3y-2040	S7AAG	120 x 125 x 65; 2 kg			●		
ADV80-2055		1.29	11.8	24.5	LR3y-2055	S7AB5	120 x 125 x 75; 2,2 kg			●		
ADV80-2075		0.89	17.4	36.5	LR3y-2075	S7AB6	150 x 155 x 79; 4,9 kg			●		
ADV80-2110		0.68	22	46.5	LR3y-3110	S7AB7	150 x 155 x 79; 5 kg			●		
ADV80-3150		0.51	30	61	LR3y-3150	S7AB8	150 x 169 x 85; 5,5 kg			●		
ADV80-3185		0.35	38	83	LR3-022	S7FF4	180 x 182 x 130; 7,8 kg			●		
ADV80-3220		0.35	45	83	LR3-022	S7FF4				●		
AFE200-4 / AFE200-6												
Input chokes are included on LCL filters, see page 134.												

(1) Integrated choke on DC-Link

(2) To reduce the line current THD even more (< 35%), use DC chokes wired between terminals C1 and C.

(*) In rated current

8.2.2. Output choke (L2) - Size 1007 ... 73550

Size	Output inverter	Choke rating [mH]	Current rating [A]	Current saturation [A]	Model	Code	Dimensions (WxWxd, mm) and weight	ADV200-4	ADV200-DC	ADV200-6	ADV100	ADV80	
ADV200-4/ ADV200-DC													
ADV-1007	HD	1.4	9.5	20	LU3-003	S7FG2	180 x 170 x 110; 6,8 kg	●					
	LD	0.87	16	34	LU3-005	S7FG3		●					
ADV-1015	HD	1.4	9.5	20	LU3-003	S7FG2		●					
	LD	0.87	16	34	LU3-005	S7FG3		●					
ADV-1022	HD	1.4	9.5	20	LU3-003	S7FG2		●					
	LD	0.87	16	34	LU3-005	S7FG3		●					
ADV-1030	HD	1.4	9.5	20	LU3-003	S7FG2		●					
	LD	0.87	16	34	LU3-005	S7FG3		●					
ADV-1040	HD	1.4	9.5	20	LU3-003	S7FG2		●					
	LD	0.87	16	34	LU3-005	S7FG3		●					
ADV-2055	HD	0.87	16	34	LU3-005	S7FG3		180 x 185 x 130; 8 kg	●				
	LD	0.51	27	57	LU3-011	S7FG4			●				
ADV-2075	HD	0.51	27	57	LU3-011	S7FG4	180 x 185 x 140; 7 kg	●					
	LD	0.43	32	68	LU3-015	S7FH2		●					
ADV-2110	HD	0.51	27	57	LU3-011	S7FG4	180 x 185 x 130; 8 kg	●					
	LD	0.43	32	68	LU3-015	S7FH2		●					
ADV-3150	HD	0.43	32	68	LU3-015	S7FH2	180 x 185 x 140; 7 kg	●					
	LD	0.33	42	72	LU3-022	S7FH3		●					
ADV-3185	HD	0.33	42	72	LU3-022	S7FH3	180 x 185 x 160; 8,2 kg	●	●				
	LD	0.23	58	100	LU3-030	S7FH4		●	●				
ADV-3220	HD	0.23	58	100	LU3-030	S7FH4	180 x 185 x 170; 10 kg	●	●				
	LD	0.24	58	100	LU3-030	S7FH4		●	●				
ADV-4300	HD	0.24	58	100	LU3-030	S7FH4	240 x 216 x 170; 16 kg	●	●				
	LD	0.18	76	130	LU3-037	S7FH5		●	●				
ADV-4370	HD	0.18	76	130	LU3-037	S7FH5	240 x 216 x 170; 16 kg	●	●				
	LD	0.12	120	205	LU3-055	S7FH6		●	●				
ADV-4450	HD	0.12	120	205	LU3-055	S7FH6	180 x 165 x 195; 15 kg	●	●				
	LD	0.07	180	310	LU3-090	S7F10		●	●				
ADV-5550	HD	0.07	180	310	LU3-090	S7F10	180 x 165 x 195; 15 kg	●	●				
	LD	0.07	180	310	LU3-090	S7F10		●	●				
ADV-5750	HD	0.07	180	310	LU3-090	S7F10	180 x 165 x 195; 15 kg	●	●				
	LD	0.07	180	310	LU3-090	S7F10		●	●				
ADV-5900	HD	0.07	180	310	LU3-090	S7F10	180 x 165 x 195; 15 kg	●	●				
	LD	0.041	310	540	LU3-160	S7FH8		●	●				
ADV-61100	HD	0.041	310	540	LU3-160	S7FH8	300 x 265 x 220; 30 kg	●	●				
	LD	0.041	310	540	LU3-160	S7FH8		●	●				
ADV-61320	HD	0.041	310	540	LU3-160	S7FH8	300 x 265 x 220; 30 kg	●	●				
	LD	0.041	310	540	LU3-160	S7FH8		●	●				
ADV-71600	HD	0.041	310	540	LU3-160	S7FH8	300 x 270 x 230, 33 kg	●	●				
	LD	0.03	400	770	LU3-200	S7AF0		●	●				
ADV-72000	HD	0.03	400	770	LU3-200	S7AF0	300 x 270 x 230, 33 kg	●	●				
	LD	0.022	580	1100	LU3-315	S7FH9		●	●				
ADV-72500	HD	0.022	580	1100	LU3-315	S7FH9	370 x 400 x 210, 65	●	●				
	LD	0.022	580	1100	LU3-315	S7FH9		●	●				

Size	Output inverter	Choke rating [mH]	Current rating [A]	Current saturation [A]	Model	Code	Dimensions (WxWxd, mm) and weight	ADV200-4	ADV200-DC	ADV200-6	ADV100	ADV80	
ADV-73150	HD	0.015	730	1240	LU3-400	S7F08	390 x 430 x 270, 73 kg	●	●				
	LD	0.015	730	1240	LU3-400	S7F08		●	●				
ADV-73550	HD	0.015	730	1240	LU3-400	S7F08		●	●				
	LD	0.015	730	1240	LU3-400	S7F08		●	●				
ADV100													
1040		1.4	9.5	20	LU3-003	S7FG2		180 x 170 x 110; 6,8 kg				●	
1055		0.87	16	34	LU3-005	S7FG3					●		
2075		0.51	27	57	LU3-011	S7FG4	180 x 185 x 130; 8 kg				●		
2110		0.51	27	57	LU3-011	S7FG4					●		
3150		0.43	32	68	LU3-015	S7FH2	180 x 185 x 140; 7 kg				●		
3185		0.33	42	72	LU3-022	S7FH3	180 x 185 x 160; 8,2 kg				●		
3220		0.23	58	100	LU3-030	S7FH4	180 x 185 x 170; 10 kg				●		
4300		0.23	58	100	LU3-030	S7FH4					●		
4370		0.18	76	130	LU3-037	S7FH5					●		
4450		0.12	120	205	LU3-055	S7FH6	240 x 216 x 170; 16 kg				●		
5550		0.07	180	310	LU3-090	S7F10	180 x 165 x 195; 15 kg				●		
5750		0.07	180	310	LU3-090	S7F10					●		
5900		0.07	180	310	LU3-090	S7F10					●		
ADV80													
ADV80-1004		1.4	2.15	3.9	LU3-QX01	S7FL2	120 x 130 x 65; 2 kg					●	
ADV80-1005		1.4	2.15	3.9	LU3-QX01	S7FL2						●	
ADV80-1007		1.4	2.15	3.9	LU3-QX01	S7FL2						●	
ADV80-2015		0.87	10.1	18.4	LU3-QX02	S7FL3						●	
ADV80-2022		0.87	10.1	18.4	LU3-QX02	S7FL3						●	
ADV80-2030		0.87	10.1	18.4	LU3-QX02	S7FL3						●	
ADV80-2040		0.87	10.1	18.4	LU3-QX02	S7FL3					●		
ADV80-2055		0.87	16	34	LU3-005	S7FG3	180 x 170 x 110; 6,8 kg					●	
ADV80-2075		0.51	27	57	LU3-011	S7FG4	180 x 185 x 130; 8 kg					●	
ADV80-2110		0.51	27	57	LU3-011	S7FG4						●	
ADV80-3150		0.43	32	68	LU3-015	S7FH2	180 x 185 x 140; 7 kg					●	
ADV80-3185		0.33	42	72	LU3-022	S7FH3	180 x 185 x 160; 8,2 kg					●	
ADV80-3220		0.23	58	100	LU3-030	S7FH4	180 x 185 x 170; 10 kg					●	

Motor cables up to 80 metres in length.

8.2.3. Output choke (L2) - ADV200-6

Size	Output inverter	Choke rating [mH]	Current rating [A]	Current saturation[A]	Model	Code	Dimensions (WxVxd, mm) and weight	ADV200-4	ADV200-DC	ADV200-6	ADV100	ADV80
ADV200-6												
ADV-5750	HD / LD	0.28	102	125	LU3-6-75	S7AE1	240 x 200 x 235; 28 kg			●		
ADV-6900	HD / LD	0.23	148	180	LU3-6-110	S7AE2	370 x 330 x 205; 50 kg			●		
ADV-61100	HD / LD	0.23	148	180	LU3-6-110	S7AE2				●		
ADV-61320	HD / LD	0.20	160	220	LU3-6-132	on request				●		
ADV-71600	HD	85	210	445	LU3-6-200	S7F017	300 x 360 x 210; 50 kg			●		
	LD	85	210	445	LU3-6-200	S7F017				●		
ADV-72000	HD	85	210	445	LU3-6-200	S7F017	300 x 350 x 210; 44 kg			●		
	LD	65	265	562	LU3-6-250	S7F018				●		
ADV-72500	HD	65	265	562	LU3-6-250	S7F018	360 x 350 x 250; 65 kg			●		
	LD	45	400	849	LU3-6-400	S7F019				●		
ADV-73150	HD	45	400	849	LU3-6-400	S7F019	360 x 350 x 250; 65 kg			●		
	LD	45	400	849	LU3-6-400	S7F019				●		
ADV-73550	HD	45	400	849	LU3-6-400	S7F019	360 x 350 x 250; 65 kg			●		
	LD	45	400	849	LU3-6-400	S7F019				●		

8.2.4. Output choke (L2) - Models with parallel connection 400 kW ... 1.65 MW

The use of output chokes is mandatory for parallel units; as a function of the application/connection, according to the following criteria:

- for applications with short motor cables (≤ 100 m long) bus bars with an integrated ferrites (see Table 1) or Only Ferrites may be used (see Table 2) or single distributor chokes may be used (see Table 3);
- for applications with long motor cables (> 100 m long) output choke may be used (see Table 4);

Table 1: Busbars with integrated distribution chokes (Motor cable length distance ≤ 100 m)

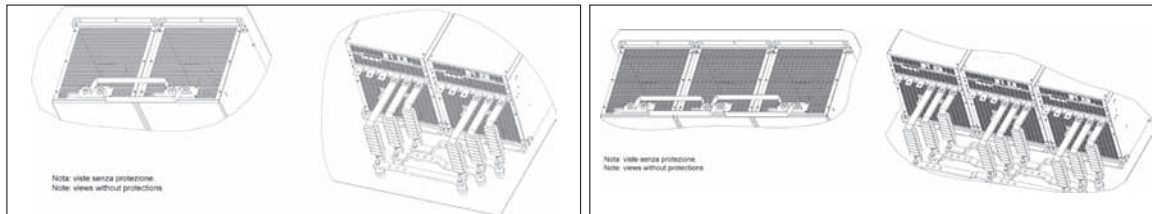

Size	Output inverter	Choke rating [μ H]	Current rating [A]	Current saturation [A]	Model	Code	ADV200-4	ADV200-DC	ADV200-6	ADV100	AFE200
ADV200-4											
400 kW	HD / LD				OUT-PW-KIT 2P	S72641	●	●			
500 kW	HD / LD				OUT-PW-KIT 2P	S72641	●	●			
630 kW	HD / LD				OUT-PW-KIT 2P	S72641	●	●			
710 kW	HD / LD				OUT-PW-KIT 2P	S72641	●	●			
900 kW	HD / LD				OUT-PW-KIT 3P	S726411	●	●			
1 MW	HD / LD				OUT-PW-KIT 3P	S726411	●	●			
ADV200-6											
400 kW	HD / LD				OUT-PW-KIT 2P-690V	S726412			●		
500 kW	HD / LD				OUT-PW-KIT 2P-690V	S726412			●		
630 kW	HD / LD				OUT-PW-KIT 2P-690V	S726412			●		
710 kW	HD / LD				OUT-PW-KIT 2P-690V	S726412			●		
900 kW	HD / LD				OUT-PW-KIT 3P-690V	S726413			●		
1 MW	HD / LD				OUT-PW-KIT 3P-690V	S726413			●		
1,35 MW				Not applicable							
1,65 MW				Not applicable							

ADV200 - 4

ADV200-DC

ADV200 - 6

ADV100

ADV80

AFE200

PROGRAM.

APPENDIX

Table 2: Ferrites (Motor cable length distance ≤ 100 m)

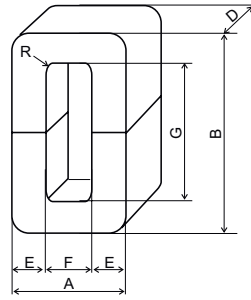

Sizes	Inverter output	Q.ty (*)	Type	Code	Dimensions (mm)						Weights (kg)	ADV200-4	ADV200-DC	ADV200-6	ADV100	AFE200
					A	B	D	E	F	G						
ADV200-4																
400 kW	HD / LD	48	Ferrite -N 57L 34P 22H ± 1.6	S7DDV	33.5	57.2	22	10	11.5 min	35 min	1.5 max	0.2	●	●		
500 kW	HD / LD	48											●	●		
630 kW	HD / LD	48											●	●		
710 kW	HD / LD	48											●	●		
900 kW	HD / LD	72											●	●		
1 MW	HD / LD	72											●	●		
ADV200-6																
400 kW	HD / LD	48	Ferrite -N 57L 34P 22H	6S7060	33.5	57.2	22	10	11.5 min	35 min	1.5 max	0.2		●	●	
400 kW	HD / LD	48												●	●	
500 kW	HD / LD	48												●	●	
500 kW	HD / LD	48												●	●	
630 kW	HD / LD	48												●	●	
710 kW	HD / LD	48												●	●	
900 kW	HD / LD	48												●	●	
1 MW	HD / LD	72												●	●	
1,35 MW	HD / LD	72												●	●	
1,65 MW	HD / LD	72												●	●	

(*) A total of 8pcs of ferrites has to be mounted on each drive module output phase.

Table 3: Distributor chokes (Motor cable length distance ≤ 100 m)

Size	Output inverter	Induttanza nominale [μH]	Choke rating [A]	Current rating [A]	Q.ty	Model	Code	Dimensions and Weights	ADV200-4	ADV200-DC	ADV200-6	ADV100	AFE200
ADV200-4													
400 kW	ADV-72000-KXX-4-MS 04	HD / LD	7,5	450	675	1	LU3-500P	S7FFI2	W = 280 mm H = 315 mm d = 155 mm	●	●		
	ADV-72000-XXX-4-SL		7,5	450	675	1	LU3-500P	S7FFI2		●	●		
500 kW	ADV-72500-KXX-4-MS 05	HD	7,5	450	675	1	LU3-500P	S7FFI2	22 kg	●	●		
	ADV-72500-XXX-4-SL		7,5	450	675	1	LU3-500P	S7FFI2		●	●		
500 kW	ADV-72500-KXX-4-MS 05	LD	5,0	730	975	1	LU3-800P	S7FFI1	W = 280 mm H = 315 mm d = 155 mm	●	●		
	ADV-72500-XXX-4-SL		5,0	730	975	1	LU3-800P	S7FFI1		●	●		
630 kW	ADV-73150-KXX-4-MS 06	HD / LD	5,0	730	975	1	LU3-800P	S7FFI1	28 kg	●	●		
	ADV-73150-XXX-4-SL		5,0	730	975	1	LU3-800P	S7FFI1		●	●		
710 kW	ADV-73150-KXX-4-MS 07	HD / LD	5,0	730	975	1	LU3-800P	S7FFI1	28 kg	●	●		
	ADV-73150-XXX-4-SL		5,0	730	975	1	LU3-800P	S7FFI1		●	●		
900 kW	ADV-73150-KXX-4-MS 09	HD / LD	5,0	730	975	1	LU3-800P	S7FFI1	W = 280 mm H = 315 mm d = 155 mm	●	●		
	ADV-73150-XXX-4-SL		5,0	730	975	1	LU3-800P	S7FFI1		●	●		
	ADV-73150-XXX-4-SL		5,0	730	975	1	LU3-800P	S7FFI1		●	●		
1 MW	ADV-73150-KXX-4-MS 10	HD / LD	5,0	730	975	1	LU3-800P	S7FFI1	28 kg	●	●		
	ADV-73150-XXX-4-SL		5,0	730	975	1	LU3-800P	S7FFI1		●	●		
	ADV-73150-XXX-4-SL		5,0	730	975	1	LU3-800P	S7FFI1		●	●		
ADV200-6													
400 kW	ADV-72000-KXX-6-MS 04	HD	25	265	562	1	LU3-6-ADV-250P	S7F023	W = 240 mm H = 215 mm d = 200 mm			●	
	ADV-72000-XXX-6-SL		25	265	562	1	LU3-6-ADV-250P	S7F023				●	
400 kW	ADV-72000-KXX-6-MS 04	LD	25	265	562	1	LU3-6-ADV-250P	S7F023	20 kg			●	
	ADV-72000-XXX-6-SL		25	265	562	1	LU3-6-ADV-250P	S7F023				●	
500 kW	ADV-72500-KXX-6-MS 05	HD	25	265	562	1	LU3-6-ADV-250P	S7F023	20 kg			●	
	ADV-72500-XXX-6-SL		25	265	562	1	LU3-6-ADV-250P	S7F023				●	
500 kW	ADV-72500-KXX-6-MS 05	LD	25	265	562	1	LU3-6-ADV-250P	S7F023	20 kg			●	
	ADV-72500-XXX-6-SL		25	265	562	1	LU3-6-ADV-250P	S7F023				●	
630 kW	ADV-73150-KXX-6-MS 06	HD / LD	15	415	796	1	LU3-6-ADV-355P	S7F022	24 kg			●	
	ADV-73150-XXX-6-SL		15	415	796	1	LU3-6-ADV-355P	S7F022				●	
710 kW	ADV-73150-KXX-6-MS 07	HD / LD	15	415	796	1	LU3-6-ADV-355P	S7F022	24 kg			●	
	ADV-73150-XXX-6-SL		15	415	796	1	LU3-6-ADV-355P	S7F022				●	
900 kW	ADV-73150-KXX-6-MS 09	HD / LD	15	415	796	1	LU3-6-ADV-355P	S7F022	W= 270 mm H = 290 mm d = 185 mm			●	
	ADV-73150-XXX-6-SL		15	415	796	1	LU3-6-ADV-355P	S7F022				●	
	ADV-73150-XXX-6-SL		15	415	796	1	LU3-6-ADV-355P	S7F022				●	
1 MW	ADV-73150-KXX-6-MS 10	HD / LD	15	415	796	1	LU3-6-ADV-355P	S7F022	24 kg			●	
	ADV-73150-XXX-6-SL		15	415	796	1	LU3-6-ADV-355P	S7F022				●	
	ADV-73150-XXX-6-SL		15	415	796	1	LU3-6-ADV-355P	S7F022				●	
1.35 MW	ADV-73550-KXX-6-MS 10	HD / LD	15	415	796	1	LU3-6-ADV-355P	S7F022	24 kg			●	
	ADV-73550-XXX-6-SL		15	415	796	1	LU3-6-ADV-355P	S7F022				●	
	ADV-73550-XXX-6-SL2		15	415	796	1	LU3-6-ADV-355P	S7F022				●	
	ADV-73550-XXX-6-SL2		15	415	796	1	LU3-6-ADV-355P	S7F022				●	
1.65 MW	ADV-73550-KXX-6-MS 17	HD / LD	15	415	796	1	LU3-6-ADV-355P	S7F022	24 kg			●	
	ADV-73550-XXX-6-SL		15	415	796	1	LU3-6-ADV-355P	S7F022				●	
	ADV-73550-XXX-6-SL2		15	415	796	1	LU3-6-ADV-355P	S7F022				●	
	ADV-73550-XXX-6-SL2		15	415	796	1	LU3-6-ADV-355P	S7F022				●	
	ADV-73550-XXX-6-SL2		15	415	796	1	LU3-6-ADV-355P	S7F022				●	

ADV200 - 4

ADV200-DC

ADV200 - 6

ADV100

ADV80

AFE200

PROGRAM.

APPENDIX

Table 4: output choke (Motor cable length distance > 100 m)

Size	Output inverter	Q.ty	Model	Code	Dimensions and Weights	ADV200-4	ADV200-DC	ADV200-6	ADV100	AFE200
ADV200-4										
400 kW	ADV-72000-KXX-4-MS 04	HD	1	LU3-200	S7AF0	W x H x d: 300 x 270 x 230 mm 33 kg	●	●		
	ADV-72000-XXX-4-SL		1	LU3-200	S7AF0		●	●		
400 kW	ADV-72000-KXX-4-MS 04	LD	1	LU3-315	S7FH9	W x H x d: 370 x 400 x 210 mm 65 kg	●	●		
	ADV-72000-XXX-4-SL		1	LU3-315	S7FH9		●	●		
500 kW	ADV-72500-KXX-4-MS 05	HD / LD	1	LU3-400	S7F08	W x H x d: 390 x 430 x 270 mm 73 kg	●	●		
	ADV-72500-XXX-4-SL		1	LU3-400	S7F08		●	●		
630 kW	ADV-73150-KXX-4-MS 06	HD / LD	1	LU3-400	S7F08		●	●		
	ADV-73150-XXX-4-SL		1	LU3-400	S7F08		●	●		
710 kW	ADV-73150-KXX-4-MS 07	HD / LD	1	LU3-400	S7F08		●	●		
	ADV-73150-XXX-4-SL		1	LU3-400	S7F08		●	●		
900 kW	ADV-73150-KXX-4-MS 09	HD / LD	1	LU3-400	S7F08		●	●		
	ADV-73150-XXX-4-SL		1	LU3-400	S7F08		●	●		
	ADV-73150-XXX-4-SL		1	LU3-400	S7F08		●	●		
1 MW	ADV-73150-KXX-4-MS 10	HD / LD	1	LU3-400	S7F08		●	●		
	ADV-73150-XXX-4-SL		1	LU3-400	S7F08	●	●			
	ADV-73150-XXX-4-SL		1	LU3-400	S7F08	●	●			
ADV200-6										
400 kW	ADV-72000-KXX-6-MS 04	HD	1	LU3-6-200	S7F017	W x H x d: = 300 x 360 x 210 mm 46 kg			●	
	ADV-72000-XXX-6-SL		1	LU3-6-200	S7F017					
400 kW	ADV-72000-KXX-6-MS 04	LD	1	LU3-6-250	S7F018				●	
	ADV-72000-XXX-6-SL		1	LU3-6-250	S7F018					
500 kW	ADV-72500-KXX-6-MS 05	HD/LD	1	LU3-6-ADV-400	S7F019	W x H x d: = 360 x 350 x 250 mm 65 kg			●	
	ADV-72500-XXX-6-SL		1	LU3-6-ADV-400	S7F019					
630 kW	ADV-73150-KXX-6-MS 06	HD	1	LU3-6-ADV-400	S7F019				●	
	ADV-73150-XXX-6-SL		1	LU3-6-ADV-400	S7F019					
630 kW	ADV-73150-KXX-6-MS 06	LD	1	LU3-6-ADV-400	S7F019				●	
	ADV-73150-XXX-6-SL		1	LU3-6-ADV-400	S7F019					
710 kW	ADV-73150-KXX-6-MS 07	HD/LD	1	LU3-6-ADV-400	S7F019				●	
	ADV-73150-XXX-6-SL		1	LU3-6-ADV-400	S7F019					
900 kW	ADV-73150-KXX-6-MS 09	HD/LD	1	LU3-6-ADV-400	S7F019				●	
	ADV-73150-XXX-6-SL		1	LU3-6-ADV-400	S7F019					
	ADV-73150-XXX-6-SL		1	LU3-6-ADV-400	S7F019					
1 MW	ADV-73150-KXX-6-MS 10	HD/LD	1	LU3-6-ADV-400	S7F019			●		
	ADV-73150-XXX-6-SL		1	LU3-6-ADV-400	S7F019					
	ADV-73150-XXX-6-SL		1	LU3-6-ADV-400	S7F019					
1.35 MW	ADV-73550-KXX-6-MS 10	HD/LD	1	LU3-6-ADV-400	S7F019			●		
	ADV-73550-XXX-6-SL		1	LU3-6-ADV-400	S7F019			●		
	ADV-73550-XXX-6-SL		1	LU3-6-ADV-400	S7F019			●		
	ADV-73550-XXX-6-SL2		1	LU3-6-ADV-400	S7F019			●		
1.65 MW	ADV-73550-KXX-6-MS 17	HD/LD	1	LU3-6-ADV-400	S7F019			●		
	ADV-73550-XXX-6-SL		1	LU3-6-ADV-400	S7F019			●		
	ADV-73550-XXX-6-SL		1	LU3-6-ADV-400	S7F019			●		
	ADV-73550-XXX-6-SL2		1	LU3-6-ADV-400	S7F019			●		
	ADV-73550-XXX-6-SL2		1	LU3-6-ADV-400	S7F019			●		

8.3 External EMC filters

Standard ADV200 and ADV100 (4300...5900) inverters are provided with an internal filter to guarantee performance levels required by EN 61800-3 (for the second environment, category C3) with a shielded motor cable, maximum 20 metres in length (up to 50 metres for size 5 and bigger). Optional external filters for different installations are listed in the table below.



Size	Heavy Duty		Light Duty		EN 61800-3 : Category / Environ- ment / Length of motor cables	ADV200-4	ADV200-6	ADV100	ADV80	AFE200
	Model	Code	Model	Code						
ADV200-4 (Supply voltage 3 x 380Vac -15% ... 500Vac +5%)										
≥ ADV-1007	ECF3	F4ZZ2	ECF3	F4ZZ2	C4 / 2nd / 100 m	●				
ADV-1007	EMI FTF-480-7	S7GHL	EMI FTF-480-7	S7GHL	C2 / 1st / 30 m	●				
ADV-1015	EMI FTF-480-7	S7GHL	EMI FTF-480-7	S7GHL	C2 / 1st / 30 m	●				
ADV-1022	EMI FTF-480-7	S7GHL	EMI FTF-480-7	S7GHL	C2 / 1st / 30 m	●				
ADV-1030	EMI FTF-480-7	S7GHL	EMI FTF-480-16	S7GHO	C2 / 1st / 30 m	●				
ADV-1040	EMI FTF-480-16	S7GHO	EMI FTF-480-16	S7GHO	C2 / 1st / 30 m	●				
ADV-2055	EMI FTF-480-16	S7GHO	EMI FTF-480-16	S7GHO	C2 / 1st / 30 m	●				
ADV-2075	EMI FTF-480-16	S7GHO	EMI FTF-480-30	S7GHP	C2 / 1st / 30 m	●				
ADV-2110	EMI FTF-480-30	S7GHP	EMI FTF-480-30	S7GHP	C2 / 1st / 30 m	●				
ADV-3150	EMI FTF-480-30	S7GHP	EMI FTF-480-42	S7GOA	C2 / 1st / 30 m	●				
ADV-3185	EMI FTF-480-42	S7GOA	EMI FTF-480-55	S7GOB	C2 / 1st / 30 m	●				
ADV-3220	EMI FTF-480-55	S7GOB	EMI FTF-480-75	S7GOC	C2 / 1st / 30 m	●				
ADV-4300	EMI FTF-480-75	S7GOC	EMI FTF-480-75	S7GOC	C2 / 1st / 30 m	●				
ADV-4370	EMI FTF-480-75	S7GOC	EMI FTF-480-100	S7GOD	C2 / 1st / 30 m	●				
ADV-4450	EMI FTF-480-100	S7GOD	EMI FTF-480-130	S7GOE	C2 / 1st / 30 m	●				
ADV-5550	EMI FTF-480-130	S7GOE	EMI FTF-480-180	S7GOF	C3 / 2nd / 100 m	●				
ADV-5750	EMI FTF-480-180	S7GOF	EMI FTF-480-180	S7GOF	C3 / 2nd / 100 m	●				
ADV-5900	EMI FTF-480-180	S7GOF	EMI-480-250	S7DGG	C3 / 2nd / 100 m	●				
ADV-61100	EMI-480-250	S7DGG	EMI-480-250	S7DGG	C3 / 2nd / 100 m	●				
ADV-61320	EMI-480-250	S7DGG	EMI-480-320	S7DGH	C3 / 2nd / 100 m	●				
ADV-71600	EMI-480-400	S7DGI	EMI-480-400	S7DGI	C3 / 2nd / 100 m	●				
ADV-72000	EMI-480-400	S7DGI	EMI-480-600	S7DGL	C3 / 2nd / 100 m	●				
ADV-72500	EMI-480-600	S7DGL	EMI-480-600	S7DGL	C3 / 2nd / 100 m	●				
ADV-73150	EMI-480-800	S7DGM	EMI-480-800	S7DGM	C3 / 2nd / 100 m	●				
ADV-73550	EMI-480-800	S7DGM	EMI-480-800	S7DGM	C3 / 2nd / 100 m	●				
400 kW	ADV-72000-KXX-4-MS 04	EMI-480-400	S7DGI	EMI-480-600	S7DGL	C3 / 2nd / 100 m	●			
	ADV-72000-XXX-4-SL	EMI-480-400	S7DGI	EMI-480-600	S7DGL	C3 / 2nd / 100 m	●			
500 kW	ADV-72500-KXX-4-MS 05	EMI-480-600	S7DGL	EMI-480-600	S7DGL	C3 / 2nd / 100 m	●			
	ADV-72500-XXX-4-SL	EMI-480-600	S7DGL	EMI-480-600	S7DGL	C3 / 2nd / 100 m	●			
630 kW	ADV-73150-KXX-4-MS 06	EMI-480-800	S7DGM	EMI-480-800	S7DGM	C3 / 2nd / 100 m	●			
	ADV-73150-XXX-4-SL	EMI-480-800	S7DGM	EMI-480-800	S7DGM	C3 / 2nd / 100 m	●			
710 kW	ADV-73150-KXX-4-MS 07	EMI-480-800	S7DGM	EMI-480-800	S7DGM	C3 / 2nd / 100 m	●			
	ADV-73150-XXX-4-SL	EMI-480-800	S7DGM	EMI-480-800	S7DGM	C3 / 2nd / 100 m	●			
900 kW	ADV-73150-KXX-4-MS 09	EMI-480-800	S7DGM	EMI-480-800	S7DGM	C3 / 2nd / 100 m	●			
	ADV-73150-XXX-4-SL	EMI-480-800	S7DGM	EMI-480-800	S7DGM	C3 / 2nd / 100 m	●			
	ADV-73150-XXX-4-SL	EMI-480-800	S7DGM	EMI-480-800	S7DGM	C3 / 2nd / 100 m	●			
1 MW	ADV-73150-KXX-4-MS 10	EMI-480-800	S7DGM	EMI-480-800	S7DGM	C3 / 2nd / 100 m	●			
	ADV-73150-XXX-4-SL	EMI-480-800	S7DGM	EMI-480-800	S7DGM	C3 / 2nd / 100 m	●			
	ADV-73150-XXX-4-SL	EMI-480-800	S7DGM	EMI-480-800	S7DGM	C3 / 2nd / 100 m	●			

ADV200 - 4

ADV200-DC

ADV200 - 6

ADV100

ADV80

AFE200

PROGRAM.

APPENDIX

Size		Heavy Duty		Light Duty		EN 61800-3 : Category / Envi- ronment / Length of motor cables	ADV200-4	ADV200-6	ADV100	ADV80	AFE200
		Model	Code	Model	Code						
ADV200-6 (Supply voltage 690 ±10%)											
ADV-6750 ... ADV-71320		EMI 690-180	S7DGP	EMI-690-250	S7DGQ	C3 / 2nd / 100 m		●			
61100		EMI-690-180	S7DGP	EMI-690-250	S7DGQ	C3 / 2nd / 100 m		●			
61320		EMI-690-180	S7DGP	EMI-690-250	S7DGQ	C3 / 2nd / 100 m		●			
71600		EMI-690-180	S7DGP	EMI-690-250	S7DGQ	C3 / 2nd / 100 m		●			
72000		EMI-690-250	S7DGQ	EMI-690-320	S7DGR	C3 / 2nd / 100 m		●			
72500		EMI-690-320	S7DGR	EMI-690-320	S7DGR	C3 / 2nd / 100 m		●			
73150		EMI-690-320	S7DGR	EMI-690-400	S7EMI12	C3 / 2nd / 100 m		●			
73550		EMI-690-400	S7EMI12	EMI-690-400	S7EMI12	C3 / 2nd / 100 m		●			
400 kW	ADV-72000-KXX-6-MS 04	EMI-690-250	S7DGQ	EMI-690-320	S7DGR	C3 / 2nd / 100 m		●			
	ADV-72000-XXX-6-SL	EMI-690-250	S7DGQ	EMI-690-320	S7DGR	C3 / 2nd / 100 m		●			
500 kW	ADV-72500-KXX-6-MS 05	EMI-690-320	S7DGR	EMI-690-320	S7DGR	C3 / 2nd / 100 m		●			
	ADV-72500-XXX-6-SL	EMI-690-320	S7DGR	EMI-690-320	S7DGR	C3 / 2nd / 100 m		●			
630 kW	ADV-731500-KXX-6-MS 06	EMI-690-320	S7DGR	EMI-690-400	S7EMI12	C3 / 2nd / 100 m		●			
	ADV-731500-XXX-6-SL	EMI-690-320	S7DGR	EMI-690-400	S7EMI12	C3 / 2nd / 100 m		●			
710 kW	ADV-735500-KXX-6-MS 07	EMI-690-400	S7EMI12	EMI-690-400	S7EMI12	C3 / 2nd / 100 m		●			
	ADV-735500-XXX-6-SL	EMI-690-400	S7EMI12	EMI-690-400	S7EMI12	C3 / 2nd / 100 m		●			
900 kW	ADV-731500-KXX-6-MS 09	EMI-690-400	S7EMI12	EMI-690-400	S7EMI12	C3 / 2nd / 100 m		●			
	ADV-731500-XXX-6-SL	EMI-690-400	S7EMI12	EMI-690-400	S7EMI12	C3 / 2nd / 100 m		●			
	ADV-731500-XXX-6-SL	EMI-690-400	S7EMI12	EMI-690-400	S7EMI12	C3 / 2nd / 100 m		●			
1 MW	ADV-735500-KXX-6-MS 10	EMI-690-400	S7EMI12	EMI-690-400	S7EMI12	C3 / 2nd / 100 m		●			
	ADV-735500-XXX-6-SL	EMI-690-400	S7EMI12	EMI-690-400	S7EMI12	C3 / 2nd / 100 m		●			
	ADV-735500-XXX-6-SL	EMI-690-400	S7EMI12	EMI-690-400	S7EMI12	C3 / 2nd / 100 m		●			
1,35 MW	ADV-73550-KXX-6-MS 10	EMI-690-400	S7EMI12	EMI-690-400	S7EMI12	C3 / 2nd / 100 m		●			
	ADV-73550-XXX-6-SL	EMI-690-400	S7EMI12	EMI-690-400	S7EMI12	C3 / 2nd / 100 m		●			
	ADV-73550-XXX-6-SL	EMI-690-400	S7EMI12	EMI-690-400	S7EMI12	C3 / 2nd / 100 m		●			
	ADV-73550-XXX-6-SL	EMI-690-400	S7EMI12	EMI-690-400	S7EMI12	C3 / 2nd / 100 m		●			
	ADV-73550-XXX-6-SL2	EMI-690-400	S7EMI12	EMI-690-400	S7EMI12	C3 / 2nd / 100 m		●			
1,65 MW	ADV-73550-KXX-6-MS 17	EMI-690-400	S7EMI12	EMI-690-400	S7EMI12	C3 / 2nd / 100 m		●			
	ADV-73550-XXX-6-SL	EMI-690-400	S7EMI12	EMI-690-400	S7EMI12	C3 / 2nd / 100 m		●			
	ADV-73550-XXX-6-SL	EMI-690-400	S7EMI12	EMI-690-400	S7EMI12	C3 / 2nd / 100 m		●			
	ADV-73550-XXX-6-SL2	EMI-690-400	S7EMI12	EMI-690-400	S7EMI12	C3 / 2nd / 100 m		●			
	ADV-73550-XXX-6-SL2	EMI-690-400	S7EMI12	EMI-690-400	S7EMI12	C3 / 2nd / 100 m		●			
ADV100 (Supply voltage 230 Vac -15% ... 500 Vac +5%)											
1040				EMI FTF-480-16	S7GHO	C2/1st/30m			●		
1055				EMI FTF-480-16	S7GHO	C2/1st/30m			●		
2075				EMI FTF-480-30	S7GHP	C2/1st/30m			●		
2110				EMI FTF-480-30	S7GHP	C2/1st/30m			●		
3150				EMI FTF-480-42	S7GOA	C2/1st/30m			●		
3185				EMI FTF-480-55	S7GOB	C2/1st/30m			●		
3220				EMI FTF-480-55	S7GOB	C2/1st/30m			●		
4300 (1)				EMI FTF-480-75	S7GOC	C2/1st/30m			●		
4370 (1)				EMI FTF-480-75	S7GOC	C2/1st/30m			●		
4450 (1)				EMI FTF-480-100	S7GOD	C2/1st/30m			●		
5550 (1)				EMI FTF-480-130	S7GOE	C3/2nd/100m			●		
5750 (1)				EMI FTF-480-180	S7GOF	C3/2nd/100m			●		
5900 (1)				EMI FTF-480-180	S7GOF	C3/2nd/100m			●		
1040 ... 5900				ECF3	F4ZZ2	C4/2nd/100m			●		
ADV80											
ADV80-1004				EMI-FTF-480-7	S7GHL	C2/2nd/10m				●	
ADV80-1005				EMI-FTF-480-7	S7GHL	C2/2nd/10m				●	

Size	Heavy Duty		Light Duty		EN 61800-3 : Category / Envi- ronment / Length of motor cables	ADV200-4	ADV200-6	ADV100	ADV80	AFE200
	Model	Code	Model	Code						
ADV80-1007			EMI-FTF-480-7	S7GHL	C2/2nd/10m				●	
ADV80-1015			EMI-FTF-480-16	S7GHO	C2/2nd/10m				●	
ADV80-2022			EMI-FTF-480-16	S7GHO	C2/2nd/10m				●	
ADV80-2030			EMI-FTF-480-16	S7GHO	C2/2nd/10m				●	
ADV80-2040			EMI-FTF-480-16	S7GHO	C2/2nd/10m				●	
ADV80-2055			EMI-FTF-480-16	S7GHO	C2/2nd/10m				●	
ADV80-2075			EMI-FTF-480-16	S7GHO	C2/2nd/10m				●	
ADV80-2110			EMI FTF-480-30	S7GHP	C3/2nd/10m				●	
ADV80-3150			EMI FTF-480-42	S7GOA	C3/2nd/10m				●	
ADV80-3185			EMI FTF-480-55	S7GOB	C3/2nd/10m				●	
ADV80-3220			EMI FTF-480-55	S7GOB	C3/2nd/10m				●	
AFE200-4/4A (2)										
AFE200-3220	EMI FN3120-480-50	S7DGV	EMI FN3120-480-80	S73EE	C3 / 2nd / 50 m					●
AFE200-4450	EMI FN3120-480-80	S73EE	EMI FN3120-480-110	S7DGZ	C3 / 2nd / 50 m					●
AFE200-5900	EMI FN3120-480-230	S74EE	EMI FN3120-480-230	S74EE	C3 / 2nd / 50 m					●
AFE200-61320	EMI FN3120-480-230	S74EE	EMI FN3359-480-320	S7GOH	C3 / 2nd / 50 m					●
AFE200-71600	EMI FN3359-480-320	S7GOH	EMI FN3359-480-400	S7GHY	C3 / 2nd / 50 m					●
AFE200-72000	EMI FN3359-480-400	S7GHY	EMI FN3359-480-400	S7GHY	C3 / 2nd / 50 m					●
AFE200-72500	EMI FN3359-480-600	S7GHW	EMI FN3359-480-600	S7GHW	C3 / 2nd / 50 m					●
AFE200-73150	EMI FN3359-480-600	S7GHW	EMI FN3359-480-600	S7GHW	C3 / 2nd / 50 m					●
AFE200-73550	EMI FN3359-480-600	S7GHW	EMI FN3359-480-600	S7GHW	C3 / 2nd / 50 m					●
400 kW	AFE200-72000-...-4-MS 04	EMI FN3359-480-400	S7GHY	EMI FN3359-480-400	S7GHY	C3 / 2nd / 50 m				●
	AFE200-72000-...-4-SL	EMI FN3359-480-400	S7GHY	EMI FN3359-480-400	S7GHY	C3 / 2nd / 50 m				●
500 kW	AFE200-72500-...-4-MS 05	EMI FN3359-480-600	S7GHW	EMI FN3359-480-600	S7GHW	C3 / 2nd / 50 m				●
	AFE200-72500-...-4-SL	EMI FN3359-480-600	S7GHW	EMI FN3359-480-600	S7GHW	C3 / 2nd / 50 m				●
630 kW	AFE200-73150-...-4-MS 06	EMI FN3359-480-600	S7GHW	EMI FN3359-480-600	S7GHW	C3 / 2nd / 50 m				●
	AFE200-73150-...-4-SL	EMI FN3359-480-600	S7GHW	EMI FN3359-480-600	S7GHW	C3 / 2nd / 50 m				●
710 kW	AFE200-73550-...-4-MS 07	EMI FN3359-480-600	S7GHW	EMI FN3359-480-600	S7GHW	C3 / 2nd / 50 m				●
	AFE200-73550-...-4-SL	EMI FN3359-480-600	S7GHW	EMI FN3359-480-600	S7GHW	C3 / 2nd / 50 m				●
900 kW	AFE200-73150-...-4-MS 09	EMI FN3359-480-600	S7GHW	EMI FN3359-480-600	S7GHW	C3 / 2nd / 50 m				●
	AFE200-73150-...-4-SL	EMI FN3359-480-600	S7GHW	EMI FN3359-480-600	S7GHW	C3 / 2nd / 50 m				●
1 MW	AFE200-73550-...-4-MS 10	EMI FN3359-480-600	S7GHW	EMI FN3359-480-600	S7GHW	C3 / 2nd / 50 m				●
	AFE200-73550-...-4-SL	EMI FN3359-480-600	S7GHW	EMI FN3359-480-600	S7GHW	C3 / 2nd / 50 m				●
AFE200-6/6A (3)										
AFE200-71600-6	EMI-FN3359HV-690-150	S7EMI13	EMI-FN3359HV-690-180	S7EMI14	C3 / 2nd / 50 m					●
AFE200-72000-6	EMI-FN3359HV-690-180	S7EMI14	EMI-FN3359HV-690-250	S7EMI15	C3 / 2nd / 50 m					●
AFE200-72500-6	EMI-FN3359HV-690-250	S7EMI15	EMI-FN3359HV-690-320	S7EMI16	C3 / 2nd / 50 m					●
AFE200-73150-6/6A	EMI-FN3359HV-690-320	S7EMI16	EMI-FN3359HV-690-320	S7EMI16	C3 / 2nd / 50 m					●
AFE200-73550-6/6A	EMI-FN3359HV-690-320	S7EMI16	EMI-FN3359HV-690-400	S7EMI17	C3 / 2nd / 50 m					●
400 kW	AFE200-72000-...-6-MS 04	EMI-FN3359HV-690-180	S7EMI14	EMI-FN3359HV-690-250	S7EMI15	C3 / 2nd / 50 m				●
	AFE200-72000-...-6-SL	EMI-FN3359HV-690-180	S7EMI14	EMI-FN3359HV-690-250	S7EMI15	C3 / 2nd / 50 m				●
500 kW	AFE200-72500-...-6-MS 05	EMI-FN3359HV-690-250	S7EMI15	EMI-FN3359HV-690-320	S7EMI16	C3 / 2nd / 50 m				●
	AFE200-72500-...-6-SL	EMI-FN3359HV-690-250	S7EMI15	EMI-FN3359HV-690-320	S7EMI16	C3 / 2nd / 50 m				●
630 kW	AFE200-73150-...-6-MS 06	EMI-FN3359HV-690-320	S7EMI16	EMI-FN3359HV-690-320	S7EMI16	C3 / 2nd / 50 m				●
	AFE200-73150-...-6-SL	EMI-FN3359HV-690-320	S7EMI16	EMI-FN3359HV-690-320	S7EMI16	C3 / 2nd / 50 m				●
710 kW	AFE200-73550-...-6-MS 07	EMI-FN3359HV-690-320	S7EMI16	EMI-FN3359HV-690-400	S7EMI17	C3 / 2nd / 50 m				●
	AFE200-73550-...-6-SL	EMI-FN3359HV-690-320	S7EMI16	EMI-FN3359HV-690-400	S7EMI17	C3 / 2nd / 50 m				●

ADV200 - 4

ADV200-DC

ADV200 - 6

ADV100

ADV80

AFE200

PROGRAM.

APPENDIX

8.4 LCL Filters

LCL filter must be connected between AFE and the AC line supply. It reduces the harmonics related to the switching frequency of the IGBT power bridge (high order harmonics). Decreasing the harmonic current distortion, it improves the line power quality and its voltage distortion. The specified LCL filters refer to the default value of the AFE200 switching frequency. This frequency must not be changed.



Size	Heavy Duty			Low Duty			ADV200-4	ADV200-6	ADV100	ADV80	AFE200	
	LCL Filters Type	Code	Q.ty	LCL Filters Type	Code	Q.ty						
AFE200-4/4A												
	AFE200-3220	LCL-Kit-AFE-4-22-HD	S7LC09	1	LCL-Kit-AFE-4-22-LD	S7LC15	1					●
	AFE200-4450	LCL-Kit-AFE-4-45-HD	S7LC01	1	LCL-Kit-AFE-4-45-LD	S7LC16	1					●
	AFE200-5900	LCL-Kit-AFE-4-90-HD	S7LC02	1	LCL-Kit-AFE-4-90-LD	S7LC17	1					●
	AFE200-61320	LCL-Kit-AFE-4-132-HD	S7LC03	1	LCL-Kit-AFE-4-132-LD/160-HD	S7LC04	1					●
	AFE200-71600	LCL-Kit-AFE-4-132-LD/160-HD	S7LC04	1	LCL-Kit-AFE-4-160-LD/200-HD	S7LC05	1					●
	AFE200-72000	LCL-Kit-AFE-4-160-LD/200-HD	S7LC05	1	LCL-Kit-AFE-4-200-LD	S7LC18	1					●
	AFE200-72500	LCL-Kit-AFE-4-250-HD	S7LC06	1	LCL-Kit-AFE-4-250-LD/315-HD	S7LC07	1					●
	AFE200-73150	LCL-Kit-AFE-4-250-LD/315-HD	S7LC07	1	LCL-Kit-AFE-4-315-LD/355-HD	S7LC08	1					●
	AFE200-73550	LCL-Kit-AFE-4-315-LD/355-HD	S7LC08	1	LCL-Kit-AFE-4-355-LD	S7LC19	1					●
400 kW	AFE200-72000-...-4-MS 04	LCL-Kit-AFE-4-160-LD/200-HD	S7LC05	1	LCL-Kit-AFE-4-200-LD	S7LC18	1					●
	AFE200-72000-...-4-SL	LCL-Kit-AFE-4-160-LD/200-HD	S7LC05	1	LCL-Kit-AFE-4-200-LD	S7LC18	1					●
500 kW	AFE200-72500-...-4-MS 05	LCL-Kit-AFE-4-250-HD	S7LC06	1	LCL-Kit-AFE-4-250-LD/315-HD	S7LC07	1					●
	AFE200-72500-...-4-SL	LCL-Kit-AFE-4-250-HD	S7LC06	1	LCL-Kit-AFE-4-250-LD/315-HD	S7LC07	1					●
630 kW	AFE200-73150-...-4-MS 06	LCL-Kit-AFE-4-250-LD/315-HD	S7LC07	1	LCL-Kit-AFE-4-315-LD/355-HD	S7LC08	1					●
	AFE200-73150-...-4-SL	LCL-Kit-AFE-4-250-LD/315-HD	S7LC07	1	LCL-Kit-AFE-4-315-LD/355-HD	S7LC08	1					●
710 kW	AFE200-73550-...-4-MS 07	LCL-Kit-AFE-4-315-LD/355-HD	S7LC08	1	LCL-Kit-AFE-4-355-LD	S7LC19	1					●
	AFE200-73550-...-4-SL	LCL-Kit-AFE-4-315-LD/355-HD	S7LC08	1	LCL-Kit-AFE-4-355-LD	S7LC19	1					●
900 kW	AFE200-73150-...-4-MS 09	LCL-Kit-AFE-4-250-LD/315-HD	S7LC07	1	LCL-Kit-AFE-4-315-LD/355-HD	S7LC08	1					●
	AFE200-73150-...-4-SL	LCL-Kit-AFE-4-250-LD/315-HD	S7LC07	1	LCL-Kit-AFE-4-315-LD/355-HD	S7LC08	1					●
	AFE200-73150-...-4-SL	LCL-Kit-AFE-4-250-LD/315-HD	S7LC07	1	LCL-Kit-AFE-4-315-LD/355-HD	S7LC08	1					●
1 MW	AFE200-73550-...-4-MS 10	LCL-Kit-AFE-4-315-LD/355-HD	S7LC08	1	LCL-Kit-AFE-4-355-LD	S7LC19	1					●
	AFE200-73550-...-4-SL	LCL-Kit-AFE-4-315-LD/355-HD	S7LC08	1	LCL-Kit-AFE-4-355-LD	S7LC19	1					●
	AFE200-73550-...-4-SL	LCL-Kit-AFE-4-315-LD/355-HD	S7LC08	1	LCL-Kit-AFE-4-355-LD	S7LC19	1					●

LCL Filters composition and dimensions • Heavy Duty

LCL Filters Type	Code	LR3-AFE (choke connected on the AFE line input)			LC-AFE (LC device composed by a capacitors bank and a line choke in a single package)		
		Type	Code	Dimensions and Weight (WxHxd)	Type	Code	Dimensions and Weight (WxHxd)
LCL-Kit-AFE-4-22-HD	S7LC09	LR3-AFE-4-22-HD	S7ALC10	300 x 225 x 185 mm, 28 kg	LC-AFE-4-22HD	S7ALC9M	192,5 x 182 x 150 mm, 10 kg
LCL-Kit-AFE-4-45-HD	S7LC01	LR3-AFE-4-45-HD	S7ALC2	370 x 255 x 250 mm, 48 kg	LC-AFE-4-45-HD	S7ALC1M	192,5 x 162 x 150 mm, 12 kg
LCL-Kit-AFE-4-90-HD	S7LC02	LR3-AFE-4-90-HD	S7ALC8	370 x 315 x 260 mm, 75 kg	LC-AFE-4-90-HD	S7ALC7M	260 x 300 x 286 mm, 31 kg
LCL-Kit-AFE-4-132-HD	S7LC03	LR3-AFE-4-132-HD	S7ALC12	370 x 410 x 275 mm, 90 kg	LC-AFE-4-132-HD	S7ALC11M	310 x 335 x 341 mm, 40 kg
LCL-Kit-AFE-4-132-LD/160-HD	S7LC04	LR3-AFE-4-160-HD	S7ALC14	430 x 475 x 335 mm, 125 kg	LC-AFE-4-160-HD	S7ALC13M	310 x 335 x 341 mm, 40 kg

LCL Filters composition and dimensions • Low Duty

LCL Filters Type	Code	LR3-AFE (choke connected on the AFE line input)			LC device composed by a capacitors bank (C-AFE) and a line choke (L-AFE) in a separate package					
		Type	Code	Dimensions and Weight (WxHxd)	L-AFE			C-AFE		
					Type	Code	Dimensions and Weight (WxHxd)	Type	Code	Dimensions and Weight (WxHxd)
LCL-Kit-AFE-4-160-LD/200-HD	S7LC05	LR3-AFE-4-200-HD	S7ALC16	430 x 480 x 340 mm, 130 kg	L-AFE-4-200-HD	S7ALC15	310 x 340 x 240 mm, 42 kg	C-AFE-4-33	S7ALC15C	395 x 215 x 140 mm, 5 kg
LCL-Kit-AFE-4-250-HD	S7LC06	LR3-AFE-4-250-HD	S7ALC4	430 x 480 x 350 mm, 150 kg	L-AFE-4-250-HD	S7ALC3	310 x 345 x 235 mm, 45 kg	C-AFE-4-47	S7ALC3C	395 x 215 x 140 mm, 6 kg
LCL-Kit-AFE-4-250-LD/315-HD	S7LC07	LR3-AFE-4-315-HD	S7ALC18	490 x 560 x 410 mm, 240 kg	L-AFE-4-315-HD	S7ALC17	415 x 450 x 355 mm, 145 kg	C-AFE-4-68	S7ALC17C	395 x 215 x 140 mm, 6 kg
LCL-Kit-AFE-4-315-LD/355-HD	S7LC08	LR3-AFE-4-355-HD	S7ALC6	490 x 560 x 425 mm, 240 kg	L-AFE-4-355-HD	S7ALC5	415 x 450 x 375 mm, 155 kg	C-AFE-4-68	S7ALC17C	395 x 215 x 140 mm, 6 kg

Size		Heavy Duty			Low Duty			ADV200-4	ADV200-6	ADV100	ADV80	AFE200
		LCL Filters Type	Code	Q.ty	LCL Filters Type	Code	Q.ty					
AFE200-6/6A												
AFE200-71600-6		LCL-Kit-AFE-6-160-HD	S7LC10	1	LCL-Kit-AFE-6-160-LD	S7LC20	1					●
AFE200-72000-6		LCL-Kit-AFE-6-200-HD	S7LC11	1	LCL-Kit-AFE-6-200-LD/250-HD	S7LC12	1					●
AFE200-72500-6		LCL-Kit-AFE-6-200-LD/250-HD	S7LC12	1	LCL-Kit-AFE-6-250-LD/315-HD	S7LC13	1					●
AFE200-73150-6/6A		LCL-Kit-AFE-6-250-LD/315-HD	S7LC13	1	LCL-Kit-AFE-6-315-LD/355-HD	S7LC14	1					●
AFE200-73550-6/6A		LCL-Kit-AFE-6-315-LD/355-HD	S7LC14	1	LCL-Kit-AFE-6-355-LD	S7LC21	1					●
400 kW	AFE200-72000-...-6-MS 04	LCL-Kit-AFE-6-200-HD	S7LC11	1	LCL-Kit-AFE-6-200-LD/250-HD	S7LC12	1					●
	AFE200-72000-...-6-SL	LCL-Kit-AFE-6-200-HD	S7LC11	1	LCL-Kit-AFE-6-200-LD/250-HD	S7LC12	1					●
500 kW	AFE200-72500-...-6-MS 05	LCL-Kit-AFE-6-200-LD/250-HD	S7LC12	1	LCL-Kit-AFE-6-250-LD/315-HD	S7LC13	1					●
	AFE200-72500-...-6-SL	LCL-Kit-AFE-6-200-LD/250-HD	S7LC12	1	LCL-Kit-AFE-6-250-LD/315-HD	S7LC13	1					●
630 kW	AFE200-73150-...-6-MS 06	LCL-Kit-AFE-6-250-LD/315-HD	S7LC13	1	LCL-Kit-AFE-6-315-LD/355-HD	S7LC14	1					●
	AFE200-73150-...-6-SL	LCL-Kit-AFE-6-250-LD/315-HD	S7LC13	1	LCL-Kit-AFE-6-315-LD/355-HD	S7LC14	1					●
710 kW	AFE200-73550-...-6-MS 07	LCL-Kit-AFE-6-315-LD/355-HD	S7LC14	1	LCL-Kit-AFE-6-355-LD	S7LC21	1					●
	AFE200-73550-...-6-SL	LCL-Kit-AFE-6-315-LD/355-HD	S7LC14	1	LCL-Kit-AFE-6-355-LD	S7LC21	1					●
900 kW	AFE200-73150-...-6-MS 09	LCL-Kit-AFE-6-250-LD/315-HD	S7LC13	1	LCL-Kit-AFE-6-315-LD/355-HD	S7LC14	1					●
	AFE200-73150-...-6-SL	LCL-Kit-AFE-6-250-LD/315-HD	S7LC13	1	LCL-Kit-AFE-6-315-LD/355-HD	S7LC14	1					●
	AFE200-73150-...-6-SL	LCL-Kit-AFE-6-250-LD/315-HD	S7LC13	1	LCL-Kit-AFE-6-315-LD/355-HD	S7LC14	1					●
1 MW	AFE200-73550-...-6-MS 10	LCL-Kit-AFE-6-315-LD/355-HD	S7LC14	1	LCL-Kit-AFE-6-355-LD	S7LC21	1					●
	AFE200-73550-...-6-SL	LCL-Kit-AFE-6-315-LD/355-HD	S7LC14	1	LCL-Kit-AFE-6-355-LD	S7LC21	1					●
	AFE200-73550-...-6-SL	LCL-Kit-AFE-6-315-LD/355-HD	S7LC14	1	LCL-Kit-AFE-6-355-LD	S7LC21	1					●
1.35MW	AFE200-73550-...-6-MS	LCL-Kit-AFE-6-315-LD/355-HD	S7LC14	1	LCL-Kit-AFE-6-355-LD	S7LC21	1					●
	AFE200-73550-...-6-SL	LCL-Kit-AFE-6-315-LD/355-HD	S7LC14	1	LCL-Kit-AFE-6-355-LD	S7LC21	1					●
	AFE200-73550-...-6-SL	LCL-Kit-AFE-6-315-LD/355-HD	S7LC14	1	LCL-Kit-AFE-6-355-LD	S7LC21	1					●
1.65MW	AFE200-73550-...-6-MS 17	LCL-Kit-AFE-6-315-LD/355-HD	S7LC14	1	LCL-Kit-AFE-6-355-LD	S7LC21	1					●
	AFE200-73550-...-6-SL	LCL-Kit-AFE-6-315-LD/355-HD	S7LC14	1	LCL-Kit-AFE-6-355-LD	S7LC21	1					●
	AFE200-73550-...-6-SL	LCL-Kit-AFE-6-315-LD/355-HD	S7LC14	1	LCL-Kit-AFE-6-355-LD	S7LC21	1					●
	AFE200-73550-...-6-SL2	LCL-Kit-AFE-6-315-LD/355-HD	S7LC14	1	LCL-Kit-AFE-6-355-LD	S7LC21	1					●

LCL Filters composition and dimensions • Heavy Duty

LCL Filters Type	Code	LR3-AFE (choke connected on the AFE line input)			LC-AFE (LC device composed by a capacitors bank and a line choke in a single package)		
		Type	Code	Dimensions and Weight (WxHxD)	Type	Code	Dimensions and Weight (WxHxD)
LCL-Kit-AFE-6-160-HD	S7LC10	LR3-AFE-6-160-HD	S7ALC20	370 x 410 x 275 mm, 90 kg	LC-AFE-6-160-HD	S7ALC21M	310 x 340 x 240 mm, 42 kg

Modelli Filtri LCL	Code	LR3-AFE (choke connected on the AFE line input)			LC device composed by a capacitors package (C-AFE) and a line choke (L-AFE) in a separate package					
		Type	Code	Dimensions and Weight (WxHxD)	L-AFE			C-AFE		
		Type	Code	Dimensions and Weight (WxHxD)	Type	Code	Dimensions and Weight (WxHxD)	Type	Code	Dimensions and Weight (WxHxD)
LCL-Kit-AFE-6-200-HD	S7LC11	LR3-AFE-6-200-HD	S7ALC22	415 x 455 x 360 mm, 150 kg	L-AFE-6-200-HD	S7ALC23	370 x 325 x 280 mm, 75 kg	C-AFE-6-22	S7ALC23C	395 x 315 x 140 mm, 6 kg
LCL-Kit-AFE-6-200-LD/250-HD	S7LC12	LR3-AFE-6-250-HD	S7ALC24	490 x 490 x 380 mm, 210 kg	L-AFE-6-250-HD	S7ALC25	370 x 250 x 300 mm, 75 kg	C-AFE-6-33	S7ALC25C	395 x 315 x 140 mm, 6 kg
LCL-Kit-AFE-6-250-LD/315-HD	S7LC13	LR3-AFE-6-315-HD	S7ALC26	490 x 560 x 370 mm, 240 kg	L-AFE-6-315-HD	S7ALC27	415 x 355 x 335 mm, 120 kg	C-AFE-6-33	S7ALC25C	395 x 315 x 140 mm, 6 kg
LCL-Kit-AFE-6-315-LD/355-HD	S7LC14	LR3-AFE-6-355-HD	S7ALC28	490 x 560 x 415 mm, 240 kg	L-AFE-6-355-HD	S7ALC29	415 x 360 x 325 mm, 100 kg	C-AFE-6-47	S7ALC29C	395 x 315 x 140 mm, 6 kg

LCL Filters composition and dimensions • Low Duty

LCL Filters Type	Code	LR3-AFE (choke connected on the AFE line input)			LC device composed by a capacitors package (C-AFE) and a line choke (L-AFE) in a separate package					
		Type	Code	Dimensions and Weight (WxHxD)	L-AFE			C-AFE		
		Type	Code	Dimensions and Weight (WxHxD)	Type	Code	Dimensions and Weight (WxHxD)	Type	Code	Dimensions and Weight (WxHxD)
LCL-Kit-AFE-6-160-LD	S7LC20	LR3-AFE-6-160-LD	S7ALC50	430 x 475 x 335 mm, 125 kg	L-AFE-6-160-LD	S7ALC51	280 x 225 x 230 mm, 24 kg	C-AFE-6-22	S7ALC23C	395 x 315 x 140 mm, 6 kg
LCL-Kit-AFE-6-200-LD/250-HD	S7LC12	LR3-AFE-6-250-HD	S7ALC24	490 x 490 x 380 mm, 210 kg	L-AFE-6-250-HD	S7ALC25	370 x 250 x 300 mm, 75 kg	C-AFE-6-33	S7ALC25C	395 x 315 x 140 mm, 6 kg
LCL-Kit-AFE-6-250-LD/315-HD	S7LC13	LR3-AFE-6-315-HD	S7ALC26	490 x 560 x 370 mm, 240 kg	L-AFE-6-315-HD	S7ALC27	415 x 355 x 335 mm, 120 kg	C-AFE-6-33	S7ALC25C	395 x 315 x 140 mm, 6 kg
LCL-Kit-AFE-6-315-LD/355-HD	S7LC14	LR3-AFE-6-355-HD	S7ALC28	490 x 560 x 415 mm, 240 kg	L-AFE-6-355-HD	S7ALC29	415 x 360 x 325 mm, 120 kg	C-AFE-6-47	S7ALC29C	395 x 315 x 140 mm, 6 kg
LCL-Kit-AFE-6-355-LD	S7LC21	LR3-AFE-6-355-LD	S7ALC52	510 x 560 x 415 mm, 250 kg	L-AFE-6-355-LD	S7ALC53	415 x 365 x 345 mm, 120 kg	C-AFE-6-47	S7ALC29C	395 x 315 x 140 mm, 6 kg

8.5 Braking resistors

Suggested braking resistors for use with an internal braking unit.



Size	Model	Code	Max. overload 1" - service 10%	Max. overload 30" - service 25%	Max. overload 5"	PBraking resistor power rating	Braking resistor value	Housing							
			Ebr (kJ)	Ebr (kJ)	Ebr (kJ)				Pnbr (W)	Rbr (Ω)	ADV200-4	ADV200-DC	ADV200-6	ADV100	ADV80
ADV200															
ADV-1007	RF 220 T 100R	S8TOCE	1.5	11		220	100	IP44	●						
ADV-1015	RF 220 T 100R	S8TOCE	1.5	11		220	100	IP44	●						
ADV-1022	RF 300 DT 100R	S8TOCB	2.5	19		300	100	IP44	●						
ADV-1030	RF 300 DT 100R	S8TOCB	2.5	19		300	100	IP44	●						
ADV-1040	RFPD 750 DT 100R	S8SY4	7.5	38		750	100	IP44	●						
ADV-2055	RFPD 750 DT 68R	S8TOCD	7.5	38		750	68	IP44	●						
ADV-2075	RFPD 900 DT 68R	S8SY5	9	48		900	68	IP44	●						
ADV-2110	RFPD 1100 DT 40R	S8SY6	11	58		1100	40	IP44	●						
ADV-3150	RFPR 1900 D 28R	S8SZ5	19	75		1900	28	IP44	●						
ADV-3185	BRT4K0-15R4	S8TOOG	40	150		4000	15.4	IP20	●						
ADV-3220	BRT4K0-15R4	S8TOOG	40	150		4000	15.4	IP20	●						
ADV-4300	BRT4K0-11R6	S8TOOH	40	150		4000	11.6	IP20	●						
ADV-4370	BRT4K0-11R6	S8TOOH	40	150		4000	11.6	IP20	●						
ADV-4450	BRT8K0-7R7	S8TOOI	40	150		8000	7.7	IP20	●						
ADV-5550	BRT8K0-7R7	S8TOOI	40	150		8000	7.7	IP20	●						
≥ ADV-5750 and ADV200-...-DC									(1)	(1)	(2)				
ADV100															
1040	RFPD 750 DT 100R	S8SY4	1	7.5		38	100	IP44					●		
1055	RFPD 750 DT 68R	S8TOCD	1	7.5		38	68	IP44					●		
2075	RFPD 900 DT 68R	S8SY5	1	9		48	68	IP44					●		
2110	RFPD 1100 DT 40R	S8SY6	1	11		58	40	IP44					●		
3150	RFPD 1900 D 28R	S8SZ5	1	19		75	28	IP44					●		
3185	BRT4K0-15R4	S8TOOG	1	40		150	15.4	IP20					●		
3220	BRT4K0-15R4	S8TOOG	1	40		150	15.4	IP20					●		
4300	BRT4K0-11R6	S8TOOH	1	40		150	11.6	IP20					●		
4370	BRT4K0-11R6	S8TOOH	1	40		150	11.6	IP20					●		
4450	BRT8K0-7R7	S8TOOI	1	40		150	7.7	IP20					●		
5550	BRT8K0-7R7	S8TOOI	1	40		150	7.7	IP20					●		
5750 ... 5900														(1)	

(1) External braking unit (series BUy-..., optional), for information please contact the Gefran Sales Office.
 (2) External braking unit (series BUy-...-6, optional), size 6750 and higher please contact the Gefran Sales Office.

Size	Model	Code	Max. overload 1"- service 10%	Max. overload 30"- service 25%	Max. overload 5"	PBraking resistor power rating	Braking resistor value	Housing	ADV200-4	ADV200-DC	ADV200-6	ADV100	ADV80
			Ebr (kJ)	Ebr (kJ)	Ebr (kJ)	Pnbr (W)	Rbr (Ω)						
ADV80													
ADV80-1004	RF 100 T 360R	S8S81	0.7	5		150	360	IP44					●
ADV80-1005	RF 100 T 360R	S8S81	0.7	5		150	360	IP44					●
ADV80-1007	RF 100 T 360R	S8S81	0.7	5		150	360	IP44					●
ADV80-1015	RF 150 T 100R	S8S82	1	9		300	100	IP44					●
ADV80-2022	RF 150 T 100R	S8S82	1	9		300	100	IP44					●
ADV80-2030	RF 150 T 100R	S8S82	1	9		300	100	IP44					●
ADV80-2040	RF 200 T 75R	S8S83	1.5	11		200	75	IP44					●
ADV80-2055	RF 200 T 68R	S8T00T	1.5	11		200	68	IP44					●
ADV80-2075	RF 400 68R	S85A16	3.5	25		400	68	IP44					●
ADV80-2110	RFPD 1100 DT 40R	S8SY6	11	58		1100	40	IP44					●
ADV80-3150	RFPD 1900 D 28R	S8SZ5	19	75		1900	28	IP44					●
ADV80-3185	BRT4K0-15R4	S8T00G	40	150		4000	15.4	IP20					●
ADV80-3220	BRT4K0-15R4	S8T00G	40	150		4000	15.4	IP20					●

Others resistors list													
Model	Code	Max. overload 1"- service 10%	Max. overload 30"- service 25%	Max. overload 5"	PBraking resistor power rating	Braking resistor value	Housing	ADV200-4	ADV200-DC	ADV200-6	ADV100	ADV80	
BDR T24K0-5R1	S8SU6				24000	5.1	IP20						
BR T12K0-5R1	S8T00L	120	330		12000	5.1	IP20						
BR T12K0-7R7	S799953				12000	7.7	IP20						
BR T2K0-28R	S8T00F	20	82		2000	28	IP20						
BR T8K0-6R2	S8T00P	80	220		8000	6.2	IP20						
RF 10K0 15R4	S8SA6			220	10000	15.4	IP20						
RF 150 T 100R	S8S82	1	9		150	100	IP44						
RF 15K0 11R6	S8SA3			330	15000	11.6	IP23						
RF 200 T 100R	S6F60	1.5	11		300	100	IP44						
RF 200 T 200R	S6F61	1.5	11		300	200	IP44						
RF 200 T 50R	S6F65	1.5	11		400	50	IP44						
RF 300 D 68R	S8TOCI	2.5	19		350	68	IP44						
RF 300 D 100R	S8TOCG	2.5	19		350	100	IP44						
RF 300 D 34R	S8TOCH	2.5	24		350	34	IP44						
RF 4K0 15R0	S8SA4			100	4000	15	IP20						
RF 5K0 11R6	S8SA1			120	6000	11.6	IP20						
RF 5K0 15R4	S8SA5			120	6000	15.4	IP20						
RF 8K0 11R6	S8SA2			160	8000	11.6	IP20						
RFPR 1200 D 10R	S8ST6	12	43		1200	10	IP44						
RFPR 1900 D 12R	S8ST7	19	75		1900	12	IP44						
RFPR 1900 D 15R	S8ST8	19	75		1900	15	IP44						
RFPR 1900 D 25R	S8SZ2	19	75		1900	25	IP44						
RFPR 1900 D 6R	S8SU1	-	75		600	40	IP44						
RFPR 1900 D 8R	S8ST5	19	75		1900	8	IP44						
RFPR 750 D 68R	S8SZ3	7.5	28		750	68	IP44						
RFPR 750 D 80R	S8SZ0	7.5	28		750	80	IP44						

Braking resistors dimensions

Braking resistors		Dimensions	Weight
Type	Code	(W x H x d) - mm	kg
BDR T24K0-5R1	S8SU6	580 x 540 x 450	42
BR T12K0-5R1	S8T00L	625 x 200 x 250	16
BR T12K0-7R7	S799953		
BR T2K0-28R	S8T00F	625 x 200 x 250	6.2
BR T8K0-6R2	S8T00P	625 x 200 x 250	11.5
BRT4K0-11R6	S8T00H	625 x 100 x 250	7
BRT4K0-15R4	S8T00G	625 x 100 x 250	7
BRT8K0-7R7	S8T00I	625 x 160 x 250	11.5
RF 100 T 360R	S8S81	90 x 27 x 36	0.2
RF 10K0 15R4	S8SA6	545 x 330 x 205	10.8
RF 150 T 100R	S8S82	155 x 27 x 36	0.2
RF 15K0 11R6	S8SA3	545 x 450 x 450	22.8
RF 200 T 100R	S6F60	200 x 27 x 36	0.7
RF 200 T 200R	S6F61	200 x 27 x 36	0.7
RF 200 T 50R	S6F65	200 x 27 x 36	0.4
RF 200 T 68R	S8T00T	300 x 27 x 36	0.2
RF 200 T 75R	S8S83	200 x 27 x 36	0.4
RF 220 T 100R	S8TOCE	300 x 27 x 36	0.5
RF 300 D 68R	S8TOCI	260 x 47 x 106	1.4
RF 300 D 100R	S8TOCG	260 x 47 x 106	1.4
RF 300 D 34R	S8TOCH	260 x 47 x 106	1.4
RF 300 DT 100R	S8TOCB	260 x 47 x 108	1.4
RF 4K0 15R0	S8SA4	545 x 150 x 190	5
RF 5K0 11R6	S8SA1	545 x 200 x 200	7.2
RF 5K0 15R4	S8SA5	545 x 200 x 200	7.2
RF 8K0 11R6	S8SA2	545 x 200 x 200	9.2
RFPD 1100 DT 40R	S8SY6	320 x 70 x 106	2.7
RFPD 750 DT 100R	S8SY4	200 x 70 x 106	1.7
RFPD 750 DT 68R	S8TOCD	200 x 70 x 106	1.7
RFPD 900 DT 68R	S8SY5	260 x 70 x 106	2.2
RFPR 1200 D 10R	S8ST6	310 x 73 x 100	3.2

Braking resistors		Dimensions	Weight
Type	Code	(W x H x d) - mm	kg
RFPR 1900 D 12R	S8ST7	365 x 75 x 100	4.0
RFPR 1900 D 15R	S8ST8	365 x 75 x 100	4.2
RFPR 1900 D 25R	S8SZ2	365 x 75 x 100	4.7
RFPR 1900 D 28R	S8SZ5	365 x 75 x 100	4.2
RFPR 1900 D 6R	S8SU1	365 x 75 x 100	4.2
RFPR 1900 D 8R	S8ST5	365 x 75 x 100	3.9
RFPR 750 D 68R	S8SZ3	245 x 75 x 100	2.7
RFPR 750 D 80R	S8SZ0	245 x 75 x 100	2.7

ADV200 - 4

ADV200-DC

ADV200 - 6

ADV100

ADV80

AFE200

PROGRAM.

APPENDIX

9. Options

Code	Option	Description	ADV200-4	ADV200-DC	ADV200-6	ADV100	ADV80	AFE200
------	--------	-------------	----------	-----------	----------	--------	-------	--------

Encoder expansion cards



S5L30	EXP-DE-I1R1F2-ADV	TTL/HTL digital incremental encoder expansion card 1 encoder input - 1 encoder output - 2 freeze channels	●	●	●			
S5L35	EXP-DE-I2R1F2-ADV	TTL/HTL digital incremental encoder expansion card 2 encoder inputs - 1 encoder output - 2 freeze channels	●	●	●			
S5L31	EXP-SE-I1R1F2-ADV	Sinusoidal incremental encoder expansion card 1 encoder input - 1 encoder output - 2 freeze channels	●	●	●			
S5L32	EXP-SESC-I1R1F2-ADV	Sincos incremental encoder expansion card 1 encoder input - 1 encoder output - 2 freeze channels	●	●	●			
S5L33	EXP-EN/SSI-I1R1F2-ADV	Absolute EnDat/SSI encoder expansion card 1 encoder input - 1 encoder output - 2 freeze channels	●	●	●			
S5L34	EXP-HIP-I1R1F2-ADV	Absolute Hiperface encoder expansion card 1 encoder input - 1 encoder output - 2 freeze channels	●	●	●			
S5L42	EXP-ASC-I1-ADV	Absolute SinCos expansion card 1 encoder input	●	●	●			
S5L43	EXP-RES-I1R1-ADV	Resolver expansion card 1 Resolver input - 1 Resolver repetition output	●	●	●			
S5L36	EXP-DE-I1-ADL	TTL/HTL digital incremental encoder expansion card 1 encoder input				●		

I/O expansion cards



S5L38	EXP-IO-D5R8-ADV	5 digital inputs / 1 digital output / 8 relay output	●	●	●			●
S526L	EXP-IO-D6A4R1-ADV	4 digital inputs / 2 digital outputs / 2 analog inputs / 2 analog outputs / 2 double contact relays	●	●	●			●
S5L40	EXP-IO-SENS-100-ADV	To acquire signals from PT100 (PT1000), (NI1000), 0-10V, 0/4...20mA, KTY84, PTC	●	●	●			●
S5L37	EXP-IO-SENS-1000-ADV		●	●	●			●
S5L41	EXP-FL-XCAN-ADV	Master CAN controller. Fast Link communication interface	●	●	●			
S568L	EXP-IO-D8R4-ADL	8 digital inputs - 4 relay					●	
S569L	EXP-IO-D12A2R4-ADL	8 digital inputs - 4 digital outputs - 2 analog outputs - 4 relay					●	
S566L	EXP-IO-D16R4-ADL	12 digital inputs - 4 digital outputs - 4 relay					●	
S567L	EXP-IO-D4-ADL	2 digital inputs - 2 digital outputs					●	
S580L	EXP-IO-D6R2-F-ADL	6 digital inputs - 2 relay					●	
S570L	EXP-IO-D8A4R4-ADL	8 digital inputs - 2 analog inputs - 2 analog outputs - 4 relay					●	

Fieldbus expansion cards



Code	Option	Description	ADV200-4	ADV200-DC	ADV200-6	ADV100	ADV80	AFE200
S5AGV10	EXP-D6A1R1-ADV80	6 digital inputs - 1 analog input - 1 relay					●	
S527L	EXP-CAN-ADV	Expansion card for CANopen ® and DeviceNet interface CANopen: - Transmission speed: up to 1 Mbit/s - Data frame: 1 SDO to access all drive parameters, 4 PDO of 4 I/O words for fast access - Bus address: 1...128 DeviceNet: - Transmission speed: 125, 250, 500 kbit/s - Bus address: 1...63 - Data frame: Explicit Messaging for access to all drive parameters, 16 Polling I/O words for fast access	●	●	●			●
S530L	EXP-PDP-ADV	Expansion card for Profibus_DP interface - Transmission speed 9.6 kbit/s ... 12 Mbit/s - Bus address: 1...125 - Data frame: configuration channel for access to all drive parameters; 16 I/O fast words for fast access - Support Sync and Freeze.	●	●	●			●
S5L29	EXP-ETH-GD-ADV200	Ethernet GD-net interface expansion card	●	●	●			●
S5L09	EXP-ETH-CAT-ADV200	EtherCAT interface expansion card	●	●	●			●
S5L19	EXP-ETH-IP-ADV200	Ethernet IP interface expansion card	●	●	●			●
S5L60	EXP-ETH-PN-ADV200	Profinet interface expansion card	●	●	●			●
S5AGV9	SBI-PDP-ADV80	Profibus-DP interface					●	

ADV200 - 4

ADV200-DC

ADV200 - 6

ADV100

ADV80

AFE200

PROGRAM.

APPENDIX

Code	Option	Description	ADV200-4	ADV200-DC	ADV200-6	ADV100	ADV80	AFE200
------	--------	-------------	----------	-----------	----------	--------	-------	--------

Bus bar for parallel connection For further information see Appendix, section 6.2.4.

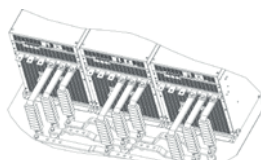
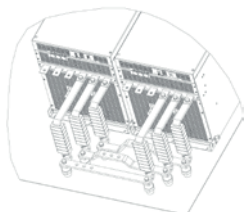

S72641	OUT-PW-KIT 2P	Bus bar for 2-bridge output power - Includes fer-rite transformer	●					
S726412	OUT-PW-KIT 2P-690V				●			
S726411	OUT-PW-KIT 3P	Bus bar for 3-bridge output power - Includes fer-rite transformer	●					
S726413	OUT-PW-KIT 3P-690V				●			

Pre-charge kit (mandatory)



S72828	PRE-CHARGE KIT-AFE-22/45-4	Pre-charge kit for AFE200-4/4A : AFE200 22kW AFE200 45kW Dimensions (WxHxd): 220 x 464 x 124 mm Weight: 6 kg						●
S728281	PRE-CHARGE KIT-AFE-90/132-4	Pre-charge kit for AFE200-4/4A : AFE200 90kW AFE200 132kW Dimensions (WxHxd): 280 x 464 x 149 mm Weight: 6 kg						●
S728282	PRE-CHARGE KIT-AFE-160/710-4	Pre-charge kit for AFE200-4/4A : AFE200 160kW AFE200 200kW AFE200 250kW AFE200 315kW AFE200 355kW AFE200 400kW AFE200 500kW AFE200 630kW AFE200 710kW Dimensions (WxHxd): 280 x 464 x 149 mm Weight: 10 kg						●
S728284	PRE-CHARGE KIT-AFE-900/1650-4	Pre-charge kit for AFE200-4/4A : AFE200 900kW AFE200 1000kW Dimensions (WxHxd): 358 x 464 x 189 mm Weight: 16 kg						●
S728283	PRE-CHARGE KIT-AFE-160/710-6	Pre-charge kit for AFE200-6/6A : AFE200 160kW AFE200 200kW AFE200 250kW AFE200 315kW AFE200 355kW AFE200 400kW AFE200 500kW AFE200 630kW AFE200 710kW Dimensions (WxHxd): 280 x 464 x 149mm Weight: 10,5 kg						●
S728285	PRE-CHARGE KIT-AFE-900/1650-6	Pre-charge kit for AFE200-6/6A : AFE200 900kW AFE200 1000kW AFE200 1350kW AFE200 1650kW Dimensions (WxHxd): 358 x 464 x 189 mm Weight: 16,5 kg						●



External Braking Unit



Code	Option	Description	ADV200-4	ADV200-DC	ADV200-6	ADV100	ADV80	AFE200
S9D55	BUy 1020	Braking unit for 230VAc...480VAc lines In= 20Arms, UL mark	●	●				
S9D56	BUy 1050	Braking unit for 230VAc...480VAc lines In= 50Arms, UL mark	●	●				
S9D57	BUy 1085	Braking unit for 230VAc...480VAc lines In= 85Arms, UL mark	●	●				
S9D30	BUy 1065-6	Braking unit for 690VAc line In= 65Arms			●			

AC/DC power supply units



S9V73	SM32-480-185A	Semi-controlled AC/DC power supply unit (internal pre-loading) - In @ 480Vac = 185A Dimensions (L x H x d - mm): 311mm * 388mm * 270mm Weight: 18 kg		●				
S9V74	SM32-480-280A	Semi-controlled AC/DC power supply unit (internal pre-loading) - In @ 480Vac = 280A Dimensions (L x H x d - mm): 311mm * 388mm * 270mm Weight: 26 kg		●				
S9V75	SM32-480-420A	Semi-controlled AC/DC power supply unit (internal pre-loading) - In @ 480Vac = 420A Dimensions (L x H x d - mm): 311mm * 388mm * 270mm Weight: 30 kg		●				
S9V76	SM32-480-650A	Semi-controlled AC/DC power supply unit (internal pre-loading) - In @ 480Vac = 650A Dimensions (L x H x d - mm): 311mm * 388mm * 305mm Weight: 31 kg		●				
S9V72	SM32-480-1050A	Semi-controlled AC/DC power supply unit (internal pre-loading) - In @ 480Vac = 1,050A Dimensions (L x H x d - mm): 525mm * 554mm * 343mm Weight: 63 kg		●				
S9V71	SM32-480-1500A	Semi-controlled AC/DC power supply unit (internal pre-loading) - In @ 480Vac = 1,500A Dimensions (L x H x d - mm): 551mm * 686mm * 380mm Weight: 85 kg		●				
S9V63X	SM32-480-2000A	Semi-controlled AC/DC power supply unit (internal pre-loading) - In @ 480Vac = 2,000A Dimensions (L x H x d - mm): 500mm * 855mm * 420mm Weight: 75 kg		●				
S7D19	LR3-090	Line choke for SM32-480-185A		●				
S7D40	LR3-160	Line choke for SM32-480-280A / 420A		●				
S7D28	LR3-315	Line choke for SM32-480-650A		●				
S7D15	LR3 869-1303-0,03	Line choke for SM32-480-1050A		●				
S7D17	LR3 1425-2138-0,019	Line choke for SM32-480-1500A		●				



Code	Option	Description	ADV200-4	ADV200-DC	ADV200-6	ADV100	ADV80	AFE200
S9V69	SM32-690-800	AC/DC power supply unit for power ratings of 500kW and 630kW Dimensions (L x H x d - mm [inches]): 500mm [19.69"] * 670mm [26.38"] * 400mm [15.75"] Weight: 49 kg [108.03 lbs]		●				
S9W20	SM32-690-1000A	AC/DC power supply unit for power ratings of 800kW Dimensions (L x H x d - mm [inches]): 500mm [19.69"] * 670mm [26.38"] * 400mm [15.75"] Weight: 49 kg [108.03 lbs]		●				
S9W21	SM32-690-1400A	AC/DC power supply unit for power ratings of 1200kW Dimensions (L x H x d - mm [inches]): 855mm [33.66"] * 670mm [26.38"] * 420mm [16.54"] Weight: 75 kg [165.35lbs]		●				
S7AF7	LR3y-6-630	Line choke for SM32-690-800		●				
S7F07	LR3y-6-800	Line choke for SM32-690-1000		●				
S7F02	LR3y-6-1200	Line choke for SM32-690-1400		●				

Connection via serial line



S533L	OPT – RS485 – ADV	Optoisolator for RS485 for Multidrop connections	●	●	●			●
S587E	OPT-QUIX	Serial line optoisolator (for Multidrop connections)					●	
S5Z40	A-RS485	External power supply for RS-485 serial network					●	
S573L	PC-OPT-ADL	Optoisolator for RS232 for Multidrop connections				●		
S50T6	Kit RS485 - PCI COM	Universal kit for RS485 serial line (PCI COM + connection cables)	●	●	●		●	●
S5Q02	Kit RS485-QX Serial adapter	RS485 serial line kit (PCI-QX + connection cable)					●	
S560T	PCI COM	Universal RS-232 / RS-485 serial interface	●	●	●		●	●
S557Z	PCI-QX	RS-232 / RS-485 serial interface					●	
8S8F59	Shielded cable for PCI 485	RS-485 serial interface cable (L = 5 m)	●	●	●			●
S7QAF9	Shielded cable for PCI-QX	RS-485 serial interface cable (L = 5 m)					●	
S5A20	USB-RS232 CONVERTER	USB - RS232 serial protocol converter	●	●	●		●	●



Various



S5P3T	KB-ADV100	Programming keypad with memory					●	
S576L	PTC-D01	Interface for PTC sensor	●	●	●			
S577L	KTY84-D01	Interface for KTY84 sensor	●	●	●			

Code	Option	Description	ADV200-4	ADV200-DC	ADV200-6	ADV100	ADV80	AFE200
S5TT0	KB-ADV Remoting Kit 5 metres	KB-ADV remoting kit with 5-metre cable	●	●	●			
S5TT1	KB-ADV Remoting Kit 10 metres	KB-ADV remoting kit with 10-metre cable	●	●	●			
8S8F59	Keypad cable 5 metres	Keypad extension length 5 metres				●		
8S874C	Keypad cable 10 metres	Keypad extension length 10 metres				●		
S72795	CAN interface cable	CAN connection cable for EXP-FL-XCAN-ADV card (L: 3 metres) - Plastic cable	●	●	●			
S728101	Fast Link interface cable 1 metre	Fast Link cable for EXP-FL-XCAN-ADV card (L: 1 metre) - Plastic cable	●	●	●			
S728102	Fast Link interface cable 2 metres	Fast Link cable for EXP-FL-XCAN-ADV card (L: 2 metres) - Plastic cable	●	●	●			
S728103	Fast Link interface cable 3 metres	Fast Link cable for EXP-FL-XCAN-ADV card (L: 3 metres) - Plastic cable	●	●	●			
S728084	Fast Link interface cable 5 metres	Fast Link cable for EXP-FL-XCAN-ADV card (L: 5 metres Reinforced) - Reinforced plastic cable	●	●	●			
8S860B	Parallel interface signal cable	Connection of parallel drive. L = 1 m. Two quick coupling male MDR connectors at the ends. Size 400...710kW = 1 cable Size 900-1000kW = 2 cables	●	●				●
8S870B	Parallel interface signal cable	Connection of parallel drive. L = 2 m. Two quick coupling male MDR connectors at the ends. Size 1,35 MW = n.1 cable Size 1,65 MW = n.2 cables	●	●				●
S574L	SD-ADL	Adapter for SD card (data loading memory)				●		
S72610	KIT-POWER-SHIELD S1-S2	Power cable shielding kit (size 1-2)				●		
S72650	KIT-POWER-SHIELD S3	Power cable shielding kit (size 3)				●		
1S3A56	CD-ROM MDPIc	MDPIc development environment for ADV200	●	●	●			
1S3E15	CD-ROM Standard Applications	ADV200 Applications: - Torque Winder (TW) - Positioning control (POS) - Electric Line shaft (ELS) <i>The applications are available on www.gefran.com.</i>	●	●	●			
1S9002	CD-ROM Configurator	GF-eXpress + ADV200 Instruction manuals	●	●	●			
1S9006	CD-ROM Configurator	GF-eXpress + ADV100 Instruction manuals				●		
1S9008	CD-ROM Configurator	GF-eXpress + ADV80 Instruction manuals					●	
1S9004	CD-ROM Configurator	GF-eXpress + AFE200 Instruction manuals						●



ADV200 - 4

ADV200-DC

ADV200 - 6

ADV100

ADV80

AFE200

PROGRAM.

APPENDIX

GEFRAN SERVICE

- We guarantee each customer a high-quality, tailored service backed by a wealth of technical and professional expertise, which makes GEFRAN a reliable, flexible partner capable of providing specialised, global support.

“ You can be assured that your plant will be backed by a wealth of professional expertise ”



Our pre-sales support includes preliminary technical and commercial advice, with recommendations for professional and economically advantageous solutions. Our aim is to provide innovative products and solutions tailored to suit each individual requirement.

www.nicsanat.com
021-87700210





Installation and Start-up

Purchasing a GEFRAN product provides access to a global package of exclusive services.

GEFRAN has an international team of engineers who are specialised in the installation and commissioning of proprietary drives and control systems. Customers can always rely on fast, professional service and an efficient telephone support line.



After-sales Service

GEFRAN offers a highly professional after-sales service to customers worldwide.

Customers know they can rely on fast, worldwide support, limiting machine downtimes to a minimum without affecting production capacity.

www.nicsanat.com
021-87700210





Calendar of courses and education days

Training addresses internal technical and service personnel of the Gefran Group and system maintenance engineers, machine manufacturers and control system designers

- ➔ "Gefran Drive & Motion" training courses are intended to provide industrial automation sector operators with a basic grounding in SIEIDrive DC, AC and Servo-brushless drives.
- ➔ The courses are structured so that participants are able to acquire a general theoretical grounding in drives and include a detailed description of Gefran products covering theoretical/practical use of the drives.



Venue of courses

The courses are held at the Gefran S.p.A. production facility - Drive & Motion Control Unit in Gerenzano (Varese), Italy.

For foreign branches, training courses can be organised at other times, directly at the branch or Gefran distributors' facilities.

Education days (on demand)

In addition to scheduled courses, problems and specific aspects of SIEIDrive products can be examined during "Education" days.

These courses, dedicated exclusively to individual requirements, are available on request and must be defined directly with sales staff at Gefran S.p.A.

The duration of "Education" days may vary according to the issues that are dealt with.

Levels

Courses are normally based on three levels of difficulty: level 1 (basic); level 2 (high) and level 3 (advanced) mainly addressing MDPIc application developers.

Frequency and number of participants

The courses planned for 2010 envisage a minimum and maximum number of participants.

The frequency of the courses shown may be changed according to demand.

Reservations

To book a place on these courses, please call us on +39 02 967601 / +39 02 96760500. This service is available at the following times: 9.00 – 12.30 / 13.30 – 17.00 or send an e-mail to: marketing@gefran.com.

Gefran S.p.A. - Drive & Motion Control Unit will book overnight hotel accommodation.



www.nicsanat.com
021-87700210





After-sales Service

“ High-level performance, from the first day onwards ”

- ➔ Faults must be detected and repaired as soon as possible in order to guarantee continuous operation of industrial production systems.
- ➔ GEFTRAN responds to this important requirement by offering a highly professional after-sales service to cover each step.



Telephone helpline

The Contact Centre helpline is available to deal with your requests and answer your technical queries.

The dedicated helpline :

 +39 02 967 60428



Online assistance

GEFRAN also operates an online technical service.

We welcome enquiries from end users, installers and project designers. Contact us any time at technoHelp@gefran.com to receive immediate assistance in the form of technical or commercial advice.



ON-SITE assistance

With offices and service centres throughout the world, GEFran guarantees a prompt, reliable service to ensure continuous plant operation.

Repairs are carried out at our works or on-site by skilled technicians.

www.nicsanat.com
021-87700210





Inverter Warranty

GEFRAN guarantees the quality and functionality of its products when dispatched and will:

- ➔ replace faulty products with an equivalent or similar product
- or:
- ➔ repair, in good time, any parts that are found to be faulty during the warranty period.

www.nicsanat.com
021-87700210





3 years Warranty

WARRANTY terms and conditions

Products to be replaced must be returned in their original packaging or in other adequate or equivalent packaging.

The customer will be responsible for the cost of forwarding the product to GEFRAN (Drive & Motion Control Unit - Gerenzano (Varese), Italy, while the latter will bear all costs relating to the materials and transport charges to replace all or part of the product.

In case of assistance provided by our technical staff, work may be performed at the GEFRAN facility.

For repairs carried out on-site at the customer's premises, GEFRAN guarantees assistance within 48 working hours following receipt of the written request.

Exclusion of WARRANTY

The warranty does not apply in the following cases, in which GEFRAN declines all responsibility:

- work, modifications or repairs carried out on the customer's own initiative
- use of the product other than for its intended purpose, incorrect use or installation under conditions other than those described in the user guide
- damage caused by foreign bodies (smoke, corrosive substances, etc.) or damage due to unforeseeable circumstances (lightning, overvoltage, damage caused by water, earthquake, fire, war, riots, etc.)
- damage during transportation or in any case occurring after the transfer of risk and damage resulting from incorrect packaging by the customer
- inadequate ventilation
- out-of-pocket expenses (travel, transport, board and lodging) incurred by technical staff in order to carry out repairs at the customer's premises are excluded.

www.nicsanat.com
021-87700210



Solutions

GEFRAN system technology

- GEFTRAN applies its application experience to the design and development of specific automation systems for a broad range of industrial sectors.
- Innovative technological solutions based on an extensive range of process control products and 45 years of experience, acquired in working alongside leading sector operators.
- GEFTRAN offers Drive Cabinet Solutions with the standard "plug and play" protocol or, upon request, in the "clean power energy" featuring the use of Active Front End regenerative power supply units with IGBT technology.
- "Custom-built" single or multiple-drive control systems to individual specifications and hardware and software system architecture for automation systems to control the very latest machines.



Plastic

Configurations GEFRAN "Drive Cabinet":



GEFRAN's Power Electronic Drive solutions have always been used with success in the various plastic processing industries.

GEFRAN has acquired a technological know-how in the control of all-electric and hybrid injection presses and of equipment used for blowing, extrusion, film processing, mixing, etc., to consolidate its undisputed leadership in terms of product and sector.

www.nicsanat.com
021-87700210





GEFRAN's Power Electronic Drive platforms, used in sheet metal, metal wire and metal processing, guarantee system efficiency and offer energy-saving technology for high power industrial machinery.

With its technological products and dedicated application programs, GEFran develops complete control systems based on the highly specialised System Drive platform.

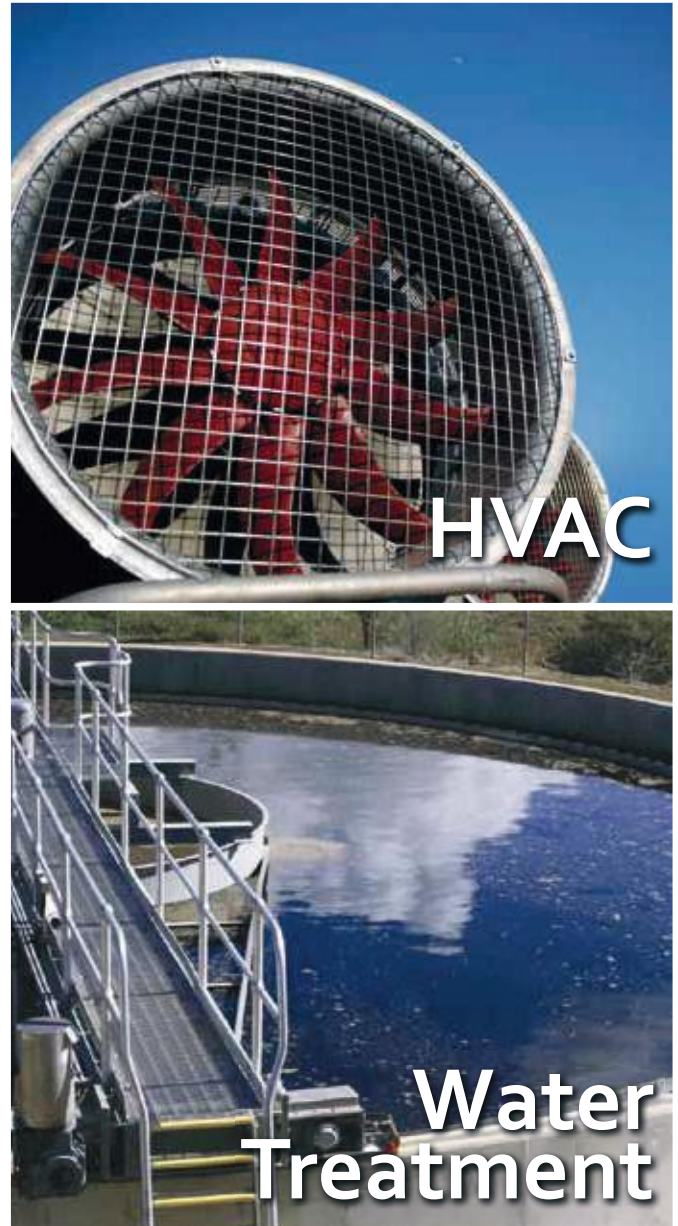

GEFRAN's Power Electronic Drive platforms offer dedicated application solutions for the air-conditioning and water treatment industries. The availability of specific power structures for variable or quadratic loads results in the best possible design in terms of technology and cost-effectiveness.

Clean power technology also guarantees better power control with real energy-saving benefits. Specific SW functions enable control of highly optimised systems.

www.nicsanat.com
021-87700210



www.nicsanat.com
021-87700210



www.nicsanat.com

021-87700210



If you have any suggestions that you think might help us to improve this catalogue, please do not hesitate to contact us at techdoc@gefran.com.

GEFRAN S.p.A. reserves the right to make changes and variations to products, data, dimensions at any time without the obligation of prior notice.

The data indicated are provided for the sole purpose of describing the product and must not be considered as legally binding characteristics.



Gefran S.p.A. operates a Quality Management System which complies with the requirements of ISO 9001:2008



The company operates a ISO 9001:2008-certified quality system.

Our primary corporate goal is customer satisfaction: it is from this that mutual collaboration, maximum trust in the company and a consolidated long-standing partnership role stem.

Gefran ensures total support through its technical services (from design and start-up right up to onstream assistance), which are more highly specialised than those which large multisector companies are able to offer.

GEFRAN always meets the demands of high-tech users with the certainty of total quality.

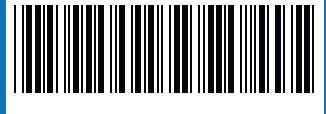

COD. IS9A1EN - 0.8 / 3-4-2014

GEFRAN

GEFRAN HEADQUARTER

Via Sebina, 74
25050 PROVAGLIO D'ISEO (BS) ITALY
Ph. +39 03098881
Fax +39 0309839063

Drive & Motion Control Unit

Via Carducci, 24
21040 GERENZANO (VA) ITALY
Ph. +39 02967601
Fax +39 029682653
info.motion@gefran.com

Technical Assistance:
technohelp@gefran.com

Customer Service
motioncustomer@gefran.com
Ph. +39 02 96760500
Fax +39 02 96760278

GEFRAN BENELUX NV

ENA 23 Zone 3, nr. 3910
Lammerdries-Zuid 14A
B-2250 OLEN
Ph. +32 (0) 14248181
Fax +32 (0) 14248180
info@gefran.be

GEFRAN DEUTSCHLAND GmbH

Philipp-Reis-Straße 9a
D-63500 Seligenstadt
Ph. +49 (0) 7144 897360
Fax +49 (0) 6182809222
vertrieb@gefran.de

SIEI AREG - GERMANY

Gottlieb-Daimler Strasse 17/3
D-74385 - Pleidelsheim
Ph. +49 (0) 7144 897360
Fax +49 (0) 7144 8973697
info@sieiareg.de

GEFRAN SUISSE SA

Sandackerstrasse, 30
9245 Oberbüren
Ph. +41 71 9554020
Fax +41 71 9554024
office@gefran.ch

SENSORMATE AG

Steigweg 8,
CH-8355 Aadorf, Switzerland
Ph. +41(0)52-2421818
Fax +41(0)52-3661884
http://www.sensormate.ch

GEFRAN FRANCE SA

4, rue Jean Desparmet - BP 8237
69355 LYON Cedex 08
Ph. +33 (0) 478770300
Fax +33 (0) 478770320
commercial@gefran.fr

GEFRAN UK Ltd

Capital House, Hadley Park East
Telford
TF1 6QJ
Ph. +44 (0) 8452 604555
Fax +44 (0) 8452 604556
sales@gefran.co.uk

GEFRAN ESPAÑA

Calle Vic, números 109-111
08160 - MONTMELÓ
(BARCELONA)
Ph. +34 934982643
Fax +34 935721571
comercial.espana@gefran.es

GEFRAN MIDDLE EAST ELEKTRIK VE ELEKTRONIK San. ve Tic. Ltd. Sti

Yesilkoy Mah. Ataturk
Cad. No: 12/1 B1 Blok K:12
D: 389 Bakirkoy /Istanbul TURKIYE
Ph. +90212 465 91 21
Fax +90212 465 91 22

GEFRAN SOUTH AFRICA Pty Ltd.

Unit 10 North Precinet
West Building
Topaz Boulevard Montague Park,
7411, Cape Town
Ph. +27 21 5525985
Fax +27 21 5525912

GEFRAN SIEI Drives Technology Co., Ltd

No. 1285, Beihe Road, Jiading
District, Shanghai, China 201807
Ph. +86 21 69169898
Fax +86 21 69169333
info@gefransiei.com.cn

GEFRAN SIEI Electric Pte. Ltd.

No. 1285, Beihe Road, Jiading
District, Shanghai, China 201807
Ph. +86 21 69169898
Fax +86 21 69169333
info@gefransiei.com.cn

GEFRAN SIEI - ASIA

31 Ubi Road 1
#02-07, Aztech Building
Singapore 408694
Ph. +65 6 8418300
Fax +65 6 7428300
info@gefana.com.sg

GEFRAN INDIA

Survey No: 182/1 KH, Bhukum, Paud road,
Taluka - Mulshi,
Pune - 411 042. MH, INDIA
Phone No.: +91-20-39394400
Fax No.: +91-20-39394401
gefran.india@gefran.in

GEFRAN TAIWAN

No.141, Wenzhi Rd., Zhongli City,
Taoyuan County 32054,
Taiwan (R.O.C.)
Ph. +886-3-4273697
eddie.liao@gefransiei.com.sg

GEFRAN Inc.

8 Lowell Avenue
WINCHESTER - MA 01890
Toll Free 1-888-888-4474
Fax +1 (781) 7291468
info.us@gefran.com

GEFRAN BRASIL ELETROELETRÔNICA

Avenida Dr. Altino Arantes,
377 Vila Clementino
04042-032 SÃO PAULO - SP
Ph. +55 (0) 1155851133
Fax +55 (0) 1132974012
comercial@gefran.com.br

www.nicsanat.com
021-87700210



www.gefran.com