

www.nicsanat.com

021-87700210



N800-Series

N800A Inverter Installation Manual



Notice

Read and understand these manuals before attempting any unpacking, assembly, operation or maintenance of the inverter

This manual should be applied only to N800A inverter.
This manual does not include all items regarding installation and maintenance procedures.
For more information, please contact authorized partners.

ISSUE DATE: 2018.5.2 (VER. 2)

www.nicsanat.com

021-87700210



1. SAFETY	1
1.1 THE SAFETY SYMBOLS USED IN THE MANUAL	1
1.2 WARNING	1
1.3 CAUTION	2
1.4 EARTHING AND EARTH FAULT PROTECTION	3
1.5 ELECTRO-MAGNETIC COMPATIBILITY (EMC)	4
1.6 USING AN RCD OR AN RCM DEVICE	4
2. RECEIVING THE DELIVERY	5
2.1 PACKAGE LABEL	5
2.2. TYPE DESIGNATION CODE	5
2.3 UNPACKING AND LIFTING THE AC DRIVE	6
2.3.1 WEIGHT OF THE AC DRIVE	6
2.3.2 LIFTING THE FRAMES MR8 AND MR9	6
2.3.3 LIFTING THE FRAMES MR10	8
2.3.3.1 LIFTING THE FRAMES MR10 WITHOUT THE EXTENSION BOX	8
2.3.3.2 LIFTING THE FRAMES MR10 WITH AN EXTENSION BOX	8
2.4 ACCESSORIES	9
2.4.1 FRAME MR4	10
2.4.2 FRAME MR5	10
2.4.3 FRAME MR6	11
2.4.4 FRAME MR7	12
2.4.5 FRAME MR8	12
2.4.6 FRAME MR9	13
2.5 "PRODUCT MODIFIED" LABEL	13
2.6 DISPOSAL	13
2.7 Warranty of the Unit	14
2.7.1 Questions on Unit	14
2.7.2 Warranty for the unit	14
3. MOUNTING	15
3.1 GENERAL INFORMATION ABOUT MOUNTING	15

3.2 DIMENSIONS FOR WALL MOUNTING	15
3.2.1 WALL MOUNTING OF MR4.....	15
3.2.2 WALL MOUNTING OF MR5.....	16
3.2.3 WALL MOUNTING OF MR6.....	17
3.2.4 WALL MOUNTING OF MR7.....	18
3.2.5 WALL MOUNTING OF MR8, IP21 AND IP54	19
3.2.6 WALL MOUNTING OF MR8, IP00	20
3.2.7 WALL MOUNTING OF MR9, IP21 AND IP54	21
3.2.8 WALL MOUNTING OF MR9, IP00	22
3.2.9 WALL MOUNTING OF MR10, IP00.....	23
3.3 DIMENSIONS FOR FLANGE MOUNTING	24
3.3.1 FLANGE MOUNTING OF MR4	28
3.3.2 FLANGE MOUNTING OF MR5	29
3.3.3 FLANGE MOUNTING OF MR6	30
3.3.4 FLANGE MOUNTING OF MR7	31
3.3.5 FLANGE MOUNTING OF MR8	32
3.3.6 FLANGE MOUNTING OF MR9	33
3.3.7 FLANGE MOUNTING OF MR10.....	34
3.4 COOLING.....	35
4. POWER CABLING	37
4.1 CABLE CONNECTIONS.....	37
4.2 UL STANDARDS ON CABLING.....	38
4.3 CABLE DIMENSIONING AND SELECTION	38
4.3.1 CABLE AND FUSE SIZES	39
4.3.2 CABLE AND FUSE SIZES, NORTH AMERICA.....	41
4.4 BRAKE RESISTOR CABLES	43
4.5 PREPARING FOR THE CABLE INSTALLATION	43
4.6 CABLE INSTALLATION.....	44
4.6.1 FRAMES MR4 TO MR7	44
4.6.2 FRAMES MR8 TO MR9	50
4.6.3 FRAMES MR10	62
4.6.3.1 CABLE INSTALLATION WITHOUT THE EXTENSION BOX	62

4.6.3.2 CABLE INSTALLATION WITH AN EXTENSION BOX	65
4.7 INSTALLATION IN A CORNER-GROUNDED NETWORK	67
5. CONTROL UNIT	68
5.1 CONTROL UNIT COMPONENTS	68
5.2 CONTROL UNIT CABLING	69
5.2.1 SELECTION OF THE CONTROL CABLES	69
5.2.2 CONTROL TERMINALS AND DIP SWITCHES	69
5.3 FIELDBUS CONNECTION	73
5.3.1 USING FIELDBUS THROUGH AN ETHERNET CABLE	74
5.3.2 USING FIELDBUS THROUGH AN RS485 CABLE	77
5.4 INSTALLATION OF OPTION BOARDS	81
5.5 INSTALLATION OF A BATTERY FOR THE REAL TIME CLOCK (RTC)	84
5.6 GALVANIC ISOLATION BARRIERS	84
6. COMMISSIONING AND ADDITIONAL INSTRUCTIONS	86
6.1 COMMISSIONING SAFETY	86
6.2 COMMISSIONING OF THE DRIVE	86
6.3 OPERATION OF THE MOTOR	87
6.3.1 CHECKS BEFORE STARTING THE MOTOR	87
6.4 MEASURING THE CABLE AND MOTOR INSULATION	87
6.5 INSTALLATION IN AN IT SYSTEM	88
6.6 MAINTENANCE	96
7. TECHNICAL DATA	98
7.1 AC DRIVE POWER RATINGS	98
7.1.1 MAINS VOLTAGE 208-240 V	98
7.1.2 MAINS VOLTAGE 380-500 V	100
7.1.3 OVERLOAD CAPABILITY	101
7.1.4 BRAKE RESISTOR RATINGS	102



7.2 N800A - TECHNICAL DATA.....	105
8. TECHNICAL DATA ON CONTROL CONNECTIONS	107
8.1 TECHNICAL DATA ON CONTROL CONNECTIONS	107

1. SAFETY

1.1 THE SAFETY SYMBOLS USED IN THE MANUAL

This manual contains warning and cautions, which are identified with safety symbols. The warnings and cautions give important information on how to prevent injury and damage to the equipment or your system. Read the warnings and cautions carefully and obey their instructions.

Table 1: The safety symbols

The safety symbol	Description
	WARNING!
	CAUTION!
	HOT SURFACE!

1.2 WARNING



WARNING!

Do not touch the components of the power unit when the drive is connected to mains. The components are live when the drive is connected to mains. A contact with this voltage is very dangerous.



WARNING!

Do not touch the motor terminals U, V, W or the brake resistor terminals when the drive is connected to mains. These terminals are live when the drive is connected to mains, also when the motor does not operate.



WARNING!

Do not touch the relay outputs or the I/O terminals. They can have a dangerous voltage also when the drive is disconnected from mains.

**WARNING!**

Before you do electrical work, make sure that there is no voltage in the components of the drive.

**WARNING!**

To do work on the terminal connections of the drive, disconnect the drive from mains and make sure that the motor has stopped. Wait 5 minutes before you open the cover of the drive. Then use a measuring device to make sure that there is no voltage. The terminal connections and the components of the drive are live 5 minutes after it is disconnected from mains and the motor has stopped.

**WARNING!**

Before you connect the drive to mains, make sure that the front cover and the cable cover of the drive are closed. The connections of the AC drive are live when the drive is connected to mains.

**WARNING!**

Disconnect the motor from the drive if an accidental start can be dangerous. When there is a power-up, a power brake or a fault reset, the motor starts immediately if the start signal is active, unless the pulse control for Start/Stop logic is selected. If the parameters, the applications or the software change, the I/O functions (including the start inputs) can change.

1.3 CAUTION**CAUTION!**

Do not move the AC drive. Use a fixed installation to prevent damage to the drive.

**CAUTION!**

Do not make measurements when the AC drive is connected to mains. It can cause damage to the drive.

**CAUTION!**

Make sure that there is reinforced protective ground connection. It is mandatory, because the touch current of the AC drives is more than 3.5 mA AC (refer to EN 61800-5-1). See chapter 1.4 Earthing and earth fault protection.

**CAUTION!**

Do not use spare parts that are not from the manufacturer. Using other spare parts can cause damage to the drive.

**CAUTION!**

Do not touch the components on the circuit boards. Static voltage can cause damage to these components.

**CAUTION!**

Make sure that the EMC level of the AC drive is correct for your mains. See chapter 6.5 Installation in an IT system. An incorrect EMC level can cause damage to the drive.

**CAUTION!**

Prevent radio interference. The AC drive can cause radio interference in a domestic environment.

**NOTE!**

If you activate the auto reset function, the motor starts automatically after an automatic fault reset. See the Application Manual.

**NOTE!**

If you use the AC drive as a part of a machine, the machine manufacturer must supply a mains disconnection device (refer to EN 60204-1).

1.4 EARTHING AND EARTH FAULT PROTECTION

**CAUTION!**

The AC drive must always be earthed with an earth conductor that is connected to the earth terminal that is identified with the symbol . Not using an earth conductor can cause damage to the drive.

The touch current of the drive is more than 3.5 mA AC. The standard EN 61800-5-1 tells that 1 or more of these conditions for the protective circuit must be true.

The connection must be fixed.

- The protective earth conductor must have a cross-sectional area of minimum 10 mm² Cu or 16 mm² Al. OR
- There must be an automatic disconnection of the mains, if the protective earth conductor breaks. See chapter 4 Power cabling. OR
- There must be a terminal for a second protective earth conductor in the same cross-sectional area as the first protective earth conductor.

Table 2: Protective earthing conductor cross-section

Cross-sectional area of the phase conductors (S) [mm ²]	The minimum cross-sectional area of the protective earthing conductor in question [mm ²]
$S \leq 16$	S
$16 < S \leq 35$	16
$35 < S$	S/2

The values of the table are valid only if the protective earthing conductor is made of the same metal as the phase conductors.

If this is not so, the cross-sectional area of the protective earthing conductor must be determined in a manner that produces a conductance equivalent to that which results from the application of this table.

- 2.5 mm² if there is mechanical protection, and
- 4 mm² if there is not mechanical protection. If you have cord-connected equipment, make sure that the protective earthing conductor in the cord is the last conductor to be interrupted, if the strain-relief mechanism breaks.

Obey the local regulations on the minimum size of the protective earthing conductor.

**NOTE!**

Because there are high capacitive currents in the AC drive, it is possible that the fault current protective switches do not operate correctly.

**CAUTION!**

Do not do voltage withstand tests on the AC drive. The manufacturer has already done the tests. Doing voltage withstand tests can cause damage to the drive.

1.5 ELECTRO-MAGNETIC COMPATIBILITY (EMC)

The drive must obey the standard IEC 61000-3-12. To obey it, the short-circuit power S_{sc} must be a minimum of 120 R_{sc} at the interface point between your mains and the public mains. Make sure that you connect the drive and the motor to mains with a short-circuit power S_{sc} that is a minimum of 120 R_{sc}. If necessary, contact your mains operator.

1.6 USING AN RCD OR AN RCM DEVICE

The drive can cause a current in the protective earthing conductor. You can use a residual current-operated protective (RCD) device, or a residual current-operated monitoring (RCM) device to give protection against a direct or an indirect contact. Use a type B RCD or RCM device on the mains side of the drive.

2. RECEIVING THE DELIVERY

2.1 PACKAGE LABEL

To make sure that the delivery is correct, compare your order data to the data on the package label. If the delivery does not agree with your order, speak to the vendor immediately.

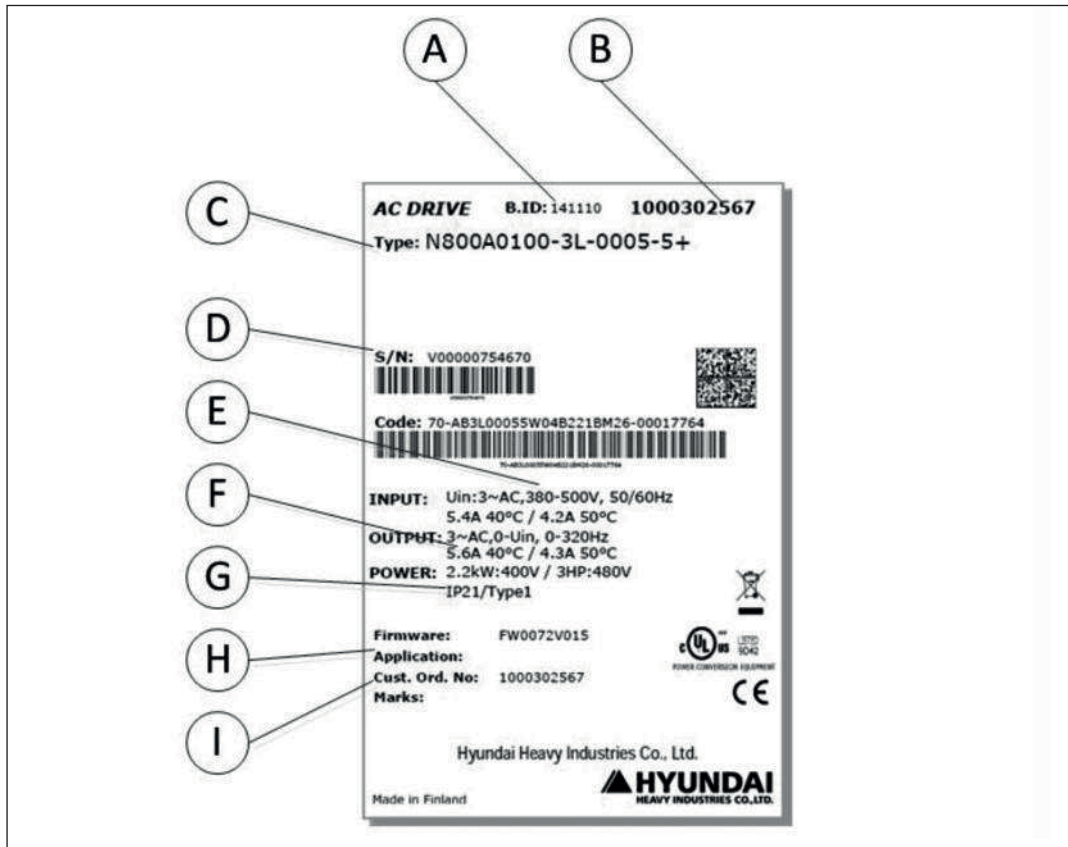

Fig. 1: The package label of the AC drives

- | | |
|------------------------------|-------------------------------------|
| A. The batch ID | F. The rated output current |
| B. The order number of Vacon | G. The IP class |
| C. The type designation code | H. The application code |
| D. The serial number | I. The order number of the customer |
| E. The mains voltage | |

2.2. TYPE DESIGNATION CODE

The type designation code of HHL is made of standard codes and optional codes. Each part of the type designation code agrees to the data in your order. The code can have this format, for example:

N800A0100-3L-0061-5 +xxxx +yyyy

Table 3: The description of the parts in the type designation code

Code	Description
N800A	This part is same for all the products.
0100	The product range: 0100 = Vacon 100
3L	Input/Function: 3L= A 3-phase input
0061	The drive rating in amperes. For example, 0061 = 61 A
5	The mains voltage: 2 = 208-240 V 5 = 380-500 V
+xxxx +yyyy	The optional codes. There are many options, for example +IP54 (an AC drive with the IP protection class IP54)

2.3 UNPACKING AND LIFTING THE AC DRIVE

2.3.1 WEIGHT OF THE AC DRIVE

The weights of AC drives of different frames are very different. It can be necessary for you to use a lifting device to move the drive from its package.

Table 4: The weights of the different frames

Frame	Weight, IP21/IP54 [kg]	Weight, IP00 [kg]	Weight, UL Type 1 / Type 12 [lb.]	Weight, UL Open Type [lb.]
MR4	6.0		13.2	
MR5	10.0		22.0	
MR6	20.0		44.1	
MR7	37.5		82.7	
MR8	66.0	62.0	145.5	136.7
MR9	119.5	103.5	263.5	228.2
MR10		205*		451.9*

*The weight without the options.

2.3.2 LIFTING THE FRAMES MR8 AND MR9

- 1) Remove the drive from the pallet where it was bolted to.
- 2) Use a lifting device that is sufficiently strong for the weight of the drive.

- 3) Put the lifting hooks symmetrically in a minimum of 2 holes.
- 4) The maximum lifting angle is 45 degrees.

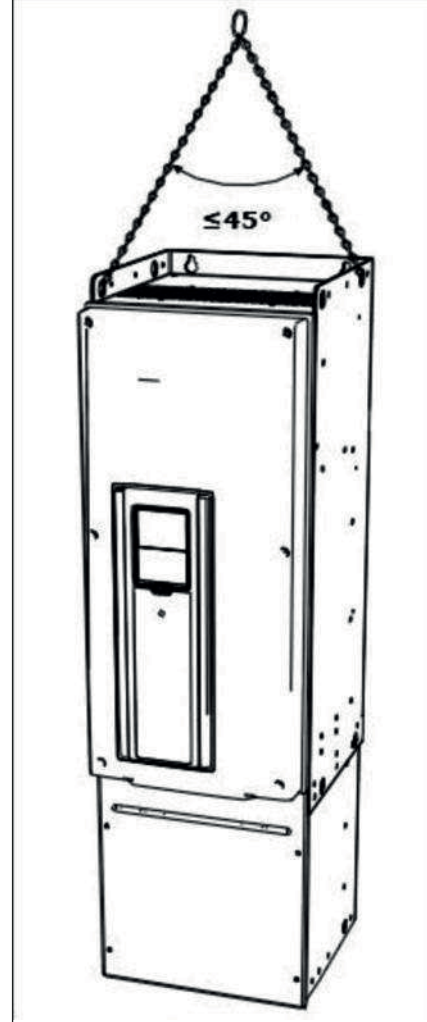

2.3.3 LIFTING THE FRAMES MR10

2.3.3.1 LIFTING THE FRAMES MR10 WITHOUT THE EXTENSION BOX

- 1) Make sure that the support is attached to the bottom of the drive. It gives the terminals protection when you lift the drive or put it vertically on the floor.

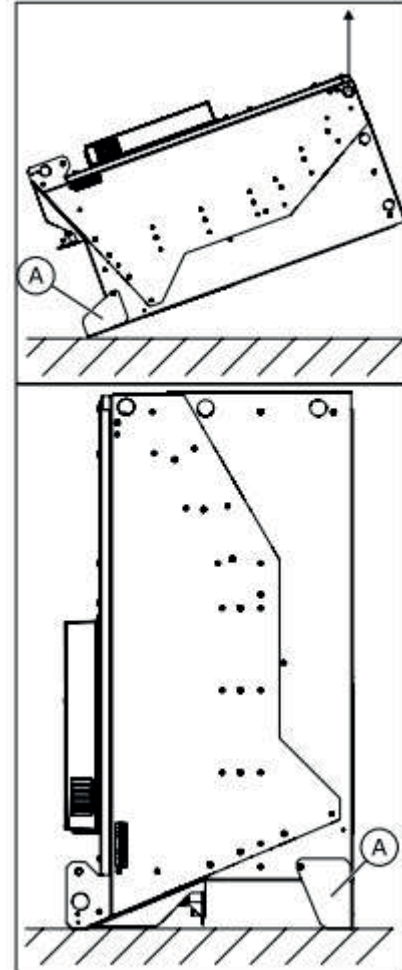

A. The support / fixing bracket

- 2) Lift the drive with a lifting device. Put the lifting hooks in the holes on the top of the cabinet. The maximum lifting angle is 60 degrees.
- 3) After the lifting, you can remove the support if necessary. You can also use it as a fixing bracket.

2.3.3.2 LIFTING THE FRAMES MR10 WITH AN EXTENSION BOX

- 1) Remove the drive from the package.
- 2) Use a lifting device that is sufficiently strong for the weight of the drive.
- 3) Put the lifting hooks in the holes on the top of the cabinet.

4) Lift the drive into a vertical position.

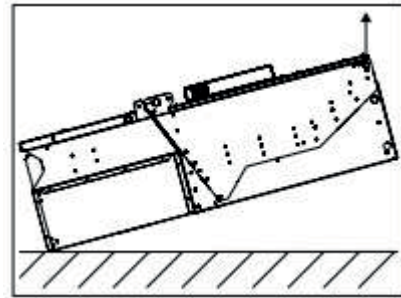

5) The maximum lifting angle is 60 degrees.

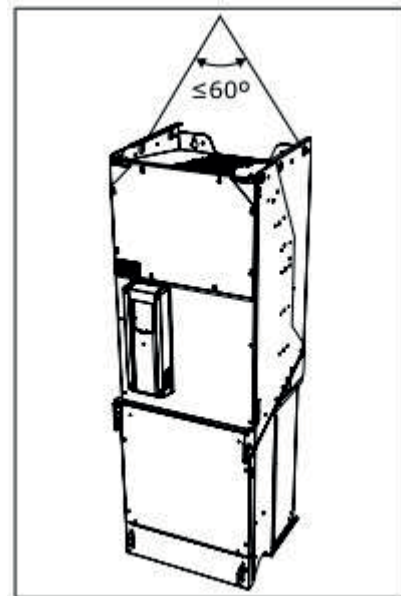

Before a AC drive is sent to the customer, the manufacturer makes many tests on the drive. After you lift the drive, do a check for signs of damage on the drive. Make sure that the contents of the package are correct. If the drive was damaged during the shipping, speak to the cargo insurance company or the carrier.

2.4 ACCESSORIES

After you open the package and lift the drive out, make sure that you received all the accessories. The content of the accessories bag is different for the different frames and protection classes.

2.4.1 FRAME MR4

Table 5: The content of accessories bag, MR4

Item	Quantity	Purpose
M4x16 screw	11	Screws for the power cable clamps (6), the control cable clamps (3), and the grounding clamps (2)
M4x8 screw	1	Screw for the optional grounding
M5x12 screw	1	Screw for the external grounding of the drive
Control cable grounding lamella	3	Control cable grounding
EMC cable clamp, size M25	3	Clamping the power cables
Grounding clamp	2	Power cable grounding
"Product modified" label	1	Data about changes
IP21: Cable grommet	3	Sealing for the cables
IP54: Cable grommet	6	Sealing for the cables

2.4.2 FRAME MR5

Table 6: The content of the accessories bag, MR5

Item	Quantity	Purpose
M4x16 screw	13	Screws for the power cable clamps (6), the control cable clamps (3), and the grounding clamps (4)
M4x8 screw	1	Screw for the optional grounding
M5x12 screw	1	Screw for the external grounding of the drive
Control cable grounding lamella	3	Control cable grounding
EMC cable clamps, size M25	1	Clamping brake cable
EMC cable clamps, size M32	2	Clamping power cables
Grounding clamp	2	Power cable grounding
"Product modified" label	1	Data about changes
IP21: Cable grommet, hole diameter 25.3 mm	1	Sealing for the cables
IP54: Cable grommet, hole diameter 25.3 mm	4	Sealing for the cables
Cable grommet, hole diameter 33.0 mm	2	Sealing for the cables

2.4.3 FRAME MR6

Table 7: The content of the accessories bag, MR6

Item	Quantity	Purpose
M4x20 screw	10	Screws for the power cable clamps (6), and the grounding clamps (4)
M4x16 screw	3	Screws for the control cable clamps
M4x8 screw	1	Screw for the optional grounding
M5x12 screw	1	Screw for the external grounding of the drive
Control cable grounding lamella	3	Control cable grounding
EMC cable clamps, size M32	1	Clamping the brake resistor cable
EMC cable clamps, size M40	2	Clamping the power cables
Grounding clamp	2	Power cable grounding
"Product modified" label	1	Data about changes
Cable grommet, hole diameter 33.0 mm	1	Sealing for the cables
Cable grommet, hole diameter 40.3 mm	2	Sealing for the cables
IP54: Cable grommet, hole diameter 25.3 mm	3	Sealing for the cables

2.4.4 FRAME MR7

Table 8: The content of the accessories bag, MR7

Item	Quantity	Purpose
M6x30 slotted nut	6	Nuts for the power cable clamps
M4x16 screw	3	Screws for the control cable clamps
M6x12 screw	1	Screw for the external grounding of the drive
Control cable grounding lamella	3	Control cable grounding
EMC cable clamps, size M25	3	Clamping the power cables
Grounding clamp	2	Power cable grounding
"Product modified" label	1	Data about changes
IP21: Cable grommet	3	Sealing for the cables
IP54: Cable grommet	3	Sealing for the cables

2.4.5 FRAME MR8

Table 9: The content of accessories bag, MR8

Item	Quantity	Purpose
M4x16 screw	3	Screws for the control cable clamps
Control cable grounding lamella	3	Control cable grounding
Cable lugs KP40	3	Clamping power cables
Cable insulator	11	To prevent contact between cables
Cable grommet, hole diameter 25.3 mm	4	Sealing for the cables
IP00: Touch shield	1	To prevent contact with live parts
IP00: M4x8 screw	2	To attach the touch protection shield

2.4.6 FRAME MR9

Table 10: The content of the accessories bag, MR9

Item	Quantity	Purpose
M4x16 screw	3	Screws for the control cable clamps
Control cable grounding lamella	3	Control cable grounding
Cable lugs KP40	5	Clamping power cables
Cable insulator	10	To prevent contact between cables
Cable grommet, hole diameter 25.3 mm	4	Sealing for the cables
IP00: Touch shield	1	To prevent contact with live parts
IP00: M4x8 screw	2	To attach the touch protection shield

2.5 "PRODUCT MODIFIED" LABEL

In the accessories bag, there is also a "product modified" label. The function of the label is to tell the service personnel about the changes that are made in the AC drive. Attach the label on the side of the AC drive to know where to find it. If you make changes in the AC drive, write the change on the label.

	<p>Product modified</p> <p>..... Date:</p> <p>..... Date:</p> <p>..... Date:</p>
--	--

2.6 DISPOSAL

	<p>When the drive is at the end of its operation life, do not discard it as a part of municipal waste. You can recycle the primary components of the drive. You must disassemble some components before you can remove the different materials. Recycle the electrical and electronic components as waste. To make sure that the waste is recycled correctly, send the waste to a re-cycling centre. You can also send the waste back to the manufacturer. Obey the local and other applicable regulations.</p>
---	---

2.7 Warranty of the Unit

2.7.1 Questions on Unit

If you have any questions regarding damage to the unit, unknown parts or for general inquiries, please contact the agency with the following information.

- 1) Inverter Model
- 2) Production Number (Serial No.)
- 3) Date of purchase
- 4) Reason for Calling
 - (1) Damaged part and its condition etc.
 - (2) Unknown parts and their contents etc.

2.7.2 Warranty for the unit

The warranty period of the unit is one year after the purchase date. However the warranty will be void if the fault is due to:

- 1) Incorrect use as directed in this manual, or attempted repair by unauthorized personnel.
- 2) Any damage sustained other than from transportation (Which should be reported immediately).
- 3) Using the unit beyond the limits of the specifications.
- 4) Natural Disasters: Earthquakes, Lightning, etc

The warranty is for the inverter only, any damage caused to other equipment by malfunction of the inverter is not covered by the warranty.

Any examination or repair after the warranty period (one-year) is not covered. And within the warranty period any repair and examination which results in information showing the fault was caused by any of the items mentioned above, the repair and examination costs are not covered. If you have any questions regarding the warranty, please contact the agency.

3. MOUNTING

3.1 GENERAL INFORMATION ABOUT MOUNTING

Install the AC drive in a vertical position on the wall. If you install the drive in a horizontal position, it is possible that some functions with the nominal values that are found in chapter 7 Technical data are not available. Attach the AC drive with the screws and other components that you received in the delivery.

3.2 DIMENSIONS FOR WALL MOUNTING

3.2.1 WALL MOUNTING OF MR4

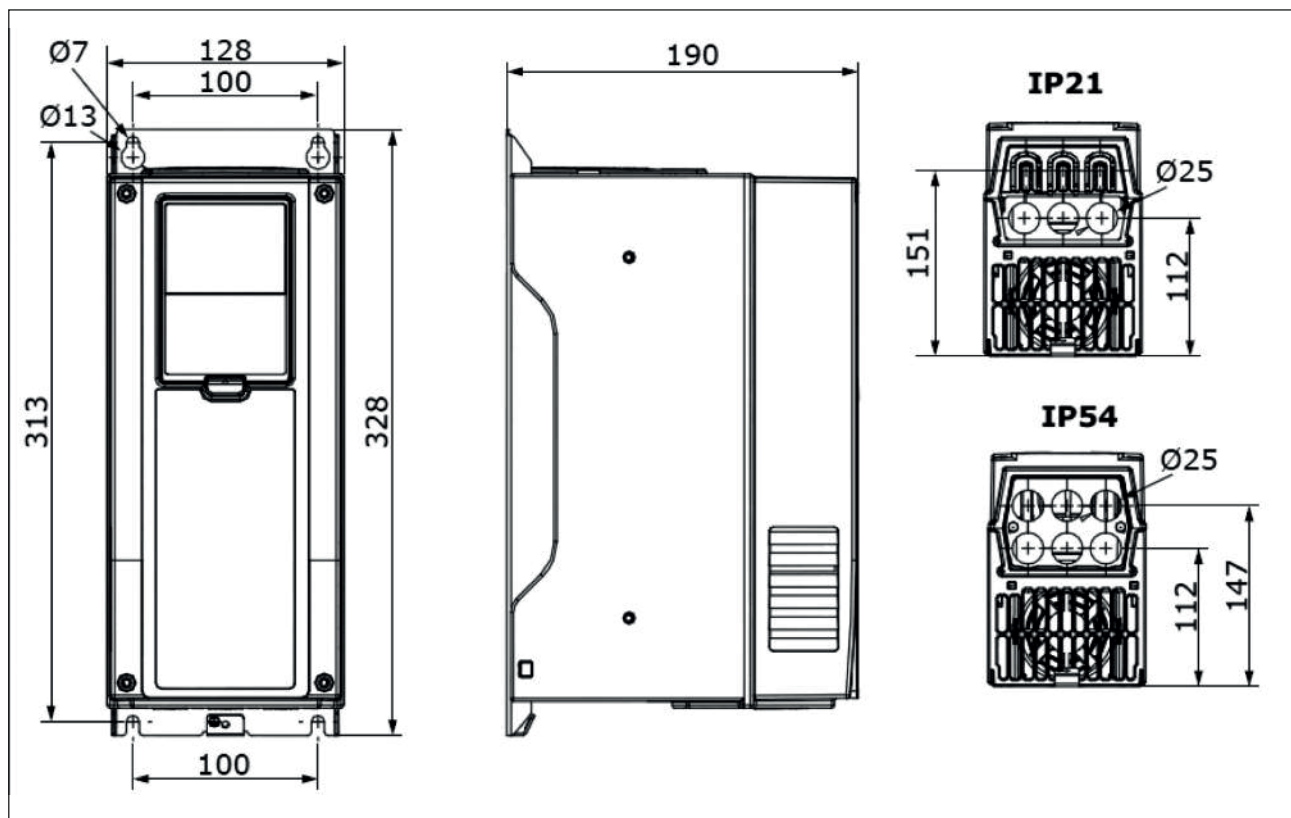

Fig. 2: The dimensions of the AC drive, MR4

3.2.2 WALL MOUNTING OF MR5

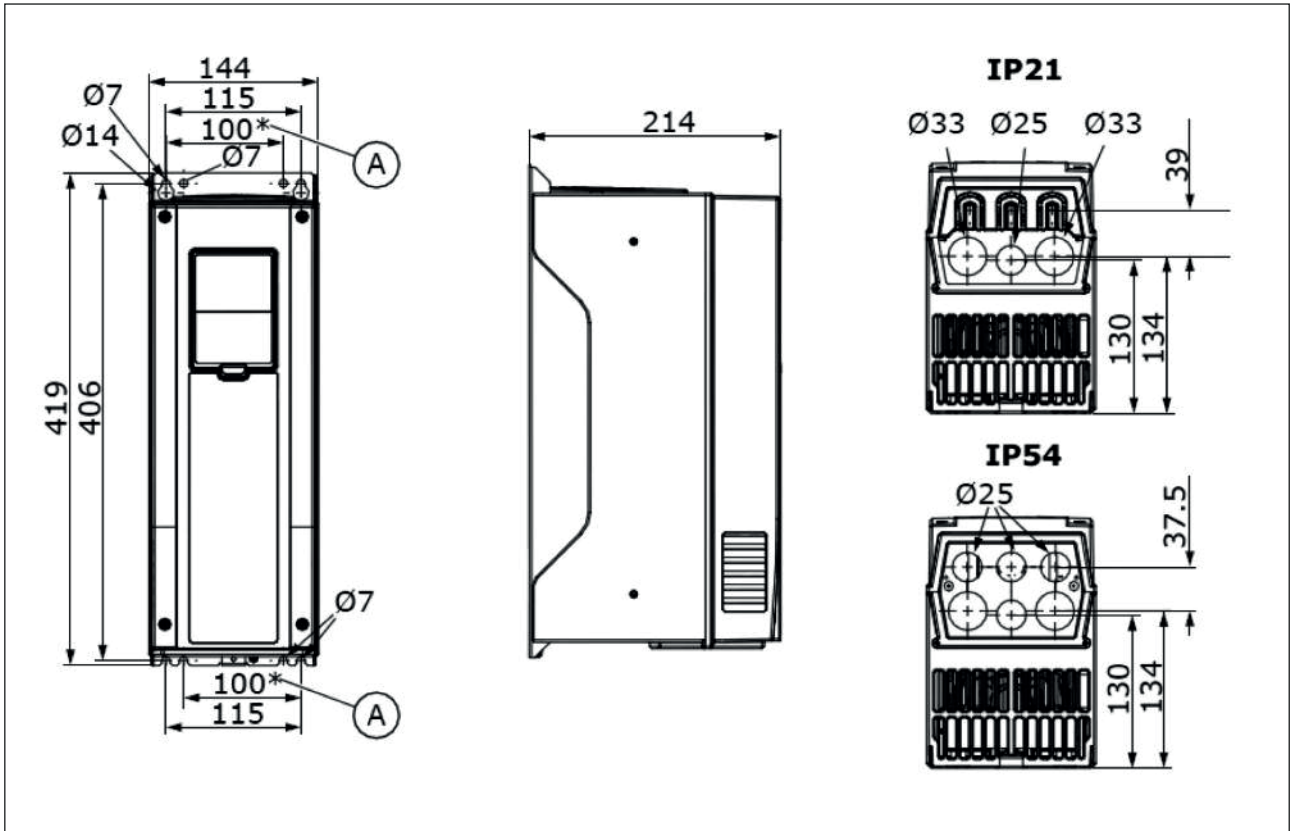

Fig. 3: The dimensions of the AC drive, MR5

3.2.3 WALL MOUNTING OF MR6

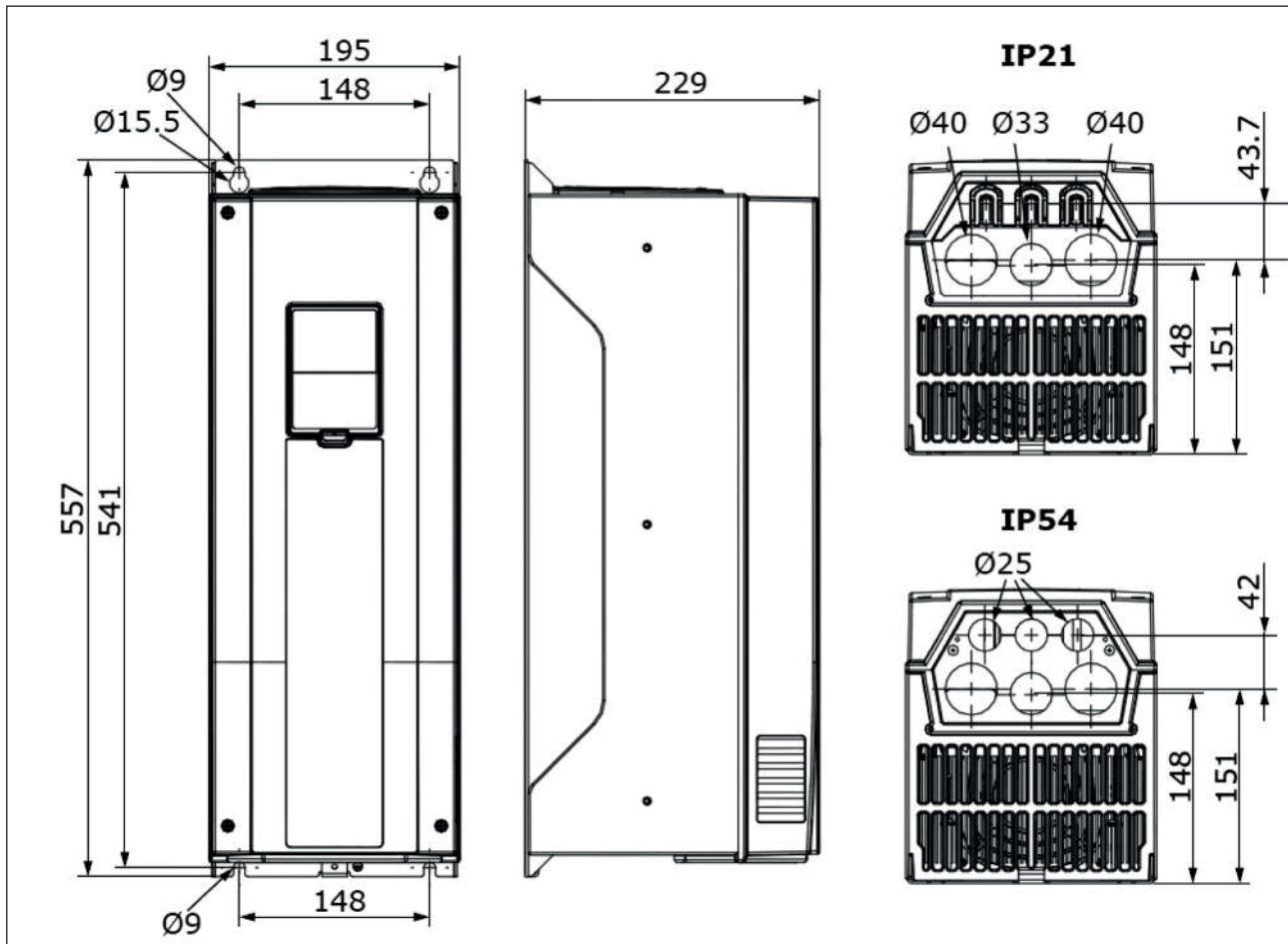

Fig. 4: The dimensions of the AC drive, MR6

3.2.4 WALL MOUNTING OF MR7

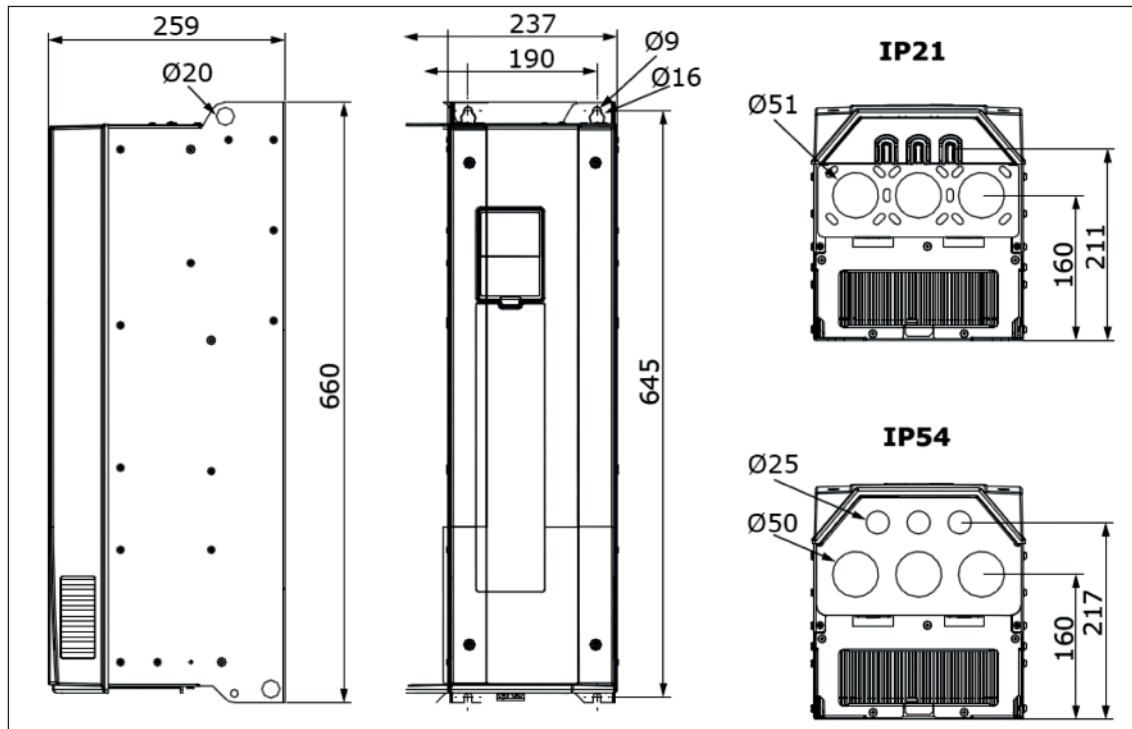

Fig. 5: The dimensions of the AC drive, MR7

3.2.5 WALL MOUNTING OF MR8, IP21 AND IP54

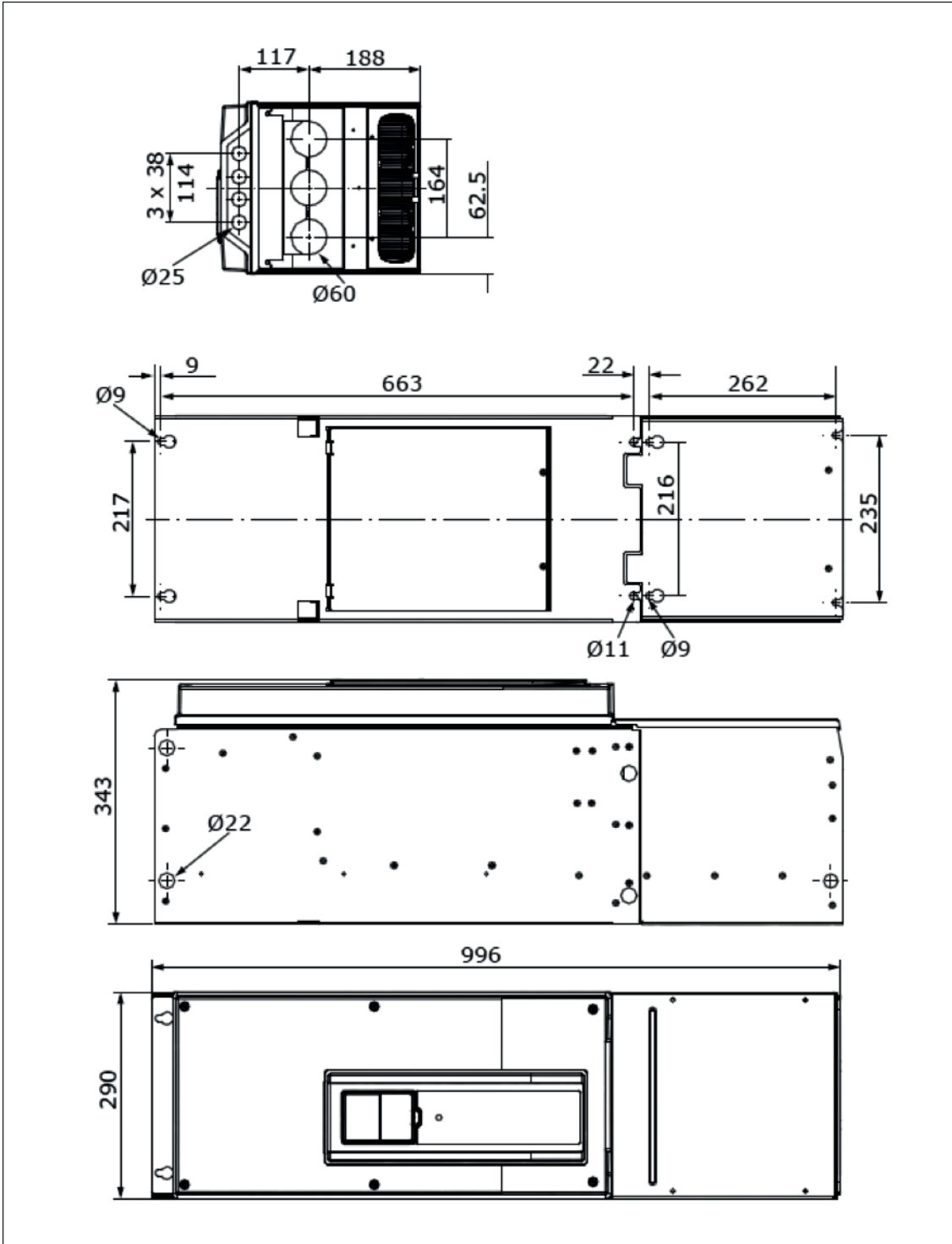

Fig. 6: The dimensions of the AC drive, MR8, IP21 and IP54

3.2.6 WALL MOUNTING OF MR8, IP00

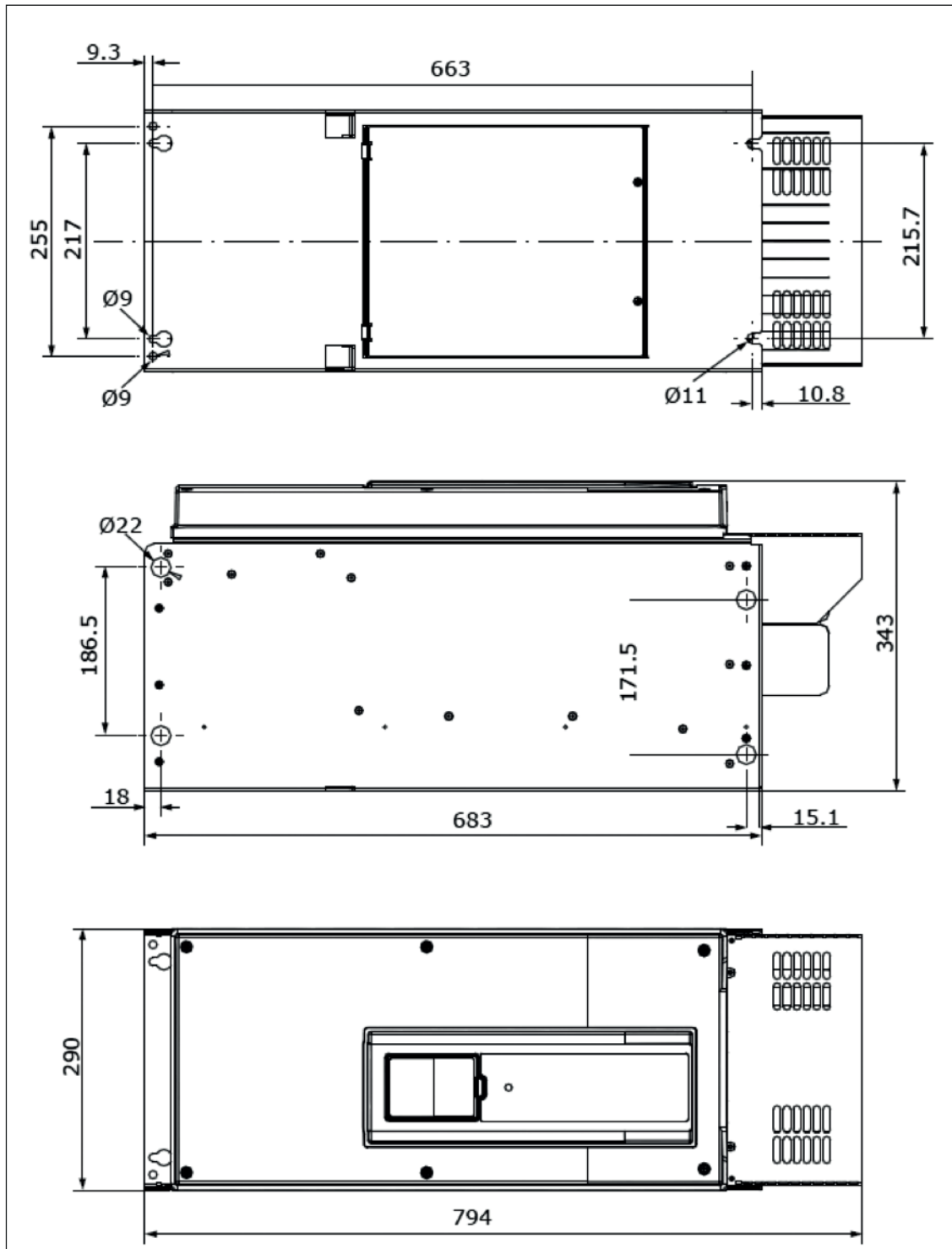

Fig. 7: The dimensions of the AC drive, MR8, IP00

3.2.7 WALL MOUNTING OF MR9, IP21 AND IP54

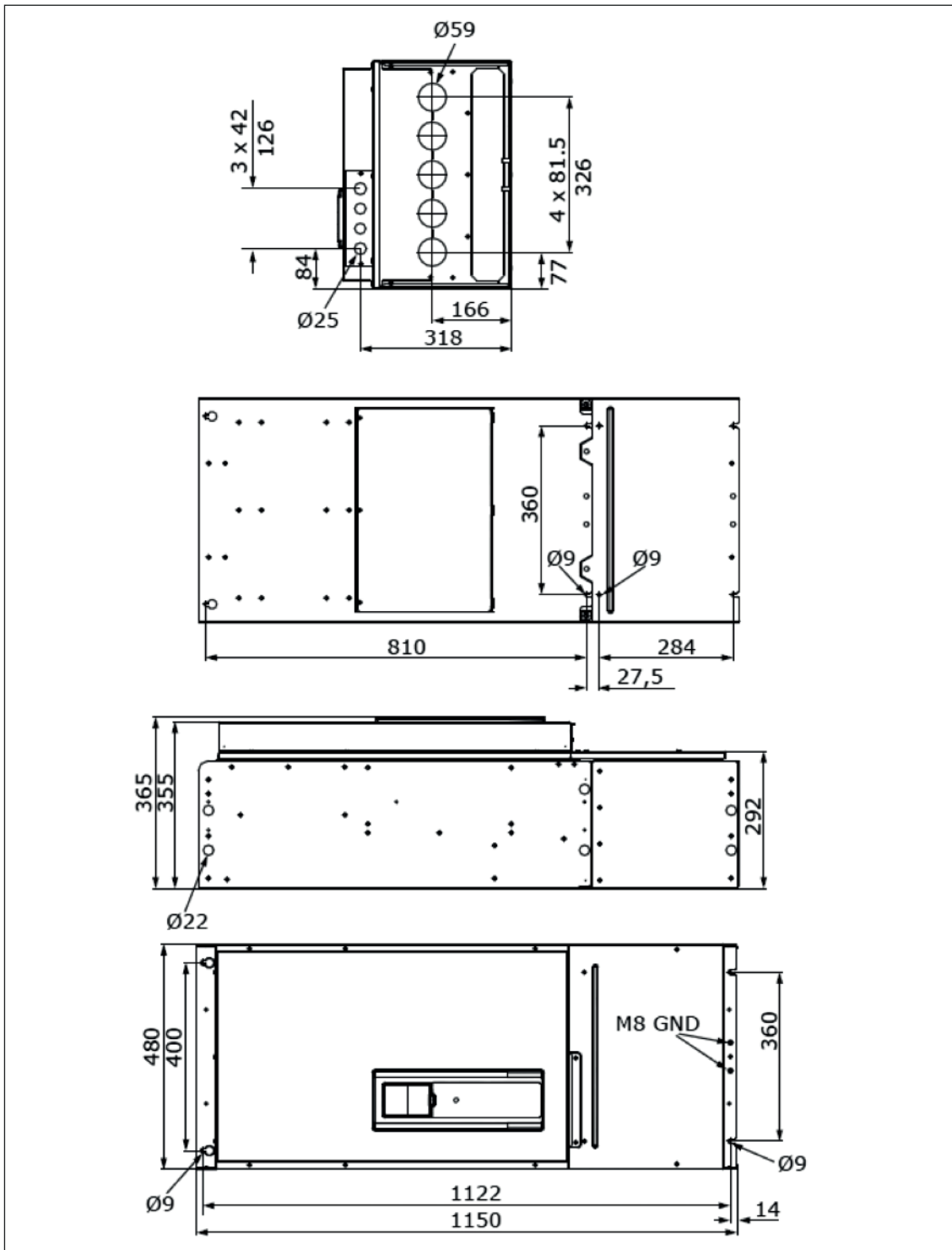

Fig. 8: The dimensions of the AC drive, MR9, IP21 and IP54

3.2.8 WALL MOUNTING OF MR9, IP00

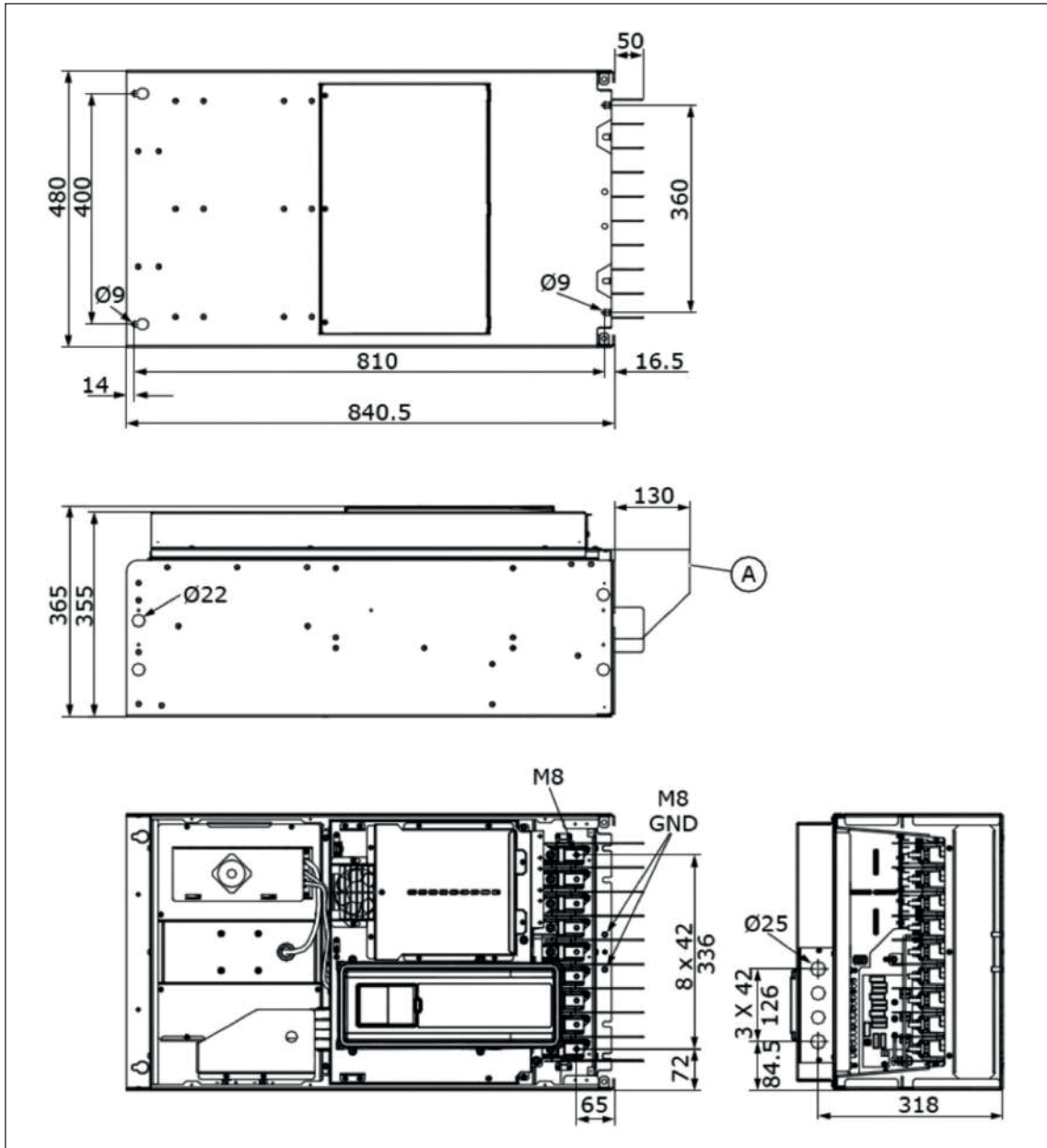

Fig. 9: The dimensions of the AC drive, MR9, IP00

A. An optional main connector covers for the cabinet installation

3.2.9 WALL MOUNTING OF MR10, IP00

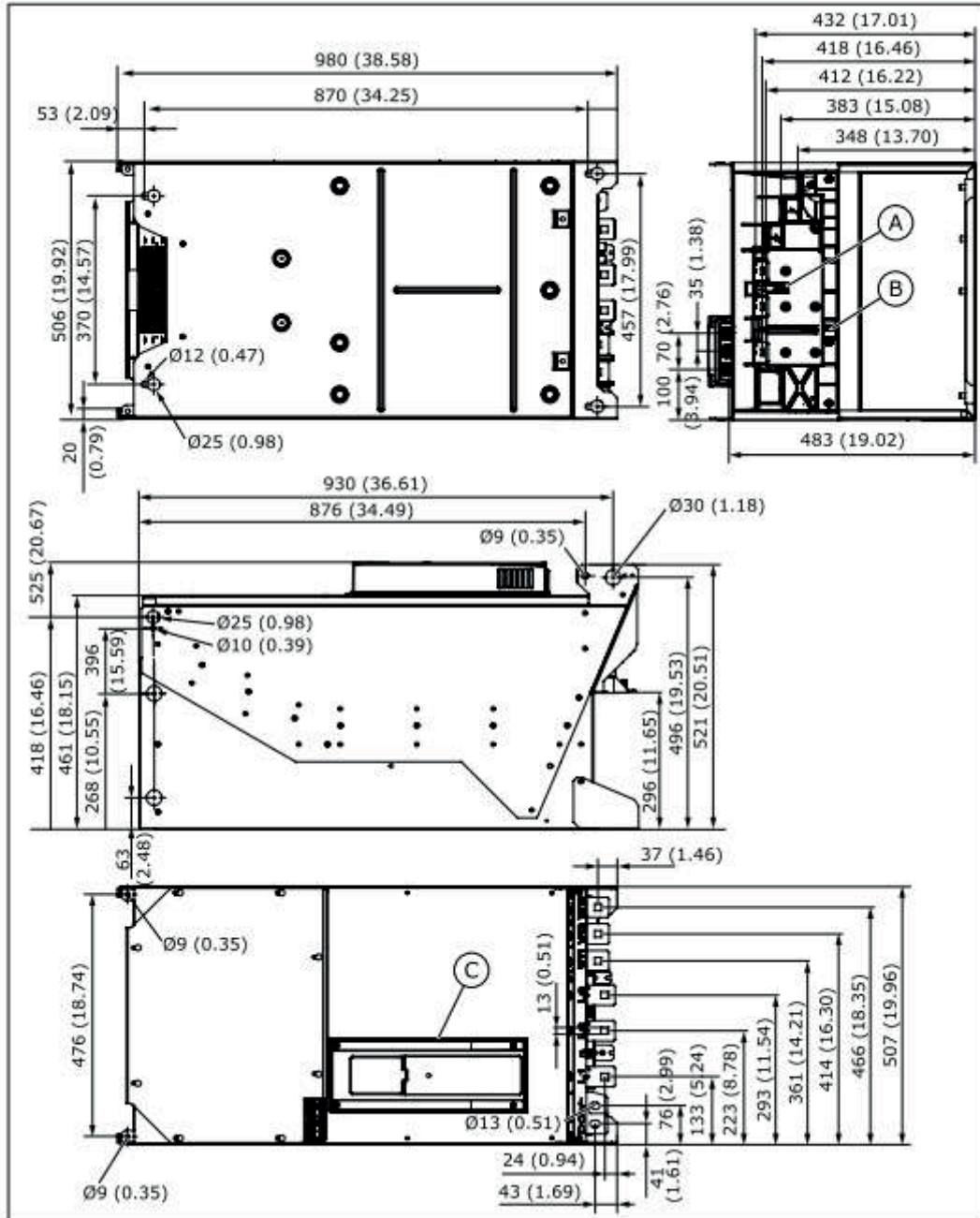

Fig. 10: The dimensions of the AC drive, MR10 without the extension box, IP00

- A. The EMC jumper
- B. M8 GND pin
- C. The control unit

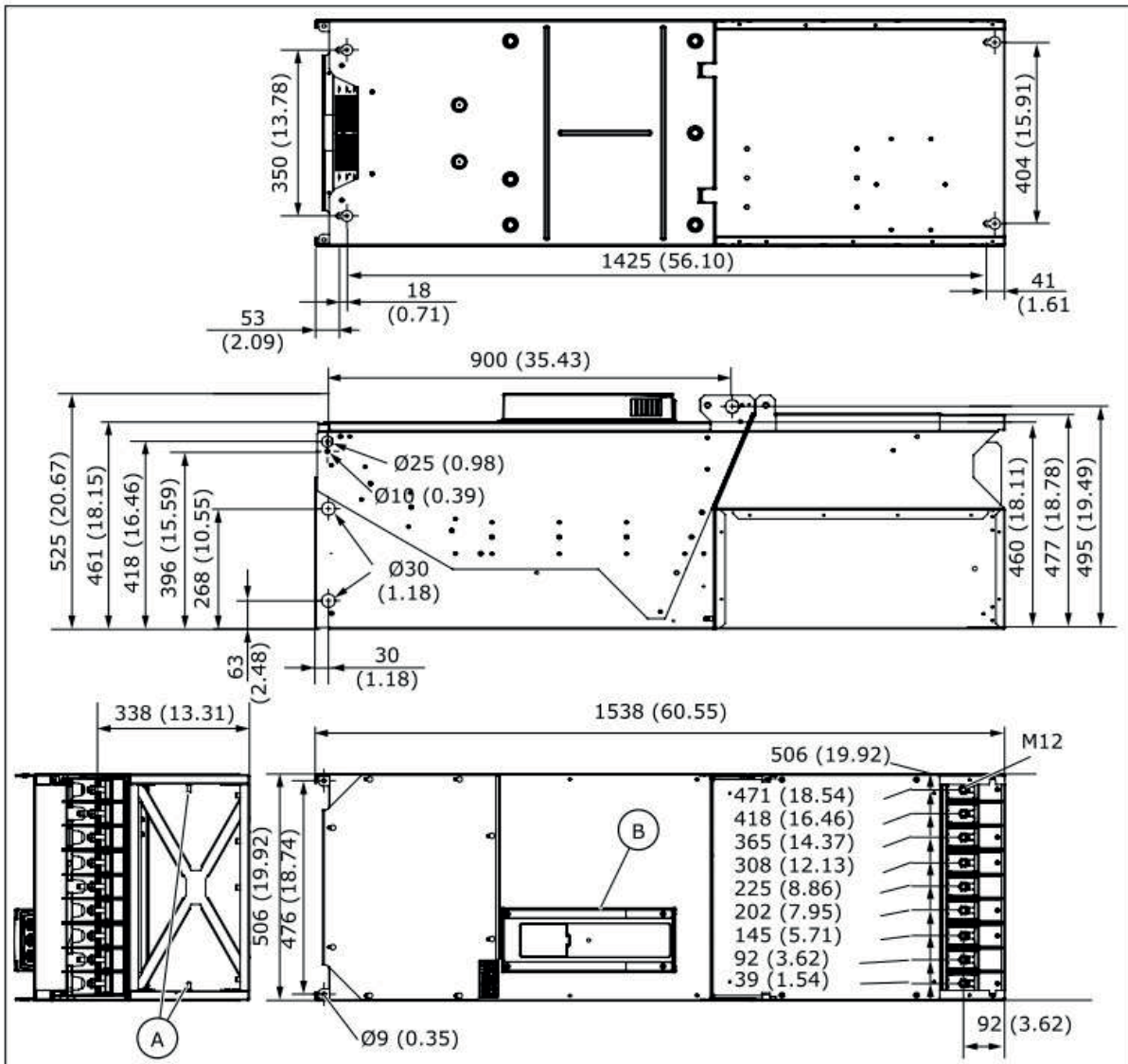

Fig. 11: The dimensions of the AC drive, MR10 with the extension box, IP00

A. M8 GND pin

B. The control unit

3.3 DIMENSIONS FOR FLANGE MOUNTING

You can also install the AC drive into the cabinet wall with a flange mounting option.



NOTE!

The protection classes are different in different sections of the drive.

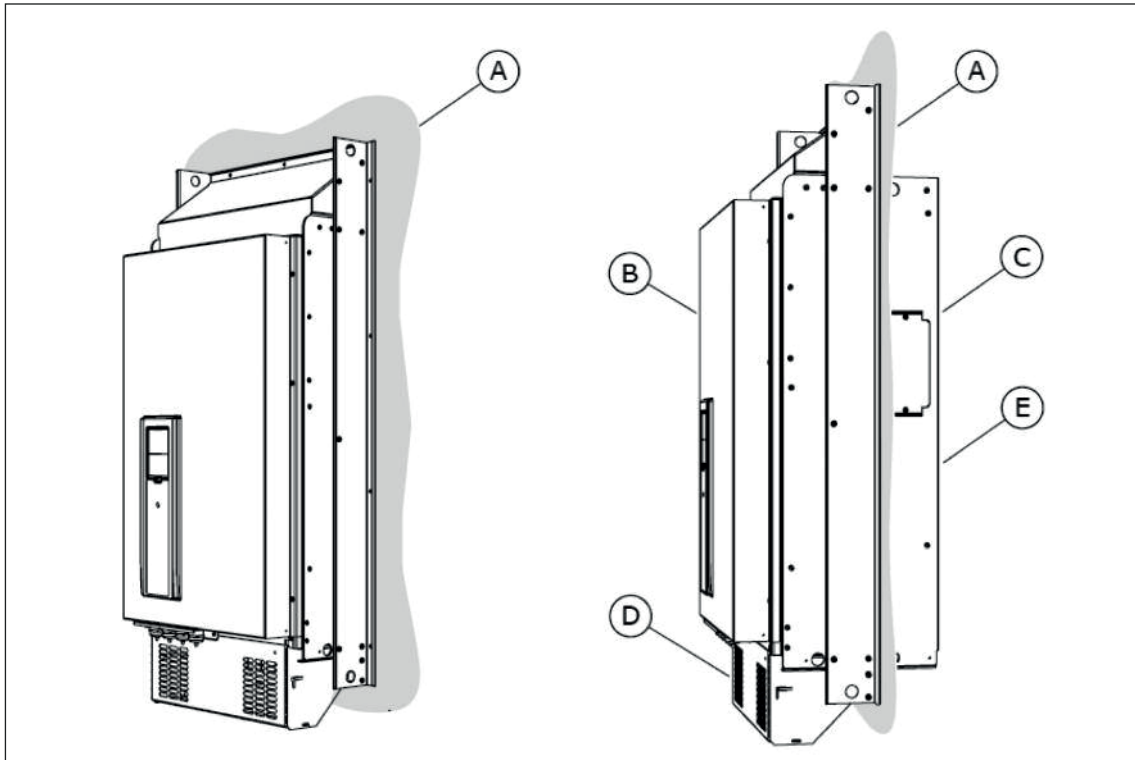

Fig. 12: Example of flange mounting (frame MR9)

- | | |
|--------------------------------------|------------------------|
| B. The cabinet wall or other surface | D. IP00 / UL Open Type |
| C. The front | E. IP54 / UL Type 12 |
| D. The rear | |

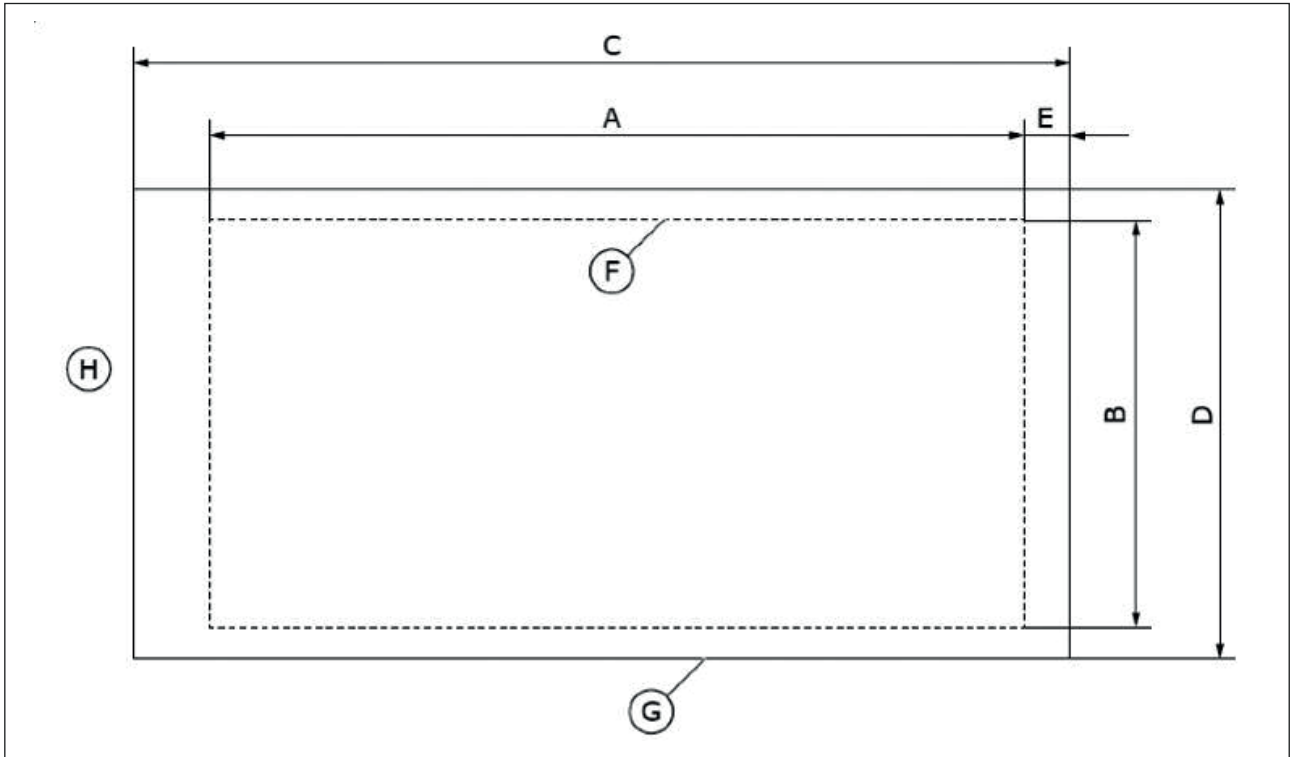

Fig. 13: The dimensions of the opening and drive outline with flange

- A. The height of the opening for the flange the mounting
- B. The width of the opening
- C. The height of the drive
- D. The width of the drive
- E. The distance between the bottom of the drive and the bottom of the opening
- F. The outline of the opening
- G. The outline of the drive
- H. The top of the drive

Table 11: The dimensions of the drive, frames MR4 to MR10

Frame	C[mm]	D[mm]	C[in]	D[in]
MR4	357	152	14.1	6.0
MR5	454	169	17.9	6.7
MR6	580	220	22.8	8.7
MR7	680	286	26.8	11.3
MR8	898	359	35.4	14.1
MR9	1060	550	41.7	21.7
MR10	1110	576	43.7	22.7

Table 12: The dimensions of the opening for the flange mounting, frames MR4 to MR9

Frame	A[mm]	B[mm]	E[mm]	A[in]	B[in]	E[in]
MR4	315	137	24	12.4	5.4	0.9
MR5	408	152	23	16.1	6.0	0.9
MR6	541	203	23	21.3	8.0	0.9
MR7	655	240	13	25.8	9.4	0.5
MR8	859	298	18	33.8	11.7	0.7
MR9	975	485	54	38.4	19.1	2.1
MR10	960	510	122	37.8	20.1	4.8

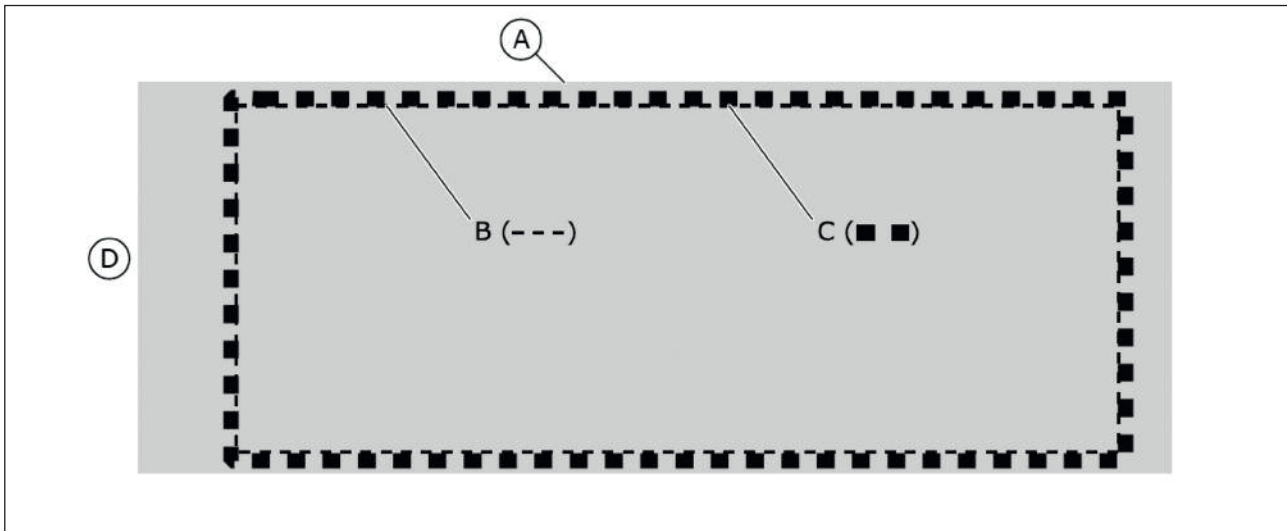

Fig. 14: Sealing of the opening for MR8 MR9, and MR10

- A. The AC drive
 B. The outline of the opening
 C. Gasket tape
 D. The top of the drive

3.3.1 FLANGE MOUNTING OF MR4

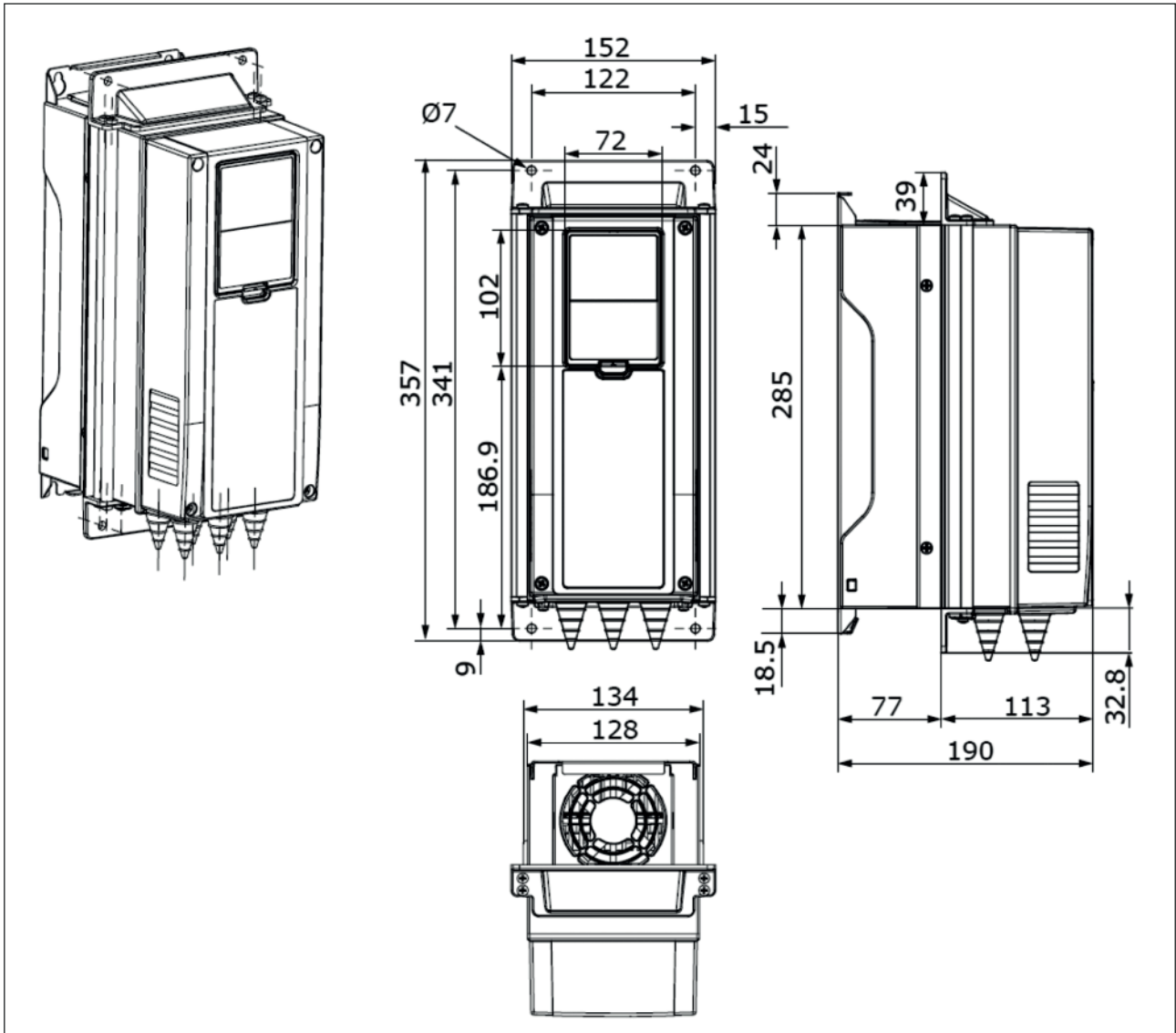

Fig. 15: The dimensions of the AC drive, flange mounting, MR4

3.3.2 FLANGE MOUNTING OF MR5

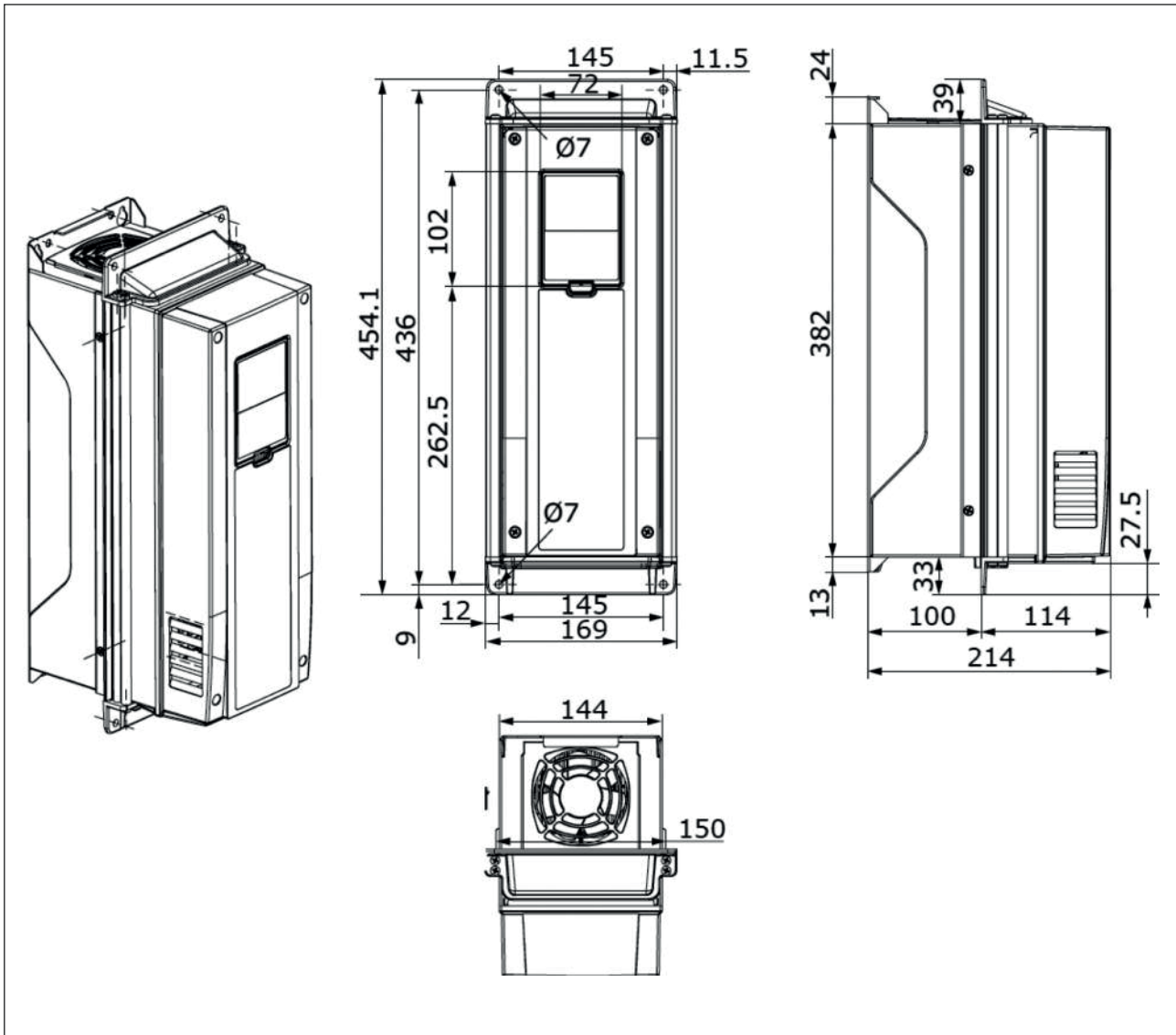

Fig. 16: The dimensions of the AC drive, flange mounting, MR5

3.3.3 FLANGE MOUNTING OF MR6

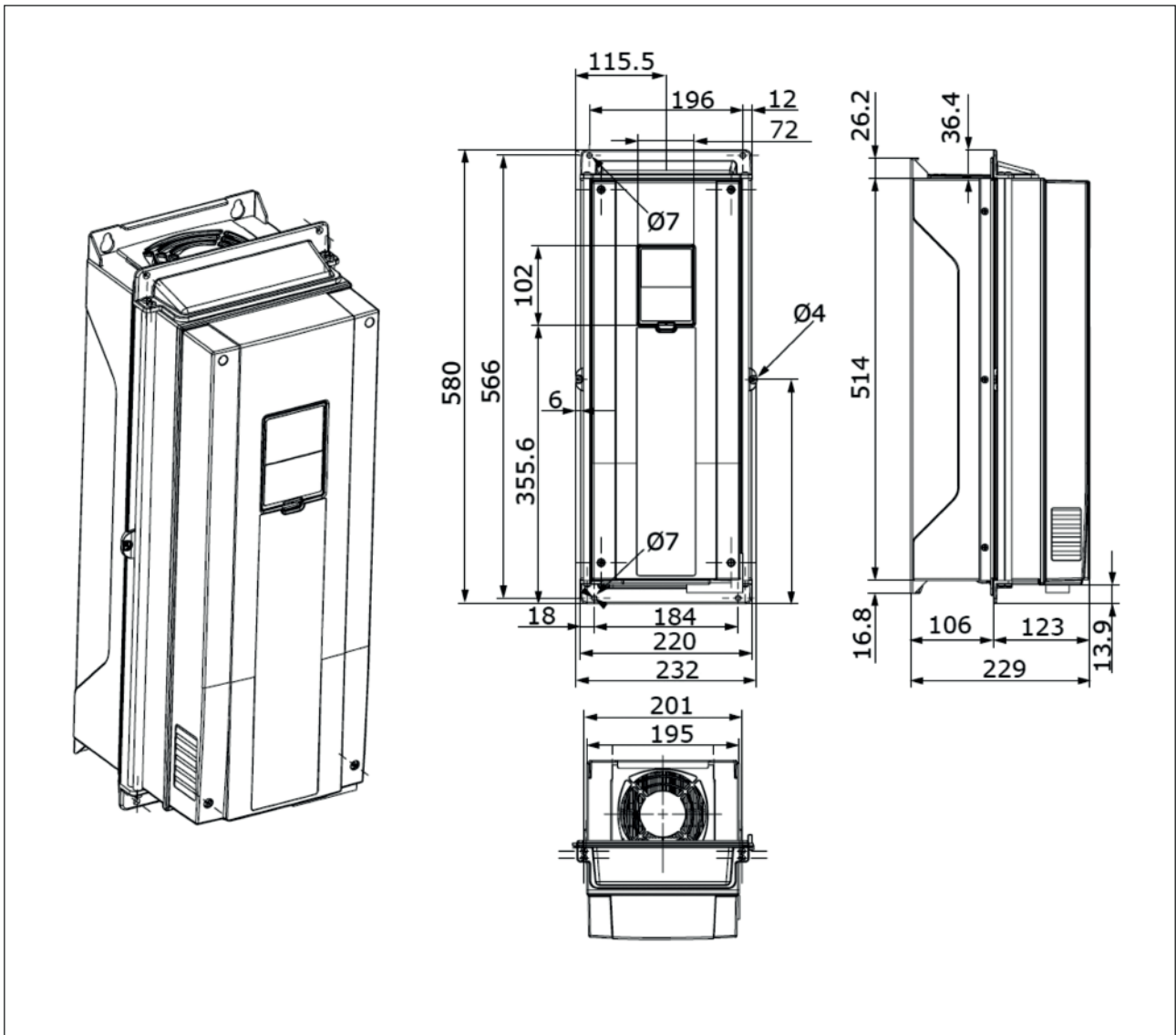

Fig. 17: The dimensions of the AC drive, flange mounting, MR6

3.3.4 FLANGE MOUNTING OF MR7

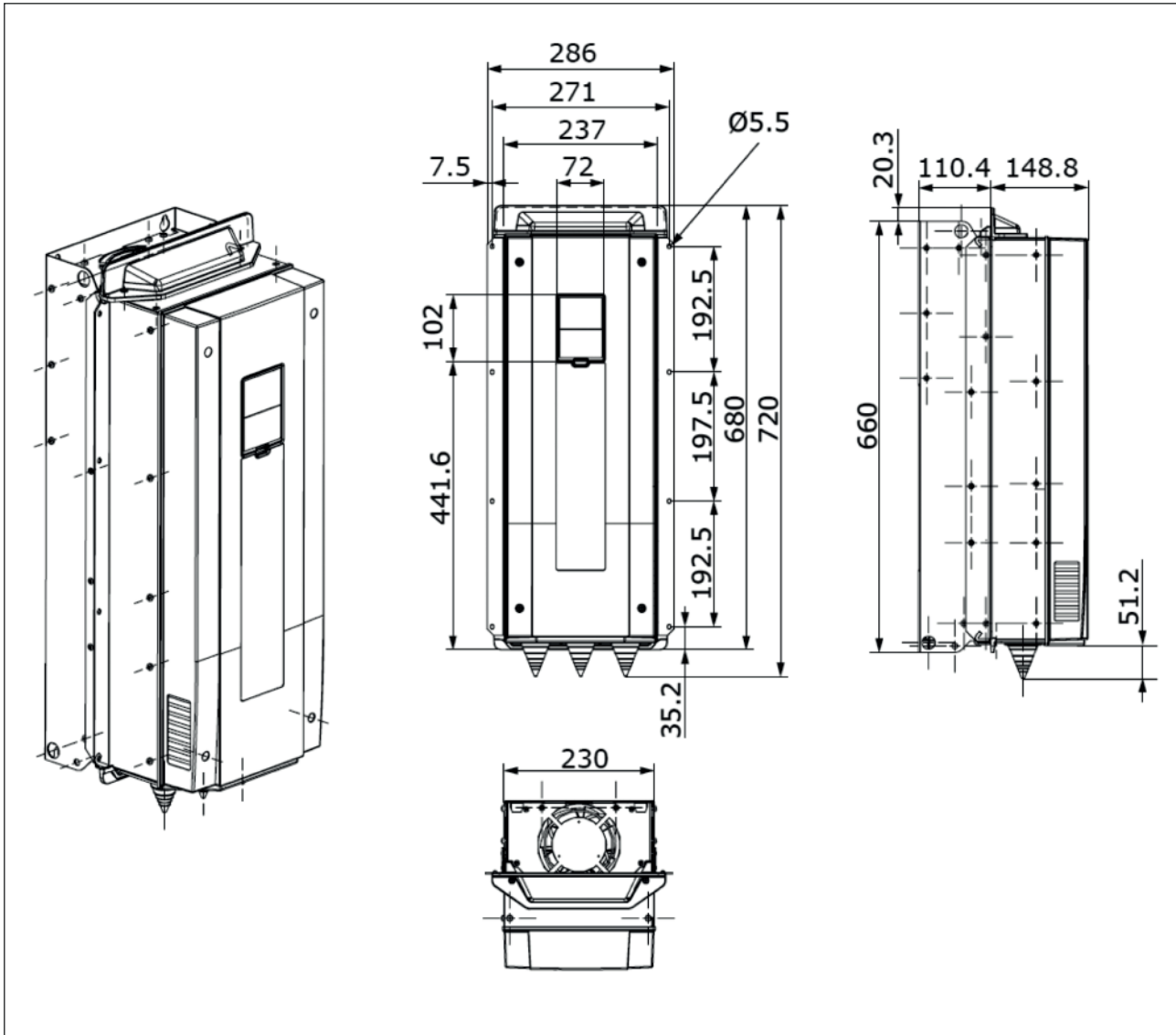

Fig. 18: The dimensions of the AC drive, flange mounting, MR7

3.3.5 FLANGE MOUNTING OF MR8

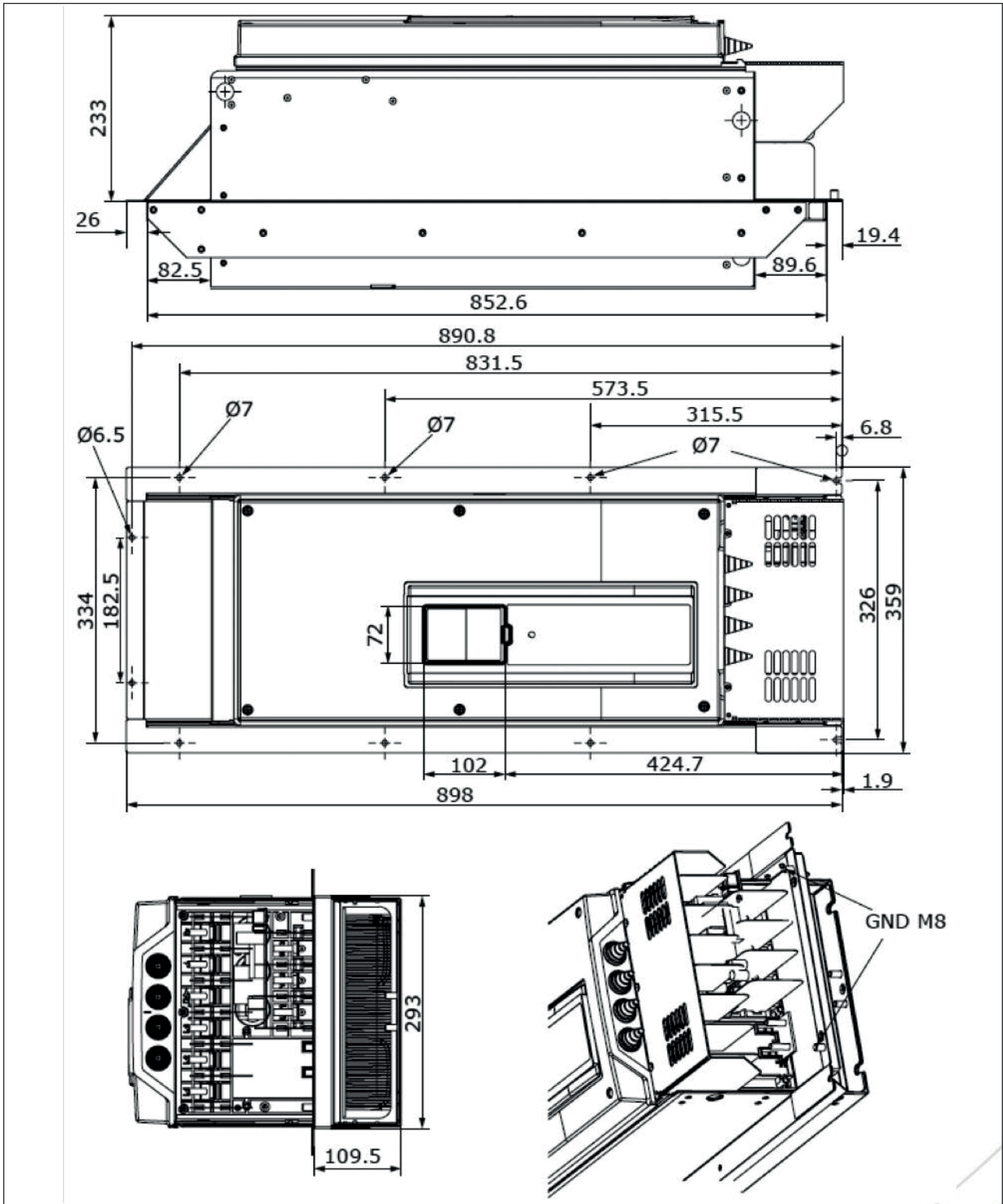

Fig. 19: The dimensions of the AC drive, flange mounting, MR8

3.3.7 FLANGE MOUNTING OF MR10

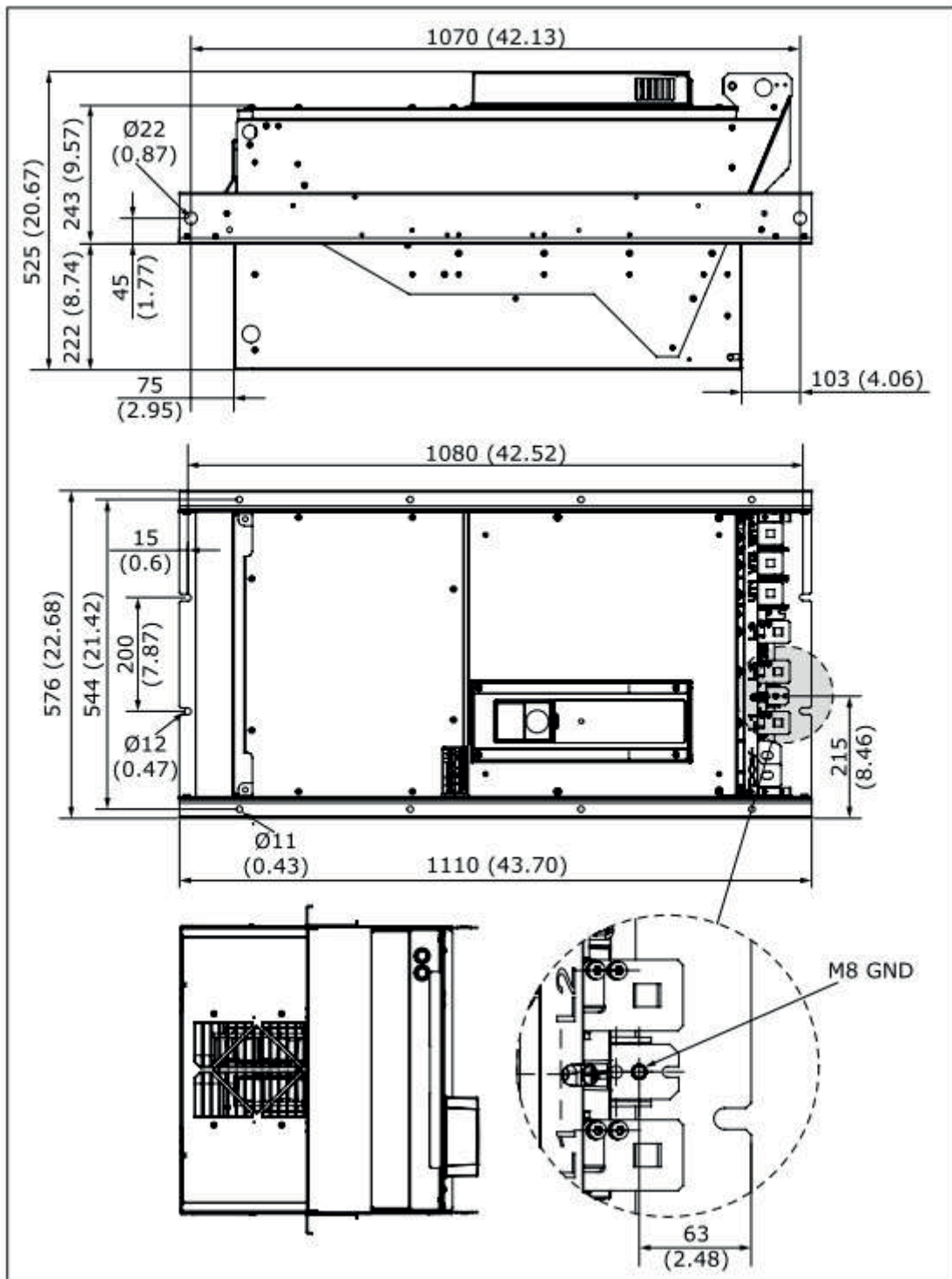

Fig. 20.1: The dimensions of the AC drive, flange mounting, MR10

3.4 COOLING

The AC drive produces heat in operation. The fan circulates air and decreases the temperature of the drive. Make sure that there is sufficiently free space around the drive.

Some free space in front of the drive is also necessary for maintenance. You must be able to open the cabinet door. When you have 2 or more drives, you can install them side by side.

Make sure that the temperature of the cooling air does not become higher than the maximum ambient operating temperature or lower than the minimum ambient operating temperature of the drive.

The air must move freely and efficiently through the cabinet and the drive. There must be a minimum of 20 cm (7.87 in) of space above the drive without obstacles that can stop the airflow. Make sure that the hot air goes out of the cabinet and does not come back into the cabinet.

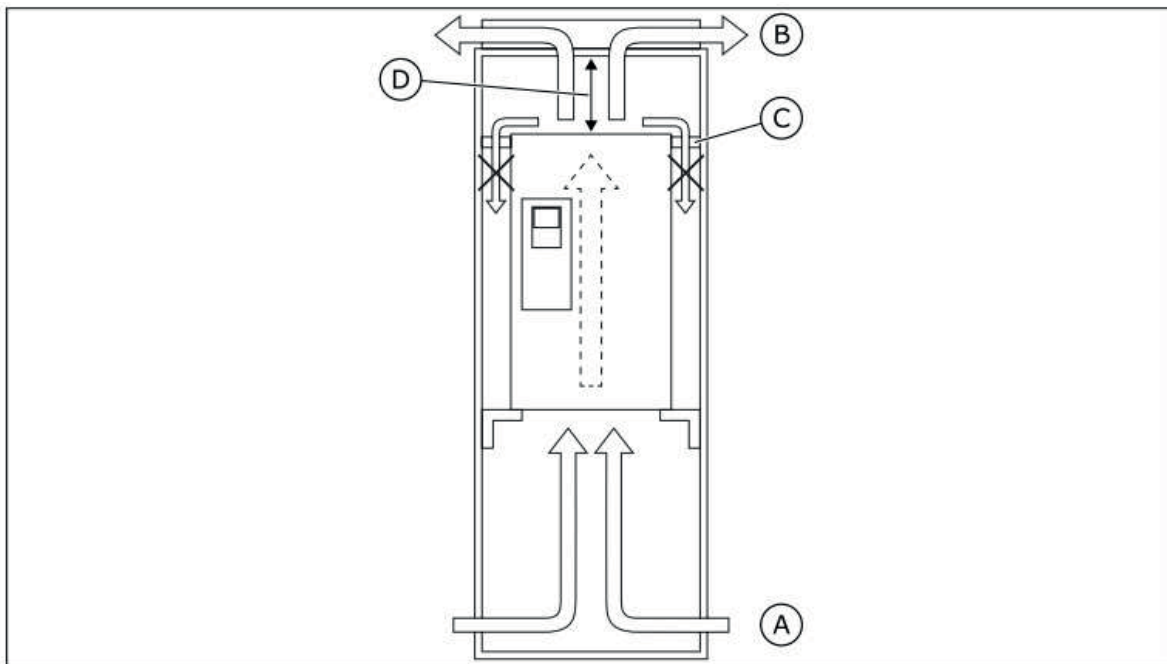

Fig. 23: The correct circulation of cooling air inside the cabinet

- A. Cooling air going in
- B. Hot air coming out
- C. Install shields to prevent recirculation of Hot air inside the cabinet.
- D. Minimum 200 mm[7.87 in]

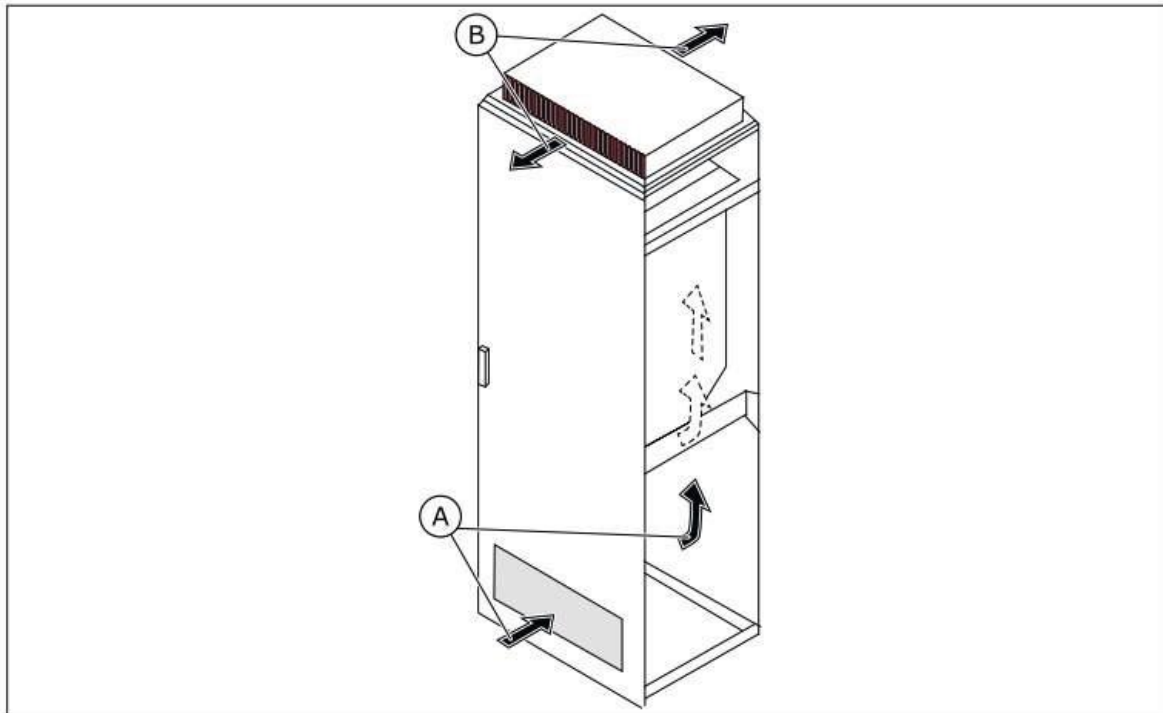

Fig. 24: The cooling air must move freely inside the cabinet

A. Cooling air going in

B. Hot air coming out

Table 14: The necessary quantity of cooling air

Frame	The quantity of cooling air [m^3/h]	The quantity of cooling air [CFM]
MR4	45	26.5
MR5	75	44.1
MR6	190	111.8
MR7	185	108.9
MR8	335	197.2
MR9	621	365.2
MR10	1400	824

This quantity of cooling air is sufficient for the AC drive. If you have other devices that cause power losses inside the cabinet, or if you use more filters (for example to have a higher level of protection), you must increase the surface area of the air intake holes.

4. POWER CABLING

4.1 CABLE CONNECTIONS

The mains cables are connected to terminals L1, L2 and L3. The motor cables are connected to terminals U, V and W.

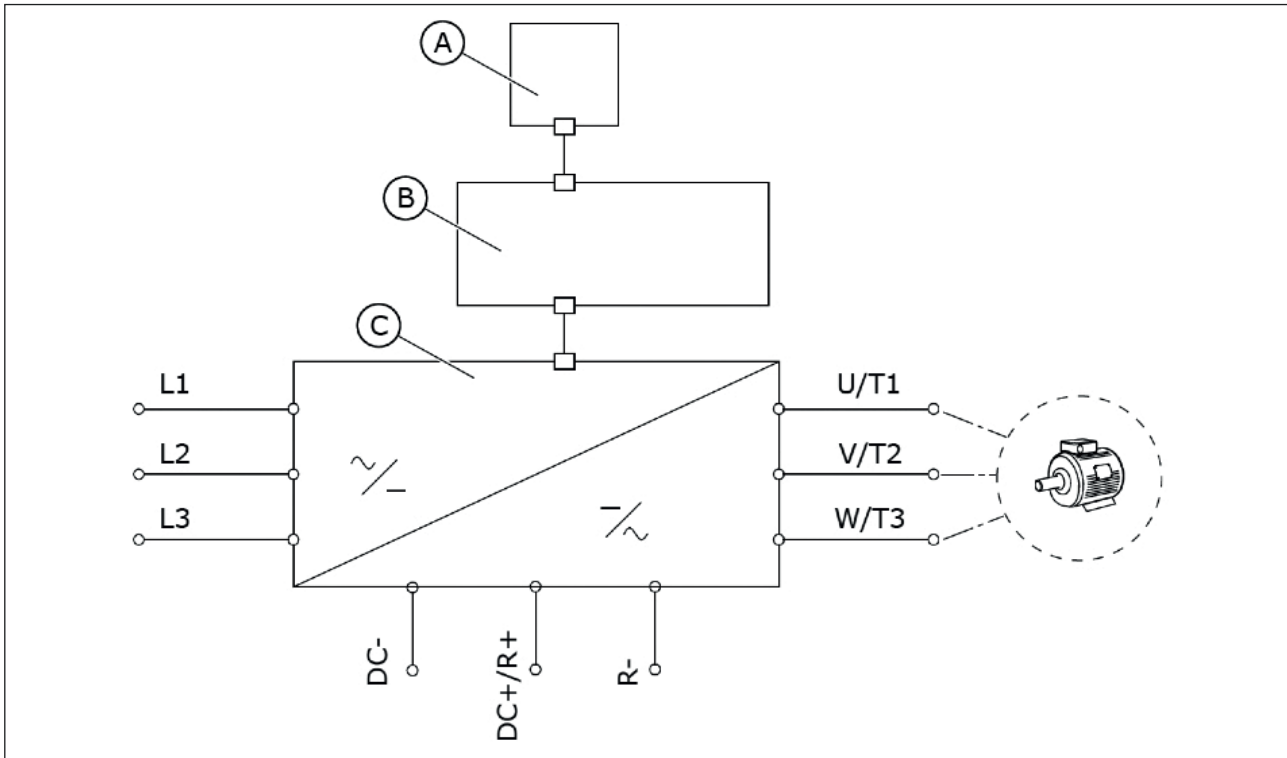

Fig. 25: The principal connection diagram

- A. The control panel
- B. The control unit
- C. The power unit

Use cables with a minimum heat resistance of +70 °C (158 °F). In the selection of the cables and the fuses, refer to the nominal output current of the drive. You can find the nominal output current on the rating plate.

Table 15: The selection of the correct cable

Cable type	EMC requirements		
	1st environment	2nd environment	
	Category C2	Category C3	Category C4
The mains cable	1	1	1
The motor cable	3*	2	2
The control cable	4	4	4

1. A power cable for a fixed installation. A cable for the specified mains voltage. A shielded cable is not necessary. We recommend an MCMK cable.
 2. A symmetrical power cable with a concentric protection wire. A cable for the specified mains voltage. We recommend an MCMK cable. See Fig. 22.
 3. A symmetrical power cable with a compact low-impedance shield. A cable for the specified mains voltage. We recommend an MCCMK, or an EMCMK cable. We recommend that the cable transfer impedance (1...30MHz) is a maximum of 100mΩ/m. See Fig. 22.
- * For the EMC level C2, it is necessary to have a 360° earthing of the shield with cable glands in the motor end.
4. A screened cable with a compact low-impedance shield, for example a JAMAK, or an SAB/ÖZCuY-O cable.

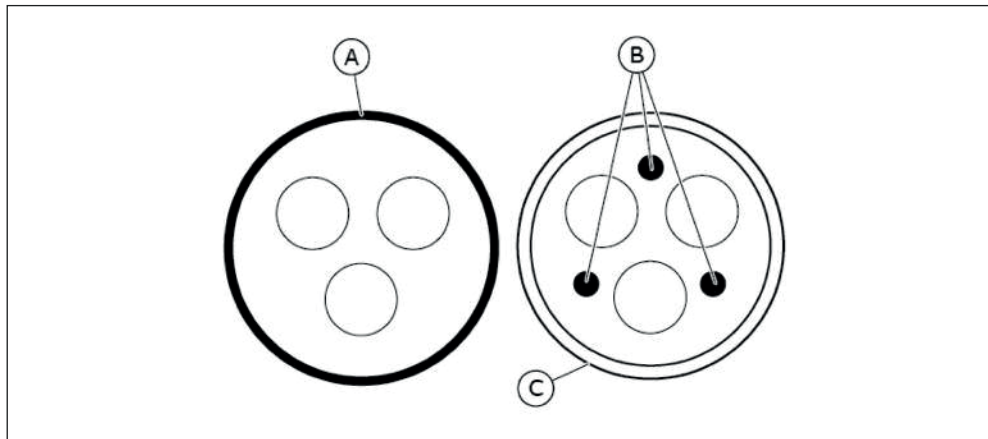

Fig. 26: Cables with PE conductors

- A. The PE conductor and the shield
- B. The PE conductors
- C. The shield

In all the frames, to obey the EMC requirements, use the default values of the switching frequencies. If you installed a safety switch, make sure that the EMC protection continues from the start of the cables until their ends.

4.2 UL STANDARDS ON CABLING

To obey the UL (Underwriters Laboratories) regulations, use a UL-approved Class I copper wire with a minimum heat resistance of 60 or 75 °C (140 or 167 °F).

You can use the drive on a circuit that gives a maximum of 100 000 rms symmetrical amperes, and a maximum of 600 V, when the drive is protected by Class T and J fuses.

4.3 CABLE DIMENSIONING AND SELECTION

These instructions are valid only for processes that have 1 motor and 1 cable connection from the AC drive to the motor. In other conditions, speak to the manufacturer to get more information.

4.3.1 CABLE AND FUSE SIZES

We recommend the fuse type gG/gL (IEC 60269-1). To make a selection of the fuse voltage rating, refer to the mains. Do not use larger fuses than what is recommended Table 16.

Make sure that the operation time of the fuse is less than 0.4 seconds. The operation time agrees with the fuse type and the impedance of the supply circuit. For more information on faster fuses, speak to the manufacturer. The manufacturer can also recommend some aR (UL recognized, IEC 60269-4) and gS (IEC 60269-4) fuse ranges.

The table also shows the typical sizes and types of cables that can be used with the AC drive. In the selection of cables, refer to local regulations, cable installation conditions and cable specification.

Table 16: The cable and fuse sizes for N800A

Frame	Type	I _L [A]	Fuse (gG/gL) [A]	Mains, motor and brake resistor* cable Cu [mm ²]	Terminal cable size	
					Main terminal [mm ²]	Earth terminal [mm ²]
MR4	0003 2—0004 2 0003 5—0004 5	3.7—4.8 3.4—4.8	6	3*1.5+1.5	1—6 solid 1—4 stranded	1—6
	0006 2—0008 2 0005 5—0008 5	6.6—8.0 5.6—8.0	10	3*1.5+1.5	1—6 solid 1—4 stranded	1—6
	0011 2—0012 2 0009 5—0012 5	11.0—12.5 9.6—12.0	16	3*2.5+2.5	1—6 solid 1—4 stranded	1—6
MR5	0018 2 0016 5	18.0 16.0	20	3*6+6	1—10 Cu	1—10
	0024 2 0023 5	24.0 23.0	25	3*6+6	1—10 Cu	1—10
	0031 2 0031 5	31.0 31.0	32	3*10+10	1—10 Cu	1—10
MR6	0038 5	38.0	40	3*10+10	2.5—50 Cu/Al	2.5—35
	0048 2 0046 5	48.0 46.0	50	3*16+16 (Cu) 3*25+16 (Al)	2.5—50 Cu/Al	2.5—35
	0062 2 0061 5	62.0 61.0	63	3*25+16 (Cu) 3*35+10 (Al)	2.5—50 Cu/Al	2.5—35
MR7	0075 2 0072 5	75.0 72.0	80	3*35+16 (Cu) 3*50+16 (Al)	6-70 mm ² Cu/Al	6-70 mm ²
	0088 2 0087 5	88.0 87.0	100	3*35+16 (Cu) 3*70+21 (Al)	6-70 mm ² Cu/Al	6-70 mm ²
	0105 2 0105 5	105.0	125	3*50+25 (Cu) 3*70+21 (Al)	6-70 mm ² Cu/Al	6-70 mm ²

Table 16: The cable and fuse sizes for N800A

Frame	Type	I _L [A]	Fuse (gG/gL) [A]	Mains, motor and brake resistor* cable Cu [mm ²]	Terminal cable size	
					Main terminal [mm]	Earth terminal [mm]
MR8	0140 2 0140 5	140.0	160	3*70+35 (Cu) 3*95+29 (Al)	Bolt size M8	Bolt size M8
	0170 2 0170 5	170.0	200	3*95+50 (Cu) 3*150+41 (Al)	Bolt size M8	Bolt size M8
	0205 2 0205 5	205.0	250	3*120+70 (Cu) 3*185+57 (Al)	Bolt size M8	Bolt size M8
MR9	0261 2 0261 5	261.0	315	3*185+95 (Cu) 2*(3*120+41) (Al)	Bolt size M8	Bolt size M8
	0310 2 0310 5	310.0	350	2*(3*95+50) (Cu) 2*(3*120+41) (Al)	Bolt size M8	Bolt size M8
MR10	0385 5	385	400	2*(3*95+50) (Cu) 2*(3*120+41) (Al)	Bolt size M12	Bolt size M8
	0460 5	460	500	2*(3*95+50) (Cu) 2*(3*120+41) (Al)	Bolt size M12	Bolt size M8
	0520 5	520	630	2*(3*95+50) (Cu) 2*(3*120+41) (Al)	Bolt size M12	Bolt size M8
	0590 5	590	630	2*(3*95+50) (Cu) 2*(3*120+41) (Al)	Bolt size M12	Bolt size M8

The dimensions of the cables must agree with the requirements of the standard IEC60364-5-52.

- The cables must be PVC-isolated.
- The maximum ambient temperature is +30 °C (86 °F).
- The maximum temperature of the cable surface is +70 °C (158 °F).
- Use only cables with a concentric copper shield.
- The maximum number of parallel cables is 9.

When you use parallel cables, make sure that you obey the requirements of the cross sectional area and the maximum number of cables.

For important information on the requirements of the earth conductor, see chapter 1.4 Earthing and earth fault protection. For the correction factors for each temperature, see the standard IEC60364-5-52.

4.3.2 CABLE AND FUSE SIZES, NORTH AMERICA

We recommend the fuse class T (UL & CSA). To make a selection of the fuse voltage rating, refer to the mains. Refer also to local regulations, cable installation conditions and cable specification. Do not use larger fuses than what is recommended Table 17.

Make sure that the operation time of the fuse is less than 0.4 seconds. The operation time agrees with the fuse type and the impedance of the supply circuit. For more information on faster fuses, speak to the manufacturer. The manufacturer can also recommend some high speed Class J (UL& CSA) and aR (UL recognized) fuse ranges.

The solid state short circuit protection does not supply protection for the branch circuit of the AC drive. To supply the branch circuit protection, refer to the National Electric Code and the local regulations. Do not use other devices than fuses to supply branch circuit protection.

Table 17: The cable and fuse sizes for N800A in North America

Frame	Type	IL [A]	Fuse (Class T/J) [A]	Mains, motor and brake resistor* cable Cu [AWG]	Terminal cable size	
					Main terminal [AWG]	Earth terminal [AWG]
MR4	0003 2 0003 5	3.7 3.4	6	AWG14	AWG24-AWG10	AWG17-AWG10
	0004 2 0004 5	4.8	6	AWG14	AWG24-AWG10	AWG17-AWG10
	0006 2 0005 5	6.6 5.6	10	AWG14	AWG24-AWG10	AWG17-AWG10
	0008 2 0008 5	8.0	10	AWG14	AWG24-AWG10	AWG17-AWG10
	0011 2 0009 5	11.0 9.6	15	AWG14	AWG24-AWG10	AWG17-AWG10
	0012 2 0012 5	12.5 12.0	20	AWG14	AWG24-AWG10	AWG17-AWG10

Frame	Type	IL [A]	Fuse (Class T/J) [A]	Mains, motor and brake resistor* cable Cu [AWG]	Terminal cable size	
					Main terminal [AWG]	Earth terminal [AWG]
MR5	0018 2 0016 5	18.0 16.0	25	AWG10	AWG20-AWG5	WG17-AWG8
	0024 2 0023 5	24.0 23.0	30	AWG10	AWG20-AWG5	WG17-AWG8
	0031 2 0031 5	31.0	40	AWG8	AWG20-AWG5	WG17-AWG8
MR6	0038 5	38.0	50	AWG4	AWG13-AWG0	AWG13-AWG2
	0048 2 0046 5	48.0 46.0	60	AWG4	AWG13-AWG0	AWG13-AWG2
	0062 2 0061 5**	62.0 61.0	80	AWG4	AWG13-AWG0	AWG13-AWG2
MR7	0075 2 0072 5	75.0 72.0	100	AWG2	AWG9-AWG2/0	AWG9-AWG2/0
	0088 2 0087 5	88.0 87.0	110	AWG1	AWG9-AWG2/0	AWG9-AWG2/0
	0105 2 0105 5	105.0	150	AWG1/0	AWG9-AWG2/0	AWG9-AWG2/0
MR8	0140 2 0140 5	140.0	200	AWG3/0	AWG1-350 kcmil	AWG1-350 kcmil
	0170 2 0170 5	170.0	225	250 kcmil	AWG1-350 kcmil	AWG1-350 kcmil
	0205 2 0205 5	205.0	250	350 kcmil	AWG1-350 kcmil	AWG1-350 kcmil
MR9	0261 2 0261 5	261.0	350	2*250 kcmil	AWG1-350 kcmil	AWG1-350 kcmil
	0310 2 0310 5	310.0	400	2*350 kcmil	AWG1-350 kcmil	AWG1-350 Kcmil
MR10	0385 5	385	500	2*250 kcmil	AWG1-350 kcmil	AWG1-350 Kcmil
	0460 5	460	600	2*350 kcmil	AWG1-350 kcmil	AWG1-350 Kcmil
	0520 5	520	700	3*4/0	AWG1-350 kcmil	AWG1-350 kcmil
	0590 5	590	800	3*250 kcmil	AWG1-350 kcmil	AWG1-350 kcmil

** To obey the UL regulations with the 500 V drive, it is necessary to have cables with a +90°C (194 °F) heat resistance.

The dimensions of the cables must agree with the requirements of the Underwriters Laboratories UL508C.

- The cables must be PVC-isolated.
- The maximum ambient temperature is +30 °C (86 °F).
- The maximum temperature of the cable surface is +70 °C (158 °F).
- Use only cables with a concentric copper shield.
- The maximum number of parallel cables is 9.

When you use parallel cables, make sure that you obey the requirements of the cross sectional area and the maximum number of cables.

For important information on the requirements of the earth conductor, see the Underwriters Laboratories standard UL508C. For the correction factors for each temperature, see the instructions of the Underwriters Laboratories UL508C.

4.4 BRAKE RESISTOR CABLES

N800A AC drives have terminals for an optional external brake resistor. These terminals are identified with R+ and R- (in MR4, MR5, MR6) or DC+/R+ and R- (in MR7, MR8, MR9). You can find the dimensions that we recommend for the brake resistor cables in the tables in chapters 4.3.1 Cable and fuse sizes and 4.3.2 Cable and fuse sizes, North America.

See the brake resistor ratings in chapter 7.1.4 Brake resistor ratings.



NOTE!

The frames MR7, MR8, and MR9 have the brake chopper, only if their type designation code has the code +DBIN. The frames MR4, MR5, and MR6 have the brake chopper as standard.

4.5 PREPARING FOR THE CABLE INSTALLATION

- Before you start, make sure that none of the components of the AC drive is live. Read carefully the warnings in chapter 1 Safety.
- Make sure that the motor cables are sufficiently far from other cables.
- If it is possible, do not put the motor cables in long parallel lines with other cables.
- If the motor cables are in parallel with other cables, obey the minimum distances.
- The distances are also valid between the motor cables and the signal cables of other systems.
- The maximum lengths of shielded motor cables are 100 m (for MR4), 150 m (for MR5 and MR6), and 200 m (for MR7, MR8, and MR9).
- The motor cables must cross other cables at an angle of 90°.
- If the cable insulation checks are necessary, see chapter 6.4 Measuring the cable and motor insulation for instructions.

Table 18: The minimum distances between cables

The distance between cables [m]	The length of the shielded cable [m]
0.3	≤ 50
1	≤ 200

4.6 CABLE INSTALLATION

4.6.1 FRAMES MR4 TO MR7

Table 19: The cable stripping lengths [mm]. See the figure in step 1.

Frame	A	B	C	D	E	F	G
MR4	15	35	10	20	7	35	As short as possible.
MR5	20	40	10	30	10	40	
MR6	20	90	15	60	15	60	
MR7	20	80	20	80	20	80	

Table 20: The cable stripping lengths [in]. See the figure in step 1.

Frame	A	B	C	D	E	F	G
MR4	0.6	1.4	0.4	0.8	0.9	1.4	As short as possible.
MR5	0.8	1.6	0.4	1.2	0.4	1.6	
MR6	0.8	3.6	0.6	2.4	0.6	2.4	
MR7	0.8	3.1	0.8	3.1	0.8	3.1	

- 1) Strip the motor cable, the mains cable, and the brake resistor cable.

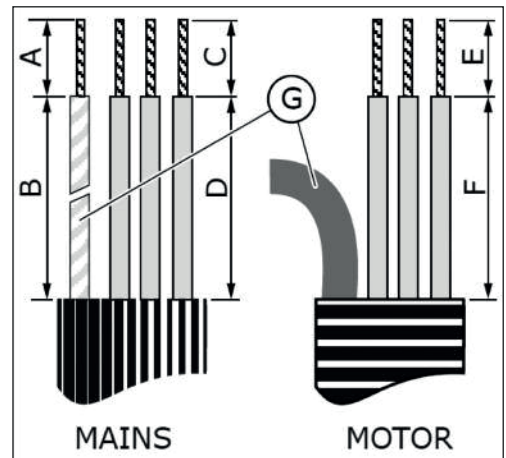

G. The earth conductor

- 2) Open the cover of the AC drive.

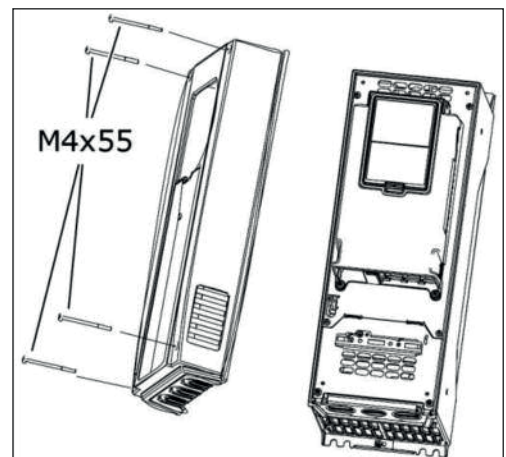

- 3) Remove the screws of the cable cover. Remove the cable cover. Do not open the cover of the power unit.

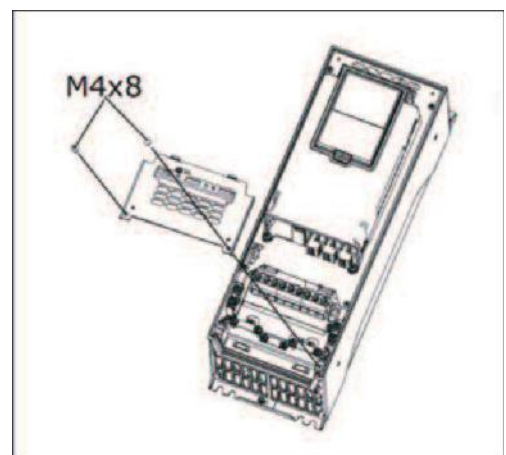

- 4) Put the grommets in the openings of the cable entry plate. These parts are included in the package. The picture shows the grommets in IP21 in the EU version.

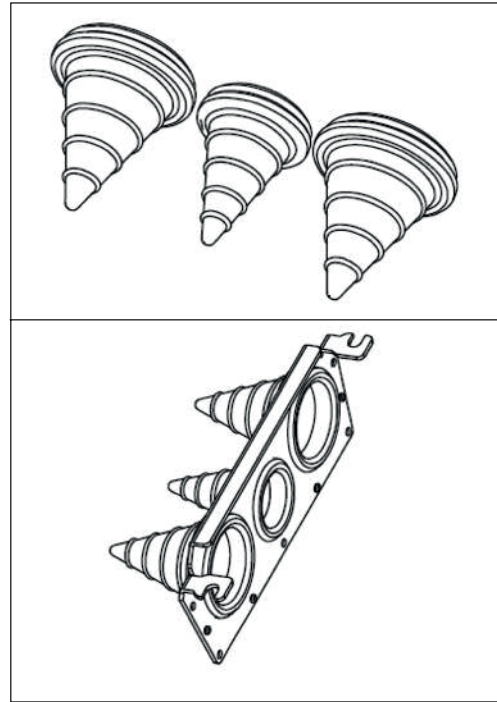

- 5) Put the cables - the mains cable, the motor cable and the optional brake cable - in the openings of the cable entry plate.
- a) Cut the grommets open to move the cables through them. If the grommets fold in when you put the cable, pull the cable back to make the grommets straight.
- b) Do not cut the grommet openings wider than what is necessary for the cables that you use.
- c) With the enclosure class IP54, the connection between the grommet and the cable must be tight. Pull the first bit of the cable out of the grommet so that it stays straight. If this is not possible, make the connection tight with some insulation tape or a cable tie.

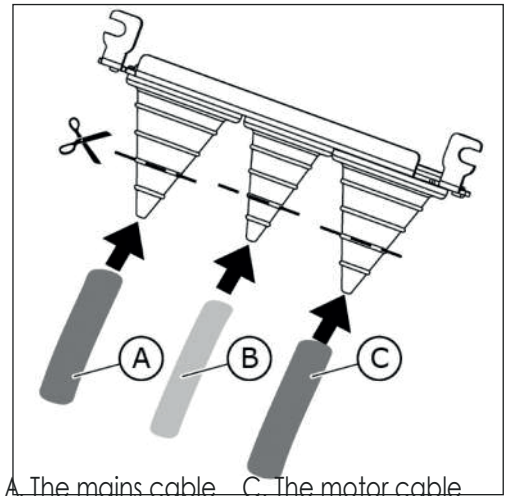

A. The mains cable C. The motor cable
B. The brake cable

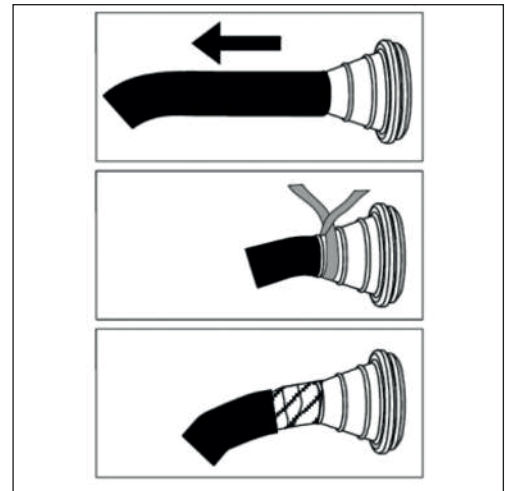

- 6) Remove the cable clamps and the grounding clamps.

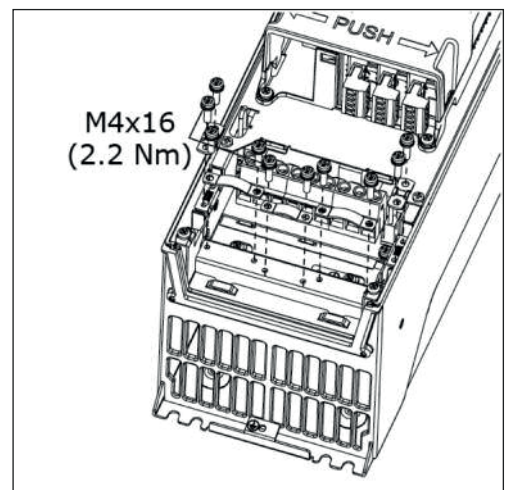

7) Put the cable entry plate with the cables into the groove on the frame of the drive.

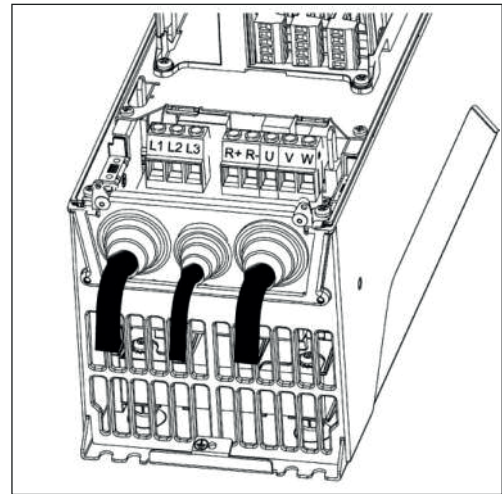

8) Connect the stripped cables.

- a) Expose the shield of all the 3 cables to make a 360-degree connection with the cable clamp.
- b) Connect the phase conductors of the mains cable and of the motor cable, and the conductors of the brake resistor cable into the correct terminals.
- c) Attach the earth conductor of each cable to an earth terminal with a clamp.
- d) See the correct tightening torques in Table 21.

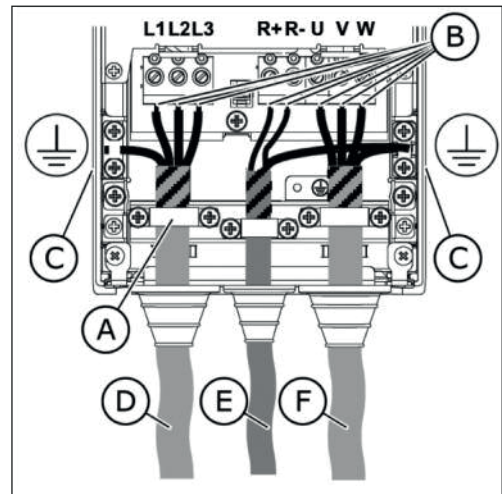

- A. The cable clamp
- B. The terminals
- C. The earth terminal
- D. The mains cable
- E. The brake resistor cable
- F. The motor cable

- 9) Make sure that the earth conductor is connected to the motor and also to the terminals that are identified with.
- a) To obey the requirements of the standard EN61800-5-1, obey the instructions in chapter 1.4 Earthing and earth fault protection.
- b) If a double earthing is necessary, use the earth terminal under the drive. Use an M5 screw and tighten it to 2.0 Nm or 17.7 lb-in.

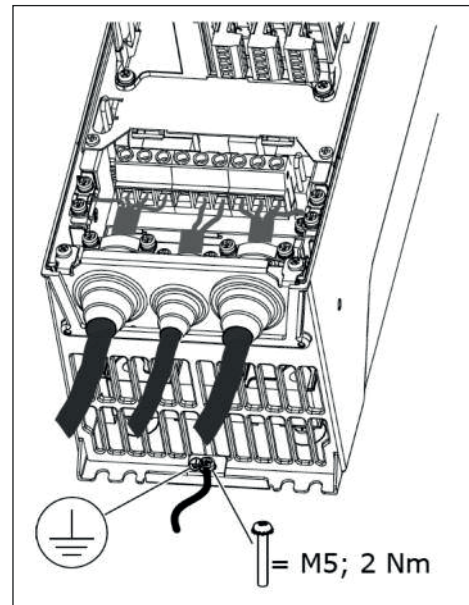

- 10) Attach again the cable cover and the cover of the drive.

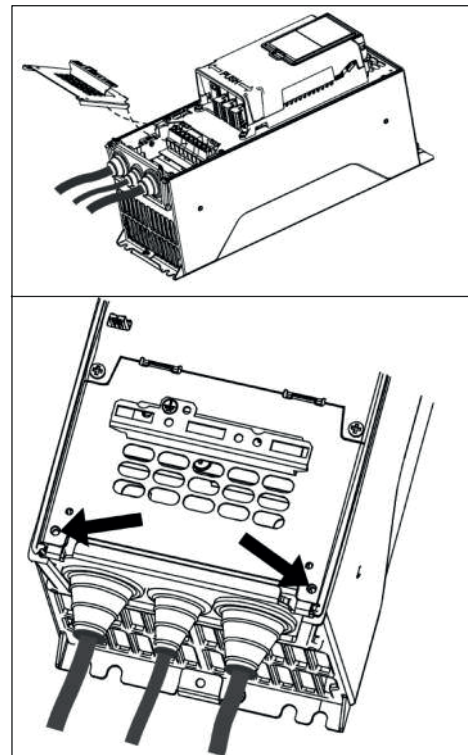

Table 21: The tightening torques of the terminals

Frame	Type	Tightening torque: the power and motor terminals		Tightening torque: the EMC grounding clamps		Tightening torque: the earth terminals	
		Nm	Ib-in.	Nm	Ib-in .	Nm	Ib-in .
MR4	0003 2—0012 2 0003 5—0012 5	0.5—0.6	4.5—5.3	1.5	13.3	2.0	17.7
MR5	0018 2—0031 2 0016 5—0031 5	1.2—1.5	10.6—13.3	1.5	13.3	2.0	17.7
MR6	0048 2—0062 2 0038 5—0061 5	10	88.5	1.5	13.3	2.0	17.7
MR7	0075 2—0105 2 0072 5—0105 5	8*/5.6**	70.8*/49.6**	1.5	13.3	8*/5.6**	70.8*/49.6**

* The tightening torque for a torx screw.

** The tightening torque for an Allen screw.

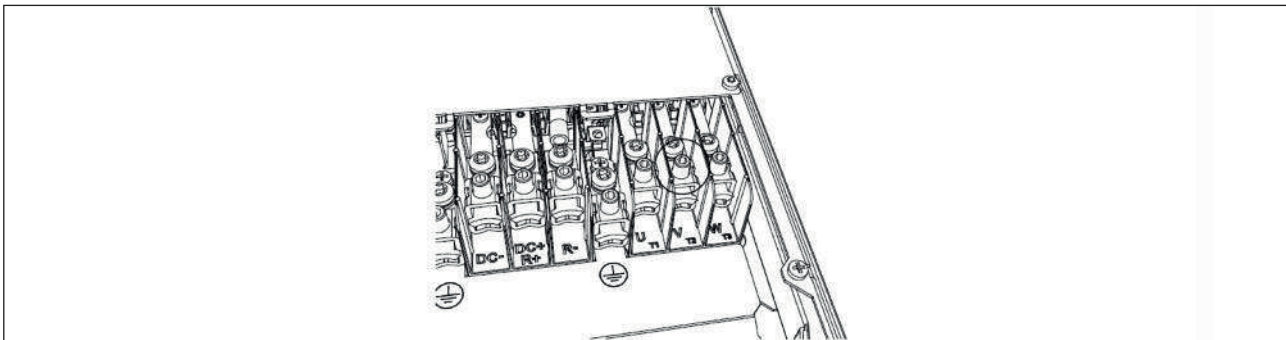

Fig. 23: The tightening torque for the Allen screw in MR7 is 5.6 Nm

4.6.2 FRAMES MR8 TO MR9

Table 22: The cable stripping lengths [mm]. See the figure in step 1.

Frame	A	B	C	D	E	F	G
MR8	40	180	25	300	25	300	As short as possible.
MR9	40	180	25	300	25	300	

Table 23: The cable stripping lengths [in]. See the figure in step 1.

Frame	A	B	C	A	E	F	G
MR8	1.6	7.1	1	11.8	1	11.8	As short as possible.
MR9	1.6	7.1	1	11.8	1	11.8	

1) Strip the motor cable, the mains cable, and the brake resistor cable.

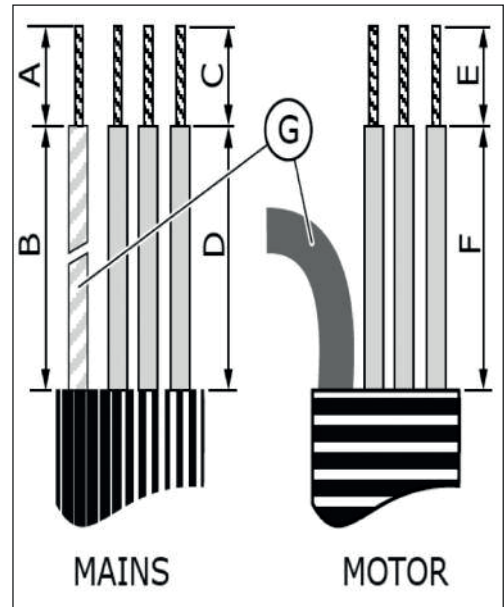

G. The earth conductor

2) MR9 only: Open the cover of the AC drive.

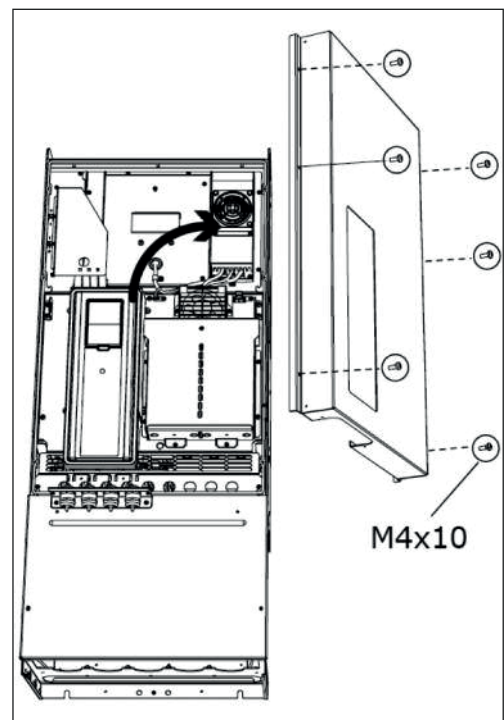

3) Remove the cable cover.

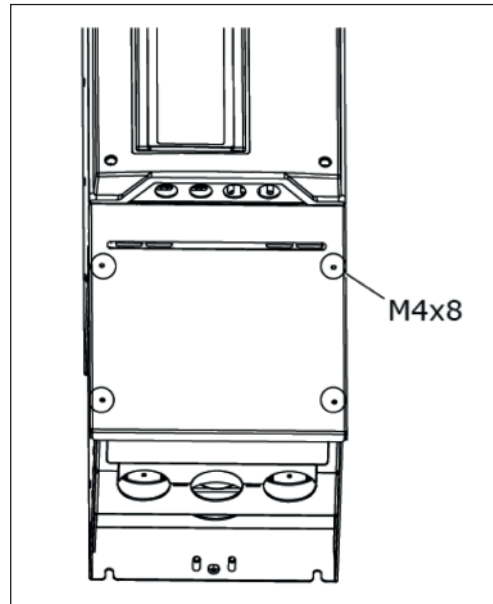

MR8

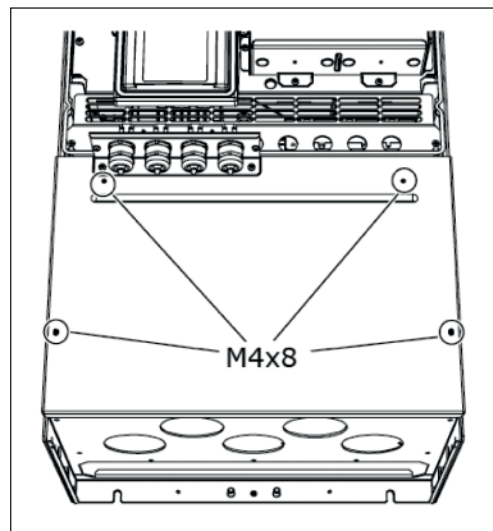

MR9

4) Remove the cable entry plate.

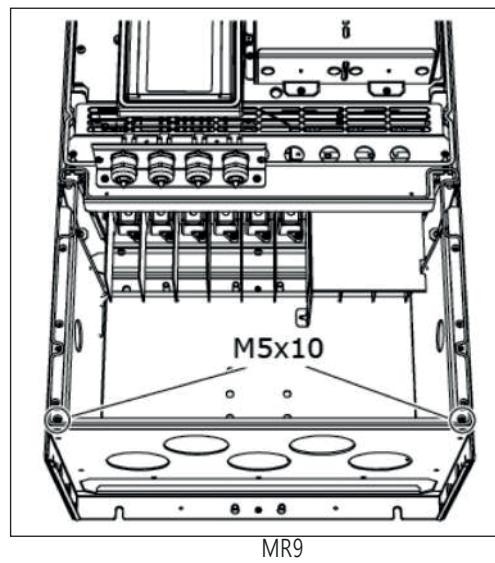
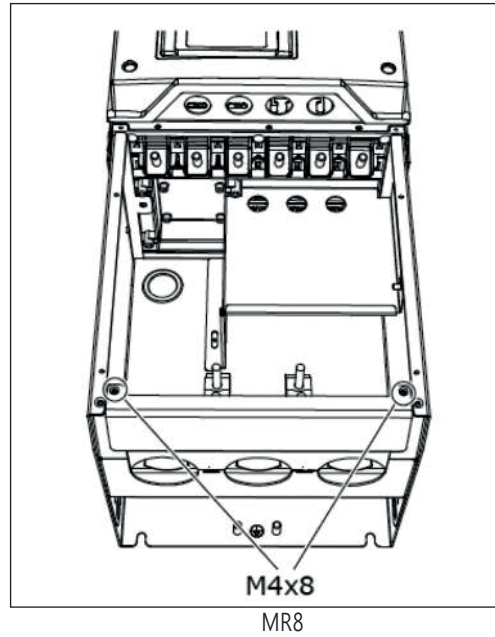

5) MR9 only: Loosen the screws and remove the sealing plate.

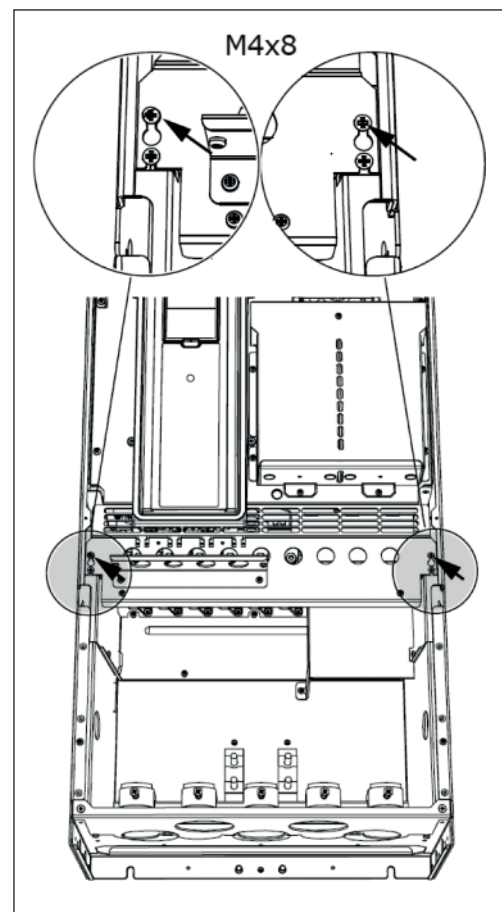

6) Remove the EMC shield plate.

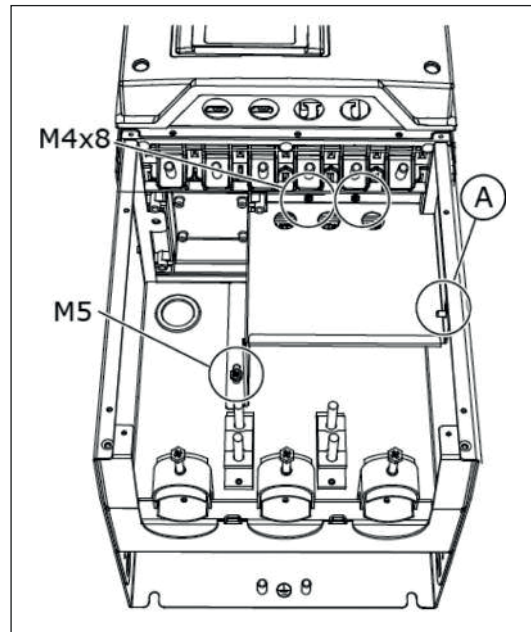

A. The wing nut in MR8

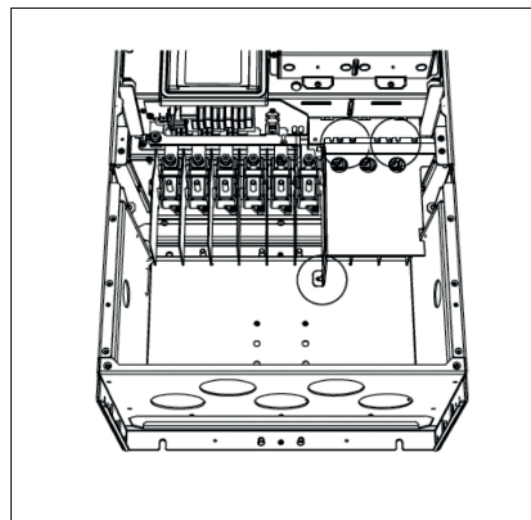

A. MR9

7) Find the terminals of the motor cables. The location of the terminals is unusual, especially in MR8.

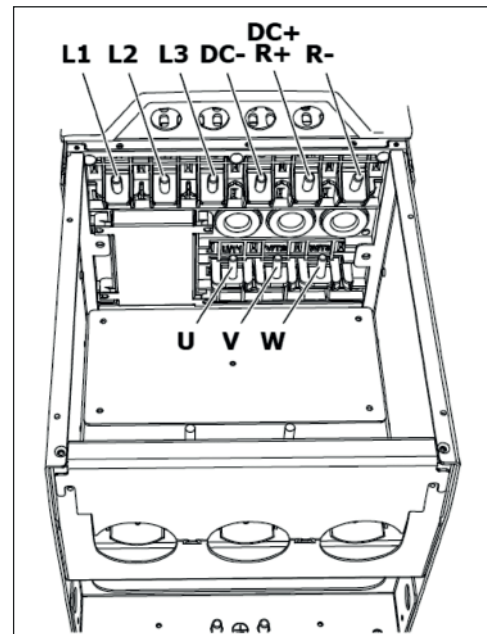

MR8

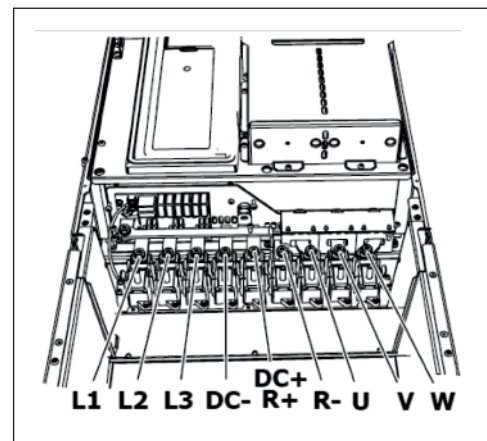

MR9

- 8) Cut the grommets open to move the cables through them.
- Do not cut the grommet openings wider than what is necessary for the cables that you use.
 - If the grommets fold in when you put the cable, pull the cable back to make the grommets straight.

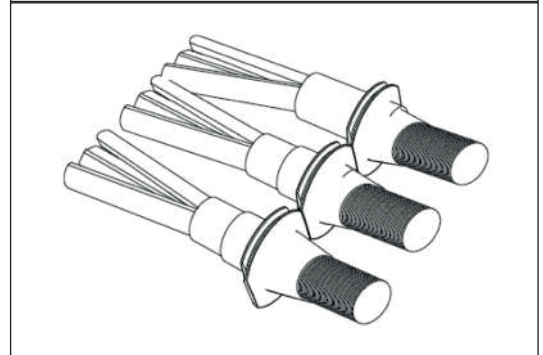
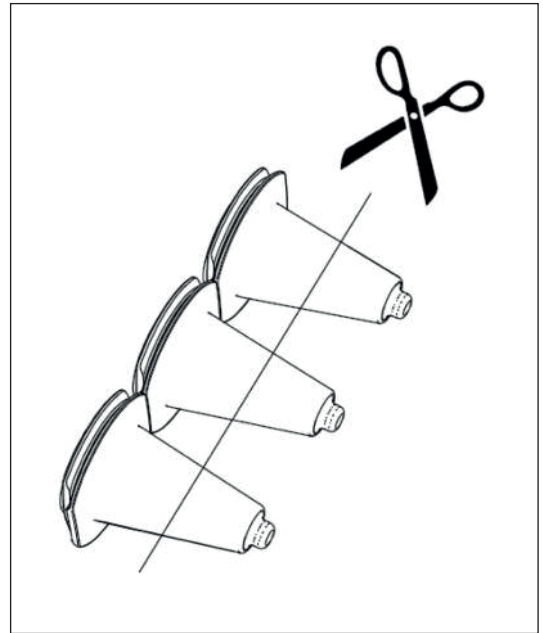

- 9) Attach the grommet and the cable so that the frame of the drive goes into the groove of the grommet.
- With the enclosure class IP54, the connection between the grommet and the cable must be tight. Pull the first bit of the cable out of the grommet so that it stays straight.
 - If this is not possible, make the connection tight with some insulation tape or a cable tie.

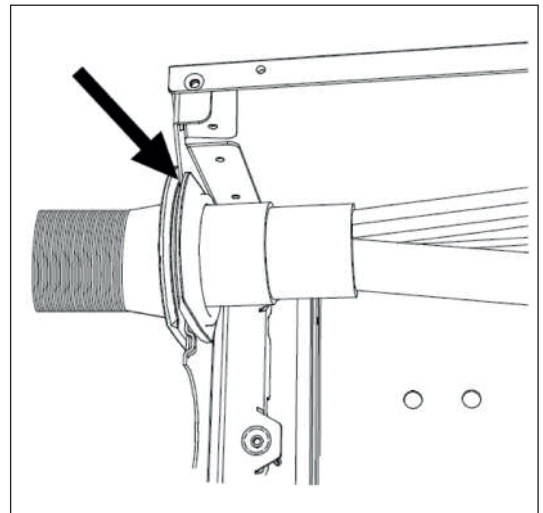

- 10) If you use thick cables, put the cable insulators in between the terminals to prevent contact between the cables.

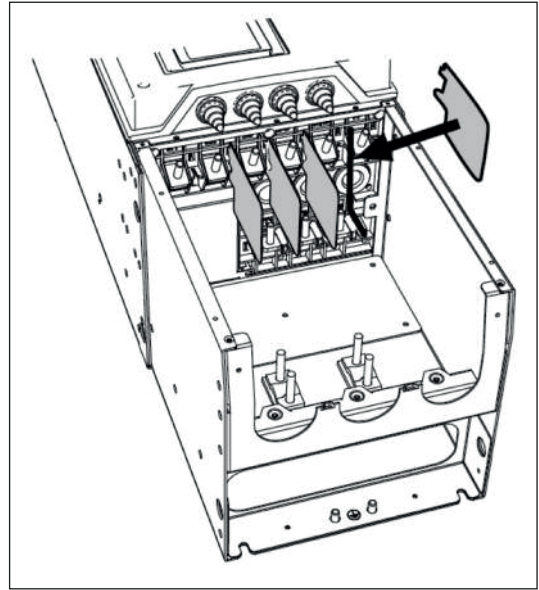

4. POWER CABLING

N800A

1) Connect the stripped cables.

- a) Connect the phase conductors of the mains cable and of the motor cable into the correct terminals. If you use a brake resistor cable, connect its conductors into the correct terminals.
- b) Attach the earth conductor of each cable to an earth terminal with a clamp.
- c) See the correct tightening torques in Table 24.

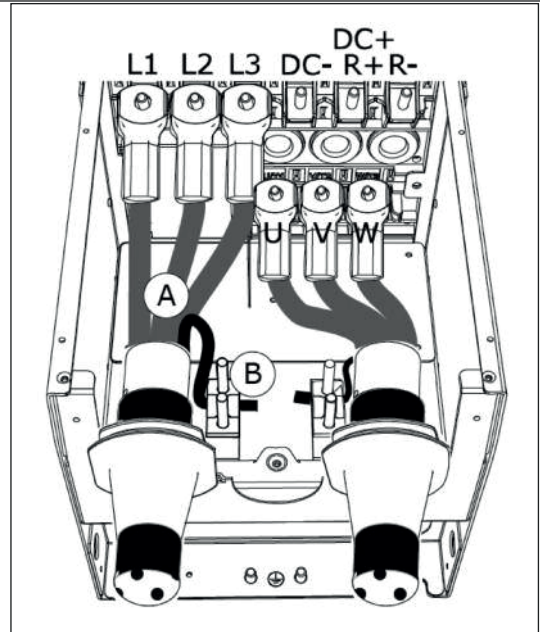

- A. Connection of the cables
- B. Make a grounding connection in MR8

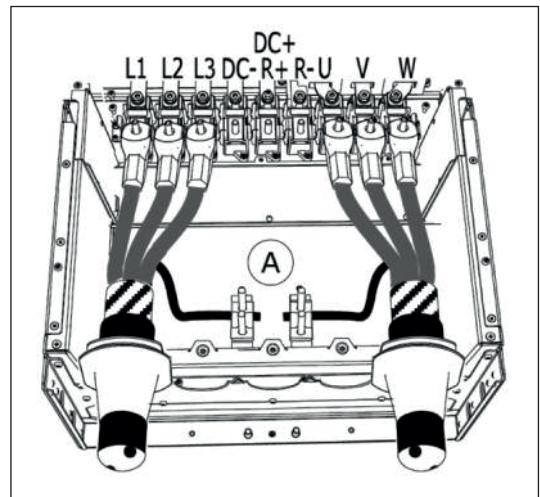

- A. Make a grounding connection in MR9

- 12) If you use many cables on one connector, put the cable lugs on top of each other.

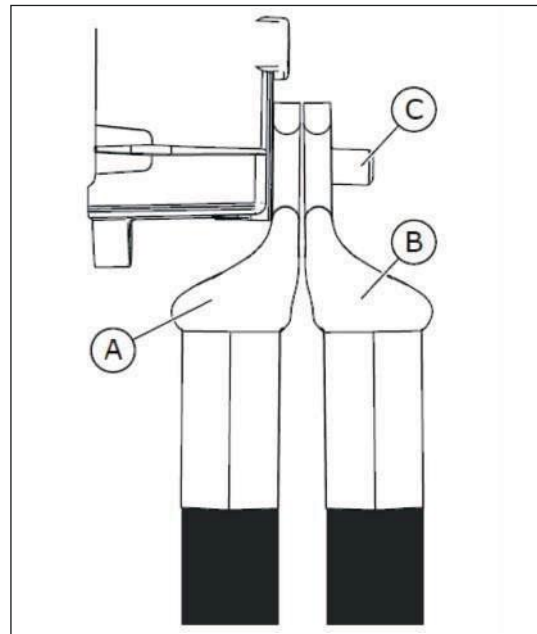

- A. The first cable lug
 B. The second cable lug
 C. The connector

- 13) Expose the shield of all 3 cables to make a 360-degree connection with the cable clamp.

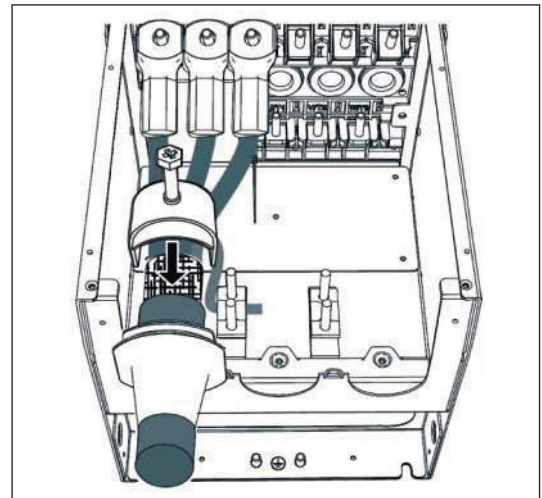

- 14) Attach again the EMC shield plate. For MR9, attach the sealing plate.

4. POWER CABLING

N800A

15) Attach the cable entry plate, and then the cable cover.

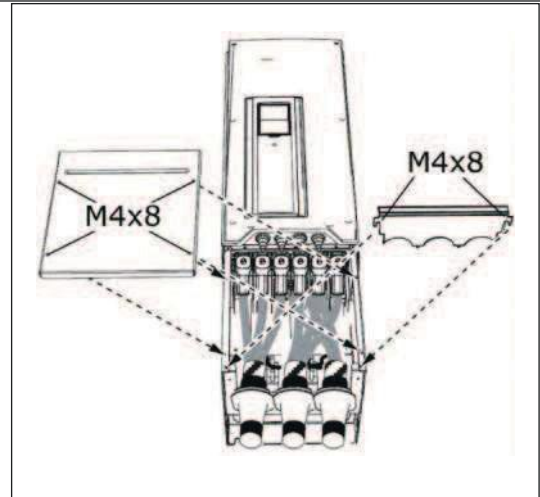

16) For MR9, attach the cover of the drive (unless you want to make the control connections first).

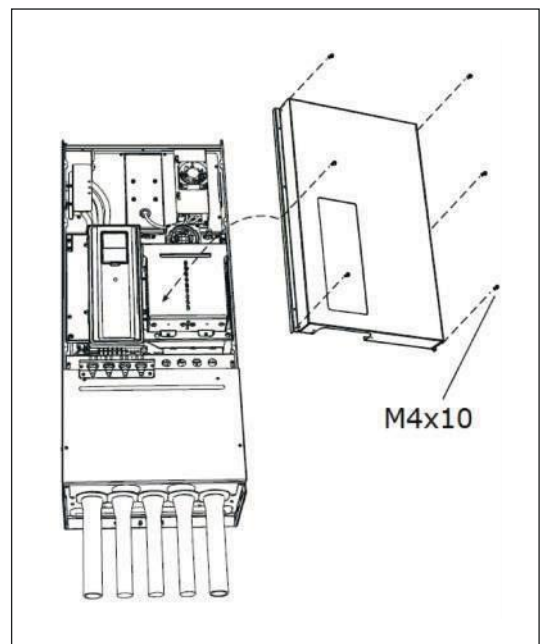

17) Make sure that the earth conductor is connected to the motor and also to the terminals that are identified with 

- To obey the requirements of the standard EN61800-5-1, obey the instructions in chapter 1.4 Earthing and earth fault protection.
- Connect the protective conductor to 1 of the screw connectors with a cable shoe and an M8 screw.

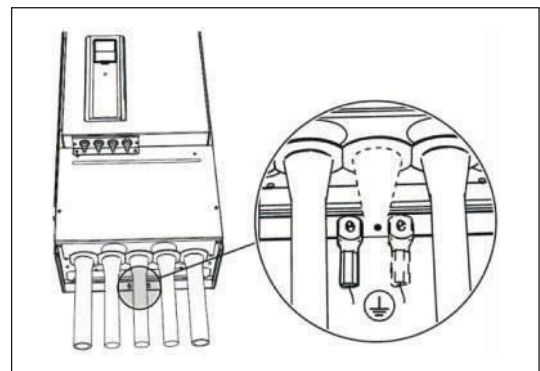

Table 24: Tightening torques of the terminals

Frame	Type	Tightening torque: the power and motor terminals		Tightening torque: the EMC grounding clamps		Tightening torque: the earth terminals	
		[Nm]	lb-in.	[fNN	lb-in.	[Nm]	lb-in.
MR8	0140 2—0205 2	20	177	1.5	13.3	20	177
	0140 5—0205 5						
MR9	0261 5—0310 5	20	177	1.5	13.3	20	177

4.6.3 FRAMES MR10

4.6.3.1 CABLE INSTALLATION WITHOUT THE EXTENSION BOX

1) Find the motor cable terminals.

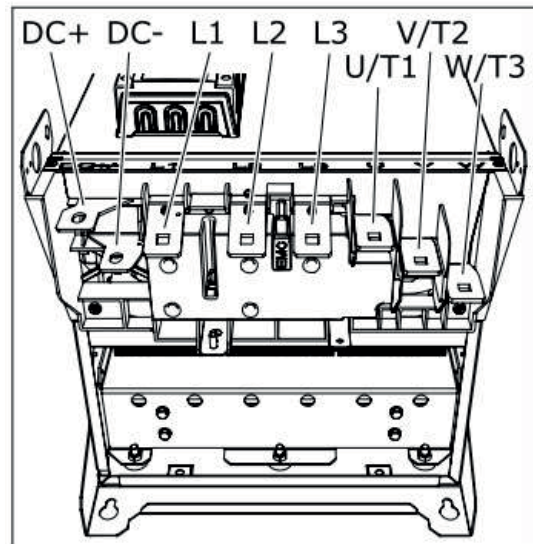

2) Use the external power connection block (+CPTB) if you have it.

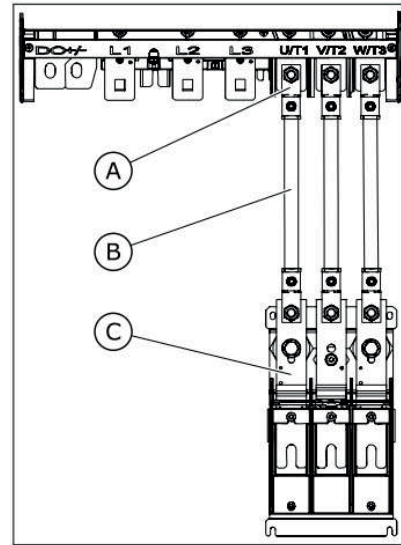

- A. The terminals U, V, W
- B. The power cable (not included
In delivery of the option)
- C. The external power connection block

3) Connect the cables. The picture shows an example of good cabling.

- a. Connect the phase conductors of the mains cable and of the motor cable into the correct terminals. If you use a brake resistor cable, connect its conductors into the correct terminals.
- b. Attach the grounding conductor of each cable to a grounding terminal with a grounding clamp for grounding conductor.
- c. Make sure that the external grounding conductor is connected to the grounding bar.

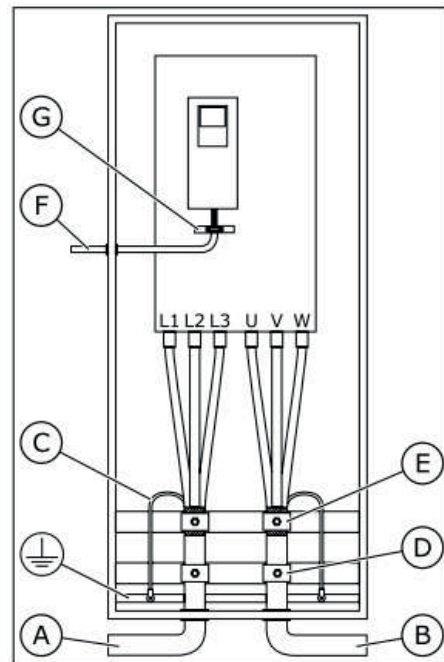

- A. The main cables
- B. The motor cables
- C. The grounding conductor
- D. Pull relief
- E. The grounding clamp for cable
Shield, 360 degree grounding
- F. The control cable
- G. The grounding bar of the
Control cable

4) If you use many cables on one connector, put the cable lugs on top of each other.

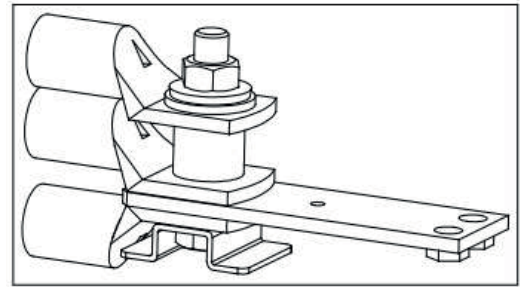

5) To make EMC grounding, expose the shield of all 3 motor cables and make a 360-degree connection between the cable and the grounding clamp for cable shield.

6) Attach the terminal cover, and then the extension box cover.

7) Make sure that the grounding conductor is connected to the motor and also to the terminals that are identified with \oplus .

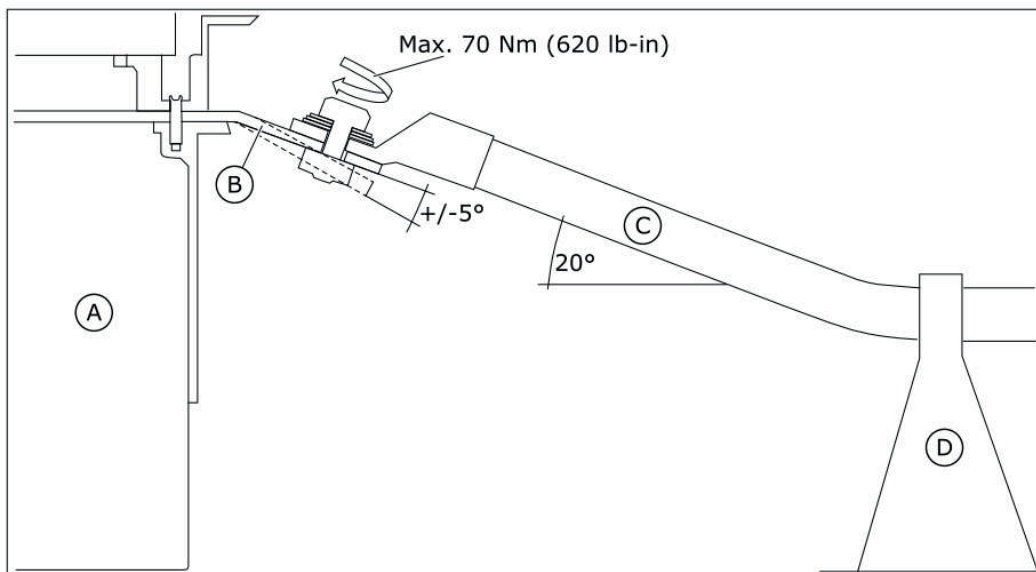

Fig. 28: Mechanical support for cables when the drive does not have the extension box

A. The AC drive
 B. The connection busbar. Terminals L1, L2, L3, U/T1, V/T2, W/T3.

C. The power cable
 D. The cable support

Table 25: Tightening torques of the terminals

Frame	Type	Tightening torque: the power and motor terminals		Tightening torque: the EMC grounding clamps		Tightening torque: the earth terminals	
		[Nm]	lb-in.	[[NN	lb-in.	[Nm]	lb-in.
MR10	0140 2—0205 2 0140 5—0205 5 0261 5—0310 5	55~70	490~620	-	-	20	177



NOTE!

You must make sure that creepage and air distances are sufficient in your installation and that they agree with the local regulations.

4.6.3.2 CABLE INSTALLATION WITH AN EXTENSION BOX

1) Loosen the screws of the terminal cover and

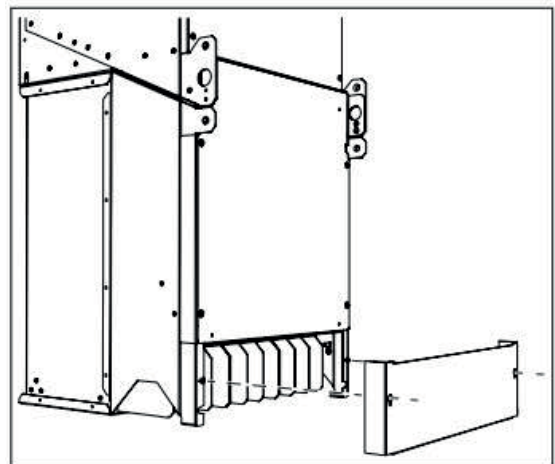

2) Find the motor cable terminals.

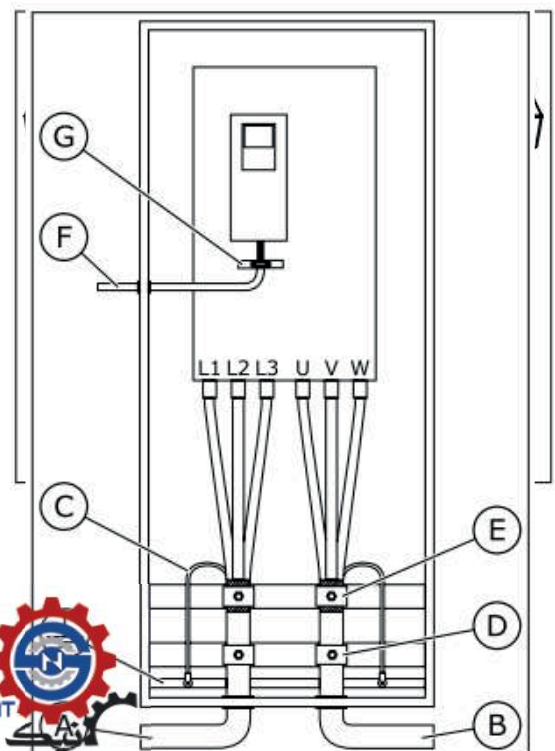

3) Connect the cables. The picture shows an example of good cabling.

- a. Connect the phase conductors of the mains cable and of the motor cable into the correct terminals. If you use a brake resistor cable, connect its conductors into the correct terminals.
- b. Attach the grounding conductor of each cable to a grounding terminal with a grounding clamp for grounding conductor.
- c. Make sure that the external grounding conductor is connected to the grounding bar.

- A. The mains cables
- B. The motor cable
- C. The grounding conductor
- D. Pull relief
- E. The grounding clamp for cable Shield, 360 degree grounding
- F. The control cable
- G. The grounding bar of the control cable

4) If you use many cables on one connector, put the cable lugs on top of each other.

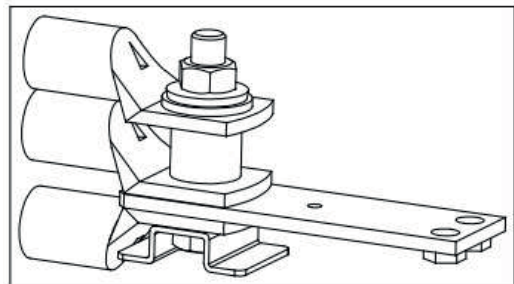

- 5) To make EMC grounding, expose the shield of all 3 motor cables and make a 360-degree connection between the cable and the grounding clamp for cable shield.
- 6) Attach the terminal cover, and then the extension box cover.
- 7) Make sure that the grounding conductor is connected to the motor and also to the terminals that are identified with .

Table 26: Tightening torques of the terminals

Frame	Type	Tightening torque: the power and motor terminals		Tightening torque: the EMC grounding clamps		Tightening torque: the earth terminals	
		[Nm]	lb-in.	[(NN	lb-in.	[Nm]	lb-in.
MR10	0140 2—0205 2 0140 5—0205 5 0261 5—0310 5	55-70	490~620	-	-	20	177

4.7 INSTALLATION IN A CORNER-GROUNDED NETWORK

You can use corner grounding with the drive types (MR7 to MR9) with a rating of 72-310 A with a 380-480 V mains, and 75-310 A with a 208-240 V mains.

In these conditions, you must change the EMC protection level to C4. See the instructions in 6.5 Installation in an IT system. Do not use corner grounding with the drive types (MR4 to MR6) with a rating of 3.4-61 A with a 380-480 V mains, or 3.7-62 A with a 208-240 V mains.

5. CONTROL UNIT

5.1 CONTROL UNIT COMPONENTS

The control unit of the AC drive contains the standard boards and the option boards. The option boards are connected to the slots of the control board (see 5.4 Installation of option boards).

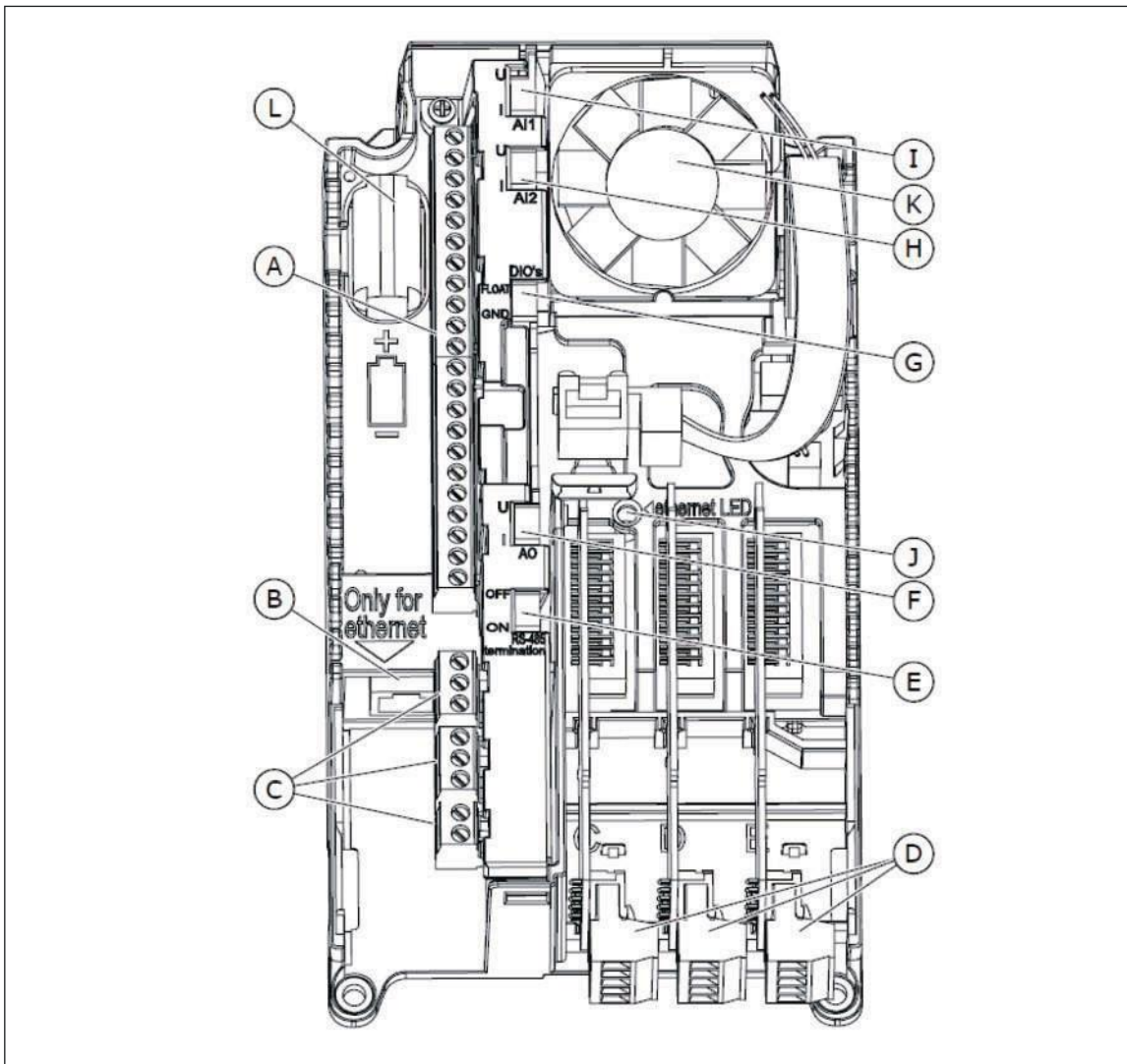

Fig. 29: The components of the control unit

- A. The terminals for the standard I/O connections
- B. The Ethernet connection
- C. The terminals for 3 relay outputs or 2 relay outputs and a thermistor
- D. The option boards
- E. A DIP switch for the RS485 bus termination
- F. A DIP switch for the signals election of Analogue Output
- G. A DIP switch for the isolation of the digital inputs from ground
- H. A DIP switch for the signal selection of Analogue Input 2
- I. A DIP switch for the signal selection of Analogue Input 1

J. The status indicator of the Ethernet connection

K. A fan (only in IP54 of MR4 and of MR5)

L. The battery for the RTC

When you receive the AC drive, the control unit contains the standard control interface. If you included special options in your order, the AC drive will be as in your order. On the next pages, you will find information on the terminals and general wiring examples.

It is possible to use the drive with an external power source with these properties: +24 VDC±10%, minimum 1000 mA. Connect the external power source to terminal 30. This voltage is sufficient to keep the control unit on and for you to set the parameters. The measurements of the main circuit (for example, the DC link voltage, and the unit temperature) are not available when the drive is not connected to mains.

5.2 CONTROL UNIT CABLING

The control board has 22 fixed I/O terminals, and the relay board has 8. You can see the standard connections of the control unit and the descriptions of signals in Fig. 25.

5.2.1 SELECTION OF THE CONTROL CABLES

The control cables must be a minimum of 0.5 mm² screened multicore cables. See more on the cable types in Table 15 The selection of the correct cable. The terminal wires must be a maximum of 2.5 mm² for the terminals of the relay board and other terminals.

Table 27: The tightening torques of the control cables

The terminal	The terminal screw	The tightening torque
		Nm
All the terminals of the I/O board and the relay board	M3	0.5

5.2.2 CONTROL TERMINALS AND DIP SWITCHES

Here you see the basic description of the terminals of the I/O board and the relay board. For more information, see 8.1 Technical data on control connections.

Some terminals are assigned for signals that have optional functions that you can use with the DIP switches. See more in 5.2.2.1 Selection of terminal functions with DIP switches.

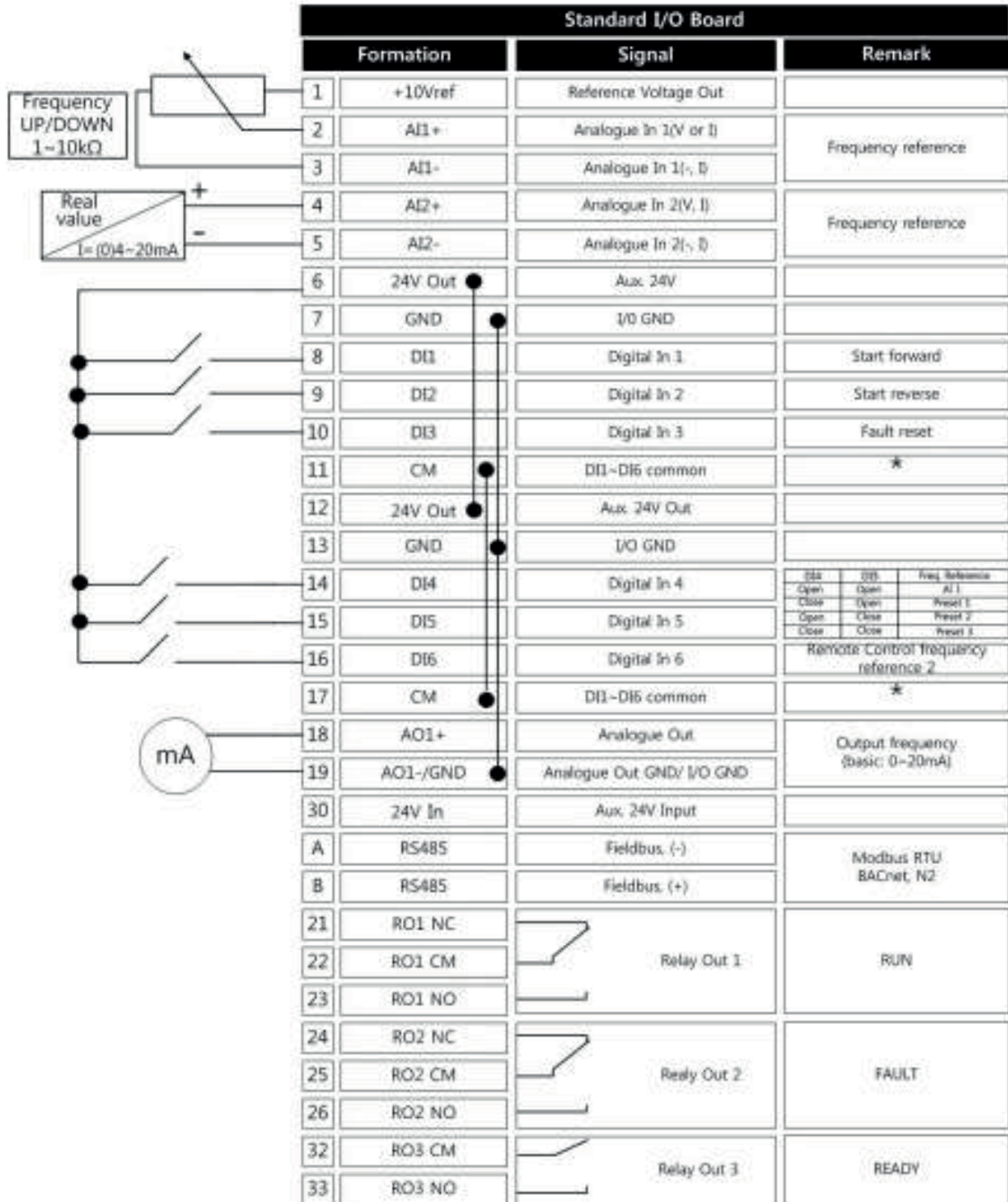

Fig. 30: The signals of the I/O terminals on the standard I/O board, and a connection example.

* You can isolate digital inputs from ground with a DIP switch. See 5.2.2.2 Isolation of digital inputs from ground.

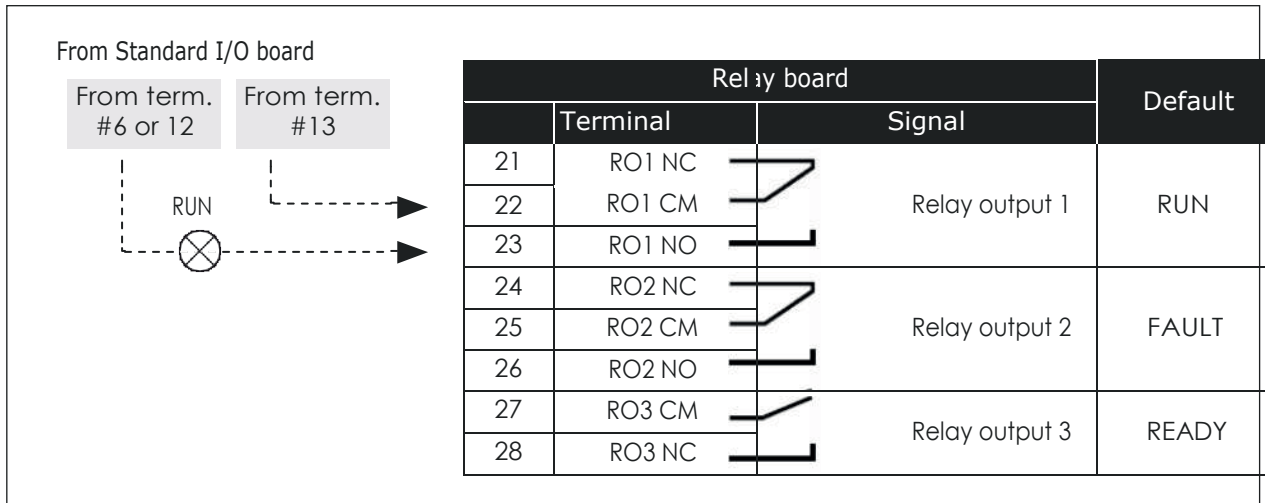

Fig. 31: The standard relay board (+SBF3)

5.2.2.1 Selection of terminal functions with DIP switches

You can make 2 selections with the DIP switches for specified terminals. The switches have 2 positions: up and down. You can see the location of the DIP switches and the possible selections in Fig. 27.

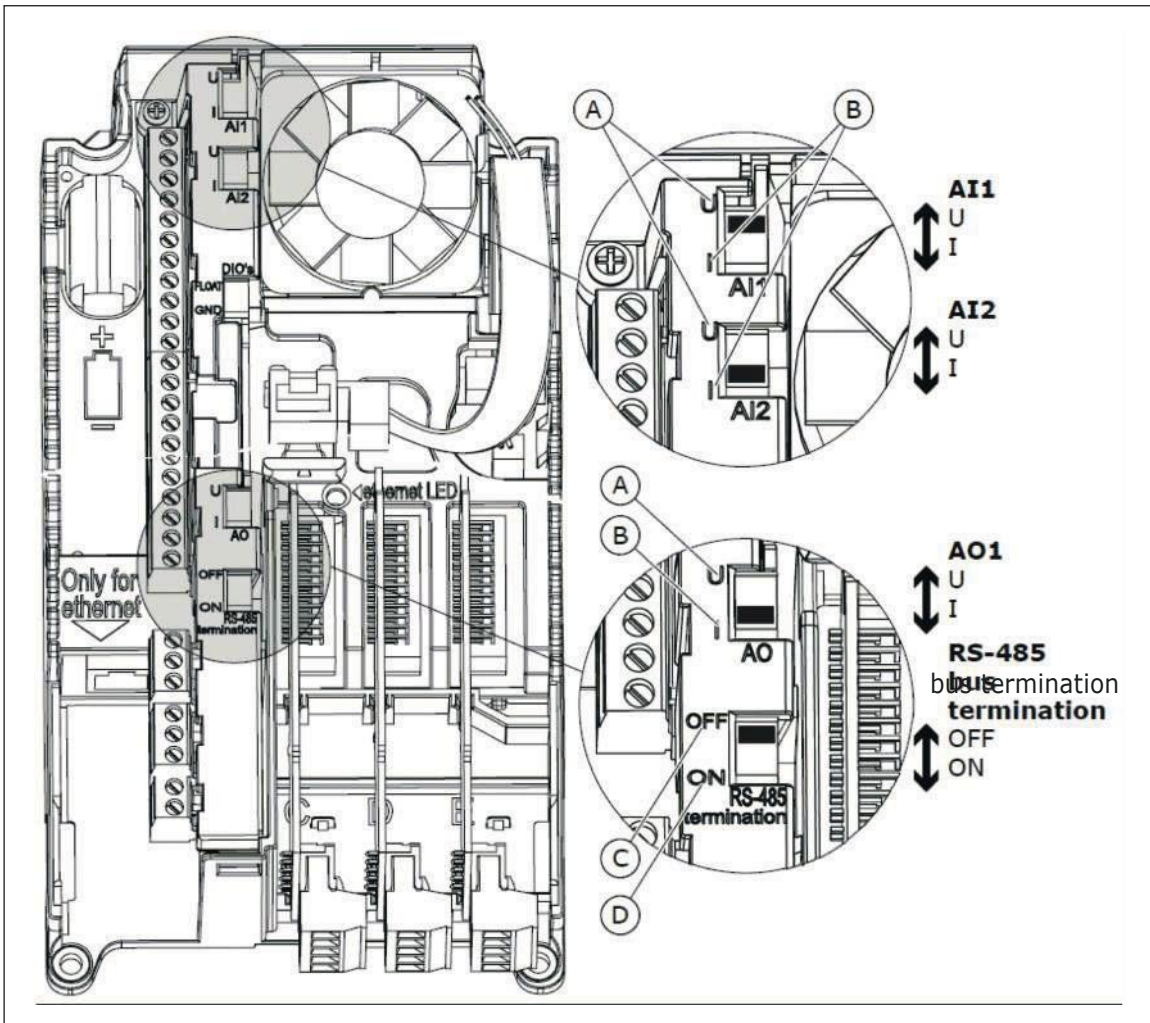

Fig. 32: The selections of the DIP switches

- A. The voltage signal, 0-10 V input
- B. The current signal, 0-20 mA input
- C. OFF
- D. ON

Table 28: The default positions of the DIP switches

The DIP switch	The default position
AI1	U
AI2	I
AO1	I
RS485 bus termination	OFF

5.2.2.2 Isolation of digital inputs from ground

It is possible to isolate from ground the digital inputs (terminals 8-10 and 14-16) on the standard I/O board. To do this, change the position of a DIP switch on the control board.

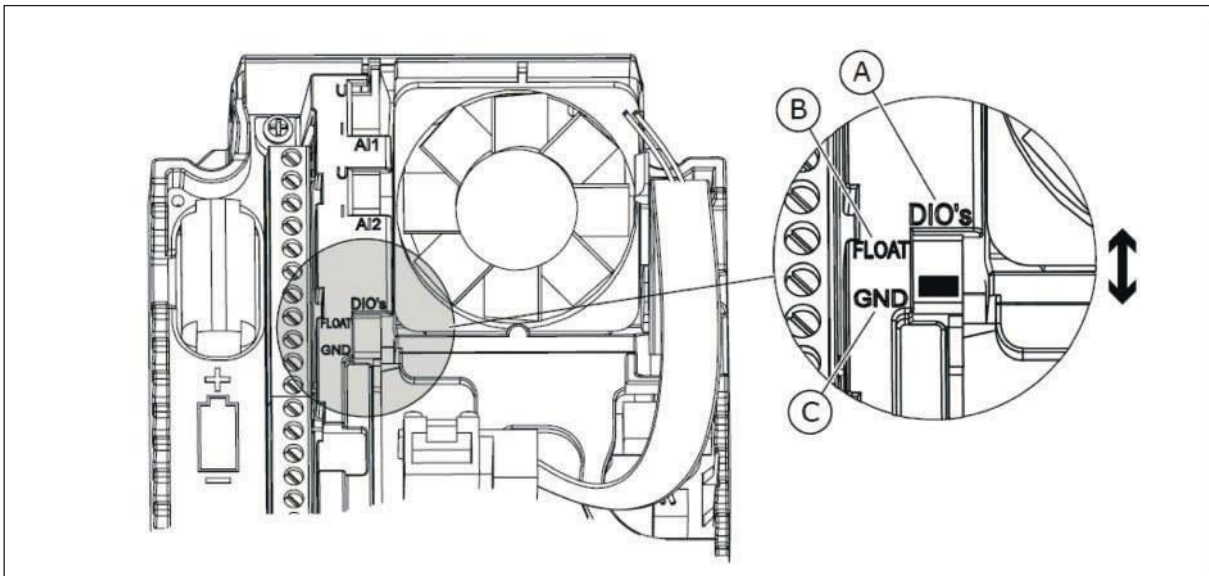

Fig. 33: Change the position of this switch to isolate the digital inputs from ground

- A. The digital inputs
- B. Floating

- C. Connected to GND (default)

5.3 FIELDBUS CONNECTION

You can connect the drive to fieldbus with an RS485 or an Ethernet cable. If you use an RS485 cable, connect it to terminal A or B of the standard I/O board. If you use an Ethernet cable, connect it to the Ethernet terminal below the cover of the drive.

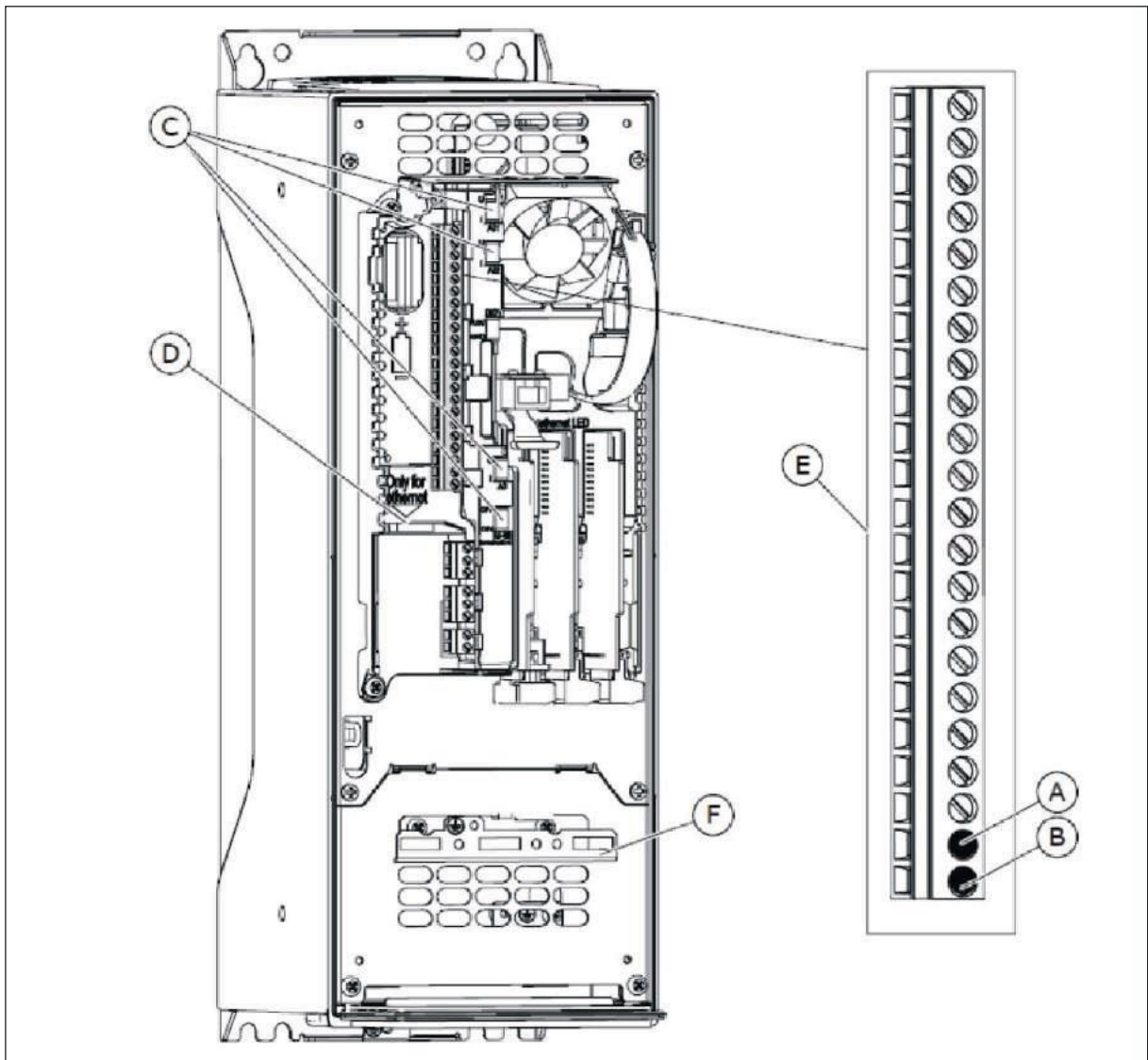

Fig. 34: The Ethernet and RS485 connections

- A. RS485 A=Data -
- B. RS485 B=Data+
- C. The DIP switches

- D. The Ethernet terminal
- E. The I/O terminals
- F. The grounding bar

5.3.1 USING FIELDBUS THROUGH AN ETHERNET CABLE

Table 29: Ethernet cable data

Item	Description
The plug type	A shielded RJ45 plug, maximum length 40 mm
The cable type	CAT5e STP
The cable length	Maximum 100 m (328 ft)

- 1) Connect the Ethernet cable to its terminal.
- 2) In IP21, cut free the opening on the cover of the AC drive for the Ethernet cable. In IP54, cut a hole in a grommet and move the cable through it.
 - a) If the grommet folds in when you put the cable, pull the cable back to make the grommet straight.
 - b) The hole in the grommet must not be wider than your cable.
 - c) Pull the first bit of the cable out of the grommet so that it stays straight. If this is not possible, make the connection tight with some insulation tape or a cable tie.

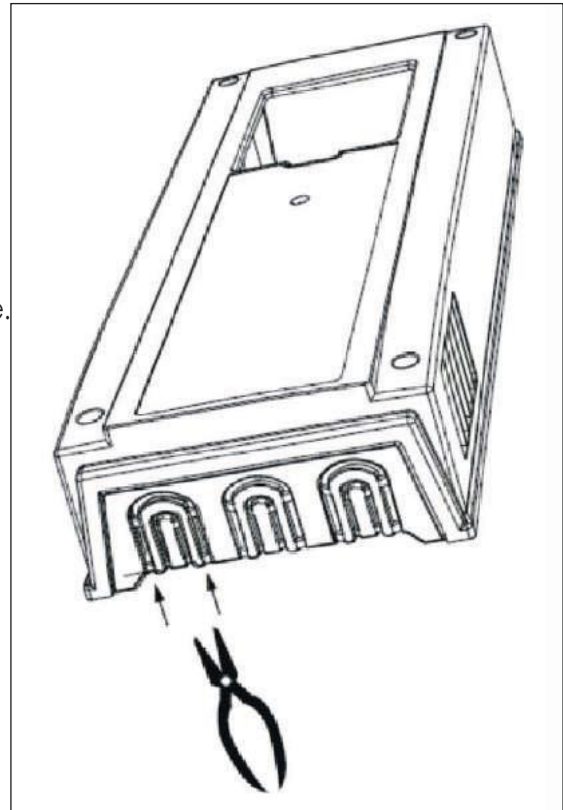

IP21

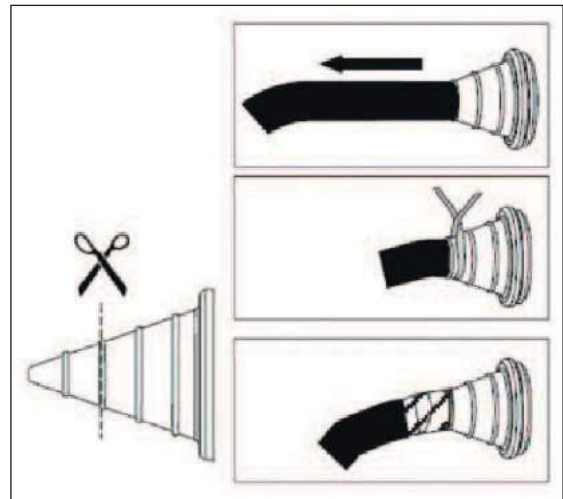

IP54

- 3) Put the cover of the drive back. Keep the distance between the Ethernet cable and the motor cable at a minimum of 30 cm.

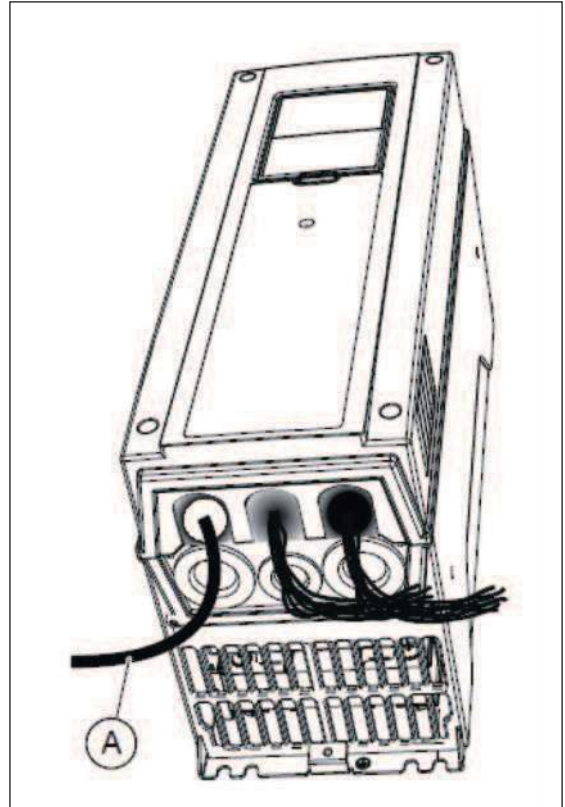

A. The Ethernet cable in IP21

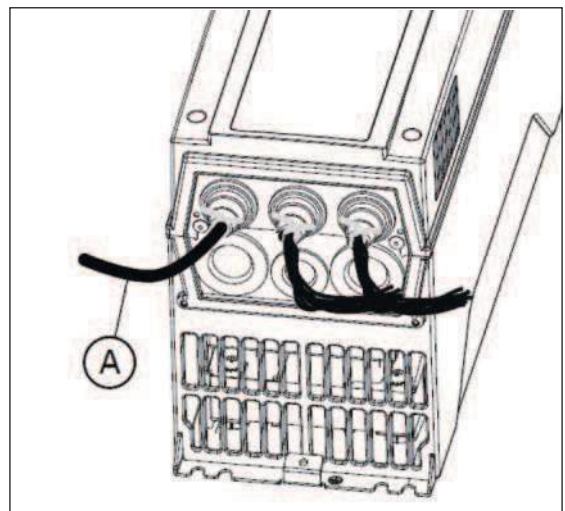

A. The Ethernet cable in IP54

See more in the Installation Manual of the fieldbus that you have.

5.3.2 USING FIELDBUS THROUGH AN RS485 CABLE

Table 30: RS485 cable data

Item	Description
The plug type	2.5 mm
The cable type	STP (shielded twisted pair), Belden 9841 or almost the same
The cable length	So that it agrees with the fieldbus. See the fieldbus manual.

- 1) Remove approximately 15 mm of the grey shield of the RS485 cable. Do this for the 2 fieldbus cables.
- a) Strip the cables for approximately 5 mm to put them in the terminals. Do not keep more than 10 mm of the cable outside the terminals.
- b) Strip the cable at such a distance from the terminal that you can attach it to the frame with the cable clamp. Strip the cable at a maximum length of 15 mm. Do not remove the aluminum shield of the cable.

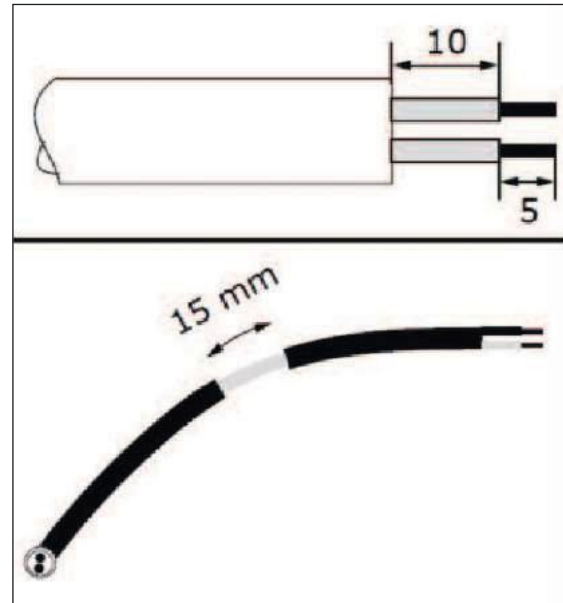

2) Connect the cable to the standard I/O board of the drive, in terminals A and B.

- A = negative
- B = positive

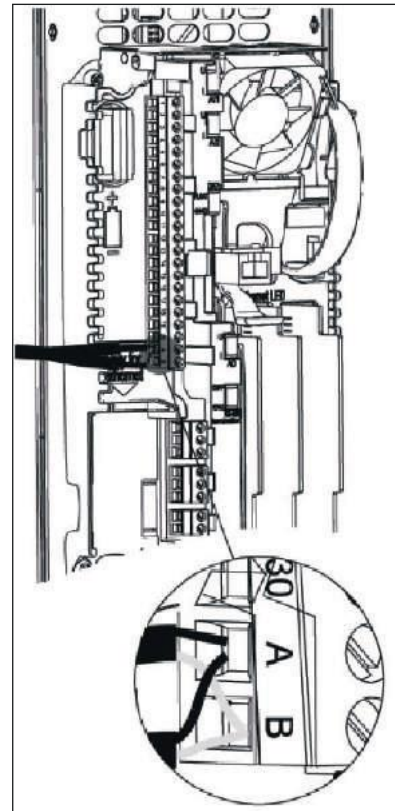

3) Attach the shield of the cable to the frame of the drive with a cable clamp to make a grounding connection.

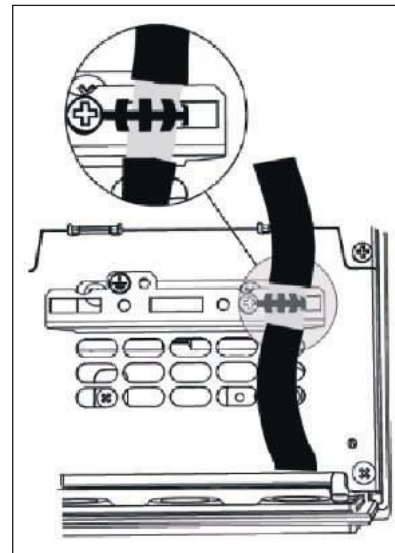

- 4) If the drive is the last device on the fieldbus line, set the bus termination.
- Find the DIP switches on the right side of the control panel of the drive.
 - Set the DIP switch of the RS485 bus termination to the ON position.
 - Biassing is built in the bus termination resistor. The resistance is 220 Ω .

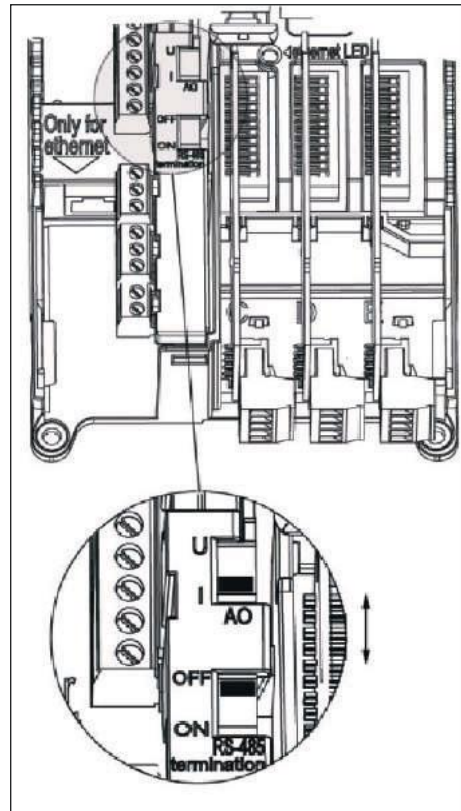

- 5) In IP21, unless you have cut the openings for other cables, cut an opening on the cover of the drive for the RS485 cable.

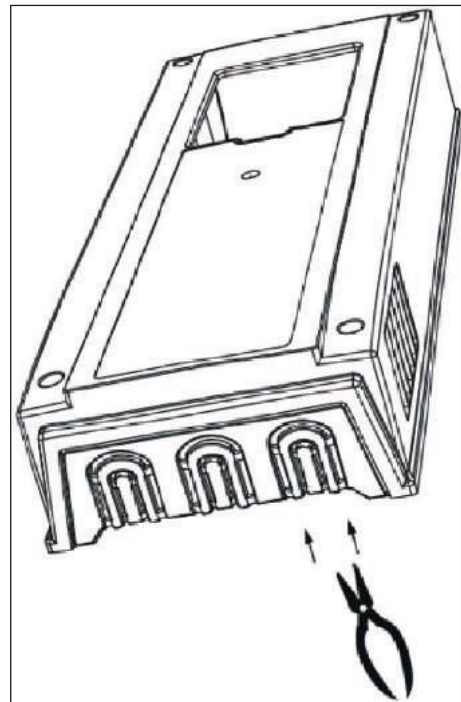

- 6) Put the cover of the drive back. Pull the RS485 cables to the side.

 - a) Keep the distance of the Ethernet, I/O and Field bus cables from the motor cable at a minimum of 30 cm.
 - b) Move the fieldbus cables away from the motor cable.

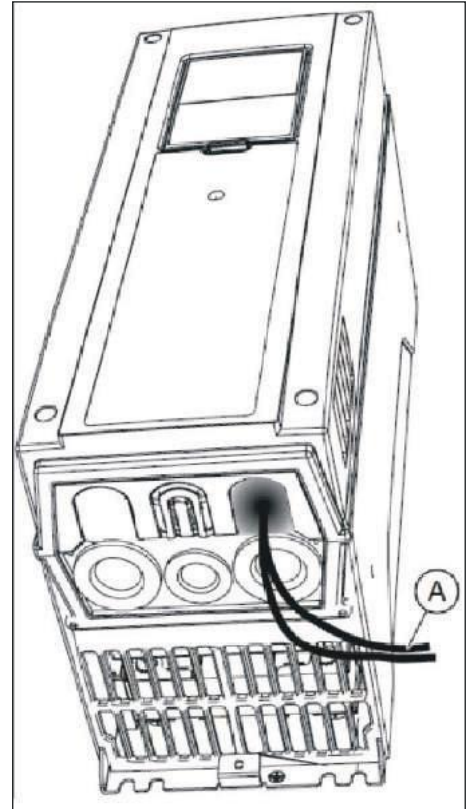

A. The fieldbus cables

- 7) Set the bus termination for the first and the last device of the fieldbus line.
We recommend that the first device on the fieldbus is the master device.

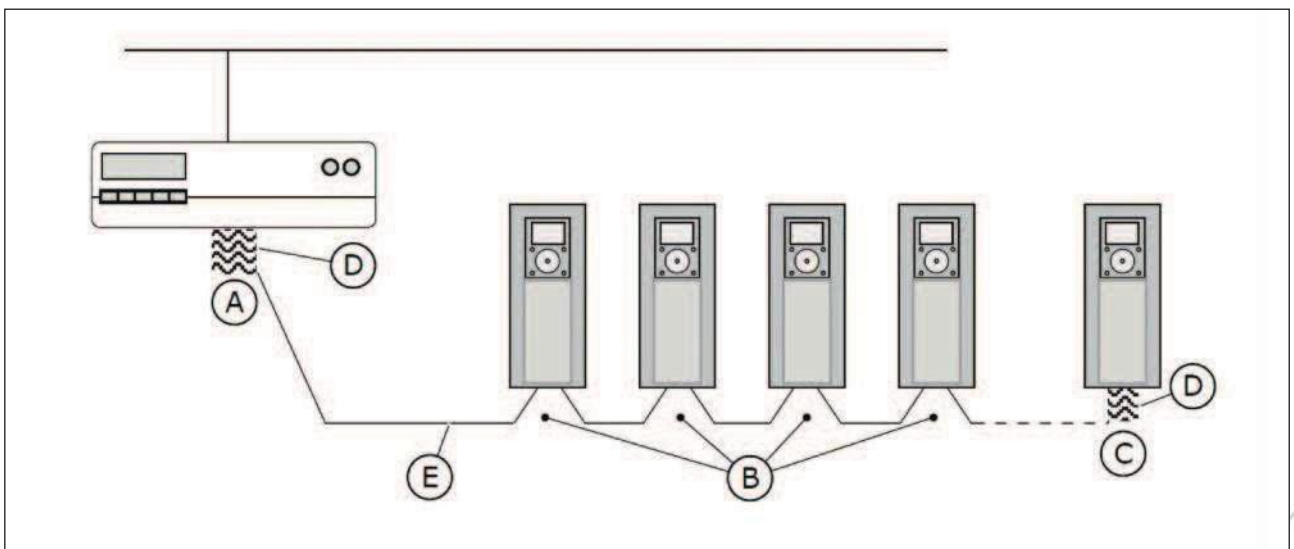

- A. The termination is activated
- B. The termination is deactivated

- C. The termination is activated with a DIP switch
- D. The bus termination. The resistance is 220 Ω.

**NOTE!**

If you do power-down to the last device, there is no bus termination.

5.4 INSTALLATION OF OPTION BOARDS**CAUTION!**

Do not install, remove, or replace option boards on the drive when the power is on. Doing this can cause damage to the boards.

Install the option boards into the option board slots of the drive. Refer to Table 29.

Table 31: The option boards and their correct option board slots

Type of the option board	Description of the option board	The correct slot or slots
OPT-B1-V	The I/O expander board	C, D, E
OPT-B2-V	The Thermistor relay board	C, D, E
OPT-B4-V	The I/O expander board	C, D, E
OPT-B5-V	The Relay board	C, D, E
OPT-B9-V	The I/O expander board	C, D, E
OPT-BF-V	The I/O expander board	C, D, E
OPT-BH-V	The Temperature measurement board	C, D, E
OPT-BJ-V	The Safe Torque Off board	E
OPT-C4-V	The LonWorks fieldbus board	D, E
OPT-E3-V	The Profibus DPV1 fieldbus board	D, E
OPT-E5-V	The Profibus DPV1 fieldbus board (with a type D connector)	D, E D, E
OPT-E6-V	The CanOpen fieldbus board	D, E
OPT-E7-V	The DeviceNet fieldbus board	D, E

THE INSTALLATION PROCEDURE

- 1) Open the cover of the AC drive.



WARNING!

Do not touch the relay outputs or the I/O terminals without measuring that there is no voltage in the terminals. They can have a dangerous voltage also when the drive is disconnected from mains.

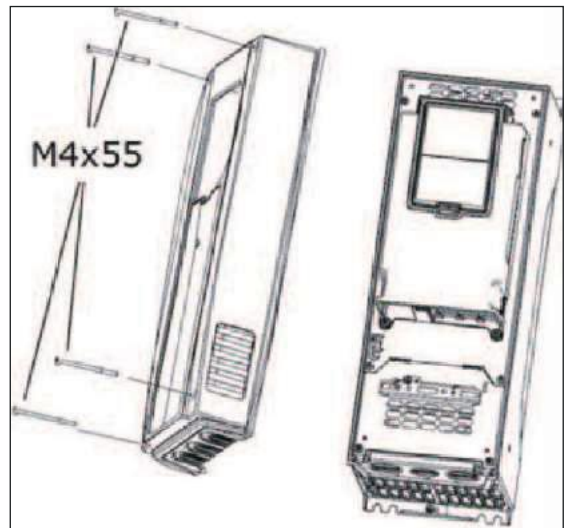

2) If you have an OPT-B or an OPT-C option board, make sure that the label on it says "dv"(dual voltage). This shows that the option board is compatible with the drive.

**NOTE!**

It is not possible to install option boards that are not compatible with the drive.

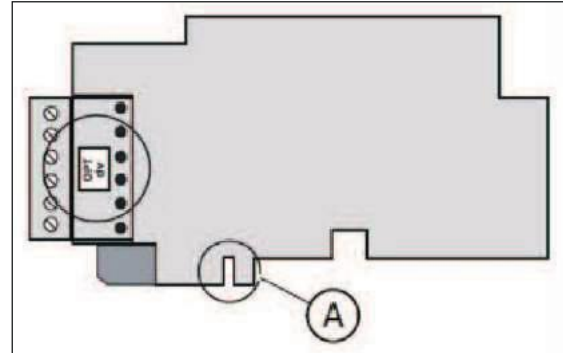

A. The slot coding

3) To get access to the option board slots, open the cover of the control unit.

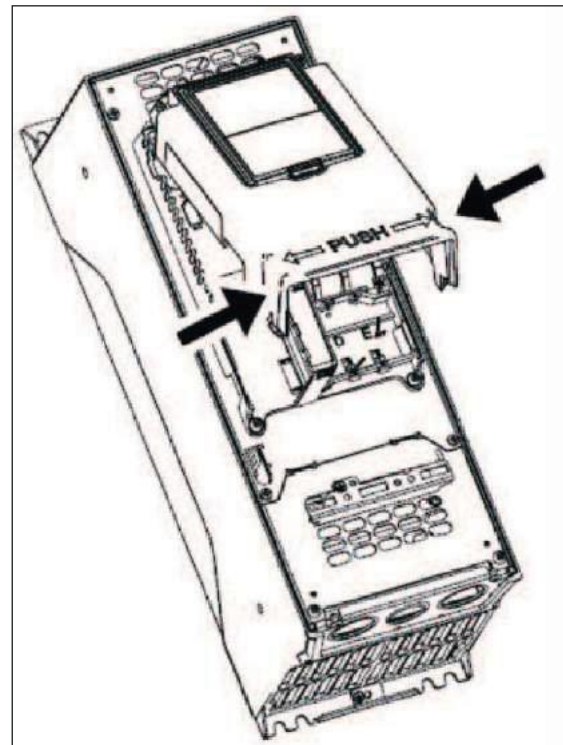

- 4) Install the option board into the correct slot: C, D or E.
See Table 29.
- a) The option board has a slot coding, because of which it is not possible to install the option board in an incorrect slot.

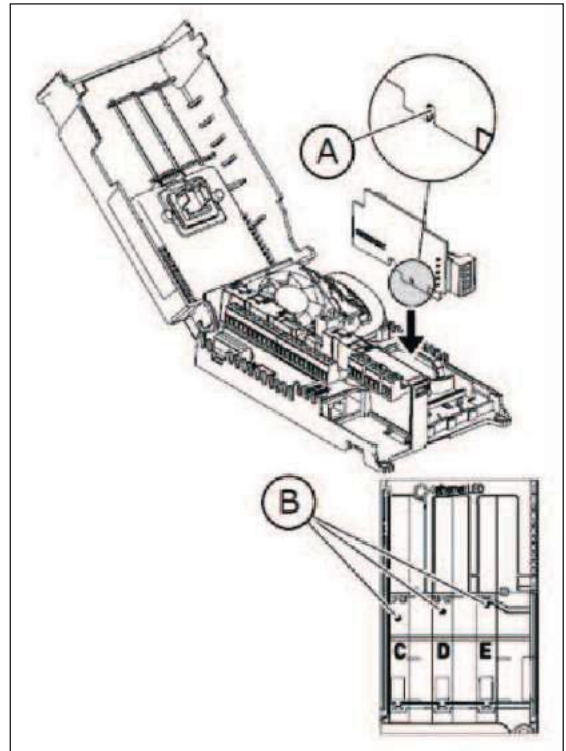

A. The slot coding B. The option board slots

- 5) Close the cover of the control unit. Put the cover of the AC drive back.

5.5 INSTALLATION OF A BATTERY FOR THE REAL TIME CLOCK (RTC)

To use the Real Time Clock (RTC), you must install a battery in the drive.

- 1) Use a 1/2 AA battery with 3.6 V and a capacity of 1000-1200 mAh. You can use, for example, a Panasonic BR-1/2 AA or a Vitzrocell SB-AA02.
- 2) Install the battery on the left side of the control panel. See Fig. 24 The components of the control unit. The battery will last approximately 10 years. See more about the functions of the RTC in the Application Manual.

5.6 GALVANIC ISOLATION BARRIERS

The control connections are isolated from mains. The GND terminals are permanently connected to I/O ground. The digital inputs on the standard I/O board can be galvanically isolated from the I/O ground. To isolate the digital inputs, use the DIP switch that has the positions FLOAT and GND.

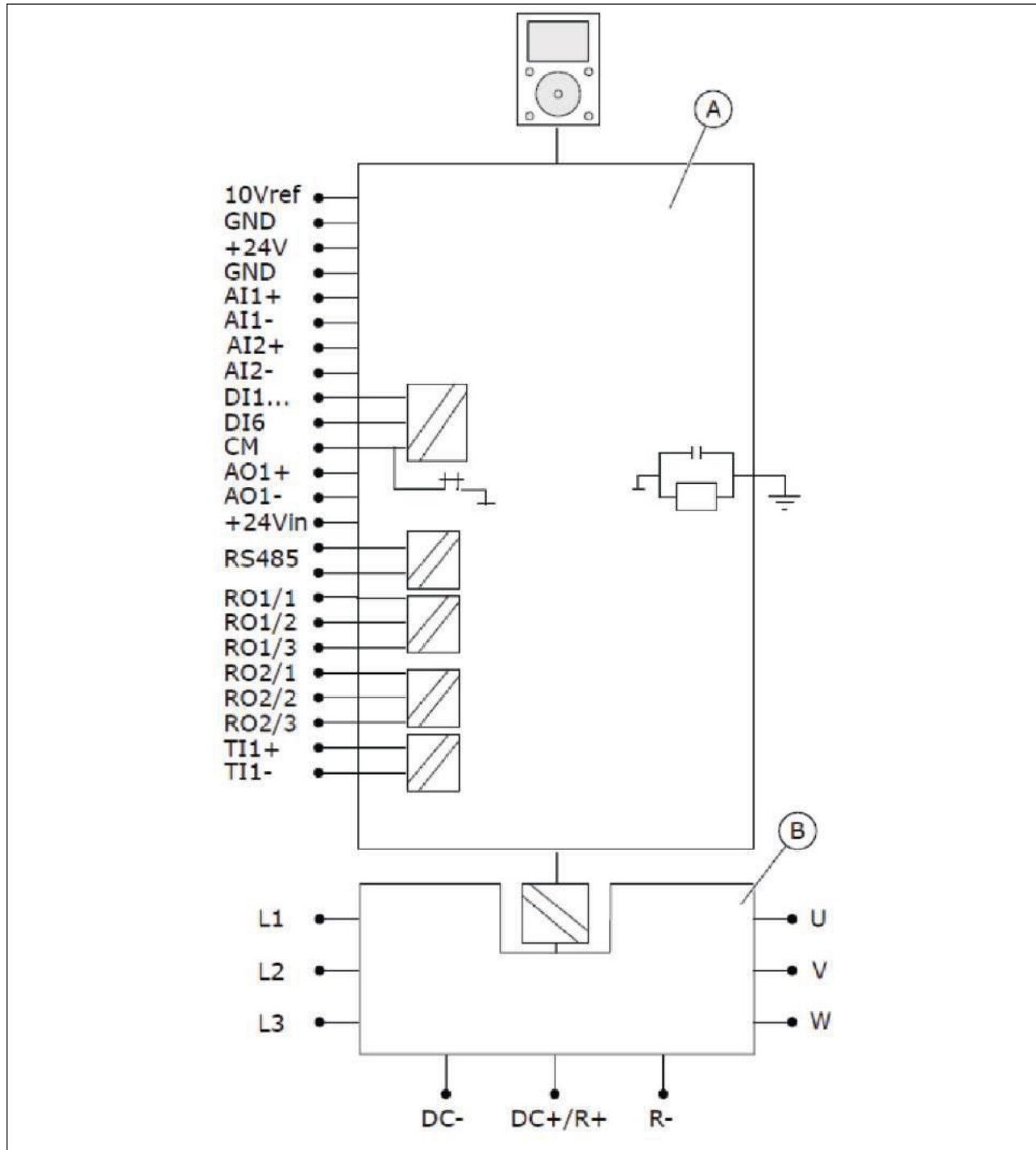

Fig. 35: The galvanic isolation barriers

A. The control unit

B. The power unit

6. COMMISSIONING AND ADDITIONAL INSTRUCTIONS

6.1 COMMISSIONING SAFETY

Before you start the commissioning, read these warnings.



WARNING!

Do not touch the internal components or the circuit boards of the drive when the drive is connected to mains. These components are live. A contact with this voltage is very dangerous. The galvanically isolated I/O terminals are not live.



WARNING!

Do not touch the motor terminals U, V, W or the brake resistor terminals when the drive is connected to mains. These terminals are live when the drive is connected to mains, also when the motor does not operate.



WARNING!

Do not make connections to or from the AC drive when it is connected to mains. There is a dangerous voltage.



WARNING!

To do work on the connections of the drive, disconnect the drive from mains. Wait 5 minutes before you open the cover of the drive. Then use a measuring device to make sure that there is no voltage. The connections of the drive are live 5 minutes after it is disconnected from mains.



WARNING!

Before you do electrical work, make sure that there is no voltage.



WARNING!

Do not touch the relay outputs or other I/O terminals than the control I/O terminals. They can have a dangerous voltage also when the drive is disconnected from mains.



WARNING!

Before you connect the drive to mains, make sure that the front cover and the cable cover of the drive are closed. The connections of the AC drive are live when the drive is connected to mains.

6.2 COMMISSIONING OF THE DRIVE

Read the safety instructions in chapters 1 Safety and 6.1 Commissioning safeties and obey them.

After the installation:

- Make sure that the motor is installed correctly.
- Make sure that the motor terminals are not connected to mains.
- Make sure that the AC drive and the motor are grounded.
- Make sure that you select the mains cable, the brake cable, and the motor cable correctly (see chapter 4.3 Cable dimensioning and selection).
- Make sure that the control cables are as far as possible from the power cables. See chapter 4.6 Cable installation.
- Make sure that the shields of the shielded cables are connected to an earth terminal that is identified with  .
- Do a check of the tightening torques of all the terminals.
- Make sure that no power correction capacitors are connected to the motor cable.
- Make sure that the cables do not touch the electrical components of the drive.
- Make sure that the common inputs of the digital input groups are connected to +24 V or ground of the I/O terminal or the external power source.
- Do a check of the quality and quantity of the cooling air. See chapter 3.4 Cooling and Table 14 The necessary quantity of cooling air.
- Make sure that there is no condensation on the inner surfaces of the AC drive.
- Make sure that there are no unwanted objects in the installation space.
- Before you connect the drive to mains, do a check of the installation and the condition of all the fuses and other protective devices.

6.3 OPERATION OF THE MOTOR**6.1.1 CHECKS BEFORE STARTING THE MOTOR**

Before you start the motor, do these checks.

- Make sure that all the START and STOP switches that are connected to the I/O terminals are in the STOP position.
- Make sure that you can start the motor safely.
- Activate the Start-up wizard. See the Application Manual for the AC drive that you have.
- Set the maximum frequency reference (that is, the maximum speed of the motor), so that it agrees with the motor and the device that is connected to the motor.

6.4 MEASURING THE CABLE AND MOTOR INSULATION

The insulation checks of the motor cable

- 1) Disconnect the motor cable from the terminals U, V, and W and from the motor.
- 2) Measure the insulation resistance of the motor cable between phase conductors 1 and 2, between phase conductors 1 and 3, and between phase conductors 2 and 3.
- 3) Measure the insulation resistance between each phase conductor and the earth conductor.
- 4) The insulation resistance must be > 1 MΩ at the ambient temperature of 20 °C (68 °F).

The insulation checks of the mains cable

- 1) Disconnect the mains cable from the terminals L1, L2, and L3 and from mains.
- 2) Measure the insulation resistance of the mains cable between phase conductors 1 and 2, between phase conductors 1 and 3, and between phase conductors 2 and 3.
- 3) Measure the insulation resistance between each phase conductor and the earth conductor.
- 4) The insulation resistance must be $>1 \text{ M}\Omega$ at the ambient temperature of $20 \text{ }^\circ\text{C}$ ($68 \text{ }^\circ\text{F}$).

The insulation checks of the motor

- 1) Disconnect the motor cable from the motor.
- 2) Open the bridging connection in the motor connection box.
- 3) Measure the insulation resistance of each motor winding. The voltage must be the same or higher than the motor nominal voltage, but not higher than 1000 V.
- 4) The insulation resistance must be $>1 \text{ M}\Omega$ at the ambient temperature of $20 \text{ }^\circ\text{C}$ ($68 \text{ }^\circ\text{F}$).
- 5) Obey the instructions of the motor manufacturer.

6.5 INSTALLATION IN AN IT SYSTEM

If your mains is impedance-grounded (IT), the AC drive must have the EMC protection level C4. If your drive has the EMC protection level C2, it is necessary to change it to C4. To do this, remove the EMC jumpers.



WARNING!

Do not make changes in the AC drive when it is connected to mains. The components of the drive are live when the drive is connected to mains.



CAUTION!

Before you connect the AC drive to mains, make sure that the EMC level of the drive is correct. An incorrect EMC level can cause damage to the drive.

6.5.1 FRAMES MR4, MR5, AND MR6

Change the EMC protection of the AC drive to level C4.

- 1) Open the cover of the AC drive.
- 2) In MR4 and MR5, to find the EMC jumpers, remove the cable cover.

3) Find the EMC jumpers that connect the RFI filters to ground.

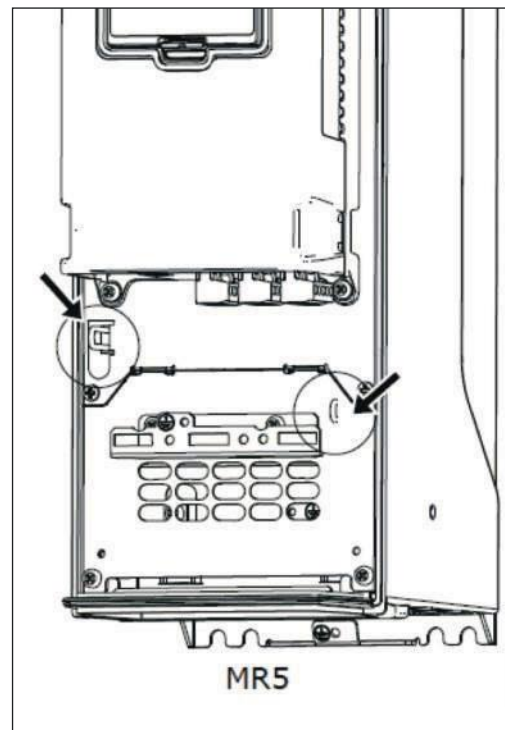
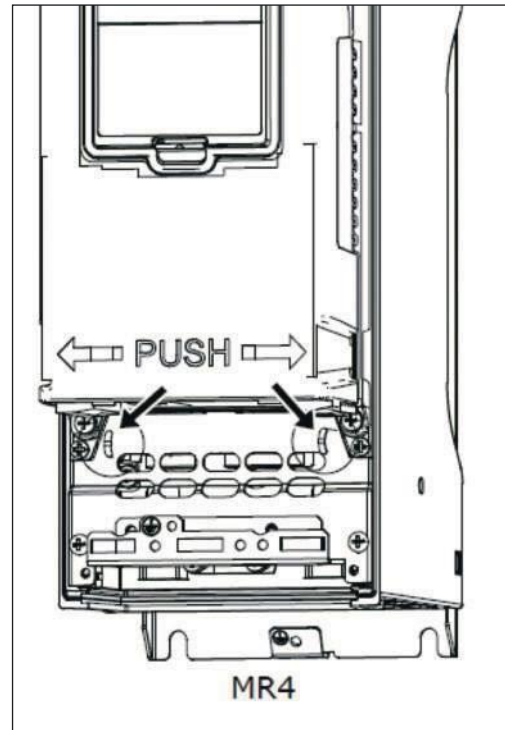

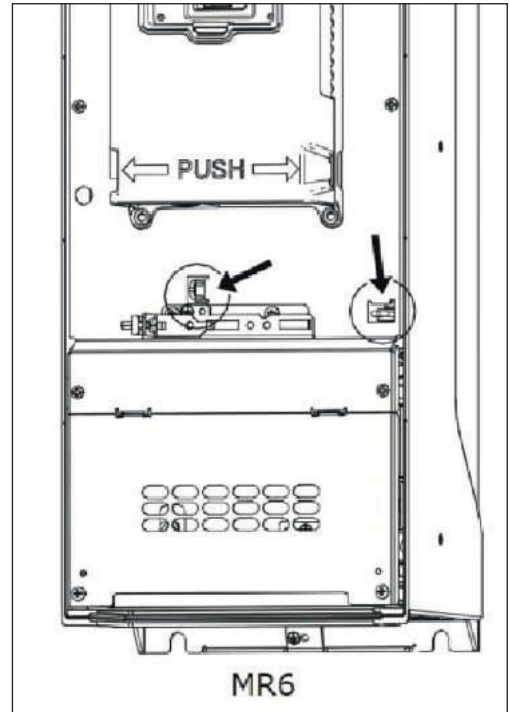

4) To disconnect the RFI filters from ground, remove the EMC jumpers.

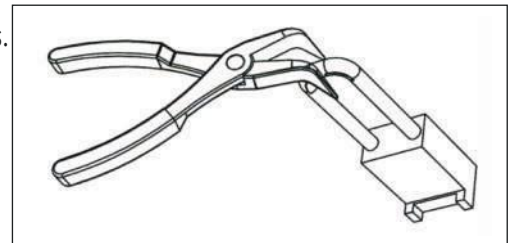

5) After the change, write "The EMC level was changed" and the date on the "product changed" label. If the label is not attached at this time, attach it on the drive near the nameplate.

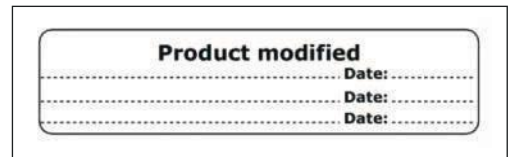

6.5.2 FRAMES MR7 AND MR8

Change the EMC protection of the AC drive to level C4.

1) Open the cover of the AC drive.

- 2) Find the EMC box. To get access to the EMC jumper, remove the cover of the EMC box.

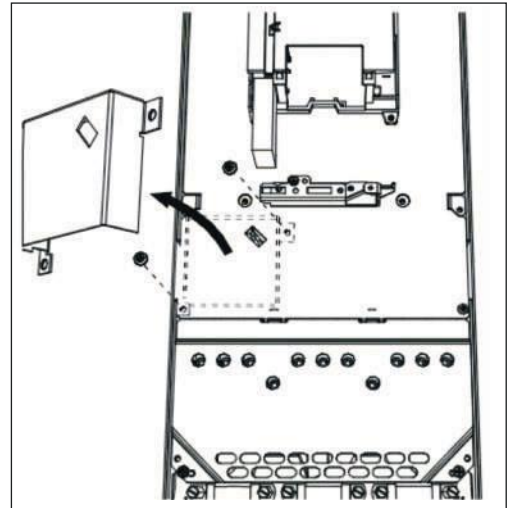

- 3) Remove the EMC jumper. Attach the cover of the EMC box again.

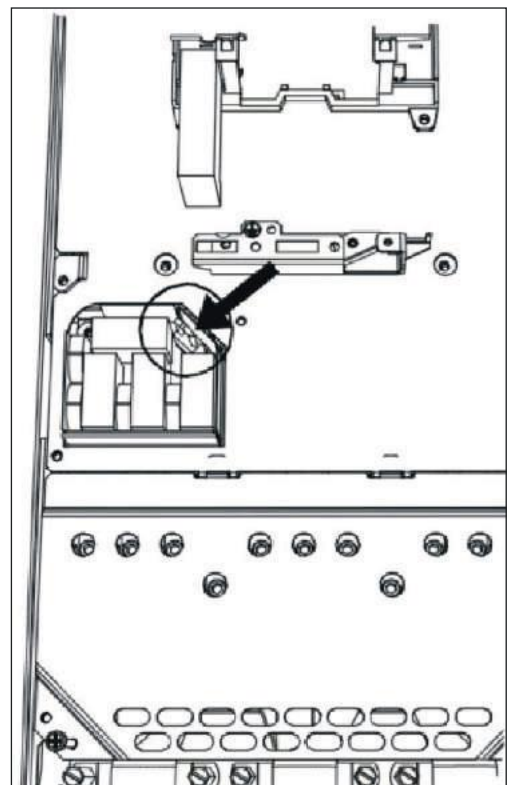

4) In MR7, find the DC grounding busbar between the connectors R - and U. To remove the busbar from the frame, remove the M4 screw.

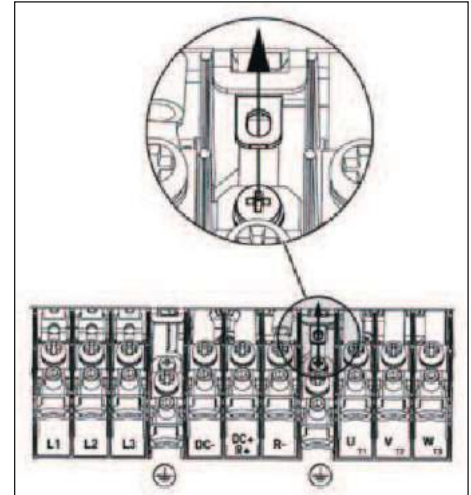

5) In MR8, find the grounding arm and push it down.

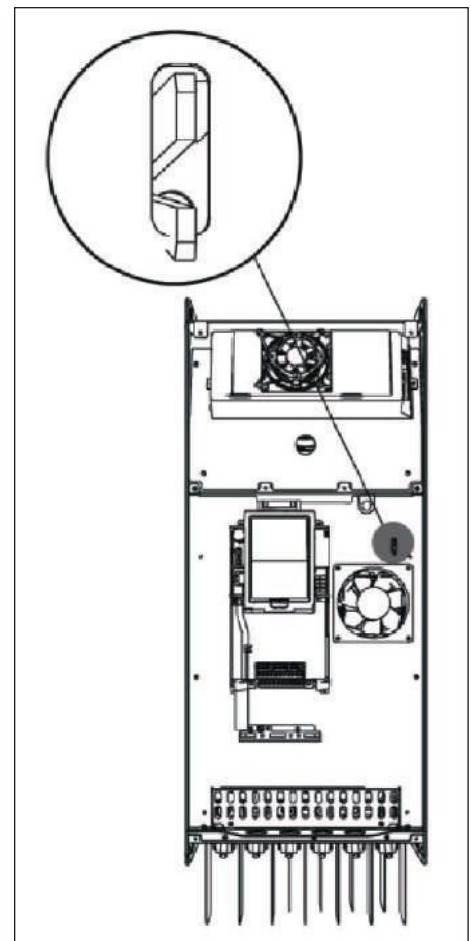

6) After the change, write "The EMC level was changed" and the date on the "product changed" label. If the label is not attached at this time, attach it on the drive near the name plate.

Product modified	
	Date:
	Date:
	Date:

6.5.3 FRAME MR9

To make a change in the EMC protection of the AC drive, you must find the 3 EMC jumpers. To change the EMC level from C2 to C4, remove the EMC jumpers. To change the EMC level from C4 to C2, install the EMC jumpers. You can find the EMC jumpers, which are not installed, in the accessories bag.

HOW TO FIND THE EMC JUMPER 1

- 1) Open the cover of the AC drive.
- 2) Remove the cover of the fan.
- 3) In IP54, also remove the fan.
- 4) Find the place of the jumper behind the fan.

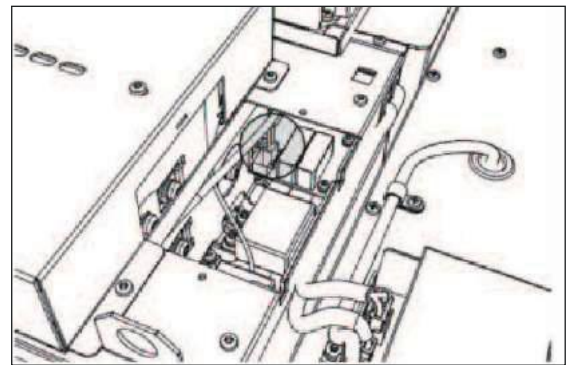

- 5) If you change the EMC level, write "The EMC level was changed" and the date on the "product changed" label. If the label is not attached at this time, attach it on the drive near the name plate.

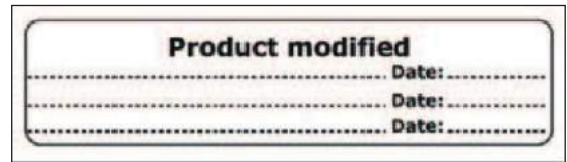

HOW TO FIND THE EMC JUMPERS 2 AND 3

- 1) Remove the cover of the extension box, the touch shield, and the I/O plate with the I/O grommet plate.
- 2) Find the 2 EMC jumpers on the EMC board. They are not adjacent to each other.

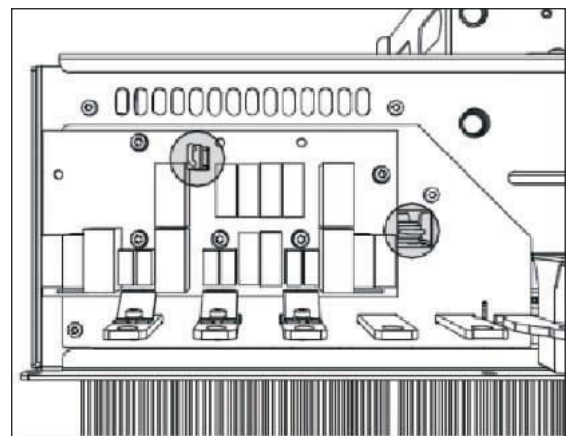

- 3) If you change the EMC level, write "The EMC level was changed" and the date on the "product changed" label. If the label is not attached at this time, attach it on the drive near the name plate.



6.5.4 FRAME MR10

Change the EMC protection of the AC drive from level C3 to level C4.

FINDING THE EMC JUMPER, WITHOUT THE EXTENSION BOX

- 1) Find the EMC jumper between the terminals L2 and L3.

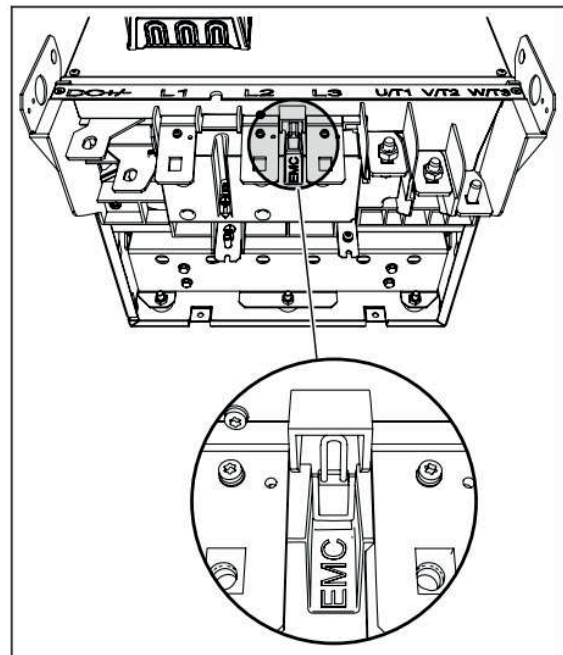

- 2) Remove the EMC jumper.

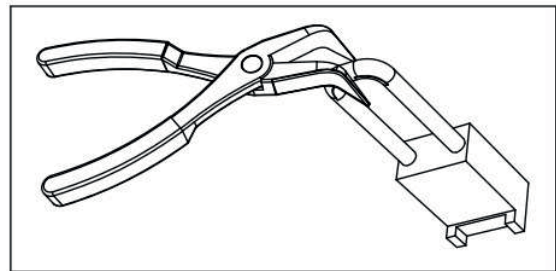

- 3) If you change the EMC level, write "The EMC level was changed" and the date on the "product modified" label. If the label is not attached at this time, attach it on the drive near the name plate.

Product modified	
.....	Date:
.....	Date:
.....	Date:

FINDING THE EMC JUMPER, WITH AN EXTENSION BOX

1) Remove the covers of the extension box.

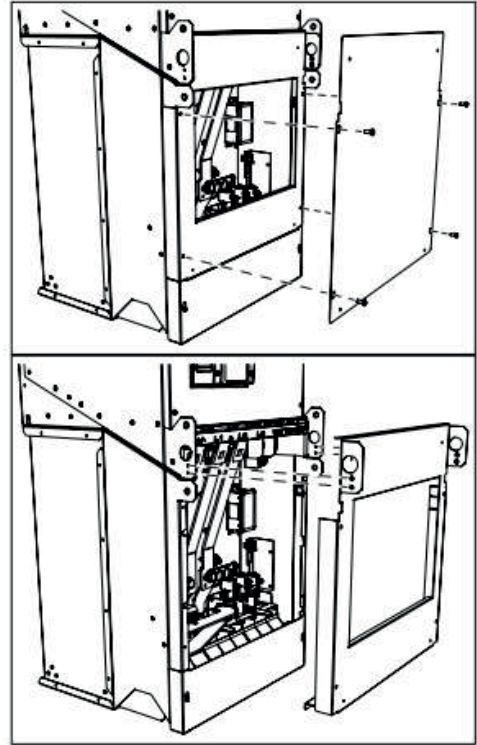

2) Find the EMC jumper between the terminals L2 and L3

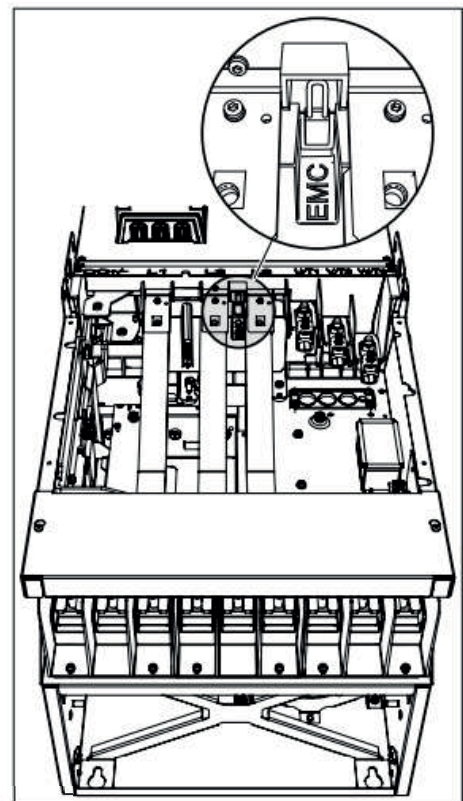

3) Remove the EMC jumper.

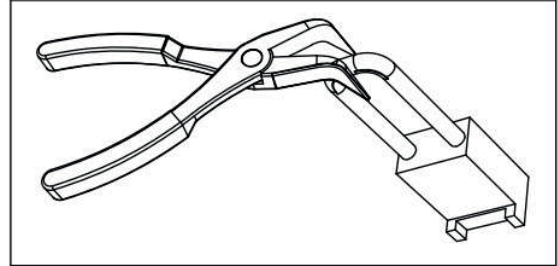

3) If you change the EMC level, write "The EMC level was changed" and the date on the "product modified" label. If the label is not attached at this time, attach it on the drive near the name plate.

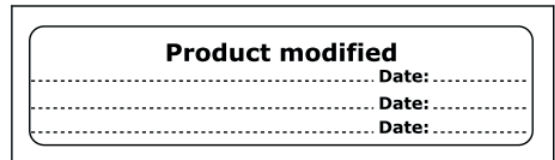

6.6 MAINTENANCE

To make sure that the drive operates correctly and has a long life, we recommend that you do regular maintenance.

Refer to the table for maintenance intervals.

It is not necessary to replace the capacitors, because capacitors of the drive are thin film capacitors.

Table 32: The maintenance intervals and tasks

Maintenance interval	Maintenance task
Regularly	Do a check of the tightening torques of the terminals. Do a check of the filters.
6-24 months(The interval is different in different environments.)	Do a check of the input and output terminals and the control I/O terminals. Make sure that the cooling fan operates correctly. Make sure that there is no corrosion on the terminals, the busbars or other surfaces. Do a check of the door filters, if you have a cabinet installation.
24 months(The interval is different in different environments.)	Clean the heatsink and the cooling tunnel.
3-6 years	In IP54, change the internal fan.
6-10 years	Change the main fan.
10 years	Replace the battery of the RTC.

7. TECHNICAL DATA

7.1 AC DRIVE POWER RATINGS

7.1.1 MAINS VOLTAGE 208-240 V

Table 33: The power ratings of N800A in mains voltage 208-240V, 50-60 Hz, 3~

Frame	Drive type	Loadability					Motor shaft power			
		Low *		High *		Max current I _s	230 V mains		230 V mains	
		Continu ous current I _L [A]	10% overload current [A]	Continu ous current I _H [A]	50% overload current [A]		10% overload 40°C [kW]	50% overload 50°C [kW]	10% overload 40°C [hp]	50% overload 50°C [hp]
MR4	0003	3.7	4.1	2.6	3.9	5.2	0.55	0.37	0.75	0.5
	0004	4.8	5.3	3.7	5.6	7.4	0.75	0.55	1	0.75
	0007	6.6	7.3	4.8	7.2	9.6	1.1	0.75	1.5	1
	0008	8.0	8.8	6.6	9.9	13.2	1.5	1.1	2	1.5
	0011	11	12.1	8	12	16	2.2	1.5	3	2
	0012	12.5	13.8	9.6	16.5	19.6	3	2.2	4	3
MR5	0018	18	19.8	12.5	18.8	25	4	3	5	4
	0024	24	26.4	18	27	36	5.5	4	7.5	5
	0031	31	34.1	25	37.5	46	7.5	5.5	10	7.5
MR6	0048	48	52.8	31	46.5	62	11	7.5	15	10
	0062	62	68.2	48	72	96	15	11	20	15
MR7	0075	75	82.5	62	93	124	18.5	15	25	20
	0088	88	96.8	75	112.5	150	22	18.5	30	25
	0105	105	115.5	88	132	176	30	22	40	30
MR8	0140	143	154	114	171	210	37	30	50	40
	0170	170	187	140	210	280	45	37	60	50
	0205	208	225.5	170	255	340	55	45	75	60
MR9	0261	261	287.1	211	316.5	410	75	55	100	75
	0310	310	341	251	376.5	502	90	75	125	100

* See chapter 7.1.3 Overload capability.

**NOTE!**

The rated currents in given ambient temperatures (in Table 36 The technical data of the N800A AC drive) are achieved only when the switching frequency \leq the factory default.

If your process includes a cyclical load, for example if there are lifts or winches, speak to the manufacturer to get the dimensioning information.

7.1.2 MAINS VOLTAGE 380-500 V

Table 34: The power ratings of N800A 100 in mains voltage 380-500V, 50-60 Hz, 3~

Frame	Drive type	Loadability					Motor shaft power			
		Low *		High *		Max current Is	400 V mains		480 V mains	
		Continu ous current I _L [A]	10% overload current [A]	Continu ous current I _H [A]	50% overload current [A]		10% overload 40°C [kW]	50% overload 50°C [kW]	10% overload 40°C [hp]	50% overload 50°C [hp]
MR4	0003	3.4	3.7	2.6	3.9	5.2	1.1	0.75	1.5	1
	0004	4.8	5.3	3.4	5.1	6.8	1.5	1.1	2.0	1.5
	0005	5.6	6.2	4.3	6.5	8.6	2.2	1.5	3.0	2
	0008	8.0	8.8	5.6	8.4	11.2	3	2.2	4.0	3
	0009	9.6	10.6	8.0	12	16	4	3	5.0	4
	0012	12	13.2	9.6	14.4	19.2	5.5	4	7.5	5
MR5	0016	16	17.6	12	18	24	7.5	5.5	10	7.5
	0023	23	25.3	16	24	32	11	7.5	15	10
	0031	31	34.1	23	34.5	46	15	11	20	15
MR6	0038	38	41.8	31	46.5	62	18.5	15	25	20
	0046	46	50.6	38	57	76	22	18.5	30	25
	0061	61	67.1	46	69	92	30	22	40	30
MR7	0072	72	79.2	61	91.5	122	37	30	50	40
	0087	87	95.7	72	108	144	45	37	60	50
	0105	105	115.5	87	130.5	174	55	45	75	60
MR8	0140	140	154	105	157.5	210	75	55	100	75
	0170	170	187	140	210	280	90	75	125	100
	0205	205	225.5	170	255	340	110	90	150	125
MR9	0261	261	287.1	205	307.5	410	132	110	200	150
	0310	310	341	251	376.5	502	160	132	250	200
MR10	0385	385	423.5	311	465.0	620	200	160	300	250
	0460	460	506.0	391	577.5	770	250	200	350	300
	0520	520	572.0	459	690.0	920	250	250	450	350
	0590**	590	649.0	515	780.0	1040	315	250	500	450

* See chapter 7.1.3 Overload capability.

**NOTE!**

The rated currents in given ambient temperatures (in Table 36 The technical data of the N800A AC drive) are achieved only when the switching frequency \leq the factory default.

If your process includes a cyclical load, for example if there are lifts or winches, speak to the manufacturer to get the dimensioning information.

7.1.3 OVERLOAD CAPABILITY

The low overload means that if 110% of the rated continuous current (I_L) is required for 1 minute every 10 minutes, the remaining 9 minutes must be approximately 98% of I_L or less.

This is to make sure that the output current is not more than I_L during the duty cycle.

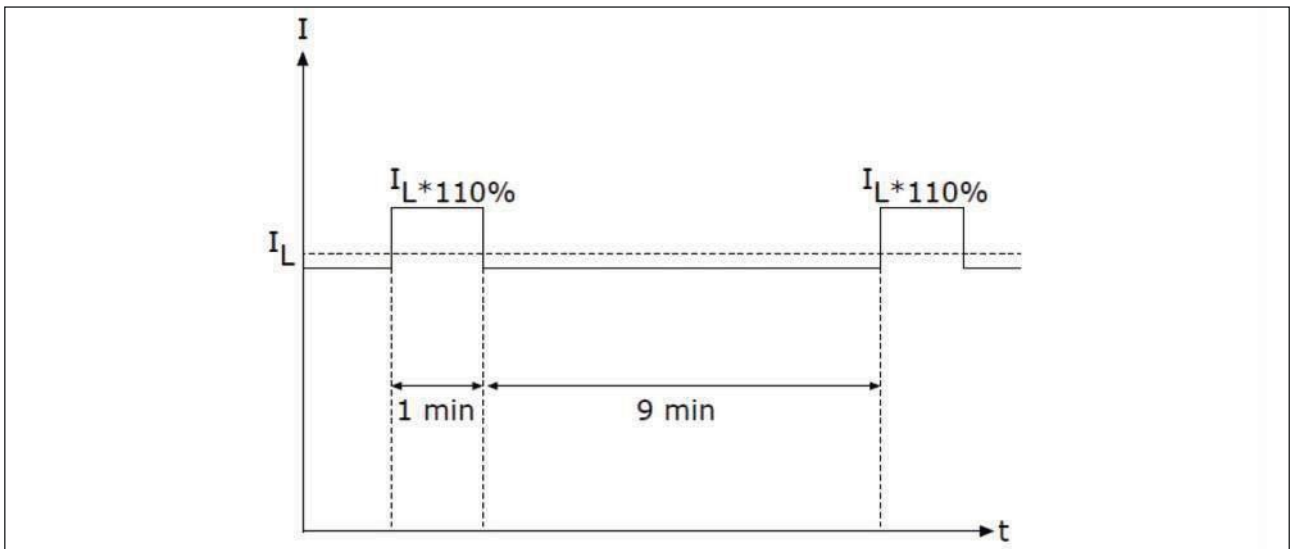

Fig. 36: Low overload in N800A

The high overload means that if 150% of the rated continuous current (I_H) is required for 1 minute every 10 minutes, the remaining 9 minutes must be approximately 92% of I_H or less.

This is to make sure that the output current is not more than I_H during the duty cycle.

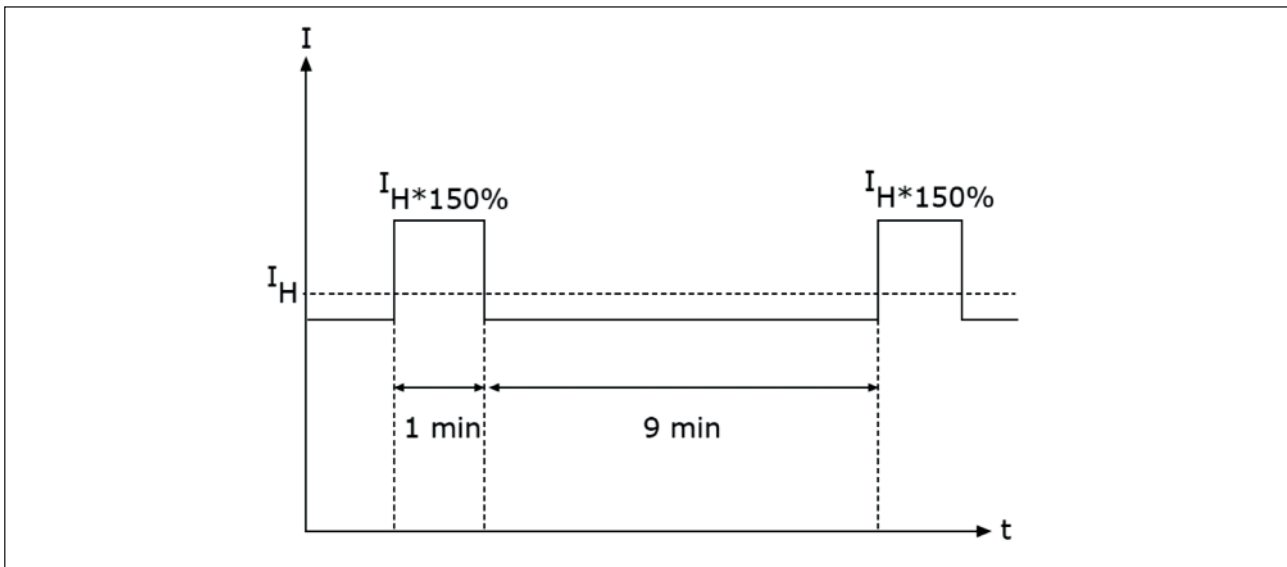

Fig. 37: High overload in N800A

For more information, refer to the standard IEC61800-2 (IEC:1998).

7.1.4 BRAKE RESISTOR RATINGS

Make sure that the resistance is higher than the set minimum resistance. The power handling capacity must be sufficient for the application.

Table 35: The recommended brake resistor types and the calculated resistance of the drive

Frame	Duty cycle	Resistance[Ω]
MR4	Light duty *	63.0
	Heavy duty *	63.0
MR5	Light duty *	41.0
	Heavy duty *	41.0
MR6	Light duty *	21.0
	Heavy duty *	21.0
MR7	Light duty *	14.0
	Heavy duty *	14.0
MR8	Light duty *	6.5
	Heavy duty *	6.5
MR9	Light duty *	3.3
	Heavy duty *	3.3
MR10	Light duty *	1.4
	Heavy duty *	1.4

- The light duty cycle is for brake resistor cyclic use (1 LD pulse in a 120-second period). The light duty resistor is rated for a 5-second ramp from full power to 0.
- The heavy duty cycle is for brake resistor cyclic use (1 HD pulse in a 120-second period). The heavy duty resistor is rated for a 3-second full power braking with a 7-second ramp to 0.

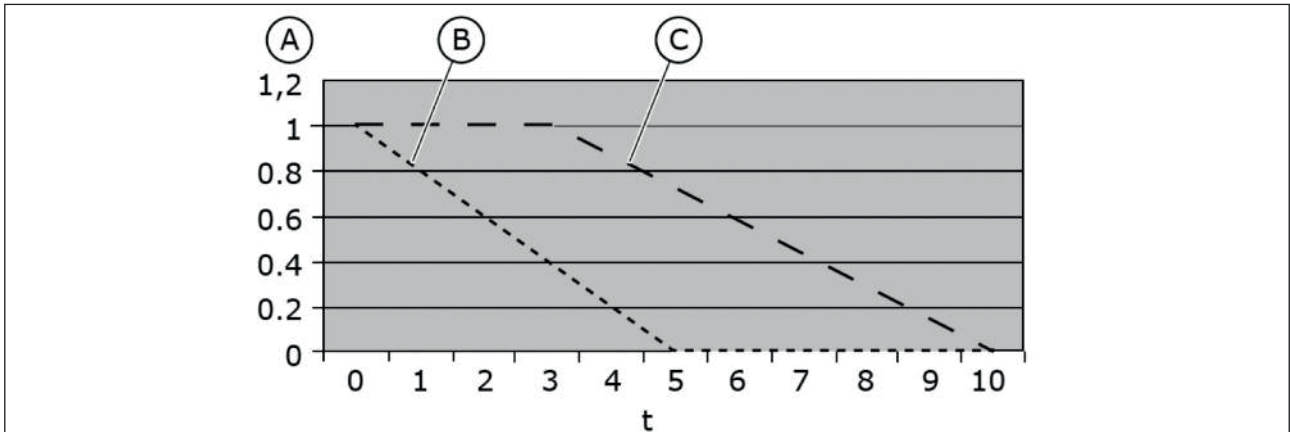

Fig. 38: The LD and HD pulses

A. Relative power
B. Light duty

C. Heavy duty

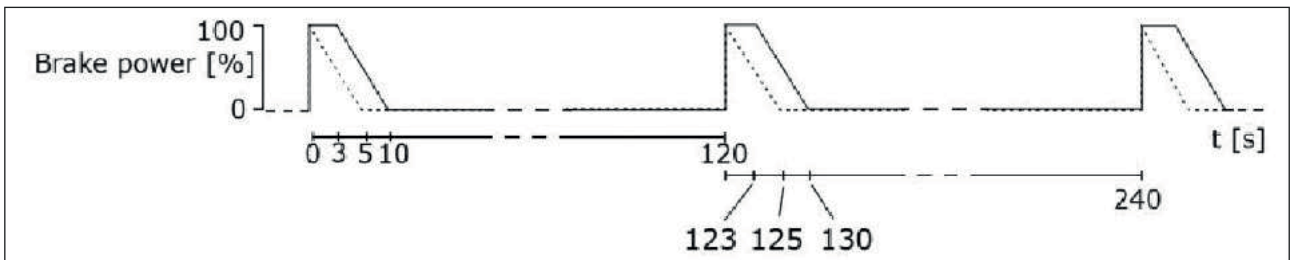

Fig. 39: The duty cycles of the LD and HD pulses Table 34: The

minimum resistance and the brake power, mains voltage 208-240V

Mains voltage 208-240 V, 50/60 Hz, 3~		
Frame	The minimum brake resistance [Ω]	Brakepower* _{@405VDC} [kW]
MR4	30.0	2.6
MR5	20.0	3.9
MR6	10.0	7.8
MR7	5.5	11.7
MR8	3.0	25.2
MR9	1.4	49.7

* When you use recommended resistor types.

Table 37: The minimum resistance and the brake power, mains voltage 380-500V

Mains voltage 380-500 V, 50/60 Hz, 3~		
Frame	The minimum brake resistance [Ω]	Brakepower* @845VDC [kW]
MR4	63.0	11.3
MR5	41.0	17.0
MR6	21.0	34.0
MR7	14.0	51.0
MR8	6.5	109.9
MR9	3.3	216.4
MR10	1.4	400

* When you use recommended resistor types.

7.2 N800A - TECHNICAL DATA

Table 38: The technical data of the N800A AC drive

Mains connection	Input voltage U _{in}	208...240 V; 380...500 V; -10%...+10%
	Input frequency	50...60 Hz -5...+10%
	Connection to mains	Once per minute or less
	Starting delay	6s(MR4 - MR6); 8s(MR7 - MR9)
Motor connection	Output voltage	0-U _{in}
	Continuous output current	I _L : Ambient temperature max. +40 °C overload 1.1 x I _L (1 min/10 min) I _H : Ambient temperature max. +50 °C overload 1.5 x I _H (1 min/10 min)
	Output frequency	0-320 Hz (standard)
	Frequency resolution	0.01 Hz
Control qualities	Switching frequency	MR4 to MR6: 1.5...10 kHz Defaults • MR4 to MR6: 6 kHz (except for 0012 2, 0031 2, 0062 2, 0012 5, 0031 5 and 0061 5: 4 kHz) MR7 to MR9: 1.5-6 kHz Defaults • MR7: 4 kHz • MR8: 3 kHz • MR9: 2 kHz Automatic switching frequency derating in case of overload.
	Frequency reference Analogue input Panel reference	Resolution 0.1% (10-bit), accuracy ±1% Resolution 0.01 Hz
	Field weakening point	8...320 Hz
	Acceleration time	0.1...3000 sec
	Deceleration time	0.1...3000 sec
Ambient conditions	Ambient operating temperature	I _L current: -10°C (no frost)...+40 °C I _H current: -10°C (no frost)...+50 °C Maximum operating temperature: +50 °C
	Storage temperature	-40 °C...+70 °C
	Relative humidity	0-95% RH, non-condensing, non-corrosive
	Air quality: • chemical vapours • mechanical particles	Tested according to IEC 60068-2-60 Test Ke: Flowing mixed gas corrosion test, Method 1 (H ₂ S [hydrogen sulfide] and SO ₂ [sulfur dioxide]) Designed according to • IEC 60721-3-3, unit in operation, class 3C3 (IP21/ULType 1 Models 3C2) • IEC 60721-3-3, unit in operation, class 3S2

Ambient conditions	Altitude	100% load capacity (no derating) up to 1000 m 1% derating for each 100m above 1000 m Maximum altitudes: • 208...240 V: 4000 m (TN and IT systems) • 380...500 V: 4000 m (TN and IT systems) Voltage for relay outputs: • Up to 3000 m : Allowed up to 240 V • 3000...4000 m: Allowed up to 120 V Corner-grounding: up to 2,000 m only (see chapter 4.7 Installation in a corner-grounded network)
	Vibration EN61800-5-1/ EN60068-2-6	5-150 Hz Displacement amplitude 1 mm (peak) at 5-15.8 Hz (MR4...MR9) Maximum acceleration amplitude 1 G at 15.8-150 Hz (MR4...MR9)
	Shock EN60068-2-27	UPS Drop Test (for applicable UPS weights) Storage and shipping: maximum 15 G, 11 ms (in package)
	Enclosure class	Standard : IP21/Type 1 (MR4...MR7), IP00 (MR8...MR9) Option : IP54/Type 12 (MR4...MR9), IP21 (MR8...MR9) NOTE! For IP54/Type 12, a control panel adapter is necessary.
EMC (at default settings)	Immunity	Fulfils EN61800-3 (2004)
	Emissions	Fulfils EN61800-3 (2004), category C4.
Noise level	Average noise level (min...max) sound pressure level in dB(A)	The sound pressure depends on the cooling fan speed, which is controlled in accordance with the drive temperature. MR4: 45...56 MR7: 43...73 MR5: 57...65 MR8: 58...73 MR6: 63...72 MR9: 54...75
Safety		EN 61800-5-1 (2007), CE (See the nameplate of the drive for more approvals.)
Protections	Overvoltage trip limit	The 240-volt drives: 456 VDC The 500-volt drives: 911 VDC
	Under voltage trip limit	Depends on mains voltage (0.8775 x mains voltage): Mains voltage 240 V: trip limit 211 VDC Mains voltage 400 V: trip limit 351 VDC Mains voltage 500 V: trip limit 421 VDC
	ETC	Earth fault protection, Mains supervision, Motor phase supervi- sion, Overcurrent protection, Unit over temperature protection, Motor overload protection, Motor stall protection, Motor underload protection, Short-circuit protection of +24 V and +10 V reference voltages

8. TECHNICAL DATA ON CONTROL CONNECTIONS

8.1 TECHNICAL DATA ON CONTROL CONNECTIONS

Table 39: The standard I/O board

Standard I/O board		
Terminal	Signal	Technical information
1	Reference output	+10 V, +3%, maximum current: 10 mA
2	Analogue input, voltage or current	Analogue input channel 1 0...+10 V (Ri= 200 k Ω) 4...20 mA (Ri=250 Ω) Resolution 0.1 %, accuracy ± 1 % Selection V/mA with dip-switches Short-circuit protected
3	Analogue input common (current)	Differential input if not connected to ground Allows ± 20 V common mode voltage to GND
4	Analogue input, voltage or current (current)	Analogue input channel 2 0...10 V (Ri=200 k Ω), 4...20 mA (Ri= 250 Ω) Resolution 0.1 %, accuracy ± 1 % Selection V/mA with dip-switches Short-circuit protected
5	Analogue input common (current)	Differential input if not connected to ground Allows ± 20 V common mode voltage to GND
6	24 V aux. voltage	+24 V, $\pm 10\%$, max volt. ripple < 100 mVrms max. 250 mA Short-circuit protected
7	I/O ground	Ground for reference and controls (connected internally to frame earth through 1 M Ω)
8	Digital input 1	Positive or negative logic Ri= min. 5 k Ω 0...5 V = 0 15...30 V = 1
9	Digital input 2	
10	Digital input 3	
11	Common A for DIN1-DIN6	Digital inputs can be disconnected from ground
12	24 V aux. voltage	+24 V, $\pm 10\%$, max volt. ripple < 100mVrmsmax. 250 mA Short-circuit protected
13	I/O ground	Ground for reference and controls (connected internally to frame earth through 1 M Ω)
14	Digital input 4	Positive or negative logic Ri= min. 5k Ω 0-5V = "0" 15-30V = "1"
15	Digital input 5	
16	Digital input 6	

Standard I/O board		
Terminal	Signal	Technical information
17	Common A for DIN1-DIN6	Digital inputs can be isolated from ground, see chapter 5.2.2.2 Isolation of digital inputs from ground.
18	Analogue signal (+output)	Analogue output channel 1, selection 0 ...20 mA, load <500 Ω Default: 0...20 mA, 0...10 V Resolution 0.1 %, accuracy ±2 % Selection V/mA with dip-switches Short-circuit protected Differential receiver/transmitter
19	Analogue output common	
30	24V auxiliary input voltage	Can be used as external power backup for the control unit
A	RS485	Differential receiver/transmitter Set bus termination with dip switches Selection of terminal functions with DIP switches Termination resistance = 220 Ω
B	RS485	

The standard relay board (+SBF3)		
Terminal	Signal	Technical information
21	Relay output 1 *	Change-over contact (SPDT) relay. 5.5 mm isolation between channels. Switching capacity • 24 VDC/8 A • 250 VAC/8 A • 125 VDC/0.4 A Minimum switching load • 5 V/10 mA
22		
23		
24	Relay output 2 *	Change-over contact (SPDT) relay. 5.5 mm isolation between channels. Switching capacity • 24 VDC/8 A • 250 VAC/8 A • 125 VDC/0.4 A Minimum switching load • 5 V/10 mA
25		
26		
32	Relay output 3 *	Normally-open (NO or SPST) contact relay. 5.5 mm isolation between channels. Switching capacity • 24 VDC/8 A • 250 VAC/8 A • 125 VDC/0.4 A Minimum switching load • 5 V/10 mA
33		

*If you use 230 VAC as control voltage from the output relays, the control circuitry must be powered with a separate isolation transformer to limit the short circuit current and the overvoltage spikes. This is to prevent welding on the relay contacts. Refer to standard EN 60204-1, section 6.2.9.



www.hyundai-electric.com



Head Office (Sales & Marketing)	55, Bundang-ro, Bundang-gu, Seongnam-si, Gyeonggi-do Tel: 82-31-8006-6796 Fax: 82-31-8006-6898
Ulsan (Factory)	700, Bangeojinsunhwan-doro, Dong-gu, Ulsan, Korea Tel: 82-52-202-8413 Fax: 82-52-202-8410
Atlanta	6100 Atlantic Blvd. Suite 201, Norcross, GA30097, USA Tel: 1-678-823-7839 Fax: 1-678-823-7553
London	2nd Floor, The Triangle, 5-17 Hammersmith Grove London, W6 0LG, UK Tel: 44-20-8741-0501 Fax: 44-20-8741-5620
Moscow	World Trade Center, Ent. 3# 1902, Krasnopresnenskays Nab. 12, Moscow, 123610, Russia Tel: 7-495-258-1381 Fax: 7-495-258-1382
Tokyo	8th Floor, Yurakucho Denki Bldg. 1-7-1 Yuraku-Cho, Chiyoda-Ku, Tokyo, 100-0006, Japan Tel: 81-03-3211-4792 Fax: 81-03-3216-0728
Osaka	I-Room 5th Floor Nagahori Plaza Bldg. 2-4-8 Minami Senba, Chuo-Ku, Osaka, 542-0081, Japan Tel: 81-06-6261-5766-7 Fax: 81-06-6261-5818
Riyadh	Office No. 230, 2nd Floor, 4th Akaria Plaza, Olaya Street, P.O.BOX 8072, Riyadh 11485, Saudi Arabia Tel: 966-11-464-4696 Fax: 966-11-462-2352
Dubai	Unit 205, Building 4, Emaar Square, Sheikh Zayed Road, Pobox 252458, Dubai, UAE Tel: 971-4-425-7995 Fax: 971-4-425-7996
Sofia	1271 Sofia 41, Rojen Blvd., Bulgaria Tel: 359-2-803-3200, 3220 Fax: 359-2-803-3203
Alabama	215 Folmar Parkway, Montgomery, AL 36105, USA Tel: 1-334-481-2000 Fax: 1-334-481-2098
Ohio	330 East First Street, Mansfield, OH 44902 USA Tel: 1-724-759-7445 Fax: 1-419-522-9386
Vladivostok	15 str. Potemkina, Artem, Primorskiy Krai, 692760, Russia Tel: 7-423-201-0110 Fax: 7-423-201-0110
Yangzhong	No.9 Xiandai Road, Xinba Scientific and Technologic Zone, Yangzhong, Jiangsu, P.R.C. Zip: 212212, China Tel: 86-511-8842-0666, 0212 Fax: 86-511-8842-0668, 0231

www.nicsanat.com
021-87700210

