



# iMASTER – A1

## User's Manual

[www.nicsanat.com](http://www.nicsanat.com)  
021-87700210



# CONTENTS

<b>1. A1 series VFD .....</b>	<b>1</b>
<b>1.1 Information before Use.....</b>	<b>1</b>
1.1.1 Check of product .....	1
1.1.2 Parts.....	1
1.1.3 Preparation of device and Parts for operation.....	2
1.1.4 Installation.....	2
1.1.5 Distribution .....	2
<b>1.2 Names and Uses of Parts .....</b>	<b>2</b>
1.2.1 End product.....	2
1.2.2 Remove the front cover .....	3
<b>2. Specifications.....</b>	<b>4</b>
<b>2.1 Specifications.....</b>	<b>4</b>
2.1.1 200V class (032A ~ 310A).....	4
2.1.2 400V class (016A ~ 217A).....	5
2.1.3 400V class (260A ~ 296A).....	6
2.1.4 Other commons .....	7
<b>3. Installation .....</b>	<b>1 0</b>
<b>3.1 Installation.....</b>	<b>1 0</b>
3.1.1 Cautions before installation.....	1 0
3.1.2 A1 Dimension (IP00) .....	1 2
<b>4. Wiring .....</b>	<b>2 0</b>
<b>4.1 Wiring .....</b>	<b>2 0</b>
4.1.1 Installation method of VFD keypad to panel.....	2 0
4.1.2 Wiring precaution.....	2 1
4.1.3 A1 Terminal Connection Diagram and Description .....	2 5
4.1.4 Terminal wiring diagram (Power terminal block).....	2 7
4.1.5 Control terminal line diagram (Basic I/O terminal block).....	2 9
<b>5. Peripheral Devices.....</b>	<b>3 3</b>
<b>5.1 Peripheral Devices.....</b>	<b>3 3</b>
5.1.1 Composition of peripheral devices.....	3 3
5.1.2 Dynamic braking unit (DBU) and Resistors .....	3 4
<b>6. Keypad .....</b>	<b>3 5</b>
<b>6.1 Keypad View &amp; Operation .....</b>	<b>3 5</b>
6.1.1 Keypad View .....	3 5
6.1.2 Keypad operation.....	3 8
<b>7. Quick Start Guide.....</b>	<b>5 0</b>
7.1 Frequency Command Source to Up/Down Arrow Keys .....	5 0
7.2 Frequency Command Source to Input Analog Voltage/ Current .....	5 1

7.3 Frequency Command Source to Input Terminal – Multi Speed Frequency.....	5 2
7.4 Frequency Command Source to Input Terminal – Up/Down .....	5 3
7.5 Frequency Command Source to Modbus RS-485.....	5 4
7.6 Run Command Source to Run / Stop Keys on Keypad.....	5 5
7.7 Run Command Source to Input Terminal .....	5 5
7.8 Run Command Source to Modbus RS-485 .....	5 6
<b>8. A1 Parameters .....</b>	<b>5 7</b>
<b>8.1 A1 Parameters Overview .....</b>	<b>5 7</b>
8.1.1 VFD running status .....	5 8
8.1.2 Frequency reference indication .....	5 8
8.1.3 Trip information.....	5 8
8.1.4 Time counter .....	6 0
8.1.5 VFD firmware Information .....	6 0
8.1.6 Standard DI, DO (RN0~RN3, AL0-AL1-AL2).....	6 1
8.1.7 Standard AI (O, OI) .....	6 2
8.1.8 Standard AO (FM, AMI) .....	6 3
8.1.9 Start/stop/direction .....	6 4
8.1.10 Start/Stop mode.....	6 6
8.1.11 Frequency reference.....	6 7
8.1.12 Acceleration/Deceleration.....	6 9
8.1.13 Speed search .....	6 9
8.1.14 Over voltage suppression .....	7 0
8.1.15 KEB.....	7 0
8.1.16 DWELL .....	7 0
8.1.17 Frequency limits.....	7 0
8.1.18 Fault functions .....	7 1
8.1.19 Motor thermal protection .....	7 2
8.1.20 System Overload/Underload detection .....	7 2
8.1.21 PID .....	7 3
8.1.22 DBR Duty Cycle .....	7 5
8.1.23 Monitoring/Scaling.....	7 5
8.1.24 Droop.....	7 5
8.1.25 RS-485 (Modbus).....	7 5
8.1.26 Fieldbus (option) .....	7 6
8.1.27 User parameters.....	7 7
8.1.28 System.....	7 8
8.1.29 Motor control.....	7 9
8.1.30 Motor data.....	8 0
<b>8.2 Parameter detail.....</b>	<b>8 1</b>
8.2.1 VFD running status .....	8 1
8.2.2 Frequency reference indication .....	8 3
8.2.3 Trip information.....	8 4
8.2.4 Time counter .....	8 6
8.2.5 VFD firmware information .....	8 8
8.2.6 Standard DI, DO .....	8 9
8.2.7 Standard AI (O, OI) .....	9 7
8.2.8 Standard AO (FM, AMI) .....	1 0 2

8.2.9	Start/Stop/Direction .....	1 0 6
8.2.10	Start/Stop mode.....	1 1 1
8.2.11	Frequency reference.....	1 1 4
8.2.12	Acceleration/Deceleration.....	1 2 4
8.2.13	Speed Search .....	1 2 8
8.2.14	Over voltage suppression .....	1 2 9
8.2.15	KEB.....	1 3 5
8.2.16	DWELL .....	1 3 6
8.2.17	Frequency limits.....	1 3 7
8.2.18	Fault functions .....	1 3 8
8.2.19	Motor thermal protection .....	1 4 3
8.2.20	System Overload/Underload detection .....	1 4 4
8.2.21	PID .....	1 4 6
8.2.22	DBR Duty cycle.....	1 5 4
8.2.23	Monitoring/Scaling.....	1 5 5
8.2.24	Droop.....	1 5 6
8.2.25	RS-485 (Modbus).....	1 5 9
8.2.26	Fieldbus (option).....	1 6 6
8.2.27	User parameters.....	1 6 7
8.2.28	System.....	1 6 8
8.2.29	Motor control.....	1 7 0
8.2.30	Motor data.....	1 7 4
<b>9.</b>	<b>Checking and Trouble shooting .....</b>	<b>1 7 7</b>
9.1	Error code.....	1 7 7
9.1.1	Error code list .....	1 7 7
9.2	Trouble Shooting .....	1 7 9
9.2.1	Trip monitor display.....	1 7 9
9.2.2	oC (Over Current).....	1 8 0
9.2.3	SC (Short Circuit).....	1 8 1
9.2.4	ETH (Motor Overload).....	1 8 2
9.2.5	IoLt (VFD Overload) .....	1 8 3
9.2.6	ov (DC link Over Voltage) .....	1 8 4
9.2.7	Lv (DC link Under Voltage).....	1 8 5
9.2.8	ot (Over Temperature).....	1 8 6
9.2.9	PF (Input Power Loss) .....	1 8 7
9.2.10	FF (Fan Fault) .....	1 8 8
9.2.11	VFD doesn't turn on.....	1 8 9
<b>10.</b>	<b>Functional Safety .....</b>	<b>1 9 0</b>
10.1	Functional Safety.....	1 9 0
10.1.1	Safety standard product .....	1 9 0
10.1.2	Safety function description and wiring diagram.....	1 9 0

# 1. A1 series VFD

## 1.1 Information before Use

### 1.1.1 Check of product

Bring the VFD out of the box, check the rating shown on a side of the product body and whether the VFD type and rated output are exactly what you ordered. Check also whether the product has been damaged during delivery.

**Model: A1-140A** (Note1)-2E- 00

A1	140A		2	E	00
name	Max. Applicable Motor Capacity		Input Voltage	Keypad	IP
A1	32A	7.5 [kW]	2: 3Phase 200 ~ 240[V]	E: LED C: LCD	00: IP00 54: IP54
	45A	11 [kW]			
	64A	15 [kW]			
	76A	18.5 [kW]			
	90A	22 [kW]			
	114A	30 [kW]			
	140A	37 [kW]			
	170A	45 [kW]			
	205A	55 [kW]			
	261A	75 [kW]			
	310A	90 [kW]			
	16A	7.5 [kW]	4: 3Phase 380 ~ 480[V]		
	23A	11 [kW]			
	32A	15 [kW]			
	38A	18.5 [kW]			
	45A	22 [kW]			
	58A	30 [kW]			
	075A	37 [kW]			
	090A	45 [kW]			
	110A	55 [kW]			
	149A	75 [kW]			
	176A	90 [kW]			
	217A	110 [kW]			
	260A	132 [kW]			
	296A	160 [kW]			

### 1.1.2 Parts

If you have any doubt about the product or found the product damaged, call our company's branch offices (see the back cover of the manual)

### 1.1.3 Preparation of device and Parts for operation

Preparation for operation might slightly vary. Prepare parts according to the use.

### 1.1.4 Installation

Make sure you install the product correctly considering the place, direction or surroundings in order to prevent decrease in the life and performance of the VFD.

### 1.1.5 Distribution

Connect the power supply, electric motor and operating signals (control signals) to the terminal block. If you fail to connect them correctly, the VFD and peripheral devices might be damaged.

## 1.2 Names and Uses of Parts

### 1.2.1 End product



### 1.2.2 Remove the front cover



## 2. Specifications

### 2.1 Specifications

#### 2.1.1 200V class (032A ~ 310A)

Model A1-xxxA <sup>(Note1)</sup> -2		032	045	064	076	090	114		
Motor Applied [kW] <sup>(Note2)</sup>		HD	5.5	7.5	11	15	18.5	22	
		ND	7.5	11	15	18.5	22	30	
Rated Output	Rated Output <sup>(Note3)</sup> Current [A]		HD	24	32	45	64	76	90
			ND	32	45	64	76	90	114
	Rated Capacity [kVA]	HD	200V	8	11	16	22	26	31
			240V	10	13	19	27	32	37
		ND	200V	11	16	22	26	31	39
			240V	13	19	27	32	37	47
Output Frequency [Hz]			0~400Hz <sup>(Note4)</sup>						
Output Voltage [V]			3 Phase 200~240V <sup>(Note5)</sup>						
Rated Input		Available Voltage [V]		3 phase 200~240V (±10%)					
		Input Frequency [Hz]		50/ 60Hz (±5%)					
		Rated Input Current [A]	HD	23	32	45	64	77	92
			ND	31	45	64	77	91	116
Power loss [kW]	HD	0.15	0.21	0.31	0.42	0.52	0.62		
	ND	0.21	0.31	0.42	0.52	0.62	0.84		
EMC Filter			Built-in 61800-3 C3						

Model A1-xxxA <sup>(Note1)</sup> -2		140	170	205	261	310	-		
Motor Applied [kW] <sup>(Note2)</sup>		HD	30	37	45	55	75	-	
		ND	37	45	55	75	90	-	
Rated Output	Rated Output <sup>(Note3)</sup> Current [A]		HD	114	140	170	211	261	-
			ND	140	170	205	261	310	-
	Rated Capacity [kVA]	HD	200V	39	48	59	73	90	-
			240V	47	58	71	88	108	-
		ND	200V	48	59	71	90	107	-
			240V	58	71	85	108	129	-
Output Frequency [Hz]			0~400Hz <sup>(Note4)</sup>						
Output Voltage [V]			3 Phase 200~240V <sup>(Note5)</sup>						
Rated Input		Available Voltage [V]		3 phase 200~240V (±10%)					
		Input Frequency [Hz]		50/ 60Hz (±5%)					
		Rated Input Current [A]	HD	102.9	126.9	154.4	187.7	257.3	-
			ND	126.9	154.4	188.7	257.3	308.8	-
Power loss [kW]	HD	0.60	0.74	0.90	1.10	1.50	-		
	ND	0.74	0.90	1.10	1.50	1.80	-		
EMC Filter			Built-in 61800-3 C3						



2.1.2 400V class (016A ~ 217A)

Model A1-xxxA <sup>(Note1)</sup> -4		016	023	032	038	045	058		
Motor Applied [kW] <sup>(Note2)</sup>		HD	5.5	7.5	11	15	18.5	22	
		ND	7.5	11	15	18.5	22	30	
Rated Output	Rated Output <sup>(Note3)</sup> Current [A]		HD	12	16	23	32	38	45
			ND	16	23	32	38	45	58
	Rated Capacity [kVA]	HD	380V	8	11	15	21	25	30
			480V	10	13	19	27	32	37
		ND	380V	11	15	21	25	30	38
			480V	13	19	27	32	37	48
Output Frequency [Hz]			0~400Hz <sup>(Note4)</sup>						
Output Voltage [V]			3 Phase 380~480V <sup>(Note5)</sup>						
Rated Input		Available Voltage [V]		3-phase 380~480V (±10%)					
		Input Frequency [Hz]		50/ 60Hz (±5%)					
Rated Input Current [A]		HD	12	16	23	32	38	46	
		ND	16	23	32	38	45	59	
Power loss [kW]		HD	0.15	0.21	0.31	0.42	0.52	0.62	
		ND	0.21	0.31	0.42	0.52	0.62	0.84	
EMC Filter			Built-in 61800-3 C3						

Model A1-xxxA <sup>(Note1)</sup> -4		075	090	110	149	176	217		
Motor Applied [kW] <sup>(Note2)</sup>		HD	30	37	45	55	75	90	
		ND	37	45	55	75	90	110	
Rated Output	Rated Output <sup>(Note3)</sup> Current [A]		HD	58	75	90	110	149	176
			ND	75	90	110	149	176	217
	Rated Capacity [kVA]	HD	380V	38	49	59	72	98	116
			480V	48	62	75	91	124	146
		ND	380V	49	59	72	98	116	143
			480V	62	75	91	124	146	180
Output Frequency [Hz]			0~400Hz <sup>(Note4)</sup>						
Output Voltage [V]			3 Phase 380~480V <sup>(Note5)</sup>						
Rated Input		Available Voltage [V]		3-phase 380~480V (±10%)					
		Input Frequency [Hz]		50/ 60Hz (±5%)					
Rated Input Current [A]		HD	59.6	73.5	89.4	109.2	149.0	178.8	
		ND	73.5	89.4	109.2	149.0	178.8	218.5	
Power loss [kW]		HD	0.60	0.74	0.90	1.10	1.50	1.80	
		ND	0.74	0.90	1.10	1.50	1.80	2.20	
EMC Filter			Built-in 61800-3 C3						

### 2.1.3 400V class (260A ~ 296A)

Model A1-xxxA <sup>(Note1)</sup> -4		260	296	-	-	-	-	
Motor Applied [kW] <sup>(Note2)</sup>		HD	110	132	-	-	-	
		ND	132	160	-	-	-	
Rated Output	Rated Output <sup>(Note3)</sup> Current [A]		HD	217	260	-	-	-
			ND	260	296	-	-	-
	Rated Capacity [kVA]	HD	380V	143	171	-	-	-
			480V	180	216	-	-	-
		ND	380V	171	195	-	-	-
			480V	216	246	-	-	-
Output Frequency [Hz]		0~400Hz <sup>(Note4)</sup>						
Output Voltage [V]		3 Phase 380~480V <sup>(Note5)</sup>						
Rated Input	Available Voltage [V]		3-phase 380~480V (±10%)					
	Input Frequency [Hz]		50/ 60Hz (±5%)					
	Rated Input Current [A]		HD	218.5	262.2	-	-	-
			ND	262.2	317.8	-	-	-
	Power loss [kW]		HD	2.20	2.64	-	-	-
ND			2.64	3.20	-	-	-	
EMC Filter			Built-in 61800-3 C3					

Note 1) The number that has included at model name means rated current of VFD

Note 2) Motor Applied indicates the maximum capacity applied to use of a standard 4 pole standard motor.

Note 3) The output of rated current is limited according to setting of the carrier frequency.

Note 4) In case of Sensorless, you can set the frequency at up to 300Hz by selecting 2 as the **'98.01' (Motor control mode)**

Note 5) The maximum output voltage does not go up over the supplied power voltage. You can select the output voltage as you want below the supplied power voltage.

## 2.1.4 Other commons

### 1) Control & Operation

Features		Performance Specification
Control Method <sup>(Note1)</sup>		V/F control, Sensorless Vector
Output Frequency Range <sup>(Note2)</sup>		0.5 ~ 400Hz (Sensorless Vector Control: 0.5 ~ 300Hz)
Frequency Accuracy		Digital command $\pm 0.01\%$ of Max Frequency / Analog Frequency $\pm 0.1\%$ ( $25 \pm 10^\circ\text{C}$ )
Frequency Resolution		Digital Setting : 0.01Hz (below 100Hz), 0.1Hz (above 100Hz) Analog setting: 0.06Hz (DC 0~10V, 4~20mA)
Voltage/ frequency Characteristic		Constant torque, Variable torque
Carrier Frequency		1~10kHz (default: ND 2kHz, HD 3kHz)
Overload Current Rate		Heavy Duty(150%, 1 min), Normal Duty(120%, 1 min)
Acceleration/Deceleration		0.1~3000 sec (Linear, S curve, U curve), 2 <sup>ND</sup> Acceleration and Deceleration
DC Injection Braking		Separately configurable start and stop up to 10 sec, 100 % motor rated current
Input Signal	Frequency	<ul style="list-style-type: none"> <li>▪ Set by Keypad (LED, LCD)</li> <li>▪ Input voltage: DC 0~10V (Input impedance 10K<math>\Omega</math>)</li> <li>▪ Input current: DC 4~20mA (Input impedance 200<math>\Omega</math>)</li> </ul>
	Run/Stop	<ul style="list-style-type: none"> <li>▪ Run / Stop key</li> <li>▪ Input Terminal: Forward Run/Reverse Run</li> <li>▪ Input Terminal: Start, Stop, FW/RV Selection</li> </ul>
	Intelligent Input Terminal	<ul style="list-style-type: none"> <li>▪ Run selection 1~2, Run source 1~3</li> <li>▪ Frequency selection 1~2</li> <li>▪ Multi-speed Inputs 1~3</li> <li>▪ Jogging 1~2</li> <li>▪ External trip 1~5</li> <li>▪ UP/DOWN</li> <li>▪ PID Integral Reset, PID Disable</li> <li>▪ 2nd Acceleration / Deceleration</li> <li>▪ Emergency Stop</li> <li>▪ Reset</li> <li>▪ Parameter lock</li> </ul>

Features		Performance Specification
Output Signal	Intelligent Output Terminal (RN0-RN1,RN2-RN3, AL0-AL1-AL2)	<ul style="list-style-type: none"> <li>▪ Run (VFD Running Status Signal)</li> <li>▪ FA1 (Frequency Arrival Signal 1)</li> <li>▪ FA2 (Frequency Arrival Signal 2)</li> <li>▪ OL (Overload Alarm)</li> <li>▪ OD (PID Error Deviation Signal)</li> <li>▪ AL (Fault Signal)</li> </ul>
	FM Output	Analog Output Meter (DC 0~10V full scale. Max • 1mA) Output Frequency, Output Current, Output Voltage, Output Power and Output Torque
	AMI Output	Analog Output Meter (4~20mA full scale. Max • 250Ω) Output Frequency, Output Current, Output Voltage, Output Power and Output Torque

2) Application & Protection Functions

Features	Performance Specification
Application Specification Functions	<ul style="list-style-type: none"> <li>▪ Curved Acceleration / Deceleration Profile,</li> <li>▪ Upper and Lower Limiters,</li> <li>▪ 8-stage Speed Profile,</li> <li>▪ Carrier Frequency Change (1 to 10Khz),</li> <li>▪ Frequency Skip</li> <li>▪ Process Jogging,</li> <li>▪ Electronic Thermal Level Adjustment,</li> <li>▪ Retry Function,</li> <li>▪ Trip History Monitor,</li> <li>▪ Auto Tuning,</li> <li>▪ V/f Characteristic Selection,</li> <li>▪ Speed Search</li> <li>▪ Automatic Torque Boost,</li> <li>▪ Frequency Conversion Display,</li> </ul>
Protection Functions	<ul style="list-style-type: none"> <li>▪ Over Current / Short Circuit</li> <li>▪ DC link Over Voltage /DC link Under Voltage,</li> <li>▪ Motor Overload,</li> <li>▪ VFD Overload</li> <li>▪ EEPROM Error,</li> <li>▪ Communication Error,</li> <li>▪ IGBT Over Temperature,</li> <li>▪ Input Phase loss,</li> <li>▪ Ground Fault,</li> <li>▪ External Event</li> <li>▪ Fan Fault</li> <li>▪ OVS Control Fail</li> <li>▪ Safety</li> </ul>

3) Use Environment & Option

Feature		Performance Specification
Environment specification	Ambient Temperature	CT (Heavy Duty) load: - 10 ~ 50°C VT (Normal Duty) load: - 10~ 40°C (It is recommended that you use less than 80% load when you use VT load at 50°C. And if ambient temperature is above 40°C, Carrier frequency should be lower than default value.)
	Storage temperature	-20~60°C
	Ambient humidity	Below 90% RH (Installed with no dew condensation)
	Vibration	5.9m/s <sup>2</sup> (0.6G). 10~55Hz
	Shock	10 Hz to 20Hz, 9.8m/s <sup>2</sup> Max, 20Hz to 55Hz, 5.9m/s <sup>2</sup> Max
	Location	Under 1000m above sea level, indoors (Installed away from corrosive gasses dust)
Standard Compliant		UL 508C, IEC 61800-3
Protective Design		IP00 open-chassis, NEMA Type 1 enclosure.
Option		Fieldbus, Ext I/O, Encoder, Remote operator, Bracket, AC reactor, Noise filter, Braking resistor, Dynamic braking unit (EMC filter and DC reactor are Built in.)

Note 1) **'98.01'(Motor control mode)** to 2 (sensorless vector control) Selected, refer to below

- Set a value more than 2kHz at **'98.03'(PWM carrier frequency)**
- Sensorless vector performance will be reduced when using a motor less than half of the rated capacity of the VFD.
- Multiple motors cannot be driven by sensorless vector control.

Note 2) To operate the motor over rated frequency, consult the motor manufacturer about the maximum allowable rotation speed.

## 3. Installation

### 3.1 Installation

#### 3.1.1 Cautions before installation

### ! CAUTION

Failure to following recommendation may result in VFD damage, Personal Injury, or Fire.

- Be sure to install the unit on flame resistant material such as metal.
- Be sure not to place anything flammable such as corrosive gas, explosive gas, inflammable gas, grinding fluid mist, salt in the vicinity
- Do not carry the unit by the top cover, but always by supporting the base of the unit
- Be sure not to let foreign matter enter such as cut wire refuse, spatter from welding, iron refuse, wire, dust, etc.
- Be sure to install the VFD in a place which can support the weight according to the specification in the manual.
- Be sure to install the unit on a perpendicular wall which is not subject to vibration.
- Be sure not to install and operate a damaged VFD or one with the missed parts
- Be sure to install the unit in an area which is not exposed to direct sunlight and well ventilated. Avoid an environment which tends to be high in temperature, high in humidity or to have condensation.

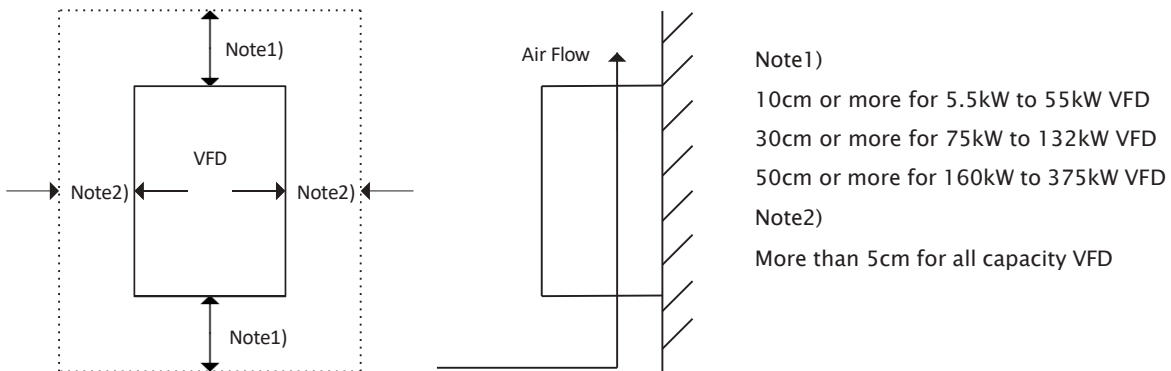

It is critical to mount the VFD to the proper surface in order to prevent any possible risk of fire. The temperature of the VFD heatsink can rise very high. The surface must be made of a non-flammable material (i.e. steel). Attention should also be made to the air gap surrounding the VFD. Especially, when there is a heat source such as a braking resistor or reactor.

## !CAUTION

- Avoid direct ray of light or a warm and humid place.
- Install the VFD in a place free from dust, corrosive gas, explosive gas, combustible gas, mist of coolant and sea damage.
- Allowable Temperature range (14 to 122°F, -10 to 50°C).
- Allowable humidity range (Below 90% RH).

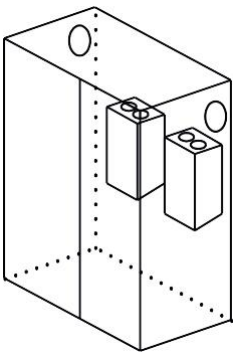

Acceptable (O)

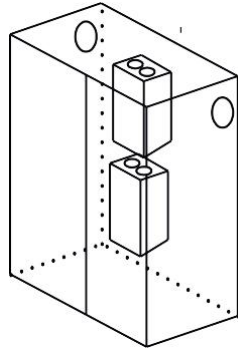

Unacceptable (X)

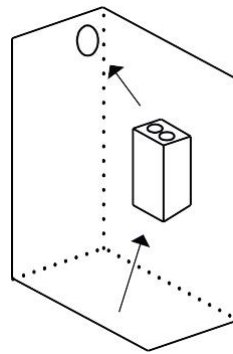

Acceptable (O)

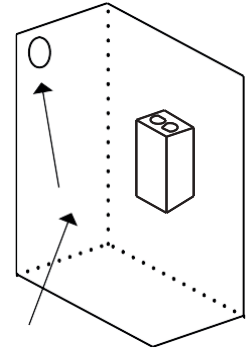

Unacceptable (X)

Mount the VFD in a vertical position using screws or bolts. The mounting surface should also be free from vibration and can easily hold the weight of the VFD.

### 3.1.2 A1 Dimension (IP00)

Summarized that is the dimension of A1 models  
Respective drawing and sizes are specified in 1) ~ 4)

Model	Frame	W [mm]	W1 [mm]	H [mm]	H1 [mm]	D [mm]	Weight [KG]
A1-032A-2	F1	180	130	400	390	235	8.00
A1-045A-2	F1	180	130	400	390	235	8.00
A1-064A-2	F1	180	130	400	390	235	8.00
A1-076A-2	F2	220	170	455	445	235	11.00
A1-090A-2	F2	220	170	455	445	235	11.00
A1-114A-2	F3	270	200	550	532	265	18.30
A1-140A-2	F3	270	200	550	532	265	24.04
A1-170A-2	F4	295	200	660	642	265	34.26
A1-205A-2	F4	295	200	660	642	265	34.26
A1-261A-2	F5	345	230	760	735	275	45.08
A1-310A-2	F5	345	230	760	735	275	46.04
A1-016A-4	F1	180	130	400	390	235	8.00
A1-023A-4	F1	180	130	400	390	235	8.00
A1-032A-4	F1	180	130	400	390	235	8.00
A1-038A-4	F2	220	170	455	445	235	11.00
A1-045A-4	F2	220	170	455	445	235	11.00
A1-058A-4	F2	220	170	455	445	235	11.00
A1-075A-4	F3	270	200	550	532	265	23.30
A1-090A-4	F3	270	200	550	532	265	23.50
A1-110A-4	F4	295	200	660	642	265	30.74
A1-149A-4	F4	295	200	660	642	265	30.94
A1-176A-4	F5	345	230	760	735	275	44.40
A1-217A-4	F5	345	230	760	735	275	44.92
A1-260A-4	F6	385	280	800	775	275	55.48
A1-296A-4	F6	385	280	800	775	275	56.24



Model	Frame	W [inch]	W1 [inch]	H [inch]	H1 [inch]	D [inch]	Weight [lbs]
A1-032A-2	F1	7.08	5.11	15.74	15.35	9.25	17.63
A1-045A-2	F1	7.08	5.11	15.74	15.35	9.25	17.63
A1-064A-2	F1	7.08	5.11	15.74	15.35	9.25	17.63
A1-076A-2	F2	8.66	6.69	17.91	17.51	9.25	24.25
A1-090A-2	F2	8.66	6.69	17.91	17.51	9.25	24.25
A1-114A-2	F3	10.63	7.87	21.65	20.94	10.43	18.3
A1-140A-2	F3	10.63	7.87	21.65	20.94	10.43	53.00
A1-170A-2	F4	11.61	7.87	25.98	25.28	10.43	75.53
A1-205A-2	F4	11.61	7.87	25.98	25.28	10.43	75.53
A1-261A-2	F5	13.58	9.06	29.92	28.94	10.83	99.38
A1-310A-2	F5	13.58	9.06	29.92	28.94	10.83	101.50
A1-016A-4	F1	7.08	5.11	15.74	15.35	9.25	17.63
A1-023A-4	F1	7.08	5.11	15.74	15.35	9.25	17.63
A1-032A-4	F1	7.08	5.11	15.74	15.35	9.25	17.63
A1-038A-4	F2	8.66	6.69	17.91	17.51	9.25	24.25
A1-045A-4	F2	8.66	6.69	17.91	17.51	9.25	24.25
A1-058A-4	F2	8.66	6.69	17.91	17.51	9.25	24.25
A1-075A-4	F3	10.63	7.87	21.65	20.94	10.43	51.37
A1-090A-4	F3	10.63	7.87	21.65	20.94	10.43	51.81
A1-110A-4	F4	11.61	7.87	25.98	25.28	10.43	67.77
A1-149A-4	F4	11.61	7.87	25.98	25.28	10.43	68.21
A1-176A-4	F5	13.58	9.06	29.92	28.94	10.83	97.89
A1-217A-4	F5	13.58	9.06	29.92	28.94	10.83	99.03
A1-260A-4	F6	15.16	11.02	31.49	30.51	10.83	122.31
A1-296A-4	F6	15.16	11.02	31.49	30.51	10.83	123.99

1) F1 (A1-032A-2, A1-045A-2, A1-064A-2 / A1-016A-4, A1-023A-4, A1-032A-4)

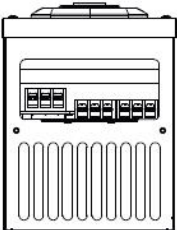
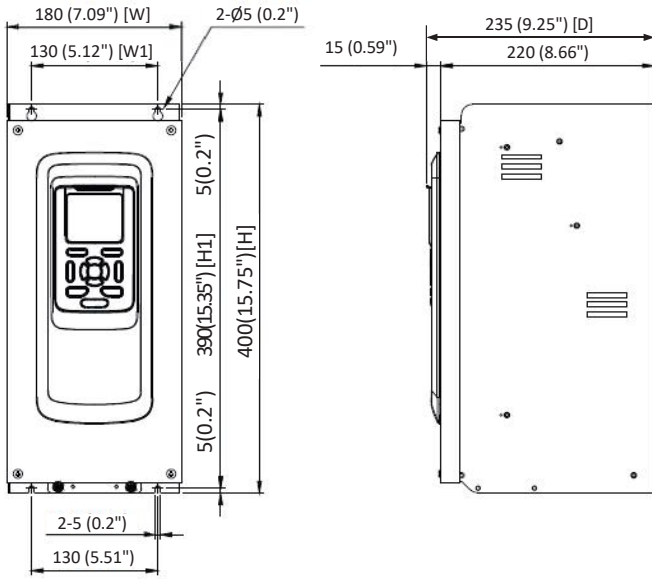
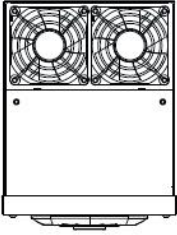

2) F2 (A1-076A-2, A1-090A-2/ A1-038A-4, A1-045A-4, A1-058A-4)

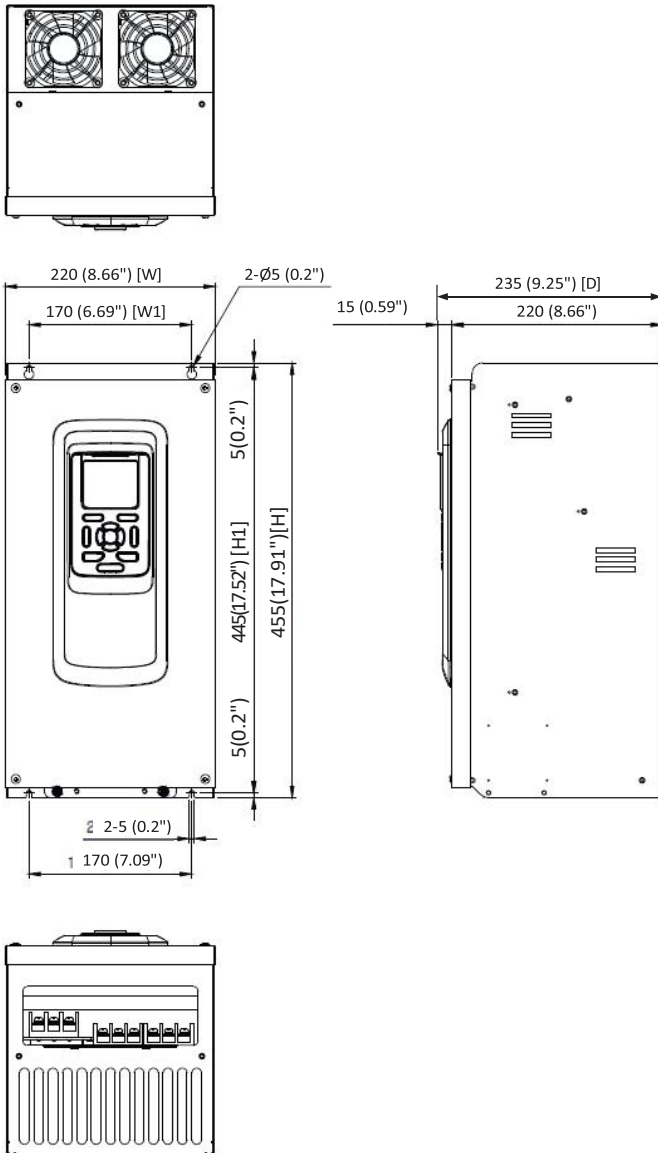

3) F3 (A1-114A-2, A1-140A-2/ A1-075A-4, A1-090A-4)

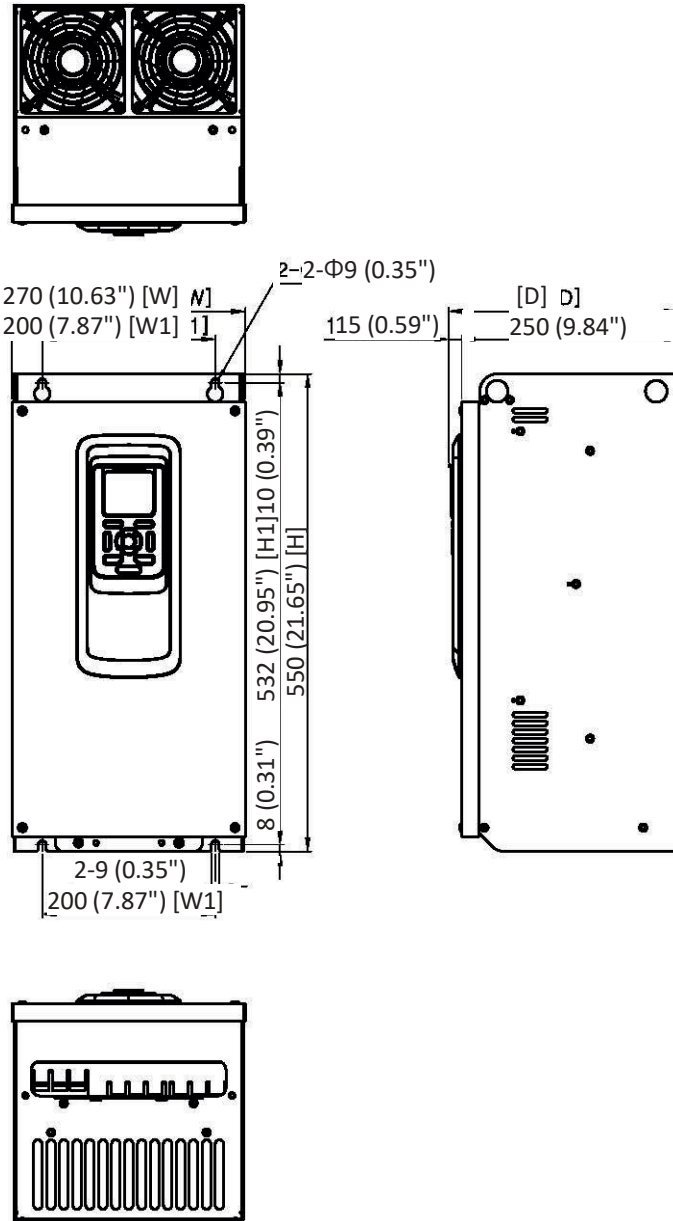

4) F4 (A1-170A-2, A1-205A-2/ A1-110A-4, A1-149A-4)

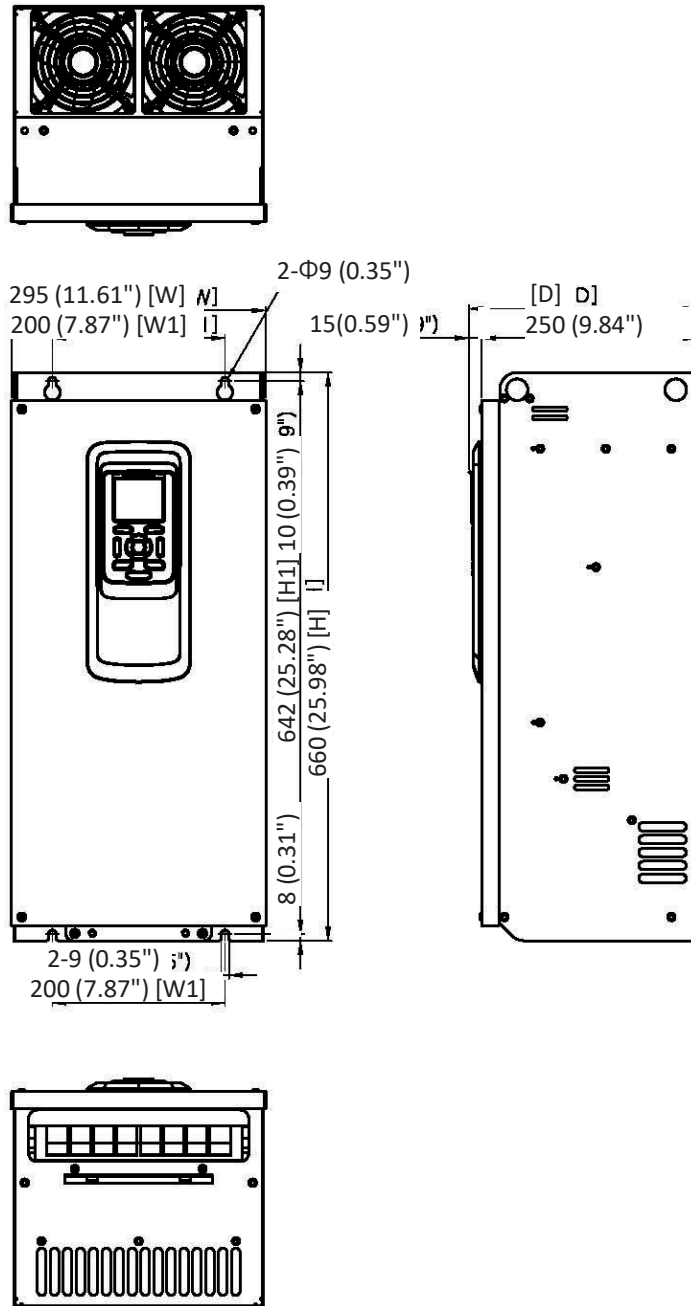

5) F5 (A1-261A-2, A1-310A-2/ A1-176A-4, A1-217A-4)

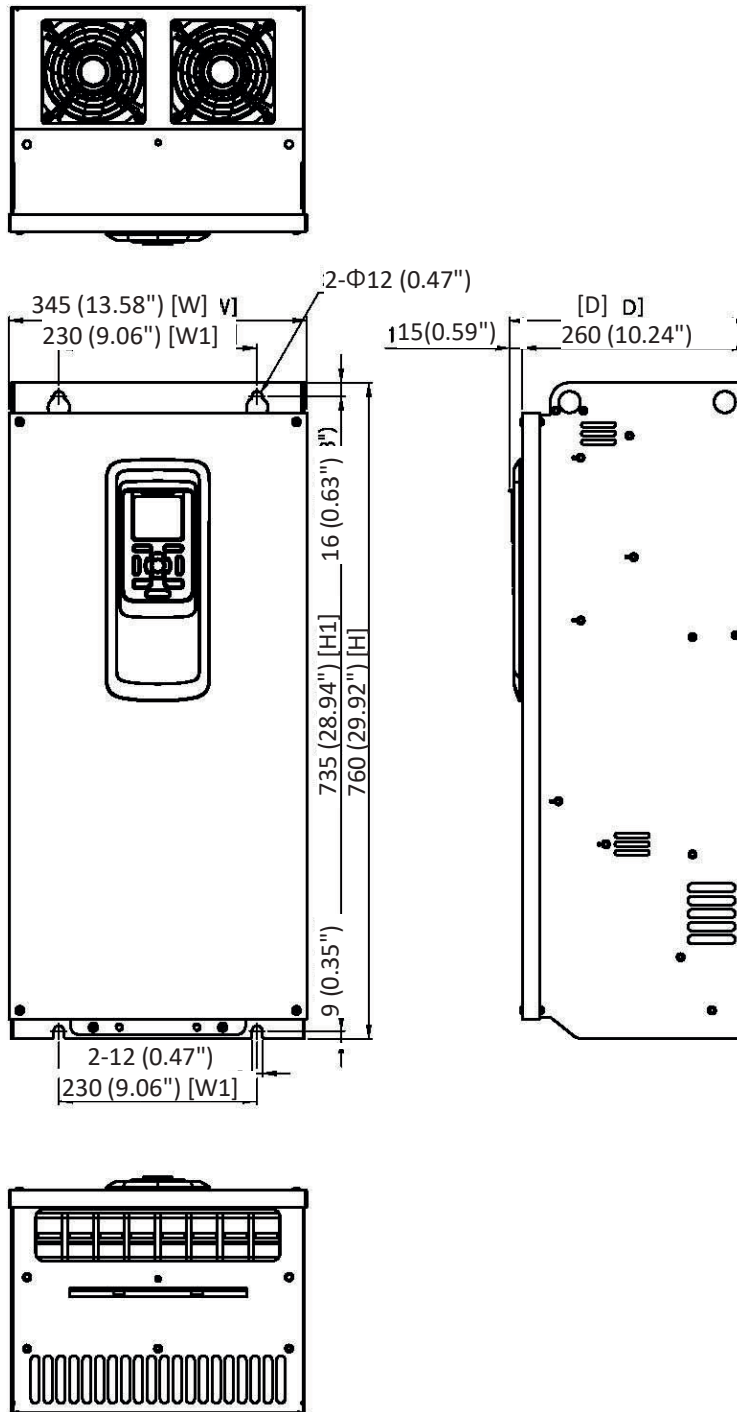

6) F6 (A1-260A-4, A1-296A-4)

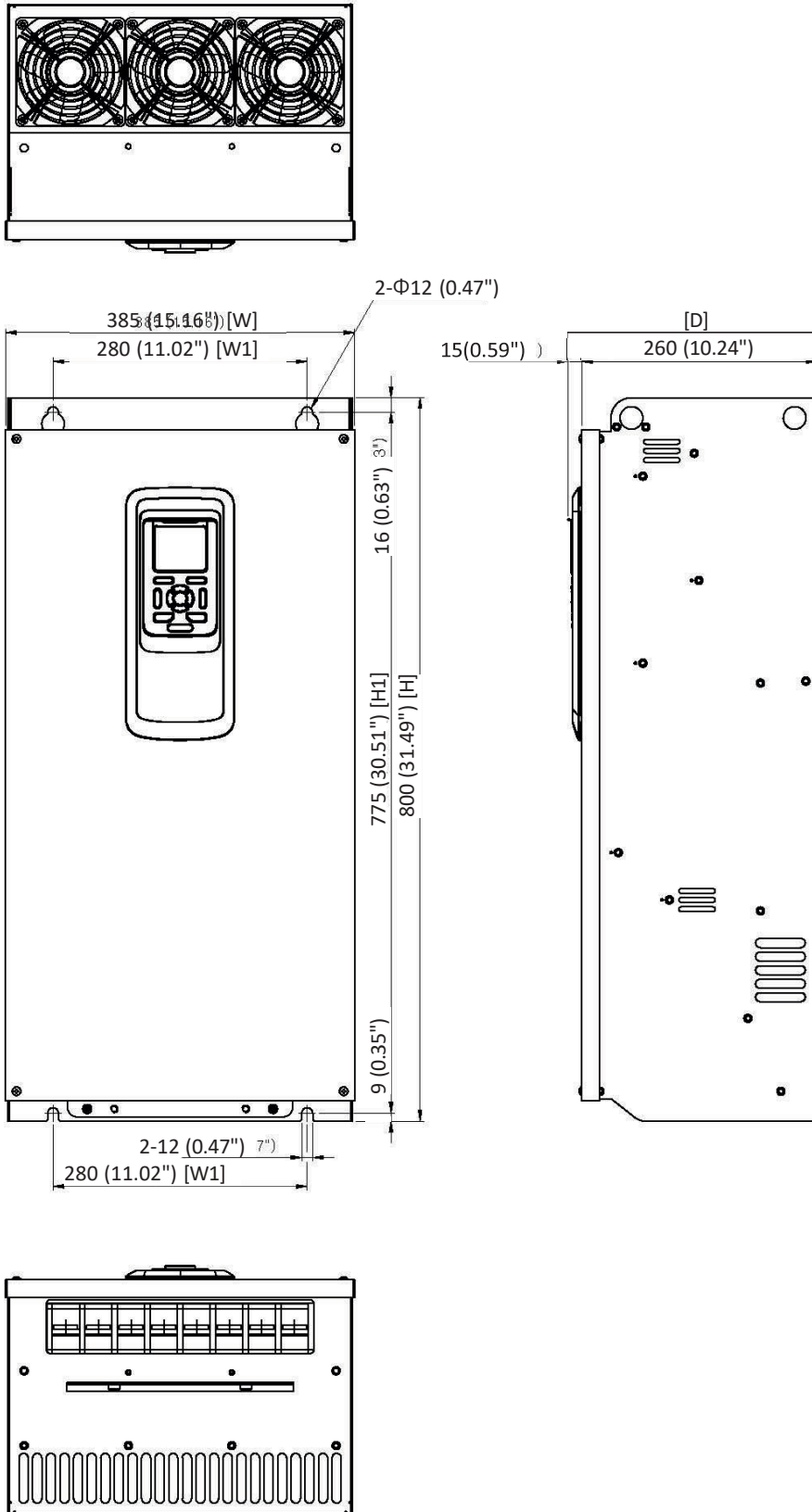

## 4. Wiring

### 4.1 Wiring

#### 4.1.1 Installation method of VFD keypad to panel

- 1) Separate the Keypad from case

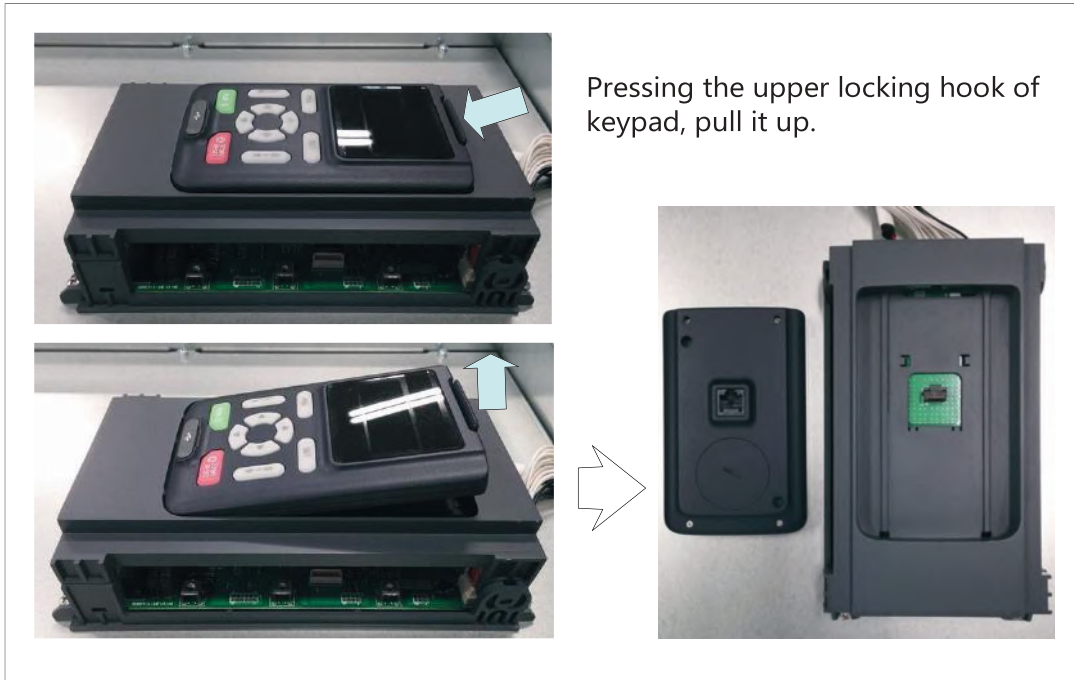

- 2) Connection

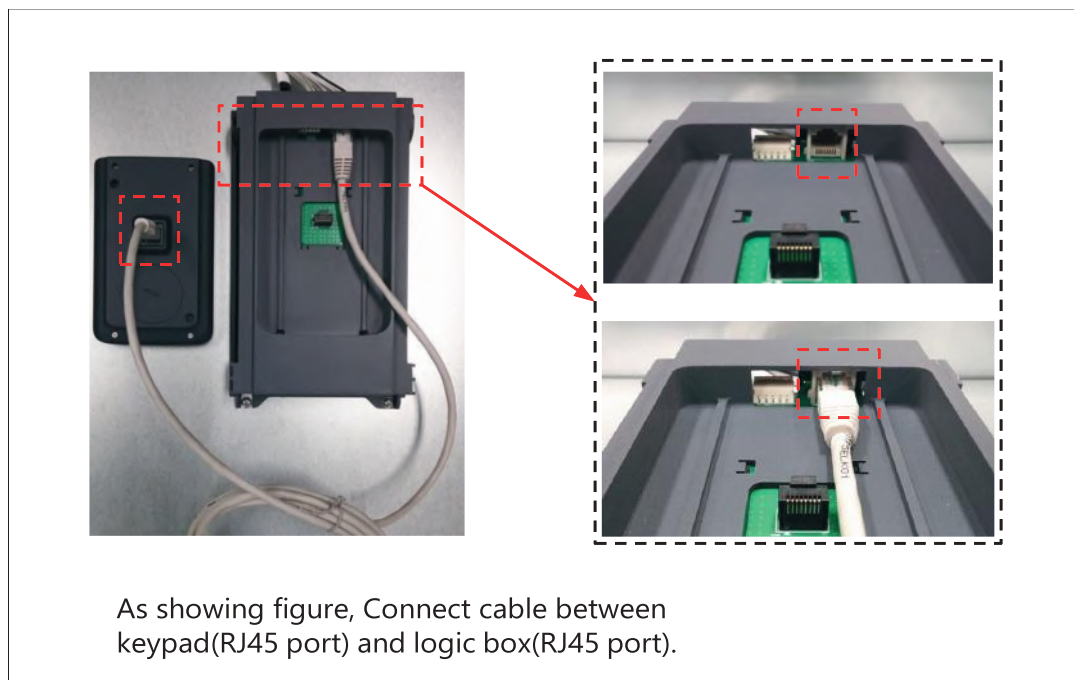



### 4.1.2 Wiring precaution

#### 1) Main Power Terminals: R(L1), S(L2), T(L3)

- Connect the main power terminals (R(L1), S(L2) and T(L3)) to the power supply through an electromagnetic contactor or an earth-leakage breaker. These devices isolate the utility power supply from the VFD and prevent the spread of damage.
- This unit is designed to be used on a three-phase power supply. If using on a single phase power supply, please contact ADT for proper sizing.
- Do not operate under the following conditions.
  - Unbalanced power supply voltage more than 3%
  - Power supply capacity more than 10 times of the capacity of VFD and case beyond 500kVA.

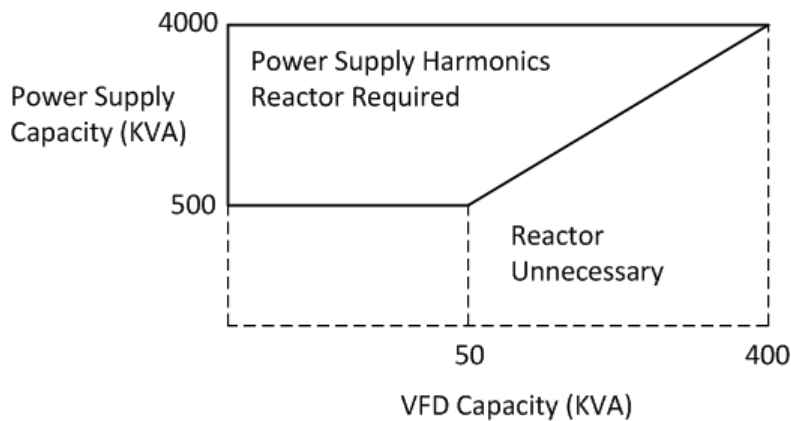

- Turning on/off the power supply more than three times in one minute, It could be damaged the recharge circuit of the VFD.

#### 2) VFD Output Terminals: U(T1), V(T2), W(T3)

- Make sure to use a heavier gauge wire when you have long motor leads. This will help to reduce the voltage drop.
- Do not install power factor correction capacitors or a surge absorber to the output of the VFD. The VFD will trip or sustain damage to the output transistors.
- If the motor cable length is more than 65 feet, it is possible that a surge voltage will be generated and may damage the motor. This is due to phenomena called "Reflective Wave". Install a dv/dt filter in front of the motor to protect it.
- In the case of two or more motors on the output of a VFD, install an independent overload protection device for each motor. Set the rated current value of the overload device to 1.1 times the motor rated current.

3) Regenerative Braking Unit Terminals: P, N (  $\geq 30\text{kW}(40\text{HP})$  Units)

- VFDs rated greater than and equal to 30KW (40HP) do not contain an internal BRD circuit. If regenerative braking is going to occur, then an external BRD circuit (Option) is required along with a resistor. (Option)
- Connect external regenerative braking unit terminals (P,N) to terminals (P,N) on the VFD.
- The braking resistor is then wired into the External BRD board, not directly to the VFD.
- The cable length between the VFD and the BRD board, BRD board and the resistor, should be less than 16 feet and twist the connecting wires to reduce inductance.

4) Earth Ground: G

- Make sure that you securely ground the VFD and motor for prevention of electric shock.
- The VFD and motor must be connected to an appropriate safety earth ground and follow all local electrical codes.
- In case connecting 2 or more VFDs, use caution not to create a ground loop situation which may cause the VFD to malfunction. Use a star configuration grounding technique.

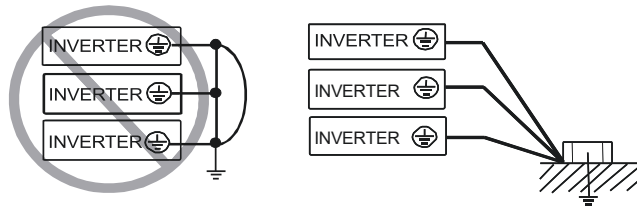

Earth Ground (G) Connection

Grounding wire should be as short as possible and should be connected to the ground point as near as possible to the VFD.

VFD Frame	Grounding Wire Size (mm <sup>2</sup> /kcmil)	
	200V class	400V class
F1	14/27.6	8/15.9
F2	22/43.4	14/27.6
F3	53.5/ 105.6	33.6/ 66.4
F4	85.0/ 167.8	53.5/ 105.6
F5	85.0/ 167.8	85.0/167.8
F6	85.0/ 167.8	85.0/167.8

5) Specifications of power terminal block and internal fuse

Tightening torque and wire range for field wiring terminals are marked adjacent to the terminal or the wiring diagram. Select a molded case circuit breaker (MCCD) with a rated current 1.5 to 2 times higher than the VFD rated current

Distribution fuse size information is shown in the table below.

The fuse must be a UL listed (in case of using in the USA), 600V, inverse time rated fuse with the current ratings shown in the table below.

Class	Motor Output (kW)	VFD Model	Power lines R,S,T, U,V,W,P,N			Screw Size of Terminal	Torque N·m (lb·in)	FUSE [A]
			AWG	kcmil	Lug width (mm/inch)			
200V Class	7.5	A1-032A-2	8	17	11.8/0.46	M4	0.20~0.60	40A
	11	A1-045A-2	8	17	11.8/0.46	M4	0.20~0.60	60A
	15	A1-064A-2	6	26	13/0.51	M5	0.40~0.80	80A
	18.5	A1-076A-2	4	42	13/0.51	M5	0.40~0.80	100A
	22	A1-090A-2	8 * 2P	(17)*2P	13/0.51	M5	0.40~0.80	125A
	30	A1-114A-2	1/0	106	22/0.87	M8	0.80~1.20 (7.08~10.6)	150A
	37	A1-140A-2	3*2P	(52.6)*2P	22/0.87	M8	0.80~1.20 (7.08~10.6)	FWH-350A
	45	A1-170A-2	2*2P	(66.4)*2P	22/0.87	M8	0.80~1.20 (7.08~10.6)	FWH-400A
	55	A1-205A-2	1*2P	(83.7)*2P	22/0.87	M8	0.80~1.20 (7.08~10.6)	FWH-400A
	75	A1-261A-2	2/0*2P	(133.1)*2P	27/1.06	M10	0.80~1.80 (7.08~15.9)	FWH-600A
	90	A1-310A-2	3/0*2P	(167.8)*2P	27/1.06	M10	0.80~1.80 (7.08~15.9)	FWH-700A
400V Class	7.5	A1-016A-4	12	6.5	11.8/0.46	M4	0.20~0.60	20A
	11	A1-023A-4	10	10	11.8/0.46	M4	0.20~0.60	30A
	15	A1-032A-4	8	17	11.8/0.46	M4	0.20~0.60	40A
	18.5	A1-038A-4	8	17	13/0.51	M5	0.40~0.80	50A
	22	A1-045A-4	8	17	13/0.51	M5	0.40~0.80	60A
	30	A1-058A-4	6	26	13/0.51	M5	0.40~0.80	80A
	37	A1-075A-4	2	66.4	16/0.63	M6	0.80~1.00 (7.08~8.85)	FWH-250A
	45	A1-090A-4	2	66.4	16/0.63	M6	0.80~1.00 (7.08~8.85)	FWH-250A

55	A1-110A-4	1/0 or 4*2P	105.5 or (41.7)*2P	22/0.87	M8	0.80~1.20 (7.08~10.6)	FWH- 250A
75	A1-149A-4	3*2P	(52.6)*3P	22/0.87	M8	0.80~1.20 (7.08~10.6)	FWH- 350A
90	A1-176A-4	2*2P	(66.4)*2P	22/0.87	M8	0.80~1.20 (7.08~10.6)	FWH- 400A
110	A1-217A-4	1/0*2P	(105.5)*2P	22/0.87	M8	0.80~1.20 (7.08~10.6)	FWH- 500A
132	A1-260A-4	2/0*2P	(133.1)*2P	24/0.94	M10	0.80~1.80 (7.08~15.9)	FWH- 600A
160	A1-296A-4	3/0*2P	(167.8)*2P	27/1.06	M10	0.80~1.80 (7.08~15.9)	FWH- 700A

\*Fuse of Bussmann was used when UL certified

### 4.1.3 A1 Terminal Connection Diagram and Description

1) A1 VFD terminal connection overview is shown below. There are three segments of Connections

- Power Circuit
- Control Circuit
- Communication Circuit

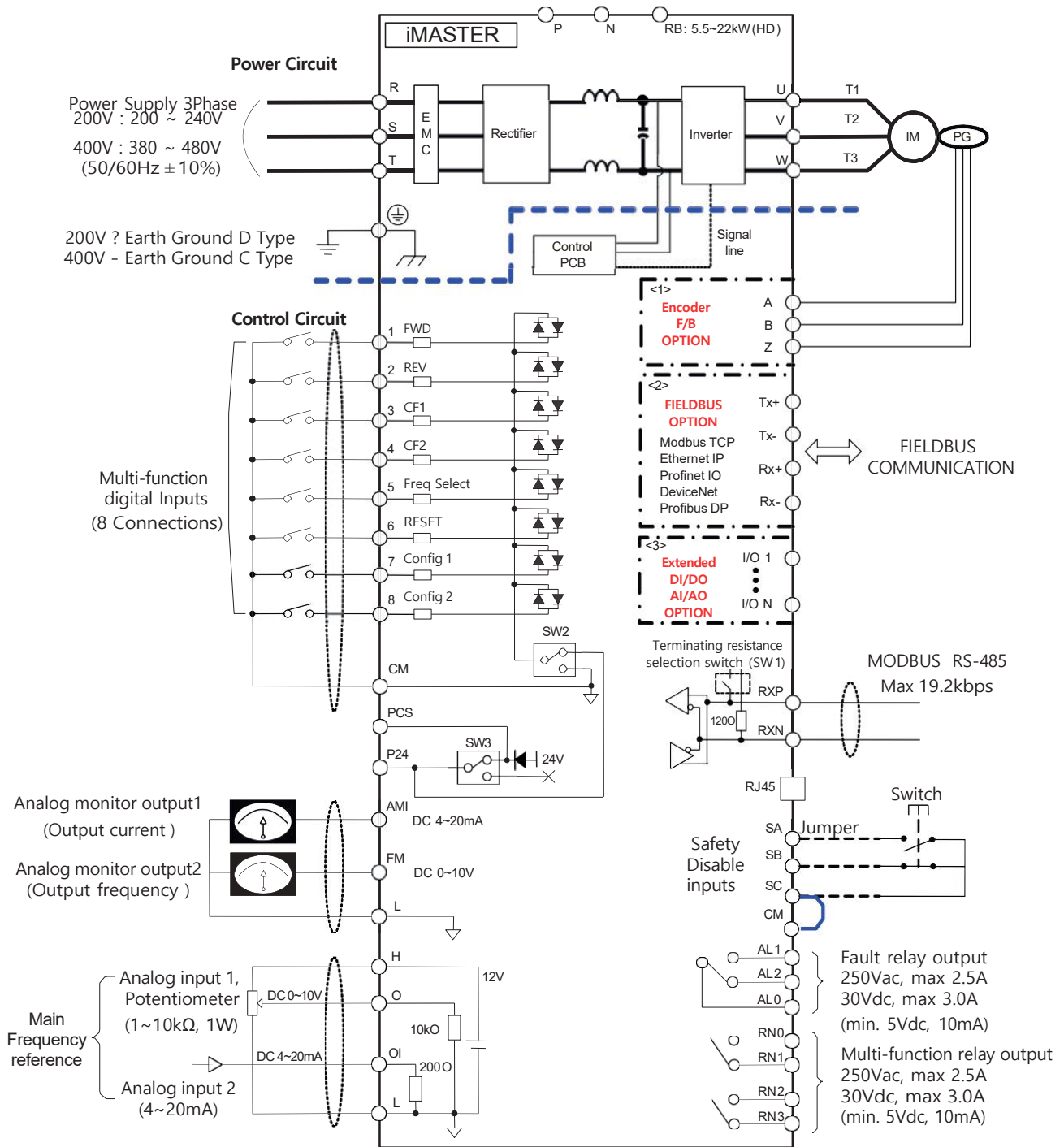

A1 VFD terminal names and descriptions are summarized

Terminal Name	In/Out	Functional Description	Value
<b>Main Circuit Connector</b>			
R,S,T (L1, L2, L3)	IN	3 Phase 50/60 Hz, AC input power supply.	200 ~240V $\pm$ 10% 380 ~480 V $\pm$ 10%
U,V,W (T1,T2,T3)	OUT	3 Phase PWM output power for motor	-
P,N	-	Optional External Braking Unit Connector. [1] 30~132 kW (40 ~ 250 HP) models	-
[2] RB	-	[3] Dynamic Braking Resistor connector 5.5~22kW	-
G	-	Ground Terminal	-
<b>Control Circuit Connector</b>			
P24	OUT	Power Supply for external device (Always ON)	24VDC $\pm$ 7%, P24+PCS = 300mA
PCS	OUT	Power Supply for external device such as PLC (Available ON or OFF)	
Multi function digital Input[1:8]	IN	8 Bit Intelligent input terminal. By programming the respective terminal, can be used as command	Contact Closed : ON Contact Open : OFF Min ON Time : 12 ms
CM	-	Common Terminal for Intelligent Input and Monitor Output	-
AMI	OUT	Analog Current Output	4~20mA, 250 $\Omega$
FM	OUT	Analog Voltage Output	0~10Vdc, 1mA
L	-	DC Power Supply Common	-
H (P12)	OUT	Power Supply for Potentiometer	12VDC
O	IN	Analog Voltage for Frequency Reference	0 ~ 10 VDC, 10 k $\Omega$
OI	IN	Analog Current for Frequency Reference	4~ 20mA, 200 $\Omega$
AL0, AL1, AL2	OUT	Intelligent output terminal: OUTPUT RELAY 1, 2 Run status signal(RUN), Frequency arrival signal(FA1), Set frequency arrival signal(FA2), Overload advance notice signal(OL), PID error deviation signal(OD), Alarm signal(AL)	AC 250V / 2.5A (resistor load) 0.2A (inductor load)
RN0, RN1 RN2, RN3	OUT	Intelligent output terminal OUTPUT RELAY 3	DC 30V / 3.0A (resistor load) 0.7A (resistor load)
SA	IN	Safety Input terminal:	-
SB		SA closed, SB open: Drive output disabled	
SC		Common terminal for Safety Input, CM connection	
<b>Communication Connector</b>			
RXP	IN/OUT	RS 485 Positive Communication Terminal	
RXN	IN/OUT	RS 485 Negative Communication Terminal	

#### 4.1.4 Terminal wiring diagram (Power terminal block)

Terminal view of corresponding VFD are shown below

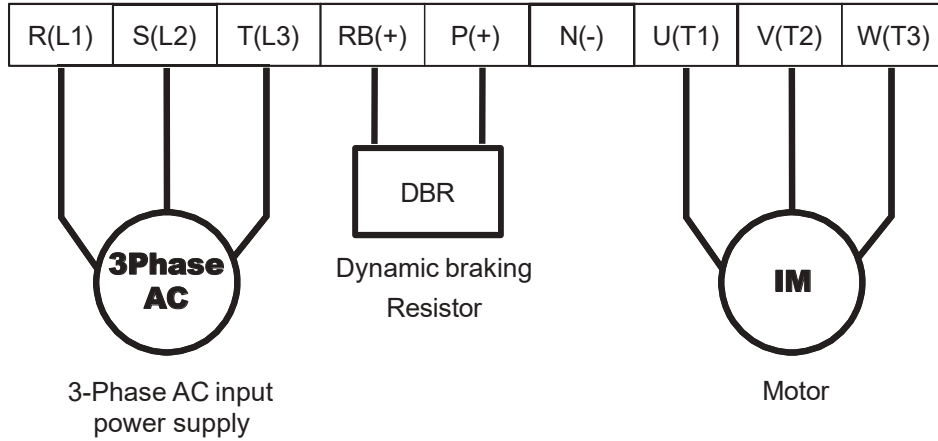

**F1, F2 Power Terminal**

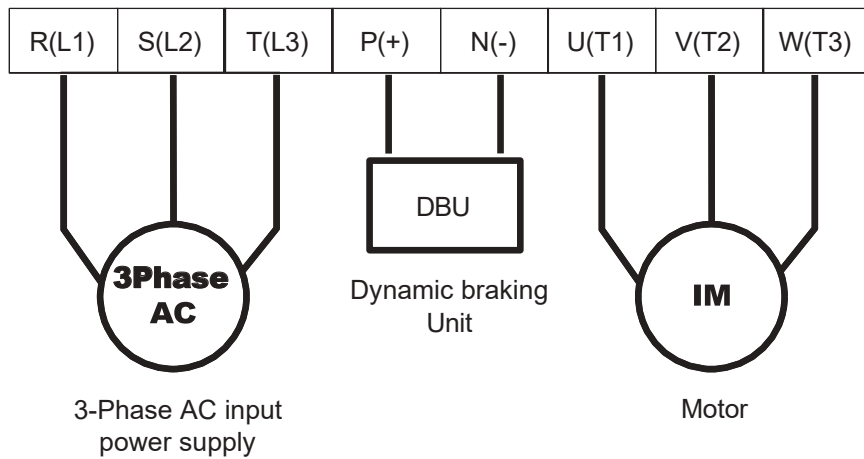

**F3~F6 Power Terminal**

Power terminal (F1,F2)

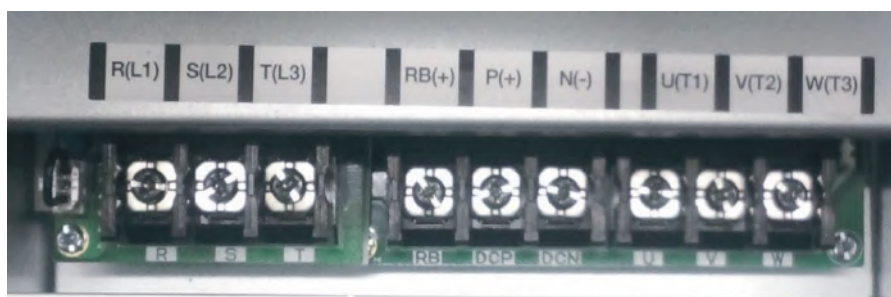

Power terminal (F3~F6)

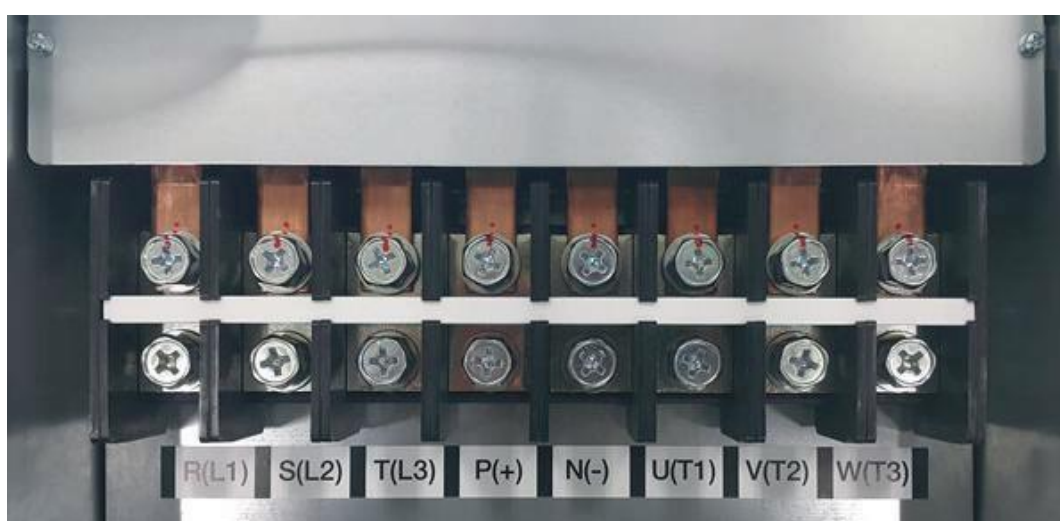



### 4.1.5 Control terminal line diagram (Basic I/O terminal block)

#### 1) External control connection terminals

The layout of external control connection terminals of the drive is shown below.

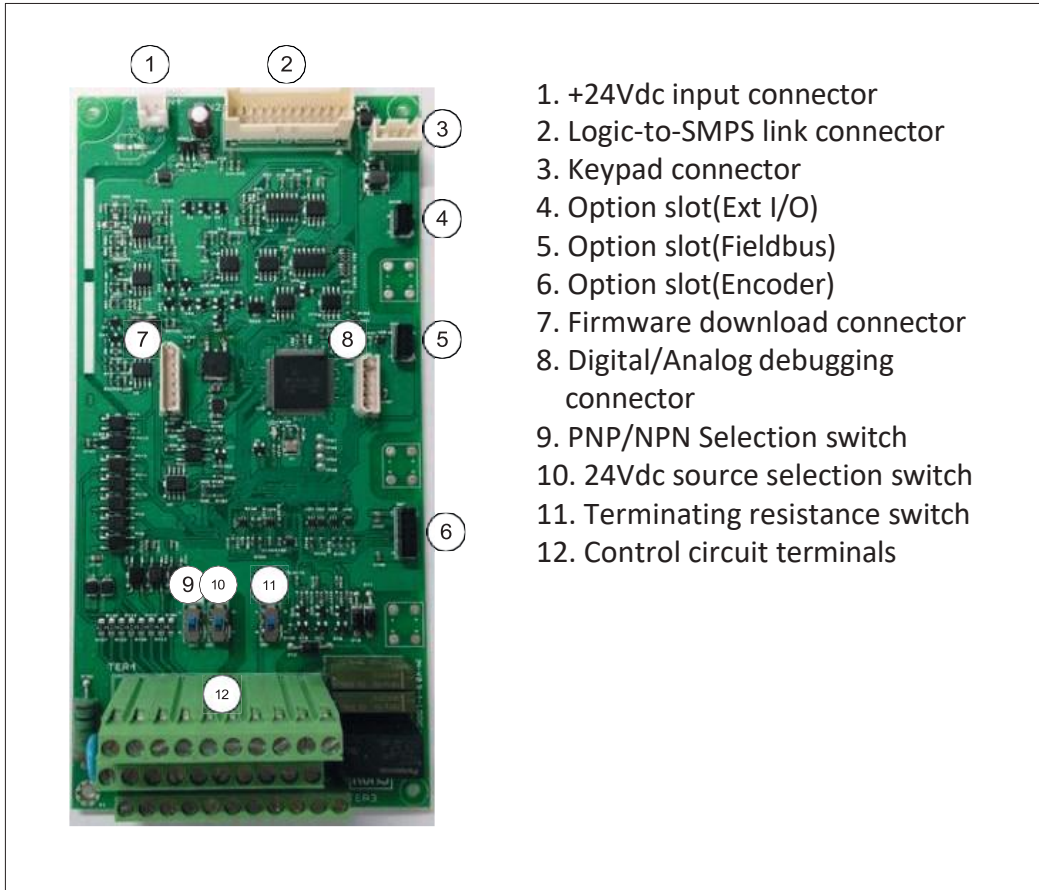

- 1. +24Vdc input connector
- 2. Logic-to-SMPS link connector
- 3. Keypad connector
- 4. Option slot(Ext I/O)
- 5. Option slot(Fieldbus)
- 6. Option slot(Encoder)
- 7. Firmware download connector
- 8. Digital/Analog debugging connector
- 9. PNP/NPN Selection switch
- 10. 24Vdc source selection switch
- 11. Terminating resistance switch
- 12. Control circuit terminals

#### 2) Control circuit terminals layout

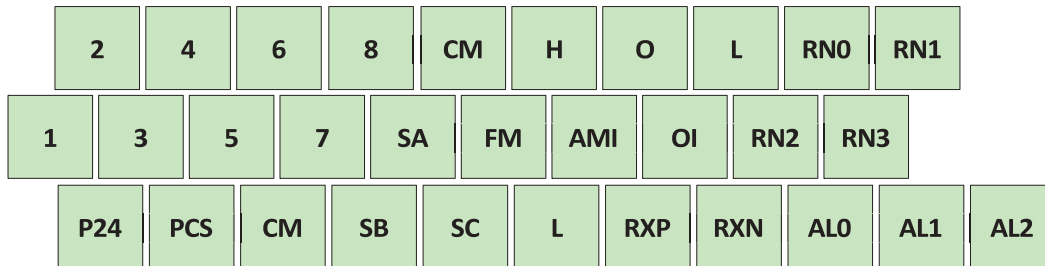

3) Configuration for Sinking and Source Modes

SW2: Sink/Source switch

SW: Power selection switch (Internal 24V or External 24V)

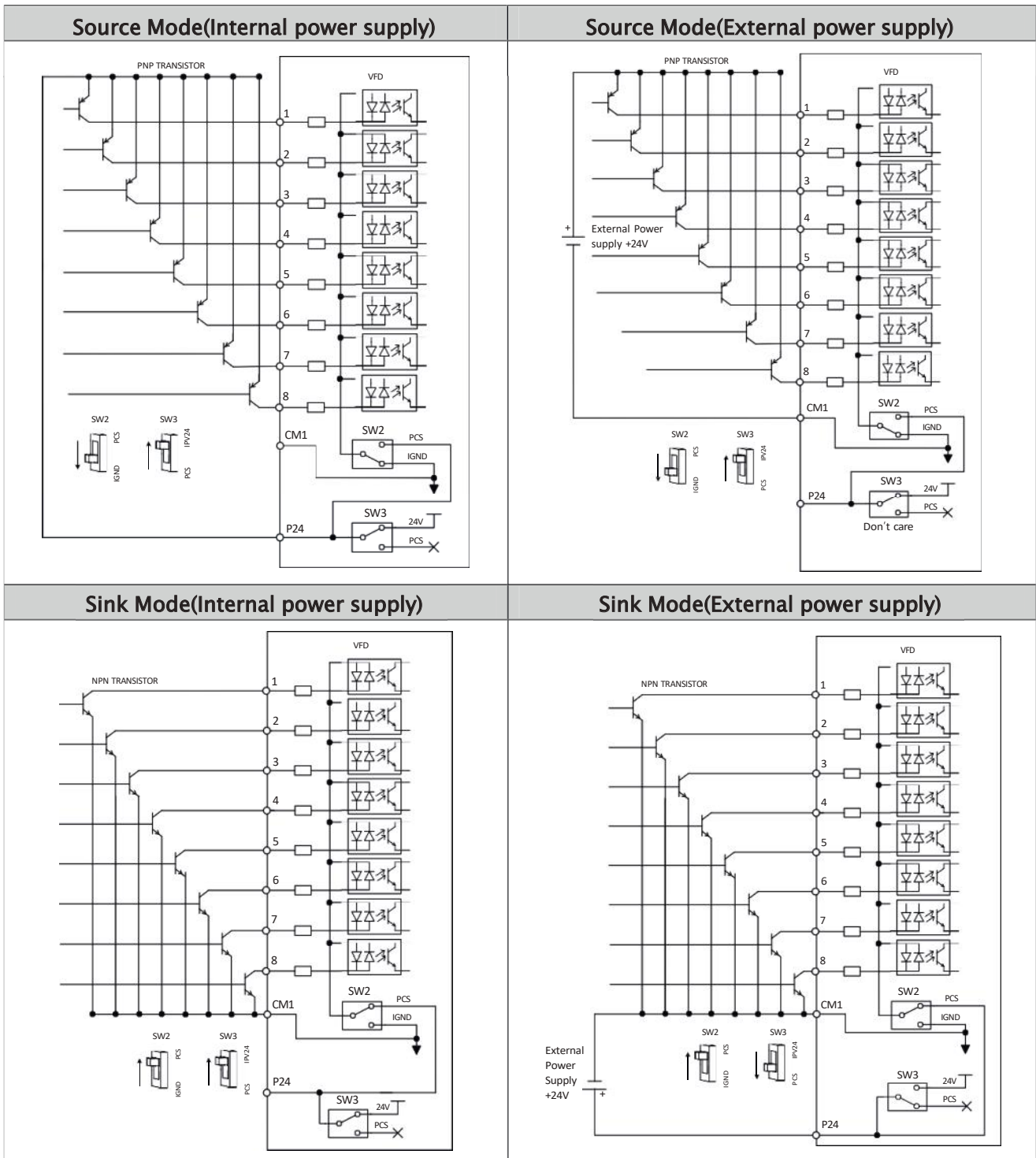

4) Sinking and Source Modes selection (Output signal)

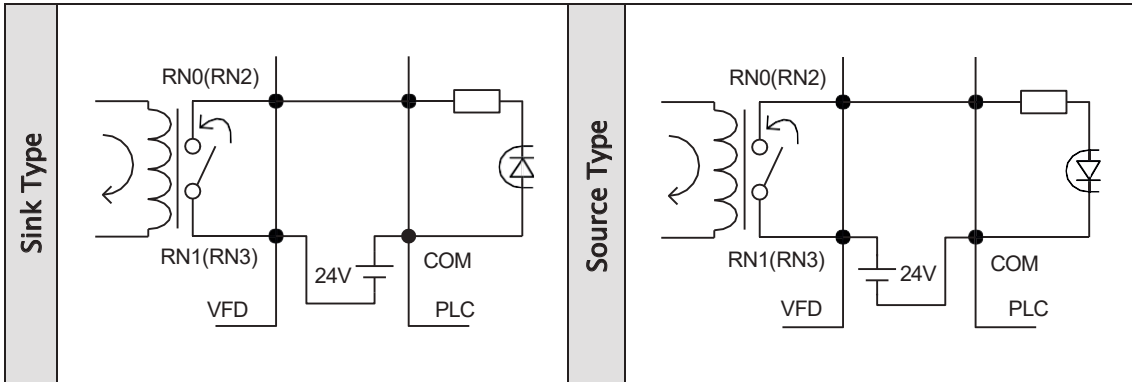

5) Communication Connect

RXP	RXN
Transmit/Receive +side	Transmit/Receive -side

The termination resistor of the RS 485 2nd communication has a purpose of preventing the distortion and attenuation of the communication line. This resistor means the impedance matching resistor in long distance transport of RS 485 data. The termination resistor is inserted only in the final stage in single line.

<Terminating resistance selection switch (SW1)>

Default Status: Terminating resistance ON

Regarding terminating resistance, only applied to RXP-RXN terminals

Turn off the switch when master communicate more than one of VFD

(For example master: PLC, DCS, PC and etc)

RS-485 Terminating resistance SW1 On: 

RS-485 Terminating resistance SW1 Off: 

### 6) Internal Wiring

- Control circuit wires are insulated from power lines (R,S,T,U,V,W)
- Use twisted screened cable for input and output wires of the control circuit terminals
- Limit the connection wires to 65 feet
- Separate the control circuit wiring from the main power and relay control wiring
- When using relays for the FW terminal or an intelligent input terminal, use a control relay that is designed to work with 24 Vdc.
- When a relay is used as an intelligent output, connect a diode for surge protection parallel to the relay coil.
- Do not short the analog voltage terminals H and L or the internal power terminals P24 and all CM's to prevent any VFD damage
- When connecting a thermistor to the TH and all CM's terminals, twist the thermistor cables and separate them from the rest. Limit the connection wires to 65 feet.

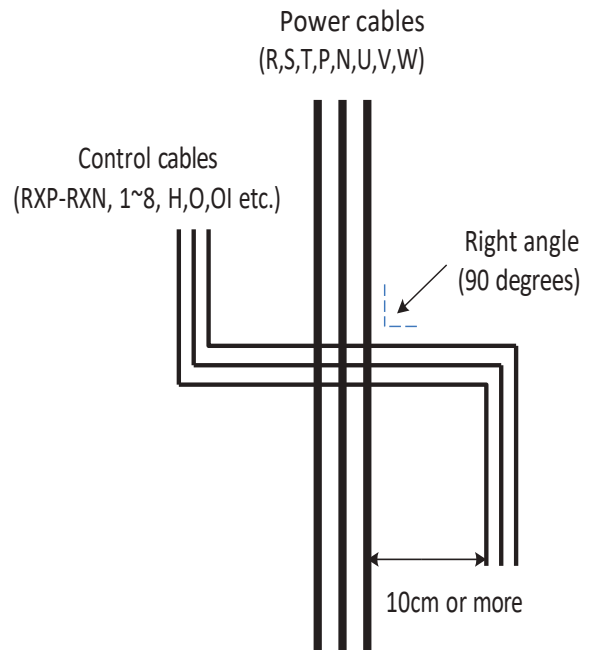

## 5. Peripheral Devices

### 5.1 Peripheral Devices

#### 5.1.1 Composition of peripheral devices

For better system performance enhancement, optional accessories may be used with VFD.

- Note1: Be sure to consider the capacity of the circuit breaker to be used.
- Note2: Be sure to use larger wire for power lines if the distance exceeds 20m.
- Note3: Be sure to use a grounding wire same size of power line or similar.

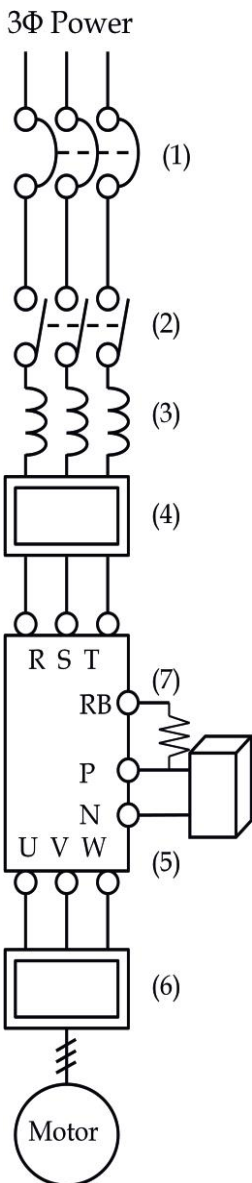

Name		Function
(1)	Circuit Breaker	High current flows in the VFD while power is supplied. Be careful when you select the switch because the VFD.
(2)	Electric contactor	This does not have to be necessarily installed, but if you do, do not start or stop the VFD frequently with the contactor. It might decrease the life of the VFD.
(3)	Input AC Reactor	Recommended to use when the unbalance voltage rate is 3% or more and power supply is 500 kVA or more, and there is a rapid change in the power supply. It also reduces harmonics and improves the power factor.
(4)	Input Noise Filter	Reduces radiation noise emitted from wire at the input.
(5)	Dynamic Braking Unit	Applied 30~132kW(HD) Used for applications that need to increase the brake torque of the VFD or to frequently start/stop and to run high inertia load.
(6)	Output Noise Filter	Reduces noise emitted from the VFD motor leads. This helps to minimize interference with sensitive equipment (ie: sensors or weight scale).
(7)	Braking Resistor	Applied 5.5~22kW(HD) Used for applications that need to increase the brake torque of the VFD or to frequently start/stop and to run high inertia load.

## 5.1.2 Dynamic braking unit (DBU) and Resistors

### 1) Dynamic Braking Resistor

200V Drive		150% Torque, 5% ED		400V Drive		150% Torque, 5% ED	
VFD Model	kW	$\Omega$	W	VFD Model	kW	$\Omega$	W
A1-032A-2	5.5	20	800	A1-016A-4	5.5	85	800
A1-045A-2	7.5	15	1200	A1-023A-4	7.5	60	1200
A1-064A-2	11	10	2400	A1-032A-4	11	40	2400
A1-076A-2	15	8	2400	A1-038A-4	15	30	2400
A1-090A-2	18.5	5	3600	A1-045A-4	18.5	20	3600
				A1-058A-4	22	20	3600

### 2) Dynamic Braking Unit

Input V	VFD Model	kW	DB Unit Model	$\Omega$	kW	Condition for using
3 PHASE 200V	A1-114A-2	22	FBU050-022-2	5	6	150% breaking 10%ED
	A1-140A-2	30	FBU100-037-2	4.5	10	
	A1-170A-2	37		4.5	10	
	A1-205A-2	45	FBU100-075-2	2.5	10	
	A1-261A-2	55		2.5	20	
	A1-310A-2	75		2.5	20	
3 PHASE 400V	A1-075A-2	30	FBU100-037-4	12	10	
	A1-090A-2	37		12	10	
	A1-110A-4	45	FBU100-075-4	6	10	
	A1-149A-4	55		6	20	
	A1-176A-4	75		6	20	
	A1-217A-4	90	FBU100-090-4	5	26	
	A1-260A-4	110	FBU100-132-4	3.4	40	
	A1-296A-4	132		3.4	40	

## 6. Keypad

### 6.1 Keypad View & Operation

#### 6.1.1 Keypad View

Standard Keypad is used in VFD parameter setting, Monitor display and VFD operations.

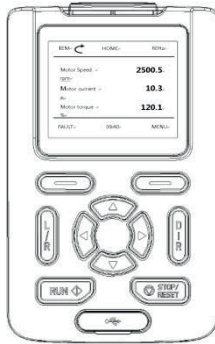

LCD TYPE

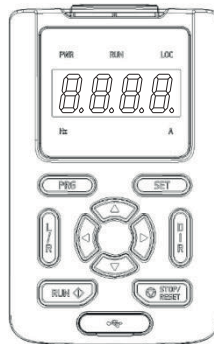

LED TYPE

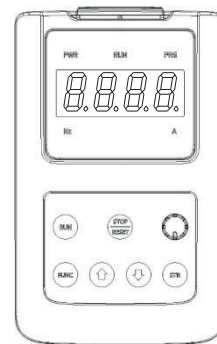

LED-knob TYPE

#### 1) Dimensions - LCD TYPE

Unit : mm(inch)

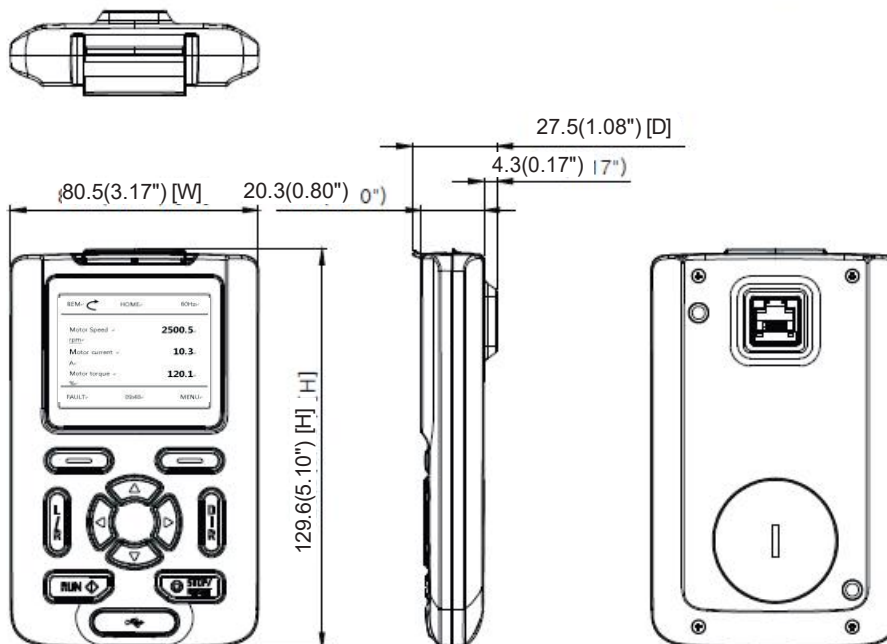

2) Dimensions - LED TYPE

Unit : mm(inch)

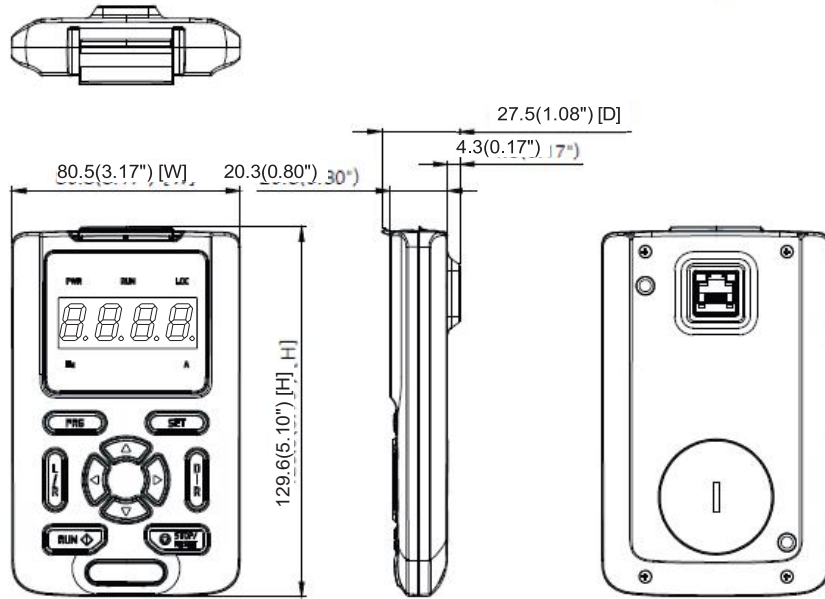

3) Dimensions - LED\_KNOB TYPE

Unit : mm(inch)

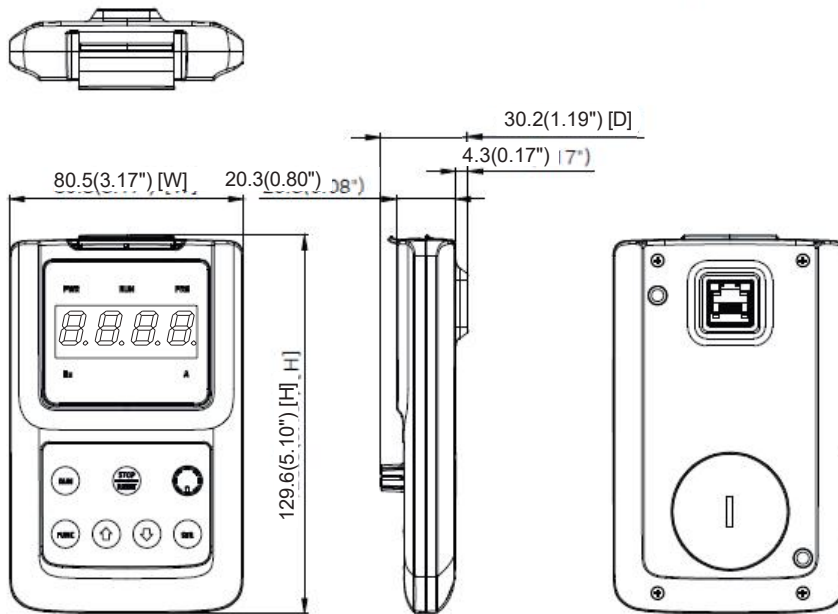



4) Dimensions – Panel Mount

Unit : mm(inch)

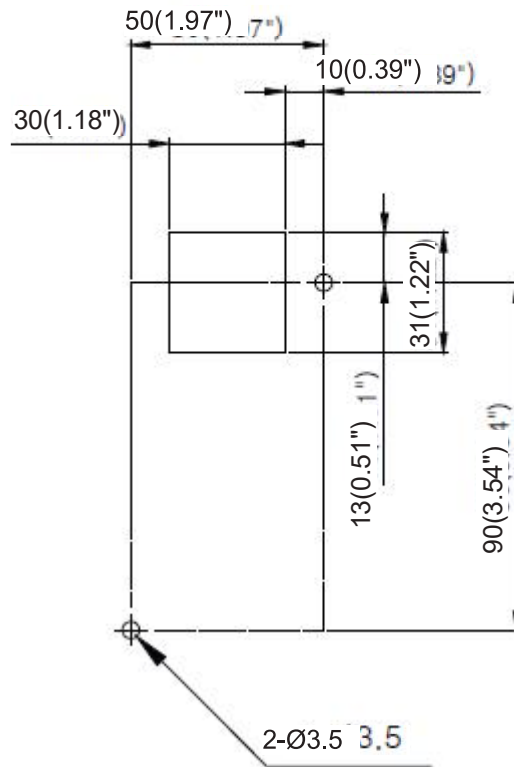

## 6.1.2 Keypad operation

### 1) Configuration of LED Keypad

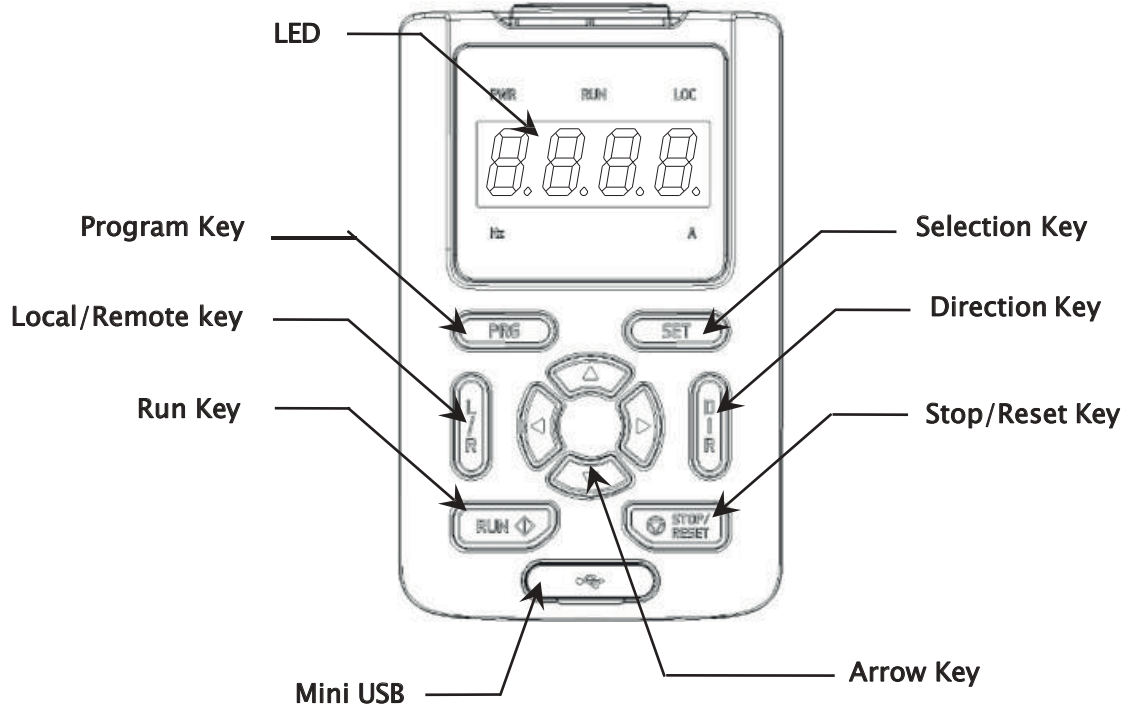

KEY	Function
PRG	<ul style="list-style-type: none"> <li>• Move to fault history</li> <li>• previous</li> <li>• Cancel at setting mode</li> </ul>
SET	<ul style="list-style-type: none"> <li>• Move to menu</li> <li>• Reset the fault when the fault is occurred</li> <li>• Select the parameters</li> <li>• Save the value of parameter</li> </ul>
Arrow keys	<ul style="list-style-type: none"> <li>• Move to display or group</li> <li>• Move the position when set the parameter value</li> </ul>
Dir key	<ul style="list-style-type: none"> <li>• Change the direction at local mode</li> </ul>
Mode key	<ul style="list-style-type: none"> <li>• Change local or remote mode</li> <li>• Start/Stop/Dir keys enable at local mode</li> </ul>
Start key	<ul style="list-style-type: none"> <li>• Start the VFD at local mode</li> </ul>
Stop key	<ul style="list-style-type: none"> <li>• Stop the VFD at local mode</li> </ul>
Mini USB	Communicate with PC tool

2) LED keypad Control method  
 (1) Movement in main MENU

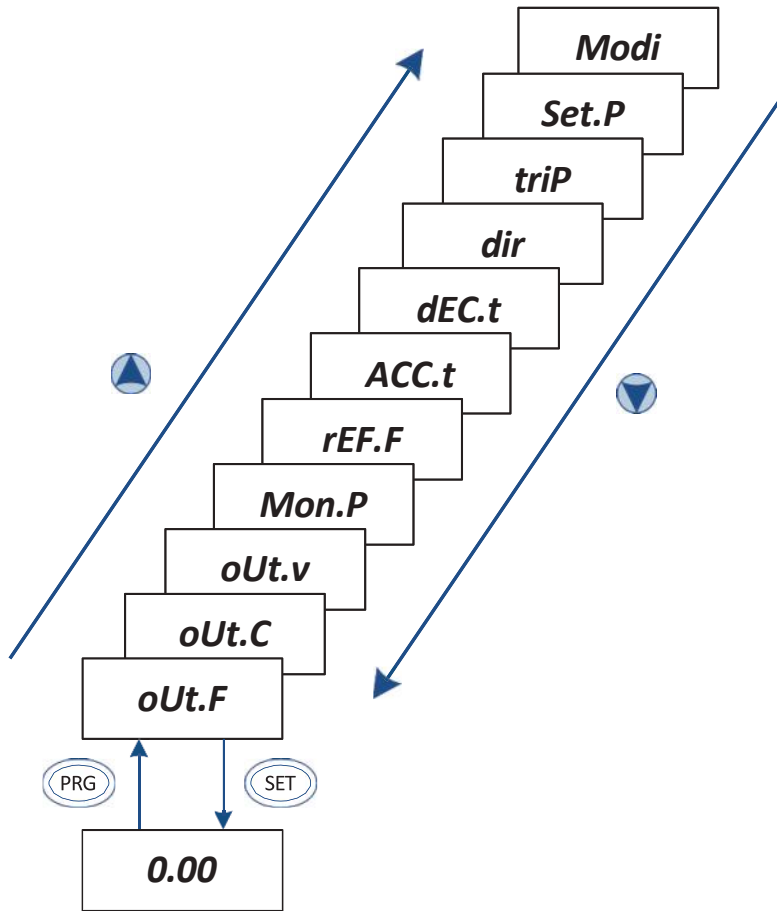

<i>oUt.F</i>	<i>Output frequency monitor (01.01)</i>
<i>oUt.C</i>	<i>Output current monitor (01.05)</i>
<i>oUt.v</i>	<i>Output voltage monitor (01.08)</i>
<i>Mon.P</i>	<i>Parameter monitors (01.XX ~ 05.XX)</i>
<i>rEF.F</i>	<i>Frequency ref input (22.01)</i>
<i>ACC.t</i>	<i>Acceleration time 1 (23.04)</i>
<i>dEC.t</i>	<i>Deceleration time 1 (23.05)</i>
<i>dir</i>	<i>Direction (20.13)</i>
<i>triP</i>	<i>Trip monitoring (03.01 ~ 03.XX)</i>
<i>Set.P</i>	<i>Parameter settings (10.XX ~ 99.XX)</i>
<i>Modi</i>	<i>Display only be modified parameters</i>

(1) Parameter movement

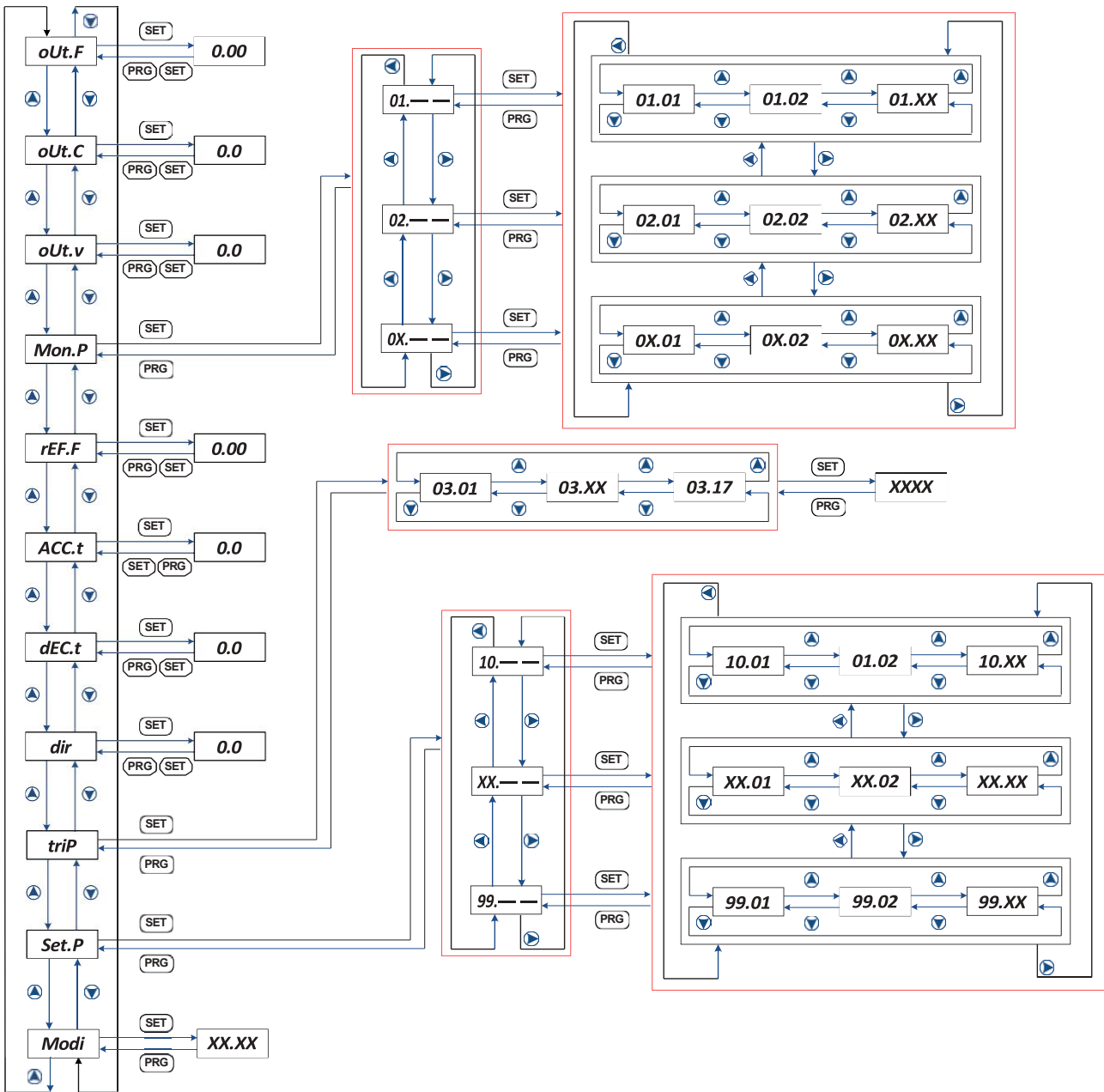

(2) Move to parameters Monitor group

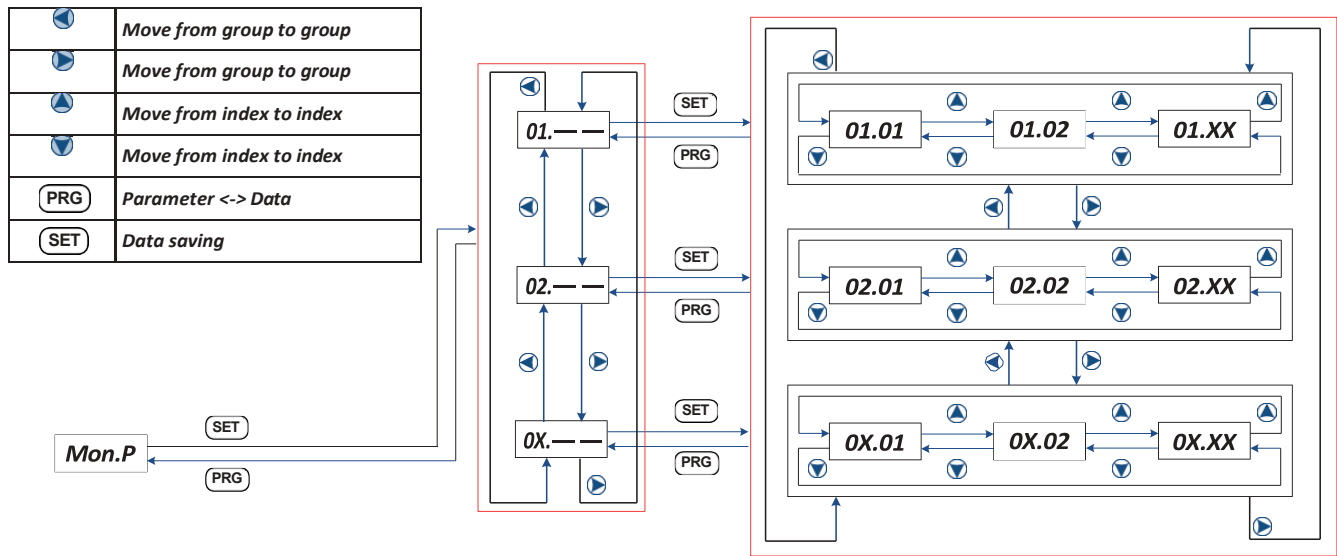

(3) Move to Trip monitor & Parameters Setting group

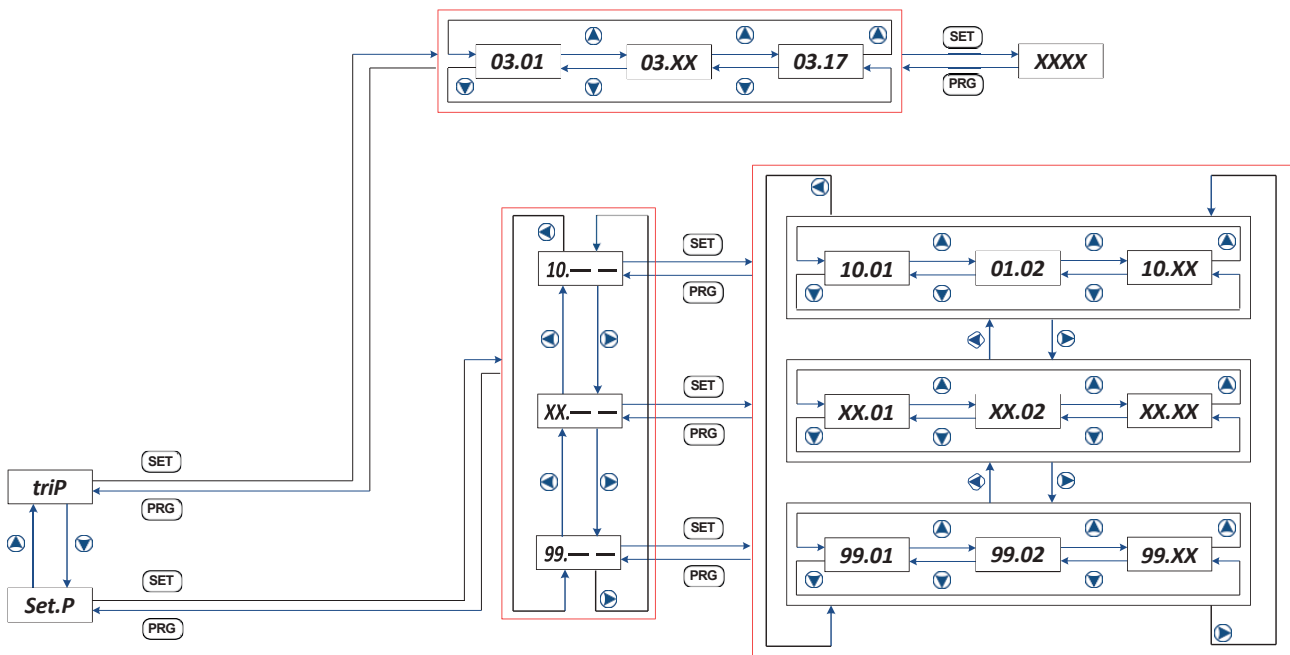

(4) Initialize Trip History or Parameter Setting

- '97.01' (Initialization mode) = 0 saving: Initialize Trip History
- '97.01' (Initialization mode) = 1 saving: Initialize Parameter Setting

3) Configuration of LCD Keypad

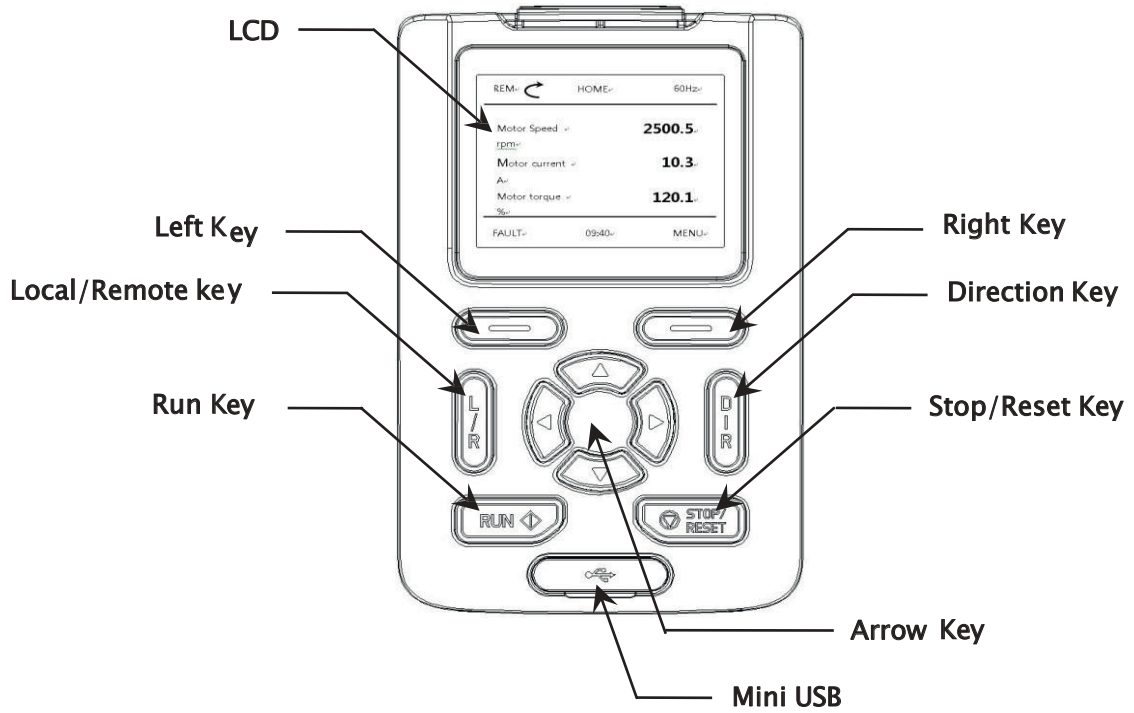

KEY	Function
Left key	<ul style="list-style-type: none"> <li>• Move to fault history</li> <li>• previous</li> <li>• Cancel at setting mode</li> </ul>
Right key	<ul style="list-style-type: none"> <li>• Move to menu</li> <li>• Reset the fault when the fault is occurred</li> <li>• Select the parameters</li> <li>• Save the value of parameter</li> </ul>
Arrow keys	<ul style="list-style-type: none"> <li>• Move to display or group</li> <li>• Move the position when set the parameter value</li> </ul>
Dir key	<ul style="list-style-type: none"> <li>• Change the direction at local mode</li> </ul>
Mode key	<ul style="list-style-type: none"> <li>• Change local or remote mode</li> <li>• Start/Stop/Dir keys enable at local mode</li> </ul>
Start key	<ul style="list-style-type: none"> <li>• Start the VFD at local mode</li> </ul>
Stop key	<ul style="list-style-type: none"> <li>• Stop the VFD at local mode</li> </ul>
Mini USB	Communicate with PC tool

4) LED keypad Control method

(1) LCD keypad monitor

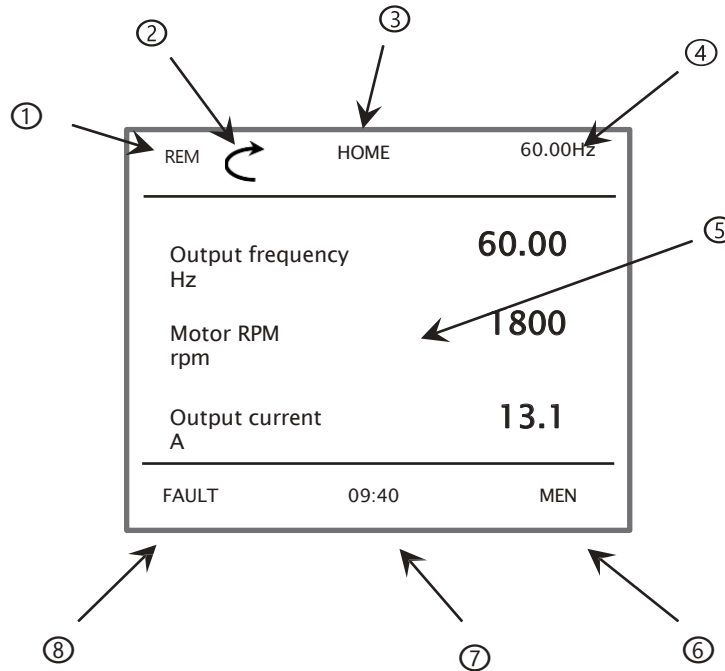

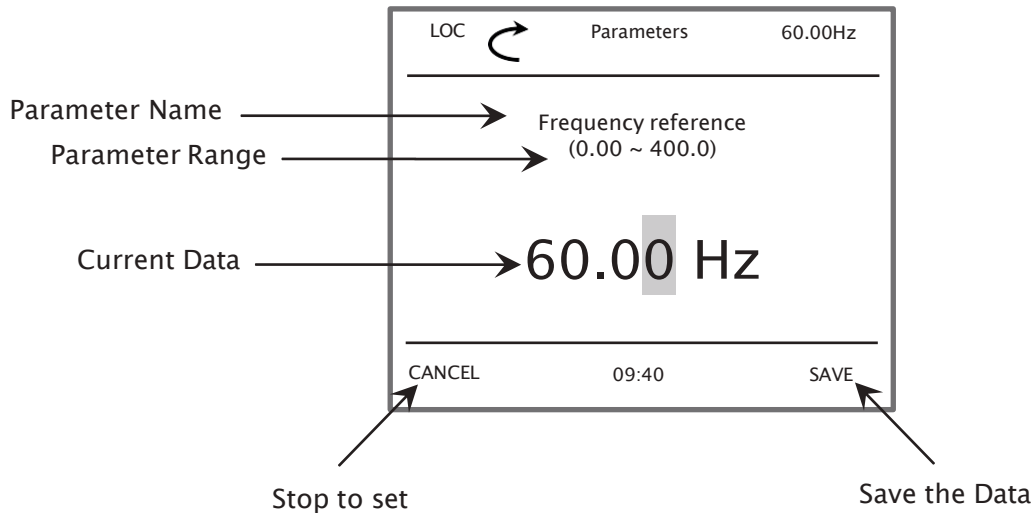

No	Function	Display	Description
1	Control location	LOC	VFD is controlled by VFD Keypad
		REM	VFD is controlled by terminal block
2	Running Status	Rotation	VFD is stop
		Rotation	VFD is running to forward
		Rotation	VFD is running to reverse
		Flickering	VFD is stopping from forward
		Flickering	VFD is stopping from reverse
3	Current Status	Home	Home mode
		Menu	Menu mode
		Fault	Fault status
4	Reference Value	00.00Hz	Display referenced value
5	Current View	-	Display selected item
6	Multi Right Key	Menu	Move to menu view
		Select	Select the item
		Save	Save the parameter data
		Reset	Reset the fault when fault is occurred
		Read	Read all parameters for copy
		Write	Write all parameters for copy
7	Time	00:00	Display the current time
8	Multi Left Key	Back	Move to previous view
		Cancel	Cancel at parameter view
		Fault	Move to fault view

(2) Parameter changes









(3) Mode shift in home mode

<p>REM  HOME 60.00Hz</p> <hr/> <p>Motor Speed <b>1775</b> rpm</p> <p>Motor current <b>10.3</b> A</p> <p>Motor torque <b>12.1</b> %</p> <hr/> <p>FAULT 09:40 MENU</p>	<p>Power on, the display emerges as shown on the left. The present mode is the HOME mode</p> <ol style="list-style-type: none"> <li>1. Press fault key once (left key)             <ul style="list-style-type: none"> <li>- Go to below A</li> </ul> </li> <li>2. Press menu key once (right key)             <ul style="list-style-type: none"> <li>- Go to below B</li> </ul> </li> </ol>
<p>REM  FAULT 60.00Hz</p> <hr/> <div style="border: 1px solid black; padding: 5px; text-align: center;"> <p><b>oC</b> Over Current</p> </div> <p>The VFD output current exceeds the rated current by more than 200%. This may occur if the motor is locked or the load is excessive.</p> <hr/> <p>BACK 09:40 RESET</p>	<p>A.</p> <p>The display emerges as shown on the left. The present mode is the FAULT mode</p>
<p>REM  MENU 60.00Hz</p> <hr/> <div style="background-color: #cccccc; padding: 5px; text-align: center;"> <p>Parameters</p> </div> <p>Parameter Copy</p> <p>Event log</p> <hr/> <p>BACK 09:40 SELECT</p>	<p>B.</p> <p>The display emerges as shown on the left. The present mode is the MENU mode</p>

※ Menu mode has six kinds of sub menu

- Parameters: change the value of parameter
- Parameter copy: all parameters read, write and verify
- Event Info: save the fault history automatically
- System info: display the system information
- Settings: configuration of LCD keypad
- Options: home display values

(4) Group shift in parameters mode

<p>REM  HOME 60.00Hz</p> <hr/> <p>Motor Speed <b>1775</b> rpm</p> <p>Motor current <b>10.3</b> A</p> <p>Motor torque <b>12.1</b> %</p> <hr/> <p>FAULT 09:40 MENU</p>	<p>Power on, the display emerges as shown on the left. The present mode is the HOME mode</p> <p>-Press the MENU key(right key) once</p>
<p>REM  MENU 60.00Hz</p> <hr/> <p><b>Parameters</b></p> <p>Parameter Copy</p> <p>Event log</p> <hr/> <p>BACK 09:40 SELECT</p>	<p>You have shifted to Parameters mode</p> <p>-Press the SELECT key(right key) once</p>
<p>REM  Parameters 60.00Hz</p> <hr/> <p><b>01 VFD running status</b></p> <p>02 Frequency reference ind</p> <p>03 Trip information</p> <hr/> <p>BACK 09:40 SELECT</p>	<p>The Display group of Parameters mode is emerged</p> <p>-Press the SELECT key(right key) once</p>
<p>REM  Parameters 60.00Hz</p> <hr/> <p><b>01.01 Output frequency monitor</b> 60.00 Hz</p> <p>01.02 Motor RPM monitor 1775 rpm</p> <p>01.04 Rotation direction monitor Forward</p> <hr/> <p>BACK 09:40</p>	<p>The sub menu of Display group mode is emerged</p>

(5) Set the frequency reference

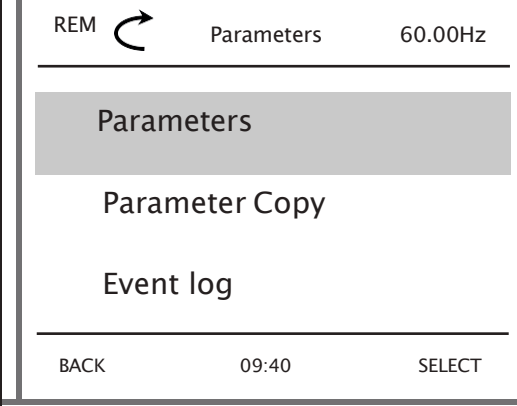
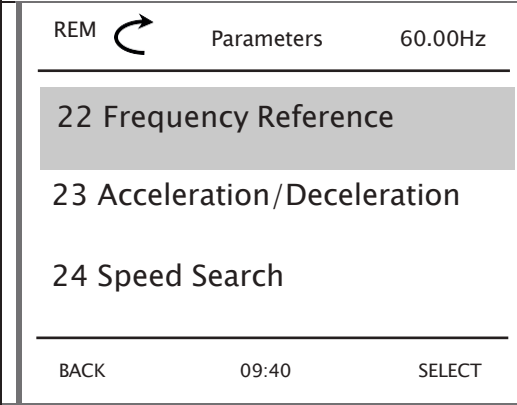
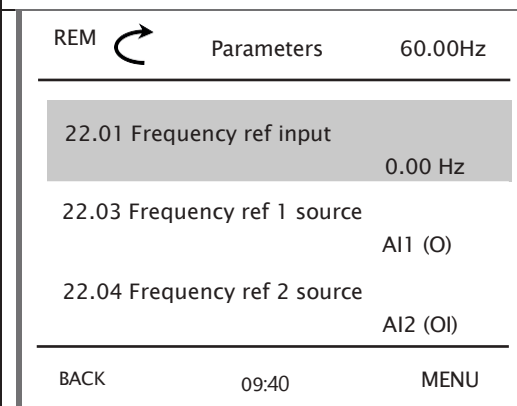
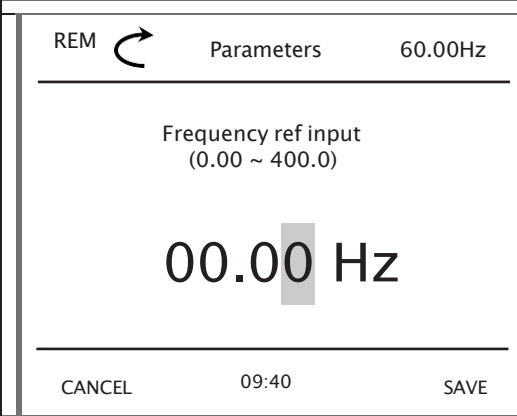
	<p>You have shifted to Parameters mode</p> <p>-Press the SELECT key (right key) once</p>
	<p>The Display group of Parameters mode is emerged. Move to 22 group</p> <p>-Press the SELECT key (right key) once</p>
	<p>The sub menu of Display group mode is emerged</p>
	<p>Set the value and press the SAVE key (right key)</p>

(6) Fault history monitoring

<p>REM ↻ Parameters 60.00Hz</p> <hr/> <p>Parameters</p> <p>Parameter Copy</p> <p>Event log</p> <hr/> <p>BACK 09:40 SELECT</p>	<p>You have shifted to Parameters mode</p> <p>-Press the SELECT key (right key) once</p>
<p>REM ↻ Parameters 60.00Hz</p> <hr/> <p>03 Trip Information</p> <p>04 Time counter</p> <p>05 VFD firmware information</p> <hr/> <p>BACK 09:40 SELECT</p>	<p>The Display group of Parameters mode is emerged. Move to 03 group</p> <p>-Press the SELECT key (right key) once</p>
<p>REM ↻ Parameters 60.00Hz</p> <hr/> <p>03.13 Trip monitor 1, source of trip (2)Over Voltage</p> <p>03.14 Trip monitor 1, frequency at trip 60.00 Hz</p> <p>03.15 Trip monitor 1, current at trip 12.0 A</p> <hr/> <p>BACK 09:40</p>	<p>There are five of trip history and details</p>
<p>REM ↻ Parameters 60.00Hz</p> <hr/> <p>03.16 Trip monitor 1, source of Vdc 800 V</p> <p>03.17 Trip monitor 1, running status at t Dec</p> <p>03.18 Trip monitor 1, DI status at trip 00000001</p> <hr/> <p>BACK 09:40</p>	<p>More details are shown next page as below</p> <p><i>'03.19' (Trip monitor 1, DO status at trip)</i></p> <p><i>'03.20' (Trip monitor 1, IGBT Temperature at trip)</i></p> <p><i>'03.21' (Trip monitor 1, Occurred time - Year)</i></p> <p><i>'03.22' (Trip monitor 1, Occurred time - Month, Day)</i></p> <p><i>'03.22' (Trip monitor 1, Occurred time - Hour, Minute)</i></p> <p><i>'03.23' (Trip monitor 1, Occurred time - Second)</i></p>

(7) Parameter setting

<p>REM ↻ Parameters 60.00Hz</p> <hr/> <p>Parameters</p> <hr/> <p>Parameter</p> <hr/> <p>Event log</p> <hr/> <p>BACK 09:40 SELECT</p>	<p>You have shifted to Parameters mode</p> <p>-Press the SELECT key(right key) once</p>
<p>REM ↻ Parameters 60.00Hz</p> <hr/> <p>97 System</p> <hr/> <p>98 Motor Control</p> <hr/> <p>99 Motor Data</p> <hr/> <p>BACK 09:40 SELECT</p>	<p>The Display group of Parameters mode is emerged.</p> <p>Move to 97 group</p> <p>-Press the SELECT key(right key) once</p>
<p>REM ↻ Parameters 60.00Hz</p> <hr/> <p>97.01 Initialization mode (0)Init Trip info</p> <hr/> <p>97.02 Parameter lock mode 0</p> <hr/> <p>BACK 09:40 SELECT</p>	<p>The details of System mode are emerged.</p> <p>-Press the SELECT key(right key) once</p>
<p>REM ↻ Parameters 60.00Hz</p> <hr/> <p>Initialization mode (0 ~ 1)</p> <hr/> <p>(1)Init All Param</p> <hr/> <p>CANCEL 09:40 SAVE</p>	<p>-Press the up arrow once</p> <p>It change to (1)Init All Param</p> <p>If you want initialize, Press the SAVE key(right key) once</p>

## 7. Quick Start Guide

In order to run the VFD, the run command source and frequency command source must be determined. Select one frequency command source and one run command source from list below and follow the instruction in the section referenced.

Default frequency command source is Analog Input Voltage, default run command source is Intelligent Input Terminal Connector (Input Terminal 1: Fwd, Input Terminal 2: Rev).

Frequency command can be done by

- Keypad – Up/Down Arrow Keys – (7.1)
- Input Terminal –
  - ❖ Analog Input Voltage/Current – (7.2)
  - ❖ Multi Frequency – (7.3)
  - ❖ Up/Down – (7.4)
- Modbus – RS485 (RXN, RXP) – (7.5)

And running/stopping command can be done by

- Keypad RUN/STOP Keys – (7.6)
- Intelligent Input Terminal Connector – (7.7)
- Modbus – RS485 (RXN, RXP) – (7.8)

### 7.1 Frequency Command Source to Up/Down Arrow Keys

- Keypad Diagram
- Programming A1 Parameters

❖ Keypad Diagram

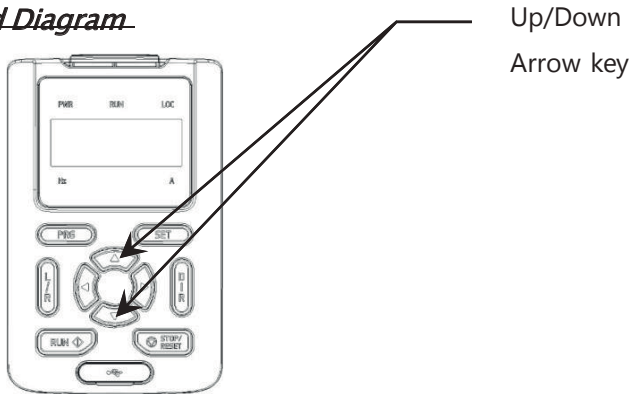

❖ Programming A1 Parameters

- On Keypad, program following parameters with corresponding values:

Code	Set Value	Description
22.03	6	Frequency Command Source to Keypad

## 7.2 Frequency Command Source to Input Analog Voltage/ Current

- Input Terminal Diagram
- Programming A1 Parameters
- Programming Frequency Set Point

### ❖ Input Terminal Diagram

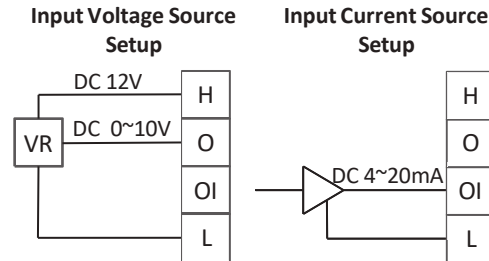
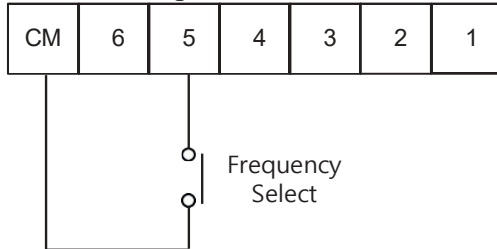

### ❖ Programming A1 Parameters

- On Keypad, program following parameters with corresponding values

Code	Set Value	Description
22.03	1	Frequency Command Source1 to Input Terminal(0~10V).
22.04	2	Frequency Command Source2 to Input Terminal(4~20mA).
22.06	6	Set Terminal 5 to Frequency Select Operation. If Closed, Select Current Source. If opened, Voltage Source.

### ❖ Setting Frequency Setpoint

- Program following parameters with specified frequency values.

Frequency setpoint follows analog reference (0 ~ 10V / 4 ~ 20 mA) from 0 to 60 Hz. Analog input settings can be modified using '11.06 ~ 11.08', '11.14 ~ 11.17'.

### 7.3 Frequency Command Source to Input Terminal – Multi Speed Frequency

- Input Terminal Diagram
- Programming A1 Parameters

❖ **Diagram**

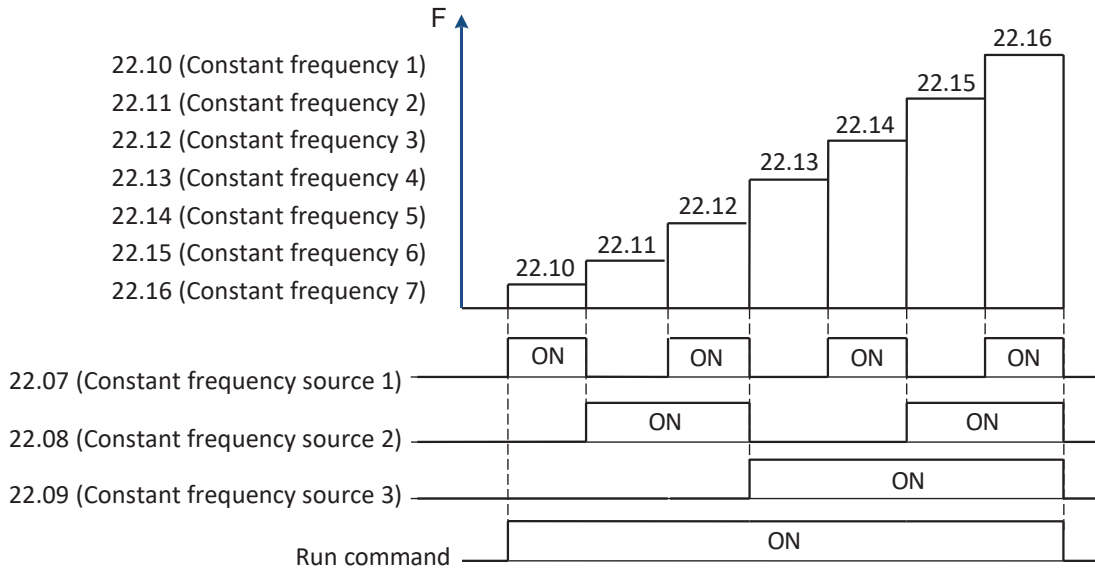

❖ **Programming A1 Parameters**

- On Keypad, program following parameters with corresponding values:

Code	Set Value	Description
22.07	4	Set Terminal 3 to Multi Speed Set CF1
22.08	5	Set Terminal 4 to Multi Speed Set CF2
22.09	8	Set Terminal 5 to Multi Speed Set CF3
22.10		
~	-	Set Frequency Value to Multi Speed by combination of CF1 ~ CF3.
22.16		



## 7.4 Frequency Command Source to Input Terminal – Up/Down

- Input Terminal Diagram
- Programming A1 Parameters

❖ **Diagram**

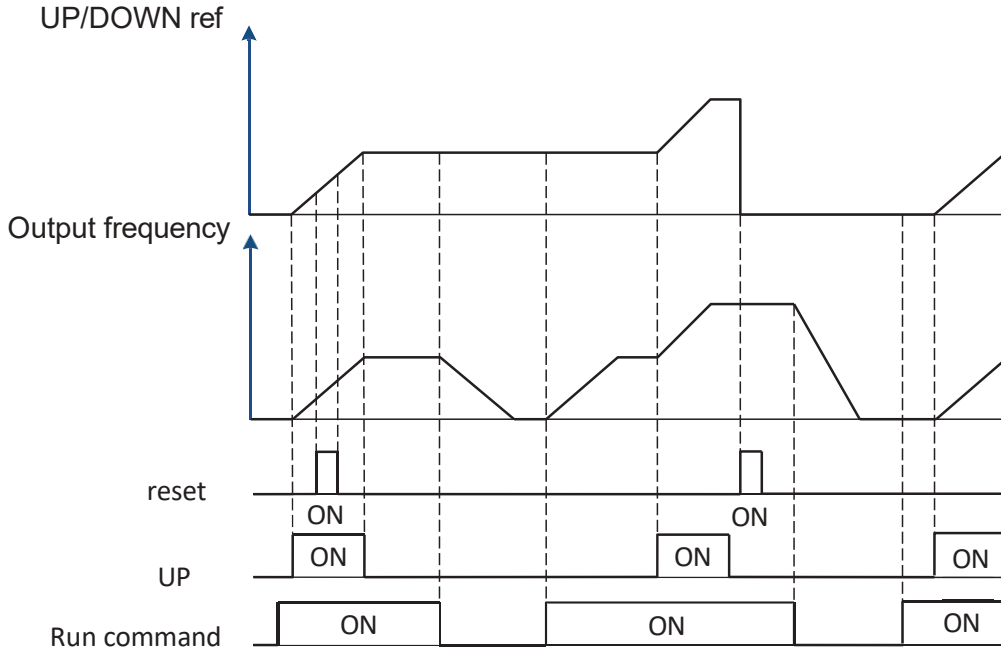

❖ **Programming A1 Parameters**

- On Keypad, program following parameters with corresponding values:

Code	Set Value	Description
22.25	-	UP/DOWN Enable, Initial value, Up/Down Source, Reset Source, etc.
~	-	
22.34	-	

## 7.5 Frequency Command Source to Modbus RS-485

- Diagram
- Programming A1 Parameters
- Set Frequency Setpoint

### ❖ Diagram

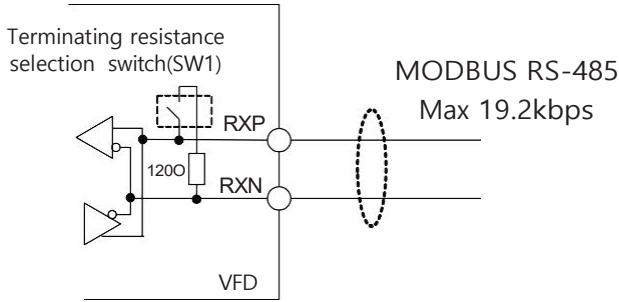

Terminal connector	Signal Descriptions
RXP	RS - 485+
RXN	RS - 485-

### ❖ Programming A1 Parameters

- On Keypad, program following parameters with corresponding values:

Code	Set Value	Description
22.03	3	Frequency Command by Modbus RS-485
50.01	1	Communication node (1 ~ 32)
50.02	0	Modbus baud rate (2,400bps ~ 19,200bps)

### ❖ Set Frequency Setpoint

- Integer data represents 0.01 Hz (ex: 6000 = 60.00 Hz)
- Ref to '8.2.23 RS-485(Modbus)'.

## 7.6 Run Command Source to Run / Stop Keys on Keypad

- Diagram
- Programming A1 Parameters

❖ **Diagram**

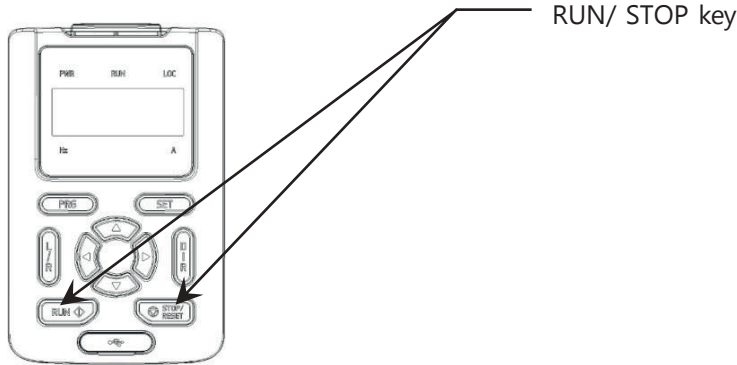

❖ **Programming A1 Parameters**

- On Keypad, program following parameters with corresponding values:

Code	Set Value	Description
20.02	9	Run Command Source to RUN / STOP Keys on Keypad

## 7.7 Run Command Source to Input Terminal

- Diagram
- Programming A1 Parameters

❖ **Diagram**

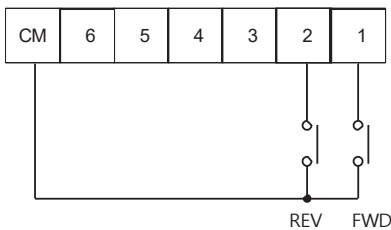

❖ **Programming Run Command Source**

- On Keypad, program following parameters with corresponding values

Code	Set Value	Description
20.02	3	Run Command Source to Input Terminal (2 Wire 2, Refer to '8.2.9 Start/Stop/Direction)

## 7.8 Run Command Source to Modbus RS-485

- Diagram
- Programming A1 Parameters
- Set Frequency Setpoint

### ❖ Diagram

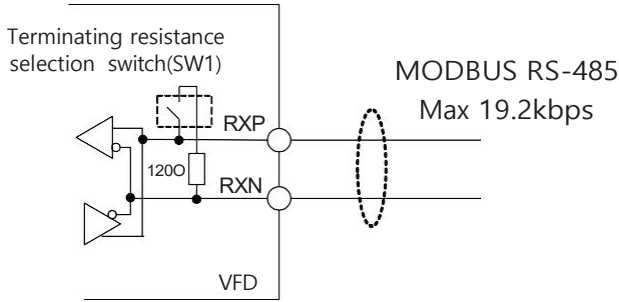

Terminal connector	Signal Descriptions
RXP	RS - 485+
RXN	RS - 485-

### ❖ Programming A1 Parameters

- On Keypad, program following parameters with corresponding values:

Code	Set Value	Description
22.03	3	Frequency Command by Modbus RS-485
50.01	1	Communication node (1 ~ 32)
50.02	0	Modbus baud rate (2,400bps ~ 19,200bps)

### ❖ Set Frequency Setpoint

- Data: (FWD: 0x0001, REV: 0x0002, RST: 0x0004)
- Ref to '8.2.23 RS-485(Modbus)'.

## 8. A1 Parameters

### 8.1 A1 Parameters Overview

A1 parameters are organized to various groups as summarized

Group	Contents	Page
01	VFD running status	58
02	Frequency reference indication	58
03	Trip information	58
04	Time counter	60
05	VFD firmware information	60
10	Standard DI, DO	61
11	Standard AI (O, OI)	62
12	Standard AO (FM, AMI)	63
20	Start/Stop/direction	64
21	Start/Stop mode	66
22	Frequency reference	67
23	Acceleration/Deceleration	69
24	Speed search	69
25	Over voltage suppression	70
26	KEB	70
27	DWELL	70
30	Frequency limits	70
31	Fault functions	71
32	Motor thermal protection	72
33	System Overload/Underload	72
40	PID	73
41	DBR duty Cycle	75
42	Monitoring/Scaling	75
43	Droop	75
50	RS-485 (Modbus)	75
51	Fieldbus (option)	76
96	User parameters	77
97	System	78
98	Motor control	78
99	Motor data	79

### 8.1.1 VFD running status

No.	Name	Range	Page
01.01	Output frequency monitor	0.00 to 400.0 [Hz]	80
01.02	Motor RPM monitor	0 to 60000 [rpm]	80
01.03	Encoder Speed monitor	0 to 60000 [rpm]	80
01.04	Rotation direction monitor	STP / FWD / REV	80
01.05	Output current monitor	0.0 to 2000 [A]	80
01.07	DC voltage monitor	0 to 1000 [V]	80
01.08	Output voltage monitor	0 to 1000 [V]	81
01.09	Output power monitor	0.0 to 1000 [kW]	81

### 8.1.2 Frequency reference indication

No.	Name	Range	Page
02.01	Final frequency reference monitor	0.00 to 400.0 [Hz]	82
02.02	Modbus frequency reference monitor	0.00 to 400.0 [Hz]	82
02.03	Fieldbus frequency reference monitor	0.00 to 400.0 [Hz]	82

### 8.1.3 Trip information

No.	Name	Range	Page
03.01	Current trip, Source of Trip	-	83
03.02	Current trip, Frequency at Trip	0.00 to 400.0 [Hz]	83
03.03	Current trip, Current at Trip	0.0 to 2000 [A]	83
03.04	Current trip, Vdc at Trip	0 to 1000 [V]	83
03.05	Current trip, Running Status at Trip	STP, ACC, STD, DEC	83
03.06	Current trip, DI Status at Trip	0x00 to 0xFF	83
03.07	Current trip, DO Status at Trip	0x00 to 0xFF	83
03.08	Current trip, IGBT Temperature at Trip	0.0 to 160.0 [°C]	83
03.09	Current trip, Occurred time (Year)	2000 to 2099 [Year]	84
03.10	Current trip, Occurred time (Month, Day)	101 to 1231 [Month, Day]	84
03.11	Current trip, Occurred time (Hour, Minute)	0 to 2359 [Hour, Minute]	84
03.12	Current trip, Occurred time (Second)	0 to 59 [Sec]	84
03.13	Trip monitor 1, Source of Trip	-	84
03.14	Trip monitor 1, Frequency at Trip	0.00 to 400.0 [Hz]	84
03.15	Trip monitor 1, Current at Trip	0.0 to 2000 [A]	84
03.16	Trip monitor 1, Vdc at Trip	0 to 1000 [V]	84
03.17	Trip monitor 1, Running Status at Trip	STP, ACC, STD, DEC	84
03.18	Trip monitor 1, DI Status at Trip	0x00 to 0xFF	84
03.19	Trip monitor 1, DO Status at Trip	0x00 to 0xFF	84
03.20	Trip monitor 1, IGBT Temperature at Trip	0.0 to 160.0 [°C]	84
03.21	Trip monitor 1, Occurred time (Year)	2000 to 2099 [Year]	84
03.22	Trip monitor 1, Occurred time (Month, Day)	101 to 1231 [Month, Day]	84
03.23	Trip monitor 1, Occurred time (Hour, Minute)	0 to 2359 [Hour, Minute]	84
03.24	Trip monitor 1, Occurred time (Second)	0 to 59 [Sec]	84
03.25	Trip monitor 2, Source of Trip	-	84
03.26	Trip monitor 2, Frequency at Trip	0.00 to 400.0 [Hz]	84
03.27	Trip monitor 2, Current at Trip	0.0 to 2000 [A]	84
03.28	Trip monitor 2, Vdc at Trip	0 to 1000 [V]	84
03.29	Trip monitor 2, Running Status at Trip	STP, ACC, STD, DEC	84
03.30	Trip monitor 2, DI Status at Trip	0x00 to 0xFF	84

No.	Name	Range	Page
03.31	Trip monitor 2, DO Status at Trip	0x00 to 0xFF	84
03.32	Trip monitor 2, IGBT Temperature at Trip	0.0 to 160.0 [°C]	84
03.33	Trip monitor 2, Occurred time (Year)	2000 to 2099 [Year]	84
03.34	Trip monitor 2, Occurred time (Month, Day)	101 to 1231 [Month, Day]	84
03.35	Trip monitor 2, Occurred time (Hour, Minute)	0 to 2359 [Hour, Minute]	84
03.36	Trip monitor 2, Occurred time (Second)	0 to 59 [Sec]	84
03.37	Trip monitor 3, Source of Trip	-	84
03.38	Trip monitor 3, Frequency at Trip	0.00 to 400.0 [Hz]	84
03.39	Trip monitor 3, Current at Trip	0.0 to 2000 [A]	84
03.40	Trip monitor 3, Vdc at Trip	0 to 1000 [V]	84
03.41	Trip monitor 3, Running Status at Trip	STP, ACC, STD, DEC	84
03.42	Trip monitor 3, DI Status at Trip	0x00 to 0xFF	84
03.43	Trip monitor 3, DO Status at Trip	0x00 to 0xFF	84
03.44	Trip monitor 3, IGBT Temperature at Trip	0.0 to 160.0 [°C]	84
03.45	Trip monitor 3, Occurred time (Year)	2000 to 2099 [Year]	84
03.46	Trip monitor 3, Occurred time (Month, Day)	101 to 1231 [Month, Day]	84
03.47	Trip monitor 3, Occurred time (Hour, Minute)	0 to 2359 [Hour, Minute]	84
03.48	Trip monitor 3, Occurred time (Second)	0 to 59 [Sec]	84
03.49	Trip monitor 4, Source of Trip	-	84
03.50	Trip monitor 4, Frequency at Trip	0.00 to 400.0 [Hz]	84
03.51	Trip monitor 4, Current at Trip	0.0 to 2000 [A]	84
03.52	Trip monitor 4, Vdc at Trip	0 to 1000 [V]	84
03.53	Trip monitor 4, Running Status at Trip	STP, ACC, STD, DEC	84
03.54	Trip monitor 4, DI Status at Trip	0x00 to 0xFF	84
03.55	Trip monitor 4, DO Status at Trip	0x00 to 0xFF	84
03.56	Trip monitor 4, IGBT Temperature at Trip	0.0 to 160.0 [°C]	84
03.57	Trip monitor 4, Occurred time (Year)	2000 to 2099 [Year]	84
03.58	Trip monitor 4, Occurred time (Month, Day)	101 to 1231 [Month, Day]	84
03.59	Trip monitor 4, Occurred time (Hour, Minute)	0 to 2359 [Hour, Minute]	84
03.60	Trip monitor 4, Occurred time (Second)	0 to 59 [Sec]	84
03.61	Trip monitor 5, Source of Trip	-	84
03.62	Trip monitor 5, Frequency at Trip	0.00 to 400.0 [Hz]	84
03.63	Trip monitor 5, Current at Trip	0.0 to 2000 [A]	84
03.64	Trip monitor 5, Vdc at Trip	0 to 1000 [V]	84
03.65	Trip monitor 5, Running Status at Trip	STP, ACC, STD, DEC	84
03.66	Trip monitor 5, DI Status at Trip	0x00 to 0xFF	84
03.67	Trip monitor 5, DO Status at Trip	0x00 to 0xFF	84
03.68	Trip monitor 5, IGBT Temperature at Trip	0.0 to 160.0 [°C]	84
03.69	Trip monitor 5, Occurred time (Year)	2000 to 2099 [Year]	84
03.70	Trip monitor 5, Occurred time (Month, Day)	101 to 1231 [Month, Day]	84
03.71	Trip monitor 5, Occurred time (Hour, Minute)	0 to 2359 [Hour, Minute]	84
03.72	Trip monitor 5, Occurred time (Second)	0 to 59 [Sec]	84
03.73	Trip Counter	0 to 40000	84

### 8.1.4 Time counter

No.	Name	Range	Page
04.01	Power on-day counter	0 to 65535 [Day]	85
04.02	Power on-time counter	0 to 1439 [Minute]	85
04.03	Run-day counter	0 to 65535 [Day]	85
04.04	Run-time counter	0 to 1439 [Minute]	85
04.05	Fan on-day counter	0 to 65535 [Day]	85
04.06	Fan on-time counter	0 to 1439 [Minute]	85
04.07	IGBT temperature	0.0 to 160.0 [°C]	86
04.08	Fieldbus status	0x00 to 0xFF	86

### 8.1.5 VFD firmware Information

No.	Name	Range	Page
05.01	Firmware name	STD: Standard	87
05.02	Firmware version	0.000 to 9.999	87
05.03	Current time (Year)	2000 to 2099 [Year]	87
05.04	Current time (Month, Day)	101 to 1231 [Month, Day]	87
05.05	Current time (Hour, Minute)	0 to 2359 [Hour, Minute]	87
05.06	Current time (Second)	0 to 59 [Sec]	87



### 8.1.6 Standard DI, DO (RN0~RN3, AL0-AL1-AL2)

No.	Name	Change during operation	Range	Default	Page
10.01	DI Status	-	0x00 to 0xFF	-	88
10.02	DI delayed status	-	0x00 to 0xFF	-	88
10.03	DI forced selection	X	0x00 to 0xFF	0x00	88
10.04	DI forced data	O	0x00 to 0xFF	0x00	88
10.05	DI contact type selection	X	0x00 to 0xFF	0x00	89
10.06	DI1 ON delay time	O	0.0 to 3000 [Sec]	0.0 Sec	89
10.07	DI1 OFF delay time	O	0.0 to 3000 [Sec]	0.0 Sec	89
10.08	DI2 ON delay time	O	0.0 to 3000 [Sec]	0.0 Sec	89
10.09	DI2 OFF delay time	O	0.0 to 3000 [Sec]	0.0 Sec	89
10.10	DI3 ON delay time	O	0.0 to 3000 [Sec]	0.0 Sec	89
10.11	DI3 OFF delay time	O	0.0 to 3000 [Sec]	0.0 Sec	89
10.12	DI4 ON delay time	O	0.0 to 3000 [Sec]	0.0 Sec	90
10.13	DI4 OFF delay time	O	0.0 to 3000 [Sec]	0.0 Sec	90
10.14	DI5 ON delay time	O	0.0 to 3000 [Sec]	0.0 Sec	90
10.15	DI5 OFF delay time	O	0.0 to 3000 [Sec]	0.0 Sec	90
10.16	DI6 ON delay time	O	0.0 to 3000 [Sec]	0.0 Sec	90
10.17	DI6 OFF delay time	O	0.0 to 3000 [Sec]	0.0 Sec	90
10.18	DI7 ON delay time	O	0.0 to 3000 [Sec]	0.0 Sec	90
10.19	DI7 OFF delay time	O	0.0 to 3000 [Sec]	0.0 Sec	90
10.20	DI8 ON delay time	O	0.0 to 3000 [Sec]	0.0 Sec	90
10.21	DI8 OFF delay time	O	0.0 to 3000 [Sec]	0.0 Sec	90
10.22	DO (RN0~RN3, AL0~AL2) delayed status	O	0x00 to 0xFF	-	91
10.23	DO (RN0~RN3, AL0~AL2) forced selection	X	0x00 to 0xFF	0x00	91
10.24	DO (RN0~RN3, AL0~AL2) forced data	O	0x00 to 0xFF	0x00	91
10.25	DO1 (RN0-RN1), DO2 (RN2-RN3) contact type selection	X	0x00 to 0xFF	0x00	91
10.26	DO1 (RN0-RN1) source	X	0. Run 1. FA1 2. FA2 3. OL 4. OD 5. AL	1	93
10.27	DO1 (RN0-RN1) ON delay time	O	0.0 to 3000 [Sec]	0.0 Sec	94
10.28	DO2 (RN0-RN1) OFF delay time	O	0.0 to 3000 [Sec]	0.0 Sec	94
10.29	DO2 (RN2-RN3) source	X	0. Run 1. FA1 2. FA2 3. OL 4. OD 5. AL	0	94
10.30	DO2 (RN2-RN3) ON delay time	O	0.0 to 3000 [Sec]	0.0 Sec	94
10.31	DO2 (RN2-RN3) OFF delay time	O	0.0 to 3000 [Sec]	0.0 Sec	94

No.	Name	Change during operation	Range	Default	Page
10.32	Alarm Relay (AL0-AL1-AL2) source	X	0. Run 1. FA1 2. FA2 3. OL 4. OD 5. AL	5	94
10.33	Alarm Relay (AL0-AL1-AL2) ON delay time	O	0.0 to 3000 [Sec]	0.0 Sec	94
10.34	Alarm Relay (AL0-AL1-AL2) OFF delay time	O	0.0 to 3000 [Sec]	0.0 Sec	94
10.35	VFD Overload warning level	X	10.0 to 200.0 [%]	100.0 %	95
10.36	FA2 reference at acceleration	X	'10.37' to '30.01' [Hz]	0.00 Hz	95
10.37	FA2 reference at deceleration	X	0.00 to '10.36' [Hz]	0.00 Hz	95
10.38	PID Error Tolerance	X	0.0 to 100.0 [%]	100.0 %	95

### 8.1.7 Standard AI (O, OI)

No.	Name	Change during operation	Range	Default	Page
11.01	AI (O, OI) forced selection	X	0x00 to 0xFF	0x00	96
11.02	AI1 (O) actual value	-	0.0 to 100.0 [%]	-	96
11.03	AI1 (O) scaled value	-	0.00 to 400.0 [Hz] - Frequency 0.0 to 100.0 [%] - PID	-	96
11.04	AI1 (O) forced value	O	0.0 to 100.0 [%]	0.00 %	96
11.05	AI1 (O) filter time	O	0 to 30000 [ms]	100 ms	97
11.06	AI1 (O) source min	X	0.0 to 100.0 [%]	0.00 %	97
11.07	AI1 (O) source max	X	0.0 to 100.0 [%]	100.0 %	97
11.08	AI1 (O) scaled at AI1 min	X	0.00 to 400.0 [Hz] - Frequency 0.0 to 100.0 [%] - PID	0.00 Hz	97
11.09	AI1 (O) scaled at AI1 max	X	0.00 to 400.0 [Hz] - Frequency 0.0 to 100.0 [%] - PID	60.00 Hz	98
11.10	AI2 (OI) actual value	-	0.0 to 100.0 [%]	-	98
11.11	AI2 (OI) scaled value	-	0.0 to 100.0 [%]	-	98
11.12	AI2 (OI) forced value	O	0.0 to 100.0 [%]	0.00 %	99
11.13	AI2 (OI) filter time	O	0 to 30000 [ms]	100 ms	99
11.14	AI2 (OI) source min	X	0.0 to 100.0 [%]	0.00 %	99
11.15	AI2 (OI) source max	X	0.0 to 100.0 [%]	100.0 %	99
11.16	AI2 (OI) scaled at AI2 min	X	0.00 to 400.0 [Hz] - Frequency 0.0 to 100.0 [%] - PID	0.00 Hz	100
11.17	AI2 (OI) scaled at AI2 max	X	0.00 to 400.0 [Hz] - Frequency 0.0 to 100.0 [%] - PID	60.00 Hz	100

### 8.1.8 Standard AO (FM, AMI)

No.	Name	Change during operation	Range	Default	Page
12.01	AO (FM, AMI) forced selection	X	0x00 to 0xFF	0x00	101
12.02	AO1 (FM) actual value	-	0.0 to 100.0 [%]	-	101
12.03	AO1 (FM) source	-	0. Out Frequency 1. Out Ampere 2. Out Voltage 3. Out Power 4. Out Torque 5. Modbus communication 6. DC link Voltage	0	101
12.04	AO1 (FM) forced value	O	0.0 to 100.0 [%]	0.00 %	102
12.05	AO1 (FM) filter time	O	0 to 30000 [ms]	100 ms	102
12.06	AO1 (FM) source min	X	0.0 to 100.0 [%]	0.00 %	103
12.07	AO1 (FM) source max	X	0.0 to 100.0 [%]	100.0 %	103
12.08	AO1 (FM) out at AO1 min	X	0.0 to 100.0 [%]	0.00 %	104
12.09	AO1 (FM) out at AO1 max	X	0.0 to 100.0 [%]	100.0 %	104
12.10	AO2 (AMI) actual value	-	0.0 to 100.0 [%]	-	104
12.11	AO2 (AMI) source	-	0. Out Frequency 1. Out Ampere 2. Out Voltage 3. Out Power 4. Out Torque 5. Modbus communication 6. DC link Voltage	1	104
12.12	AO2 (AMI) forced value	O	0.0 to 100.0 [%]	0.00 %	104
12.13	AO2 (AMI) filter time	O	0 to 30000 [ms]	100 ms	104
12.14	AO2 (AMI) source min	X	0.0 to 100.0 [%]	0.00 %	104
12.15	AO2 (AMI) source max	X	0.0 to 100.0 [%]	100.0 %	104
12.16	AO2 (AMI) out at AO2 min	X	0.0 to 100.0 [%]	0.00 %	104
12.17	AO2 (AMI) out at AO2 max	X	0.0 to 100.0 [%]	100.0 %	104
12.18	AO2 (AMI) Initial Current	X	0.00 to 0.60[mA]	0.40mA	105

### 8.1.9 Start/stop/direction

No.	Name	Change during operation	Range	Default	Page
20.01	Ext1 / Ex2 selection	X	0. Ext1 1. Ext2 2. DI1 3. DI2 4. DI3 5. DI4 6. DI5 7. DI6 8. DI7 9. DI8	0	105
20.02	Ext1 commands	X	0. Not Selected 1. 1 Wire 2. 2 Wire 1 3. 2 Wire 2 4. 2 Wire 3 5. 3 Wire 1 6. 3 Wire 2 7. Modbus 8. Fieldbus 9. Keypad	3	106
20.03	Ext1 in source 1	X	0. Not Selected 1. Selected 2. DI1	2	108
20.04	Ext1 in source 2	X	3. DI2 4. DI3 5. DI4 6. DI5	3	108
20.05	Ext1 in source 3	X	7. DI6 8. DI7 9. DI8	0	108

No.	Name	Change during operation	Range	Default	Page
20.06	Ext2 commands	X	0. Not Selected 1. 1 Wire 2. 2 Wire 1 3. 2 Wire 2 4. 2 Wire 3 5. 3 Wire 1 6. 3 Wire 2 7. Modbus 8. Fieldbus 9. Keypad	0	108
20.07	Ext2 in source 1	X	0. Not Selected	0	108
20.08	Ext2 in source 2	X	1. Selected	0	108
20.09	Ext2 in source 3	X	2. DI1	0	108
20.10	Jogging enable	X	3. DI2	0	109
20.11	Jogging 1 start source	X	4. DI3	0	109
20.12	Jogging 2 start source	X	5. DI4	0	109
20.13	Direction	X	6. DI5	0	109
			7. DI6	0	109
			8. DI7	0	109
			9. DI8	0	109
			0. Forward	0	109
			1. Reverse	0	109

### 8.1.10 Start/Stop mode

No.	Name	Change during operation	Range	Default	Page
21.01	Torque boost mode	X	0. Manual torque boost 1. Automatic torque boost	0	110
21.02	Magnetization time	X	0.0 to 3000 [Sec]	0.0 Sec	110
21.03	Magnetization Level	X	0.0 to 200.0 [%]	30.0 %	110
21.04	Stop mode	O	0. Ramp (Dec) 1. Coast (Free-run)	0	110
21.05	DC current control (DC brake)	X	0. Disable 1. Enable	0	111
21.06	DC hold frequency	X	0.00 to 10.00 [Hz]	0.50 Hz	111
21.07	DC hold time	X	0.0 to 3000 [Sec]	0.0 Sec	111
21.08	DC hold delay time	X	0.0 to 50.0 [Sec]	0.0 Sec	111
21.09	DC current reference	X	0.0 to 100.0 [%]	10.0 %	111
21.10	Emergency stop mode	O	0. Ramp (Dec) 1. Coast (Free-run)	0	112
21.11	Emergency stop source	O	0. Active 1. Inactive 2. DI1 3. DI2 4. DI3 5. DI4 6. DI5 7. DI6 8. DI7 9. DI8	1	112
21.12	DC current control P gain	O	1 ~ 10000	1000	112
21.13	DC current control I gain	O	0 ~ 10000	500	112

### 8.1.11 Frequency reference

No.	Name	Change during operation	Range	Default	Page
22.01	Frequency ref input (keypad)	O	0.00 to 400.0 [Hz]	0.00 Hz	114
22.03	Frequency ref 1 source	X	0. Not Selected 1. AI1 (O) 2. AI2 (OI) 3. Modbus	1	114
22.04	Frequency ref 2 source	X	4. Field bus 5. PID 6. Keypad 7. UP / DOWN	2	114
22.05	Frequency ref 1 /ref 2 combination	X	0. <b>'22,03'</b> 1. <b>'22,03' + '22.04'</b> 2. <b>'22,03' - '22.04'</b> 3. <b>'22,03' x '22.04'</b> 4. MIN ( <b>'22,03'</b> , <b>'22.04'</b> ) 5. MAX ( <b>'22,03'</b> , <b>'22.04'</b> )	0	115
22.06	Frequency ref 1 /ref 2 selection	X	0. <b>'22.05'</b> setting value 1. <b>'22.04'</b> setting value 2. DI1 3. DI2 4. DI3 5. DI4 6. DI5 7. DI6 8. DI7 9. DI8	0	115
22.07	Constant frequency source 1	X	0. Not selected 1. Selected 2. DI1	0	116
22.08	Constant frequency source 2	X	3. DI2 4. DI3 5. DI4	0	117
22.09	Constant frequency source 3	X	6. DI5 7. DI6 8. DI7 9. DI8	0	117
22.10	Constant frequency 1	X	0.00 to 400.0 [Hz]	5.00 Hz	117
22.11	Constant frequency 2	X	0.00 to 400.0 [Hz]	10.00 Hz	117
22.12	Constant frequency 3	X	0.00 to 400.0 [Hz]	20.00 Hz	117
22.13	Constant frequency 4	X	0.00 to 400.0 [Hz]	30.00 Hz	117
22.14	Constant frequency 5	X	0.00 to 400.0 [Hz]	40.00 Hz	117
22.15	Constant frequency 6	X	0.00 to 400.0 [Hz]	50.00 Hz	117
22.16	Constant frequency 7	X	0.00 to 400.0 [Hz]	60.00 Hz	117
22.17	Jogging 1 ref	X	0.00 to 400.0 [Hz]	0.00 Hz	118
22.18	Jogging 2 ref	X	0.00 to 400.0 [Hz]	0.00 Hz	118

No.	Name	Change during operation	Range	Default	Page
22.19	Skip frequency 1 low	X	0.00 to 400.0 [Hz]	0.00 Hz	119
22.20	Skip frequency 1 high	X	0.00 to 400.0 [Hz]	0.00 Hz	119
22.21	Skip frequency 2 low	X	0.00 to 400.0 [Hz]	0.00 Hz	119
22.22	Skip frequency 2 high	X	0.00 to 400.0 [Hz]	0.00 Hz	119
22.23	Skip frequency 3 low	X	0.00 to 400.0 [Hz]	0.00 Hz	119
22.24	Skip frequency 3 high	X	0.00 to 400.0 [Hz]	0.00 Hz	119
22.25	UP/DOWN function	X	0. Disable 1. Enable	0	120
22.26	UP/DOWN initial value	X	0.00 to 400.0 [Hz] - frequency 0.0 to 100.0 [%] - PID	0.00 Hz	120
22.27	UP/DOWN up source	X	0. Not selected 1. Selected 2. DI1 3. DI2 4. DI3	0	120
22.28	UP/DOWN down source	X	5. DI4 6. DI5 7. DI6 8. DI7 9. DI8	0	120
22.29	UP/DOWN ref changing time	X	0.0 to 3000 [Sec]	10.0 Sec	121
22.30	UP/DOWN min value	X	0.00 to 400.0 [Hz] - frequency 0.0 to 100.0 [%] - PID	0.00 Hz	121
22.31	UP/DOWN max value	X	0.00 to 400.0 [Hz] - frequency 0.0 to 100.0 [%] - PID	60.00 Hz	121
22.32	UP/DOWN ref monitor	X	0.00 to 400.0 [Hz] - frequency 0.0 to 100.0 [%] - PID	-	121
22.33	UP/DOWN initial value saving	X	0. Not saving 1. Saving	0	121
22.34	UP/DOWN ref reset source	X	0. Not selected 1. Selected 2. DI1 3. DI2 4. DI3 5. DI4 6. DI5 7. DI6 8. DI7 9. DI8	0	122



### 8.1.12 Acceleration/Deceleration

No.	Name	Change during operation	Range	Default	Page
23.03	Ramp set selection	-	0. Acc/Dec Time1 1. Acc/Dec Time2 2. Frequency 3. DI1 4. DI2 5. DI3 6. DI4 7. DI5 8. DI6 9. DI7 10. DI8	0	123
23.04	Acceleration time 1	O	0.0 to 3000 [Sec]	30.0 Sec	124
23.05	Deceleration time 1	O	0.0 to 3000 [Sec]	30.0 Sec	124
23.06	Acceleration time 2	O	0.0 to 3000 [Sec]	30.0 Sec	124
23.07	Deceleration time 2	O	0.0 to 3000 [Sec]	30.0 Sec	125
23.08	Acceleration pattern selection	O	0. Linear	0	125
23.09	Deceleration pattern selection	O	1. S Curve 2. U Curve	0	125
23.10	Acceleration time transition frequency	O	0.00 to 400.0 [Hz]	0.00 Hz	126
23.11	Deceleration time transition frequency	O	0.00 to 400.0 [Hz]	0.00 Hz	126
23.12	Jogging acceleration time	O	0.0 to 3000 [Sec]	30.0 Sec	126
23.13	Jogging deceleration time	O	0.0 to 3000 [Sec]	30.0 Sec	126
23.14	Emergency stop time	O	0.0 to 3000 [Sec]	3.0 Sec	126

### 8.1.13 Speed search

No.	Name	Change during operation	Range	Default	Page
24.01	Speed search start mode	O	0. Start from 0 Hz 1. Start from frequency corresponding motor speed	0	127
24.03	Voltage increment in speed search mode	O	10 to 300 [%]	100 %	127

### 8.1.14 Over voltage suppression

No.	Name	Change during operation	Range	Default	Page
25.01	OVS selection	O	0: Disable 1: Enable	0	129
25.02	Maximum OVS output frequency	O	0.0 to 300.0 [Hz]	20.00 Hz	129
25.03	OVS P gain	O	0 to 10000	1000	129
25.04	OVS I gain	O	0 to 10000 [Sec]	100 Sec	129
25.05	OVS D gain	O	0 to 10000 [Sec]	0 Sec	130
25.06	q-Current reference	O	-100.0 to 100.0	0.0	130
25.07	Filter bandwidth	O	0.0 to 1000 [ms]	1 ms	130
25.08	Limit time	O	0.0 to 100 [Sec]	0.5 Sec	131
25.09	OVS Vdc Level (HF)	O	0 to 2000 [V]	700 V	131
25.10	OVS Vdc Level (LF)	O	0 to 1000 [V]	350 V	131

### 8.1.15 KEB

No.	Name	Change during operation	Range	Default	Page
26.01	KEB selection	X	0: Disable 1: Enable	0	133
26.02	KEB gain	X	1 to 1000	100	133

### 8.1.16 DWELL

No.	Name	Change during operation	Range	Default	Page
27.01	DWELL reference at start	X	0.00 to 400.0 [Hz]	0.00 Hz	134
27.02	DWELL time at start	X	0.0 to 10.0 [Sec]	0.0 Sec	134
27.03	DWELL reference at stop	X	0.00 to 400.0 [Hz]	0.00 Hz	134
27.04	DWELL time at stop	X	0.0 to 10.0 [Sec]	0.0 Sec	134

### 8.1.17 Frequency limits

No.	Name	Change during operation	Range	Default	Page
30.01	Maximum frequency	O	0.00 to 400.0 [Hz]	60.00 Hz	135
30.02	Minimum frequency	O	0.00 to 400.0 [Hz]	0.00 Hz	135

### 8.1.18 Fault functions

No.	Name	Change during operation	Range	Default	Page
31.01	External event 1 source	-	0. Active	1	136
31.02	External event 2 source	-	1. Inactive	1	136
31.03	External event 3 source	-	2. DI1	1	136
31.04	External event 4 source	-	3. DI2	1	136
31.05	External event 5 source	-	4. DI3	1	136
31.06	Fault reset selection	X	5. DI4	7	136
31.07	Restart mode selection	X	6. DI5	0	137
31.08	Alarm relay operation mode	X	7. DI6	0	137
31.09	Restart delay time	X	8. DI7	1.0 Sec	137
31.10	Automatic reset item 1	X	9. DI8	0x00	138
31.11	Automatic reset item 2	X	0. No Restart	0x00	138
31.12	User reset item selection	X	1. Restart from 0Hz	0	138
31.13	Restart trial 1	X	2. Resume at frequency corresponding motor speed	0	138
31.14	Restart trial 2	X	3. Resume at motor speed, then decelerated stop	0	138
31.15	Earth Fault	X	0. Inactive for the Under Voltage trip signal	0.0 %	139
31.16	Supply phase loss	O	1. Inactive during auto reset	10 Sec	139
31.17	Stall function	X	2. Active every trip	3	139
31.18	Stall current limit	X	3. Inactive during auto reset (Only active for the Under Voltage trip signal endlessly)	150.0 %	139
31.19	Stall deceleration time	O	0.3 to 10.0 [Sec]	1.0 Sec	140
31.22	RS485 Modbus time out check	O	0x00 ~ 0xFF	0	140

	enable		1. Only During VFD is Running		
31.23	RS485 Modbus time out	O	0 to 60 [Sec] 0: Disable	0 Sec	140

### 8.1.19 Motor thermal protection

No.	Name	Change during operation	Range	Default	Page
32.01	Electronic thermal overload level	X	20.0 to 120.0 [%]	110.0 %	141
32.02	Electronic thermal overload profile	X	0. Self Cooling 1. Forced Cooling	0	141
32.03	Fan operation mode	X	0. Always running 1. Only During VFD is running	0	141
32.04	Fan off delay time	X	0.0 to 1000.0 [Sec]	30.0 Sec	141

### 8.1.20 System Overload/Underload detection

No.	Name	Change during operation	Range	Default	Page
33.01	System Load Detection Selection	X	0: Disabled 1: Overload Detection 2: Underload Detection 3: Overload/Underload Detection 4: Overload Detection with Fault(oLdt) 5: Underload Detection with Fault(uLdt) 6: Overload/Underload Detection with Fault(oLdt, uLdt)	0	142
33.02	System Overload Detection Level	X	2. 20.0 to 200.0[%]	100.0%	142
33.03	System Underload Detection Level	X	2. 20.0 to 200.0[%]	100.0%	142
33.04	System Overload/Underload Detection Time	X	0.0 to 60.0[sec]	10.0 Sec	143
33.05	System Overload/Underload Detection Safe Zone	X	0.0 to '30.01'[Hz]	0.00Hz	143

### 8.1.21 PID

No.	Name	Change during operation	Range	Default	Page
40.01	PID function	X	0. Disable 1. Enable	0	144
40.02	PID reference	O	0.0 to 100.0 [%]	0.0 %	144
40.03	PID reference source	X	0. AI1 (O) 1. AI2 (OI) 2. <b>'40.02'</b> 3. Modbus 4. Fieldbus	2	145
40.04	PID feedback source	X	0. AI1 (O) 1. AI2 (OI)	1	145
40.05	PID P gain	O	0.1 to 1000.0 [%]	100.0 %	145
40.06	PID I gain	O	0.0 to 3600.0 [Sec]	1.0 Sec	146
40.07	PID D gain	O	0.00 to 10.00 [Sec]	0.00 Sec	146
40.08	PID Err limit	O	0.0 to 100.0 [%]	100.0 %	146
40.09	PID output high limit	O	-100.0 to 100.0 [%]	100.0 %	146
40.10	PID output low limit	O	-100.0 to 100.0 [%]	0.0 %	146
40.11	PID output invert	X	0. Disable 1. Enable	0	146
40.12	PID scale factor	X	0.1 to 1000 [%]	100.0 %	146
40.13	Pre PID frequency	X	0.00 to 400.0 [Hz]	0.00 Hz	147
40.14	PID sleep frequency	X	0.00 to 400.0 [Hz]	0.00 Hz	147
40.15	PID sleep/wake up delay time	X	0.0 to 30.0 [Sec]	0.0 Sec	147
40.16	PID wake up frequency	X	<b>'40.14'</b> to 400.0 [Hz]	0.00 Hz	148
40.17	PID feedback monitor	-	0.0 to 100.0 [%]	-	148
40.18	PID output monitor	-	0.0 to 100.0 [%]	-	148

No.	Name	Change during operation	Range	Default	Page
40.19	PID integral reset source	X	0. Not selected 1. Selected 2. DI1 3. DI2 4. DI3 5. DI4	0	148
40.20	PID disable source	X	6. DI5 7. DI6 8. DI7 9. DI8	0	149
40.21	ref source 1 at PID disable	X	0. Not selected 1. AI1 (O) 2. AI2 (OI) 3. Modbus	1	149
40.22	ref source 2 at PID disable	X	4. Fieldbus 5. PID 6. Keypad 7. UP/DOWN	2	150
40.23	ref 1 /ref 2 combination at PID disable	X	0. <b>'40.21'</b> 1. <b>'40.21' + '40.22'</b> 2. <b>'40.21' - '40.22'</b> 3. <b>'40.21' x '40.22'</b> 4. MIN ( <b>'40.21'</b> , <b>'40.22'</b> ) 5. MAX ( <b>'40.21'</b> , <b>'40.22'</b> )	0	150
40.24	ref 1 /ref 2 selection at PID disable	X	0. <b>'40.23'</b> setting value 1. <b>'40.22'</b> setting value 2. DI1 3. DI2 4. DI3 5. DI4 6. DI5 7. DI6 8. DI7 9. DI8	0	150

### 8.1.22 DBR Duty Cycle

No.	Name	Change during operation	Range	Default	Page
41.01	DBR Mode	X	0: DBR disabled 1: Only during VFD running 2: Always	1	152
41.02	DBR Duty cycle	X	0.0~50.0%	10.0	152

### 8.1.23 Monitoring/Scaling

No.	Name	Change during operation	Range	Default	Page
42.01	Frequency scaling	X	0.00 to 400.0 [Hz]	60.00 Hz	153
42.02	Rpm display scale factor	O	1 to 9999	100	153
42.10	Flux braking operating frequency	X	0 to 10.00 [Hz]	5.00 Hz	153

### 8.1.24 Droop

No.	Name	Change during operation	Range	Default	Page
43.01	Droop type	O	0: No droop control 1: Open loop 2: F/B (0~10V) 3: F/B (4~20mA)	0	154
43.02	Droop start frequency	O	0.00 to 400.0 [Hz]	0.00 Hz	154
43.04	Droop gain	O	0.00 to 50.00	5.00	155
43.05	Droop start torque	O	0.0 to 100.0 [%]	0.0 %	155
43.06	Droop ramp time	O	1.0 to 100.0 [Sec]	20.0 Sec	155

### 8.1.25 RS-485 (Modbus)

No.	Name	Change during operation	Range	Default	Page
50.01	Modbus node ID	X	1 to 32	1	157
50.02	Modbus baud rate	X	1. 2,400 [bps] 2. 4,800 [bps] 3. 9,600 [bps] 4. 19,200 [bps]	3	157

### 8.1.26 Fieldbus (option)

No.	Name	Change during operation	Range	Default	Page
51.01	Fieldbus option type	X	0: Modbus 1: Profibus-DP 2: Device-Net 3: Ethernet series 4: Reserved	4	164
51.02	Fieldbus station number	X	32: Ethernet series 63: Device-Net 125: Profibus-DP	125	164
51.03	Fieldbus byte swap	X	0: Normal 1: Swap	1	164
51.08	Fieldbus input data 1	X	0x0000 to 0xFFFF	0x0603	164
51.09	Fieldbus input data 2	X	0x0000 to 0xFFFF	0x0001	164
51.10	Fieldbus input data 3	X	0x0000 to 0xFFFF	0x0202	164
51.11	Fieldbus input data 4	X	0x0000 to 0xFFFF	0x0203	164
51.12	Fieldbus input data 5	X	0x0000 to 0xFFFF	0x0201	164
51.13	Fieldbus input data 6	X	0x0000 to 0xFFFF	0x0101	164
51.14	Fieldbus input data 7	X	0x0000 to 0xFFFF	0x0102	164
51.15	Fieldbus input data 8	X	0x0000 to 0xFFFF	0x010C	164
51.16	Fieldbus input data 9	X	0x0000 to 0xFFFF	0x010d	164
51.17	Fieldbus input data 10	X	0x0000 to 0xFFFF	0x0111	164
51.18	Fieldbus input data 11	X	0x0000 to 0xFFFF	0x0115	164
51.19	Fieldbus input data 12	X	0x0000 to 0xFFFF	0x0000	164
51.20	Fieldbus output data 1	X	0x0000 to 0xFFFF	0x0202	164
51.21	Fieldbus output data 2	X	0x0000 to 0xFFFF	0x0203	164
51.22	Fieldbus output data 3	X	0x0000 to 0xFFFF	0x0201	164
51.23	Fieldbus output data 4	X	0x0000 to 0xFFFF	0x0002	164
51.24	Fieldbus output data 5	X	0x0000 to 0xFFFF	0x0000	164
51.25	Fieldbus output data 6	X	0x0000 to 0xFFFF	0x0000	164
51.26	Fieldbus output data 7	X	0x0000 to 0xFFFF	0x0000	164
51.27	Fieldbus output data 8	X	0x0000 to 0xFFFF	0x0000	164
51.28	Fieldbus output data 9	X	0x0000 to 0xFFFF	0x0000	164
51.29	Fieldbus output data 10	X	0x0000 to 0xFFFF	0x0000	164
51.30	Fieldbus output data 11	X	0x0000 to 0xFFFF	0x0000	164
51.31	Fieldbus output data 12	X	0x0000 to 0xFFFF	0x0000	164
51.32	Fieldbus status	X	0x0000 to 0xFFFF	-	164
51.33	Fieldbus version	X	0x0000 to 0xFFFF	-	164



## 8.1.27 User parameters

No.	Name	Change during operation	Range	Default	Page
96.01	User parameter selection	X	0. Disable 1. Enable	0	165
96.02	User para. config 1	X	'00.00' ~ '99.99'	'22.03'	165
96.03	User para. config 2	X	'00.00' ~ '99.99'	'20.02'	165
96.04	User para. config 3	X	'00.00' ~ '99.99'	'01.01'	165
96.05	User para. config 4	X	'00.00' ~ '99.99'	'23.04'	165
96.06	User para. config 5	X	'00.00' ~ '99.99'	'23.05'	165
96.07	User para. config 6	X	'00.00' ~ '99.99'	'99.02'	165
96.08	User para. config 7	X	'00.00' ~ '99.99'	'99.01'	165
96.09	User para. config 8	X	'00.00' ~ '99.99'	'99.04'	165
96.10	User para. config 9	X	'00.00' ~ '99.99'	'99.03'	165
96.11	User para. config 10	X	'00.00' ~ '99.99'	'30.01'	165
96.12	User para. config 11	X	'00.00' ~ '99.99'	'00.00'	165
96.13	User para. config 12	X	'00.00' ~ '99.99'	'00.00'	165
96.14	User para. config 13	X	'00.00' ~ '99.99'	'00.00'	165
96.15	User para. config 14	X	'00.00' ~ '99.99'	'00.00'	165
96.16	User para. config 15	X	'00.00' ~ '99.99'	'00.00'	165
96.17	User para. config 16	X	'00.00' ~ '99.99'	'00.00'	165
96.18	User para. config 17	X	'00.00' ~ '99.99'	'00.00'	165
96.19	User para. config 18	X	'00.00' ~ '99.99'	'00.00'	165
96.20	User para. config 19	X	'00.00' ~ '99.99'	'00.00'	165
96.21	User para. config 20	X	'00.00' ~ '99.99'	'00.00'	165
96.22	User para. config 21	X	'00.00' ~ '99.99'	'00.00'	165
96.23	User para. config 22	X	'00.00' ~ '99.99'	'00.00'	165
96.24	User para. config 23	X	'00.00' ~ '99.99'	'00.00'	165
96.25	User para. config 24	X	'00.00' ~ '99.99'	'00.00'	165
96.26	User para. config 25	X	'00.00' ~ '99.99'	'00.00'	165
96.27	User para. config 26	X	'00.00' ~ '99.99'	'00.00'	165
96.28	User para. config 27	X	'00.00' ~ '99.99'	'00.00'	165
96.29	User para. config 28	X	'00.00' ~ '99.99'	'00.00'	165
96.30	User para. config 29	X	'00.00' ~ '99.99'	'00.00'	165
96.31	User para. config 30	X	'00.00' ~ '99.99'	'00.00'	165
96.32	User para. config 31	X	'00.00' ~ '99.99'	'00.00'	165
96.33	User para. config 32	X	'00.00' ~ '99.99'	'00.00'	165

### 8.1.28 System

No.	Name	Change during operation	Range	Default	Page
97.01	Initialization mode	X	0: Clear trip history 1: Clear all parameters	0	166
97.02	Parameter lock mode	X	0: All parameters are locked except <b>'97.12'</b> by <b>'97.03'</b> 1: All parameters are locked except <b>'97.12'</b> and <b>'02.01'</b> by <b>'97.03'</b> 2: All parameters are locked except <b>'97.12'</b> 3: All parameters are locked except <b>'97.12'</b> and <b>'20.01'</b> 4: All parameters are locked except <b>'97.12'</b> and <b>'20.01', '23.04', '23.05'</b>	0	166
97.03	Parameter lock source	X	0. Not Selected 1. Selected 2. DI1 3. DI2 4. DI3 5. DI4 6. DI5 7. DI6 8. DI7 9. DI8	0	166
97.04	Current time setting (Year)	O	2000 ~ 2099	2016	167
97.05	Current time setting (Month, Day)	O	101 ~ 1231	224	167
97.06	Current time setting (Hour, Minute)	O	0 ~ 2359	0	167
97.07	Current time setting (Second)	O	0 ~ 59	0	167

### 8.1.29 Motor control

No.	Name	Change during operation	Range	Default	Page
98.01	Motor control mode	X	0. CT (V/f) 1. VT (V/f) 2. SLV	0	168
98.02	HD/ND (torque type) selection	X	0. HD type 1. ND type	0	169
98.03	PWM carrier frequency	O	1.0 to 10.0 [kHz] or 16.0[kHz]	Per Capacity	169
98.04	PWM carrier mode	O	0. Normal 1. Swing PWM1	0	169
98.05	Voltage gain factor	O	20.0 to 110.0 [%]	100.0 %	170
98.06	Flux braking function	O	0. Disable 1. Enable	1	170
98.07	Flux braking reference	O	100 to 140 [%]	110 %	170
98.09	Manual torque boost voltage reference	X	0.00 to 50.00 [%]	1.0 %	170
98.10	Manual torque boost frequency reference	X	0.0 to 100.0 [%]	100.0 %	171
98.11	Motoring Slip Compensation	O	0 to 200 [%]	0 %	171
98.12	Regeneration Slip Compensation	O	0 to 200 [%]	0 %	171

### 8.1.30 Motor data

No.	Name	Change during operation	Range	Default	Page
99.01	Motor type	X	2.2L: 2.2kW 3.7L: 3.7kW 5.5L: 5.5kW 7.5L: 7.5kW 11L: 11kW 15L: 15kW 18.5L: 18.5kW 22L: 22kW 30L: 30kW 37L: 37kW 45L: 45kW 55L: 55kW 75L: 75kW 90L: 90kW 2.2H: 2.2kW 3.7H: 3.7kW 5.5H: 5.5kW 7.5H: 7.5kW 11H: 11kW 15H: 15kW 18.5H: 18.5kW 22H: 22kW 30H: 30kW 37H: 37kW 45H: 45kW 55H: 55kW 75H: 75kW 90H: 90kW 110H: 110kW 132H: 132kW 160H: 160kW 200H: 200kW 220H: 220kW 250H: 250kW 280H: 280kW 320H: 320kW 350H: 350kW	153	172
99.02	Motor rated voltage	X	200V/220V/230V/240V /380V/400V/415V/440V/460V/480V	Per Capacity	172
99.03	Motor rated frequency	X	0.00 to 400.0 [Hz]	60.00 Hz	172
99.04	Motor rated current	X	0.1 to 800.0 [A]	Per Capacity	172
99.05	Motor flux current	X	0.1 to 400.0 [A]	Per Capacity	173
99.06	Motor rated slip frequency	X	0.01 to 10.0 [%]	Per Capacity	173
99.07	Motor pole setting	X	2: 2 Poles 4: 4 Poles 6: 6 Poles 8: 8 Poles	4	173
99.08	Auto tuning	X	0. Disable 1. Enable	0	173
99.09	Motor data selection	X	0. Standard data 1. Auto tuning data	0	174
99.10	Motor resistance R1	X	0.1 to 30.0 [Ohm]	Per Capacity	174
99.11	Motor transient inductance Lsig	X	0.01 to 100.0 [mH]	Per Capacity	174
99.12	Motor resistance R1 (Auto tuned data)	X	0.1 to 30.0 [Ohm]	Per Capacity	174
99.13	Motor Transient inductance Lsig (Auto tuned data)	X	0.01 to 100.0 [mH]	Per Capacity	174

## 8.2 Parameter detail

### 8.2.1 VFD running status

- **01.01 Output frequency monitor**

- *Range: 0.00 ~ 400.0 Hz*

Real time display of output frequency of the VFD  
It displays in 0.01 unit if the frequency is under 100Hz  
It displays in 0.1 unit if the frequency is above 100Hz

- **01.02 Motor RPM monitor**

- *Range: 0 ~ 60000 RPM*

below determined by equation:

$120 \times '01.01' (\text{Output frequency}) \times '42.02' (\text{RPM display scale factor}) / '99.07' (\text{Motor Pole setting})$

ex1)  $'01.01' = 60\text{Hz}$ ,  $'42.02' = 100$ ,  $'99.07' = 4$  :  $'01.02' = 1800\text{rpm}$

ex2)  $'01.01' = 60\text{Hz}$ ,  $'42.02' = 50$ ,  $'99.07' = 4$  :  $'01.02' = 900\text{rpm}$

- **01.03 Encoder Speed monitor**

- *Range: 0 ~ 60000 RPM*

Displays the RPM received from the encoder.

- **01.04 Rotation direction monitor**

- *STP: Stop*
- *FWD: Forward Run*
- *REV: Reverse Run*

Real time display of rotation of the VFD

- **01.05 Output current monitor**

- *Range: 0.0 ~ 2000 A*

Real time display of output current of the VFD  
It displays in 0.1 unit if the output current is under 1000A  
It displays in 1 unit if the output current is above 1000A

- **01.07 DC voltage monitor**

- *Range: 0 ~ 1000 V*

Real time voltage on DC bus

- **01.08 Output voltage monitor**

- *Range: 0 ~ 1000 V*

Real time display of output voltage of the VFD

- **01.09 Output power monitor**

- *Range: 0.0 ~ 1000 kW*

Real time display of power consumption of the VFD

It displays in 0.1 unit if the motor current is under 1000kW

It displays in 1 unit if the motor current is above 1000kW

below determined by equation:

Power:  $\sqrt{3} \times V \times I$

ex) **'01.09'** = 1.37 X **'01.05'** (Motor current monitor) X **'01.08'** (Output voltage monitor)

## 8.2.2 Frequency reference indication

- **02.01 Final frequency reference monitor**

- *Range: 0.00 ~ 400.0 Hz*

Displays the reference by panel  
refer to '**22.XX**' block diagram

- **02.02 Modbus frequency reference monitor**

- *Range: 0.00 ~ 400.0 Hz*

Displays the reference by modbus  
It can be shown the value even without setting '**22.03**' and '**22.04**'  
❖ *Related Parameters: '50.01', '50.02'*

- **02.03 Field frequency reference monitor**

- *Range: 0.00 ~ 400.0 Hz*

Displays the reference by Fieldbus  
It can be shown the value even without setting '**22.03**' and '**22.04**'  
❖ *Related Parameters: '51.01' ~ '51.26'*

### 8.2.3 Trip information

*When fault occurs, the VFD automatically displays this parameter  
Additional information of the fault can be accessed by using up arrow key*

- **03.01 Current trip, Source of trip**  
Displays source of trip
- **03.02 Current trip, Frequency at trip**  
Displays frequency at trip
- **03.03 Current trip, Current at trip**  
Displays current at trip
- **03.04 Current trip, Vdc at trip**  
Displays Vdc at trip
- **03.05 Current trip, Running Status at trip**  
Displays VFD status at trip
- **03.06 Current trip, DI Status at trip**  
Displays digital input status at trip  
refer to '10.01' (DI status)
- **03.07 Current trip, DO Status at trip**  
Displays digital output status at trip  
refer to '10.22' (DO status)
- **03.08 Current trip, IGBT Temperature at trip**  
Displays IGBT temperature at trip



- **03.09 Current trip, Occurred time (Year)**

Displays year at trip  
If today is 2016, it shows 2016

- **03.10 Current trip, Occurred time (Month, Day)**

Displays month and day at trip  
If today is December 31th, it shows 1231

- **03.11 Current trip, Occurred time (Hour, Minute)**

Displays hour and minutes at trip  
If time is 11:59PM, it shows 2359

- **03.12 Current trip, Occurred time (Second)**

Displays second at trip  
If second of time is 59, it shows 59

1. The five of trip history will save in the '**03.13**' ~ '**03.72**' parameter as above
2. If new trip is occurred, it saves and the oldest trip history will be deleted
3. The trip count never be changed if someone will not initialize a value

## 8.2.4 Time counter

- **04.01 Power on-day counter**

- *Range: 0 ~ 65536 Day*

The counter runs when the VFD power is on

- **04.02 Power on-time counter**

- *Range: 0 ~ 1439 min*

The counter runs when the VFD power is on

Whenever the counter rolls over, **'04.01' (Power on-day counter)** is incremented and this parameter turns to zero

- **04.03 Run-day counter**

- *Range: 0 ~ 65536 Day*

The counter runs when the VFD modulates

- **04.04 Run-time counter**

- *Range: 0 ~ 1439 min*

The counter runs when the VFD modulates

Whenever the counter rolls over, **'04.03' (Run-day counter)** is incremented and this parameter turns to zero

- **04.05 Fan on-day counter**

- *Range: 0 ~ 65536 Day*

The counter runs when the cooling fan is running

- **04.06 Fan on-time counter**

- *Range: 0 ~ 1439 min*

The counter runs when the cooling fan is running

Whenever the counter rolls over, **'04.05' (Fan on-day counter)** is incremented and this parameter turns to zero

- **04.07 IGBT temperature**

- *Range: 0.0 ~ 160.0 °C*

It displays IGBT temperature by NCT sensor

- **04.08 Fieldbus status**

- *Range: 0x00 ~ 0xFF*

It displays status of fieldbus option card

## 8.2.5 VFD firmware information

- **05.01 Firmware name**

- *STD: Standard*

It displays firmware name  
General VFD shows STD

- **05.02 Firmware version**

- *Range: 0.000 ~ 9.999*

It displays firmware version

- **05.03 Current time (Year)**

- *Range: 2000 ~ 2099*

It displays current year  
If today is 2016, it shows 2016

- **05.04 Current time (Month, Day)**

- *Range: 101 ~ 1231*

It displays current month and day  
If today is December 31th, it shows 1231

- **05.05 Current time (Hour, Minute)**

- *Range: 0 ~ 2359*

It displays current hour and minute  
If time is 11:59PM, it shows 2359

- **05.06 Current time (Second)**

- *Range: 0 ~ 59*

It displays current second  
If second of time is 59, it shows 59

## 8.2.6 Standard DI, DO

- **10.01 DI status**

- *Range: 0x00 ~ 0xFF*

It displays the status of digital input

Example Data: 0000000000001111

Meaning: DI8~DI5 OFF, DI4~DI1 ON

15	14	13	12	11	10	9	8	7	6	5	4	3	2	1	0
It displays when extension I/O card is connected								DI8	DI7	DI6	DI5	DI4	DI3	DI2	DI1

- **10.02 DI Delayed status**

- *Range: 0x00 ~ 0xFF*

It displays the status of digital input that delayed

Example Data: 0000000011110000

Meaning: DI8~DI5 ON, DI4~DI1 OFF

15	14	13	12	11	10	9	8	7	6	5	4	3	2	1	0
It displays when extension I/O card is connected								DI8	DI7	DI6	DI5	DI4	DI3	DI2	DI1

- **10.03 DI Forced selection**

- *Range: 0x00 ~ 0xFF*
- *Initial value: 0x00*

The statuses of the digital input can be overridden for example testing purposes

A bit in parameter '**10.04' (DI forced data)** is provided for each digital input and its value is applied whenever the corresponding bit in this parameter is 1

- **10.04 DI Forced data**

- *Range: 0x00 ~ 0xFF*
- *Initial value: 0x00*

Allows the data value of a forced digital input to be changed from 0 to 1

It is only possible to forced an input that has been selected in parameter '**10.03' (DI forced selection)**

● **10.05 DI contact type selection**

- Range: 0x00 ~ 0xFF
- Initial value: 0x00

It is possible to change the status of DI input type as N.O or N.C

Example Data: 0000000011110000

Meaning: DI8~DI5 Normal close type, DI4~DI1 Normal open type

15	14	13	12	11	10	9	8	7	6	5	4	3	2	1	0
It displays when extension I/O card is connected								DI8	DI7	DI6	DI5	DI4	DI3	DI2	DI1

● **10.06 DI1 ON delay time**

- Range: 0.0 ~ 3000 Sec in 0.1 Sec
- Initial value: 0.0 Sec

Defines the activation delay for digital input DI1

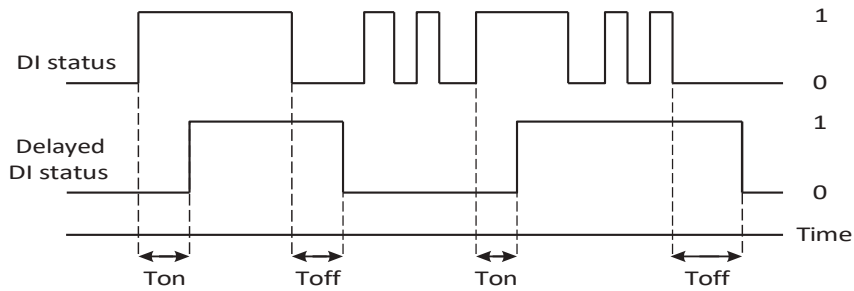

- Ton: '10.06' (DI1 On delay time)
- Toff: '10.07' (DI1 Off delay time)

● **10.07 DI1 OFF delay time**

- Range: 0.0 ~ 3000 Sec in 0.1 Sec
- Initial value: 0,0 Sec

Defines the activation ON delay for digital input DI1

● **10.08 DI2 ON delay time**

- See the parameter '10.05' (DI1 ON delay)

● **10.09 DI2 OFF delay time**

- See the parameter '10.06' (DI1 OFF delay)

● **10.10 DI3 ON delay time**

- See the parameter '10.05' (DI1 ON delay)

● **10.11 DI3 OFF delay time**

- See the parameter '10.06' (DI1 OFF delay)

- 10.12 DI4 ON delay time
  - *See the parameter '10.05' (DI1 ON delay)*
- 10.13 DI4 OFF delay time
  - *See the parameter '10.06' (DI1 OFF delay)*
- 10.14 DI5 ON delay time
  - *See the parameter '10.05' (DI1 ON delay)*
- 10.15 DI5 OFF delay time
  - *See the parameter '10.06' (DI1 OFF delay)*
- 10.16 DI6 ON delay time
  - *See the parameter '10.05' (DI1 ON delay)*
- 10.17 DI6 OFF delay time
  - *See the parameter '10.06' (DI1 OFF delay)*
- 10.18 DI7 ON delay time
  - *See the parameter '10.05' (DI1 ON delay)*
- 10.19 DI7 OFF delay time
  - *See the parameter '10.06' (DI1 OFF delay)*
- 10.20 DI8 ON delay time
  - *See the parameter '10.05' (DI1 ON delay)*
- 10.21 DI8 OFF delay time
  - *See the parameter '10.06' (DI1 OFF delay)*

● **10.22 DO (RN0~RN3, AL0~AL2) delayed status**

- *Range: 0x00 ~ 0xFF*

It displays the relay outputs Terminal Status

Example Data: 0000000000000011

Meaning: AL OFF, DO2~DO1 ON

15	14	13	12	11	10	9	8	7	6	5	4	3	2	1	0
It displays when extension I/O card is connected													AL	DO2	DO1

● **10.23 DO (RN0~RN3, AL0~AL2) forced selection**

- *Range: 0x00 ~ 0xFF*
- *Initial value: 0x00*

The statuses of the digital output can be overridden for example testing purposes

A bit in parameter **'10.22' (DO forced data)** is provided for each digital output and its value is applied whenever the corresponding bit in this parameter is 1

● **10.24 DO (RN0~RN3, AL0~AL2) forced data**

- *Range: 0x00 ~ 0xFF*
- *Initial value: 0x00*

Allows the data value of a forced digital output to be changed from 0 to 1

It is only possible to forced an output that has been selected in parameter **'10.22' (DO forced selection)**

● **10.25 DO1 (RN0~RN1), DO2 (RN2~RN3) contact type selection**

- *Range: 0x00 ~ 0xFF*
- *Initial value: 0x00*

It is possible to change the status of DO1 and DO2 output type as N.O or N.C

Example Data: 0000000000000010

Meaning: DO2 (RN2~RN3) Normal close type, DO1 (RN0~RN1) Normal open type

15	14	13	12	11	10	9	8	7	6	5	4	3	2	1	0
It displays when extension I/O card is connected													AL	DO2	DO1



● 10.26 DO1 (RN0-RN1) source

- 0: RUN VFD Run Signal
- 1: FA1 Frequency Arrival 1 ----- Initial value
- 2: FA2 Frequency Arrival 2
- 3: OL Overload Warning Signal
- 4: OD Output Deviation Excess for PID control
- 5: AL Fault Signal

▪ Set 0: RUN VFD Run Signal

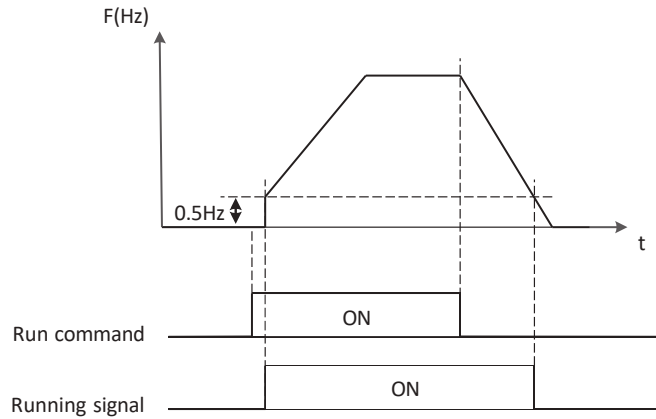

▪ Set 1: FA1 Frequency Arrival 1

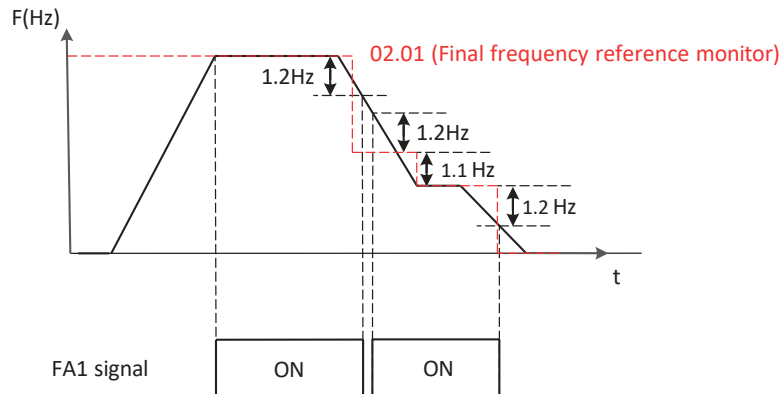

▪ Set 2: FA2 Frequency Arrival 2

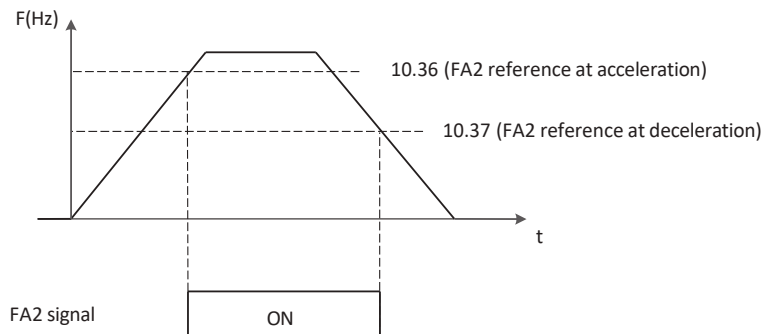

▪ Set 3: OL Overload Warning Signal

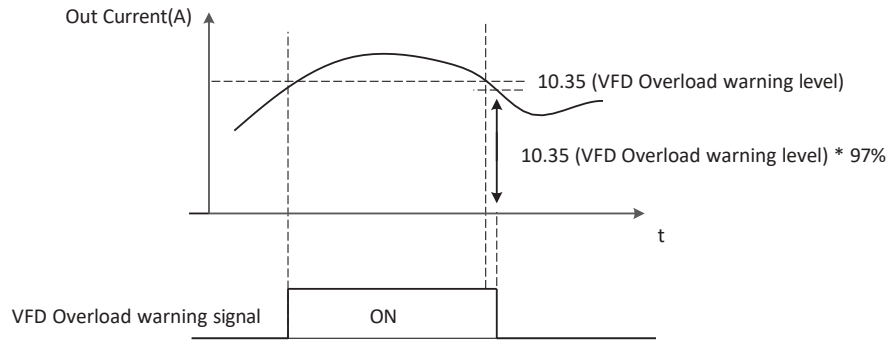

▪ Set 4: OD Output Deviation Excess for PID control

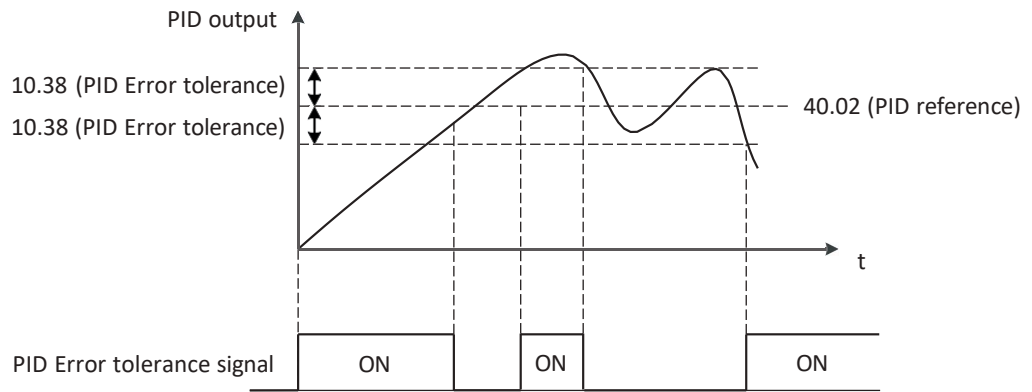

▪ Set 5: AL Fault Signal

● **10.27 DO1 (RN0-RN1) ON delay time**

- *Range: 0.0 ~ 3000 Sec in 0.1 Sec*
- *Initial value: 0.0 Sec*

Defines the activation delay for relay output DO1

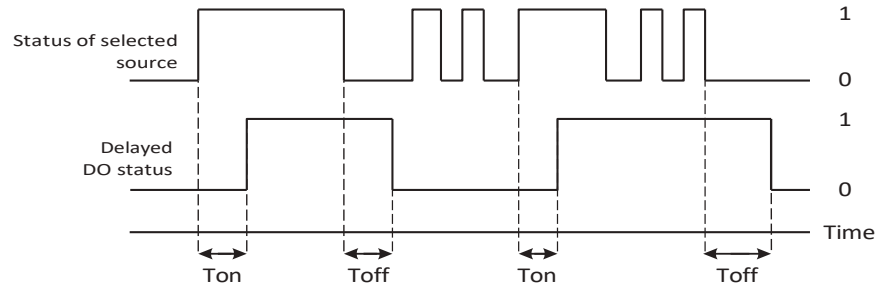

- Ton: '10.27' DO1 (RN0-RN1) On delay time
- Toff: '10.28' DO1 (RN0-RN1) Off delay time

● **10.28 DO1 (RN0-RN1) OFF delay time**

- *Range: 0.0 ~ 3000 Sec in 0.1 Sec*
- *Initial value: 0.0 Sec*

Defines the activation ON delay for relay output DO1

● **10.29 DO2 (RN2-RN3) source**

▪ *See the parameter '10.26' (DO1 source)*

● **10.30 DO2 (RN2-RN3) ON delay time**

▪ *See the parameter '10.27 (DO1 ON delay)*

● **10.31 DO2 (RN2-RN3) OFF delay time**

▪ *See the parameter '10.28 (DO1 OFF delay)*

● **10.32 Alarm (AL0-AL1-AL2) relay source**

- *See the parameter '10.26' (DO1 source)*

● **10.33 Alarm (AL0-AL1-AL2) relay ON delay time**

- *See the parameter '10.27 (DO1 ON delay)*

● **10.34 Alarm (AL0-AL1-AL2) OFF delay time**

- *See the parameter '10.28 (DO1 OFF delay)*

- **10.35 VFD overload warning level**

- *Range: 10.0 ~ 200.0 % in 0.1 %*
- *Initial value: 100.0 %*

Program a level of the VFD motor current

- **10.36 FA2 reference at acceleration**

- *Range: '10.37' ~ 400Hz in 0.01 Hz*
- *Initial value: 0.0 Hz*

Program the frequency arrival threshold during acceleration

❖ *Related Parameters: '10.26'*

- **10.37 FA2 reference at deceleration**

- *Range: 0.00 ~ '10.36' Hz in 0.01 Hz*
- *Initial value: 0.0 Hz*

Program the frequency arrival threshold during deceleration

❖ *Related Parameters: '10.26'*

- **10.38 PID Error tolerance**

- *Range: 0.0 ~ 100.0 % in 0.1 %*
- *Initial value: 100.0 %*

Program the allowable PID loop error magnitude

❖ *Related Parameters: '10.26'*

## 8.2.7 Standard AI (O, OI)

- **11.01 AI (O, OI) forced selection**

- *Range: 0x00 ~ 0xFF*
- *Initial value: 0x00*

Example Data: 0000000000000010

Meaning: R01, AI2 ON, AI1 OFF

15	14	13	12	11	10	9	8	7	6	5	4	3	2	1	0
It displays when extension I/O card is connected														AI2 (OI)	AI1 (O)

The statuses of the analog input can be overridden for example testing purposes  
A bit in parameters '**11.04**' (**AI1 forced value**) and '**11.12**' (**AI2 forced value**) are provided for each analog input and its value is applied whenever the corresponding bit in this parameter is 1

- **11.02 AI1 (O) actual value**

- *Range: 0.00 ~ 100.0 % in 0.01 %*

Displays the value of analog input AI1 (O) in V  
(Depending on the input is set to voltage by a hardware setting)

- **11.03 AI1 (O) scaled value**

- *Range: 0.00 ~ 400.00 Hz in 0.01 Hz - frequency*
- *Range: 0.00 ~ 100.0 % in 0.01 % - PID*

Displays the value of analog input AI1 (O) after scaling

❖ *Related Parameters: '11.08', '11.09'*

- **11.04 AI1 (O) forced value**

- *Range: 0.00 ~ 100.0 % in 0.01 %*
- *Initial value: 0.00 %*

Allows the data value of a forced analog input to be changed from 0.0 to 100.0  
It is only possible to forced an input that has been selected in parameter '**11.01**' (**AI forced selection**)

- **11.05 AI1 (O) filter time**
  - *Range: 0 ~ 30000 ms in 1 ms*
  - *Initial value: 100 ms*

Defines the filter time constant for analog input AI1 (O)  
 The filter time is that VFD is realized 63% of 100%

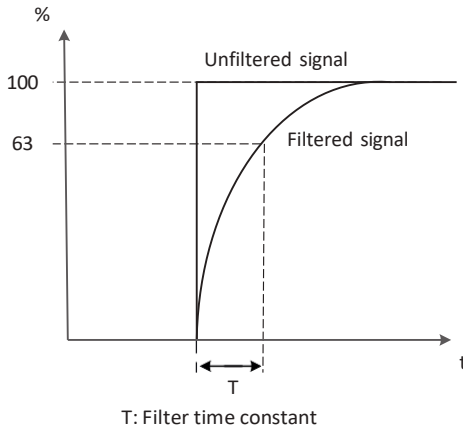

- **11.06 AI1 (O) source min**
  - *Range: 0.00 ~ 100.0 % in 0.01 %*
  - *Initial value: 0.00 %*

Defines the minimum site value for analog input AI1  
 Set the value actually sent to the drive when the analog signal from plant is wound to its minimum setting.

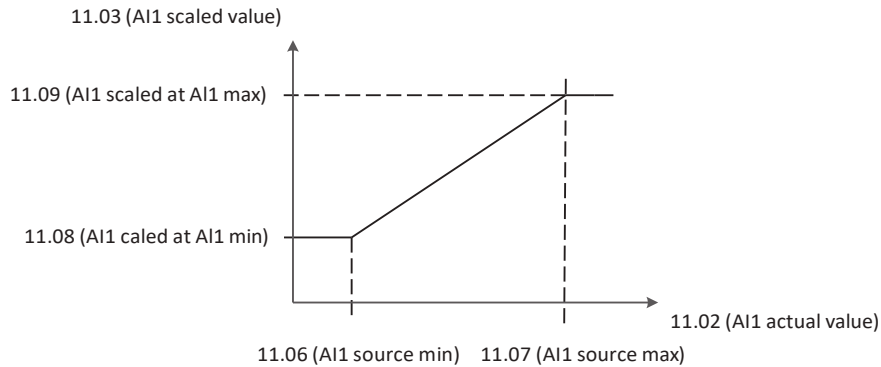

- **11.07 AI1 (O) source max**
  - *Range: 0.00 ~ 100.0 % in 0.01 %*
  - *Initial value: 100.0 %*

Defines the maximum site value for analog input AI1  
 Set the value actually sent to the drive when the analog signal from plant is wound to its maximum setting.

- **11.08 AI1 (O) scaled at AI1 min**
  - *Range: 0.00 ~ 400.0 Hz in 0.01 Hz – Frequency*
  - *Range: 0.0 ~ 100.0 % in 0.1 % – PID*
  - *Initial value: 0.00 Hz*

Defines the real internal value that corresponds to the minimum analog input AI1 value defined by parameter **'11.06' (AI1 source min)**

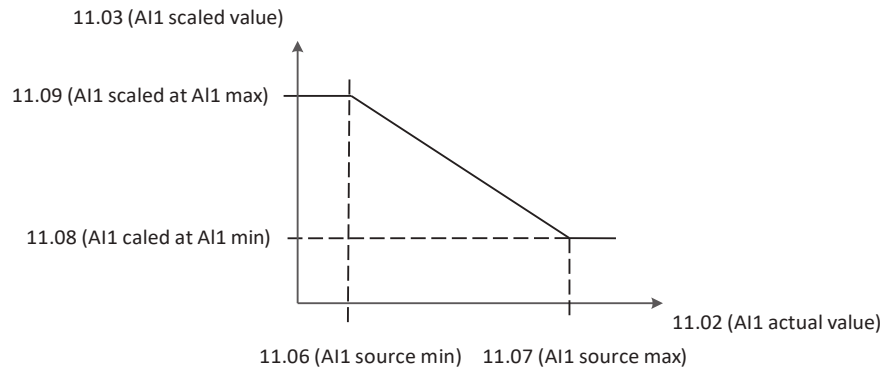

❖ Changing the polarity settings of **'11.08' (AI1 scaled at AI1 min)** and **'11.09' (AI1 scaled at AI1 max)** can effectively invert the analog input

- **11.09 AI1 (O) scaled at AI1 max**
  - *Range: 0.00 ~ 400.0 Hz in 0.01 Hz – Frequency*
  - *Range: 0.0 ~ 100.0 % in 0.1 % – PID*
  - *Initial value: 60.00 Hz*

Defines the real internal value that corresponds to the maximum analog input AI1 value defined by parameter **'11.07' (AI1 source max)**

- **11.10 AI2 (OI) actual value**
  - *Range: 0.00 ~ 100.0 % in 0.01 %*

Displays the value of analog input AI2 (OI) in mA  
(Depending on the input is set to current by a hardware setting)

- **11.11 AI2 (OI) scaled value**
  - *Range: 0.00 ~ 400.00 Hz in 0.01 Hz – frequency*
  - *Range: 0.00 ~ 100.0 % in 0.01 % – PID*

Displays the value of analog input AI2 after scaling  
❖ *Related Parameters: '11.16', '11.17'*

- **11.12 AI2 (OI) forced value**
  - Range: 0.00 ~ 100.0 % in 0.01 %
  - Initial value: 0.00 %

Allows the data value of a forced analog input to be changed from 0.0 to 100.0  
It is only possible to forced an input that has been selected in parameter '11.01' (AI forced selection)

- **11.13 AI2 (OI) filter time**
  - Range: 0 ~ 30000 ms in 1 ms
  - Initial value: 100 ms

Defines the filter time constant for analog input AI2 (OI)  
The filter time is that VFD is realized 63% of 100%

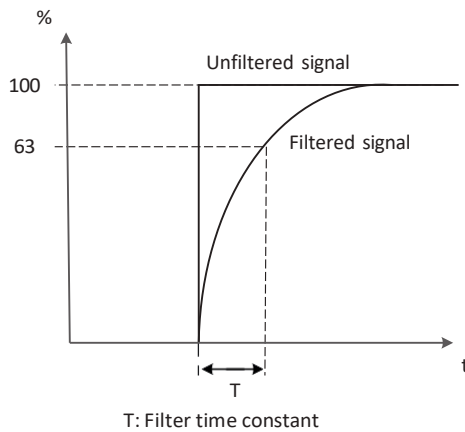

- **11.14 AI2 (OI) source min**
  - Range: 0.00 ~ 100.0 % in 0.01 %
  - Initial value: 0.0 %

Defines the minimum site value for analog input AI2 (OI)  
Set the value actually sent to the drive when the analog signal from plant is wound to its minimum setting.

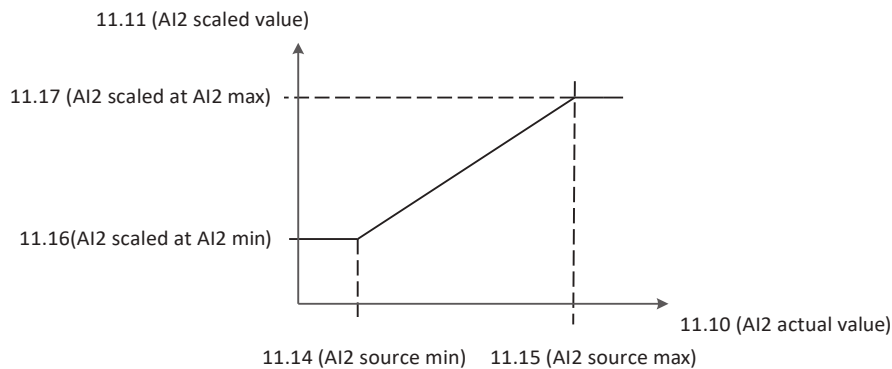



- **11.15 AI2 (OI) source max**

- *Range: 0.00 ~ 100.0 % in 0.01 %*
- *Initial value: 100.0 %*

Defines the maximum site value for analog input AI2 (OI)

Set the value actually sent to the drive when the analog signal from plant is wound to its maximum setting.

- **11.16 AI2 (OI) scaled at AI2 min**

- *Range: 0.00 ~ 400.0 Hz in 0.01 Hz – Frequency*
- *Range: 0.0 ~ 100.0 % in 0.1 % – PID*
- *Initial value: 0.00 Hz*

Defines the real internal value that corresponds to the minimum analog input AI2 value defined by parameter '**11.14**' (*AI2 source min*)

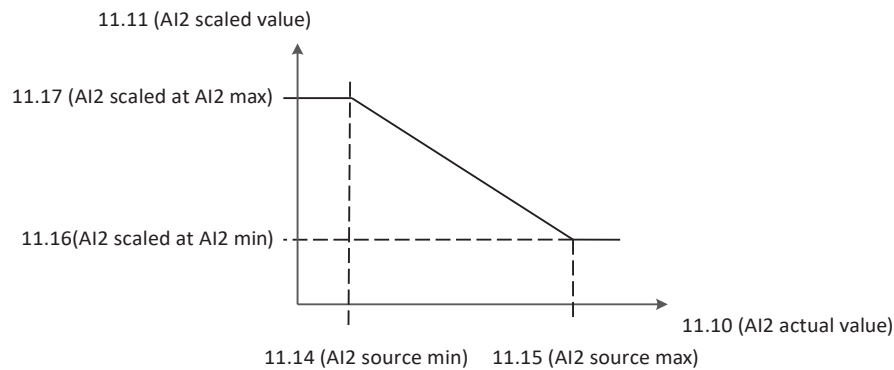

✧ Changing the polarity settings of '**11.16**' (*AI2 scaled at AI2 min*) and '**11.17**' (*AI2 scaled at AI2 max*) can effectively invert the analog input

- **11.17 AI2 scaled at AI2 max**

- *Range: 0.00 ~ 400.0 Hz in 0.01 Hz – Frequency*
- *Range: 0.0 ~ 100.0 % in 0.1 % – PID*
- *Initial value: 60.00 Hz*

Defines the real internal value that corresponds to the maximum analog input AI2 value defined by parameter '**11.15**' (*AI 2 source max*)

## 8.2.8 Standard AO (FM, AMI)

- **12.01 AO (FM, AMI) forced selection**

- *Range: 0x00 ~ 0xFF*
- *Initial value: 0x00*

Example Data: 0000000000000010

Meaning: R01, AO2 (AMI) ON, AO1 (FM) OFF

15	14	13	12	11	10	9	8	7	6	5	4	3	2	1	0
It displays when extension I/O card is connected														AO2 (AMI)	AO1 (FM)

The statuses of the analog input can be overridden for example testing purposes  
A bit in parameters '**12.04**' (**AO1 forced value**) and '**12.12**' (**AO2 forced value**) are provided for each analog input and its value is applied whenever the corresponding bit in this parameter is 1

- **12.02 AO1 (FM) actual value**

- *Range: 0.00 ~ 100.0 % in 0.01 %*

Displays the value of AO1 (FM) in V

- **12.03 AO1 (FM) source**

- *0: Out Frequency -----Initial value*
- *1: Out Ampere*
- *2: Out Voltage*
- *3: Out Power*
- *4: Out torque*
- *5: Modbus communication*
- *6: DC link Voltage*

Program what output performance to be monitored from following selections

- **Set 0: Output Frequency**  
The highest analog output value is the maximum frequency value. The indicator accuracy after the adjustment is about +/- 5%.
- **Set 1: Output Current**  
The highest analog value is the 200% of rated VFD current. The indicator accuracy after the adjustment is about +/- 10%.
- **Set 2: Output Voltage**  
The highest analog value is the 100% of rated VFD voltage out. The indicator accuracy after the adjustment is about +/- 10%.

- **Set 3: Output Power**  
The highest analog value is the 200% of rated VFD power out. The indicator accuracy after the adjustment is about +/- 10%.
- **Set 4: Output Torque**  
The highest analog value is the 200% of rated VFD output torque. The indicator accuracy after the adjustment is about +/- 10%.

- **Set 5: Modbus communication**  
Special addresses 0x1004, 0x1005 can be used to control AO1 (FM) and AO2 (AMI).  
For how to use communication frame, refer to 50. RS-485 (Modbus) parameter.  
example)  
01 06 1004 2710 CRC: AO1 (FM) 50% (5V) output  
01 06 1005 2710 CRC: AO2 (AMI) 50% (12mA) output

Address	function	Explanation
0x1004	AO1 (FM) value Output	0 to 10000 (0.1 scale, 0 to 10V, 0 to 100%)
0x1005	AO2 (AMI) value output	0 to 10000 (0.1 scale, 4 ~ 20mA, 0 ~ 100%)

- **Set 6: DC link Voltage**  
The 400Vac class outputs 0 ~ 820Vdc and the 200Vac class outputs 0 ~ 410Vdc as 0 ~ 10V.  
The indicator accuracy after adjustment is about +/- 10%.

● **12.04 AO1 (FM) forced value**

- *Range: 0.00 ~ 100.0 % in 0.01 %*
- *Initial value: 0.0 %*

Allows the data value of a forced analog output to be changed from 0.0 to 100.0  
It is only possible to forced an input that has been selected in parameter  
**'12.01' (AO forced selection)**

● **12.05 AO1 (FM) filter time**

- *Range: 0 ~ 30000 ms in 1 ms*
- *Initial value: 100 ms*
- 

Defines the filter time constant for analog input AO1  
The filter time is that VFD is realized 63% of 100%

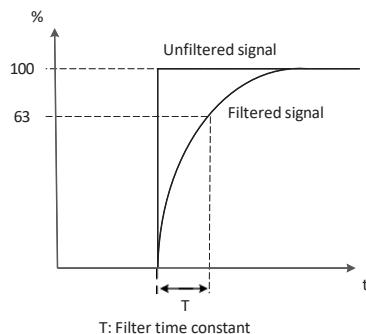

**12.06 AO1 (FM) source min**

- Range: 0.00 ~ 100.0 % in 0.01 %
- Initial value: 0.0 %

Defines the real minimum value of the signal selected by parameter **'12.03'(AO1 source)** that corresponds to the minimum required AO1 output value

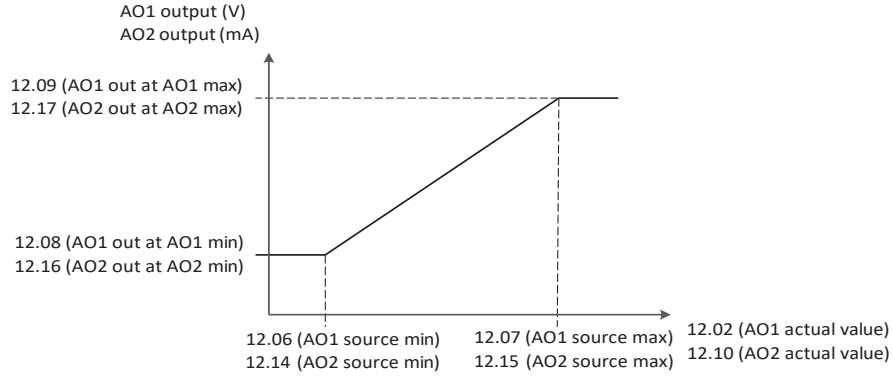

✧ Changing the polarity settings of **'12.08'(AO1 out at AO1 min)** and **'12.09'(AO1 out at AO1 max)** can effectively invert the analog output

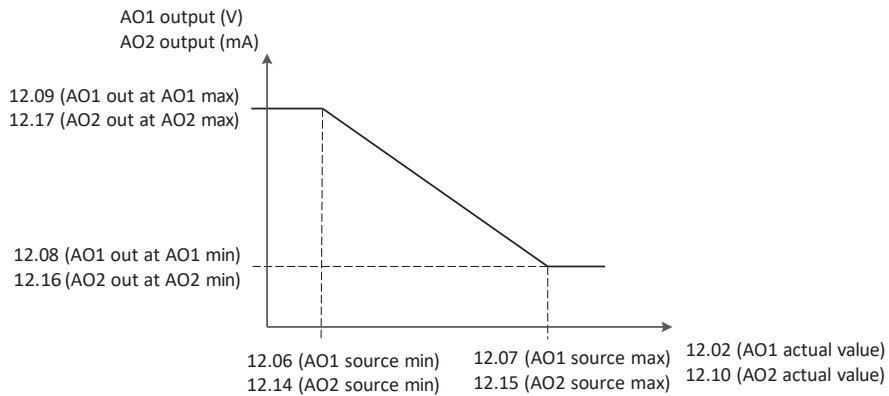

● **12.07 AO1 (FM) source max**

- Range: 0.00 ~ 100.0 % in 0.01 %
- Initial value: 100.0 %

Defines the real maximum value of the signal selected by parameter **'12.03'(AO1 source)** that corresponds to the maximum required AO1 output value defined by parameter **'12.09'(AO1 out at AO1 max)**

- **12.08 AO1 (FM) out at AO1 min**

- *Range: 0.00 ~ 100.0 % in 0.01 %*
- *Initial value: 0.0 %*

Defines the real minimum output value for analog output AO1  
See also drawing at parameter '**12.06**' (*AO1 source min*)

- **12.09 AO1 (FM) out at AO1 max**

- *Range: 0.00 ~ 100.0 % in 0.01 %*
- *Initial value: 100.0 %*

Defines the real maximum output value for analog output AO1  
See also drawing at parameter '**12.07**' (*AO1 source max*)

- **12.10 AO2 (AMI) actual value**

- *Range: 0.00 ~ 100.0 % in 0.01 %*

Displays the value of AO2 (AMI) in mA

- **12.11 AO2 (AMI) source**

- *See the parameter '**12.03**' (*AO1 source*)*

- **12.12 AO2 (AMI) forced value**

- *See the parameter '**12.04**' (*AO1 forced value*)*

- **12.13 AO2 (AMI) filter time**

- *See the parameter '**12.05**' (*AO1 filter time*)*

- **12.14 AO2 (AMI) source min**

- *See the parameter '**12.06**' (*AO1 source min*)*

- **12.15 AO2 (AMI) source max**

- *See the parameter '**12.07**' (*AO1 source max*)*

- **12.16 AO2 (AMI) out at AO2 min**

- *See the parameter '**12.08**' (*AO1 out at AO1 min*)*

- **12.17 AO2 (AMI) out at AO2 max**

- *See the parameter '**12.09**' (*AO1 out at AO1 max*)*

- **12.18 AO2 (AMI) Initial Current**

- *Range: 0.00 ~ 0.60mA in 0.01 mA*
- *Initial value: 0.40mA*
- *Defines the Initial Current of the analog output AO2 (AMI).*

## 8.2.9 Start/Stop/Direction

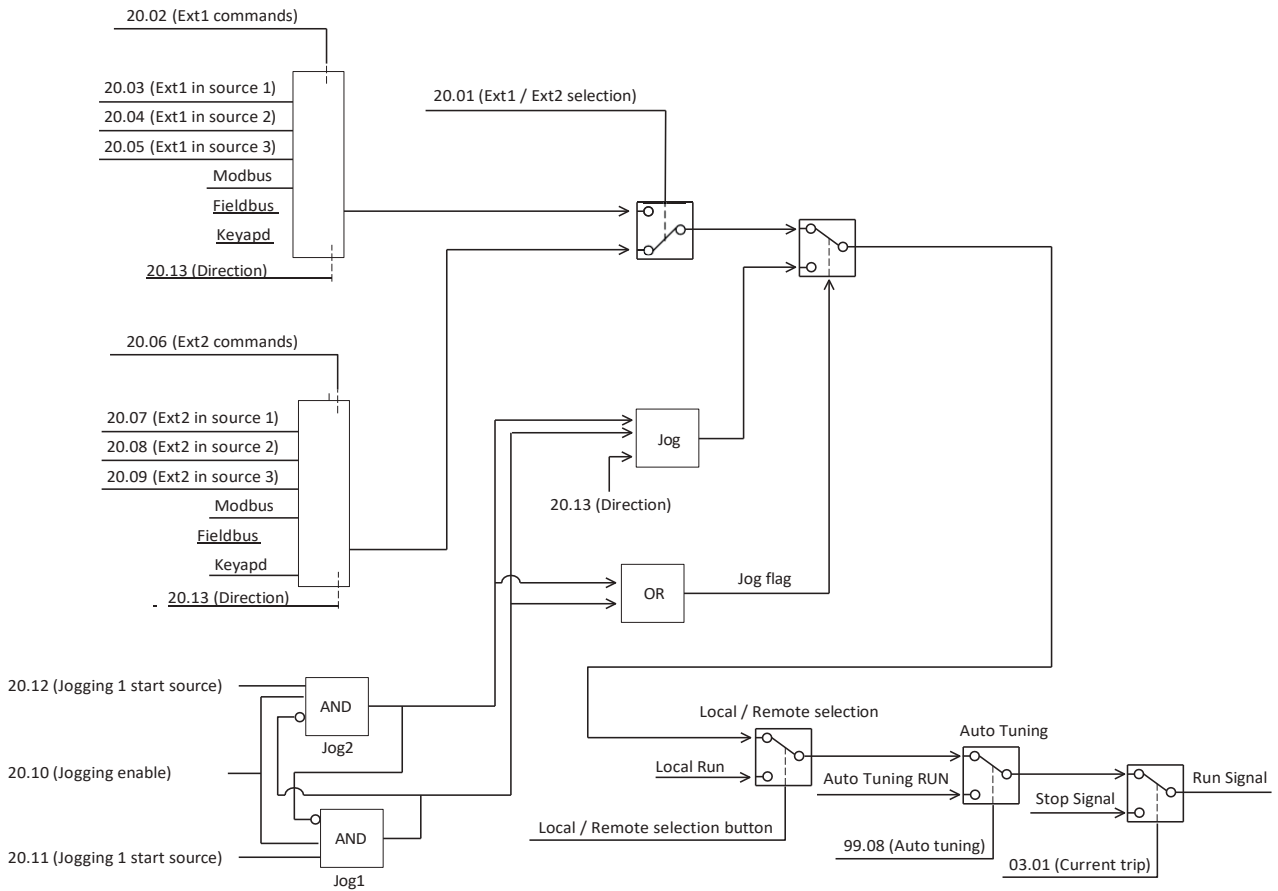

### ● 20.01 Ext1 /Ext2 selection

- 0: Ext1 -----Initial value
- 1: Ext2
- 2: DI1
- 3: DI2
- 4: DI3
- 5: DI4
- 6: DI5
- 7: DI6
- 8: DI7
- 9: DI8

It can use to external commands as local/remote function

- **Set 0: Ext1**  
It works by value at '20.02'(Ext1 commands)
- **Set 1: Ext2**  
It works by value at '20.03'(Ext2 commands)
- **Set 2~9: DI1~DI8**  
If set terminal input is OFF, operation command method 1,  
When it is ON, it operates with operation command method 2.

● 20.02 Ext1 commands

- 0: Not selected
- 1: 1 Wire
- 2: 2 Wire 1 -----Initial value
- 3: 2 Wire 2
- 4: 2 Wire 3
- 5: 3 Wire 1
- 6: 3 Wire 2
- 7: Modbus
- 8: Fieldbus
- 9: Keypad

Selects the source of start, stop and direction commands for external control location 1 (EXT1)

▪ Set 0: Not selected

No start or stop command sources selected.

▪ Set 1: 1 Wire

The source of the start and stop commands is selected by parameter '20.03' (Ext1 in source 1)

The state transitions of the source bits are interpreted as follows:

State of source 1 ('20.03')	Command
1	Start
0	Stop

▪ Set 2: 2 Wire 1

The source selected by '20.03' (Ext1 in source 1) is the start signal

The source selected by '20.04' (Ext1 in source 2) determines the direction

The state transitions of the source bits are interpreted as follows:

State of source 1 ('20.03')	State of source 2 ('20.04')	Command
0	Any	Stop
1	0	Start forward
1	1	Start reverse

▪ Set 3: 2 Wire 2

The source selected by '20.03' (Ext1 in source 1) is the forward start signal

The source selected by '20.04' (Ext1 in source 2) is the reverse start signal

The state transitions of the source bits are interpreted as follows:

State of source 1 ('20.03')	State of source 2 ('20.04')	Command
0	0	Stop
1	0	Start forward
0	1	Start reverse
1	1	Stop

▪ **Set 4: 2 Wire 3**

The source of the start and stop commands are selected by parameters **'20.03' (Ext1 in source 1)** and **'20.04' (Ext1 in source 2)**

The state transitions of the source bits are interpreted as follows:

State of source 1 ('20.03')	State of source 2 ('20.04')	Command
0 -> 1	1	Start
Any	0	Stop

- ✧ when **'20.04' (Ext1 in source 2)** is 0,  
The start and stop keys on the control panel are disabled

▪ **Set 5: 3 Wire 1**

The source of the start and stop commands are selected by parameters **'20.03' (Ext1 in source 1)** and **'20.04' (Ext1 in source 2)**

The source selected by **'20.05' (Ext1 in source 3)** determines the direction

The state transitions of the source bits are interpreted as follows:

State of source 1 ('20.03')	State of source 2 ('20.04')	State of source 3 ('20.05')	Command
0 -> 1	1	0	Start forward
0 -> 1	1	1	Start reverse
Any	0	Any	Stop

- ✧ when **'20.04' (Ext1 in source 2)** is 0,  
The start and stop keys on the control panel are disabled

▪ **Set 6: 3 Wire 2**

The source of the start and stop commands are selected by parameters **'20.03' (Ext1 in source 1)**, **'20.04' (Ext1 in source 2)** and **'20.05' (Ext1 in source 3)**

The source selected by **'20.05' (Ext1 in source 3)** determines the direction

The state transitions of the source bits are interpreted as follows:

State of source 1 ('20.03')	State of source 2 ('20.04')	State of source 3 ('20.05')	Command
0 -> 1	Any	1	Start forward
Any	0 -> 1	1	Start reverse
Any	Any	0	Stop

▪ **Set 7: Modbus**

The start and stop command are taken from terminal RXP-RXN

▪ **Set 8: Fieldbus**

The start and stop command are taken from fieldbus adapter

▪ **Set 9: Keypad**

The start and stop command are taken from keypad on the VFD



- **20.03 Ext1 in source 1**
  - *0: Not selected*
  - *1: Selected*
  - *2: DI1 ----- Initial value*
  - *3: DI2*
  - *4: DI3*
  - *5: DI4*
  - *6: DI5*
  - *7: DI6*
  - *8: DI7*
  - *9: DI8*

Selects source 1 for parameter *'20.02' (Ext1 commands)*

- **Set 0: Not selected**  
Always off
- **Set 1: selected**  
Always on
- **Set 2~9 : DI1~ DI8**  
It works by digital input which is selected

- **20.04 Ext1 in source 2**
  - *See the parameter '20.03' (Ext1 in source 1)*
- **20.05 Ext1 in source 3**
  - *See the parameter '20.03' (Ext1 in source 1)*
- **20.06 Ext2 commands**
  - *See the parameter '20.02' (Ext1 commands)*
- **20.07 Ext2 in source 1**
  - *See the parameter '20.03' (Ext1 in source 1)*
- **20.08 Ext2 in source 2**
  - *See the parameter '20.03' (Ext1 in source 1)*
- **20.09 Ext2 in source 3**
  - *See the parameter '20.03' (Ext1 in source 1)*

### ● 20.10 Jogging enable

- 0: Not selected ----- Initial value
- 1: Selected
- 2: DI1
- 3: DI2
- 4: DI3
- 5: DI4
- 6: DI5
- 7: DI6
- 8: DI7
- 9: DI8

Selects the method for a jog enable

- **Set 0: Not selected**  
Always off
- **Set 1: selected**  
Always on
- **Set 2~9 : DI1~ DI8**  
It works by digital input which is selected

### ● 20.11 Jogging 1 start source

- See the parameter '20.10' (jogging enable)

Selects the source for the activation of jogging function 1

- ◇ Both of jogging sources have interlocked each other.  
If one of the jogging operates, other jogging can't operate

- **Set 0: Not selected**  
Always off
- **Set 1: selected**  
Always on
- **Set 2~9 : DI1~ DI8**  
It works by digital input which is selected

### ● 20.12 Jogging 2 start source

- See the parameter '20.10' (jogging enable)

### ● 20.13 Direction

- 0: Forward ----- Initial value
- 1: Reverse

Sets the direction of VFD to forward or reverse at keypad operation only

## 8.2.10 Start/Stop mode

- **21.01 Torque boost mode**

- 0: Manual torque boost ----- Initial value
- 1: Automatic torque boost

Select a torque boost mode

It is working only V/F mode at '98.01' (*Motor control mode*) and will compensate for starting torque.

If '21.01' (*torque boost mode*) = 1, recommended the following

1. Put the plate data of motor in '99.01' ~ '99.07'
2. Get the motor data by the Auto Tuning
3. Use auto tuning data at '99.09' (*Motor data selection*)

- **21.02 Magnetization time**

- Range: 0.0 ~ 3000 Sec in 0.1 Sec
- Initial value: 0.0 Sec

Set the time for DC Injection Braking duration before VFD start

It will be operated when '21.02' (*Magnetization time*) and '21.03' (*Magnetization level*) have set above zero

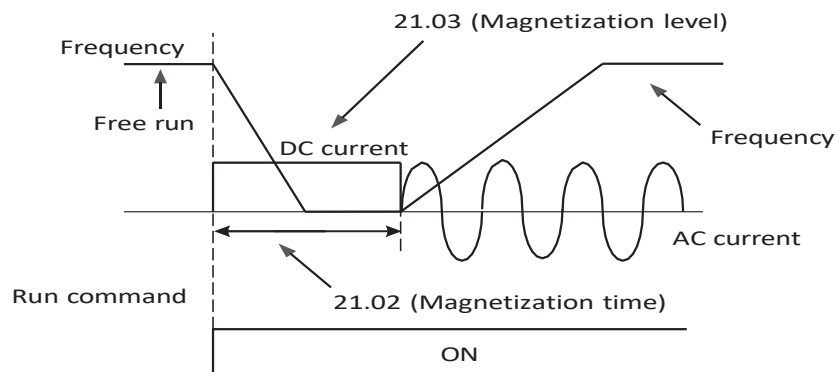

- **21.03 Magnetization Level**

- Range: 0.0 ~ 200.0 % in 0.1 %
- Initial value: 30.0 %

Set the level for DC Injection Braking duration before VFD start

- **21.04 Stop mode**

- 0: Ramp to Stop (Deceleration)-----Initial value
- 1: Coast to Stop (Free Run to Stop)

Select a stop method when Stop command is given.

● **21.05 DC current control (DC Brake)**

- 0: Disable ----- Initial value
- 1: Enable

It can select to use the DC Injection braking function  
By adding the forced to the rotor, slowing the motor to stop

❖ Related Parameters: '21.05' ~ '21.09'

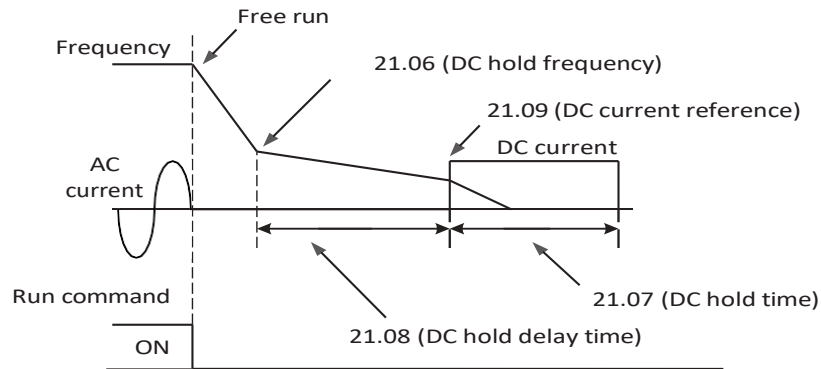

● **21.06 DC hold frequency**

- Range: 0.00 ~ 10.00 Hz in 0.01 Hz
- Initial value: 0.50 Hz

Program the VFD frequency out when DC injection braking function kicks in.  
If set '21.06' (**DC hold frequency**) to 0.5Hz, when VFD frequency out reaches to 0.5 Hz, DC braking function is activated.

● **21.07 DC hold time**

- Range: 0.0 ~ 3000 Sec in 0.1 Sec
- Initial value: 0.0 Sec

Program the DC Injection Braking duration

● **21.08 DC hold delay time**

- Range: 0.0 ~ 50.0 Sec in 0.1 Sec
- Initial value: 0.0 Sec

Program the delay time when the DC braking function actually starts form when VFD out is the frequency value in '21.06' (**DC hold frequency**)

● **21.09 DC current reference**

- Range: 0.0 ~ 100.0 % in 0.1 %
- Initial value: 10.0 %

Program the level of DC injection braking forced of rated electric power of A1

- **21.10 Emergency stop mode**

- *0: Ramp to Stop (Deceleration)-----Initial value*
- *1: Coast to Stop (Free Run to Stop)*

Selects the way the motor is stopped when an emergency stop command is received. The source of the emergency stop signal is selected by '21.11' (*Emergency stop source*)

- **21.11 Emergency stop source**

- *0: Active*
- *1: Inactive ----- Initial value*
- *2: DI1*
- *3: DI2*
- *4: DI3*
- *5: DI4*
- *6: DI5*
- *7: DI6*
- *8: DI7*
- *9: DI8*

Selects the source of the emergency stop signal

- **Set 0: Active**  
Always on
- **Set 1: Inactive**  
Always off
- **Set 2~9 : DI1 ~ DI8**  
It works by digital input which is selected

- **21.12 DC Brake P gain**

- *Range: 0 ~ 10000*
- *Initial value: 1000*

Real time editable P gain for DC Brake Control.

- **21.13 DC Brake I gain**

- *Range: 0 ~ 10000*
- *Initial value: 500*

Real time editable I gain for DC Brake Control.

### 8.2.11 Frequency reference

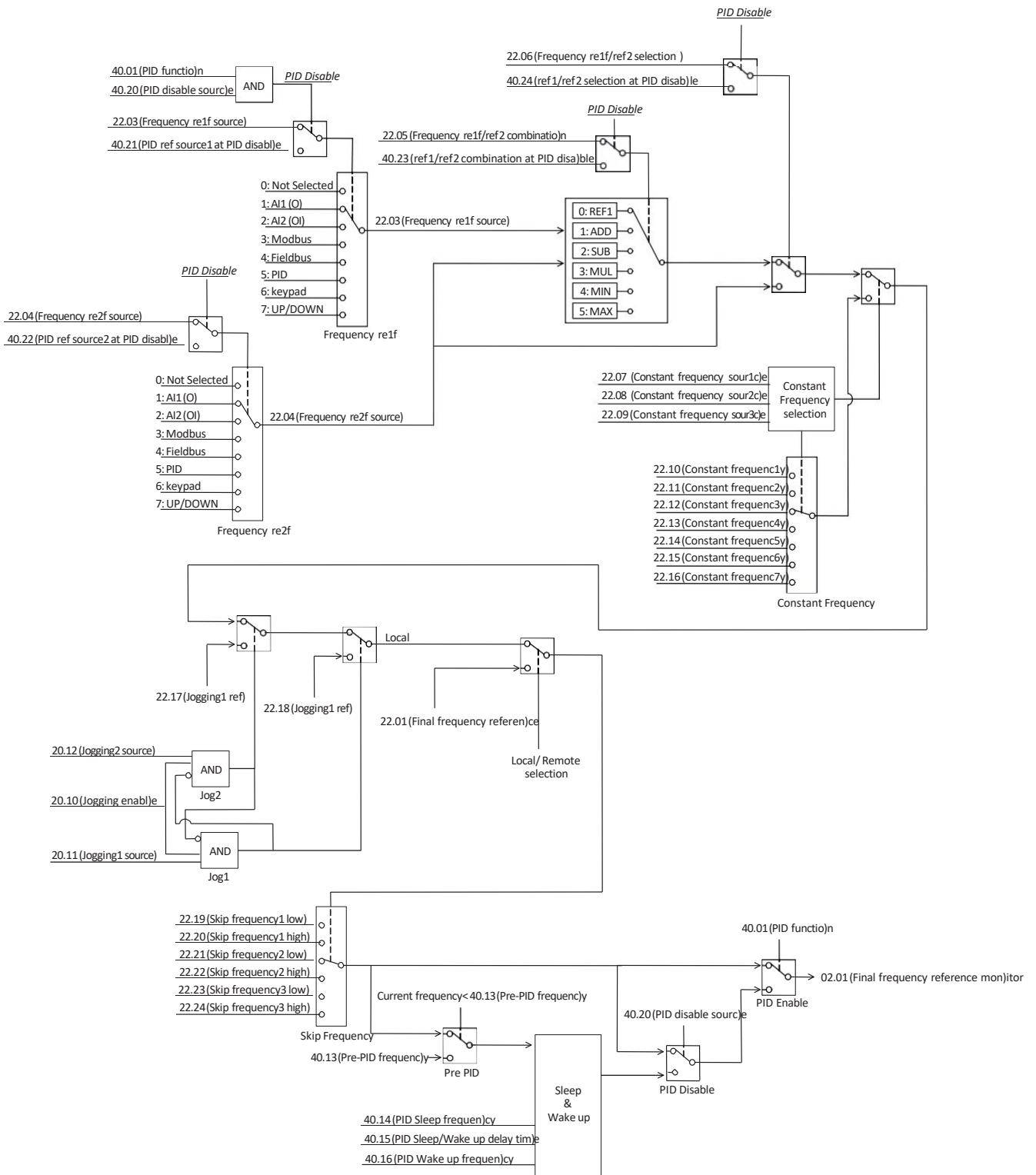

- **22.01 Frequency reference input (Only Keypad)**

- *Range: 0.00 ~ 400Hz in 0.01 Hz*
- *Initial value: 0.00 Hz*

Program the frequency reference that can be used at local mode

If it is remote mode, the parameter has to be keypad as below

*'22.03' (Frequency ref 1 source) = keypad* or *'22.04' (Frequency ref 2 source) = keypad*

- **22.03 Frequency ref 1 source**

- *0: Not selected*
- *1: AI1 (O) scaled----- Initial value*
- *2: AI2 (OI) scaled*
- *3: Modbus*
- *4: Fieldbus*
- *5: PID*
- *6: Keypad*
- *7: UP/DOWN*

Selects the source of the Frequency ref 1

- **Set 0: Not selected**  
Always off
- **Set 1: AI1 (O) scaled**  
It can set the frequency reference by the DC 0~10V
- **Set 2: AI2 (OI) scaled**  
It can set the frequency reference by the DC 4~20mA
- **Set 3: Modbus**  
It can set the frequency reference by the modbus communication
- **Set 4: Fieldbus**  
Always on It can set the frequency reference by the fieldbus communication
- **Set 5: PID**  
Always on It can set the frequency reference by the PID control
- **Set 6: Keypad**  
Always on It can set the frequency reference by the Keypad
- **Set 7: UP/DOWN**  
Always on It can set the frequency reference by the UP/DOWN function

- **22.04 Frequency ref 2 source**

- *See the parameter '22.03' (Frequency ref 1 source)*

● **22.05 Frequency ref 1 /ref 2 combination**

- 0: '22.03'-----Initial value
- 1: '22.03' + '22.04'
- 2: '22.03' - '22.04'
- 3: '22.03' x '22.04'
- 4: MIN ('22.03', '22.03')
- 5: MAX ('22.03', '22.03')

Selects a mathematical function between the reference sources selected by parameters '22.03' (Frequency ref 1 source) and '22.04' (Frequency ref 2 source)

- Set 0: '22.03'  
'22.03' (Frequency ref 1 source)
- Set 1: '22.03' + '22.04'  
'22.03' (Frequency ref 1 source) + '22.04' (Frequency ref 2 source)
- Set 2: '22.03' - '22.04'  
'22.03' (Frequency ref 1 source) - '22.04' (Frequency ref 2 source)
- Set 3: '22.03' x '22.04'  
'22.03' (Frequency ref 1 source) x '22.04' (Frequency ref 2 source)
- Set 4: MIN ('22.03' + '22.04')  
MIN '22.03' (Frequency ref 1 source), '22.04' (Frequency ref 2 source)
- Set 5: MAX ('22.03' + '22.04')  
MAX '22.03' (Frequency ref 1 source), '22.04' (Frequency ref 2 source)

● **22.06 Frequency ref 1 /ref 2 selection**

- 0: '22.05' setting value ----- Initial value
- 1: '22.04' setting value
- 2: DI1
- 3: DI2
- 4: DI3
- 5: DI4
- 6: DI5
- 7: DI6
- 8: DI7
- 9: DI8

Configures the selection between frequency references 1 and 2

- Set 0: '22.05' setting value  
The frequency is used by '22.05'(Frequency ref 1 /ref 2 combination) set value
- Set 1: '22.04' setting value  
The frequency is used by '22.04' (Frequency ref 2 source)
- Set 2~9 : DI1 ~ DI8  
If the digital input which is selected has OFF, it will applied by ref 1  
If the digital input which is selected has ON, it will applied by ref 2



● **22.07 Constant frequency source 1**

- 0: Not selected----- Initial value
- 1: Selected
- 2: DI1
- 3: DI2
- 4: DI3
- 5: DI4
- 6: DI5
- 7: DI6
- 8: DI7
- 9: DI8

Selects the source of the constant frequency

- **Set 0: Not selected**  
Always off
- **Set 1: selected**  
Always on
- **Set 2~9 : DI1~ DI8**  
It works by digital input which is selected

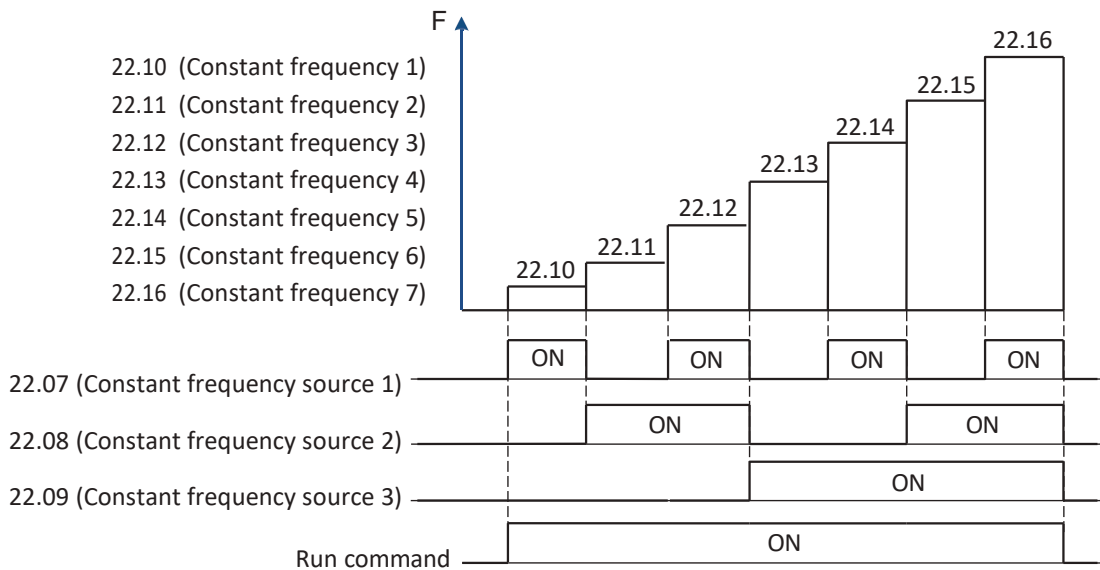

Source defined by par '22.07'	Source defined by par '22.08'	Source defined by par '22.09'	Constant frequency active
OFF	OFF	OFF	None
ON	OFF	OFF	'22.10' (Constant frequency1)
OFF	ON	OFF	'22.11' (Constant frequency2)
ON	ON	OFF	'22.12' (Constant frequency3)
OFF	OFF	ON	'22.13' (Constant frequency4)
ON	OFF	ON	'22.14' (Constant frequency5)
OFF	ON	ON	'22.15' (Constant frequency6)
ON	ON	ON	'22.16' (Constant frequency7)

- 22.08 Constant frequency source 2
  - See the parameter '20.07' (Constant frequency source 1)
- 22.09 Constant frequency source 3
  - See the parameter '20.07' (Constant frequency source 1)
- 22.10 Constant frequency 1
  - Range: 0.00 ~ 400Hz in 0.01 Hz
  - Initial value: 5.00 Hz
  - See the parameter '20.07' (Constant frequency source 1)
- 22.11 Constant frequency 2
  - See the parameter '20.07' (Constant frequency source 1)
- 22.12 Constant frequency 3
  - See the parameter '20.07' (Constant frequency source 1)
- 22.13 Constant frequency 4
  - See the parameter '20.07' (Constant frequency source 1)
- 22.14 Constant frequency 5
  - See the parameter '20.07' (Constant frequency source 1)
- 22.15 Constant frequency 6
  - See the parameter '20.07' (Constant frequency source 1)
- 22.16 Constant frequency 7
  - See the parameter '20.07' (Constant frequency source 1)

- **22.17 Jogging 1 ref**
  - *Range: 0.00 ~ 400Hz in 0.01 Hz*
  - *Initial value: 0.00 Hz*

Jogging frequency is used to move/rotate the motor in small increment at low frequency. It is selected using input terminal.

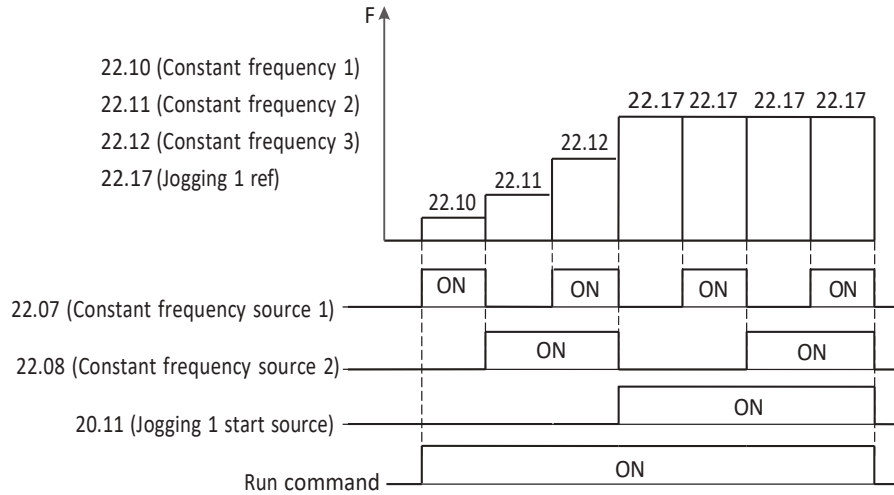

- **22.18 Jogging 2 ref**
  - *See the parameter '20.17' (jogging 1 ref)*
  - *Initial value: 0.00 Hz*

- **22.19 Skip frequency 1 low**
  - *Range: 0.00 ~ 400Hz in 0.01 Hz*
  - *Initial value: 0.00 Hz*

Program 3 output frequency values to mitigate different resonance points at which vibration can cause damages to the equipment such as fans or pumps.

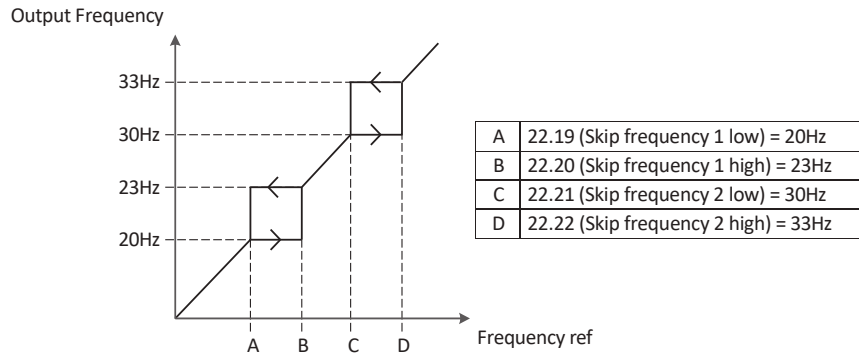

- **22.20 Skip frequency 1 high**
  - *See the parameter '20.19' (Skip frequency 1 low)*
- **22.21 Skip frequency 2 low**
  - *See the parameter '20.19' (Skip frequency 1 low)*
- **22.22 Skip frequency 2 high**
  - *See the parameter '20.19' (Skip frequency 1 low)*
- **22.23 Skip frequency 3 low**
  - *See the parameter '20.29' (Skip frequency 1 low)*
- **22.24 Skip frequency 3 high**
  - *See the parameter '20.19' (Skip frequency 1 low)*

● 22.25 UP/DOWN function

- 0: Disable ----- Initial value
- 1: Enable

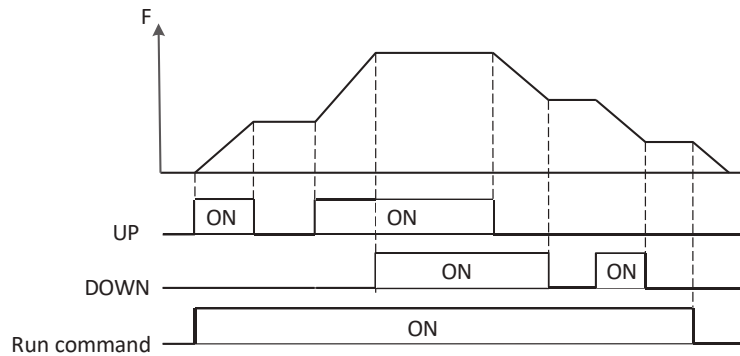

● 22.26 UP/DOWN initial value

- Range: 0.00 ~ 400 Hz in 0.01 Hz – frequency
- Range: 0.0 ~ 100 % in 0.1 % – PID
- Initial value: 0.00 Hz

Program the UP/DOWN initial value

When run command is input, VFD is running to initial value without up or down source

● 22.27 UP/DOWN up source

- 0: Not selected----- Initial value
- 1: Selected
- 2: DI1
- 3: DI2
- 4: DI3
- 5: DI4
- 6: DI5
- 7: DI6
- 8: DI7
- 9: DI8

Selects the source of the UP/DWON up

- **Set 0: Not selected**  
Always off
- **Set 1: selected**  
Always on
- **Set 2~9 : DI1 ~ DI8**  
It works by digital input which is selected

● 22.28 UP/DOWN down source

- See the parameter '20.27' (UP/DOWN up source)

● **22.29 UP/DOWN ref changing time**

- Range: 0.0 ~ 3000 Sec in 0.1 Hz Sec
- Initial value: 10.0 Sec

It can change the time that UP/DOWN reference is respond  
When run command is input, VFD can run to initial value without up or down source

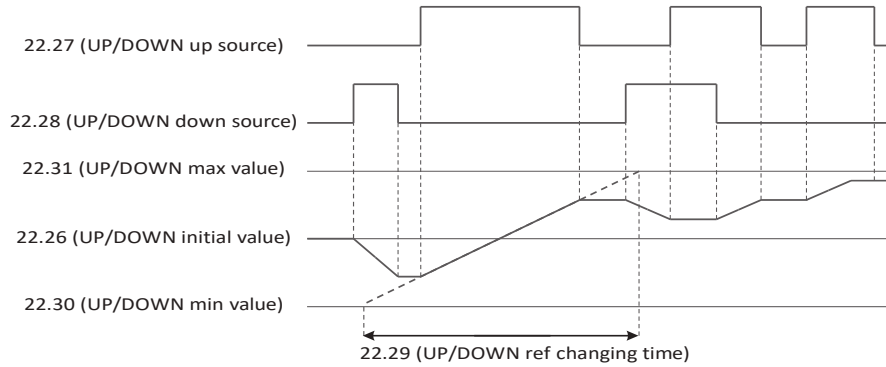

● **22.30 UP/DOWN min value**

- Range: 0.00 ~ 400 Hz in 0.01 Hz – frequency
- Range: 0.0 ~ 100 % in 0.1 % – PID
- Initial value: 0.00 Hz

This parameter works when the '22.25' (UP/DOWN function) is 1 (Enable)  
UP/DOWN can't operate below the min value

● **22.31 UP/DOWN max value**

- Range: 0.00 ~ 400 Hz in 0.01 Hz – frequency
- Range: 0.0 ~ 100 % in 0.1 % – PID
- Initial value: 60.00 Hz

This parameter works when the '22.25' (UP/DOWN function) is 1 (Enable)  
UP/DOWN can't operate above the max value

● **22.32 UP/DOWN ref monitor**

- Range: 0.00 ~ 400 Hz in 0.01 Hz – frequency
- Range: 0.0 ~ 100 % in 0.1 % – PID

This parameter displays UP/DOWN reference value

● **22.33 UP/DOWN initial value saving**

- 0: Not saving ---- Initial value
- 1: Saving

Selects that whether initial value going to save or not

● 22.34 UP/DOWN ref reset source

- 0: Not selected----- Initial value
- 1: Selected
- 2: DI1
- 3: DI2
- 4: DI3
- 5: DI4
- 6: DI5
- 7: DI6
- 8: DI7
- 9: DI8

Selects the source of the UP/DOWN ref reset  
It is not works when the up or down source has inputted

- **Set 0: Not selected**  
Always off
- **Set 1: selected**  
Always on
- **Set 2~9 : DI1 ~ DI8**  
It works by digital input which is selected

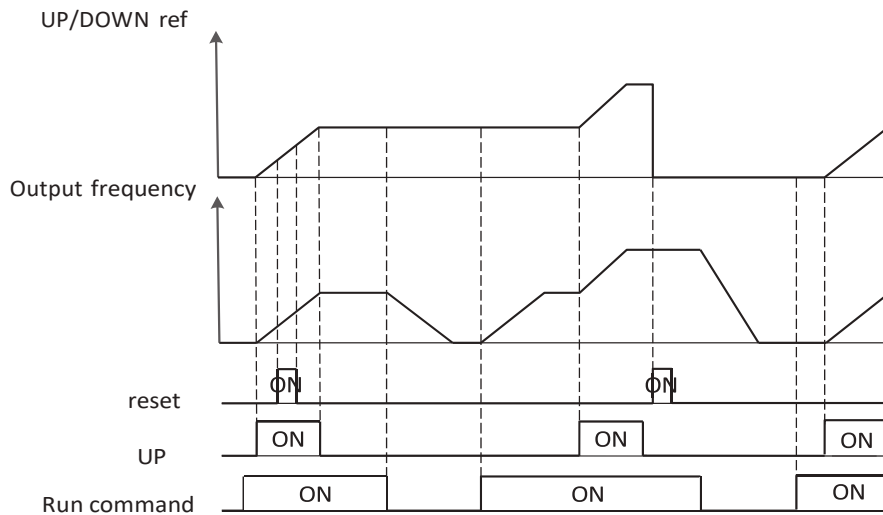

## 8.2.12 Acceleration/Deceleration

### ● 23.03 Ramp set selection

- 0: Acc/Dec time 1 ----- Initial value
- 1: Acc/Dec time 2
- 2: Frequency
- 3: DI1
- 4: DI2
- 5: DI3
- 6: DI4
- 7: DI5
- 8: DI6
- 9: DI7
- 10: DI8

#### ▪ Set 0: Acc/Dec time 1

It uses the time '23.04' (Acceleration time 1) and '23.05' (Deceleration time 1)

#### ▪ Set 1: Acc/Dec time 2

It uses the time '23.06' (Acceleration time 2) and '23.07' (Deceleration time 2)

#### ▪ Set 2: Frequency

It changes by the frequency as below picture

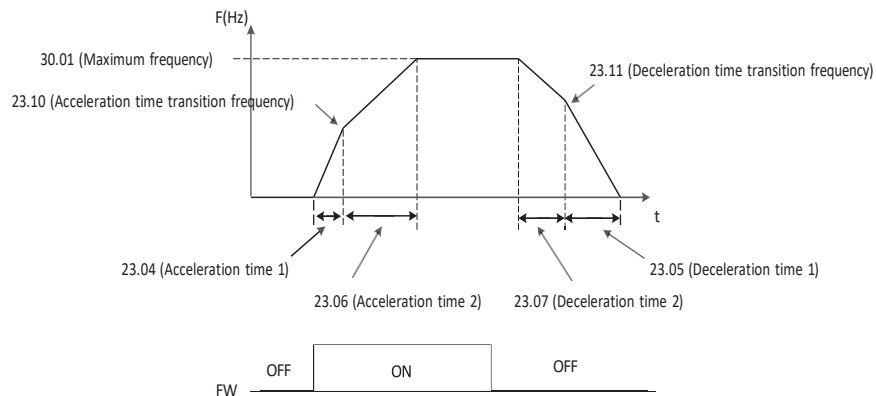

#### ▪ Set 3~10 : DI1~ DI8

It changes by the digital input as below picture

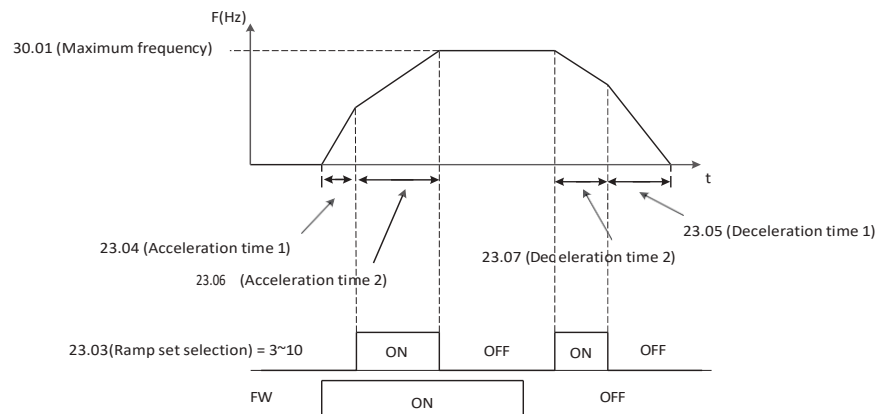



- **23.04 Acceleration time 1**
  - *Range: 0.1 ~ 3000 Sec in 0.1 Sec*
  - *Initial value: 30.0 Sec*
  
  - **'23.03' (Ramp set selection)** is 0  
Always on
  - **'23.03' (Ramp set selection)** is 1  
Always off
  - **'23.03' (Ramp set selection)** is 2  
It not works if the output frequency is above  
**'23.10' (Acceleration time transition frequency)**
  - **'23.03' (Ramp set selection)** is 3~9  
It works by digital input which is selected
    - ❖ Related Parameters: **'23.06', '23.07', '23.10', '23.11'**
  
- **23.05 Deceleration time 1**
  - *Range: 0.1 ~ 3000 Sec in 0.1 Sec*
  - *Initial value: 30.0 Sec*
  
  - **'23.03' (Ramp set selection)** is 0  
Always on
  - **'23.03' (Ramp set selection)** is 1  
Always off
  - **'23.03' (Ramp set selection)** is 2  
It not works if the output frequency is above  
**'23.11' (Deceleration time transition frequency)**
  - **'23.03' (Ramp set selection)** is 3~9  
It works by digital input which is selected
    - ❖ Related Parameters: **'23.06', '23.07', '23.10', '23.11'**
  
- **23.06 Acceleration time 2**
  - *Range: 0.1 ~ 3000 Sec in 0.1 Sec*
  - *Initial value: 30.0 Sec*
  
  - **'23.03' (Ramp set selection)** is 0  
Always off
  - **'23.03' (Ramp set selection)** is 1  
Always on
  - **'23.03' (Ramp set selection)** is 2  
It not works if the output frequency is below  
**'23.10' (Acceleration time transition frequency)**
  - **'23.03' (Ramp set selection)** is 3~9  
It works by digital input which is selected
    - ❖ Related Parameters: **'23.06', '23.07', '23.10', '23.11'**

- **23.07 Deceleration time 2**
  - *Range: 0.1 ~ 3000 Sec in 0.1 Sec*
  - *Initial value: 30.0 Sec*
  
  - **'23.03' (Ramp set selection)** is 0  
Always off
  - **'23.03' (Ramp set selection)** is 1  
Always on
  - **'23.03' (Ramp set selection)** is 2  
It not works if the output frequency is below  
**'23.11' (Deceleration time transition frequency)**
  - **'23.03' (Ramp set selection)** is 3~9  
It works by digital input which is selected
    - ❖ Related Parameters: **'23.06', '23.07', '23.10', '23.11'**

- **23.08 Acceleration pattern selection**

- *0: Linear----- Initial value*
- *1: S Curve*
- *2: U Curve*

Select acceleration curve type

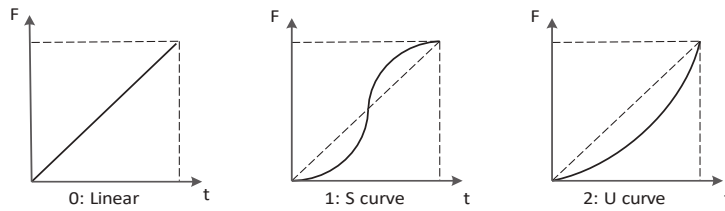

- **23.09 Deceleration pattern selection**

- *0: Linear----- Initial value*
- *1: S Curve*
- *2: U Curve*

Select deceleration curve type

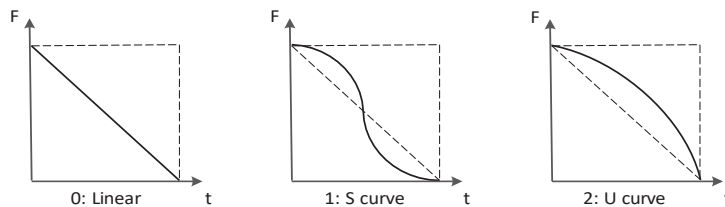

- **23.10 Acceleration time transition frequency**

- *Range: 0.00 ~ 400Hz in 0.01 Hz*
- *Initial value: 0.00 Hz*

In addition to acceleration time 1 in '**23.04'** (*Acceleration time 1*), '**23.06'** (*acceleration time 2*) can be specified. Its value can also be entered by '**23.03'** (*Ramp set selection*)

❖ Related Parameters: '**23.03'**, '**23.04'**, '**23.06'**

- **23.11 Deceleration time transition frequency**

- *Range: 0.00 ~ 400Hz in 0.01 Hz*
- *Initial value: 0.00 Hz*

In addition to deceleration time 1 in '**23.05'** (*Deceleration time 1*), '**23.07'** (*Deceleration time 2*) can be specified. Its value can also be entered by '**23.03'** (*Ramp set selection*)

❖ Related Parameters: '**23.03'**, '**23.05'**, '**23.07'**

- **23.12 Jogging acceleration time**

- *Range: 0.0 ~ 3000 Sec in 0.1 Sec*
- *Initial value: 30.0 Sec*

It works when the jogging is operated

❖ Related Parameters: '**22.17'**, '**22.18'**

- **23.13 Jogging deceleration time**

- *Range: 0.0 ~ 3000 Sec in 0.1 Sec*
- *Initial value: 30.0 Sec*

It works when the jogging is ON

❖ Related Parameters: '**22.17'**, '**22.18'**

- **23.14 Emergency stop time**

- *Range: 0.0 ~ 3000 Sec in 0.1 Sec*
- *Initial value: 3.0 Sec*

It works when the emergency source is ON

❖ Related Parameters: '**21.11'**

### 8.2.13 Speed Search

- **24.01 Speed search start mode**

- *0: Start from 0 Hz -----Initial value*
- *1: Start from frequency corresponding motor speed*

In case of VFD starting operation, the start frequency of the VFD can be selected as follows

❖ Related Parameters: **'24.03'**

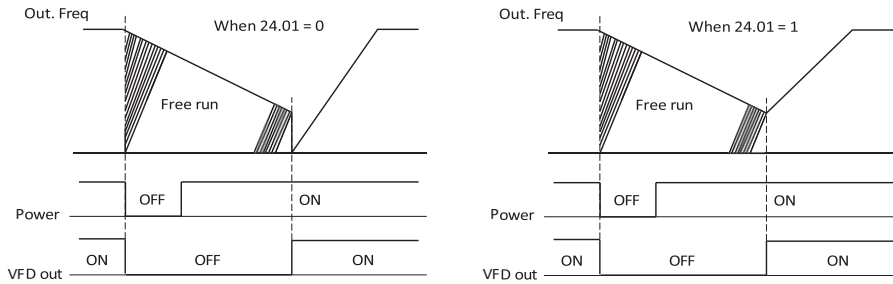

- **24.03 Voltage increment in speed search mode**

- *0: Range: 10 ~ 300 % in 1 %*
- *Initial value: 100 %*

In case of the lower starting current level during speed search motion on the basis of the motor rated current, the increase level of the output voltage is set from 10% to 300%

### 8.2.14 Over voltage suppression

The Overvoltage Suppression (OVS) feature will over speed the motor up to the **'25.02' (Maximum OVS Output Frequency)** to prevent motor regeneration and creating an Overvoltage Fault. If the OVS runs at maximum frequency for longer than the **'25.08' (Limit Time)**, the unit will fault on ovFS.

#### OVS Functional Description

- By calculating torque in real time, reduce regeneration energy by increasing speed.
- For speed control, PI controller is applied.
- If torque is bigger than 0, "PI Out" become 0 by "PI Limiter"; no increase in frequency value
- If torque is lower than 0, "PI Out" would be increased to **'25.02' (Max Add Freq) + Ref Frequency** ; frequency value increased
- If output of PI controller is reached to **'25.02' (Max Add Freq) + Ref Frequency** : the counter is started.
- When the value of counter is reached to **'25.08' (wRegen Time)**, the trip (ovFS) will be occur.

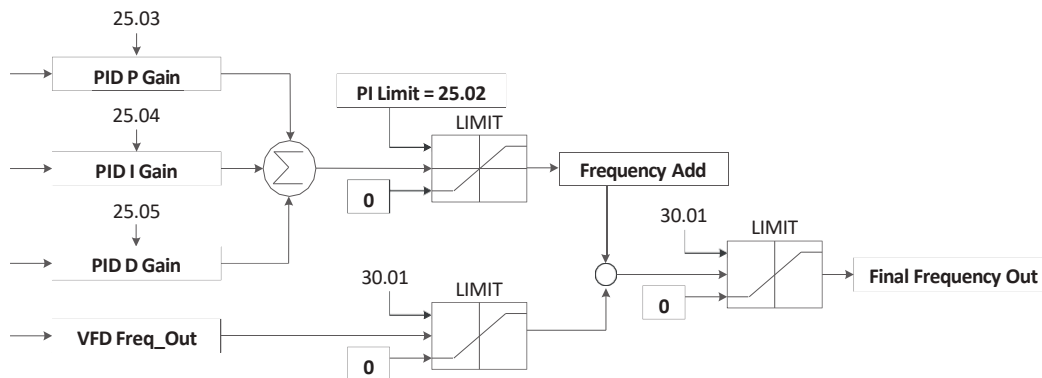

#### Sample parameters

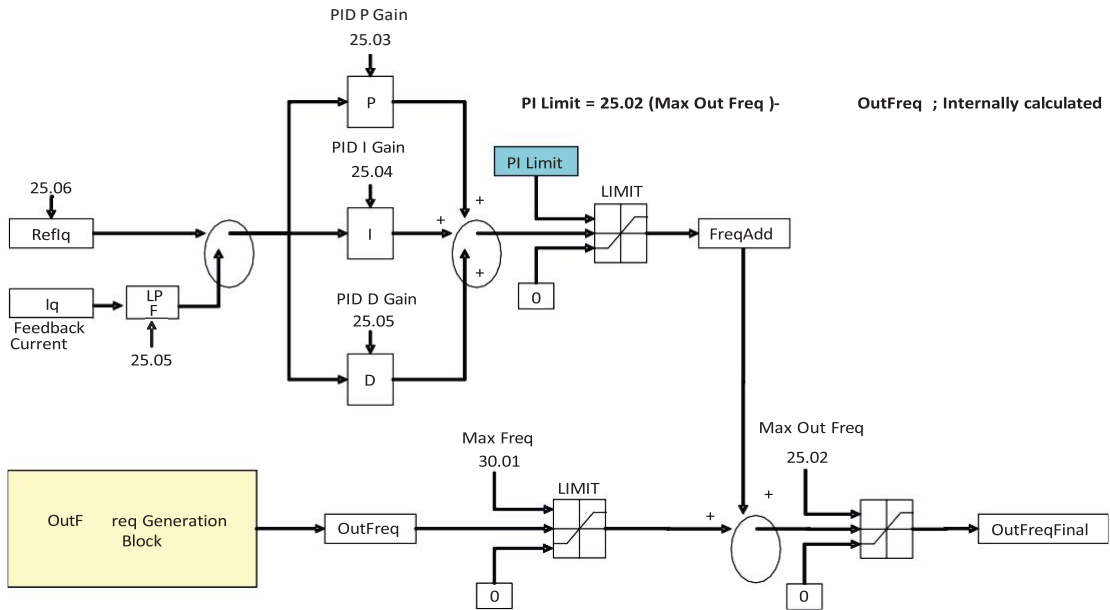

Meaning of 25.02 is changed from Max Add Freq to Max Out Freq

● **25.01 OVS selection**

- 0: Disable ---- Initial value
- 1: Enable

Select to enable the Voltage Suppression Control function.

● **25.02 Maximum OVS output frequency**

- Range: 0.0 Hz ~ 300.0 Hz in 0.01 Hz
- Initial value: 20.00 Hz

Real time editable a maximum frequency limit for OVS function

❖ Related Parameters:

● **25.03 OVS P gain**

- Range: 0 ~ 10000 in 1
- Initial value: 1000

Real time editable P gain for OVS PID loop

- $PIOut = err * Kp$
- $Hz = err(\%) * Kp * scalefactor(50 * 1e-6)$

Example

- err 10%,  $Kp = 1000$   
 ⇒  $PIOut = 0.5Hz$
- ✓ Recommended Value in test bench  
 ⇒ 1000 or less than 5000

● **25.04 OVS I gain**

- *Range: 0 ~ 10000 Sec in 1 Sec*
- *Initial value: 100 Sec*

Real time editable I gain for OVS PID loop

- $PIOut = \int(err * Ki)$
- $Hz += err(\%) * Ki * scalefactor(50 * 1e-6), dT = 1ms$

### Example ( Integration Time to 10Hz on Error)

- err 10%, Ki = 1000
  - ⇒ Time to 10Hz on 10% Error = 20ms
- err 10%, Ki = 100
  - ⇒ Time to 10Hz on 10% Error = 200ms
- err 10%, Ki = 10
  - ⇒ Time to 10Hz on 10% Error = 2000ms
- ✓ Recommended Value in test bench
  - ⇒ 100 or less than 500

## ● 25.05 OVS D gain

- *Range: 0 ~ 10000 Sec in 1Sec*
- *Initial value: 0 Sec*

Real time editable D gain for OVS PID loop. Its value depends on '**25.07**' (*Filter bandwidth*), filter bandwidth. Thus, if '**25.07**' (*Filter bandwidth*) is not changed, no need to change '**25.05**' (*OVS D gain*) value. Most application, this value should not be set over 3000

- ✓ Recommended Value as a function of '**25.07**' (*Filter bandwidth*)
  - ⇒ If '**25.07**' < 10 → '**25.05**' : 0 ~ 500
  - ⇒ If '**25.07**' < 30 → '**25.05**' : 500 ~ 1000
  - ⇒ If '**25.07**' < 50 → '**25.05**' : 1000 ~ 1500

## ● 25.06 q-Current reference

- *Range: -100.0 ~ 100.0 in 0.1*
- *Initial value: 0.0*

Real time editable q axis reference current compensates Torque Estimate Error.

- If Torque estimate offset is bigger than 0
  - ⇒ No increase in output frequency even if regeneration is occurred.
  - ⇒ This situation could be end with OV Trip.
  - ⇒ If so, set '**25.06**' (*q-Current reference*) to a positive value
- If Torque estimation offset smaller than 0
  - ⇒ No increase in output frequency even if regeneration is not occurred.
  - ⇒ Output Frequency could be increased to Max. Freq (Reference Frequency + '**25.02**' (*Maximum OVS output frequency*)) and end up with ovFS (OVS control Fail)
  - ⇒ If so, set '**25.06**' (*q-Current reference*) to a negative value

● 25.07 Filter bandwidth

- Range: 0.0 ~ 1000 milliseconds in 0.1 ms
- Initial value: 1 ms

Real time editable Iq feedback Low Pass Filter time constant

- If output Frequency is not stable,
  - ⇒ Increase '25.07' (Filter bandwidth) value
- Recommended Value as a function of '25.05' (OVS D gain), '25.07' (Filter bandwidth) value should be set accordingly
  - ⇒ Not set over 50

● 25.08 Limit time

- Range: 0.0 ~ 100 Sec in 0.1 Sec
- Initial value: 0.5 Sec

Real time editable OVS control fails check time. If PID output is saturated to '25.02' (Maximum OVS output frequency) during this time period, VFD will stop and ovFS will be occurred.

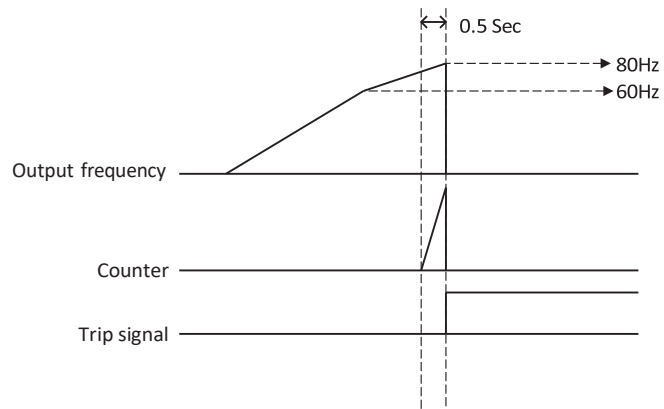
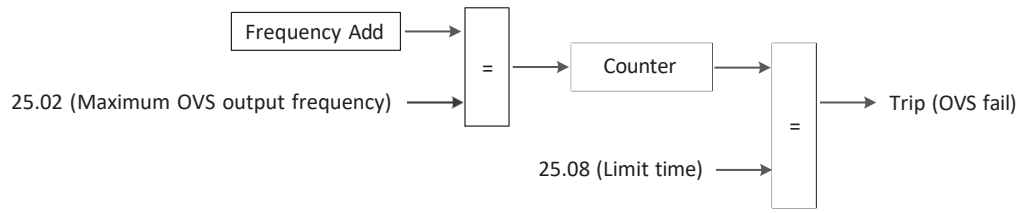

예) 25.08 (OVS limit) = 0.5 Sec

Case1) if frequency is increased at no regeneration condition,

- Cause: when a current feedback value is corrupted by noise.
- Measures:
  - ✓ Change a '25.07' (Filter bandwidth) and '25.05' (OVS D gain)
  - ✓ Please set the '25.07' (Filter bandwidth) between 5 and 30 (ex 5, 10, 20, 30ms)



Increasing '25.07' (Filter bandwidth) results the delay in calculating torque so '25.05' (OVS D gain) should be set

Please set the '25.05' (OVS D gain) between 500 to 1000

- ✓ Experimental values on MG-Set test are

'25.07' (Filter bandwidth) = 30, '25.05' (OVS D gain) = 1000

Case2) if overvoltage trip is occurred at normal operation,

- Cause: Torque is over estimated due to motor parameter error or current sensing error.

- Measures :

- ✓ Change a '25.06' (q-Current reference)

Please set the '25.07' (Filter bandwidth) between 30 to 100

If this value is set too high, Frequency output can be saturated to maximum frequency.

### Calculated torque output

User can monitor calculated torque by 2 methods

#### ■ Parameters

No.	Name	Description	default	Run-time Edit
'12.03'	wAODef (AO1 source)	0 ~ 4	0	X
'12.11'	wAODef2 (AO2 source)	0 ~ 4	1	X

#### ■ Analog output (DC voltage)

- '12.03' (AO1 source)

Set '12.03' = 4 display calculated torque value (-150% ~ +150%) by analog output.

AO1 output	Torque
0V	-150%
5V	0%
10V	+150%

(※ '12.03' = 0~3 are the same as existed function)

#### ■ Analog output (current)

- '12.11' (AO2 source)

Set '12.11' = 4 display calculated torque value (-150% ~ +150%) by analog output.

AO2 output	Torque
4mA	-150%
12mA	0%
20mA	+150%

(※ '12.11' = 0~3 are the same as existed function)

- Special parameter: Calculated torque read frame by Modbus

- CMD : 03 (Read)

- Parameter : 10 (Calculated Torque)

	Communication Number	CMD	Parameter	Data	CRC
TX	01	03	000A	0001	
RX	01	03	000A	Torque value	

- **25.09 OVS Vdc Level (HF)**

- *Range: 0 V ~ 2000 V*
- *Initial value: 700V*

Sets the Vdc level(HF).

- **25.10 OVS Vdc Level (LF)**

- *Range: 0 V ~ 1000V*
- *Initial value: 350V*

Sets the Vdc level(LF).

※This document are written by result of test bench.

Field engineer should be tuned for each field situation by consider above case study.

## 8.2.15 KEB

If a power outage occurs, the DC link voltage goes down and a low voltage failure occur blocking output. This function maintains the DC link voltage by controlling the VFD output frequency during the outage, thereby helping maintain the VFD between the instantaneous outage and the low voltage failure for a longer time.

- **26.01 KEB selection**

- *0: Disable----- Initial value*
- *1: Enable*

Select KEB with when the input power off.

If disable, normal decelerating operation is carried out until low voltage

If enable, VFD DC part is charged with the regenerative energy that is generated from the motor by controlling the VFD output frequency

- **26.02 KEB gain – new**

- *Range: 1 ~ 1000 in 1*
- *Initial value: 100*

This is the gain used for controlling the KEB operation by using the inertia moment amount of the load.

If the inertia of load is high, decrease the gain

If the inertia of load is low, increase the gain

## 8.2.16 DWELL

The DWELL function temporarily holds the frequency reference at a predefined value for a set time then continues accelerating or decelerating.

The DWELL function helps prevent speed loss when starting and stopping a heavy load with induction motors. When running a PM motor in V/f control, the pause in acceleration allows the PM motor rotor to align with the stator field of the motor and reduce the starting current.

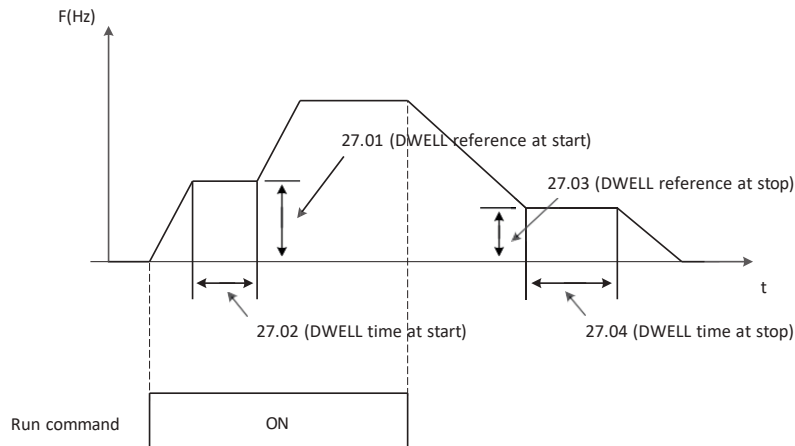

- **27.01 DWELL reference at start**

- Range: 0.00 ~ 400.0 Hz in 0.01
- Initial value: 0.00 Hz

Program DWELL frequency at start

- **27.02 DWELL time at start**

- Range: 0.0 ~ 10.0 Sec in 0.1
- Initial value: 0.0 Sec

Program DWELL time at start

- **27.03 DWELL reference at stop**

- Range: 0.00 ~ 400.0Hz in 0.01
- Initial value: 0.00 Hz

Program DWELL frequency at stop

- **27.04 DWELL time at stop**

- Range: 0.0 ~ 10.0 Sec in 0.1
- Initial value: 0.0 Sec

Program DWELL time at stop

## 8.2.17 Frequency limits

- **30.01 Maximum frequency**

- *Range: 0.00 ~ 400.0 Hz in 0.01 Hz (Sensorless Vector: 0.00 ~ 300.00Hz)*
- *Initial value: 60.00 Hz*

Define the maximum allowed frequency

If Frequency command is analog input, Max freq must also be set to '**11.09**', '**11.17**'.

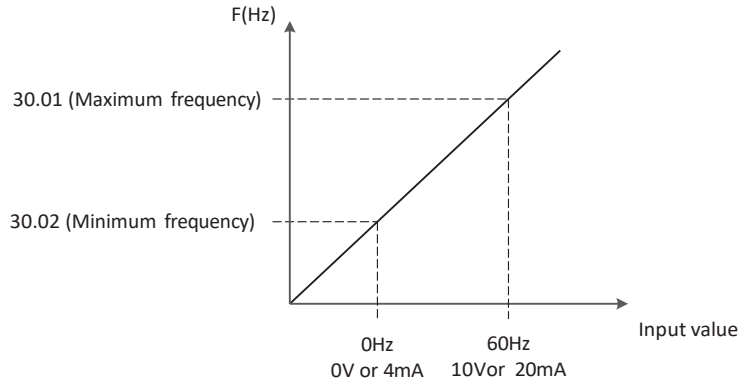

- **30.02 Minimum frequency**

- *Range: 0.00 ~ 400.0 Hz in 0.01 Hz*
- *Initial value: 0.00 Hz*

Define the minimum allowed frequency

If Frequency command is analog input, Min freq must also be set to '**11.08**', '**11.16**'.

## 8.2.18 Fault functions

- **31.01 External event 1 source**
  - 0: Active (Active high signal)
  - 1: Inactive (Active low signal)----- Initial value
  - 2: DI1
  - 3: DI2
  - 4: DI3
  - 5: DI4
  - 6: DI5
  - 7: DI6
  - 8: DI7
  - 9: DI8
  
- **31.02 External event 2 source**
  - See the parameter '31.01' (External event 1 source)
  
- **31.03 External event 3 source**
  - See the parameter '31.01' (External event 1 source)
  
- **31.04 External event 4 source**
  - See the parameter '31.01' (External event 1 source)
  
- **31.05 External event 5 source**
  - See the parameter '31.01' (External event 1 source)
  
- **31.06 Fault(Trip) reset selection**
  - 0: Not selected
  - 1: Selected
  - 2: DI1
  - 3: DI2
  - 4: DI3
  - 5: DI4
  - 6: DI5
  - 7: DI6----- Initial value
  - 8: DI7
  - 9: DI8

Define the source of external event 1

Selects the source of an external fault reset signal

The signal resets the drive after a fault trip if the cause of the fault no longer exists.

● **31.07 Restart mode selection**

- 0: No Restart ----- Initial value
- 1: Restart from 0Hz
- 2: Resume at frequency corresponding motor speed
- 3: Resume at motor speed, then decelerated stop

Select what action to take when a trip occurs that has set at '31.10' (**Automatic reset item 1**) and '31.11' (**Automatic reset item 2**) if the consecutive trip does not occur within 60 seconds, an accumulated trip count is reset to 0

❖ Related Parameters: '31.09' ~ '31.14'

● **31.08 Alarm relay operation mode**

- 0: Inactive for the Under voltage trip signal ----- Initial value
- 1: Inactive during auto reset
- 2: Active every trip
- 3: Inactive during auto reset (Only active for the Under voltage trip signal endlessly)

Select what action to take when a trip occur that alarm relay

❖ Related Parameters: '31.07'

● **31.09 Restart delay time**

- Range: 0.3 ~ 10.0 Sec in 0.1 Sec
- Initial value: 1.0 Sec

Program delay time when VFD restarts

1) Momentary Power Failure Period < 1 Sec

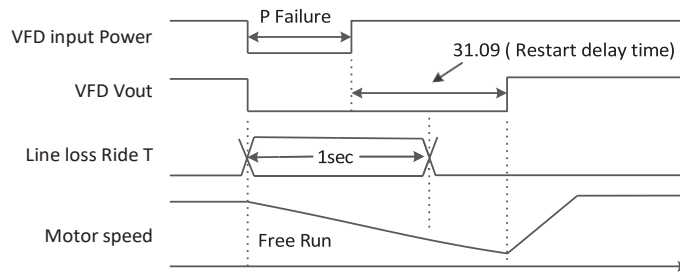

2) Momentary Power Failure Period > 1 Sec

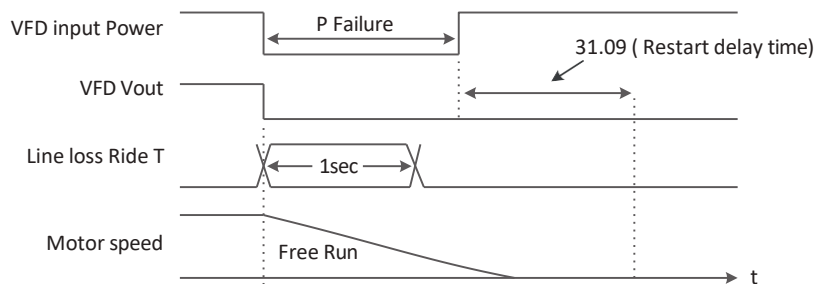

● **31.10 Automatic reset item 1**

- Range: 0x00 ~0xFF
- Initial value: 0x00

Selects faults that are automatically reset the parameter is a 16-bit word with each bit corresponding to a fault type. Whenever a bit is set to 1, the corresponding fault is automatically reset. The bits of this binary number correspond to the following faults

15	14	13	12	11	10	9	8	7	6	5	4	3	2	1	0
EE 5	EE 4	EE 3	EE 2	EE 1	User	-	-	-	-	-	-	Sc	Lv	ov	oC

● **31.11 Automatic reset item 2**

- See the parameter '31.10' (Automatic reset item 1)

● **31.12 User reset item selection**

- Range: 0~32
- Initial value: 0

Defines the fault that can be automatically reset using parameter '31.10' (Automatic reset item 1) or '31.10' (Automatic reset item 1), bit 10

Value	Type of Trip	Value	Type of Trip
0	-	16	-
1	oC (Over Current)	17	SAFE (Safety Fault)
2	ov (Over Voltage)	18	-
3	Lv (low Voltage)	19	ovSF (OVS Fail)
4	Sc (Short circuit)	20	-
5	-	21	-
6	ot (Over Temperature)	22	EE2 (External Emergency 2)
7	EtH(Motor Over Load)	23	EE3 (External Emergency 3)
8	EE1 (External Emergency 1)	24	EE4 (External Emergency 4)
9	E2PE (EEPROM Error)	25	EE5 (External Emergency 5)
10	CE (Communication Error)	26	-
11	-	27	FF (Fan Fault)
12	GF (Ground Fault)	28	Profibus-DP Trip
13	-	29	Device-Net trip
14	Iolt (VFD Over Load)	30	System OL trip
15	PF (Input Phase Loss Fault)	31	System UL trip
		32	Day of use Limited Trip

● **31.13 Restart trial 1**

- Range: 0 ~10 in 1
- Initial value: 0

Defines the number of automatic fault resets at '31.10' (Automatic reset item 1)

● **31.14 Restart trial 2**

- Range: 0 ~10 in 1
- Initial value: 0



Defines the number of automatic fault resets at '31.11' (*Automatic reset item 2*)

### ● 31.15 Earth Fault

- 0: Disabled
- Range: 0.0 ~ 100.0 % in 0.1 %
- Initial value: 0.0 %

Program to enable the Ground fault detection and its fault level as a percentage of rated current

### ● 31.16 Supply phase loss

- 0: Disabled
- Range: 0 ~ 30 Sec in 1 Sec
- Initial value: 10 Sec

Enables & sets the time period to determine if an Input Phase Loss occurs. The VFD monitors the ripple on the DC bus voltage and if it occurs for the programmed magnitude and time period an Input Phase Loss fault will occur. The ripple on the DC bus will cause heating to the DC Bus capacitors which will shorten their life.

### ● 31.17 Stall function

- 0: No Operation
- 1: VFD overload
- 2: Over voltage
- 3: VFD overload and Over voltage ----- Initial value

Select a overload or overvoltage restriction modes

- **Set 0: No Operation**  
*Overload Restriction Mode=Off, Overvoltage Restriction Mode=Off*
- **Set 1: VFD overload**  
*Overload Restriction Mode=On, Overvoltage Restriction Mode=Off*
- **Set 2: Over voltage**  
*Overload Restriction Mode=Off, Overvoltage Restriction Mode=On*
- **Set 3: VFD overload and Over voltage**  
*Overload Restriction Mode=On, Overvoltage Restriction Mode=On*  
❖ Related Parameters: '31.18', '31.19'

### ● 31.18 Stall current limit

- Range: 20.0 ~ 200.0 % in 0.1 %
- Initial value: 150.0 % (HD), 120.0 % (ND)

Program the level for overload restriction of the VFD rated current

● **31.19 Stall deceleration time**

- Range: 0.1 ~ 10.0 Sec in 0.1 Sec
- Initial value: 1.0 Sec

Program the deceleration time for rate when the VFD detects the overload

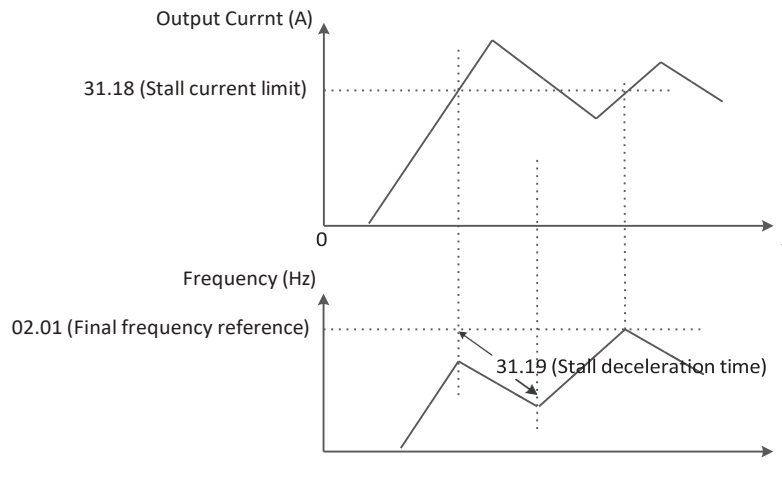

● **31.22 RS485 Modbus time out check enable**

- 0: Always Running ----- Initial value
- 1: Only during VFD is Running

Select a time out detection mode.

❖ Related Parameters: '31.23'

● **31.23 RS485 Modbus time out time**

- 0: Disable
- Range: 0 ~ 60 Sec in 1 Sec
- Initial value: 0 Sec

Select a time out detection period when communication discontinues. If no communication event occurs during this time period, a communication fault will occur.

## 8.2.19 Motor thermal protection

- **32.01 Electronic thermal overload level**

- 20.0 ~ 120.0 % in 0.1 %
- Initial value: 110.0 %

Program a level of the rated motor current (VFD Rated Current)

- ❖ Related Parameters: '32.02'

- **32.02 Electronic thermal overload profile**

- 0: Self Cooling-----Initial value
- 1: Forced Cooling

Select a cooling method

- **Set 0: Self Cooling**  
*Fan is mounted on the motor shaft*
- **Set 1: Forced Cooling**  
*Fan is powered by external power source*

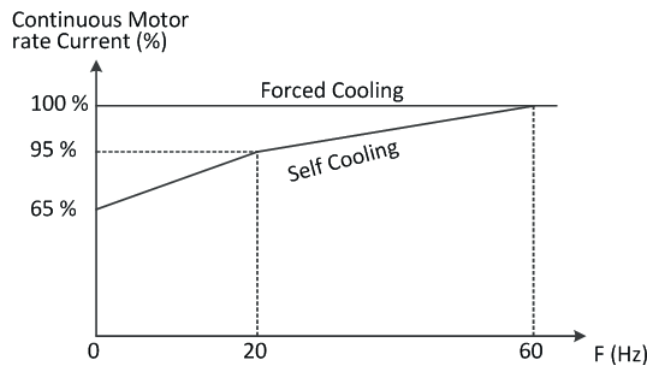

- **32.03 Fan operation mode**

- 0: Always running----- Initial value
- 1: Only during VFD is running

Select fan operation

- **32.04 Fan off delay time**

- 0.0 to 1000.0 Sec 0.1 Sec
- Initial value: 30.0 Sec

Run only When the '32.03'(Fan operation mode) is 1

- ❖ Related Parameters: '32.04'

## 8.2.20 System Overload/Underload detection

The drive provides two independent torque detection functions that trigger an alarm or fault signal when the load is too heavy or suddenly drops

- **33.01 System Load Detection Selection**

- 0: Disabled
- 1: Overload Detection
- 2: Underload Detection
- 3: Overload/Underload Detection
- 4: Overload Detection with Fault (oLdt)
- 5: Underload Detection with Fault (uLdt)
- 6: Overload/Underload Detection with Fault (oLdt, uLdt)

- **33.02 System Overload Detection Level**

- Range: 20.0 ~ 200.0 % in 0.1 %

Sets the System Overload level. This feature is triggered when the motor current exceeds this level. 100% level is based off of the value in 99.04(Motor rated current)

### System Overload Detection

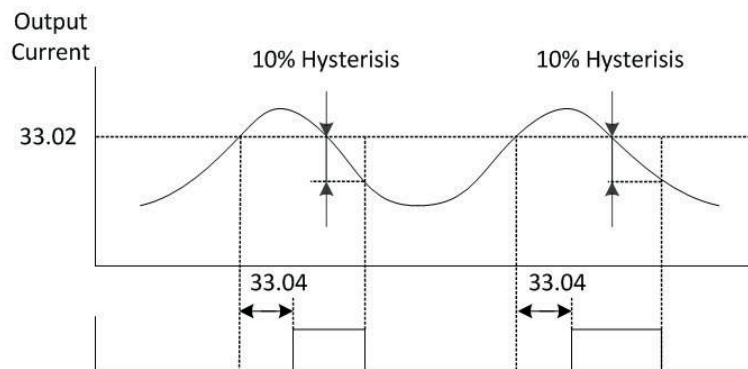

33.02 (System OL Level)  
33.04 (System OL/UL Detection Time)

● **33.03 System Underload Detection Level**

- *Range: 20.0 ~ 200.0 % in 0.1 %*

Sets the System Underload level. This feature is triggered when the motor current exceeds this level. 100% level is based off of the value in H05.

**System Underload Detection**

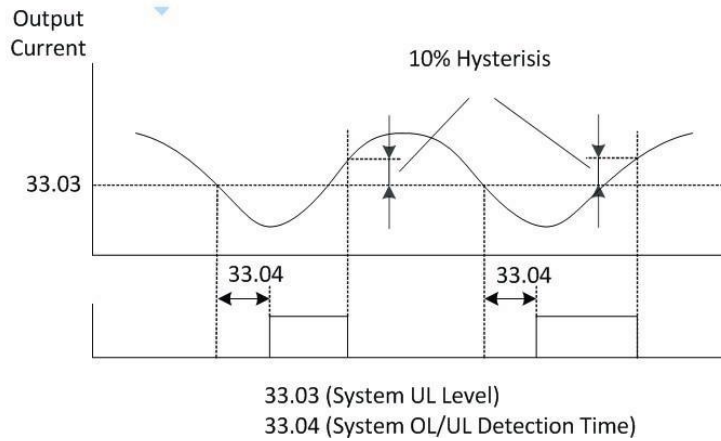

● **33.04 System Overload/Underload Detection Time**

- *Range: 0.0 ~ 60.0 Sec in 0.1 Sec*
- *Initial value : 10.0 sec*
- Sets the System Overload/Underload Detection time.

● **33.05 System Overload/Underload Detection safe zone**

- *Range: 0.00 ~ Max frequency (30.01) in 0.01 Hz*
- *Initial value : 0.00Hz*

Sets the level at which this feature is disabled.  
System Overload/Underload detection doesn't work below '33.05' value

### 8.2.21 PID

The PID function enables the system running at the reference automatically by regulating the process using the system feedback, error term. It is used for Cubic Feet of Air it moves per minute (CFM) for fan application, Gallons per minute (GPM) for pump application, pressure control, heating application, etc.

Basic PID Overview

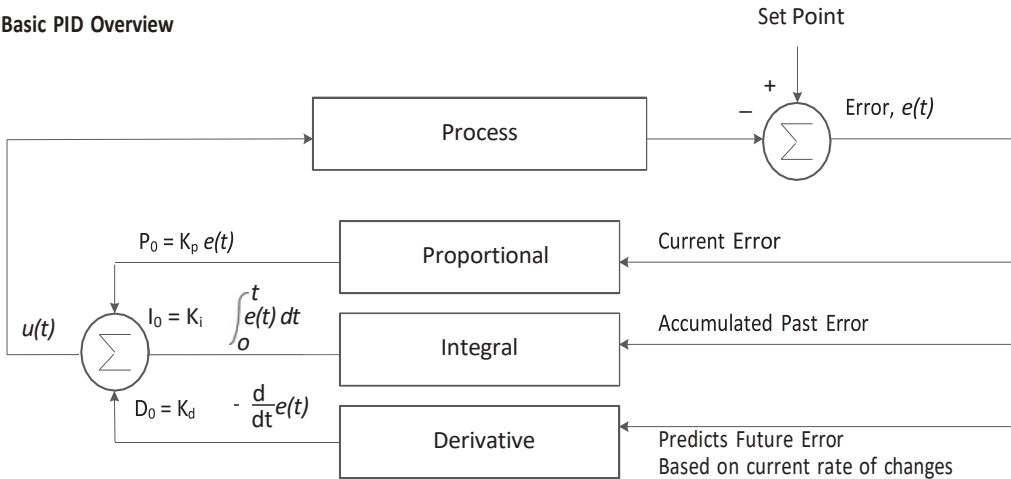

#### PID Functional Description

- Reference: Desired System Output Value
- Error: Difference between System output and reference
- Proportional (P) Term: Current Error
- Integral (I) Term: Accumulated Past Error
- Derivative (D) Term: Predicted Future Error based on current rate of changes

- **40.01 PID function select**

- 0: Disable----- Initial value
- 1: Enable

Select PID function type

- ❖ Related Parameters: '40.01' ~ '40.24'

- **40.02 PID reference**

- Range: 0.0 ~ 100.0 % in 0.01 %
- Initial value: 0.0 %

It can be worked when '40.03'(PID reference source) set 2

- ❖ Related Parameters: '40.03'

● **40.03 PID reference source**

- 0: AI1 (O)
- 1: AI2 (OI)
- 2: Keypad----- Initial value
- 3: Modbus
- 4: Fieldbus
- 5: UP/DOWN

Select PID Reference source

- **Set 0: AI1 (O)**  
*Set the PID reference by DC 0~10V through at O-L terminals*
- **Set 1: AI2 (OI)**  
*Set the PID reference by DC 4~20mA through at OI-L terminals*
- **Set 2: Keypad**  
*Set the PID reference by '40.02'(PID reference) parameter*
- **Set 3: Modbus**  
*Set the PID reference by Modbus communication through at RXP-RXN terminals*
- **Set 4: Fieldbus**  
*Set the PID reference by Fieldbus through at option card adapter*
- **Set 5: UP/DOWN**  
*Set the PID reference by UP/DOWN through external command*

● **40.04 PID feedback source**

- 0: AI1 (O)
- 1: AI2 (OI)----- Initial value

Select the source how to get feedback

- **Set 0: AI1 (O)**  
*Get the PID feedback by DC 0~10V*
- **Set 1: AI2 (OI)**  
*Get the PID feedback by DC 4~20mA*

● **40.05 PID P gain**

- *Range: 0.1 ~ 1000 % in 0.1 %*
- *Initial value: 100.0 %*

Select the PID P gain value

- It sets the output rate of error between reference value and the feedback value
- For faster response speed, enlarge the P gain value
- If P gain is set too large, oscillation or over shooting may occur

- **40.06 PID I gain**

- *Range: 0.0 ~ 3600 Sec in 0.1 Sec*
- *Initial value: 1.0 Sec*

Select the Integral time to accumulate PID error value

- For faster response speed, shorten the accumulate time
- If I gain time is set too short, oscillation or over shooting may occur

- **40.07 PID D gain**

- *Range: 0.0 ~ 10.00 Sec in 0.01 Sec*
- *Initial value: 0.0 Sec*

Program the derivative time for PID function

- For faster response speed, lengthen the D gain time
- If D gain time is set too long, system may become unstable

- **40.08 PID Err limit**

- *Range: 0.0 ~ 100.0 % in 0.1 %*
- *Initial value: 100.0 %*

Program error limit level, ratio to the maximum error

- **40.09 PID output high limit**

- *Range: -100.0 ~ 100.0 % in 0.1 %*
- *Initial value: 100.0 %*

Program the maximum PID output as percentage of the maximum output frequency

- **40.10 PID output low limit**

- *0: Disable the low limit*
- *Range: -100.0 ~ 100.0 % in 0.1 %*
- *Initial value: 0.0 %*

Program the minimum PID output as a percentage of the minimum output frequency

- **40.11 PID output invert**

- *0: Disable----- Initial value*
- *1: Enable*

Program to enable the PID output invert

- **40.12 PID scale factor**

- *Range: 0.1 ~ 1000 % in 0.1 %*
- *Initial value: 100.0 %*

Program the minimum PID output as a percentage of the minimum output frequency



- **40.13 Pre PID frequency**
  - *0: Disable Pre PID function*
  - *Range: 0.00 ~ 400.0 Hz in 0.01 Hz*
  - *Initial value: 0.00 Hz*

Program the frequency reference when PID function is activated. Once the VFD frequency out reaches this value in '**40.13 (Pre PID frequency)**' PID control function is enabled and the VFD is operated in closed loop control.

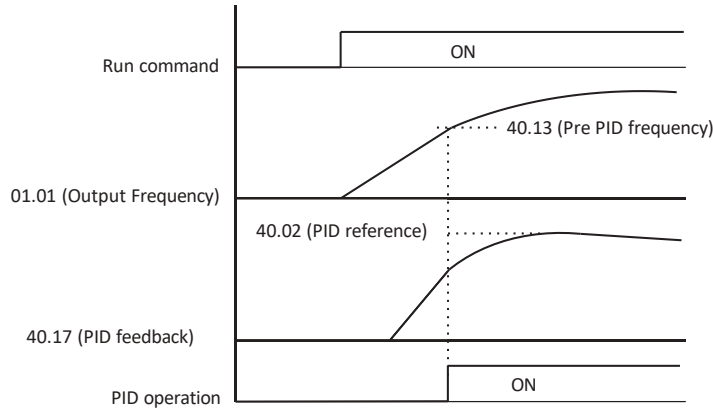

- **40.14 PID sleep frequency**
  - *Range: 0.00 ~ 400.0 Hz in 0.01 Hz*
  - *Initial value: 0.00 Hz*

Program the frequency reference when the VFD goes sleep

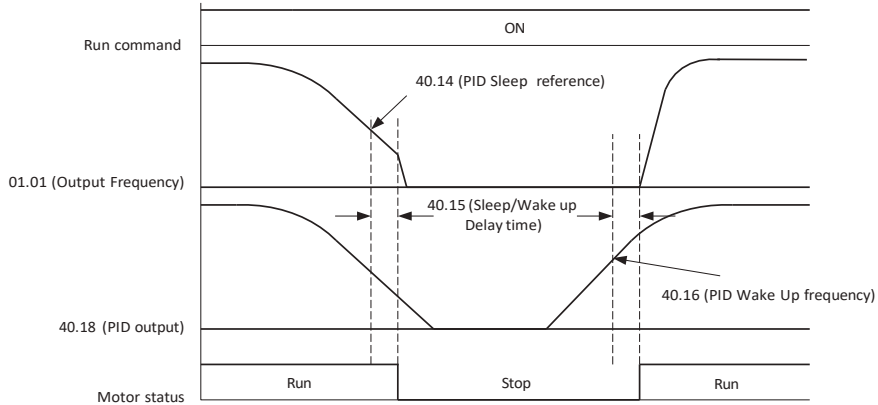

- **40.15 PID sleep/wake delay time**
  - *Range: 0.0 ~ 30.0 Sec in 0.1 Sec*
  - *Initial value: 0.0 Sec*

Program the frequency reference when the VFD goes sleep

- **40.16 PID wake frequency**
  - *Range: '40.14' ~ 400.0 Hz in 0.01 Hz*
  - *Initial value: 0.00 Hz*

Program the frequency reference when the VFD wakes up from the sleep mode for the specified operation

- **40.17 PID feedback monitor**
  - *Range: 0.00 ~ 100.0%*

Real time display of PID feedback

- **40.18 PID output monitor**
  - *Range: 0.00 ~ 100.0%*

Real time display of PID output

- **40.19 PID integral reset source**
  - *0: Not selected ----- Initial value*
  - *1: Selected*
  - *2: DI1*
  - *3: DI2*
  - *4: DI3*
  - *5: DI4*
  - *6: DI5*
  - *7: DI6*
  - *8: DI7*
  - *9: DI8*

Selects the source of the PID integral reset

- **Set 0: Not selected**  
Always off
- **Set 1: selected**  
Always on
- **Set 2~9 : DI1 ~ DI8**  
It works by digital input which is selected

● **40.20 PID disable source**

- *0: Not selected ----- Initial value*
- *1: Selected*
- *2: DI1*
- *3: DI2*
- *4: DI3*
- *5: DI4*
- *6: DI5*
- *7: DI6*
- *8: DI7*
- *9: DI8*

Selects the source of the PID disable

- **Set 0: Not selected**  
Always off
- **Set 1: selected**  
Always on
- **Set 2~9 : DI1 ~ DI8**  
It works by digital input which is selected

● **40.21 ref source 1 at PID disable**

- *0: Not selected*
- *1: AI1 (O) scaled ----- Initial value*
- *2: AI2 (OI) scaled*
- *3: Modbus*
- *4: Fieldbus*
- *5: PID*
- *6: Keypad*
- *7: UP/DOWN*

Selects the source of the ref 1 at PID disable

- **Set 0: Not selected**  
Always off
- **Set 1: AI1 (O) scaled**  
It can set the frequency reference by the DC 0~10V
- **Set 2: AI2 (OI) scaled**  
It can set the frequency reference by the DC 4~20mA
- **Set 3: Modbus**  
It can set the frequency reference by the modbus communication
- **Set 4: Fieldbus**  
Always on It can set the frequency reference by the fieldbus communication
- **Set 5: PID**  
Always on It can set the frequency reference by the PID control
- **Set 6: Keypad**  
Always on It can set the frequency reference by the Keypad
- **Set 7: UP/DOWN**  
Always on It can set the frequency reference by the UP/DOWN function

- 40.22 ref source 2 at PID disable
  - See the parameter '40.21' (ref source 1 at PID disable)
  
- 40.23 ref 1 /ref 2 combination at PID disable
  - 0: '40.21'-----Initial value
  - 1: '40.21' + '40.22'
  - 2: '40.21' - '40.22'
  - 3: '40.21' x '40.22'
  - 4: MIN ('40.21', '40.22')
  - 5: MAX ('40.21', '40.22')

Selects a mathematical function between the reference sources selected by parameters '40.21' (ref source 1 at PID disable) and '40.22' (ref source 2 at PID disable)

- Set 0: '40.21'  
'40.21' (ref source 1 at PID disable)
- Set 1: '40.21'+ '40.22'  
'40.21' (ref source 1 at PID disable) + '40.22' (ref source 2 at PID disable)
- Set 2: '40.21'- '40.22'  
'40.21' (ref source 1 at PID disable) - '40.22' (ref source 2 at PID disable)
- Set 3: '40.21'x '40.22'  
'40.21' (ref source 1 at PID disable) x '40.22' (ref source 2 at PID disable)
- Set 3: MIN ('40.21', '40.22')  
MIN '40.21' (ref source 1 at PID disable), '40.22' (ref source 2 at PID disable)
- Set 5: MAX ('40.21', '40.22')  
MAX '40.21' (ref source 1 at PID disable), '40.22' (ref source 2 at PID disable)

● 40.24 ref 1 /ref 2 selection at PID disable

- 0: '40.23' setting value ----- Initial value
- 1: '40.22' setting value
- 2: DI1
- 3: DI2
- 4: DI3
- 5: DI4
- 6: DI5
- 7: DI6
- 8: DI7
- 9: DI8

Configures the selection between frequency references 1 and 2

- **Set 0: '40.23' setting value**  
The frequency is used by '40.23'(ref 1 /ref 2 combination at PID disable) set value
- **Set 1: '40.22' setting value**  
The frequency is used by '40.22'(ref source 2 at PID disable)
- **Set 2~9 : DI1~ DI8**  
If the digital input which is selected has OFF, it will applied by ref 1  
If the digital input which is selected has ON, it will applied by ref 2

PID Control Diagram

The overall PID control diagram with respective parameters is shown in below

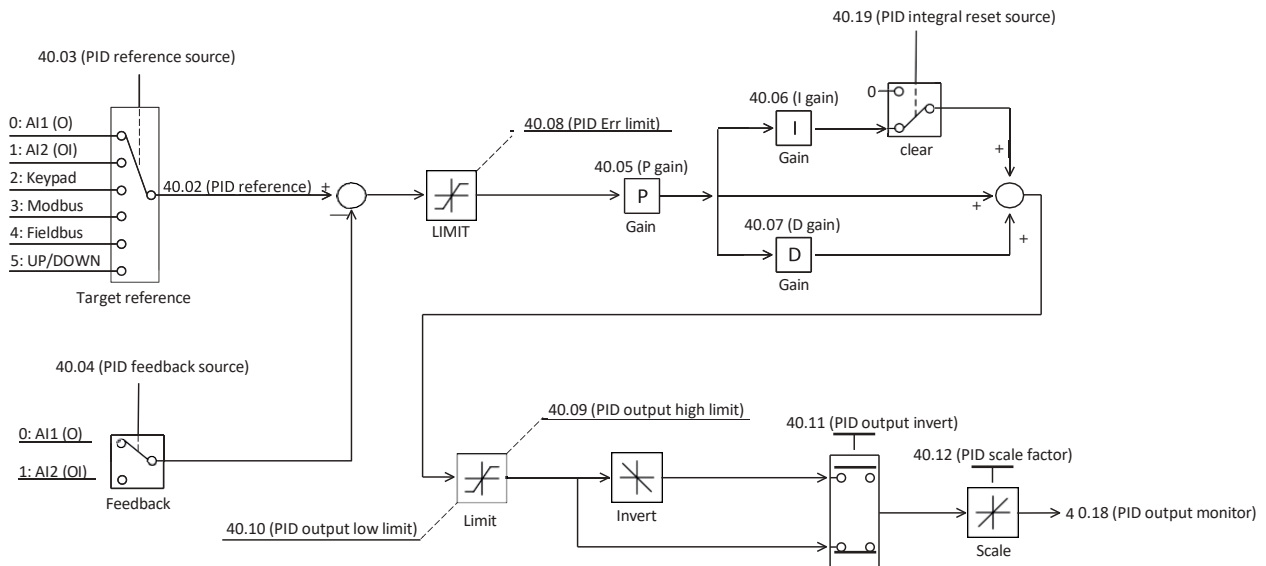

## 8.2.22 DBR Duty cycle

The DBR function is only applicable under 22kW model.

Regenerative energy from the motor is dissipated by the heat through this braking resistor.

- **41.01 DBR Mode**

- *0: DBR disabled*
- *1: Only during VFD Running (Default)*
- *2: Always*

- **41.02 DBR Duty Cycle**

- *Range: 0.0 ~ 50.0% in 0.1%*
- *Initial value: 10.0*

Select a percentage value of total DBR on time before the overheating fault occurs.

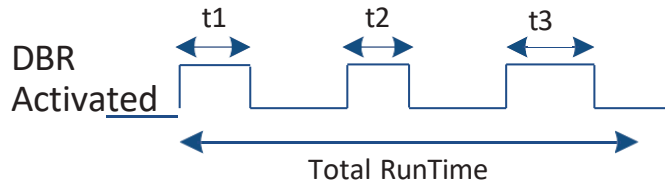

$$\text{DBR Usage Rate} = \frac{t1 + t2 + t3}{\text{Total RunTime}}$$

### 8.2.23 Monitoring/Scaling

- **42.01 Accel&decel Standard frequency**

- Range: 0.00 ~ 400.0 Hz in 0.1 Hz
- Initial value: 60.00 Hz

This parameter is standard of all acceleration and deceleration

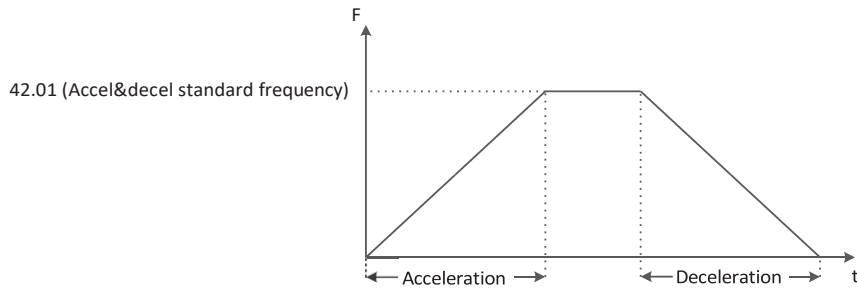

- **42.02 RPM display scale factor**

- Range: 1 ~ 9999 in 1
- Initial value: 100

Program RPM scale factor for '01.02' (Motor RPM monitor)

Below determined by equation:

$$120 \times '01.01' (\text{Output frequency}) \times '42.02' (\text{RPM display scale factor}) \div '99.07' (\text{Motor Pole setting})$$

ex1) '01.01' = 60Hz, '42.02' = 100, '99.07' = 4: '01.02' = 1800rpm

ex2) '01.01' = 60Hz, '42.02' = 50, '99.07' = 4: '01.02' = 900rpm

❖ Related Parameters: '01.02'

- **42.10 Flux break Standard frequency**

- Range: 0.00 ~ 10.00Hz in 0.01
- Initial value: 5.00 Hz

The absolute value that '01.02' (Final frequency reference) - '01.01' (Output frequency) is smaller than '42.10' (Flux break standard frequency), Flux break is disable during deceleration

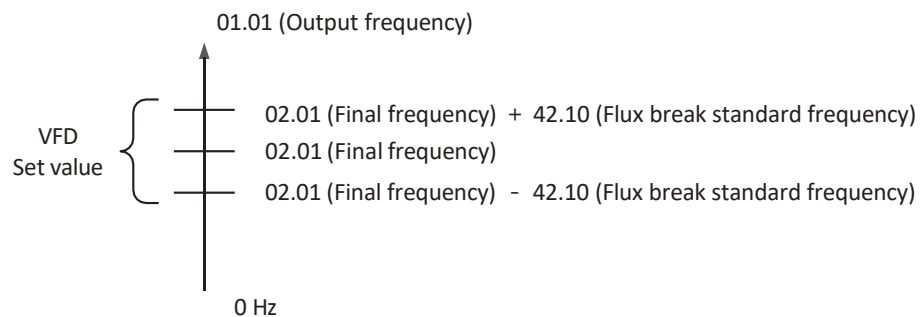

## 8.2.24 Droop

Droop control automatically balances the load level between two motors driving the same load. Output frequency is changed by the amount of output torque.

Output frequency decreased or increased depends on the amount of load that detects the output torque in real time.

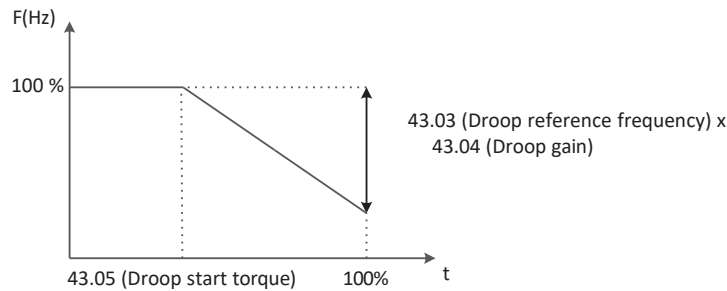

$$\text{Control frequency} = \frac{(\text{Output torque} - \text{Droop Start Torque})}{100\% - \text{Droop Start Torque}} \times \text{Droop Gain} \times \text{Droop Ref. Freq}$$

### ● 43.01 Droop type

- 0: No droop control -----Initial value
- 1: Open loop
- 2: F/B (0~10V)
- 3: F/B (4~20mA)

#### ▪ Set 0: No droop control

Droop control disable

#### ▪ Set 1: Open loop

Droop control without feedback (Open loop)

#### ▪ Set 2 : F/B (0~10V)

Connected the torque output of VFD A to the voltage input (O) of VFD B

#### ▪ Set 3 : F/B (4~20mA)

Connected the torque output of VFD A to the voltage input (OI) of VFD B

### ● 43.02 Droop start frequency

- Range: 0.00 ~ 400.0 Hz in 0.01 Hz
- Initial value: 0.00 Hz

Set the droop control starting frequency.

The droop control doesn't work under B50 value.



- **43.04 Droop gain**

- *Range: 0.00 ~ 50.00 in 0.01*
- *Initial value: 5.00*

Sets the reduced rate of output frequency when at the 100% output torque gain while operating in the droop control

- **43.05 Droop start torque**

- *Range: 0.0 ~ 100.0 % in 0.1 %*
- *Initial value: 0.0 %*

Set the amount of output torque at start in droop control

- **43.06 Droop ramp time**

- *Range: 1.0 ~ 100.0 Sec in 0.1 Sec*
- *Initial value: 20.0 Sec*

Set the response time of output change when operating droop control

- If this time is short, it occur the vibration
- If this time is long, it occur the delayed response of droop control

Example

- 1) Increased the load ratio up to 100%  
Output frequency decreased by the amount of load



Ch1	: Out Freq. (12Hz/div)	time 5s/div
Ch2	: Estimated Torque	
Ch3	: Calculated Droop Freq	
Ch4	: Output Current(100A/div)	

- 2) Put 100% step load and removed 100% load in a moment  
Put the step load (100%) for 8 seconds and then remove the step load.  
The droop control decreased the output frequency for '**43.06'** (*Droop ramp time*) =5s at step load.  
The droop control increased the output frequency for '**43.06'** (*Droop ramp time*) =5s at no step load.

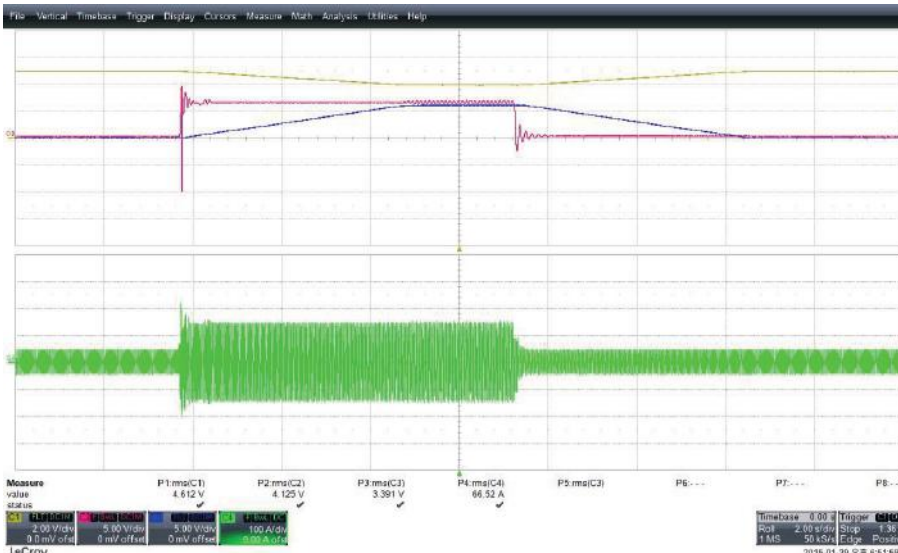

Ch1	: Out Freq. (12Hz/div)	time 5s/div
Ch2	: Estimated Torque	
Ch3	: Calculated Droop Freq	
Ch4	: Output Current(100A/div)	

## 8.2.25 RS-485 (Modbus)

- **50.01 Modbus node ID**

- *Range: 1 ~ 32 in 1*
- *Initial value: 1*

Node ID for Modbus communication

❖ Related Parameters: **'50.02'**

- **50.02 Modbus baud rate**

- *1: 2,400 bps*
- *2: 4,800 bps*
- *3: 9,600 bps ----- Initial value*
- *4: 19,200 bps*

Select a baud rate for Modbus communication

1) RXP / PXN / Connector

- RXP: + Transmit/Receive Port
- RXN: - Transmit/Receive Port

Program A1 Parameters to enable remote control

Code	Minimum	Maximum	Initial Value	Unit	Description
'50.01'	1	32	1	-	Modbus node ID
'50.02'	0	4	0	-	9600bps

2) RS485 Interface Description

Item	Description	Remark
Interface	RS485	
Communication method	Half duplex	
Communication speed	9600	Fixing
Communication code	Binary code	
Data bits	8	Fixing
Parity	No.	Fixing
Stop bit	1	Fixing
Starting method	External request	VFD is only slave part.
Wait time	10~1000ms	
Connection type	1 : N (Max32)	
Error check	Frame / CRC / CMD / MAXREQ / parameter	Communication number is selected at '50.01'

Communication sequence

The communication sequence is as follows

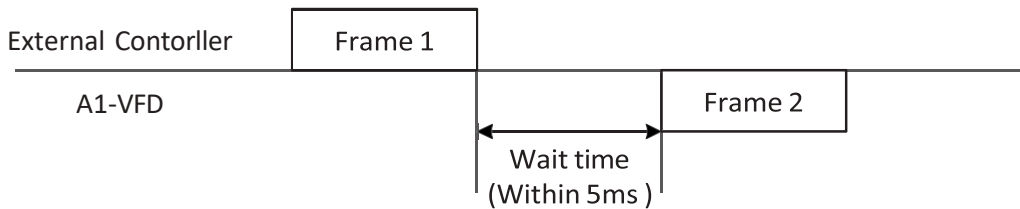

- Frame Start: Frame start is recognized by signal line data transmitted
- Frame Complete: Frame completion is recognized by no data during 4, 5-character time
- Frame 1: Transmit from external controller to VFD
- Frame 2: Indication reflects from VFD to external controller

### 3) Communication Frame Type and Form

#### External Controller Transmit Frame

Modbus node ID	Command	Parameter	Parameter Count	CRC Hi	CRC Lo
----------------	---------	-----------	-----------------	--------	--------

	Description	Data size	Specifications
Modbus node ID	Target VFD Modbus node ID	1 byte	1~32
Command	Frame type	1 byte	0x03
Parameter	Parameter	2 byte	1 <sup>st</sup> byte : Group 2 <sup>nd</sup> byte : Index <sup>(Note1)</sup>
Parameter number	Request parameter number	2 byte	1 <sup>st</sup> byte : 0x00 2 <sup>nd</sup> byte : N(0x01~0x08)
CRC Hi	-	1 byte	Higher 8bit of 16bit CRC
CRC Lo	-	1 byte	Lower 8bit of 16bit CRC

#### VFD response frame

Modbus node ID	Order	Byte Number	Data 1	...	Data N	CRC Hi	CRC Lo
----------------	-------	-------------	--------	-----	--------	--------	--------

	Description	Data size	Specifications
Modbus node ID	Target VFD Modbus node ID	1 byte	1~32
Command	Frame type	1 byte	0x03
Byte Number	Data Byte number	1 byte	Request parameter number x 2
Data 1	Parameter 1	2 byte	Parameter value
Data N	Parameter N	2 byte	Nth parameter value
CRC Hi	-	1 byte	Higher 8bit of 16bit CRC
CRC Lo	-	1 byte	Lower 8bit of 16bit CRC

\* Frame Size = 5 + Request parameter number x 2

**External transmit frame**

Modbus node ID	Order	Parameter	Data	CRC Hi	CRC Lo
----------------	-------	-----------	------	--------	--------

	Description	Data size	Specifications
Modbus node ID	Target VFD Modbus node ID	1 byte	1~32
Command	Frame type	1 byte	0x06
Parameter	Parameter	2 byte	1 <sup>st</sup> byte : Group 2 <sup>nd</sup> byte : Index
Data	Data	2 byte	Setting value
CRC Hi	-	1 byte	Higher 8bit of 16bit CRC
CRC Lo	-	1 byte	Lower 8bit of 16bit CRC

**VFD response frame**

Modbus node ID	Order	Parameter	Data	CRC Hi	CRC Lo
----------------	-------	-----------	------	--------	--------

	Description	Data size	Specifications
Modbus node ID	Target VFD Modbus node ID	1 byte	1~32
Command	Frame type	1 byte	0x06
Parameter	Parameter	2 byte	1 <sup>st</sup> byte : Group 2 <sup>nd</sup> byte : Index
Data	Data	2 byte	Setting value is response
CRC Hi	-	1 byte	Higher 8bit of 16bit CRC
CRC Lo	-	1 byte	Lower 8bit of 16bit CRC

**4) Parameter Setting & Trip information**

**Parameter Setting**

1<sup>st</sup> byte: Group number

2<sup>nd</sup> byte: Parameter number

Ex) The case of '99.01' parameter reading or writing

1<sup>st</sup>byte: 0x63

2<sup>nd</sup>byte: 0x01

**Data value is transmitted except decimal point.**

Ex1) Frequency reference 60Hz (Parameter: 0x0004, Data: 0x1770)

Command	Parameter	Communication Data	Data (Conversion hexa to decimal)
0x0006	0x0004	6000(60.00Hz => 6000)	1 <sup>st</sup> byte : 0x17 2 <sup>nd</sup> byte : 0x70

Ex2) Acceleration time 1 (Parameter: 0x1704, Data: 0x0064)

Command	Parameter	Communication Data	Data (Conversion hexa to decimal)
0x0006	0x1704	100(10.0sec => 100)	1 <sup>st</sup> byte : 0x00 2 <sup>nd</sup> byte : 0x64

Ex3) Run command (Parameter: 0x0002, Data: FWD)

Bit7	Bit6	Bit5	Bit4	Bit3	Bit2	Bit1	Bit0
Reserved					RST	REV	FWD

Command	Parameter	Data
0x0006	0x0002	0x0001(FWD: 0x0001, REV: 0x0002, RST: 0x0004)

### Trip information items

Value	Type of Trip	Value	Type of Trip
0	-	16	-
1	oC (Over Current)	17	SAFE (Safety Fault)
2	ov (Over Voltage)	18	-
3	Lv (low Voltage)	19	ovSF (OVS Fail)
4	Sc (Short circuit)	20	-
5	-	21	-
6	ot (Over Temperature)	22	EE2 (External Emergency 2)
7	EtH(Motor Over Load)	23	EE3 (External Emergency 3)
8	EE1 (External Emergency 1)	24	EE4 (External Emergency 4)
9	E2PE (EEPROM Error)	25	EE5 (External Emergency 5)
10	CE (Communication Error)	26	-
11	-	27	FF (Fan Fault)
12	GF (Ground Fault)	28	Profibus-DP Trip
13	-	29	Device-Net trip
14	lolt (VFD Over Load)	30	System OL trip
15	PF (Input Phase Loss Fault)	31	System UL trip
		32	Day of use Limited Trip

### Trip information Parameter

	Current Trip	Previous Trip1	Previous Trip2	Previous Trip3	Previous Trip4	Previous Trip5	Trip count
1 <sup>st</sup> byte	0x03	0x03	0x03	0x03	0x03	0x03	0x03
2 <sup>nd</sup> byte	0x01	0x0D	0x19	0x25	0x31	0x3D	0x49

### 5) 16 bit CRC generation

The step of CRC generation is as follows:

1. All of 16-bit Parameter is 1.0xffff
2. The exclusive OR of 16-bit Parameter and 8-bit Parameter.
3. Shift right side 1 bit 16-bit Parameter
4. If the result of step 3 is 1, exclusive OR 16-bit Parameter and 0xa001.
5. Execute 8 times step 3 and step 4.
6. Execute step 2~6 until data completion.
7. Exchange the step 6 result of higher 8bit and lower 8bit.

Ex) the case of d01 output frequency reading.

Byte 1	Byte 2	Byte 3	Byte 4	Byte 5	Byte 6
Communication Number	Command	Parameter		Parameter number	
0x01	0x03	0x01	0x01	0x00	0x01

### The sequence of addition Byte (01x01)

16-BIT PARAMETER (Exclusive OR)	MSB			Flag	
01	1111	1111	1111	1111	
	0000	0001			
	1111	1111	1111	1110	
Shift 1	0111	1111	1111	1111	
Shift 2	0011	1111	1111	1111	1
Polynomial	1010	0000	0000	0001	
	1001	1111	1111	1110	
Shift 3	0100	1111	1111	1111	
Shift 4	0010	0111	1111	1111	1
Polynomial	1010	0000	0000	0001	
	1000	0111	1111	1110	
Shift 5	0100	0011	1111	1111	
Shift 6	0010	0001	1111	1111	1
Polynomial	1010	0000	0000	0001	
	1000	0001	1111	1110	
Shift 7	0100	0000	1111	1111	
Shift 8	0010	0000	0111	1111	1
Polynomial	1010	0000	0000	0001	
	1000	0000	0111	1110	



Byte 1~6	CRC of operation results
0x01	0x807e
0x03	0x3364
0x01	0x30e1
0x01	0x8831
0x00	0xd449
0x01	0x36d4

Change upper and lower 8 bit of result 0x36d4: 0xd436

Byte7: Upper 8 bit of CRC = 0xd4

Byte8: Lower 8 bit of CRC = 0x36

## 8.2.26 Fieldbus (option)

Fieldbus card is option to buy addition  
More information refer to extra manual of fieldbus

- **51.01 Fieldbus option type**
  - *0: Modbus-RTU*
  - *1: Profibus-DP*
  - *2: Device-Net*
  - *3: Ethernet series*
  - *4: Reserved ----- Initial value*
  
- **51.02 Fieldbus station number**
  - *32: etc*
  - *63: Device-Net*
  - *125: Profibus-DP ----- Initial value*
  
- **51.03 Fieldbus byte swap**
  - *0: Normal*
  - *1: Swap----- Initial value*
  
- **51.08 ~ 51.19 Fieldbus input data 1~12**
  - *0x0000 ~ 0xFFFF*
  
- **51.20 ~ 51.31 Fieldbus output data 1~12**
  - *0x0000 ~ 0xFFFF*
  
- **51.32 Fieldbus status**
  - *0x0000 ~ 0xFFFF*
  
- **51.33 Fieldbus version**
  - *0x0000 ~ 0xFFFF*

## 8.2.27 User parameters

- **96.01 User parameter selection**

- *0: Disable----- Initial value*
- *1: Enable*

If set 1, it will display only user parameter that has registered  
So when user parameter adds or changes, it has to be set 0

- **96.02 ~ 96.33 User parameter configuration 1~32**

- *Range: '01.01'~'99.99'*

It can register maximum 32ea

## 8.2.28 System

- **97.01 Initialization mode**

- *0: Clear trip history ----- Initial value*
- *1: Clear all parameters*

If set 0, all parameters will reset to initial value except '99.02' (Motor rated voltage)

- **97.02 Parameter lock mode**

- *0: All parameters are locked except '97.02' by '97.03' ----- Initial value*
- *1: All parameters are locked except '97.02' and '02.01' by '97.03'*
- *2: All parameters are locked except '97.02'*
- *3: All parameters are locked except '97.02' and '20.01'*
- *4: All parameters are locked except '97.02' and '20.01', '23.04', '23.05'*
  - ❖ Related Parameters: '99.03'

This parameter used to protect that changes parameter by other person

- **97.03 Software lock source**

- *0: Not selected----- Initial value*
- *1: Selected*
- *2: DI1*
- *3: DI2*
- *4: DI3*
- *5: DI4*
- *6: DI5*
- *7: DI6*
- *8: DI7*
- *9: DI8*

Selects the source of software lock

- **Set 0: Not selected**  
Always off
- **Set 1: selected**  
Always on
- **Set 2~9 : DI1~ DI8**  
It works by digital input which is selected

- **97.04 Current time setting (Year)**

- *Range: 2000 ~ 2099*
- *Initial value: 2016*

Put the value of current year

- **97.05 Current time setting (Month, Day)**

- *Range: 101 ~ 1231*
- *Initial value: 224*

Put the value of current month and day

- **97.06 Current time setting (Hour, Minute)**

- *Range: 0 ~ 2359*
- *Initial value: 0*

Put the value of current hour and minute

- **97.07 Current time setting (Second)**

- *Range: 0 ~ 59*
- *Initial value: 0*

Put the value of current second

## 8.2.29 Motor control

- **98.01 Motor control mode**

- 0: CT (V/f) ----- Initial value
- 1: VT (V/f)
- 2: SLV

- **Set 0: CT(V/f) – Constant Torque**

Frequency and voltage are controlled proportionately

Frequency rises until '**30.01**' (*Maximum frequency*) and voltage never rises above '**99.02**' (*Motor rated voltage*)

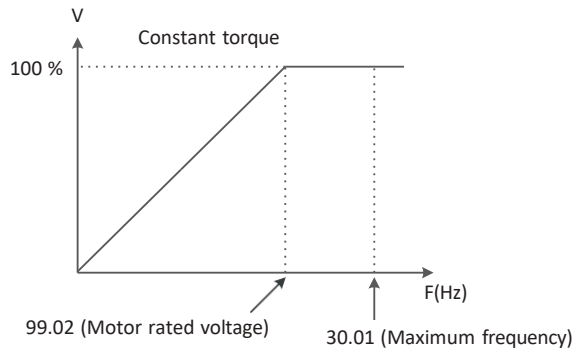

- **Set 1: VT(V/f) – Variable Torque**

Reduced torque is effective for fan or pump application which do not require high torque at low frequency. By reducing the output voltage, increased efficiency, lower noise, and lower vibration.

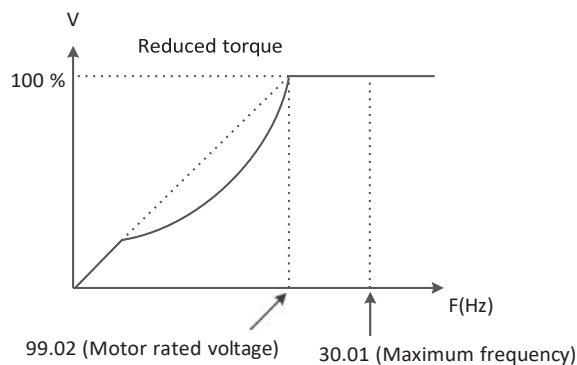

- **Set 2: SLV – Sensorless Vector**

For Sensorless Vector method, per specified output voltage, current, motor parameters, motor rpm, the corresponding torque value is calculated. At very low frequency up to 0.5 Hz, high torque operation is possible

● **98.02 HD/ND (torque type) select**

- *0: Heavy duty (HD) ----- Initial value*
- *1: Normal duty (ND)*

Depending on this parameter, VFD rated current, PWM carrier frequency and Stall level will be changed

- **Set 0: Heavy duty (HD)**  
Hoists, conveyors, pump process; select HD
- **Set 1: Normal duty (ND)**  
Fans, or centrifugal pump applications; select ND  
❖ Related Parameters: **'31.18', '98.03',**

● **98.03 PWM carrier frequency**

- *Range: 1.0 ~ 10.0 kHz in 0.1 kHz*
- *Initial value: 3.0 kHz*

Select Heavy Duty or Normal Duty factory setting per VFD model and loading type  
If the value is high, noise of motor is decreased and noise and temperature of VFD is increased

Model	Range	Model	HD ('98.02' = 0)	ND ('98.02' = 1)
A1-032A-2 A1-045A-2 A1-064A-2 A1-076A-2 A1-090A-2 A1-114A-2	1.0 ~ 10.0 kHz	A1-032A-2 A1-045A-2 A1-064A-2 A1-076A-2 A1-090A-2 A1-114A-2	5.0 kHz	3.0 kHz
A1-140A-2 A1-170A-2 A1-205A-2 A1-261A-2 A1-310A-2	1.0 ~ 10.0 kHz	A1-140A-2 A1-170A-2 A1-205A-2 A1-261A-2 A1-310A-2	3.0 kHz	2.0 kHz
A1-016A-4 A1-023A-4 A1-032A-4 A1-038A-4	1.0 ~ 16.0 kHz	A1-016A-4 A1-023A-4 A1-032A-4 A1-038A-4 A1-045A-4 A1-058A-4	5.0 kHz	3.0 kHz
A1-045A-4 A1-058A-4 A1-075A-4 A1-090A-4 A1-110A-4 A1-149A-4 A1-176A-4 A1-217A-4 A1-260A-4 A1-296A-4	1.0 ~ 10.0 kHz	A1-075A-4 A1-090A-4 A1-110A-4 A1-149A-4 A1-176A-4 A1-217A-4 A1-260A-4 A1-296A-4	3.0 kHz	2.0 kHz

● **98.04 PWM carrier mode**

- *0: Normal ----- Initial value*
- *1: Swing PWM1*

Swing PWM1 is used to decrease noise of motor  
It changes the PWM carrier frequency in between 2.25 kHz and 2.75 kHz

- **98.05 Voltage gain factor**
  - *Range: 20.0 ~ 110.0 % in 0.1 %*
  - *Initial value: 100.0 %*

The output voltage cannot exceed the input voltage

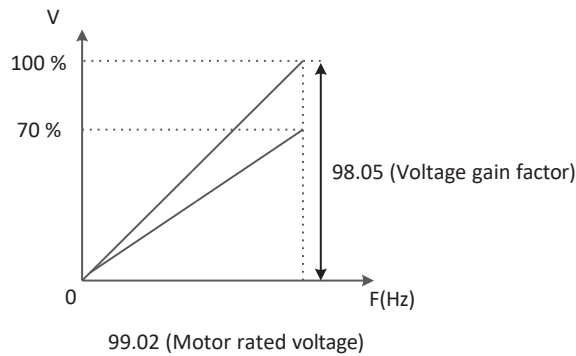

- **98.06 Flux braking function**
  - *0: Disable*
  - *1: Enable ---- Initial value*

It can select to use Flux braking Function

❖ Related Parameters: *'42.10', '98.07'*

- **98.07 Flux braking reference**
  - *Range: 100 ~ 140 % in 1*
  - *Initial value: 110 %*

It can program a Flux braking reference

- **98.09 Manual torque boost voltage reference**
  - *Range: 0.00 ~ 50.00 % in 0.01 %*
  - *Initial value: 1.0 %*

For Manual Torque Boost mode, program the value in % of an output voltage

It not works in auto torque mode or sensorless mode

❖ Related Parameters: *'21.01', '98.01', '98.10'*



- **98.10 Manual torque boost frequency reference**

- *Range: 0.0 ~ 100.0 % in 0.1 %*
- *Initial value: 100.0 %*

Program the frequency breakpoint

It not works in auto torque mode or sensorless mode

❖ Related Parameters: **'21.01', '98.01', '98.09'**

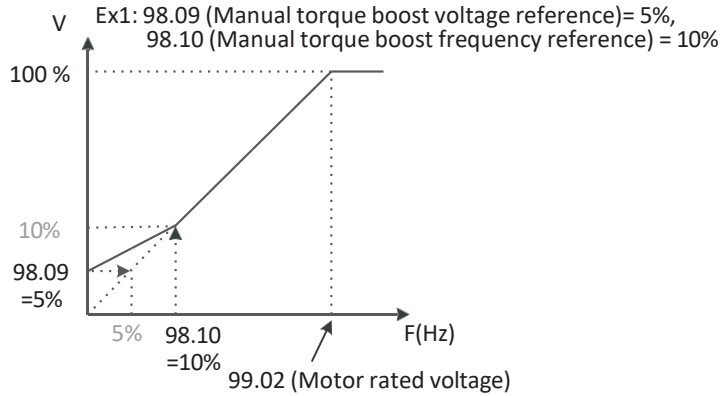

- **98.11 Motoring Slip Compensation**

- *Range: 0 ~ 200 % in 1%*
- *Initial value: 0 %*

When a load is applied, Slip is compensated to keep the speed constant.  
(Apply V/f Control only)

- **98.12 Regeneration Slip Compensation**

- *Range: 0 ~ 200 % in 1%*
- *Initial value: 0 %*

When a load is applied, Slip is compensated to keep the speed constant.  
(Apply V/f Control only)

### 8.2.30 Motor data

- **99.01 Motor capacity**

- 2.2kW, 3.7kW, 5.5kW, 7.5kW, 11kW, 15kW, 18.5kW, 22kW, 30kW, 37kW, 45kW, 55kW, 75kW, 90kW, 110kW, 132kW, 160kW, 200kW, 220kW, 250kW, 280kW, 320kW, 350kW
- Initial value: depend on VFD models

Program a capacity of motor

Ex) 30L: 30kW-200V, 30H: 30kW-400V

- **99.02 Motor rated voltage**

- 200V Class setting: 200/220/230/240
- 400V Class setting: 380/400/415/440/460/480
- Initial value: depend on VFD models

Program a rated voltage of the motor nameplate

- **99.03 Motor rated frequency**

- Range: 0.00 ~ 400Hz in 0.01 Hz
- Initial value: 60.00 Hz

Program a rated frequency of the motor nameplate

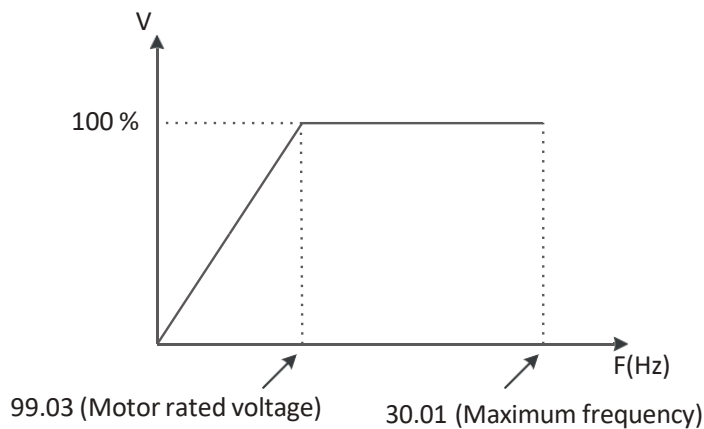

- **99.04 Motor rated current**

- Range: 0.1 ~ 800.0 A in 0.1 A
- Initial value: depend on VFD models

Program a rated current of the motor nameplate

● **99.05 Motor flux current**

- *Range: 0.1 ~ 400.0 A in 0.1 A*
- *Initial value: depend on VFD models*

Program the no load (flux) current value

Not all motors will have this information on the nameplate

✧ The value is approximately 30% of rate current

● **99.06 Motor rated slip**

- *Range: 0.01 ~ 10.0 % in 0.1 %*
- *Initial value: depend on VFD models*

Program the slip percent of the motor rated nameplate rpm

Rated slip frequency: [(rated speed – speed of nameplate) / rated speed] x 100

Ex) [(1800rpm – 1750rpm) / 1800rpm] X 100 = 2.78%

● **99.07 Motor Pole setting**

- *2: 2 Poles*
- *4: 4 Poles ----- Initial value*
- *6: 6 Poles*
- *8: 8 Poles*

Program a number of poles to the corresponding motor used with the VFD

*Ex1) 2 Poles for 3600rpm (60Hz), 3000rpm (50Hz)*

*Ex2) 4 Poles for 1800rpm (60Hz), 1500rpm (50Hz)*

*Ex3) 6 Poles for 1200rpm (60Hz), 1000rpm (50Hz)*

*Ex4) 8 Poles for 900rpm (60Hz), 750rpm (50Hz)*

● **99.08 Auto tuning**

- *0: Disable ----- Initial value*
- *1: Enable*

Program to enable auto tuning function

Motor parameters are calculated using the internal auto tuning algorithm and automatically set for sensorless vector control design

Auto tuning process

1. Put the data at '**99.01**' (*Motor capacity*) ~ '**99.07**' (*Motor Pole setting*)
2. Set 1 at '**99.08**' (*Auto tuning*)
3. Push the Run button on the keypad

- Complete successful: 

- Occurred error: 

- **99.09 Motor data selection**
  - *0: Standard motor data----- Initial value*
  - *1: Auto tuning data*

Program to select between standard motor data and auto tuned data

- **99.10 Motor resistance R1**
  - *Range: 0.1 ~ 30.0 Ohm in 0.001 Ohm*
  - *Initial value: depend on VFD models*

The initial value is Hyundai motor data

- **99.11 Transient inductance**
  - *Range: 0.01 ~ 100.0 mH in 0.01 mH*
  - *Initial value: depend on VFD models*

The initial value is Hyundai motor data

- **99.12 Motor resistance R1 (Auto tuned data)**
  - *Range: 0.1 ~ 30.0 Ohm in 0.001 Ohm*
  - *Initial value: depend on VFD models*

Value determined during auto tuning process

- **99.13 Transient inductance (Auto tuned data)**
  - *Range: 0.01 ~ 100.0 mH in 0.01 mH*
  - *Initial value: depend on VFD models*

Value determined during auto tuning process

## 9. Checking and Trouble shooting

### 9.1 Error code

#### 9.1.1 Error code list

Name	Cause(s)	Error Code
Over Current	When the VFD output current exceeds the rated current by more than approximately 200% during the motor locked or reduced in speed. Protection circuit activates, halting VFD output.	oC
Short Circuit	The VFD output was short-circuited. This condition causes excessive current for the VFD, so the VFD output is turned off.	oC or SC
Motor Overload	When the VFD output current causes the motor to overload, the electronic thermal trip in the VFD cuts off the VFD output.	EtH
VFD Overload	The power IGBT is protected from over heat. The operating time of VFD is 1 minute with 150% load of HD or 120% load of ND. The operating time is changed depending on carrier frequency, load, ambient temperature and power rating.	IoLt
DC link Over Voltage	If regenerative energy from the motor or the main power supply voltage is high, the protective circuit activates to cut off the VFD output when the voltage of DC link exceeds the specification	ov
DC link Under Voltage	When input voltage drops below the low-voltage detection level, the control circuit does not function normally. So when the input voltage is below the specification, the VFD output is cut off.	Lv
EEPROM Error	The VFD output is cut off when EEPROM in the VFD has an error due to external noise, excessive temperature rise, or other factor	E2PE
Communication Error	Communication error between VFD and its operator. If the Reset signal persists for more than 4 seconds, it will occur.	CE
IGBT Over Temperature	When the temperature in the main circuit increases due to cooling fan stop, the VFD output is cut off. (only for the model type with cooling fan)	ot

Name	Cause(s)	Error Code
Input Phase Loss	A function that detects phase loss in the input AC source. Detection is performed using the fluctuation in the main circuit's DC voltage. Also, in the case of degradation of main capacitors it could be occurred.	PF
Ground Fault	When ground fault is detected on running condition, the output is cut off.	GF
Fan Fault	The Fan fault is indicated when the fan is not rotated	FF
OVS control fail	The OVS output frequency is higher than maximum OVS output frequency during the setting time when the OVS function is enabled	ovSF
External Event	When the external equipment or unit has an error, the VFD receives the corresponding signal and cuts off the output.	EE1~EE5
Safety input trip	When the terminal of safety has opened	SAFE
System Overload Detection Fault	The output current of the drive is greater than the detection level set for this feature when it enabled	oLdt
System Underload Detection Fault	The output current of the drive is less than the detection level set for this feature when it enabled	uLdt
Braking Resistor Overload Trip	When DBR exceeds the duty cycle of the braking resistor this fault will occur. The circuit is designed to calculate and protect the braking resistor from thermally overheating	brot
Day of use Limited Trip	Day of use Limited Trip	dL

## 9.2 Trouble Shooting

### 9.2.1 Trip monitor display

- Display the trip source and operation status when occurred the trip
- Display until the previous five trip event in *'03.13' ~ '03.72'*
- Each trip contents are displayed below flow
  - 1) Source of trip
  - 2) Frequency at trip
  - 3) Current at trip
  - 4) Vdc at trip
  - 5) Running status at trip
  - 6) DI status at trip
  - 7) DO status at trip
  - 8) Temperature at trip
  - 9) Torque at trip

Trip event	Contents	Description
Trip monitor 1	<i>'03.13' ~ '03.24'</i>	Source, Frequency, Current, Vdc, Running status, DI status, DO status, Temperature, Torque
Trip monitor 2	<i>'03.25' ~ '03.36'</i>	Same with the Trip monitor 1
Trip monitor 3	<i>'03.37' ~ '03.48'</i>	Same with the Trip monitor 1
Trip monitor 4	<i>'03.49' ~ '03.60'</i>	Same with the Trip monitor 1
Trip monitor 5	<i>'03.61' ~ '03.72'</i>	Same with the Trip monitor 1
Trip counter	<i>'03.73'</i>	Displays the trip accumulation count

## 9.2.2 oC (Over Current)

### 1) Diagnostic flow chart

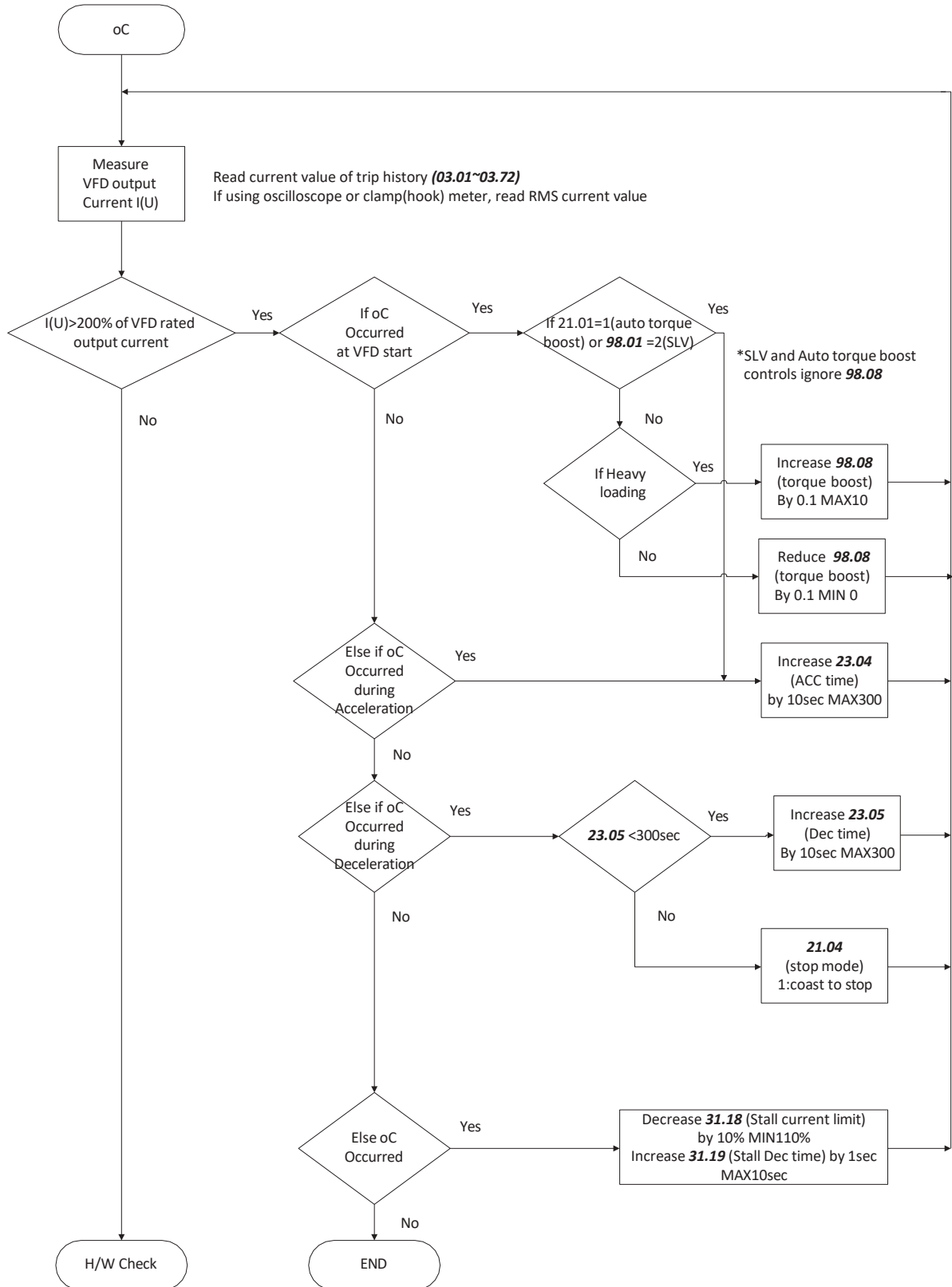



### 9.2.3 SC (Short Circuit)

#### 1) Diagnostic flowchart

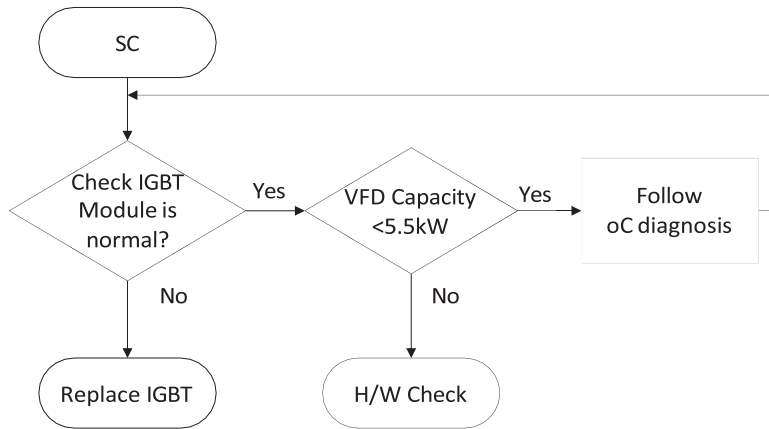

### 9.2.4 ETH (Motor Overload)

1) Diagnostic flowchart

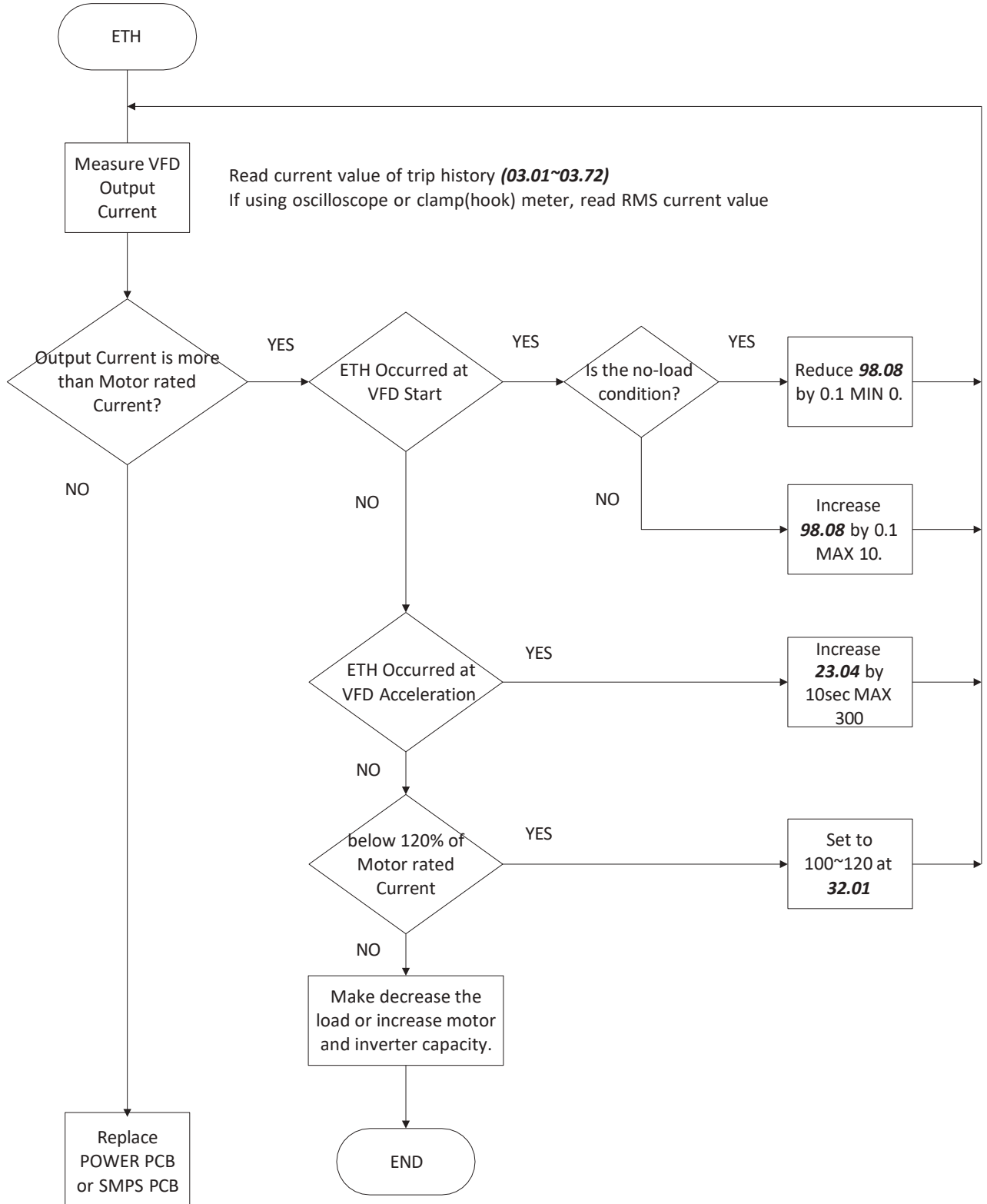

### 9.2.5 IoLt (VFD Overload)

1) Diagnostic flowchart

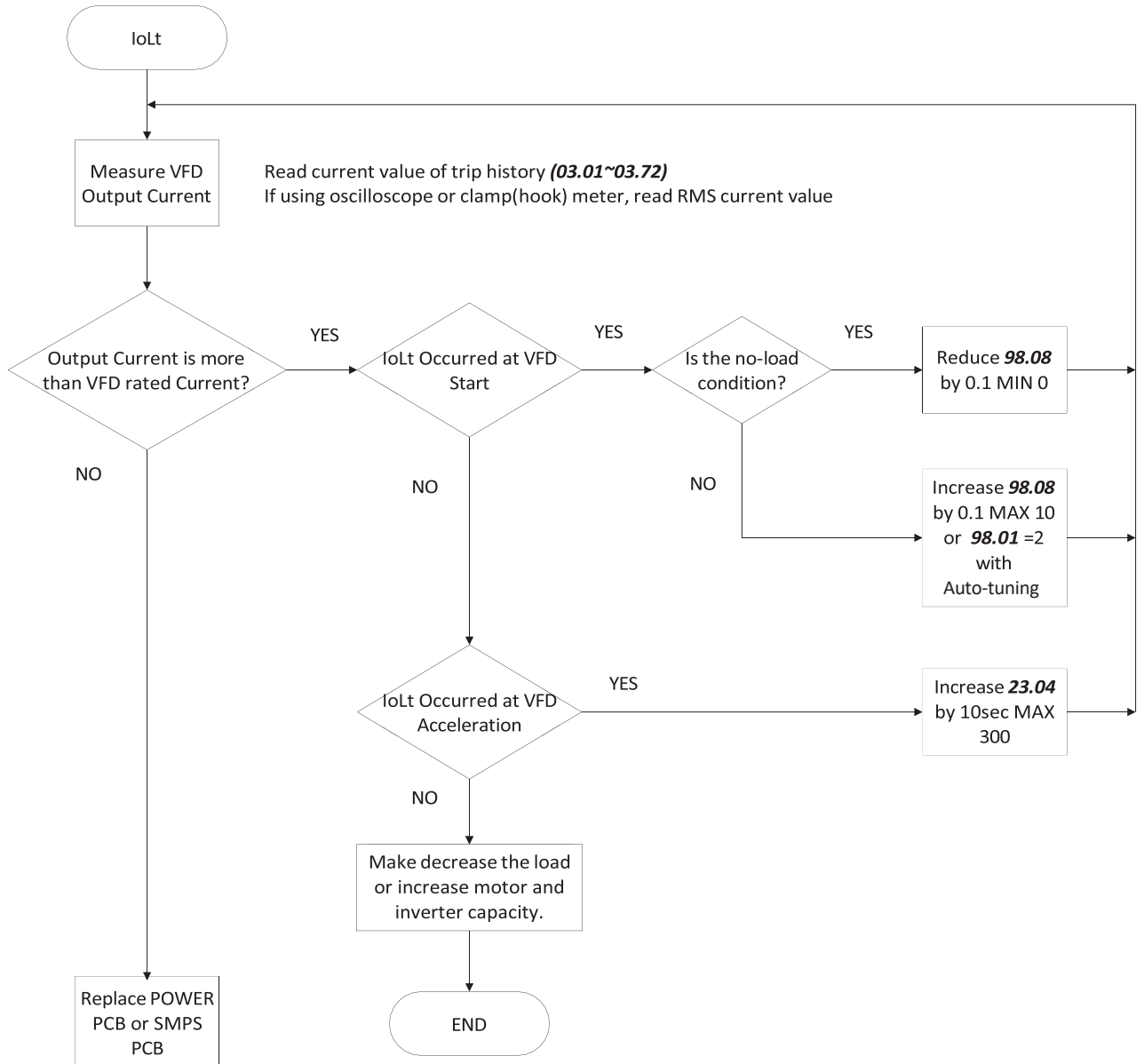

### 9.2.6 ov (DC link Over Voltage)

1) Diagnostic flow chart

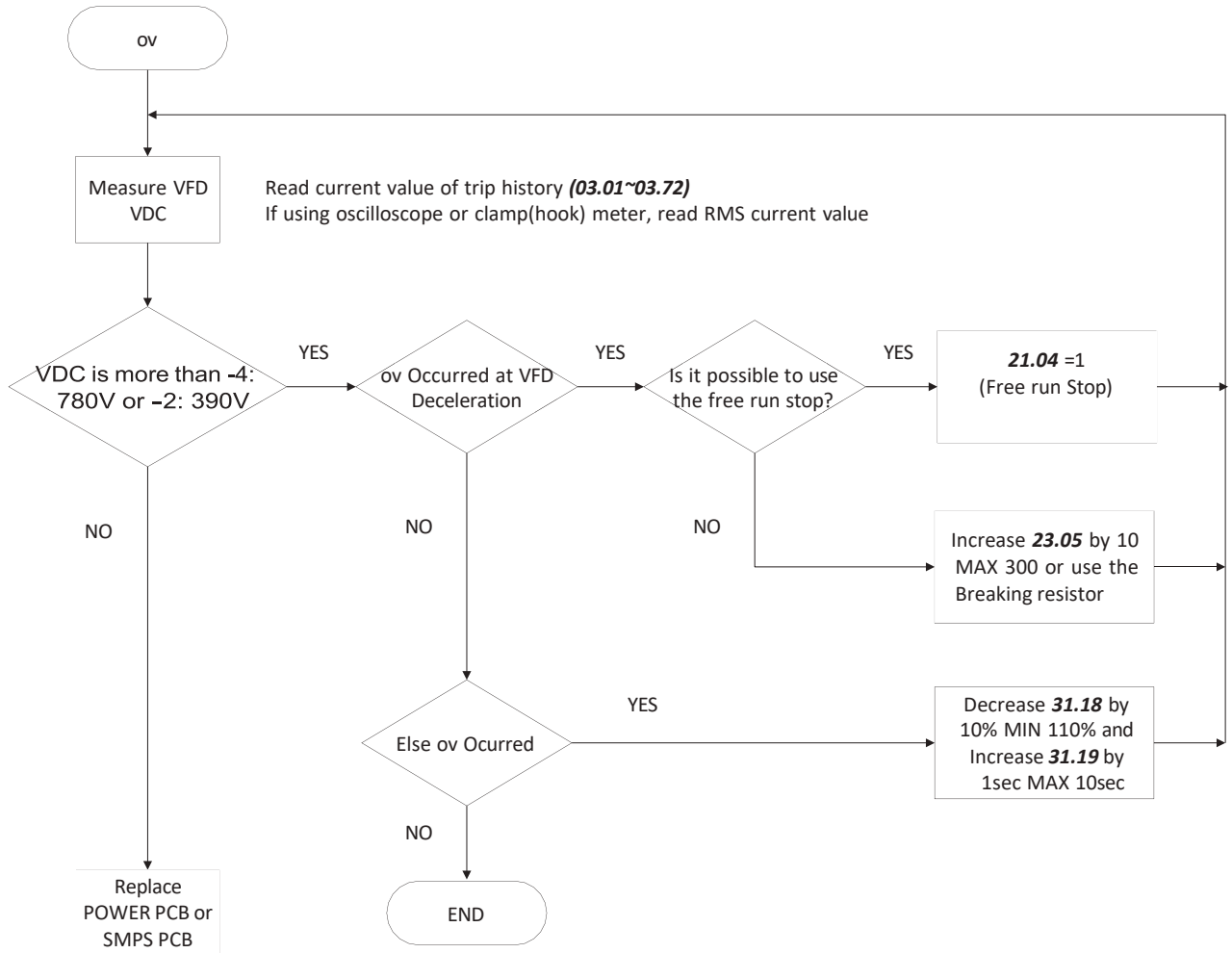

### 9.2.7 Lv (DC link Under Voltage)

1) Diagnostic flow chart

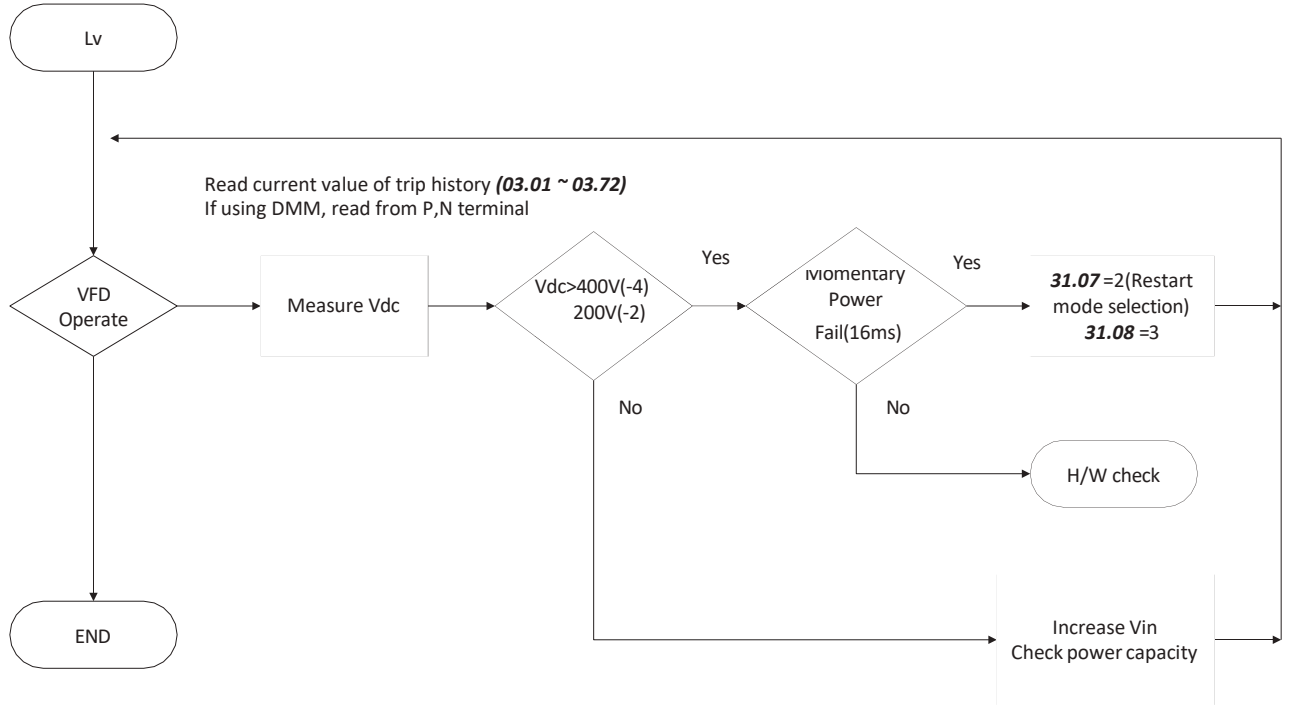

### 9.2.8 ot (Over Temperature)

1) Diagnostic flow chart

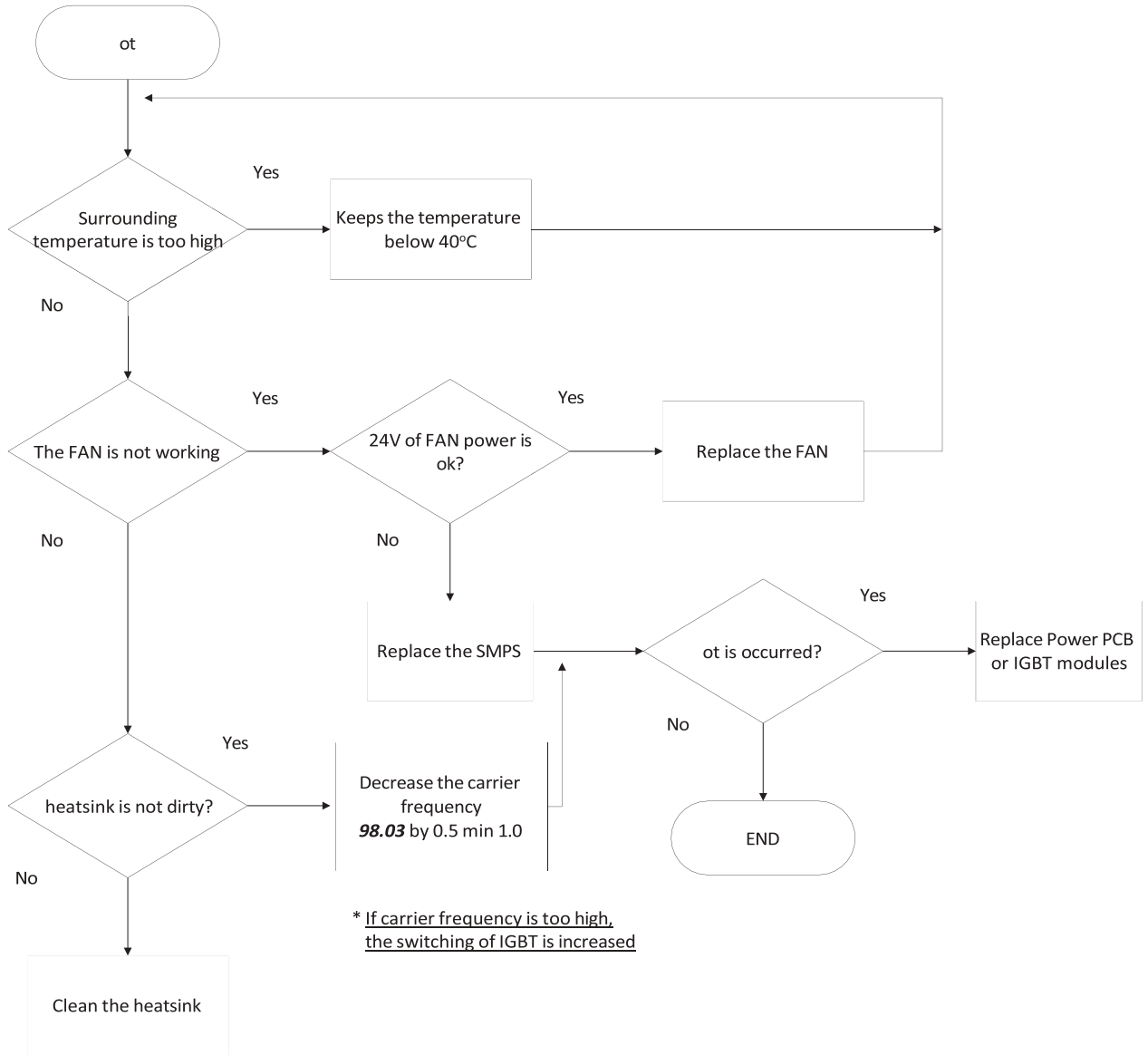

### 9.2.9 PF (Input Power Loss)

1) Diagnostic flow chart

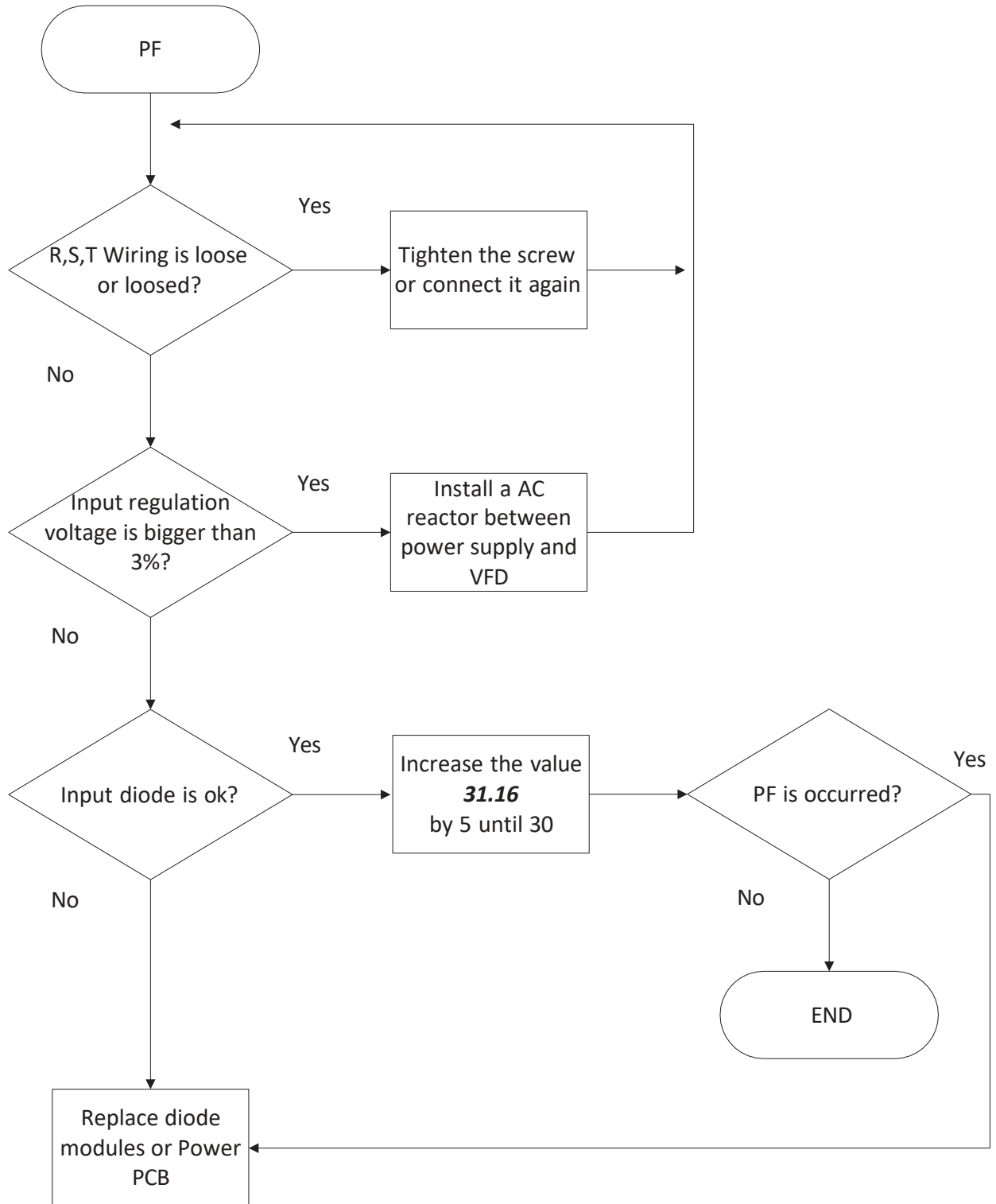

### 9.2.10 FF (Fan Fault)

1) Diagnostic flow chart

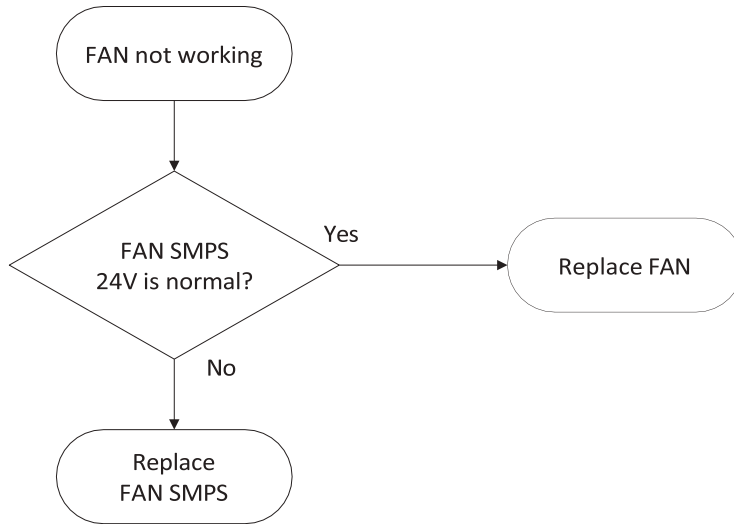



### 9.2.11 VFD doesn't turn on

1) Diagnostic flow chart

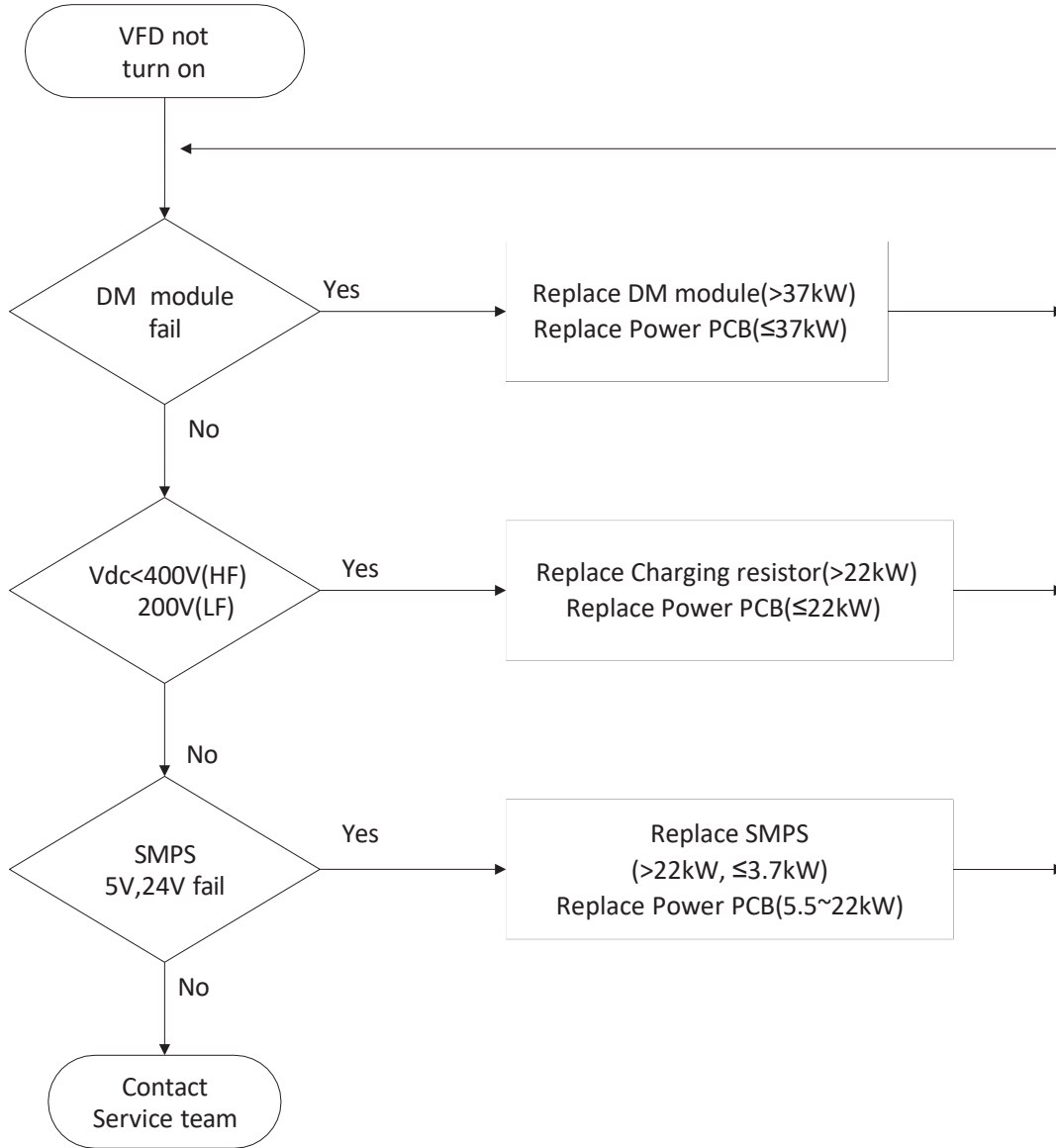

# 10. Functional Safety

## 10.1 Functional Safety

### 10.1.1 Safety standard product

- A1 offers safety option to reduce the risk of an emergency situation by off the VFD output to protect the operator when using the machine. Performance level of safety features are as follows
  - EN 61508: SIL 2
- When using the safety function, make sure that the system of risk assessment need to be carried out and if it meets the safety requirements
- Operating wiring or maintenance, VFD must be turned off  
Safety function is not electrically isolated or completely blocks the power of motor

### 10.1.2 Safety function description and wiring diagram

- Safety function is STO function to cut off power supply from motor (Cutting off VFD output current) by impeding gate with hard-wired and not to cause a torque
- VFD cut off output when SA input closed or SB input open
- STO function has 2 channels (SA, SB) the input signal is connected to independently. The signal cut off the output of the VFD control circuit drive signal and power module. During operation, safety function is activated, the VFD cut off the output and the status of motor is "Free run" and message is displayed on the keypad ("Safety Opt Err" message) to turn off the trip, when VFD of state is normal, press the reset key

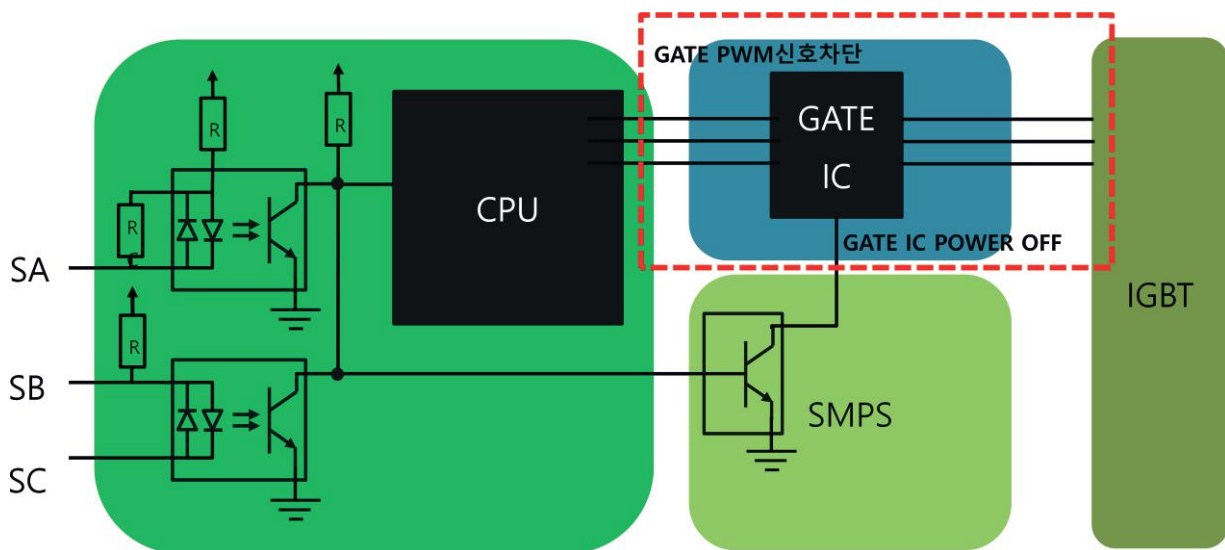



<b>Maker</b>	<b>Advanced Drive Technology</b>	<b>Installation Date</b>	
<b>Model No.</b>	<b>imaster - A1</b>	<b>Warranty Period</b>	
<b>Customer Information</b>	<b>Name</b>		
	<b>Address</b>		
	<b>Tel.</b>		
<b>Sales Office (Distributor)</b>	<b>Name</b>		
	<b>Address</b>		
	<b>Tel.</b>		

- Warranty period is 12 months after installation or 18 months after manufactured when the installation date is unidentified. However, the guarantee term may vary on the sales term

#### IN-WARRANTY service information

If the defective part has been identified under normal and proper use within the guarantee term, contact your local authorized ADT distributor or Service center

#### OUT-WARRANTY service information

The guarantee will not apply in the following cases, even if the guarantee term has not expired

- Damage was caused by misuse, negligence or accident
- Damage was caused by abnormal voltage and peripheral device' malfunction (failure)
- Damage was caused by an earthquake, fire, flooding, lightning, or other natural calamities
- When ADT nameplate is not attached
- When the warranty period has expired

## Revision History

No	Date	Edition	Changes
1	2016.06	First Edition	-
2	2016.12	2 <sup>nd</sup> Edition	Add 5.5~22kW(HD) Specification, DBR Duty cycle
3	2017.5	3 <sup>rd</sup> Edition	Add Quick start guide
4	2017.9	4 <sup>th</sup> Edition	Modify some parameter's initial value. (31.18, 32.01, 32.02)
5			
6			
7			
8			
9			
10			
11			
12			
13			
14			
15			
16			
17			
18			
19			
20			
21			
22			
23			
24			
25			
26			
27			
28			
29			
30			

[www.nicsanat.com](http://www.nicsanat.com)

021-87700210

