



Advanced simple Inverter

iMaster-U1

www.nicsanat.com

021-87700210



⚠ CAUTION



Thank you for purchasing our iMaster-U1 of inverters.

- This product is designed to drive a three-phase induction motor. Read through this instruction manual and be familiar with the handling procedure for correct use.
- Improper handling might result in incorrect operation, a short life, or even a failure of this product as well as the motor.
- Deliver this quick guide to the end user of this product. Keep this in a safe place until this product is discarded.
- For more details, refer to the instruction manual on website. (www.adtech21.com)

■ Safety precautions



Read this manual thoroughly before proceeding with installation, connections (wiring), operation, or maintenance and inspection. Ensure you have sound knowledge of the device and familiarize yourself with all safety information and precautions before proceeding to operate the inverter.

Safety precautions are classified into the following two categories in this manual.

 WARNING	Failure to heed the information indicated by this symbol may lead to dangerous conditions, possibly resulting in death or serious bodily injuries.
 CAUTION	Failure to heed the information indicated by this symbol may lead to dangerous conditions, possibly resulting in minor or light bodily injuries and/or substantial property damage.

Failure to heed the information contained under the CAUTION title can also result in serious consequences. These safety precautions are of utmost importance and must be observed at all times.

■ Operation

 WARNING 
<ul style="list-style-type: none"> • Be sure to install the terminal block cover before turning the power on. Do not remove the cover while power is applied. Otherwise electric shock could occur. • Do not operate switches with wet hands. Doing so could cause electric shock. • If the retry function has been selected, the inverter may automatically restart and drive the motor depending on the cause of tripping. Design the machinery or equipment so that human safety is ensured after restarting. • If the stall prevention function (current limiter), automatic deceleration, and overload prevention control have been selected, the inverter may operate at an acceleration /deceleration time or frequency different from the set ones. Design the machine so that safety is ensured even in such cases. Otherwise an accident could occur. • The STOP key is only effective when function setting (Function code F02) is established to enable the STOP key. Prepare an emergency stop switch separately. If you disable the STOP key priority function and enable operation by external commands, you cannot emergency-stop the inverter using the STOP key on the built-in keypad. • If an alarm reset is made with the operation signal turned on, a sudden start will occur. Ensure that the operation signal is turned off in advance. Otherwise an accident could occur.

1. Operation Environment

Table 1.1 Environment Requirements

Item	Specifications								
Site location	Indoors								
Ambient temperature	-10 to +50°C (IP20) (Note 1)								
Relative humidity	5 to 95% (No condensation)								
Atmosphere	The inverter must not be exposed to dust, direct sunlight, corrosive gases, flammable gas, oil mist, vapor or water drops. (Note 2) The atmosphere can contain only a low level of salt. (0.01 mg/cm ² or less per year) The inverter must not be subjected to sudden changes in temperature that will cause condensation to form.								
Altitude	1,000 m max. (Note 3)								
Atmospheric pressure	86~106kPa								
Vibration	<table border="0"> <tr> <td>3mm (Max. amplitude)</td> <td>2 to less than 9 Hz</td> </tr> <tr> <td>9.8m/s²</td> <td>9 to less than 20 Hz</td> </tr> <tr> <td>2m/s²</td> <td>20 to less than 55 Hz</td> </tr> <tr> <td>1m/s²</td> <td>55 to less than 200Hz</td> </tr> </table>	3mm (Max. amplitude)	2 to less than 9 Hz	9.8m/s ²	9 to less than 20 Hz	2m/s ²	20 to less than 55 Hz	1m/s ²	55 to less than 200Hz
3mm (Max. amplitude)	2 to less than 9 Hz								
9.8m/s ²	9 to less than 20 Hz								
2m/s ²	20 to less than 55 Hz								
1m/s ²	55 to less than 200Hz								

Table 1.2 Output Current Derating Factor in Relation to Altitude

Altitude	Output current Derating factor
~ 1000m	1.00
1000~1500m	0.97
1500~2000m	0.95
2000~2500m	0.91
2500~3000m	0.88

(Note1) When inverters are mounted side-by-side without any gap between them, the ambient temperature should be within the range from -10 to +40°C

(Note2) Do not install the inverter in an environment where it may be exposed to cotton waste or moist dust or dirt which will clog the heat sink in the inverter. If the inverter is to be used in such an environment, install it in the panel of your system or other dustproof containers.

(Note3) If you use the inverter in an altitude above 1000m, you should apply an output current derating factor as listed in Table 2.2

2. Installing the Inverter

(1) Mounting base

The temperature of the heat sink may rise up to approx. 90°C during operation of the inverter, so the inverter should be mounted on a base made of material that can withstand temperatures of this level.

WARNING

Install the inverter on a base made of metal or other non-flammable material.
A fire may result with other material.

(2) Clearances

Ensure that the minimum clearances indicated in Figure 2.1 are maintained at all times. When installing the inverter in the panel of your system, take extra care with ventilation inside the panel as the temperature around the inverter tends to increase.

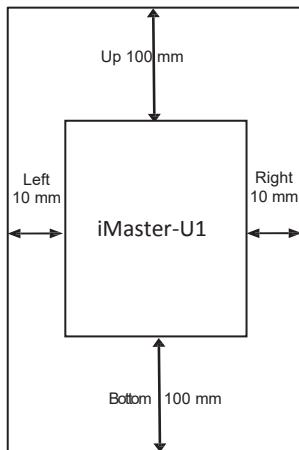

Figure 2.1 Mounting Direction and Required Clearances

When mounting two or more inverters

When mounting two or more inverters in the same unit or panel, basically lay them out side by side. As long as the ambient temperature is 40°C or lower, inverters can be mounted side by side without any clearance between them. When the inverters necessarily mounted one above the other be sure to separate them with a partition plate or the like so that any heat radiating from an inverter will not affect the one(s) above.

(3) Mounting direction

Secure the inverter to the mounting base with four screws or bolts (M4) so that the iMaster-U1 logo faces outwards. Tighten those screws or bolts perpendicular to the mounting base.

Note Do not mount the inverter upside down or horizontally. Doing so will reduce the heat dissipation efficiency of the inverter and cause the overheat protection function to operate, so the inverter will not run.

CAUTION

Prevent lint, paper fibers, sawdust, dust, metallic chips, or other foreign materials from getting into the inverter or from accumulation on the heat sink.

This may result in a fire or accident.

3. Wiring

Follow the procedure below.

(In the following description, the inverter has already been installed)

3.1 Removing and mounting the terminal block covers

- ① Loosen the screw securing the control circuit terminal block cover.
- ② Insert your finger in the cutout (near "PULL") in the bottom of the control circuit terminal block cover, and then pull the cover towards you.
- ③ Hold both side of the main circuit terminal block cover between thumb and forefinger and slide it towards you.
- ④ After performing wiring, mount the main circuit terminal block cover and control circuit terminal block cover in the reverse order of removal.

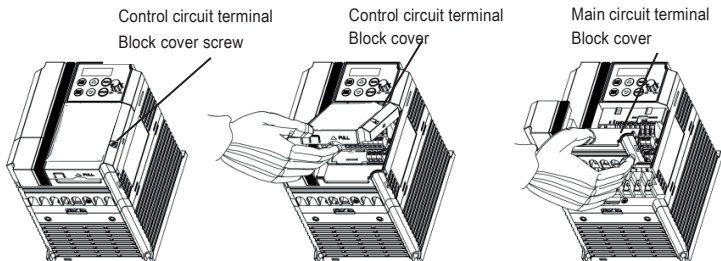

[Removing the Terminal block cover]

3.2 Terminal arrangement and screw specifications

The figures below show the arrangement of the main and control circuit terminals which differ according to inverter type. The two terminals prepared for grounding, which are indicated by the symbol G in Figures A to C, make no distinction between the power supply side (primary circuit) and the motor side (secondary circuit).

(1) Arrangement of the main circuit terminals

Table 3.1 Main Circuit Terminals

Power	Nominal Applied motor (kW)	Inverter type	Terminal screw size	Tightening torque (N·m)	Refer to
Three-phase 400 V	0.4	U1-0040-4	M4	1.2	Fig A
	0.75	U1-0075-4			
	1.5	U1-0150-4			
	2.2	U1-0220-4			
	4.0(3.7)	U1-0400-4			
Single-phase 200 V	0.4	U1-0040-7	M3	0.5	Fig B
	0.75	U1-0075-7	M4	1.2	Fig C
	1.5	U1-0150-7			
	2.2	U1-0220-7			

Figure A

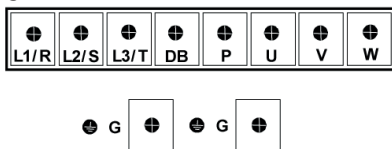

Figure B

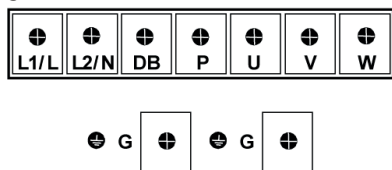
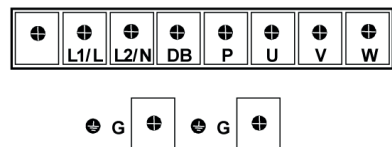
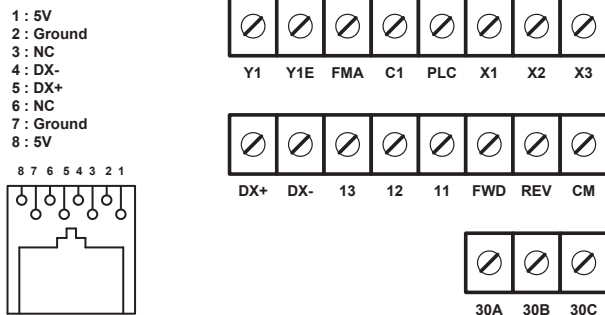

Figure C



(2) Arrangement of the control circuit terminals (all models)



Screw size: M2.5 Tightening torque: 0.4Nm

Table 3.2 Control Circuit Terminals



Terminal symbol	Screwdriver (Shape of tip, BxA) Thickness of tip: B	Allowable wire size	Bare wire length 	Ferrule terminal* Opening dimension in the terminal block 
[Y1]~[X3]	Flat screw drive (0.6 x 3.5 mm)	AWG22 to AWG14 (0.34 to 2.1 mm ²)	4.5 to 5 mm	5 (W) x 2.5 (H) mm
Other than above	Flat screw drive (0.6 x 3.5 mm)	AWG24 to AWG14 (0.25 to 2.1 mm ²)	5 to 6 mm	2.3 (W) x 2.5 (H) mm

Table 3.3 Recommended Ferrule Terminals

Screw size	Wire size	Type (216-□□□)			
		With insulated collar		Without insulated collar	
		Short type	Long type	Short type	Long type
M2 or M2.5	AWG22 (0.34 mm ²)	322	302	152	132
	AWG20 (0.50 mm ²)	221	201	121	101
	AWG18 (0.75 mm ²)	222	202	122	102

The length of bared wires to be inserted into ferrule terminals is 5.0mm or 8.0mm for the short or long type, respectively.

The following crimping tool is recommended: Variocrimp 4 (pat No. 206-204)

3.3 Recommended wire sized

Table 3.4 lists the recommended wire sizes. The recommended wire sizes for the main circuit terminals for an ambient temperature of 50°C are indicated for two types of wire: HIV single wire (for the maximum allowable temperature 75°C).

Table 3.4 Recommended wire sizes

Power supply voltage	Nominal applied motor (kW)	Inverter type	Recommended wire size (mm ²) ^{*1}			
			Main			Control Circuit
			Main circuit power input [L1/R, L2/S, L3/T] [L1/L, L2/N] Grounding (⊕G)	Inverter output [U, V, W]	Braking resistor [P, DB]	
Three-phase 400 V	0.4	U1-0040-4	2.0(2.0)			
	0.75	U1-0075-4				
	1.5	U1-0150-4				
	2.2	U1-0220-4				
	4.0(3.7)	U1-0400-4				
Single-phase 200 V	0.4	U1-0040-7	2.0(2.0)	2.0(2.0)	2.0(2.5)	
	0.75	U1-0075-7				
	1.5	U1-0150-7	2.0(3.5)			
	2.2	U1-0220-7	5.5(5.5)			

*1 Use crimp terminals covered with an insulated sheath or insulating tube. Recommended wire sizes are for HIV/IV (PVC in the EU)

⚠ WARNING ⚠

To prevent the risk of hazardous accidents that could be caused by damage of the inverter, install the specified MCCB in the supply side (primary side) according to the following tables.

- Breaking capacity: Min. 10kA
- Rated voltage: Min. 500V

Power supply voltage	Nominal applied motor (kW)	Inverter type	Fuse Rating (A)	Rated current(A) Of MCCB (w/o DCR)
Three-phase 400V	0.4	U1-0040-4	3	6
	0.75	U1-0075-4	6	
	1.5	U1-0150-4	10	
	2.2	U1-0220-4	15	
	4.0(3.7)	U1-0400-4	20	
Single-phase 200V	0.4	U1-0040-7	10	10
	0.75	U1-0075-7	15	16
	1.5	U1-0150-7	30	20
	2.2	U1-0220-7	40	35

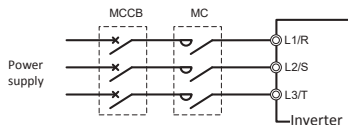

3.4 Wiring for main circuit terminals and grounding terminals

Follow the procedure below.

Figure 3.1 illustrates the wiring procedure with peripheral equipment.

Wiring procedure

- ① Grounding terminal $\oplus G^{\times 1}$
- ② Inverter output terminals (U,V, and W) and grounding terminal $\oplus G^{\times 1}$
- ③ Braking resistor connection terminals (P and DB) $^{\times 2}$
- ④ Main circuit power input terminals (L1/R, L2/S and L3/T) or (L1/L and L2/N)
 - ※1 Use either one of these two grounding terminals on the main circuit terminal block.
 - ※2 Perform wiring as necessary.

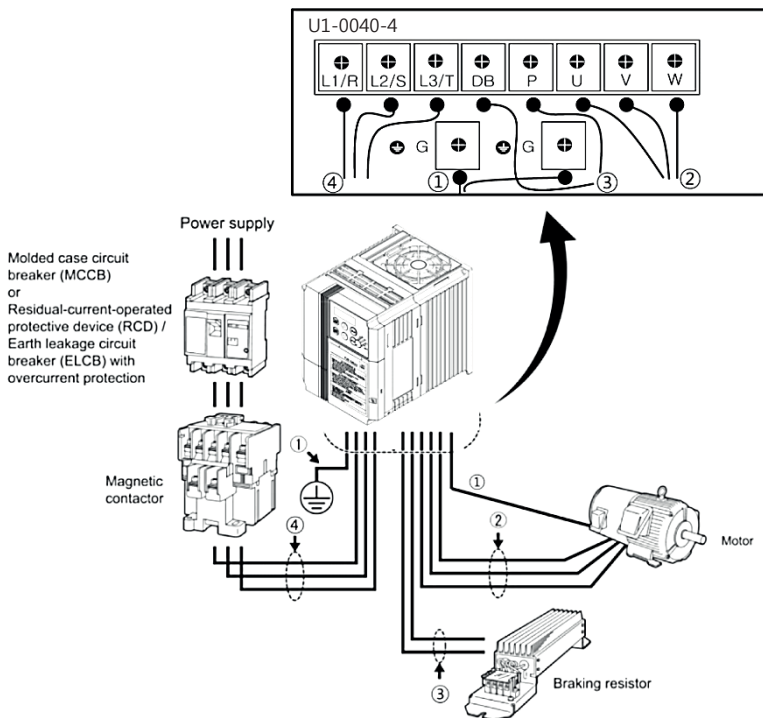

Figure 3.1 Wiring procedures for Peripheral Equipment

The wiring procedure for the U1-0040-4 is given below as an example. For other inverter types, perform wiring in accordance with their individual terminal arrangement.

① Grounding terminal (⊕G)

Be sure to ground either of the two grounding terminals for safety and noise reduction. It is stipulated by the Electric Facility Technical Standard that all metal frames of electrical equipment must be grounded to avoid electric shock, fire and other disasters.

G rounding terminals should be grounded as follows:

- 1) Ground the inverter in compliance with the national or local electric code.
- 2) Connect a thick grounding wire with a large surface area.
Keep the wiring length as short as possible.

② Inverter output terminals, U,V,W and grounding terminal (⊕G)

- 1) Connect the three wires of the three-phase motor to terminals U, V, and W, aligning phases each other.
- 2) Connect the grounding wire of terminals U, V, and W to the grounding terminal.



- The wiring length between the inverter and motor should not exceed 50m. If it exceeds 50m, it is recommended that an output circuit filter (option) be inserted.
- Do not use one multicore cable to connect several inverters with motors.
- If a magnetic contactor (MC) is inserted in the inverter's output (secondary) circuit, it should be switched on and off when both the inverter and motor are completely stopped.

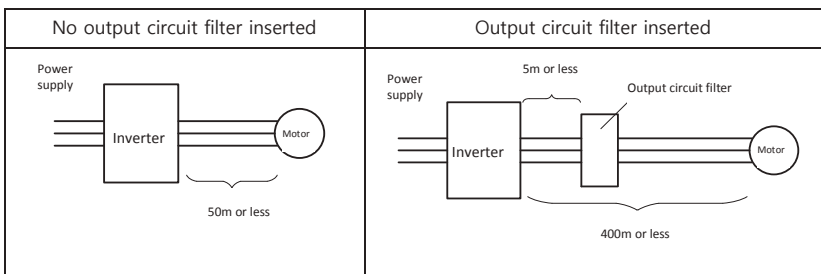

- Do not connect a phase-advancing capacitor or surge absorber to the inverter's output lines (secondary circuit)
- If the wiring length is long, the stray capacitance between the wires will increase, resulting in an outflow of the leakage current. It will activate the overcurrent protection, increase the leakage current, or will not assure the accuracy of the current display. In the worst case, the inverter could be damaged.
- If more than one motor is to be connected to a single inverter, the wiring length should be the total length of the wires to the motors.

Note Driving 400V series motor

- If a thermal relay is installed in the path between the inverter and the motor to protect the motor from overheating, the thermal relay may malfunction even with a wiring length shorter than 50m. In this situation, add an output circuit filter (option) or lower the carrier frequency (Function code F26: Motor sound)
- If the motor is driven by a PWM-type inverter, surge voltage that is generated by switching the inverter component may be superimposed on the output voltage and may be applied to the motor terminals. Particularly if the wiring length is long, the surge voltage may deteriorate the insulation resistance of the motor. Consider any of the following measures.
 - Use a motor with insulation that withstands the surge voltage.
 - Connect an output circuit filter (option) to the output terminals (secondary circuits) of the inverter.
 - Minimized the wiring length between the inverter and motor (10 to 20m or less)

③ Braking resistor terminals, P and DB

- 1) Connect terminals P and DB of a braking resistor (option) to terminals P and DB on the main circuit terminal block.
- 2) Arrange the inverter and braking resistor to keep the wiring length to 5m or less twist the two wires or route them together in parallel.

④ Main circuit power input terminals, L1/R, L2/S, and L3/T (for three-phase voltage input) or L1/L and L2/N (for single-phase voltage input)

- 1) For safety, make sure that the molded case circuit breaker (MCCB) or magnetic contactor (MC) is turned off before wiring the main circuit power input terminals.
- 2) Connect the main circuit power supply wires (L1/R, L2/S and L3/T or L1/L and L2/N) to the input terminals of the inverter via an MCCB or residual-current-operated protective device (RCD)/earth leakage circuit breaker (ELCB)*, and MC if necessary.

*With overcurrent protection

It is recommended that a magnetic contactor be inserted which can be manually activated.

Note









This is to allow you to disconnect the inverter from the power supply in an emergency (e.g., when the protective function is activated) so as to prevent a failure or accident from causing the secondary problems.

4. Names and Functions of Keypad Components

As shown in the figure at right, the keypad consists of a four-digit 7-segment LED monitor, a potentiometer (POT), and six keys. The keypad allows you to start and stop the motor, monitor running status, configure the function code data, check I/O signal states, and display maintenance information and alarm information.



Table 4.1 Names and Functions of Keypad Components

Monitor, Potentiometer and Keys	Functions
	<p>Four-digit, 7-segment LED monitor which displays the following according to the operation modes *.</p> <ul style="list-style-type: none"> ■ In Running mode: Running status information (e.g., output frequency, current, and voltage) ■ In Programming mode: Menu, function codes and their data ■ In Alarm mode: Alarm code which identifies the error factor if the protective function is activated.
	Potentiometer (POT) which is used to manually set a reference frequency, auxiliary frequencies 1 and 2 or PID process command
	RUN - Press this key to run the motor.
	STOP - Press this key to stop the motor.
	UP/DOWN keys. Press these keys to select the setting items and change the function code data displayed on the LED monitor.
	<p>Program/Reset key which switches the operation modes* of the inverter.</p> <ul style="list-style-type: none"> ■ In Running mode: Pressing this key switches the inverter to Programming mode. ■ In Programming mode: Pressing this key switches the inverter to Running mode. ■ In Alarm mode: Pressing this key after removing the error factor switches the inverter to Running mode
	<p>Function/Data key which switches the operation you want to do in each mode as follows</p> <ul style="list-style-type: none"> ■ In Running mode: Pressing this key switches the information to be displayed concerning the status of the inverter (output frequency, output current, output voltage, etc.). ■ In Programming mode: Pressing this key displays the function codes and sets their data entered with the  and  keys or the POT. ■ In Alarm mode: Pressing this key displays detailed alarm information.

5. If an Alarm Code Appears on the LED Monitor

Quick reference table of alarm codes

Alarm code	Name	Alarm code	Name
<i>OC1</i>	Instantaneous overcurrent	<i>dbH</i>	Braking resistor overheated
<i>OC2</i>		<i>OL1</i>	Motor 1 overload
<i>OC3</i>		<i>OLU</i>	Inverter overload
<i>OU1</i>	Overvoltage	<i>Er1</i>	Memory error
<i>OU1</i>		<i>Er2</i>	Keypad communication error
<i>OU3</i>		<i>Er3</i>	CPU error
<i>LU</i>	Under voltage	<i>Er6</i>	Operation protection
<i>Lin</i>	Input phase loss	<i>Er7</i>	Tuning error
<i>OPL</i>	Output phase loss	<i>Er8</i>	RS-485 communications error
<i>OH1</i>	Heat sink overheat	<i>ErF</i>	Data saving error during under voltage
<i>OH2</i>	External alarm	<i>Err</i>	Mock Alarm
<i>OH4</i>	Motor protection (PTC thermistor)	<i>Gof</i>	PID feedback wire break

6. Specifications

6.1 Single-phase 200V class series

Item		Specification				
Type(U1-xxxx-7)		0040	0075	0150	0220	
Applicable motor rating(kW) ※1		0.4	0.75	1.5	2.2	
Output Ratings	Rated capacity(kVA) ※2	0.9	1.6	2.8	3.8	
	Rated voltage (V) ※3	Three-phase, 200 to 240 V (with AVR function)				
	Raged current (A) ※4	3.5 (2.5)	4.2 (4.2)	9.2 (7.5)	10.0 (10.0)	
	Overload capability	150% of rated output current for 1 min or 200% of rated output current for 0.5 s (for the rated current given in parentheses)				
	Rated frequency (Hz)	50/60 Hz				
Input Ratings	Phases, voltages, frequency	Single-phase, 200 to 240 V, 50/60 Hz				
	Voltage and frequency variations	Voltage: +10 to -10%, Frequency : +5 to -5%				
	Rated current(A)※6	(w/o DCR)	5.4	9.7	16.4	24.0
	Required power supply capacity (kVA) ¹⁷	0.7		1.3	2.4	3.5
Braking	Torque(%)※8	100		50	30	
	DC braking	Braking starting frequency*9: 0.0 to 60.0 Hz, Braking time: 0.0 to 30.0 s, Braking level: 0 to 100%				
	Braking transistor	Built-in				
Applicable safety standards		UL61800-5-1, IEC 61800-5-1				
Enclosure		IP20 (IEC 60529), UL open type(UL50)				
Cooling method		Fan cooling				
Mass(kg)		0.6	0.6	1.0	1.0	

※1 Fuji 4-pole standard motors

※2 Refers to the rated capacity assuming the rated output voltage as 220 V.

※3 Output voltages cannot exceed the power supply voltage.

※4 The load shall be reduced so that the continuous operating current is the rated current in parentheses or less if the carrier frequency is set to 3 kHz or above or the ambient temperature exceeds 40°C.

※6 Refers to the estimated value to apply when the power supply capacity is 500 kVA (inverter capacity x 10 when the inverter capacity exceeds 50 kVA) and the inverter is connected to the %X = 5% power supply.

※8 Refers to the average braking torque to apply when the motor running alone decelerates from 60 Hz with the AVR control being OFF. (It varies with the efficiency of the motor.)

※9 Available only for induction motor drive.

6.2 Three-phase 400V class series

Item		Specification					
Type(U1-xxxx-4)		0040	0075	0150	0220	0400	
Applicable motor rating(kW) ※1		0.4	0.75	1.5	2.2	4.0	
Output Ratings	Rated capacity(kVA) ※2	1.1	1.9	3.2	4.1	6.8	
	Rated voltage (V) ※3	Three-phase, 380 to 480 V (with AVR function)					
	Rated current (A) ※4	1.8 (1.5)	2.5 (2.5)	4.3 (4.2)	6.3 (5.5)	10.5 (9.0)	
	Overload capability	150% of rated output current for 1 min or 200% of rated output current for 0.5 s (for the rated current given in parentheses)					
	Rated frequency (Hz)	50/60 Hz					
Input Ratings	Phases, voltages, frequency	Three-phase, 380 to 480 V, 50/60 Hz					
	Voltage and frequency variations	Voltage: +10 to -15% (Interphase voltage unbalance: 2% or less)※5, Frequency: +5 to -5%					
	Rated current(A)※6	(w/o DCR)	1.7	3.1	5.9	8.2	13.0
	Required power supply capacity (kVA)※7		0.6	1.1	2.0	2.9	4.9
Braking	Torque(%)※8	100		50	30		
	DC braking	Braking starting frequency*9: 0.0 to 60.0 Hz, Braking time: 0.0 to 30.0 s, Braking level: 0 to 100%					
	Braking transistor	Built-in					
Applicable safety standards		UL61800-5-1, IEC 61800-5-1					
Enclosure		IP20 (IEC 60529), UL open type (UL50)					
Cooling method		Natural cooling		Fan cooling			
Mass(kg)		0.8	0.8	1.0	1.0	1.3	

※1 Fuji 4-pole standard motors.

※2 Refers to the rated capacity assuming the rated output voltage as 440V.

※3 Output voltages cannot exceed the power supply voltage.

※5
$$\text{Interphase voltage unbalance(\%)} = \frac{\text{Max. voltage(V)} - \text{Min. voltage (V)}}{3 - \text{phase average voltage (V)}} \times 67$$
 (Refer to IEC 61800-3)

※8 Refers to the average braking torque to apply when the motor running alone decelerates from 60 Hz with the AVR control being OFF. (It varies with the efficiency of the motor.)

※9 Available only for induction motor drive.

7. Connection diagram in operation by external signal inputs

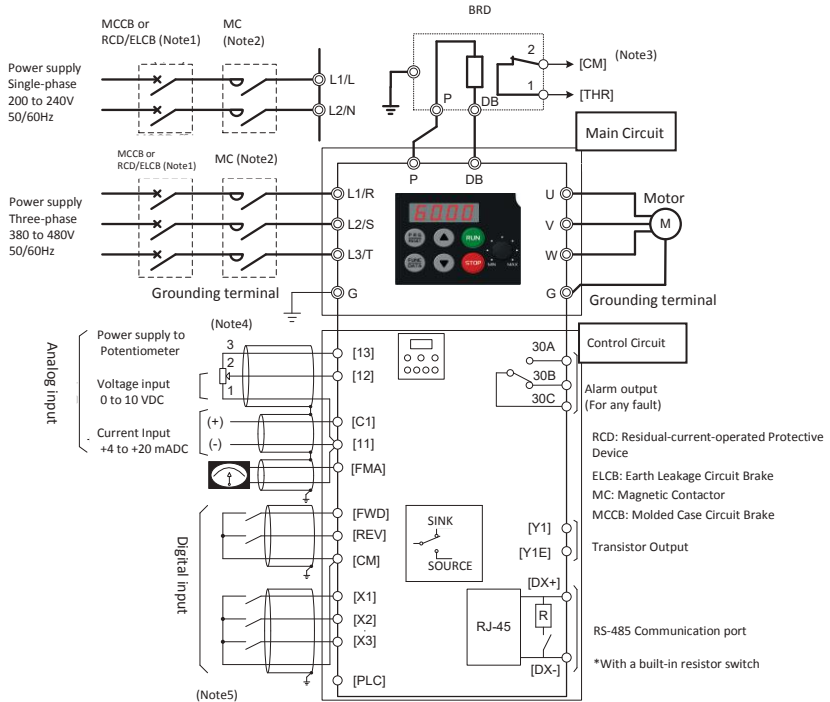

- (Note1) Install a recommended molded case circuit breaker (MCCB) or a residual-current-operated protective device (RCD)/earth leakage circuit breaker (ELCB) (with overcurrent protection) in the primary circuit of the inverter to protect wiring. Do not use an MCCB or RCD/ELCB whose capacity exceeds the recommended rated current.
- (Note2) A magnetic contactor (MC) should, if necessary, be mounted independent of the MCCB or ELCB to cut off the power fed to the inverter. MCs or solenoids that will be installed close to the inverter require surge absorbers to be connected in parallel to their coils.
- (Note3) The THR function can be used by assigning "9" (External alarm) to any of terminals [X1] to [X3], [FWD] or [REV] (function code E01 to E03, E98, or E99).
- (Note4) Frequency can be set by connecting a frequency setting device (external potentiometer) between terminals [11], [12] and [13] instead of inputting voltage signal (0 to +10 VDC or 0 to +5VDC) between terminals [12] and [11]
- (Note5) For the wiring of the control circuit, use shielded or twisted wires. When shielded wires are used, connect the shields to earth. To prevent malfunction due to noise, keep the control circuit wiring away from the main circuit wiring as far as possible (recommended: 10 cm or longer), and never set them in the same wire duct. When crossing the control circuit wiring with the main circuit wiring, set them at right angles.

8. External Dimensions

Unit: mm

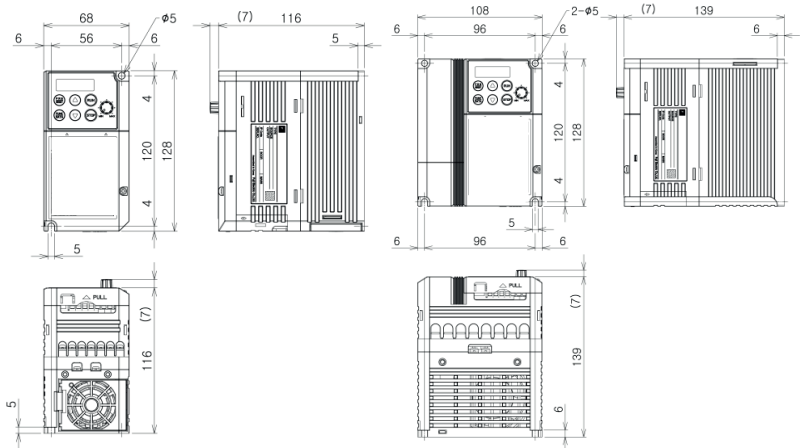

[U1-0040-7/U1-0075-7]

[U1-0150-7/U1-0220-7/
U1-0040-4~U1-0220-4]

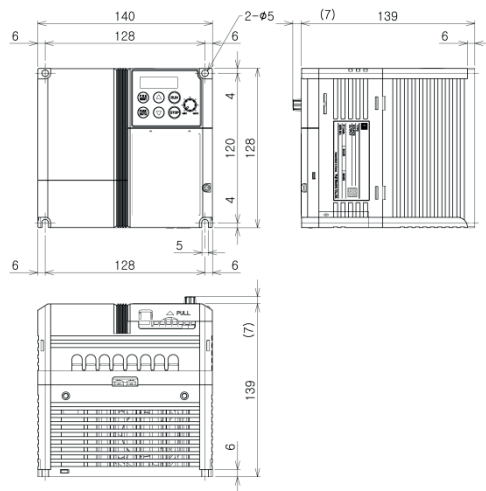

[U1-0400-4]





9. Function Code Tables

Function codes enable the iMaster-U1 of inverters to be set up to match your system requirements. Each function code consists of a 3-letter alphanumeric string. The first letter is an alphabet that identifies its group and the following two letters are numerals that identify each individual code in the group. The function codes are classified into seven groups: Fundamental Functions (F codes), Extension Terminal Functions (E codes), Control Functions (C codes), Motor 1 Parameters (P codes), High Performance Functions (H codes), Application Functions (J codes) and Link Functions (y codes). To determine the property of each function code, set data to the function code.

(This manual only shows F functions, refer to the instruction on website for more functions.)

Changing, Validation, and Save function code data when the motor is running

Function codes are indicated by the following based on whether they can be changed or not when the inverter is running:

Nation	Possibility	Validation and Save function code data
Y*	Possible	If the data of the codes marked with Y* is changed, the change will immediately take effect; however, the change is not saved into the inverter's memory. To save the change, press the  key. If you press the  key to exit the current state, then the changed data will be discarded and the previous data will take effect for the inverter operation.
Y	Possible	The data of the codes marked with Y can be changed with the  key regardless of whether the motor is running or not. Pressing the  key will make the change effective and save it into the inverter's memory.
N	Impossible	—

Using negative logic for programmable I/O terminals

The negative logic signaling system can be used for digital input terminals and transistor output terminals by setting the function code data specifying the properties for those terminals. Negative logic refers to the inverted On/Off state of input or output signal. An active-On signal in the normal logic system is functionally equivalent to active-Off signal in the negative logic system. An active-On can be switched to active-Off signal, and vice versa, with the function code data setting.

Example: "Coast to a stop" command BX assigned to any of digital input terminals [X1] to [x3] using any of function codes E01 through E03.

Function code data	BX
7	Turning BX ON causes the motor to coast to a stop. (Active ON)
1007	Turning BX OFF causes the motor to coast to a stop. (Active OFF)

Limitation of data displayed on the LED monitor

Only four digits can be displayed on the 4-digit LED monitor. If you enter more than 4 digits of data valid for a function code, any digits after the 4th digit of the set data will not be displayed; however they will be processed correctly.

The following tables list the function codes available for the iMaster-U1 inverters.

F Code: Fundamental Functions

Code	Name	Data setting range	Increments	Unit	Change when running	Data copy	Default
F00	Data protection	0 : Disable both data protection and digital reference protection 1 : Enable data protection and disable digital reference protection 2 : Disable data protection and enable digital reference protection 3 : Enable both data protection and digital reference protection (Press the STOP button at the same time if you want to change the setting)	-	-	Y	Y	0
F01	Frequency Command 1	0 : UP/DOWN keys on keypad (▲/▼) 1 : Voltage input to terminal [I2] (0 to +10VDC) 2 : Current input to terminal [C1] (4 to 20 mA DC) 3 : Sum of voltage and current inputs to terminals [I2] and [C1] 4 : Built-in potentiometer (POT) 7 : Terminal command UP/DOWN control 9 : Terminal command UP/DOWN control (ACC/DEC Time2)*4	-	-	N	Y	4
F02	Operation Method	0 : RUN/STOP keys on keypad (Motor rotational direction specified by terminal command FWD/REV) 1 : Terminal command FWD or REV 2 : RUN/STOP keys on keypad (forward) 3 : RUN/STOP keys on keypad (reverse)	-	-	N	Y	2
F03	Maximum Frequency 1	25.0 ~ 400.0Hz	0.1	Hz	N	Y	60.0
F04	Base Frequency 1	25.0 ~ 400.0Hz	0.1	Hz	N	Y	60.0
F05	Rated Voltage at Base Frequency 1	0 : Output a voltage in proportion to input voltage 80 ~ 240 : Output an AVR-controlled voltage (for 200 V class series) 160 ~ 500 : Output an AVR-controlled voltage (for 400 V class series)	1	V	N	Y2	0
F06	Maximum Output Voltage 1	80 ~ 240 : Output an AVR-controlled voltage (for 200 V class series) 160 ~ 500 : Output an AVR-controlled voltage (for 400 V class series)	1	V	N	Y2	220 380
F07	Acceleration Time 1	0.01 ~ 3600s	0.01	s	Y	Y	6.00
F08	Deceleration Time 2	0.01 ~ 3600s	0.01	s	Y	Y	6.00
F09	Torque Boost 1	0.0 ~ 20.0 (percentage with respect to "F05: Rated Voltage at Base Frequency 1") Note: This setting takes effect when F37 = 0 or 1.	0.1	%	Y	Y	See Table A

(F Codes continued)

Code	Name	Data setting range	Increments	Unit	Change when running	Data copy	Default
F10	Electronic Thermal Overload Protection for Motor 1 (characteristics)	1 : For a general-purpose motor with shaft-driven cooling fan 2 : For an inverter-driven motor with separately powered cooling fan	-	-	Y	Y	1
F11	(Overload detection level)	0.00: Disable, 0.01 ~ 100.0A to 135% of the rated current (allowable continuous drive current) of the motor	0.0	A	Y	Y1 Y2	See Table A
F12	(Thermal time constant)	0.5 ~ 75.0min	0.1	min	Y	Y	5.0
F14	start Mode after Momentary Power Failure (Mode selection)	0 : Disable restart (Trip immediately) 1 : Disable restart (Trip after a recovery from power failure) 2 : Trip after decelerate-to-stop *2 4 : Enable restart (Restart at the frequency at which the power failure occurred, for general loads) 5 : Enable restart (Restart at the starting frequency)	-	-	Y	Y	1
F15	Frequency Limiter (High)	0.0 ~ 400.0Hz	0.1	Hz	Y	Y	70.0
F16	(Low)	0.0 ~ 400.0Hz	0.1	Hz	Y	Y	0.0
F18	Bias (Frequency command 1)	-100.00 ~ 100.00% *2	0.01	%	Y*	Y	0.00
F20	DC Braking 1 (Braking starting frequency)	0.0 ~ 60.0Hz	0.1	Hz	Y	Y	0.0
F21	(Braking level)	0 ~ 100% *2	1	%	Y	Y	0.00
F22	(Braking time)	0.00s (Disable), 0.01 ~ 30.00s	0.01	s	Y	Y	0.00
F23	Starting Frequency 1	0.1 ~ 60.0Hz	0.1	Hz	Y	Y	1.0
F24	(Continues time)	0.00 ~ 10.00s	0.01	s	Y	Y	0.00
F25	Stop Frequency	0.1 ~ 60.0Hz	0.1	Hz	Y	Y	0.2
F26	Motor Sound (Carrier frequency)	0.75 ~ 16kHz	1	kHz	Y	Y	2
F27	(Tone)	0 : Level 0 (Disable) 1 : Level 1	-	-	Y	Y	0
F30	Analog Output FMA (Voltage adjustment)	0 ~ 300%	1	%	Y*	Y	100
F31	(Function)	Select a function to be monitored from the followings 0 : Output frequency 1 (before slip compensation) 1 : Output frequency 2 (after slip compensation) 2 : Output current 3 : Output voltage 7 : PID feedback amount (PV) 9 : DC link bus voltage 14 : Calibration 15 : PID command (SV) 16 : PID output (MV)	-	-	Y	Y	0

(F Codes continued)

Code	Name	Data setting range	Increments	Unit	Change when running	Data copy	Default
F37	Load Selection/Auto Torque Boost	0 : Variable torque load 1 : Constant torque load 2 : Auto-torque boost	-	-	N	Y	1
F39	Stop Frequency (Continues time)	0.00 ~ 10.00s	0.01	s	Y	Y	0.00
F42	Control Mode Selection 1	0 : V/f control with slip compensation inactive 1 : Dynamic torque vector control 2 : V/f control with slip compensation active)	-	-	N	Y	0
F43	Current Limiter (Mode selection)	0: Disable (No current limiter works.) 1 : Enable at constant speed (Disable during ACC/DEC) 2 : Enable during ACC/constant speed operation	-	-	Y	Y	2
F44	(Level)	20 ~ 200% *3 (The data is interpreted as the rated output current of the inverter for 100 %.) *2	1	%	Y	Y	180 *5
F50	Electronic Thermal Overload Protection for Braking Resistor (Discharging capability)	1 ~ 900kW, OFF(Cancel)	1	kWs	Y	Y1 Y2	OFF
F51	(Allowable average loss)	0.001 ~ 50.00kW	0.001	kW	Y	Y1 Y2	0.001

*1 When you make settings from the keypad, the incremental unit is restricted by the number of digits that the LED monitor can display.

(Example) If the setting range is from -200.00 to 200.00, the incremental unit is:

"1" for -200 to -100, "0.1" for -99.9 to -10.0 and for 100.0 to 200.0, and "0.01" for -9.99 to -0.01 and for 0.00 to 99.99.

*2 The percentage is relative to the rated output current.

*3 Applies to product version B■ or later.(■ : Any letter of the alphabet).

*4 Applies to product version E■ or later.(■ : Any letter of the alphabet).

*5 Applies to product version F■ or later.(■ : Any letter of the alphabet).

E codes: Extension Terminal Functions

Code	Name	Data setting range	Increment	Unit	Change when running	Data copying	Default setting
E01	Terminal [X1] Function	Selecting function code data assigns the corresponding function to terminals [X1] to [X3] as listed below.	-	-	N	Y	0
E02	Terminal [X2] Function	0 (1000): Select multistep frequency (SS1)	-	-	N	Y	7
E03	Terminal [X3] Function	1 (1001): Select multistep frequency (SS2) 2 (1002): Select multistep frequency (SS4) 3 (1003): Select multistep frequency (SS8) 4 (1004): Select ACC/DEC time (RT1) 6 (1006): Enable 3-wire operation (HLD) 7 (1007): Coast to a stop (BX) 8 (1008): Reset alarm (RST) 9 (1009): Enable external alarm trip (THR) 10 (1010): Ready for jogging (JOG) 11 (1011): Select frequency command 2/1 (Hz2/Hz1) 13: Enable DC braking (DCBRK) 17 (1017): UP (Increase output frequency) (UP) 18 (1018): DOWN (Decrease output frequency) (DOWN) 19 (1019): Enable data change with keypad (WE-KP) 20 (1020): Cancel PID control (Hz/PID) 21 (1021): Switch normal/inverse operation (IVS) 24 (1024): Enable communications link via RS-485 (LE) 33 (1033): Reset PID integral and differential components (PID-RST) 34 (1034): Hold PID integral component (PID-HLD) 90(1090) : Traverse On (TRV) 91(1091) : Traverse Up Offset (TRV UP_OFFSET) 92(1092) : Traverse Dn Offset (TRV DN_OFFSET) 97(1097) : Switch Operation Direction *3 (DIR) Setting the value in parentheses () shown above assigns a negative logic input (Active-OFF) to a terminal. Note that, in the case of THR, data "1009" is for normal logic (Active-ON) and "9," for negative logic (Active-OFF). Signals having no value in parentheses () cannot be used for negative logic.	-	-	N	Y	8
E10	Acceleration Time 2	0.01 to 3600	0.01	s	Y	Y	6.00
E11	Deceleration Time 2	0.01 to 3600	0.01	s	Y	Y	6.00

(E Codes continued)

Code	Name	Data setting range	Increment	Unit	Change when running	Data copying	Default setting
E20	Terminal [Y1] Function	Selecting function code data assigns the corresponding function to terminals [Y1] and [30A/B/C] as listed below.	-	-	N	Y	0
E27	Terminal [30A/B/C] Function	0 (1000): Inverter running (<i>RUN</i>) 1 (1001): Frequency arrival signal (<i>FAR</i>) 2 (1002): Frequency detected (<i>FDT</i>) 3 (1003): Undervoltage detected (Inverter stopped) (<i>LU</i>) 5 (1005): Inverter output limiting (<i>IOL</i>) 6 (1006): Auto-restarting after momentary power failure (<i>IPF</i>) 7 (1007): Motor overload early warning (<i>OL</i>) 26 (1026): Auto-resetting (<i>TRY</i>) 35 (1035): Inverter running 2 (<i>RUN2</i>) 36 (1036): Overload prevention control (<i>OLP</i>) 37 (1037): Current detected (<i>ID</i>) 38 (1038): Current detected 2 (<i>ID2</i>) 41 (1041): Low current detected (<i>IDL</i>) 43 (1043): Under PID control (<i>PID-CTL</i>) 44 (1044): Motor stopped due to slow flowrate under PID control (<i>PID-STP</i>) 56 (1056): Motor overheat detected by thermistor (<i>THM</i>) 57 (1057): Brake signal (<i>BRKS</i>) 59 (1059): Terminal [C1] wire break (<i>C1OFF</i>) 84 (1084): Maintenance timer (<i>MNT</i>) 87 (1087): Frequency arrival detected (<i>FARFDT</i>) 90(1090): Traverse Up (<i>TRV_UP</i>) 91(1091): Traverse Out (<i>TRV_OUT</i>) 99 (1099): Alarm output (for any alarm) (<i>ALM</i>) Setting the value in parentheses () shown above assigns a negative logic output to a	-	-	N	Y	99
E30	Frequency Arrival (Hysteresis width)	0.0 to 10.0	0.1	Hz	Y	Y	2.5
E31	Frequency Detection (Detection level)	0.0 to 400.0	0.1	Hz	Y	Y	60.0
E32	(Hysteresis width)	0.0 to 400.0	0.1	Hz	Y	Y	1.0
E34	Overload Early Warning/ Current Detection/Low Current Detection (Level)	0.00 (Disable), 0.01 to 100.0 Current value of 1 to 200% of the inverter rated current	0.01	A	Y	Y1 Y2	See Table A
E35	(Timer)	0.01 to 600.0 *1	0.01	s	Y	Y	10.00

*1 When you make settings from the keypad, the incremental unit is restricted by the number of digits that the LED monitor can display.

(Example) If the setting range is from -200.00 to 200.00, the incremental unit is:

"1" for -200 to -100, "0.1" for -99.9 to -10.0 and for 100.0 to 200.0, and "0.01" for -9.99 to -0.01 and for 0.00 to 99.99.

(E Codes continued)

Code	Name	Data setting range	Increment	Unit	Change when running	Data copying	Default setting
E37	Current Detection 2 (Level) (Timer)	0.00 (Disable), 0.01 to 100.0 Current value of 1 to 200% of the inverter rated current	0.01	A	Y	Y1 Y2	See Table A
E38		0.01 to 600.00 *1	0.01	s	Y	Y	10.00
E39	Coefficient for Constant Feeding Rate Time	0.000 to 9.999	0.001	-	Y	Y	0.000
E40	PID Display Coefficient A	-999 to 0.00 to 9990 *2	0.01	-	Y	Y	100
E41	PID Display Coefficient B	-999 to 0.00 to 9990 *2	0.01	-	Y	Y	0.00
E42	LED Display Filter	0.0 to 5.0	0.1	s	Y	Y	0.5
E43	LED Monitor (Display item)	0: Speed monitor (select by E48) 3: Output current 4: Output voltage 10: PID command 12: PID feedback amount 13: Timer 14: PID output	-	-	Y	Y	0
E48	LED Monitor (Speed monitor item)	0: Output frequency (Before slip compensation) 1: Output frequency (After slip compensation) 2: Reference frequency 4: Load shaft speed in r/min 5: Line speed in m/min 6: Constant feeding rate time	-	-	Y	Y	0
E50	Coefficient for Speed Indication	0.01 to 200.0 *1	0.01	-	Y	Y	30.00
E52	Keypad (Menu display mode)	0: Function code data editing mode (Menu #1) 1: Function code data check mode (Menu #2) 2: Full-menu mode (Menus #0 through #6)	-	-	Y	Y	0

(Note) E45, E46 and E47 appear on the LED monitor, but cannot be used by this inverter.

*1 When you make settings from the keypad, the incremental unit is restricted by the number of digits that the LED monitor can display.

(Example) If the setting range is from -200.00 to 200.00, the incremental unit is:

"1" for -200 to -100, "0.1" for -99.9 to -10.0 and for 100.0 to 200.0, and "0.01" for -9.99 to -0.01 and for 0.00 to 99.99.

*2 The significant figure is in three digits, so the incremental unit changes depending upon the magnitude of absolute values. (Example) The incremental unit is "10" for 1000 to 9990, "1" for -999 to -100 and for 100 to 999, "0.1" for -99.9 to -10.0 and for 10.0 to 99.9, and "0.01" for -9.99 to 9.99.

(E Codes continued)

Code	Name	Data setting range	Increment	Unit	Change when running	Data copying	Default setting
E60	Built-in Potentiometer (Function selection)	0: None 1: Auxiliary frequency command 1 2: Auxiliary frequency command 2 3: PID process command 1	1	—	N	Y	0
E61	Terminal [12] Extended Function	Selecting function code data assigns the corresponding function to terminals [12] and [C1] as listed below. 0: None	—	—	N	Y	0
E62	Terminal [C1] Extended Function	1: Auxiliary frequency command 1 2: Auxiliary frequency command 2 3: PID process command 1 5: PID feedback value	—	—	N	Y	0
E98	Terminal [FWD] Function	Selecting function code data assigns the corresponding function to terminals [FWD] and [REV] as listed below.	—	—	N	Y	98
E99	Terminal [REV] Function	0 (1000): Select multistep frequency (SS1) 1 (1001): Select multistep frequency (SS2) 2 (1002): Select multistep frequency (SS4) 3 (1003): Select multistep frequency (SS8) 4 (1004): Select ACC/DEC time (RT1) 6 (1006): Enable 3-wire operation (HLD) 7 (1007): Coast to a stop (BX) 8 (1008): Reset alarm (RST) 9 (1009): Enable external alarm trip (THR) 10 (1010): Ready for jogging (JOG) 11 (1011): Select frequency command 2/1 (Hz2/Hz1) 13: Enable DC braking (DCBRK) 17 (1017): UP (Increase output frequency) (UP) 18 (1018): DOWN (Decrease output frequency) (DOWN) 19 (1019): Enable data change with keypad (WE-KP) 20 (1020): Cancel PID control (Hz/PID) 21 (1021): Switch normal/inverse operation (IVS) 24 (1024): Enable communications link via RS-485 (LE) 33 (1033): Reset PID integral and differential components (PID-RST) 34 (1034): Hold PID integral component (PID-HLD) 90(1090): Traverse On (TRV) 91(1091): Traverse Up Offset (TRV_UP_OFFSET) 92(1092): Traverse Dn Offset (TRV_Dn_OFFSET) 97(1097) : Switch Operation Direction *3 (DIR) 98: Run forward (FWD) 99: Run reverse (REV) Setting the value in parentheses () shown above assigns a negative logic input (Active-OFF) to a terminal. Note that, in the case of THR , data "1009" is for normal logic (Active-ON) and "9," for negative logic (Active-OFF). Signals having no value in parentheses () cannot be used for negative logic.	—	—	N	Y	99

*3 Applies to product version E■ or later.(■ : Any letter of the alphabet).

C codes: Control Functions

Code	Name	Data setting range	Increment	Unit	Change when running	Data copying	Default setting
C01	Jump Frequency 1	0.0 to 400.0	0.1	Hz	Y	Y	0.0
C02	2				Y	Y	0.0
C03	3 (Hysteresis width)				Y	Y	0.0
C04					0.0 to 30.0	0.1	Hz
C05	Multistep Frequency 1	0.00 to 400.0 *1	0.01	Hz	Y	Y	0.00
C06	2				Y	Y	0.00
C07	3				Y	Y	0.00
C08	4				Y	Y	0.00
C09	5				Y	Y	0.00
C10	6				Y	Y	0.00
C11	7				Y	Y	0.00
C12	8				Y	Y	0.00
C13	9				Y	Y	0.00
C14	10				Y	Y	0.00
C15	11				Y	Y	0.00
C16	12				Y	Y	0.00
C17	13				Y	Y	0.00
C18	14				Y	Y	0.00
C19	15				Y	Y	0.00
C20	Jogging Frequency	0.00 to 400.0 *1	0.01	Hz	Y	Y	0.00
C21	Timer Operation	0: Disable 1: Enable	-	-	N	Y	0
C30	Frequency Command 2	0: UP/DOWN keys on keypad 1: Voltage input to terminal [12] (0 to +10 VDC) 2: Current input to terminal [C1] (4 to 20 mA DC) 3: Sum of voltage and current inputs to terminals [12] and [C1] 4: Built-in potentiometer (POT) 7: Terminal command UP/DOWN control 9: Terminal command UP/DOWN control (ACC/DEC Time2) *2	-	-	N	Y	2
C32	Analog Input Adjustment for Terminal [12] (Gain)	0.00 to 200.0 *1	0.01	%	Y*	Y	100.0
C33	(Filter time constant) (Gain)	0.00 to 5.00	0.01	s	Y	Y	0.05
C34	base point)	0.00 to 100.0 *1	0.01	%	Y*	Y	100.00
C37	Analog Input Adjustment for Terminal [C1] (Gain)	0.00 to 200.0 *1	0.01	%	Y*	Y	100.00
C38	(Filter time constant) (Gain)	0.00 to 5.00	0.01	s	Y	Y	0.05
C39	base point)	0.00 to 100.0 *1	0.01	%	Y*	Y	100.00
C40	Terminal [C1] Input Range Selection	0: 4 to 20 mA 1: 0 to 20 mA	-	-	N	Y	0
C50	Bias (Frequency command 1) (Bias base point)	0.00 to 100.0 *1	0.01	%	Y*	Y	0.00
C51	Bias (PID command 1) (Bias value)	-100.0 to 100.0 *1	0.01	%	Y*	Y	0.00
C52	(Bias base point)	0.00 to 100.0 *1	0.01	%	Y*	Y	0.00

(C Codes continued)

Code	Name	Data setting range	Increment	Unit	Change when running	Data copying	Default setting
C99	Digital Reference Frequency	0.00 to 400.00	0.01	Hz	-	Y	0.00

*1 When you make settings from the keypad, the incremental unit is restricted by the number of digits that the LED monitor can display.(Example) If the setting range is from -200.00 to 200.00, the incremental unit is:

"1" for -200 to -100, "0.1" for -99.9 to -10.0 and for 100.0 to 200.0, and "0.01" for -9.99 to -0.01 and for 0.00 to 99.99.

*2 Applies to product version E■ or later.(■ : Any letter of the alphabet).

P codes: Motor1 Parameters

Code	Name	Data setting range	Increment	Unit	Change when running	Data copying	Default setting
P02	Motor 1(Rated capacity)	0.01 to 30.00	0.01	kW	N	Y1 Y2	See Table A.
P03	(Rated current)	0.00 to 100.0	0.01	A	N	Y1 Y2	Rated value of Fuji standard motor
P04	(Auto-tuning)	0: Disable 1: Tune when the motor stops (%R1, %X)	-	-	N	N	0
P06	(No-load current)	0.00 to 50.00	0.01	A	N	Y1 Y2	Rated value of Fuji standard motor
P07	(%R1)	0.00 to 50.00	0.01	%	Y	Y1 Y2	
P08	(%X)	0.00 to 50.00	0.01	%	Y	Y1 Y2	
P09	(Slip compensation gain for driving)	0.0 to 200.0	0.1	%	Y*	Y	
P10	(Slip compensation response time)	0.01 to 10.00	0.01	s	Y	Y1 Y2	1.00
P11	(Slip compensation gain for braking)	0.0 to 200.0	0.1	%	Y*	Y	100.0
P12	(Rated slip frequency)	0.00 to 15.00	0.01	Hz	N	Y1 Y2	Rated value of Fuji standard motor
P99	Motor 1 Selection	0: Motor characteristic 0 (Fuji standard IM 8-series)	-	-	N	Y1 Y2	0

H codes: High Performance Functions

Code	Name	Data setting range	Increment	Unit	Change when running	Data copying	Default setting
H03	Data Initialization	0: Disable initialization 1: Initialize all function code data to the factory defaults 2: Initialize motor 1 parameters	-	-	N	N	0
H04	Auto-reset (Times)	0 (Disable), 1 to 10	1	time	Y	Y	0
H05	(Reset interval)	0.5 to 20.0	0.1	s	Y	Y	5.0
H06	Cooling Fan ON/OFF Control	0: Disable (Cooling fan always ON) 1: Enable (ON/OFF control effective)	-	-	Y	Y	0
H07	Acceleration/Deceleration Pattern	0: Linear 1: S-curve (Weak) 2: S-curve (Arbitrary: According to H57 to H60 *1)	-	-	Y	Y	0
H08	Rotational Direction Limitation	0: Disable 1: Enable (Reverse rotation inhibited) 2: Enable (Forward rotation inhibited)	-	-	N	Y	0
H11	Deceleration Mode	0: Normal deceleration 1: Coast-to-stop	-	-	Y	Y	0
H12	Instantaneous Overcurrent Limiting (Mode selection)	0: Disable 1: Enable	-	-	Y	Y	1
H13	Restart Mode after Momentary Power Failure (Restart time)	0.1 to 10.0	0.1	s	Y	Y1 Y2	0.5
H14	(Frequency fall rate)	0.00 0.01 to 100.00 999	0.01	Hz/s	Y	Y	999
H15	(Continuous running level)	200 to 300 (for 200 V class series) 400 to 600 (for 400 V class series)	1	V	Y	Y2	235 470
H26	Thermistor for Motor (Mode selection)	0: Disable 1: Enable (With PTC, the inverter immediately trips with Oh4 displayed.) 2: Enable (With PTC, the inverter issues output signal THM and continues to run.)	-	-	Y	Y	0
H27	(Level)	0.00 to 5.00	0.01	V	Y	Y	1.6
H30	Communications Link Function (Mode selection)	Frequency command Run command 0: F01/C30 F02 1: RS-485 F02 2: F01/C30 RS-485 3: RS-485 RS-485	-	-	Y	Y	0
H43	Cumulative Run Time of Cooling Fan	Indication for replacement of cooling fan (0 to 9999, in units of 10 hours)	-	10h	Y	N	-
H44	Startup Counter of Motor 1	Indication of cumulative startup count (0000 to FFFF in hex.)	-	-	Y	N	-
H45	Mock Alarm	0: Disable 1: Enable (Once a mock alarm occurs, the data automatically returns to 0.)	-	-	Y	N	0

(H Codes continued)

Code	Name	Data setting range	Increment	Unit	Change when running	Data copying	Default setting
H50	Non-linear V/f Pattern 1 (Frequency)	0.0 (Cancel), 0.1 to 400.0	0.1	Hz	N	Y	0.0
H51	(Voltage)	0 to 240: Output an AVR-controlled voltage (for 200 V class series) 0 to 500: Output an AVR-controlled voltage (for 400 V class series)	1	V	N	Y2	0.0
H52	Non-linear V/f Pattern 2 (Frequency)	0.0 (Cancel), 0.1 to 400.0	0.1	Hz	N	Y	0.0
H53	(Voltage)	0 to 240: Output an AVR-controlled voltage (for 200 V class series) 0 to 500: Output an AVR-controlled voltage (for 400 V class series)	1	V	N	Y2	0
H54	ACC/DEC Time (Jogging operation)	0.01 to 3600	0.01	s	Y	Y	6.00
H57 *1	1st S-curve acceleration range (At the start)	0 to 50%	1	%	Y	Y	10
H58 *1	2nd S-curve acceleration range (At the end)	0 to 50%	1	%	Y	Y	10
H59 *1	1st S-curve deceleration range (At the start)	0 to 50%	1	%	Y	Y	10
H60 *1	2nd S-curve deceleration range (At the end)	0 to 50%	1	%	Y	Y	10
H61	UP/DOWN Control (Initial frequency setting)	0: 0.00 1: Last UP/DOWN command value on releasing a run command	-	-	N	Y	1
H63	Low Limiter (Mode selection)	0: Limit by F16 (Frequency limiter: Low) and continue to run 1: If the output frequency lowers below the one limited by F16 (Frequency limiter: Low), decelerate to stop the motor.	-	-	Y	Y	0
H64	(Lower limiting frequency)	0.0 (Depends on F16 (Frequency limiter: Low)) 0.1 to 60.0	0.1	Hz	Y	Y	2.0
H69	Automatic Deceleration (Anti-regenerative control) (Mode selection)	0: Disable 1: Enable (Lengthen the deceleration time to three times the specified time under voltage limiting control.) 4: Enable (Torque limit control: Disable force-to-stop processing.)	-	-	Y	Y	0
H70	Overload Prevention Control	0.00: Follow deceleration time specified by F08/E11 0.01 to 100.0, 999 (Cancel)	0.01	Hz/s	Y	Y	999
H71	Deceleration Characteristics	0: Disable 1: Enable	-	-	Y	Y	0
H76	Automatic Deceleration (Frequency increment limit for braking)	0.0 to 400.0	0.1	Hz	Y	Y	5.0
H78	Maintenance Interval	0: Disable, 1 to 9999 (in units of 10 hours)	1	-	Y	N	8760
H79	Preset Startup Count for Maintenance	0000: Disable, 0001 to FFFF (hex.)	1	-	Y	N	0000
H80	Output Current Fluctuation Damping Gain for Motor 1	0.00 to 5.00	0.01	-	Y	Y	0.80

(H Codes continued)

Code	Name	Data setting range	Increment	Unit	Change when running	Data copying	Default setting
H89	Electronic Thermal Overload Protection for Motor (Data retention)	0: Disable 1: Enable	-	-	Y	Y	1
H91	PID Feedback Wire Break Detection (Terminal [C1])	0.0: Disable alarm detection 0.1 to 60.0: After the specified time, cause alarm	0.1	S	Y	Y	0.0
H92	Continuity of Running (P)	0.000 to 10.000 times; 999	0.001	time	Y	Y1 Y2	999
H93	(I)	0.010 to 10.000 s; 999	0.001	S	Y	Y1 Y2	999
H94	Cumulative Run Time of Motor 1	0 to 9999 (in units of 10 hours)	-	-	N	N	-
H95	DC Braking (Braking response mode)	0: Slow 1: Quick	-	-	Y	Y	0
H96	STOP Key Priority/Start Check Function	Data STOP key priority Start check function 0: Disable Disable 1: Enable Disable 2: Disable Enable 3: Enable Enable	-	-	Y	Y	0
H97	Clear Alarm Data	0: Disable 1: Clear alarm data	-	-	Y	N	0
H98	Protection/Maintenance Function (Mode selection)	0 to 7 (decimal) Bit 0: Lower the carrier frequency automatically (0: Disable; 1: Enable) Bit 1: Detect input phase loss (0: Disable; 1: Enable) Bit 2: Detect output phase loss (0: Disable; 1: Enable)	-	-	Y	Y	3

*1 Applies to product version E■ or later.(■ : Any letter of the alphabet).

J codes: Application Functions

Code	Name	Data setting range	Increment	Unit	Change when running	Data copying	Default setting
J01	PID Control (Mode selection)	0: Disable 1: Enable (Process control, normal operation) 2: Enable (Process control, inverse operation)	-	-	N	Y	0
J02	(Remote command SV)	0: UP/DOWN keys on keypad 1: PID process command 1 (Analog input terminals [12] and [C1]) 3: Terminal command UP/DOWN control 4: Command via communications link	-	-	N	Y	0
J03	P (Gain)	0.000 to 30.00 *1	0.001	times	Y	Y	0.100
J04	I (Integral time)	0.0 to 3600 *1	0.1	S	Y	Y	0.0
J05	D (Differential time)	0.00 to 600.0 *1	0.01	S	Y	Y	0.00
J06	(Feedback filter)	0.0 to 900.0	0.1	S	Y	Y	0.5
J15	(Operation level for slow flowrate stop)	0.0 (Disable), 1.0 to 400.0	0.1	Hz	Y	Y	0.0
J16	(Elapsed time from slow flowrate stop)	0 to 3600	1	S	Y	Y	30
J17	(Initiation frequency)	0.0 to 400.0	0.1	Hz	Y	Y	0.0
J23	(Initiation deviation level for slow flowrate stop)	0.0 to 100.0	0.1	%	Y	Y	0.0
J24	(Start latency time for slow flowrate stop)	0 to 3660	1	S	Y	Y	0
J68	Braking Signal (Brake OFF current)	0 to 200	1	%	Y	Y	100
J69	(Brake OFF frequency)	0.0 to 25.0	0.1	Hz	Y	Y	1.0
J70	(Brake OFF Timer)	0.0 to 5.0	0.1	S	Y	Y	1.0
J71	(Brake ON frequency)	0.0 to 25.0	0.1	Hz	Y	Y	1.0
J72	(Brake ON timer)	0.0 to 5.0	0.1	S	Y	Y	1.0
J80*2	Traverse Standard Frequency Select	0 : Output frequency 1 : Maximum frequency (F03)	1	-	Y	Y	0
J81*2	Traverse down step	0.0 ~ 20.0%	0.1	%	Y	Y	0
J82*2	Traverse acceleration time2	0.1 ~ 300.0sec	0.1	S	Y	Y	25.0
J83*2	Traverse deceleration time2	0.1 ~ 300.0sec	0.1	S	Y	Y	25.0
J84*2	Traverse acceleration time3	0.1 ~ 300.0sec	0.1	S	Y	Y	25.0
J85*2	Traverse deceleration time3	0.1 ~ 300.0sec	0.1	S	Y	Y	25.0
J90	Traverse selection	0: Disabled 1: Enabled (pattern 1) 2 : Enabled (pattern 2) *2 3 : Enabled (pattern 3) *2	1	-	Y	Y	0
J91	Traverse acceleration time	0.1 to 300.0 sec*2	0.1	S	Y	Y	25.0
J92	Traverse deceleration time	0.1 to 300.0 sec*2	0.1	S	Y	Y	25.0
J93	Traverse step	0.0 to 20.0%	0.1	%	Y	Y	10.0
J94	Traverse jump step	0.0 to 50.0%	0.1	%	Y	Y	10.0
J95	Traverse up offset	0.0 to 20.0%	0.1	%	Y	Y	0.0
J96	Traverse down offset	0.0 to 20.0%	0.1	%	Y	Y	0.0

y codes: Link Functions

Code	Name	Data setting range	Increment	Unit	Change when running	Data copying	Default setting
y01	RS-485 Communication 1 (Station address)	1 to 255	1	-	N	Y	1
y02	(Communications error processing)	0: Immediately trip with alarm cr8 1: Trip with alarm cr8 after running for the period specified by timer y03 2: Retry during the period specified by timer y03. If the retry fails, trip with alarm cr8. If it succeeds, continue to run. 3: Continue to run	-	-	Y	Y	0
y03		0.0 to 60.0	0.1	s	Y	Y	2.0
y04	(Baud rate) (Timer)	0: 2400 bps 1: 4800 bps 2: 9600 bps 3: 19200 bps 4: 38400 bps	-	-	Y	Y	3
y05		0: 8 bits	-	-	N	Y	0
y06	(Data length) (Parity check) (Stop bits)	3: None (1 stop bit for Modbus RTU)	-	-	N	Y	3
y07	(No-response error detection time)	1: 1 bit	-	-	N	Y	1
y08	(Response interval)	0: No detection 1 to 60	1	s	Y	Y	0
y09	(Protocol selection)	0.00 to 1.00	0.01	s	Y	Y	0.01
y10		0: Modbus RTU protocol	-	-	N	Y	0
y97	Communication Data Storage Selection *1	0: Save into nonvolatile storage (Rewritable times limited) 1: Write into temporary storage (Rewritable times unlimited) 2: Save all data from temporary storage to nonvolatile one (After saving data, the y97 data automatically reverts to "1.")	-	-	Y	Y	0
y99	Loader Link Function (Mode selection)	Frequency command Run command 0: Follow H30 data Follow H30 data 1: Via RS-485 link Follow H30 data (Loader) 2: Follow H30 data Via RS-485 link (Loader) (Loader) 3: Via RS-485 link Via RS-485 link (Loader) (Loader)	-	-	Y	N	0

*1 When you make settings from the keypad, the incremental unit is restricted by the number of digits that the LED monitor can display.

(Example) If the setting range is from -200.00 to 200.00, the incremental unit is:

"1" for -200 to -100, "0.1" for -99.9 to -10.0 and for 100.0 to 200.0, and "0.01" for -9.99 to -0.01 and for 0.00 to 99.99.

*2 Applies to product version F■ or later.(■ : Any letter of the alphabet).

Table A Fuji Standard Motor Parameters

Power supply voltage	Applicable motor rating (kW)	Inverter type	Fuji's standard torque boost (%)	Nominal rated current of Fuji standard motor (A)	Nominal rated capacity of Fuji standard motor (kW)	Restart mode after momentary power failure (Restart time) (s)
			Function code F09	Function codes F11/E34/E37	Function code P02	Function code H13
Three-phase 400 V	0.4	U1-0040-4	7.1	1.04	0.40	0.5
	0.75	U1-0075-4	6.8	1.72	0.75	
	1.5	U1-0150-4	6.8	3.10	1.50	
	2.2	U1-0220-4	6.8	4.54	2.20	
	4.0(3.7)	U1-0400-4	5.5	7.43	3.70	
Single-phase 200 V	0.4	U1-0040-7	7.1	2.10	0.40	0.5
	0.75	U1-0075-7	6.8	3.29	0.75	
	1.5	U1-0150-7	6.8	5.56	1.50	
	2.2	U1-0220-7	6.8	8.39	2.20	

10. Compliance with standards

10.1 Conformity to the Low Voltage Directive in the EU

If installed according to the guidelines given below, inverters marked with CE are considered as compliant with the Low Voltage Directive in Europe.

CAUTION

1. The ground terminal G should always be connected to the ground. Do not use only a residual-current-operated protective device (RCD)/earth leakage circuit breaker (ELCB)* as the sole method of electric shock protection. Be sure to use ground wires whose size is greater than power supply lines.
* With overcurrent protection.
2. When used with the inverter, a molded case circuit breaker (MCCB), residual-current-operated protective device (RCD)/earth leakage circuit breaker (ELCB) or magnetic contactor (MC) should conform to the EN or IEC standards.
3. When you use a residual-current-operated protective device (RCD)/earth leakage circuit breaker (ELCB) for protection from electric shock in direct or indirect contact power lines or nodes, be sure to install **type B of RCD/ELCB** on the input (primary) of the inverter if the power source is three-phase 200/400 V. For single-phase 200 V power supplies, use **type A**.

When you use no RCD/ELCB, take any other protective measure that isolates the electric equipment from other equipment on the same power supply line using double or reinforced insulation or that isolates the power supply lines connected to the electric equipment using an isolation transformer.

4. The inverter should be used in an environment that does not exceed Pollution Degree 2 requirements. If the environment conforms to Pollution Degree 3 or 4, install the inverter in an enclosure of IP54 or higher.
5. Install the inverter, input or output filter in an enclosure with minimum degree of protection of IP2X (Top surface of enclosure shall be minimum IP4X when it can be easily accessed), to prevent human body from touching directly to live parts of these equipment.
6. To make an inverter with no integrated EMC filter conform to the EMC directive, it is necessary to connect an external EMC filter to the inverter and install them properly so that the entire equipment including the inverter conforms to the EMC directive.
7. Do not connect any copper wire directly to grounding terminals. Use crimp terminals with tin or equivalent plating to connect them.
8. When using inverters at an altitude of more than 2000 m (6600 ft), note that the basic insulation applies to the insulation degree of the control circuitry. At an altitude of more than 3000 m (9800 ft), inverters cannot be used.
9. The power supply mains neutral has to be earthed for the three-phase 400 V class inverter.
10. The inverter has been tested with EN61800-5-1 5.2.3.6.3 Short-circuit Current Test under the following conditions.

Short-circuit current in the supply: 5 kA

Maximum 240 V

Maximum 480 V

10.1 Conformity to the Low Voltage Directive in the EU (Continued)

⚠ CAUTION

Use wires listed in IEC60364-5-52.

Power supply voltage	Applicable motor rating (kW)	Inverter type	Recommended wire size (mm ²)			
			*2 Main circuit power input [L1/R, L2/S, L3/T] [L1/L, L2/N] Grounding [⊕G]	*2 Inverter output [U, V, W]	*2 Braking resistor [P, DB]	Control circuit (30A, 30B, 30C)
Three-phase 400 V	0.4	U1-0040-4	2.0(2.0)			0.5
	0.75	U1-0075-4				
	1.5	U1-0150-4				
	2.2	U1-0220-4				
	4.0 (3.7)	U1-0400-4				
Single-phase 200 V	0.4	U1-0040-7	2.0(2.0)	2.0(2.0)	2.0(2.5)	
	0.75	U1-0075-7				
	1.5	U1-0150-7	2.0(3.5)			
	2.2	U1-0220-7	5.5(5.5)			

MCCB: Molded case circuit breaker
RCD: Residual-current-operated protective device
ELCB: Earth leakage circuit breaker

*1 The frame size and model of the MCCB or RCD/ELCB (with overcurrent protection) will vary, depending on the power transformer capacity. Refer to the related technical documentation for details.

*2 The recommended wire size for main circuits is for the "Use Copper Conductors Only, 75 °C." at an ambient temperature of 50°C.

10.1 Conformity to the Low Voltage Directive in the EU (Continued)

⚠ WARNING ⚠

To prevent the risk of hazardous accidents that could be caused by damage of the inverter, install the specified fuses in the supply side (primary side) according to the following tables.

- Breaking capacity: Min. 10 kA
- Rated voltage: Min. 500 V

Power supply voltage	Applicable motor rating (kW)	Inverter type	Rated Current(A) of MCCB (w/o DCR)
Three-phase 400V	0.4	U1-0040-4	6
	0.75	U1-0075-4	
	1.5	U1-0150-4	10
	2.2	U1-0220-4	15
	4.0(3.7)	U1-0400-4	20
Single-phase 200V	0.4	U1-0040-7	10
	0.75	U1-0075-7	15
	1.5	U1-0150-7	20
	2.2	U1-0220-7	35

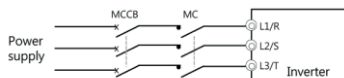

10.2 Conformity with UL standards and cUL-listed for Canada

UL/cUL-listed inverters are subject to the regulations set forth by the UL standards and CSA standards (cUL-listed for Canada) by installation within precautions listed below.

⚠ CAUTION ⚠

Integral solid state short circuit protection does not provide branch circuit protection. Branch circuit protection must be provided in accordance with the National Electrical Code and any additional local codes.

1. Solid state motor overload protection (motor protection by electronic thermal overload relay) is provided in each model.
Adjust function codes F10 to F12 and H89 to set the protection level.
2. Connect the power supply satisfying the characteristics shown in the table below as an input power supply of the inverter. (Short circuit rating)
3. Use 75°C (167°F) Cu wire only.
4. Use Class 1 wire only for control circuits.

10.2 Conformity with UL standards and cUL-listed for Canada (Continued)

⚠ CAUTION

Short circuit rating

When protected by a circuit breaker, suitable for use on a circuit capable of delivering not more than B rms symmetrical amperes, A volts maximum.

■ kW rating

Power supply voltage	Inverter type	Power supply max. voltage	Power supply current
Three-phase 400V	U1-0040-4	480VAC	5,000 A or less
	U1-0075-4		
	U1-0150-4		
	U1-0220-4		
	U1-0400-4		
Single-phase 200V	U1-0040-7	240VAC	5,000 A or less
	U1-0075-7		
	U1-0150-7		
	U1-0220-7		

10.2 Conformity with UL standards and cUL-listed for Canada (Continued)

⚠ CAUTION

5. Install UL certified circuit breaker rated 240V or more for 200V input, 480V or more for 400V input, between the power supply and the inverter, referring to the table below.

Power supply voltage	Inverter type	Required torque lb-in (N·m)			Wire size AWG or kcmil (mm ²)			Circuit Breaker(A)
		Main terminal	Control circuit		Main terminal	Control circuit		
			*1 TERM1	*2 TERM2-1 TERM2-2		*3	*1 TERM1	
Three-phase 400V	U1-0040-4	10.6 -12.4 (1.2-1.4)	3.6 (0.4)	4.5 (0.5)	AWG20 to AWG10	AWG 22 to AWG 14 (0.34 to 2.1 mm ²)	AWG26 to AWG14 (0.25 to 2.1 mm ²)	6
	U1-0075-4							6
	U1-0150-4							10
	U1-0220-4							15
	U1-0400-4							20
Single-phase 200V	U1-0040-7	8.7 (0.98)	3.6 (0.4)	4.5 (0.5)	AWG22 to AWG16			10
	U1-0075-7							15
	U1-0150-7	10.6 -12.4 (1.2-1.4)	3.6 (0.4)	4.5 (0.5)	AWG20 to AWG10			20
	U1-0220-7							35

*1 First row in the box [Y1]~[X3]

*2 Other than the TERM1

*3 Values in [] mean the size (AWG) of Grounding wire if exist.

10.2 Conformity with UL standards and cUL-listed for Canada (Continued)

CAUTION

6. To comply with CSA for 200 VAC input models, transient surge suppression shall be installed on the line side of this equipment and shall be rated 240 V (phase to ground), 240 V (phase to phase), suitable for overvoltage category 3, and shall provide protection for a rated impulse withstand voltage peak of 4 kV. (3.7 kW (5 HP) or below)

To comply with CSA for 400 VAC input models, transient surge suppression shall be installed on the line side of this equipment and shall be rated 278 V (phase to ground), 480 V (phase to phase), suitable for overvoltage category 3, and shall provide protection for a rated impulse withstand voltage peak of 4 kV.

7. All models rated 380-480 V input voltage ratings shall be connected to TN-C system power source, i.e. 3-phase, 4-wire, wye (480Y/277V), so that the phase-to-ground rated system voltage is limited to 300 V maximum.
8. Maximum surrounding air temperature rating of 50 °C (122 °F)..
9. For use in pollution degree 2 environments only.

installation

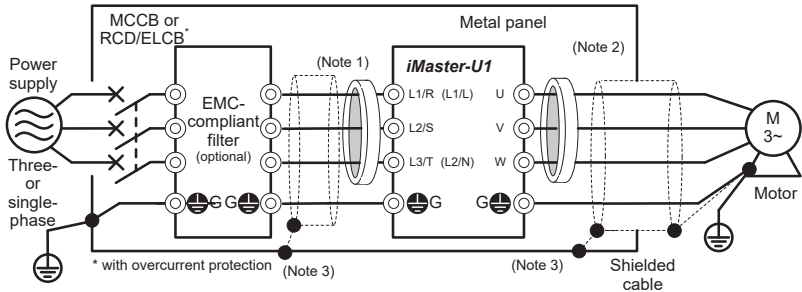

Figure 10.1 Installing the Inverter with EMC-compliant Filter into a Metal Panel

- Note 1:** Pass the EMC filter input wires (shielded cable and grounding wire in a bundle) through the ferrite bead core for reducing radio noise two times.
- Note 2:** Pass the EMC filter output wires (shielded cable and grounding wire in a bundle) through the ferrite bead core for reducing radio noise two times.
- Note 3:** Connect the shielding layer of the shielded cable to the motor and panel electrically and ground the motor and panel.

Note Radiated noise varies greatly depending upon the installation environment. When no ferrite bead core is used, make sure that the radiated noise does not exceed the permissible level.

Leakage current

Table 11.2 Leakage Current of EMC-compliant Filter

Input power	Inverter type	Filter type	Leakage current (mA)
Three-phase 400 V	U1-0040-4	B84143A0010A166	3.1
	U1-0075-4	B84143A0010A166	3.1
	U1-0150-4	B84143A0010A166	3.1
	U1-0220-4	B84143A0010A166	3.1
	U1-0400-4	B84143AC020A166	3.1
Single-phase 200 V	U1-0040-7	B84142A0010A166	2.59
	U1-0075-7	B84142A0010A166	2.59
	U1-0150-7	B84142A0030R166	1.73
	U1-0220-7	B84142A0030R166	1.73

11. Product warranty

To all our customers who purchase ADT Co., Ltd. products included in this documentation:

Please take the following items into consideration when placing your order.

When requesting an estimate and placing your orders for the products included in these materials, please be aware that any items such as specifications which are not specifically mentioned in the contract, catalog, specifications or other materials will be as mentioned below.

In addition, the products included in these materials are limited in the use they are put to and the place where they can be used, etc., and may require periodic inspection. Please confirm these points with your sales representative or directly with this company.

Furthermore, regarding purchased products and delivered products, we request that you take adequate consideration of the necessity of rapid receiving inspections and of product management and maintenance even before receiving your products.

[1] Free of charge warranty period and warranty range

(1) Free of charge warranty period

- 1) The product warranty period is "1 year from the date of purchase" or 18 months from the manufacturing date imprinted on the name place, whichever date is earlier.
- 2) However, in cases where the use environment, conditions of use, use frequency and times used, etc., have an effect on product life, this warranty period may not apply.
- 3) Furthermore, the warranty period for parts restored by ADT Co., Ltd.'s Service Department is "6 months from the date that repairs are completed."

(2) Warranty range

- 1) In the event that breakdown occurs during the product's warranty period which is the responsibility of ADT Co., Ltd., ADT Co., Ltd. will replace or repair the part of the product that has broken down free of charge at the place where the product was purchased or where it was delivered. However, if the following cases are applicable, the terms of this warranty may not apply.
 - ① The breakdown was caused by inappropriate conditions, environment, handling or use methods, etc. which are not specified in the catalog, operation manual, specifications or other relevant documents.
 - ② The breakdown was caused by the product other than the purchased or delivered ADT Co., Ltd.'s product.
 - ③ The breakdown was caused by the product other than ADT Co., Ltd.'s product, such as the customer's equipment or software design, etc.
 - ④ Concerning the ADT Co., Ltd.'s programmable products, the breakdown was caused by a program other than a program supplied by this company, or the results from using such a program.
 - ⑤ The breakdown was caused by modifications or repairs affected by a party other than ADT Co., Ltd.
 - ⑥ The breakdown was caused by improper maintenance or replacement using consumables, etc. specified in the operation manual or catalog, etc.
 - ⑦ The breakdown was caused by a science or technical problem that was not foreseen when making practical application of the product at the time it was purchased or delivered.

- ⑧ The product was not used in the manner the product was originally intended to be used.
 - ⑨ The breakdown was caused by a reason which is not this company's responsibility, such as lightning or other disaster.
- 2) Furthermore, the warranty specified herein shall be limited to the purchased or delivered product alone.
- 3) The upper limit for the warranty range shall be as specified in item (1) above and any damages (damage to or loss of machinery or equipment, or lost profits from the same, etc.) consequent to or resulting from breakdown of the purchased or delivered product shall be excluded from coverage by this warranty.

www.nicsanat.com

021-87700210



ADT Co., LTD.

56 Beolmal-ro, Dongan-gu, Anyang city, Gyunggi-do, 14509 Korea

TEL : 031-459-5051 FAX : 031-459-5053
