

Inovance MD310T5.5B

AC Drive



\$325.00

In Stock

Qty Available: 1

Used and in Good Condition

Open Web Page

<https://www.artisanng.com/70365-1>



ARTISAN[®]
TECHNOLOGY GROUP

Your **definitive** source
for quality pre-owned
equipment.

Artisan Technology Group

(217) 352-9330 | sales@artisanng.com | artisanng.com

All trademarks, brandnames, and brands appearing herein are the property of their respective owners.

- Critical and expedited services
- In stock / Ready-to-ship
- We buy your excess, underutilized, and idle equipment
- Full-service, independent repair center

Artisan Scientific Corporation dba Artisan Technology Group is not an affiliate, representative, or authorized distributor for any manufacturer listed herein.

www.nicsanat.com

021-87700210



INOVANCE



User Guide

MD310 AC Drive

General Purpose Open Loop

Shenzhen Inovance Technology Co., Ltd.

Add.: Building E, Hongwei Industry Park, Liuxian Road, Baocheng No. 70 Zone, Bao' an District, Shenzhen
 Tel: +86-755-2979 9595
 Fax: +86-755-2961 9897
 Service Hotline: 400-777-1260
<http://www.inovance.com>

Suzhou Inovance Technology Co., Ltd.

Add.: No. 16 Youxiang Road, Yuexi Town, Wuzhong District, Suzhou 215104, P.R. China
 Tel: +86-512-6637 6666
 Fax: +86-512-6285 6720
 Service Hotline: 400-777-1260
<http://www.inovance.com>



User Guide

Contents

Safety Information and Precautions	2
1 Product Information	5
1.1 Nameplate	5
1.2 Designation	5
1.3 General Specifications	5
2 Wiring	7
2.1 Typical Wiring	7
2.2 Terminals	8
2.3 Control Circuit Wire Size and Torque Specification	9
2.4 EMC Jumper/Screw	9
2.5 Grid System Requirement	11
3 Easy Setup	12
3.1 Logic of Control	12
3.2 Step By Step Setup	14
4 Troubleshooting	27
4.1 Faults and Solutions	27
4.2 Common Symptoms And Diagnostics	30
5 Parameter Table	32
5.1 General Parameters	32
5.2 Monitoring Parameters	60
Revision History	62

Safety Information and Precautions

This guide is packaged together with the product for MD310 AC Drive. It contains basic information for quick start of the drive.

■ Electrical Safety

Extreme care must be taken at all times when working with the AC Drive or within the area of the AC Drive. The voltages used in the AC Drive can cause severe electrical shock or burns and is potentially lethal. Only authorized and qualified personnel should be allowed to work on AC Drives.

■ Machine/System Design and Safety of Personnel

Machine/system design, installation, commissioning startups and maintenance must be carried out by personnel who have the necessary training and experience. They must read this safety information and the contents of this manual. If incorrectly installed, the AC Drive may present a safety hazard.

The AC Drive uses high voltages and currents (including DC), carries a high level of stored electrical energy in the DC bus capacitors even after power OFF. These high voltages are potentially lethal.

The AC Drive is NOT intended to be used for safety related applications/functions. The electronic “STOP & START” control circuits within the AC Drive must not be relied upon for the safety of personnel. Such control circuits do not isolate mains power voltages from the output of the AC Drive. The mains power supply must be disconnected by an electrical safety isolation device before accessing the internal parts of the AC Drive.

Safety risk assessments of the machine or process system which uses an AC Drive must be undertaken by the user and or by their systems integrator/designer. In particular the safety assessment/design must take into consideration the consequences of the AC Drive failing or tripping out during normal operation and whether this leads to a safe stop position without damaging machine, adjacent equipment and machine operators/users. This responsibility lies with the user or their machine/process system integrator.

The system integrator/designer must ensure the complete system is safe and designed according to the relevant safety standards. Inovance Technology and Authorized Distributors can provide recommendations related to the AC drive to ensure long term safe operation.

■ Electrical Installation - Safety

Electrical shock risk is always present within an AC Drive including the output cable leading to the motor terminals. Where dynamic brake resistors are fitted external to the AC Drive, care must be taken with regards to live contact with the brake resistors, terminals which are at high DC voltage and potentially lethal. Cables from the AC Drive to the dynamic brake resistors should be double insulated as DC voltages are typically 600 to 700 VDC.

Mains power supply isolation switch should be fitted to the AC Drive. The mains power supply must be disconnected via the isolation switch before any cover of the AC Drive can be removed or before any servicing work is undertaken stored charge in the DC bus capacitors of the PWM AC Drive is potentially lethal after the AC supply has been disconnected. The AC supply must be isolated at least 10 minutes before any work can be undertaken as the stored charge will have been discharged through the internal bleed resistor fitted across the DC bus capacitors.

Whenever possible, it is good practice to check the DC bus voltage with a VDC meter before accessing the AC Drive bridge. Where the AC Drive input is connected to the mains supply with a plug and socket, then upon disconnecting the plug and socket, be aware that the plug pins may be exposed and internally connected to the DC bus capacitors (via the internal bridge rectifier in reversed bias). Wait 10 minutes to allow stored charge in the DC bus capacitors to be dissipated by the bleed resistors before commencing work on the AC Drive.

■ Electrical Shock Hazard

Ensure the protective earthing conductor complies with technical standards and local safety regulations. Because the leakage current exceeds 3.5 mA in all models, IEC 61800-5-1 states that either the power supply must be automatically disconnected in case of discontinuity of the protective earthing conductor or a protective earthing conductor with across-section of at least 10 mm² (Cu) or 16 mm² (Al) must be used. Or use two PE wires and each wire must satisfy the IEC requirements independently. Failure to comply may result in death or serious injury.

When using an earth leakage circuit breaker, use a residual current operated protective device (RCD) of type B (breaker which can detect both AC and DC). Leakage current can cause unprotected components to operate incorrectly. If this is a problem, lower the carrier frequency, replace the components in question with parts protected against harmonic current, or increase the sensitivity amperage of the leakage breaker to at least 100 mA per drive.

Factors in determining leakage current:

- 1) Size of the AC drive
- 2) AC drive carrier frequency
- 3) Motor cable type and length
- 4) EMI/RFI filter

■ Approvals

Certification marks on the product nameplate indicate compliance with the corresponding certificates and standards.

Certification	Mark	Directives		Standard
CE		EMC directives	2014/30/EU	EN 61800-3
		LVD directives	2014/35/EU	EN 61800-5-1
		RoHS directives	2011/65/EU	EN 50581
TUV		-		EN 61800-5-1
UL		-		UL508C/UL61800-5-1
				C22.2 No.14-13



NOTE

- ◆ The above EMC directives are complied with only when the EMC electric installation requirements are strictly observed.
- ◆ Machines and devices used in combination with this drive must also be CE certified and marked. The integrator who integrates the drive with the CE mark into other devices has the responsibility of ensuring compliance with CE standards and verifying that conditions meet European standards.
- ◆ The installer of the drive is responsible for complying with all relevant regulations for wiring, circuit fuse protection, earthing, accident prevention and electromagnetic (EMC regulations). In particular fault discrimination for preventing fire risk and solid earthing practices must be adhered to for electrical safety (also for good EMC practice).
- ◆ For more information on certification, consult our distributor or sales representative.

■ Motor Thermal Protection

Motor thermal protection is not assessed by UL.

1 Product Information

1.1 Nameplate

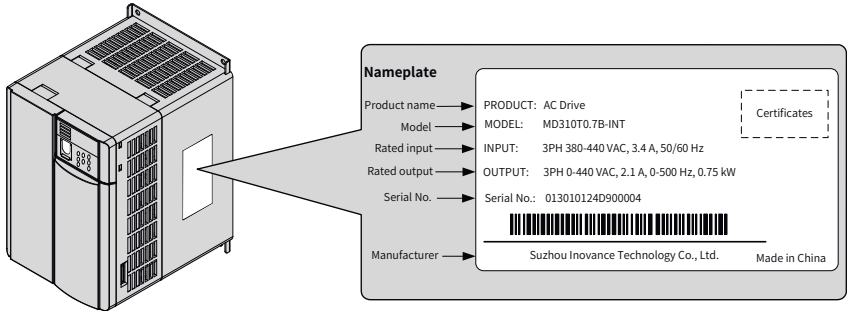

1.2 Designation

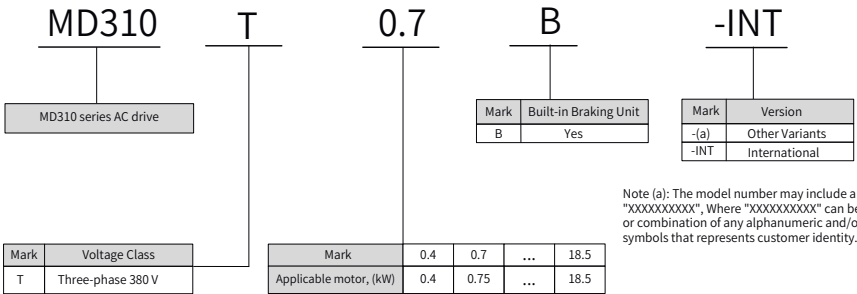

1.3 General Specifications

Voltage Class		Three-phase 380 VAC									
Drive Model		MD310 T0.4B	MD310 T0.7B	MD310 T1.5B	MD310 T2.2B	MD310 T3.7B	MD310 T5.5B	MD310 T7.5B	MD310 T11B	MD310 T15B	MD310 T18.5B
Frame Size		1		2		3		4		5	
Dimension ⁽¹⁾	H [mm]	128			185		234		270		
	W [mm]	108			130		140		180		
	D [mm]	148	158		164		171		175.5		
	A [mm]	96			108		122		160		
	B [mm]	118			198		248		284		
	H1 [mm]	-			209		260		298		308

www.nicsanat.com
021-87700210



1 Product Information

Voltage Class		Three-phase 380 VAC										
Mounting Hole Diameter		Φ5					Φ6					
Drive Input	Rated Input Voltage	Three-phase 380 to 440 V, -15% to 10%										
	Rated Input Current [A]	1.9	3.4	5.0	5.8	10.5	14.6	20.5	26.0	35.0	38.5	
	Rated input frequency	50/60 Hz, ±5%										
Drive Output	Applicable Motor	[kW]	0.4	0.75	1.5	2.2	3.7	5.5	7.5	11	15	18.5
		[HP]	0.5	1	2	3	5	7.5	10	15	20	25
	Output Current, [A]		1.5	2.1	3.8	5.1	9.0	13.0	17.0	25.0	32.0	37
	Power Capacity, [kVA]		1.0	1.5	3.0	4.0	5.9	8.9	11.0	17.0	21.0	24.0
	Overload Capacity ^[2]		120% for 1 hour & 150% for 60 Sec & 180% for 2 Sec									
	Max. output voltage		Three-phase 380 VAC (proportional to input voltage)									
	Max. output frequency		300 Hz for SVC control, 500 Hz for V/F control									
Braking Resistor	Recommended Power, [kW]	≥ 0.15	≥ 0.15	≥ 0.15	≥ 0.25	≥ 0.30	≥ 0.40	≥ 0.50	≥ 0.80	≥ 1.00	≥ 1.30	
	Recommended Resistance, min. [Ω]	≥ 300	≥ 300	≥ 220	≥ 200	≥ 130	≥ 90	≥ 65	≥ 43	≥ 32	≥ 25	
Cooling Method		Air					Fan					

[1] Dimensions are shown in Figure1-1 and Figure1-2

[2] At 6 kHz carrier frequency without derating

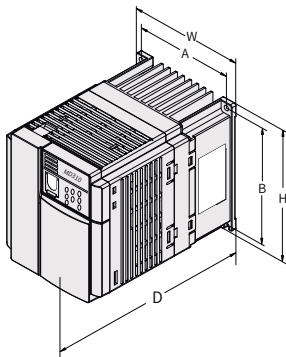

Figure 1-1 Model of 0.4 to 2.2 kW

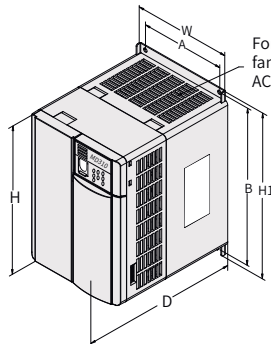
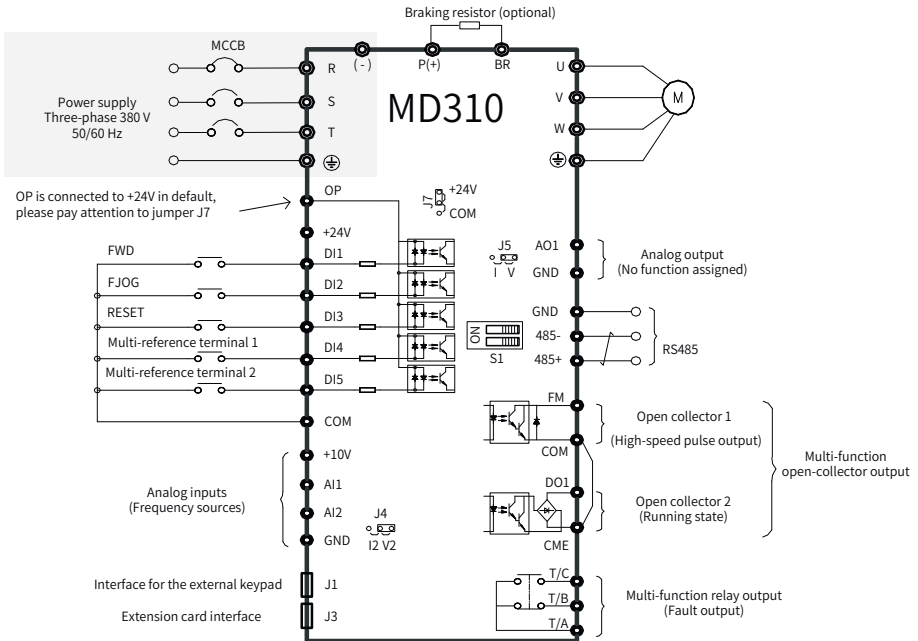

Figure 1-2 Model of 3.7 to 18.5 kW

2 Wiring

2.1 Typical Wiring

■ Wiring of Three-phase 380 VAC Power Supply



2.2 Terminals

■ Terminals of Main Circuit

Table 2-1 Main circuit terminals of three-phase

Terminal	Terminal Name	Description
R, S, T	Three-phase power supply input terminals	Connect to the three-phase AC power supply.
P(+), (-)	Positive and negative terminals of DC bus	Common DC bus input point.
P(+), BR	Connecting terminals of braking resistor	Connect to a braking resistor.
U, V, W	Output terminals	Connect to a three-phase motor.
	Grounding terminal	Must be grounded.

■ Terminals of Control Circuit

Terminal	Terminal Name	Description
+10V-GND	+10 VDC power supply	Provide +10 VDC power supply externally. Usually, it provides power supply to the external potentiometer with resistance range of 1 to 5 k Ω . Max. output current: 10 mA.
+24V-COM	+24 VDC power supply	Provide +24 VDC power supply externally. Usually, it provides power supply to DI/DO terminals and external sensors. Max. output current: 200 mA.
OP	Input terminal of external power supply	Connect to +24 VDC by default. Whether it connects to +24 V or COM is decided by jumper J7. When DI1 to DI5 need to be driven by the external signal, OP needs to be connected to the external power supply and be disconnected from +24 VDC.
AI1-GND	Analog input 1	AI1 input voltage range: 0 to 10 VDC. AI2 input range: 0 to 10 VDC or 4 to 20 mA. Impedance: 22 k Ω .
AI2-GND	Analog input 2	
DI1-COM	Digital input 1	Optical coupling isolation, compatible with dual-polarity input. Impedance: 2.4 k Ω . Input voltage range: 9 to 30 VDC.
DI2-COM	Digital input 2	
DI3-COM	Digital input 3	
DI4-COM	Digital input 4	
DI5-COM	High-speed pulse input	Besides features of DI1 to DI4, it can be used for high-speed pulse input. Max. input frequency: 20 kHz.
AO1-GND	Analog output 1	Voltage or current output, determined by jumper J5 on the control board. Output voltage range: 0 to 10 VDC. Output current range: 0 to 20 mA.

DO1-CME	Digital output 1	Multi-function open-collector output. Voltage range: 0 to 24 VDC. Current range: 0 to 50 mA. Output pulse frequency range: 0 to 50 kHz. For jumper J6, CME and COM are shorted by default.
FM-COM	High-speed pulse output	
485+-485-	Communication terminal	Modbus protocol (baud rate: 300 to 115200 bps) Max. nodes: 32. Terminal resistance switch: S1.
T/A-T/B	Normally closed terminal	Contact driving capacity: 250 VAC, 3 A; 30 VDC, 1 A.
T/A-T/C	Normally open terminal	

2.3 Control Circuit Wire Size and Torque Specification

Please use a ferrule-type terminal with insulated sleeves. Prepare wire ends with insulated sleeves before connecting to the drive. See the following figure for ferrule dimensions.

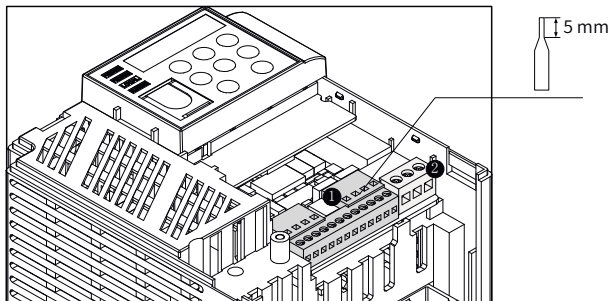

Terminal Block		Single Wire (AWG/mm ²)	Twisted Wire (AWG/mm ²)	Tightening Torque (N · m)
Control circuit	1	AWG 24 to 18 (0.2 to 0.75 mm ²)		0.2
	2	AWG 24 to 18 (0.2 to 0.75 mm ²)		0.51

2.4 EMC Jumper/Screw

The AC drive has built-in safety capacitor. If the leakage current of the entire system is too large at power-on and the RCD acts, you can cut the EMC jumper or remove the EMC screw to reduce leakage current to ground.

The position and cutting method of the EMC jumper is shown in the following figure.

- 1) Snip off the two protective caps on the housing by using a cutting plier.

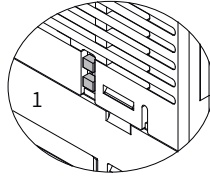
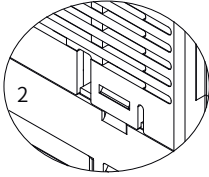

- 2) Then cut the exposed metal jumper.

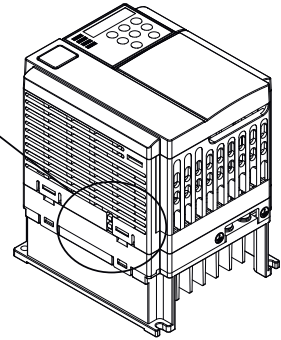
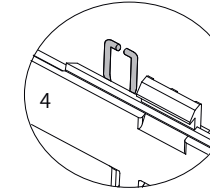
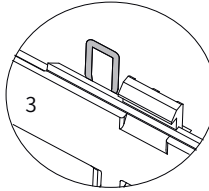

Figure 2-1 EMC jumper position and cutting method of MD310T0.4B to MD310T5.5B

For the MD310T7.5B to MD310T18.5B, remove the No.2 EMC screw, as shown in the following figure.

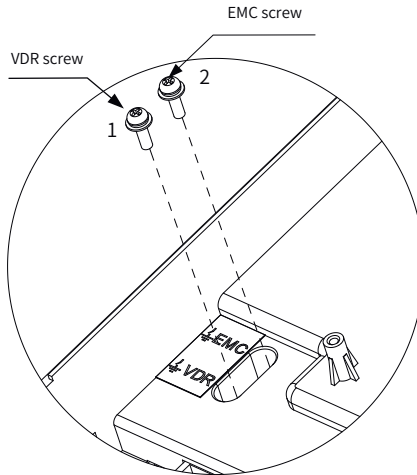

Figure 2-2 EMC screw position



NOTE

- ◆ The screw is connected by default.
- ◆ The screw cannot be re-connected once it is cut. This will result in an increase in leakage current to ground during drive running. Take full consideration before cutting the jumper.

2.5 Grid System Requirement

The drive is applicable to system with neutral point grounded. If the drive is used in an IT power system (neutral point not grounded), remove both VDR and EMC screws for the MD310T0.4B to MD310T5.5B.

MD310T0.4 B to MD310T2.2B

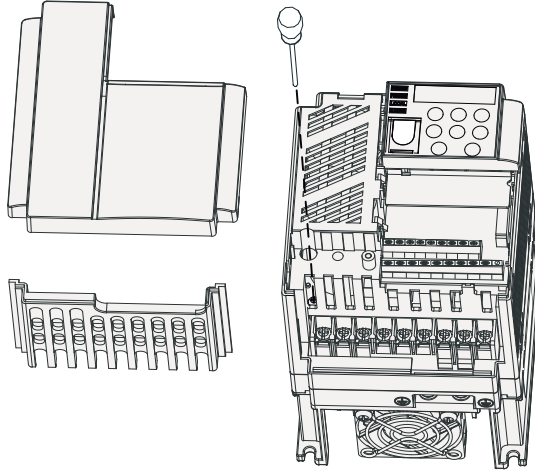

MD310T3.7B and MD310T5.5B

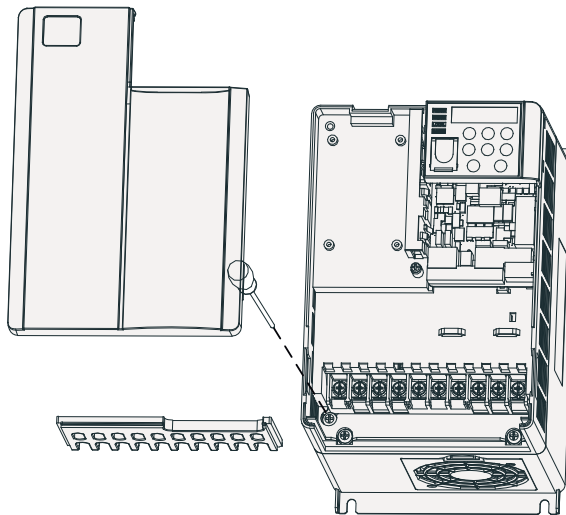

For the MD310T7.5B to MD310T18.5B, it is necessary to remove the VDR and EMC screws, that is, No.1 screw and No.2 screw, as shown in Figure 2-2. Filter cannot be installed. Otherwise, personal injury and damage to AC drive may result.

3 Easy Setup

3.1 Logic of Control

■ Complete Timing Diagram

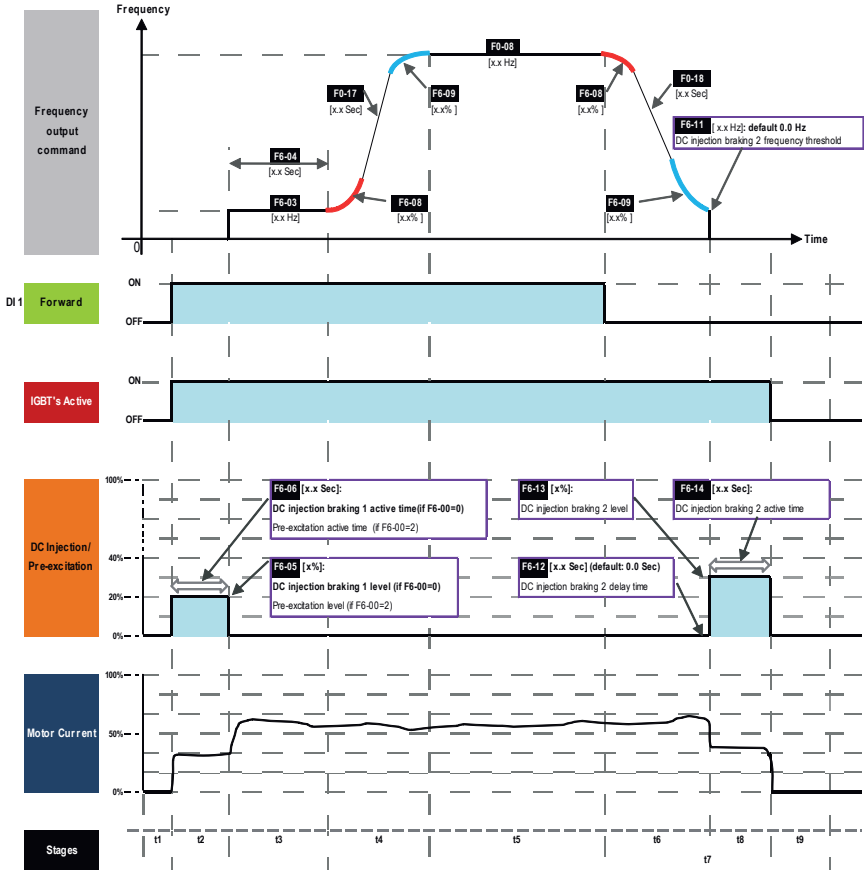

■ Timing Diagram Description

Event	Description	Para. No.	Status
t1	The AC drive waits for the RUN signal.	-	Inhabit
t2	The AC drive receives the Forward RUN command.	-	RUN
	The IGBT becomes active.	-	
	DC injection braking 1/Pre-excitation is enabled if F6-06 > 0. (if F6-00 = 0, it is "DC injection braking 1"; if F6-00 = 2, it is "Pre-excitation")	F6-05 F6-06	
t3	DC injection braking 1/Pre-excitation is disabled.	-	RUN
	The startup frequency becomes active if F6-04 > 0.	F6-03 F6-04	
t4	The startup frequency becomes inactive.	-	RUN
	The motor ramps up to the expected frequency.	F0-17	
	S-curve active	F6-08 F6-09	
t5	Motor runs at expected frequency.	F0-08	RUN
t6	The Forward RUN command is cancelled.	-	RUN
	The motor ramps down to zero frequency.	F0-18	
	S-curve active	F6-08 F6-09	
t7	The frequency output command reaches the DC injection braking 2 frequency threshold.	F6-11	RUN (if F6-12 = 0) Inhabit (if F6-12 > 0)
	The IGBT shall become inactive if DC injection braking 2 delay time is not zero.	F6-12	
	After the delay time set in F6-12, the IGBT becomes active again	-	
t8	DC injection braking 2 is enabled if F6-14 > 0	F6-13	RUN
		F6-14	
t9	DC injection braking 2 is disabled.	-	Inhabit
	The IGBT turns inactive.	-	

3.2 Step By Step Setup

■ Setup Flowchart

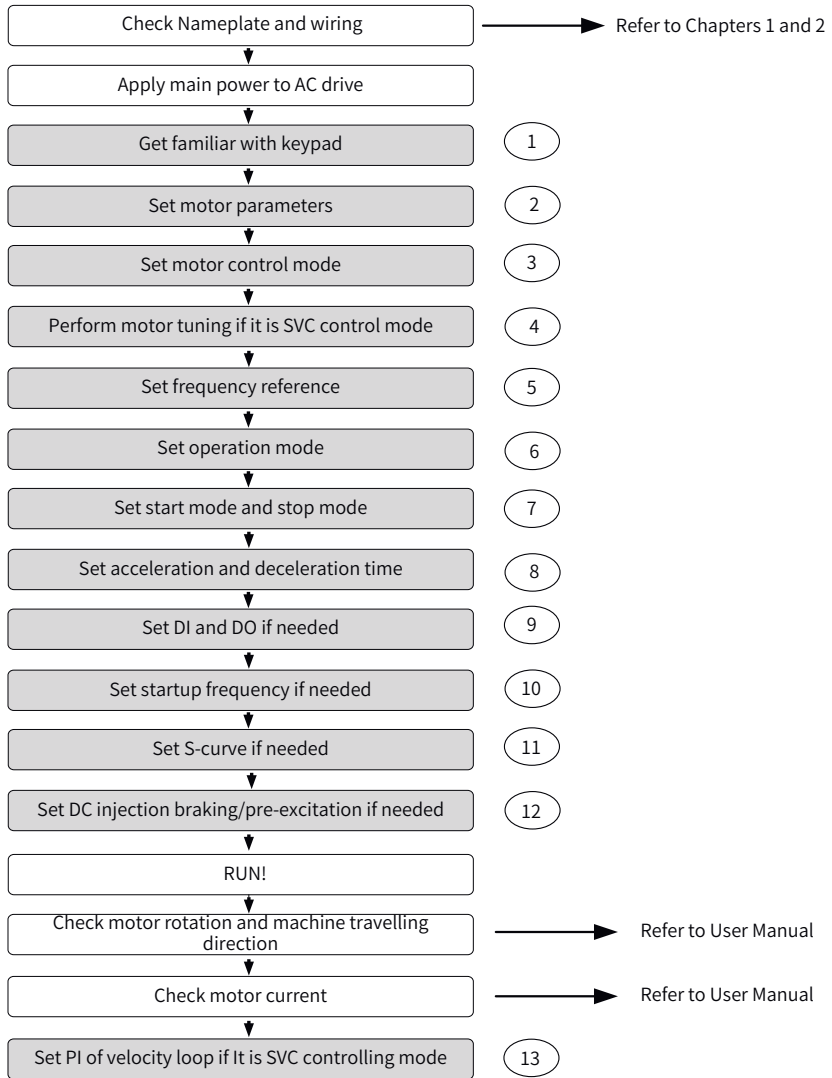

Step 1: Get Familiar With Keypad

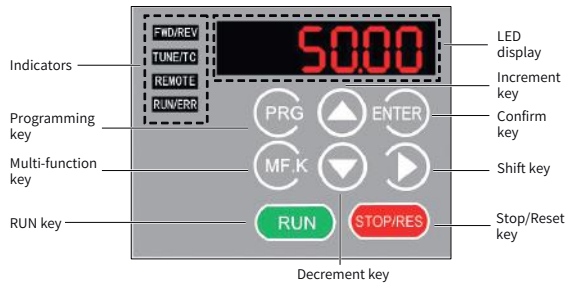

■ Indicators

FWD/REV : It indicates forward or reverse rotation.

OFF indicates forward rotation and ON indicates reverse rotation.

TUNE/TC : ON indicates torque control mode, blinking slowly indicates auto-tuning state, blinking quickly indicates fault state.

REMOTE : It indicates whether the AC drive is operated by means of keypad, terminals or communication.

OFF indicates keypad control, ON indicates terminal control, and blinking indicates communication control.

RUN/ERR : It indicates the state of the AC drive.

OFF indicates the stop state, ON (green) indicates the running state, and ON (red) indicates the faulty state.



■ LED Display

The 5-digit LED display is able to display the frequency reference, output frequency, monitoring data and fault codes.

■ Keys On Keypad

Key	Key Name	Function
	Programming	Enter or exit Level I menu.
	Confirm	Enter the menu interfaces level by level, and confirm the parameter setting.
	Increment	Increase data or Para. No..
	Decrement	Decrease data or Para. No..
	Shift	Select the displayed parameters in turn in the stop or running state, and select the digit to be modified when modifying parameters.
	RUN	Start the AC drive in the keypad operation mode.

3 Easy Setup

Key	Key Name	Function
	Stop/Reset	Stop the AC drive when it is in the running state and perform the reset operation when it is in the faulty state. The functions of this key are restricted by F7-02.
	Multifunction	Perform function switchover (such as quick switchover of command source or direction) according to the setting of F7-01.

Para. No.	Para. Name	Setting Range	Unit	Default	Commission
F7-01	MF.K key function selection	0: MF.K key disabled 1: Switchover from remote control (terminal or communication) to keypad control 2: Switchover between forward rotation and reverse rotation 3: Forward jog 4: Reverse jog 5: Individualized parameter display	N.A.	0	
F7-02	STOP/RESET key function	0: STOP/RESET key enabled only in keypad control 1: STOP/RESET key enabled in any operation mode	N.A.	1	

■ Keypad Operation

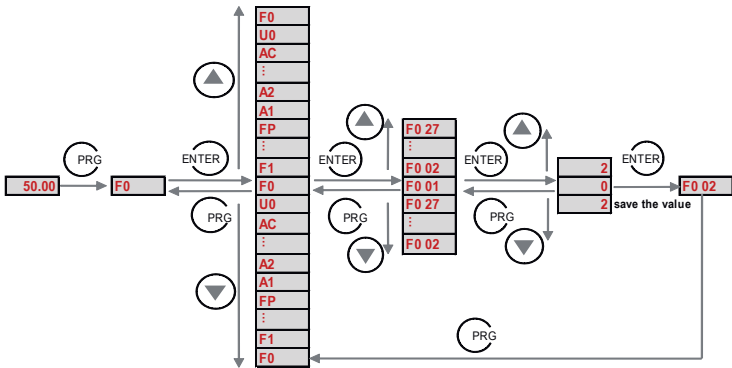

■ Para. No. Arrangement

Para. Group	Description	Remark
F0 to FP	Standard parameter group	Standard function parameters
A0 to AC	Advanced parameter group	AI/AO correction
U0	Running state parameter group	Display of basic parameters

Step 2: Set Motor Parameters

Para. No.	Para. Name	Setting Range	Unit	Default	Commission
F1-00	Motor type selection	0: Common asynchronous motor 1: Variable-frequency asynchronous motor	N.A.	0	
F1-01	Rated motor power	0.1 to 30.0	kW	Model dependent	
F1-02	Rated motor voltage	1 to 1000	V	Model dependent	
F1-03	Rated motor current	0.01 to 655.35	A	Model dependent	
F1-04	Rated motor frequency	0.01 to max frequency	Hz	Model dependent	
F1-05	Rated motor speed	1 to 65535	RPM	Model dependent	

Step 3: Set Motor Control Mode

Para. No.	Para. Name	Setting Range	Unit	Default	Commission
F0-01	Motor 1 control mode	0: Sensorless vector control (SVC) 2: Voltage/Frequency control (V/F)	N.A.	2	

Step 4: Perform Motor Tuning If It's SVC Control Mode

Para. No.	Para. Name	Setting Range	Unit	Default	Commission
F1-37	Auto-tuning selection	0: No auto-tuning 1: Static auto-tuning 1 2: Complete dynamic auto-tuning 3: Static auto-tuning 2	N.A.	0	

Step 5: Set Frequency Reference

Para. No.	Para. Name	Setting Range	Unit	Default	Commission
F0-03	Main frequency source X selection	0: Digital setting F0-08 (non-retentive at power down) 1: Digital setting F0-08 (retentive at power down) 2: AI1 3: AI2 4: Reserved 5: Pulse reference (DI5) 6: Multi-reference 7: Simple PLC 8: PID 9: Communication reference	N.A.	0	

3 Easy Setup

Para. No.	Para. Name	Setting Range	Unit	Default	Commission
F0-04	Auxiliary frequency source Y selection	The same as F0-03 (Main frequency source X selection)	N.A.	0	

Para. No.	Para. Name	Setting Range	Unit	Default	Commission
F0-07	Frequency source superposition selection	 Main and auxiliary calculation relationship 0: Main + Auxiliary 1: Main - Auxiliary 2: Maximum of main and auxiliary 3: Minimum of main and auxiliary Frequency reference setting channel selection 0: Main frequency reference setting channel 1: Main + auxiliary operation 2: Switchover between main and auxiliary 3: Switchover between main and main + auxiliary calculation 4: Switchover between auxiliary and main + auxiliary calculation	N.A.	00	
F0-08	Preset frequency	0.00 to max frequency	Hz	50.00	

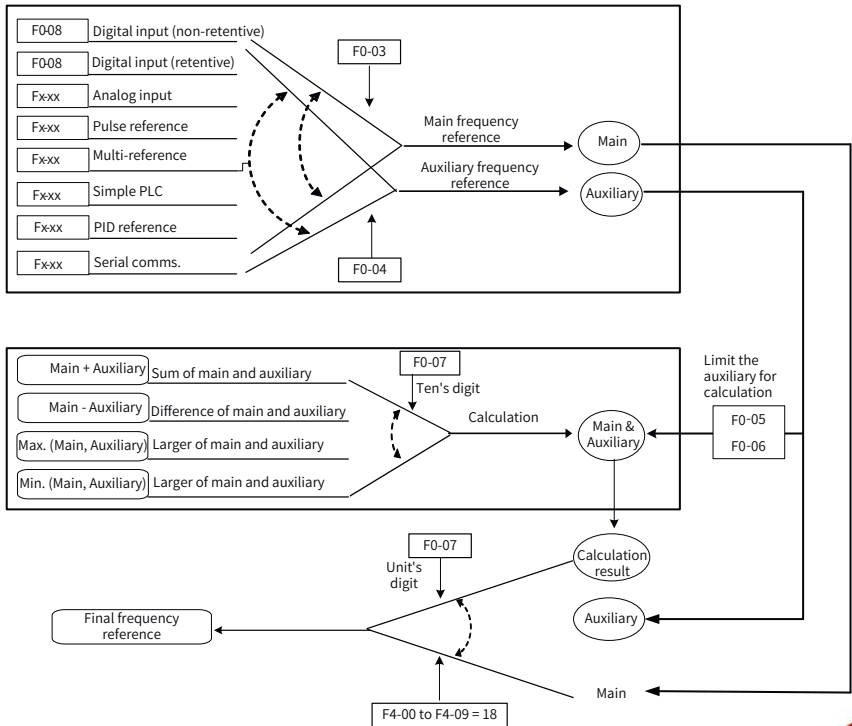

Step 6: Select Operation Mode

Para. No.	Para. Name	Setting Range	Unit	Default	Commission
F0-02	Command source selection	0: Keypad control 1: Terminal control 2: Communication control	N.A.	0	
F4-11	Terminal command mode	0: Two-wire control mode 1 1: Two-wire control mode 2 2: Three-wire control mode 1 3: Three-wire control mode 2	N.A.	0	

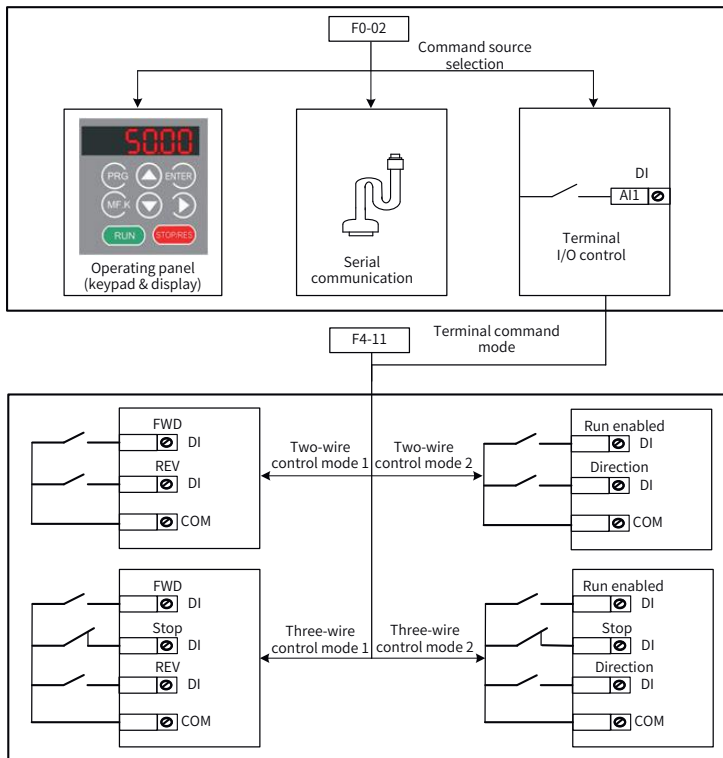
**Step 7: Set Start Mode And Stop Mode**

Para. No.	Para. Name	Setting Range	Unit	Default	Commission
F6-00	Start mode	0: Direct startup 1: Reserved 2: Pre-excited startup	N.A.	0	
F6-10	Stop mode	0: Decelerate to stop 1: Coast to stop	N.A.	0	

Step 8: Set Acceleration And Deceleration Parameters

Para. No.	Para. Name	Setting Range	Unit	Default	Commission
F0-17	Acceleration time 1	0.00 to 650.00 (if F0-19 = 2) 0.0 to 6500.0 (if F0-19 = 1) 0 to 65000 (if F0-19 = 0)	s	Model dependent	
F0-18	Deceleration time 1	0.00 to 650.00 (if F0-19 = 2) 0.0 to 6500.0 (if F0-19 = 1) 0 to 65000 (if F0-19 = 0)	s	Model dependent	
F0-19	Acceleration/Deceleration time unit	0: 1s 1: 0.1s 2: 0.01s	N.A.	1	
F6-07	Acceleration/Deceleration mode	0: Linear mode 1: S-curve mode A 2: S-curve mode B	N.A.	0	

Step 9: Set DI And DO If Needed

■ DI Setting

Para. No.	Para. Name	Setting Range	Unit	Default	Commission
F4-00	DI1 function selection	0: No function 1: Forward RUN (FWD) 2: Reverse RUN (REV) 3: Three-wire control 4: Forward JOG (FJOG) 5: Reverse JOG (RJOG) 6: Terminal UP 7: Terminal DOWN	N.A.	1 FWD	
F4-01	DI2 function selection	8: Coast to stop 9: Fault reset (RESET) 10: RUN pause 11: External fault normally open (NO) input 12: Multi-reference terminal 1 13: Multi-reference terminal 2 14: Multi-reference terminal 3 15: Multi-reference terminal 4	N.A.	4 FJOG	
F4-02	DI3 function selection	16: Terminal 1 for acceleration/ deceleration time selection 17: Terminal 2 for acceleration/ deceleration time selection 18: Frequency source switchover 19: UP and DOWN setting clear (terminal, keypad) 20: Command source switchover terminal 1 21: Acceleration/Deceleration prohibited	N.A.	9 RESET	

Para. No.	Para. Name	Setting Range	Unit	Default	Commission
F4-03	DI4 function selection	22: PID pause 23: PLC status reset 24: Wobble pause 25: Counter input 26: Counter reset 27: Length count input 28: Length reset	N.A.	12 Multi-reference terminal 1	
F4-04	DI5 function selection	29: Torque control prohibited 30: Pulse input (enabled only for DI5) 31: Reserved 32: Immediate DC injection braking 33: External fault normally closed (NC) input 34: Frequency modification forbidden 35: PID action direction reverse 36: External STOP terminal 1 37: Command source switchover terminal 2 38: PID integral disabled 39: Switchover between main frequency source X and preset frequency 40: Switchover between auxiliary frequency source Y and preset frequency 41: Motor selection terminal 1 42: Reserved 43: PID parameter switchover 44: User-defined fault 1 45: User-defined fault 2 46: Speed control/Torque control switchover 47: Emergency stop 48: External STOP terminal 2 49: Deceleration DC injection braking 50: Clear the current running time 51: Two-wire/Tree-wire switchover 52: Reverse frequency prohibited 53-59: Reserved	N.A.	13 Multi-reference terminal 2	
F4-10	DI filter time	0.000 to 1.000	s	0.010	

3 Easy Setup

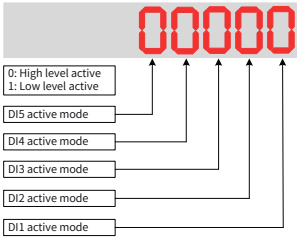
Para. No.	Para. Name	Setting Range	Unit	Default	Commission
F4-35	DI1 delay	0.0 to 3600.0	s	0.0	
F4-36	DI2 delay	0.0 to 3600.0	s	0.0	
F4-37	DI3 delay	0.0 to 3600.0	s	0.0	
F4-38	DI active mode selection 1		N.A.	00000	



NOTE

- ◆ The screw is connected by default.
- ◆ The screw cannot be re-connected once it is cut. This will result in an increase in leakage current to ground during drive running. Take full consideration before cutting the jumper.

■ DO Setting

Para. No.	Para. Name	Setting Range	Unit	Default	Commission
F5-00	FM terminal output mode	0: Pulse output (FMP) 1: Switch signal output (FMR)	N.A.	0	

Para. No.	Para. Name	Setting Range	Unit	Default	Commission
F5-01	FMR function (open-collector output terminal) selection	0: No output 1: AC drive running 2: Fault output 3: Frequency-level detection FDT1 output 4: Frequency reached 5: Zero-speed running (no output at stop) 6: Motor overload pre-warning	N.A.	0 No output	
F5-02	Relay function (T/A-T/ B-T/C) selection	7: AC drive overload pre-warning 8: Set count value reached 9: Designated count value reached 10: Length reached 11: PLC cycle completed 12: Accumulative running time reached 13: Frequency limited	N.A.	2 Fault output	
F5-03	Extension card relay function (P/A-P/ B-P/C) selection	14: Torque limited 15: Ready for RUN 16: Reserved 17: Frequency upper limit reached 18: Frequency lower limit reached (no output at stop) 19: Undervoltage state output 20: Communication setting	N.A.	0 No output	
F5-04	DO1 function selection (open-collector output terminal)	21: Reserved 22: Reserved 23: Zero-speed running 2 (having output at stop) 24: Accumulative power-on time reached 25: Frequency level detection FDT2 output 26: Frequency 1 reached 27: Frequency 2 reached 28: Current 1 reached 29: Current 2 reached 30: Timing duration reached	N.A.	1 AC drive running	
F5-05	Extension card DO2 function selection	31: AI1 input limit exceeded 32: Load lost 33: Reverse running 34: Zero current state 35: IGBT temperature reached 36: Output current limit exceeded 37: Frequency lower limit reached (having output at stop) 38: Alarm output 39: Reserved 40: Current running time reached 41: Fault output (no output at undervoltage)	N.A.	4 Frequency reached	

Para. No.	Para. Name	Setting Range	Unit	Default	Commission
F5-17	FMR output delay time	0.0 to 3600.0	s	0.0	
F5-18	Relay 1 output delay time	0.0 to 3600.0	s	0.0	
F5-19	Relay 2 output delay time	0.0 to 3600.0	s	0.0	
F5-20	DO1 output delay time	0.0 to 3600.0	s	0.0	
F5-21	DO2 output delay time	0.0 to 3600.0	s	0.0	
F5-22	DO active mode selection		N.A.	00000	



NOTE

- ◆ Positive logic means that, DO output terminal is normally the default state.
- ◆ Negative logic means the opposite situation.

Step 10: Set Startup Frequency If Needed

Para. No.	Para. Name	Setting Range	Unit	Default	Commission
F6-03	Startup frequency	0.00 to 10.00	Hz	0.00	
F6-04	Startup frequency active time	0.0 to 100.0	s	0.0	

Step 11: Set S-Curve If Needed

Para. No.	Para. Name	Setting Range	Unit	Default	Commission
F6-07	Acceleration/ Deceleration mode	0: Linear mode 1: S-curve mode A 2: S-curve mode B	N.A.	0	1
F6-08	Time proportion of S-curve start segment	0.0 to [100.0 minus F6-09]	%	30.0	
F6-09	Time proportion of S-curve end segment	0.0 to [100.0 minus F6-08]	%	30.0	

Step 12: Set DC Injection Braking/Pre-excitation If Needed

Para. No.	Para. Name	Setting Range	Unit	Default	Commission
F6-00	Start mode	0: Direct startup 1: Reserved 2: Pre-excited startup	N.A.	0	
F6-05	DC injection braking 1 level	0 to 100	%	0	
F6-06	DC injection braking 1 active time	0.0 to 100.0	s	0.0	
F6-11	DC injection braking 2 frequency threshold	0.00 to 10.00	Hz	0.00	
F6-12	DC injection braking 2 delay time	0.0 to 100.0	s	0.0	
F6-13	DC injection braking 2 level	0 to 100	%	50	
F6-14	DC injection braking 2 active time	0.0 to 100.0	s	0.0	

**NOTE**

- ◆ Only when F6-00 = 0, parameters F6-05 and F6-06 are related to DC injection braking 1.

Para. No.	Para. Name	Setting Range	Unit	Default	Commission
F6-00	Start mode	0: Direct startup 1: Reserved 2: Pre-excited startup (asynchronous motor)	N.A.	0	2
F6-05	Pre-excitation level	0 to 100	%	50	
F6-06	Pre-excitation active time	0.0 to 100.0	s	0.0	

**NOTE**

- ◆ Only when F6-00 = 2, parameters F6-05 and F6-06 are related to pre-excitation.

Step 13: Set PI of Velocity Loop If It's SVC Control Mode

Para. No.	Para. Name	Setting Range	Unit	Default	Commission
F2-00	Speed loop proportional gain 1	1 to 100	N.A.	30	
F2-01	Speed loop integral time 1	0.01 to 10.00	s	0.50	
F2-02	Switchover frequency 1	0.00 to F2-05	Hz	5.00	
F2-03	Speed loop proportional gain 2	1 to 100	N.A.	20	
F2-04	Speed loop integral time 2	0.01 to 10.00	s	1.00	

4 Troubleshooting

4.1 Faults and Solutions

Display	Fault Name	Possible Causes	Solutions
Err02	Overcurrent during acceleration	<ol style="list-style-type: none"> 1. The output circuit is short circuited. 2. The acceleration time is too short. 3. Manual torque boost or V/F curve is not appropriate. 4. The power supply is too low. 5. The startup operation is performed on the rotating motor. 6. A sudden load is added during acceleration. 7. The AC drive model is of too small power class. 	<ol style="list-style-type: none"> 1: Eliminate short circuit. 2: Increase the acceleration time. 3: Adjust the manual torque boost or V/F curve. 4: Check that the power supply is normal. 5: Select speed tracking restart or start the motor after it stops. 6: Remove the added load. 7: Select a drive of higher power class.
Err03	Overcurrent during deceleration	<ol style="list-style-type: none"> 1. The output circuit is short circuited. 2. The deceleration time is too short. 3. The power supply is too low. 4. A sudden load is added during deceleration. 5. The braking resistor is not installed. 	<ol style="list-style-type: none"> 1: Eliminate short circuit. 2: Increase the deceleration time. 3: Check the power supply, and ensure it is normal. 4: Remove the added load. 5: Install the braking resistor.
Err04	Overcurrent at constant speed	<ol style="list-style-type: none"> 1. The output circuit is short circuited. 2. The power supply is too low. 3. A sudden load is added during operation. 4. The AC drive model is of too small power class. 	<ol style="list-style-type: none"> 1: Eliminate short circuit. 2: Adjust power supply to normal range. 3: Remove the added load. 4: Select a drive of higher power class.
Err05	Overvoltage during acceleration	<ol style="list-style-type: none"> 1. The DC bus voltage is too high. 2. An external force drives the motor during acceleration. 3. The acceleration time is too short. 4. The braking resistor is not installed. 	<ol style="list-style-type: none"> 1: Replace with a proper braking resistor. 2: Cancel the external force or install braking resistor. 3: Increase the acceleration time. 4: Install a braking resistor.
Err06	Overvoltage during deceleration	<ol style="list-style-type: none"> 1. The DC bus voltage is too high. 2. An external force drives the motor during deceleration. 3. The deceleration time is too short. 4. The braking resistor is not installed. 	<ol style="list-style-type: none"> 1: Replace with a proper braking resistor. 2: Cancel the external force or install braking resistor. 3: Increase the deceleration time. 4: Install the braking resistor
Err07	Overvoltage at constant speed	<ol style="list-style-type: none"> 1. The DC bus voltage is too high. 2. An external force drives the motor during deceleration. 	<ol style="list-style-type: none"> 1: Replace with a proper braking resistor. 2: Cancel the external force.

4 Troubleshooting

Display	Fault Name	Possible Causes	Solutions	
Voltage thresholds				
Voltage Class		DC Bus Overvoltage	DC Bus Undervoltage	Braking Unit Operation Level
Single-phase 220 V		400 V	200 V	381 V
Three-phase 220 V		400 V	200 V	381 V
Three-phase 380 V		810 V	350 V	700 V
Err08	Control power fault	The input voltage exceeds the allowed range.	Adjust the input voltage to within the allowed range.	
Err09	Undervoltage	<ol style="list-style-type: none"> 1. Instantaneous power failure occurs. 2. The input voltage exceeds the allowed range 3. The DC bus voltage is too low. 4. The rectifier bridge and buffer resistor are faulty. 5. The drive board is faulty. 6. The control board is faulty. 	<ol style="list-style-type: none"> 1: Reset the fault. 2: Adjust the input voltage to within the allowed range. 3 to 6: Seek for maintenance. 	
Err10	Drive overload	<ol style="list-style-type: none"> 1. The load is too heavy or the rotor is locked. 2. The drive is of too small power class. 	<ol style="list-style-type: none"> 1: Reduce the load, or check the motor, or check the machine whether it is locking the rotor. 2: Select a drive of higher power class. 	
Err11	Motor overload	<ol style="list-style-type: none"> 1. F9-01 is too small. 2. The load is too heavy or the rotor is locked. 3. The drive is of too small power class. 	<ol style="list-style-type: none"> 1: Set F9-01 correctly. 2: Reduce the load, or check the motor, or check the machine whether it is locking the rotor. 3: Select a drive of larger power class. 	
Err12	Power input phase loss	<ol style="list-style-type: none"> 1. The three-phase power supply is abnormal. 2. The drive board is faulty. 3. The lightning protection board is faulty. 4. The control board is faulty. 	<ol style="list-style-type: none"> 1: Check the power supply. 2 to 4: Seek for maintenance. 	
Err13	Power output phase loss	<ol style="list-style-type: none"> 1. The cable between drive and motor is faulty. 2. The drive's three-phase output is unbalanced when the motor is running. 3. The drive board is faulty 4. The IGBT is faulty. 	<ol style="list-style-type: none"> 1: Check the cable. 2: Check the motor windings. 3 to 4: Seek for maintenance. 	
Err14	IGBT overheat	<ol style="list-style-type: none"> 1. The ambient temperature is too high. 2. The air filter is blocked. 3. The cooling fan is damaged. 4. The thermal sensor of IGBT is damaged. 5. The IGBT is damaged. 	<ol style="list-style-type: none"> 1: Reduce the ambient temperature. 2: Clean the air filter. 3 to 5: Seek for maintenance. 	

Display	Fault Name	Possible Causes	Solutions
Err15	External equipment fault	1. External fault signal is input via DI. 2. External fault signal is input via VDI.	Reset the fault.
Err16	Communication fault	1. The host computer is abnormal. 2. The communication cable is faulty. 3. The extension card type set in F0-28 is incorrect. 4. The communication parameters in group FD are set improperly.	1: Check cabling of the host computer. 2: Check the communication cabling. 3: Set F0-28 correctly. 3: Set the communication parameters properly.
Err18	Current detection fault	The drive board is faulty.	Replace the drive board.
Err19	Motor tuning fault	1. Motor parameters are wrong. 2. Motor tuning overtime.	1. Check motor parameters F1-00 to F1-05. 2. Check the wiring between drive and motor.
Err21	EEPROM read-write fault	The EEPROM chip is damaged.	Replace the main control board.
Err23	Short circuit to ground	The motor is short-circuited to ground.	Replace the cables or motor.
Err26	Accumulative running time reached	The accumulative running time reaches the setting of F8-17.	Clear the record by performing parameter initialization (set FP-01 to 2).
Err27	User-defined fault 1	1. The user-defined fault 1 signal is input via DI. 2. User-defined fault 1 signal is input via VDI.	Reset the fault.
Err28	User-defined fault 2	1. The user-defined fault 2 signal is input via DI 2. The user-defined fault 2 signal is input via VDI.	Reset the fault.
Err29	Accumulative power-on time reached	The accumulative power-on time reaches the setting of F8-16.	Clear the record by performing parameter initialization (set FP-01 to 2).
Err30	Off load fault	Offload when it's running.	Check the connection between motor and load.
Err31	PID feedback lost during running	The PID feedback is lower than FA-26.	Check the PID feedback signal or set FA-26 to a proper value.
Err33	Communication receiving timeout inside drive board	1. Wirings become loose inside the AC drive 2. The drive board is abnormal. 3. The control board is abnormal.	1. Connect all wirings securely. 2 and 3. Seek for maintenance.

4 Troubleshooting

Display	Fault Name	Possible Causes	Solutions
Err40	Quick current limit	<ol style="list-style-type: none"> 1. The load is too heavy or the rotor is locked. 2. The drive is of too small power class. 	<ol style="list-style-type: none"> 1: Reduce the load, or check the motor, or check the machine whether it is locking the rotor. 2: Select a drive of higher power class.
Err41	Motor switchover fault during running	The current motor is switched over via a terminal during running of the AC drive.	Switch over the motor only after the AC drive stops.
Err42	Overspeed error	<ol style="list-style-type: none"> 1. Locked-rotor occurs on the motor. 2. F9-69 and F9-70 are set improperly. 3. Wirings between the AC drive and motor are abnormal. 	<ol style="list-style-type: none"> 1. Check whether the machine is abnormal, whether motor auto-tuning is not performed, and whether the setting of F2-10 is small. 2. Set F9-69 and F9-70 properly. 3. Check whether wirings between the AC drive and motor break. If yes, reconnect the wirings securely.
Err96	Communication receiving timeout inside control board	<ol style="list-style-type: none"> 1. Wirings become loose inside the AC drive 2. The drive board is abnormal. 3. The control board is abnormal. 	<ol style="list-style-type: none"> 1. Connect all wirings securely. 2 and 3. Seek for maintenance.

4.2 Common Symptoms And Diagnostics

Fault Name	Possible Causes	Solutions
There is no display at power-on.	<ol style="list-style-type: none"> 1. There is no power supply or the power supply is too low. 2. The switching power supply on the drive board is faulty. 3. The rectifier bridge is damaged. 4. The buffer resistor of the drive is damaged. 5. The control board or the keypad is faulty. 6. The cable between the control board and the drive board or keypad breaks. 	<ol style="list-style-type: none"> 1: Check the power supply. 2 to 5: Seek for maintenance. 6: Re-connect the 4-core and 28-core flat cables, or seek for maintenance.
"HC" is displayed at power-on.	<ol style="list-style-type: none"> 1. The cable between the drive board and the control board is in poor contact. 2. The control board is damaged. 3. The motor winding or the motor cable is short-circuited to the ground. 4. The power supply is too low. 	<ol style="list-style-type: none"> 1: Re-connect the 4-core and 28-core flat cables, or seek for maintenance. 2: Seek for maintenance. 3: Check the motor or replace it, and check the motor cable. 4. Check the power supply according to chapter 1.3.

Fault Name	Possible Causes	Solutions
"Err23" is displayed at power-on.	<ol style="list-style-type: none"> 1. The motor or output cables are short circuited to ground. 2. The AC drive is damaged. 	<ol style="list-style-type: none"> 1. Measure insulation of the motor and output cables. 2. Seek for maintenance.
The display is normal upon power-on, but "HC" is displayed after startup and the motor stops immediately.	<ol style="list-style-type: none"> 1. The cooling fan is damaged or the rotor is locked. 2. A certain terminal is short-circuited. 	<ol style="list-style-type: none"> 1: Replace cooling fan, or check the machine whether it is locking the rotor. 2: Eliminate short circuit.
Err14 is reported frequently.	<ol style="list-style-type: none"> 1. The carrier frequency is set too high. 2. The cooling fan is damaged, or the air filter is blocked. 3. Components (thermal coupler or others) inside the drive are damaged. 	<ol style="list-style-type: none"> 1: Reduce F0-15. 2: Replace the fan and clean the air filter. 3: Seek for maintenance.
The motor does not rotate after the AC drive outputs a non-zero reference.	<ol style="list-style-type: none"> 1. The motor or motor cable is damaged. 2. The motor parameters are set improperly. 3. The cable between the drive board and the control board is in poor contact. 4. The drive board is faulty. 5. The rotor is locked. 	<ol style="list-style-type: none"> 1: Check the motor, or check the cable between the drive and the motor. 2: Check and re-set motor parameters. 3: Re-connect the 4-core and 28-core flat cables, or seek for maintenance. 4: Seek for maintenance. 5: Check the machine whether it is locking the rotor.
The DI terminals are disabled.	<ol style="list-style-type: none"> 1. The DI parameters are set incorrectly. 2. The input signal is incorrect. 3. The wire jumper between OP and +24V is in poor contact. 4. The control board is faulty. 	<ol style="list-style-type: none"> 1: Check and reset DI parameters in group F4. 2: Check the input signals, or check the input cable. 3: Check the jumper between OP and +24 V. 4: Seek for maintenance.
The drive reports overcurrent and overvoltage frequently.	<ol style="list-style-type: none"> 1. The motor parameters are set improperly. 2. The acceleration/deceleration time is too small. 3. The load fluctuates. 	<ol style="list-style-type: none"> 1: Reset motor parameters. 2: Set proper acceleration/ deceleration time. 3: Check the machine, or seek for maintenance.
Err17 is reported at power-on or during running.	The soft start contactor is not closed.	<ol style="list-style-type: none"> 1. Check whether the contactor wiring becomes loose 2. Check whether the contactor is faulty. 3. Check whether 24 V power supply of the contactor is faulty. 4. Seek for maintenance
Display at power-on	Related device on the control board is damaged.	Seek for maintenance www.nicsanat.com 021-87700210

5 Parameter Table

5.1 General Parameters

■ Group F0: Standard Parameters

Para. No.	Para. Name	Setting Range	Unit	Default	Commission
F0-01	Motor 1 control mode	0: Sensorless vector control (SVC) 2: Voltage/Frequency control (V/F)	N.A.	2	
F0-02	Command source selection	0 to 2	N.A.	0	
F0-03	Main frequency source X selection	0 to 9	N.A.	0	
F0-04	Auxiliary frequency source Y selection	The same as F0-03 (Main frequency source X selection)	N.A.	0	
F0-05	Range base of auxiliary frequency Y for X and Y operation superposition	0: Relative to max. frequency 1: Relative to main frequency X	N.A.	0	
F0-06	Range of auxiliary frequency Y for X and Y operation superposition	0 to 150	%	100	
F0-07	Frequency source superposition selection	00 to 34	N.A.	00	
F0-08	Preset frequency	0.00 to max frequency (F0-10)	N.A.	50.00	
F0-09	Rotation direction	0: Same direction 1: Reverse direction	N.A.	0	
F0-10	Max. frequency	50.00 to 600.00	Hz	50.00	
F0-11	Source of frequency upper limit	0 to 5	N.A.	0	
F0-12	Frequency upper limit	Frequency lower limit (F0-14) to max. frequency (F0-10)	Hz	50.00	
F0-13	Frequency upper limit offset	0.00 to max frequency (F0-10)	Hz	0.00	

Para. No.	Para. Name	Setting Range	Unit	Default	Commission
F0-14	Frequency lower limit	0.00 to frequency upper limit (F0-12)	Hz	0.00	
F0-15	Carrier frequency	0.8 to 16.0	kHz	Model dependent	
F0-16	Carrier frequency adjustment with temperature	0: No 1: Yes	N.A.	1	
F0-17	Acceleration time 1	0.00 to 650.00 (if F0-19 = 2) 0.0 to 6500.0 (if F0-19 = 1) 0 to 65000 (if F0-19 = 0)	s	Model dependent	
F0-18	Deceleration time 1	0.00 to 650.00 (if F0-19 = 2) 0.0 to 6500.0 (if F0-19 = 1) 0 to 65000 (if F0-19 = 0)	s	Model dependent	
F0-19	Acceleration/Deceleration time unit	0: 1 1: 0.1 2: 0.01	s	1	
F0-21	Frequency offset of auxiliary frequency source for X and Y operation superposition	0.00 to max frequency (F0-10)	Hz	0.00	
F0-22	Reserved	-	-	-	
F0-23	Retentive of digital setting frequency upon stop	0: Not retentive 1: Retentive	N.A.	0	
F0-24	Motor parameter group selection	0: Motor parameter group 1 1: Motor parameter group 2	N.A.	0	
F0-25	Acceleration/Deceleration time base frequency	0: Max. frequency (F0-10) 1: Frequency reference 2: 100	Hz	0	
F0-26	Base frequency for UP/DOWN modification during running	0: Running frequency 1: Frequency reference	N.A.	0	
F0-27	Binding command source to frequency source	0000 to 9999	N.A.	0000	

5 Parameter Table

■ Group F1: Motor 1 Parameters

Para. No.	Para. Name	Setting Range	Unit	Default	Commission
F1-00	Motor type selection	0: Common asynchronous motor 1: Variable frequency asynchronous motor	N.A.	0	
F1-01	Rated motor power	0.1 to 30.0	kW	Model dependent	
F1-02	Rated motor voltage	1 to 1000	V	Model dependent	
F1-03	Rated motor current	0.01 to 655.35	A	Model dependent	
F1-04	Rated motor frequency	0.01 to max frequency	Hz	Model dependent	
F1-05	Rated motor speed	1 to 65535	RPM	Model dependent	
F1-06	Stator resistance (asynchronous motor)	0.001 to 65.535	Ω	Model dependent	
F1-07	Rotor resistance	0.001 to 65.535	Ω	Model dependent	
F1-08	Leakage inductive reactance	0.01 to 655.35	mH	Model dependent	
F1-09	Leakage inductive reactance	0.1 to 6553.5	mH	Model dependent	
F1-10	No-load current (asynchronous motor)	0.01 to F1-03	A	Model dependent	
F1-37	Auto-tuning selection	0: No auto-tuning 1: Static auto-tuning 1 2: Complete dynamic auto-tuning 3: Static auto-tuning 2	N.A.	0	

■ Group F2: Vector Control

Para. No.	Para. Name	Setting Range	Unit	Default	Commission
F2-00	Speed loop proportional gain 1	1 to 100	N.A.	30	
F2-01	Speed loop integral time 1	0.01 to 10.00	s	0.50	
F2-02	Switchover frequency 1	0.00 to F2-05	Hz	5.00	
F2-03	Speed loop proportional gain 2	1 to 100	Hz	20	
F2-04	Speed loop integral time 2	0.01 to 10.00s	s	1.00	
F2-06	Vector control slip gain	50 to 200	%	100	
F2-07	Time constant of speed loop filter	0.000 to 1.000	s	0.050	
F2-08	Vector control over-excitation gain	0 to 200	N.A.	0	
F2-09	Torque upper limit source in speed control mode	0 to 7	N.A.	0	
F2-10	Digital setting of torque upper limit in speed control mode	0.0 to 200.0	%	150.0	
F2-11	Selection of torque upper limit reference setting channel in speed control mode (regenerative)	0 to 8	N.A.	0	
F2-12	Digital setting of torque upper limit in speed control mode (regenerative)	0.0 to 200.0	%	150.0	
F2-13	Excitation adjustment proportional gain	0 to 60000	N.A.	10	
F2-14	Excitation adjustment integral gain	0 to 60000	N.A.	10	
F2-15	Torque adjustment proportional gain	0 to 60000	N.A.	10	
F2-16	Torque adjustment integral gain	0 to 60000	N.A.	10	
F2-17	Speed loop property	00 to 11	N.A.	00	
F2-18	Torque feedforward gain	20 to 100	N.A.	80	
F2-21	Max. torque coefficient of field weakening area	50 to 200	%	80	
F2-22	Regenerative power limit	0.0: not limited 0.1 to 200.0	%	0.0	

5 Parameter Table

■ Group F3: V/F Control

Para. No.	Para. Name	Setting Range	Unit	Default	Commission
F3-00	V/F curve setting	0 to 9	N.A.	0	
F3-01	Torque boost	0.0 to 30.0	%	0.0	
F3-02	Cut-off frequency of torque boost	0.00 to max output frequency	Hz	50.00	
F3-03	Multi-point V/F frequency 1 (F1)	0.00 to F3-05	Hz	0.00	
F3-04	Multi-point V/F voltage 1	0.0 to 100.0	%	0.0	
F3-05	Multi-point V/F frequency 2	F3-03 to F3-07	Hz	0.00	
F3-06	Multi-point V/F voltage 2	0.0 to 100.0	%	0.0	
F3-07	Multi-point V/F frequency 3	F3-05 to rated motor frequency (F1-04)	Hz	0.00	
F3-08	Multi-point V/F voltage 3	0.0 to 100.0	%	0.0	
F3-09	V/F slip compensation gain	0 to 200.0	%	0.0	
F3-10	V/F over-excitation gain	0 to 200	%	64	
F3-11	V/F oscillation suppression gain	0 to 100	%	Model dependent	
F3-12	Oscillation suppression mode selection	0 to 4	N.A.	3	
F3-13	Voltage source for V/F separation	0 to 8	N.A.	0	
F3-14	Voltage digital setting for V/F separation	0 to rated motor voltage	V	0	
F3-15	Voltage rise time of V/F separation	0.0 to 1000.0	s	0.0	
F3-16	Voltage decline time of V/F separation	0.0 to 1000.0	s	0.0	
F3-17	Stop mode selection for V/F separation	0: Frequency and voltage declining to 0 independently 1: Frequency declining after voltage declining to 0	N.A.	0	
F3-18	Current limit level	50 to 200	%	150	

Para. No.	Para. Name	Setting Range	Unit	Default	Commission
F3-19	Current limit selection	0: Disabled 1: Enabled	N.A.	1	
F3-20	Current limit gain	0 to 100	N.A.	20	
F3-21	Compensation factor of speed multiplying current limit level	0 to 200	%	50	
F3-22	Voltage limit	200.0 to 810.0	V	760.0	
F3-23	Voltage limit selection	0: Disabled 1: Enabled	N.A.	1	
F3-24	Frequency gain for voltage limit	0 to 100	N.A.	30	
F3-25	Voltage gain for voltage limit	0 to 100	N.A.	30	
F3-26	Frequency rise threshold during voltage limit	0 to 50	Hz	5	
F3-27	Slip compensation time constant	0.1 to 10.0	s	0.5	

■ Group F4: Input Terminals

Para. No.	Para. Name	Setting Range	Unit	Default	Commission
F4-00	DI1 function selection	0 to 59	N.A.	1	
F4-01	DI2 function selection	0 to 59	N.A.	4	
F4-02	DI3 function selection	0 to 59	N.A.	9	
F4-03	DI4 function selection	0 to 59	N.A.	12	
F4-04	DI5 function selection	0 to 59	N.A.	13	
F4-05	DI6 function selection	0 to 59	N.A.	0	
F4-06	DI7 function selection	0 to 59	N.A.	0	
F4-07	DI8 function selection	0 to 59	N.A.	0	
F4-08	DI9 function selection	0 to 59	N.A.	0	
F4-09	DI10 function selection	0 to 59	N.A.	0	
F4-10	DI filter time	0.000 to 1.000	s	0.010	
F4-11	Terminal command mode	0: Two-wire control mode 1 1: Two-wire control mode 2 2: Three-wire control mode 1 3: Three-wire control mode 2	N.A.	0	
F4-12	Terminal UP/DOWN rate	0.01 to 65.535	Hz/s	1.000	
F4-13	AI curve 1 minimum input	0.00 to F4-15	V	0.00	

5 Parameter Table

Para. No.	Para. Name	Setting Range	Unit	Default	Commission
F4-14	Corresponding setting of AI curve1 minimum input	-100.0 to 100.0	%	0.0	
F4-15	AI curve 1 max input	F4-13 to 10.00	V	10.00	
F4-16	Corresponding setting of AI curve1 max input	-100.0 to 100.0	%	100.0	
F4-17	AI1 filter time	0.00 to 10.00	s	0.10	
F4-18	AI curve 2 minimum input	0.00 to F4-20	V	0.00	
F4-19	Corresponding setting of AI curve2 minimum input	-100.0 to 100.0	%	0.0	
F4-20	AI curve 2 max input	F4-18 to 10.00	V	10.00	
F4-21	Corresponding setting of AI curve2 max input	-100.0 to 100.0	%	100.0	
F4-22	AI2 filter time	0.00 to 10.00	s	0.10	
F4-23	AI curve 3 minimum input	-10.00 to F4-25	V	-10.00	
F4-24	Corresponding setting of AI curve3 minimum input	-100.0 to 100.0	%	-100.0	
F4-25	AI curve 3 max input	F4-23 to 10.00	V	10.00	
F4-26	Corresponding setting of AI curve3 max input	-100.0 to 100.0	%	100.0	
F4-27	AI3 filter time	0.00 to 10.00	s	0.10	
F4-28	Pulse minimum input	0.00 to F4-30	kHz	0.00	
F4-29	Corresponding setting of pulse minimum input	-100.0 to 100.0	%	0.0	
F4-30	Pulse max input	F4-28 to 20.00	kHz	20.00	
F4-31	Corresponding setting of pulse max input	-100.0 to 100.0	%	100.0	
F4-32	Pulse filter time	0.00 to 10.00	s	0.10	
F4-33	AI curve selection	111 to 555	N.A.	321	
F4-34	Setting for AI less than minimum input	000 to 111	N.A.	000	
F4-35	DI1 delay time	0.0 to 3600.0	s	0.0	
F4-36	DI2 delay time	0.0 to 3600.0	s	0.0	

Para. No.	Para. Name	Setting Range	Unit	Default	Commission
F4-37	DI3 delay time	0.0 to 3600.0	s	0.0	
F4-38	DI active mode selection 1	00000 to 11111	N.A.	00000	
F4-39	DI active mode selection 2	00000 to 11111	N.A.	00000	

■ Group F5: Output Terminals

Para. No.	Para. Name	Setting Range	Unit	Default	Commission
F5-00	FM terminal output mode	0 to 1	N.A.	0	
F5-01	FMR function (open-collector output terminal) selection	0 to 41	N.A.	0	
F5-02	Relay function (T/A-T/B-T/C) selection	0 to 41	N.A.	2	
F5-03	Extension card relay function (P/A-P/B-P/C) selection	0 to 41	N.A.	0	
F5-04	DO1 function selection (open-collector output terminal)	0 to 41	N.A.	1	
F5-05	Extension card DO2 function selection	0 to 41	N.A.	4	
F5-06	FMP function selection	0 to 16	N.A.	0	
F5-07	AO1 function selection	0 to 16	N.A.	0	
F5-08	AO2 function selection	0 to 16	N.A.	1	
F5-09	Max. FMP output frequency	0.01 to 50.00	kHz	50.00	
F5-10	AO1 zero offset coefficient	-100.0 to 100.0	%	0.0	
F5-11	AO1 gain	-10.00 to 10.00	N.A.	1.00	
F5-12	AO2 zero offset coefficient	-100.0 to +100.0	%	0.00	
F5-13	AO2 gain	-10.00 to +10.00	N.A.	1.00	
F5-17	FMR output delay time	0.0 to 3600.0	s	0.0	
F5-18	Relay 1 output delay time	0.0 to 3600.0	s	0.0	
F5-19	Relay 2 output delay time	0.0 to 3600.0	s	0.0	
F5-20	DO1 output delay time	0.0 to 3600.0	s	0.0	
F5-21	DO2 output delay time	0.0 to 3600.0	s	0.0	
F5-22	DO active mode selection	00000 to 11111	N.A.	00000	

5 Parameter Table

■ Group F6: Start/Stop Control

Para. No.	Para. Name	Setting Range	Unit	Default	Commission
F6-00	Start mode	0: Direct startup 1: Reserved 2: Pre-excited startup (asynchronous motor)	N.A.	0	
F6-01	Mode of catching a spinning motor	0: From stop frequency 1: From zero speed 2: From max. frequency	N.A.	0	
F6-02	Speed of catching a spinning motor	1 to 100	N.A.	20	
F6-03	Startup frequency	0.00 to 10.00	Hz	0.00	
F6-04	Startup frequency active time	0.0 to 100.0	s	0.0	
F6-05	DC injection braking 1 level/Pre-excitation level	0 to 100	%	50	
F6-06	DC injection braking 1 active time/Pre-excitation active time	0.0 to 100.0	s	0.0	
F6-07	Acceleration/ Deceleration mode	0: Linear mode 1: S-curve mode A 2: S-curve mode B	N.A.	0	
F6-08	Time proportion of S-curve start segment	0.0 to (100.0 minus F6-09)	%	30.0	
F6-09	Time proportion of S-curve end segment	0.0 to (100.0 minus F6-08)	%	30.0	
F6-10	Stop mode	0: Decelerate to stop 1: Coast to stop	N.A.	0	
F6-11	DC injection braking 2 frequency threshold	0.00 to 10.00	Hz	0.00	
F6-12	DC injection braking 2 delay time	0.0 to 100.0	s	0.0	
F6-13	DC injection braking 2 level	0 to 100	%	50	
F6-14	DC injection braking 2 active time	0.0 to 100.0	s	0.0	
F6-15	Reserved	-	-	-	
F6-18	Catching a spinning motor current limit	30 to 200	%	Model dependent	
F6-21	Demagnetization time	0.00 to 5.00	s	Model dependent	
F6-22	Min. output frequency	0.00 to F6-11	Hz	0.00	
F6-23	Factory reserved	1 to 100	N.A.	10	

■ Group F7: Keypad Control And LED Display

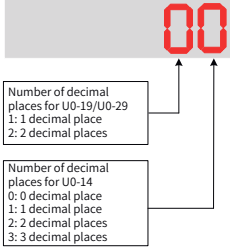
Para. No.	Para. Name	Setting Range	Unit	Default	Commission
F7-01	MF.K Key function selection	0 to 5	N.A.	5	
F7-02	STOP/RESET key function	0 to 1	N.A.	1	
F7-03	LED display running parameters 1	0000 to FFFF	N.A.	1F	
F7-04	LED display running parameters 2	0000 to FFFF	N.A.	0	
F7-05	LED display stop parameters	0000 to FFFF	N.A.	33	
F7-06	Load speed display coefficient	0.0001 to 6.5000	N.A.	1.0000	
F7-07	Heatsink temperature of AC drive IGBT	0 to 100	°C	-	
F7-08	Product number	N.A.	N.A.	N.A.	
F7-09	Accumulative running time	0 to 65535	h	N.A.	
F7-10	Performance software version	N.A.	N.A.	N.A.	
F7-11	Functional software version	N.A.	N.A.	N.A.	
F7-12	Number of decimal places for load speed display		N.A.	21	
F7-13	Accumulative power-on time	0 to 65535	h	N.A.	
F7-14	Accumulative power consumption	0 to 65535	kWh	N.A.	
F7-15	Temporary performance software version	N.A.	N.A.	N.A.	
F7-16	Temporary functional software version	N.A.	N.A.	N.A.	

5 Parameter Table

■ Group F8: Auxiliary Functions

Para. No.	Para. Name	Setting Range	Unit	Default	Commission
F8-00	JOG running frequency	0.00 to max frequency	Hz	2.00	
F8-01	JOG acceleration time	0.0 to 6500.0	s	20.0	
F8-02	JOG deceleration time	0.0 to 6500.0	s	20.0	
F8-03	Acceleration time 2	0.0 to 6500.0	s	Model dependent	
F8-04	Deceleration time 2	0.0 to 6500.0	s	Model dependent	
F8-05	Acceleration time 3	0.0 to 6500.0	s	Model dependent	
F8-06	Deceleration time 3	0.0 to 6500.0	s	Model dependent	
F8-07	Acceleration time 4	0.0 to 500.0	s	Model dependent	
F8-08	Deceleration time 4	0.0 to 6500.0	s	Model dependent	
F8-09	Frequency jump 1	0.00 to max frequency	Hz	0.00	
F8-10	Frequency jump 2	0.00 to max frequency	Hz	0.00	
F8-11	Frequency jump amplitude	0.00 to max frequency	Hz	0.00	
F8-12	Forward/Reverse rotation dead-zone time	0.0 to 3000.0	s	0.0	
F8-13	Reverse control	0: Enabled 1: Disabled	N.A.	0	
F8-14	Running mode when set frequency lower than frequency lower limit	0: Run at frequency lower limit 1: Stop 2: Run at zero speed	N.A.	0	
F8-15	Droop control	0.00 to 10.00	Hz	0.00	
F8-16	Accumulative power-on time threshold	0 to 65000	h	0	
F8-17	Accumulative running time threshold	0 to 65000	h	0	
F8-18	Startup protection	0: No 1: Yes	N.A.	0	
F8-19	Frequency detection value (FDT1)	0.00 to max frequency	Hz	50.00	
F8-20	Frequency detection hysteresis (FDT1 hysteresis)	0.0 to 100.0 (FDT1 level)	%	5.0	
F8-21	Detection range of frequency reached	0.00 to 100 (max frequency)	%	0.0	

Para. No.	Para. Name	Setting Range	Unit	Default	Commission
F8-22	Jump frequency during acceleration/deceleration	0: Disabled 1: Enabled	N.A.	1	
F8-25	Frequency switchover point between acceleration time 1 and acceleration time 2	0.00 to max frequency	Hz	0.00	
F8-26	Frequency switchover point between deceleration time 1 and deceleration time 2	0.00 to max frequency	Hz	0.00	
F8-27	Terminal JOG priority	0: Disabled 1: Enabled	N.A.	0	
F8-28	Frequency detection value (FDT2)	0.00 to max frequency	N.A.	50.00	
F8-29	Frequency detection hysteresis (FDT2 hysteresis)	0.0 to 100.0 (FDT2 level)	%	5.0	
F8-30	Detection value 1 of any frequency reaching	0.00 to max frequency	Hz	50.00	
F8-31	Detection amplitude 1 of any frequency reaching	0.0 to 100.0 (max frequency)	%	0.0	
F8-32	Detection value 2 of any frequency reaching	0.00 to max frequency	Hz	50.00	
F8-33	Detection amplitude 2 of any frequency reaching	0.0 to 100.0 (max frequency)	%	0.0	
F8-34	Zero current detection level	0.0 to 300.0 (rated motor current as 100%)	%	5.0	
F8-35	Zero current detection delay	0.01 to 600.00	s	0.10	
F8-36	Output overcurrent threshold	0.0 (no detection) 0.1 to 300.0 (rated motor current)	%	200.0	
F8-37	Output overcurrent detection delay	0.00 to 600.00	s	0.00	
F8-38	Detection value 1 of any current reached	0.0 to 300.0 (rated motor current)	%	100.0	
F8-39	Detection amplitude 1 of any current reached	0.0 to 300.0 (rated motor current)	%	0.0	
F8-40	Detection value 2 of any current reached	0.0 to 300.0 (rated motor current)	%	100.0	
F8-41	Detection amplitude 2 of any current reached	0.0 to 300.0 (rated motor current)	%	0.0	
F8-42	Timing function	0: Disabled 1: Enabled	N.A.	0	
F8-43	Timing duration source	0 to 3	N.A.	0	

5 Parameter Table

Para. No.	Para. Name	Setting Range	Unit	Default	Commission
F8-44	Timing duration	0.0 to 6500.0	min	0.0	
F8-45	AI1 input voltage lower limit	0 to F8-46	V	3.10	
F8-46	AI1 input voltage upper limit	F8-45 to 11.00	V	6.80	
F8-47	IGBT temperature threshold	0 to 100	°C	75	
F8-48	Cooling fan working mode	0: Fan working during running 1: Fan working continuously	N.A.	0	
F8-49	Wakeup frequency	Dormant frequency (F8-51) to max frequency (F0-10)	Hz	0.00	
F8-50	Wakeup delay	0.0 to 6500.0	s	0.0	
F8-51	Hibernating frequency	0.00 to wakeup frequency (F8-49)	Hz	0.00	
F8-52	Hibernating delay	0.0 to 6500.0	s	0.0	
F8-53	Current running time reached	0.0 to 6500.0	min	0.0	
F8-54	Output power correction coefficient	0.0 to 200.0	%	100.0	
F8-55	Deceleration time for emergency stop	0.00 to 650.00 (F0-19 = 2) 0.0 to 6500.0 (F0-19 = 1) 0 to 65000 (F0-19 = 0)	s	0.1	

■ Group F9: Fault And Protection

Para. No.	Para. Name	Setting Range	Unit	Default	Commission
F9-00	Motor overload protection	0: Disabled 1: Enabled	N.A.	1	
F9-01	Motor overload protection gain	0.20 to 10.00	N.A.	1.00	
F9-02	Motor overload pre-warning coefficient	50 to 100	%	80	
F9-07	Short-circuit to ground upon power-on	0: Disabled 1: Enabled	N.A.	1	
F9-08	Braking unit applied voltage	650.0 to 810.0	V	380 V: 700 V	
F9-09	Auto reset times	0 to 20	N.A.	0	
F9-10	DO action during fault auto reset	0: Not act 1: Act	N.A.	0	
F9-11	Delay of fault auto reset	0.1 to 100.0	s	1.0	
F9-12	Power input phase loss protection	0: Disabled 1: Enabled	N.A.	0	
F9-13	Power output phase loss protection	Units position: Output phase loss protection 0: Disabled 1: Enabled Tens position: Output phase loss protection before running 0: Disabled 1: Enabled	N.A.	01	
F9-14	1st fault type	0 to 96	N.A.	N.A.	
F9-15	2nd fault type	0 to 96	N.A.	N.A.	
F9-16	3rd (latest) fault type	0 to 96	N.A.	N.A.	
F9-17	Frequency upon 3rd fault	N.A.	N.A.	N.A.	
F9-18	Current upon 3rd fault	N.A.	N.A.	N.A.	
F9-19	Bus voltage upon 3rd fault	N.A.	N.A.	N.A.	
F9-20	Input terminal status upon 3rd fault	N.A.	N.A.	N.A.	
F9-21	Output terminal status upon 3rd fault	N.A.	N.A.	N.A.	
F9-22	AC drive status upon 3rd fault	N.A.	N.A.	N.A.	

5 Parameter Table

Para. No.	Para. Name	Setting Range	Unit	Default	Commission
F9-23	Power-on time upon 3rd fault	N.A.	N.A.	N.A.	
F9-24	Running time upon 3rd fault	N.A.	N.A.	N.A.	
F9-27	Frequency upon 2nd fault	N.A.	N.A.	N.A.	
F9-28	Current upon 2nd fault	N.A.	N.A.	N.A.	
F9-29	Bus voltage upon 2nd fault	N.A.	N.A.	N.A.	
F9-30	Input terminal status upon 2nd fault	N.A.	N.A.	N.A.	
F9-31	Output terminal status upon 2nd fault	N.A.	N.A.	N.A.	
F9-32	Frequency upon 2nd fault	N.A.	N.A.	N.A.	
F9-33	Current upon 2nd fault	N.A.	N.A.	N.A.	
F9-34	Bus voltage upon 2nd fault	N.A.	N.A.	N.A.	
F9-37	Input terminal status upon 1st fault	N.A.	N.A.	N.A.	
F9-38	Output terminal status upon 1st fault	N.A.	N.A.	N.A.	
F9-39	Frequency upon 1st fault	N.A.	N.A.	N.A.	
F9-40	Current upon 1st fault	N.A.	N.A.	N.A.	
F9-41	Bus voltage upon 3rd fault	N.A.	N.A.	N.A.	
F9-42	Input terminal status upon 1st fault	N.A.	N.A.	N.A.	
F9-43	Output terminal status upon 1st fault	N.A.	N.A.	N.A.	
F9-44	Frequency upon 1st fault	N.A.	N.A.	N.A.	
F9-47	Fault protection action selection 1	00000 to 22222	N.A.	0000	
F9-48	Fault protection action selection 2	00000 to 21111	N.A.	0000	
F9-49	Fault protection action selection 3	00000 to 22222	N.A.	0000	
F9-54	Frequency selection for continuing to run upon fault	0 to 4	N.A.	0	

Para. No.	Para. Name	Setting Range	Unit	Default	Commission
F9-55	Backup frequency upon abnormality	0.0 to 100.0 (max frequency)	Hz	100.0	
F9-59	Action selection at instantaneous power failure	0: Invalid 1: Decelerate 2: Decelerate to stop	N.A.	0	
F9-60	Pause judging voltage at instantaneous power failure	80 to 100	%	85	
F9-61	Voltage recovery judging time at instantaneous power failure	0.0 to 100.0	s	0.5	
F9-62	Judging voltage at instantaneous power failure	60 to F9-60 (standard bus voltage)	%	80	
F9-63	Protection upon load lost	0: Disabled 1: Enabled	N.A.	0	
F9-64	Load lost detection level	0.0 to 100.0	%	10.0	
F9-65	Load lost detection time	0.0 to 60.0	s	1.0	
F9-66	Min. PID error 2	0.0 to 100.0	%	0.0	
F9-69	Overspeed detection level	0.0 to 50.0 (max. output frequency)	%	20.0	
F9-70	Overspeed detection time	0.0: No detection 0.1 to 60.0	s	0.0	
F9-71	Power dip ride-through gain Kp	0 to 100	N.A.	40	
F9-72	Power dip ride-through integral coefficient	0 to 100	N.A.	30	
F9-73	Deceleration time of power dip ride-through	0.0 to 300.0	s	20.0	

5 Parameter Table

■ Group FA: Process Control And PID Function

Para. No.	Para. Name	Setting Range	Unit	Default	Commission
FA-00	PID reference source	0 to 6	N.A.	0	
FA-01	PID digital reference	0.0 to 100.0	%	50.0	
FA-02	PID feedback source	0 to 8	N.A.	0	
FA-03	PID action direction	0: Forward action 1: Reverse action	N.A.	0	
FA-04	PID setting feedback range	0 to 65535	N.A.	1000	
FA-05	Proportional gain Kp1	0.0 to 100.0	N.A.	20.0	
FA-06	Integral time Ti1	0.01 to 10.00	s	2.00	
FA-07	Differential time Td1	0.000 to 10.000	s	0.000	
FA-08	Cut-off frequency of PID reverse rotation	0.000 to max frequency	Hz	2.00	
FA-09	PID deviation limit	0.0 to 100.0	%	0.0	
FA-10	PID differential limit	0.00 to 100.00	%	0.10	
FA-11	PID setting change time	0.00 to 650.00	s	0.00	
FA-12	PID feedback filter time	0.00 to 60.00	s	0.00	
FA-13	PID output filter time	0.00 to 60.00	s	0.00	
FA-14	Min. PID operation frequency	0.00 to 10.00	Hz	0.00	
FA-15	Proportional gain Kp2	0.0 to 100.0	N.A.	20.0	
FA-16	Integral time Ti2	0.01 to 10.00	s	2.00	
FA-17	Differential time Td2	0.000 to 10.000	s	0.000	
FA-18	PID parameter switchover condition	0 to 3	N.A.	0	
FA-19	PID parameter switchover deviation 1	0.0 to FA-20	%	20.0	
FA-20	PID parameter switchover deviation 2	FA-19 to 100.0	%	80.0	
FA-21	PID initial value	0.0 to 100.0	%	0.0	
FA-22	PID initial value holding time	0.00 to 650.00	s	0.00	

Para. No.	Para. Name	Setting Range	Unit	Default	Commission
FA-23	Max. deviation between two PID outputs in forward direction	0.00 to 100.00	%	1.00	
FA-24	Max. deviation between two PID outputs in reverse direction	0.00 to 100.00	%	1.00	
FA-25	PID integral property	00 to 11	N.A.	00	
FA-26	Detection value of PID feedback loss	0.0: Not judging feedback loss 0.1 to 100.0	%	0.0	
FA-27	Detection time of PID feedback loss	0.0 to 20.0	s	0.0	
FA-28	PID operation at stop	0: No PID operation at stop 1: PID operation at stop	N.A.	0	

■ Group FB: Wobble Frequency, Fixed Length And Count

Para. No.	Para. Name	Setting Range	Unit	Default	Commission
FB-00	Wobble setting mode	0: Relative to the central frequency 1: Relative to the max frequency	N.A.	0	
FB-01	Wobble frequency amplitude	0.0 to 100.0	%	0.0	
FB-02	Wobble step	0.0 to 50.0	%	0.0	
FB-03	Wobble cycle	0.1 to 3000.0	s	10.0	
FB-04	Triangular wave rising time coefficient	0.0 to 100.0	%	50.0	
FB-05	Set length	0 to 65535	m	1000	
FB-06	Actual length	0 to 65535	m	-	
FB-07	Number of pulses per meter	0.1 to 6553.5	N.A.	100.0	
FB-08	Set count value	1 to 65535	N.A.	1000	
FB-09	Designated count value	1 to 65535	N.A.	1000	

5 Parameter Table

■ Group FC: Multi-Reference And Simple PLC Function

Para. No.	Para. Name	Setting Range	Unit	Default	Commission
FC-00	Reference 0	-100.0 to 100.0	%	0.0	
FC-01	Reference 1	-100.0 to 100.0	%	0.0	
FC-02	Reference 2	-100.0 to 100.0	%	0.0	
FC-03	Reference 3	-100.0 to 100.0	%	0.0	
FC-04	Reference 4	-100.0 to 100.0	%	0.0	
FC-05	Reference 5	-100.0 to 100.0	%	0.0	
FC-06	Reference 6	-100.0 to 100.0	%	0.0	
FC-07	Reference 7	-100.0 to 100.0	%	0.0	
FC-08	Reference 8	-100.0 to 100.0	%	0.0	
FC-09	Reference 9	-100.0 to 100.0	%	0.0	
FC-10	Reference 10	-100.0 to 100.0	%	0.0	
FC-11	Reference 11	-100.0 to 100.0	%	0.0	
FC-12	Reference 12	-100.0 to 100.0	%	0.0	
FC-13	Reference 13	-100.0 to 100.0	%	0.0	
FC-14	Reference 14	-100.0 to 100.0	%	0.0	
FC-15	Reference 15	-100.0 to 100.0	%	0.0	
FC-16	Simple PLC running mode	0 to 2	N.A.	0	
FC-17	Simple PLC retentive selection	00 to 11	N.A.	00	
FC-18	Running time of simple PLC reference 0	0.0 to 6500.0	s or h	0.0	
FC-19	Acceleration/deceleration time of simple PLC reference 0	0 to 3	N.A.	0	
FC-20	Running time of simple PLC reference 1	0.0 to 6500.0	s or h	0.0	
FC-21	Acceleration/deceleration time of simple PLC reference 1	0 to 3	N.A.	0	
FC-22	Running time of simple PLC reference 2	0.0 to 6500.0	s or h	0.0	
FC-23	Acceleration/deceleration time of simple PLC reference 2	0 to 3	N.A.	0	
FC-24	Running time of simple PLC reference 3	0.0 to 6500.0	s or h	0.0	
FC-25	Acceleration/deceleration time of simple PLC reference 3	0 to 3	N.A.	0	
FC-26	Running time of simple PLC reference 4	0.0 to 6500.0	s or h	0.0	
FC-27	Acceleration/deceleration time of simple PLC reference 4	0 to 3	N.A.	0	
FC-28	Running time of simple PLC reference 5	0.0 to 6500.0	s or h	0.0	

Para. No.	Para. Name	Setting Range	Unit	Default	Commission
FC-29	Acceleration/deceleration time of simple PLC reference 5	0 to 3	N.A.	0	
FC-30	Running time of simple PLC reference 6	0.0 to 6500.0	s or h	0.0	
FC-31	Acceleration/deceleration time of simple PLC reference 6	0 to 3	N.A.	0	
FC-32	Running time of simple PLC reference 7	0.0 to 6500.0	s or h	0.0	
FC-33	Acceleration/deceleration time of simple PLC reference 7	0 to 3	N.A.	0	
FC-34	Running time of simple PLC reference 8	0.0 to 6500.0	s or h	0.0	
FC-35	Acceleration/deceleration time of simple PLC reference 8	0 to 3	N.A.	0	
FC-36	Running time of simple PLC reference 9	0.0 to 6500.0	s or h	0.0	
FC-37	Acceleration/deceleration time of simple PLC reference 9	0 to 3	N.A.	0	
FC-38	Running time of simple PLC reference 10	0.0 to 6500.0	s or h	0.0	
FC-39	Acceleration/deceleration time of simple PLC reference 10	0 to 3	N.A.	0	
FC-40	Running time of simple PLC reference 11	0.0 to 6500.0	s or h	0.0	
FC-41	Acceleration/deceleration time of simple PLC reference 11	0 to 3	N.A.	0	
FC-42	Running time of simple PLC reference 12	0.0 to 6500.0	s or h	0.0	
FC-43	Acceleration/deceleration time of simple PLC reference 12	0 to 3	N.A.	0	
FC-44	Running time of simple PLC reference 13	0.0 to 6500.0	s or h	0.0	
FC-45	Acceleration/deceleration time of simple PLC reference 13	0 to 3	N.A.	0	
FC-46	Running time of simple PLC reference 14	0.0 to 6500.0	s or h	0.0	
FC-47	Acceleration/deceleration time of simple PLC reference 14	0 to 3	N.A.	0	
FC-48	Running time of simple PLC reference 15	0.0 to 6500.0	s or h	0.0	
FC-49	Acceleration/deceleration time of simple PLC reference 15	0 to 3	N.A.	0	
FC-50	Time unit of simple PLC running	0: s (second); 1: h (hour)	N.A.	0	
FC-51	Reference 0 source	0 to 6	N.A.	0	

5 Parameter Table

■ Group FD: Communication

Para. No.	Para. Name	Setting Range	Unit	Default	Commission
FD-00	Baud rate	0000 to 9999	N.A.	5005	
FD-01	Data format symbol	0 to 3	N.A.	0	
FD-02	Local address	0: Broadcast address; 1 to 247	N.A.	1	
FD-03	Response delay	0 to 20	ms	2	
FD-04	Communication timeout	0.0 (invalid); 0.1 to 60.0	s	0.0	
FD-05	Communication protocol	30, 31	N.A.	31	
FD-06	Current resolution read by communication	0: 0.01 1: 0.1	A	0	
FD-07	Factory reserved	0: Background software invalid 1: Background software valid	N.A.	0	
FD-08	Extension card communication timeout time	0.0: Invalid 0.1 to 60.0	s	0.0	

■ Group FE: User-Defined Parameters

Para. No.	Para. Name	Setting Range	Unit	Default	Commission
FE-00	User-defined function code 0	F0-00 to FP-xx, A1-00 to Ax-xx, U0-xx to U0-xx	N.A.	F0-01	
FE-01	User-defined function code 1		N.A.	F0-02	
FE-02	User-defined function code 2		N.A.	F0-03	
FE-03	User-defined function code 3		N.A.	F0-07	
FE-04	User-defined function code 4		N.A.	F0-08	
FE-05	User-defined function code 5		N.A.	F0-17	
FE-06	User-defined function code 6		N.A.	F0-18	
FE-07	User-defined function code 7		N.A.	F3-00	
FE-08	User-defined function code 8		N.A.	F3-01	
FE-09	User-defined function code 9		N.A.	F4-00	
FE-10	User-defined function code 10		N.A.	F4-01	
FE-11	User-defined function code 11		N.A.	F4-02	
FE-12	User-defined function code 12		N.A.	F5-02	
FE-13	User-defined function code 13		N.A.	F5-07	
FE-14	User-defined function code 14		N.A.	F6-00	
FE-15	User-defined function code 15		N.A.	F6-10	
FE-16	User-defined function code 16		N.A.	F0-00	
FE-17	User-defined function code 17		N.A.	F0-00	
FE-18	User-defined function code 18		N.A.	F0-00	
FE-19	User-defined function code 19		N.A.	F0-00	
FE-20	User-defined function code 20		N.A.	F0-00	
FE-21	User-defined function code 21		N.A.	F0-00	
FE-22	User-defined function code 22		N.A.	F0-00	
FE-23	User-defined function code 23		N.A.	F0-00	
FE-24	User-defined function code 24		N.A.	F0-00	
FE-25	User-defined function code 25		N.A.	F0-00	
FE-26	User-defined function code 26		N.A.	F0-00	
FE-27	User-defined function code 27		N.A.	F0-00	
FE-28	User-defined function code 28		N.A.	F0-00	
FE-29	User-defined function code 29		N.A.	F0-00	
FE-30	User-defined function code 30		N.A.	F0-00	
FE-31	User-defined function code 31	N.A.	F0-00		

5 Parameter Table

■ Group FP: Para. No. Management

Para. No.	Para. Name	Setting Range	Unit	Default	Commission
FP-00	User password	0 to 65535	N.A.	0	
FP-01	Parameter initialization	0: No operation 01: Restore factory settings except motor parameters 02: Clear records 04: Restore user backup parameters 501: Back up current user parameters 10: Initialization of power cable payoff parameters 20: Initialization of mechanical movement (vertical, horizontal, arm swing) industry parameters 21: Initialization of inertia industry (fan) parameters 22: Initialization of lathe industry parameters 23: Initialization of quick start/ stop industry (printing machine) parameters	N.A.	0	
FP-02	AC drive parameter display property	00 to 11	N.A.	11	
FP-03	Individualized parameter display property	00 to 11	N.A.	00	
FP-04	Parameter modification property	0: Modifiable 1: Not modifiable	N.A.	0	

■ Group A0: Torque Control

Para. No.	Para. Name	Setting Range	Unit	Default	Commission
A0-00	Speed/Torque control selection	0: Speed control 1: Torque control	N.A.	0	
A0-01	Torque setting source in torque control	0 to 7	N.A.	0	
A0-03	Torque digital setting in torque control	-200.0 to 200.0	%	150.0	
A0-05	Forward max frequency in torque control	0.00 to max frequency (F0-10)	Hz	50.00	
A0-06	Reverse max frequency in torque control	0.00 to max frequency (F0-10)	Hz	50.00	

A0-07	Acceleration time in torque control	0.00 to 650.00	s	0.00	
A0-08	Deceleration time in torque control	0.00 to 650.00	s	0.00	

■ Group A1: Virtual DI/DO

Para. No.	Para. Name	Setting Range	Unit	Default	Commission
A1-00	VDI1 function selection	0 to 59	N.A.	0	
A1-01	VDI2 function selection	0 to 59	N.A.	0	
A1-02	VDI3 function selection	0 to 59	N.A.	0	
A1-03	VDI4 function selection	0 to 59	N.A.	0	
A1-04	VDI5 function selection	0 to 59	N.A.	0	
A1-05	VDI state setting mode	00000 to 11111	N.A.	00000	
A1-06	VDI state selection	00000 to 11111	N.A.	00000	
A1-07	Function selection for AI1 used as DI	0 to 59	N.A.	0	
A1-08	Function selection for AI2 used as DI	0 to 59	N.A.	0	
A1-09	Function selection for AI3 used as DI	0 to 59	N.A.	0	
A1-10	State selection for AI used as DI	000 to 111	N.A.	000	
A1-11	VDO1 function selection	0 to 41	N.A.	0	
A1-12	VDO2 function selection	0 to 41	N.A.	0	
A1-13	VDO3 function selection	0 to 41.	N.A.	0	
A1-14	VDO4 function selection	0 to 41	N.A.	0	
A1-15	VDO5 function selection	0 to 41	N.A.	0	
A1-16	VDO1 output delay	0.0 to 3600.0	s	0.0	
A1-17	VDO2 output delay	0.0 to 3600.0	s	0.0	
A1-18	VDO3 output delay	0.0 to 3600.0	s	0.0	
A1-19	VDO4 output delay	0.0 to 3600.0	s	0.0	
A1-20	VDO5 output delay	0.0 to 3600.0	s	0.0	
A1-21	VDO state selection	00000 to 11111	N.A.	00000	

5 Parameter Table

■ Group A2: Motor 2 Parameters

Para. No.	Para. Name	Setting Range	Unit	Default	Commission
A2-00	Motor type selection	0: Common asynchronous motor 1: Variable frequency asynchronous motor	N.A.	0	
A2-01	Rated motor power	0.1 to 30.0	kW	Model dependent	
A2-02	Rated motor voltage	1 to 1000	V	Model dependent	
A2-03	Rated motor current	0.01 to 655.35	A	Model dependent	
A2-04	Rated motor frequency	0.01 to max frequency	Hz	Model dependent	
A2-05	Rated motor speed	1 to 65535	RPM	Model dependent	
A2-06	Stator resistance	0.001 to 65.535 0.0001 to 6.5535	Ω	Model dependent	
A2-07	Rotor resistance	0.001 to 65.535	Ω	Model dependent	
A2-08	Leakage inductive reactance	0.01 to 655.35	mH	Model dependent	
A2-09	Mutual inductive reactance	0.1 to 6553.5	mH	Model dependent	
A2-10	No-load current	0.01 to A2-03	A	Model dependent	
A2-37	Auto-tuning selection	0: No auto-tuning 1: Static auto-tuning 1 2: Complete auto-tuning 3: Static auto-tuning 2	N.A.	0	
A2-38	Speed loop proportional gain 1	1 to 100	N.A.	30	
A2-39	Speed loop integral time 1	0.01 to 10.00	s	0.50	
A2-40	Switchover frequency 1	0.00 to A2-43	Hz	5.00	
A2-41	Speed loop proportional gain 2	1 to 100	N.A.	20	
A2-42	Speed loop integral time 2	0.01 to 10.00	s	1.00	
A2-43	Switchover frequency 2	A2-40 to max output frequency	Hz	10.00	
A2-44	Vector control slip gain	50 to 200	%	100	
A2-45	Time constant of speed loop filter	0.000 to 1.000	s	0.050	

Para. No.	Para. Name	Setting Range	Unit	Default	Commission
A2-46	Vector control over-excitation gain	0 to 200	N.A.	0	
A2-47	Torque upper limit source in speed control mode	0 to 7	N.A.	0	
A2-48	Digital setting of torque upper limit in speed control mode	0.0 to 200.0	%	150.0	
A2-49	Selection of torque upper limit reference setting channel in speed control mode (regenerative)	0 to 8	N.A.	0	
A2-50	Digital setting of torque upper limit in speed control mode (regenerative)	0.0 to 200.0	%	150.0	
A2-51	Excitation adjustment proportional gain	0 to 60000	N.A.	10	
A2-52	Excitation adjustment integral gain	0 to 60000	N.A.	10	
A2-53	Torque adjustment proportional gain	0 to 60000	N.A.	10	
A2-54	Torque adjustment integral gain	0 to 60000	N.A.	10	
A2-55	Speed loop property	00 to 11	N.A.	00	
A2-56	Torque feedforward gain	20 to 100	N.A.	80	
A2-59	Max. torque coefficient in field weakening area	50 to 200	%	80	
A2-60	Regenerative power limit	0.0: Not limited 0.1% to 200.0	%	0.0	
A2-61	Motor 2 control mode	0: Sensorless vector control (SVC) 2: Voltage/Frequency (V/F) control	N.A.	2	
A2-62	Motor 2 acceleration/ deceleration time	0: Same as motor 1 1: Acceleration/ Deceleration time 1 2: Acceleration/ Deceleration time 2 3: Acceleration/ Deceleration time 3 4: Acceleration/ Deceleration time 4	N.A.	0	
A2-63	Motor 2 torque boost	0.0: Fixed torque boost, 0.1 to 30	%	Model dependent	
A2-65	Motor 2 oscillation suppression gain	0 to 100	N.A.	Model	

5 Parameter Table

■ Group A5: Control Optimization

Para. No.	Para. Name	Setting Range	Unit	Default	Commission
A5-00	DPWM switchover frequency upper limit	0.00 to max output frequency	Hz	Model dependent	
A5-01	PWM modulation mode	0: Asynchronous modulation 1: Synchronous modulation	N.A.	0	
A5-02	Dead zone compensation mode selection	0: No compensation 1: Compensation	N.A.	1	
A5-03	Random PWM depth	0 to 10	N.A.	0	
A5-04	Fast current limit	0: Disabled 1: Enabled	N.A.	1	
A5-05	Max output voltage coefficient	100 to 110	%	105	
A5-06	Undervoltage threshold	300.0 to 600.0V	V	350.0	
A5-07	SVC optimization mode selection	0: Not optimized 1: Optimization mode 1 2: Optimization mode 2	N.A.	1	
A5-08	Factory reserved	0.0: Invalid 0.1 to 6.0	kHz	0.0	
A5-09	Overvoltage threshold	200.0 to 900.0	V	820.0	

■ Group A6: AI Curve Setting

Para. No.	Para. Name	Setting Range	Unit	Default	Commission
A6-00	AI curve 4 minimum input	-10.00 to A6-02	V	0.00	
A6-01	Corresponding setting of AI curve 4 minimum input	-100.0 to 100.0	%	0.0	
A6-02	AI curve 4 inflexion 1 input	A6-00 to A6-04	V	3.00	
A6-03	Corresponding setting of AI curve 4 inflexion 1 input	-100.0 to 100.0	%	30.0	
A6-04	AI curve 4 inflexion 1 input	A6-02 to A6-06	V	6.00	
A6-05	Corresponding setting of AI curve 4 inflexion 1 input	-100.0 to 100.0	%	60.0	
A6-06	AI curve 4 max input	A6-06 to 10.00	V	10.00	
A6-07	Corresponding setting of AI curve 4 max input	-100.0 to 100.0	%	100.0	
A6-08	AI curve 5 minimum input	-10.00 to A6-10	V	0.00	
A6-09	Corresponding setting of AI curve 5 minimum input	-100.0 to 100.0	%	0.0	
A6-10	AI curve 5 inflexion 1 input	A6-08 to A6-12	V	3.00	

A6-11	Corresponding setting of AI curve 5 inflexion 1 input	-100.0 to 100.0	%	30.0	
A6-12	AI curve 5 inflexion 1 input	A6-10 to A6-14	V	6.00	
A6-13	Corresponding setting of AI curve 5 inflexion 1 input	-100.0 to 100.0	%	60.0	
A6-14	AI curve 5 max input	A6-14 to 10.00	V	10.00	
A6-15	Corresponding setting of AI curve 5 max input	-100.0 to 100.0	%	100.0	
A6-24	Jump point of AI1 input corresponding setting	-100.0 to 100.0	%	0.0	
A6-25	Jump amplitude of AI1 input corresponding setting	0.0 to 100.0	%	0.5	
A6-26	Jump point of AI2 input corresponding setting	-100.0 to +100.0	%	0.0	
A6-27	Jump amplitude of AI2 input corresponding setting	0.0 to 100.0	%	0.5	
A6-28	Jump point of AI3 input corresponding setting	-100.0 to +100.0	%	0.0	
A6-29	Jump amplitude of AI3 input corresponding setting	0.0 to 100.0	%	0.5	

■ Group AC: AI/AO Correction

Para. No.	Para. Name	Setting Range	Unit	Default	Commission
AC-00	AI1 measured voltage 1	-10.000 to 10.000	V	Factory corrected	
AC-01	AI1 displayed voltage 1	-10.000 to 10.000	V	Factory corrected	
AC-02	AI1 measured voltage 2	-10.000 to 10.000	V	Factory corrected	
AC-03	AI1 displayed voltage 2	-10.000 to 10.000	V	Factory corrected	
AC-04	AI2 measured voltage 1	-10.000 to 10.000	V	Factory corrected	
AC-05	AI2 displayed voltage 1	-10.000 to 10.000	V	Factory corrected	
AC-06	AI2 measured voltage 2	-10.000 to 10.000	V	Factory corrected	
AC-07	AI2 displayed voltage 2	-10.000 to 10.000	V	Factory corrected	
AC-08	AI3 measured voltage 1	-10.000 to 10.000	V	Factory corrected	
AC-09	AI3 displayed voltage 1	-10.000 to 10.000	V	Factory corrected	
AC-10	AI3 measured voltage 2	-10.000 to 10.000	V	Factory corrected	
AC-11	AI3 displayed voltage 2	-10.000 to 10.000	V	Factory corrected	
AC-12	AO1 target voltage 1	-10.000 to 10.000	V	Factory corrected	
AC-13	AO1 measured voltage 1	-10.000 to 10.000	V	Factory corrected	
AC-14	AO1 target voltage 2	-10.000 to 10.000	V	Factory corrected	
AC-15	AO1 measured voltage 2	-10.000 to 10.000	V	Factory corrected	
AC-16	AO2 target voltage 1	-10.000 to 10.000	V	Factory corrected	

5 Parameter Table

Para. No.	Para. Name	Setting Range	Unit	Default	Commission
AC-17	AO2 measured voltage 1	-10.000 to 10.000	V	Factory corrected	
AC-18	AO2 target voltage 2	-10.000 to 10.000	V	Factory corrected	
AC-19	AO2 measured voltage 2	-10.000 to 10.000	V	Factory corrected	

5.2 Monitoring Parameters

■ Group U0: Monitoring

Para. No.	Para. Name	Setting Range	Unit	Default	Commission
U0-00	Running frequency	N.A.	Hz	N.A.	
U0-01	Set frequency	N.A.	Hz	N.A.	
U0-02	Bus voltage	N.A.	V	N.A.	
U0-03	Output voltage	N.A.	V	N.A.	
U0-04	Output current	N.A.	A	N.A.	
U0-05	Output power	N.A.	kW	N.A.	
U0-06	Output torque	N.A.	%	N.A.	
U0-07	DI state	N.A.	N.A.	N.A.	
U0-08	DO state	N.A.	N.A.	N.A.	
U0-09	AI1 voltage	N.A.	V	N.A.	
U0-10	AI2 voltage	N.A.	V	N.A.	
U0-11	AI3 voltage	N.A.	V	N.A.	
U0-12	Count value	N.A.	N.A.	N.A.	
U0-13	Length value	N.A.	N.A.	N.A.	
U0-14	Load speed	N.A.	N.A.	N.A.	
U0-15	PID setting	N.A.	N.A.	N.A.	
U0-16	PID feedback	N.A.	N.A.	N.A.	
U0-17	PLC stage	N.A.	N.A.	N.A.	
U0-18	Input pulse frequency	N.A.	kHz	N.A.	
U0-19	Feedback speed	N.A.	Hz	N.A.	
U0-20	Remaining running time	N.A.	Min	N.A.	
U0-21	AI1 voltage before correction	N.A.	V	N.A.	
U0-22	AI2 voltage before correction	N.A.	V	N.A.	
U0-23	AI3 voltage before correction	N.A.	V	N.A.	
U0-24	Linear speed	N.A.	m/Min	N.A.	
U0-25	Accumulative power-on time	N.A.	Min	N.A.	
U0-26	Accumulative running time	N.A.	Min	N.A.	
U0-27	Pulse input frequency	N.A.	Hz	N.A.	
U0-28	Communication setting value	N.A.	%	N.A.	
U0-29	Reserved	N.A.	N.A.	N.A.	
U0-30	Main frequency X	N.A.	Hz	N.A.	

Para. No.	Para. Name	Setting Range	Unit	Default	Commission
U0-31	Auxiliary frequency Y	N.A.	Hz	N.A.	
U0-32	Viewing any register address value	N.A.	N.A.	N.A.	
U0-34	Motor temperature	N.A.	°C	N.A.	
U0-35	Target torque	N.A.	%	N.A.	
U0-37	Power factor angle	N.A.	°	N.A.	
U0-39	Target voltage for V/F separation	N.A.	V	N.A.	
U0-40	Output voltage for V/F separation	N.A.	V	N.A.	
U0-41	DI state visual display	N.A.	N.A.	N.A.	
U0-42	DO state visual display	N.A.	N.A.	N.A.	
U0-43	DI function state visual display 1	N.A.	N.A.	N.A.	
U0-44	DI function state visual display 2	N.A.	N.A.	N.A.	
U0-61	AC drive state	N.A.	N.A.	N.A.	

■ Group U3: Extension Card Communication Control

Para. No.	Para. Name	Setting Range	Unit	Default	Commission
U3-00 to U3-15	Reserved	N.A.	N.A.	N.A.	
U3-16	Frequency setting	N.A.	Hz	N.A.	
U3-17	Control command	N.A.	N.A.	N.A.	
U3-18	DO control	N.A.	N.A.	N.A.	
U3-19	AO1 control	N.A.	N.A.	N.A.	
U3-20	AO2 control	N.A.	N.A.	N.A.	
U3-21	FMP control	N.A.	N.A.	N.A.	
U3-22	Reserved	N.A.	N.A.	N.A.	
U3-23	Motor speed control	N.A.	RPM	N.A.	

Revision History

Date	Version	Change Description
May 2018	B02	Updated the description of the function code F9-13 in the parameter table in " 5 Parameter Table ".



User Guide

MD310 AC Drive

General Purpose Open Loop

Shenzhen Inovance Technology Co., Ltd.

Add.: Building E, Hongwei Industry Park, Liuxian Road, Baocheng No. 70 Zone, Bao' an District, Shenzhen
 Tel: +86-755-2979 9595
 Fax: +86-755-2961 9897
 Service Hotline: 400-777-1260
<http://www.inovance.com>

Suzhou Inovance Technology Co., Ltd.

Add.: No. 16 Youxiang Road, Yuexi Town, Wuzhong District, Suzhou 215104, P.R. China
 Tel: +86-512-6637 6666
 Fax: +86-512-6285 6720
 Service Hotline: 400-777-1260
<http://www.inovance.com>

www.nicsanat.com
 021-87700210



Artisan Technology Group is an independent supplier of quality pre-owned equipment

Gold-standard solutions

Extend the life of your critical industrial, commercial, and military systems with our superior service and support.

We buy equipment

Planning to upgrade your current equipment? Have surplus equipment taking up shelf space? We'll give it a new home.

Learn more!

Visit us at artisanng.com for more info on price quotes, drivers, technical specifications, manuals, and documentation.

Artisan Scientific Corporation dba Artisan Technology Group is not an affiliate, representative, or authorized distributor for any manufacturer listed herein.

We're here to make your life easier. How can we help you today?

(217) 352-9330 | sales@artisanng.com | artisanng.com

