

The right choice for the ultimate yield!

LS ELECTRIC strives to maximize your profits in gratitude for choosing us as your partner.

# AC Variable Speed Drive

[www.nicsanat.com](http://www.nicsanat.com)

021-87700210

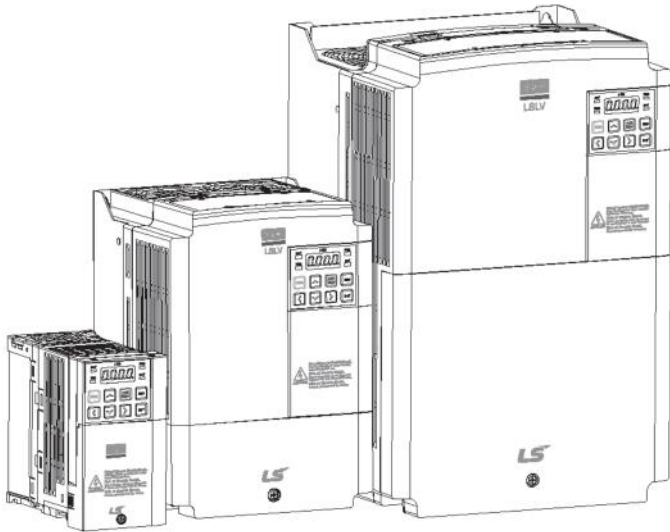

## LSLV-S100series

### Safety Instructions

- Read this manual carefully before installing, wiring, operating, servicing or inspecting this equipment.
- Keep this manual within easy reach for quick reference.

**LS**ELECTRIC

This operation manual is intended for users with basic knowledge of electricity and electric devices.

\* LSLV-S100 is the official name for S100.

[www.nicsanat.com](http://www.nicsanat.com)

021-87700210



# Safety Information

Read and follow all safety instructions in this manual precisely to avoid unsafe operating conditions, property damage, personal injury, or death.

## Safety symbols in this manual

### Danger

Indicates an imminently hazardous situation which, if not avoided, will result in severe injury or death.

### Warning

Indicates a potentially hazardous situation which, if not avoided, could result in injury or death.

### Caution

Indicates a potentially hazardous situation that, if not avoided, could result in minor injury or property damage.

## Safety information

### Danger

- Do not open the cover of the equipment while it is on or operating. Likewise, do not operate the inverter while the cover is open. Exposure of high voltage terminals or charging area to the external environment may result in an electric shock. Do not remove any covers or touch the internal circuit boards (PCBs) or electrical contacts on the product when the power is on or during operation. Doing so may result in serious injury, death, or serious property damage.
- Do not open the cover of the equipment even when the power supply to the inverter has been turned off unless it is necessary for maintenance or regular inspection. Opening the cover may result in an electric shock even when the power supply is off.
- The equipment may hold charge long after the power supply has been turned off. Use a multi-meter to make sure that there is no voltage before working on the inverter, motor or motor cable.

## Warning

- This equipment must be grounded for safe and proper operation.
- Do not supply power to a faulty inverter. If you find that the inverter is faulty, disconnect the power supply and have the inverter professionally repaired.
- The inverter becomes hot during operation. Avoid touching the inverter until it has cooled to avoid burns.
- Do not allow foreign objects, such as screws, metal chips, debris, water, or oil to get inside the inverter. Allowing foreign objects inside the inverter may cause the inverter to malfunction or result in a fire.
- Do not operate the inverter with wet hands. Doing so may result in electric shock.
- Check the information about the protection level for the circuits and devices.

The following connection terminals and devices are the Protective Class 0. It means that the circuit protection level depends on the basic insulation. If there is no basic insulation is failed, it may cause electric shock accident. When installing or wiring the connection terminals and devices, take the same protective action as with the power wire.

- Multi-function Input: P1-P7, CM
- Analog Frequency Input: VR, V1, I2, TI
- Safety Function: SA, SB, SC
- Analog Output: AO, AO1, AO2, TO
- Digital Output: Q1, EG, 24, A1, B1, C1, A2, C2
- Communication: S+/ S-/ SG
- Fan

- The protection level of this equipment (inverter) is the Electrical Protective Class I.

## ⚠ Caution

- Do not modify the interior workings of the inverter. Doing so will void the warranty.
- The inverter is designed for 3-phase motor operation. Do not use the inverter to operate a single phase motor.
- Do not place heavy objects on top of electric cables. Doing so may damage the cable and result in an electric shock.

## Note

Maximum allowed prospective short-circuit current at the input power connection is defined in IEC 60439-1 as 100 kA. Depending on the selected MCCB, the LSLV-S100 Series is suitable for use in circuits capable of delivering a maximum of 100 kA RMS symmetrical amperes at the drive's maximum rated voltage. The following table shows the recommended MCCB for RMS symmetrical amperes.

## Remarque

Le courant maximum de court-circuit présumé autorisé au connecteur d'alimentation électrique est défini dans la norme IEC 60439-1 comme égal à 100 kA. Selon le MCCB sélectionné, la série LSLV-S100 peut être utilisée sur des circuits pouvant fournir un courant RMS symétrique de 100 kA maximum en ampères à la tension nominale maximale du variateur. Le tableau suivant indique le MCCB recommandé selon le courant RMS symétrique en ampères.

Working Voltage	UTE100(E/N)	UTS150(N/H/L)	ABS33c	ABS53c	ABS63c	ABS103c
240V(50/60Hz)	50/65 kA	65/100/150 kA	30 kA	35 kA	35 kA	85 kA
480V(50/60Hz)	25/35 kA	35/65/100 kA	7.5 kA	10 kA	10 kA	26 kA

Working Voltage	UTS150 (N/H/L)	UTS250 (N/H/L)	UTS400 (N/H/L)	ABS103c	ABS203c	ABS403c
480V(50/60Hz)	35/65/100kA	35/65/100kA	35/65/100kA	26kA	26kA	35kA

# Table of Contents

<b>1</b>	<b>Preparing the Installation.....</b>	<b>1</b>
1.1	Product Identification.....	1
1.2	Part Names.....	3
1.2.1	0.4-22kW Models.....	3
1.2.2	30-75kW Models.....	5
1.2.3	IP66 Models.....	6
1.3	Installation Considerations.....	8
1.4	Selecting and Preparing a Site for Installation.....	9
1.5	Cable Selection.....	13
<b>2</b>	<b>Installing the Inverter.....</b>	<b>15</b>
2.1	Mounting the Inverter.....	17
2.2	Cable Wiring.....	21
2.3	Post-Installation Checklist.....	54
2.4	Test Run.....	56
<b>3</b>	<b>Learning to Perform Basic Operations.....</b>	<b>59</b>
3.1	About the Keypad.....	59
3.1.1	0.4-22kW Models.....	59
3.1.2	30-75kW Models.....	60
3.1.3	About the Display.....	61
3.1.4	Operation Keys.....	65
3.1.5	Control Menu.....	67
3.2	Learning to Use the Keypad.....	71
3.2.1	Display Mode Selection (30-75kW models only).....	71
3.2.2	Group and Code Selection.....	74
3.2.3	Navigating Directly to Different Codes.....	79
3.2.4	Setting Parameter Values.....	81
3.2.5	Configuring the [ESC] Key (0.4-22kW models only).....	84
3.3	Actual Application Examples.....	85
3.3.1	Acceleration Time Configuration (0.4-22kW models only).....	85
3.3.2	Frequency Reference Configuration (0.4-22kW models only).....	86
3.3.3	Jog Frequency Configuration (0.4-22kW models only).....	87

3.3.4	Initializing All Parameters .....	88
3.3.5	Frequency Setting (Keypad) and Operation (via Terminal Input) .....	90
3.3.6	Frequency Setting (Potentiometer) and Operation (Terminal Input).....	91
3.3.7	Frequency Setting (Potentiometer) and Operation (Keypad) ..	92
3.4	Monitoring the Operation .....	94
3.4.1	0.4-22kW Models.....	94
3.4.2	30-75kW Models.....	97
<b>4</b>	<b>Table of Functions.....</b>	<b>103</b>
4.1	Operation Group.....	103
4.2	Drive group (PAR→dr).....	105
4.3	Basic Function group (PAR→bA).....	110
4.4	Expanded Function group (PAR→Ad).....	115
4.5	Control Function group (PAR→Cn).....	121
4.6	Input Terminal Block Function group (PAR→In).....	130
4.7	Output Terminal Block Function group (PAR→OU).....	136
4.8	Communication Function group (PAR→CM) .....	141
4.9	Application Function group (PAR→AP) .....	146
4.10	Protection Function group (PAR→Pr).....	149
4.11	2nd Motor Function group (PAR→M2) .....	154
4.12	User Sequence group (US) .....	157
4.13	User Sequence Function group(UF).....	160
4.14	Groups for LCD Keypad Only .....	180
4.14.1	Trip Mode (TRP Last-x).....	180
4.14.2	Config Mode (CNF) .....	180
<b>5</b>	<b>Troubleshooting .....</b>	<b>185</b>
5.1	Trips and Warnings .....	185
5.1.1	Fault Trips.....	186
5.1.2	Warning Messages.....	189
5.2	Troubleshooting Fault Trips .....	190
5.3	Troubleshooting Other Faults .....	192
<b>6</b>	<b>Maintenance .....</b>	<b>197</b>

6.1	Regular Inspection Lists.....	197
6.1.1	Daily Inspections.....	197
6.1.2	Annual Inspections.....	198
6.1.3	Bi-annual Inspections.....	200
6.2	Replacing Major Components.....	201
6.2.1	Exchange Cycle for Major Components.....	201
6.3	Storage and Disposal.....	201
6.3.1	Storage.....	201
6.3.2	Disposal.....	202
<b>7</b>	<b>Technical Specification.....</b>	<b>203</b>
7.1	Input and Output Specification.....	203
7.1.1	0.4-22kW Models.....	203
7.1.2	30-75kW Models.....	209
7.2	Product Specification Details.....	210
7.3	External Dimensions.....	213
7.3.1	0.4-22kW Models.....	213
7.3.2	30-75kW Models.....	219
7.3.3	IP66 Models.....	221
7.4	Peripheral Devices.....	228
7.4.1	0.4-22kW Models.....	228
7.4.2	30-75kW Models.....	229
7.5	Fuse and Reactor Specifications.....	229
7.5.1	0.4-22kW Models.....	229
7.5.2	30-75kW Models.....	230
7.6	Terminal Screw Specification.....	231
7.6.1	Input/Output Terminal Screw Specification.....	231
7.6.2	Control Circuit Terminal Screw Specification.....	232
7.7	Dynamic Braking Unit(DBU) and Resistors.....	234
7.7.1	Braking Resistor Specification (0.4-22kW).....	234
7.7.2	Dynamic Braking Unit (30-75kW).....	235
7.7.3	Terminal arrangement.....	235
7.7.4	Dynamic Braking Unit Dimensions.....	237
7.7.5	Display Functions.....	239



7.7.6	Dynamic Braking Unit Resistors .....	239
7.8	Continuous Rated Current Derating.....	240
7.9	Heat Emission .....	243
7.10	Remote Option .....	244
<b>8</b>	<b>Applying Drives to Single-Phase Input Application.....</b>	<b>245</b>
8.1	Introduction .....	245
8.2	Power(HP), Input Current and Output Current.....	246
8.3	Input Frequency and Voltage Tolerance .....	247
	<b>Product Warranty .....</b>	<b>248</b>
	<b>Index .....</b>	<b>256</b>

# 1 Preparing the Installation

This chapter provides details on product identification, part names, correct installation and cable specifications. To install the inverter correctly and safely, carefully read and follow the instructions.

## 1.1 Product Identification

The S100 Inverter is manufactured in a range of product groups based on drive capacity and power source specifications. Product name and specifications are detailed on the rating plate. The illustration on the next page shows the location of the rating plate. Check the rating plate before installing the product and make sure that the product meets your requirements. For more detailed product specifications, refer to [7.1 Input and Output Specification](#) on page [203](#).

### Note

Check the product name, open the packaging, and then confirm that the product is free from defects. Contact your supplier if you have any issues or questions about your product.

<b>LSLV0055S100-4EOFNS</b>			
<b>INPUT</b>	380-480V	3 Phase	50/60Hz
	HD: 11.0A,	ND: 14.7A	
<b>OUTPUT</b>	0-Input V	3 Phase	0.01-400Hz
	HD: 12A,	ND: 16A	
	9.1kVA		
	Ser. No 55025310146		
	Inspected by D. K. YU		

Model name  
Power source specifications  
Output specifications

## LSLV 0055 S100 - 4EOFNS

Motor capacity

0004 - 0.4KW	0150 - 15KW
0008 - 0.75KW	0185 - 18.5KW
0015 - 1.5KW	0220 - 22KW
0022 - 2.2KW	0300 - 30KW
0037 - 3.7KW	0370 - 37KW
0040 - 4.0KW	0450 - 45KW
0055 - 5.5KW	0550 - 55KW
0075 - 7.5KW	0750 - 75KW
0110 - 11KW	

Series name

Input voltage

- 1 - Single phase 200V
- 2 - 3-phase 200V
- 3 - 3-phase 400V

Keypad

- E - LED Keypad
- C - LCD Keypad

UL Type

- O - UL Open Type
- X - IP66

EMC filter

- N - Non-EMC
- F - Built-in EMC

Reactor

- N - Non-Reactor
- D - Built-in DCL

I/O

- M - 3.5mm
- S - 5mm

## 1.2 Part Names

The illustration below displays part names. Details may vary between product groups.

### 1.2.1 0.4-22kW Models

#### 0.4-2.2kW (Single Phase) and 0.4-4.0kW (3-Phase)

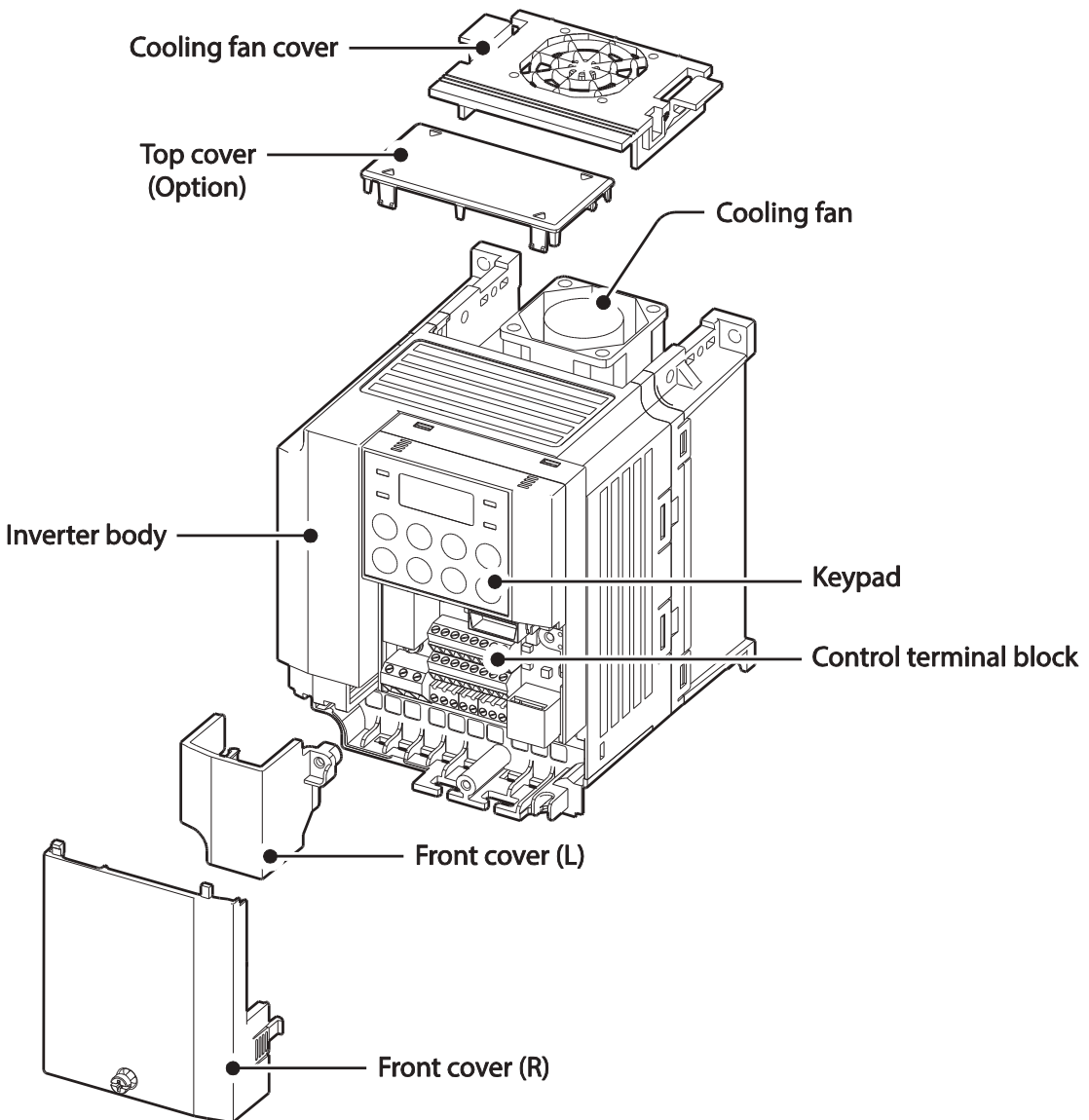

5.5-22kW(3-Phase)

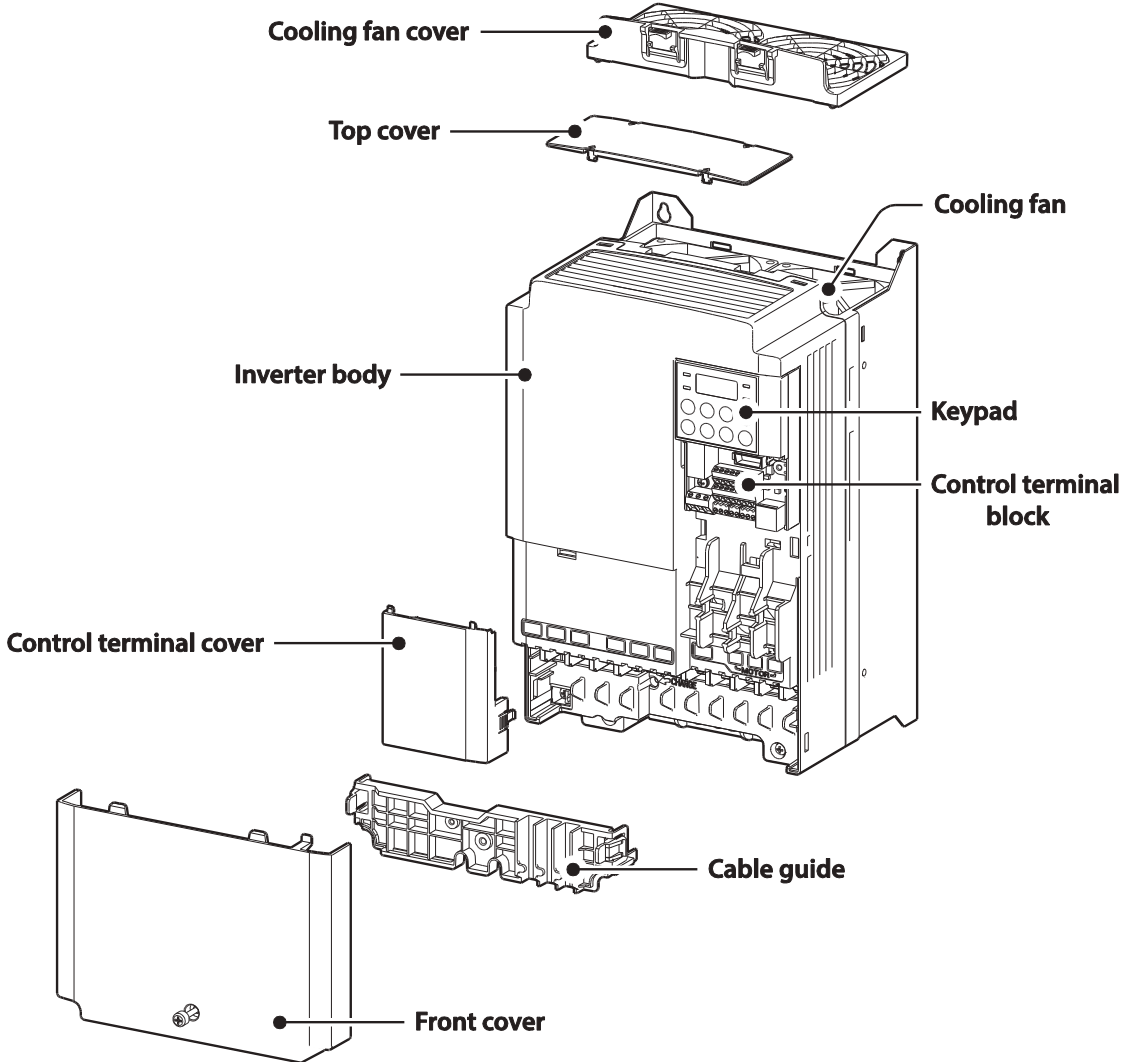

## 1.2.2 30-75kW Models

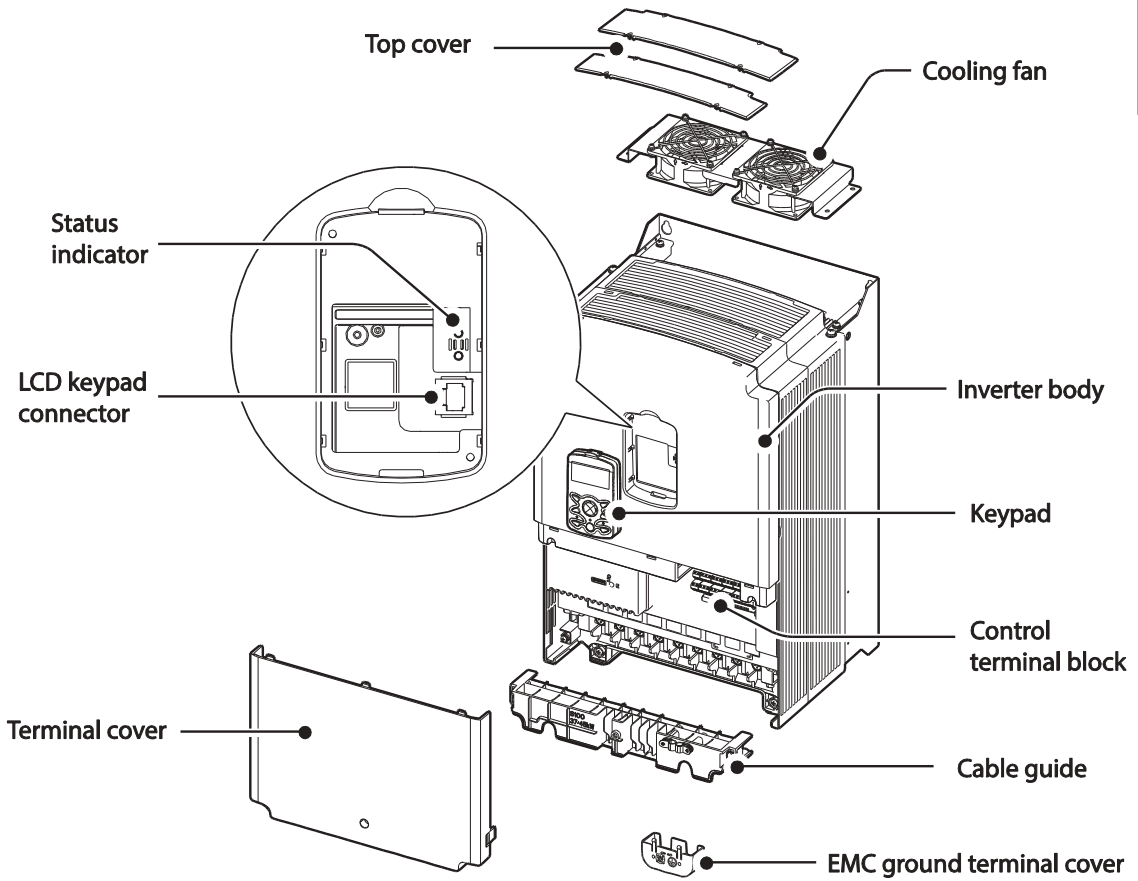

### Note

The grounding terminal cover of EMC is not existed in the 55-75kW inverters.

### 1.2.3 IP66 Models

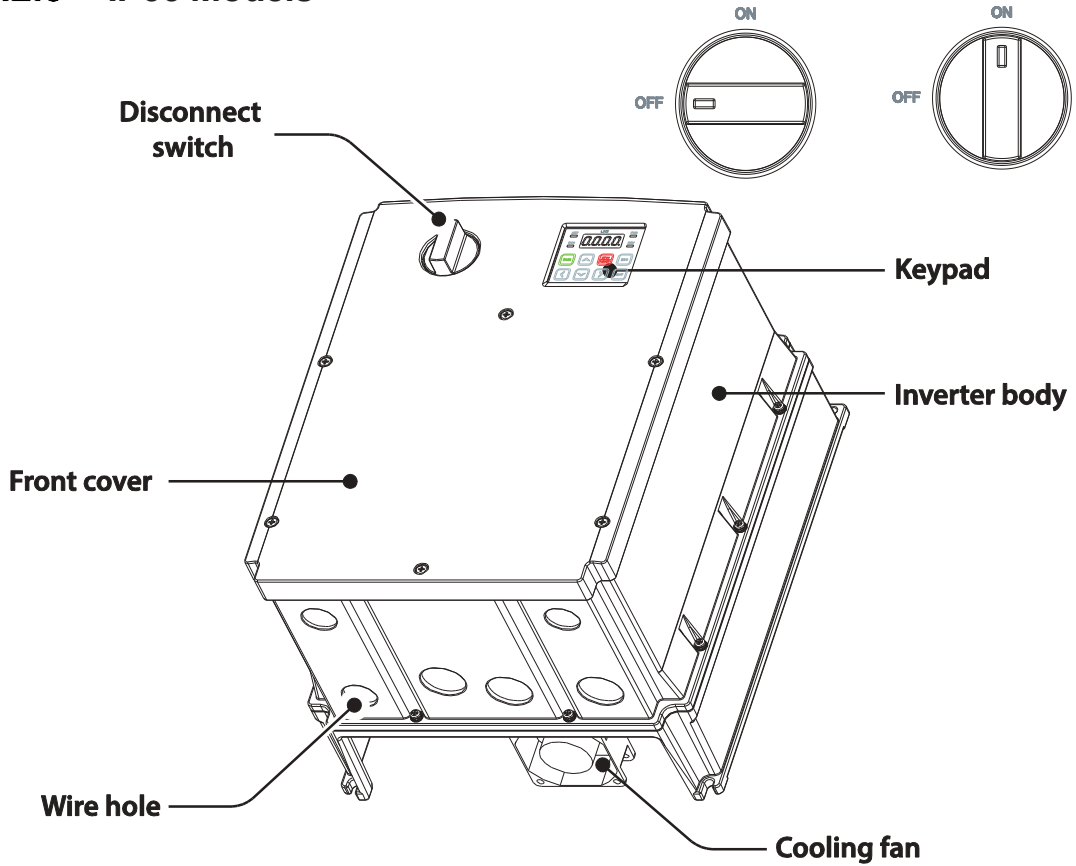

**Do not operate Disconnect Switch when motor is operating.**

The installation location for cooling fan varies according to product capacity.  
Inside the product: 0.4-4.0kW; bottom of the product: 5.5-7.5kW; inside and top of the product: 11-22kW.

NP(Non-PDS) type have not the Power Disconnect Switch.

**Front cover removed**

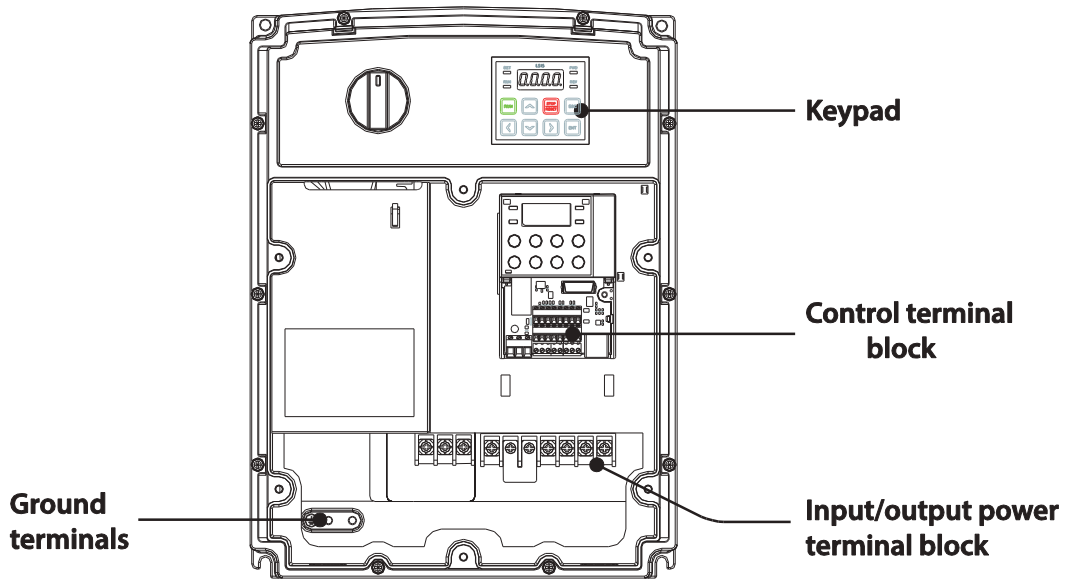



## 1.3 Installation Considerations

Inverters are composed of various precision, electronic devices, and therefore the installation environment can significantly impact the lifespan and reliability of the product. The table below details the ideal operation and installation conditions for the inverter.

Items	Description
Ambient Temperature*	Heavy Duty: 14–104°F (-10–50°C) Normal Duty: 14–122°F (-10– 40°C)
Ambient Humidity	90% relative humidity (no condensation)
Storage Temperature	- 4–149°F (-20–65°C)
Environmental Factors	An environment free from corrosive or flammable gases, oil residue or dust
Altitude / Vibration	Maximum 1000m above sea level for standard operation. From 1000 to 4000m, the rated input voltage and rated output current of the drive must be derated by 1% for every 100m. / less than 1G (9.8m/sec <sup>2</sup> )
Air Pressure	70 –106kPa

\* The ambient temperature is the temperature measured at a point 2" (5 cm) from the surface of the inverter.

\* IP66 models only support heavy load operation, and an ambient temperature of between -10°C – +40°C.

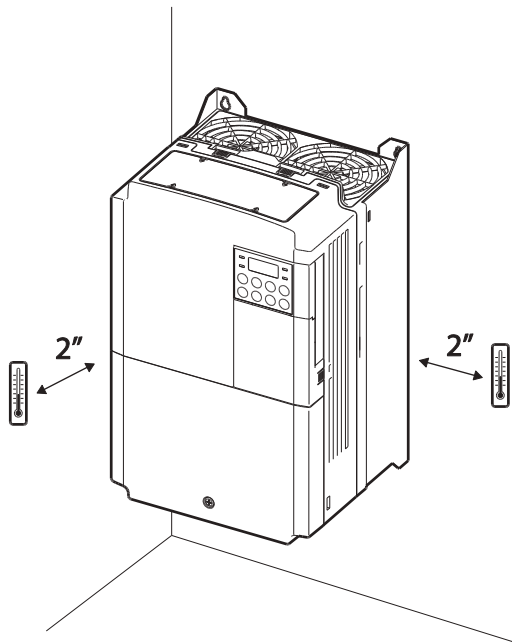

### ⚠ Caution

Do not allow the ambient temperature to exceed the allowable range while operating the inverter.

## 1.4 Selecting and Preparing a Site for Installation

When selecting an installation location consider the following points:

- The location must be free from vibration, and the inverter must be installed on a wall that can support the inverter's weight.
- The inverter can become very hot during operation. Install the inverter on a surface that is fire-resistant or flame-retardant and with sufficient clearance around the inverter to allow air to circulate. The illustrations below detail the required installation clearances.

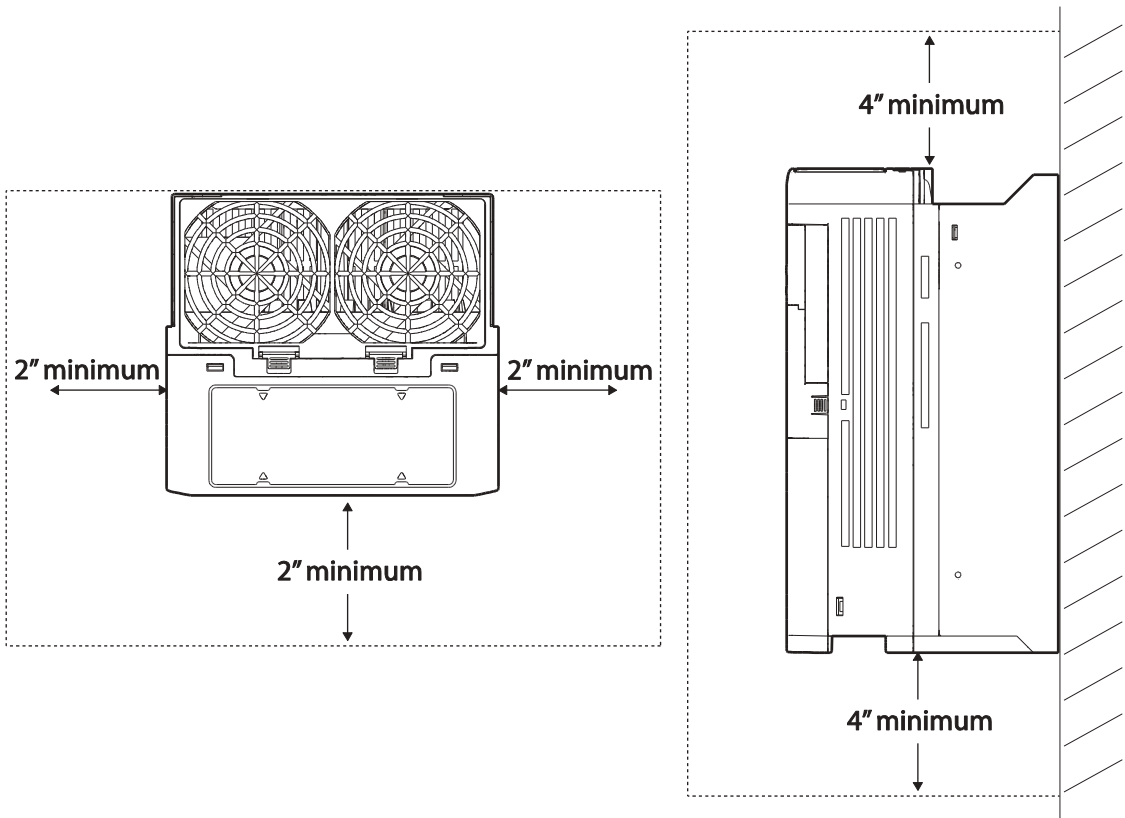

- Ensure sufficient air circulation is provided around the inverter when it is installed. If the inverter is to be installed inside a panel, enclosure, or cabinet rack, carefully consider the position of the inverter's cooling fan and the ventilation louver. The cooling fan must be positioned to efficiently transfer the heat generated by the operation of the inverter.

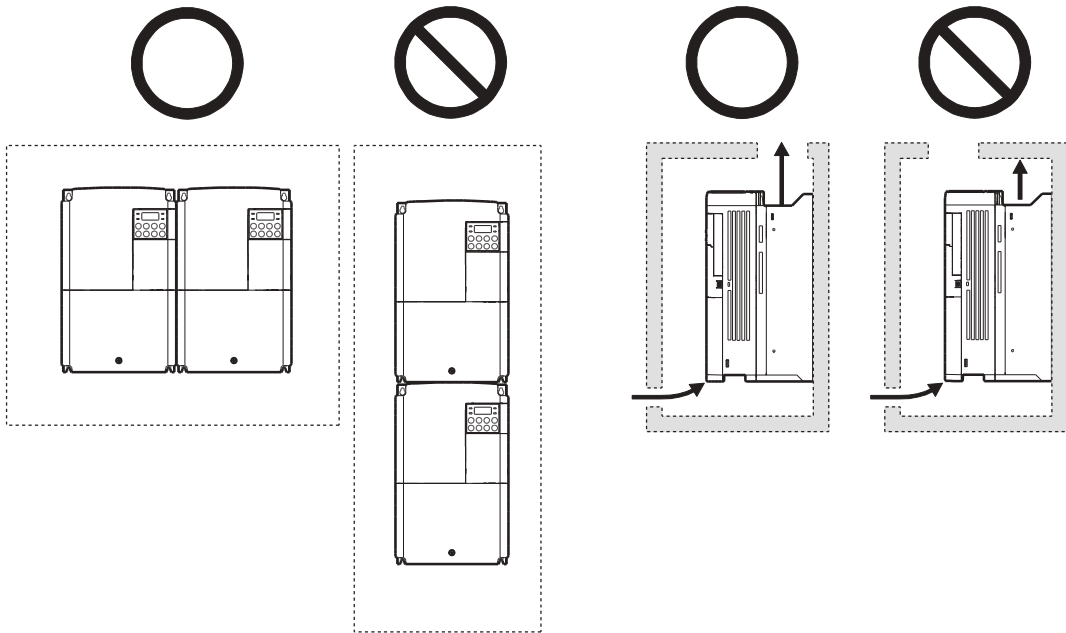

- If you are installing multiple inverters in one location, arrange them side-by-side and remove the top covers. The top covers MUST be removed for side-by-side installations. Use a flat head screwdriver to remove the top covers.
- Side-by-side operation only supports 0.4-22kW, IP20 models.

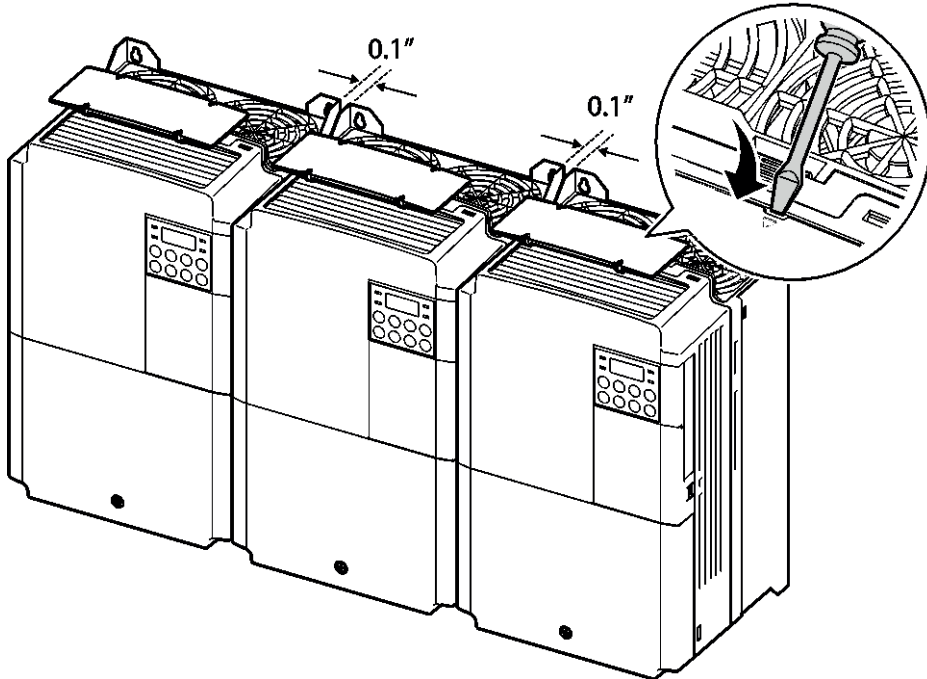

- If you are installing multiple inverters, of different ratings, provide sufficient clearance to meet the clearance specifications of the larger inverter.

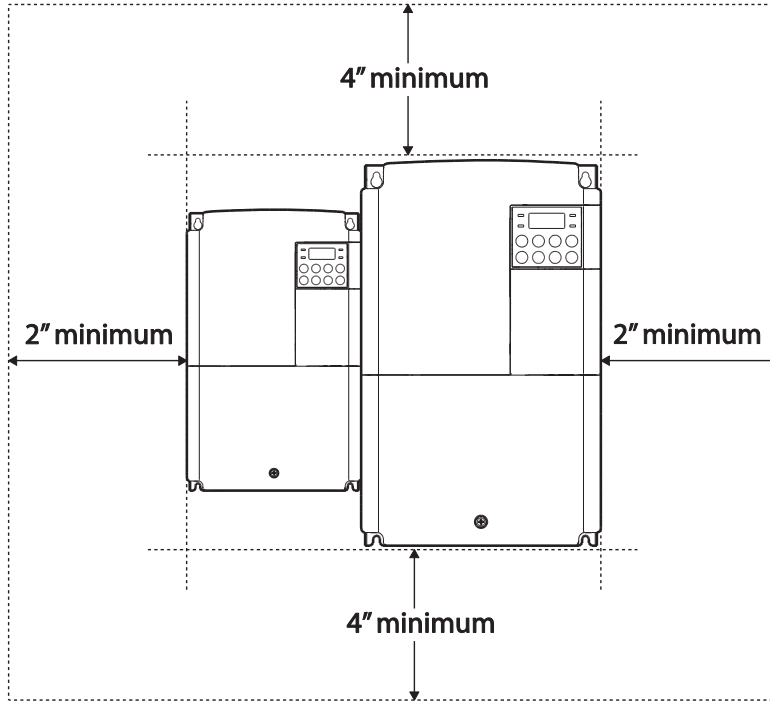

## 1.5 Cable Selection

When you install power and signal cables in the terminal blocks, only use cables that meet the required specification for the safe and reliable operation of the product. Refer to the following information to assist you with cable selection.

### ⚠ Caution

- Wherever possible use cables with the largest cross-sectional area for mains power wiring, to ensure that voltage drop does not exceed 2%.
- Use copper cables rated for 600V, 75°C for power terminal wiring.
- Use copper cables rated for 300V, 75°C for control terminal wiring.

### Ground Cable and Power Cable Specifications (0.4-22kW)

Load (kW)		Ground		Power I/O					
		mm <sup>2</sup>	AWG	mm <sup>2</sup>		AWG			
				R/S/T	U/V/W	R/S/T	U/V/W		
Single Phase 200V	0.4	4	12	2	2	14	14		
	0.75								
	1.5			3.5	3.5	12	12		
	2.2								
3-Phase 200V	0.4	4	12	2	2	14	14		
	0.75								
	1.5			3.5	3.5	12	12		
	2.2								
	3.7	6	10	6	6	10	10		
	4								
	5.5			16	6	10	10	8	8
	7.5								
	11					16	6	16	16
15									
3-Phase 400V	0.4	4	12	2	2	14	14		
	0.75								
	1.5			2.5	2.5	14	14		
	2.2								
	3.7	4	12	4	4	12	12		
	4								
	5.5			10	8	6	6	10	10
	7.5								
	11	16	6	10	10	8	8		
	15								
18.5									
22									

### Ground Cable and Power Cable Specifications (30-75kW)

Load (kW)		Ground		Power I/O			
		mm <sup>2</sup>	AWG	mm <sup>2</sup>		AWG	
				R/S/T	U/V/W	R/S/T	U/V/W
3-Phase 400V	30	16	5	25	25	4	4
	37						
	45						
	55	35	3	70	70	1/0	1/0
	75						

### Signal (Control) Cable Specifications

Terminals	Signal Cable			
	Without Crimp Terminal Connectors (Bare wire)		With Crimp Terminal Connectors (Bootlace Ferrule)	
	mm <sup>2</sup>	AWG	mm <sup>2</sup>	AWG
P1~P7*/CM/VR/V1/I2 /AO1, AO2/Q1/EG/24/TI/ TO* /SA, SB, SC/S+, S-, SG	0.75	18	0.5	20
A1/B1/C1/A2/C2	1.0	17	1.5	15

\* Standard I/O doesn't support P6/P7/TI/TO terminal. Refer to [Step 4 Control Terminal Wiring](#) on page 39.

## 2 Installing the Inverter

This chapter describes the physical and electrical installation methods, including mounting and wiring of the product. Refer to the flowchart and basic configuration diagram provided below to understand the procedures and installation methods to be followed to install the product correctly.

### Installation Flowchart

The flowchart lists the sequence to be followed during installation. The steps cover equipment installation and testing of the product. More information on each step is referenced in the steps.

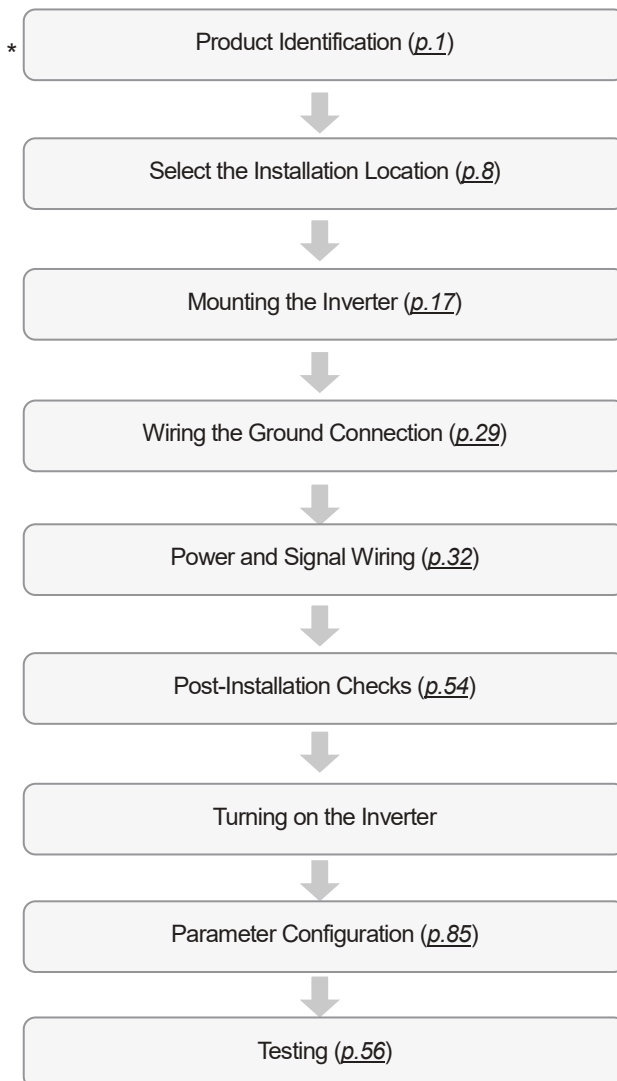



## Basic Configuration Diagram

The reference diagram below shows a typical system configuration showing the inverter and peripheral devices.

Prior to installing the inverter, ensure that the product is suitable for the application (power rating, capacity, etc). Ensure that all of the required peripherals and optional devices (resistor brakes, contactors, noise filters, etc.) are available. For more details on peripheral devices, refer to [7.4 Peripheral Devices](#) on page [228](#).

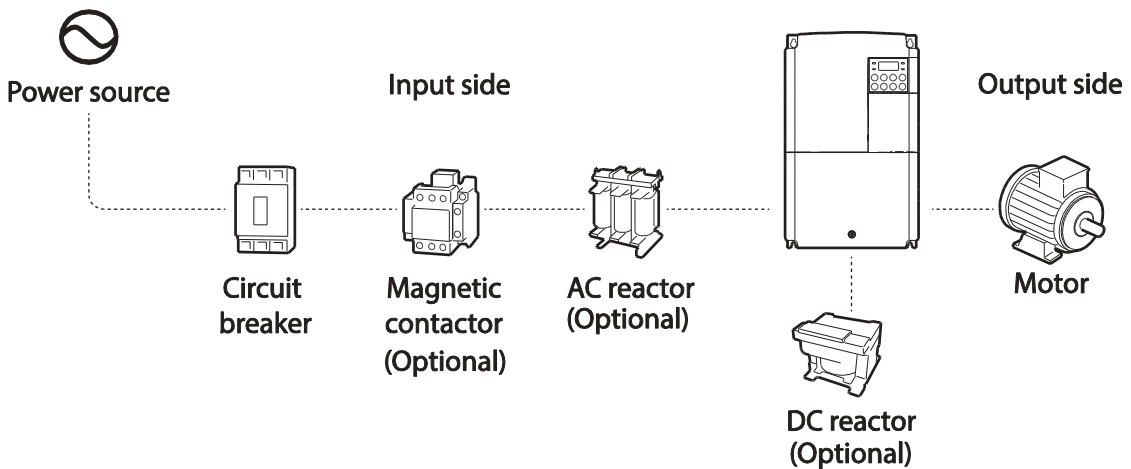

### ⚠ Caution

- Figures in this manual are shown with covers or circuit breakers removed to show a more detailed view of the installation arrangements. Install covers and circuit breakers before operating the inverter. Operate the product according to the instructions in this manual.
- Do not start or stop the inverter using a magnetic contactor, installed on the input power supply.
- If the inverter is damaged and loses control, the machine may cause a dangerous situation. Install an additional safety device such as an emergency brake to prevent these situations.
- High levels of current draw during power-on can affect the system. Ensure that correctly rated circuit breakers are installed to operate safely during power-on situations.
- Reactors can be installed to improve the power factor. Note that reactors may be installed within 30 ft (9.14 m) from the power source if the input power exceeds 10 times of inverter capacity. Refer to [7.5 Fuse and Reactor Specifications](#) on page [229](#) and carefully select a reactor that meets the requirements.
- 30-75kW models have a built-in DC Reactor.

## 2.1 Mounting the Inverter

Mount the inverter on a wall or inside a panel following the procedures provided below. Before installation, ensure that there is sufficient space to meet the clearance specifications, and that there are no obstacles impeding the cooling fan's air flow.

Select a wall or panel suitable to support the installation. Refer to 7.3 External Dimensions on page 213 and check the inverter's mounting bracket dimensions.

- 1 Use a level to draw a horizontal line on the mounting surface, and then carefully mark the fixing points.
- 2 Drill the two upper mounting bolt holes, and then install the mounting bolts. Do not fully tighten the bolts at this time. Fully tighten the mounting bolts after the inverter has been mounted.

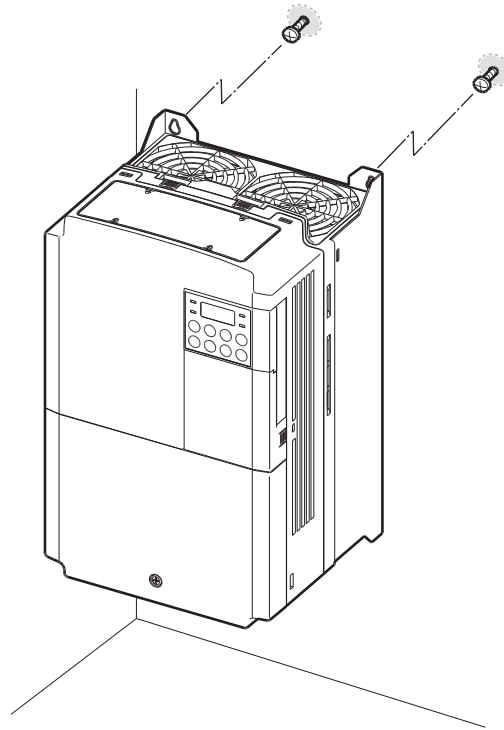

- 3 Mount the inverter on the wall or inside a panel using the two upper bolts, and then fully tighten the mounting bolts. Ensure that the inverter is placed flat on the mounting surface, and that the installation surface can securely support the weight of the inverter.

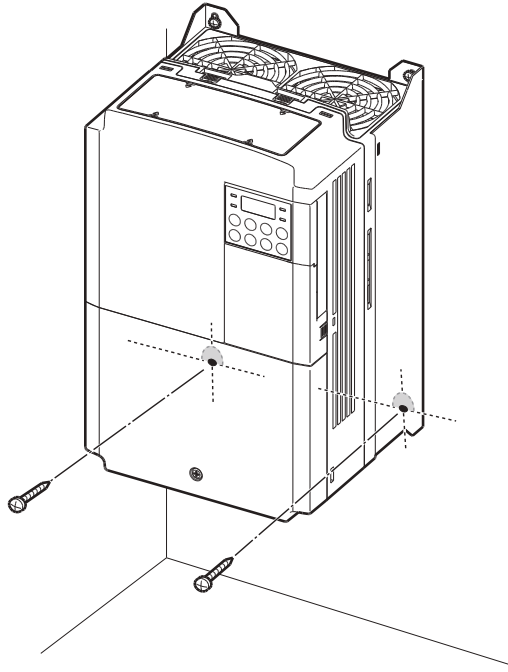

## Note

The quantity and dimensions of the mounting brackets vary based on frame size. Refer to [7.3 External Dimensions](#) on page [213](#) for detailed information about your model.

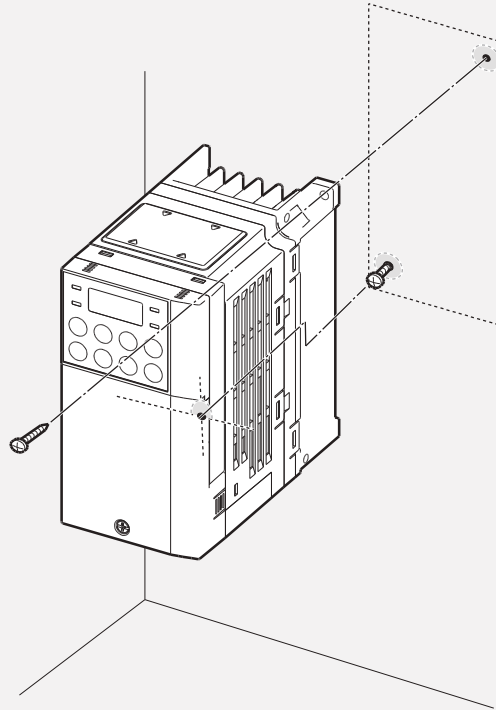

0.4kW (Single Phase) and 0.4-0.8kW (3-phase) inverters have only two mounting brackets.

## ⚠ Caution

- Do not transport the inverter by lifting with the inverter's covers or plastic surfaces. The inverter may tip over if covers break, causing injuries or damage to the product. Always support the inverter using the metal frames when moving it.
- High-capacity inverters are very heavy and bulky. Use an appropriate transport method that is suitable for the weight.
- Do not install the inverter on the floor or mount it sideways against a wall. The inverter **MUST** be installed vertically, on a wall or inside a panel, with its rear flat on the mounting surface.

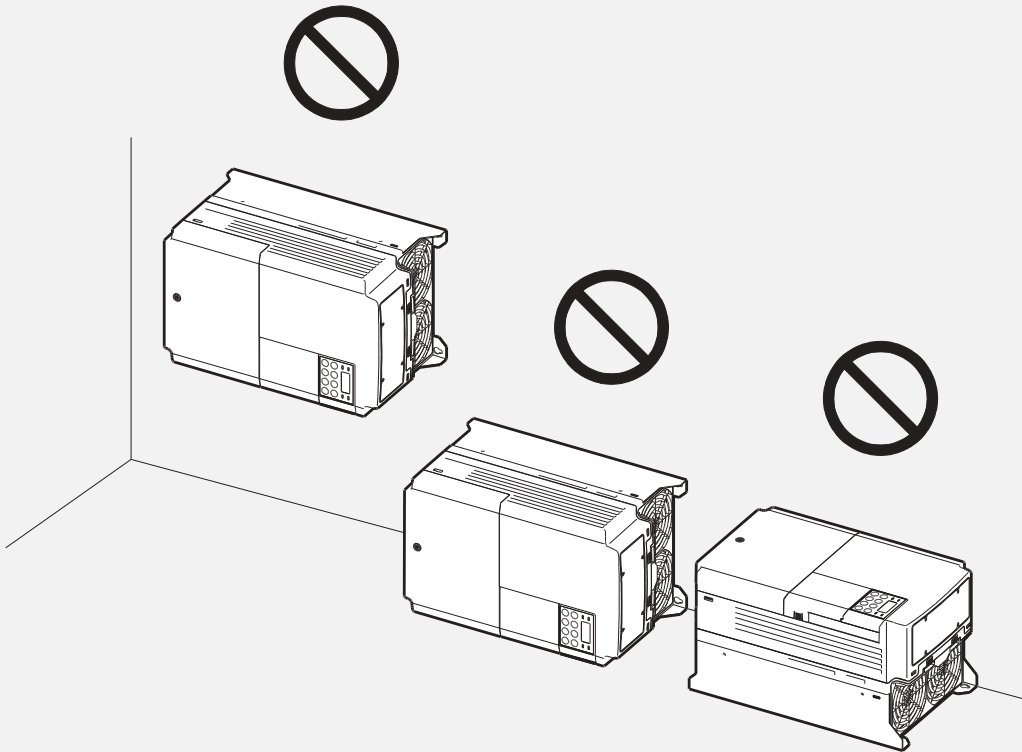

## 2.2 Cable Wiring

Open the front cover, remove the cable guides and control terminal cover, and then install the ground connection as specified. Complete the cable connections by connecting an appropriately rated cable to the terminals on the power and control terminal blocks.

Read the following information carefully before carrying out wiring connections to the inverter. All warning instructions must be followed.

### ⚠ Caution

- Install the inverter before carrying out wiring connections.
- Ensure that no small metal debris, such as wire cut-offs, remain inside the inverter. Metal debris in the inverter may cause inverter failure.
- Tighten terminal screws to their specified torque. Loose terminal block screws may allow the cables to disconnect and cause short circuit or inverter failure. Refer to [7.6 Terminal Screw Specification](#) on page [231](#) for torque specifications.
- Do not place heavy objects on top of electric cables. Heavy objects may damage the cable and result in electric shock.
- The power supply system for this equipment (inverter) is a grounded system. Only use a grounded power supply system for this equipment (inverter). Do not use a TT, TN, IT, or corner grounded system with the inverter.
- The equipment may generate direct current in the protective ground wire. When installing the residual current device (RCD) or residual current monitoring (RCM), only Type B RCDs and RCMs can be used.
- Use cables with the largest cross-sectional area, appropriate for power terminal wiring, to ensure that voltage drop does not exceed 2%.
- Use copper cables rated at 600V, 75°C for power terminal wiring.
- Use copper cables rated at 300V, 75°C for control terminal wiring.
- Separate control circuit wires from the main circuits and other high voltage circuits(200V relay sequence circuit).
- Check for short circuits or wiring failure in the control circuit. They could cause system failure or device malfunction.
- Use shielded cables when wiring the control circuit. Failure to do so may cause malfunction due to interference. If a ground is needed, use STP (Shielded Twisted Pair) cables.
- If you need to re-wire the terminals due to wiring-related faults, ensure that the inverter keypad display is turned off and the charge lamp under the front cover is off before working on wiring connections. The inverter may hold a high voltage electric charge long after the power supply has been turned off.

## Step 1 Front Cover, Control Terminal Cover and Cable Guide

The front cover, control terminal cover and cable guide must be removed to install cables. Refer to the following procedures to remove the covers and cable guide. The steps to remove these parts may vary depending on the inverter model.

### 0.8-1.5kW (single phase), 1.5-2.2kW (3-phase)

- 1 Loosen the bolt that secures the front cover (right side). Push and hold the latch on the right side of the cover. Then remove the cover by lifting it from the bottom and moving it away from the front of the inverter.

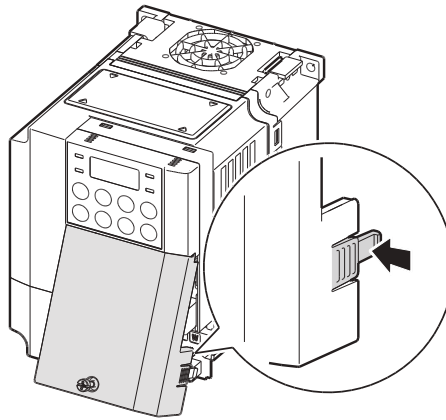

- 2 Remove the bolt that secures the front cover (left side) (1). Push and hold the latch on the left side of the cover. Then remove the cover by lifting it from the bottom and moving it away from the front of the inverter (2).

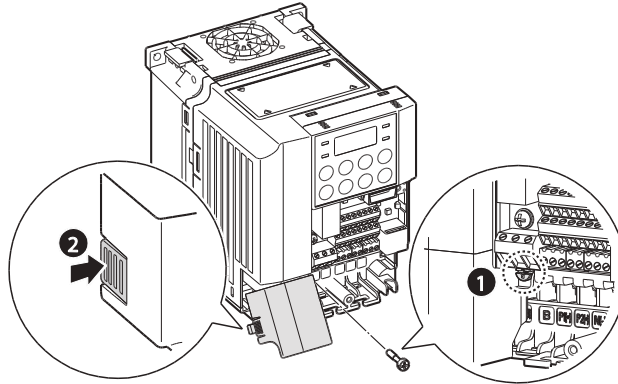

- 3 Connect the cables to the power terminals and the control terminals. For cable specifications, refer to 1.5 Cable Selection on page 13.



### 5.5-22kW (3-phase)

- 1 Loosen the bolt that secures the front cover. Then remove the cover by lifting it from the bottom and away from the front.

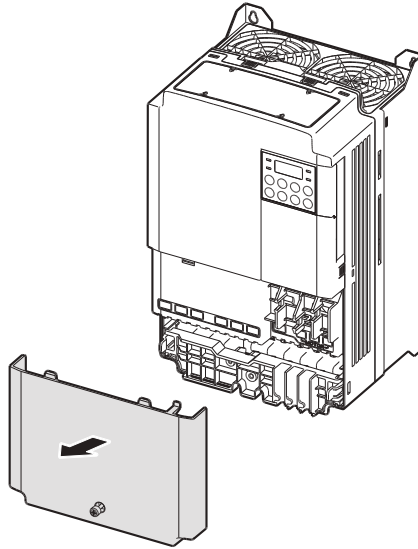

- 2 Push and hold the levers on both sides of the cable guide (1) and then remove the cable guide by pulling it directly away from the front of the inverter (2). In some models where the cable guide is secured by a bolt, remove the bolt first.

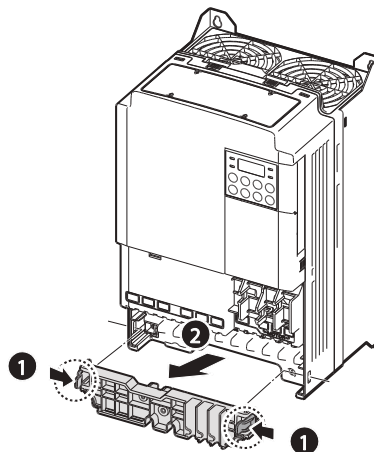

- 3 Push and hold the tab on the right side of the control terminal cover. Then remove the cover by lifting it from the bottom and moving it away from the front of the inverter.

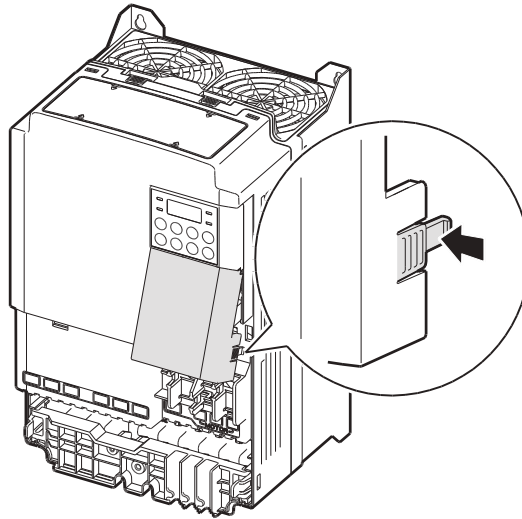

- 4 Connect the cables to the power terminals and the control terminals. For cable specifications, refer to 1.5 Cable Selection on page 13.

#### Note

To connect an LCD loader, remove the plastic knock-out from the bottom of the front cover (right side). Connect the signal cable of the LCD loader to the RJ-45 port on the control board. (0.4-22kW models only)

### 30-75kW(3-phase 4type)

- 1 Loosen the bolt that secures the terminal cover (❶). Push and hold the latch on the right side of the cover (❷). Then remove the cover by lifting it from the bottom and moving it away from the front of the inverter.

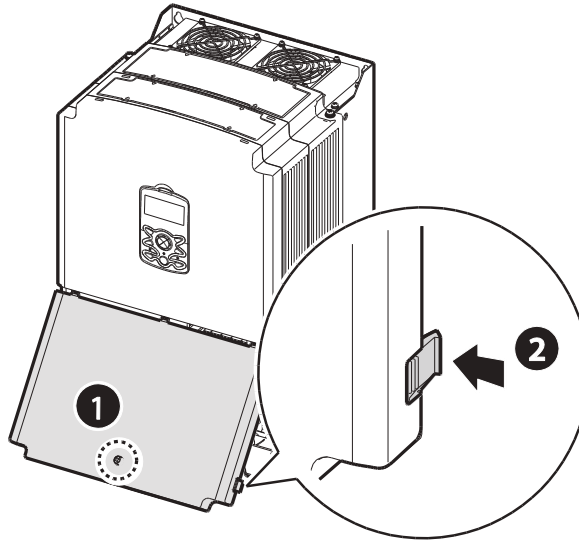

- 2 Connect the cables to the power terminals and the control terminals. For cable specifications, refer to 1.5 Cable Selection on page 13.

IP66

**0.4-15kW (3-phase 2type), 0.4-22kW (3-phase 4type)**

- 1 Loosen the bolt that secures the front cover. Then remove the cover by lifting it from the bottom and moving it away from the front of the inverter.

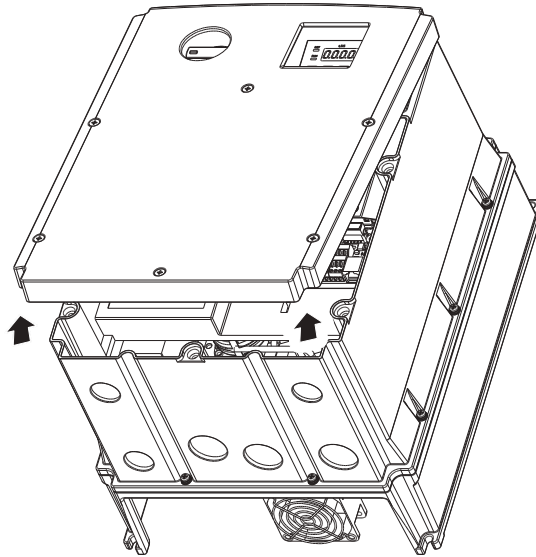

- 2 Set the bushing to every wiring hole before installing to power and I/O board terminals. Use the bushing that is NEMA 4X (IP66) or more.

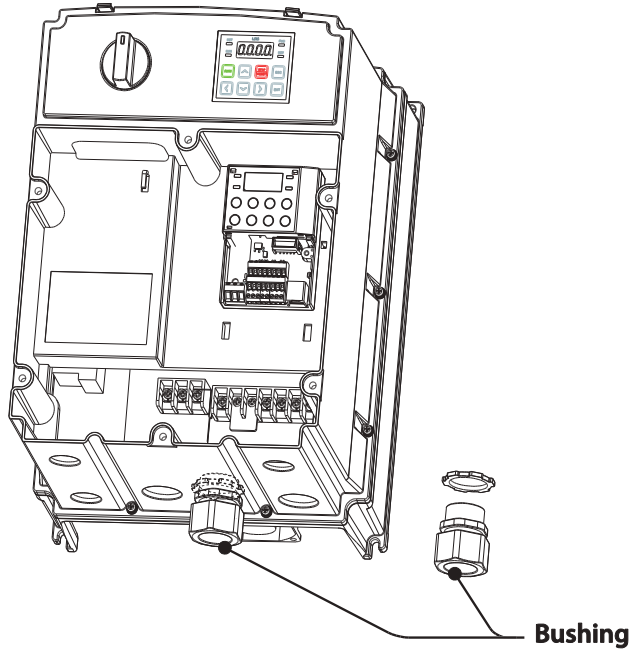

- 3 Connect the cables to the power terminals and the control terminals. For cable specifications, refer to 1.5 Cable Selection on page 13.

#### Note

To connect an LCD loader, remove the plastic knock-out from the bottom of the front cover (right side). Connect the signal cable of the LCD loader to the RJ-45 port on the control board. (0.4-22kW models only)

## Step 2 Ground Connection

Remove the front cover(s), cable guide, and the control terminal cover. Then follow the instructions below to install the ground connection for the inverter.

### Note

- 200 V products require Class 3 grounding. Resistance to ground must be  $< 100\Omega$ .
- 400 V products require Special Class 3 grounding. Resistance to ground must be  $< 10\Omega$ .

### ⚠ Warning

Install ground connections for the inverter and the motor by following the correct specifications to ensure safe and accurate operation. Using the inverter and the motor without the specified grounding connections may result in electric shock.

### 0.4-22kW

- 1 Locate the ground terminal and connect an appropriately rated ground cable to the terminals. Refer to [1.5 Cable Selection](#) on page 13 to find the appropriate cable specification for your installation.

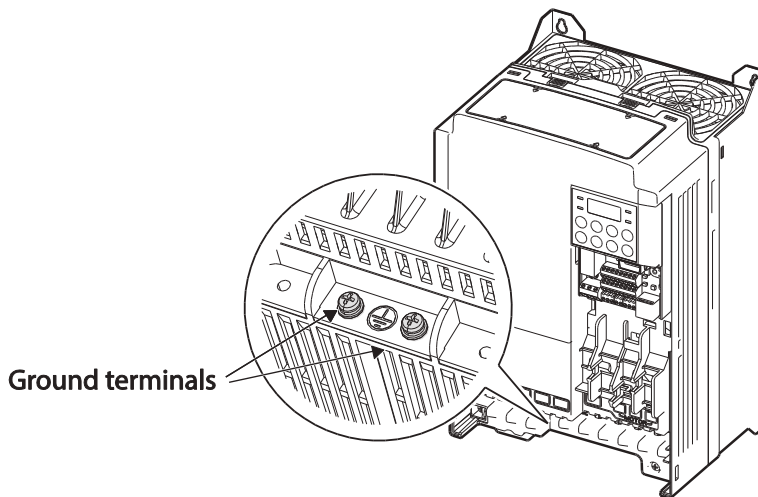

- 2 Connect the other ends of the ground cables to the supply earth (ground) terminal.

### 30-75kW

- 1 Locate the ground terminal and connect an appropriately rated ground cable to the terminals. Refer to [1.5 Cable Selection](#) on page [13](#) to find the appropriate cable specification for your installation.

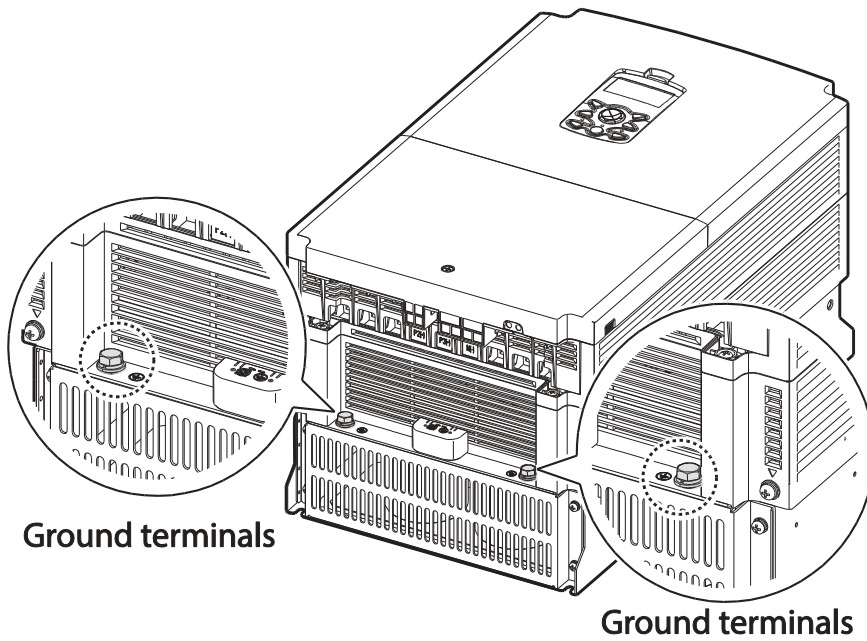

- 2 Connect the other ends of the ground cables to the supply earth (ground) terminal.

## IP66

- 1 Locate the ground terminal and connect an appropriately rated ground cable to the terminals. Refer to [1.5 Cable Selection](#) on page [13](#) to find the appropriate cable specification for your installation.

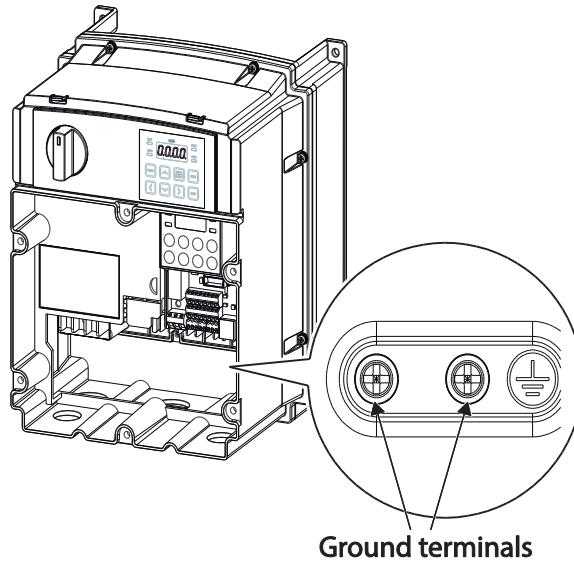

- 2 Connect the other ends of the ground cables to the supply earth (ground) terminal.



### Step 3 Power Terminal Wiring

The following illustration shows the terminal layout on the power terminal block. Refer to the detailed descriptions to understand the function and location of each terminal before making wiring connections. Ensure that the cables selected meet or exceed the specifications in [1.5 Cable Selection](#) on page [13](#) before installing them.

#### ⚠ Caution

- Apply rated torques to the terminal screws. Loose screws may cause short circuits and malfunctions. Tightening the screw too much may damage the terminals and cause short circuits and malfunctions.
- Use copper wires only with 600V, 75°C rating for the power terminal wiring, and 300V, 75°C rating for the control terminal wiring.
- Do not connect two wires to one terminal when wiring the power.
- Power supply wirings must be connected to the R, S, and T terminals. Connecting them to the U, V, W terminals causes internal damages to the inverter. Motor should be connected to the U, V, and W Terminals. Arrangement of the phase sequence is not necessary.

#### ⚠ Attention

- Appliquer des couples de marche aux vis des bornes. Des vis desserrées peuvent provoquer des courts-circuits et des dysfonctionnements. Ne pas trop serrer la vis, car cela risqué d'endommager les bornes et de provoquer des courts-circuits et des dysfonctionnements. Utiliser uniquement des fils de cuivre avec une valeur nominale de 600 V, 75 °C pour le câblage de la borne d'alimentation, et une valeur nominale de 300 V, 75 °C pour le câblage de la borne de commande.
- Ne jamais connecter deux câbles à une borne lors du câblage de l'alimentation.
- Les câblages de l'alimentation électrique doivent être connectés aux bornes R, S et T. Leur connexion aux bornes U, V et W provoque des dommages internes à l'onduleur. Le moteur doit être raccordé aux bornes U, V et W. L'arrangement de l'ordre de phase n'est pas nécessaire.

0.4-22kW

**0.4kW (single phase), 0.4-0.8kW (3-phase)**

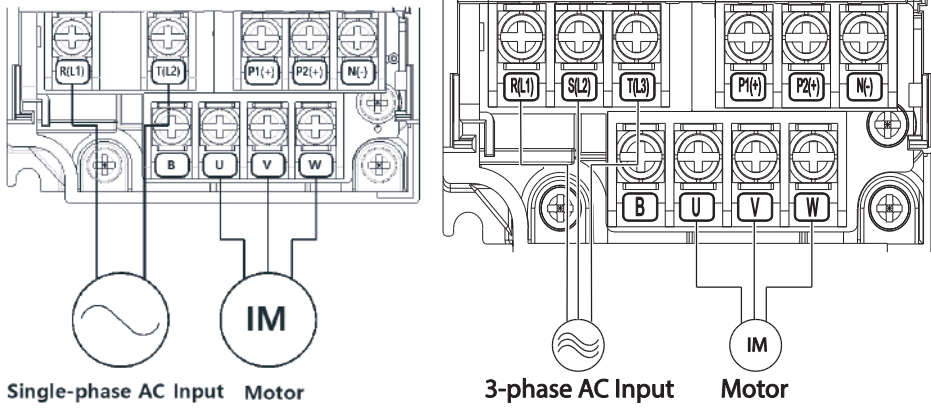

Installation

**0.8-1.5kW (single phase), 1.5-2.2kW (3-phase)**

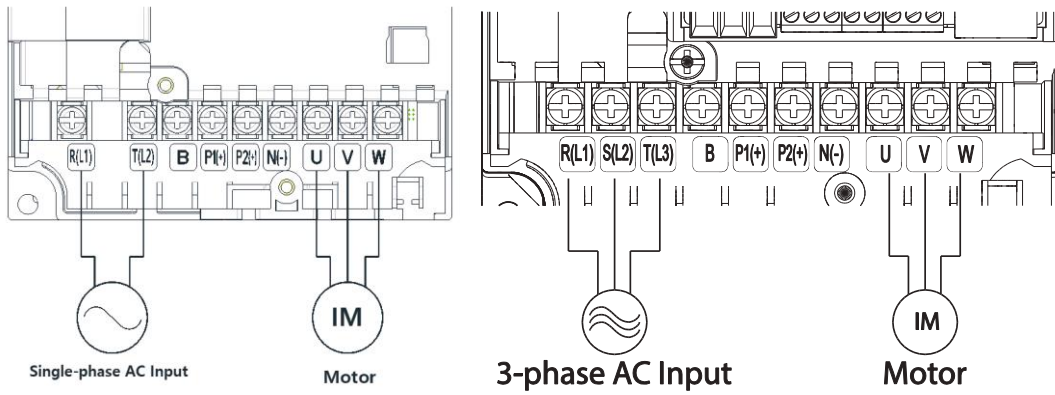

### 2.2kW (single phase), 3.7-4.0kW (3-phase)

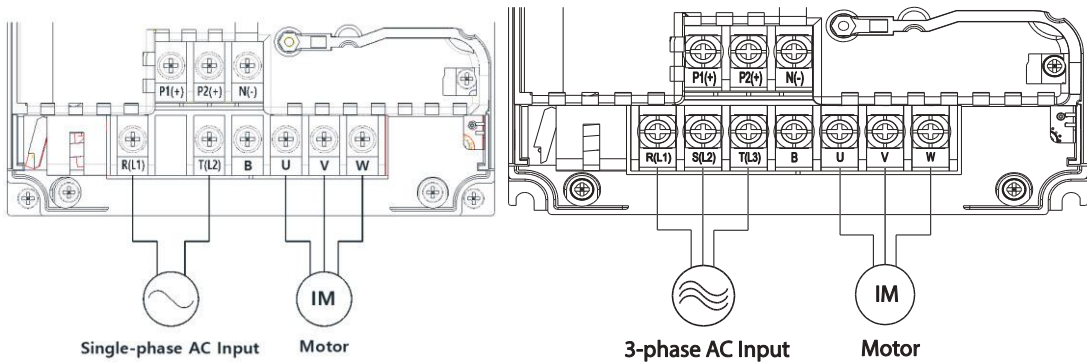

### 5.5-22kW (3-phase)

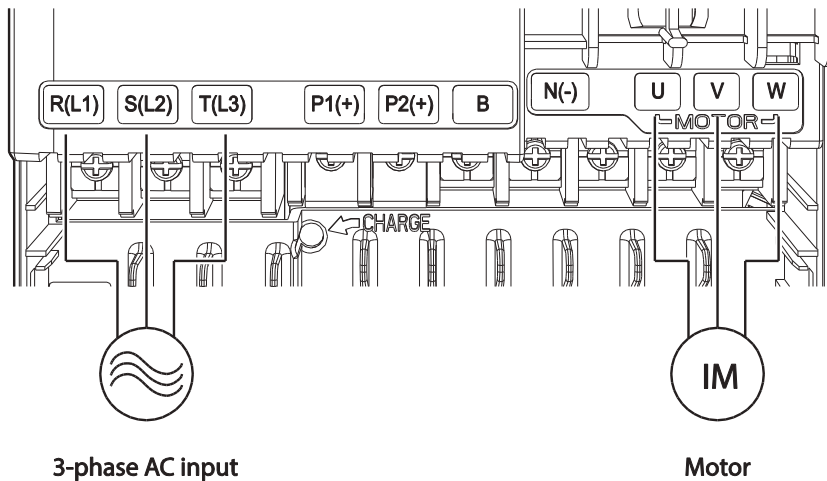

### Power Terminal Labels and Descriptions (0.4-22kW)

Terminal Labels	Name	Description
R(L1)/S(L2)/T(L3)	AC power input terminal	Mains supply AC power connections.
P1(+)/N(-)	DC link terminal	DC voltage terminals.
P1(+)/P2(+)	DC reactor terminal	DC reactor wiring connection. (When you use the DC reactor, must remove short-bar)
P2(+)/B	Brake resistor terminals	Brake resistor wiring connection.
U/V/W	Motor output terminals	3-phase induction motor wiring connections.

### 30-75kW (3-phase)

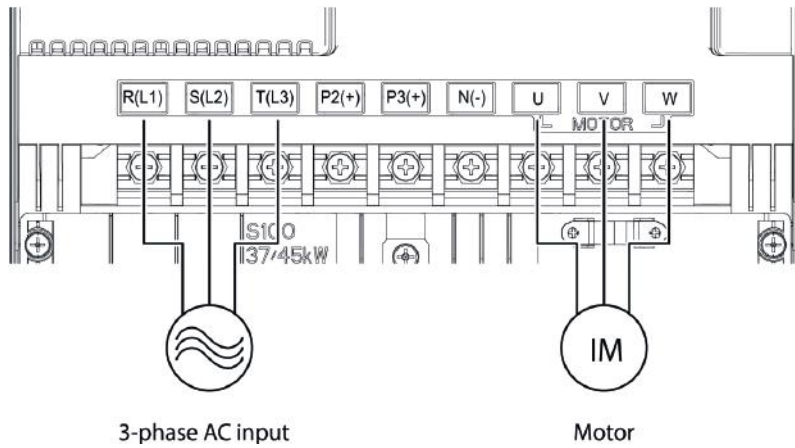

### Power Terminal Labels and Descriptions (30-75kW)

Terminal Labels	Name	Description
R(L1)/S(L2)/T(L3)	AC power input terminal	Mains supply AC power connections.
P2(+)/N(-)	DC link terminal	DC voltage terminals.
P3(+)/N(-)	Brake unit terminals	Brake unit wiring connection.
U/V/W	Motor output terminals	3-phase induction motor wiring connections.

IP66

0.4-0.8kW (3-phase)

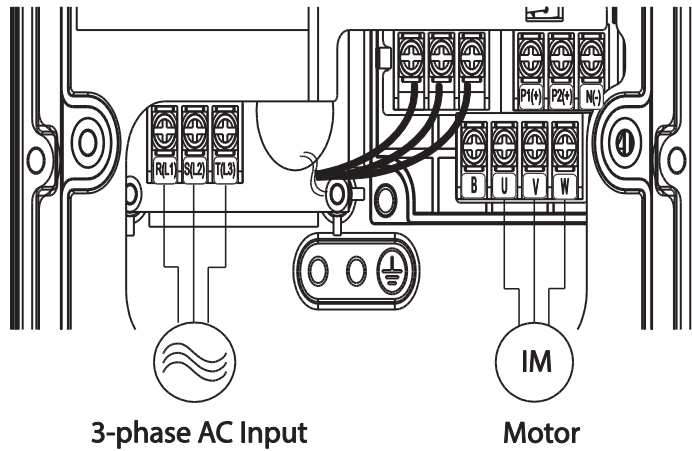

1.5-2.2kW (3-phase)

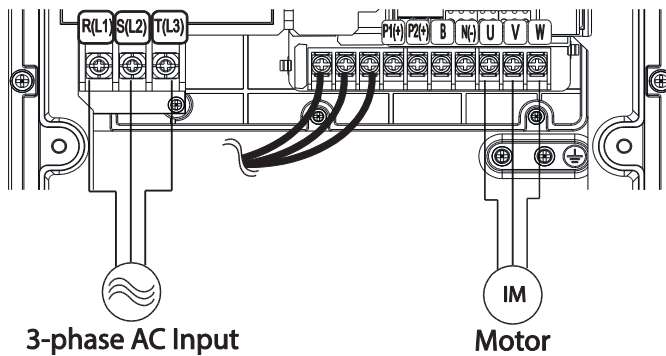

### 3.7-4.0kW (3-phase)

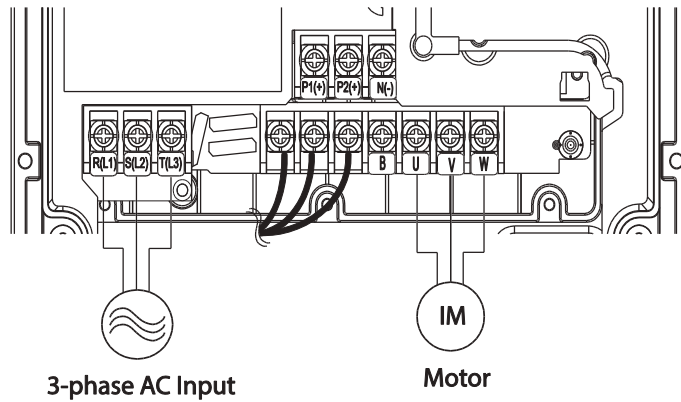

Installation

### 5.5-22kW (3-phase)

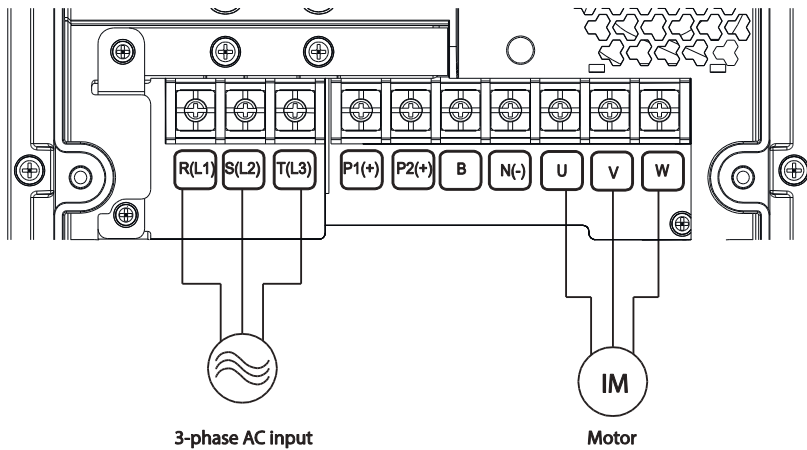

### Power Terminal Labels and Descriptions (IP66)

Terminal Labels	Name	Description
R(L1)/S(L2)/T(L3)	AC power input terminal	Mains supply AC power connections.
P1(+)/N(-)	DC link terminal	DC voltage terminals.
P1(+)/P2(+)	DC reactor terminal	DC reactor wiring connection. (Remove the short-bar when you use the DC reactor.)
P2(+)/B	Brake resistor terminals	Brake resistor wiring connection.
U/V/W	Motor output terminals	3-phase induction motor wiring connections.

## Note

- Do not use 3 core cables to connect a remotely located motor with the inverter.
- When you operating Brake resistor, the motor may vibrate under the Flux braking operation. In this case, please turn off the Flux braking(Pr.50).
- Make sure that the total cable length does not exceed 665ft (202m). For inverters < = 4.0kW capacity, ensure that the total cable length does not exceed 165ft (50m).
- Long cable runs can cause reduced motor torque in low frequency applications due to voltage drop. Long cable runs also increase a circuit's susceptibility to stray capacitance and may trigger over-current protection devices or result in malfunction of equipment connected to the inverter.
- Voltage drop is calculated by using the following formula:  

$$\text{Voltage Drop (V)} = \frac{[\sqrt{3} \times \text{cable resistance (m}\Omega\text{/m)} \times \text{cable length (m)} \times \text{current(A)}]}{1000}$$
- Use cables with the largest possible cross-sectional area to ensure that voltage drop is minimized over long cable runs. Lowering the carrier frequency and installing a micro surge filter may also help to reduce voltage drop.

Distance	< 165ft (50m)	< 330ft (100m)	> 330ft (100m)
Allowed Carrier Frequency	< 15 kHz (30-75kW: < 5 kHz)	< 5 kHz	< 2.5 kHz

## Warning

Do not connect power to the inverter until installation has been fully completed and the inverter is ready to be operated. Doing so may result in electric shock.

## Caution

- Power supply cables must be connected to the R, S, and T terminals. Connecting power cables to other terminals will damage the inverter.
- Use insulated ring lugs when connecting cables to R/S/T and U/V/W terminals.
- The inverter's power terminal connections can cause harmonics that may interfere with other communication devices located near to the inverter. To reduce interference the installation of noise filters or line filters may be required.
- To avoid circuit interruption or damaging connected equipment, do not install phase-advanced condensers, surge protection, or electronic noise filters on the output side of the inverter.
- To avoid circuit interruption or damaging connected equipment, do not install magnetic contactors on the output side of the inverter.

## Step 4 Control Terminal Wiring

The illustrations below show the detailed layout of control wiring terminals, and control board switches. Refer to the detailed information provided below and 1.5 Cable Selection on page 13 before installing control terminal wiring and ensure that the cables used meet the required specifications.

### 0.4-22kW

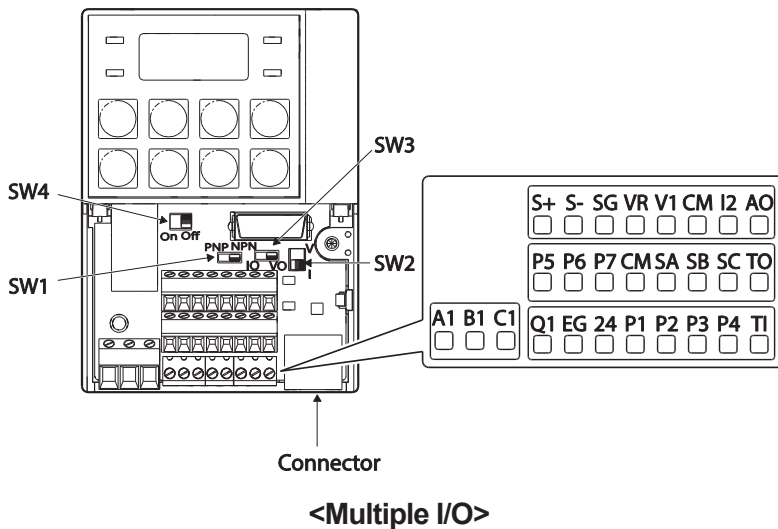
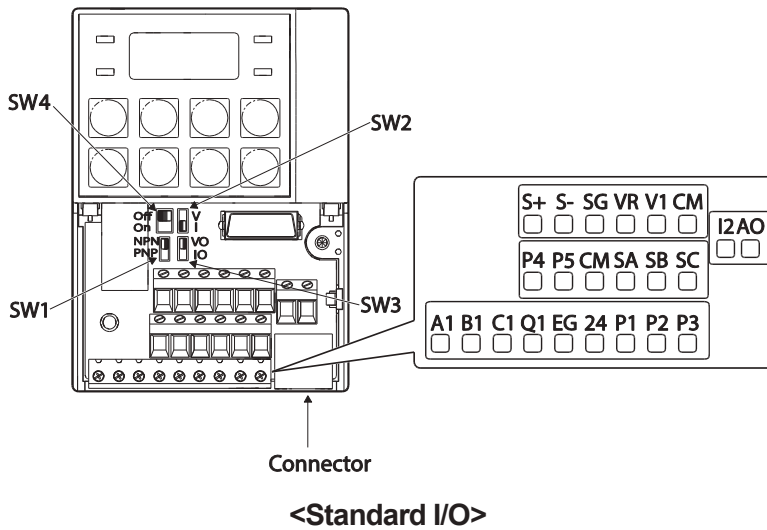



### 30-75kW

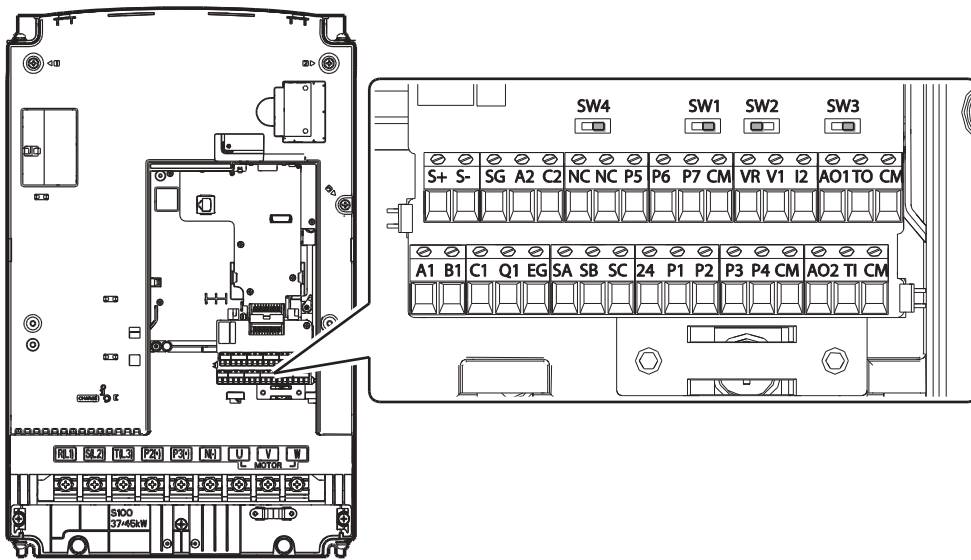

<30-75kW I/O>

### Control Board Switches

Switch	Description
SW1	NPN/PNP mode selection switch
SW2	analog voltage/current input terminal selection switch
SW3	analog voltage/current output terminal selection switch
SW4	Terminating Resistor selection switch

### Connector (0.4-22kW models only)

Name	Description
Connector	Connect to iS7 Loader or Smart Copier

0.4-22kW

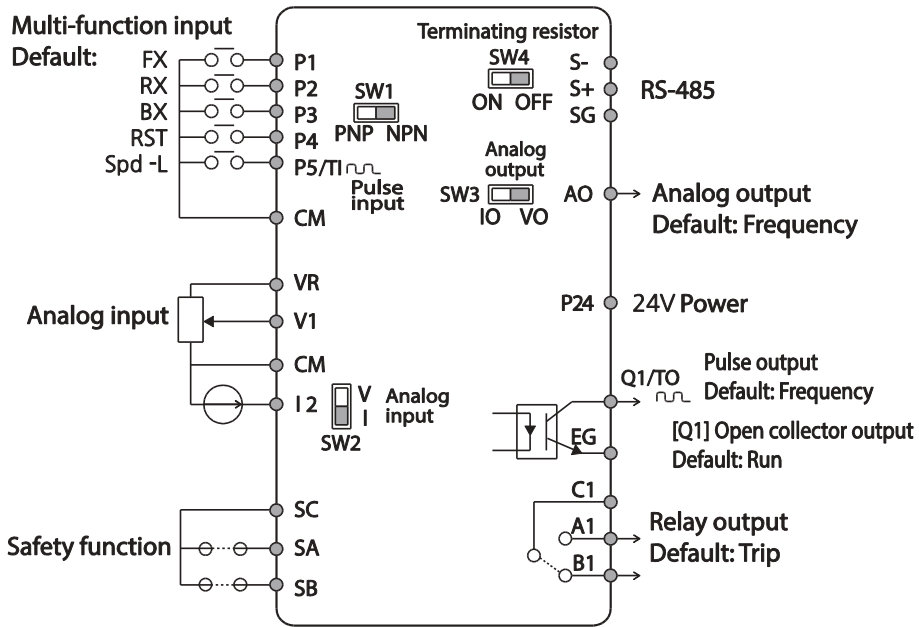

<Standard I/O>

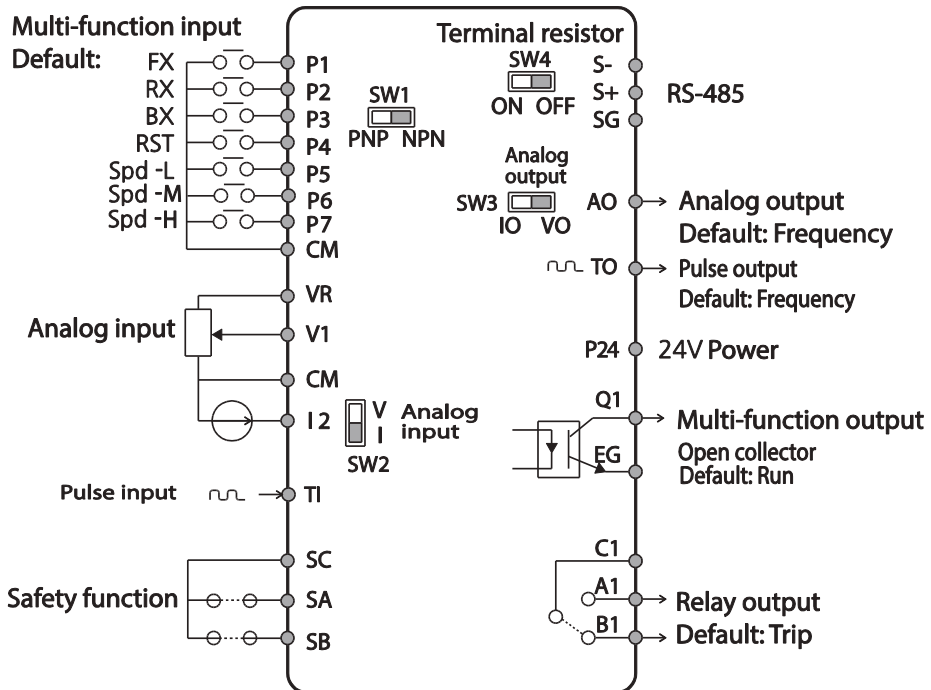

<Multiple I/O>

### 30-75kW

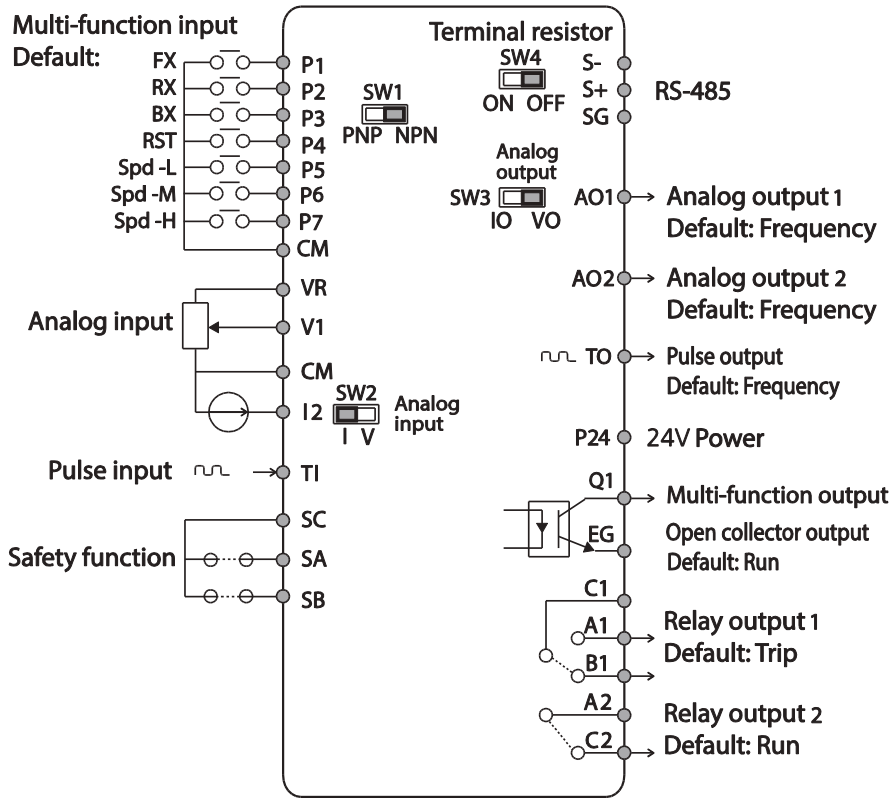

### Input Terminal Labels and Descriptions

Function	Label	Name	Description
Multi-function terminal configuration	P1-P7	Multi-function Input 1-7	Configurable for multi-function input terminals. (Standard I/O is only provided for P5.)
	CM	Common Sequence	Common terminal for analog terminal inputs and outputs.
Analog input configuration	VR	Potentiometer frequency reference input	Used to setup or modify a frequency reference via analog voltage or current input. <ul style="list-style-type: none"> <li>Maximum Voltage Output: 12V</li> <li>Maximum Current Output: 100mA,</li> <li>Potentiometer: 1-5kΩ</li> </ul>
	V1	Voltage input for frequency reference input	Used to setup or modify a frequency reference via analog voltage input terminal. <ul style="list-style-type: none"> <li>Unipolar: 0-10V (12V Max.)</li> <li>Bipolar: -10-10V (±12V Max.)</li> </ul>
	I2	Voltage/current input for	Used to setup or modify a frequency reference via analog voltage or current input terminals.

Function	Label	Name	Description
		frequency reference input	Switch between voltage (V2) and current (I2) modes using a control board switch (SW2). V2 Mode: <ul style="list-style-type: none"> <li>• Unipolar: 0–10V (12V Max.)</li> </ul> I2 Mode <ul style="list-style-type: none"> <li>• Input current: 4–20mA</li> <li>• Maximum Input current: 24mA</li> <li>• Input resistance: 249Ω</li> </ul>
	TI	Pulse input for frequency reference input (pulse train)	Setup or modify frequency references using pulse inputs from 0 to 32kHz. <ul style="list-style-type: none"> <li>• Low Level: 0–2.5V</li> <li>• High Level: 3.5–12V</li> </ul> (In case of Standard I/O, Pulse input TI and Multi-function terminal P5 share the same terminal. Set the In.69 P5 Define to 54(TI).)
Safety functionality configuration	SA	Safety input A	Used to block the output from the inverter in an emergency. Conditions: <ul style="list-style-type: none"> <li>• Normal Operation: Both the SA and SB terminals are connected to the SC terminal.</li> <li>• Output Block: One or both of the SA and SB terminals lose connection with the SC terminal.</li> </ul>
	SB	Safety input B	
	SC	Safety input power source	DC 24V, < 25mA

## Output/Communication Terminal Labels and Descriptions

Function	Label	Name	Description
Analog output	AO, AO1	Voltage/Current Output	Used to send inverter output information to external devices: output frequency, output current, output voltage, or a DC voltage. Operate switch (SW3) to select the signal output type (voltage or current) at the AO terminal. Output Signal Specifications: <ul style="list-style-type: none"> <li>• Output voltage: 0–10V</li> <li>• Maximum output voltage/current: 12V/10mA</li> <li>• Output current: 0–20mA</li> <li>• Maximum output current: 24mA</li> <li>• Factory default output: Frequency</li> </ul>
	AO2	Analog voltage output terminal	Use to send inverter output information, such as output frequency, output current, output voltage, or DC voltage to external devices. <ul style="list-style-type: none"> <li>• Output voltage: 0-10 V</li> <li>• Maximum output voltage/current: 12V/10 mA</li> </ul>
	TO	Pulse Output	Sends pulse signals to external devices to provide a single output value from the inverter of either: output frequency, output current, output voltage, or DC voltage. Output Signal Specifications: <ul style="list-style-type: none"> <li>• Output frequency: 0–32kHz</li> <li>• Output voltage: 0–12V</li> <li>• Factory default output: Frequency</li> </ul> (In case of Standard I/O, Pulse output TO and Multi-function output Q1 share the same terminal. Set the OU.33Q1 Define to 38(TO).) When connecting to a pulse between the S100 inverters, <ul style="list-style-type: none"> <li>• Multiple I/O &lt;-&gt; Multiple I/O : Connect to TO -&gt; TI, CM -&gt; CM</li> <li>• Standard I/O &lt;-&gt; Standard I/O : Connect to Q1 -&gt; P5, EG -&gt; CM</li> <li>• Multiple I/O &lt;-&gt; Standard I/O : Do not support.</li> </ul>
Digital output	Q1	Multi-functional (open collector)	DC 26V, 100mA or less Factory default output: Run
	EG	Common	Common ground contact for an open collector (with external power source)
	24	External 24V	Maximum output current: 150mA

Function	Label	Name	Description
		power source	
	A1/C1/B1	Fault signal output	Sends out alarm signals when the inverter's safety features are activated (AC 250V < 1A, DC 30V < 1A). <ul style="list-style-type: none"> <li>Fault condition: A1 and C1 contacts are connected (B1 and C1 open connection)</li> <li>Normal operation: B1 and C1 contacts are connected (A1 and C1 open connection)</li> </ul>
	A2, C2	Multi-functional relay output terminal	The signal is generated while operating. Define and use the multi-functional relay output terminal (Less than AC250 V 5A, Less than DC30 V 5A).
Communication	S+/S-/SG	RS-485 signal line	Used to send or receive RS-485 signals.
	NC	NC	Not in use.

### Preinsulated Crimp Terminal Connectors (Bootlace Ferrule) .

Use preinsulated crimp terminal connectors to increase reliability of the control terminal wiring. Refer to the specifications below to determine the crimp terminals to fit various cable sizes.

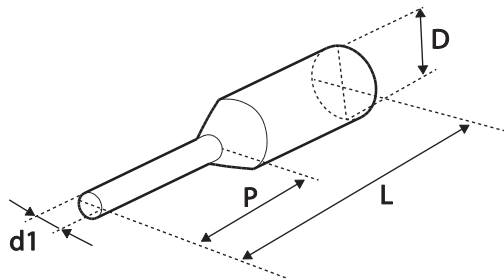

P/N	Cable Spec.		Dimensions (inches/mm)				Manufacturer
	AWG	mm <sup>2</sup>	L*	P	d1	D	
CE002506	26	0.25	10.4	6.0	1.1	2.5	JEONO (Jeono Electric, <a href="http://www.jeono.com/">http://www.jeono.com/</a> )
CE002508			12.4	8.0			
CE005006	22	0.50	12.0	6.0	1.3	3.2	
CE007506	20	0.75	12.0	6.0	1.5	3.4	

\* If the length (L) of the crimp terminals exceeds 0.5" (12.7mm) after wiring, the control terminal cover may not close fully.

To connect cables to the control terminals without using crimp terminals, refer to the following illustration detailing the correct length of exposed conductor at the end of the control cable.

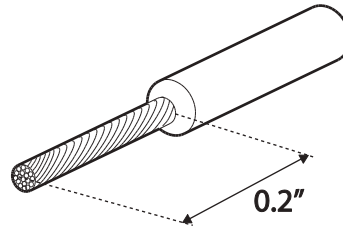

### Note

- While making wiring connections at the control terminals, ensure that the total cable length does not exceed 165ft (50m).
- Ensure that the length of any safety related wiring does not exceed 100ft (30m).
- Ensure that the cable length between an LCD keypad and the inverter does not exceed 10ft (3.04m). Cable connections longer than 10ft (3.04m) may cause signal errors.
- Use ferrite material to protect signal cables from electro-magnetic interference.
- Take care when supporting cables using cable ties, to apply the cable ties no closer than 6 inches from the inverter. This provides sufficient access to fully close the front cover.
- When making control terminal cable connections, use a small flat-tip screw driver (0.1in wide (2.5mm) and 0.015in thick (0.4mm) at the tip).

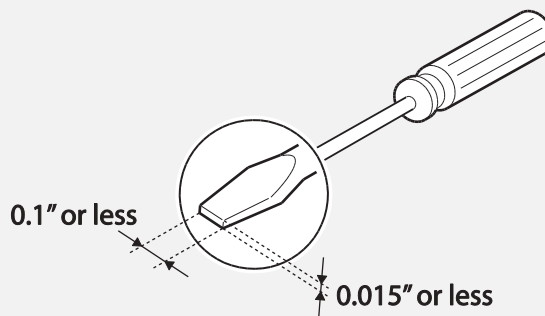

### ⚠ Warning

SA,SB, SC, they are shorted, have 24V voltage. Do not connect power to the inverter until installation has been fully completed and the inverter is ready to be operated. Doing so may result in electric shock.

## Step 5 PNP/NPN Mode Selection

The S100 inverter supports both PNP (Source) and NPN (Sink) modes for sequence inputs at the terminal. Select an appropriate mode to suit requirements using the PNP/NPN selection switch (SW1) on the control board. Refer to the following information for detailed applications.

### PNP Mode (Source)

Select PNP using the PNP/NPN selection switch (SW1). Note that the factory default setting is NPN mode. CM is the common ground terminal for all analog inputs at the terminal, and P24 is 24V internal source. If you are using an external 24V source, build a circuit that connects the external source (-) and the CM terminal.

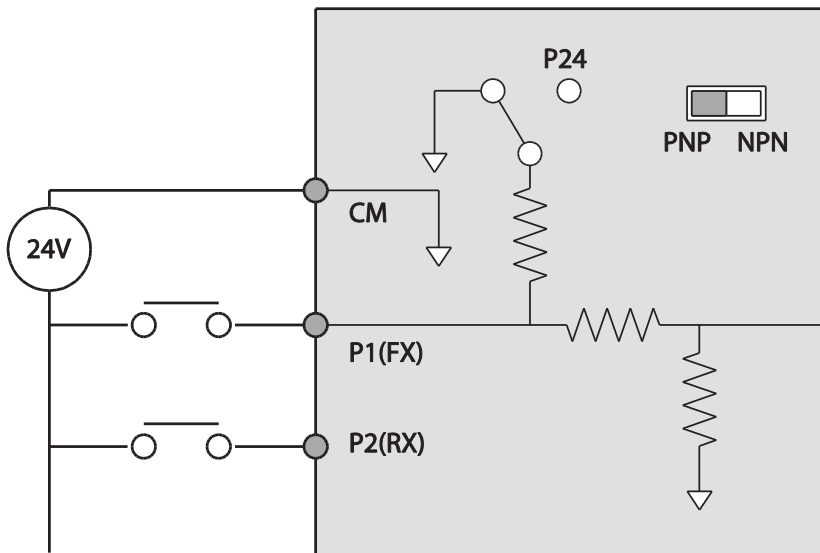



## NPN Mode (Sink)

Select NPN using the PNP/NPN selection switch (SW1). Note that the factory default setting is NPN mode. CM is the common ground terminal for all analog inputs at the terminal, and P24 is 24V internal source.

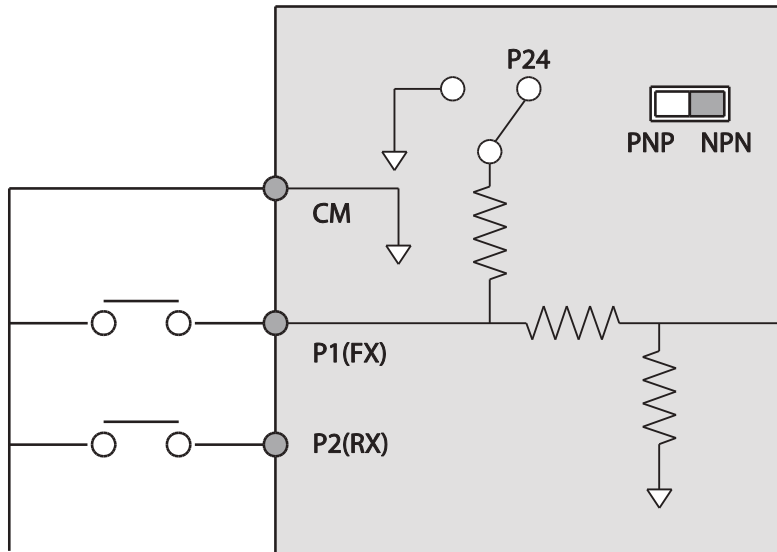

## Step 6 Disabling the EMC Filter for Power Sources with Asymmetrical Grounding

S100 built-in EMC filter prevents electromagnetic interference by reducing radio emissions from the inverter. EMC filter is activated as a factory default design. If an inverter uses a power source with an asymmetrical grounding connection or non-grounding, the EMC filter MUST be turned off. EMC filter use is not always recommended, as it increases leakage current. Refer to Product Identification on page 1 to check if inverters have built-in EMC filters.

### Note

S100, 400 V, 55-75 kW products do not have built-in EMC filters.

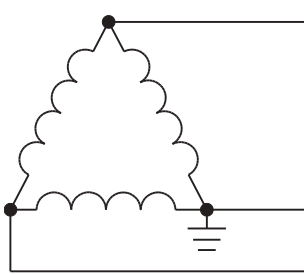
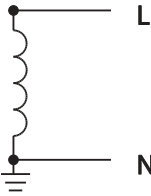
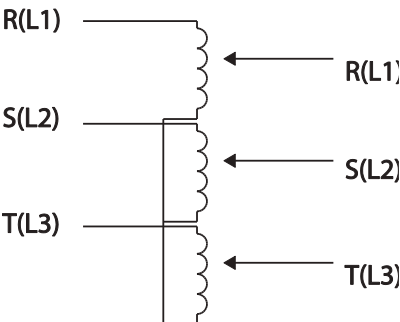
Asymmetrical Grounding Connection			
One phase of a delta connection is grounded		R(L1) S(L2) T(L3)	Intermediate grounding point on one phase of a delta connection
The end of a single phase is grounded		L N	A 3-phase connection without grounding
		R(L1) S(L2) T(L3)	



### ⚠ Danger

- Do not activate the EMC filter if the inverter uses a power source with an asymmetrical grounding structure, for example a grounded delta connection. Personal injury or death by electric shock may result.
- Wait at least 10 minutes before opening the covers and exposing the terminal connections. Before starting work on the inverter, test the connections to ensure all DC voltage has been fully discharged. Personal injury or death by electric shock may result.

## Disabling the Built-in EMC Filter

### 0.4-22kW

Before using the inverter, confirm the power supply's grounding system. Disable the EMC filter if the power source has an asymmetrical grounding connection. Refer to the figures below to locate the EMC filter on/off terminal and replace the metal bolt with the plastic bolt. If the EMC filter is required in the future, reverse the steps and replace the plastic bolt with the metal bolt to reconnect the EMC filter.

Steel bolt	Plastic bolt
	
EMC ON	EMC OFF

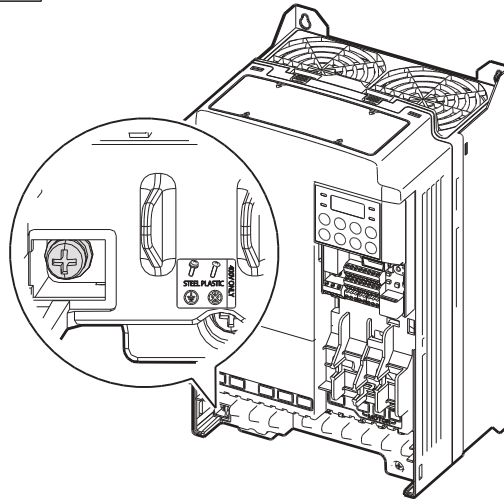

### 30-75kW

Follow the instructions listed below to disable the EMC filters.

- 1 Remove the EMC ground cover located at the bottom of the inverter.

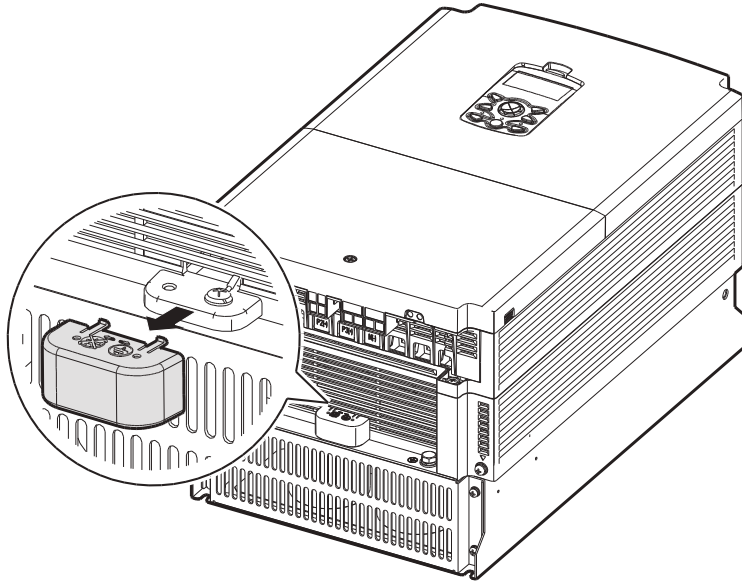

- 2 Remove the EMC ground cable from the right terminal (EMC filter-ON / factory default), and connect it to the left terminal (EMC filter-OFF / for power sources with asymmetrical grounding).

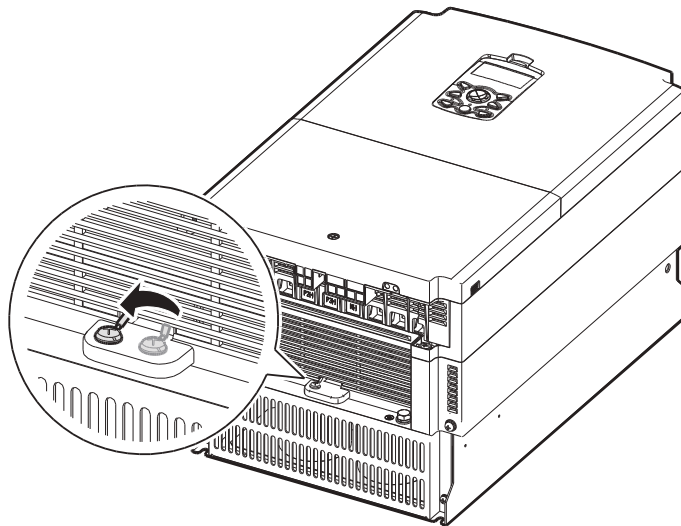

## Note

The terminal on the right is used to ENABLE the EMC filter (factory default). The terminal on the left is used to DISABLE the EMC filter (for power sources with asymmetrical grounding).

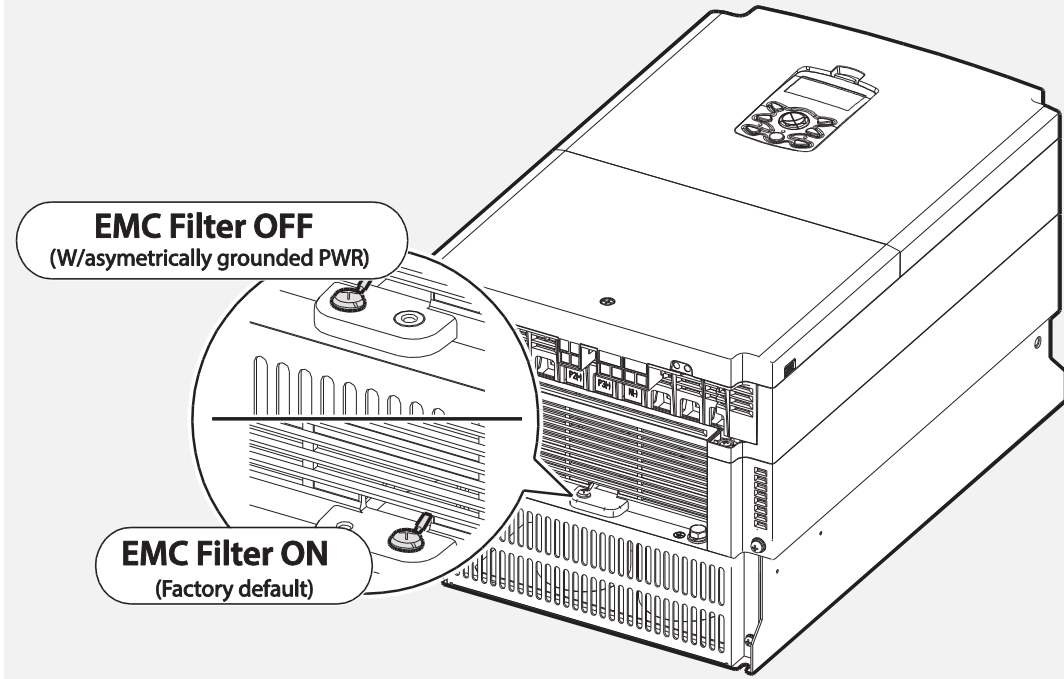

## Step 7 Selecting the brake unit (30-75kW models only)

Select the brake unit as following:

UL form	Capacity of applied motor	Braking unit
Non UL type (A type)	30-37kW	SV037DBH-4
	45-55kW	SV075DBH-4, SV075DB-4
	75kW	
Non UL type (B type)	30-37kW	LSLV0370DBU-4LN
		LSLV0370DBU-4HN
	45-75kW	LSLV0750DBU-4LN
UL type	30-37kW	SV370DBU-4U
	45-55kW	SV550DBU-4U
	75kW	SV750DBU-4U

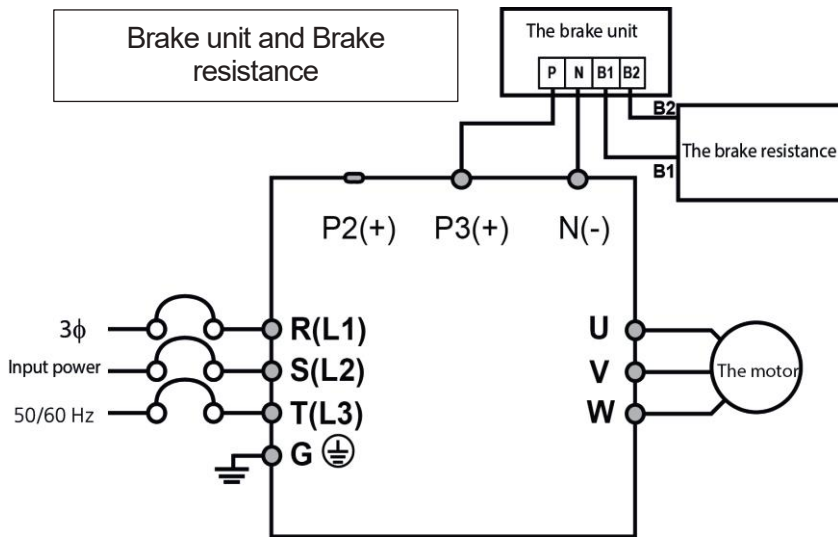

## Step 8 Re-assembling the Covers and Routing Bracket

After completing the wiring and basic configurations, re-assemble the control terminal cover, cable routing bracket, and front cover respectively. Note that the assembly procedure may vary according to the product group or frame size of the product.

## 2.3 Post-Installation Checklist

After completing the installation, check the items in the following table to make sure that the inverter has been safely and correctly installed.

Items	Check Point	Ref.	Result
Installation Location/Power I/O Verification	Is the installation location appropriate?	<u>p.8</u>	
	Does the environment meet the inverter's operating conditions?	<u>p.9</u>	
	Does the power source match the inverter's rated input?	<u>p.203</u>	
	Is the inverter's rated output sufficient to supply the equipment? (Degraded performance will result in certain circumstances. Refer to <u>7.8 Continuous Rated Current Derating</u> on page 240 for details.)	<u>p.203</u>	
Power Terminal Wiring	Is a circuit breaker installed on the input side of the inverter?	<u>p.16</u>	
	Is the circuit breaker correctly rated?	<u>p.203</u>	
	Are the power source cables correctly connected to the R/S/T terminals of the inverter? (Caution: connecting the power source to the U/V/W terminals may damage the inverter.)	<u>p.32</u>	
	Are the motor output cables connected in the correct phase rotation (U/V/W)? (Caution: motors will rotate in reverse direction if three phase cables are not wired in the correct rotation.)	<u>p.30</u>	
	Are the cables used in the power terminal connections correctly rated?	<u>p.13</u>	
	Is the inverter grounded correctly?	<u>p.29</u>	
	Are the power terminal screws and the ground terminal screws tightened to their specified torques?	<u>p. 32</u>	
	Are the overload protection circuits installed correctly on the motors (if multiple motors are run using one inverter)?	-	
	Is the inverter separated from the power source by a magnetic contactor (if a braking resistor is in use)?	<u>p.16</u>	
Are advanced-phase capacitors, surge protection and electromagnetic interference filters installed correctly? (These devices MUST not be installed on the output side of the inverter.)	<u>p.30</u>		
Control Terminal Wiring	Are STP (shielded twisted pair) cables used for control terminal wiring?	-	
	Is the shielding of the STP wiring properly grounded?	-	
	If 3-wire operation is required, are the multi-function input terminals defined prior to the installation of the control wiring connections?	<u>p.39</u>	

Items	Check Point	Ref.	Result
	Are the control cables properly wired?	<u>p.39</u>	
	Are the control terminal screws tightened to their specified torques?	<u>p.21</u>	
	Is the total cable length of all control wiring < 165ft (100m)?	<u>p.46</u>	
	Is the total length of safety wiring < 100ft (30m)?	<u>p.46</u>	
Miscellaneous	Are optional cards connected correctly?	-	
	Is there any debris left inside the inverter?	<u>p.21</u>	
	Are any cables contacting adjacent terminals, creating a potential short circuit risk?	-	
	Are the control terminal connections separated from the power terminal connections?	-	
	Have the capacitors been replaced if they have been in use for > 2 years?	-	
	Have the fans been replaced if they have been in use for > 3 years?	-	
	Has a fuse been installed for the power source?	<u>p.229</u>	
	Are the connections to the motor separated from other connections?	-	

### Note

STP (Shielded Twisted Pair) cable has a highly conductive, shielded screen around twisted cable pairs. STP cables protect conductors from electromagnetic interference.



## 2.4 Test Run

After the post-installation checklist has been completed, follow the instructions below to test the inverter.

- 1 Turn on the power supply to the inverter. Ensure that the keypad display light is on.
- 2 Select the command source.
- 3 Set a frequency reference, and then check the following:
  - If V1 is selected as the frequency reference source, does the reference change according to the input voltage at VR?
  - If V2 is selected as the frequency reference source, is the voltage/current selector switch (SW2) set to voltage, and does the reference change according to the input voltage?
  - If I2 is selected as the frequency reference source, is the voltage/current selector switch (SW2) set to current, and does the reference change according to the input current?
- 4 Set the acceleration and deceleration time.
- 5 Start the motor and check the following:
  - Ensure that the motor rotates in the correct direction (refer to the note below).
  - Ensure that the motor accelerates and decelerates according to the set times, and that the motor speed reaches the frequency reference.

## Note

If the forward command (Fx) is on, the motor should rotate counterclockwise when viewed from the load side of the motor. If the motor rotates in the reverse direction, switch the cables at the U and V terminals.

## Remarque

Si la commande avant (Fx) est activée, le moteur doit tourner dans le sens anti-horaire si on le regarde côté charge du moteur. Si le moteur tourne dans le sens inverse, inverser les câbles aux bornes U et V.

## Verifying the Motor Rotation

- 1 On the keypad, set the drv (Frequency reference source) code in the Operation group to 0 (Keypad).
- 2 Set a frequency reference.
- 3 Press the [RUN] key. Motor starts forward operation.
- 4 Observe the motor's rotation from the load side and ensure that the motor rotates counterclockwise (forward).

If the motor rotates in the reverse direction, two of the U/V/W terminals need to be switched.

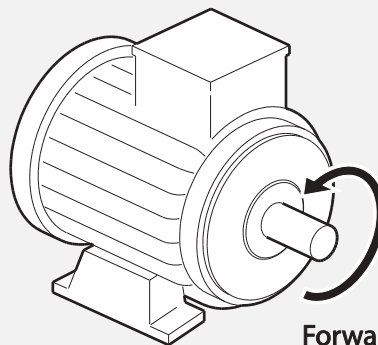

Forward operation

## ⚠ Caution

- Check the parameter settings before running the inverter. Parameter settings may have to be adjusted depending on the load.
- To avoid damaging the inverter, do not supply the inverter with an input voltage that exceeds the rated voltage for the equipment.
- Before running the motor at maximum speed, confirm the motor's rated capacity. As inverters can be used to easily increase motor speed, use caution to ensure that motor speeds do not accidentally exceed the motor's rated capacity.

Memo

## 3 Learning to Perform Basic Operations

This chapter describes the keypad layout and functions. It also introduces parameter groups and codes, required to perform basic operations. The chapter also outlines the correct operation of the inverter before advancing to more complex applications. Examples are provided to demonstrate how the inverter actually operates.

### 3.1 About the Keypad

The keypad is composed of two main components – the display and the operation (input) keys. Refer to the following illustration to identify part names and functions.

#### 3.1.1 0.4-22kW Models

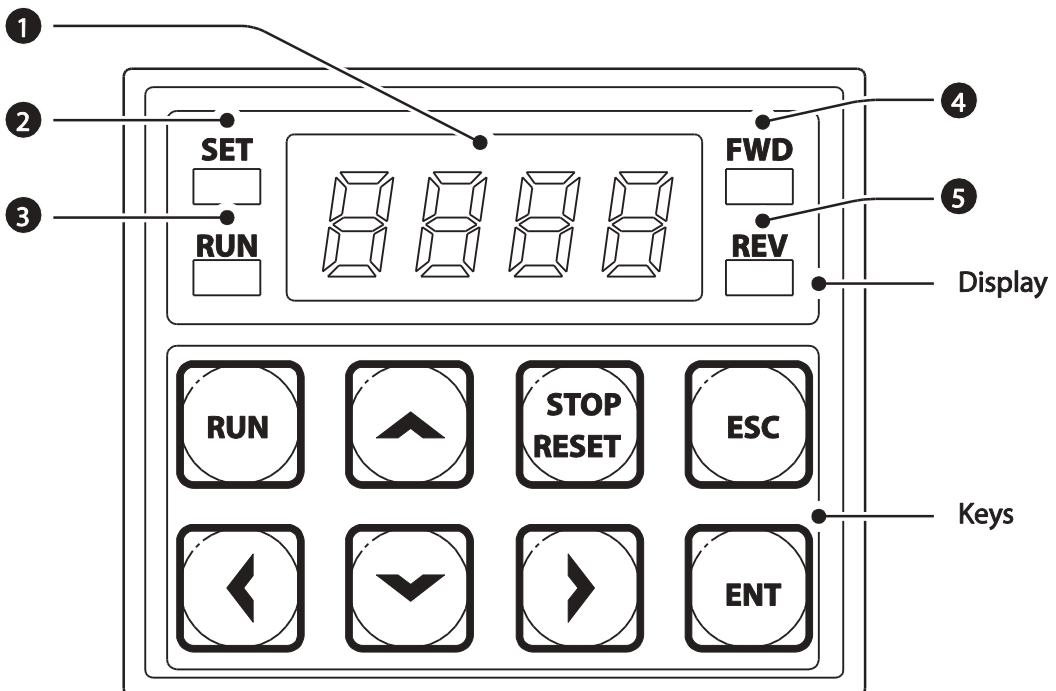

### 3.1.2 30-75kW Models

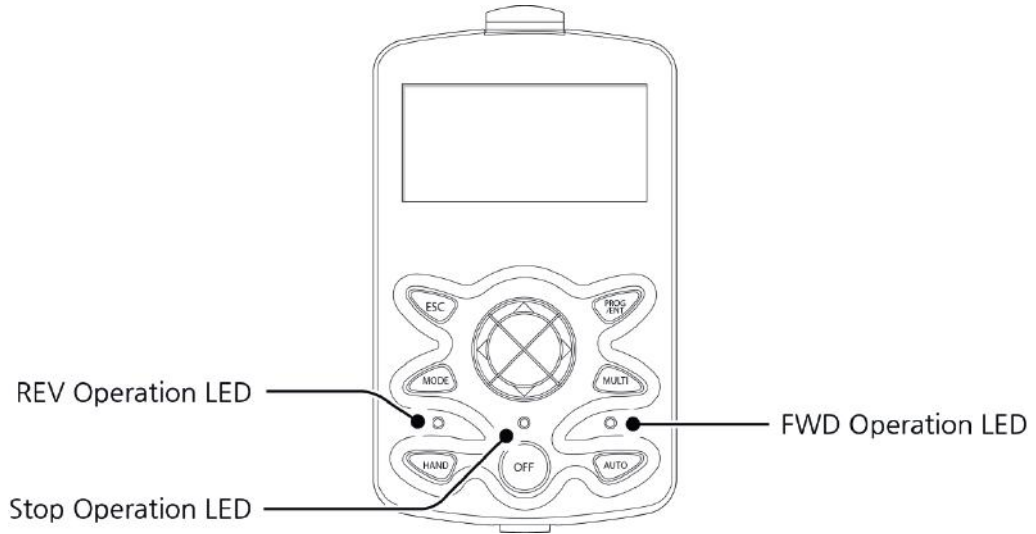

### 3.1.3 About the Display

The following table lists display part names and their functions.

#### 3.1.3.1 0.4-22kW Models

No.	Name	Function
①	7-Segment Display	Displays current operational status and parameter information.
②	SET Indicator	LED flashes during parameter configuration and when the ESC key operates as the multi-function key.
③	RUN Indicator	LED turns on (steady) during an operation, and flashes during acceleration or deceleration.
④	FWD Indicator	LED turns on (steady) during forward operation.
⑤	REV Indicator	LED turns on (steady) during reverse operation.

The table below lists the way that the keypad displays characters (letters and numbers).

0	0	A	A	K	K	U	U
1	1	b	B	L	L	v	V
2	2	C	C	m	M	w	W
3	3	d	D	n	N	x	X
4	4	E	E	O	O	y	Y
5	5	F	F	P	P	z	Z
6	6	G	G	Q	Q	-	-
7	7	H	H	R	R	-	-
8	8	I	I	S	S	-	-
9	9	J	J	T	T	-	-

### 3.1.3.2 30-75kW Models

#### Monitor mode display

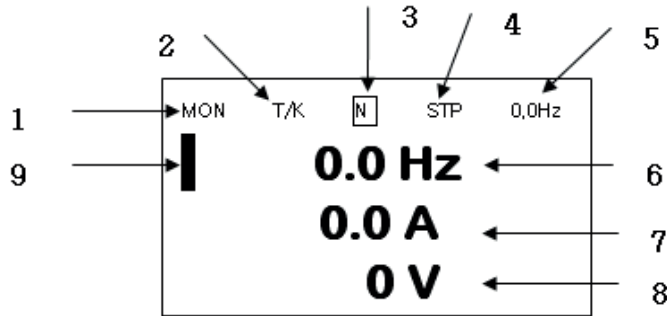

#### Parameter settings display

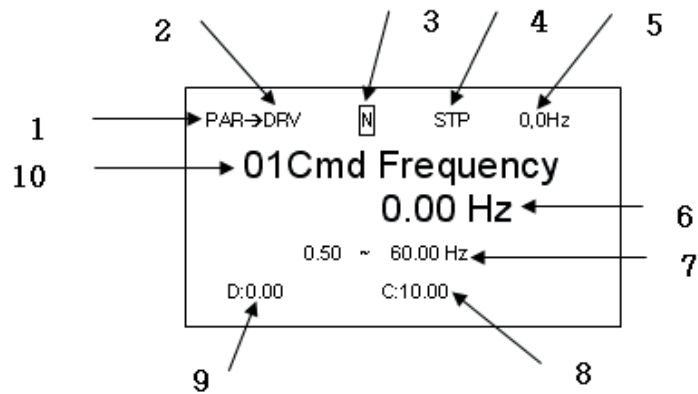

### Names displayed in monitor mode and parameter settings

No.	Names displayed in monitor mode	No.	Names displayed in parameter settings
1	Mode	1	Mode
2	Operating/frequency command	2	Group
3	Multi-functional key settings	3	Multi-functional key settings
4	Inverter operation status	4	Inverter operation status
5	Items displayed in the status window	5	Items displayed in the status window
6	Monitor mode display 1	6	Display parameters
7	Monitor mode display 2	7	Available settings range
8	Monitor mode display 3	8	Existing setting values
9	Monitor mode cursor	9	Factory default values
		10	Code numbers and names

### Display details

No.	Name	Display	Description
1	Mode	MON	Monitor Mode
		PAR	Parameter Mode
		TRP	Trip Mode
		CNF	Config Mode
2	Operation commands	K	Keypad operation command
		O	Field Bus communication option operation command
		A	Application option operation command
		R	Internal 485 operation command
		T	Terminal operation command
	Frequency commands	K	Keypad frequency command
		V	V1 input frequency command
		P	Pulse input frequency command
		U	Frequency command for UP operation (Up - Down operation)
		D	Frequency command for DOWN operation (Up - Down operation)
S	Frequency command for STOP operation (Up - Down operation)		
O	FBus Option frequency command		



No.	Name	Display	Description
		J	Jog frequency command
		R	Int 485 frequency command
		1 ~9, A~F	Multi-step frequency command
3	Multi-functional key settings	JOG Key	Keypad JOG operation mode
		Local/Remote	Able to select either local or remote operation
		UserGrpSelKey	Register or delete user group parameters in parameter mode
4	Inverter operation status	STP	Motor stopped
		FWD	Operating in forward direction
		REV	Operating in reverse direction
		DC	DC output
		WAN	Warning
		STL	Stall
		SPS	Speed Search
		OSS	S/W overcurrent protective function is on
		OSH	H/W overcurrent protective function is on
		TUN	Auto Tuning







## 3.1.4 Operation Keys

### 3.1.4.1 0.4-22kW Models

#### ⓘ Caution









Install a separate emergency stop switch in the circuit. The [STOP/RESET] key on the keypad works only when the inverter has been configured to accept an input from the keypad.

The following table lists the names and functions of the keypad's operation keys.

Key	Name	Description
	[RUN] key	Used to run the inverter (inputs a RUN command).
	[STOP/RESET] key	STOP: stops the inverter. RESET: resets the inverter following fault or failure condition.
	[▲] key, [▼] key	Switch between codes, or to increase or decrease parameter values.
	[◀] key, [▶] key	Switch between groups, or to move the cursor during parameter setup or modification.
	[ENT] key	Used to select, confirm, or save a parameter value.
	[ESC] key	A multi-function key used to configure different functions, such as: <ul style="list-style-type: none"> <li>• Jog operation</li> <li>• Remote/Local mode switching</li> <li>• Cancellation of an input during parameter setup</li> </ul>

### 3.1.4.2 30-75kW Models

The following table lists the names and functions of the LCD's operation keys.







Key	Name	Description
	[MODE] Key	Used to switch between modes.
	[PROG / Ent] Key	Used to select, confirm, or save a parameter value.
	[UP] key [DOWN] key	Switch between codes or increase or decrease parameter values.
	[LEFT] key [RIGHT] key	Switch between groups or move the cursor during parameter setup or modification.
	[MULTI] Key	Used to perform special functions, such as user code registration.
	[ESC] Key	Used to cancel an input during parameter setup. <ul style="list-style-type: none"> <li>Pressing the [ESC] key before pressing the [PROG / ENT] key reverts the parameter value to the previously set value.</li> <li>Pressing the [ESC] key while editing the codes in any function group makes the keypad display the first code of the function group.</li> <li>Pressing the [ESC] key while moving through the modes makes the keypad display Monitor mode.</li> </ul>
	[FWD] Key	Used to operate the motor in the forward direction.
	[REV] Key	Used to operate the motor in the reversed direction.
	[STOP/RESET] Key	Used to stop motor operation. Used to reset the inverter following fault or failure condition.

### 3.1.5 Control Menu

#### 0.4-22kW Control Menu

The following table lists the functions groups under Parameter mode.

Function Group Name	Keypad Display	LCD Display	Description
Operation	0.00	DRV-01	Configures reference frequencies.
	ACC	DRV-03	Configures acceleration times.
	dEC	DRV-04	Configures deceleration times.
	drv	DRV-06	Used to select operation command.
	Fp9	DRV-07	Configures operation frequencies.
	St 1	BAS-50	Configures the Step Freq. 1 of the multi-step frequencies.
	St 2	BAS-51	Configures Step Freq. 2 of the multi-step frequencies.
	St 3	BAS-52	Configures Step Freq. 2 of the multi-step frequencies.
	CUr	Monitor Line Display (CNF-20~23)	Displays current output current.
	rPn		Displays current speed of a load (RPM).
	dCL		Displays current DC LINK voltage.
	uDL		Displays current output voltage.
	nOn	TRP Last-1	Displays recent trip history.
drC	-	Used to select motor operation direction.	
Drive	dr	DRV	Configures parameters for basic operations. These include jog operation, motor capacity evaluation, torque boost, and other keypad related parameters.
Basic	bA	BAS	Configures basic operation parameters. These parameters include motor parameters and multi-step frequency parameters.
Advanced	Ad	ADV	Configures acceleration or deceleration patterns, frequency limits, etc.
Control	Cn	CON	Configures sensorless vector-related features.
Input Terminal	in	IN	Configures input terminal-related features, including digital multi-functional inputs and analog inputs.
Output Terminal	ou	OUT	Configures output terminal-related features

Function Group Name	Keypad Display	LCD Display	Description
			such as relays and analog outputs.
Communication		COM	Configures communication features for RS-485 or other communication options.
Application		APP	Configures functions related to PID control.
Protection		PRT	Configures motor and inverter protection features.
Motor 2 (Secondary motor)		M2	Configures secondary motor related features. The secondary motor (M2) group appears on the keypad only when one of the multi-function input terminals (In.65–In.71) has been set to 26 (Secondary motor).
User Sequence		USS	Used to implement simple sequences with various function blocks.
User Sequence Function		USF	

### 30-75kW Control Menu

The S100 inverter uses 5 modes to monitor or configure different functions. The parameters in Parameter mode are divided into smaller groups of relevant functions. Press the [Mode] key to change to Parameter mode.

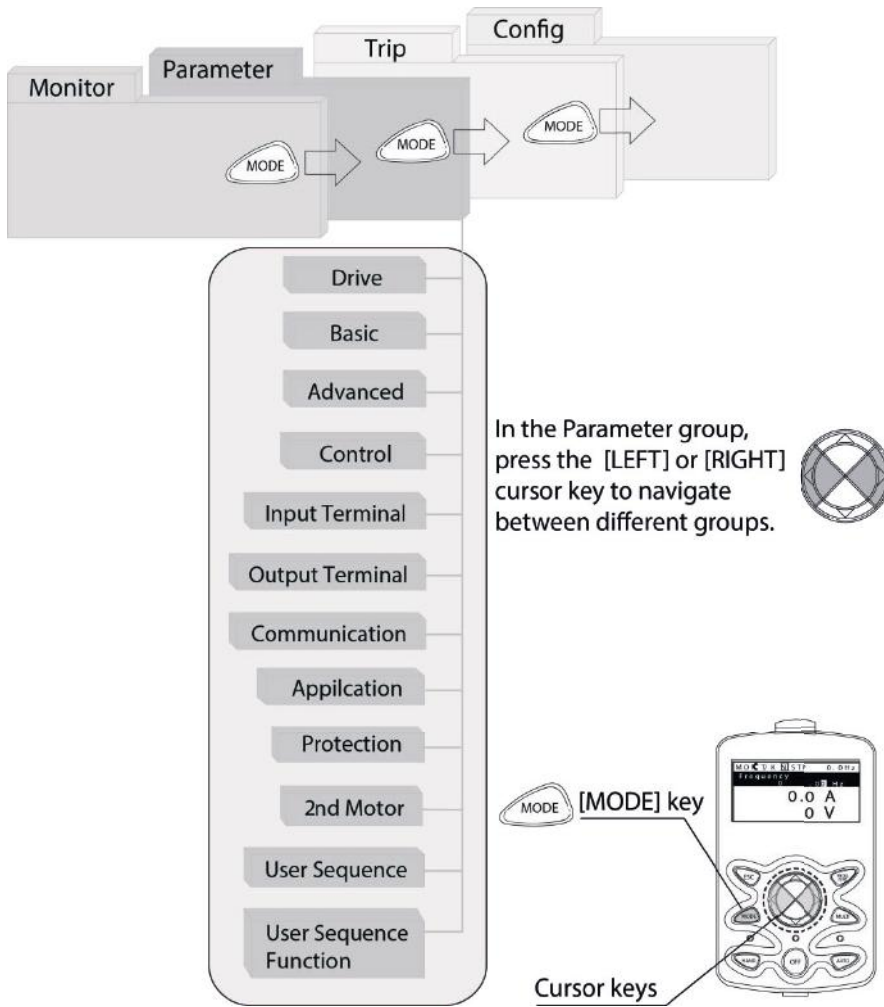

The following table lists the 5 display modes used to control the inverter functions.

Mode Name	LCD Display	Description
Monitor mode	MON	Displays the inverter's operation status information. In this mode, information including the inverter's frequency reference, operation frequency, output current, and voltage may be monitored.
Parameter mode	PAR	Used to configure the functions required to operate the inverter. These functions are divided into 14 groups based on purpose and complexity.
Trip mode	TRP	Used to monitor the inverter's fault trip information, including the previous fault trip history. When a fault trip occurs during inverter operation, the operation frequency, output current, and output voltage of the inverter at the time of the fault may be monitored. This mode is not displayed if the inverter is not at fault and fault trip history does not exist.
Config mode	CNF	Used to configure the inverter features that are not directly related to the operation of the inverter. The settings you can configure in the Config mode include keypad display language options, monitor mode environment settings, communication module display settings, and parameter duplication and initialization.

## 3.2 Learning to Use the Keypad

The keypad enables movement between groups and codes. It also enables users to select and configure functions. At code level, you can set parameter values to turn on or off specific functions, or decide how the functions will be used. Refer to [4 Table of Functions](#) on page [103](#) to find the functions you need.

Confirm the correct values (or the correct range of the values), and then follow the examples below to configure the inverter with the keypad.

### 3.2.1 Display Mode Selection (30-75kW models only)

The following figure illustrates how the display modes change when you press the [Mode] button on the keypad. You can continue to press the [Mode] key until you get to the desired mode.

User mode and Trip mode are not displayed when all the inverter settings are set to the factory default (User mode must be configured before it is displayed on the keypad, and Trip mode is displayed only when the inverter is at fault, or has previous trip fault history).

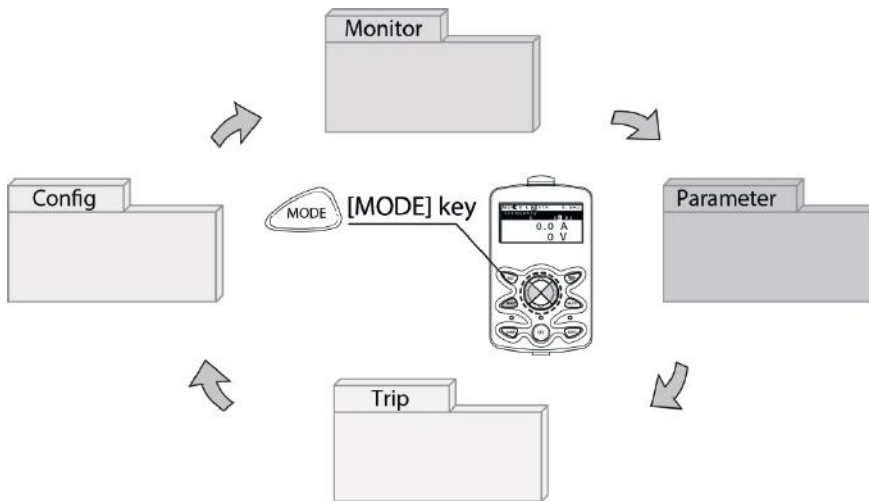



### Mode selection in factory default condition

<p>MON T/K [N] STP 0,0Hz</p> <p><b>0.0 Hz</b></p> <p><b>0.0 A</b></p> <p><b>0 V</b></p>	<ul style="list-style-type: none"> <li>• When the power is turned on, Monitor mode is displayed.</li> <li>• Press the [MODE] key.</li> </ul>
<p>PAR → DRV [N] STP 0,0Hz</p> <p>00 Jump Code 9 CODE</p> <p>01 Cmd Frequency 0,00 Hz</p> <p>02 Cmd Torque 0,0 %</p>	<ul style="list-style-type: none"> <li>• Parameter mode</li> <li>• Press the [MODE] key.</li> </ul>
<p>CNF [N] STP 0,0Hz</p> <p>00 Jump Code 40 CODE</p> <p>01 Language Sel English</p> <p>02 LCD Contrast</p> <p>□□□□□□□□□□□□□□□□</p>	<ul style="list-style-type: none"> <li>• Config (CNF) mode</li> <li>• Press the [MODE] key.</li> </ul>
<p>MON T/K [N] STP 0,0Hz</p> <p><b>0.0 Hz</b></p> <p><b>0.0 A</b></p> <p><b>0 V</b></p>	<ul style="list-style-type: none"> <li>• Monitor mode is displayed again.</li> </ul>

### Switching between groups when Trip mode is added

Trip mode is accessible only when the inverter has trip fault history. Refer to [3 Learning to Perform Basic Operations](#) on page [59](#) for information about monitoring faults.

<p>MON T/K <input checked="" type="checkbox"/> STP 0,0Hz</p> <p><b>0.0 Hz</b></p> <p><b>0.0 A</b></p> <p><b>0 V</b></p>	<ul style="list-style-type: none"> <li>• When the power is turned on, Monitor mode is displayed.</li> <li>• Press the [MODE] key.</li> </ul>
<p>PAR → DRV <input checked="" type="checkbox"/> STP 0,0Hz</p> <p>00 Jump Code <b>9 CODE</b></p> <p>01 Cmd Frequency 0,00 Hz</p> <p>02 Cmd Torque 0,0 %</p>	<ul style="list-style-type: none"> <li>• Parameter mode</li> <li>• Press the [MODE] key.</li> </ul>
<p>TRP Last-1</p> <p>00 Trip Name (1) <b>External Trip</b></p> <p>01 Output Freq 0,00 Hz</p> <p>02 Output Current 0,0 A</p>	<ul style="list-style-type: none"> <li>• Trip mode</li> <li>• Press the [MODE] key.</li> </ul>
<p>CNF <input checked="" type="checkbox"/> STP 0,0Hz</p> <p>00 Jump Code <b>40 CODE</b></p> <p>01 Language Sel English</p> <p>02 LCD Contrast <input type="checkbox"/><input type="checkbox"/><input type="checkbox"/><input type="checkbox"/><input type="checkbox"/><input type="checkbox"/><input type="checkbox"/><input type="checkbox"/><input type="checkbox"/><input type="checkbox"/><input type="checkbox"/><input type="checkbox"/><input type="checkbox"/><input type="checkbox"/><input type="checkbox"/><input type="checkbox"/><input type="checkbox"/><input type="checkbox"/><input type="checkbox"/><input type="checkbox"/><input type="checkbox"/><input type="checkbox"/></p>	<ul style="list-style-type: none"> <li>• CNF mode</li> <li>• Press the [MODE] key.</li> </ul>
<p>MON T/K <input checked="" type="checkbox"/> STP 0,0Hz</p> <p><b>0.0 Hz</b></p> <p><b>0.0 A</b></p> <p><b>0 V</b></p>	<ul style="list-style-type: none"> <li>• Monitor mode is displayed again.</li> </ul>

### 3.2.2 Group and Code Selection

Follow the examples below to learn how to switch between groups and codes.

#### 3.2.2.1 0.4-22kW Models

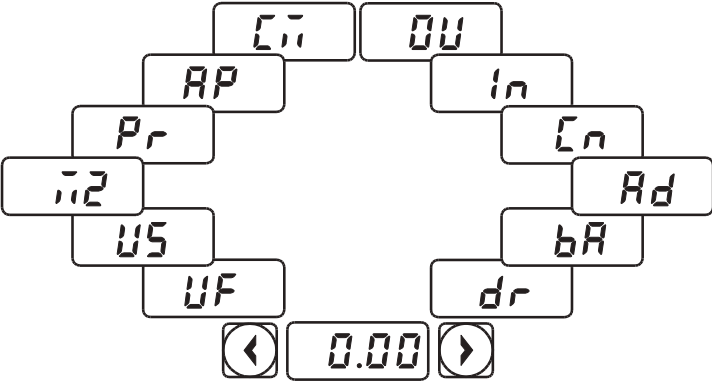
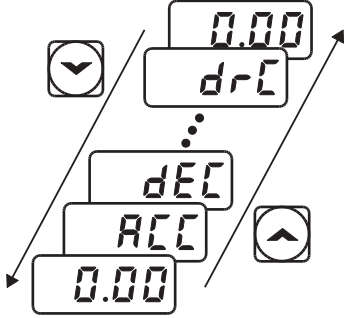
Step	Instruction	Keypad Display
1	Move to the group you want using the [◀] and [▶] keys.	
2	Move up and down through the codes using the [▲] and [▼] keys until you locate the code that you require.	
3	Press the [ENT] key to save the change.	-

### Note

For some settings, pressing the [▲] or [▼] key will not increase or decrease the code number by 1. Code numbers may be skipped and not be displayed. This is because certain code numbers have been intentionally left blank (or reserved) for new functions to be added in the future. Also some features may have been hidden (disabled) because a certain code has been set to disable the functions for relevant codes.

As an example, if Ad.24 (Frequency Limit) is set to 0 (No), the next codes, Ad.25 (Freq Limit Lo) and Ad.26 (Freq Limit Hi), will not be displayed. If you set code Ad.24 to 1 (Yes) and enable the frequency limit feature, codes Ad.25 and 26 will appear to allow the maximum and minimum frequency limitations to be set up.

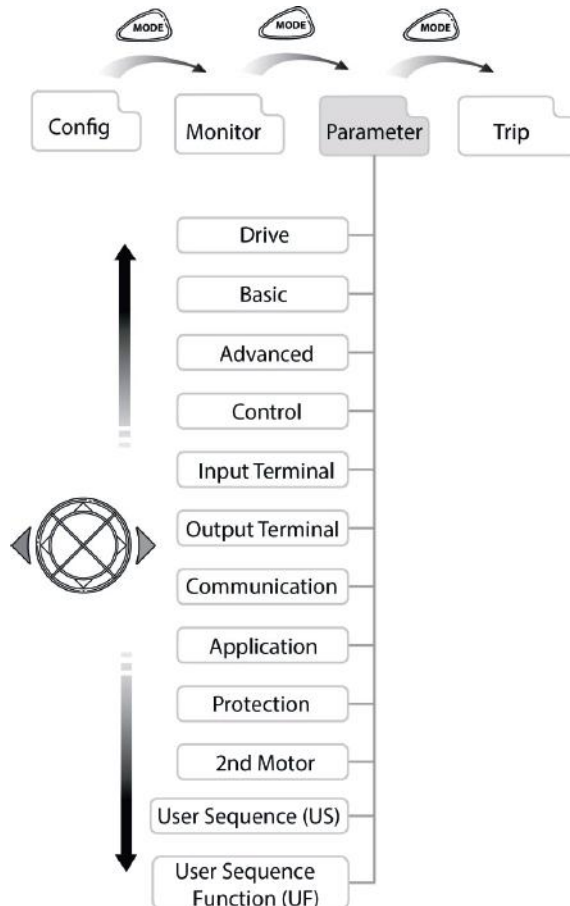

### 3.2.2.2 30-75kW Models (Switching Groups)

Press the [MODE] key to display a specific mode. Modes displayed change in the following order:



## Switching between Groups in Parameter Display Mode

After entering Parameter mode from Monitor mode, press the [ ] key to change the display as shown below. Press the [ ] key to return to the previous mode.

<p>MON T/K [M] STP 0,0Hz   <b>0.0 Hz</b>  <b>0.0 A</b>  <b>0 V</b></p>	<ul style="list-style-type: none"> <li>• When the power is turned on, Monitor mode is displayed.</li> <li>• Press the [MODE] key.</li> </ul>
<p>PAR →DRV [M] STP 0,0Hz  <b>00 Jump Code</b> 9 CODE  01 Cmd Frequency 0.00 Hz  02 Cmd Torque 0.0 %</p>	<ul style="list-style-type: none"> <li>• Parameter mode</li> <li>• Drive group is displayed.</li> <li>• Press the [▶] key.</li> </ul>
<p>PAR →BAS [M] STP 0,0Hz  <b>00 Jump Code</b> 20 CODE  01 Aux Ref Src None  02 Cmd 2nd Src Fx/Rx-1</p>	<ul style="list-style-type: none"> <li>• Basic group (BAS)</li> <li>• Press the [▶] key.</li> </ul>
<p>PAR →ADV [M] STP 0,0Hz  <b>00 Jump Code</b> 24 CODE  01 Acc Pattern Linear  02 Dec Pattern Linear</p>	<ul style="list-style-type: none"> <li>• Advanced group (ADV)</li> <li>• Press the [▶] key seven times.</li> </ul>
<p>PAR →PRT [M] STP 0,0Hz  <b>00 Jump Code</b> 40 CODE  04 Load Duty Heavy Duty  05 Phase Loss Chk </p>	<ul style="list-style-type: none"> <li>• Protection group (PRT)</li> <li>• Press the [▶] key.</li> </ul>
<p>PAR →DRV [M] STP 0,0Hz  <b>00 Jump Code</b> 9 CODE  01 Cmd Frequency 0.00 Hz  02 Cmd Torque 0.0 %</p>	<ul style="list-style-type: none"> <li>• Parameter mode Drive group (DRV) is displayed again.</li> </ul>

### 3.2.2.3 30-75kW Models (Code Navigation)

#### Code Navigation in Monitor mode

In monitor mode, press the [▲], [▼] key to display frequency, the output current, or voltage according to the cursor position.

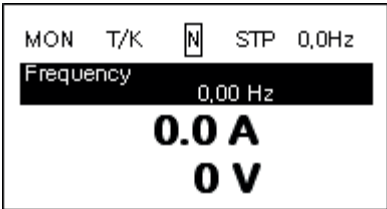
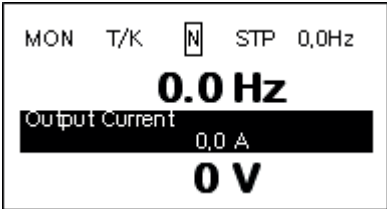
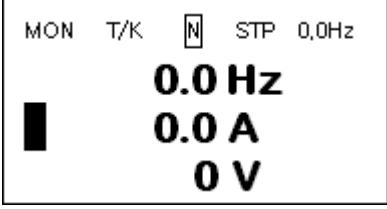
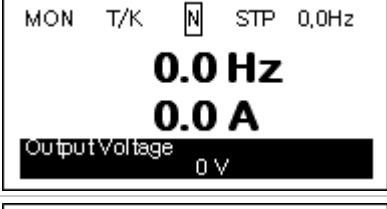
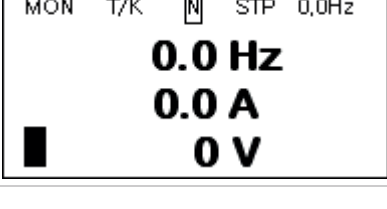
	<ul style="list-style-type: none"> <li>• When the power is turned on, Monitor mode is displayed.</li> <li>• The cursor appears to the left of the frequency information.</li> <li>• Press the [▼] key.</li> </ul>
	<ul style="list-style-type: none"> <li>• Information about the second item in Monitor mode (Output Current) is displayed.</li> <li>• Wait for 2 seconds until the information on the display disappears.</li> </ul>
	<ul style="list-style-type: none"> <li>• Information about the second item in Monitor mode (Output Current) disappears and the cursor reappears to the left of the second item.</li> <li>• Press the [▼] key.</li> </ul>
	<ul style="list-style-type: none"> <li>• Information about the third item in Monitor mode (Output Voltage) is displayed.</li> <li>• Wait for 2 seconds until the information on the display disappears.</li> </ul>
	<ul style="list-style-type: none"> <li>• Information about the third item in Monitor mode (Output Voltage) disappears and the cursor appears to the left of the third item.</li> <li>• Press the [▼] key twice.</li> </ul>

<p>MON T/K <input checked="" type="checkbox"/> STP 0,0Hz Frequency 0,00 Hz <b>0.0 A</b> <b>0 V</b></p>	<ul style="list-style-type: none"> <li>Information about the first item in Monitor mode (Frequency) is displayed.</li> </ul>
<p>MON T/K <input checked="" type="checkbox"/> STP 0,0Hz <b>0.0 Hz</b> <b>0.0 A</b> <b>0 V</b></p>	<ul style="list-style-type: none"> <li>Information about the first item in Monitor mode (Frequency) disappears and the cursor appears to the left of the first item.</li> </ul>

### Code Navigation in Parameter mode

The following examples show you how to move through codes in different function groups (Drive group and Basic group) in Parameter mode. In parameter mode, press the [▲] or [▼] key to move to the desired functions.

<p>MON T/K <input checked="" type="checkbox"/> STP 0,0Hz <b>0.0 Hz</b> <b>0.0 A</b> <b>0 V</b></p>	<ul style="list-style-type: none"> <li>When the power is on, monitor mode is displayed.</li> <li>Press the [MODE] key.</li> </ul>
<p>PAR → DRV <input checked="" type="checkbox"/> STP 0,0Hz 00 Jump Code 9 CODE 01 Cmd Frequency 0.00 Hz 02 Acc Time 20.0 sec</p>	<ul style="list-style-type: none"> <li>Drive group (DRV) in Parameter mode is displayed. If any other group is displayed, press the [MODE] key until the Drive group is displayed, or press the [ESC] key.</li> </ul>
<p>PAR → DRV <input checked="" type="checkbox"/> STP 0,0Hz 00 Jump Code 9 CODE 01 Cmd Frequency 0.00 Hz 02 Acc Time 20.0 sec</p>	<ul style="list-style-type: none"> <li>Press the [▼] key to move to the second code (DRV-01) of Drive group.</li> <li>Press the [▶] key</li> </ul>
<p>PAR → BAS <input checked="" type="checkbox"/> STP 0,0Hz 00 Jump Code 20 CODE 01 Aux Ref Src None 02 Cmd 2nd Src Fx/Rx-1</p>	<ul style="list-style-type: none"> <li>Basic group is displayed.</li> <li>Press the [▲] or [▼] key to move to the desired codes and configure the inverter functions.</li> </ul>

### 3.2.3 Navigating Directly to Different Codes

#### 3.2.3.1 0.4-22kW Models

The following example details navigating to code dr. 95, from the initial code in the Drive group (dr. 0). This example applies to all groups whenever you would like to navigate to a specific code number.

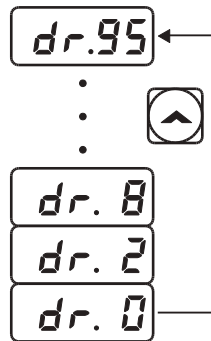

Step	Instruction	Keypad Display
1	Ensure that you are currently at the first code of the Drive group (dr.0).	
2	Press the [ENT] key. Number '9' will flash.	
3	Press the [▼] key to display '5,' the first 1s' place of the group destination, '95.'	
4	Press the [◀] key to move to the 10s' place. The cursor will move to the left and '05' will be displayed. This time, the number '0' will be flashing.	
5	Press the [▲] key to increase the number from '0' to '9,' the 10s place digit of the destination, '95.'	
6	Press the [ENT] key. Code dr.95 is displayed.	



### 3.2.3.2 30-75kW Models

Parameter mode and Config mode allow direct jumps to specific codes. The code used for this feature is called the Jump Code. The Jump Code is the first code of each mode. The Jump Code feature is convenient when navigating for a code in a function group that has many codes.

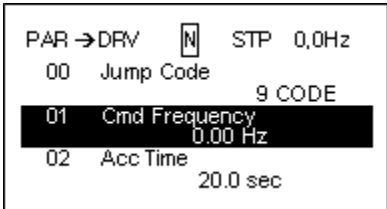
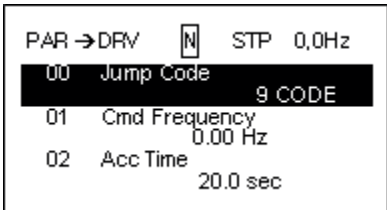
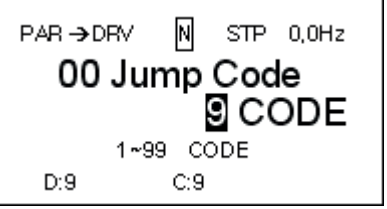
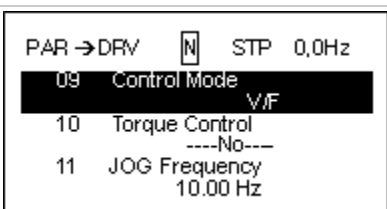
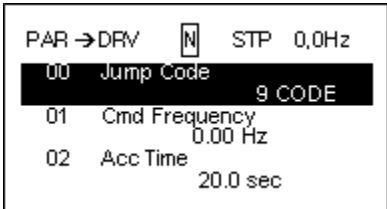

The following example shows how to navigate directly to code DRV- 09 from the initial code (DRV-00 Jump Code) in the Drive group.

 <p>PAR → DRV [N] STP 0,0Hz 00 Jump Code 9 CODE 01 Cmd Frequency 0.00 Hz 02 Acc Time 20.0 sec</p>	<ul style="list-style-type: none"> <li>The Drive group (DRV) is displayed in Parameter mode. Make sure that the first code in the Drive group (DRV 00 Jump Code) is currently selected.</li> <li>Press the [PROG/ENT] key.</li> </ul>
 <p>PAR → DRV [N] STP 0,0Hz 00 Jump Code 9 CODE 01 Cmd Frequency 0.00 Hz 02 Acc Time 20.0 sec</p>	<ul style="list-style-type: none"> <li>The Code input screen is displayed and the cursor flashes. A flashing cursor indicates that it is waiting for user input.</li> </ul>
 <p>PAR → DRV [N] STP 0,0Hz 00 Jump Code 9 CODE 1~99 CODE D:9 C:9</p>	<ul style="list-style-type: none"> <li>Press the [▲] key to increase the number to 9, and then press the [PROG/ENT] key.</li> </ul>
 <p>PAR → DRV [N] STP 0,0Hz 09 Control Mode V/F 10 Torque Control ---No--- 11 JOG Frequency 10.00 Hz</p>	<ul style="list-style-type: none"> <li>DRV-09 (Control Mode) is displayed.</li> </ul>
 <p>PAR → DRV [N] STP 0,0Hz 00 Jump Code 9 CODE 01 Cmd Frequency 0.00 Hz 02 Acc Time 20.0 sec</p>	<ul style="list-style-type: none"> <li>Press the [ESC] key to go back to the initial code of the Drive group.</li> </ul>

## 3.2.4 Setting Parameter Values

### 3.2.4.1 0.4-22kW Models

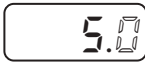
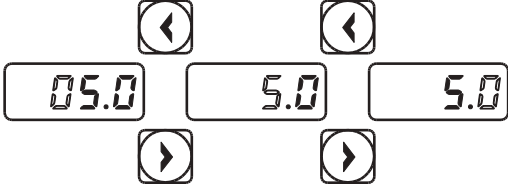
Enable or disable features by setting or modifying parameter values for different codes. Directly enter setting values, such as frequency references, supply voltages, and motor speeds. Follow the instructions below to learn to set or modify parameter values.

Step	Instruction	Keypad Display
1	Select the group and code to setup or modify parameter settings, and then press the [ENT] key. The first number on the right side of the display will flash.	
2	Press the [◀] or [▶] key to move the cursor to the number that you would like to modify.	
3	Press the [▲] or [▼] key to adjust the value, and then press the [ENT] key to confirm it. The selected value will flash on the display.	
4	Press the [ENT] key again to save the change.	-

#### Note

- A flashing number on the display indicates that the keypad is waiting for an input from the user. Changes will be saved when the [ENT] key is pressed while the number is flashing. The setting change will be canceled if you press any other key.
- Each code's parameter values have default features and ranges specified. Refer to [4 Table of Functions](#) on page [103](#) for information about the features and ranges before setting or modifying parameter values.

### 3.2.4.2 30-75kW Models

#### Parameter settings available in Monitor mode

The S100 inverter allows basic parameters to be modified in Monitor mode. The following example shows how to set the frequency.

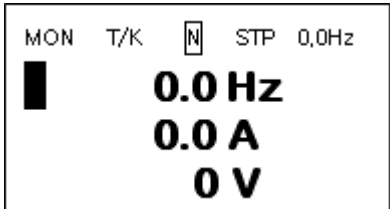
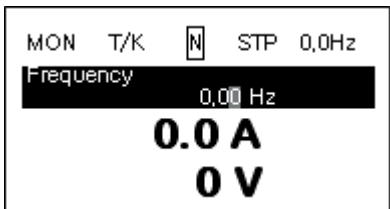
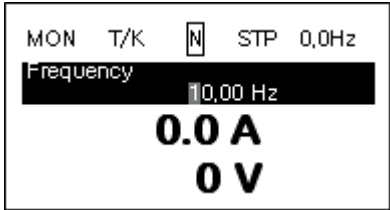
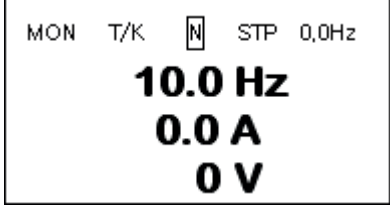
	<ul style="list-style-type: none"> <li>• Make sure that the cursor is at the frequency reference item and that the frequency setting is set to 'Keypad' in DRV-09.</li> <li>• Press the [PROG/ENT] key.</li> </ul>
	<ul style="list-style-type: none"> <li>• When the cursor is on the frequency reference item, detailed information is displayed and the cursor flashes on the input line.</li> <li>• Press the shift key to go to the desired frequency.</li> </ul>
	<ul style="list-style-type: none"> <li>• Press the [▲] key to set the frequency to 10 Hz.</li> <li>• Press the [PROG/ENT] key.</li> </ul>
	<ul style="list-style-type: none"> <li>• The frequency is set to 10 Hz.</li> </ul>

## Parameter settings in other modes and groups



The following example shows how to change the frequency in the Drive group. This example can also be applied to other modes and groups.

<pre> PAR → DRV  [N] STP 0,0Hz 00 Jump Code          9 CODE 01 Cmd Frequency      0.00 Hz 02 Cmd Torque         0.0 %                     </pre>	<ul style="list-style-type: none"> <li>This is the initial display for Parameter mode.</li> <li>Press the [▼] key.</li> </ul>
<pre> PAR → DRV  [N] STP 0,0Hz 00 Jump Code          9 CODE 01 Cmd Frequency      0.00 Hz 02 Cmd Torque         0.0 %                     </pre>	<ul style="list-style-type: none"> <li>DRV-01 code is selected.</li> <li>Press the [PROG/ENT] key.</li> </ul>
<pre> PAR → DRV  [N] STP 0,0Hz 01Cmd Frequency 0.00 Hz 0.50 ~ 60.00 Hz D:0.00      C:10.00                     </pre>	<ul style="list-style-type: none"> <li>The frequency can be changed at the flashing digit.</li> <li>Press the [◀]/ [▶] key to move the cursor to the desired digit.</li> </ul>
<pre> PAR → DRV  [N] STP 0,0Hz 01Cmd Frequency  10.00 Hz 0.50 ~ 60.00 Hz D:0.00      C:10.00                     </pre>	<ul style="list-style-type: none"> <li>Press the [▲] key to enter 10 Hz, and then press the [PROG/ENT] key.</li> </ul>
<pre> PAR → DRV  [N] STP 0,0Hz 00 Jump Code          9 CODE 01 Cmd Frequency      10.00 Hz 02 Cmd Torque         0.0 %                     </pre>	<ul style="list-style-type: none"> <li>The frequency is changed to 10 Hz.</li> </ul>

### 3.2.5 Configuring the [ESC] Key (0.4-22kW models only)

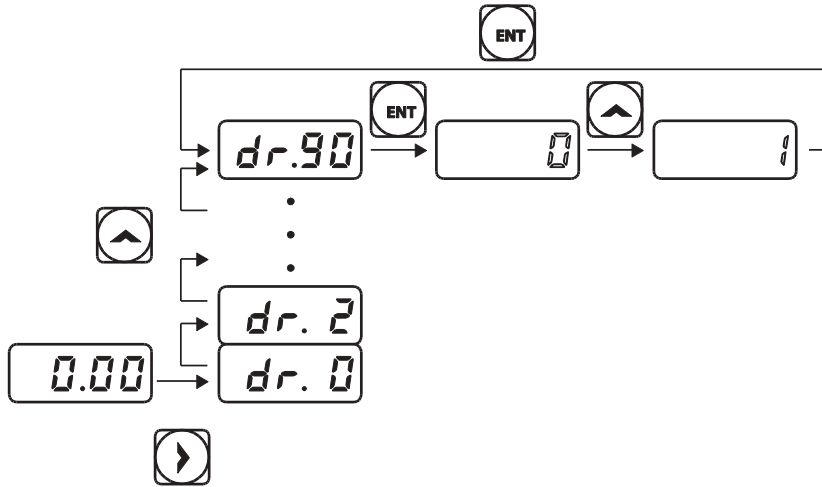
The [ESC] key is a multi-functional key that can be configured to carry out a number of different functions. The following example shows how to configure the [ESC] key to perform a jog operation.

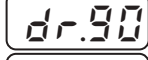
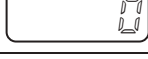
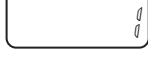

Step	Instruction	Keypad Display
1	Ensure that you are currently at the first code of the Operation group, and that code 0.00 (Command Frequency) is displayed.	
2	Press the [▶] key. You have moved to the initial code of the Drive group (dr.0).	
3	Press the [▲] or [▼] key to select code 90 (ESC key configuration), and then press the [ENT] key. Code dr.90 currently has an initial parameter value of, 0 (adjust to the initial position).	 
4	Press the [▲] key to modify the value to 1 (Jog key) and then press the [ENT] key. The new parameter value will flash.	
5	Press the [ENT] key again to save changes.	-

#### Note

- If the code dr. 90 (ESC key configuration) is set to 1 (JOG Key) or 2 (Local/Remote), the SET indicator will flash when the [ESC] key is pressed.
- The factory default setting for code dr. 90 is 0 (move to the initial position). You can navigate back to the initial position (code 0.00 of the Operation group) immediately, by pressing the [ESC] key while configuring any codes in any groups.

### 3.3 Actual Application Examples

#### 3.3.1 Acceleration Time Configuration (0.4-22kW models only)

The following is an example demonstrating how to modify the ACC (Acceleration time) code value (from 5.0 to 16.0) from the Operation group.

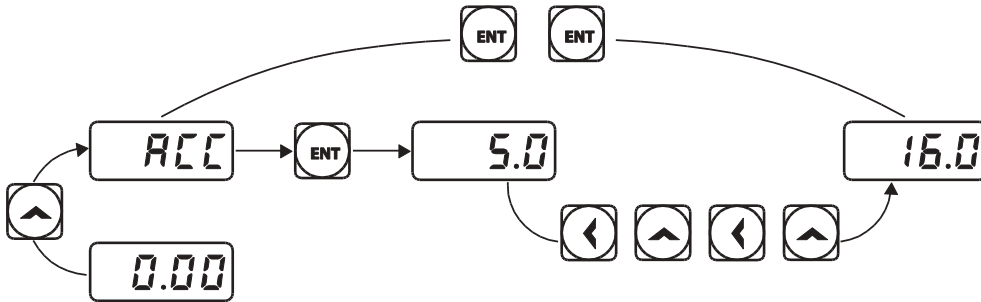

Step	Instruction	Keypad Display
1	Ensure that the first code of the Operation group is selected, and code 0.00 (Command Frequency) is displayed.	0.00
2	Press the [▲] key. The display will change to the second code in the Operation group, the ACC (Acceleration Time) code.	ACC
3	Press the [ENT] key. The number '5.0' will be displayed, with '0' flashing. This indicates that the current acceleration time is set to 5.0 seconds. The flashing value is ready to be modified by using the keypad.	5.0
4	Press the [◀] key to change the first place value. '5' will be flashing now. This indicates the flashing value, '5' is ready to be modified.	5.0
5	Press the [▲] key to change the number '5' into '6', the first place value of the target number '16.'	6.0
6	Press the [◀] key to move to the 10s, place value. The number in the 10s position, '0' in '06' will start to flash	06.0
7	Press the [▲] key to change the number from '0' to '1', to match the 10s place value of the target number '16,' and then press the [ENT] key. Both digits will flash on the display.	16.0
8	Press the [ENT] key once again to save changes. 'ACC' will be displayed. The change to the acceleration time setup has been completed.	ACC

### 3.3.2 Frequency Reference Configuration (0.4-22kW models only)

The following is an example to demonstrate configuring a frequency reference of 30.05 (Hz) from the first code in the Operation group (0.00).



Step	Instruction	Keypad Display
1	Ensure that the first code of the Operation group is selected, and the code 0.00 (Command Frequency) is displayed.	0.00
2	Press the [ENT] key. The value, 0.00 will be displayed with the '0' in the 1/100s place value flashing.	0.00
3	Press the [◀] key 3 times to move to the 10s place value. The '0' at the 10s place value will start to flash.	00.00
4	Press the [▲] key to change it to '3,' the 10s place value of the target frequency, '30.05.'	30.00
5	Press the [▶] key 3 times. The '0' at the 1/100s place position will flash.	30.00
6	Press the [▲] key to change it to '5,' the 1/100 place value of the target frequency, '30.05,' and then press the [ENT] key. The parameter value will flash on the display.	30.05
7	Press the [ENT] key once again to save changes. Flashing stops. The frequency reference has been configured to 30.05 Hz.	30.05

#### Note



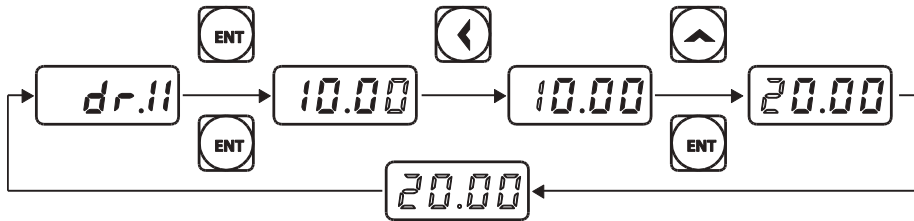

- A flashing number on the display indicates that the keypad is waiting for an input from the user. Changes are saved when the [ENT] key is pressed while the value is flashing. Changes will be canceled if any other key is pressed.
- The S100 inverter keypad display can display up to 4 digits. However, 5-digit figures can be used and are accessed by pressing the [◀] or [▶] key, to allow keypad input.

### 3.3.3 Jog Frequency Configuration (0.4-22kW models only)

The following example demonstrates how to configure Jog Frequency by modifying code 11 in the Drive group (Jog Frequency) from 10.00(Hz) to 20.00(Hz). You can configure the parameters for different codes in any other group in exactly the same way.

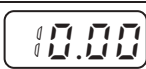
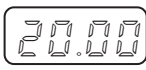

Basic Ops.

Step	Instruction	Keypad Display
1	Go to code 11(Jog Frequency) in the Drive group.	
2	Press the [ENT] key. The current Jog Frequency value (10.00) for code dr.11 is displayed.	
3	Press the [◀] key 3 times to move to the 10s place value. Number '1' at the 10s place position will flash.	
4	Press the [▲] key to change the value to '2,' to match the 10s place value of the target value'20.00,' and then press the [ENT] key. All parameter digits will flash on the display.	
5	Press the [ENT] key once again to save the changes. Code dr.11 will be displayed. The parameter change has been completed.	



### 3.3.4 Initializing All Parameters

#### 3.3.4.1 0.4-22kW Models

The following example demonstrates parameter initialization using code dr.93 (Parameter Initialization) in the Drive group. Once executed, parameter initialization will delete all modified values for all codes and groups.

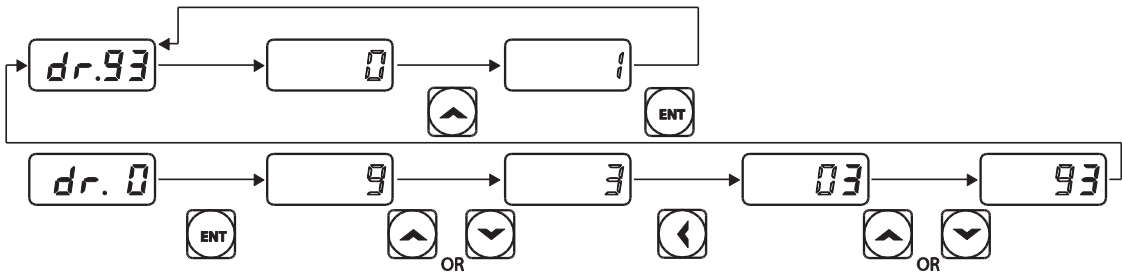

Step	Instruction	Keypad Display
1	Go to code 0 (Jog Frequency) in the Drive group.	dr.0
2	Press the [ENT] key. The current parameter value (9) will be displayed.	9
3	Press the [q] key to change the first place value to '3' of the target code, '93.'	3
4	Press the [◀] key to move to the 10s place position. '03' will be displayed.	03
5	Press the [▲] or [▼] key to change the '0' to '9' of the target code, '93.'	93
6	Press the [ENT] key. Code dr.93 will be displayed.	dr.93
7	Press the [ENT] key once again. The current parameter value for code dr.93 is set to 0 (Do not initialize).	0
8	Press the [▲] key to change the value to 1 (All Grp), and then press the [ENT] key. The parameter value will flash.	1
9	Press the [ENT] key once again. Parameter initialization begins. Parameter initialization is complete when code dr.93 reappears on the display.	dr.93

#### Note

Following parameter initialization, all parameters are reset to factory default values. Ensure that parameters are reconfigured before running the inverter again after an initialization.

### 3.3.4.2 30-75kW Models

The following example demonstrates how to revert all the parameter settings back to the factory default (Parameter Initialization). Parameter initialization may be performed for separate groups in Parameter mode as well.

<p>MON T/K <b>N</b> STP 0,0A</p> <p><b>0.0 Hz</b> <b>0.0 A</b> <b>0 V</b></p>	<ul style="list-style-type: none"> <li>• Monitor mode is displayed.</li> </ul>
<p>CNF <b>N</b> STP 0,0A</p> <p>00 Jump Code <b>9 CODE</b></p> <p>01 Language Sel English</p> <p>02 Inv SW Ver Version 1.00</p>	<ul style="list-style-type: none"> <li>• Press the [MODE] key to move to the Config (CNF) mode.</li> </ul>
<p>CNF <b>N</b> STP 0,0A</p> <p>31 Option-2 Type None</p> <p>32 Option-3 Type None</p> <p><b>40 Parameter Init</b> ----No---</p>	<ul style="list-style-type: none"> <li>• Press the [▼] key to go to CNF-40 (Parameter Init).</li> <li>• Press the [PROG/ENT] key.</li> </ul>
<p>CNF <b>N</b> STP 0,0A</p> <p><b>40 Parameter Init</b></p> <p>0 ----No---</p> <p><b>1 All Groups</b></p> <p>2 DRV</p>	<ul style="list-style-type: none"> <li>• In the list of options, select All Groups, and then press the [PROG/ENT] key.</li> </ul>
<p>CNF <b>N</b> STP 0,0A</p> <p>31 Option-2 Type None</p> <p>32 Option-3 Type None</p> <p><b>40 Parameter Init</b> ----No---</p>	<ul style="list-style-type: none"> <li>• The parameter initialization option is displayed again when the initialization is complete.</li> </ul>

### 3.3.5 Frequency Setting (Keypad) and Operation (via Terminal Input)

Step	Instruction	Keypad Display
1	Turn on the inverter.	-
2	Ensure that the first code of the Operation group is selected, and code 0.00 (Command Frequency) is displayed, then press the [ENT] key. The first digit on the right will flash.	0.00
3	Press the [◀] key 3 times to go to the 10s place position. The number '0' at the 10s place position will flash.	00.00
4	Press the [▲] key to change it to 1, and then press the [ENT] key. The parameter value (10.00) will flash.	10.00
5	Press the [ENT] key once again to save changes. A change of reference frequency to 10.00 Hz has been completed.	10.00
6	Refer to the wiring diagram at the bottom of the table, and close the switch between the P1 (FX) and CM terminals. The RUN indicator light flashes and the FWD indicator light comes on steady. The current acceleration frequency is displayed.	SET RUN 10.00 FWD REV
7	When the frequency reference is reached (10Hz), open the switch between the P1 (FX) and CM terminals. The RUN indicator light flashes again and the current deceleration frequency is displayed. When the frequency reaches 0Hz, the RUN and FWD indicator lights turn off, and the frequency reference (10.00Hz) is displayed again.	SET RUN 10.00 FWD REV

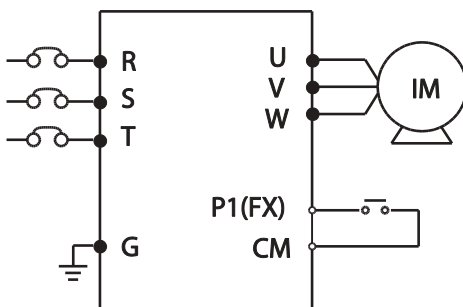

[Wiring Diagram]

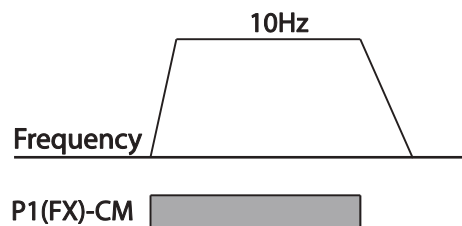

[Operation Pattern]

## Note

The instructions in the table are based on the factory default parameter settings. The inverter may not work correctly if the default parameter settings are changed after the inverter is purchased. In such cases, initialize all parameters to reset the values to factory default parameter settings before following the instructions in the table.

### 3.3.6 Frequency Setting (Potentiometer) and Operation (Terminal Input)

Step	Instruction	Keypad Display
1	Turn on the inverter.	-
2	Ensure that the first code of the Operation group is selected, and the code 0.00 (Command Frequency) is displayed.	0.00
3	Press the [▲] key 4 times to go to the Frq (Frequency reference source) code.	Frq
4	Press the [ENT] key. The Frq code in the Operation group is currently set to 0 (keypad).	0
5	Press the [▲] key to change the parameter value to 2 (Potentiometer), and then press the [ENT] key. The new parameter value will flash.	2
6	Press the [ENT] key once again. The Frq code will be displayed again. The frequency input has been configured for the potentiometer.	Frq
7	Press the [▼] key 4 times. Returns to the first code of the Operation group (0.00). From here frequency setting values can be monitored.	0.00
8	Adjust the potentiometer to increase or decrease the frequency reference to 10Hz.	-
9	Refer to the wiring diagram at the bottom of the table, and close the switch between the P1 (FX) and CM terminals. The RUN indicator light flashes and the FWD indicator light comes on steady. The current acceleration frequency is displayed.	SET RUN 10.00 FWD REV
10	When the frequency reference is reached (10Hz), open the switch between the P1 (FX) and CM terminals. The RUN indicator light flashes again and the current deceleration frequency is displayed. When the frequency reaches 0Hz, the RUN and FWD indicators turn off, and the frequency reference (10.00Hz) is displayed again.	SET RUN 10.00 FWD REV

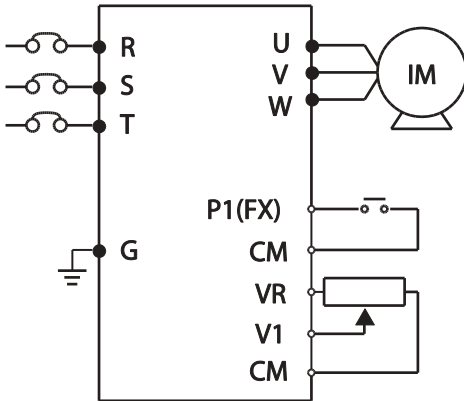

[Wiring Diagram]

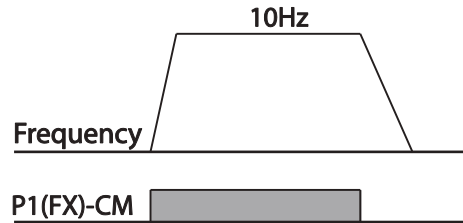





[Operation Pattern]

### Note

The instructions in the table are based on the factory default parameter settings. The inverter may not work correctly if the default parameter settings are changed after the inverter is purchased. In such cases, initialize all parameters to reset the factory default parameter settings before following the instructions in the table.

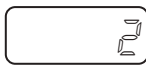
## 3.3.7 Frequency Setting (Potentiometer) and Operation (Keypad)

Step	Instruction	Keypad Display
1	Turn on the inverter.	-
2	Ensure that the first code of the Operation group is selected, and the code 0.00 (Command Frequency) is displayed.	0.00
3	Press the [▲] key 4 times to go to the drv code.	drv
4	Press the [ENT] key. The drv code in the Operation group is currently set to 1 (Analog Terminal).	1
5	Press the [▼] key to change the parameter value to 0 (Keypad), and then press the [ENT] key. The new parameter value will flash.	0
6	Press the [ENT] key once again. The drv code is displayed again. The frequency input has been configured for the keypad.	drv
7	Press the [▲] key. To move to the Frq (Frequency reference source) code.	Frq
8	Press the [ENT] key. The Frq code in the Operation group is set to 0 (Keypad).	0

Step	Instruction	Keypad Display
9	Press the [▲] key to change it to 2 (Potentiometer), and then press the [ENT] key. The new parameter value will flash.	
10	Press the [ENT] key once again. The Frq code is displayed again. The frequency input has been configured for potentiometer.	
11	Press the [▼] key 4 times. Returns to the first code of the Operation group (0.00). From here frequency setting values can be monitored.	
12	Adjust the potentiometer to increase or decrease the frequency reference to 10Hz.	-
13	Press the [RUN] key on the keypad. The RUN indicator light flashes and the FWD indicator light comes on steady. The current acceleration frequency is displayed.	
14	When the frequency reaches the reference (10Hz), press the [STOP/RESET] key on the keypad. The RUN indicator light flashes again and the current deceleration frequency is displayed. When the frequency reaches 0Hz, the RUN and FWD indicator lights turn off, and the frequency reference (10.00Hz) is displayed again.	

Basic Ops.

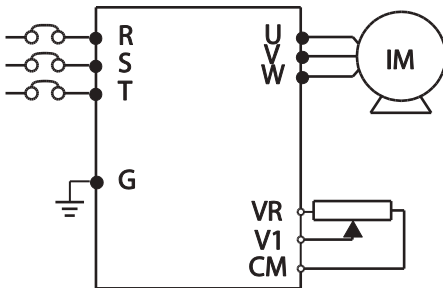

[Wiring Diagram]

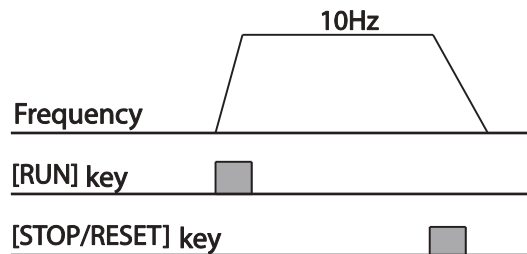

[Operation Pattern]

### Note

The instructions in the table are based on the factory default parameter settings. The inverter may not work correctly if the default parameter settings are changed after the inverter is purchased. In such cases, initialize all parameters to reset the factory default parameter settings before following the instructions in the table.

## 3.4 Monitoring the Operation

### 3.4.1 0.4-22kW Models

#### 3.4.1.1 Output Current Monitoring

The following example demonstrates how to monitor the output current in the Operation group using the keypad.

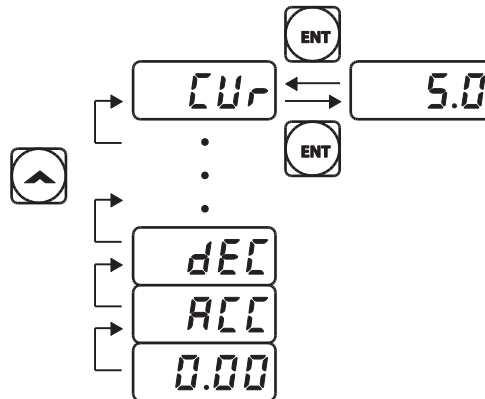

Step	Instruction	Keypad Display
1	Ensure that the first code of the Operation group is selected, and the code 0.00 (Command Frequency) is displayed.	0.00
2	Press the [▲] or [▼] key to move to the Cur code.	Cur
3	Press the [ENT] key. The output current (5.0A) is displayed.	5.0
4	Press the [ENT] key again. Returns to the Cur code.	Cur

#### Note

You can use the dCL (DC link voltage monitor) and vOL (output voltage monitor) codes in the Operation group in exactly the same way as shown in the example above, to monitor each function's relevant values.

### 3.4.1.2 Fault Trip Monitoring

The following example demonstrates how to monitor fault trip conditions in the Operation group using the keypad.

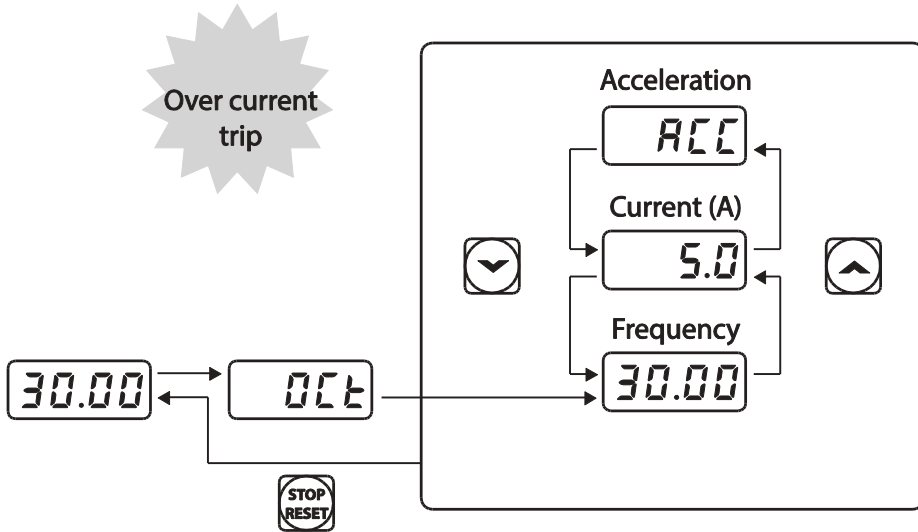

Step	Instruction	Keypad Display
1	Refer to the example keypad display. An over current trip fault has occurred.	0ct
2	Press the [ENT] key, and then the [▲] key. The operation frequency at the time of the fault (30.00Hz) is displayed.	30.00
3	Press the [▲] key. The output current at the time of the fault (5.0A) is displayed.	5.0
4	Press the [▲] key. The operation status at the time of the fault is displayed. ACC on the display indicates that the fault occurred during acceleration.	ACC
5	Press the [STOP/RESET] key. The inverter resets and the fault condition is cleared. The frequency reference is displayed on the keypad.	30.00



### Note

- If multiple fault trips occur at the same time, a maximum of 3 fault trip records can be retrieved as shown in the following example.

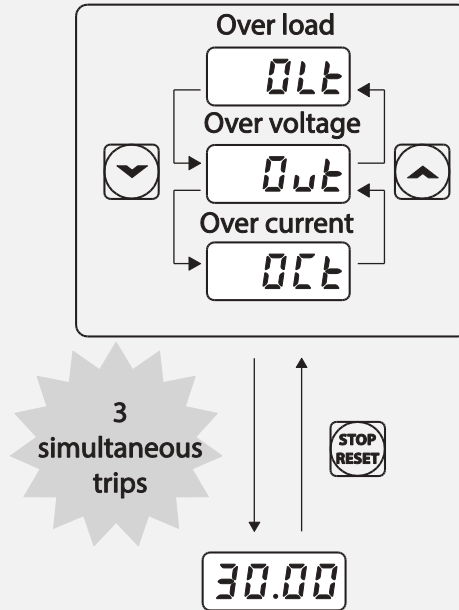

- If a warning condition occurs while running at a specified frequency, the current frequency and the `UArn` signal will be displayed alternately, at 1 second intervals.

### 3.4.2 30-75kW Models

#### How to use Monitor mode

There are 3 types of items that may be monitored in Monitor mode. Some items, including frequency, may be modified. Users can select the items to be displayed in Config mode (CNF).

<p>MON T/K <input checked="" type="checkbox"/> STP 0.0Hz</p> <p><b>10.0 Hz</b></p> <p><b>0.0 A</b></p> <p><b>0 V</b></p>	<ul style="list-style-type: none"> <li>• Monitor mode</li> <li>• Frequency, current, and voltage are set as the default monitored items.</li> <li>• The target frequency is displayed when the inverter is stopped. The operation frequency is displayed while operating.</li> </ul>
<p>CNF <input checked="" type="checkbox"/> STP 0.0Hz</p> <p>21 Monitor Line-1 Frequency</p> <p>22 Monitor Line-2 Output Current</p> <p>23 Monitor Line-3 Output Voltage</p>	<ul style="list-style-type: none"> <li>• Configure the items to be displayed in Config mode (CNF) 21~23.</li> <li>• Press the [▼] key to go to 23.</li> </ul>
<p>CNF <input checked="" type="checkbox"/> STP 0.0Hz</p> <p>21 Monitor Line-1 Frequency</p> <p>22 Monitor Line-2 Output Current</p> <p>23 Monitor Line-3 Output Voltage</p>	<ul style="list-style-type: none"> <li>• Press the[PROG/ENT] key to change 23 to output power.</li> </ul>
<p>MON T/K <input checked="" type="checkbox"/> STP 0.0Hz</p> <p><b>0.0 Hz</b></p> <p><b>0.0 A</b></p> <p><b>0.0 kW</b></p>	<ul style="list-style-type: none"> <li>• Press the[ESC] key to ensure that the third item in Monitor mode is changed to output power.</li> </ul>

### Items available for monitoring

Mode	Number	Display	Setting Range	Initial value	
CNF	20	Anytime Para	0 Frequency	0: Frequency	
	21	Monitor Line-1	1 Speed	0: Frequency	
	22	Monitor Line-2	2 Output Current	2:Output Current	
	23	Monitor Line-3	3	Output Voltage	3:Output Voltage
			4	Output Power	
			5	WHour Counter	
			6	DCLink Voltage	
			7	DI State	
			8	DO State	
			9	V1 Monitor[V]	
			10	V1 Monitor[%]	
			13	V2 Monitor[V]	
			14	V2 Monitor[%]	
			15	I2 Monitor[mA]	
	16	I2 Monitor[%]			
	17	PID Output			
	18	PID ref Value			
	19	PID Fbk Value			
	20	Torque			
	21	Torque Limit			
	22	Trq Bias Ref			
	23	Speed Limit			

## How to use the status bar

On the top-right corner of the display, there is a display item. This item is displayed as long as the inverter is on, regardless of the mode the inverter is operating in.

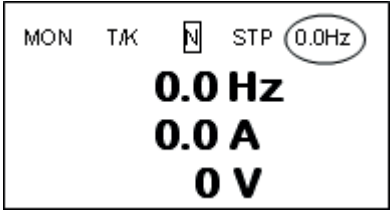
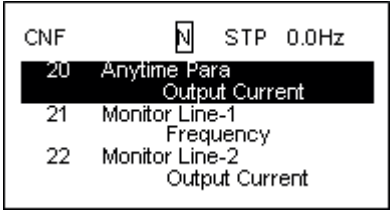
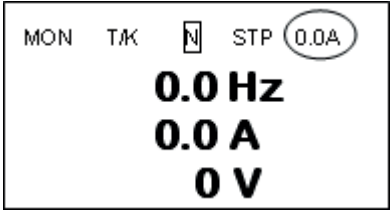
 <p>MON TK <span style="border: 1px solid black; padding: 0 2px;">N</span> STP 0.0Hz</p> <p><b>0.0 Hz</b></p> <p><b>0.0 A</b></p> <p><b>0 V</b></p>	<ul style="list-style-type: none"> <li>• Monitor mode</li> <li>• In the top-right corner of the display, the frequency reference is displayed (factory default).</li> </ul>
 <p>CNF <span style="border: 1px solid black; padding: 0 2px;">N</span> STP 0.0Hz</p> <p>20 Anytime Para Output Current</p> <p>21 Monitor Line-1 Frequency</p> <p>22 Monitor Line-2 Output Current</p>	<ul style="list-style-type: none"> <li>• Enter Config mode and go to CNF-20 to select the item to display.</li> <li>• Press the [PROG/ENT] key to change the item to 'Output Current.'</li> <li>• On the top-right corner of the display, the unit changes from 'Frequency' to 'Current.'</li> </ul>
 <p>MON TK <span style="border: 1px solid black; padding: 0 2px;">N</span> STP 0.0A</p> <p><b>0.0 Hz</b></p> <p><b>0.0 A</b></p> <p><b>0 V</b></p>	<ul style="list-style-type: none"> <li>• In monitor mode, the status bar item is changes to 'Current.'</li> </ul>

## Monitoring Faults during Inverter Operation

The following example shows how to monitor faults that occurred during inverter operation.

<p>TRP current</p> <p><b>Over Voltage (01)</b></p> <p>01 Output Freq 48.30 Hz</p> <p>02 Output Current 33.3 A</p>	<ul style="list-style-type: none"> <li>If a fault trip occurs during inverter operation, the inverter enters Trip mode automatically and displays the type of fault trip that occurred.</li> </ul>
<p>TRP Last-1</p> <p>01 Output Freq 48.30 Hz</p> <p>02 Output Current 33.3 A</p> <p>03 Inverter State Stop</p>	<ul style="list-style-type: none"> <li>Press the [▼] key to view the information on the inverter at the time of fault, including the output frequency, output current, and operation type.</li> </ul>
<p>MON T/K <span style="border: 1px solid black; padding: 0 2px;">N</span> STP 0.0A</p> <p><b>0.0 Hz</b></p> <p><b>0.0 A</b></p> <p><b>0 V</b></p>	<ul style="list-style-type: none"> <li>When the inverter is reset and the fault trip is released, the keypad display returns to the screen it was at when the fault trip occurred.</li> </ul>

## Monitoring Multiple Fault Trips

The following example shows how to monitor multiple faults that occur at the same time.

<p>TRP current</p> <p><b>Over Voltage (02)</b></p> <p>01 Output Freq 48.30 Hz</p> <p>02 Output Current 33.3 A</p>	<ul style="list-style-type: none"> <li>• If multiple fault trips occur at the same time, the number of fault trips occurred is displayed on the right side of the fault trip type.</li> <li>• Press the [PROG/ENT] key.</li> </ul>
<p>TRP current</p> <p><b>00 Trip Name (02)</b></p> <p>0 Over Voltage</p> <p>1 External Trip</p>	<ul style="list-style-type: none"> <li>• The types of fault trips that occurred are displayed.</li> <li>• Press the [PROG/ENT] key.</li> </ul>
<p>TRP current</p> <p><b>Over Voltage (02)</b></p> <p>01 Output Freq 48.30 Hz</p> <p>02 Output Current 33.3 A</p>	<ul style="list-style-type: none"> <li>• The display returns to the screen it was at when the fault trip occurred.</li> </ul>

## Fault trip history saving and monitoring

When fault trips occur, the trip mode saves the content. Up to five fault trips are saved in the history. Trip mode saves when the inverter is reset, and when a Low Voltage fault trip occurs due to power outages. If a trip occurs more than five times, the information for the five previous trips are automatically deleted.

<p>TRP current</p> <p><b>Over Voltage (02)</b></p> <p>01 Output Freq 48.30 Hz</p> <p>02 Output Current 33.3 A</p>	<ul style="list-style-type: none"> <li>• If a fault trip occurs during inverter operation, the inverter enters Trip mode automatically and displays the type of fault trip that occurred.</li> </ul>
<p>MON T/K <b>N</b> STP 0,0A</p> <p><b>0.0 Hz</b></p> <p><b>0.0 A</b></p> <p><b>0 V</b></p>	<ul style="list-style-type: none"> <li>• After the [RESET] key or terminal is pressed, the fault trip is saved automatically and returns to the screen it was on before the fault trip occurred.</li> <li>• Press the [MODE] key to enter Trip mode.</li> </ul>

TRIP current

00 Trip Name (02)  
Over Voltage  
01 Output Freq  
48.30 Hz  
02 Output Current  
33.3 A

- The most recent fault trip is saved in Last-1 code.
- Press the [▶] key.

TRIP current

00 Trip Name (01)  
External Trip  
01 Output Freq  
48.30 Hz  
02 Output Current  
33.3 A

- The fault trip changes position and is saved in Last-2 code.
- When a fault trip occurs again, the content in Last-2 is moved to Last-3.

## 4 Table of Functions

This chapter lists all the function settings for S100 series inverter. Set the parameters required according to the following references. If a set value input is out of range, the following messages will be displayed on the keyboard. In these cases, the inverter will not operate with the [ENT] key.

- Set value not allocated: **rd**
- Set value repetition (multi-function input, PID reference, PID feedback related): **OL**
- Set value not allowed (select value, V2, I2): **no**

### 4.1 Operation Group

The Operation group is used only in the basic keypad mode. It will not be displayed on an LCD loader.

**SL:** Sensorless vector control (dr.09) , I – IM Sensorless, P – PM Sensorless

**\*O/X:** Write-enabled during operation, **7/L/A:** Keypad/LCD keypad/Common

Code	Comm. Address	Name	Keypad Display	Setting Range	Initial Value	Property*	V/F	SL	
	0h1F00	Target frequency	0.00	0-Maximum frequency(Hz)	0.00	O/7	O	I/P	
-	0h1F01	Acceleration time	ACC	0.0-600.0(s)	20.0	O/7	O	I/P	
-	0h1F02	Deceleration time	dEC	0.0-600.0(s)	30.0	O/7	O	I/P	
-	0h1F03	Command source	drv	0	Keypad	1: Fx/Rx-1	X/7	O	I/P
				1	Fx/Rx-1				
				2	Fx/Rx-2				
				3	Int 485				
				4	Field Bus <sup>1</sup>				
-	0h1F04	Frequency reference source	Frq	0	Keypad-1	0: Keypad -1	X/7	O	I/P
				1	Keypad-2				
				2	V1				
				4	V2				
				5	I2				
				6	Int 485				
				8	Field Bus				
				12	Pulse				
-	0h1F05	Multi-step	St1	0.00-Maximum	10.00	O/7	O	I/P	

<sup>1</sup> Table of options are provided separately in the option manual.



Code	Comm. Address	Name	Keypad Display	Setting Range	Initial Value	Property*	V/F	SL	
		speed frequency 1		frequency(Hz)					
-	0h1F06	Multi-step speed frequency 2	St2	0.00-Maximum frequency(Hz)	20.00	O/7	O	I/P	
-	0h1F07	Multi-step speed frequency 3	St3	0.00-Maximum frequency(Hz)	30.00	O/7	O	I/P	
-	0h1F08	Output current	CUr			-/7	O	I/P	
-	0h1F09	Motor revolutions per minute	Rpm			-/7	O	I/P	
-	0h1F0A	Inverter direct current voltage	dCL	-	-	-/7	O	I/P	
-	0h1F0B	Inverter output voltage	vOL			-/7	O	I/P	
-	0h1F0C	Out of order signal	nOn			-/7	O	I/P	
-	0h1F0D	Select rotation direction	drC	F	Forward run	F	O/7	O	I/P
				r	Reverse run				

## 4.2 Drive group (PAR→dr)

In the following table, data shaded in grey will be displayed when the related code has been selected.

**SL:** Sensorless vector control (dr.09) , I – IM Sensorless, P – PM Sensorless

**\*O/X:** Write-enabled during operation, **7/L/A:** Keypad/LCD keypad/Common

Code	Comm. Address	Name	LCD Display	Setting Range	Initial value	Property*	V/F	SL	
00	-	Jump Code	Jump Code	1-99	9	O/A	O	I/P	
01 <sup>2</sup>	0h1101	Target frequency	Cmd Frequency	Start frequency - Maximum frequency(Hz)	0.00	O/L	O	I/P	
02	0h1102	Torque command	Cmd Torque	-180~180[%]	0.0	O/A	X	I	
03 <sup>2</sup>	0h1103	Acceleration time	Acc Time	0.0-600.0(s)	20.0	O/L	O	I/P	
04 <sup>2</sup>	0h1104	Deceleration time	Dec Time	0.0-600.0(s)	30.0	O/L	O	I/P	
06 <sup>2</sup>	0h1106	Command source	Cmd Source	0	Keypad	1: Fx/Rx-1	X/L	O	I/P
				1	Fx/Rx-1				
				2	Fx/Rx-2				
				3	Int 485				
				4	Field Bus				
5	UserSeqLink								
07 <sup>2</sup>	0h1107	Frequency reference source	Freq Ref Src	0	Keypad-1	0: Keypad-1	X/L	O	I/P
				1	Keypad-2				
				2	V1				
				4	V2				
				5	I2				
				6	Int 485				
				8	Field Bus				
				9	UserSeqLink				
				12	Pulse				
08	0h1108	Torque reference setting	Trq Ref Src	0	Keypad-1	0: Keypad-1	X/A	X	I
				1	Keypad-2				
				2	V1				
				4	V2				
				5	I2				
				6	Int 485				
				8	FieldBus				
				9	UserSeqLink				

Function Table

<sup>2</sup> Displayed when an LCD keypad is in use.

Code	Comm. Address	Name	LCD Display	Setting Range	Initial value	Property*	V/F	SL	
				12	Pulse				
09	0h1109	Control mode	Control Mode	0	V/F	0: V/F	X/A	O	I/P
				2	Slip Compen				
				4	IM Sensorless				
				6	PM S/L				
10	0h110A	Torque Control	Torque Control	0	No	0: No	X/A	X	I
				1	Yes				
11	0h110B	Jog frequency	Jog Frequency	0.00, Start frequency-Maximum frequency(Hz)		10.00	O/A	O	I/P
12	0h110C	Jog run acceleration time	Jog Acc Time	0.0-600.0(s)		20.0	O/A	O	I/P
13	0h110D	Jog run deceleration time	Jog Dec Time	0.0-600.0(s)		30.0	O/A	O	I/P
14	0h110E	Motor capacity	Motor Capacity	0: 0.2kW, 1: 0.4kW, 2: 0.75kW, 3: 1.1kW, 4: 1.5kW, 5: 2.2kW, 6: 3.0kW, 7: 3.7kW, 8: 4.0kW, 9: 5.5kW, 10: 7.5kW, 11: 11.0kW, 12: 15.0kW, 13: 18.5kW, 14: 22.0kW, 15: 30.0kW, 16: 37kW, 17: 45.0kW, 18: 55.0kW, 19: 75kW, 20: 90kW		Varies by Motor capacity	X/A	O	I/P
15	0h110F	Torque boost options	Torque Boost	0	Manual	0: Manual	X/A	O	X
				1	Auto1				

Code	Comm. Address	Name	LCD Display	Setting Range	Initial value	Property*	V/F	SL
				2   Auto2				
16 <sup>3</sup>	0h1110	Forward Torque boost	Fwd Boost	0.0-15.0(%)	2.0	X/A	O	X
17 <sup>3</sup>	0h1111	Reverse Torque boost	Rev Boost	0.0-15.0(%)	2.0	X/A	O	X
18	0h1112	Base frequency	Base Freq	30.00~400.00(Hz) [V/F, Slip Compen] 40.00~120.00(Hz) [IM Sensorless] 30.00~180.00(Hz) [PM Sensorless]	60.00	X/A	O	I/P
19	0h1113	Start frequency	Start Freq	0.01-10.00(Hz)	0.50	X/A	O	I/P
20	0h1114	Maximum frequency	Max Freq	40.00~400.00(Hz) [V/F, Slip Compen] 40.00~120.00(Hz) [IM Sensorless] 40.00~180.00(Hz) [PM Sensorless]	60.00	X/A	O	I/P
21	0h1115	Select speed unit	Hz/Rpm Sel	0   Hz Display 1   Rpm Display	0:Hz Display	O/L	O	I/P
22 <sup>4</sup>	0h1116	(+)Torque gain	(+)Trq Gain	50.0 ~ 150.0[%]	100.0	O/A	X	I
23 <sup>4</sup>	0h1117	(-)Torque gain	(-)Trq Gain	50.0 ~ 150.0[%]	100.0	O/A	X	I
24 <sup>4</sup>	0h1118	(-)Torque gain 0	(-)Trq Gain0	50.0 ~ 150.0[%]	80.0	O/A	X	I
25 <sup>4</sup>	0h1119	(-)Torque offset	(-)Trq Offset	0.0 ~ 100.0[%]	40.0	O/A	X	I
80 <sup>5</sup>	0h1150	Select ranges at power input	-	Select ranges inverter displays at power input 0   Run frequency 1   Acceleration time 2   Deceleration time 3   Command	0: run frequency	O/7	O	I/P

Function Table

<sup>3</sup> Displayed when dr.15 is set to 0 (Manual) or 2(Auto2)

<sup>4</sup> Displayed when dr.10 is set to 1 (YES)

<sup>5</sup> Will not be displayed when an LCD keypad is in use

Code	Comm. Address	Name	LCD Display	Setting Range	Initial value	Property*	V/F	SL
				source				
				4 Frequency reference source				
				5 Multi-step speed frequency1				
				6 Multi-step speed frequency2				
				7 Multi-step speed frequency3				
				8 Output current				
				9 Motor RPM				
				10 Inverter DC voltage				
				11 User select signal (dr.81)				
				12 Currently out of order				
				13 Select run direction				
				14 output current2				
				15 Motor RPM2				
				16 Inverter DC voltage2				
				17 User select signal2 (dr.81)				
81 <sup>6</sup>	0h1151	Select monitor code	-	Monitors user selected code				
				0 Output voltage(V)	0:			
				1 Output electric power(kW)	output voltage	O/7	O	I/P
				2 Torque(kgf · m)				
85 <sup>6</sup>	0h1155	Parameter Read	-	0 No	0:No	X/7	O	I/P
				1 Yes				
86 <sup>6</sup>	0h1156	Parameter	-	0 No	0:No	X/7	O	I/P

<sup>6</sup> Displayed when a Remote is in use.

Code	Comm. Address	Name	LCD Display	Setting Range	Initial value	Property*	V/F	SL
		Write		1 Yes				
89 <sup>5</sup>	0h03E3	Display changed parameter	-	0 View All	0: View All	O/7	O	I/P
				1 View Changed				
90 <sup>5</sup>	0h115A	[ESC] key functions	-	0 Move to initial position	0: None	X/7	O	I/P
				1 JOG Key				
				2 Local/Remote				
91	0h115B	Smart copy	SmartCopy	0 None	0:None	X/A	O	I/P
				1 SmartDownload				
				3 SmartUpload				
92 <sup>6</sup>	0h115C	Parameter Save	-	0 No	0:No	X/7	O	I/P
				1 Yes				
93 <sup>5</sup>	0h115D	Parameter initialization	-	0 No	0:No	X/7	O	I/P
				1 All Grp				
				2 dr Grp				
				3 bA Grp				
				4 Ad Grp				
				5 Cn Grp				
				6 In Grp				
				7 OU Grp				
				8 CM Grp				
				9 AP Grp				
				12 Pr Grp				
				13 M2 Grp				
				14 US Grp				
				15 UF Grp				
16 run Grp								
94 <sup>5</sup>	0h115E	Password registration		0-9999		O/7	O	I/P
95 <sup>5</sup>	0h115F	Parameter lock settings		0-9999		O/7	O	I/P
97 <sup>5</sup>	0h1161	Software version	-			-/7	O	I/P
98	0h1162	Display I/O board version	IO S/W Ver			-/A	O	I/P
99	0h1163	Display I/O board H/W version	IO H/W Ver	0 Multiple IO	Standard IO	-/A	O	I/P
				1 Standard IO				
				2 Standard IO (M)				

Function Table

### 4.3 Basic Function group (PAR→bA)

In the following table, the data shaded in grey will be displayed when a related code has been selected.

**SL:** Sensorless vector control function (dr.09) , I – IM Sensorless, P – PM Sensorless

**\*O/X:** Write-enabled during operation, **7/L/A:** Keypad/LCD keypad/Common

Code	Comm. Address	Name	LCD Display	Setting Range	Initial Value	Property*	V/F	SL	
00	-	Jump Code	Jump Code	1-99	20	O	O	I/P	
01	0h1201	Auxiliary reference source	Aux Ref Src	0	None	0:None	X/A	O	I/P
				1	V1				
				3	V2				
				4	I2				
				6	Pulse				
02 <sup>7</sup>	0h1202	Auxiliary command calculation type	Aux Calc Type	0	M+(G*A)	0: M+(GA)	X/A	O	I/P
				1	Mx (G*A)				
				2	M/(G*A)				
				3	M+[M*(G*A)]				
				4	M+G*2(A-50%)				
				5	Mx[G*2(A-50%)				
				6	M/[G*2(A-50%)]				
				7	M+M*G*2(A-50%)				
03 <sup>7</sup>	0h1203	Auxiliary command gain	Aux Ref Gain	-200.0-200.0(%)	100.0	O/A	O	I/P	
04	0h1204	2nd command source	Cmd 2nd Src	0	Keypad	1: Fx/Rx-1	X/A	O	I/P
				1	Fx/Rx-1				
				2	Fx/Rx-2				
				3	Int 485				
				4	FieldBus				
05	0h1205	2nd frequency source	Freq 2nd Src	0	Keypad-1	0: Keypad-1	O/A	O	I/P
				1	Keypad-2				
				2	V1				
				4	V2				
				5	I2				
				6	Int 485				
				8	FieldBus				
				9	UserSeqLink				
				12	Pulse				

<sup>7</sup> Displayed if bA.01 is not set to 0 (None).

Code	Comm. Address	Name	LCD Display	Setting Range	Initial Value	Property*	V/F	SL	
06	0h1206	2nd Torque command source	Trq 2nd Src	0	Keypad-1	0: Keypad-1	O	X	I
				1	Keypad-2				
				2	V1				
				4	V2				
				5	I2				
				6	Int 485				
				8	FieldBus				
				9	UserSeqLink				
				12	Pulse				
07	0h1207	V/F pattern options	V/F Pattern	0	Linear	0: Linear	X/A	O	X
				1	Square				
				2	User V/F				
				3	Square 2				
08	0h1208	Acc/dec standard frequency	Ramp T Mode	0	Max Freq	0: Max Freq	X/A	O	I/P
				1	Delta Freq				
09	0h1209	Time scale settings	Time Scale	0	0.01 sec	1:0.1 sec	X/A	O	I/P
				1	0.1 sec				
				2	1 sec				
10	0h120A	Input power frequency	60/50 Hz Sel	0	60Hz	0:60Hz	X/A	O	I/P
				1	50Hz				
11	0h120B	Number of motor poles	Pole Number	2-48			X/A	O	I/P
12	0h120C	Rated slip speed	Rated Slip	0-3000(Rpm)		Dependent on motor setting	X/A	O	I
13	0h120D	Motor rated current	Rated Curr	1.0-1000.0(A)			X/A	O	I/P
14	0h120E	Motor no-load current	No-load Curr	0.0-1000.0(A)			X/A	O	I
15	0h120F	Motor rated voltage	Rated Volt	170-480(V)		0	X/A	O	I/P
16	0h1210	Motor efficiency	Efficiency	64-100(%)		Dependent on motor setting	X/A	O	I/P
17	0h1211	Load inertia rate	Inertia Rate	0-8			X/A	O	I/P
18	0h1212	Trim power display	Trim Power %	70-130(%)			O/A	O	I/P
19	0h1213	Input power voltage	AC Input Volt	170-480V		220/380V	O/A	O	I/P
20	-	Auto Tuning	Auto Tuning	0	None	0:None	X/A	X	I/P
				1	All (Rotation type)				
				2	ALL (Static type)				
				3	Rs+Lsigma (Rotation				

Function Table



Code	Comm. Address	Name	LCD Display	Setting Range	Initial Value	Property*	V/F	SL
				type)				
				6 Tr (Static type)				
				7 All PM				
21	-	Stator resistance	Rs	Dependent on motor setting	Dependent on motor setting	X/A	X	I/P
22	-	Leakage inductance	Lsigma			X/A	X	I
23	-	Stator inductance	Ls			X/A	X	I
24 <sup>8</sup>	-	Rotor time constant	Tr	25-5000(ms)	-	X/A	X	I
25 <sup>8</sup>	-	Stator inductance scale	Ls Scale	50 ~ 150[%]	100	X/A	X	I
26 <sup>8</sup>	-	Rotor time constant scale	Tr Scale	50 ~ 150[%]	100	X/A	X	I
28 <sup>9</sup>	-	D-axis inductance	Ld (PM)	Settings vary depending on the motor specifications.	0	X/A	X	P
29 <sup>9</sup>		Q-axis inductance	Lq (PM)		0	X/A	X	P
30 <sup>9</sup>		Flux reference	PM Flux Ref		0.147	X/A	X	P
31 <sup>8</sup>		Regeneration inductance scale	Ls Regen Scale	70 ~ 100[%]	80	X/A	X	I
32 <sup>9</sup>	-	Q-axis inductance scale	Lq(PM) Scale	50-150[%]	100	X/A	X	P
34 <sup>9</sup>	-	PM auto tuning level	Ld,Lq Tune Lev	20.0-50.0[%]	33.3	X/A	X	P
35 <sup>9</sup>	-	PM auto tuning frequency	Ld,Lq Tune Hz	80.0-150.0[%]	100.0	X/A	X	P
41 <sup>10</sup>	0h1229	User frequency1	User Freq 1	0.00-Maximum frequency(Hz)	15.00	X/A	O	X
42 <sup>10</sup>	0h122A	User voltage1	User Volt 1	0-100(%)	25	X/A	O	X

<sup>8</sup> Displayed when dr.09 is set to 4(IM Sensorless)

<sup>9</sup> Displayed when dr.09 (Control Mode) is set to 6 (PM Sensorless).

<sup>10</sup> Displayed if either bA.07 or M2.25 is set to 2 (User V/F).

Code	Comm. Address	Name	LCD Display	Setting Range	Initial Value	Property*	V/F	SL
43 <sup>10</sup>	0h122B	User frequency2	User Freq 2	0.00-0.00-Maximum frequency(Hz)	30.00	X/A	O	X
44 <sup>10</sup>	0h122C	User voltage2	User Volt 2	0-100(%)	50	X/A	O	X
45 <sup>10</sup>	0h122D	User frequency3	User Freq 3	0.00-Maximum frequency(Hz)	45.00	X/A	O	X
46 <sup>10</sup>	0h122E	User voltage3	User Volt 3	0-100(%)	75	X/A	O	X
47 <sup>10</sup>	0h122F	User frequency4	User Freq 4	0.00-Maximum frequency(Hz)	Maximum frequency	X/A	O	X
48 <sup>10</sup>	0h1230	User voltage4	User Volt 4	0-100(%)	100	X/A	O	X
50 <sup>11</sup>	0h1232	Multi-step speed frequency1	Step Freq-1	0.00-Maximum frequency(Hz)	10.00	O/L	O	I/P
51 <sup>11</sup>	0h1233	Multi-step speed frequency2	Step Freq-2	0.00-Maximum frequency(Hz)	20.00	O/L	O	I/P
52 <sup>11</sup>	0h1234	Multi-step speed frequency3	Step Freq-3	0.00-Maximum frequency(Hz)	30.00	O/L	O	I/P
53 <sup>12</sup>	0h1235	Multi-step speed frequency4	Step Freq-4	0.00-Maximum frequency(Hz)	40.00	O/A	O	I/P
54 <sup>12</sup>	0h1236	Multi-step speed frequency5	Step Freq-5	0.00-Maximum frequency(Hz)	50.00	O/A	O	I/P
55 <sup>12</sup>	0h1237	Multi-step speed frequency6	Step Freq-6	0.00-Maximum frequency(Hz)	Maximum frequency	O/A	O	I/P
56 <sup>12</sup>	0h1238	Multi-step speed frequency7	Step Freq-7	0.00-Maximum frequency(Hz)	Maximum frequency	O/A	O	I/P
70	0h1246	Multi-step acceleration time1	Acc Time-1	0.0-600.0(s)	20.0	O/A	O	I/P
71	0h1247	Multi-step deceleration time1	Dec Time-1	0.0-600.0(s)	20.0	O/A	O	I/P
72 <sup>13</sup>	0h1248	Multi-step	Acc Time-2	0.0-600.0(s)	30.0	O/A	O	I/P

Function Table

<sup>11</sup> Displayed when an LCD keypad is in use.

<sup>12</sup> Displayed if one of In.65-71 is set to Speed-L/M/H.

Code	Comm. Address	Name	LCD Display	Setting Range	Initial Value	Property*	V/F	SL
		acceleration time2						
73 <sup>13</sup>	0h1249	Multi-step deceleration time2	Dec Time-2	0.0-600.0(s)	30.0	O/A	O	I/P
74 <sup>13</sup>	0h124A	Multi-step acceleration time3	Acc Time-3	0.0-600.0(s)	40.0	O/A	O	I/P
75 <sup>13</sup>	0h124B	Multi-step deceleration time3	Dec Time-3	0.0-600.0(s)	40.0	O/A	O	I/P
76 <sup>13</sup>	0h124C	Multi-step acceleration time4	Acc Time-4	0.0-600.0(s)	50.0	O/A	O	I/P
77 <sup>13</sup>	0h124D	Multi-step deceleration time4	Dec Time-4	0.0-600.0(s)	50.0	O/A	O	I/P
78 <sup>13</sup>	0h124E	Multi-step acceleration time5	Acc Time-5	0.0-600.0(s)	40.0	O/A	O	I/P
79 <sup>13</sup>	0h124F	Multi-step deceleration time5	Dec Time-5	0.0-600.0(s)	40.0	O/A	O	I/P
80 <sup>13</sup>	0h1250	Multi-step acceleration time6	Acc Time-6	0.0-600.0(s)	30.0	O/A	O	I/P
81 <sup>13</sup>	0h1251	Multi-step deceleration time6	Dec Time-6	0.0-600.0(s)	30.0	O/A	O	I/P
82 <sup>13</sup>	0h1252	Multi-step acceleration time7	Acc Time-7	0.0-600.0(s)	20.0	O/A	O	I/P
83 <sup>13</sup>	0h1253	Multi-step deceleration time7	Dec Time-7	0.0-600.0(s)	20.0	O/A	O	I/P

<sup>13</sup> Displayed one of In.65-71 is set to Xcel-L/M/H.

## 4.4 Expanded Function group (PAR→Ad)

In the following table, the data shaded in grey will be displayed when a related code has been selected.

**SL:** Sensorless vector control (dr.09) , I – IM Sensorless, P – PM Sensorless

**\*O/X:** Write-enabled during operation, **7/L/A:** Keypad/LCD keypad/Common

Code	Comm. Address	Name	LCD Display	Setting Range		Initial Value	Property*	V/F	SL
00	-	Jump Code	Jump Code	1-99		24	O/A	O	I/P
01	0h1301	Acceleration pattern	Acc Pattern	0	Linear	0: Linear	X/A	O	I/P
02	0h1302	Deceleration pattern	Dec Pattern	1	S-curve		X/A	O	I/P
03 <sup>14</sup>	0h1303	S-curve acceleration start point gradient	Acc S Start	1-100(%)		40	X/A	O	I/P
04 <sup>14</sup>	0h1304	S-curve acceleration end point gradient	Acc S End	1-100(%)		40	X/A	O	I/P
05 <sup>15</sup>	0h1305	S-curve deceleration start point gradient	Dec S Start	1-100(%)		40	X/A	O	I/P
06 <sup>15</sup>	0h1306	S-curve deceleration end point gradient	Dec S End	1-100(%)		40	X/A	O	I/P
07	0h1307	Start Mode	Start Mode	0	Acc	0:Acc	X/A	O	I/P
				1	DC-Start				
08 <sup>16</sup>	0h1308	Stop Mode	Stop Mode	0	Dec	0:Dec	X/A	O	I/P
				1	DC-Brake				
				2	Free-Run				
				4	Power Braking				
09	0h1309	Selection of prohibited rotation	Run Prevent	0	None	0: None	X/A	O	I/P
				1	Forward Prev				

Function Table

<sup>14</sup> Displayed when Ad. 01 is set to 1 (S-curve).

<sup>15</sup> Displayed when Ad. 02 is set to 1 (S-curve).

<sup>16</sup> DC braking and power braking (Ad.08, stop mode options 1 and 4) are not available when dr.09 (Control Mode) is set to 6 (PM Sensorless).

Code	Comm. Address	Name	LCD Display	Setting Range		Initial Value	Property*	V/F	SL
		direction		2	Reverse Prev				
10	0h130A	Starting with power on	Power-on Run	0 1	No Yes	0:No	O/A	O	I/P
12 <sup>17</sup>	0h130C	DC braking time at startup	DC-Start Time	0.00-60.00(s)		0.00	X/A	O	I/P
13	0h130D	Amount of applied DC	DC Inj Level	0-200(%)		50	X/A	O	I/P
14 <sup>18</sup>	0h130E	Output blocking time before DC braking	DC-Block Time	0.00- 60.00(s)		0.10	X/A	O	I/P
15 <sup>18</sup>	0h130F	DC braking time	DC-Brake Time	0.00- 60.00(s)		1.00	X/A	O	I/P
16 <sup>18</sup>	0h1310	DC braking rate	DC-Brake Level	0-200(%)		50	X/A	O	I/P
17 <sup>18</sup>	0h1311	DC braking frequency	DC-Brake Freq	Start frequency-60Hz		5.00	X/A	O	I/P
20	0h1314	Dwell frequency on acceleration	Acc Dwell Freq	Start frequency-Maximum frequency(Hz)		5.00	X/A	O	I/P
21	0h1315	Dwell operation time on acceleration	Acc Dwell Time	0.0-60.0(s)		0.0	X/A	O	I/P
22	0h1316	Dwell frequency on deceleration	Dec Dwell Freq	Start frequency-Maximum frequency(Hz)		5.00	X/A	O	I/P
23	0h1317	Dwell operation time on deceleration	Dec Dwell Time	0.0-60.0(s)		0.0	X/A	O	I/P
24	0h1318	Frequency limit	Freq Limit	0 1	No Yes	0:No	X/A	O	I/P
25 <sup>19</sup>	0h1319	Frequency lower limit value	Freq Limit Lo	0.00-Upper limit frequency(Hz)		0.50	O/A	O	I/P
26 <sup>19</sup>	0h131A	Frequency	Freq Limit Hi	Lower limit		maximum	X/A	O	I/P

<sup>17</sup> Displayed when Ad. 07 is set to 1 (DC-Start).

<sup>18</sup> Displayed when Ad. 08 is set to 1 (DC-Brake).

<sup>19</sup> Displayed when Ad. 24 is set to 1 (Yes).

Code	Comm. Address	Name	LCD Display	Setting Range	Initial Value	Property*	V/F	SL
		upper limit value		frequency- Maximum frequency(Hz)	frequency			
27	0h131B	Frequency jump	Jump Freq	0   No 1   Yes	0:No	X/A	O	I/P
28 <sup>20</sup>	0h131C	Jump frequency lower limit1	Jump Lo 1	0.00-Jump frequency upper limit1(Hz)	10.00	O/A	O	I/P
29 <sup>20</sup>	0h131D	Jump frequency upper limit1	Jump Hi 1	Jump frequency lower limit1- Maximum frequency(Hz)	15.00	O/A	O	I/P
30 <sup>20</sup>	0h131E	Jump frequency lower limit2	Jump Lo 2	0.00-Jump frequency upper limit2(Hz)	20.00	O/A	O	I/P
31 <sup>20</sup>	0h131F	Jump frequency upper limit2	Jump Hi 2	Jump frequency lower limit2- Maximum frequency(Hz)	25.00	O/A	O	I/P
32 <sup>20</sup>	0h1320	Jump frequency lower limit3	Jump Lo 3	0.00-Jump frequency upper limit3(Hz)	30.00	O/A	O	I/P
33 <sup>20</sup>	0h1321	Jump frequency upper limit3	Jump Hi 3	Jump frequency lower limit3- Maximum frequency(Hz)	35.00	O/A	O	I/P
41 <sup>21</sup>	0h1329	Brake release current	BR Rls Curr	0.0-180.0(%)	50.0	O/A	O	I/P
42 <sup>21</sup>	0h132A	Brake release delay time	BR Rls Dly	0.00-10.00(s)	1.00	X/A	O	I/P
44 <sup>21</sup>	0h132C	Brake release Forward frequency	BR Rls Fwd Fr	0.00-Maximum frequency(Hz)	1.00	X/A	O	I/P
45 <sup>21</sup>	0h132D	Brake release Reverse frequency	BR Rls Rev Fr	0.00-Maximum frequency(Hz)	1.00	X/A	O	I/P
46 <sup>21</sup>	0h132E	Brake engage delay	BR Eng Dly	0.00-10.00(s)	1.00	X/A	O	I/P

Function  
Table

<sup>20</sup> Displayed when Ad. 27 is set to 1 (Yes).

<sup>21</sup> Displayed if either OU.31~33 is set to 35 (BR Control).

Code	Comm. Address	Name	LCD Display	Setting Range	Initial Value	Property*	V/F	SL	
		time							
47 <sup>21</sup>	0h132F	Brake engage frequency	BR Eng Fr	0.00-Maximum frequency(Hz)	2.00	X/A	O	I/P	
50	0h1332	Energy saving operation	E-Save Mode	0	None	0:None	X /A	O	X
				1	Manual				
				2	Auto				
51 <sup>22</sup>	0h1333	Energy saving level	Energy Save	0-30(%)	0	O/A	O	X	
60	0h133C	Acc/Dec time transition frequency	Xcel Change Fr	0.00-Maximum frequency(Hz)	0.00	X/A	O	I/P	
61	0h133D	Rotation count speed gain	Load Spd Gain	0.1~6000.0[%]	100.0	O/A	O	I/P	
62	0h133E	Rotation count speed scale	Load Spd Scale	0	x 1	0: x 1	O/A	O	I/P
				1	x 0.1				
				2	x 0.01				
				3	x 0.001				
				4	x 0.0001				
63	0h133F	Rotation count speed unit	Load Spd Unit	0	Rpm	0: rpm	O/A	O	I/P
				1	mpm				
64	0h1340	Cooling fan control	FAN Control	0	During Run	0:During Run	O/A	O	I/P
				1	Always ON				
				2	Temp Control				
65	0h1341	Up/down operation frequency save	U/D Save Mode	0	No	0:No	O/A	O	I/P
				1	Yes				
66	0h1342	Output contact On/Off control options	On/Off Ctrl Src	0	None	0:None	X/A	O	I/P
				1	V1				
				3	V2				
				4	I2				
				6	Pulse				
67	0h1343	Output contact On level	On-Ctrl Level	Output contact off level-100.00%	90.00	X/A	O	I/P	
68	0h1344	Output contact Off level	Off-Ctrl Level	-100.00-output contact on level (%)	10.00	X/A	O	I/P	
70	0h1346	Safe operation	Run En Mode	0	Always Enable	0:Always	X/A	O	I/P

<sup>22</sup> Displayed if Ad.50 is not set to 0 (None).

Code	Comm. Address	Name	LCD Display	Setting Range		Initial Value	Property*	V/F	SL
		selection		1	DI Dependent	Enable			
71 <sup>23</sup>	0h1347	Safe operation stop options	Run Dis Stop	0	Free-Run	0:Free-Run	X/A	O	I/P
				1	Q-Stop				
				2	Q-Stop Resume				
72 <sup>23</sup>	0h1348	Safe operation deceleration time	Q-Stop Time	0.0-600.0(s)		5.0	O/A	O	I/P
74 <sup>24</sup>	0h134A	Selection of regeneration evasion function for press	RegenAvd Sel	0	No	0:No	X/A	O	I
				1	Yes				
75 <sup>24</sup>	0h134B	Voltage level of regeneration evasion motion for press	RegenAvd Level	200V : 300-400V		350	X/A	O	I
				400V : 600-800V		700			
76 <sup>25</sup>	0h134C	Compensation frequency limit of regeneration evasion for press	CompFreq Limit	0.00- 10.00Hz		1.00	X/A	O	I
77 <sup>25</sup>	0h134D	Regeneration evasion for press P gain	RegenAvd Pgain	0.0- 100.0%		50.0	O/A	O	I
78 <sup>25</sup>	0h134E	Regeneration evasion for press I gain	RegenAvd I gain	20-30000(ms)		500	O/A	O	I
79	0h134F	DB Unit turn on voltage level	DB Turn On Lev	200V: Min <sup>26</sup> ~400[V]		390[V]	X/A	O	I/P
				400V: Min <sup>26</sup> ~800[V]		780[V]			
80	0h1350	Fire mode selection	Fire Mode Sel	0	None	0:None	X/A	O	I/P
				1	Fire Mode				
				2	Fire Mode				

Function Table

<sup>23</sup> Displayed when Ad.70 is set to 1 (DI Dependent).

<sup>24</sup> Displayed when dr.09 (Control Mode) is not set to 6 (PM Sensorless).

<sup>25</sup> Displayed when Ad.74 is set to 1 (Yes).

<sup>26</sup> DC voltage value (convert bA.19 AC Input voltage) + 20V (200V type) or + 40V (400V type)



Code	Comm. Address	Name	LCD Display	Setting Range	Initial Value	Property*	V/F	SL	
				Test					
81 <sup>27</sup>	0h1351	Fire mode frequency	Fire Mode Freq	0.00~60.00(Hz)	60.00	X/A	O	I/P	
82 <sup>27</sup>	0h1352	Fire mode direction	Fire Mode Dir	0	Forward	0: Forward	X/A	O	I/P
				1	Reverse				
83 <sup>27</sup>		Fire Mode Count	Fire Mode Cnt	Cannot be modified					
85 <sup>27</sup>	0h1355	Up-down mode selection	U/D Mode Sel	0	U/D Normal	0: U/D Normal	X/A	O	I/P
				1	U/D Step				
				2	U/D Step+ Norm				
86 <sup>27</sup>	0h1356	Up-down step frequency	U/D Step Freq	0-maxFreq	0	O/A	O	I/P	
87 <sup>27</sup>	0h1357	Overmodulation mode selection	OVM Mode Sel	0	No	0: No	X/A	O	X
				1	Yes				

<sup>27</sup> Displayed when Ad.80 is set to 1 (Yes).

## 4.5 Control Function group (PAR→Cn)

In the following table, the data shaded in grey will be displayed when a related code has been selected.

**SL:** Sensorless vector control (dr.09) , I – IM Sensorless, P – PM Sensorless

**\*O/X:** Write-enabled during operation, **7/L/A:** Keypad/LCD keypad/Common

Code	Comm. Address	Name	LCD Display	Setting Range		Initial Value	Property*	V/F	SL
00	-	Jump Code	Jump Code	1-99		4	O/A	O	I/P
04	0h1404	Carrier frequency	Carrier Freq	Heavy Duty	V/F: 1.0~15.0 (kHz) <sup>28</sup> IM: 2.0~15.0 (kHz) PM: 2.0~10.0 (kHz)	3.0	X/A	O	I/P
				Normal Duty <sup>29</sup>	V/F: 1.0~ 5.0 (kHz) <sup>30</sup> IM: 2.0~5.0 (kHz)	2.0			
05	0h1405	Switching mode	PWM Mode	0	Normal PWM	0:Normal PWM	X/A	O	I
				1	Lowleakage PWM				
09 <sup>31</sup>	0h1409	Initial excitation time	PreExTime	0.00-60.00(s)		1.00	X/A	X	I
10 <sup>31</sup>	0h140A	Initial excitation amount	Flux Force	100.0-300.0(%)		100.0	X/A	X	I

Function Table

<sup>28</sup> The setting range is for 5.5-22kW models. For more information on the entire capacities, refer to 7.8 Continuous Rated Current Derating.

<sup>29</sup> PM synchronous motor sensorless vector control mode does not support normal duty operation [when dr.09 (Control Mode) is set to 6 (PM Sensorless)].

<sup>30</sup> Refer to the Footnote 28.

<sup>31</sup> Displayed when dr.09 (Control Mode) is not set to 6 (PM Sensorless).

Code	Comm. Address	Name	LCD Display	Setting Range	Initial Value	Property*	V/F	SL	
11	0h140B	Continued operation duration	Hold Time	0.00-60.00(s)	0.00	X/A	X	I	
12 <sup>32</sup>	0h140D	PM S/L speed controller proportional gain1	ASR P Gain 1	0~5000	100	X/A	X	P	
13 <sup>32</sup>	0h140F	PM S/L speed controller integral gain1	ASR P Gain 1	0~5000	150	X/A	X	P	
15 <sup>32</sup>	0h1410	PM S/L speed controller proportional gain2	ASR P Gain 1	0~5000	100	X/A	X	P	
16 <sup>32</sup>	0h1410	PM S/L speed controller integral gain2	ASR P Gain 1	0~9999	150	X/A	x	P	
20 <sup>31</sup>	0h1414	Sensorless 2 <sup>nd</sup> gain display setting	SL2 G View Sel	0	No	0:No	O/A	X	I
				1	Yes				
21 <sup>31</sup>	0h1415	Sensorless speed controller proportional gain1	ASR-SL P Gain1	0-5000(%)	Dependent on motor setting	O/A	X	I	
22 <sup>31</sup>	0h1416	Sensorless speed controller integral gain1	ASR-SL I Gain1	10-9999(ms)		O/A	X	I	
23 <sup>33</sup>	0h1417	Sensorless speed	ASR-SL P Gain2	1.0-1000.0(%)		O/A	X	I	

<sup>32</sup> Displayed when dr.09 (Control Mode) is set to 6 (PM Sensorless).

<sup>33</sup> Displayed when dr.09 is set to 4 (IM Sensorless) and Cn.20 is set to 1 (YES).

Code	Comm. Address	Name	LCD Display	Setting Range	Initial Value	Property*	V/F	SL
		controller proportional gain2						
24 <sup>33</sup>	0h1418	Sensorless speed controller integral gain2	ASR-SL I Gain2	1.0-1000.0(%)		O/A	X	I
25 <sup>33</sup>	0h1419	Sensorless speed controller integral gain 0	ASR-SL I Gain0	10~9999(ms)		O/A	X	I
26 <sup>33</sup>	0h141A	Flux estimator proportional gain	Flux P Gain	10-200(%)		O/A	X	I
27 <sup>33</sup>	0h141B	Flux estimator integral gain	Flux I Gain	10-200(%)		O/A	X	I
28 <sup>33</sup>	0h141C	Speed estimator proportional gain	S-Est P Gain1	0-32767		O/A	X	I
29 <sup>33</sup>	0h141D	Speed estimator integral gain1	S-Est I Gain1	100-1000		O/A	X	I
30 <sup>33</sup>	0h141E	Speed estimator integral gain2	S-Est I Gain2	100-10000		O/A	X	I
31 <sup>33</sup>	0h141F	Sensorless current controller proportional gain	ACR SL P Gain	10-1000		O/A	X	I
32 <sup>33</sup>	0h1420	Sensorless current controller integral gain	ACR SL I Gain	10 -1000		O/A	X	I
33 <sup>34</sup>	0h1421	PM D-axis back-EMF	PM EdGain Perc	0~300.0[%]	100.0	X/A	X	P

Function Table

<sup>34</sup> Displayed when dr.09 (Control Mode) is set to 6 (PM Sensorless).

Code	Comm. Address	Name	LCD Display	Setting Range	Initial Value	Property*	V/F	SL
		estimation gain [%]						
34 <sup>34</sup>	0h1422	PM Q-axis back-EMF estimation gain [%]	PM EqGain Perc	0~300.0[%]	100.0	X/A	X	P
35 <sup>34</sup>	0h1423	Initial pole position detection retry number	PD Repeat Num	0~10	2	X/A	X	P
36 <sup>34</sup>	0h1424	Initial pole position detection pulse interval	Pulse Interval	1~100	20	X/A	X	P
37 <sup>34</sup>	0h1425	Initial pole position detection current level [%]	Pulse Curr %	10~100	15	X/A	X	P
38 <sup>34</sup>	0h1426	Initial pole position detection voltage level [%]	Pulse Volt %	100~4000	500	X/A	X	P
39 <sup>34</sup>	0h1427	PM dead time range [%]	PMdeadBand Per	50.0~100.0	100.0	X/A	X	P
40 <sup>34</sup>	0h1428	PM dead time voltage [%]	PMdeadVolt Per	50.0~100.0	100.0	X/A	X	P
41 <sup>34</sup>	0h1429	Speed estimator P gain1	PM SpdEst Kp	0~32000	100	X/A	X	P
42 <sup>34</sup>	0h142A	Speed estimator I gain1	PM SpdEst Ki	0~32000	10	X/A	X	P
43 <sup>34</sup>	0h142B	Speed estimator P gain2	PM SpdEst Kp 2	0~32000	300	X/A	X	P
44 <sup>34</sup>	0h142C	Speed estimator I gain2	PM SpdEst Ki 2	0~32000	30	X/A	X	P
45 <sup>34</sup>	0h142D	Speed estimator feed forward high speed	PM Flux FF %	0~100[%]	30.0	X/A	X	P

Code	Comm. Address	Name	LCD Display	Setting Range	Initial Value	Property*	V/F	SL	
		rate [%]							
46 <sup>34</sup>	0h142E	Initial pole position detection options	Init Angle Sel	0	None	1	X/A	P	
				1	Angle				
				2	Align				
48 <sup>34</sup>	-	Current controller P gain	ACR P Gain	0-10000	1200	O/A	X	I/P	
49 <sup>34</sup>	-	Current controller I gain	ACR I Gain	0-10000	120	O/A	X	I/P	
50 <sup>34</sup>	0h1432	Voltage controller limit	V Con HR	0~100.0[%]	10.0	X/A	X	P	
51 <sup>34</sup>	0h1433	Voltage controller I gain	V Con Ki	0~1000.0[%]	10.0	X/A	X	P	
52	0h1434	Torque controller output filter	Torque Out LPF	0-2000(ms)	0	X/A	X	I/P	
53	0h1435	Torque limit setting options	Torque Lmt Src	0	Keypad-1	0: Keypad-1	X/A	X	I/P
				1	Keypad-2				
				2	V1				
				4	V2				
				5	I2				
				6	Int 485				
				8	FieldBus				
				9	UserSeqLink				
				12	Pulse				
54 <sup>35</sup>	0h1436	Positive-direction reverse torque limit	FWD +Trq Lmt	0.0-200.0(%)	180	O/A	X	I/P	
55 <sup>35</sup>	0h1437	Positive-direction regeneration torque limit	FWD -Trq Lmt	0.0-200.0(%)	180	O/A	X	I/P	
56 <sup>35</sup>	0h1438	Negative-direction regeneration torque limit	REV +Trq Lmt	0.0-200.0(%)	180	O/A	X	I/P	

Function Table

<sup>35</sup> Displayed when dr.09 is set to 4 (IM Sensorless). This will change the initial value of the parameter at Ad.74 (Torque limit) to 150%.

Code	Comm. Address	Name	LCD Display	Setting Range	Initial Value	Property*	V/F	SL	
57 <sup>35</sup>	0h1439	Negative-direction reverse torque limit	REV -Trq Lmt	0.0-200.0(%)	180	O/A	X	I/P	
62 <sup>35</sup>	0h143E	Speed limit Setting	Speed Lmt Src	0	Keypad-1	0: Keypad-1	X/A	X	I/P
				1	Keypad-2				
				2	V1				
				4	V2				
				5	I2				
				6	Int 485				
				7	FieldBus				
				8	UserSeqLink				
63 <sup>35</sup>	0h143F	Positive-direction speed limit	FWD Speed Lmt	0.00~ Maximum frequency (Hz)	60.00	O/A	X	I/P	
64 <sup>35</sup>	0h1440	Negative-direction speed limit	REV Speed Lmt	0.00~ Maximum frequency (Hz)	60.00	O/A	X	I/P	
65 <sup>35</sup>	0h1441	Speed limit operation gain	Speed Lmt Gain	100~5000[%]	500	O/A	X	I/P	
69 <sup>36</sup>		PM speed search current	SS Pulse Curr	15	10~100	O/A	X	P	
70	0h 1446	Speed search mode selection	SS Mode	0	Flying Start-1 <sup>37</sup>	0: Flying Start-1	X/A	O	I/P
				1	Flying Start-2				
				2	Flying Start-3 <sup>36</sup>				
71	0h1447	Speed search operation selection	Speed Search	bit	0000-1111	0000 <sup>38</sup>	X/A	O	I/P
				0001	Selection of speed search on acceleration				
				0010	When starting on				

<sup>36</sup> Displayed when dr.09 (Control Mode) is set to 6 (PM Sensorless).

<sup>37</sup> Will not be displayed if dr.09 is set to 4 (IM Sensorless).

<sup>38</sup> The initial value 0000 will be displayed on the keypad as .

Code	Comm. Address	Name	LCD Display	Setting Range	Initial Value	Property*	V/F	SL
				initialization after fault trip				
				0100 When restarting after instantaneous power interruption				
				1000 When starting with power on				
72 <sup>39</sup>	0h1448	Speed search reference current	SS Sup-Current	80-200(%)	150	O/A	O	I/P
73 <sup>40</sup>	0h1449	Speed search proportional gain	SS P-Gain	0-9999	Flying Start-1 : 100 Flying Start-2 : 600 <sup>41</sup>	O/A	O	I
74 <sup>40</sup>	0h144A	Speed search integral gain	SS I-Gain	0-9999	Flying Start-1 : 200 Flying Start-2 : 1000	O/A	O	I
75 <sup>40</sup>	0h144B	Output blocking time before speed search	SS Block Time	0.0-60.0(s)	1.0	X/A	O	I/P
76 <sup>40</sup>	0h144C	Speed search Estimator gain	Spd Est Gain	50-150(%)	100	O/A	O	I
77	0h144D	Energy buffering	KEB Select	0 No 1 KEB-1	0:No	X/A	O	I/P

Function Table

<sup>39</sup> Displayed when any of the Cn.71 code bits are set to 1 and Cn70 is set to 0 (Flying Start-1).

<sup>40</sup> Displayed when any of the Cn.71 code bits are set to 1.

<sup>41</sup> The initial value is 1200 when the motor-rated capacity is less than 7.5 kW



Code	Comm. Address	Name	LCD Display	Setting Range	Initial Value	Property*	V/F	SL
		selection		2   KEB-2				
78 <sup>42</sup>	0h144E	Energy buffering start level	KEB Start Lev	110.0-200.0(%)	130.0	X/A	O	I/P
79 <sup>42</sup>	0h144F	Energy buffering stop level	KEB Stop Lev	Cn78~210.0(%)	135.0	X/A	O	I/P
80 <sup>42</sup>	0h1450	Energy buffering P gain	KEB P Gain	0-20000	1500	O/A	O	I/P
81 <sup>42</sup>	0h1451	Energy buffering I gain	KEB I Gain	1~20000	500	O/A	O	I/P
82 <sup>42</sup>	0h1452	Energy buffering Slip gain	KEB Slip Gain	0~2000.0%	30.0	O/A	O	I
83 <sup>42</sup>	0h1453	Energy buffering acceleration time	KEB Acc Time	0.0~600.0(s)	10.0	O/A	O	I/P
85 <sup>43</sup>	0h1455	Flux estimator proportional gain1	Flux P Gain1	100-700	370	O/A	X	I
86 <sup>43</sup>	0h1456	Flux estimator proportional gain2	Flux P Gain2	0-100	0	O/A	X	I
87 <sup>43</sup>	0h1457	Flux estimator proportional gain3	Flux P Gain3	0-500	100	O/A	X	I
88 <sup>43</sup>	0h1458	Flux estimator integral gain1	Flux I Gain1	0-200	50	O/A	X	I
89 <sup>43</sup>	0h1459	Flux estimator integral gain2	Flux I Gain2	0-200	50	O/A	X	I
90 <sup>43</sup>	0h145A	Flux estimator integral	Flux I Gain3	0-200	50	O/A	X	I

<sup>42</sup> Displayed when Cn.77 is not set to 0 (No).

<sup>43</sup> Displayed when Cn.20 is set to 1 (Yes).

Code	Comm. Address	Name	LCD Display	Setting Range	Initial Value	Property*	V/F	SL
		gain3						
91 <sup>43</sup>	0h145B	Sensorless voltage compensation1	SL Volt Comp1	0-60	Dependent on motor setting	O/A	X	I
92 <sup>43</sup>	0h145C	Sensorless voltage compensation2	SL Volt Comp2	0-60		O/A	X	I
93 <sup>43</sup>	0h145D	Sensorless voltage compensation3	SL Volt Comp3	0-60		O/A	X	I
94 <sup>43</sup>	0h145E	Sensorless field weakening start frequency	SL FW Freq	80.0-110.0(%)	100.0	X/A	X	I
95 <sup>43</sup>	0h145F	Sensorless gain switching frequency	SL Fc Freq	0.00-8.00(Hz)	2.00	X/A	X	I

Function Table

## 4.6 Input Terminal Block Function group (PAR→In)

In the following table, the data shaded in grey will be displayed when a related code has been selected.

**SL:** Sensorless vector control (dr.09) , I – IM Sensorless, P – PM Sensorless

**\*O/X:** Write-enabled during operation, **7/L/A:** Keypad/LCD keypad/Common

Code	Comm. Address	Name	LCD Display	Setting Range	Initial Value	Property*	V/F	SL	
00	-	Jump Code	Jump Code	1-99	65	O/A	O	I/P	
01	0h1501	Frequency for maximum analog input	Freq at 100%	Start frequency- Maximum frequency(Hz)	Maximum frequency	O/A	O	I/P	
02	0h1502	Torque at maximum analog input	Torque at100%	0.0-200.0(%)	100.0	O/A	X	X	
05	0h1505	V1 input voltage display	V1 Monitor(V)	-12.00-12.00(V)	0.00	-/A	O	I/P	
06	0h1506	V1 input polarity selection	V1 Polarity	0	Unipolar	0: Unipolar	X/A	O	I/P
				1	Bipolar				
07	0h1507	Time constant of V1 input filter	V1 Filter	0-10000(ms)	10	O/A	O	I/P	
08	0h1508	V1 Minimum input voltage	V1 Volt x1	0.00-10.00(V)	0.00	O/A	O	I/P	
09	0h1509	V1 output at Minimum voltage (%)	V1 Perc y1	0.00-100.00(%)	0.00	O/A	O	I/P	
10	0h150A	V1 Maximum input voltage	V1 Volt x2	0.00-12.00(V)	10.00	O/A	O	I/P	
11	0h150B	V1 output at Maximum voltage (%)	V1 Perc y2	0.00-100.00(%)	100.00	O/A	O	I/P	
12 <sup>44</sup>	0h150C	V1 Minimum input voltage	V1 -Volt x1'	-10.00- 0.00(V)	0.00	O/A	O	I/P	
13 <sup>44</sup>	0h150D	V1 output at Minimum voltage (%)	V1 -Perc y1'	-100.00-0.00(%)	0.00	O/A	O	I/P	
14 <sup>44</sup>	0h150E	V1	V1 -Volt x2'	-12.00- 0.00(V)	-10.00	O/A	O	I/P	

<sup>44</sup> Displayed when In.06 is set to 1 (Bipolar).

Code	Comm. Address	Name	LCD Display	Setting Range	Initial Value	Property*	V/F	SL	
		Maximum input voltage							
15 <sup>44</sup>	0h150F	V1 output at Maximum voltage (%)	V1 -Perc y2'	-100.00-0.00(%)	-100.00	O/A	O	I/P	
16	0h1510	V1 rotation direction change	V1 Inverting	0	No	0: No	O/A	O	I/P
				1	Yes				
17	0h1511	V1 quantization level	V1 Quantizing	0.00 <sup>45</sup> , 0.04-10.00(%)	0.04	X/A	O	I/P	
35 <sup>46</sup>	0h1523	V2 input voltage display	V2 Monitor(V)	0.00-12.00(V)	0.00	-/A	O	I/P	
37 <sup>46</sup>	0h1525	V2 input filter time constant	V2 Filter	0-10000(ms)	10	O/A	O	I/P	
38 <sup>46</sup>	0h1526	V2 Minimum input voltage	V2 Volt x1	0.00-10.00(V)	0.00	O/A	X	I/P	
39 <sup>46</sup>	0h1527	V2 output at Minimum voltage (%)	V2 Perc y1	0.00-100.00(%)	0.00	O/A	O	I/P	
40 <sup>46</sup>	0h1528	V2 Maximum input voltage	V2 Volt x2	0.00-10.00(V)	10	O/A	X	I/P	
41 <sup>46</sup>	0h1529	V2 output at Maximum voltage (%)	V2 Perc y2	0.00-100.00(%)	100.00	O/A	O	I/P	
46 <sup>46</sup>	0h152E	V2 rotation direction change	V2 Inverting	0	No	0:No	O/A	O	I/P
				1	Yes				
47 <sup>46</sup>	0h152F	V2 quantization level	V2 Quantizing	0.00 <sup>45</sup> , 0.04-10.00(%)	0.04	O/A	O	I/P	
50 <sup>47</sup>	0h1532	I2 input current display	I2 Monitor (mA)	0-24(mA)	0.00	-/A	O	I/P	
52 <sup>47</sup>	0h1534	I2 input filter time	I2 Filter	0-10000(ms)	10	O/A	O	I/P	

<sup>45</sup> Quantizing is not used when set to 0.

<sup>46</sup> Displayed when V is selected on the analog current/voltage input circuit selection switch (SW2).

<sup>47</sup> Displayed when I is selected on the analog current/voltage input circuit selection switch (SW2).

Code	Comm. Address	Name	LCD Display	Setting Range	Initial Value	Property*	V/F	SL	
		constant							
53 <sup>47</sup>	0h1535	I2 minimum input current	I2 Curr x1	0.00-20.00(mA)	4.00	O/A	O	I/P	
54 <sup>47</sup>	0h1536	I2 output at Minimum current (%)	I2 Perc y1	0.00-100.00(%)	0.00	O/A	O	I/P	
55 <sup>47</sup>	0h1537	I2 maximum input current	I2 Curr x2	0.00-24.00(mA)	20.00	O/A	O	I/P	
56 <sup>47</sup>	0h1538	I2 output at Maximum current (%)	I2 Perc y2	0.00-100.00(%)	100.00	O/A	O	I/P	
61 <sup>47</sup>	0h153D	Changing rotation direction of I2	I2 Inverting	0	No	0:No	O/A	O	I/P
				1	Yes				
62 <sup>47</sup>	0h153E	I2 quantization level	I2 Quantizing	0.00 <sup>45</sup> ,0.04-10.00(%)	0.04	O/A	O	I/P	
65	0h1541	P1 terminal function setting	P1 Define	0	None	1:Fx	X/A	O	I/P
				1	Fx				
66	0h1542	P2 terminal function setting	P2 Define	2	Rx	2:Rx	X/A	O	I/P
67	0h1543	P3 terminal function setting	P3 Define	3	RST	5:BX	X/A	O	I/P
68	0h1544	P4 terminal function setting	P4 Define	4	External Trip	3:RST	X/A	O	I/P
69	0h1545	P5 terminal function setting	P5 Define	5	BX	7:Sp-L	X/A	O	I/P
70	0h1546	P6 terminal function setting	P6 Define	6	JOG	8:Sp-M	X/A	O	I/P
71	0h1547	P7 terminal function setting	P7 Define	7	Speed-L	9:Sp-H	X/A	O	I/P
				8	Speed-M				
				9	Speed-H				
				11	XCEL-L				
				12	XCEL-M				
				13	RUN				

Function Table

Code	Comm. Address	Name	LCD Display	Setting Range	Initial Value	Property*	V/F	SL
				Enable				
				14 3-Wire				
				15 2nd Source				
				16 Exchange				
				17 Up				
				18 Down				
				20 U/D Clear				
				21 Analog Hold				
				22 I-Term Clear				
				23 PID Openloop				
				24 P Gain2				
				25 XCEL Stop				
				26 2nd Motor				
				34 Pre Excite				
				38 Timer In				
				40 dis Aux Ref				
				46 FWD JOG				
				47 REV JOG				
				49 XCEL-H				
				50 User Seq				
				51 Fire Mode				
				52 KEB-1 Select				
				54 TI <sup>48</sup>				
84	0h1554	Multi-function input terminal On filter selection	DI Delay Sel	P7 ~ P1	1 1111 <sup>49</sup>	O/A	O	I/P
				0 Disable (Off)				
				1 Enable (On)				
85	0h1555	Multi-function input terminal On filter	DI On Delay	0-10000(ms)	10	O/A	O	I/P

<sup>48</sup> Displayed only when the P5 terminal function is selected in Standard I/O.

<sup>49</sup> The initial value 11111 will be displayed on the keypad as 

Code	Comm. Address	Name	LCD Display	Setting Range	Initial Value	Property*	V/F	SL	
86	0h1556	Multi-function input terminal Off filter	DI Off Delay	0-10000(ms)	3	O/A	O	I/P	
87	0h1557	Multi-function input contact selection	DI NC/NO Sel	P7 – P1		0 0000 <sup>50</sup>	X/A	O	I/P
				0	A contact (NO)				
				1	B contact (NC)				
89	0h1559	Multi-step command delay time	InCheck Time	1-5000(ms)	1	X/A	O	I/P	
90	0h155A	Multi-function input terminal status	DI Status	P7 – P1		0 0000 <sup>50</sup>	-A	O	I/P
				0	release(Off)				
				1	Connection (On)				
91	0h155B	Pulse input amount display	Pulse Monitor (kHz)	0.00-50.00(kHz)	0.00	-A	O	I/P	
92	0h155C	TI input filter time constant	TI Filter	0-9999(ms)	10	O/A	O	I/P	
93	0h155D	TI Minimum input pulse	TI Pls x1	0.00-32.00(kHz)	0.00	O/A	O	I/P	
94	0h155E	TI output at Minimum pulse (%)	TI Perc y1	0.00-100.00(%)	0.00	O/A	O	I/P	
95	0h155F	TI Maximum input pulse	TI Pls x2	0.00-32.00(kHz)	32.00	O/A	O	I/P	
96	0h1560	TI Output at Maximum pulse (%)	TI Perc y2	0-100(%)	100.00	O/A	O	I/P	
97	0h1561	TI rotation direction change	TI Inverting	0	No	0:No	O/A	O	I/P
				1	Yes				
98	0h1562	TI quantization level	TI Quantizing	0.00 <sup>45</sup> , 0.04-10.00(%)	0.04	O/A	O	I/P	
99	0h1563	SW1(NPN/NP) SW2(V1/V2)	IO SW State	Bit	00~11	00	-A	O	I/P
				00	V2, NPN				
				01	V2, PNP				

<sup>50</sup> The initial value 0000 will be displayed on the keypad as .

Code	Comm. Address	Name	LCD Display	Setting Range		Initial Value	Property*	V/F	SL
		[12] status		10	12, NPN				
				11	12, PNP				



## 4.7 Output Terminal Block Function group (PAR→OU)

In the following table, the data shaded in grey will be displayed when a related code has been selected.

**SL:** Sensorless vector control (dr.09) , I – IM Sensorless, P – PM Sensorless

**\*O/X:** Write-enabled during operation, **7/L/A:** Keypad/LCD keypad/Common

Code	Comm. Address	Name	LCD Display	Setting Range	Initial Value	Property*	V/F	SL	
00	-	Jump Code	JumpCode	1-99	30	O/A	O	I/P	
01	0h1601	Analog output 1 item	AO1 Mode	0	Frequency	0: Frequency	O/A	O	I/P
				1	Output Current				
				2	Output Voltage				
				3	DCLink Voltage				
				4	Torque				
				5	Output Power				
				6	Idse				
				7	Iqse				
				8	Target Freq				
				9	Ramp Freq				
				10	Speed Fdb				
				12	PID Ref Value				
				13	PID Fdb Value				
				14	PID Output				
				15	Constant				
02	0h1602	Analog output 1 gain	AO1 Gain	-1000.0-1000.0(%)	100.0	O/A	O	I/P	
03	0h1603	Analog output 1 bias	AO1 Bias	-100.0-100.0(%)	0.0	O/A	O	I/P	
04	0h1604	Analog output 1 filter	AO1 Filter	0-10000(ms)	5	O/A	O	I/P	
05	0h1606	Analog constant output 1	AO1 Const %	0.0-100.0(%)	0.0	O/A	O	I/P	
06	0h1606	Analog output 1 monitor	AO1 Monitor	0.0-1000.0(%)	0.0	-/A	O	I/P	
07	0h1607	Analog output 2 item	AO2 Mode	0	Frequency	0: Frequency	O/A	O	I/P
				1	Output Current				
				2	Output Voltage				
				3	DCLink Voltage				

Code	Comm. Address	Name	LCD Display	Setting Range	Initial Value	Property*	V/F	SL
				4 Torque				
				5 Output Power				
				6 Idse				
				7 Iqse				
				8 Target Freq				
				9 Ramp Freq				
				10 Speed Fdb				
				12 PID Ref Value				
				13 PID Fdb Value				
				14 PID Output				
				15 Constant				
08	0h1608	Analog output 2 gain	AO2 Gain	-1000.0~1000.0(%)	100.0	O/A	O	I/P
09	0h1609	Analog output 2 bias	AO2 Bias	-100.0~100.0(%)	0.0	O/A	O	I/P
10	0h160A	Analog output 2 filter	AO2 Filter	0~10000(ms)	5	O/A	O	I/P
11	0h160B	Analog constant output 2	AO2 Const %	0.0~100.0(%)	0.0	O/A	O	I/P
12	0h160C	Analog output 2 monitor	AO2 Monitor	0.0~1000.0(%)	0.0	-/A	O	I/P
30	0h161E	Fault output item	Trip Out Mode	bit 000-111	010 <sup>51</sup>	O/A	O	I/P
				1 Low voltage				
				2 Any faults other than low voltage				
				3 Automatic restart final failure				
31 (32)	0h161F (0h1620)	Multi-function relay 1 item (Relay 2)	Relay 1 (Relay 2)	0 None	29:Trip (14:Run)	O/A	O	I/P
				1 FDT-1				
				2 FDT-2				
				3 FDT-3				
				4 FDT-4				
				5 Over Load				
				6 IOL				
				7 Under Load				
8 Fan Warning								

Function Table

<sup>51</sup> The initial value 0010 will be displayed on the keypad as .

Code	Comm. Address	Name	LCD Display	Setting Range	Initial Value	Property*	V/F	SL	
				9	Stall				
				10	Over Voltage				
				11	Low Voltage				
				12	Over Heat				
				13	Lost Command				
				14	Run				
				15	Stop				
				16	Steady				
				17	Inverter Line				
				18	Comm Line				
				19	Speed Search				
				22	Ready				
				28	Timer Out				
				29	Trip				
				31	DB Warn%ED				
				34	On/Off Control				
				35	BR Control				
				38	Fire Mode				
				40	KEB Operating				
				33	0h1621				Multi-function output1 item
1	FDT-1								
2	FDT-2								
3	FDT-3								
4	FDT-4								
5	Over Load								
6	IOL								
7	Under Load								
8	Fan Warning								
9	Stall								
10	Over Voltage								
11	Low Voltage								
12	Over Heat								
13	Lost Command								
14	Run								
15	Stop								
16	Steady								
17	Inverter Line								
18	Comm Line								
19	Speed Search								
22	Ready								
28	Timer Out								
29	Trip								

Code	Comm. Address	Name	LCD Display	Setting Range	Initial Value	Property*	V/F	SL	
				31   DB Warn%ED					
				34   On/Off Control					
				35   BR Control					
				38   Fire Mode					
				39   TO					
				40   KEB Operating					
41	0h1629	Multi-function output monitor	DO Status	-	00	-/A	-	-	
50	0h1632	Multi-function output On delay	DO On Delay	0.00-100.00(s)	0.00	O/A	O	I/P	
51	0h1633	Multi-function output Off delay	DO Off Delay	0.00-100.00(s)	0.00	O/A	O	I/P	
52	0h1634	Multi-function output contact selection	DO NC/NO Sel	Q1, Relay1		00 <sup>52</sup>	X/A	O	I/P
				0	A contact (NO)				
				1	B contact (NC)				
53	0h1635	Fault output On delay	TripOut OnDly	0.00-100.00(s)	0.00	O/A	O	I/P	
54	0h1636	Fault output Off delay	TripOut OffDly	0.00-100.00(s)	0.00	O/A	O	I/P	
55	h1637	Timer On delay	TimerOn Delay	0.00-100.00(s)	0.00	O/A	O	I/P	
56	0h1638	Timer Off delay	TimerOff Delay	0.00-100.00(s)	0.00	O/A	O	I/P	
57	0h1639	Detected frequency	FDT Frequency	0.00-Maximum frequency(Hz)	30.00	O/A	O	I/P	
58	0h163A	Detected frequency band	FDT Band	0.00-Maximum frequency(Hz)	10.00	O/A	O	I/P	
61	0h163D	Pulse output gain	TO Mode	0	Frequency	0: Frequency	O/A	O	I/P
				1	Output Current				
				2	Output Voltage				

Function Table

<sup>52</sup> The initial value 0000 will be displayed on the keypad as .

Code	Comm. Address	Name	LCD Display	Setting Range	Initial Value	Property*	V/F	SL
				3 DCLink Voltage				
				4 Torque				
				5 Output Power				
				6 Idse				
				7 Iqse				
				8 Target Freq				
				9 Ramp Freq				
				10 Speed Fdb				
				12 PID Ref Value				
				13 PID Fdb Value				
				14 PID Output				
				15 Constant				
62	0h163E	Pulse output gain	TO Gain	-1000.0-1000.0(%)	100.0	O/A	O	I/P
63	0h163F	Pulse output bias	TO Bias	-100.0-100.0(%)	0.0	O/A	O	I/P
64	0h1640	Pulse output filter	TO Filter	0-10000(ms)	5	O/A	O	I/P
65	0h1641	Pulse output constant output 2	TO Const %	0.0-100.0(%)	0.0	O/A	O	I/P
66	0h1642	Pulse output monitor	TO Monitor	0.0-1000.0(%)	0.0	O/A	O	I/P

## 4.8 Communication Function group (PAR→CM)

In the following table, the data shaded in grey will be displayed when a related code has been selected.

**SL:** Sensorless vector control (dr.09) , I – IM Sensorless, P – PM Sensorless

**\*O/X:** Write-enabled during operation, **7/L/A:** Keypad/LCD keypad/Common

Code	Comm. Address	Name	LCD Display	Setting Range	Initial Value	Property*	V/F	SL
00	-	Jump Code	Jump Code	1-99	20	O/A	O	I/P
01	0h1701	Built-in communication inverter ID	Int485 St ID	1-250	1	O/A	O	I/P
02 <sup>53</sup>	0h1702	Built-in communication protocol	Int485 Proto	0 ModBus RTU 2 LS Inv 485	0: ModBus RTU	O/A	O	I/P
03 <sup>53</sup>	0h1703	Built-in communication speed	Int485 BaudR	0 1200 bps 1 2400 bps 2 4800 bps 3 9600 bps 4 19200 bps 5 38400 bps 6 56 Kbps 7 115 Kbps <sup>54</sup>	3: 9600 bps	O/A	O	I/P
04 <sup>53</sup>	0h1704	Built-in communication frame setting	Int485 Mode	0 D8/PN/S1 1 D8/PN/S2 2 D8/PE/S1 3 D8/PO/S1	0: D8/PN/S1	O/A	O	I/P
05 <sup>53</sup>	0h1705	Transmission delay after reception	Resp Delay	0-1000(ms)	5ms	O/A	O	I/P
06 <sup>55</sup>	0h1706	Communication option S/W version	FBus S/W Ver	-	0.00	O/A	O	I/P
07 <sup>55</sup>	0h1707	Communication option inverter ID	FBus ID	0-255	1	O/A	O	I/P

Function Table

<sup>53</sup> Will not be displayed when P2P and MultiKPD is set.

<sup>54</sup> 115,200bps

<sup>55</sup> Displayed only when a communication option card is installed.

Code	Comm. Address	Name	LCD Display	Setting Range	Initial Value	Property*	V/F	SL
08 <sup>55</sup>	0h1708	FIELD BUS communication speed	FBUS BaudRate	-	12Mbps	-/A	O	I/P
09 <sup>55</sup>	0h1709	Communication option LED status	FieldBus LED	-	-	O/A	O	I/P
30	0h171E	Number of output parameters	ParaStatus Num	0-8	3	O/A	O	I/P
31 <sup>56</sup>	0h171F	Output Communication address1	Para Stauts-1	0000-FFFF Hex	000A	O/A	O	I/P
32 <sup>56</sup>	0h1720	Output Communication address2	Para Stauts-2	0000-FFFF Hex	000E	O/A	O	I/P
33 <sup>56</sup>	0h1721	Output Communication address3	Para Stauts-3	0000-FFFF Hex	000F	O/A	O	I/P
34 <sup>56</sup>	0h1722	Output Communication address4	Para Stauts-4	0000-FFFF Hex	0000	O/A	O	I/P
35 <sup>56</sup>	0h1723	Output Communication address5	Para Stauts-5	0000-FFFF Hex	0000	O/A	O	I/P
36 <sup>56</sup>	0h1724	Output Communication address6	Para Stauts-6	0000-FFFF Hex	0000	O/A	O	I/P
37 <sup>56</sup>	0h1725	Output Communication address7	Para Stauts-7	0000-FFFF Hex	0000	O/A	O	I/P
38 <sup>56</sup>	0h1726	Output Communication address8	Para Stauts-8	0000-FFFF Hex	0000	O/A	O	I/P
50	0h1732	Number of input parameters	Para Ctrl Num	0-8	2	O/A	O	I/P
51 <sup>57</sup>	0h1733	Input Communication address1	Para Control-1	0000-FFFF Hex	0005	X/A	O	I/P
52 <sup>57</sup>	0h1734	Input Communication	Para Control-2	0000-FFFF Hex	0006	X/A	O	I/P

<sup>56</sup> Only the range of addresses set at COM-30 is displayed.

<sup>57</sup> Only the range of addresses set at COM-50 is displayed.

Code	Comm. Address	Name	LCD Display	Setting Range	Initial Value	Property*	V/F	SL	
		address2							
53 <sup>57</sup>	0h1735	Input Communication address3	Para Control-3	0000-FFFF Hex	0000	X/A	O	I/P	
54 <sup>57</sup>	0h1736	Input Communication address4	Para Control-4	0000-FFFF Hex	0000	X/A	O	I/P	
55 <sup>57</sup>	0h1737	Input Communication address5	Para Control-5	0000-FFFF Hex	0000	X/A	O	I/P	
56 <sup>57</sup>	0h1738	Input Communication address6	Para Control-6	0000-FFFF Hex	0000	X/A	O	I/P	
57 <sup>57</sup>	0h1739	Input Communication address7	Para Control-7	0000-FFFF Hex	0000	X/A	O	I/P	
58 <sup>57</sup>	0h173A	Input Communication address8	Para Control-8	0000-FFFF Hex	0000	X/A	O	I/P	
68	0h1744	Field bus data swap	FBus Swap Sel	0	No	0	X/A	O	I/P
				1	Yes				
70	0h1746	Communication multi-function input 1	Virtual DI 1	0	None	0:None	O/A	O	I/P
71	0h1747	Communication multi-function input 2	Virtual DI 2	1	Fx	0:None	O/A	O	I/P
72	0h1748	Communication multi-function input 3	Virtual DI 3	2	Rx	0:None	O/A	O	I/P
73	0h1749	Communication multi-function input 4	Virtual DI 4	3	RST	0:None	O/A	O	I/P
74	0h174A	Communication multi-function input 5	Virtual DI 5	4	External Trip	0:None	O/A	O	I/P
75	0h174B	Communication multi-function input 6	Virtual DI 6	5	BX	0:None	O/A	O	I/P
76	0h174C	Communication multi-function input 7	Virtual DI 7	6	JOG	0:None	O/A	O	I/P
77	0h174D	Communication multi-function input 8	Virtual DI 8	7	Speed-L	0:None	O/A	O	I/P
				8	Speed-M				
				9	Speed-H				
				11	XCEL-L				

Function Table



Code	Comm. Address	Name	LCD Display	Setting Range	Initial Value	Property*	V/F	SL	
				12 XCEL-M					
				13 RUN Enable					
				14 3-Wire					
				15 2nd Source					
				16 Exchange					
				17 Up					
				18 Down					
				20 U/D Clear					
				21 Analog Hold					
				22 I-Term Clear					
				23 PID Openloop					
				24 P Gain2					
				25 XCEL Stop					
				26 2nd Motor					
				34 Pre Excite					
				38 Timer In					
				40 dis Aux Ref					
				46 FWD JOG					
				47 REV JOG					
				49 XCEL-H					
				50 User Seq					
				51 Fire Mode					
				52 KEB-1 Select					
				54 TI <sup>58</sup>					
86	0h1756	Communication multi-function input monitoring	Virt DI Status	-	0	X/A	O	I/P	
90	0h175A	Selection of data frame communication monitor	Comm Mon Sel	0	Int485	0	O/A	O	I/P
				1	KeyPad				
91	0h175B	Data frame Rev count	Rcv Frame Num	0~65535	0	O/A	O	I/P	
92	0h175C	Data frame Err count	Err Frame Num	0~65535	0	O/A	O	I/P	
93	0h175D	NAK frame count	NAK Frame Num	0~65535	0	O/A	O	I/P	
94 <sup>59</sup>	-	Communication	Comm	0 No	0:No	-/A	O	I/P	

<sup>58</sup> Displayed only when the P5 terminal function is selected in Standard I/O.

Code	Comm. Address	Name	LCD Display	Setting Range		Initial Value	Property*	V/F	SL
		data upload	Update	1	Yes				
95	0h1760	P2P communication selection	Int 485 Func	0	Disable All	0: Disable All	X/A	O	I/P
				1	P2P Master				
				2	P2P Slave				
				3	M-KPD Ready				
96 <sup>60</sup>	-	DO setting selection	P2P OUT Sel	Bit	000~111	0:No	O/A	O	I/P
				001	Analog output				
				010	Multi-function relay				
				100	Multi-function output				

Function Table

<sup>59</sup> Displayed only when a communication option card is installed.

<sup>60</sup> Displayed when AP.01 is set to 2 (Proc PID).

## 4.9 Application Function group (PAR→AP)

In the following table, the data shaded in grey will be displayed when a related code has been selected.

**SL:** Sensorless vector control (dr.09) , I – IM Sensorless, P – PM Sensorless

**\*O/X:** Write-enabled during operation, **7/L/A:** Keypad/LCD keypad/Common

Code	Comm. Address	Name	LCD Display	Setting Range	Initial Value	Property*	V/F	SL	
00	-	Jump Code	Jump Code	1-99	20	O/A	O	I/P	
01	0h1801	Application function selection	App Mode	0	None	0: None	X/A	O	I/P
				1	-				
				2	Proc PID				
02	-	Enable user sequence	User Seq En	0	No	0:No	X/A	O	I/P
				1	Yes				
16 <sup>61</sup>	0h1810	PID output monitor	PID Output	(%)	0.00	-/A	O	I/P	
17 <sup>61</sup>	0h1811	PID reference monitor	PID Ref Value	(%)	50.00	-/A	O	I/P	
18 <sup>61</sup>	0h1812	PID feedback monitor	PID Fdb Value	(%)	0.00	-/A	O	I/P	
19 <sup>61</sup>	0h1813	PID reference setting	PID Ref Set	-100.00-100.00(%)	50.00	O/A	O	I/P	
20 <sup>61</sup>	0h1814	PID reference source	PID Ref Source	0	Keypad	0: Keypad	X/A	O	I/P
				1	V1				
				3	V2				
				4	I2				
				5	Int 485				
				7	FieldBus				
				8	UserSeqLink				
				11	Pulse				
21 <sup>61</sup>	0h1815	PID feedback source	PID F/B Source	0	V1	0:V1	X/A	O	I/P
				2	V2				
				3	I2				
				4	Int 485				
				6	FieldBus				
				7	UserSeqLink				
				10	Pulse				
				22 <sup>61</sup>	0h1816				
23 <sup>61</sup>	0h1817	PID controller	PID I-Time	0.0-200.0(s)	10.0	O/A	O	I/P	

<sup>61</sup> Displayed when AP.01 is set to 2 (Proc PID).

Code	Comm. Address	Name	LCD Display	Setting Range	Initial Value	Property*	V/F	SL	
		integral time							
24 <sup>61</sup>	0h1818	PID controller differentiation time	PID D-Time	0-1000(ms)	0	O/A	O	I/P	
25 <sup>61</sup>	0h1819	PID controller feed-forward compensation gain	PID F-Gain	0.0-1000.0(%)	0.0	O/A	O	I/P	
26 <sup>61</sup>	0h181A	Proportional gain scale	P Gain Scale	0.0-100.0(%)	100.0	X/A	O	I/P	
27 <sup>61</sup>	0h181B	PID output filter	PID Out LPF	0-10000(ms)	0	O/A	O	I/P	
28 <sup>61</sup>	0h181C	PID Mode	PID Mode	0	Process PID	0	X/A	O	I/P
				1	Normal PID				
29 <sup>61</sup>	0h181D	PID upper limit frequency	PID Limit Hi	PID lower limit frequency-300.00(Hz)	60.00	O/A	O	I/P	
30 <sup>61</sup>	0h181E	PID lower limit frequency	PID Limit Lo	-300.00 -PID upper limit frequency(Hz)	-60.00	O/A	O	I/P	
31 <sup>61</sup>	0h181F	PID output inverse	PID Out Inv	0	No	0:No	X/A	O	I/P
				1	Yes				
32 <sup>61</sup>	0h1820	PID output scale	PID Out Scale	0.1-1000.0(%)	100.0	X/A	O	I/P	
34 <sup>61</sup>	0h1822	PID controller motion frequency	Pre-PID Freq	0.00-Maximum frequency(Hz)	0.00	X/A	O	I/P	
35 <sup>61</sup>	0h1823	PID controller motion level	Pre-PID Exit	0.0-100.0(%)	0.0	X/A	O	I/P	
36 <sup>61</sup>	0h1824	PID controller motion delay time	Pre-PID Delay	0-9999(s)	600	O/A	O	I/P	
37 <sup>61</sup>	0h1825	PID sleep mode delay time	PID Sleep DT	0.0-999.9(s)	60.0	O/A	O	I/P	
38 <sup>61</sup>	0h1826	PID sleep mode frequency	PID Sleep Freq	0.00-Maximum frequency(Hz)	0.00	O/A	O	I/P	
39 <sup>61</sup>	0h1827	PID wake-up level	PIDWakeUp Lev	0-100(%)	35	O/A	O	I/P	
40 <sup>61</sup>	0h1828	PID wake-up mode setting	PID WakeUp Mod	0	Below Level	0:Below Level	O/A	O	I/P
				1	Above Level				

Function Table

Code	Comm. Address	Name	LCD Display	Setting Range	Initial Value	Property*	V/F	SL
				2 Beyond Level				
42 <sup>61</sup>	0h182A	PID controller unit selection	PID Unit Sel	0 %	0:%	O/A	O	I/P
				1 Bar				
				2 mBar				
				3 Pa				
				4 kPa				
				5 Hz				
				6 rpm				
				7 V				
				8 I				
				9 kW				
				10 HP				
				11 °C				
				12 °F				
				13 CUST				
				14 PSI				
				15 inWC				
16 gl/m								
43 <sup>61</sup>	0h182B	PID unit gain	PID Unit Gain	0.00-300.00(%)	100.00	O/A	O	I/P
44 <sup>61</sup>	0h182C	PID unit scale	PID Unit Scale	0 x100	2:x 1	O/A	O	I/P
				1 x10				
				2 x 1				
				3 x 0.1				
				4 x 0.01				
45 <sup>61</sup>	0h182D	PID 2nd proportional gain	PID P2-Gain	0.0-1000.0(%)	100.0	X/A	O	I/P

## 4.10 Protection Function group (PAR→Pr)

In the following table, the data shaded in grey will be displayed when a related code has been selected.

**SL:** Sensorless vector control (dr.09) , I – IM Sensorless, P – PM Sensorless

**\*O/X:** Write-enabled during operation, **7/L/A:** Keypad/LCD keypad/Common

Code	Comm. Address	Name	LCD Display	Setting Range	Initial Value	Property*	V/F	SL	
00	-	Jump Code	Jump Code	1-99	40	O/A	O	I/P	
04	0h1B04	Load level setting	Load Duty	0 <sup>62</sup>	Normal Duty	1:Heavy Duty	X/A	O	I/P
				1	Heavy Duty				
05	0h1B05	Input/output open-phase protection	Phase Loss Chk	bit	00-11	00 <sup>63</sup>	X/A	O	I/P
				01	Output open phase				
				10	Input open phase				
06	0h1B06	Input voltage range during open-phase	IPO V Band	1-100(V)	15	X/A	O	I/P	
07	0h1B07	Deceleration time at fault trip	Trip Dec Time	0.0-600.0(s)	3.0	O/A	O	I/P	
08	0h1B08	Selection of startup on trip reset	RST Restart	0	No	0:No	O/A	O	I/P
				1	Yes				
09	0h1B09	Number of automatic restarts	Retry Number	0-10	0	O/A	O	I/P	

Function Table

<sup>62</sup> IP66 models do not support normal duty setting.

<sup>63</sup> The initial value 0000 will be displayed on the keypad as .

Code	Comm. Address	Name	LCD Display	Setting Range	Initial Value	Property*	V/F	SL	
10 <sup>64</sup>	0h1B0A	Automatic restart delay time	Retry Delay	0.0-60.0(s)	1.0	O/A	O	I/P	
12	0h1B0C	Motion at speed command loss	Lost Cmd Mode	0	None	0:None	O/A	O	I/P
				1	Free-Run				
				2	Dec				
				3	Hold Input				
				4	Hold Output				
				5	Lost Preset				
13 <sup>65</sup>	0h1B0D	Time to decide speed command loss	Lost Cmd Time	0.1-120(s)	1.0	O/A	O	I/P	
14 <sup>65</sup>	0h1B0E	Operation frequency at speed command loss	Lost Preset F	Start frequency-Maximum frequency(Hz)	0.00	O/A	O	I/P	
15 <sup>65</sup>	0h1B0F	Analog input loss decision level	AI Lost Level	0	Half x1	0:Half of x1	O/A	O	I/P
				1	Below x1				
17	0h1B11	Overload warning selection	OL Warn Select	0	No	0:No	O/A	O	I/P
				1	Yes				
18	0h1B12	Overload alarm level	OL Warn Level	30-180(%)	150	O/A	O	I/P	
19	0h1B13	Overload warning time	OL Warn Time	0.0-30.0(s)	10.0	O/A	O	I/P	
20	0h1B14	Motion at overload fault	OL Trip Select	0	None	1:Free-Run	O/A	O	I/P
				1	Free-Run				
				2	Dec				
21	0h1B15	Overload fault level	OL Trip Level	30-200(%)	180	O/A	O	I/P	
22	0h1B16	Overload fault time	OL Trip Time	0.0-60.0(s)	60.0	O/A	O	I/P	
25	0h1B19	Underload	UL Warn Sel	0	No	0:No	O/A	O	I/P

<sup>64</sup> Displayed when Pr.09 is set higher than 0.

<sup>65</sup> Displayed when Pr.12 is not set to 0 (NONE).

Code	Comm. Address	Name	LCD Display	Setting Range		Initial Value	Property*	V/F	SL
		warning selection		1	Yes				
26	0h1B1A	Underload warning time	UL Warn Time	0.0-600.0(s)		10.0	O/A	O	I/P
27	0h1B1B	Underload fault selection	UL Trip Sel	0	None	0:None	O/A	O	I/P
				1	Free-Run				
				2	Dec				
28	0h1B1C	Underload fault time	UL Trip Time	0.0-600.0(s)		30.0	O/A	O	I/P
29	0h1B1D	Underload lower limit level	UL LF Level	10-30(%)		30	O/A	O	I/P
30	0h1B1E	Underload upper limit level	UL BF Level	30-100(%)		30	O/A	O	I/P
31	0h1B1F	No motor motion at detection	No Motor Trip	0	None	0:None	O/A	O	I/P
				1	Free-Run				
32	0h1B20	No motor detection current level	No Motor Level	1-100(%)		5	O/A	O	I
33	0h1B21	No motor detection delay	No Motor Time	0.1-10.0(s)		3.0	O/A	O	I
40	0h1B28	Electronic thermal fault selection	ETH Trip Sel	0	None	0:None	O/A	O	I/P
				1	Free-Run				
				2	Dec				
41	0h1B29	Motor cooling fan type	Motor Cooling	0	Self-cool	0:Self-cool	O/A	O	I/P
				1	Forced-cool				
42	0h1B2A	Electronic thermal 1 minute rating	ETH 1min	120-200(%)		150	O/A	O	I/P
43	0h1B2B	Electronic thermal continuous rating	ETH Cont	50-150(%)		120	O/A	O	I/P
45	0h1B2D	BX trip mode	BX Mode	0	Free-Run	0	X/A	O	I/P
				1	Dec				
50	0h1B32	Stall prevention	Stall Prevent	bit	00000-11111	0 0000	X/A	O	X

Function Table



Code	Comm. Address	Name	LCD Display	Setting Range	Initial Value	Property*	V/F	SL
		motion and flux braking		00001	Accelerating (Mode 1)			
				10001	Accelerating (Mode 2)			
				00010	At constant speed (Mode 1)			
				10010	At constant speed (Mode 2)			
				#0100	At deceleration			
				#1000	FluxBraking			
51	0h1B33	Stall frequency1	Stall Freq 1	Start frequency- Stall frequency2(Hz)	60.00	O/A	O	X
52	0h1B34	Stall level1	Stall Level 1	30-250(%)	180	X/A	O	X
53	0h1B35	Stall frequency2	Stall Freq 2	Stall frequency1- Stall frequency3(Hz)	60.00	O/A	O	X
54	0h1B36	Stall level2	Stall Level 2	30-250(%)	180	X/A	O	X
55	0h1B37	Stall frequency3	Stall Freq 3	Stall frequency2- Stall frequency4(Hz)	60.00	O/A	O	X
56	0h1B38	Stall level3	Stall Level 3	30-250(%)	180	X/A	O	X
57	0h1B39	Stall frequency4	Stall Freq 4	Stall frequency3- Maximum frequency(Hz)	60.00	O/A	O	X
58	0h1B3A	Stall level4	Stall Level 4	30-250(%)	180	X/A	O	X
59	0h1B3B	Flux braking gain	Flux Brake Kp	0 ~ 150[%]	0	O/A	O	I
66	0h1B42	DB resistor warning level	DB Warn %ED	0-30(%)	0	O/A	O	I/P
73	0h1B22	Speed deviation trip	Speed Dev Trip	0   No 1   Yes	0:No	O/A	O	I/P
74 <sup>66</sup>	0h1B23	Speed deviation	Speed Dev Band	1 ~ 20	5	O/A	O	I/P

<sup>66</sup> Displayed when Pr.73 is set to 1(YES)

Code	Comm. Address	Name	LCD Display	Setting Range	Initial Value	Property*	V/F	SL	
		band							
75 <sup>66</sup>	0h1B24	Speed deviation time	Speed Dev Time	0 ~ 120	60	O/A	O	I/P	
79	0h1B4F	Cooling fan fault selection	FAN Trip Mode	0	Trip	1:Warning	O/A	O	I/P
				1	Warning				
80	0h1B50	Motion selection at option trip	Opt Trip Mode	0	None	1:Free-Run	O/A	O	I/P
				1	Free-Run				
				2	Dec				
81	0h1B51	Low voltage fault decision delay time	LVT Delay	0.0-60.0(s)	0.0	X/A	O	I/P	
82	0h1B52	LV2 Selection	LV2 Enable	Bit	00-11	00	X/A	O	I/P
				00	No				
				01	LV2, history X				
				10	No				
				11	LV2, history O				
90 <sup>66</sup>	0h1B5A	Warning information	-	-	-	-/7	O	I/P	
91 <sup>66</sup>	0h1B5B	Fault history 1	-	-	-	-/7	O	I/P	
92 <sup>66</sup>	0h1B5C	Fault history 2	-	-	-	-/7	O	I/P	
93 <sup>66</sup>	0h1B5D	Fault history 3	-	-	-	-/7	O	O	
94 <sup>66</sup>	0h1B5E	Fault history 4	-	-	-	-/7	O	O	
95 <sup>66</sup>	0h1B5F	Fault history 5	-	-	-	-/7	O	O	
96 <sup>66</sup>	0h1B60	Fault history deletion	-	0	No	0:No	-/7	O	O
				1	Yes				

Function Table

## 4.11 2nd Motor Function group (PAR→M2)

The 2nd Motor function group will be displayed if any of In.65-71 are set to 26 (2nd MOTOR). In the following table, the data shaded in grey will be displayed when a related code has been selected.

**SL:** Sensorless vector control (dr.09) , I – IM Sensorless, P – PM Sensorless

**\*O/X:** Write-enabled during operation, **7/L/A:** Keypad/LCD keypad/Common

Code	Comm. Address	Name	LCD Display	Setting Range	Initial Value	Property*	V/F	SL	
00	-	Jump Code	Jump Code	1-99	14	O/A	O	I	
04	0h1C04	Acceleration time	M2-Acc Time	0.0-600.0(s)	20.0	O/A	O	I	
05	0h1C05	Deceleration time	M2-Dec Time	0.0-600.0(s)	30.0	O/A	O	I	
06	0h1C06	Motor capacity	M2-Capacity	0	0.2 kW	-	X/A	O	I
				1	0.4 kW				
				2	0.75 kW				
				3	1.1 kW				
				4	1.5 kW				
				5	2.2 kW				
				6	3.0 kW				
				7	3.7 kW				
				8	4.0 kW				
				9	5.5 kW				
				10	7.5 kW				
				11	11.0 kW				
				12	15.0 kW				
				13	18.5 kW				
				14	22.0 kW				
				15	30.0 kW				
				16	37.0 kW				
				17	45.0 kW				
				18	55.0 kW				
				19	75.0 kW				
				20	90.0 kW				
07	0h1C07	Base frequency	M2-Base Freq	30.00-400.00(Hz)	60.00	X/A	O	I	
08	0h1C08	Control mode	M2-Ctrl Mode	0	V/F	0:V/F	X/A	O	I
				2	Slip Compen				
				4	IM Sensorless				
				6	PM Sensorless				

Code	Comm. Address	Name	LCD Display	Setting Range	Initial Value	Property*	V/F	SL	
10	0h1C0A	Number of motor poles	M2-Pole Num	2-48	Dependent on motor settings	X/A	O	I	
11	0h1C0B	Rated slip speed	M2-Rated Slip	0-3000(rpm)		X/A	O	I	
12	0h1C0C	Motor rated current	M2-Rated Curr	1.0-1000.0(A)		X/A	O	I	
13	0h1C0D	Motor no-load current	M2-Noload Curr	0.5-1000.0(A)		X/A	O	I	
14	0h1C0E	Motor rated voltage	M2-Rated Volt	170-480(V)		X/A	O	I	
15	0h1C0F	Motor efficiency	M2-Efficiency	64-100(%)		X/A	O	I	
16	0h1C10	Load inertia rate	M2-Inertia Rt	0-8		X/A	O	I	
17	-	Stator resistance	M2-Rs	Dependent on motor settings		X/A	O	I	
18	-	Leakage inductance	M2-Lsigma			X/A	O	I	
19	-	Stator inductance	M2-Ls			X/A	O	I	
20 <sup>67</sup>	-	Rotor time constant	M2-Tr		25-5000(ms)	X/A	O	I	
25	0h1C19	V/F pattern	M2-V/F Patt	0	Linear	0: Linear	X/A	O	I
				1	Square				
				2	User V/F				
26	0h1C1A	Forward Torque boost	M2-Fwd Boost	0.0-15.0(%)	2.0	X/A	O	I	
27	0h1C1B	Reverse Torque boost	M2-Rev Boost	0.0-15.0(%)		X/A	O	I	
28	0h1C1C	Stall prevention level	M2-Stall Lev	30-150(%)	150	X/A	O	I	
29	0h1C1D	Electronic thermal 1 minute rating	M2-ETH 1min	100-200(%)	150	X/A	O	I	
30	0h1C1E	Electronic thermal continuous rating	M2-ETH Cont	50-150(%)	100	X/A	O	I	
40	0h1C28	Rotation count	Load Spd	0~6000.0[%]	100.0	O/A	O	I	

<sup>67</sup> Displayed when M2.08 is set to 4(IM Sensorless)

Code	Comm. Address	Name	LCD Display	Setting Range	Initial Value	Property*	V/F	SL	
		speed gain	Gain						
41	0h1C29	Rotation count speed scale	Load Spd Scale	0	x 1	0: x 1	O/A	O	I
				1	x 0.1				
				2	x 0.01				
				3	x 0.001				
				4	x 0.0001				
42	0h1C2A	Rotation count speed unit	Load Spd Unit	0	Rpm	0: rpm	O/A	O	I
				1	mpm				

## 4.12 User Sequence group (US)

This group appears when AP.02 is set to 1 (Yes) or CM.95 is set to 2 (P2P Master). The parameter cannot be changed while the user sequence is running.

**SL:** Sensorless vector control function (dr.09) , I – IM Sensorless, P – PM Sensorless

**\*O/X:** Write-enabled during operation, **7/L/A:** keypad/LCD keypad/common

Code	Comm. Address	Name	LCD Display	Setting Range	Initial Value	Property*	V/F	SL	
00	-	Jump code	Jump Code	1-99	31	O/A	O	I/P	
01	0h1D01	User sequence operation command	User Seq Con	0	Stop	0:Stop	X/A	O	I/P
				1	Run				
				2	Digital In Run				
02	0h1D02	User sequence operation loop time	US Loop Time	0	0.01s	1:0.02s	X/A	O	I/P
				1	0.02s				
				2	0.05s				
				3	0.1s				
				4	0.5s				
				5	1s				
11	0h1D0B	Output address link1	Link UserOut1	0-0xFFFF	0	X/A	O	I/P	
12	0h1D0C	Output address link2	Link UserOut2	0-0xFFFF	0	X/A	O	I/P	
13	0h1D0D	Output address link3	Link UserOut3	0-0xFFFF	0	X/A	O	I/P	
14	0h1D0E	Output address link4	Link UserOut4	0-0xFFFF	0	X/A	O	I/P	
15	0h1D0F	Output address link5	Link UserOut5	0-0xFFFF	0	X/A	O	I/P	
16	0h1D10	Output address link6	Link UserOut6	0-0xFFFF	0	X/A	O	I/P	
17	0h1D11	Output address link7	Link UserOut7	0-0xFFFF	0	X/A	O	I/P	
18	0h1D12	Output address link8	Link UserOut8	0-0xFFFF	0	X/A	O	I/P	
19	0h1D13	Output address link9	Link UserOut9	0-0xFFFF	0	X/A	O	I/P	
20	0h1D14	Output address link10	Link UserOut10	0-0xFFFF	0	X/A	O	I/P	
21	0h1D15	Output address link11	Link UserOut11	0-0xFFFF	0	X/A	O	I/P	
22	0h1D16	Output address link12	Link UserOut12	0-0xFFFF	0	X/A	O	I/P	
23	0h1D17	Output address link13	Link UserOut13	0-0xFFFF	0	X/A	O	I/P	

Function Table

Code	Comm. Address	Name	LCD Display	Setting Range	Initial Value	Property*	V/F	SL
24	0h1D18	Output address link14	Link UserOut14	0-0xFFFF	0	X/A	O	I/P
25	0h1D19	Output address link15	Link UserOut15	0-0xFFFF	0	X/A	O	I/P
26	0h1D1A	Output address link16	Link UserOut16	0-0xFFFF	0	X/A	O	I/P
27	0h1D1B	Output address link17	Link UserOut17	0-0xFFFF	0	X/A	O	I/P
28	0h1D1C	Output address link18	Link UserOut18	0-0xFFFF	0	X/A	O	I/P
31	0h1D1F	Input constant setting1	Void Para1	-9999-9999	0	X/A	O	I/P
32	0h1D20	Input constant setting2	Void Para2	-9999-9999	0	X/A	O	I/P
33	0h1D21	Input constant setting3	Void Para3	-9999-9999	0	X/A	O	I/P
34	0h1D22	Input constant setting4	Void Para4	-9999-9999	0	X/A	O	I/P
35	0h1D23	Input constant setting5	Void Para5	-9999-9999	0	X/A	O	I/P
36	0h1D24	Input constant setting6	Void Para6	-9999-9999	0	X/A	O	I/P
37	0h1D25	Input constant setting7	Void Para7	-9999-9999	0	X/A	O	I/P
38	0h1D26	Input constant setting8	Void Para8	-9999-9999	0	X/A	O	I/P
39	0h1D27	Input constant setting9	Void Para9	-9999-9999	0	X/A	O	I/P
40	0h1D28	Input constant setting10	Void Para10	-9999-9999	0	X/A	O	I/P
41	0h1D29	Input constant setting11	Void Para11	-9999-9999	0	X/A	O	I/P
42	0h1D2A	Input constant setting12	Void Para12	-9999-9999	0	X/A	O	I/P
43	0h1D2B	Input constant setting13	Void Para13	-9999-9999	0	X/A	O	I/P
44	0h1D2C	Input constant setting14	Void Para14	-9999-9999	0	X/A	O	I/P
45	0h1D2D	Input constant setting15	Void Para15	-9999-9999	0	X/A	O	I/P
46	0h1D2E	Input constant setting16	Void Para16	-9999-9999	0	X/A	O	I/P
47	0h1D2F	Input constant setting17	Void Para17	-9999-9999	0	X/A	O	I/P
48	0h1D30	Input constant	Void Para18	-9999-9999	0	X/A	O	I/P

Code	Comm. Address	Name	LCD Display	Setting Range	Initial Value	Property*	V/F	SL
		setting18						
49	0h1D31	Input constant setting19	Void Para19	-9999-9999	0	X/A	O	I/P
50	0h1D32	Input constant setting20	Void Para20	-9999-9999	0	X/A	O	I/P
51	0h1D33	Input constant setting21	Void Para21	-9999-9999	0	X/A	O	I/P
52	0h1D34	Input constant setting22	Void Para22	-9999-9999	0	X/A	O	I/P
53	0h1D35	Input constant setting23	Void Para23	-9999-9999	0	X/A	O	I/P
54	0h1D36	Input constant setting24	Void Para24	-9999-9999	0	X/A	O	I/P
55	0h1D37	Input constant setting25	Void Para25	-9999-9999	0	X/A	O	I/P
56	0h1D38	Input constant setting26	Void Para26	-9999-9999	0	X/A	O	I/P
57	0h1D39	Input constant setting27	Void Para27	-9999-9999	0	X/A	O	I/P
58	0h1D3A	Input constant setting28	Void Para28	-9999-9999	0	X/A	O	I/P
59	0h1D3B	Input constant setting29	Void Para29	-9999-9999	0	X/A	O	I/P
60	0h1D3C	Input constant setting30	Void Para30	-9999-9999	0	X/A	O	I/P
80	0h1D50 S	Analog input 1	P2P In V1	0-12,000		-/A	O	I/P
81	0h1D51	Analog input2	P2P In I2	-12,000-12,000		-/A	O	I/P
82	0h1D52	Digital input	P2P In DI	0-0x7F		-/A	O	I/P
85	0h1D55	Analog output	P2P OutAO1	0-10,000	0	X/A	O	I/P
89	0h1D58	Digital output	P2P OutDO	0-0x03	0	X/A	O	I/P

Function Table



## 4.13 User Sequence Function group(UF)

This group appears when AP.02 is set to 1 (Yes) or CM.95 is set to 2 (P2P Master). The parameter cannot be changed while the user sequence is running.

**SL:** Sensorless vector control function (dr.09) , I – IM Sensorless, P – PM Sensorless

**\*O/X:** Write-enabled during operation, **7/L/A:** keypad/LCD keypad/common

Code	Comm. Address	Name	LCD Display	Setting Range	Initial Value	Property*	V/F	SL	
00	-	Jump code	Jump Code	1-99	41	O/A	O	I/P	
01	0h1E01	User function1	User Func1	0	NOP	0:NOP	X/A	O	I/P
				1	ADD				
				2	SUB				
				3	ADDSUB				
				4	MIN				
				5	MAX				
				6	ABS				
				7	NEGATE				
				8	MPYDIV				
				9	REMAINDER				
				10	COMPARE-GT				
				11	COMPARE-GEQ				
				12	COMPARE-EQUAL				
				13	COMPARE-NEQUAL				
				14	TIMER				
				15	LIMIT				
				16	AND				
				17	OR				
				18	XOR				
				19	ANDOR				
				20	SWITCH				
				21	BITTEST				
				22	BITSET				
				23	BITCLEAR				
				24	LOWPASSFILTER				
				25	PI_CONTORL				
				26	PI_PROCESS				

Code	Comm. Address	Name	LCD Display	Setting Range		Initial Value	Property*	V/F	SL
				27	UPCOUNT				
				28	DOWNCOUNT				
02	0h1E02	User function input1-A	User Input1-A	0-0xFFFF		0	X/A	O	I/P
03	0h1E03	User function input1-B	User Input1-B	0-0xFFFF		0	X/A	O	I/P
04	0h1E04	User function input1-C	User Input1-C	0-0xFFFF		0	X/A	O	I/P
05	0h1E05	User function output1	User Output1	-32767-32767		0	-/A	O	I/P
06	0h1E06	User function 2	User Func2	0	NOP	0:NOP	X/A	O	I/P
				1	ADD				
				2	SUB				
				3	ADDSUB				
				4	MIN				
				5	MAX				
				6	ABS				
				7	NEGATE				
				8	MPYDIV				
				9	REMAINDER				
				10	COMPARE-GT				
				11	COMPARE-GEQ				
				12	COMPARE-EQUAL				
				13	COMPARE-NEQUAL				
				14	TIMER				
				15	LIMIT				
				16	AND				
				17	OR				
				18	XOR				
				19	ANDOR				
				20	SWITCH				
				21	BITTEST				
				22	BITSET				
23	BITCLEAR								

Function Table

Code	Comm. Address	Name	LCD Display	Setting Range	Initial Value	Property*	V/F	SL
				24   LOWPASSFILTER				
				25   PI_CONTORL				
				26   PI_PROCESS				
				27   UPCOUNT				
				28   DOWNCOUNT				
07	0h1E07	User function input2-A	User Input2-A	0-0xFFFF	0	X/A	O	I/P
08	0h1E08	User function input2-B	User Input2-B	0-0xFFFF	0	X/A	O	I/P
09	0h1E09	User function input2-C	User Input2-C	0-0xFFFF	0	X/A	O	I/P
10	0h1E0A	User function output2	User Output2	-32767-32767	0	-/A	O	I/P
11	0h1E0B	User function3	User Func3	0   NOP	0:NOP	X/A	O	I/P
				1   ADD				
				2   SUB				
				3   ADDSUB				
				4   MIN				
				5   MAX				
				6   ABS				
				7   NEGATE				
				8   MPYDIV				
				9   REMAINDER				
				10   COMPARE-GT				
				11   COMPARE-GEQ				
				12   COMPARE-EQUAL				
				13   COMPARE-NEQUAL				
				14   TIMER				
				15   LIMIT				
				16   AND				
17   OR								
18   XOR								
19   ANDOR								
20   SWITCH								

Code	Comm. Address	Name	LCD Display	Setting Range	Initial Value	Property*	V/F	SL	
				21	BITTEST				
				22	BITSET				
				23	BITCLEAR				
				24	LOWPASSFILTER				
				25	PI_CONTORL				
				26	PI_PROCESS				
				27	UPCOUNT				
				28	DOWNCOUNT				
12	0h1E0C	User function input3-A	User Input3-A	0-0xFFFF		0	X/A	O	I/P
13	0h1E0D	User function input3-B	User Input3-B	0-0xFFFF		0	X/A	O	I/P
14	0h1E0E	User function input3-C	User Input3-C	0-0xFFFF		0	X/A	O	I/P
15	0h1E0F	User function output3	User Output3	-32767-32767		0	-/A	O	I/P
16	0h1E10	User function4	User Func4	0	NOP	0:NOP	X/A	O	I/P
				1	ADD				
				2	SUB				
				3	ADDSUB				
				4	MIN				
				5	MAX				
				6	ABS				
				7	NEGATE				
				8	MPYDIV				
				9	REMAINDER				
				10	COMPARE-GT				
				11	COMPARE-GEQ				
				12	COMPARE-EQUAL				
				13	COMPARE-NEQUAL				
14	TIMER								
15	LIMIT								
16	AND								

Function Table

Code	Comm. Address	Name	LCD Display	Setting Range	Initial Value	Property*	V/F	SL	
				17 OR					
				18 XOR					
				19 ANDOR					
				20 SWITCH					
				21 BITTEST					
				22 BITSET					
				23 BITCLEAR					
				24 LOWPASSFILTER					
				25 PI_CONTORL					
				26 PI_PROCESS					
				27 UPCOUNT					
				28 DOWNCOUNT					
17	0h1E11	User function input4-A	User Input4-A	0-0xFFFF	0	X/A	O	I/P	
18	0h1E12	User function input4-B	User Input4-B	0-0xFFFF	0	X/A	O	I/P	
19	0h1E13	User function input4-C	User Input4-C	0-0xFFFF	0	X/A	O	I/P	
20	0h1E14	User function output4	User Output4	-32767-32767	0	-/A	O	I/P	
21	0h1E15	User function5	User Func5	0	NOP	0:NOP	X/A	O	I/P
				1	ADD				
				2	SUB				
				3	ADDSUB				
				4	MIN				
				5	MAX				
				6	ABS				
				7	NEGATE				
				8	MPYDIV				
				9	REMAINDER				
				10	COMPARE-GT				
				11	COMPARE-GEQ				
				12	COMPARE-EQUAL				
				13	COMPARE-NEQUAL				
14	TIMER								

Code	Comm. Address	Name	LCD Display	Setting Range	Initial Value	Property*	V/F	SL	
				15	LIMIT				
				16	AND				
				17	OR				
				18	XOR				
				19	ANDOR				
				20	SWITCH				
				21	BITTEST				
				22	BITSET				
				23	BITCLEAR				
				24	LOWPASSFILTER				
				25	PI_CONTORL				
				26	PI_PROCESS				
				27	UPCOUNT				
				28	DOWNCOUNT				
22	0h1E16	User function input5-A	User Input5-A	0-0xFFFF		0	X/A	O	I/P
23	0h1E17	User function input5-B	User Input5-B	0-0xFFFF		0	X/A	O	I/P
24	0h1E18	User function input5-C	User Input5-C	0-0xFFFF		0	X/A	O	I/P
25	0h1E19	User function output5	User Output5	-32767-32767		0	-/A	O	I/P
26	0h1E1A	User function6	User Func6	0	NOP	0:NOP	X/A	O	I/P
				1	ADD				
				2	SUB				
				3	ADDSUB				
				4	MIN				
				5	MAX				
				6	ABS				
				7	NEGATE				
				8	MPYDIV				
				9	REMAINDER				
				10	COMPARE-GT				
				11	COMPARE-GEQ				
				12	COMPARE-EQUAL				
13	COMPARE-								

Function Table

Code	Comm. Address	Name	LCD Display	Setting Range	Initial Value	Property*	V/F	SL	
				14	NEQUAL				
				15	TIMER				
				16	LIMIT				
				17	AND				
				18	OR				
				19	XOR				
				20	ANDOR				
				21	SWITCH				
				22	BITTEST				
				23	BITSET				
				24	BITCLEAR				
				25	LOWPASSFILTER				
				26	PI_CONTORL				
				27	PI_PROCESS				
				28	UPCOUNT				
				28	DOWNCOUNT				
27	0h1E1B	User function input6-A	User Input6-A	0-0xFFFF		0	X/A	O	I/P
28	0h1E1C	User function input6-B	User Input6-B	0-0xFFFF		0	X/A	O	I/P
29	0h1E1D	User function input6-C	User Input6-C	0-0xFFFF		0	X/A	O	I/P
30	0h1E1E	User function output6	User Output6	-32767-32767		0	-/A	O	I/P
31	0h1E1F	User function7	User Func7	0	NOP	0:NOP	X/A	O	I/P
				1	ADD				
				2	SUB				
				3	ADDSUB				
				4	MIN				
				5	MAX				
				6	ABS				
				7	NEGATE				
				8	MPYDIV				
				9	REMAINDER				
				10	COMPARE-GT				
				11	COMPARE-GEQ				

Code	Comm. Address	Name	LCD Display	Setting Range	Initial Value	Property*	V/F	SL	
				12	COMPARE-EQUAL				
				13	COMPARE-NEQUAL				
				14	TIMER				
				15	LIMIT				
				16	AND				
				17	OR				
				18	XOR				
				19	ANDOR				
				20	SWITCH				
				21	BITTEST				
				22	BITSET				
				23	BITCLEAR				
				24	LOWPASSFILTER				
				25	PI_CONTORL				
				26	PI_PROCESS				
				27	UPCOUNT				
				28	DOWNCOUNT				
32	0h1E20	User function input7-A	User Input7-A	0-0xFFFF		0	X/A	O	I/P
33	0h1E21	User function input7-B	User Input7-B	0-0xFFFF		0	X/A	O	I/P
34	0h1E22	User function input7-C	User Input7-C	0-0xFFFF		0	X/A	O	I/P
35	0h1E23	User function output7	User Output7	-32767-32767		0	-/A	O	I/P
36	0h1E24	User function8	User Func8	0	NOP	0:NOP	X/A	O	I/P
				1	ADD				
				2	SUB				
				3	ADDSUB				
				4	MIN				
				5	MAX				
				6	ABS				
				7	NEGATE				
				8	MPYDIV				
				9	REMAINDER				

Function Table



Code	Comm. Address	Name	LCD Display	Setting Range	Initial Value	Property*	V/F	SL	
				10	COMPARE-GT				
				11	COMPARE-GEQ				
				12	COMPARE-EQUAL				
				13	COMPARE-NEQUAL				
				14	TIMER				
				15	LIMIT				
				16	AND				
				17	OR				
				18	XOR				
				19	ANDOR				
				20	SWITCH				
				21	BITTEST				
				22	BITSET				
				23	BITCLEAR				
				24	LOWPASSFILTER				
				25	PI_CONTORL				
				26	PI_PROCESS				
				27	UPCOUNT				
				28	DOWNCOUNT				
37	0h1E25	User function input8-A	User Input8-A	0-0xFFFF		0	X/A	O	I/P
38	0h1E26	User function input8-B	User Input8-B	0-0xFFFF		0	X/A	O	I/P
39	0h1E27	User function input8-C	User Input8-C	0-0xFFFF		0	X/A	O	I/P
40	0h1E28	User function output8	User Output8	-32767-32767		0	-/A	O	I/P
41	0h1E29	User function9	User Func9	0	NOP	0:NOP	X/A	O	I/P
				1	ADD				
				2	SUB				
				3	ADDSUB				
				4	MIN				
				5	MAX				
				6	ABS				
				7	NEGATE				

Code	Comm. Address	Name	LCD Display	Setting Range	Initial Value	Property*	V/F	SL	
				8	MPYDIV				
				9	REMAINDER				
				10	COMPARE-GT				
				11	COMPARE-GEQ				
				12	COMPARE-EQUAL				
				13	COMPARE-NEQUAL				
				14	TIMER				
				15	LIMIT				
				16	AND				
				17	OR				
				18	XOR				
				19	ANDOR				
				20	SWITCH				
				21	BITTEST				
				22	BITSET				
				23	BITCLEAR				
				24	LOWPASSFILTER				
				25	PI_CONTORL				
				26	PI_PROCESS				
				27	UPCOUNT				
				28	DOWNCOUNT				
42	0h1E2A	User function input9-A	User Input9-A	0-0xFFFF		0	X/A	O	I/P
43	0h1E2B	User function input9-B	User Input9-B	0-0xFFFF		0	X/A	O	I/P
44	0h1E2C	User function input9-C	User Input9-C	0-0xFFFF		0	X/A	O	I/P
45	0h1E2D	User function output9	User Output9	-32767-32767		0	-/A	O	I/P
46	0h1E2E	User function10	User Func10	0	NOP	0:NOP	X/A	O	I/P
				1	ADD				
				2	SUB				
				3	ADDSUB				
				4	MIN				
				5	MAX				
				6	ABS				

Function Table

Code	Comm. Address	Name	LCD Display	Setting Range	Initial Value	Property*	V/F	SL	
				7	NEGATE				
				8	MPYDIV				
				9	REMAINDER				
				10	COMPARE-GT				
				11	COMPARE-GEQ				
				12	COMPARE-EQUAL				
				13	COMPARE-NEQUAL				
				14	TIMER				
				15	LIMIT				
				16	AND				
				17	OR				
				18	XOR				
				19	ANDOR				
				20	SWITCH				
				21	BITTEST				
				22	BITSET				
				23	BITCLEAR				
				24	LOWPASSFILTER				
				25	PI_CONTORL				
				26	PI_PROCESS				
				27	UPCOUNT				
				28	DOWNCOUNT				
47	0h1E2F	User function input10-A	User Input10-A	0-0xFFFF		0	X/A	O	I/P
48	0h1E30	User function input10-B	User Input10-B	0-0xFFFF		0	X/A	O	I/P
49	0h1E31	User function input10-C	User Input10-C	0-0xFFFF		0	X/A	O	I/P
50	0h1E32	User function output10	User Output 10	-32767-32767		0	-/A	O	I/P
51	0h1E33	User function11	User Func11	0	NOP	0:NOP	X/A	O	I/P
				1	ADD				
				2	SUB				

Code	Comm. Address	Name	LCD Display	Setting Range	Initial Value	Property*	V/F	SL	
				3	ADDSUB				
				4	MIN				
				5	MAX				
				6	ABS				
				7	NEGATE				
				8	MPYDIV				
				9	REMAINDER				
				10	COMPARE-GT				
				11	COMPARE-GEQ				
				12	COMPARE-EQUAL				
				13	COMPARE-NEQUAL				
				14	TIMER				
				15	LIMIT				
				16	AND				
				17	OR				
				18	XOR				
				19	ANDOR				
				20	SWITCH				
				21	BITTEST				
				22	BITSET				
				23	BITCLEAR				
				24	LOWPASSFILTER				
				25	PI_CONTORL				
				26	PI_PROCESS				
				27	UPCOUNT				
				28	DOWNCOUNT				
52	0h1E34	User function input11-A	User Input11-A	0-0xFFFF		0	X/A	O	I/P
53	0h1E35	User function input11-B	User Input11-B	0-0xFFFF		0	X/A	O	I/P
54	0h1E36	User function input11-C	User Input11-C	0-0xFFFF		0	X/A	O	I/P
55	0h1E37	User function output11	User Output	-32767-32767		0	-/A	O	I/P

Function Table

Code	Comm. Address	Name	LCD Display	Setting Range	Initial Value	Property*	V/F	SL	
			11						
56	0h1E38	User function12	User Func12	0	NOP	0:NOP	X/A	O	I/P
				1	ADD				
				2	SUB				
				3	ADDSUB				
				4	MIN				
				5	MAX				
				6	ABS				
				7	NEGATE				
				8	MPYDIV				
				9	REMAINDER				
				10	COMPARE-GT				
				11	COMPARE-GEQ				
				12	COMPARE-EQUAL				
				13	COMPARE-NEQUAL				
				14	TIMER				
				15	LIMIT				
				16	AND				
				17	OR				
				18	XOR				
				19	ANDOR				
				20	SWITCH				
				21	BITTEST				
				22	BITSET				
				23	BITCLEAR				
				24	LOWPASSFILTER				
				25	PI_CONTORL				
				26	PI_PROCESS				
				27	UPCOUNT				
28	DOWNCOUNT								
57	0h1E39	User function input12-A	User Input12-A	0-0xFFFF	0	X/A	O	I/P	
58	0h1E3A	User function input12-B	User Input12-	0-0xFFFF	0	X/A	O	I/P	

Code	Comm. Address	Name	LCD Display	Setting Range	Initial Value	Property*	V/F	SL	
			B						
59	0h1E3B	User function input12-C	User Input12-C	0-0xFFFF	0	X/A	O	I/P	
60	0h1E3C	User function output12	User Output 12	-32767-32767	0	-/A	O	I/P	
61	0h1E3D	User function13	User Func13	0	NOP	0:NOP	X/A	O	I/P
				1	ADD				
				2	SUB				
				3	ADDSUB				
				4	MIN				
				5	MAX				
				6	ABS				
				7	NEGATE				
				8	MPYDIV				
				9	REMAINDER				
				10	COMPARE-GT				
				11	COMPARE-GEQ				
				12	COMPARE-EQUAL				
				13	COMPARE-NEQUAL				
				14	TIMER				
				15	LIMIT				
				16	AND				
				17	OR				
				18	XOR				
				19	ANDOR				
				20	SWITCH				
				21	BITTEST				
				22	BITSET				
				23	BITCLEAR				
				24	LOWPASSFILTER				
				25	PI_CONTORL				
				26	PI_PROCESS				
				27	UPCOUNT				

Function Table

Code	Comm. Address	Name	LCD Display	Setting Range	Initial Value	Property*	V/F	SL
				28   DOWNCOUNT				
62	0h1E3E	User function input13-A	User Input13-A	0-0xFFFF	0	X/A	O	I/P
63	0h1E3F	User function input13-B	User Input13-B	0-0xFFFF	0	X/A	O	I/P
64	0h1E40	User function input13-C	User Input13-C	0-0xFFFF	0	X/A	O	I/P
65	0h1E41	User function output13	User Output 13	-32767-32767	0	-/A	O	I/P
66	0h1E42	User function14	User Func14	0   NOP	0:NOP	X/A	O	I/P
				1   ADD				
				2   SUB				
				3   ADDSUB				
				4   MIN				
				5   MAX				
				6   ABS				
				7   NEGATE				
				8   MPYDIV				
				9   REMAINDER				
				10   COMPARE-GT				
				11   COMPARE-GEQ				
				12   COMPARE-EQUAL				
				13   COMPARE-NEQUAL				
				14   TIMER				
				15   LIMIT				
				16   AND				
17   OR								
18   XOR								
19   ANDOR								
20   SWITCH								
21   BITTEST								
22   BITSET								
23   BITCLEAR								

Code	Comm. Address	Name	LCD Display	Setting Range	Initial Value	Property*	V/F	SL
				24   LOWPASSFILTER				
				25   PI_CONTORL				
				26   PI_PROCESS				
				27   UPCOUNT				
				28   DOWNCOUNT				
67	0h1E43	User function input14-A	User Input14-A	0-0xFFFF	0	X/A	O	I/P
68	0h1E44	User function input14-B	User Input14-B	0-0xFFFF	0	X/A	O	I/P
69	0h1E45	User function input14-C	User Input14-C	0-0xFFFF	0	X/A	O	I/P
70	0h1E46	User function output14	User Output 14	-32767-32767	0	-/A	O	I/P
71	0h1E47	User function15	User Func15	0   NOP	0:NOP	X/A	O	I/P
				1   ADD				
				2   SUB				
				3   ADDSUB				
				4   MIN				
				5   MAX				
				6   ABS				
				7   NEGATE				
				8   MPYDIV				
				9   REMAINDER				
				10   COMPARE-GT				
				11   COMPARE-GEQ				
				12   COMPARE-EQUAL				
				13   COMPARE-NEQUAL				
				14   TIMER				
15   LIMIT								
16   AND								
17   OR								
18   XOR								
19   ANDOR								

Function Table



Code	Comm. Address	Name	LCD Display	Setting Range	Initial Value	Property*	V/F	SL	
				20 SWITCH					
				21 BITTEST					
				22 BITSET					
				23 BITCLEAR					
				24 LOWPASSFILTER					
				25 PI_CONTORL					
				26 PI_PROCESS					
				27 UPCOUNT					
				28 DOWNCOUNT					
72	0h1E48	User function input15-A	User Input15-A	0-0xFFFF	0	X/A	O	I/P	
73	0h1E49	User function input15-B	User Input15-B	0-0xFFFF	0	X/A	O	I/P	
74	0h1E4A	User function input15-C	User Input15-C	0-0xFFFF	0	X/A	O	I/P	
75	0h1E4B	User function output15	User Output 15	-32767-32767	0	-/A	O	I/P	
76	0h1E4C	User function 16	User Func16	0	NOP	0:NOP	X/A	O	I/P
				1	ADD				
				2	SUB				
				3	ADDSUB				
				4	MIN				
				5	MAX				
				6	ABS				
				7	NEGATE				
				8	MPYDIV				
				9	REMAINDER				
				10	COMPARE-GT				
				11	COMPARE-GEQ				
				12	COMPARE-EQUAL				
				13	COMPARE-NEQUAL				
				14	TIMER				
15	LIMIT								

Code	Comm. Address	Name	LCD Display	Setting Range	Initial Value	Property*	V/F	SL	
				16 AND					
				17 OR					
				18 XOR					
				19 ANDOR					
				20 SWITCH					
				21 BITTEST					
				22 BITSET					
				23 BITCLEAR					
				24 LOWPASSFILTER					
				25 PI_CONTORL					
				26 PI_PROCESS					
				27 UPCOUNT					
				28 DOWNCOUNT					
77	0h1E4D	User function input16-A	User Input16-A	0-0xFFFF	0	X/A	O	I/P	
78	0h1E4E	User function input16-B	User Input16-B	0-0xFFFF	0	X/A	O	I/P	
79	0h1E4F	User function input16-C	User Input16-C	0-0xFFFF	0	X/A	O	I/P	
80	0h1E50	User function output16	User Output 16	-32767-32767	0	-/A	O	I/P	
81	0h1E51	User function 17	User Func17	0	NOP	0:NOP	X/A	O	I/P
				1	ADD				
				2	SUB				
				3	ADDSUB				
				4	MIN				
				5	MAX				
				6	ABS				
				7	NEGATE				
				8	MPYDIV				
				9	REMAINDER				
				10	COMPARE-GT				
				11	COMPARE-GEQ				
12	COMPARE-EQUAL								

Function Table

Code	Comm. Address	Name	LCD Display	Setting Range	Initial Value	Property*	V/F	SL	
				13	COMPARE-NEQUAL				
				14	TIMER				
				15	LIMIT				
				16	AND				
				17	OR				
				18	XOR				
				19	ANDOR				
				20	SWITCH				
				21	BITTEST				
				22	BITSET				
				23	BITCLEAR				
				24	LOWPASSFILTER				
				25	PI_CONTORL				
				26	PI_PROCESS				
				27	UPCOUNT				
				28	DOWNCOUNT				
82	0h1E52	User function input17-A	User Input17-A	0-0xFFFF		0	X/A	O	I/P
83	0h1E53	User function input17-B	User Input17-B	0-0xFFFF		0	X/A	O	I/P
84	0h1E54	User function input17-C	User Input17-C	0-0xFFFF		0	X/A	O	I/P
85	0h1E55	User function output17	User Output 17	-32767-32767		0	-/A	O	I/P
86	0h1E56	User function 18	User Func18	0	NOP	0:NOP	X/A	O	I/P
				1	ADD				
				2	SUB				
				3	ADDSUB				
				4	MIN				
				5	MAX				
				6	ABS				
				7	NEGATE				
				8	MPYDIV				
				9	REMAINDER				

Code	Comm. Address	Name	LCD Display	Setting Range	Initial Value	Property*	V/F	SL
				10 COMPARE-GT				
				11 COMPARE-GEQ				
				12 COMPARE-EQUAL				
				13 COMPARE-NEQUAL				
				14 TIMER				
				15 LIMIT				
				16 AND				
				17 OR				
				18 XOR				
				19 ANDOR				
				20 SWITCH				
				21 BITTEST				
				22 BITSET				
				23 BITCLEAR				
				24 LOWPASSFILTER				
				25 PI_CONTORL				
				26 PI_PROCESS				
				27 UPCOUNT				
				28 DOWNCOUNT				
87	0h1E57	User function input18-A	User Input18-A	0-0xFFFF	0	X/A	O	I/P
88	0h1E58	User function input18-B	User Input18-B	0-0xFFFF	0	X/A	O	I/P
89	0h1E59	User function input18-C	User Input18-C	0-0xFFFF	0	X/A	O	I/P
90	0h1E5A	User function output18	User Output 18	-32767-32767	0	-/A	O	I/P

Function Table

## 4.14 Groups for LCD Keypad Only

### 4.14.1 Trip Mode (TRP Last-x)

Code	Name	LCD Display	Setting Range	Initial Value	
00	Trip type display	Trip Name(x)	-	-	
01	Frequency reference at trip	Output Freq	-	-	
02	Output current at trip	Output Current	-	-	
03	Acceleration/Deceleration state at trip	Inverter State	-	-	
04	DC section state	DCLink Voltage	-	-	
05	NTC temperature	Temperature	-	-	
06	Input terminal state	DI Status	-	0000 0000	
07	Output terminal state	DO Status	-	000	
08	Trip time after Power on	Trip On Time	-	0/00/00 00:00	
09	Trip time after operation start	Trip Run Time	-	0/00/00 00:00	
10	Delete trip history	Trip Delete?	0	No	
			1	Yes	

### 4.14.2 Config Mode (CNF)

Code	Name	LCD Display	Setting Range	Initial Value
00	Jump code	Jump Code	1-99	42
01	Keypad language selection	Language Sel	0 : English	0 : English
02	LCD contrast adjustment	LCD Contrast	-	-
03	Multi keypad ID	Multi KPD ID	3-99	3
10	Inverter SW version	Inv S/W Ver	-	-
11	LCD keypad S/W version	Keypad S/W Ver	-	-
12	LCD keypad title version	KPD Title Ver	-	-
20	Status window display item	Anytime Para	0   Frequency	0: Frequency

Code	Name	LCD Display	Setting Range		Initial Value
21	Monitor mode display item1	Monitor Line-1	1	Speed	0: Frequency
22	Monitor mode display item2	Monitor Line-2	2	Output Current	2:Output Current
23	Monitor mode display item3	Monitor Line-3	3	Output Voltage	3:Output Voltage
			4	Output Power	
			5	WHour Counter	
			6	DCLink Voltage	
			7	DI State	
			8	DO State	
			9	V1 Monitor(V)	
			10	V1 Monitor(%)	
			13	V2 Monitor(V)	
			14	V2 Monitor(%)	
			15	I2 Monitor(mA)	
			16	I2 Monitor(%)	
			17	PID Output	
			18	PID Ref Value	
			19	PID Fdb Value	
			20	Torque	
21	Torque Limit				
23	Speed Limit				
24	Load Speed				
25	Temperature				
24	Monitor mode initialization	Mon Mode Init	0	No	0:No
			1	Yes	
30	Option slot 1 type display	Option-1 Type	0	None	0:None
31	Option slot 2 type display	Option-2 Type	6	Ethernet	0:None
32	Option slot 3 type display	Option-3 Type	9	CANopen	0:None
40	Parameter initialization	Parameter Init	0	No	
			1	All Grp	
			2	DRV Grp	
			3	BAS Grp	
			4	ADV Grp	

Function Table

Code	Name	LCD Display	Setting Range	Initial Value
			5 CON Grp	
			6 IN Grp	
			7 OUT Grp	
			8 COM Grp	
			9 APP Grp	
			11 APO Grp <sup>68</sup>	
			12 PRT Grp	
			13 M2 Grp	
			14 US Grp	
			15 UF Grp	
41	Display changed Parameter	Changed Para	0 View All 1 View Changed	0:View All
42	Multi key item	Multi Key Sel	0 None 1 JOG Key 2 Local/Remote 3 UserGrp SelKey 4 Multi KPD	0:None
43	Macro function item	Macro Select	0 None	0:None
44	Trip history deletion	Erase All Trip	0 No 1 Yes	0:No
45	User registration code deletion	UserGrp AllDel	0 No 1 Yes	0:No
46	Read parameters	Parameter Read	0 No 1 Yes	0:No
47	Write parameters	Parameter Write	0 No 1 Yes	0: No
48	Save parameters	Parameter Save	0 No 1 Yes	0:No
50	Hide parameter mode	View Lock Set	0-9999	Un-locked
51	Password for hiding parameter mode	View Lock Pw	0-9999	Password
52	Lock parameter edit	Key Lock Set	0-9999	Un-locked
53	Password for locking parameter edit	Key Lock Pw	0-9999	Password
60	Additional title update	Add Title Up	0 No	0:No

<sup>68</sup> Supported only Extension I/O(Optional)

Code	Name	LCD Display	Setting Range		Initial Value
			1	Yes	
61	Simple parameter setting	Easy Start On	0	No	1:Yes
			1	Yes	
62	Power consumption initialization	WHCount Reset	0	No	0:No
			1	Yes	
70	Accumulated inverter motion time	On-time	00000DAY 00:00		-
71	Accumulated inverter operation time	Run-time	00000DAY 00:00		-
72	Accumulated inverter operation time initialization	Time Reset	0	No	0:No
			1	Yes	
74	Accumulated cooling fan operation time	Fan Time	00000DAY 00:00		-
75	Reset of accumulated cooling fan operation time	Fan Time Rst	0	No	0:No
			1	Yes	

Function  
Table





## 5 Troubleshooting

This chapter explains how to troubleshoot a problem when inverter protective functions, fault trips, warning signals, or a fault occurs. If the inverter does not work normally after following the suggested troubleshooting steps, please contact the LS ELECTRIC customer service center.

### 5.1 Trips and Warnings









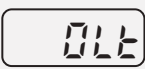

When the inverter detects a fault, it stops the operation (trips) or sends out a warning signal. When a trip or warning occurs, the keypad displays the information briefly. If the LCD keypad is used, detailed information is shown on the LCD display. Users can read the warning message at Pr.90. When more than 2 trips occur at roughly the same time, the keypad (basic keypad with 7-segment display) displays the higher priority fault trip information, while the LCD keypad shows the information for the fault trip that occurred first.

The fault conditions can be categorized as follows:

- Level: When the fault is corrected, the trip or warning signal disappears and the fault is not saved in the fault history.
- Latch: When the fault is corrected and a reset input signal is provided, the trip or warning signal disappears.
- Fatal: When the fault is corrected, the fault trip or warning signal disappears only after the user turns off the inverter, waits until the charge indicator light goes off, and turns the inverter on again. If the inverter is still in a fault condition after powering it on again, please contact the supplier or the LS ELECTRIC customer service center.

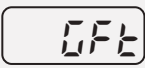
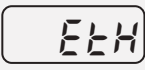
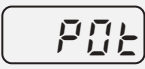
## 5.1.1 Fault Trips

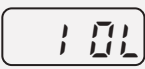







### Protection Functions for Output Current and Input Voltage

Keypad Display	LCD Display	Type	Description
	Over Load	Latch	Displayed when the motor overload trip is activated and the actual load level exceeds the set level. Operates when Pr.20 is set to a value other than 0.
	Under Load	Latch	Displayed when the motor underload trip is activated and the actual load level is less than the set level. Operates when Pr.27 is set to a value other than 0.
	Over Current1	Latch	Displayed when inverter output current exceeds 200% of the rated current.
	Over Voltage	Latch	Displayed when internal DC circuit voltage exceeds the specified value.
	Low Voltage	Level	Displayed when internal DC circuit voltage is less than the specified value.
	Low Voltage2	Latch	Displayed when internal DC circuit voltage is less than the specified value during inverter operation.
	Ground Trip*	Latch	Displayed when a ground fault trip occurs on the output side of the inverter and causes the current to exceed the specified value. The specified value varies depending on inverter capacity.
	E-Thermal	Latch	Displayed based on inverse time-limit thermal characteristics to prevent motor overheating. Operates when Pr.40 is set to a value other than 0.
	Out Phase Open	Latch	Displayed when a 3-phase inverter output has one or more phases in an open circuit condition. Operates when bit 1 of Pr.05 is set to 1.
	In Phase Open	Latch	Displayed when a 3-phase inverter input has one or more phases in an open circuit condition. Operates only when bit 2 of Pr.05 is set to 1.
	Inverter OLT	Latch	Displayed when the inverter has been protected from overload and resultant overheating, based on inverse time-limit thermal characteristics. Allowable overload rates for the inverter are 150% for 1 min and 200% for 4 sec. Protection is based on inverter rated capacity, and may vary depending on the device's capacity.
	No Motor Trip	Latch	Displayed when the motor is not connected during inverter operation. Operates when Pr.31 is set to 1.

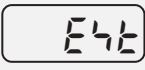

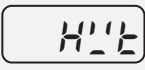

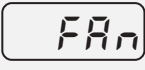
\* S100 inverters rated for 4.0kW or less do not support the ground fault trip (GFT) feature. Therefore, an over current trip (OCT) or over voltage trip (OVT) may occur when there is a low-resistance ground fault.

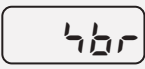
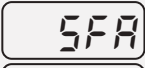
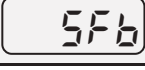
\* For products with built-in filters, CPU Reset or OCT or OC2 Trip can occur in an anomaly in which the Surge input (such as Lightning Surge) is received.



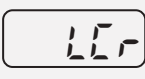

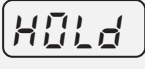
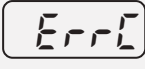
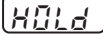
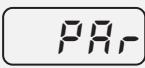

## Protection Functions Using Abnormal Internal Circuit Conditions and External Signals

Keypad Display	LCD Display	Type	Description
	Over Heat	Latch	Displayed when the temperature of the inverter heat sink exceeds the specified value.
	Over Current2	Latch	Displayed when the DC circuit in the inverter detects a specified level of excessive, short circuit current.
	External Trip	Latch	Displayed when an external fault signal is provided by the multi-function terminal. Set one of the multi-function input terminals at In.65-71 to 4 (External Trip) to enable external trip.
	BX	Level	Displayed when the inverter output is blocked by a signal provided from the multi-function terminal. Set one of the multi-function input terminals at In.65-71 to 5 (BX) to enable input block function.
	HW-Diag	Fatal	Displayed when an error is detected in the memory (EEPROM), analog-digital converter output (ADC Off Set), or CPU watchdog (Watch Dog-1, Watch Dog-2).  EEP Err: An error in reading/writing parameters due to keypad or memory (EEPROM) fault.  ADC Off Set: An error in the current sensing circuit (U/V/W terminal, current sensor, etc.).
	NTC Open	Latch	Displayed when an error is detected in the temperature sensor of the Insulated Gate Bipolar Transistor (IGBT).
	Fan Trip	Latch	Displayed when an error is detected in the cooling fan. Set Pr.79 to 0 to activate fan trip (for models below 22kW capacity).
	Pre-PID Fail	Latch	Displayed when pre-PID is operating with functions set at AP.34–AP.36. A fault trip occurs when a controlled variable (PID feedback) is measured below the set value and the low feedback continues, as it is treated as a load fault.
	Ext-Brake	Latch	Operates when the external brake signal is provided by the multi-function terminal. Occurs when the inverter output starting current remains below the set value at Ad.41. Set either OU.31 or OU.32 to 35 (BR Control).
 	Safety A(B) Err	Latch	Displayed when at least one of the two safety input signals is off.

## Protection Functions for Communication Options

Keypad Display	LCD Display	Type	Description
	Lost Command	Level	Displayed when a frequency or operation command error is detected during inverter operation by controllers other than the keypad (e.g., using a terminal block and a communication mode). Activate by setting Pr.12 to any value other than 0.
 	IO Board Trip	Latch	Displayed when the I/O board or external communication card is not connected to the inverter or there is a bad connection.
			Displayed when the  error code continues for more than 5 sec. (‘Errc’ -> ‘-rrc’ -> E-rc’ -> ‘Er-c’ -> ‘Err-’ -> ‘- -rc’ -> ‘Er- -’ -> ‘- - - -’ -> ‘Errc’ -> ...)
	ParaWrite Trip	Latch	Displayed when communication fails during parameter writing. Occurs when using an LCD keypad due to a control cable fault or a bad connection.
	Option Trip-1	Latch	Displayed when a communication error is detected between the inverter and the communication board. Occurs when the communication option card is installed.

## 5.1.2 Warning Messages

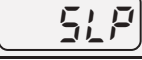
Keypad Display	LCD Display	Description
	Over Load	Displayed when the motor is overloaded. Operates when Pr.17 is set to 1. To operate, select 5. Set the digital output terminal or relay (OU.31 or OU.33) to 5 (Over Load) to receive overload warning output signals.
	Under Load	Displayed when the motor is underloaded. Operates when Pr.25 is set to 1. Set the digital output terminal or relay (OU.31 or OU.33) to 7 (Under Load) to receive underload warning output signals.
	INV Over Load	Displayed when the overload time equivalent to 60% of the inverter overheat protection (inverter IOLT) level, is accumulated. Set the digital output terminal or relay (OU.31 or OU.33) to 6 (IOL) to receive inverter overload warning output signals.
	Lost Command	Lost command warning alarm occurs even with Pr.12 set to 0. The warning alarm occurs based on the condition set at Pr.13- 15. Set the digital output terminal or relay (OU.31 or OU.33) to 13 (Lost Command) to receive lost command warning output signals. If the communication settings and status are not suitable for P2P, a Lost Command alarm occurs.
	Fan Warning	Displayed when an error is detected from the cooling fan while Pr.79 is set to 1. Set the digital output terminal or relay (OU.31 or OU.33) to 8 (Fan Warning) to receive fan warning output signals
	DB Warn %ED	Displayed when the DB resistor usage rate exceeds the set value. Set the detection level at Pr.66.
	Retry Tr Tune	Tr tune error warning alarm is activated when Dr.9 is set to 4. The warning alarm occurs when the motor's rotor time constant (Tr) is either too low or too high.
	PID Sleep	When the PID operation enters sleep mode, a warning occurs.

## 5.2 Troubleshooting Fault Trips

When a fault trip or warning occurs due to a protection function, refer to the following table for possible causes and remedies.

Type	Cause	Remedy
Over Load	The load is greater than the motor's rated capacity.	Ensure that the motor and inverter have appropriate capacity ratings.
	The set value for the overload trip level (Pr.21) is too low.	Increase the set value for the overload trip level.
Under Load	There is a motor-load connection problem.	Replace the motor and inverter with models with lower capacity.
	The set value for underload level (Pr.29, Pr.30) is less than the system's minimum load.	Reduce the set value for the underload level.
Over Current1	Acc/Dec time is too short, compared to load inertia (GD2).	Increase Acc/Dec time.
	The inverter load is greater than the rated capacity.	Replace the inverter with a model that has increased capacity.
	The inverter supplied an output while the motor was idling.	Operate the inverter after the motor has stopped or use the speed search function (Cn.60).
	The mechanical brake of the motor is operating too fast.	Check the mechanical brake.
Over Voltage	Deceleration time is too short for the load inertia (GD2).	Increase the acceleration time.
	A generative load occurs at the inverter output.	Use the braking unit.
	The input voltage is too high.	Determine if the input voltage is above the specified value.
Low Voltage	The input voltage is too low.	Determine if the input voltage is below the specified value.
	A load greater than the power capacity is connected to the system (e.g., a welder, direct motor connection, etc.)	Increase the power capacity.
	The magnetic contactor connected to the power source has a faulty connection.	Replace the magnetic contactor.
Low Voltage2	The input voltage has decreased during the operation.	Determine if the input voltage is above the specified value.
	An input phase-loss has occurred.	Check the input wiring.
	The power supply magnetic contactor is faulty.	Replace the magnetic contractor.
Ground Trip	A ground fault has occurred in the inverter output wiring.	Check the output wiring.
	The motor insulation is damaged.	Replace the motor.
E-Thermal	The motor has overheated.	Reduce the load or operation frequency.
	The inverter load is greater than the	Replace the inverter with a model

Type	Cause	Remedy
	rated capacity.	that has increased capacity.
	The set value for electronic thermal protection is too low.	Set an appropriate electronic thermal level.
	The inverter has been operated at low speed for an extended duration.	Replace the motor with a model that supplies extra power to the cooling fan.
Output Phase Open	The magnetic contactor on the output side has a connection fault.	Check the magnetic contactor on the output side.
	The output wiring is faulty.	Check the output wiring.
Input Phase Open	The magnetic contactor on the input side has a connection fault.	Check the magnetic contactor on the input side.
	The input wiring is faulty.	Check the input wiring.
	The DC link capacitor needs to be replaced.	Replace the DC link capacitor. Contact the retailer or the LS ELECTRIC customer service center.
Inverter OLT	The load is greater than the rated motor capacity.	Replace the motor and inverter with models that have increased capacity.
	The torque boost level is too high.	Reduce the torque boost level.
Over Heat	There is a problem with the cooling system.	Determine if a foreign object is obstructing the air inlet, outlet, or vent.
	The inverter cooling fan has been operated for an extended period.	Replace the cooling fan.
	The ambient temperature is too high.	Keep the ambient temperature below 50°C.
Over Current2	Output wiring is short-circuited.	Check the output wiring.
	There is a fault with the electronic semiconductor (IGBT).	Do not operate the inverter. Contact the retailer or the LS ELECTRIC customer service center.
NTC Open	The ambient temperature is too low.	Keep the ambient temperature above -10°C.
	There is a fault with the internal temperature sensor.	Contact the retailer or the LS ELECTRIC customer service center.
FAN Trip / FAN Warning	A foreign object is obstructing the fan's air vent.	Remove the foreign object from the air inlet or outlet.
	The fan connector is not connected.	Connect the fan connector.
	The cooling fan needs to be replaced.	Replace the cooling fan.



## 5.3 Troubleshooting Other Faults

When a fault other than those identified as fault trips or warnings occurs, refer to the following table for possible causes and remedies.

Type	Cause	Remedy
Parameters cannot be set.	The inverter is in operation (driving mode).	Stop the inverter to change to program mode and set the parameter.
	The parameter access is incorrect.	Check the correct parameter access level and set the parameter.
	The password is incorrect.	Check the password, disable the parameter lock and set the parameter.
	Low voltage is detected.	Check the power input to resolve the low voltage and set the parameter.
The motor does not rotate.	The frequency command source is set incorrectly.	Check the frequency command source setting.
	The operation command source is set incorrectly.	Check the operation command source setting.
	Power is not supplied to the terminal R/S/T.	Check the terminal connections R/S/T and U/V/W.
	The charge lamp is turned off.	Turn on the inverter.
	The operation command is off.	Turn on the operation command (RUN).
	The motor is locked.	Unlock the motor or lower the load level.
	The load is too high.	Operate the motor independently.
	An emergency stop signal is input.	Reset the emergency stop signal.
	The wiring for the control circuit terminal is incorrect.	Check the wiring for the control circuit terminal.
	The input option for the frequency command is incorrect.	Check the input option for the frequency command.
	The input voltage or current for the frequency command is incorrect.	Check the input voltage or current for the frequency command.
	The PNP/NPN mode is selected incorrectly.	Check the PNP/NPN mode setting.
	The frequency command value is too low.	Check the frequency command and input a value above the minimum frequency.
The [STOP/RESET] key is pressed.	Check that the stoppage is normal, if so resume operation normally.	
Motor torque is too low.	Change the operation modes (V/F, IM, and Sensorless). If the fault remains, replace the inverter with a	

Type	Cause	Remedy
		model with increased capacity.
The motor rotates in the opposite direction to the command.	The wiring for the motor output cable is incorrect.	Determine if the cable on the output side is wired correctly to the phase (U/V/W) of the motor.
	The signal connection between the control circuit terminal (forward/reverse rotation) of the inverter and the forward/reverse rotation signal on the control panel side is incorrect.	Check the forward/reverse rotation wiring.
The motor only rotates in one direction.	Reverse rotation prevention is selected.	Remove the reverse rotation prevention.
	The reverse rotation signal is not provided, even when a 3-wire sequence is selected.	Check the input signal associated with the 3-wire operation and adjust as necessary.
The motor is overheating.	The load is too heavy.	Reduce the load.
		Increase the Acc/Dec time.
		Check the motor parameters and set the correct values.
		Replace the motor and the inverter with models with appropriate capacity for the load.
	The ambient temperature of the motor is too high.	Lower the ambient temperature of the motor.
	The phase-to-phase voltage of the motor is insufficient.	Use a motor that can withstand phase-to-phase voltages surges greater than the maximum surge voltage.
Only use motors suitable for applications with inverters.		
Connect the AC reactor to the inverter output (set the carrier frequency to 2 kHz).		
	The motor fan has stopped or the fan is obstructed with debris.	Check the motor fan and remove any foreign objects.
The motor stops during acceleration or when connected to load.		Reduce the load.
	The load is too high.	Replace the motor and the inverter with models with capacity appropriate for the load.
The motor does not accelerate. /The acceleration time is too long.	The frequency command value is low.	Set an appropriate value.
	The load is too high.	Reduce the load and increase the acceleration time. Check the mechanical brake status.
	The acceleration time is too long.	Change the acceleration time.

Type	Cause	Remedy
	The combined values of the motor properties and the inverter parameter are incorrect.	Change the motor related parameters.
	The stall prevention level during acceleration is low.	Change the stall prevention level.
	The stall prevention level during operation is low.	Change the stall prevention level.
	Starting torque is insufficient.	Change to vector control operation mode. If the fault is still not corrected, replace the inverter with a model with increased capacity.
Motor speed varies during operation.	There is a high variance in load.	Replace the motor and inverter with models with increased capacity.
	The input voltage varies.	Reduce input voltage variation.
	Motor speed variations occur at a specific frequency.	Adjust the output frequency to avoid a resonance area.
The motor rotation is different from the setting.	The V/F pattern is set incorrectly.	Set a V/F pattern that is suitable for the motor specification.
The motor deceleration time is too long even with Dynamic Braking (DB) resistor connected.	The deceleration time is set too long.	Change the setting accordingly.
	The motor torque is insufficient.	If motor parameters are normal, it is likely to be a motor capacity fault. Replace the motor with a model with increased capacity.
	The load is higher than the internal torque limit determined by the rated current of the inverter.	Replace the inverter with a model with increased capacity.
Operation is difficult in underload applications.	The carrier frequency is too high.	Reduce the carrier frequency.
	Over-excitation has occurred due to an inaccurate V/F setting at low speed.	Reduce the torque boost value to avoid over-excitation.
While the inverter is in operation, a control unit malfunctions or noise occurs.	Noise occurs due to switching inside the inverter.	Change the carrier frequency to the minimum value.
		Install a micro surge filter in the inverter output.
When the inverter is operating, the earth leakage breaker is activated.	An earth leakage breaker will interrupt the supply if current flows to ground during inverter operation.	Connect the inverter to a ground terminal. Check that the ground resistance is less than 100Ω for 200V inverters and less than 10Ω for 400V inverters.

Type	Cause	Remedy
		Check the capacity of the earth leakage breaker and make the appropriate connection, based on the rated current of the inverter. Lower the carrier frequency. Make the cable length between the inverter and the motor as short as possible.
The motor vibrates severely and does not rotate normally.	Phase-to-phase voltage of 3-phase power source is not balanced.	Check the input voltage and balance the voltage. Check and test the motor's insulation.
The motor makes humming, or loud noises.	Resonance occurs between the motor's natural frequency and the carrier frequency.	Slightly increase or decrease the carrier frequency.
	Resonance occurs between the motor's natural frequency and the inverter's output frequency.	Slightly increase or decrease the carrier frequency. Use the frequency jump function to avoid the frequency band where resonance occurs.
The motor vibrates/hunts.	The frequency input command is an external, analog command.	In situations of noise inflow on the analog input side that results in command interference, change the input filter time constant (In.07).
	The wiring length between the inverter and the motor is too long.	Ensure that the total cable length between the inverter and the motor is less than 200m (50m for motors rated 3.7 kW or lower).
The motor does not come to a complete stop when the inverter output stops.	It is difficult to decelerate sufficiently, because DC braking is not operating normally.	Adjust the DC braking parameter.
		Increase the set value for the DC braking current. Increase the set value for the DC braking stopping time.
The output frequency does not increase to the frequency reference.	The frequency reference is within the jump frequency range.	Set the frequency reference higher than the jump frequency range.
	The frequency reference is exceeding the upper limit of the frequency command.	Set the upper limit of the frequency command higher than the frequency reference.
	Because the load is too heavy, the stall prevention function is working.	Replace the inverter with a model with increased capacity.
The cooling fan does not rotate.	The control parameter for the cooling fan is set incorrectly.	Check the control parameter setting for the cooling fan.

Memo

## 6 Maintenance

This chapter explains how to replace the cooling fan, the regular inspections to complete, and how to store and dispose of the product. An inverter is vulnerable to environmental conditions and faults also occur due to component wear and tear. To prevent breakdowns, please follow the maintenance recommendations in this section.

### ⓘ Caution

- Before you inspect the product, read all safety instructions contained in this manual.
- Before you clean the product, ensure that the power is off.
- Clean the inverter with a dry cloth. Cleaning with wet cloths, water, solvents, or detergents may result in electric shock or damage to the product.

## 6.1 Regular Inspection Lists

### 6.1.1 Daily Inspections

Inspection area	Inspection item	Inspection details	Inspection method	Judgment standard	Inspection equipment
All	Ambient environment	Is the ambient temperature and humidity within the design range, and is there any dust or foreign objects present?	Refer to <u>1.3 Installation Considerations</u> on page <u>8</u> .	No icing (ambient temperature: -10 - +40) and no condensation (ambient humidity below 50%)	Thermometer, hygrometer, recorder
	Inverter	Is there any abnormal vibration or noise?	Visual inspection	No abnormality	
	Power voltage	Are the input and output voltages normal?	Measure voltages between R/ S/ T-phases in. the inverter terminal block.	Refer to <u>7.1 Input and Output Specification</u> on page <u>203</u> .	Digital multimeter tester
Input/Output circuit	Smoothing capacitor	Is there any leakage from the inside?	Visual inspection	No abnormality	-

Inspection area	Inspection item	Inspection details	Inspection method	Judgment standard	Inspection equipment
		Is the capacitor swollen?			
Cooling system	Cooling fan	Is there any abnormal vibration or noise?	Turn off the system and check operation by rotating the fan manually.	Fan rotates smoothly	-
Display	Measuring device	Is the display value normal?	Check the display value on the panel.	Check and manage specified values.	Voltmeter, ammeter, etc.
Motor	All	Is there any abnormal vibration or noise?	Visual inspection	No abnormality	-
		Is there any abnormal smell?	Check for overheating or damage.		

## 6.1.2 Annual Inspections

Inspection area	Inspection item	Inspection details	Inspection method	Judgment standard	Inspection equipment
Input/Output circuit	All	Megger test (between input/output terminals and earth terminal)	Disconnect inverter and short R/S/T/U/V/W terminals, and then measure from each terminal to the ground terminal using a Megger.	Must be above 5 MΩ	DC 500 V Megger
		Is there anything loose in the device?	Tighten up all screws.	No abnormality	
		Is there any evidence of parts overheating?	Visual inspection		
	Cable connections	Are there any corroded	Visual inspection	No abnormality	-

Inspection area	Inspection item	Inspection details	Inspection method	Judgment standard	Inspection equipment
		cables?			
		Is there any damage to cable insulation?			
	Terminal block	Is there any damage?	Visual inspection	No abnormality	-
	Smoothing condenser	Measure electrostatic capacity.	Measure with capacity meter.	Rated capacity over 85%	Capacity meter
	Relay	Is there any chattering noise during operation?	Visual inspection	No abnormality	-
		Is there any damage to the contacts?	Visual inspection		
Braking resistor	Is there any damage from resistance?	Visual inspection	No abnormality	Digital multimeter / analog tester	
	Check for disconnection.	Disconnect one side and measure with a tester.	Must be within $\pm 10\%$ of the rated value of the resistor.		
Control circuit Protection circuit	Operation check	Check for output voltage imbalance while the inverter is in operation.	Measure voltage between the inverter output terminal U/ V/ W.	Balance the voltage between phases: within 4V for 200V series and within 8V for 400V series.	Digital multimeter or DC voltmeter
		Is there an error in the display circuit after the sequence protection test?	Test the inverter output protection in both short and open circuit conditions.	The circuit must work according to the sequence.	
Cooling system	Cooling fan	Are any of the fan parts	Check all connected	No abnormality	-



Inspection area	Inspection item	Inspection details	Inspection method	Judgment standard	Inspection equipment
		loose?	parts and tighten all screws.		
Display	Display device	Is the display value normal?	Check the command value on the display device.	Specified and managed values must match.	Voltmeter, Ammeter, etc.

### 6.1.3 Bi-annual Inspections

Inspection area	Inspection item	Inspection details	Inspection method	Judgment standard	Inspection equipment
Motor	Insulation resistance	Megger test (between the input, output and earth terminals).	Disconnect the cables for terminals U/V/W and test the wiring.	Must be above 5 MΩ	DC 500 V Megger

#### ⓘ Caution

Do not run an insulation resistance test (Megger) on the control circuit as it may result in damage to the product.

## 6.2 Replacing Major Components

Refer to following for information on replacing major components.

### 6.2.1 Exchange Cycle for Major Components

Following table shows the cycles and information for major components.

Components	Exchange standard	Symptom	Action
Cooling fan	3 years	Spinning failure	Make inquiries to the A/S center and replace it with a new product.
Main circuit electrolytic condenser	3 years	Capacity reduction	Make inquiries to the A/S center and replace it with a new product.
Main circuit relay	-	Operation failure	Make inquiries to the A/S center.

#### Note

The life times of major components are based on the operating rated load consecutively. The lifetime may be different according to conditions and environment.

## 6.3 Storage and Disposal

### 6.3.1 Storage

If you are not using the product for an extended period, store it in the following way:

- Store the product in the same environmental conditions as specified for operation (refer to [1.3 Installation Considerations](#) on page 8).
- When storing the product for a period longer than 3 months, store it between 10°C and 30°C, to prevent depletion of the electrolytic capacitor.
- Do not expose the inverter to snow, rain, fog, or dust.
- Package the inverter in a way that prevents contact with moisture. Keep the moisture level below 70% in the package by including a desiccant, such as silica gel.

### 6.3.2 Disposal

When disposing of the product, categorize it as general industrial waste. Recyclable materials are included in the product, so recycle them whenever possible. The packing materials and all metal parts can be recycled. Although plastic can also be recycled, it can be incinerated under controlled conditions in some regions.

#### ⚠ Caution

If the inverter has not been operated for a long time, capacitors lose their charging characteristics and are depleted. To prevent degradation, turn on the product once a year and allow the device to operate for 30-60 min. Run the device under no-load conditions.

## 7 Technical Specification

### 7.1 Input and Output Specification

#### 7.1.1 0.4-22kW Models

##### Single Phase 200V (0.4-2.2 kW)

Model □□□□S100-1□□□□□			0004	0008	0015	0022	
Applied motor	Heavy load	HP	0.5	1.0	2.0	3.0	
		kW	0.4	0.75	1.5	2.2	
	Normal load	HP	1.0	2.0	3.0	5.0	
		kW	0.75	1.5	2.2	3.7	
Rated output	Rated capacity (kVA)	Heavy load	1.0	1.9	3.0	4.2	
		Normal load	1.2	2.3	3.8	4.6	
	Rated current (A)	Heavy load	2.5	5.0	8.0	11.0	
		Normal load	3.1	6.0	9.6	12.0	
	Output frequency		0-400 Hz (IM Sensorless: 0-120 Hz)				
	Output voltage (V)		3-phase 200-240 V				
Working voltage (V)		Single phase 200-240 V AC (-15% to +10%)					
Rated input	Input frequency		50-60 Hz (±5%)				
	Rated current (A)	Heavy load	4.4	9.3	15.6	21.7	
		Normal load	5.8	11.7	19.7	24.0	
Weight (lb/kg)	Non-EMC Filter Type		2.0/0.9	2.9/1.3	3.3/1.5	4.4/2.0	
	EMC Filter Type		2.5/1.1	3.4/1.6	3.9/1.8	4.9/2.2	
	IP66 Type(EMC)		8.2/3.7	11.7/5.3	12.1/5.5	12.4/5.6	
	IP66 Type(Non-EMC)		7.9/3.6	11.5/5.2	11.9/5.4	12.1/5.5	

- The standard motor capacity is based on a standard 4-pole motor.
- The standard used for 200 V inverters is based on a 220 V supply voltage, and for 400V inverters is based on a 440 V supply voltage.
- The rated output current is limited based on the carrier frequency set at Cn.04.
- The output voltage becomes 20~40% lower during no-load operations to protect the inverter from the impact of the motor closing and opening (0.4-4.0kW models only).
- IP66 models do not support normal load operation.

### 3 Phase 200V (0.4-4 kW)

Model □□□□S100-2□□□□□			0004	0008	0015	0022	0037	0040	
Applied motor	Heavy load	HP	0.5	1.0	2.0	3.0	5.0	5.4	
		kW	0.4	0.75	1.5	2.2	3.7	4.0	
	Normal load	HP	1.0	2.0	3.0	5.0	5.4	7.5	
		kW	0.75	1.5	2.2	3.7	4.0	5.5	
Rated output	Rated capacity (kVA)	Heavy load	1.0	1.9	3.0	4.2	6.1	6.5	
		Normal load	1.2	2.3	3.8	4.6	6.9	6.9	
	Rated current [3-Phase input] (A)	Heavy load	2.5	5.0	8.0	11.0	16.0	17.0	
		Normal load	3.1	6.0	9.6	12.0	18.0	18.0	
	Rated current [Single-Phase input] (A)	Heavy load	1.5	2.8	4.6	6.1	8.8	9.3	
		Normal load	1.8	3.3	5.7	6.6	9.9	9.9	
	Output frequency		0-400 Hz (IM Sensorless: 0-120 Hz)						
	Output voltage (V)		3-phase 200-240 V						
Rated input	Working voltage (V)		3-phase 200-240 VAC (-15% to +10%) Single phase 240VAC(-5% to +10%)						
	Input frequency		50-60 Hz (±5%) (In case of single phase input, input frequency is only 60Hz(±5%).)						
	Rated current (A)	Heavy load	2.2	4.9	8.4	11.8	17.5	18.5	
		Normal load	3.0	6.3	10.8	13.1	19.4	19.4	
Weight (lb/kg)	Non-EMC Filter Type		2.0/0.9	2.0/0.9	2.9/1.3	3.3/1.5	4.4/2.0	4.4/2.0	
	IP66 Type(Non-EMC)		7.9/3.6	7.9/3.6	11.5/5.2	11.9/5.4	12.1/5.5	12.1/5.5	

- The standard motor capacity is based on a standard 4-pole motor.
- The standard used for 200 V inverters is based on a 220 V supply voltage, and for 400V inverters is based on a 440 V supply voltage.
- The rated output current is limited based on the carrier frequency set at Cn.04.
- The output voltage becomes 20~40% lower during no-load operations to protect the inverter from the impact of the motor closing and opening (0.4-4.0kW models only).
- IP66 models do not support normal load operation.

### 3 Phase 200V (5.5-15 kW)

Model □□□□S100-2□□□□□			0055	0075	0110	0150	
Applied motor	Heavy load	HP	7.5	10	15	20	
		kW	5.5	7.5	11	15	
	Normal load	HP	10	15	20	25	
		kW	7.5	11	15	18.5	
Rated output	Rated capacity (kVA)	Heavy load	9.1	12.2	17.5	22.9	
		Normal load	11.4	15.2	21.3	26.3	
	Rated current [3-Phase input] (A)	Heavy load	24.0	32.0	46.0	60.0	
		Normal load	30.0	40.0	56.0	69.0	
	Rated current [Single-Phase input] (A)	Heavy load	13.0	18.0	26.0	33.0	
		Normal load	16.0	22.0	31.0	38.0	
	Output frequency		0-400 Hz (IM Sensorless : 0-120 Hz)				
	Output voltage (V)		3 phase 200-240V				
Rated input	Working voltage (V)		3 phase 200-240VAC (-15% to +10%) Single phase 240VAC(-5% to +10%)				
	Input frequency		50-60 Hz (±5%) (In case of single phase input, input frequency is only 60Hz(±5%.))				
	Rated current (A)	Heavy load	25.8	34.9	50.8	66.7	
		Normal load	32.7	44.2	62.3	77.2	
Weight (lb/kg)	Non-EMC Filter Type		6.8/3.1	6.8/3.1	9.7/4.4	15.2/6.9	
	IP66 Type(Non-EMC)		19.4/8.8	19.4/8.8	20.7/9.4	26.2/11.9	

- The standard motor capacity is based on a standard 4-pole motor
- The standard used for 200 V inverters is based on a 220 V supply voltage, and for 400V inverters is based on a 440 V supply voltage.
- The rated output current is limited based on the carrier frequency set at Cn.04.
- IP66 models do not support normal load operation.

### 3-Phase 400V (0.4-4 kW)

Model □□□□S100-4□□□□□		0004	0008	0015	0022	0037	0040	
Applied motor	Heavy load	HP	0.5	1.0	2.0	3.0	5.0	5.4
		kW	0.4	0.75	1.5	2.2	3.7	4.0
	Normal load	HP	1.0	2.0	3.0	5.0	5.4	7.5
		kW	0.75	1.5	2.2	3.7	4.0	5.5
Rated output	Rated capacity (kVA)	Heavy load	1.0	1.9	3.0	4.2	6.1	6.5
		Normal load	1.5	2.4	3.9	5.3	7.6	7.6
	Rated current [3-Phase input] (A)	Heavy load	1.3	2.5	4.0	5.5	8.0	9.0
		Normal load	2.0	3.1	5.1	6.9	10.0	10.0
	Rated current [Single-Phase input] (A)	Heavy load	0.8	1.5	2.3	3.1	4.8	5.4
		Normal load	1.3	1.9	3.0	3.9	5.9	5.9
	Output frequency		0-400 Hz (IM Sensorless: 0-120 Hz)					
	Output voltage (V)		3-phase 380-480V					
	Rated input	Working voltage (V)		3-phase 380-480VAC (-15% to +10%) Single phase 480VAC(-5% to +10%)				
		Input frequency		50-60 Hz (±5%) (In case of single phase input, input frequency is only 60Hz(±5%.))				
Rated current (A)		Heavy load	1.1	2.4	4.2	5.9	8.7	9.8
		Normal load	2.0	3.3	5.5	7.5	10.8	10.8
Weight (lb/kg)	EMC Filter Type		2.6/1.2	2.6/1.2	3.9/1.8	4.0/1.8	4.9/2.2	4.9/2.2
	Non-EMC Filter Type		2.0/0.9	2.0/0.9	2.9/1.3	3.3/1.5	4.4/2.0	4.4/2.0
	IP66 Type(EMC)		8.2/3.7	8.2/3.7	11.7/5.3	12.1/5.5	12.4/5.6	12.4/5.6
	IP66 Type(Non-EMC)		7.9/3.6	7.9/3.6	11.5/5.2	11.9/5.4	12.1/5.5	12.1/5.5

- The standard motor capacity is based on a standard 4-pole motor.
- The standard used for 200 V inverters is based on a 220 V supply voltage, and for 400V inverters is based on a 440 V supply voltage.
- The rated output current is limited based on the carrier frequency set at Cn.04.
- The output voltage becomes 20~40% lower during no-load operations to protect the inverter from the impact of the motor closing and opening (0.4-4.0kW models only).
- IP66 models do not support normal load operation.

### 3-Phase 400V (5.5-22 kW)

Model □□□□S100-4□□□□□			0055	0075	0110	0150	0185	0220
Applied motor	Heavy load	HP	7.5	10	15	20	25	30
		kW	5.5	7.5	11	15	18.5	22
	Normal load	HP	10	15	20	25	30	40
		kW	7.5	11	15	18.5	22	30
Rated output	Rated capacity (kVA)	Heavy load	9.1	12.2	18.3	22.9	29.7	34.3
		Normal load	12.2	17.5	22.9	29.0	33.5	44.2
	Rated current [3-Phase input] (A)	Heavy load	12.0	16.0	24.0	30.0	39.0	45.0
		Normal load	16.0	23.0	30.0	38.0	44.0	58.0
	Rated current [Single-Phase input] (A)	Heavy load	7.1	9.5	15.0	18.0	23.0	27.0
		Normal load	9.5	14.0	18.0	23.0	27.0	35.0
	Output frequency		0-400 Hz (IM Sensorless: 0-120 Hz)					
Output voltage (V)		3-phase 380-480V						
Rated input	Working voltage (V)		3-phase 380-480VAC (-15% to +10%) Single phase 480VAC(-5% to +10%)					
	Input frequency		50-60 Hz (±5%) (In case of single phase input, input frequency is only 60Hz(±5%.)					
	Rated current (A)	Heavy load	12.9	17.5	26.5	33.4	43.6	50.7
Normal load		17.5	25.4	33.4	42.5	49.5	65.7	
Weight (lb/kg)	EMC Filter Type		7.3/3.3	7.5/3.4	10.1/4.6	10.5/4.8	16.5/7.5	16.5/7.5
	IP66 Type(EMC)		19.4/8.8	19.6/8.9	21.2/9.6	21.6/9.8	27.3/12.4	27.3/12.4
	IP66 Type(Non-EMC)		19.0/8.6	19.2/8.7	20.7/9.4	21.2/9.6	26.9/12.2	26.9/12.2

- The standard motor capacity is based on a standard 4-pole motor.
- The standard used for 200 V inverters is based on a 220 V supply voltage, and for 400V inverters is based on a 440 V supply voltage.
- The rated output current is limited, based on the carrier frequency set at Cn.04.
- IP66 models do not support normal load operation.



## Note

### Precautions for 1-phase input to 3-phase drive

- Please connect single-phase input to R(L1) and T(L3).
- AC or DC reactor is necessary to reduce DC ripple. Please select built-in reactor type for 30-75kW. For 0.4-22kW, external AC or DC reactor should be installed.
- Same peripheral devices (including a fuse and reactor) as 3-phase can be used for 1-phase as well.
- If phase open trip occurs, please turn off the input phase open protection(PR-05).
- Protection for output current like OCT or IOLT is based on 3-phase input ratings which is larger than single-phase input. User should set the parameters that are relative to motor information(bA-11~16), overload trip(Pr-17~22) and E-thermal functions(Pr-40~43)
- Performance of sensorless control could be unstable depending on DC ripple.
- The minimum input voltage must be larger than 228Vac for 240Vac supply and 456Vac for 480Vac supply to ensure motor voltage production of 207Vac and 415Vac, respectively.
- To minimize the effect of voltage deprivation, please choose 208Vac motor for 240Vac supply and 400Vac motor for 480Vac supply.

## 7.1.2 30-75kW Models

### 3-Phase 400 V (30–75 kW)

Model □□□□S100–4□□□		0300	0370	0450	0550	0750	
Applied motor	HP	40	50	60	75	100	
	kW	30	37	45	55	75	
Rated output	Rated capacity (kVA)	Heavy load	46	57	69	84	116
		Normal load	55	67	78	106	126
	Rated current [3-Phase input] (A)	Heavy load	61	75	91	110	152
		Normal load	75	91	107	142	169
	Rated current [Single-Phase input] (A)	Heavy load	32	39	47	57	78
		Normal load	39	47	55	73	87
	Output frequency		0-400 Hz (IM Sensorless: 0-120 Hz)				
	Output voltage (V)		3-phase 380-480 V				
Rated input	Working voltage (V)		3-phase 380-480 VAC (-15% to +10%) Single phase 480VAC(-5% to +10%)				
	Input frequency		50-60 Hz (±5%) (In case of single phase input, input frequency is only 60Hz(±5%).)				
	Rated current (A)	Heavy load	56	69	85	103	143
		Normal load	69	85	100	134	160
Weight (lb/kg)	EMC Filter Type		57/26	77/35	77/35	-	-
	Non-EMC Filter Type		55/25	75/34	75/34	95/43	95/43

- 30-75kW models do not support IP66 certification.
- The 55-75 kW inverters do not have built-in EMC since they satisfy EMC standards even without it.

## 7.2 Product Specification Details

Items		Description		
Control	Control method	V/F control, slip compensation, sensorless vector		
	Frequency settings power resolution	Digital command: 0.01 Hz Analog command: 0.06 Hz (60 Hz standard)		
	Frequency accuracy	1% of maximum output frequency		
	V/F pattern	Linear, square reduction, user V/F		
	Overload capacity	Heavy load rated current: 150% 1 min, normal load rated current: 120% 1 min		
	Torque boost	Manual torque boost, automatic torque boost		
Operation	Operation type	Select key pad, terminal strip, or communication operation		
	Frequency settings	Analog type: -10~10V, 0~10V, 4~20mA Digital type: key pad, pulse train input		
	Operation function	<ul style="list-style-type: none"> <li>• PID control</li> <li>• 3-wire operation</li> <li>• Frequency limit</li> <li>• Second function</li> <li>• Anti-forward and reverse direction rotation</li> <li>• Commercial transition</li> <li>• Speed search</li> <li>• Power braking</li> <li>• Leakage reduction</li> </ul>	<ul style="list-style-type: none"> <li>• Up-down operation</li> <li>• DC braking</li> <li>• Frequency jump</li> <li>• Slip compensation</li> <li>• Automatic restart</li> <li>• Automatic tuning</li> <li>• Energy buffering</li> <li>• Flux braking</li> <li>• Fire Mode</li> </ul>	
	Input	Multi function terminal (7EA) P1-P7	Select PNP (Source) or NPN (Sink) mode. Functions can be set according to In.65- In.71 codes and parameter settings. (Standard I/O is only provided for P5.)	
			<ul style="list-style-type: none"> <li>• Forward direction operation</li> <li>• Reset</li> <li>• Emergency stop</li> <li>• Multi step speed frequency-high/med/low</li> <li>• DC braking during stop</li> <li>• Frequency increase</li> <li>• 3-wire</li> <li>• Local/remote operation mode transition</li> <li>• Select acc/dec/stop</li> </ul>	<ul style="list-style-type: none"> <li>• Reverse direction operation</li> <li>• External trip</li> <li>• Jog operation</li> <li>• Multi step acc/dec-high/med/low</li> <li>• Second motor selection</li> <li>• Frequency reduction</li> <li>• Fix analog command frequency</li> <li>• Transition from PID to general operation</li> </ul>
		Pulse train	0-32 kHz, Low Level: 0-2.5V, High Level: 3.5-12V	
	Output	Multi function	Fault output and inverter operation status output	Less than DC 24V, 50mA

Items		Description	
	open collector terminal		Less than (N.O., N.C.) AC250V 1A, Less than DC 30V, 1A
	Multi function relay terminal		
	Analog output, Analog output 1	0-12Vdc (0-24mA): Select frequency, output current, output voltage, DC terminal voltage and others	
	Analog output 2	0-12Vdc: Select frequency, output current, output voltage, DC terminal voltage and others	
	Pulse train	Maximum 32 kHz, 10-12V	
Protection function	Trip	<ul style="list-style-type: none"> <li>• Over current trip</li> <li>• External signal trip</li> <li>• ARM short circuit current trip</li> <li>• Over heat trip</li> <li>• Input imaging trip</li> <li>• Ground trip</li> <li>• Motor over heat trip</li> <li>• I/O board link trip</li> <li>• No motor trip</li> <li>• Parameter writing trip</li> <li>• Emergency stop trip</li> <li>• Command loss trip</li> <li>• External memory error</li> <li>• CPU watchdog trip</li> <li>• Motor normal load trip</li> </ul>	<ul style="list-style-type: none"> <li>• Over voltage trip</li> <li>• Temperature sensor trip</li> <li>• Inverter over heat</li> <li>• Option trip</li> <li>• Output imaging trip</li> <li>• Inverter overload trip</li> <li>• Fan trip</li> <li>• Pre-PID operation failure</li> <li>• External brake trip</li> <li>• Low voltage trip during operation</li> <li>• Low voltage trip</li> <li>• Safety A(B) trip</li> <li>• Analog input error</li> <li>• Motor overload trip</li> </ul>
	Alarm	Command loss trip alarm, overload alarm, normal load alarm, inverter overload alarm, fan operation alarm, resistance braking rate alarm, number of corrections on rotor tuning error	
	Instantaneous blackout	Heavy load less than 15 ms (normal load less than 8 ms): continue operation (must be within the rated input voltage and rated output range) Heavy load more than 15 ms (normal load more than 8 ms ): auto restart operation	
Structure/ working environment	Cooling type	Forced fan cooling structure (excluding some models)	
	Protection structure	<ul style="list-style-type: none"> <li>• IP 20 , UL Open Type (UL Enclosed Type 1 is satisfied by conduit installation</li> </ul>	

Items	Description
	option.) • IP66(NEMA 4X Indoor Only)
Input Mode	• 0.4-22kW: Keypad (LCD loader: Installation available but sold separately.) • 30-75kW: LCD loader
Ambient temperature	Heavy load: -10-50°C (14-122°F), normal load: -10-40°C (14-104°F) No ice or frost should be present. Working under normal load at 50°C (122°F), it is recommended that less than 80% load is applied.
Ambient humidity	Relative humidity less than 90% RH (to avoid condensation forming)
Storage temperature.	-20°C-65°C (-4-149°F)
Surrounding environment	Prevent contact with corrosive gases, inflammable gases, oil stains, dust, and other pollutants (Pollution Degree 3 Environment).
Operation altitude / Vibration	Maximum 1000m above sea level for standard operation. From 1000 to 4000m, the rated input voltage and rated output current of the drive must be derated by 1% for every 100m. / less than 1G (9.8m/sec <sup>2</sup> )
Pressure	70-106 kPa

\* , \*\* IP66 models do not support normal load operation.

## 7.3 External Dimensions

### 7.3.1 0.4-22kW Models

0.4 kW (Single Phase), 0.4-0.8 kW (3-Phase)

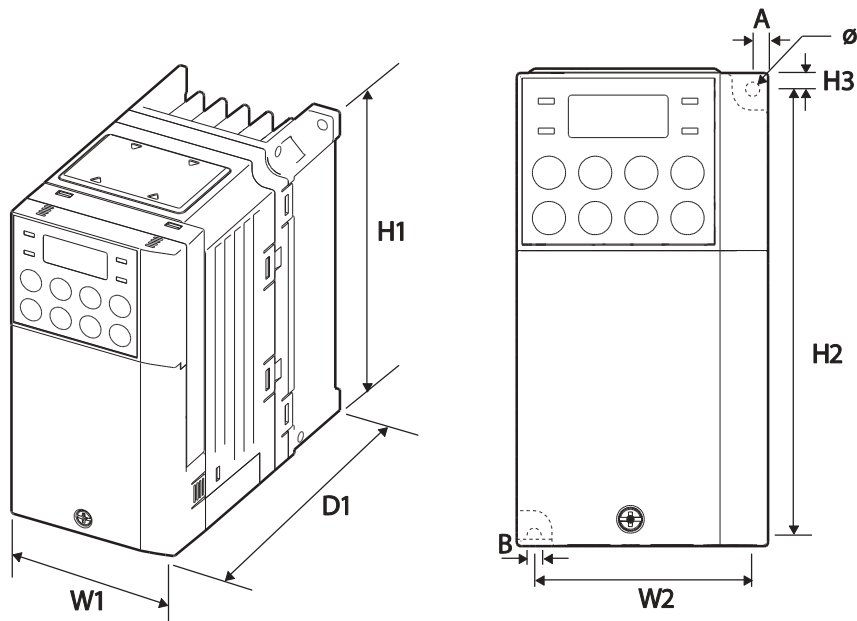

0.8kW-1.5kW(Single Phase 200V), 1.5kW-2.2kW(3-Phase 400V) EMC filter Type

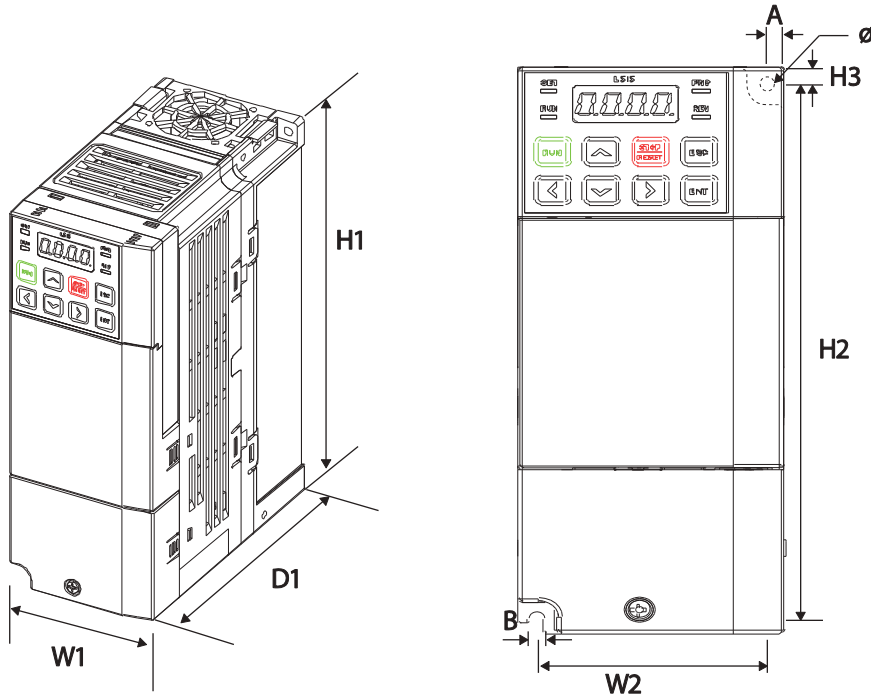

Items	W1	W2	H1	H2	H3	D1	A	B	Φ
0004S100-1, 0008S100-2, 0008S100-4	68 (2.68)	61.1 (2.41)	128 (5.04)	119 (4.69)	5 (0.20)	128 (5.04)	3.5 (0.14)	4 (0.16)	4 (0.16)
0004S100-2, 0004S100-4	68 (2.68)	61.1 (2.41)	128 (5.04)	119 (4.69)	5 (0.20)	123 (4.84)	3.5 (0.14)	4 (0.16)	4.2 (0.17)
004S100-1, 004S100-4, 008S100-4 EMC Type	68 (2.68)	63.5 (2.50)	180 (7.09)	170.5 (6.71)	5 (0.20)	130 (5.12)	4.5 (0.18)	4.5 (0.18)	4.2 (0.17)

Units: mm (inches)

**0.8-1.5 kW (Single Phase), 1.5-2.2 kW(3-Phase)**

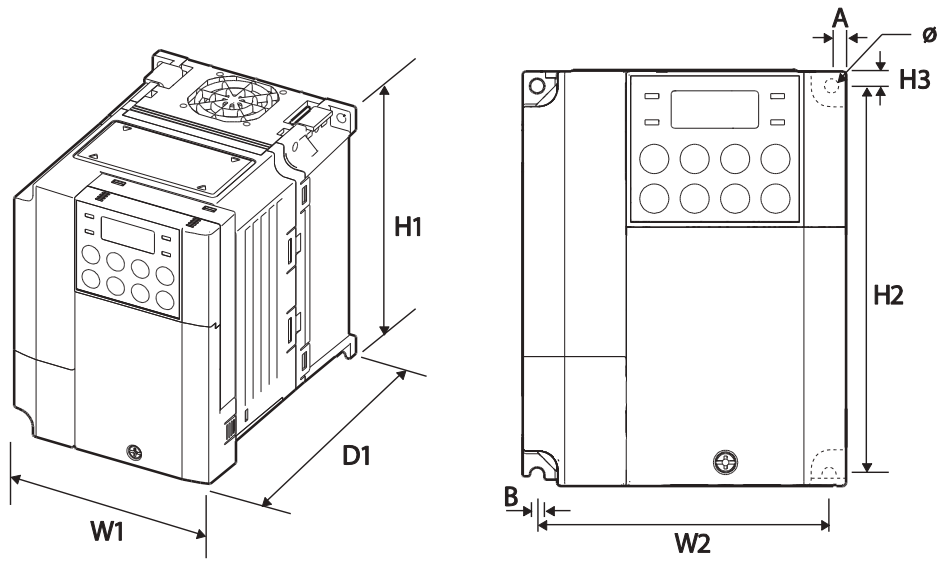

**0.8kW-1.5kW(Single Phase 200V), 1.5kW-2.2kW(3-Phase 400V) EMC filter Type**

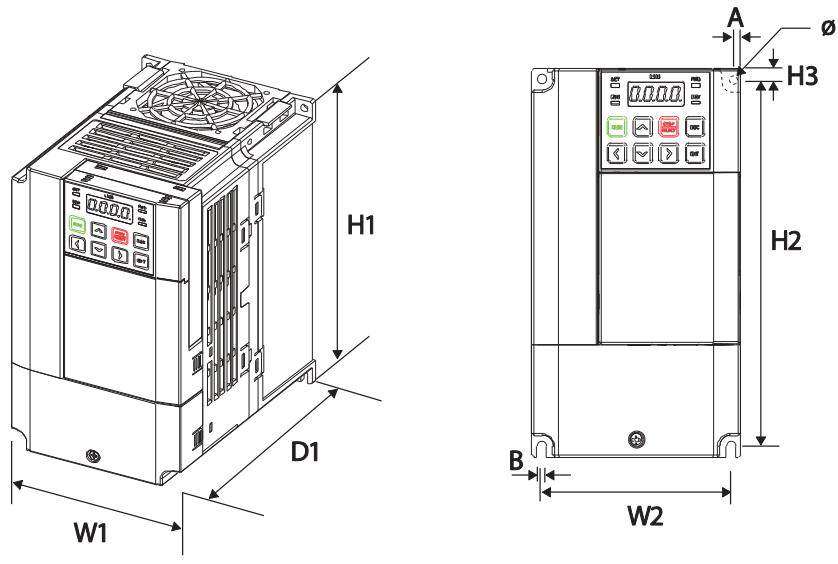



Items	W1	W2	H1	H2	H3	D1	A	B	Φ
0008S100-1, 0015S100-2, 0015S100-4	100 (3.94)	91 (3.58)	128 (5.04)	120 (4.72)	4.5 (0.18)	130 (5.12)	4.5 (0.18)	4.5 (0.18)	4.5 (0.18)
0015S100-1, 0022S100-2, 0022S100-4	100 (3.94)	91 (3.58)	128 (5.04)	120 (4.72)	4.5 (0.18)	145 (5.71)	4.5 (0.18)	4.5 (0.18)	4.5 (0.18)
0008S100-1, 0015S100-1, 0015S100-4, 0022S100-4 EMC Type	100 (3.94)	91 (3.58)	180 (7.09)	170 (6.69)	5 (0.20)	140 (5.51)	4.5 (0.18)	4.5 (0.18)	4.2 (0.17)

Units: mm (inches)

### 2.2 kW (Single Phase), 3.7-4.0 kW (3 Phase)

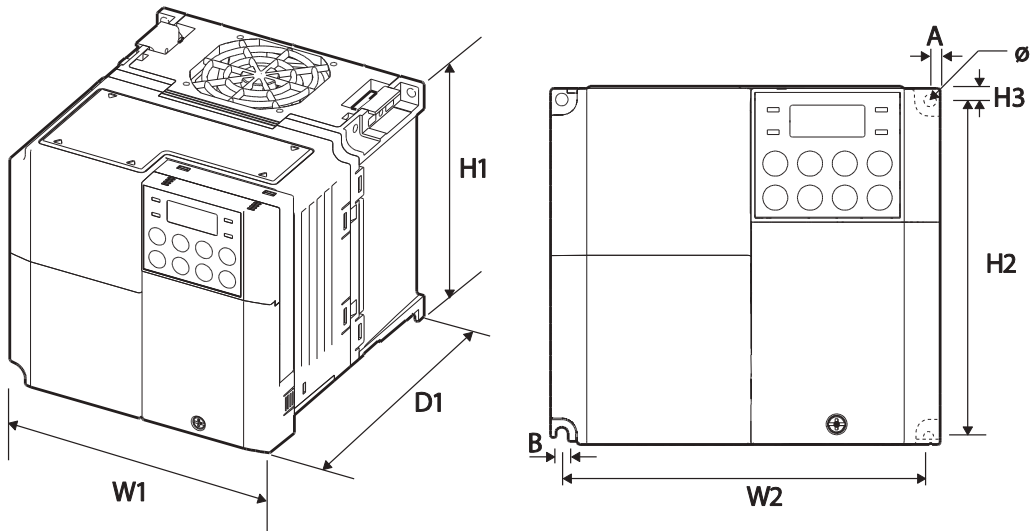

## 2.2kW(Single Phase 200V), 3.7-4.0kW(3-Phase 400V) EMC filter Type

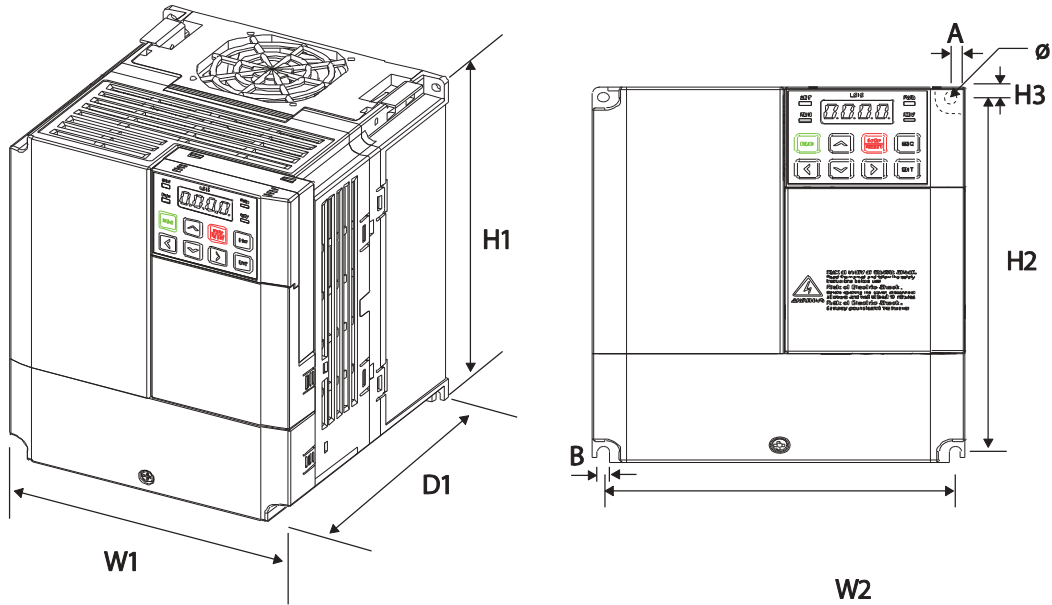

Items	W1	W2	H1	H2	H3	D1	A	B	Φ
0022S100-1 0037S100-2 0040S100-2 0037S100-4 0040S100-4	140 (5.51)	132.2 (5.20)	128 (5.04)	120.7 (4.75)	3.7 (0.15)	145 (5.71)	3.9 (0.15)	4.4 (0.17)	4.5 (0.18)
0022S100-1, 0037S100-4, 0040S100-4 EMC Type	140 (5.51)	132 (5.20)	180 (7.09)	170 (6.69)	5 (0.20)	140 (5.51)	4 (0.16)	4 (0.16)	4.2 (0.17)

Units: mm (inches)

### 5.5-22 kW (3-Phase)

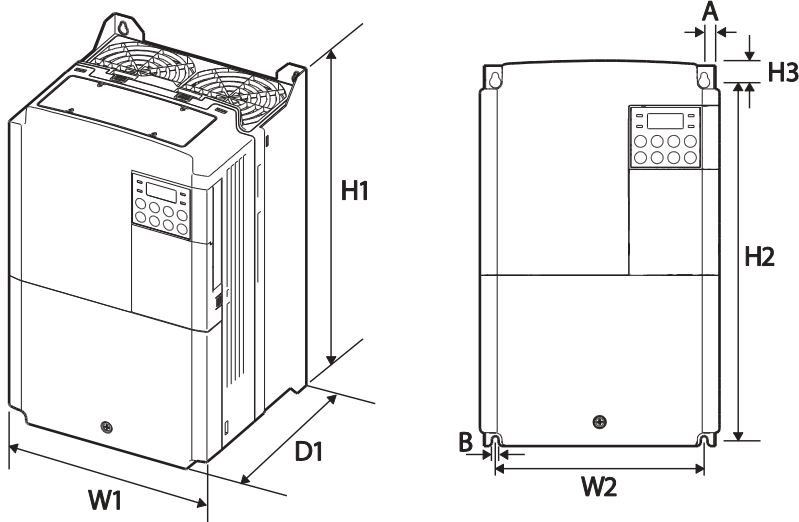

	Items	W1	W2	H1	H2	H3	D1	A	B	Φ
3-phase 200V	0055S100-2	160	137	232	216.5	10.5	140	5	5	-
	0075S100-2	(6.30)	(5.39)	(9.13)	(8.52)	(0.41)	(5.51)	(0.20)	(0.20)	-
	0110S100-2	180	157	290	273.7	11.3	163	5	5	-
	0150S100-2	(7.09)	(6.18)	(11.4)	(10.8)	(0.44)	(6.42)	(0.20)	(0.20)	-
3-phase 400V	0150S100-2	220	193.8	350	331	13	187	6	6	-
		(8.66)	(7.63)	(13.8)	(13.0)	(0.51)	(7.36)	(0.24)	(0.24)	-
	0055S100-4	160	137	232	216.5	10.5	140	5	5	-
	0075S100-4	(6.30)	(5.39)	(9.13)	(8.52)	(0.41)	(5.51)	(0.20)	(0.20)	-
	0110S100-4	180	157	290	273.7	11.3	163	5	5	-
	0150S100-4	(7.09)	(6.18)	(11.4)	(10.8)	(0.44)	(6.42)	(0.20)	(0.20)	-
	0185S100-4	220	193.8	350	331	13	187	6	6	-
	0220S100-4	(8.66)	(7.63)	(13.8)	(13.0)	(0.51)	(7.36)	(0.24)	(0.24)	-

Units: mm (inches)

### 7.3.2 30-75kW Models

#### 30 kW (3-Phase)

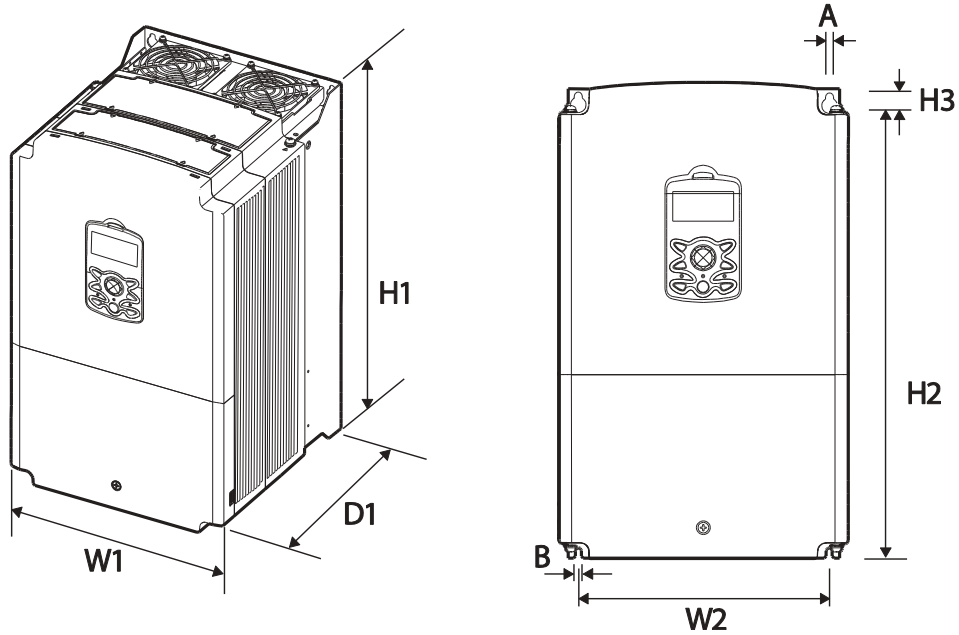

#### 37-45 kW (3-Phase)

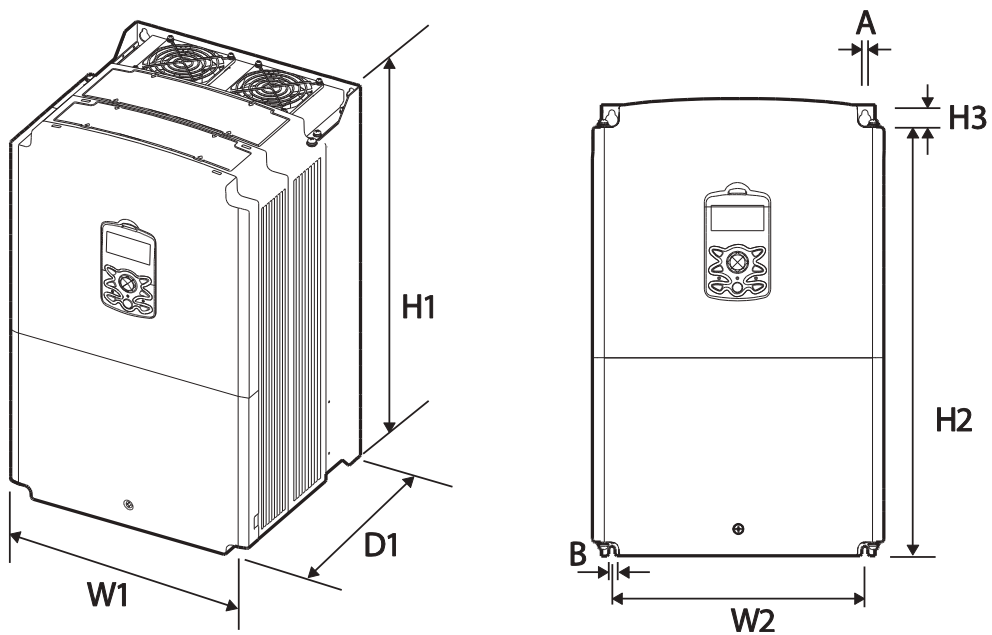

55–75 kW (3-Phase)

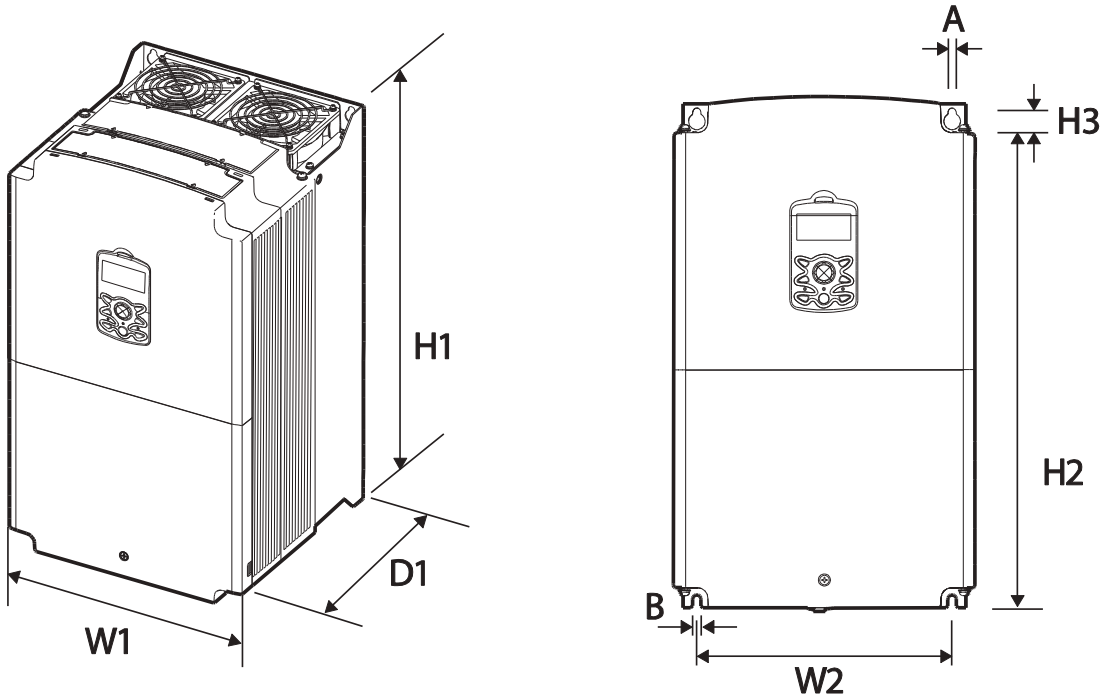

Items	W1	W2	H1	H2	H3	D1	A	B
0300S100-4	275 (10.8)	232	450 (17.7)	428.5	14	284 (11.2)	7 (0.28)	7 (0.28)
0370S100-4 0450S100-4	325 (12.8)	282	510 (20.1)	486.5	16			
0550S100-4 0750S100-4		275	550 (21.7)	524.5		309 (12.2)	9	9

Units: mm (inches)

### 7.3.3 IP66 Models

#### 0.4-4.0kW – NP (Non PDS) type

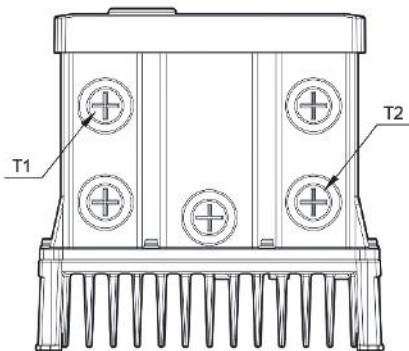
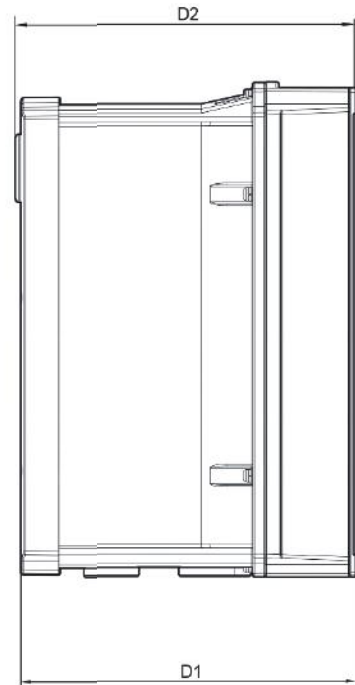
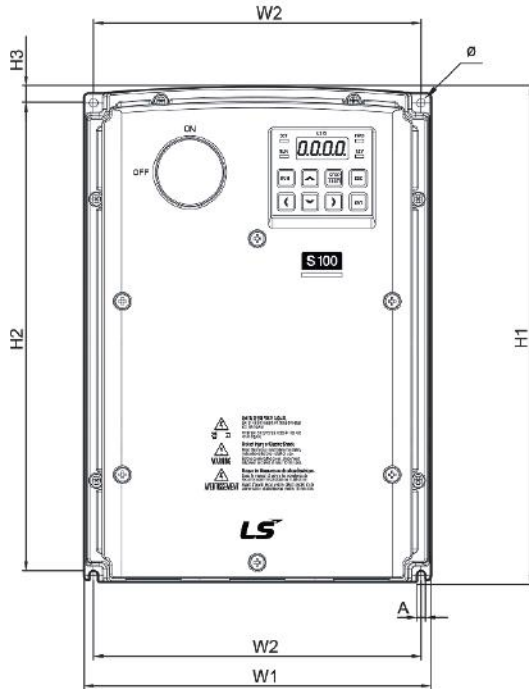

### 0.4-4.0kW –PDS type

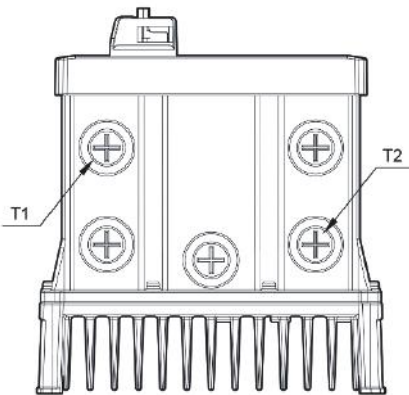
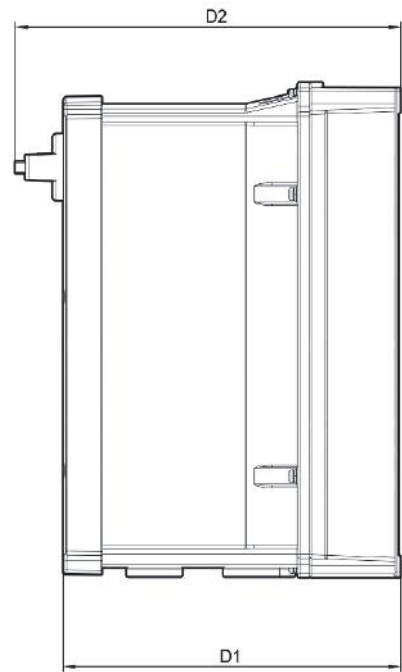
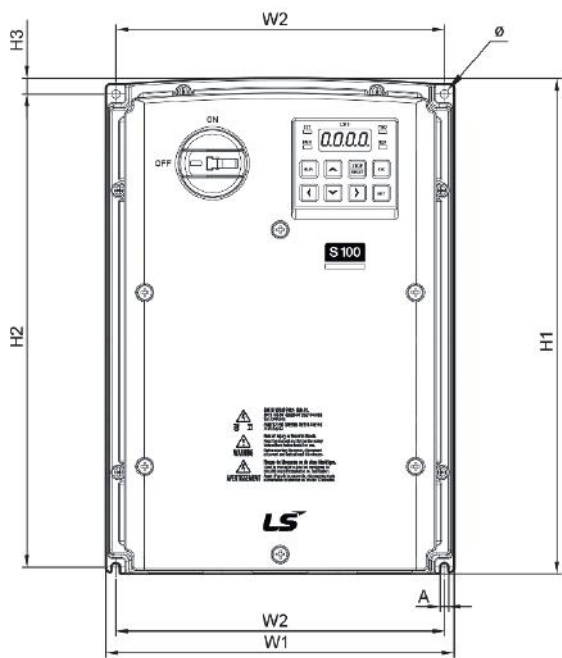

Items	W1	W2	H1	H2	H3	D1	D2	A	Φ	T1	T2
0004S100-1	180 (7.09)	170 (6.69)	256.6 (1010)	245 (9.65)	8.2 (0.32)	174.1 (6.85)	Non-PDS : 177.1 (6.97) PDS : 188.2 (7.41)	4.5 (0.18)	4.5 (0.18)	22.3 (0.88)	-
0004S100-2											
0008S100-2											
0004S100-4											
0008S100-4											
0008S100-1	220 (8.66)	204 (8.03)	258.8 (10.19)	241 (9.49)	11.8 (0.46)	201 (7.91)	Non-PDS : 204 (8.03) PDS : 215 (8.46)	5.5 (0.22)	5.5 (0.22)	22.3 (0.88)	28.6 (1.13)
0015S100-1											
0022S100-1											
0015S100-2											
0022S100-2											
0037S100-2											
0040S100-2											
0015S100-4											
0022S100-4											
0037S100-4											
0040S100-4											

Units: mm (inches)



### 5.5-7.5kW – NP (Non PDS) type

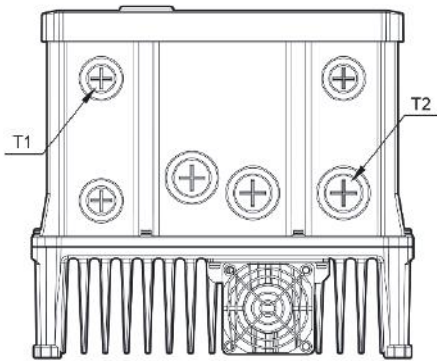
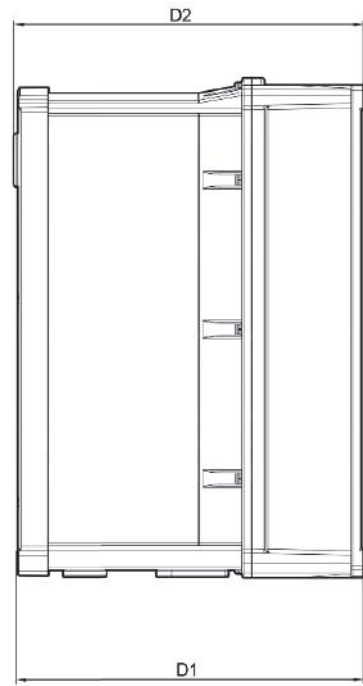
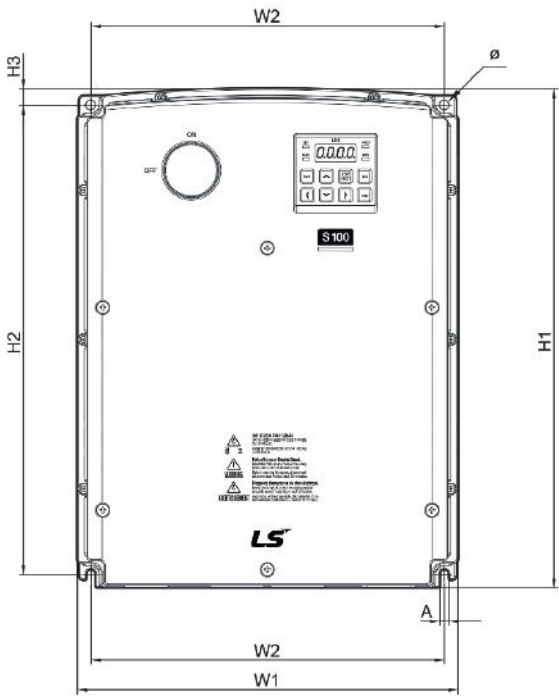

### 5.5-7.5kW – PDS type

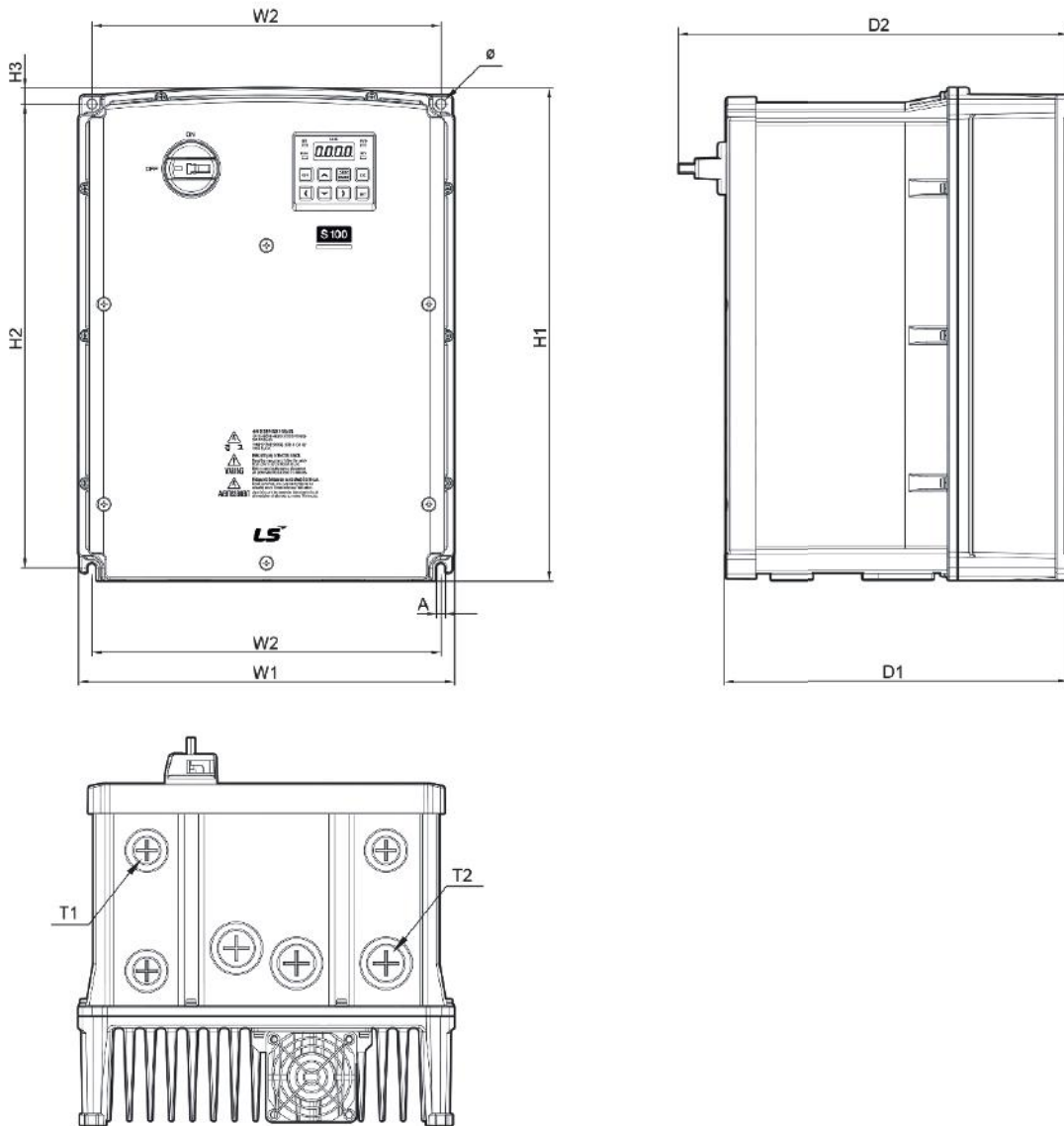

Items	W1	W2	H1	H2	H3	D1	D2	A	Φ	T1	T2
0055S100-2	250 (9.84)	232 (9.13)	328 (12.91)	308 (12.13)	11 (0.43)	227.2 (8.94)	Non-PDS :	6 (0.24)	6 (0.24)	22.3 (0.88)	28.6 (1.13)
0075S100-2							230.1 (9.06)				
0055S100-4							PDS:				
0075S100-4							241.2 (9.50)				

Units: mm (inches)

### 11.0-22.0kW – NP (Non PDS) type

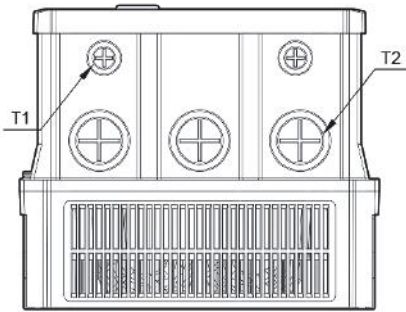
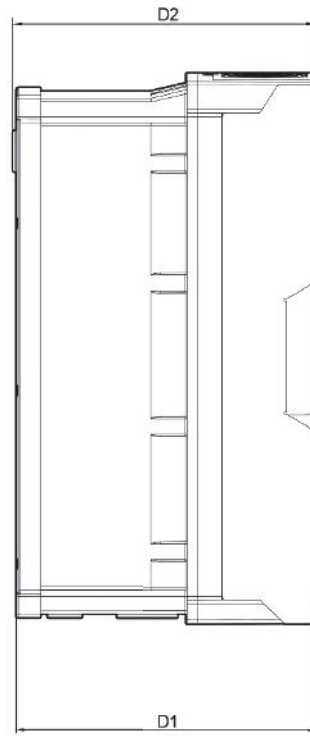
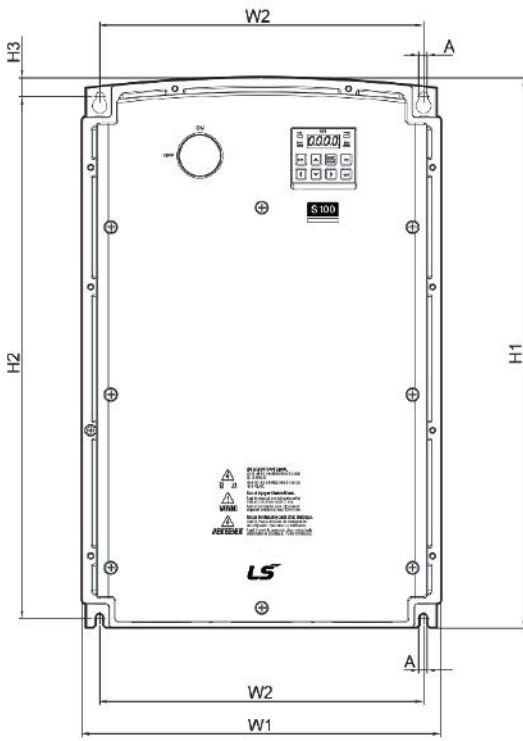

### 11.0-22.0kW –PDS type

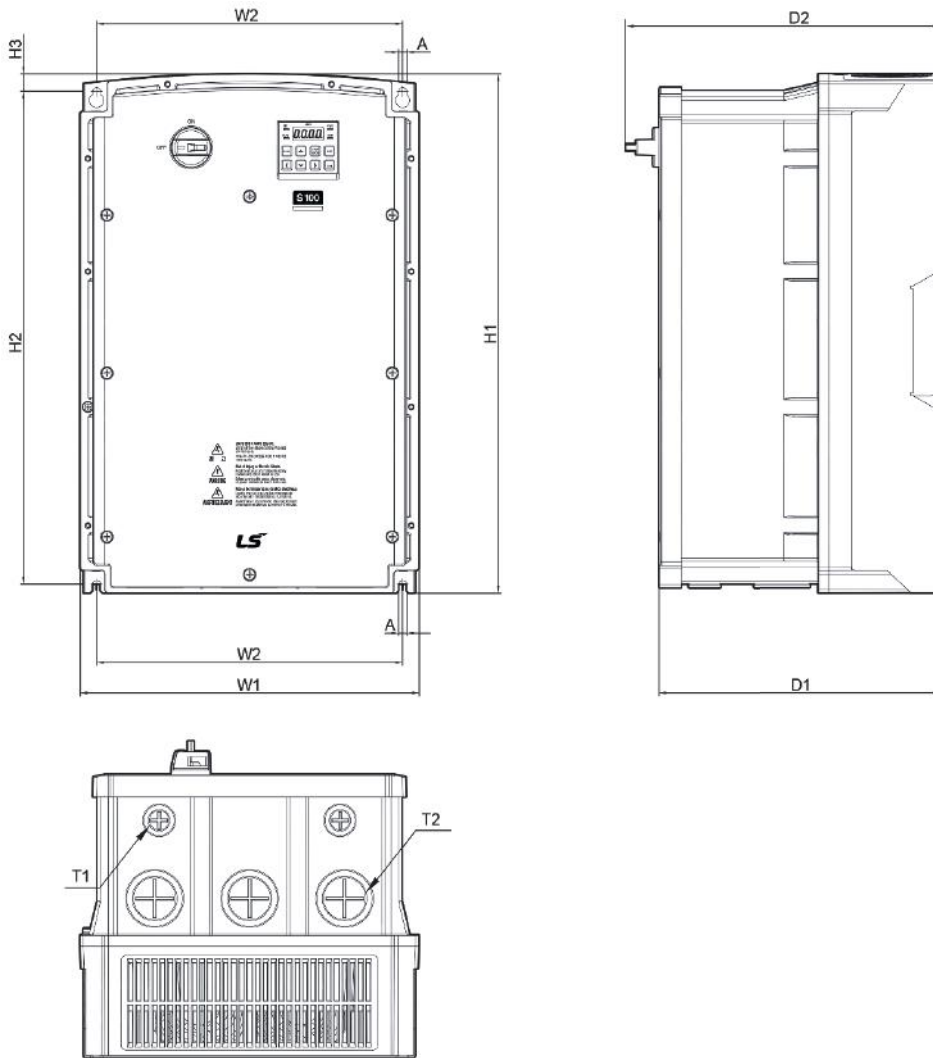

Items	W1	W2	H1	H2	H3	D1	D2	A	T1	T2
0110S100-2	260 (10.24)	229.2 (9.02)	399.6 (15.73)	377 (14.84)	14.6 (0.57)	245.4 (9.66)	Non-PDS :	6.5 (0.26)	22.3 (0.88)	34.9 (1.37)
0150S100-2							248.5 (9.78)			
0110S100-4							PDS :			
0150S100-4							259.6 (10.22)			
0185S100-4	300 (11.81)	270.8 (10.66)	460 (18.11)	436.5 (17.19)	15.5 (0.61)	250 (9.84)	Non-PDS :	7 (0.28)	22.3 (0.88)	44.5 (1.75)
0220S100-4							253.1 (9.96) PDS : 264 (10.39)			

Units: mm (inches)

## 7.4 Peripheral Devices

### 7.4.1 0.4-22kW Models

**Compatible Circuit Breaker, Leakage Breaker and Magnetic Contactor Models  
(manufactured by LS ELECTRIC)**

Product (kW)	Circuit Breaker				Leakage Breaker		Magnetic Contactor		
	Model	Current (A)	Model	Current (A)	Model	Current (A)	Model	Current (A)	
Single phase 200V	0.4	ABS33c	UTE100	5	EBS33c	5	MC-6a	9	
	0.75			10		10	MC-9a, MC-9B	11	
	1.5			15		15	MC-18a, MC-18B	18	
	2.2			20		20	MC-22b	22	
3- phase 200V	0.4	ABS33c	UTE100	5	EBS33c	5	MC-6a	9	
	0.75			10		10	MC-9a, MC-9b	11	
	1.5			15		15	MC-18a, MC-18b	18	
	2.2			20		20	MC-22b	22	
	3.7			30		30	MC-32a	32	
	4								
	5.5	ABS53c	50	50	EBS53c	50	MC-50a	55	
	7.5	ABS63c	60	60	EBS63c	60	MC-65a	65	
	11	ABS103c	100	90	EBS103c	100	MC-85a	85	
15	125		UTS150	125		125	MC-130a	130	
3- phase 400V	0.4	ABS33c	UTE100	3	EBS33c	5	MC-6a	7	
	0.75			5		MC-6a			
	1.5			10		10	10	MC-9a, MC-9b	9
	2.2							MC-12a, MC-12b	
	3.7			15		20	15	MC-18a, MC-18b	18
	4			20					
	5.5			30		30	30	MC-22b	22
	7.5							MC-32a	
11	ABS53c	50	50	EBS53c	50	MC-50a	50		

Product		Circuit Breaker			Leakage Breaker		Magnetic Contactor		
	15	ABS63c	60		60	EBS63c	60	MC-65a	65
	18.5	ABS103c	75		80	EBS103c	75	MC-75a	75
	22		100		90		100	MC-85a	85

## 7.4.2 30-75kW Models

Compatible Circuit Breaker, Leakage Breaker and Magnetic Contactor Models  
(manufactured by LS ELECTRIC)

Product(kW)	Circuit Breaker				Leakage Breaker		Magnetic Contactor	
	Model	Current (A)	Model	Current (A)	Model	Current (A)	Model	Current (A)
30 kW-4	ABS103c	125	UTS150	125	EBS103c	125	MC-100a	105
37 kW-4	ABS203c	150		150	EBS203c	150	MC-130a	130
45 kW-4		175	UTS250	175		175	MC-150a	150
55 kW-4		225		225		225	225	MC-185a
75 kW-4	ABS403c	300	UTS400	300	EBS403c	300	MC-225a	225

## 7.5 Fuse and Reactor Specifications

### 7.5.1 0.4-22kW Models

Product (kW)		AC Input Fuse		AC Reactor		DC Reactor				
		Current (A)	Voltage (V)	Inductance (mH)	Current(A)	Inductance (mH)	Current (A)			
Single phase 200V	0.4	10	600	1.20	10	4	8.67			
	0.75									
	1.5	15			0.88			14	3	13.05
	2.2	20			0.56			20	1.3	18.45

Product (kW)		AC Input Fuse		AC Reactor		DC Reactor	
3-phase 200V	0.4	10		1.20	10	4	8.67
	0.75			0.88	14	3	13.05
	1.5	15		0.56	20	1.33	18.45
	2.2	20		0.39	30		26.35
	3.7	32		0.30	34	1.60	32
	4	50		0.22	45	1.25	43
	5.5	50		0.16	64	0.95	61
	7.5	63		0.13	79	0.70	75
	11	80		4.81	4.8	16	4.27
	15	100		3.23	7.5	12	6.41
3-phase 400V	0.4	10		2.34	10	8	8.9
	0.75			1.22	15	5.4	13.2
	1.5			1.12	19	3.20	17
	2.2	15		0.78	27	2.50	25
	3.7	20		0.59	35	1.90	32
	4	32		0.46	44	1.40	41
	5.5			1.12	19	3.20	17
	7.5	35		0.40	52	1.00	49
	11	50		0.30	68	0.70	64
	15	63					
	18.5	70					
	22	100					

## 7.5.2 30-75kW Models

Product (kW)	AC Input Fuse		AC Reactor	
	Current (A)	Voltage (V)	Inductance(mH)	Current(A)
30 kW-4	125 A	600	0.29	69
37 kW-4			0.24	85
45 kW-4	160 A		0.20	100
55 kW-4	200 A		0.15	134
75 kW-4			0.13	160

### ⚠ Caution

Only use Class H or RK5, UL listed input fuses and UL listed circuit breakers. See the table above for the voltage and current ratings for fuses and circuit breakers.

### ⚠ Attention

Utiliser UNIQUEMENT des fusibles d'entrée homologués de Classe H ou RK5 UL et des disjoncteurs UL. Se reporter au tableau ci-dessus pour la tension et le courant nominal des fusibles et des disjoncteurs.

## 7.6 Terminal Screw Specification

### 7.6.1 Input/Output Terminal Screw Specification

#### 7.6.1.1 0.4-22kW Models

Product (kW)		Terminal Screw Size	Screw Torque (Kgf·cm/Nm)
Single phase 200V	0.4	M3.5	8.2~10.2 / 0.8~1.0
	0.75		
	1.5		
	2.2	M4	12.2~14.3 / 1.2~1.4
3-phase 200V	0.4	M3.5	8.2~10.2 / 0.8~1.0
	0.75		
	1.5		
	2.2		
	3.7	M4	12.2~14.3 / 1.2~1.4
	4		
	5.5		
	7.5	M5	20.4~24.5 / 2.0~2.4
	11		
15			
3-phase 400V	0.4	M3.5	8.2~10.2 / 0.8~1.0
	0.75		
	1.5		
	2.2		
	3.7	M4	12.2~14.3 / 1.2~1.4



Product (kW)	Terminal Screw Size	Screw Torque (Kgf·cm/Nm)
4	M5	20.4~24.5 / 2.0~2.4
5.5		
7.5		
11		
15		
18.5		
22		

### 7.6.1.2 30-75kW Models

Product (kW)	Terminal Screw Size	Screw Torque (Kgf·cm/Nm)
30-75 kW	M8	56.1~67.3 / 5.5~6.6

## 7.6.2 Control Circuit Terminal Screw Specification

### 7.6.2.1 0.4-22kW Models

Terminal	Terminal Screw Size	Screw Torque (Kgf·cm/Nm)
P1-P7/ CM/VR/V1/I2/AO/Q1/EG/24/TI /TO/ SA,SB,SC/S+,S-,SG	M2	2.2-2.5/0.22-0.25
A1/B1/C1	M2.6	4.0/0.4

\* Standard I/O doesn't support P6/P7/TI/TO terminal. Refer to [Step 4 Control Terminal Wiring](#) on page 39.

### 7.6.2.2 30-75kW Models

Terminal	Terminal Screw Size	Screw Torque (Kgf·cm/Nm)
P1~P7/CM/VR/V1/I2/AO1/AO 2/Q1/EG/24/TI/TO/SA,SB,SC/ S+,S-,SG/A1,B1,C1/A2,C2	M2.6	0.4

### ⚠ Caution

Apply the rated torque when tightening terminal screws. Loose screws may cause short circuits and malfunctions. Overtightening terminal screws may damage the terminals and cause short circuits and malfunctions. Use copper conductors only, rated at 600V, 75°C for power terminal wiring, and rated at 300V, 75°C for control terminal wiring.

### ⚠ Attention

Appliquer des couples de marche aux vis des bornes. Des vis desserrées peuvent provoquer des courts-circuits et des dysfonctionnements. Ne pas trop serrer la vis, car cela risque d'endommager les bornes et de provoquer des courts-circuits et des dysfonctionnements. Utiliser uniquement des fils de cuivre avec une valeur nominale de 600 V, 75 °C pour le câblage de la borne d'alimentation, et une valeur nominale de 300 V, 75 °C pour le câblage de la borne de commande.

## 7.7 Dynamic Braking Unit(DBU) and Resistors

### 7.7.1 Braking Resistor Specification (0.4-22kW)

Product (kW)		Resistance ( $\Omega$ )	Rated Capacity (W)
Single phase 200V	0.4	300	100
	0.75	150	150
	1.5	60	300
	2.2	50	400
3-phase 200V	0.4	300	100
	0.75	150	150
	1.5	60	300
	2.2	50	400
	3.7	33	600
	4	33	600
	5.5	20	800
	7.5	15	1,200
	11	10	2,400
15	8	2,400	
3-phase 400V	0.4	1,200	100
	0.75	600	150
	1.5	300	300
	2.2	200	400
	3.7	130	600
	4	130	600
	5.5	85	1,000
	7.5	60	1,200
	11	40	2,000
	15	30	2,400
	18.5	20	3,600
	22	20	3,600

- The standard for braking torque is 150% and the working rate (%ED) is 5%. If the working rate is 10%, the rated capacity for braking resistance must be calculated at twice the standard.

## 7.7.2 Dynamic Braking Unit (30-75kW)

UL form	Capacity of applied motor	Braking unit	Terminal arrangement & Dimensions
UL type (A type)	30-37kW	SV370DBU-4U	Refer to Group 1.
	45-55kW	SV550DBU-4U	
	75kW	SV750DBU-4U	
Non UL type (B type)	30-37kW	SV037DBH-4	Refer to Group 2.
	45-75kW	SV075DBH-4	Refer to Group 3.
		SV075DB-4	
Non UL type (C type)	30-37kW	LSLV0370DBU-4HN	Refer to Group 4.
		LSLV0370DBU-4LN	Refer to Group 5.
	45-75kW	LSLV0750DBU-4LN	

### Note

- It is not necessary to use option type dynamic braking unit for S100 below 22kW capacity because basically the dynamic braking unit is built in.
- You must refer to dynamic braking unit manual for usage recommended dynamic braking unit in the table above due to changeable table.

## 7.7.3 Terminal arrangement

Group 1:



Group 2:



Terminals	Functions
G	Ground Terminal
B2	Terminal for connection with B2 of DBU
B1	Terminal for connection with B1 of DBU
N	Terminal for connection with N of Inverter
P	Terminal for connection with P1 of Inverter

Group 3:

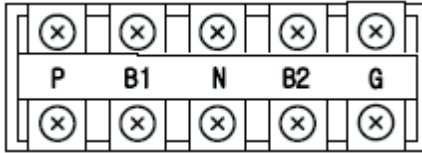

Terminals	Functions
G	Ground Terminal
B2	Terminal for connection with B2 of DBU
B1	Terminal for connection with B1 of DBU
N	Terminal for connection with N of Inverter
P	Terminal for connection with P1 of Inverter

Group 4,5:

P(+) N(-) B1 B2 N.C E

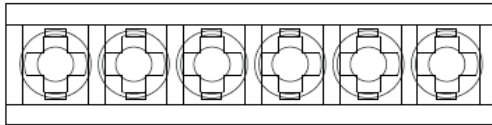

Terminals	Functions
P(+)	Terminal for connection with P of Inverter
N(-)	Terminal for connection with N of Inverter
B1	Terminal for connection with B1 of DBU
B2	Terminal for connection with B2 of DBU
N.C	Unused
E	Ground Terminal

#### Note

- You must refer to dynamic braking unit manual for choice the braking resistor to use the dynamic braking unit.
- For detailed information on DBU wiring, refer to 2.2 Cable Wiring, Step 7 Selecting the brake unit (30-75kW models only) on page 53.

## 7.7.4 Dynamic Braking Unit Dimensions

Group 1

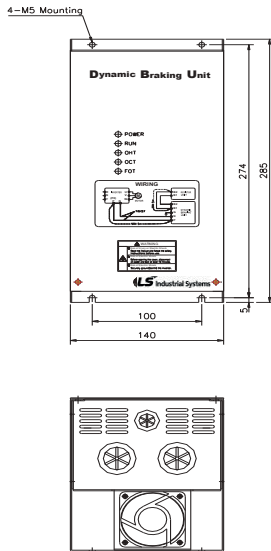

Group 2

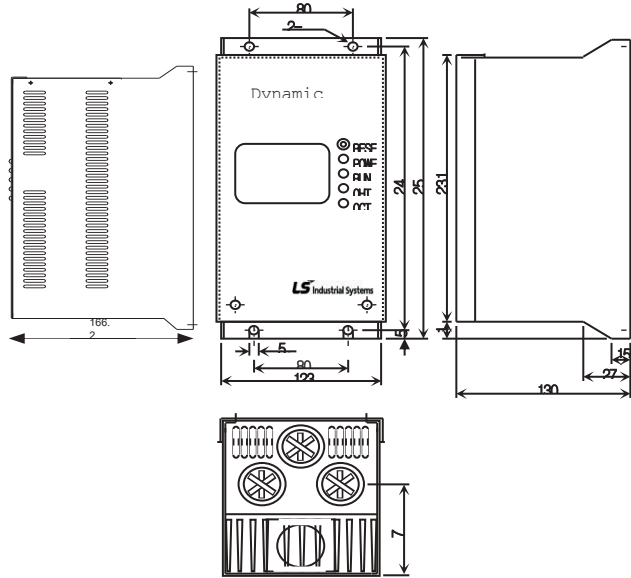

Group 3

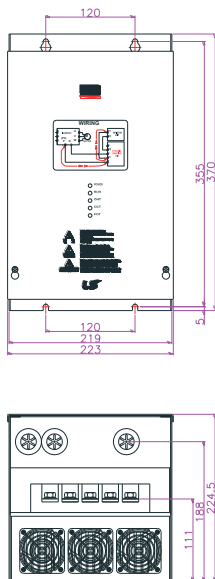

Group 5

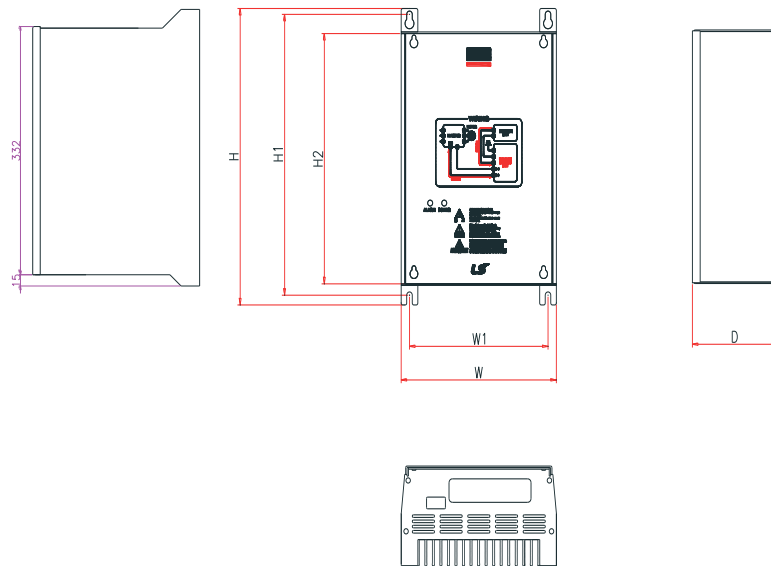

Voltage (V)	Capacity of applied motor(kW)	Dimension (mm)				Hole position for installation (mm)		Weight (kg)	Hole size for installation (φ)
		W	H	H2	D	W1	H1		
440	30~37	140	227.4	192	76.4	125	215.4	1.56	M4
	45~75							1.85	

Group 4

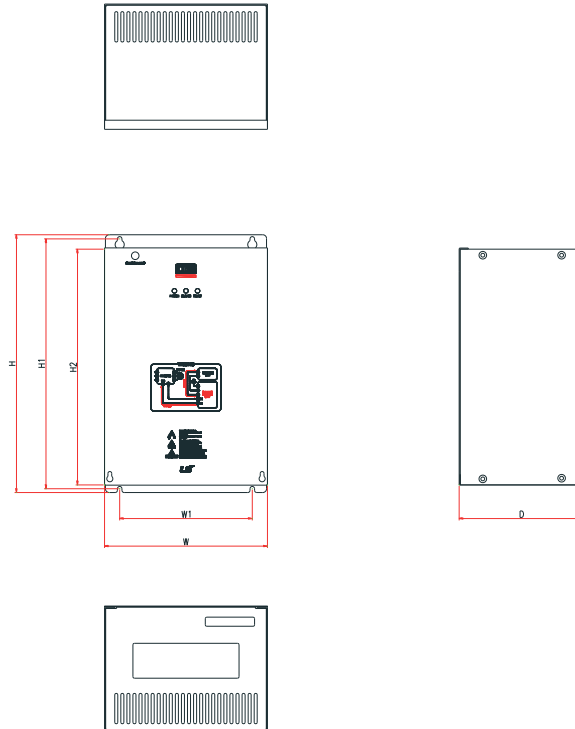

Voltage (V)	Capacity of applied motor(kW)	%ED	Dimension (mm)				Hole position for installation (mm)		Weight (kg)	Hole size for installation (φ)
			W	H	H2	D	W1	H1		
440	30~37	50	140	227.4	192	76.4	125	215.4	1.56	M4

## 7.7.5 Display Functions

DB Resistors connect with B1, B2 of DB Unit. DBU has 3 LEDs. Red LED which is located in middle displays supplying main power, one Green LED which is right side displays under braking and another green LED which is left side displays Over Heat Trip(OHT).

Displays	Function description
POWER (Red LED)	POWER LED is turned On when main power is supplied. Generally, POWER LED is turn On while main power supplied because DBU is connected with inverter.
RUN (Green LED)	RUN LED is turned off while DBU is ON by regenerative energy of Motor.
OHT (Green LED)	Under Braking, if the temperature is exceeded over setting value due to over heat of Heatsink, Cut the TURN ON signal of DBU and LED is turn on by working overheat protection function.

## 7.7.6 Dynamic Braking Unit Resistors

Product(kW)	DB Unit	Resistor( $\Omega$ )	Capacity(W)	Reference
30kW	SV370DBU-4U	16.9	6,400	100% braking torque, 10%ED
37kW	SV370DBU-4U	16.9	6,400	
45kW	SV550DBU-4U	11.4	9,600	
55kW	SV550DBU-4U	11.4	9,600	
75kW	SV750DBU-4U	8.4	12,800	

### Note

- The resistance/rated capacity/braking torque/%ED of DB Resistor are valid only for the DB unit of type A and the values of DB Resistor for type B and C refer to the manual of DB Unit..
- Rating Watt of DBU has to be doubled when %ED is doubled.



## 7.8 Continuous Rated Current Derating

### Carrier Frequency Setting Range and Default Values (by product capacity)

Refer to the following graphs for carrier frequency ranges and default values by product capacity.

Capacity	Heavy Duty					Normal Duty				
	Setting Range				Default Values	Setting Range				Default Values
	V/F		S/L			V/F		S/L		
	Min.	Max.	Min.	Max.		Min.	Max.	Min.	Max.	
0.4-4.0kW	2	15	2	15	3	2	5	2	5	2
5.5-22kW	1	15	2	15		1	5	2	5	
30-45kW	1	10	2	10		1	5	2	5	
55/75kW	1	7	2	7		1	3	2	3	

### Continuous Rated Current Derating by Carrier Frequency

The continuous rated current of the inverter is limited based on the carrier frequency. Refer to the following graph.

Continuous Rated Current Graph (0.4-22kW Heavy Duty)

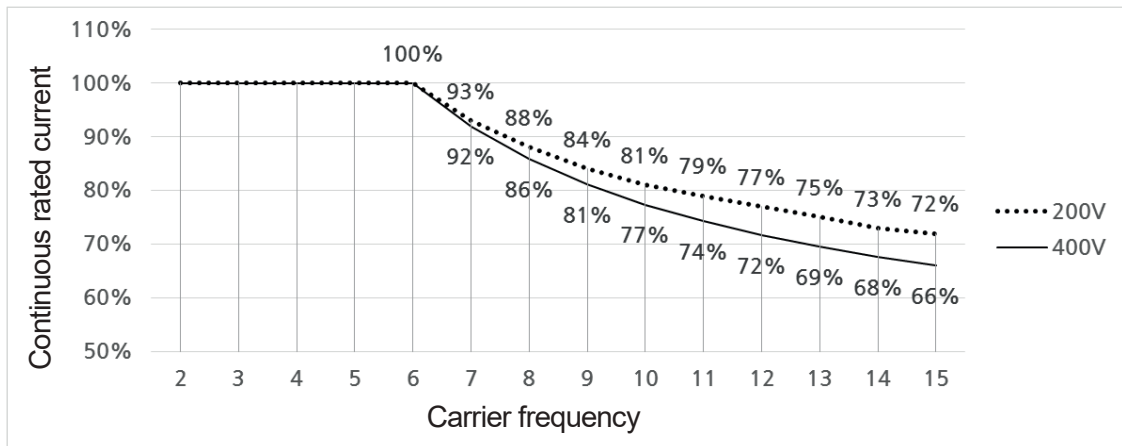

Continuous Rated Current Graph (30-75kW Heavy Duty)

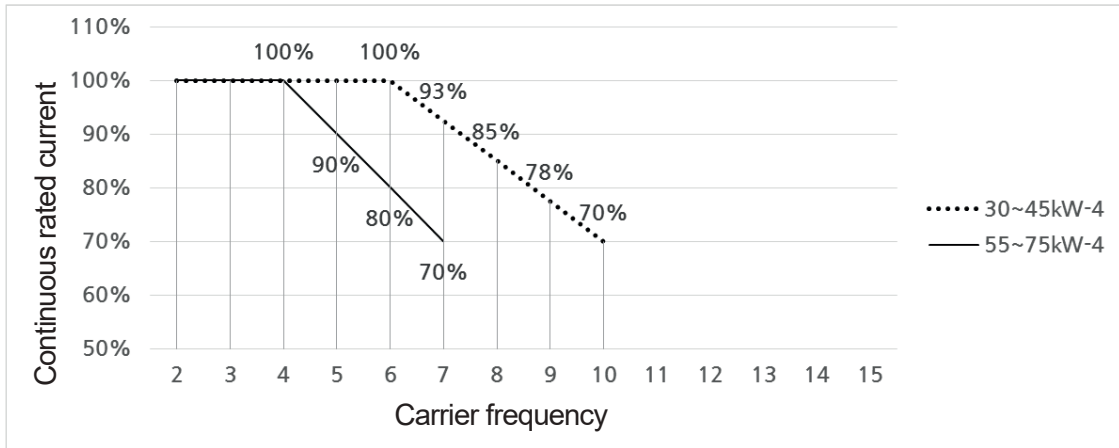

Continuous Rated Current Graph (0.4-75kW Normal Duty)

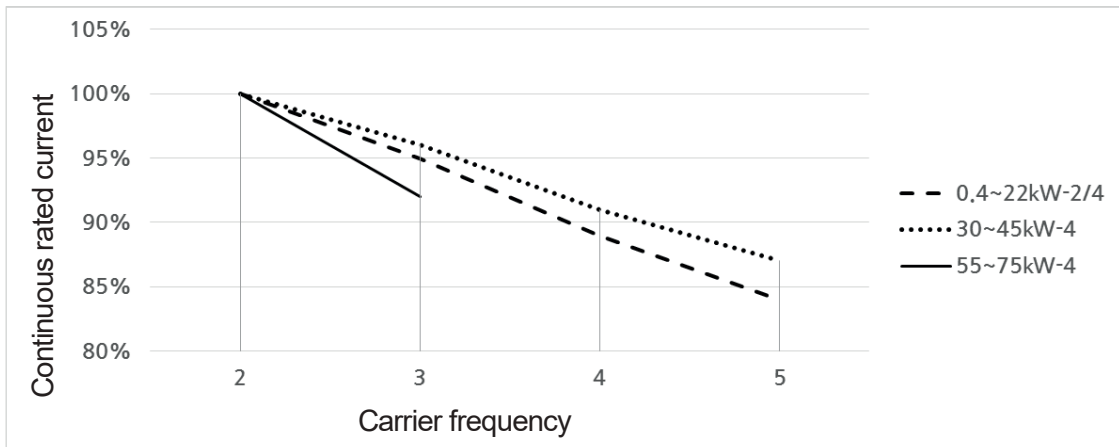

Capacity (kW)	DR (%)	Capacity (kW)	DR (%)	Capacity (kW)	DR (%)
0.4kW-2	85%	15kW-2	90%	11kW-4	85%
0.8kW-2	88%	0.4kW-4	74%	15kW-4	84%
1.5kW-2	88%	0.8kW-4	85%	18.5kW-4	92%
2.2kW-2	94%	1.5kW-4	84%	22kW-4	83%
3.7kW-2	92%	2.2kW-4	85%	30kW-4	86%
4.0kW-2	96%	3.7kW-4	85%	37kW-4	87%
5.5kW-2	85%	4.0kW-4	93%	45kW-4	89%
7.5kW-2	85%	5.5kW-4	81%	55kW-4	83%
11kW-2	87%	7.5kW-4	77%	75kW-4	92%

\* DR (%) includes maximum carrier frequency values by product capacity.

### Continuous Rated Current Derating by Input Voltage

The continuous rated current of the inverter is limited based on the input voltage. Refer to the following graph.

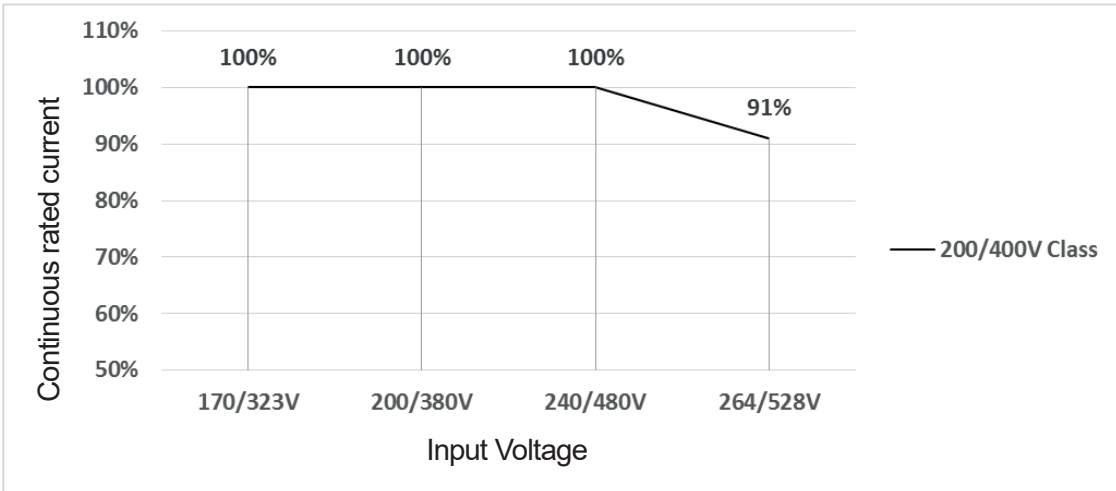

### Continuous Rated Current Derating by Ambient Temperature and Installation Type

The constant-rated current of the inverter is limited based on the ambient temperature and installation type. Refer to the following graph. A side-by-side operation is only available with 0.4-22kW IP20.

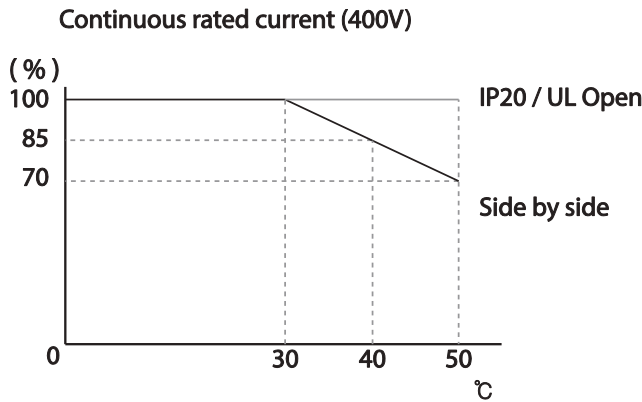

## 7.9 Heat Emission

The following graph shows the inverters' heat emission characteristics (by product capacity).

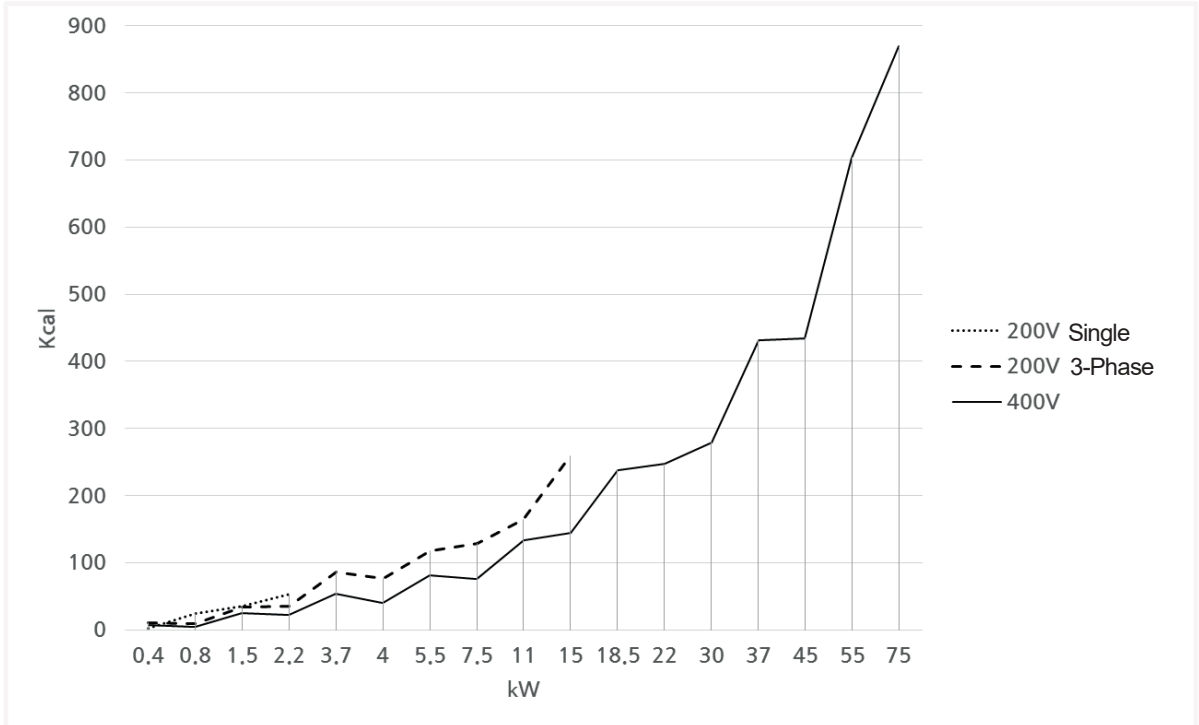

Capacity	Heat Emission(Kcal)	Capacity	Heat Emission(Kcal)	Capacity	Heat Emission(Kcal)
0.4kW-1	3	7.5kW-2	128	11kW-4	133
0.8kW-1	25	11kW-2	164	15kW-4	145
1.5kW-1	36	15kW-2	260	18.5kW-4	238
2.2kW-1	53	0.4kW-4	7	22kW-4	247
0.4kW-2	10	0.8kW-4	4	30kW-4	280
0.8kW-2	9	1.5kW-4	24	37kW-4	432
1.5kW-2	34	2.2kW-4	22	45kW-4	434
2.2kW-2	36	3.7kW-4	54	55kW-4	703
3.7kW-2	86	4.0kW-4	40	75kW-4	869
4.0kW-2	77	5.5kW-4	82		
5.5kW-2	118	7.5kW-4	75		

Heat emission data is based on operations with default carrier frequency settings, under normal operating conditions.

## 7.10 Remote Option

The composition consists of a remote control loader and cables(1m,2m,3m,5m).

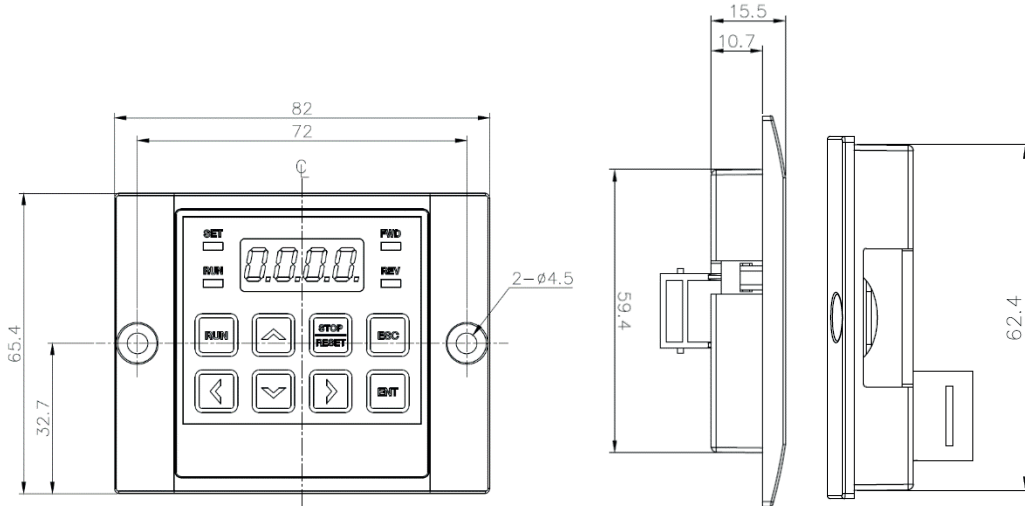

Scale : mm

### Installation.

- 5 Take off the top cover of the I/O board kit and remove the hole cover to connect remote cable on the side.
- 6 Connect the other side of the remote cable to the remote keypad as shown below.

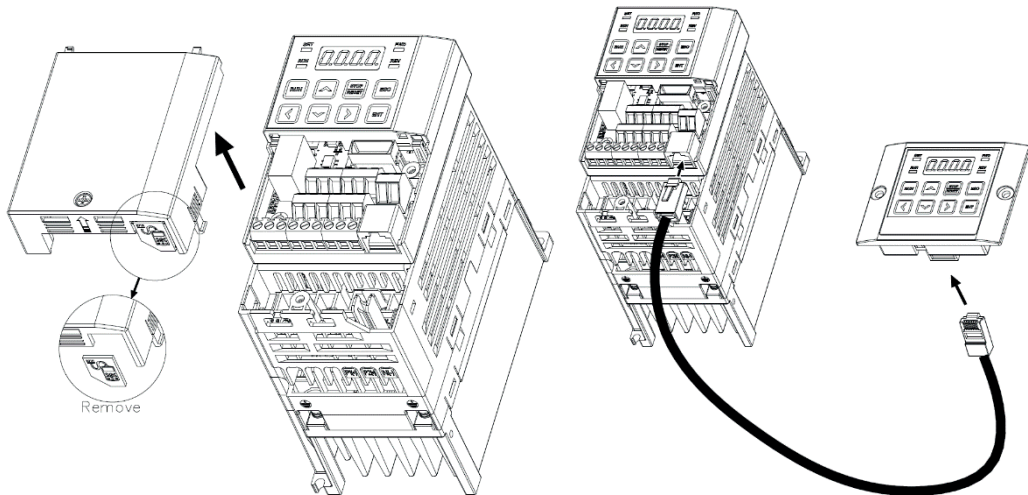

# 8 Applying Drives to Single-Phase Input Application

## 8.1 Introduction

LSLV-S100 is a three-phase standard variable frequency drive(VFD). When applying single-phase power to a three-phase VFD, there are several constraints that need to be considered. Standard Pulse-Width-Modulated (PWM) VFDs use a 6-pulse diode rectifier. The 6-pulse rectification results in 360 Hz DC bus ripple when used with a three-phase 60 Hz supply.

However, under single-phase use, the DC bus ripple becomes 120 Hz and the VFDs DC bus circuit is subject to higher stress in order to deliver equivalent power.

Additionally, input currents and harmonics increase beyond those encountered with three-phase input.

Input current distortion of 90% THD and greater can be expected under single-phase input, compared to approximately 40% with three-phase input as indicated in Figure 2.

Therefore, single-phase use requires the three-phase VFD power rating be reduced (derated) to avoid over stressing the rectifier and DC link components.

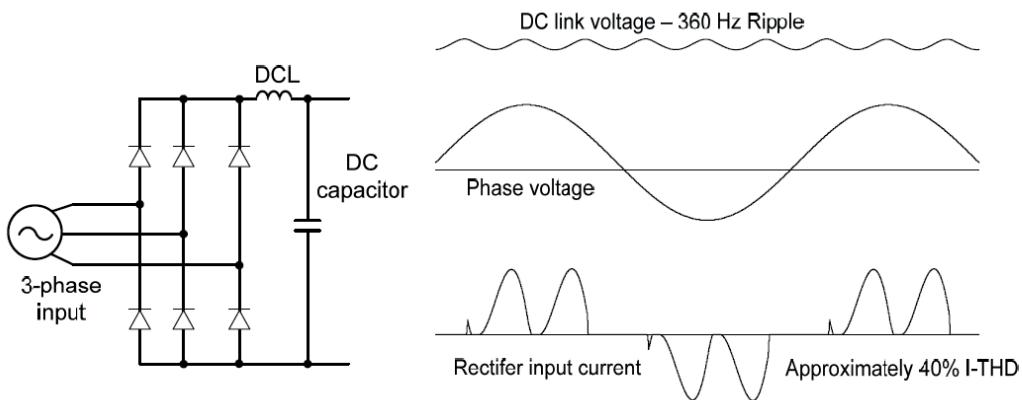

Figure-1 Typical Three-Phase Configuration

Input Application

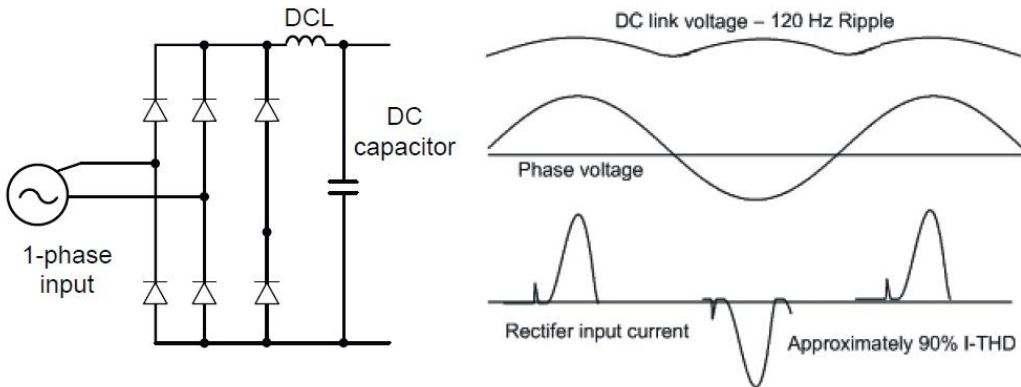

Figure-2 Typical Single-Phase Configuration

## 8.2 Power(HP), Input Current and Output Current

When using a three-phase VFD with single-phase input, derating the drive's output current and horsepower will be necessary because of the increase in DC bus ripple voltage and current. In addition, the input current through the remaining two phases on the diode bridge converter will approximately double, creating another derating consideration for the VFD. Input current harmonic distortion will increase beyond that with a three-phase supply making the overall input power factor low. Input current distortion over 100% is likely under single-phase conditions without a reactor. Therefore, the reactor is always required. When using a motor that is selected by the three-phase drive rating criteria when using single-phase input, it may result in poor performance, premature drive failure. The selected drive of single-phase current ratings must meet or exceed the motor current rating.

## 8.3 Input Frequency and Voltage Tolerance

The single-phase current ratings are valid for 60Hz input only. The AC supply voltage must be within the required voltage range of 240/480Vac +10% to -5% to maximize motor power production. Standard product with three-phase voltage input has an allowable range of +10% to -15%. Therefore, a stricter input voltage tolerance of +10 to -5% applies when using the drive with a single-phase supply. The average bus voltage with single-phase input is lower than the equivalent of a three-phase input. Therefore, the maximum output voltage (motor voltage) will be lower with a single-phase input. The minimum input voltage must be no less than 228Vac for 240 volt models and 456Vac for 480 volt models, to ensure motor voltage production of 207Vac and 415Vac, respectively. Thus, if full motor torque must be developed near base speed (full power) it will be necessary to maintain a rigid incoming line voltage so that adequate motor voltage can be produced. Operating a motor at reduced speed (reduced power), or using a motor with a base voltage that is lower than the incoming AC supply rating (ex. 208Vac motor with a 240Vac supply), will also minimize the effect of voltage deprivation. (240VAC Input → 208V motor, 480VAC Input → 400V motor)



# Product Warranty

## Warranty Information

Fill in this warranty information form and keep this page for future reference or when warranty service may be required.

<b>Product Name</b>	LS ELECTRIC Standard Inverter	<b>Date of Installation</b>	
<b>Model Name</b>	LSLV-S100	<b>Warranty Period</b>	
<b>Customer Info</b>	Name (or company)		
	Address		
	Contact Info.		
<b>Retailer Info</b>	Name		
	Address		
	Contact info.		

## Warranty Period

The product warranty covers product malfunctions, under normal operating conditions, for 12 months from the date of installation. If the date of installation is unknown, the product warranty is valid for 18 months from the date of manufacturing. Please note that the product warranty terms may vary depending on purchase or installation contracts.

## Warranty Service Information

During the product warranty period, warranty service (free of charge) is provided for product malfunctions caused under normal operating conditions. For warranty service, contact an official LS ELECTRIC agent or service center.

### Non-Warranty Service

A service fee will be incurred for malfunctions in the following cases:

- intentional abuse or negligence
- power supply problems or from other appliances being connected to the product
- acts of nature (fire, flood, earthquake, gas accidents etc.)
- modifications or repair by unauthorized persons
- missing authentic LS ELECTRIC rating plates
- expired warranty period

### Visit Our Website

Visit us at <https://www.lselectric.co.kr> for detailed service information.

## EC DECLARATION OF CONFORMITY

---

We, the undersigned,

Representative: LS Electric Co., Ltd.  
Address: LS Tower, 127, LS-ro, Dongan-gu,  
Anyang-si, Gyeonggi-do,  
Korea

Manufacturer: LS Electric Co., Ltd.  
Address: 56, Samseong 4-gil, Mokcheon-eup,  
Dongnam-gu, Cheonan-si, Chungcheongnam-do,  
Korea

Certify and declare under our sole responsibility that the following apparatus:

Type of Equipment: Inverter (Power Conversion Equipment)  
Model Name: LSLV-S100 series  
Trade Mark: LS Electric Co., Ltd.

Conforms with the essential requirements of the directives:

2014/35/EU Directive of the European Parliament and of the Council on the harmonisation of the laws of the Member States relating to the making available on the market of electrical equipment designed for use within certain voltage limits

2014/30/EU Directive of the European Parliament and of the Council on the harmonisation of the laws of the Member States relating to electromagnetic compatibility

Based on the following specifications applied:

EN 61800-3:2004/A1:2012  
EN 61800-5-1:2007

and therefore complies with the essential requirements and provisions of the 2014/35/CE and 2014/30/CE Directives.

Place: Cheonan, Chungnam,  
Korea

문상춘 2016.1.13

(Signature Date)

Mr. Sang Chun Moon / General Manager  
(Full name / Position)

## UL mark



The UL mark applies to products in the United States and Canada. This mark indicates that UL has tested and evaluated the products and determined that the products satisfy the UL standards for product safety. If a product received UL certification, this means that all components inside the product had been certified for UL standards as well.

Suitable for Installation in a compartment Handling Conditioned Air

## CE mark



The CE mark indicates that the products carrying this mark comply with European safety and environmental regulations. European standards include the Machinery Directive for machine manufacturers, the Low Voltage Directive for electronics manufacturers and the EMC guidelines for safe noise control.

### Low Voltage Directive

We have confirmed that our products comply with the Low Voltage Directive (EN 61800-5-1).

### EMC Directive

The Directive defines the requirements for immunity and emissions of electrical equipment used within the European Union. The EMC product standard (EN 61800-3) covers requirements stated for drives.

## EAC mark



The EAC (EurAsian Conformity) mark is applied to the products before they are placed on the market of the Eurasian Customs Union member states.

It indicates the compliance of the products with the following technical regulations and requirements of the Eurasian Customs Union:

Technical Regulations of the Customs Union 004/2011 "On safety of low voltage equipment"

Technical Regulations of the Customs Union 020/2011 "On electromagnetic compatibility of technical products"

## EMI / RFI POWER LINE FILTERS

LS inverters, S100 series

**VMC**  
vector motor control

### RFI FILTERS

THE LS RANGE OF POWER LINE FILTERS **FEB (Standard)** and **FF (Ferrite)** SERIES, HAVE BEEN SPECIFICALLY DESIGNED WITH HIGH FREQUENCY **LS INVERTERS**. THE USE OF LS FILTERS, WITH THE INSTALLATION ADVICE OVERLEAF HELP TO ENSURE TROUBLE FREE USE ALONG SIDE SENSITIVE DEVICES AND COMPLIANCE TO CONDUCTED EMISSION AND IMMUNITY STANDARS TO EN 50061.

### CAUTION

**IN CASE OF A LEAKAGE CURRENT PROTECTIVE DEVICES IS USED ON POWER SUPPLY, IT MAY BE FAULT AT POWER-ON OR OFF. IN AVOID THIS CASE, THE SENSE CURRENT OF PROTECTIVE DEVICE SHOULD BE LARGER**

### RECOMMENDED INSTALLATION INSTRUCTIONS

To conform to the EMC directive, it is necessary that these instructions be followed as closely as possible. Follow the usual safety procedures when working with electrical equipment. All electrical connections to the filter, inverter and motor must be made by a qualified electrical technician.

- 1-) Check the filter rating label to ensure that the current, voltage rating and part number are correct.
- 2-) For best results the filter should be fitted as closely as possible to the incoming mains supply of the wiring enclosure, usually directly after the enclosures circuit breaker or supply switch.
- 3-) The back panel of the wiring cabinet of board should be prepared for the mounting dimensions of the filter. Care should be taken to remove any paint etc... from the mounting holes and face area of the panel to ensure the best possible earthing of the filter.
- 4-) Mount the filter securely.
- 5-) Connect the mains supply to the filter terminals marked **LINE**, connect any earth cables to the earth stud provided. Connect the filter terminals marked **LOAD** to the mains input of the inverter using short lengths of appropriate gauge cable.
- 6-) Connect the motor and fit the **ferrite core** ( output chokes ) as close to the Inverter as possible. Armoured or screened cable should be used with the 3 phase conductors only threaded twice through the center of the ferrite core. The earth conductor should be securely earthed at both inverter and motor ends. The screen should be connected to the enclosure body via and earthed cable gland.
- 7-) Connect any control cables as instructed in the inverter instructions manual.

IT IS IMPORTANT THAT ALL LEAD LENGHTS ARE KEPT AS SHORT AS POSSIBLE AND THAT INCOMING MAINS AND OUTGOING MOTOR CABLES ARE KEPT WELL SEPARATED.

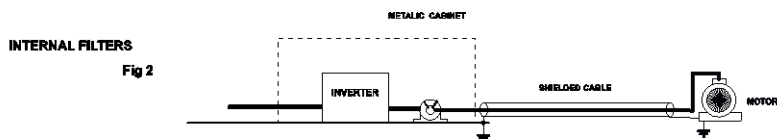
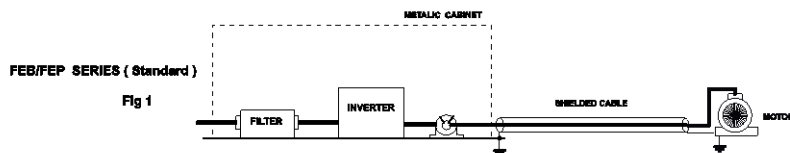

PR0064

Footprint Filters											EN 55011 CLASS B IEC/EN 61800-3 C2
Inverter	Power	Code	Current [A]	Voltage [Vac]	Leakage Current[mA]		Dimension [L,W,H]	Mounting [Y,X]	Weight [Kg]	Fig.	Output Choke
					Nom.	Max.					
LSLV0004S100-1	0.4kW	FFS100-M010-2	10	250	-	3.5	176x71.5x45	162x50	0.6	B	FS-1
LSLV0008S100-1	0.75kW	FFS100-M011-2	10	250	-	3.5	176x103.5x45	162x82	0.8	B	FS-1
LSLV0015S100-1	1.5kW	FFS100-M020-2	20	250	-	3.5	176x103.5x45	162x82	0.8	B	FS-2
LSLV0022S100-1	2.2kW	FFS100-M021-2	20	250	-	3.5	176x143.5x45	162x122	0.9	B	FS-2
LSLV0004S100-2	0.4kW	FFS100-T006-2	6	220-480	0.3	18	176x71.5x45	162x50	1.6	B	FS-2
LSLV0008S100-2	0.75kW										
LSLV0015S100-2	1.5kW	FFS100-T012-2	12	220-480	0.3	18	176x103.5x45	162x82	1.6	B	FS-2
LSLV0022S100-2	2.2kW										
LSLV0037S100-2	3.7kW	FFS100-T020-2	20	220-480	0.3	27	176x143.5x45	162x122	1.8	B	FS-2
LSLV0040S100-2	4.0kW										
LSLV0004S100-4	0.4kW	FFS100-T006-2	6	220-480	0.3	18	176x71.5x45	162x50	1.6	B	FS-2
LSLV0008S100-4	0.75kW										
LSLV0015S100-4	1.5kW	FFS100-T012-2	12	220-480	0.3	18	176x103.5x45	162x82	1.6	B	FS-2
LSLV0022S100-4	2.2kW										
LSLV0037S100-4	3.7kW	FFS100-T020-2	20	220-480	0.3	27	176x143.5x45	162x122	1.8	B	FS-2
LSLV0040S100-4	4.0kW										

Standard Filters											EN 55011 CLASS A IEC/EN 61800-3 C3
Inverter	Power	Code	Current [A]	Voltage [Vac]	Leakage Current[mA]		Dimension [L,W,H]	Mounting [Y,X]	Weight [Kg]	Fig.	Output Choke
					Nom.	Max.					
LSLV0055S100-2	5.5kW	FLD 3042	42A	220-480	0.5	27	335x60x150	35x320	2.8	C	FS-2
LSLV0075S100-2	7.5kW	FLD 3055	55A	220-480	0.5	27	335x60x150	35x320	3.1	C	FS-2
LSLV0110S100-2	11kW	FLD 3075	75A	220-480	0.5	27	335x60x150	35x320	4	C	FS-2
LSLV0150S100-2	15kW	FLD 3100	100A	220-480	0.5	27	330x80x220	55x314	5.5	C	FS-3

Internal Filters											EN 55011 CLASS A IEC/EN 61800-3 C3
Inverter	Power	Code	Current [A]	Voltage [Vac]	Leakage Current[mA]		Dimension [L,W,H]	Mounting [Y,X]	Weight [Kg]	Fig.	Output Choke
					Nom.	Max.					
LSLV0055S100-4	5.5kW	X									FS-2
LSLV0075S100-4	7.5kW										FS-2
LSLV0110S100-4	11kW										FS-2
LSLV0150S100-4	15kW										FS-3
LSLV0185S100-4	18.5kW										FS-3
LSLV0220S100-4	22kW										FS-3
LSLV0300S100-4	30kW										FS-3
LSLV0370S100-4	37kW										FS-3
LSLV0450S100-4	45kW										FS-3

Non-Filters											EN 55011 CLASS A IEC/EN 61800-3 C3
Inverter	Power	Code	Current [A]	Voltage [Vac]	Leakage Current[mA]		Dimension [L,W,H]	Mounting [Y,X]	Weight [Kg]	Fig.	Output Choke
					Nom.	Max.					
LSLV0550S100-4	55kW	X									FS-3
LSLV0750S100-4	75kW										FS-3



<FIG. A(FEPT Series)>

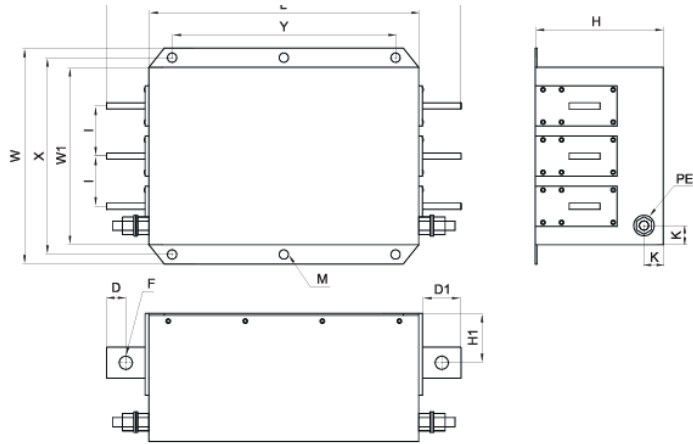

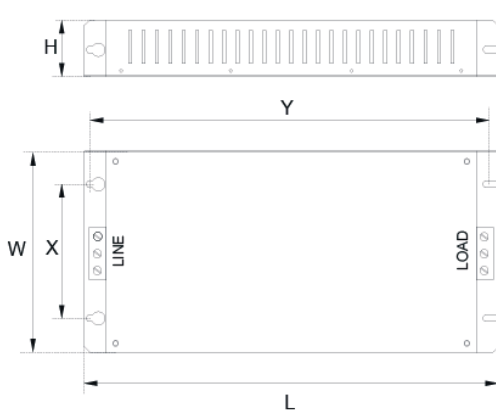
<FIG. B(FF Series)>

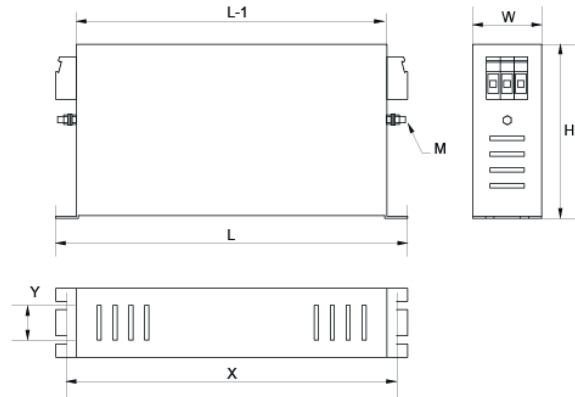

<FIG. C(FLD Series)>

**VMC**  
vector motor control

Vector Motor Control Ibérica S.L.  
C/ Mar del Caribe, 10  
Pol. Ind. La Torre del Rector  
08130 Santa Perpètua de Mogoda  
(BARCELONA) ESPAÑA  
Tel. (+34) 935 748 206  
Fax (+34) 935 748 248  
info@vmc.es  
www.vmc.es

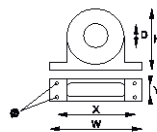

**FS SERIES ( output chokes )**

CODE	D	W	H	X	Ø
FS-1	21	88	80	22	4
FS-2	28,5	105	62	80	5
FS-3	48	150	110	125 x 30	5

# Manual Revision History

## Revision History

No	Date	Edition	Changes
1	2013.12	First Release	-
2	2014.11	2 <sup>nd</sup> Edition	S/W Version up(V2.0)
3	2015.06	3 <sup>rd</sup> Edition	S/W Version up(V2.3)
4	2016.09	4 <sup>th</sup> Edition	S/W Version up(V2.5)
5	2019.05	5 <sup>th</sup> Edition	Three manuals are unified
6	2020.05	6 <sup>th</sup> Edition	S/W Version up(V2.8)



# Index

## I

[DOWN] key .....	66
[ESC] key .....	66
[HAND] key .....	66
[LEFT] key .....	66
[MODE] key .....	66
[MULTI] key .....	66
[OFF] key .....	66
[PROG / Ent] key .....	66
[RIGHT] key .....	66
[STOP/RESET] key .....	66
[UP] key .....	66

## 2

24 terminal .....	44, 47
2nd Motor Function group... Refer to M2 (2nd Motor Function group ) group	

## 3

3-phase 200V (0.4~4k W).....	204
3-phase 200V (5.5~15 kW).....	205
3-phase 400V (0.4~4 kW).....	206
3-phase 400V (5.5~22 kW).....	207, 209

## 4

4-pole standard motor .....	203, 206, 207
-----------------------------	---------------

## 7

7-segment display .....	61
letters.....	61
numbers .....	61

## A

A1/C1/B1 terminal.....	45
AC power input terminal .....	Refer to <i>R/S/T terminal</i> , Refer to <i>R/S/T terminal</i> , Refer to <i>R/S/T terminal</i>
Ad (Expanded function group).....	115

advanced features group.....	68
Advanced function group..Refer to ADV (advanced) function group	
analog input.....	42, 67, 68
analog input selection switch(SW2).....	40
analog output .....	44
AO terminal .....	44
analog output selection switch(SW3) .....	40
AO terminal .....	44
analog output selection switch(SW3).....	40
AP(Application Function group) .....	146
asymmetric ground power .....	49
asymmetric ground structure	
EMC filter .....	49
Auto Tuning .....	111

## B

bA(Basic function group) .....	110
basic configuration diagram.....	16
Basic group .....	Refer to BAS (Basic function group)
basic operation.....	59
Bootlace Ferrule .....	45
brake resistor .....	34, 35, 37
braking resistance	
braking torque .....	234
braking resistors.....	16
BX .....	187

## C

cable .....	13, 23, 25, 26, 28, 29, 30, 31, 32, 39
selection .....	13, 23, 25, 26, 28, 29, 30, 31, 32, 39
shielded twisted pair.....	55
signal(control) cable specifications .....	14
Cable	
Ground Specifications.....	13
Power I/O Cable Specifications .....	13
cable tie .....	46
carrier frequency .....	38
charge indicator .....	21, 185, 192
charge lamp .....	21
cleaning .....	197
CM terminal.....	42, 47
CM(communication function group) .....	141

Cn (Control Function group) .....	121
CNF (configuration mode).....	70
common terminal .....	Refer to <i>EG terminal</i>
Communication function group.....	Refer to COM (communication function group)
Considerations for the installation	
Air Pressure.....	8
Altitude/Vibration .....	8
Ambient Humidity.....	8
Environmental Factors .....	8
Considerations for the installation	
Ambient Temperature .....	8
Control groupRefer to CON (Control Function group)	
control terminal board wiring .....	39
cursor keys .....	66
[DOWN] key .....	66
[LEFT] key .....	66
[RIGHT] key.....	66
[UP] key .....	66

## D

delta wiring.....	49, 208
disposal .....	197, 202
dr(Drive group) .....	105
Drive group .....	Refer to DRV (Drive group)

## E

earth leakage breaker.....	194
EG terminal.....	44
EMC filter .....	49
asymmetric power.....	49
disable.....	49
enable .....	50
ESC key.....	65
cancel input.....	65
Jog key.....	84
external 24V power terminal ...	Refer to <i>24 terminal</i>
external dimensions	
0.8~1.5kW(Single Phase), 1.5~2.2kW(3 Phase)	
.....	215, 224
5.5~22kW(3 phase).....	218
External dimensions .....	213, 221
External dimensions	
0.4kW(Single Phase), 0.4~0.8kW(3 Phase)..	213
External dimensions	

0.4kW(Single Phase), 0.4~0.8kW(3 Phase) .	221
External Trip .....	187

## F

factory default.....	92, 93
Fan Trip.....	187
Fan Warning.....	189
fatal.....	185
fault	
fatal .....	185
latch.....	185
level.....	185
<b>fault monitoring</b>	
<b>multiple fault trips</b> .....	101
fault signal output terminal .....	Refer to <i>A1/C1/B1 terminal</i>
fault trip mode .....	70
ferrite .....	46
frequency setting	
variable resistor.....	91
frequency setting (Pulse train) terminal ...	Refer to <i>I terminal</i>
frequency setting(voltage) terminal.....	Refer to <i>V terminal</i>
fuse .....	230
Fuse and Reactor Specifications .....	229

## G

ground.....	29
class 3 ground.....	29
class 3 ground .....	29
ground terminal .....	29, 30, 31
Ground	
Ground Cable Specifications.....	13
Ground Trip .....	186
ground fault trip .....	186

## H

Heavy Duty.....	8
heavy load .....	203

## I

I2 42	
analog input selection switch(SW2).....	43
frequency setting(current/voltage) terminal .....	42
In Phase Open .....	186
In(Input Terminal Block Function group).....	130
input and output specification	
applied motor.....	203
rated input.....	203
rated output.....	203
input terminal .....	42
CM terminal .....	42
I2 terminal .....	42
P1-P7 terminal.....	42
SA terminal .....	43
SB terminal .....	43
SC terminal.....	43
TI terminal.....	43
V1 terminal.....	42
VR terminal.....	42
Input terminal function group .....	Refer to IN (Input terminal function group)
inspection	
annual inspection .....	198
bi-annual inspection).....	200
installation .....	15
basic configuration diagram.....	16
Installation flowchart .....	15
wiring.....	21
Installation	
Mounting the Inverter.....	17
installation considerations .....	8
IP 20 .....	211

## J

Jog Operation	
[ESC] key configuration.....	84

## K

keypad.....	59
[ESC] key.....	66
[HAND] key.....	66
[MODE] key.....	66
[MULTI] key .....	66

[OFF] key.....	66
[PROG / Ent] key.....	66
[STOP/RESET] key.....	66
configuration mode.....	70
cursor keys .....	66
display.....	59
monitor mode.....	70
navigating between groups .....	69
operation keys .....	59
parameter mode .....	70
trip mode.....	70
keypad display .....	61
keypad key .....	65
[▲]/[▼]/[◀]/[▶] key .....	65
[ESC] key .....	65
[RUN] key .....	65
[STOP/RESET] key.....	65

## L

latch.....	185
LCD keypad .....	25, 28
wiring length .....	46
leakage breaker .....	228
level .....	185
locating the installation site .....	9
location .....	9
Lost Command .....	188, 189
Low Voltage.....	186

## M

M2(2nd Motor Function group) .....	154
magnetic contactor .....	38
Magnetic contactor .....	228
maintenance .....	197
megger test .....	198
micro surge filter .....	38
monitor.....	94
monitoring	
monitor mode.....	70
monitor mode display.....	62
motor rotational direction.....	57
mounting bolt.....	17
mounting bracket .....	19
multi function input terminal	
In.65~71 .....	132

Px terminal function setting .....	132
multi function input terminal	
Px Define .....	132
Multi-function (open collector) output terminal	
Multi-function output item1(Q1 Define) .....	138
Multi-function relay 1 item(Relay 1) .....	137
multi-function input terminal .....	42
factory default .....	42
P1-P7 .....	Refer
multi-function key .....	61
Multi Key Sel .....	182
multi-function key options .....	182
multi-function(open collector) output terminal .. Refer	
to Q1 terminal	

## N

N- terminal(- DC link terminal) .....	34, 37
No Motor Trip .....	186
noise .....	49
Normal Duty .....	8
normal load .....	203
NPN mode(Sink) .....	48

## O

oOut Phase Open .....	186
operation group .....	103
OU(Output Terminal Block Function group) .....	136
output terminal .....	Refer to R/S/T terminal, Refer to
R/S/T terminal, Refer to R/S/T terminal	
Output terminal function group .....	Refer to OUT
(Output terminal function group)	
output/communication terminal .....	44
24 terminal .....	44
A1/C1/B1 terminal .....	45
AO terminal .....	44
EG terminal .....	44
Q1 terminal .....	44
S+/S-/SG terminal .....	45
TO terminal .....	44
Over Current1 .....	186
Over Current2 .....	187
Over Heat .....	187
Over Load .....	186
overload warning .....	189

Over Voltage .....	186
--------------------	-----

## P

P1+ terminals(+ DC link terminals) .....	34, 35, 37
parameter .....	81
parameter setting .....	81
parameter settings .....	82
parameter mode .....	70
part names .....	3
parts illustrated .....	3
Peripheral devices .....	228
phase-to-phase voltage .....	193
PID control	
PID feedback .....	187
PNP mode(Source) .....	47
PNP/NPN mode selection switch(SW1) .....	40
NPN mode(Sink) .....	48
PNP mode(Source) .....	47
post-installation checklist .....	54
power terminal .....	37
N- terminal .....	34, 37
P2+/B terminal .....	34, 35, 37
U/V/W terminal .....	34, 35, 37
power terminal board wiring .....	32
power terminals	
R/S/T terminals .....	34, 35, 37
Pr(Protection Function group) .....	149
Preinsulated Crimp Terminal .....	45
Pulse output terminal .....	Refer to TO terminal

## Q

Q1 terminal .....	44
-------------------	----

## R

R/S/T terminal .....	38
R/S/T terminals .....	34, 35, 37, 192
rated .....	204
braking resistance rated capacity .....	234
dynamic raking capacity .....	239
rated input .....	204
rated output .....	204
reactor .....	16, 230
RS-485	
signal terminal .....	45

RS-485 signal input terminal..... Refer to *S+/S-/SG terminal*

## S

S+/S-/SG terminal .....	45
SA terminal .....	43
safety information .....	ii
safety input power terminal .....	Refer to <i>SC terminal</i>
safety inputA terminal .....	Refer to <i>SA terminal</i>
Safety inputB terminal .....	Refer to <i>SB terminal</i>
SB terminal .....	43
SC terminal .....	43
screw specification	
control circuit terminal screw .....	232
input/output terminal screw .....	231
screw size .....	231
screw torque .....	231
sequence common terminal .Refrtr to <i>CM terminal</i>	
serge killer .....	54
single phase 200V (0.4~2.2 kW) .....	203
storage .....	201
Storing Temperature .....	8
surge killer .....	38
SW1 .....	Refer to PNP/NPN mode selection switch(SW1), Refer to PNP/NPN mode selection switch(SW1)
SW2.....	Refer to analog input selection switch(SW2)
SW3	Refer to analog output selection switch(SW3)
switch .....	40
analog input selection switch(SW2) .....	40
analog output selection switch(SW3).....	40
PNP/NPN mode selection switch(SW1).....	40

## T

target frequency	
Cmd Frequency .....	105
technical specification .....	203
terminal for frequency reference setting .Refer to <i>VR terminal</i>	
test run .....	56
TI terminal .....	43
protection features group .PRT (protection features) group	

TO terminal .....	44
torque .....	38
trip .....	185
trip condition monitor .....	95
trip mode.....	70
Trip	
troubleshooting .....	190
troubleshooting .....	185
other faults .....	192
troubleshooting fault trips .....	190

## U

UV/W terminal.....	34, 37, 38
UV/W terminals.....	35, 192
UF .....	160
Under Load	
underload trip .....	186
underload warning.....	189
US .....	157
User mode.....	69
using the keypad .....	71
groups/codes .....	74
Jog Operation key .....	84
parameter settings.....	82
switching between groups in parameter display mode.....	76
using the using the keypad	
parameter setting.....	81

## V

V1 terminal .....	42
V2	
analog input selection switch(SW2) .....	43
variable resistor.....	91
voltage drop .....	38
voltage/current output terminal Refer to <i>AO terminal</i>	
VR terminal.....	42

## W

warning .....	185
wiring.....	21
circuit breaker.....	228
control terminal board wiring .....	39
copper cable .....	21

cover disassembly .....	22
ferrite .....	46
ground .....	29
power terminal board wiring.....	32
re-assembling the covers.....	53
signal wiring.....	45
torque .....	21

wiring length .....	38, 46
---------------------	--------

ㅈ

중량(kg) .....	203
--------------	-----

[www.nicsanat.com](http://www.nicsanat.com)

021-87700210

