

LITEON

Intelligent Integration with Innovation

LITE-ON Technology

The Best Partner for Smart Manufacturing



www.nicsanat.com

021-87700210





LITEON®

LITE-ON is already part of your life

Founded in 1975, LITE-ON Technology Corp. (TWSE: 2301) is a worldwide leading provider of optoelectronics, information technology, storage devices, and mobile devices components. Its product portfolio spans a broad range of applications, including computers, communications, consumer electronics, automotive electronics, LED lighting, cloud computing, industrial automation as well as biotech and healthcare. With 50 factories, 30 branches, 250 hubs and over 60,000 employees globally, LITE-ON is already part of your daily life.

50%

of the world's PC power supplies are made by LITE-ON

#1

market share in PC and laptop WiFi and BT modules in the world

#1

market share in desktop housing and keyboard in the world

#1

market share in street lamp and signal light in the US

15%

of the world's automotive LED are made by LITE-ON

100K+

VFD installed globally since the inception of industrial automation department in 2015



INDEX:

Pages 5 - 11

Compact Vector Drive EVO 6000 Series

0.2kW~3.7kW / .25HP~5HP

- ◆ Presses
- ◆ Ceramic Machines
- ◆ Plastic Machines
- ◆ Textile Machinery
- ◆ Fans & Pumps
- ◆ Disc Coal Feeders
- ◆ Feeders
- ◆ Belts Conveyors
- ◆ Pulverized Coal Feeders



Pages 12 - 25

Compact Vector Drive EVO 6800 Series

0.37kW~132kW / 5HP~150HP

- ◆ Feeders
- ◆ Winding Machines
- ◆ Conveyors
- ◆ Woodworking machinery
- ◆ Food Processing Machines
- ◆ Fans & Pumps
- ◆ Labeling Machines
- ◆ Knitting Machines
- ◆ Packaging Machines
- ◆ Industrial Sewing Machines



MODEL DEFINITION

EVO	6000	43	S
Product EVO: LITE-ON AC drive	Series 6800 : 6800 series 6000 : 6000 series	Input Voltage 21 : 200V single phase 23 : 200V 3 phase 43 : 400V 3 phase	Version S: Standard version
0D4	E	20	F
Power Rating 0D2 : .2KW (.25HP) 0D4 : .4KW (.5HP) D75 : .75KW (1HP) 1D5 : 1.5KW : (2HP) 2D2 : 2.2KW : (3HP) 3D7 : 3.7KW : (5HP) 5D5 : 5.5KW : (7.5HP) 7D5 : 7.5KW : (10HP) 075 : 75KW (100HP) 090 : 90KW (125KW) 110 " 110KW (150HP)	Keypad E: LED display	Enclosure 20 : IP20 N1 : NEMA1	Filter _ : None F : EMI filter built-in

SIMPLE SELECTION CHART

Series	EVO6000	EVO6800
Power range	200V : .2-3.7KW (.25-5HP) 400V: .75-3.7KW (1-5HP)	200v: 5.5-11KW (7.5-15HP) 400V: 3.7-110KW (5-150HP)
Voltage range	200V: 1-phase 200-240V / 3-phases 200-220V 400V: 3-phases 380-480V	200V: 1-phase / 3-phases 200-240V 400V: 3-phases 380-480V
Certification	UL / cUL / CE	UL / cUL / CE
IP level	IP20	IP20 & IP21 with NEMA1 kit
Control mode	a. V/F b. SVVC (Sensorless Voltage Vector Control)	a. V/F b. SVVC (Sensorless Voltage Vector Control)
Communication options	CANopen* / Option card	CANopen* / EtherNet / IP* option card
LED Keypad	standard built-in	Remote Keypad
Other design	1. Remote keypad 2. Copy unit 3. Din rail	1. Copy unit
Applications	Fan/Pump Food process machine Feeder Plastic Machines Conveyors Textile machines etc.	FAN/Pump Machine-tools Compressors Feeder Presses Plastic Machines Conveyors Ceramic Machines Packing Machines Bagging Machines Labeling Machines Textile machines etc.

EVO6000 SERIES DRIVES

INVERTER

- ◆ Ultra Compact Vector AC Drive / EVO 6000 Series
- ◆ Economic, Reliable, Use-Friendly and small size design
- ◆ Applicable for various machines and industries.
- ◆ CE / UL Certificate



FEATURES



Outstanding Control

- ◆ V/F control
- ◆ Unique Sensorless Voltage Vector
- ◆ Accurate speed control 1:40 (V/F), 1:100 (SVVC)
- ◆ Excellent starting torque at low speed - 3Hz 150% (V/F), 1Hz 150% (SVVC)



User-friendly Design

- ◆ Ultra compact design to save room and facilitate easy replacement.
- ◆ Quick-release fan. Easy to maintain quick-release fan.
- ◆ Nonslip setting dial for convenient adjustment.
- ◆ Arrow key for speedy parameter setting.
- ◆ Supports Din Rail and side-by-side installation.
- ◆ Common DC bus to save cost for installation



Customized machine

- ◆ Support industry-specific machine



Reliable Partner

- ◆ Guarantee best-quality key components from top European and Japanese suppliers for longer operation life span.



Flexible Expansion

- ◆ Remote keypad(Max. 50 meters).
- ◆ Copy unit



Global Certifications

- ◆ All models comply with EU RoHS standards.
- ◆ Conformity to CE / UL / CUL.



COST EFFECTIVE SOLUTION FOR INCREASED EFFICIENCY

- Derated torque significantly reduces your energy bills for applications such as fans and pumps. This saves as much as 88% of energy when running at half of the rated speed.

- Adjust your conveyor speed and start smoothly to improve productivity, lower failure rate, abrasion and life span. Reduce your energy cost by running in energy saving mode.

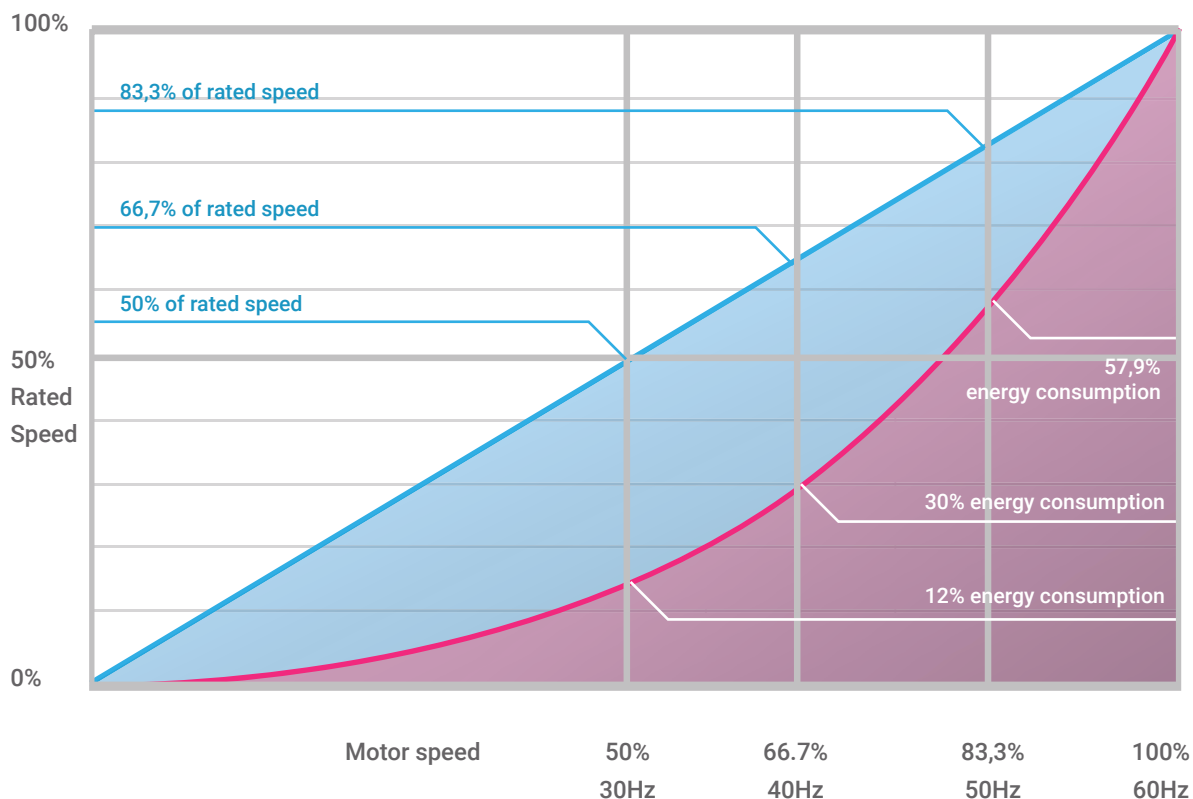

APPLICATION

- ◆ Winding Machines
- ◆ Food Processing Machines
- ◆ Feeders
- ◆ Woodworking machinery
- ◆ Conveyors
- ◆ Fans & Pumps
- ◆ Knitting Machines
- ◆ Packaging Machines
- ◆ Labeling Machines
- ◆ Industrial Sewing Machines

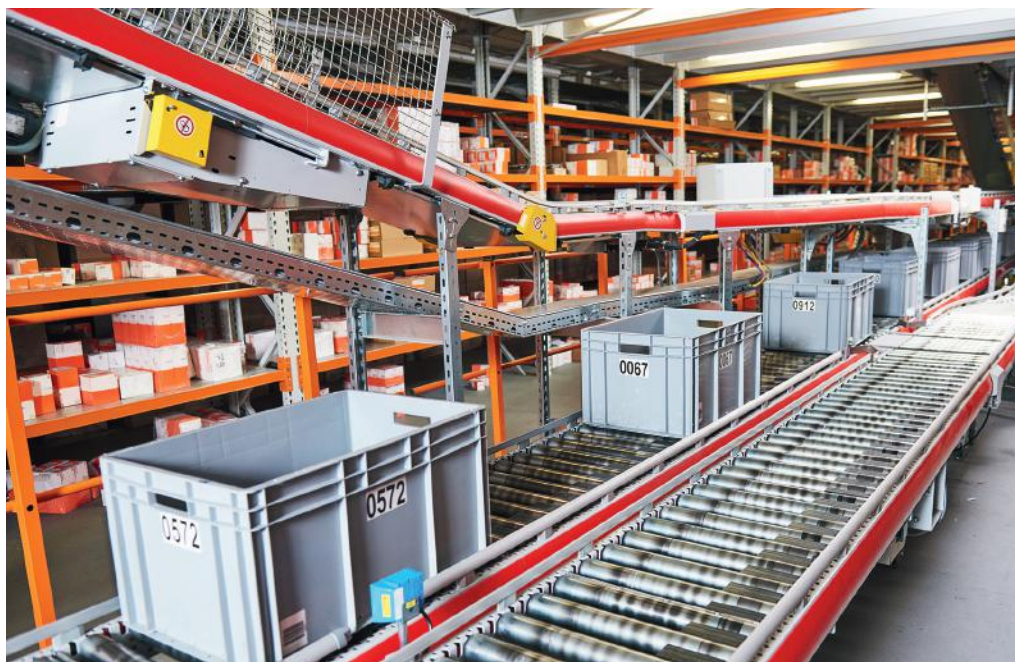

RATINGS - 200V Class

200V Class							
Model	EVO600021S	0D2	0D4	D75	1D5	2D2	--
Frame		1			2		
Model	EVO600023S	0D2	0D4	D75	1D5	2D2	3D7
Frame		1			2		
Max. Motor Capacitor	HP	0.25	0.5	1	2	3	5
	kW	0.2	0.4	0.75	1.5	2.2	3.7
Input Voltage (V) / Frequency (Hz)		Single phase, 3 phases, 200 ~ 240 V, -15% ~ +10%, 50 / 60 Hz					
Rated Output	Current (Amp)	1.6	2.5	4.2	7.5	11	17
	Frequency (Hz)	0 ~ 400 Hz					
	Carrier Frequency (kHz)	2 ~ 12 Hz					
Cooling Method		Fanless			Fan		

RATINGS - 400V Class

400V Class					
Model	EVO600043S	D75	1D5	2D2	3D7
Frame		1		2	
Max. Motor Capacitor	HP	1	2	3	5
	kW	0.75	1.5	2.2	3.7
Input Voltage (V) / Frequency (Hz)		3 phases, 380 ~ 480 V, -15% ~ +10%, 50 / 60 Hz			
Rated Output	Current (Amp)	2.5	4.2	5.5	8.2
	Frequency (Hz)	0 ~ 400 Hz			
	Carrier Frequency (kHz)	2 ~ 12 Hz			
Cooling Method		Fanless		Fan	

DIMENSIONS

FRAME	W	W1	H	H1	D	S1	∅
1	72 (2.83)	59 (2.32)	174.2 (6.86)	151.2 (5.97)	135.6 (5.34)	5.4 (0.21)	5.4 (0.21)
2	100 (3.94)	89 (3.50)	174.2 (6.86)	162.9 (6.41)	135.6 (5.34)	5.4 (0.23)	5.8 (0.23)

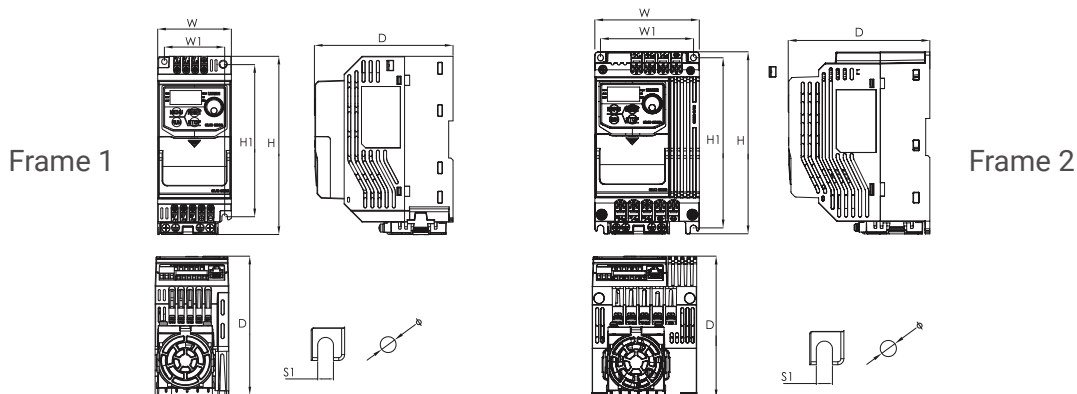

GENERAL SPECIFICATION

Item		Specification
Control Characteristic	Control Method	V/F, Sensorless Voltage Vector Control (SVVC)
	Output Frequency	0 ~ 400 Hz
	Frequency Accuracy	Digital reference: within $\pm 0.01\%$ of the Max. output frequency
		Analog reference: within $\pm 0.01\%$ of the Max. output frequency
	Frequency Setting Resolution	Digital input: 0.01 Hz
		Analog Output: 1 / 1000 of max. frequency
	Starting Torque	150% / 3 Hz (V/F)
		150% / 1 Hz (SVVC)
	Speed Control Range	1:40 (V/F)
		1:100 (SVVC)
	Acc. / Dec. Time	0.0 ~ 3600.0 sec
	Braking Torque	approx. 20%
V / F Pattern	15 fixed and 1 programmable	
Overload Capacity	150% for 1 min. every 10 min.	
Parameter Function	Overtorque / Undertorque Detection, Multi - Speed Operation, Acc. / Dec. Switch, S-Curve Acc. / Dec., 3.-Wire Sequence Control, Auto-tuning Cooling Fan ON / OFF Switch, Slip Compensation, Torque Compensation, Frequency Jump, Upper / lower Limits for Frequency Command, DC Draking at Run / Stop, PID Control including Pause Function, Energy Saving Mode, Fault Restart, Traverse, etc.	
Operating Environment	Area of Use	Indoor without corrosive gas/liquid or flammable gas/liquid/oil mist/dust
	Ambient Temperature	-10°C ~ + 50°C , below 90% RH without froze or condensation
	Storage Temperature	-20°C ~ + 60°C
	Altitude	Under 1000 meters
	Vibration	Below 9.8 m/s ² (10~20Hz), below 5.9 m/s ² (20~55Hz)
	Enclosure	IP 20
Number of I/O	Analog Input (AI)	1 point AI:0~5v / 0~10V / 0 or 4~20mA
	Digital Input (DI)	6 points
	Analog Output (AO)	1 point FM: 0~10v
	Relay Output (RO)	1 point
Build-In	Modbus (RS-485 port)	
Option (under development)	Profibus - DP - CANopen - DeviceNet	

TERMINAL BLOCK DESCRIPTION

Type	Terminal Name	Code	Terminal Description		
Main Circuit	AC power input	R/L1	Input power terminal		
		S/L2			
		T/L3			
	Braking module	DC+	Please purchase optional braking module to connect		
		DC-			
	AC drive output	U/T1	Please connect to AC motor		
		V/T2			
W/T3					
Ground terminal	E	Ground terminal for AC drive. Please ensure grounding is properly wired.			
Control Circuit	Digital input terminal 1	S1	Photo coupler: input voltage 24V/8mA Default setting on sink mode. Use Sink/Source DIP switch on the control board to set sink/source mode for multi-function digital inputs.	ON: Forward / OFF : Stop	
	Digital input terminal 2	S2		ON: Reverse / OFF : Stop	
	Digital input terminal 3	S3		External fault (normal open)	
	Digital input terminal 4	S4		Fault reset	
	Digital input terminal 5	S5		Jog command	
	Digital input terminal 6	S6		ON : External baseblock	
	Digital input common	COM	Common terminal of digital input		
	Digital input signal power	+24V	Digital control signal common +24V/50mA		
	Auxiliary power	+V	Auxiliary power terminal for analog input +10V/5mA		
	Analog input terminal 1	A1	Programmable analog input 0 ~ 5V / 0 ~ 10V / 0 or 4 ~ 20mA	Main frequency command	
	Analog input	FM	Programmable analog input 0 ~ 10V	Output frequency	
	Analog signal common	AC	Common terminal of analog signal		
	Relay	R1A	Normal open terminal	Relay output DC30V 1A AC250V 3A	
		R1B	Normal closed terminal		
R1C		Common terminal			
Com.	RS-485 port	RJ45	To connect RS-485 communication at max. speed 38400 bps		

Notes:

If you have any question, please contact our authorized distributors or LITE-ON.

WIRING DIAGRAM

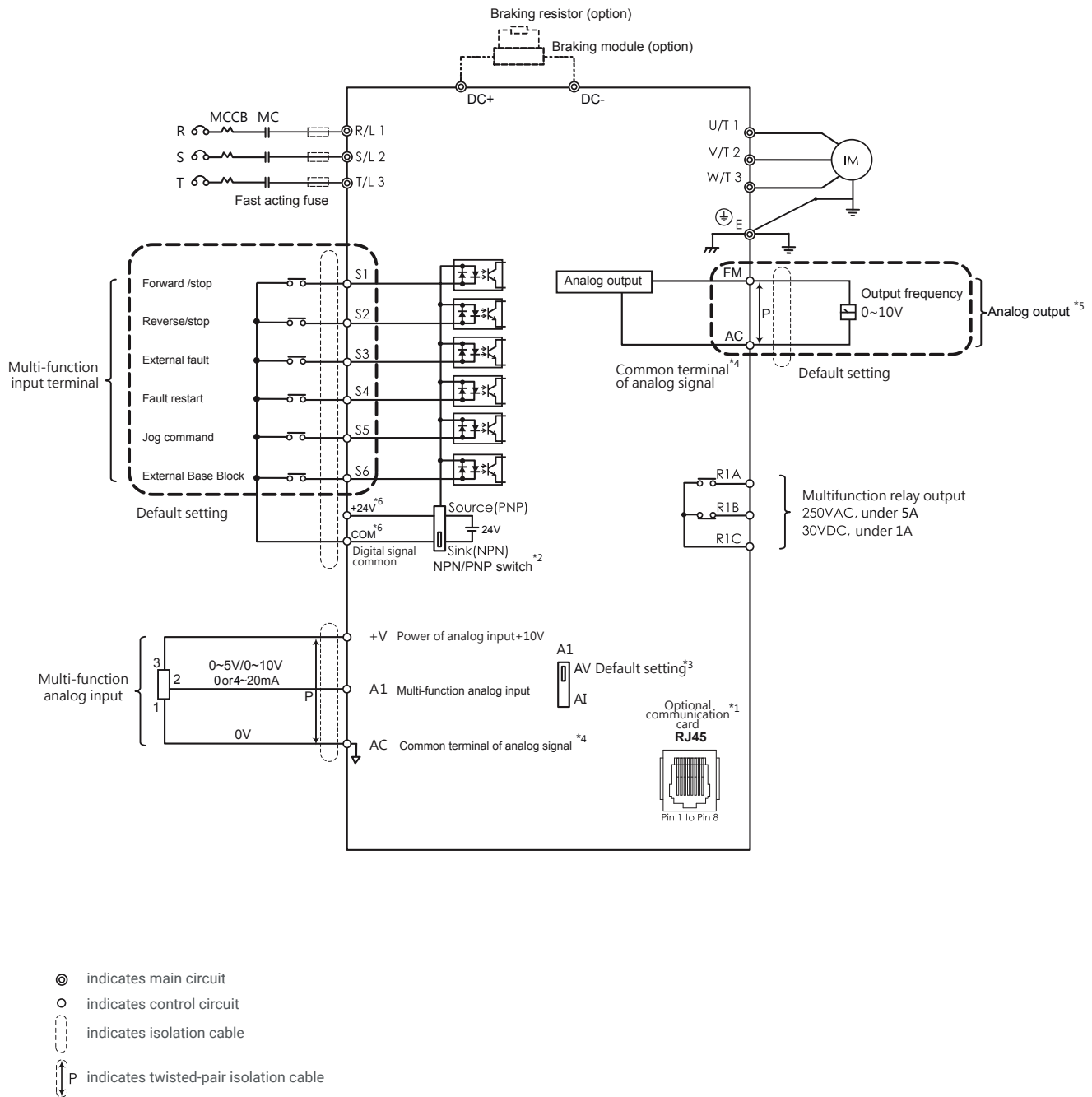

Notes:

- *1. RJ45 is port of optional communication card. Please refer to user manual when installing it.
- *2. Multi-function analog input S1~S6 can be switched between Sink(NPN) or Source(PNP) mode. Default: NPN mode.
- *3. A1 is used to set analog input as voltage input or current input.
- *4. AC is common terminal of analog signal (Analog Common).
- *5. Analog output is used to connect frequency meter, current meter, voltage meter and power meter.
- *6. This catalog includes the blueprint of our products in the future. For more precise specifications, please refer to the quick start that alongside with our products. If you have any question, please contact our authorized distributors or LITE-ON.

EVO6800 SERIES DRIVES

INVERTER

Compact Vector AC Drive / EVO 6800 Series

- ◆ Strong performance for V/F control. Completely protection by the voltage, ampere and temperature detection system. Specific hardware design and software functions to meet the harsh environment required.

- ◆ CE / UL Certificate



FEATURES



Multiple Installations / Remote Keypad

- ◆ Full power ranges can be flange / wall mounted.
- ◆ Standard with LED remote keypad, maximum extend to 200m



Excellent Overload Capability

- ◆ The improved current overload capabilities make our Drive a better performance during acceleration/ deceleration, and overcome more harsh applications.



Kinetic Energy Braking

- ◆ When the power shuts down, the regeneration from motor braking is utilized to keep the AC drive powered until power supply recovers.

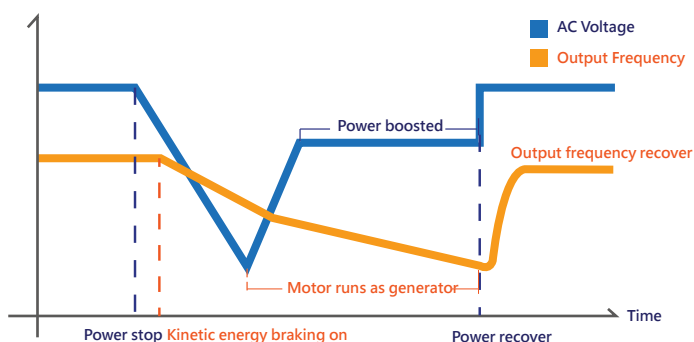

Compact Design & Full Power Range Applications

- ◆ The compact design and full power ranges of EVO6800 provides the benefits of saving space and being able to adapt in many different applications and environments.



Global Certifications

- ◆ All models comply with EU RoHS standards.
- ◆ Conformity to CE / UL / CUL.



APPLICATION

- ◆ Presses
- ◆ Ceramic Machines
- ◆ Plastic Machines
- ◆ Textile Machinery
- ◆ Fans & Pumps
- ◆ Disc Coal Feeders
- ◆ Feeders
- ◆ Belts Conveyors
- ◆ Pulverized Coal Feeders



RATINGS - 400V Class

400V Class													
Model	EVO680043S		3D7			5D5			7D5			011	
Frame			2						3				
Max. Motor Capacity	HP	HD	5			7.5			10			15	
		ND	7.5			10			15			20	
	kW	HD	3.7			5.5			7.5			11	
		ND	5.5			7.5			11			15	
Input Voltage (V) / Frequency (Hz)			3 Phases, 380V ~ 480V, -15% ~ + 10%, 50/60 Hz										
Rating Output	Current		9.5			12.6			18.5			25	
			12.6			17			25			31	
	Max. Output (Hz)		0 ~ 480 Hz										
Carrier Frequency (kHz)		2 ~ 15 kHz											
Cooling Method			Fan										
400V Class													
Model	EVO680043S		015	018	022	030	037	045	055	075	090	110	
Frame			4		5		6			7			
Max. Motor Capacity	HP	HD	20	25	30	40	50	60	75	100	125	150	
		ND	25	30	40	50	60	75	100	125	150	175	
	kW	HD	15	18.5	22	30	37	45	55	75	90	110	
		ND	18.5	22	30	37	45	55	75	90	110	132	
Input Voltage (V) / Frequency (Hz)			3 Phases, 380V ~ 480V, -15% ~ + 10%, 50/60 Hz										
Rating Output	Current		32	38	45	60	75	92	115	150	180	215	
			38	45	60	75	92	115	150	180	215	248*2	
	Max. Output (Hz)		0 ~ 400 Hz										
Carrier Frequency (kHz)		2 ~ 15 kHz				2 ~ 12 kHz			2 ~ 10 kHz				
Cooling Method			Fan										

DIMENSIONS

Unit: mm / inch

Frame	W	W1	H	H1	D	D1	S1	ø	ø1	ø2	ø3	ø4
1												
2	145 (5.71)	128 (5.04)	184 (7.25)	172 (6.77)	168 (6.56)	161 (6.34)	5.5 (0.22)	5.5 (0.22)	22 (0.87)	28 (1.10)		
3	225 (8.79)	202 (7.89)	260 (10.16)	242 (9.46)	198 (7.74)	190 (7.42)	6.5 (0.25)	6.5 (0.25)	22 (0.86)	35 (1.36)	44 (1.73)	
4	235 (9.25)	212 (8.35)	340 (13.38)	322 (12.68)	218 (8.59)	210 (8.27)	6.5 (0.25)	6.5 (0.25)	22 (0.86)	28 (1.10)	35 (1.36)	
5	281 (11.06)	257 (10.11)	385 (15.15)	367 (14.45)	219 (8.62)	211 (8.30)	6.5 (0.25)	6.5 (0.25)	22 (0.86)	28 (1.10)	35 (1.36)	44 (1.73)
6	304 (11.88)	270 (10.55)	550 (21.48)	530 (20.70)	323 (12.62)	315 (12.30)	11 (0.43)	11 (0.43)				
7	344 (13.43)	260 (10.15)	665 (25.97)	640 (25.00)	358 (13.98)	350 (13.67)	11 (0.43)	11 (0.43)	19 (0.74)			

DIMENSIONS

Frame 2

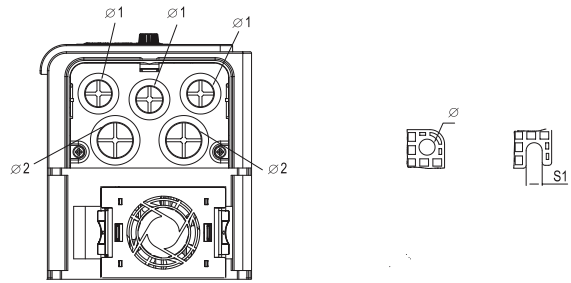
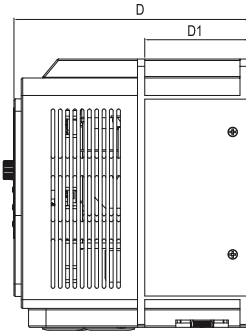
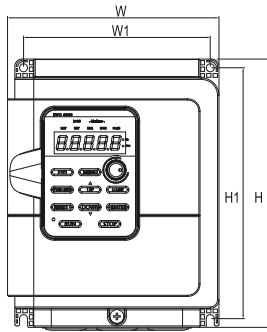

Frame 3

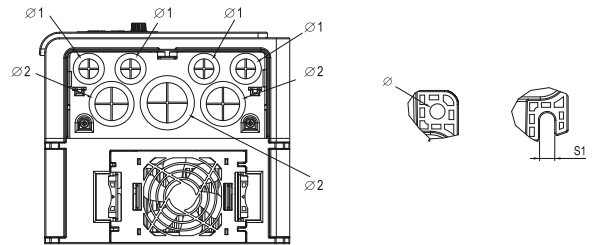
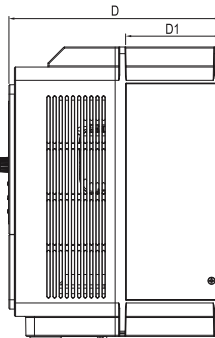
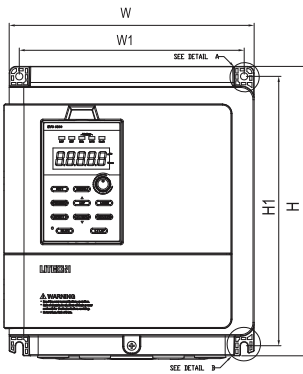

Frame 4

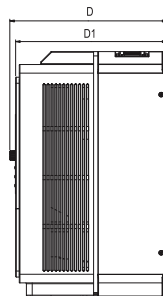
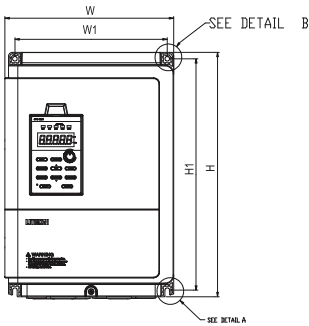

Frame 5

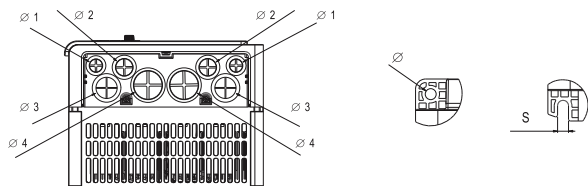
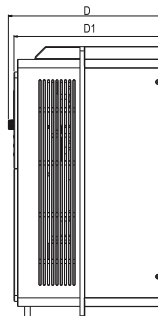
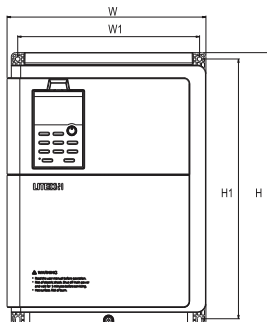

DIMENSIONS

Frame 6

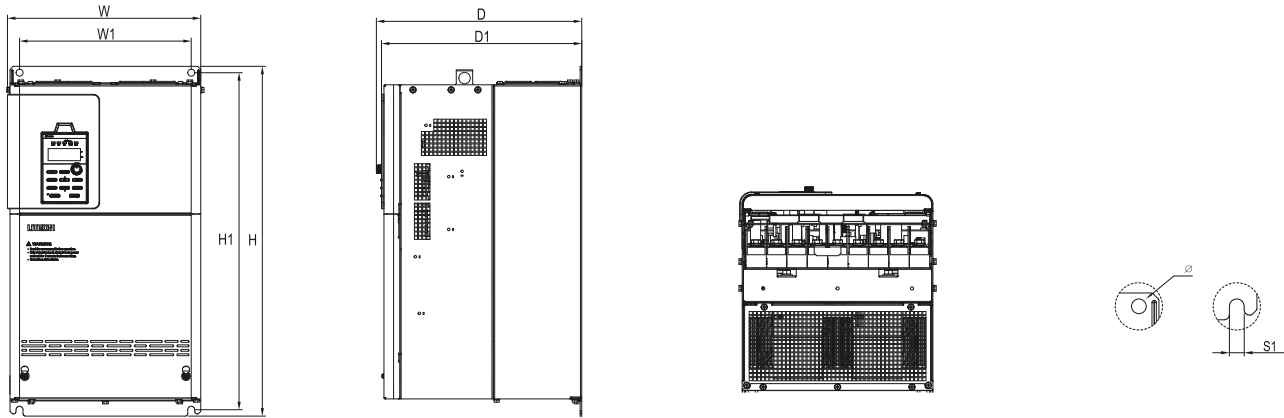

Frame 7

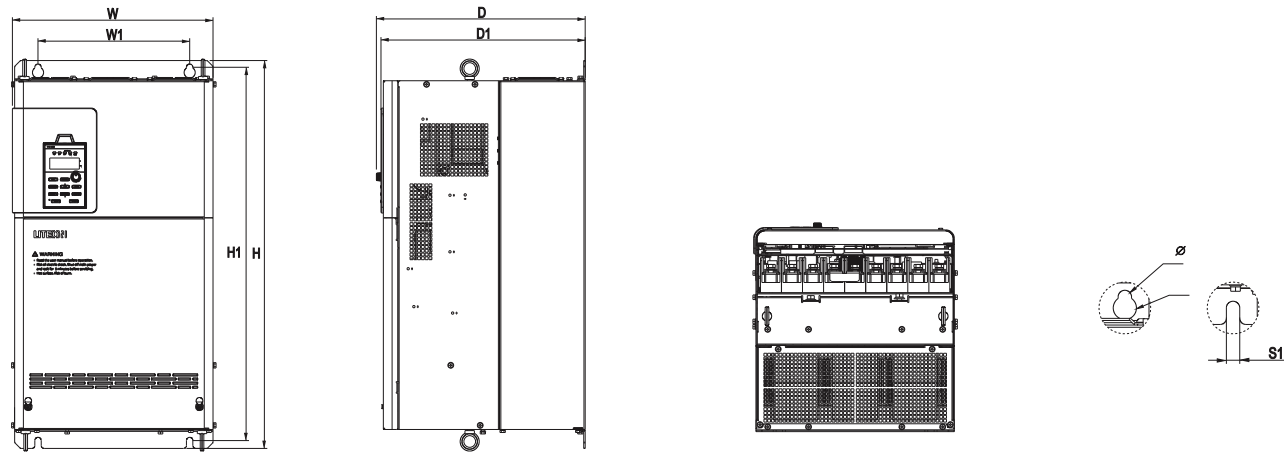

TERMINAL BLOCK DESCRIPTION

- 200V

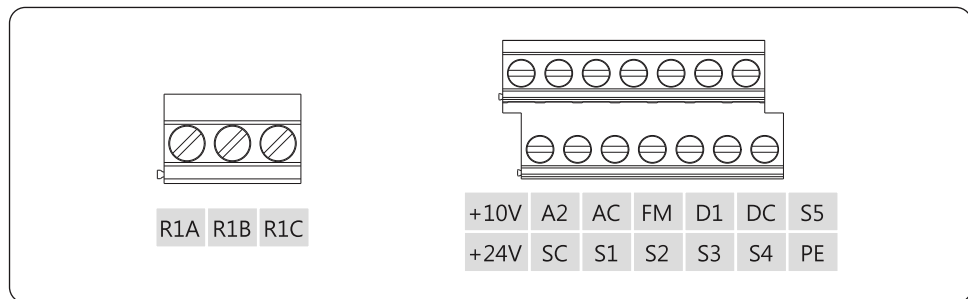
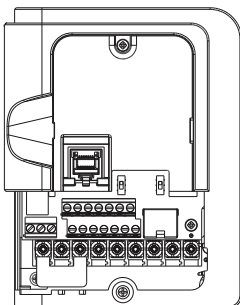

TERMINAL BLOCK DESCRIPTION

- 400V F1~F2

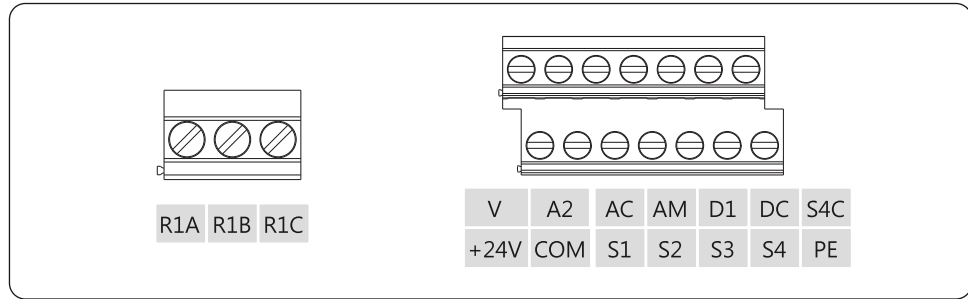
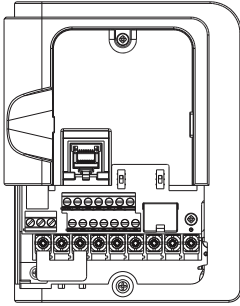

- 400V F3~F7

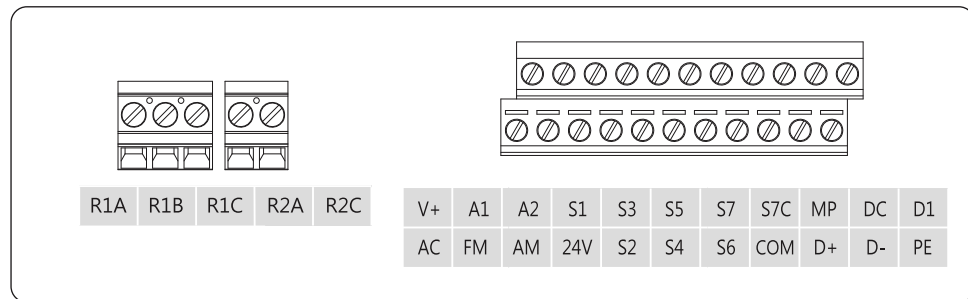
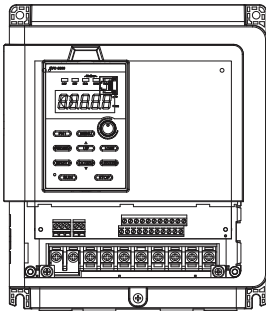

KEYPAD DIMENSIONS

Frame	W	W1	W2	H	H1	H2	D	D1
F1-F2	66	40	18.5	90	64	17.6	16	8.2
F3-F7	72	36	18	110	93	18.9	15	8.5

● F1 - F2

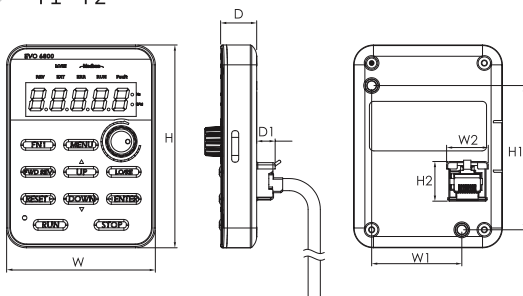

● F3 - F7

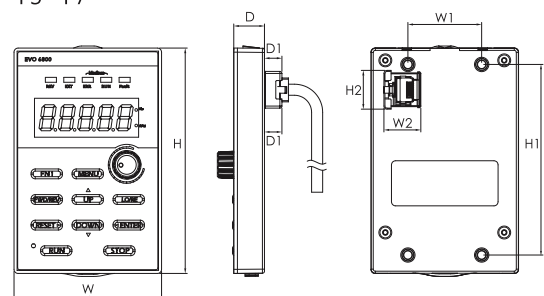

GENERAL SPECIFICATION

Item		Specification
Control Characteristic	Control Method	V / F, Sensorless Voltage Vector Control (SVVC)
	Output Frequency	0 ~ 400 Hz
	Frequency Accuracy	Digital reference: within $\pm 0.01\%$ of the Max. output frequency
		Analog reference: within $\pm 0.01\%$ of the Max. output frequency
	Frequency Setting Resolution	Digital input: 0.01 Hz
		Analog Output: 1/1000 of Max. frequency
	Starting Torque*	150% / 3 Hz (V/F)
		150% / 1 Hz (IM Sensorless Voltage Control)
	Speed Control Range*	1:40 (V/F)
		1:100 (Sensorless Voltage Vector Control)
	Speed Control Accuracy	$\pm 0.2\%$ in Sensorless Voltage Vector Control
	Speed Response	> 5 Hz in Sensorless Voltage Vector Control
	Acc / Dec Time	0.0 ~ 6000.0 sec
Speed Response	approx. 20%	
Overload Capacity	150% for 1 min. within every 10 min.	
Operating Environment	Area of Use	Indoor without corrosive gas / liquid or flammable gas / liquid / oil mist / dust
	Ambient Temperature	-10°C ~ +50°C, -10°C ~ +40°C (NEMA type 1), below 90% RH without froze or condensation
	Storage Temperature	-20°C ~ +60°C
	Altitude	Up to 1000 meters
	Vibration	Below 9.8 m/s ² (10 ~ 20 Hz), below 5.9 m/s ² (20 ~ 55Hz)
	Enclosure	IP20, NEMA1 (with NEMA kit option)
Number of I/O F1-F2	Analog Input (AI)	1 point (A2:0 ~ 5V, 0 ~ 10V, 0 or 4 ~ 20mA)
	Digital Input (DI)	200V: 5 points; 400V: 4 points
	Analog Output (AO)	200V: FM 0 ~ 10V 400V : AM 0 ~ 10V / 0 or 4 ~ 20mA
	Digital Output (DO)	1 point
	Relay Output (RO)	1 point
Number of I/O F3-F7	Analog input (AI)	2 points (A1:0 ~ 10V, -10 ~ 10V / A2: 0 or 4 ~ 20mA, 0 ~ 10V, 0 ~ 5V)
	Digital input (DI)	7 points
	Analog Output (AO)	2 points (FM:0 ~ 10V, -10V ~ 10V / AM: 0 or 4 ~ 20mA, 0 ~ 10V)
	Digital Output (DO)	1 point
	Relay Output (RO)	2 points
	Pulse Input (PI)	1 point (1 Common digital input point)
	Pulse Output (PO)	1 point
Build - In	Modbus (RS-485), communication at max.speed 115200 bps	
Option) (under development	Profibus - DP, CANopen, EtherCAT	

*The data is tested under laboratory environment conditions.

TERMINAL BLOCK DESCRIPTION

200V				
Type	Terminal Name	Code	Terminal Description	
Main Circuit (200V)	AC power input	R/L1	Input power terminal	
		S/L2		
		T/L3		
	Braking resistor	B1	200V: Braking transistor built-in. Please purchase optional braking resistor to connect	
		B2		
	AC drive output	U/T1	Please connect to AC motor	
		V/T2		
W/T3				
Ground terminal	E	Ground terminal for AC drive. Please ensure grounding is properly wired.		
Control Circuit	Digital input terminal 1	S1	Photo coupler: input voltage 24V/8mA Default setting on sink mode. Use Sink/Source DIP switch on the control board to set sink/source mode for multi-function digital inputs.	ON: Forward / OFF : Stop
	Digital input terminal 2	S2		ON: Reverse / OFF : Stop
	Digital input terminal 3	S3		External fault 1 (normal open)
	Digital input terminal 4	S4		Fault reset
	Digital input terminal 5	S5		Multi-speed freq. command
	Digital output terminal 1	D1	Programmable digital output terminal, Photo coupler output 30V/2 ~ 15mA	
	Digital output common	DC	Digital output terminal	
	Digital input common	SC	Common terminal of digital input for NPN/PNP mode switch.	
	Digital input signal power	+24V	Digital control signal common +24V/50mA	
	Auxiliary power	+10V	Auxiliary power terminal for analog input +10V/20mA	
	Analog input terminal 1	A1	Programmable analog input 0 or 4 ~ 20mA / 0 ~ 10V/ 0 ~ 5V Main frequency command	
	Analog signal common	AC	Common terminal of analog signal	
	Analog output	FM	Programmable analog output, 0 ~ 10V	
	Shielded Ground	PE	Ground terminal for control signal shielded cable to effectively suppress external interference. Please ensure this is properly wired.	
	Relay 1	R1A	Normal open terminal	Relay output
		R1B	Common terminal of analog signal	DC30V 3A
		R1C	Programmable analog output, 0 ~ 10V	AC250V 5A
Com.	RS-485 port	RJ45	To connect RS-485 communication at max. speed 115200 bps	

TERMINAL BLOCK DESCRIPTION

400V F1 ~ F2				
Type	Terminal Name	Code	Terminal Description	
Main Circuit (400V)	AC power input	R/L1	Input power terminal	
		S/L2		
		T/L3		
	Braking resistor	B1	400V: Braking transistor built-in. Please purchase optional braking resistor to connect	
		B2		
	DC Power negative output	-	DC Power negative input	
	AC drive output	U/T1	Please connect to AC motor	
V/T2				
W/T3				
Control Circuit	Digital input terminal 1	S1	Photo couple: input voltage 24V/8mA Default setting on sink mode. Use Sink / Source DIP switch on the control board to set sink / source mode for multi-function digital input.	ON: Forward / OFF : Stop
	Digital input terminal 2	S2		ON: Reverse / OFF : Stop
	Digital input terminal 3	S3		External fault 1 (normal open)
	Digital input terminal 4	S4	Pulse input terminal 50kHz	Fault reset
	Digital input common	S4C	Common terminal of digital input	Frequency command
	Digital output terminal 1	D1	Programmable digital output terminal. Photo coupler output Pulse output 50kHz/24V 15mA	Zero speed
				Frequency command
	Digital output common	DC	Digital output terminal	
	Digital input signal power	+24V	Digital control signal common +24V/200mA	
	Auxiliary power	+V	Auxiliary power terminal for analog input +10V/5mA	
	Analog input terminal 2	A2	Programmable analog input 0 or 4 ~ 20mA / 0 ~ 10V/ 0 ~ 5V	
	Analog signal common	AC	Common terminal of analog signal	
	Analog output	AM	Programmable analog output, 0 or 4 ~ 20mA / 0 ~ 10V	
	Analog signal common	AC	Common terminal of analog signal	
	Relay 1	R1A	Normal open terminal	Relay output
R1B		Normal closed terminal	DC30V 3A	
R1C		Common terminal	AC250V 5A	
Com.	RS-485 port	RJ45	To connect RS-485 communication at max. speed 115200 bps	

TERMINAL BLOCK DESCRIPTION

400V F3 ~ F7				
Type	Terminal Name	Code	Terminal Description	
Main Circuit	AC power input	R/L1	Input power terminal	
		S/L2		
		T/L3		
	Braking resistor	B1	400V Class, ≤ 37kW: Braking transistor built-in. Please purchase optional braking resistor to connect.	
		B2	200V Class, ≤ 22kW: Braking transistor built-in. Please purchase optional braking resistor to connect.	
	Braking module	DC+	400V Class, ≥ 45kW: Please purchase optional braking resistor to connect.	
		DC-	200V Class, ≥ 30kW: Please purchase optional braking resistor to connect.	
	DC reactor	DC+1	400V Class, 11kW ~ 132kW: Please remove the jumper and connect DC reactor to these terminals. 400 class ≥ 45kW: selection of build-in DC reactor is available.	
		DC+2		
		P/DC+		
	AC drive output	U/T1	Please connect to AC motor	
		V/T2		
		W/T3		
Ground terminal	E	Ground terminal for AC drive. Please ensure grounding is properly wired.		
Control Circuit	Auxiliary power	V+	Auxiliary power terminal for analog input +10/20mA	
	Analog signal common	AC	Common terminal of analog signal	
	Analog input terminal 1	A1	Programmable analog input 1, 0 ~ 10V / -10 ~ +10V	Main frequency command
	Analog input terminal 2	A2	Programmable analog input 2, 0 or 4 ~ 20mA / 0 ~ 10V / 0 ~ 5V	Auxiliary freq. command
	Analog output 1	FM	Programmable analog output, 0 ~ 10V / -10 ~ +10V	Output frequency
	Analog output 2	AM	Programmable E6e analog output, 0 or 4 ~ 20mA / 0 ~ 10V	Output current
	Digital input signal power	24V	Power terminal for digital control signal +24V / 200mA	
	Digital input terminal 1	S1	Photo coupler: input voltage 24V/8mA Default setting on sink mode. Use Sink/Source DIP switch on the control board to set sink/source mode for multi-function digital inputs.	ON: Forward / OFF: Stop
	Digital input terminal 1	S2		ON: Reverse/ OFF: Stop
	Digital input terminal 1	S3		External fault 1(normal open)
	Digital input terminal 1	S4		Fault reset
	Digital input terminal 1	S5		Multi-spec freq. command 1
	Digital input terminal 1	S6		Multi-spec freq. command 2
	Digital input terminal 1	S7		
	Digital input terminal common	S7C	Digital input terminal common	
	Digital input common	COM	Common terminal of digital input	
	Pulse train output terminal	MP	Programmable pulse train output, voltage output 30V / 30mA, max.freq. 50kHz	Freq. command (default)
	Digital output terminal 1	D1	Programmable digital output terminal, Photo coupler output 48V/2 ~ 50mA	
	Digital output common	DC	Digital output terminal	
	RS-485 port	D+	To connect RS-485 communication at max. speed 115200 bps	
		D-		
	Shielded Ground	PE	Ground terminal for control signal shielded cable to effectively suppress external interference. Please ensure this is properly wired.	
	Relay 1	R1A	Normal open terminal	
		R1B	Normal closed terminal	
		R1C	Common terminal	
	Relay 2	R2A	Normal open terminal 2	
		R2C	Common terminal 2	
Com.	RS-485 port	RJ45	To connect RS-485 communication at max. speed 115200 bps	

WIRING DIAGRAM

200V

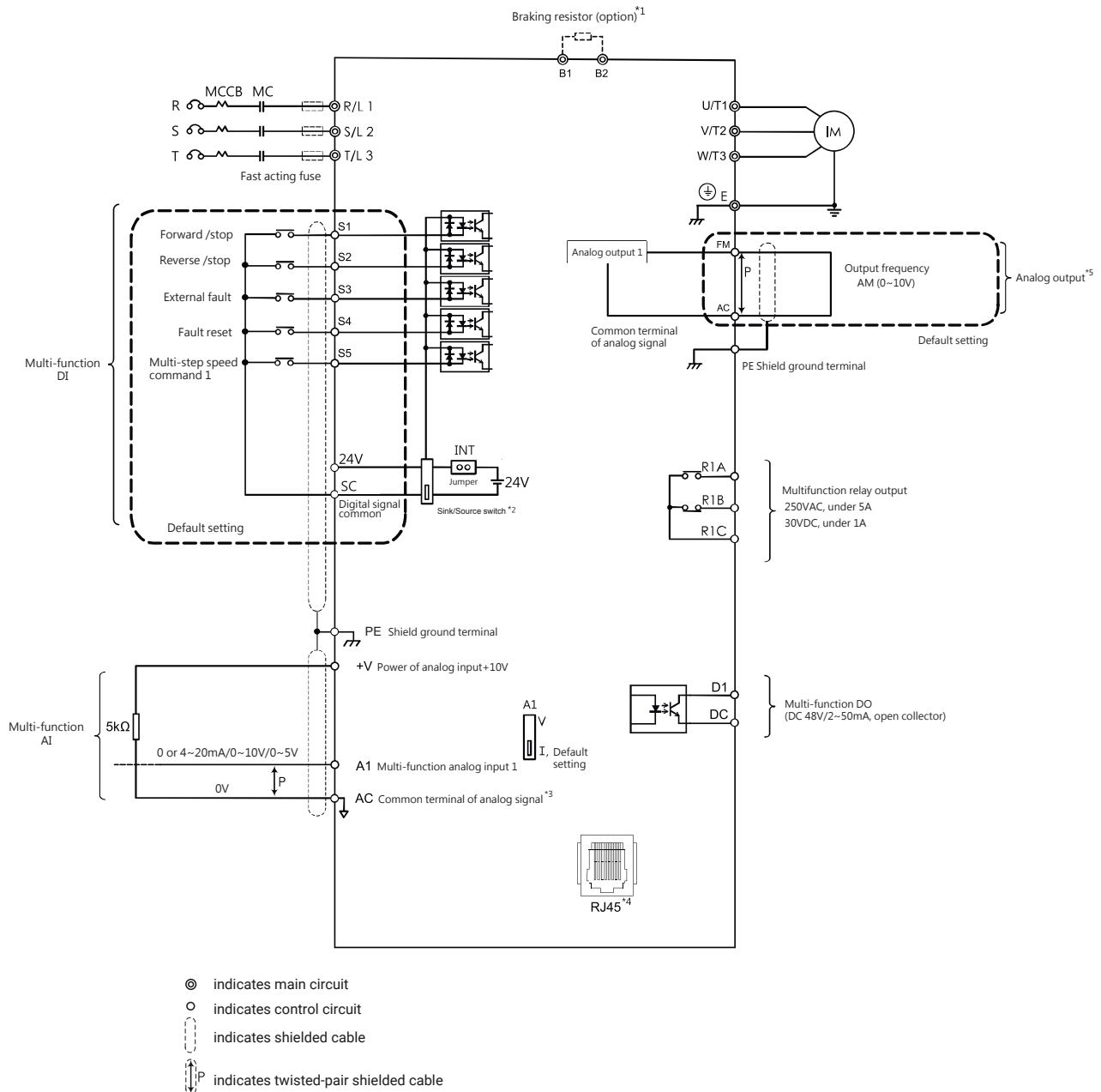

Notes:

- *1. When using braking resistor, please ensure stall prevention function is off.
- *2. Multi-function analog input S1~S7 can be switched between Sink(NPN) or Source(PNP) mode. Default NPN mode.
- *3. AC is common terminal of analog signal (Analog Common).
- *4. RJ45 is the communication port of RS-485.
- *1. When using braking resistor, please ensure stall prevention function is off.
- *5. Analog output is used to connect frequency meter, current meter, voltage meter and power meter.
- *6. This catalog includes the blueprint of our products in the future. For more precise specifications, please refer to the quick start that alongside with our products. If you have any question, please contact our authorized distributors or LITE-ON

WIRING DIAGRAM

400V F1~F2

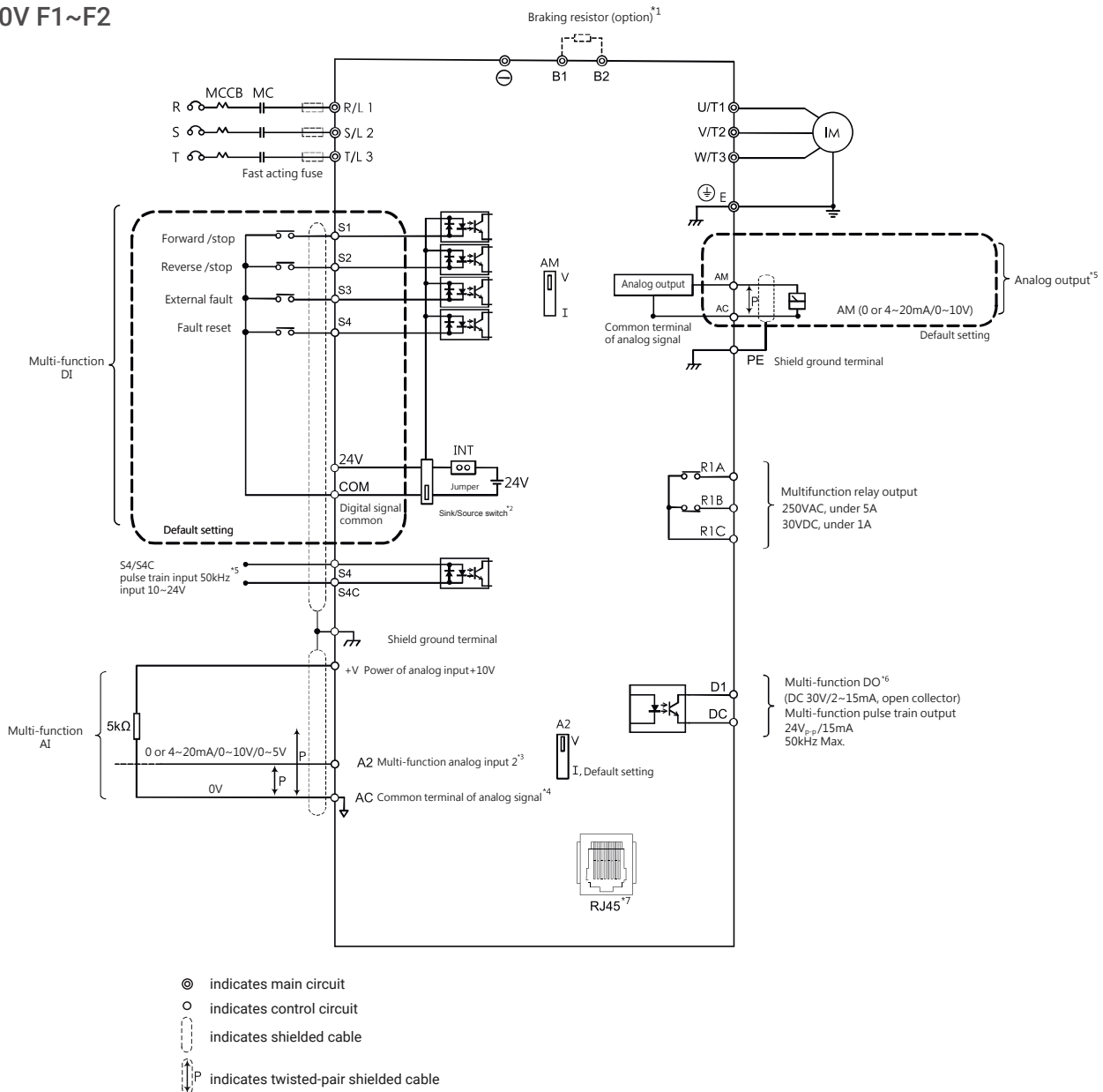

Notes:

- *1. When using braking resistor, please ensure stall prevention function is off.
- *2. Multi-function analog input S1~S7 can be switched between Sink(NPN) or Source(PNP) mode. Default NPN mode.
- *3. Switch A2 is used to set analog input as voltage input or current input.
- *4. AC is common terminal of analog signal (Analog Common).
- *5. Pulse input and digital inputs share the same terminal (5.5kW or less shared S4,7.5kW more common S7).
- *6. Pulse output and digital outputs share the same terminal (5.5kW or less shared S4,7.5kW more common S7)
- *7. RJ45 is the communication port of RS-485.
- *8. Analog output is used to connect frequency meter, current meter, voltage meter and power meter
- *9. This catalog includes the blueprint of our products in the future. For more precise specifications, please refer to the quick start that alongside with our products. If you have any question, please contact our authorized distributors or LITE-ON

WIRING DIAGRAM

400V F3~F7

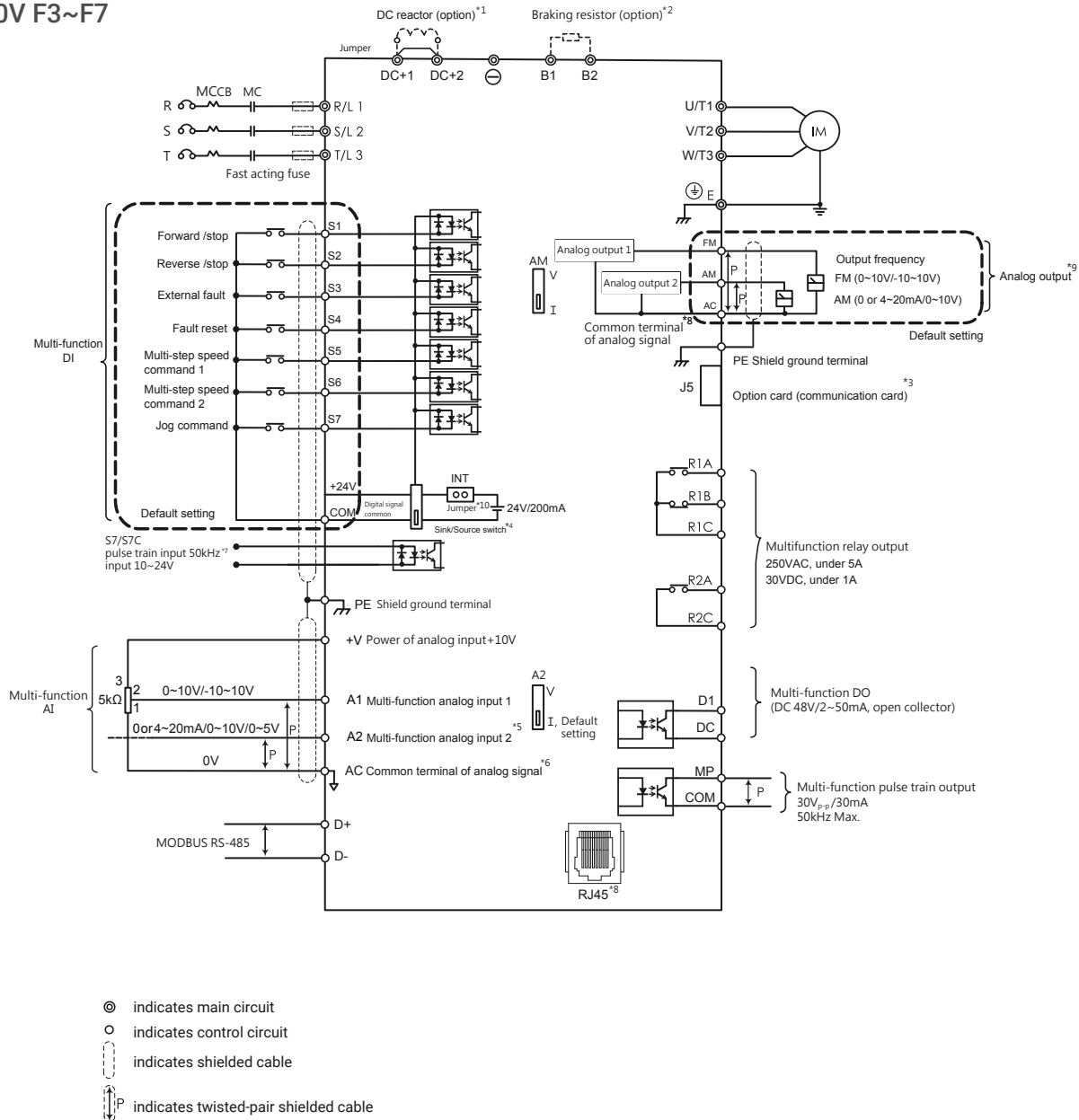

Notes:

- *1. Please remove DC+(+1/+2) jumper when installing DC reactor.
- *2. When using braking resistor, please ensure stall prevention function is off.
- *3. J5 is port of optional communication card. Please refer to user manual when installing it.
- *4. Multi-function analog input S1~S7 can be switched between Sink(NPN) or Source(PNP) mode. Default NPN mode.
- *5. Switch A2 is used to set analog input as voltage input or current input.
- *6. AC is common terminal of analog signal (Analog Common).
- *7. Pulse input and digital inputs share the same terminal (5.5kW or less shared S4,7.5kW more common S7).
- *8. RJ45 is the communication port of RS-485.
- *9. Analog output is used to connect frequency meter, current meter, voltage meter and power meter.
- *10. Insert the jumper to control board to use the internal 24V signal or remove it to use the external 24V signal

REMOTE KEYPAD EVO6-KIT-RK

- ◆ Monitors and edits parameter settings.
- ◆ Supports installation on the cabinet without any extra kit.
- ◆ Maximim 50 meter cable length.
- ◆ Same keys as the built-in LED keypad.
- ◆ Connected via RJ45.
- ◆ Supports 2 installation types.

- Remote keypad size

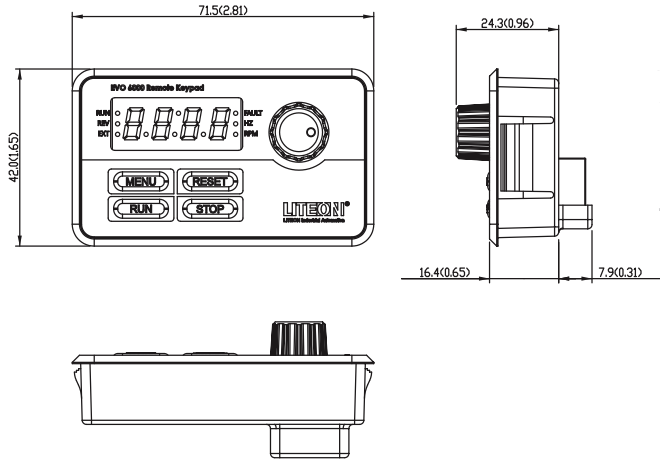

- Screw Installation

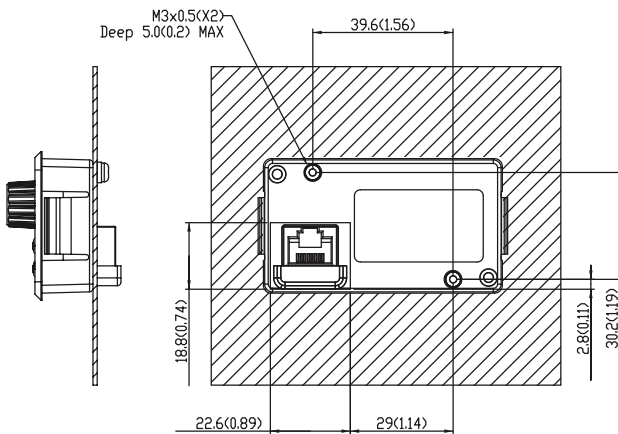

- Embedded Installation
- Board thickness=1.2mm (0.05inches)

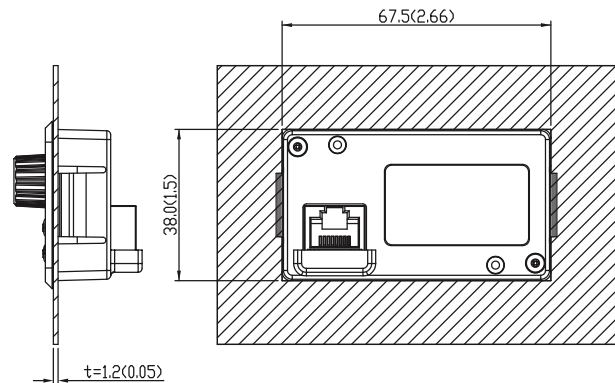

- Embedded Installation
- Board thickness=1.6mm (0.06inches)

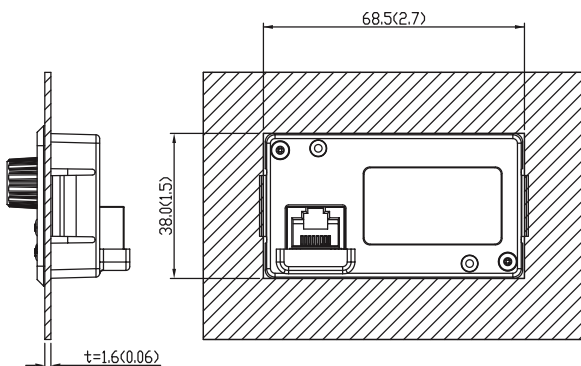

- Embedded Installation
- Board thickness=2.0mm (0.08inches)

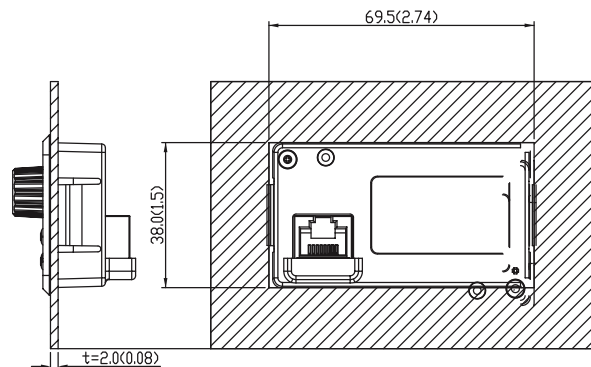

COPY UNIT

- ◆ The Copy Unit provides user convenience to manage a large number of EVO series AC motor drive parameters. This unit can set parameter of inverter quickly and saved up to 8 sets of parameter in this device. Please use RJ45 cable(less than 10m) for connecting to AC motor drive.
- ◆ Quickly copy all parameter settings at once.
- ◆ Saves up to 8 sets of inverter setting.
- ◆ Reads and loads parameter settings.
- ◆ Setting comparison function built-in.
- ◆ Connected via RJ45.

• Copy unite size

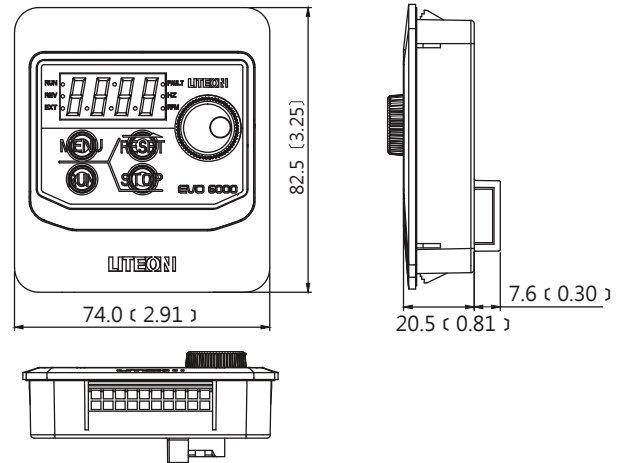

• Screw Installation

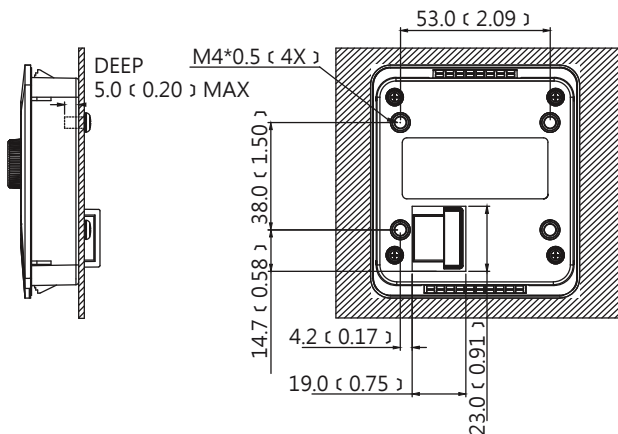

- Embedded Installation
- Board thickness=1.2mm (0.05inches)

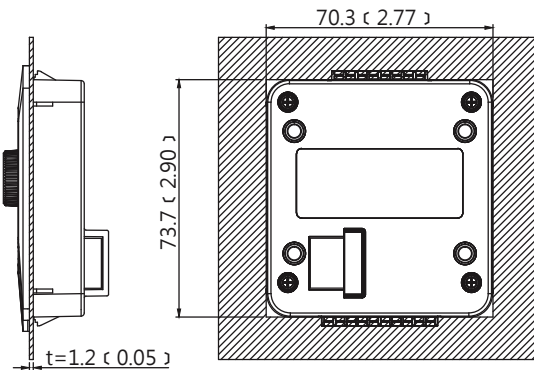

- Embedded Installation
- Board thickness=1.6mm (0.06inches)

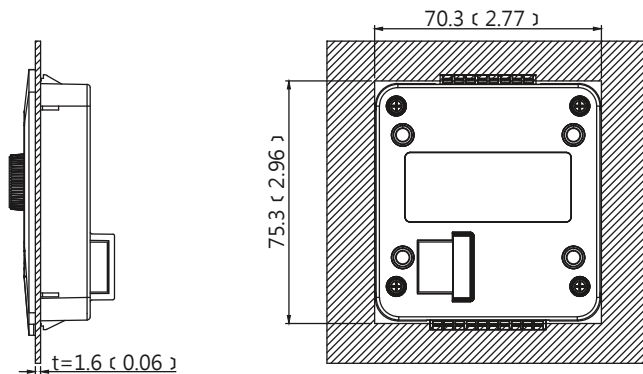

- Embedded Installation
- Board thickness=2.0mm (0.08inches)

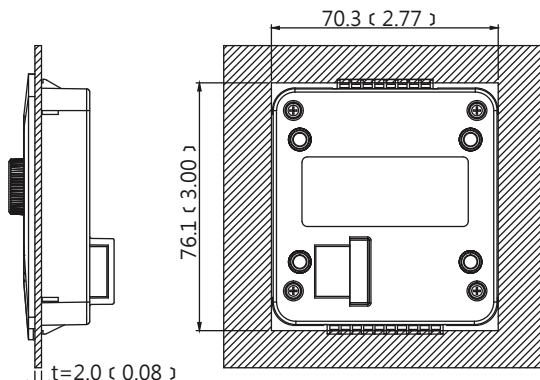

ACCESSORIES

EVO Series Common Accessories		
Name	Model Number	Description
Copy unit	EVO-KIT-CU	Allows parameter uploads / downloads and comparison
Communication converter	EVO-KIT-DON	USB converter RS485
RJ45 cable	EVO-CBL-MRJ	Connect AC drive to PC or remote keypad use cable (indicates 1, 3, 5, 10, 20 meters)
USB cable	EVO-CBL-MUSB	Connect AC drive to PC use cable (indicates 1, 3, 5 meters)
EVO 6800 Series		
Name	Model Number	Description
CANopen communication card	EVO68 - Comm - CO	Connects AC drive with CANopen for remote setting and monitoring
Remote keypad	EVO68 - KIT - RK	Connects remote keypad for remote setting and monitoring (indicates S: frame 1-2, L:frame 3-7)
Plastic keypad tray	EVO68 - KIT - PT	Plastic tray for keypad cabinet installation (indicates S: frame 1-2, L: frame 3-7)
NEMA 1 kit	EVO68 - KIT - N1	Upgrade AC drive enclosure to NEMA 1
EVO 6000 Series		
Name	Model Number	Description
CANopen communication card	EVO6 - Comm - CO	Connects AC drive with CANopen for remote setting and monitoring
Braking unit	EVO68 - DBU - 2*	Connects AC drive terminal DC+, DC- to significantly improve braking.
	EVO68 - DBU - 4	Please ensure braking resistor is properly installed. (indicates 1D5, 3D7 model)
Braking resistor	Please refer to manual when selecting resistor type	Connects braking module to dissipate regenerative power
DIN rail	EVO6 - KIT - DR	Accessory for DIN rail installation (indicates frame 1 or 2)
Remote keypad	EVO6 - KIT - RK	Connects remote keypad for remote setting and monitoring (indicates Blank: Square, D: Horizontal, S: Vertical)

LITE-ON GROUP OPERATIONS ACROSS AMERICA, EUROPE AND ASIA.



www.nicsanat.com

021-87700210



www.nicsanat.com
021-87700210



GET MORE INFORMATION

LITEON Industrial Automation
www.liteon-ia.com

FOLLOW US

[Facebook.com/liteonia](https://www.facebook.com/liteonia)

WeChat ID:
LITE-ON_IA



LINE ID:
@liteon_ia



CONTACT US

Techtop Industries Incorporated
2815 Colonades Court
Peachtree Corners, GA 30071
(678) 436-5540
Email: Info@techtopynd.com
www.techtopynd.com



Specification are subject to change without notice.
If you have any question, please contact our authorized distributors or LITE-ON
Copyright © LITE-ON Industrial Automation. All rights reserved