

• 15P0102B1 •

SINUS PENTA

MULTIFUNCTION AC DRIVE

USER MANUAL - Installation Guide -

Issued on 25/09/2013
R.06.2

English

- This manual is integrant and essential to the product. Carefully read the instructions contained herein as they provide important hints for use and maintenance safety.
- This device is to be used only for the purposes it has been designed to. Other uses should be considered improper and dangerous. The manufacturer is not responsible for possible damages caused by improper, erroneous and irrational uses.
- Elettronica Santerno is responsible for the device in its original setting.
- Any changes to the structure or operating cycle of the device must be performed or authorized by Elettronica Santerno.
- Elettronica Santerno assumes no responsibility for the consequences resulting by the use of non-original spare-parts.
- Elettronica Santerno reserves the right to make any technical changes to this manual and to the device without prior notice. If printing errors or similar are detected, the corrections will be included in the new releases of the manual.
- The information contained herein is the property of Elettronica Santerno and cannot be reproduced. Elettronica Santerno enforces its rights on the drawings and catalogues according to the law.



www.nicsanat.com
021-87700210



REVISION INDEX

The following subjects covered in this User Manual (Installation Instructions) R.06.2 have been added, changed or suppressed in respect to revision R.06.

The User Manuals mentioned in this manual have been added below.

The following sections: Nameplate, Transport and Handling, Unpacking, Scheduled Maintenance have been added.

Warnings concerning Motor and bearings insulation protection, Sensors integrated in the motor, Critical torsional speeds, Transient torque analysis have been added.

Notes concerning Installation clearance, Touch current in the ground conductor, Decisive voltage class according to IEC 61800-5-1 for terminal boards have been added.

A section covering additional safety standards for permanent magnets motors has been added.

In the Modular IP00 STAND-ALONE Models (S64–S90) section, Partial dimensions, Partial weights and Partial power dissipation have been removed (only Overall dimensions, Overall weights and Overall power dissipation are now mentioned).

The noise levels (db(A)) for stand-alone models and modular models have been added. No noise levels have been added for the Box and Cabinet models.

The phrase “The precharge circuit of DC-bus capacitors is not present” has been better explained and replaced with “The precharge circuit of DC-bus capacitors is not present (in S64, S74 and S84) or upstream of the DC power supply terminals (in S41, S42, S51, S52, S60)”.

The phrase “DC current power supply” has been replaced with “DC voltage power supply”.

The term “reactor” has been replaced with “inductor”.

The IP54 models, S05 0020 2T and S14 0032 5T/6T, have been removed because unavailable.

Maximum surrounding air temperature increased to 55°C following the Type Tests required by DNV Marine Certification.

SANTERNO USER MANUALS MENTIONED IN THIS INSTALLATION GUIDE

The following Santerno User Manuals are mentioned throughout this Installation Guide:

- **15R0102B1** Sinus Penta - Programming Guide
- **15N0102B1** Sinus Penta - ES821 Spare User Manual
- **15Q0102B00** Sinus Penta - Guide to the Regenerative Application
- **15Q0102B10** Sinus Penta - Guide to the Multipump Application
- **15Q0102B200** Sinus Penta - Guide to the Synchronous Motor Application
- **15P0101B1** Sinus Penta - Assembly Instructions for Modular Inverters
- **15G0010B1** PROFIdrive COMMUNICATIONS BOARD - Installation and Programming Instructions
- **15G0851B100** DATA LOGGER ES851 - Programming Instructions
- **16B0901B1** Remote Drive DRIVE REMOTE CONTROL - User Manual
- **15M0102B10** Sinus Penta - Guide for Capacitor Reforming

0. TABLE OF CONTENTS

REVISION INDEX	2
SANTERNO USER MANUALS MENTIONED IN THIS INSTALLATION GUIDE	2
0. TABLE OF CONTENTS.....	3
0.1. Index of Figures.....	10
1. GENERAL DESCRIPTION.....	15
1.1. Feature List.....	16
1.2. Special Applications Available on Sinus Penta.....	17
2. SAFETY STATEMENTS.....	18
2.1. Installing and Operating the Equipment.....	18
2.2. Permanent Magnet Motors.....	20
3. EQUIPMENT DESCRIPTION AND INSTALLATION.....	21
3.1. Products Covered in this Manual.....	21
3.2. Delivery Check.....	22
3.2.1. Nameplate.....	23
3.2.2. Transport and Handling.....	25
3.2.3. Unpacking.....	25
3.3. Installing the Equipment.....	27
3.3.1. Environmental Requirements for the Equipment Installation, Storage and Transport.....	27
3.3.2. Air Cooling.....	29
3.3.3. Scheduled Maintenance.....	32
3.3.4. Air Filters.....	32
3.3.5. Heat Sink and Ambient Temperature Check.....	34
3.3.5.1. Control Board.....	34
3.3.5.2. Cleaning the Heat Sink.....	34
3.3.6. Cooling Fans.....	34
3.3.6.1. Replacing the Cooling Fans.....	34
3.3.7. Capacitors.....	34
3.3.7.1. Capacitor Reforming.....	34
3.3.7.2. Replacing a Capacitor.....	34
3.3.8. Bypass Contactor.....	35
3.3.8.1. Replacing the Bypass Contactor.....	35
3.3.9. Size, Weight, Dissipated Power, Noise Level.....	36
3.3.9.1. IP20 and IP00 STAND-ALONE Models (S05–S60) Class 2T.....	36
3.3.9.2. IP20 and IP00 STAND-ALONE Models (S05–S60) Class 4T.....	37
3.3.9.3. IP20 and IP00 STAND-ALONE Models (S12–S52) Class 5T-6T.....	38
3.3.9.4. Modular IP00 STAND-ALONE Models (S64–S90).....	39
3.3.9.5. IP54 STAND-ALONE Models (S05–S30) Class 2T.....	44
3.3.9.6. IP54 STAND-ALONE Models (S05–S30) Class 4T.....	45
3.3.9.7. IP54 STAND-ALONE Models (S12–S32) Class 5T-6T.....	46
3.3.9.8. IP54 BOX Models (S05–S20) Class 2T.....	47
3.3.9.9. IP54 BOX Models (S05–S20) Class 4T.....	48
3.3.9.10. IP24 and IP54 Cabinet Models (S15–S90).....	49
3.3.10. Standard Mounting and Piercing Templates (IP20 and IP00 Stand-Alone Models S05–S60).....	51
3.3.11. Through-Panel Assembly and Piercing Templates (IP20 and IP00 Stand-Alone Models S05–S52).....	53
3.3.11.1. Sinus Penta S05.....	53
3.3.11.2. Sinus Penta S12.....	54
3.3.11.3. Sinus Penta S14.....	55
3.3.11.4. Sinus Penta S15–S20–S30.....	56
3.3.11.5. Sinus Penta S22–S32.....	57
3.3.11.6. Sinus Penta S41–S42–S51–S52.....	59
3.3.12. Standard Mounting and Piercing Templates (IP00 Modular Models S64–S90).....	61
3.3.12.1. Installation and Lay-out of the Connections of a Modular Inverter (S65).....	63
3.3.13. Standard Mounting and Piercing Templates (IP54 Stand-Alone Models S05–S32).....	64

3.4.	Power Connections	65
3.4.1.	Wiring Diagram for inverters S05–S60	67
3.4.2.	Wiring Diagram for Modular Inverters S64–S90	69
3.4.2.1.	External Connections for Modular Inverters S65 and S70	69
3.4.2.2.	External Connections for Modular Inverters S64	70
3.4.2.3.	External Connections for Modular Inverters S74, S75 and S80	71
3.4.2.4.	External Connections for Modular inverters S84 and S90	71
3.4.2.5.	12-pulse Connection for Modular Inverters	71
3.4.2.6.	Internal Connections for Modular Inverters S65 and S70	73
3.4.2.7.	Internal Connections for Modular Inverters S64	80
3.4.2.8.	Internal Connections for Modular Inverters S74, S75 and S80	84
3.4.2.9.	Internal Connections for Modular Inverters S84 and S90	84
3.4.3.	Power Terminals for S05–S52	85
3.4.4.	Power Terminals Modified for a DC Inductor	88
3.4.5.	Connection Bars for S60 Inverters	89
3.4.6.	Connection Bars for Modular Inverters S64–S70	90
3.4.7.	Connection Bars for Modular Inverters S74–S80	91
3.4.8.	Connection Bars for Modular Inverters S84–S90	92
3.4.9.	Auxiliary Power Supply Terminals	93
3.4.10.	Cross-sections of the Power Cables and Sizes of the Protective Devices	93
3.4.10.1.	2T Voltage Class	94
3.4.10.2.	UL-approved Fuses - 2T Voltage Class	95
3.4.10.3.	UL-approved Surge Protective Devices (SPDs) - 2T Voltage Class	96
3.4.10.4.	4T Voltage Class	97
3.4.10.5.	UL-approved Fuses - 4T Voltage Class	100
3.4.10.6.	5T and 6T Voltage Classes	101
3.4.10.7.	UL-approved Fuses - 5T and 6T Voltage Classes	103
3.4.11.	Inverter and Motor Ground Connection	104
3.5.	Control Terminals	105
3.5.1.	Main Features	105
3.5.1.1.	Gaining Access to Control Terminals and Power Terminals in IP20 and IP00 Models ..	107
3.5.1.2.	Gaining Access to Control Terminals and Power Terminals in IP54 Models	108
3.5.1.3.	Grounding Shielded Cable Braiding	109
3.5.2.	Control Board Signals and Programming	110
3.5.2.1.	Display and Indicator LEDs	111
3.5.2.2.	DIP-switches	114
3.5.2.3.	Configuration Jumpers	116
3.5.3.	Digital Inputs (Terminals 14 to 21)	117
3.5.3.1.	START (Terminal 14)	117
3.5.3.2.	ENABLE (Terminal 15)	118
3.5.3.3.	RESET (Terminal 16)	118
3.5.3.4.	Connecting the Encoder and Frequency Input (Terminals 19 to 21)	119
3.5.3.5.	Technical Sheet for Digital Inputs	120
3.5.4.	Analog Inputs (Terminals 1 to 9)	121
3.5.4.1.	REF Single-ended Reference Input (Terminal 2)	122
3.5.4.2.	Differential Auxiliary Inputs (Terminals 5–8)	123
3.5.4.3.	Motor Thermal Protection Input (PTC, Terminals 7-8)	125
3.5.4.4.	Technical Sheet for Analog Inputs	127
3.5.5.	Digital Outputs (Terminals 24 to 34)	128
3.5.5.1.	Push-Pull Output MDO1 and Wiring Diagrams (Terminals 24 to 26)	128
3.5.5.2.	Open-collector MDO2 Output and Wiring Diagrams (Terminals 27-28)	130
3.5.5.3.	Relay Outputs (Terminals 29-34)	131
3.5.5.4.	Technical Sheet for Digital Outputs	132
3.5.6.	Analog Outputs (Terminals 10 to 13)	133
3.5.6.1.	Technical Sheet for Analog Outputs	133
3.6.	Operating and Remoting the Keypad	134
3.6.1.	Indicator LEDs on the Display/Keypad	134
3.6.2.	Function Keys	135
3.6.3.	Setting the Operating Mode	136
3.6.3.1.	Adjusting the Display Contrast	136

3.6.3.2.	Adjusting the Display Contrast, Back-light and Buzzer.....	136
3.6.4.	Remoting the Display/Keypad	137
3.6.5.	Using the Display/Keypad for Parameter Transfer.....	140
3.7.	Serial Communications	141
3.7.1.	General Features.....	141
3.7.2.	Direct Connection	142
3.7.3.	Multidrop Network Connection	142
3.7.3.1.	Connection	142
3.7.3.2.	Line Terminators	144
3.7.4.	How to Use Isolated Serial Board ES822 (Optional).....	145
3.7.5.	The Software	145
3.7.6.	Serial Communication Ratings	145
3.8.	Auxiliary Power Supply.....	146
4.	START UP	147
4.1.	“IFD” Motor Control	148
4.2.	“VTC” Motor Control	150
4.3.	“FOC” Motor Control.....	152
4.4.	“SYN” Motor Control.....	155
5.	TECHNICAL SPECIFICATIONS.....	156
5.1.	Choosing the Product.....	158
5.1.1.	LIGHT Applications: Overload up to 120% (60/120s) or up to 144% (3s)	161
5.1.1.1.	Technical Sheet for 2T and 4T Voltage Classes.....	161
5.1.1.2.	Technical Sheet for 5T and 6T Voltage Classes.....	163
5.1.2.	STANDARD Applications: Overload up to 140% (60/120s) or up to 168% (3s)	164
5.1.2.1.	Technical Sheet for 2T and 4T Voltage Classes.....	164
5.1.2.2.	Technical Sheet for 5T and 6T Voltage Classes.....	166
5.1.3.	HEAVY Applications: Overload up to 175% (60/120s) or up to 210% (3s).....	167
5.1.3.1.	Technical Sheet for 2T and 4T Voltage Classes.....	167
5.1.3.2.	Technical Sheet for 5T and 6T Voltage Classes.....	169
5.1.4.	STRONG Applications: Overload up to 200% (60/120s) or up to 240% (3s).....	170
5.1.4.1.	Technical Sheet for 2T and 4T Voltage Classes.....	170
5.1.4.2.	Technical Sheet for 5T and 6T Voltage Classes.....	172
5.2.	Carrier Frequency Setting	173
5.2.1.	IP20 and IP00 Models – Class 2T-4T	173
5.2.2.	IP20 and IP00 Models – Class 5T-6T	175
5.2.3.	IP54 Models – Class 2T-4T	176
5.2.4.	IP54 Models – Class 5T-6T	177
5.3.	Operating Temperatures Based On Application Category.....	178
6.	ACCESSORIES	181
6.1.	Resistive Braking.....	181
6.1.1.	Braking Resistors	182
6.1.1.1.	Applications with DUTY CYCLE 10% - Class 2T	182
6.1.1.2.	Applications with DUTY CYCLE 20% - Class 2T	183
6.1.1.3.	Applications with DUTY CYCLE 50% - Class 2T	184
6.1.1.4.	Applications with DUTY CYCLE 10% - Class 4T	185
6.1.1.5.	Applications with DUTY CYCLE 20% - Class 4T	186
6.1.1.6.	Applications with DUTY CYCLE 50% - Class 4T	187
6.1.1.7.	Applications with DUTY CYCLE 10% - Class 5T.....	188
6.1.1.8.	Applications with DUTY CYCLE 20% - Class 5T.....	189
6.1.1.9.	Applications with DUTY CYCLE 50% - Class 5T.....	190
6.1.1.10.	Applications with DUTY CYCLE 10% - Class 6T	191
6.1.1.11.	Applications with DUTY CYCLE 20% - Class 6T	192
6.1.1.12.	Applications with DUTY CYCLE 50% - Class 6T	193
6.2.	Braking Unit (BU200) for S60.....	194
6.2.1.	Delivery Check.....	194
6.2.1.1.	Nameplate for BU200.....	195
6.2.2.	Operation.....	196
6.2.2.1.	Configuration Jumpers	196
6.2.2.2.	Adjusting Trimmers	197
6.2.2.3.	Indicator LEDs.....	198

6.2.3.	Ratings.....	198
6.2.4.	Installing the Braking Unit.....	199
6.2.4.1.	Environmental Requirements for the Braking Unit Installation, Storage and Transport ..	199
6.2.4.2.	Cooling System and Dissipated Power	199
6.2.4.3.	Mounting.....	200
6.2.4.4.	Lay-Out of Power Terminals and Signal Terminals	201
6.2.4.5.	Wiring	202
6.2.4.6.	Master – Slave Connection	203
6.2.5.	Braking Resistors for BU200 2T	204
6.2.5.1.	Applications with DUTY CYCLE 10% - Class 2T	204
6.2.5.2.	Applications with DUTY CYCLE 20% - Class 2T	205
6.2.5.3.	Applications with DUTY CYCLE 50% - Class 2T	205
6.2.6.	Braking Resistors for BU200 4T	206
6.2.6.1.	Applications with DUTY CYCLE 10% - Class 4T	206
6.2.6.2.	Applications with DUTY CYCLE 20% - Class 4T	207
6.2.6.3.	Applications with DUTY CYCLE 50% - Class 4T	207
6.3.	Braking Units for S41–S51 (BU700 2T-4T) and S42–S52 (BU600 5T-6T).....	208
6.3.1.	Delivery Check.....	208
6.3.1.1.	Nameplate for BU600.....	208
6.3.2.	Operating Mode.....	209
6.3.3.	Specifications.....	211
6.3.4.	Installing the Braking Unit.....	211
6.3.4.1.	Environmental Requirements for the Braking Unit Installation, Storage and Transport ..	211
6.3.4.2.	Mounting the Braking Unit.....	212
6.3.4.3.	Lay-Out of Power Terminals and Signal Terminals	213
6.3.4.4.	Wiring Diagram.....	216
6.3.5.	Braking Resistors for BU700 2T-4T.....	217
6.3.5.1.	Applications with DUTY CYCLE 10% - Class 2T	217
6.3.5.2.	Applications with DUTY CYCLE 20% - Class 2T	217
6.3.5.3.	Applications with DUTY CYCLE 50% - Class 2T	218
6.3.5.4.	Applications with DUTY CYCLE 10% - Class 4T	218
6.3.5.5.	Applications with DUTY CYCLE 20% - Class 4T	219
6.3.5.6.	Applications with DUTY CYCLE 50% - Class 4T	219
6.3.6.	Braking Resistors for BU600 5T-6T.....	220
6.3.6.1.	Applications with DUTY CYCLE 10% - Class 5T	220
6.3.6.2.	Applications with DUTY CYCLE 20% - Class 5T	220
6.3.6.3.	Applications with DUTY CYCLE 50% - Class 5T	221
6.3.6.4.	Applications with DUTY CYCLE 10% - Class 6T	221
6.3.6.5.	Applications with DUTY CYCLE 20% - Class 6T	222
6.3.6.6.	Applications with DUTY CYCLE 50% - Class 6T	222
6.4.	Braking Unit BU1440 for Modular Inverters	223
6.4.1.	Delivery Check.....	223
6.4.1.1.	Nameplate for BU1440.....	223
6.4.2.	Operation	224
6.4.3.	Ratings.....	224
6.4.4.	Installing the Braking Unit.....	224
6.4.4.1.	Environmental Requirements for the Braking Unit Installation, Storage and Transport ..	224
6.4.4.2.	Mounting the Braking Unit.....	225
6.4.4.3.	Wiring Diagram.....	226
6.4.5.	Braking Resistors for BU1440 4T	231
6.4.5.1.	Applications with DUTY CYCLE 10% - Class 4T	231
6.4.5.2.	Applications with DUTY CYCLE 20% - Class 4T	232
6.4.5.3.	Applications with DUTY CYCLE 50% - Class 4T	232
6.4.6.	Braking Resistors for BU1440 5T-6T	233
6.4.6.1.	Applications with DUTY CYCLE 10% - Class 5T	233
6.4.6.2.	Applications with DUTY CYCLE 20% - Class 5T	234
6.4.6.3.	Applications with DUTY CYCLE 50% - Class 5T	234
6.4.6.4.	Applications with DUTY CYCLE 10% - Class 6T	235
6.4.6.5.	Applications with DUTY CYCLE 20% - Class 6T	235
6.4.6.6.	Applications with DUTY CYCLE 50% - Class 6T	236

6.4.7.	Available Braking Resistors.....	237
6.4.7.1.	350W Models (IP55).....	237
6.4.7.2.	1300W Models (IP33).....	238
6.4.7.3.	IP55 Models from 1100W to 2200W	239
6.4.7.4.	IP20 Models from 4kW-8kW-12kW	241
6.4.7.5.	IP23 Boxes from 4kW to 64kW	243
6.5.	Keypad Remoting Kits.....	248
6.5.1.	Remoting the Keypad on the Cabinet	248
6.5.2.	Remoting a Keypad Controlling Multiple Inverters	248
6.5.2.1.	Kit Component Parts	248
6.5.2.2.	Operating Conditions.....	249
6.5.2.3.	Connecting the Keypad	249
6.5.2.4.	The Communications Protocol	250
6.5.2.5.	Connection	251
6.6.	Inductors.....	252
6.6.1.	Input Inductors	252
6.6.2.	Output Inductors (DU/DT Filters).....	255
6.6.3.	Applying the Inductor to the Inverter	256
6.6.3.1.	Class 2T – AC and DC Inductors	256
6.6.3.2.	Class 4T – AC and DC Inductors	257
6.6.3.3.	Class 5T-6T – AC and DC Inductors.....	258
6.6.4.	Inductance Ratings.....	260
6.6.4.1.	Class 2T-4T – AC 3-Phase Inductors	260
6.6.4.2.	Class 5T-6T – AC 3-Phase Inductors	260
6.6.4.3.	Class 2T-4T – DC Inductors.....	262
6.6.4.4.	Class 5T-6T – DC Inductors.....	262
6.6.4.5.	Class 2T, 4T, 5T, 6T – 3-Phase DU/DT Inductors	264
6.6.5.	Class 2T – 3-Phase AC Inductors in IP54 Cabinet	265
6.6.6.	Class 4T – 3-Phase AC Inductors in IP54 Cabinet	266
6.6.7.	Class 5T-6T – 3-Phase AC Inductors In IP54 Cabinet.....	267
6.6.8.	Output Single-Phase Inductors for Modular Inverters S75, S80, S90.....	269
6.6.8.1.	AC single-phase Inductors – Class 4T-5T-6T	269
6.6.9.	Sinusoidal Filters	270
6.7.	ES836/2 Encoder Board (Slot A)	271
6.7.1.	Identification Data	271
6.7.2.	Environmental Requirements	271
6.7.3.	Electrical Specifications.....	272
6.7.4.	Installing ES836/2 Encoder Board on the Inverter (Slot A).....	273
6.7.5.	Terminals in Encoder Board.....	274
6.7.6.	Configuration DIP-switches	274
6.7.7.	Jumper Selecting the Type of Encoder Supply	275
6.7.8.	Adjusting Trimmer	276
6.7.9.	Encoder Wiring and Configuration.....	276
6.7.10.	Wiring the Encoder Cable.....	281
6.8.	ES913 Line Driver Encoder Board (Slot A).....	282
6.8.1.	Identification Data	282
6.8.2.	Environmental Requirements	282
6.8.3.	Electrical Specifications.....	283
6.8.4.	Installing the Line Driver Board on the Inverter (Slot A).....	284
6.8.5.	Terminals in the Line Driver Encoder Board	285
6.8.6.	Configuration DIP-switches	285
6.8.7.	Encoder Supply Selection Jumper	286
6.8.8.	Adjusting Trimmer	287
6.9.	ES822 Isolated Serial Board (Slot B).....	288
6.9.1.	Identification Data	288
6.9.2.	Environmental Requirements	288
6.9.3.	Electrical Features.....	289
6.9.4.	Installing ES822 Board on the Inverter (Slot B).....	290
6.9.5.	Setting ES822 Board	291
6.9.5.1.	Jumper for RS232/RS485 Selection	291

6.9.5.2.	DIP-switch for RS485 Terminator	292
6.10.	Optional Boards For Fieldbus (Slot B)	293
6.10.1.	Identification Data	294
6.10.2.	Installing the Fieldbus Board on the Inverter (Slot B).....	294
6.10.3.	Fieldbus PROFIBUS-DP® Board	297
6.10.3.1.	Profibus® Fieldbus Connector.....	298
6.10.3.2.	Configuration of the Profibus-DP Communications Board	298
6.10.3.3.	Connection to the Fieldbus	300
6.10.4.	PROFIdrive® Fieldbus Board.....	301
6.10.5.	DeviceNet® Fieldbus Board	301
6.10.5.1.	DeviceNet® Fieldbus Terminals	302
6.10.5.2.	Board Configuration	302
6.10.5.3.	Connection to the Fieldbus	303
6.10.6.	CANopen® Fieldbus Board	305
6.10.6.1.	CANopen® Fieldbus Connector	306
6.10.6.2.	Board Configuration	306
6.10.6.3.	Connection to the Fieldbus	307
6.10.7.	Ethernet Board.....	308
6.10.7.1.	Ethernet Connector.....	309
6.10.7.2.	Connection to the Network	309
6.10.7.3.	Board Configuration	311
6.10.8.	Status LEDs.....	316
6.10.8.1.	LEDs for Fieldbus Interface CPU Diagnostics.....	316
6.10.8.2.	LEDs for PROFIBUS-DP® Board Diagnostics	317
6.10.8.3.	LEDs for DeviceNet® Board Diagnostics	317
6.10.8.4.	LEDs for CANopen® Board Diagnostics	318
6.10.8.5.	LEDs for Ethernet Board Diagnostics	318
6.10.9.	Environmental Requirements Common to All Boards.....	318
6.11.	ES919 Communications Board (Slot B).....	319
6.11.1.	Identification Data	319
6.11.2.	Environmental Requirements Common to All Boards.....	319
6.11.3.	Electrical Features Common to All Boards.....	319
6.11.4.	Installing ES919 Board on the Inverter (Slot B).....	320
6.11.5.	ES919 Board for Metasys® N2	321
6.11.5.1.	Configuration.....	321
6.11.5.2.	RS485 Connector	321
6.11.5.3.	LEDs on the ASP485 ProtoCessor Module	322
6.11.5.4.	Baud Rate DIP-switches.....	322
6.11.5.5.	Address DIP-Switches	322
6.11.6.	ES919 Board for BACnet/Ethernet.....	323
6.11.6.1.	Ethernet Connector.....	323
6.11.6.2.	LEDs on the FFP485 ProtoCessor Module	324
6.11.6.3.	Troubleshooting Tips	324
6.11.6.4.	Board Configuration.....	325
6.11.7.	ES919 Board for BACnet/RS485.....	326
6.11.7.1.	RS485 Connector	326
6.11.7.2.	Board Configuration	327
6.12.	ES851 Datalogger Board (Slot B)	328
6.12.1.	Identification Data	329
6.12.2.	Installing ES851 Board on the Inverter (Slot B).....	329
6.12.3.	Connectivity	331
6.12.3.1.	Wiring RS232 Serial Links	332
6.12.3.2.	Wiring RS485 Serial Link.....	333
6.12.3.3.	COM1 Configuration and Wiring.....	335
6.12.3.4.	COM2 Configuration and Wiring.....	337
6.12.3.5.	Types of Ethernet Connections	338
6.12.3.6.	Ethernet Port Wiring.....	340
6.13.	ES851-RTC Real Time Clock (Slot B)	341
6.13.1.	Identification Data	341
6.13.2.	Installing ES851-RTC Board on the Inverter (Slot B).....	342

6.13.2.1.	DIP-switch Configuration	342
6.14.	ES847 I/O Expansion Board (Slot C)	343
6.14.1.	Signal Conditioning and I/O Expansion Board	343
6.14.2.	Identification Data	344
6.14.3.	Installing ES847 Board on the Inverter (Slot C)	344
6.14.4.	ES847 Board Terminals	346
6.14.5.	Configuration DIP-switches	348
6.14.6.	Possible Settings for DIP-switches SW1 and SW2	349
6.14.7.	Wiring Diagrams	351
6.14.7.1.	Connection of "Fast" Differential Analog Inputs	351
6.14.7.2.	Connection of "Fast" Current Inputs	352
6.14.7.3.	Connecting "Slow" Analog Inputs to Voltage Sources	352
6.14.7.4.	Connecting "Slow" Analog Inputs to Current Sources	353
6.14.7.5.	Connecting "Slow" Analog Inputs to Thermistor PT100	353
6.14.7.6.	Connecting Isolated Digital Inputs	354
6.14.7.7.	Connection to an Encoder or a Frequency Input	355
6.14.7.8.	Connection to Isolated Digital Outputs	356
6.14.8.	Environmental Requirements	357
6.14.9.	Electrical Ratings	358
6.14.9.1.	Analog Inputs	358
6.14.9.2.	Digital Inputs	360
6.14.9.3.	Digital Outputs	361
6.14.9.4.	Supply Outputs	361
6.15.	ES870 Relay I/O Expansion Board (Slot C)	362
6.15.1.	Identification Data	362
6.15.2.	Installing ES870 Board on the Inverter (Slot C)	363
6.15.3.	ES870 Board Terminals	364
6.15.3.1.	Connection to an Encoder or a Frequency Input	365
6.16.	ES914 Power Supply Unit Board	366
6.16.1.	Identification Data	368
6.16.2.	Wiring ES914 Board	368
6.17.	"Loc-0-Rem" Key Selector Switch And Emergency Push-Button for IP54 Models	373
6.17.1.	Wiring IP54 Inverters with Optional "LOC-0-REM" Key Selector Switch and Emergency Push-button	374
6.18.	ES860 SIN/COS Encoder Board (Slot A)	375
6.18.1.	Identification Data	376
6.18.2.	Installing ES860 Board on the Inverter (Slot A)	376
6.18.2.1.	Sin/Cos Encoder Connector	378
6.18.3.	ES860 Configuration and Operating Modes	379
6.18.3.1.	Configuring and Adjusting the Encoder Supply Voltage	380
6.18.4.	Connecting the Encoder Cable	381
6.18.5.	Environmental Requirements	382
6.18.6.	Electrical Ratings	382
6.19.	ES861 Resolver and Incremental Encoder Board (Slot C)	384
6.19.1.	Identification Data	385
6.19.2.	Installing ES861 Board on the Inverter (Slot C)	385
6.19.2.1.	Resolver Connector	388
6.19.2.2.	Incremental Encoder and Digital Lines Connectors	389
6.19.3.	ES861 Configuration and Operating Modes	390
6.19.3.1.	Configuring and Adjusting the Encoder Supply Voltage	390
6.19.4.	Connecting the Resolver Cable	392
6.19.5.	Environmental Requirements	393
6.19.6.	Electrical Ratings	393
6.20.	ES950 BiSS/EnDat Encoder Board (Slot C)	395
6.20.1.	Identification Data	396
6.20.2.	Installing ES950 Board on the Inverter (Slot C)	397
6.20.2.1.	BiSS/EnDat Encoder Connector	399
6.20.2.2.	Incremental Encoder and Digital Line Connectors	400
6.20.3.	ES950 Configuration and Operating Modes	401
6.20.3.1.	BiSS Operating Mode	402

6.20.3.2.	EnDat Operating Mode	402
6.20.3.3.	Configuring and Adjusting the Encoder Supply Voltage	402
6.20.4.	Connecting the Encoder Cable.....	404
6.20.5.	Environmental Requirements	406
6.20.6.	Electrical Ratings	406
6.21.	Encoder Board Hiperface ES966 (Slot C).....	408
6.21.1.	Part Number	408
7.	NORMATIVE REFERENCES	409
7.1.	Electromagnetic Compatibility Directive	409
7.1.1.	RADIOFREQUENCY DISTURBANCE.....	412
7.1.1.1.	The Power Supply Mains	413
7.1.1.2.	Output Toroid Filters.....	413
7.1.1.3.	The Cabinet.....	413
7.1.1.4.	Input and Output Filters.....	416
7.2.	Low Voltage Directive.....	416
8.	INDEX.....	417

0.1. Index of Figures

Figure 1:	Packaging of the Sinus Penta	22
Figure 2:	Example of a nameplate affixed on the drive metal enclosure	23
Figure 3:	Example of a nameplate.....	23
Figure 4:	Lifting the packing from underneath.....	25
Figure 5:	How to open the packaging.....	25
Figure 6:	“This side up” pictogram.....	26
Figure 7:	The Sinus Penta is unpacked.....	26
Figure 8:	Sinus Penta packing box with the internal protective elements	26
Figure 9:	Clearance to be observed between two inverters	29
Figure 10:	Clearance to allow when installing the Inverter/Power supply unit modules	30
Figure 11:	Piercing template for STAND-ALONE models from S05 to S52 included	51
Figure 12:	Piercing template for size S60.....	52
Figure 13:	Fittings for through-panel assembly for Sinus Penta S05.....	53
Figure 14:	Piercing templates for through-panel assembly for Sinus Penta S05.....	53
Figure 15:	Fittings for through-panel assembly for Sinus Penta S12.....	54
Figure 16:	Piercing template for through-panel assembly for Sinus Penta S12.....	54
Figure 17:	Fittings for through-panel assembly for Sinus Penta S14.....	55
Figure 18:	Piercing template for through-panel assembly for Sinus Penta S14.....	55
Figure 19:	Through-panel assembly and piercing template for Sinus Penta S15, S20 and S30.....	56
Figure 20:	Fittings for through-panel assembly for Sinus Penta S22 and S32	57
Figure 21:	Piercing template for through-panel assembly for Sinus Penta S22 and S32.....	58
Figure 22:	Mechanical parts for the through-panel assembly for Sinus Penta S41, S42, S51 and S52.....	59
Figure 23:	Piercing templates for the through-panel assembly for Sinus Penta S41, S42, S51 and S52	60
Figure 24:	Piercing templates for modular units.....	62
Figure 25:	Piercing templates for control unit (stand-alone model).....	62
Figure 26:	Installation example for Sinus Penta S65 (in cabinet)	63
Figure 27:	Piercing template for IP54 inverter.....	64
Figure 28:	Wiring diagram	67

Figure 29: External connections for modular inverters S65-S70.....	69
Figure 30: External connections for modular inverters S64	70
Figure 31: Layout of 12-pulse connection	71
Figure 32: Single optical fibre connector	73
Figure 33: Double optical fibre connector.....	74
Figure 34: Internal wiring for Sinus Penta S65-S70	76
Figure 35: ES840 Supply Board	77
Figure 36: ES841 Inverter Module Gate Unit Board.....	77
Figure 37: ES843 Bus-bar Voltage Acquisition Board.....	78
Figure 38: Position of the fastening screws in the terminal board cover and the control unit.....	78
Figure 39: ES842 Control Unit.....	79
Figure 40: Single optical-fibre connector.....	80
Figure 41: Double optical-fibre connector.....	81
Figure 42: Internal wiring for inverters S64.....	83
Figure 43: Connection bars in S41-S42-S51-S52.....	87
Figure 44: S60 Connection bars.....	89
Figure 45: Connection bars for S64-S70	90
Figure 46: Connection bars for S74-S80	91
Figure 47: Connection bars for S84-S90	92
Figure 48: Control terminals	106
Figure 49: Gaining access to the control terminals	107
Figure 50: Clamping a signal shielded cable.....	109
Figure 51: Control board: signals and programming	110
Figure 52: Gaining access to DIP-switches SW1 and SW2.....	114
Figure 53: Gaining access to DIP-switch SW3 and connector RS485 (Sinus Penta S05 to S22).....	114
Figure 54: Position of DIP-switch SW3 and connector RS485 (Sinus Penta S30 to S60).....	115
Figure 55: PNP command (active to +24V).....	117
Figure 56: Connecting an incremental encoder	119
Figure 57: Signal sent from a push-pull, +24V output	120
Figure 58: Potentiometer linked to the REF Input	122
Figure 59: Wiring of a PLC analog output, axis control board, etc.....	123
Figure 60: Wiring of unipolar remote potentiometer 0 ÷ REF max	124
Figure 61: 4 ÷ 20 mA Sensor wiring	124
Figure 62: Standard pattern of the thermistor resistor for the motor thermal protection	125
Figure 63: PNP output wiring for relay control.....	128
Figure 64: NPN output wiring for relay control	129
Figure 65: Cascade connection: frequency output → frequency input	129
Figure 66: PNP output wiring for relay control.....	130
Figure 67: NPN output wiring for relay control	130
Figure 68: Display/keypad	134
Figure 69: Removing the display/keypad module	138
Figure 70: Front/rear view of the display/keypad and its shell.	139
Figure 71: Example of multidrop and direct connection	141
Figure 72: Pin lay-out of serial link 1 connector	143
Figure 73: Recommended wiring diagram for “2-wire” MODBUS connection.....	143
Figure 74: Nameplate for BU200	195
Figure 75: Positions of BU200 configuration jumpers	196
Figure 76: Positions of BU200 adjusting trimmers	197
Figure 77: Position of the Indicator LEDs	198
Figure 78: Dimensions and fixing points of BU200	200
Figure 79: Terminals in BU200.....	201
Figure 80: Connecting one BU200 to the inverter	202
Figure 81: Master – Slave multiple connection	203
Figure 82: Nameplate for BU600	208
Figure 83: BRAKE connector supplied with the Sinus Penta	209
Figure 84: Cable connecting the Sinus Penta to braking unit BU600	209
Figure 85: Diagnostic LEDs.....	210
Figure 86: Dimensions and fixing points of BU600/BU700	212
Figure 87: Power terminals.....	213
Figure 88: Signal terminals.....	215

Figure 89: Wiring diagram for S41-S51/S42-S52 with braking unit BU600/700.....	216
Figure 90: Nameplate for BU1440.....	223
Figure 91: Dimensions and fixing points of BU1440	225
Figure 92: External power connections for modular inverters S65-S70 provided with braking unit BU1440	226
Figure 93: External power connections for modular inverters S75-S80 provided with braking unit BU1440	227
Figure 94: ES841 Unit gate board for the braking unit.....	228
Figure 95: Connection points on ES842 for the braking unit optical fibres	229
Figure 96: Internal wiring of inverters S65-S70 provided with a braking unit.....	230
Figure 97: Overall dimensions, resistor 56-100Ω/350W	237
Figure 98: Overall dimensions and ratings for braking resistor 75Ω/1300W.....	238
Figure 99: Overall dimensions and mechanical features for braking resistors from 1100W to 2200W	239
Figure 100: Overall dimensions for braking resistors 4kW, 8kW, 12kW	241
Figure 101: Overall dimensions of IP23 Box resistors	243
Figure 102: Position of electrical connections in box resistors.....	243
Figure 103: Wiring diagram of the keypad remoting kit controlling multiple inverters	250
Figure 104: Wiring diagram for optional inductors.....	252
Figure 105: Amplitude of harmonic currents (approximate values).....	254
Figure 106: Output inductor wiring	255
Figure 107: Mechanical features of a 3-phase inductor	261
Figure 108: Mechanical features of a DC inductor	263
Figure 109: Mechanical features of the 3-phase du/dt inductors	264
Figure 110: Mechanical features of a 3-phase inductor for Class 2T-4T in IP54 cabinet	268
Figure 111: Mechanical features of a single-phase output inductor.....	269
Figure 112: Sinusoidal filter	270
Figure 113: Encoder board (ES836/2).....	271
Figure 114: Position of slot A for the installation of the encoder board.....	273
Figure 115: Encoder board fastened to its slot.....	273
Figure 116: Positions of DIP-switches and their factory-setting.....	274
Figure 117: LINE DRIVER or PUSH-PULL encoder with complementary outputs	277
Figure 118: PUSH-PULL encoder with single-ended outputs	278
Figure 119: PNP or NPN encoder with single-ended outputs and load resistors with external wiring.....	279
Figure 120: PNP or NPN encoder with single-ended outputs and internal load resistors.....	280
Figure 121: Wiring the encoder cable.....	281
Figure 122: ES913 Encoder board	282
Figure 123: Position of slot A for the installation of the encoder board.....	284
Figure 124: Encoder board fastened to its slot.....	284
Figure 125: Position of the configuration DIP-switches.....	285
Figure 126: Location of the jumpers selecting the encoder supply voltage	287
Figure 127: ES822 board	288
Figure 128: Position of the slot for the installation of the serial isolated board	290
Figure 129: Jumper setting RS232/RS485.....	291
Figure 130: Configuration of terminator DIP-switch for line RS485	292
Figure 131: Location of the slot B inside the terminal board cover of the Sinus PENTA inverters	295
Figure 132: Checking contacts in the slot B	295
Figure 133: Fastening the communications board to slot B	296
Figure 134: PROFIBUS-DP® fieldbus communications board	297
Figure 135: Example of a Profibus network (the correct setting of the line terminators is highlighted)	299
Figure 136: Example of the rotary-switch position to set Profibus address “19”.....	299
Figure 137: DeviceNet® Fieldbus communications board	301
Figure 138: Outline of the topology of a DeviceNet trunk line	303
Figure 139: CANopen® fieldbus communications board	305
Figure 140: Example of the position of the rotary-switches for 125kbits/s and Device Address 29	306
Figure 141: Ethernet Fieldbus Communications Board.....	308
Figure 142: Cable of Cat. 5 for Ethernet and standard colour arrangement in the connector	309
Figure 143: Setting a computer for a point-to-point connection to the inverter	312
Figure 144: Setting the DIP-switches to set the IP address 192.168.0.2.....	313
Figure 145: Example of the ping command to the IP address of the inverter interface board	314
Figure 146: Anybus IP config utility	314
Figure 147: Setting ModScan for a Modbus/TCP connection	315
Figure 148: Display of the output variables of the inverter through the Modbus/TCP protocol.....	315

Figure 149: Position of indicator LEDs on the board.....	316
Figure 150: Position of the slot for ES919 board.....	320
Figure 151: ES919 Board for Metasys® N2.....	321
Figure 152: ES919 Board for BACnet/Ethernet.....	323
Figure 153: BACnet LEDs.....	324
Figure 154: BACnet IP Configuration.....	325
Figure 155: ES919 Board for BACnet/RS485.....	326
Figure 156: BACnet MSTP Configuration.....	327
Figure 157: ES851 DataLogger Board.....	328
Figure 158: Position of the slot for the installation of ES851 DataLogger board.....	329
Figure 159: ES851 DataLogger fitted into slot B.....	330
Figure 160: Recommended wiring diagram for the connection of 2-wire MODBUS devices.....	333
Figure 161: Cable of Cat. 5 for Ethernet and standard colour arrangement in the connector.....	338
Figure 162: Location of the Ethernet port.....	340
Figure 163: Wiring of the Ethernet cable.....	340
Figure 164: Real Time Clock ES851-RTC Board.....	341
Figure 165: Signal conditioning and additional I/Os board (ES847).....	343
Figure 166: Removing the inverter cover; location of slot C.....	344
Figure 167: Fitting the strips inside ES847 board and fixing the board on slot C.....	345
Figure 168: Connection of a bipolar voltage source to a differential input.....	351
Figure 169: Connection of 0÷20mA (4÷20mA) sensors to “fast” current inputs.....	352
Figure 170: Connecting a voltage source to a “slow” analog input.....	352
Figure 171: Connecting thermoresistors PT100 to analog channels XAIN8–11 / T1–4.....	353
Figure 172: PNP input wiring.....	354
Figure 173: Connecting the incremental encoder to fast inputs XMDI7 and XMDI8.....	355
Figure 174: Signal sent from a 24V, Push-pull frequency output.....	355
Figure 175: Connection of a PNP output for relay control.....	356
Figure 176: Connection of an NPN output for relay control.....	356
Figure 177: Relay I/O expansion board ES870.....	362
Figure 178: Removing the inverter cover; location of slot C.....	363
Figure 179: ES914 Power supply unit board.....	366
Figure 180: Basic wiring diagram for ES914 board.....	367
Figure 181: Block-diagram with 3-zone insulation.....	367
Figure 182: Position of the LEDs and DIP-switches in ES914 board.....	372
Figure 183: Wiring diagram for IP54 inverters.....	374
Figure 184: ES860 Sin/Cos Encoder board.....	375
Figure 185: Location of Slot A inside the terminal board covers in Sinus PENTA inverters.....	376
Figure 186: Fitting the ES860 board inside the inverter.....	377
Figure 187: Pin layout on the high density connector.....	378
Figure 188: DIP-switch SW1 setting in three-channel mode.....	379
Figure 189: DIP-switch SW1 setting for five-channel mode.....	379
Figure 190: Position of the jumper and voltage adjusting trimmer.....	380
Figure 191: Recommended dual shielded connection for encoder cable.....	381
Figure 192: ES861 Incremental Encoder and Resolver expansion board.....	384
Figure 193: Location of slot C inside the terminal board cover of the Sinus Penta inverter.....	386
Figure 194: Terminal strips inserted into SLOT C.....	386
Figure 195: Fitting the ES861 board inside the inverter.....	387
Figure 196: Pin layout on the D-sub 9-pin female connector.....	388
Figure 197: Input-output signal terminal boards.....	389
Figure 198: Jumpers and trimmer for power supply configuration.....	390
Figure 199: Recommended dual shielded connection for resolver cable.....	392
Figure 200: ES950 encoder BiSS/EnDat board.....	395
Figure 201: Location of slot C inside the terminal board cover in Sinus PENTA inverters.....	397
Figure 202: Terminal strips inserted into SLOT C.....	398
Figure 203: Fitting the ES950 board inside the inverter.....	398
Figure 204: Pin layout on CN7 D-sub 15-pin female connector.....	399
Figure 205: Input-output signal terminal board.....	400
Figure 206: Block diagram for ES950 board interface.....	401
Figure 207: Jumpers and trimmer for power supply configuration.....	403
Figure 208: Recommended dual shielded connection for encoder cable.....	405

Figure 209: Disturbance sources in a power drive system equipped with an inverter 412
Figure 210: Example of correct wiring of an inverter inside a cabinet..... 415
Figure 211: Wiring the toroid filter for the inverters of the Sinus Penta series 416

1. GENERAL DESCRIPTION

Inverters are electronic devices capable of powering an AC electric motor and of imposing speed and torque values. The inverters of the PENTA series manufactured by Elettronica Santerno SpA allow adjusting speed and torque values of three-phase asynchronous and synchronous motors and brushless, permanent-magnet AC motors by way of several control modes. Control modes may be user-defined and allow obtaining the best performance in terms of fine-tuning and energy saving for any industrial application.

The PENTA inverters provided with the standard firmware feature the control modes below:

- **IFD** control mode: voltage / frequency scalar control for asynchronous motors,
- **VTC** control mode: sensorless vector control for asynchronous motors.
- **FOC** control mode: vector control with encoder feedback for asynchronous motors,

The following applications are also available by re-programming the firmware (this can be done by the user as well):

- **SYN** control mode: vector control with feedback from encoder for PMSM synchronous motors;
- Specific applications featuring the most popular automation functions.

See Special Applications Available on Sinus Penta for more details.

Available Sinus Penta models range from 1.5kW to 3MW.

AVAILABLE Sinus Penta MODELS



NOTE

Products may have different ratings and/or appearance than the ones shown in the picture above. The proportion of one enclosure to the other is shown as an example and is not binding.

1.1. Feature List

- One product, multiple functions:
 - vector-modulation **IFD** function for general-purpose applications (V/f pattern);
 - sensorless, vector **VTC** function for high torque demanding performance (direct torque control);
 - vector **FOC** function with an encoder for accurate torque requirements and wide speed range;
 - **SYN** function for synchronous motors (see Special Applications Available on Sinus Penta);
 - **RGN** AFE (Active Front End) function for power exchange with the mains, with unitary power factor and very low harmonic current (see Special Applications Available on Sinus Penta);
 - special optional functions for any application (such as **MUP** function for Multipump) (see Special Applications Available on Sinus Penta).
- Wide range of supply voltage values (200 VAC ÷ 690 VAC) both for stand-alone models and cabinet models.
- Standard DC power supply, 280 to 970 VDC.
- Wide power range from 1.5kW a 3MW.
- Wide range of voltage values and power values for the electric motors to be connected to any inverter model.

MODEL	LIGHT	STANDARD	HEAVY	STRONG
Sinus Penta 0025 4TBA2X2	22kW	18.5kW	15kW	11kW

- Built-in filters for the whole Sinus Penta range in compliance with regulation EN 61800-3, issue 2 concerning emission limits.
 - The new hardware configuration is standard supplied with a safety system including redundant contacts for the inhibition of firing pulses in the power circuit, in compliance with the latest requirements of the safety regulations in force, EN 61800-5-1/EN 61800-5-2. (However, respect the specific rules of the field of application).
 - Compact and light, the new series of Sinus Penta models may be installed in cabinets and offers a better price/performance ratio.
- Detection of the heat sink temperatures and control component temperatures.
- Automatic control of the cooling system. The ventilation system activates only when required. This ensures greater energy saving, minor wear of the cooling fans and reduced noise; In case of equipment failure, it is possible to adjust the system speed in order not to stop the equipment and to limit dissipated power.
- Built-in braking module up to Size S32 included.
- Noiseless operation ensured by high modulation frequency programmable up to 16 kHz.
- Motor thermal protection to be integrated both through thermal relay function and PTC input (in compliance with DIN44081/2).
- Remotable control panel with a 12-key LCD display showing full words for easier managing and programming of the displayed measures. Five languages available.
- Function parameter saving to remotable display/keypad and possibility of data transfer to multiple inverters.
- Four access levels to the operation parameters and preset parameters for the most common applications.
- PC interface for WINDOWS environment with the RemoteDrive software available in six foreign languages.
- RS485 MODBUS RTU Serial communication for serial links to PCs, PLCs and control interfaces.
- Fieldbuses with internal optional interface boards.

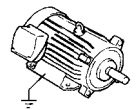
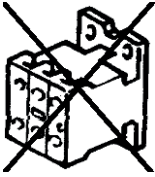

1.2. Special Applications Available on Sinus Penta

Beside basic parameterization, Sinus Penta drives also implement operating modes and optional functional modes named **APPLICATIONS**, which can be obtained through firmware updating and additional external components.

Optional operating modes available for the inverters of the PENTA series are **multipump control application**, **regenerative inverter control application** and **synchronous motor control application**.

In the future, additional optional operating modes will be available, which include application software, instruction manual and dedicated interface board (if any). They implement the most common automation applications, thus replacing PLCs or dedicated control board, and they reduce to a minimum the electric equipment required, thus ensuring lower maintenance costs.



NOTE

In order to upload and install your application SW and update the firmware packets of your Sinus Penta, you can use our RemoteDrive software. Refer to the User Manual related to each individual application for detailed instructions.

The **Multipump application (MUP)** allows obtaining a divided pumping plant, with pressure delivery control, flow control or level control; this application does not need any PLC, because the inverter is capable of controlling multiple pumps at a time.

The **Regenerative application (RGN)** allows PENTA inverters to be used as AC/DC converters for the DC supply of multiple inverters. When operating as an AC/DC converter, the PENTA operates as a bidirectional mains interface both to power connected inverters and to regenerate the braking powers of the connected motors. Mains power supply always provides sinusoidal currents and a unitary power factor, thus avoiding using braking resistors, power factor correction capacitor banks and damping systems of the harmonics delivered to the mains.

The **Synchronous Motor application (SYN)** allows PENTA inverters to control permanent magnet synchronous motors (PMSM). Optional boards are required, which are described later on in this manual.

Any detail concerning functionality is given in the User Manuals related to each individual application.

2. SAFETY STATEMENTS

This section contains safety statements. The non-observance of these safety instructions may cause serious injury or death and equipment failure. Carefully read the instructions below before installing, starting and operating the inverter.

Only competent personnel must carry out the equipment installation.

SYMBOLS:



DANGER

Indicates operating procedures that, if not correctly performed, may cause serious injury or death due to electric shock.



CAUTION

Indicates operating procedures that, if not carried out, may cause serious equipment failure.



NOTE

Indicates important hints concerning the equipment operation.

2.1. Installing and Operating the Equipment



NOTE

Always read this instruction manual before starting the equipment.

The ground connection of the motor casing should follow a separate path to avoid possible interferences.

ALWAYS PROVIDE PROPER GROUNDING OF THE MOTOR CASING AND THE INVERTER FRAME.

If a differential relay against electric shocks is intended to be used, this must be a "B-type" differential relay.

The inverter may generate an output frequency up to 1000 Hz; this may cause a motor rotation speed up to 20 (twenty) times the rated motor speed—for 50Hz motors: never use the motor at a higher speed than the max. allowable speed stated on the motor nameplate.

ELECTRIC SHOCK HAZARD – Never touch the inverter electrical parts when the inverter is on; always wait at least 20 minutes after switching off the inverter before operating on the inverter.



DANGER

Never perform any operation on the motor when the inverter is on.

Do not perform electrical connections on the motor or the inverter if the inverter is on. Electric shock hazard exists on output terminals (U,V,W) and resistive braking module terminals (+, -, B) even when the inverter is disabled. Wait at least 20 minutes after switching off the inverter before operating on the electrical connection of the motor or the inverter.

MECHANICAL MOTION – The inverter determines mechanical motion. It is the operator's responsibility to ensure that this does not give rise to any dangerous situation.

EXPLOSION AND FIRE – Explosion and fire hazard exists if the equipment is installed in presence of flammable fumes. Do not install the inverter in places exposed to explosion and fire hazard, even if the motor is installed there.

Do not connect supply voltages exceeding the equipment rated voltage to avoid damaging the internal circuits.

If the inverter is installed in environments exposed to flammable and/or explosive substances (zones AD according to standards IEC 64-2), please refer to IEC 64-2, EN 60079-10 and related standards.

Do not connect the equipment power supply to the output terminals (U,V,W), to the resistive braking module terminals (+, -, B) and to the control terminals. The equipment power supply must be connected only to terminals R,S,T.

Do not short-circuit terminals (+) and (-) and terminals (+) and (B); do not connect any braking resistors with lower ratings than the required ratings.

Do not start or stop the motor using a contactor over the inverter power supply. If a contactor is installed between the inverter and the motor, make sure that it is switched over only when the inverter is disabled. Do not connect any power factor correction capacitor to the motor.

Operate the inverter only if a proper grounding is provided.

If an alarm trips, a comprehensive review of the Diagnostic section in the Sinus Penta's Programming Guide is recommended; restart the equipment only after removing the cause responsible for the alarm trip.



CAUTION

Do not perform any insulation test between the power terminals or the control terminals.

Make sure that the fastening screws of the control terminal board and the power terminal board are properly tightened.

Prior to install the product, check the tightening of the factory-made link between power terminals 47/D and 47/+ in the models where this link is provided.

Do not connect single-phase motors.

Always use a motor thermal protection (use the inverter motor thermal model or a thermoswitch installed in the motor).

Respect the environmental requirements for the equipment installation.

The bearing surface of the inverter must be capable of withstanding high temperatures (up to 90°C).

The inverter electronic boards contain components which may be affected by electrostatic discharges. Do not touch them unless it is strictly necessary. Always be very careful so as to prevent any damage caused by electrostatic discharges.



ATTENTION

Static Sensitive Devices. Handle Only at Static Safe Work Stations.

ATTENTION

Circuits sensibles à l'électricité statique. Manipulation uniquement autorisée sur un poste de travail protégé.

ACHTUNG

Elektrostatisch gefährdete Bauelemente. Handhabung daher nur an geschützten Arbeitsplätzen erlaubt.

Before programming and starting the inverter, make sure that the connected motor and all the controlled devices can be used for the whole speed range allowed by the converter. The inverter may be programmed to control the motor at higher or lower rpm in respect to the speed obtained by connecting the motor directly to the power supply line.

Motor insulation and bearing protection

Regardless of the output frequency, the inverter output includes impulses of approx. 1.35 times the equivalent grid voltage with a very short rise time. This applies to all inverters based on IGBT technology.

The impulse voltage may be approx. twofold at the motor terminals, based on the reflection and attenuation of the terminals and motor cable. This may cause additional stress to the motor and the motor insulation cable.

The variable speed drives characterized by rapid rise voltage impulses and by high switching frequencies may cause current impulses through the motor bearings, that could gradually wear the housings of the bearings and the rolling parts.



CAUTION

The motor insulation stress may be avoided by adopting optional du/dt filters (see section Output Inductors (DU/DT Filters)). The du/dt filters also reduce the shaft currents.

Sensors integrated into the motor

For the electrical and insulation specifications, please refer to the Control Terminals section and/or to the optional boards which those sensors are connected to.

Critical torsional speed

If required, set up the critical torsional speed of the connected motor (see Prohibit Speeds menu in the Sinus Penta's Programming Guide).

Transient torque analysis

If required, limit the transient torque of the connected motor (see Limits menu in the Sinus Penta's Programming Guide).

2.2. Permanent Magnet Motors

This section covers additional safety statements concerning Sinus Penta drives used with permanent magnet motors. The non-observance of the safety instructions below may cause serious injuries or death and equipment failure.



DANGER

Do not operate on the converter when the permanent magnet motor is rotating. Even if the power supply is cut out and the inverter is stopped, the permanent magnet motor, when rotating, powers the DC-link of the converter, and voltage is applied to the power supply links.

Do the following prior to install and service the inverter:

- Stop the motor.
- Make sure that the motor cannot rotate when operating on the equipment.
- Make sure that no voltage is applied to the power terminals in the converter.



DANGER

Do not exceed the motor rated rpm. Exceeding the motor rpm may cause overvoltage leading to damage or explosion of the converter DC-Link.

The permanent magnet motor control is made possible only by using the application firmware "PS" of the Sinus Penta for permanent magnet synchronous motors.

3. EQUIPMENT DESCRIPTION AND INSTALLATION

The inverters of the Sinus Penta series are full digital inverters capable of controlling asynchronous and synchronous motors up to 3 MW.

Inverters of the Sinus Penta series are designed and manufactured in Italy by the technicians of Elettronica Santerno; they incorporate the most advanced features offered by the latest electronic technologies.

Sinus Penta inverters fit any application thanks to their advanced features, among which: 32-bit multiprocessor control board; vector modulation; power control with the latest IGBTs; high immunity to radio interference; high overload capability.

Any value of the quantities required for the equipment operation may be easily programmed through the keypad, the alphanumeric display and the parameter menus and submenus.

The inverters of the Sinus Penta series are provided with the following features:

- wide power supply voltage range: 380-500Vac (-15%,+10%) for voltage class 4T;
- four classes of power supply: 2T (200-240Vac), 4T (380-500Vac), 5T (500-600Vac), 6T (575-690Vac);
- built-in EMC filters available for industrial environment;
- built-in EMC filters available for domestic environment (Sizes S05 and S12);
- DC voltage power supply available;
- built-in braking module (up to Size S32; S12 5T excepted);
- RS485 serial interface with communications protocol according to the MODBUS RTU standard;
- degree of protection IP20 (up to Size S32; IP00 for greater sizes);
- possibility of providing IP54 (up to Size S32);
- 3 analog inputs, 0 ± 10 VDC, $0 (4) \div 20$ mA; one input may be configured as a motor PTC input;
- 8 optoisolated digital inputs (PNP inputs);
- 3 configurable analog outputs $0 \div 10$ V, $4 \div 20$ mA, $0 \div 20$ mA;
- 1 optoisolated, "open collector" static digital output;
- 1 optoisolated, "push-pull", high-speed static digital output at high switching ratio;
- 2 relay digital outputs with change-over contacts;
- fan control (Sizes S15, S20 and modular drives excepted).

A comprehensive set of diagnostic messages allows a quick fine-tuning of the parameters during the equipment starting and a quick resolution of any problem during the equipment operation.

The inverters of the Sinus Penta series have been designed and manufactured in compliance with the requirements of the "Low Voltage Directive", the "Machine Directive", and the "Electromagnetic Compatibility Directive".

3.1. Products Covered in this Manual

This manual covers any inverter of the Sinus Penta, Sinus Penta BOX, Sinus Penta CABINET series.

Any detail concerning optional functionality is given in separate manuals covering Sinus Penta software applications.

3.2. Delivery Check

Make sure that the equipment is not damaged and that it complies with the equipment you ordered by referring to the nameplate located on the inverter front part. The inverter nameplate is described below. If the equipment is damaged, contact the supplier or the insurance company concerned. If the equipment does not comply with the one you ordered, please contact the supplier as soon as possible.

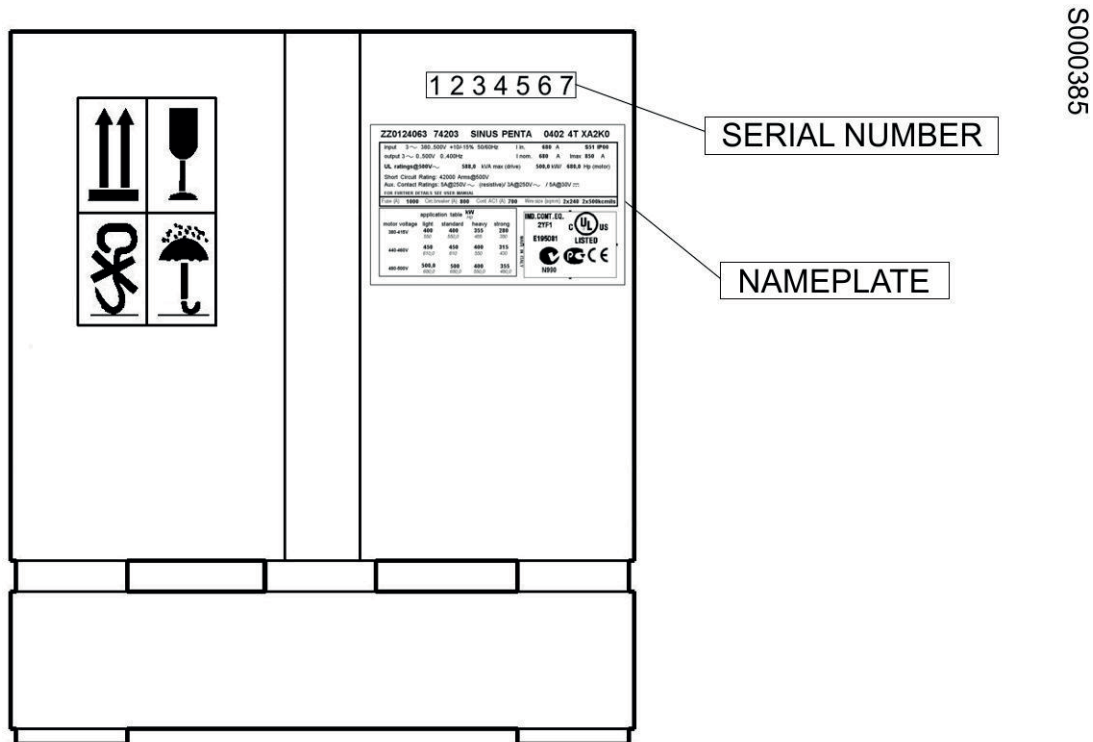

Figure 1: Packaging of the Sinus Penta

If the equipment is stored before being started, make sure that the ambient conditions do not exceed the ratings mentioned in Installing the Equipment section. The equipment guarantee covers any manufacturing defect. The manufacturer has no responsibility for possible damages occurred when shipping or unpacking the inverter. The manufacturer is not responsible for possible damages or faults caused by improper and irrational uses; wrong installation; improper conditions of temperature, humidity, or the use of corrosive substances. The manufacturer is not responsible for possible faults due to the inverter operation at values exceeding the inverter ratings and is not responsible for consequential and accidental damages. The equipment is covered by a 3-year guarantee starting from the date of delivery.

3.2.1. Nameplate

The product is identified by the nameplate affixed on the enclosure side.

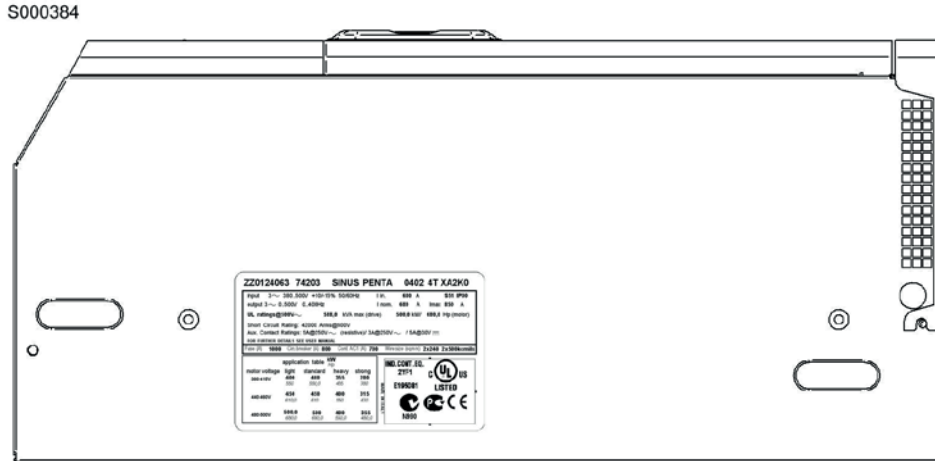

Figure 2: Example of a nameplate affixed on the drive metal enclosure

Example of a nameplate for Voltage Class 4T.

S000386

ZZ0124063 74203 SINUS PENTA 0402 4T XA2K0				
input	3~	380..500V +10/-15%	50/60Hz	I in. 680 A S51 IP00
output	3~	0..500V	0..400Hz	I nom. 680 A I _{max} 850 A
UL ratings@500V~		588,0 kVA max (drive)		500,0 kW/ 680,0 Hp (motor)
Short Circuit Rating: 42000 Arms@500V				
Aux. Contact Ratings: 5A@250V~ (resistive)/ 3A@250V~ / 5A@30V ~				
FOR FURTHER DETAILS SEE USER MANUAL				
Fuse (A)	1000	Circ. breaker (A)	800	Cont. AC1 (A) 700 Wire size (sqmm) 2x240 2x500kcmils
application table ^{kw} / _{Hp}				
motor voltage	light	standard	heavy	strong
380-415V	400	400	355	280
	550	550,0	485	380
440-460V	450	450	400	315
	610,0	610	550	430
480-500V	500,0	500	400	355
	680,0	680,0	550,0	480,0
IND. CONT. EQ. 2YF1 C UL US E195081 LISTED N990				
MADE IN ITALY				

Figure 3: Example of a nameplate

Product coding:

SINUS	PENTA	0402	4	T	X	A2	K	0
1	2	3	4	5	6	7	8	9



NOTE Not all the combinations below are possible.

1	Product line: SINUS stand-alone inverter SINUS BOX inverter contained inside a box SINUS CABINET inverter contained inside a cabinet
2	PENTA control
3	Inverter Model
4	Supply voltage: 2 = Power supply 200÷240VAC; 280÷340VDC 4 = Power supply 380÷500VAC; 530÷705VDC 5 = Power supply 500÷600VAC; 705÷845VDC 6 = Power supply 575÷690VAC; 845÷970VDC
5	Type of power supply: T = three-phase C = DC voltage
6	Braking module: X = no internal braking chopper B = built-in braking chopper
7	Type of EMC filter: I = no filter provided; A1 = integrated filter, EN 61800-3 issue 2 FIRST ENVIRONMENT Category C2, EN55011 gr.1 cl. A for industrial and domestic users. A2 = integrated filter, EN 61800-3 issue 2 SECOND ENVIRONMENT Category C3, EN55011 gr.2 cl. A for industrial users. B = integrated input filter (type A1) plus external, output toroid filter, EN 61800-3 issue 2 FIRST ENVIRONMENT Category C1, EN55011 gr.1 cl. B for industrial and domestic users.
8	Control panel: X = no control panel provided (display/keypad) K = control panel and back-lit, 16 x 4 character LCD display provided
9	Degree of protection of stand-alone inverters: 0 = IP00 (Sizes greater than S32) 2 = IP20 (up to Size S32) 5 = IP54 (possible up to Size S32)

3.2.2. Transport and Handling

The Sinus Penta packing ensures easy and safe handling. Handling shall be done using a transpallet or a lift truck with a carrying capacity of at least 100 kg, in order not to damage the product.

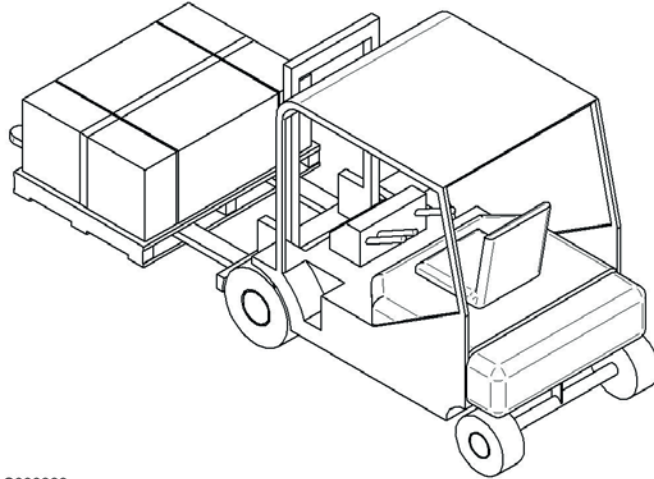

S000383

Figure 4: Lifting the packing from underneath

3.2.3. Unpacking

Get near the installation place, then unpack following the instructions provided below.



CAUTION The whole original packing is to be kept for the full duration of the warranty period.

1. Cut with pincers the plastic straps that fix the package of the Sinus Penta to the pallet.
2. Cut with a cutter the adhesive tape closing the box on the side where the package orientation symbol is reproduced (see Figure 5).

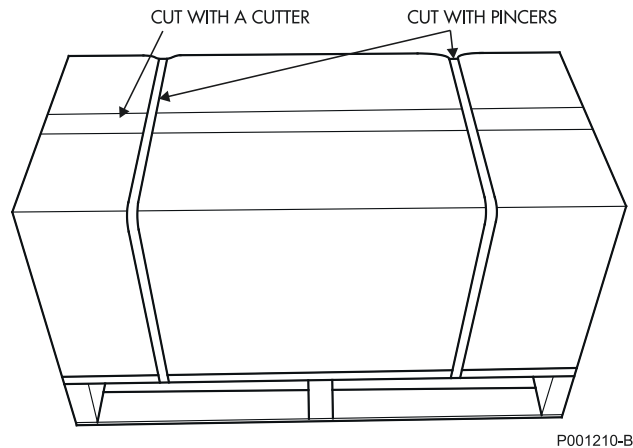

P001210-B

Figure 5: How to open the packaging



Figure 6: “This side up” pictogram

3. Remove the Sinus Penta from its packing by lifting it from its sides. To avoid damaging the packing, lift the product keeping it horizontal to the floor (see Figure 7).

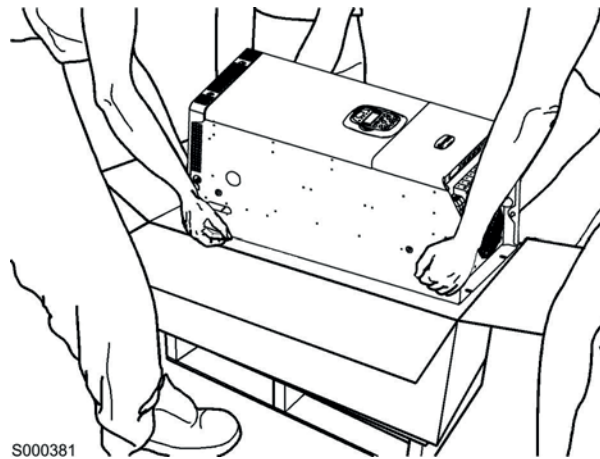

Figure 7: The Sinus Penta is unpacked

4. Put all the packing elements in the box and store it in a dry environment.

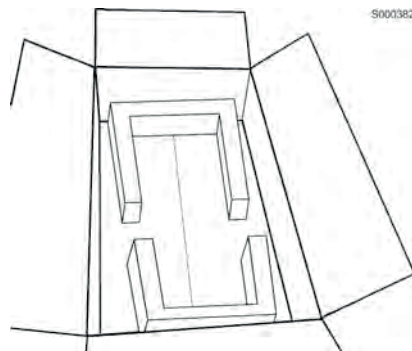

Figure 8: Sinus Penta packing box with the internal protective elements

3.3. Installing the Equipment

The inverters of the Sinus Penta series are Open Type Equipment – degree of protection IP00 and IP20 – that can be installed inside another enclosure featuring degree of protection IP3X as a minimum requirement. Only models featuring degree of protection IP54 may be wall-mounted.



NOTE The inverter must be installed vertically.

The ambient conditions, the instructions for the mechanical assembly and the electrical connections of the inverter are detailed in the sections below.



CAUTION Do not install the inverter horizontally or upside-down.



CAUTION Do not mount any heat-sensitive components on top of the inverter to prevent them from damaging due to hot exhaust air.



CAUTION The inverter rear panel may reach high temperatures; make sure that the inverter bearing surface is not heat-sensitive.



CAUTION The inverter shall be mounted on a stiff surface.

3.3.1. **Environmental Requirements for the Equipment Installation, Storage and Transport**

Any electronic board installed in the inverters manufactured by Elettronica Santerno is tropicalized. This enhances electrical insulation between the tracks having different voltage ratings and ensures longer life of the components. It is however recommended that the requirements below be met:

Maximum surrounding air temperature	-10°C to +55°C It might be necessary to apply 2% derating of the rated current for every degree beyond the stated temperatures depending on the inverter model and the application category (see Operating Temperatures Based On Application Category).
Ambient temperatures for storage and transport	-25°C to + 70°C
Installation environment	Pollution degree 2 or better (according to IEC 61800-5-1). Do not install in direct sunlight and in places exposed to conductive dust, corrosive gases, vibrations, water sprinkling or dripping (except for IP54 models); do not install in salty environments.
Altitude	Max. altitude for installation 2000 m a.s.l. For installation above 2000 m and up to 4000 m, please contact Elettronica Santerno. Above 1000 m, derate the rated current by 1% every 100 m.
Operating ambient humidity	From 5% to 95%, from 1g/m ³ to 29g/m ³ , non-condensing and non-freezing (class 3k3 according to EN50178)
Storage ambient humidity	From 5% to 95%, from 1g/m ³ to 29g/m ³ , non-condensing and non-freezing (class 1k3 according to EN50178)
Ambient humidity during transport	Max. 95%, up to 60g/m ³ ; condensation may appear when the equipment is not running (class 2k3 according to EN50178)
Storage and operating atmospheric pressure	From 86 to 106 kPa (classes 3k3 and 1k4 according to EN50178)
Atmospheric pressure during transport	From 70 to 106 kPa (class 2k3 according to EN50178).



CAUTION

As environmental conditions strongly affect the inverter life, do not install the equipment in places that do not have the above-mentioned ambient conditions.



CAUTION

Always transport the equipment within its original package.

3.3.2. Air Cooling

Make sure to allow adequate clearance around the inverter for the free circulation of air through the equipment. The table below shows the min. clearance to leave in respect to other devices installed near the inverter. The different sizes of the inverter are considered.

Size	A – Side clearance (mm)	B – Side clearance between two inverters (mm)	C – Bottom clearance (mm)	D – Top clearance (mm)
S05	20	40	50	100
S12	30	60	60	120
S14	30	60	80	150
S15	30	60	80	150
S20	50	100	100	200
S22	50	100	100	200
S30	100	200	200	200
S32	100	200	200	250
S41	50	50	200	300
S42	50	50	200	300
S51	50	50	200	300
S52	50	50	200	300
S60	150	300	500	300

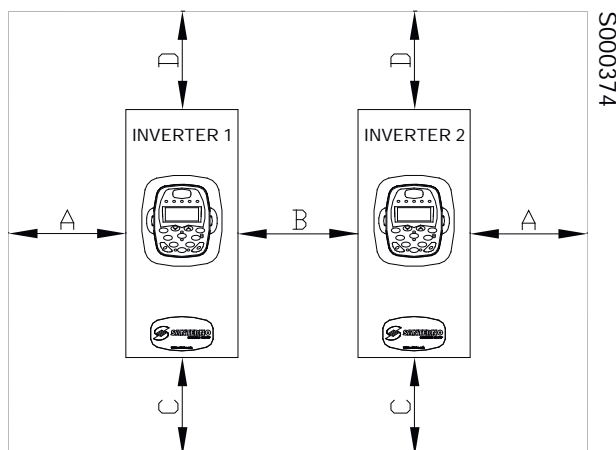

Figure 9: Clearance to be observed between two inverters

Size	Minimum side clearance between two inverter modules (mm)	Maximum side clearance between two inverter modules (mm)	Maximum side clearance between two supply modules (mm)	Maximum side clearance between inverter modules and supply modules (mm)	Top clearance (mm)	Bottom clearance (mm)	Clearance between two inverter units (mm)
S64-S90	20	50	50	400	100	See Figure 10	300

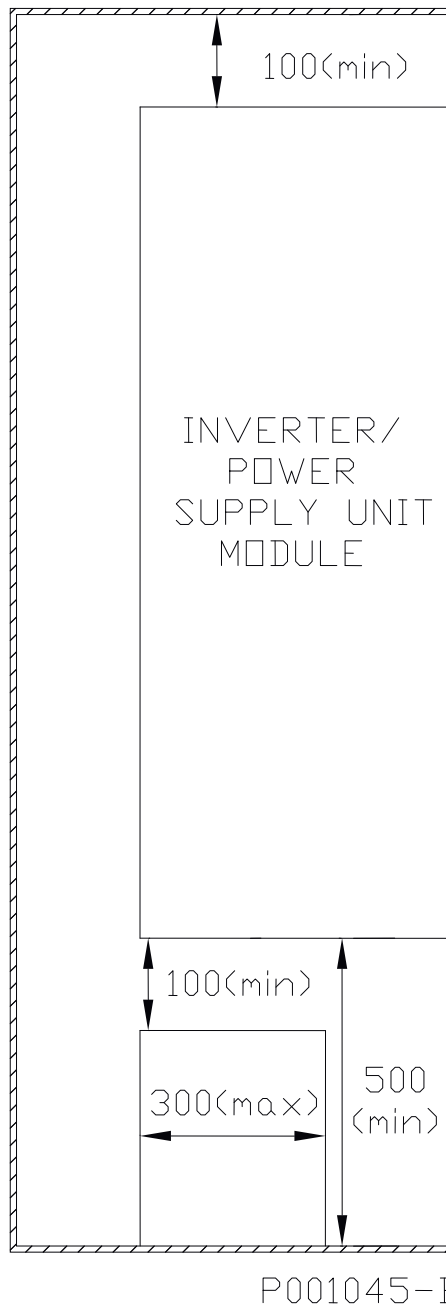

Figure 10: Clearance to allow when installing the Inverter/Power supply unit modules

The air circulation through the enclosure must avoid warm air intake; make sure to provide adequate air-cooling through the inverter. The technical data related to dissipated power is shown in the ratings table.

To calculate the air delivery required for the cabinet cooling consider coefficients for ambient temperature of about 35°C and altitudes lower than or equal to 1000 m a.s.l.

The air delivery required is equal to $Q = (P_{ti} - P_{dsu}) / \Delta t \times 3.5$ [m³/h]:

P_{ti} is the overall thermal power dissipated inside the cabinet and expressed in W,

P_{dsu} is the thermal power dissipated from the cabinet surface,

Δt is the difference between the air temperature inside the cabinet and the air temperature outside the cabinet (temperatures are expressed in degrees centigrade, °C).

For sheet-steel enclosures, power dissipated from the cabinet walls (**P_{dsu}**) may be calculated as follows:

$$P_{dsu} = 5.5 \times \Delta t \times S$$

where **S** is equal to the enclosure overall surface in m².

Q is the air flow (expressed in m³ per hour) circulating through the ventilation slots and is the main dimensioning factor to be considered in order to choose the most suitable air-cooling systems.

Example:

Enclosure with a totally free external surface housing a **Sinus Penta 0113** and a 500 VA transformer dissipating 15 W.

Total power to be dissipated inside the enclosure (**P_{ti}**):

generated from the inverter	P_i	2150
generated from other components	P_a	15W
P_{ti}	P_i + P_a	2165W

Temperatures:

Max. inside temperature desired	T_i	40°C
Max. outside temperature	T_e	35°C
Difference between temp. T_i and T_e	Δt	5°C

Size of the enclosure (metres):

Width	W	0.6m
Height	H	1.8m
Depth	D	0.6m

Free external surface of the enclosure **S**:

$$S = (W \times H) + (W \times H) + (D \times H) + (D \times H) + (D \times W) = 4.68 \text{ m}^2$$

Thermal power dissipated outside the enclosure **P_{dsu}** (only for sheet-steel enclosures):

$$P_{dsu} = 5.5 \times \Delta t \times S = 128 \text{ W}$$

Remaining power to be dissipated:

$$P_{ti} - P_{dsu} = 2037 \text{ W}$$

To dissipate **P_{diss.}** left, provide a ventilation system with the following air delivery **Q**:

$$Q = (P_{ti} - P_{dsu}) / \Delta t \times 3.5 = 1426 \text{ m}^3/\text{h}$$

3.3.3. Scheduled Maintenance

If installed in an adequate place, the inverter scheduled maintenance is reduced to a minimum. The minimum maintenance intervals are indicated in the table below.

Maintenance tasks	Minimum frequency	What to do
Capacitor reforming	Every 12 months if the inverter is stored in a warehouse	See section Capacitor Reforming
Heat sink cleaning check, ambient temperature check	Depending on dust concentration (every 6...12 months)	See section Heat Sink and Ambient Temperature
Air filter cleaning (IP54 models only)	Depending on dust concentration (every 6...12 months)	See section Air Filters
Cooling fan check; replacement, if required	Depending on dust concentration (every 6...12 months)	See section Cooling Fans
Cooling fan replacement	Every 6 years	See section Cooling Fans
Heat sink replacement (if ambient temperature $\geq 35^{\circ}\text{C}$, but ranging within allowable rated values)	Every 10 years or 20,000 hours	See section Replacing a Capacitor
Heat sink replacement (if ambient temperature $< 35^{\circ}\text{C}$)	Every 12 years	See section Replacing a Capacitor
Bypass contactor	Every 10 years	See section Bypass Contactor

Please refer to the Programming Guide (Maintenance menu) for the creation of warnings as reminders of the scheduled maintenance activities.

3.3.4. Air Filters

The air filters are to be periodically cleaned in IP54 models only.

1. Remove voltage from the inverter.
2. Loosen the side screws on the cover.

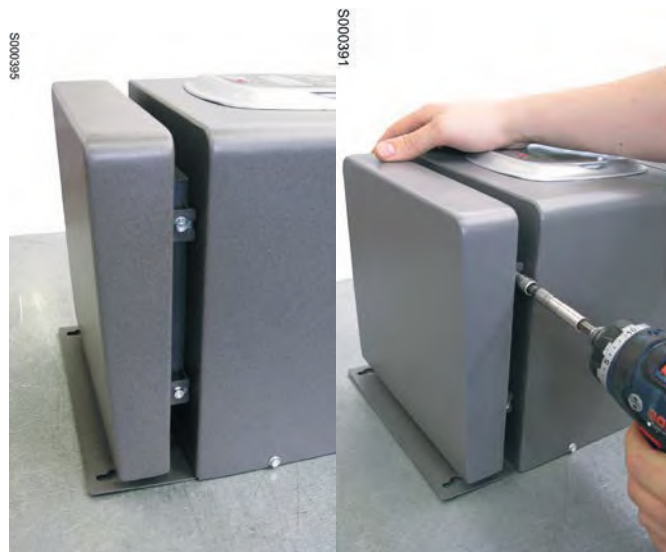

3. Pull out the cover in the direction of the arrow.



4. Loosen the fastening screws of the frame.



5. Clean the air filter and replace it, if required.



6. Close the inverter by refitting the air filter, then the cover.

7. Apply voltage to the inverter.

3.3.5. Heat Sink and Ambient Temperature Check

Dust builds up in the inverter cooling fans, as well as on the heat sink temperature sensors and the ambient temperature sensors. This may alter the readout values.

Periodically check the consistency of the temperature data. If required, clean the control board, (ambient temperature detection) and heat sink (heat sink temperature detection).

3.3.5.1. Control Board

- 1.Remove voltage from the inverter.
- 2.Remove the cover from the inverter.
- 3.Clean the control board with a soft brush.
- 4.Refit the inverter cover.
- 5.Apply voltage to the inverter.



CAUTION

It is forbidden to use compressed air, that contains humidity and impurity.
It is recommended that a vacuum cleaner be used along with the soft brush.

3.3.5.2. Cleaning the Heat Sink

Please contact Elettronica Santerno's Customer Service.

3.3.6. Cooling Fans

The minimum expected lifetime of the inverter cooling fans is approx. 50,000 hours. The actual lifetime depends on the operating mode of the inverter, the ambient temperature and the environmental pollution.

When the cooling fans are particularly noisy or the heat sink temperature rises, this means that an imminent fault is likely to occur, even if the fans have been regularly cleaned over time. If the inverter is used in a critical stage of a process, replace the fans as soon as those symptoms occur.

3.3.6.1. Replacing the Cooling Fans

Please contact Elettronica Santerno's Customer Service.

3.3.7. Capacitors

The DC-link of the inverter requires several electrolytic capacitors, whose expected lifetime is approx. 40,000 to 50,000 hours. The actual endurance depends on the inverter load and the ambient temperature. The capacitors lifetime may be increased by reducing the ambient temperature.

Capacitor faults cannot be predicted. Normally, when a capacitor fault occurs, the mains fuses blow or an alarm message appears. Please contact Elettronica Santerno's Customer Service if you suppose that a capacitor fault has occurred.

3.3.7.1. Capacitor Reforming

Reform the spare capacitors once a year as detailed in the Guide for Capacitor Reforming.

3.3.7.2. Replacing a Capacitor

Please contact Elettronica Santerno's Customer Service.

3.3.8. Bypass Contactor

Except for models S41/42/51/52 and \geq S64, the pre-charge circuit of the capacitors utilizes a bypass contactor whose expected lifetime is approx. 10 years. The actual duration of the bypass contactor depends on how many times the inverter is powered on and on the dust concentration in the installation environment. Normally, an alarm message is displayed when a bypass contactor fault occurs.

3.3.8.1. Replacing the Bypass Contactor

Please contact Elettronica Santerno's Customer Service.

3.3.9. Size, Weight, Dissipated Power, Noise Level

3.3.9.1. IP20 and IP00 STAND-ALONE Models (S05–S60) Class 2T

Size	Sinus Penta MODEL	W	H	D	Weight	Power dissipated at Inom	Noise level
		mm	mm	mm	kg	W	db(A)
S05	0007	170	340	175	7	160	46
	0008				7	170	
	0010				7	220	
	0013				7	220	
	0015				7	230	
	0016				7	290	
	0020				7	320	
S12	0023	215	401	225	11	390	57
	0033				12	500	
	0037				12	560	
S15	0040	225	466	331	22.5	820	48
	0049				22.5	950	
S20	0060	279	610	332	33.2	950	58
	0067				33.2	1250	
	0074				36	1350	
	0086				36	1500	
S30	0113	302	748	421	51	2150	61
	0129				51	2300	
	0150				51	2450	66
	0162				51	2700	
S41	0180	500	882	409	117	2550	64
	0202				117	3200	
	0217				121	3450	
	0260				121	3950	
S51	0313	578	882	409	141	4400	65
	0367				141	4900	
	0402				141	6300	
S60	0457	890	1310	530	260	7400	61
	0524				260	8400	



NOTE Degree of protection IP20 up to Size S30; IP00 for greater Sizes.

3.3.9.2. IP20 and IP00 STAND-ALONE Models (S05–S60) Class 4T

Size	Sinus Penta MODEL	W	H	D	Weight	Power Dissipated at Inom	Noise level
		mm	mm	mm	kg	W	db(A)
S05	0005	170	340	175	7	215	46
	0007				7	240	
	0009				7	315	
	0011				7	315	
	0014				7	315	
S12	0016	215	401	225	10.5	430	42
	0017				10.5	490	
	0020				10.5	490	
	0025				11.5	520	
	0030				11.5	520	53
	0034				12.5	680	
	0036				12.5	710	
S15	0040	225	466	331	22.5	820	48
	0049				22.5	950	
S20	0060	279	610	332	33.2	950	57
	0067				33.2	1250	
	0074				36	1350	
	0086				36	1500	
S30	0113	302	748	421	51	2150	61
	0129				51	2300	
	0150				51	2450	66
	0162				51	2700	
S41	0180	500	882	409	117	2550	63
	0202				117	3200	
	0217				121	3450	
	0260				121	3950	
S51	0313	578	882	409	141	4400	65
	0367				141	4900	
	0402				141	6300	
S60	0457	890	1310	530	260	7400	61
	0524				260	8400	



P000042-B



NOTE Degree of protection IP20 up to Size S30; IP00 for greater Sizes.

3.3.9.3. IP20 and IP00 STAND-ALONE Models (S12–S52) Class 5T-6T

Size	Sinus Penta MODEL	W	H	D	Weight	Power dissipated at Inom	Noise Level
		mm	mm	mm	kg	W	db(A)
S12 5T	0003	215	401	225	10	160	50
	0004				10	180	
	0006				10.5	205	
	0012				10.5	230	
	0018				10.5	270	
S14	0003	270	527	240	17.5	170	49
	0004				17.5	190	
	0006				17.5	210	
	0012				17.5	240	
	0018				17.5	280	
	0019				17.5	320	
	0021				17.5	370	
	0022				18	470	
	0024				18	550	
	0032				18.5	670	
S22	0042	283	833	353	51	750	68
	0051				51	950	
	0062				54	1000	
	0069				54	1200	
S32	0076	367	880	400	80	1400	63
	0088				80	1700	
	0131				84	2100	
	0164				84	2500	
S42	0181	500	968	409	128	3450	63
	0201				128	3900	
	0218				136	4550	
	0259				136	4950	
S52	0290	578	968	409	160	5950	69
	0314				160	6400	
	0368				160	7000	
	0401				160	7650	

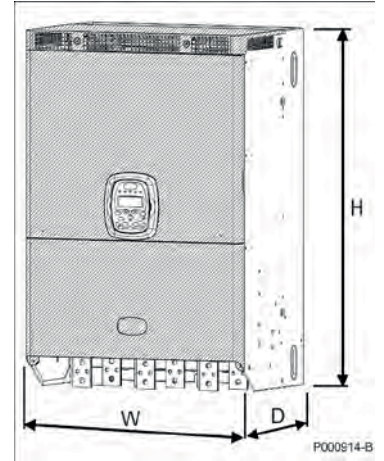

NOTE Degree of protection IP20 up to Size S32; IP00 for greater Sizes.

3.3.9.4. Modular IP00 STAND-ALONE Models (S64–S90)

To obtain high-power inverters, the following individual modules are matched together:

- Control unit, containing the control board and ES842 board
- Power supply unit module, composed of a 3-phase power rectifier and its control and power supply circuits
- Inverter module, composed of an inverter phase and its control circuits
- Braking unit.

Four types of inverter modules are available:

- basic version
- version with integrated control unit
- version with integrated auxiliary supply unit (to be used for those models which are not equipped with the power supply module – sizes S64, S74, and S84);
- version with integrated splitter unit (to be used for the Penta sizes where parallel-connected inverter modules are installed – sizes S74, S75, S80, S84 and S90).

Match the modules above to obtain the proper inverter dimensioning for your application:

		Number of power supply modules			
		0	1	2	3
Number of IGBT modules	3	S64	S65	S70	–
	6	S74	–	S75	S80
	9	S84	–	–	S90



CAUTION

The busbars connecting the different modules are not supplied by Elettronica Santerno.



CAUTION

Properly configure ES842 control board inside the control unit.
When ordering the inverter, always state the inverter configuration you want to obtain.

a) control unit

The control unit can be installed separately from the inverter modules or inside an inverter module (this option must be stated when ordering the inverter). Dimensions of the control unit (separate from the inverter).

EQUIPMENT	W	H	D	Weight	Dissipated power
	mm	mm	mm	kg	W
Control unit	222	410	189	6	100



NOTE

In the standard configuration, the control unit is installed on an inverter module.

b) Inverter modules and power supply unit

Configuration: power supply delivered from the mains

Models where no parallel-connected inverter modules are installed (S65 and S70)

Size	Sinus Penta Model	Voltage class	Modules		Overall Dimensions	Overall Weight	Overall Power dissipated at Inom	Noise Level
			Power Supply Modules	Inverter Modules	WxHxD	kg	kW	db(A)
S65	0598	4T	1	3	980x1400x560	440	9.75	71
	0748	4T	1	3			10.75	
	0831	4T	1	3			12.90	
	0457	5T-6T	1	3			9.15	
	0524	5T-6T	1	3			9.80	
	0598	5T-6T	1	3			11.25	
	0748	5T-6T	1	3			12.45	
S70	0831	5T-6T	2	3	1230x1400x560	550	14.90	72

Models including parallel-connected inverter modules (S75, S80 and S90)

Size	Sinus Penta Model	Voltage Class	Voltage class		Modules	Overall Dimensions	Overall Weight	Noise Level
			Power Supply Modules	Inverter Modules (*)				
S75	0964	4T	2	6	1980x1400x560	880	17.20	73
	1130	4T	2	6			18.90	
	1296	4T	2	6			21.10	
	0964	5T-6T	2	6			18.40	
	1130	5T-6T	2	6			22.80	
S80	1296	5T-6T	3	6	2230x1400x560	990	24.90	74
S90	1800	4T	3	9	2980x1400x560	1320	29.25	75
	2076	4T	3	9			32.25	
	1800	5T-6T	3	9			33.75	
	2076	5T-6T	3	9			37.35	

(*): Three inverter modules are to be provided with an integrated splitter unit.

c) Inverter modules, power supply unit and braking unit

Configuration: power supply delivered from the mains; integrated braking unit

Models where no parallel-connected inverter modules are installed (S65 and S70)

Size	Sinus Penta Model	Voltage class	Modules			Overall Dimensions	Overall Weight	Power Dissipated with 50% Braking Duty Cycle	Noise Level
			Power Supply Modules	Inverter Modules	Braking Modules				
			WxHxD	kg	kW	db(A)			
S65	0598	4T	1	3	1	1230x1400x560	550	10.55	71
	0748	4T	1	3	1			11.65	
	0831	4T	1	3	1			13.90	
	0457	5T-6T	1	3	1			10.05	
	0524	5T-6T	1	3	1			10.80	
	0598	5T-6T	1	3	1			12.45	
	0748	5T-6T	1	3	1			13.75	
S70	0831	5T-6T	2	3	1	1480x1400x560	660	14.90	72

Models including parallel-connected inverter modules (S75, S80 and S90)

Size	Sinus Penta Model	Voltage class	Modules			Overall Dimensions	Overall Weight	Power Dissipated with 50% Braking Duty Cycle	Noise Level
			Power Supply Modules	Inverter Modules (*)	Braking Modules (**)				
			WxHxD	kg	kW	db(A)			
S75	0964	4T	2	6	1	2230x1400x560	990	18.50	74
	1130	4T	2	6	1			20.40	
	1296	4T	2	6	2	2480x1400x560	1100	22.90	
	0964	5T-6T	2	6	1	2230x1400x560	990	20.30	
	1130	5T-6T	2	6	2	2480x1400x560	1100	25.00	
S80	1296	5T-6T	3	6	2	2730x1400x560	1210	27.30	75
S90	1800	4T	3	9	2	3480x1400x560	1540	31.25	76
	2076	4T	3	9	2			34.85	
	1800	5T-6T	3	9	2			36.75	
	2076	5T-6T	3	9	2			41.15	

(*): Three inverter modules are to be provided with an integrated splitter unit.

(**): When using two braking modules, one braking module is to be provided with an integrated splitter unit.

d) Inverter modules only

Configuration:

- inverter powered directly from a DC voltage power supply source;
- inverter used as a regenerative power supply unit (for more details, please refer to the technical documentation relating to the Regenerative Penta Drive)

Models where no parallel-connected inverter modules are installed (S64)

Size	Sinus Penta Model	Voltage Class	Modules		Overall Dimensions	Overall Weight	Overall Power dissipated at Inom	Noise Level
			Inverter Modules with Aux. Power Supply Unit	Inverter modules (*)				
S64	0598	4C	1	2	730x1400x560	338	7.50	69
	0748	4C	1	2			8.25	
	0831	4C	1	2			9.90	
	0457	5C-6C	1	2			7.20	
	0524	5C-6C	1	2			7.80	
	0598	5C-6C	1	2			8.85	
	0748	5C-6C	1	2			9.75	
	0831	5C-6C	1	2			11.70	

(*): One inverter module must be provided with an integrated auxiliary power supply unit.

Models including parallel-connected inverter modules (S74 and S84)

Size	Sinus Penta Model	Voltage Class	Modules		Overall Dimensions	Overall Weight	Overall Power dissipated at Inom	Noise Level
			Inverter Modules with Aux. Power Supply Unit	Inverter modules (*)				
S74	0964	4C	2	4	1480x1400 x560	676	13.20	72
	1130	4C	2	4			14.40	
	1296	4C	2	4			15.60	
	0964	5C-6C	2	4			14.40	
	1130	5C-6C	2	4			18.00	
	1296	5C-6C	2	4			19.20	
S84	1800	4C	3	6	2230x1400x560	1014	22.50	74
	2076	4C	3	6			24.75	
	1800	5C-6C	3	6			26.55	
	2076	5C-6C	3	6			29.25	

(*): Three inverter modules are to be provided with an integrated splitter unit.

e) Inverter modules and braking module only

Configuration: inverter powered directly from a DC voltage power supply source with a braking unit.

Models where no parallel-connected inverter modules are installed (S64)

Size	Sinus Penta Model	Voltage Class	Modules			Overall Dimensions	Overall Weight	Overall Power Dissipated with 50% Braking Duty Cycle	Noise Level
			Inverter Modules with Aux. Power Supply Unit	Inverter Modules (*)	Braking Module				
S64	0598	4C	1	2	1	980x1400x560	448	8.30	71
	0748	4C	1	2	1			9.15	
	0831	4C	1	2	1			10.90	
	0457	5C-6C	1	2	1			8.10	
	0524	5C-6C	1	2	1			8.80	
	0598	5C-6C	1	2	1			10.05	
	0748	5C-6C	1	2	1			11.05	
	0831	5C-6C	1	2	1			13.20	

(*): One inverter module must be provided with an integrated auxiliary power supply unit.

Models including parallel-connected inverter modules (S74 and S84)

Size	Sinus Penta Model	Voltage Class	Modules			Overall Dimensions	Overall Weight	Overall Power Dissipated with 50% Braking Duty Cycle	Noise Level
			Inverter Modules with Aux. Power Supply Unit	Inverter Modules (*)	Braking Module (**)				
S74	0964	4C	2	4	1	1730x1400x560	786	14.50	74
	1130	4C	2	4	1			15.90	
	1296	4C	2	4	2			1980x1400x560	
	0964	5C-6C	2	4	1	1730x1400x560	786	16.30	
	1130	5C-6C	2	4	2			20.20	
	1296	5C-6C	2	4	2			1980x1400x560	
S84	1800	4C	3	6	2	2730x1400x560	1234	24.50	75
	2076	4C	3	6	2			27.35	
	1800	5C-6C	3	6	2			29.55	
	2076	5C-6C	3	6	2			33.05	

(*): Three inverter modules are to be provided with an integrated splitter unit.

(**): When using two braking modules, one braking module is to be provided with an integrated splitter unit.

3.3.9.5. IP54 STAND-ALONE Models (S05–S30) Class 2T

Size	Sinus Penta Model	W	H	D	Weight	Power Dissipated at Inom.	Noise Level
		mm	mm	mm	kg	W	db(A)
S05	0007	214	577	227	15.7	160	46
	0008					170	
	0010					220	
	0013					220	
	0015					230	
	0016					290	
	0020					Unavailable model as IP54	
S12	0023	250	622	268	23.8	390	65
	0033					500	
	0037					560	
S15	0040	288	715	366	40	820	47
	0049					950	
S20	0060	339	842	366	54.2	1050	59
	0067					1250	
	0074				57	1350	
	0086					1500	
S30	0113	359	1008	460	76	2150	61
	0129					2300	
	0150					2450	66
	0162					2700	

OPTIONAL FEATURES:

Front key-operated selector switch for LOCAL/REMOTE control and EMERGENCY pushbutton.



NOTE When housing optional features, depth increases by 40mm.



3.3.9.6. IP54 STAND-ALONE Models (S05–S30) Class 4T

Size	Sinus Penta Model	W	H	D	Weight	Power Dissipated at Inom.	Noise Level
		mm	mm	mm	kg	W	db(A)
S05	0005	214	577	227	15.7	215	46
	0007					240	
	0009					315	
	0011					315	
	0014					315	
S12	0016	250	622	268	22.3	430	57
	0017					490	
	0020					490	
	0025				23.3	520	
	0030					520	
	0034				24.3	680	
	0036					710	
S15	0040	288	715	366	40	820	47
	0049					950	
S20	0060	339	842	366	54.2	1050	59
	0067					1250	
	0074					1350	
	0086				57	1500	
	0113					2150	
S30	0129	359	1008	406	76	2300	61
	0150					2450	66
	0162					2700	

OPTIONAL FEATURES:

Front key-operated selector switch for LOCAL/REMOTE control and EMERGENCY pushbutton.



NOTE When housing optional features, depth increases by 40mm.



3.3.9.7. IP54 STAND-ALONE Models (S12–S32) Class 5T-6T

Size	Sinus Penta Model	W	H	D	Weight	Power dissipated at Inom	Noise Level
		mm	mm	mm	kg	W	db(A)
S12 5T	0003	250	622	268	22.5	160	50
	0004					180	
	0006					205	
	0012				23	230	
	0018					270	
S14	0003	305	751	290	30	170	49
	0004					190	
	0006					210	
	0012					240	
	0018					280	
	0019					320	
	0021					370	
	0022					480	
	0024				30.5	560	52
	0032					Unavailable model as IP54	
S22	0042	349	1095	393	80	750	68
	0051					950	
	0062				83	1000	
	0069					1200	
S32	0076	431	1160	471	118	1400	63
	0088					1700	
	0131				122	2100	
	0164					2500	

OPTIONAL FEATURES:

Front key-operated selector switch for LOCAL/REMOTE control and EMERGENCY pushbutton.



NOTE When housing optional features, depth increases by 40mm.



3.3.9.8. IP54 BOX Models (S05–S20) Class 2T

Size	Sinus Penta Model		W	H	D	Weight	Power dissipated at Inom.
			mm	mm	mm	kg	W
S05B	Sinus Penta BOX	0007	400	600	250	27.9	160
	Sinus Penta BOX	0008				27.9	170
	Sinus Penta BOX	0010				27.9	220
	Sinus Penta BOX	0013				27.9	220
	Sinus Penta BOX	0015				27.9	230
	Sinus Penta BOX	0016				27.9	290
	Sinus Penta BOX	0020				27.9	320
S12B	Sinus Penta BOX	0023	500	700	300	48.5	390
	Sinus Penta BOX	0033				49.5	500
	Sinus Penta BOX	0037				49.5	560
S15B	Sinus Penta BOX	0040	600	1000	400	78.2	820
	Sinus Penta BOX	0049				78.2	950
S20B	Sinus Penta BOX	0060	600	1200	400	109.5	1050
	Sinus Penta BOX	0067				109.5	1250
	Sinus Penta BOX	0074				112.3	1350
	Sinus Penta BOX	0086				112.3	1500

OPTIONAL FEATURES:

- Disconnecting switch with line fast fuses.
- Line magnetic circuit breaker with release coil.
- Line contactor in AC1.
- Front key-operated selector switch for LOCAL/REMOTE control and EMERGENCY push-button.
- Line input impedance.
- Motor-side output impedance.
- Output toroid filter.
- Motor forced-cooling circuit.
- Anticondensation heater.
- Additional terminal board for input/output wires.

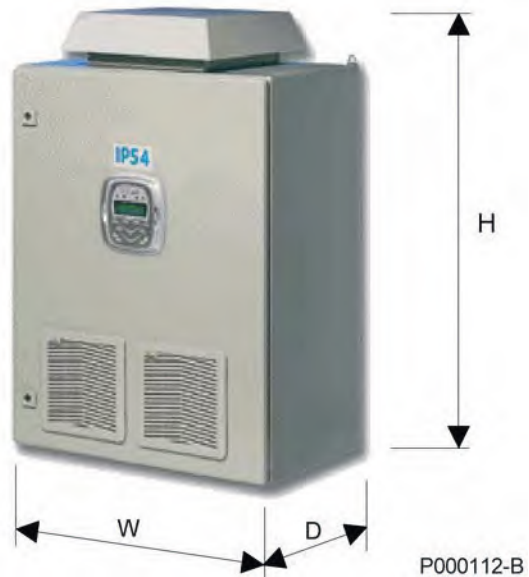

NOTE Dimensions and weights may vary depending on optional components required.

3.3.9.9. IP54 BOX Models (S05–S20) Class 4T

Size	Sinus Penta Model		W	H	D	Weight	Power dissipated at Inom.
			mm	mm	mm	kg	W
S05B	Sinus Penta BOX	0005	400	600	250	27.9	215
	Sinus Penta BOX	0007				27.9	240
	Sinus Penta BOX	0009				27.9	315
	Sinus Penta BOX	0011				27.9	315
	Sinus Penta BOX	0014				27.9	315
S12B	Sinus Penta BOX	0016	500	700	300	48.5	430
	Sinus Penta BOX	0017				48.5	490
	Sinus Penta BOX	0020				48.5	490
	Sinus Penta BOX	0025				49.5	520
	Sinus Penta BOX	0030				49.5	520
	Sinus Penta BOX	0034				50.5	680
	Sinus Penta BOX	0036				50.5	710
S15B	Sinus Penta BOX	0040	600	1000	400	78.2	820
	Sinus Penta BOX	0049				78.2	950
S20B	Sinus Penta BOX	0060	600	1200	400	109.5	1050
	Sinus Penta BOX	0067				109.5	1250
	Sinus Penta BOX	0074				112.3	1350
	Sinus Penta BOX	0086				112.3	1500

OPTIONAL FEATURES:

- Disconnecting switch with line fast fuses.
- Line magnetic circuit breaker with release coil.
- Line contactor in AC1.
- Front key-operated selector switch for LOCAL/REMOTE control and EMERGENCY push-button.
- Line input impedance.
- Motor-side output impedance.
- Output toroid filter.
- Motor forced-cooling circuit.
- Anticondensation heater.
- Additional terminal board for input/output wires.



NOTE Dimensions and weights may vary depending on optional components required.

3.3.9.10. IP24 and IP54 Cabinet Models (S15–S90)

Size	Sinus Penta CABINET Model	Voltage Class	W	H	D	Weight	Power dissipated at Inom
			mm	mm	mm	kg	W
S15C	0040	2T-4T	600	2000	500	130	820
	0049						950
S20C	0060					1050	
	0067					1250	
	0074					1350	
	0086					1500	
S22C	0042	5T-6T	600	2000	500	158	750
	0051					950	
	0062					1000	
S30C	0069	2T-4T	600	2000	600	162	1200
	0113						2150
	0129						2300
	0150						2450
S32C	0162	5T-6T	600	2000	600	191	2700
	0076						1400
	0088						1700
	0131						2100
S41C	0164	2T-4T	1000	2000	600	280	2500
	0180						3200
	0202						3450
	0217						3950
S42C	0260	5T-6T	1000	2000	600	300	3450
	0181						3900
	0201						4550
	0218						4950
S51C	0259	2T-4T	1200	2000	600	350	4400
	0313						4900
	0367						6300
S52C	0402	5T-6T	1200	2000	600	370	5950
	0290						6400
	0314						7000
	0368						7650
	0401						

(continued)

(continued)

S60C	0457	2T-4T 5T-6T	1600	2350	800	586	7400
	0524						8400
S65C	0598	4T	2200			854	9750
	0748						10750
	0831					12900	
	0457	5T-6T				1007	9150
	0524						9800
	0598						11250
0748	12450						
S70C	0831		2600				
S75C	0964	4T	3600	1468	17200		
	1130				18900		
	1296				21100		
	0964	5T-6T			18400		
	1130				22800		
S80C	1296		4000		1700	24900	
S90C	1800	4T	4600	2300	29250		
	2076				32250		
	1800	5T-6T			33750		
	2076				37350		



NOTE Dimensions and weights may vary depending on optional components required.

AVAILABLE OPTIONAL COMPONENTS:

- Disconnecting switch with line fast fuses.
- Line magnetic circuit breaker with release coil.
- AC1 Line contactor.
- Front key-operated selector switch for **LOCAL/REMOTE** control and **EMERGENCY pushbutton**.
- Line input impedance.
- Motor-side output impedance.
- Additional terminal board for input/output wires.
- Output toroid filter. Motor forced-cooling circuit.
- Braking unit for size \geq S41.
- Anticondensation heater.
- PT100 instruments for motor temperature control.
- Optional features/components by request.

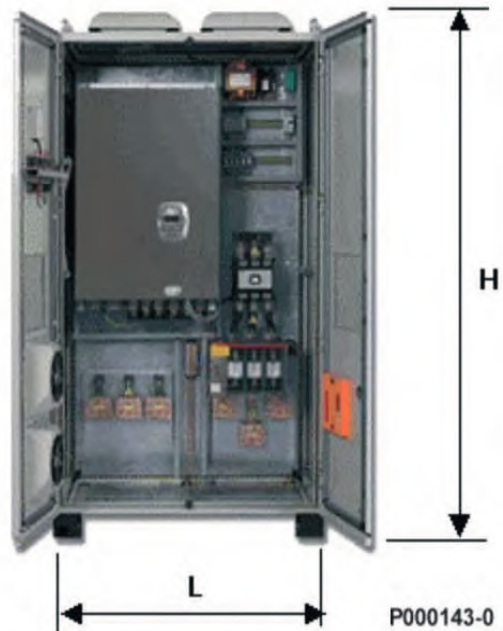

NOTE The value "H" includes the fans and the cabinet base.

3.3.10. Standard Mounting and Piercing Templates (IP20 and IP00 Stand-Alone Models S05–S60)

Sinus Penta Size	Piercing Templates (mm) (Standard Mounting)					Fastening screws
	X	X1	Y	D1	D2	
S05	156	-	321	4.5	-	M4
S12	192	-	377	6	12.5	M5
S14	247	-	506	6	13	M5
S15	185	-	449	7	15	M6
S20	175	-	593	7	15	M6
S22	175	-	800	7	15	M6
S30	213	-	725	9	20	M8
S32	213	-	847	9	20	M8
S41	380	190	845	12	24	M8-M10
S42	380	190	931	12	24	M8-M10
S51	440	220	845	12	24	M8-M10
S52	440	220	931	12	24	M10
S60	570	285	1238	13	28	M10-M12



NOTE Degree of protection IP20 up to Size S32; IP00 for greater Sizes.

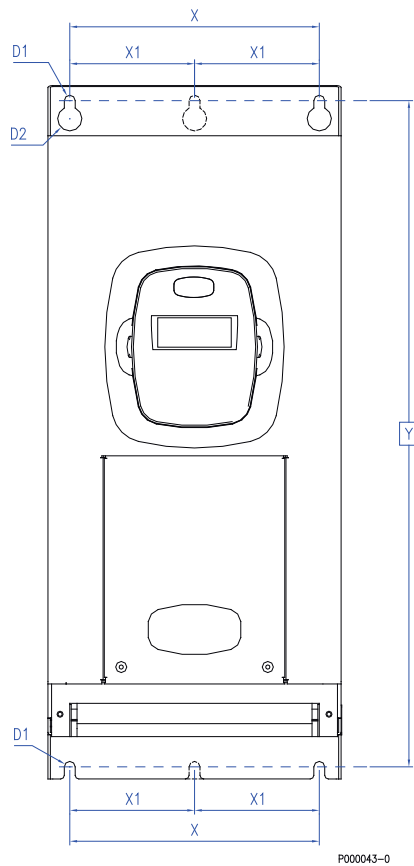

Figure 11: Piercing template for STAND-ALONE models from S05 to S52 included

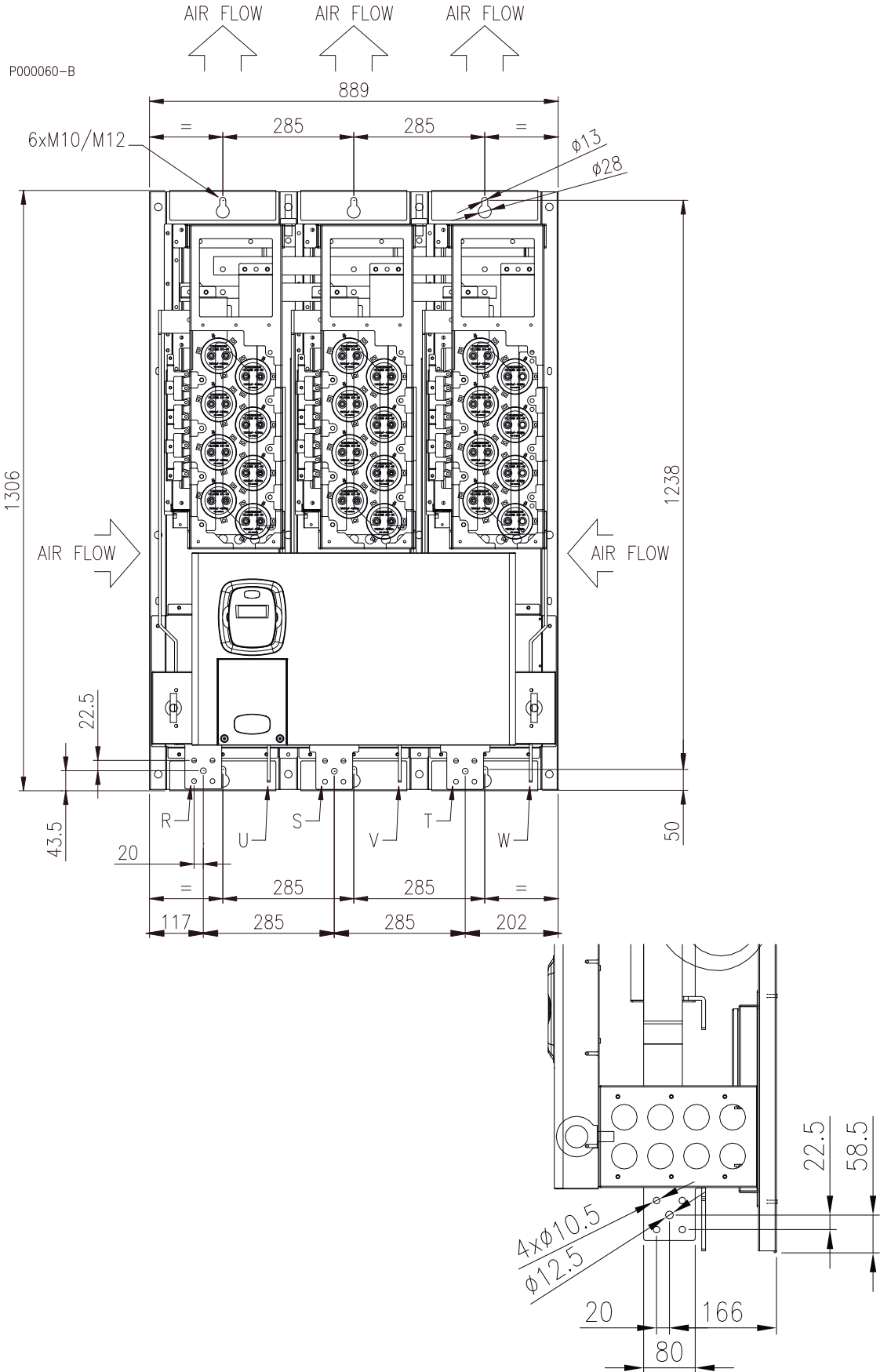

Figure 12: Piercing template for size S60

3.3.11. Through-Panel Assembly and Piercing Templates (IP20 and IP00 Stand-Alone Models S05–S52)

The through-panel assembly allows segregating the air flow cooling the power section in order to avoid dissipating power related to inverter loss inside the inverter case. The inverters available for through-panel assembly are from size S05 to S52, both IP20 and IP00. As a result, unless other features are included, the IP44 rating for the cabinet becomes IP40.

3.3.11.1. Sinus Penta S05

For this inverter size, no actual through-panel assembly is used, but the air flow of the power section is segregated from the air flow of the control section by installing two optional mechanical parts to be assembled with five (5) M4 self-forming screws.

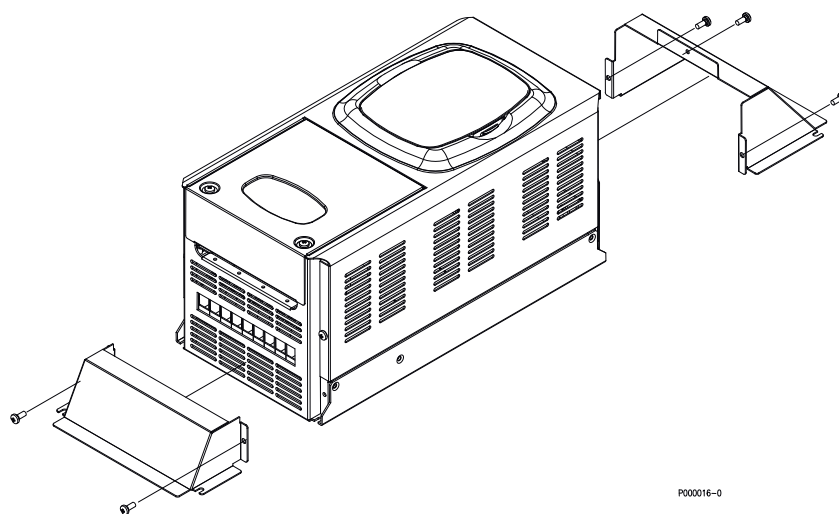

Figure 13: Fittings for through-panel assembly for Sinus Penta S05

The equipment height becomes 488 mm with the two additional components (see figure on the left below). The same figure below also shows the piercing template of the mounting panel, including four M4 holes for the inverter mounting and two slots (142 x 76 mm and 142 x 46 mm) for the air-cooling of the power section.

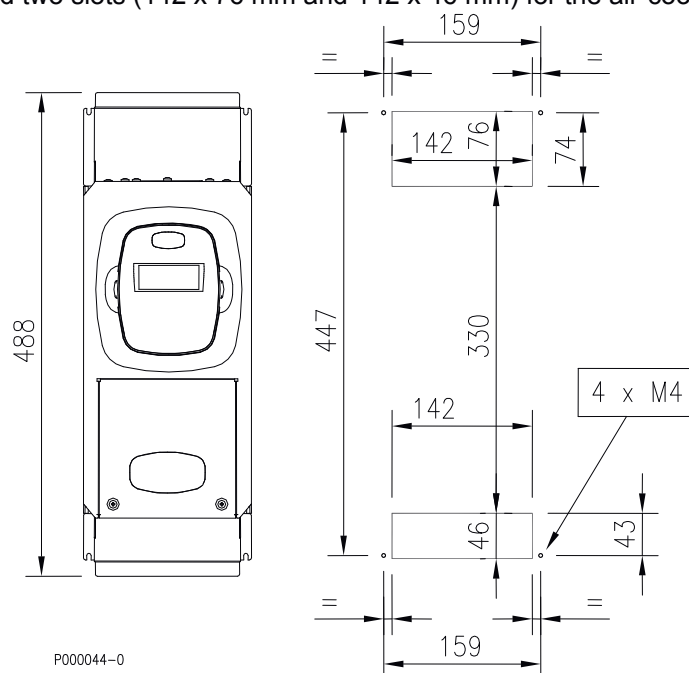
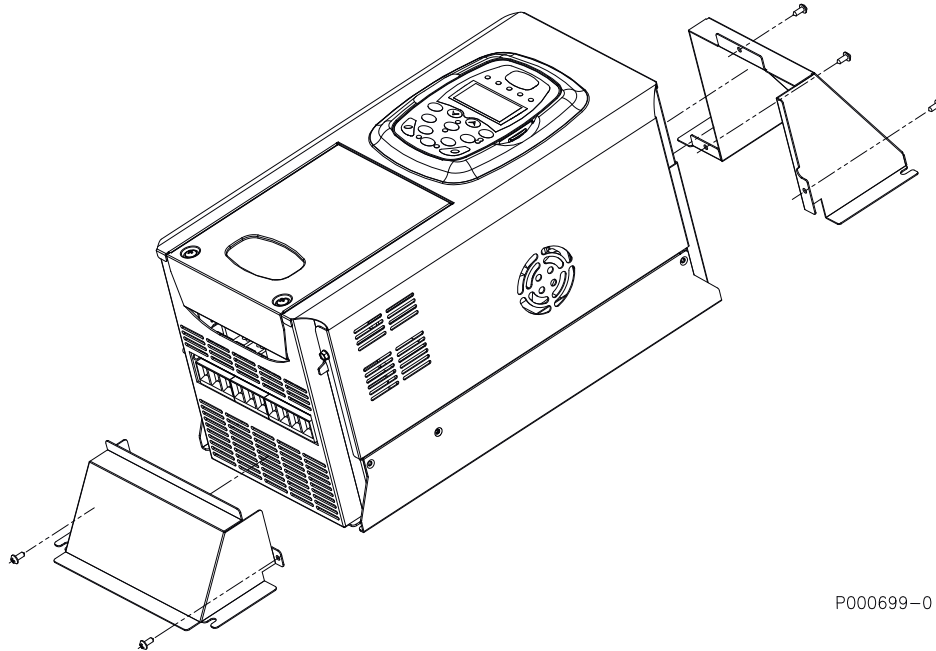

Figure 14: Piercing templates for through-panel assembly for Sinus Penta S05

3.3.11.2. Sinus Penta S12

For this inverter size, no actual through-panel assembly is used, but the air flow of the power section is segregated from the air flow of the control section by installing two optional mechanical parts to be assembled with five (5) M4 self-forming screws (see figure below).



P000699-0

Figure 15: Fittings for through-panel assembly for Sinus Penta S12

The equipment height becomes 583 mm with the two additional components (see figure on the left below). The same figure below also shows the piercing template of the mounting panel, including four M4 holes for the inverter mounting and two slots (175 x 77 mm and 175 x 61 mm) for the air-cooling of the power section.

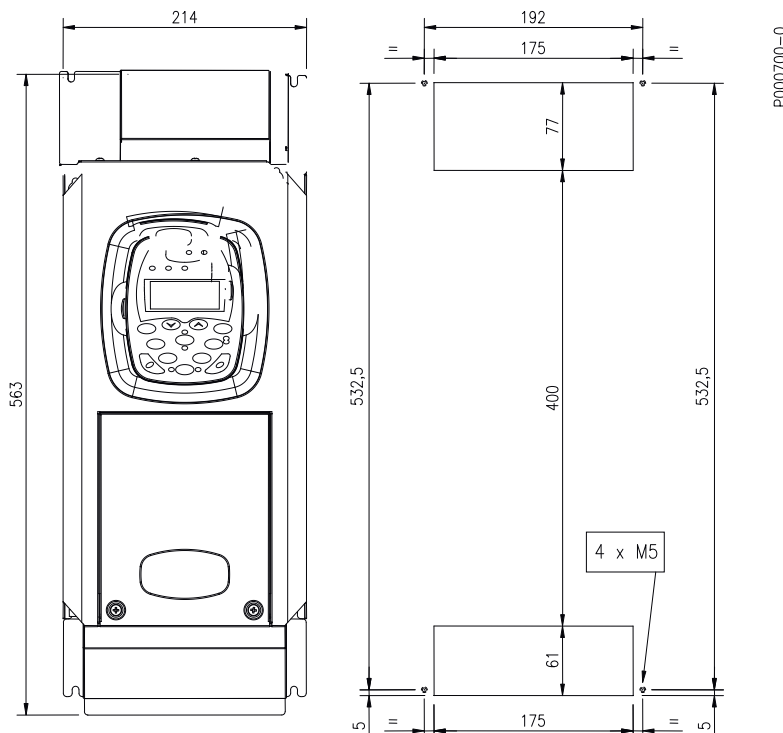
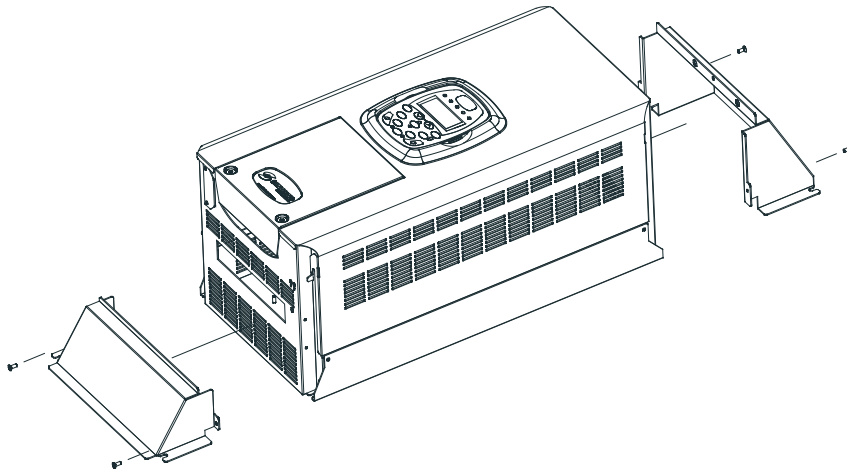

Figure 16: Piercing template for through-panel assembly for Sinus Penta S12

3.3.11.3. Sinus Penta S14

For this inverter size, no actual through-panel assembly is used, but the air flow of the power section is segregated from the air flow of the control section by installing two optional mechanical parts to be assembled with four (4) M4 self-forming screws (see figure below).



S000268

Figure 17: Fittings for through-panel assembly for Sinus Penta S14

The equipment height becomes 690 mm with the two additional components (see figure on the left below). The same figure below also shows the piercing template of the mounting panel, including four M4 holes for the inverter mounting and two slots (232 x 81 mm both) for the air-cooling of the power section.

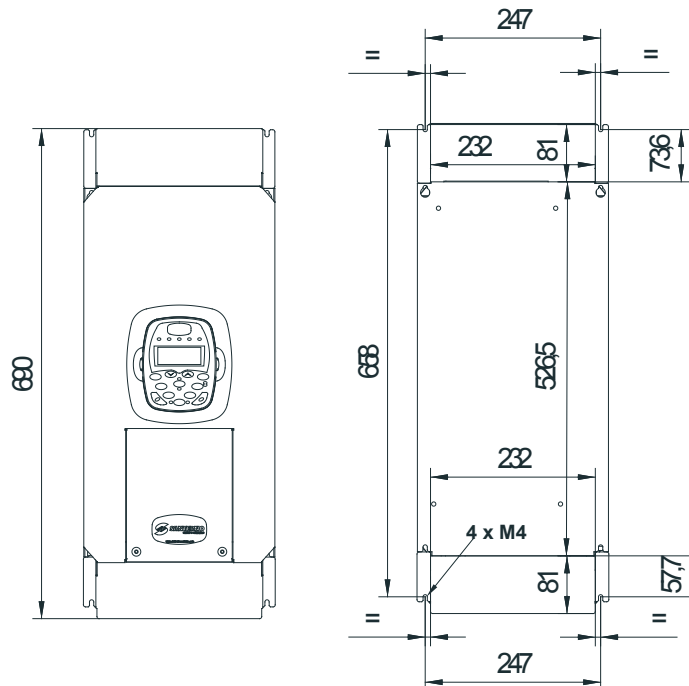

S000268

Figure 18: Piercing template for through-panel assembly for Sinus Penta S14

3.3.11.4. Sinus Penta S15–S20–S30

No additional mechanical component is required for the through-panel assembly of these three Sinus Penta sizes. The piercing template shown in the figure below is to be made on the mounting panel. Measures are shown in the table. The figure below also shows the side view of the through-panel assembly of the equipment. The air flows and the front and rear projections are highlighted as well (see measures in the table).

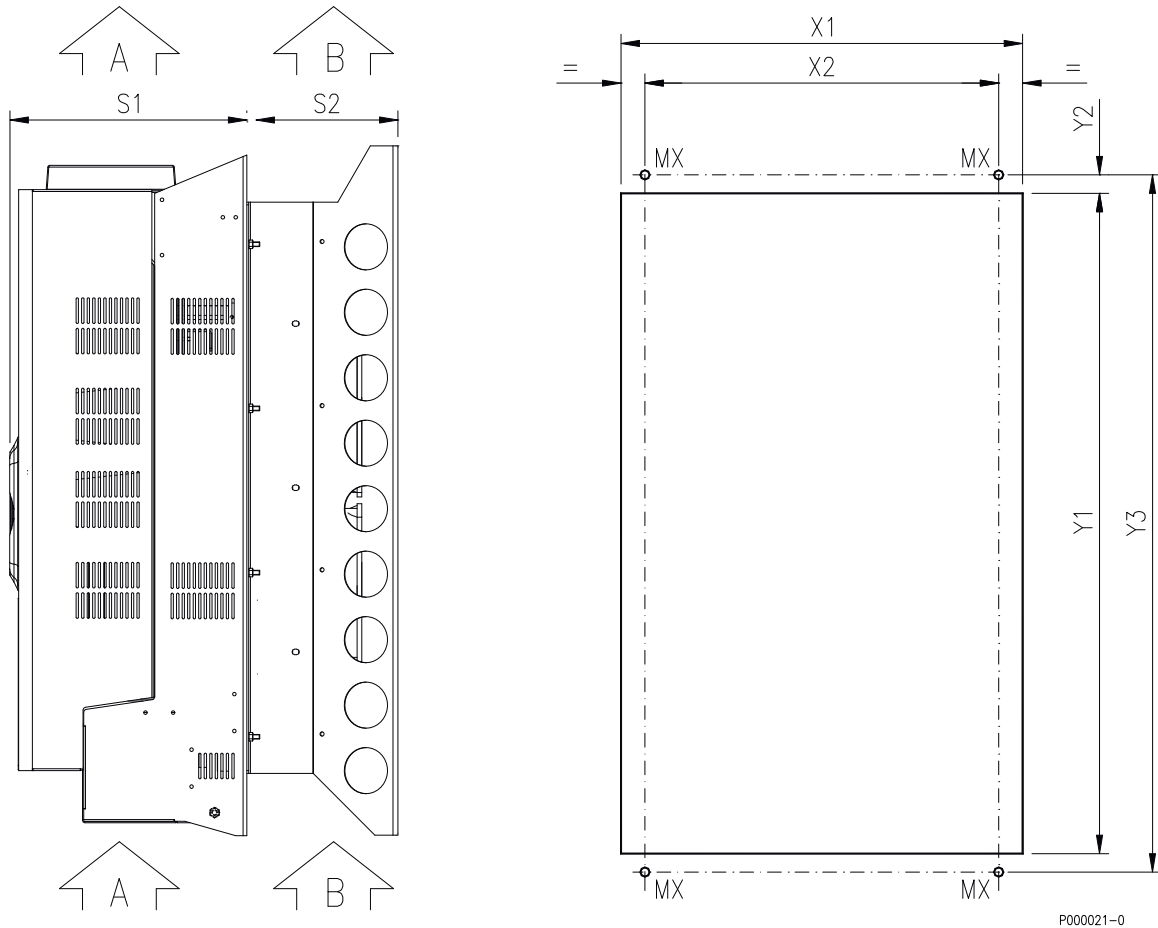

Figure 19: Through-panel assembly and piercing template for Sinus Penta S15, S20 and S30

Inverter size	Front and rear projection		Slot size for through-panel assembly		Templates for fastening holes			Thread and fastening screws
	S1	S2	X1	Y1	X2	Y2	Y3	MX
S15	256	75	207	420	185	18	449	4 x M6
S20	256	76	207	558	250	15	593	4 x M6
S30	257	164	270	665	266	35	715	4 x M8

3.3.11.5. Sinus Penta S22–S32

For these inverter sizes, no actual through-panel assembly is used, but the air flow of the power section is segregated from the air flow of the control section by installing two optional mechanical parts to be assembled as shown below. The screws are included in the mounting kit.

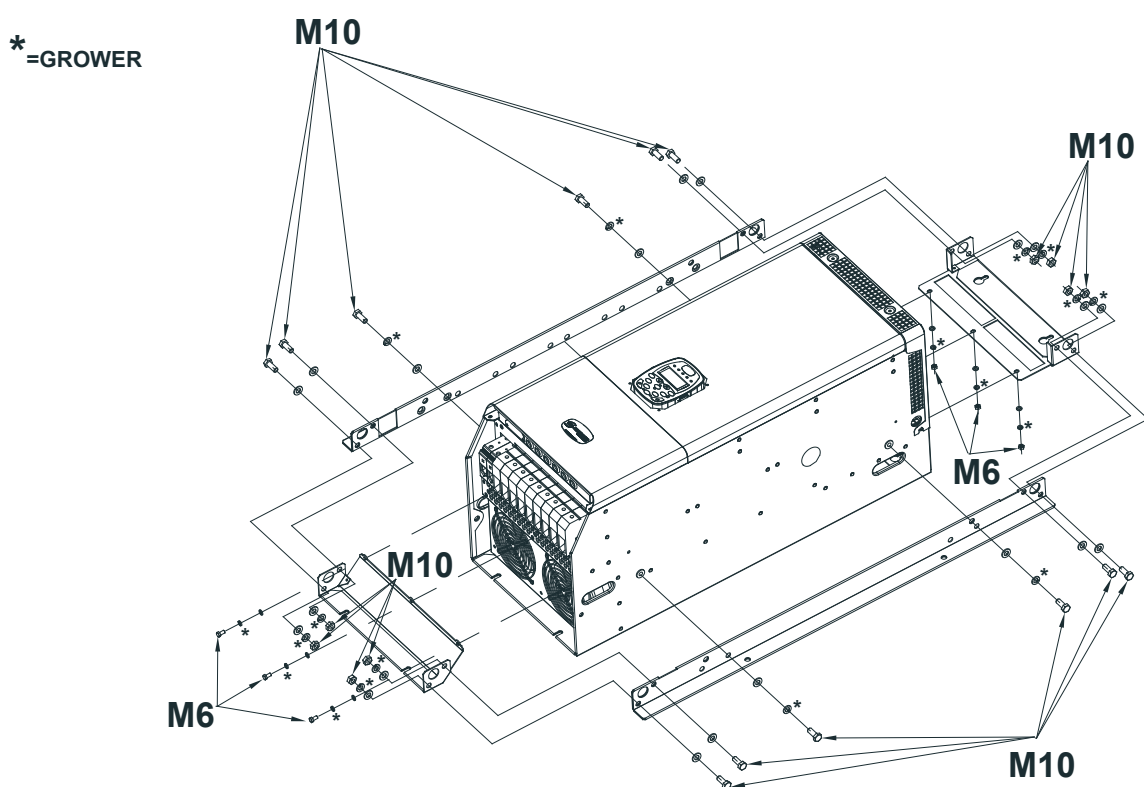
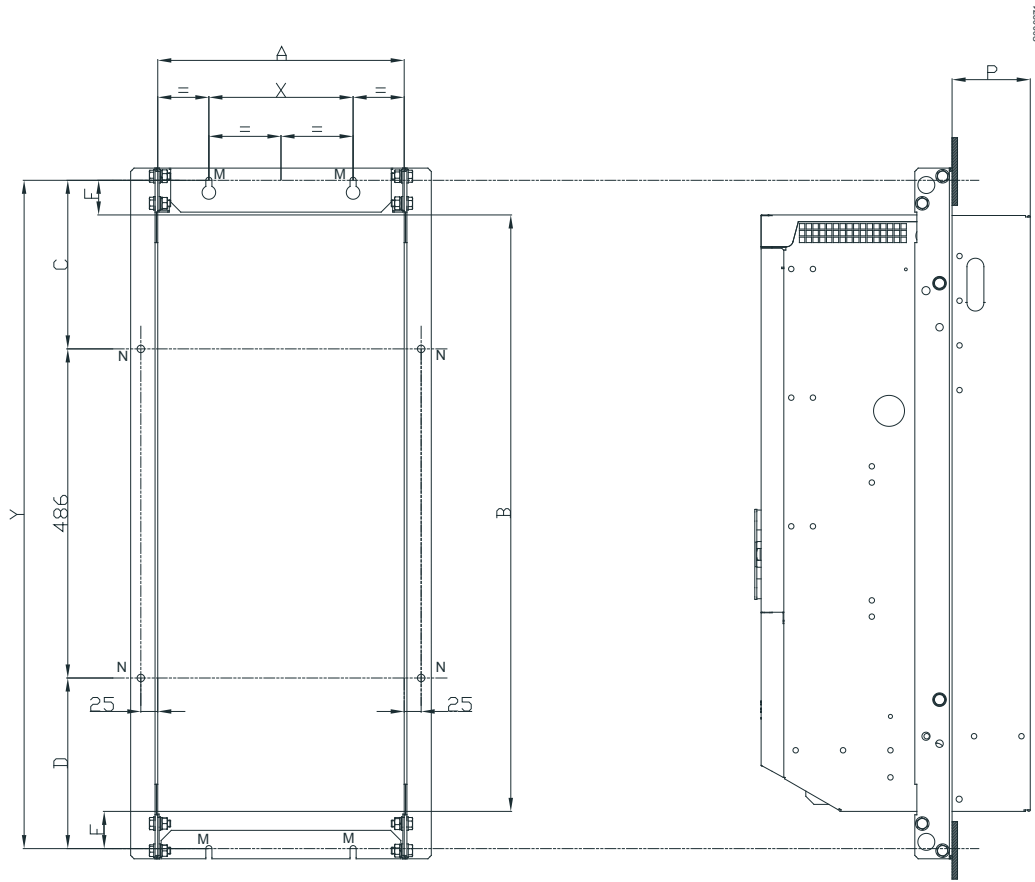

Figure 20: Fittings for through-panel assembly for Sinus Penta S22 and S32

The figure below shows the piercing templates of the mounting panel, including the inverter fixing holes and the hole for the power section air cooling flow.



		MEASURE (mm)										
		A	B	C	D	E	F	X	Y	M	N	P
SIZE	S22	280	832	228	229	56	54	175	943	M6	M6	67
	S32	364	880	249	252	55	51	213	987	M8	M6	115.5

Figure 21: Piercing template for through-panel assembly for Sinus Penta S22 and S32

3.3.11.6. Sinus Penta S41–S42–S51–S52

For this inverter size, no actual through-panel assembly is used, but the air flow of the power section is segregated from the air flow of the control section. This application requires mounting some additional mechanical parts as shown below (the screws are included in the mounting kit).

* =GROWER

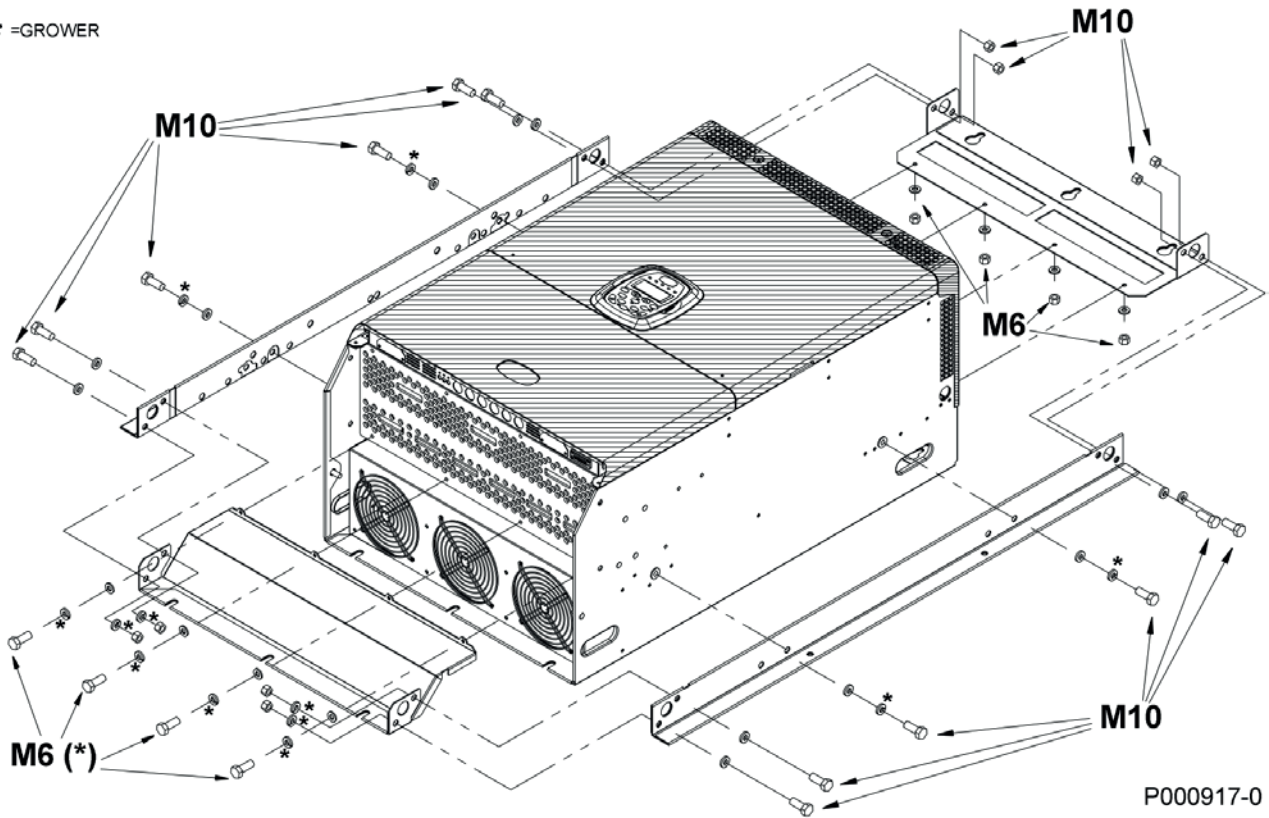

P000917-0

Figure 22: Mechanical parts for the through-panel assembly for Sinus Penta S41, S42, S51 and S52

The figure below shows the piercing templates for the through-panel assembly of the inverter, including six M8 holes and the hole for the air-cooling of the power section.

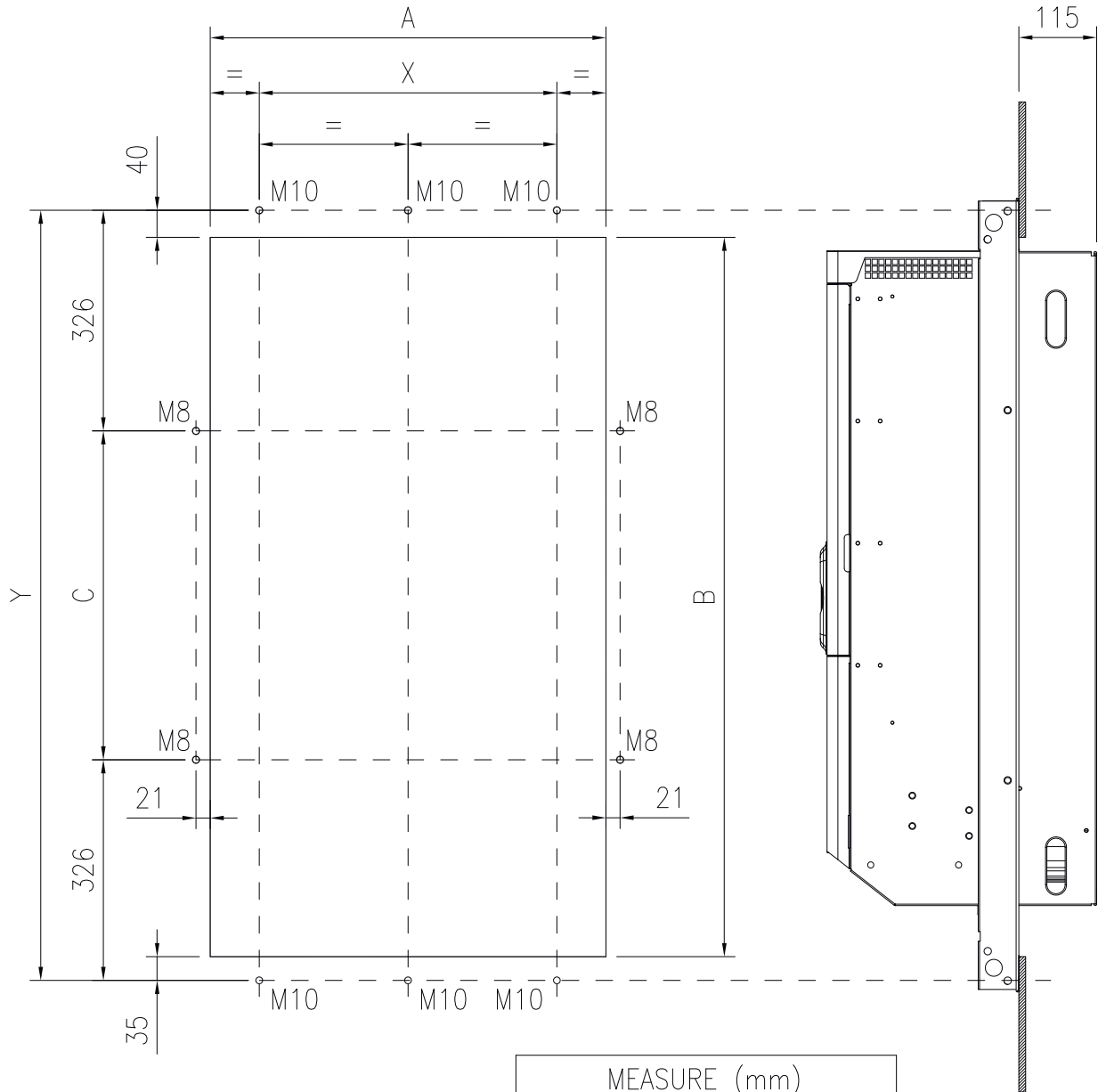

P001032-0

		MEASURE (mm)				
		A	B	C	X	Y
SIZE	S41	510	977	400	380	1052
	S42	510	1063	486	380	1138
	S51	585	977	400	440	1052
	S52	585	1063	486	440	1138

Figure 23: Piercing templates for the through-panel assembly for Sinus Penta S41, S42, S51 and S52

3.3.12. Standard Mounting and Piercing Templates (IP00 Modular Models S64–S90)

High-power inverters include single function modules.
The control unit may be installed separately or inside a module.
Mounting options are shown below:

a) Control unit integrated into the inverter

MODULE	Piercing Templates (mm) (Single Module)					Modules Fitted							
	X	Y	D1	D2	Fastening screws	Inverter Size							
						S64	S65	S70	S74	S75	S80	S84	S90
POWER SUPPLY UNIT	178	1350	11	25	M10	-	1	2	-	2	3	-	3
INVERTER	178	1350	11	25	M10	1	2	2	-	2	2	2	5
INVERTER WITH INTEGRATED CONTROL UNIT	178	1350	11	25	M10	1	1	1	1	1	1	1	1
INVERTER WITH INTEGRATED AUXILIARY POWER SUPPLY UNIT	178	1350	11	25	M10	1	-	-	2	-	-	3	-
INVERTER WITH INTEGRATED SPLITTER UNIT	178	1350	11	25	M10	-	-	-	3	3	3	3	3

b) Control unit separate from the inverter module

MODULE	Fixing Templates (mm) (Single Module)					Modules Fitted							
	X	Y	D1	D2	Fastening screws	Inverter Size							
						S64	S65	S70	S74	S75	S80	S84	S90
POWER SUPPLY UNIT	178	1350	11	25	M10	-	1	2	-	2	3	-	3
INVERTER	178	1350	11	25	M10	2	3	3	1	3	3	3	6
INVERTER WITH INTEGRATED CONTROL UNIT	178	1350	11	25	M10	1	-	-	2	-	-	3	-
INVERTER WITH INTEGRATED AUXILIARY POWER SUPPLY UNIT	178	1350	11	25	M10	-	-	-	3	3	3	3	3
INVERTER WITH INTEGRATED SPLITTER UNIT	184	396	6	14	M5	1	1	1	1	1	1	1	1

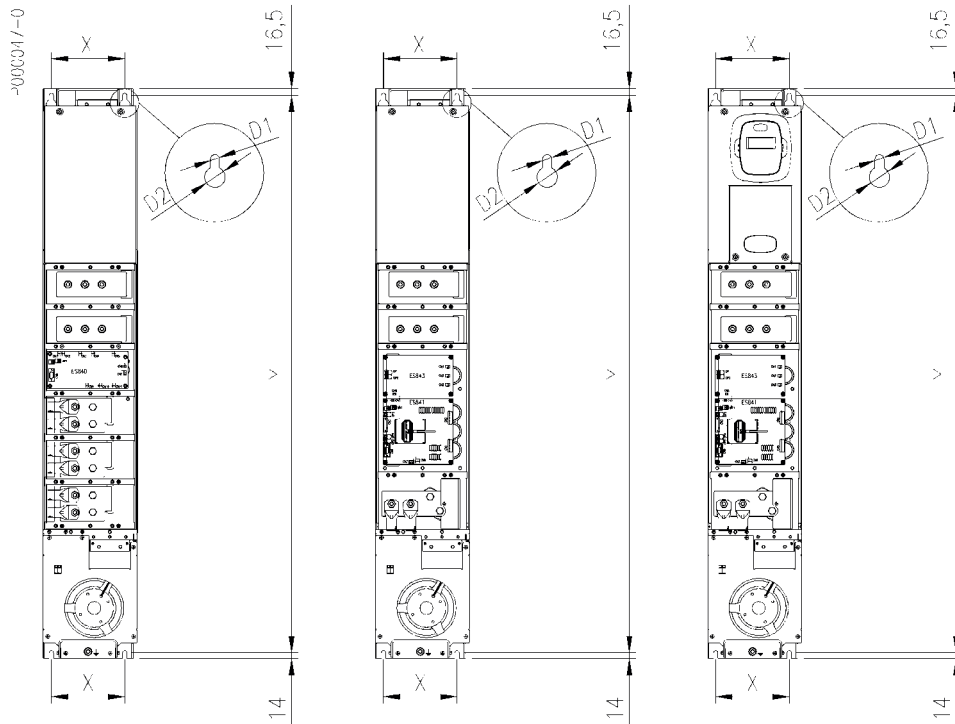

Supply Module

Inverter

Inverter Module with control unit

Figure 24: Piercing templates for modular units

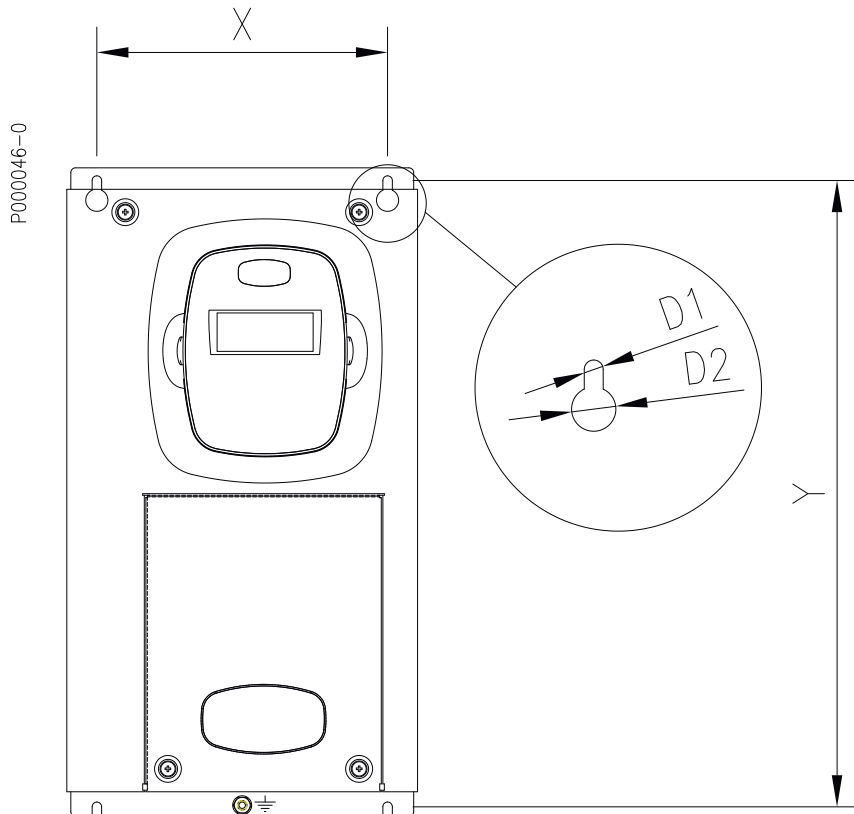
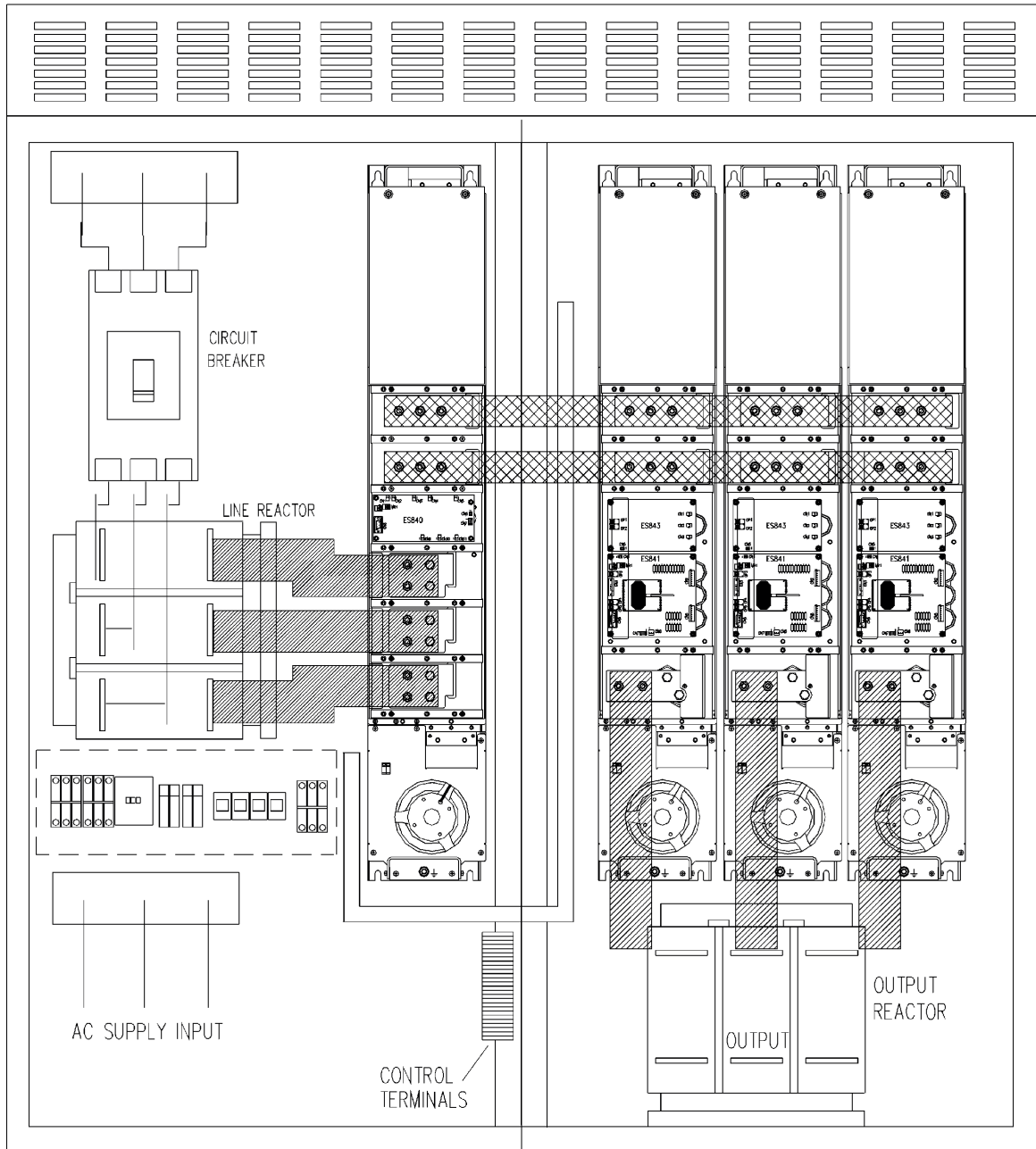

Figure 25: Piercing templates for control unit (stand-alone model)

3.3.12.1. *Installation and Lay-out of the Connections of a Modular Inverter (S65)*



P000011-B

Figure 26: Installation example for Sinus Penta S65 (in cabinet)

3.3.13. Standard Mounting and Piercing Templates (IP54 Stand-Alone Models S05–S32)

Sinus Penta IP54 Size	Fixing templates (mm) (standard mounting)				Fastening screws
	X	Y	D1	D2	
S05	177	558	7	15	M6
S12	213	602.5	7	15	M6
S14	260	732	7	15	M6
S15	223	695	10	20	M8
S20	274	821	10	20	M8
S22	250	1050	10	20	M8
S30	296	987	10	20	M8
S32	300	1130	9	20	M8

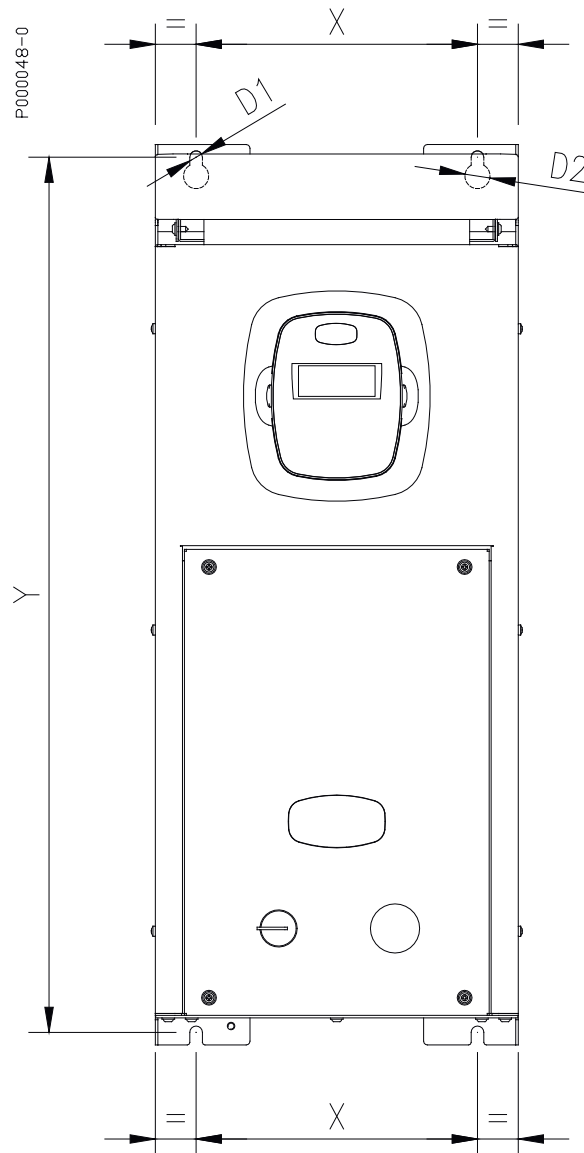

Figure 27: Piercing template for IP54 inverter

3.4. Power Connections

The inverters of the Sinus Penta series are designed both for DC and AC power supply. The wiring diagrams below show the inverter connection to a low-voltage 3-phase mains. 12-pulse or 18-pulse connections are also possible for modular inverters. In that case, a dedicated transformer and a suitable number of power supply modules are required (see 12-pulse Connection for Modular Inverters).

For certain sizes, VDC direct connection is also available with no need to change the inverter layout; only, a safety fuse is to be installed in the VDC supply line—please refer to Cross-sections of the Power Cables and Sizes of the Protective Devices for the safety fuses to be installed.



CAUTION

For sizes S41, S42, S51, S52, S60, S64, S74, S84, an external precharge system is required, because the precharge circuit is not fitted inside the inverter or is located upstream of the DC voltage power supply terminals.

DC voltage power supply is normally used for the parallel connection of multiple inverters inside the same cubicle. Output DC power supply units (both uni-directional and bi-directional, with power ratings ranging from 5kW to 2000kW for 200Vac to 690Vac rated voltage) can be supplied by Elettronica Santerno.

To access the power terminals, please refer to sections Gaining Access to Control Terminals and Power Terminals in IP20 and IP00 and Gaining Access to Control Terminals and Power Terminals in IP54 Models.



DANGER

Before changing the equipment connections, shut off the inverter and wait at least 20 minutes to allow for the discharge of the heat sinks in the DC-link.

Use only B-type differential circuit breakers.

Connect power supply only to the power supply terminals. The connection of power supply to any other terminal can cause the inverter fault.

Always make sure that the supply voltage ranges between the limits stated in the inverter nameplate.

Always connect the ground terminal to avoid electric shock hazard and to limit disturbance. Always provide a grounding connection to the motor; if possible, ground the motor directly to the inverter.

The user has the responsibility to provide a grounding system in compliance with the regulations in force.

After connecting the equipment, check the following:

- all wires must be properly connected;
- no link is missing;
- no short-circuit is occurring between the terminals and between the terminals and the ground.

To perform a UL compliant installation, the Wire Connectors shall be any Listed (ZMVF) or R/C Wire Connectors and Soldering Lugs (ZMVF2), used with 60°C/75°C copper (Cu) conductor only, within electrical ratings and used with its properly evaluated crimping tool.



CAUTION

The Field Wiring Terminals shall be used with the tightening torque values specified in the Table of the corresponding section in this Manual.

The Auxiliary Wiring Terminal Blocks, provided for end-use installation connection with external devices, shall be used within the ratings specified. Refer to Cross-sections of the Power Cables and Sizes of the Protective Devices.

Do not start or stop the inverter using a contactor installed over the inverter power supply line.

The inverter power supply must always be protected by fast fuses or by a thermal/magnetic circuit breaker.

Do not apply single-phase voltage.

Always mount antidisturbance filters on the contactor coils and the solenoid valve coils.

At power on, if the inverter commands “ENABLE” (terminal 15) and “START” (terminal 14) are active, the motor will immediately start when the main reference is other than zero. This may be very dangerous. To prevent the motor from accidentally starting, refer to the Programming Guide to set configuration parameters accordingly. In that case, the motor will start only after opening and closing the command contact on terminal 15.

3.4.1. Wiring Diagram for inverters S05–S60

P000818-B

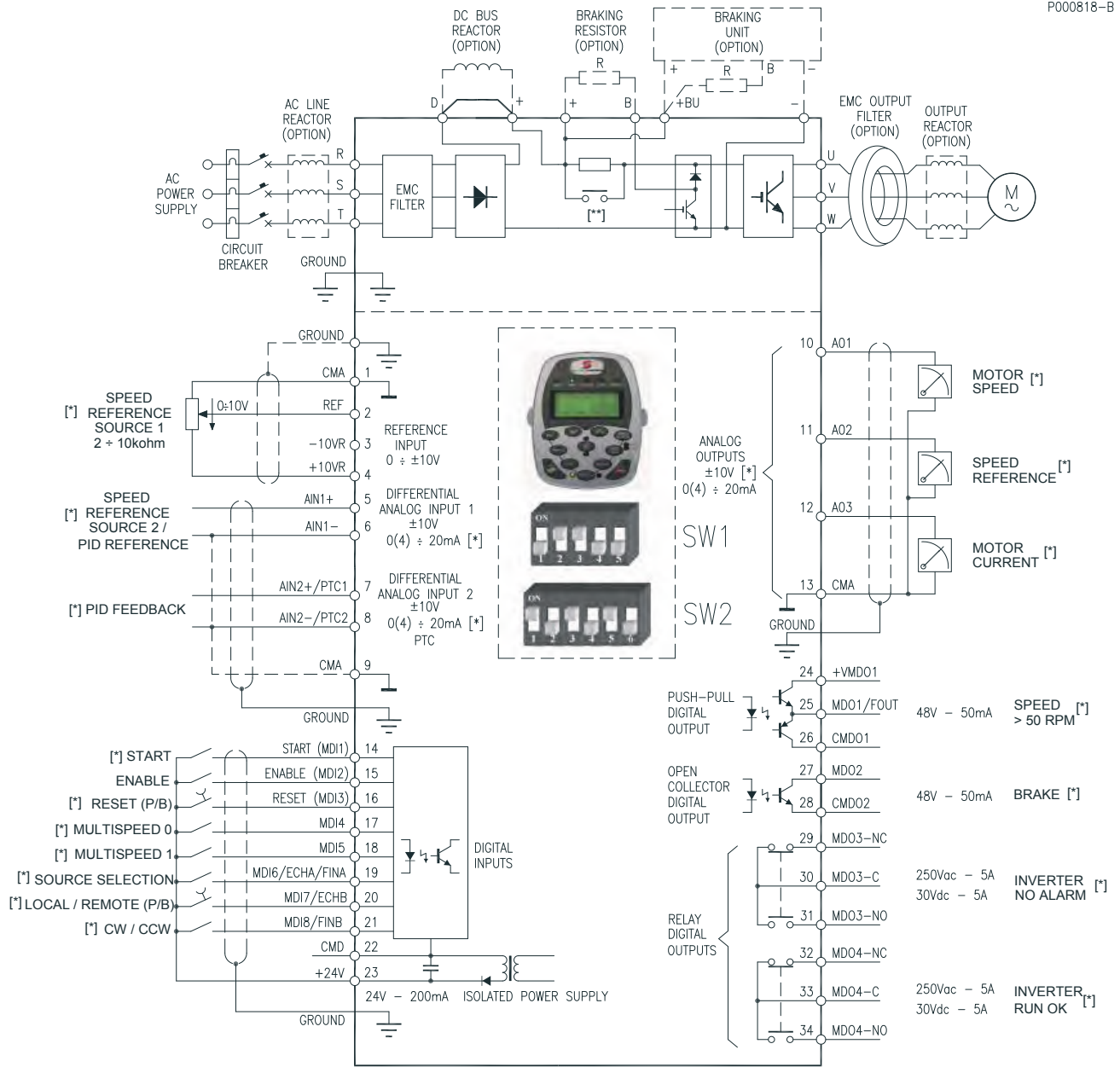

[*] FACTORY DEFAULTS

[**] PRECHARGE CIRCUIT (SEE BELOW)

Figure 28: Wiring diagram



CAUTION

In case of fuse line protection, always install the fuse failure detection device, that disables the inverter, to avoid single-phase operation of the equipment.



NOTE

The wiring diagram relates to factory-setting. Please refer to the Power Terminals section for the ID numbers of the wiring terminals.



NOTE

Please refer to the Inductors section for the applicable input and output inductors.



CAUTION

For inverter sizes S15, S20 and S30 and for modular inverters S65 to S90, specify if the DC inductors are required when ordering the equipment.



[*]

NOTE

Factory settings can be changed by changing the configuration of the DIP-switches and/or by changing the parameters pertaining to the terminals concerned (see Sinus Penta's Programming Guide).



CAUTION

When no DC inductor is used, terminals **D** and **+** must be short-circuited (factory setting).



[**]

CAUTION

Please contact Elettronica Santerno if DC voltage power supply is to be supplied to Sinus Penta S41, S42, S51, S52, S60, as the precharge circuit in the DC-bus capacitors is installed upstream of the DC voltage power supply terminals.



[**]

CAUTION

Please contact Elettronica Santerno if DC voltage power supply is to be supplied to Sinus Penta S64, S74, S84, as no precharge circuit for the DC-bus capacitors is provided.



CAUTION

For S60 inverters only: if the supply voltage is other than 500Vac, the wiring of the internal auxiliary transformer must be changed accordingly (see Figure 44).

3.4.2. Wiring Diagram for Modular Inverters S64–S90

3.4.2.1. External Connections for Modular Inverters S65 and S70

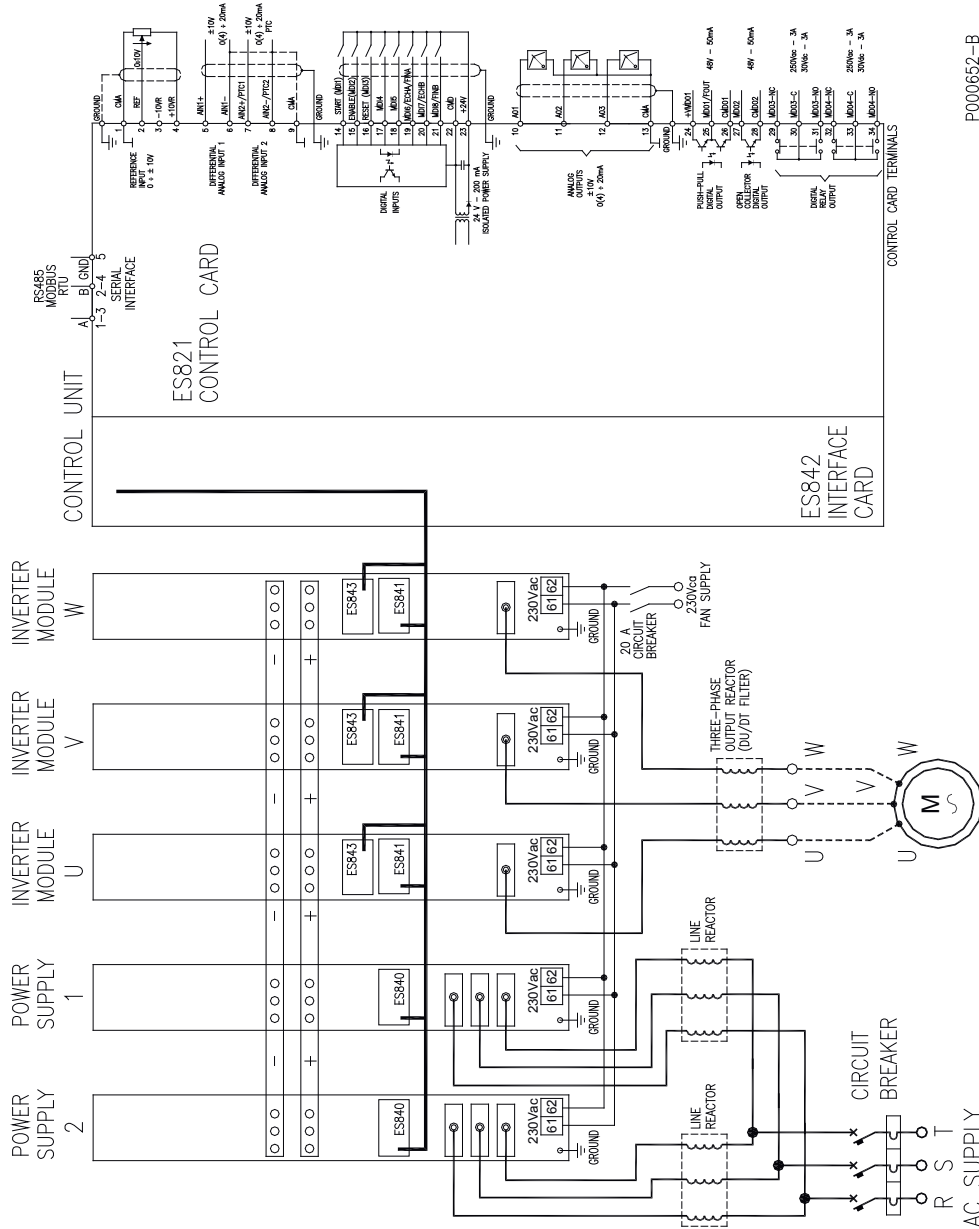

P000652-B

Figure 29: External connections for modular inverters S65-S70



NOTE Power supply unit 2 is available for size S70 only.



NOTE For the installation of a BU, see the section covering the braking unit.



CAUTION In the event of fuse line protection, always install the fuse failure detection device. If a fuse blows, this must disable the inverter to avoid single-phase operation of the equipment.



NOTE Please refer to the Inductors section for the inductors to be used.

3.4.2.2. External Connections for Modular Inverters S64

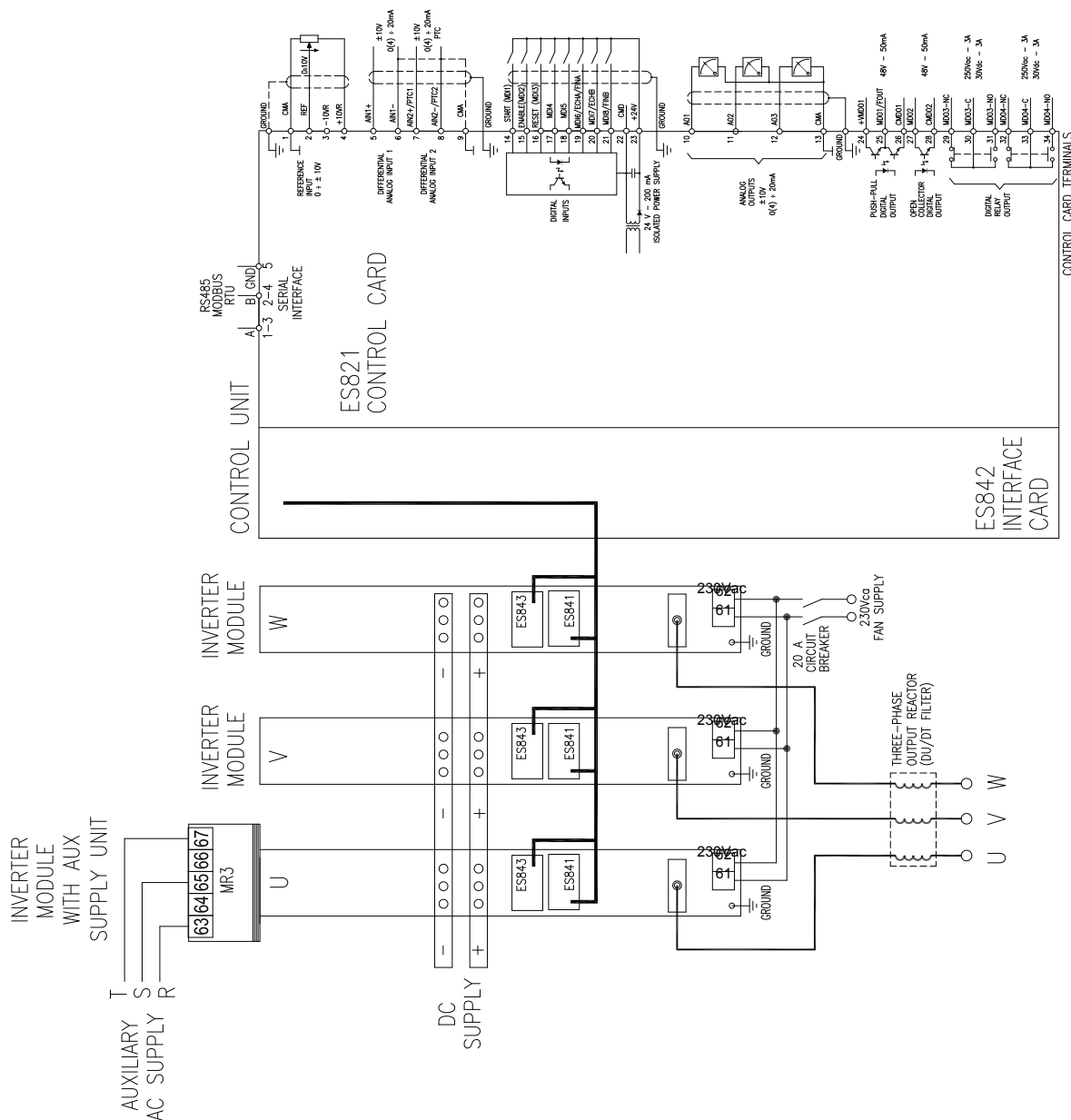

P000654-B

Figure 30: External connections for modular inverters S64



CAUTION

The capacitors inside the DC voltage power supply unit must always be precharged. Failure to do so will damage the inverter as well as its power supply unit.



NOTE

Please refer to the Inductors section for the inductors to be used.

3.4.2.3. External Connections for Modular Inverters S74, S75 and S80

Please refer to the Assembly Instructions for Modular Inverters.

3.4.2.4. External Connections for Modular inverters S84 and S90

Please refer to the Assembly Instructions for Modular Inverters.

3.4.2.5. 12-pulse Connection for Modular Inverters

12-pulse connection allows reducing current harmonics in the inverter supply line. This solution reduces power supply harmonics by suppressing the lowest harmonics: the 5th and 7th harmonics are suppressed, so the first harmonics to be found are the 11th and the 13th, followed by the 23rd and the 25th and so on, with their corresponding low levels. The power supply current is very close to a sinusoid.

The 12-pulse connection requires a transformer with two secondaries shifted by 30° and an even number of power supply units in the modular inverter.

The basic wiring diagram of the 12-pulse connection is shown below:

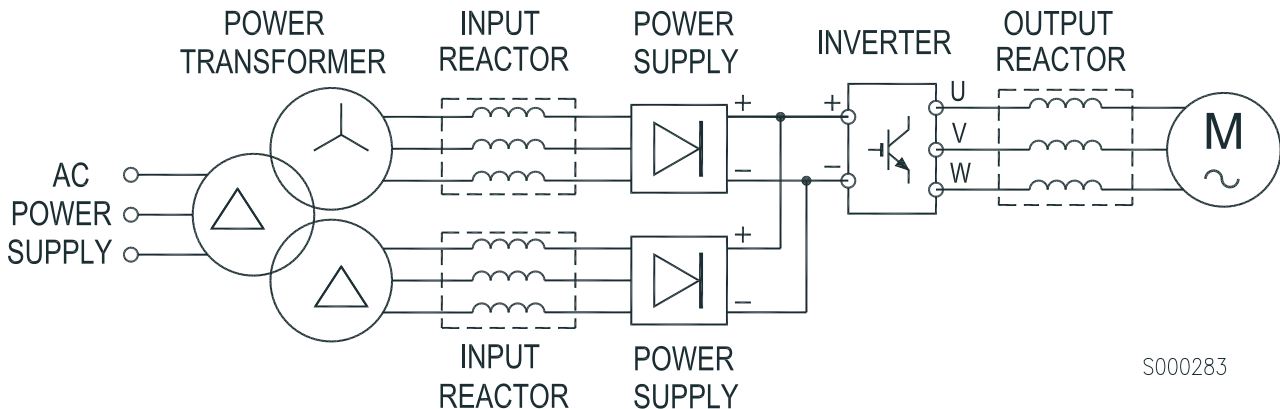

Figure 31: Layout of 12-pulse connection

A 18-pulse connection may be obtained with a configuration similar to the configuration above. The 18-pulse connection requires a transformer with N.3 secondaries shifted by 20° and N. 3 power supply units in the modular inverter.

The tables below summarise the possible power supply modes for modular inverters. The standard configurations described in the sections above are on green shading (in particular, see the Modular IP00 STAND-ALONE Models (S64–S90)); otherwise, if a different number of modules is required, this is marked on yellow shading.

Modular inverters power supplied
- through AC 380-500Vac or DC voltage (4C):

Model	Standard AC (4T)	DC Voltage (4C)	AC 12-pulse	AC 18-pulse
0598, 0748, 0831	S65	S64	S70	S65 + 2 Power Supply units
0964, 1130, 1296	S75	S74	S75	S80
1800, 2076	S90	S84	S90 + 1 Power Supply unit	S90

Modular inverters power supplied
- through AC 500-600Vac voltage or DC voltage (5C);
- through AC 575-690Vac or DC voltage (6C):

Model	Standard AC (5T/6T)	DC Voltage (5C/6C)	AC 12-pulse	AC 18-pulse
0457, 0524, 0598, 0748	S65	S64	S70	S65 + 2 Power Supply units
0831	S70	S64	S70	S65 + 2 Power Supply units
0964, 1130	S75	S74	S75	S80
1296	S80	S74	S75	S90
1800, 2076	S90	S84	S90 + 1 Power Supply unit	S90

3.4.2.6. Internal Connections for Modular Inverters S65 and S70

The following connections are needed:

N. 2 copper bar 60*10mm power connections between power supply and inverter arms for DC voltage supply.

N. 5 connections with 9-pole shielded cable (S70) or N. 4 connections with 9-pole shielded cable (S65) for analog measures.

Type of cable: shielded cable

n. of wires: 9

diameter of each wire: AWG20÷24 (0.6÷0.22mm²)

connectors: 9-pole female SUB-D connectors;

connections inside the cable:

Connector	Female SUB-D conn.	Female SUB-D conn.
pin	1 →	1
pin	2 →	2
pin	3 →	3
pin	4 →	4
pin	5 →	5
pin	6 →	6
pin	7 →	7
pin	8 →	8
pin	9 →	9

The following connections are required:

- from control unit to supply 1 (supply 1 control signals)
- from control unit to supply 2 (size S70 only) (supply 2 control signals)
- from control unit to inverter arm U (phase U control signals)
- from control unit to inverter arm V (phase V control signals)
- from control unit to inverter arm W (phase W control signals)

N. 4 connections with unipolar cable pairs, type AWG17-18 (1mm²), for AC, low voltage supply.

- from supply 1 to control unit (power supply + 24 V control unit)
- from supply 1 to driver boards of each power arm (supply line can run from supply to one driver board—e.g. arm U—to arm V, then to arm W) (24 V supply for IGBT driver boards)

N. 7 optical fibre connections, 1mm, standard single plastic material (typical damping: 0.22dB/m), with connectors type Agilent HFBR-4503/4513.

HFBR-4503/4513 — Simplex Latching

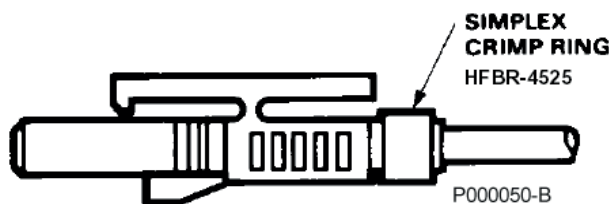

Figure 32: Single optical fibre connector

Connections required:

- from control unit to arm U driver board (fault U signal)
- from control unit to arm V driver board (fault V signal)
- from control unit to arm W driver board (fault W signal)
- from control unit to bus voltage reading board assembled on inverter arm U (VB signal)
- from control unit to bus voltage reading board assembled on inverter arm U (sense U signal)
- from control unit to bus voltage reading board assembled on inverter arm V (sense V signal)
- from control unit to bus voltage reading board assembled on inverter arm W (sense W signal)

N.3 optical fibre connections. 1mm, standard double plastic material (typical damping 0.22dB/m), with connectors type Agilent HFBR-4516.

HFBR-4516 — Duplex Latching

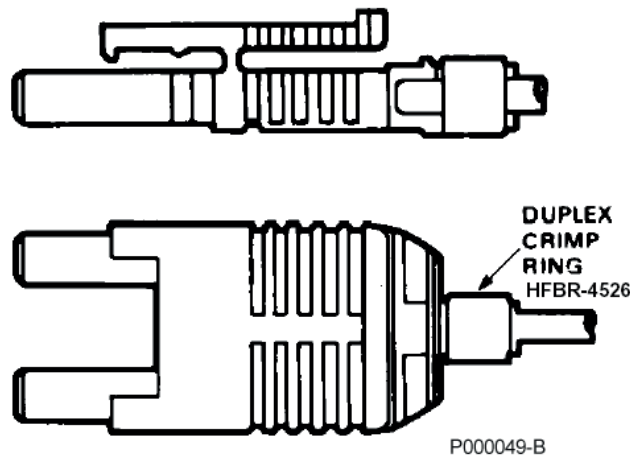

Figure 33: Double optical fibre connector

Connections required:

- from control unit to arm U driver board (IGBT top and bottom control signals)
- from control unit to arm V driver board (IGBT top and bottom control signals)
- from control unit to arm W driver board (IGBT top and bottom control signals)

INTERNAL CONNECTIONS (S65-S70) WIRE CONNECTIONS

Signal	Type of connection	Cable marking	Component	Board	Connector	Component	Board	Connector
control signals, supply 1	9-pole shielded cable	C-PS1	control unit	ES842	CN4	supply 1	ES840	CN8
control signals, supply 2 (*)	9-pole shielded cable	C-PS2	control unit	ES842	CN3	supply 2	ES840	CN8
control signals, phase U	9-pole shielded cable	C-U	control unit	ES842	CN14	phase U	ES841	CN6
control signals, phase V	9-pole shielded cable	C-V	control unit	ES842	CN11	phase V	ES841	CN6
control signals, phase W	9-pole shielded cable	C-W	control unit	ES842	CN8	phase W	ES841	CN6

+24V Power supply, control unit	unipolar cable, 1mm ²	24V-CU	supply 1	ES840	MR1-1	control unit	ES842	MR1-1
0VD Power supply, control unit	unipolar cable, 1mm ²		supply 1	ES840	MR1-2	control unit	ES842	MR1-2
+24VD Power supply, driver boards ES841	unipolar cable, 1mm ²	24V-GU	supply 1	ES840	MR1-3	phase U	ES841	MR1-1
0VD Power supply, driver boards ES841	unipolar cable, 1mm ²		supply 1	ES840	MR1-4	phase U	ES841	MR1-2
+24VD Power supply, driver boards ES841	unipolar cable, 1mm ²	24V-GV	phase U	ES841	MR1-3	phase V	ES841	MR1-1
0VD Power supply, driver boards ES841	unipolar cable, 1mm ²		phase U	ES841	MR1-4	phase V	ES841	MR1-2
+24VD Power supply, driver boards ES841	unipolar cable, 1mm ²	24V-GW	phase V	ES841	MR1-3	phase W	ES841	MR1-1
0VD Power supply, driver boards ES841	unipolar cable, 1mm ²		phase V	ES841	MR1-4	phase W	ES841	MR1-2

OPTICAL FIBRE CONNECTIONS

IGBT command, phase U	double optical fibre	G-U	control unit	ES842	OP19-OP20	phase U	ES841	OP4-OP5
IGBT command, phase V	double optical fibre	G-V	control unit	ES842	OP13-OP14	phase V	ES841	OP4-OP5
IGBT command, phase W	double optical fibre	G-W	control unit	ES842	OP8-OP9	phase W	ES841	OP4-OP5

IGBT fault, phase U	single optical fibre	FA-U	control unit	ES842	OP15	phase U	ES841	OP3
IGBT fault, phase V	single optical fibre	FA-V	control unit	ES842	OP10	phase V	ES841	OP3
IGBT fault, phase W	single optical fibre	FA-W	control unit	ES842	OP5	phase W	ES841	OP3
bus bar voltage reading	single optical fibre	VB	control unit	ES842	OP2	one phase	ES843	OP2
IGBT status, phase U	single optical fibre	ST-U	control unit	ES842	OP16	phase U	ES843	OP1
IGBT status, phase V	single optical fibre	ST-V	control unit	ES842	OP11	phase V	ES843	OP1
IGBT status, phase W	single optical fibre	ST-W	control unit	ES842	OP6	phase W	ES843	OP1

(*) Available for S70 only



CAUTION

Carefully check that connections are correct. Wrong connections can adversely affect the equipment operation.



CAUTION

NEVER supply voltage to the equipment if optical fibre connectors are disconnected.

The diagram below illustrates the connections required for the components of the modular inverter model.

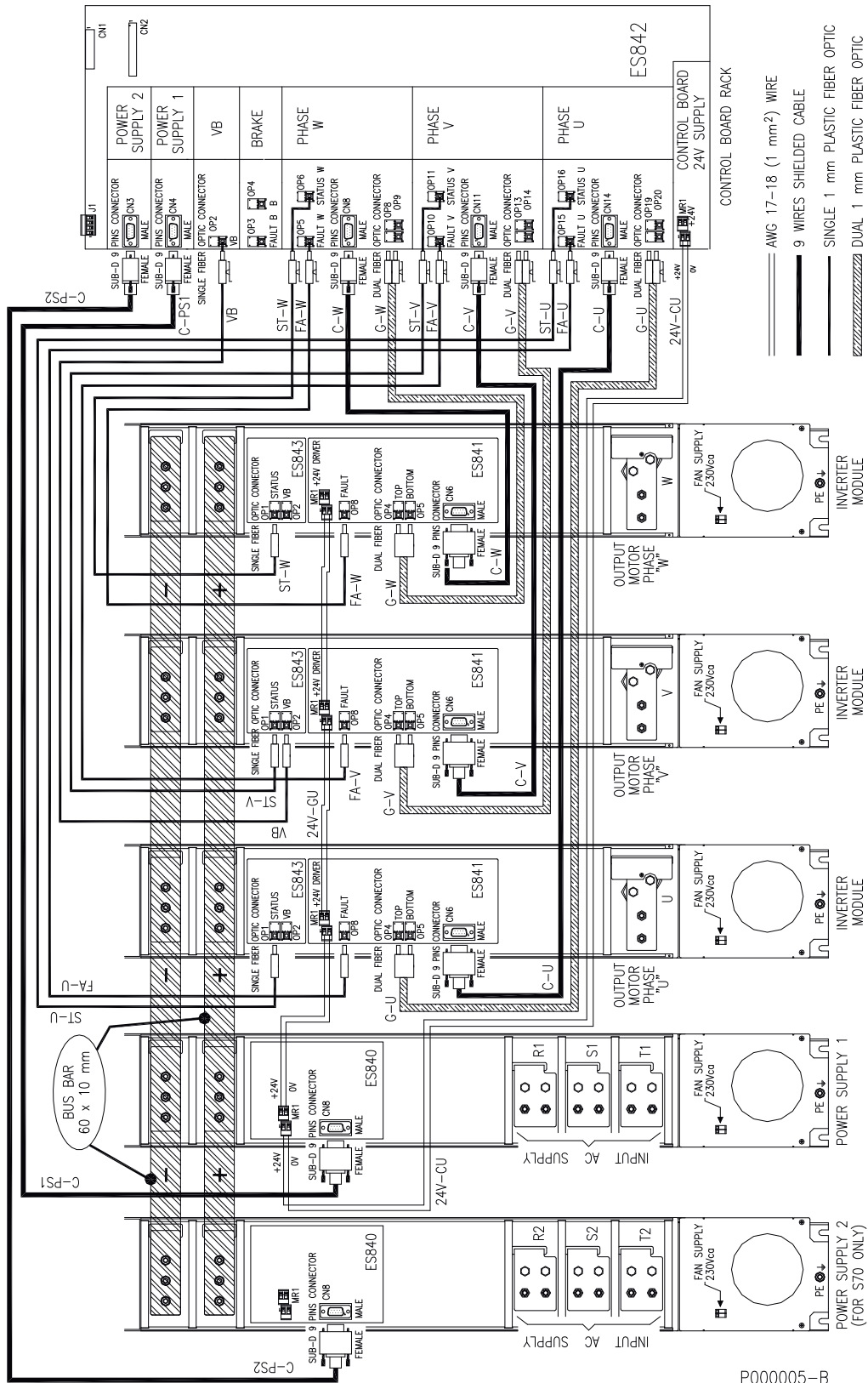

P000005-B

Figure 34: Internal wiring for Sinus Penta S65-S70

Do the following to obtain internal wiring:

- Gain access to boards ES840, ES841 and ES843. The first board is located on the front part of the supply module; the remaining two boards are located on the front part of each inverter module. Remove the front covers made of Lexan by loosening the cover fastening screws;

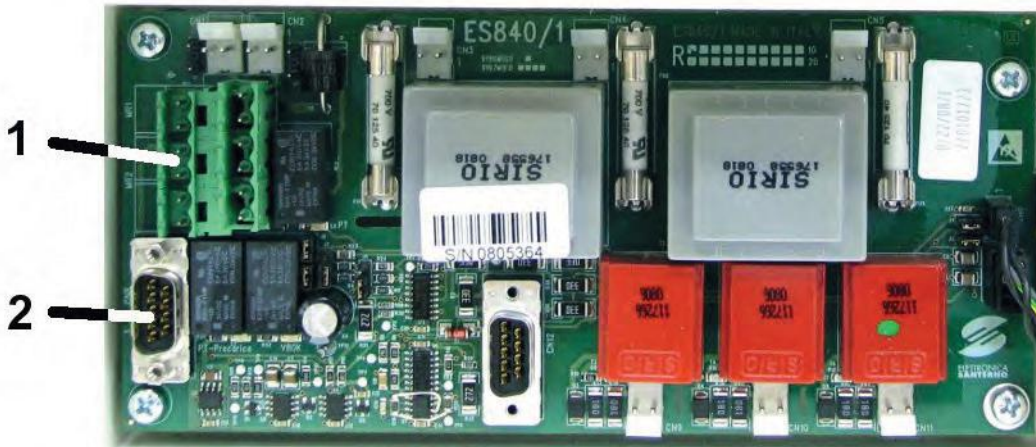

S000119

Figure 35: ES840 Supply Board

- MR1: +24V Control Unit and Gate Unit supply
- CN8: Power Supply control signal connector

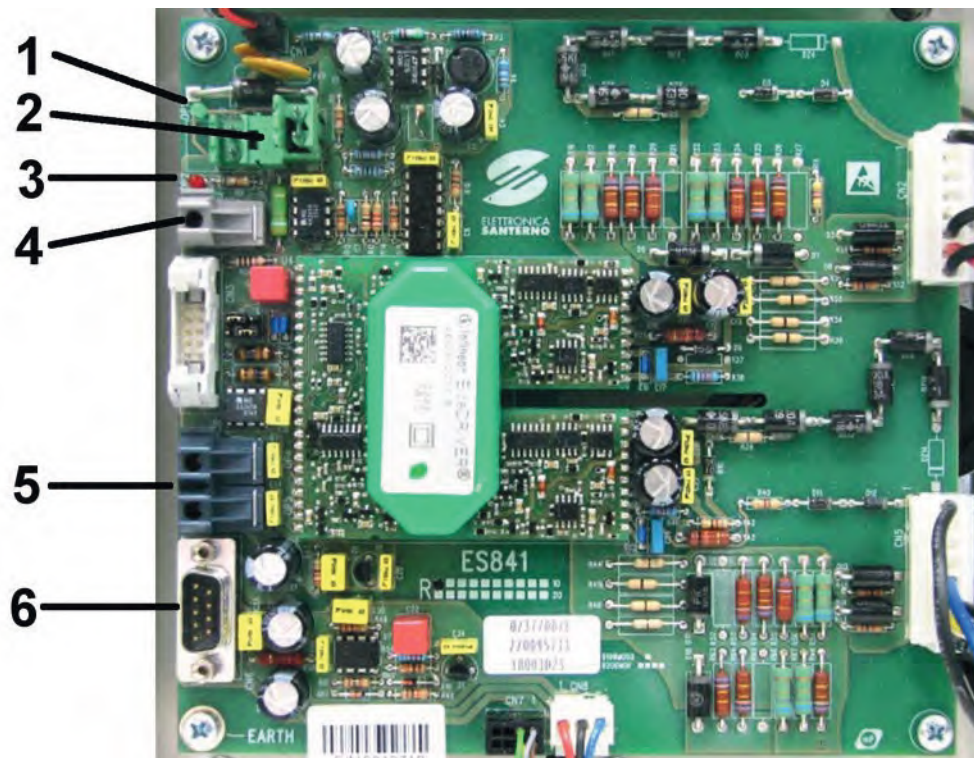

S000118

Figure 36: ES841 Inverter Module Gate Unit Board

- OP1: Board OK
- MR1: 24V gate unit supply
- OP2: Board Fault
- OP3: IGBT Fault
- OP4, OP5: IGBT gate commands
- CN3: Inverter module signal connector



S000120

Figure 37: ES843 Bus-bar Voltage Acquisition Board

1 – OP1: IGBT status

2 – OP2: Bus bar voltage reading

- 2) Gain access to ES842 board located on the control unit; do the following:
 remove keypad (if fitted) (see Remoting the Display/Keypad)
 remove the cover of the terminal board after removing its fastening screws
 remove the cover of the control unit after removing its fastening screws



S000132

Figure 38: Position of the fastening screws in the terminal board cover and the control unit

1 – Control unit cover fixing screws

2 – Control terminal cover screws

3) You can then access to connectors in control board ES842.

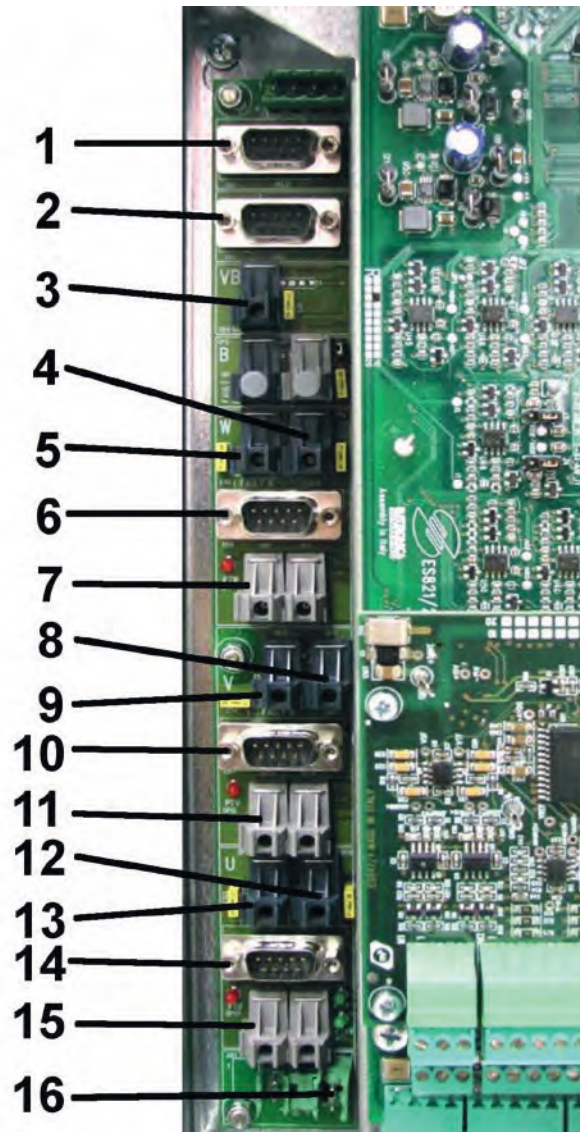

S000133

Figure 39: ES842 Control Unit

- 1 – CN3: Power Supply 2 Signal Connector
- 2 – CN2: Power Supply 1 Signal Connector
- 3 – OP2: VB
- 4 – OP6: Status IGBT W
- 5 – OP5: Fault IGBT W
- 6 – CN8: Inverter Module W Signal Connector
- 7 – OP8, OP9: Gate W
- 8 – OP11: Status IGBT V
- 9 – OP10: Fault IGBT V
- 10 – CN11: Inverter Module V Signal Connector
- 11 – OP13, OP14: Gate V
- 12 – OP16: Status IGBT U
- 13 – OP15: Fault IGBT U
- 14 – CN14: Inverter Module U Signal Connector
- 15 – OP19, OP20: Gate U
- 16 – MR1: 24V Control Unit Supply

- 4) Use the connection cable kit to connect the inverter components to each other. Make sure that the tab of the optical fibre connectors is turned outwards to the connector fixed in the control board.
- 5) Reassemble the covers made of Lexan and the covering of the control unit, making sure not to flatten any cable/optical fibre.

3.4.2.7. Internal Connections for Modular Inverters S64

The following links are required:

N. 2 power connections with 60*10mm copper bar between the inverter arms in order to deliver DC voltage.

N. 4 connections with 9-pole shielded cable.

Type of cable: shielded cable

N. of conductors: 9

Diameter of each conductor: AWG20÷24 (0.6÷0.22mm²)

Connectors: 9-pole SUB-D female connectors

Connections within the cable:

Connector	SUB-D female connector	SUB-D female connector
pin	1→	1
pin	2→	2
pin	3→	3
pin	4→	4
pin	5→	5
pin	6→	6
pin	7→	7
pin	8→	8
pin	9→	9

The following links are required:

- from control unit to inverter arm with auxiliary power supply unit (control signals for auxiliary power supply)
- from control unit to inverter arm U (phase U control signals)
- from control unit to inverter arm V (phase V control signals)
- from control unit to inverter arm W (phase W control signals)

N. 4 connections with AWG17-18 (1mm²) unipolar cable pairs delivering low-voltage DC power supply.

- from inverter arm with auxiliary power supply unit to control unit (control unit +24V voltage supply)
- from inverter arm with auxiliary power supply unit to driver boards of each power arm of the inverter (the power supply can be transferred from the supply unit to a driver board, in arm U for instance, then to arm V, finally to arm W). (IGBT driver board 24V power supply.)

N. 7 optical-fibre connections, 1mm, single standard plastics (0.22dB/m typical attenuation) with Agilent HFBR-4503/4513 connectors.

HFBR-4503/4513 — Simplex Latching

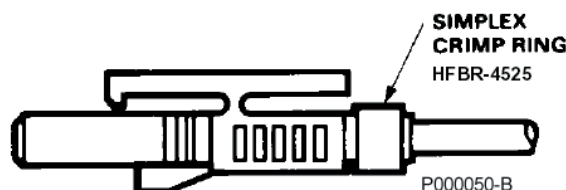

Figure 40: Single optical-fibre connector

The following links are required:

- from control unit to driver board in inverter arm U (U fault signal)
- from control unit to driver board in inverter arm V (V fault signal)
- from control unit to driver board in inverter arm W (W fault signal)
- from control unit to bus voltage detecting board installed on inverter arm U (VB signal)
- from control unit to bus voltage reading board assembled on inverter arm U (sense U signal)
- from control unit to bus voltage reading board assembled on inverter arm V (sense V signal)
- from control unit to bus voltage reading board assembled on inverter arm W (sense W signal)

N.3 optical-fibre connections, 1mm, double standard plastics (0.22dB/m typical attenuation) with Agilent HFBR-4516 connectors.

HFBR-4516 — Duplex Latching

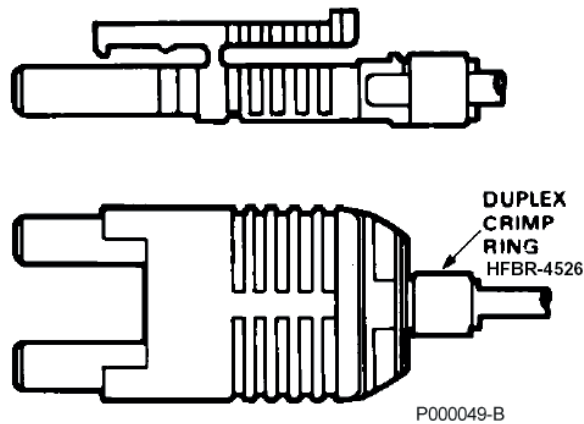

Figure 41: Double optical-fibre connector

The following links are required:

- from control unit to driver board in inverter arm U (top and bottom IGBT control signals)
- from control unit to driver board in inverter arm V (top and bottom IGBT control signals)
- from control unit to driver board in inverter arm W (top and bottom IGBT control signals)

**INTERNAL CONNECTIONS FOR S64
WIRE CONNECTIONS**

Signal	Type of Connection	Cable Marking	Component	Board	Connector	Component	Board	Connector
control signals for phase U	9-pole shielded cable	C-U	control unit	ES842	CN14	phase U	ES841	CN6
control signals for phase V	9-pole shielded cable	C-V	control unit	ES842	CN11	phase V	ES841	CN6
control signals for phase W	9-pole shielded cable	C-W	control unit	ES842	CN8	phase W	ES841	CN6

+24V control unit power supply	unipolar cable, 1mm ²	24V-CU	inverter arm with auxiliary power supply unit	auxiliary power supply unit	MR1-1	control unit	ES842	MR1-1
0V control unit power supply	unipolar cable, 1mm ²		inverter arm with auxiliary power supply unit	auxiliary power supply unit	MR1-2	control unit	ES842	MR1-2
ES841 driver board +24VD power supply	unipolar cable, 1mm ² (*)	24V-GU	inverter arm with auxiliary power supply unit	auxiliary power supply unit	MR2-1	phase U	ES841	MR1-1
ES841 driver board +0VD power supply	unipolar cable, 1mm ² (*)		inverter arm with auxiliary power supply unit	auxiliary power supply unit	MR2-1	phase U	ES841	MR1-2
ES841 driver board +24VD power supply	unipolar cable, 1mm ²	24V-GV	phase U	ES841	MR1-3	phase V	ES841	MR1-1
ES841 driver board +0VD power supply	unipolar cable, 1mm ²		phase U	ES841	MR1-4	phase V	ES841	MR1-2
ES841 driver board +24VD power supply	unipolar cable, 1mm ²	24V-GW	phase V	ES841	MR1-3	phase W	ES841	MR1-1
ES841 driver board +0VD power supply	unipolar cable, 1mm ²		phase V	ES841	MR1-4	phase W	ES841	MR1-2

OPTICAL FIBRE CONNECTIONS

IGBT command, phase U	double optical fibre	G-U	control unit	ES842	OP19-OP20	phase U	ES841	OP4-OP5
IGBT command, phase V	double optical fibre	G-V	control unit	ES842	OP13-OP14	phase V	ES841	OP4-OP5
IGBT command, phase W	double optical fibre	G-W	control unit	ES842	OP8-OP9	phase W	ES841	OP4-OP5

IGBT fault, phase U	single optical fibre	FA-U	control unit	ES842	OP15	phase U	ES841	OP3
IGBT fault, phase V	single optical fibre	FA-V	control unit	ES842	OP10	phase V	ES841	OP3
IGBT fault, phase W	single optical fibre	FA-W	control unit	ES842	OP5	phase W	ES841	OP3
bus bar voltage reading	single optical fibre	VB	control unit	ES842	OP2	one phase	ES843	OP2
IGBT status, phase U	single optical fibre	ST-U	control unit	ES842	OP16	phase U	ES843	OP1
IGBT status, phase V	single optical fibre	ST-V	control unit	ES842	OP11	phase V	ES843	OP1
IGBT status, phase W	single optical fibre	ST-W	control unit	ES842	OP6	phase W	ES843	OP1

(*): Factory-set connection provided



CAUTION Make sure that links are correct, as incorrect links cause the inverter malfunctioning.



CAUTION NEVER power the inverter when the optical-fibre connectors are not connected.

The figure below shows the links required for the components of the modular inverter.

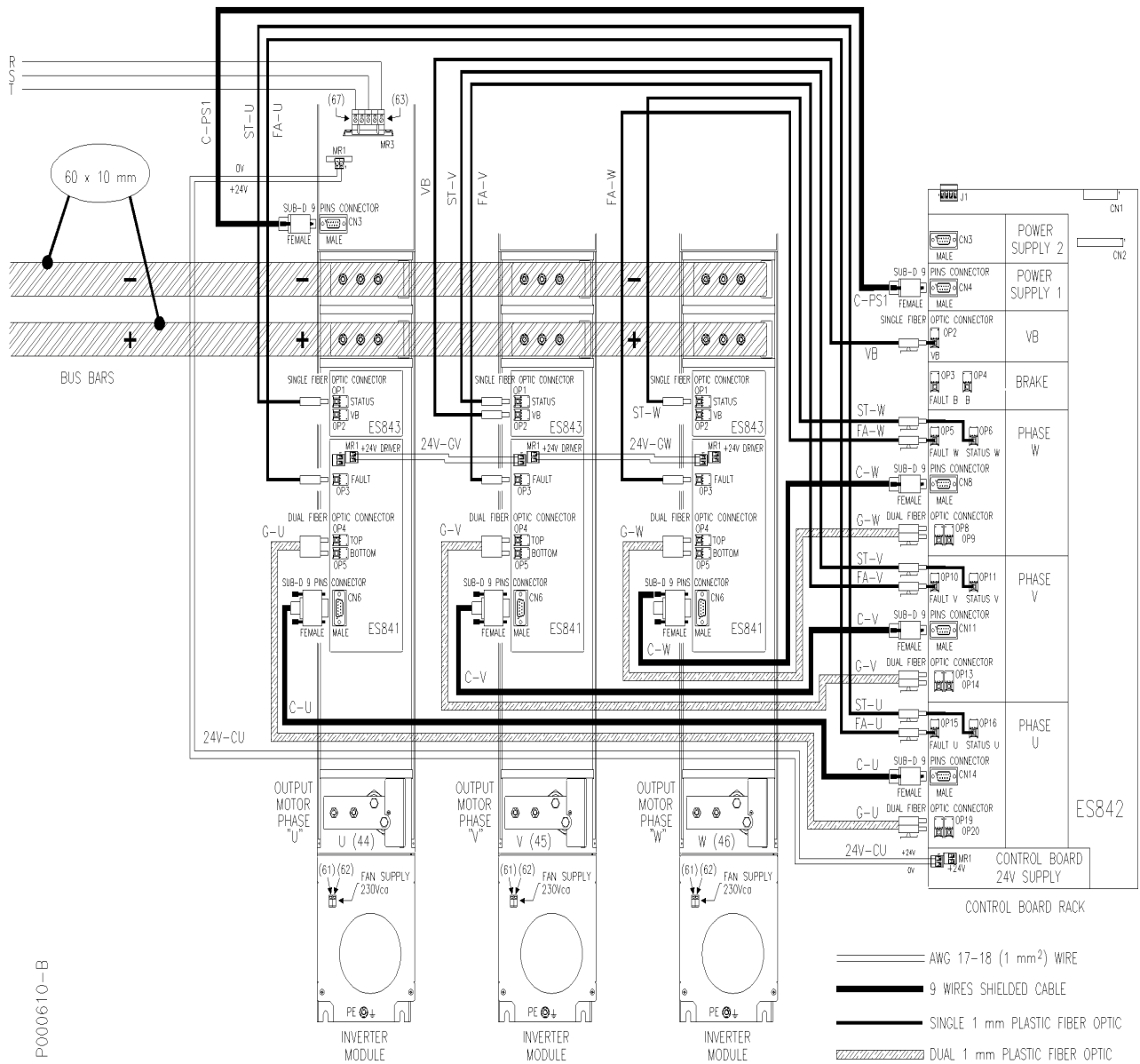

Figure 42: Internal wiring for inverters S64

3.4.2.8. Internal Connections for Modular Inverters S74, S75 and S80

Please refer to the Assembly Instructions for Modular Inverters.

3.4.2.9. Internal Connections for Modular Inverters S84 and S90

Please refer to the Assembly Instructions for Modular Inverters.

3.4.3. Power Terminals for S05–S52

DESCRIPTION	
41/R – 42/S – 43/T	Inputs for three-phase supply (the phase sequence is not important).
44/U – 45/V – 46/W	Three-phase motor outputs.
47/+	Link to the DC voltage positive pole. It can be used for - DC voltage supply; - DC inductors; - the external braking resistor and the external braking unit (for the drive models which are NOT provided with terminal 50/+ dedicated to the external braking resistor) - the external braking unit.
47/D	When fitted, link to the positive pole of the continuous AC rectified voltage. It can be used for the inductor—if no DC inductor is used, terminal 47/D must be short-circuited to terminal 47/+ using a cable/bar having the same cross-section as the cables used for power supply; factory setting).
48/B	When available, it can be used to connect the IGBT brake for braking resistors.
49/–	Link to the negative pole of the DC voltage. It can be used for - DC voltage power supply; - the external braking unit
50/+	When available, it can be used to connect the positive pole of the DC voltage to be used for the external braking resistor only.

S05 (4T)–S15–S20 Terminal board:

41/R	42/S	43/T	44/U	45/V	46/W	47/+	48/B	49/–
------	------	------	------	------	------	------	------	------

S05 (2T) Terminal board:

41/R	42/S	43/T	44/U	45/V	46/W	47/+	47/D	48/B	49/–
------	------	------	------	------	------	------	------	------	------



CAUTION

Connection bars **47D** and **47+** are short-circuited as a factory setting. The DC inductor, if any, shall be linked between bars **47D** and **47+** after removing the short-circuit.



CAUTION

If DC voltage power supply is required and if an external braking resistor is to be installed, remove the short-circuit between **47/D** and **47/+** and use terminal **47/+**.



CAUTION

Use terminals **47/+** and **48/B** if an external braking resistor is to be installed.

S12 Terminal board (2T-4T)–S14:

41/R	42/S	43/T	47/+	47/D	48/B	49/–	44/U	45/V	46/W
------	------	------	------	------	------	------	------	------	------



CAUTION

Connection bars **47/D** and **47/+** are short-circuited as a factory setting. The DC inductor, if any, shall be linked between bars **47/D** and **47/+** after removing the short-circuit.



CAUTION

If DC voltage power supply is required and if an external braking resistor is to be installed, remove the short-circuit between **47/D** and **47/+** and use terminal **47/+**.



CAUTION

Use terminals **47/+** and **48/B** if an external braking resistor is to be installed.

S12 Terminal board (5T):

41/R	42/S	43/T	47/+	47/D	49/–	44/U	45/V	46/W
------	------	------	------	------	------	------	------	------

S22-32 Terminal board:

48/B	50/+	47/D	47/+	49/–	41/R	42/S	43/T	44/U	45/V	46/W
------	------	------	------	------	------	------	------	------	------	------



CAUTION

Connection bars **47/D** and **47/+** are short-circuited as a factory setting. The DC inductor, if any, shall be linked between bars **47/D** and **47/+** after removing the short-circuit.



CAUTION

If DC voltage power supply is required and if an external braking resistor is to be installed, remove the short-circuit between **47/D** and **47/+** and use terminal **47/+**.



NOTE

Connect the braking resistor to terminals **50/+** and **48/B**.
Avoid using terminals **50/+** and **48/B** for applying DC power supply.

S30 Terminal board:

41/R	42/S	43/T	44/U	45/V	46/W	47/+	49/–	48/B	50/+
------	------	------	------	------	------	------	------	------	------



NOTE

Connect the braking resistor to terminals **50/+** and **48/B**.
Avoid using terminals **50/+** and **48/B** for applying DC voltage power supply.

Connection bars for S41–S42–S51–S52:

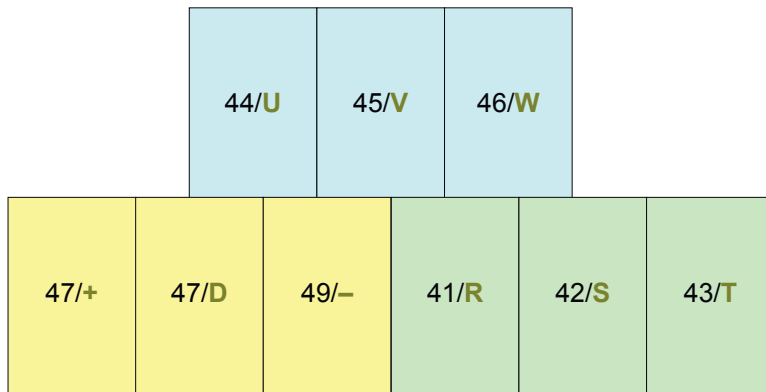

CAUTION

Connection bars **47/D** and **47/+** are short-circuited as a factory setting. The DC inductor, if any, shall be linked between bars **47/D** and **47/+** after removing the short-circuit.



CAUTION

Please contact Elettronica Santerno if DC voltage power supply is to be applied to Sinus Penta S41, S42, S51, S52 (precharge circuit for the DC-bus capacitor upstream of the DC voltage power supply terminals).



NOTE

Use terminals **47/+** and **49/-** if the external braking unit is to be installed.

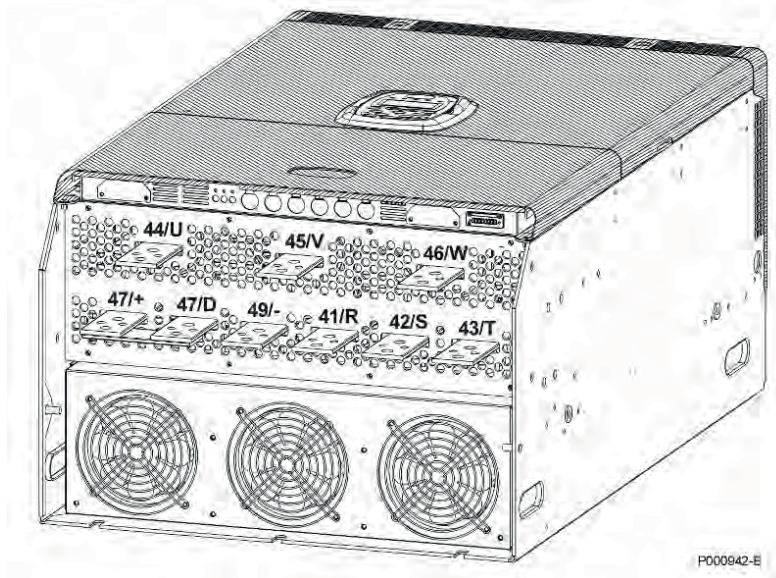

Figure 43: Connection bars in S41–S42–S51–S52

3.4.4. Power Terminals Modified for a DC Inductor

When a DC inductor is required for Sinus Penta S15-20-30, this must be specified when ordering the equipment.



CAUTION For inverter sizes S15, S20, S30, the DC inductor required is to be specified when ordering the equipment.



NOTE The terminals changed for the connection of a DC inductor are **white on grey shading**.



CAUTION Models S05(4T) cannot be changed for the connection of a DC inductor.

S15-S20 Terminal board:

41/R	42/S	43/T	44/U	45/V	46/W	47/D	47/+	48/B
------	------	------	------	------	------	------	------	------



NOTE Use terminals **47/+** and **48/B** if an external braking resistor is to be installed.

S30 Terminal board:

41/R	42/S	43/T	44/U	45/V	46/W	47/D	47/+	48/B	n.u.
------	------	------	------	------	------	------	------	------	------



NOTE Use terminals **47/+** and **48/B** if an external braking resistor is to be installed.

3.4.5. Connection Bars for S60 Inverters

P000715-B

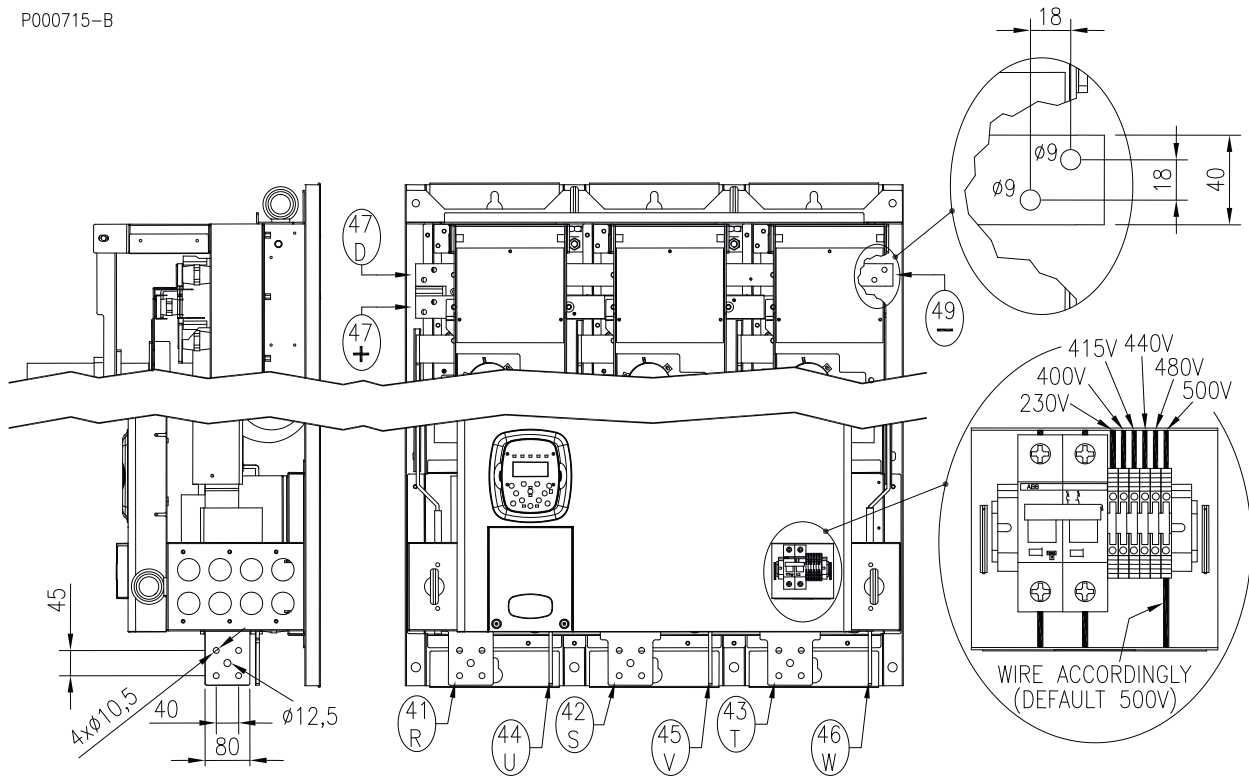

Figure 44: S60 Connection bars

Figure 44 shows the location and dimension of the bars connecting S60 Sinus Penta drives to the mains and the motor. The figure also shows the position and the wiring instructions for the built-in power supply transformer. The transformer must be wired based on the rated supply voltage being used.



CAUTION

Connection bars **47/D** and **47/+** are short-circuited as a factory setting. The DC inductor, if any, shall be linked between bars **47/D** and **47/+** after removing the short-circuit.



CAUTION

Please contact Elettronica Santerno if DC voltage power supply is to be applied to Sinus Penta S60 (precharge circuit for the DC-bus capacitor upstream of the DC voltage power supply terminals).

3.4.6. Connection Bars for Modular Inverters S64–S70

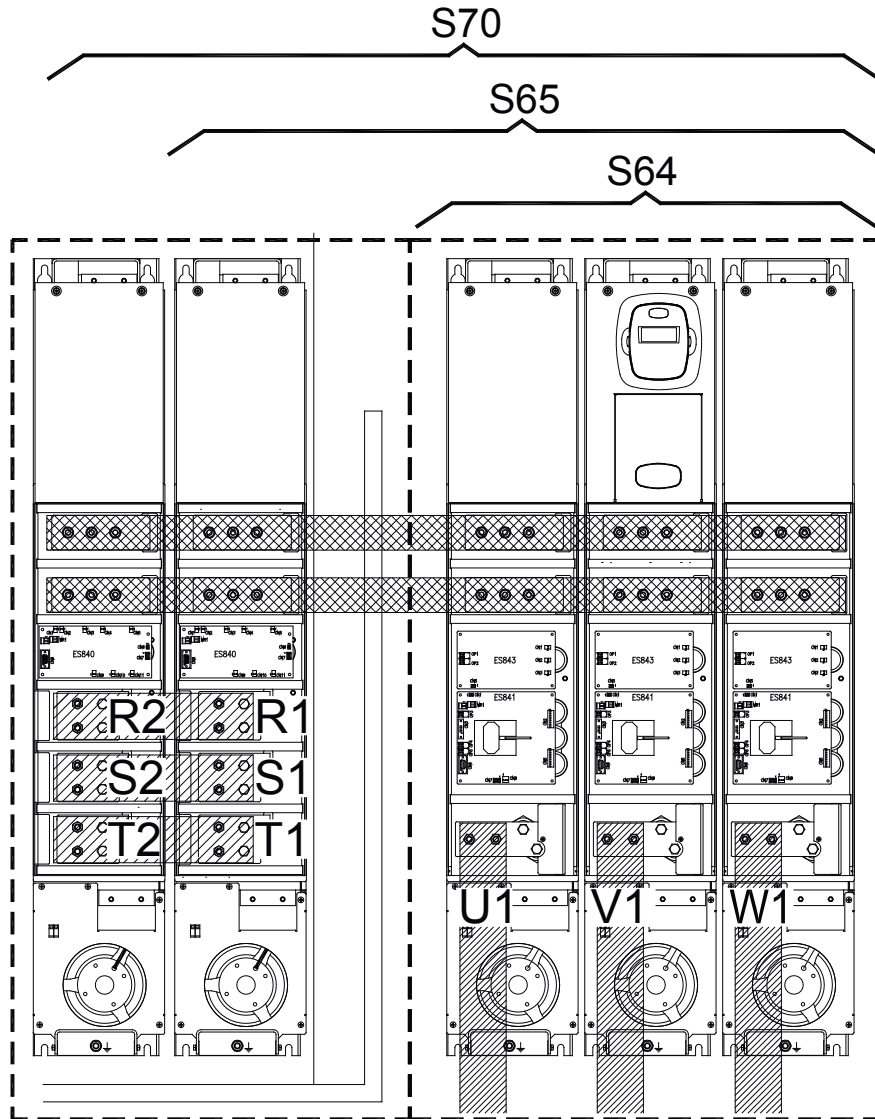

P000650-B

Figure 45: Connection bars for S64-S70

CAUTION When a DC inductor is required for Sinus Penta S65 and S70, this must be specified when ordering the equipment.

CAUTION When a DC inductor is to be installed, special-purpose bars are required.

3.4.7. Connection Bars for Modular Inverters S74–S80

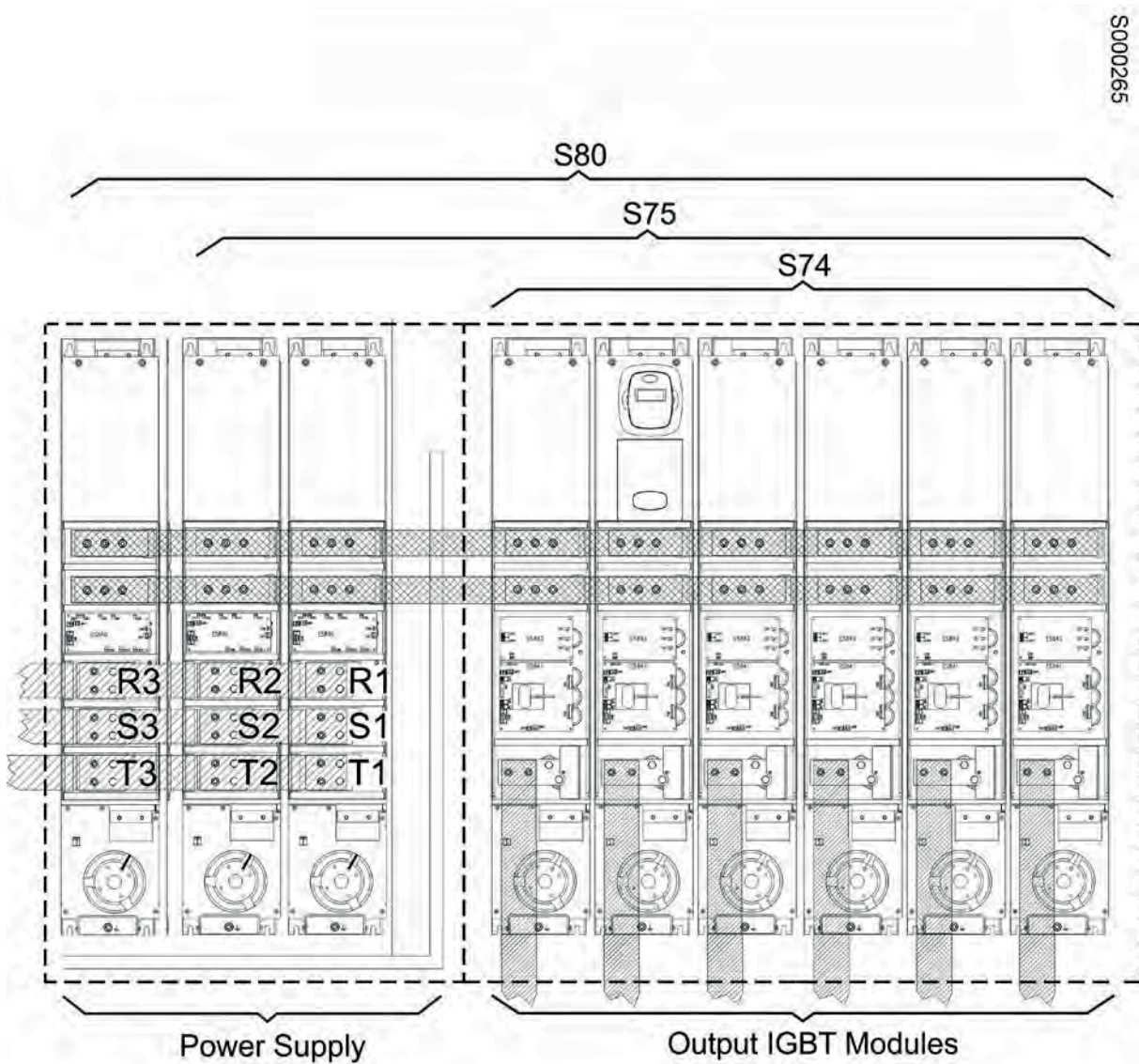

Figure 46: Connection bars for S74-S80

CAUTION When a DC inductor is required for Sinus Penta S75 and S80, this must be specified when ordering the equipment.

CAUTION When a DC inductor is to be installed, special-purpose bars are required.

3.4.8. Connection Bars for Modular Inverters S84–S90

S000266

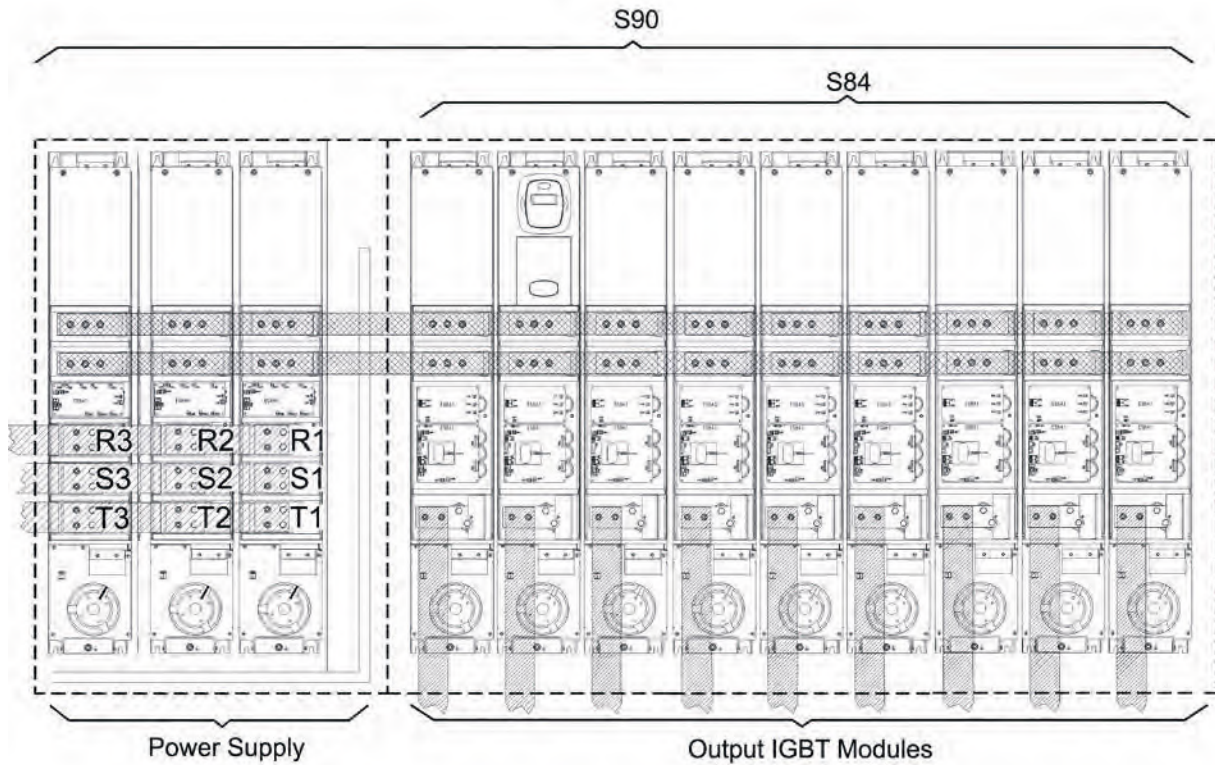

Figure 47: Connection bars for S84-S90



CAUTION When a DC inductor is required for Sinus Penta S90, this must be specified when ordering the equipment.



CAUTION When a DC inductor is to be installed, special-purpose bars are required.



CAUTION Please contact Elettronica Santerno if DC supply is to be applied to Sinus Penta S64 to S84 (the precharge circuit of DC-bus capacitors is not present).



CAUTION The mounting layout in the figures above may vary based on the accessories being used (input and output inductors, sinusoidal filters, harmonic filters).

3.4.9. Auxiliary Power Supply Terminals

The auxiliary power supply terminals are provided in the Penta models requiring auxiliary power supply links to be used to power air-cooling systems or to power internal circuits.

Inverter	Terminal	Description	Ratings
S64–S74–S84	63/Raux 65/Saux 67/Taux	Inputs for auxiliary 3-phase power supply	380-500Vac 100mA for 47-class inverters 660-690Vac 0.5A for 6T-class inverters
S65–S64– S70–S74–S75– S80–S84–S90	61–62	Inputs for fan power supply	230Vac/2A

3.4.10. Cross-sections of the Power Cables and Sizes of the Protective Devices

The minimum requirements of the inverter cables and the protective devices needed to protect the system against short-circuits are given in the tables below. It is however recommended that the applicable regulations in force be observed; also check if voltage drops occur for cable links longer than 100m.

For the largest inverter sizes, special links with multiple conductors are provided for each phase. For example, 2x150 in the column relating to the cable cross-section means that two 150mm² parallel conductors are required for each phase.

Multiple conductors shall have the same length and must run parallel to each other, thus ensuring even current delivery at any frequency value. Paths having the same length but a different shape deliver uneven current at high frequency.

Also, do not exceed the tightening torque for the terminals to the bar connections. For connections to bars, the tightening torque relates to the bolt tightening the cable lug to the copper bar. The cross-section values given in the tables below apply to copper cables.

The links between the motor and the Penta drive must have the same lengths and must follow the same paths. Use 3-phase cables where possible.

3.4.10.1. 2T Voltage Class

Size	Sinus Penta Model	Rated Inverter Current	Cable Cross-section Fitting the Terminal	Cable Stripping	Tightening Torque	Cable Cross-section to Mains and Motor Side	Fast Fuses (700V) + Disc. Switch	Magnetic Circuit Breaker	AC1 Contactor
		A	mm ² (AWG/kcmils)	mm	Nm	mm ² (AWG/kcmils)	A	A	A
S05	0007	12.5	0.5÷10 (20÷6AWG)	10	1.2-1.5	2.5 (12AWG)	16	16	25
	0008	15		10	1.2-1.5		16	16	25
	0010	17		10	1.2-1.5	4 (10AWG)	20	25	25
	0013	19		10	1.2-1.5		20	25	25
	0015	23		10	1.2-1.5		25	25	25
	0016	27		10	1.2-1.5	8 (8AWG)	32	32	45
	0020	30		10	1.2-1.5		50	50	45
S12	0023	38	0.5÷25 (20÷4AWG)	18	2.5	10 (6AWG)	63	63	60
	0033	51		18	2.5	16 (5AWG)	80	80	80
	0037	65		18	2.5		80	80	80
S15	0040	72	4÷25 (12÷4AWG)	15	2.5	25 (4AWG)	100	100	100
	0049	80		15	2.5		125	100	100
S20	0060	88	25÷50 (3÷1/0AWG)	24	6-8	35 (2AWG)	125	125	125
	0067	103		24	6-8	50 (1/0AWG)	125	125	125
	0074	120		24	6-8		160	160	145
	0086	135		24	6-8		200	160	160
S30	0113	180	35÷185 (2AWG÷350kcmils)	30	10	95 (4/0AWG)	250	200	250
	0129	195		30	10	120 (250kcmils)	250	250	250
	0150	215		30	10		315	400	275
	0162	240		30	10		400	400	275
S41	0180	300	Bus bar	-	30	185 (400kcmils)	350	400	400
	0202	345	Bus bar	-	30	240 (500kcmils)	500	400	450
	0217	375	Bus bar	-	30	2x120 (2x4/0AWG)	550	630	450
	0260	425	Bus bar	-	30	2x120 (2x250kcmils)	630	630	500
S51	0313	480	Bus bar	-	50	2x150 (2x300kcmils)	700	630	550
	0367	550	Bus bar	-	50	2x185 (2x350kcmils)	800	800	600
	0402	680	Bus bar	-	50	2x240 (2x500kcmils)	1000	800	700
S60	0457	720	Bus bar	-	50	3x150 (3x300kcmils)	1000	800	800
	0524	800	Bus bar	-	50	3x185 (3x350kcmils)	1000	1000	1000



CAUTION

Always use the correct cable cross-sections and activate the protective devices provided for the inverter. Failure to do so will cause the non-compliance to standard regulations of the system where the inverter is installed.

3.4.10.2. UL-approved Fuses - 2T Voltage Class

UL-approved semiconductor fuses, which are recommended for the Sinus Penta drives, are listed in the table below.

In multiple cable installations, install one fuse per phase (NOT one fuse per conductor).

Fuses suitable for the protection of semiconductors produced by other manufacturers may be used, provided that they have the same or better ratings and

- are Nonrenewable UL Listed Cartridge Fuses, or UL Recognized External Semiconductor Fuses;
- are of the type specifically approved also with reference to the Canadian Standard.

Size	Sinus Penta Model	UL-approved Fuses Manufactured by:							
		SIBA Sicherungen-Bau GmbH (200 kA _{RMS} Symmetrical A.I.C.)				Bussmann Div Cooper (UK) Ltd (200 kA _{RMS} Symmetrical A.I.C.)			
		Mod. No.	Ratings			Mod. No.	Ratings		
Current A _{RMS}	I ² t (230V) A ² sec		Vac	Current A _{RMS}	I ² t (230V) A ² sec		Vac		
S05	0008 0010 0013	60 033 05 16	16	48	600	170M1409	16	22	700
		60 033 05 20	20	80		170M1410	20	35	
			50 142 06 25	25		140	170M1411	25	
	S12	0015 0016	50 142 06 32	32	315	FWP-35B	35	40	
			50 142 06 50	50	400	FWP-50B	50	150	
		0020 0023		20 412 20 80	80	1120	FWP-70B	70	
0033 0037			20 412 20 100	100	1720	FWP-80B	80	600	
	S15	0040 0049	20 412 20 125	125	3100	FWP-100B	100	900	
S20			0060 0067	20 412 20 160	160	6700	FWP-125A	125	3650
	0074 0086	20 412 20 200		200	12000	FWP-150A	150	5850	
S30		0113 0129	20 412 20 250	250	20100	FWP-175A	175	8400	
	0150 0162		20 412 20 315	315	37000	FWP-225A	225	15700	
		0180 0202	20 412 20 400	400	68000	FWP-250A	250	21300	
	0217 0260		20 622 32 450	450	47300	FWP-350A	350	47800	
S41		0202 0217	20 622 32 500	500	64500	FWP-450A	450	68500	
	0217 0260		20 622 32 550	550	84000	FWP-500A	500	85000	
S51		0260 0313	20 622 32 630	630	129000	FWP-600A	600	125000	
	0313 0367		20 622 32 700	700	177000	FWP-700A	700	54000	
S60		0402 0457	20 622 32 800	800	250000	FWP-800A	800	81000	
	0457 0524		20 622 32 1000	1000	542000	FWP-1000A	1000	108000	
			20 632 32 1250	1250	924000	FWP-1200A	1200	198000	

3.4.10.3. UL-approved Surge Protective Devices (SPDs) - 2T Voltage Class

UL-approved Surge Protective Devices (SPDs), which are recommended for Sinus Penta 2T models, are listed in the table below.

Other devices or systems produced by different manufacturers may be used, provided that they

- are evaluated based on the requirements in Standard UL 1449;
- are evaluated also to withstand the available short circuit current when tested in accordance with UL 1449;
- are of the type specifically approved also with reference to the Canadian Standard;
- have Max Voltage Protective Rating of 1kV, non MOV type.

Size	Sinus Penta Model	Rated Inverter Current A	UL-approved SPDs Manufactured by								
			Phoenix Contact			Dehn			ERICO		
			P/N	Ratings		P/N	Ratings		P/N	Ratings	
				Short Circuit Current (kA)	Protection Level (kV)		Short Circuit Current (kA)	Protection Level (kV)		Short Circuit Current (kA)	Protection Level (kV)
S05	0007	12.5	VAL-MS 230 ST (2798844)	5	<1	952 300	5	<1	TDS1501 SR240 (item N.702406 for Europe)	5	<1
	0008	15									
	0010	17									
	0013	19									
	0015	23									
	0016	27									
S12	0020	30									
	0023	38									
	0033	51									
	0037	65									

3.4.10.4. 4T Voltage Class

Size	Sinus Penta Model	Rated Inverter Current A	Cable Cross-section Fitting the Terminal mm ² (AWG/kcmils)	Cable Stripping mm	Tightening Torque Nm	Cable Cross-section to Mains and Motor Side mm ² (AWG/kcmils)	Fast Fuses (700V) + Disc. Switch A	Magnetic Circuit Breaker A	AC1 Contactor A
S05		10.5	0.5÷10 (20÷6AWG)	10	1.2-1.5	2.5 (12AWG)	16	16	25
	0007	12.5		10	1.2-1.5	4 (10AWG)	16	16	25
	0009	16.5		10	1.2-1.5		25	25	25
	0011	16.5		10	1.2-1.5		25	25	25
	0014	16.5		10	1.2-1.5		32	32	30
S12	0016	26		10	1.2-1.5	10 (6AWG)	40	40	45
	0017	30		10	1.2-1.5		40	40	45
	0020	30		10	1.2-1.5		40	40	45
	0025	41		10	1.2-1.5		63	63	55
	0030	41		10	1.2-1.5	63	63	60	
	0034	57	0.5÷25 (20÷4AWG)	18	2.5	16 (5AWG)	100	100	100
	0036	60		18	2.5	25 (4AWG)	100	100	100
	0040	72		15	2.5	100	100	100	
S15	0049	80	4÷25 (12÷4AWG)	15	2.5	25 (4AWG)	125	100	100
S20	0060	88	25÷50 (3÷1/0 AWG)	24	6-8	35 (2AWG)	125	125	125
	0067	103		24	6-8	50 (1/0AWG)	125	125	125
	0074	120		24	6-8		160	160	145
	0086	135		24	6-8		200	160	160
S30	0113	180	35÷185 (2AWG÷ 350kcmils)	30	10	95 (4/0AWG)	250	200	250
	0129	195		30	10	120 (250kcmils)	250	250	250
	0150	215		30	10		315	400	275
	0162	240		30	10		400	400	275

(continued)

(continued)

Size	Sinus Penta Model	Rated Inverter Current	Cable Cross-section Fitting the Terminal	Cable Stripping	Tightening Torque	Cable Cross-section to Mains and Motor Side	Fast Fuses (700V) + Disc. Switch	Magnetic Circuit Breaker	AC1 Contactor
		A	mm ² (AWG/kcmils)	mm	Nm	mm ² (AWG/kcmils)	A	A	A
S41	0180	300	Bus bar	-	30	185 (400kcmils)	350	400	400
	0202	345	Bus bar	-	30	240 (500kcmils)	500	400	450
	0217	375	Bus bar	-	30	2x120 (2x250kcmils)	550	630	450
	0260	425	Bus bar	-	30	2x120 (2x250kcmils)	630	630	500
S51	0313	480	Bus bar	-	50	2x150 (2x300kcmils)	700	630	550
	0367	550	Bus bar	-	50	2x185 (2x350kcmils)	800	800	600
	0402	680	Bus bar	-	50	2x240 (2x500kcmils)	1000	800	700
S60	0457	720	Bus bar	-	50	3x150 (3x300kcmils)	1000	800	800
	0524	800	Bus bar	-	50	3x185 (3x350kcmils)	1000	1000	1000
S65	0598	900	Bus bar	-	M10: 50 M12: 110	3x240 (3x500kcmils)	1250	1250	1000
	0748	1000	Bus bar	-	M10: 50 M12: 110	3x240 (3x500kcmils)	1250	1250	1200
	0831	1200	Bus bar	-	M10: 50 M12: 110	4x240 (4x500kcmils)	1600	1600	1600
S75	0964	1480	Bus bar	-	M10: 50 M12: 110	6x150 (6x300kcmils)	2x1000	2000	2x1000
	1130	1700	Bus bar	-	M10: 50 M12: 110	6x185 (6x350kcmils)	2x1250	2000	2x1200
	1296	2100	Bus bar	-	M10: 50 M12: 110	6x240 (6x500kcmils)	2x1250	2500	2x1200
S90	1800	2600	Bus bar	-	M10: 50 M12: 110	9x240 (9x500kcmils)	3x1250	4000	3x1000
	2076	3000	Bus bar	-	M10: 50 M12: 110	9x240 (9x500kcmils)	3x1250	4000	3x1200



CAUTION

Always use the correct cable cross-sections and activate the protective devices provided for the inverter. Failure to do so will cause the non-compliance to standard regulations of the system where the inverter is installed.

Size	Sinus Penta Model	Rated Output Current	Rated Input Current	Cable Cross-section Fitting the Terminal	Tightening Torque	Motor Cable Cross-section
		A	Adc	mm ² (AWG/kcmils)	Nm	mm ² (AWG/kcmils)
S64	0598	900	1000	Bus bar	M10: 50 M12: 110	3x240 (3x500kcmils)
	0748	1000	1100	Bus bar	M10: 50 M12: 110	3x240 (3x500kcmils)
	0831	1200	1400	Bus bar	M10: 50 M12: 110	4x240 (4x500kcmils)
S74	0964	1480	1750	Bus bar	M10: 50 M12: 110	6x150 (6x300kcmils)
	1130	1700	2000	Bus bar	M10: 50 M12: 110	6x185 (6x350kcmils)
	1296	2100	2280	Bus bar	M10: 50 M12: 110	6x240 (6x500kcmils)
S84	1800	2600	2860	Bus bar	M10: 50 M12: 110	9x240 (9x500kcmils)
	2076	3000	3300	Bus bar	M10: 50 M12: 110	9x240 (9x500kcmils)



CAUTION

Always use the correct cable cross-sections and activate the protective devices installed on the DC voltage power supply line. Failure to do so will cause the non-compliance to standard regulations of the system where the inverter is installed.

3.4.10.5. UL-approved Fuses - 4T Voltage Class

UL-approved semiconductor fuses, which are recommended for the Sinus Penta drives, are listed in the table below.

In multiple cable installations, install one fuse per phase (NOT one fuse per conductor).

Fuses suitable for the protection of semiconductors produced by other manufacturers may be used, provided that they have the same or better ratings and:

- are Nonrenewable UL Listed Cartridge Fuses, or UL Recognized External Semiconductor Fuses;
- are of the type specifically approved also with reference to the Canadian Standard.

Size	Sinus Penta Model	UL-approved Fuses Manufactured by:									
		SIBA Sicherungen-Bau GmbH (200 kA _{RMS} Symmetrical A.I.C.)				Bussmann Div Cooper (UK) Ltd (100/200 kA _{RMS} Symmetrical A.I.C.)					
		Mod. No.	Ratings			Mod. No.	Ratings				
Current Arms	I ² t (500V) A ² sec		Vac	Current Arms	I ² t (500V) A ² sec		Vac				
S05	0005	20 412 34 16	16	122	690	170M1409	16	36	700		
	0007										
	0009	20 412 04 25	25	140	660	170M1410	20	58			
	0011										
	0014										
S12	0016	50 142 06 40	40	430	700	FWP-40B	40	160			
	0017										
	0020	20 412 20 63	63	980		FWP-60B	60	475			
	0025										
	0030										
	0034										
	0036										
S15	0040	20 412 20 100	100	2800	FWP-100B	100	1750				
	0049										
S20	0060	20 412 20 125	125	5040	FWP-125A	125	5400				
	0067										
	0074	20 412 20 160	160	10780				FWP-150A		150	8700
	0086										
S30	0113	20 412 20 250	250	32760	FWP-175A	175	12300				
	0129										
	0150	20 412 20 315	315	60200				FWP-225A	225	23000	
	0162										
	0180										
S41	0202	20 622 32 450	450	77000	FWP-250A	250	32000				
	0217										
	0260	20 622 32 500	500	105000				FWP-350A	350	70800	
	0313										
	0367										
S51	0402	20 622 32 630	630	210000	FWP-450A	450	101400				
	0457										
	0524	20 622 32 700	700	287000				FWP-500A	500	125800	
0598											
S60	0748	20 622 32 900	900	665000	FWP-600A	600	185000				
	0831										
	0964	20 622 32 1000	1000	602000				FWP-700A	700	129000	
1130											
S65	1296	20 632 32 1000	1000	602000	FWP-900A	900	228000				
	1800										
	2076	20 632 32 1250	1250	1225000				FWP-1000A	1000	258000	
0524											
S75	0598	20 632 32 1400	1400	1540000	FWP-1200A	1200	473000				
	0748										
	0831	2x20 622 32 800	2x800	2x406000				170M6067	1400	1700000	
0964											
S90	1130	2x20 632 32 1000	2x1000	2x602000	170M6069	1600	2700000				
	1296										
	1800	2x20 622 32 1250	2x1250	2x1225000				2xFWP-1000A	2x1000	2x258000	
2076											
S90	1800	2x20 632 32 1400	2x1400	2x1540000	2xFWP-1200A	2x1200	2x473000				
	2076										
	2076	3x20 632 32 1400	3x1400	3x1540000				3x170M6067	3x1400	3x1700000	
2076											



NOTE

In modular sizes (S65–S90), each supply arm shall be protected by a separate fuse (see table above).

3.4.10.6. 5T and 6T Voltage Classes

Size	Sinus Penta Model	Rated Inverter Current	Terminal Cross-section	Cable Stripping	Tightening Torque	Cable Cross-section to Mains and Motor Side	Fast Fuses (700V) + Disc. Switch	Magnetic Circuit Breaker	AC1 Contactor
		A	mm ² (AWG or kcmils)	mm	Nm	mm ² (AWG or kcmils)	A	A	A
S12 5T S14 6T	0003	7	0.5÷16 (20÷5AWG)	10	1.2-1.5	2.5 (12AWG)	16	16	25
	0004	9		10	1.2-1.5		16	16	25
	0006	11		10	1.2-1.5	4 (10AWG)	32	32	30
	0012	13		10	1.2-1.5		32	32	30
	0018	17		10	1.2-1.5		32	32	30
S14	0019	21	0.5÷25 (20÷4 AWG)	18	2.5-4.5	10 (6AWG)	40	40	45
	0021	25		18	2.5-4.5		40	40	45
	0022	33		18	2.5-4.5		63	63	60
	0024	40		18	2.5-4.5		63	63	60
	0032	52		18	2.5-4.5	16 (5AWG)	100	100	100
S22	0042	60	25÷50 (4÷1/0 AWG)	20	2.5-5	35 (2 AWG)	100	100	100
	0051	80		20	2.5-5		100	100	100
	0062	85		20	2.5-5	50 (1/0AWG)	125	125	125
	0069	100		20	2.5-5		125	125	125
S32	0076	125	25÷95 (4÷4/0AWG)	30	15-20	70 (2/0AWG)	200	200	250
	0088	150		30	15-20		200	200	250
	0131	190	35÷150 (2/0AWG÷ 300kcmils)	30	15-20	120 (250kcmils)	315	400	275
	0164	230		30	15-20		315	400	275
S42	0181	305	Bus bar	-	30	240 (500kcmils)	400	400	400
	0201	330	Bus bar	-	30		450	400	450
	0218	360	Bus bar	-	30	2x120 (2x250kcmils)	500	400	450
	0259	400	Bus bar	-	30		630	630	500
S52	0290	450	Bus bar	-	50	2x150 (2x300kcmils)	630	630	550
	0314	500	Bus bar	-	50		700	630	550
	0368	560	Bus bar	-	50	2x185 (2x350kcmils)	800	800	600
	0401	640	Bus bar	-	50	2x240 (2x500kcmils)	900	800	700
S65	0457	720	Bus bar	-	M10: 50 M12: 110	3x150 (3x300kcmils)	900	800	800
	0524	800	Bus bar	-	M10: 50 M12: 110	3x185 (3x350kcmils)	1000	1000	1000
	0598	900	Bus bar	-	M10: 50 M12: 110	3x240 (3x500kcmils)	1250	1250	1000
	0748	1000	Bus bar	-	M10: 50 M12: 110		1400	1250	1200
S70	0831	1200	Bus bar	-	M10: 50 M12: 110	4x240 (4x500kcmils)	2x800	1600	2x800
S75	0964	1480	Bus bar	-	M10: 50 M12: 110	6x150 (6x300kcmils)	2x1000	2000	2x1000
	1130	1700	Bus bar	-	M10: 50 M12: 110	6x185 (6x400kcmils)	2x1250	2000	2x1000
S80	1296	2100	Bus bar	-	M10: 50 M12: 110	6x240 (6x500kcmils)	3x1000	2500	3x1000
S90	1800	2600	Bus bar	-	M10: 50 M12: 110	9x240 (9x500kcmils)	3x1000	4000	3x1000
	2076	3000	Bus bar	-	M10: 50 M12: 110	9x240 (9x500kcmils)	3x1250	4000	3x1000



CAUTION

Always use the correct cable cross-sections and activate the protective devices provided for the inverter. Failure to do so will cause the non-compliance to standard regulations of the system where the inverter is installed.



NOTE

In modular sizes S65–S90, each supply arm shall be protected by a separate fuse (see table above).

Size	Sinus Penta Model	Rated Output Current	Rated Input Current	Cable Cross-section Fitting the Terminal	Tightening Torque	Motor Cable Cross-section
		A	Adc	mm ² (AWG or kcmils)	Nm	mm ² (AWG or kcmils)
S64	0457	720	750	Bus bar	M10: 50 M12: 110	3x150 (3x300kcmils)
	0524	800	840	Bus bar	M10: 50 M12: 110	3x185 (3x350kcmils)
	0598	900	950	Bus bar	M10: 50 M12: 110	3x240 (3x500kcmils)
	0748	1000	1070	Bus bar	M10: 50 M12: 110	3x240 (3x500kcmils)
	0831	1200	1190	Bus bar	M10: 50 M12: 110	4x240 (4x500kcmils)
S74	0964	1480	1500	Bus bar	M10: 50 M12: 110	6x150 (6x300kcmils)
	1130	1700	1730	Bus bar	M10: 50 M12: 110	6x185 (6x400kcmils)
	1296	2100	1980	Bus bar	M10: 50 M12: 110	6x240 (6x500kcmils)
S84	1800	2600	2860	Bus bar	M10: 50 M12: 110	9x240 (9x500kcmils)
	2076	3000	3300	Bus bar	M10: 50 M12: 110	9x240 (9x500kcmils)



CAUTION

Always use the correct cable cross-sections and activate the protective devices installed on the DC voltage power supply line. Failure to do so will cause the non-compliance to standard regulations of the system where the inverter is installed.

3.4.10.7. UL-approved Fuses - 5T and 6T Voltage Classes

UL-approved semiconductor fuses, which are recommended for the Sinus Penta drives, are listed in the table below.

In multiple cable installations, install one fuse per phase (NOT one fuse per conductor).

Fuses suitable for the protection of semiconductors produced by other manufacturers may be used, provided that they have the same or better ratings and

- are Nonrenewable UL Listed Cartridge Fuses, or UL Recognized External Semiconductor Fuses;
- are of the type specifically approved also with reference to the Canadian Standard.

Size	Sinus Penta Model	UL-approved Fuses Manufactured by:						
		SIBA Sicherungen-Bau GmbH (200 kARMS Symmetrical A.I.C.)			Bussmann Div Cooper (UK) Ltd (100/200 kARMS Symmetrical A.I.C.)			
		Mod. No.	Ratings		Mod. No.	Ratings		
Current Arms	I ² t (690V) kA ² sec		Vac	Current Arms		I ² t (690V) kA ² sec	Vac	
S12 5T S14 6T	0003	20 412 34 16	16	0.18 (0.14@575V)	690	170M1409	16	0.05 (0.04@575V)
	0004							
	0006							
	0012							
	0018	20 412 04 25	25	0.08 (0.16@575V)		170M1411	25	0.14 (0.11@575V)
S14	0019	20 412 04 25	25	0.22		170M1411	25	0.14
	0021	20 412 04 32	32	1.50		170M1412	32	0.29
	0022	20 412 20 40	40	0.55		FWP-40B	40	0.32
	0024	20 412 20 50	50	0.85		FWP-50B	50	0.6
	0032	20 412 20 63	63	1.54		FWP-70B	70	2.0
S22	0042	20 412 20 80	80	2.86		FWP-80B	80	2.4
	0051	20 412 20 100	100	4.40		FWP-100B	100	3.5
	0062	20 412 20 125	125	7.92		FWP-125B	125	7.3
	0069	20 412 20 160	160	16.94		FWP-150A	150	11.7
S32	0076	20 412 20 180	180	25.41		FWP-175A	175	16.7
	0088	20 412 20 200	200	30.25		FWP-200A	200	31.3
	0131	20 412 20 250	250	51.48		FWP-250A	250	42.5
	0164	20 412 20 315	315	94.6		FWP-300A	300	71.2
S42	0181	20 412 20 315	315	94.6	700	FWP-400A	400	125
	0201	20 622 32 450	450	113		FWP-450A	450	137
	0218	20 622 32 500	500	155		FWP-500A	500	170
	0259	20 622 32 630	630	309		FWP-600A	600	250
S52	0290	20 622 32 630	630	309		FWP-600A	600	250
	0314	20 622 32 700	700	422		FWP-700A	700	300
	0368	20 622 32 800	800	598		FWP-800A	800	450
	0401	20 622 32 900	900	979		FWP-900A	900	530
S65	0457	20 622 32 900	900	979		FWP-900A	900	530
	0524	20 622 32 1000	1000	1298		FWP-1000A	1000	600
	0598	20 632 32 1250	1250	1802		FWP-1200A	1200	1100
	0748	20 632 32 1400	1400	2266		2xFWP-700A	2x700	2x300
S70	0831	2x20 622 32 800	2x800	2x598		2xFWP-800A	2x800	2x450
S75	0964	2x20 622 32 1000	2x1000	2x1298		2xFWP-1000A	2x1000	2x600
	1130	2x20 632 32 1250	2x1250	2x1802		2xFWP-1200A	2x1200	2x1100
S80	1296	3x20 622 32 1000	3x1000	3x1298		3xFWP-1000A	3x1000	3x600
S90	1800	3x20 632 32 1250	3x1250	3x1802		3xFWP-1200A	3x1200	3x1100
	2076	3x20 632 32 1400	3x1400	3x2266		6xFWP-800A	6x800	6x450



NOTE

In modular sizes S65–S90, each supply arm shall be protected by a separate fuse (see table above).

3.4.11. Inverter and Motor Ground Connection

A bolted screw for the inverter enclosure grounding is located close to the power wiring terminals. The grounding screw is identified by the symbol below:



Always ground the inverter to a state-of-the-art mains. To reduce disturbance and radiated interference to a minimum, connect the motor grounding conductor directly to the inverter following a parallel path to the motor supply cables.



DANGER

Always connect the inverter grounding terminal to the grid grounding using a conductor complying with the safety regulations in force (see table below).

Always connect the motor casing to the inverter grounding to avoid dangerous voltage peaks and electric shock hazard.



DANGER

Always provide a proper grounding of the inverter frame and the motor casing.

The touch current in the ground protective conductor exceeds 3.5mAac/10 mAdc. Please refer to the table below for the dimensioning of the protective conductors.



NOTE

To fulfil UL conformity requirements of the system where the inverter is installed, use a "UL R/C" or "UL Listed" lug to connect the inverter to the grounding system. Use a loop lug fitting the ground screw and having the same cross-section as the ground cable being used.

Protective earthing conductor cross-section (refer to EN 61800-5-1):

Cross-sectional area of phase conductors of the inverter (mm ²)	Minimum cross-sectional area of the corresponding protective earthing conductor (mm ²)
$S \leq 10$	10 (*)
$10 < S \leq 16$	S (*)
$16 < S \leq 35$	16
$35 < S$	S/2



NOTE

The values in the table above are valid only if the protective earthing conductor is made of the same metal as the phase conductors.

If this is not so, the cross-sectional area of the protective earthing conductor shall be determined in a manner which produces a conductance equivalent to that which results from the application of the table above.



NOTE (*)

In any case, a cross-section of the protective earthing conductor of at least 10 mm² Cu or 16 mm² Al is required to maintain safety in case of damage to or disconnection of the protective earthing conductor (refer to EN 61800-5-1 about Touch current).

3.5. Control Terminals

3.5.1. Main Features

Screwable terminal board in six extractable sections suitable for cross-sections $0.08 \div 1.5\text{mm}^2$ (AWG 28-16). Decisive voltage class A according to IEC 61800-5-1.

No.	Name	Description	I/O Features	DIP-switch
1	CMA	0V for main reference (connected to control 0V)	Control board zero volt	
2	REF	Input for single-ended main reference to be configured either as a voltage input or as a current input	Vfs = $\pm 10\text{ V}$, Rin = $50\text{k}\Omega$; Resolution: 12 bits 0 (4) $\div 20\text{ mA}$, Rin = $250\ \Omega$; Resolution: 11 bit	SW1-1: Off (default) SW1-1: On
3	-10VR	Negative reference supply output for external potentiometer	-10V Imax: 10mA	
4	+10VR	Positive reference supply output for external potentiometer	+10V Imax: 10mA	
5	AIN1+	Differential auxiliary analog input 1 to be configured either as a voltage input or as a current input	Vfs = $\pm 10\text{ V}$, Rin = $50\text{k}\Omega$; Resolution: 12 bits	SW1-2: Off
6	AIN1-		0 (4) $\div 20\text{ mA}$, Rin = $250\ \Omega$; Resolution: 11 bits	SW1-2: On (default)
7	AIN2+/PTC1	Differential auxiliary analog input 2 to be configured either as a voltage input or as a current input, or to be configured as a PTC acquisition input for motor protection	Vfs = $\pm 10\text{ V}$, Rin = $50\text{k}\Omega$; Resolution: 12 bits	SW1-3: Off SW1-4,5: Off
8	AIN2-/ PTC2		0 (4) $\div 20\text{ mA}$, Rin = $250\ \Omega$; Resolution: 11 bits	SW1-3: On SW1-4,5: Off (default)
			Motor protection PTC reading according to DIN44081/DIN44082	SW1-3: Off SW1-4,5: On
9	CMA	0V for auxiliary inputs (connected to control 0V)		
10	AO1	Analogue output 1 to be configured either as a voltage output or as a current output	Vout = $\pm 10\text{ V}$; Ioutmax = 5 mA ; Resolution: 11 bits 0 (4) $\div 20\text{ mA}$; Voutmax = 10 V Resolution: 10 bits	SW2-1: On; SW2-2: Off (default) SW2-1: Off; SW2-2: On
11	AO2	Analogue output 2 to be configured either as a voltage output or as a current output	Vout = $\pm 10\text{ V}$; Ioutmax = 5 mA Resolution: 11 bits 0 (4) $\div 20\text{ mA}$; Voutmax = 10 V Resolution: 10 bits	SW2-3: On; SW2-4: Off (default) SW2-3: Off; SW2-4: On
12	AO3	Analogue output 3 to be configured either as a voltage output or as a current output	Vout = $\pm 10\text{ V}$; Ioutmax = 5 mA Resolution: 11 bits 0 (4) $\div 20\text{ mA}$; Voutmax = 10 V Resolution: 10 bits	SW2-5: On; SW2-6: Off (default) SW2-5: Off; SW2-6: On
13	CMA	0V for main reference (connected to control 0V)		
14	START (MDI1)	Active input: inverter running. Inactive input: main ref. is reset and the motor stops with a deceleration ramp Multifunction digital input 1	Optoisolated digital inputs 24 VDC; positive logic (PNP): active with greater signal in respect to CMD (terminal 22). In compliance with EN 61131-2 as type-1 digital inputs with rated voltage equal to 24 VDC. Max. response time to processor: $500\ \mu\text{s}$	
15	ENABLE (MDI2)	Active input: inverter running enabled Inactive input: motor idling regardless of control mode; inverter not switching		
16	RESET (MDI3)	Alarm reset function Multifunction digital input 3		
17	MDI4	Multifunction digital input 4		
18	MDI5	Multifunction digital input 5		
19	MDI6 / ECHA / FINA	Multifunction digital input 6; Encoder dedicated input, push-pull 24 V single-ended phase A, frequency input A	Optoisolated digital inputs 24 VDC; positive logic (PNP): active with greater signal in respect to CMD (terminal 22). In compliance with EN 61131-2 as type-1 digital inputs with rated voltage equal to 24 VDC. Max. response time to processor: $600\ \mu\text{s}$	
20	MDI7 / ECHB	Multifunction digital input 7; Encoder dedicated input, push-pull 24 V single-ended, phase B		
21	MDI8 / FINB	Multifunction digital input 8; Frequency dedicated input B		
22	CMD	0V digital input isolated to control 0V	Optoisolated digital input zero volt	
23	+24V	Auxiliary supply output for optoisolated multifunction digital inputs	+24V $\pm 15\%$; Imax: 200mA Protect with resetting fuse	
24	+VMDO1	Supply input for MDO1 output	20 \div 48 VDC; IDC = 10 mA + output current (max 60 mA)	

(continued)

(continued)

25	MDO1/ FOUT	Multifunction digital output 1; frequency output	Optoisolated digital output (push-pull); Iout = 50 mA max; fout max 100 kHz.	
26	CMDO1	0V Multifunction digital output 1	Common for supply and MDO1 output	
27	MDO2	Multifunction digital output 2	Isolated digital output (open collector); Vomax = 48 V; Iomax = 50mA	
28	CMDO2	Common for multifunction digital output 2	Common for multifunction output 2	

Screwable terminal board in two extractable sections suitable for cross-sections 0.2 ÷ 2.5 mm² (AWG 24-12).

Recommended cross-sections 2.5÷4.0mm² (AWG 12-10).

N.	Name	Description	I/O Features	DIP-switch
29	MDO3-NC	Multifunction, relay digital output 3 (NC contact)	Change-over contact: with low logic level, common terminal is closed with NC terminal; with high logic level, common terminal is open with NO; Vomax = 250 VAC, Iomax = 5A Vomax = 30 VDC, Iomax = 5A	
30	MDO3-C	Multifunction, relay digital output 3 (common)		
31	MDO3-NO	Multifunction, relay digital output 3 (NO contact)		
32	MDO4-NC	Multifunction, relay digital output 4 (NC contact)		
33	MDO4-C	Multifunction, relay digital output 4 (common)		
34	MDO4-NO	Multifunction, relay digital output 4 (NO contact).		

Analog outputs are inactive under the following circumstances (digital outputs inactive and 0V / 0mA for analog outputs):



NOTE

- inverter off
- inverter initialization after startup
- inverter in emergency mode (see Sinus Penta's Programming Guide)
- updating of the application firmware

Always consider those conditions when operating the inverter.

The firmware considers encoder inputs MDI6/ECHA, MDI7/ECHB as ENCODER A in the terminal board.



NOTE

Inserting an optional board in slot C reallocates the digital inputs and only MDI6 and MDI7 functions are active, while the ENCODER A acquisition function is reallocated to the optional board. For more details, see ES836/2 Encoder Board (Slot A), ES913 Line Driver Encoder Board (Slot A) and the Sinus Penta's Programming Guide.

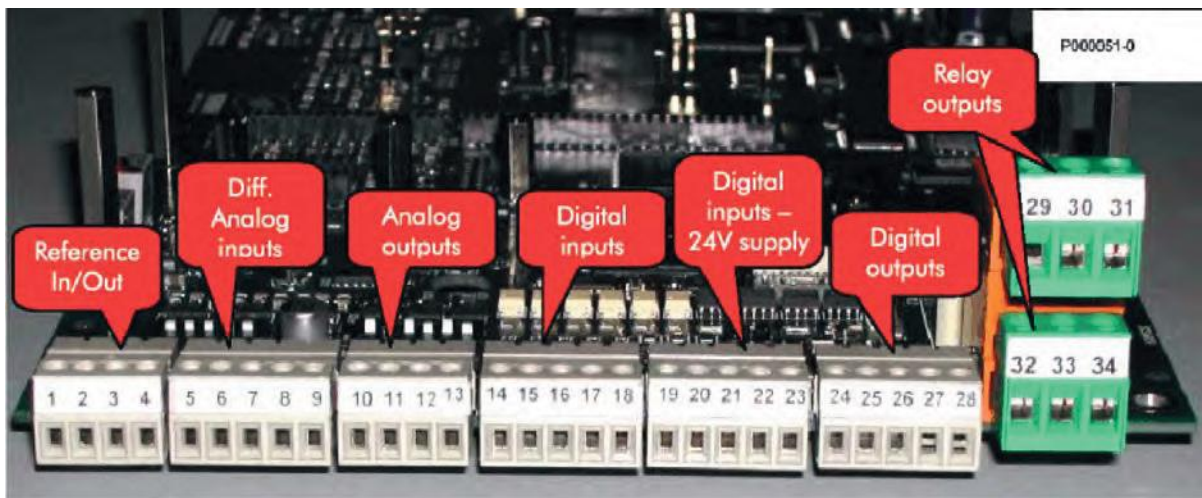

Figure 48: Control terminals

3.5.1.1. Gaining Access to Control Terminals and Power Terminals in IP20 and IP00 Models



DANGER

Before gaining access to the components inside the inverter, remove voltage from the inverter and wait at least 20 minutes. Wait for a complete discharge of the internal components to avoid any electric shock hazard.



DANGER

Do not connect or disconnect signal terminals or power terminals when the inverter is on to avoid electric shock hazard and to avoid damaging the inverter.



NOTE

All fastening screws for removable parts (terminal cover, serial interface connector, cable path plates, etc.) are black, rounded-head, cross-headed screws.

Only these screws may be removed when connecting the equipment. If other screws or bolts are removed, the product guarantee will be no longer valid.

To access the inverter control terminals, loosen the two fastening screws shown in the figure below and remove the cover.

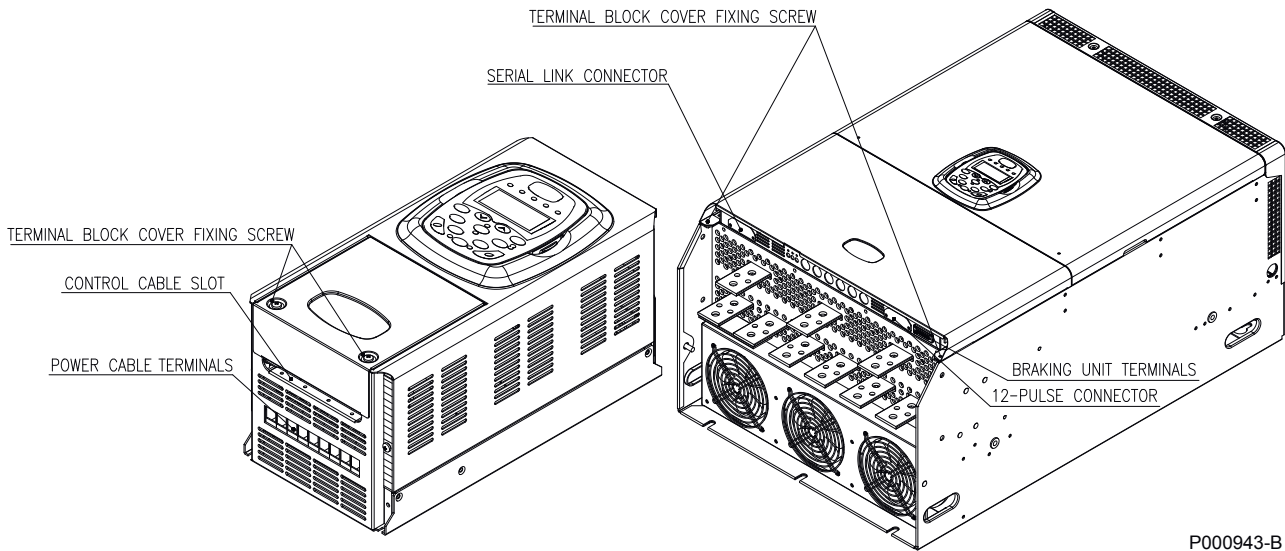

Figure 49: Gaining access to the control terminals

Size S05 to S15: remove the cover to reach power terminals as well. Upper sizes: removing the cover allows reaching control signals only.

3.5.1.2. Gaining Access to Control Terminals and Power Terminals in IP54 Models



DANGER

Before gaining access to the components inside the inverter, remove voltage from the inverter and wait at least 20 minutes. Wait for a complete discharge of the internal components to avoid any electric shock hazard.



DANGER

Do not connect or disconnect signal terminals or power terminals when the inverter is on to avoid electric shock hazard and to avoid damaging the inverter.



NOTE

All fastening screws for removable parts (terminal cover, serial interface connector, cable path plates, etc.) are black, rounded-head, cross-headed screws.

Only these screws may be removed when connecting the equipment. If other screws or bolts are removed, this will void the product warranty.

To reach the control terminals and power terminals, remove the front panel by removing its fastening screws. The following can be accessed:

- control terminals,
- power terminals,
- serial interface connector.

For ingoing/outgoing cables, pierce some holes in the inverter bottom plate. To remove the inverter bottom plate, remove its fastening screws.



CAUTION

For ingoing/outgoing cables through the inverter bottom plate, the following safety measures are required to maintain degree of protection IP54: cable-glands or similar with degree of protection not lower than IP54.



CAUTION

Always remove the inverter bottom plate before piercing holes for ingoing/outgoing cables, thus preventing metals chips from entering the equipment.

3.5.1.3. Grounding Shielded Cable Braiding

The inverters of the Sinus Penta series include special conductor terminals connected to the inverter grounding (conductor terminals are located near the control terminals). Their function is dual: they allow cables to be mechanically fastened and they allow braiding of signal shielded cables to be grounded. The figure shows how to wire a shielded cable.

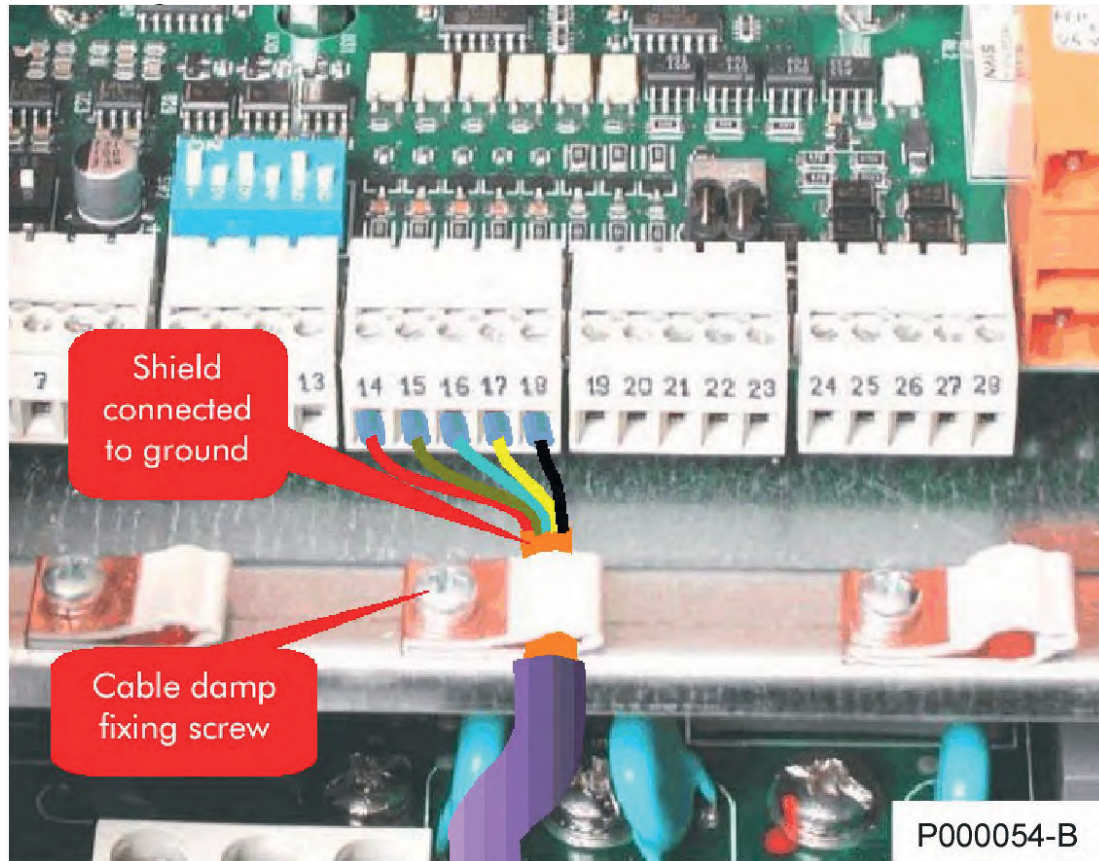

Figure 50: Clamping a signal shielded cable



CAUTION

If no state-of-the-art wiring is provided, the inverter will be more easily affected by disturbance. Do not forget that disturbance may also accidentally trigger the motor startup.

3.5.2. Control Board Signals and Programming

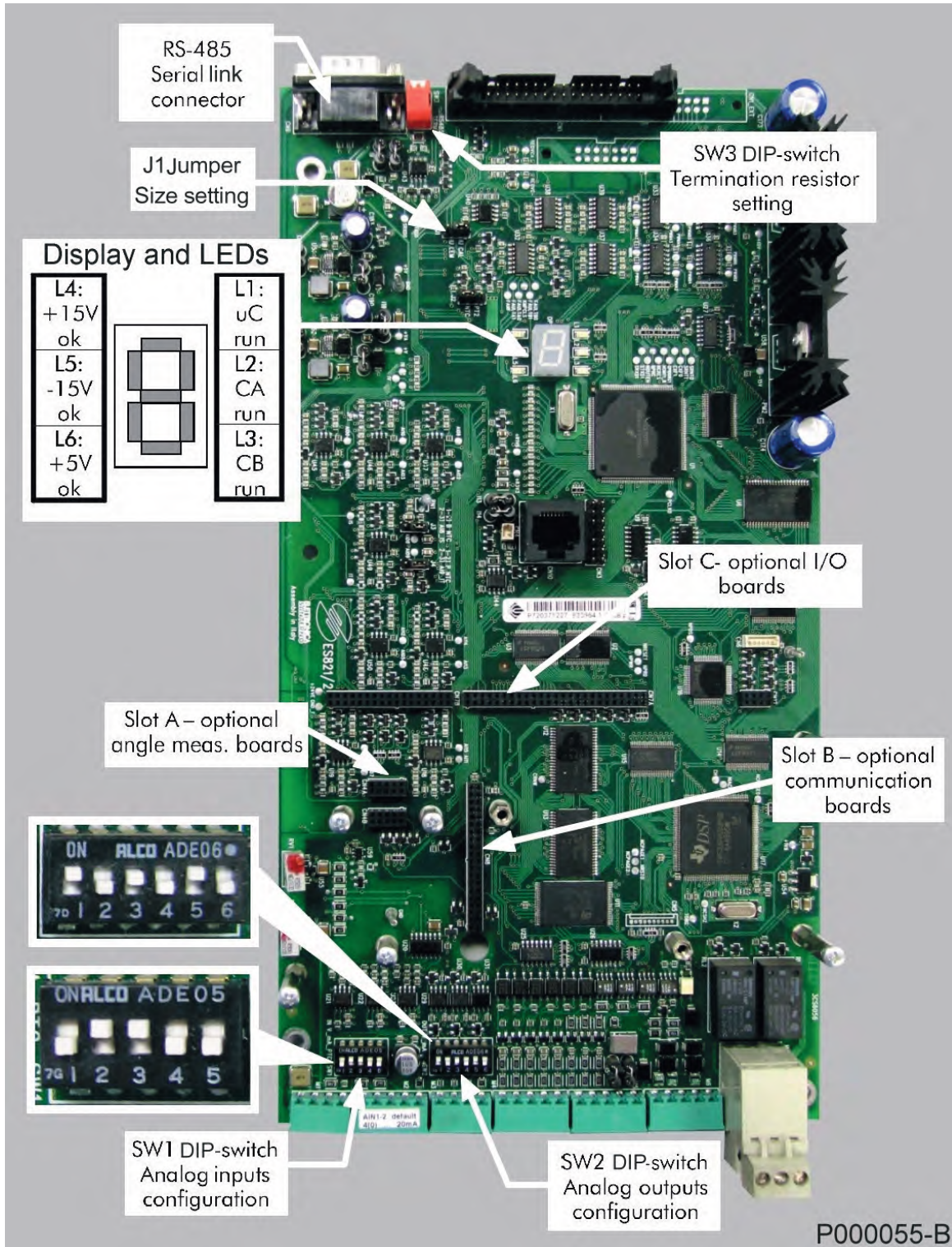

Figure 51: Control board: signals and programming

3.5.2.1. Display and Indicator LEDs

The board display and indicator LEDs allow viewing the inverter operating condition even if no user interface (display/keypad) is provided. The keypad housing allows displaying the indicator lights.

The indicator LEDs are the following:

- **Green LED L1 (uC run):** If on, it indicates that processors are active. If it does not turn on when the inverter is normally operating, this means that the power supply unit or the control board is faulty.
- **Yellow LED L2 (CA run):** If on, it indicates that the power converter is switching and is powering the connected load (terminals U, V, W). If off, all switching devices of the power converter are inactive and the connected load is not powered.











CAUTION





Electric shock hazard exists even if the power converter is not operating and the inverter is disabled. Possible dangerous voltage peaks on terminals U, V, W may occur. Wait at least 20 minutes after switching off the inverter before operating on the electrical connection of the motor or the inverter.



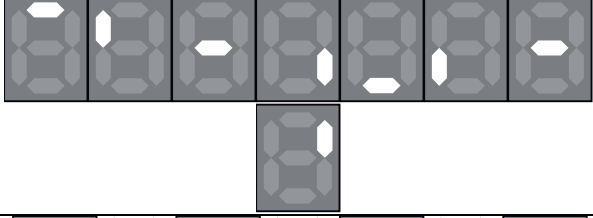
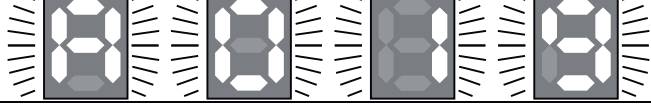

- **Yellow LED L3 (CB run):** In Sinus Penta Drives it never turn on
- **Green LED L4 (+15V ok):** It comes on when it detects positive analog power supply (+15V). If it does not turn on when the inverter is normally operating, this means that the power supply unit or the control board is faulty.
- **Green LED L5 (-15V ok):** It comes on when it detects negative power supply (-15V). If it does not turn on when the inverter is normally operating, this means that the power supply unit or the control board is faulty.
- **Green LED L6 (+5V ok):** It comes on when it detects I/O power supply (+5V). It turns off to indicate the following conditions:
 - o Short-circuit over the power supply delivered to connector RS485 output.
 - o Short-circuit over the power supply delivered to the connector output of the remotable keypad.
 - o Parameter quick storage and autoreset procedure due to "VDC undervoltage".





The messages appearing on the 7-segment display are the following:

Normal operation and alarms	
Symbol or sequence displayed	Inverter condition
	Inverter initialization stage.
	Inverter ready waiting for the enable command: digit "0" NOT flashing.
	Inverter ready waiting for the ENABLE command 0->1: number "1" fixed; see Sinus Penta's Programming Guide, parameter C181 .
	Inverter ready waiting for the START command 0->1: number "2" fixed; see Sinus Penta's Programming Guide, Power Down and DC Braking menus.

	Motor not running because the PID value is disabled: number "3" fixed; see Sinus Penta's Programming Guide, parameters P254 and P255 .
	Motor not running because the PID value is disabled: number "4" fixed; see Sinus Penta's Programming Guide, parameters P065 and P066 .
	IFD enabled but waiting for the START signal: number "6" fixed.
	IFD enabled and START signal on but waiting for reference: number "7" fixed, the actual value of the reference is below the minimum value.
	Waiting for precharge: number "8" fixed; inverter is waiting for VDC voltage inside the capacitor to exceed the minimum operating value.
	Inverter enabled (power devices activated): a segment rotates to form an 8-shaped figure.
	Emergency condition: a 3-digit alarm code cyclically flashes on the display (the example shows alarm A019).

Hardware failure messages	
Symbol or sequence displayed	Inverter condition
	<p>Hardware Failure</p> <p>The self-diagnostics function integrated to the control board detected a hardware/software failure.</p> <p>Please contact ELETTRONICA SANTERNO's Customer Service.</p>
	
	
	
	

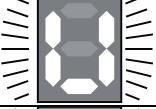
Operating firmware update (flash memory) messages	
Symbol or sequence displayed	Inverter condition
	Flash memory deletion: letter 'E' flashing.
	Flash memory programming: letter 'P' flashing.
	An alarm tripped while deleting or programming the software flash memory. Repeat programming: letter 'A' flashing .
	Autoreset: letter 'C' flashing.

Current limit and voltage limit while running	
Symbol or sequence displayed	Inverter condition
	<u>Current limit while accelerating or voltage limit due to overload conditions</u> ; letter 'H' flashing if the output current is limited to the values set in the operating parameters.
	<u>Output voltage limit</u> ; letter 'L' flashing if no voltage is delivered to the motor due to a V_{DC} too weak value.
	<u>Voltage limit when decelerating</u> ; letter U flashing if V_{DC} in the equipment exceeds the rated value by 20% during dynamic braking.
	<u>Braking function active</u> ; letter D flashing when the inverter is stopping the motor by applying DC voltage. See Sinus Penta's Programming Guide, DC Braking function.



NOTE

The display can be seen only after removing the remotable keypad. Please refer to the relevant section for more details.

3.5.2.2. DIP-switches

The inverter control board includes three banks of DIP-switches (SW1, SW2, and SW3) for the following functions:

- DIP-switch SW1: analog input configuration
- DIP-switch SW2: analog output configuration
- DIP-switch SW3: line termination over line RS485

To gain access to DIP-switches SW1 and SW2, remove the front cover of the control terminals by loosening the relevant fastening screws.

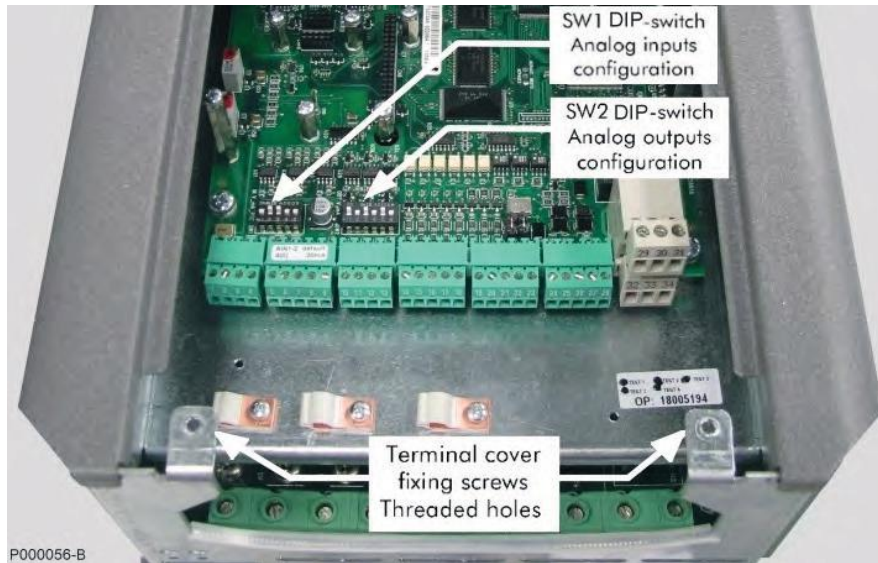

Figure 52: Gaining access to DIP-switches SW1 and SW2

To gain access to DIP-switch SW3, remove the protecting cover for connector RS485. Sinus Penta S05 to S22: DIP-switch SW3 is located on the control board next to interface connector RS485; remove the inverter upper cover to gain access to DIP-switch SW3.

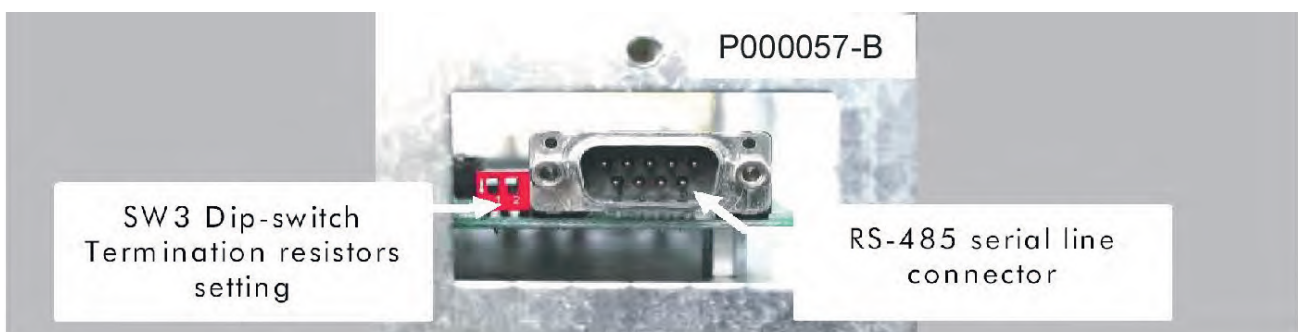

Figure 53: Gaining access to DIP-switch SW3 and connector RS485 (Sinus Penta S05 to S22)

Sinus Penta S30 to S60: interface connector RS485 and DIP-switch SW3 are located next to the control terminal board cover.

Sinus Penta S65 and S70: to gain access to DIP-switch SW3, remove the cover located on the rear part of the control board.

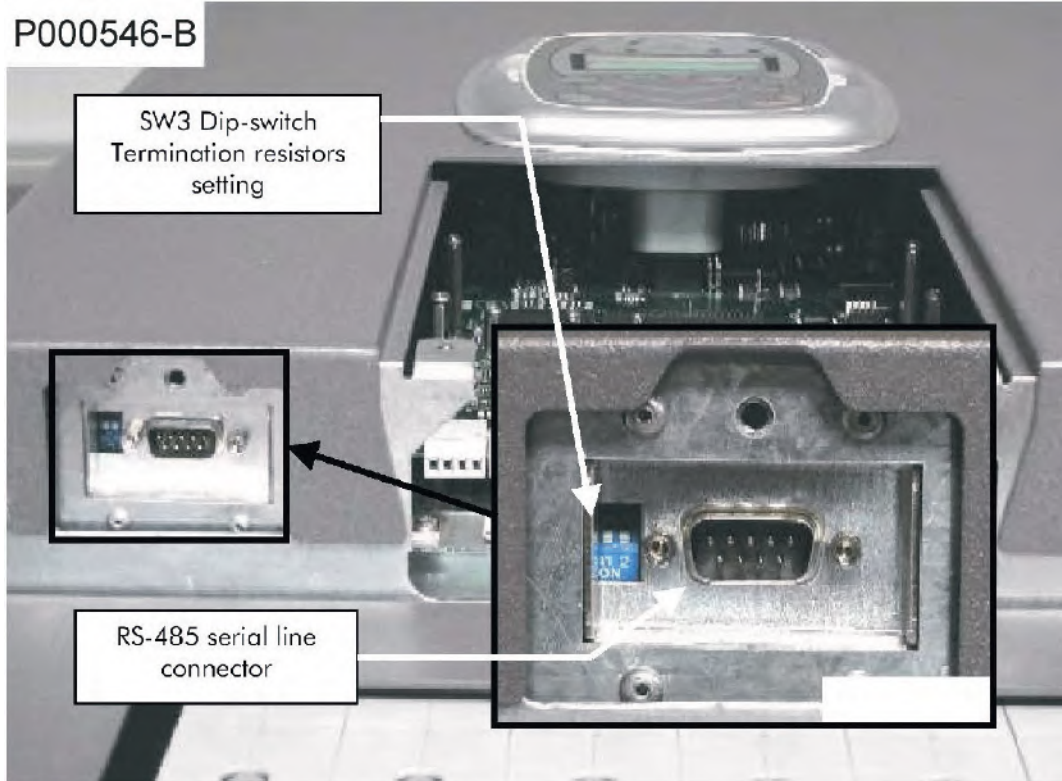

Figure 54: Position of DIP-switch SW3 and connector RS485 (Sinus Penta S30 to S60)

For IP54 inverters, you can gain access to serial port connector RS485 and to dipswitch SW3 from the inside of the front door covering wires and cables.

DIP-switch functionality is detailed in the tables below

DIP-switch SW1: analog input configuration		
Switch(es)	Functionality	
SW1-1	OFF: REF voltage input (DEFAULT)	ON: REF analog input (current input)
SW1-2	OFF: AIN1 voltage input	ON: AIN1 analog input (current input) (DEFAULT)
SW1-3	OFF: AIN2 voltage input or motor protection PTC acquisition	ON: AIN2 analog input (current input) (DEFAULT)
SW1-4, SW1-5	Both OFF: AIN2 current input or voltage input based on SW1-3 (DEFAULT)	Both ON: AIN2 input for motor protection PTC acquisition

DIP-switch SW2: analog output configuration		
Switches	Functionality	
SW2-1, SW2-2	1=ON, 2=OFF: AO1 voltage output (DEFAULT)	1=OFF, 2=ON: AO1 current output
SW2-3, SW2-4	3=ON, 4=OFF: AO2 voltage output (DEFAULT)	3=OFF, 4=ON: AO2 current output
SW2-5, SW2-6	5=ON, 6=OFF: AO3 voltage output (DEFAULT)	5=OFF, 6=ON: AO3 current output

DIP-switch SW3: interface RS485 terminator	
Switches	Functions
SW3-1, SW3-2	Both OFF: RS485 terminator disabled (DEFAULT) Both ON: RS485 terminator enabled

DIP-switch factory setting is as follows:

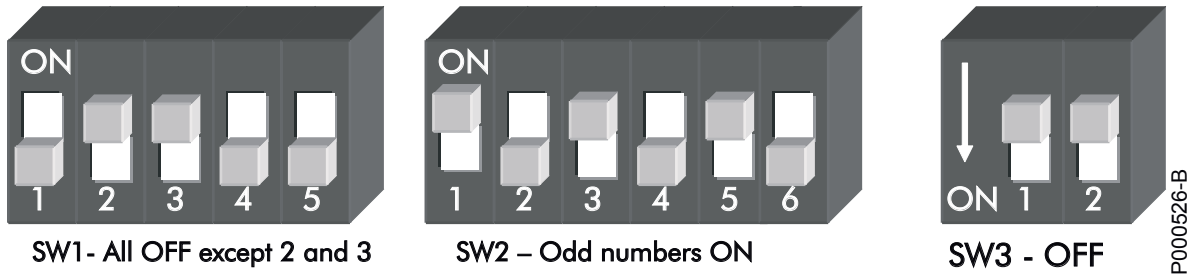

Factory setting provides the following operating modes:

- REF Analog input (voltage input) and two current analog inputs (AIN1, AIN2)
- Voltage analog outputs
- Terminator RS485 off

3.5.2.3. Configuration Jumpers

The inverter control board is provided with two configuration jumpers called J1 and J2 for the setup of the inverter size. These jumpers are factory-set based on the inverter size required and must not be tampered with.

When a spare control board is installed, jumper J1 only is to be set up accordingly. In that case, the spare control board is supplied in "Spare" mode.

Jumper	Position
J1	1-2 = IU CAL 2-3 = IU LEM - See ES821 Spare User Manual
J2	LEAVE POSITION UNCHANGED

3.5.3. Digital Inputs (Terminals 14 to 21)

All digital inputs are galvanically isolated in respect to zero volt of the inverter control board. Consider isolated power supply on terminals 23 and 22 or 24V auxiliary supply before activating the inverter digital inputs.

The figure below shows the different control modes based on the inverter supply or the output of a control system (e.g. PLC). Internal supply (+24 VDC)—terminal 23—is protected by a 200mA self-resetting fuse.

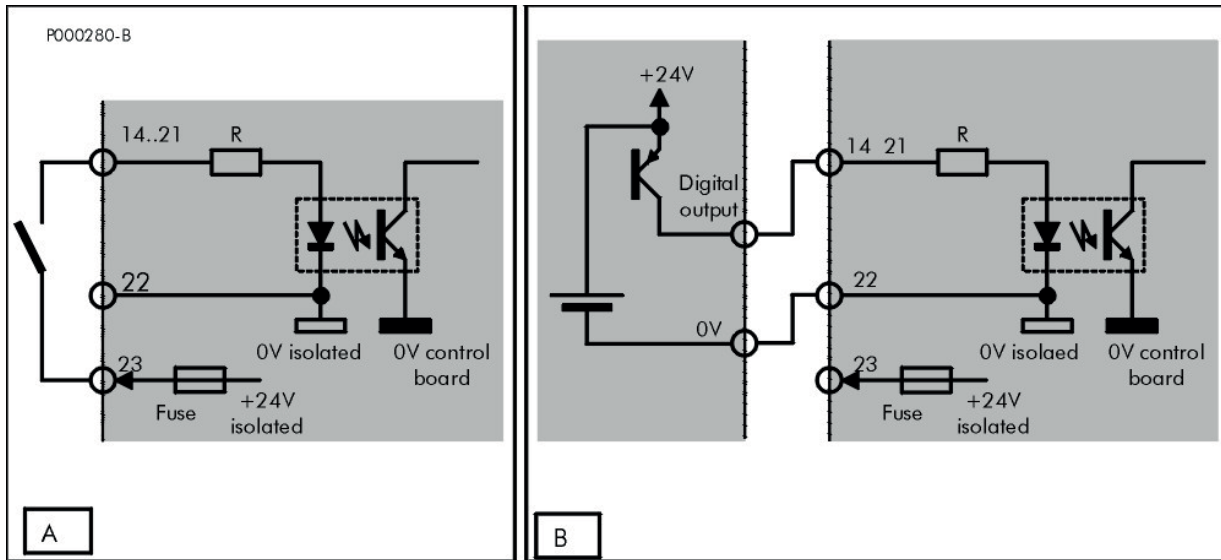

Figure 55: PNP command (active to +24V)

A) through a voltage-free contact

B) outcoming from a different device (PLC, digital output board, etc.)



NOTE

Terminal 23 (digital input zero volt) is galvanically isolated from terminals 1, 9, 13 (control board zero volt) and from terminals 26 and 28 (common terminals of the digital outputs).

The digital input condition is displayed on the inverter display/keypad in the Measures menu as measure **M033**. Logic levels are displayed as □ for the inactive input and as ■ for the active input.

The inverter firmware acknowledges all inputs as multifunction inputs. Dedicated functions assigned to terminals START (14), ENABLE (15), RESET (16), MDI6 / ECHA / FINA(19), MDI7 / ECHB (20), and MDI8 / FIN B(21) are also available.

3.5.3.1. START (Terminal 14)

To enable the Start input, set the control modes via terminal board (factory setting). When the START input is active, the main reference is enabled; otherwise, the main reference is set to zero. The output frequency or the speed motor drops to zero in respect to the preset deceleration ramp.

3.5.3.2. ENABLE (Terminal 15)

The ENABLE input is always to be activated to enable the inverter operation regardless of the control mode. If the ENABLE input is disabled, the inverter output voltage is always set to zero, so the motor performs a coast to stop.

The internal circuit managing the ENABLE signal is redundant and is more efficient in avoiding sending any switching signal to the three-phase converter. Certain applications allow getting rid of the contactor installed between the inverter and the motor. Always consider any specific standard for the inverter application and observe the safety regulations in force.

3.5.3.3. RESET (Terminal 16)

If an alarm trips, the inverter stops, the motor performs a coast to stop and the display shows an alarm message. Open the reset input for a while (factory setting: MDI3 on terminal 16), or press the RESET key on the keypad to reset the alarm. This happens only if the cause responsible for the alarm has disappeared. If factory setting is used, once the inverter is unlocked, it is not necessary to activate and deactivate the ENABLE command to restart the inverter.



NOTE

Factory setting does not reset alarms at power off. Alarms are stored and displayed at next power on and the inverter is locked. A manual reset is then required to unlock the inverter.



CAUTION

If an alarm trips, see the Diagnostics section in the Sinus Penta's Programming Guide and reset the equipment after detecting the cause responsible for the alarm.



DANGER

Electric shock hazard persists even when the inverter is locked on output terminals (U, V, W) and on the terminals used for the connection of resistive braking devices (+, -, B).



CAUTION

The motor performs a coast to stop when the inverter is locked due to an alarm trip or when the ENABLE input is inactive. In case a mechanical load with persistent resisting torque (e.g. lifting applications) is used, a motor coast to stop may cause the load to drop. In that case, always provide a mechanical locking device (brake) for the connected load.

3.5.3.4. Connecting the Encoder and Frequency Input (Terminals 19 to 21)

Functionality of the programmable digital inputs is given in the Programming Guide. Digital inputs MDI5, MDI6, MDI7 may acquire fast digital signals and be used for the connection of an incremental encoder (push-pull encoder, single-ended encoder) and/or for the acquisition of a frequency input. An incremental encoder must be connected to “fast” inputs MDI6/ECHA/FINA(19) and MDI7/ECHB (20) as shown in the figure below.

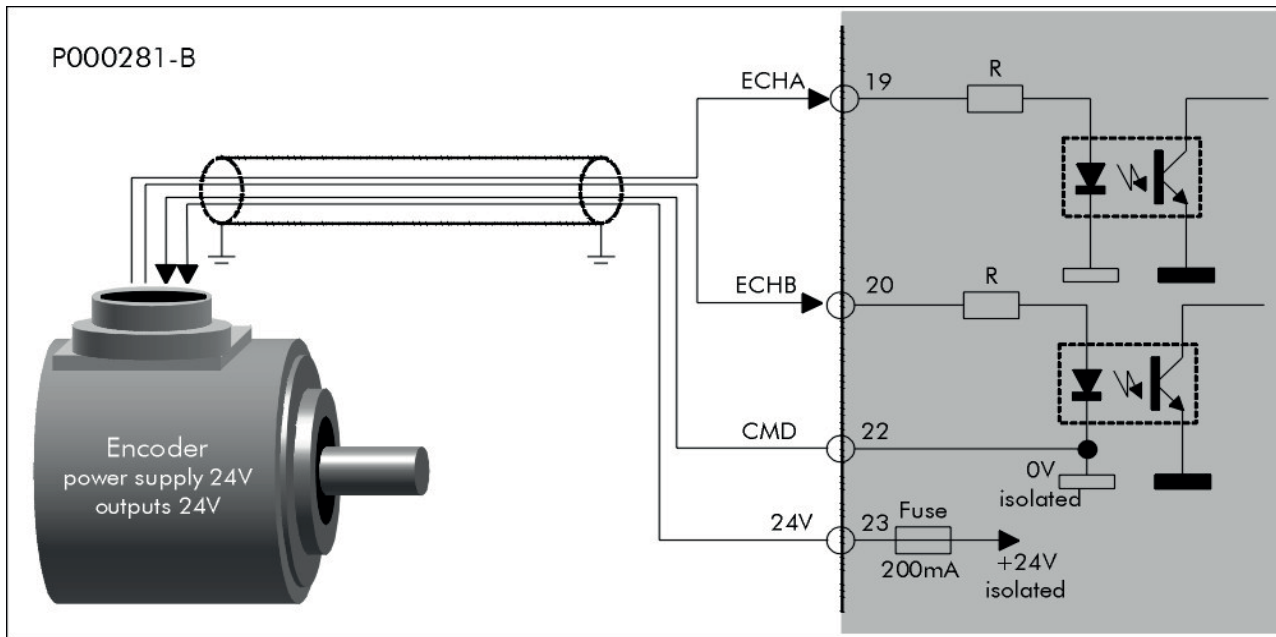

Figure 56: Connecting an incremental encoder

An incremental encoder must have PUSH-PULL outputs and must be powered at 24V directly to the inverter isolated power supply delivered to terminals +24V (23) and CMD (22). Max. allowable feeding current is 200mA and is protected by a self-resetting fuse.

Only encoders of that type may be connected to Sinus Penta’s terminal board. Max. signal frequency is 155kHz for 1024 pls/rev at 9000 rpm. To acquire different encoder types or to acquire an encoder without engaging any multifunction input, fit optional board for encoder acquisition in SLOT A.

The encoder acquired via terminal board is indicated as ENCODER A by the inverter firmware, whereas the encoder acquired via optional board is indicated as ENCODER B by the inverter firmware. Therefore, two encoders may be connected to the same inverter. (See the Encoder/Frequency Inputs menu in the Sinus Penta’s Programming Guide.)

Input MDI8/FINB allows acquiring a square-wave frequency signal from 10kHz to 100kHz. Then, the frequency signal will be converted into an analog value to be used as a frequency reference. Frequency values corresponding to the minimum reference and the maximum reference may be set as operating parameters.

Signals must be sent from a Push-pull, 24V output with a common reference to terminal CMD (22) (see figure below).

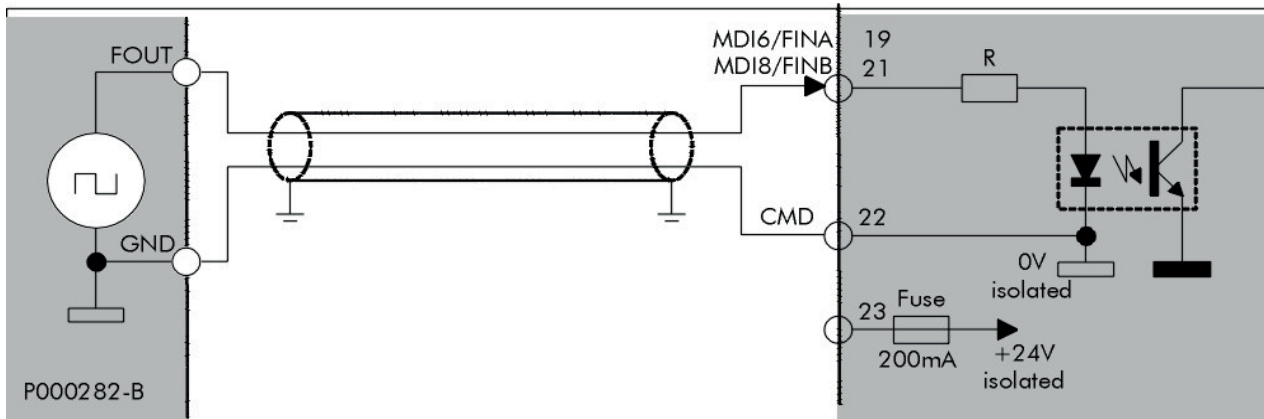

Figure 57: Signal sent from a push-pull, +24V output

3.5.3.5. Technical Sheet for Digital Inputs

Specification	Min.	Type	Max.	Unit of m.
MDI input voltage related to CMD	-30		30	V
Voltage for logic level 1 between MDI and CMD	15	24	30	V
Voltage for logic level 0 between MDI and CMD	-30	0	5	V
Current absorbed by MDI at logic level 1	5	9	12	mA
Input frequency for "fast" inputs MDI6, MDI7, MDI8			155	kHz
Duty-cycle allowed for frequency input	30	50	70	%
Min. time period at high level for "fast" inputs MDI6, MDI7, MDI8	4.5			μs
Voltage of isolation test between CMD (22) in respect to CMA (1,9)	500Vac, 50Hz, 1min.			



CAUTION

Avoid exceeding min. and max. input voltage values not to cause irreparable damages to the equipment.



NOTE

Isolated supply output is protected by a self-resetting fuse capable of preventing the inverter internal power supply unit from damaging due to a short-circuit. Nevertheless, if a short-circuit occurs, the inverter could lock and stop the motor.

3.5.4. Analog Inputs (Terminals 1 to 9)

The inverters of the Sinus Penta series are provided with three analog inputs, one single-ended input and two differential inputs. Analog inputs may be configured either as voltage inputs or as current inputs. AIN2 input may be used to acquire a PTC thermistor in compliance with DIN44081/DIN44082 for the motor thermal protection. In that case, up to 6 PTCs can be series-connected; functionality of the overtemperature alarm is not altered. Two reference outputs with rated values +10 V and -10 V are also available for the direct connection of a reference potentiometer.

Configuration as voltage input, current input or motor PTC input is done via the DIP-switches (see the DIP-switches section).

Five firmware acquisition modes are available (see Sinus Penta's Programming Guide) for three hardware settings as shown in the table:

Type of preset data acquisition	HW configuration for SW1	Full-scale values and notes
Unipolar 0 ÷ 10 V	Voltage input	0 ÷ 10 V
Bipolar ± 10 V	Voltage input	- 10 V ÷ + 10 V
Unipolar 0 ÷ 20 mA	Current input	0 mA ÷ 20 mA
Unipolar 4 ÷ 20 mA	Current input	4 mA ÷ 20 mA; wire disconnection alarm with current values under 2 mA
PTC acquisition	PTC input	Motor overtemperature alarm if PTC resistance exceeds threshold defined in DIN44081/DIN44082



NOTE

Firmware parameter setting must be consistent with DIP-switch setting. Otherwise, no predictable result is given for acquired values.



NOTE

Any voltage or current value exceeding full-scale values or dropping below min. values will generate an acquired value limited to the max. measure or the min. measure respectively.



CAUTION

Voltage inputs have high input impedance and must always be closed when active. Isolating a conductor connected to an analog input set as a voltage input will not ensure that its channel reading will be equal to zero. Zero is detected only if the input is short-circuited or wired to a low-impedance signal source. Relay contact should not series-connected to the inputs to reset the detected value.

You can adjust the relationship between the analog input set as a voltage input or a current input and the detected value by altering those parameters that regulate upper values (full-scale values) and lower values, thus adjusting the analog channel gain and offset. You can also adjust the signal filtering time constant. For any detail concerning functionality and programming of analog input parameters, see Sinus Penta's Programming Guide.

3.5.4.1. REF Single-ended Reference Input (Terminal 2)

Reference input REF (2) is assigned to the inverter speed reference (factory setting) and is a single-ended input related to terminal CMA (1).

The figure below shows wiring to a unipolar potentiometer, a bipolar potentiometer and a sensor with 4÷20mA current output. The REF input is factory-set as a ±10V voltage input.

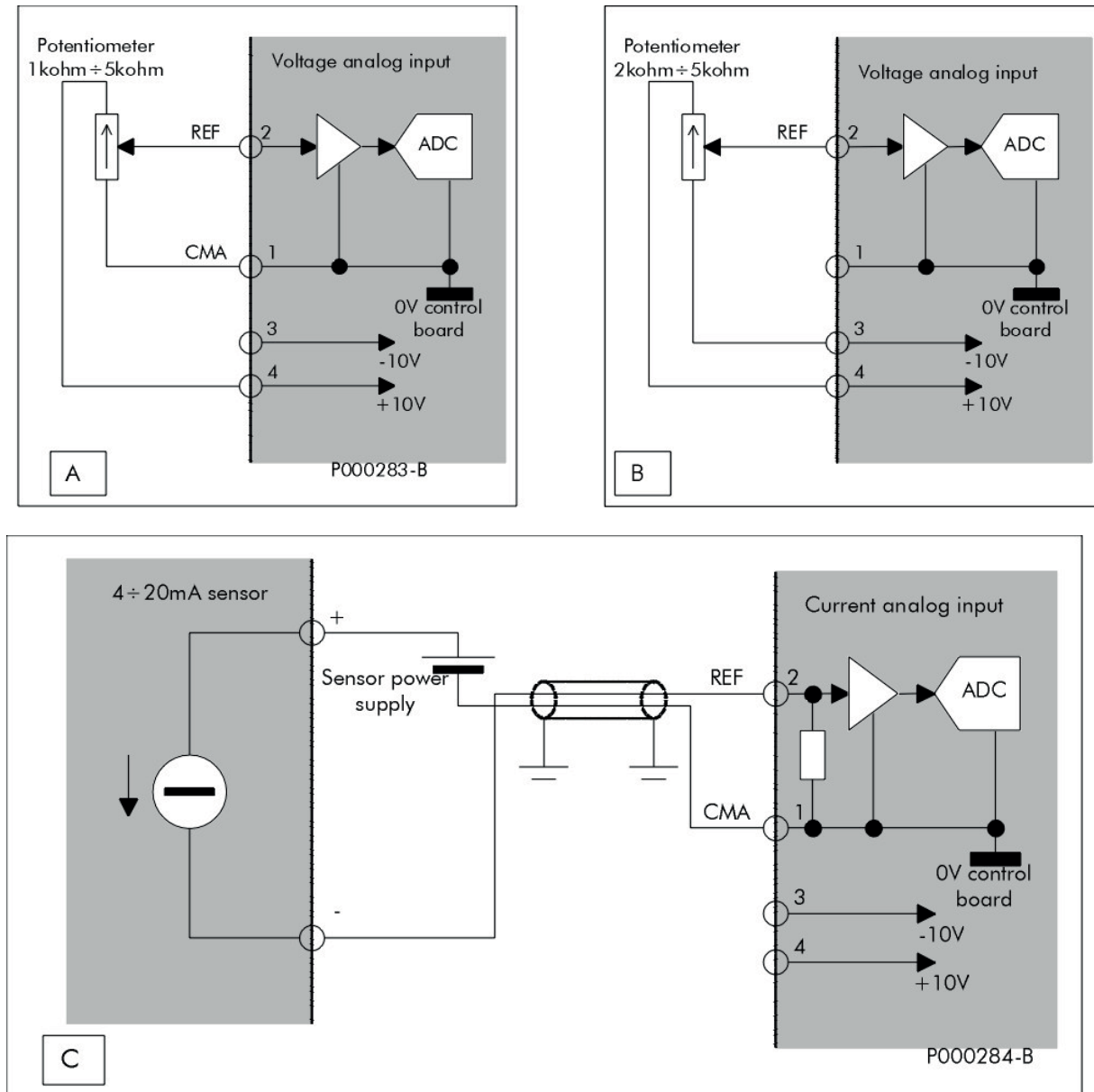

Figure 58: Potentiometer linked to the REF Input

- A) for unipolar command 0÷REFMAX
- B) Potentiometer wiring for bipolar command -REFmax÷+REFmax
- C) 4÷20mA Sensor wiring



NOTE

Do not apply +24V voltage available on terminal 23 of the control board to supply 4÷20mA analog sensors, because it is used for the common terminal of the digital inputs (CMD – terminal 22), not for the common terminal of CMA analog inputs. Galvanic isolation exists between the two terminals and must not be suppressed.

3.5.4.2. Differential Auxiliary Inputs (Terminals 5–8)

Auxiliary inputs allow auxiliary voltage and current values for signals exceeding ground signals up to a preset maximum voltage value in common mode.

A differential input weakens disturbance due to “ground potentials” occurring when the signal is sent from a source that is located far from the inverter. Disturbance is weakened only if wiring is correct.

Each input is provided with a positive terminal and a negative terminal of the differential amplifier. Both terminals must be connected to the signal source and the signal grounding respectively. Make sure that the common mode voltage between the signal source grounding and the grounding of auxiliary inputs CMA (terminal 9) does not exceed the max. allowable voltage value in common mode.

When an input is used as a current input, the differential amplifier detects the voltage value in the terminals of a drop resistance (low ohm value). The max. voltage for the negative terminal of the differential input must not exceed the voltage value in common mode (see Technical Sheet for Analog Inputs). AIN1 and AIN2 inputs are factory-set as 4(0)...20mA current inputs.

Do the following to obtain noise rejection benefits:

- provide a common path of the differential pair
- make sure that the signal source grounding does not exceed input voltage in common mode.

The typical wiring is shown below:

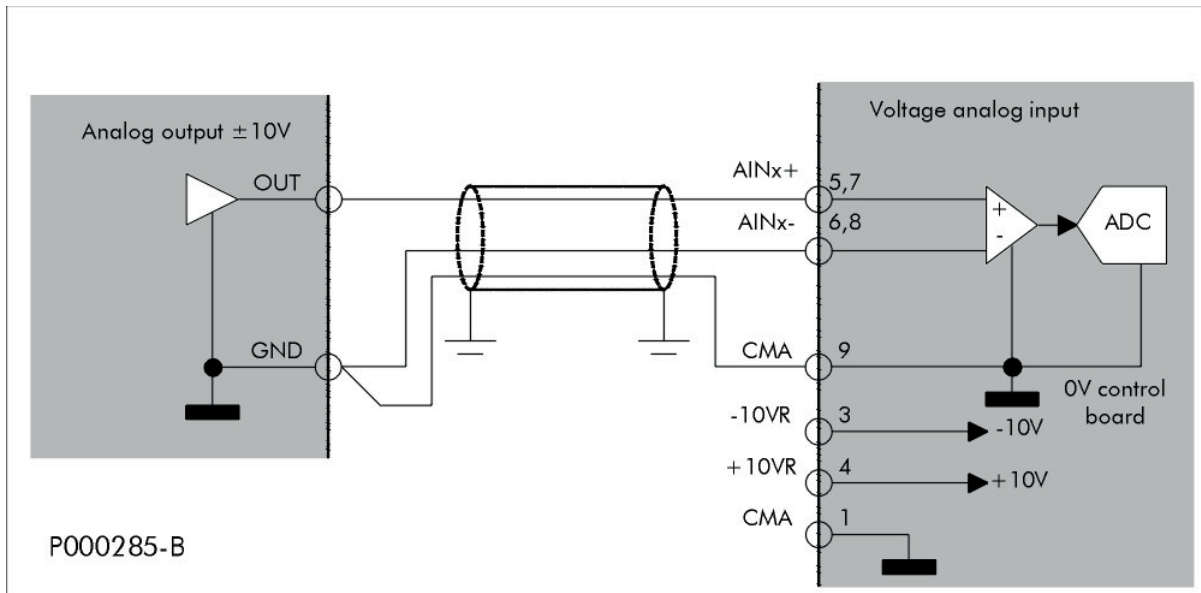

Figure 59: Wiring of a PLC analog output, axis control board, etc.



NOTE

Wiring between terminal CMA and the signal source grounding is required for proper data acquisition. Wiring may also be performed outside the shielded cable.

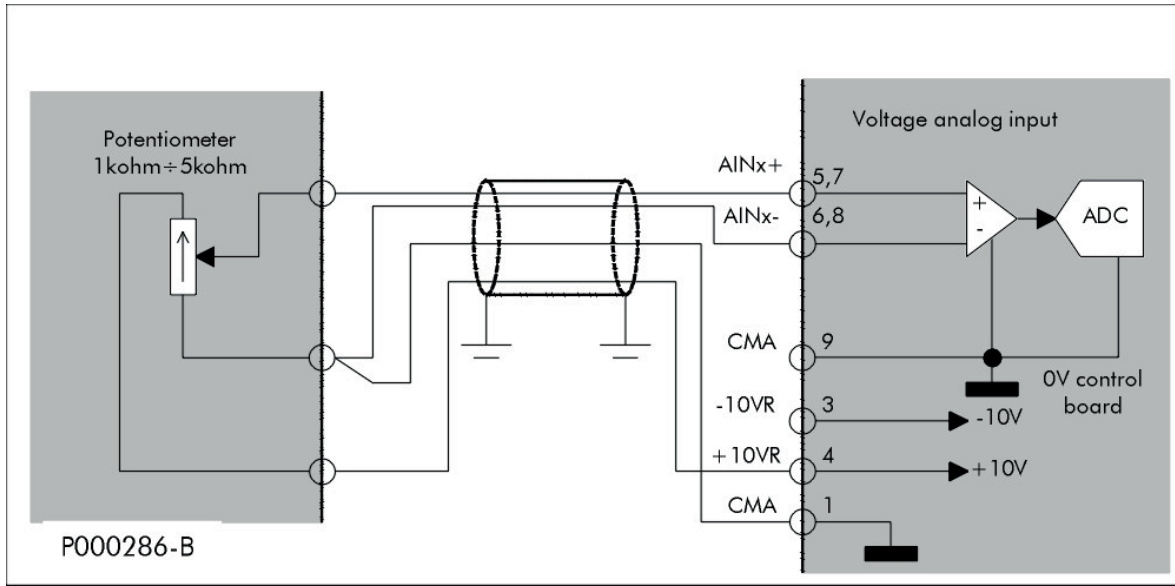

Figure 60: Wiring of unipolar remote potentiometer 0 ÷ REF max

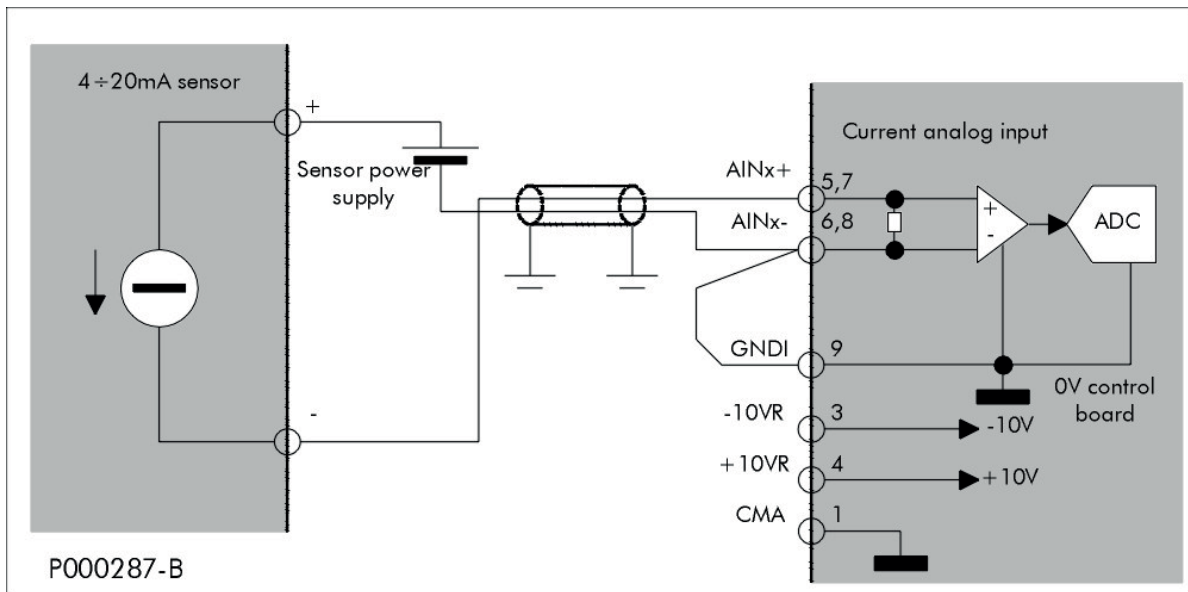

Figure 61: 4 ÷ 20 mA Sensor wiring

3.5.4.3. Motor Thermal Protection Input (PTC, Terminals 7-8)

The inverter manages the signal sent from one or more thermistors (up to 6 thermistors) incorporated in the motor windings to obtain a hardware thermal protection of the motor. The thermistor ratings must comply with IEC 34-11-2 (BS4999 Pt.111 - DIN44081/DIN44082) or to thermistors named "Mark A" in standard IEC60947-8:

- Resistor corresponding to Tnf temperature value: 1000 Ω (typical rating)
- Resistor at Tnf -5°C: < 550 Ω
- Resistor at Tnf +5°C: > 1330 Ω

The typical resistor pattern in respect to temperature is shown in the figure below.

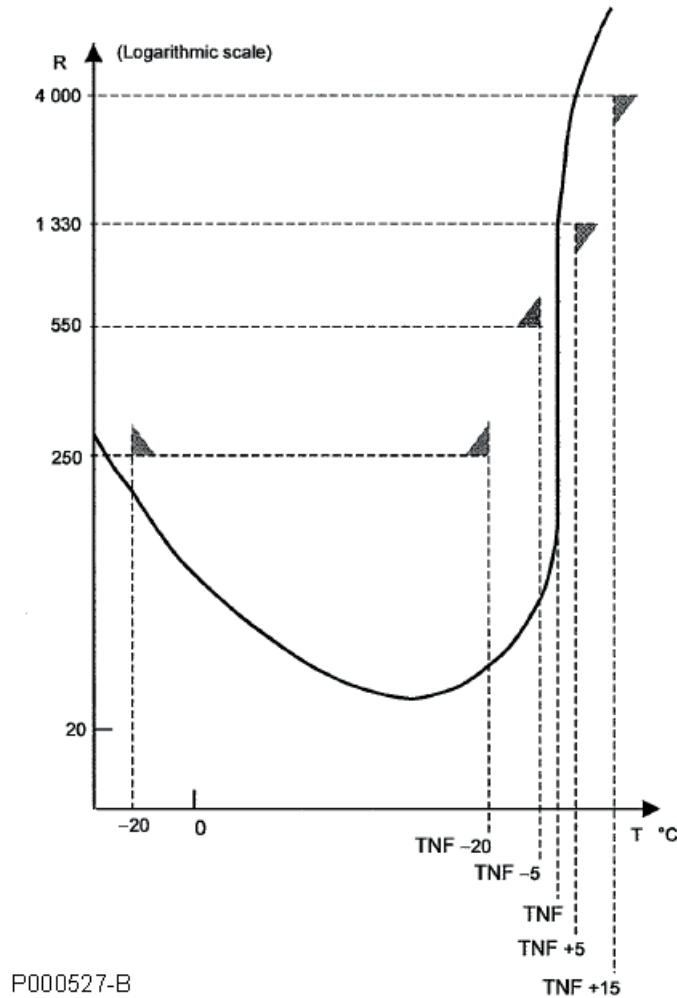

Figure 62: Standard pattern of the thermistor resistor for the motor thermal protection

Tnf temperature is the thermistor rated transient temperature to be adjusted based on the max. allowable temperature of the motor windings. The inverter sends a motor overheating alarm when it detects the thermistor resistance transient temperature of at least one of the series-connected thermistors, but does not display the real temperature of the motor windings. An alarm trips even if a short-circuit condition is detected in the thermistor circuit wiring.



NOTE

Maximum six (6) series-connected PTCs can be acquired. Motors usually have three or six series-connected PTCs, one or two per phase. If multiple sensors are series-connected, a false alarm trip may occur even when the motor is cold.

Do the following to use the thermistor:

- 1) Configure analog input AIN2/PTC by setting SW1-3: Off, SW1-4: On, SW1-5: On.
- 2) Connect the motor thermal protection terminals between terminals 7 and 8 in the control board.
- 3) In the Thermal Protection menu, set the motor protection method with PTC (refer to Sinus Penta's Programming Guide).



CAUTION

PTCs are located inside the motor winding coils. Make sure that their isolating features comply with the requirements for double insulation or reinforced insulation (SELV circuit).

3.5.4.4. Technical Sheet for Analog Inputs

Specification	Min.	Type	Max.	Unit of m.
Input impedance in voltage configuration (REF input)	10k			Ω
Input impedance in voltage configuration (differential inputs AIN1, AIN2)		80k		Ω
Input impedance in current configuration		250		Ω
Offset cumulative error and gain in respect to full-scale value			0.25	%
Temperature coefficient of gain error and offset			200	ppm/ $^{\circ}$ C
Digital resolution in voltage mode			12	bit
Digital resolution in current mode			11	bit
Value of voltage LSB		4.88		mV
Value of current LSB		9.8		μ A
Max. voltage of differential input common mode	-7		+7	V
Rejection ratio for differential input common mode at 50Hz	50			dB
Persistent overload with no damaging in voltage mode	-50		50	V
Persistent overload with no damaging in current mode	-23		23	mA
Input filter cut frequency (first prevailing order) over REF		230		Hz
Input filter cut frequency (first prevailing order) over AIN1, AIN2		500		Hz
Sampling time ⁽¹⁾	0.6		1.2	ms
Max. current of resistance measure in PTC acquisition mode			2.2	mA
Resistive trip threshold for PTC protection	3300	3600	3930	Ω
Resistive trip threshold for PTC protection deactivation	1390	1500	1620	Ω
Resistive trip threshold for PTC short-circuit		20		Ω
Tolerance of reference output voltage +10 VR, -10 VR			0.8	%
Current absorbed by reference outputs			10	mA

Note: (1) depending on the switching time period set for the connected motor



CAUTION

Avoid exceeding min. and max. input voltage values not to cause irreparable damages to the equipment.



NOTE

Reference outputs are electronically protected against temporary short-circuits. After wiring the inverter, make sure that the output voltage is correct, as a persistent short-circuit may damage the equipment.

3.5.5. Digital Outputs (Terminals 24 to 34)

The Sinus Penta is provided with four digital outputs: one push-pull output, one open-collector output and two relay outputs. All outputs are optoisolated; the push-pull output and the open-collector output are isolated by an optoisolator; relay outputs are isolated by their relays. Each output has a common terminal segregated from the others, thus allowing connecting it to different devices without creating any ground loop.

3.5.5.1. Push-Pull Output MDO1 and Wiring Diagrams (Terminals 24 to 26)

Push-Pull MDO1 output (terminal 25) may also be used as a frequency output thanks to its powerful passband. Below you will find the wiring diagrams relating to the control of PNP/NPN loads and the cascade-connection of multiple inverters through frequency output and input.

Because supply line and common terminal of output MDO1 are isolated, you can use both 24V supply and auxiliary supply (24V or 48V – see dashed lines in the figures).

Output MDO1 is active (positive voltage related to CMDO1) when it is controlled by the load control (symbol ■ displayed next to output MDO1, parameter M056). As a result, a load connected as a PNP output and powered between output MDO1 and common CMDO1 will activate, whereas a load connected as a NPN output between supply line +VMDO1 and output MDO1 will deactivate.

Cascade connection frequency output → frequency input from a master inverter to a slave inverter allows a high-resolution transfer (up to 16 bits) of a reference between the two inverters. This also provides disturbance immunity because data are digitally transferred and the control board grounding is galvanically isolated.

A single master inverter may also control several slave inverters. To do so, use a shielded cable to perform a star connection (a wire for each slave inverter will come from the output frequency).

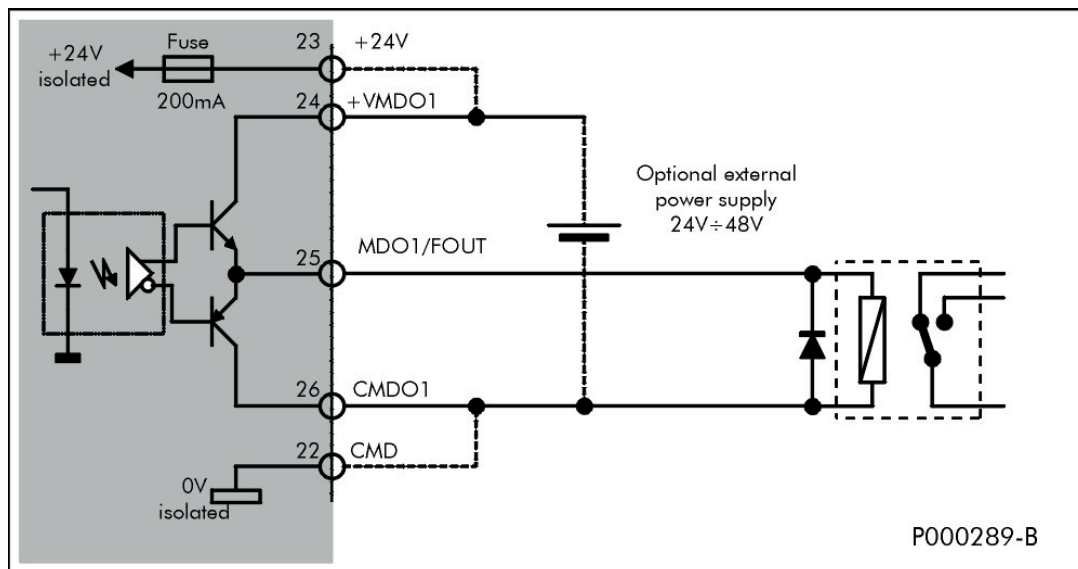

Figure 63: PNP output wiring for relay control

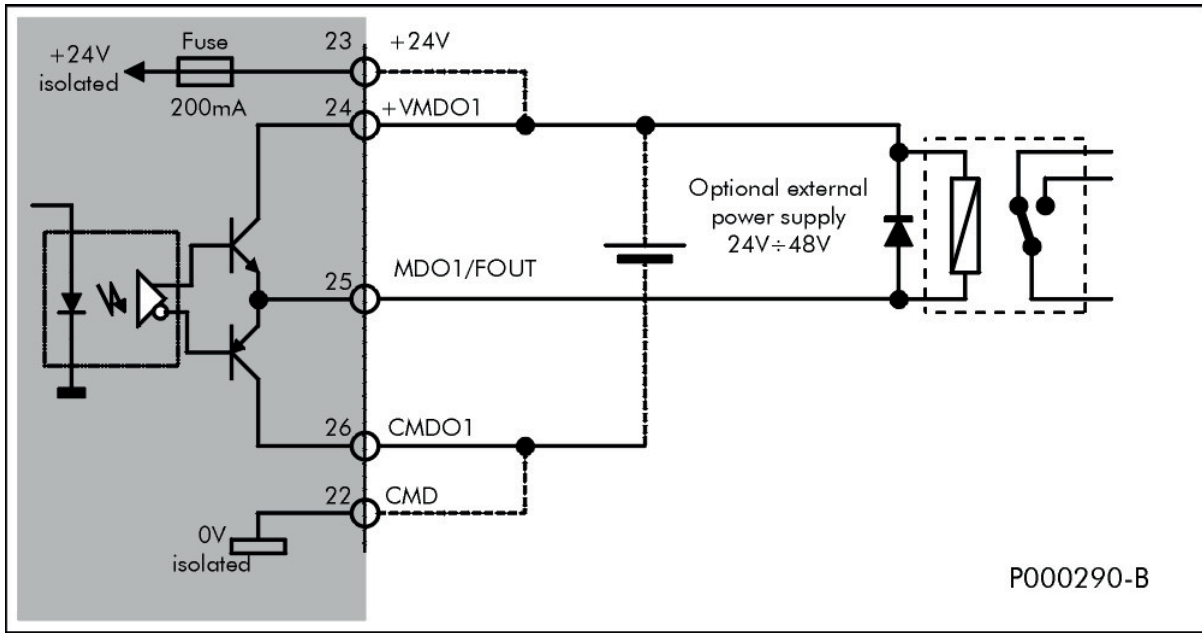

Figure 64: NPN output wiring for relay control

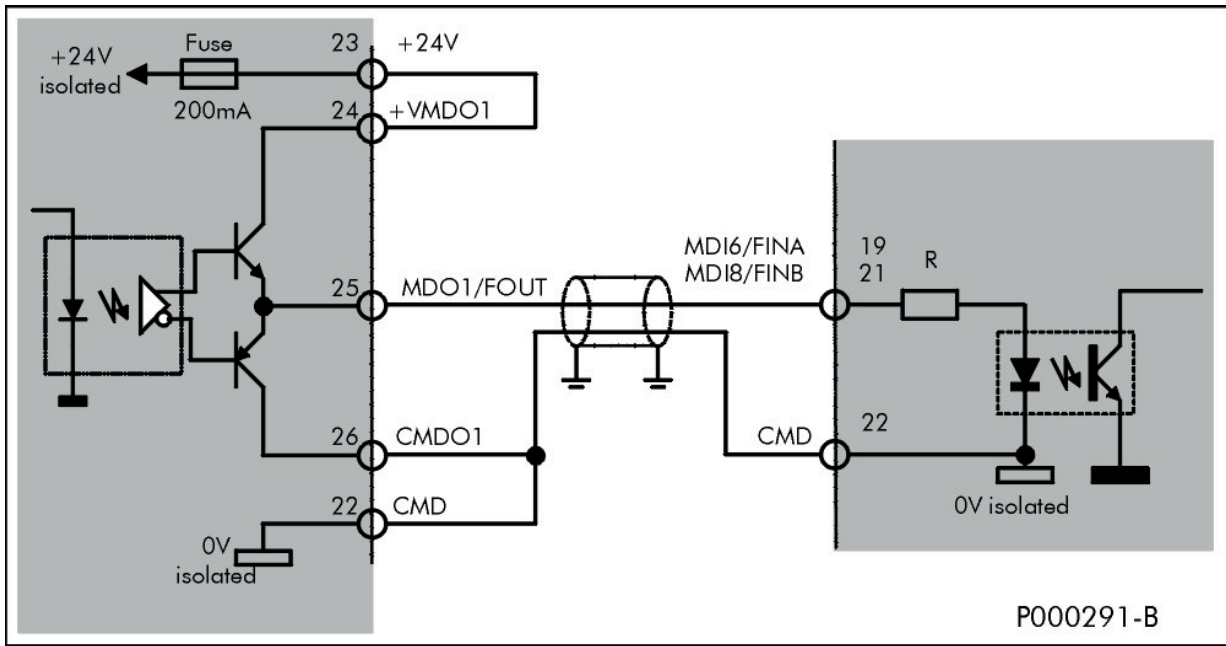

Figure 65: Cascade connection: frequency output → frequency input



CAUTION

Always use a freewheeling diode for inductive loads (e.g. relay coils). Diode wiring is shown in the figure.



NOTE

Connect *either* isolated inverter supply *or* auxiliary supply to power the output (dashed lines in the figure).

3.5.5.2. Open-collector MDO2 Output and Wiring Diagrams (Terminals 27-28)

Multifunction output MDO2 (terminal 27) is provided with common terminal CMDO2 (terminal 28), which is galvanically isolated from the other outputs. Output MDO2 may be used for PNP and NPN connected loads (see wiring diagrams below).

Similarly to a closed contact, electrical conductivity is to be found on open-collector output between terminal MDO2 and terminal CMDO2 when OC output is active, i.e. when symbol ■ is displayed for output MDO2 (parameter **M056**). Both PNP and NPN connected loads are activated.

Power supply may result from the inverter isolated supply or from an auxiliary source (24V or 48V; see dashed lines in the figure).

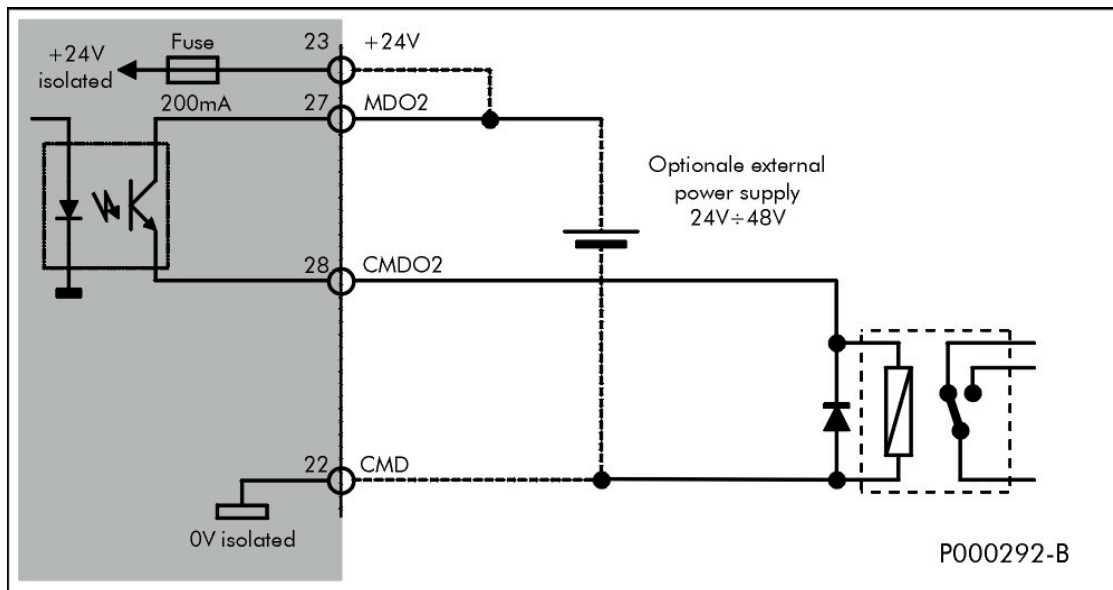

Figure 66: PNP output wiring for relay control

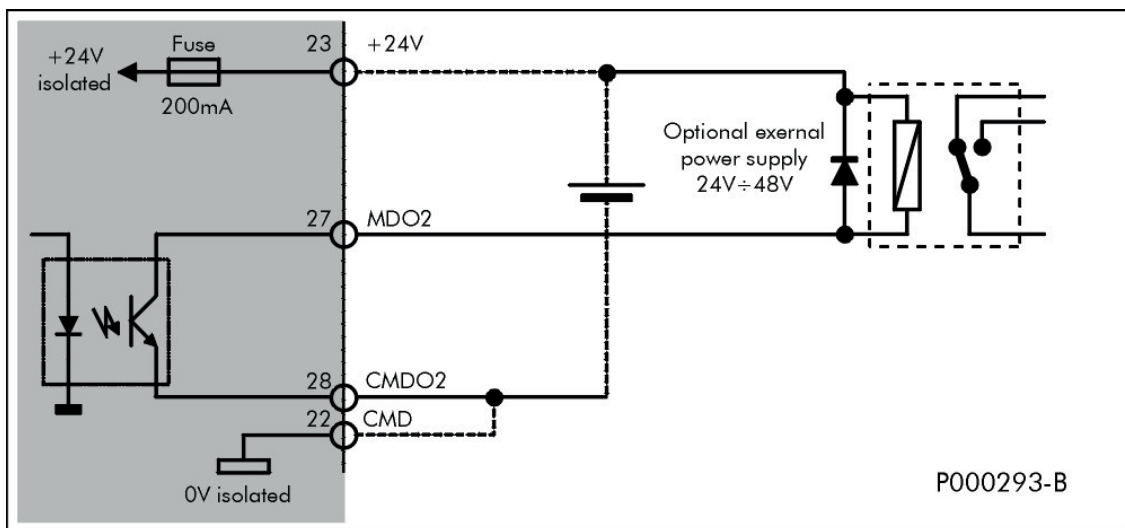

Figure 67: NPN output wiring for relay control



CAUTION

Always use a freewheeling diode for inductive loads (e.g. relay coils). Diode wiring is shown in the figure.



NOTE

Connect *either* isolated inverter supply *or* auxiliary supply to feed the output (dashed lines in the figure).

3.5.5.3. Relay Outputs (Terminals 29..34)

Two relay outputs are available with potential-free change-over contacts. Each output is equipped with three terminals: a normally closed (NC) terminal, a common terminal (C), and a normally open terminal (NO).

Relays may be configured as MDO3 and MDO4 outputs. When outputs MDO3 and MDO4 are active (symbol ■ displayed for MDO1, measure parameter M056), close the normally open contact and the common contact and open the normally closed contact.

**CAUTION**

Contacts may shut off up to 250VAC. Do not touch the terminal board or the control board circuits to avoid electric shock hazard when voltage exceeds 50VAC or 120VDC.

**CAUTION**

Never exceed max. voltage and max. current values allowed by relay contacts (see relay specifications).

**CAUTION**

Use freewheeling diode for DC voltage inductive loads. Use antidisturbance filters for AC inductive loads.

**NOTE**

Like any multifunction output, relay outputs may be configured based on a comparison to an analog value (see Sinus Penta's Programming Guide). In that case, particularly if enabling delay time is set to zero, relays will cyclically energize/de-energize and this will strongly affect their durability. We suggest that output MDO1 or MDO2 be used, which is not affected by repeated energizing/de-energizing.

3.5.5.4. Technical Sheet for Digital Outputs

Specification	Min.	Type	Max.	Unit of m.
Voltage range for MDO1 and MDO2 outputs	20	24	50	V
Max. current to be switched for outputs MDO1 and MDO2			50	mA
Voltage drop for output MDO1 (based on deactivated CMDO1 or based on activated +VMDO1)			3	V
VOLTAGE DROP FOR ACTIVATED MDO2 OUTPUT			2	V
CURRENT LEAKAGE FOR DEACTIVATED MDO2 OUTPUT			4	μA
Duty-cycle for MDO1 output used as a frequency output at 100kHz	40	50	60	%
Isolation test voltage between CMDO1 (26) and CMDO2 (27) based on GNDR (1) and GNDI (9)	500Vac, 50Hz, 1min.			
Voltage and current limit for relay contacts MDO3, MDO4	5A, 250Vac 5A, 30Vdc			
Residual resistance with closed contact for outputs MDO3 and MDO4			30	mΩ
Durability of relay contacts MDO3 and MDO4 from a mechanical and electrical point of view		5x10 ⁷ /10 ⁵		oper.
Max. allowable frequency for relay outputs MDO3 and MDO4			30	oper./s



CAUTION

Avoid exceeding min. and max. input voltage values not to cause irreparable damages to the equipment.



NOTE

Digital outputs MDO1 and MDO2 are protected against transient short-circuits by a self-resetting fuse. After wiring the inverter, make sure that the output voltage is correct, as a persistent short-circuit may damage the equipment.



NOTE

Isolated supply output is protected by a self-resetting fuse capable of preventing the inverter internal power supply unit from damaging due to a short-circuit. Nevertheless, if a short-circuit occurs, the inverter could lock and stop the motor.

3.5.6. Analog Outputs (Terminals 10 to 13)

Three analog outputs are available: AO1 (terminal 10), AO2 (terminal 11) and AO3 (terminal 12), related to common terminal CMA (terminal 13). They can be set as voltage outputs or current outputs. Each analog output is controlled by a DAC (digital to analog converter), that can be configured in order to output—as analog signals—three measured values chosen among the available values for each application (see Sinus Penta's Programming Guide). The operating mode, gain, offset and filtering time constant (if any) may be defined by the user. The inverter firmware allows four operating modes that must match with the setup of the configuration DIP-switches (see Sinus Penta's Programming Guide).

Type of acquisition set for the inverter parameters	Hardware configuration for SW2	Full-scale value and notes
±10 V	Voltage output	-10V ÷ +10V
0 ÷ 10 V	Voltage output	0÷10V
0 ÷ 20 mA	Current output	0mA ÷ 20mA
4 ÷ 20 mA	Current output	4mA ÷ 20mA



CAUTION

Never deliver input voltage to analog outputs. Do not exceed max. allowable current.



NOTE

Digital outputs MDO1 and MDO2 are protected against transient short-circuits by a self-resetting fuse. After wiring the inverter, make sure that the output voltage is correct, as a persistent short-circuit may damage the equipment.

3.5.6.1. Technical Sheet for Analog Outputs

Specification	Min.	Type	Max.	Unit of m.
Load impedance with voltage outputs	2000			Ω
Load impedance with current outputs			500	Ω
Max. capacitive load to be connected to voltage outputs			10	nF
Offset cumulative error and typical gain related to full-scale value			1.5	%
Temperature coefficient of gain error and offset			300	ppm/°C
Digital resolution in voltage configuration			11	bit
Digital resolution in current configuration			10	bit
Value of voltage LSB		11.1		mV
Value of current LSB		22.2		μA
Stabilization time within 2% of the final value		1.11		ms
Time period of output activation		500		μs



NOTE

Analog outputs configured as voltage outputs are controlled by operational amplifiers that are subject to fluctuations. Do not install filter capacitors on analog output supply mains. If noise is detected at the system input connected to the analog outputs, switch to current output mode.

3.6. Operating and Remoting the Keypad

For the parameter programming and view a display/keypad is located on the front part of the Sinus Penta drives. The display/keypad is fitted on the drive front part; press the side tabs to remove the display/keypad. For more details, see the Remoting the Display/Keypad section below.

3.6.1. Indicator LEDs on the Display/Keypad

Eleven LEDs are located on the keypad, along with a 4-line, 16-character LCD display, a buzzer and 12 function keys. The display shows parameter values, diagnostic messages and the quantities processed by the inverter.

For any detail concerning menus and submenus, parameter programming, measure selection and messages displayed, please refer to the Sinus Penta's Programming Guide.

The figure below shows the location of the indicator Leds and their functionality.

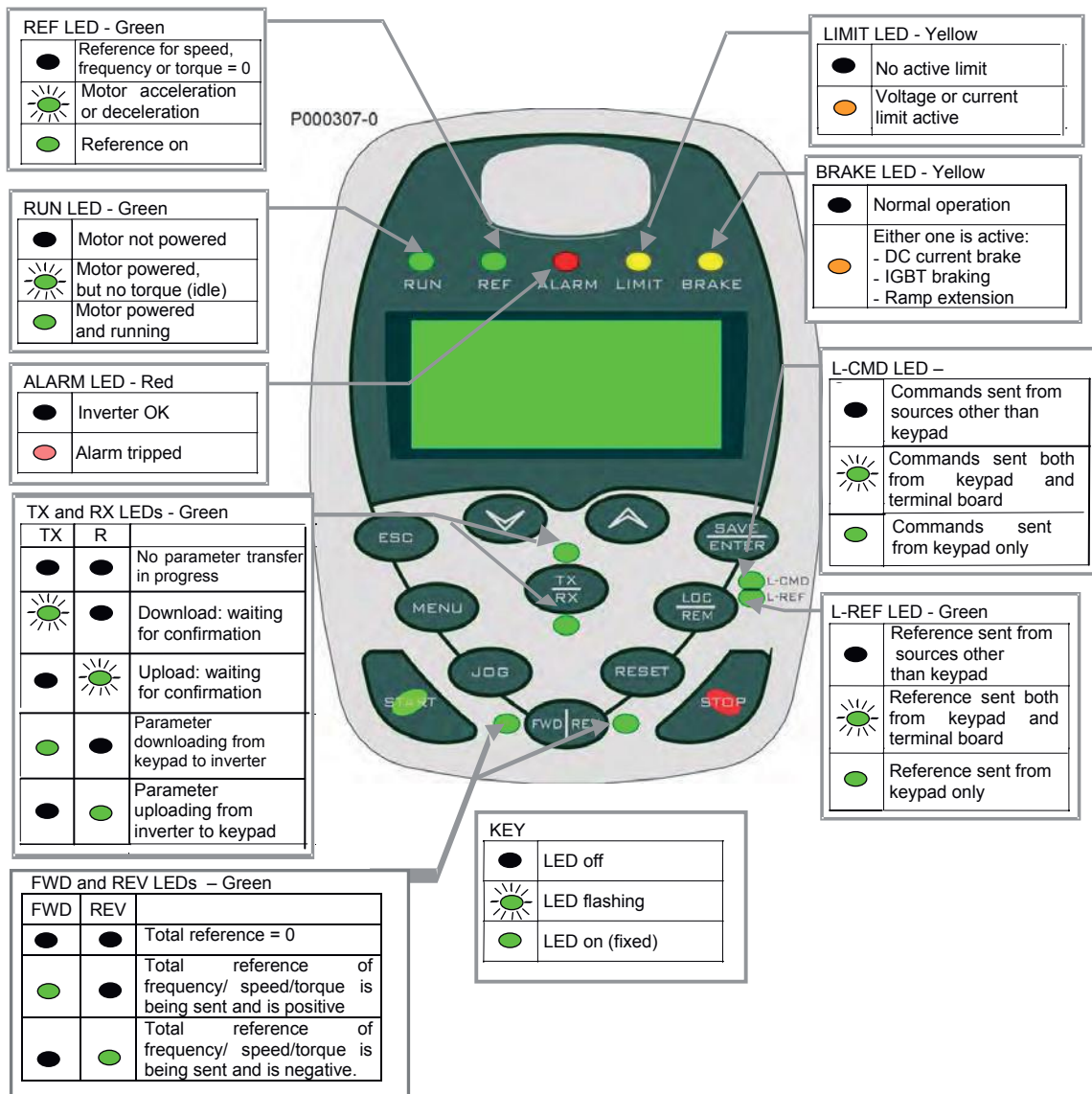















Figure 68: Display/keypad

3.6.2. Function Keys

The table below details the display/keypad function keys:

Key	Functions
	Quits menus and sub-menus and confirms a new parameter value (when the editing mode is activated, the cursor starts flashing), which is not saved to non-volatile memory (the value is lost when the inverter is turned off). If the Operator mode is set up and the keypad is locked on the Keypad page, press ESC for at least 5 s to restart navigation.
	Down arrow; scrolls through the menus and submenus, the pages in a submenu or the parameters in descending order. While programming, it decrements the parameter value. Hold it down along with the increment key  to access the next menu.
	Up arrow; scrolls through the menus and submenus, the pages in a submenu or the parameters in ascending order. While programming, it increments the parameter value.
	Accesses menus and submenus. In programming mode (cursor flashing) this key saves to non-volatile memory (EEPROM) the value of the parameter being altered. This prevents any parameter modification from being cleared in case of mains loss. If pressed when the Keypad page is displayed, the SAVE/ENTER key allows displaying the "Keypad Help" page, where the variables viewed in the previous page are detailed.
	If pressed more than once, it scrolls through the menus: start page → access page for parameter alteration → ID SW page → keypad → start page, and so on.
	Enters the pages for the parameter DOWNLOAD from the keypad to the inverter (TX) or allows parameter UPLOAD from the inverter to the keypad (RX); if pressed more than once, the TX/RX key allows selecting either operating mode. The active selection is highlighted by the page displayed; the relevant TX or RX LED starts flashing. To confirm Upload/Download, press the Save/Enter key when the wanted selection is active.
	If pressed once, reference and commands are forced via keypad; press it again to return to the prior configuration or to change the active reference in the Keypad page depending on the preset type of Keypad page (see the Display menu in the Sinus Penta's Programming Guide).
	Resets the alarm tripped once the cause responsible for the alarm has disappeared. Press it for 8 seconds to reset the control board, thus allowing the microprocessors to be reinitialized and to activate R parameters with no need to shut off the inverter.
	If enabled, it starts the motor (at least one of the command sources is represented by the keypad).
	If enabled, it stops the motor (at least one of the command sources is represented by the keypad).
	The Jog key is active only when at least one of the command sources is represented by the keypad; if depressed, it enters the Jog reference set in the relevant parameter.
	If enabled (at least one of the command sources is represented by the keypad), it reverses the sign of the overall reference. Press this key again to change the reference sign.



NOTE

Parameter increment or decrement (flashing cursor) is immediately effective or is enabled after quitting the programming mode (fixed cursor) depending on the parameter type. Numeric parameters activate as soon as they are altered; alphanumeric parameters activate after quitting the programming mode. Please refer to the Sinus Penta's Programming Guide for any detail.

3.6.3. Setting the Operating Mode

The display/keypad allows selecting two different configuration modes. To do so, press the SAVE | ENTER key for a few seconds, or press TX | RX + SAVE | ENTER for a few seconds. If the SAVE key is pressed, only the LCD contrast may be adjusted; press TX | RX + SAVE to adjust the display contrast, enable or disable the buzzer and turn on/off the display backlight.

3.6.3.1. Adjusting the Display Contrast

Press the SAVE | ENTER key for more than 5 seconds; *** TUNING *** is displayed; the indicator Leds come on and configure as a 5-dot bar extending proportionally to the contrast value set. Press ∇ or \blacktriangle to adjust the display contrast. Press SAVE | ENTER for at least 2 seconds to store the new contrast setting.

3.6.3.2. Adjusting the Display Contrast, Back-light and Buzzer

Press TX | RX + SAVE | ENTER for more than 5 seconds. Press ∇ or \blacktriangle to scroll through seven parameters relating to the display/keypad. Press ∇ or \blacktriangle to decrement or increment the parameter value. Press SAVE | ENTER to store the new parameter value to non-volatile memory. The different parameters and their description are detailed in the table below.

Parameter	Possible values	Description
SW Version	-	Version of the firmware implemented in the display/keypad (cannot be modified)
Language		Inactive parameter (please refer to the Programming Guide to set a new dialog language)
Baudrate	4800 9600 19200 38400	Baudrate in bps between the Penta and the display/keypad
Contrast value	nnn	Numeric value of the contrast register ranging from 0 (low) to 255 (high)
Buzzer	KEY	Buzzer beeps whenever a key is pressed
	REM	Buzzer controlled by the inverter (Inactive function)
	OFF	Buzzer always off
Back-light	ON	LCD back-light always on
	REM	LCD back-light controlled by the inverter (Inactive function)
	OFF	LCD back-light always off
Address	0	Imposes scanning the addresses of multidrop inverters connected to the display/keypad
	1÷247	MODBUS address of the inverter: allows selecting an inverter among multidrop inverters connected to one display/keypad

Once new parameter values are set, press the SAVE | ENTER key for more than two seconds to return to the inverter ordinary operation.

3.6.4. Remoting the Display/Keypad

The REMOTING KIT is required to remote the keypad. The remoting kit includes:

- Plastic shell
- Keypad mounting plate
- Fastening brackets
- Remoting wire (length: 5 m)



NOTE

The cable length can be 3m or 5m (state cable length when ordering the equipment).

Do the following:

1 – Pierce the holes as shown in the figure (template 138 x109 mm).

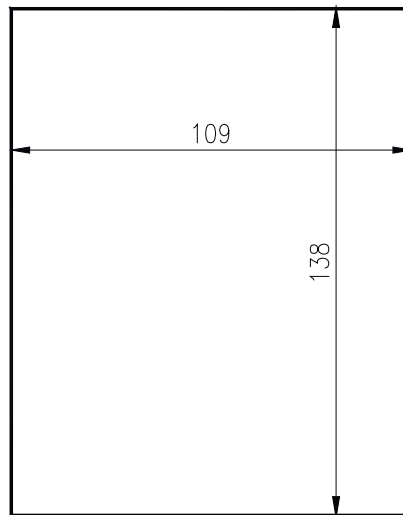

P000564-0

2 – Apply the self-adhesive mounting plate on the rear part of the plastic shell between the shell and the cabinet; make sure that holes coincide.

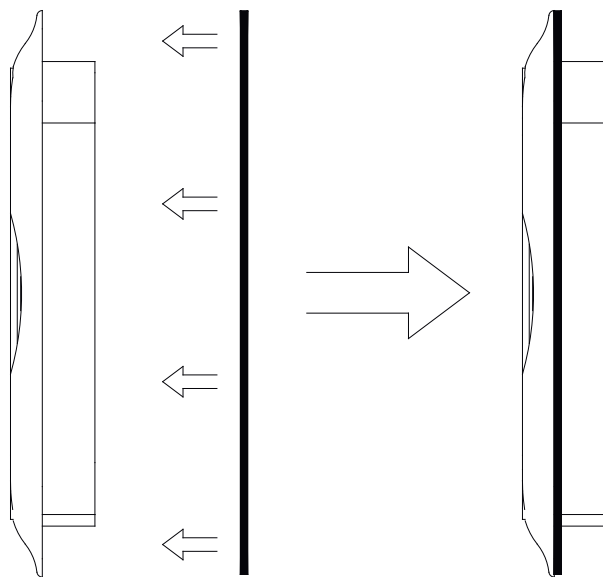

P000565-0

3 – Fit the plastic shell in the relevant slot.

4 – Fasten the plastic shell using the brackets supplied and tighten the fastening screws. Four self-threaded screws are supplied to fasten the brackets to the mounting plate; four fastening screws are also supplied to fix the shell to the panel.

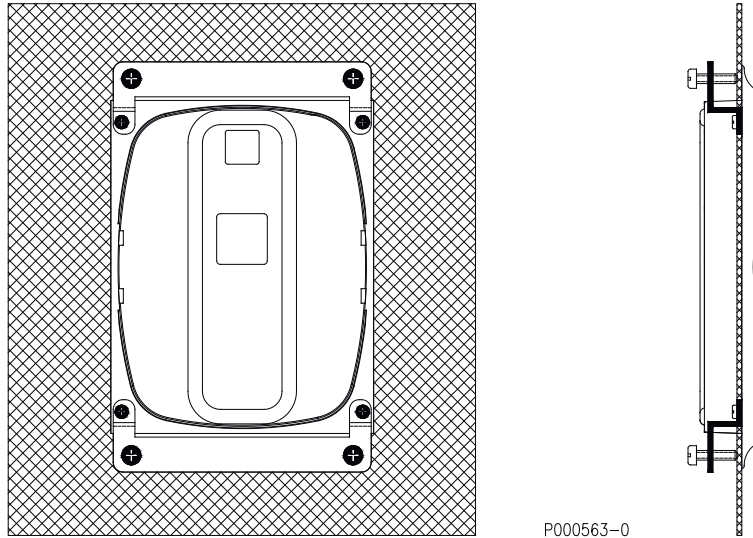

5 – Remove the display/keypad from the inverter (Figure 69). A short wire with 8-pole telephone connectors is used to connect the display/keypad to the inverter. Press the cable tab to disconnect it.

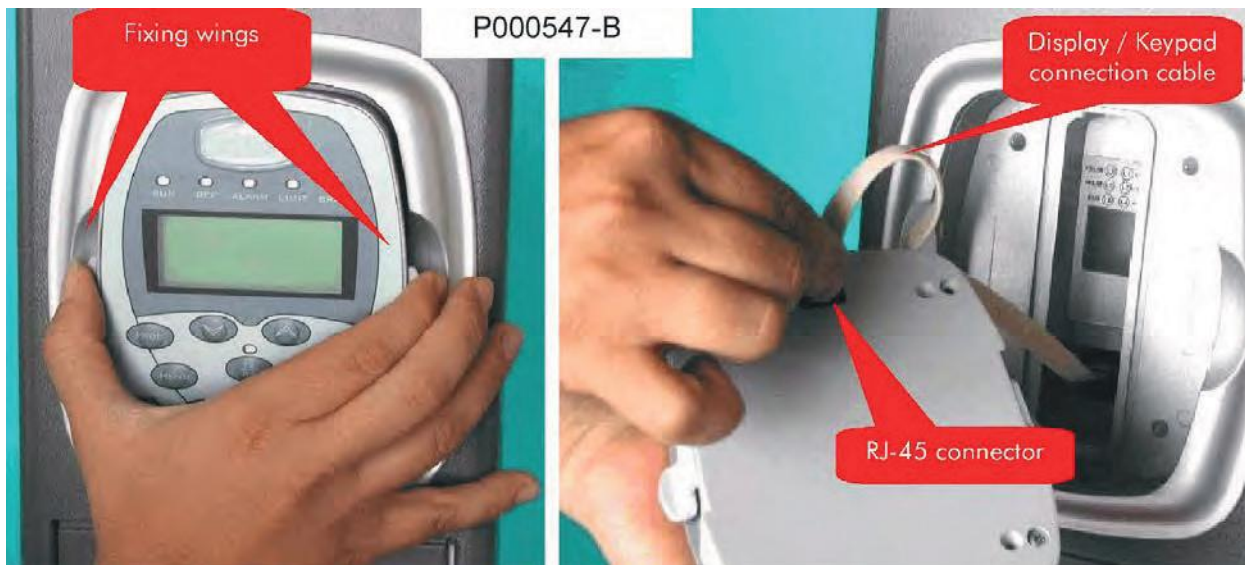

Figure 69: Removing the display/keypad module

6 – Connect the keypad to the inverter using the wire supplied. On the keypad side, the wire is provided with a telephone connector and a loop lug connected to the wire shielding braiding. Fasten the loop to the panel grounding using one of the mounting jig fastening screws. Tighten the screw in an uncoated area of the panel, to ensure it is electrically connected to the ground. Panel grounding must comply with the safety regulations in force.

7 – Fit the display/keypad to its housing (side tabs snap); make sure that the telephone connector is connected both to the keypad and to the inverter. Avoid stretching the keypad wire.

The remoting kit ensures degree of protection IP54 for the front panel.



Figure 70: Front/rear view of the display/keypad and its shell.



CAUTION

Never connect and disconnect the keypad when the inverter is on. Temporary overload may lock the inverter due to alarm trip.



CAUTION

Only use wires supplied by Elettronica Santerno for the keypad wiring. Wires with a different contactor arrangement will cause irreparable damages to the inverter and the display/keypad. A remoting wire with different specifications may cause disturbance and affect communications between the inverter and the display/keypad.



CAUTION

Properly connect the remoting wire by grounding its braiding as explained above. The remoting wire must not be parallel-connected to the power wires connecting the motor or feeding the inverter. This will reduce disturbance between the inverter and the display/keypad connection to a minimum.

3.6.5. Using the Display/Keypad for Parameter Transfer

The display/keypad can be used for parameter transfer between two inverters. Do the following to transfer parameters from an inverter to the display/keypad: connect the display keypad to inverter #2 and download parameters from the display/keypad to the inverter. Follow the instructions given in section 3.6.4 to fit/remove the display/keypad from the inverter. More details are given in the Sinus Penta's Programming Guide.



CAUTION

Never connect and disconnect the keypad when the inverter is on. Temporary overload may lock the inverter due to alarm trip.



CAUTION

Only use wires supplied by Elettronica Santerno for the keypad wiring. Wires with a different contactor arrangement will cause irreparable damages to the inverter and the display/keypad. A remoting wire with different specifications may cause disturbance and affect communications between the inverter and the display/keypad.

3.7. Serial Communications

3.7.1. General Features

The inverters of the Sinus Penta series may be connected to peripheral devices through a serial link; this enables both reading and writing of all parameters normally accessed through the display/keypad. Two-wire RS485 is used, which ensures a better immunity to disturbance even on long cable paths, thus limiting communication errors.

The inverter will typically behave as a slave device (i.e. it only answers to queries sent by another device); a master device (typically a computer) is then needed to start serial communication. The inverter may be connected directly to a computer or a multidrop network of inverters controlled by a master computer (see Figure 71 below).

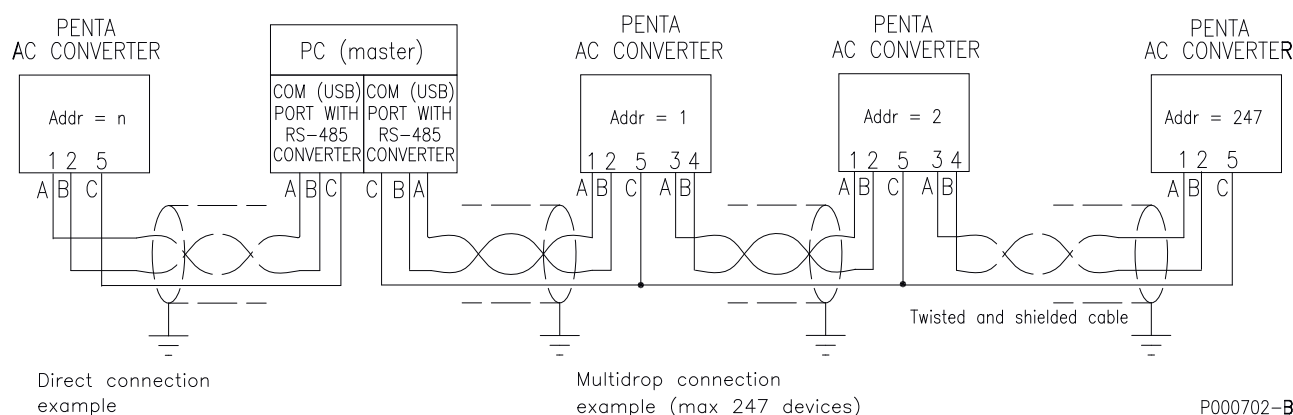

Figure 71: Example of multidrop and direct connection

The Sinus Penta is supplied with a connector which is equipped with 2 pins for each signal of the RS485 pair, thus allowing easier multidrop links with no need to connect two conductors to the same pin, and thus avoiding creating a star network, which is not recommended for this type of bus.



Any information sent to/from the inverter through the display/keypad unit may be obtained also via serial link using the RemoteDrive software offered by Elettronica Santerno. The RemoteDrive allows the following functions: image acquisition, keypad simulation, oscilloscope functions and multifunction tester, table compiler including operation data log, parameter setup and data reception-transmission-storage from and to a computer, scan function for the automatic detection of the connected inverters (up to 247 inverters may be connected). Please refer to Remote Drive DRIVE REMOTE CONTROL - User Manual for the inverters of the Sinus PENTA series manufactured by Elettronica Santerno.

The inverter is provided with two serial communication ports. The basic port (Serial Link 0, see Programming Guide) is provided with a male D-connector described in the wiring section above; the second port (Serial Link 1, see Programming Guide), which is provided with RJ-45 connector, is used for the connection of the display/keypad. When the display/keypad is not used, a master MODBUS device (such as a computer where the RemoteDrive is installed) can be connected to Serial Link 1 port through a DB9-RJ45 adaptor (see also Remoting a Keypad Controlling Multiple Inverters).

3.7.2. Direct Connection

Electrical standard RS485 may be connected directly to the computer if this is provided with a special port of this type. In case your computer is provided with a serial port RS232-C or a USB port, a RS232-C/ RS485 converter or a USB/RS485 converter is required.

Electronica Santerno may supply both converters as optional components.

Logic “1” (normally called a MARK) means that terminal TX/RX A is positive in respect to terminal TX/RX B (vice versa for logic “0”, normally called a SPACE).

3.7.3. Multidrop Network Connection

Sinus Penta inverters may be connected to a network through electrical standard RS485, allowing a bus-type control of each device; up to 247 inverters may be interconnected depending on the link length and baud rate.

Each inverter has its own identification number, which can be set in the Serial Network menu as a unique code in the network connected to the PC.

3.7.3.1. Connection

For the connection to serial link 0 use the 9-pole, male D connector located on the control board (sizes S05..S15) or on the inverter bottom besides the terminal board (sizes \geq S20).

The D connector pins are the following.

PIN	FUNCTION
1 – 3	(TX/RX A) Differential input/output A (bidirectional) according to standard RS485. Positive polarity in respect to pins 2 – 4 for one MARK. Signal D1 according to MODBUS-IDA association.
2 – 4	(TX/RX B) Differential input/output B (bidirectional) according to standard RS485. Negative polarity in respect to pins 1 – 3 for one MARK. Signal D0 according to MODBUS-IDA association.
5	(GND) control board zero volt. Common according to MODBUS-IDA association.
6	(VTEST) Auxiliary supply input – (see Auxiliary Power Supply)
7 – 8	not connected
9	+ 5 V, max 100 mA for power supply of optional RS485/RS232 converter

The D-connector metal frame is connected to the grounding. Wire duplex cable braiding to the metal frame of the female connector to be connected to the inverter. To avoid obtaining a too high common voltage for driver RS485 of the master or the multidrop-connected devices, connect together terminals GND (if any) for all devices. This ensures equipotentiality for all signal circuits, thus providing the best operating conditions for drivers RS485; however, if devices are connected to each other with analog interfaces, this can create ground loops. If disturbance occurs when communication interfaces and analog interface operate at a time, use optional, galvanically isolated RS485 communications interface.

Otherwise, serial link 1 can be connected through RJ-45 connector. Pins of RJ-45 connector are the following:

PIN	FUNCTION
1-2-4	+ 5 V, max. 100mA for the power supply of external optional RS485/RS232 converter.
3	(TX/RX B) Differential input/output B (bidirectional) according to standard RS485. Negative polarity in respect to pins 1 – 3 for one MARK. Signal D1 according to MODBUS-IDA association.
5	(TX/RX A) Differential input/output A (bidirectional) according to standard RS485. Positive polarity in respect to pins 2 – 4 for one MARK. Signal D1 according to MODBUS-IDA association.
6-7-8	(GND) control board zero volt. Common according to MODBUS-IDA association.

The pin lay-out of RJ-45 connector is shown in the figure below:

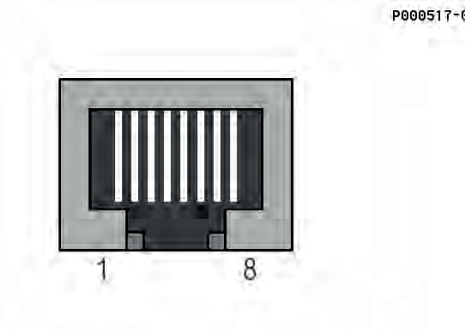

Figure 72: Pin lay-out of serial link 1 connector

MODBUS-IDA association (www.modbus.org) defines the type of wiring for MODBUS communications via serial link RS485 as a “2-wire cable”. The following specifications are recommended:

Type of cable	Shielded cable composed of balanced D1/D0 pair + common conductor (“Common”)
Min. cross-section of conductors	AWG24 corresponding to 0.25mm ² . For long cable length, larger cross-sections up to 0.75mm ² are recommended.
Max. length	500 metres (based on the max. distance between two stations)
Characteristic impedance	Better if exceeding 100Ω (120Ω is typically recommended)
Standard colours	Yellow/brown for D1/D0 pair, grey for “Common” signal

The figure below shows the reference wiring diagram recommended from MODBUS-IDA association for the connection of “2-wire” devices:

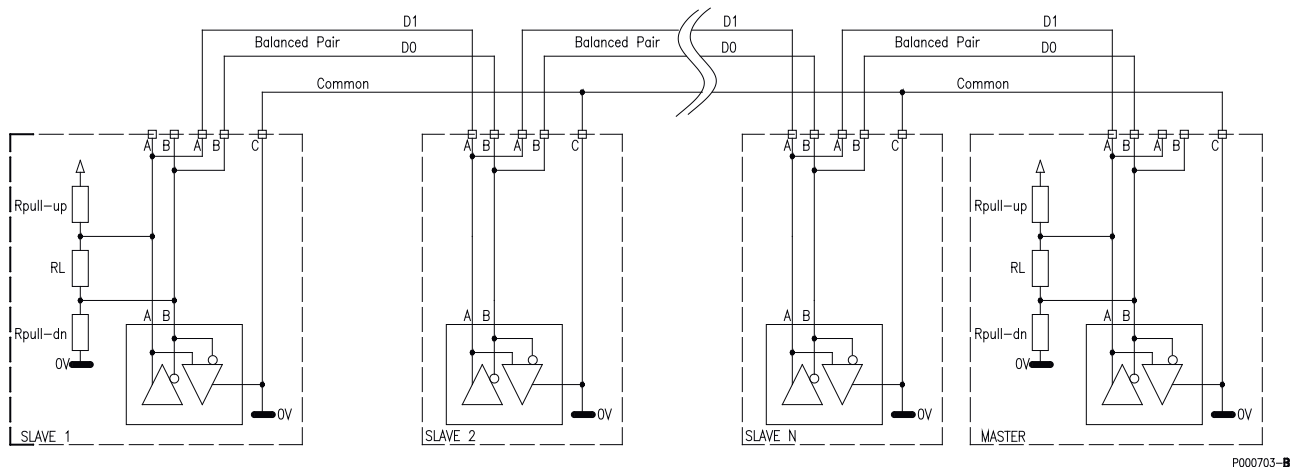

Figure 73: Recommended wiring diagram for “2-wire” MODBUS connection

Note that the network comprising the termination resistor and the polarization resistors is integrated into the inverter and can be activated via appropriate DIP-switches. Figure 73 shows the termination network in the devices at both ends of the chain. The terminator must be inserted in those devices only.



NOTE

Four-pair data transfer cables of Category 5 are normally used for serial links. Although their usage is not recommended, cables of Category 5 can be used for short cable paths. Note that the colours of such cables are different from the colours defined by MODBUS-IDA association. One pair is used for D1/D0 signals, one pair is used as a “Common” conductor, while the remaining two pairs must not be connected to any other device, or must be connected to the “Common”.



NOTE

All devices connected to the communication multidrop network should be grounded to the same conductor to minimize any difference of ground potentials between devices that can affect communication.



NOTE

The common terminal for the supply of the inverter control board is isolated from grounding. If one or multiple inverters are connected to a communication device with a grounded common (typically a computer), a low-impedance path between control boards and grounding occurs. High-frequency disturbance could come from the inverter power components and interfere with the communication device operation.

If this happens, provide the communication device with a galvanically isolated interface, type RS485/RS232.

3.7.3.2. Line Terminators

Provide a linear wiring (not a star wiring) for multidrop line RS485. To do so, two pins for each line signal are provided on the inverter connector. The incoming line may be connected to pins 1 and 2, whereas the outgoing line may be connected to pins 3 and 4.

The first device in the multidrop connection will have only one outgoing line, while the last device will have only one incoming line. The line terminator is to be installed on the first device and the last device. In serial link 0, the terminator is selected through DIP-switch SW3 in the control board (see DIP-switches section) for Sinus Penta inverters.

The line master (computer) is typically placed at the beginning or at the end of a multidrop connection; in that case, the line terminator of the farthest inverter from the master computer (or the only inverter in case of direct connection to the master computer) shall be enabled: DIP-switch SW3, selector switches 1 and 2 in position ON.

The line terminator of the other inverters in intermediate positions shall be disabled: DIP-switch SW3, selector switches 1 and 2 in position OFF.



NOTE

Communication does not take place or is adversely affected if multidrop terminators are not properly set, especially in case of a high baud rate. If more than two terminators are fitted, some drivers can enter the protection mode due to thermal overload, thus stopping dialoguing with some of the connected devices.



CAUTION

The line terminator in serial link 1, which is available on the keypad connector, is always ON and cannot be disabled. This avoids any multidrop connection of multiple inverters. A multidrop network can be used for point-to-point communications with the master computer or for the first/last inverter in a multidrop chain. If a multidrop network is connected to serial link 1 port, communications will not take place and the network-connected devices will be damaged by the large resistive load of the parallel-connected terminator resistors.

3.7.4. How to Use Isolated Serial Board ES822 (Optional)

ES822 optional board allows the connection to a serial link RS485 or RS232. ES822 board, to be installed inside the inverter, allows the inverter to be connected both to a computer through RS232—with no need to use additional devices—and to serial link RS485. Board ES822 also provides galvanic isolation between the serial link and the control board grounding of the inverter, thus avoiding ground loops and enhancing immunity to disturbance of the serial link. For more details, see ES822 Isolated Serial Board (Slot B).

The activation of ES822 results in the automatic switching of serial link 0, which is electrically suppressed from the standard serial connector of the inverter.

3.7.5. The Software

The serial communication protocol is MODBUS RTU standard.

Parameters are queried as they are read using the keys and the display. Parameter alteration is also managed along with the display/keypad. Note that the inverter will always consider the latest value set either via serial link or by the inverter.

The terminal board inputs may be controlled by the field or the serial link, depending on the condition of the relevant parameters (see Sinus Penta's Programming Guide).

However, the ENABLE command is always to be sent via terminal board regardless of the inverter programming mode.

3.7.6. Serial Communication Ratings

Baud rate:	configurable between 1200 and 38,400 bps (default value: 38,400 bps)
Data format:	8 bits
Start bit:	1
Parity: (1)	NO, EVEN, ODD
Stop bit:	2,1
Protocol:	MODBUS RTU
Supported functions:	03 h (Read Holding Registers) 10 h (Preset Multiple Registers)
Device address:	configurable between 1 and 247 (default value: 1)
Electric standard:	RS485
Inverter response delay:	configurable between 0 and 1000 ms (default value: 5 ms)
End of message timeout:	configurable between 0 and 10,000 ms (default value: 0 ms)
Communications Watch Dog: (2)	configurable between 0 and 65,000 s (default value: disabled)

(1) Ignored when receiving

(2) If set up, an alarm trips if no legal message is sent within the timeout period.



NOTE

For the parameters relating to the configuration of the serial communications, see Sinus Penta's Programming Guide.

3.8. Auxiliary Power Supply

The VTEST auxiliary supply pin is located on the connector of serial port 0. If 9VDC voltage (in respect to GND) is delivered to the VTEST input, the inverter control board activates, as well as the keypad and the optional boards (if any). This mode is very useful when you need to:

- 1) read and write the inverter parameters with no need to apply AC 3-phase supply;
- 2) keep "ON" the control board, the keypad and the optional boards in case of AC 3-phase supply loss (backup functionality).

When auxiliary supply is applied and no AC 3-phase supply is delivered, the alarms relating to the power section are disabled and the motor cannot be started up.

The auxiliary supply input features are the following:

Features	Min.	Type	Max.	Unit of m.
Auxiliary supply voltage	7.5	9	12	VDC
Absorbed current		1.1	1.8	A
"Inrush" current at power on			3	A



CAUTION

The power supply unit voltage and current delivery capacity must meet the requirements of the test supply. Lower ratings than the supply test can cause the control board failure and the irreparable loss of the user-defined parameters. On the other hand, higher ratings can cause irreparable damage to the inverter control board. Switching power supply units installed in the control board are characterized by strong "inrush" current at power on. Make sure that the power supply unit being used is capable of delivering such current ratings.

Elettronica Santerno provides a suitable power supply unit as an option; see ES914 Power Supply Unit Board.

4. START UP

This section covers the basic startup procedures for IFD, VTC, FOC asynchronous motor control configurations.

Any detail concerning startup procedures of the devices configured as “RGN” (regenerative inverter) is given in the Guide to the Regenerative Application.

Any detail concerning startup procedures of the devices configured as “SYN” (application for synchronous motors) is given in the Guide to the Synchronous Motor Application.

For more details on the equipment functionality, please consult Sinus Penta’s Programming Guide.



DANGER

Before changing the equipment connections, shut off the inverter and wait at least 20 minutes to allow for the discharge of the heat sinks in the DC-link.



DANGER

At startup, if the connected motor rotates in the wrong direction, send a low frequency reference in IFD mode and check to see if the direction of rotation is correct. In respect to its shaft, the motor normally rotates clockwise if the connection sequence is U, V, W and if a positive reference is set (FWD). Contact the motor manufacturer to check the preset direction of rotation of the motor.



CAUTION

When an alarm message is displayed, find the cause responsible for the alarm trip before restarting the equipment.

4.1. “IFD” Motor Control

Sinus Penta drives are factory set with the IFD (**C010**) control algorithm, allowing the first startup of the equipment. The default functions of the drive terminals are given in the table below. For more details, please refer to the Sinus Penta’s Programming Guide.

- 1) Wiring:** Follow the instructions stated in the SAFETY STATEMENTS and Installing the Equipment sections.
- 2) Power on:** Power on the drive and do not close the link to the **START** input to prevent the motor from running. Make sure that the display/keypad is on.
- 3) Parameter setting:** For easier startup of the Sinus Penta, you can activate the Start Up menu. The Start Up menu is a wizard allowing programming the main parameters for the connected motor.

Set the following from the Start Up menu:

1. The actual supply voltage of the Penta in **C008**. You can select a range for the rated mains voltage or the power supply from DC-Bus stabilised from a Regenerative Penta;
2. Motor ratings:
 - **C015** (fmot1) Rated frequency
 - **C016** (rpmnom1) Rated RPM
 - **C017** (Pmot1) Rated power
 - **C018** (Imot1) Rated current
 - **C019** (Vmot1) Rated voltage
 - **C029** (Speedmax1) Max. desired speed.
3. The type of V/f pattern of the motor in **C013**. If the connected load has a quadratic trend of the torque in respect to the rpm (centrifugal pumps, fans, etc...) set **C034** (preboost1) to 0%.

- 4) Autotune:** **Although it is not strictly necessary for the IFD control algorithm, the Autotune function is always recommended.**

Open the **ENABLE** command, access the Autotune menu and set **I073** [1: Motor Tune] and **I074** = [0: All Ctrl no rotation]. Use the **ESC** key to accept changes. Close the **ENABLE** command and wait until tune is complete (Warning “**W32** Open Enable” is displayed). The drive has computed and saved the values for **C022** (stator resistance) and **C023** (leakage inductance).

If alarm “**A097** Motor Wires KO” trips, check the motor wiring. If alarm “**A065** Autotune KO” trips, this means that the **ENABLE** command has opened before autotune was complete. In this case, reset the drive sending a command from terminal MDI3, or press the **RESET** key in the display/keypad and perform the autotune procedure again.

- 5) Overload:** Set the maximum overload current with parameters **C043**, **C044**, **C045**.

- 6) Startup:** Activate the **ENABLE** input (terminal 15) and the **START** input (terminal 14) and send a speed reference: the RUN LED and REF LED will come on and the motor will start. Make sure that the motor is rotating in the correct direction. If not, set parameter **C014** (Phase Rotation) to [1:Yes], or open the **ENABLE** and **START** inputs, remove voltage from the drive and, after waiting at least 20 minutes, swap two of the motor phases.

7) Possible failures: If no failure occurred, go to step 8. Otherwise, check the drive connections paying particular attention to supply voltages, DC link and input reference.

Also check if alarm messages are displayed. In the Measures menu, check the reference speed (**M001**), the supply voltage to the control section (**M030**), the DC link voltage (**M029**), and the condition of control terminals (**M033**). Check to see if the readout matches with the measured values.

8) Additional parameter alterations: When parameter **P003** = Standby Only (condition required for altering C parameters), you can alter **Cxxx** parameters in the Configuration menu only when the drive is DISABLED or STOPPED, whereas if **P003** = Standby + Fluxing, you can alter **Cxxx** parameters when the motor is stopped but the drive is enabled.

You can write down any custom parameters in the table on the last pages of the Sinus Penta's Programming Guide.

9) Reset: If an alarm trips, find the cause responsible for the alarm and reset the drive. Close input MDI3 (terminal 16) or press the **RESET** on the display/keypad.



NOTE When the IFD control algorithm is used, only speed references can be set up.

4.2. “VTC” Motor Control

- 1) Wiring:** Follow the instructions given in the SAFETY STATEMENTS and Installing the Equipment sections.
- 2) Power on:** Power on the drive and do not close the link to the **START** input to prevent the motor from running. Make sure that the display/keypad is on.
- 3) Parameter setting:** For easier startup of the Sinus Penta, you can activate the Start Up menu. The Start Up menu is a wizard allowing programming the main parameters for the connected motor.

Set the following from the Start Up menu:

1. The actual supply voltage of the Penta in **C008**. You can select a range for the rated mains voltage or the power supply from DC-Bus stabilised from a Regenerative Penta;
2. VTC as the control algorithm in **C010**;
3. Motor ratings:
 - **C015** (fmot1) Rated frequency
 - **C016** (rpmnom1) Rated RPM
 - **C017** (Pmot1) Rated power
 - **C018** (Imot1) Rated current
 - **C019** (Vmot1) Rated voltage
 - **C029** (Speedmax1) Max. desired speed.

- 4) Autotune:** Open the **ENABLE** command and access the Autotune menu and set **I073** [1: Motor Tune] and **I074** = [0: All Ctrl no rotation]. Use the **ESC** key to accept changes. Close the **ENABLE** command and wait until tune is complete (Warning “**W32** Open Enable” is displayed). The drive has computed and saved the values for **C022** (stator resistance) and **C023** (leakage inductance).

If alarm “**A097** Motor Wires KO” trips, check the motor wiring. If alarm “**A065** Autotune KO” trips, this means that the **ENABLE** command has opened before autotune was complete. In this case, reset the drive sending a command from terminal MDI3, or press the **RESET** key in the display/keypad and perform the autotune procedure again.

- 5) Overload:** In parameter **C048** set the torque limit expressed as a percentage of the rated motor torque.
- 6) Startup:** Activate the **ENABLE** input (terminal 15) and the **START** input (terminal 14) and send a speed reference. The RUN LED and REF LED will come on and the motor will start. Make sure that the motor is rotating in the correct direction. If not, set parameter **C014** (Phase Rotation) to [1:Yes] (Motor Control menu) or open the ENABLE and START inputs, remove voltage from the drive and, after waiting at least 20 minutes, swap two of the motor phases.

7) Speed regulator adjustment:

If overshoot occurs when the speed setpoint is attained or if a system instability is detected (uneven motor operation), adjust the parameters relating to the speed loop (Speed Loop And Current Balancing menu). Set the two parameters relating to integral time (**P125**, **P126**) as [Disabled] and set low values for the parameters relating to proportional gain (**P128**, **P129**). Set equal values for **P128** and **P129** and increase them until overshoot takes place when the setpoint is attained. Decrease **P128** and **P129** by approx. 30%, then decrease the high values set for integral time in **P125** and **P126** (keep both values equal) until an acceptable setpoint response is obtained. Check to see if the motor runs smoothly at constant speed.

8) Possible failures:

If no failure occurred, go to step 9. Otherwise, check the drive connections paying particular attention to supply voltages, DC link and input reference. Also check if alarm messages are displayed. In the Measures menu, check the speed reference (**M000**), the reference speed processed by the ramps (**M002**), the supply voltage of the control section (**M030**), the DC-link voltage (**M029**), the condition of the control terminals (**M033**). Check to see if these readouts match with the measured values.

9) Additional parameter alterations:

When parameter **P003** = Standby Only (condition required for altering C parameters), you can alter **Cxxx** parameters in the CONFIGURATION menu only when the drive is DISABLED or STOPPED, whereas if **P003** = Standby + Fluxing, you can alter **Cxxx** parameters when the motor is stopped but the drive is enabled.

You can write down any custom parameters in the table on the last pages of the Sinus Penta's Programming Guide.

10) Reset:

If an alarm trips, find the cause responsible for the alarm and reset the drive. Close input MDI3 (terminal 16) or press the **RESET** on the display/keypad.

4.3. “FOC” Motor Control

- 1) **Wiring:** Follow the instructions stated in the SAFETY STATEMENTS and Installing the Equipment sections.
- 2) **Power on:** Power on the drive and do not close the link to the **START** input to prevent the motor from running. Make sure that the display/keypad is on.
- 3) **Parameter setting:** For easier startup of the Sinus Penta, you can activate the Start Up menu. The Start-Up Menu is a wizard allowing programming the main parameters for the connected motor.

Set the following from the Start Up menu:

1. The actual supply voltage of the Penta in **C008**. You can select a range for the rated mains voltage or the power supply from DC-Bus stabilised from a Regenerative Penta;
2. FOC as the control algorithm in **C010**;
3. Motor ratings:
 - **C015** (fmot1) Rated frequency
 - **C016** (rpmnom1) Rated RPM
 - **C017** (Pmot1) Rated power
 - **C018** (Imot1) Rated current
 - **C019** (Vmot1) Rated voltage
 - **C029** (Speedmax1) Max. desired speed.

If the no-load current of the motor is known, in **C021** (I_0) set the value of I_0 expressed as a percentage of the rated motor current.

If the no-load current of the motor is not known, but the motor can run with no connected load, start the motor at its rated speed in IFD mode, read the current value detected by the drive (parameter **M026**) in the Measures menu and use it as the first attempt value for I_0 .

NOTE: If the connected motor must run at higher speed than its rated speed (flux weakening), measure the no-load current value at its rated speed to ensure better performances.

If the no-load current of the motor is not known and the motor cannot run in no-load conditions, use a first attempt value for I_0 that is automatically computed by the drive, as described in step 5.

NOTE: When parameter **C021** (I_0)=0, whenever the motor autotune (step 5) is performed, the drive will automatically set a value depending on the motor ratings.

Once a no-load current value is entered in **C021**, the value of the parameter relating to mutual inductance (**C024**) will be automatically computed when parameters **I073**= [1: Motor Tune] and **I074**= [1: FOC Auto no rotation] are set up as for current autotune (**C024** is computed even if no autotune procedure occurs).

4) Encoder TEST: The motor must run when testing the encoder.

Set the source of the encoder signal used as a speed feedback (Encoder A in terminal board, Encoder B from **ES836** or **ES913** optional board) with parameter **C189**; enter the number of pulse/rev with parameter **C190** or **C191**.

In the Motor Control menu, set the parameter relating to the speed feedback from encoder: **C012** = Yes.

Open the **ENABLE** command and set parameter **I073** (Select Autotune Type) as "Encoder Tune". Use the **ESC** key to confirm changes. Close the **ENABLE** command and wait until encoder tune is complete ("**W32** Open Enable" is displayed).

Once encoder tune is complete, the display will show one of the following messages:

"**W31** Encoder Ok"; the speed feedback is correct. If the speed detected by the encoder is opposite to the desired speed, the drive will automatically reverse the feedback sign (parameter **C199**).

"**A59** Encoder Fault"; the speed detected from the encoder is not consistent with the control speed. Possible causes:

- Wrong number of pls/rev of the encoder
- Wrong power supply of the Encoder (e.g. +5V instead of +24V): check the encoder ratings and the position of jumpers and DIP-switches for the encoder supply in the optional encoder board
- Wrong configuration of the DIP-switches for the encoder selection (push-pull or line-driver encoder) in the optional encoder board
- No connection to the encoder channel (check wiring)
- At least one Encoder channel is faulty (replace the encoder).

5) Autotune of the stator resistance and leakage inductance:

Open the **ENABLE** command and set **I073** [1: Motor Tune] and **I074** = [0: All Ctrl no rotation]. Use the **ESC** key to accept changes. Close the **ENABLE** command and wait until autotune is complete (warning "**W32** Open Enable" is displayed). The drive has computed and saved the values for **C022** and **C023**. If alarm "**A097** Motor wires KO" trips, check the motor wiring. If alarm "**A065** Autotune KO" trips, this means that the **ENABLE** command has opened before autotune was completed. In this case, reset the drive sending a command from terminal MDI3, or press the **RESET** key in the display/keypad and perform the autotune procedure again.

6) Autotune of the current loop:

Open the **ENABLE** command and set **I073** [1: Motor Tune] and **I074** = [1: FOC Auto no rot.]. Use the **ESC** key to accept changes. Close the **ENABLE** command and wait until autotune is complete (warning "**W32** Open Enable" is displayed). The drive has computed and saved the values for **P155** and **P156**. If alarm "**A065** Autotune KO" trips, this means that the **ENABLE** command has opened before autotune was completed or that the autotune algorithm failed. In this case, reset the drive sending a command from terminal MDI3, or press the **RESET** key in the display/keypad and perform the autotune procedure again.

NOTE: if the **ENABLE** command was not opened before autotune was over, decrease by 5% the no-load current value set in **C021** and perform the autotune procedure again.

- 7) Tuning the rotor time constant:** The rotor time constant (**C025**) is estimated with a special autotune procedure allowing the motor to run even in no-load conditions.
- Open the **ENABLE** command and set **I073** [1: Motor Tune] and **I074** = [2: FOC Auto + rot]. Use the ESC key to accept changes. Close the **ENABLE** command and wait until autotune is over (warning "**W32** Open Enable" is displayed). When autotune is complete, the value obtained for the rotor time constant is automatically saved in parameter **C025**.
- If the motor cannot run in no-load conditions, use a first attempt value for I_0 that is automatically computed by the drive, as described in step 5.
- 8) Startup:** Now that all the parameters have been set for the FOC motor control algorithm, activate the **ENABLE** input (terminal 15) and the **START** input (terminal 14) and send a speed reference: the RUN LED and REF LED will come on and the motor will start. Make sure that the motor is rotating in the correct direction. If not, set parameter **C014** (Phase Rotation) to [1:Yes], or open the **ENABLE** and **START** inputs, remove voltage from the drive and, after waiting at least 20 minutes, swap two of the motor phases.
- 9) Speed regulator adjustment:** If overshoot occurs when the speed setpoint is attained or if a system instability is detected (uneven motor operation), adjust the parameters relating to the speed loop (Speed Loop and Current Balancing menu). Set the two parameters relating to integral time (**P125**, **P126**) as [Disabled] and set low values for the parameters relating to proportional gain (**P128**, **P129**). Set equal values for **P128** and **P129** and increase them until overshoot takes place when the setpoint is attained. Decrease **P128** and **P129** by approx. 30%, then decrease the high values set for integral time in **P125** and **P126** (keep both values equal) until an acceptable setpoint response is obtained. Check to see if the motor runs smoothly at constant speed.
- 10) Possible failures:** If alarm "**A060** Fault No Curr." trips, this means that the current loop is not properly tuned. Follow the instructions given in step 6 and decrease the value of I_0 (parameter **C021** in the Motor Control menu).
- If the motor is noisy when starting, this means that the rotor time constant is not correct. Follow the instructions given in step 7 again, or manually change the value of the rotor time constant (parameter **C025**) for a smooth motor startup.
- If no failure occurred, go to step 11. Otherwise, check the drive connections paying particular attention to supply voltages, DC link and input reference. Also check if alarm messages are displayed. In the Measures menu, check the speed reference (**M000**), the reference speed processed by the ramps (**M002**), the supply voltage of the control section (**M030**), the DC link voltage (**M029**), the condition of the control terminals (**M033**). Check to see if these readouts match with the measured values.
-

11) Additional parameter alterations:

For the optimization of the motor performance, manually adjust parameters **C021** (no-load current), **C024** (mutual inductance), **C025** (rotor time constant). Consider the following:

C021 Too high values → Lower torque, especially at rated speed, because most part of the voltage imposed by the drive is used to magnetize the motor instead of generating a proper motor torque;

- **C021** Too low values → Because of the motor flux weakening, higher current ratings are needed;

- **C024** Mutual inductance → This is computed each time the no-load current level is altered. This is not binding for the motor control, but strongly affects the correct estimation of the output torque; in case of overestimation, decrease **C024**, and vice versa;

- **C025** Optimum value → To obtain the optimum value of the rotor time constant, the best way consists in performing several attempts with a constant load but with different values of **C025**. The optimum value is the one ensuring to obtain the output torque with the lower current (see **M026** in the Motor Measures menu).

When parameter **P003** = Standby Only (condition required for altering C parameters), you can alter **Cxxx** parameters in the Configuration menu only when the drive is DISABLED or STOPPED, whereas if **P003** = Standby + Fluxing, you can alter **Cxxx** parameters when the motor is stopped, but the drive is enabled.

Before altering any parameters, remember that the correct code for parameter **P000** must be previously set up.

You can write down any custom parameters in the table on the last pages of the Sinus Penta's Programming Guide.

12) Reset:

If an alarm trips, find the cause responsible for the alarm and reset the drive. Close input MDI3 (terminal 16) or press the **RESET** on the display/keypad.

4.4. "SYN" Motor Control

Any detail concerning startup procedures of the Sinus Penta configured as "SYN" (application for synchronous motors) is given in the Sinus Penta SYN APPLICATION manual.

5. TECHNICAL SPECIFICATIONS

Earthing system

TN-S, TN-C, TN-CS, TT (not corner earthed) systems
For IT (ungrounded) systems please contact Elettronica Santerno

Power Range

- kW connected motor/voltage range
- 1.5~260kW 200÷240Vac, 3phase
- 2.2~1750kW 380÷415Vac, 3phase
- 3~2000kW 440÷460Vac, 3phase
- 3.7~2100kW 480÷500Vac, 3phase
- 3~2500kW 575Vac, 3phase
- 3~3000kW 660÷690Vac, 3phase

- Degree of protection/size

STAND ALONE: IP20 from Size S05 to Size S32,
IP00 from Size S41 to Size S90,
IP54 from Size S05 to Size S32

BOX: IP54

CABINET: IP24 and IP54.

Overvoltage category

III (refer to EN 61800-5-1)

MTBF

25,000 hours at 40°C and rated output current.

Specifications for motor wiring

- Motor voltage range/precision

0÷V_{mains}, ±2%

- Current/torque to motor/time

105÷200% for 2 min. every 20 min. up to S30.

105÷200% for 1 min. every 10 min. from S32.

- Starting torque/max. time

240% for a short time

- Output frequency/resolution (*)

0÷1000 Hz, resolution 0.01 Hz

- Braking torque:

DC braking 30%*C_n

Braking while decelerating up to 20%*C_n (with no braking resistor)

Braking while decelerating up to 150%*C_n (with braking resistors)

- Carrier frequency with adjustable silent random modulation (for more details, please refer to the Carrier Frequency Setting section and the Sinus Penta's Programming Guide.

Mains

- VAC supply voltage/tolerance

2T → 200÷240 Vac, 3phase, -15% +10%

4T → 380÷500 Vac, 3phase, -15% +10%

5T → 500÷600 Vac, 3phase, -15% +10%

6T → 575÷690 Vac, 3phase, -15% +10%

Maximum voltage imbalance: ±3% of the rated supply voltage

- VDC supply voltage/tolerance

2T → 280÷340 Vdc, -15% +10%

4T → 530÷705 Vdc, -15% +10%

5T → 705÷845 Vdc, -15% +10%

6T → 845÷970 Vdc, -15% +10%

The DC voltage power supply for size S41, S42, S51, S52, S60, S64, S74 and S84 requires an external precharge circuit of the DC bus capacitors.

- Supply frequency (Hz)/tolerance

50÷60Hz, ±20%

Environmental Requirements

- Ambient temperature

-10°C to +55°C

It might be necessary to apply 2% derating of the rated current for every degree beyond the stated temperatures depending on the inverter model and the application category (see Operating Temperatures Based On Application Category).

- Storage temperature

-25 ÷ +70°C

- Humidity

5 ÷ 95% (non-condensing)

- Altitude

Max. altitude for installation 2000 m a.s.l. For installation above 2000 m and up to 4000 m, please contact Elettronica Santerno.

Above 1000 m, derate the rated current by 1% every 100 m.

- Vibrations

Lower than 9.8 m/sec² (= 1.0G)

- Installation environment

Do not install in direct sunlight and in places exposed to conductive dust, corrosive gases, vibrations, water sprinkling or dripping; do not install in salty environments.

- Operating atmospheric pressure

86 ÷ 106 kPa

- Cooling system

Forced air-cooling



NOTE (*)

The maximum output frequency is limited in respect to the preset carrier frequency (for more details, please refer to the Programming Guide).

MOTOR CONTROL	Motor control methods	IFD = Voltage/Frequency with symmetrical PWM modulation VTC = Vector Torque Control (Sensorless vector direct torque control) FOC = Field adjustment with field regulation and torque for asynchronous motors SYN = Vector for permanent magnet synchronous motors (PMSM)	
	Frequency / speed setting resolution	Digital reference: 0.1 Hz (IFD control); 1 rpm (VTC control); 0.01 rpm (FOC control) 12-bit Analog reference: 4096 in respect to speed range	
	Speed precision	Open loop: $\pm 0.5\%$ of max. speed Closed loop (with an encoder): $< 0.01\%$ of max. speed	
	Overload capacity	Up to 2 times rated current for 120 sec.	
	Starting torque	Up to 200% Cn for 120 secs and 240% Cn for a short duration	
	Torque boost	Programmable for a rated torque increase	
OPERATION	Input signals	Operation method	Operation via terminal board, keypad, MODBUS RTU serial interface, field bus interface
		Reference analog inputs / auxiliary inputs	3 analog inputs to be configured as voltage/current inputs: - 1 single-ended input, max. resolution 12 bits - 2 differential inputs, max resolution 12 bits Analog quantities from keypad, serial interface, field bus
		Digital inputs	8 digital inputs; 3 preset inputs (ENABLE, START, RESET) and 5 configurable inputs
		Multispeed	15 sets of programmable speed values $\pm 32,000$ rpm; first 3 sets with resolution 0.01 rpm (FOC control)
		Ramps	4 + 4 accel./decel. ramps, 0 to 6,500 secs; possibility to set user-defined patterns.
	Output signals	Digital outputs	4 configurable digital outputs with possibility to set internal timers for activation/deactivation delay: 1 push-pull output, 20-48 Vdc, 50 mA max. 1 open collector, NPN/PNP output, 5-48 Vdc, 50 mA max 2 relay outputs with change-over contacts, 250 Vac, 30 Vdc, 5A
		Auxiliary voltage	24 Vdc $\pm 5\%$, 200 mA
		Reference voltage for potentiometer	+ 10 Vdc $\pm 0.8\%$, 10 mA -10 Vdc $\pm 0.8\%$, 10 mA
Analog outputs		3 configurable analog outputs, $-10 \div 10$ Vdc, $0 \div 10$ Vdc, 0(4) $\div 20$ mA, resolution 9/11 bits	
PROTECTIONS	Alarms	Inverter thermal protection, motor thermal protection, mains failure, overvoltage, undervoltage, overcurrent at constant speed or ground failure, overcurrent while accelerating, overcurrent while decelerating, overcurrent during speed search (IFD SW only), auxiliary trip from digital input, serial communication failure, control board failure, precharge circuit failure, inverter overload conditions for long duration, unconnected motor, encoder (if any) failure, overspeed.	
	Warning	INVERTER OK, INVERTER ALARM, acceleration – constant rpm – deceleration, current/torque limiting, POWER DOWN, SPEED SEARCHING, DC braking, autotune.	
COMMUNICATION DISPLAY	Operating data	Frequency/torque/speed reference, output frequency, motor speed, torque demand, generated torque, current to motor, voltage to motor, DC bus voltage, motor-absorbed power, digital input condition, digital output condition, trip log (last 5 alarms), operating time, auxiliary analog input value, PID reference, PID feedback, PID error value, PID regulator output, PID feedback with programmable multiplying factor.	
	Serial link	Standard incorporated RS485 multidrop 247 drops MODBUS RTU communication protocol	
	Field bus	Profibus-DP®, DeviceNet®, CANopen®, Ethernet (MODBUS® TCP/IP), Interbus®, ControlNet®, Lonworks® with optional internal board	
SAFETY REQUIREMENTS		EN 61800-5-1, EN 61800-5-2, EN 60204-1	
PERFORMANCE FUNCTIONALITY		AND EN 61800-2 and EN 60146-1-1	
Compliance		   	

5.1. Choosing the Product

The inverters of the Sinus Penta series are dimensioned based on the application allowable current and overload.

The Sinus Penta series is characterized by 3 current values:

- **Inom** is the continuous current that can be delivered;
- **I_{max}** is the max. current that can be delivered under overload conditions for a time period of 120s every 20 min or for a time period of 60s every 10 min based on the different inverter models;
- **I_{peak}** is the maximum current that can be delivered under overload conditions for a time period of 3s.

Each inverter model may be connected to different motor power sizes depending on load performance. Four types of torque/current overloads are available:

Overload	Up to		Applicability
	(60/120s)	(3s)	
LIGHT	120%	144%	Light loads with constant/quadratic torque (pumps, fans, etc.);
STANDARD	140%	168%	Standard loads with constant torque (conveyors, mixers, extruders, etc.);
HEAVY	175%	210%	Heavy loads with constant torque (lifts, presses, bridge cranes, mills, etc.);
STRONG	200%	240%	Very heavy loads with constant torque (spindles, axis control, etc.).

The table below indicates the overload class typically required for each application. Dimensioning is not binding; the torque model required by the duty cycle of the connected machine should be known.

Application	OVERLOAD			
	LIGHT	STANDARD	HEAVY	STRONG
Atomizer, bottle washer, screw compressor (no-load), damped axial fan, undamped axial fan, centrifugal damped fan, undamped centrifugal fan, high-pressure fan, bore pumps, centrifugal pumps, positive displacement pumps, dust collector, grinder, etc.	*			
Slurry pump, ..	*	*		
Agitator, centrifuge, piston compressor (no-load), screw compressor (loaded), roller conveyor, cone crusher, rotary crusher, vertical impact crusher, debarker, edger, hydraulic power pack, mixer, rotary table, sanding machine, bandsaw, disk saw, separator, shredder, chopper, twister/spinner, industrial washer, palletizer, extruder, etc.		*		
Conveyor belt, drier, slicer, tumbler, mechanical press, forming machine, shears, winding/unwinding machine, drawplate, calender, screw injection moulding machine, etc.		*	*	
Piston compressor (loaded), conveyor screw, crusher jaw, mill, ball mill, hammer mill, roller mill, planer, pulper, vibrating screen, hoist and crane displacement, loom, etc.			*	
Mandrel, axis control, lifting application, hydraulic power pack injection press, etc.			*	*

The tables contained in the following pages state the power of the motors to be connected to Sinus Penta inverters based on their overload classes.



NOTE Data contained in the tables below relate to standard 4-pole motors.

MAKE SURE THAT:

- The rated current of the connected motor is lower than I_{nom} (tolerance: +5%).
- If multiple motors are connected, the sum of their rated current values must not exceed I_{nom} .
- The ratio between the inverter maximum current and the rated motor current is included in the overload class required.

EXAMPLE:

Application: Bridge crane
Motor used: 37kW
Rated current: 68A
Rated voltage: 400V
Required overload: 160%

Heavy application

Inverter ratings:

Inom: at least 68A
Imax: at least 68A x 1.6=102A

According to the table, Sinus Penta 0060 providing Inom=88A and Imax=112A is to be used for this type of application.



CAUTION

When multiple motors are connected, it can happen that the inverter does not detect whether a motor enters a stall condition or exceeds power ratings. In that case, motors can be seriously damaged and fire hazard exists. Always provide a failure detection system for each motor, independent of the inverter, in order to lock all motors when failures occur.

5.1.1. LIGHT Applications: Overload up to 120% (60/120s) or up to 144% (3s)

5.1.1.1. Technical Sheet for 2T and 4T Voltage Classes

Size	Sinus Penta Model	Applicable Motor Power												Inom	Imax	Ipeak (3s)
		200-240Vac			380-415Vac			440-460Vac			480-500Vac					
		kW	HP	A	kW	HP	A	kW	HP	A	kW	HP	A			
S05	SINUS 0005	-	-	-	4.5	6	9.0	5.5	7.5	9.7	6.5	9	10.2	10.5	11.5	14
	SINUS 0007	3	4	11.2	5.5	7.5	11.2	7.5	10	12.5	7.5	10	11.8	12.5	13.5	16
	SINUS 0008	3.7	5	13.2	-	-	-	-	-	-	-	-	-	15	16	19
	SINUS 0009	-	-	-	7.5	10	14.5	9.2	12.5	16	9.2	12.5	14.3	16.5	17.5	19
	SINUS 0010	4	5.5	14.6	-	-	-	-	-	-	-	-	-	17	19	23
	SINUS 0011	-	-	-	7.5	10	14.8	9.2	12.5	16	11	15	16.5	16.5	21	25
	SINUS 0013	4.5	6	15.7	-	-	-	-	-	-	-	-	-	19	21	25
	SINUS 0014	-	-	-	7.5	10	14.8	9.2	12.5	16	11	15	16.5	16.5	25	30
	SINUS 0015	5.5	7.5	19.5	-	-	-	-	-	-	-	-	-	23	25	30
	SINUS 0016	7.5	10	25.7	-	-	-	-	-	-	-	-	-	27	30	36
SINUS 0020	9.2	12.5	30	-	-	-	-	-	-	-	-	-	30	36	43	
S12	SINUS 0016	-	-	-	11	15	21	15	20	25	15	20	23.2	27	30	36
	SINUS 0017	-	-	-	15	20	29	18.5	25	30	18.5	25	28	30	32	37
	SINUS 0020	-	-	-	15	20	29	18.5	25	30	18.5	25	28	30	36	43
	SINUS 0023	11	15	36	-	-	-	-	-	-	-	-	-	38	42	51
	SINUS 0025	-	-	-	22	30	41	22	30	36	22	30	33	41	48	58
	SINUS 0030	-	-	-	22	30	41	22	30	36	25	35	37	41	56	67
	SINUS 0033	15	20	50	-	-	-	-	-	-	-	-	-	51	56	68
	SINUS 0034	-	-	-	30	40	55	30	40	48	37	50	53	57	63	76
	SINUS 0036	-	-	-	30	40	55	37	50	58	37	50	53	60	72	86
	SINUS 0037	18.5	25	61	-	-	-	-	-	-	-	-	-	65	72	83
S15	SINUS 0040	22	30	71	37	50	67	45	60	70	50	70	70	72	80	88
	SINUS 0049	25	35	80	45	60	80	50	65	75	55	75	78	80	96	115
S20	SINUS 0060	28	38	88	50	70	87	55	75	85	65	90	88	88	112	134
	SINUS 0067	30	40	96	55	75	98	65	90	100	75	100	103	103	118	142
	SINUS 0074	37	50	117	65	90	114	75	100	116	85	115	120	120	144	173
	SINUS 0086	45	60	135	75	100	133	90	125	135	90	125	127	135	155	186
S30	SINUS 0113	55	75	170	100	135	180	110	150	166	132	180	180	180	200	240
	SINUS 0129	65	90	195	110	150	191	125	170	192	140	190	195	195	215	258
	SINUS 0150	70	95	213	120	165	212	132	180	198	150	200	211	215	270	324
	SINUS 0162	75	100	231	132	180	228	150	200	230	175	238	240	240	290	324

(continued)

(continued)

S41	SINUS 0180	90	125	277	160	220	273	200	270	297	220	300	300	300	340	408
	SINUS 0202	110	150	332	200	270	341	220	300	326	250	340	337	345	420	504
	SINUS 0217	120	165	375	220	300	375	250	340	366	260	350	359	375	460	552
	SINUS 0260	132	180	390	250	340	421	280	380	410	300	410	418	425	560	672
S51	SINUS 0313	160	220	475	280	380	480	315	430	459	355	485	471	480	600	720
	SINUS 0367	185	250	550	315	430	528	375	510	540	400	550	544	550	680	792
	SINUS 0402	200	270	593	400	550	680	450	610	665	500	680	673	680	850	1020
S60	SINUS 0457	250	340	732	400	550	680	450	610	665	500	680	673	720	880	1056
	SINUS 0524	260	350	780	450	610	765	500	680	731	560	760	751	800	960	1152
S65¹⁾	SINUS 0598	-	-	-	500	680	841	560	760	817	630	860	864	900	1100	1320
	SINUS 0748	-	-	-	560	760	939	630	860	939	710	970	960	1000	1300	1560
	SINUS 0831	-	-	-	710	970	1200	800	1090	1160	900	1230	1184	1200	1440	1728
S75¹⁾	SINUS 0964	-	-	-	900	1230	1480	1000	1360	1431	1100	1500	1480	1480	1780	2136
	SINUS 1130	-	-	-	1000	1360	1646	1170	1600	1700	1270	1730	1700	1700	2040	2448
	SINUS 1296	-	-	-	1200	1650	2050	1400	1830	2000	1460	1990	2050	2100	2520	3024
S90¹⁾	SINUS 1800	-	-	-	1500	2000	2500	1750	2400	2500	1850	2500	2500	2600	3100	3600
	SINUS 2076	-	-	-	1750	2400	2900	2000	2720	2900	2100	2900	2900	3000	3600	3600
Inverter supply voltage		200-240Vac;			380-500Vac;											
		280-360Vdc.			530-705Vdc.											
¹⁾ Input inductor and output inductor required.																

Key:

Inom = continuous rated current of the inverter

Imax = max. current produced by the inverter for 120 seconds every 20 min up to S30, and for 60 seconds every 10 min for S41 and greater

Ipeak = deliverable current for max. 3 seconds

5.1.1.2. Technical Sheet for 5T and 6T Voltage Classes

Size	Sinus Penta Model	Applicable Motor Power						Inom	Imax	Ipeak (3s)	
		575Vac			660-690Vac						
		kW	HP	A	kW	HP	A				
S12 5T S14 6T	SINUS 0003	4	5.5	5.7	5.5	7.5	6.3	7	8.5	10	
	SINUS 0004	5.5	7.5	7.6	7.5	10	8.4	9	11	13	
	SINUS 0006	7.5	10	10	9.2	12.5	10.2	11	13.5	16	
	SINUS 0012	9.2	12.5	12.5	11	15	12.1	13	16	19	
	SINUS 0018	11	15	14	15	20	16.8	17	21	25	
S14	SINUS 0019	15	20	20	18.5	25	21	21	25	30	
	SINUS 0021	18.5	25	25	22	30	23	25	30	36	
	SINUS 0022	22	30	28	30	40	33	33	40	48	
	SINUS 0024	30	40	39	37	50	39	40	48	58	
	SINUS 0032	37	50	47	45	60	46	52	63	76	
S22	SINUS 0042	45	60	55	55	75	56	60	72	86	
	SINUS 0051	55	75	70	75	100	78	80	96	115	
	SINUS 0062	65	90	83	75	100	78	85	110	132	
	SINUS 0069	75	100	95	90	125	94	105	135	162	
S32	SINUS 0076	90	125	115	110	150	113	125	165	198	
	SINUS 0088	110	150	138	132	180	133	150	200	240	
	SINUS 0131	132	180	168	160	220	158	190	250	300	
	SINUS 0164	160	220	198	220	300	220	230	300	360	
S42	SINUS 0181	220	300	275	250	340	250	305	380	420	
	SINUS 0201	250	340	300	315	430	310	330	420	420	
	SINUS 0218	300	410	358	355	485	350	360	465	560	
	SINUS 0259	330	450	395	400	550	390	400	560	560	
S52	SINUS 0290	355	485	420	450	610	440	450	600	720	
	SINUS 0314	400	550	480	500	680	480	500	665	798	
	SINUS 0368	450	610	532	560	770	544	560	720	850	
	SINUS 0401	560	770	630	630	860	626	640	850	850	
S65 ¹⁾	SINUS 0457	630	860	720	710	970	696	720	880	1056	
	SINUS 0524	710	970	800	800	1090	773	800	960	1152	
	SINUS 0598	800	1090	900	900	1230	858	900	1100	1320	
	SINUS 0748	900	1230	1000	1000	1360	954	1000	1300	1440	
S70 ¹⁾	SINUS 0831	1000	1360	1145	1240	1690	1200	1200	1440	1440	
S75 ¹⁾	SINUS 0964	1270	1730	1480	1530	2090	1480	1480	1780	2136	
	SINUS 1130	1460	1990	1700	1750	2380	1700	1700	2040	2448	
S80 ¹⁾	SINUS 1296	1750	2380	2100	2100	2860	2100	2100	2520	2520	
S90 ¹⁾	SINUS 1800	2000	2720	2400	2400	3300	2400	2600	3100	3600	
	SINUS 2076	2500	3400	3000	3000	4000	3000	3000	3600	3600	
Inverter supply voltage		500-600Vac; 705-845Vdc.			600-690Vac; 845-970Vdc.						
¹⁾ Input inductor and output inductor required.											

5.1.2. STANDARD Applications: Overload up to 140% (60/120s) or up to 168% (3s)

5.1.2.1. Technical Sheet for 2T and 4T Voltage Classes

Size	Sinus Penta Model	Applicable Motor Power												Inom	Imax	Ipeak (3 s.)
		200-240Vac			380-415Vac			440-460Vac			480-500Vac					
		kW	HP	A	kW	HP	A	kW	HP	A	kW	HP	A			
S05	SINUS 0005	-	-	-	4	5.5	8.4	4.5	6	7.8	5.5	7.5	9.0	10.5	11.5	14
	SINUS 0007	2.2	3	8.5	4.5	6	9.0	5.5	7.5	9.7	6.5	9	10.2	12.5	13.5	16
	SINUS 0008	3	4	11.2	-	-	-	-	-	-	-	-	-	15	16	19
	SINUS 0009	-	-	-	5.5	7.5	11.2	7.5	10	12.5	7.5	10	11.8	16.5	17.5	19
	SINUS 0010	3.7	5	13.2	-	-	-	-	-	-	-	-	-	17	19	23
	SINUS 0011	-	-	-	7.5	10	14.8	9.2	12.5	15.6	9.2	12.5	14.3	16.5	21	25
	SINUS 0013	4	5.5	14.6	-	-	-	-	-	-	-	-	-	19	21	25
	SINUS 0014	-	-	-	7.5	10	14.8	9.2	12.5	15.6	11	15	16.5	16.5	25	30
	SINUS 0015	4.5	6	15.7	-	-	-	-	-	-	-	-	-	23	25	30
	SINUS 0016	5.5	7.5	19.5	-	-	-	-	-	-	-	-	-	27	30	36
SINUS 0020	7.5	10	25.7	-	-	-	-	-	-	-	-	-	30	36	43	
S12	SINUS 0016	-	-	-	9.2	12.5	17.9	11	15	18.3	15	20	23.2	27	30	36
	SINUS 0017	-	-	-	11	15	21	11	15	18.3	15	20	23.2	30	32	37
	SINUS 0020	-	-	-	15	20	29	15	20	25	18.5	25	28	30	36	43
	SINUS 0023	9.2	12.5	30	-	-	-	-	-	-	-	-	-	38	42	51
	SINUS 0025	-	-	-	18.5	25	35	18.5	25	30	22	30	33	41	48	58
	SINUS 0030	-	-	-	22	30	41	22	30	36	25	35	37	41	56	67
	SINUS 0033	11	15	36	-	-	-	-	-	-	-	-	-	51	56	68
	SINUS 0034	-	-	-	25	35	46	30	40	48	30	40	44	57	63	76
	SINUS 0036	-	-	-	30	40	55	30	40	48	37	50	53	60	72	86
SINUS 0037	15	20	50	-	-	-	-	-	-	-	-	-	65	72	83	
S15	SINUS 0040	18.5	25	61	30	40	55	37	50	58	40	55	58	72	80	88
	SINUS 0049	22	30	71	37	50	67	45	60	70	45	60	64	80	96	115
S20	SINUS 0060	25	35	80	45	60	80	55	75	85	55	75	78	88	112	134
	SINUS 0067	30	40	96	55	75	98	60	80	91	65	90	88	103	118	142
	SINUS 0074	37	50	117	65	90	114	70	95	107	75	100	103	120	144	173
	SINUS 0086	40	55	127	75	100	133	75	100	116	85	115	120	135	155	186
S30	SINUS 0113	45	60	135	90	125	159	90	125	135	90	125	127	180	200	240
	SINUS 0129	55	75	170	100	135	180	110	150	166	110	150	153	195	215	258
	SINUS 0150	65	90	195	110	150	191	132	180	198	150	200	211	215	270	324
	SINUS 0162	75	100	231	132	180	228	150	200	230	160	220	218	240	290	324

(continued)

(continued)

S41	SINUS 0180	80	110	250	160	220	273	185	250	279	200	270	273	300	340	408
	SINUS 0202	90	125	277	200	270	341	220	300	326	250	340	337	345	420	504
	SINUS 0217	110	150	332	220	300	375	250	340	375	260	350	359	375	460	552
	SINUS 0260	132	180	390	250	340	421	280	380	410	300	410	418	425	560	672
S51	SINUS 0313	150	200	458	280	380	480	315	430	459	355	485	471	480	600	720
	SINUS 0367	160	220	475	315	430	528	375	510	540	400	550	544	550	680	792
	SINUS 0402	185	250	550	400	550	680	450	610	665	500	680	673	680	850	1020
S60	SINUS 0457	220	300	661	400	550	680	450	610	665	500	680	673	720	880	1056
	SINUS 0524	260	350	780	450	610	765	500	680	731	560	770	751	800	960	1152
S65 ¹⁾	SINUS 0598	-	-	-	500	680	841	560	760	817	630	860	864	900	1100	1320
	SINUS 0748	-	-	-	560	760	939	630	860	939	710	970	960	1000	1300	1560
	SINUS 0831	-	-	-	630	860	1080	800	1090	1160	800	1090	1067	1200	1440	1728
S75 ¹⁾	SINUS 0964	-	-	-	800	1090	1334	900	1230	1287	1000	1360	1317	1480	1780	2136
	SINUS 1130	-	-	-	900	1230	1480	1100	1500	1630	1170	1600	1570	1700	2040	2448
	SINUS 1296	-	-	-	1200	1650	2050	1400	1830	2000	1460	1990	2050	2100	2520	3024
S90 ¹⁾	SINUS 1800	-	-	-	1400	1910	2400	1700	2300	2400	1750	2400	2400	2600	3100	3600
	SINUS 2076	-	-	-	1750	2400	2900	2000	2720	2900	2100	2900	2900	3000	3600	3600
Inverter supply voltage		200-240Vac; 280-360Vdc.			380-500Vac; 530-705Vdc.											
¹⁾ Input inductor and output inductor required.																

Key:

Inom = continuous rated current of the inverter

Imax = max. current produced by the inverter for 120s every 20 min up to S30, for 60s every 10 min for S41 and greater

Ipeak = deliverable current for max. 3 seconds

5.1.2.2. Technical Sheet for 5T and 6T Voltage Classes

Size	Sinus Penta Model	Applicable Motor Power						Inom	Imax	Ipeak (3 s.)
		575Vac			660-690Vac					
		kW	HP	A	kW	HP	A			
S12 5T S14 6T	SINUS 0003	4	5.5	5.7	4	5.5	4.8	7	8.5	10
	SINUS 0004	5.5	7.5	7.6	5.5	7.5	6.3	9	11	13
	SINUS 0006	7.5	10	10	7.5	10	8.4	11	13.5	16
	SINUS 0012	7.5	10	10	9.2	12.5	10.2	13	16	19
	SINUS 0018	11	15	14	11	15	12.1	17	21	25
S14	SINUS 0019	11	15	14	15	20	16.8	21	25	30
	SINUS 0021	15	20	20	18.5	25	21	25	30	36
	SINUS 0022	22	30	28	22	30	23	33	40	48
	SINUS 0024	25	35	32	30	40	33	40	48	58
	SINUS 0032	37	50	47	37	50	39	52	63	76
S22	SINUS 0042	45	60	55	45	60	46	60	72	86
	SINUS 0051	55	75	70	55	75	56	80	96	115
	SINUS 0062	65	90	83	75	100	77	85	110	132
	SINUS 0069	75	100	95	90	125	95	105	135	162
S32	SINUS 0076	90	125	115	110	150	113	125	165	198
	SINUS 0088	110	150	135	132	180	133	150	200	240
	SINUS 0131	132	180	168	160	220	158	190	250	300
	SINUS 0164	160	220	198	200	270	198	230	300	360
S42	SINUS 0181	220	300	275	250	340	250	305	380	420
	SINUS 0201	250	340	300	315	430	310	330	420	420
	SINUS 0218	300	410	358	315	430	310	360	465	560
	SINUS 0259	330	450	395	400	550	390	400	560	560
S52	SINUS 0290	355	485	420	450	610	440	450	600	720
	SINUS 0314	400	550	480	450	610	440	500	665	798
	SINUS 0368	450	610	532	500	680	480	560	720	850
	SINUS 0401	450	610	532	630	860	626	640	850	850
S65 ¹⁾	SINUS 0457	560	770	630	630	860	626	720	880	1056
	SINUS 0524	630	860	720	710	970	696	800	960	1152
	SINUS 0598	710	970	800	900	1230	858	900	1100	1320
	SINUS 0748	900	1230	1000	1000	1360	954	1000	1300	1440
S70 ¹⁾	SINUS 0831	1000	1360	1145	1100	1500	1086	1200	1440	1440
S75 ¹⁾	SINUS 0964	1180	1610	1369	1410	1920	1369	1480	1780	2136
	SINUS 1130	1350	1840	1569	1620	2210	1569	1700	2040	2448
S80 ¹⁾	SINUS 1296	1750	2380	2100	1850	2520	1800	2100	2520	2520
S90 ¹⁾	SINUS 1800	2000	2720	2400	2400	3300	2400	2600	3100	3600
	SINUS 2076	2500	3400	3000	3000	4000	3000	3000	3600	3600
Inverter supply voltage		500-600Vac; 705-845Vdc.			600-690Vac; 845-970Vdc.					
¹⁾ Input inductor and output inductor required.										

Key:

Inom = continuous rated current of the inverter

Imax = max. current produced by the inverter for 60 seconds every 10 min

Ipeak = deliverable current for max. 3 seconds

5.1.3. HEAVY Applications: Overload up to 175% (60/120s) or up to 210% (3s)

5.1.3.1. Technical Sheet for 2T and 4T Voltage Classes

Size	Sinus Penta Model	Applicable Motor Power												Inom	Imax	Ipeak (3 s.)
		200-240Vac			380-415Vac			440-460Vac			480-500Vac					
		kW	HP	A	kW	HP	A	kW	HP	A	kW	HP	A			
S05	SINUS 0005	-	-	-	3	4	6.4	3.7	5	6.6	4.5	6	7.2	10.5	11.5	14
	SINUS 0007	1.8	2.5	7.3	4	5.5	8.4	4.5	6	7.8	5.5	7.5	9.0	12.5	13.5	16
	SINUS 0008	2.2	3	8.5	-	-	-	-	-	-	-	-	-	15	16	19
	SINUS 0009	-	-	-	4.5	6	9.0	5.5	7.5	9.7	7.5	10	11.8	16.5	17.5	19
	SINUS 0010	3	4	11.2	-	-	-	-	-	-	-	-	-	17	19	23
	SINUS 0011	-	-	-	5.5	7.5	11.2	7.5	10	12.5	9.2	12.5	14.3	16.5	21	25
	SINUS 0013	3.7	5	13.2	-	-	-	-	-	-	-	-	-	19	21	25
	SINUS 0014	-	-	-	7.5	10	14.8	9.2	12.5	15.6	11	15	16.5	16.5	25	30
	SINUS 0015	4	5.5	14.6	-	-	-	-	-	-	-	-	-	23	25	30
	SINUS 0016	4.5	6	15.7	-	-	-	-	-	-	-	-	-	27	30	36
SINUS 0020	5.5	7.5	19.5	-	-	-	-	-	-	-	-	-	30	36	43	
S12	SINUS 0016	-	-	-	9.2	12.5	17.9	11	15	18.3	12.5	17	18.9	27	30	36
	SINUS 0017	-	-	-	9.2	12.5	17.9	11	15	18.3	12.5	17	18.9	30	32	37
	SINUS 0020	-	-	-	11	15	21	15	20	25	15	20	23.2	30	36	43
	SINUS 0023	7.5	10	25.7	-	-	-	-	-	-	-	-	-	38	42	51
	SINUS 0025	-	-	-	15	20	29	18.5	25	30	18.5	25	28	41	48	58
	SINUS 0030	-	-	-	18.5	25	35	22	30	36	22	30	33	41	56	67
	SINUS 0033	11	15	36	-	-	-	-	-	-	-	-	-	51	56	68
	SINUS 0034	-	-	-	22	30	41	25	35	40	28	38	41	57	63	76
	SINUS 0036	-	-	-	25	35	46	30	40	48	30	40	44	60	72	86
SINUS 0037	15	20	50	-	-	-	-	-	-	-	-	-	65	72	83	
S15	SINUS 0040	15	20	50	25	35	46	30	40	48	37	50	53	72	80	88
	SINUS 0049	18.5	25	61	30	40	55	37	50	58	45	60	64	80	96	115
S20	SINUS 0060	22	30	71	37	50	67	45	60	70	50	70	70	88	112	134
	SINUS 0067	25	35	80	45	60	80	50	70	75	55	75	78	103	118	142
	SINUS 0074	30	40	96	50	70	87	55	75	85	65	90	88	120	144	173
	SINUS 0086	32	45	103	55	75	98	65	90	100	75	100	103	135	155	186
S30	SINUS 0113	45	60	135	75	100	133	75	100	116	90	125	127	180	200	240
	SINUS 0129	50	70	150	80	110	144	90	125	135	110	150	153	195	215	258
	SINUS 0150	55	75	170	90	125	159	110	150	166	132	180	180	215	270	324
	SINUS 0162	65	90	195	110	150	191	132	180	198	140	190	191	240	290	324

(continued)

(continued)

S41	SINUS 0180	75	100	231	132	180	228	160	220	237	160	220	218	300	340	408
	SINUS 0202	80	110	250	150	200	264	185	250	279	200	270	273	345	420	504
	SINUS 0217	110	150	332	185	250	321	220	300	326	220	300	300	375	460	552
	SINUS 0260	110	150	332	200	270	341	260	350	390	280	380	393	425	560	672
S51	SINUS 0313	132	180	390	220	300	375	260	350	390	300	400	413	480	600	720
	SINUS 0367	150	200	458	250	340	421	315	430	459	355	485	471	550	680	792
	SINUS 0402	160	220	475	315	430	528	375	510	540	400	550	544	680	850	1020
S60	SINUS 0457	200	270	593	315	430	528	400	550	576	450	610	612	720	880	1056
	SINUS 0524	220	300	661	355	480	589	450	610	665	500	680	673	800	960	1152
S65 ¹⁾	SINUS 0598	-	-	-	400	550	680	500	680	731	560	760	751	900	1100	1320
	SINUS 0748	-	-	-	500	680	841	560	760	817	630	860	864	1000	1300	1560
	SINUS 0831	-	-	-	560	760	939	630	860	939	710	970	960	1200	1440	1728
S75 ¹⁾	SINUS 0964	-	-	-	710	970	1200	800	1090	1160	900	1230	1184	1480	1780	2136
	SINUS 1130	-	-	-	800	1090	1334	900	1230	1287	1000	1360	1317	1700	2040	2448
	SINUS 1296	-	-	-	1000	1360	1650	1100	1500	1630	1170	1600	1560	2100	2520	3024
S90 ¹⁾	SINUS 1800	-	-	-	1200	1650	2050	1450	1970	2050	1500	2000	2050	2600	3100	3600
	SINUS 2076	-	-	-	1400	1910	2400	1700	2300	2400	1750	2400	2400	3000	3600	3600
Inverter supply voltage		200-240Vac; 280-360Vdc			380-500Vac; 530-705Vdc											
¹⁾ Input inductor and output inductor required.																

Key:

Inom = continuous rated current of the inverter

I_{max} = max. current produced by the inverter for 120s every 20 min up to S30, for 60s every 10 min for S41 and greater

I_{peak} = deliverable current for max. 3 seconds

5.1.3.2. Technical Sheet for 5T and 6T Voltage Classes

Size	Sinus Penta Model	Applicable Motor Power						Inom	Imax	Ipeak (3 s.)
		575Vac			660-690Vac					
		kW	HP	A	kW	HP	A			
S12 5T S14 6T	SINUS 0003	3	4	4.4	4	5.5	4.8	7	8.5	10
	SINUS 0004	4	5.5	5.7	4	5.5	4.8	9	11	13
	SINUS 0006	5.5	7.5	7.6	7.5	10	8.4	11	13.5	16
	SINUS 0012	7.5	10	10	7.5	10	8.4	13	16	19
	SINUS 0018	9.2	12.5	12.5	11	15	12.1	17	21	25
S14	SINUS 0019	11	15	14	11	15	12.1	21	25	30
	SINUS 0021	15	20	20	15	20	16.8	25	30	36
	SINUS 0022	18.5	25	25	22	30	23	33	40	48
	SINUS 0024	22	30	28	22	30	23	40	48	58
	SINUS 0032	30	40	39	37	50	39	52	63	76
S22	SINUS 0042	37	50	47	37	50	39	60	72	86
	SINUS 0051	45	60	55	55	75	56	80	96	115
	SINUS 0062	55	75	70	55	75	56	85	110	132
	SINUS 0069	55	75	70	75	100	78	105	135	162
S32	SINUS 0076	75	100	95	90	125	94	125	165	198
	SINUS 0088	110	150	135	110	150	113	150	200	240
	SINUS 0131	110	150	135	160	220	158	190	250	300
	SINUS 0164	132	180	168	185	250	185	230	300	360
S42	SINUS 0181	185	250	225	220	300	220	305	380	420
	SINUS 0201	200	270	240	250	340	250	330	420	420
	SINUS 0218	220	300	275	315	430	310	360	465	560
	SINUS 0259	280	380	336	355	485	341	400	560	560
S52	SINUS 0290	300	400	358	400	550	390	450	600	720
	SINUS 0314	330	450	395	450	610	440	500	665	798
	SINUS 0368	355	485	420	500	680	480	560	720	850
	SINUS 0401	400	550	473	560	770	544	640	850	850
S65 ¹⁾	SINUS 0457	500	680	585	560	770	544	720	880	1056
	SINUS 0524	560	770	630	630	860	626	800	960	1152
	SINUS 0598	630	860	720	710	970	696	900	1100	1320
	SINUS 0748	710	970	800	900	1230	858	1000	1300	1440
S70 ¹⁾	SINUS 0831	800	1090	900	1000	1360	954	1200	1440	1440
S75 ¹⁾	SINUS 0964	1000	1360	1145	1220	1660	1187	1480	1780	2136
	SINUS 1130	1170	1600	1360	1400	1910	1360	1700	2040	2448
S80 ¹⁾	SINUS 1296	1340	1830	1560	1610	2190	1560	2100	2520	2520
S90 ¹⁾	SINUS 1800	1750	2400	2050	2100	2860	2100	2600	3100	3600
	SINUS 2076	2000	2720	2400	2400	3300	2400	3000	3600	3600
Inverter Supply Voltage		500-600Vac; 705-845Vdc.			600-690Vac; 845-970Vdc.					
¹⁾ Input inductor and output inductor required.										

Key:

Inom = continuous rated current of the inverter

Imax = max. current produced by the inverter for 60 seconds every 10 min

Ipeak = deliverable current for max. 3 seconds

5.1.4. STRONG Applications: Overload up to 200% (60/120s) or up to 240% (3s)

5.1.4.1. Technical Sheet for 2T and 4T Voltage Classes

Size	Sinus Penta Model	Applicable Motor Power												Inom	Imax	Ipeak (3s)
		200-240Vac			380-415Vac			440-460Vac			480-500Vac					
		kW	HP	A	kW	HP	A	kW	HP	A	kW	HP	A			
S05	SINUS 0005	-	-	-	2.2	3	4.9	3	4	5.6	3.7	5	6.1	10.5	11.5	14
	SINUS 0007	1.5	2	6.1	3	4	6.4	3.7	5	6.6	4.5	6	7.2	12.5	13.5	16
	SINUS 0008	1.8	2.5	7.3	-	-	-	-	-	-	-	-	-	15	16	19
	SINUS 0009	-	-	-	4	5.5	8.4	4.5	6	7.8	5.5	7.5	9.0	16.5	17.5	19
	SINUS 0010	2.2	3	8.5	-	-	-	-	-	-	-	-	-	17	19	23
	SINUS 0011	-	-	-	4.5	6	9.0	5.5	7.5	9.7	7.5	10	11.8	16.5	21	25
	SINUS 0013	3	4	11.2	-	-	-	-	-	-	-	-	-	19	21	25
	SINUS 0014	-	-	-	5.5	7.5	11.2	7.5	10	12.5	9.2	12.5	14.3	16.5	25	30
	SINUS 0015	3.7	5	13.2	-	-	-	-	-	-	-	-	-	23	25	30
	SINUS 0016	4	5.5	14.6	-	-	-	-	-	-	-	-	-	27	30	36
SINUS 0020	4.5	6	15.7	-	-	-	-	-	-	-	-	-	30	36	43	
S12	SINUS 0016	-	-	-	7.5	10	14.8	9.2	12.5	15.6	11	15	16.5	27	30	36
	SINUS 0017	-	-	-	7.5	10	14.8	9.2	12.5	15.6	12.5	17	18.9	30	32	37
	SINUS 0020	-	-	-	9.2	12.5	17.9	11	15	18.3	12.5	17	18.9	30	36	43
	SINUS 0023	5.5	7.5	19.5	-	-	-	-	-	-	-	-	-	38	42	51
	SINUS 0025	-	-	-	11	15	21	15	20	25	15	20	23.2	41	48	58
	SINUS 0030	-	-	-	15	20	29	18.5	25	30	18.5	25	28	41	56	67
	SINUS 0033	7.5	10	25.7	-	-	-	-	-	-	-	-	-	51	56	68
	SINUS 0034	-	-	-	18.5	25	35	22	30	36	22	30	33	57	63	76
	SINUS 0036	-	-	-	22	30	41	25	35	40	28	38	41	60	72	86
	SINUS 0037	11	15	36	-	-	-	-	-	-	-	-	-	65	72	83
S15	SINUS 0040	12.5	17	41	22	30	41	25	35	40	30	40	44	72	80	88
	SINUS 0049	15	20	50	25	35	46	30	40	48	37	50	53	80	96	115
S20	SINUS 0060	18.5	25	61	30	40	55	37	50	58	45	60	64	88	112	134
	SINUS 0067	20	27	66	32	45	59	40	55	63	50	70	70	103	118	142
	SINUS 0074	22	30	71	37	50	67	45	60	70	55	75	78	120	144	173
	SINUS 0086	25	35	80	45	60	80	55	75	85	65	90	88	135	155	186
S30	SINUS 0113	30	40	96	55	75	98	65	88	100	75	100	103	180	200	240
	SINUS 0129	37	50	117	65	90	114	75	100	116	85	115	120	195	215	258
	SINUS 0150	45	60	135	75	100	133	90	125	135	90	125	127	215	270	324
	SINUS 0162	55	75	170	90	125	159	110	150	166	110	150	153	240	290	324

(continued)

(continued)

S41	SINUS 0180	60	85	185	110	150	191	120	165	184	132	180	180	300	340	408
	SINUS 0202	65	90	195	132	180	228	150	200	230	160	220	218	345	420	504
	SINUS 0217	75	100	231	150	200	260	160	220	245	185	250	257	375	460	552
	SINUS 0260	90	125	277	160	220	273	200	270	307	200	270	273	425	560	672
S51	SINUS 0313	110	150	332	185	250	321	220	300	326	250	340	337	480	600	720
	SINUS 0367	120	165	375	200	270	341	250	340	366	260	350	359	550	680	792
	SINUS 0402	132	180	390	280	380	480	315	430	462	355	480	471	680	850	1020
S60	SINUS 0457	160	220	475	280	380	480	330	450	493	375	510	497	720	880	1056
	SINUS 0524	185	250	550	315	430	528	375	510	540	400	550	544	800	960	1152
S65 ¹⁾	SINUS 0598	-	-	-	355	480	589	400	550	591	450	610	612	900	1100	1320
	SINUS 0748	-	-	-	400	550	680	500	680	731	560	760	751	1000	1300	1560
	SINUS 0831	-	-	-	450	610	765	560	760	817	630	860	864	1200	1440	1728
S75 ¹⁾	SINUS 0964	-	-	-	560	770	939	710	970	1043	800	1090	1067	1480	1780	2136
	SINUS 1130	-	-	-	710	970	1200	800	1090	1160	900	1230	1184	1700	2040	2448
	SINUS 1296	-	-	-	800	1090	1334	900	1230	1287	1000	1360	1317	2100	2520	3024
S90 ¹⁾	SINUS 1800	-	-	-	1000	1360	1650	1170	1600	1650	1200	1650	1650	2600	3100	3600
	SINUS 2076	-	-	-	1200	1650	2050	1450	1970	2050	1500	2000	2050	3000	3600	3600
Inverter supply voltage		200-240Vac; 280-360Vdc.			380-500Vac; 530-705Vdc.											
¹⁾ Input inductor and output inductor required.																

Key:

Inom = continuous rated current of the inverter

I_{max} = max. current produced by the inverter for 120s every 20 min up to S30, for 60s every 10 min for S41 and greater

I_{peak} = deliverable current for max. 3 seconds

5.1.4.2. Technical Sheet for 5T and 6T Voltage Classes

Size	Sinus Penta Model	Applicable Motor Power						Inom	Imax	Ipeak (3s)	
		575Vac			660-690Vac						
		kW	HP	A	kW	HP	A				
S12 5T S14 6T	SINUS 0003	3	4	4.4	3	4	3.7	7	8.5	10	
	SINUS 0004	4	5.5	5.7	4	5.5	4.8	9	11	13	
	SINUS 0006	4	5.5	5.7	5.5	7.5	6.3	11	13.5	16	
	SINUS 0012	5.5	7.5	7.6	7.5	10	8.4	13	16	19	
	SINUS 0018	7.5	10	10	9.2	12.5	10.2	17	21	25	
S14	SINUS 0019	9.2	12.5	12.5	11	15	12	21	25	30	
	SINUS 0021	11	15	14	11	15	12	25	30	36	
	SINUS 0022	15	20	20	18.5	25	21	33	40	48	
	SINUS 0024	18.5	25	25	22	30	23	40	48	58	
	SINUS 0032	25	35	32	30	40	33	52	63	76	
S22	SINUS 0042	30	40	39	30	40	33	60	72	86	
	SINUS 0051	37	50	47	45	60	46	80	96	115	
	SINUS 0062	45	60	55	55	75	56	85	110	132	
	SINUS 0069	45	60	55	55	75	56	105	135	162	
S32	SINUS 0076	55	75	70	75	100	77	125	165	198	
	SINUS 0088	75	100	95	90	125	95	150	200	240	
	SINUS 0131	90	125	115	110	150	115	190	250	300	
	SINUS 0164	110	150	138	132	180	140	230	300	360	
S42	SINUS 0181	160	220	198	200	270	198	305	380	420	
	SINUS 0201	160	220	198	220	300	220	330	420	420	
	SINUS 0218	200	270	240	250	340	250	360	465	560	
	SINUS 0259	220	300	275	315	430	310	400	560	560	
S52	SINUS 0290	250	340	300	355	480	341	450	600	720	
	SINUS 0314	280	380	336	375	510	360	500	665	798	
	SINUS 0368	315	430	367	400	550	390	560	720	850	
	SINUS 0401	355	480	410	500	680	480	640	850	850	
S65 ¹⁾	SINUS 0457	400	550	480	500	680	480	720	880	1056	
	SINUS 0524	450	610	532	560	770	544	800	960	1152	
	SINUS 0598	560	770	630	630	860	626	900	1100	1320	
	SINUS 0748	630	860	720	800	1090	773	1000	1300	1440	
S70 ¹⁾	SINUS 0831	710	970	800	900	1230	858	1200	1440	1440	
S75 ¹⁾	SINUS 0964	900	1230	1000	1000	1360	954	1480	1780	2136	
	SINUS 1130	1000	1360	1145	1100	1500	1086	1700	2040	2448	
S80 ¹⁾	SINUS 1296	1150	1570	1337	1380	1880	1337	2100	2520	2520	
S90 ¹⁾	SINUS 1800	1460	1990	1700	1750	2380	1700	2600	3100	3600	
	SINUS 2076	1750	2400	2050	2100	2860	2100	3000	3600	3600	
Inverter supply voltage		500-600Vac; 705-845Vdc			600-690Vac; 845-970Vdc						

¹⁾ Input inductor and output inductor required.

Key:

Inom = continuous rated current of the inverter

Imax = max. current produced by the inverter for 60 seconds every 10 min

Ipeak = deliverable current for max. 3 seconds

5.2. Carrier Frequency Setting

The continuous current (I_{nom}) generated by the inverter in continuous operation type S1 at 40°C depends on carrier frequency. The higher the carrier frequency, the more the motor is silent; the control performance is enhanced, but this causes a greater heating of the inverter, thus affecting energy saving. Using long cables (especially shielded cables) for connecting the motor is not recommended when the carrier frequency is high.

The max. recommended carrier values that can be set in parameter **C002** (Carrier Frequency menu) based on the continuous current delivered by the Sinus Penta are given in the tables below.

Higher combinations of carrier frequency and continuous output DC currents may trigger alarm **A094** (Heat sink overtemperature).

For example, if a Penta S05 0014 4T with 11kHz carrier frequency is to be used, the max. continuous output current exceeding $0.70 \cdot I_{nom}$ may trigger alarm **A094**.



CAUTION

The FOC control algorithm exploits:

- $f_{carrier\ max}$ if $f_{carrier\ max} < 8\text{kHz}$ (whatever the value in **C002**);
- 8kHz if $f_{carrier\ max} > 8\text{kHz}$ and **C002** < 8kHz;
- **C002** if $f_{carrier\ max} > 8\text{kHz}$ and **C002** > 8kHz.

5.2.1. IP20 and IP00 Models – Class 2T-4T

Size	Sinus Penta Model	Maximum Recommended Carrier Frequency (kHz) (parameters C001 and C002) based on the output current				Carrier (kHz)	
		I_{nom}	$0.85 \cdot I_{nom}$	$0.70 \cdot I_{nom}$	$0.55 \cdot I_{nom}$	Def.	Max.
S05 4T	0005	12.8	16	16	16	5	16
	0007	10	12.8	16	16	5	16
	0009	5	8	11	16	5	16
	0011	5	8	11	16	5	16
	0014	5	8	11	16	5	16
S05 2T	0007	16	16	16	16	5	16
	0008	10	10	10	10	5	10
	0010	10	10	10	10	5	10
	0013	10	10	10	10	5	10
	0015	10	10	10	10	5	10
	0016	10	10	10	10	3	10
	0020	5	10	10	10	3	10
S12 4T	0016	10	10	10	10	3	10
	0017	8	10	10	10	3	10
	0020	8	10	10	10	3	10
	0025	5	6	7	7	3	7
	0030	5	6	7	7	3	7
	0034	5	10	10	10	3	10
	0036	5	10	10	10	3	10
S12 2T	0023	10	10	10	10	3	10
	0033	10	10	10	10	3	10
	0037	3	8	10	10	3	10
S15 2T/4T	0040	5	8	16	16	3	16
	0049	3	5	10	12.8	3	12.8

(continued)

(continued)

Size	Sinus Penta Model	Maximum Recommended Carrier Frequency (kHz) (parameters C001 and C002) based on the output current				Carrier (kHz)	
		Inom	0.85* Inom	0.70* Inom	0.55* Inom	Def.	Max.
S20 2T/4T	0060	10	10	10	10	3	10
	0067	10	10	10	10	3	10
	0074	10	10	10	10	3	10
	0086	5	5	10	10	3	10
S30 2T/4T	0113	4	8	10	10	2	10
	0129	3	6	10	10	2	10
	0150	4	5	5	5	2	5
	0162	3	4	5	5	2	5
S41 2T/4T	0180	4	5	5	5	2	5
	0202	4	5	5	5	2	5
	0217	3	4	5	5	2	5
	0260	2	3	5	5	2	5
S51 2T/4T	0313	5	5	5	5	2	5
	0367	3	5	5	5	2	5
	0402	2	3	5	5	2	5
S60 2T/4T	0457	5	5	5	5	2	4
	0524	4	5	5	5	2	4
S65 4T	0598	4	4	4	4	2	4
	0748	4	4	4	4	2	4
	0831	4	4	4	4	2	4
S75 4T	0964	4	4	4	4	2	4
	1130	4	4	4	4	2	4
	1296	4	4	4	4	2	4
S90 4T	1800	2	4	4	4	2	4
	2076	2	4	4	4	2	4

5.2.2. IP20 and IP00 Models – Class 5T-6T

Size	Sinus Penta Model	Maximum Recommended Carrier Frequency (kHz) (parameters C001 and C002) based on the output current				Carrier (kHz)	
		Inom	0.85* Inom	0.70* Inom	0.55* Inom	Def.	Max.
S12 5T	0003	5	5	5	5	3	5
	0004	5	5	4	5	3	5
	0006	5	5	5	5	3	5
	0012	4	5	5	5	3	5
	0018	3	4	5	5	3	5
S14 6T	0003	5	5	5	5	3	5
	0004	5	5	5	5	3	5
	0006	5	5	5	5	3	5
	0012	5	5	5	5	3	5
	0018	5	5	5	5	3	5
S14 5T/6T	0019	5	5	5	5	3	5
	0021	5	5	5	5	3	5
	0022	5	5	5	5	3	5
	0024	4	5	5	5	3	5
	0032	3	4	5	5	3	5
S22 5T/6T	0042	5	5	5	5	3	5
	0051	4	5	5	5	3	5
	0062	4	5	5	5	3	5
	0069	3	4	5	5	3	5
S32 5T/6T	0076	4	4	4	4	2	4
	0088	4	4	4	4	2	4
	0131	3	4	4	4	2	4
	0164	2	3	4	4	2	4
S42 5T/6T	0181	2	3	4	4	2	4
	0201	2	3	4	4	2	4
	0218	2	2	3	4	2	4
	0259	2	2	3	4	2	4
S52 5T/6T	0290	3	4	4	4	2	4
	0314	3	3	4	4	2	4
	0368	2	3	4	4	2	4
	0401	2	2	3	4	2	4
S65 5T/6T	0457	4	4	4	4	2	4
	0524	4	4	4	4	2	4
	0598	3	4	4	4	2	4
	0748	2	2	2	2	2	2
S70 5T/6T	0831	2	2	2	2	2	2
S75 5T/6T	0964	2	2	2	2	2	2
	1130	2	2	2	2	2	2
S80 5T/6T	1296	2	2	2	2	2	2
S90 5T/6T	1800	2	2	2	2	2	2
	2072	2	2	2	2	2	2

5.2.3. IP54 Models – Class 2T-4T

Size	Sinus Penta Model	Maximum Recommended Carrier Frequency (kHz) (parameters C001 and C002) based on the output current				Carrier (kHz)	
		Inom	0.85* Inom	0.70* Inom	0.55* Inom	Def.	Max.
S05 4T	0005	12.8	16	16	16	5	16
	0007	10	12.8	16	16	5	16
	0009	5	8	11	16	5	16
	0011	5	8	11	16	5	16
	0014	5	8	11	16	5	16
S05 2T	0007	16	16	16	16	5	16
	0008	10	10	10	10	5	10
	0010	10	10	10	10	5	10
	0013	10	10	10	10	5	10
	0015	10	10	10	10	5	10
	0016	10	10	10	10	3	10
	0020	Unavailable model as IP54					
S12 4T	0016	10	10	10	10	3	10
	0017	8	10	10	10	3	10
	0020	8	10	10	10	3	10
	0025	4	6	7	7	3	7
	0030	4	6	7	7	3	7
	0034	3	6	10	10	3	10
	0036	3	6	8	10	3	10
S12 2T	0023	10	10	10	10	3	10
	0033	10	10	10	10	3	10
	0037	3	8	10	10	3	10
S15 2T/4T	0040	5	8	16	16	3	16
	0049	3	5	10	12.8	3	12.8
S20 2T/4T	0060	10	10	10	10	3	10
	0067	10	10	10	10	3	10
	0074	10	10	10	10	3	10
	0086	5	5	10	10	3	10
S30 2T/4T	0113	4	8	10	10	2	10
	0129	3	6	10	10	2	10
	0150	4	5	5	5	2	5
	0162	3	4	5	5	2	5

5.2.4. IP54 Models – Class 5T-6T

Size	Sinus Penta Model	Maximum Recommended Carrier Frequency (kHz) (parameters C001 and C002) based on the output current				Carrier (kHz)	
		Inom	0.85* Inom	0.70* Inom	0.55* Inom	Def.	Max.
S12 5T	0003	5	5	5	5	3	5
	0004	5	5	4	5	3	5
	0006	5	5	5	5	3	5
	0012	4	5	5	5	3	5
	0018	3	4	5	5	3	5
S14 6T	0003	5	5	5	5	3	5
	0004	5	5	5	5	3	5
	0006	5	5	5	5	3	5
	0012	5	5	5	5	3	5
	0018	5	5	5	5	3	5
S14 5T/6T	0019	5	5	5	5	3	5
	0021	5	5	5	5	3	5
	0022	5	5	5	5	3	5
	0024	4	5	5	5	3	5
	0032	Unavailable model as IP54					
S22 5T/6T	0042	5	5	5	5	3	5
	0051	4	5	5	5	3	5
	0062	4	5	5	5	3	5
	0069	3	4	5	5	3	5
S32 5T/6T	0076	4	4	4	4	2	4
	0088	4	4	4	4	2	4
	0131	3	4	4	4	2	4
	0164	2	3	4	4	2	4

5.3. Operating Temperatures Based On Application Category



NOTE

The tables below relate to operating current values equal to or lower than the current rating stated in the relevant application sheet.

Size	Sinus Penta Model	APPLICATION - CLASS 2T-4T			
		LIGHT	STANDARD	HEAVY	STRONG
		Maximum allowable operating temperature (°C) without derating. Apply 2% derating of the rated current for every degree over but not exceeding 55°C maximum.			
S05	0005	50	50	50	50
	0007	50	50	50	50
	0009	40	45	50	50
	0011	40	40	45	50
	0014	40	40	40	50
	0015	50	50	50	50
	0016	45	50	50	50
S12	0020	40	45	50	50
	0016	45	45	50	50
	0017	40	45	50	50
	0020	40	40	50	50
	0023	50	50	50	50
	0025	40	40	50	50
	0030	40	40	45	50
	0033	45	50	50	50
S15	0034	40	45	50	50
	0036	40	40	45	50
S20	0037	40	40	45	50
	0040	40	45	50	50
	0049	40	40	50	50
	0060	45	45	50	50
S30	0067	40	40	50	50
	0074	45	45	50	50
	0086	40	40	50	50
	0113	45	45	50	50
S30	0129	40	45	50	50
	0150	45	45	50	50
	0162	40	40	50	50

(continued)

(continued)

Size	Sinus Penta Model	APPLICATION - CLASS 2T-4T			
		LIGHT	STANDARD	HEAVY	STRONG
		Maximum allowable operating temperature (°C) without derating. Apply 2% derating of the rated current for every degree over but not exceeding 55°C maximum.			
S41	0180	45	50	50	50
	0202	40	50	50	50
	0217	45	45	50	50
	0260	40	40	45	50
S51	0313	50	50	50	50
	0367	50	50	50	50
	0402	40	40	45	50
S60	0457	45	45	50	50
	0524	40	40	50	50
S65	0598	50	50	50	50
	0748	45	45	50	50
	0831	40	40	50	50
S75	0964	50	50	50	50
	1130	45	45	50	50
	1296	40	40	50	50
S90	1800	50	50	50	50
	2076	45	45	50	50

Size	Sinus Penta Model	APPLICATION – CLASS 5T-6T			
		LIGHT	STANDARD	HEAVY	STRONG
		Maximum allowable operating temperature (°C) without derating. Apply 2% derating of the rated current for every degree over but not exceeding 55°C maximum.			
S12 5T	0003	50	50	50	50
	0004	50	50	50	50
	0006	50	50	50	50
	0012	50	50	50	50
	0018	40	40	50	50
S14 6T	0003	50	50	50	50
	0004	50	50	50	50
	0006	50	50	50	50
	0012	50	50	50	50
	0018	50	50	50	50
S14	0019	50	50	50	50
	0021	50	50	50	50
	0022	50	50	50	50
	0024	50	50	50	50
	0032	40	50	50	50
S22	0042	50	50	50	50
	0051	45	50	50	50
	0062	45	45	50	50
	0069	40	40	45	50
S32	0076	50	50	50	50
	0088	50	50	50	50
	0131	45	45	45	50
	0164	40	45	45	50
S42	0181	50	50	50	50
	0201	40	40	45	50
	0218	45	45	50	50
	0259	40	40	45	50
S52	0290	50	50	50	50
	0314	50	50	50	50
	0368	45	45	50	50
	0401	40	40	45	50
S65	0457	50	50	50	50
	0524	50	50	50	50
	0598	50	50	50	50
	0748	45	45	50	50
S70	0831	40	40	50	50
S75	0964	50	50	50	50
	1130	45	45	50	50
S80	1296	40	40	50	50
S90	1800	50	50	50	50
	2076	45	45	50	50

6. ACCESSORIES

6.1. Resistive Braking

When a large braking torque is required or the load connected to the motor is pulled (as for instance in lifting applications), the power regenerated by the motor is to be dissipated. This can be obtained either by dissipating energy to braking resistors (in that case a braking module is required), or by powering the inverter via the DC-bus using a system able to deliver energy to the mains. Both solutions are available.

The first solution is described below; for the second solution, please refer to the technical documentation pertaining to the Regenerative Inverter.

The braking modules are integrated into the Sinus Penta up to S32 included; for greater sizes, the braking modules are to be externally installed. The resistors allowing dissipating the energy regenerated by the inverter are to be connected to the braking modules.

From size S05 to size S32, Sinus Penta inverters are supplied with a built-in braking module. The braking resistor is to be connected outside the inverter to terminal B and terminal + (see Power Terminals for S05–S52); properly set the parameters relating to the inverter braking (see the Sinus Penta's Programming Guide). External braking units are used for greater sizes; please refer to the relevant sections in this manual also for the description of the suitable braking resistors.

When choosing the braking resistor, consider the inverter supply voltage (voltage class), the braking resistor Ohm value and rated power. The voltage class and the Ohm value determine the instant power dissipated in the braking resistor and are relating to the motor power; the rated power determines the mean power to be dissipated in the braking resistor and is relating to the duty cycle of the equipment, i.e. to the resistor activation time in respect to the duty cycle full time (the duty cycle of the resistor is equal to the motor braking time divided by the equipment duty cycle).

It is not possible to connect resistors with a Ohm value lower than the min. value acknowledged by the inverter.

The following pages contain application tables stating the resistors to be used depending on the inverter model, the application requirements and the supply voltage. The braking resistor power is given as an approximate empirical value; the correct dimensioning of the braking resistor is based on the equipment duty cycle and the power regenerated during the braking stage.

6.1.1. Braking Resistors



NOTE The wire cross-sections given in the table relate to one wire per braking resistor.



DANGER The braking resistor case may reach 200°C based on the operating cycle.



CAUTION The power dissipated by the braking resistors may be the same as the rated power of the connected motor multiplied by the braking duty-cycle; use a proper air-cooling system. Do not install braking resistors near heat-sensitive equipment or objects.



CAUTION Do not connect to the inverter any braking resistor with an Ohm value lower than the value given in the tables.

6.1.1.1. Applications with DUTY CYCLE 10% - Class 2T

Size	Model	BRAKING RESISTORS					
		Min. Applicable Resistor (Ω)	Type	Degree of Protection	Type of Connection	Value (Ω)	Wire cross-section mm ² (AWG)
S05	0007	25.0	56Ω-350W	IP55	A	56	2.5(14)
	0008	25.0	2*56Ω-350W	IP55	B	28	2.5(14)
	0010	25.0	2*56Ω-350W	IP55	B	28	2.5(14)
	0013	18.0	2*56Ω-350W	IP55	B	28	2.5(14)
	0015	18.0	2*56Ω-350W	IP55	B	28	2.5(14)
	0016	18.0	3*56Ω-350W	IP55	B	18.7	2.5(14)
	0020	18.0	3*56Ω-350W	IP55	B	18.7	2.5(14)
S12	0023	15.0	15Ω-1100W	IP55	A	15	4(12)
	0033	10.0	10Ω-1500W	IP54	A	10	4(12)
	0037	10.0	10Ω-1500W	IP54	A	10	4(12)
S15	0040	7.5	2*15Ω-1100W	IP55	A	7.5	4(12)
	0049	5.0	5Ω-4000W	IP20	A	5.0	10(8)
S20	0060	5.0	5Ω-4000W	IP20	A	5.0	10(8)
	0067	5.0	5Ω-4000W	IP20	A	5.0	10(8)
	0074	4.2	5Ω-4000W	IP20	A	5.0	10(8)
	0086	4.2	5Ω-4000W	IP20	A	5.0	10(8)
S30	0113	3.0	3.3Ω-8000W	IP20	A	3.3	10(8)
	0129	3.0	3.3Ω-8000W	IP20	A	3.3	10(8)
	0150	2.5	3.3Ω-8000W	IP20	A	3.3	10(8)
	0162	2.5	3.3Ω-8000W	IP20	A	3.3	10(8)

Type of connection:

A - One resistor

B - Two or multiple parallel-connected resistors



CAUTION

The cables of the braking resistors shall have insulation features and heat-resistance features suitable for the application. The minimum rated voltage of the cables must be 450/700V.

6.1.1.2. Applications with DUTY CYCLE 20% - Class 2T

Size	Model	BRAKING RESISTORS					
		Min. Applicable Resistor (Ω)	Type	Degree of Protection	Type of Connection	Value (Ω)	Wire cross-section mm ² (AWG)
S05	0007	25.0	2*100Ω-350W	IP55	B	50	2.5(14)
	0008	25.0	2*56Ω-350W	IP55	B	28	2.5(14)
	0010	25.0	2*56Ω-350W	IP55	B	28	2.5(14)
	0013	18.0	4*100Ω-350W	IP55	B	25	2.5(14)
	0015	18.0	4*100Ω-350W	IP55	B	25	2.5(14)
	0016	18.0	25Ω-1800W	IP54	A	25	2.5(14)
	0020	18.0	25Ω-1800W	IP54	A	25	2.5(14)
S12	0023	15.0	15Ω-2200W	IP54	A	15	4(12)
	0033	10.0	2*25Ω-1800W	IP54	B	12.5	2.5(14)
	0037	10.0	2*25Ω-1800W	IP54	B	12.5	2.5(14)
S15	0040	7.5	2*15Ω-2200W	IP54	B	7.5	2.5(14)
	0049	5	5Ω-4000W	IP20	A	5	6(10)
S20	0060	5.0	5Ω-8000W	IP20	A	5	10(8)
	0067	5.0	5Ω-8000W	IP20	A	5	10(8)
	0074	4.2	5Ω-8000W	IP20	A	5	10(8)
	0086	4.2	5Ω-8000W	IP20	A	5	10(8)
S30	0113	3.0	3.3Ω-12000W	IP20	A	3.3	16(6)
	0129	3.0	3.3Ω-12000W	IP20	A	3.3	16(6)
	0150	2.5	3.3Ω-12000W	IP20	A	3.3	16(6)
	0162	2.5	3.3Ω-12000W	IP20	A	3.3	16(6)

Type of connection:

A - One resistor

B - Two or multiple parallel-connected resistors



CAUTION

The cables of the braking resistors shall have insulation features and heat-resistance features suitable for the application. The minimum rated voltage of the cables must be 450/700V.

6.1.1.3. Applications with DUTY CYCLE 50% - Class 2T

Size	Model	BRAKING RESISTORS					
		Min. Applicable Resistor (Ω)	Type	Degree of Protection	Type of Connection	Value (Ω)	Wire cross-section mm^2 (AWG)
S05	0007	25.0	50 Ω -1100W	IP55	A	50	2.5(14)
	0008	25.0	25 Ω -1800W	IP54	A	25	2.5(14)
	0010	25.0	25 Ω -1800W	IP54	A	25	2.5(14)
	0013	18.0	25 Ω -4000W	IP20	A	25	2.5(14)
	0015	18.0	25 Ω -4000W	IP20	A	25	2.5(14)
	0016	18.0	25 Ω -4000W	IP20	A	25	2.5(14)
	0020	18.0	20 Ω -4000W	IP20	A	20	4(12)
S12	0023	15.0	20 Ω -4000W	IP20	A	20	6(10)
	0033	10.0	10 Ω -8000W	IP20	A	10	10(8)
	0037	10.0	10 Ω -8000W	IP20	A	10	10(8)
S15	0040	6.6	6.6 Ω -12000W	IP20	A	6.6	16(6)
	0049	6.6	6.6 Ω -12000W	IP20	A	6.6	16(6)
S20	0060	5.0	6.6 Ω -12000W	IP20	A	6.6	16(6)
	0067	5.0	2*10 Ω -8000W	IP20	B	5	10(8)
	0074	4.2	2*10 Ω -8000W	IP20	B	5	10(8)
	0086	4.2	2*10 Ω -8000W	IP20	B	5	10(8)
S30	0113	3.0	2*6.6 Ω -12000W	IP20	B	3.3	16(6)
	0129	3.0	2*6.6 Ω -12000W	IP20	B	3.3	16(6)
	0150	2.5	3*10 Ω -12000W	IP20	B	3.3	10(8)
	0162	2.5	3*10 Ω -12000W	IP20	B	3.3	10(8)

Type of connection:

A - One resistor

B - Two or multiple parallel-connected resistors



CAUTION

The cables of the braking resistors shall have insulation features and heat-resistance features suitable for the application. The minimum rated voltage of the cables must be 450/700V.

6.1.1.4. Applications with DUTY CYCLE 10% - Class 4T

Size	Model	BRAKING RESISTORS					
		Min. Applicable Resistor (Ω)	Type	Degree of Protection	Type of Connection	Value (Ω)	Wire cross-section mm^2 (AWG)
S05	0005	50	75 Ω -550W	IP33	A	75	2.5(14)
	0007	50	75 Ω -550W	IP33	A	75	2.5(14)
	0009	50	50 Ω -1100W	IP55	A	50	2.5(14)
	0011	50	50 Ω -1100W	IP55	A	50	2.5(14)
	0014	50	50 Ω -1100W	IP55	A	50	2.5(14)
S12	0016	40	50 Ω -1500W	IP54	A	50	2.5(14)
	0017	40	50 Ω -1500W	IP54	A	50	2.5(14)
	0020	40	50 Ω -1500W	IP54	A	50	2.5(14)
	0025	20	25 Ω -1800W	IP54	A	25	4(12)
	0030	20	25 Ω -1800W	IP54	A	25	4(12)
	0034	20	20 Ω -4000W	IP20	A	20	4(12)
	0036	20	20 Ω -4000W	IP20	A	20	4(12)
S15	0040	15	15 Ω -4000W	IP20	A	15	6(10)
	0049	10	15 Ω -4000W	IP20	A	15	6(10)
S20	0060	10	10 Ω -8000W	IP20	A	10	10(8)
	0067	10	10 Ω -8000W	IP20	A	10	10(8)
	0074	7.5	10 Ω -8000W	IP20	A	10	10(8)
	0086	7.5	10 Ω -8000W	IP20	A	10	10(8)
S30	0113	6	6.6 Ω -12000W	IP20	A	6.6	10(8)
	0129	6	6.6 Ω -12000W	IP20	A	6.6	10(8)
	0150	5	5 Ω -16000W	IP20	A	5	16(6)
	0162	5	5 Ω -16000W	IP20	A	5	16(6)

Type of connection:
A - One resistor



CAUTION

The cables of the braking resistors shall have insulation features and heat-resistance features suitable for the application. The minimum rated voltage of the cables must be 0.6/1kV.

6.1.1.5. Applications with DUTY CYCLE 20% - Class 4T

Size	Model	BRAKING RESISTORS					
		Min. Applicable Resistor (Ω)	Type	Degree of Protection	Type of Connection	Value (Ω)	Wire cross-section mm^2 (AWG)
S05	0005	50	50 Ω -1100W	IP55	A	50	2.5(14)
	0007	50	50 Ω -1100W	IP55	A	50	2.5(14)
	0009	50	50 Ω -1100W	IP55	A	50	2.5(14)
	0011	50	50 Ω -1500W	IP54	A	50	2.5(14)
	0014	50	50 Ω -1500W	IP54	A	50	2.5(14)
S12	0016	40	50 Ω -2200W	IP54	A	50	2.5(14)
	0017	40	50 Ω -2200W	IP54	A	50	2.5(14)
	0020	40	50 Ω -4000W	IP20	A	50	2.5(14)
	0025	20	25 Ω -4000W	IP20	A	25	6(10)
	0030	20	25 Ω -4000W	IP20	A	25	6(10)
	0034	20	20 Ω -4000W	IP20	A	20	6(10)
	0036	20	20 Ω -4000W	IP20	A	20	6(10)
S15	0040	15	15 Ω -8000W	IP23	A	15	10(8)
	0049	10	10 Ω -12000W	IP20	A	10	10(8)
S20	0060	10	10 Ω -12000W	IP20	A	10	16(6)
	0067	10	10 Ω -12000W	IP20	A	10	16(6)
	0074	7.5	10 Ω -16000W	IP23	A	10	16(6)
	0086	7.5	10 Ω -16000W	IP23	A	10	16(6)
S30	0113	6	2*3.3 Ω -8000W	IP20	C	6.6	16(6)
	0129	6	2*3.3 Ω -8000W	IP20	C	6.6	16(6)
	0150	5	2*10 Ω -12000W	IP20	B	5	16(6)
	0162	5	2*10 Ω -12000W	IP20	B	5	16(6)

Type of connection:

- A - One resistor
- B - Two or multiple parallel-connected resistors
- C - Two series-connected resistors



CAUTION

The cables of the braking resistors shall have insulation features and heat-resistance features suitable for the application. The minimum rated voltage of the cables must be 0.6/1kV.

6.1.1.6. Applications with DUTY CYCLE 50% - Class 4T

Size	Model	BRAKING RESISTORS					
		Min. Applicable Resistor (Ω)	Type	Degree of Protection	Type of Connection	Value (Ω)	Wire cross-section mm ² (AWG)
S05	0005	50	50 Ω -4000W	IP23	A	50	4(12)
	0007	50	50 Ω -4000W	IP23	A	50	4(12)
	0009	50	50 Ω -4000W	IP23	A	50	4(12)
	0011	50	50 Ω -4000W	IP23	A	50	4(12)
	0014	50	50 Ω -4000W	IP23	A	50	4(12)
S12	0016	40	50 Ω -8000W	IP23	A	50	4(12)
	0017	40	50 Ω -8000W	IP23	A	50	4(12)
	0020	40	50 Ω -8000W	IP23	A	50	4(12)
	0025	20	20 Ω -12000W	IP23	A	20	10(8)
	0030	20	20 Ω -12000W	IP23	A	20	10(8)
	0034	20	20 Ω -16000W	IP23	A	20	10(8)
	0036	20	20 Ω -16000W	IP23	A	20	10(8)
S15	0040	15	15 Ω -24000W	IP23	A	15	16(6)
	0049	10	15 Ω -24000W	IP23	A	15	16(6)
S20	0060	10	10 Ω -24000W	IP23	A	10	16(6)
	0067	10	10 Ω -24000W	IP23	A	10	16(6)
	0074	7.5	2*15 Ω -24000W	IP23	B	7.5	16(6)
	0086	7.5	2*15 Ω -24000W	IP23	B	7.5	16(6)
S30	0113	6	6 Ω -64000W	IP23	A	6	35(2)
	0129	6	6 Ω -64000W	IP23	A	6	35(2)
	0150	5	5 Ω -64000W	IP23	A	5	50(1/0)
	0162	5	5 Ω -64000W	IP23	A	5	50(1/0)

Type of connection:

A - One resistor

B - Two or multiple parallel-connected resistors



CAUTION

The cables of the braking resistors shall have insulation features and heat-resistance features suitable for the application. The minimum rated voltage of the cables must be 0.6/1kV.

6.1.1.7. Applications with DUTY CYCLE 10% - Class 5T

Size	Model	BRAKING RESISTOR					
		Min. Applicable Resistor (Ω)	Type	Degree of Protection	Type of Connection	Value (Ω)	Wire cross-section mm ² (AWG)
S14	0003	120	250 Ω -1100W	IP55	A	250	10(8)
	0004	120	180 Ω -1100W	IP55	A	180	10(8)
	0006	60	120 Ω -1800W	IP55	A	120	10(8)
	0012	60	100 Ω -2200W	IP55	A	100	10(8)
	0018	60	82 Ω -4000W	IP20	A	82	10(8)
	0019	40	60 Ω -4000W	IP20	A	60	10(8)
	0021	40	45 Ω -4000W	IP23	A	45	10(8)
	0022	25	45 Ω -4000W	IP23	A	45	10(8)
	0024	25	30 Ω -4000W	IP23	A	30	10(8)
	0032	20	22 Ω -8000W	IP23	A	22	10(8)
S22	0042	12	22 Ω -8000W	IP23	A	22	10(8)
	0051	12	18 Ω -8000W	IP23	A	18	10(8)
	0062	12	15 Ω -12000W	IP23	A	15	10(8)
	0069	12	12 Ω -12000W	IP23	A	12	10(8)
S32	0076	8	10 Ω -12000W	IP23	A	10	16(6)
	0088	8	8.2 Ω -16000W	IP23	A	8.2	16(6)
	0131	5	6.6 Ω -24000W	IP23	A	6.6	16(6)
	0164	5	5 Ω -24000W	IP23	A	5	16(6)

Type of connection:

A - One resistor



CAUTION

The cables of the braking resistors shall have insulation features and heat-resistance features suitable for the application. The minimum rated voltage of the cables must be 0.6/1kV.

6.1.1.8. Applications with DUTY CYCLE 20% - Class 5T

Size	Model	BRAKING RESISTOR					
		Min. Applicable Resistor (Ω)	Type	Degree of Protection	Type of Connection	Value (Ω)	Wire cross-section mm ² (AWG)
S14	0003	120	250 Ω -1500W	IP55	A	250	10(8)
	0004	120	180 Ω -1500W	IP55	A	180	10(8)
	0006	60	120 Ω -4000W	IP20	A	120	10(8)
	0012	60	100 Ω -4000W	IP20	A	100	10(8)
	0018	60	82 Ω -4000W	IP23	A	82	10(8)
	0019	40	60 Ω -4000W	IP23	A	60	10(8)
	0021	40	45 Ω -8000W	IP20	A	45	10(8)
	0022	25	45 Ω -8000W	IP23	A	45	10(8)
	0024	25	30 Ω -8000W	IP23	A	30	10(8)
	0032	20	22 Ω -12000W	IP23	A	22	10(8)
S22	0042	12	22 Ω -12000W	IP23	A	22	10(8)
	0051	12	18 Ω -12000W	IP23	A	18	10(8)
	0062	12	15 Ω -16000W	IP23	A	15	10(8)
	0069	12	12 Ω -16000W	IP23	A	12	10(8)
S32	0076	8	10 Ω -24000W	IP23	A	10	16(6)
	0088	8	8.2 Ω -24000W	IP23	A	8.2	16(6)
	0131	5	6.6 Ω -32000W	IP23	A	6.6	25(3)
	0164	5	5 Ω -48000W	IP23	A	5	25(3)

Type of connection:

A- One resistor



CAUTION

The cables of the braking resistors shall have insulation features and heat-resistance features suitable for the application. The minimum rated voltage of the cables must be 0.6/1kV.

6.1.1.9. Applications with DUTY CYCLE 50% - Class 5T

Size	Model	BRAKING RESISTOR					
		Min. Applicable Resistor (Ω)	Type	Degree of Protection	Type of Connection	Value (Ω)	Wire cross-section mm ² (AWG)
S14	0003	120	250 Ω -2200W	IP55	A	250	16(6)
	0004	120	180 Ω -4000W	IP20	A	180	16(6)
	0006	60	120 Ω -4000W	IP23	A	120	16(6)
	0012	60	100 Ω -4000W	IP23	A	100	16(6)
	0018	60	82 Ω -8000W	IP20	A	82	16(6)
	0019	40	60 Ω -8000W	IP23	A	60	16(6)
	0021	40	45 Ω -12000W	IP20	A	45	16(6)
	0022	25	45 Ω -12000W	IP23	A	45	16(6)
	0024	25	30 Ω -16000W	IP23	A	30	16(6)
	0032	20	22 Ω -16000W	IP23	A	22	16(6)
S22	0042	12	22 Ω -24000W	IP23	A	22	16(6)
	0051	12	18 Ω -24000W	IP23	A	18	16(6)
	0062	12	15 Ω -32000W	IP23	A	15	16(6)
	0069	12	12 Ω -48000W	IP23	A	12	16(6)
S32	0076	8	10 Ω -48000W	IP23	A	10	25(3)
	0088	8	8.2 Ω -64000W	IP23	A	8.2	25(3)
	0131	5	6.6 Ω -64000W	IP23	A	6.6	50(1/0)
	0164	5	2x10 Ω -48000W	IP23	B	5	50(1/0)

Type of connection:

A - One resistor

B - Two series-connected resistors



CAUTION

The cables of the braking resistors shall have insulation features and heat-resistance features suitable for the application. The minimum rated voltage of the cables must be 0.6/1kV.

6.1.1.10. Applications with DUTY CYCLE 10% - Class 6T

Size	Model	BRAKING RESISTOR					
		Min. Applicable Resistor (Ω)	Type	Degree of Protection	Type of Connection	Value (Ω)	Wire cross-section mm ² (AWG)
S14	0003	150	250 Ω -1500W	IP55	A	250	10(8)
	0004	150	180 Ω -2200W	IP55	A	180	10(8)
	0006	80	150 Ω -2200W	IP55	A	150	10(8)
	0012	80	120 Ω -4000W	IP20	A	120	10(8)
	0018	80	82 Ω -4000W	IP20	A	82	10(8)
	0019	50	60 Ω -4000W	IP23	A	60	10(8)
	0021	50	60 Ω -4000W	IP23	A	60	10(8)
	0022	30	45 Ω -4000W	IP23	A	45	10(8)
	0024	30	30 Ω -8000W	IP23	A	30	10(8)
	0032	25	30 Ω -8000W	IP23	A	30	10(8)
S22	0042	15	22 Ω -8000W	IP23	A	22	10(8)
	0051	15	18 Ω -12000W	IP23	A	18	10(8)
	0062	15	15 Ω -12000W	IP23	A	15	10(8)
	0069	15	15 Ω -12000W	IP23	A	15	10(8)
S32	0076	10	10 Ω -16000W	IP23	A	10	16(6)
	0088	10	10 Ω -24000W	IP23	A	10	16(6)
	0131	6	6.6 Ω -24000W	IP23	A	6.6	16(6)
	0164	6	6 Ω -32000W	IP23	A	6	16(6)

Type of connection:

A - One resistor



CAUTION

The cables of the braking resistors shall have insulation features and heat-resistance features suitable for the application. The minimum rated voltage of the cables must be 0.6/1kV.

6.1.1.11. Applications with DUTY CYCLE 20% - Class 6T

Size	Model	BRAKING RESISTOR					
		Min. Applicable Resistor (Ω)	Type	Degree of Protection	Type of Connection	Value (Ω)	Wire cross-section mm ² (AWG)
S14	0003	150	250 Ω -2200W	IP55	A	250	10(8)
	0004	150	180 Ω -4000W	IP20	A	180	10(8)
	0006	80	150 Ω -4000W	IP20	A	150	10(8)
	0012	80	120 Ω -4000W	IP23	A	120	10(8)
	0018	80	82 Ω -4000W	IP23	A	82	10(8)
	0019	50	60 Ω -4000W	IP23	A	60	10(8)
	0021	50	60 Ω -8000W	IP23	A	60	10(8)
	0022	30	45 Ω -8000W	IP23	A	45	10(8)
	0024	30	30 Ω -8000W	IP23	A	30	10(8)
S22	0032	25	30 Ω -12000W	IP23	A	30	10(8)
	0042	15	22 Ω -12000W	IP23	A	22	10(8)
	0051	15	18 Ω -16000W	IP23	A	18	10(8)
	0062	15	15 Ω -16000W	IP23	A	15	10(8)
	0069	15	15 Ω -16000W	IP23	A	15	10(8)
S32	0076	10	10 Ω -24000W	IP23	A	10	16(6)
	0088	10	10 Ω -32000W	IP23	A	10	16(6)
	0131	6	6.6 Ω -48000W	IP23	A	6.6	25(3)
	0164	6	6 Ω -48000W	IP23	A	6	25(3)

Type of connection:

A - One resistor



CAUTION

The cables of the braking resistors shall have insulation features and heat-resistance features suitable for the application. The minimum rated voltage of the cables must be 0.6/1kV.

6.1.1.12. Applications with DUTY CYCLE 50% - Class 6T

Size	Model	BRAKING RESISTOR					
		Min. Applicable Resistor (Ω)	Type	Degree of Protection	Type of Connection	Value (Ω)	Wire cross-section mm ² (AWG)
S14	0003	150	250 Ω -4000W	IP20	A	250	16(6)
	0004	150	180 Ω -4000W	IP23	A	180	16(6)
	0006	80	150 Ω -4000W	IP23	A	150	16(6)
	0012	80	120 Ω -8000W	IP20	A	120	16(6)
	0018	80	82 Ω -8000W	IP23	A	82	16(6)
	0019	50	60 Ω -8000W	IP23	A	60	16(6)
	0021	50	60 Ω -12000W	IP23	A	60	16(6)
	0022	30	45 Ω -16000W	IP23	A	45	16(6)
	0024	30	30 Ω -16000W	IP23	A	30	16(6)
S22	0032	25	30 Ω -24000W	IP23	A	30	16(6)
	0042	15	22 Ω -24000W	IP23	A	22	16(6)
	0051	15	18 Ω -32000W	IP23	A	18	16(6)
	0062	15	15 Ω -48000W	IP23	A	15	16(6)
S32	0069	15	15 Ω -48000W	IP23	A	15	16(6)
	0076	10	10 Ω -64000W	IP23	A	10	25(3)
	0088	10	10 Ω -64000W	IP23	A	10	25(3)
	0131	6	2x3 Ω -48000W	IP23	C	6	50(1/0)
	0164	6	2x3 Ω -48000W	IP23	C	6	50(1/0)

Type of connection:

A - One resistor

C - Two series-connected resistors



CAUTION

The cables of the braking resistors shall have insulation features and heat-resistance features suitable for the application. The minimum rated voltage of the cables must be 0.6/1kV.

6.2. Braking Unit (BU200) for S60

An external braking unit is available for size S60.

This braking unit may be used instead of BU700 also for S41-S51. See Braking Units for S41-S51 (BU700 2T-4T) and S42-S52 (BU600 5T-6T).

The braking power required to brake a rotating object is proportional to the total moment of inertia of the rotating object, to speed variations, and to absolute speed, while it inversely proportional to the deceleration time required.

This braking power is dissipated to a resistor (external to the braking unit) with an Ohm value depending on the inverter model and the average power to be dissipated.

6.2.1. Delivery Check

Make sure that the equipment is not damaged and it complies with the equipment you ordered by referring to its front nameplate (see figure below).

If the equipment is damaged, contact the supplier or the insurance company concerned.

If the equipment does not comply with the one you ordered, please contact the supplier as soon as possible.

If the equipment is stored before being started, make sure that temperatures range from $-25^{\circ}\text{C} \div +70^{\circ}\text{C}$ and that relative humidity is $<95\%$ (non-condensing).

The equipment guarantee covers any manufacturing defect. The manufacturer has no responsibility for possible damages due to the equipment transportation or unpacking. The manufacturer is not responsible for possible damages or faults caused by improper and irrational uses; wrong installation; improper conditions of temperature, humidity, or the use of corrosive substances. The manufacturer is not responsible for possible faults due to the equipment operation at values exceeding the equipment ratings and is not responsible for consequential and accidental damages.

The braking unit BU200 is covered by a two-year guarantee starting from the date of delivery.

6.2.1.1. Nameplate for BU200

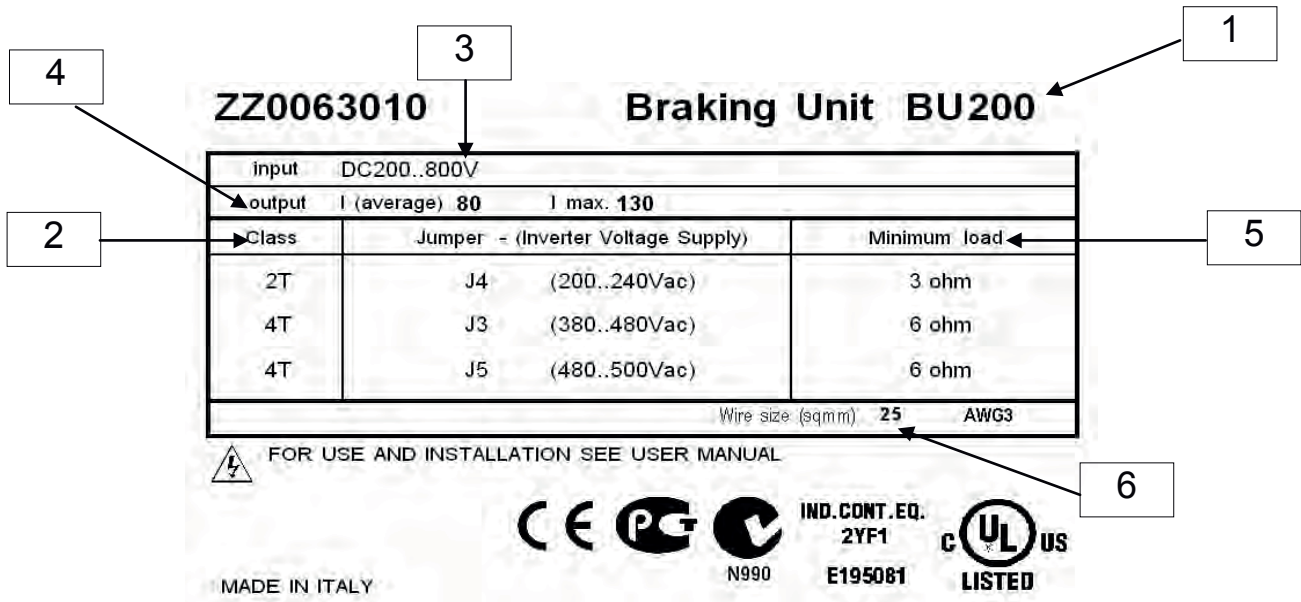

Figure 74: Nameplate for BU200

Numbered items in the figure above:

1. Model: BU200 – braking unit
2. Voltage class: List of applicable voltage classes
3. Supply ratings: 200÷800 Vdc (DC supply voltage produced by the inverter terminals)
4. Output current: 80A (average) – continuous average current in output cables
130A (max.) – max. current in output cables (may be held for a timer longer than the time given in column “Max. Duration of Continuous Operation” in the resistors tables below)
5. Min. load: Minimum value of the resistor to be connected to the output terminals (see application tables below)
6. Cable cross-section: Dimensioning of the power cables

6.2.2. Operation

The basic size of the braking unit can be used with a braking resistor avoiding exceeding a max. instant current of 130 A, corresponding to a maximum braking power of approx. 97.5 kW (class 4T) and to an average power of 60 kW (class 4T). For applications requiring higher braking power values, multiple braking units can be parallel-connected in order to obtain a greater braking power based on the number of braking units.

To ensure that the overall braking power is evenly distributed to all braking units, configure one braking unit in MASTER mode and the remaining braking units in SLAVE mode, and connect the output signal of the MASTER unit (terminal 8 in connector M1) to the forcing input for all SLAVE braking units (terminal 4 in connector M1).

6.2.2.1. Configuration Jumpers

Jumpers located on the control board for BU200 are used for the configuration of the braking unit. Their positions and functions are as follows:

Jumper	Function
J1	If on, it configures the SLAVE operating mode
J2	If on, it configures the MASTER operating mode



NOTE

Either one of the two jumpers must always be “on”. Avoid enabling both jumpers at a time.

Jumper	Function
J3	To be activated for class 4T inverters and mains voltage [380 Vac to 480 Vac]
J4	To be activated for class 2T inverters and mains voltage [200 Vac to 240 Vac]
J5	To be activated for class 4T inverters and mains voltage [481 Vac to 500 Vac]
J6	To be activated for special adjustment requirements



NOTE

One of the four jumpers must always be “ON”. Avoid enabling two or more jumpers at a time.

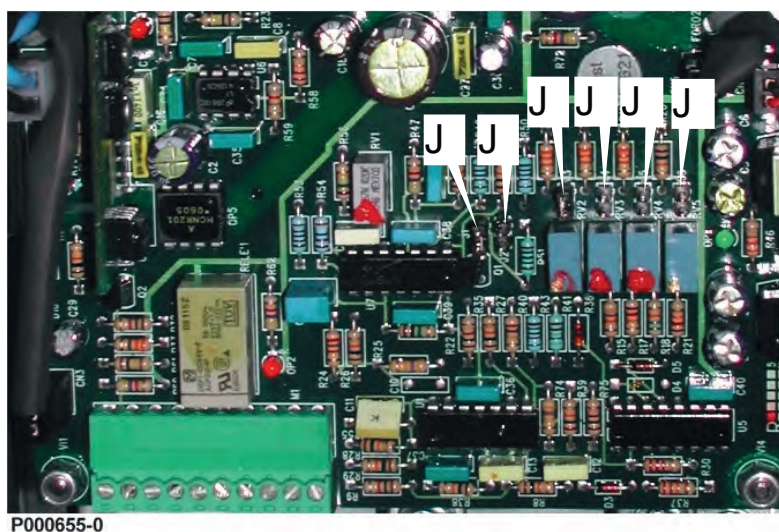

Figure 75: Positions of BU200 configuration jumpers



DANGER

Before changing jumper positions, remove voltage from the equipment and wait at least 20 minutes.



CAUTION

Never set jumpers to a voltage value lower than the inverter supply voltage. This will avoid continuous activation of the braking unit.

6.2.2.2. Adjusting Trimmers

Four trimmers are installed on the inverter control board. Depending on the jumper configuration, each trimmer allows the fine-tuning of the braking unit voltage threshold trip.

Jumper-trimmer matching is as follows:

Mains voltage [Vac]	Jumper	Trimmer	Minimum braking voltage [Vdc]	Rated braking voltage [Vdc]	Maximum braking voltage [Vdc]
200÷240 (2T)	J4	RV3	339	364	426
380÷480 (4T)	J3	RV2	700	764	826
481÷500 (4T)	J5	RV4	730	783	861
230÷500	J6	RV5	464	650	810



CAUTION

The maximum values in the table above are theoretical values for special applications only. Their use must be authorized by Elettronica Santerno. For standard applications, never change the factory-set rated value.

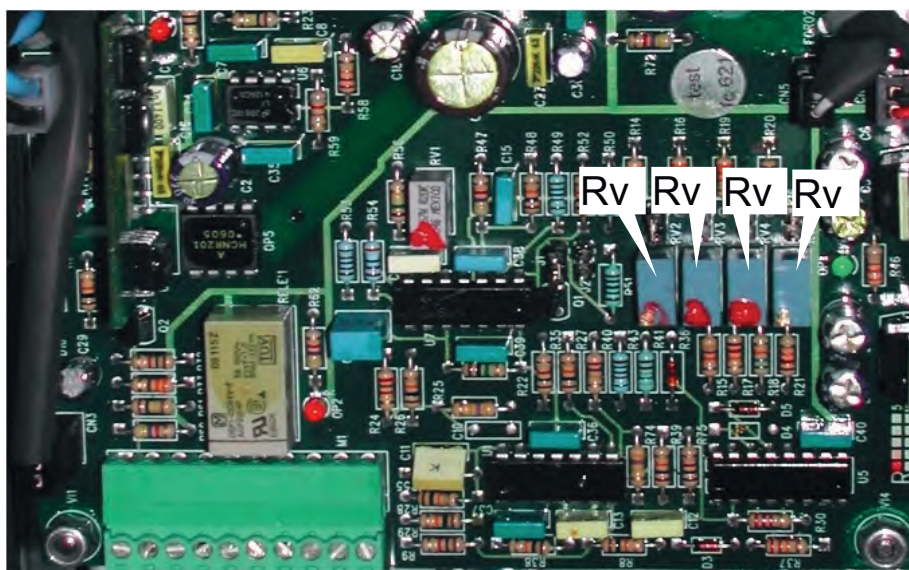

P000655-0

Figure 76: Positions of BU200 adjusting trimmers

6.2.2.3. Indicator LEDs

The indicator LEDs below are located on the front part of the braking units:

- OK LED** Normally “on”; the equipment is running smoothly. This LED turns off due to overcurrent or power circuit failure.
- B LED** Normally off”; this LED turns on when the braking unit activates.
- TMAX LED** Normally “off”; this LED turns on when the thermoswitch located on the heat sink of the braking unit trips; if overtemperature protection trips, the equipment is locked until temperature drops below the alarm threshold.

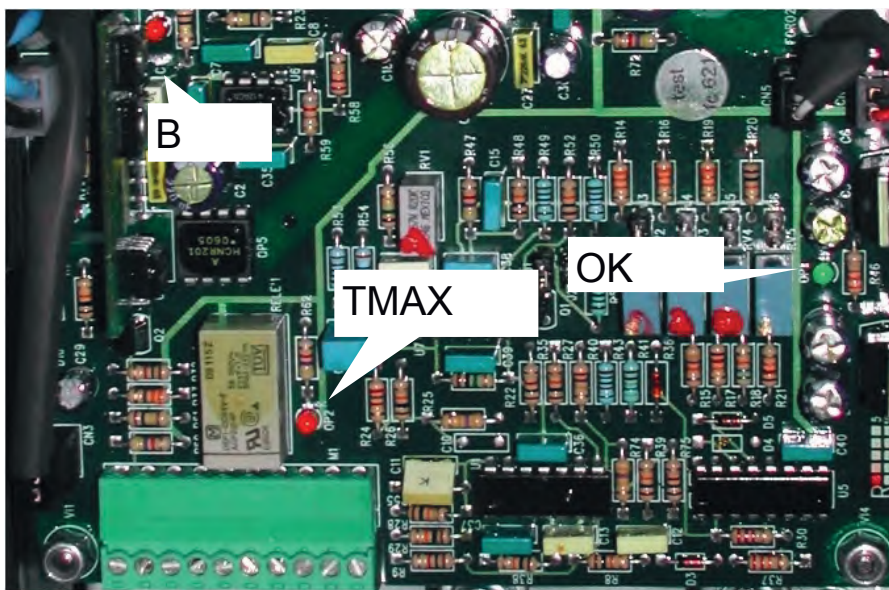

P000655-0

Figure 77: Position of the Indicator LEDs

6.2.3. Ratings

SIZE	Max. Braking Current (A)	Average Braking Current (A)	INVERTER SUPPLY VOLTAGE and JUMPER POSITIONS		
			200-240Vac (class 2T)	380-480Vac (class 4T)	481-500Vac (class 4T)
			J4	J3	J5
			MIN. BRAKING RESISTOR (Ω)		
BU200	130	80	3	6	6

6.2.4. Installing the Braking Unit

6.2.4.1. Environmental Requirements for the Braking Unit Installation, Storage and Transport

Maximum surrounding air temperature	-10 to +40°C with no derating from +40°C to +55°C with a 2% derating of the rated current for each degree beyond +40°C.
Ambient temperatures for storage and transport	-25°C to +70°C.
Installation environment	Pollution degree 2 or better (according to IEC 61800-5-1). Do not install in direct sunlight and in places exposed to conductive dust, corrosive gases, vibrations, water sprinkling or dripping (depending on IP ratings); do not install in salty environments.
Altitude	Max. altitude for installation 2000 m a.s.l. For installation above 2000 m and up to 4000 m, please contact Elettronica Santerno. Above 1000 m, derate the rated current by 1% every 100 m.
Operating ambient humidity	From 5% to 95%, from 1g/m ³ to 25g/m ³ , non-condensing and non-freezing (class 3k3 according to EN50178).
Storage ambient humidity	From 5% to 95%, from 1g/m ³ to 25g/m ³ , non-condensing and non-freezing (class 1k3 according to EN50178).
Ambient humidity during transport	Max. 95%; up to 60g/m ³ , condensation may appear when the equipment is not running (class 2k3 according to EN50178).
Storage and operating atmospheric pressure	From 86 to 106 kPa (classes 3k3 and 1k4 according to EN50178).
Atmospheric pressure during transport	From 70 to 106 kPa (class 2k3 according to EN50178).



CAUTION

Ambient conditions strongly affect the inverter life. Do not install the equipment in places that do not have the above-mentioned ambient conditions.

6.2.4.2. Cooling System and Dissipated Power

The braking unit is provided with a heat sink reaching a max. temperature of 80°C. Make sure that the bearing surface for the braking unit is capable of withstanding high temperatures. Max. dissipated power is approx. 150 W and depends on the braking cycle required for the operating conditions of the load connected to the motor.



CAUTION

The max. temperature alarm for the braking unit shall be used as a digital signal to control the inverter stop.

6.2.4.3. Mounting

- The braking unit (BU200) must be installed in an upright position inside a cabinet;
- Make sure to allow a min. clearance of 5 cm on both types and 10 cm on top and bottom; use cable-glands to maintain IP20 rating;
- Fix the BU200 with four MA4 screws.

Dimensions (mm)			Distance between fixing points (mm)		Type of screws	Weight (kg)
W	H	D	X	Y		
139	247	196	120	237	M4	4

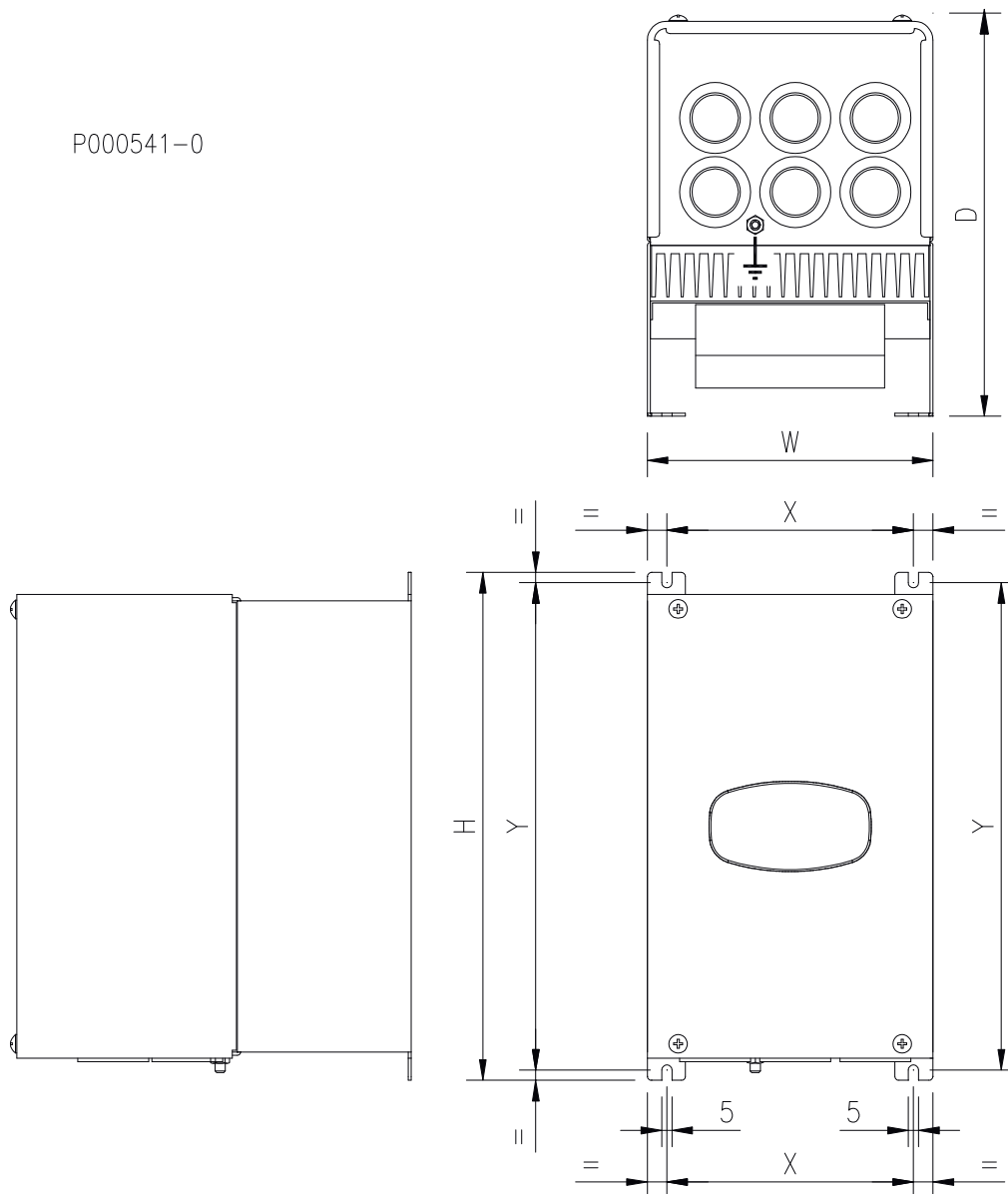

Figure 78: Dimensions and fixing points of BU200

6.2.4.4. Lay-Out of Power Terminals and Signal Terminals

Remove the cover of the braking unit to gain access to its terminal blocks. Just loosen the four fixing screws of the cover located on the front side and on the bottom side of the braking unit. Loosen the fastening screws to slide off the cover from above. Power terminals consist of copper bars, that can be reached through the three front holes.

Terminal	N.	Type of terminal	Cable cross-section (mm ²)	Connection
+	20	Copper bar	25	Inverter DC side connected to terminal +
B	21	Copper bar	See Resistors table	Connection to braking resistor
-	22	Copper bar	25	Inverter DC side connected to terminal -

Terminal block M1:

N.	Name	Description	Notes	Features	Cable cross-section (mm ²)
M1 : 1		Not used			
M1 : 2	0VE	Signal zero volt		Control board zero volt	0.5÷1
M1 : 3	Vin	Modulation input (0÷10 V)	To be used for special applications	Rin=10kΩ	0.5÷1
M1 : 4	Sin	Logic input for signal sent from Master	The SLAVE brakes if a signal > 6 V is sent	Max. 30V	0.5÷1
M1 : 5	RL-NO	NO contact of "thermoswitch on" relay	The relay energizes when an overtemperature alarm trips for BU200	250Vac, 5A 30Vdc, 5A	0.5÷1
M1 : 6	RL-C	Common of the contact of "thermoswitch on" relay			0.5÷1
M1 : 7	RL-NC	NC contact of "thermoswitch on" relay			0.5÷1
M1 : 8	Mout	Digital output for Slave command signal	High level output when the Master is braking	PNP output (0-15V)	0.5÷1
M1 : 9		Not used			
M1 : 10		Not used			

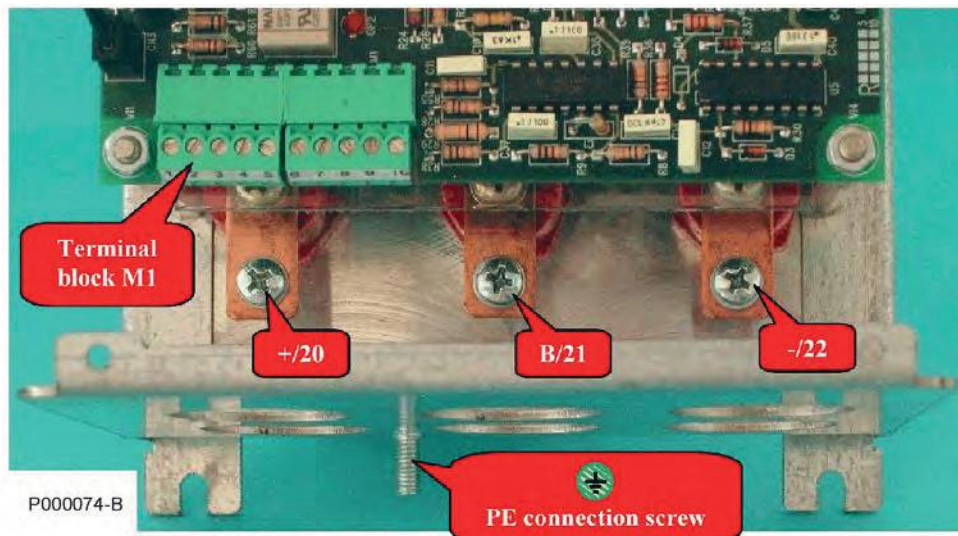
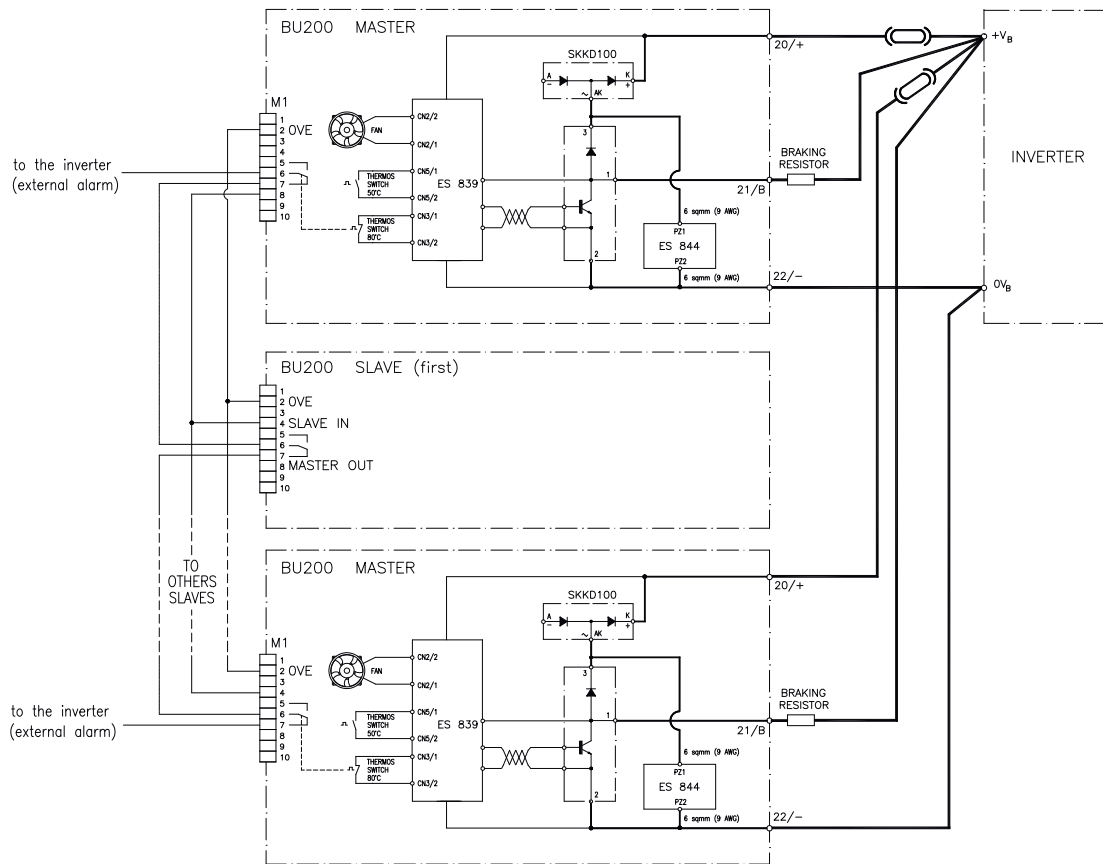

Figure 79: Terminals in BU200

6.2.4.6. Master – Slave Connection

The Master-Slave connection must be used when multiple braking units are connected to the same inverter. An additional connection must be done between the Master output signal (terminal 8 in M1) and the Slave input signal (terminal 4 in M1); zero volt of the signal connector in the Master module (terminal 2 in M1) must be connected to zero volt of the signal connector in the Slave module (terminal 2 in M1). The connection of more than two modules must always be done by configuring one module like a master and the other modules like slaves. Use configuration jumpers accordingly. The max. temperature alarm of the braking unit must be used as a digital signal to control the inverter stop. All contacts (voltage-free contacts) in all braking modules may be series-connected as shown in the diagram below:



P000599-B

Figure 81: Master – Slave multiple connection



NOTE

NEVER connect signal zero volt (terminal 2 in M1) to zero volt of the inverter power supply voltage (-).



NOTE

We recommend installing a 50A fuse with DC current of at least 700 Vdc (type URDC SIBA series, NH1 fuse) provided with a safety contact.



CAUTION

Link the safety contact of the fuse being used with the external alarm of BU200.

6.2.5. Braking Resistors for BU200 2T

Refer to the tables below for the connection of the braking resistors.



NOTE

The wire cross-sections given in the table relate to one wire per braking resistor.



CAUTION

The cables of the braking resistors shall have insulation features and heat-resistance features suitable for the application. The minimum rated voltage of the cables must be 450/700V.



DANGER

Based on the functioning cycle, the surface of the braking resistors may reach 200°C.



CAUTION

The power dissipated by the braking resistors may be the same as the rated power of the connected motor multiplied by the braking duty-cycle; use a proper air-cooling system. Do not install braking resistors near heat-sensitive equipment or objects.



CAUTION

Do not connect to the inverter any braking resistor with an Ohm value lower than the value given in the tables.

6.2.5.1. Applications with DUTY CYCLE 10% - Class 2T

Size	Sinus Penta Model	Braking Unit	Braking Resistors						
			Resistors to be used				Type of connection	Value (Ω)	Wire Cross-section mm ² (AWG or kcmils)
			Q.ty	Q.ty	Recommended Value (Ω)	Power (kW)			
S41	0180	2	2	3.3	8	IP20	M	3.3/2	10(8)
	0202	2	2	3.3	8	IP20	M	3.3/2	10(8)
	0217	3	3	3.3	8	IP20	N	3.3/3	10(8)
	0260	3	3	3.3	8	IP20	N	3.3/3	10(8)
S51	0313	4	4	3.3	8	IP20	O	3.3/4	10(8)
	0367	5	5	3.3	8	IP20	P	3.3/5	10(8)
	0402	5	5	3.3	8	IP20	P	3.3/5	10(8)
S60	0457	6	6	3.3	8	IP20	Q	3.3/6	10(8)
	0524	6	6	3.3	8	IP20	Q	3.3/6	10(8)

6.2.5.2. Applications with DUTY CYCLE 20% - Class 2T

Size	Sinus Penta Model	Braking Unit	Braking Resistors						
			Resistors to be used				Type of connection	Value (Ω)	Wire Cross-section mm ² (AWG or kcmils)
			Q.ty	Q.ty	Recommended Value (Ω)	Power (kW)			
S41	0180	2	2	3.3	8	IP20	M	3.3/2	16(6)
	0202	2	2	3.3	8	IP20	M	3.3/2	16(6)
	0217	3	3	3.3	12	IP20	N	3.3/3	16(6)
	0260	3	3	3.3	12	IP20	N	3.3/3	16(6)
S51	0313	4	4	3.3	12	IP20	O	3.3/4	16(6)
	0367	5	5	3.3	12	IP20	P	3.3/5	16(6)
	0402	5	5	3.3	12	IP20	P	3.3/5	16(6)
S60	0457	6	6	3.3	12	IP20	Q	3.3/6	16(6)
	0524	6	6	3.3	12	IP20	Q	3.3/6	16(6)

6.2.5.3. Applications with DUTY CYCLE 50% - Class 2T

Size	Sinus Penta Model	Braking Unit	Braking Resistors						
			Resistors to be used				Type of connection	Value (Ω)	Wire Cross-section mm ² (AWG or kcmils)
			Q.ty	Q.ty	Recommended Value (Ω)	Power (kW)			
S41	0180	2	4	6.6	12	IP20	V	3.3/2	16(6)
	0202	2	4	6.6	12	IP20	V	3.3/2	16(6)
	0217	3	6	6.6	12	IP20	N	3.3/3	16(6)
	0260	3	6	6.6	12	IP20	N	3.3/3	16(6)
S51	0313	4	8	6.6	12	IP20	Y	3.3/4	16(6)
	0367	5	10	6.6	12	IP20	Y	3.3/5	16(6)
	0402	5	10	6.6	12	IP20	W	3.3/5	16(6)
S60	0457	6	12	6.6	12	IP20	Z	3.3/6	16(6)
	0524	6	12	6.6	12	IP20	Z	3.3/6	16(6)

M-Two units, each of them including a braking module connected to its braking resistor
 N-Three units, each of them including a braking module connected to its braking resistor
 O-Four units, each of them including a braking module connected to its braking resistor
 P-Five units, each of them including a braking module connected to its braking resistor
 Q-Six units, each of them including a braking module connected to its braking resistor

V-Two units, each of them including a braking module connected to two parallel-connected braking resistors
 X-Three units, each of them including a braking module connected to two parallel-connected braking resistors

Y-Four units, each of them including a braking module connected to two parallel-connected braking resistors
 W-Five units, each of them including a braking module connected to two parallel-connected braking resistors
 Z-Six units, each of them including a braking module connected to two parallel-connected braking resistors

6.2.6. Braking Resistors for BU200 4T



NOTE

The wire cross-sections given in the table relate to one wire per braking resistor.



CAUTION

The cables of the braking resistors shall have insulation features and heat-resistance features suitable for the application. The minimum rated voltage of the cables must be 0.6/1kV.



DANGER

Based on the functioning cycle, the surface of the braking resistors may reach 200°C.



CAUTION

The power dissipated by the braking resistors may be the same as the rated power of the connected motor multiplied by the braking duty-cycle; use a proper air-cooling system. Do not install braking resistors near heat-sensitive equipment or objects.



CAUTION

Do not connect to the inverter any braking resistor with an Ohm value lower than the value given in the tables.

6.2.6.1. Applications with DUTY CYCLE 10% - Class 4T

Size	Sinus Penta Model	Braking Unit	Braking Resistors						
			Resistors to be used				Type of Connection	Value (Ω)	Wire Cross-section mm ² (AWG or kcmils)
			Q.ty	Q.ty	Recommended Value (Ω)	Power (kW)			
S41	0180	2	2	6.6	12	IP20	M	6.6/2	16(6)
	0202	2	2	6.6	12	IP20	M	6.6/2	16(6)
	0217	3	3	6.6	12	IP20	N	6.6/3	16(6)
	0260	3	3	6.6	12	IP20	N	6.6/3	16(6)
S51	0313	3	3	6.6	12	IP20	N	6.6/3	16(6)
	0367	4	4	6.6	12	IP20	O	6.6/4	16(6)
	0402	4	4	6.6	12	IP20	O	6.6/4	16(6)
S60	0457	4	4	6.6	12	IP20	O	6.6/4	16(6)
	0524	5	5	6.6	12	IP20	P	6.6/5	16(6)

6.2.6.2. Applications with DUTY CYCLE 20% - Class 4T

Size	Sinus Penta Model	Braking Unit	Braking Resistors						
			Resistors to be used				Type of Connection	Value (Ω)	Wire Cross-section mm ² (AWG or kcmils)
			Q.ty	Q.ty	Recommended Value (Ω)	Power (kW)			
S41	0180	2	2	6.6	24	IP20	M	6.6/2	16(6)
	0202	2	2	6.6	24	IP20	M	6.6/2	16(6)
	0217	3	3	6.6	24	IP20	N	6.6/3	16(6)
	0260	3	3	6.6	24	IP20	N	6.6/3	16(6)
S51	0313	3	3	6.6	24	IP20	N	6.6/3	16(6)
	0367	4	4	6.6	24	IP20	O	6.6/4	16(6)
	0402	4	4	6.6	24	IP20	O	6.6/4	16(6)
S60	0457	4	4	6.6	24	IP20	O	6.6/4	16(6)
	0524	5	5	6.6	24	IP20	P	6.6/5	16(6)

6.2.6.3. Applications with DUTY CYCLE 50% - Class 4T

Size	Sinus Penta Model	Braking Unit	Braking Resistors						
			Resistors to be used				Type of Connection	Value (Ω)	Wire Cross-section mm ² (AWG or kcmils)
			Q.ty	Q.ty	Recommended Value (Ω)	Power (kW)			
S41	0180	3	3	10	24	IP23	N	10/3	16(6)
	0202	3	3	10	24	IP23	N	10/3	16(6)
	0217	4	4	10	24	IP23	O	10/4	16(6)
	0260	5	4	10	24	IP23	O	10/4	16(6)
S51	0313	5	5	10	24	IP23	P	10/5	16(6)
	0367	6	6	10	24	IP23	Q	10/6	16(6)
	0402	7	7	10	24	IP23	R	10/7	16(6)
S60	0457	7	7	10	24	IP23	R	10/7	16(6)
	0524	8	8	10	24	IP23	S	10/8	16(6)

M-Two units, each of them including a braking module connected to its braking resistor
N-Three units, each of them including a braking module connected to its braking resistor
O-Four units, each of them including a braking module connected to its braking resistor
P-Five units, each of them including a braking module connected to its braking resistor
Q-Six units, each of them including a braking module connected to its braking resistor
R-Seven units, each of them including a braking module connected to its braking resistor
S-Eight units, each of them including a braking module connected to its braking resistor

6.3. Braking Units for S41–S51 (BU700 2T-4T) and S42–S52 (BU600 5T-6T)

Two braking units are available for sizes S41–S51 (BU700 2T-4T) and S42–S52 (BU600 5T-6T). These braking units must not be used for inverter sizes other than the ones above.

6.3.1. Delivery Check

Make sure that the equipment is not damaged and that it complies with the equipment you ordered by referring to the nameplate located on the inverter front part (see figure below). If the equipment is damaged, contact the supplier or the insurance company concerned. If the equipment does not comply with the one you ordered, please contact the supplier as soon as possible.

If the equipment is stored before being started, make sure that temperatures range from -25°C to $+70^{\circ}\text{C}$ and that relative humidity is $<95\%$ (non-condensing).

The equipment guarantee covers any manufacturing defect. The manufacturer has no responsibility for possible damages occurred while shipping or unpacking the equipment. The manufacturer is not responsible for possible damages or faults caused by improper and irrational uses; wrong installation; improper conditions of temperature, humidity, or the use of corrosive substances. The manufacturer is not responsible for possible faults due to the equipment operation at values exceeding the equipment ratings. The manufacturer is not responsible for consequential and accidental damages.

The braking unit is covered by a two-year guarantee starting from the date of delivery.

6.3.1.1. Nameplate for BU600

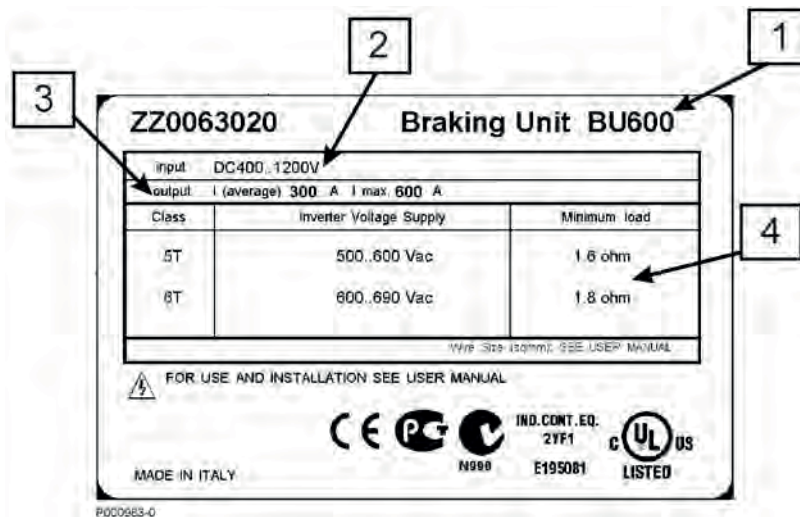
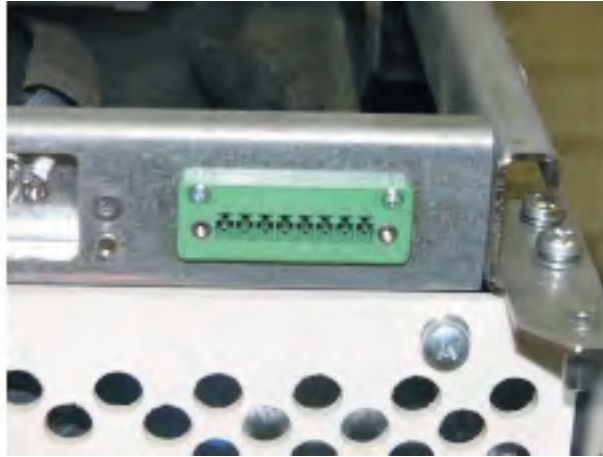

Figure 82: Nameplate for BU600

- | | |
|--------------------|--|
| 1. Model: | BU600 – Braking module |
| 2. Supply ratings: | DC supply voltage deriving directly from the inverter terminals: 400 to 1200 Vdc for BU600 5-6T |
| 3. Output current: | 300A (average) – continuous average current in output cables
600A (max.) – max. current in output cables (may be held for a timer longer than the time given in column “Max. Duration of Continuous Operation” in the resistors tables below) |
| 4. Min. load: | Minimum value of the resistor to be connected to the output terminals (see application tables below) |

6.3.2. Operating Mode

The braking module is powered and controlled directly by the inverter.
The signals on terminal M1 of the braking module are to be connected to the signals on the BRAKE connector of the inverter using the cable supplied.



S000135

Figure 83: BRAKE connector supplied with the Sinus Penta



S000136

Figure 84: Cable connecting the Sinus Penta to braking unit BU600

The following diagnostic LEDs are provided:

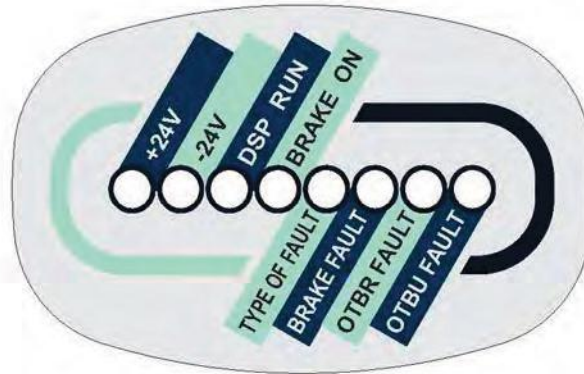

S000134

Figure 85: Diagnostic LEDs

+24V, -24V: Both “on” when the braking unit is powered on

DSP RUN [*]: “On” when the on-board microcontroller is on

BRAKE ON: “On” when the braking IGBT is ON

TYPE OF FAULT [*]: Code of the active fault

BRAKE FAULT: “On” when a fault occurs; it turns off only when the RESET input in terminal board M2 is activated.

OTBR FAULT: “On” when the thermoswitch trips (it comes on in conjunction with the BRAKE FAULT LED). It turns off when the fault condition is reset.

OTBU FAULT: IGBT thermal protection tripped (it comes on in conjunction with the BRAKE FAULT LED). It turns off when the fault condition is reset.



[*] NOTE This function is not available.

6.3.3. Specifications

MODEL	Max. Braking Current (A)	Average Braking Current (A)	Penta Supply Voltage	Min. Braking Resistor (Ω)	Power Dissipated (at Average Braking Current) (W)
BU700 2T-4T	700	350	200-240Vac	0.54	700
BU700 2T-4T	700	350	380-500Vac	1.1	700
BU600 5T-6T	600	300	500-600Vac	1.6	700
BU600 5T-6T	600	300	600-690Vac	1.8	700

6.3.4. Installing the Braking Unit

6.3.4.1. Environmental Requirements for the Braking Unit Installation, Storage and Transport

Maximum surrounding air temperature	-10 to +40°C with no derating From +40°C to +55°C with a 2% derating of the rated current for each degree beyond +40°C.
Ambient temperatures for storage and transport	-25°C to +70°C
Installation environment	Pollution degree 2 or better (according to IEC 61800-5-1). Do not install in direct sunlight and in places exposed to conductive dust, corrosive gases, vibrations, water sprinkling or dripping; do not install in salty environments.
Altitude	Max. altitude for installation 2000 m a.s.l. For installation above 2000 m and up to 4000 m, please contact Elettronica Santerno. Above 1000 m, derate the rated current by 1% every 100 m.
Operating ambient humidity	From 5% to 95%, from 1g/m ³ to 25g/m ³ , non-condensing and non-freezing (class 3k3 according to EN50178).
Storage ambient humidity	From 5% to 95%, from 1g/m ³ to 25g/m ³ , non-condensing and non-freezing (class 1k3 according to EN50178).
Ambient humidity during transport	Max. 95%, up to 60g/m ³ ; condensation may appear when the equipment is not running (class 2k3 according to EN50178).
Storage and operating atmospheric pressure	From 86 to 106 kPa (classes 3k3 and 1k4 according to EN50178).
Atmospheric pressure during transport	From 70 to 106 kPa (class 2k3 according to EN50178).



CAUTION

Ambient conditions strongly affect the inverter life. Do not install the equipment in places that do not have the above-mentioned ambient conditions.

6.3.4.2. Mounting the Braking Unit

The braking unit BU600/BU700 must be installed in upright position on the left of the inverter inside a cabinet. Its overall dimensions and fixing points are given in the figure below.

Dimensions (mm)			Fixing Points (mm)				Type of Screws	Weight (kg)
W	H	D	X	Y	D1	D2	M8-M10	72
248	881.5	399	170	845	12	24		

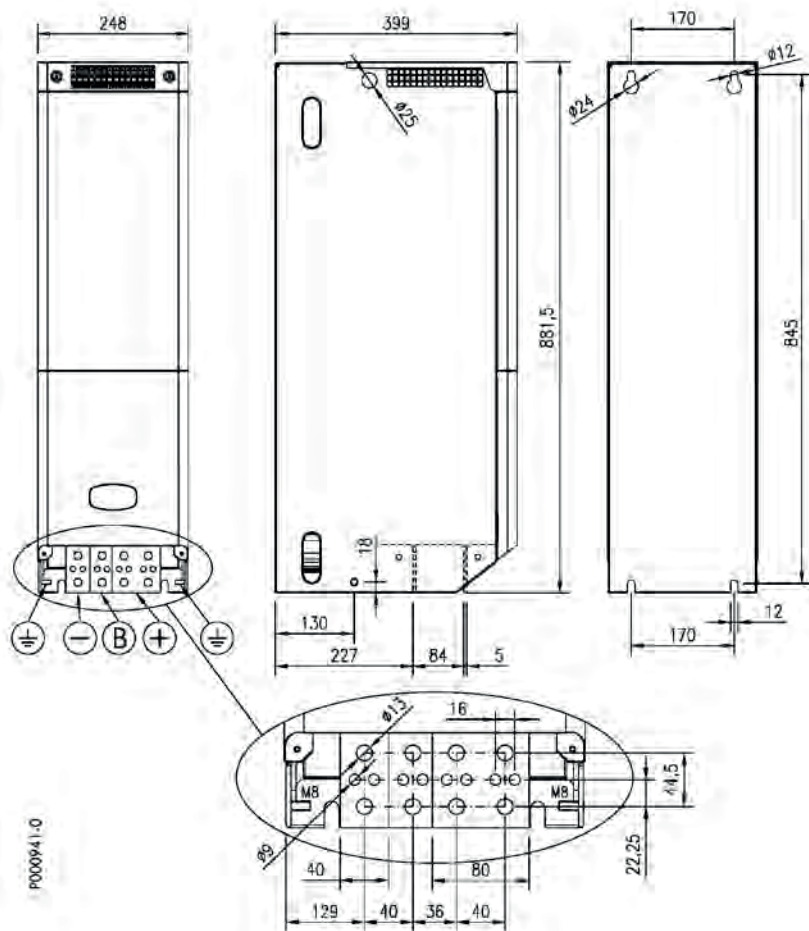

Figure 86: Dimensions and fixing points of BU600/BU700

6.3.4.3. Lay-Out of Power Terminals and Signal Terminals

Power connections

Link the braking module to the inverter and to the braking resistor as described below.

Terminal	Type	Tightening Torque (Nm)	Connection Bar Cross-section mm ² (AWG or kcmils)	NOTES
+	Bus bar	30	240 (500kcmils)	To be connected to terminal 47/+ of the inverter and to one terminal of the braking resistor
B	Bus bar	30	See Resistors Table	To be connected to the remaining terminal of the braking resistor
-	Bus bar	30	240 (500kcmils)	To be connected to terminal 49/- of the inverter

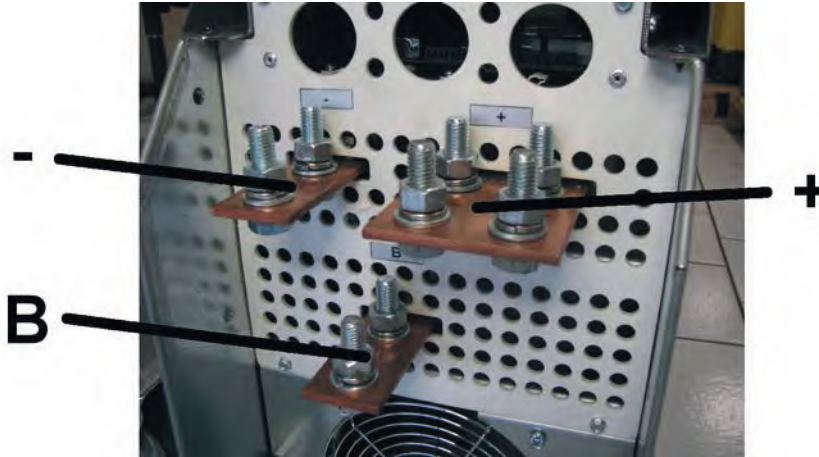

Figure 87: Power terminals

Signal connections

Terminals M1 – Connect to the inverter using the cable supplied.

N.	Name	Description	I/O Features	NOTES	Cable Cross-section Fitting the Terminal mm ² (AWG/kcmils)	Tightening Torque (Nm)
1	BRAKE	Braking module signal command	0-24V (active at +24V)	to be connected to terminal 1 in the brake terminals of the inverter using the cable supplied	0.25÷1.5mm ² (AWG 24-16)	0.22-0.25
2	0V	Ground	0V	to be connected to terminal 2 in the brake terminals of the inverter using the cable supplied	0.25÷1.5mm ² (AWG 24-16)	0.22-0.25
3	BRERR	Not available	-	-	-	-
4	BU	Braking module fitted	0-24V (0V with braking module fitted)	to be connected to terminal 4 in the brake terminals of the inverter using the cable supplied	0.25÷1.5mm ² (AWG 24-16)	0.22-0.25
5	SLAVE	Not available	-	-	-	-
6	0V	Ground	0V	to be connected to terminal 6 in the brake terminals of the inverter using the cable supplied	0.25÷1.5mm ² (AWG 24-16)	0.22-0.25
7	CANL	Not available	-	-	-	-
8	CANH		-	-	-	-

Terminals M2

N.	Name	Description	I/O Features	NOTES	Cable Cross-section Fitting the Terminal mm ² (AWG/kcmils)	Tightening Torque (Nm)
1	24VE	Auxiliary 24V voltage generated internally to the braking module	24V 100mA	Available to send the Reset signal	0.25÷1.5mm ² (AWG 24-16)	0.22-0.25
2	RESET	Braking module fault reset command	0-24V (active at 24V)	To be connected to +24VE by means of a push-button for fault reset	0.25÷1.5mm ² (AWG 24-16)	0.22-0.25
3	24VE	Auxiliary 24V voltage generated internally to the braking module	24V 10mA	To be connected to the thermoswitch in the braking resistor	0.25÷1.5mm ² (AWG 24-16)	0.22-0.25
4	PTR	Input for the braking resistor thermoswitch	0-24V (with +24V braking resistor OK)	To be connected to the thermoswitch in the braking resistor	0.25÷1.5mm ² (AWG 24-16)	0.22-0.25

Terminals M3 (unavailable functions)

N.	Name	Description	I/O Features	NOTES	Cable Cross-section Fitting the Terminal mm ² (AWG/kcmils)	Tightening Torque (Nm)
1	RL1-NC	N/A	-	-	-	-
2	RL1-C	N/A			-	-
3	RL1-NO	N/A			-	-

Terminals M4 (unavailable functions)

N.	Name	Description	I/O Features	NOTES	Cable Cross-section Fitting the Terminal mm ² (AWG/kcmils)	Tightening Torque (Nm)
1	RL2-NC	N/A	-	-	-	-
2	RL2-C	N/A			-	-
3	RL2-NO	N/A			-	-

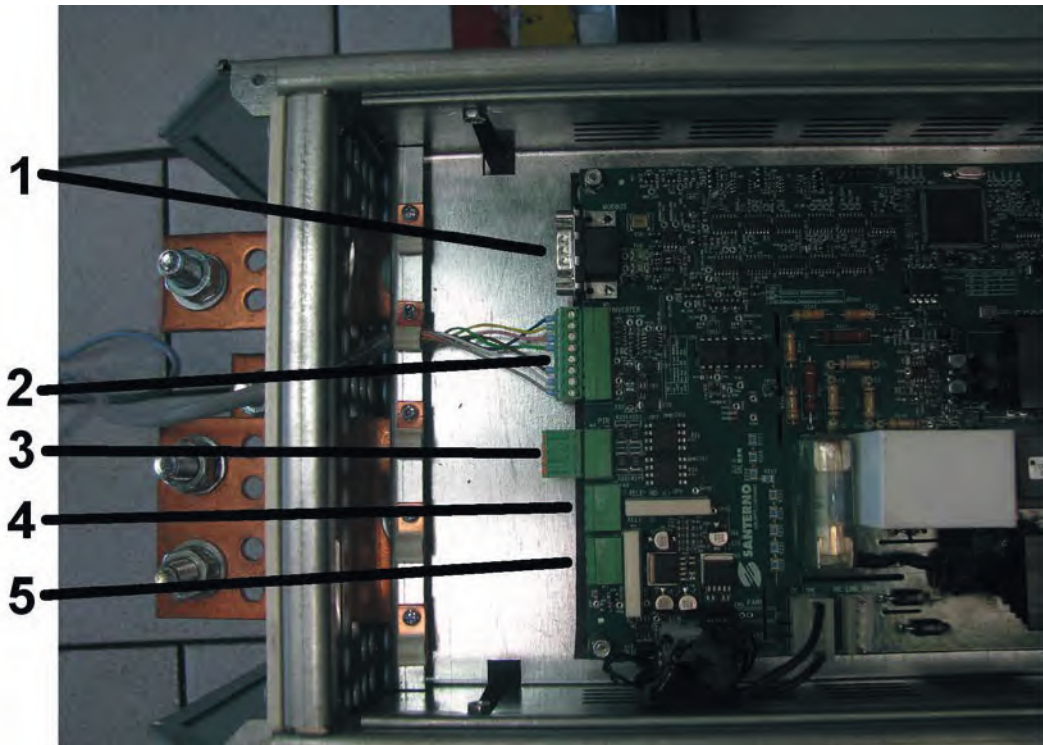

S000158

Figure 88: Signal terminals

1. Serial port [*]
2. M1 - BRAKE terminals
3. M2 - Reset signal
4. M3 - [*]
5. M4 - [*]



NOTE [*] Unavailable function.

6.3.4.4. Wiring Diagram

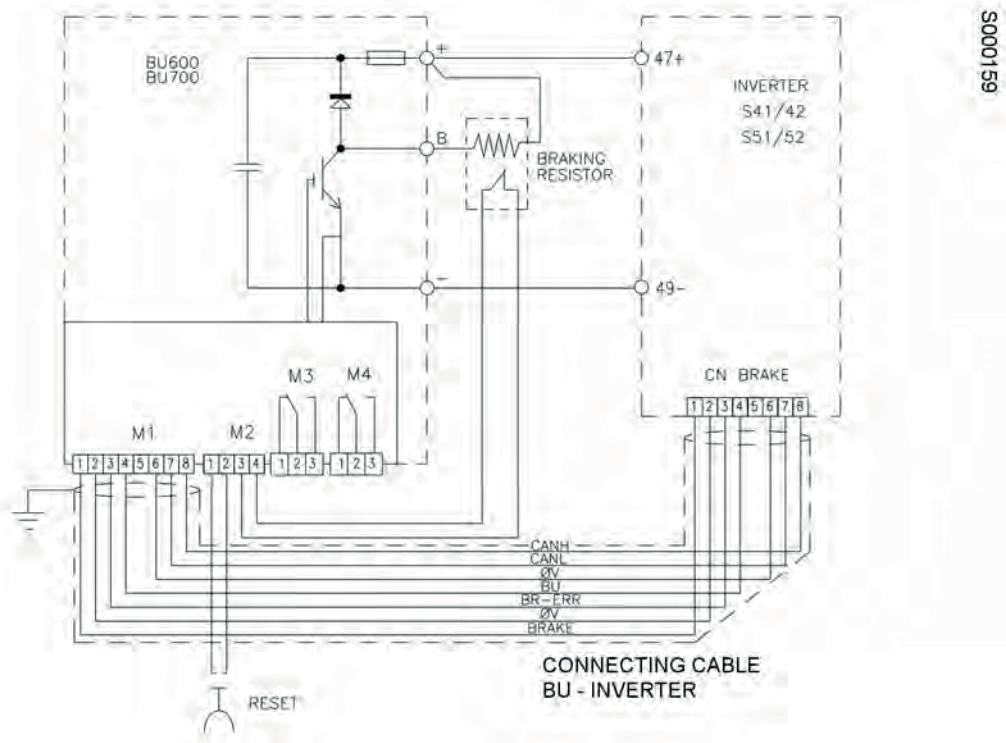

Figure 89: Wiring diagram for S41-S51/S42-S52 with braking unit BU600/700

6.3.5. Braking Resistors for BU700 2T-4T



NOTE

The wire cross-sections given in the table relate to one wire per braking resistor.



DANGER

Based on the functioning cycle, the surface of the braking resistor may reach 200°C.



CAUTION

The power dissipated by the braking resistors may be the same as the rated power of the connected motor multiplied by the braking duty-cycle; use a proper air-cooling system. Do not install braking resistors near heat-sensitive equipment or objects.



CAUTION

Do not connect to the inverter any braking resistor with an Ohm value lower than the value given in the tables.

6.3.5.1. Applications with DUTY CYCLE 10% - Class 2T

SIZE	Sinus Penta Model	Braking Unit	Braking Resistors						
			Resistors to be used				Type of Connection	Value (Ω)	Wire Cross-section mm ² (AWG or kcmils)
			Q.ty	Q.ty	Recommended Value (Ω)	Power (kW)			
S41	0180	1	2	3.3	8	IP20	B	1.65	16(6)
	0202	1	2	3.3	8	IP20	B	1.65	16(6)
	0217	1	3	3.3	8	IP20	B	1.1	16(6)
	0260	1	3	3.3	8	IP20	B	1.1	16(6)
S51	0313	1	4	3.3	8	IP20	B	0.825	16(6)
	0367	1	4	3.3	8	IP20	B	0.825	16(6)
	0402	1	1	0.6	48	IP23	A	0.6	95(4/0)

6.3.5.2. Applications with DUTY CYCLE 20% - Class 2T

SIZE	Sinus Penta Model	Braking Unit	Braking Resistors						
			Resistors to be used				Type of Connection	Value (Ω)	Wire Cross-section mm ² (AWG or kcmils)
			Q.ty	Q.ty	Recommended Value (Ω)	Power (kW)			
S41	0180	1	2	3.3	12	IP20	B	1.65	16(6)
	0202	1	2	3.3	12	IP20	B	1.65	16(6)
	0217	1	3	3.3	12	IP20	B	1.1	16(6)
	0260	1	3	3.3	12	IP20	B	1.1	16(6)
S51	0313	1	4	3.3	12	IP20	B	0.825	16(6)
	0367	1	4	3.3	12	IP20	B	0.825	16(6)
	0402	1	1	0.6	64	IP23	A	0.6	185(350)

6.3.5.3. Applications with DUTY CYCLE 50% - Class 2T

SIZE	Sinus Penta Model	Braking Unit	Braking Resistors						
			Resistors to be used				Type of Connection	Value (Ω)	Wire Cross-section mm ² (AWG or kcmils)
			Q.ty	Q.ty	Recommended Value (Ω)	Power (kW)			
S41	0180	1	4	6.6	12	IP20	B	1.65	16(4)
	0202	1	4	6.6	12	IP20	B	1.65	16(4)
	0217	1	1	1.2	64	IP23	A	1.2	120(250)
	0260	1	1	1.2	64	IP23	A	1.2	120(250)
S51	0313	1	2	1.6	48	IP23	B	0.8	95(4/0)
	0367	1	2	1.6	48	IP23	B	0.8	95(4/0)
	0402	1	2	1.2	64	IP23	B	0.6	120(250)

Type of connection:

A-One resistor

B-Two or more parallel-connected resistors



CAUTION

The cables of the braking resistors shall have insulation features and heat-resistance features suitable for the application. The minimum rated voltage of the cables must be 450/700V.

6.3.5.4. Applications with DUTY CYCLE 10% - Class 4T

SIZE	Sinus Penta Model	Braking Unit	Braking Resistors						
			Resistors to be used				Type of Connection	Value (Ω)	Wire Cross-section mm ² (AWG or kcmils)
			Q.ty	Q.ty	Recommended Value (Ω)	Power (kW)			
S41	0180	1	1	3.6	16	IP23	A	3.6	25(3)
	0202	1	1	3	24	IP23	A	3.0	25(3)
	0217	1	1	2.8	32	IP23	A	2.8	35(2)
	0260	1	1	2.4	32	IP23	A	2.4	35(2)
S51	0313	1	1	1.8	32	IP23	A	1.8	50(1/0)
	0367	1	1	1.8	32	IP23	A	1.8	50(1/0)
	0402	1	1	1.4	48	IP23	A	1.4	70(2/0)

6.3.5.5. Applications with DUTY CYCLE 20% - Class 4T

SIZE	Sinus Penta Model	Braking Unit	Braking Resistors						
			Resistors to be used				Type of Connection	Value (Ω)	Wire Cross-section mm ² (AWG or kcmils)
			Q.ty	Q.ty	Recommended Value (Ω)	Power (kW)			
S41	0180	1	1	3.6	32	IP23	A	3.6	50(1/0)
	0202	1	1	3	48	IP23	A	3.0	50(1/0)
	0217	1	1	2.8	48	IP23	A	2.8	70(2/0)
	0260	1	1	2.4	48	IP23	A	2.4	70(2/0)
S51	0313	1	1	1.8	64	IP23	A	1.8	95(4/0)
	0367	1	1	1.8	64	IP23	A	1.8	95(4/0)
	0402	1	2	2.8	48	IP23	B	1.4	70(2/0)

6.3.5.6. Applications with DUTY CYCLE 50% - Class 4T

SIZE	Sinus Penta Model	Braking Unit	Braking Resistors						
			Resistors to be used				Type of Connection	Value (Ω)	Wire Cross-section mm ² (AWG or kcmils)
			Q.ty	Q.ty	Recommended Value (Ω)	Power (kW)			
S41	0180	1	2	6.6	48	IP23	B	3.3	35(2)
	0202	1	2	6.0	64	IP23	B	3.0	35(2)
	0217	1	2	5.0	64	IP23	B	2.5	50(1/0)
	0260	1	2	5.0	64	IP23	B	2.5	50(1/0)
S51	0313	1	4	1.6	48	IP23	D	1.6	95(4/0)
	0367	1	4	1.6	48	IP23	D	1.6	95(4/0)
	0402	1	4	1.4	64	IP23	D	1.4	95(4/0)

Type of connection:

- A-One resistor
- B-Two or more parallel-connected resistors
- D-Four resistors (parallel connection of two series of two resistors)



CAUTION

The cables of the braking resistors shall have insulation features and heat-resistance features suitable for the application. The minimum rated voltage of the cables must be 0.6/1kV.

6.3.6. Braking Resistors for BU600 5T-6T



NOTE

The wire cross-sections given in the table relate to one wire per braking resistor.



DANGER

Based on the functioning cycle, the surface of the braking resistor may reach 200°C.



CAUTION

The power dissipated by the braking resistors may be the same as the rated power of the connected motor multiplied by the braking duty-cycle; use a proper air-cooling system. Do not install braking resistors near heat-sensitive equipment or objects.



CAUTION

Do not connect to the inverter any braking resistor with an Ohm value lower than the value given in the tables.

6.3.6.1. Applications with DUTY CYCLE 10% - Class 5T

SIZE	Model	Braking Unit	Braking Resistors						
			Resistors to be used				Type of Connection	Value (Ω)	Wire Cross-section mm ² (AWG or kcmils)
			Q.ty	Q.ty	Recommended Value (Ω)	Power (kW)			
S42	0181	1	1	4.2	32	IP23	A	4.2	25(3)
	0201	1	1	3.6	32	IP23	A	3.6	35(2)
	0218	1	1	3.6	32	IP23	A	3.6	35(2)
	0259	1	1	3.0	32	IP23	A	3.0	35(2)
S52	0290	1	1	3.0	32	IP23	A	3.0	70(2/0)
	0314	1	1	2.4	48	IP23	A	2.4	70(2/0)
	0368	1	1	2.4	48	IP23	A	2.4	70(2/0)
	0401	1	1	1.8	64	IP23	A	1.8	95(4/0)

6.3.6.2. Applications with DUTY CYCLE 20% - Class 5T

SIZE	Model	Braking Unit	Braking Resistors						
			Resistors to be used				Type of Connection	Value (Ω)	Wire Cross-section mm ² (AWG or kcmils)
			Q.ty	Q.ty	Recommended Value (Ω)	Power (kW)			
S42	0181	1	1	4.2	48	IP23	A	4.2	50(1/0)
	0201	1	1	3.6	64	IP23	A	3.6	50(1/0)
	0218	1	2	6.0	32	IP23	B	3.0	25(3)
	0259	1	2	6.0	32	IP23	B	3.0	25(3)
S52	0290	1	2	6.0	32	IP23	B	3.0	25(3)
	0314	1	2	5.0	48	IP23	B	2.5	35(2)
	0368	1	2	5.0	48	IP23	B	2.5	35(2)
	0401	1	2	3.6	64	IP23	B	1.8	50(1/0)

6.3.6.3. Applications with DUTY CYCLE 50% - Class 5T

SIZE	Model	Braking Unit	Braking Resistors						
			Resistors to be used				Type of Connection	Value (Ω)	Wire Cross-section mm ² (AWG or kcmils)
			Q.ty	Q.ty	Recommended Value (Ω)	Power (kW)			
S42	0181	1	4	4.2	32	IP23	D	4.2	35(2)
	0201	1	4	3.6	48	IP23	D	3.6	50(1/0)
	0218	1	4	3.6	48	IP23	D	3.6	50(1/0)
	0259	1	4	3.0	48	IP23	D	3.0	70(2/0)
S52	0290	1	4	2.4	48	IP23	D	2.4	70(2/0)
	0314	1	4	2.4	48	IP23	D	2.4	70(2/0)
	0368	1	4	2.4	64	IP23	D	2.4	70(2/0)
	0401	1	4	1.8	64	IP23	D	1.8	95(4/0)

Type of connection:

- A - One resistor
- B - Two or more parallel-connected resistors
- D - Four resistors (parallel connection of two series of two resistors)



CAUTION

The cables of the braking resistors shall have insulation features and heat-resistance features suitable for the application. The minimum rated voltage of the cables must be 0.6/1kV.

6.3.6.4. Applications with DUTY CYCLE 10% - Class 6T

SIZE	Model	Braking Unit	Braking Resistor						
			Resistors to be used				Type of Connection	Value (Ω)	Wire Cross-section mm ² (AWG or kcmils)
			Q.ty	Q.ty	Recommended Value (Ω)	Power (kW)			
S42	0181	1	1	5.0	32	IP23	A	5.0	25(3)
	0201	1	1	3.6	32	IP23	A	3.6	35(2)
	0218	1	1	3.6	32	IP23	A	3.6	35(2)
	0259	1	1	3.6	48	IP23	A	3.6	70(2/0)
S52	0290	1	1	3.0	48	IP23	A	3.0	70(2/0)
	0314	1	1	2.4	48	IP23	A	2.4	70(2/0)
	0368	1	1	2.4	64	IP23	A	2.4	95(4/0)
	0401	1	1	1.8	64	IP23	A	1.8	120(250)

6.3.6.5. Applications with DUTY CYCLE 20% - Class 6T

SIZE	Model	Braking Unit	Braking Resistor						
			Resistors to be used				Type of Connection	Value (Ω)	Wire Cross-section mm ² (AWG or kcmils)
			Q.ty	Q.ty	Recomm ended Value (Ω)	Power (kW)			
S42	0181	1	1	5.0	48	IP23	A	4.2	50(1/0)
	0201	1	1	3.6	64	IP23	A	3.6	50(1/0)
	0218	1	1	3.6	64	IP23	A	3.6	50(1/0)
	0259	1	2	6.6	48	IP23	B	3.3	25(3)
S52	0290	1	2	6.0	48	IP23	B	3.0	35(2)
	0314	1	2	5.0	48	IP23	B	2.5	35(2)
	0368	1	2	5.0	64	IP23	B	2.5	50(1/0)
	0401	1	2	3.6	64	IP23	B	1.8	70(2/0)

6.3.6.6. Applications with DUTY CYCLE 50% - Class 6T

SIZE	Model	Braking Unit	Braking Resistor						
			Resistors to be used				Type of Connection	Value (Ω)	Wire Cross-section mm ² (AWG or kcmils)
			Q.ty	Q.ty	Recomm ended Value (Ω)	Power (kW)			
S42	0181	1	4	5.0	32	IP23	D	5.0	25(3)
	0201	1	4	3.6	48	IP23	D	3.6	70(2/0)
	0218	1	4	3.6	48	IP23	D	3.6	70(2/0)
	0259	1	4	3.6	48	IP23	D	3.6	70(2/0)
S52	0290	1	4	2.8	64	IP23	D	2.8	70(2/0)
	0314	1	4	2.4	64	IP23	D	2.4	70(2/0)
	0368	1	4	2.4	64	IP23	D	2.4	120(250)
	0401	1	4	1.8	64	IP23	D	1.8	120(250)

Type of connection:

A - One resistor

B - Two or more parallel-connected resistors

D - Four resistors (parallel connection of two series of two resistors)



CAUTION

The cables of the braking resistors shall have insulation features and heat-resistance features suitable for the application. The minimum rated voltage of the cables must be 0.6/1kV.

6.4. Braking Unit BU1440 for Modular Inverters

A braking unit to be applied to modular inverters only is available. The inverter size must be equal to or larger than S65.

6.4.1. Delivery Check

Make sure that the equipment is not damaged and that it complies with the equipment you ordered by referring to the nameplate located on the inverter front part (see figure below). If the equipment is damaged, contact the supplier or the insurance company concerned. If the equipment does not comply with the one you ordered, please contact the supplier as soon as possible.

If the equipment is stored before being started, make sure that temperatures range from -25°C to $+70^{\circ}\text{C}$ and that relative humidity is $<95\%$ (non-condensing).

The equipment guarantee covers any manufacturing defect. The manufacturer has no responsibility for possible damages occurred while shipping or unpacking the equipment. The manufacturer is not responsible for possible damages or faults caused by improper and irrational uses; wrong installation; improper conditions of temperature, humidity, or the use of corrosive substances. The manufacturer is not responsible for possible faults due to the equipment operation at values exceeding the equipment ratings. The manufacturer is not responsible for consequential and accidental damages.

The braking unit is covered by a 12-month guarantee starting from the date of delivery.

6.4.1.1. Nameplate for BU1440

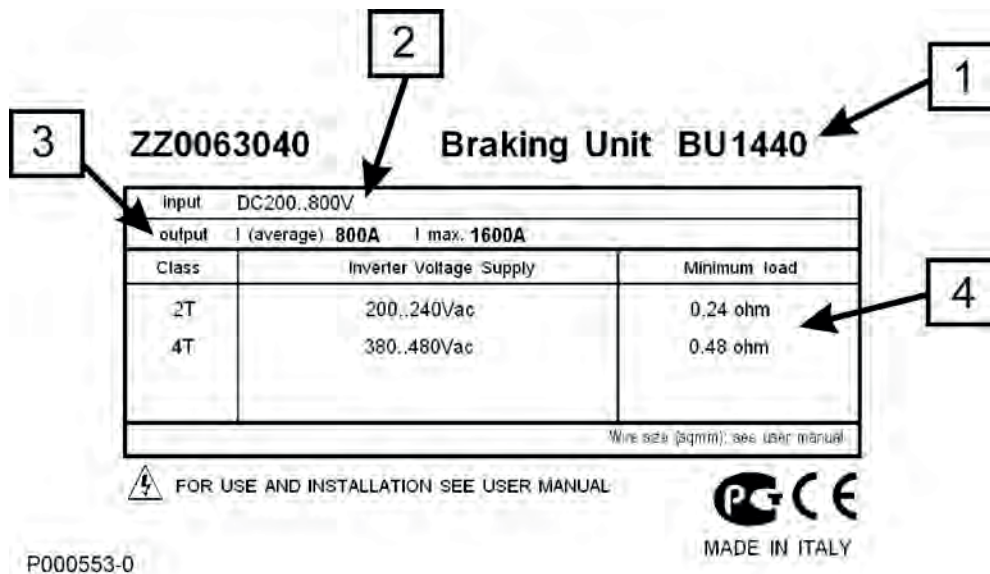

Figure 90: Nameplate for BU1440

- | | | |
|----|-----------------|---|
| 1. | Model: | BU1440 – Braking module |
| 2. | Supply ratings: | DC supply voltage deriving directly from the inverter terminals: 200 to 800 Vdc for BU1440 4T; 600÷1200 Vdc for BU1440 5T-6T |
| 3. | Output current: | 800A (average) – continuous average current in output cables
1600A (max.) – max. current in output cables (may be held for a timer longer than the time given in column “Max. Duration of Continuous Operation” in the resistors tables above) |
| 4. | Min. load: | Minimum value of the resistor to be connected to the output terminals (see application tables below) |

6.4.2. Operation

Each size of the braking unit can be used with a braking resistor avoiding exceeding the max. instant current stated in its specifications.

The braking unit is controlled directly by the control unit. Braking units cannot be parallel-connected when applied to modular inverters.

6.4.3. Ratings

SIZE	Max. braking current (A)	Average braking current (A)	Inverter supply voltage	Min. braking resistor (Ω)	Dissipated power (at average braking current) (W)
BU1440-4T	1600	800	380-500Vac	0.48	1800
BU1440-5T	1600	800	500-600Vac	0.58	2100
BU1440-6T	1600	800	600-690Vac	0.69	2200

6.4.4. Installing the Braking Unit

6.4.4.1. Environmental Requirements for the Braking Unit Installation, Storage and Transport

Maximum surrounding air temperature	-10 to +40°C with no derating From +40°C to +55°C with a 2% derating of the rated current for each degree beyond +40°C.
Ambient temperatures for storage and transport	-25°C to +70°C
Installation environment	Pollution degree 2 or better (according to IEC 61800-5-1). Do not install in direct sunlight and in places exposed to conductive dust, corrosive gases, vibrations, water sprinkling or dripping; do not install in salty environments.
Altitude	Max. altitude for installation 2000 m a.s.l. For installation above 2000 m and up to 4000 m, please contact Elettronica Santerno. Above 1000 m, derate the rated current by 1% every 100 m.
Operating ambient humidity	From 5% to 95%, from 1g/m ³ to 25g/m ³ , non-condensing and non-freezing (class 3k3 according to EN50178)
Storage ambient humidity	From 5% to 95%, from 1g/m ³ to 25g/m ³ , non-condensing and non-freezing (class 1k3 according to EN50178).
Ambient humidity during transport	Max. 95%, up to 60g/m ³ ; condensation may appear when the equipment is not running (class 2k3 according to EN50178)
Storage and operating atmospheric pressure	From 86 to 106 kPa (classes 3k3 and 1k4 according to EN50178)
Atmospheric pressure during transport	From 70 to 106 kPa (class 2k3 according to EN50178)



CAUTION

Ambient conditions strongly affect the inverter life. Do not install the equipment in places that do not have the above-mentioned ambient conditions.

6.4.4.2. Mounting the Braking Unit

Install braking unit BU1440 for modular inverters in an upright position inside a cabinet, next to the other inverter modules. Its overall dimensions are the same as those of an inverter arm. For more details, please refer to the paragraph relating to the mechanical installation of the modular inverters.

Dimensions (mm)			Fixing points (mm)				Screws	Weight (kg)
W	H	D	X	Y	D1	D2	M10	110
230	1400	480	120	237	11	25		

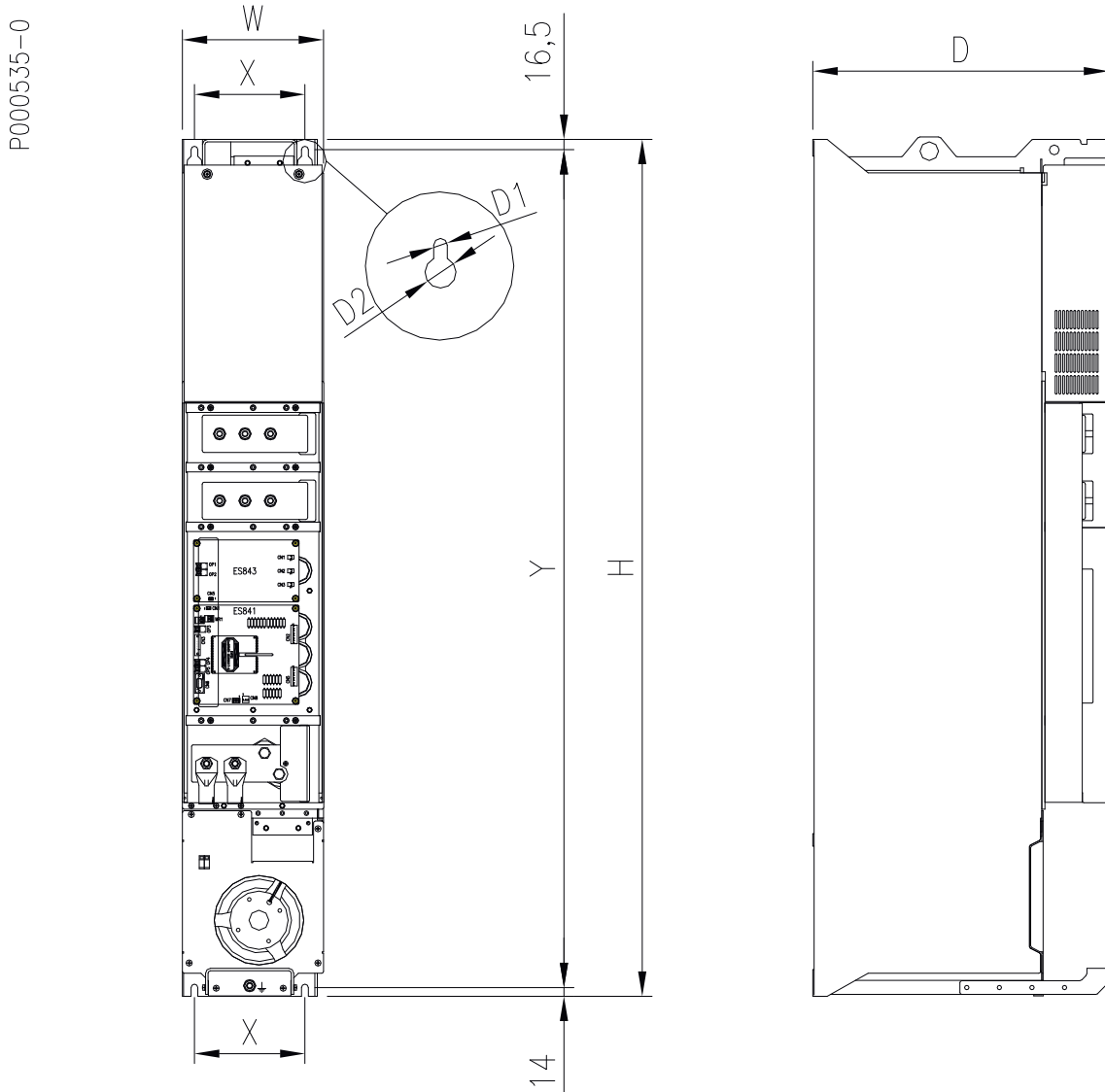
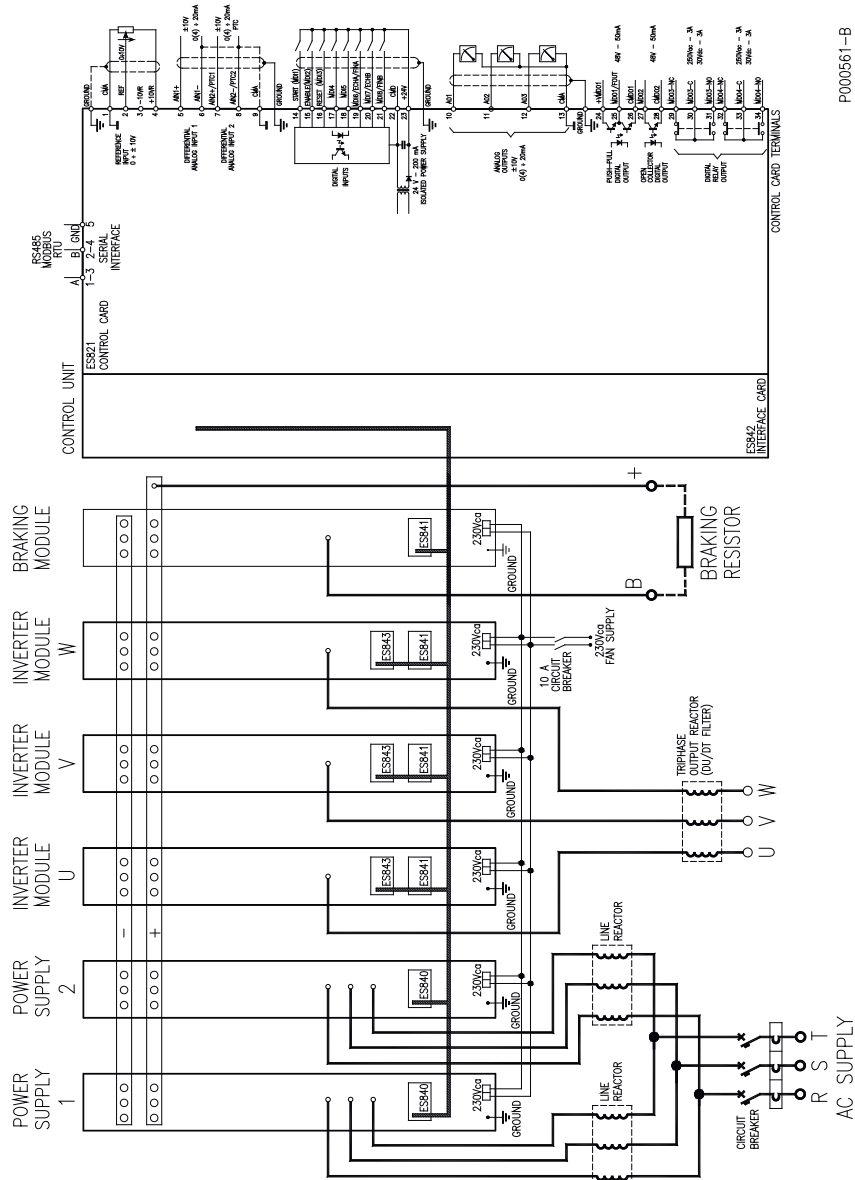

Figure 91: Dimensions and fixing points of BU1440

6.4.4.3. Wiring Diagram

Power connections

The braking unit must be connected to the inverter and the braking resistor.
The connection to the inverter is direct through 60*10mm copper plates connecting the different inverter modules. The braking resistor is connected to the + bar and to the braking unit.
Also connect the single-phase 230Vac supply of the cooling fan.



P000561-B

Figure 92: External power connections for modular inverters S65-S70 provided with braking unit BU1440



NOTE Power supply unit n.2 (power supply 2) is available for size S70.

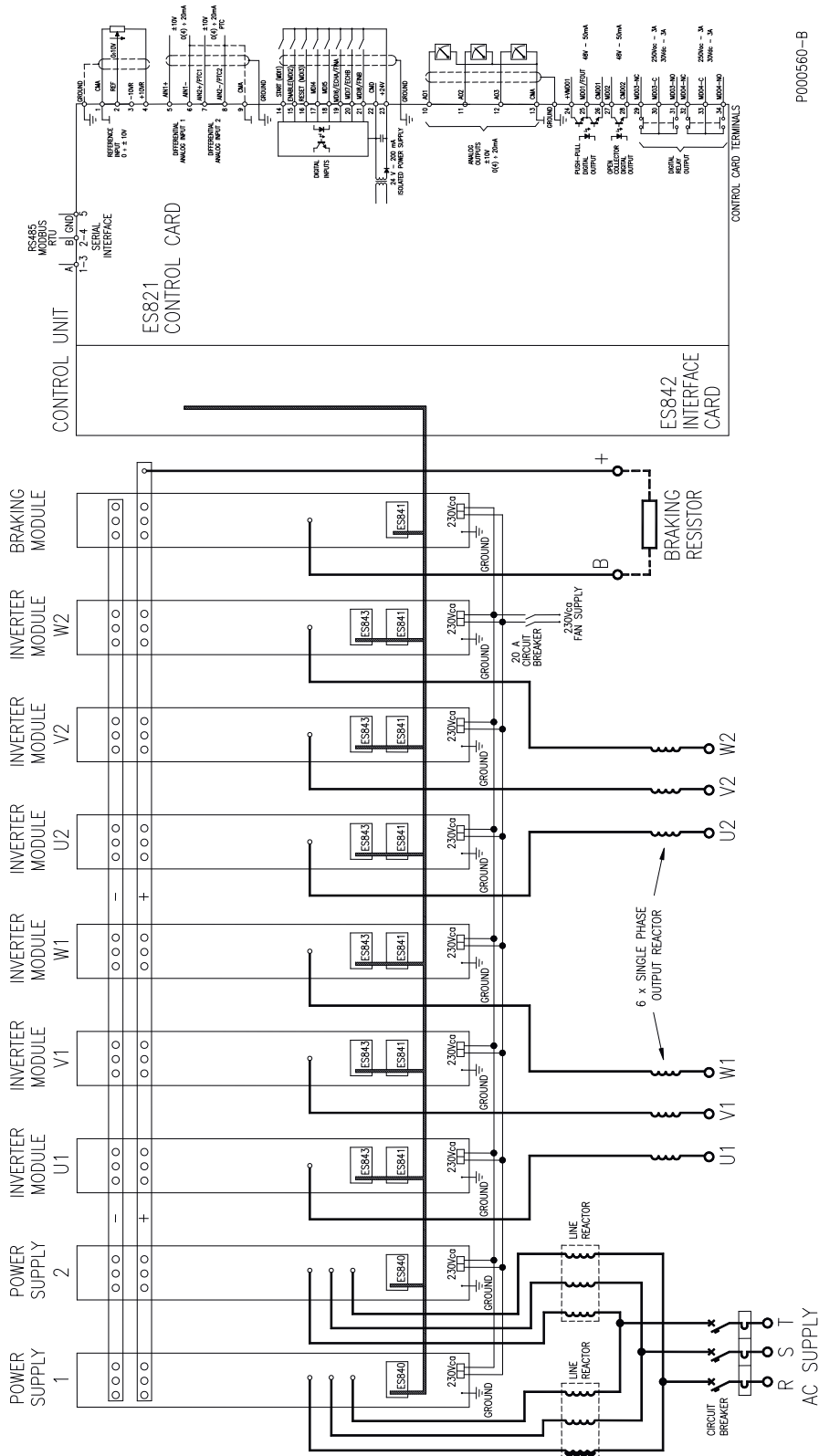

P000560-B

Figure 93: External power connections for modular inverters S75-S80 provided with braking unit BU1440



NOTE Power supply unit n. 3 is available for size S80.

Signal connections



CAUTION

Make sure that the control device is properly set-up when using the braking arm. When ordering the inverter, always state the inverter configuration you want to obtain.

Because the braking arm is controlled directly by the control device, the following wiring is required:

- connect +24V supply of gate unit ES841 of the braking unit through a pair of unipolar wires (AWG17-18 - 1mm²)
- connect braking IGBT to the fault IGBT signal through 2 optical fibres (diameter: 1mm) made of plastic (typical attenuation coefficient: 0.22dB/m) provided with Agilent HFBR-4503/4513 connectors.

The wiring diagram is as follows:

Signal	Type of wiring	Wire marking	Component	Board	Connector	Component	Board	Connector
+24VD Driver board ES841 power supply	Unipolar wire 1mm ²	24V-GB	Phase W	ES841	MR1-3	Braking unit	ES841	MR1-1
0VD Driver board ES841 power supply	Unipolar wire 1mm ²		Phase W	ES841	MR1-4	Braking unit	ES841	MR1-2
Brake IGBT command	Single optical fibre	G-B	Control unit	ES842	OP-4	Braking unit	ES841	OP5
Brake IGBT fault	Single optical fibre	FA-B	Control unit	ES842	OP-3	Braking unit	ES841	OP3



CAUTION

Do not remove the cap of connector OP4 in ES841 control board of the the braking module.

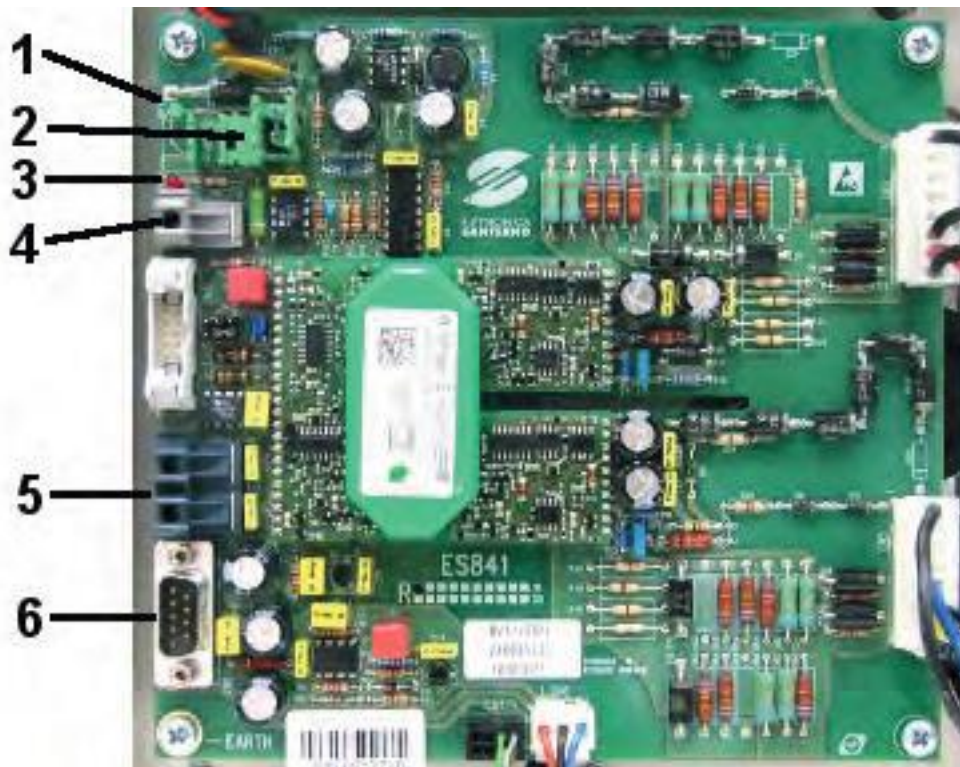

Figure 94: ES841 Unit gate board for the braking unit

1. OP1: Green LED – Board OK
2. MR1: 24V gate unit supply
3. OP2: Red LED - Board faulty[*]
4. OP3: IGBT Fault [*]
5. OP4-OP5: IGBT gate commands. OP4 MUST BE SEALED – DO NOT CONNECT
6. CN3: MUST NOT BE CONNECTED



NOTE [*]

The “IGBT Fault” signal, if the OP2 LED remains OFF, indicates that the thermoswitch has tripped.

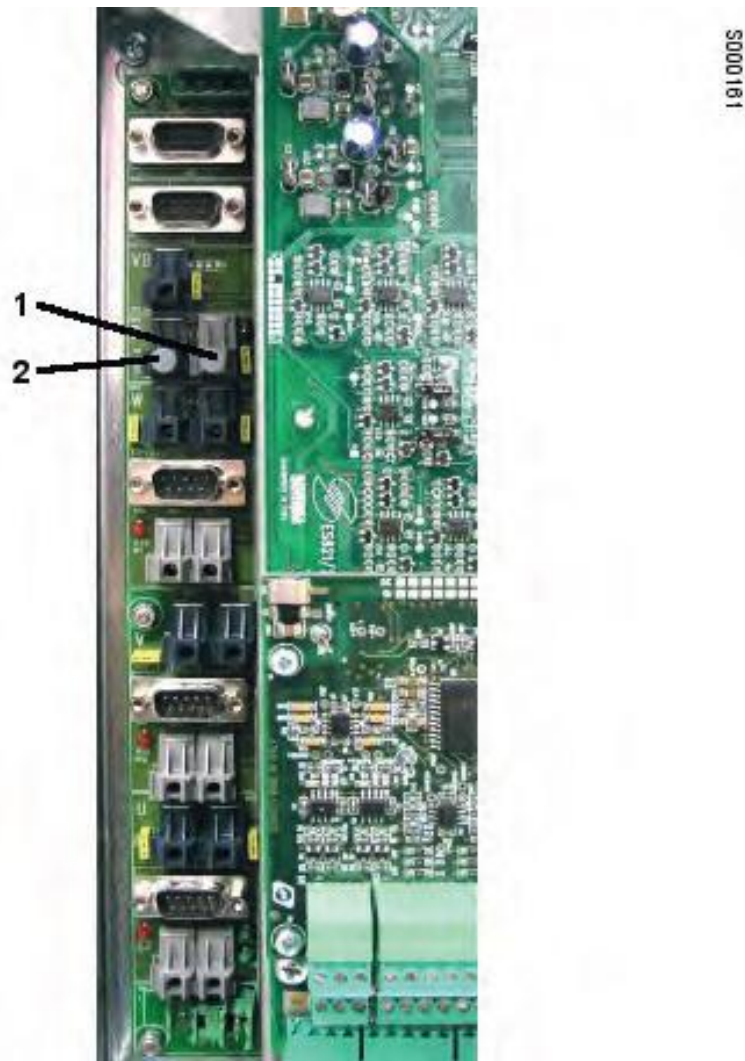

Figure 95: Connection points on ES842 for the braking unit optical fibres

7. OP4: Gate command for IGBT Brake
8. OP3: IGBT Fault Signal

The figure below shows the internal wiring of inverters S65-S70 provided with a braking unit.

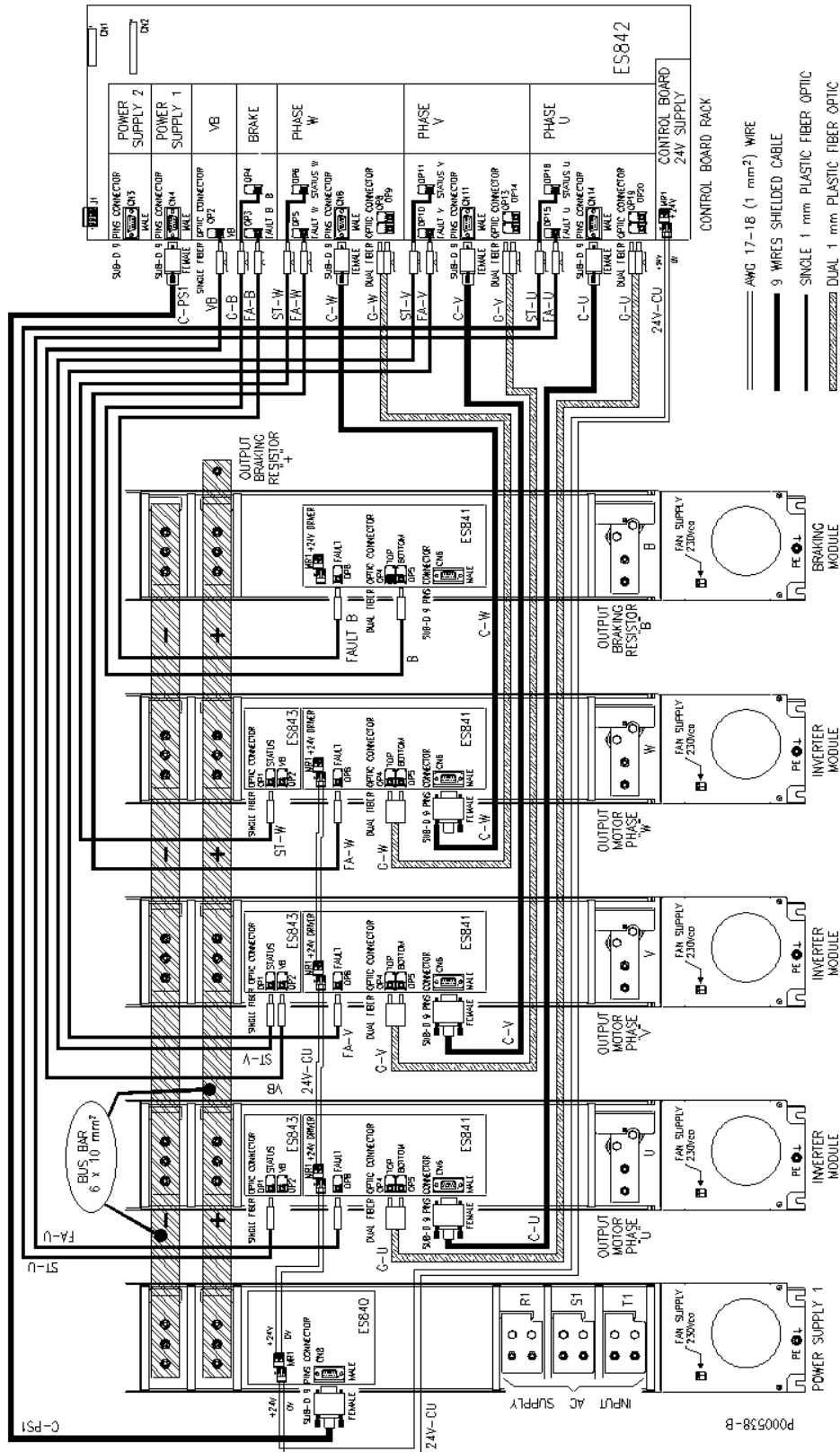

Figure 96: Internal wiring of inverters S65-S70 provided with a braking unit

6.4.5. Braking Resistors for BU1440 4T



NOTE

The wire cross-sections given in the table relate to one wire per braking resistor.



DANGER

Based on the functioning cycle, the surface of the braking resistor may reach 200°C.



CAUTION

The cables of the braking resistors shall have insulation features and heat-resistance features suitable for the application. The minimum rated voltage of the cables must be 0.6/1kV.



CAUTION

The power dissipated by the braking resistors may be the same as the rated power of the connected motor multiplied by the braking duty-cycle; use a proper air-cooling system. Do not install braking resistors near heat-sensitive equipment or objects.



CAUTION

Do not connect to the inverter any braking resistor with an Ohm value lower than the value given in the tables.

6.4.5.1. Applications with DUTY CYCLE 10% - Class 4T

SIZE	Sinus Penta Model	Braking Unit Q.ty	Braking Resistor						
			Resistors to be used				Type of Connection	Value (Ω)	Wire Cross-section mm ² (AWG or kcmils)
			Q.ty	Recommended Value (Ω)	Power (kW)	Degree of Protection			
S65	0598	1	1	1.2	64	IP23	A	1.2	95(4/0)
	0748	1	1	1.2	64	IP23	A	1.2	95(4/0)
	0831	1	2	1.6	48	IP23	B	0.8	120(250)
S75	0964	1	2	1.2	48	IP23	B	0.6	120(250)
	1130	1	2	1.2	64	IP23	B	0.6	120(250)
	1296	2	4	1.8	32	IP23	V	0.45	95(4/0)
S90	1800	2	4	1.6	48	IP23	V	0.4	120(250)
	2076	2	4	1.2	48	IP23	V	0.3	120(250)

6.4.5.2. Applications with DUTY CYCLE 20% - Class 4T

SIZE	Sinus Penta Model	Braking Unit	Braking Resistor						
			Resistors to be used				Type of Connection	Value (Ω)	Wire Cross-section mm ² (AWG or kcmils)
		Q.ty	Q.ty	Recommended Value (Ω)	Power (kW)	Degree of Protection			
S65	0598	1	2	2.4	64	IP23	B	1.2	120(250)
	0748	1	2	2.4	64	IP23	B	1.2	120(250)
	0831	1	3	2.4	48	IP23	B	0.8	120(250)
S75	0964	1	4	2.4	64	IP23	B	0.6	120(250)
	1130	1	4	2.4	64	IP23	B	0.6	120(250)
	1296	2	4	1.8	64	IP23	V	0.45	120(250)
S90	1800	2	6	2.4	48	IP23	V	0.4	120(250)
	2076	2	8	2.4	64	IP23	V	0.3	120(250)

6.4.5.3. Applications with DUTY CYCLE 50% - Class 4T

SIZE	Sinus Penta Model	Braking Unit	Braking Resistor						
			Resistors to be used				Type of Connection	Value (Ω)	Wire Cross-section mm ² (AWG or kcmils)
		Q.ty	Q.ty	Recommended Value (Ω)	Power (kW)	Degree of Protection			
S65	0598	1	4	1.2	64	IP23	D	1.2	120(250)
	0748	1	4	1.2	64	IP23	D	1.2	120(250)
	0831	1	6	1.2	64	IP23	E	0.8	120(250)
S75	0964	1	8	1.2	64	IP23	F	0.6	120(250)
	1130	1	8	1.2	64	IP23	F	0.6	120(250)
	1296	2	12	1.4	64	IP23	ME	0.47	120(250)
S90	1800	2	12	1.2	64	IP23	ME	0.4	120(250)
	2076	2	16	1.2	64	IP23	MF	0.3	120(250)

A - One resistor

B - Two or multiple parallel-connected resistors

C - Two series-connected resistors

D - Four resistors (parallel-connection of two series of two resistors)

E - Six resistors (parallel-connection of three series of two resistors)

F - Eight resistors (parallel-connection of four series of two resistors)

V - Two units, each of them including a braking module connected to two or more parallel-connected braking resistors

ME - Two units, each of them including a braking module connected to six braking resistors (parallel-connection of three series of two resistors)

MF - Two units, each of them including a braking module connected to eight braking resistors (parallel-connection of four series of two resistors)

6.4.6. Braking Resistors for BU1440 5T-6T



NOTE

The wire cross-sections given in the table relate to one wire per braking resistor.



DANGER

Based on the functioning cycle, the surface of the braking resistor may reach 200°C.



CAUTION

The power dissipated by the braking resistors may be the same as the rated power of the connected motor multiplied by the braking duty-cycle; use a proper air-cooling system. Do not install braking resistors near heat-sensitive equipment or objects.



CAUTION

Do not connect to the inverter any braking resistor with an Ohm value lower than the value given in the tables.

6.4.6.1. Applications with DUTY CYCLE 10% - Class 5T

SIZE	Sinus Penta Model	Braking Unit	Braking Resistor						
			Resistors to be used				Type of Connection	Value (Ω)	Wire Cross-section mm ² (AWG or kcmils)
			Q.ty	Q.ty	Recommended Value (Ω)	Power (kW)			
S65	0457	1	1	1.6	64	IP23	A	1.6	95(1/0)
	0524	1	2	2.8	48	IP23	B	1.4	50(1/0)
	0598	1	2	2.4	48	IP23	B	1.2	50(1/0)
	0748	1	2	2.1	48	IP23	B	1.05	95(4/0)
S70	0831	1	2	1.8	64	IP23	B	0.9	95(4/0)
S75	0964	1	3	2.4	48	IP23	B	0.8	50(1/0)
	1130	1	3	1.8	64	IP23	B	0.6	95(4/0)
S80	1296	1	3	1.6	64	IP23	B	0.53	95(4/0)
S90	1800	2	4	1.8	64	IP23	V	0.45	95(4/0)
	2076	2	6	2.4	48	IP23	V	0.4	50(1/0)

6.4.6.2. Applications with DUTY CYCLE 20% - Class 5T

SIZE	Sinus Penta Model	Braking Unit	Braking Resistor						
			Resistors to be used				Type of Connection	Value (Ω)	Wire Cross-section mm ² (AWG or kcmils)
			Q.ty	Q.ty	Recommended Value (Ω)	Power (kW)			
S65	0457	1	2	3.6	64	IP23	B	1.8	95(4/0)
	0524	1	3	4.2	64	IP23	B	1.4	50(1/0)
	0598	1	3	3.6	64	IP23	B	1.2	50(1/0)
	0748	1	3	2.8	64	IP23	B	0.93	70(2/0)
S70	0831	1	3	2.4	64	IP23	B	0.8	95(4/0)
S75	0964	1	4	2.8	64	IP23	B	0.7	70(2/0)
	1130	1	6	3.6	64	IP23	B	0.6	50(1/0)
S80	1296	1	6	3.0	64	IP23	B	0.5	70(2/0)
S90	1800	2	6	2.4	64	IP23	V	0.4	95(4/0)
	2076	2	8	2.8	64	IP23	V	0.35	70(2/0)

6.4.6.3. Applications with DUTY CYCLE 50% - Class 5T

SIZE	Sinus Penta Model	Braking Unit	Braking Resistor						
			Resistors to be used				Type of Connection	Value (Ω)	Wire Cross-section mm ² (AWG or kcmils)
			Q.ty	Q.ty	Recommended Value (Ω)	Power (kW)			
S65	0457	1	6	2.4	64	IP23	E	1.6	70(4/0)
	0524	1	6	2.1	64	IP23	E	1.4	95(4/0)
	0598	1	8	2.4	64	IP23	F	1.2	70(2/0)
	0748	1	8	1.8	64	IP23	F	0.9	95(4/0)
S70	0831	1	8	1.8	64	IP23	F	0.9	95(4/0)
S75	0964	1	10	1.8	64	IP23	G	0.7	95(4/0)
	1130	1	12	1.8	64	IP23	H	0.6	95(4/0)
S80	1296	1	14	1.8	64	IP23	I	0.51	95(4/0)
S90	1800	2	16	1.8	64	IP23	MF	0.45	95(4/0)
	2076	2	20	1.8	64	IP23	MG	0.35	95(4/0)

A - One resistor

B - Two or more parallel-connected resistors

D - Four resistors (parallel-connection of two series of two resistors)

E - Six resistors (parallel-connection of three series of two resistors)

F-Eight resistors (parallel-connection of four series of two resistors)

G - Ten resistors (parallel-connection of five series of two resistors)

H - Twelve resistors (parallel-connection of six series of two resistors)

I - Fourteen resistors (parallel-connection of seven series of two resistors)

V - Two units, each of them including a braking module connected to two or more parallel-connected braking resistors

MF - Two units, each of them including a braking module connected to eight braking resistors (parallel-connection of four series of two resistors)

MG - Two units, each of them including a braking module connected to ten braking resistors (parallel-connection of five series of two resistors)



CAUTION

The cables of the braking resistors shall have insulation features and heat-resistance features suitable for the application. Based on the duty-cycle, the surface of the braking resistor may reach 200°C. The minimum rated voltage of the cables must be 0.6/1kV.

6.4.6.4. Applications with DUTY CYCLE 10% - Class 6T

SIZE	Sinus Penta Model	Braking Unit	Braking Resistor						
			Resistors to be used				Type of Connection	Value (Ω)	Wire Cross-section mm ² (AWG or kcmils)
			Q.ty	Recommended Value (Ω)	Power (kW)	Degree of Protection			
S65	0457	1	2	3.6	48	IP23	B	1.8	70(2/0)
	0524	1	2	2.8	48	IP23	B	1.4	70(2/0)
	0598	1	2	2.8	48	IP23	B	1.4	70(2/0)
	0748	1	2	2.4	48	IP23	B	1.2	70(2/0)
S70	0831	1	2	1.8	64	IP23	B	0.9	120(250)
S75	0964	1	3	2.4	64	IP23	B	0.8	70(2/0)
	1130	2	4	2.4	64	IP23	V	0.6	70(2/0)
S80	1296	2	4	2.1	64	IP23	V	0.52	95(4/0)
S90	1800	2	4	1.8	64	IP23	V	0.45	120(250)
	2076	2	6	2.4	64	IP23	V	0.4	70(2/0)

6.4.6.5. Applications with DUTY CYCLE 20% - Class 6T

SIZE	Sinus Penta Model	Braking Unit	Braking Resistor						
			Resistors to be used				Type of Connection	Value (Ω)	Wire Cross-section mm ² (AWG or kcmils)
			Q.ty	Recommended Value (Ω)	Power (kW)	Degree of Protection			
S65	0457	1	3	5.0	64	IP23	B	1.7	50(1/0)
	0524	1	3	4.2	64	IP23	B	1.4	50(1/0)
	0598	1	3	4.2	64	IP23	B	1.4	70(2/0)
	0748	1	3	3.6	64	IP23	B	1.2	70(2/0)
S70	0831	1	4	3.6	64	IP23	B	0.9	70(2/0)
S75	0964	1	6	1.2	64	IP23	E	0.8	120(250)
	1130	2	8	1.2	64	IP23	MD	0.6	120(250)
S80	1296	2	8	1.2	64	IP23	MD	0.6	120(250)
S90	1800	2	8	3.6	64	IP23	V	0.45	70(2/0)
	2076	2	12	1.2	64	IP23	ME	0.4	120(250)

6.4.6.6. Applications with DUTY CYCLE 50% - Class 6T

Size	Sinus Penta Model	Braking Unit	Braking Resistor						
			Resistors to be used				Type of Connection	Value (Ω)	Wire Cross-section mm ² (AWG or kcmils)
			Q.ty	Recommended Value (Ω)	Power (kW)	Degree of Protection			
S65	0457	1	6	2.4	64	IP23	E	1.6	95(4/0)
	0524	1	8	2.8	64	IP23	F	1.4	70(2/0)
	0598	1	8	2.8	64	IP23	F	1.4	70(2/0)
	0748	1	8	2.4	64	IP23	F	1.2	95(4/0)
S70	0831	1	10	2.4	64	IP23	G	0.96	95(4/0)
S75	0964	1	12	2.4	64	IP23	H	0.8	70(2/0)
	1130	2	16	2.4	64	IP23	MF	0.6	95(4/0)
S80	1296	2	16	2.1	64	IP23	MF	0.52	120(250)
S90	1800	2	20	2.4	64	IP23	MG	0.48	95(4/0)
	2076	2	24	2.4	64	IP23	MH	0.4	70(2/0)

A - One resistor

B - Two or more parallel-connected resistors

D - Four resistors (parallel-connection of two series of two resistors)

E-Six resistors (parallel-connection of three series of two resistors)

F - Eight resistors (parallel-connection of four series of two resistors)

G - Ten resistors (parallel-connection of five series of two resistors)

H - Twelve resistors (parallel-connection of six series of two resistors)

V - Two units, each of them including a braking resistor connected to two or more parallel-connected braking resistors

MD - Two units, each of them including a braking module connected to four braking resistors (parallel-connection of two series of two resistors)

MF - Two units, each of them including a braking module connected to eight braking resistors (parallel-connection of four series of two resistors)

MG - Two units, each of them including a braking module connected to ten braking resistors (parallel-connection of five series of two resistors)

MH - Two units, each of them including a braking module connected to twelve braking resistors (parallel-connection of six series of two resistors)



CAUTION

The cables of the braking resistors shall have insulation features and heat-resistance features suitable for the application. Based on the duty-cycle, the surface of the braking resistor may reach 200°C. The min. rated voltage of the cables must be 0.6/1kV.

6.4.7. Available Braking Resistors

The specifications given for each resistor model also include the mean power to be dissipated and the max. operating time, depending on the inverter voltage class.

Based on these values, parameters **C211** and **C212** (concerning braking features) in the Resistor Braking menu can be set up. (See relevant section in the Sinus Penta's Programming Guide).

The max. operating time set in **C211** is factory-set in order not to exceed the allowable time for each resistor model (see section below).

Parameter **C212** represents the max. duty-cycle of the resistor and is to be set to a value lower than or equal to the value stated in the dimensioning table (see sections above).



DANGER Braking resistors may reach temperatures higher than 200°C.



CAUTION For parameters **C211** and **C212**, do not set values exceeding the max. allowable values stated in the tables above. Failure to do so will cause irreparable damage to the braking resistors; also, fire hazard exists.



CAUTION Braking resistors may dissipate up to 50% of the rated power of the connected motor; use a proper air-cooling system. Do not install braking resistors near heat-sensitive equipment or objects.

6.4.7.1. 350W Models (IP55)

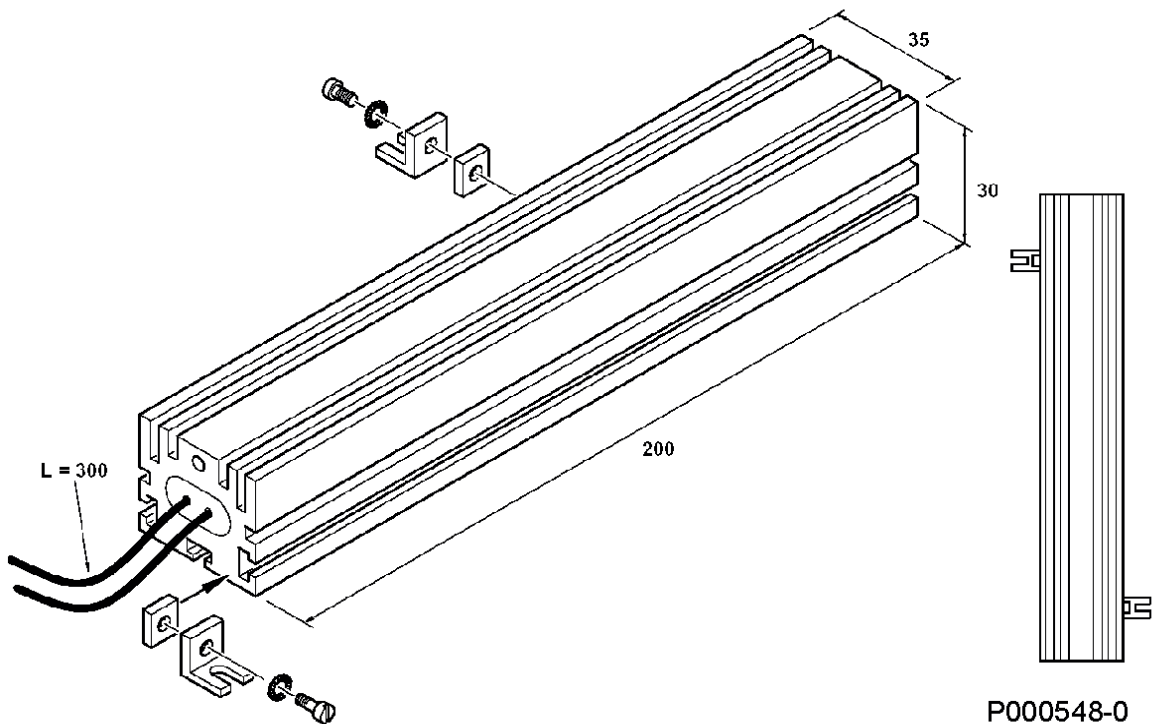
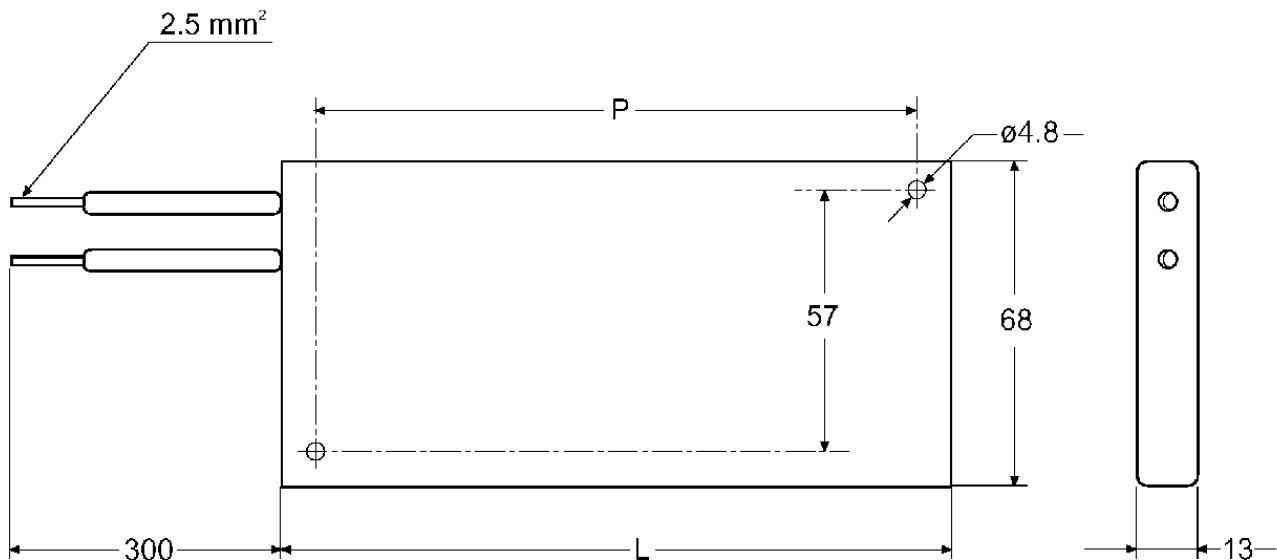

Figure 97: Overall dimensions, resistor 56-100Ω/350W

Type	Weight (g)	Average Power to be Dissipated (W)	Max. Duration of Continuous Operation for 200-240Vac (s)*
56Ω/350W RE2643560	400	350	3.5
100Ω/350W RE2644100	400	350	6

(*) Max. value to be set in parameter **C211** for single resistors or parallel-connected configurations. Duration is longer for different configurations (two or more series-connected resistors).
When setting the braking duty cycle in **C212**, make sure that the maximum power dissipated from the braking resistor being used is not exceeded.

6.4.7.2. 1300W Models (IP33)



P000549-0

Figure 98: Overall dimensions and ratings for braking resistor 75Ω/1300W

Type	L (mm)	D (mm)	Weight (g)	Mean power to be dissipated (W)	Max. duration of continuous operation for 380-500Vac (s)*
75Ω/1300W RE3063750	195	174	500	550	4

(*) Max. value to be set in parameter **C211** for single resistors or parallel-connected configurations. Duration is longer for different configurations (two or more series-connected resistors).
When setting the braking duty cycle in **C212**, make sure that the maximum power dissipated from the braking resistor being used is not exceeded.

6.4.7.3. IP55 Models from 1100W to 2200W

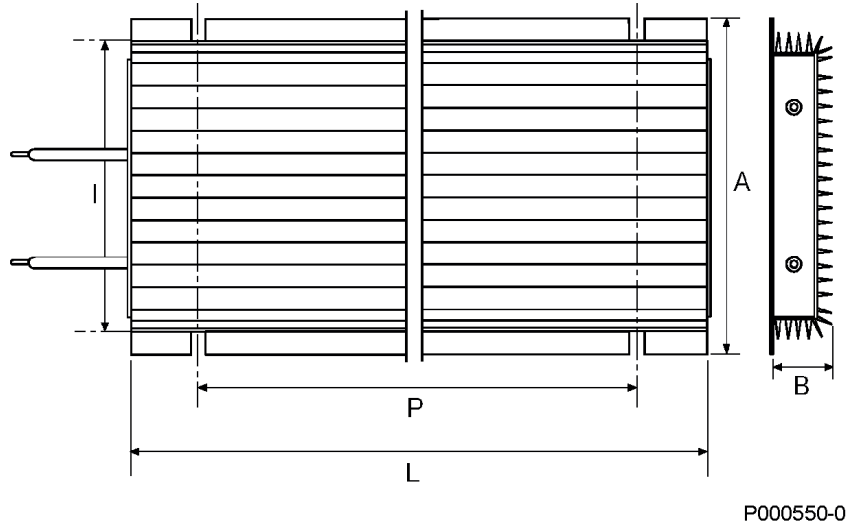

Figure 99: Overall dimensions and mechanical features for braking resistors from 1100W to 2200W

RESISTOR	A (mm)	B (mm)	L (mm)	I (mm)	P (mm)	Weight (g)	Average power that can be dissipated (W)	Max. duration of continuous operation (s) (*)			
								at 200-240Vac	at 380-500Vac	at 500-575Vac	at 660-690Vac
15Ω/1100W RE3083150	95	30	320	80-84	240	1250	950	3	Not applicable		
20Ω/1100W RE3083200								4	Not applicable		
50Ω/1100W RE3083500								11	3	Not applicable	
180Ω/1100W RE3084180								Not limited	10	6	4
250Ω/1100W RE3084250									14	9	6
10Ω/1500W RE3093100	120	40	320	107-112	240	2750	1100	3	Not applicable		
39Ω/1500W RE3093390								12	3	Not applicable	
50Ω/1500W RE3093500								16	4	Not applicable	
180Ω/1500W RE3094180								Not limited	14	8	6
250Ω/1500W RE3094250									20	12	8
25Ω/1800W RE3103250	120	40	380	107-112	300	3000	1300	9	3	Not applicable	
120Ω/1800W RE3104120								Not limited	11	7	4
250Ω/1800W RE3104250									24	14	10
15Ω/2200W RE3113150	190	67	380	177-182	300	7000	2000	8	3	Not applicable	
50Ω/2200W RE3113500								29	7	4	3
75Ω/2200W RE3113750								Not limited	11	6	4
100Ω/2200W RE3114100									14	9	6
150Ω/2200W RE3114150									22	13	9
180Ω/2200W RE3114180									26	16	11
250Ω/2200W RE3114250									36	22	15

(*) Max. value to be set in parameter **C211** for single resistors or parallel-connected configurations. Duration is longer for different configurations (two or more series-connected resistors).
When setting the braking duty cycle in **C212**, make sure that the maximum power dissipated from the braking resistor being used is not exceeded.

6.4.7.4. IP20 Models from 4kW-8kW-12kW

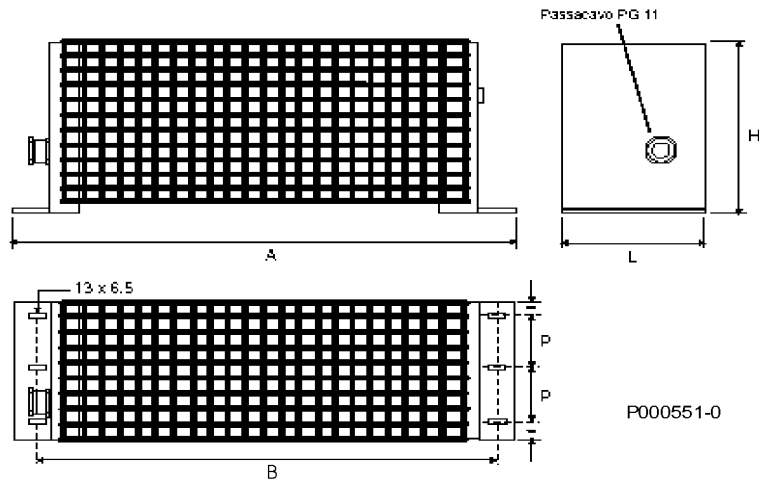

Figure 100: Overall dimensions for braking resistors 4kW, 8kW, 12kW

RESISTOR	A (mm)	B (mm)	L (mm)	I (mm)	P (mm)	Weight (g)	Average power that can be dissipated (W)	Max. duration of continuous operation (s) (*)										
								at 200-240Vac	at 380-500Vac	at 500-575Vac	at 660-690Vac							
5Ω/4kW RE3482500	620	600	100	250	40	5.5	4000	7	Not applicable									
15Ω/4kW RE3483150								21	5	Not applicable								
20Ω/4kW RE3483200								28	7	4	3							
25Ω/4kW RE3483250								35	8	5	3							
39Ω/4kW RE3483390								Not limited	13	8	5							
50Ω/4kW RE3483500									17	11	7							
60Ω/4kW RE3483600									21	13	9							
82Ω/4kW RE3483820									29	18	12							
100Ω/4kW RE3484100									35	22	15							
120Ω/4kW RE3484120									42	26	18							
150Ω/4kW RE3484150									Not limited	33	22							
180Ω/4kW RE3484180										39	27							
250Ω/4kW RE3484250										Not limited	37							
3.3Ω/8kW RE3762330									620	600	160	250	60	10.6	8000	9	Not applicable	
5Ω/8kW RE3762500								14										
10Ω/8kW RE3763100	28	7	4	3														
45Ω/8kW RE3763450	Not limited	32	19	13														
82Ω/8kW RE3763820		Not limited	36	24														
120Ω/8kW RE3764120		Not limited	36															
3.3Ω/12kW RE4022330	620	600	200	250	80	13.7	12000	14	Not applicable									
6.6Ω/12kW RE4022660								28	7	4	3							
10Ω/12kW RE4023100								42	10	6	4							
45Ω/12kW RE4023450								Not limited	48	29	20							

(*) Max. value to be set in parameter **C211** for single resistors or parallel-connected configurations. Duration is longer for different configurations (two or more series-connected resistors).
When setting the braking duty cycle in **C212**, make sure that the maximum power dissipated from the braking resistor being used is not exceeded.



CAUTION

Because the metal frame of the braking resistor can reach high temperatures, appropriate cables capable of withstanding high temperatures must be used.

6.4.7.5. IP23 Boxes from 4kW to 64kW

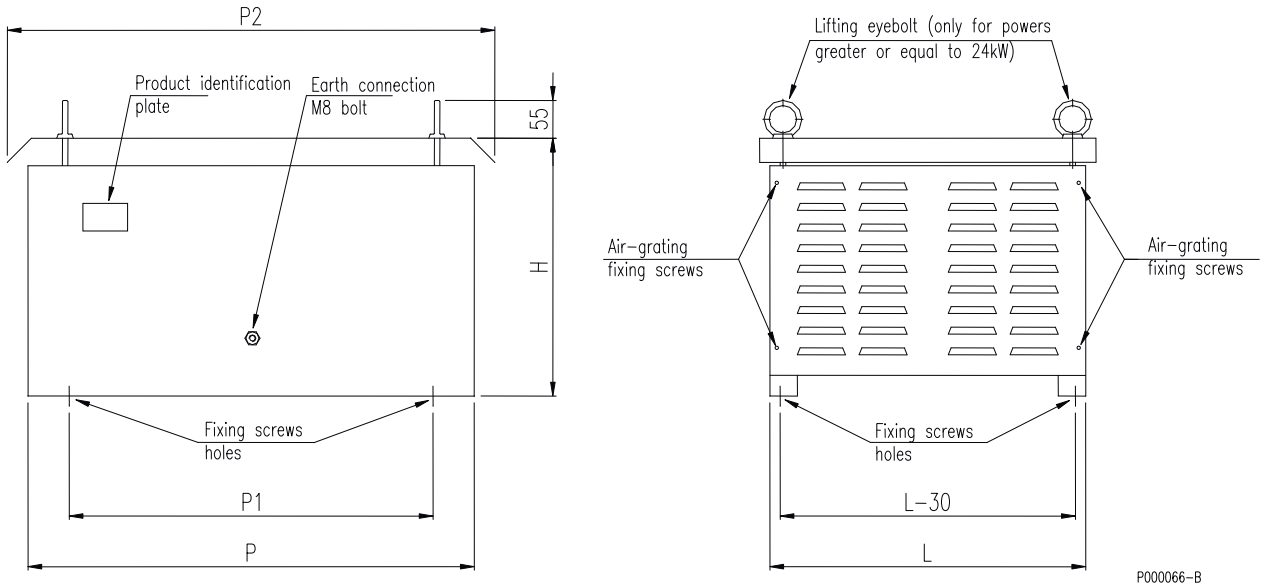

Figure 101: Overall dimensions of IP23 Box resistors

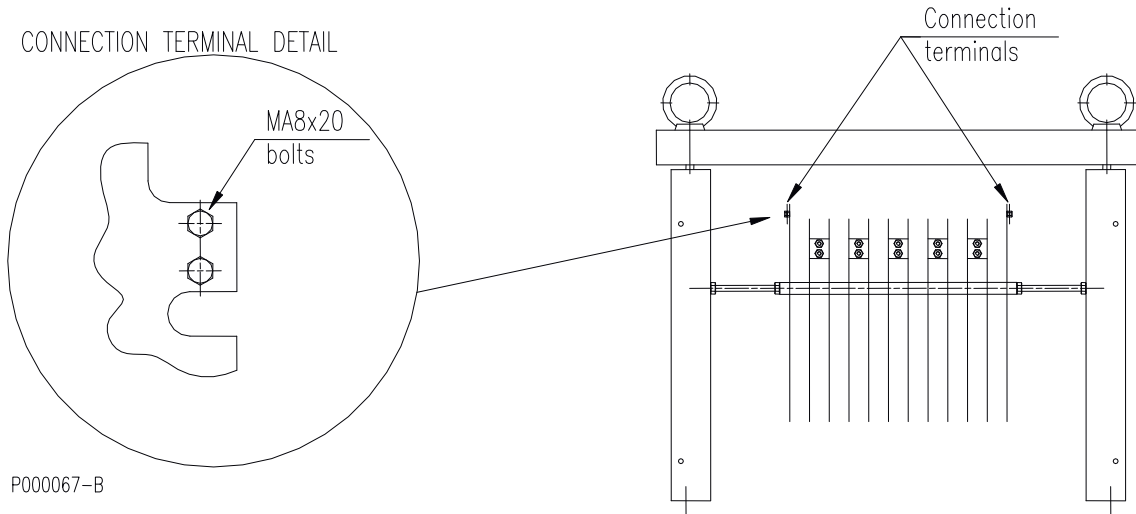

Figure 102: Position of electrical connections in box resistors

Remove the grids to gain access to wiring terminals (loosen fastening screws).



NOTE

The figure shows 20Ω/12kW resistor. In certain models, remove both panels to gain access to the wiring terminals.



CAUTION

Because the metal frame of the braking resistor can reach high temperatures, appropriate cables capable of withstanding high temperatures must be used.

RESISTOR	P (mm)	P1 (mm)	P2 (mm)	L (mm)	H (mm)	Weight (kg)	Average power (W) that can be dissipated	Max. duration of continuous operation (s) (*)			
								at 200-240Vac	at 380-500Vac	at 500-575Vac	at 660-690Vac
30Ω/4kW RE3503300	650	530	710	320	375	20	4000	85	21	13	9
45Ω/4kW RE3503450								128	32	19	13
50Ω/4kW RE3503500								not limited	35	22	15
60Ω/4kW RE3503600									42	26	18
82Ω/4kW RE3503820									58	36	24
100Ω/4kW RE3504100									71	44	30
120Ω/4kW RE3504120									85	53	36
150Ω/4kW RE3504150									not limited	66	45
180Ω/4kW RE3504180										79	54
15Ω/8kW RE3783150									650	530	710
18Ω/8kW RE3783180	not limited	25	15	10							
22Ω/8kW RE3783220		31	19	13							
30Ω/8kW RE3783300		42	26	18							
45Ω/8kW RE3783450		64	39	27							
50Ω/8kW RE3783500		71	44	30							
60Ω/8kW RE3783600		85	53	36							
82Ω/8kW RE3783820		not limited	72	49							
10Ω/12kW RE4053100		650	530	710	460	375	34	12000			
12Ω/12kW RE4053120	not limited								25	15	10
15Ω/12kW RE4053150									32	19	13
18Ω/12kW RE4053180									38	23	16
20Ω/12kW RE4053200									42	26	18
22Ω/12kW RE4053220									46	29	19
30Ω/12kW RE4053300									64	39	27
45Ω/12kW RE4053450									96	59	40
60Ω/12kW RE4053600									not limited	79	54

RESISTOR	P (mm)	P1 (mm)	P2 (mm)	L (mm)	H (mm)	Weight (kg)	Average power (W) that can be dissipated	Max. duration of continuous operation (s) (*)			
								at 200-240Vac	at 380-500Vac	at 500-575Vac	at 660-690Vac
3.6Ω/16kW RE4162360	650	530	710	550	375	40	16000	40	10	not applicable	not applicable
5Ω/16kW RE4162500								57	14		
6.6Ω/16kW RE4162660								75	18	11	
8.2Ω/16kW RE4162820								not limited	23	14	9
10Ω/16kW RE4163100									28	18	12
12Ω/16kW RE4163120									34	21	14
15Ω/16kW RE4163150									42	27	18
18Ω/16kW RE4163180									51	31	21
20Ω/16kW RE4163200									57	35	24
22Ω/16kW RE4163220									62	39	26
30Ω/16kW RE4163300									85	53	36
45Ω/16kW RE4163450									not limited	79	54
3Ω/24kW RE4292300									650	530	710
5Ω/24kW RE4292500	85	21	13	9							
6.6Ω/24kW RE4292660	not limited	28	17	11							
8.2Ω/24kW RE4292820		34	21	14							
10Ω/24kW RE4293100		42	27	18							
15Ω/24kW RE4293150		64	40	27							
18Ω/24kW RE4293180		76	47	32							
22Ω/24kW RE4293220		93	58	39							
30Ω/24kW RE4293300		not limited	79	54							

RESISTOR	P (mm)	P1 (mm)	P2 (mm)	L (mm)	H (mm)	Weight (kg)	Average power (W) that can be dissipated	Max. duration of continuous operation (s) (*)										
								at 200-240Vac	at 380-500Vac	at 500-575Vac	at 660-690Vac							
1.8Ω/32kW RE4362180	650	530	710	990	375	68	32000	60	16	not applicable	not applicable							
2.4Ω/32kW RE4362240								54	13									
2.8Ω/32kW RE4362280								63	15									
3Ω/32kW RE4362300								68	17	10								
3.6Ω/32kW RE4362360								82	20	12								
4.2Ω/32kW RE4362420								96	23	14		10						
5Ω/32kW RE4362500								114	28	17		12						
6Ω/32kW RE4362600								not limited	34	21		14						
6.6Ω/32kW RE4362660									37	23		15						
10Ω/32kW RE4363100									56	35		24						
15Ω/32kW RE4363150									85	53		36						
18Ω/32kW RE4363180									102	63		43						
0.45Ω/48kW RE4461450									650	530		710	750	730	101	48000	15	not applicable
0.6Ω/48kW RE4461600								20										
0.8Ω/48kW RE4461800	27																	
1.2Ω/48kW RE4462120	40	10																
1.4Ω/48kW RE4462140	47	11																
1.6Ω/48kW RE4462160	54	13																
2.1Ω/48kW RE4462210	71	17	11															
2.4Ω/48kW RE4462240	81	20	12															
2.8Ω/48kW RE4462280	95	23	14	10														
3Ω/48kW RE4462300	not limited	25	16	10														
3.6Ω/48kW RE4462360		30	19	13														
4.2Ω/48kW RE4462420		35	22	15														
5Ω/48kW RE4462500		42	26	18														

RESISTOR	P (mm)	P1 (mm)	P2 (mm)	L (mm)	H (mm)	Weight (kg)	Average power (W) that can be dissipated	Max. duration of continuous operation (s) (*)				
								at 200-240Vac	at 380-500Vac	at 500-575Vac	at 660-690Vac	
6Ω/48kW RE4462600	650	530	710	750	730	101	48000	not limited	51	31	21	
6.6Ω/48kW RE4462660									56	35	23	
10Ω/48kW RE4463100									85	53	36	
12Ω/48kW RE4463120									not limited	63	43	
15Ω/48kW RE4463150										79	54	
0.3Ω/64kW RE4561300	650	530	710	990	730	128	64000	13	not applicable	not applicable	not applicable	
0.45Ω/64W RE4561450								20				
0.6Ω/64kW RE4561600								27				
0.8Ω/64kW RE4561800								36				
1.2Ω/64kW RE4562120								54	13			
1.4Ω/64kW RE4562140								63	15	10		
1.6Ω/64kW RE4562160								72	18	11		
1.8Ω/64kW RE4562180								81	20	12		
2.1Ω/64kW RE4562210								95	23	14		10
2.4Ω/64kW RE4562240								109	27	17		11
2.8Ω/64kW RE4562280								not limited	31	19	13	
3Ω/64kW RE4562300									34	21	14	
3.6Ω/64kW RE4562360									40	25	17	
4.2Ω/64kW RE4562420									47	29	20	
5Ω/64kW RE4552500									56	35	24	
6Ω/64kW RE4562600									68	42	29	
6.6Ω/64kW RE4562660									75	46	31	
8.2Ω/64kW RE4562820									93	58	39	
10Ω/64kW RE4563100									not limited	70	48	

(*) Max. value to be set in parameter **C211** for single resistors or parallel-connected configurations. Duration is longer for different configurations (two or more series-connected resistors).
When setting the braking duty cycle in **C212**, make sure that the maximum power dissipated from the braking resistor being used is not exceeded.

6.5. Keypad Remoting Kits

6.5.1. Remoting the Keypad on the Cabinet

The inverter keypad may be remoted. A special kit is supplied, which includes the following:

- plastic frame allowing installing the keypad on the front wall of the cabinet,
- keypad jig allowing installing the keypad on the front door of the cabinet,
- seal between keypad frame and cabinet,
- remoting cable (length: 5 m).

If the kit supplied is properly assembled, degree of protection IP54 is obtained for the front panel in the cabinet.

For any details on how to remote the keypad, please refer to Operating and Remoting the Keypad.

6.5.2. Remoting a Keypad Controlling Multiple Inverters

The keypad remoting kit is used to connect a standard Sinus Penta keypad to one or multiple inverters manufactured by Elettronica Santerno via an RS485 link using protocol MODBUS RTU. The keypad can then communicate with one device at a time and will become the network master, thus avoiding communicating with any other master devices (e.g. PLCs).

The keypad automatically detects which device it is connected to. If multiple devices are connected, you can select the device to be used from a selection list.



NOTE The devices connected to the same network must have different addresses. Otherwise, no communication is possible.



NOTE The sections below state the applicability of the keypad remoting kit to the products manufactured by Elettronica Santerno.

6.5.2.1. Kit Component Parts

The kit for the keypad used via serial link RS485 includes the following component parts:

N.1 Interface converter provided with one RJ45 plug on one side, and with a 9-pole, female sub-D connector on the other side.

N.1 230 VAC – 9 VAC power supply unit, for separate supply from standard keypad.

DESCRIPTION	PART NUMBER
Adaptor kit for keypad connection via RS485	ZZ0101850

6.5.2.2. Operating Conditions

Operating temperature:	-10 to +55°C ambient temperature (contact Elettronica Santerno for higher ambient temperatures)
Relative humidity:	5 to 95% (non-condensing)
Max. operating altitude:	2000 m a.s.l. For installation above 2000 m and up to 4000 m, please contact Elettronica Santerno.
Max. consumption over 9 V power supply:	300 mA
Max. baud rate:	38.400 bps

6.5.2.3. Connecting the Keypad

Inverter-side connection: use a 9-pole, male D connector. To gain access to the D connector, just remove the cover on top of the inverter (size S05..S15), or remove the cover from the inverter bottom, located next to the control terminals (size \geq S20). If multiple inverters are connected to the same network, use a connector having the same features as the connector installed on the inverter.

The connector pins are detailed in the table below.

PIN	FUNCTION
1 – 3	(TX/RX A) Differential input/output A (bidirectional) according to standard RS485. Positive polarity in respect to pins 2 – 4 for one MARK.
2 – 4	(TX/RX B) Differential input/output B (bidirectional) according to standard RS485. Negative polarity in respect to pins 1 – 3 for one MARK.
5	(GND) control board zero volt
6	(VTEST) Test supply input – do not connect
7 – 8	Not connected
9	+ 5 V, max. 100 mA power supply



NOTE

The metal frame of the connector is connected to the inverter grounding. Connect the braiding of the twisted pair data cable to the metal frame of the female connector to be connected to the inverter.

Connector RJ 45 must be connected to the keypad.
This connector has the following connections:

PIN	FUNCTION
4	(TX/RX A) Differential input/output A (bidirectional) according to standard RS485. Positive polarity in respect to pin 6 for one MARK.
6	(TX/RX B) Differential input/output B (bidirectional) according to standard RS485. Negative polarity in respect to pin 4 for one MARK.
1-2-3	(GND) keypad zero volt.
5-7-8	+ 5 V, max. 100 mA power supply

The figure below shows the wiring diagram:

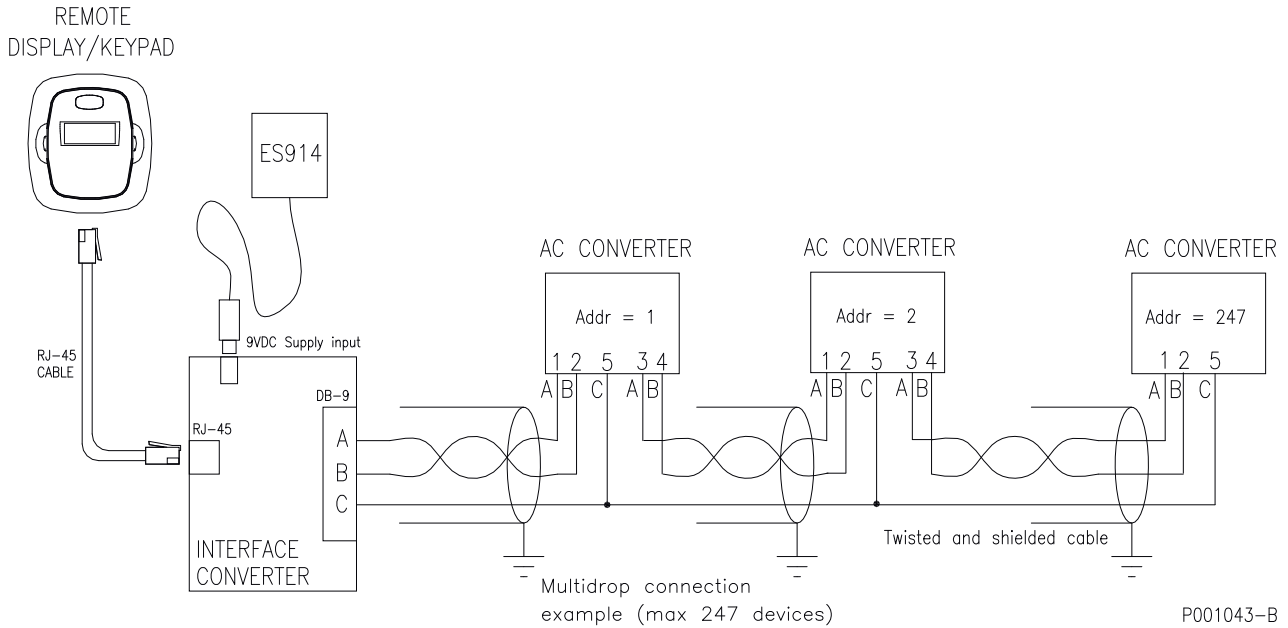

Figure 103: Wiring diagram of the keypad remoting kit controlling multiple inverters

6.5.2.4. The Communications Protocol

Standard MODBUS RTU protocol is used for communications.

Set the values below for the inverter/keypad; please refer to the Programming Manual of the inverter being used for the setup of the relevant parameters (see Sinus Penta's Programming Guide):

Setting values to the inverter

Baud rate:	38.400 bps
Data format:	8 bits
Start bit:	1
Parity:	NO
Stop bit:	2
Protocol:	MODBUS RTU
Device address:	configurable between 1 and 247 to avoid conflicts (default address is 1)
Electric standard:	RS485
Inverter response delay:	5 ms
End of message timeout:	2 ms

Setting values to the keypad

Device address:	configurable between 0 and 247 (default address is 1)
-----------------	---

In order to scan the connected inverters, set the device address to 0 for the keypad. The keypad can communicate with one device at a time, based on the address that has been set up.



CAUTION

If different parameter values are set, communication errors between the inverter and the keypad may occur.

6.5.2.5. Connection

Remove voltage from the inverter(s). Then proceed as follows:

Disconnect the keypad installed on the inverter (if any)

Please refer to the Installation Manual of the inverter being used.

Connect the cable to the interface converter and the keypad

Connect connector DB9 to the inverter or to network RS485. The converter side with telephone connector RJ45 must be already connected to the keypad.

Check that communication is correct

Turn on one of the inverters connected to the network. The keypad shows POWER ON. To scan the inverters connected to the network, set the device address on the keypad to 0. The list of the connected devices appears on the display/keypad. Select the device to be used to start communicating with the keypad, using all functionalities offered by the connected device. Please refer to the User Manual of the device being used for the operation of the keypad connected to the device.

Segregate the keypad power supply using the power supply unit

Connect the power supply unit supply output to the proper plug and set the toggle to ON.

6.6. Inductors

6.6.1. Input Inductors

We suggest that a three-phase inductor, or a DC-BUS DC inductor be installed on the supply line to obtain the following benefits:

- limit input current peaks on the input circuit of the inverter and value di/dt due to the input rectifier and to the capacitive load of the capacitors set;
- reducing supply harmonic current;
- increasing power factor, thus reducing line current;
- increasing the duration of line capacitors inside the inverter.

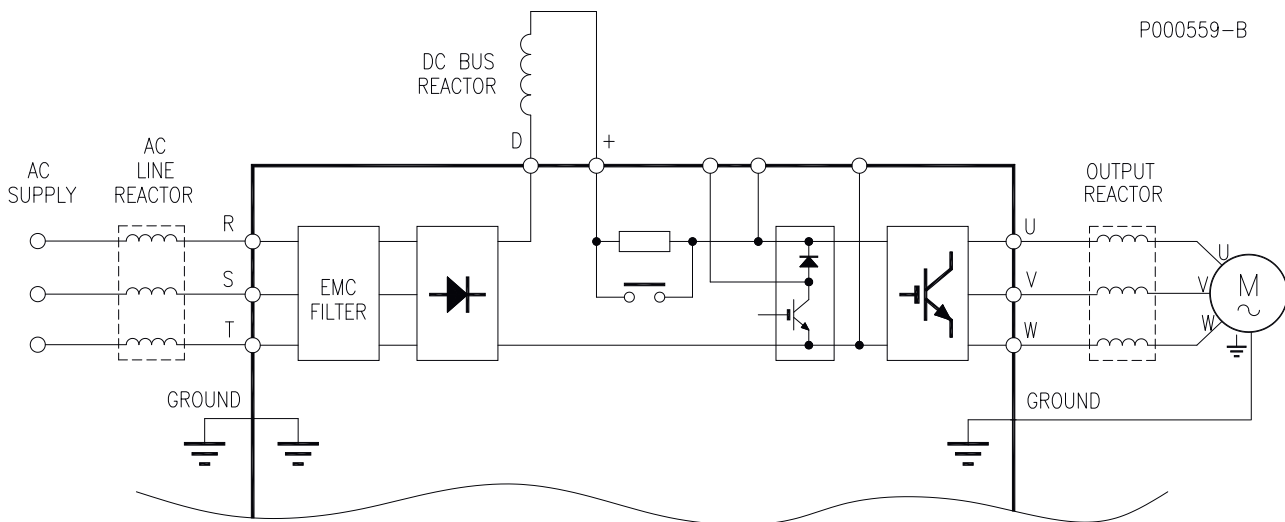

Figure 104: Wiring diagram for optional inductors

Harmonic currents

The shapes of the different waves (current or voltage) may be expressed as the sum of the basic frequency (50 or 60Hz) and its multiples. In balanced, three-phase systems, only odd harmonic current exists, as even current is neutralized by symmetrical considerations.

Harmonic current is generated by non-linear loads absorbing non-sinusoidal current. Typical sources of this type are bridge rectifiers (power electronics), switching power supply units and fluorescent lamps.

Three-phase rectifiers absorb line current with a harmonic content $n=6K\pm 1$ with $K=1,2,3,\dots$ (e.g. 5th,7th,11th,13th,17th,19th, etc.).

Harmonic current amplitude decreases when frequency increases. Harmonic current carries no active power; it is additional current carried by electrical cables. Typical effects are: conductor overload, power factor decrease and measurement systems instability. Voltage generated by current flowing in the transformer inductor may also damage other appliances or interfere with mains-synchronized switching equipment.



Solving the problem

Harmonic current amplitude decreases when frequency increases; as a result, reducing high-amplitude components determines the filtering of low-frequency components. The better way is to increase low-frequency impedance by installing an inductor. Power drive systems with no mains-side inductor generate larger harmonic currents than power drives which do have an inductor.

The inductor may be installed both on AC-side, as a 3-phase inductor on the supply line, and on DC-side, as a single-phase inductor installed between the rectifier bridge and the capacitor bank inside the inverter. Even greater benefits are obtained if an inductor is installed both on AC-side and on DC-side.

Unlike DC inductors, AC inductors filter high-frequency components as well as low-frequency components with greater efficiency.



CAUTION

A DC inductor can be connected to inverters sizes S15, S20, S30. This must be specified when ordering the equipment (see Power Terminals Modified for a DC Inductor).



CAUTION

No DC inductor can be installed in S05(4T) inverters.



CAUTION

When a DC inductor is used, it can happen that no braking resistor can be connected when an external braking unit is connected, and vice versa (see Power Terminals Modified for a DC Inductor).

Harmonic currents in the inverter power supply

The amplitude of harmonic currents and their incidence on the mains voltage is strongly affected by the features of the mains where the equipment is installed. The ratings given in this manual fit most applications. For special requirements, please contact Elettronica Santerno's After-sales service.

For more details and for analytical calculations based on the configuration of the grid connection you can use the Easy Harmonics application from Elettronica Santerno.



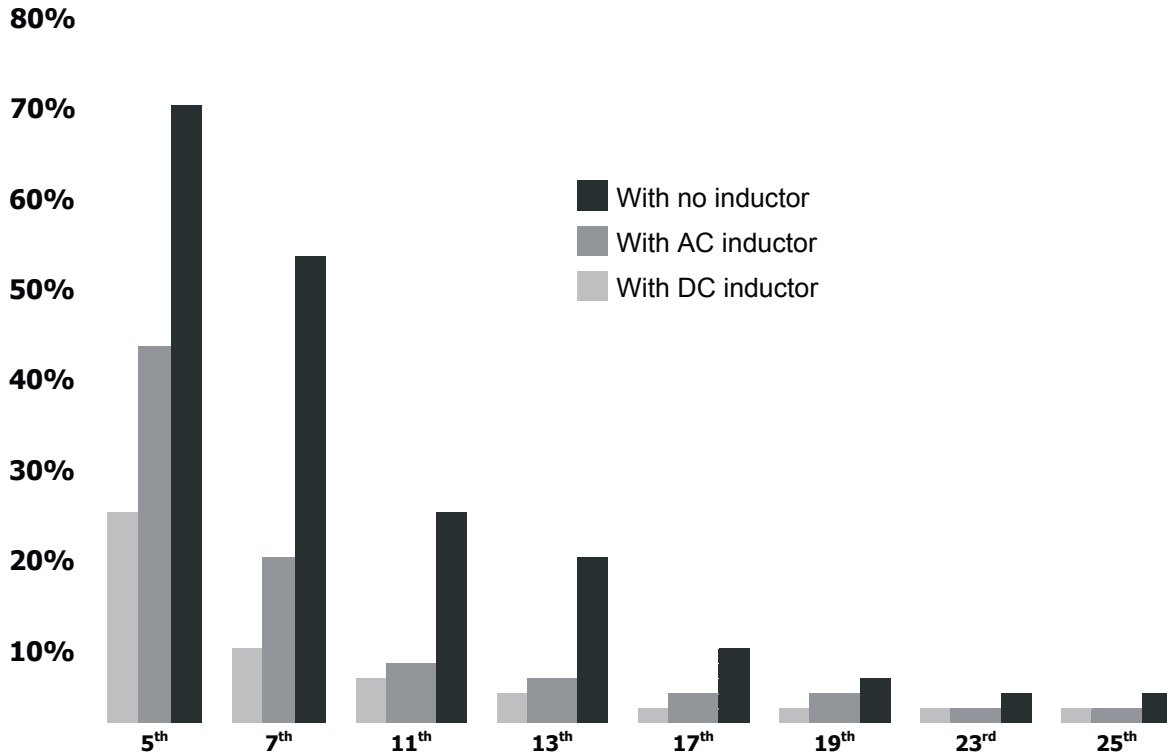

Figure 105: Amplitude of harmonic currents (approximate values)



CAUTION

Always use an input inductor under the following circumstances: mains instability; converters installed for DC motors; loads generating strong voltage variations at startup; power factor correction systems.

Use the input inductor under the following circumstances:

when Penta drives up to S12 included are connected to grids with a short-circuit power over 500kVA;



CAUTION

with Penta drives from S15 to S60 when the short-circuit power is 20 fold the inverter power;

with Penta S65 or greater, unless the inverter or the inverters are powered via a dedicated transformer;

with modular inverters provided with multiple power supply units (sizes S70, S75, S80 and S90).

The ratings of optional inductor recommended based on the inverter model are detailed in the section below.

6.6.2. Output Inductors (DU/DT Filters)

Installations requiring cable lengths over 100m between the inverter and the motor may cause overcurrent protections to frequently trip. This is due to the wire parasite capacity generating current pulses at the inverter output; those current pulses are generated from the high du/dt ratio of the inverter output voltage. The current pulses may be limited by an inductor installed on the inverter output. Shielded cables even have a higher capacity and may cause problems with shorter cable lengths.

The maximum distance between the motor and the inverter is given as an example, as parasite capacity is also affected by the type of wiring path and wiring system. For instance, when several inverters and their connected motors are networked, segregating the inverter wires from the motor wires will avoid capacitive couplings between the wiring of each motor.

An adverse effect can also be the stress produced on the motor insulation due to the high du/dt ratio at the inverter output.



CAUTION

Using du/dt filters is always recommended when the motor cable length is over 100m. The output inductor is always required when using parallel-connected inverters.



CAUTION

The inductors stated in the tables below may be used when the inverter output frequency is not over 60 Hz or 120Hz. For higher output frequency, a special inductor for the max. allowable operating frequency must be used. Please contact Elettronica Santerno.



NOTE

When using parallel-connected motors, always consider the total length of the cables being used (sum of the cable length of each motor).

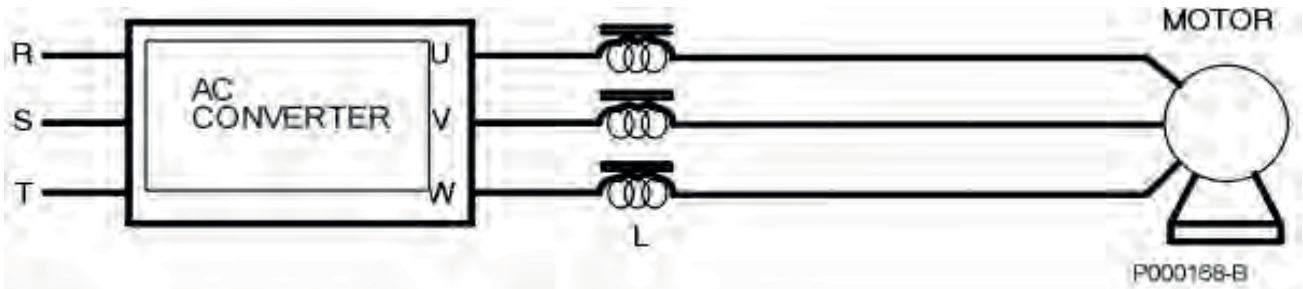

Figure 106: Output inductor wiring

6.6.3. Applying the Inductor to the Inverter



NOTE IP54 rated 3-phase inductors are available for inverters up to S32 included.

6.6.3.1. Class 2T – AC and DC Inductors

SIZE	Sinus Penta MODEL	INPUT AC 3-PHASE INDUCTOR	DC INDUCTOR	OUTPUT AC INDUCTOR	MAX. OUTPUT FREQ. (Hz)
S05	0007	IM0126004 2.0mH–11Arms	IM0140054 8mH–10.5A/12.8Apeak	IM0126004 2.0mH–11Arms (3-phase)	60
	0008	IM0126044 1.27mH–17Arms	IM0140104 5.1mH–17A/21Apeak	IM0126044 1.27mH–17Arms (3-phase)	60
	0010				
	0015	IM0126084 0.7mH–32Arms	IM0140154 2.8mH–32.5A/40.5Apeak	IM0126084 0.7mH–32Arms (3-phase)	60
	0016				
	0020				
S12	0023	IM0126124 0.51mH – 43Arms	IM0140204 2.0mH–47A/58.5 Apeak	IM0126124 0.51mH–43Arms (3-phase)	60
	0033	IM0126144 0.3mH–68Arms	IM0140254 1.2mH–69A/87Apeak	IM0126144 0.32mH–68Arms (3-phase)	60
	0037				
S15	0040	IM0126164 0.24mH–92Arms	IM0140284 (*) 0.96mH–100A/160Apeak	IM0126164 0.24mH–92Arms (3-phase)	60
	0049				
	0060				
S20	0067	IM0126204 0.16mH–142Arms	IM0140304 (*) 0.64mH–160A/195Apeak	IM0126204 0.16mH–142Arms (3-phase)	60
	0074				
	0086				
S30	0113	IM0126244 0.09mH–252Arms	IM0140404 (*) 0.36mH–275A/345Apeak	IM0126244 0.09mH–252Arms (3-phase)	60
	0129				
	0150				
	0162				
S41	0180	IM0126282 0.063mH –360Arms	IM0140454 0.18mH–420A/520Apeak	IM0138200 0.070mH –360Arms (3-phase)	120
	0202				
	0217	IM0126332 0.05 mH–455Arms	IM0140604 0.14mH–520A/650Apeak	IM0138250 0.035mH –440Arms (3-phase)	120
	0260				
S51	0313	IM0126372 0.031mH–720Arms	IM0140664 0.09mH–830A/1040Apeak	IM0138300 0.025mH–700Arms (3-phase)	120
	0367				
	0402				
S60	0457	IM0126404 0.023mH–945Arms	IM0140754 0.092mH– 1040A/1300Apeak	IM0126404 0.023mH–945Arms (3-phase)	60
	0524				



CAUTION (*) For the inverter sizes S15, S20, S30, the DC inductors required are to be specified when ordering the equipment.

6.6.3.2. Class 4T – AC and DC Inductors

SIZE	Sinus Penta MODEL	INPUT AC 3-PHASE INDUCTOR	DC INDUCTOR	OUTPUT AC INDUCTOR	MAX. OUTPUT FREQ. (Hz)
S05	0005	IM0126004 2.0mH–11Arms	Not applicable	IM0126004 2.0mH–11Arms (3-phase)	60
	0007	IM0126044 1.27mH–17Arms		IM0126044 1.27mH–17Arms (3-phase)	60
	0009				
	0011				
	0014				
S12	0016	IM0126084 0.7mH–32Arms	IM0140154 2.8mH–32.5Arms/40.5Apeak	IM0126084 0.7mH–32Arms (3-phase)	60
	0017				
	0020				
	0025	IM0126124 0.51mH–43Arms	IM0140204 2.0mH– 47Arms/58.5 Apeak	IM0126124 0.51mH–43Arms (3-phase)	60
	0030				
	0034	IM0126144 0.3mH–68Arms	IM0140254 1.2mH–69Arms/87Apeak	IM0126144 0.32mH–68Arms (3-phase)	60
0036					
S15	0040	IM0126164 0.24mH–92Arms	IM0140284 (*) 0.96mH–100A/160Apeak	IM0126164 0.24mH–92Arms (3-phase)	60
	0049				
	0060				
S20	0067	IM0126204 0.16mH–142Arms	IM0140304 (*) 0.64mH–160Arms/195Apeak	IM0126204 0.16mH–142Arms (3-phase)	60
	0074				
	0086				
	0113				
S30	0129	IM0126244 0.09mH–252Arms	IM0140404 (*) 0.36mH– 275Arms/345 Apeak	IM0126244 0.09mH–252Arms (3-phase)	60
	0150				
	0162				
	0180				
S41	0202	IM0126282 0.063mH –360Arms	IM0140454 0.18mH–420A/520Apeak	IM0138200 0.070mH–360Arms (3-phase)	120
	0217				
	0260	IM0126332 0.05 mH–455Arms	IM0140604 0.14mH–520A/650Apeak	IM0138250 0.035mH–440Arms (3-phase)	120
S51	0313	IM0126372 0.031mH–720Arms	IM0140664 0.09mH–830A/1040Apeak	IM0138300 0.025mH–700Arms (3-phase)	120
	0367				
	0402				
S60	0457	IM0126404 0.023mH–945Arms	IM0140754 0.092mH– 1040Arms/1300Apeak	IM0126404 0.023mH–945Arms (3-phase)	60
	0524				
S65	0598	IM0126444 0.018mH–1260Arms	IM0140854 (*) 0.072mH– 1470Arms/1850Apeak	IM0126444 0.018mH–1260Arms (3-phase)	60
	0748				
	0831				
S75	0964	2 x IM0126404 0.023mH–945A	2 x IM0140754 (*) 0.092mH– 1040Arms/1300Apeak	6 x IM0141782 0.015mH–1250Arms (single-phase)	60
	1130				
	1296	2 x IM0126444 0.018mH–1260A	2 x IM0140854 (*) 0.072mH– 1470Arms/1850Apeak		
S90	1800	3 x IM0126404 0.023mH–945Arms	3 x IM0140754 (*) 0.092mH– 1040Arms/1300Apeak	9 x IM0141782 0.015mH–1250Arms (single-phase)	60
	2076	3 x IM0126444 0.018mH–1260Arms	3 x IM0140854 (*) 0.072mH– 1470Arms/1850Apeak		



CAUTION (*)

For the inverter sizes S15, S20, S30, S65, S75 and S90, the DC inductors required are to be specified when ordering the equipment.

6.6.3.3. Class 5T-6T – AC and DC Inductors

SIZE	Sinus Penta MODEL	INPUT AC 3-PHASE INDUCTOR	DC INDUCTOR	OUTPUT AC INDUCTOR	MAX. OUTPUT FREQ. (Hz)	
S12 5T S14 6T	0003	IM0127042 6.4mH–6.5Arms	Please contact Elettronica Santerno	IM0138000 1.5mH–9.5Arms (3-phase)	120	
	0004	IM0127062		IM0138010 1.0mH–14Arms (3-phase)	120	
	0006	4.1mH–10.5Arms				
	0012	IM0127082				
	0018	2.6mH–16Arms				
S14	0019	IM0127102		IM0138020 0.8mH–18.5Arms (3-phase)	120	
	0021	1.8mH–23Arms		IM0138030 0.60mH–27Arms (3-phase)	120	
	0022	IM0127122		IM0138040 0.42mH–43Arms (3-phase)	120	
	0024	1.1mH–40Arms		IM0138045 0.28mH–65Arms (3-phase)	120	
	0032	IM0127142				
S22	0042	0.7mH–57Arms		IM0141404 1.2mH– 110Arms/140Apeak	IM0138050 0.17mH–105Arms (3-phase)	120
	0051	IM0127167				
	0062	0.43mH–95Arms				
	0069					
S32	0076	IM0127202		IM0141414 0.80mH– 160Arms/205Apeak	IM0138100 0.11mH–165Arms (3-phase)	120
	0088	0.29mH–140Arms	IM0141424 0.66mH– 240Arms/310Apeak	IM0138150 0.075mH–240Arms (3-phase)	120	
	0131	IM0127227				
	0164	0.19mH–210Arms				
S42	0181	IM0127274	IM0141434 0.32mH– 375Arms/490Apeak	IM0138200 0.070mH –360Arms (3-phase)	120	
	0201	0.12mH–325A	IM0141554 0.27mH– 475Arms/625Apeak	IM0138250 0.035mH –440Arms (3-phase)	120	
	0218	IM0127330				
	0259	0.096mH–415Arms				
S52	0290	IM0127350 0.061mH–650Arms	IM0141664 0.17mH– 750Arms/980Apeak	IM0138300 0.025mH–700Arms (3-phase)	120	
	0314					
	0368					
	0401					
S65	0457	IM0127404 0.040mH–945Arms	IM0141804 (*) 0.160mH– 1170Arms/1530Apeak	IM0127404 0.040mH–945Arms (3-phase)	60	
	0524					
	0598					
S70	0748	IM0127444 0.030mH–1260Arms	IM0141904 (*) 0.120mH– 1290Arms/1680Apeak	IM0127444 0.030mH–1260Arms (3-phase)	60	
	0831	2 x IM0127364 0.058mH–662Arms	2 x IM0141704 (*) 0.232mH– 830Arms/1080Apeak			
S75	0964	2 x IM0127404 0.040mH–945Arms	2 x IM0141804 (*) 0.160mH– 1170Arms/1530Apeak	6 x IM0141782 0.015mH–1250Arms (single-phase)	60	
	1130	2 x IM0127444 0.030mH–1260Arms				
S80	1296	3 x IM0127404 0.040mH–945Arms	3 x IM0141804 (*) 0.160mH– 1170Arms/1530Apeak	9 x IM0141782 0.015mH–1250Arms (single-phase)	60	
S90	1800	3 x IM0127444 0.030mH–1260Arms	3 x IM0141904 (*) 0.120mH– 1290Arms/1680Apeak			
		2076				



CAUTION (*)

For the inverter sizes S65, S70, S75, S80 e S90, the DC inductors required are to be specified when ordering the equipment.

6.6.4. Inductance Ratings

6.6.4.1. Class 2T-4T – AC 3-Phase Inductors

INDUCTOR MODEL	TYPE	INDUCTANCE RATINGS		DIMENSIONS							HOLE	WGT	LOSSES
		mH	A	TYPE	L	H	P	M	E	G			
IM0126004	Input-output	2.00	11	A	120	125	75	25	67	55	5	2.9	29
IM0126044	Input-output	1.27	17	A	120	125	75	25	67	55	5	3	48
IM0126084	Input-output	0.70	32	B	150	130	115	50	125	75	7x14	5.5	70
IM0126124	Input-output	0.51	43	B	150	130	115	50	125	75	7x14	6	96
IM0126144	Input-output	0.30	68	B	180	160	150	60	150	82	7x14	9	150
IM0126164	Input-output	0.24	92	B	180	160	150	60	150	82	7x14	9.5	183
IM0126204	Input-output	0.16	142	B	240	210	175	80	200	107	7x14	17	272
IM0126244	Input-output	0.09	252	B	240	210	220	80	200	122	7x14	25	342
IM0126282	Input only	0.063	360	C	300	286	205	100	250	116	9x24	44	350
IM0126332	Input only	0.050	455	C	300	317	217	100	250	128	9x24	54	410
IM0126372	Input only	0.031	720	C	360	342	268	120	325	176	9x24	84	700
IM0126404	Input-output	0.023	945	C	300	320	240	100	250	143	9x24	67	752
IM0126444	Input-output	0.018	1260	C	360	375	280	120	250	200	12	82	1070

6.6.4.2. Class 5T-6T – AC 3-Phase Inductors

INDUCTOR MODEL	INPUT/OUTPUT	INDUCTANCE RATINGS		DIMENSIONS							HOLE	WGT	LOSSES
		mH	A	TYPE	L	H	P	M	E	G			
IM0127042	Input only	6.4	6.5	Please contact Elettronica Santerno									
IM0127062	Input only	4.1	10.5										
IM0127082	Input only	2.6	16										
IM0127102	Input only	1.8	23										
IM0127122	Input only	1.1	40										
IM0127142	Input only	0.70	57										
IM0127167	Input only	0.43	95										
IM0127202	Input only	0.29	140	B	300	254	190	100	250	113	9x24	35	240
IM0127227	Input only	0.19	210	B	300	285	218	100	250	128	9x24	48	260
IM0127274	Input only	0.12	325	C	300	286	234	100	250	143	9x24	60	490
IM0127330	Input only	0.096	415	C	360	340	250	120	325	166	9x24	80	610
IM0127364	Input-output	0.058	662	C	360	310	275	120	325	166	9x24	79	746
IM0127350	Input only	0.061	650	C	360	411	298	120	240	220	9x24	113	920
IM0127404	Input-output	0.040	945	C	360	385	260	120	250	200	12	88	1193
IM0127444	Input-output	0.030	1260	C	420	440	290	140	300	200	12	110	1438

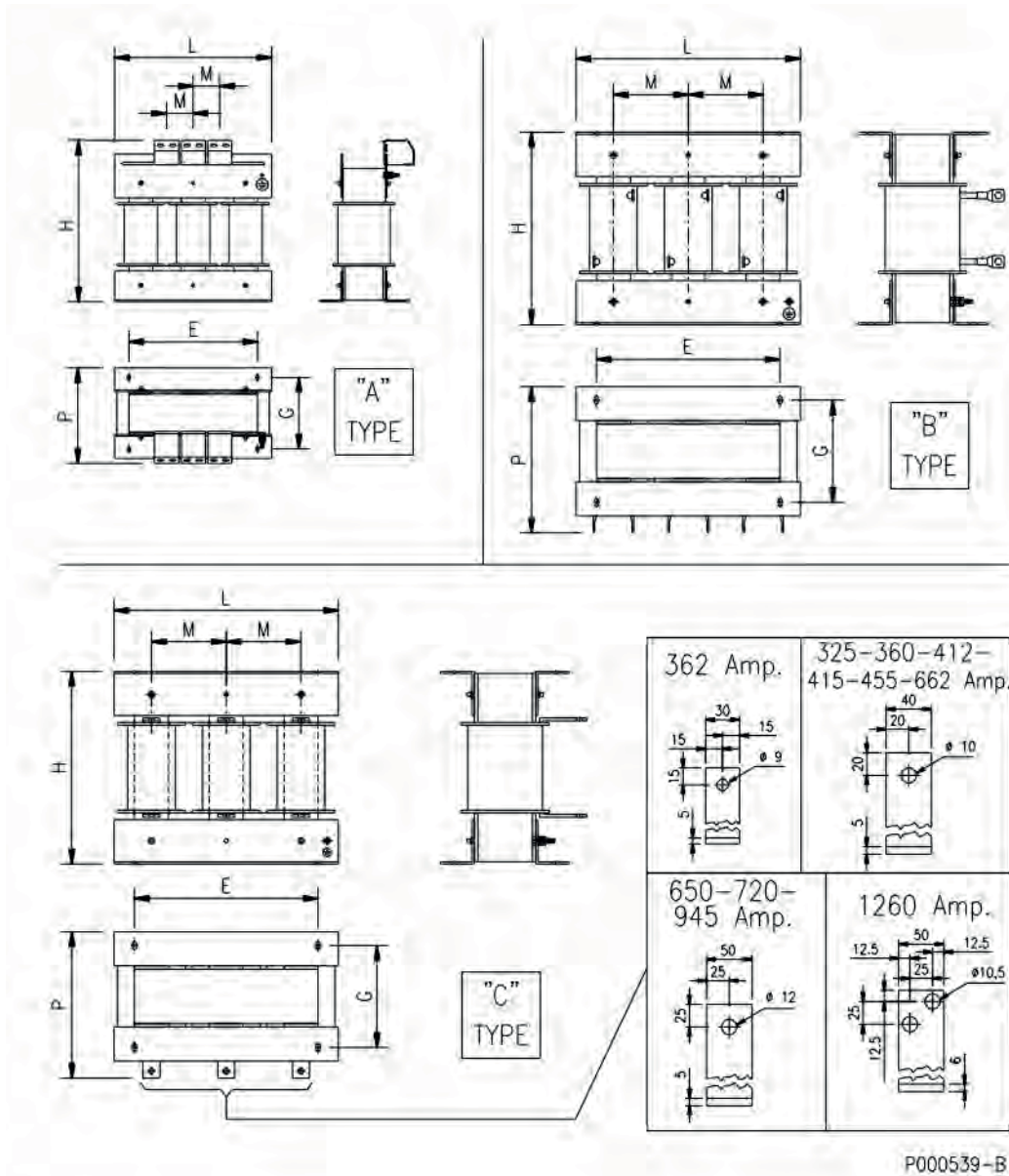

Figure 107: Mechanical features of a 3-phase inductor

6.6.4.3. Class 2T-4T – DC Inductors

INDUCTOR MODEL	USE	INDUCTANCE RATINGS		TYPE	DIMENSIONS						HOLE mm	WEIGHT kg	LOSSES W
		mH	A		L	H	P	M	E	G			
IM0140054	DC BUS	8.0	10.5	A	110	125	100	60	90	65	7x10	4.5	20
IM0140104	DC BUS	5.1	17	A	110	125	100	60	90	65	7x10	5	30
IM0140154	DC BUS	2.8	32.5	A	120	140	160	60	100	100	7x10	8	50
IM0140204	DC BUS	2.0	47	A	160	240	160	80	120	97	7x14	12	80
IM0140254	DC BUS	1.2	69	A	160	240	160	80	120	97	7x14	13	90
IM0140284	DC BUS	0.96	100	A	170	240	205	80	155	122	7x18	21	140
IM0140304	DC BUS	0.64	160	A	240	260	200	120	150	121	9x24	27	180
IM0140404	DC BUS	0.36	275	A	260	290	200	130	150	138	9x24	35	320
IM0140454	DC BUS	0.18	420	B	240	380	220	120	205	156	9x24	49	290
IM0140604	DC BUS	0.14	520	B	240	380	235	120	205	159	9x24	57	305
IM0140664	DC BUS	0.090	830	B	260	395	270	130	225	172	9x24	75	450
IM0140754	DC BUS	0.092	1040	C	310	470	320	155	200	200	12	114	780
IM0140854	DC BUS	0.072	1470	C	330	540	320	165	250	200	12	152	950

6.6.4.4. Class 5T-6T – DC Inductors

INDUCTOR MODEL	USE	INDUCTANCE RATINGS		TYPE	DIMENSIONS						HOLE mm	WEIGHT kg	LOSSES W
		mH	A		L	H	P	M	E	G			
IM0141404	DC BUS	1.2	110	A	170	205	205	80	155	122	7x18	21	165
IM0141414	DC BUS	0.80	160	A	200	260	215	100	150	111	9x24	27	240
IM0141424	DC BUS	0.66	240	A	240	340	260	120	205	166	9x24	53	370
IM0141434	DC BUS	0.32	375	B	240	380	235	120	205	159	9x24	56	350
IM0141554	DC BUS	0.27	475	B	240	380	265	120	205	179	9x24	66	550
IM0141664	DC BUS	0.17	750	B	260	395	295	130	225	197	9x24	90	580
IM0141704	DC BUS	0.232	830	C	330	550	340	165	250	200	12	163	800
IM0141804	DC BUS	0.16	1170	C	350	630	360	175	250	200	12	230	1200
IM0141904	DC BUS	0.12	1290	C	350	630	360	175	250	200	12	230	1300

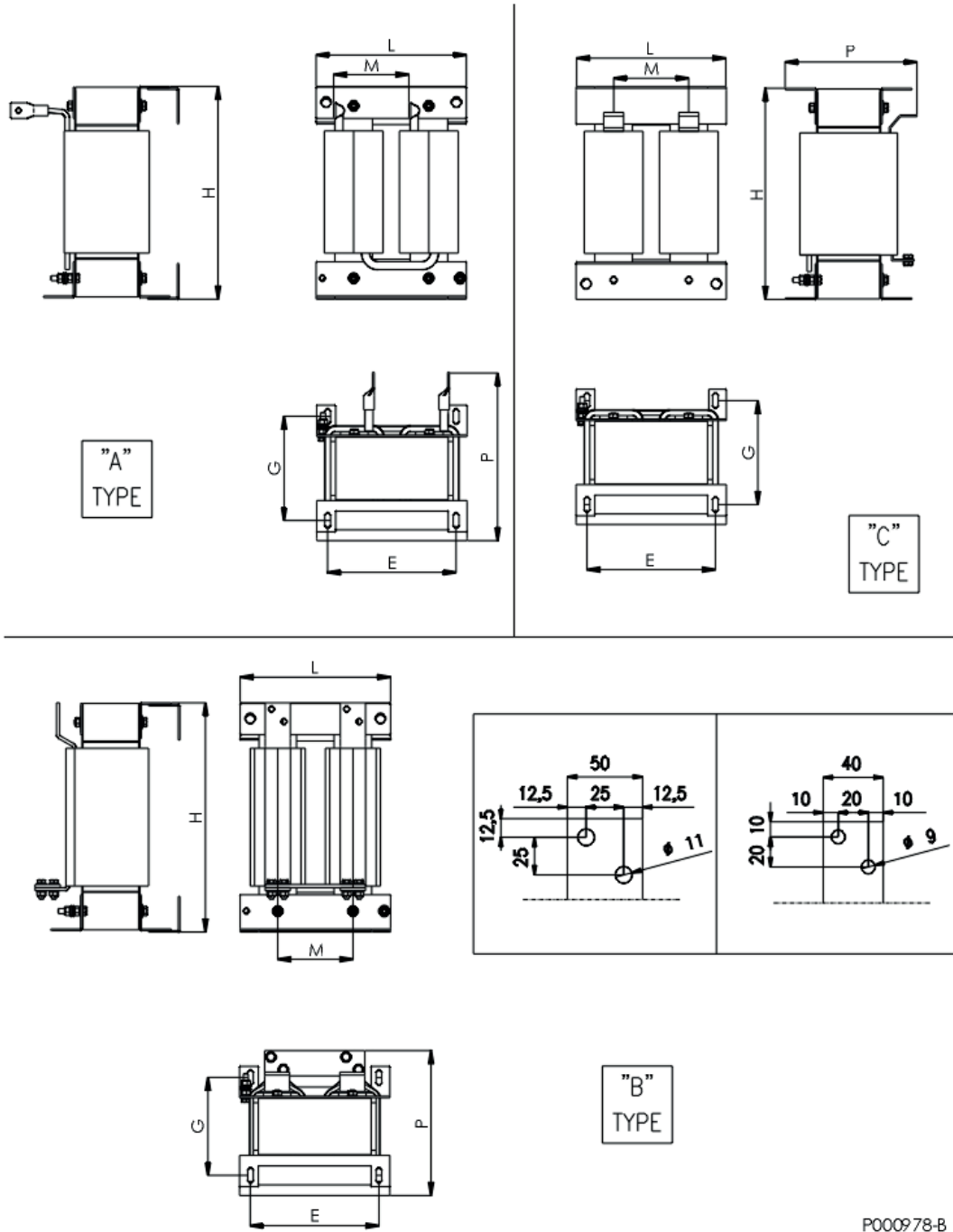

P000978-B

Figure 108: Mechanical features of a DC inductor

6.6.4.5. Class 2T, 4T, 5T, 6T – 3-Phase DU/DT Inductors

INDUCTOR MODEL	USE	INDUCTANCE RATINGS		DIMENSIONS							HOLE mm	WGT kg	LOSSES W
		mH	A	TYPE	L	H	P	M	E	G			
IM0138000	Output only	1.5	9.5	Please contact Elettronica Santerno									
IM0138010	Output only	1.0	14										
IM0138020	Output only	0.80	18.5										
IM0138030	Output only	0.60	27										
IM0138040	Output only	0.42	43										
IM0138045	Output only	0.28	65										
IM0138050	Output only	0.17	105	A	300	259	192	100	250	123	9x24	39	270
IM0138100	Output only	0.11	165	A	300	258	198	100	250	123	9x24	42	305
IM0138150	Output only	0.075	240	A	300	321	208	100	250	123	9x24	52	410
IM0138200	Output only	0.070	360	B	360	401	269	120	250	200	12x25	77	650
IM0138250	Output only	0.035	440	B	360	401	268	120	250	200	12x25	75	710
IM0138300	Output only	0.025	700	B	360	411	279	120	250	200	12x25	93	875

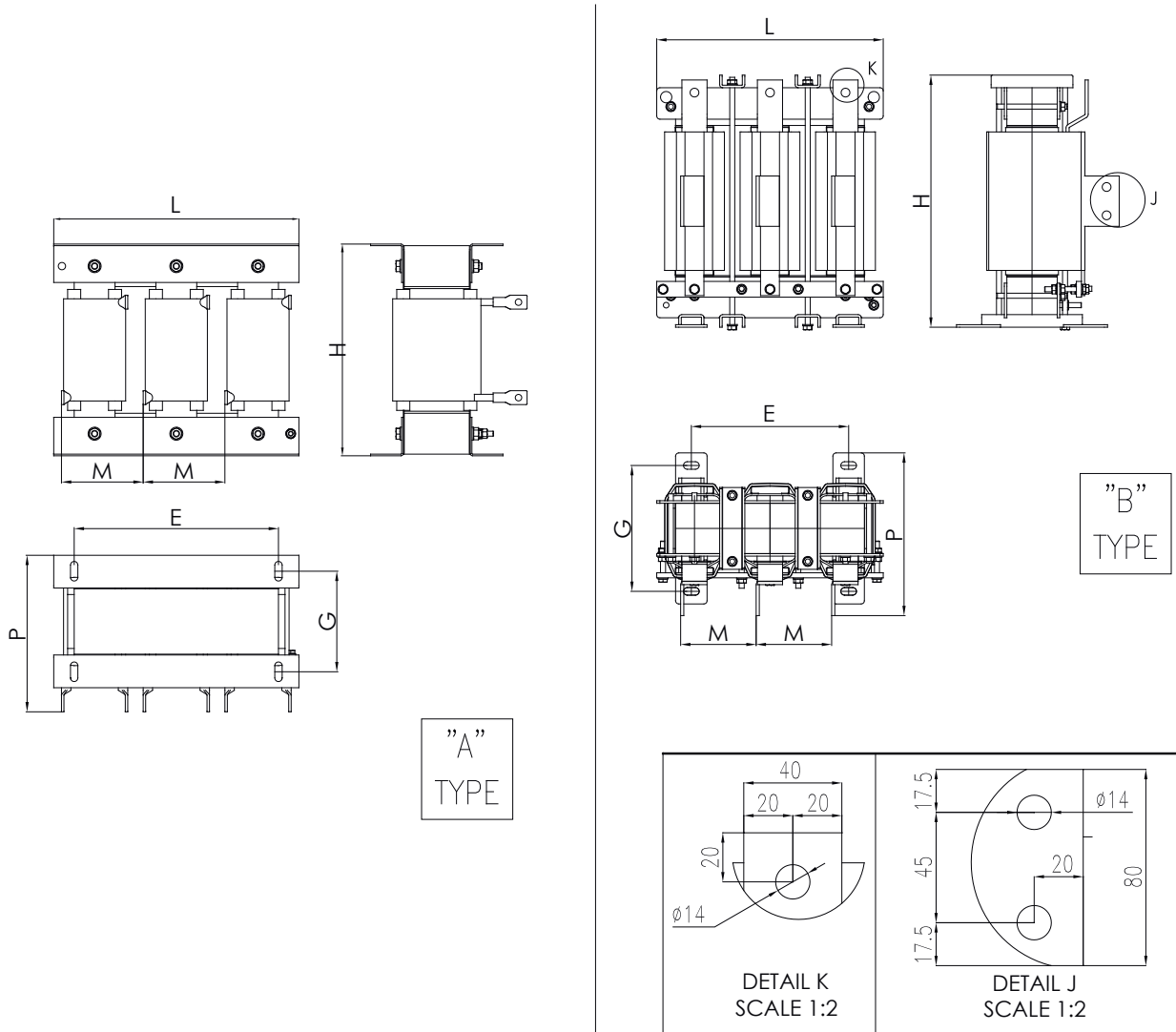

P000979-B

Figure 109: Mechanical features of the 3-phase du/dt inductors

6.6.5. Class 2T – 3-Phase AC Inductors in IP54 Cabinet

SIZE	Sinus Penta MODEL	INDUCTOR MODEL	USE	MECHANICAL DIMENSIONS (see Figure 110)	WEIGHT	LOSSES
				TYPE		
S05	0007	ZZ0112020	Input-output	A	7	48
	0008					
	0010					
	0015	ZZ0112030	Input-output	A	9.5	70
	0016					
0020						
S12	0023	ZZ0112040	Input-output	A	10	96
	0033	ZZ0112045	Input-output	B	14	150
	0037					
S15	0040	ZZ0112050	Input-output	B	14.5	183
	0049					
S20	0060	ZZ0112060	Input-output	C	26	272
	0067					
	0074					
	0086					
S30	0113	ZZ0112070	Input-output	C	32.5	342
	0129					
	0150					
	0162					

6.6.6. Class 4T – 3-Phase AC Inductors in IP54 Cabinet

SIZE	Sinus Penta MODEL	INDUCTOR MODEL	USE	MECHANICAL DIMENSIONS (see Figure 110)	WEIGHT	LOSSES
				TYPE		
S05	0005	ZZ0112010	Input-output	A	6.5	29
	0007	ZZ0112020	Input-output	A	7	48
	0009					
	0011					
	0014					
S12	0016	ZZ0112030	Input-output	A	9.5	70
	0017					
	0020					
	0025	ZZ0112040	Input-output	A	10	96
	0030					
	0034	ZZ0112045	Input-output	B	14	150
0036						
S15	0040	ZZ0112050	Input-output	B	14.5	183
	0049					
S20	0060	ZZ0112060	Input-output	C	26	272
	0067					
	0074					
	0086					
S30	0113	ZZ0112070	Input-output	C	32.5	342
	0129					
	0150					
	0162					

6.6.7. Class 5T-6T – 3-Phase AC Inductors In IP54 Cabinet

SIZE	Sinus Penta MODEL	INDUCTOR MODEL	USE	MECHANICAL DIMENSIONS	WEIGHT	LOSSES
				TYPE	kg	W
S12 5T S14 6T	0003	ZZ0112110	Input only	Please contact Elettronica Santerno		
	0004	ZZ0112120	Input only			
	0006		Input only			
	0012	ZZ0112130	Input only			
0018	Input only					
S14	0019	ZZ0112140	Input only			
	0021		Input only			
	0022	ZZ0112150	Input only			
	0024		Input only			
S22	0032	ZZ0112160	Input only			
	0042		Input only			
	0051	ZZ0112170	Input only			
	0062		Input only			
S32	0069	ZZ0112180	Input only			
	0076		Input only			
	0088	ZZ0112190	Input only			
	0131		Input only			
	0164					

SIZE	Sinus Penta MODEL	INDUCTOR MODEL	USE	MECHANICAL DIMENSIONS	WEIGHT	LOSSES
				TYPE	kg	W
S12 5T S14 6T	0003	ZZ0112115	Output only	Please contact Elettronica Santerno		
	0004		Output only			
	0006	ZZ0112125	Output only			
	0012		Output only			
S14	0018	ZZ0112135	Output only			
	0019	ZZ0112145	Output only			
	0021		Output only			
	0022	ZZ0112155	Output only			
0024	Output only					
S22	0032	ZZ0112165	Output only			
	0042		Output only			
	0051	ZZ0112175	Output only			
	0062		Output only			
S32	0069	ZZ0112185	Output only			
	0076		Output only			
	0088	ZZ0112195	Output only			
	0131		Output only			
	0164					

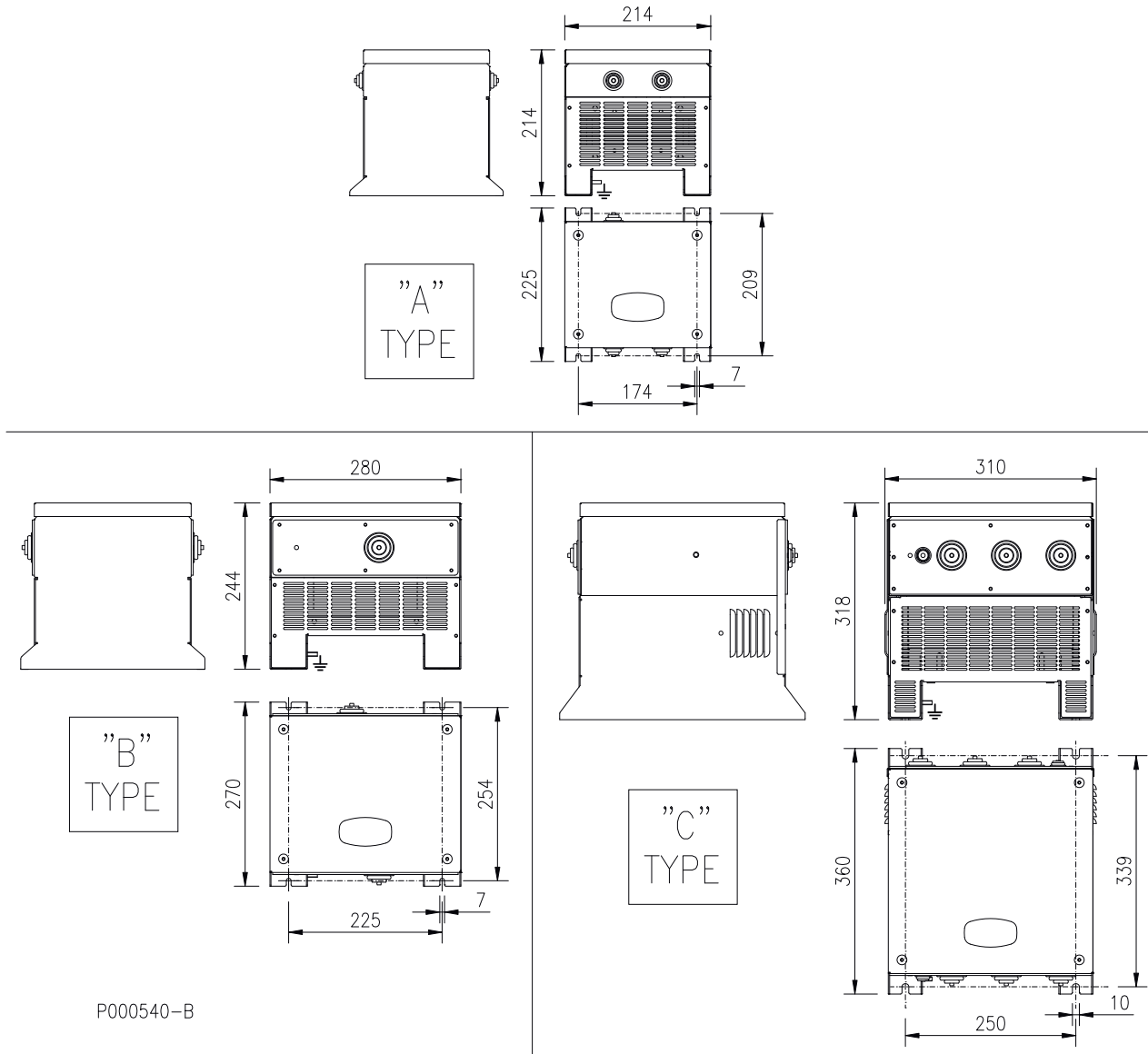
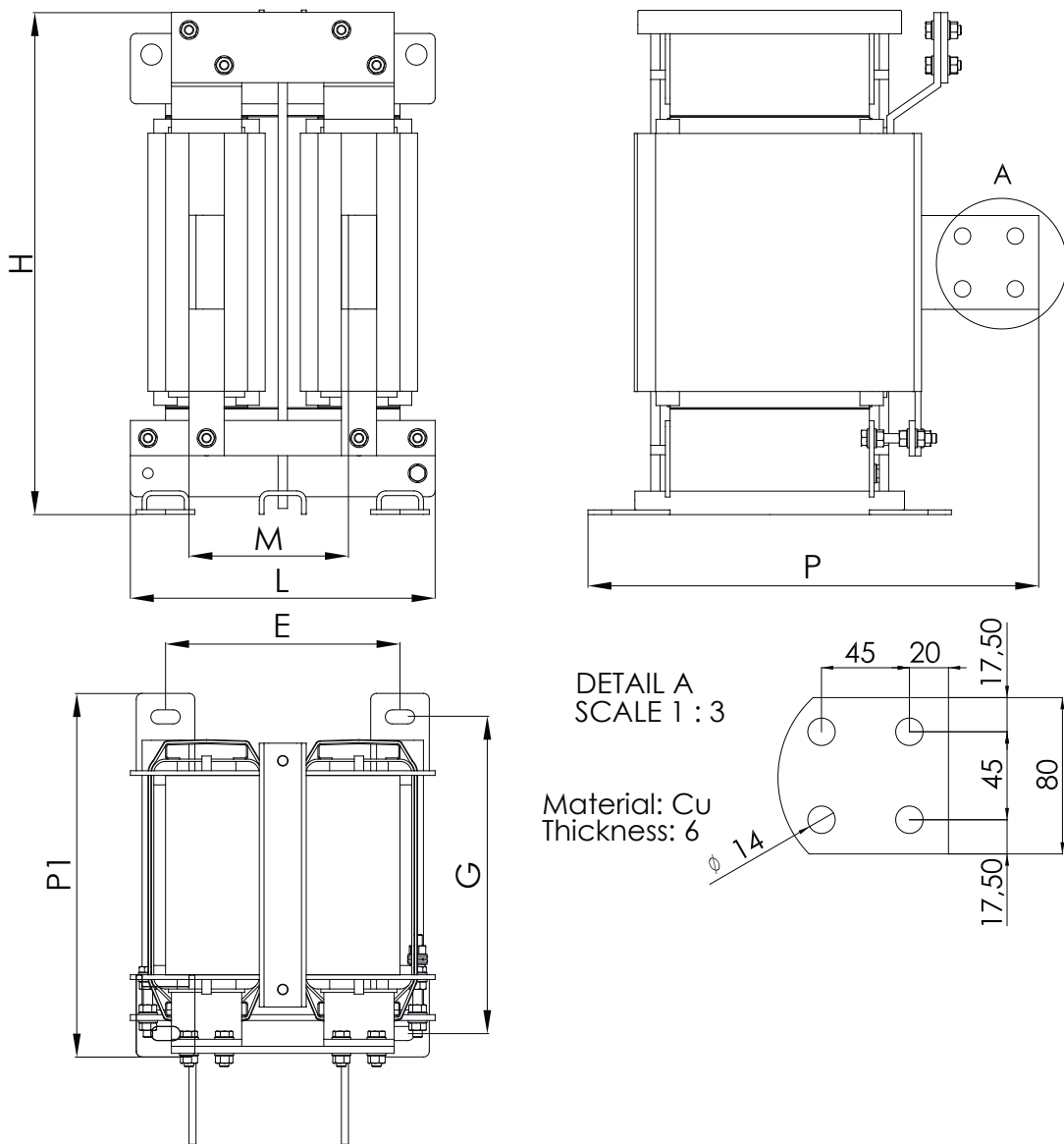

Figure 110: Mechanical features of a 3-phase inductor for Class 2T-4T in IP54 cabinet

6.6.8. Output Single-Phase Inductors for Modular Inverters S75, S80, S90

6.6.8.1. AC single-phase Inductors – Class 4T-5T-6T

INDUCTOR MODEL	USE	INDUCTOR RATINGS		DIMENSIONS							HOLE	WEIGHT	LOSSES
		mH	A	L	H	P	P1	M	E	G			
IM0141782	Output S75, S80, S90	0.015	1250	260	430	385	310	136	200	270	9x24	100	940



P000980-B

Figure 111: Mechanical features of a single-phase output inductor

6.6.9. Sinusoidal Filters

The sinusoidal filter is a system component to be installed between the inverter and the motor to enhance the equipment performance:

- a) **The sinusoidal filter reduces the voltage peak in the motor terminals:** The overvoltage in the motor terminals may reach 100% under certain load conditions.
- b) **The sinusoidal filter reduces the motor losses.**
- c) **The sinusoidal filter reduces the motor noise:** The motor noise can be reduced of approx. 8 dBA because the high-frequency component of the current flowing in the motor and the cables is reduced. A noiseless motor is particularly suitable for residential environments.
- d) **The sinusoidal filter reduces the probability of EMC disturbance:** When the cables between the inverter and the motor are too long, the square-wave voltage produced by the inverter is a source of electromagnetic disturbance.
- e) **The sinusoidal filter allows controlling transformers:** “Normal” transformers can be powered directly from the inverter that do not need to be properly dimensioned to withstand the carrier frequency voltage.
- f) The inverter can be used as a **voltage generator at constant voltage and constant frequency.**

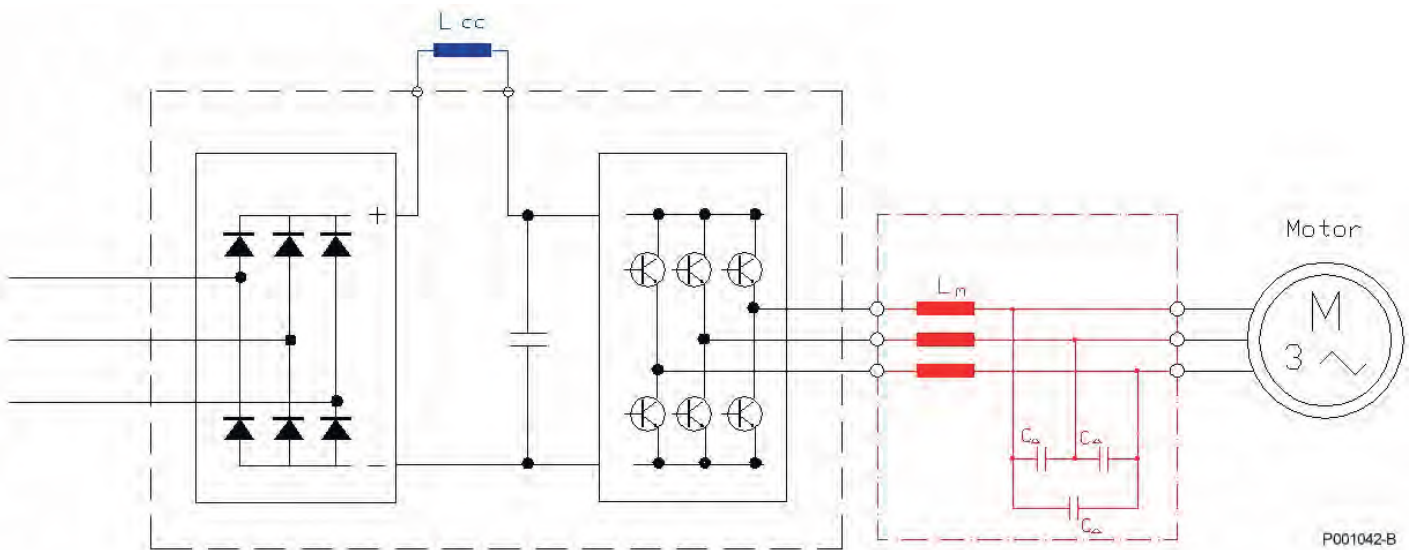

Figure 112: Sinusoidal filter

6.7. ES836/2 Encoder Board (Slot A)

Board for incremental, bidirectional encoder to be used as a speed feedback for inverters of the SINUS series. It allows the acquisition of encoders with power supply ranging from 5 to 15VDC (adjustable output voltage) with complementary outputs (line driver, push-pull, TTL outputs). It can also be connected to 24VDC encoders with both complementary and single-ended push-pull or PNP/NPN outputs. The encoder board is to be installed into SLOT A. See section Installing ES836/2 Encoder Board on the Inverter .

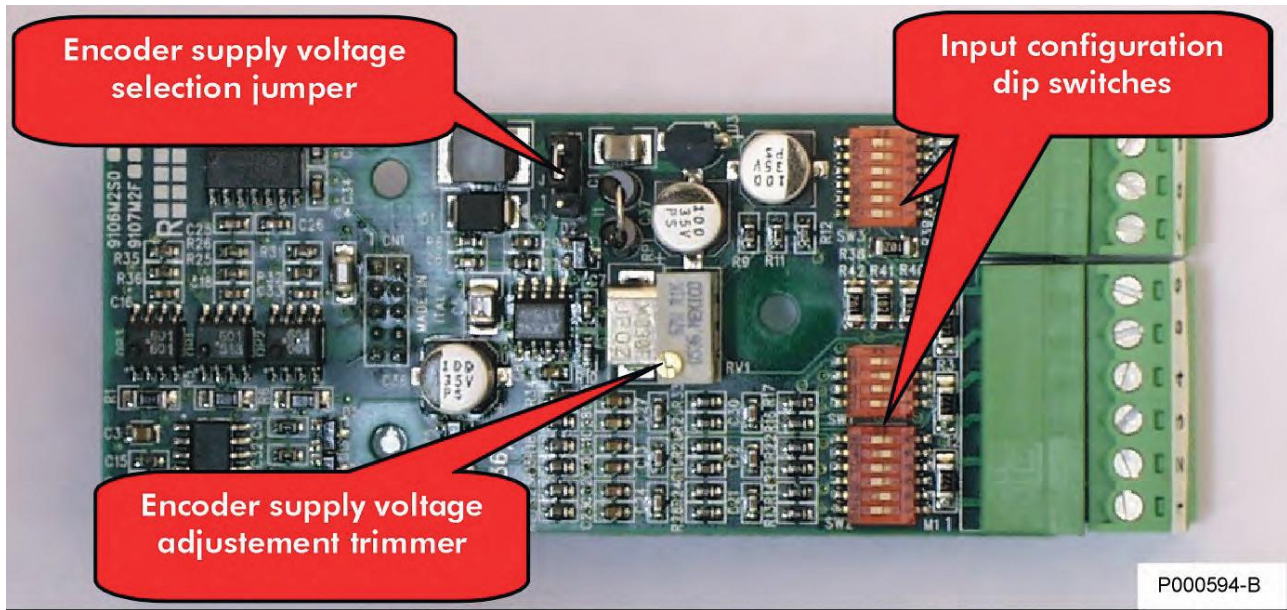

Figure 113: Encoder board (ES836/2)

6.7.1. Identification Data

Description	Part Number	COMPATIBLE ENCODERS	
		POWER SUPPLY	OUTPUT
ES836/2 Encoder board	ZZ0095834	5Vdc÷15Vdc, 24Vdc	LINE DRIVER, NPN, PNP, complementary PUSH-PULL, NPN, PNP, single-ended PUSH-PULL

6.7.2. Environmental Requirements

Operating temperature	-10 to +55°C ambient temperature (contact Elettronica Santerno for higher ambient temperatures)
Relative humidity	5 to 95% (non-condensing)
Max. operating altitude	2000 m a.s.l. For installation above 2000 m and up to 4000 m, please contact Elettronica Santerno.

6.7.3. Electrical Specifications

Decisive voltage class A according to IEC 61800-5-1.

<i>Electrical Specifications</i>	<i>Ratings</i>			
	<i>Min.</i>	<i>Type</i>	<i>Max.</i>	<i>Unit</i>
Encoder supply current, + 24 V, protected with resettable fuse			200	mA
Electronically protected encoder supply current, +12V			350	mA
Electronically protected encoder supply current, +5V			900	mA
Adjustment range for encoder supply voltage (5V mode)	4.4	5.0	7.3	V
Adjustment range for encoder supply voltage (12V mode)	10.3	12.0	17.3	V
Input channels	Three channels: A, B, and zero notch Z			
Type of input signals	Complementary or single-ended			
Voltage range for encoder input signals	4		24	V
Pulse max. frequency with noise filter "on"	77kHz (1024pls @ 4500rpm)			
Pulse max. frequency with noise filter "off"	155kHz (1024pls @ 9000rpm)			
Input impedance in NPN or PNP mode (external pull-up or pull-down resistors required)		15k		Ω
Input impedance in push-pull or PNP and NPN mode when internal load resistors (at max. frequency) are connected		3600		Ω
Input impedance in line-driver mode or complementary push-pull signals with internal load resistors activated via SW3 (at max. frequency) (see Configuration DIP-switches)		780		Ω

ISOLATION:

The encoder supply line and inputs are galvanically isolated from the inverter control board grounding for a 500 VAC/1 minute test. The encoder supply grounding is in common with control board digital inputs available in the terminal board.

6.7.4. Installing ES836/2 Encoder Board on the Inverter (Slot A)



DANGER

Before gaining access to the components inside the inverter, remove voltage from the inverter and wait at least 20 minutes. Wait for a complete discharge of the internal capacitors to avoid any electric shock hazard.



CAUTION

Electric shock hazard: do not connect/disconnect the signal terminals or the power terminals when the inverter is on. This also prevents the inverter from being damaged.



NOTE

All the screws used to fasten removable parts (terminals cover, serial interface connector, cable plates, etc.) are black, round-head, cross-head screws. When wiring the inverter, remove only this type of screws. If different screws or bolts are removed, the inverter warranty will be no longer valid.

1. Remove voltage from the inverter and wait at least 20 minutes.
2. Remove the cover to gain access to the inverter control terminals. The fixing spacers and the signal connector are located on the left.

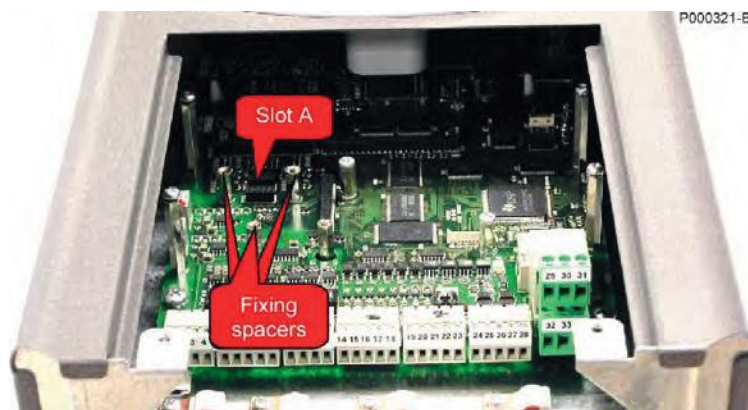

Figure 114: Position of slot A for the installation of the encoder board

3. Fit the encoder board and make sure that all contacts enter the relevant housing in the signal connector. Fasten the encoder board to the fixing spacers using the screws supplied.
4. Configure the DIP-switches and the jumper located on the encoder board based on the connected encoder. Check that the supply voltage delivered to the terminal output is correct.
5. Close the inverter frame by reassembling the cover allowing gaining access to the inverter control terminals.



Figure 115: Encoder board fastened to its slot

6.7.5. Terminals in Encoder Board

A 9-pole terminal board is located on the front side of the encoder board for the connection to the encoder.

Terminal board, pitch 3.81 mm in two separate extractable sections (6-pole and 3-pole sections)		
Terminal	Signal	Type and Features
1	CHA	Encoder input channel A true polarity
2	$\overline{\text{CHA}}$	Encoder input channel A inverse polarity
3	CHB	Encoder input channel B true polarity
4	$\overline{\text{CHB}}$	Encoder input channel B inverse polarity
5	CHZ	Encoder input channel Z (zero notch) true polarity
6	$\overline{\text{CHZ}}$	Encoder input channel Z (zero notch) inverse polarity
7	+VE	Encoder supply output 5V...15V or 24V
8	GNDE	Encoder supply ground
9	GNDE	Encoder supply ground

For the encoder connection to the encoder board, see wiring diagrams on the following pages.

6.7.6. Configuration DIP-switches

Encoder board ES836/2 is provided with two DIP-switch banks to be set up depending on the type of connected encoder. The DIP-switches are located in the front left corner of the encoder board and are adjusted as shown in the figure below.

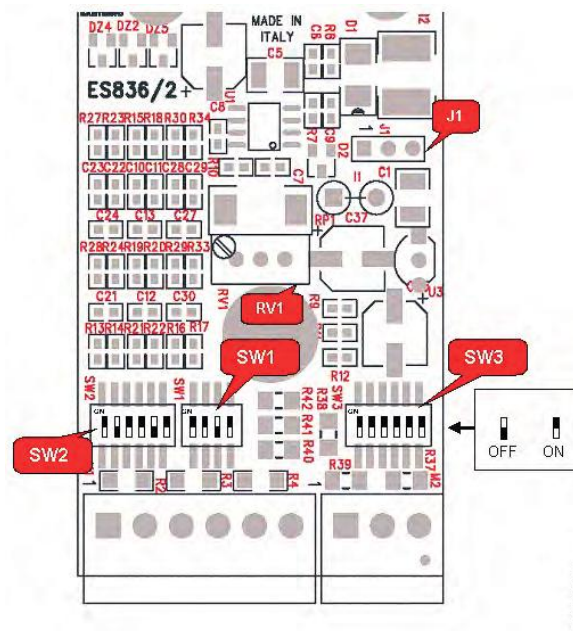

Figure 116: Positions of DIP-switches and their factory-setting

DIP-switch functionality and factory-settings are detailed in the table below.

Switch (factory-setting)	OFF - open	ON - closed
SW2.1	Channel B, NPN or PNP	Channel B, Line driver or Push-Pull (default)
SW2.2	Channel B with complementary signals (default)	Channel B with only one single-ended signal
SW2.3	Channel B with no band limit	Channel B with band limit (default)
SW2.4	Channel Z, NPN or PNP	Channel Z, Line driver or Push-Pull (default)
SW2.5	Channel Z with complementary signals (default)	Channel Z with only one single-ended signal
SW2.6	Channel Z with no band limit	Channel Z with band limit (default)
SW1.1	12V Supply voltage (J1 in pos. 2-3)	5V Supply Voltage (J1 in pos. 2-3) (default)
SW1.2	Channel A, NPN or PNP	Channel A, Line driver or Push-Pull (default)
SW1.3	Channel A with complementary signals (default)	Channel A with only one single-ended signal
SW1.4	Channel A with no band limit	Channel A with band limit (default)
SW3.1	Load resistors disabled	Load resistors towards ground enabled for all encoder signals (required for 5V Line driver or Push-pull encoders, especially if long cables are used – default setting)
SW3.2		
SW3.3		
SW3.4		
SW3.5		
SW3.6		



CAUTION

Keep SW3 contacts “ON” only if a complementary Push-pull or Line-driver encoder is used (power supply: 5V or 12V). Otherwise, set contacts to OFF.



NOTE

Put ALL contacts in DIP-switch SW3 to ON or OFF. Different configurations may cause the malfunctioning of the encoder board.

6.7.7. Jumper Selecting the Type of Encoder Supply

Two-position jumper J1 installed on encoder board ES836/2 allows setting the encoder supply voltage. It is factory-set to pos. 2-3. Set jumper J1 to position 1-2 to select non-tuned, 24V encoder supply voltage. Set jumper J1 to position 2-3 to select tuned, 5/12V encoder supply voltage. Supply values of 5V or 12V are to be set through DIP-switch SW1.1 (see table above).

6.7.8. Adjusting Trimmer

Trimmer RV1 installed on ES836/2 allows adjusting the encoder supply voltage. This can compensate voltage drops in case of long distance between the encoder and the encoder board, or allows feeding an encoder with intermediate voltage values if compared to factory-set values.

Tuning procedure:

1. Put a tester on the encoder supply connector (encoder side of the connecting cable); make sure that the encoder is powered.
2. Rotate the trimmer clockwise to increase supply voltage. The trimmer is factory set to deliver 5V and 12V (depending on the DIP-switch selection) to the power supply terminals. For a power supply of 5V, supply may range from 4.4V to 7.3V; for a power supply of 12V, supply may range from 10.3V to 17.3V.



NOTE

Output voltage cannot be adjusted by trimmer RV1 (jumper J1 in pos. 1-2) for 24V power supply.



CAUTION

Power supply values exceeding the encoder ratings may damage the encoder. Always use a tester to check voltage delivered from ES836 board before wiring.



CAUTION

Do not use the encoder supply output to power other devices. Failure to do so would increase the hazard of control interference and short-circuits with possible uncontrolled motor operation due to the lack of feedback.



CAUTION

The encoder supply output is isolated from the common terminal of the analog signals incoming to the terminals of the control board (CMA). Do not link the two common terminals together.

6.7.9. Encoder Wiring and Configuration

The figures below show how to connect and configure the DIP-switches for the most popular encoder types.



CAUTION

A wrong encoder-board connection may damage both the encoder and the board.



NOTE

In all the figures below, DIP-switches SW1.4, SW2.3, SW2.6 are set to ON, i.e. 77 kHz band limit is on. If a connected encoder requires a higher output frequency, set DIP-switches to OFF.



NOTE

The max. length of the encoder wire depends on the encoder outputs, not on the encoder board (ES836). Please refer to the encoder ratings.



NOTE

DIP-switch SW1.1 is not shown in the figures below because its setting depends on the supply voltage required by the encoder. Refer to the DIP-switch setting table to set SW1.1.



NOTE

Zero notch connection is optional and is required only for particular software applications. However, for those applications that do not require any zero notch, its connection does not affect the inverter operation. See Sinus Penta's Programming Guide for details.

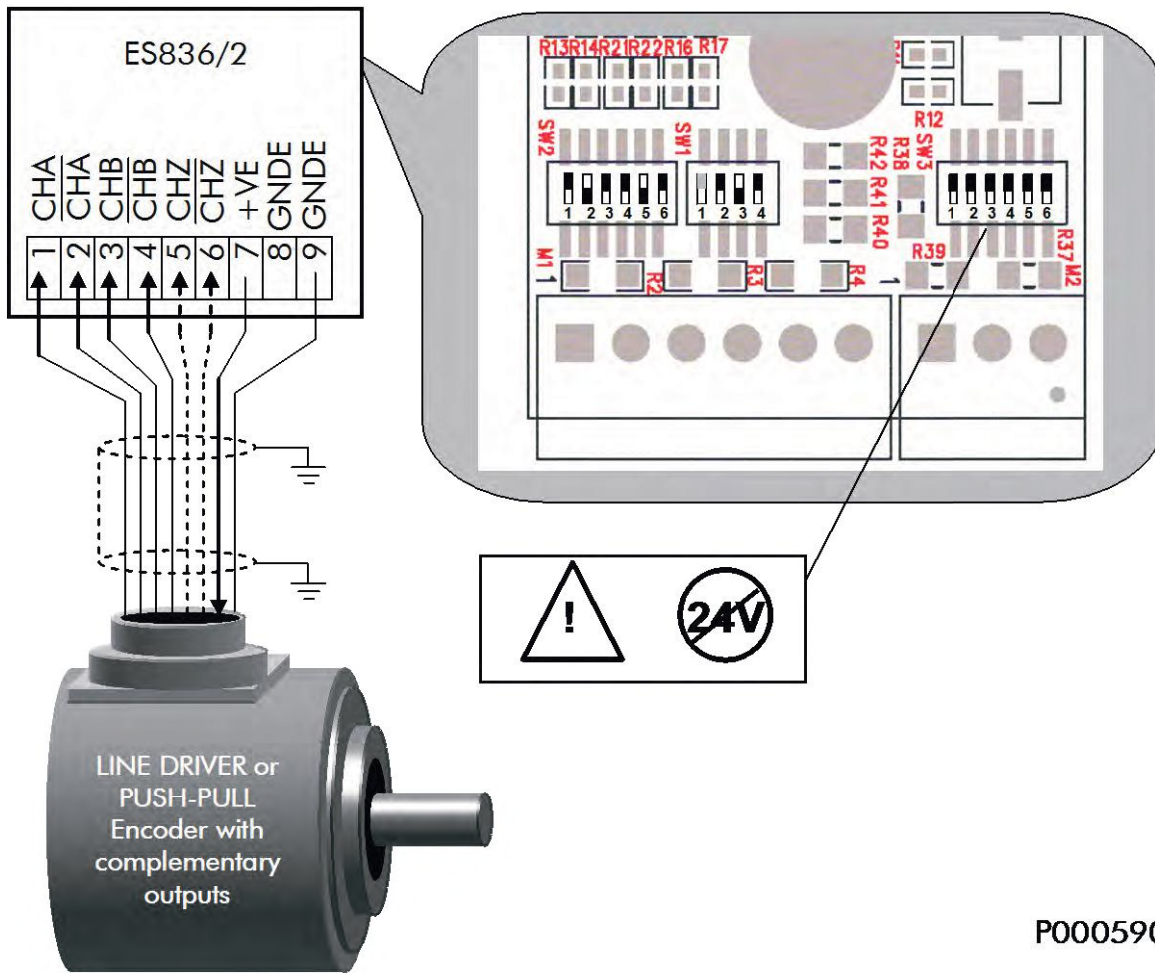

P000590-B

Figure 117: LINE DRIVER or PUSH-PULL encoder with complementary outputs



CAUTION

Put SW3 contacts to ON only if a complementary Push-pull or Line driver encoder is used (power supply: 5V or 12V). If a 24V push-pull encoder is used, put contacts to OFF.

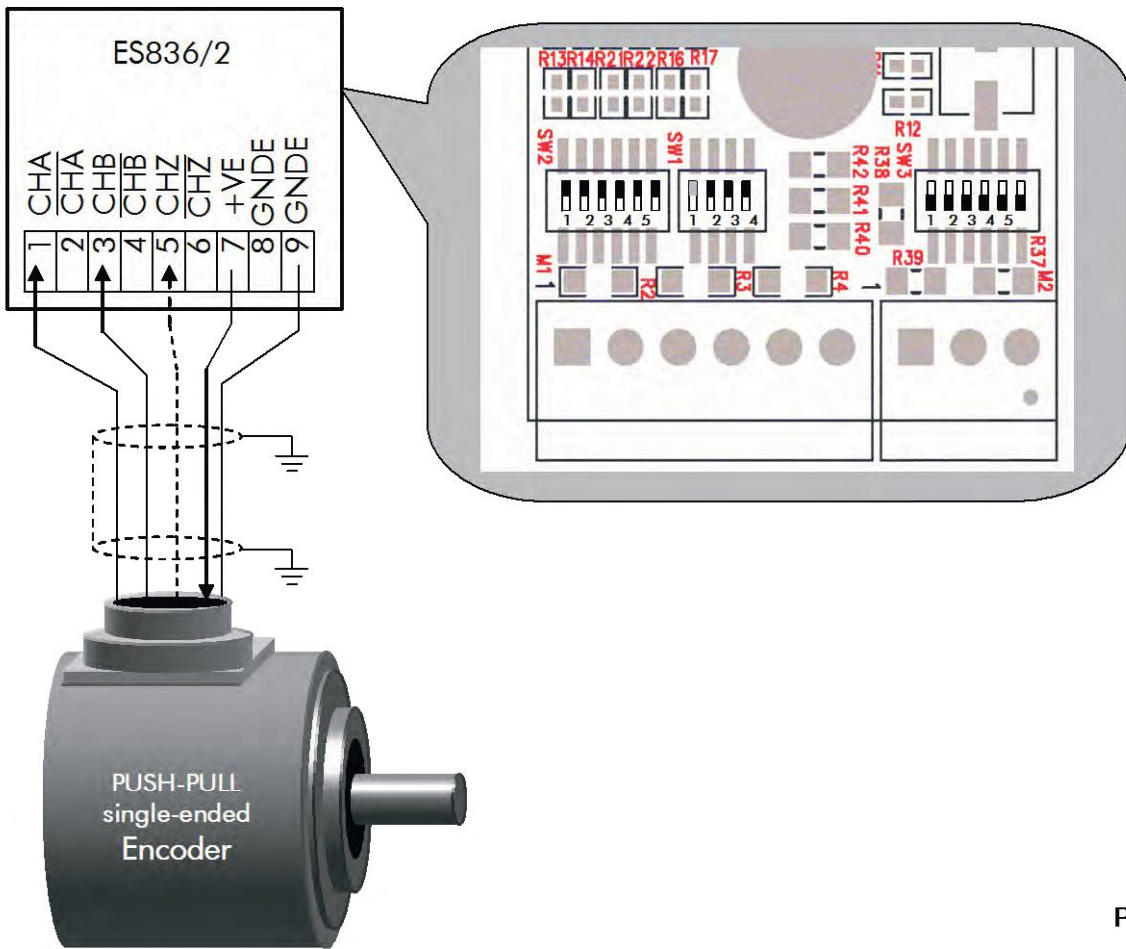

Figure 118: PUSH-PULL encoder with single-ended outputs



CAUTION

Because settings required for a single-ended encoder deliver a reference voltage to terminals 2, 4, 6, the latter are not to be connected. Failures will occur if terminals 2, 4, 6 are connected to encoder conductors or to other conductors.



NOTE

Only push-pull, single-ended encoders may be used, with an output voltage equal to the supply voltage. Only differential encoders may be connected if their output voltage is lower than the supply voltage.

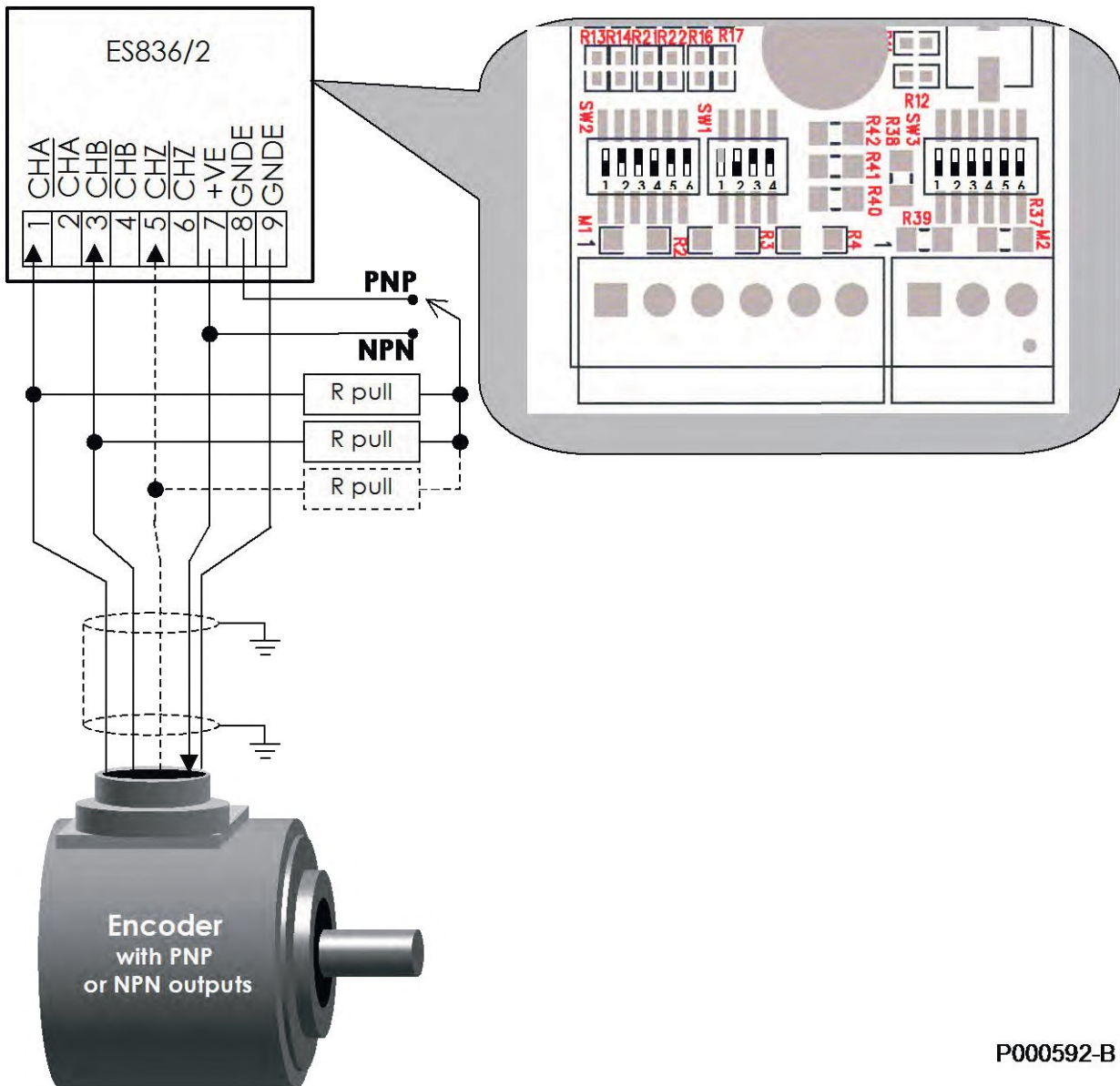

P000592-B

Figure 119: PNP or NPN encoder with single-ended outputs and load resistors with external wiring



NOTE

NPN or PNP encoder outputs require a pull-up or pull-down resistive load to the supply or to the common. As load resistor ratings are defined by the manufacturer of the encoder, external wiring is required, as shown in the figure above. Connect the resistor common to the supply line for NPN encoders supply or to the common for PNP encoders.

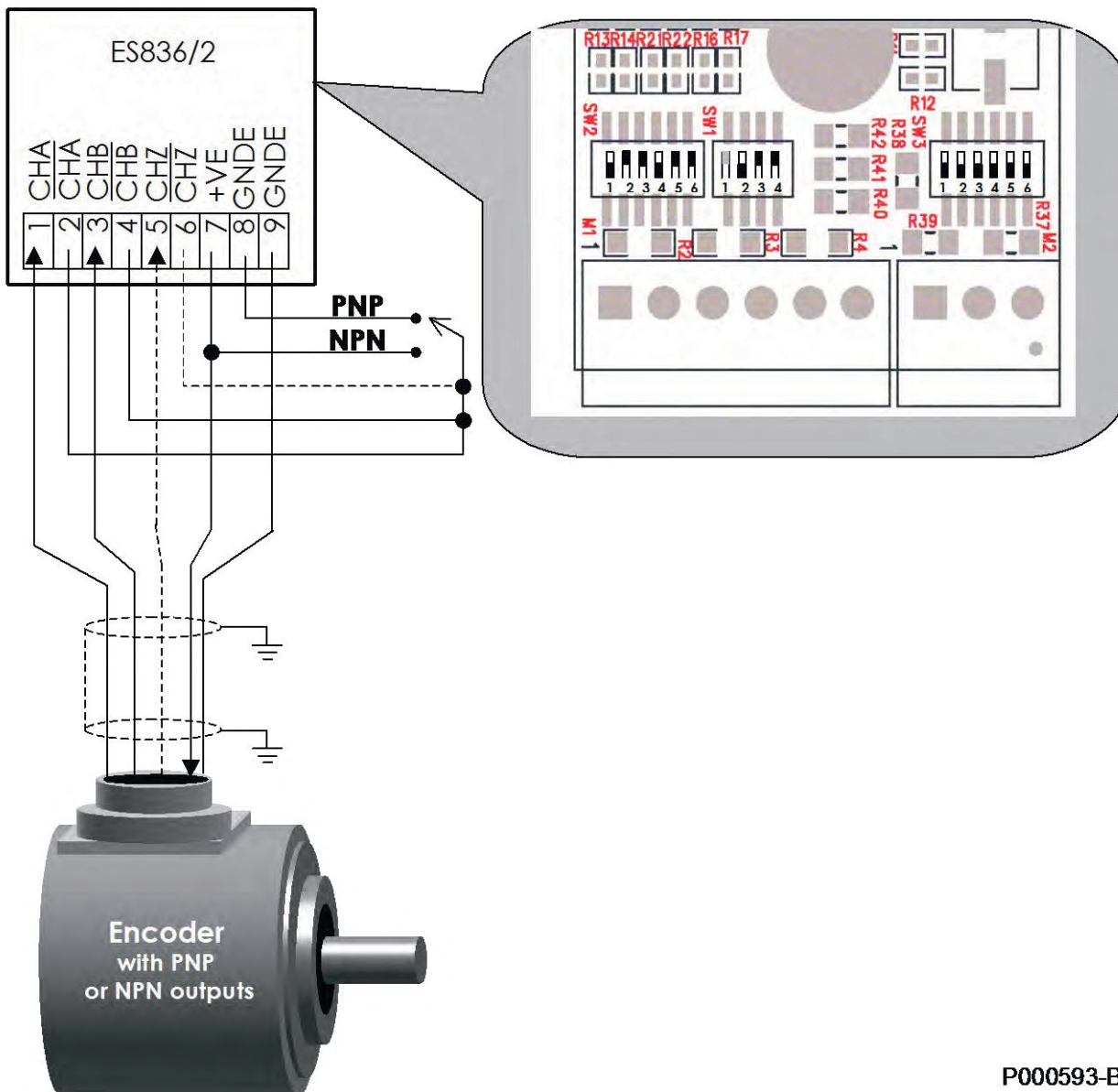

P000593-B

Figure 120: PNP or NPN encoder with single-ended outputs and internal load resistors



NOTE

Incorporated load resistors may be used only if NPN or PNP encoders are compatible with pull-up or pull-down external resistors (4.7kΩ).



NOTE

NPN or PNP encoders cause pulse distortions due to a difference in ramp up and ramp down edges. Distortion depends on the load resistor ratings and the wire stray capacitance. PNP or NPN encoders should not be used for applications with an encoder output frequency exceeding a few kHz dozens. For such applications, use encoders with Push-Pull outputs, or better with a differential line-driver output.

6.7.10. Wiring the Encoder Cable

Use a shielded cable to connect the encoder to its control board; shielding should be grounded to both ends of the cable. Use the special clamp to fasten the encoder wire and ground the cable shielding to the inverter.



Figure 121: Wiring the encoder cable

Do not stretch the encoder wire along with the motor supply cable.

Connect the encoder directly to the inverter using a cable with no intermediate devices, such as terminals or return connectors.

Use a model of encoder suitable for your application (as for connection length and max. rev number).

Preferably use encoder models with complementary LINE-DRIVER or PUSH-PULL outputs. Non-complementary PUSH-PULL, PNP or NPN open-collector outputs offer a lower immunity to noise.

The encoder electrical noise occurs as difficult speed adjustment or uneven operation of the inverter; in the worst cases, it can lead to the inverter stop due to overcurrent conditions.

6.8. ES913 Line Driver Encoder Board (Slot A)

Board for incremental, bidirectional encoder to be used as a speed feedback for the inverters of the SINUS series. It allows the acquisition of encoders with power supply ranging from 5 to 24VDC (adjustable output voltage) with line driver outputs.

The encoder board is to be installed into SLOT A. See Installing the Line Driver Board on the Inverter (Slot A).

P001034-B

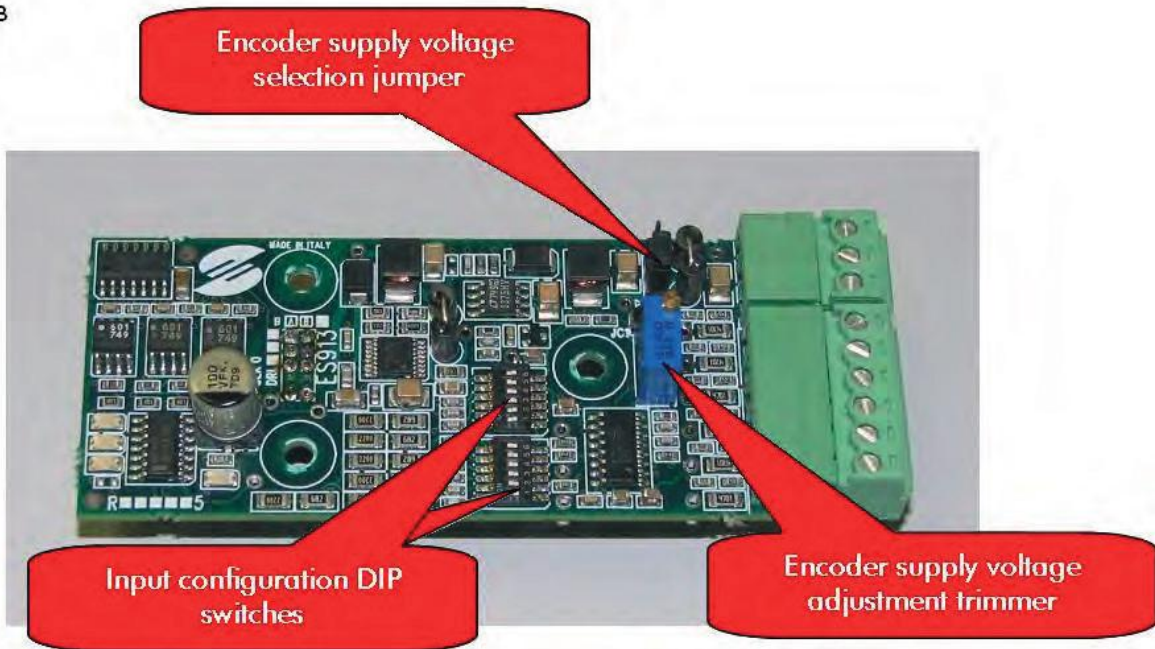

Figure 122: ES913 Encoder board

6.8.1. Identification Data

Description	Part Number	COMPATIBLE ENCODERS	
		POWER SUPPLY	OUTPUT
HTL Encoder board	ZZ0095837	5Vdc-24Vdc	LINE DRIVER

6.8.2. Environmental Requirements

Operating temperature	-10 to +55°C ambient temperature (contact Elettronica Santerno for higher ambient temperatures)
Relative humidity	5 to 95% (non-condensing)
Max. operating altitude	2000 m a.s.l. For installation above 2000 m and up to 4000 m, please contact Elettronica Santerno.

6.8.3. Electrical Specifications

Decisive voltage class A according to IEC 61800-5-1

<i>Electrical Specifications</i>	<i>Value</i>			
	<i>Min.</i>	<i>Typ.</i>	<i>Max.</i>	<i>Unit</i>
Encoder supply current, + 24 V, protected with resettable fuse			200	mA
Electronically protected encoder supply current, +12V			400	mA
Electronically protected encoder supply current, +5V			1000	mA
Adjustment range for encoder supply voltage (5V mode)	4.4	5.0	7.3	V
Adjustment range for encoder supply voltage (12V mode)	10.4	12.0	17.3	V
Input channels	Three channels: A, B and zero notch Z			
Type of input signals	Complementary (line driver)			
Voltage range for encoder input signals	4		30	V
Pulse max. frequency with noise filter "On"	77kHz (1024pls @ 4500rpm)			
Pulse max. frequency with noise filter "Off"	155kHz (1024pls @ 9000rpm)			

ISOLATION:

The encoder supply line and inputs are galvanically isolated from the inverter control board grounding for a 500VAC test voltage for 1 minute. The encoder supply grounding is in common with control board digital inputs available in the terminal board.

6.8.4. Installing the Line Driver Board on the Inverter (Slot A)



DANGER

Before gaining access to the components inside the inverter, remove voltage from the inverter and wait at least 20 minutes. Wait for a complete discharge of the internal capacitors to avoid any electric shock hazard.



CAUTION

Electric shock hazard: do not connect/disconnect the signal terminals or the power terminals when the inverter is on. This also prevents the inverter from being damaged.



NOTE

All the screws used to fasten removable parts (terminals cover, serial interface connector, cable plates, etc.) are black, round-head, cross-head screws. When wiring the inverter, remove only this type of screws. If different screws or bolts are removed, the inverter warranty will be no longer valid.

- 1) Remove voltage from the inverter and wait at least 20 minutes.
- 2) Remove the cover allowing gaining access to the inverter control terminals. The fixing spacers and the signal connector are located on the left.

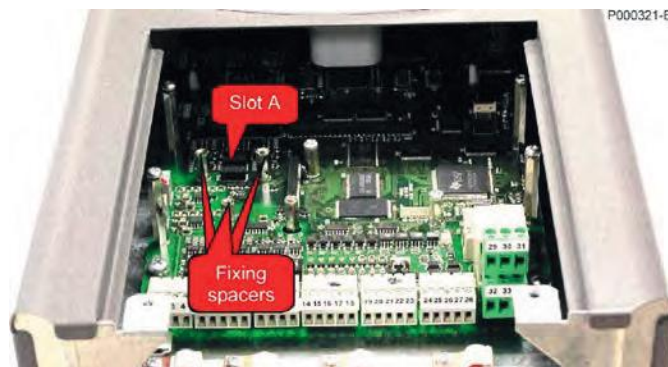

Figure 123: Position of slot A for the installation of the encoder board

Fit the encoder board and make sure that all contacts enter the relevant housing in the signal connector. Fasten the encoder board to the fixing spacers using the screws supplied.

- 4) Configure the DIP-switches and the jumper located on the encoder board based on the connected encoder. Check that the supply voltage delivered to the terminal output is correct.
- 5) Power on the inverter and set up parameters relating to the encoder feedback (see Sinus Penta's Programming Instructions manual).



Figure 124: Encoder board fastened to its slot

6.8.5. Terminals in the Line Driver Encoder Board

A 9-POLE TERMINAL BOARD IS LOCATED ON THE FRONT SIDE OF THE ENCODER BOARD FOR THE CONNECTION TO THE ENCODER.

Terminal board, pitch 3.81mm in two separate extractable sections (6-pole and 3-pole sections)		
Terminal	Signal	Type and Features
1	CHA	Encoder input channel A true polarity
2	$\overline{\text{CHA}}$	Encoder input channel A inverse polarity
3	CHB	Encoder input channel B true polarity
4	$\overline{\text{CHB}}$	Encoder input channel B inverse polarity
5	CHZ	Encoder input channel Z (zero notch) true polarity
6	$\overline{\text{CHZ}}$	Encoder input channel Z (zero notch) inverse polarity
7	+VE	Encoder supply output 5V...15V or 24V
8	GNDE	Encoder supply ground
9	GNDE	Encoder supply ground

For the encoder connection to the encoder board, see wiring diagrams on the following pages.

6.8.6. Configuration DIP-switches

The encoder board (ES913) is provided with two DIP-switch banks. The DIP-switches are located in the front left corner of the board and are adjusted as shown in the figure below.

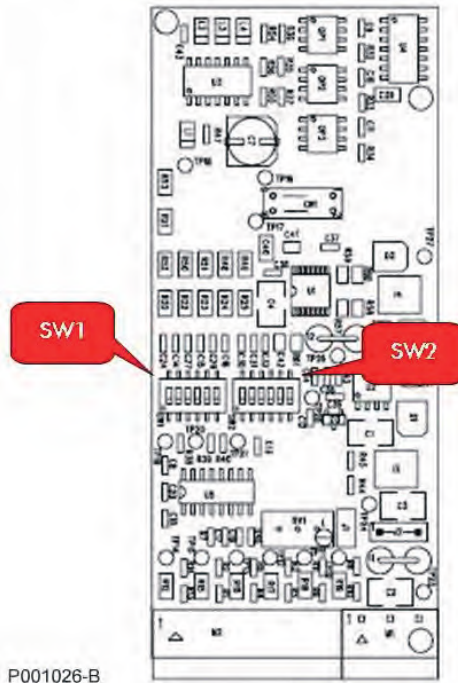

Figure 125: Position of the configuration DIP-switches

DIP-switch functionality and factory-settings are detailed in the table below.

SW1.1	SW1.2	
OFF	OFF	Channel A band limit disabled
OFF	ON	Min. channel A band limit
ON	OFF	Average channel A band limit
ON	ON	Max. channel A band limit (default)

SW1.3	SW1.4	
OFF	OFF	Channel B band limit disabled
OFF	ON	Min. channel B band limit
ON	OFF	Average channel B band limit
ON	ON	Max. channel B band limit (default)

SW1.5	SW1.6	
OFF	OFF	Channel Z band limit disabled
OFF	ON	Min. channel Z band limit
ON	OFF	Average channel Z band limit
ON	ON	Max. channel Z band limit (default)

SW2.1	OFF	Termination resistor between A and A# = 13.6kΩ (default)
	ON	Termination resistor between A and A# = 110Ω (only for input signals at 5V)
SW2.2	OFF	Termination resistor between B and B # = 13.6kΩ (default)
	ON	Termination resistor between B and B # = 110Ω (only for input signals at 5V)
SW2.3	OFF	Termination resistor between Z and Z# = 13.6kΩ (default)
	ON	Termination resistor between Z and Z# = 110Ω (only for input signals at 5V)
SW2.4	OFF	Termination capacitor between A and A# off
	ON	Termination capacitor between A and A# = 110pF (default)
SW2.5	OFF	Termination capacitor between B and B# off
	ON	Termination capacitor between B and B# = 110pF (default)
SW2.6	OFF	Termination capacitor between Z and Z# off
	ON	Termination capacitor between Z and Z# = 110pF (default)



CAUTION Do not select any termination resistor equal to 110Ω for encoder signal amplitude over 7.5V.

6.8.7. Encoder Supply Selection Jumper

Jumpers J1 and J2 select the encoder voltage supply among +5V, +12V, +24V:

Jumper J1	Jumper J2	Encoder Supply Voltage
X	2-3	+24V
Open	1-2	+12V
Closed (default)	1-2 (default)	+5V

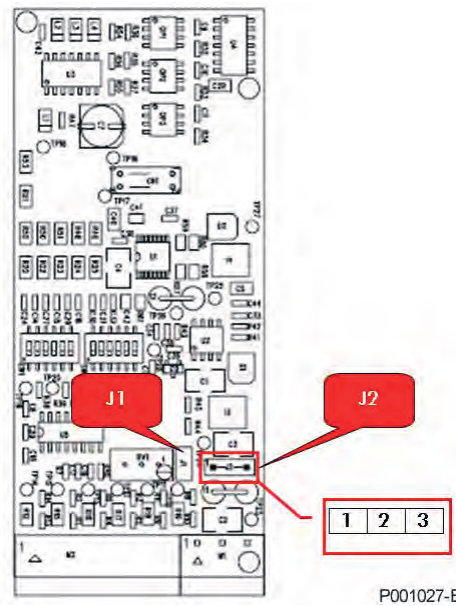

Figure 126: Location of the jumpers selecting the encoder supply voltage

6.8.8. Adjusting Trimmer

Trimmer RV1 located on ES913 board allows adjusting the encoder supply voltage. This can compensate voltage drops in case of long distance between the encoder and the encoder board, or allows feeding an encoder with intermediate voltage values if compared to factory-set values.

Tuning procedure:

1. Put a tester on the encoder supply connector (encoder side of the connecting cable); make sure that the encoder is powered.
2. Rotate the trimmer clockwise to increase supply voltage. The trimmer is factory set to deliver 5V and 12V (depending on the DIP-switch selection) to the power supply terminals. For a power supply of 5V, supply may range from 4.4V to 7.3V; for a power supply of 12V, supply may range from 10.4V to 17.3V.



NOTE

The output voltage cannot be adjusted by trimmer RV1 (jumper J1 in pos. 1-2) for 24V power supply.



CAUTION

Power supply values exceeding the encoder ratings may damage the encoder. Always use a tester to check voltage delivered from the ES913 board before wiring.



CAUTION

Do not use the encoder supply output to power other devices. Failure to do so will increase the hazard of control interference and short-circuits with possible uncontrolled motor operation due to the lack of feedback.



CAUTION

The encoder supply output is isolated from the common terminal of the analog signals incoming to the terminals of the control board (CMA). Do not link the two common terminals together.

6.9. ES822 Isolated Serial Board (Slot B)

The isolated serial board RS232/485 controlling Sinus Penta inverters allows connecting a computer through RS232 interface or allows a multidrop connection of Modbus devices through RS485 interface. It provides galvanic isolation of interface signals relating to both the control board ground and the terminal board common of the control board.

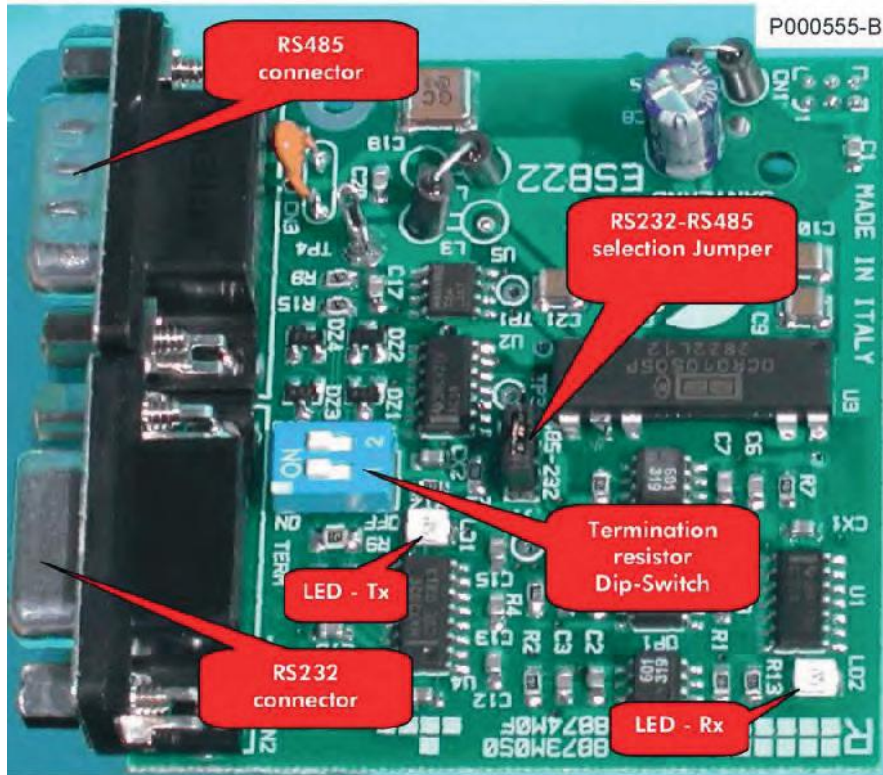

Figure 127: ES822 board

6.9.1. Identification Data

Description	Part Number
Isolated serial board - RS232/485	ZZ0095850

6.9.2. Environmental Requirements

Operating temperature	-10 to +55°C ambient temperature (contact Elettronica Santerno for higher ambient temperatures)
Relative humidity	5 to 95% (non-condensing)
Max. operating altitude	2000 m a.s.l. For installation above 2000 m and up to 4000 m, please contact Elettronica Santerno.

6.9.3. Electrical Features

WIRING:

Once ES822 board is fitted, connector RS485 installed on the inverter will automatically disable. D-type, 9-pole male connector (RS485) or female connector (RS232-DTE) located on ES822 board activate depending on the position of J1.

Contacts of CN3, D-type, 9-pole male connector (RS485) are as follows:

PIN	FUNCTION
1 - 3	(TX/RX A) Differential input/output A (bidirectional) according to standard RS485. Positive polarity in respect to pins 2 – 4 for one MARK.
2 - 4	(TX/RX B) Differential input/output B (bidirectional) according to standard RS485. Negative polarity in respect to pins 1 – 3 for one MARK.
5	(GND) control board zero volt
6 - 7	Not connected
8	(GND) control board zero volt
9	+5 V, max 100mA for the power supply of an auxiliary RS485/RS232 converter (if any)

Contacts of CN2, D-type, 9-pole female connector (RS232-DCE) are as follows:

PIN	FUNCTION
1 - 9	Not connected
2	(TX A) Output according to standard RS232
3	(RX A) Input according to standard RS232
5	(GND) zero volt
4 - 6	To be connected together for loopback DTR-DSR
7 - 8	To be connected together for loopback RTS-CTS

6.9.4. Installing ES822 Board on the Inverter (Slot B)



DANGER

Before gaining access to the components inside the inverter, remove voltage from the inverter and wait at least 20 minutes. Wait for a complete discharge of the internal capacitors to avoid any electric shock hazard.



CAUTION

Electric shock hazard: do not connect/disconnect the signal terminals or the power terminals when the inverter is on. This also prevents the inverter from being damaged.



NOTE

All the screws used to fasten removable parts (terminals cover, serial interface connector, cable plates, etc.) are black, round-head, cross-head screws. When wiring the inverter, remove only this type of screws. If different screws or bolts are removed, the inverter warranty will be no longer valid.

1. Turn off the inverter and wait at least 20 minutes.
2. Remove the cover to access to the inverter control terminals. The fixing spacers for the encoder board and signal connector are located on the right.

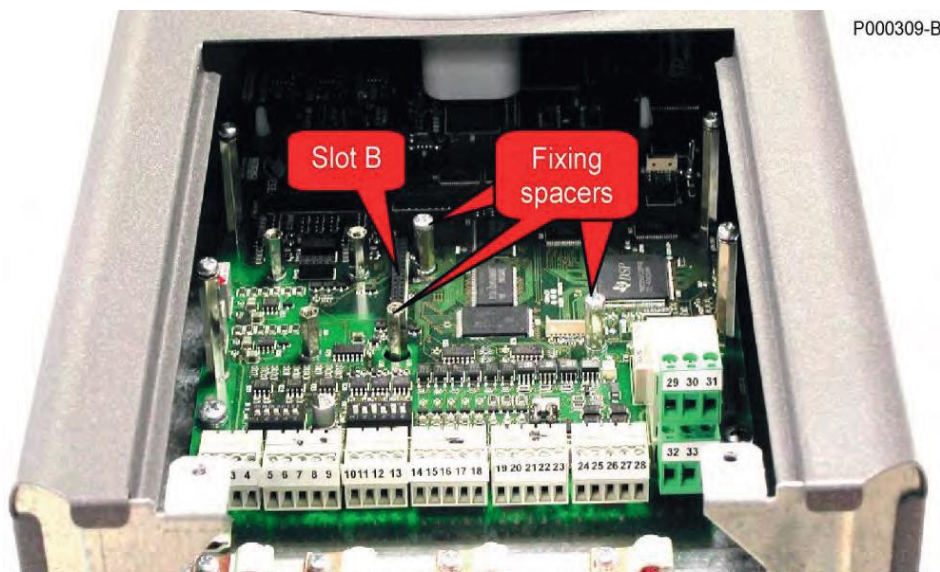

Figure 128: Position of the slot for the installation of the serial isolated board

3. Fit ES822 board and make sure that all contacts enter the relevant housing in the signal connector. Fasten the encoder board to the fixing spacers using the screws supplied.
4. Configure DIP-switches and the jumper located on the encoder board based on the connected encoder.
5. Close the inverter frame by reassembling the cover allowing gaining access to the inverter control terminals.

6.9.5. Setting ES822 Board

6.9.5.1. Jumper for RS232/RS485 Selection

Jumper J1 sets ES822 board to operate as RS485 interface or as RS232 interface.

With a jumper between pins 1-2 CN3-(RS485) is enabled (default).

With a jumper between pins 2-3 CN2-(RS232) is enabled.

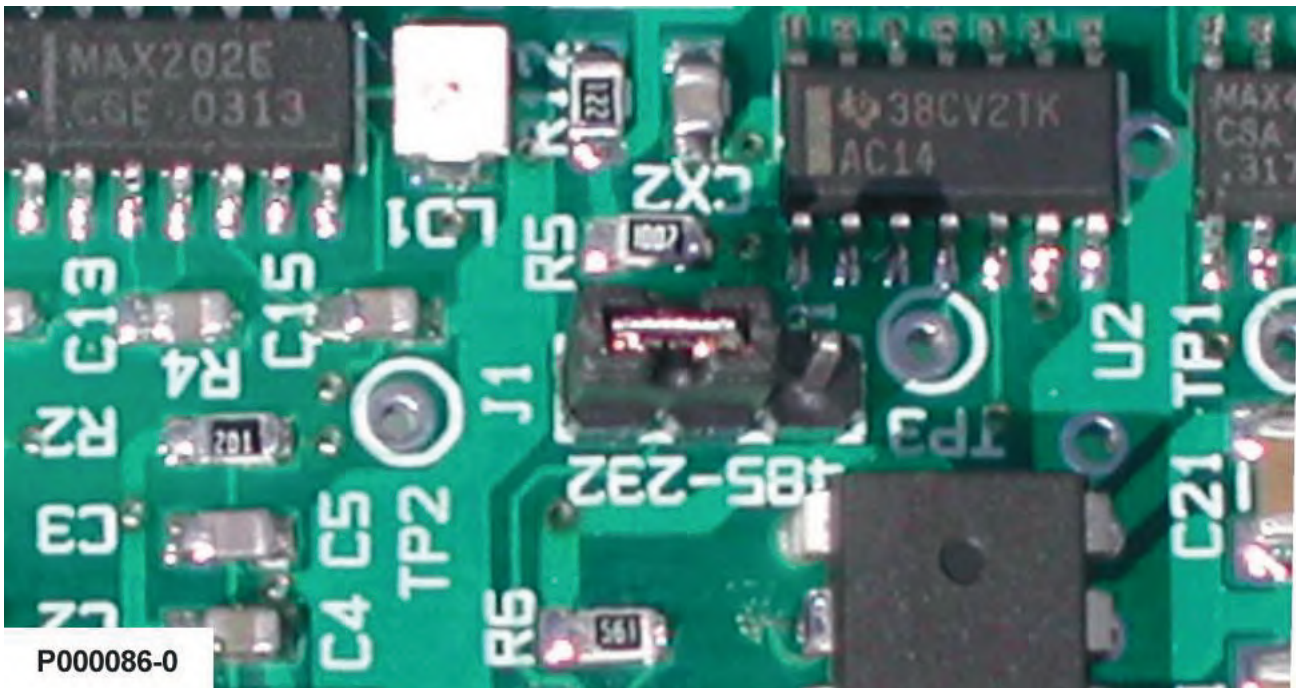

Figure 129: Jumper setting RS232/RS485

6.9.5.2. DIP-switch for RS485 Terminator

Please refer to the Serial Communications section.

For serial link RS485 in ES822 board, the line terminator is selected through DIP-switch SW1 as shown in the figure below.

When the line master (computer) is located at the beginning or at the end of the serial link, the line terminator of the farthest inverter from the master computer (or the only inverter in case of direct connection to the master computer) shall be enabled.

Line terminator enables by setting selector switches 1 and 2 to ON in DIP-switch SW1. The line terminator of the other inverters in intermediate positions shall be disabled: DIP-switch SW1, selector switches 1 and 2 in position OFF(default setting).

In order to use RS232-DTE link, no adjustment of DIP-switch SW1 is required.

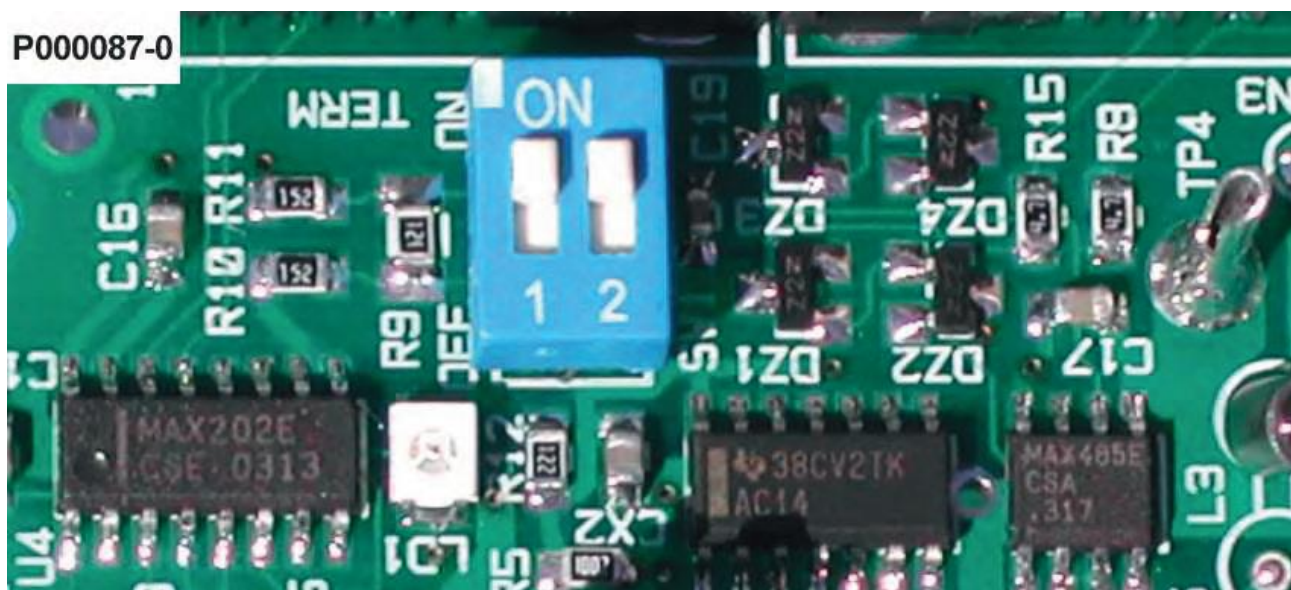

Figure 130: Configuration of terminator DIP-switch for line RS485

6.10. Optional Boards For Fieldbus (Slot B)

Several interface boards (optional) are available for the connection of the inverters of the Sinus PENTA series to automation systems based on Fieldbus. Optional boards allow interfacing systems based on:

- Profibus-DP[®],
- PROFIdrive[®],
- DeviceNet[®] (CAN),
- CANopen[®] (CAN),
- Ethernet (MODBUS TCP/IP),
- Interbus[®],
- ControlNet[®],
- Lonworks[®].



The inverters of the Sinus PENTA series can house only one optional board per fieldbus. This board allows controlling the inverter through the desired bus starting from a control device (PLC, industrial computer, etc.). The control method from fieldbus integrates the control methods from local terminals, remote terminals (through MODBUS serial link) and from keypad, which are provided from the inverter. For more details on the inverter command modes and the possible matching among the different sources, refer to the Sinus Penta's Programming Guide (Control Method menu and Fieldbus menu).

The sections below cover the installation procedure and the configuration and diagnostics of the different types of optional boards.



NOTE

The read/write scan rate for Sinus Penta drives is 2ms. Please refer to the Programming Guide for details.



CAUTION

Other communications protocols are available. Please refer to ES919 Communications Board (Slot B).

6.10.1. Identification Data

Each kit including optional boards for fieldbuses also includes a CD-ROM containing detailed documentation (instruction manuals in English, utilities and configuration files), which is required for the inverter configuration and integration to the automation system based on fieldbus.

Type of Fieldbus	Part Number
Profibus-DP®	ZZ4600045
PROFIdrive®	ZZ4600042
DeviceNet®	ZZ4600055
Interbus®	ZZ4600060
CANOpen®	ZZ4600070
ControlNet®	ZZ4600080
Lonworks®	ZZ4600085
Ethernet+IT	ZZ4600100



NOTE

The Interbus, ControlNet and Lonworks boards are not described in this manual.
Please refer to the CD-ROM supplied in the kit.

6.10.2. Installing the Fieldbus Board on the Inverter (Slot B)



DANGER

Before gaining access to the components inside the inverter, remove voltage from the inverter and wait at least 20 minutes. Wait for a complete discharge of the internal capacitors to avoid any electric shock hazard.



CAUTION

Electric shock hazard: do not connect/disconnect the signal terminals or the power terminals when the inverter is on. This also prevents the inverter from being damaged.



NOTE

All the screws used to fasten removable parts (terminals cover, serial interface connector, cable plates, etc.) are black, round-head, cross-head screws. When wiring the inverter, remove only this type of screws. If different screws or bolts are removed, the inverter warranty will be no longer valid.

- 1) Remove voltage from the inverter and wait at least 20 minutes.
- 2) The electronic components in the inverter and the communications board are sensitive to electrostatic discharge. Be careful when you reach the component parts inside the inverter and when you handle the communications board. The board should be installed in a workstation equipped with proper grounding and provided with an antistatic surface. If this is not possible, the installer must wear a ground bracelet properly connected to the PE conductor.



- 3) Loosen the two front screws located in the lower part of the inverter cover to remove the covering of the terminal board. In the PENTA's control board, you can then reach the slot B, where you can install the Profibus communications board.

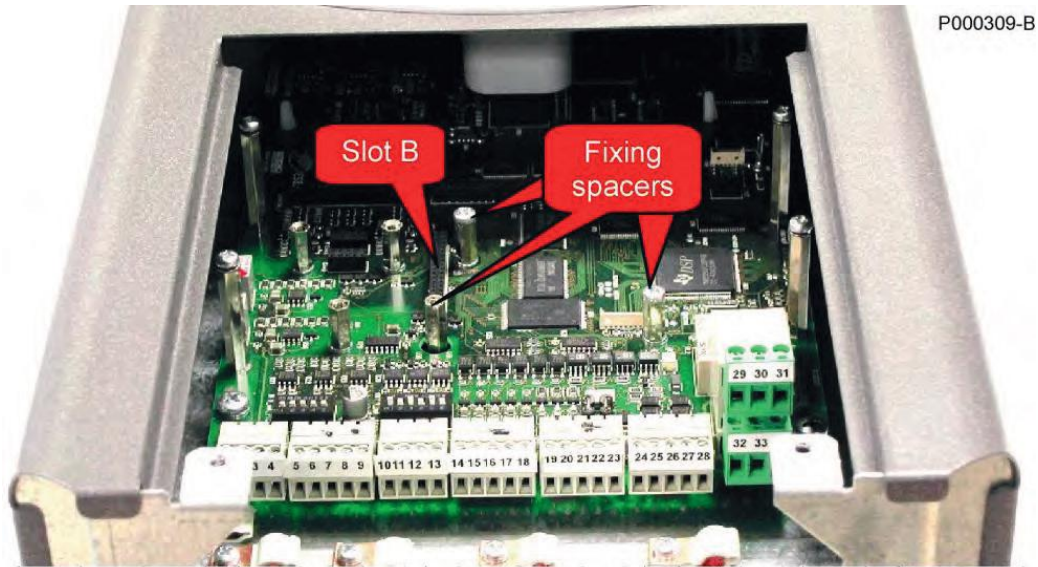

Figure 131: Location of the slot B inside the terminal board cover of the Sinus PENTA inverters

- 4) Insert the communications board in the slot B; make sure that the comb connector in the board is inserted in the front part of the slot only, and that the last 6 pins are not connected. If installation is correct, the three fastening holes will match with the housings of the fastening screws for the fixing spacers. Tighten the board fixing screws as shown in Figure 132 and Figure 133.

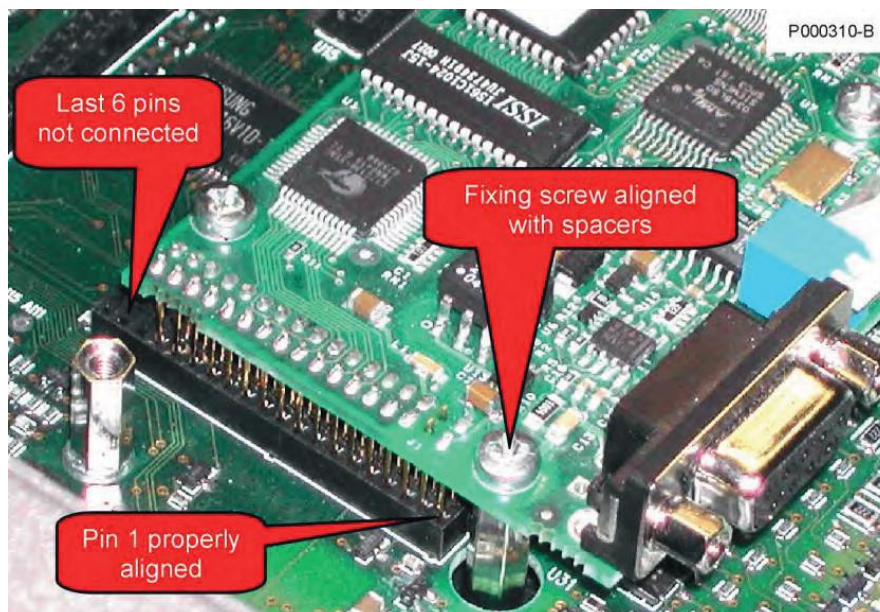

Figure 132: Checking contacts in the slot B

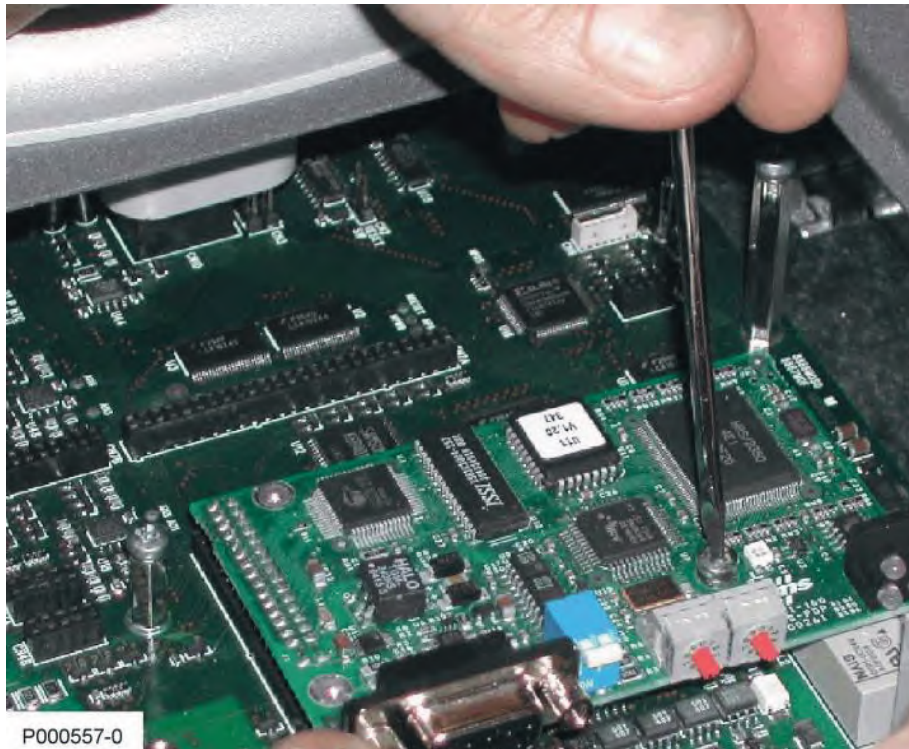

Figure 133: Fastening the communications board to slot B

- 5) Configure the DIP-switches and rotary-switches following the instructions given in the relevant section.
- 6) Connect the Fieldbus cable by inserting its connector or by connecting the wires to the terminals.
- 7) Close the inverter frame by reassembling the cover allowing gaining access to the inverter control terminals.

6.10.3. Fieldbus PROFIBUS-DP[®] Board

PROFIBUS-DP[®] is a registered trademark of PROFIBUS International.

The Profibus communications board allows interfacing between an inverter of the Sinus PENTA Series and an external control unit, such as a PLC, using a PROFIBUS-DP communications interface.

The Sinus PENTA inverter operates as a Slave device and is controlled by a Master device (PLC) through command messages and reference values which are equivalent to the ones sent via terminal board. The Master device is also capable of detecting the operating status of the inverter. More details about Profibus communications are given in the Sinus Penta's Programming Guide.

Profibus communications board has the following features:

- Type of fieldbus: PROFIBUS-DP EN 50170 (DIN 19245 Part 1) with protocol version 1.10
- Automatic detection of the baud rate ranging from 9600 bits/s to 12 Mbits/s
- Communications device: PROFIBUS bus link, type A or B as mentioned in EN50170
- Type of fieldbus: Master-Slave communications; max. 126 stations in multidrop connection
- Fieldbus connector: female, 9-pin, DSUB connector
- Wire: copper twisted pair (EIA RS485)
- Max. length of the bus: 200m @ 1.5Mbits/s (can be longer if repeaters are used)
- Isolation: the bus is galvanically isolated from the electronic devices via a DC/DC converter
- The bus signals (link A and link B) are isolated via optocouplers
- PROFIBUS –DP communications ASIC: chip Siemens SPC3
- Hardware configurability: bus terminator switch and rotary-switch assigning the address to the node
- Status indicators: indicator Led for board status and indicator Led for fieldbus status.

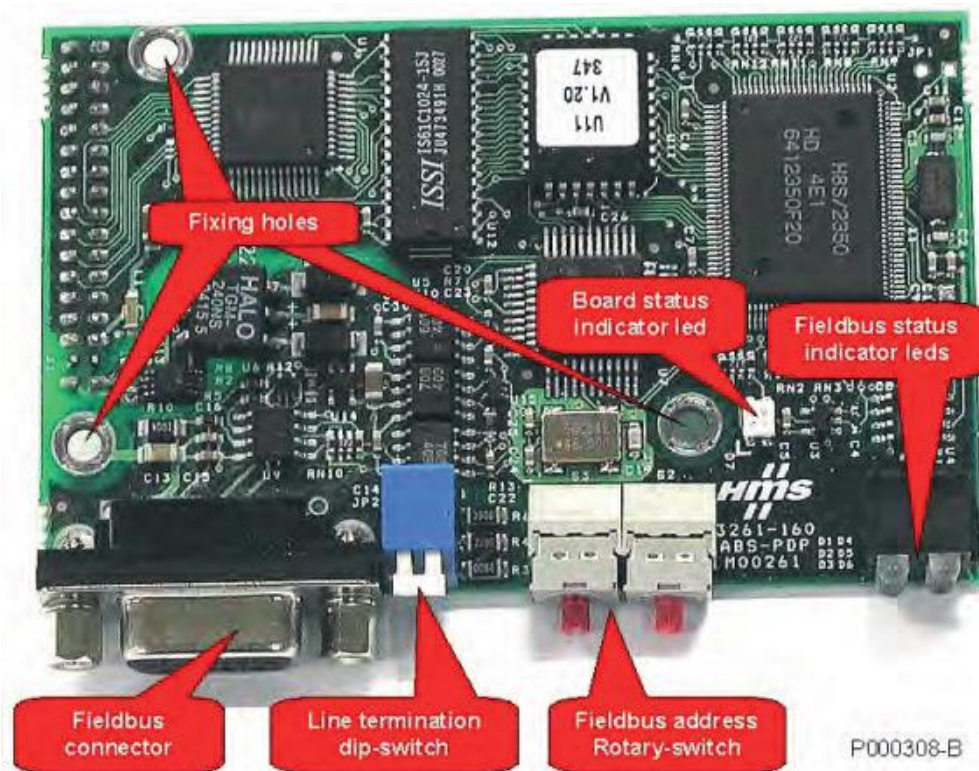

Figure 134: PROFIBUS-DP[®] fieldbus communications board

6.10.3.1. Profibus® Fieldbus Connector

Female, 9-pin, D-sub connector.

Pin location:

N.	Name	Description
-	Shield	Connector frame connected to PE
1	N.C.	
2	N.C.	
3	B-Line	Positive RxD/TxD according to RS 485 specifications
4	RTS	Request To Send – active high level when sending
5	GND	Bus ground isolated from control board 0V
6	+5V	Bus driver supply isolated from control board circuits
7	N.C.	
8	A-Line	Negative RxD/TxD according to RS 485 specifications
9	N.C.	

6.10.3.2. Configuration of the Profibus-DP Communications Board

PROFIBUS-DP communications board is provided with one DIP-switch and two rotary-switches used to set the operating mode.

The DIP-switch located next to the fieldbus connector allows activating the line terminator. The terminator is activated by pushing the lever downwards, as shown below.

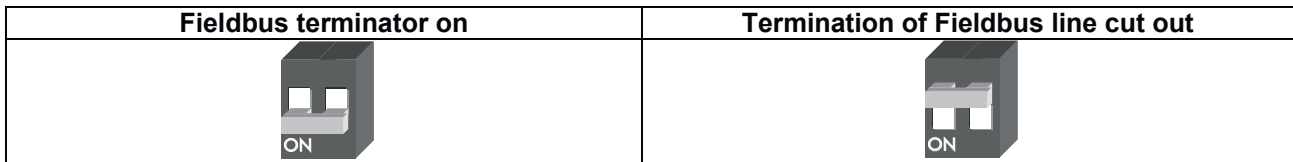

The termination of the fieldbus line should be cut in only with the first and last device of a chain, as illustrated in Figure 135.

The figure shows a common configuration where the first device is the Master (PLC, Bus Bridge or Repeater), but this device can be connected also in central position. Anyway, the rule stating that termination should always be connected to first or last device, is always valid.

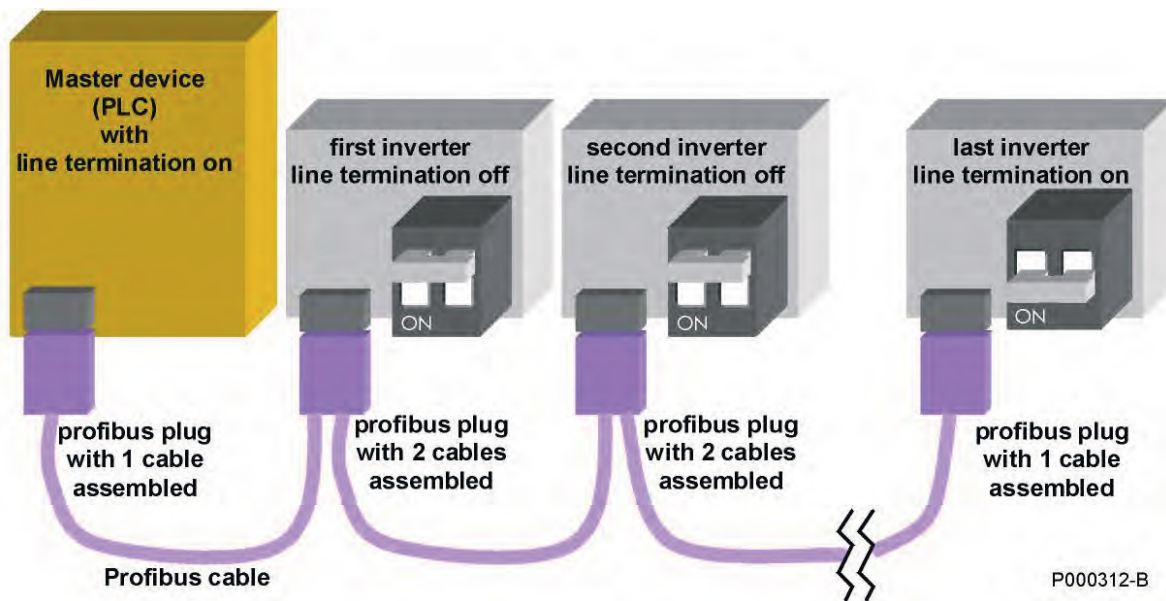

Figure 135: Example of a Profibus network (the correct setting of the line terminators is highlighted)

Each device in the network must have its own Profibus address. The addresses of the inverters of the Sinus PENTA series are set through the rotary-switches installed in the interface board. Each rotary-switch is provided with a pin that can be turned to position 0-9 using a small screwdriver. The rotary-switch on the left sets the tenths of the Profibus address, while the rotary switch on the right sets the units. Figure 136 shows an example of the correct position to set address "19".

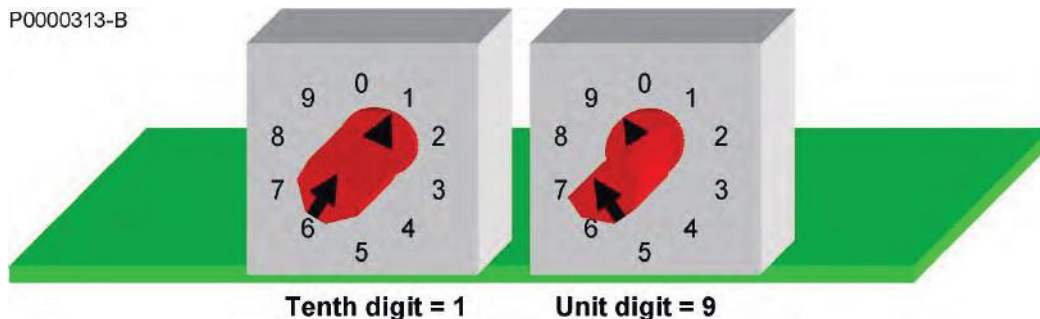

Figure 136: Example of the rotary-switch position to set Profibus address "19"



NOTE

The rotary-switches allow setting Profibus addresses ranging from 1 to 99. Addresses exceeding 99 are not yet allowed.

6.10.3.3. Connection to the Fieldbus

Make sure that wiring is correct, especially if the fieldbus operates at high baud rates (higher than or equal to 1.5Mb/s).

Figure 135 is an example of a Profibus link connecting multiple devices.

Use special Profibus cables (“Profibus Standard Bus Cable”, Type A); do not exceed the max. allowable connection length based on the baud rate; use proper connectors.

The table below shows the standard baud rate values and the corresponding max. length of the bus if cables of Type A are used.

<i>Allowable Baudrate</i>	<i>Max. Length for Cable of Type A</i>
9.6 kbits/s	1.2 km
19.2 kbits/s	1.2 km
45.45 kbits/s	1.2 km
93.75 kbits/s	1.2 km
187.5 kbits/s	1 km
500 kbits/s	400 m
1.5 Mbits/s	200 m
3 Mbits/s	100 m
6 Mbits/s	100 m
12 Mbits/s	100 m

We recommend that Profibus FC (FastConnect) connectors be used. They offer the following benefits:

- No welding required for the connections inside the cable
- One ingoing cable and one outgoing cable can be used, so that connections of intermediate nodes can be stubless, thus avoiding signal reflections
- The internal resistors can be connected through a switch located on the connector frame
- Profibus FC connectors are provided with an internal impedance adapting network to compensate for the connector capacity.



NOTE

If you use Profibus FC connectors with internal terminators, you can activate either the connector terminal or the board terminals (in the first/last device only). Do not activate both terminators at a time and do not activate terminators in intermediate nodes.



NOTE

A more comprehensive overview of the Profibus is given at <http://www.profibus.com/>. In particular, you can download the “Installation Guideline for PROFIBUS DP/FMS”, containing detailed wiring information, and the document named “Recommendations for Cabling and Assembly” containing important guidelines to avoid the most common wiring errors.

6.10.4. PROFIdrive® Fieldbus Board

PROFIdrive® is a registered trademark of PROFIBUS International.

Any detail is given in the PROFIdrive COMMUNICATIONS BOARD - Installation and Programming Instructions.

As per the board configuration, please refer to the Configuration of the Profibus-DP Communications Board section.

6.10.5. DeviceNet® Fieldbus Board

DeviceNet is a registered trademark of open DeviceNet Vendor Association.

The DeviceNet® communications board allows interfacing a Sinus PENTA drive with an external control unit through a communications interface using a CAN protocol of the DeviceNet 2.0 type. The baud rate and the MAC ID can be set through the on-board DIP-switches. Max. 512 bytes for input/output data are available; some of them are used for the interfacing with the inverter. Refer to the Sinus Penta's Programming Guide for more details on the inverter control modes through the DeviceNet fieldbus board.

The main features of the interface board are the following:

- Baud Rate: 125, 250, 500 kbits/s
- DIP-switch for baud rate and MAC ID selection
- Optically isolated DeviceNet interface
- Max. 512 bytes for input & output data
- Max. 2048 bytes for input & output data through mailbox
- DeviceNet Specification version: Vol 1: 2.0, Vol 2: 2.0
- Configuration test version: A-12

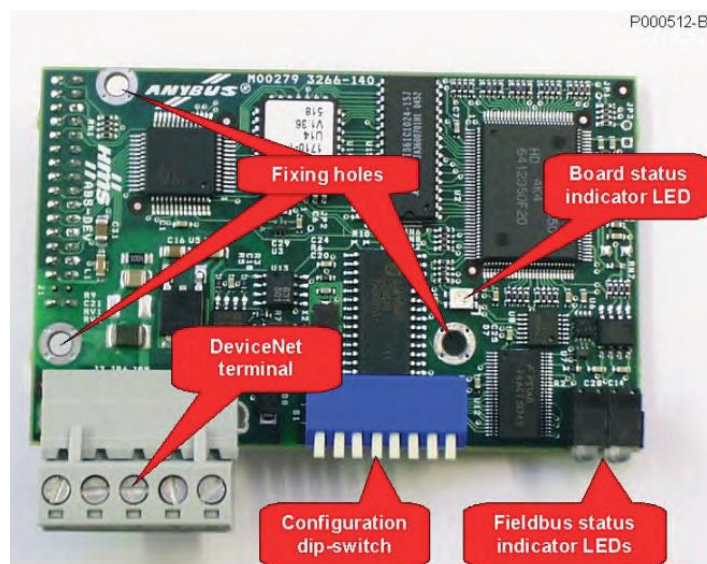

Figure 137: DeviceNet® Fieldbus communications board

6.10.5.1. DeviceNet® Fieldbus Terminals

The DeviceNet Fieldbus communications board is provided with a removable, screwable terminal board (pitch 5.08). The bus interface circuitry has an external supply of 24VDC $\pm 10\%$, as prescribed from the CAN DeviceNet specifications.

Terminal arrangement as stated in the table:

N.	Name	Description
1	V-	Negative voltage for bus supply
2	CAN_L	CAN_L bus line
3	SHIELD	Cable shielding
4	CAN_H	CAN_H bus line
5	V+	Positive voltage for bus supply

6.10.5.2. Board Configuration

The on-board DIP-switches allow setting the baud rate and the MAC ID identifying the device in the DeviceNet network.

DIP-switches 1 and 2 allow setting the baud rate, that must be the same for all the related devices. The DeviceNet standard allows three baud rates: 125, 250 and 500 kbits/s. Possible settings are the following:

Baudrate	Setting of SW.1 & SW.2	
125 kbits/s	sw.1=OFF	sw.2=OFF
250 kbits/s	sw.1=OFF	sw.2=ON
500 kbits/s	sw.1=ON	sw.2=OFF

The MAC ID can be set between 0 and 63 by entering the configuration of the binary number for six DIP-switches, from sw.3 to sw.8. The most significant bit (MSB) is set through sw.3, while the least significant bit (LSB) is set through sw.8.

Some possible settings are shown in the table below:

MAC ID	SW.3 (MSB)	SW.4	SW.5	SW.6	SW.7	SW.8 (LSB)
0	OFF	OFF	OFF	OFF	OFF	OFF
1	OFF	OFF	OFF	OFF	OFF	ON
2	OFF	OFF	OFF	OFF	ON	OFF
3	OFF	OFF	OFF	OFF	ON	ON
.....
62	ON	ON	ON	ON	ON	OFF
63	ON	ON	ON	ON	ON	ON

If multiple devices are connected to the same bus, different MAC IDs are to be set.

6.10.5.3. Connection to the Fieldbus

The wiring quality is fundamental for the best reliability of the bus operation. The higher the baud rates, the shortest the bus lengths allowed.

Reliability is strongly affected by the type of wiring and the wire topology. The DeviceNet standard allows four types of wires based on the type of related devices. It also allows connecting signal dispatching nodes, line terminators and supply couplers. Two types of lines are defined: the trunk line and the drop lines. The figure below illustrates the topology of a typical DeviceNet trunk line.

P000513-B

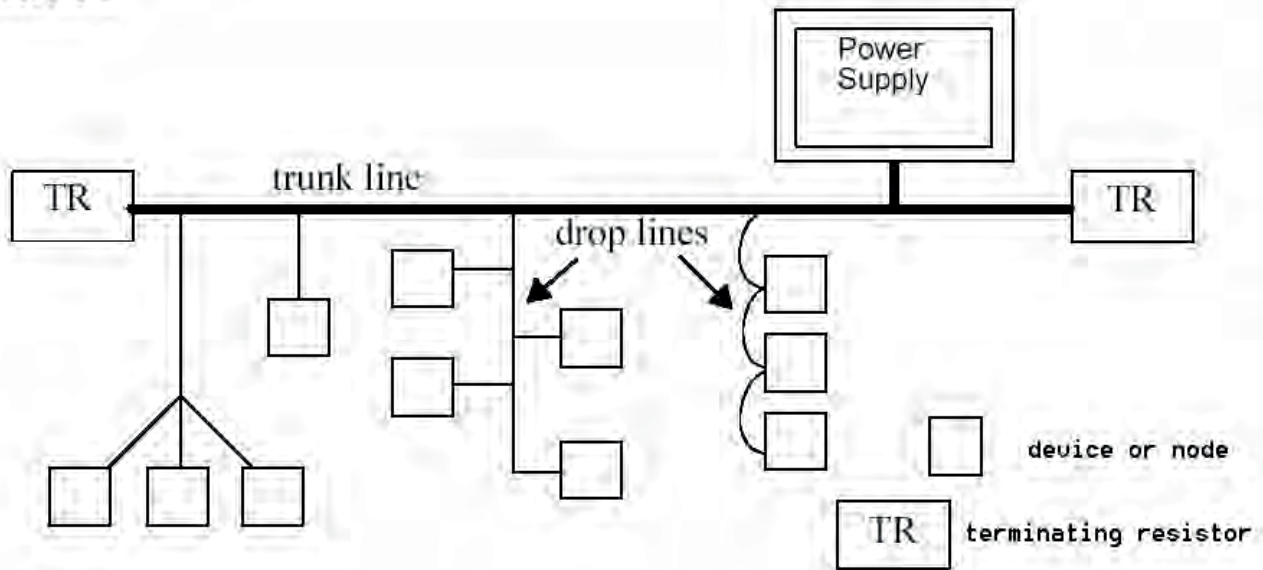

Figure 138: Outline of the topology of a DeviceNet trunk line

The inverter equipped with a DeviceNet interface board is typically connected through a drop line consisting of a 5-conductor shielded cable. The DeviceNet standard defines three shielded cables based on their diameter: THICK, MID, and THIN cables. The maximum electric length between two DeviceNet devices depends on the baud rate and the type of cable being used. The table below shows the maximum lengths that are recommended based on these variables. The FLAT cable can be used for the main trunk line if drop lines are connected through a system that does not require welding.

Baud Rate	Max. length with FLAT cable	Max. length with THICK cable	Max. length with MID cable	Max. length with THIN cable
125 kbits/s	420m	500m	300m	100m
250 kbits/s	200m	250m	250m	100m
500 kbits/s	75m	100m	100m	100m



NOTE

Each DeviceNet trunk line must meet some geometric requirements and must provide two terminator nodes and at least one supply node, because devices can be totally or partially powered via the bus. The type of the cable being used also determines the max. supply current available for the bus devices.



NOTE

For a more comprehensive overview of the DeviceNet standard, go to ODVA's home page (<http://www.odva.org>).

In particular, you can refer to the "Planning and Installation Manual" document.



NOTE

In case of failures or disturbance in the DeviceNet communications, please fill in the "DeviceNet Baseline & Test Report" form in the Appendix C of the "Planning and Installation Manual" before contacting the After-sales service.

6.10.6. CANopen® Fieldbus Board

CANopen® and CiA® are registered trademarks of CAN in Automation e.V.

The CANopen communications board allows interfacing a Sinus PENTA drive with an external control unit using communications interface operating with a CAN protocol of the CANopen type complying with the CIA DS-301 V3.0 specifications. The baud rate and the Device Address can be set through the on-board rotary switches. Eight baud rate levels can be set, up to 1Mbit/s. Refer to the Sinus Penta's Programming Guide for more details on the inverter control modes through the CANopen fieldbus board.

The main features of the interface board are the following:

- Unscheduled data exchange support
- Synch & Freeze operating mode
- Possibility of setting Slave Watch-dog timer
- Eight baud rate levels, from 10kbits/s to 1Mbit/s
- Possibility of setting different Device Addresses up to max. 99 nodes
- Optically isolated CAN interface
- CANopen conformity: CIA DS-301 V3.0

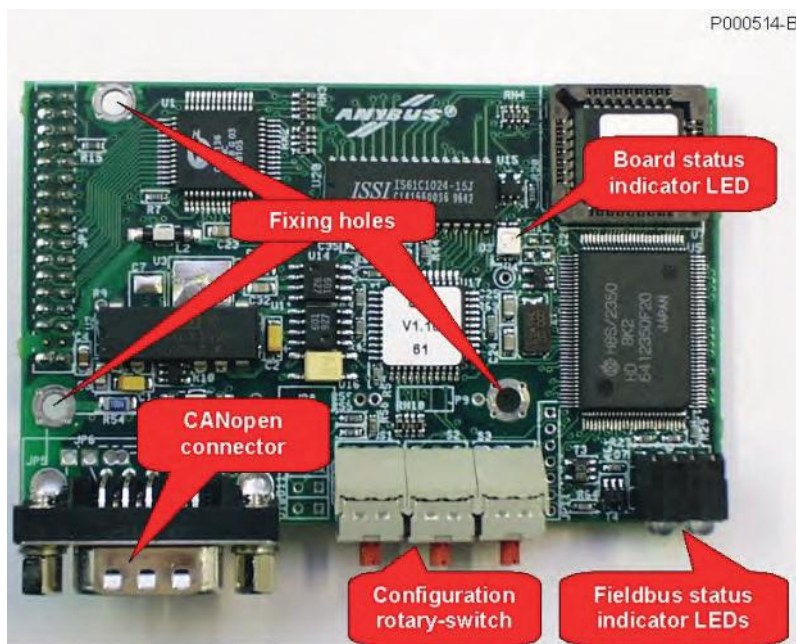

Figure 139: CANopen® fieldbus communications board

6.10.6.1. CANopen® Fieldbus Connector

The CANopen® communications board is provided with a 9-pin male “D” connector. The bus interface circuitry is internally supplied, as prescribed by the CANopen® specifications.

Pins are arranged as follows:

N.	Name	Description
Shell	CAN_SHLD	Cable shielding
1	-	
2	CAN_L	CAN_L line
3	CAN_GND	Common terminal of the CAN driver circuit
4	-	
5	CAN_SHLD	Cable shielding
6	GND	Option common terminal internally connected to pin 3
7	CAN_H	CAN_H line
8	-	
9	(reserved)	do not use



CAUTION

The CANopen connector is the same type as the connector fitted in all the inverters of the Sinus PENTA series for the Modbus serial communications, but the pin arrangement and the internal circuitry are totally different. Make sure that connectors are not mismatched! A wrong connection of the CANopen connector to the Modbus interface or vice versa can damage the inverter and the other devices connected to the Modbus and CANopen networks.

6.10.6.2. Board Configuration

The CANopen communications board shall be used with three rotary-switches for configuration, which are required to set up the inverter operating mode. The rotary-switches also allow setting the baud rate and the Device Address. The figure below shows the position of the rotary-switches and a setting example with a baud rate of 125kbits/s and a Device Address equal to 29.

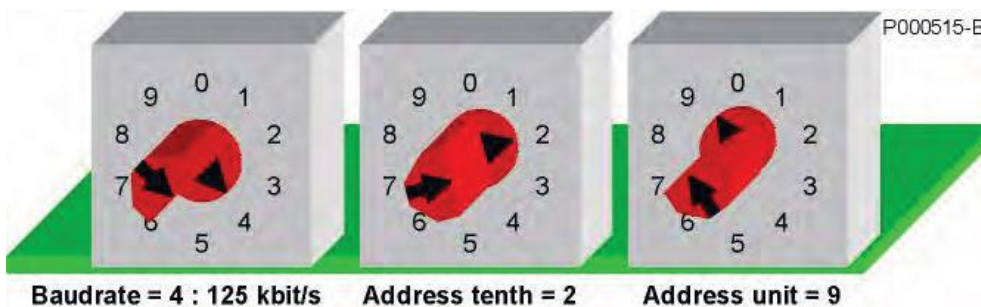

Figure 140: Example of the position of the rotary-switches for 125kbits/s and Device Address 29



NOTE

Device Address = 0 is not allowed by the CANopen specifications. Values ranging from 1 to 99 can be selected.

The table below shows the possible settings of the rotary-switches for the baud rate selection.

Rotary-switch setting	Baudrate
0	setting not allowed
1	10 kbits/s
2	20 kbits/s
3	50 kbits/s
4	125 kbits/s
5	250 kbits/s
6	500 kbits/s
7	800 kbits/s
8	1000 kbits/s
9	setting not allowed

6.10.6.3. Connection to the Fieldbus

High quality wiring is fundamental for the correct operation of the bus. For CANopen wiring, a shielded twisted pair with known resistance and impedance is recommended. The conductor unit is also fundamental for the quality of the signal. The higher the baud rates, the shortest the bus lengths allowed. The maximum length of the bus is also affected by the number of nodes. The tables below indicate the cable specifications based on the cable length and the variation features of the max. length based on the number of nodes and the cross-section of the conductors.

Tables refer to copper wires with a characteristic impedance of 120Ω and a typical propagation delay of 5ns/m .

Bus length [m]	Max. specific resistance of the cable [$\text{m}\Omega/\text{m}$]	Recommended cross-section for conductors [mm^2]	Recommended terminator resistance [Ω]	Max. baud rate [Kbit/s]
0÷40	70	0.25÷0.34	124	1000 kbits/s
40÷300	60	0.34÷0.6	150÷300	500 kbits/s (max. 100m)
300÷600	40	0.5÷0.75	150÷300	100 kbits/s (max. 500m)
600÷1000	26	0.75÷0.8	150÷300	50 kbits/s

The total resistance of the cable and number of nodes determine the max. allowable length for the cable as per static features, not for dynamic features. Indeed, the max. voltage delivered by a node with a dominant bus is reduced by the resistive divider consisting of the cable resistor and the terminator resistors. The residual voltage must exceed the dominant voltage of the receiving node. The table below indicates the max. length values based on the cable cross-section, i.e. the cable resistance, and the number of nodes.

Cross-section of the conductors [mm^2]	Max. wiring length [m] based on the number of nodes		
	number of nodes < 32	number of nodes < 64	number of nodes < 100
0,25	200	170	150
0,5	360	310	270
0,75	550	470	410



NOTE

Each CANopen trunk line shall meet particular geometric requirements and shall be equipped with two terminator nodes provided with adequate resistors. Refer to the document CiA DR-303-1 "CANopen Cabling and Connector Pin Assignment" and to all the application notes available from <http://www.can-cia.org>.

6.10.7. Ethernet Board

Ethernet communications board allows interfacing a Sinus PENTA inverter to an external control unit with a communications interface operating with a Modbus/TCP Ethernet (IEEE 802) protocol complying with the Modbus-IDA V1.0 specifications. The IP rating for the communications board can be configured both through the on-board DIP-switches and automatically (network assignation through a DHCP protocol).

The communications board performs automatic negotiation with the mains if the baud rate is set to 10 or 100 Mbits/s.

The module also supports IT (Information Technology) functionality with FTP, HTTP, SMTP standard protocols, allowing exchanging files through the internal storage, operating as Web Servers with dynamic pages and sending e-mail messages. These functions can be used by advanced users and are detailed in the Instruction Manual contained in the CD-ROM supplied with the communications board.

The main features of the interface board are the following:

- Parameter configuration for Ethernet connection through DIP-switches, DHCP/BOOTP, ARP or internal Web server
- Modbus/TCP slave functions of class 0, class 1 and partially class 2
- Possibility of supporting EtherNet/IP level 2 I/O Server CIP (ControlNet & DeviceNet)
- Transparent socket interface for potential implementation of “over TCP/IP” dedicated protocols
- Ethernet interface galvanically isolated through a transformer
- E-mail (SMTP) functionality
- Resident WEB pages that can be downloaded from an FTP server

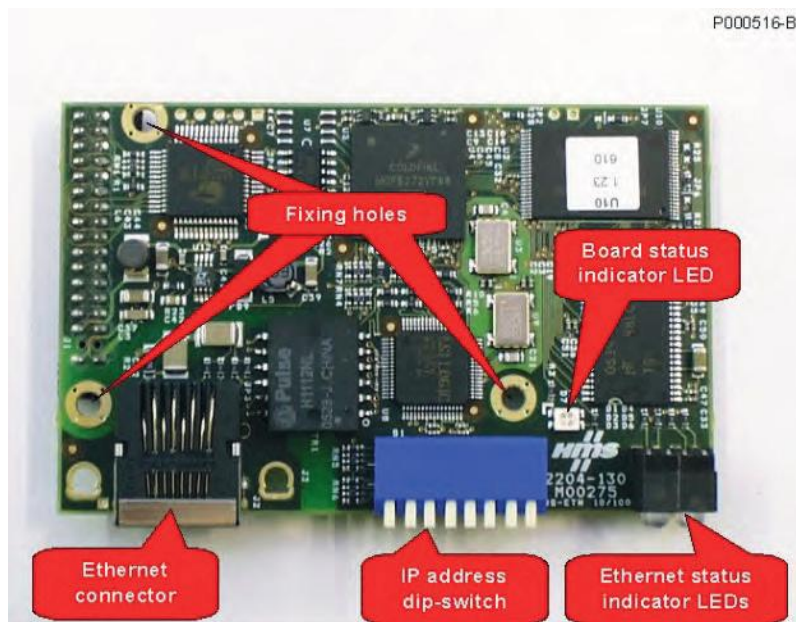

Figure 141: Ethernet Fieldbus Communications Board

6.10.7.1. Ethernet Connector

The board is provided with a standard RJ-45 connector (IEEE 802) for Ethernet connection 10/100 (100Base-T, 10Base-T). The pin arrangement is the same as the one used for each network board computers are equipped with.

Pin arrangement:

N.	Name	Description
1	TD+	Positive signal transmission line
2	TD-	Negative signal transmission line
3	RD+	Line receiving positive signals
4	Term	Terminated pair – not used
5	Term	Terminated pair – not used
6	RD-	Line receiving negative signals
7	Term	Terminated pair – not used
8	Term	Terminated pair – not used

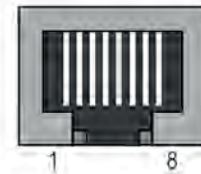

6.10.7.2. Connection to the Network

Ethernet interface board can be connected to an Ethernet control device with a Modbus/TCP master protocol (computer or PLC) through a LAN (Ethernet business network) or a direct point-to-point connection. The board connection through a LAN is similar to a computer connection. Use a standard cable for a Switch or Hub connection or a Straight-Through Cable TIA/EIA-568-B of class 5 UTP (Patch cable for LAN).



NOTE

The Ethernet interface board cannot be connected to old LANs using Thin Ethernet (10base2) coaxial cables. Connection to this type of LANs is possible using a Hub provided with both Thin Ethernet (10base2) connectors and 100Base-T or 10Base-T connectors. The LAN topology is a star one, with each node connected to the Hub or the Switch through its cable.

The figure below shows the pair arrangement in a 5 UTP cable and the standard colour arrangement to obtain the Straight-Through cable.

P000518-B

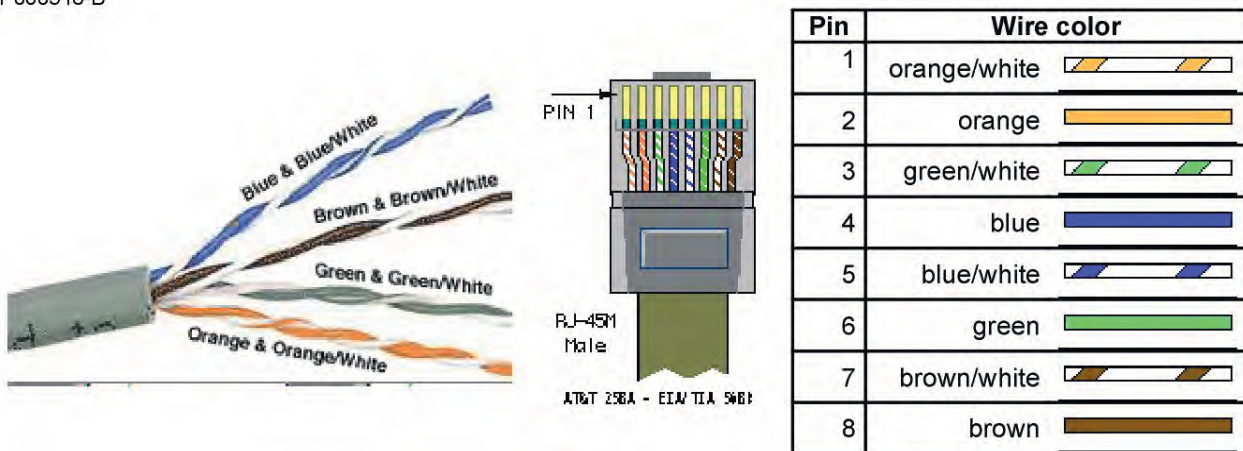

















Figure 142: Cable of Cat. 5 for Ethernet and standard colour arrangement in the connector

Direct point-to-point connection is obtained with a Cross-Over Cable TIA/EIA-568-B, cat. 5. This type of cable performs a cross-over of the pairs so that the TD+/TD- pair corresponds to the RD+/RD- pair, and vice versa.

The table below shows the colour matching on the connector pins for the Cross-Over Cable and the cross-over diagram of the two pairs used from 100Base-T or 10Base-T connection.

Pin and wire colour (first part of the connector)			Pin and wire colour (last part of the connector)		
1	white/orange		1	white/green	
2	orange		2	green	
3	white/green		3	white/orange	
4	blue		4	white/brown	
5	white/blue		5	brown	
6	green		6	orange	
7	white/brown		7	blue	
8	brown		8	white/blue	



NOTE

The inverter is typically installed with other electric/electronic devices inside a cubicle. Normally, the electromagnetic pollution inside the cubicle is remarkable and is due to both radiofrequency disturbance caused by the inverters and to bursts caused by the electromechanical devices. To avoid propagating disturbance to Ethernet cables, they must be segregated and kept as far as possible from the other power cables and signal cables in the cubicle.

Disturbance propagation to Ethernet cables may affect the correct operation of the inverter and the other devices (computers, PLCs, Switches, Routers) connected to the same LAN.



NOTE

The maximum length of the LAN cable, cat. 5 UTP allowed by IEEE 802 standards results from the max. transit time allowed from the protocol and is equal to 100m. The longer the cable length, the higher the risk of communications failure.



NOTE

For Ethernet wiring, only use cables certified for LAN cables of 5 UTP category or higher. For standard wiring, avoid creating your own cables; Straight-Through or Cross-Over cables should be purchased from an authorised dealer.



NOTE

For a proper configuration and utilisation of the communications board, the user should know the basics of the TCP/IP protocol and should get familiar with the MAC address, the IP address and the ARP (Address Resolution Protocol). The basic document on the Web is "RFC1180 – A TCP/IP Tutorial".

6.10.7.3. Board Configuration

The first step in configuring the Ethernet interface board consists in communicating with the board through a computer in order to update the configuration file (etccfg.cfg) stored to the non-volatile memory of the board. The configuration procedure is different if you use a point-to-point connection to the computer, if the board is connected to a LAN that is not provided with a DHCP server and if the board is connected to a LAN that is provided with a DHCP server. The section below covers these types of connection.



NOTE

For the connection to the LAN, consult your network administrator, who can tell if the LAN is provided with a DHCP server. If this is not the case, your network administrator will assign the static IP addresses for each inverter.

Point-to-point connection to the computer

If a point-to-point connection to the computer is used, first configure the network board of the computer by setting a static IP address as 192.168.0.nnn, where nnn is any number ranging from 1 to 254.

To set the static IP address with Windows 2000™ or Windows XP™, open the Network Properties folder; in the field for the properties of the TCP/IP protocol, set the address value, e.g. 192.168.0.1. Figure 143 shows the correct setting of the computer properties for Windows 2000™. Settings are very similar for computers running on Windows XP™.

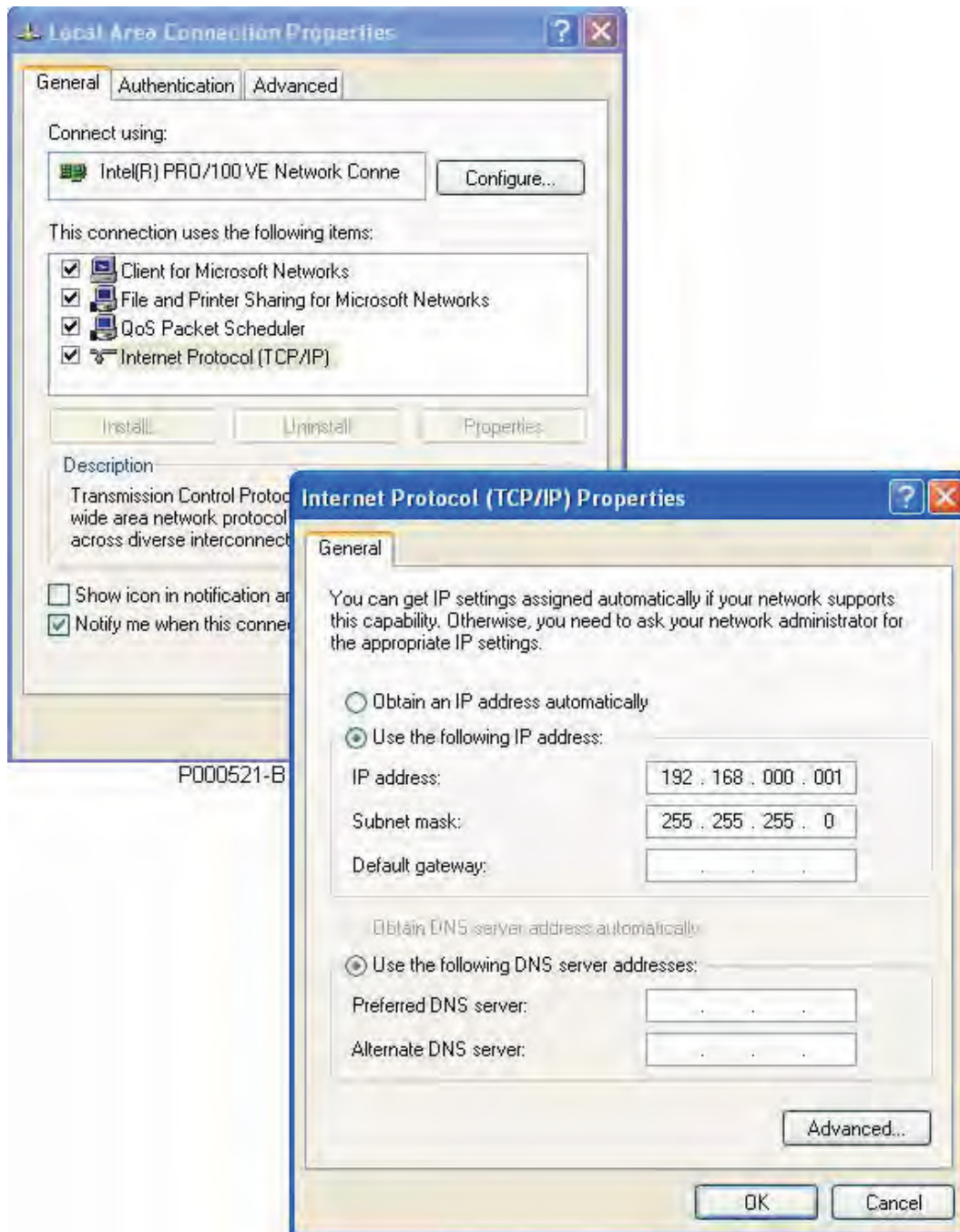

Figure 143: Setting a computer for a point-to-point connection to the inverter

After configuring your computer as described above, in the DIP-switches of the communications board set a binary number different from 0, different from 255 and different from the number set in the low portion of the IP address of the computer. For example, number 2 can be set by lowering (logic 1) only switch 7 as shown in the figure below.

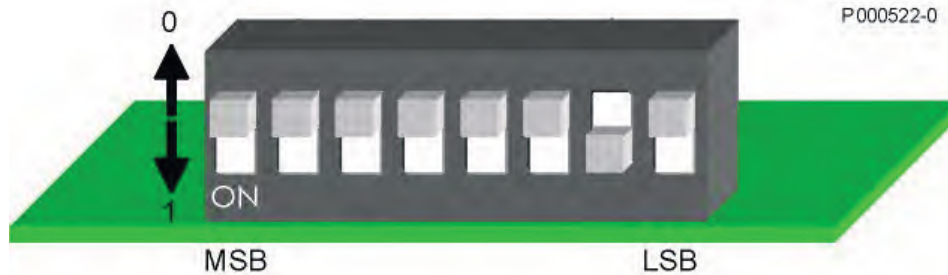

Figure 144: Setting the DIP-switches to set the IP address 192.168.0.2.

If the computer is connected to the inverter through a Cross-Over Cable, a local network is created, which is composed of two participant nodes (the computer and the inverter), with 192.168.0.1 and 192.168.0.2 as IP addresses respectively. When the inverter is powered on, the LINK LED (see below) in the interface board should turn on. The following command:

```
ping 192.168.0.2
```

launched by a command line window of the computer performs the correct connection to the board.

Connection with a computer through a LAN without any DHCP server

The network administrator will assign a static IP address for each inverter to be connected to the LAN.

Suppose that the IP address assigned from the administrator to an inverter is 10.0.254.177 and proceed as follows:

- Set all the DIP-switches in the Ethernet interface board to 0 ("up" position)
- Connect the board to the LAN using a Straight-Through cable and power on the inverter
- Make sure that the green light of the LINK LED (see below) comes on
- Note down the MAC address of the Ethernet board that is written on a label placed at the bottom of the printed circuit.

Suppose that the MAC address of the interface board is 00-30-11-02-2A-02

- In a computer connected to the same LAN (connected to the same sub-network, i.e. with an IP address equal to 10.0.254.xxx), open the command interpreter window and enter the following commands:

```
arp -s 10.0.254.177 00-30-11-02-2A-02
ping 10.0.254.177
arp -d 10.0.254.177
```

In the ARP table of the computer, the first command will create a static entry assigning the matching between the MAC address of the board and the static IP address.

The ping command queries the interface board to check the connection and returns the transit time of the data packet between the computer and the board through the network, as shown in Figure 145.

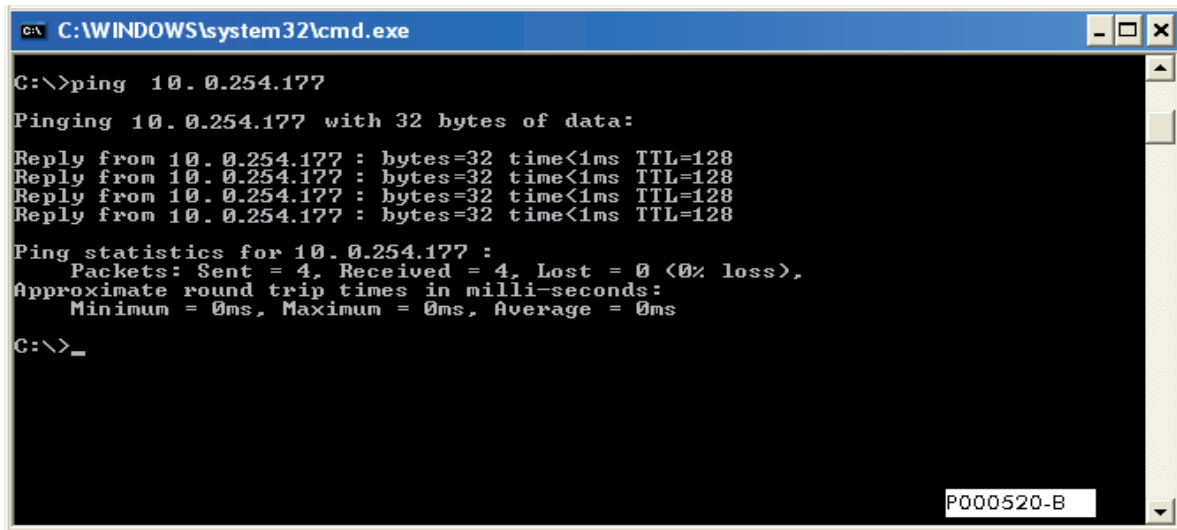

Figure 145: Example of the ping command to the IP address of the inverter interface board

When the interface board is sent the data packet, it gets the MAC address-IP address match as a permanent match, then it compiles and saves an “ethcfg.cfg” file, where the IP address 10.0.254.177 is stored as its own address each time the inverter is turned on.

Command number 3 is optional and removes the static match IP-MAC related to the inverter Ethernet board from the ARP table of the inverter.

Connection with a computer through a LAN equipped with a DHCP server

If an inverter equipped with an Ethernet board is connected to the LAN and if all the DIP-switches are set to zero (“up” position), when the inverter is powered on, automatic negotiation with the DHCP server takes place and the inverter is assigned an IP address chosen among the available ones. This configuration is then stored to the “ethcfg.cfg” file.

The “Anybus IP config” utility contained in the CD-ROM can be used to query all the inverters with an Ethernet interface in the LAN from the same computer and, if required, the network access parameters can be reconfigured. The figure below shows the page of the programme when an inverter is acknowledged. Multiple inverters can be identified from the same network through their own value of the MAC address.

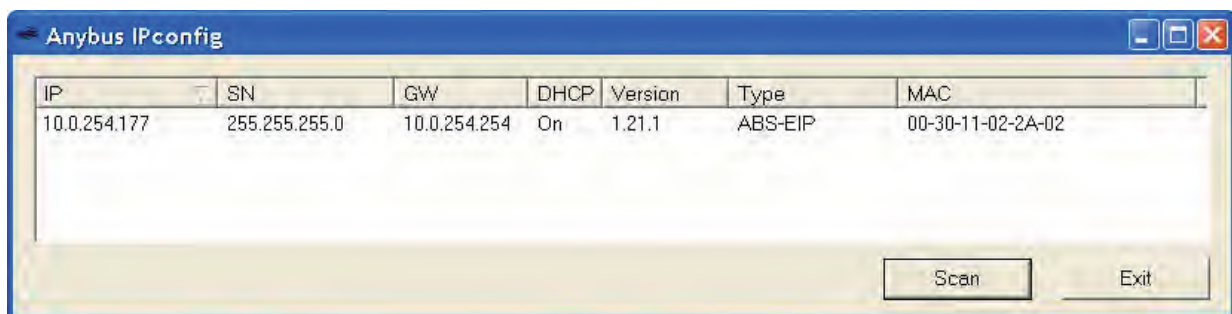
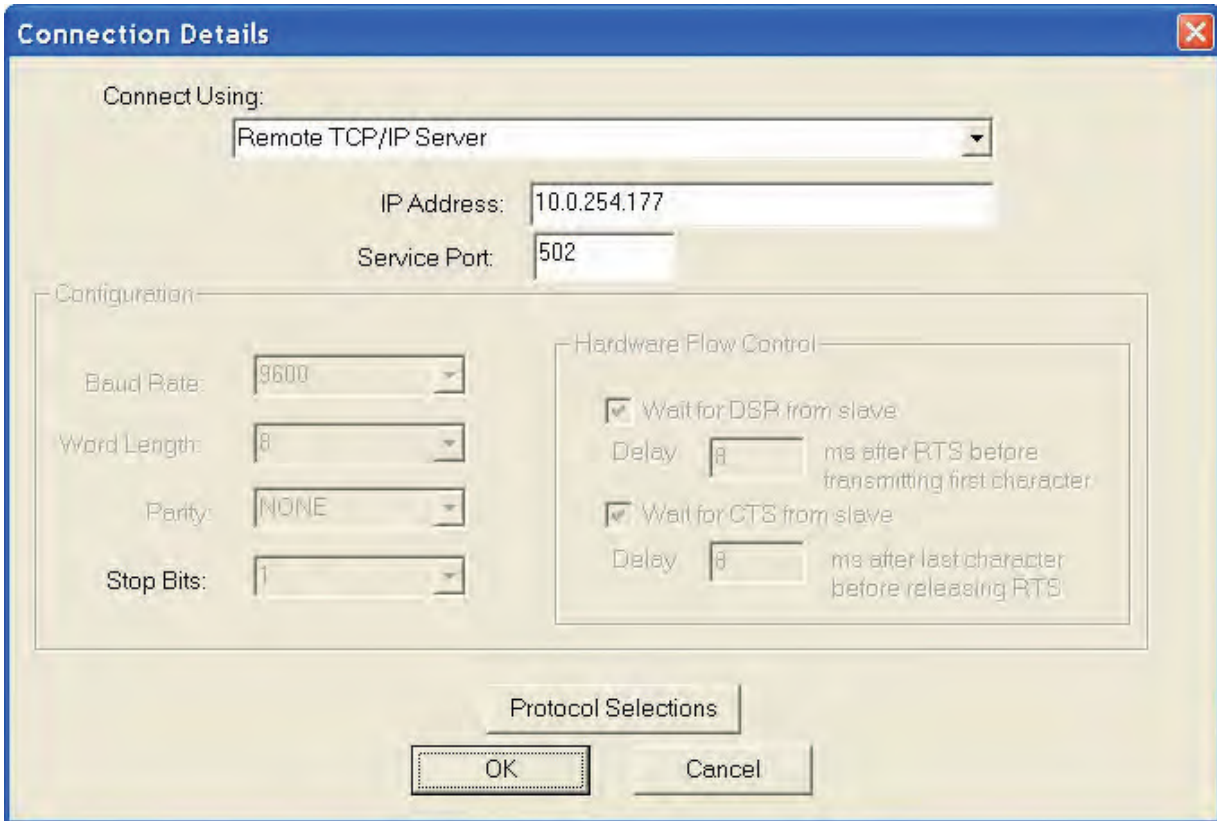

Figure 146: Anybus IP config utility

Query of the inverter data through the ModScan programme

Once configuration is achieved and the IP address of the interface board is available, you can query the inverter variables through the Modbus/TCP protocol. WinTECH’s ModScan application (<http://www.win-tech.com/>) allows displaying the variables read with the Modbus.

The figure below shows the setting shield of ModScan for the connection of a board with the IP address 10.0.254.177. For the Modbus/TCP connection, port 502 is provided by the Ethernet interface. Port 502 is to be used for all the Modbus transactions.



P000524-B

Figure 147: Setting ModScan for a Modbus/TCP connection

Figure 148 shows a ModScan shield related to the 10 output variables of the inverter. These variables are acquired in real time and are provided by the Modbus/TCP protocol. Refer to Sinus Penta's Programming Guide, Fieldbus Configuration menu, for any detail about the map and the meaning of the input/output variables.

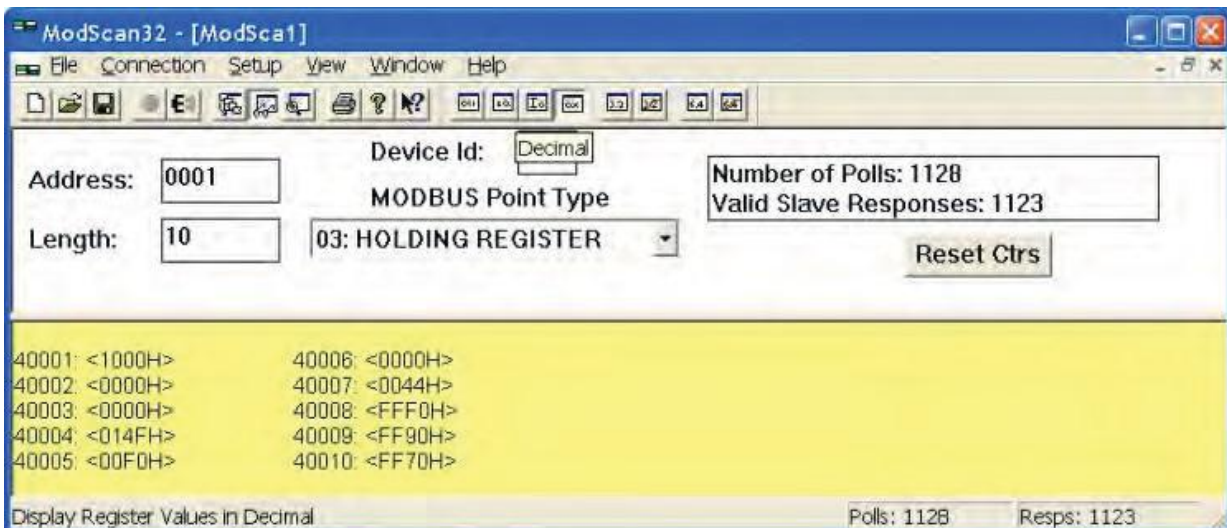

P000525-B

Figure 148: Display of the output variables of the inverter through the Modbus/TCP protocol



NOTE

Unlike the Modbus RTU connection through the serial link, the Modbus/TCP connection is characterised by an offset of 400h (1024) for write variables, because the Ethernet board dialogues with the inverter and splits a buffer shared for two segments of 1kbyte each. One segment is dedicated to the messages sent from the inverter to the Fieldbus, the other is dedicated to the messages sent from the Fieldbus to the inverter. In order to write the interface variable 001: **M042-Speed Reference** from FIELDBUS (whole part) (refer to Sinus Penta's Programming Guide), the Modbus/TCP transaction must be addressed to log 1025, not to log 1.



NOTE

The Ethernet board also offers advanced IT functionality. For example, you can send e-mail messages following particular events occurring in the inverter, or you can create a dynamic web page inside the inverter to display its operating conditions. For advanced functionality, refer to the relevant manual contained in the CD-ROM supplied with the optional board kit.

6.10.8. Status LEDs

Each option fieldbus board is equipped with a column provided with four LEDs installed on its front edge to monitor the bus status and with one LED (red/green) installed on the communications board for debugging, as shown in the figure below.

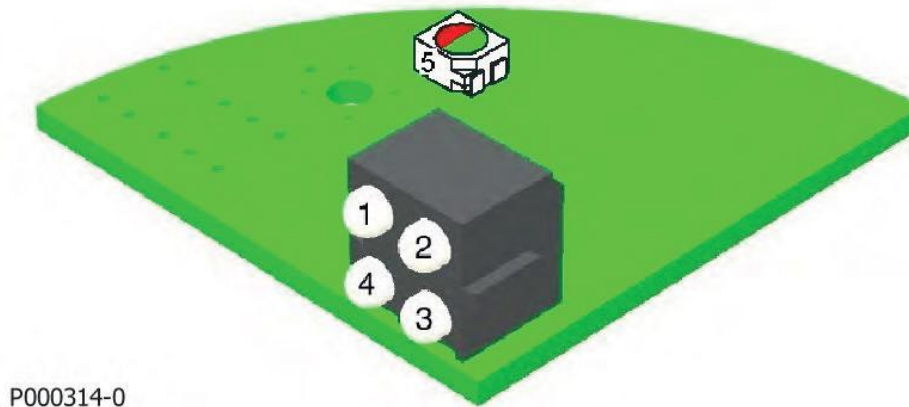

P000314-0

Figure 149: Position of indicator LEDs on the board

The red/green LED mounted on the board relates to all interface models, whereas the LEDs mounted on the board column have different meanings based on the type of fieldbus being used.

6.10.8.1. LEDs for Fieldbus Interface CPU Diagnostics

The LED located on the printed circuit of any version of the interface board indicates the status of the CPU dedicated to communication. The table below shows the possible type of signals.

N. & Name	Function
5. Board diagnostics	<p>Red – Unknown internal error, or module operating in bootloader mode</p> <p>1 Hz Red blinker – RAM fault</p> <p>2 Hz Red blinker – ASIC or FLASH fault</p> <p>4 Hz Red blinker – DPRAM fault</p> <p>2 Hz Green blinker – Module not initialized</p> <p>1 Hz Green blinker – Module initialized and operating.</p>

6.10.8.2. LEDs for PROFIBUS-DP[®] Board Diagnostics

In the PROFIBUS-DP board, LED 1 is inactive; the remaining LEDs are described below:

N. & Name	Function
2. On-Line	It indicates that the inverter is on-line on the fieldbus: Green – The module is on-line; data exchange is allowed. Off – The module is not on-line.
3. Off-Line	It indicates that the inverter is off-line on the fieldbus: Red – The module is off-line; data exchange is not allowed. Off – The module is not off-line.
4. Fieldbus Diagnostics	It indicates some possible errors: 1 Hz Red blinker – Configuration error: the length of IN messages and OUT messages set while initializing the module does not match with the message length set while initializing the network. 2 Hz Red blinker – User Parameter error: the data length and/or contents for the User Parameters set while initializing the module does not match with the data length and/or contents set while initializing the network. 4 Hz Flash blinker – Error while initializing the Fieldbus communications ASIC. Off – No error found.

6.10.8.3. LEDs for DeviceNet[®] Board Diagnostics

In the DeviceNet[®] board, LEDs 1 and 4 are not used; the remaining LEDs are described below:

N. & Name	Function
2. Network status	It indicates the status of the DeviceNet communications: Off – The module is not On-Line Green – DeviceNet communications in progress and correct Flashing green – The module is ready for communication but is not connected to the network Red – A critical error occurred (too erroneous data items) and the module switched to the “link failure” status Flashing red – A timeout occurred when exchanging data
3. Module status	It indicates the status of the communication module: Off – The module is off Green – The module is operating Flashing green – The length of the two data packets exceeds the preset value Red – An unresettable event error occurred Flashing red – A resettable event error occurred

6.10.8.4. LEDs for CANopen® Board Diagnostics

In the CANopen board, LED 1 is not used; the remaining LEDs are described below:

N. & Name	Function
2. Run	It indicates the status of the CANopen interface of the module: Off – The interface is off One flash – The interface status is STOP Flashing – The interface is being initialized On – The interface is operating
3. Error	It indicates the error status of the CANopen interface: Off – No error One flash – The frame error counter has reached the warning limit Two flashes – A Control Error event (guard event or heartbeat event) occurred Three flashes – A synchronisation error event occurred: the SYNC message was not received within the time-out On – The bus is disabled due to an unresettable event error
4. Power	Off – The module is off On – The module is on

The word “Flashing” in the table indicates a LED that comes on for 200ms every 200ms; “One flash”, “Two flashes” and “Three flashes” indicate a LED that comes on one, twice or three times for 200ms every 200ms and with an inactivity time of 1000ms.

6.10.8.5. LEDs for Ethernet Board Diagnostics

In the Ethernet board, the diagnostics LEDs indicate the status of the connection to the LAN:

N. & Name	Function
1. Link	Off – The module has not detected any legal carrier signal and is not in the LINK status On – The module has detected a legal carrier signal and is in the LINK status
2. Module status	Off – The module is off Green – The module is properly operating Flashing green – The module was not configured and communication is in stand-by Flashing red – the module has detected a resettable event error Red – the module has detected an unresettable event error Flashing red/green – the module is performing a self-test at power on
3. Network status	Off – The IP address has not yet been assigned Green – At least one active Ethernet/IP connection is in progress Flashing green – No active Ethernet/IP connection is in progress Flashing red – “Timeout” of one or more links performed directly to the module Red – The module has detected that its IP is used by another device in the LAN Flashing red/green – The module is performing a self-test at power on
4. Activity	Flashing green – A data packet is being transmitted or received

6.10.9. Environmental Requirements Common to All Boards

Operating temperature	–10 to +55°C ambient temperature (contact Elettronica Santerno for higher ambient temperatures)
Relative humidity	5 to 95% (non-condensing)
Max. operating altitude	2000 m a.s.l. For installation above 2000 m and up to 4000 m, please contact Elettronica Santerno.

6.11. ES919 Communications Board (Slot B)

ES919 communications board makes other communications protocol available in addition to the protocols described in Optional Boards For Fieldbus (Slot B). These communications boards allow Metasys N2- and BACnet-based systems.



P000973-0

- Metasys® N2,
- BACnet®.



CAUTION

When ES919 board is fitted into slot B, no other board (ES847, ES861, ES870, ES950) can be fitted into slot C.



CAUTION

ES919 board behaves as a serial gateway and makes all the Mxxx measures and the Ixxx inputs available to the addresses given in the Sinus Penta's Programming Guide.



CAUTION

The "Fieldbus" section in the Sinus Penta's Programming Guide does not apply to ES919 comms board.

6.11.1. Identification Data

<i>Description</i>	<i>Part Number</i>
BACnet/RS485 Sinus Penta Module	ZZ0102402
BACnet/Ethernet Sinus Penta Module	ZZ0102404
Metasys N2 Sinus Penta Module	ZZ0102406

6.11.2. Environmental Requirements Common to All Boards

Operating temperature	-10 to +55°C ambient temperature (contact Elettronica Santerno for higher ambient temperatures)
Relative humidity	5 to 95% (non-condensing)
Max. operating altitude	2000 m a.s.l. For installation above 2000 m and up to 4000 m, please contact Elettronica Santerno.

6.11.3. Electrical Features Common to All Boards



CAUTION

ES919 is enabled through switch SW1 (factory setting). If enabled (LED L1 ON), the RS485 serial port located on the inverter (serial link 0 – CN9 in the control board) is automatically disabled.

The operation of ES919 control board is as follows:

SW1	OFF	L3(EN)	OFF
		L1(TX)	OFF
		L2(RX)	OFF
	ON (default)	L3(EN)	ON
		L1(TX)	FLASHING (IF COMMUNICATION IS OK)
		L2(RX)	FLASHING (IF COMMUNICATION IS OK)

6.11.4. Installing ES919 Board on the Inverter (Slot B)



DANGER

Before gaining access to the components inside the inverter, remove voltage from the inverter and wait at least 20 minutes. Wait for a complete discharge of the internal capacitors to avoid any electric shock hazard.



CAUTION

Electric shock hazard: do not connect/disconnect the signal terminals or the power terminals when the inverter is on. This also prevents the inverter from being damaged.



NOTE

All the screws used to fasten removable parts (terminals cover, serial interface connector, cable plates, etc.) are black, round-head, cross-head screws. When wiring the inverter, remove only this type of screws. If different screws or bolts are removed, the inverter warranty will be no longer valid.



NOTE

If ES919 board is configured as BACnet Ethernet, one of the three fixing screws is located beneath the Ethernet module.

1. Remove voltage from the inverter and wait at least 20 minutes.
2. Remove the inverter cover for accessing the control terminals. The fixing spacers and the signal connector are located on the right.

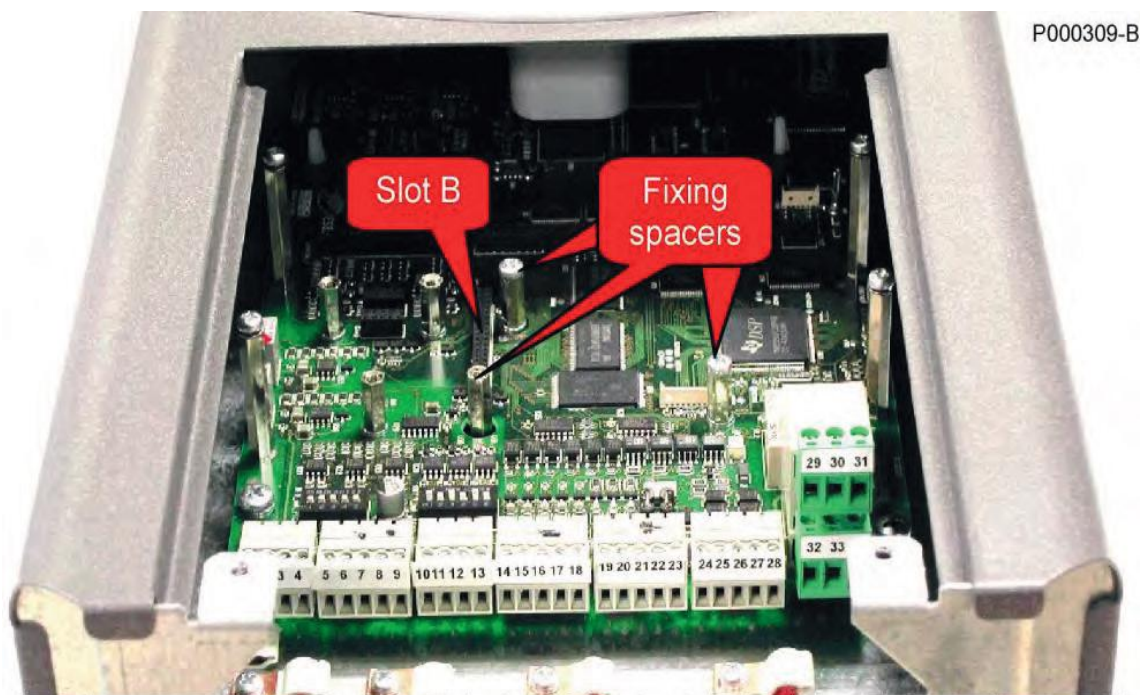

Figure 150: Position of the slot for ES919 board

3. Fit ES919 board and make sure that all contacts enter the relevant housing in the signal connector. Fasten the encoder board to the fixing spacers using the screws supplied.
4. Enable the communication port with switch SW1.
5. Close the inverter frame by reassembling the cover allowing gaining access to the inverter control terminals.

6.11.5. ES919 Board for Metasys® N2

ES919 board for Metasys® N2 uses RS485 serial port to communicate with the system via the communication protocol “Metasys N2” by Johnson Controls (<http://www.johnsoncontrols.com>). Metasys is a registered trademark of Johnson Controls Inc. Please visit www.johnsoncontrols.com.

ES919 board includes the ProtoCessor ASP-485 module.

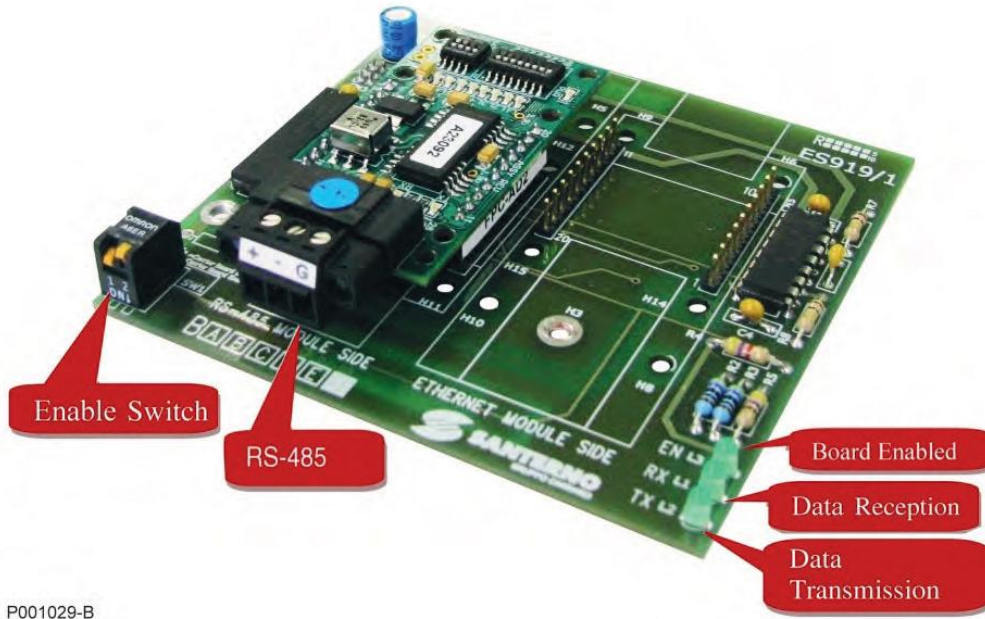

P001029-B

Figure 151: ES919 Board for Metasys® N2

6.11.5.1. Configuration

	Fieldbus Port	Inverter Port
Protocol	MetasysN2	MODBUS RTU
Default Baud	9600 8N1	38400 8N2
Default Station ID	11	1

6.11.5.2. RS485 Connector

The communications port includes a positive pole (+), a negative pole (-) and the ground (G).

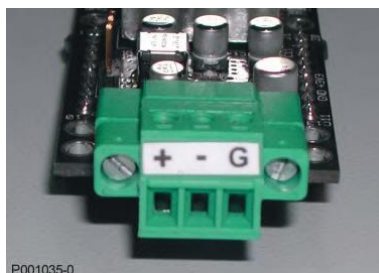

P001035-0

6.11.5.3. LEDs on the ASP485 ProtoCessor Module

BLUE		ORANGE		YELLOW		RED	
[L8]	[L7]	[L6]	[L5]	[L4]	[L3]	[L2]	[L1]
COMMS		RUN		NO DEFAULT		ERROR	

LED	COLOUR	DESCRIPTION
L8	BLUE	ON: Field Port packet received OFF: Field Port response sent
L7	BLUE	ON: Inverter Port Send Poll OFF: Inverter Port Receive Valid Response
L6	ORANGE	ON (flashing 2Hz): ProtoCessor is running normally OFF: ProtoCessor is not running
L5	ORANGE	Not Used
L4	YELLOW	ON: MODBUS Slave address set by DIP-switch OFF: MODBUS Default Address at factory default = 11
L3	YELLOW	ON: Baud Rate set by DIP-switch OFF: Baud Rate at factory default = 9600
L2	RED	ON: Bad Poll, No Map Descriptor found OFF: Once Exception response has been sent [*]
L1	RED	ON: Panic OFF: No Panic has occurred

[*] If you receive a poll for data that does not exist, you turn that LED on briefly. Basically, the system received a valid poll, but could not find a corresponding data point.

6.11.5.4. Baud Rate DIP-switches

B1	
0	Use factory default Baud Rate = 9600 (L3 = OFF)
1	Use Baud from Switches as per table below (L3 = ON)

B2	B3	B4	Baud Rate
0	0	0	1200
1	0	0	2400
0	1	0	4800
1	1	0	9600
0	0	1	19200
1	0	1	38400
0	1	1	57600
1	1	1	115200

6.11.5.5. Address DIP-Switches

A1-A8	
	Corresponds to the Metasys N2 Address L4 will indicate that the DIP-switch address is being used

6.11.6. ES919 Board for BACnet/Ethernet

The Module BACnet/Ethernet board uses the Ethernet port to communicate with the system using the BACnet communications protocol.

BACnet - A Data Communication Protocol for Building Automation and Control Networks. Developed under the auspices of the American Society of Heating, Refrigerating and Air-Conditioning Engineers (ASHRAE), BACnet is an American national standard, a European standard, a national standard in more than 30 Countries, and an ISO global standard (**ISO 16484-5**). The protocol is supported and maintained by ASHRAE Standing Standard Project Committee 135 (SSPC 135).

Please see <http://www.bacnet.org>.

This board is composed of the ProtoCessor FFP-485 communications module.

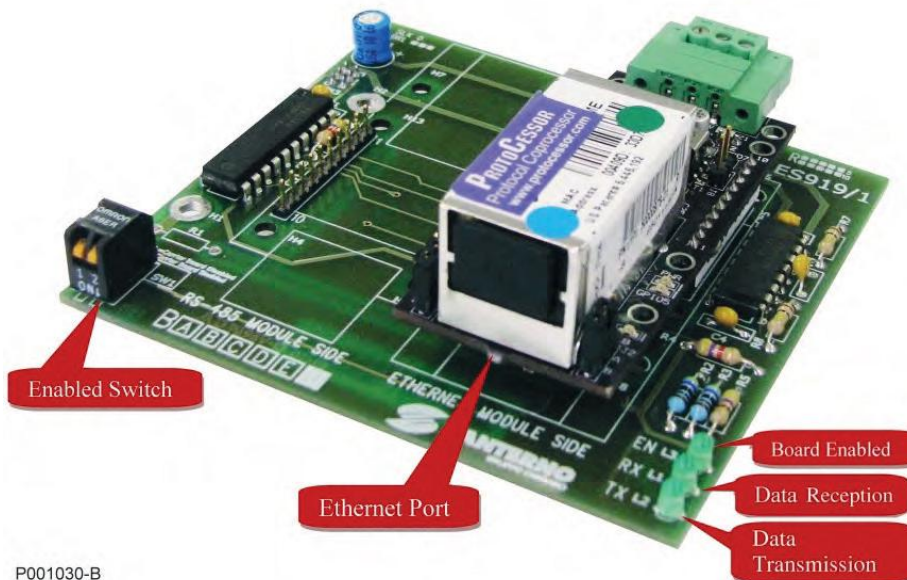

Figure 152: ES919 Board for BACnet/Ethernet

6.11.6.1. Ethernet Connector

The standard RJ45 connector (IEEE 802) located on the module can be used only for an Ethernet 10/100 (100Base-T, 10Base-T) connection. Pins are located as in any computer card.

Pins are as follows:

N.	Name	Description
1	TD+	Positive signal transmission line
2	TD-	Negative signal transmission line
3	RD+	Positive signal reception line
4	Term	Terminated pair - not used
5	Term	Terminated pair - not used
6	RD-	Negative signal reception line
7	Term	Terminated pair - not used
8	Term	Terminated pair - not used

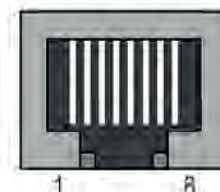

P899517-0

6.11.6.2. LEDs on the FFP485 ProtoCessor Module

LED	COLOUR	DESCRIPTION
PWR	YELLOW	ON: Module powered OFF: Module not powered
LA	RED	ON (flashing 1Hz): Normal operation OFF: PANIC
LB	RED	ON (flashing 1Hz): Normal operation OFF: PANIC
GP105	RED	ON (goes solid after 45-60s): Normal operation OFF: during the first 45-60s
Rx	YELLOW	Flashing when a message is received on the field port
Tx	YELLOW	Flashing when a message is sent on the field port

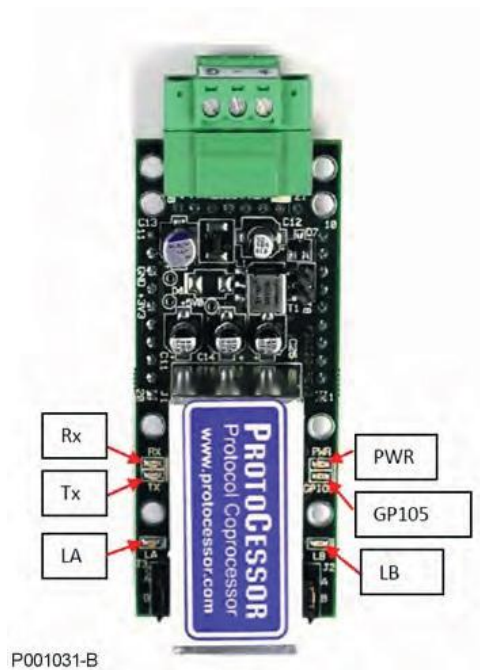

Figure 153: BACnet LEDs

6.11.6.3. Troubleshooting Tips

If **PWR** LED does not come on and LA and LB do not flash, please contact ELETTRONICA SANTERNO's Customer Service.

If **PWR** LED does not come on but the LA and LB flash, then the **PWR** LED is faulty.

If **LA** and **LB** do not start flashing, this may indicate a problem with the ProtoCessor. Contact ELETTRONICA SANTERNO's Customer Service.

If **GP105** never comes on, please contact ELETTRONICA SANTERNO's Customer Service.

If **TX** and or **RX** do not flash, this may indicate a problem with the field wiring; the configuration in the ProtoCessor on the field side; incorrect polling parameters (such as COMM properties like baud, parity, etc).

6.11.6.4. Board Configuration

The BACnet fieldbus communication kit contains the BACnet configuration software. This software allows the user to set parameters for a specific BACnet installation. After installation, run the “Sinus Penta BACnet configurator.exe” file, which will load the BACnet configuration software.



Figure 154: BACnet IP Configuration

To configure and download the settings follow the steps below:

1. Set up a connection on IP address 192.168.1.X from the host PC (Default IP address of the BACnet fieldbus card is 192.168.1.24). DISABLE ANY OTHER NETWORK CARD, ANY FIREWALL OR ANITIVIRUS programs.
2. Connect the host PC to the BACnet device using an Ethernet crossover cable or straight-through cable if connecting from a Hub/Switch.
3. Ping the BACnet device using the “Ping BACnet gateway” button within the BACnet configurator software to ensure communication has been achieved. A command window will appear, containing the IP address of any BACnet fieldbus devices that the host PC can detect.
4. Select your choice of BACnet IP within the BACnet configuration software.
5. Enter a desired IP address, Subnet mask and BACnet port, and select DHCP if required.
6. Enter the BACnet device instance and the Network Number.
7. Click on “Create Files”.
8. Click on “Download config file” to configure the BACnet fieldbus network card.
9. Click on “Download IP data file” to configure the BACnet fieldbus network card.
10. Click on “Restart BACnet Device” after the download has completed.

6.11.7. ES919 Board for BACnet/RS485

The BACnet/RS485 Module card uses RS485 serial port to communicate with the system via the BACnet MSTP communications protocol.

The card is composed of the ProtoCessor FFP-485 module (see 6.11.6.2 LEDs on the FFP485 ProtoCessor Module and 6.11.6.3 Troubleshooting Tips) and of support/interface board ES919.

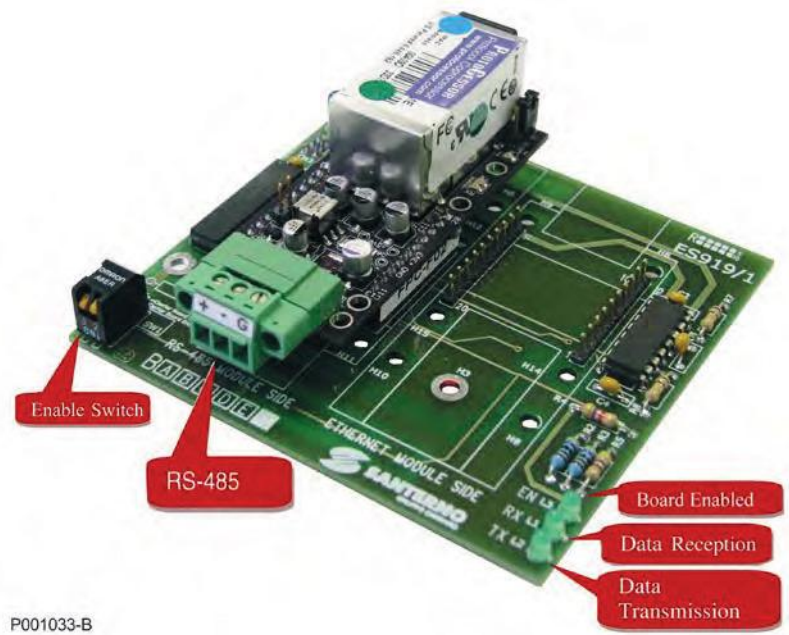

Figure 155: ES919 Board for BACnet/RS485



CAUTION

Although communication is made through RS485 serial port, the board shall be configured through the Ethernet port, as explained in the Board Configuration section.

6.11.7.1. RS485 Connector

The communications port includes the positive pole, the negative pole and the ground.

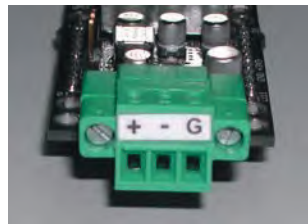

6.11.7.2. Board Configuration

The BACnet fieldbus communication kit contains BACnet configuration software. This software allows the user to set parameters for a specific BACnet installation

After installation, run the “Sinus Penta BACnet configurator.exe” file which will load the BACnet configuration software.

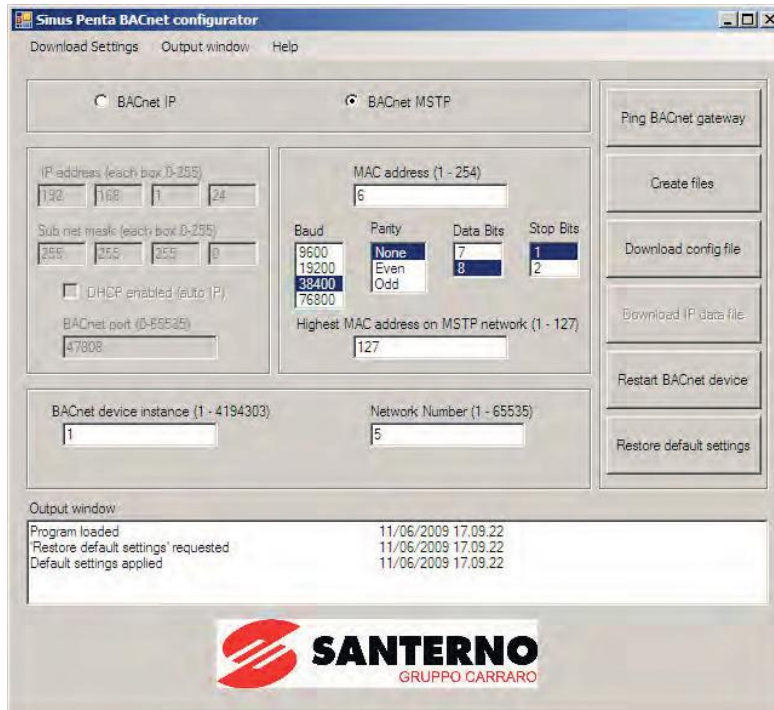

Figure 156: BACnet MSTP Configuration

To configure and download the settings follow the steps below:

1. Mount the BACnet device in the way shown in Figure 152.
2. In order to configure a BACnet MSTP network, you need to configure each module through Ethernet interface.
3. Set up a connection on IP address 192.168.1.X from the host PC (the default IP address of the BACnet fieldbus card is 192.168.1.24). DISABLE ANY OTHER NETWORK CARD, ANY FIREWALL OR ANITIVIRUS program.
4. Connect the host PC to the BACnet device using an Ethernet crossover cable or straight through cable if connecting from a Hub/Switch.
5. Ping the BACnet device using the “Ping BACnet gateway” button within the BACnet configurator software to ensure communication has been achieved. A command window will appear, containing the IP address of any BACnet fieldbus devices that the host PC can detect.
6. Select your choice of BACnet MSTP within the BACnet configuration software.
7. Enter the MAC address, baud rate, parity, # stop bits, # data bits and highest MAC address on the network.
8. Enter the BACnet device instance and the Network Number.
9. Click on “Create Files”.
10. Click on “Download config file” to configure the BACnet fieldbus network card.
11. Click on “Restart BACnet Device” after the download has completed.
12. Mount the BACnet device in the way shown in Figure 155.
13. Connect the device to the BACnet MSTP network and test if the device can be achieved.

6.12. ES851 Datalogger Board (Slot B)

ES851 DataLogger is an optional board allowing acquiring the operating variables of a plant and interfacing to a supervisor computer, even a remote computer, through different connecting modes for data logging and monitoring of the devices connected to the plant.

The main features of the DataLogger are the following:

- 8-Mb Data Flash, allowing setting how many variables and which variables are acquired, as well as their acquisition time, for optimum performance of the available memory;
- RS485 and RS232 interface with Modbus-RTU protocol;
- Ethernet interface with TCP/IP protocol;
- Interface for the connection via GSM modem and analog modem;
- SMS functionality for events monitored by the DataLogger (available only when a GSM modem is used).



Figure 157: ES851 DataLogger Board

Each DataLogger is capable of monitoring up to 15 devices through RS485 or RS232 network with Modbus protocol. ES851 is the master and the connected devices are the slaves.

A remote computer can be connected to the plant via RS485 or RS232 serial links, via modem or via Ethernet. The RemoteDrive software allows performing any operation both on the plant devices and on ES851 (scanning the devices connected to the DataLogger and activating data acquisition except for the devices excluded from logging—see the Programming Instructions of ES851 DataLogger for more details). The connection modes and specifications are detailed in the following sections.

6.12.1. Identification Data

Description	Part Number
ES851 FULL DATALOGGER	ZZ0101820

6.12.2. Installing ES851 Board on the Inverter (Slot B)



DANGER

Before gaining access to the components inside the inverter, remove voltage from the inverter and wait at least 20 minutes. Wait for a complete discharge of the internal capacitors to avoid any electric shock hazard.



CAUTION

Electric shock hazard: do not connect/disconnect the signal terminals or the power terminals when the inverter is on. This also prevents the inverter from being damaged.



NOTE

All the screws used to fasten removable parts (terminals cover, serial interface connector, cable plates, etc.) are black, round-head, cross-head screws. When wiring the inverter, remove only this type of screws. If different screws or bolts are removed, the inverter warranty will be no longer valid.

1. Remove voltage from the inverter and wait at least 20 minutes.
2. Remove the cover allowing gaining access to the inverter control terminals. The fixing spacers and the signal connector are located on the right.

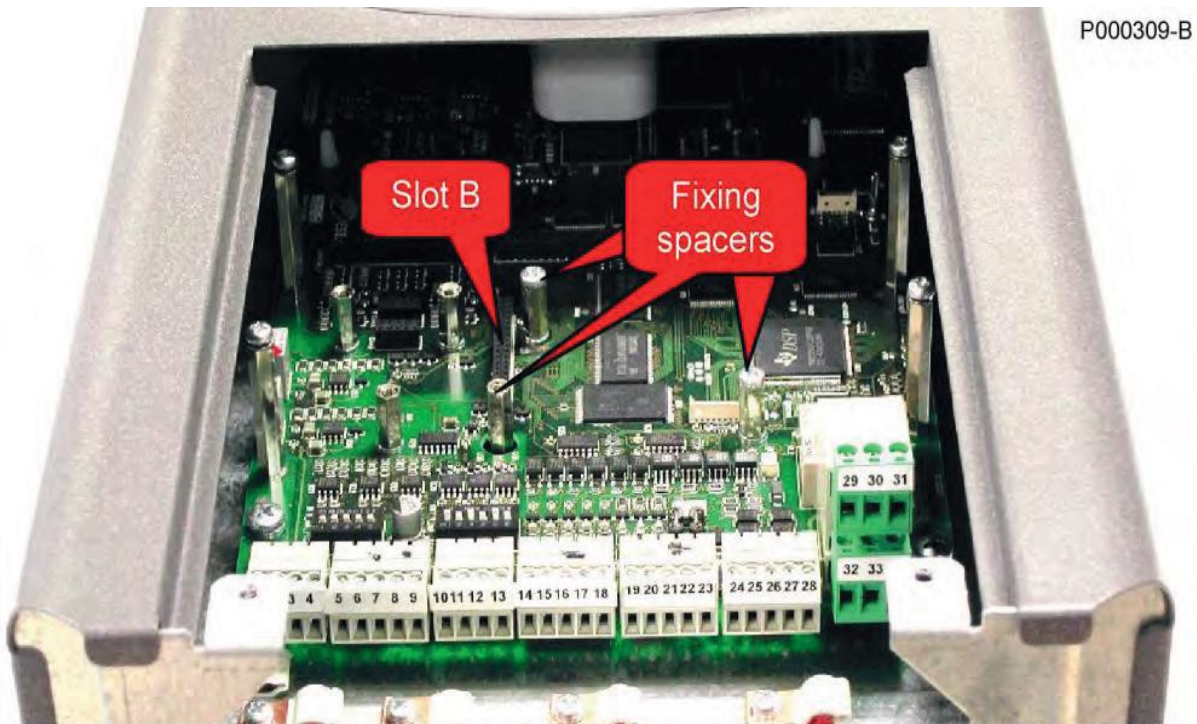

Figure 158: Position of the slot for the installation of ES851 DataLogger board

3. Fit ES851 board and make sure that all contacts enter the relevant housing in the signal connector. Fasten the board to the fixing spacers using the screws supplied.



Figure 159: ES851 DataLogger fitted into slot B

4. Connect the communications cables to the relevant ports based on the type of communications to be established. Set DIP-switches accordingly (see sections below).
5. Close the inverter frame by reassembling the cover allowing gaining access to the inverter control terminals.

6.12.3. Connectivity



CAUTION

Remove voltage from the inverter before wiring ES851 DataLogger board. Take any safety measure required before touching the connectors and handling the DataLogger board.

ES851 is provided with the following serial communications ports:

Port	Description	Terminal Board	Link
COM1 RS232	Modem/PC connection	ES851 – CN3	DB9 – Male
COM1 RS485	Slave supervisor connection	ES851 - CN11	DB9 – Male
COM2 RS485	Master Supervisor connection	ES851 - CN8	DB9 - Female
	Ethernet connection	ES851 - CN2	RJ45



NOTE

CN3 - RS232 connection replaces CN11 - RS485 connection. Factory setting is CN3 - RS232.



NOTE

The Master or Slave operating mode of the COM ports can be changed by setting some configuration parameters of ES851 board accordingly (please refer to the DATA LOGGER ES851 - Programming Instructions for further details). The preset configurations are given in the table above.



NOTE

A modem connection can replace the Ethernet connection. The ES851 DataLogger board does NOT support the modem connection and the Ethernet connection.

6.12.3.1. Wiring RS232 Serial Links

RS232 serial link is factory set for COM1 port.

RS232 links are needed for some communication options required by ES851 DataLogger:

- Direct connection to a computer with a null modem cable (MODBUS RTU protocol in slave mode);
- Connection via analog/digital modem to a remote computer;

For null modem connections, the DB9 connector is connected to the computer through a null modem RS232 cable (cross-over cable).

For connections via analog modem, the DB9 connector is connected through an RS232 cable not crossed-over.

RS232 Serial communication ratings:

Baud rate:	Configurable between 1200..115200 bps (default value: 38400 bps)
Data format:	8-bit
Start bit:	1
Parity: (1)	NO, EVEN, ODD (default: NO)
Stop bits:	2,1 (default: 2)
Protocol:	MODBUS RTU
Supported functions:	03h (Read Holding Registers) 10h (Preset Multiple Registers)
Device address:	Configurable between 1 and 247 (default value: 1)
Electric standard:	RS232
Waiting time between packets:	Configurable between 0 and 50 ms (default value: 20 ms)
Timeout:	Configurable between 0 and 1000 ms (default value: 500 ms)

- 1) Ignored when receiving communication messages.

6.12.3.2. Wiring RS485 Serial Link

RS485 links are needed for certain communication options required by ES851 DataLogger:

- Direct connection to a computer with a properly wired cable and an RS485/USB or RS485/RS232 converter (MODBUS RTU protocol in slave mode or PPP protocol);
- Direct connection to the multidrop network of the plant devices (MODBUS RTU in master mode).

The MODBUS-IDA (<http://www.modbus.org>) Association defines the type of connection for MODBUS communications over serial link RS485, which is used by the Sinus Penta, as a “2-wire cable”. Specifications are the following:

Type of cable	Shielded cable composed of a balanced pair named D1/D0 + common conductor (“Common”).
Recommended cable model	Belden 3106 (distributed from Cavitec)
Maximum length	500 meters based on the max. distance measured between two stations.
Characteristic impedance	Greater than 100Ω (recommended), typically 120Ω.
Standard colours	Yellow/brown for the D1/D0 pair, grey for the “Common” signal.

The typical wiring diagram recommended by the MODBUS-IDA Association for the connection of “2-wire” devices is shown in Figure 160.

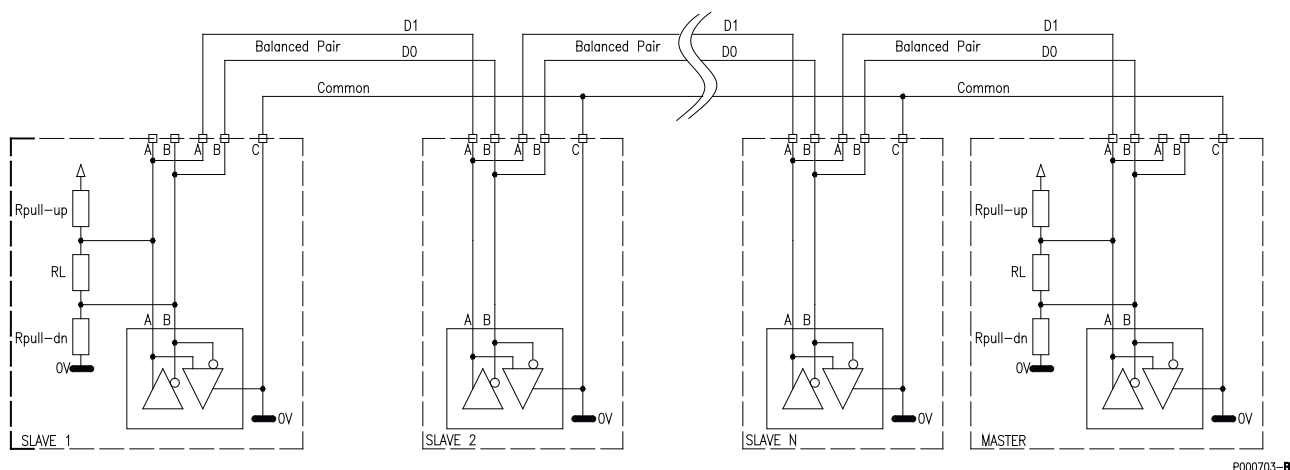

Figure 160: Recommended wiring diagram for the connection of 2-wire MODBUS devices

The network composed of the termination resistor and the polarization resistors is incorporated into the inverter and can be activated via DIP-switches. The figure above shows the termination network for the devices located at both ends of the network, where the terminator must be installed.

For multidrop connections, 1 to 128 devices may be connected. Make sure that the ID of each device is properly configured (please refer to the DATA LOGGER ES851 - Programming Instructions).



NOTE

All the devices connected to the communication multidrop network should be grounded to the same conductor (0V) to minimize any difference of ground potentials between devices that can adversely affect communications.

Provide a linear wiring (not a star wiring) for multidrop line RS485: the first device in the multidrop connection will have only one outgoing line, while the last device will have only one incoming line. The line terminator is to be installed on the first device and the last device.

The line master device (ES851) is typically placed at the beginning or at the end of a multidrop connection; in that case, the line terminator of the farthest inverter from the master computer shall be "ON".



NOTE

Communication does not take place or is adversely affected if multidrop terminators are not properly set up, especially in case of high baud rate. If more than two terminators are fitted, some drivers can enter the protection mode due to thermal overload, thus stopping dialoguing with some of the connected devices.

RS485 Serial communication ratings:

Baud rate:	Configurable between 1200..115200 bps (default value: 38400 bps)
Data format:	8-bit
Start bit:	1
Parity: (1)	NO, EVEN, ODD (default: NO)
Stop bits:	2,1 (default: 2)
Protocol:	MODBUS RTU
Supported functions:	03h (Read Holding Registers) 10h (Preset Multiple Registers)
Device address:	Configurable between 1 and 247 (default value: 1)
Electric standard:	RS232
Waiting time between packets:	Configurable between 0 and 50 ms (default value: 20 ms)
Timeout:	Configurable between 0 and 1000 ms (default value: 500 ms)

- 1) Ignored when receiving communication messages.

6.12.3.3. COM1 Configuration and Wiring

DB9 flying connector (COM1) brings CN3/CN11 connector of ES851/1 board outside the inverter; this should be fastened to a bracket mounted on the right side of the inverter frame.

The type of port (RS232 or RS485) to be used can be selected. The flying cable is to be connected to CN3 or CN11 for RS232 or RS485 respectively (factory setting: CN3). Use SW4-1 to activate the port you chose.

SW4 [default]	Function
1 [ON]	ON RS232 Interface activated OFF RS485 Interface activated
2 [OFF]	Not used
3 [OFF]	Both ON to activate RS485 terminator
4 [OFF]	Both OFF to deactivate RS485 terminator

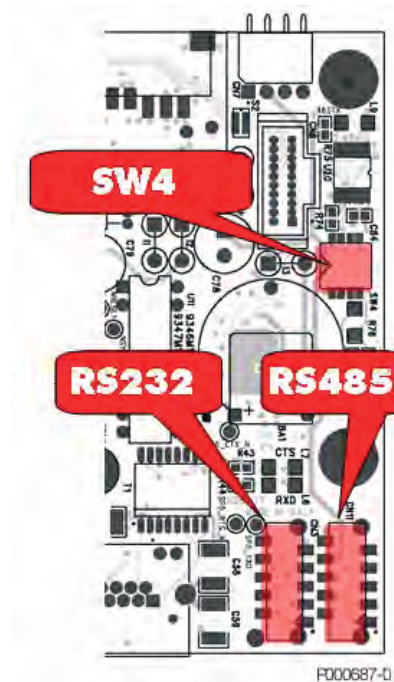

▪ RS232 Modbus RTU Mode

The pin layout for flying COM1 connector is as follows:

DB9Connector Pin N.	Name	Description
-	Shield	Frame of the connector connected to the PE
1	CD	Carrier Detect
2	RD	Received Data
3	TD	Transmitted Data
4	DTR	Data Terminal Ready
5	GND	Ground
6	DSR	Data Set Ready
7	RTS	Request To Send
8	CTS	Clear To Send
9	RI	Ring Indicator

▪ RS485 Modbus RTU Mode



CAUTION This is NOT the default operating mode for ES851 DataLogger board.



CAUTION For COM1 port, RS485 mode is an ALTERNATIVE to RS232. Either one must be used.

The pin layout for flying COM1 connector is as follows:

DB9 Connector Pin N.	Name	Description
1 – 3	A-Line	(TX/RX A) Differential input/output A (bidirectional) according to RS485 standard. Positive polarity in respect to pins 2 – 4 for one MARK.
2 – 4	B-Line	(TX/RX B) Differential input/output B (bidirectional) according to RS485 standard. Negative polarity in respect to pins 1 – 3 for one MARK.
5	GND	(0V) Control board zero volt.
6	N.C.	Not connected.
7-8	GND	(GND) Control board zero volt.
9	+5V	+5 V, max. 100mA for the power supply of the external optional RS485/RS232 converter.

6.12.3.4. COM2 Configuration and Wiring

DB9 female connector (COM2) on ES851 is preset as RS485 Modbus Master. The DIP-switch SW2 allows RS485 driver power supply to be set as “internal” (via ES851) or as external and allows the line termination to be activated/deactivated.

SW2 [default]	Function
1 [ON]	Both ON to activate the internal power supply of the driver
2 [ON]	Both OFF to deliver external power supply
3 [ON]	Both ON to enable line termination
4 [ON]	Both OFF to disable the line terminator

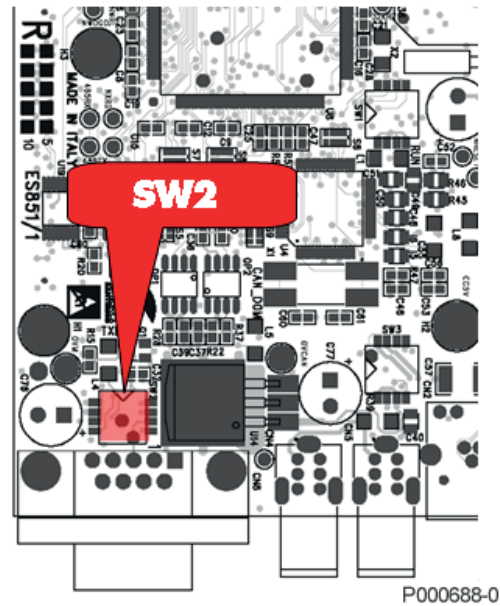

DB9 connector pins:

DB9 Connector Pin N.	Name	Description
-	Shield	Frame of the connector connected to the PE.
1	N.C.	
2	N.C.	
3	A-Line	RxD/TxD positive according to RS485 specifications.
4	PB_RTS	Request To Send – high active when sending.
5	GND	(0V) zero volt of the bus isolated in respect to 0V of the control board.
6	+5V	Bus driver supplied isolated from the control board circuits.
7	N.C.	
8	B-Line	RxD/TxD negative according to RS485 specifications.
9	N.C.	

6.12.3.5. Types of Ethernet Connections

The Sinus Penta, if supplied with ES851 DataLogger, is provided with the standard RJ45 connector (IEEE 802) for 10/100 (100Base-T, 10Base-T) Ethernet connection. Pins are arranged as follows (same layout as in network boards used for personal computers):

N.	Name	Description
1	TD+	Positive signal transmission line
2	TD-	Negative signal transmission line
3	RD+	Positive signal receiving line
4	Term	Terminated pair, not used
5	Term	Terminated pair, not used
6	RD-	Negative signal receiving line
7	Term	Terminated pair, not used
8	Term	Terminated pair, not used

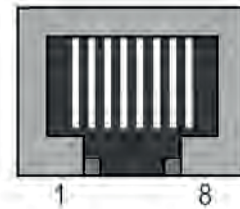

ES851 can be connected, through Ethernet interface, to an Ethernet control device with a master (PC) in one of the following ways:

- **Through a LAN** (Ethernet business network);
- **Through a router** (e.g. ISDN, ADSL, GPRS) [starting from SW version DL166X of ES851 control board]
- **Through a direct point-to-point connection.**



CAUTION

The link to a router is available only if you purchased the LINK service for the connection to the Internet.

If you purchased the LINK service for the connection to the Internet, the Internet connection through a LAN is obtained by connecting ES851 to the LAN using a standard Straight-Through Cable TIA/EIA-568-B of class 5 UTP (Patch cable for LAN), as shown in Figure 161. In that case, the plant can be accessed from any remote computer that can be connected to the Internet.

Connection through a LAN



CAUTION

The DHCP, DNS function shall be available for the LAN. Also, the LAN must be connected to the Internet.



NOTE

The Ethernet interface board cannot be connected to old LANs using Thin Ethernet (10base2) coaxial cables. Connection to this type of LANs is possible using a Hub provided with both Thin Ethernet (10base2) connectors and 100Base-T or 10Base-T connectors. The LAN topology is a star one, with each node connected to the Hub or the Switch through its cable.

P000518-B

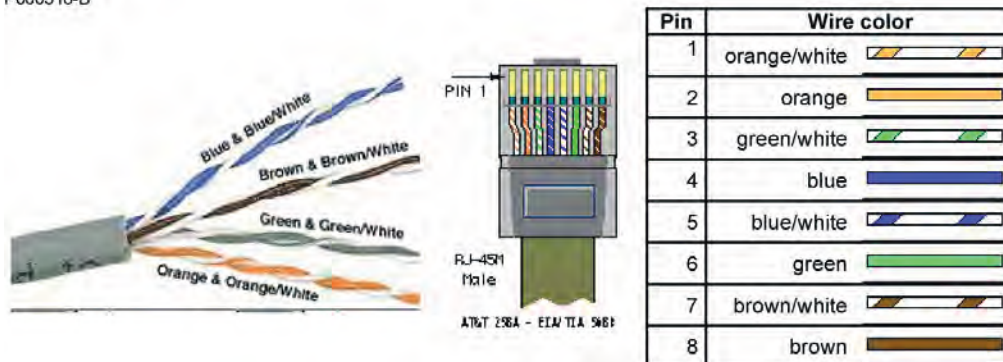

Figure 161: Cable of Cat. 5 for Ethernet and standard colour arrangement in the connector

If you did not purchase the option for the connection to the Internet (LINK service), ES851 can be connected to the LAN so that ES851 and the plant can be detected from the LAN ONLY, once the DataLogger parameters have been programmed accordingly. Please refer to the DATA LOGGER ES851 - Programming Instructions for more details.

Connection through a router

If you purchased the LINK service for the connection to the Internet, the Internet connection through a router is obtained by connecting ES851 to the router using the cable supplied.

Point-to-point connection

Special software programming is required for the point-to-point connection. Please refer to the DATA LOGGER ES851 - Programming Instructions for more details.

Direct point-to-point connection is obtained with a Cross-Over Cable TIA/EIA-568-B, cat. 5. This type of cable performs a cross-over of the pairs so that the TD+/TD- pair corresponds to the RD+/RD- pair, and vice versa.

The table below shows the colour matching on the connector pins for the Cross-Over Cable and the cross-over diagram of the two pairs used from 100Base-T or 10Base-T connection.

- EIA/TIA 568 standard patch cable, UTP/STP type, cat. 5 P000689-B

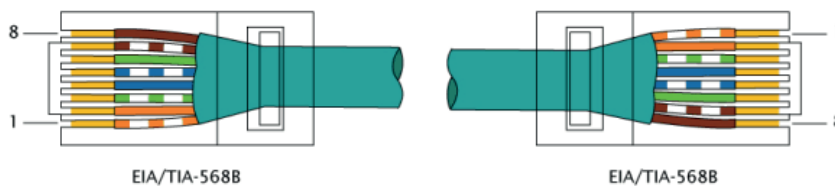

- EIA/TIA 568 cross-over cable, UTP/STP type, cat. 5

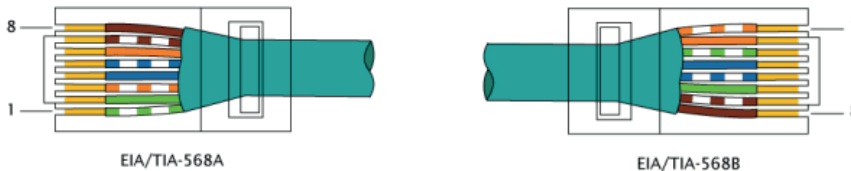

The inverter is typically installed with other electric/electronic devices inside a cubicle. Normally, the electromagnetic pollution inside the cubicle is remarkable and is due to both radiofrequency disturbance caused by the inverters and to bursts caused by the electromechanical devices. To avoid propagating disturbance to Ethernet cables, they must be segregated and kept as far as possible from the other power cables and signal cables in the cubicle. Disturbance propagation to Ethernet cables may affect the correct operation of the inverter and the other devices (computers, PLCs, Switches, Routers) connected to the same LAN.



NOTE

The maximum length of the LAN cable, cat. 5 UTP allowed by IEEE 802 standards results from the max. transit time allowed from the protocol and is equal to 100m. The longer the cable length, the higher the risk of communications failure.



NOTE

For Ethernet wiring, only use cables certified for LAN cables of 5 UTP category or higher. For standard wiring, avoid creating your own cables; Straight-Through or Cross-Over cables should be purchased from an authorised dealer.



NOTE

6.12.3.6. Ethernet Port Wiring



CAUTION

Remove voltage from the Penta drive before wiring ES851 DataLogger board. Take any safety measure required before touching the connectors and handling the DataLogger board.



Figure 162: Location of the Ethernet port

Remove the cover and access to the control board of the Sinus Penta. Insert the male connector to the female RJ45 connector located on ES851. Press until the tab snaps.

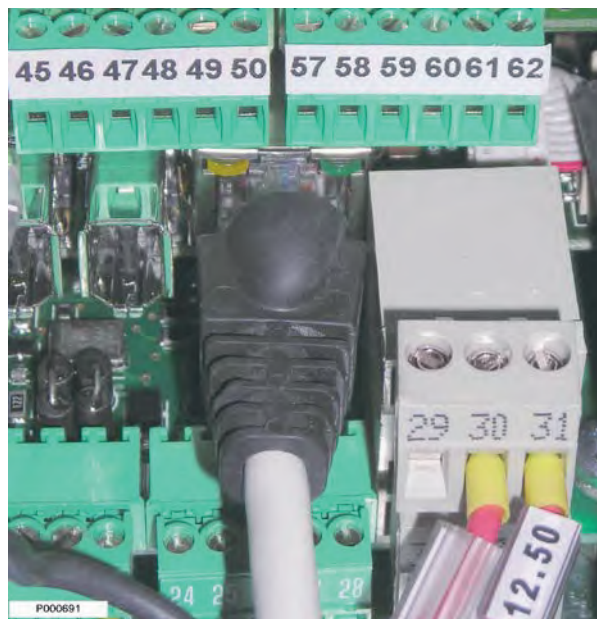
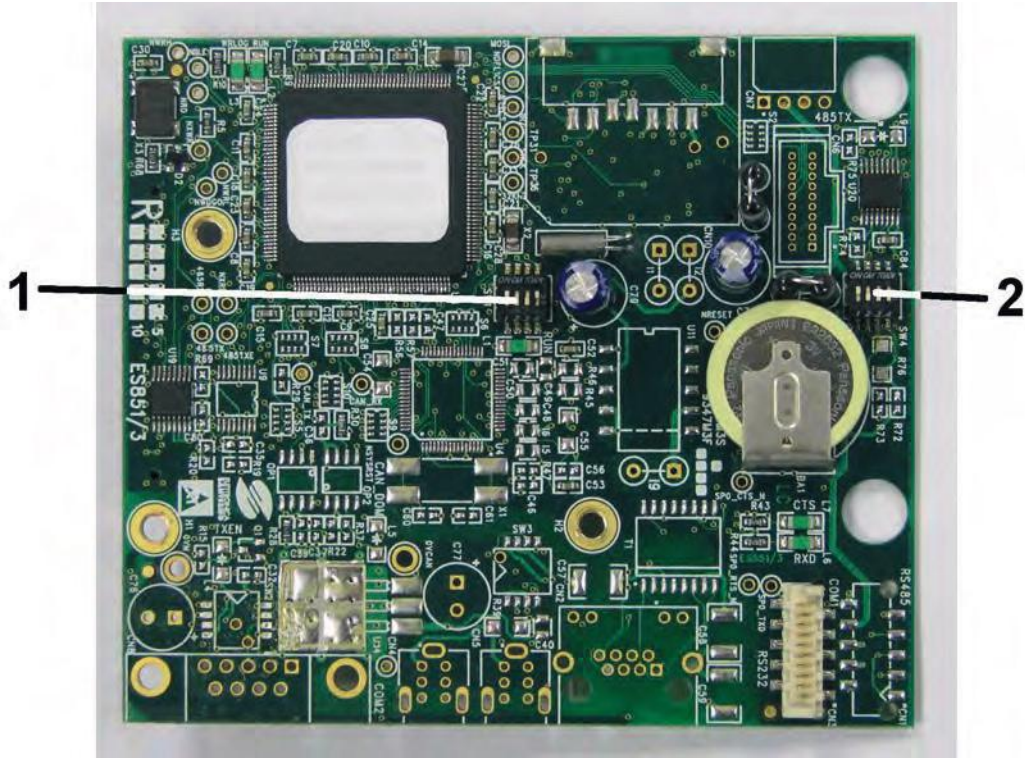

Figure 163: Wiring of the Ethernet cable

6.13. ES851-RTC Real Time Clock (Slot B)

The Real Time Clock ES851 RTC optional board is provided with a clock indicating date and time that is functioning even when the inverter is not powered. The inverter firmware may use date and time info to manage different timed events.



S000234

Figure 164: Real Time Clock ES851-RTC Board

1. DIP-switch SW1
2. DIP-switch SW4



NOTE The same software functionality performed by the Real Time Clock ES851-RTC is performed by the DataLogger ES851 as well.

6.13.1. Identification Data

<i>Description</i>	<i>Part Number</i>
ES851 RTC	ZZ0101825

6.13.2. Installing ES851-RTC Board on the Inverter (Slot B)



DANGER

Before gaining access to the components inside the inverter, remove voltage from the inverter and wait at least 20 minutes. Wait for a complete discharge of the internal capacitors to avoid any electric shock hazard.



CAUTION

Electric shock hazard: do not connect/disconnect the signal terminals or the power terminals when the inverter is on. This also prevents the inverter from being damaged.



NOTE

All the screws used to fasten removable parts (terminals cover, serial interface connector, cable plates, etc.) are black, round-head, cross-head screws. When wiring the inverter, remove only this type of screws. If different screws or bolts are removed, the inverter warranty will be no longer valid.

Follow the instructions given for the DataLogger ES851 (see ES851 Datalogger Board (Slot B)).

6.13.2.1. *DIP-switch Configuration*

The configuration below of the DIP-switches located on ES851-RTC board (Figure 164) is to be left unchanged:

SW1: 1-ON, 2-OFF, 3-ON, 4-ON
SW4: 1-ON, 2-OFF, 3-OFF, 4-OFF

6.14. ES847 I/O Expansion Board (Slot C)

6.14.1. Signal Conditioning and I/O Expansion Board

ES847 Board allows implementing an additional I/O set for any product of the PENTA series. Additional functionality includes:

- XAIN1/2/3/4: Four “fast” sampling analog inputs, 12-bit, $\pm 10V$ f.s;
- XAIN5/6: Two “fast” sampling analog inputs, 12-bit, for AC current measure via CTs or for 0-20mA sensor measures; resolution: 11 bits;
- XAIN7: One “fast” sampling analog input for $\pm 160mA$ f.s. sensor measures; resolution: 12 bits (Energy Counter option);
- XAIN8/9/10/11: Four “slow” sampling inputs, 12-bit, configurable as 0-10V f.s., 0-20 mA f.s., 0-100 mV f.s., temperature acquisition via two-wire thermistor PT100;
- XAIN12/13: Two “slow” sampling analog inputs, 12-bit, 0-10V f.s.;
- VAP/VBP/VCP: Three voltage inputs for ADE (Energy Counter option);
- IAP/IBP/ICP: Three current inputs for ADE (Energy Counter option);
- XMD1/2/3/4/5/6/7/8: Eight PNP, 24V multifunction digital inputs; three of them are “fast propagation” inputs and can be used for the acquisition of a PUSH-PULL, 24V encoder;
- XMDO1/2/3/4: Six multifunction digital outputs, OC outputs free from potential to be used both as PNP and NPN inputs, $V_{omax}=48V$, $I_{omax}=50mA$, providing short-circuit protection through a resettable fuse.



CAUTION

Not all I/Os are controlled from all the products of the Sinus Penta series. Please refer to the DIP-switch/Note column in ES847 Board Terminals and to the User Manuals of the Sinus Penta's applications (Guide to the Multipump Application and Guide to the Regenerative Application).



CAUTION

If ES847 board is mounted in slot C, ES919 cannot be mounted in slot B (see ES919 Communications Board (Slot B)).

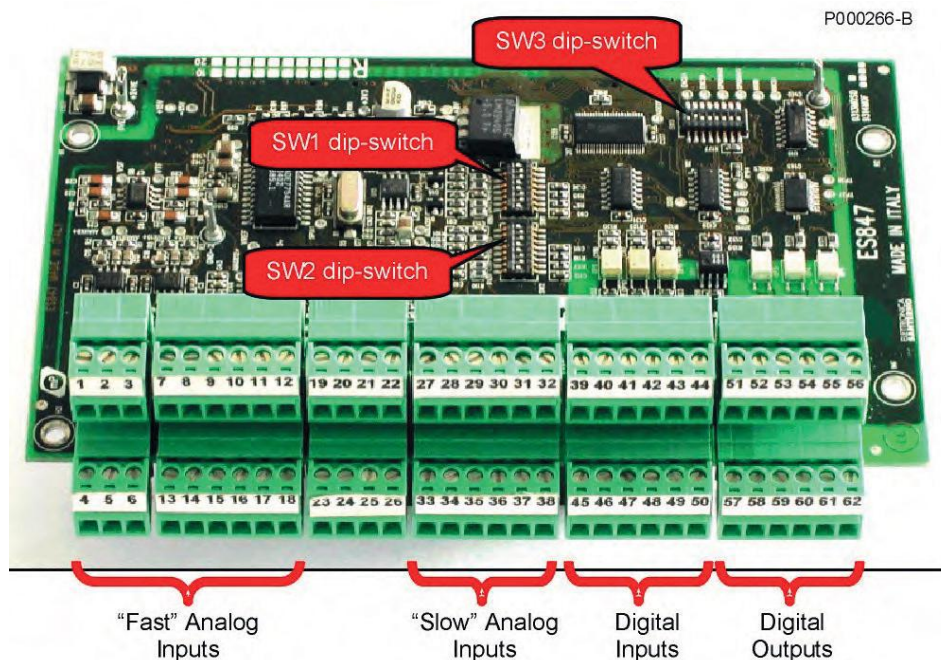

Figure 165: Signal conditioning and additional I/Os board (ES847)

6.14.2. Identification Data

Description	Part Number
ES847/1 Signal conditioning	ZZ0101814

6.14.3. Installing ES847 Board on the Inverter (Slot C)



DANGER

Before gaining access to the components inside the inverter, remove voltage from the inverter and wait at least 20 minutes. Wait for a complete discharge of the internal capacitors to avoid any electric shock hazard.



CAUTION

Electric shock hazard: do not connect/disconnect the signal terminals or the power terminals when the inverter is on. This also prevents the inverter from being damaged.



NOTE

All the screws used to fasten removable parts (terminals cover, serial interface connector, cable plates, etc.) are black, round-head, cross-head screws. When wiring the inverter, remove only this type of screws. If different screws or bolts are removed, the inverter warranty will be no longer valid.

1. Remove voltage from the inverter and wait at least 20 minutes.
2. Remove the whole inverter covering by loosening the four hexagonal screws located on the top side and bottom side of the inverter to reach the fixing spacers and the signal connector (Figure 166 – Slot C.)



CAUTION

Before removing the inverter cover, draw out the keypad and disconnect the cable connecting the keypad to the control board to avoid damaging the link between the keypad and the control board.

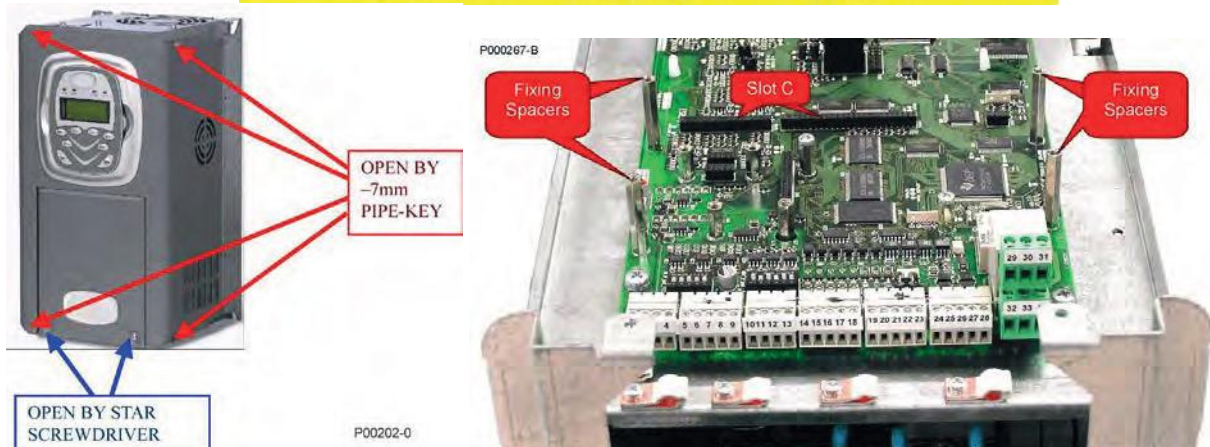

Figure 166: Removing the inverter cover; location of slot C

3. Insert the two contact strips supplied in the bottom part of ES847 board; make sure that each contact enters its slot in the connector. Insert ES847 board over the control board of the PENTA inverter; make sure that each contact enters its slot in the signal connector. Use the screws supplied to fasten board ES847 to the fixing spacers (Figure 167).

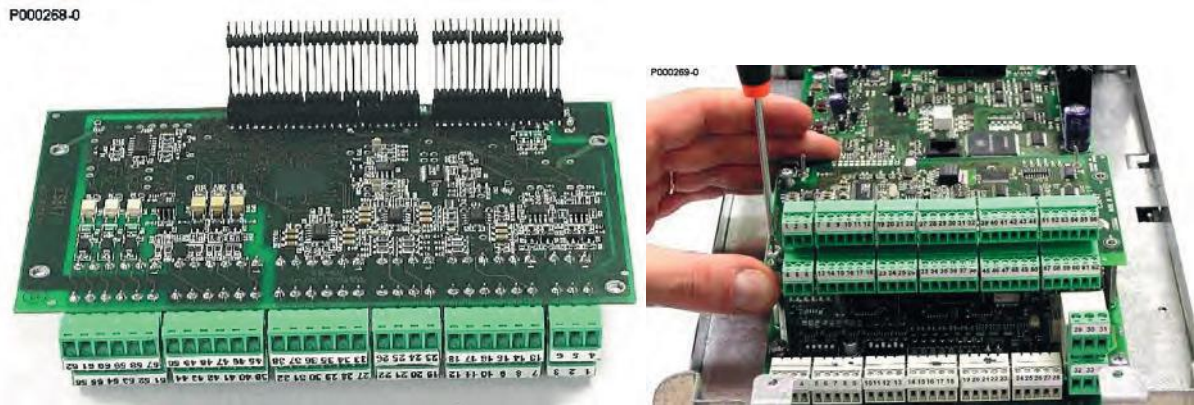

Figure 167: Fitting the strips inside ES847 board and fixing the board on slot C

4. Configure the DIP-switches located on board ES847 based on the type of signals to be acquired (see relevant section).
5. For the terminal board wiring, follow the instructions given in the section below.
6. Close the inverter frame by reassembling the cover allowing gaining access to the inverter control terminals.

6.14.4. ES847 Board Terminals

Screwable terminal board including 12 sections (each section can be individually removed) for 0.08 to 1.5mm² (AWG 28-16) cables. **Decisive voltage class A according to IEC 61800-5-1.**

N.	Name	Description	I/O Features	DIP-switch/Notes
1-2	XAIN1+ XAIN1-	"Fast" differential auxiliary analog input, $\pm 10V$ f.s., number 1	Vfs = $\pm 10V$, Rin= 10k Ω ; Resolution: 12 bits	n.u.
3	CMA	0V for analog inputs (common to control 0V)	Control board zero Volt	
4-5	+15VM -15VM	Stabilized, bipolar output protected from short-circuits for auxiliary circuits.	+15V, -15V; Iout max: 100mA	
6	CMA	0V for analog inputs (common to control 0V)	Control board zero Volt	
7-8	XAIN2+ XAIN2-	"Fast" differential auxiliary analog input, $\pm 10V$ f.s. number 2	Vfs = $\pm 10V$, Rin= 10k Ω ; Resolution: 12 bits	n.u.
9-10	XAIN3+ XAIN3-	"Fast" differential auxiliary analog input, $\pm 10V$ f.s. number 3	Vfs = $\pm 10V$, Rin= 10k Ω ; Resolution: 12 bits	n.u.
11-12	XAIN4+ XAIN4-	"Fast" differential auxiliary analog input, $\pm 10V$ f.s. number 4	Vfs = $\pm 10V$, Rin= 10k Ω ; Resolution: 12 bits	PD
13	XAIN5	"Fast" auxiliary analog input (current input), number 5	Ifs = $\pm 20mA$, Rin= 200 Ω ; Resolution: 12 bits	PD
14	CMA	0V for analog inputs for XAIN5 return	Control board zero Volt	
15	XAIN6	"Fast" auxiliary analog input (current input), number 6	Ifs = $\pm 20mA$, Rin= 200 Ω ; Resolution: 12 bits	n.u.
16	CMA	0V for analog inputs for XAIN6 return	Control board zero Volt	
17	XAIN7	"Fast" auxiliary current analog input, number 7 (Energy Counter option)	Ifs = $\pm 160mA$, Rin= 33 Ω ; Resolution: 12 bits	PR
18	CMA	0V for analog inputs (common with control 0V)	Control board zero Volt	
19	VAP	Voltage analog input from ES917 – phase R (Energy Counter Option)	Vfs = $\pm 10V$, Rin= 50k Ω ; Resolution: 12 bits	PR
20	VBP	Voltage analog input from ES917 – phase S (Energy Counter Option)	Vfs = $\pm 10V$, Rin= 50k Ω ; Resolution: 12 bits	PR
21	VCP	Voltage analog input from ES917 – phase T (Energy Counter Option)	Vfs = $\pm 10V$, Rin= 50k Ω ; Resolution: 12 bits	PR
22	CMA	0V for analog inputs (common with control 0V)	Control board zero Volt	
23	IAP	Current analog input from CT – phase R (Energy Counter Option)	Ifs = $\pm 150mA$, Rin= 33 Ω ; Resolution: 12 bits	PR
24	IBP	Current analog input from CT – phase S (Energy Counter Option)	Ifs = $\pm 150mA$, Rin= 33 Ω ; Resolution: 12 bits	PR
25	ICP	Current analog input from CT – phase T (Energy Counter Option)	Ifs = $\pm 150mA$, Rin= 33 Ω ; Resolution: 12 bits	PR
26	CMA	0V for analog inputs (common with control 0V)	Control board zero Volt	

PD: Used from the Sinus Penta firmware only.

PR: Used from the firmware of the Regenerative application when the Energy Counter option is installed.

27	XAIN8/T1+	"Slow" configurable auxiliary analog input, number 8	Vfs = 10V, Rin = 30kΩ	SW1.3 = ON SW1.1-2-4 = OFF
			Vfs = 100mV, Rin = 1MΩ	SW1.4 = ON SW1.1-2-3 = OFF
			I _{fs} = 20mA, Rin = 124.5Ω	SW1.2 = ON SW1.1-3-4 = OFF
		Thermistor temperature measure, number 1	Temperature measure with PT100 Compliant with IEC 60751 or DIN 43735	SW1.1-4 = ON SW1.2-3 = OFF (default)
28	CMA/T1-	0V for analog inputs for XAIN8 return	Control board zero Volt	
29	XAIN9/T2+	"Slow" configurable auxiliary analog input, number 9	Vfs = 10V, Rin = 30kΩ	SW1.7 = ON SW1.5-6-8 = OFF
			Vfs = 100mV, Rin = 1MΩ	SW1.8 = ON SW1.5-6-7 = OFF
			I _{fs} = 20mA, Rin = 124.5Ω	SW1.6 = ON SW1.5-7-8 = OFF
		Thermistor temperature measure, number 2	Temperature measure with PT100 Compliant with IEC 60751 or DIN 43735	SW1.5-8 = ON SW1.6-7 = OFF (default)
30	CMA/T2-	0V for analog inputs for XAIN9 return	Control board zero Volt	
31	XAIN10/T3+	"Slow" configurable auxiliary analog input, number 10	Vfs = 10V, Rin = 30kΩ	SW2.3 = ON SW2.1-2-4 = OFF
			Vfs = 100mV, Rin = 1MΩ	SW2.4 = ON SW2.1-2-3 = OFF
			I _{fs} = 20mA, Rin = 124.5Ω	SW2.2 = ON SW2.1-3-4 = OFF
		Thermistor temperature measure, number 3	Temperature measure with PT100 Compliant with IEC 60751 or DIN 43735	SW2.1-4 = ON SW2.2-3 = OFF (default)
32	CMA/T3-	0V for analog inputs for XAIN10 return	Control board zero Volt	
33	XAIN11/T4+	"Slow" configurable auxiliary analog input, number 11	Vfs = 10V, Rin = 30kΩ	SW2.7 = ON SW2.5-6-8 = OFF
			Vfs = 100mV, Rin = 1MΩ	SW2.8 = ON SW2.5-6-7 = OFF
			I _{fs} = 20mA, Rin = 124.5Ω	SW2.6 = ON SW2.5-7-8 = OFF
		Thermistor temperature measure, number 4	Temperature measure with PT100 Compliant with IEC 60751 or DIN 43735	SW2.5-8 = ON SW2.6-7 = OFF (default)
34	CMA/T4-	0V for analog inputs for XAIN11 return	Control board zero Volt	
35	XAIN12	"Slow" voltage auxiliary analog input, number 12	Vfs = 10V, Rin = 30kΩ	n.u.
36	CMA	0V for analog inputs for XAIN12 return	Control board zero Volt	n.u.
37	XAIN13	"Slow" voltage auxiliary analog input, number 13	Vfs = 10V, Rin = 30kΩ	n.u.
38	CMA	0V for analog inputs for XAIN13 return	Control board zero Volt	n.u.

39	XMDI1	Multifunction auxiliary digital input 1	24Vdc Optoisolated digital inputs; positive logic (PNP); active with high level signal in respect to CMD (terminals 43 and 50). In compliance with EN 61131-2 as type 1 digital inputs (24Vdc rated voltage).	Maximum response time to processor: 500µs
40	XMDI2	Multifunction auxiliary digital input 2		
41	XMDI3	Multifunction auxiliary digital input 3		
42	XMDI4	Multifunction auxiliary digital input 4		
43	CMD	0 V digital input isolated to control 0 V		Maximum response time to processor: 600ns
44	+24V	Auxiliary supply output for optoisolated multifunction digital inputs		
45	XMDI5	Auxiliary multifunction digital input 5		
46	XMDI6 / ECHA / FINA	Auxiliary multifunction digital input 6 / Single-ended, push-pull 24V encoder input, phase A / Frequency input A		
47	XMDI7 / ECHB	Auxiliary multifunction digital input 7 / Single-ended, push-pull 24V encoder input, phase B		
48	XMDI8 / FINB	Auxiliary multifunction digital input 8 / Frequency input B		
49	+24V	Auxiliary supply output for optoisolated multifunction digital inputs	+24V±15% ; I _{max} : 200mA Protected by resettable fuse	
50	CMD	0 V digital input isolated to control 0 V	Optoisolated digital input zero volt	
51	XMDO1	Multifunction auxiliary digital output 1 (collector)	Open collector isolated digital outputs, V _{omax} = 48V; I _{omax} = 50mA	
52	CMDO1	Multifunction auxiliary digital output 1 (emitter)		
53	XMDO2	Multifunction auxiliary digital output 2 (collector)		
54	CMDO2	Multifunction auxiliary digital output 2 (emitter)		
55	XMDO3	Multifunction auxiliary digital output 3 (collector)		
56	CMDO3	Multifunction auxiliary digital output 3 (emitter)		
57	XMDO4	Multifunction auxiliary digital output 4 (collector)		
58	CMDO4	Multifunction auxiliary digital output 4 (emitter)		
59	XMDO5	Multifunction auxiliary digital output 5 (collector)		
60	CMDO5	Multifunction auxiliary digital output 5 (emitter)		
61	XMDO6	Multifunction auxiliary digital output 6 (collector)		
62	CMDO6	Multifunction auxiliary digital output 6 (emitter)		



NOTE

All digital outputs are inactive under the following conditions:

- inverter off;
- inverter initialization stage after power on;
- firmware updating.

Consider this when choosing the inverter application.

6.14.5. Configuration DIP-switches

ES847 board is provided with three configuration DIP-switches (Figure 165) setting the operating mode as in the table below.

SW1	Sets the operating mode for “slow” analog inputs XAIN8 and XAIN9
SW2	Sets the operating mode for “slow” analog inputs XAIN10 and XAIN11
SW3	Factory-setting: SW3.2=SW3.5=SW3.7=ON; the other DIP-switches are OFF <u>– Do not change factory-setting–</u>

6.14.6. Possible Settings for DIP-switches SW1 and SW2

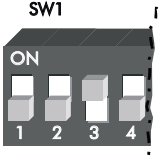
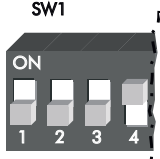
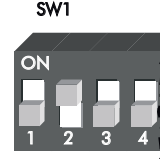
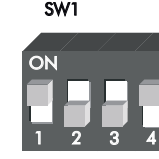
Configuring Slow Analog Channel XAIN8			
Mode: 0-10V f.s. (Default configuration)	Mode: 0-100mV f.s.	Mode: 0-20mA f.s.	Temperature Reading with Thermistor PT100 (default)
			

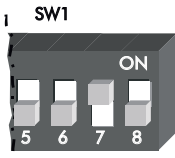
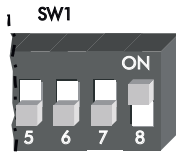
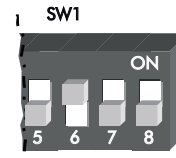
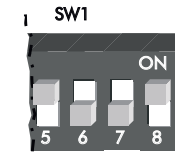
Setting Slow Analog Channel XAIN9			
Mode: 0-10V f.s. (Default configuration)	Mode: 0-100mV f.s.	Mode: 0-20mA f.s.	Temperature Reading with Thermistor PT100 (default)
			

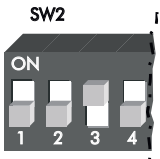
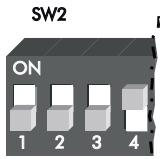
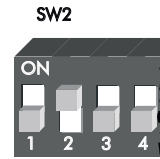
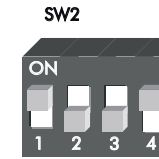
Setting Slow Analog Channel XAIN10			
Mode: 0-10V f.s. (Default configuration)	Mode: 0-100mV f.s.	Mode: 0-20mA f.s.	Temperature Reading with Thermistor PT100 (default)
			

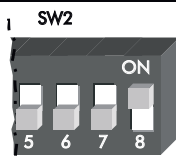
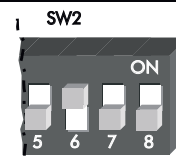
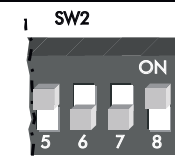
Setting Slow Analog Channel XAIN11			
Mode: 0-10V f.s. (Default configuration)	Mode: 0-100mV f.s.	Mode: 0-20mA f.s.	Temperature Reading with Thermistor PT100 (default)
			

Five acquisition firmware modes are available (see Sinus Penta's Programming Guide) corresponding to four hardware settings (see table below).

Type of Preset Acquisition	Mode Set for SW1 and SW2	Full-scale Values and Notes
Voltage: 0÷10V	Mode: 0-10V f.s.	0÷10V
Voltage: 0÷100mV	Mode: 0-100mV f.s.	0÷100mV
Current: 0÷20 mA	Mode: 0-20mA f.s.	0mA ÷ 20mA
Current: 4÷20 mA	Mode: 0-20mA f.s.	4mA ÷ 20mA. Alarm for measure < 2mA (cable disconnection) or for measure > 25mA.
Temperature	Temperature Reading with Thermistor PT100 (default)	-50°C ÷ 125°C. Disconnection alarm or short-circuit sensor if resistance measure is lower/higher than the preset range.



NOTE

Firmware settings must be consistent with DIP-switch settings. Otherwise, unpredictable results for real acquisition are produced.



NOTE

A voltage/current value exceeding the input range will be saturated at minimum or maximum value.



CAUTION

Inputs configured as voltage inputs have high input impedance and must be closed when active. The disconnection of the conductor relating to an analog input configured as a voltage input does not ensure that the channel reading is "zero". Proper "zero" reading occurs only if the input is connected to a low-impedance signal source or is short-circuited. Do not series-connect relay contacts to inputs to obtain "zero" reading.

6.14.7. Wiring Diagrams

6.14.7.1. Connection of “Fast” Differential Analog Inputs

A differential input allows weakening disturbance due to “ground potentials” generated when the signal is acquired from remote sources. Disturbance is weaker only if wiring is correct.

Each input is provided with a positive terminal and a negative terminal of the differential amplifier. They are to be connected to the signal source and to its ground respectively. Common voltage for the signal source ground and the ground of the CMA auxiliary inputs must not exceed the maximum allowable value.

To reduce noise for a differential input, do the following:

- ensure a common path for the differential torque
- connect the source common to CMA input in order not to exceed the common mode input voltage
- use a shielded cable and connect its braiding to the terminal located next to the inverter terminal boards.

ES847 Board is also provided with an auxiliary supply output protected by a fuse which can be used to power external sensors. Do not exceed the max. current ratings.

Wiring is shown in the figure below:

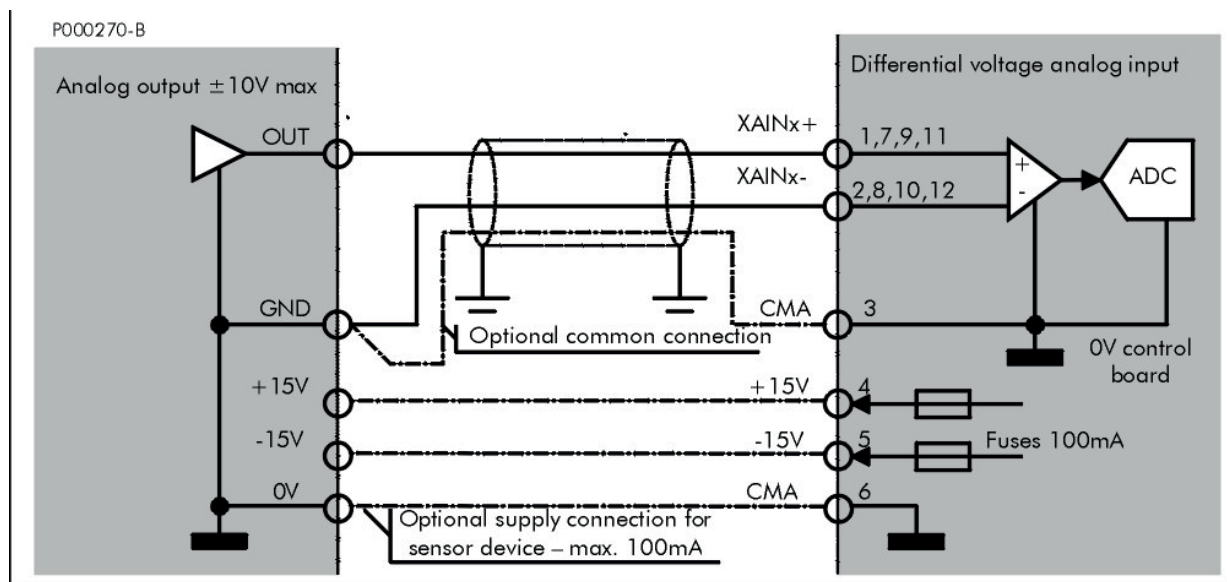

Figure 168: Connection of a bipolar voltage source to a differential input



NOTE

Connecting terminal CMA to the signal source ground ensures better acquisition standards. Wiring can be external to the shielded cable or it can consist of the optional common connection of the auxiliary supply.



NOTE

Auxiliary supply outputs are electronically protected against temporary short-circuits. After wiring the inverter, check output voltage, because a permanent short-circuit can damage the inverter.

6.14.7.2. Connection of “Fast” Current Inputs

Three “fast” low-impedance analog inputs are available, which are capable of acquiring sensors with current output. The correct wiring is shown in the diagram below.

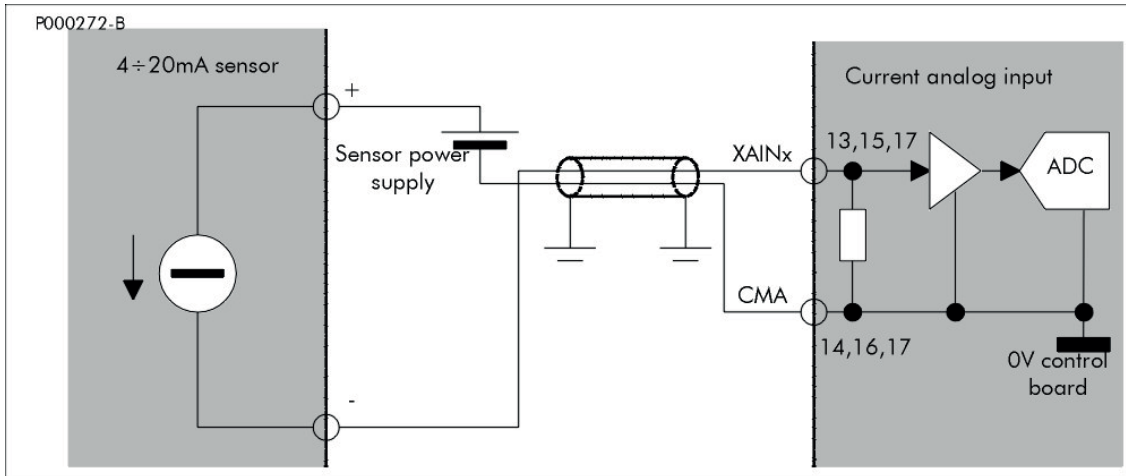

Figure 169: Connection of 0÷20mA (4÷20mA) sensors to “fast” current inputs



NOTE

Do not use +24V power supply, available on terminals 44 and 49 in ES847 board, to power 4÷20mA sensors, because it is to be used for the common of the digital inputs (CMD – terminals 43 and 50), not for the common of the analog inputs (CMA). Terminals 44 and 49 are galvanically isolated and must be kept galvanically isolated.

6.14.7.3. Connecting “Slow” Analog Inputs to Voltage Sources

Use a shielded pair data cable and connect its braiding to the side of ES847 board. Connect the cable braiding to the inverter frame using the special conductor terminals located next to the terminal boards. Although “slow” acquisition analog channels have a cut-off frequency slightly exceeding 10Hz and the mains frequency, which is the main disturbance source, is weakened, make sure that wiring is correct, particularly if the full-scale value is 100mV and if wires are longer than 10 m. The figure below shows a wiring example for the acquisition of a voltage source.

Properly set the DIP-switches for the configuration of the analog channel being used: set the full-scale value to 10V or to 100mV. The setting of the programming parameter must be consistent with the hardware setting.

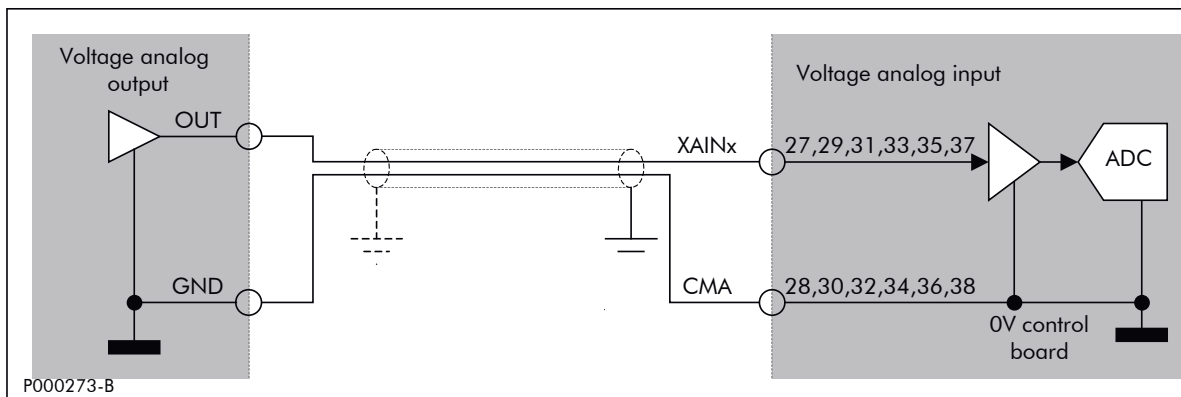

Figure 170: Connecting a voltage source to a “slow” analog input

6.14.7.4. Connecting “Slow” Analog Inputs to Current Sources

Figure 169 shows how to connect “slow” analog inputs to current sources. Channels XAIN8, XAIN9, XAIN10, XAIN11—corresponding to terminals 27, 29, 31, 33—are capable of acquiring current signals with a full-scale value of 20mA. Properly set the DIP-switches for the configuration of the analog channel being used: set the full-scale value to 20mA and set the relevant programming parameter to 0÷20mA or 4÷20mA.

6.14.7.5. Connecting “Slow” Analog Inputs to Thermistor PT100

ES847 board allows reading temperatures directly from the connection of standard thermistors PT100 complying with DIN EN 60751. Two-wire connection is used for easier wiring. Use relatively short cables and make sure that cables are not exposed to sudden temperature variations when the inverter is running. Proper wiring is shown in Figure 171: use a shielded cable and connect its braiding to the inverter metal frame through the special conductor terminals.

If a cable longer than approx. 10 metres is used, measure calibration is required. For example, if a 1mm² (AWG 17) shielded pair data cable is used, this results in a reading error of approx. +1°C every 10 metres. To perform measure calibration, instead of the sensor connect a PT100 sensor emulator set to 0°C (or a 100Ω 0.1% resistor) to the line terminals, then enable the measure zeroing function. More details are given in the Sinus Penta’s Programming Guide.

PT100 emulator allows checking the measure before connecting the sensor.

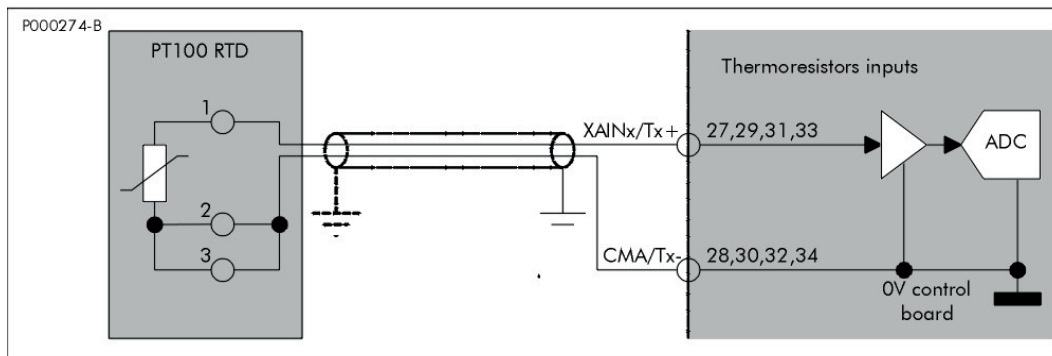

Figure 171: Connecting thermoresistors PT100 to analog channels XAIN8–11 / T1–4



NOTE

Firmware settings must be consistent with DIP-switch settings. Otherwise, unpredictable results for real acquisition are produced.



NOTE

A voltage/current value exceeding the input range will be saturated at minimum or maximum value.



CAUTION

Inputs configured as voltage inputs have high input impedance and must be closed when active. The disconnection of the conductor relating to an analog input configured as a voltage input does not ensure that the channel reading is zero. Proper “zero” reading occurs only if the input is connected to a low-impedance signal source or is short-circuited. Do not series-connect relay contacts and inputs to obtain “zero” reading.

6.14.7.6. Connecting Isolated Digital Inputs

All digital inputs are galvanically isolated from zero volt of the inverter control board. To activate isolated digital inputs, use either isolated supply delivered to terminals 44 and 49 or 24Vdc auxiliary supply. Figure 172 shows the digital input control mode exploiting power inside the inverter and exploiting the output of a control device, such as a PLC. Internal supply (+24 Vdc, terminals 44 and 49) is protected by a 200mA self-resetting fuse.

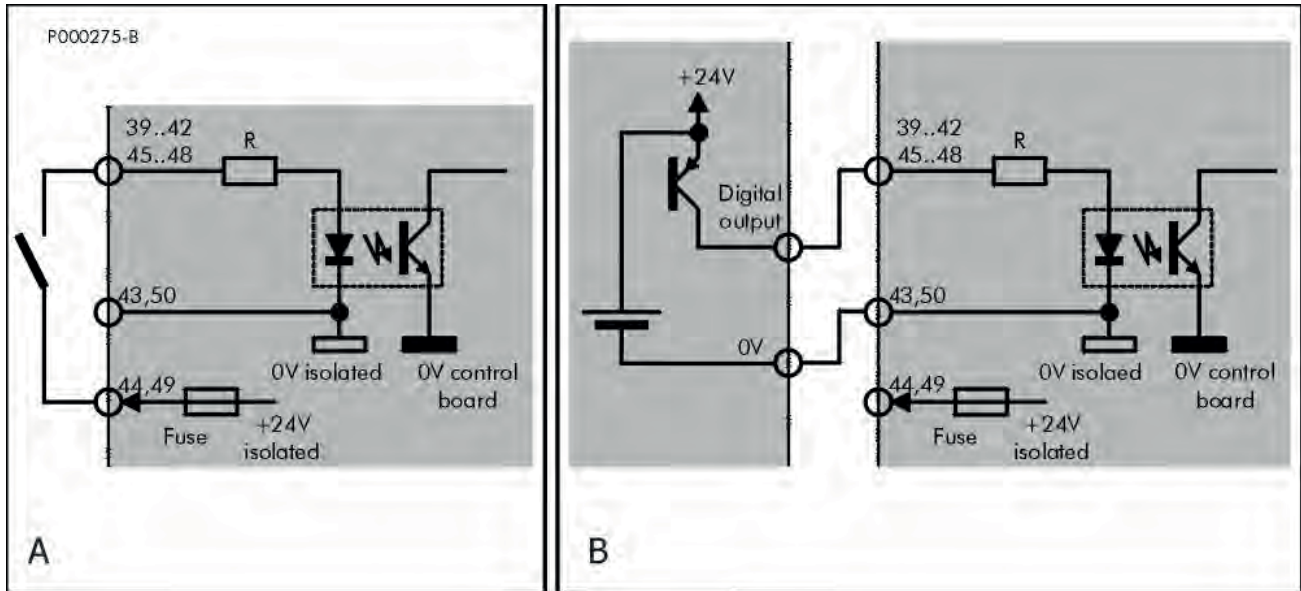

Figure 172: PNP input wiring

A: PNP Command (active to +24V) sent via a voltage free contact

B: PNP Command (active to +24V) sent from a different device (PLC, digital output board, etc.)

6.14.7.7. Connection to an Encoder or a Frequency Input

Auxiliary digital inputs XMDI6, XMDI7, XMDI8 may acquire fast digital signals and may be used for the connection to a push-pull single-ended incremental encoder or for the acquisition of a frequency input. Important: When ES847 board is fitted, encoder B functions are no more implemented by the basic terminal board of the control board, but are implemented by ES847 board. The incremental encoder must be connected to “fast” digital inputs XMDI6 and XMDI7, as shown in Figure 173.

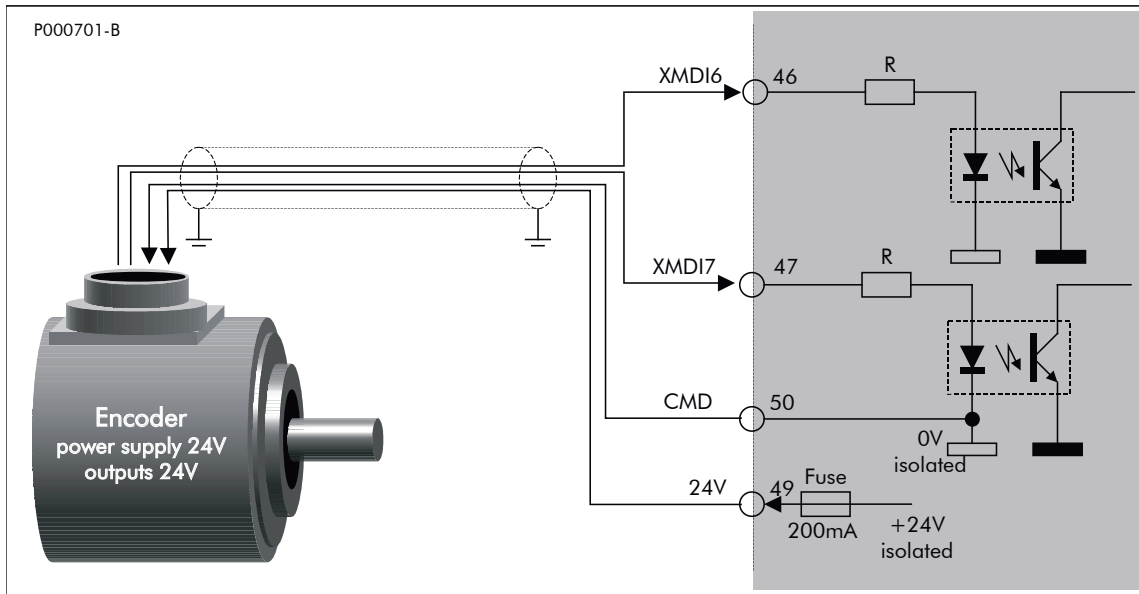

Figure 173: Connecting the incremental encoder to fast inputs XMDI7 and XMDI8

The encoder shall have PUSH-PULL outputs; its 24V power supply is delivered directly by the isolated supply internal to the inverter—terminals +24V (49) and CMD (50). The maximum allowable supply current is 200mA and is protected by a resettable fuse.

Only encoders described above can be acquired directly by the terminal board of the Sinus Penta; encoder signals shall have a maximum frequency of 155kHz, corresponding to 1024 pulse/rev at 9000 rpm. Input XMDI8 can also acquire a square-wave frequency signal ranging from 10kHz to 100kHz, which is converted into an analog value to be used as a reference. Frequency values corresponding to the min. and max. reference can be set up as parameters. Do not exceed the allowable duty-cycle ratings for the frequency inputs. Signals are sent from a 24V Push-pull output with a reference common to terminal CMD (50), as shown in Figure 174).

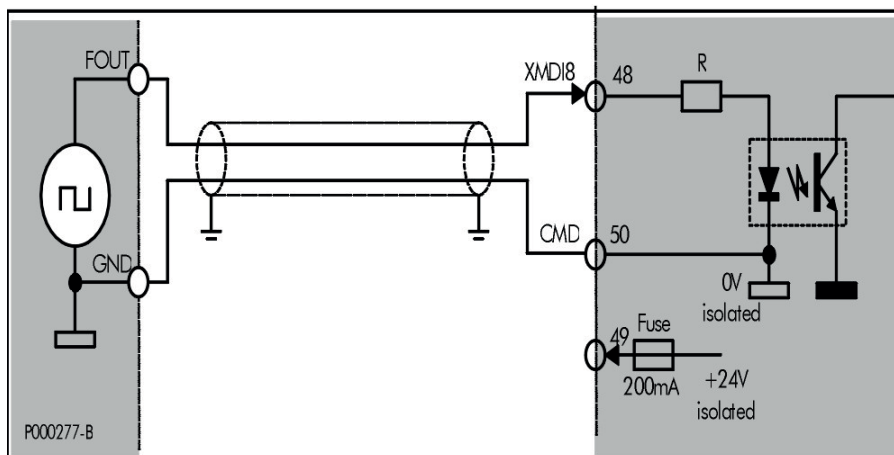

Figure 174: Signal sent from a 24V, Push-pull frequency output

6.14.7.8. Connection to Isolated Digital Outputs

Multifunction outputs XMDO1..8 (terminals 51..62) are all provided with a common terminal (CMDO1..8) which is isolated from the other outputs. They can be used to control both PNP and NPN loads, based on the wiring diagrams shown in Figure 175 and Figure 176.

Electrical conductivity (similar to a closed contact) is to be found between terminal MDO2 and CMDO2 when the output is active, i.e. when the ■ symbol is displayed next to the output. Loads connected as PNP or as NPN are activated.

Outputs can be powered by the inverter isolated power supply or by an external source (24 or 48V – see dashed lines in the figure below).

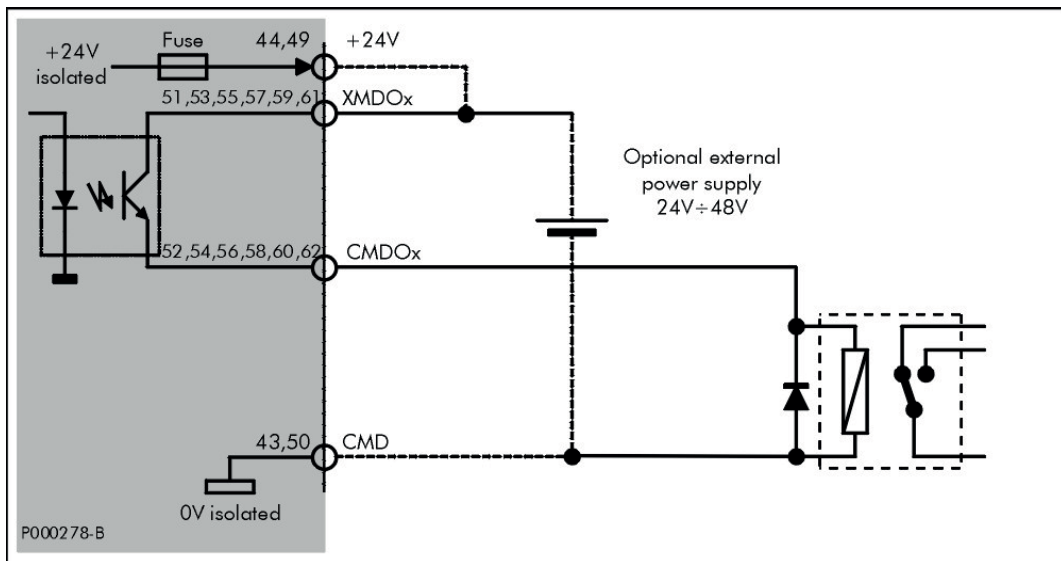

Figure 175: Connection of a PNP output for relay control

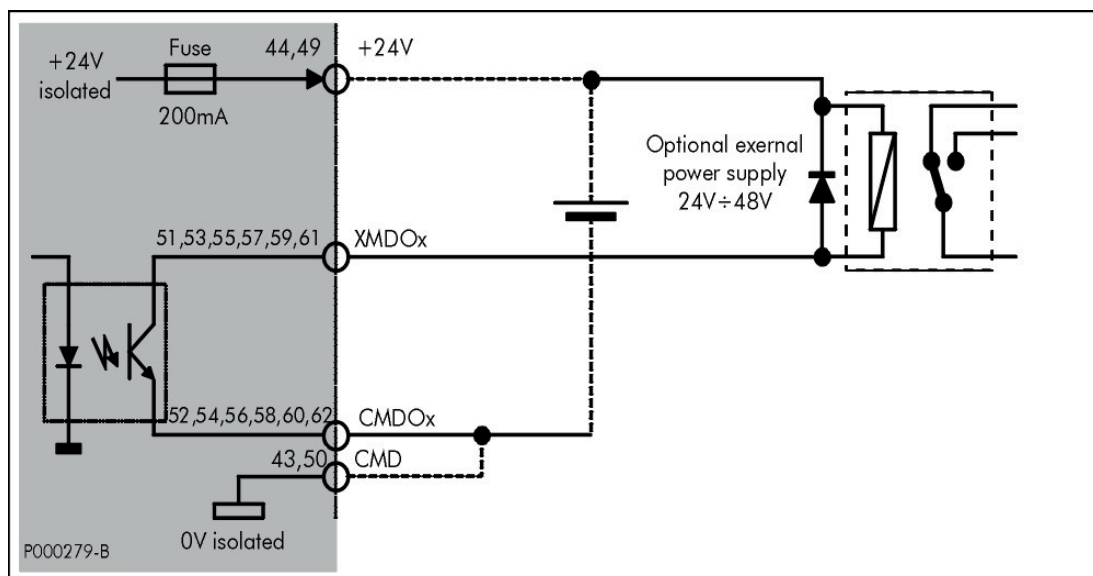

Figure 176: Connection of an NPN output for relay control



CAUTION

When inductive loads (e.g. relay coils) are connected, always use the freewheel diode, which is to be connected as shown in the figure.



NOTE

Do not simultaneously connect the isolated internal supply and the auxiliary supply to power the isolated digital outputs. Dashed lines in the figures are alternative to standard wiring.



NOTE

Digital outputs XMDO1..8 are protected from a temporary short-circuit by a resettable fuse. After wiring the inverter, check the output voltage, as a permanent short-circuit can cause irreversible damage.

6.14.8. Environmental Requirements

Operating temperature	-10 to +55°C ambient temperature (contact Elettronica Santerno for higher ambient temperatures)
Relative humidity	5 to 95% (non-condensing)
Max. operating altitude	2000 m a.s.l. For installation above 2000 m and up to 4000 m, please contact Elettronica Santerno.

6.14.9. Electrical Ratings

6.14.9.1. Analog Inputs

<i>Fast Sampling Analog Inputs, $\pm 10V$ f.s.</i>	Value			
	Min.	Type	Max.	Unit
Input impedance		10		k Ω
Offset cumulative error and gain in respect to full-scale value		0.5		%
Temperature coefficient of the gain error and offset			200	ppm/ $^{\circ}C$
Digital resolution			12	bit
Value of voltage LSB		5.22		mV/LSB
Common mode maximum voltage over differential inputs	-15		+15	V
Permanent overload over inputs with no damage	-30		+30	V
Input filter cut-off frequency (2nd order Butterworth filter)		5.1		kHz
Sampling time (depending on the software being used)	0.2		1.2	ms

<i>Fast Sampling Analog Inputs for Current Measure</i>	Value			
	Min.	Type	Max.	Unit
Input impedance		200		Ω
Offset cumulative error and gain in respect to full-scale value		0.5		%
Temperature coefficient of the gain error and offset			200	ppm/ $^{\circ}C$
Digital resolution			12	bit
Value of current LSB		13		μA /LSB
Equivalent resolution in 0-20mA acquisition mode			10.5	bit
Permanent overload over inputs with no damage	-5		+5	V
Input filter cut-off frequency (2nd order Butterworth filter)		5.1		kHz
Sampling time (depending on the software being used)	0.2		1.2	ms

<i>Slow Sampling Analog Inputs Configured in 0-10V mode</i>	Value			
	Min.	Type	Max.	Unit
Input impedance		40		kΩ
Offset cumulative error and gain in respect to full-scale value		0.5		%
Temperature coefficient of the gain error and offset			200	ppm/°C
Digital resolution			12	bit
Value of voltage LSB		2.44		mV/LSB
Permanent overload over inputs with no damage	-30		+30	V
Input filter cut-off frequency (1st order low pass filter)		13		Hz
Sampling time (depending on the software being used)	10		1000	ms

<i>Slow Sampling Analog Inputs Configured in 0-20mA mode</i>	Value			
	Min.	Type	Max.	Unit
Input impedance		124.5		Ω
Offset cumulative error and gain in respect to full-scale value		0.5		%
Temperature coefficient of the gain error and offset			200	ppm/°C
Digital resolution			12	bit
Value of current LSB		4.90		μA/LSB
Permanent overload over inputs with no damage	-3.7		+3,7	V
Input filter cut-off frequency (1st order low pass filter)		13		Hz
Sampling time (depending on the software being used)	10		1000	ms

<i>Slow Sampling Analog Inputs Configured in 0-100mV mode</i>	Value			
	Min.	Type	Max.	Unit
Input impedance	1			MΩ
Offset cumulative error and gain in respect to full-scale value		0.2		%
Temperature coefficient of the gain error and offset			50	ppm/°C
Digital resolution			12	bit
Value of voltage LSB		24.7		μV/LSB
Permanent overload over inputs with no damage	-30		+30	V
Input filter cut-off frequency (1st order low pass filter)		13		Hz
Sampling time (depending on the software being used)	10		1000	ms

<i>Slow Sampling Analog Inputs Configured in PT100 Temperature Measure Mode</i>	<i>Value</i>			
	<i>Min</i>	<i>Type</i>	<i>Max</i>	<i>Unit .</i>
Type of probe	Two-wire PT100 Thermistor			
Measure range	-50		260	°C
Polarization current for PT100		0.49		mA
Measure temperature coefficient			50	ppm/°C
Digital resolution			11	bit
Measure max. cumulative error for temperature ranging from -40 to +55°C		0.5	1.5	°C
Mean value of temperature LSB (linearization SW function)		0.135		°C/LSB
Permanent overload over inputs with no damage	-10		+10	V
Input filter cut-off frequency (1st order low pass filter)		13		Hz
Sampling time (depending on the software being used)	10		1000	ms

6.14.9.2. *Digital Inputs*

<i>Features of the Digital Inputs</i>	<i>Value</i>			
	<i>Min.</i>	<i>Type</i>	<i>Max.</i>	<i>Unit</i>
Input voltage for XMDix in respect to CMD	-30		30	V
Voltage corresponding to logic level 1 between XMDix and CMD	15	24	30	V
Voltage corresponding to logic level 0 between XMDix and CMD	-30	0	5	V
Current absorbed by XMDix at logic level 1	5	9	12	mA
Input frequency over "fast" inputs XMDI6..8			155	kHz
Allowable duty-cycle for frequency inputs	30	50	70	%
Min. time at high level for "fast" inputs XMDI6..8	4.5			µs
Isolation test voltage between terminals CMD (43 and 50) in respect to terminals CMA (3-6-14-16-18-28-30-32-34-36-38)	500Vac, 50Hz, 1min.			

6.14.9.3. Digital Outputs

Features of the Digital Outputs	Value			
	Min.	Type	Max.	Unit
Working voltage range for outputs XMDO1..8	20	24	50	V
Max. current that can be switched from outputs XMDO1..8			50	mA
Voltage drop of outputs XMDO1..8, when active			2	V
Leakage current of outputs XMDO1..8, when active			4	μA
Isolation test voltage between terminals CMDO1..8 and CMA	500Vac, 50Hz, 1min.			

6.14.9.4. Supply Outputs

Features of the Analog Supply Outputs	Value			
	Min.	Type	Max.	Unit
Voltage available on terminal +15V (4) in respect to CMA (6)	14.25	15	15.75	V
Voltage available on terminal -15V (5) in respect to CMA (6)	-15.75	-15	-14.25	V
Max. current that can be delivered from +15V output and that can be absorbed by output -15V			100	mA

Features of the Digital Supply Outputs	Value			
	Min.	Type	Max.	Unit
Voltage available on +24V terminals (44, 49) in respect to CMD (43, 50)	21	24	27	V
Max. current that can be delivered from +24V output			200	mA



CAUTION

Irreversible faults occur if the min./max. input/output voltage ratings are exceeded.



NOTE

The isolated supply output and the analog auxiliary output are protected by a resettable fuse capable of protecting the power supply unit inside the inverter against short-circuits. Nevertheless, in case of short-circuit, it can happen that the inverter does not temporarily lock and does not stop the motor.

6.15. ES870 Relay I/O Expansion Board (Slot C)

ES870 board is an expansion board for the digital I/Os of all the products of the Sinus Penta series. ES870 board includes:

- XMDI1/2/3/4/5/6/7/8: Eight 24V multifunction digital inputs, type PNP. Three inputs are “fast propagation” inputs that can be used also for PUSH-PULL 24V encoder acquisition;
- XMDO1/2/3/4/5/6: Six multifunction relay digital outputs (Vomax = 250 VAC, Iomax = 5A, Vomax = 30 VDC, Iomax = 5A).

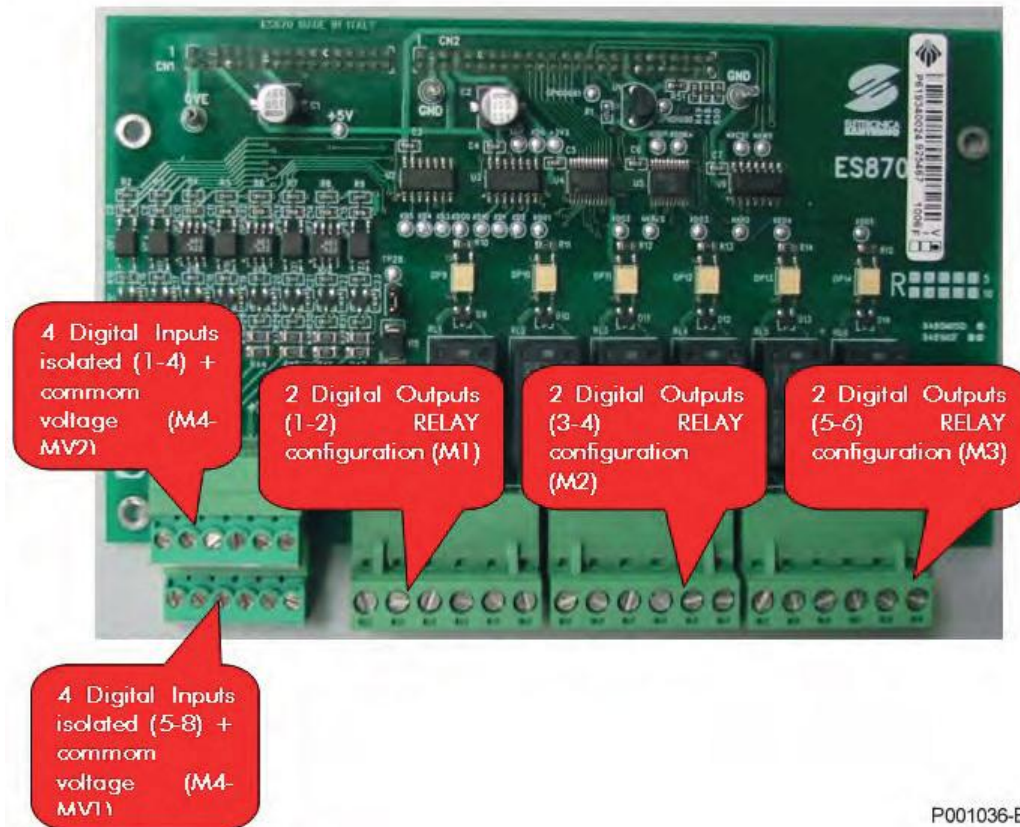

P001036-B

Figure 177: Relay I/O expansion board ES870



CAUTION

If ES870 board is fitted into slot C, ES919 cannot be mounted in slot B (see ES919 Communications Board (Slot B)).

6.15.1. Identification Data

Description	Part Number
Relay I/O Board	ZZ0101840

6.15.2. Installing ES870 Board on the Inverter (Slot C)



DANGER

Before gaining access to the components inside the inverter, remove voltage from the inverter and wait at least 20 minutes. Wait for a complete discharge of the internal capacitors to avoid any electric shock hazard.



CAUTION

Electric shock hazard: do not connect/disconnect the signal terminals or the power terminals when the inverter is on. This also prevents the inverter from being damaged.



NOTE

All the screws used to fasten removable parts (terminals cover, serial interface connector, cable plates, etc.) are black, round-head, cross-head screws. When wiring the inverter, remove only this type of screws. If different screws or bolts are removed, the inverter warranty will be no longer valid.

1. Remove voltage from the inverter and wait at least 20 minutes.
2. Remove the whole inverter covering by loosening the four hexagonal screws located on the top side and bottom side of the inverter to reach the fixing spacers and the signal connector (Figure 178 – Slot C.)



CAUTION

Before removing the inverter cover, draw out the keypad and disconnect the cable connecting the keypad to the control board to avoid damaging the link between the keypad and the control board.

P000099-0		ATTENTION Static Sensitive Devices. Handle Only at Static Safe Work Stations.	ATTENTION Circuits sensibles à l'électricité statique. Manipulation uniquement autorisée sur un poste de travail protégé.	ACHTUNG Elektrostatisch gefährdete Bauelemente. Handhabung daher nur an geschützten Arbeitsplätzen erlaubt.
-----------	---	--	--	--

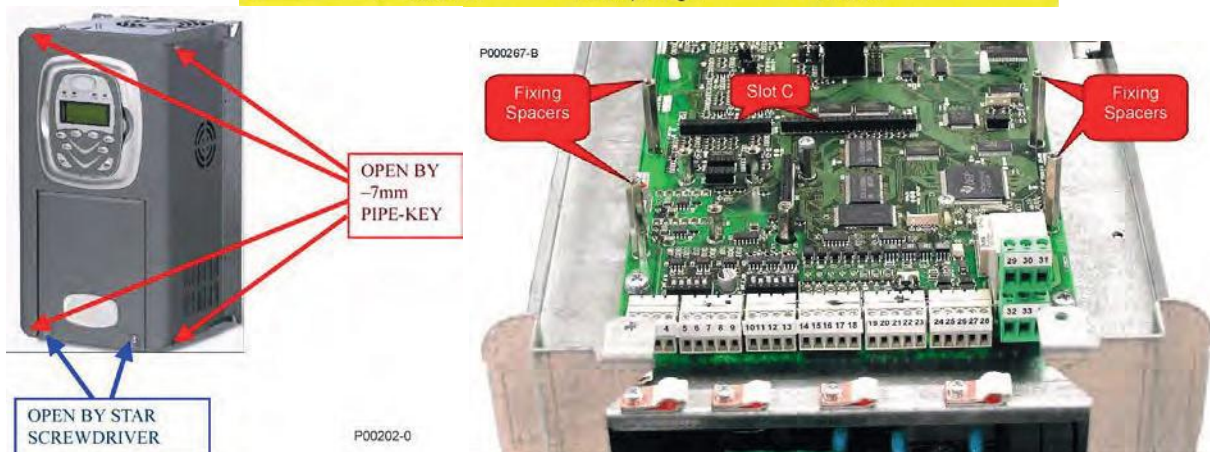

Figure 178: Removing the inverter cover; location of slot C

3. Insert the two contact strips supplied in the bottom part of ES870 board; make sure that each contact enters its slot in the connector. Insert ES870 board over the control board of the PENTA inverter; make sure that each contact enters its slot in the signal connector. Use the screws supplied to fasten board ES870 to the fixing spacers.
4. For the terminal board wiring, follow the instructions given in the section below.
5. Close the inverter frame by reassembling the cover allowing gaining access to the inverter control terminals.

6.15.3. ES870 Board Terminals

Screwable terminal board in two extractable sections suitable for cross-sections 0.08 ÷ 1.5mm² (AWG 28-16)

N.	Name	Description	I/O Features	Note
1	XMDI1	Multifunction auxiliary digital input 1	Optoisolated digital inputs 24 VDC; positive logic (PNP): active with positive input in respect to 0VE (terminal 6). In compliance with EN 61131-2 as type-1 digital inputs with rated voltage equal to 24 VDC.	Maximum response time to microprocessor: 500µs
2	XMDI2	Multifunction auxiliary digital input 2		
3	XMDI3	Multifunction auxiliary digital input 3		
4	XMDI4	Multifunction auxiliary digital input 4	+24V±15%; I _{max} output: 125mA; I _{input} max: 75mA Protected with resetting fuse.	
5	CMD	0V digital inputs isolated in respect to control 0V		
6	+24V	Auxiliary supply output for multifunction optoisolated digital inputs	Optoisolated digital input zero volt; test voltage 500Vac 50Hz 1' in respect to inverter CMA inputs	Maximum response time to microprocessor: 600ns
7	XMDI5	Multifunction auxiliary digital input 5	Optoisolated digital inputs 24 VDC; positive logic (PNP): active with positive input in respect to 0VE (terminal 6). In compliance with EN 61131-2 as type-1 digital inputs with rated voltage equal to 24 VDC.	
8	XMDI6 / ECHA / FINA	Multifunction auxiliary digital input 6 /Push-pull 24V single-ended phase A encoder input/Frequency input A		
9	XMDI7 / ECHB	Multifunction auxiliary digital input 7/ Push-pull 24V single-ended phase B encoder input		
10	XMDI8 / FINB	Multifunction auxiliary digital input 8/ Frequency input B	+24V±15% ; I _{max} output: 125mA; I _{max} input: 75mA Protected with resetting fuse.	
11	+24VE	Auxiliary supply output/input for optoisolated multifunction digital inputs/relay coils (*)		
12	0VE	0V digital inputs isolated in respect to control 0V	Optoisolated digital input zero volt; test voltage 500Vac 50Hz 1' in respect to inverter CMA inputs	



(*)
NOTE

The total load on +24VE inverter connection must not exceed 200mA. The total load is referred to all +24VE connections available on the main terminal board and the option terminal board. The relay coils fitted on ES870 optional board can sink up to 75mA from +24VE. Coil consumption must be subtracted from the 200mA rated current capability. By opening jumper J1, terminal n. 5 and 11 can be used as +24Vdc supply input for relay coils, unloading the inverter internal power supply.

Screwable terminal board in three extractable sections suitable for cross-sections 0.2 ÷ 2.5mm² (AWG 24-12)

N.	Name	Description	I/O Features
13	XDO1-NC	Multifunction, relay digital output 1 (NC contact)	Change-over contact: with low logic level, common terminal is closed with NC terminal; with high logic level, common terminal is open with NO; Resistive load capability: Vomax = 250 VAC, Iomax = 5A Vomax = 30 VDC, Iomax = 5A Inductive load capability (L/R=7ms): Vomax = 250 VAC, Iomax = 1.5A Vomax = 30 VDC, Iomax = 1.5A Isolation test voltage between contacts and coil 2500Vac 50Hz, 1' Min. load: 15mA, 10Vdc
14	XDO1-C	Multifunction, relay digital output 1 (common)	
15	XDO1-NO	Multifunction, relay digital output 1 (NO contact)	
16	XDO2-NC	Multifunction, relay digital output 2 (NC contact)	
17	XDO2-C	Multifunction, relay digital output 2 (common)	
18	XDO2-NO	Multifunction, relay digital output 2 (NO contact)	
19	XDO3-NC	Multifunction, relay digital output 3 (NC contact)	
20	XDO3-C	Multifunction, relay digital output 3 (common)	
21	XDO3-NO	Multifunction, relay digital output 3 (NO contact)	
22	XDO4-NC	Multifunction, relay digital output 4 (NC contact)	
23	XDO4-C	Multifunction, relay digital output 4 (common)	
24	XDO4-NO	Multifunction, relay digital output 4 (NO contact)	
25	XDO5-NC	Multifunction, relay digital output 5 (NC contact)	
26	XDO5-C	Multifunction, relay digital output 5 (common)	
27	XDO5-NO	Multifunction, relay digital output 5 (NO contact)	
28	XDO6-NC	Multifunction, relay digital output 6 (NC contact)	
29	XDO6-C	Multifunction, relay digital output 6 (common)	
30	XDO6-NO	Multifunction, relay digital output 6 (NO contact)	

6.15.3.1. Connection to an Encoder or a Frequency Input

Auxiliary digital inputs XMDI6, XMDI7, XMDI8 may acquire fast digital signals and may be used for the connection to a push-pull single-ended incremental encoder or for the acquisition of a frequency input.



NOTE When ES847 board is fitted, encoder B functions are no more implemented by the basic terminal board of the control board, but are implemented by ES847 board.

The electrical ratings of the aux digital inputs above are the same as the corresponding inputs in optional control board ES847.

For more details, please refer to Connection to an Encoder or a Frequency Input and ES847 Board Terminals.

6.16. ES914 Power Supply Unit Board



Figure 179: ES914 Power supply unit board

Description of ES914 board

ES914 board provides insulated power supply to the inverters of the Sinus Penta series through RS485 connector (see Auxiliary Power Supply). It is supplied on a board-holder support with rear plug connector for DIN rail type OMEGA 35mm.

ES914 board also provides insulation of RS485 signals on the inverter connector. Using ES914 board is recommended for galvanic insulation between the control circuits of the inverter and the external communication circuits.

3-zone insulation is provided: the 24Vdc supply input section, the RS485 section on the Master side and RS485 + 9Vdc supply output on the inverter side are electrically isolated (see Figure 181).

ES914 board transmits data in just one direction at a time (half-duplex transmission).

Transmission is typically started by the Master device, that transmits a poll packet. When receiving the start bit and the poll packet, the communication channel of the Master port opens towards the inverter port and it is kept open until the whole packet is received for a time over 4 byte-time at allowable minimum baud-rate. When the transmission time is over, both ports go idle.

The inverter then transmits the response packet. When the start bit of the response packet is received, the communications channel opens on the inverter side towards the Master port; when a second delay time has elapsed, the transmission cycle is complete.

ES914 board is equipped with two indicator LEDs indicating RS485 communication failures. Wiring mismatch (if any) is also detected.

ES914 board is provided with transient voltage suppressors (TVS) for the suppression of surge transients caused by bad weather events affecting RS485 serial communication cable reaching the Master device (the external device dialoguing with the inverter via ES914 board). ES914 board complies with EN 61000-4-5: Level 4, Criterion B.

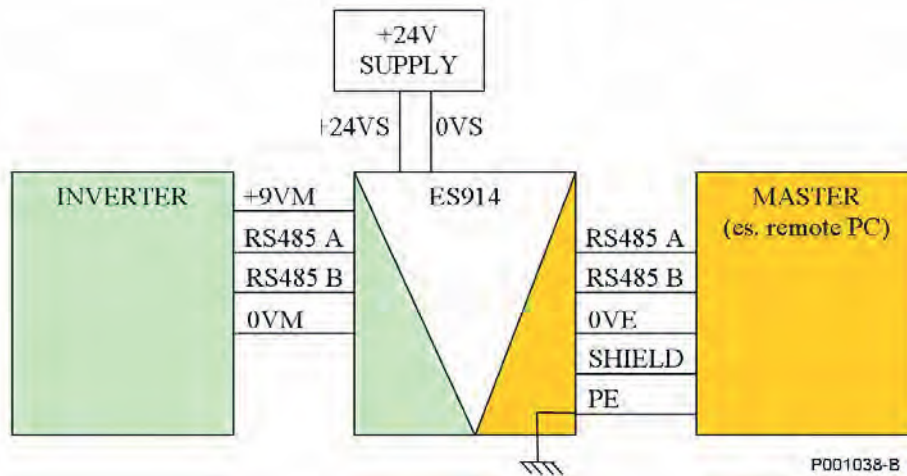

SHIELDED CABLE FOR RS485 LINK
PE-SHIELD Connection:

- Optional on inverter-side
- On master-side, it makes the signal discharger totally ineffective

Figure 180: Basic wiring diagram for ES914 board

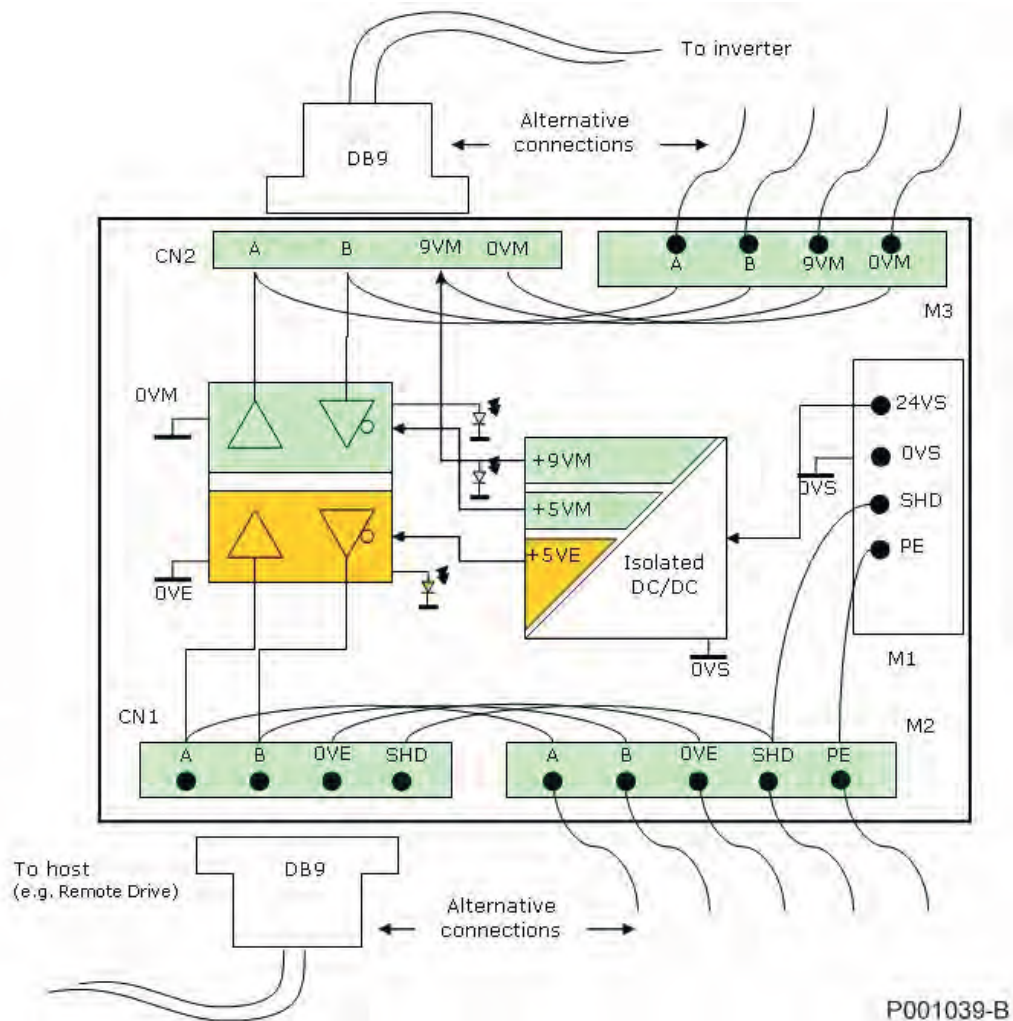

Figure 181: Block-diagram with 3-zone insulation

6.16.1. Identification Data

Description	Part Number
ES914 Adaptor for aux. power supply	ZZ0101790

6.16.2. Wiring ES914 Board

ES914 board includes three terminal boards and two connectors.

The signal connections going to the RS485 Master and to the inverter are available both on the screwable terminals and to DB9 connectors. This allows maximum wiring flexibility.

The SHIELD and PE conductors are located on the power supply input terminals. The PE conductor is to be connected to the safety conductor of the cabinet where the equipment is installed. The SHIELD connector is the shield of the communication cable reaching the RS485 Master. You can then decide whether and where to connect the cable shield.

The specifications of the terminals and the connectors are given below.

- M1 Terminals: power supply of ES914 board – separable terminals, 3.81mm pitch, suitable for 0.08 ÷ 1.5mm² (AWG 28-16) cables.

Terminal N.	Name	Description
1	+24VS	ES914 Power supply input
2	0VS	ES914 Power supply common
3	SHD	Shield of RS485 wire for external connections
4	PE	Protective Earth

- M2 Terminals: RS485 connection to the Master: separable terminals, 3.81mm pitch, suitable for 0.08 ÷ 1.5mm² (AWG 28-16) cables.

Terminal N.	Name	Description
5	RS485 Am	RS485 signal (A) – Master
6	RS485 Bm	RS485 signal (B) – Master
7	0VE	Common for connections to the Master
8	SHD	Shield of RS485 wire
9	PE	Protective Earth

- CN1 Connector: RS485 connection to the Master: male DB9 connector

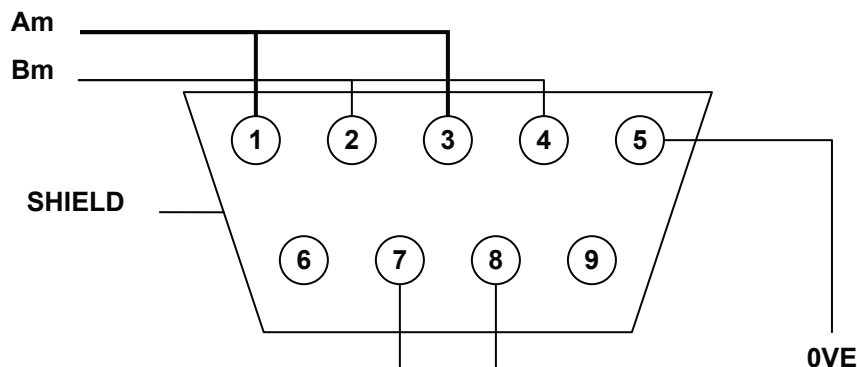

- M3 Terminals: RS485 connection to the inverter: separable terminals, 3.81mm pitch, suitable for $0.08 \div 1.5\text{mm}^2$ (AWG 28-16) cables.

Terminal N.	Name	Description
10	RS485 Ai	RS485 (A) signal – Inverter
11	RS485 Bi	RS485 (B) signal – Inverter
12	0VM	Common for connections to the inverter
13	+9VM	Inverter power supply output

- CN2 connector: RS485 connection to the inverter: female DB9 connector

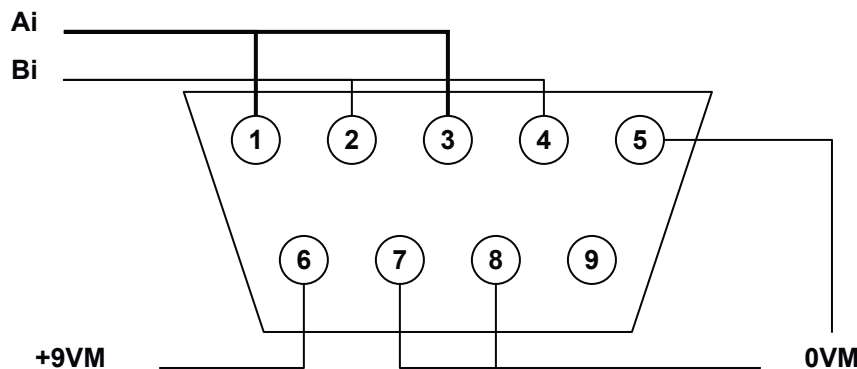

Recommended connection to the inverter

It is recommended that a shielded cable with DB9 connectors be used. Connect both ends of the cable shield so that it is the same PE voltage as the inverter. The shielded cable shall have at least one twisted pair for signals RS485 A and B. Two additional conductors and one additional twisted pair for the conductors of the inverter auxiliary power supply +9VM and 0VM are also required. Make sure that the cable length and cross-section are adequate, thus avoiding excessive voltage drop. For cable length up to 5m, the recommended minimum cross-section is 0.2mm^2 (AWG24) for the signal conductors and the power supply conductors.

Recommended connection to the Master

It is recommended that a shielded cable with at least one twisted pair be used. The cable shield shall be connected to the SHIELD terminal of the connector. The connection of the cable shield allows full exploitation of the suppressors located on the Master conductors.

The shielded cable shall have at least one twisted pair for signals RS485 A and B and shall propagate the common signal (0VE).

The following specifications are recommended for the shielded cable:

Type of cable	Shielded cable composed of a balanced pair named D1/D0 + common conductor ("Common").
Recommended cable model	Belden 3106 (distributed from Cavitec)
Min. cross-section of the conductors	AWG24 corresponding to 0.25mm^2 . For long cable length, larger cross-sections up to 0.75mm^2 are recommended.
Max. cable length	500 metres (based on the max. distance between two stations)
Characteristic impedance	Better if exceeding 100Ω (120Ω is typically recommended)
Standard colours	Yellow/brown for D1/D0 pair, grey for "Common" signal

Power Supply LEDs

ES914 board is equipped with three indicator LEDs for indicating the status of the power supply voltage.

LED	Colour	Function
L1	Green	Presence of power supply voltage (5V) in inverter-side RS485 circuits
L2	Green	Presence of inverter power supply voltage (9V)
L3	Green	Presence of power supply voltage (5V) in Master-side RS485 circuits

RS485 FAULT Signals

ES914 board is equipped with two LEDs indicating the fault status for the RS485 signals both on the inverter side and to the Master side. The FAULT indication is valid only when the line is properly terminated, i.e. DIP-switches SW1 and SW2 are "ON".

LED	Colour	Function
L5	Red	Inverter-side RS485 signal fault
L6	Red	Master-side RS485 signal fault

The following faults can be detected:

- Differential voltage between A and B lower than 450mV
- A or B exceed the common mode voltage range [-7V; 12V]
- A or B connected to fixed voltage (this condition can be detected only when communication is in progress).

Diagnostic Display

Figure 182 shows the indicator LEDs and the configuration DIP-switches of ES914 board.

Configuration of ES914 board

ES914 board includes two 2-position DIP-switches. These DIP-switches allow RS485 line termination to be configured both on inverter-side and on master-side.

DIP-switch	Function	Notes
SW1	Master-side RS485 termination	ON: 150Ω resistor between A and B; 430Ω resistor between A and +5VE; 430Ω resistor between B and 0VE (default) OFF: no termination and polarisation resistor
SW2	Inverter-side RS485 termination	ON: 150Ω resistor between A and B; 430Ω resistor between A and +5VM; 430Ω resistor between B and 0VM (default) OFF: no termination and polarisation resistor

<i>Electrical Specifications</i>	<i>Value</i>			
	<i>Min.</i>	<i>Typ.</i>	<i>Max.</i>	<i>Unit</i>
Operating temperature range of the components (standard version)	0		70	°C
Max. relative humidity (non-condensing)			95	%
Environment pollution degree (according to IEC 61800-5-1)			2	
Degree of protection of the plastic case	IP20			
Insulation test voltage between the encoder signals and the power supply ground	500Vac 1'			
<i>Connection to the inverter</i>	<i>Value</i>			
	<i>Min.</i>	<i>Typ.</i>	<i>Max.</i>	<i>Unit</i>
Input voltage	19	24	30	V
Power supply voltage to the inverter	8.5	9.16	11.1	V
Inverter power supply output current			830	mA
Input lines	Two lines: signals A and B, RS485 bus			
Type of input signals	RS485 Standard (from 4800bps to 115200bps)			
<i>Connection to the power supply line</i>	<i>Value</i>			
	<i>Min.</i>	<i>Typ.</i>	<i>Max.</i>	<i>Unit</i>
+24V Power supply absorption			700	mA
<i>Compliance</i>				
EN 61000-4-5	Level 4, Criterion B			



P001040-B

Figure 182: Position of the LEDs and DIP-switches in ES914 board

6.17. “Loc-0-Rem” Key Selector Switch And Emergency Push-Button for IP54 Models

The IP54 models can be provided with a key selector switch and an emergency push-button (optional devices supplied by request).

The key selector switch selects the following operating modes:

POSITION	OPERATING MODE	DESCRIPTION
LOC	INVERTER IN LOCAL MODE	The inverter operates in “Local” mode; the Start command and the frequency/speed reference are sent via display/keypad. Press the Start button to start the inverter; the Enable command (terminal 15) is sent from the selector switch if terminals 1 and 2 are connected together (factory-setting). Important: C180 = MDI 4 (Local/Remote command selection for digital input MDI4).
0	INVERTER DISABLED	Inverter disabled
REM	INVERTER IN REMOTE MODE	The control mode is defined by programming in parameters C140 ÷ C147 of the Control Method menu. The Enable command (terminal 15) is sent from the selector switch if terminals 1 and 2 are connected together (factory-setting).

When pressed, the emergency push-button immediately stops the inverter.

An auxiliary terminal board with voltage-free contacts is provided for the selector switch status, the emergency push-button status and the Enable command.

TERMINALS	FEATURES	FUNCTION	DESCRIPTION
1	Optoisolated digital input	ENABLE	Connect terminal 1 to terminal 2 to enable the inverter (terminals 1 and 2 are connected together—factory-setting)
2	0 V digital inputs	CMD	digital input ground
3-4	voltage-free contacts (230V - 3A, 24V - 2.5A)	STATUS OF LOC-0-REM SELECTOR SWITCH	contacts closed: selector switch in position LOC; contacts open: selector switch in position 0 or REM
5-6	voltage-free contacts (230V - 3A, 24V - 2.5A)	STATUS OF LOC-0-REM SELECTOR SWITCH	contacts closed: selector switch in position REM; contacts open: selector switch in position 0 or LOC
7-8	voltage-free contacts (230V - 3A, 24V - 2.5 A)	STATUS OF EMERGENCY PUSH-BUTTON	contacts closed: emergency push-button not depressed contacts open: emergency push-button depressed



NOTE

When the key selector switch and the emergency push-button are installed, multifunction digital input MDI4 (terminal 12) cannot be used. The ground of multifunction digital inputs is available also on terminal 2 in the auxiliary terminal board.

6.17.1. Wiring IP54 Inverters with Optional “LOC-0-REM” Key Selector Switch and Emergency Push-button

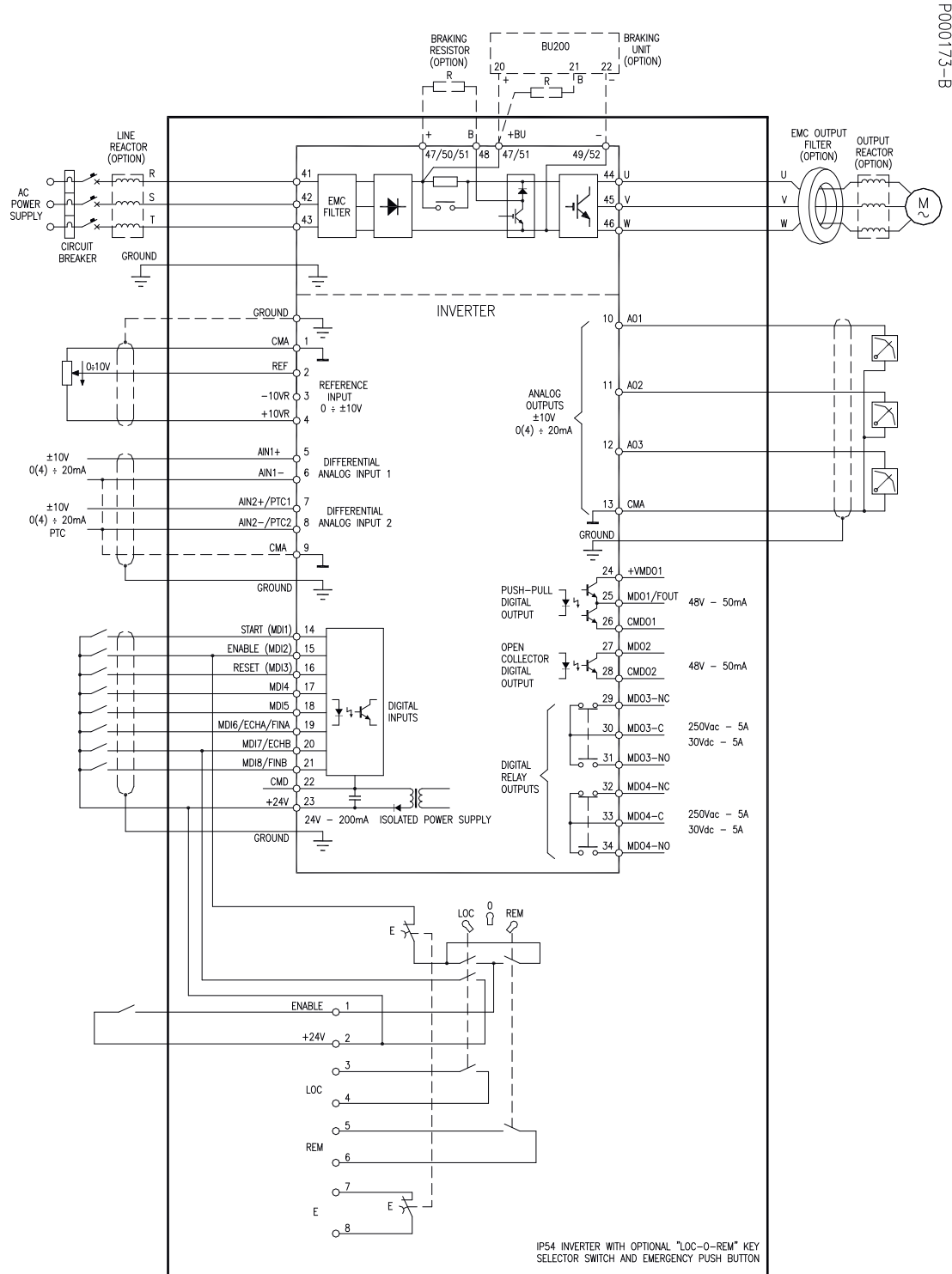

P000173-B

Figure 183: Wiring diagram for IP54 inverters

6.18. ES860 SIN/COS Encoder Board (Slot A)

The ES860 Sin/Cos Encoder board allows interfacing encoders provided with 1Volt peak-to-peak analog outputs. Those encoders may be used to provide speed feedback and/or position feedback for the inverters of the Sinus PENTA series.



NOTE Please refer to the Programming Guide and the Guide to the Synchronous Motor Application for the available control algorithms.

The ES860 board may be configured to operate in two acquisition modes as follows:

- **Three-channel mode:** increments low speed resolution and is suitable for slow rotation speed actuators requiring very accurate measurement of speed and position.
- **Five-channel mode:** detects the absolute mechanical position as soon as the inverter is first started up.

The board features are given below:

- Acquisition of five 1Volt peak-to-peak analog inputs on balanced line
- Two channels acquired via zero crossing and bidirectional digital counter with quadrature direction discriminator and x4 resolution multiplication factor (e.g. 1024 ppr to 4096 ppr)
- Zero index control for accurate alignment
- Two channels acquired in analog mode for absolute angle detection (12-bit resolution)
- Max. 140kHz input frequency in zero crossing channels for speeds up to 800rpm with 1024 ppr; alternatively up to 2000rpm with 4096 ppr
- Maximum 1kHz input frequency in analog channels
- Ability to re-direct analog signals to zero crossing channels
- Galvanic isolation in all channels for both digital and analog inputs
- 5V and 12V power supply output allowing fine tuning of the output voltage, isolated from the common for power supply output and signal output of the inverter.

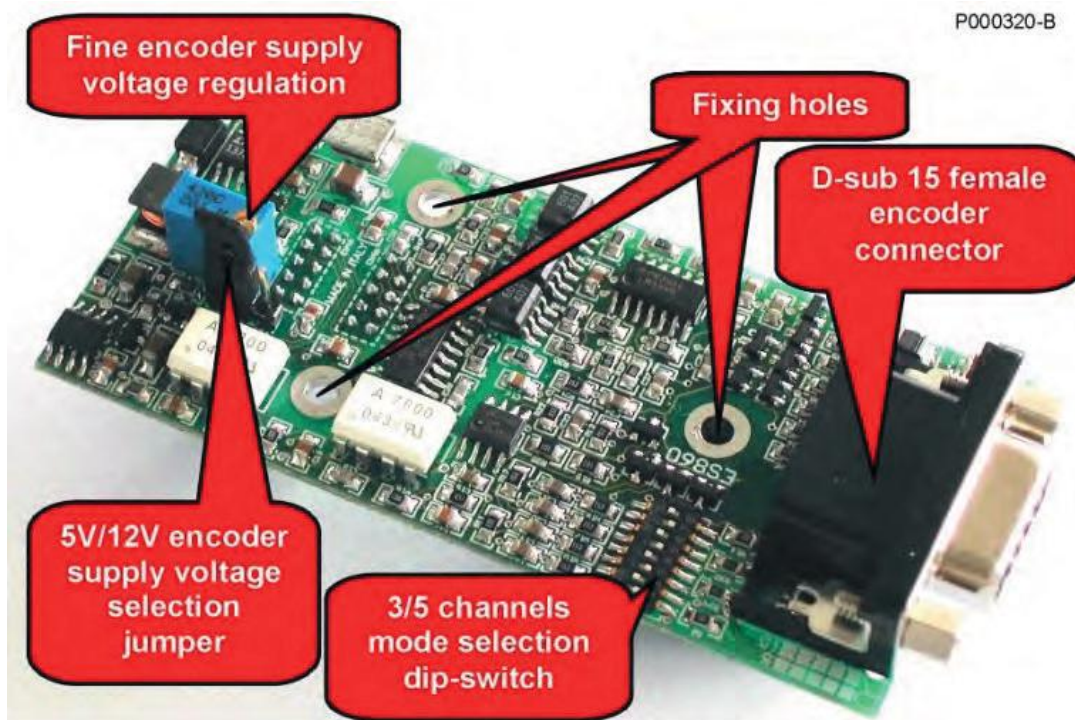

Figure 184: ES860 Sin/Cos Encoder board

6.18.1. Identification Data

Description	Part Number	Compatibility
ES860 SIN/COS Encoder Interface Board	ZZ0101830	Any inverter of the Sinus PENTA series with control board ES927 installed. Sin/Cos type Encoder with 5V, 12V, 15V, (5÷15V) power supply and 1Vpp output on 3 or 5 differential channels.

6.18.2. Installing ES860 Board on the Inverter (Slot A)

1. Remove voltage from the inverter and wait at least 20 minutes.
2. The electronic components in the inverter and the communications board are sensitive to electrostatic discharge. Take any safety measure before operating inside the inverter and before handling the board. The board should be installed in a workstation equipped with proper grounding and provided with an antistatic surface. If this is not possible, the installer must wear a ground bracelet properly connected to the PE conductor.



3. Remove the protective cover of the inverter terminal board by unscrewing the two screws on the front lower part of the cover. Slot A where the ES860 board will be installed is now accessible, as shown in the figure below.

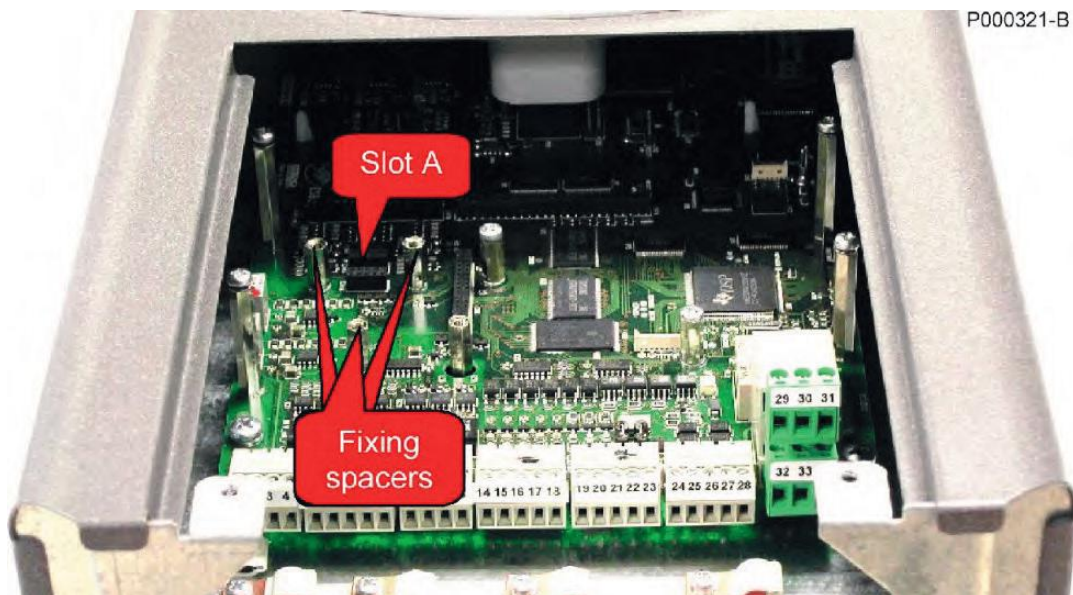

Figure 185: Location of Slot A inside the terminal board covers in Sinus PENTA inverters.

4. Insert ES860 board into Slot A. Carefully align the contact pins with the two connectors in the slot. If the board is properly installed, the three fixing holes are aligned with the housing of the relevant fixing spacers screws. Check if alignment is correct, then fasten the three fixing screws as show in the figure below.

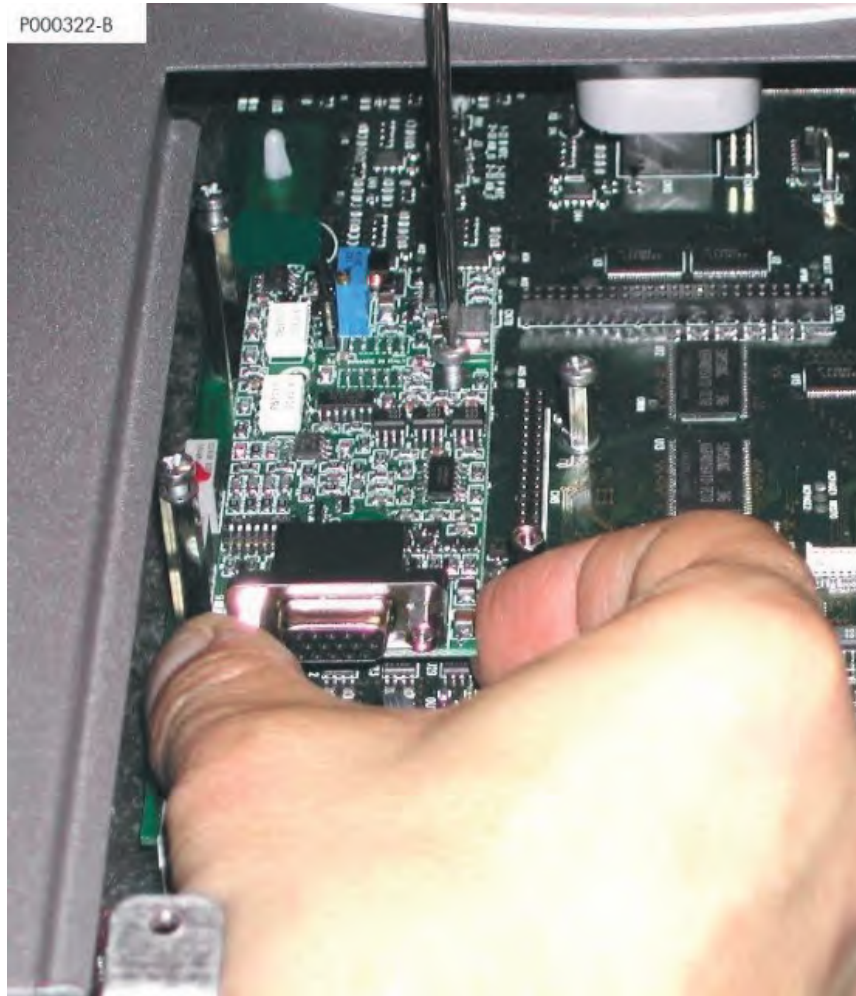

Figure 186: Fitting the ES860 board inside the inverter.

5. Set the correct encoder power supply and the DIP-switch configuration.
6. Power the inverter and check if the supply voltage delivered to the encoder is appropriate. Set up the parameters relating to "Encoder A" as described in the Programming Guide.
7. Remove voltage from the inverter, wait until the inverter has come to a complete stop and connect the encoder cable.



DANGER

Before gaining access to the components inside the inverter, remove voltage from the inverter and wait at least 20 minutes. Wait for the complete discharge of the internal capacitors to avoid electric shock hazard.



WARNING

Do not connect or disconnect signal terminals or power terminals when the inverter is powered to avoid electric shock hazard and to avoid damaging the inverter.



NOTE

All fastening screws for removable parts (terminal cover, serial interface connector, cable path plates, etc.) are black, rounded-head, cross-headed screws.

Only these screws may be removed when connecting the equipment. Removing different screws or bolts will void the product guarantee.

6.18.2.1. Sin/Cos Encoder Connector

High density D-sub 15-pin female connector (three rows). The figure shows a front view of the pin layout.



Figure 187: Pin layout on the high density connector

No.	Name	Description
1	C-	Negative sine signal (absolute position)
2	D-	Negative cosine signal (absolute position)
3	A-	Negative sine signal
4	B-	Negative cosine signal
5	n.c.	
6	C+	Positive sine signal (absolute position)
7	D+	Positive cosine signal (absolute position)
8	A+	Positive sine signal
9	B+	Positive cosine signal
10	n.c.	
11	n.c.	
12	+VE	Encoder power output
13	0VE	Common for power supply and signals
14	R-	Negative zero index signal acquired with zero crossing
15	R+	Zero index signal acquired with zero crossing
Shell	PE	Connector shield connected to Inverter PE conductor

6.18.3. ES860 Configuration and Operating Modes

The ES860 Encoder Interface Board may power both 5V and 12V encoders and allows acquiring two types of encoders with 1Volt peak-to-peak sinusoidal outputs:

Three-channel mode: signals A (sine), B (cosine), R (zero index).

Input signals C+, C-, D+, D- are not used in three-channel mode. DIP-switch SW1 is to be set as in the figure below: odd-numbered switches to ON and the even-numbered switches to OFF.



Figure 188: DIP-switch SW1 setting in three-channel mode

Five-channel mode: signals A (sine), B (cosine), R (zero index), C (sine, absolute position), D (cosine, absolute position).

All input signals are used in five-channel mode. DIP-switch SW1 shall be set as in the figure below: even-numbered switches to ON, odd-numbered switches to OFF.



Figure 189: DIP-switch SW1 setting for five-channel mode



CAUTION

Do not alter the DIP-switch configuration and do not enable the configuration switches when the inverter is powered. Unexpected changes in switch settings, even of short duration, cause irreparable damage to the board and the encoder.

6.18.3.1. Configuring and Adjusting the Encoder Supply Voltage

The ES860 board may power encoders having different power supply voltage ratings. A selection Jumper and a power supply voltage regulation Trimmer are available, as shown in the figure below.

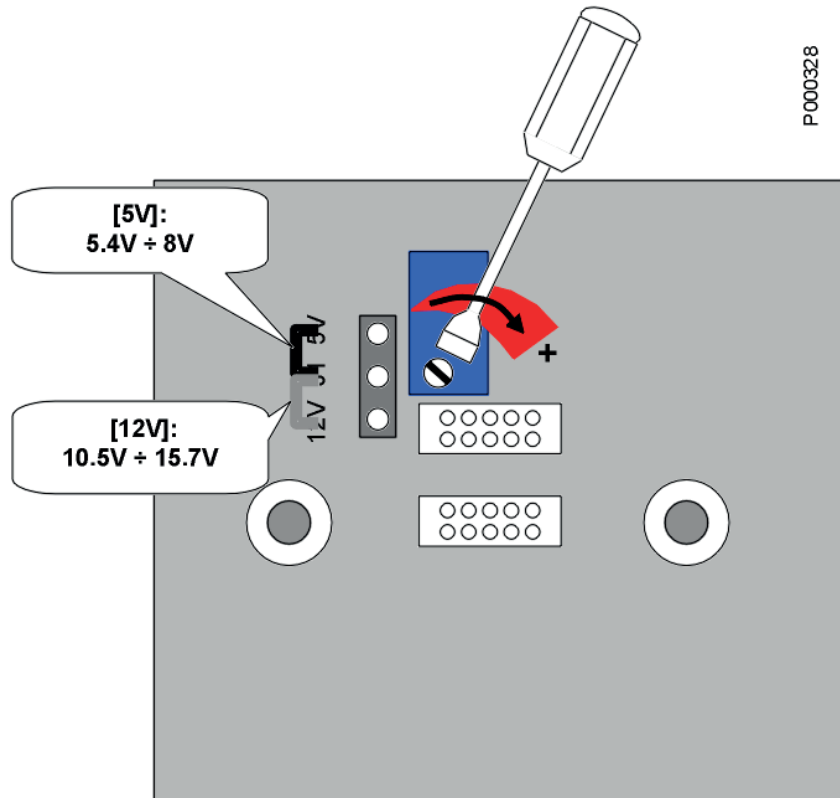

Figure 190: Position of the jumper and voltage adjusting trimmer.

The ES860 board is factory-set with a minimum output voltage of 5.4V for the power supply of 5V rated encoders. Take account of $\pm 10\%$ due to voltage drops in cables and connector contactors. By using the trimmer, 8V voltage may be supplied.

Set the jumper to 12V to supply 12V or 15V encoders. It is now possible to operate on the trimmer to adjust voltage from 10.5 to 15.7V. Turn the trimmer clockwise to increase output voltage.

Power supply voltage is to be measured at the encoder supply terminals, thus taking account of cable voltage drops, particularly if a long cable is used.



CAUTION

Supplying the encoder with inadequate voltage may damage the component. Before connecting the cable and after configuring ES860 board, always use a tester to check the voltage supplied by the board itself.



NOTE

The encoder power supply circuit is provided with an electronic current limiter and a resettable fuse. Should a short-circuit occur in the supply output, shut down the inverter and wait a few minutes to give the resettable fuse time to reset.

6.18.4. Connecting the Encoder Cable

State-of-the-art connections are imperative. Use shielded cables and correctly connect cable shielding. The recommended connection diagram consists in a multipolar, dual shielded cable. The inner shield shall be connected to the connector case connected to the ES860 board, while the outer shield shall be connected to the encoder frame, usually in common with the motor frame. If the inner shield is not connected to the encoder frame, this can be connected to the inner braid. The motor must always be earthed as instructed with a dedicated conductor connected directly to the inverter earthing point and routed parallel to the motor power supply cables. It is not advisable to route the Encoder cable parallel to the motor power cables. It is preferable to use a dedicated signal cable conduit. The figure below illustrates the recommended connection method.

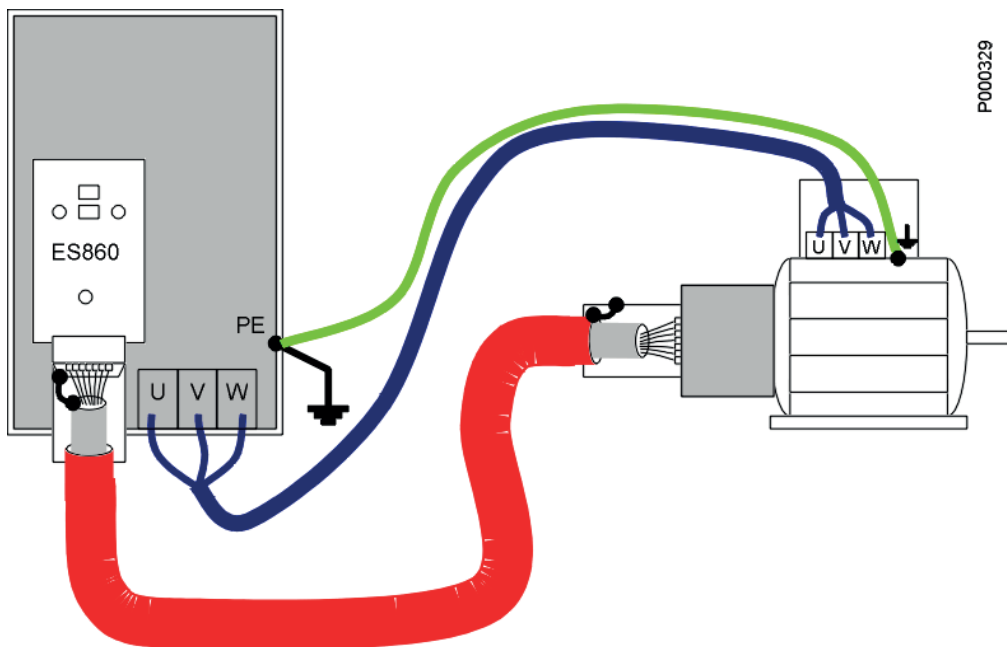

Figure 191: Recommended dual shielded connection for encoder cable.



NOTE

The encoder supply output and the encoder signal common are isolated in respect to the common of the analog signals fitted in the inverter terminal board (CMA). Do not connect any conductors in common between the encoder signals and the signals in the inverter terminal board. This prevents isolation from being adversely affected.



CAUTION

The connector of the ES860 board shall be connected exclusively to the encoder using one single cable.

Correctly fasten the cable and the connectors both on the encoder side and on ES860 board side. The disconnection of one cable or even a single conductor may lead to inverter malfunction and may cause the motor to run out of control.

6.18.5. Environmental Requirements

Operating temperatures	-10 to +55°C ambient temperature (contact Elettronica Santerno for higher ambient temperatures)
Relative humidity	5 to 95% (non-condensing)
Max. allowable operating altitude	2000 m a.s.l. For installation above 2000 m and up to 4000 m, please contact Elettronica Santerno.

6.18.6. Electrical Ratings

Class A voltage according to IEC 61800-5-1

<i>Encoder supply output</i>	<i>Ratings</i>			
	<i>Min</i>	<i>Typ</i>	<i>Max</i>	<i>Unit</i>
Encoder output current, +12V configuration			300	mA
Encoder output current, +5V configuration			500	mA
Short-circuit protection level			900	mA
Encoder supply voltage adjusting range in 5V Mode	5.4	5.3	8.0	V
Encoder supply voltage adjusting range in 12V Mode	10.5	12.0	15.7	V

<i>Static characteristics for signal inputs</i>	<i>Ratings</i>			
	<i>Min</i>	<i>Typ</i>	<i>Max</i>	<i>Unit</i>
Type of input signals, A,B	Differential analog type ~1Vpp			
Differential peak-to-peak input voltage range	0.8	1.0	1.2	Vpp
Input common mode voltage range	0		5	V
Input impedance	120			ohm
Type of input signals, C,D	Differential analog type ~1Vpp			
Differential input voltage range	0.8	1.0	1.2	Vpp
Input common mode voltage range	0		5	V
Input impedance	1			Kohm
Type of input signal R	Differential analog type ~0.5Vpp/1Vpp			
Differential encoder signal input voltage range	0.2	0.5	1.1	Vpp
Input common mode voltage range	0		5	V
Input impedance	120			ohm

<i>Max. absolute values</i>	<i>Value</i>			
	<i>Min</i>	<i>Typ</i>	<i>Max</i>	<i>Unit</i>
Maximum allowable common mode voltage amplitude causing no damage	-20		+25	V
Maximum allowable differential voltage amplitude on channels A, B, R	-3.5		+3.5	V
Maximum allowable differential voltage amplitude on channels C and D	-10		+10	V



CAUTION

Exceeding the maximum differential input or common mode voltages will result in irreparable damage to the apparatus.

<i>Dynamic characteristics of the input signals</i>	<i>Value</i>
Maximum frequency of the signals acquired in analog mode – channels C, D or channels A, B in three-channel mode	1000Hz (60,000rpm @ 1 p/rev) (60 rpm @ 1,024 p/rev)
Maximum frequency of signals acquired with digital counting on zero crossing – channels A, B	140kHz (1,024pls @ 8,200rpm)
Minimum duration of zero crossing pulse – channel R	3.5 <input type="checkbox"/>



CAUTION

Exceeding the input signal frequency limits will result in a wrong measurement of the encoder position and speed. Depending on the control method selected for the inverter, it may also cause the motor to run out of control.

6.19. ES861 Resolver and Incremental Encoder Board (Slot C)

The ES861 board acquires resolver signals and converts them into 12-bit digital signals that can be used as speed and/or position feedback for the inverters of the Sinus PENTA series.



NOTE Please refer to the Programming Guide and the Guide to the Synchronous Motor Application for the available control algorithms.

The ES861 board also generates the sinusoidal signal for the resolver excitation and features dedicated logics for the acquisition of differential signals sent from incremental encoders and for the control of optoisolated digital inputs and outputs.

Main features of the ES861 board:

- Resolver to Digital (RtD) conversion allowing selecting motor position readout or speed readout.
- Configurable frequency and gain of the excitation signal and the reading signals from the Resolver.
- Incremental encoder output generated from RtD to line-driver (TIA/EIA-422) at 1024 pls/rev, repeated also to the internal bus of the inverter.
- Encoder input compatible with optoisolated line-driver (TIA/EIA-422) encoders.
- Possibility of enabling a frequency divider (by 2, 4, 8) for incremental encoder signals coming from line-driver encoders, or for signals obtained from RtD conversion.
- Configurable encoder supply output (5V, 12V, 24V) allowing output voltage fine-tuning, isolated from control logics.
- Acquisition of No.3 optoisolated digital inputs.
- Control of No.3 optoisolated digital outputs.

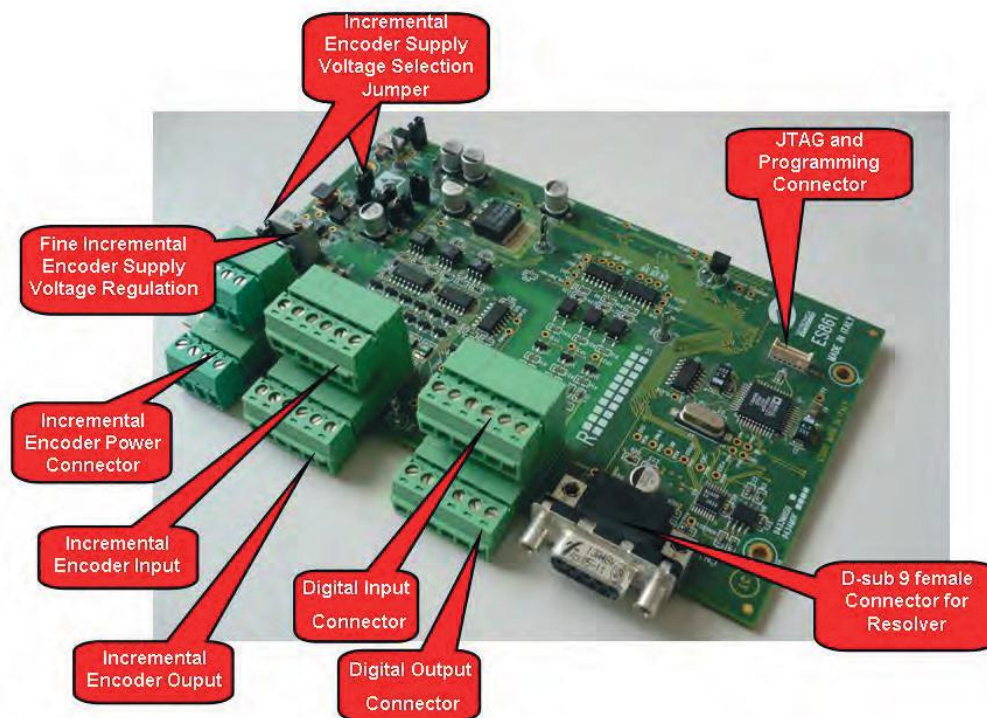

Figure 192: ES861 Incremental Encoder and Resolver expansion board



CAUTION

If ES861 board is fitted into slot C, ES919 board cannot be fitted into slot B (see ES919 Communications Board (Slot B)).

Features of the encoder inputs:

- 77kHz (1024pls @ 4500rpm) for max. input frequency with digital filter enabled
- 155kHz (1024pls @ 9000rpm) for max. input frequency with digital filter disabled
- Input with differential or single-ended signals
- Input signal error detection.

Features of the resolver inputs:

- Configurable excitation frequency ranging from 10kHz to 20 kHz
- Max. 30 mA RMS current at excitation output
- Max. 14 V RMS voltage at excitation output
- Detection of the PTC signal from the Resolver
- 12-bit RtD for positioning (0.0879° x LSB) or speed acquisition range [-60000 ÷ 60000] rpm.

6.19.1. Identification Data

<i>Description</i>	<i>Part Number</i>	<i>Compatibility</i>
ES861 Incremental Encoder and Resolver expansion board	ZZ0101860	All the inverters of the Sinus PENTA series with control board ES927 installed. <ul style="list-style-type: none"> - Sin/Cos resolver inputs, 3.6Vpp ± 10% ranging from 10 kHz to 20 kHz. - Incremental encoders with signals on balanced line according to standard TIA/EIA-422 and power supply ranging from 5 to 24V.

6.19.2. Installing ES861 Board on the Inverter (Slot C)

1. Remove voltage from the inverter and wait at least 20 minutes.
2. The electronic components of the inverter and the board are sensitive to electrostatic discharges. Take any safety measure before operating inside the inverter and before handling the board. The board should be installed in a workstation equipped with proper grounding and provided with an antistatic surface. If this is not possible, the installer must wear a ground bracelet properly connected to the PE conductor.

	ATTENTION	ATTENTION	ACHTUNG
	Static Sensitive Devices. Handle Only at Static Safe Work Stations.	Circuits sensibles à l'électricité statique. Manipulation uniquement autorisée sur un poste de travail protégé.	Elektrostatisch gefährdete Bauelemente. Handhabung daher nur an geschützten Arbeitsplätzen erlaubt.

3. Remove the protective cover of the inverter terminal board by unscrewing the two screws on the front lower part of the cover. Slot C where ES861 board will be installed is now accessible, as shown in the figure below.
4. Insert the ES861 board into Slot C. Carefully align the contact pins with the two connectors in the slot (CN7A and CN7B). If the board is properly installed, the four fixing holes are aligned with the housing of the relevant fixing spacers screws. Check if alignment is correct, then fasten the four fixing screws as show in the figure below.

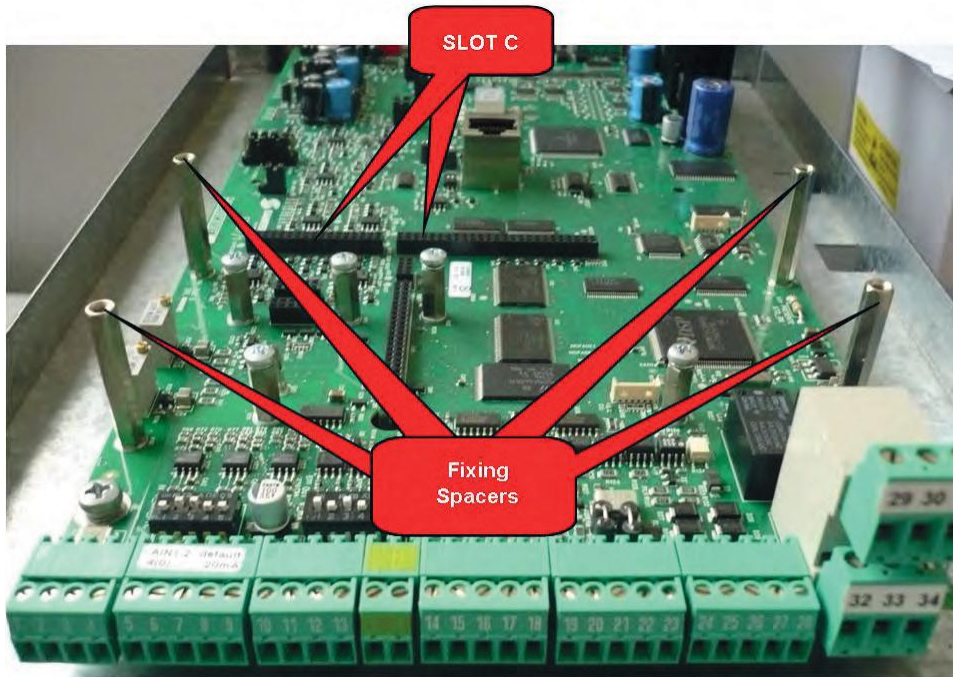

Figure 193: Location of slot C inside the terminal board cover of the Sinus Penta inverter

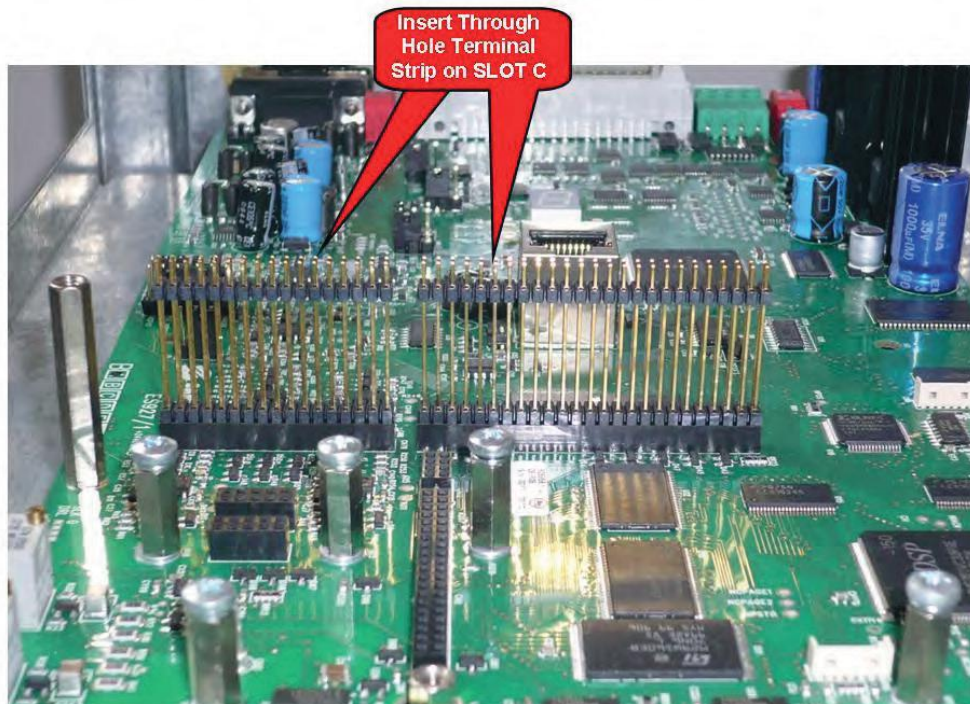

Figure 194: Terminal strips inserted into SLOT C

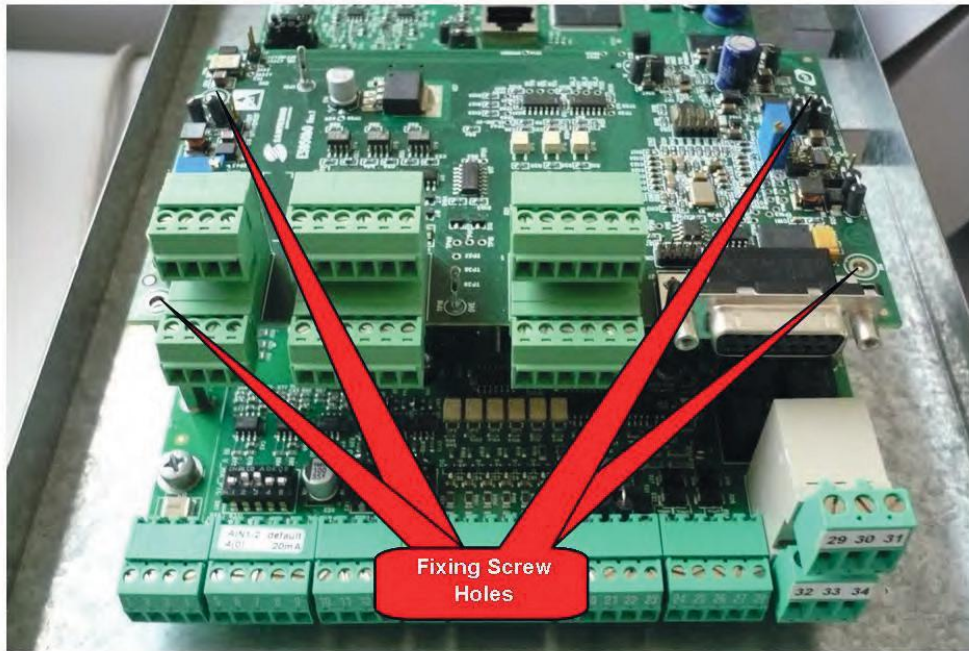

Figure 195: Fitting the ES861 board inside the inverter.

5. Configure the supply voltage for the incremental encoder (please refer to the relevant User Manual) by setting the configuration jumper accordingly.
6. Power the inverter and check if the supply voltage delivered to the encoder is appropriate. Set up the parameters relating to "Encoder A" as described in the Programming Guide.
7. Remove voltage from the inverter, wait until the inverter has come to a complete stop and connect the encoder/resolver cable.



DANGER

Before gaining access to the components inside the inverter, remove voltage from the inverter and wait at least 20 minutes. Wait for the complete discharge of the internal capacitors to avoid electric shock hazard.



WARNING

Do not connect or disconnect signal terminals or power terminals when the inverter is powered to avoid electric shock hazard and to avoid damaging the inverter.



NOTE

All fastening screws for removable parts (terminal cover, serial interface connector, cable path plates, etc.) are black, rounded-head, cross-headed screws.

Only these screws may be removed when connecting the equipment. Removing different screws or bolts will void the product guarantee.

6.19.2.1. Resolver Connector

D-sub 9-pin female connector. The figure shows a front view of the PIN layout.

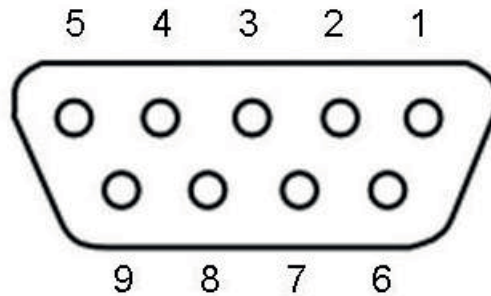

Figure 196: Pin layout on the D-sub 9-pin female connector.

N.	Name	Description
1	EXC+	Resolver excitation output (direct signal)
2	EXC-	Resolver excitation output (inverted signal)
3	SIN+	Sine signal input (direct)
4	SIN-	Sine signal input (inverted)
5	COS+	Cosine signal input (direct)
6	COS-	Cosine signal input (inverted)
7	PTC1	Terminal 1 of the Resolver PTC
8	PTC2	Terminal 2 of the Resolver PTC
9	0V	Board logics power supply common

6.19.2.2. Incremental Encoder and Digital Lines Connectors

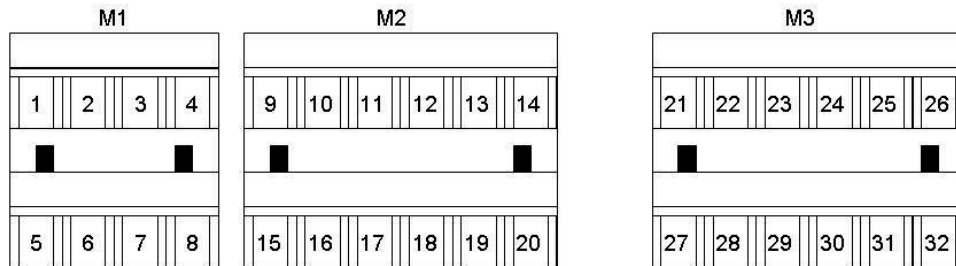

Figure 197: Input-output signal terminal boards

N.	Name	Description
1	+VEOUT	Incremental encoder power supply output
2	0VE	Isolated power supply common
3	0VE	Isolated power supply common
4	0VM	Isolated 5V power supply generated internally for control logics
5	+5V_EXT	Input for external power supply for incremental encoder
6	+5VM_INT	Isolated 5V power supply generated internally on ES861 board (5VM)
7	+0V_EXT	External power supply common
8	0VM	Isolated 5V power supply generated internally for control logics
9	CHA	Channel A input for positive incremental encoder
10	/CHA	Channel A input for inverted incremental encoder
11	CHB	Channel B input for positive incremental encoder
12	/CHB	Channel B input for inverted incremental encoder
13	CHZ	Positive zero index signal
14	/CHZ	Negative zero index signal
15	CHA_U	Incremental encoder A signal output from resolver conversion or from encoder input (CHA pin 9) – positive signal
16	/CHA_U	Incremental encoder A signal output from resolver conversion or from encoder input (/CHA pin 10) – negative signal
17	CHB_U	Incremental encoder B signal output from resolver conversion or from encoder input (CHB pin 11) – positive signal
18	/CHB_U	Incremental encoder B signal output from resolver conversion or from encoder input (/CHB pin 12) – negative signal
19	CHZ_U	Incremental encoder Z signal output from resolver conversion or from encoder input (CHZ pin 13) – positive signal
20	/CHZ_U	Incremental encoder Z signal output from resolver conversion or from encoder input (/CHZ pin 14) – negative signal
21	XMDI1	Digital input
22	XMDI2	Digital input
23	XMDI3	Digital input
24	n.c.	
25	n.c.	
26	CMD	Common for digital inputs
27	XMDO1	Digital output 1 (collector)
28	CMDO1	Digital output 1 (emitter)
29	XMDO2	Digital output 2 (collector)
30	CMDO2	Digital output 2 (emitter)
31	XMDO3	Digital output 3 (collector)
32	CMDO3	Digital output 3 (emitter)

6.19.3. ES861 Configuration and Operating Modes

The ES861 board may power both 5V to 24V encoders and allows acquiring signals coming from the Resolver in order to convert the position/speed data into a 12-bit word.

6.19.3.1. Configuring and Adjusting the Encoder Supply Voltage

The ES861 board may power encoders having different power supply voltage ratings. A selection jumper and a power supply voltage regulation trimmer are available as shown in the figure below. The jumpers and the trimmer are located on the top side of the board. The possible configurations are given in the table below:

Incremental encoder power supply: VE OUT				No VE OUT
	24V	12V	5V	
J1	X	OFF	ON	X
J2	2-3	1-2	1-2	X
J3	ON	ON	ON	OFF

In 24V mode, the output voltage is fixed and cannot be adjusted. In 5 and 12V mode, the output voltage can be fine-tuned: in 5V mode, the no-load voltage may range from 4.5 to 7V by adjusting each individual trimmer accordingly; in 12V mode, the no-load voltage may range from 10.5 to 17V.

Turn the trimmer clockwise to increase output voltage.

Power supply voltage is to be measured at the encoder supply terminals, thus taking account of cable voltage drops, particularly if a long cable is used.

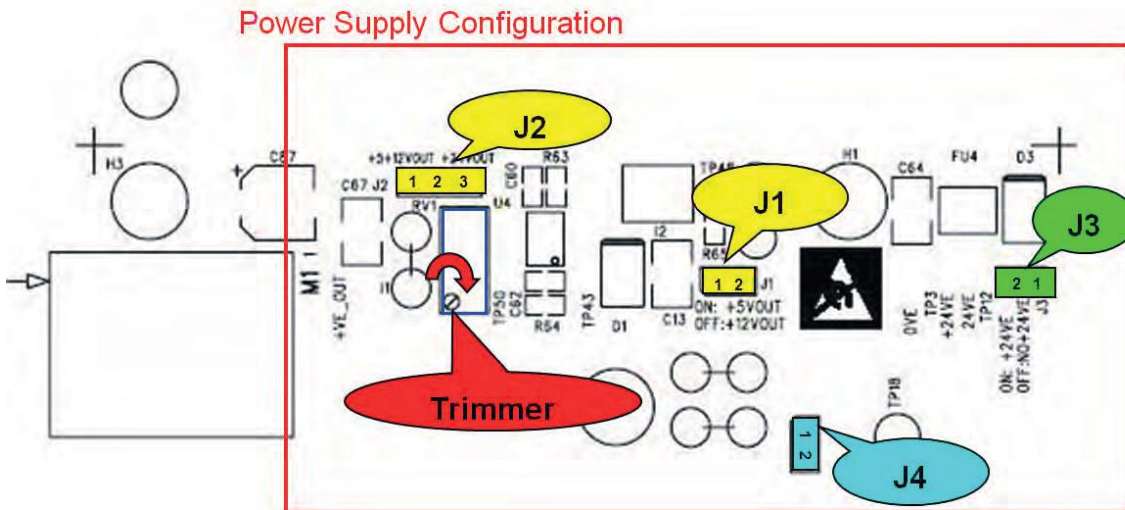

Figure 198: Jumpers and trimmer for power supply configuration.

Different configurations are available as per line-driver encoders (TX/RX):

Jumper J4 off:

- Output line-driver encoders supplied from 5V external source: pin 5 in M1 "+5V_EXT" at 5V and pin 7 in M1 "0V_EXT" at 0V (see Figure 197).

- Input line-driver encoders supplied from 5V external source: pin 6 in M1 “+5VM_INT” at 5V and pin 8 in M1 “0VM_INT” at 0V. If the same external source is to be used also for the line-driver encoders in RX mode, create a jumper between pins 5 and 6 in M1 and a jumper between pins 7 and 8.

Jumper J4 on:

- Output line-driver encoders supplied from 5V external source: pin 5 in M1 “+5V_EXT” at 5V and pin 7 in M1 “0V_EXT” at 0V. If the same external source is to be used also for the line-driver encoders in RX mode, create a jumper between pins 5 and 6 in M1 and a jumper between pins 7 and 8.
- Input line-driver encoders supplied from isolated 5V supply generated internally to the inverter.



CAUTION

Supplying the encoder with inadequate voltage may damage the component. Before connecting the cable and after configuring the ES861 board, always use a tester to check the voltage supplied by the board itself.



NOTE

The encoder power supply circuit is provided with an electronic current limiter and a resettable fuse. Should a short-circuit occur in the supply output, shut down the inverter and wait a few minutes to give the resettable fuse time to reset.

6.19.4. Connecting the Resolver Cable

State-of-the-art connections are imperative. Use shielded cables and correctly connect cable shielding. The recommended connection diagram consists in a multipolar, dual shielded cable. The inner shield shall be connected to the connector case connected to ES861 board, while the outer shield shall be connected to the encoder frame, usually in common with the motor frame. If the inner shield is not connected to the encoder frame, this can be connected to the inner braid. The motor must always be earthed as instructed with a dedicated conductor attached directly to the inverter earthing point and routed parallel to the motor power supply cables. It is not advisable to route the encoder cable parallel to the motor power cables. It is preferable to use a dedicated signal cable conduit. The figure below illustrates the recommended connection method.

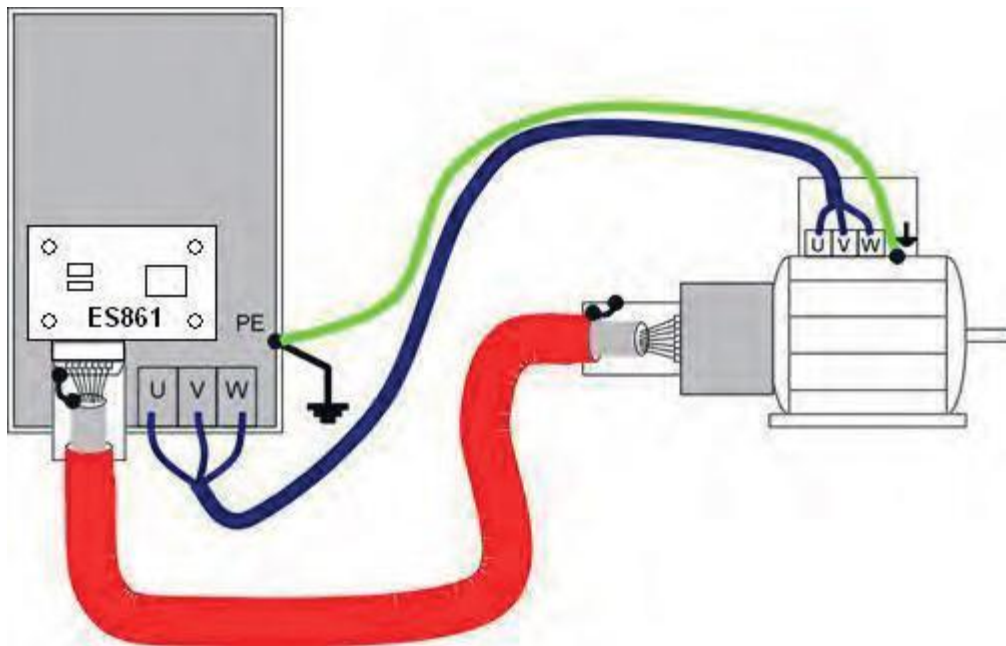

Figure 199: Recommended dual shielded connection for resolver cable.



NOTE

The encoder supply output and the encoder signal common are isolated in respect to the common of the analog signals fitted in the inverter terminal board (CMA). Do not connect any conductors in common between the encoder signals and the signals in the inverter terminal board. This prevents isolation from being adversely affected.

The connector of ES861 board shall be connected exclusively to the encoder using one single cable.



CAUTION

Correctly fasten the cable and the connectors both on the encoder side and on ES860 board side. The disconnection of one cable or even a single conductor may lead to inverter malfunction and may cause the motor to run out of control.

6.19.5. Environmental Requirements

Operating temperatures	-10 to +55°C ambient temperature (contact Elettronica Santerno for higher ambient temperatures)
Relative humidity	5 to 95% (non-condensing)
Max. allowable operating altitude	2000 m a.s.l. For installation above 2000 m and up to 4000 m, please contact Elettronica Santerno.

6.19.6. Electrical Ratings

Decisive voltage class A according to IEC 61800-5-1

<i>Incremental encoder power supply output</i>	Value			
	Min	Typ	Max	Unit
Encoder output current, +24V configuration			150	mA
Encoder output current, +12V configuration			200	mA
Encoder output current, +5V configuration			500	mA
24VE Short-circuit protection level			300	mA
Encoder supply voltage adjusting range in 5V mode (no-load voltage)	4.5	5.3	7	V
Encoder supply voltage adjusting range in 12V mode (no-load voltage)	10.5	12.0	17	V

<i>Static characteristics for signal inputs</i>	Value			
	Min	Typ	Max	Unit
Type of input signals, SIN, COS	Resolver signals			
Differential input voltage range	3.24	3.6	3.96	V
Input common mode voltage range in respect to REFOUT @ 10 kHz			100	mV
Input common mode voltage range in respect to AGND	0.2		5	V
Input impedance	1			Mohm
Type of input signals, CHA, CHB, CHZ	Standard TIA/EIA-422			
Differential input voltage range			±7	V
Input common mode voltage range			±7	V
Input impedance	150			ohm
Type of input signals MDI1, MDI2, MDI3 in respect to COM_MDI	Digital signals from the field			
Input voltage range	15	24	30	V

<i>Max. absolute values</i>	<i>Value</i>			
	<i>Min</i>	<i>Typ</i>	<i>Max</i>	<i>Unit</i>
Maximum allowable common mode voltage amplitude for channels CHA, CHB, CHZ	-25		+25	V



CAUTION

Exceeding the maximum differential input or common mode voltages will result in irreparable damage to the apparatus.

<i>Dynamic characteristics of the Resolver to Digital converter</i>	<i>Value</i>			
	<i>Min</i>	<i>Typ</i>	<i>Max</i>	<i>Unit</i>
Band (signal amplitude modulating frequency)	1.5	1.7	2	kHz
Tracking Rate			60000	rpm



CAUTION

Exceeding the input signal frequency limits will result in a wrong measurement of the encoder position and speed. Depending on the control method selected for the inverter, it may also cause the motor to run out of control.

<i>Static characteristics of the digital outputs and the encoder</i>	<i>Value</i>			
	<i>Min</i>	<i>Typ</i>	<i>Max</i>	<i>Unit</i>
Type of input signals CHA_U, CHB_U, CHZ_U	Standard TIA/EIA-422			
High logic level voltage	2.5			V
Low logic level voltage			0.5	V
Limited common mode voltage	±5.6			V
Maximum current	50			mA
Type of output signals, MDOC-E1, MDOC-E2, MDOC-E3	"Open Collector" switch			
Voltage applicable to MDOC without static absorption in "open" configuration			5	V
Maximum current that can be absorbed in "closed" configuration			50	mA



CAUTION

Exceeding the range in the table may cause irreparable damage to the equipment.

<i>Static and dynamic characteristics for resolver signal excitation</i>	<i>Value</i>			
	<i>Min</i>	<i>Typ</i>	<i>Max</i>	<i>Unit</i>
EXC, /EXC Output Voltage (load ±100µA)	3.34	3.6	3.83	V _{pp}
EXC, /EXC Center Voltage	2.39	2.47	2.52	V
EXC, /EXC Frequency	10, 12, 15, 20			kHz

6.20. ES950 BiSS/EnDat Encoder Board (Slot C)



The ES950 BiSS/EnDat encoder board allows connecting absolute encoders with digital serial interface using mutually exclusive BiSS and EnDat 2.2 protocols and allows using them to provide speed feedback and/or position feedback for the inverters of the Sinus PENTA series.



NOTE

Please refer to the Programming Guide and Guide to the Synchronous Motor Application for the available control algorithms.

The absolute measurement allows detecting the exact position of the motor as soon as the inverter is started, thus avoiding demanding alignment checks.

The ES950 board also features control logics for additional functions, such as the acquisition of differential incremental signals from external encoders and the control of optoisolated digital inputs/outputs.

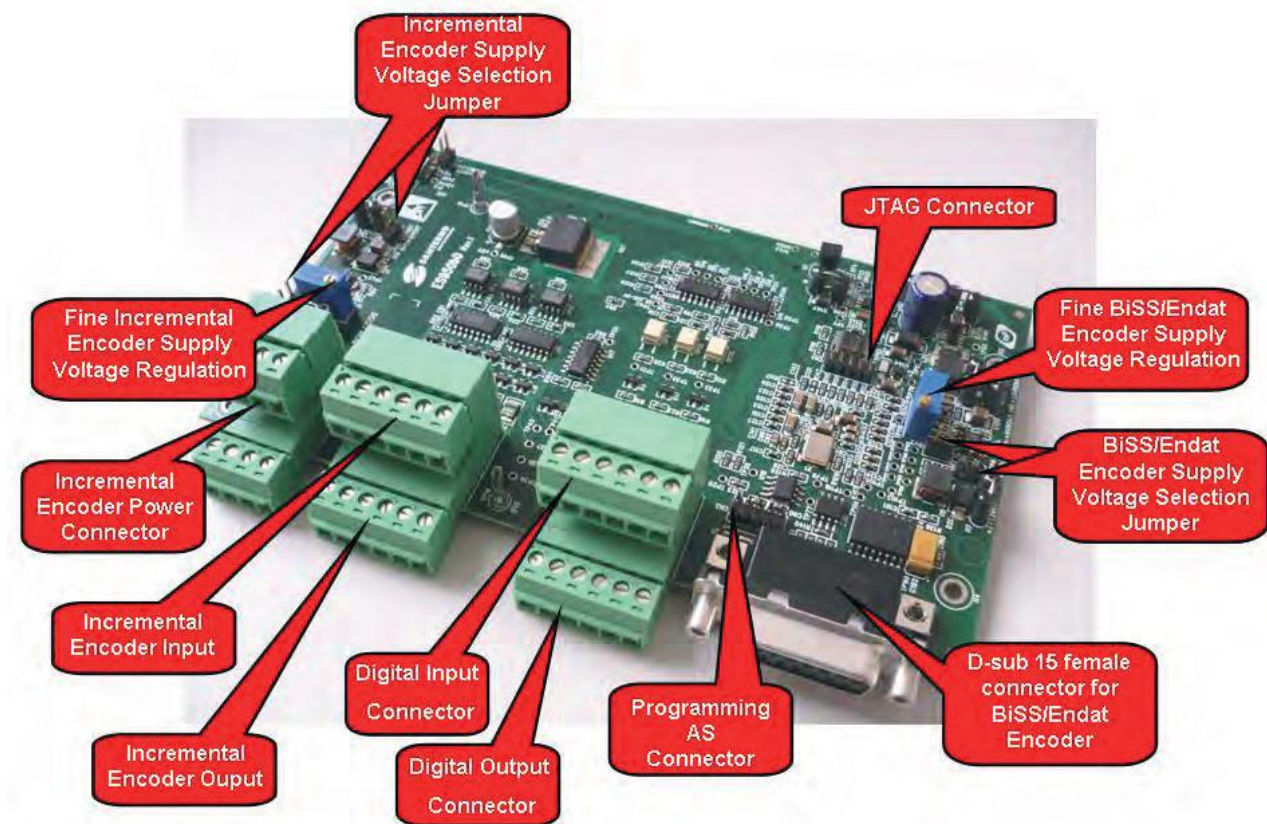

Figure 200: ES950 encoder BiSS/EnDat board.



CAUTION

If ES950 board is fitted into slot C, ES919 board cannot be fitted into slot B (see ES919 Communications Board (Slot B)).

Features of the ES950 board:

- Acquisition of absolute position from SingleTurn/MultiTurn Encoder with balanced digital output (TIA/EIA-485) according to EnDat 2.2 protocol, up to max. 8MHz transmission frequency and variable resolution depending on the type of encoder.
- Acquisition of absolute position from SingleTurn/MultiTurn Encoder with balanced digital output (TIA/EIA-485) according to BiSS protocol, up to max. 10MHz transmission frequency and variable resolution depending on the type of encoder.
- Acquisition of differential incremental encoder signals compatible with optoisolated line-driver (TIA/EIA-422) encoders.
- Galvanic isolation on all the lines.
- Configurable 5V, 12V, 24V output for BiSS/EnDat encoder supply allowing fine-tuning, isolated from the control logics.
- Configurable 5V, 12V, 24V output for external incremental encoders allowing fine-tuning, isolated from the control logics.
- Possibility of repeating the acquired incremental signals over line-driver (TIA/EIA-422) standard.
- Possibility of enabling a frequency divider (by 2, 4, 8) for incremental encoder signals coming from line-driver encoders.
- Acquisition of No.3 optoisolated digital inputs.
- Control of No.3 optoisolated digital outputs.

The features for the incremental encoder inputs are as follows:

- 77kHz (1024pls @ 4500rpm) max. input frequency when the digital filter is enabled
- 155kHz (1024pls @ 9000rpm) max. input frequency when the digital filter is disabled
- Input with differential or single-ended signals
- Input signal error detection.

6.20.1. Identification Data

<i>Description</i>	<i>Part Number</i>	<i>Compatibility</i>
ES950 EnDat Encoder Interface board	ZZ0101880	All the inverters of the Sinus PENTA series equipped with ES927 control board. <ul style="list-style-type: none"> - Absolute encoders with balanced digital EnDat interface according to TIA/EIA-485 standard and power supply voltage ranging from 5 to 24V. - Incremental encoders with balanced line signals according to TIA/EIA-422 standard and power supply voltage ranging from 5 to 24V.

<i>Description</i>	<i>Part Number</i>	<i>Compatibility</i>
ES950 BiSS Encoder Interface board	ZZ0101890	All the inverters of the Sinus PENTA series equipped with ES927 control board. <ul style="list-style-type: none"> - Absolute encoders with balanced digital BiSS interface according to TIA/EIA-485 standard and power supply ranging from 5 to 24V. - Incremental encoders with balanced line signals according to TIA/EIA-422 standard and power supply voltage ranging from 5 to 24V.

6.20.2. Installing ES950 Board on the Inverter (Slot C)

1. Remove voltage from the inverter and wait at least 20 minutes.
2. The electronic components in the inverter and the communications board are sensitive to electrostatic discharge. Take any safety measure before operating inside the inverter and before handling the board. The board should be installed in a workstation equipped with proper grounding and provided with an antistatic surface. If this is not possible, the installer must wear a ground bracelet properly connected to the PE conductor.



3. Remove the protective cover of the inverter terminal board by unscrewing the two screws on the front lower part of the cover. Slot C housing the control board of the inverter where ES950 board will be installed is now accessible, as shown in the figure below.
4. Insert ES950 board into Slot C. Carefully align the contact pins with connectors CN7A and CN7B in the slot. If the board is properly installed, the three fixing holes are aligned with the housing of the relevant fixing spacers screws. Check if alignment is correct, then fasten the three fixing screws as show in the figure below.

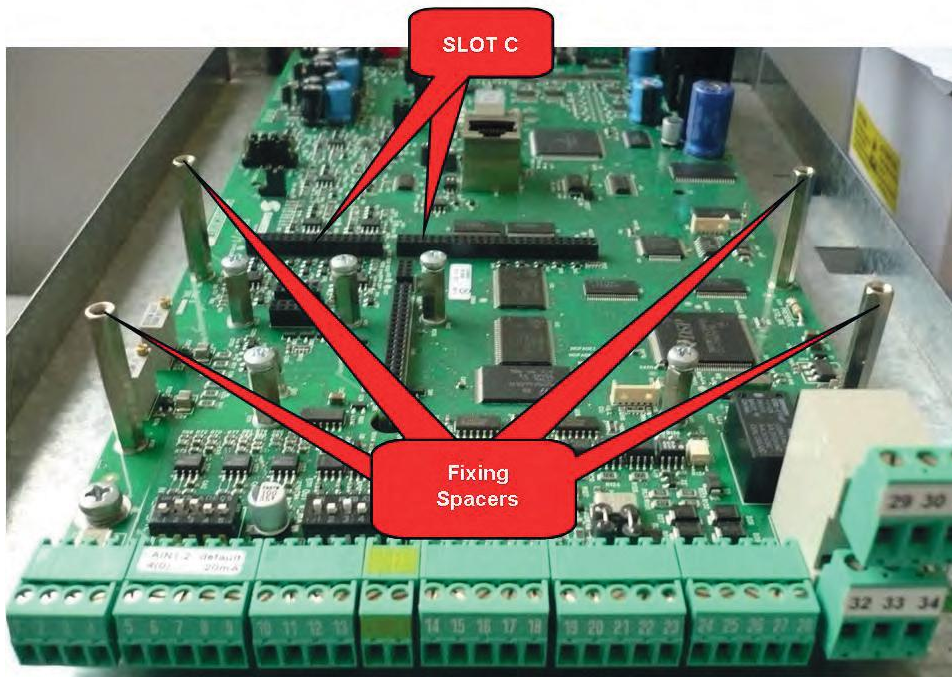

Figure 201: Location of slot C inside the terminal board cover in Sinus PENTA inverters.

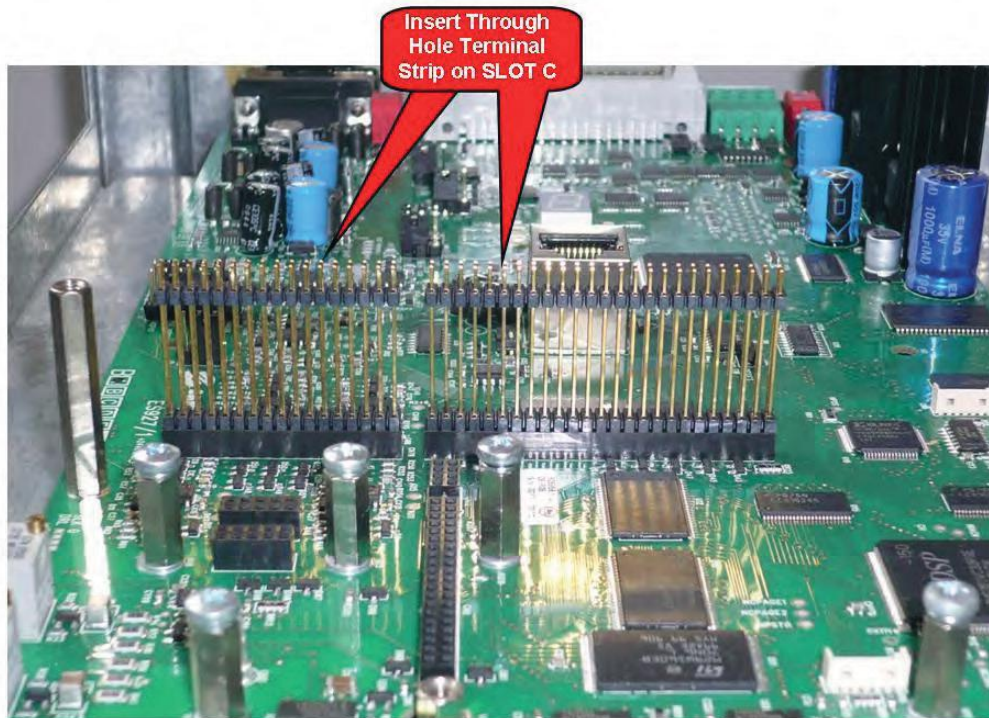

Figure 202: Terminal strips inserted into SLOT C

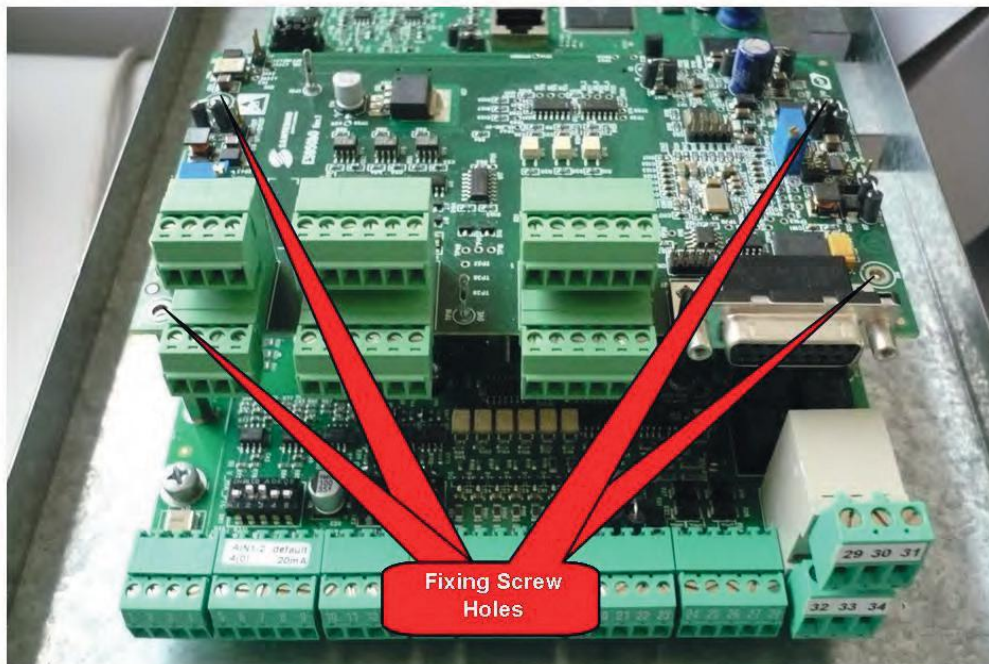

Figure 203: Fitting the ES950 board inside the inverter

5. Configure the supply voltage for the incremental encoder (please refer to the relevant User Manual) by setting the configuration jumper accordingly.
6. Power the inverter and check if the supply voltage delivered to the encoder is appropriate. Set up the parameters relating to the encoder as described in the Programming Guide.
7. Remove voltage from the inverter, wait until the inverter has come to a complete stop and connect the encoder cable.



DANGER

Before gaining access to the components inside the inverter, remove voltage from the inverter and wait at least 20 minutes. Wait for the complete discharge of the internal capacitors to avoid electric shock hazard.



CAUTION

Do not connect or disconnect signal terminals or power terminals when the inverter is powered to avoid electric shock hazard and to avoid damaging the inverter.



NOTE

All fastening screws for removable parts (terminal cover, serial interface connector, cable path plates, etc.) are black, rounded-head, cross-headed screws.

Only these screws may be removed when connecting the equipment. Removing different screws or bolts will void the product guarantee.

6.20.2.1. BiSS/EnDat Encoder Connector

D-sub 15-pin female connector (two rows). The figure shows a front view of the pin layout.

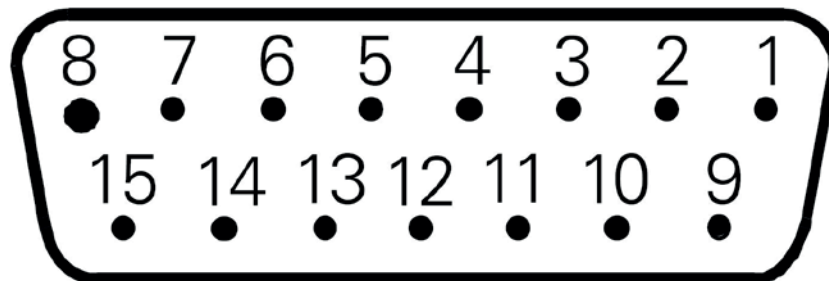

Figure 204: Pin layout on CN7 D-sub 15-pin female connector.

N.	Name	Description
1	0VE	Common for power supply and signals
2	0VE	Common for power supply and signals
3	+VEOUT_EB	Encoder power supply output
4	+VEOUT_EB	Encoder power supply output
5	DATA+	Positive data signal
6	Earth	Earth connection (PE conductor) if J7 is closed
7	n.c.	
8	TCLK+	Positive clock signal
9	reserved	
10	reserved	
11	n.c.	
12	n.c.	
13	DATA-	Negative data signal
14	n.c.	
15	TCLK-	Negative clock signal
Shell	PE	Connector shield connected to PE conductor of the inverter

6.20.2.2. Incremental Encoder and Digital Line Connectors

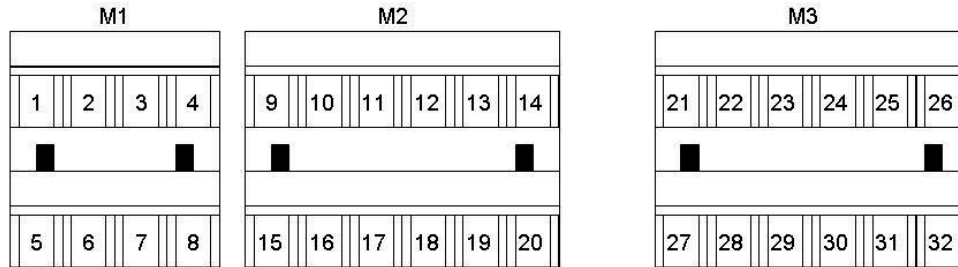

Figure 205: Input-output signal terminal board

N.	Name	Description
1	+VEOUT	Incremental encoder power supply output
2	0VE	Isolated power supply common
3	0VE	Isolated power supply common
4	0VE	Isolated power supply common
5	+5V_EXT	External power supply input for incremental encoder
6	+5V_INT	Isolated 5V power supply generated from ES950 board
7	+0V_EXT	External power supply common
8	0VE	Isolated power supply common
9	CHA	Channel A input for positive incremental encoder
10	/CHA	Channel A input for negative incremental encoder
11	CHB	Channel B input for positive incremental encoder
12	/CHB	Channel B input for negative incremental encoder
13	CHZ	Positive zero index signal
14	/CHZ	Negative zero index signal
15	CHA_U	Encoder simulation (CHA pin 9) - positive signal
16	/CHA_U	Encoder simulation (/CHA pin 10)- negative signal
17	CHB_U	Encoder simulation (CHB pin 11)- positive signal
18	/CHB_U	Encoder simulation (/CHB pin 12) - negative signal
19	CHZ_U	Encoder simulation (CHZ pin 13)- positive signal
20	/CHZ_U	Encoder simulation (/CHZ pin 14) - negative signal
21	XMDI1	Digital input
22	XMDI2	Digital input
23	XMDI3	Digital input
24	n.c.	
25	n.c.	
26	CMD	Common for digital inputs
27	XMDO1	Digital output 1
28	CMDO1	Common for digital input 1
29	XMDO2	Digital output 2
30	CMDO2	Common for digital output 2
31	XMDO3	Digital output 3
32	CMDO3	Common for digital output 3

6.20.3. ES950 Configuration and Operating Modes

The ES950 encoder interface board may power both 5V to 24V encoders and allows absolute encoders readout via two different protocols based on the same types of signals: one data line and one clock line.

1	BiSS mode	BiSS Encoder (differential lines DATA+/ DATA-, TCLK+/ TCLK-)
2	EnDat mode	EnDat Encoder (differential lines DATA+/ DATA-, TCLK+/ TCLK-)

The figure shows the block diagram of the ES950 board for encoder interfacing (independently of whether using the BiSS or EnDat protocol) and for interfacing with the ES927 control board. The figure also shows the acquisition logics for the digital lines from/to the field and the interface with external incremental encoders (if any).

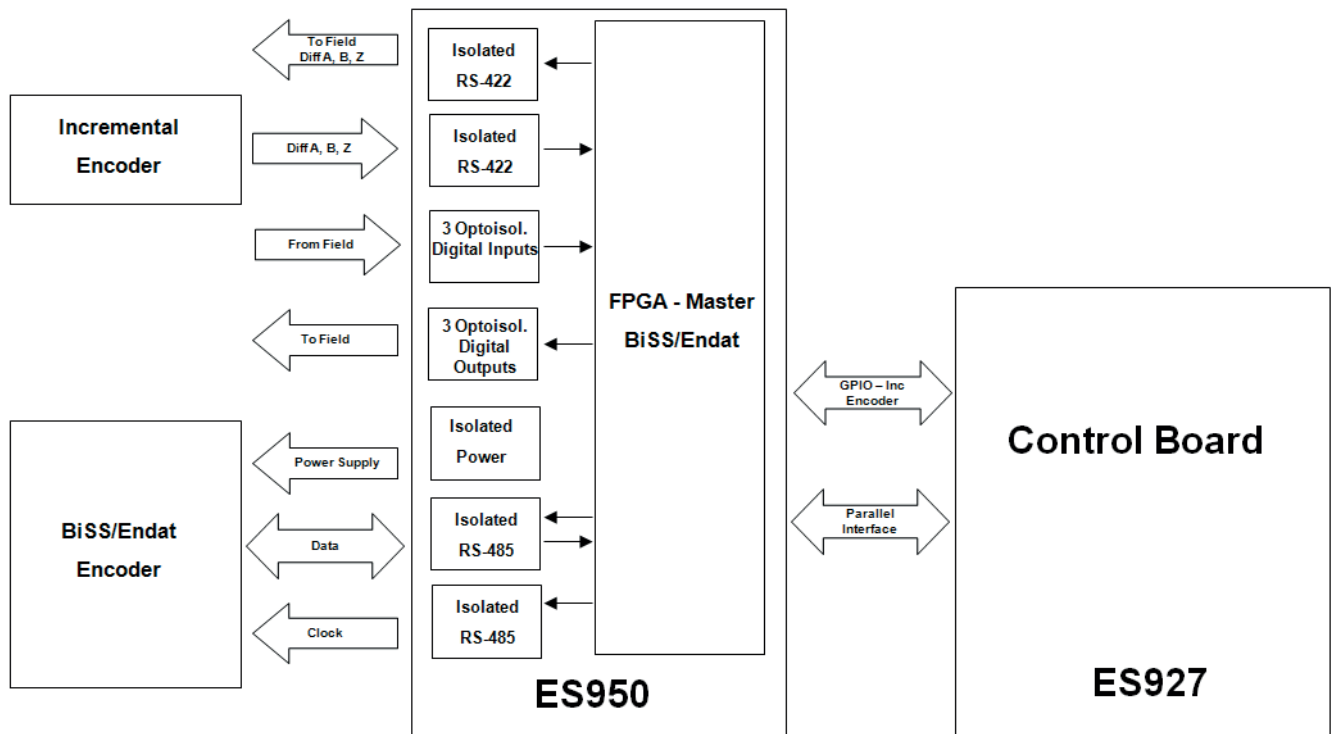

Figure 206: Block diagram for ES950 board interface.

BiSS/EnDat absolute encoders are power supplied via the ES950 board according to their own specifications. Power supply is isolated in respect to the control logics. BiSS/EnDat absolute encoders interface with a Master implemented on FPGA controlling the different protocols to send absolute position information to the control board via parallel interface.

Through the FPGA Master via parallel interface, the control board may read/write additional information internally to the encoder.

The states of the optoisolated digital inputs/outputs can be accessed via parallel interface as well, whereas the incremental lines coming from the relevant encoder, even if going through the FPGA Master, reach the control board via dedicated lines.

The ES950 board also features an error detecting mechanism for the signals sent from the incremental encoder.

Dedicated outputs make it possible to repeat the acquired encoder signals possibly applying a frequency divider by 2, 4, 8.

The protocol is chosen by programming the board (in off-line mode) accordingly and by setting proper parameters in the control board software.

6.20.3.1. *BiSS Operating Mode*

BiSS is an open source serial protocol developed by IC-HAUS. The configuration adopted for the Sinus PENTA system uses the point-point version B allowing reading the encoder absolute position (divided into SingleTurn and MultiTurn depending on the encoder being used) and allowing R/W of the logs internal to the encoder.

6.20.3.2. *EnDat Operating Mode*

EnDat is a serial protocol proprietary of Heidenhain. It is dedicated to point-to-point connections with absolute encoders (absolute position information divided by SingleTurn and MultiTurn depending on the encoder). In the Sinus Penta system, the EnDat protocol allows reading the encoder absolute position and allows R/W of the logs internal to the encoder.

6.20.3.3. *Configuring and Adjusting the Encoder Supply Voltage*

The ES950 board may power encoders having different power supply voltage ratings. A selection jumper and a power supply voltage regulation trimmer are available as shown in Figure 207. The jumpers and the trimmer are located on the top side of the board. The possible configurations are given in the table below.

Incremental encoder supply: VE OUT				No VE OUT
	24V	12V	5V	
J1	X	OFF	ON	X
J2	2-3	1-2	1-2	X
J3	ON	ON	ON	OFF

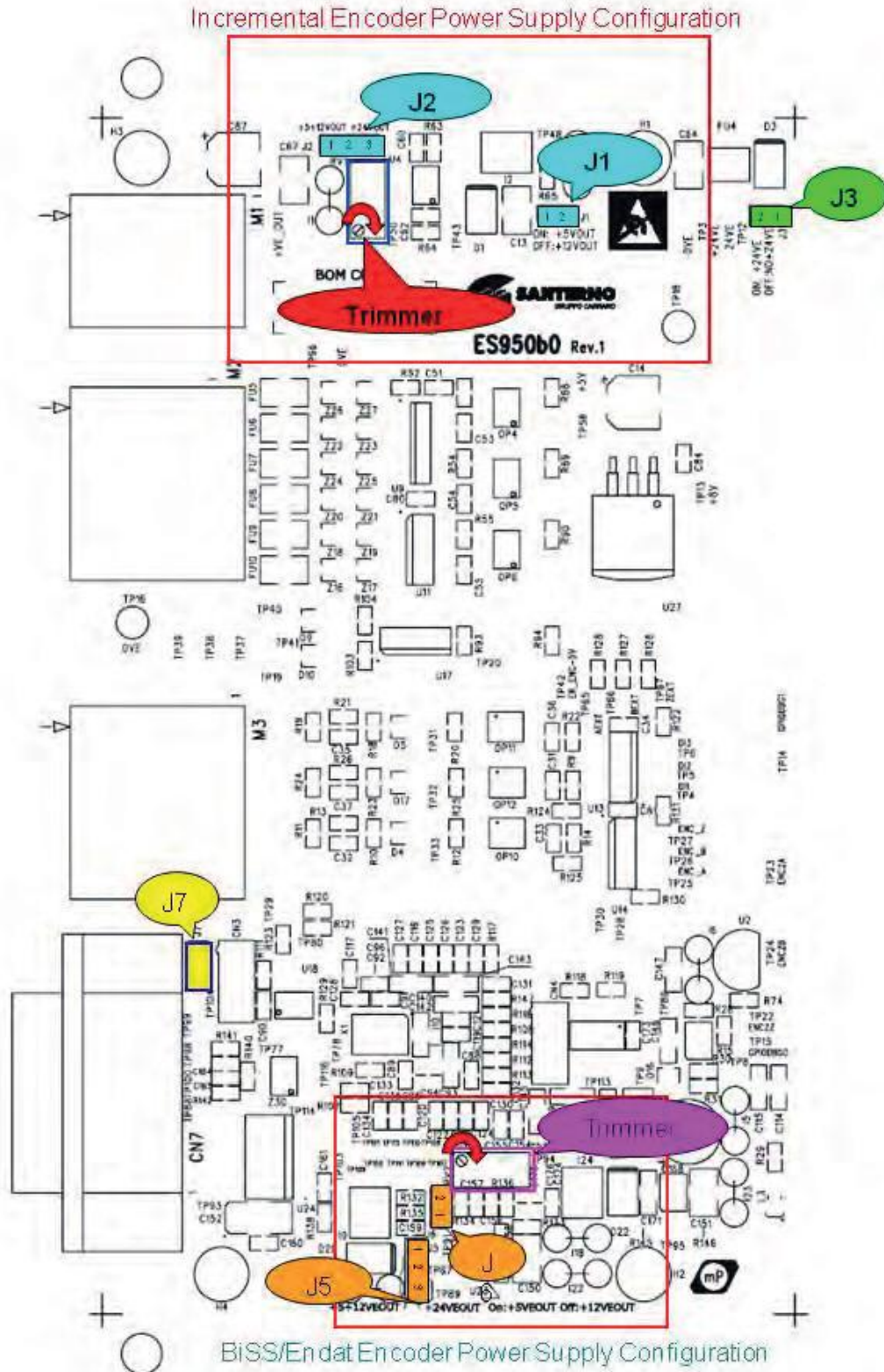

Figure 207: Jumpers and trimmer for power supply configuration

BiSS/EnDat encoder supply: VE OUT EB				No VE OUT EB
	24V	12V	5V	
J6	X	OFF	ON	X
J5	2-3	1-2	1-2	X
J3	ON	ON	ON	OFF

In 24V mode, the output voltage is fixed and cannot be adjusted. In 5 and 12V mode, the output voltage can be fine-tuned: in 5V mode, the no-load voltage may range from 4.5 to 7V by adjusting each individual trimmer accordingly; in 12V mode, the no-load voltage may range from 10.5 to 17V.

Turn the trimmer clockwise to increase output voltage.

This allows meeting the Biss/EnDat encoder requirements by taking account of voltage drops in cables and connector contacts.

- Encoder EnDat (Heidenhain): power supply typically ranges from [3.6÷14]V, [3.6÷5.25]V, [5±5%]V depending on the type of encoder being used. The latest standard, EnDat 2.2, covers [3.6÷14]V.
- Encoder BiSS: [7÷30]V, [10÷30]V, [5±10%]V

Power supply voltage is to be measured at the encoder supply terminals, thus taking account of cable voltage drops, particularly if a long cable is used.



CAUTION

Supplying the encoder with inadequate voltage may damage the component. Before connecting the cable and after configuring the ES950 board, always use a tester to check the voltage supplied by the board itself.



NOTE

The encoder power supply circuit is provided with an electronic current limiter and a resettable fuse. Should a short-circuit occur in the supply output, shut down the inverter and wait a few minutes to give the resettable fuse time to reset.

6.20.4. Connecting the Encoder Cable

State-of-the-art connections are imperative. Use shielded cables and correctly connect cable shielding.

Connect the external shielding directly to the connector plug (ES950 side) and to the connector or to a pin (if any) connected to the encoder frame (motor side). The CN7 connector plug is internally grounded.

If the cable has multiple shieldings, connect the internal shieldings to each other and connect them to the common 0V power supply and signals in ES950 (pin 1 or 2 in 15-pin CN7 connector). Do not connect the internal and external shieldings to each other, either along the cable or to the encoder.

The recommended connection diagram consists in a multipolar, dual shielded cable. The inner shield shall be connected to the connector case connected to ES950 board, while the outer shield shall be connected to the encoder frame, usually in common with the motor frame. If the inner shield is not connected to the encoder frame, this can be connected to the inner braid.

The motor must always be earthed as instructed with a dedicated conductor attached directly to the inverter earthing point and routed parallel to the motor power supply cables.

It is not advisable to route the Encoder cable parallel to the motor power cables. It is preferable to use a dedicated signal cable conduit.

The welding jumper J7 enables grounding pin 6 in CN7 connector:

J7	ON	Pin 6 connected to PE conductor through ES950.
	OFF	Pin 6 <i>not</i> connected to PE conductor through ES950.

The figure below illustrates the recommended connection method.

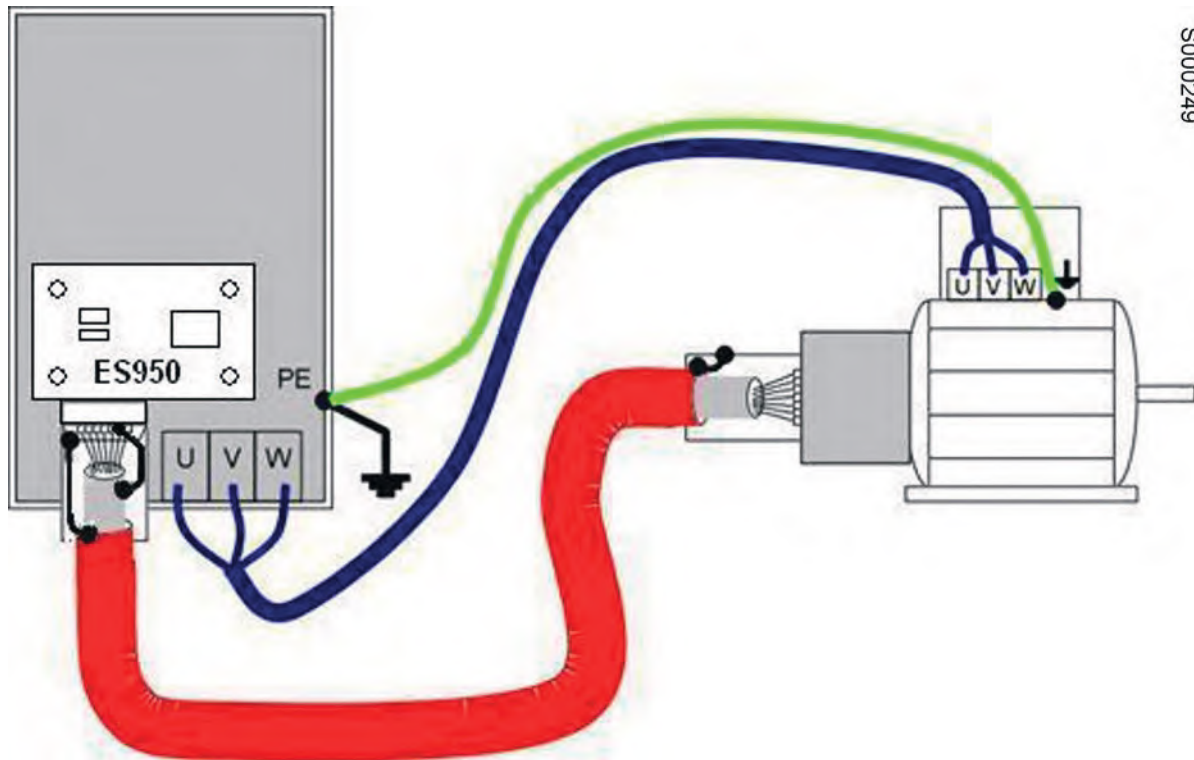

S000249

Figure 208: Recommended dual shielded connection for encoder cable



NOTE

The encoder supply output and the encoder signal common are isolated in respect to the common of the analog signals fitted in the inverter terminal board (CMA). Do not connect any conductors in common between the encoder signals and the signals in the inverter terminal board. This prevents isolation from being adversely affected.

The connector of ES950 board shall be connected exclusively to the encoder using one single cable.



CAUTION

Correctly fasten the cable and the connectors both on the encoder side and on ES950 board side. The disconnection of one cable or even a single conductor can lead to inverter malfunction and may cause the motor to run out of control.

6.20.5. Environmental Requirements

Operating temperatures	-10 to +55°C ambient temperature (contact Elettronica Santerno for higher ambient temperatures)
Relative humidity	5 to 95% (non-condensing)
Max. allowable operating altitude	2000 m a.s.l. For installation above 2000 m and up to 4000 m, please contact Elettronica Santerno.

6.20.6. Electrical Ratings

Decisive voltage class A according to IEC 61800-5-1

<i>Encoder supply output</i>	Value			
	Min	Typ	Max	Unit
Encoder output current, +24V configuration			150	mA
Encoder output current, +12V configuration			200	mA
Encoder output current, +5V configuration			500	mA
24VE Short-circuit protection level			300	mA
Encoder supply voltage adjusting range in 5V mode (no-load voltage)	4.5	5.3	7	V
Encoder supply voltage adjusting range in 12V mode (no-load voltage)	10.5	12.0	17	V

<i>Static characteristics of the input signals</i>	Value			
	Min	Typ	Max	Unit
Type of input signals DATA+, DATA-, TCLK+, TCLK-	Standard TIA/EIA-485			
Differential input voltage range			12/-7	V
Input common mode voltage range			12/-7	V
Input impedance (termination)	120			ohm
Type of input signals CHA, CHB, CHZ	Standard TIA/EIA-422			
Differential input voltage range			±7	V
Input common mode voltage range			±7	V
Input impedance	150			ohm
Type of input signals MDI1, MDI2, MDI3 in respect to COM_MDI	Digital signals from the field			
Input voltage range	15	24	30	V

<i>Max. absolute values</i>	<i>Value</i>			
	<i>Min</i>	<i>Typ</i>	<i>Max</i>	<i>Unit</i>
Maximum allowable common mode voltage amplitude causing no damage on inputs DATA+, DATA-, TCLK+, TCLK-	-7		+12	V
Maximum allowable differential voltage amplitude on channels CHA, CHB, CHZ	-25		+25	V



CAUTION

Exceeding the maximum differential input or common mode voltages will result in irreparable damage to the apparatus.

<i>Dynamic characteristics of the input signals</i>	<i>Value</i>
Max. frequency of Biss protocol digital signals	10 MHz
Max. frequency of EnDat protocol digital signals	8 MHz



CAUTION

Exceeding the input signal frequency limits will result in a wrong measurement of the encoder position and speed. Depending on the control method selected for the inverter, it may also cause the motor to run out of control.

<i>Static characteristics of the encoder and digital outputs</i>	<i>Value</i>			
	<i>Min</i>	<i>Typ</i>	<i>Max</i>	<i>Unit</i>
Type of input signals CHA_U, CHB_U, CHZ_U	Standard TIA/EIA-422			
High logic level voltage	2.5			V
Low logic level voltage			0.5	V
Limited common mode voltage	±5.6			V
Maximum current	50			mA
Type of input signals MDOC-E1, MDOC-E2, MDOC-E3	"Open Collector"			
Voltage applicable to MDOC with no static absorption in "open" configuration			5	V
Maximum current that can be absorbed in "closed" configuration			50	mA



CAUTION

Exceeding the maximum differential input or common mode voltages will result in irreparable damage to the apparatus.

6.21. Encoder Board Hiperface ES966 (Slot C)



The encoder board Hiperface ES966 enables interfacing absolute encoders with digital serial outputs based on Hiperface protocol that can be used as speed feedback and/or position feedback on the Sinus Penta inverters.



NOTE Please refer to the Programming Guide and to the Guide to the Synchronous Motor Application to check the available control algorithms.

The absolute measure allows getting the exact position of the motor when the system is started; in addition, the current delivered at start is such as to ensure the maximum torque, with no need to perform complex alignment adjustments at start.

Encoder board ES966 features additional functions, such as the acquisition of differential incremental signals from external encoders and the control of optoisolated digital inputs and outputs.

6.21.1. Part Number

<i>Description</i>	<i>Part Number</i>	<i>Compatibility</i>
ES966 Encoder Hiperface	ZZ0101895	All inverters of the Sinus Penta series equipped with control board ES927. - Absolute encoders with Hiperface interface

7. NORMATIVE REFERENCES

The inverters of the Sinus Penta line comply with the following:

- Electromagnetic Compatibility Directive 2004/108/CE
- Low Voltage Directive 2006/95/CE

7.1. Electromagnetic Compatibility Directive

In most systems, the processing control also requires additional devices, such as computers, captors, and so on, that are usually installed one next to the other, thus causing disturbance:

- Low frequency – harmonics.
- High frequency – electromagnetic interference (EMI)

High frequency interference

High frequency interference is disturbance or radiated interference with >9kHz frequency. Critical values range from 150kHz to 1000MHz.

Interference is often caused by switching to be found in any device, i.e. switching power supply units and drive output modules. High frequency disturbance may interfere with the correct operation of the other devices. High frequency noise produced by a device may cause malfunctions in measurement systems and communication systems, so that radio receivers only receive electrical noise. This may cause unexpected faults.

Immunity and emissions may be concerned (EN 61800-3, ed. 2).

EN 61800-3 defines the immunity levels and the emission levels required for the devices designed to operate in different environments. Drives manufactured by ELETTRONICA SANTERNO are designed to operate under the most different conditions, so they all ensure high immunity against RFI and high reliability in any environment.

The table below defines PDS (Power Drive Systems) of EN 61800-3 ed.2.

FIRST ENVIRONMENT	Environment including domestic devices and industrial devices which are connected directly to a low-voltage mains (with no intermediate transformer) for domestic usage.
SECOND ENVIRONMENT	Environment including industrial connections different from "First Environment" connections.
PDS of Category C1	PDS with rated voltage lower than 1000 V to be used in the First Environment.
PDS of Category C2	PDS with rated voltage lower than 1000 V; if used in the First Environment, they are intended to be installed and commissioned by professional users only.
PDS of Category C3	PDS with rated voltage lower than 1000 V to be used in the Second Environment.
PDS of Category C4	PDS with rated voltage equal to or higher than 1000 V or with a current equal to or higher than 400A to be used in complex systems installed in the Second Environment.

Emission Limits

The standards in force also define the allowable emission level for different environments.
The diagrams below pertain to the emission limits allowed by EN 61800-3 ed.2.

P000091-A

"FIRST ENVIRONMENT" Disturbance Limits

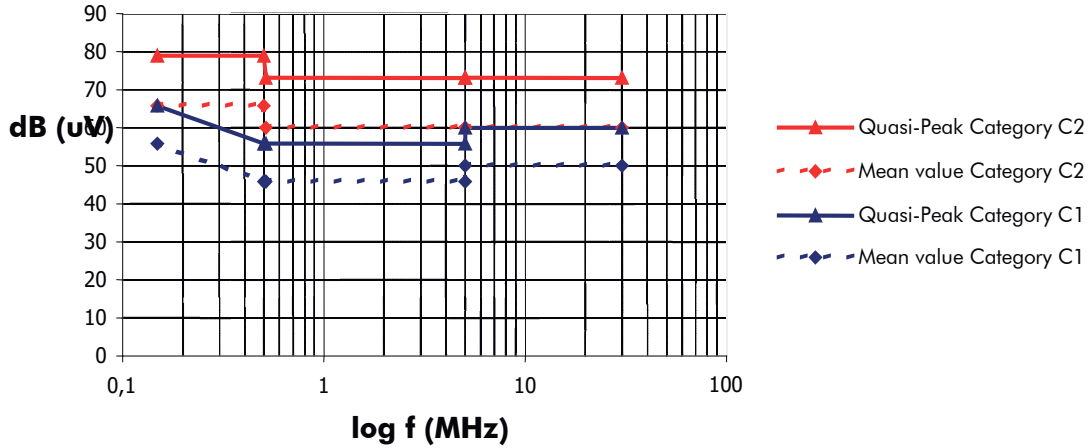

- **A1** = EN 61800-3 issue 2 FIRST ENVIROMENT, Category C2, EN55011 gr.1 cl. A, EN50081-2, EN61800-3/A11.
- **B** = EN 61800-3 issue 2 FIRST ENVIROMENT, Category C1, EN55011 gr.1 cl. B, EN50081-1,-2, EN61800-3/A11.

P000092-A

"SECOND ENVIRONMENT" Disturbance Limits

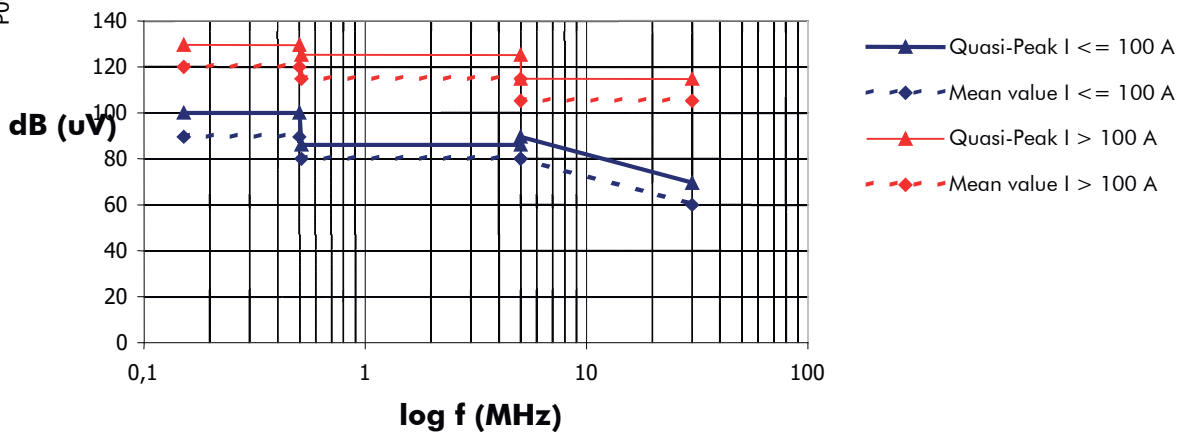

- **A2** = EN 61800-3 issue 2 SECOND ENVIRONMENT Category C3, EN55011 gr.2 cl. A, EN61800-3/A11.

The inverters manufactured by ELETTRONICA SANTERNO allow choosing among four levels:
I no suppression of the emissions for users who use power drive systems in a non-vulnerable environment and who directly provide for the suppression of the emissions;

A2 suppression of the emissions for power drive systems installed in the SECOND ENVIRONMENT, Category C3.

A1 suppression of the emissions for power drive systems installed in the FIRST ENVIRONMENT, Category C2.

B suppression of the emissions for power drive systems installed in the FIRST ENVIRONMENT, Category C1.

Additional external RFI filters may be installed to bring emissions of devices of level **I** or **A1** to level **B**.

Immunity levels

Electromagnetic disturbance is caused by harmonics, semiconductor switching, voltage variation-fluctuation-dissymmetry, mains failures and frequency variations; electrical equipment must be immune from electromagnetic disturbance.

The following tests are required by EN 61800-3 Ed.2:

EN 61800-3 Ed.2	- Immunity: EN 61000-4-2/IEC1000-4-2 Electromagnetic Compatibility (EMC). Part 4: Testing and Measurement Techniques. Section 2: Electrostatic Discharge Immunity Test. Basic EMC Publication.
	EN 61000-4-3/IEC1000-4-3 Electromagnetic Compatibility (EMC). Part 4: Testing and Measurement Techniques. Section 3: Radiated, Radio-frequency, Electromagnetic Field Immunity Test.
	EN 61000-4-4/IEC1000-4-4 Electromagnetic Compatibility (EMC). Part 4: Testing and Measurement Techniques. Section 4: Electrical Fast Transient/Burst Immunity Test. Basic EMC Publication.
	EN 61000-4-5/IEC1000-4-5 Electromagnetic Compatibility (EMC). Part 4: Testing and Measurement Techniques. Section 5: Surge Immunity Test.
	EN 61000-4-6/IEC1000-4-6 Electromagnetic Compatibility (EMC). Part 4: Testing and Measurement Techniques. Section 6: Immunity from Radiofrequency Fields Induced Disturbance.

ELETTRONICA SANTERNO certifies all its products in compliance with immunity standards in force. All classes are provided with CE Declaration of European Conformity according to Electromagnetic Compatibility Directive 2004/108/CE (please visit santerno.com).



CAUTION

Products with ID "I" in column 7 in the nameplate (Delivery Check section):
 These devices are not provided with RFI filters. They can produce radio interference in domestic environments; additional measures should be taken to suppress radio interference.



CAUTION

Products with ID "A2" in column 7 in the nameplate (Delivery Check section);
 the following regulation is provided:
 These are category C2 devices according to EN 61800-3. They can produce radio interference in domestic environments; additional measures should be taken to suppress radio interference.



CAUTION

Products with ID "A1" in column 7 in the nameplate (Delivery Check section):
 These are category C3 devices according to EN 61800-3. They can produce radio interference in domestic environments; additional measures should be taken to suppress radio interference.



CAUTION

EMC filters are designed for grounded networks (TN). Filters for floating networks (IT) can be supplied on demand.

7.1.1. RADIOFREQUENCY DISTURBANCE

Radiofrequency disturbance (RFI) may occur where the inverter is installed.

Electromagnetic emissions produced by the electrical components installed inside a cabinet may occur as conduction, radiation, inductive coupling or capacitive coupling.

Emissions disturbance can be the following:

- Radiated interference from electrical components or power wiring cables inside the cabinet;
- Disturbance and radiated interference from outgoing cables (power supply unit cables, motor cables, signal cables).

The figure shows how disturbance takes place:

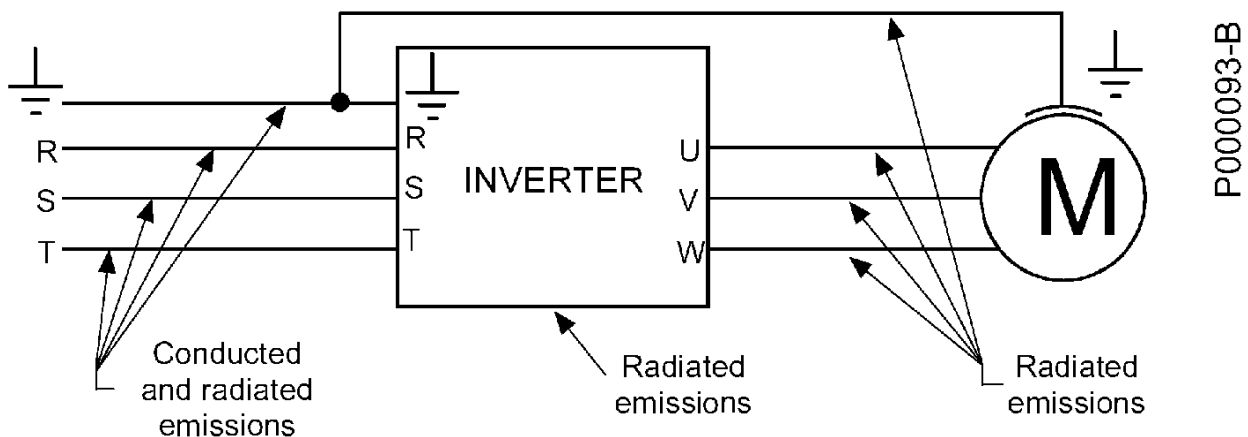

Figure 209: Disturbance sources in a power drive system equipped with an inverter

The measures to be taken to suppress disturbance include: grounding enhancement; changes made to the cabinet structure; installation of mains filters on the line and installation of output toroid filters on the motor cables; optimization of the wiring and cable shielding.

Always restrict as much as possible the area exposed to disturbance, so as to limit interferences with the other components in the cabinet.

Grounding

Disturbance occurring in the grounding circuit affects the other circuits through the grounding mains or the casing of the connected motor.

Disturbance may interfere with the following appliances which are installed on the machines and which are sensitive to radiated interference, as they are measurement circuits operating at low voltage (μV) or current signal levels (μA):

- transducers (tachos, encoders, resolvers);
- thermoregulators (thermocouples);
- weighing systems (loading cells);
- PLC or NC inputs/outputs;
- photocells or magnetic proximity switches.

Disturbance is mainly due to high-frequency currents flowing in the grounding mains and the machine metal components; disturbance occurs in the sensitive sections of components (optical transducer, magnetic transducer, capacitive transducer). Disturbance may also occur in appliances installed on machines with the same grounding or metal and mechanical interconnections.

A possible solution is to enhance the inverter, motor and cabinet grounding, as high-frequency currents flowing in the grounding between the inverter and the motor (capacity distributed to the ground of the motor cable and casing) may cause a strong difference of potential in the system.

7.1.1.1. The Power Supply Mains

Disturbance and radiated interference occur in the mains.

Limiting disturbance results in weakening radiated interference.

Disturbance on the mains may interfere with devices installed on the machine or devices installed even some hundred meters far from the machine and which are connected to the same mains.

The following appliances are particularly sensitive to disturbance:

- computers;
- radio receivers and TV receivers;
- biomedical equipment;
- weighing systems;
- machines using thermoregulation;
- telephone systems.

Mains disturbance may be limited by installing a mains filter to reduce RFI.

ELETTRONICA SANTERNO adopted this solution to suppress RFI.

7.1.1.2. Output Toroid Filters

Ferrite is a simple radiofrequency filter. Ferrite cores are high-permeable ferromagnetic materials used to weaken cable disturbance:

- in case of three-phase conductors, all phases must go through the ferrite;
- in case of single-phase conductors (or 2-wire line) both phases must go through the ferrite (incoming and outgoing conductor cables that are to be filtered must go through the ferrite).

7.1.1.3. The Cabinet

To prevent input and output of electromagnetic emissions to and from the cabinet, draw particular attention to the cabinet doors, opening and cable paths.

A) Use a seam-welded metal frame ensuring electrical continuity.

B) Provide an unpainted, reference grounding support on the frame bottom. This steel sheet or metal grill is to be connected to the metal frame, which is also connected to the ground mains of the equipment. All components must be bolted directly to the grounding support.

C) Hinged parts or mobile parts (i.e. doors) must be made of metal and capable of restoring electrical conductivity once closed.

D) Segregate cables based on the type and intensity of electrical quantities and the type of devices which they are connected to (components that may generate electromagnetic disturbance and components that are particularly sensitive to disturbance):

High sensitivity	Analog inputs and outputs: voltage reference and current reference sensors and measurement circuits (ATs and VTs) DC supply (10V, 24V)
Low sensitivity	digital inputs and outputs: optoisolated commands, relay outputs
Low perturbation	filtered AC supply
High perturbation	Power circuits in general inverter non-filtered AC supply contactors inverter-motor wires

Measures to take when wiring the cabinet or the system:

- Sensitive signals and perturber signals must never exist within a cable.
- Avoid that cables carrying sensitive signals and perturber signals run parallel at short distance: whenever possible, paths of cables carrying sensitive signals and perturber signals should be reduced to a minimum.
- Move away as much as possible any cables carrying sensitive signals and perturber signals. The distance between segregated cables should be proportional to the cable length. Whenever possible, cable crossing should be perpendicular.

Wires connecting the motor or load mainly generate disturbance. Disturbance is important in inverter power drive systems or the devices installed on the machine, and could interfere with any equipment installed on the machine or with local communication circuits located near the inverter (radiotelephones, mobile phones). Follow the instructions below to solve these problems:

- Provide for a motor cable path as short as possible.
 - Shield the power cables to the motor; ground shielding both to the inverter and to the motor. Excellent results are obtained using cables in which the protection connection (yellow-green cable) is external to the shielding (this type of cables are available on the market with a cross-section up to 35mm² per phase); if no shielded cable having a suitable cross-section is available, segregate power cables in grounded, metal raceways.
 - Shield signal cables and ground shielding on the inverter side.
 - Segregate power cable from signal cables.
 - Leave a clearance of at least 0.5m between signal cables and Motor cables.
 - Series-connect a common mode inductor (toroid) (approx. 100 μ H) to the inverter-Motor connection.
- Limiting the disturbance in the motor cables will also limit mains disturbance.

Shielded cables allow both signal sensitive cables and perturber cables to run in the same raceway. When using shielded cables, 360° shielded is obtained with collars directly bolted to the ground support.

The figure below illustrates the correct wiring of an enclosure containing an inverter; example of the correct wiring of an inverter installed inside an enclosure.

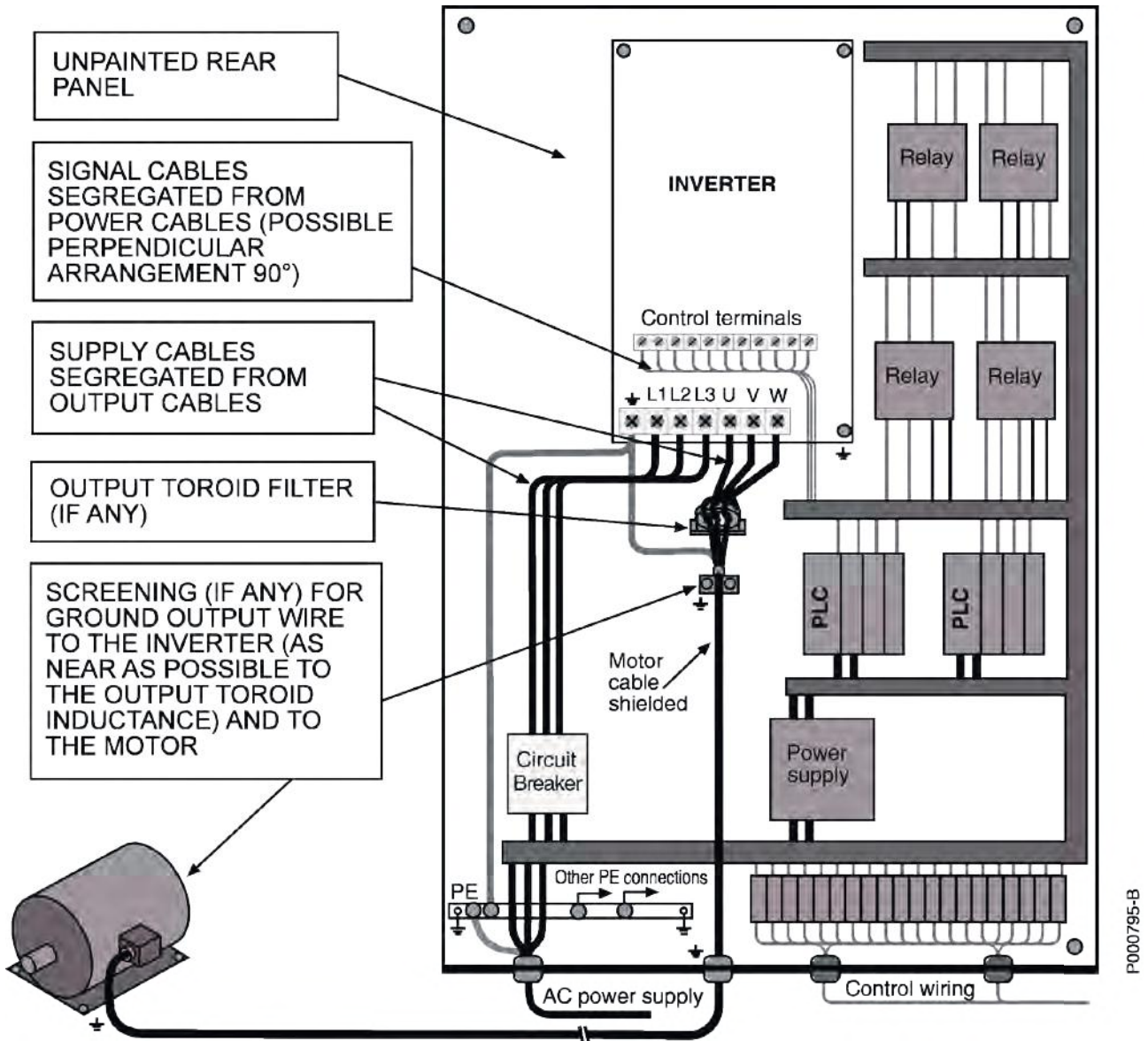

Figure 210: Example of correct wiring of an inverter inside a cabinet

7.1.1.4. Input and Output Filters

The inverters of the Sinus Penta series may be delivered with incorporated input filters; in that case, models are marked with A1, A2, B in the ID number.

If built-in filters are fitted, disturbance amplitude ranges between allowable emission limits.

As for devices of group 1, class B for standard EN55011 and VDE0875G, just install an additional output toroid filter (e.g. type 2xK618) on the models with incorporated filter A1; make sure that the three cables between the motor and the inverter go through the core. The figure shows the wiring diagram for the line, the inverter and the motor.

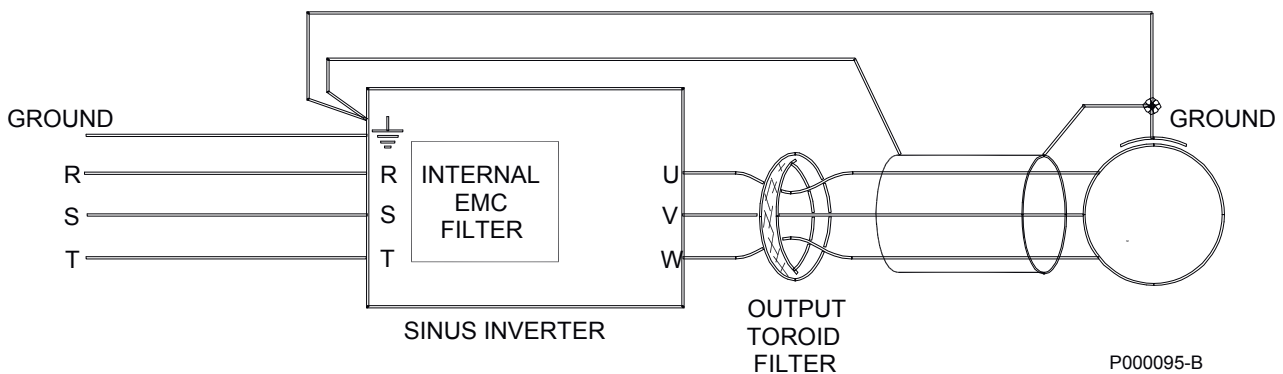

Figure 211: Wiring the toroid filter for the inverters of the Sinus Penta series



NOTE

Install the output filter near the inverter to comply with the standards in force (leave a minimum clearance for the cable connections).



NOTE

Install the toroid filter by leading the connection cables between the motor and the inverter inside the toroid.

7.2. Low Voltage Directive

Low Voltage Directive 2006/95/CE	IEC EN 61800-5-1	Adjustable speed electrical power drive systems. Part 5-1: Safety requirements – Electrical, thermal and energy.
	IEC EN 61800-5-2	Adjustable speed electrical power drive systems. Part 5-2: Safety requirements – Functional safety.
	IEC EN 60204-1	Safety of machinery. Electrical equipment of machines. Part: General requirements.

8. INDEX

A			
Air cooling	29	ES870.....	362
Alarms	111; 157	ES913.....	106; 282
Application		ES914.....	366
Heavy	159	ES919.....	319
Light	159	ES950.....	395
Standard.....	159	ES966.....	408
Strong.....	159		
Autotune.....	148; 150; 154	F	
Auxiliary power supply	146	Feedback	
		Encoder	284
		Speed	153; 271; 282
		Filters	
		Toroid	413
		FOC.....	15; 16; 152
B			
BACNet/Ethernet.....	323	G	
BACNet/RS485	326	Ground connection	18; 104
BiSS	395		
Board		H	
DataLogger	328	Handling	25
Encoder.....	271; 273	Hiperface	408
Fieldbus.....	293	HTL.....	282
I/O Expansion.....	343		
Line Driver Encoder	106; 282; 284	I	
Power Supply Unit.....	366	I/O Expansion	
Relay I/O Expansion	362	Wiring	351
Box.....	47	IFD	15; 16; 148
BU1440	223	Input	
BU200	194	inductors.....	252
BU600	208	Inputs	
BU700	208	Analog	121; 127; 352; 353; 354; 358
		Auxiliary.....	123
		Digital	117; 120; 360
		Frequency	119
C			
Cabinet.....	49; 413	K	
Carrier frequency	156; 173	Key selector switch.....	373; 374
Choosing the product.....	158	Keypad	134
Clock	341	Remoting	78; 134; 137; 248
Current loop	154		
D			
Dissipated power.....	31; 36	L	
Disturbance	412	LEDs.....	134
Download	135	Line Driver Encoder	
		Configuration	286
		Terminal board	285
		LOC.....	373; 374
E			
Enable	118	M	
Encoder.....	119; 355; 365	Mains failure	411
Configuration	275	Maintenance.....	32
Configuration examples.....	276	Metasys® N2.....	321
Terminals	274	Motor	
Testing	153	applicable	156
Wiring.....	281	Tune	148; 150; 152
Environmental requirements	27; 156		
ES822	288		
ES836	271		
ES847	343		
ES851	328; 341		
ES860	375		
ES861	384		

Motor control 148; 150; 152; 155

N

Noise Level 36

O

Output
 Filters 416
 Frequency 156
 Inductors 255
 Outputs
 Analog 133
 Digital 128; 130; 132; 356; 361
 Frequency 129
 Relay 131
 Overload 158
 Heavy 167
 Light 161
 Standard 164
 Strong 170

P

Permanent Magnets Motors 20
 Piercing templates 51; 53; 61; 64
 Power
 Cables 93; 414
 Connections 63
 Terminals 19; 65; 107; 108
 PTC 105; 121; 125

R

REM 373; 374
 Reset 105; 118
 Resolver 384
 RTC 341

S

Safety 18; 148; 150; 152

Serial board 288
 Serial communications 141; 145
 SIN/COS Encoder 375
 Sinusoidal filters 270
 Size 36
 Slot A 273; 282; 284
 Slot B 290; 294; 320; 329; 342
 Slot C 344; 363
 Spare 116
 Speed loop 151; 154
 Speed regulator 151; 154
 Standard mounting 51; 61; 64
 Start 19; 117
 Start up 147; 148; 150; 152; 155
 SYN 15; 16; 155

T

Terminals
 Control 105
 Power 85
 Thermal protection 19; 125
 Through-panel assembly 53
 Twelve-Pulse Connection 65; 71

U

UL-Approved Fuses 95; 100; 103
 UL-Approved Surge Protective Devices 96
 Unpacking 25
 Upload 135

V

Voltage Class
 2T-4T 164; 167; 170
 5T-6T 163; 166; 169; 172
 VTC 15; 16; 150

W

Wiring diagram 67; 69

www.nicsanat.com

021-87700210

