

# Altivar 31H

Installation manual

Variable speed drives  
for asynchronous motors

[www.nicsanat.com](http://www.nicsanat.com)

021-87700210



# Contents

Drive references	2
Mounting	4
Wiring	8

**NOTE: Please also refer to the Programming Manual.**

When the drive is powered up, the power components and some of the control components are connected to the line supply. It is extremely dangerous to touch them. *The drive cover must be kept closed.*

In general, the drive power supply must be disconnected before any operation on either the electrical or mechanical parts of the installation or *machine*. After the ALTIVAR has been switched off and the display has disappeared completely, *wait for 10 minutes before working on the equipment*. This is the time required for the capacitors to discharge.

The motor can be stopped during operation by inhibiting start commands or the speed reference while the drive remains powered up. If personnel safety requires prevention of sudden restarts, this electronic locking system is not sufficient: *fit a cut-off on the power circuit.*

The drive is fitted with safety devices which, in the event of a fault, can shut down the drive and consequently the motor. The motor itself may be stopped by a mechanical blockage. Finally, voltage variations, especially line supply failures, can also cause shutdowns.

If the cause of the shutdown disappears, there is a risk of restarting which may endanger certain machines or installations, especially those which must conform to safety regulations.

*In this case the user must take precautions against the possibility of restarts, in particular by using a low speed detector to cut off power to the drive if the motor performs an unprogrammed shutdown.*

The drive must be installed and set up in accordance with both international and national standards. Bringing the device into conformity is the responsibility of the systems integrator who must observe the EMC directive among others within the European Union.

The specifications contained in this document must be applied in order to comply with the essential requirements of the EMC directive.

The Altivar 31 must be considered as a component: it is neither a machine nor a device ready for use in accordance with European directives (machinery directive and electromagnetic compatibility directive). It is the responsibility of the end user to ensure that the machine meets these standards.

The drive must not be used as a safety device for machines posing a potential risk of material damage or personal injury (lifting equipment, for example). In such applications, overspeed checks and checks to ensure that the trajectory remains under constant control must be made by separate devices which are independent of the drive.

The products and equipment described in this document may be changed or modified at any time, either from a technical point of view or in the way they are operated. Their description can in no way be considered contractual.

## Drive references

### Single phase supply voltage: 200...240 V 50/60 Hz

3-phase motor 200...240 V

Motor	Line supply (input)				Drive (output)			Altivar 31 Reference (5)	
	Max. line current (2)		Max. prospective line Isc	Apparent power	Max. inrush current (3)	Nominal current In (1)	Max. transient current (1) (4)		Power dissipated at nominal load
Power indicated on plate (1)	at 200 V	at 240 V						kA	
kW/HP	A	A	kA	kVA	A	A	A	W	
0.18/0.25	3.0	2.5	1	0.6	10	1.5	2.3	24	<b>ATV31H018M2</b>
0.37/0.5	5.3	4.4	1	1.0	10	3.3	5.0	41	<b>ATV31H037M2</b>
0.55/0.75	6.8	5.8	1	1.4	10	3.7	5.6	46	<b>ATV31H055M2</b>
0.75/1	8.9	7.5	1	1.8	10	4.8/4.2 (6)	7.2	60	<b>ATV31H075M2</b>
1.1/1.5	12.1	10.2	1	2.4	19	6.9	10.4	74	<b>ATV31HU11M2</b>
1.5/2	15.8	13.3	1	3.2	19	8.0	12.0	90	<b>ATV31HU15M2</b>
2.2/3	21.9	18.4	1	4.4	19	11.0	16.5	123	<b>ATV31HU22M2</b>

### 3-phase supply voltage: 200...240 V 50/60 Hz

3-phase motor 200...240 V

Motor	Line supply (input)				Drive (output)			Altivar 31 Reference (5)	
	Max. line current (2)		Max. prospective line Isc	Apparent power	Max. inrush current (3)	Nominal current In (1)	Max. transient current (1) (4)		Power dissipated at nominal load
Power indicated on plate (1)	at 200 V	at 240 V						kA	
kW/HP	A	A	kA	kVA	A	A	A	W	
0.18/0.25	2.1	1.9	5	0.7	10	1.5	2.3	23	<b>ATV31H018M3X</b>
0.37/0.5	3.8	3.3	5	1.3	10	3.3	5.0	38	<b>ATV31H037M3X</b>
0.55/0.75	4.9	4.2	5	1.7	10	3.7	5.6	43	<b>ATV31H055M3X</b>
0.75/1	6.4	5.6	5	2.2	10	4.8	7.2	55	<b>ATV31H075M3X</b>
1.1/1.5	8.5	7.4	5	3.0	10	6.9	10.4	71	<b>ATV31HU11M3X</b>
1.5/2	11.1	9.6	5	3.8	10	8.0	12.0	86	<b>ATV31HU15M3X</b>
2.2/3	14.9	13.0	5	5.2	10	11.0	16.5	114	<b>ATV31HU22M3X</b>
3/3	19.1	16.6	5	6.6	19	13.7	20.6	146	<b>ATV31HU30M3X</b>
4/5	24	21.1	5	8.4	19	17.5	26.3	180	<b>ATV31HU40M3X</b>
5.5/7.5	36.8	32.0	22	12.8	23	27.5	41.3	292	<b>ATV31HU55M3X</b>
7.5/10	46.8	40.9	22	16.2	23	33.0	49.5	388	<b>ATV31HU75M3X</b>
11/15	63.5	55.6	22	22.0	93	54.0	81.0	477	<b>ATV31HD11M3X</b>
15/20	82.1	71.9	22	28.5	93	66.0	99.0	628	<b>ATV31HD15M3X</b>

(1) These power ratings and currents are for a maximum ambient temperature of 50°C and a switching frequency of 4 kHz in continuous operation. The switching frequency is adjustable from 2 to 16 kHz.

Above 4 kHz, the drive will reduce the switching frequency in the event of excessive temperature rise. The temperature rise is controlled by a PTC probe in the power module. Nonetheless, the nominal drive current should be derated if operation above 4 kHz needs to be continuous.

Derating curves are shown on page 6 as a function of switching frequency, ambient temperature and mounting conditions.

(2) Current on a line supply with the "Max. prospective line Isc" indicated.

(3) Peak current on power-up, for the max. voltage (240 V + 10%).

(4) For 60 seconds.

(5) Reference for a drive with built-in terminal but no control unit. For a drive with control potentiometer and RUN/STOP buttons, add an A at the end of the reference, e.g.: ATV31H018M2A.

(6) 4.8 A at 200 V/4.6 A at 208 V/4.2 A at 230 V and 240 V.

## Drive references

### 3-phase supply voltage: 380...500 V 50/60 Hz

3-phase motor 380...500 V

Motor	Line supply (input)				Drive (output)			Altivar 31 Reference (5)	
	Max. line current (2)		Max. prospective line Isc	Apparent power	Max. inrush current (3)	Nominal current In (1)	Max. transient current (1) (4)		Power dissipated at nominal load
Power indicated on plate (1)	at 380 V	at 500 V						kA	
kW/HP	A	A	kA	kVA	A	A	A	W	
0.37/0.5	2.2	1.7	5	1.5	10	1.5	2.3	32	<b>ATV31H037N4</b>
0.55/0.75	2.8	2.2	5	1.8	10	1.9	2.9	37	<b>ATV31H055N4</b>
0.75/1	3.6	2.7	5	2.4	10	2.3	3.5	41	<b>ATV31H075N4</b>
1.1/1.5	4.9	3.7	5	3.2	10	3.0	4.5	48	<b>ATV31HU11N4</b>
1.5/2	6.4	4.8	5	4.2	10	4.1	6.2	61	<b>ATV31HU15N4</b>
2.2/3	8.9	6.7	5	5.9	10	5.5	8.3	79	<b>ATV31HU22N4</b>
3/3	10.9	8.3	5	7.1	10	7.1	10.7	125	<b>ATV31HU30N4</b>
4/5	13.9	10.6	5	9.2	10	9.5	14.3	150	<b>ATV31HU40N4</b>
5.5/7.5	21.9	16.5	22	15.0	30	14.3	21.5	232	<b>ATV31HU55N4</b>
7.5/10	27.7	21.0	22	18.0	30	17.0	25.5	269	<b>ATV31HU75N4</b>
11/15	37.2	28.4	22	25.0	97	27.7	41.6	397	<b>ATV31HD11N4</b>
15/20	48.2	36.8	22	32.0	97	33.0	49.5	492	<b>ATV31HD15N4</b>

### 3-phase supply voltage: 525...600 V 50/60 Hz

3-phase motor 525...600 V

Motor	Line supply (input)				Drive (output)			Altivar 31 Reference	
	Max. line current (2)		Max. prospective line Isc	Apparent power	Max. inrush current (3)	Nominal current In (1)	Max. transient current (1) (4)		Power dissipated at nominal load
Power indicated on plate (1)	at 525 V	at 600 V						kA	
kW/HP	A	A	kA	kVA	A	A	A	W	
0.75/1	2.8	2.4	5	2.5	12	1.7	2.6	36	<b>ATV31H075S6X</b>
1.5/2	4.8	4.2	5	4.4	12	2.7	4.1	48	<b>ATV31HU15S6X</b>
2.2/3	6.4	5.6	5	5.8	12	3.9	5.9	62	<b>ATV31HU22S6X</b>
4/5	10.7	9.3	5	9.7	12	6.1	9.2	94	<b>ATV31HU40S6X</b>
5.5/7.5	16.2	14.1	22	15.0	36	9.0	13.5	133	<b>ATV31HU55S6X</b>
7.5/10	21.3	18.5	22	19.0	36	11.0	16.5	165	<b>ATV31HU75S6X</b>
11/15	27.8	24.4	22	25.0	117	17.0	25.5	257	<b>ATV31HD11S6X</b>
15/20	36.4	31.8	22	33.0	117	22.0	33.0	335	<b>ATV31HD15S6X</b>

(1) These power ratings and currents are for a maximum ambient temperature of 50°C and a switching frequency of 4 kHz in continuous operation. The switching frequency is adjustable from 2 to 16 kHz.  
Above 4 kHz, the drive will reduce the switching frequency in the event of excessive temperature rise. The temperature rise is controlled by a PTC probe in the power module. Nonetheless, the nominal drive current should be derated if operation above 4 kHz needs to be continuous.  
Derating curves are shown on page 6 as a function of switching frequency, ambient temperature and mounting conditions.

(2) Current on a line supply with the "Max. prospective line Isc" indicated.

(3) Peak current on power-up, for the max. voltage (500 V + 10%, 600 V + 10%).

(4) For 60 seconds.

(5) Reference for a drive with built-in terminal but no control unit. For a drive with control potentiometer and RUN/STOP buttons, add an A at the end of the reference, e.g.: ATV31H037N4A.

# Mounting

## Dimensions and weights

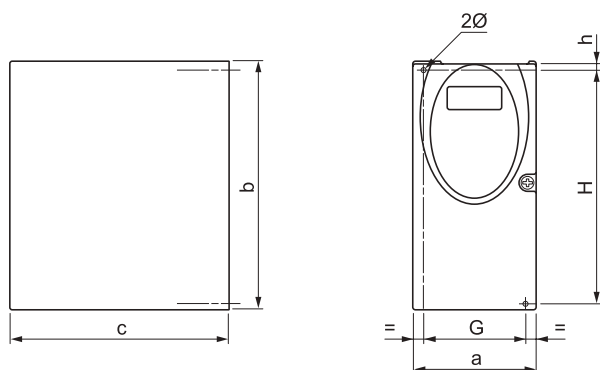

ATV31		a mm	b mm	c (1) mm	G mm	hr mm	H mm	Ø mm	For screw	Weight kg
H018M3X, H037M3X	Size 1	72	145	120	60±1	5	121.5±1	2 x 5	M4	0.9
H055M3X, H075M3X	Size 2	72	145	130	60±1	5	121.5±1	2 x 5	M4	0.9
H018M2, H037M2	Size 3	72	145	130	60±1	5	121.5±1	2 x 5	M4	1.05
H055M2, H075M2	Size 4	72	145	140	60±1	5	121.5±1	2 x 5	M4	1.05
HU11M3X, HU15M3X	Size 5	105	143	130	93±1	5	121.5±1	2 x 5	M4	1.25
HU11M2, HU15M2, HU22M3X, H037N4, H055N4, H075N4, HU11N4, HU15N4, H075S6X, HU15S6X	Size 6	105	143	150	93±1	5	121.5±1	2 x 5	M4	1.35

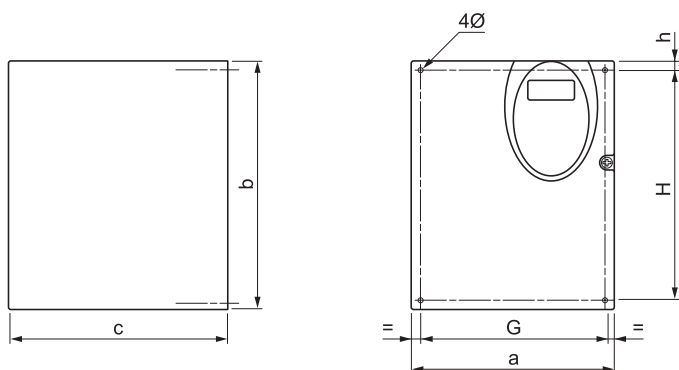

ATV31		a mm	b mm	c (1) mm	G mm	hr mm	H mm	Ø mm	For screw	Weight kg
HU22M2, HU30M3X, HU40M3X, HU22N4, HU30N4, HU40N4, HU22S6X, HU40S6X	Size 7	140	184	150	126±1	6.5	157±1	4 x 5	M4	2.35
HU55M3X, HU75M3X, HU55N4, HU75N4, HU55S6X, HU75S6X	Size 8	180	232	170	160±1	5	210±1	4 x 5	M4	4.70
HD11M3X, HD15M3X, HD11N4, HD15N4, HD11S6X, HD15S6X	Size 9	245	330	190	225±1	7	295±1	4 x 6	M5	9.0

(1) For drives in the A range, add 8 mm for the protruding potentiometer button.

# Mounting

## Mounting and temperature conditions

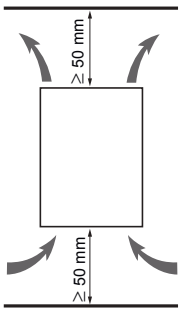

Install the unit vertically, at  $\pm 10^\circ$ .

Do not place it close to heating elements.

Leave sufficient free space to ensure that the air required for cooling purposes can circulate from the bottom to the top of the unit.

Free space in front of unit: 10 mm minimum.

When IP20 protection is adequate, we recommend that the protective cover on the top of the drive be removed, as shown below.

## Removing the protective cover

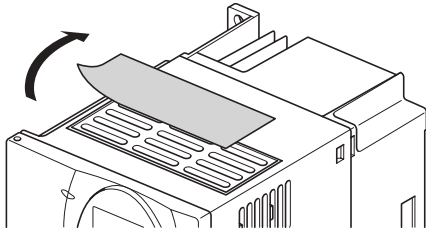

Example ATV31HU11M3X

## 3 types of mounting are possible:

**Type A mounting:** Free space  $\geq 50$  mm on each side, with protective cover fitted

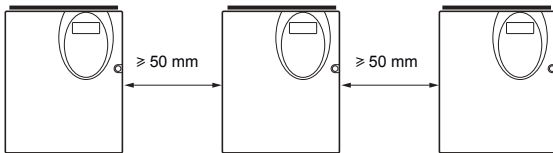

**Type B mounting:** Drives mounted side-by-side, protective cover removed (the degree of protection becomes IP20)

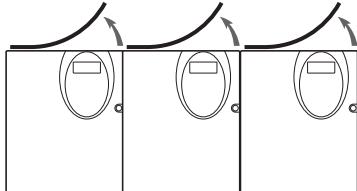

**Type C mounting:** Free space  $\geq 50$  mm on each side, protective cover removed (the degree of protection becomes IP20)

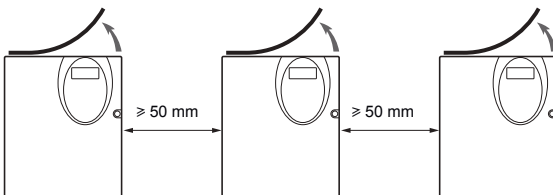

# Mounting

Derating curves for the drive current  $I_n$  as a function of the temperature, switching frequency and type of mounting.

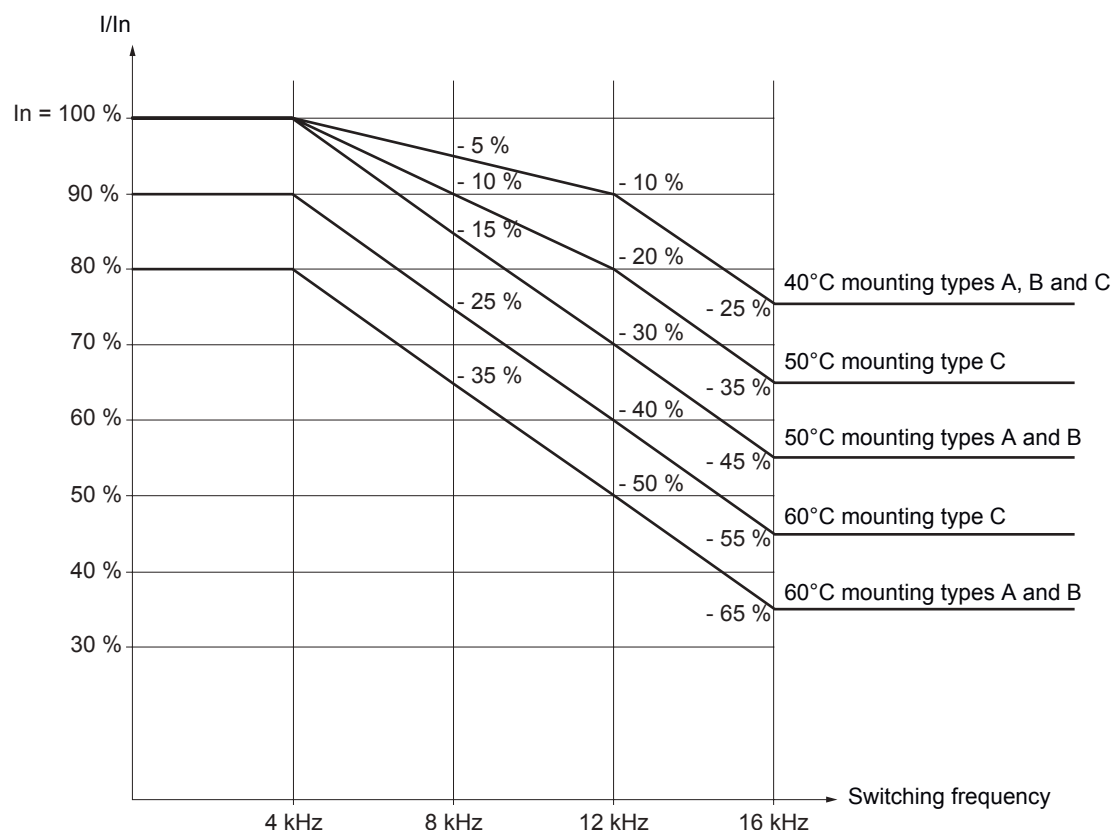

For intermediate temperatures (e.g. 55°C), interpolate between 2 curves.

**If you are installing the drives in enclosures, make provision for a flow of air at least equal to the value given in the table below for each drive.**

ATV31	Flow rate in m <sup>3</sup> /hour
H018M2, H037M2, H055M2, H018M3X, H037M3X, H055M3X, H037N4, H055N4, H075N4, HU11N4 H075S6X, HU15S6X	18
H075M2, HU11M2, HU15M2 H075M3X, HU11M3X, HU15M3X HU15N4, HU22N4 HU22S6X, HU40S6X	33
HU22M2, HU22M3X, HU30M3X, HU40M3X HU30N4, HU40N4 HU55S6X, HU75S6X	93
HU55M3X HU55N4, HU75N4 HD11S6X	102
HU75M3X, HD11M3X, HD11N4, HD15N4 HD15S6X	168
HD15M3X	216

# Mounting

## Electromagnetic compatibility

### EMC mounting plate: Supplied with the drive

Fix the EMC equipotentiality mounting plate to the holes in the ATV 31 heatsink using the 2 screws supplied, as shown in the drawings below.

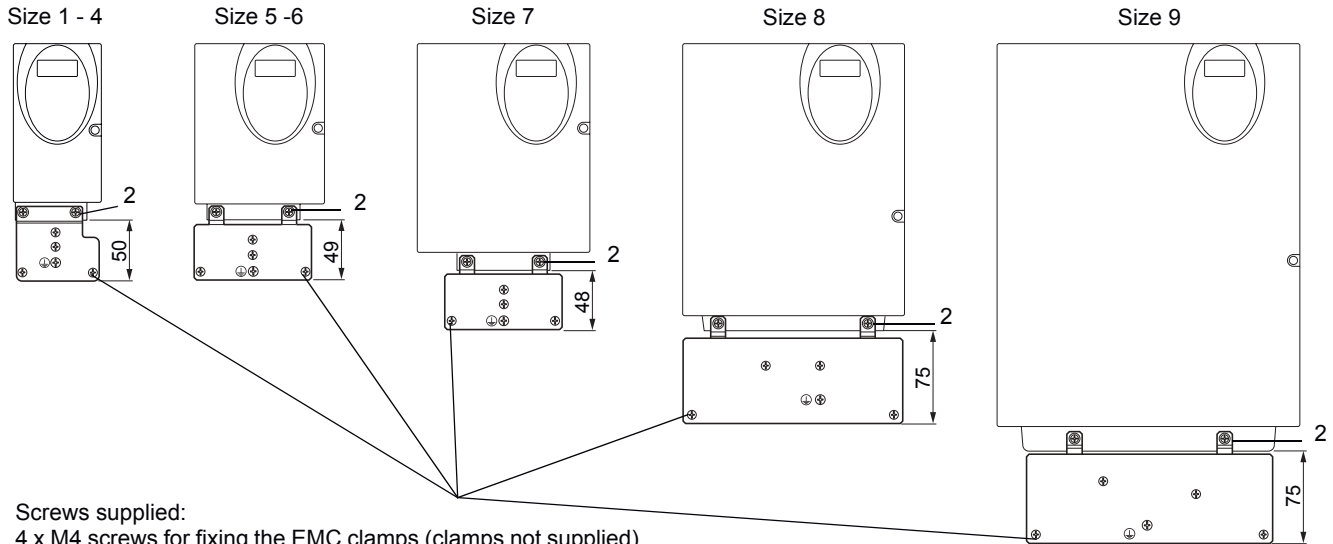

Screws supplied:  
 4 x M4 screws for fixing the EMC clamps (clamps not supplied)  
 1 x M5 screw for ground

ATV31	
H018M3X, H037M3X	Size 1
H055M3X, H075M3X	Size 2
H018M2, H037M2	Size 3
H055M2, H075M2	Size 4
HU11M3X, HU15M3X	Size 5
HU11M2, HU15M2, HU22M3X, H037N4, H055N4, H075N4, HU11N4, HU15N4, H075S6X, HU15S6X	Size 6

ATV31	
HU22M2, HU30M3X, HU40M3X, HU22N4, HU30N4, HU40N4, HU22S6X, HU40S6X	Size 7
HU55M3X, HU75M3X, HU55N4, HU75N4, HU55S6X, HU75S6X	Size 8
HD11M3X, HD15M3X, HD11N4, HD15N4, HD11S6X, HD15S6X	Size 9



# Wiring

## Access to terminals

To access the terminals, open the cover as shown in the example below.

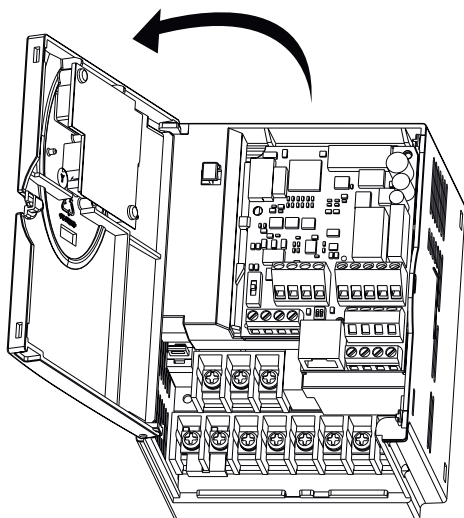

Example ATV31HU11M2

## Power terminals



Connect the power terminals before connecting the control terminals.

### Power terminal characteristics

Altivar ATV 31	Maximum connection capacity		Tightening torque in Nm
	AWG	mm <sup>2</sup>	
H018M2, H037M2, H055M2, H075M2, H018M3X, H037M3X, H055M3X, H075M3X, HU11M3X, HU15M3X	AWG 14	2.5	0.8
HU11M2, HU15M2, HU22M2, HU22M3X, HU30M3X, HU40M3X, H037N4, H055N4, H075N4, HU11N4, HU15N4, HU22N4, HU30N4, HU40N4 H075S6X, HU15S6X, HU22S6X, HU40S6X	AWG 10	6	1.2
HU55M3X, HU75M3X, HU55N4, HU75N4, HU55S6X, HU75S6X	AWG 6	16	2.5
HD11M3X, HD15M3X, HD11N4, HD15N4, HD11S6X, HD15S6X	AWG 3	25	4.5

### Power terminal functions

Terminal	Function	For Altivar ATV 31
⊥	Ground terminal	All ratings
R/L1 S/L2	Power supply	ATV31●●●●M2
R/L1 S/L2 T/L3		ATV31●●●●M3X ATV31●●●●N4 ATV31●●●●S6X
PO		All ratings
PA/+	Output to braking resistor (+ polarity)	All ratings
PB	Output to braking resistor	All ratings
PC/-	DC bus - polarity	All ratings
U/T1 V/T2 W/T3	Outputs to the motor	All ratings



Never remove the commoning link between PO and PA/+. The PO and PA/+ terminal screws must always be fully tightened as a high current flows through the commoning link.

# Wiring

## Arrangement of the power terminals

ATV 31H018M3X, H037M3X, H055M3X, H075M3X

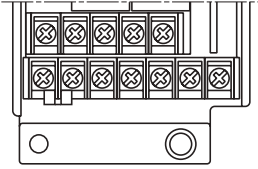

⊥	⊥	R/L1	S/L2	T/L3			
P0	PA+	PB	PC-	U/T1	V/T2	W/T3	

ATV 31H018M2, H037M2, H055M2, H075M2

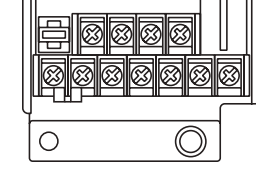

⊥	⊥	R/L1	S/L2				
P0	PA+	PB	PC-	U/T1	V/T2	W/T3	

ATV 31HU11M3X, HU15M3X, HU22M3X, HU30M3X, HU40M3X,  
H037N4, H055N4, H075N4, HU11N4, HU15N4, HU22N4,  
HU30N4, HU40N4, H075S6X, HU15S6X, HU22S6X,  
HU40S6X

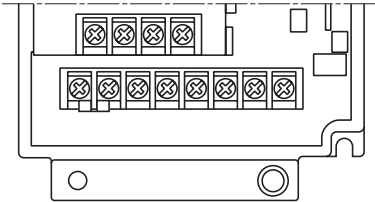

⊥	R/L1	S/L2	T/L3				
P0	PA+	PB	PC-	U/T1	V/T2	W/T3	⊥

ATV 31HU11M2, HU15M2, HU22M2

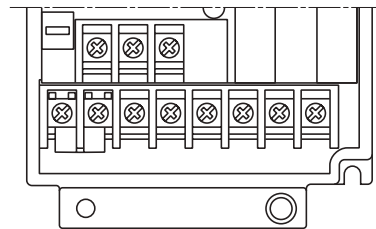

⊥	R/L1	S/L2					
P0	PA+	PB	PC-	U/T1	V/T2	W/T3	⊥

ATV 31HU55M3X, HU75M3X, HU55N4, HU75N4, HU55S6X, HU75S6X

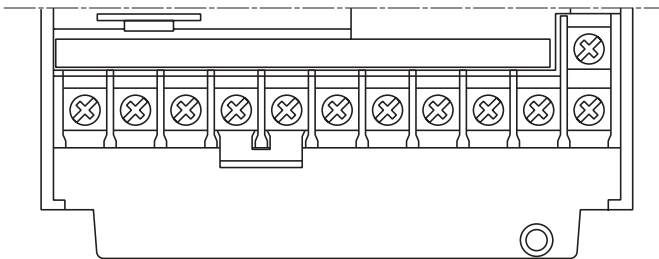

												⊥
R/L1	S/L2	T/L3	P0	PA+	PB	PC-	U/T1	V/T2	W/T3			⊥

ATV 31HD11M3X, HD15M3X, HD11N4, HD15N4, HD11S6X, HD15S6X

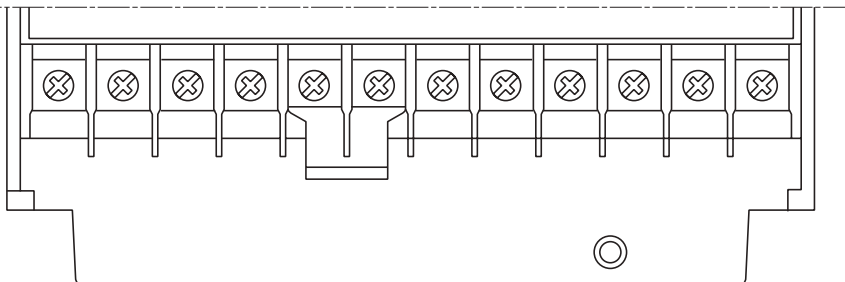

⊥	R/L1	S/L2	T/L3	P0	PA+	PB	PC-	U/T1	V/T2	W/T3	⊥
---	------	------	------	----	-----	----	-----	------	------	------	---

# Wiring

## Control terminals

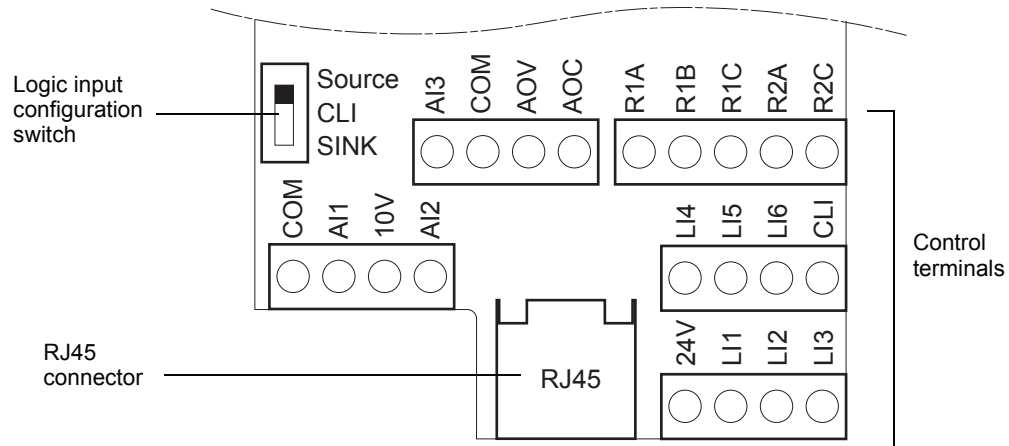

- Maximum connection capacity: 2.5 mm<sup>2</sup> - AWG 14
- Max. tightening torque: 0.6 Nm

# Wiring

## Control terminals

### Arrangement, characteristics and functions of the control terminals

Terminal	Function	Electrical characteristics
R1A R1B R1C	Common point C/O contact (R1C) of programmable relay R1	<ul style="list-style-type: none"> <li>• Min. switching capacity: 10 mA for 5 V <math>\text{---}</math></li> <li>• Max. switching capacity on resistive load (<math>\cos \varphi = 1</math> and <math>L/R = 0</math> ms): 5 A for 250 V <math>\sim</math> and 30 V <math>\text{---}</math></li> </ul>
R2A R2C	N/O contact of programmable relay R2	<ul style="list-style-type: none"> <li>• Max. switching capacity on inductive load (<math>\cos \varphi = 0.4</math> and <math>L/R = 7</math> ms): 1.5 A for 250 V <math>\sim</math> and 30 V <math>\text{---}</math></li> <li>• Sampling time 8 ms</li> <li>• Service life: 100,000 operations at max. switching power 1,000,000 operations at min. switching power</li> </ul>
COM	Analog I/O common	0 V
AI1	Analog voltage input	Analog input 0 + 10 V (max. safe voltage 30 V) <ul style="list-style-type: none"> <li>• Impedance 30 k<math>\Omega</math></li> <li>• Resolution 0.01 V, 10-bit converter</li> <li>• Precision <math>\pm 4.3\%</math>, linearity <math>\pm 0.2\%</math>, of max. value</li> <li>• Sampling time 8 ms</li> <li>• Operation with shielded cable 100 m max.</li> </ul>
10 V	Power supply for setpoint potentiometer 1 to 10 k $\Omega$	+10 V (+ 8% - 0), 10 mA max, protected against short-circuits and overloads
AI2	Analog voltage input	Bipolar analog input 0 $\pm$ 10 V (max. safe voltage $\pm 30$ V) <b>The + or - polarity of the voltage on AI2 affects the direction of the setpoint and therefore the direction of operation.</b> <ul style="list-style-type: none"> <li>• Impedance 30 k<math>\Omega</math></li> <li>• Resolution 0.01 V, 10-bit + sign converter</li> <li>• Precision <math>\pm 4.3\%</math>, linearity <math>\pm 0.2\%</math>, of max. value</li> <li>• Sampling time 8 ms</li> <li>• Operation with shielded cable 100 m max.</li> </ul>
AI3	Analog current input	Analog input X - Y mA. X and Y can be programmed from 0 to 20 mA <ul style="list-style-type: none"> <li>• Impedance 250 <math>\Omega</math></li> <li>• Resolution 0.02 mA, 10-bit converter</li> <li>• Precision <math>\pm 4.3\%</math>, linearity <math>\pm 0.2\%</math>, of max. value</li> <li>• Sampling time 8 ms</li> </ul>
COM	Analog I/O common	0 V
AOV or AOC	Analog voltage output AOV or Analog current output AOC or Logic voltage output AOC AOV or AOC can be assigned (either, but not both)	Analog output 0 to 10 V, min. load impedance 470 $\Omega$ or Analog output X - Y mA. X and Y can be programmed from 0 to 20 mA, max. load impedance 800 $\Omega$ <ul style="list-style-type: none"> <li>• Resolution 8 bits (1)</li> <li>• Precision <math>\pm 1\%</math> (1)</li> <li>• Linearity <math>\pm 0.2\%</math> (1)</li> <li>• Sampling time 8 ms</li> </ul> This analog output can be configured as a 24 V logic output on AOC, min. load impedance 1.2 k $\Omega$ . (1) Characteristics of digital/analog converter.
24 V	Logic input power supply	+ 24 V protected against short-circuits and overloads, min. 19 V, max. 30 V Max. customer current available 100 mA
LI1 LI2 LI3	Logic inputs	Programmable logic inputs <ul style="list-style-type: none"> <li>• + 24 V power supply (max. 30 V)</li> <li>• Impedance 3.5 k<math>\Omega</math></li> <li>• State 0 if &lt; 5 V, state 1 if &gt; 11 V (voltage difference between LI- and CLI)</li> <li>• Sampling time 4 ms</li> </ul>
LI4 LI5 LI6	Logic inputs	Programmable logic inputs <ul style="list-style-type: none"> <li>• + 24 V power supply (max. 30 V)</li> <li>• Impedance 3.5 k<math>\Omega</math></li> <li>• State 0 if &lt; 5 V, state 1 if &gt; 11 V (voltage difference between LI- and CLI)</li> <li>• Sampling time 4 ms</li> </ul>
CLI	Logic input common	See page 12.

# Wiring

## Wiring diagram for factory settings

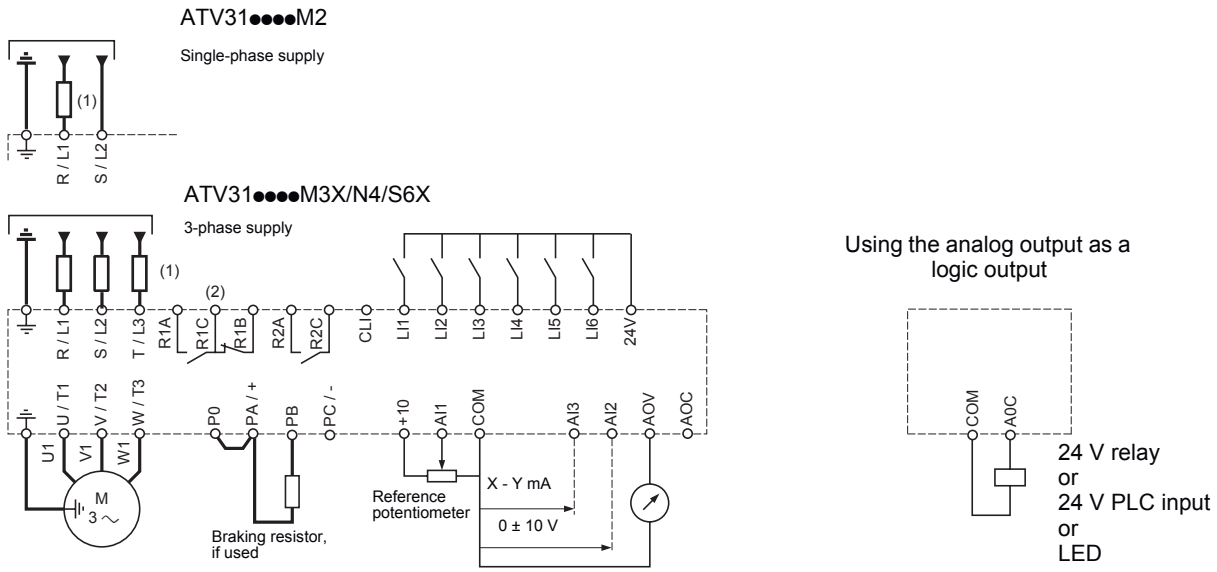

- (1) Line choke, if used (single phase or 3-phase)
- (2) Fault relay contacts, for remote indication of the drive status.

**Note:** Fit interference suppressors to all inductive circuits near the drive or coupled to the same circuit (relays, contactors, solenoid valves, etc).

**Choice of associated components:**  
Please refer to the catalogue.

## Logic input switch

This switch assigns the logic input common link to 0V, 24 V or "floating":

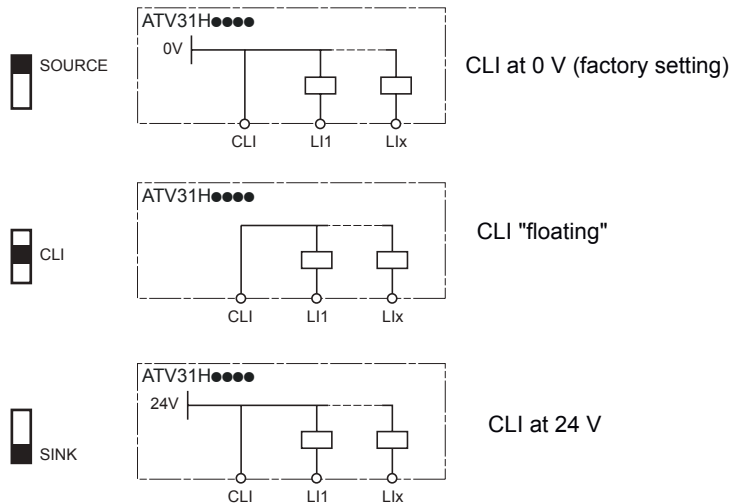

# Wiring

## Examples of recommended circuit diagrams

### Using volt-free contacts

- Switch in "Source" position  
(ATV31 factory setting for types other than ATV31●●●●A)

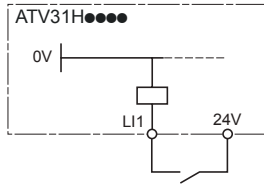

- Switch in "SINK" position  
(factory setting for ATV31●●●●A)

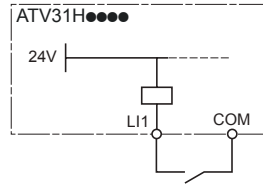

In this instance, the common must never be connected to earth or earth ground, as this presents a risk of unintended equipment operation on the first insulation fault.

### Using PLC transistor outputs

- Switch in CLI position

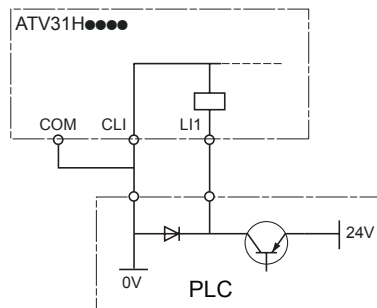

- Switch in CLI position

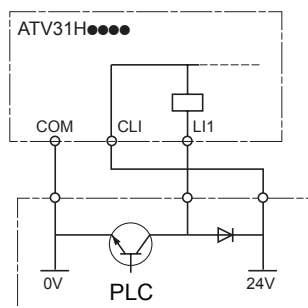

## Wiring recommendations

### Power

The drive must be earthed to conform with the regulations concerning high leakage currents (over 3.5 mA).

When upstream protection by means of a "residual current device" is required by the installation standards, a type A device should be used for single-phase drives and type B for 3-phase drives. Choose a suitable model incorporating:

- HF current filtering
- A time delay which prevents tripping caused by the load from stray capacitance on power-up. The time delay is not possible for 30 mA devices. In this case, choose devices with immunity against accidental tripping, for example RCDs with reinforced immunity from the s.i range (Merlin Gerin brand).

If the installation includes several drives, provide one "residual current device" per drive.

Keep the power cables separate from circuits in the installation with low-level signals (detectors, PLCs, measuring apparatus, video, telephone).

If you are using cables > 50 m between the drive and the motor, add output filters (please refer to the catalogue).

### Control

Keep the control circuits away from the power cables. For control and speed reference circuits, we recommend using shielded twisted cables with a pitch of between 25 and 50 mm, connecting the shielding to ground at each end.

# Wiring

## Operation on an IT system

IT system: Isolated or impedance earthed neutral.

Use a permanent insulation monitor compatible with non-linear loads (a Merlin Gerin type XM200, for example).

ATV 31●●●M2 and N4 drives feature built-in RFI filters. These filters can be isolated from ground for operation on an IT system as follows:

**ATV31H018M2 to U22M2 and ATV31H037N4 to U40N4:**

Pull out the jumper on the left of the ground terminal as illustrated below.

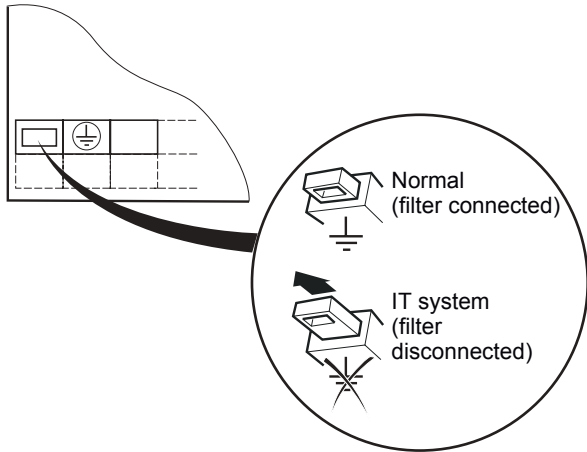

**ATV31HU55N4 to D15N4:**

Move the cable tag on the top left of the power terminals as illustrated below (example ATV31HU55N4):

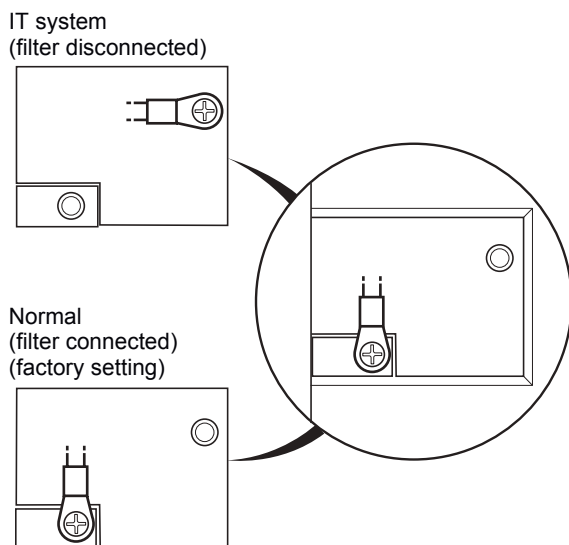

# Wiring

## Electromagnetic compatibility

### Principle

- Grounds between the drive, motor and cable shielding must have "high frequency" equipotentiality.
- Use shielded cables with shielding connected to ground throughout 360° at both ends for the motor cable **6**, braking resistor (if used) **8**, and control-signalling cables **7**. Metal ducting or conduit can be used for part of the shielding length provided that there is no break in continuity.
- Ensure maximum separation between the power supply cable (line supply) and the motor cable.

### Installation diagram (examples)

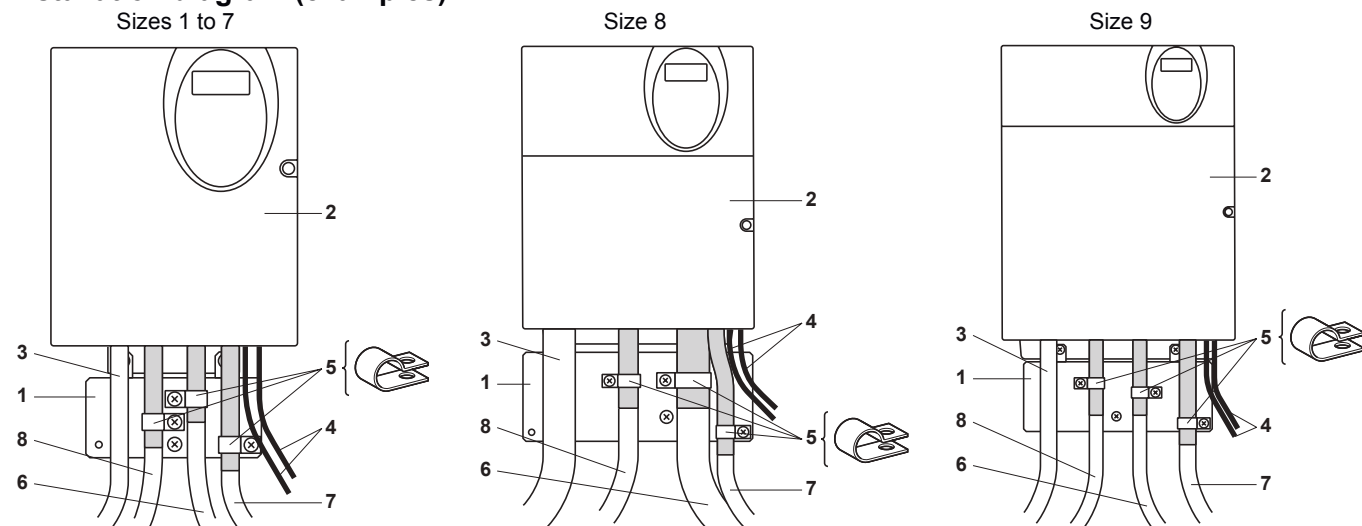

	Size 1	Size 2	Size 3	Size 4	Size 5	Size 6	Size 7	Size 8	Size 9
ATV31	H018M3X, H037M3X	H055M3X, H075M3X	H018M2, H037M2	H055M2, H075M2	HU11M3X, HU15M3X	HU11M2, HU15M2 HU22M3X H037N4, H055N4, H075N4, HU11N4, HU15N4 H075S6X, HU15S6X	HU22M2 HU30M3X, HU40M3X HU22N4, HU30N4, HU40N4 HU22S6X, HU40S6X	HU55M3X, HU75M3X HU55N4, HU75N4 HU55S6X, HU75S6X	HD11M3X, HD15M3X HD11N4, HD15N4 HD11S6X, HD15S6X

1 Sheet steel grounded plate supplied with the drive, to be fitted as indicated on the diagram.

2 Altivar 31

3 Non-shielded power supply wires or cable

4 Non-shielded wires for relay contacts

5 Fix and ground the shielding of cables **6**, **7** and **8** as close as possible to the drive:

- Strip the shielding.

- Use stainless steel cable clamps of an appropriate size on the parts from which the shielding has been stripped, to attach them to the plate **1**.

The shielding must be clamped tightly enough to the metal plate to ensure correct contact.

6 Shielded cable for motor connection with shielding connected to ground at both ends.

The shielding must be continuous and intermediate terminals must be in EMC shielded metal boxes.

For 0.18 to 1.5 kW drives, if the switching frequency is higher than 12 kHz, use cables with low linear capacitance: max. 130 pF (picoFarads) per metre.

7 Shielded cable for connecting the control/signalling wiring.

For applications requiring several conductors, use cables with a small cross-section (0.5 mm<sup>2</sup>).

The shielding must be connected to ground at both ends. The shielding must be continuous and intermediate terminals must be in EMC shielded metal boxes.

8 Shielded cable for connecting braking resistor (if fitted).

The shielding must be continuous and intermediate terminals must be in EMC shielded metal boxes.

#### Note:

- If using an additional input filter, it should be mounted under the drive and connected directly to the line supply via an unshielded cable. Link 3 on the drive is then via the filter output cable.
- The HF equipotential ground connection between the drive, motor and cable shielding does not remove the need to connect the PE protective conductors (green-yellow) to the appropriate terminals on each unit.



[www.nicsanat.com](http://www.nicsanat.com)

021-87700210



NIC SANAT

انیک صنعت