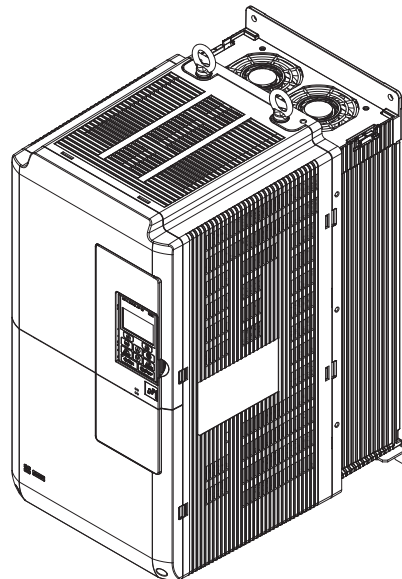


YASKAWA U1000 Series Quick Start Guide

Type: CIMR-UC

Rated Output Current: 200 V Class: 22 to 248 A
400 V Class: 9.6 to 930 A

To properly use the product, read this manual thoroughly and retain for easy reference, inspection, and maintenance. Ensure the end user receives this manual.



www.nicsanat.com

021-87700210

Receiving 1

Mechanical Installation 2

Electrical Installation 3

Start-Up Programming & Operation 4

Troubleshooting 5

Specifications A

Parameter List B

Standards Compliance C

www.nicsanat.com

021-87700210



Copyright © 2014 YASKAWA ELECTRIC CORPORATION.

All rights reserved. No part of this publication may be reproduced, stored in a retrieval system, or transmitted, in any form, or by any means, mechanical, electronic, photocopying, recording, or otherwise, without the prior written permission of Yaskawa. No patent liability is assumed with respect to the use of the information contained herein. Moreover, because Yaskawa is constantly striving to improve its high-quality products, the information contained in this manual is subject to change without notice. Every precaution has been taken in the preparation of this manual. Nevertheless, Yaskawa assumes no responsibility for errors or omissions. Neither is any liability assumed for damages resulting from the use of the information contained in this publication.

www.nicsanat.com

021-87700210



Table of Contents

i.	Preface & General Safety	5
	Preface	5
	General Safety	5
1.	Receiving	15
	Model Number and Nameplate Check	15
2.	Mechanical Installation	18
	Mechanical Installation	18
3.	Electrical Installation	24
	Standard Connection Diagram	24
	Main Circuit Connection Diagram	29
	Main Circuit Wiring	30
	Control Circuit Wiring	40
	Control I/O Connections	47
	Enable the Internal EMC Filter	50
	24 V Control Power Supply Unit Wiring	54
	Wiring Checklist	58
4.	Start-Up Programming & Operation	60
	Using the Digital Operator	60
	Powering Up the Drive	63
	Basic Drive Setup Adjustments	64
	Auto-Tuning	79
	No-Load Operation Test Run	81
	Test Run with Load Connected	81
	Test Run Checklist	82
5.	Troubleshooting	84
	Fault Detection	84
	Alarm Detection	88
	Operator Programming Errors	90
	Auto-Tuning Fault Detection	91
A.	Specifications	93
	Drive Specifications	93
B.	Parameter List	95
	A: Initialization Parameters	95
	b: Application	95
	C: Tuning	96
	d: Reference Settings	96
	E: Motor Parameters	97
	H: Multi-Function Terminals	97
	L: Protection Function	100
	o: Operator Related Settings	101
	T: Motor Tuning	101

Table of Contents

C. Standards Compliance	102
European Standards	102
UL Standards	108
Safe Disable Input Function	122
Revision History.....	126

www.nicsanat.com

021-87700210



i Preface & General Safety

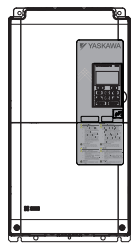
◆ Preface

Yaskawa manufactures products used as components in a wide variety of industrial systems and equipment. The selection and application of Yaskawa products remain the responsibility of the equipment manufacturer or end user. Yaskawa accepts no responsibility for the way its products are incorporated into the final system design. Under no circumstances should any Yaskawa product be incorporated into any product or design as the exclusive or sole safety control. Without exception, all controls should be designed to detect faults dynamically and fail safely under all circumstances. All systems or equipment designed to incorporate a product manufactured by Yaskawa must be supplied to the end user with appropriate warnings and instructions as to the safe use and operation of that part. Any warnings provided by Yaskawa must be promptly provided to the end user. Yaskawa offers an express warranty only as to the quality of its products in conforming to standards and specifications published in the Yaskawa manual. **NO OTHER WARRANTY, EXPRESS OR IMPLIED, IS OFFERED.** Yaskawa assumes no liability for any personal injury, property damage, losses, or claims arising from misapplication of its products.

This manual is designed to ensure correct and suitable application of U1000 Series Drives. Read this manual before attempting to install, operate, maintain, or inspect a drive and keep it in a safe, convenient location for future reference. Be sure you understand all precautions and safety information before attempting application.

■ Applicable Documentation

The following manuals are available for U1000 series drives:

	YASKAWA U1000 Series Quick Start Guide (this book)
	This guide is packaged together with the product. It contains basic information on safety precautions, model list, and wiring. Use this manual for basic settings and trial operation.
	YASKAWA U1000 Series Technical Manual
	This manual is included on the CD-ROM packaged with the product (Yaskawa AC Drive Manuals, TOBC C710616 21). The manual contains information required to install and wire the drive, in addition to an overview of fault diagnostics, maintenance safety, and parameter settings. Contact a Yaskawa representative to obtain the manual. The manual is also available for download on our documentation website, e-mechatronics.com .

◆ General Safety

■ Supplemental Safety Information

General Precautions

- The diagrams in this manual may be indicated without covers or safety shields to show details. Restore covers or shields before operating the drive and run the drive according to the instructions described in this manual.
- Any illustrations, photographs, or examples used in this manual are provided as examples only and may not apply to all products to which this manual is applicable.
- The products and specifications described in this manual or the content and presentation of the manual may be changed without notice to improve the product and/or the manual.
- When ordering a new copy of the manual due to damage or loss, contact your Yaskawa representative or the nearest Yaskawa sales office and provide the manual number shown on the front cover.
- If nameplate becomes worn or damaged, order a replacement from your Yaskawa representative or the nearest Yaskawa sales office.

i Preface & General Safety

WARNING

Read and understand this manual before installing, operating or servicing this drive. The drive must be installed according to this manual and local codes.

The following conventions are used to indicate safety messages in this manual. Failure to heed these messages could result in serious or possibly even fatal injury or damage to the products or to related equipment and systems.

DANGER

Indicates a hazardous situation, which, if not avoided, will result in death or serious injury.

WARNING

Indicates a hazardous situation, which, if not avoided, could result in death or serious injury.

WARNING! will also be indicated by a bold key word embedded in the text followed by an italicized safety message.

CAUTION

Indicates a hazardous situation, which, if not avoided, could result in minor or moderate injury.

CAUTION! will also be indicated by a bold key word embedded in the text followed by an italicized safety message.

NOTICE

Indicates a property damage message.

NOTICE: will also be indicated by a bold key word embedded in the text followed by an italicized safety message.

■ Safety Messages

DANGER

Heed the safety messages in this manual.

Failure to comply will result in death or serious injury.

The operating company is responsible for any injuries or equipment damage resulting from failure to heed the warnings in this manual.

Electrical Shock Hazard

Do not connect or disconnect wiring while the power is on.

Failure to comply will result in death or serious injury.

Before servicing, disconnect all power to the equipment. The capacitor for the control power supply remains charged even after the power supply is turned off. After shutting off the power, wait for at least the amount of time specified on the drive before touching any components.

WARNING**Sudden Movement Hazard**

System may start unexpectedly upon application of power, resulting in death or serious injury.

Clear all personnel from the drive, motor and machine area before applying power. Secure covers, couplings, shaft keys and machine loads before applying power to the drive.

When using DriveWorksEZ to create custom programming, the drive I/O terminal functions change from factory settings and the drive will not perform as outlined in this manual.

Unpredictable equipment operation may result in death or serious injury.

Take special note of custom I/O programming in the drive before attempting to operate equipment.

Electrical Shock Hazard

Do not attempt to modify or alter the drive in any way not explained in this manual.

Failure to comply could result in death or serious injury.

Yaskawa is not responsible for any modification of the product made by the user. This product must not be modified.

Do not allow unqualified personnel to use equipment.

Failure to comply could result in death or serious injury.

Installation, maintenance, inspection and servicing must be performed only by authorized personnel familiar with installation, adjustment and maintenance of AC drives.

Do not remove covers or touch circuit boards while the power is on.

Failure to comply could result in death or serious injury.

Do not turn on the power for the EMC Filter Module only.

Failure to comply will result in death or serious injury.

The output terminals remain charged even after the power supply is turned off. Always connect the EMC Filter Module as shown in the standard connection diagram and turn on the EMC Filter Module according to the diagram.

Make sure the protective earthing conductor complies with technical standards and local safety regulations.

When an EMC filter is installed or with models CIMR-U□4□0302 and larger, the leakage current exceeds 3.5 mA. Therefore according to IEC/EN 61800-5-1 automatic power supply interruption in case of discontinuity of the protective earthing conductor must be provided or a protective earthing conductor with a cross section of at least 10 mm² (Cu) or 16 mm² (Al) must be used.

Use appropriate equipment for residual current monitoring/detection (RCM/RCD).

This drive can cause a residual current with a DC component in the protective earthing conductor. Where a residual current operated protective or monitoring device is used for protection in case of direct or indirect contact, always use an RCM or RCD of type B according to IEC/EN 60755.

Fire Hazard

Do not use an improper voltage source.

Failure to comply could result in death or serious injury by fire.

Verify that the rated voltage of the drive matches the voltage of the incoming power supply before applying power.

Do not use improper combustible materials for the drive and harmonic filter module.

Failure to comply could result in death or serious injury by fire.

Attach the drive and harmonic filter module to metal or other noncombustible material.

Tighten all terminal screws to the specified tightening torque.

Loose electrical connections could result in death or serious injury by fire due to overheating of electrical connections.

i Preface & General Safety

WARNING

Crush Hazard

Do not use this drive in lifting applications without installing external safety circuitry to prevent accidental dropping of the load.

The drive does not possess built-in load drop protection for lifting applications.

Failure to comply could result in death or serious injury from falling loads.

Install electrical and/or mechanical safety circuit mechanisms independent of drive circuitry.

If using a crane or a lifter to transport the drive, make sure that only qualified personnel are allowed operating.

Incorrect operation may cause the drive to suddenly drop, resulting in serious injury.

Only allow qualified personnel to operate a crane or hoist to transport the drive.

Failure to comply could result in death or serious injury from falling equipment.

CAUTION

Crush Hazard

Do not carry the drive by the front cover.

Failure to comply may result in minor or moderate injury from the main body of the drive falling.

NOTICE

Observe proper electrostatic discharge procedures (ESD) when handling the drive and circuit boards.

Failure to comply may result in ESD damage to the drive circuitry.

Do not perform a withstand voltage test on any part of the drive.

Failure to comply could result in damage to the sensitive devices within the drive.

Do not operate damaged equipment.

Failure to comply could result in further damage to the equipment.

Do not connect or operate any equipment with visible damage or missing parts.

If a fuse is blown or equipment for residual current monitoring/detection (RCM/RCD) is tripped, check the wiring and the selection of the peripheral devices.

Contact your supplier if the cause cannot be identified after checking the above.

Do not restart the drive or immediately operate the peripheral devices if a fuse is blown or equipment for residual current monitoring/detection (RCM/RCD) is tripped.

Check the wiring and the selection of peripheral devices to identify the cause.

Contact your supplier before restarting the drive or the peripheral devices if the cause cannot be identified.

Install adequate branch circuit short circuit protection per applicable codes.

Failure to comply could result in damage to the drive.

The drive is suitable for circuits capable of delivering not more than 100,000 RMS symmetrical Amperes, 240 Vac maximum (200 V Class), 480 Vac maximum (400 V Class: CIMR-U□4E□□□□, CIMR-U□4W□□□□), and 500 Vac maximum (400 V Class: CIMR-U□4A□□□□, CIMR-U□4P□□□□).

Do not expose the drive to halogen group disinfectants.

Failure to comply may cause damage to the electrical components in the drive.

Do not pack the drive in wooden materials that have been fumigated or sterilized.

Do not sterilize the entire package after the product is packed.

■ Application Notes

Selection

Drive Rated Output Current

Make sure that the motor rated current is less than the rated output current for the drive.

When running more than one motor in parallel from a single drive, the capacity of the drive should be larger than [motor rated current \times 1.1]. Run only one motor from each drive when using vector control. It is not possible to run more than one motor from one drive with vector control.

When 2 Seconds is Required for Momentary Power Loss Ride-Thru Time

Use the units listed below when continuing drive operation after the power is restored even after a momentary loss of power of 2 seconds occurs:

- 200 V class Momentary Power Loss Ride-Thru unit: Model No. P0010
- 400 V class Momentary Power Loss Ride-Thru unit: Model No. P0020

Drive Start-Up Time

The drive requires 1.5 seconds to prepare for operation after the power is turned on. Be mindful of this delay when using an external reference input.

Note: 1.5 seconds is the required time when no optional devices are used with the drive. When using an optional communication device, the time required for the drive to be ready for operation will vary in accordance with the start up time of the communication card.

Selection of Power Supply Capacity

Use a power supply that is greater than the rated input capacity (kVA) of the drive. If the power supply is lower than the rated capacity of the drive, the device will be unable to run the application properly and will trigger a fault.

The rated input capacity of the drive, S_{CONV} (kVA), can be calculated by the following formula:

$$S_{CONV} = \sqrt{3} \times I_{in} \times V_{in} / 1000$$

(I_{in} : Rated input current [A], V_{in} : Applicable power supply voltage [V])

Connection to Power Supply

The total impedance of the power supply and wiring for the rated current of the drive is $\%Z = 10\%$ or more. Power voltage distortion may occur when the impedance of the power supply is too large. When wiring over long distances, be sure to take preventative measures such as using thick cables or series wiring to lower the impedance of wiring. Contact Yaskawa for details.

Grounding the Power Supply

Yaskawa recommends using a dedicated ground for the power supply, as the drive is designed to run with a 1:1 ratio relative to the power supply. Ground other devices should as directed in the specifications for those devices. Take particular care when connecting sensitive electronic equipment such as OA devices. Separate ground lines and install a noise filter to prevent problems from noise.

When Using a Generator as a Power Supply

Select the generator capacity approximately twice as large as the drive input power supply capacity. Set the deceleration time or load so that the regenerative power from the motor will be 10% or less of the generator capacity. For further information, contact a Yaskawa representative.

When a Phase Advance Capacitor or Thyristor Controller is Provided for the Power Supply

The drive does not require a phase advance capacitor. Installing a phase advance capacitor to the drive will weaken the power factor.

For the phase advance capacitor that has already been installed on the same power supply system as the drive, attach a phase-advance capacitor with a series reactor to prevent oscillation with the drive.

Contact Yaskawa when a device generating voltage surge or voltage distortion such as DC motor drive thyristor controller or magnetic agitator is installed on the same power supply system.

i Preface & General Safety

Prevention Against EMC or Harmonic Leakage Current

Use units with built-in EMC filters that have the CE marking.

Be sure to use a stand-alone EMC filter for models CIMR-U□4□0477 to 4□0930.

Use a zero-phase reactor as a noise filter when a device that will be affected by noise is near the drive.

Effects of Power Supply Distortion

Distortion of the power supply voltage increases the harmonics contents due to power supply harmonics entering the drive.

Starting Torque

The startup and acceleration characteristics of the motor are restricted to the drive's overload current rating (HD: 150% 60 s, ND: 120% 60 s).

The overload rating for the drive determines the starting and accelerating characteristics of the motor. Expect lower torque than when running from line power. To achieve a higher starting torque, use a larger drive, or a drive and motor with larger capacity.

Output Short Circuit

In an elevator with a synchronous motor, the three-phase motor line can be short-circuited to generate a holding force for the motor while stopping, and to generate a large braking force during power loss or emergency stop. In this case, select the appropriate motors and perform an interlock. Failure to comply could cause damage the drive and motor or mechanical shock. Contact Yaskawa or your nearest sales representative for details.

Emergency Stop

When the drive faults out, the output is shut off. This, however, does not stop the motor immediately. Some type of mechanical brake may be needed if it is necessary to halt the motor faster than the Fast Stop function is able to.

Repetitive Starting/Stopping

Cranes (hoists), elevators, punching presses, and other such applications with frequent starts and stops often exceed 150% of their rated output current values. Heat stress generated from repetitive high current can shorten the life span of the IGBTs. The expected lifetime of the IGBTs is about 8 million start and stop cycles with a 4 kHz carrier frequency (a 3 kHz carrier frequency for CIMR-U□4□0477 to 4□0930) and a 150% peak current.

For crane-type applications using an inching function in which the motor is quickly started and stopped, Yaskawa recommends selecting a large enough drive so that peak current levels remain below 150% of the drive rated current.

Run only one motor from each drive when using vector control. It is not possible to run more than one motor from one drive with vector control.

Carrier Frequency Derating

When the carrier frequency of the drive is increased above the factory default setting, the rated output current of the drive should be reduced. Refer to Technical Manual for details.

Installation

Enclosure Panels

Keep the drive in a clean environment by either selecting an area free of airborne dust, lint, and oil mist, or install the drive in an enclosure panel. Be sure to leave the required space between drives to provide for cooling, and that proper measures are taken so that the ambient temperature remains within allowable limits. Keep flammable materials away from the drive. If the drive must be used in an area where it is subjected to oil mist and excessive vibration, protective designs are available. Contact Yaskawa or your Yaskawa agent for details.

Installation Direction

The drive should be installed upright as specified in the manual. For more information on installation, refer to [Mechanical Installation on page 18](#).

Settings

Upper Limits

The drive is capable of running the motor up to 400 Hz. Due to the danger of accidentally operating at high speed, be sure to set the upper limit for the frequency. The default setting for the maximum output frequency is 50 Hz.

DC Injection Braking

Motor overheat can result if there is too much current used during DC Injection Braking, or if the time for DC Injection Braking is too long.

Acceleration/Deceleration Times

Acceleration and deceleration times are affected by how much torque the motor generates, the load torque, and the moment of inertia. Set a longer accel/decel time when Stall Prevention is enabled. The accel/decel times are lengthened for as long as the Stall Prevention function is operating. For faster acceleration and deceleration, use a larger drive and motor.

General Handling**Wiring Check**

Be sure to perform a final check of all sequence wiring and other connections before turning the power on. Make sure there are no short circuits on the control terminals (+V, AC, etc.), as this could damage the drive.

Selecting a Circuit Breaker or Leakage Circuit Breaker

Yaskawa recommends installing equipment for residual current monitoring/detection (RCM/RCD) to the power supply side. The RCM/RCD should be designed for use with an AC drive (e.g. Type B according to IEC/EN 60755).

Select a MCCB (Molded Case Circuit Breaker) or RCM/RCD with a rated current that is 1.5 to 2 times higher than the rated current of the drive in order to avoid nuisance trips caused by harmonics in the drive input current.

Magnetic Contactor Installation

Use a magnetic contactor (MC) to ensure that power to the drive can be completely shut off when necessary. The MC should be wired so that it opens when a fault output terminal is triggered.

Avoid switching a magnetic contactor on the power supply side more frequently than once every 30 minutes. Frequent switching can cause damage to the drive.

Inspection and Maintenance

Capacitors for the control power supply take time to discharge even after the power has been shut off. After shutting off the power, wait for at least the amount of time specified on the drive before touching any components.

The heatsink can become quite hot during operation, and proper precautions should be taken to prevent burns. When replacing the cooling fan, shut off the power and wait at least 15 minutes to be sure that the heatsink has cooled down.

Even when the power has been shut off for a drive running a PM motor, voltage continues to be generated at the motor terminals while the motor coasts to stop. Take the precautions described below to prevent shock and injury:

- In Applications where the machine can still rotate even though the drive has fully stopped a load switch for disconnecting motor and drive should be installed to the output side of the drive.
- Do not allow an external force to rotate the motor beyond the maximum allowable speed, also when the drive has been shut off.
- Wait for at least the time specified on the warning label after opening the load switch on the output side before inspecting the drive or performing any maintenance.
- Do not open and close the load switch while the motor is running, as this can damage the drive.
- If the motor is coasting, make sure the power to the drive is turned on and the drive output has completely stopped before closing the load switch.

Wiring

All wire ends should use ring terminals for UL/cUL compliance. Use only the tools recommended by the terminal manufacturer for crimping.

Transporting the Drive

Never steam clean the drive.

During transport, keep the drive from coming into contact with salts, fluorine, bromine, phthalate ester, and other such harmful chemicals.

i Preface & General Safety

■ Notes on Motor Operation

Using a Standard Motor

Low Speed Range

The cooling fan of a standard motor is usually designed to sufficiently cool the motor at the rated speed. As the self-cooling capability of such a motor decreases with the speed, applying full torque at low speed will possibly damage the motor. To prevent motor damage from overheat, reduce the load torque as the motor slows.

Insulation Tolerance

Consider voltage tolerance levels and insulation in applications with an input voltage of over 440 V or particularly long wiring distances. Contact Yaskawa or your Yaskawa agent for consultation.

High Speed Operation

Problems may occur with the motor bearings and dynamic balance of the machine when operating a motor beyond its rated speed. Contact the motor or machine manufacturer.

Torque Characteristics

Torque characteristics differ compared to operating the motor directly from line power. The user should have a full understanding of the load torque characteristics for the application.

Vibration and Shock

The U1000 lets the user choose between high carrier PWM control. Selecting Closed Loop Vector Control can help reduce motor oscillation.

- Take particular caution when using a variable speed drive for an application that is conventionally run from line power at a constant speed. If resonance occurs shock-absorbing rubber should be installed around the base of the motor and the Jump Frequency function should be enabled to prevent continuous operation in the resonant frequency range.
- Mechanical resonance can occur with long motor shafts and in applications such as turbines, blowers, and fans with high inertia loads.

Audible Noise

Noise created during run varies by the carrier frequency setting. When using a high carrier frequency, audible noise from the motor is comparable to the motor noise generated when running from line power. Operating above the rated speed can create unpleasant motor noise.

Using a Synchronous Motor

- Contact Yaskawa or your Yaskawa agent if you plan to use any other synchronous motor not endorsed by Yaskawa.
- A single drive is not capable of running multiple synchronous motors at the same time. Use a standard induction motor for such setups.
- At start, a synchronous motor may rotate slightly in the opposite direction of the Run command depending on parameter settings and rotor position.
- The amount of starting torque that can be generated differs by each control mode and by the type of motor being used. Set up the motor with the drive after verifying the starting torque, allowable load characteristics, impact load tolerance, and speed control range.

Contact Yaskawa or your Yaskawa agent if you plan to use a motor that does not fall within these specifications.

- In Open Loop Vector Control for PM motors, the allowable load inertia is approximately 50 times higher than the motor inertia or less. Contact Yaskawa or your Yaskawa agent concerning applications with a larger inertia.
- When using a holding brake in Open Loop Vector Control for PM motors, release the brake prior to starting the motor. Failure to set the proper timing can result in speed loss. Not for use with conveyor, transport, or hoist type applications.
- Use the Speed Search function to restart a coasting motor rotating over 200 Hz while in V/f Control.

■ Applications with Specialized Motors

Applications with Specialized Motors

Multi-Pole Motor

Because the rated current will differ from a standard motor, be sure to check the maximum current when selecting a drive. Always stop the motor before switching between the number of motor poles. If a regenerative overvoltage fault occurs or if overcurrent protection is triggered, the motor will coast to stop.

Submersible Motor

Because motor rated current is greater than a standard motor, select the drive accordingly. Be sure to use a large enough motor cable to avoid decreasing the maximum torque level on account of voltage drop caused by a long motor cable.

Explosion-Proof Motor

Both the motor and drive need to be tested together to be certified as explosion-proof. The drive is not designed for explosion proof areas.

Furthermore, if an encoder is attached to an explosion-proof motor make sure the encoder is explosion-proof too. Use an insulating signal converter for connecting the encoder signal lines to the drives speed feedback option card.

Geared Motor

To avoid gear damage when operating at low speeds or very high speeds, make sure that both the gear and lubricant are rated for the desired speed range. Consult with the manufacturer for applications that require operation outside the rated speed range of the motor or gear box.

Single-Phase Motor

Variable speed drives are not designed for operation with single phase motors. Using capacitors to start the motor causes excessive current to flow and can damage drive components. A split-phase start or a repulsion start can end up burning out the starter coils because the internal centrifugal switch is not activated. The U1000 is for use with three-phase motors only.

Motor with Brake

Caution should be taken when using a drive to operate a motor with a built-in holding brake. If the brake is connected to the output side of the drive, it may not release at start due to low voltage levels. A separate power supply should be installed for the motor brake. Motors with a built-in brake tend to generate a fair amount of noise when running at low speeds.

Notes on Power Transmission Parts (belts, chains, gear boxes, ...)

Installing a drive in a machine that was directly connected to the power supply allows to adjust the machine speed. Continuous operation above or below the rated speed can wear out lubrication material in gear boxes and other power transmission parts. In order to avoid machine damage make sure lubrication is sufficient within the whole speed range. Note that operation above the rated speed can increase the noise generated by the machine.

i Preface & General Safety

■ Drive Label Warnings

Always heed the warning information listed in *Figure 1* in the position shown in *Figure 2*.

WARNING



-  **Risk of electric shock.**
 - Read manual before installing.
 - Wait 5 minutes for capacitor discharge after disconnecting power supply.
 - To conform to CE requirements, make sure to ground the supply neutral for 400V class.
 - After disconnecting from power supply, please wait 5 minutes before inspecting, performing maintenance or wiring the drive.
-  **Hot Surfaces**
 - Wait 5 minutes or longer until the unit has cooled.

Figure 1 Warning Information

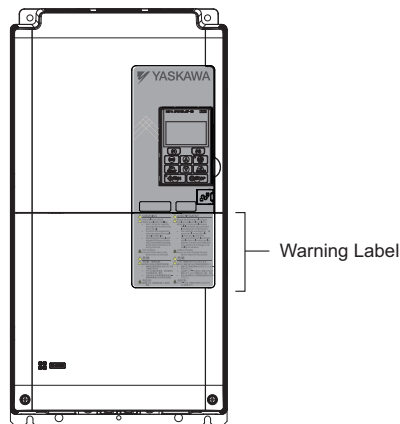


Figure 2 Warning Information Position

■ Warranty Information

Restrictions

U1000 was not designed or manufactured for use in devices or systems that may directly affect or threaten human lives or health.

Customers who intend to use the product described in this manual for devices or systems relating to transportation, health care, space aviation, atomic power, electric power, or in underwater applications must first contact their Yaskawa representatives or the nearest Yaskawa sales office.

This product has been manufactured under strict quality-control guidelines. However, if this product is to be installed in any location where failure of this product could involve or result in a life-and-death situation or loss of human life or in a facility where failure may cause a serious accident or physical injury, safety devices must be installed to minimize the likelihood of any accident.

1 Receiving

Note: The models and capacities in shown here are based on standard settings and operation conditions. Higher carrier frequencies, higher ambient temperatures, operating temperatures, and altitudes require derating.

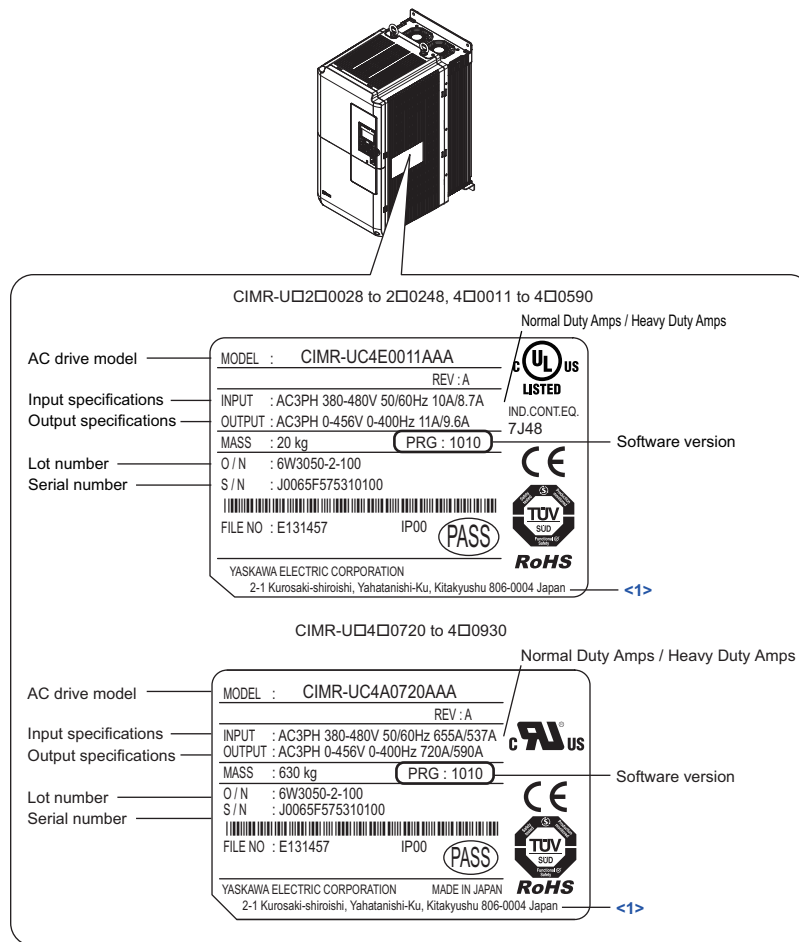
◆ Model Number and Nameplate Check

Please perform the following tasks after receiving the drive:

- Inspect the drive for damage.
If the drive appears damaged upon receipt, contact the shipper immediately.
- Verify receipt of the correct model by checking the information on the nameplate.
- If you have received the wrong model or the drive does not function properly, contact your supplier.

■ Nameplate

CIMR-U□2□0028 to 2□0248, 4□0011 to 4□0930

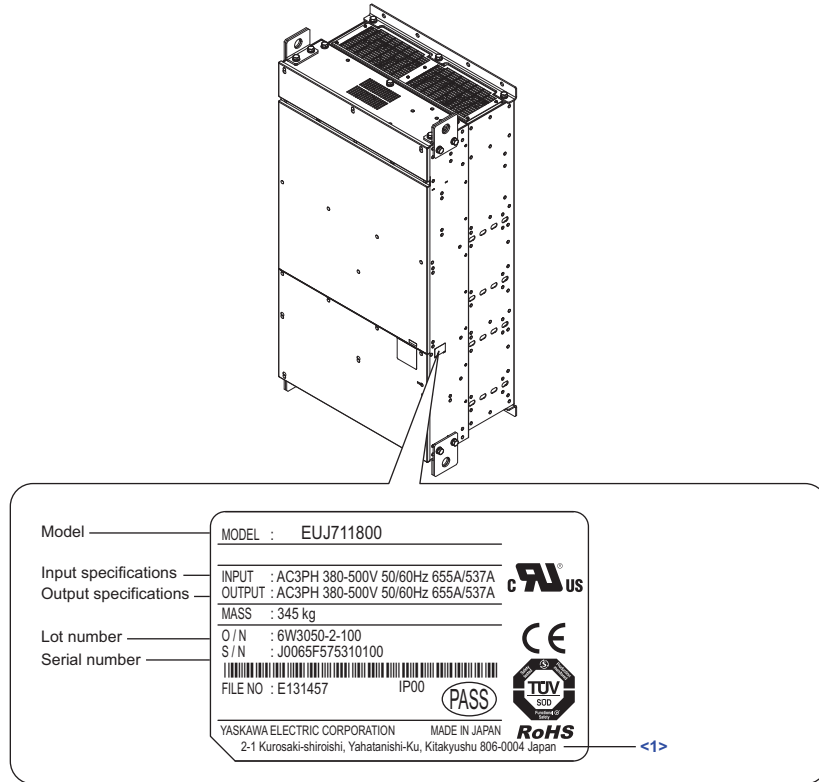


<1> The address of the head office of Yaskawa Electric Corporation (responsible for product liability) is shown on the nameplate.

Figure 3 Nameplate Information (CIMR-U□2□0028 to 2□0248, 4□0011 to 4□0930)

1 Receiving

Harmonic Filter Module

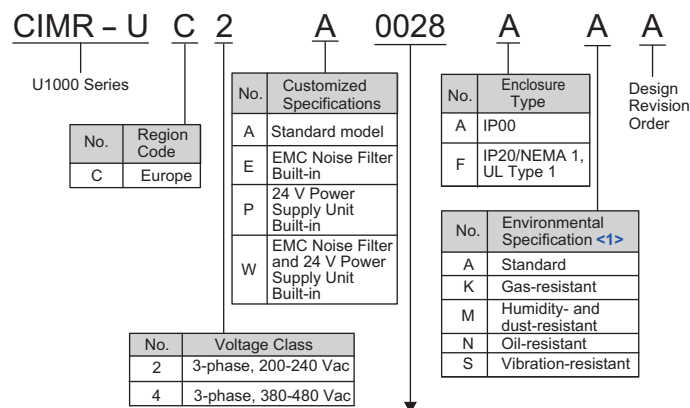


<1> The address of the head office of Yaskawa Electric Corporation (responsible for product liability) is shown on the nameplate.

Figure 4 Nameplate Information (Harmonic Filter Module)

Model Number

CIMR-U□2□0028 to 2□0248, 4□0011 to 4□0930



Refer to Table 1 and Table 2.

<1> Drives with these specifications do not guarantee complete protection for the environmental conditions indicated.

Three-Phase 200 V

Table 1 Model Number and Specifications (200 V)

No.	Rated Output Current (A)	
	Heavy Duty (HD) [C6-01 = 0]	Normal Duty (ND) [C6-01 = 1]
0028	22	28
0042	28	42
0054	42	54
0068	54	68
0081	68	81
0104	81	104
0130	104	130
0154	130	154
0192	154	192
0248	192	248

Three-Phase 400 V

Table 2 Model Number and Specifications (400 V)

No.	Rated Output Current (A)	
	Heavy Duty (HD) [C6-01 = 0]	Normal Duty (ND) [C6-01 = 1]
0011	9.6	11
0014	11	14
0021	14	21
0027	21	27
0034	27	34
0040	34	40
0052	40	52
0065	52	65
0077	65	77
0096	77	98
0124	96	124
0156	124	156
0180	156	180
0216	180	216
0240	216	240
0302	240	302
0361	302	361
0414	361	414
0477	414	477
0590	477	590
0720	590	720
0900	720	900
0930	900	930

Note: Set C6-01 to select Normal duty and Heavy duty (default).

2 Mechanical Installation

2 Mechanical Installation

◆ Mechanical Installation

This section outlines specifications, procedures, and the environment for proper mechanical installation of the drive and harmonic filter module.

■ Installation Environment

To help prolong the optimum performance life of the drive, install the drive in an environment matching the specifications in [Table 3](#) and [Table 4](#).

CIMR-U□□0028 to 2□0248, 4□0011 to 4□0930

Table 3 Installation Environment (CIMR-U□□0028 to 2□0248, 4□0011 to 4□0930)

Environment	Conditions
Installation Area	Indoors
Ambient Temperature	-10 to 40°C (IP20/NEMA 1, UL Type 1 enclosure) -10 to 50°C (IP00 enclosure) Drive reliability improves in environments without wide temperature fluctuations. When using the drive in an enclosure panel, install a cooling fan or air conditioner in the area to ensure that the air temperature inside the enclosure does not exceed the specified levels. Do not allow ice to develop on the drive.
Humidity	95% RH or less and free of condensation
Storage Temperature	-20°C to +60°C
Surrounding Area	Install the drive in an area free from: <ul style="list-style-type: none"> oil mist and dust metal shavings, oil, water or other foreign materials radioactive materials combustible materials (e.g., wood) harmful gases and liquids excessive vibration chlorides direct sunlight
Altitude	1000 m, up to 3000 m with derating
Vibration	10 to 20 Hz: 9.8 m/s ² (4□0477 to 4□0930: 5.9 m/s ²) 20 to 55 Hz: 5.9 m/s ² (2□0104 to 2□0248, 4□0096 to 4□0930: 2.0 m/s ²)
Orientation	Install the drive vertically to maintain maximum cooling effects.

NOTICE: Avoid placing drive peripheral devices, transformers, or other electronics near the drive as the noise created can lead to erroneous operation. If such devices must be used in close proximity to the drive, take proper steps to shield the drive from noise.

NOTICE: Prevent foreign matter such as metal shavings and wire clippings from falling into the drive during installation. Failure to comply could result in damage to the drive. Place a temporary cover over the top of the drive during installation. Remove the temporary cover before startup, as the cover will reduce ventilation and cause the drive to overheat.

Harmonic Filter Module

Table 4 Installation Environment (Harmonic Filter Module)

Environment	Conditions
Installation Area	Indoors
Ambient Temperature	IP00 enclosure: -10°C to +50°C Harmonic filter module reliability improves in environments without wide temperature fluctuations. When using the harmonic filter module in an enclosure panel, install a cooling fan or air conditioner in the area to ensure that the air temperature inside the enclosure does not exceed the specified levels. Do not allow ice to develop on the harmonic filter module.
Humidity	95% RH or less and free of condensation
Storage Temperature	-20°C to +60°C

2 Mechanical Installation

Environment	Conditions
Surrounding Area	Install the harmonic filter module in an area free from: <ul style="list-style-type: none"> • oil mist and dust • metal shavings, oil, water or other foreign materials • radioactive materials • combustible materials (e.g., wood) • harmful gases and liquids • excessive vibration • chlorides • direct sunlight
Altitude	1000 m, up to 3000 m with derating
Vibration	10 to 20 Hz: 5.9 m/s ² 20 to 55 Hz: 2.0 m/s ²
Orientation	Install the harmonic filter module vertically to maintain maximum cooling effects.

NOTICE: Avoid placing harmonic filter module peripheral devices, transformers, or other electronics near the harmonic filter module as the noise created can lead to erroneous operation. If such devices must be used in close proximity to the harmonic filter module, take proper steps to shield the harmonic filter module from noise.

NOTICE: Prevent foreign matter such as metal shavings and wire clippings from falling into the harmonic filter module during installation. Failure to comply could result in damage to the harmonic filter module. Place a temporary cover over the top of the harmonic filter module during installation. Remove the temporary cover before startup, as the cover will reduce ventilation and cause the harmonic filter module to overheat.

■ Installation Orientation and Spacing

Install the drive upright as illustrated in **Figure 5** to maintain proper cooling.

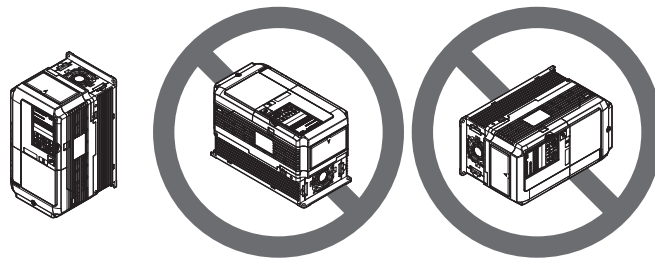


Figure 5 Correct Installation Orientation

Single Drive Installation

Figure 6 and **Figure 7** show the installation distance required to maintain sufficient space for airflow and wiring.

CIMR-U□2□0028 to 2□0248, 4□0011 to 4□0590

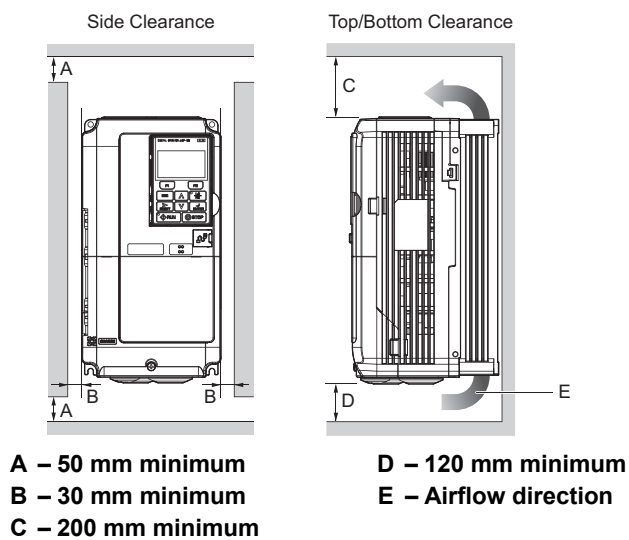


Figure 6 Correct Installation Spacing

Note: IP20/NEMA 1, UL Type 1 enclosure and IP00 enclosure models require the same amount of space above and below the drive for installation.

2 Mechanical Installation

CIMR-U□4□0720 to 4□0930 and Harmonic Filter Module

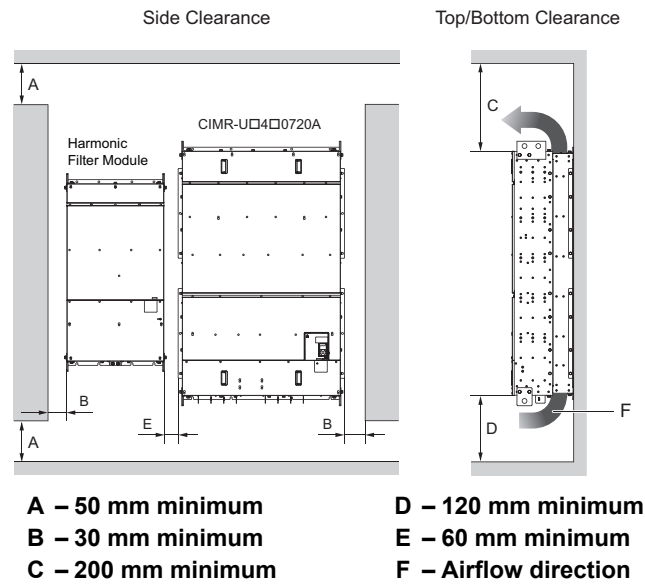


Figure 7 Correct Installation Spacing (CIMR-U□4□0720A and Harmonic Filter Module)

■ Instructions on Installation

Eye bolts and hanging brackets are used to install the drive or to temporarily lift the drive when replacing it. Using the eye bolts and hanging brackets, the drive can be installed in an enclosure panel or on a wall. Do not leave the drive suspended by the wires in a horizontal or vertical position for long periods of time. Do not transport the drive over long distances. Read the following precautions and instructions before installing the drive.

WARNING! *Crush Hazard. Observe the following instructions and precautions. Failure to comply could result in serious injury or death from falling equipment.*

- Only use vertical suspension to temporarily lift the drive during installation to an enclosure panel. Do not use vertical suspension to transport the drive.
- Confirm that the spring washer is completely closed prior to lifting to prevent damage to the drive.
- Use screws to securely affix the drive front cover, terminal blocks, and other drive components prior to vertical suspension.
- Do not subject the drive to vibration or impact greater than 1.96 m/s² (0.2 G) while it is suspended by the wires.
- Do not leave the drive unattended while it is suspended by the wires.
- Do not attempt to flip the drive over while it is suspended by the wires.

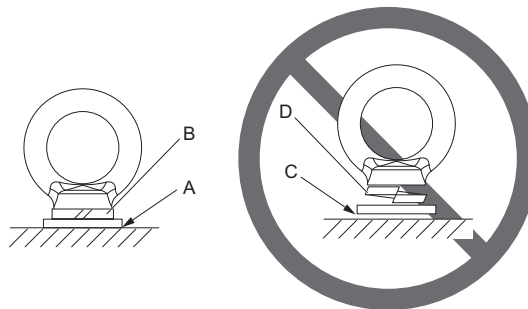


Figure 8 Spring Washer

Horizontal Suspension of the Drive Models 2□0154 to 2□0248 and 4□0156 to 4□0930, and Harmonic Filter Module

To make a wire hanger or frame for use when lifting the drive with a crane, lay the drive in a horizontal position and pass a wire through the hanging brackets.

Note: Use the hanging brackets on the top and hanging holes of the bottom cover when lifting models 2□0154F, 2□0192F, 4□0156F, 4□0180F.

2□0154A, 2□0192A, 2□0248,
4□0156A, 4□0180A, 4□0216 to 4□0590,
4□0720A to 4□0930A, Harmonic Filter Module

2□0154F, 2□0192F, 4□0156F, 4□0180F

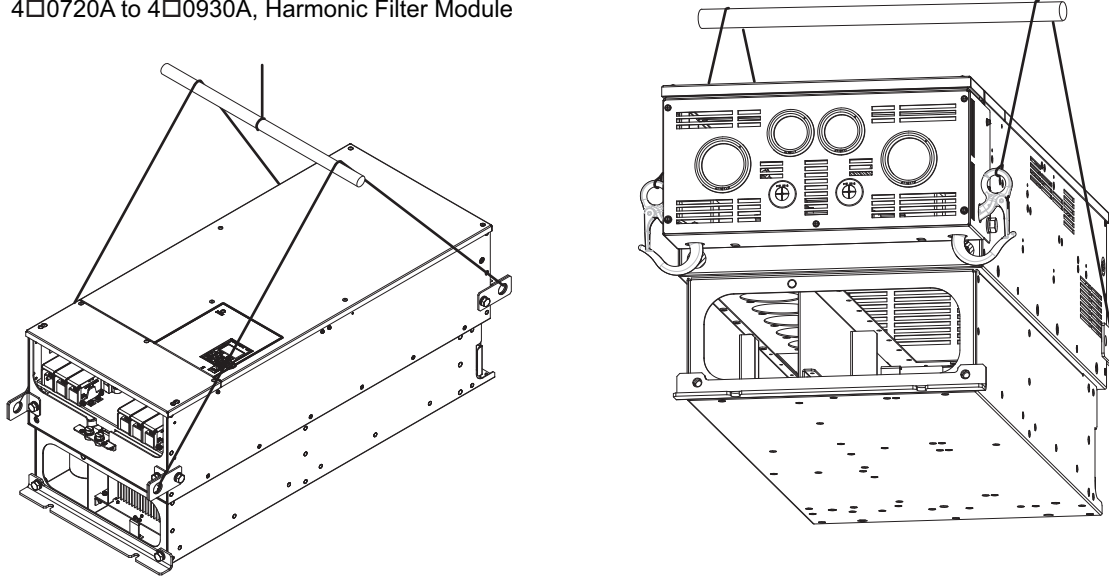


Figure 9 Horizontal Suspension (2□0154)

Vertical Suspension of the Drive

Follow the procedure described below when suspending the drive with eye bolts or hanging brackets.

Models 2□0028 to 2□0130 and 4□0011 to 4□0124

WARNING! Crush Hazard. Use an adequate length of wire to ensure a 50° or wider suspension angle as illustrated in **Figure 10**. The maximum allowable load of the eye bolts cannot be guaranteed when the drive is suspended with the wires at angles less than 50°. Failure to comply may result in serious injury or death from falling equipment.

1. Pass wire through the holes of the two eye bolts or two hanging brackets.

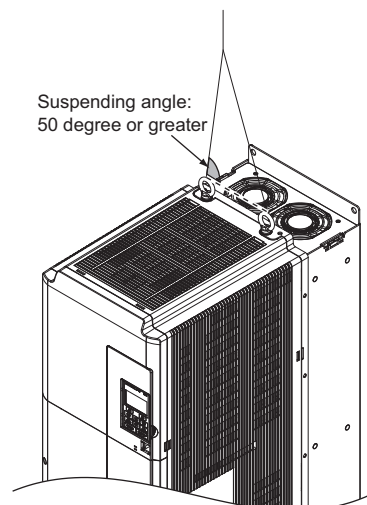


Figure 10 Drive Suspension Using Wires and Eye Bolts (2□0028)

2. Gradually take up the slack in the wires and hoist the drive after the wires are stretched tight.
3. Lower the drive when ready to install in the enclosure panel. Stop lowering the drive when it is near the floor then begin lowering the drive again very slowly until the drive is placed correctly.

2 Mechanical Installation

2□0154 to 2□0248, 4□0156 to 4□0414

WARNING! Crush Hazard. Use an adequate length of wire to ensure a 50° or wider suspension angle as illustrated in **Figure 12**. The maximum allowable load of the eye bolts cannot be guaranteed when the drive is suspended with the wires at angles less than 50°. Failure to comply may result in serious injury or death from falling equipment.

1. Remove the two hanging brackets from the drive lower side panels and bolt them on the top panel.

Note:

1. Tighten the hanging brackets with the specified tightening torque: M10: 18 to 23 N·m, M12: 32 to 40 N·m.
2. Four hanging brackets are attached to the top of IP20/NEMA 1, UL Type 1 drives 2□0154F, 2□0192F, 4□0156F, and 4□0180F.

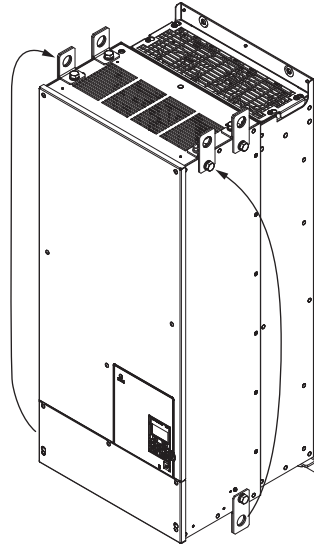


Figure 11 Location of Hanging Brackets (2□0154 to 2□0248, 4□0156 to 4□0414)

2. Pass wire through the holes of all four hanging brackets.

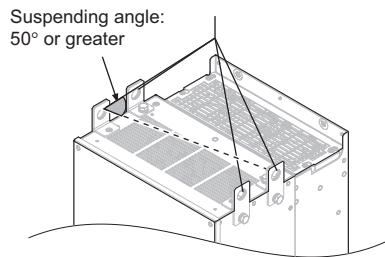


Figure 12 Drive Suspension Using Wires and Hanging Brackets (2□0154 to 2□0248, 4□0156 to 4□0414)

3. Gradually take up the slack in the wires and hoist the drive after the wires are stretched tight.
4. Lower the drive when ready to install in the enclosure panel. Stop lowering the drive when it is near the floor, then slowly begin lowering the drive again very slowly until the drive is placed correctly.

4□0477 to 4□0930

1. Pass wire through the holes of all four hanging brackets.

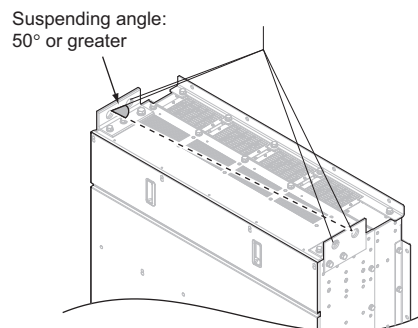


Figure 13 Drive Suspension Using Wires and Hanging Brackets (4□0477 to 4□0930)

2. Gradually take up the slack in the wires and hoist the drive after the wires are stretched tight.
3. Lower the drive when ready to install in the enclosure panel. Stop lowering the drive when it is near the floor, then slowly begin lowering the drive again very slowly until the drive is placed correctly.

Harmonic Filter Module

1. Pass wire through the holes of all four hanging brackets.

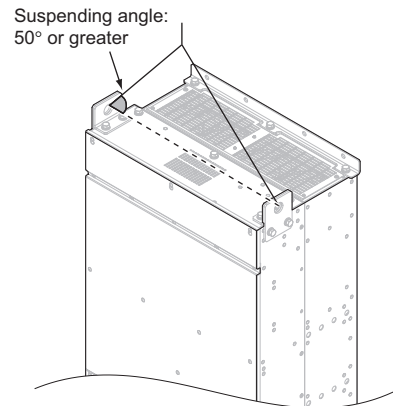


Figure 14 Harmonic Filter Module Suspension Using Wires and Hanging Brackets (EUJ7118□□□)

2. Gradually take up the slack in the wires and hoist the harmonic filter module after the wires are stretched tight.
3. Lower the harmonic filter module when ready to install in the enclosure panel. Stop lowering the harmonic filter module when it is near the floor, then slowly begin lowering the harmonic filter module again very slowly until the harmonic filter module is placed correctly.

■ Exterior and Mounting Dimensions

CIMR-U□2□0028 to 2□0248, 4□0011 to 4□0930

Refer to Technical Manual for dimensions of the drives.

Harmonic Filter Module

Refer to Technical Manual for dimensions of the harmonic filter modules.

3 Electrical Installation

3 Electrical Installation

◆ Standard Connection Diagram

Connect the drive and peripheral devices as shown in [Figure 15](#) and [Figure 16](#). It is possible to set and run the drive via the digital operator without connecting digital I/O wiring. This section does not discuss drive operation; [Refer to Start-Up Programming & Operation on page 60](#) for instructions on operating the drive.

Models CIMR-U□4□0720 to 4□0930 need main circuit wiring and connecting with the module communications connector. Refer to [Module Communications Connector on page 45](#) for details.

WARNING! Sudden Movement Hazard. Do not close the wiring for the control circuit unless the multifunction input terminal parameters are properly set. Improper sequencing of run/stop circuitry could result in death or serious injury from moving equipment.

WARNING! Sudden Movement Hazard. Ensure start/stop and safety circuits are wired properly and in the correct state before energizing the drive. Failure to comply could result in death or serious injury from moving equipment. When programmed for 3-Wire control, a momentary closure on terminal S1 may cause the drive to start.

WARNING! Sudden Movement Hazard. When using a 3-Wire sequence, set the drive to 3-Wire sequence prior to wiring the control terminals and set parameter b1-17 to 0 so the drive will not accept a Run command at power up (default). If the drive is wired for a 3-Wire sequence but set up for a 2-Wire sequence (default), and parameter b1-17 is set to 1 so the drive accepts a Run command at power up, the motor will rotate in reverse direction at drive power up and may cause injury.

WARNING! Sudden Movement Hazard. Confirm the drive I/O signals and external sequence before executing the application preset function. Executing the application preset function or setting A1-06 ≠ 0 will change the drive I/O terminal functions and may cause unexpected equipment operation. Failure to comply may cause death or serious injury.

WARNING! When using the automatic fault restart function with wiring designed to shut off the power supply upon drive fault, make sure the drive does not trigger a fault output during fault restart (L5-02 = 0, default). Failure to comply will prevent the automatic fault restart function from working properly.

NOTICE: Inadequate wiring could result in damage to the drive. Install adequate branch circuit protection per applicable codes. The drive is suitable for circuits capable of delivering not more than 100,000 RMS symmetrical amperes, 240 Vac maximum (200 V Class), 480 Vac maximum (400 V Class: CIMR-U□4E□□□□/4W□□□□), and 500 Vac maximum (400 V Class: CIMR-U□4A□□□□/4P□□□□).

NOTICE: When the input voltage is 440 V or higher or the wiring distance is greater than 100 meters, pay special attention to the motor insulation voltage or use a drive duty motor. Failure to comply could lead to motor insulation breakdown.

NOTICE: Do not connect AC control circuit ground to drive enclosure. Improper drive grounding can cause control circuit malfunction.

NOTICE: The minimum load for the relay outputs M1-M2, M3-M4, M5-M6, and MA-MB-MC is 10 mA.

NOTICE: Correctly set Sink/Source jumper S3 for internal power supply. Failure to comply may result in damage to the drive. Refer to [Control I/O Connections on page 47](#) for details.

NOTICE: Create a sequence to shut off power on the power supply side by using a fault relay output as shown in the standard connection diagram, or create a sequence that prevents the motor shaft from being turned by an external force. If you continue to input power from a power supply with a large distortion or if an external force causes the motor shaft to continue turning even after an SoH (Snubber Discharge Resistor Overheat) occurs, the snubber resistor may break.

NOTICE: Do not connect more than one multi-function input to one terminal. Improper wiring may result in drive malfunction. Use an external power supply when sharing a terminal with more than one input. Do not use the built-in +24 V power supply.

NOTICE: Systems should be interlocked to shut off power to the drive if the drive experiences a fault for models CIMR-U□4□0477 to 4□0930. Refer to Technical Manual for details.

■ CIMR-U□2□0028 to 2□0248, 4□0011 to 4□0590

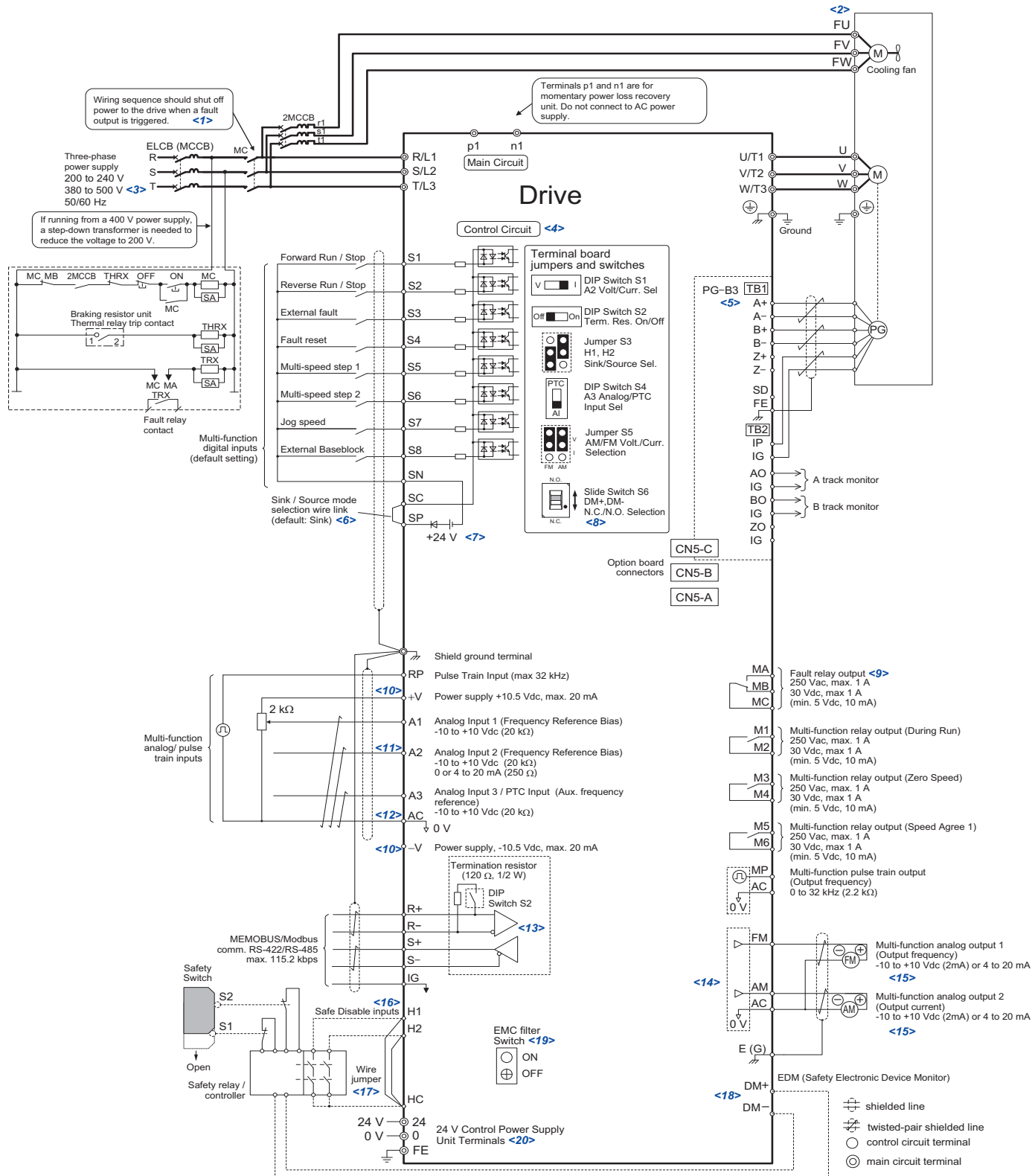


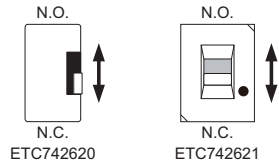
Figure 15 Drive Standard Connection Diagram (example: CIMR-U□2□0028)

- <1> Note that if the drive is set to trigger a fault output whenever the fault restart function is activated (L5-02 = 1), then a sequence to interrupt power when a fault occurs will result in shutting off the power to the drive as the drive attempts to restart itself. The default setting for L5-02 is 0 (fault output not active during restart attempt).
- <2> Self-cooling motors do not require wiring that would be necessary with motors using a cooling fan.
- <3> Use a three-phase power supply with a voltage of 380 to 480 V for drive models 4□0011 to 4□0414 (built-in EMC filter) and 4□0477 to 4□0590 (with stand-alone EMC filter).
- <4> Supplying power to the control circuit separately from the main circuit requires a 24 V power supply.
- <5> For control modes that do not use a motor speed feedback signal, PG option card wiring is not necessary.

Electrical Installation

3 Electrical Installation

- <6> This figure shows an example of a sequence input to S1 through S8 using a non-powered relay or an NPN transistor. Install the wire link between terminals SC-SP for Sink mode and SC-SN for Source mode. Leave it out for external power supply. Never short terminals SP and SN as doing so will damage the drive. Refer to *Control I/O Connections on page 47* for details.
- <7> The maximum current supplied by this voltage source is 150 mA if no digital input option card DI-A3 is used.
- <8> Available slide switch S6 is models ETC742620 and ETC742621.



- <9> Wire the fault relay output separately from the main circuit power supply and other power lines.
- <10> The maximum output current capacity for the +V and -V terminals on the control circuit is 20 mA. Never short terminals +V, -V, and AC, as this can cause erroneous operation or damage the drive.
- <11> Set DIP switch S1 to select between a voltage or current input signal to terminal A2. The default setting is for current input.
- <12> Set DIP switch S4 to select between analog or PTC input for terminal A3.
- <13> Enable the termination resistor in the last drive in a MEMOBUS network by setting DIP switch S2 to the ON position.
- <14> Use jumper S5 to selection between voltage or current output signals at terminal AM and FM. Set parameters H4-07 and H4-08 accordingly.
- <15> Monitor outputs work with devices such as analog frequency meters, ammeters, voltmeters, and wattmeters. They are not intended for use as a feedback-type of signal.
- <16> Use jumper S3 to select between Sink mode, Source mode or external power supply for the Safe Disable inputs.
- <17> Disconnect the wire jumper between H1 - HC and H2 - HC when utilizing the Safe Disable input.
- <18> Slide the switch S6 to select N.C. or N.O. as the state of the DM+ and DM- terminals for EDM output.
- <19> Models CIMR-U□□E□□□□ and □W□□□□ have EMC filter switch. Models CIMR-U□4□0477 to 4□0590 with a stand-alone EMC filter do not have the EMC filter switch.
- <20> Models CIMR-U□□P□□□□ and □W□□□□ have terminals 24, 0, and FE. The main circuit power supply can be turned off separately even when power is supplied to the control circuit.

■ CIMR-U□4□0720 to 4□0930

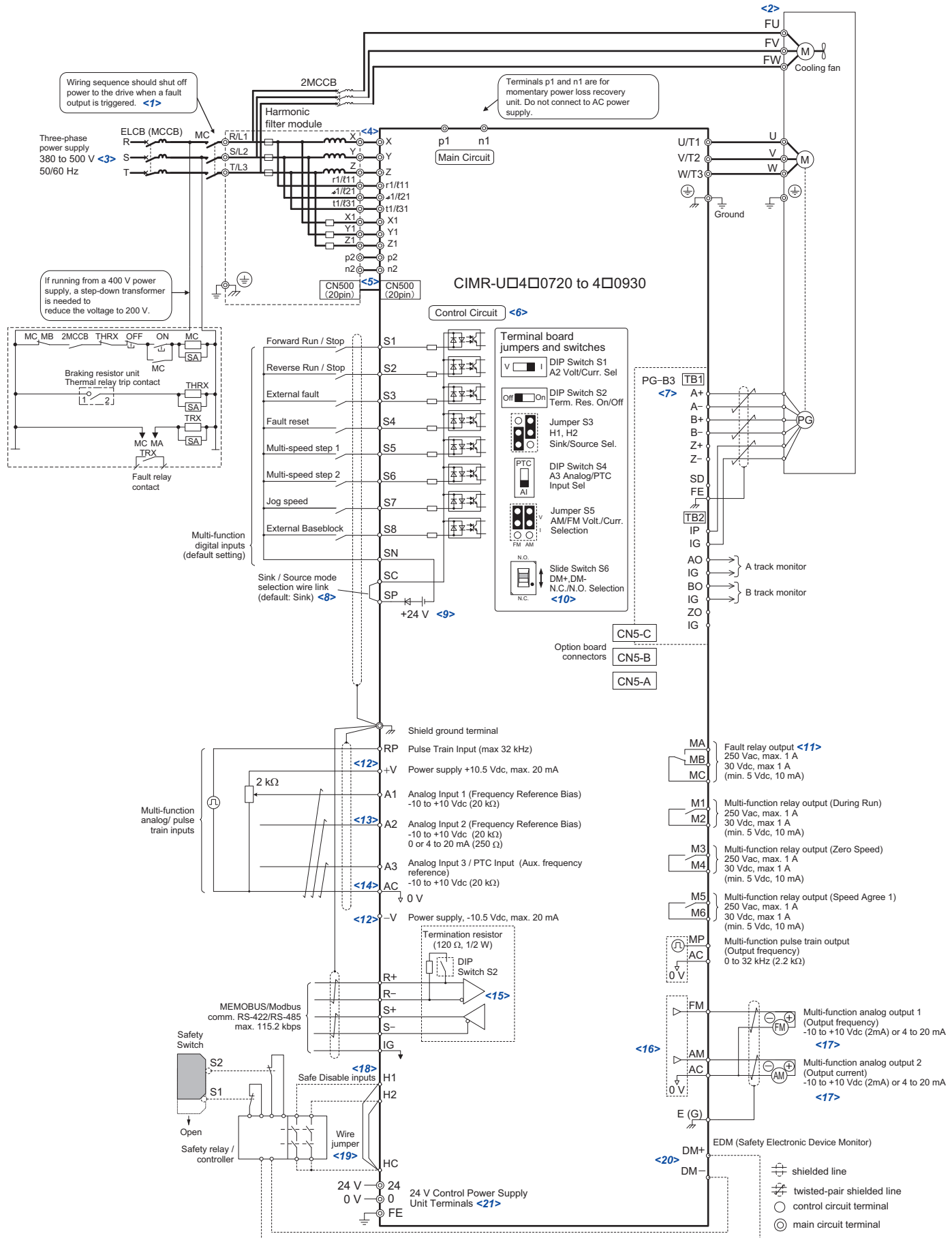
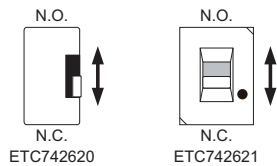


Figure 16 Drive Standard Connection Diagram (example: CIMR-U□2□0720)

3 Electrical Installation

- <1> Note that if the drive is set to trigger a fault output whenever the fault restart function is activated (L5-02 = 1), then a sequence to interrupt power when a fault occurs will result in shutting off the power to the drive as the drive attempts to restart itself. The default setting for L5-02 is 0 (fault output not active during restart attempt).
- <2> Self-cooling motors do not require wiring that would be necessary with motors using a cooling fan.
- <3> Use a three-phase power supply with a voltage of 380 to 480 V for drive models 4□0720 to 4□0930 (with stand-alone EMC filter).
- <4> The cable between CIMR-U□4□0720 to 4□0930 and harmonic filter module should not exceed 5 m.
- <5> Be sure to wire module connector CN500 to connect the standard configuration device (harmonic filter module) and the models CIMR-U□4□0720 to 4□0930 before turning on or operating the models CIMR-U□4□0720 to 4□0930.
- <6> Supplying power to the control circuit separately from the main circuit requires a 24 V power supply.
- <7> For control modes that do not use a motor speed feedback signal, PG option card wiring is not necessary.
- <8> This figure shows an example of a sequence input to S1 through S8 using a non-powered relay or an NPN transistor. Install the wire link between terminals SC-SP for Sink mode and SC-SN for Source mode. Leave it out for external power supply. Never short terminals SP and SN as doing so will damage the drive. Refer to *Control I/O Connections on page 47* for details.
- <9> The maximum current supplied by this voltage source is 150 mA if no digital input option card DI-A3 is used.
- <10> Available slide switch S6 is models ETC742620 and ETC742621.



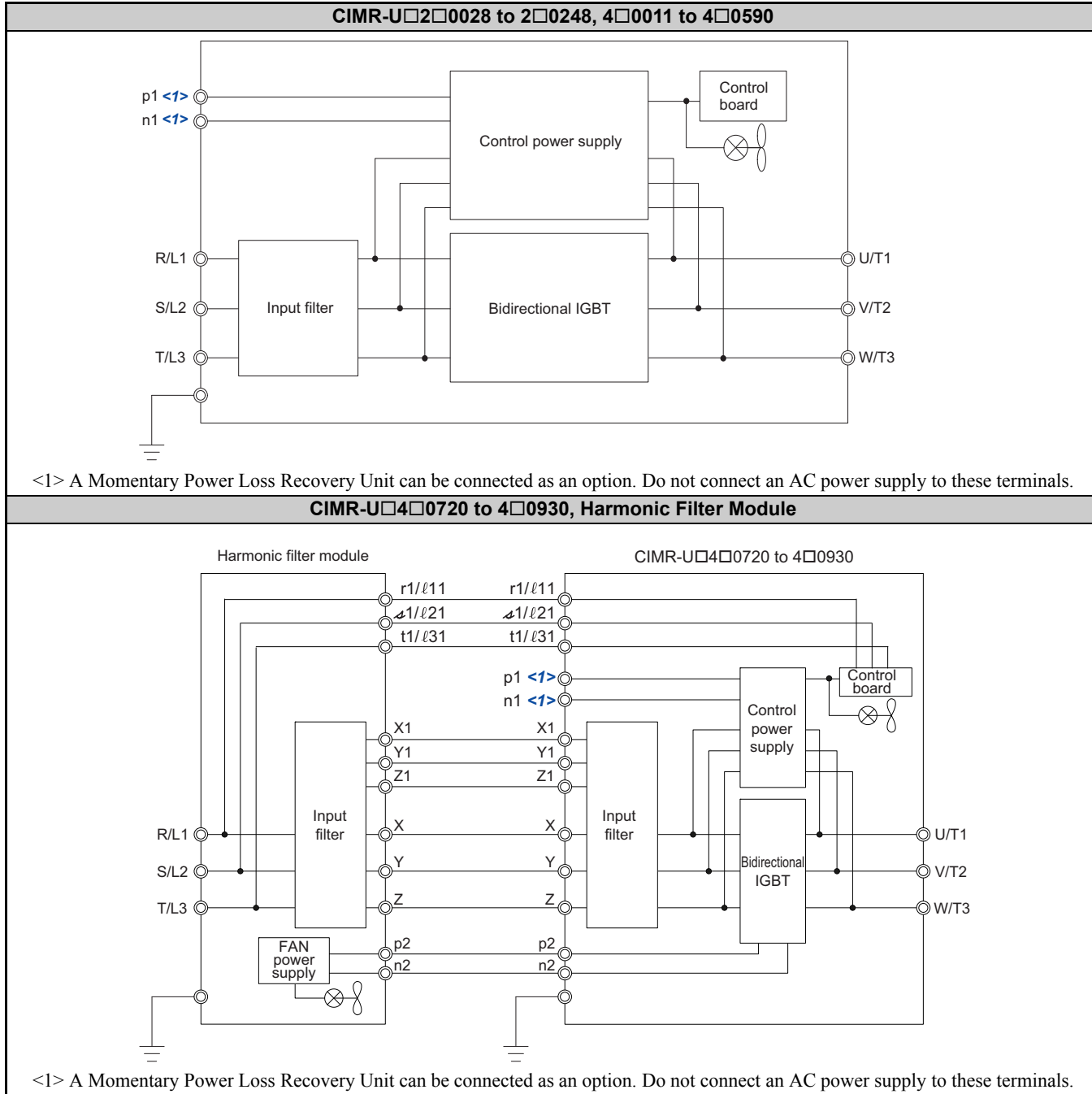
- <11> Wire the fault relay output separately from the main circuit power supply and other power lines.
- <12> The maximum output current capacity for the +V and -V terminals on the control circuit is 20 mA. Never short terminals +V, -V, and AC, as this can cause erroneous operation or damage the drive.
- <13> Set DIP switch S1 to select between a voltage or current input signal to terminal A2. The default setting is for current input.
- <14> Set DIP switch S4 to select between analog or PTC input for terminal A3.
- <15> Enable the termination resistor in the last drive in a MEMOBUS network by setting DIP switch S2 to the ON position.
- <16> Use jumper S5 to selection between voltage or current output signals at terminal AM and FM. Set parameters H4-07 and H4-08 accordingly.
- <17> Monitor outputs work with devices such as analog frequency meters, ammeters, voltmeters, and wattmeters. They are not intended for use as a feedback-type of signal.
- <18> Use jumper S3 to select between Sink mode, Source mode or external power supply for the Safe Disable inputs.
- <19> Disconnect the wire jumper between H1 - HC and H2 - HC when utilizing the Safe Disable input.
- <20> Slide the switch S6 to select N.C. or N.O. as the state of the DM+ and DM- terminals for EDM output.
- <21> Models CIMR-U□□P□□□□ and □W□□□□□ have terminals 24, 0, and FE. The main circuit power supply can be turned off separately even when power is supplied to the control circuit.

Note: Be sure to use a stand-alone EMC filter for models CIMR-U□4□0720 to 4□0930.

◆ Main Circuit Connection Diagram

Refer to the *Figure 17* when wiring the main circuit of the drive.

Figure 17 Drive main circuit configurations



3 Electrical Installation

◆ Main Circuit Wiring

This section describes the functions, specifications, and procedures required to safely and properly wire the main circuit in the drive.

NOTICE: Do not solder the ends of wire connections to the drive. Soldered wiring connections can loosen over time. Improper wiring practices could result in drive malfunction due to loose terminal connections.

NOTICE: Do not switch the drive input to start or stop the motor. Frequently switching the drive on and off shortens the life of the DC bus charge circuit and the control power supply capacitors, and can cause premature drive failures. For the full performance life, refrain from switching the drive on and off more than once every 30 minutes.

■ Main Circuit Terminal Functions

CIMR-2□0028 to 2□0248, 4□0011 to 4□0590

Table 5 Main Circuit Terminal Functions (CIMR-2□0028 to 2□0248, 4□0011 to 4□0590)

Voltage Class	Three-Phase 200 V Class	Three-Phase 400 V Class	Function	Page
CIMR-U□	2□0028 to 2□0248	4□0011 to 4□0590		
Terminal	Type			
R/L1, S/L2, T/L3	Main circuit power supply input		Connects line power to the drive.	25
U/T1, V/T2, W/T3	Drive output		Connects to the motor.	25
p1, n1	Momentary power loss recovery unit input		These are the DC voltage terminals that connect to a momentary power loss recovery unit.	–
⊕	100 Ω or less	10 Ω or less	Grounding terminal	40

CIMR-4□0720 to 4□0930

Table 6 Main Circuit Terminal Functions (CIMR-4□0720 to 4□0930)

Voltage Class	Three-Phase 400 V Class	Function	Page
CIMR-U□	4□0720 to 4□0930		
Terminal	Type		
X, Y, Z	Main circuit power supply input 1	These are the power supply input terminals that connect to the harmonic filter module.	27
X1, Y1, Z1	Main circuit power supply input 2	These are the power supply input terminals that connect to the harmonic filter module.	
r1/ℓ11, s1/ℓ21, t1/ℓ31	Power Supply Voltage Detection Input	These terminals are to connect to the harmonic filter module and to detect the power supply voltage order and voltage levels.	
U/T1, V/T2, W/T3	Drive output	Connects to the motor.	
p1, n1	Momentary power loss recovery unit input	These are the DC voltage terminals that connect to a momentary power loss recovery unit.	–
p2, n2	DC voltage output	These are the DC voltage terminals that connect to the harmonic filter module.	–
⊕	10 Ω or less	Grounding terminal	40

Harmonic Filter Module

Table 7 Main Circuit Terminal Functions (EUJ7118□□.□)

Terminal	Type	Function	Page
R/L1, S/L2, T/L3	Main circuit power supply input	Connects line power to the harmonic filter module.	27
r1/ℓ11, s1/ℓ21, t1/ℓ31	Power Supply Voltage Detection Input	These terminals are to connect to the drive models CIMR-U□4□0720 to 4□0930 and to detect the power supply voltage order and voltage levels.	
X, Y, Z	Filter module output 1	These are the harmonic filter module output terminals that connect to the drive models CIMR-U□4□0720 to 4□0930.	
X1, Y1, Z1	Filter module output 2	These are the harmonic filter module output terminals that connect to the drive models CIMR-U□4□0720 to 4□0930.	
p2, n2	DC voltage output	These are the DC voltage output terminals that connect to the drive models CIMR-U□4□0720 to 4□0930.	–
⊕	10 Ω or less	Grounding terminal	40

■ Protecting Main Circuit Terminals

Insulation Caps or Sleeves

Use insulation caps or sleeves when wiring the drive with crimp terminals. Take particular care to ensure that the wiring does not touch nearby terminals or the surrounding case.

Insulation Barrier

Insulation barriers are packaged with drive models CIMR-U□4□0477 through 4□0930 to provide added protection between terminals. Yaskawa recommends using the insulation barriers provided to ensure proper wiring. See *Figure 18* for instructions on where the insulation barriers should be placed.

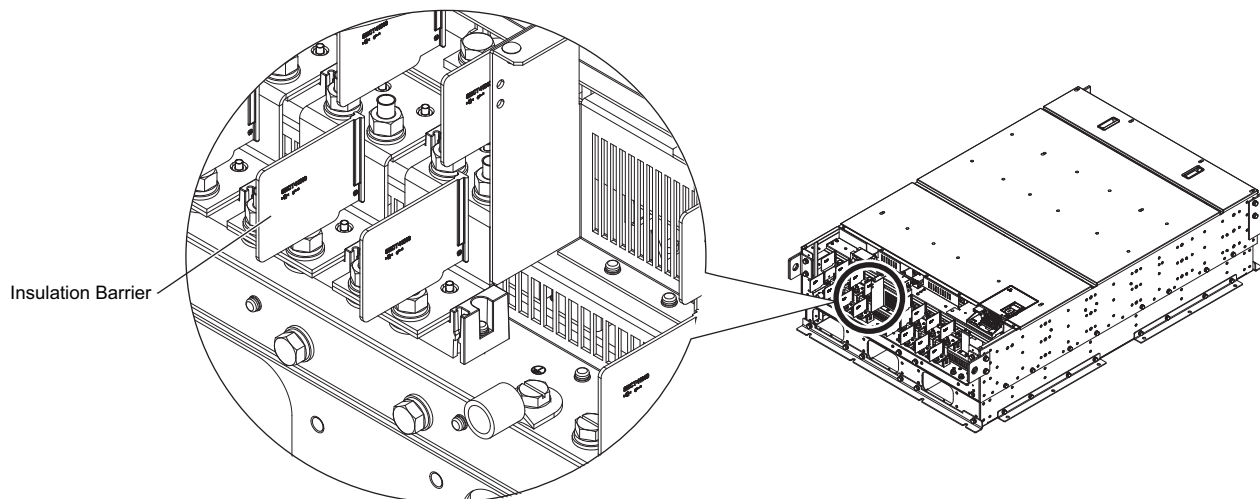


Figure 18 Installing insulation barriers

Main Circuit Protective Cover

Close the protective cover after wiring the main circuit terminals on 2□0028 to 2□0081, 4□0011 to 4□0077.

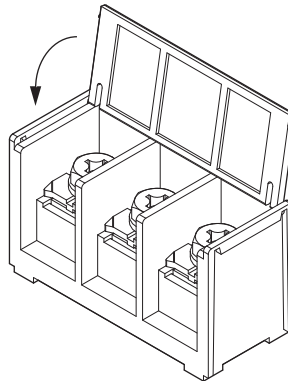


Figure 19 Main Circuit Protective Cover (2□0028 to 2□0081, 4□0011 to 4□0077)

3 Electrical Installation

Attach the protective covers after wiring the main circuit terminals, p1, and n1 terminals on models 2□0104 to 2□0248, 4□0096 to 4□0590, and the p1, n1, p2, n2, r1, s1, and t1 terminals on models 4□0720 to 4□0930.

Figure 20 shows an example of a main circuit protective cover for model 2□0104.

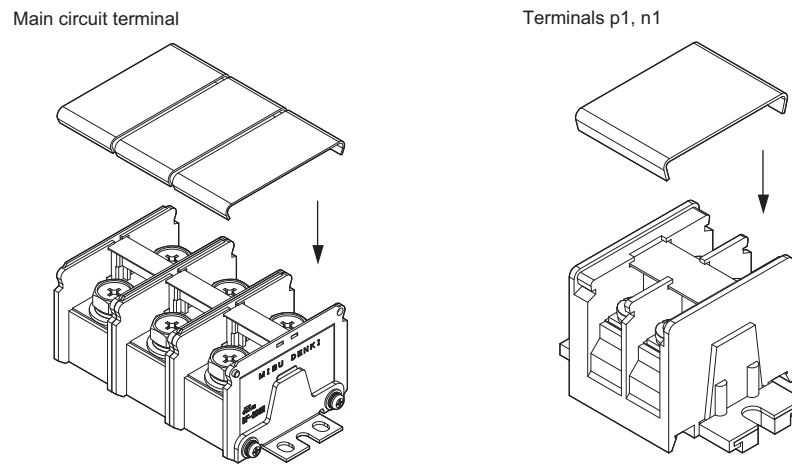


Figure 20 Protective Cover (2□0104)

■ Main Circuit Wire Gauges and Tightening Torque

Select the appropriate wires and crimp terminals from [Table 8](#) through [Table 10](#).

Note: Wire gauge recommendations based on drive continuous current ratings (ND) using 75°C 600 Vac vinyl-sheathed wire assuming ambient temperature within 40°C and wiring distance less than 100 m.

- Consider the amount of voltage drop when selecting wire gauges. Increase the wire gauge when the voltage drop is greater than 2% of motor rated voltage. Ensure the wire gauge is suitable for the terminal block. Use the following formula to calculate the amount of voltage drop:

$$\text{Line drop voltage (V)} = \sqrt{3} \times \text{wire resistance } (\Omega/\text{km}) \times \text{wire length (m)} \times \text{motor rated current (A)} \times 10^{-3}$$

- [Refer to UL Standards Compliance on page 108](#) for information on UL compliance.

The wire gauges listed in the following tables are Yaskawa recommendations. Refer to local codes for proper wire gauge selections.

3 Electrical Installation

Three-Phase 200 V Class

Table 8 Wire Gauge and Torque Specifications (Three-Phase 200 V Class)

Model CIMR-U□	Terminal	For Asia <1>		For U.S.A. <2>		For Europe and China <3>		Screw Size	Tightening Torque N·m (lb.in.)
		Recomm. Gauge mm ²	Applicable Gauge mm ²	Recomm. Gauge AWG, kcmil	Applicable Gauge AWG, kcmil	Recomm. Gauge mm ²	Applicable Gauge mm ²		
2□0028	R/L1, S/L2, T/L3	5.5	3.5 to 8	8	10 to 8	4	2.5 to 10	M5	2.3 to 2.7 (20.4 to 23.9)
	U/T1, V/T2, W/T3	5.5	3.5 to 8	8	10 to 8	4	2.5 to 10	M5	
	⊕	5.5	5.5 to 14	8	10 to 6	6	6 to 16	M6	3.9 to 4.9 (34.7 to 43.4)
	p1, n1	2	2 to 3.5	14	14 to 12	2.5	2.5 to 4	M4	1 to 1.4 (8.9 to 12.4)
2□0042	R/L1, S/L2, T/L3	14	5.5 to 22	6	8 to 3	10	5.5 to 25	M6	4 to 6 (35.4 to 53.1)
	U/T1, V/T2, W/T3	14	5.5 to 22	6	8 to 3	10	5.5 to 25	M6	
	⊕	5.5	5.5 to 22	8	10 to 3	10	6 to 25	M8	8.8 to 10.8 (78.1 to 95.5)
	p1, n1	2	2 to 3.5	14	14 to 12	2.5	2.5 to 4	M4	1 to 1.4 (8.9 to 12.4)
2□0054	R/L1, S/L2, T/L3	14	14 to 22	4	6 to 3	16	10 to 25	M6	4 to 6 (35.4 to 53.1)
	U/T1, V/T2, W/T3	14	14 to 22	4	6 to 3	16	10 to 25	M6	
	⊕	8	8 to 22	6	8 to 3	10	10 to 25	M8	8.8 to 10.8 (78.1 to 95.5)
	p1, n1	2	2 to 3.5	14	14 to 12	2.5	2.5 to 4	M4	1 to 1.4 (8.9 to 12.4)
2□0068	R/L1, S/L2, T/L3	22	14 to 22	4	4 to 3	16	16 to 25	M6	4 to 6 (35.4 to 53.1)
	U/T1, V/T2, W/T3	22	14 to 22	4	4 to 3	16	16 to 25	M6	
	⊕	14	14 to 22	6	6 to 3	16	16 to 25	M8	8.8 to 10.8 (78.1 to 95.5)
	p1, n1	2	2 to 3.5	14	14 to 12	2.5	2.5 to 4	M4	1 to 1.4 (8.9 to 12.4)
2□0081	R/L1, S/L2, T/L3	8 × 2P	8 to 22 × 2P	6 × 2P	6 to 3 × 2P	25	16 to 25	M6	4 to 6 (35.4 to 53.1)
	U/T1, V/T2, W/T3	8 × 2P	8 to 22 × 2P	6 × 2P	6 to 3 × 2P	25	16 to 25	M6	
	⊕	14	14 to 22	6	6 to 3	16	16 to 25	M8	8.8 to 10.8 (78.1 to 95.5)
	p1, n1	2	2 to 3.5	14	14 to 12	2.5	2.5 to 4	M4	1 to 1.4 (8.9 to 12.4)
2□0104	R/L1, S/L2, T/L3	38	8 to 60 × 2P	1	6 to 1/0 × 2P	35	10 to 50 × 2P	M8	8 to 10 (70.8 to 88.5)
	U/T1, V/T2, W/T3	38	8 to 60 × 2P	1	6 to 1/0 × 2P	35	10 to 50 × 2P	M8	
	⊕	22	22 to 38	4	4 to 1	25	10 to 35	M8	8.8 to 10.8 (78.1 to 95.5)
	p1, n1	2	2 to 3.5	14	14 to 12	2.5	2.5 to 4	M4	1.2 to 2.0 (10.4 to 17.4)
2□0130	R/L1, S/L2, T/L3	22 × 2P	14 to 60 × 2P	4 × 2P	6 to 1/0 × 2P	16 × 2P	10 to 50 × 2P	M8	8 to 10 (70.8 to 88.5)
	U/T1, V/T2, W/T3	22 × 2P	14 to 60 × 2P	4 × 2P	6 to 1/0 × 2P	16 × 2P	10 to 50 × 2P	M8	
	⊕	22	22 to 38	4	4 to 1	16	16 to 35	M8	8.8 to 10.8 (78.1 to 95.5)
	p1, n1	2	2 to 3.5	14	14 to 12	2.5	2.5 to 4	M4	1.2 to 2.0 (10.4 to 17.4)
2□0154	R/L1, S/L2, T/L3	22 × 2P	22 to 100 × 2P	3 × 2P	4 to 4/0 × 2P	25 × 2P	16 to 95 × 2P	M10	15 to 20 (130 to 173)
	U/T1, V/T2, W/T3	22 × 2P	22 to 100 × 2P	3 × 2P	4 to 4/0 × 2P	25 × 2P	16 to 95 × 2P	M10	
	⊕	22	22 to 60	4	4 to 2/0	25	25 to 70	M10	17.7 to 22.6 (156 to 200)
	p1, n1	2	2 to 3.5	14	14 to 12	2.5	2.5 to 4	M4	1.2 to 2.0 (10.4 to 17.4)

Electrical Installation

3 Electrical Installation

Model CIMR-U□	Terminal	For Asia <1>		For U.S.A. <2>		For Europe and China <3>		Screw Size	Tightening Torque N·m (lb.in.)
		Recomm. Gauge mm ²	Applicable Gauge mm ²	Recomm. Gauge AWG, kcmil	Applicable Gauge AWG, kcmil	Recomm. Gauge mm ²	Applicable Gauge mm ²		
2□0192	R/L1, S/L2, T/L3	38 × 2P	22 to 100 × 2P	1 × 2P	3 to 4/0 × 2P	35 × 2P	25 to 95 × 2P	M10	15 to 20 (130 to 173)
	U/T1, V/T2, W/T3	38 × 2P	22 to 100 × 2P	1 × 2P	3 to 4/0 × 2P	35 × 2P	25 to 95 × 2P	M10	
	⊕	22	22 to 60	3	4 to 2/0	25	25 to 70	M10	17.7 to 22.6 (156 to 200)
	p1, n1	2	2 to 3.5	14	14 to 12	2.5	2.5 to 4	M4	1.2 to 2.0 (10.4 to 17.4)
2□0248	R/L1, S/L2, T/L3	50 × 2P	38 to 100 × 2P	2/0 × 2P	1 to 4/0 × 2P	50 × 2P	35 to 95 × 2P	M10	15 to 20 (130 to 173)
	U/T1, V/T2, W/T3	50 × 2P	38 to 100 × 2P	2/0 × 2P	1 to 4/0 × 2P	50 × 2P	35 to 95 × 2P	M10	
	⊕	22	22 to 100	3	4 to 4/0	35	25 to 95	M12	31.4 to 39.2 (278 to 347)
	p1, n1	2	2 to 3.5	14	14 to 12	2.5	2.5 to 4	M4	1.2 to 2.0 (10.4 to 17.4)

<1> Gauges listed here are for use in Japan.
 <2> Gauges listed here are for use in the United States.
 <3> Gauges listed here are for use in Europe and China.

Three-Phase 400 V Class

Table 9 Wire Gauge and Torque Specifications (Three-Phase 400 V Class)

Model CIMR-U□	Terminal	For Asia <1>		For U.S.A. <2>		For Europe and China <3>		Screw Size	Tightening Torque N·m (lb.in.)
		Recomm. Gauge mm ²	Applicable Gauge mm ²	Recomm. Gauge AWG, kcmil	Applicable Gauge AWG, kcmil	Recomm. Gauge mm ²	Applicable Gauge mm ²		
4□0011	R/L1, S/L2, T/L3	2	2 to 8	14	14 to 8	2.5	2.5 to 10	M5	2.3 to 2.7 (20.4 to 23.9)
	U/T1, V/T2, W/T3	2	2 to 8	14	14 to 8	2.5	2.5 to 10	M5	
	⊕	3.5	2 to 14	10	12 to 6	2.5	2.5 to 16	M6	3.9 to 4.9 (34.7 to 43.4)
	p1, n1	2	2 to 3.5	14	14 to 12	2.5	2.5 to 4	M4	1 to 1.4 (8.9 to 12.4)
4□0014	R/L1, S/L2, T/L3	2	2 to 8	12	14 to 8	2.5	2.5 to 10	M5	2.3 to 2.7 (20.4 to 23.9)
	U/T1, V/T2, W/T3	2	2 to 8	12	14 to 8	2.5	2.5 to 10	M5	
	⊕	3.5	2 to 14	10	12 to 6	2.5	2.5 to 16	M6	3.9 to 4.9 (34.7 to 43.4)
	p1, n1	2	2 to 3.5	14	14 to 12	2.5	2.5 to 4	M4	1 to 1.4 (8.9 to 12.4)
4□0021	R/L1, S/L2, T/L3	3.5	2 to 8	10	12 to 8	2.5	2.5 to 10	M5	2.3 to 2.7 (20.4 to 23.9)
	U/T1, V/T2, W/T3	3.5	2 to 8	10	12 to 8	2.5	2.5 to 10	M5	
	⊕	3.5	2 to 14	10	12 to 6	2.5	2.5 to 16	M6	3.9 to 4.9 (34.7 to 43.4)
	p1, n1	2	2 to 3.5	14	14 to 12	2.5	2.5 to 4	M4	1 to 1.4 (8.9 to 12.4)
4□0027	R/L1, S/L2, T/L3	5.5	3.5 to 8	8	10 to 8	4	2.5 to 10	M5	2.3 to 2.7 (20.4 to 23.9)
	U/T1, V/T2, W/T3	5.5	3.5 to 8	8	10 to 8	4	2.5 to 10	M5	
	⊕	5.5	3.5 to 14	8	12 to 6	4	4 to 16	M6	3.9 to 4.9 (34.7 to 43.4)
	p1, n1	2	2 to 3.5	14	14 to 12	2.5	2.5 to 4	M4	1 to 1.4 (8.9 to 12.4)

3 Electrical Installation

Model CIMR-U□	Terminal	For Asia <1>		For U.S.A. <2>		For Europe and China <3>		Screw Size	Tightening Torque N·m (lb.in.)
		Recomm. Gauge mm ²	Applicable Gauge mm ²	Recomm. Gauge AWG, kcmil	Applicable Gauge AWG, kcmil	Recomm. Gauge mm ²	Applicable Gauge mm ²		
4□0034	R/L1, S/L2, T/L3	8	5.5 to 8	8	8	6	4 to 10	M5	2.3 to 2.7 (20.4 to 23.9)
	U/T1, V/T2, W/T3	8	5.5 to 8	8	8	6	4 to 10	M5	
	⊕	5.5	5.5 to 14	8	10 to 6	6	6 to 16	M6	3.9 to 4.9 (34.7 to 43.4)
	p1, n1	2	2 to 3.5	14	14 to 12	2.5	2.5 to 4	M4	1 to 1.4 (8.9 to 12.4)
4□0040	R/L1, S/L2, T/L3	14	8 to 22	8	8 to 3	10	6 to 25	M6	4 to 6 (35.4 to 53.1)
	U/T1, V/T2, W/T3	14	8 to 22	8	8 to 3	10	6 to 25	M6	
	⊕	5.5	5.5 to 22	8	10 to 3	10	6 to 25	M8	8.8 to 10.8 (78.1 to 95.5)
	p1, n1	2	2 to 3.5	14	14 to 12	2.5	2.5 to 4	M4	1 to 1.4 (8.9 to 12.4)
4□0052	R/L1, S/L2, T/L3	14	14 to 22	6	8 to 3	10	10 to 25	M6	4 to 6 (35.4 to 53.1)
	U/T1, V/T2, W/T3	14	14 to 22	6	8 to 3	10	10 to 25	M6	
	⊕	8	8 to 22	6	8 to 3	10	10 to 25	M8	8.8 to 10.8 (78.1 to 95.5)
	p1, n1	2	2 to 3.5	14	14 to 12	2.5	2.5 to 4	M4	1 to 1.4 (8.9 to 12.4)
4□0065	R/L1, S/L2, T/L3	22	14 to 22	4	6 to 3	16	10 to 25	M6	4 to 6 (35.4 to 53.1)
	U/T1, V/T2, W/T3	22	14 to 22	4	6 to 3	16	10 to 25	M6	
	⊕	14	14 to 22	6	6 to 3	16	16 to 25	M8	8.8 to 10.8 (78.1 to 95.5)
	p1, n1	2	2 to 3.5	14	14 to 12	2.5	2.5 to 4	M4	1 to 1.4 (8.9 to 12.4)
4□0077	R/L1, S/L2, T/L3	22	22	3	4 to 3	25	16 to 25	M6	4 to 6 (35.4 to 53.1)
	U/T1, V/T2, W/T3	22	22	3	4 to 3	25	16 to 25	M6	
	⊕	14	14 to 22	6	6 to 3	16	16 to 25	M8	8.8 to 10.8 (78.1 to 95.5)
	p1, n1	2	2 to 3.5	14	14 to 12	2.5	2.5 to 4	M4	1 to 1.4 (8.9 to 12.4)
4□0096	R/L1, S/L2, T/L3	38	8 to 60 × 2P	1	8 to 1/0 × 2P	35	10 to 50 × 2P	M8	8 to 10 (70.8 to 88.5)
	U/T1, V/T2, W/T3	38	8 to 60 × 2P	1	8 to 1/0 × 2P	35	10 to 50 × 2P	M8	
	⊕	22	22 to 38	4	4 to 1	25	10 to 35	M8	8.8 to 10.8 (78.1 to 95.5)
	p1, n1	2	2 to 3.5	14	14 to 12	2.5	2.5 to 4	M4	1.2 to 2.0 (10.4 to 17.4)
4□0124	R/L1, S/L2, T/L3	22 × 2P	14 to 60 × 2P	4 × 2P	6 to 1/0 × 2P	16 × 2P	10 to 50 × 2P	M8	8 to 10 (70.8 to 88.5)
	U/T1, V/T2, W/T3	22 × 2P	14 to 60 × 2P	4 × 2P	6 to 1/0 × 2P	16 × 2P	10 to 50 × 2P	M8	
	⊕	22	22 to 38	4	4 to 1	16	16 to 35	M8	8.8 to 10.8 (78.1 to 95.5)
	p1, n1	2	2 to 3.5	14	14 to 12	2.5	2.5 to 4	M4	1.2 to 2.0 (10.4 to 17.4)
4□0156	R/L1, S/L2, T/L3	22 × 2P	22 to 100 × 2P	3 × 2P	4 to 4/0 × 2P	25 × 2P	16 to 95 × 2P	M10	15 to 20 (130 to 173)
	U/T1, V/T2, W/T3	22 × 2P	22 to 100 × 2P	3 × 2P	4 to 4/0 × 2P	25 × 2P	16 to 95 × 2P	M10	
	⊕	22	22 to 60	4	4 to 2/0	25	25 to 70	M10	17.7 to 22.6 (156 to 200)
	p1, n1	2	2 to 3.5	14	14 to 12	2.5	2.5 to 4	M4	1.2 to 2.0 (10.4 to 17.4)

Electrical Installation

3 Electrical Installation

Model CIMR-U□	Terminal	For Asia <1>		For U.S.A. <2>		For Europe and China <3>		Screw Size	Tightening Torque N·m (lb.in.)
		Recomm. Gauge mm ²	Applicable Gauge mm ²	Recomm. Gauge AWG, kcmil	Applicable Gauge AWG, kcmil	Recomm. Gauge mm ²	Applicable Gauge mm ²		
4□0180	R/L1, S/L2, T/L3	30 × 2P	22 to 100 × 2P	2 × 2P	3 to 4/0 × 2P	25 × 2P	25 to 95 × 2P	M10	15 to 20 (130 to 173)
	U/T1, V/T2, W/T3	30 × 2P	22 to 100 × 2P	2 × 2P	3 to 4/0 × 2P	25 × 2P	25 to 95 × 2P	M10	
	⊕	22	22 to 60	3	4 to 2/0	25	25 to 70	M10	17.7 to 22.6 (156 to 200)
	p1, n1	2	2 to 3.5	14	14 to 12	2.5	2.5 to 4	M4	1.2 to 2.0 (10.4 to 17.4)
4□0216	R/L1, S/L2, T/L3	38 × 2P	30 to 100 × 2P	1/0 × 2P	2 to 4/0 × 2P	35 × 2P	25 to 95 × 2P	M10	15 to 20 (130 to 173)
	U/T1, V/T2, W/T3	38 × 2P	30 to 100 × 2P	1/0 × 2P	2 to 4/0 × 2P	35 × 2P	25 to 95 × 2P	M10	
	⊕	22	22 to 100	3	4 to 4/0	35	25 to 95	M12	31.4 to 39.2 (278 to 347)
	p1, n1	2	2 to 3.5	14	14 to 12	2.5	2.5 to 4	M4	1.2 to 2.0 (10.4 to 17.4)
4□0240	R/L1, S/L2, T/L3	50 × 2P	38 to 100 × 2P	1/0 × 2P	1/0 to 4/0 × 2P	50 × 2P	35 to 95 × 2P	M10	15 to 20 (130 to 173)
	U/T1, V/T2, W/T3	50 × 2P	38 to 100 × 2P	1/0 × 2P	1/0 to 4/0 × 2P	50 × 2P	35 to 95 × 2P	M10	
	⊕	38	30 to 100	2	2 to 4/0	50	35 to 95	M12	31.4 to 39.2 (278 to 347)
	p1, n1	2	2 to 3.5	14	14 to 12	2.5	2.5 to 4	M4	1.2 to 2.0 (10.4 to 17.4)
4□0302	R/L1, S/L2, T/L3	80 × 2P	50 to 100 × 2P	3/0 × 2P	1/0 to 4/0 × 2P	70 × 2P	50 to 95 × 2P	M10	15 to 20 (130 to 173)
	U/T1, V/T2, W/T3	80 × 2P	50 to 100 × 2P	3/0 × 2P	1/0 to 4/0 × 2P	70 × 2P	50 to 95 × 2P	M10	
	⊕	38	38 to 150	1	1 to 300	70	35 to 150	M12	31.4 to 39.2 (278 to 347)
	p1, n1	2	2 to 3.5	14	14 to 12	2.5	2.5 to 4	M4	1.2 to 2.0 (10.4 to 17.4)
4□0361	R/L1, S/L2, T/L3	100 × 2P	80 to 100 × 2P	4/0 × 2P	3/0 to 4/0 × 2P	95 × 2P	70 to 95 × 2P	M10	15 to 20 (130 to 173)
	U/T1, V/T2, W/T3	100 × 2P	80 to 100 × 2P	4/0 × 2P	3/0 to 4/0 × 2P	95 × 2P	70 to 95 × 2P	M10	
	⊕	60	60 to 150	1/0	1/0 to 300	95	70 to 150	M12	31.4 to 39.2 (278 to 347)
	p1, n1	2	2 to 3.5	14	14 to 12	2.5	2.5 to 4	M4	1.2 to 2.0 (10.4 to 17.4)
4□0414	R/L1, S/L2, T/L3	125 × 2P	100 to 150 × 2P	300 × 2P	4/0 to 300 × 2P	95 × 2P	95 to 150 × 2P	M12	25 to 35 (217 to 304)
	U/T1, V/T2, W/T3	125 × 2P	100 to 150 × 2P	300 × 2P	4/0 to 300 × 2P	95 × 2P	95 to 150 × 2P	M12	
	⊕	60	60 to 200	1/0	1/0 to 400	95	70 to 240	M12	31.4 to 39.2 (278 to 347)
	p1, n1	2	2 to 3.5	14	14 to 12	2.5	2.5 to 4	M4	1.2 to 2.0 (10.4 to 17.4)

3 Electrical Installation

Model CIMR-U□	Terminal	For Asia <1>		For U.S.A. <2>		For Europe and China <3>		Screw Size	Tightening Torque N·m (lb.in.)
		Recomm. Gauge mm ²	Applicable Gauge mm ²	Recomm. Gauge AWG, kcmil	Applicable Gauge AWG, kcmil	Recomm. Gauge mm ²	Applicable Gauge mm ²		
4□0477	R/L1, S/L2, T/L3	150 × 2P	125 to 150 × 2P	3/0 × 4P	300 × 2P 2/0 to 300 × 4P	120 × 2P	95 to 150 × 2P	M12	31.4 to 39.2 (278 to 347)
	U/T1, V/T2, W/T3	150 × 2P	125 to 150 × 2P	3/0 × 4P	300 × 2P 2/0 to 300 × 4P	120 × 2P	95 to 150 × 2P	M12	31.4 to 39.2 (278 to 347)
	⊕	60	60 to 150	1/0	1/0 to 300	120	95 to 150	M12	31.4 to 39.2 (278 to 347)
	p1, n1	2	2 to 3.5	14	14 to 12	2.5	2.5 to 4	M4	1.2 to 2.0 (10.4 to 17.4)
4□0590	R/L1,S/L2,T/L3	80 × 4P	150 × 2P 60 to 150 × 4P	250 × 4P	3/0 to 300 × 4P	95 × 4P	120 to 150 × 2P 70 to 150 × 4P	M12	31.4 to 39.2 (278 to 347)
	U/T1,V/T2,W/T3	80 × 4P	150 × 2P 60 to 150 × 4P	250 × 4P	3/0 to 300 × 4P	95 × 4P	120 to 150 × 2P 70 to 150 × 4P	M12	31.4 to 39.2 (278 to 347)
	⊕	60	60 to 150	2/0	2/0 to 300	95 × 2P	120 to 150 95 to 150 × 2P	M12	31.4 to 39.2 (278 to 347)
	p1,n1	2	2 to 3.5	14	14 to 12	2.5	2.5 to 4	M4	1.2 to 2.0 (10.4 to 17.4)
4□0720	X, Y, Z	100 × 4P	80 to 150 × 4P	300 × 4P	250 to 300 × 4P	120 × 4P	95 to 150 × 4P	M12	31.4 to 39.2 (278 to 347)
	X1, Y1, Z1	38	38 to 60	1/0	1/0 to 2/0	35	35 to 50	M8	5.4 to 6.0 (47.8 to 53.0)
	U/T1, V/T2, W/T3	100 × 4P	80 to 150 × 4P	300 × 4P	250 to 300 × 4P	120 × 4P	95 to 150 × 4P	M12	31.4 to 39.2 (278 to 347)
	⊕	38 × 2P	100 to 150 38 to 150 × 2P	3/0	3/0 to 300	120 × 2P	95 to 150 × 2P	M12	31.4 to 39.2 (278 to 347)
	r1, s1, t1	2	2 to 3.5	14	14 to 12	2.5	2.5 to 4	M4	1.2 to 2.0 (10.4 to 17.4)
	p1, n1	2	2 to 14	14	14 to 6	2.5	2.5 to 16	M5	2.0 to 2.5 (17.4 to 21.7)
	p2, n2	2	2 to 3.5	14	14 to 12	2.5	2.5 to 4	M4	1.2 to 2.0 (10.4 to 17.4)
4□0900	X, Y, Z	150 × 4P	100 to 150 × 4P	4/0 × 8P	300 × 4P 2/0 to 300 × 8P	150 × 4P	120 to 150 × 4P	M12	31.4 to 39.2 (278 to 347)
	X1, Y1, Z1	38	38 to 60	1/0	1/0 to 2/0	35	35 to 50	M8	5.4 to 6.0 (47.8 to 53.0)
	U/T1, V/T2, W/T3	150 × 4P	100 to 150 × 4P	4/0 × 8P	300 × 4P 2/0 to 300 × 8P	150 × 4P	120 to 150 × 4P	M12	31.4 to 39.2 (278 to 347)
	⊕	60 × 2P	60 to 150 × 2P	4/0	4/0 to 300	150 × 2P	120 to 150 × 2P	M12	31.4 to 39.2 (278 to 347)
	r1, s1, t1	2	2 to 3.5	14	14 to 12	2.5	2.5 to 4	M4	1.2 to 2.0 (10.4 to 17.4)
	p1, n1	2	2 to 14	14	14 to 6	2.5	2.5 to 16	M5	2.0 to 2.5 (17.4 to 21.7)
	p2, n2	2	2 to 3.5	14	14 to 12	2.5	2.5 to 4	M4	1.2 to 2.0 (10.4 to 17.4)

Electrical Installation

3

3 Electrical Installation

Model CIMR-U□	Terminal	For Asia <1>		For U.S.A. <2>		For Europe and China <3>		Screw Size	Tightening Torque N·m (lb.in.)
		Recomm. Gauge mm ²	Applicable Gauge mm ²	Recomm. Gauge AWG, kcmil	Applicable Gauge AWG, kcmil	Recomm. Gauge mm ²	Applicable Gauge mm ²		
4□0930	X, Y, Z	150 × 4P	150 × 4P	4/0 × 8P	4/0 to 300 × 8P	150 × 4P	150 × 4P	M12	31.4 to 39.2 (278 to 347)
	X1, Y1, Z1	38	38 to 60	1/0	1/0 to 2/0	35	35 to 50	M8	5.4 to 6.0 (47.8 to 53.0)
	U/T1, V/T2, W/T3	150 × 4P	150 × 4P	4/0 × 8P	4/0 to 300 × 8P	150 × 4P	150 × 4P	M12	31.4 to 39.2 (278 to 347)
	⊕	60 × 2P	60 to 150 × 2P	4/0	4/0 to 300	150 × 2P	150 × 2P	M12	31.4 to 39.2 (278 to 347)
	r1, r1, t1	2	2 to 3.5	14	14 to 12	2.5	2.5 to 4	M4	1.2 to 2.0 (10.4 to 17.4)
	p1, n1	2	2 to 14	14	14 to 6	2.5	2.5 to 16	M5	2.0 to 2.5 (17.4 to 21.7)
	p2, n2	2	2 to 3.5	14	14 to 12	2.5	2.5 to 4	M4	1.2 to 2.0 (10.4 to 17.4)

<1> Gauges listed here are for use in Japan.
 <2> Gauges listed here are for use in the United States.
 <3> Gauges listed here are for use in Europe and China.

Harmonic Filter Module

Table 10 Harmonic Filter Module Wire Gauge and Torque Specifications for CIMR-U□4□0720 to 4□0930

Model	Terminal	For Asia <1>		For U.S.A. <2>		For Europe and China <3>		Screw Size	Tightening Torque N·m (lb.in.)
		Recomm. Gauge mm ²	Applicable Gauge mm ²	Recomm. Gauge AWG, kcmil	Applicable Gauge AWG, kcmil	Recomm. Gauge mm ²	Applicable Gauge mm ²		
EUJ71183□.□	R/L1, S/L2, T/L3	100 × 4P	80 to 150 × 4P	300 × 4P	250 to 300 × 4P	120 × 4P	95 to 150 × 4P	M12	31.4 to 39.2 (278 to 347)
	X, Y, Z	100 × 4P	80 to 150 × 4P	300 × 4P	250 to 300 × 4P	120 × 4P	95 to 150 × 4P	M12	31.4 to 39.2 (278 to 347)
	X1, Y1, Z1	38	38 to 60	1/0	1/0 to 2/0	35	35 to 50	M8	5.4 to 6.0 (47.8 to 53.0)
	⊕	38 × 2P	100 to 150 38 to 150 × 2P	3/0	3/0 to 300	120 × 2P	95 to 150 × 2P	M12	31.4 to 39.2 (278 to 347)
	r1, r1, t1	2	2 to 3.5	14	14 to 12	2.5	2.5 to 4	M4	1.2 to 2.0 (10.4 to 17.4)
	p2, n2	2	2 to 3.5	14	14 to 12	2.5	2.5 to 4	M4	1.2 to 2.0 (10.4 to 17.4)
EUJ71184□.□	R/L1, S/L2, T/L3	150 × 4P	100 to 150 × 4P	4/0 × 8P	300 × 4P 2/0 to 300 × 8P	150 × 4P	120 to 150 × 4P	M12	31.4 to 39.2 (278 to 347)
	X, Y, Z	150 × 4P	100 to 150 × 4P	4/0 × 8P	300 × 4P 2/0 to 300 × 8P	150 × 4P	120 to 150 × 4P	M12	31.4 to 39.2 (278 to 347)
	X1, Y1, Z1	38	38 to 60	1/0	1/0 to 2/0	35	35 to 50	M8	5.4 to 6.0 (47.8 to 53.0)
	⊕	60 × 2P	60 to 150 × 2P	4/0	4/0 to 300	150 × 2P	120 to 150 × 2P	M12	31.4 to 39.2 (278 to 347)
	r1, r1, t1	2	2 to 3.5	14	14 to 12	2.5	2.5 to 4	M4	1.2 to 2.0 (10.4 to 17.4)
	p2, n2	2	2 to 3.5	14	14 to 12	2.5	2.5 to 4	M4	1.2 to 2.0 (10.4 to 17.4)
EUJ71185□.□	R/L1, S/L2, T/L3	150 × 4P	150 × 4P	4/0 × 8P	4/0 to 300 × 8P	150 × 4P	150 × 4P	M12	31.4 to 39.2 (278 to 347)
	X, Y, Z	150 × 4P	150 × 4P	4/0 × 8P	4/0 to 300 × 8P	150 × 4P	150 × 4P	M12	31.4 to 39.2 (278 to 347)
	X1, Y1, Z1	38	38 to 60	1/0	1/0 to 2/0	35	35 to 50	M8	5.4 to 6.0 (47.8 to 53.0)
	⊕	60 × 2P	60 to 150 × 2P	4/0	4/0 to 300	150 × 2P	150 × 2P	M12	31.4 to 39.2 (278 to 347)
	r1, r1, t1	2	2 to 3.5	14	14 to 12	2.5	2.5 to 4	M4	1.2 to 2.0 (10.4 to 17.4)
	p2, n2	2	2 to 3.5	14	14 to 12	2.5	2.5 to 4	M4	1.2 to 2.0 (10.4 to 17.4)

<1> Gauges listed here are for use in Japan.
 <2> Gauges listed here are for use in the United States.
 <3> Gauges listed here are for use in Europe and China.

3 Electrical Installation

■ Main Circuit Terminal and Motor Wiring

This section outlines the various steps, precautions, and checkpoints for wiring the main circuit terminals and motor terminals.

NOTICE: When connecting the motor to the drive output terminals U/T1, V/T2, and W/T3, the phase order for the drive and motor should match. Failure to comply with proper wiring practices may cause the motor to run in reverse if the phase order is backward.

NOTICE: Do not connect phase-advancing capacitors or LC/RC noise filters to the output circuits. Failure to comply could result in damage to the drive, phase-advancing capacitors, LC/RC noise filters or ground fault circuit interrupters.

Ground Wiring

Follow the precautions to wire the ground for one drive or a series of drives.

WARNING! Electrical Shock Hazard. Always use a ground wire that complies with technical standards on electrical equipment and minimize the length of the ground wire. Improper equipment grounding may cause dangerous electrical potentials on equipment chassis, which could result in death or serious injury.

WARNING! Electrical Shock Hazard. Be sure to ground the drive ground terminal. Improper equipment grounding could result in death or serious injury by contacting ungrounded electrical equipment.

NOTICE: Do not share the ground wire with other devices such as welding machines or large-current electrical equipment. Improper equipment grounding could result in drive or equipment malfunction due to electrical interference.

NOTICE: When using more than one drive, ground multiple drives according to instructions. Improper equipment grounding could result in abnormal operation of drive or equipment.

Refer to **Figure 21** when using multiple drives or when using multiple models CIMR-U□4□0720 to 4□0930 that are connected with harmonic filter module. Do not loop the ground wire.

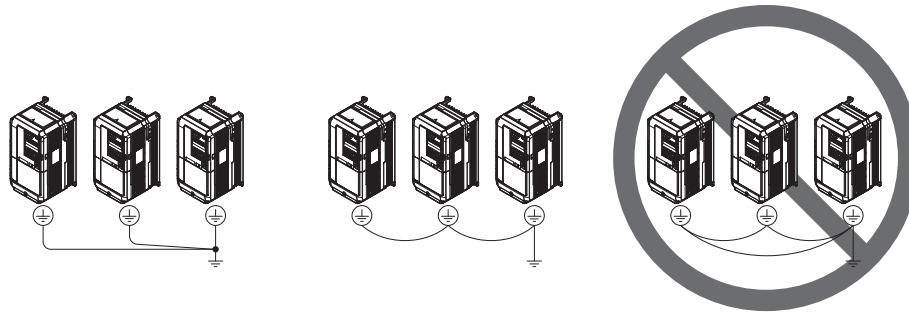


Figure 21 Multiple Drive Wiring

◆ Control Circuit Wiring

■ Control Circuit Terminal Block Functions

Drive parameters determine which functions apply to the multi-function digital inputs (S1 to S8), multi-function digital outputs (M1 to M6), multi-function analog inputs (A1 to A3), and multi-function analog monitor outputs (FM, AM). The default setting is listed next to each terminal in **Figure 15** and **Figure 16**.

WARNING! Sudden Movement Hazard. Always check the operation and wiring of control circuits after being wired. Operating a drive with untested control circuits could result in death or serious injury.

WARNING! Sudden Movement Hazard. Confirm the drive I/O signals and external sequence before starting test run. Setting parameter A1-06 may change the I/O terminal function automatically from the factory setting. Failure to comply may result in death or serious injury.

Input Terminals

Table 11 lists the input terminals on the drive. Text in parenthesis indicates the default setting for each multi-function input.

Table 11 Control Circuit Input Terminals

Type	No.	Terminal Name (Function)	Function (Signal Level) Default Setting	Page
Multi-Function Digital Inputs	S1	Multi-function input 1 (Closed: Forward run, Open: Stop)	Photocoupler 24 Vdc, 8 mA Set the wire jumper between SC and SN or SC and SP for selection of sinking/sourcing mode and power supply. Refer to <i>Sinking/Sourcing Mode for Digital Inputs on page 47.</i>	97
	S2	Multi-function input 2 (Closed: Reverse run, Open: Stop)		
	S3	Multi-function input 3 (External fault, N.O.)		
	S4	Multi-function input 4 (Fault reset)		
	S5	Multi-function input 5 (Multi-step speed reference 1)		
	S6	Multi-function input 6 (Multi-step speed reference 2)		
	S7	Multi-function input 7 (Jog reference)		
	S8	Multi-function input 8 (Baseblock command (N.O.))		
	SC	Multi-function input common	Multi-function input common	
	SP	Digital input power supply +24 Vdc	24 Vdc power supply for digital inputs, 150 mA max (only when not using digital input option DI-A3)	47
	SN	Digital input power supply 0 V	NOTICE: Do not jumper or short terminals SP and SN. Failure to comply will damage the drive.	
Safe Disable Inputs	H1	Safe Disable input 1	24 Vdc, 8 mA	122
	H2	Safe Disable input 2	One or both open: Output disabled Both closed: Normal operation Internal impedance: 3.3 kΩ Off time of at least 1 ms Disconnect the wire jumpers shorting terminals H1, H2, and HC to use the Safe Disable inputs. Set the S3 jumper to select between sinking, sourcing mode, and the power supply as explained in <i>Sinking/Sourcing Mode Selection for Safe Disable Inputs on page 48.</i>	
	HC	Safe Disable function common	Safe disable function common	
Analog Inputs / Pulse Train Input	RP	Multi-function pulse train input (Frequency reference)	Input frequency range: 0 to 32 kHz Signal Duty Cycle: 30 to 70% High level: 3.5 to 13.2 Vdc, low level: 0.0 to 0.8 Vdc Input impedance: 3 kΩ	100 120
	+V	Power supply for analog inputs	10.5 Vdc (max allowable current 20 mA)	120
	-V	Power supply for analog inputs	-10.5 Vdc (max allowable current 20 mA)	—
	A1	Multi-function analog input 1 (Frequency reference bias)	-10 to 10 Vdc, 0 to 10 Vdc (input impedance: 20 kΩ)	65
	A2	Multi-function analog input 2 (Frequency reference bias)	-10 to 10 Vdc, 0 to 10 Vdc (input impedance: 20 kΩ) 4 to 20 mA, 0 to 20 mA (input impedance: 250 Ω) Voltage or current input must be selected by DIP switch S1 and H3-09	65
	A3	Multi-function analog input 3 (auxiliary frequency reference) / PTC Input	-10 to 10 Vdc, 0 to 10 Vdc (input impedance: 20 kΩ) Use DIP switch S4 on the terminal board to select between analog and PTC input.	—
	AC	Frequency reference common	0 V	65
	E (G)	Ground for shielded lines and option cards	—	—

3 Electrical Installation

Output Terminals

Table 12 lists the output terminals on the drive. Text in parenthesis indicates the default setting for each multi-function output.

Table 12 Control Circuit Output Terminals

Type	No.	Terminal Name (Function)	Function (Signal Level) Default Setting	Page
Fault Relay Output	MA	N.O. output (Fault)	30 Vdc, 10 mA to 1 A; 250 Vac, 10 mA to 1 A Minimum load: 5 Vdc, 10 mA	-
	MB	N.C. output (Fault)		
	MC	Fault output common		
Multi-Function Digital Output <1>	M1	Multi-function digital output (During run)	30 Vdc, 10 mA to 1 A; 250 Vac, 10 mA to 1 A Minimum load: 5 Vdc, 10 mA	98
	M2			
	M3	Multi-function digital output (Zero Speed)		
	M4			
	M5	Multi-function digital output (Speed Agree 1)		
M6				
Monitor Output	MP	Pulse train output (Output frequency)	32 kHz (max)	100
	FM	Analog monitor output 1 (Output frequency)	-10 to +10 Vdc, 0 to +10 Vdc, or 4-20 mA	99
	AM	Analog monitor output 2 (Output current)	Use jumper S5 on the terminal board to select between voltage or current output signals. Resolution: 1/1000	
	AC	Monitor common	0 V	-
Safety Monitor Output	DM+	Safety monitor output	Outputs status of Safe Disable function. Closed when both Safe Disable channels are closed. Up to +48 Vdc 50 mA. Slide the switch S6 to select N.C. or N.O. as the state of the DM+ and DM- terminals for EDM output as explained on 122 page.	122
	DM-	Safety monitor output		

<1> Refrain from assigning functions to digital relay outputs that involve frequent switching, as doing so may shorten relay performance life. Switching life is estimated at 200,000 times (assumes 1 A, resistive load).

Serial Communication Terminals

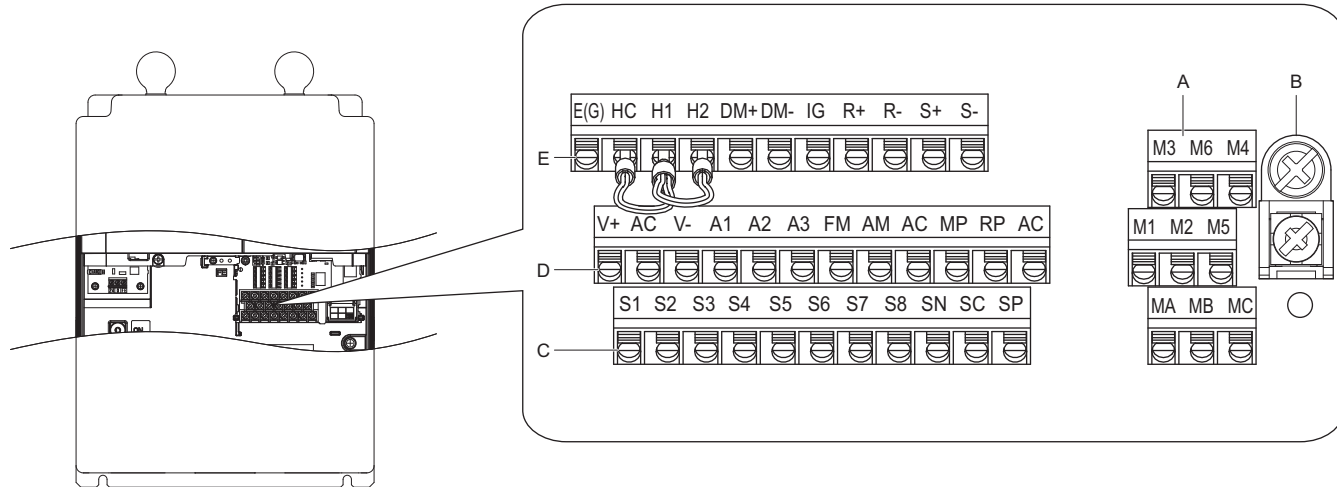
Table 13 Control Circuit Terminals: Serial Communications

Type	No.	Signal Name	Function (Signal Level)	
MEMOBUS/Modbus Communication <1>	R+	Communications input (+)	MEMOBUS/Modbus communication: Use a RS-485 or RS-422 cable to connect the drive.	RS-422/RS-485 MEMOBUS/Modbus communication protocol 115.2 kbps (max.)
	R-	Communications input (-)		
	S+	Communications output (+)		
	S-	Communications output (-)		
	IG	Shield ground	0 V	

<1> Enable the termination resistor in the last drive in a MEMOBUS/Modbus network by setting DIP switch S2 to the ON position. For more information on the termination resistor, see Control I/O Connections on page 47.

Terminal Configuration

The control circuit terminals should be arranged as shown in *Figure 22*.



- A – Terminal Block (TB 2)
- B – Terminal Block (TB 5)
- C – Terminal Block (TB 1)
- D – Terminal Block (TB 3)
- E – Terminal Block (TB 4)

Figure 22 Control Circuit Terminal Arrangement

Wire Size

Select appropriate wire type and gauges from *Table 14*. For simpler and more reliable wiring, use crimp ferrules on the wire ends. Refer to *Ferrule-Type Wire Terminals on page 44* for ferrule terminal types and sizes.

Table 14 Wire Gauges

Terminal Block	Terminal	Screw Size	Tightening Torque N·m (lb.in.)	Bare Wire Terminal		Ferrule-Type Terminal		Wire Type
				Recommended wire size mm ² (AWG)	Applicable wire size mm ² (AWG)	Recommended wire size mm ² (AWG)	Applicable wire size mm ² (AWG)	
TB1, TB2, TB3, TB4	S1-S8, SC, SP, SN, RP, +V, -V, A1, A2, A3, AC, M1-M6, MA, MB, MC, MP, AM, FM, AC, S+, S-, R+, R-, IG, HC, H1, H2, DM+, DM-	-	-	0.75 (18)	Stranded wire: 0.2 to 1.0 (24 to 17) Solid wire: 0.2 to 1.5 (24 to 16)	0.5 (20)	0.25 to 0.5 (24 to 20)	Shielded line, etc.
	1.0 (16)							
TB5	E (G)	M3.5	0.5 to 1.0 (4.4 to 8.9)	1.25 (12)	0.5 to 2 (20 to 14)	-	-	

3 Electrical Installation

Ferrule-Type Wire Terminals

Yaskawa recommends using CRIMPFOX 6, a crimping tool manufactured by PHOENIX CONTACT, to prepare wire ends with insulated sleeves before connecting to the drive. Refer to [Table 15](#) for dimensions.

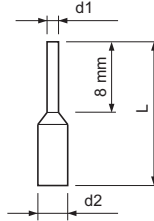


Figure 23 Ferrule Dimensions

Table 15 Ferrule Terminal Types and Sizes

Size mm ² (AWG)	Type	L (mm)	d1 (mm)	d2 (mm)	Manufacturer
0.25 (24)	AI 0.25-8YE	12.5	0.8	2.0	PHOENIX CONTACT
0.34 (22)	AI 0.34-8TQ	12.5	0.8	2.0	
0.5 (20)	AI 0.5-8WH AI 0.5-8OG	14	1.1	2.5	

■ Wiring the Control Circuit Terminal

This section describes the proper procedures and preparations for wiring the control terminals.

WARNING! *Electrical Shock Hazard. Do not remove covers or touch the circuit boards while the power is on. Failure to comply could result in death or serious injury.*

NOTICE: *Separate control circuit wiring from main circuit wiring and other high-power lines. Improper wiring practices could result in drive malfunction due to electrical interference.*

The main circuit terminals vary by the drive models.

•CIMR-U□2□0028 to 2□0248, 4□0011 to 4□0414: R/L1, S/L2, T/L3, U/T1, V/T2, W/T3, p1, n1

•CIMR-U□4□0477 to 4□0930: X, Y, Z, X1, Y1, Z1, r1/l11, a1/l21, t1/l31, U/T1, V/T2, W/T3, p1, n1, p2, n2

NOTICE: *Separate wiring for output terminals MA, MB, MC, M1, and M2 to M6 from wiring to other control circuit lines. Improper wiring practices could result in drive or equipment malfunction or nuisance trips.*

NOTICE: *Use a class 2 power supply (UL standard) when connecting to the control terminals. Improper application of peripheral devices could result in drive performance degradation due to improper power supply.*

NOTICE: *Insulate shields with tape or shrink tubing to prevent contact with other signal lines and equipment. Improper wiring practices could result in drive or equipment malfunction due to short circuit.*

NOTICE: *Connect the shield of shielded cable to the appropriate ground terminal. Improper equipment grounding could result in drive or equipment malfunction or nuisance trips.*

Wire the control circuit only after terminals have been properly grounded and main circuit wiring is complete. Refer to [Figure 24](#) and [Figure 25](#) for details. Prepare the ends of the control circuit wiring as shown in [Figure 26](#). Refer to [Wire Size on page 43](#).

NOTICE: *Use shielded twisted-pair cables as indicated to prevent operating faults. Improper wiring practices could result in drive or equipment malfunction due to electrical interference.*

Connect control wires as shown in *Figure 24* and *Figure 25*.

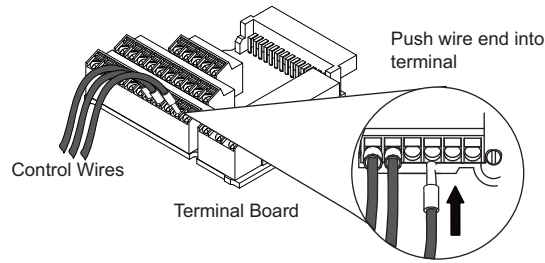


Figure 24 Terminal Board Wiring Guide

To disconnect control wires from the terminals use the procedure described in *Figure 25*. Grasp the wire where it enters the terminal with a pair of pliers, then use a straight-edge screw driver to release the terminal and pull the wire out. If it fits tightly, e.g. if ferrules are used, turn the wire for about 45° and then pull it gently out. Use this procedure to remove the wire jumper between terminals HC, H1 and H2 that is preinstalled at shipping.

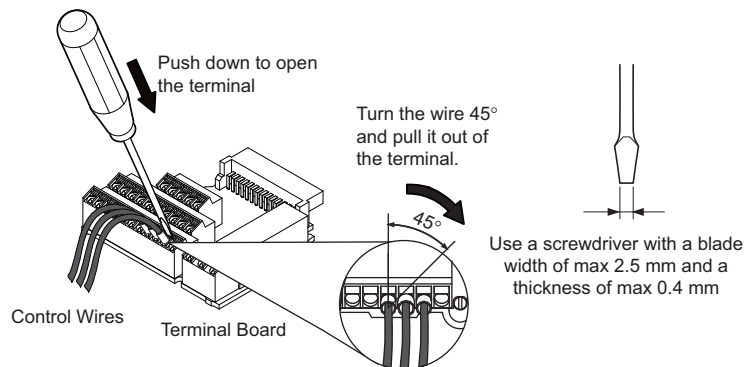
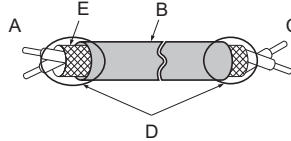


Figure 25 Removing Wires from the Terminal Board

When setting the frequency by analog reference from an external potentiometer, use shielded twisted-pair wires (preparing wire ends as shown in *Figure 26* and connect the shield to the ground terminal (E [G]) of the drive.



- A – Drive side
- B – Insulation
- C – Control device side
- D – Shield sheath (insulate with tape)
- E – Shield

Figure 26 Preparing the Ends of Shielded Cables

NOTICE: The analog signal wiring between the drive and the operator station or peripheral equipment should not exceed 50 meters when using an analog signal from a remote source to supply the frequency reference. Failure to comply could result in poor system performance.

■ Module Communications Connector

A connector to connect models CIMR-U□4□0720 to 4□0930 and the harmonic filter module is called module connector (CN500).

Be sure to connect the harmonic filter module before turning on or operating the models CIMR-U□4□0720 to 4□0930.

Module Communications Connector Functions

Table 16 Module Communications Connector (CN500) Functions

No.	Name	Function	Page
CN500	Module Communications Connector	Connector to communicate information for turning on or operating the models CIMR-U□4□0720 to 4□0930.	27

3 Electrical Installation

Module Communications Connector Location CIMR-U□4□0720 to 4□0930

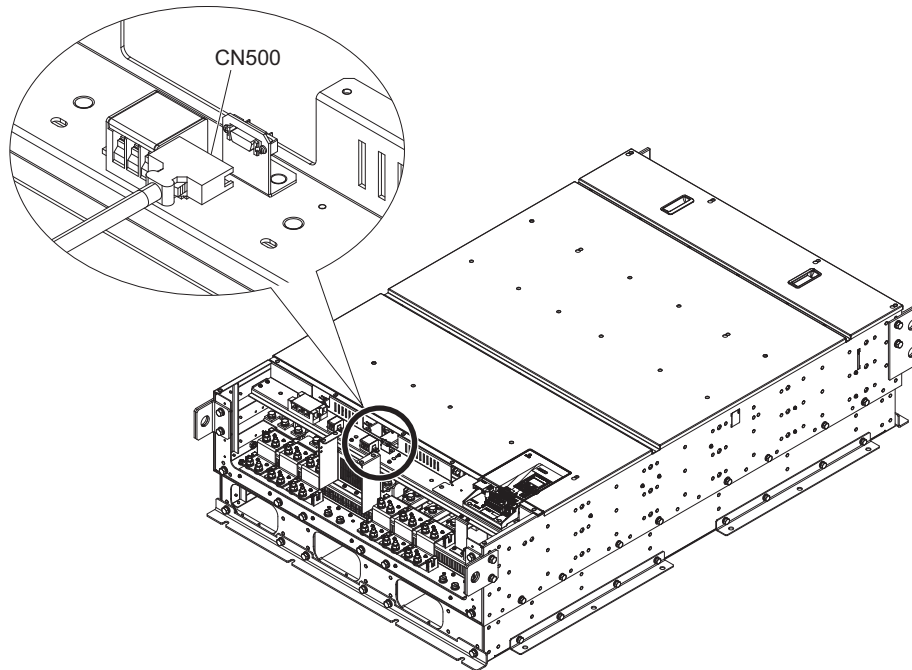


Figure 27 Module Communications Connector Location (CIMR-U□4□0720 to 4□0930)

Harmonic Filter Module

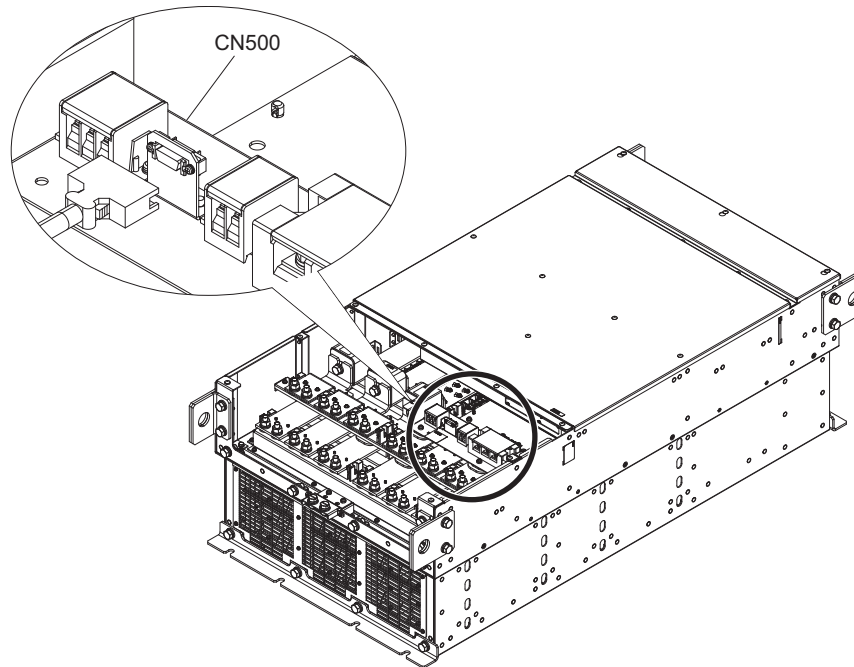
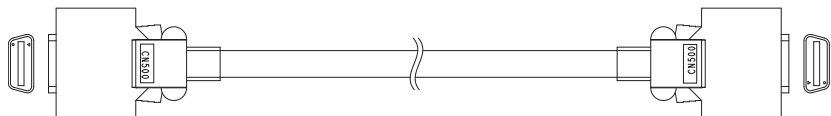


Figure 28 Module Communications Connector Location (Harmonic Filter Module)

Cable Specifications

Use a cable packaged with the harmonic filter module to connect with connector CN500.

Table 17 Module Communications Connector (CN500) Cable Specifications

Cable Length	Cable Connector Exterior	Dimensions
Approximately 5 m	Half pitch I/O connector (1.27 mm)	

Precautions when Wiring Module Communications Connector

After inserting the connector, pull the cable gently, and make sure that the connector is securely inserted.

◆ Control I/O Connections

■ Switches and Jumpers on the Terminal Board

The terminal board is equipped with several switches used to adapt the drive I/Os to the external control signals. *Figure 29* shows the location of these switches.

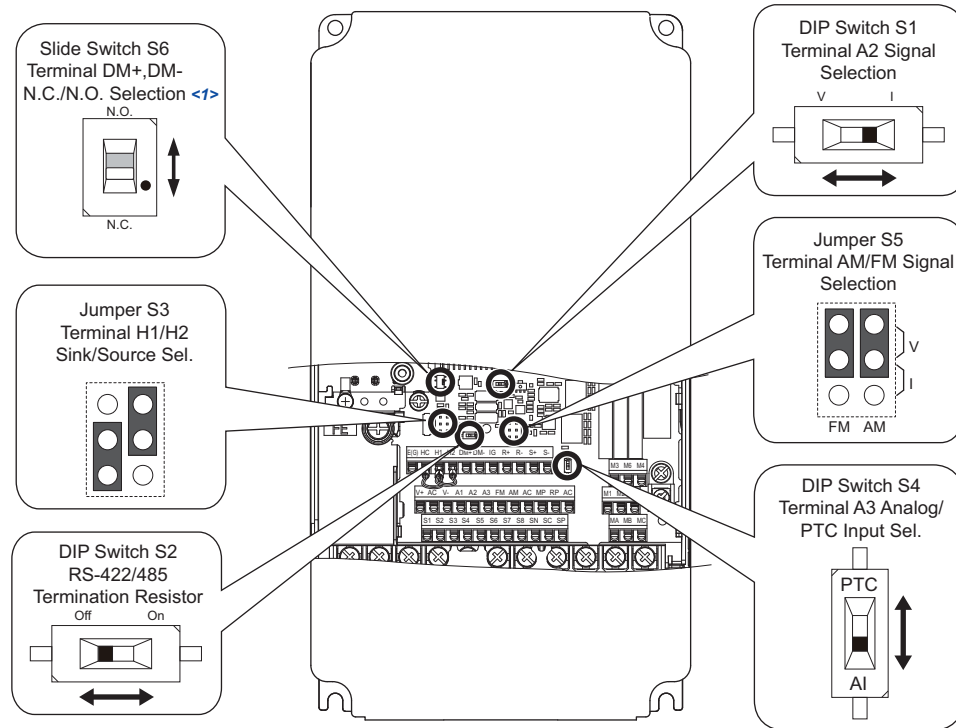
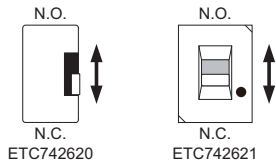


Figure 29 Locations of Jumpers and Switches on the Terminal Board

<1> Available slide switch S6 is models ETC742620 and ETC742621.



■ Sinking/Sourcing Mode for Digital Inputs

Use the wire jumper between terminals SC and SP or SC and SN to select between Sink mode, Source mode or external power supply for the digital inputs S1 to S8 as shown in *Table 18* (Default: Sink mode, internal power supply).

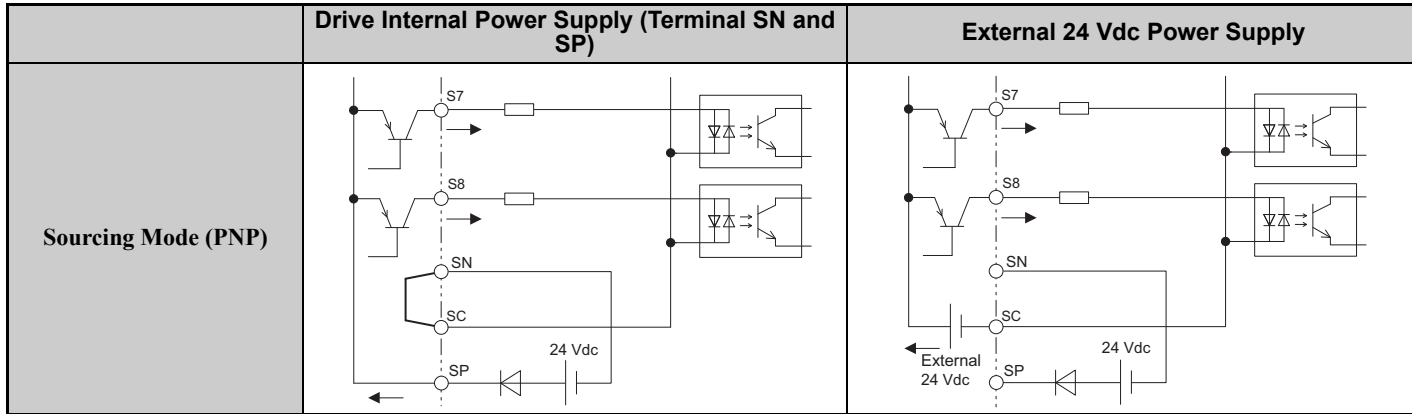
Note: Never short terminals SP and SN as doing so will damage the drive.

Table 18 Digital Input Sink / Source / External Power Supply Selection

	Drive Internal Power Supply (Terminal SN and SP)	External 24 Vdc Power Supply
Sinking Mode (NPN)		

Electrical Installation

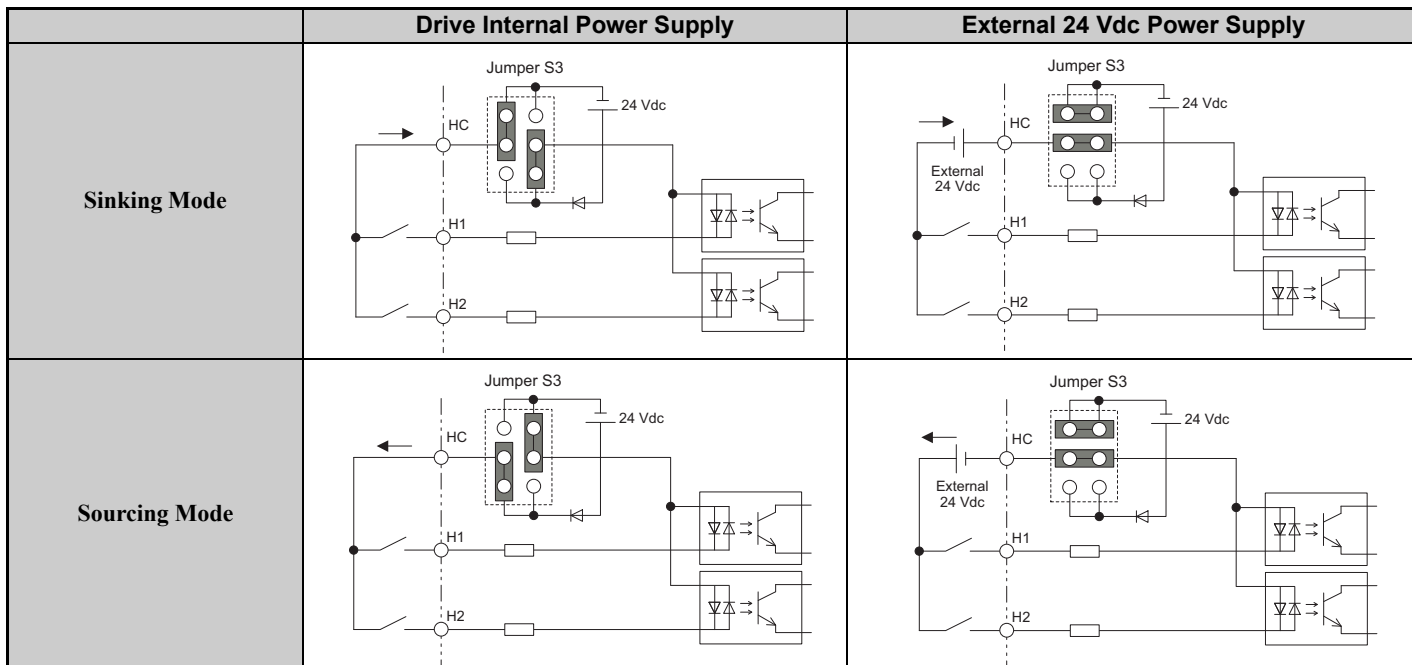
3 Electrical Installation



■ Sinking/Sourcing Mode Selection for Safe Disable Inputs

Use jumper S3 on the terminal board to select between Sink mode, Source mode or external power supply for the Safe Disable inputs H1 and H2 as shown in [Table 18](#) (Default: Source mode, internal power supply.) Refer to [Switches and Jumpers on the Terminal Board on page 47](#) for locating jumper S3.

Table 19 Safe Disable Input Sink / Source / External Power Supply Selection



■ Terminal A2 Input Signal Selection

Terminal A2 can be used to input either a voltage or a current signal. Select the signal type using switch S1 as explained in [Table 20](#). Set parameter H3-09 accordingly as shown in [Table 21](#). Refer to [Switches and Jumpers on the Terminal Board on page 47](#) for locating switch S1.

Note: If terminals A1 and A2 are both set for frequency bias (H3-02 = 0 and H3-10 = 0), both input values will be combined to create the frequency reference.

Table 20 DIP Switch S1 Settings

Setting	Description
V (left position)	Voltage input (-10 to +10 V)
I (right position) (default)	Current input (4 to 20 mA or 0 to 20 mA): default setting

Table 21 Parameter H3-09 Details

No.	Parameter Name	Description	Setting Range	Default Setting
H3-09	Terminal A2 signal level selection	Selects the signal level for terminal A2. 0: 0 to 10 Vdc 1: -10 to 10 Vdc 2: 4 to 20 mA 3: 0 to 20 mA	0 to 3	2

■ Terminal A3 Analog/PTC Input Selection

Terminal A3 can be configured either as multi-function analog input or as PTC input for motor thermal overload protection. Use switch S4 to select the input function as described in [Table 22](#). Refer to [Switches and Jumpers on the Terminal Board on page 47](#) for locating switch S4.

Table 22 DIP Switch S4 Settings

Setting	Description
AI (lower position) (default)	Analog input for the function selected in parameter H3-06
PTC (upper position)	PTC input. Parameter H3-06 must be set to E (PTC input)

■ Terminal AM/FM Signal Selection

The signal type for terminals AM and FM can be set to either voltage or current output using jumper S5 on the terminal board as explained in [Table 23](#). When changing the setting of jumper S5, parameters H4-07 and H4-08 must be set accordingly. The default selection is voltage output for both terminals. Refer to [Switches and Jumpers on the Terminal Board on page 47](#) for locating jumper S5.

Table 23 Jumper S5 Settings





	Voltage Output	Current Output
Terminal AM		
Terminal FM		

Table 24 Parameter H4-07, H4-08 Details

No.	Parameter Name	Description	Setting Range	Default Setting
H4-07	Terminal AM signal level selection	0: 0 to 10 Vdc 1: -10 to 10 Vdc 2: 4 to 20 mA	0 to 2	0
H4-08	Terminal FM signal level selection			

This drive is equipped with a built in termination resistor for the RS-422/RS-485 communication port. DIP switch S2 enables or disabled the termination resistor as shown in [Table 25](#). The OFF position is the default. The termination resistor should be placed to the ON position when the drive is the last in a series of slave drives. Refer to [Switches and Jumpers on the Terminal Board on page 47](#) for locating switch S2.

Table 25 MEMOBUS/Modbus Switch Settings

S2 Position	Description
ON	Internal termination resistor ON
OFF	Internal termination resistor OFF (default setting)

Note: Refer to Technical Manual for details on MEMOBUS/Modbus.

3 Electrical Installation

◆ Enable the Internal EMC Filter

■ Internal EMC Filter

An EMC filter module is built in model CIMR-U□□E□□□□/□□□W□□□□. The EMC filter module can be switched between enabled (ON) or disabled (OFF).

Note: Models CIMR-U□4□0477 to 4□0930 are not available. Be sure to use a stand-alone EMC filter for models CIMR-U□4□0477 to 4□0930.

DANGER! *Electrical Shock Hazard. Do not touch SW screw while power is applied to the drive. Failure to comply will result in death or serious injury.*

WARNING! *Electrical Shock Hazard. Connect the ground cable correctly. Failure to comply may result in death or serious injury.*

NOTICE: *When disabling the internal EMC filter, move the screws from ON to OFF and then tighten to the specified torque. Completely removing the screws or tightening the screws to an incorrect torque may cause drive failure.*

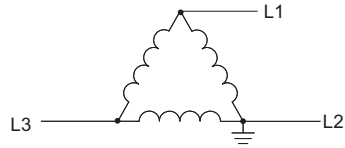
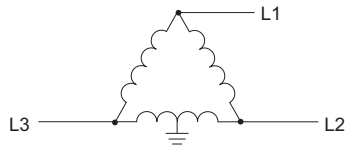
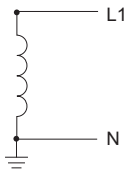
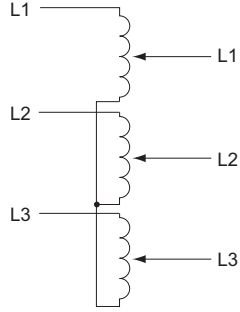
Note: For floating, impedance grounded, or asymmetrically grounded networks, disconnect the internal EMC filter by moving the SW screw to the OFF position.

Use size M4 internal EMC filter screws with 1.0 to 1.3 N·m tightening torque.

Asymmetrical Grounded Network

Table 26 shows asymmetrical grounded networks. Asymmetrical networks require first moving the SW screw to disconnect the internal ground connection. (Drives are shipped with SW screw installed at the OFF position.)

Table 26 Asymmetrical Grounded Network

Grounded at the corner of the delta	
Grounded at the middle of the side	
Single-phase, grounded at the end point	
Three-phase variable transformer without solidly grounded neutral	

3 Electrical Installation

If EMC is a concern and the network is grounded symmetrically, install the SW screw to the ON position. Installing the SW screw enables the internal EMC filter (Drives are shipped with SW screw installed at the OFF position).

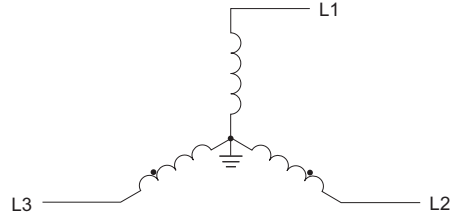
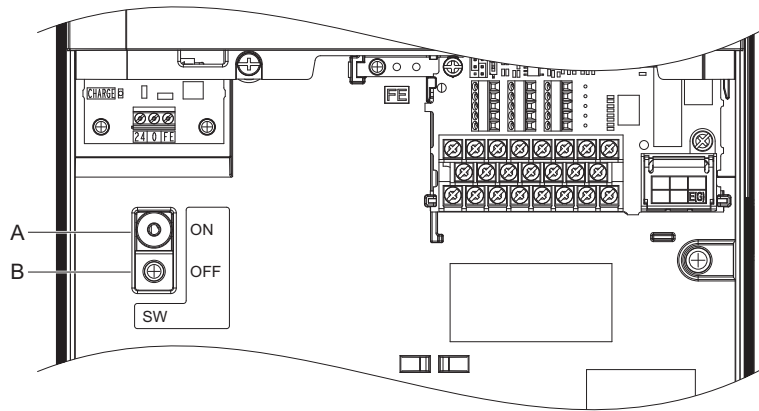


Figure 30 Symmetrical Grounded Network

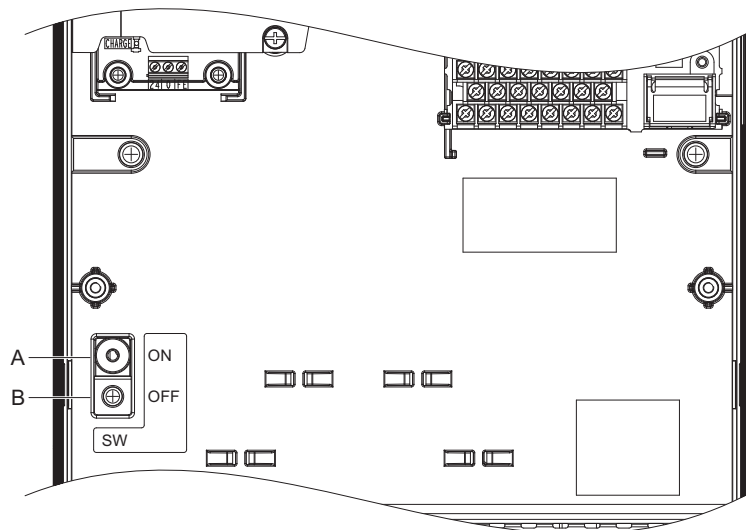
EMC Filter Switch Location



A – SW (ON)

B – Screw (OFF)

Figure 31 EMC Filter Switch Location (2E0028, 2W0028, 4E0011 to 4E0034, 4W0011 to 4W0034)

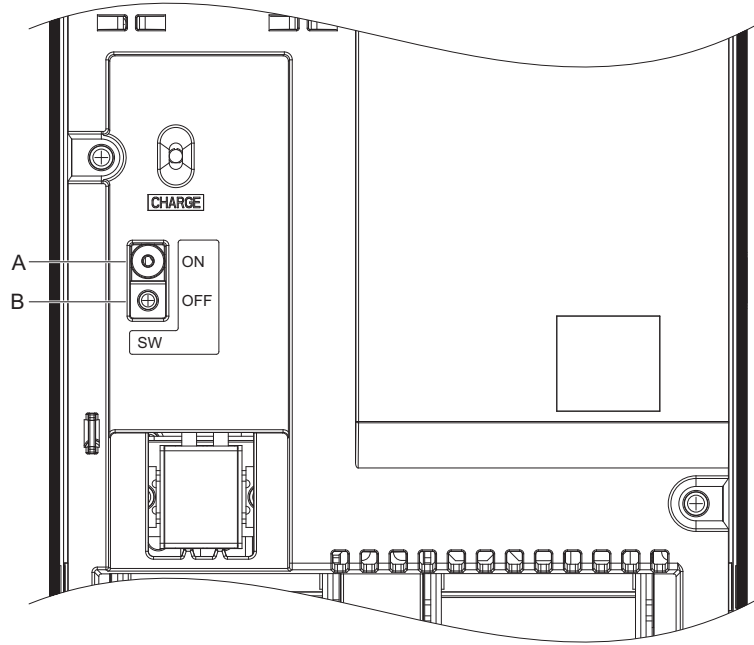


A – SW (ON)

B – Screw (OFF)

Figure 32 EMC Filter Switch Location (2E0042, 2E0054, 2W0042, 2W0054, 4E0040 to 4E0077, 4W0040 to 4W0077)

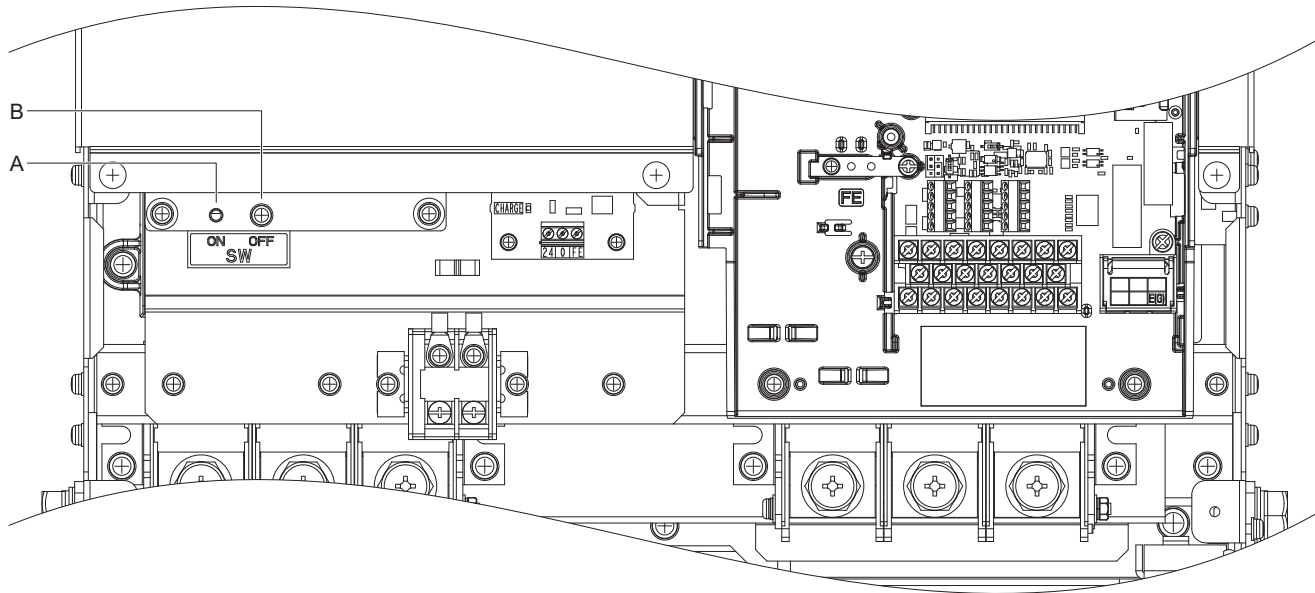
3 Electrical Installation



A – SW (ON)

B – Screw (OFF)

Figure 33 EMC Filter Switch Location (2E0104, 2E0130, 2W0104, 2W0130, 4E0096, 4E0124, 4W0096, 4W0124)



A – SW (ON)

B – Screw (OFF)

Figure 34 EMC Filter Switch Location (2E0154, 2E0192, 2W0154, 2W0192, 4E0156, 4E0180, 4W0156, 4W0180)

3 Electrical Installation

◆ 24 V Control Power Supply Unit Wiring

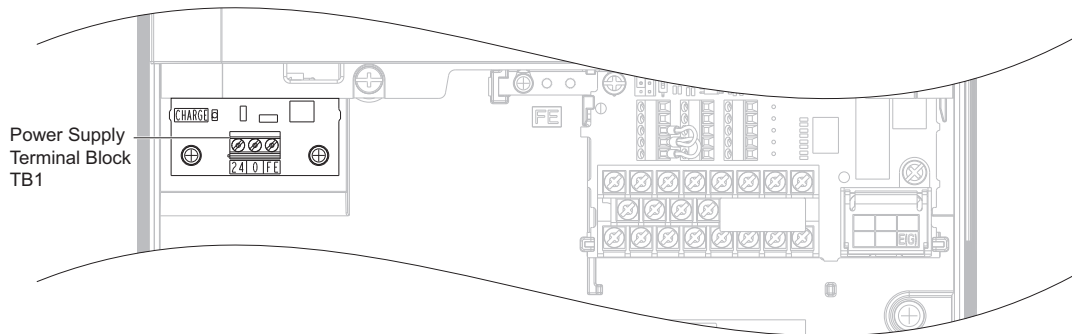
■ 24 V Control Power Supply Unit

The 24 V Control Power Supply Unit maintains drive control circuit power in the event of a main power outage. As long as the control circuit has power, network communications and I/O data remain operational. The unit provides external power to the control circuit only, and does not provide power to the main circuit of the drive.

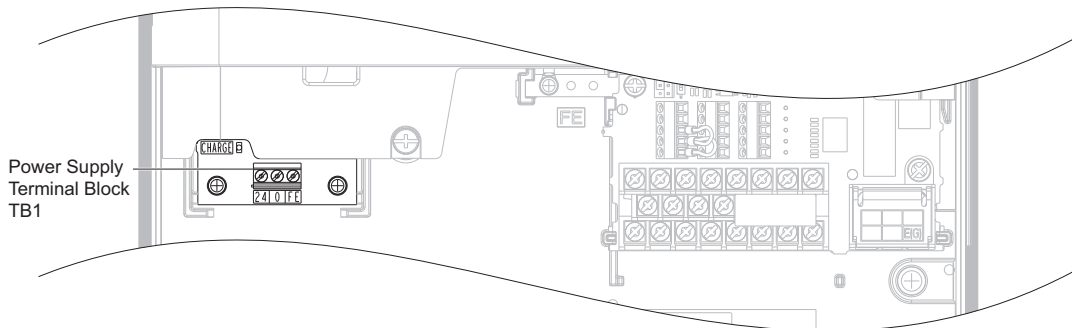
It is possible to read fault and parameter data in the drive via the operator or network communications when the drive switches to the unit as a back-up power supply.

Note: Parameter settings cannot be changed without drive main circuit power regardless of whether the control circuit has enough power to operate. Parameter settings cannot be changed without drive main circuit power regardless of whether the control circuit has enough power to operate.

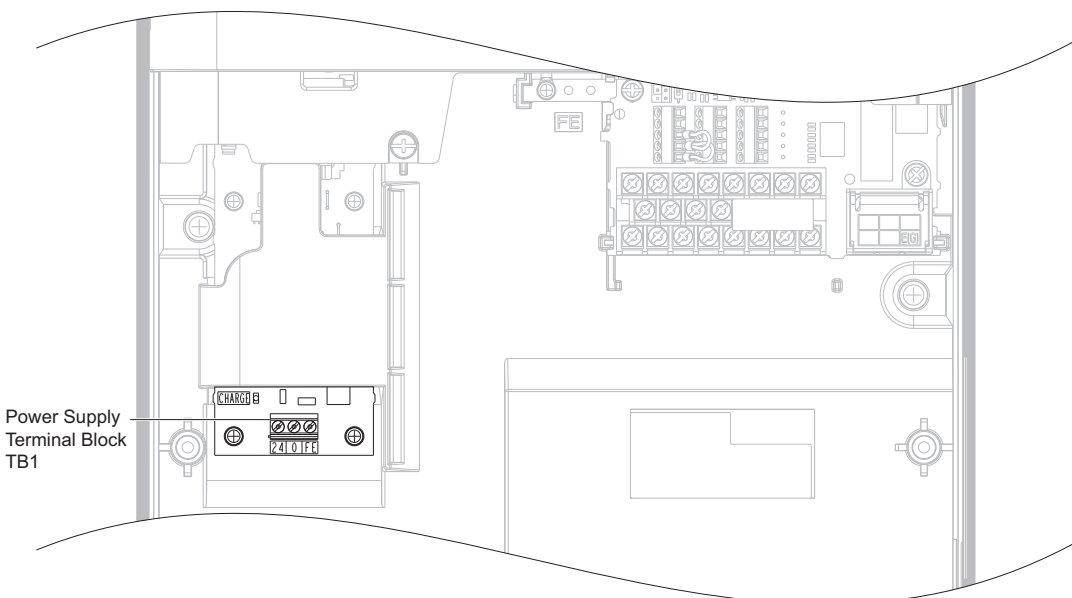
24 V Control Power Supply Unit Location



**Figure 37 24 V Control Power Supply Unit Location
(Models 2P0028, 2W0028, 4P0011 to 4P0034, and 4W0011 to 4W0034)**

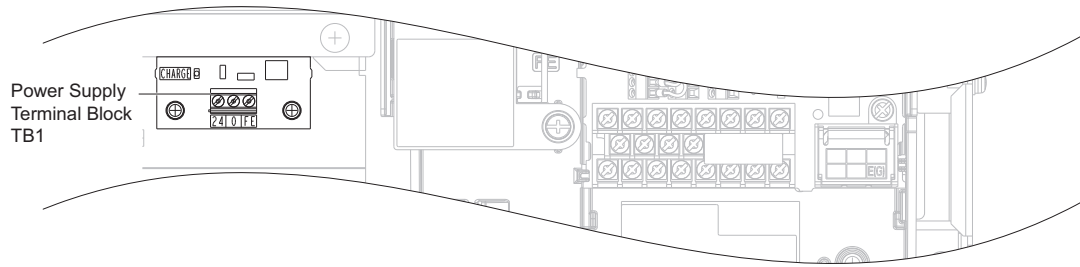


**Figure 38 24 V Control Power Supply Unit Location
(Models 2P0042 to 2P0081, 2W0042 to 2W0081, 4P0040 to 4P0077, and 4W0040 to 4W0077)**

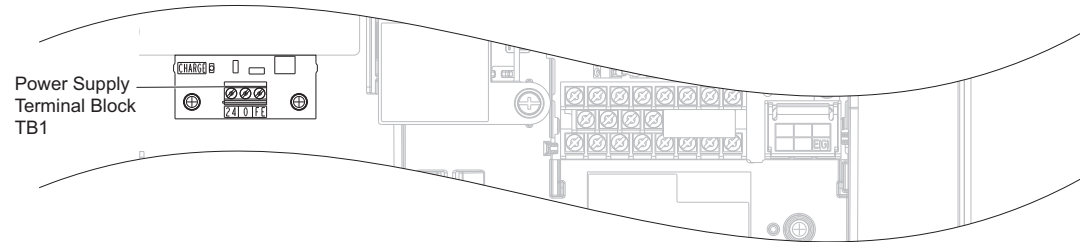


**Figure 39 24 V Control Power Supply Unit Location
(Models 2P0104, 2W0104, 2P0130, 2W0130, 4P0096, 4W0096, 4P0124, and 4W0124)**

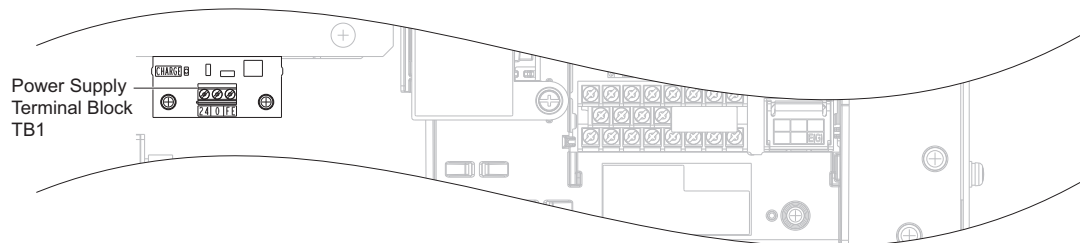
3 Electrical Installation



**Figure 40 24 V Control Power Supply Unit Location
(Models 2P0154, 2W0154, 2P0192, 2W0192, 4P0156, 4W0156, 4P0180, and 4W0180)**



**Figure 41 24 V Control Power Supply Unit Location
(Models 2P0248, 2W0248, 4P0216, 4W0216, 4P0240, and 4W0240)**



**Figure 42 24 V Control Power Supply Unit Location
(Models 4P0302 to 4P0414 and 4W0302 to 4W0414)**

3 Electrical Installation

■ Power Supply Terminal Block TB1 Wiring

Power Supply Terminal Block TB1 Wiring Procedure

1. Select an external power supply.

When the 24 V Control Power Supply Unit is first switched on, two times the normal current will flow through the unit for approximately 0.5 seconds. The unit requires at least 3 A to function properly.

WARNING! *Electrical Shock Hazard. Use a battery or a double-reinforced UL Class 2 power supply to provide power to the 24 V Control Power Supply Unit. Using a different type of power supply may result in death or serious injury by electrical shock or fire.*

NOTICE: *Do not install multiple 24 V Control Power Supply Unit. Failure could cause erroneous operation or damage the drive.*

2. Use a flat-blade screwdriver to loosen the screws on the terminal block TB1, connect wiring to the 24, 0, and FE terminals as shown in **Figure 43**, then tighten the terminal screws to hold wiring in place.

Refer to **Table 31** to confirm that the proper tightening torque is applied to each terminal. Take particular precaution to ensure that each wire is properly connected and wire insulation is not accidentally pinched into electrical terminals.

NOTICE: *Be sure to properly connect an external 24 Vdc power source to the terminal block TB1. Refer to **Table 31** for details. Improper wiring practices could damage the 24 V Control Power Supply Unit due to incorrect terminal connections.*

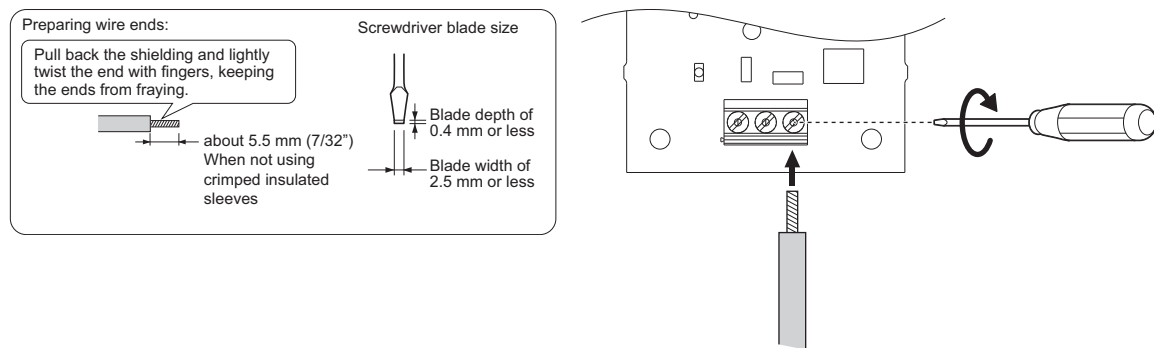


Figure 43 Wire the Option Plug

WARNING! *Fire Hazard. Tighten terminal screws to the specified tightening torque. Loose electrical connections could result in death or serious injury by fire due to overheating. Tightening screws beyond the specified tightening torque may cause erroneous operation, damage the terminal block, or cause a fire.*

NOTICE: *Heat shrink tubing or electrical tape may be required to ensure that cable shielding does not contact other wiring. Insufficient insulation may cause a short circuit and damage the drive.*

Tools Required for Installation

A straight-edge screwdriver (blade depth: 0.4 mm, width: 2.5 mm) is required to install the unit and wire the option terminal block.

Note: Tools required to prepare option cables for wiring are not listed in this manual.

Power Supply Terminal Block TB1 Functions

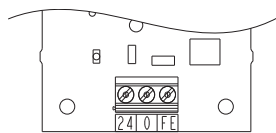


Figure 44 Power Supply Terminal Block TB1

Table 27 Power Supply Terminal Block TB1 Functions

Terminal	Function
24	+24 Vdc Input
0	0 V
FE	Ground

Wire Gauges and Tightening Torques

Table 28 Wire Gauges and Tightening Torques

Terminal Number	Screw Size	Tightening Torque N·m (in·lb)	Bare Cable		Crimp Terminals		Wire Type
			Recomm. Gauges mm ² (AWG)	Applicable Gauges mm ² (AWG)	Recomm. Gauges mm ² (AWG)	Applicable Gauges mm ² (AWG)	
24, 0, FE	M2	0.22 to 0.25 (1.95 to 2.21)	0.75 (18 AWG)	Standard wire: 0.25 to 1.0 (24 to 17 AWG) Single line: 0.25 to 1.5 (24 to 16 AWG)	0.5 (20 AWG)	0.25 to 0.5 (24 to 20 AWG)	Shielded cable, etc.

Ferrule-Type Wire Terminations

Crimp a ferrule to signal wiring to improve wiring simplicity and reliability. Use CRIMPFOX6, a crimping tool manufactured by PHOENIX CONTACT.

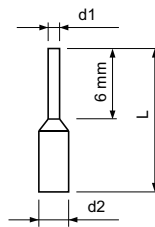


Figure 45 Ferrule Dimensions

Table 29 Ferrule Terminal Types and Sizes

Size mm ² (AWG)	Type	L (mm)	d1 (mm)	d2 (mm)	Manufacturer
0.25 (24)	AI 0.25-6YE AI 0.25-6BU	10.5	0.8	2.0	PHOENIX CONTACT
0.34 (22)	AI 0.34-6TQ	10.5	0.8	2.0	
0.5 (20)	AI 0.5-6WH	12	1.1	2.5	

Power Supply and the Control Circuit

Table 30 outlines the various conditions under which the option provides power to the control circuit.

Table 30 Power Supply and Control Circuit

Drive Main Circuit Input Power Supply	Power from 24 V Control Power Supply Unit	Control Circuit Operation in Drive	Drive Operation
ON	ON	Operating	Possible
ON	OFF		Possible
OFF	ON		Not possible
OFF	OFF	Stopping	Not possible

UL and CE Compliance

External Power Supply

Use a Class 2 power supply as defined by UL standards for the customer-supplied power supply connection to the 24 V Control Power Supply Unit.

■ **24 V Control Power Supply Unit Specifications**

Table 31 24 V Control Power Supply Unit Specifications

Item	Specifications
Input Operating Voltage	24 Vdc ± 20% (19.2 V to 28.8 V)
Input Current	1.9 A
Consumption Power	38 W
Compliance	UL <1>, CE

<1> Use a Class 2 power supply with a capacity of 24 V to comply with UL standards.

3 Electrical Installation

◆ Wiring Checklist

<input checked="" type="checkbox"/>	No.	Item	Page
Drive, peripherals, option cards			
<input type="checkbox"/>	1	Check drive model number to ensure receipt of correct model.	15
<input type="checkbox"/>	2	Make sure you have the correct peripheral devices.	–
<input type="checkbox"/>	3	Check the option card model number.	–
Installation area and physical setup			
<input type="checkbox"/>	4	Ensure that the area surrounding the drive complies with specifications.	18
Power supply voltage, output voltage			
<input type="checkbox"/>	5	The voltage from the power supply should be within the input voltage specification range of the drive.	–
<input type="checkbox"/>	6	The voltage rating for the motor should match the drive output specifications.	15
<input type="checkbox"/>	7	Verify that the drive is properly sized to run the motor.	15
<input type="checkbox"/>	8	Power supply voltage of models CIMR-U□4□0477 to 4□0930 should not exceed 480 V when connecting with recommended EMC filters.	27 93
Main circuit wiring			
<input type="checkbox"/>	9	Confirm proper branch circuit protection as specified by national and local codes.	24
<input type="checkbox"/>	10	Properly wire the power supply to drive terminals R/L1, S/L2, and T/L3.	29
<input type="checkbox"/>	11	Properly wire the drive and motor together. The motor lines and drive output terminals U/T1, V/T2, and W/T3 should match in order to produce the desired phase order. If the phase order is incorrect, the drive will rotate in the opposite direction.	40
<input type="checkbox"/>	12	Use 600 Vac vinyl-sheathed wire for the power supply and motor lines. Wire gauge recommendations based on using 75°C, 600 Vac vinyl-sheathed wire.	32
<input type="checkbox"/>	13	Use the correct wire gauges for the main circuit. <i>Refer to Main Circuit Wire Gauges and Tightening Torque on page 32.</i> <ul style="list-style-type: none"> When using comparatively long motor cable, calculate the amount of voltage drop. <div style="border: 1px solid black; padding: 5px; width: fit-content; margin: 5px 0;"> $\text{Motor rated voltage (V)} \times 0.02 \geq \sqrt{3} \times \text{wire resistance } (\Omega/\text{km}) \times \text{cable length (m)} \times \text{motor rated current (A)} \times 10^{-3}$ </div> If the cable between the drive and motor exceeds 50 m, adjust the carrier frequency set to C6-02 accordingly. 	32 32 –
<input type="checkbox"/>	14	Properly ground the drive.	40
<input type="checkbox"/>	15	Tightly fasten all terminal screws (control circuit terminals, grounding terminals). <i>Refer to Main Circuit Wire Gauges and Tightening Torque on page 32.</i>	32
<input type="checkbox"/>	16	Set up overload protection circuits when running multiple motors from a single drive. <div style="text-align: center; margin: 10px 0;"> </div> <p>Note: Close MC1 through MCn before operating the drive (MC1 through MCn cannot be switched off during run).</p>	–
<input type="checkbox"/>	17	Verify that ground wiring for models 2E□□□□/2W□□□□/4E□□□□/4W□□□□ is correct before turning on the EMC filter switch.	50
<input type="checkbox"/>	18	Verify phase advancing capacitors, input noise filters, or ground fault circuit interrupters are NOT installed on the output side of the drive.	–

3 Electrical Installation

<input checked="" type="checkbox"/>	No.	Item	Page
<input type="checkbox"/>	19	Properly wire the power lines to terminals X, Y, and Z of models CIMR-U□4□0720 to 4□0930, and terminals X, Y, and Z of the harmonic filter module.	30
<input type="checkbox"/>	20	Properly wire the power lines to terminals X1, Y1, and Z1 of models CIMR-U□4□0720 to 4□0930, and terminals X1, Y1, and Z1 of the harmonic filter module.	
<input type="checkbox"/>	21	Properly wire the power lines to terminals p2 and n2 of models CIMR-U□4□0720 to 4□0930, and terminals p2 and n2 of the harmonic filter module.	
<input type="checkbox"/>	22	The cable between CIMR-U□4□0720 to 4□0930 and harmonic filter module should not exceed 5 m.	
<input type="checkbox"/>	23	The resistance value between the terminals R/L1, S/L2, and T/L3 of the harmonic filter module should exceed 1000 Ω when connected to models CIMR-U□4□0720 to 4□0930. If the resistance value does not exceed 1000 Ω, check for main circuit wiring mistakes between the harmonic filter module and models CIMR-U□4□0720 to 4□0930.	
<input type="checkbox"/>	24	Systems should be interlocked to shut off power to the drive if the drive experiences a fault for models CIMR-U□4□0477 to 4□0930.	-
Control circuit wiring			
<input type="checkbox"/>	25	Use twisted-pair line for all drive control circuit wiring.	44
<input type="checkbox"/>	26	Ground the shields of shielded wiring to the GND ⊕ terminal.	44
<input type="checkbox"/>	27	If using a 3-wire sequence, properly set parameters for multi-function contact input terminals S1 through S8, and properly wire control circuits.	-
<input type="checkbox"/>	28	Properly wire any option cards.	43
<input type="checkbox"/>	29	Check for any other wiring mistakes. Only use a multimeter to check wiring.	-
<input type="checkbox"/>	30	Properly fasten the control circuit terminal screws in the drive. <i>Refer to Main Circuit Wire Gauges and Tightening Torque on page 32.</i>	32
<input type="checkbox"/>	31	Pick up all wire clippings.	-
<input type="checkbox"/>	32	Ensure that no frayed wires on the terminal block are touching other terminals or connections.	-
<input type="checkbox"/>	33	Properly separate control circuit wiring and main circuit wiring.	-
<input type="checkbox"/>	34	Analog signal line wiring should not exceed 50 m.	-
<input type="checkbox"/>	35	Safe Disable input wiring should not exceed 30 m.	-
<input type="checkbox"/>	36	Verify the logic of Safety Monitor Output Signal (DM+, DM-).	122
<input type="checkbox"/>	37	Disconnect the internal EMC filter by moving the SW screw to the OFF position for floating, impedance grounded, or asymmetrically grounded networks.	50
<input type="checkbox"/>	38	Properly wire the control signal lines to terminal CN500 of models CIMR-U□4□0720 to 4□0930, and terminal CN500 of the harmonic filter module.	27
<input type="checkbox"/>	39	The cable between CIMR-U□4□0720 to 4□0930 and harmonic filter module should not exceed 5 m.	45

4 Start-Up Programming & Operation

4 Start-Up Programming & Operation

◆ Using the Digital Operator

Use the digital operator to enter run and stop commands, display data, edit parameters, as well as display fault and alarm information.

■ Keys and Displays

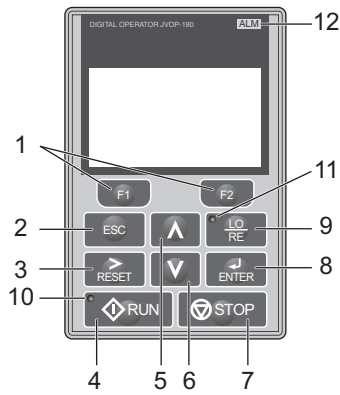


Figure 46 Keys and Displays on the Digital Operator

No.	Display	Name	Function
1		Function Key (F1, F2)	The functions assigned to F1 and F2 vary depending on the menu that is currently displayed. The name of each function appears in the lower half of the display window.
2		ESC Key	<ul style="list-style-type: none"> Returns to the previous display. Moves the cursor one space to the left. Pressing and holding this button will return to the Frequency Reference display.
3		RESET Key	<ul style="list-style-type: none"> Moves the cursor to the right. Resets the drive to clear a fault situation.
4		RUN Key	Starts the drive in the LOCAL mode. The Run LED <ul style="list-style-type: none"> is on, when the drive is operating the motor. flashes during deceleration to stop or when the frequency reference is 0. flashes quickly the drive is disabled by a DI, the drive was stopped using a fast stop DI or a run command was active during power up.
5		Up Arrow Key	Scrolls up to display the next item, selects parameter numbers and increments setting values.
6		Down Arrow Key	Scrolls down to display the previous item, selects parameter numbers and decrements setting values.
7		STOP Key <->	Stops drive operation.
8		ENTER Key	<ul style="list-style-type: none"> Enters parameter values and settings. Selects a menu item to move between displays.
9		LO/RE Selection Key <->	Switches drive control between the operator and frequency setting (LOCAL) and the control circuit terminals and frequency setting (REMOTE). The LED is on when the drive is in the LOCAL mode (operation from keypad).
10		RUN Light	Lit while the drive is operating the motor. Refer to Technical Manual for details.
11		LO/RE Light	Lit while the operator is selected to run the drive (LOCAL mode). Refer to Technical Manual for details.
12		ALM LED Light	Refer to Technical Manual for details.

<1> The STOP key has highest priority. Pressing the STOP key will always cause the drive to stop the motor, even if a Run command is active at any external Run command source. To disable the STOP key priority, set parameter o2-06 to 0.

<2> The LO/RE key can only switch between LOCAL and REMOTE when the drive is stopped. To disable the LO/RE key to prohibit switching between LOCAL and REMOTE, set parameter o2-01 to 0.

■ LCD Display

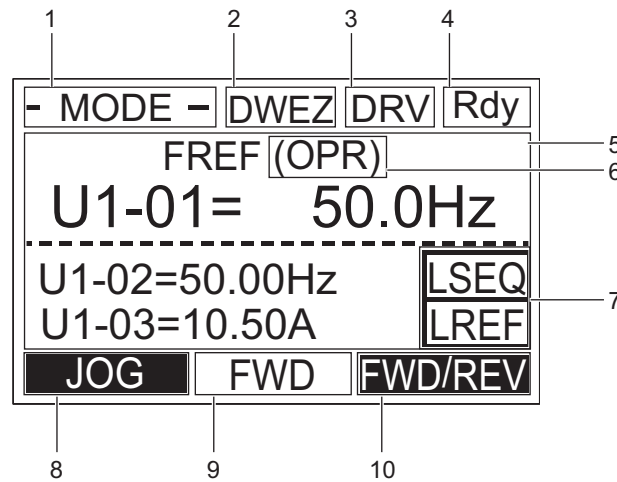


Figure 47 LCD Display

Table 32 Display and Contents

No.	Name	Display	Content
1	Operation Mode Menus	MODE	Displayed when in Mode Selection.
		MONITR	Displayed when in Monitor Mode.
		VERIFY	Indicates the Verify Menu.
		PRMSET	Displayed when in Parameter Setting Mode.
		A.TUNE	Displayed during Auto-Tuning.
		SETUP	Displayed when in Setup Mode.
2	DriveWorksEZ Function Selection	DWEZ	Displayed when DriveWorksEZ is being used.
3	Mode Display Area	DRV	Displayed when in Drive Mode.
		PRG	Displayed when in Programming Mode.
4	Ready	Rdy	Indicates the drive is ready to run.
5	Data Display	-	Displays specific data and operation data.
6	Frequency Reference Assignment <->	OPR	Displayed when the frequency reference is assigned to the LCD Operator.
		AI	Displayed when the frequency reference is assigned to the drives Analog Input.
		COM	Displayed when the frequency reference is assigned to the drives MEMOBUS/Modbus Communication Inputs.
		OP	Displayed when the frequency reference is assigned to a drive Option Unit.
		RP	Displayed when the frequency reference is assigned to the drives Pulse Train Input.
7	LO/RE Display <->	RSEQ	Displayed when the reference is supplied from a remote source.
		LSEQ	Displayed when the reference is supplied from the operator keypad.
		RREF	Displayed when the frequency reference is supplied from a remote source.
		LREF	Displayed when the frequency reference is supplied from the operator keypad.
8	Function Key 1 (F1)	JOG	Pressing runs the motor at the Jog frequency.
		HELP	Pressing displays the Help menu.
		←	Pressing scrolls the cursor to the left.
		HOME	Pressing returns to the top menu (Frequency Reference).
		ESC	Pressing returns to the previous display.
9	FWD/REV	FWD	Indicates forward motor operation.
		REV	Indicates reverse motor operation.

Start-Up Programming & Operation

4 Start-Up Programming & Operation

No.	Name	Display	Content
10	Function Key 2 (F2)	FWD/REV	Pressing switches between forward and reverse.
		DATA	Pressing scrolls to the next display.
		→	Pressing scrolls the cursor to the right.
		RESET	Pressing resets the existing drive fault or error.

<1> Displayed when in Frequency Reference Mode.

<2> Displayed when in Frequency Reference Mode and Monitor Mode.

■ Menu Structure for Digital Operator

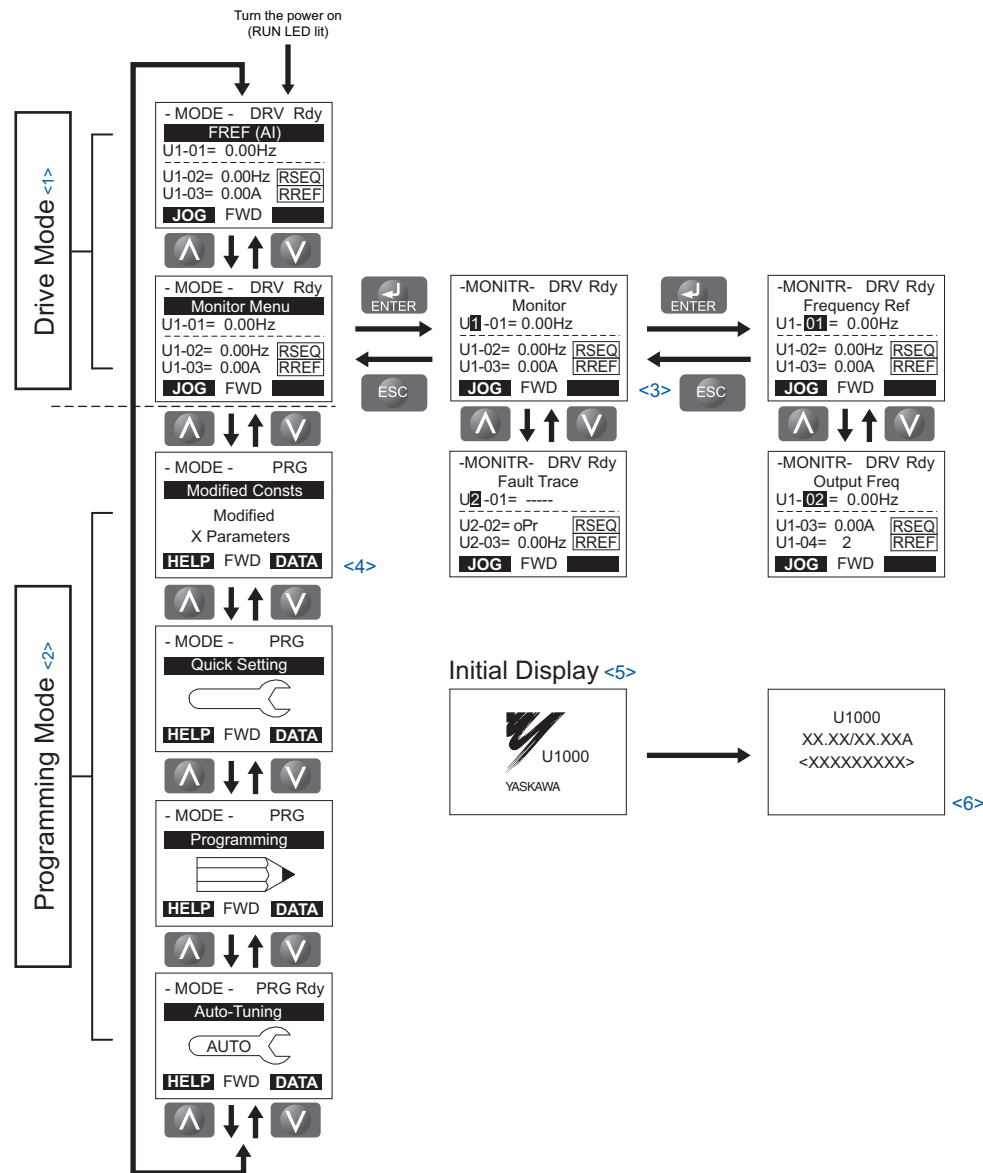


Figure 48 Digital Operator Menu and Screen Structure

<1> Pressing will start the motor.

<2> Drive cannot operate the motor.

<3> Flashing characters are shown as **■**.

<4> X characters are shown in this manual. The LCD Operator will display the actual setting values.

<5> The Frequency Reference appears after the initial display which shows the product name.

<6> The information that appears on the display will vary depending on the drive.

■ Flowchart A: Basic Start-up and Motor Tuning

Flowchart A describes a basic start-up sequence. This sequence varies slightly depending on the application. Use drive default parameter settings in simple applications that do not require high precision.

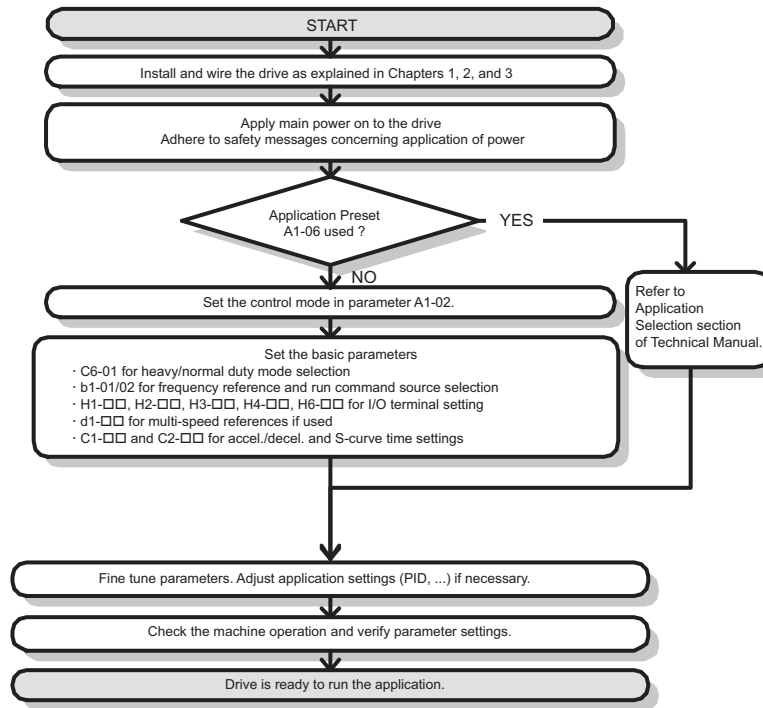


Figure 49 Basic Start-up

Note: When the motor cable length has changed for more than 50 m after Auto-Tuning has been performed (e.g., after the drive has been set up and then later installed in a different location), execute Stationary Auto-Tuning for resistance between motor lines once the drive is installed in its final installation location.

◆ Powering Up the Drive

■ Powering Up the Drive and Operation Status Display

Powering Up the Drive

Review the following checklist before turning the power on.

Item to Check	Description
Power supply voltage	Ensure the power supply voltage is correct: 200 V class: 3-phase 200 to 240 Vac 50/60 Hz 400 V class: CIMR-U□4A□□□□, CIMR-U□4P□□□□: 3-phase 380 to 500 Vac 50/60 Hz 400 V class: CIMR-U□4E□□□□, CIMR-U□4W□□□□: 3-phase 380 to 480 Vac 50/60 Hz
	Properly wire the power supply input terminals (R/L1, S/L2, T/L3).
	Check for proper grounding of drive and motor. Use a power supply with a capacity that is equal to or greater than the unit capacity.
Drive output terminals and motor terminals	Properly wire drive output terminals U/T1, V/T2, and W/T3 with motor terminals U, V, and W.
Control circuit terminals	Check control circuit terminal connections.
Drive control terminal status	Open all control circuit terminals (off).
Status of the load and connected machinery	Decouple the motor from the load.

Start-Up Programming & Operation

4 Start-Up Programming & Operation

◆ Basic Drive Setup Adjustments

This section explains the basic settings required for initial drive operation. Checking these basic parameter settings during start-up will help to ensure a successful drive start-up. If more information is required for parameters not listed in this section, Refer to *Parameter List on page 95* as required for a complete listing of drive parameters.

■ A1-02: Control Method Selection

Selects the Control Method (also referred to as the “control mode”) the drive uses to operate the motor. If the drive is set up to run two motors, then A1-02 determines the control mode for motor 1.

Note: When changing control modes, all parameter settings depending upon the setting of A1-02 will be reset to the default.

No.	Parameter Name	Setting Range	Default
A1-02	Control Method Selection	0, 1, 2, 3, 5, 6, 7	0

Control Modes for Induction Motors (IM)

Setting 0: V/f Control for Induction Motors

V/f Control is for simple speed control and multiple motor applications with low demands to dynamic response or speed accuracy. This control mode should be used when the motor parameters are unknown and Auto-Tuning cannot be performed. The speed control range is 1:40.

Setting 1: V/f Control with PG Speed Feedback

For general-purpose applications that do not require high dynamic response but high speed accuracy. This mode should be used if the motor parameters are unknown and Auto-Tuning cannot be performed. The speed control range is 1:40.

Setting 2: Open Loop Vector Control

For general, variable-speed applications with a speed control range of 1:120 that require precise speed control, quick torque response, and high torque at low speed without using a speed feedback signal from the motor.

Setting 3: Closed Loop Vector Control

For general, variable-speed applications that required precise speed control down to zero speed, fast torque response, or precise torque control. A speed feedback signal from the motor is required. The speed control range is up to 1:1500.

Control Modes for Permanent Magnet Motors (SPM or IPM)

Setting 5: Open Loop Vector Control for PM

For general, variable-speed applications with low demands to dynamic response or speed accuracy. The drive can control an SPM or IPM motor with a speed range of 1:20.

Setting 6: Advanced Open Loop Vector Control for PM

For general, variable-speed applications that require precise speed control and torque limit. The drive can control an IPM motor with a speed range of 1:20. Set High Frequency Injection parameter n8-57 to 1 to achieve a speed control range as high as 1:100.

Setting 7: Closed Loop Vector Control for PM

This mode can be used for high precision control of a PM motor in constant torque or variable torque applications. The speed control range reaches 1:1500. A speed feedback signal is required.

■ A1-03: Initialize Parameters

Resets parameters back to the original default values. After initialization, the setting for A1-03 automatically returns to 0.

No.	Parameter Name	Setting Range	Default
A1-03	Initialize Parameters	0, 1110, 2220, 3330, 5550	0

Setting 1110: User Initialize

Drive parameters are reset to values selected by the user as User Settings. User Settings are stored when parameter o2-03 is set to “1: Set defaults”.

Note: A “user-initialization” resets all parameters to a user-defined set of default values that were previously saved to the drive. To clear the user-defined default values, set parameter o2-03 to 2.

4 Start-Up Programming & Operation

Setting 2220: 2-Wire Initialization

Resets parameters except following parameters back to their original default settings with digital inputs S1 and S2 configured as Forward run and Reverse run, respectively: A1-00, A1-02, E1-03, E5-01 to E5-07, E5-09, E5-24, F6-□□/ F7-□□, L8-35, o2-04.

Setting 3330: 3-Wire Initialization

The drive parameters are returned to factory default values with digital inputs S1, S2, and S5 configured as Run, Stop, and Forward/Reverse respectively. Also refer to digital input functions.

Setting 5550: oPE04 Reset

If parameters on a certain drive have been edited and then a different terminal block is installed with different settings saved in its built-in memory, an oPE04 error will appear on the display. To use the parameter settings saved to the terminal block memory, set A1-03 to 5550.

■ b1-01: Frequency Reference Selection 1

Use parameter b1-01 to select the frequency reference source 1 for the REMOTE mode.

- Note:**
1. If a Run command is input to the drive but the frequency reference entered is 0 or below the minimum frequency, the RUN indicator LED on the digital operator will light. However, the RUN indicator LED will light in zero speed control when A1-02 is set to 3, 5, or 6.
 2. Press the LO/RE key to set the drive to LOCAL and use the operator keypad to enter the frequency reference.

No.	Parameter Name	Setting Range	Default
b1-01	Frequency Reference Selection 1	0 to 4	1

Setting 0: Operator keypad

Using this setting, the frequency reference can be input by using the operator keypad.

Setting 1: Terminals (analog input terminals)

Using this setting, an analog frequency reference can be entered as a voltage or current signal from terminals A1, A2, or A3.

Switching between Main/Auxiliary Frequency References

The frequency reference input can be switched between the analog terminals A1, A2, and A3 using multi-speed inputs. Refer to *Multi-Step Speed Selection on page 72* for details on using this function.

Setting 2: MEMOBUS/Modbus Communications

This setting requires entering the frequency reference via the RS-485/422 serial communications port (control terminals R+, R-, S+, and S-).

Setting 3: Option card

This setting requires entering the frequency reference via an option board plugged into connector CN5-A on the drive control board. Consult the option board manual for instructions on integrating the drive with the communication system.

- Note:** If the frequency reference source is set for an option PCB (b1-01 = 3), but an option board is not installed, an oPE05 operation error will be displayed on the digital operator and the drive will not run.

Setting 4: Pulse Train Input

When b1-01 is set to 4, the frequency reference must be provided by a pulse train signal to terminal RP. Follow the directions below to make sure the pulse train signal is working properly.

Verifying Pulse Train is Working Properly

- Make sure that b1-01 is set to 4 and H6-01 is set to 0.
- Set the pulse input scaling H6-02 to the pulse train frequency value that equals 100% of the frequency reference.
- Enter a pulse train signal to terminal RP and check if the correct frequency reference is displayed.

4 Start-Up Programming & Operation

■ b1-02: Run Command Selection 1

Parameter b1-02 determines the Run command source 1 in the REMOTE mode.

No.	Parameter Name	Setting Range	Default
b1-02	Run Command Selection 1	0 to 3	1

Setting 0: Operator

This setting requires entering the Run command via the digital operator RUN key and also illuminates the LO/RE indicator on the digital operator.

Setting 1: Control Circuit Terminal

This setting requires that the Run and Stop commands are entered from the digital input terminals. The following sequences can be used:

- 2-wire sequence 1:
Setting A1-03 to 2220 initializes the drive and presets terminals S1 and S2 to FWD/Stop and REV/Stop. These are the default settings of the drive.
- 2-wire sequence 2:
Two inputs (Start/Stop-FWD/REV).
- 3-wire sequence:
Setting A1-03 to 3330 initializes the drive and presets terminals S1, S2, and S5 to Start, Stop, and FWD/REV.

Setting 2: MEMOBUS/Modbus Communications

To issue a Run command via serial communications, set b1-02 to 2 and connect the RS-485/RS-422 serial communication cable to control terminals R+, R-, S+, and S- on the removable terminal block.

Setting 3: Option Card

To issue the Run command via the communication option board, set b1-02 to 3 and plug a communication option board into the CN5-A port on the control PCB. Refer to the manual supplied with the option board for instructions on integrating the drive into the communication system.

Note: If b1-02 is set to 3, but an option board is not installed in CN5-A, an oPE05 operation error will be displayed on the digital operator and the drive will not run.

■ b1-03: Stopping Method Selection

Select how the drive stops the motor when the Run command is removed or when a Stop command is entered.

No.	Parameter Name	Setting Range	Default
b1-03	Stopping Method Selection	0 to 3, 9 <1>	0

<1> The setting range is 0, 1, or 3 in CLV, OLV/PM, AOLV/PM, or CLV/PM.

Setting 0: Ramp to stop

When the Run command is removed, the drive will decelerate the motor to stop. The deceleration rate is determined by the active deceleration time. The default deceleration time is set to parameter C1-02.

When the output frequency falls below the level set in parameter b2-01, the drive will start DC injection or Zero Speed Control depending on the selected control mode.

V/f, V/f w/PG and OLV (A1-02 = 0, 1, 2)

For these control modes, parameter b2-01 sets the starting frequency for DC Injection Braking at stop. Once the output frequency falls below the setting of b2-01, DC Injection Braking is enabled for the time set in parameter b2-04.

4 Start-Up Programming & Operation

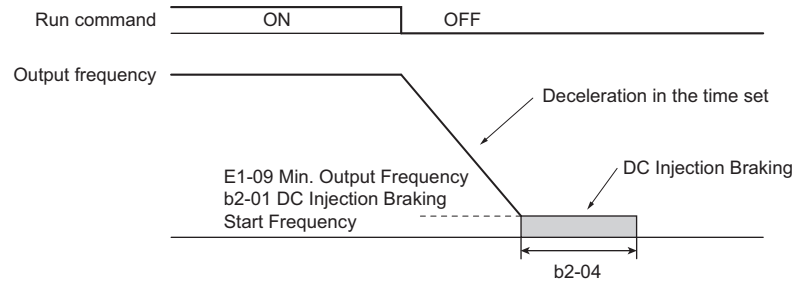


Figure 50 DC Injection Braking at Stop for V/f, V/f w/PG and OLV

Note: If b2-01 is set to a smaller value than parameter E1-09 (minimum output frequency), then DC Injection Braking will begin as soon as the frequency falls to the value set to E1-09.

OLV/PM and AOLV/PM (A1-02 = 5, 6)

When the output frequency falls below the setting of b2-01, drive output is shut down, and DC Injection Braking is performed for the time set in b2-04.

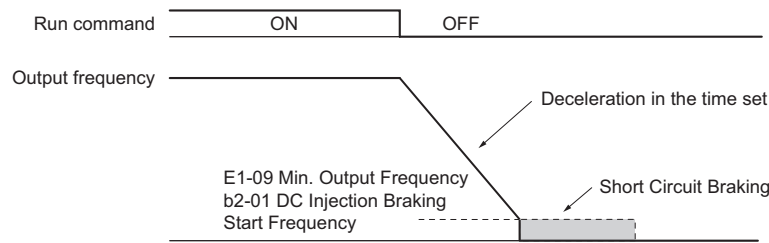


Figure 51 Coast to Stop (OLV/PM, AOLV/PM)

Note: If b2-01 is set to a smaller value than parameter E1-09 (minimum output frequency), then DC Injection Braking will begin as soon as the frequency falls to the value set to E1-09.
The drive will not perform short-circuit braking when b2-01 = E1-09 = 0 Hz.

CLV and CLV/PM (A1-02 = 3, 7)

For these control modes, parameter b2-01 sets the starting frequency for Zero Speed Control (not position lock) at stop. Once the output frequency falls below the setting of b2-01, Zero Speed Control is enabled for the time set in parameter b2-04.

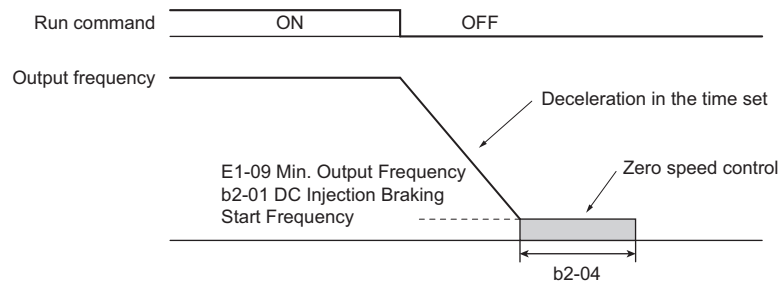


Figure 52 Zero Speed Control at Stop in CLV and CLV/PM

Note: If b2-01 is set to lower than the minimum output frequency (E1-09), then Zero Speed Control begins at the frequency set to E1-09.

Setting 1: Coast to stop

When the Run command is removed, the drive will shut off its output and the motor will coast (uncontrolled deceleration) to stop. The stopping time is determined by the inertia and the friction in the driven system.

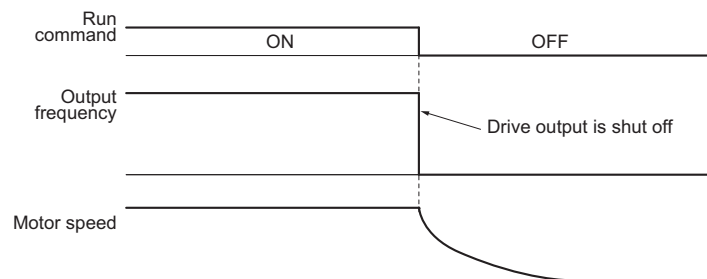


Figure 53 Coast to Stop

4 Start-Up Programming & Operation

Note: After a stop is initiated, any subsequent Run command entered will be ignored until the momentary power loss minimum baseblock time (L2-03) has expired. Do not enter Run command until it has come to a complete stop. To start the motor back up before it has stopped completely, use DC Injection at start.

Setting 2: DC Injection Braking to stop

When the Run command is removed, the drive will enter baseblock (turn off its output) for the momentary power loss minimum baseblock time (L2-03). Once the minimum baseblock time has expired, the drive will brake the motor by injecting DC current into the motor windings. The stopping time is significantly faster than when compared with simply coasting to stop. The level of current used for DC Injection Braking is set by parameter b2-02 (default = 50%).

Note: This function is not available in Closed Loop Vector Control (A1-02 = 3) and the control modes for PM motors (A1-02 = 5, 6, 7).

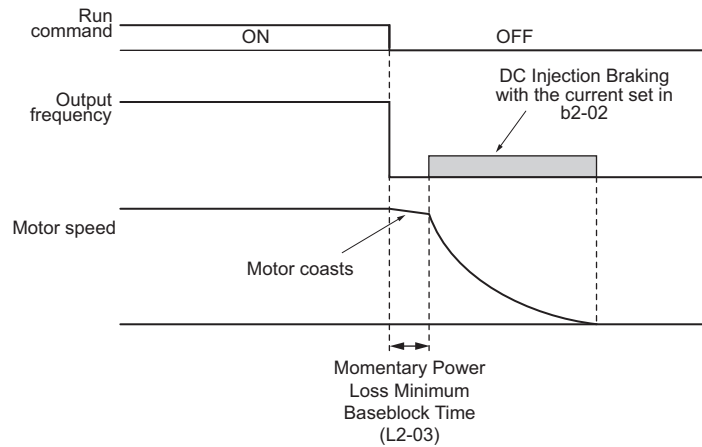


Figure 54 DC Injection Braking to Stop

The time for DC Injection Braking is determined by the value set to b2-04 and by the output frequency at the time the Run command is removed. It can be calculated by:

$$\text{DC Injection brake time} = \frac{(b2-04) \times 10 \times \text{Output frequency}}{\text{Max. output frequency (E1-04)}}$$

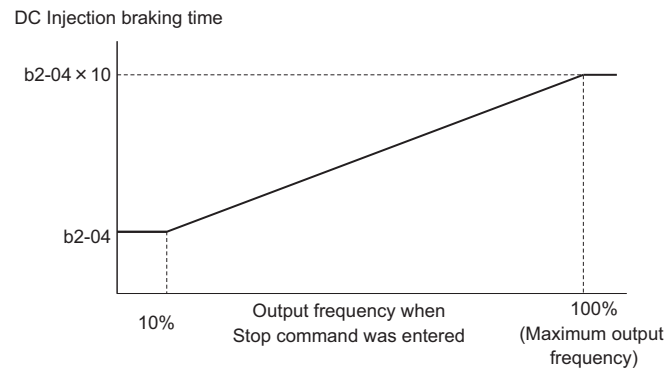


Figure 55 DC Injection Braking Time Depending on Output Frequency

Note: If an overcurrent (oC) fault occurs during DC Injection Braking to stop, lengthen the momentary power loss minimum baseblock time (L2-03) until the fault no longer occurs.

Setting 3: Coast to Stop with Timer

When the Run command is removed, the drive will turn off its output and the motor will coast to stop. If a Run command is input before the time t (value of C1-02) has expired, the drive will not start. A Run command activated during time t must be cycled after t has expired in order to start the drive.

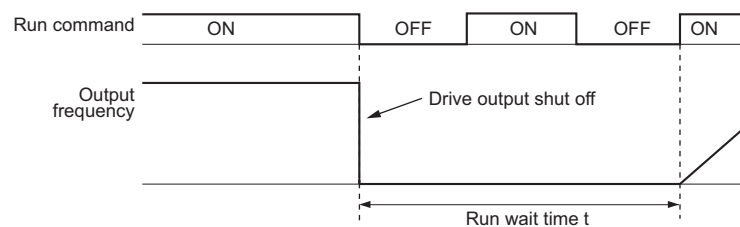


Figure 56 Coast to Stop with Timer

4 Start-Up Programming & Operation

The wait time t is determined by the output frequency when the Run command is removed and by the active deceleration time.

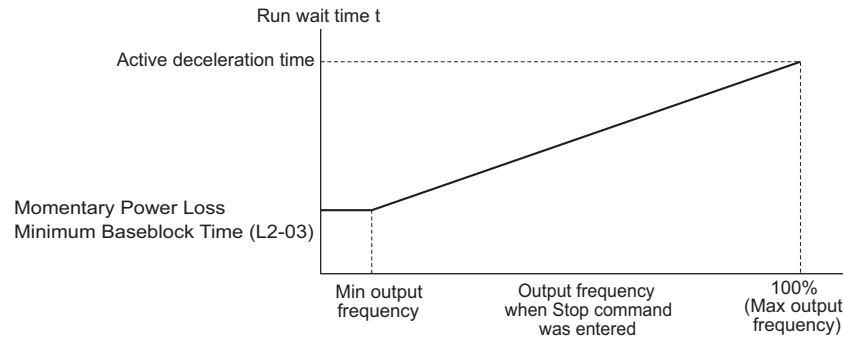


Figure 57 Run Wait Time Depending on Output Frequency

Setting 9: Simple Positioning Stop

This method of stopping the motor always decelerates the same distance to stop as shown in *Figure 58*. The stopping distance $S1$ is calculated using the maximum output frequency setting E1-04 and the selected deceleration time. If the drive is stopped from a frequency lower than the maximum speed it keeps the current speed. When the distance traveled becomes equal to $S1 - S2$, the drive decelerates to stop using the current deceleration time. The stopping accuracy can be adjusted using the positioning gain set in parameter d4-12.

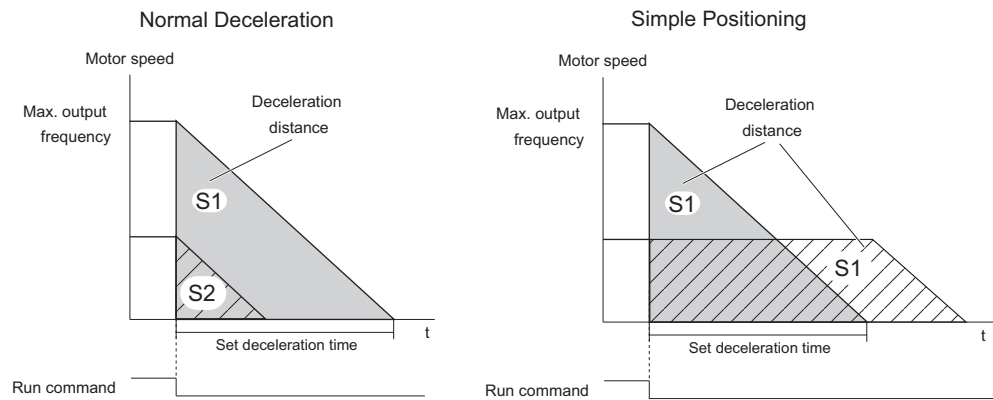


Figure 58 Simple Positioning Deceleration

Precautions when using Simple Positioning:

- Changing the deceleration time during the deceleration will result in inaccurate positioning as the calculation considers the deceleration time that was active only when the Run command was removed.
- The Dwell function must be deactivated (b6-03 and b6-04 = 0).
- Stall Prevention during stop must be deactivated (L3-04 = 0). For regenerative loads a braking option might be necessary.
- High Slip Braking must be deactivated (H1-□□ must be different from 68).
- The S-curves at deceleration start and deceleration end must be inactive (C2-03/C2-04 = 0).

■ b1-04: Reverse Operation Selection

For some applications, reverse motor rotation is not appropriate and may cause problems (e.g., air handling units, pumps, etc.).

Note: Setting parameter b1-04 to 1 instructs the drive to ignore any Reverse run commands.

No.	Parameter Name	Setting Range	Default
b1-04	Reverse Operation Selection	0 or 1	0

Setting 0: Reverse operation enabled

Possible to operate the motor in both forward and reverse directions.

Setting 1: Reverse operation disabled

Drive disregards a Reverse run command or a negative frequency reference.

4 Start-Up Programming & Operation

■ C1-01 to C1-08: Accel, Decel Times 1 to 4

Four different sets of acceleration and deceleration times can be set in the drive. They can be selected by digital inputs, by the motor selection, or can be switched automatically. Acceleration time parameters always set the time to accelerate from 0 Hz to the maximum output frequency (E1-04). Deceleration time parameters always set the time to decelerate from maximum output frequency to 0 Hz. C1-01 and C1-02 are the default active accel/decel settings.

No.	Parameter Name	Setting Range	Default
C1-01	Acceleration Time 1	0.0 to 6000.0 s <1>	10.0 s
C1-02	Deceleration Time 1		
C1-03	Acceleration Time 2		
C1-04	Deceleration Time 2		
C1-05	Acceleration Time 3 (Motor 2 Accel Time 1)		
C1-06	Deceleration Time 3 (Motor 2 Decel Time 1)		
C1-07	Acceleration Time 4 (Motor 2 Accel Time 2)		
C1-08	Deceleration Time 4 (Motor 2 Decel Time 2)		

<1> The setting range for the acceleration and deceleration times is determined by the accel/decel time setting units in C1-10. For example, if the time is set in units of 0.01 s (C1-10 = 0), the setting range becomes 0.00 to 600.00 s.

Switching Acceleration Times by Digital Input

Accel/decel times 1 are active by default if no input is set. The accel/decel times 2, 3, and 4 can be activated by digital inputs (H1-□□ = 7 and 1A) as explained in [Table 33](#).

Table 33 Accel/Decel Time Selection by Digital Input

Accel/Decel Time Sel. 1 H1-□□ = 7	Accel/Decel Time Sel. 2 H1-□□ = 1A	Active Times	
		Acceleration	Deceleration
0	0	C1-01	C1-02
1	0	C1-03	C1-04
0	1	C1-05	C1-06
1	1	C1-07	C1-08

[Figure 59](#) shows an operation example for changing accel/decel. times. The example below requires that the stopping method be set for “Ramp to stop” (b1-03 = 0).

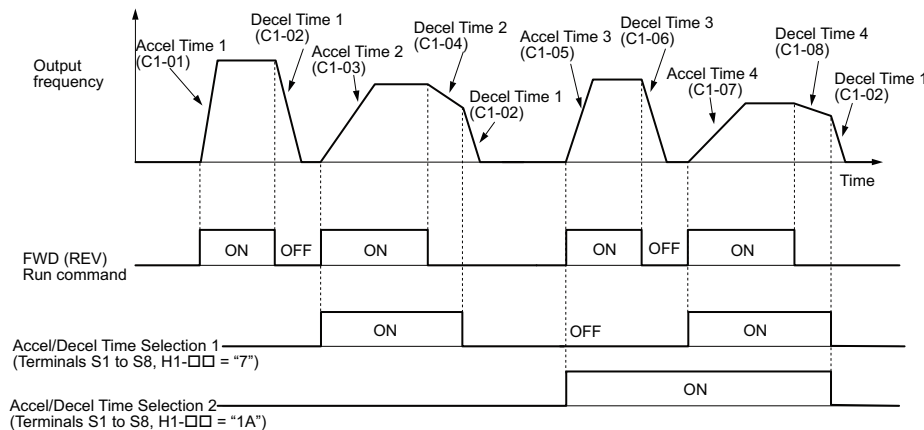


Figure 59 Timing Diagram of Accel/Decel Time Change

Switching Acceleration and Deceleration Times by Motor Selection

When switching between motor 1 and 2 using a digital input (H1-□□ = 16), parameters C1-01 to C1-04 become accel/decel time 1 and 2 for motor 1, while C1-05 to C1-08 become accel/decel time 1 and 2 for motor 2. Accel/decel times 1 and 2 can be switched for each motor using a digital inputs set to H1-□□ = 7 like shown in [Table 34](#).

- Note:**
1. The motor 2 selection function cannot be used when PM motor is used.
 2. The digital input setting “Accel/Decel time 2 selection” (H1-□□ = 1A) cannot be used together with motor 1/2 switching. Trying to do so triggers an oPE03 error, indicating a contradictory multifunction input settings.

4 Start-Up Programming & Operation

Table 34 Motor Switching and Accel/Decel Time Combinations

Accel/Decel Time 1 (H1-□□ = 7)	Motor 1 Selected (Terminal set to H1-□□ = 16 OFF)		Motor 2 Selected (Terminal set to H1-□□ = 16 ON)	
	Accel	Decel	Accel	Decel
Open	C1-01	C1-02	C1-05	C1-06
Closed	C1-03	C1-04	C1-07	C1-08

Switching Accel/Decel Times by a Frequency Level

The drive can switch between different acceleration and deceleration times automatically. The drive will switch from accel/decel time 4 in C1-07 and C1-08 to the default accel/decel time in C1-01 and C1-02 (C1-05 and C1-06 for motor 2) when the output frequency exceeds the frequency level set in parameter C1-11. When it falls below this level, the accel/decel times are switched back. *Figure 60* shows an operation example.

Note: Acceleration and deceleration times selected by digital inputs have priority over the automatic switching by the frequency level set to C1-11. For example, if accel/decel time 2 is selected, the drive will use this time only and not switch from accel/decel time 4 to the selected one.

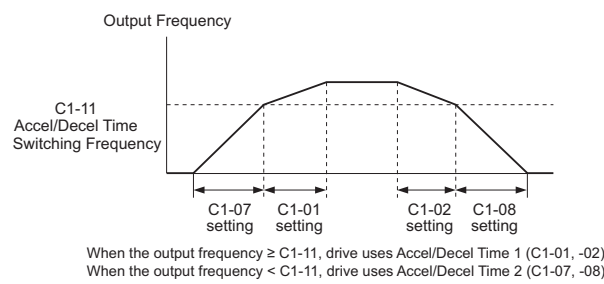


Figure 60 Accel/Decel Time Switching Frequency

■ C6-01: Drive Duty Mode Selection

The drive has two different “duty modes” to select from based on the load characteristics. The drive rated current, overload capacity, and maximum output frequency will change depending upon the duty mode selection. Use parameter C6-01 to select Heavy Duty (HD) or Normal Duty (ND) for the application. The default setting is ND. Refer to the U1000 Technical Manual for details.

No.	Parameter Name	Setting Range	Default
C6-01	Drive Duty Mode Selection	0 or 1	1 (ND)

Table 35 Differences between Heavy and Normal Duty

Characteristics	Heavy Duty Rating (HD)	Normal Duty Rating (ND)
C6-01	0	1
Performance		
Application	Use Heavy Duty Rating for applications requiring a high overload tolerance with constant load torque. Such applications include extruders and conveyors.	Use Normal Duty Rating for applications in which the torque requirements drop along with the speed. Examples include fans and pumps where a high overload tolerance is not required.
Over load capability (oL2)	150% of drive rated Heavy Duty current for 60 s	120% of drive rated Normal Duty current for 60 s
Stall Prevention during Acceleration (L3-02)	150%	120%
Stall Prevention during Run (L3-06)	150%	120%
Default Carrier Frequency	4 kHz <I>	4 kHz <I>

<I> The carrier frequency is 3 kHz for models CIMR-U□4□0477 to 4□0930.

Start-Up Programming & Operation

4 Start-Up Programming & Operation

Note: By changing the Duty Mode selection, the E2-□□ parameters are automatically set to appropriate values (E4-□□ for motor 2). Parameter settings determined by motor capacity are recalculated automatically when the Duty Mode selection is changed. This includes b8-04, L2-03, n5-02, C5-17, and C5-37.

■ C7-60: Output Voltage Limit Mode Selection

Sets the mode to limit the output voltage.

Set this parameter to 0 (Harmonic suppression priority mode) to give priority to harmonic suppression. The maximum output voltage is automatically limited to suppress harmonics.

Set this parameter to 1 (High output voltage mode) to give priority to the output voltage over harmonic suppression. The effectiveness of harmonic suppression will be reduced because the maximum output voltage will be used.

No.	Parameter Name	Setting Range	Default
C7-60	Output Voltage Limit Mode Selection	0, 1	1

Setting 0: Harmonic Suppression Priority Mode

Setting 1: High Output Voltage Mode

■ d1-01 to d1-17: Frequency Reference 1 to 16 and Jog Frequency Reference

Up to 17 preset frequency references (including the Jog reference) can be programmed in the drive. The drive lets the user switch between these frequency references during run by using the digital input terminals. The drive uses the acceleration and deceleration times that have been selected when switching between each frequency reference.

The Jog frequency must be selected by a separate digital input and overrides all other frequency references.

The multi-speed references 1, 2, and 3 can be provided by analog inputs.

No.	Parameter Name	Setting Range	Default
d1-01 to d1-16	Frequency Reference 1 to 16	0.00 to 400.00 Hz <1><2>	0.00 Hz <2>
d1-17	Jog Frequency Reference	0.00 to 400.00 Hz <1><2>	6.00 Hz <2>

<1> The upper limit is determined by the maximum output frequency (E1-04) and upper limit for the frequency reference (d2-01).

<2> Setting units are determined by parameter o1-03. The default is "Hz" (o1-03 = 0) in V/f, V/f w/PG, OLV, CLV, and OLV/PM control modes. The default for AOLV/PM and CLV/PM control modes expresses the frequency reference as a percentage (o1-03 = 1).

Multi-Step Speed Selection

To use several speed references for a multi-step speed sequence, set the H1-□□ parameters to 3, 4, 5, and 32. To assign the Jog reference to a digital input, set H1-□□ to 6.

Notes on using analog inputs as Multi-Step Speed 1, 2, and 3:

• Multi-Step Speed 1

When setting terminal A1's analog input to Multi-Step Speed 1, set b1-01 to 1, and when setting d1-01 (Frequency Reference 1) to Multi-Step Speed 1, set b1-01 to 0.

• Multi-Step Speed 2

When setting terminal A3's analog input to Multi-Step Speed 2, set H3-06 (Terminal A3 Function Selection) to 2 (Auxiliary frequency reference 1). When setting d1-02 (Frequency Reference 2) to Multi-Step Speed 2, set H3-06 to F (Through mode).

• Multi-Step Speed 3

When setting terminal A2's analog input to Multi-Step Speed 3, set H3-10 (Terminal A2 Function Selection) to 3 (Auxiliary frequency reference 2).

When inputting 0 to 10 V to terminal A2's analog input, set H3-09 to 0, and DIP switch S1 on the control circuit terminal board to V (voltage).

4 Start-Up Programming & Operation

The different speed references can be selected as shown in *Table 36*. *Figure 61* illustrates the multi-step speed selection.

Table 36 Multi-Step Speed Reference and Terminal Switch Combinations

Reference	Multi-Step Speed Reference 1 H1-□□ = 3	Multi-Step Speed Reference 2 H1-□□ = 4	Multi-Step Speed Reference 3 H1-□□ = 5	Multi-Step Speed Reference 4 H1-□□ = 32	Jog Reference Selection H1-□□ = 6
Frequency Reference 1 (set in b1-01)	OFF	OFF	OFF	OFF	OFF
Frequency Reference 2 (d1-02 or input terminal A1, A2, A3)	ON	OFF	OFF	OFF	OFF
Frequency Reference 3 (d1-03 or input terminal A1, A2, A3)	OFF	ON	OFF	OFF	OFF
Frequency Reference 4 (d1-04)	ON	ON	OFF	OFF	OFF
Frequency Reference 5 (d1-05)	OFF	OFF	ON	OFF	OFF
Frequency Reference 6 (d1-06)	ON	OFF	ON	OFF	OFF
Frequency Reference 7 (d1-07)	OFF	ON	ON	OFF	OFF
Frequency Reference 8 (d1-08)	ON	ON	ON	OFF	OFF
Frequency Reference 9 (d1-09)	OFF	OFF	OFF	ON	OFF
Frequency Reference 10 (d1-10)	ON	OFF	OFF	ON	OFF
Frequency Reference 11 (d1-11)	OFF	ON	OFF	ON	OFF
Frequency Reference 12 (d1-12)	ON	ON	OFF	ON	OFF
Frequency Reference 13 (d1-13)	OFF	OFF	ON	ON	OFF
Frequency Reference 14 (d1-14)	ON	OFF	ON	ON	OFF
Frequency Reference 15 (d1-15)	OFF	ON	ON	ON	OFF
Frequency Reference 16 (d1-16)	ON	ON	ON	ON	OFF
Jog Frequency Reference (d1-17) <1>	-	-	-	-	ON

<1> The Jog frequency overrides whatever frequency reference is being used.

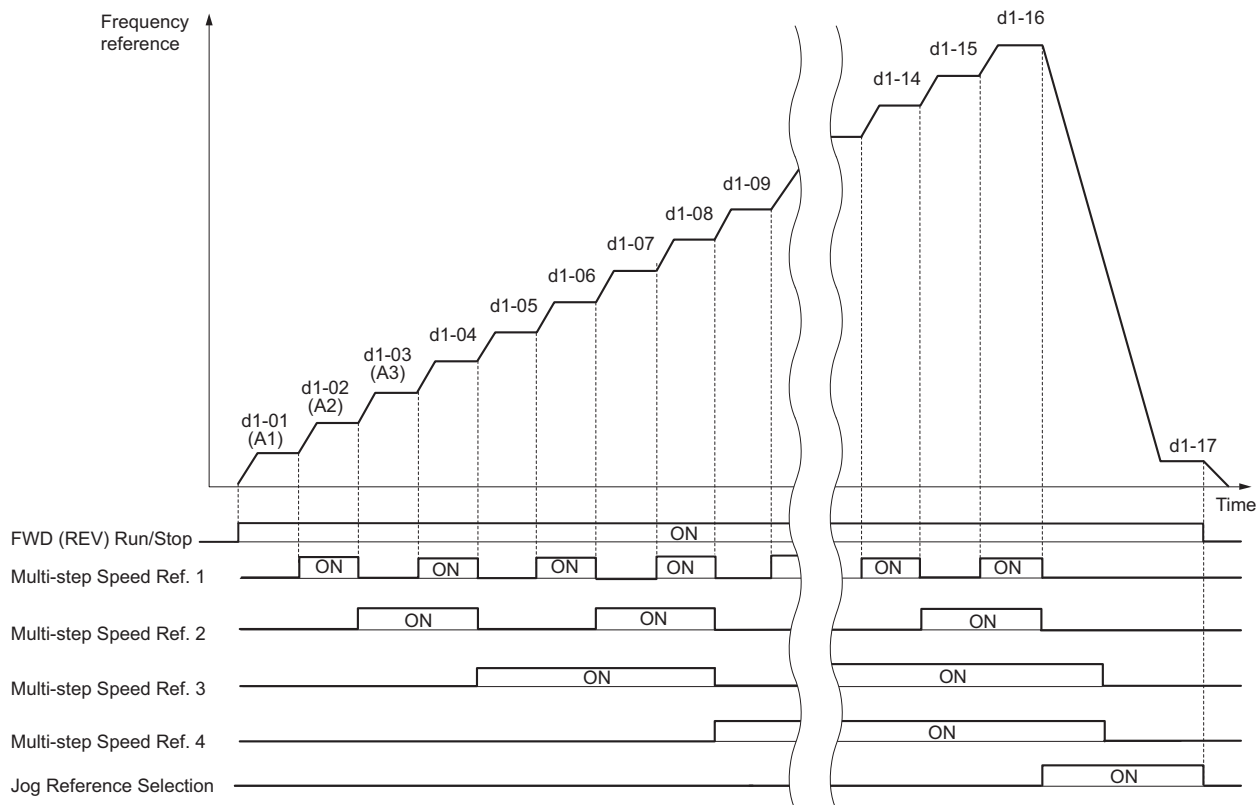


Figure 61 Preset Reference Timing Diagram

4 Start-Up Programming & Operation

■ d2-01: Frequency Reference Upper Limit

Sets the maximum frequency reference as a percentage of the maximum output frequency. This limit applies to all frequency references.

Even if the frequency reference is set to a higher value, the drive internal frequency reference will not exceed this value.

No.	Parameter Name	Setting Range	Default
d2-01	Frequency Reference Upper Limit	0.0 to 110.0%	100.0%

■ d2-02: Frequency Reference Lower Limit

Sets the minimum frequency reference as a percentage of the maximum output frequency. This limit applies to all frequency references.

If a lower reference than this value is entered, the drive will run at the limit set to d2-02. If the drive is started with a lower reference than d2-02, it will accelerate up to d2-02.

No.	Parameter Name	Setting Range	Default
d2-02	Frequency Reference Lower Limit	0.0 to 110.0%	0.0%

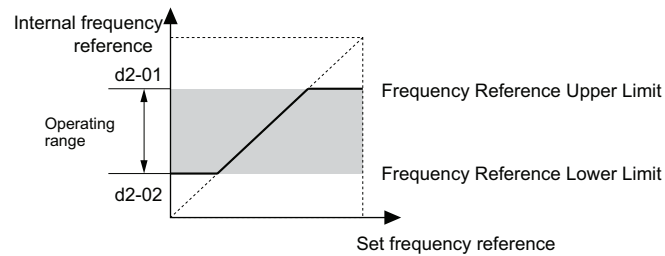


Figure 62 Frequency Reference: Upper and Lower Limits

■ E2-01: Motor Rated Current

Provides motor control, protects the motor, and calculates torque limits. Set E2-01 to the full load amps (FLA) stamped on the motor nameplate. If Auto-Tuning completes successfully, the value entered to T1-04 will automatically be saved to E2-01.

No.	Parameter Name	Setting Range	Default
E2-01	Motor Rated Current	10% to 150% of the drive rated current.	Determined by C6-01 and o2-04

Note: 1. Display is in the following units.

- CIMR-U□2□0028, 2□0042, and 4□0011 to 4□0027: 0.01 A units
- CIMR-U□2□0054 to 2□0248, and 4□0034 to 4□0930: 0.1 A units

2. If the motor rated current in E2-01 is set equal to or less than the motor no-load current in E2-03, than a parameter setting error will occur (oPE02). E2-03 must be set correctly to prevent this error.

■ H1-01 to H1-08: Functions for Terminals S1 to S8

These parameters assign functions to the multi-function digital inputs. Refer to the U1000 Technical Manual for details.

No.	Parameter Name	Setting Range	Default
H1-01	Multi-Function Digital Input Terminal S1 Function Selection	1 to 9F	40 (F) <1>: Forward Run Command (2-wire sequence)
H1-02	Multi-Function Digital Input Terminal S2 Function Selection	1 to 9F	41 (F) <1>: Reverse Run Command (2-wire sequence)
H1-03	Multi-Function Digital Input Terminal S3 Function Selection	0 to 9F	24: External Fault (N.O., always detected, coast to stop)
H1-04	Multi-Function Digital Input Terminal S4 Function Selection	0 to 9F	14: Fault Reset
H1-05	Multi-Function Digital Input Terminal S5 Function Selection	0 to 9F	3 (0) <1>: Multi-Step Speed Reference 1
H1-06	Multi-Function Digital Input Terminal S6 Function Selection	0 to 9F	4 (3) <1>: Multi-Step Speed Reference 2
H1-07	Multi-Function Digital Input Terminal S7 Function Selection	0 to 9F	6 (4) <1>: Jog Reference Selection
H1-08	Multi-Function Digital Input Terminal S8 Function Selection	0 to 9F	8: External Baseblock Command

<1> Number appearing in parenthesis is the default value after performing a 3-Wire initialization (A1-03 = 3330).

4 Start-Up Programming & Operation

■ H2-01 to H2-03: Terminal M1-M2, M3-M4, and M5-M6 Function Selection

The drive has three multi-function output terminals. Refer to the U1000 Technical Manual for details.

No.	Parameter Name	Setting Range	Default
H2-01	Terminal M1-M2 Function Selection	0 to 192	0: During run
H2-02	Terminal M3-M4 Function Selection	0 to 192	1: Zero Speed
H2-03	Terminal M5-M6 Function Selection	0 to 192	2: Speed agree 1

■ L1-01: Motor Overload Protection Selection

The drive has an electronic overload protection function that estimates the motor overload level based on output current, output frequency, thermal motor characteristics, and time. An oL1 fault will be triggered when motor overload is detected and drive output will be shut off.

L1-01 sets the overload protection function characteristics according to the motor being used.

No.	Name	Setting Range	Default
L1-01	Motor Overload Protection Selection	0 to 6	Determined by A1-02

- Note:**
1. When the motor protection function is enabled (L1-01¹ 0), an oL1 alarm can be output through one of the multi-function outputs by setting H2-01 to 1F. The output will close when the motor overload level reaches 90% of the oL1 detection level.
 2. Select a method to protect the motor from overheat by setting L1-01 between 1 and 6 when running a single motor from the drive. An external thermal relay is not needed.

Setting 0: Disabled (motor overload protection is not provided)

This setting should be used if no motor overheat protection is desired or if multiple motors are connected to a single drive. In this case it is recommended that you install a thermal relay for each motor as shown in [Figure 63](#).

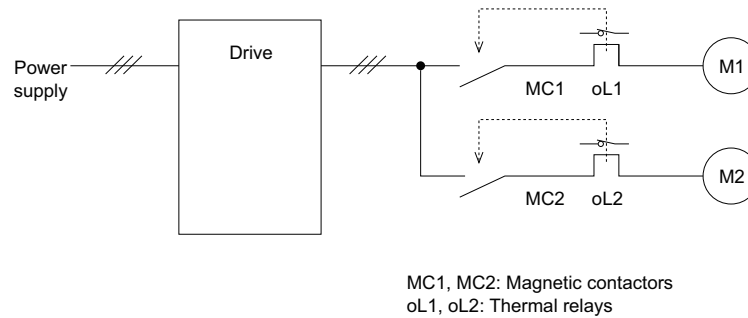


Figure 63 Example of Protection Circuit Design for Multiple Motors

NOTICE: Thermal protection cannot be provided when running multi-motors simultaneously with the same drive, or when using motors with a current rating that is relatively high when compared with other standard motors (such as a submersible motor). Failure to comply could result in motor damage. Disable the electronic overload protection of the drive (L1-01 = "0: Disabled") and protect each motor with individual motor thermal overloads.

4 Start-Up Programming & Operation

Setting 1: General-purpose motor (standard self-cooled)

Because the motor is self-cooled, the overload tolerance drops when the motor speed is lowered. The drive appropriately adjusts the electrothermal trigger point according to the motor overload characteristics, protecting the motor from overheat throughout the entire speed range.

Overload Tolerance	Cooling Ability	Overload Characteristics
<p>Rated Speed=100% Speed A: Max. speed for 200LJ and above B: Max. speed for 160MJ to 180 LJ C: Max. speed for 132MJ and below</p>	<p>Motor designed to operate from line power. Motor cooling is most effective when running at rated base frequency (check the motor nameplate or specifications).</p>	<p>Continuous operation at less than line power frequency with 100% load can trigger motor overload (oL1). A fault is output and the motor will coast to stop.</p>

Setting 2: Drive dedicated motor (speed range for constant torque: 1:10)

Use this setting when operating a drive duty motor that allows constant torque in a speed range of 1:10. The drive will allow the motor to run with 100% load from 10% up to 100% speed. Running at slower speeds with full load can trigger an overload fault.

Overload Tolerance	Cooling Ability	Overload Characteristics
<p>Rated Speed=100% Speed A: Max. speed for 200LJ and above B: Max. speed for 160MJ to 180 LJ C: Max. speed for 132MJ and below</p>	<p>Motor is designed to effectively cool itself even at low speeds.</p>	<p>Continuous operation with 100% load from 5 Hz to 50 Hz.</p>

Setting 3: Vector motor (speed range for constant torque: 1:100)

Use this setting when operating a drive-dedicated motor that allows constant torque in a speed range of 1:100. This motor type is allowed to run with 100% load from 1% up to 100% speed. Running slower speeds with full load can trigger an overload fault.

Overload Tolerance	Cooling Ability	Overload Characteristics
<p>Rated Speed=100% Speed A: Max. speed for 200LJ and above B: Max. speed for 160MJ to 180 LJ C: Max. speed for 132MJ and below</p>	<p>Motor is designed to effectively cool itself at ultra-low speeds.</p>	<p>Continuous operation with 100% load from 0.5 Hz to 50 Hz.</p>

4 Start-Up Programming & Operation

Setting 4: PM derated torque motor

This setting is for operating a PM motor. PM motors for derated torque have a self-cooling design, so the overload tolerance drops as the motor slows. Electronic thermal overload is triggered in accordance with the motor overload characteristics, providing overheat protection across the entire speed range.

Overload Tolerance	Cooling Ability	Overload Characteristics
	<p>Motor is designed to produce 100% torque at base speed. Built with effective cooling capabilities.</p>	<p>Reaching 100% when operating at below the base frequency will cause a motor overload fault (oL1). The drive fault output closes and the motor coasts to stop.</p>

Setting 5: Constant torque PM motors (constant torque range of 1:500)

Sets protection characteristics needed when driving a PM with constant torque. These motors allow for a speed control from 0.2% to 100% when operating with 100% load. Slower speeds with 100% load will trigger overload.

Overload Tolerance	Cooling Ability	Overload Characteristics
	<p>Motor is designed to effectively cool itself at ultra-low speeds (about 0.2% of base speed).</p>	<p>Continuous operation with 100% load from 0.2% to 100% of base speed.</p>

Setting 6: General-purpose motor (50 Hz)

Because the motor (50 Hz) is self-cooled, the overload tolerance drops when the motor speed is lowered. The drive appropriately adjusts the electrothermal trigger point according to the motor overload characteristics, protecting the motor from overheat throughout the entire speed range.

Overload Tolerance	Cooling Ability	Overload Characteristics
<p>Rated Speed=100% Speed A: Max. speed for 200LJ and above B: Max. speed for 160MJ to 180 LJ C: Max. speed for 132MJ and below</p>	<p>Motor designed to operate from line power. Motor cooling is most effective when running at rated base frequency (check the motor nameplate or specifications).</p>	<p>Continuous operation at less than line power frequency with 100% load can trigger motor overload (oL1). A fault is output and the motor will coast to stop.</p>

4 Start-Up Programming & Operation

■ L1-02: Motor Overload Protection Time

There is normally no need to change this parameter from the default value. Sets the time it takes the drive to detect motor overheat due to overload. If the motor overload tolerance protection time when an overload of 150% is imposed after continuous operation at 100% is clear, set that time as the value.

No.	Name	Setting Range	Default
L1-02	Motor Overload Protection Time	0.1 to 5.0 minutes	1.0 minutes

- Defaulted to operate with an allowance of 150% overload operation for one minute in a hot start; after continuous operation at 100%.
- **Figure 64** shows an example of the electrothermal protection operation time using a general-purpose motor operating at 50 Hz with L1-02 set to one minute.

Motor overload protection operates in the area between a cold start and a hot start.

- Cold start: Characteristics of motor protection operation time in response to an overload situation that was suddenly reached when starting a stationary motor.
- Hot start: Characteristics of motor protection operation time in response to an overload situation that occurred while the motor was operating continuously at or below its rated current.

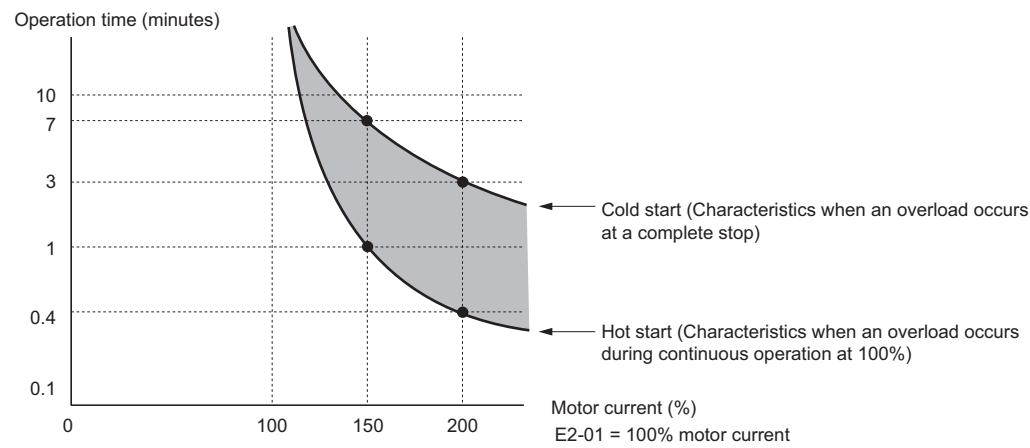


Figure 64 Protection Operation Time for General Purpose Motors at the Rated Output Frequency

■ Motor Protection Using a Positive Temperature Coefficient (PTC)

A motor PTC can be connected to an analog input of the drive. This input is used by the drive for motor overheat protection.

When the PTC input signal reaches the motor overheat alarm level, an oH3 alarm will be triggered and the drive will continue operation as selected in L1-03. When the PTC input signal reaches the overheat fault level, an oH4 fault will be triggered, a fault signal will be output, and the drive will stop the motor using the stop method determined in L1-04.

4 Start-Up Programming & Operation

Connect the PTC between terminals AC and A3 and set jumper S4 on the terminal board to “PTC” like shown in **Figure 65**. Set parameter H3-05 to 0 and parameter H3-06 to E.

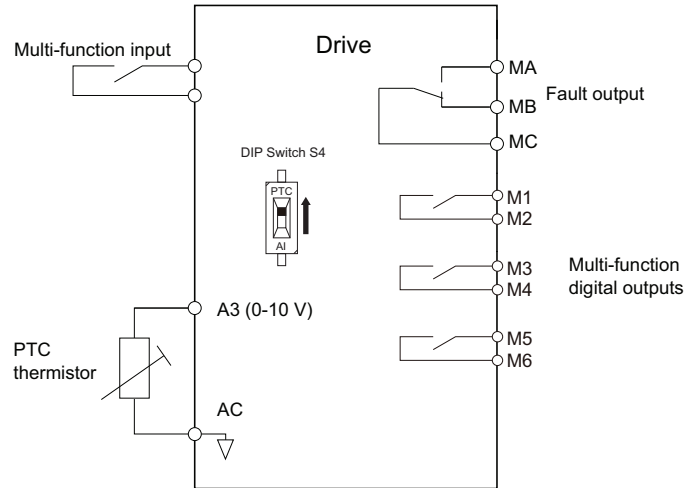


Figure 65 Connection of a Motor PTC

The PTC must have the following characteristics for one motor phase. The drives motor overload detection expects 3 of these PTCs to be connected in series.

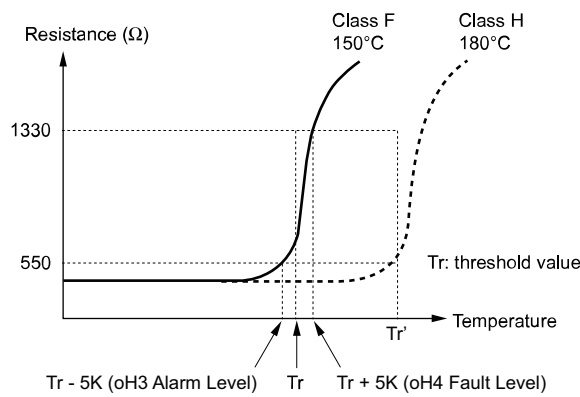


Figure 66 Motor PTC Characteristics

Overheat detection using a PTC can be set up by parameters L1-03, L1-04, and L1-05 as explained below.

◆ Auto-Tuning

■ Types of Auto-Tuning

The drive offers different types of Auto-Tuning for induction motors and permanent magnet motors. The type of Auto-Tuning used differs further based on the control mode and other operating conditions. Refer to the tables below to select the type of Auto-Tuning that best suits the application. **Flowchart A: Basic Start-up and Motor Tuning on page 63** or Technical Manual for details.

Note: The drive will only show Auto-Tuning parameters that are valid for the control mode that has been set to A1-02. If the control mode is for an induction motor, the Auto-Tuning parameters for PM motors will not be available. If the control mode is for a PM motor, the Auto-Tuning parameters for induction motors will not be available. Inertia Tuning and ASR Gain Tuning parameters and setting options will be visible only when the drive is set for operation with Closed Loop Vector or CLV/PM.

4 Start-Up Programming & Operation

Auto-Tuning for Induction Motors

This feature automatically sets the V/f pattern and motor parameters E1-□□ and E2-□□ (E3-□□, E4-□□ for motor 2) for an induction motor. In Closed Loop Vector, some F1-□□ parameters for speed feedback detection are also set up.

Table 37 Types of Auto-Tuning for Induction Motors

Type	Setting	Application Conditions and Benefits	Control Mode			
			V/f	V/f w/PG	OLV	CLV
Rotational Auto-Tuning	T1-01 = 0	<ul style="list-style-type: none"> Motor can be decoupled from the load and rotate freely while Auto-Tuning is performed. Motor and load can not be decoupled but the motor load is below 30%. Rotational Auto-Tuning gives the most accurate results, and is therefore highly recommended if possible. 	N/A	N/A	YES	YES
Stationary Auto-Tuning 2	T1-01 = 4	<ul style="list-style-type: none"> Motor and load can not be decoupled and the load is higher than 30%. A motor test report is available. Once the no-load current and the rated slip have been entered, the drive calculates and sets all other motor-related parameters. 	N/A	N/A	YES	YES
Stationary Auto-Tuning for Line-to-Line Resistance	T1-01 = 2	<ul style="list-style-type: none"> The drive is used in V/f Control and other Auto-Tuning selections not possible. Drive and motor capacities differ. Tunes the drive after the cable between the drive and motor has been replaced with a cable over 50 m long. Assumes Auto-Tuning has already been performed. Should not be used for any vector control modes unless the motor cable has changed. 	YES	YES	YES	YES
Rotational Auto-Tuning for V/f Control	T1-01 = 3	<ul style="list-style-type: none"> Recommended for applications using Speed Estimation Speed Search or using the Energy Saving function in V/f Control. Assumes motor can rotate while Auto-Tuning is performed. Increases accuracy for certain functions like torque compensation, slip compensation, Energy Saving, and Speed Search. 	YES	YES	N/A	N/A
Stationary Auto-Tuning 3	T1-01 = 5	<ul style="list-style-type: none"> A motor test report listing motor data is not available. Motor can be driven with a normal duty mode after Auto-Tuning. A trial run is performed after Auto-Tuning to automatically calculate motor parameters needed for vector control. 	N/A	N/A	YES	YES

T1-01: Auto-Tuning Mode Selection

Sets the type of Auto-Tuning to be used. *Refer to Auto-Tuning for Induction Motors on page 80* for details on the different types of Auto-Tuning.

No.	Name	Setting Range	Default
T1-01	Auto-Tuning Mode Selection	V/f: 2, 3 V/f w/PG: 2, 3 OLV: 0, 2, 4, 5 CLV: 0, 2, 4, 5, 8, 9	2 (V/f, V/f w/PG) 0 (OLV, CLV)

Setting 0: Rotational Auto-Tuning

Setting 2: Stationary Auto-Tuning for Line-to-Line Resistance

Setting 3: Rotational Auto-Tuning for V/f Control

Setting 4: Stationary Auto-Tuning 2

Setting 5: Stationary Auto-Tuning 3

Setting 8: Inertia Tuning

Setting 9: ASR Gain Auto-Tuning

Note: Inertia Tuning and ASR Gain Auto-Tuning might not be available if gears are between the machine and the motor shaft.

◆ No-Load Operation Test Run

■ No-Load Operation Test Run

This section explains how to operate the drive with the motor decoupled from the load during a test run.

Before Starting the Motor

Check the following items before operation:

- Ensure the area around the motor is safe.
- Ensure external emergency stop circuitry is working properly and other safety precautions have been taken.

During Operation

Check the following items during operation:

- The motor should rotate smoothly (i.e., no abnormal noise or oscillation).
- The motor should accelerate and decelerate smoothly.

◆ Test Run with Load Connected

■ Test Run with the Load Connected

After performing a no-load test run, connect the motor and proceed to run the motor and load together.

Notes on Connected Machinery

- Clear the area around the motor.
- The motor should come to a complete stop without problems.
- Connect the load and machinery to the motor.
- Fasten all installation screws properly. Check that the motor and connected machinery are held in place.
- Confirm that the Fast Stop circuit or mechanical safety measures operate correctly.
- Be ready to press the STOP button in case of emergency.

Checklist Before Operation

- The motor should rotate in the proper direction.
- The motor should accelerate and decelerate smoothly.

Operating the Motor under Loaded Conditions

Test run the application similarly to the no-load test procedure when connecting the machinery to the motor.

- Watch monitor parameter U1-03 during operation to ensure there is no overcurrent.
- If the application permits running the load in the reverse direction, try changing motor direction and the frequency reference while watching for abnormal motor oscillation or vibration.
- Correct any problems that occur with hunting, oscillation, or other control-related issues. Refer to Technical Manual for details.

4 Start-Up Programming & Operation

◆ Test Run Checklist

Review the checklist before performing a test run. Check each item that applies.

<input checked="" type="checkbox"/>	No.	Checklist	Page
<input type="checkbox"/>	1	Thoroughly read the manual before performing a test run.	–
<input type="checkbox"/>	2	Turn the power on.	63


Check the items that correspond to the control mode being used.

WARNING! Ensure start/stop and safety circuits are wired properly and in the correct state before energizing the drive. Failure to comply could result in death or serious injury from moving equipment. When programmed for 3-Wire control, a momentary closure on terminal S1 may cause the drive to start.

<input checked="" type="checkbox"/>	No.	Checklist	Page
V/f Control (A1-02 = 0) and V/f Control with PG (A1-02 = 1)			
<input type="checkbox"/>	3	Select the best V/f pattern according to the application and motor characteristics. Example: Set E1-03 to 0 when using a motor with a rated frequency of 50.0 Hz.	–
<input type="checkbox"/>	4	Perform Rotational Auto-Tuning for V/f Control if using Energy Saving functions.	79
V/f Control with PG (A1-02 = 1)			
<input type="checkbox"/>	5	Setup the PG feedback parameters correctly and make sure the encoder pulse counting direction is correct.	–
<input type="checkbox"/>	6	Set the proportional gain for ASR speed control to C5-01 and the integral time to C5-02.	–
Open Loop Vector Control (A1-02 = 2) or Closed Loop Vector Control (A1-02 = 3)			
<input type="checkbox"/>	7	Decouple motor shafts and machines when performing Rotational Auto-Tuning.	79
<input type="checkbox"/>	8	Set Auto-Tuning mode to T1-01 (set to 0 for Rotational Auto-Tuning).	80
<input type="checkbox"/>	9	Enter the following data according to the information listed on the motor nameplate. <ul style="list-style-type: none"> • Motor rated power to T1-02 (kW) • Motor rated voltage to T1-03 (V) • Motor rated current to T1-04 (A) • Motor base frequency to T1-05 (Hz) • Number of motor poles to T1-06 • Motor base speed to T1-07 (min⁻¹) 	–
Closed Loop Vector Control (A1-02 = 3)			
<input type="checkbox"/>	10	Set F1-01 and F1-05.	–
<input type="checkbox"/>	11	Set the proportional gain for ASR speed control to C5-01 and the integral time to C5-02. Perform ASR Tuning if possible.	–
Open Loop Vector Control for PM (A1-02 = 5)			
<input type="checkbox"/>	12	Perform Auto-Tuning as described.	–
Advanced Open Loop Vector Control for PM (A1-02 = 6)			
<input type="checkbox"/>	13	Perform Auto-Tuning as described.	–
<input type="checkbox"/>	14	Set the proportional gain for ASR speed control to C5-01 and the integral time to C5-02.	–
Closed Loop Vector Control for PM (A1-02 = 7)			
<input type="checkbox"/>	15	Set PM motor data using E5-□□ parameters.	–
<input type="checkbox"/>	16	Set the proportional gain for ASR speed control to C5-01 and the integral time to C5-02. Perform ASR Tuning if possible.	–
<input type="checkbox"/>	17	Set F1-01 and F1-05.	–
<input type="checkbox"/>	18	Set the offset between the rotor magnetic axis and the Z-pulse of the encoder connected to E5-11.	–

4 Start-Up Programming & Operation

Proceed to the following checklist after checking items 3 through 18.

<input checked="" type="checkbox"/>	No.	Checklist	Page
<input type="checkbox"/>	19	The DRV should be displayed on the LCD operator after giving a Run command.	–
<input type="checkbox"/>	20	To give a Run command and frequency reference from the digital operator, press  to set to LOCAL. The LO/RE key will light.	60
<input type="checkbox"/>	21	If the motor rotates in the opposite direction during the test run, switch two of the drive output terminals (U/T1, V/T2, W/T3) or change parameter b1-14.	–
<input type="checkbox"/>	22	In accordance with load condition, set Heavy Duty or Normal Duty mode using C6-01. Heavy Duty is the default setting.	71
<input type="checkbox"/>	23	Set the correct values for the motor rated current (E2-01, E4-01, E5-03) and motor protection (L1-01) to ensure motor thermal protection.	74
<input type="checkbox"/>	24	If the Run command and frequency reference are provided via the control circuit terminals, set the drive for REMOTE and be sure the LO/RE light is out.	–
<input type="checkbox"/>	25	If the control circuit terminals should supply the frequency reference, select the correct voltage input signal level (0 to 10 V or -10 to +10 V) or the correct current input signal level (4 to 20 mA or 0 to 20 mA).	65
<input type="checkbox"/>	26	Apply the proper signal level (-10 to +10 V or 0 to 10 V) to terminal A1, A2, or A3.	–
<input type="checkbox"/>	27	Apply the proper signal level (-10 to +10 V, 4 to 20 mA or 0 to 20 mA) to terminal A2.	–
<input type="checkbox"/>	28	Set the level for current signal to H3-09 (set to 2 for 4 to 20 mA, or 3 for 0 to 20 mA). Set terminal A2 function to H3-10 (set to 0 for Frequency Bias).	–
<input type="checkbox"/>	29	Set DIP switch S1 on the drive to “I” when using terminal A2 as current input. Set DIP switch S1 on the drive to “V” when using terminal A2 as voltage input.	48
<input type="checkbox"/>	30	If the frequency reference is supplied via one of the analog inputs, make sure the analog input produces the desired frequency reference. Make the following adjustments if the drive does not operate as expected: <ul style="list-style-type: none"> Gain adjustment: Set the maximum voltage/current signal and adjust the analog input gain (H3-03 for input A1, H3-11 for input A2, H3-07 for analog input A3) until the frequency reference value reaches the desired value. Bias adjustment: Set the minimum voltage/current signal and adjust the analog input bias (H3-04 for input A1, H3-12 for input A2, H3-08 for analog input A3) until the frequency reference value reaches the desired minimum value. 	–

5 Troubleshooting

5 Troubleshooting

◆ Fault Detection

■ Fault Displays

Faults are detected for drive protection that cause the drive to stop while toggling the form-C output associated with terminals MA-MB-MC.

Remove the cause of the fault and manually clear the fault before attempting to run the drive again.

Table 38 Detailed Fault Displays

Digital Operator Display		Fault Name
Aov	Aov	Power Supply Overvoltage
		The input power supply voltage became equal to or higher than the Input Power Supply Overvoltage Detection Level. 200 V Class: Approximately 277 Vrms 400 V Class: Approximately 630 Vrms
AUv	AUv	Power Supply Undervoltage
		The input power supply voltage became equal to or lower than the Input Power Supply Undervoltage Detection Level (L2-21). 200 V Class: Approximately 150 Vrms 400 V Class: Approximately 300 Vrms
bUS	bUS	Option Communication Error • After establishing initial communication, the connection was lost. • Only detected when the run command frequency reference is assigned to an option card.
CE	CE	MEMOBUS/Modbus Communication Error Control data was not received for the CE detection time set to H5-09.
CF	CF	Control Fault The torque limit was reached continuously for 3 seconds after the Stop command was input and deceleration was not possible in Open Loop Vector Control.
CoF	CoF	Current Offset Fault The current sensor is damaged or there was residual induction current in the motor (e.g., during sudden deceleration or when coasting) when the drive attempted to start the motor.
[CPF00 to CPF03, CPF07, CPF08, CPF11 to CPF14, CPF16 to CPF24, CPF26 to CPF35, CPF40 to CPF45 <▶]	CPF00 to CPF03, CPF07, CPF08, CPF11 to CPF14, CPF16 to CPF24, CPF26 to CPF35, CPF40 to CPF45	Control Circuit Error
[CPF06]	CPF06	Control Circuit Error There is an error in the data saved to EEPROM.
[CPF25]	CPF25	Terminal Board not Connected
dEv	dEv	Speed Deviation (for Control Mode with PG) The deviation between the speed detection value for the pulse input and the speed reference after speed agreement was reached exceeded the setting value of F1-10 for the time set in F1-11 or longer when the Operation Selection at Deviation was set to continue operation (F1-04 = 3).
doH	doH	Damping Resistor Overheat The temperature of the built-in damping resistor exceeded the set value.
dv1	dv1	Z Pulse Fault The motor turned one full rotation without the Z pulse being detected. Note: Available in CLV/PM control mode only.
dv2	dv2	Z Pulse Noise Fault Detection The Z pulse is out of phase by more than 5 degrees for the number of times specified in parameter F1-17. Note: Available in CLV/PM control mode only.

5 Troubleshooting

Digital Operator Display		Fault Name
dv3	dv3	Inversion Detection The torque reference and acceleration are in opposite directions from one another (one is in reverse and the other is forward) while at the same time the speed reference and actual motor speed differ by over 30% for the number of pulses set to F1-18. Note: Available in CLV/PM control mode only.
		Inversion Prevention Detection Pulses indicate that the motor is rotating in the opposite direction of the speed reference. Set the number of pulses to trigger inverse detection to F1-19. Note: 1. Disable inverse detection in applications where the motor may rotate in the opposite direction of the speed reference. Setting F1-19 to 0 disables this feature. 2. Available in CLV/PM control mode only.
dv7	dv7	Polarity Judge Timeout
dWAL	dWAL	DriveWorksEZ Fault
dWFL	dWFL	
dWF1	dWF1	EEPROM Memory DriveWorksEZ Data Error There is an error in the DriveWorksEZ program saved to EEPROM.
E5	E5	MECHATROLINK Watchdog Timer Error The watchdog has timed out.
EF0	EF0	Option Card External Fault An external fault condition is present.
EF1	EF1	External Fault (input terminal S1) External fault at multi-function input terminal S1.
EF2	EF2	External Fault (input terminal S2) External fault at multi-function input terminal S2.
EF3	EF3	External Fault (input terminal S3) External fault at multi-function input terminal S3.
EF4	EF4	External Fault (input terminal S4) External fault at multi-function input terminal S4.
EF5	EF5	External Fault (input terminal S5) External fault at multi-function input terminal S5.
EF6	EF6	External Fault (input terminal S6) External fault at multi-function input terminal S6.
EF7	EF7	External Fault (input terminal S7) External fault at multi-function input terminal S7.
EF8	EF8	External Fault (input terminal S8) External fault at multi-function input terminal S8.
Err	Err	EEPROM Write Error Data cannot be written to the EEPROM.
FAn	FAn	Fan Fault Fan failed.
FbH	FbH	Excessive PID Feedback PID feedback input is greater than the level set b5-36 for longer than the time set to b5-37. To enable fault detection, set b5-12 = 2 or 5.
FbL	FbL	PID Feedback Loss This fault occurs when PID feedback loss detection is programmed to trigger a fault (b5-12 = 2 or 5) and the PID feedback level is below the detection level set to b5-13 for longer than the time set to b5-14.
Fdv	Fdv	Power Supply Frequency Fault The input power supply frequency exceeded the allowable frequency fluctuation.
GF	GF	Ground Fault A current short to ground exceeded 50% of rated current on the output side of the drive.
LF	LF	Output Phase Loss • Phase loss on the output side of the drive. • Phase Loss Detection is enabled when L8-07 is set to 1 or 2.
LF2	LF2	Output Current Imbalance One or more of the phases in the output current is lost.

Troubleshooting

5

5 Troubleshooting

Digital Operator Display		Fault Name
LSo ⇄	LSo	LSo Fault
		Pull-out has been detected at low speed.
nSE	nSE	Node Setup Error
		A terminal assigned to the node setup function closed during run.
oC	oC	Overcurrent
		Drive sensors have detected an output current greater than the specified overcurrent level.
oFA00	oFA00	Option Card Connection Error at Option Port CN5-A
		Option compatibility error
oFA01	oFA01	Option Card Fault at Option Port CN5-A
		Option not properly connected
oFA03 to oFA06	oFA03 to oFA06	Option Card Error Occurred at Option Port CN5-A
oFA10, oFA11	oFA10, oFA11	
oFA12 to oFA17	oFA12 to oFA17	Option Card Connection Error (CN5-A)
oFA30 to oFA43	oFA30 to oFA43	Comm. Option Card Connection Error (CN5-A)
oFb00	oFb00	Option Card Fault at Option Port CN5-B
		Option compatibility error
oFb01	oFb01	Option Card Fault at Option Port CN5-B
		Option not properly connected
oFb02	oFb02	Option Card Fault at Option Port CN5-B
		Same type of option card already connected
oFb03 to oFb11	oFb03 to oFb11	Option Card Error Occurred at Option Port CN5-B
oFb12 to oFb17	oFb12 to oFb17	
oFC00	oFC00	Option Card Connection Error at Option Port CN5-C
		Option compatibility error
oFC01	oFC01	Option Card Fault at Option Port CN5-C
		Option not properly connected
oFC02	oFC02	Option Card Fault at Option Port CN5-C
		Same type of option card already connected
oFC03 to oFC11	oFC03 to oFC11	Option Card Error Occurred at Option Port CN5-C
oFC12 to oFC17	oFC12 to oFC17	
oFC50 to oFC55	oFC50 to oFC55	Option Card Error Occurred at Option Port CN5-C
oH	oH	Heatsink Overheat
		The temperature of the heatsink exceeded the overheat pre-alarm level set to L8-02. Default value for L8-02 is determined by the drive model selection (o2-04).
oH1	oH1	Overheat 1 (Heatsink Overheat)
		The temperature of the heatsink exceeded the drive overheat level. The overheat level is determined by drive capacity (o2-04).
oH3	oH3	Motor Overheat Alarm (PTC Input)
		<ul style="list-style-type: none"> The motor overheat signal to analog input terminal A1, A2, or A3 exceeded the alarm detection level. Detection requires multi-function analog input H3-02, H3-10, or H3-06 be set to "E".
oH4	oH4	Motor Overheat Fault (PTC Input)
		<ul style="list-style-type: none"> The motor overheat signal to analog input terminal A1, A2, or A3 exceeded the fault detection level. Detection requires that multi-function analog input H3-02, H3-10, or H3-06 = "E".
oL1	oL1	Motor Overload
		The electronic motor overload protection tripped.
oL2	oL2	Drive Overload
		The thermal sensor of the drive triggered overload protection.
oL3	oL3	Overtorque Detection 1
		The current has exceeded the value set for torque detection level 1 (L6-02) for longer than the allowable time (L6-03).

5 Troubleshooting

Digital Operator Display		Fault Name
oL4	oL4	Overtorque Detection 2
		The current has exceeded the value set for torque detection level 2 (L6-05) for longer than the allowable time (L6-06).
oL5	oL5	Mechanical Weakening Detection 1
		Overtorque occurred, matching the conditions specified in L6-08.
oPr	oPr	External Digital Operator Connection Fault
		The external operator has been disconnected from the drive. Note: An oPr fault will occur when all of the following conditions are true: • Output is interrupted when the operator is disconnected (o2-06 = 1). • The Run command is assigned to the operator (b1-02 = 0 and LOCAL has been selected).
oS	oS	Overspeed
		The motor speed feedback exceeded the F1-08 setting.
ov	ov	Control Circuit Overvoltage
		Voltage in the control circuit has exceeded the overvoltage level. • For 200 V class: approximately 450 V • For 400 V class: approximately 900 V
PGo	PGo	PG Disconnect (for any control modes using a PG option card)
		No PG pulses are received for longer than the time set to F1-14.
PGoH	PGoH	PG Hardware Fault (detected when using a PG-X3 option card)
		PG cable is not connected properly.
SCF	SCF	Safety Circuit Fault
		Safety Circuit Fault is detected.
SEr	SEr	Too Many Speed Search Restarts
		The number of Speed Search restarts exceeded the number set to b3-19.
SoH	SoH	Snubber Discharge Resistor Overheat
SrC	SrC	Phase Order Detection Fault
		The phase rotation direction for the input power supply changed.
Srr	Srr	Internal Resistance Fault
		An operation failure occurred in the snubber discharge resistor circuit.
STo	STo	Pull-Out Detection
		Motor pull out or step out has occurred. Motor has exceeded its pull-out torque.
SvE	SvE	Zero Servo Fault
		Position deviation during zero servo.
UL3	UL3	Undertorque Detection 1
		The current has fallen below the minimum value set for torque detection level 1 (L6-02) for longer than the allowable time (L6-03).
UL4	UL4	Undertorque Detection 2
		The current has fallen below the minimum value set for torque detection level 2 (L6-05) for longer than the allowable time (L6-06).
UL5	UL5	Mechanical Weakening Detection 2
		The operation conditions matched the conditions set to L6-08.
Uv1	Uv1	Control Circuit Undervoltage Fault
		One of the following conditions occurred: • For 200 V class: approximately 175 V • For 400 V class: approximately 350 V
Uv2	Uv2	Control Power Supply Voltage Fault
		Voltage is too low for the control drive input power.
Uv3	Uv3	Undervoltage 3 (Soft-Charge Bypass Circuit Fault)
		The soft-charge bypass circuit has failed.

- <1> Displayed as CPF00 or CPF20 when occurring at drive power up. When one of the faults occurs after successfully starting the drive, the display will show CPF01 or CPF21.
- <2> This function prevents continuous operation in reverse when using high frequency injection (n8-57 = 1) in the Advanced Open Loop Vector Control mode for PM motors (A1-02 = 6) with a motor for which no motor code has been entered (it does not simply prevent reverse operation). Set L8-93, L8-94, and L8-95 to low values within range of erroneous detection to quickly detect undesirable reverse operation.

Troubleshooting

5 Troubleshooting

◆ Alarm Detection

■ Alarm Codes

Alarms are drive protection functions that do not necessarily cause the drive to stop. Once the cause of an alarm is removed, the drive will return to the same status it was before the alarm occurred.

When an alarm has been triggered, the ALM light on the digital operator display blinks and the alarm code display flashes. If a multi-function output is set for an alarm (H2-□□ = 10), that output terminal will be triggered.

Note: If a multi-function output is set to close when an alarm occurs (H2-□□ = 10), it will also close when maintenance periods are reached, triggering alarms LT-1 through LT-3 (triggered only if H2-□□ = 2F).

Table 39 Alarm Codes

Digital Operator Display		Minor Fault Name
<i>AEr</i>	AEr	Station Address Setting Error (CC-Link, CANopen, MECHATROLINK)
		Option card node address is outside the acceptable setting range.
<i>AUv</i>	AUv	Power Supply Undervoltage
		The input power supply voltage became equal to or lower than the Input Power Supply Undervoltage Detection Level (L2-21). 200 V Class: Approximately 150 Vrms 400 V Class: Approximately 300 Vrms
<i>bb</i>	bb	Baseblock
		Drive output interrupted as indicated by an external baseblock signal.
<i>bUS</i>	bUS	Option Communication Error
		<ul style="list-style-type: none"> After initial communication was established, the connection was lost. Assign a Run command frequency reference to the option card.
<i>CALL</i>	CALL	Serial Communication Transmission Error
		Communication has not yet been established.
<i>CE</i>	CE	MEMOBUS/Modbus Communication Error
		Control data was not received correctly for two seconds.
<i>CrST</i>	CrST	Cannot Reset
<i>CyC</i>	CyC	MECHATROLINK Comm. Cycle Setting Error
		Comm. Cycle Setting Error was detected.
<i>dEv</i>	dEv	Speed Deviation (for Control Mode with PG)
		The deviation between the speed detection value for the pulse input and the speed reference after speed agreement was reached exceeded the setting value of F1-10 for the time set in F1-11 or longer when the Operation Selection at Deviation was set to continue operation (F1-04 = 3).
<i>dnE</i>	dnE	Drive Disabled
<i>doH</i>	doH	Damping Resistor Overheat
		The temperature of the built-in damping resistor exceeded the set value.
<i>EF</i>	EF	Forward/Reverse Run Command Input Error
		Both forward run and reverse run closed simultaneously for over 0.5 s.
<i>EF0</i>	EF0	Option Card External Fault
		An external fault condition is present.
<i>EF1</i>	EF1	External fault (input terminal S1)
		External fault at multi-function input terminal S1.
<i>EF2</i>	EF2	External fault (input terminal S2)
		External fault at multi-function input terminal S2.
<i>EF3</i>	EF3	External fault (input terminal S3)
		External fault at multi-function input terminal S3.
<i>EF4</i>	EF4	External fault (input terminal S4)
		External fault at multi-function input terminal S4.
<i>EF5</i>	EF5	External fault (input terminal S5)
		External fault at multi-function input terminal S5.
<i>EF6</i>	EF6	External fault (input terminal S6)
		External fault at multi-function input terminal S6.

5 Troubleshooting

Digital Operator Display		Minor Fault Name
EF7	EF7	External fault (input terminal S7)
		External fault at multi-function input terminal S7.
EF8	EF8	External fault (input terminal S8)
		External fault at multi-function input terminal S8.
FbH	FbH	Excessive PID Feedback
		The PID feedback input is higher than the level set in b5-36 for longer than the time set in b5-37, and b5-12 is set to 1 or 4.
FbL	FbL	PID Feedback Loss
		The PID feedback input is lower than the level set in b5-13 for longer than the time set in b5-14 is set to 1 or 4.
Fdv	Fdv	Power Supply Frequency Fault
		The input power supply frequency exceeded the allowable frequency fluctuation.
Hbb	Hbb	Safe Disable Signal Input
		Both Safe Disable Input channels are open.
HbbF	HbbF	Safe Disable Signal Input
		One Safe Disable channel is open while the other one is closed.
HCA	HCA	Current Alarm
		Drive current exceeded overcurrent warning level (150% of the rated current).
LT-1	LT-1	Cooling Fan Maintenance Time
		The cooling fan has reached its expected maintenance period and may need to be replaced. Note: An alarm output (H2-□□ = 10) will only be triggered if both (H2-□□ = 2F and H2-□□ = 10) are set.
LT-2	LT-2	Capacitor Maintenance Time
		The main circuit and control circuit capacitors are nearing the end of their expected performance life. Note: An alarm output (H2-□□ = 10) will only be triggered if H2-□□ = 2F.
LT-3	LT-3	Soft Charge Bypass Relay Maintenance Time
		The DC bus soft charge relay is nearing the end of its expected performance life. Note: An alarm output (H2-□□ = 10) will only be triggered if H2-□□ = 2F.
oH	oH	Heatsink Overheat
		The temperature of the heatsink exceeded the overheat pre-alarm level set to L8-02 (90-100°C). Default value for L8-02 is determined by drive capacity (o2-04).
oH2	oH2	Heatsink Overheat Warning
		“Heatsink Overheat Warning” was input to a multi-function input terminal, S1 through S8 (H1-□□ = B)
oH3	oH3	Motor Overheat
		The motor overheat signal entered to a multi-function analog input terminal exceeded the alarm level (H3-02, H3-06 or H3-10 = E).
oL3	oL3	Overtorque 1
		Drive output current (or torque in OLV, CLV, AOLV/PM, CLV/PM) was greater than L6-02 for longer than the time set in L6-03.
oL4	oL4	Overtorque 2
		Drive output current (or torque in OLV, CLV, AOLV/PM, CLV/PM) was greater than L6-05 for longer than the time set in L6-06.
oL5	oL5	Mechanical Weakening Detection 1
		Overtorque occurred, matching the conditions specified in L6-08.
oS	oS	Overspeed
		The motor speed feedback exceeded the F1-08 setting.
ov	ov	Control Circuit Overvoltage
		Voltage in the control circuit exceeded the trip point. For 200 V class: approximately 450 V For 400 V class: approximately 900 V
PASS	PASS	MEMOBUS/Modbus Comm. Test Mode Complete
PGo	PGo	PG Disconnect (for Control Mode with PG)
		Detected when no PG pulses are received for a time longer than setting in F1-14.
PGoH	PGoH	PG Hardware Fault (detected when using a PG-X3 option card)
		PG cable has become disconnected.

5 Troubleshooting

Digital Operator Display		Minor Fault Name
rUn	rUn	Motor Switch during Run A command to switch motors was entered during run.
SE	SE	MEMOBUS/Modbus Communication Test Mode Error Note: This alarm will not trigger a multi-function output terminal that is set for alarm output (H2-□□ = 10).
SrC	SrC	Phase Order Detection Fault The phase rotation direction for the input power supply changed.
UL3	UL3	Undertorque Detection 1 Drive output current (or torque in OLV, CLV, AOLV/PM, CLV/PM) less than L6-02 for longer than L6-03 time.
UL4	UL4	Undertorque Detection 2 Drive output current (or torque in OLV, CLV, AOLV/PM, CLV/PM) less than L6-05 for longer than L6-06 time.
Uv	Uv	Control Circuit Undervoltage One of the following conditions occurred: • Contactor to suppress inrush current in the drive was opened. • Low voltage in the control drive input power. This alarm outputs only if L2-01 is not 0 and control power supply voltage is under L2-05.

◆ Operator Programming Errors

■ oPE Codes

An Operator Programming Error (oPE) occurs when a contradictory parameter is set or an individual parameter is set to an inappropriate value.

The drive will not operate until the parameter or parameters causing the problem are set correctly. An oPE, however, does not trigger an alarm or fault output. If an oPE occurs, investigate the cause and *refer to oPE Codes on page 90* for the appropriate action. When an oPE appears on the operator display, press the ENTER button to view U1-18 and see the parameter that is causing the oPE error (U1-18).

Table 40 oPE Codes

Digital Operator Display		Error Name
oPE01	oPE01	Unit Capacity Setting Fault Unit capacity and the value set to o2-04 do not match.
oPE02	oPE02	Parameter Range Setting Error Use U1-18 to find parameters set outside the range.
oPE03	oPE03	Multi-Function Input Selection Error A contradictory setting is assigned to multi-function contact inputs H1-01 to H1-08.
oPE04	oPE04	Terminal Board Mismatch Error
oPE05	oPE05	Run Command/Frequency Reference Source Selection Error
oPE06	oPE06	Control Method Selection Error Correct the setting for the control method.
oPE07	oPE07	Multi-Function Analog Input Selection Error A contradictory setting is assigned to multi-function analog inputs H3-02, H3-10, or H3-06 and PID functions conflict.
oPE08	oPE08	Parameter Selection Error A function has been set that cannot be used in the motor control method selected.
oPE09	oPE09	PID Control Selection Fault PID control function selection is incorrect. Requires that PID control is enabled (b5-01 = 1 to 4).
oPE10	oPE10	V/f Data Setting Error The following setting errors have occurred where: • E1-09 ≤ E1-07 < E1-06 ≤ E1-11 ≤ E1-04 • E3-09 ≤ E3-07 < E3-06 ≤ E3-11 ≤ E3-04

5 Troubleshooting

Digital Operator Display		Error Name
<i>oPE11</i>	oPE11	Carrier Frequency Setting Error Correct the setting for the carrier frequency.
<i>oPE13</i>	oPE13	Pulse Monitor Selection Error Incorrect setting of monitor selection for pulse train (H6-06).
<i>oPE15</i>	oPE15	Torque Control Setting Error Parameters settings that are not allowed in combination with Torque Control have been set.
<i>oPE16</i>	oPE16	Energy Savings Constants Error
<i>oPE18</i>	oPE18	Online Tuning Parameter Setting Error Parameters that control Online Tuning are not set correctly.
<i>oPE20</i>	oPE20	PG-F3 Setting Error The encoder signal frequency is too high.
<i>oPE30</i>	oPE30	Incorrect Input Voltage Adjustment The input voltage offset adjustment has not been performed.

◆ Auto-Tuning Fault Detection

Auto-Tuning faults in this section are displayed on the digital operator and will cause the motor to coast to a stop. Auto-tuning faults do not trigger a multi-function digital output set for fault or alarm output.

An (End□) error on the digital operator display indicates Auto-Tuning has successfully completed with discrepancies in the calculations. Check the cause of the (End□) error using the tables in this section and perform Auto-Tuning again after fixing the cause.

The drive may be used in the application if no cause can be identified despite the existence of an (End□) error.

An (Er-□□) error indicates that Auto-Tuning has not completed successfully. Check for the cause of the error using the tables in this section, and perform Auto-Tuning again after fixing the cause.

■ Auto-Tuning Codes

Table 41 Auto-Tuning Codes


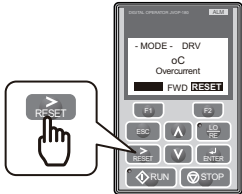
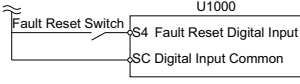
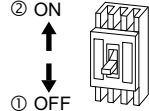
Digital Operator Display		Error Name
<i>End1</i>	End1	Excessive V/f Setting (detected only during Rotational Auto-Tuning, and displayed after Auto-Tuning is complete)
<i>End2</i>	End2	Motor Iron-Core Saturation Coefficient (detected only during Rotational Auto-Tuning and displayed after Auto-Tuning is complete)
<i>End3</i>	End3	Rated Current Setting Alarm (displayed after Auto-Tuning is complete)
<i>End4</i>	End4	Adjusted Slip Calculation Error
<i>End5</i>	End5	Resistance Tuning Error
<i>End6</i>	End6	Leakage Inductance Alarm
<i>End7</i>	End7	No-Load Current Alarm
<i>Er-01</i>	Er-01	Motor Data Error
<i>Er-02</i>	Er-02	Minor Fault
<i>Er-03</i>	Er-03	STOP Button Input
<i>Er-04</i>	Er-04	Line-to-Line Resistance Error
<i>Er-05</i>	Er-05	No-Load Current Error
<i>Er-08</i>	Er-08	Rated Slip Error
<i>Er-09</i>	Er-09	Acceleration Error
<i>Er-10</i>	Er-10	Motor Direction Error
<i>Er-11</i>	Er-11	Motor Speed Error
<i>Er-12</i>	Er-12	Current Detection Error
<i>Er-13</i>	Er-13	Leakage Inductance Error

5 Troubleshooting

Digital Operator Display		Error Name
Er-14	Er-14	Motor Speed Error 2
Er-15	Er-15	Torque Saturation Error
Er-16	Er-16	Inertia ID Error
Er-17	Er-17	Reverse Prohibited Error
Er-18	Er-18	Induction Voltage Error
Er-19	Er-19	PM Inductance Error
Er-20	Er-20	Stator Resistance Error
Er-21	Er-21	Z Pulse Correction Error
Er-25	Er-25	High Frequency Injection Parameter Tuning Error

■ Fault Reset Methods

When a fault occurs, the cause of the fault must be removed and the drive must be restarted. The table below lists the different ways to restart the drive.

After the Fault Occurs	Procedure	
Fix the cause of the fault, restart the drive, and reset the fault	Press  on the digital operator when error code is displayed.	
Resetting via Fault Reset Digital Input S4	Close then open the fault signal digital input via terminal S4. S4 is set for "Fault Reset" as default (H1-04 = 14).	
If the above methods do not reset the fault, turn off the drive main power supply. Reapply power after the digital operator display is out.		

Note: If the Run command is present, the drive will disregard any attempts to reset the fault. The Run command must first be removed before a fault situation can be cleared.

A Specifications

◆ Drive Specifications

- Note:** 1. Perform rotational Auto-Tuning to obtain the performance specifications given below.
 2. For optimum performance life of the drive, install the drive in an environment that meets the required specifications.

Item	Specification
Control Method	The following control methods can be set using drive parameters: <ul style="list-style-type: none"> • V/f Control (V/f) • V/f Control with PG (V/f w/PG) • Open Loop Vector Control (OLV) • Closed Loop Vector Control (CLV) • Open Loop Vector Control for PM (OLV/PM) • Advanced Open Loop Vector Control for PM (AOLV/PM) • Closed Loop Vector Control for PM (CLV/PM)
Frequency Control Range	0.01 to 400 Hz
Frequency Accuracy (Temperature Fluctuation)	Digital input: within $\pm 0.01\%$ of the max output frequency (-10°C to $+40^{\circ}\text{C}$) Analog input: within $\pm 0.1\%$ of the max output frequency ($25^{\circ}\text{C} \pm 10^{\circ}\text{C}$)
Frequency Setting Resolution	Digital inputs: 0.01 Hz Analog inputs: 1/2048 of the maximum output frequency setting (11 bit plus sign)
Output Frequency Resolution	0.001 Hz
Frequency Setting Signal	Main speed frequency reference: DC -10 to +10 V (20 k Ω), DC 0 to +10 V (20 k Ω), 4 to 20 mA (250 Ω), 0 to 20 mA (250 Ω), Main speed reference: Pulse train input (max. 32 kHz)
Starting Torque	V/f, V/f w/PG: 150% at 3 Hz OLV: 200% at 0.3 Hz <-> CLV, AOLV/PM, CLV/PM: 200% at 0.0 min ⁻¹ <-> OLV/PM: 100% at 3 Hz
Speed Control Range	V/f, V/f w/PG: 1:40 OLV: 1:200 CLV, CLV/PM: 1:1500 OLV/PM: 1:20 AOLV/PM: 1:100
Speed Control Accuracy	OLV: $\pm 0.2\%$ ($25^{\circ}\text{C} \pm 10^{\circ}\text{C}$), CLV: $\pm 0.02\%$ ($25^{\circ}\text{C} \pm 10^{\circ}\text{C}$) <->
Speed Response	OLV: 10 Hz ($25^{\circ}\text{C} \pm 10^{\circ}\text{C}$) CLV: 250 Hz ($25^{\circ}\text{C} \pm 10^{\circ}\text{C}$)
Torque Limit	Parameters setting allow separate limits in four quadrants (available in OLV, CLV, AOLV/PM, CLV/PM)
Accel/Decel Time	0.0 to 6000.0 s (4 selectable combinations of independent acceleration and deceleration settings)
Braking Torque	Same value as overload tolerance
V/f Characteristics	User-selected programs and V/f preset patterns possible
Main Control Functions	Torque Control, Droop Control, Speed/torque Control Switching, Feed Forward Control, Zero Servo Function, Momentary Power Loss Ride-Thru, Speed Search, Synchronous Transfer with Commercial Power Supply, Overtorque/Undertorque Detection, Torque Limit, 17 Step Speed (max), Accel/decel Switch, S-curve Accel/decel, 3-wire Sequence, Auto-tuning (rotational, stationary tuning), Dwell, Cooling Fan on/off Switch, Slip Compensation, Torque Compensation, Frequency Jump, Upper/lower Limits for Frequency Reference, DC Injection Braking at Start and Stop, PID Control (with sleep function), Energy Saving Control, MEMOBUS/Modbus Comm. (RS-422/RS-485 max, 115.2 kbps), Fault Restart, Application Presets, DriveWorksEZ (customized function), Removable Terminal Block with Parameter Backup Function, Online Tuning, Overexcitation Deceleration, Inertia (ASR) Tuning, High Frequency Injection, etc.

Specifications

A

A Specifications

Item	Specification
Power Supply Regeneration	Available
Motor Protection	Electronic thermal overload relay
Momentary Overcurrent Protection	Drive stops when output current reaches about 200% of the rated current
Overload Protection	Drive stops after 60 s at 150% of rated Heavy Duty output current <2>
Overvoltage Protection	200 V class: Stops when input voltage exceeds approx. 315 V 400 V class: Stops when input voltage exceeds approx. 630 V
Undervoltage Protection	200 V class: Stops when input voltage falls below approx. 150 V 400 V class: Stops when input voltage falls below approx. 300 V
Momentary Power Loss Ride-Thru	Immediately stop after 2 ms or longer power loss. <4> Continuous operation during power loss than 2 s (standard) <5>
Heatsink Overheat Protection	Thermistor
Stall Prevention	Stall Prevention is available during acceleration, deceleration, and during run.
Ground Protection	Electronic circuit protection <6>
Charge LED of Capacitor for Control Power Supply	Remains lit until control power supply voltage falls below 50 V
Area of Use	Indoors
Ambient Temperature	-10 to 40°C (IP20/NEMA 1, UL Type 1 enclosure) -10 to 50°C (IP00 enclosure)
Humidity	95 RH% or less (no condensation)
Storage Temperature	-20°C to 60°C (short-term temperature during transportation)
Altitude	Up to 1000 meters <7>
Vibration/Shock	10 to 20 Hz: 9.8 m/s ² (2□0028 to 2□0248, 4□0011 to 4□0414) 10 to 20 Hz: 5.9 m/s ² (4□0477 to 4□0930) 20 to 55 Hz: 5.9 m/s ² (2□0028 to 2□0081, 4□0011 to 4□0077) 20 to 55 Hz: 2.0 m/s ² (2□0104 to 2□0248, 4□0096 to 4□0930)
Standards	<ul style="list-style-type: none"> • UL508C • IEC/EN 61800-3, IEC/EN 61800-5-1 • EN ISO 13849-1 Cat.3 PLe, IEC/EN 61508 SIL3
Protection Design	IP00 enclosure, IP20/NEMA 1, UL Type 1 enclosure <8>


- <1> Current derating is required. Select control modes in accordance with the drive capacity.
 <2> The accuracy of these values depends on motor characteristics, ambient conditions, and drive settings. Specifications may vary with different motors and with changing motor temperature. Contact Yaskawa for consultation.
 <3> Overload protection may be triggered when operating with 150% of the rated output current if the output frequency is less than 6 Hz.
 <4> May be shorter due to load conditions and motor speed.
 <5> A separate Momentary Power Loss Ride-Thru Unit is required for the drives if the application needs to continue running during a momentary power loss up to 2 s.
 <6> A ground protection is triggered when a ground short circuit occurs while the drive is running. The ground protection cannot be provided when the impedance of the ground fault path is too low, or when the drive is powered up while a ground fault is present at the output.
 <7> Up to 3000 m with output current and voltage derating.
 <8> An IP20/NEMA 1, UL Type 1 enclosure drive requires a NEMA 1 kit. Removing the top protective cover and bottom cover on an IP20/NEMA 1, UL Type 1 enclosure drive may convert this drive to an IP20 conformity. Models CIMR-U□4□0720 to 4□0930 are not compatible with IP20/NEMA 1, UL Type 1 enclosure.

B Parameter List

The most important parameters are listed in the tables below. Refer to the U1000 Technical Manual for all other parameters.

◆ A: Initialization Parameters

The A parameter group creates the operating environment for the drive. This includes the parameter Access Level, Motor Control Method, Password, User Parameters and more.

 : Indicates that the parameter setting can be changed while the drive is operating the motor

Motor 2: Refers the second motor when the drive is operating two motors (use input terminals to switch between motors).

■ A1: Initialization

No.	Name	Description	Setting
A1-02 <>	Control Method Selection	0: V/f Control 1: V/f Control with PG 2: Open Loop Vector Control 3: Closed Loop Vector Control 5: Open Loop Vector Control for PM 6: Advanced Open Loop Vector Control for PM 7: Closed Loop Vector Control for PM	Default: 0 Min: 0 Max: 7
A1-06	Application Preset	0: General-purpose 1: Water supply pump 2: Conveyor 3: Exhaust fan 4: HVAC fan 5: Air compressor 6: Hoist 7: Crane (Traveling)	Default: 0 Min: 0 Max: 7

<3> The parameter setting is not reset to the default value when A1-03 is used to initialize the drive.

◆ b: Application

Application parameters configure the source of the Run command, DC Injection Braking, Speed Search, timer functions, PID control, the Dwell function, Energy Savings, and a variety of other application-related settings.

■ b1: Operation Mode Selection

No.	Name	Description	Setting
b1-01	Frequency Reference Selection 1	0: Digital operator 1: Analog input terminals 2: MEMOBUS/Modbus communications 3: Option PCB 4: Pulse train input (terminal RP)	Default: 1 Min: 0 Max: 4
b1-02	Run Command Selection 1	0: Digital operator 1: Digital input terminals 2: MEMOBUS/Modbus communications 3: Option PCB	Default: 1 Min: 0 Max: 3
b1-03	Stopping Method Selection	0: Ramp to stop 1: Coast to stop 2: DC Injection Braking to stop 3: Coast with timer 9: Simple Positioning	Default: 0 Min: 0 Max: 9 <11>
b1-04	Reverse Operation Selection	0: Reverse enabled. 1: Reverse disabled.	Default: 0 Min: 0 Max: 1

<11> Setting range is 0, 1, or 3 when the control mode is CLV, OLV/PM, AOLV/PM, or CLV/PM.

B Parameter List

◆ C: Tuning

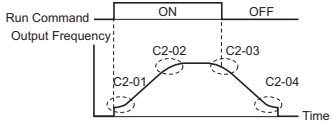
C parameters are used to adjust the acceleration and deceleration times, S-curves, slip compensation, torque compensation, and carrier frequency selections.

■ C1: Acceleration and Deceleration Times

No.	Name	Description	Setting
C1-01 ◀▶RUN	Acceleration Time 1	Sets the time to accelerate from 0 to maximum frequency.	Default: 10.0 s Min: 0.0 s Max: 6000.0 s <12>
C1-02 ◀▶RUN	Deceleration Time 1	Sets the time to decelerate from maximum frequency to 0.	

<12> Setting range value is dependent on parameter C1-10, Accel/Decel Time Setting Units. When C1-10 = 0 (units of 0.01 seconds), the setting range becomes 0.00 to 600.00 seconds.

■ C2: S-Curve Characteristics

No.	Name	Description	Setting
C2-01	S-Curve Characteristic at Accel Start	The S-curve can be controlled at the four points shown below. 	Default: 0.20 s <10> Min: 0.00 s Max: 10.00 s
C2-02	S-Curve Characteristic at Accel End		Default: 0.20 s Min: 0.00 s Max: 10.00 s
C2-03	S-Curve Characteristic at Decel Start		Default: 0.20 s Min: 0.00 s Max: 10.00 s
C2-04	S-Curve Characteristic at Decel End		Default: 0.00 s Min: 0.00 s Max: 10.00 s

<10> Default setting is determined by the control mode (A1-02).

■ C6: Carrier Frequency

No.	Name	Description	Setting
C6-01	Drive Duty Mode Selection	0: Heavy Duty (HD) Over load capability: 150% of drive rated Heavy Duty current for 60 s 1: Normal Duty (ND) Over load capability: 120% of drive rated Normal Duty current for 60 s	Default: 1 Min: 0 Max: 1

■ C7: Voltage Adjustment

No.	Name	Description	Setting
C7-60	Output Voltage Limit Mode Selection	0: Harmonic suppression priority mode 1: High output voltage mode	Default: 1 Min: 0 Max: 1

◆ d: Reference Settings

Reference parameters are used to set the various frequency reference values during operation.

■ d1: Frequency Reference

No.	Name	Description	Setting
d1-01 to d1-16 ◀▶RUN	Frequency Reference 1 to 16	Sets the frequency reference for the drive. Setting units are determined by parameter o1-03. Note: The value set to o1-03 is changed to 1 and the unit is changed to percentage automatically when A1-02 is set to 6 or 7	Default: 0.00 Hz Min: 0.00 Hz Max: 400.00 Hz <20> <63>

<20> Range upper limit is determined by the maximum output frequency (E1-04) and the upper limit of the frequency reference (d2-01).
<63> The value of o1-03 is changed to 1 and the unit is also changed to a percentage (%) when the control mode is set to CLV/PM or AOLV/PM.

B Parameter List

■ d2: Frequency Upper/Lower Limits

No.	Name	Description	Setting
d2-01	Frequency Reference Upper Limit	Sets the frequency reference upper limit as a percentage of the maximum output frequency.	Default: 100.0% Min: 0.0% Max: 110.0%
d2-02	Frequency Reference Lower Limit	Sets the frequency reference lower limit as a percentage of the maximum output frequency.	Default: 0.0% Min: 0.0% Max: 110.0%

◆ E: Motor Parameters

■ E2: Motor 1 Parameters

No.	Name	Description	Setting
E2-01	Motor Rated Current	Sets the motor nameplate full load current in Amps. Automatically set during Auto-Tuning.	Default: <9> Min: 10% of drive rated current Max: 150% of drive rated current <72>

<9> Default setting value is dependent on the drive model (o2-04) and the Drive Duty (C6-01).

<72> Display is in the following units.

- CIMR-U□2□0028, 2□0042, and 4□0011 to 4□0027: 0.01 A units
- CIMR-U□2□0054 to 2□0248, and 4□0034 to 4□0930: 0.1 A units

◆ H: Multi-Function Terminals

H parameters assign functions to the multi-function input and output terminals.

■ H1: Multi-Function Digital Inputs

No.	Name	Description	Setting
H1-01	Multi-Function Digital Input Terminal S1 Function Selection	Assigns a function to the multi-function digital inputs. Note: Unused terminals should be set to F.	Default: 40 (F) <31> Min: 1 Max: 9F
H1-02	Multi-Function Digital Input Terminal S2 Function Selection		Default: 41 (F) <31> Min: 1 Max: 9F
H1-03	Multi-Function Digital Input Terminal S3 Function Selection		Default: 24 Min: 0 Max: 9F
H1-04	Multi-Function Digital Input Terminal S4 Function Selection		Default: 14 Min: 0 Max: 9F
H1-05	Multi-Function Digital Input Terminal S5 Function Selection		Default: 3 (0) <31> Min: 0 Max: 9F
H1-06	Multi-Function Digital Input Terminal S6 Function Selection		Default: 4 (3) <31> Min: 0 Max: 9F
H1-07	Multi-Function Digital Input Terminal S7 Function Selection		Default: 6 (4) <31> Min: 0 Max: 9F
H1-08	Multi-Function Digital Input Terminal S8 Function Selection		Default: 8 Min: 0 Max: 9F

<31> Value in parenthesis is the default setting when a 3-wire initialization is performed (A1-03 = 3330).

Parameter List





B

B Parameter List



■ H2: Multi-Function Digital Outputs

No.	Name	Description	Setting
H2-01	Terminal M1-M2 Function Selection (Relay)	Assigns a function to the multi-function digital outputs.	Default: 0 Min: 0 Max: 192
H2-02	Terminal M3-M4 Function Selection (Relay)		Default: 1 Min: 0 Max: 192
H2-03	Terminal M5-M6 Function Selection (Relay)		Default: 2 Min: 0 Max: 192
H2-06	Power Consumption Output Unit Selection	Sets the units for the output signal when one of the multi-function terminals is set to power consumption pulse output (H2-01, H2-02, or H2-03 = 39) or regenerated power pulse output (H2-01, H2-02, or H2-03 = 3A). Outputs a 200 ms pulse signal when the watt-hour counter increases by the units selected. 0: 0.1 kWh units 1: 1 kWh units 2: 10 kWh units 3: 100 kWh units 4: 1000 kWh units Note: The Setting range is 1 to 4 in the drive software versions S1014 and earlier.	Default: 1 Min: 0 Max: 4
H2-07	Memobus Regs1 Address Select	Sets the addresses of the MEMOBUS/Modbus registers from which data will be sent to contact outputs 62 and 162.	Default: 1 Min: 1 Max: 1FFFH
H2-08	Memobus Regs1 Bit Select	Sets the bits for the MEMOBUS/Modbus registers from which data will be sent to contact outputs 62 and 162.	Default: 0 Min: 0 Max: FFFFH
H2-09	Memobus Regs2 Address Select	Sets the addresses of the MEMOBUS/Modbus registers from which data will be sent to contact outputs 63 and 163.	Default: 1 Min: 1 Max: 1FFFH
H2-10	Memobus Regs2 Bit Select	Sets the bits for the MEMOBUS/Modbus registers from which data will be sent to contact outputs 63 and 163.	Default: 0 Min: 0 Max: FFFFH





■ H3: Multi-Function Analog Inputs

No.	Name	Description	Setting
H3-01	Terminal A1 Signal Level Selection	0: 0 to 10 V 1: -10 to 10 V	Default: 0 Min: 0 Max: 1
H3-02	Terminal A1 Function Selection	Sets the function of terminal A1.	Default: 0 Min: 0 Max: 32
H3-03	 Terminal A1 Gain Setting	Sets the level of the input value selected in H3-02 when 10 V is input at terminal A1.	Default: 100.0% Min: -999.9% Max: 999.9%
H3-04	 Terminal A1 Bias Setting	Sets the level of the input value selected in H3-02 when 0 V is input at terminal A1.	Default: 0.0% Min: -999.9% Max: 999.9%
H3-05	Terminal A3 Signal Level Selection	0: 0 to 10 V 1: -10 to 10 V	Default: 0 Min: 0 Max: 1
H3-06	Terminal A3 Function Selection	Sets the function of terminal A3.	Default: 2 Min: 0 Max: 32
H3-07	 Terminal A3 Gain Setting	Sets the level of the input value selected in H3-06 when 10 V is input at terminal A3.	Default: 100.0% Min: -999.9% Max: 999.9%
H3-08	 Terminal A3 Bias Setting	Sets the level of the input value selected in H3-06 when 0 V is input at terminal A3.	Default: 0.0% Min: -999.9% Max: 999.9%

B Parameter List

No.	Name	Description	Setting
H3-09	Terminal A2 Signal Level Selection	0: 0 to 10 V 1: -10 to 10 V 2: 4 to 20 mA 3: 0 to 20 mA Note: Use DIP switch S1 to set input terminal A2 for a current or a voltage input signal.	Default: 2 Min: 0 Max: 3
H3-10	Terminal A2 Function Selection	Sets the function of terminal A2.	Default: 0 Min: 0 Max: 32
H3-11	 Terminal A2 Gain Setting	Sets the level of the input value selected in H3-10 when 10 V (20 mA) is input at terminal A2.	Default: 100.0% Min: -999.9% Max: 999.9%
H3-12	 Terminal A2 Bias Setting	Sets the level of the input value selected in H3-10 when 0 V (0 or 4 mA) is input at terminal A2.	Default: 0.0% Min: -999.9% Max: 999.9%
H3-13	Analog Input Filter Time Constant	Sets a primary delay filter time constant for terminals A1, A2, and A3. Used for noise filtering.	Default: 0.03 s Min: 0.00 s Max: 2.00 s
H3-14	Analog Input Terminal Enable Selection	Determines which of the analog input terminals will be enabled or disabled when a digital input programmed for “Analog input enable” (H1-□□ = C) is activated. The terminals other than the one set as the target are not influenced by input signals. 1: Terminal A1 only 2: Terminal A2 only 3: Terminals A1 and A2 only 4: Terminal A3 only 5: Terminals A1 and A3 6: Terminals A2 and A3 7: All terminals enabled	Default: 7 Min: 1 Max: 7
H3-16	Terminal A1 Offset	Adds an offset when the analog signal to terminal A1 is at 0 V.	Default: 0 Min: -500 Max: 500
H3-17	Terminal A2 Offset	Adds an offset when the analog signal to terminal A2 is at 0 V.	Default: 0 Min: -500 Max: 500
H3-18	Terminal A3 Offset	Adds an offset when the analog signal to terminal A3 is at 0 V.	Default: 0 Min: -500 Max: 500

H4: Multi-Function Analog Outputs

No.	Name	Description	Setting
H4-01	Multi-Function Analog Output Terminal FM Monitor Selection	Selects the data to be output through multi-function analog output terminal FM. Set the desired monitor parameter to the digits available in U□-□□. For example, enter “103” for U1-03.	Default: 102 Min: 000 Max: 999
H4-02	 Multi-Function Analog Output Terminal FM Gain	Sets the signal level at terminal FM that is equal to 100% of the selected monitor value.	Default: 100.0% Min: -999.9% Max: 999.9%
H4-03	 Multi-Function Analog Output Terminal FM Bias	Sets the signal level at terminal FM that is equal to 0% of the selected monitor value.	Default: 0.0% Min: -999.9% Max: 999.9%
H4-04	Multi-Function Analog Output Terminal AM Monitor Selection	Selects the data to be output through multi-function analog output terminal AM. Set the desired monitor parameter to the digits available in U□-□□. For example, enter “103” for U1-03.	Default: 103 Min: 000 Max: 999
H4-05	 Multi-Function Analog Output Terminal AM Gain	Sets the signal level at terminal AM that is equal to 100% of the selected monitor value.	Default: 50.0% Min: -999.9% Max: 999.9%
H4-06	 Multi-Function Analog Output Terminal AM Bias	Sets the signal level at terminal AM that is equal to 0% of the selected monitor value.	Default: 0.0% Min: -999.9% Max: 999.9%
H4-07	Multi-Function Analog Output Terminal FM Signal Level Selection	0: 0 to 10 V 1: -10 to 10 V 2: 4 to 20 mA	Default: 0 Min: 0 Max: 2

Parameter List

B

B Parameter List

No.	Name	Description	Setting
H4-08	Multi-Function Analog Output Terminal AM Signal Level Selection	0: 0 to 10 V 1: -10 to 10 V 2: 4 to 20 mA	Default: 0 Min: 0 Max: 2

■ H6: Pulse Train Input/Output

No.	Name	Description	Setting
H6-01	Pulse Train Input Terminal RP Function Selection	0: Frequency reference 1: PID feedback value 2: PID setpoint value 3: V/f Control with Simple PG feedback (possible only when using motor 1 in V/f Control)	Default: 0 Min: 0 Max: 3
H6-02	Pulse Train Input Scaling	Sets the terminal RP input signal frequency that is equal to 100% of the value selected in H6-01.	Default: 1440 Hz Min: 100 Hz Max: 32000 Hz
H6-03	Pulse Train Input Gain	Sets the level of the value selected in H6-01 when a frequency with the value set in H6-02 is input.	Default: 100.0% Min: 0.0% Max: 1000.0%
H6-04	Pulse Train Input Bias	Sets the level of the value selected in H6-01 when 0 Hz is input.	Default: 0.0% Min: -100.0% Max: 100.0%
H6-05	Pulse Train Input Filter Time	Sets the pulse train input filter time constant.	Default: 0.10 s Min: 0.00 s Max: 2.00 s
H6-06	Pulse Train Monitor Selection	Select the pulse train monitor output function (value of the □-□□ part of U□-□□). Example: To select U5-01, set "501".	Default: 102 Min: 000 Max: 809
H6-07	Pulse Train Monitor Scaling	Sets the terminal MP output signal frequency when the monitor value is 100%. As an example, have the pulse train monitor output equal the output frequency, set H6-06 to 102 and H6-07 to 0.	Default: 1440 Hz Min: 0 Hz Max: 32000 Hz
H6-08	Pulse Train Input Minimum Frequency	Sets the minimum frequency for the pulse train input to be detected. Enabled when H6-01 = 0, 1, or 2.	Default: 0.5 Hz Min: 0.1 Hz Max: 1000.0 Hz

◆ L: Protection Function

L parameters provide protection to the drive and motor, such as: control during momentary power loss, Stall Prevention, frequency detection, fault restarts, overtorque detection, torque limits, and other types of hardware protection.

■ L1: Motor Protection

No.	Name	Description	Setting
L1-01	Motor Overload Protection Selection	0: Disabled 1: General purpose motor (standard fan cooled) 2: Drive dedicated motor with a speed range of 1:10 3: Vector motor with a speed range of 1:100 4: PM motor with variable torque 5: PM motor with constant torque control 6: General purpose motor (50 Hz) The drive may not be able to provide protection when multiple motors are used, even if overload is enabled in L1-01. Set L1-01 to 0 and install separate thermal relay to each motor.	Default: <10> Min: 0 Max: 6
L1-02	Motor Overload Protection Time	Sets the motor thermal overload protection (oL1) time.	Default: 1.0 min Min: 0.1 min Max: 5.0 min

<10> Default setting is determined by the control mode (A1-02).

B Parameter List

◆ o: Operator Related Settings

The o parameters are used to set up the digital operator displays.

■ o2: Digital Operator Keypad Functions

No.	Name	Description	Setting
o2-19	Selection of Parameter Write During UV	Selects whether parameter settings can be changed during a control circuit undervoltage condition. To be used with 24 V Power Supply Unit Built-in model. 0: Disabled 1: Enabled	Default: 0 Min: 0 Max: 1

◆ T: Motor Tuning

Enter data into the following parameters to tune the motor and drive for optimal performance

■ T1: Induction Motor Auto-Tuning

No.	Name	Description	Setting
T1-01 <37>	Auto-Tuning Mode Selection	0: Rotational Auto-Tuning 2: Stationary Auto-Tuning for Line-to-Line Resistance 3: Rotational Auto-Tuning for V/f Control (necessary for Energy Savings and Speed Estimation Speed Search) 4: Stationary Auto-Tuning 2 5: Stationary Auto-Tuning 3 8: Inertia Tuning (perform Rotational Auto-Tuning prior to Inertia Tuning) 9: ASR Gain Tuning (perform Rotational Auto-Tuning prior to ASR Gain Auto-Tuning) Note: Inertia Tuning and ASR Gain Auto-Tuning might not be available if gears are between the machine and the motor shaft.	Default: 0 Min: 0 Max: 4, 5, 8, 9 <10>

<10> Default setting is determined by the control mode (A1-02).

<37> The availability of certain Auto-Tuning methods depends on the control mode selected for the drive.

C Standards Compliance

C Standards Compliance

◆ European Standards



Figure 67 CE Mark

The CE mark indicates that a product is in compliance with applicable European Directives for safety and environmental regulations. It is required for engaging in business and commerce in Europe.

The applicable European Directives for this product are as follows. We declared the CE marking based on the harmonized standards in the following table.

Applicable European Directive	Applicable Harmonized Standards
Low Voltage Directive (2006/95/EC)	IEC/EN 61800-5-1: 2007
EMC Guidelines (2004/108/EC)	EN 61800-3: 2004/A1: 2012 IEC 61800-3: 2004/A1: 2011
Machinery Directive (2006/42/EC)	EN ISO 13849-1/AC:2008 (PL e (Cat.3)) IEC 62061/A1:2012 (SIL CL 3) EN 62061/A1:2013 (SIL CL 3) IEC/EN 61800-5-2:2007 (SIL3)

The user(s) is solely responsible for ensuring that the end products used with this drive comply with all applicable European directives and with other national regulations (if required).

■ CE Low Voltage Directive Compliance

This drive has been tested according to European standard IEC/EN 61800-5-1, and it fully complies with the Low Voltage Directive.

To comply with the Low Voltage Directive, be sure to meet the following conditions when combining this drive with other devices:

Area of Use

Do not use drives in areas with pollution higher than degree 2 and overvoltage category 3 in accordance with IEC/EN 664.

Grounding

The drive is designed to be used in T-N (grounded neutral point) networks. If installing the drive in other types of grounded systems, contact your Yaskawa representative for instructions. *Refer to Enable the Internal EMC Filter on page 50* for details.

Guarding Against Harmful Materials

When installing IP00 enclosure drives, use an enclosure that prevents foreign material from entering the drive from above or below.

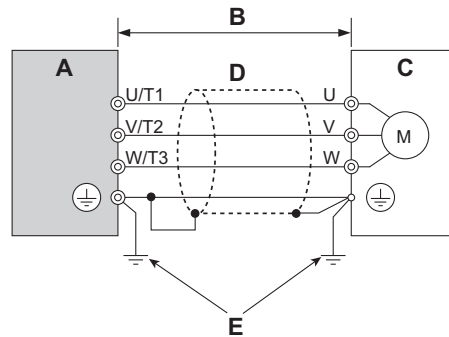
■ EMC Guidelines Compliance for CIMR-U□□E□□□□/□W□□□□

Drives with built-in EMC filters (CIMR-U□□E□□□□/□W□□□□) are tested according to European standards IEC/EN 61800-3: 2004/A1: 2012 and complies with EMC guidelines. Use drives with built-in EMC filters to comply with EMC guidelines.

**EMC Filter Installation
Installation Method**

Verify the following installation conditions to ensure that other devices and machinery used in combination with this drive (CIMR-U□□E□□□□/□W□□□□) also comply with EMC guidelines.

1. Place the drive in the enclosure.
2. Use braided shield cable for the drive and motor wiring, or run the wiring through a metal conduit.
3. Keep wiring as short as possible. Ground the shield on both the drive side and the motor side.



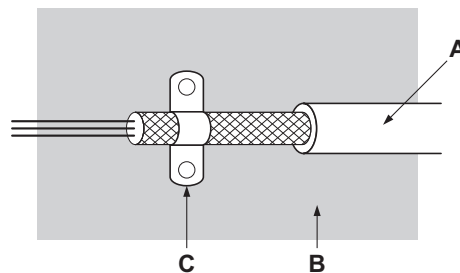
- A – Drive
- B – 10 m max cable length between drive and motor
- C – Motor
- D – Metal conduit
- E – Ground wire should be as short as possible.

Figure 68 Installation Method

4. Make sure the protective earthing conductor complies with technical standards and local safety regulations.

WARNING! Electrical Shock Hazard.

Because the leakage current exceeds 3.5 mA in models CIMR-U□□4□0302 and larger, IEC/EN 61800-5-1 states that either the power supply must be automatically disconnected in case of discontinuity of the protective earthing conductor or a protective earthing conductor with a cross-section of at least 10 mm² (Cu) or 16 mm² (Al) must be used. Failure to comply may result in death or serious injury.

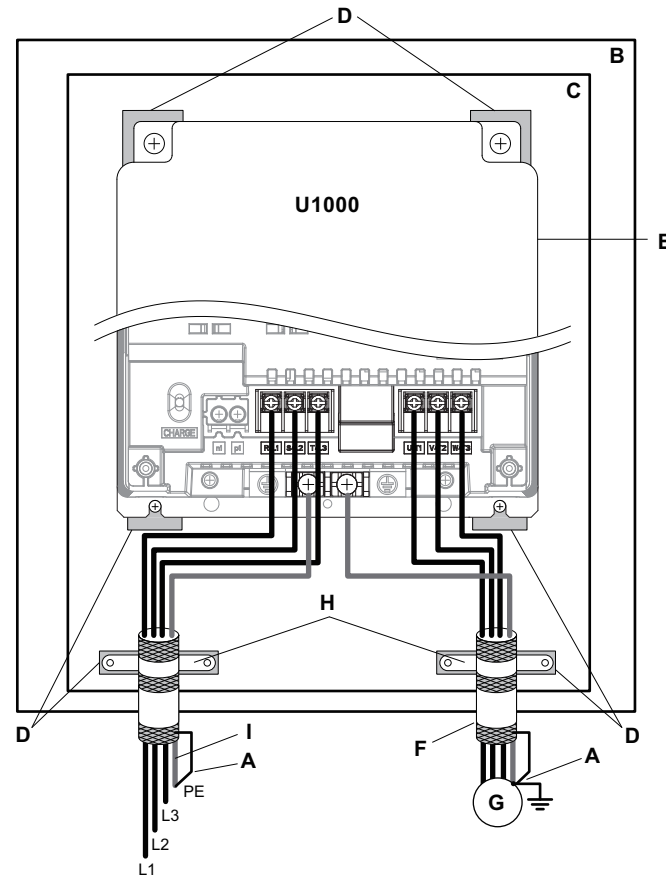


- A – Braided shield cable
- B – Metal panel
- C – Cable clamp (conductive)

Figure 69 Ground Area

C Standards Compliance

Three-Phase 200 V/400 V Class



- | | |
|---|---|
| A – Ground the cable shield | F – Motor cable (braided shield cable, max. 10 m) |
| B – Enclosure panel | G – Motor |
| C – Metal plate | H – Cable clamp |
| D – Grounding surface (remove any paint or sealant) | I – Ground plate (scrape off any visible paint) |
| E – Drive | |

Figure 70 EMC Filter and Drive Installation for CE Compliance (Three-Phase 200 V/400 V Class)

■ EMC Guidelines Compliance for CIMR-U□4□0477□□□ to 4□0930□□□

Drives with stand-alone EMC filters (CIMR-U□4□0477□□□ to 4□0930□□□) are tested according to European standards IEC/EN 61800-3: 2004/A1: 2012 and complies with EMC guidelines. Use drives with stand-alone EMC filters to comply with EMC guidelines.

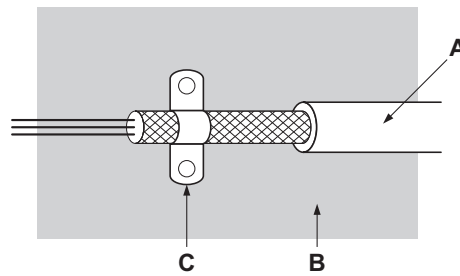
EMC Filter Installation Installation Method

Verify the following installation conditions to ensure that other devices and machinery used in combination with this drive (CIMR-U□4□0477□□□ to 4□0930□□□) also comply with EMC guidelines. Refer to *EMC Filters on page 106* for EMC filter selection.

1. Install an EMC filter to the input side specified by Yaskawa for compliance with European standards.
2. Place the drive in the enclosure.
3. Use braided shield cable for the drive and motor wiring, or run the wiring through a metal conduit.
4. Keep wiring as short as possible. Ground the shield on both the drive side and the motor side.
5. Make sure the protective earthing conductor complies with technical standards and local safety regulations.

WARNING! Electrical Shock Hazard.

Because the leakage current exceeds 3.5 mA in models CIMR-U□4□0302 and larger, IEC/EN 61800-5-1 states that either the power supply must be automatically disconnected in case of discontinuity of the protective earthing conductor or a protective earthing conductor with a cross-section of at least 10 mm² (Cu) or 16 mm² (Al) must be used. Failure to comply may result in death or serious injury.



A – Braided shield cable
B – Metal panel
C – Cable clamp (conductive)

Figure 71 Ground Area

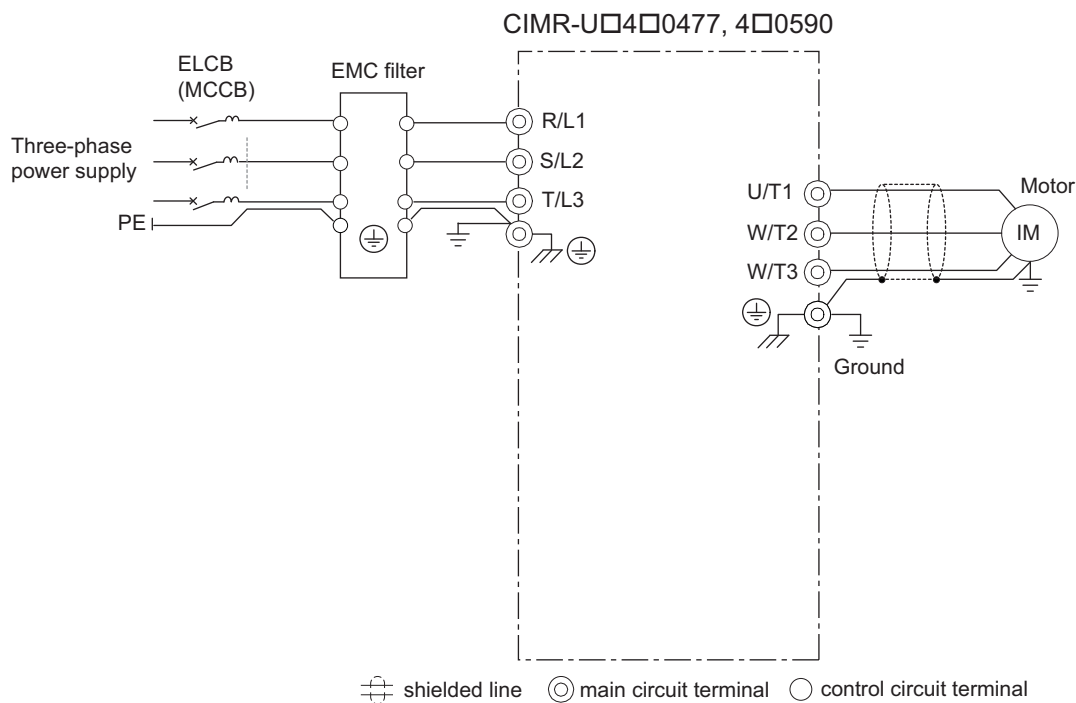


Figure 72 Wiring Diagram for EMC (4□0477, 4□0590)

C Standards Compliance

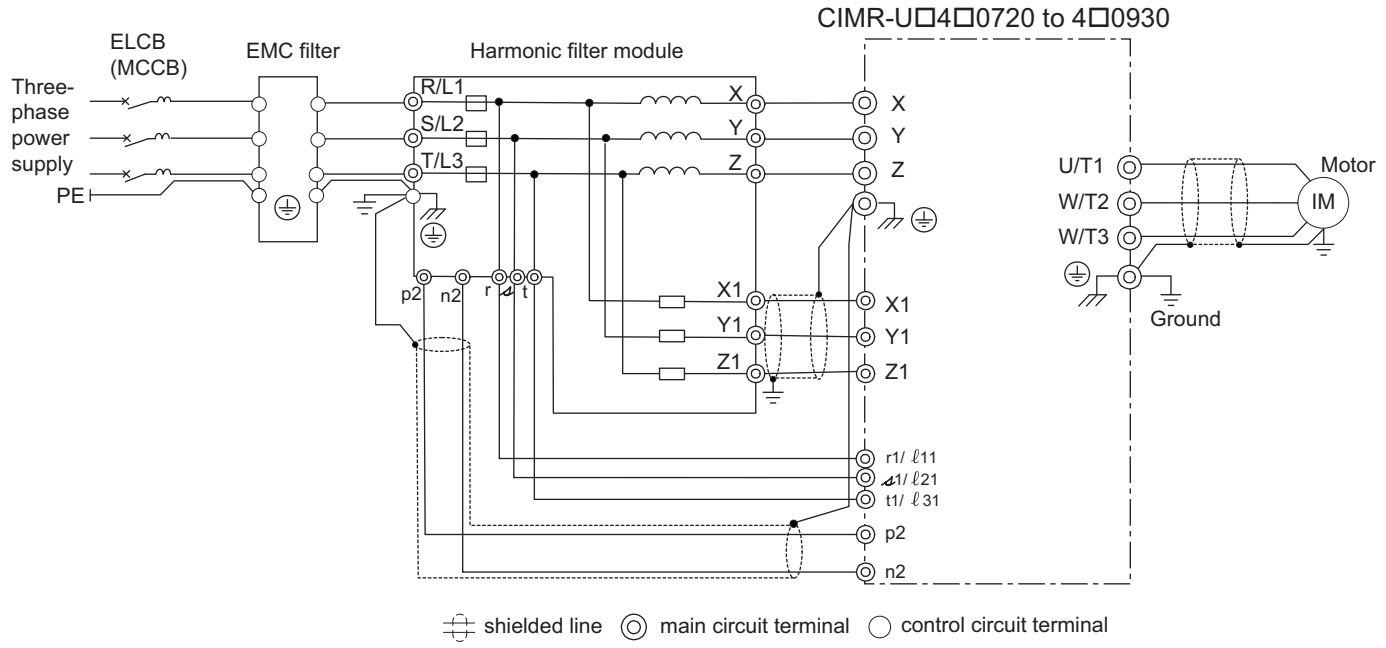


Figure 73 Wiring Diagram for EMC (4□0720 to 4□0930)

EMC Filters

The drive should be installed with the EMC filters listed in [Table 42](#) in order to comply with the IEC/EN 61800-3 requirements.

Table 42 IEC/EN 61800-3 Filters

Model	Type	Manufacture	Rated Current (A)	Weight kg	Dimensions [W × H × D] mm	Y × X mm	Figure
400 V Class							
4A0477	B84143B1000S080	EPCOS	1000	18.5	410×140×260	235×240	Figure 74
4A0590	B84143B1000S080	EPCOS	1000	18.5	410×140×260	235×240	Figure 74
4A0720	B84143B1600S080	EPCOS	1600	24.5	490×140×260	235×240	Figure 75
4A0900	B84143B1600S080	EPCOS	1600	24.5	490×140×260	235×240	Figure 75
4A0930	B84143B1600S080	EPCOS	1600	24.5	490×140×260	235×240	Figure 75

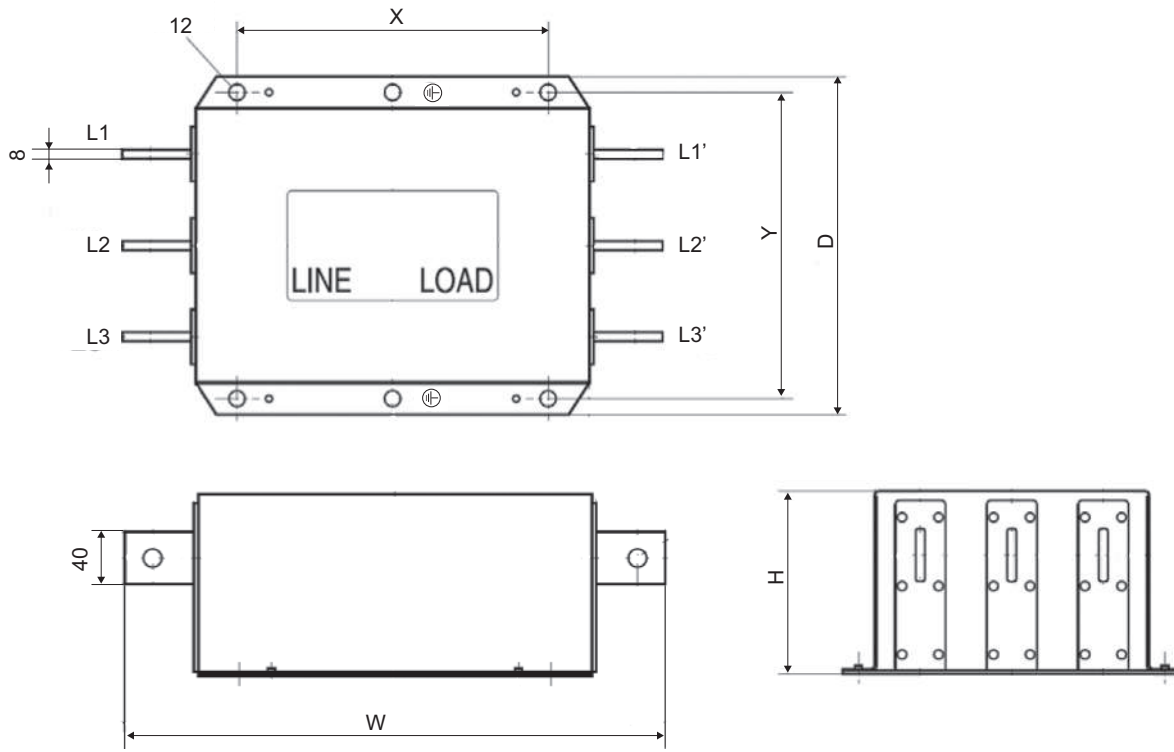


Figure 74 EMC Filter Dimensions (4□0477, 4□0590)

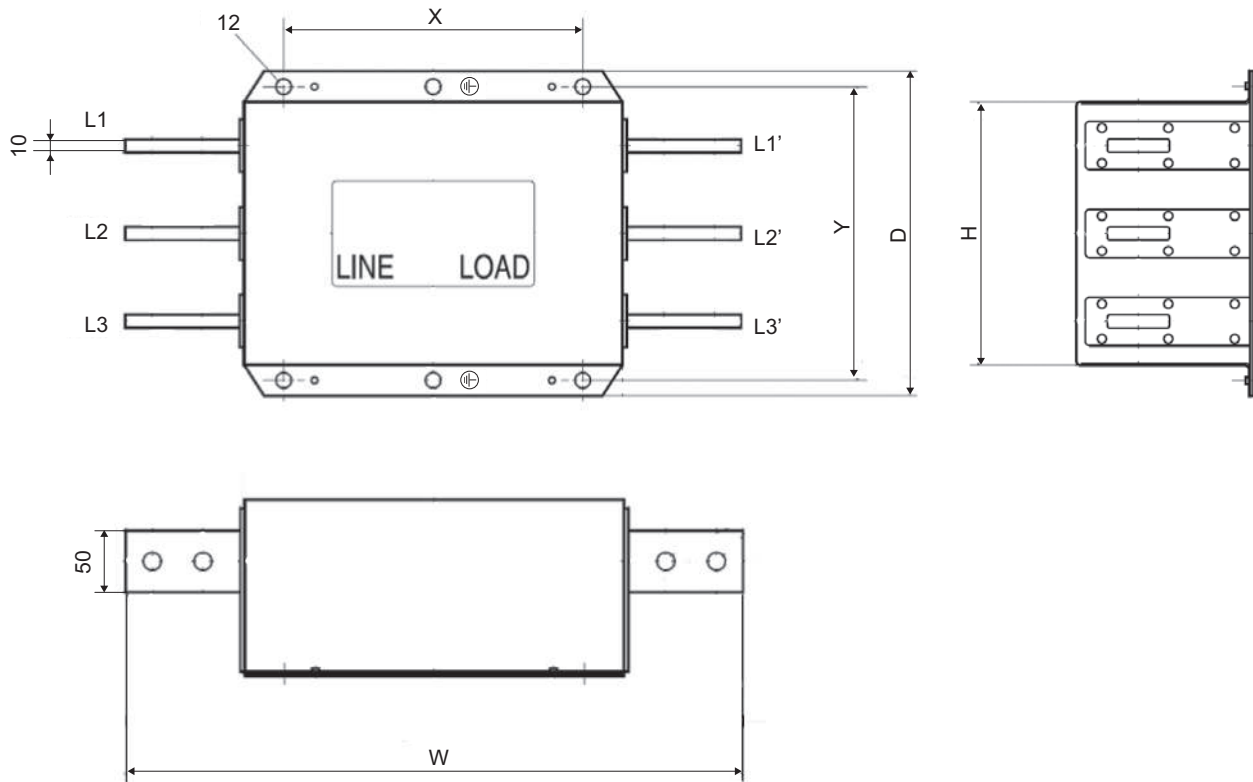


Figure 75 EMC Filter Dimensions (4□0720 to 4□0930)



C Standards Compliance

◆ UL Standards

■ UL Standards Compliance

The UL/cUL mark applies to products in the United States and Canada. It indicates that UL has performed product testing and evaluation, and determined that their stringent standards for product safety have been met. For a product to receive UL certification, all components inside that product must also receive UL certification.



Figure 76 UL/cUL Mark

This drive is tested in accordance with UL standard UL508C and complies with UL requirements. The conditions described below must be met to maintain compliance when using this drive in combination with other equipment:

Conditions of Acceptability

- With respect to models CIMR-U□4□0720 to 4□0930, a harmonic filter module shall be installed on the input of the drive (see [Table 43](#)).

Table 43 Correspondence of Harmonic Filter Module and CIMR-U□4□0720 to 4□0930

Model CIMR-U□	Harmonic Filter Module
4□0720	EUJ71183□.□
4□0900	EUJ71184□.□
4□0930	EUJ71185□.□

- The drive and its peripheral devices shall be installed in a suitable enclosure in the end use.

Installation Area

Do not install the drive to an area greater than pollution degree 2 (UL standard).

Ambient Temperature

- 10 to 40°C (IP20/NEMA 1, UL Type 1 enclosure)
- 10 to 50°C (IP00 enclosure)

Main Circuit Terminal Wiring

Yaskawa recommends using closed-loop crimp terminals on all drive models. Use only the tools recommended by the terminal manufacturer for crimping.

The wire gauges listed in [Table 44](#) to [Table 46](#) are Yaskawa recommendations. Refer to local codes for proper wire gauge selections.

- Note:** The mark ⊕ indicates the terminals for protective ground connection.
 Grounding impedance;
 200 V: 100 Ω or less
 400 V: 10 Ω or less

Wire Gauges and Tightening Torques

CIMR-U□2□0028 to 2□0248, 4□0011 to 4□0930

Table 44 Wire Gauge and Torque Specifications (Three-Phase 200 V Class)

Model CIMR-U□	Terminal	Recomm. Gauge AWG, kcmil	Applicable Gauge AWG, kcmil	Screw Size	Tightening Torque N·m (lb.in.)
2□0028	R/L1, S/L2, T/L3	8	10 to 8	M5	2.3 to 2.7 (20.4 to 23.9)
	U/T1, V/T2, W/T3	8	10 to 8	M5	
	⊕	8	10 to 6	M6	3.9 to 4.9 (34.7 to 43.4)
	p1, n1	14	14 to 12	M4	1 to 1.4 (8.9 to 12.4)
2□0042	R/L1, S/L2, T/L3	6	8 to 3	M6	4 to 6 (35.4 to 53.1)
	U/T1, V/T2, W/T3	6	8 to 3	M6	
	⊕	8	10 to 3	M8	8.8 to 10.8 (78.1 to 95.5)
	p1, n1	14	14 to 12	M4	1 to 1.4 (8.9 to 12.4)
2□0054	R/L1, S/L2, T/L3	4	6 to 3	M6	4 to 6 (35.4 to 53.1)
	U/T1, V/T2, W/T3	4	6 to 3	M6	
	⊕	6	8 to 3	M8	8.8 to 10.8 (78.1 to 95.5)
	p1, n1	14	14 to 12	M4	1 to 1.4 (8.9 to 12.4)
2□0068	R/L1, S/L2, T/L3	4	4 to 3	M6	4 to 6 (35.4 to 53.1)
	U/T1, V/T2, W/T3	4	4 to 3	M6	
	⊕	6	6 to 3	M8	8.8 to 10.8 (78.1 to 95.5)
	p1, n1	14	14 to 12	M4	1 to 1.4 (8.9 to 12.4)
2□0081	R/L1, S/L2, T/L3	6 × 2P	6 to 3 × 2P	M6	4 to 6 (35.4 to 53.1)
	U/T1, V/T2, W/T3	6 × 2P	6 to 3 × 2P	M6	
	⊕	6	6 to 3	M8	8.8 to 10.8 (78.1 to 95.5)
	p1, n1	14	14 to 12	M4	1 to 1.4 (8.9 to 12.4)
2□0104	R/L1, S/L2, T/L3	1	6 to 1/0 × 2P	M8	8 to 10 (70.8 to 88.5)
	U/T1, V/T2, W/T3	1	6 to 1/0 × 2P	M8	
	⊕	4	4 to 1	M8	8.8 to 10.8 (78.1 to 95.5)
	p1, n1	14	14 to 12	M4	1.2 to 2.0 (10.4 to 17.4)
2□0130	R/L1, S/L2, T/L3	4 × 2P	6 to 1/0 × 2P	M8	8 to 10 (70.8 to 88.5)
	U/T1, V/T2, W/T3	4 × 2P	6 to 1/0 × 2P	M8	
	⊕	4	4 to 1	M8	8.8 to 10.8 (78.1 to 95.5)
	p1, n1	14	14 to 12	M4	1.2 to 2.0 (10.4 to 17.4)
2□0154	R/L1, S/L2, T/L3	3 × 2P	4 to 4/0 × 2P	M10	15 to 20 (130 to 173)
	U/T1, V/T2, W/T3	3 × 2P	4 to 4/0 × 2P	M10	
	⊕	4	4 to 2/0	M10	17.7 to 22.6 (156 to 200)
	p1, n1	14	14 to 12	M4	1.2 to 2.0 (10.4 to 17.4)

C Standards Compliance

Model CIMR-U□	Terminal	Recomm. Gauge AWG, kcmil	Applicable Gauge AWG, kcmil	Screw Size	Tightening Torque N·m (lb.in.)
2□0192	R/L1, S/L2, T/L3	1 × 2P	3 to 4/0 × 2P	M10	15 to 20 (130 to 173)
	U/T1, V/T2, W/T3	1 × 2P	3 to 4/0 × 2P	M10	
	⊕	3	4 to 2/0	M10	17.7 to 22.6 (156 to 200)
	p1, n1	14	14 to 12	M4	1.2 to 2.0 (10.4 to 17.4)
2□0248	R/L1, S/L2, T/L3	2/0 × 2P	1 to 4/0 × 2P	M10	15 to 20 (130 to 173)
	U/T1, V/T2, W/T3	2/0 × 2P	1 to 4/0 × 2P	M10	
	⊕	3	4 to 4/0	M12	31.4 to 39.2 (278 to 347)
	p1, n1	14	14 to 12	M4	1.2 to 2.0 (10.4 to 17.4)

Table 45 Wire Gauge and Torque Specifications (Three-Phase 400 V Class)

Model CIMR-U□	Terminal	Recomm. Gauge AWG, kcmil	Applicable Gauge AWG, kcmil	Screw Size	Tightening Torque N·m (lb.in.)
4□0011	R/L1, S/L2, T/L3	14	14 to 8	M5	2.3 to 2.7 (20.4 to 23.9)
	U/T1, V/T2, W/T3	14	14 to 8	M5	
	⊕	10	12 to 6	M6	3.9 to 4.9 (34.7 to 43.4)
	p1, n1	14	14 to 12	M4	1 to 1.4 (8.9 to 12.4)
4□0014	R/L1, S/L2, T/L3	12	14 to 8	M5	2.3 to 2.7 (20.4 to 23.9)
	U/T1, V/T2, W/T3	12	14 to 8	M5	
	⊕	10	12 to 6	M6	3.9 to 4.9 (34.7 to 43.4)
	p1, n1	14	14 to 12	M4	1 to 1.4 (8.9 to 12.4)
4□0021	R/L1, S/L2, T/L3	10	12 to 8	M5	2.3 to 2.7 (20.4 to 23.9)
	U/T1, V/T2, W/T3	10	12 to 8	M5	
	⊕	10	12 to 6	M6	3.9 to 4.9 (34.7 to 43.4)
	p1, n1	14	14 to 12	M4	1 to 1.4 (8.9 to 12.4)
4□0027	R/L1, S/L2, T/L3	8	10 to 8	M5	2.3 to 2.7 (20.4 to 23.9)
	U/T1, V/T2, W/T3	8	10 to 8	M5	
	⊕	8	12 to 6	M6	3.9 to 4.9 (34.7 to 43.4)
	p1, n1	14	14 to 12	M4	1 to 1.4 (8.9 to 12.4)
4□0034	R/L1, S/L2, T/L3	8	8	M5	2.3 to 2.7 (20.4 to 23.9)
	U/T1, V/T2, W/T3	8	8	M5	
	⊕	8	10 to 6	M6	3.9 to 4.9 (34.7 to 43.4)
	p1, n1	14	14 to 12	M4	1 to 1.4 (8.9 to 12.4)
4□0040	R/L1, S/L2, T/L3	8	8 to 3	M6	4 to 6 (35.4 to 53.1)
	U/T1, V/T2, W/T3	8	8 to 3	M6	
	⊕	8	10 to 3	M8	8.8 to 10.8 (78.1 to 95.5)
	p1, n1	14	14 to 12	M4	1 to 1.4 (8.9 to 12.4)
4□0052	R/L1, S/L2, T/L3	6	8 to 3	M6	4 to 6 (35.4 to 53.1)
	U/T1, V/T2, W/T3	6	8 to 3	M6	
	⊕	6	8 to 3	M8	8.8 to 10.8 (78.1 to 95.5)
	p1, n1	14	14 to 12	M4	1 to 1.4 (8.9 to 12.4)

C Standards Compliance

Model CIMR-U□	Terminal	Recomm. Gauge AWG, kcmil	Applicable Gauge AWG, kcmil	Screw Size	Tightening Torque N·m (lb.in.)
4□0065	R/L1, S/L2, T/L3	4	6 to 3	M6	4 to 6 (35.4 to 53.1)
	U/T1, V/T2, W/T3	4	6 to 3	M6	
	⊕	6	6 to 3	M8	8.8 to 10.8 (78.1 to 95.5)
	p1, n1	14	14 to 12	M4	1 to 1.4 (8.9 to 12.4)
4□0077	R/L1, S/L2, T/L3	3	4 to 3	M6	4 to 6 (35.4 to 53.1)
	U/T1, V/T2, W/T3	3	4 to 3	M6	
	⊕	6	6 to 3	M8	8.8 to 10.8 (78.1 to 95.5)
	p1, n1	14	14 to 12	M4	1 to 1.4 (8.9 to 12.4)
4□0096	R/L1, S/L2, T/L3	1	8 to 1/0 × 2P	M8	8 to 10 (70.8 to 88.5)
	U/T1, V/T2, W/T3	1	8 to 1/0 × 2P	M8	
	⊕	4	4 to 1	M8	8.8 to 10.8 (78.1 to 95.5)
	p1, n1	14	14 to 12	M4	1.2 to 2.0 (10.4 to 17.4)
4□0124	R/L1, S/L2, T/L3	4 × 2P	6 to 1/0 × 2P	M8	8 to 10 (70.8 to 88.5)
	U/T1, V/T2, W/T3	4 × 2P	6 to 1/0 × 2P	M8	
	⊕	4	4 to 1	M8	8.8 to 10.8 (78.1 to 95.5)
	p1, n1	14	14 to 12	M4	1.2 to 2.0 (10.4 to 17.4)
4□0156	R/L1, S/L2, T/L3	3 × 2P	4 to 4/0 × 2P	M10	15 to 20 (130 to 173)
	U/T1, V/T2, W/T3	3 × 2P	4 to 4/0 × 2P	M10	
	⊕	4	4 to 2/0	M10	17.7 to 22.6 (156 to 200)
	p1, n1	14	14 to 12	M4	1.2 to 2.0 (10.4 to 17.4)
4□0180	R/L1, S/L2, T/L3	2 × 2P	3 to 4/0 × 2P	M10	15 to 20 (130 to 173)
	U/T1, V/T2, W/T3	2 × 2P	3 to 4/0 × 2P	M10	
	⊕	3	4 to 2/0	M10	17.7 to 22.6 (156 to 200)
	p1, n1	14	14 to 12	M4	1.2 to 2.0 (10.4 to 17.4)
4□0216	R/L1, S/L2, T/L3	1/0 × 2P	2 to 4/0 × 2P	M10	15 to 20 (130 to 173)
	U/T1, V/T2, W/T3	1/0 × 2P	2 to 4/0 × 2P	M10	
	⊕	3	4 to 4/0	M12	31.4 to 39.2 (278 to 347)
	p1, n1	14	14 to 12	M4	1.2 to 2.0 (10.4 to 17.4)
4□0240	R/L1, S/L2, T/L3	1/0 × 2P	1/0 to 4/0 × 2P	M10	15 to 20 (130 to 173)
	U/T1, V/T2, W/T3	1/0 × 2P	1/0 to 4/0 × 2P	M10	
	⊕	2	2 to 4/0	M12	31.4 to 39.2 (278 to 347)
	p1, n1	14	14 to 12	M4	1.2 to 2.0 (10.4 to 17.4)
4□0302 <▷	R/L1, S/L2, T/L3	3/0 × 2P	1/0 to 4/0 × 2P	M10	15 to 20 (130 to 173)
	U/T1, V/T2, W/T3	3/0 × 2P	1/0 to 4/0 × 2P	M10	
	⊕	1	1 to 300	M12	31.4 to 39.2 (278 to 347)
	p1, n1	14	14 to 12	M4	1.2 to 2.0 (10.4 to 17.4)

C Standards Compliance

Model CIMR-U□	Terminal	Recomm. Gauge AWG, kcmil	Applicable Gauge AWG, kcmil	Screw Size	Tightening Torque N·m (lb.in.)
4□0361 <->	R/L1, S/L2, T/L3	4/0 × 2P	3/0 to 4/0 × 2P	M10	15 to 20 (130 to 173)
	U/T1, V/T2, W/T3	4/0 × 2P	3/0 to 4/0 × 2P	M10	
	⊕	1/0	1/0 to 300	M12	31.4 to 39.2 (278 to 347)
	p1, n1	14	14 to 12	M4	1.2 to 2.0 (10.4 to 17.4)
4□0414 <->	R/L1, S/L2, T/L3	300 × 2P	4/0 to 300 × 2P	M12	25 to 35 (217 to 304)
	U/T1, V/T2, W/T3	300 × 2P	4/0 to 300 × 2P	M12	
	⊕	1/0	1/0 to 400	M12	31.4 to 39.2 (278 to 347)
	p1, n1	14	14 to 12	M4	1.2 to 2.0 (10.4 to 17.4)
4□0477 <->	R/L1, S/L2, T/L3	3/0 × 4P	300 × 2P 2/0 to 300 × 4P	M12	31.4 to 39.2 (278 to 347)
	U/T1, V/T2, W/T3	3/0 × 4P	300 × 2P 2/0 to 300 × 4P	M12	31.4 to 39.2 (278 to 347)
	⊕	1/0	1/0 to 300	M12	31.4 to 39.2 (278 to 347)
	p1, n1	14	14 to 12	M4	1.2 to 2.0 (10.4 to 17.4)
4□0590 <->	R/L1, S/L2, T/L3	250 × 4P	3/0 to 300 × 4P	M12	31.4 to 39.2 (278 to 347)
	U/T1, V/T2, W/T3	250 × 4P	3/0 to 300 × 4P	M12	31.4 to 39.2 (278 to 347)
	⊕	2/0	2/0 to 300	M12	31.4 to 39.2 (278 to 347)
	p1, n1	14	14 to 12	M4	1.2 to 2.0 (10.4 to 17.4)
4□0720 <->	X, Y, Z	300 × 4P	250 to 300 × 4P	M12	31.4 to 39.2 (278 to 347)
	X1, Y1, Z1	1/0	1/0 to 2/0	M8	5.4 to 6.0 (47.8 to 53.0)
	U/T1, V/T2, W/T3	300 × 4P	250 to 300 × 4P	M12	31.4 to 39.2 (278 to 347)
	⊕	3/0	3/0 to 300	M12	31.4 to 39.2 (278 to 347)
	r1, 1, t1	14	14 to 12	M4	1.2 to 2.0 (10.4 to 17.4)
	p1, n1	14	14 to 6	M5	2.0 to 2.5 (17.4 to 21.7)
	p2, n2	14	14 to 12	M4	1.2 to 2.0 (10.4 to 17.4)
4□0900 <->	X, Y, Z	4/0 × 8P	300 × 4P 2/0 to 300 × 8P	M12	31.4 to 39.2 (278 to 347)
	X1, Y1, Z1	1/0	1/0 to 2/0	M8	5.4 to 6.0 (47.8 to 53.0)
	U/T1, V/T2, W/T3	4/0 × 8P	300 × 4P 2/0 to 300 × 8P	M12	31.4 to 39.2 (278 to 347)
	⊕	4/0	4/0 to 300	M12	31.4 to 39.2 (278 to 347)
	r1, 1, t1	14	14 to 12	M4	1.2 to 2.0 (10.4 to 17.4)
	p1, n1	14	14 to 6	M5	2.0 to 2.5 (17.4 to 21.7)
	p2, n2	14	14 to 12	M4	1.2 to 2.0 (10.4 to 17.4)

C Standards Compliance

Model CIMR-U□	Terminal	Recomm. Gauge AWG, kcmil	Applicable Gauge AWG, kcmil	Screw Size	Tightening Torque N·m (lb.in.)
4□0930 <1>	X, Y, Z	4/0 × 8P	4/0 to 300 × 8P	M12	31.4 to 39.2 (278 to 347)
	X1, Y1, Z1	1/0	1/0 to 2/0	M8	5.4 to 6.0 (47.8 to 53.0)
	U/T1, V/T2, W/T3	4/0 × 8P	4/0 to 300 × 8P	M12	31.4 to 39.2 (278 to 347)
	⊕	4/0	4/0 to 300	M12	31.4 to 39.2 (278 to 347)
	r1, s1, t1	14	14 to 12	M4	1.2 to 2.0 (10.4 to 17.4)
	p1, n1	14	14 to 6	M5	2.0 to 2.5 (17.4 to 21.7)
	p2, n2	14	14 to 12	M4	1.2 to 2.0 (10.4 to 17.4)

<1> When an EMC filter is installed, additional measures must be taken in order to comply with IEC/EN61800-5-1. *Refer to EMC Filter Installation on page 103.*

Harmonic Filter Module

Table 46 Harmonic Filter Module Wire Gauge and Torque Specifications for CIMR-U□4□0720 to 4□0930

Model	Terminal	Recomm. Gauge AWG, kcmil	Applicable Gauge AWG, kcmil	Screw Size	Tightening Torque N·m (lb.in.)
EUJ71183□.□ <1>	R/L1, S/L2, T/L3	300 × 4P	250 to 300 × 4P	M12	31.4 to 39.2 (278 to 347)
	X, Y, Z	300 × 4P	250 to 300 × 4P	M12	31.4 to 39.2 (278 to 347)
	X1, Y1, Z1	1/0	1/0 to 2/0	M8	5.4 to 6.0 (47.8 to 53.0)
	⊕	3/0	3/0 to 300	M12	31.4 to 39.2 (278 to 347)
	r1, s1, t1	14	14 to 12	M4	1.2 to 2.0 (10.4 to 17.4)
	p2, n2	14	14 to 12	M4	1.2 to 2.0 (10.4 to 17.4)
EUJ71184□.□ <1>	R/L1, S/L2, T/L3	4/0 × 8P	300 × 4P 2/0 to 300 × 8P	M12	31.4 to 39.2 (278 to 347)
	X, Y, Z	4/0 × 8P	300 × 4P 2/0 to 300 × 8P	M12	31.4 to 39.2 (278 to 347)
	X1, Y1, Z1	1/0	1/0 to 2/0	M8	5.4 to 6.0 (47.8 to 53.0)
	⊕	4/0	4/0 to 300	M12	31.4 to 39.2 (278 to 347)
	r1, s1, t1	14	14 to 12	M4	1.2 to 2.0 (10.4 to 17.4)
	p2, n2	14	14 to 12	M4	1.2 to 2.0 (10.4 to 17.4)
EUJ71185□.□ <1>	R/L1, S/L2, T/L3	4/0 × 8P	4/0 to 300 × 8P	M12	31.4 to 39.2 (278 to 347)
	X, Y, Z	4/0 × 8P	4/0 to 300 × 8P	M12	31.4 to 39.2 (278 to 347)
	X1, Y1, Z1	1/0	1/0 to 2/0	M8	5.4 to 6.0 (47.8 to 53.0)
	⊕	4/0	4/0 to 300	M12	31.4 to 39.2 (278 to 347)
	r1, s1, t1	14	14 to 12	M4	1.2 to 2.0 (10.4 to 17.4)
	p2, n2	14	14 to 12	M4	1.2 to 2.0 (10.4 to 17.4)

<1> When wiring the ground wire, additional measures must be taken in accordance with IEC/EN 61800-5-1.

Standards
Compliance

C Standards Compliance

Closed-Loop Crimp Terminal Recommendations

Yaskawa recommends using closed-loop crimp terminals on all drive models. UL approval requires the use of UL Listed crimp terminals when wiring the drive main circuit terminals on models CIMR-U□2□0068 to 2□0248 and 4□0052 to 4□0414. Use only crimping tools as specified by the crimp terminal manufacturer. Yaskawa recommends crimp terminals made by JST and Tokyo DIP (or equivalent) for the insulation cap.

Table 47 to **Table 49** match the wire gauges and terminal screw sizes with Yaskawa - recommended crimp terminals, tools, and insulation caps. Refer to the appropriate Wire Gauge and Torque Specifications table for the wire gauge and screw size for your drive model. Place orders with a Yaskawa representatives or the Yaskawa sales department.

CIMR-U□2□0028 to 2□0248, 4□0011 to 4□0590

Table 47 Closed-Loop Crimp Terminal Size (CIMR-U□2□0028 to 2□0248, 4□0011 to 4□0590)

Drive Model	Wire Gauge (AWG, kcmil)	Screw Size	Crimp Terminal Model Number	Tool		Insulation Cap Model No.	Code <2>
	R/L1, S/L2, T/L3 U/T1, V/T2, W/T3			Machine No.	Die Jaw		
Three-Phase 200 V Class Drives							
2□0028	10	M5	R5.5-5	YA-4	AD-900	TP-005	100-054-030
	8 <1>	M5	R8-5	YA-4	AD-901	TP-008	100-054-032
2□0042	8	M6	R8-6	YA-4	AD-901	TP-008	100-065-184
	6 <1>	M6	R14-6	YA-4	AD-902	TP-014	100-051-261
	4	M6	R22-6	YA-5	AD-953	TP-022	100-051-262
2□0054	3	M6	R22-6	YA-5	AD-953	TP-022	100-051-262
	6	M6	R14-6	YA-5	AD-952	TP-014	100-051-261
	4 <1>	M6	R22-6	YA-5	AD-953	TP-022	100-051-262
2□0068	3	M6	R22-6	YA-5	AD-953	TP-022	100-051-262
	4 <1>	M6	R22-6	YA-5	AD-953	TP-022	100-051-262
2□0081	6 <1>	M6	R14-6	YA-5	AD-952	TP-014	100-051-261
	4	M6	R22-6	YA-5	AD-953	TP-022	100-051-262
	3	M6	R22-6	YA-5	AD-953	TP-022	100-051-262
2□0104	6	M8	R14-8	YA-4	AD-902	TP-014	100-054-035
	4	M8	R22-8	YA-5	AD-953	TP-022	100-051-263
	3	M8	R22-8	YA-5	AD-953	TP-022	100-051-263
	2	M8	R38-8	YA-5	AD-954	TP-038	100-051-264
	1 <1>	M8	R38-8	YA-5	AD-954	TP-038	100-051-264
2□0130	1/0	M8	R60-8	YA-5	AD-955	TP-060	100-051-265
	6	M8	R14-8	YA-5	AD-952	TP-014	100-054-035
	4 <1>	M8	R22-8	YA-5	AD-953	TP-022	100-051-263
	3	M8	R22-8	YA-5	AD-953	TP-022	100-051-263
	2	M8	R38-8	YA-5	AD-954	TP-038	100-051-264
2□0154	1	M8	R38-8	YA-5	AD-954	TP-038	100-051-264
	1/0	M8	R60-10	YA-5	AD-955	TP-060	100-051-266
	2/0	M10	70-10	YF-1 YET-300-1	TD-322 TD-311	TP-080	100-064-251
	3/0	M10	80-10	YF-1 YET-300-1	TD-323 TD-312	TP-080	100-051-267
	4/0	M10	R100-10	YF-1	TD-324	TP-100	100-051-269
	4	M10	R22-10	YA-5	AD-953	TP-022	100-061-113
	3 <1>	M10	R22-10	YA-5	AD-953	TP-022	100-061-113

C Standards Compliance

Drive Model	Wire Gauge (AWG, kcmil)	Screw Size	Crimp Terminal Model Number	Tool		Insulation Cap Model No.	Code <2>
	R/L1, S/L2, T/L3 U/T1, V/T2, W/T3			Machine No.	Die Jaw		
2□0192	3	M10	R22-10	YA-5	AD-953	TP-022	100-061-113
	2	M10	R38-10	YA-5	AD-954	TP-038	100-061-114
	1 <2>	M10	R38-10	YA-5	AD-954	TP-038	100-061-114
	1/0	M10	R60-10	YA-5	AD-955	TP-060	100-051-266
	2/0	M10	70-10	YF-1 YET-300-1	TD-322 TD-311	TP-080	100-064-251
	3/0	M10	80-10	YF-1 YET-300-1	TD-323 TD-312	TP-080	100-051-267
	4/0	M10	R100-10	YF-1 YET-300-1	TD-324 TD-312	TP-100	100-051-269
2□0248	1	M10	R38-10	YA-5	AD-954	TP-038	100-061-114
	1/0	M10	R60-10	YF-1 YET-300-1	TD-321 TD-311	TP-060	100-051-266
	2/0 <2>	M10	70-10	YF-1 YET-300-1	TD-322 TD-311	TP-080	100-064-251
	3/0	M10	80-10	YF-1 YET-300-1	TD-323 TD-312	TP-080	100-051-267
	4/0	M10	R100-10	YF-1 YET-300-1	TD-324 TD-312	TP-100	100-051-269
Three-Phase 400 V Class Drives							
4□0011	14 <2>	M5	R2-5	YA-4	AD-900	TP-003	100-123-030
	12	M5	R5.5-5	YA-4	AD-900	TP-005	100-054-030
	10	M5	R5.5-5	YA-4	AD-900	TP-005	100-054-030
	8	M5	R8-5	YA-4	AD-901	TP-008	100-054-032
4□0014	14	M5	R2-5	YA-4	AD-900	TP-003	100-123-030
	12 <2>	M5	R5.5-5	YA-4	AD-900	TP-005	100-054-030
	10	M5	R5.5-5	YA-4	AD-900	TP-005	100-054-030
	8	M5	R8-5	YA-4	AD-901	TP-008	100-054-032
4□0021	12	M5	R5.5-5	YA-4	AD-900	TP-005	100-054-030
	10 <2>	M5	R5.5-5	YA-4	AD-900	TP-005	100-054-030
	8	M5	R8-5	YA-4	AD-901	TP-008	100-054-032
4□0027	10	M5	R5.5-5	YA-4	AD-900	TP-005	100-054-030
4□0034	8 <2>	M5	R8-5	YA-4	AD-901	TP-008	100-054-032
4□0040	8 <2>	M6	R8-6	YA-4	AD-901	TP-008	100-065-184
	6	M6	R14-6	YA-4	AD-902	TP-014	100-051-261
	4	M6	R22-6	YA-5	AD-953	TP-022	100-051-262
	3	M6	R22-6	YA-5	AD-953	TP-022	100-051-262
4□0052	8	M6	R8-6	YA-4	AD-901	TP-008	100-065-184
	6 <2>	M6	R14-6	YA-4	AD-902	TP-014	100-051-261
	4	M6	R22-6	YA-5	AD-953	TP-022	100-051-262
	3	M6	R22-6	YA-5	AD-953	TP-022	100-051-262
4□0065	6	M6	R14-6	YA-5	AD-952	TP-014	100-051-261
	4 <2>	M6	R22-6	YA-5	AD-953	TP-022	100-051-262
	3	M6	R22-6	YA-5	AD-953	TP-022	100-051-262
4□0077	4	M6	R22-6	YA-5	AD-953	TP-022	100-051-262
	3 <2>	M6	R22-6	YA-5	AD-953	TP-022	100-051-262
4□0096	8	M8	R8-8	YA-4	AD-901	TP-008	100-061-111
	6	M8	R14-8	YA-4	AD-902	TP-014	100-054-035
	4	M8	R22-8	YA-5	AD-953	TP-022	100-051-263
	3	M8	R22-8	YA-5	AD-953	TP-022	100-051-263
	2	M8	R38-8	YA-5	AD-954	TP-038	100-051-264
	1 <2>	M8	R38-8	YA-5	AD-954	TP-038	100-051-264
	1/0	M8	R60-8	YA-5	AD-955	TP-060	100-051-265

Standards Compliance

C Standards Compliance

Drive Model	Wire Gauge (AWG, kcmil)	Screw Size	Crimp Terminal Model Number	Tool		Insulation Cap Model No.	Code <2>
	R/L1, S/L2, T/L3 U/T1, V/T2, W/T3			Machine No.	Die Jaw		
4□0124	6	M8	R14-8	YA-5	AD-952	TP-014	100-054-035
	4 <1>	M8	R22-8	YA-5	AD-953	TP-022	100-051-263
	3	M8	R22-8	YA-5	AD-953	TP-022	100-051-263
	2	M8	R38-8	YA-5	AD-954	TP-038	100-051-264
	1	M8	R38-8	YA-5	AD-954	TP-038	100-051-264
	1/0	M8	R60-8	YA-5	AD-955	TP-060	100-051-265
4□0156	4	M10	R22-10	YA-5	AD-953	TP-022	100-061-113
	3 <1>	M10	R22-10	YA-5	AD-953	TP-022	100-061-113
	2	M10	R38-10	YA-5	AD-954	TP-038	100-061-114
	1	M10	R38-10	YA-5	AD-954	TP-038	100-061-114
	1/0	M10	R60-10	YA-5	AD-955	TP-060	100-051-266
	2/0	M10	70-10	YF-1 YET-300-1	TD-322 TD-311	TP-080	100-064-251
	3/0	M10	80-10	YF-1 YET-300-1	TD-323 TD-312	TP-080	100-051-267
	4/0	M10	R100-10	YF-1 YET-300-1	TD-324 TD-312	TP-100	100-051-269
4□0180	3	M10	R22-10	YA-5	AD-953	TP-022	100-061-113
	2 <1>	M10	R38-10	YA-5	AD-954	TP-038	100-061-114
	1	M10	R38-10	YA-5	AD-954	TP-038	100-061-114
	1/0	M10	R60-10	YA-5	AD-955	TP-060	100-051-266
	2/0	M10	70-10	YF-1 YET-300-1	TD-322 TD-311	TP-080	100-064-251
	3/0	M10	80-10	YF-1 YET-300-1	TD-323 TD-312	TP-080	100-051-267
	4/0	M10	R100-10	YF-1 YET-300-1	TD-324 TD-312	TP-100	100-051-269
4□0216	2	M10	R38-10	YA-5	AD-954	TP-038	100-061-114
	1	M10	R38-10	YA-5	AD-954	TP-038	100-061-114
	1/0 <1>	M10	R60-10	YF-1 YET-300-1	TD-321 TD-311	TP-060	100-051-266
	2/0	M10	70-10	YF-1 YET-300-1	TD-322 TD-311	TP-080	100-064-251
	3/0	M10	80-10	YF-1 YET-300-1	TD-323 TD-312	TP-080	100-051-267
	4/0	M10	R100-10	YF-1 YET-300-1	TD-324 TD-312	TP-100	100-051-269
4□0240	1/0 <1>	M10	R60-10	YF-1 YET-300-1	TD-321 TD-311	TP-060	100-051-266
	2/0	M10	70-10	YF-1 YET-300-1	TD-322 TD-311	TP-080	100-064-251
	3/0	M10	80-10	YF-1 YET-300-1	TD-323 TD-312	TP-080	100-051-267
	4/0	M10	R100-10	YF-1 YET-300-1	TD-324 TD-312	TP-100	100-051-269
4□0302	1/0	M10	R60-10	YF-1 YET-300-1	TD-321 TD-311	TP-060	100-051-266
	2/0	M10	70-10	YF-1 YET-300-1	TD-322 TD-311	TP-080	100-064-251
	3/0 <1>	M10	80-10	YF-1 YET-300-1	TD-323 TD-312	TP-080	100-051-267
	4/0	M10	R100-10	YF-1 YET-300-1	TD-324 TD-312	TP-100	100-051-269

C Standards Compliance

Drive Model	Wire Gauge (AWG, kcmil)	Screw Size	Crimp Terminal Model Number	Tool		Insulation Cap Model No.	Code <2>
	R/L1, S/L2, T/L3 U/T1, V/T2, W/T3			Machine No.	Die Jaw		
4□0361	3/0	M10	80-10	YF-1 YET-300-1	TD-323 TD-312	TP-080	100-051-267
	4/0 <1>	M10	R100-10	YF-1 YET-300-1	TD-324 TD-312	TP-100	100-051-269
4□0414	4/0	M12	R100-12	YF-1 YET-300-1	TD-324 TD-312	TP-100	100-051-270
	250	M12	R150-12	YF-1 YET-300-1	TD-325 TD-313	TP-150	100-051-273
	300 <1>	M12	R150-12	YF-1 YET-300-1	TD-325 TD-313	TP-150	100-051-273
4□0477	2/0	M12	70-12	YF-1 YET-300-1	TD-322 TD-311	TP-080	100-054-036
	3/0 <1>	M12	80-12	YF-1 YET-300-1	TD-323 TD-312	TP-080	100-051-268
	4/0	M12	R100-12	YF-1 YET-300-1	TD-324 TD-312	TP-100	100-051-270
	250	M12	R150-12	YF-1 YET-300-1	TD-325 TD-313	TP-150	100-051-273
	300	M12	R150-12	YF-1 YET-300-1	TD-325 TD-313	TP-150	100-051-273
4□0590	3/0	M12	80-12	YF-1 YET-300-1	TD-323 TD-312	TP-080	100-051-268
	4/0	M12	R100-12	YF-1 YET-300-1	TD-324 TD-312	TP-100	100-051-270
	250 <1>	M12	R150-12	YF-1 YET-300-1	TD-325 TD-313	TP-150	100-051-273
	300	M12	R150-12	YF-1 YET-300-1	TD-325 TD-313	TP-150	100-051-273
4□0720	1/0	M12	R60-12	YF-1 YET-300-1	TD-321 TD-311	TP-060	100-066-160
	2/0	M12	70-12	YF-1 YET-300-1	TD-322 TD-311	TP-080	100-054-036
	4/0	M12	R100-12	YF-1 YET-300-1	TD-324 TD-312	TP-100	100-051-270
	250	M12	R150-12	YF-1 YET-300-1	TD-325 TD-313	TP-150	100-051-273
	300 <1>	M12	R150-12	YF-1 YET-300-1	TD-325 TD-313	TP-150	100-051-273
4□0900	1/0	M12	R60-12	YF-1 YET-300-1	TD-321 TD-311	TP-060	100-066-160
	2/0	M12	70-12	YF-1 YET-300-1	TD-322 TD-311	TP-080	100-054-036
	3/0	M12	80-12	YF-1 YET-300-1	TD-323 TD-312	TP-080	100-051-268
	4/0 <1>	M12	R100-12	YF-1 YET-300-1	TD-324 TD-312	TP-100	100-051-270
	250	M12	R150-12	YF-1 YET-300-1	TD-325 TD-313	TP-150	100-051-273
	300	M12	R150-12	YF-1 YET-300-1	TD-325 TD-313	TP-150	100-051-273

C Standards Compliance

Drive Model	Wire Gauge (AWG, kcmil)	Screw Size	Crimp Terminal Model Number	Tool		Insulation Cap Model No.	Code <2>
	R/L1, S/L2, T/L3 U/T1, V/T2, W/T3			Machine No.	Die Jaw		
4□0930	1/0	M12	R60-12	YF-1 YET-300-1	TD-321 TD-311	TP-060	100-066-160
	2/0	M12	70-12	YF-1 YET-300-1	TD-322 TD-311	TP-080	100-054-036
	4/0 <1>	M12	R100-12	YF-1 YET-300-1	TD-324 TD-312	TP-100	100-051-270
	250	M12	R150-12	YF-1 YET-300-1	TD-325 TD-313	TP-150	100-051-273
	300	M12	R150-12	YF-1 YET-300-1	TD-325 TD-313	TP-150	100-051-273

<1> Recommended wire gauges.

<2> Codes refer to a set of three crimp terminals and three insulation caps. Prepare input and output wiring using two sets for each connection.

Note: Use crimp insulated terminals or insulated shrink tubing for wiring connections. Wires should have a continuous maximum allowable temperature of 75°C 600 Vac UL-approved vinyl-sheathed insulation.

CIMR-U□4□0720 to 4□0930

Table 48 Closed-Loop Crimp Terminal Size (CIMR-U□4□0720 to 4□0930)

Drive Model	Wire Gauge (AWG, kcmil)	Screw Size	Crimp Terminal Model Number	Tool		Insulation Cap Model No.	Code <2>
	X, Y, Z U/T1, V/T2, W/T3			Machine No.	Die Jaw		
Three-Phase 400 V Class Drives							
4□0720	1/0	M12	R60-12	YF-1 YET-300-1	TD-321 TD-311	TP-060	100-066-160
	2/0	M12	70-12	YF-1 YET-300-1	TD-322 TD-311	TP-080	100-054-036
	4/0	M12	R100-12	YF-1 YET-300-1	TD-324 TD-312	TP-100	100-051-270
	250	M12	R150-12	YF-1 YET-300-1	TD-325 TD-313	TP-150	100-051-273
	300 <1>	M12	R150-12	YF-1 YET-300-1	TD-325 TD-313	TP-150	100-051-273
4□0900	1/0	M12	R60-12	YF-1 YET-300-1	TD-321 TD-311	TP-060	100-066-160
	2/0	M12	70-12	YF-1 YET-300-1	TD-322 TD-311	TP-080	100-054-036
	3/0	M12	80-12	YF-1 YET-300-1	TD-323 TD-312	TP-080	100-051-268
	4/0 <1>	M12	R100-12	YF-1 YET-300-1	TD-324 TD-312	TP-100	100-051-270
	250	M12	R150-12	YF-1 YET-300-1	TD-325 TD-313	TP-150	100-051-273
	300	M12	R150-12	YF-1 YET-300-1	TD-325 TD-313	TP-150	100-051-273
4□0930	1/0	M12	R60-12	YF-1 YET-300-1	TD-321 TD-311	TP-060	100-066-160
	2/0	M12	70-12	YF-1 YET-300-1	TD-322 TD-311	TP-080	100-054-036
	4/0 <1>	M12	R100-12	YF-1 YET-300-1	TD-324 TD-312	TP-100	100-051-270
	250	M12	R150-12	YF-1 YET-300-1	TD-325 TD-313	TP-150	100-051-273
	300	M12	R150-12	YF-1 YET-300-1	TD-325 TD-313	TP-150	100-051-273

<1> Recommended wire gauges.

C Standards Compliance

<2> Codes refer to a set of three crimp terminals and three insulation caps. Prepare input and output wiring using two sets for each connection.

Note: Use crimp insulated terminals or insulated shrink tubing for wiring connections. Wires should have a continuous maximum allowable temperature of 75°C 600 Vac UL-approved vinyl-sheathed insulation.

Harmonic Filter Module

Table 49 Harmonic Filter Module Closed-Loop Crimp Terminal Size for CIMR-U□4□0720 to 4□0930

Model	Wire Gauge (AWG, kcmil) R/L1, S/L2, T/L3 X, Y, Z	Screw Size	Crimp Terminal Model Number	Tool		Insulation Cap Model No.	Code <2>
				Machine No.	Die Jaw		
Three-Phase 400 V Class Harmonic Filter Modules							
EUJ71183□.□	1/0	M12	R60-12	YF-1 YET-300-1	TD-321 TD-311	TP-060	100-066-160
	2/0	M12	70-12	YF-1 YET-300-1	TD-322 TD-311	TP-080	100-054-036
	4/0	M12	R100-12	YF-1 YET-300-1	TD-324 TD-312	TP-100	100-051-270
	250	M12	R150-12	YF-1 YET-300-1	TD-325 TD-313	TP-150	100-051-273
	300 <1>	M12	R150-12	YF-1 YET-300-1	TD-325 TD-313	TP-150	100-051-273
EUJ71184□.□	1/0	M12	R60-12	YF-1 YET-300-1	TD-321 TD-311	TP-060	100-066-160
	2/0	M12	70-12	YF-1 YET-300-1	TD-322 TD-311	TP-080	100-054-036
	3/0	M12	80-12	YF-1 YET-300-1	TD-323 TD-312	TP-080	100-051-268
	4/0 <1>	M12	R100-12	YF-1 YET-300-1	TD-324 TD-312	TP-100	100-051-270
	250	M12	R150-12	YF-1 YET-300-1	TD-325 TD-313	TP-150	100-051-273
	300	M12	R150-12	YF-1 YET-300-1	TD-325 TD-313	TP-150	100-051-273
EUJ71185□.□	1/0	M12	R60-12	YF-1 YET-300-1	TD-321 TD-311	TP-060	100-066-160
	2/0	M12	70-12	YF-1 YET-300-1	TD-322 TD-311	TP-080	100-054-036
	4/0 <1>	M12	R100-12	YF-1 YET-300-1	TD-324 TD-312	TP-100	100-051-270
	250	M12	R150-12	YF-1 YET-300-1	TD-325 TD-313	TP-150	100-051-273
	300	M12	R150-12	YF-1 YET-300-1	TD-325 TD-313	TP-150	100-051-273

<1> Recommended wire gauges.

<2> Codes refer to a set of three crimp terminals and three insulation caps. Prepare input and output wiring using two sets for each connection.

Note: Use crimp insulated terminals or insulated shrink tubing for wiring connections. Wires should have a continuous maximum allowable temperature of 75°C 600 Vac UL-approved vinyl-sheathed insulation.

C Standards Compliance

Low Voltage Wiring for Control Circuit Terminals

Wire low voltage wires with NEC Class 1 circuit conductors. Refer to national state or local codes for wiring. If external power supply used, it shall be UL Listed Class 2 power source only or equivalent. Refer to NEC Article 725 Class 1, Class 2, and Class 3 Remote-Control, Signaling, and Power Limited Circuits for requirements concerning class 1 circuit conductors and class 2 power supplies.

Table 50 Control Circuit Terminal Power Supply

Input/Output	Terminal Signal	Power Supply Specifications
Open Collector Outputs	DM+, DM-	Requires class 2 power supply.
Digital inputs	S1-S8, SN, SC, SP, HC, H1, H2	Use the internal LVLC power supply of the drive. Use class 2 for external power supply.
Analog inputs/outputs	+V, -V, A1, A2, A3, AC, AM, FM	Use the internal LVLC power supply of the drive. Use class 2 for external power supply.

Drive Short-Circuit Rating

The drive is suitable for use on a circuit capable of delivering not more than 100,000 RMS symmetrical Amperes, 240 Vac maximum (200 V Class) and 480 Vac maximum (400 V class: 4E□□□□ and 4W□□□□), and 500 Vac maximum (400 V class: 4A□□□□ and 4P□□□□) with built-in fuses manufactured by Hinode Electric Co., Ltd. and Mersen.

Branch Circuit Protection

For installation in the United States, branch circuit protection must be provided in accordance with the National Electrical Code (NEC) and any applicable local codes. To fulfill this requirement, use the UL classified fuses.

For installation in Canada, branch circuit protection must be provided in accordance with the Canadian Electrical Code and any applicable provincial codes. To fulfill this requirement, use the UL classified fuses.

■ Drive Motor Overload Protection

Set parameter E2-01 (motor rated current) to the appropriate value to enable motor overload protection. The internal motor overload protection is UL Listed and in accordance with the NEC and CEC.

E2-01 Motor Rated Current

Setting Range: 10% to 150% of the drive rated current

Default Setting: Model Dependent

Parameter E2-01 (motor rated current) protects the motor if parameter L1-01 is not set to 0 (default is 1, enabling protection for standard induction motors).

If Auto-Tuning has been performed successfully, the motor data entered to T1-04 and T2-06 is automatically written into parameter E2-01. If Auto-Tuning has not been performed, manually enter the correct motor rated current to parameter E2-01.

L1-01 Motor Overload Protection Selection

The drive has an electronic overload protection function (oL1) based on time, output current, and output frequency, which protects the motor from overheating. The electronic thermal overload function is UL-recognized, so it does not require an external thermal relay for single motor operation.

This parameter selects the motor overload curve used according to the type of motor applied.

Table 51 Overload Protection Settings

Setting	Description	
0	Disabled	Disabled the drive's internal motor overload protection.
1	Standard fan cooled motor (default)	Selects protection characteristics for a standard self cooled motor with limited cooling capabilities when running below the rated speed. The motor overload detection level (oL1) is automatically reduces when running below the motor rated speed.
2	Drive duty motor with a speed range of 1:10	Selects protection characteristics for a motor with self-cooling capability within a speed range of 10:1. The motor overload detection level (oL1) is automatically reduced when running below 1/10 of the motor rated speed.

C Standards Compliance

Setting	Description	
3	Vector motor with a speed range of 1:100	Selects protection characteristics for a motor capable of cooling itself at any speed – including zero speed (externally cooled motor). The motor overload detection level (oL1) is constant over the entire speed range.
4	Permanent Magnet motor with variable torque	Selects protection characteristics for a variable torque PM motor. The motor overload detection level (oL1) is automatically reduces when running below the motor rated speed.
5	Permanent Magnet motor with constant torque	Selects protection characteristics for a constant torque PM motor. The motor overload detection level (oL1) is constant over the whole speed range.
6	Standard fan cooled motor (50 Hz)	Selects protection characteristics for a standard self cooled motor with limited cooling capabilities when running below the rated speed. The motor overload detection level (oL1) is automatically reduces when running below the motor rated speed.

When connecting the drive to more than one motor for simultaneous operation, disable the electronic overload protection (L1-01 = 0) and wire each motor with its own motor thermal overload relay.

Enable the motor overload protection (L1-01 = 1 to 6) when connecting the drive to a single motor, unless another motor overload preventing device is installed. The drive electronic thermal overload function causes an oL1 fault, which shuts off the output of the drive and prevents additional overheating of the motor. The motor temperature is continually calculated as long as the drive is powered up.

L1-02 Motor Overload Protection Time

Setting Range: 0.1 to 5.0 min

Factory Default: 1.0 min

Parameter L1-02 determines how long the motor is allowed to operate before the oL1 fault occurs when the drive is running at 50 Hz and at 150% of the full load amp rating (E2-01) of the motor. Adjusting the value of L1-02 can shift the set of oL1 curves up the y axis of the diagram below, but will not change the shape of the curves.

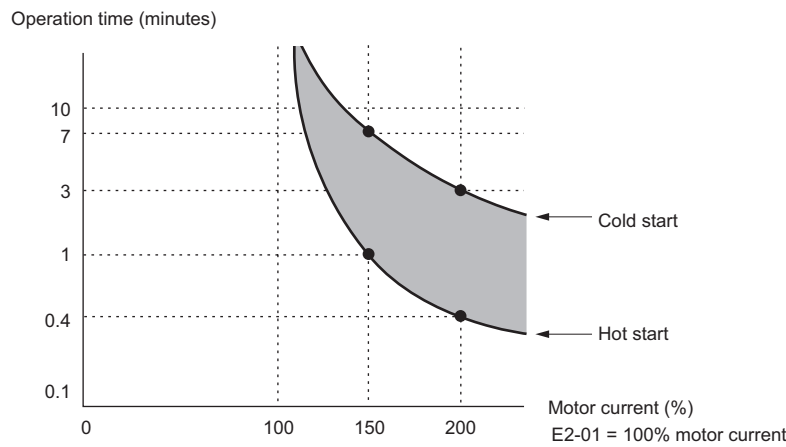


Figure 77 Motor Overload Protection Time

L1-03 Motor Overheat Alarm Operation Selection (PTC Input)

Setting	Description
0	Ramp to Stop
1	Coast to Stop
2	Fast-Stop
3	Alarm Only (default setting)

L1-04 Motor Overheat Fault Operation Selection (PTC Input)

Setting	Description
0	Ramp to Stop
1	Coast to Stop (default setting)
2	Fast-Stop

C Standards Compliance

◆ Safe Disable Input Function

This section explains the Safe Disable function. Contact Yaskawa if more information is required.

■ Safety Standards

The TUV mark indicates compliance with safety standards.



Figure 78 TUV mark

Table 52 Safety Standards and Applicable Harmonized Standards

Safety Standards	Applicable Harmonized Standards
Functional Safety	IEC/EN 61508 series: 2010 (SIL3)
	IEC 62061/A1:2012 (SIL CL 3)
	EN 62061/A1:2013 (SIL CL 3)
	IEC 61800-5-2: 2007 (SIL3)
	EN 61800-5-2: 2007 (SIL3)
Safety of Machinery	EN ISO 13849-1/AC:2008 (PL e (Cat.3))
EMC	IEC/EN 61326-3-1: 2008 (EMC-related)

The Safe Disable function is in compliance with these standards.

■ Specifications

The Safe Disable inputs provide a stop function in compliance with “Safe Torque Off” as defined in the IEC/EN 61800-5-2. Safe Disable inputs have been designed to meet the requirements of the EN ISO 13849-1 and IEC/EN 61508.

A Safe Disable Status Monitor for error detection in the safety circuit is also provided.

Table 53 Specifications for Safe Disable Function

Inputs / Outputs	<ul style="list-style-type: none"> Input signal specifications Signal ON level: 18 to 28 Vdc Signal OFF level: -4 to 4 Vdc Inputs: 2 Safe Disable inputs H1, H2 Outputs: 1 Safe Disable Monitor output EDM (DM+, DM-) 	
Response Time from Input Open to Drive Output Stop	less than 3 ms	
Response Time from Input Open of H1 and H2 Terminals to EDM	less than 4 ms	
Failure Probability	Demand Rate Low	PF _D = 11.04E ⁻⁶
	Demand Rate High or Continuous	PF _H = 2.67E ⁻⁹
Performance Level	The Safe Disable inputs satisfy the following requirements (DC from EDM considered). Performance Level (PL) e according to EN ISO 13849-1	
HFT (Hardware Fault Tolerance)	N = 1	
Classification of Subsystem	Type B	

■ Precautions

DANGER! *Sudden Movement Hazard.* Improper use of the Safe Disable function will result in serious injury or death. Make sure the entire system or machinery uses the Safe Disable function in compliance with safety requirements. When implementing the Safe Disable function into the safety system of a machine, a thorough risk assessment and validation for the whole system must be carried out to ensure it complies with relevant safety norms (e.g., ISO/EN 13849, IEC/EN 61508, IEC/EN 62061).

DANGER! *Sudden Movement Hazard.* When using a PM motor, even if the drive output is shut off by the Safe Disable function, a break down of two output transistors can cause current to flow through the motor winding, resulting in a rotor movement for a maximum angle of 180 degrees (electrically). Ensure this condition will not affect the safety of the application when using the Safe Disable function. Failure to comply will result in death or serious injury.

DANGER! *Electrical Shock Hazard.* The Safe Disable function can switch off the drive output, but does not cut the drive power supply and cannot electrically isolate the drive output from the input. Always shut off the drive power supply when performing maintenance or installations on the drive input side as well as the drive output side. Failure to comply will result in death or serious injury.

WARNING! *Sudden Movement Hazard.* If the motor is subjected to an external force, use a mechanical brake that meets the safety requirements of entire system or machinery to stop the machine connected to the load. The motor will move when an external gravitational force in the vertical axis is applied even if the Safety Disable function is in operation. Failure to comply may result in serious injury or death.

WARNING! *Sudden Movement Hazard.* Connect the Safe Disable inputs to the devices in compliance with safety requirements. Failure to comply will result in death or serious injury.

WARNING! *Sudden Movement Hazard.* When using the Safe Disable inputs, make sure to remove the wire links between terminals H1, H2, and HC that were installed prior to shipment. Failing to do so will keep the Safe Disable circuit from operating properly and can cause injury or even death.

WARNING! All safety features (including Safe Disable) should be inspected daily and periodically. If the system is not operating normally, there is a risk of serious personal injury.

WARNING! Only a qualified technician with a thorough understanding of the drive, the instruction manual, and safety standards should be permitted to wire, inspect, and maintain the Safe Disable input. Failure to comply may result in serious injury or death.

NOTICE: The Safe Disable Monitor (output terminals DM+ and DM-) should not be used for any other purpose than to monitor the Safe Disable status or to discover a malfunction in the Safe Disable inputs. The monitor output is not considered a safe output.

NOTICE: When utilizing the Safe Disable function, use only the EMC filters recommended in [EMC Filter Installation on page 103](#).

■ Using the Safe Disable Function

The Safe Disable inputs offer a stop function in compliance with “Safe Torque Off,” as defined in IEC/EN 61800-5-2. Safe Disable inputs have been designed to meet the requirements in [Table 52](#).

A Safe Disable Status Monitor for error detection in the safety circuit is also provided.

Safe Disable Circuit

The Safe Disable circuit consists of two independent input channels that can block the output transistors (terminals H1 and H2). The input can either use the drive internal power supply or an external power supply. Use jumper S3 on the terminal board to select between Sink or Source mode with either internal or external power supply.

A photocoupler output is available to monitor the status of the Safe Disable terminals DM+ and DM-. [Refer to Output Terminals on page 42](#) for signal specifications when using this output.

C Standards Compliance

Additionally a Safe Disable monitor function can be assigned to one of the digital outputs (H2-□□ = 58).

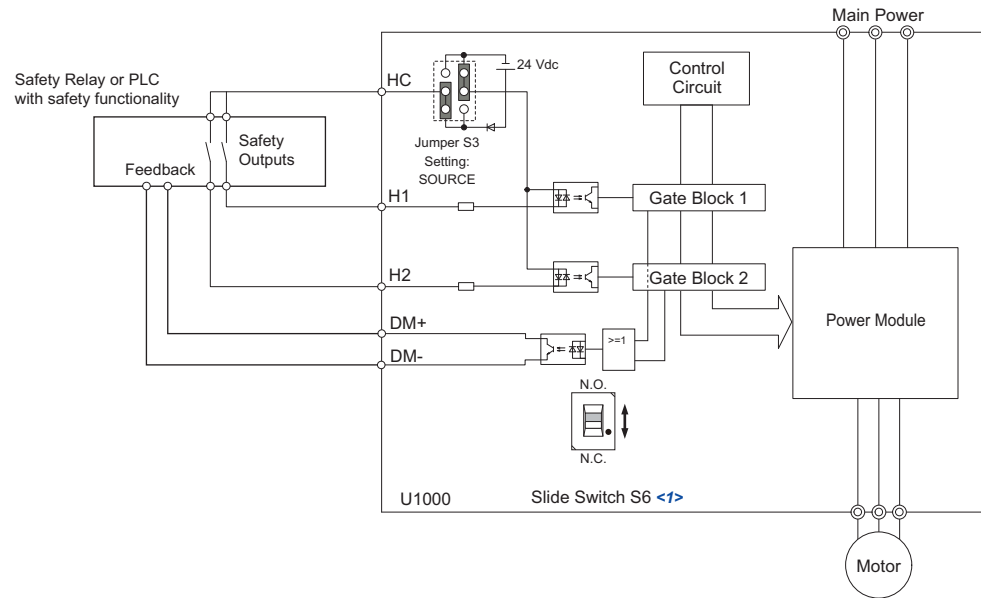
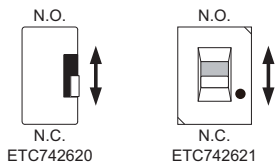


Figure 79 Safe Disable Function Wiring Example (Source Mode)

<1> Available slide switch S6 is models ETC742620 and ETC742621.



Disabling and Enabling the Drive Output (“Safe Torque Off”)

Figure 80 illustrates a Safe Disable input operation example.

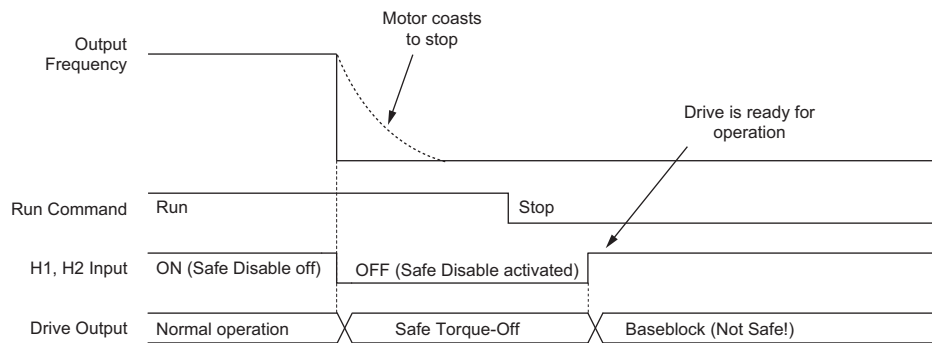


Figure 80 Safe Disable Operation

Entering the “Safe Torque Off” State

Whenever either one Safe Disable input or both inputs open, the motor torque is shut off by switching off the drive output. If the motor was running before the Safe Disable inputs opened, it will coast to stop, regardless of the stopping method set in parameter b1-03.

Notice that the “Safe Torque Off” state can only be achieved using the Safe Disable function. Removing the Run command stops the drive and shuts the output off (baseblock), but does not create a “Safe Torque Off” status.

Note: To avoid an uncontrolled stop during normal operation, make sure that the Safe Disable inputs are opened first when the motor has completely stopped.

Returning to Normal Operation after Safe Disable

The Safe Disable function can only be deactivated when a Run command is not active.

When Safe Disable was activated during stop, normal operation can be resumed by simply turning on both Safe Disable inputs (i.e., by deactivating “Safe Torque Off”).

When Safe Disable was activated during run, first the Run command has to be removed and then the Safe Disable inputs have to be turned on before the drive can be restarted.

Safe Disable Monitor Output Function and Digital Operator Display

Table 54 explains the drive output and Safe Disable monitor state depending on the Safe Disable inputs.

Table 54 Safety Input and EDM Terminal Status

Safe Disable Input Status		Safe Disable Status Monitor, DM+ - DM-		Drive Output Status	Digital Operator Display
Input 1, H1-HC	Input 2, H2-HC	S6 Selected N.C.	S6 Selected N.O.		
OFF	OFF	ON	OFF	Safely disabled, "Safe Torque Off"	Hbb (flashes)
ON	OFF	OFF	ON	Safely disabled, "Safe Torque Off"	HbbF (flashes)
OFF	ON	OFF	ON	Safely disabled, "Safe Torque Off"	HbbF (flashes)
ON	ON	OFF	ON	Baseblock, ready for operation	Normal display

Safe Disable Status Monitor

With the Safe Disable monitor output (terminals DM+ and DM-), the drive provides a safety status feedback signal. This signal should be read by the device that controls the Safe Disable inputs (PLC or a safety relay) in order to prohibit leaving the "Safe Torque Off" status in case the safety circuit malfunctions. Refer to the instruction manual of the safety device for details on this function.

Digital Operator Display

When both Safe Disable inputs are open, "Hbb" will flash in the digital operator display.

Should only one of the Safe Disable channels be on while the other is off, "HbbF" will flash in the display to indicate that there is a problem in the safety circuit or in the drive. This display should not appear under normal conditions if the Safe Disable circuit is utilized properly. *Refer to Alarm Codes on page 88* to resolve possible errors.

If a fault in the safety circuit of the drive is detected, "SCF" will be displayed in the LCD operator. This indicates damage to the drive. Refer to *Fault Displays on page 84* for details.

Validating Safe Disable Function

When you start-up, replace parts or conduct maintenance, you must always perform the following validation test on the safe disable inputs after completing the wiring. (Check results should be maintained as a record of tests performed.)

- When the H1 and H2 signals turn OFF, confirm that "Hbb" is displayed on the LCD operator, and that the motor is not in operation.
- Monitor the ON/OFF status of the H1 and H2 signals and confirm the EDM signal by referring to *Table 54*.

If the ON/OFF status of the signals do not coincide with the display, the following must be considered: an error in the external device, disconnection of the external wiring, short circuit in the external wiring, or a failure in the drive. Find the cause and correct the problem.

- Confirm that the EDM signal is OFF while in normal operation.
- In normal operation, confirm the EDM signal by referring to *Table 54*.

Revision History

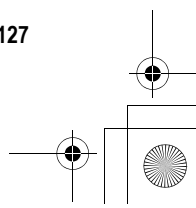
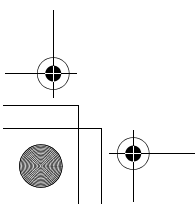
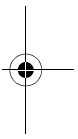
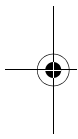
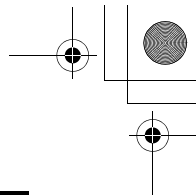
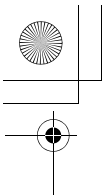
The revision dates and the numbers of the revised manuals appear on the bottom of the back cover.

MANUAL NO. TOEP C710636 03B <1>
 Published in Japan December 2015

Revision number

Date of publication

Date of Publication	Revision Number	Section	Revised Content
December 2015	<1>	Front cover	Revision: Format
		All	Addition: Larger drive capacities added along with corresponding data Three-phase 400V: CIMR-U□4□0477 to 4□0930 Harmonic Filter Module: EUJ71183□.□ to EUJ71185□.□ Revision: • Reviewed and corrected entire documentation. • Upgraded drive software version to PRG: 1015 to PRG: 1017.
		Appendix D	Addition: EMC Guidelines Compliance for CIMR-U□4□0477□□□ to 4□0930□□□
		Back cover	Revision: Address, Format
June 2014	–	–	First Edition



英文 No.6-5 (A4) YEU向けインバータ装置用取扱説明書

www.nicsanat.com

021-87700210



YASKAWA U1000 Series Quick Start Guide

YASKAWA EUROPE GmbH
Hauptstraße 185, 65760 Eschborn, Germany
Phone: +49-6196-569-300 Fax: +49-6196-569-398
http://www.yaskawa.eu.com E-mail: info@yaskawa.eu.com

DRIVE CENTER (INVERTER PLANT)
2-13-1, Nishimiyaichi, Yukuhashi, Fukuoka, 824-8511, Japan
Phone: +81-930-25-2548 Fax: +81-930-25-3431
http://www.yaskawa.co.jp

YASKAWA AMERICA, INC.
2121, Norman Drive South, Waukegan, IL 60085, U.S.A.
Phone: +1-800-YASKAWA (927-5292) or +1-847-887-7000 Fax: +1-847-887-7310
http://www.yaskawa.com

YASKAWA

YASKAWA ELECTRIC CORPORATION

In the event that the end user of this product is to be the military and said product is to be employed in any weapons systems or the manufacture thereof, the export will fall under the relevant regulations as stipulated in the Foreign Exchange and Foreign Trade Regulations. Therefore, be sure to follow all procedures and submit all relevant documentation according to any and all rules, regulations and laws that may apply. Specifications are subject to change without notice for ongoing product modifications and improvements.

© 2014-2015 YASKAWA ELECTRIC CORPORATION



TOEPC71063603

www.nicsanat.com

021-87700210



MANUAL NO. TOEP C710636 03B <1>
Published in Japan December 2015
15-11-8_YEU
Original instructions