

YASKAWA

YASKAWA AC Drive GA700

High Performance General Applications Drive

Standards Compliance

Type: CIPR-GA70Cxxxxxxxx
Models: 200 V class: 0.55 to 110 kW
400 V class: 0.55 to 355 kW

To properly use the product, read this manual thoroughly and retain for easy reference, inspection, and maintenance. Ensure the end user receives this manual.

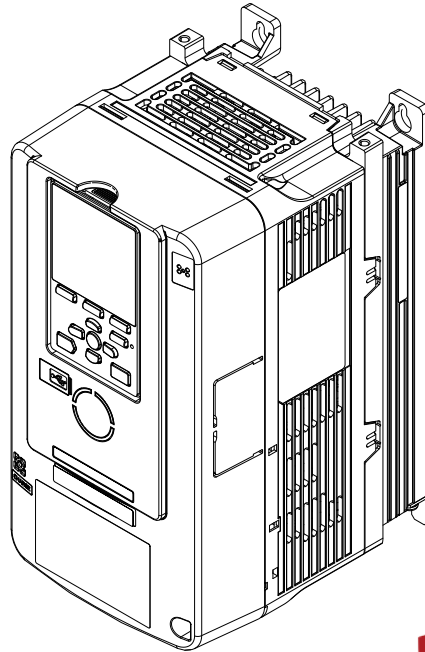

www.nicsanat.com

021-87700210

MANUAL NO. TOEP C710617 18B

Standards Compliance S.C.

1 European Standards



Figure 1.1 CE Mark

The CE Mark indicates that the product meets environmental and safety standards in the European Union. Products manufactured, sold, or imported within the European Union are required to display the CE Mark.

European Union standards include standards for electrical appliances (Low Voltage Directive), standards for electrical noise (EMC Directive), and standards for machinery (Machinery Directive).

This product displays the CE Mark in accordance with the Low Voltage Directive, the EMC Directive, and the Machinery Directive.

Table 1.1 Harmonized Standard

European Directive	Harmonized Standard
CE Low Voltage Directive Compliance 2014/35/EU	IEC/EN 61800-5-1:2007
EMC Directive 2014/30/EU	EN 61800-3 2004+A1:2012
Machinery Directive 2006/42/EC	<ul style="list-style-type: none"> • EN ISO 13849-1/AC:2009 (PL e (Cat.III)) • IEC 62061/A1:2012 (SIL CL 3) • EN 62061/A1:2013 (SIL CL 3) • IEC/EN 61800-5-2:2007 (SIL3)

*1 Approval pending for models 2169 to 2415, 4371 to 4675.

Note:

Indicates that the device or machine containing this product is covered by the CE Mark.

The customer is responsible for displaying the CE Mark on the final device containing this product. Customers must verify themselves that the final device is compliant with EU standards.

◆ CE Low Voltage Directive Compliance

It has been confirmed that this product complies with the CE Low Voltage Directive by conducting a test according to IEC/EN 61800-5-1:2007.

The following conditions must be satisfied for machines and devices incorporating this product to comply with the CE Low Voltage Directive.

■ Area of Use

Install this product in a location with overvoltage category III and pollution degree 2 or less which are defined by IEC/EN 60664.

■ Wiring Diagram

Figure 1.2 shows an example of a drive that is wired for compliance with the CE Low Voltage Directive.

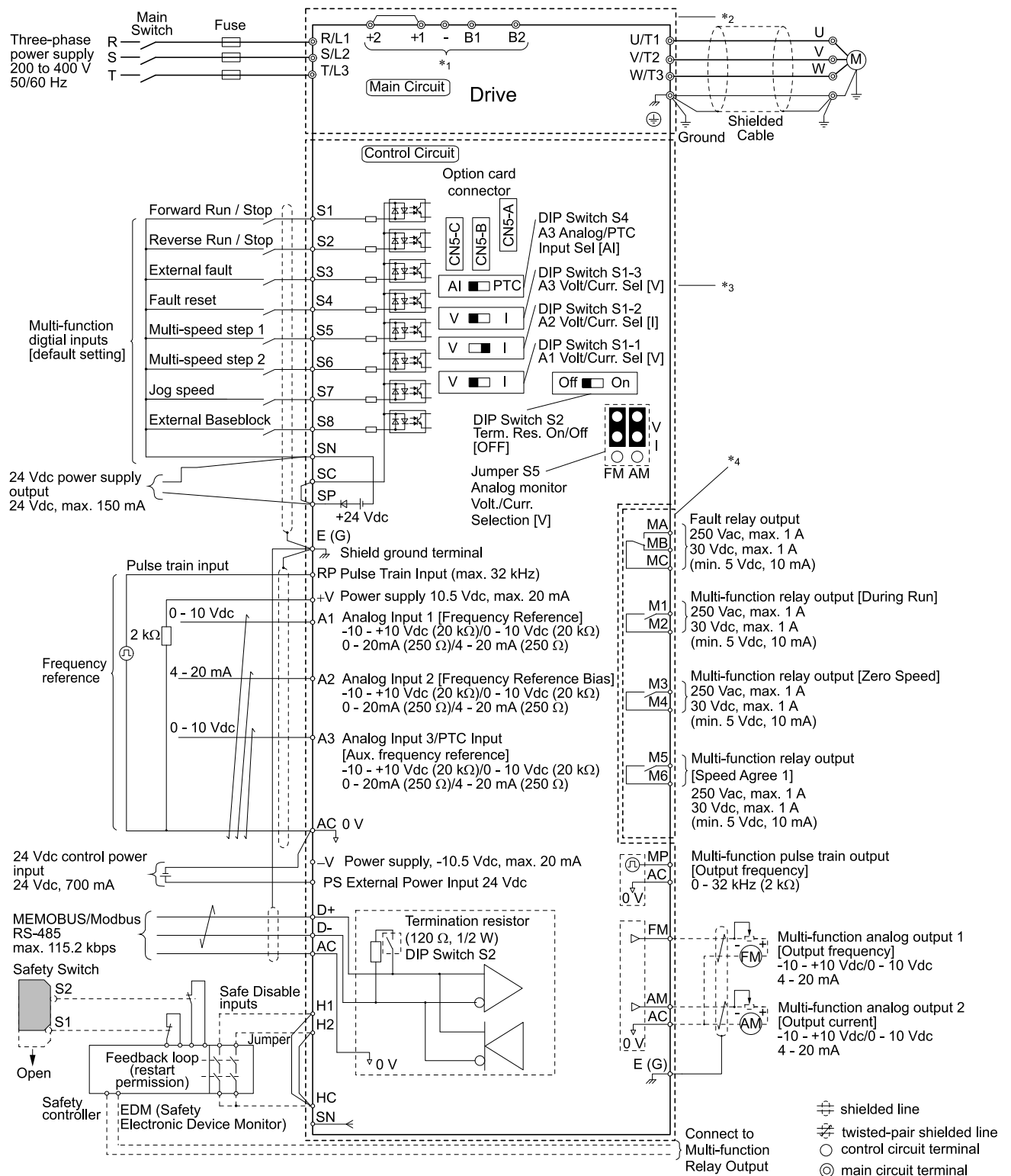

Figure 1.2 Wiring Diagram for Low Voltage Directive Compliance

- *1 Use terminals -, +1, +2, B1, and B2 to connect options to the drive. Never connect power supply lines to these terminals.
- *2 For circuit protection, the main circuit is separated from the surface case that would otherwise come into contact with the main circuit.
- *3 The control circuit is a Safety Extra-Low Voltage circuit, and therefore the control circuit must be separated from other circuits by reinforced insulation. Ensure that the Safety Extra-Low Voltage circuit is connected as required.
- *4 Reinforced insulation separates the output terminals from other circuits. Users may also connect circuits that are not Safety Extra-Low Voltage circuits if the drive output is 250 Vac 1 A max. or 30 Vdc 1 A max.

■ Main Circuit Wire Gauges and Tightening Torques

Note:

- Wire gauge recommendations based on drive continuous current ratings using 75 °C (167 °F) 600 V class 2 heat resistant indoor PVC wire. Assume the following usage conditions:
 - Ambient temperature: 40 °C (104 °F) or lower
 - Wiring distance: 100 m (3281 ft.) or shorter
 - Rated current (ND) value
- Use terminals +1, +2, +3, -, B1, and B2 to connect peripheral options such as a DC reactor or a braking resistor. Do not connect anything other than optional devices.
- When connecting peripheral devices or options to terminals +1,+2, +3, -, B1, and B2, refer to the specific instruction manual of each device for wire gauges. Contact Yaskawa or your nearest sales representative if the wire gauge recommended for the peripheral device or optional recommended gauge is out of the range of the applicable gauge for the drive.

Table 1.2 Wire Gauges and Tightening Torques for 200 V Class Drives

Model	Terminal	Recommended Gauge mm ²	Applicable Gauge mm ²	Wire Stripping Length mm *1	Terminal Screw		Tightening Torque N·m (lb·in)
					Size	Shape	
2004	R/L1, S/L2, T/L3	2.5	2.5 - 10	10	M4	Slot (-)	1.5 - 1.7 (13.5 - 15)
	U/T1, V/T2, W/T3	2.5	2.5 - 10	10	M4	Slot (-)	1.5 - 1.7 (13.5 - 15)
	-, +1, +2	2.5	2.5 - 16	18	M5	Slot (-)	2.3 - 2.5 (19.8 - 22) *2
	B1, B2	2.5	2.5 - 4	10	M4	Slot (-)	1.5 - 1.7 (13.5 - 15)
	⊕	2.5 *3	2.5 - 6	-	M4	Phillips/slot combo	1.2 - 1.5 (10.6 - 13.3)
2006	R/L1, S/L2, T/L3	2.5	2.5 - 10	10	M4	Slot (-)	1.5 - 1.7 (13.5 - 15)
	U/T1, V/T2, W/T3	2.5	2.5 - 10	10	M4	Slot (-)	1.5 - 1.7 (13.5 - 15)
	-, +1, +2	2.5	2.5 - 16	18	M5	Slot (-)	2.3 - 2.5 (19.8 - 22) *2
	B1, B2	2.5	2.5 - 4	10	M4	Slot (-)	1.5 - 1.7 (13.5 - 15)
	⊕	2.5 *3	2.5 - 6	-	M4	Phillips/slot combo	1.2 - 1.5 (10.6 - 13.3)
2010	R/L1, S/L2, T/L3	2.5	2.5 - 10	10	M4	Slot (-)	1.5 - 1.7 (13.5 - 15)
	U/T1, V/T2, W/T3	2.5	2.5 - 10	10	M4	Slot (-)	1.5 - 1.7 (13.5 - 15)
	-, +1, +2	2.5	2.5 - 16	18	M5	Slot (-)	2.3 - 2.5 (19.8 - 22) *2
	B1, B2	2.5	2.5 - 4	10	M4	Slot (-)	1.5 - 1.7 (13.5 - 15)
	⊕	2.5 *3	2.5 - 6	-	M4	Phillips/slot combo	1.2 - 1.5 (10.6 - 13.3)

Model	Terminal	Recommended Gauge mm ²	Applicable Gauge mm ²	Wire Stripping Length mm */	Terminal Screw		Tightening Torque N-m (lb-in)
					Size	Shape	
2012	R/L1, S/L2, T/L3	2.5	2.5 - 10	10	M4	Slot (-)	1.5 - 1.7 (13.5 - 15)
	U/T1, V/T2, W/T3	2.5	2.5 - 10	10	M4	Slot (-)	1.5 - 1.7 (13.5 - 15)
	-, +1, +2	2.5	2.5 - 16	18	M5	Slot (-)	2.3 - 2.5 (19.8 - 22) *2
	B1, B2	2.5	2.5 - 4	10	M4	Slot (-)	1.5 - 1.7 (13.5 - 15)
	⊕	2.5 *3	2.5 - 6	-	M4	Phillips/slot combo	1.2 - 1.5 (10.6 - 13.3)
2018	R/L1, S/L2, T/L3	2.5	2.5 - 10	10	M4	Slot (-)	1.5 - 1.7 (13.5 - 15)
	U/T1, V/T2, W/T3	2.5	2.5 - 10	10	M4	Slot (-)	1.5 - 1.7 (13.5 - 15)
	-, +1, +2	4	2.5 - 16	18	M5	Slot (-)	2.3 - 2.5 (19.8 - 22) *2
	B1, B2	2.5	2.5 - 4	10	M4	Slot (-)	1.5 - 1.7 (13.5 - 15)
	⊕	2.5 *3	2.5 - 6	-	M4	Phillips/slot combo	1.2 - 1.5 (10.6 - 13.3)
2021	R/L1, S/L2, T/L3	6	2.5 - 10	10	M4	Slot (-)	1.5 - 1.7 (13.5 - 15)
	U/T1, V/T2, W/T3	2.5	2.5 - 10	10	M4	Slot (-)	1.5 - 1.7 (13.5 - 15)
	-, +1, +2	6	2.5 - 16	18	M5	Slot (-)	2.3 - 2.5 (19.8 - 22) *2
	B1, B2	2.5	2.5 - 4	10	M4	Slot (-)	1.5 - 1.7 (13.5 - 15)
	⊕	6 *3	4 - 6	-	M4	Phillips/slot combo	1.2 - 1.5 (10.6 - 13.3)
2030	R/L1, S/L2, T/L3	10	2.5 - 10	10	M4	Slot (-)	1.5 - 1.7 (13.5 - 15)
	U/T1, V/T2, W/T3	6	2.5 - 10	10	M4	Slot (-)	1.5 - 1.7 (13.5 - 15)
	-, +1, +2	10	2.5 - 16	18	M5	Slot (-)	2.3 - 2.5 (19.8 - 22) *2
	B1, B2	2.5	2.5 - 4	10	M4	Slot (-)	1.5 - 1.7 (13.5 - 15)
	⊕	10 *3	6 - 10	-	M5	Phillips/slot combo	2.0 - 2.5 (17.7 - 22.1)

1 European Standards

Model	Terminal	Recommended Gauge mm ²	Applicable Gauge mm ²	Wire Stripping Length mm */	Terminal Screw		Tightening Torque N·m (lb·in)
					Size	Shape	
2042	R/L1, S/L2, T/L3	10	2.5 - 10	10	M4	Slot (-)	1.5 - 1.7 (13.5 - 15)
	U/T1, V/T2, W/T3	10	2.5 - 10	10	M4	Slot (-)	1.5 - 1.7 (13.5 - 15)
	-, +1, +2	16	2.5 - 16	18	M5	Slot (-)	2.3 - 2.5 (19.8 - 22) *2
	B1, B2	4	2.5 - 4	10	M4	Slot (-)	1.5 - 1.7 (13.5 - 15)
	⊕	10	6 - 10	-	M5	Phillips/slot combo	2.0 - 2.5 (17.7 - 22.1)
2056	R/L1, S/L2, T/L3	25	10 - 25	18	M5	Slot (-)	2.3 - 2.5 (19.8 - 22) *2
	U/T1, V/T2, W/T3	16	6 - 16	18	M5	Slot (-)	2.3 - 2.5 (19.8 - 22) *2
	-, +1, +2	35	10 - 35	20	M6	Hex socket cap (WAF: 5 mm)	5 - 5.5 (45 - 49)
	B1, B2	10	2.5 - 10	10	M4	Slot (-)	1.5 - 1.7 (13.5 - 15)
	⊕	16	10 - 16	-	M6	Phillips/slot combo	5.4 - 6.0 (47.8 - 53.1)
2070	R/L1, S/L2, T/L3	35	25 - 35	20	M6	Hex socket cap (WAF: 5 mm)	5 - 5.5 (45 - 49)
	U/T1, V/T2, W/T3	16	16	20	M6	Hex socket cap (WAF: 5 mm)	5 - 5.5 (45 - 49)
	-, +1, +2	50	35 - 50	20	M6	Hex socket cap (WAF: 5 mm)	5 - 5.5 (45 - 49)
	B1, B2	10	2.5 - 10	10	M4	Slot (-)	1.5 - 1.7 (13.5 - 15)
	⊕	16	16 - 25	-	M6	Phillips/slot combo	5.4 - 6.0 (47.8 - 53.1)
2082	R/L1, S/L2, T/L3	35	25 - 35	20	M6	Hex socket cap (WAF: 5 mm)	5 - 5.5 (45 - 49)
	U/T1, V/T2, W/T3	25	16 - 25	20	M6	Hex socket cap (WAF: 5 mm)	5 - 5.5 (45 - 49)
	-, +1, +2	50	35 - 50	20	M6	Hex socket cap (WAF: 5 mm)	5 - 5.5 (45 - 49)
	B1, B2	16	2.5 - 16	10	M4	Slot (-)	1.5 - 1.7 (13.5 - 15)
	⊕	16	16 - 25	-	M6	Phillips/slot combo	5.4 - 6.0 (47.8 - 53.1)

Model	Terminal	Recommended Gauge mm ²	Applicable Gauge mm ²	Wire Stripping Length mm <i>*1</i>	Terminal Screw		Tightening Torque N-m (lb-in)
					Size	Shape	
2110	R/L1, S/L2, T/L3	35	25 - 35	27	M6	Hex socket cap (WAF: 5 mm)	8 - 9 (71 - 80)
	U/T1, V/T2, W/T3	35	25 - 35	27	M6	Hex socket cap (WAF: 5 mm)	8 - 9 (71 - 80)
	-, +1	50	25 - 50	27	M8	Hex socket cap (WAF: 6 mm)	10 - 12 (89 - 107)
	B1, B2	25	6 - 25	21	M6	Hex socket cap (WAF: 5 mm)	3 - 3.5 (27 - 31)
	⊕	16	16 - 25	-	M6	Hex bolt (cross-slotted)	5.4 - 6.0 (47.8 - 53.1)
2138	R/L1, S/L2, T/L3	50	50	27	M6	Hex socket cap (WAF: 5 mm)	8 - 9 (71 - 80)
	U/T1, V/T2, W/T3	50	50	27	M6	Hex socket cap (WAF: 5 mm)	8 - 9 (71 - 80)
	-, +1	70	50 - 70	27	M8	Hex socket cap (WAF: 6 mm)	10 - 12 (89 - 107)
	B1, B2	35	6 - 35	21	M6	Hex socket cap (WAF: 5 mm)	3 - 3.5 (27 - 31)
	⊕	25	25	-	M6	Hex bolt (cross-slotted)	5.4 - 6.0 (47.8 - 53.1)
2169	R/L1, S/L2, T/L3	70 <i>*4</i>	95	37	M10	Hex socket cap (WAF: 8 mm)	12 - 14 (107 - 124)
	U/T1, V/T2, W/T3	70 <i>*4</i>	95	37	M10	Hex socket cap (WAF: 8 mm)	12 - 14 (107 - 124)
	-, -, +1, +1 <i>*5</i>	35 <i>*3 *4</i>	50 <i>*3 *4</i>	28	M6	Hex socket cap (WAF: 5 mm)	8 - 9 (71 - 80)
	+3	50	50 - 70	28	M8	Hex socket cap (WAF: 6 mm)	8 - 9 (71 - 80)
	⊕	35	25 - 35	-	M8	Hex bolt (slotted)	9.0 - 11 (79.7 - 97.4)
2211	R/L1, S/L2, T/L3	95	95	37	M10	Hex socket cap (WAF: 8 mm)	12 - 14 (107 - 124)
	U/T1, V/T2, W/T3	95	95	37	M10	Hex socket cap (WAF: 8 mm)	12 - 14 (107 - 124)
	-, -, +1, +1 <i>*5</i>	50 <i>*3 *4</i>	50 <i>*3 *4</i>	28	M6	Hex socket cap (WAF: 5 mm)	8 - 9 (71 - 80)
	+3	70	50 - 70	28	M8	Hex socket cap (WAF: 6 mm)	8 - 9 (71 - 80)
	⊕	50	25 - 50	-	M8	Hex bolt (slotted)	9.0 - 11 (79.7 - 97.4)

1 European Standards

Model	Terminal	Recommended Gauge mm ²	Applicable Gauge mm ²	Wire Stripping Length mm *1	Terminal Screw		Tightening Torque N·m (lb·in)
					Size	Shape	
2257	R/L1, S/L2, T/L3	50 × 2P *4	70 - 95 × 2P	-	M10	Hex self-locking nut	20 (177)
	U/T1, V/T2, W/T3	50 × 2P *4	70 - 95 × 2P	-	M10	Hex self-locking nut	20 (177)
	-, +1	70 × 2P	70 - 120 × 2P	-	M10	Hex self-locking nut	20 (177)
	+3	35 × 2P	35 - 70 × 2P	-	M10	Hex self-locking nut	20 (177)
	⊕	95	95 - 150	-	M10	Hex bolt (slotted)	18 - 23 (159 - 204)
2313	R/L1, S/L2, T/L3	70 × 2P	70 - 95 × 2P	-	M10	Hex self-locking nut	20 (177)
	U/T1, V/T2, W/T3	70 × 2P	70 - 95 × 2P	-	M10	Hex self-locking nut	20 (177)
	-, +1	95 × 2P	70 - 120 × 2P	-	M10	Hex self-locking nut	20 (177)
	+3	50 × 2P	35 - 70 × 2P	-	M10	Hex self-locking nut	20 (177)
	⊕	95	95 - 150	-	M10	Hex bolt (slotted)	18 - 23 (159 - 204)
2360	R/L1, S/L2, T/L3	Preparing					
	U/T1, V/T2, W/T3						
	-, +1						
	+3						
	⊕						
2415	R/L1, S/L2, T/L3	Preparing					
	U/T1, V/T2, W/T3						
	-, +1						
	+3						
	⊕						

- *1 Remove the insulator from the tips of wires to the length shown in "Wire Stripping Length."
- *2 When using wire with a gauge over 30 mm², tighten to a tightening torque of 4.1 to 4.5 N·m (36 to 40 lb·in.).
- *3 Install RCM/RCD to maintain compliance with IEC/EN 61800-5-1:2007 with use of wire of this gauge.
- *4 Use cables in the range of applicable gauges to meet the IP20 protective level.
- *5 Terminals - and + have two screws. Recommended Gauge indicates the wire gauge per one terminal.

Table 1.3 Wire Gauges and Tightening Torques for 400 V Class Drives

Model	Terminal	Recommended Gauge mm ²	Applicable Gauge mm ²	Wire Stripping Length mm <i>*1</i>	Terminal Screw		Tightening Torque N·m (lb·in)
					Size	Shape	
4002	R/L1, S/L2, T/L3	2.5	2.5 - 10	10	M4	Slot (-)	1.5 - 1.7 (13.5 - 15)
	U/T1, V/T2, W/T3	2.5	2.5 - 10	10	M4	Slot (-)	1.5 - 1.7 (13.5 - 15)
	-, +1, +2	2.5	2.5 - 16	18	M5	Slot (-)	2.3 - 2.5 (19.8 - 22) <i>*2</i>
	B1, B2	2.5	2.5 - 4	10	M4	Slot (-)	1.5 - 1.7 (13.5 - 15)
	⊕	2.5 <i>*3</i>	2.5 - 4	-	M4	Phillips/slot combo	1.2 - 1.5 (10.6 - 13.3)
4004	R/L1, S/L2, T/L3	2.5	2.5 - 10	10	M4	Slot (-)	1.5 - 1.7 (13.5 - 15)
	U/T1, V/T2, W/T3	2.5	2.5 - 10	10	M4	Slot (-)	1.5 - 1.7 (13.5 - 15)
	-, +1, +2	2.5	2.5 - 16	18	M5	Slot (-)	2.3 - 2.5 (19.8 - 22) <i>*2</i>
	B1, B2	2.5	2.5 - 4	10	M4	Slot (-)	1.5 - 1.7 (13.5 - 15)
	⊕	2.5 <i>*3</i>	2.5 - 4	-	M4	Phillips/slot combo	1.2 - 1.5 (10.6 - 13.3)
4005	R/L1, S/L2, T/L3	2.5	2.5 - 10	10	M4	Slot (-)	1.5 - 1.7 (13.5 - 15)
	U/T1, V/T2, W/T3	2.5	2.5 - 10	10	M4	Slot (-)	1.5 - 1.7 (13.5 - 15)
	-, +1, +2	2.5	2.5 - 16	18	M5	Slot (-)	2.3 - 2.5 (19.8 - 22) <i>*2</i>
	B1, B2	2.5	2.5 - 4	10	M4	Slot (-)	1.5 - 1.7 (13.5 - 15)
	⊕	2.5 <i>*3</i>	2.5 - 6	-	M4	Phillips/slot combo	1.2 - 1.5 (10.6 - 13.3)
4007	R/L1, S/L2, T/L3	2.5	2.5 - 10	10	M4	Slot (-)	1.5 - 1.7 (13.5 - 15)
	U/T1, V/T2, W/T3	2.5	2.5 - 10	10	M4	Slot (-)	1.5 - 1.7 (13.5 - 15)
	-, +1, +2	2.5	2.5 - 16	18	M5	Slot (-)	2.3 - 2.5 (19.8 - 22) <i>*2</i>
	B1, B2	2.5	2.5 - 4	10	M4	Slot (-)	1.5 - 1.7 (13.5 - 15)
	⊕	2.5 <i>*3</i>	2.5 - 6	-	M4	Phillips/slot combo	1.2 - 1.5 (10.6 - 13.3)

1 European Standards

Model	Terminal	Recommended Gauge mm ²	Applicable Gauge mm ²	Wire Stripping Length mm *1/	Terminal Screw		Tightening Torque N·m (lb·in)
					Size	Shape	
4009	R/L1, S/L2, T/L3	2.5	2.5 - 10	10	M4	Slot (-)	1.5 - 1.7 (13.5 - 15)
	U/T1, V/T2, W/T3	2.5	2.5 - 10	10	M4	Slot (-)	1.5 - 1.7 (13.5 - 15)
	-, +1, +2	2.5	2.5 - 16	18	M5	Slot (-)	2.3 - 2.5 (19.8 - 22) *2
	B1, B2	2.5	2.5 - 4	10	M4	Slot (-)	1.5 - 1.7 (13.5 - 15)
	⊕	2.5 *3	2.5 - 6	-	M4	Phillips/slot combo	1.2 - 1.5 (10.6 - 13.3)
4012	R/L1, S/L2, T/L3	2.5	2.5 - 10	10	M4	Slot (-)	1.5 - 1.7 (13.5 - 15)
	U/T1, V/T2, W/T3	2.5	2.5 - 10	10	M4	Slot (-)	1.5 - 1.7 (13.5 - 15)
	-, +1, +2	2.5	2.5 - 16	18	M5	Slot (-)	2.3 - 2.5 (19.8 - 22) *2
	B1, B2	2.5	2.5 - 4	10	M4	Slot (-)	1.5 - 1.7 (13.5 - 15)
	⊕	2.5 *3	2.5 - 6	-	M4	Phillips/slot combo	1.2 - 1.5 (10.6 - 13.3)
4018	R/L1, S/L2, T/L3	2.5	2.5 - 10	10	M4	Slot (-)	1.5 - 1.7 (13.5 - 15)
	U/T1, V/T2, W/T3	2.5	2.5 - 10	10	M4	Slot (-)	1.5 - 1.7 (13.5 - 15)
	-, +1, +2	4	2.5 - 16	18	M5	Slot (-)	2.3 - 2.5 (19.8 - 22) *2
	B1, B2	2.5	2.5 - 4	10	M4	Slot (-)	1.5 - 1.7 (13.5 - 15)
	⊕	2.5 *3	2.5 - 6	-	M5	Phillips/slot combo	2.0 - 2.5 (17.7 - 22.1)
4023	R/L1, S/L2, T/L3	6	2.5 - 10	10	M4	Slot (-)	1.5 - 1.7 (13.5 - 15)
	U/T1, V/T2, W/T3	4	2.5 - 10	10	M4	Slot (-)	1.5 - 1.7 (13.5 - 15)
	-, +1, +2	6	2.5 - 16	18	M5	Slot (-)	2.3 - 2.5 (19.8 - 22) *2
	B1, B2	2.5	2.5 - 4	10	M4	Slot (-)	1.5 - 1.7 (13.5 - 15)
	⊕	6 *3	4 - 6	-	M5	Phillips/slot combo	2.0 - 2.5 (17.7 - 22.1)

Model	Terminal	Recommended Gauge mm ²	Applicable Gauge mm ²	Wire Stripping Length mm */	Terminal Screw		Tightening Torque N-m (lb-in)
					Size	Shape	
4031	R/L1, S/L2, T/L3	10	10 - 25	18	M5	Slot (-)	2.3 - 2.5 (19.8 - 22) *2
	U/T1, V/T2, W/T3	6	6 - 16	18	M5	Slot (-)	2.3 - 2.5 (19.8 - 22) *2
	-, +1, +2	10	10 - 35	20	M6	Hex socket cap (WAF: 5 mm)	5 - 5.5 (45 - 49)
	B1, B2	2.5	2.5 - 10	10	M4	Slot (-)	1.5 - 1.7 (13.5 - 15)
	⊕	10 *3	6 - 10	-	M6	Phillips/slot combo	5.4 - 6.0 (47.8 - 53.1)
4038	R/L1, S/L2, T/L3	10	10 - 25	18	M5	Slot (-)	2.3 - 2.5 (19.8 - 22) *2
	U/T1, V/T2, W/T3	6	6 - 16	18	M5	Slot (-)	2.3 - 2.5 (19.8 - 22) *2
	-, +1, +2	16	10 - 35	20	M6	Hex socket cap (WAF: 5 mm)	5 - 5.5 (45 - 49)
	B1, B2	4	2.5 - 10	10	M4	Slot (-)	1.5 - 1.7 (13.5 - 15)
	⊕	10	6 - 16	-	M6	Phillips/slot combo	5.4 - 6.0 (47.8 - 53.1)
4044	R/L1, S/L2, T/L3	16	4 - 16	18	M5	Slot (-)	2.3 - 2.5 (19.8 - 22) *2
	U/T1, V/T2, W/T3	10	6 - 10	18	M5	Slot (-)	2.3 - 2.5 (19.8 - 22) *2
	-, +1, +2	25	6 - 25	18	M5	Slot (-)	2.3 - 2.5 (19.8 - 22) *2
	B1, B2	6	2.5 - 6	10	M4	Slot (-)	1.5 - 1.7 (13.5 - 15)
	⊕	16	10 - 16	-	M6	Phillips/slot combo	5.4 - 6.0 (47.8 - 53.1)
4060	R/L1, S/L2, T/L3	16	4 - 16	18	M5	Slot (-)	2.3 - 2.5 (19.8 - 22) *2
	U/T1, V/T2, W/T3	16	6 - 16	18	M5	Slot (-)	2.3 - 2.5 (19.8 - 22) *2
	-, +1	25	6 - 25	18	M5	Slot (-)	2.3 - 2.5 (19.8 - 22) *2
	B1, B2	10	2.5 - 10	10	M4	Slot (-)	1.5 - 1.7 (13.5 - 15)
	⊕	16	10 - 16	-	M6	Phillips/slot combo	5.4 - 6.0 (47.8 - 53.1)

1 European Standards

Model	Terminal	Recommended Gauge mm ²	Applicable Gauge mm ²	Wire Stripping Length mm *1	Terminal Screw		Tightening Torque N·m (lb·in)
					Size	Shape	
4075	R/L1, S/L2, T/L3	25	2.5 - 25	18	M5	Slot (-)	2.3 - 2.5 (19.8 - 22) *2
	U/T1, V/T2, W/T3	25	2.5 - 25	18	M5	Slot (-)	2.3 - 2.5 (19.8 - 22) *2
	-, +1	25	4 - 25	18	M5	Slot (-)	2.3 - 2.5 (19.8 - 22) *2
	B1, B2	10	2.5 - 10	10	M4	Slot (-)	1.5 - 1.7 (13.5 - 15)
	⊕	16	16 - 25	-	M6	Hex bolt (cross-slotted)	5.4 - 6.0 (47.8 - 53.1)
4089	R/L1, S/L2, T/L3	25	10 - 25	18	M5	Slot (-)	2.3 - 2.5 (19.8 - 22) *2
	U/T1, V/T2, W/T3	25	10 - 25	18	M5	Slot (-)	2.3 - 2.5 (19.8 - 22) *2
	-, +1	35	16 - 35	20	M6	Hex socket cap (WAF: 5 mm)	5 - 5.5 (45 - 49)
	B1, B2	16	4 - 16	18	M5	Slot (-)	2.3 - 2.5 (19.8 - 22) *2
	⊕	16	16 - 25	-	M6	Hex bolt (cross-slotted)	5.4 - 6.0 (47.8 - 53.1)
4103	R/L1, S/L2, T/L3	35 *4	50	27	M6	Hex socket cap (WAF: 5 mm)	8 - 9 (71 - 80)
	U/T1, V/T2, W/T3	35 *4	50	27	M6	Hex socket cap (WAF: 5 mm)	8 - 9 (71 - 80)
	-, +1	50	50 - 70	27	M8	Hex socket cap (WAF: 6 mm)	10 - 12 (89 - 107)
	B1, B2	25	6 - 35	21	M6	Hex socket cap (WAF: 5 mm)	3 - 3.5 (27 - 31)
	⊕	16	16 - 25	-	M6	Hex bolt (cross-slotted)	5.4 - 6.0 (47.8 - 53.1)
4140	R/L1, S/L2, T/L3	50 *4	95	37	M10	Hex socket cap (WAF: 8 mm)	12 - 14 (107 - 124)
	U/T1, V/T2, W/T3	50 *4	95	37	M10	Hex socket cap (WAF: 8 mm)	12 - 14 (107 - 124)
	-, -, +1, +1 *5	25 *3 *4	50 *3	28	M6	Hex socket cap (WAF: 5 mm)	8 - 9 (71 - 80)
	B1, B2	50	50 - 70	28	M8	Hex socket cap (WAF: 6 mm)	8 - 9 (71 - 80)
	⊕	25	25	-	M8	Hex bolt (slotted)	9.0 - 11 (79.7 - 97.4)

Model	Terminal	Recommended Gauge mm ²	Applicable Gauge mm ²	Wire Stripping Length mm */	Terminal Screw		Tightening Torque N-m (lb-in)
					Size	Shape	
4168	R/L1, S/L2, T/L3	70 *4	95	37	M10	Hex socket cap (WAF: 8 mm)	12 - 14 (107 - 124)
	U/T1, V/T2, W/T3	70 *4	95	37	M10	Hex socket cap (WAF: 8 mm)	12 - 14 (107 - 124)
	-, -, +1, +1 *5	35 *3 *4	50 *3	28	M6	Hex socket cap (WAF: 5 mm)	8 - 9 (71 - 80)
	B1, B2	50	50 - 70	28	M8	Hex socket cap (WAF: 6 mm)	8 - 9 (71 - 80)
	⊕	35	25 - 35	-	M8	Hex bolt (slotted)	9.0 - 11 (79.7 - 97.4)
4208	R/L1, S/L2, T/L3	50 × 2P *4	70 - 95 × 2P	-	M10	Hex self-locking nut	20 (177)
	U/T1, V/T2, W/T3	50 × 2P *4	70 - 95 × 2P	-	M10	Hex self-locking nut	20 (177)
	-, +1	70 × 2P	70 - 120 × 2P	-	M10	Hex self-locking nut	20 (177)
	+3	35 × 2P	35 - 70 × 2P	-	M10	Hex self-locking nut	20 (177)
	⊕	50	50 - 150	-	M10	Hex bolt (slotted)	18 - 23 (159 - 204)
4250	R/L1, S/L2, T/L3	50 × 2P *4	70 - 95 × 2P	-	M10	Hex self-locking nut	20 (177)
	U/T1, V/T2, W/T3	50 × 2P *4	70 - 95 × 2P	-	M10	Hex self-locking nut	20 (177)
	-, +1	70 × 2P	70 - 120 × 2P	-	M10	Hex self-locking nut	20 (177)
	+3	50 × 2P	35 - 70 × 2P	-	M10	Hex self-locking nut	20 (177)
	⊕	70	70 - 240	-	M10	Hex bolt (slotted)	18 - 23 (159 - 204)
4296	R/L1, S/L2, T/L3	70 × 2P	70 - 95 × 2P	-	M10	Hex self-locking nut	20 (177)
	U/T1, V/T2, W/T3	70 × 2P	70 - 95 × 2P	-	M10	Hex self-locking nut	20 (177)
	-, +1	95 × 2P	70 - 120 × 2P	-	M10	Hex self-locking nut	20 (177)
	+3	70 × 2P	35 - 70 × 2P	-	M10	Hex self-locking nut	20 (177)
	⊕	95	95 - 240	-	M10	Hex bolt (slotted)	18 - 23 (159 - 204)
4371	R/L1, S/L2, T/L3	Preparing					
	U/T1, V/T2, W/T3						
	-, +1						
	+3						
	⊕						

Model	Terminal	Recommended Gauge mm ²	Applicable Gauge mm ²	Wire Stripping Length mm */	Terminal Screw		Tightening Torque N·m (lb·in)
					Size	Shape	
4389	R/L1, S/L2, T/L3						Preparing
	U/T1, V/T2, W/T3						
	-, +1						
	+3						
	⊕						
4453	R/L1, S/L2, T/L3 R1/L11, S1/L21, T1/L31						Preparing
	U/T1, V/T2, W/T3						
	-, +1						
	+3						
	⊕						
4568	R/L1, S/L2, T/L3 R1/L11, S1/L21, T1/L31						Preparing
	U/T1, V/T2, W/T3						
	-, +1						
	+3						
	⊕						
4675	R/L1, S/L2, T/L3 R1/L11, S1/L21, T1/L31						Preparing
	U/T1, V/T2, W/T3						
	-, +1						
	+3						
	⊕						

- *1 Remove the insulator from the tips of wires to the length shown in “Wire Stripping Length.”
- *2 When using wire with a gauge over 30 mm², tighten to a tightening torque of 4.1 to 4.5 N·m (36 to 40 lb·in.).
- *3 Install RCM/RCD to maintain compliance with IEC/EN 61800-5-1:2007 with use of wire of this gauge.
- *4 Use cables in the range of applicable gauges to meet the IP20 protective level.
- *5 Terminals - and + have two screws. Recommended Gauge indicates the wire gauge per one terminal.

■ Drive Circuit Protection and Short Circuit Current Rating

Install the drive circuit protection devices listed in the following tables on the input side of the drive to comply with IEC/EN61800-5-1:2007 and in the event of a short circuit in the internal circuitry.

NOTICE Do not energize or operate equipment soon after a fuse blows or RCM/RCD trips. Check the condition of cable wiring and peripheral devices to identify the root cause. If the root cause cannot be determined, do not turn on the power or operate equipment. Contact Yaskawa Support immediately.

Three-phase 200 V Class**Table 1.4 Drive Circuit Protection and Short Circuit Rating (200 V class)**

Model	Semiconductor Fuse Rated Current Manufacturer: EATON/Bussmann
2004	FWH-45B
2006	FWH-45B
2010	FWH-45B
2012	FWH-50B
2018	FWH-80B
2021	FWH-80B
2030	FWH-125B
2042	FWH-150B
2056	FWH-200B
2070	FWH-225A
2082	FWH-225A FWH-250A *1
2110	FWH-225A FWH-250A *1
2138 *2	FWH-275A FWH-300A *1
2169 *2	FWH-275A FWH-350A *1
2211 *2	FWH-325A FWH-450A *1
2257 *2	FWH-600A
2313 *2	FWH-800A
2360 *2	FWH-1000A
2415 *2	FWH-1400A

*1 Fuses with larger rated currents are recommended for application with repetitive operations.

*2 Approval pending. Contact Yaskawa or your nearest sales representative for more information.

Three-phase 400 V Class**Table 1.5 Drive Circuit Protection and Short Circuit Rating (400 V class)**

Model	Semiconductor Fuse Rated Current Manufacturer: EATON/Bussmann
4002	FWH-50B
4004	FWH-50B
4005	FWH-50B
4007	FWH-60B
4009	FWH-60B
4012	FWH-60B
4018	FWH-80B
4023	FWH-90B
4031	FWH-150B
4038	FWH-200B
4044	FWH-200B
4060	FWH-225A
4075	FWH-250A

Model	Semiconductor Fuse Rated Current Manufacturer: EATON/Bussmann
4089	FWH-275A
4103 *1	FWH-275A
4140 *1	FWH-300A
4168 *1	FWH-325A FWH-400A *2
4208 *1	FWH-500A
4250 *1	FWH-600A
4296 *1	FWH-700A
4371 *1	FWH-800A
4414 *1	FWH-1000A
4453 *1	FWH-1200A
4568 *1	FWH-1200A
4675 *1	FWH-1400A FWH-1600A *2

*1 Approval pending. Contact Yaskawa or your nearest sales representative for more information.

*2 Fuses with larger rated currents are recommended for application with repetitive operations.

■ CE Standards Compliance for DC Power Supply Input

Fuses must be installed for DC power input to comply with the CE Standards.

Figure 1.3 illustrates a wiring example when using the DC power supply with 2 drives connected in parallel.

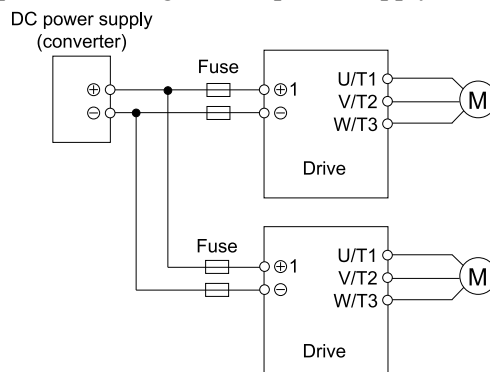

Figure 1.3 Wiring Example for DC Power Input

Note:

- Install a fuse for each drive when using multiple drives. Replace all the fuses if any of them is blown out.
- Install the external filter (system) to maintain compliance with the EMC Directive.
- Do not ground the main circuit bus.

Refer to Table 1.6 and Table 1.7 for the recommended fuses.

Three-Phase 200 V Class

Table 1.6 Recommended Fuse (Three-Phase 200 V Class)

Drive Model	Fuse Manufacturer: Bussmann	
	Model	Qty
2004	FWH-45B	2
2006	FWH-45B	2
2010	FWH-45B	2
2012	FWH-50B	2
2018	FWH-80B	2
2021	FWH-80B	2

Drive Model	Fuse Manufacturer: Bussmann	
	Model	Qty
2030	FWH-125B	2
2042	FWH-150B	2
2056	FWH-200B	2
2070	FWH-250A	2
2082	FWH-250A FWH-300A *1	2
2110	FWH-250A FWH-275A *1	2
2138	FWH-300A FWH-350A *1	2
2169 *2	FWH-350A FWH-450A *1	2
2211 *2	FWH-450A FWH-600A *1	2
2257 *2	FWH-600A FWH-700A *1	2
2313 *2	FWH-800A FWH-1000A *1	2
2360 *2	FWH-1000A	2
2415 *2	FWH-1400A	2

*1 We recommend a fuse with a large rated current for applications involving repeated loads.

*2 Approval pending. Contact Yaskawa or your nearest sales representative.

Three-Phase 400 V Class

Table 1.7 Recommended Fuse (Three-Phase 400 V Class)

Drive Model	Fuse Manufacturer: Bussmann	
	Model	Qty
4002	FWH-50B	2
4004	FWH-50B	2
4005	FWH-50B	2
4007	FWH-60B	2
4009	FWH-60B	2
4012	FWH-60B	2
4018	FWH-80B	2
4023	FWH-90B	2
4031	FWH-150B	2
4038	FWH-200B	2
4044	FWH-200B	2
4060	FWH-225A	2
4075	FWH-250A	2
4089	FWH-275A	2
4103	FWH-275A	2
4140	FWH-300A FWH-325A *1	2

Drive Model	Fuse Manufacturer: Bussmann	
	Model	Qty
4168	FWH-400A FWH-450A *1	2
4208	FWH-500A FWH-600A *1	2
4250	FWH-600A FWH-700A *1	2
4296	FWH-700A FWH-800A *1	2
4371 *2	FWH-800A FWH-1000A *1	2
4389 *2	FWH-1000A FWH-1200A *1	2
4453 *2	FWH-1200A FWH-1400A *1	2
4568 *2	FWH-1200A FWH-1600A *1	2
4675 *2	FWH-1600A	2

*1 We recommend a fuse with a large rated current for applications involving repeated loads.

*2 Approval pending. Contact Yaskawa or your nearest sales representative.

◆ EMC Directive

The drive was tested in accordance with European standard EN 61800-3:2004+A1:2012, and is compliant with the EMC Directive.

Use drives with built-in EMC filters or install external EMC filters to the drive input side to comply with the EMC Directive. *Refer to Installing a Drive to Conform to the EMC Directive on page 18* for the installation of the EMC filter.

■ Ground Wiring

⚠ WARNING *Electrical Shock Hazard. Do not remove covers or touch the circuit boards while the power is on. Failure to comply could cause death or serious injury.*

⚠ WARNING *Electrical Shock Hazard. Ground the neutral point on the power supply of drive models 2xxxB/C and 4xxxA/B/C to comply with the EMC Directive before turning on the EMC filter or if there is high resistance grounding. Failure to obey can cause death or serious injury.*

■ Installing a Drive to Conform to the EMC Directive

Install drive models 2xxxB/C and 4xxxB/C as described in the following procedure to comply with the EMC Directive when the drive is a single unit or integrated into a larger device.

1. Attach the drive to a metal plate or other noncombustible material.
2. Wire the drive and motor.

3. Ground the shield braid of the braided shield cable to the metal plate. Yaskawa recommends using cable clamps.

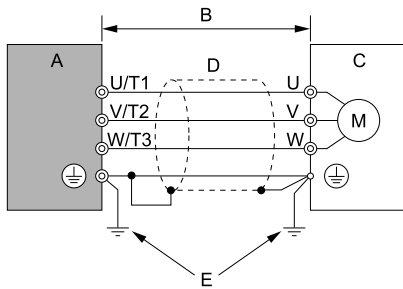

- A - Drive
- B - 10 m (32.8 ft.) max.
- C - Motor
- D - Metal conduit
- E - Ground wire

Figure 1.4 Wiring the drive and motor

Note:

- Use braided shielded cable for the drive and motor wiring or pass the wires through a metal conduit.
- The maximum wiring length between the drive and motor is 10 m (32.8 ft).
- Keep the ground wire as short as possible.

4. Ground the motor cable using cable clamp to affix to the metal plate.

Note:

Make sure the protective earthing conductor complies with technical standards and local safety regulations.

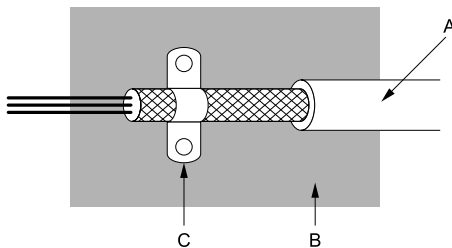

- A - Braided shielded cable
- B - Metal plate
- C - Cable clamp (conductive)

Figure 1.5 Ground the shield

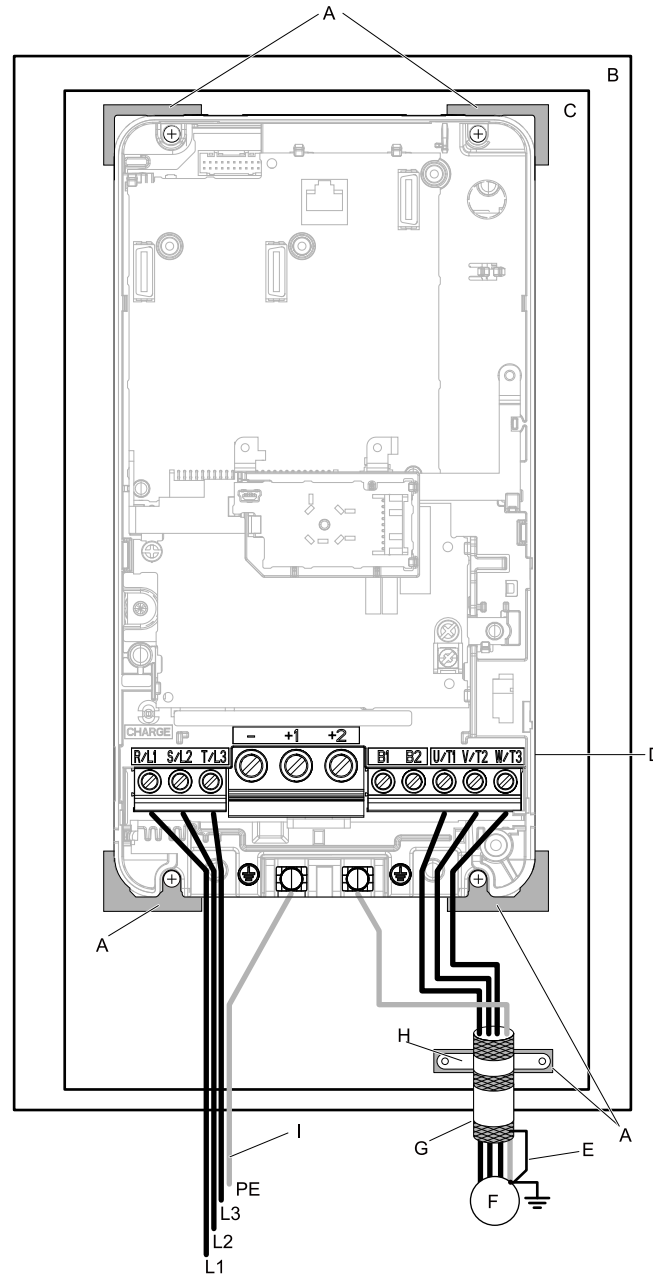

- | | |
|--|------------------------|
| A - Grounding surface (remove any paint or sealant) | F - Motor |
| B - Enclosure panel | G - Motor cable |
| C - Metal plate | H - Cable clamp |
| D - Drive | I - Ground wire |
| E - Shielded wire | |

Figure 1.6 Install a drive with a built-in EMC filter

5. Connect a DC reactor to reduce harmonic distortion. [Refer to DC Reactor on page 25](#) for details.

Note:

- Install a DC reactor specified in this manual for compliance with IEC/EN 61000-3-2 for drive models 2004, 2006, 4002, or 4004.
- The terminal blocks are different between the drive and the DC reactor. The drive has European type terminal blocks, and the DC reactor has screw type terminal blocks. Correctly prepare the ends of the wiring.

◆ Enabling the Internal EMC Filter

To turn on (enable) and off (disable) the EMC filter built in the drive models 2xxxB, 2xxxC, 4xxxB, and 4xxxC, change the mounting position of the screw.

⚠ WARNING *Electrical Shock Hazard. Confirm that the power to the drive is OFF and the CHARGE LED light is off before moving the EMC switch screws. Failure to comply could cause death or serious injury.*

⚠ WARNING *Electrical Shock Hazard. Do not remove covers or touch the circuit boards while the power is on. Failure to comply could cause death or serious injury.*

⚠ WARNING *Electrical Shock Hazard. Ground the neutral point on the power supply of drive models 2xxxB/C and 4xxxA/B/C to comply with the EMC Directive before turning on the EMC filter or if there is high resistance grounding. Failure to obey can cause death or serious injury.*

⚠ WARNING *Electrical Shock Hazard. Connect the ground cable correctly. Failure to comply could cause death or serious injury.*

NOTICE *Do not completely remove the screws or tighten the screws to an incorrect torque when disabling the EMC filter. Failure to comply could cause drive failure.*

NOTICE *Move the EMC switch screws to the OFF position for networks that are not symmetrically grounded. Failure to comply could cause damage to the drive.*

To make this product comply with the EMC Directive, confirm that the symmetric grounding network is applied, and mount the screw of the EMC filter switch to the ON position to turn on (enable) the built-in EMC filter. The screw of the EMC filter switch is set to OFF position by default.

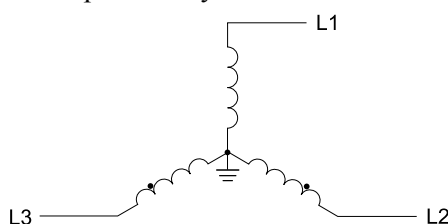

Figure 1.7 Symmetric Grounding

NOTICE *When using a drive with a non-grounding network, high resistance grounding, asymmetric grounding network, place the screw for the EMC filter switch in the OFF position and disable the built-in EMC filter. Failure to follow the instructions may damage the drive.*

Table 1.8 shows the asymmetric grounding network.

Table 1.8 Asymmetric Grounding

Type of Grounding	Description
Grounding on a corner of the delta connection	<p>The diagram shows a delta connection of three inductors L1, L2, and L3. One corner of the delta is connected to a ground symbol.</p>
Grounding on a line of the delta connection	<p>The diagram shows a delta connection of three inductors L1, L2, and L3. One of the lines (winding) of the delta is connected to a ground symbol.</p>
Grounding on an end of the single-phase connection	<p>The diagram shows a single-phase connection with inductor L1 and a neutral line N. The end of the neutral line N is connected to a ground symbol.</p>
Three-phase variable transformer without neutral grounding	<p>The diagram shows a three-phase variable transformer with three windings labeled L1, L2, and L3. None of the windings are connected to a ground symbol.</p>

Table 1.9 EMC Filter Switch Layout Drawing

Model	Switch layout drawing
2004B - 2042B, 4002B - 4023B 2004C - 2042C, 4002C - 4023C	Figure 1.8
2056B, 4031B, 4038B 2056C, 4031C, 4038C	Figure 1.9
2070B, 2082B, 4044B, 4060B 2070C, 2082C, 4044C, 4060C	Figure 1.10
2110B, 4075B, 2138B - 2211B, 4089B - 4168B 2110C, 4075C, 2138C - 2211C, 4089C - 4168C	Figure 1.11
2257B - 2415B, 4208B - 4675B 2257C - 2415C, 4208C - 4675C	Figure 1.12

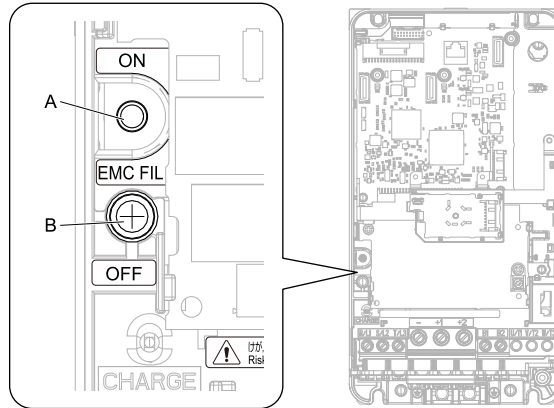

A - SW (ON)

B - Screw (OFF)

Figure 1.8 EMC Filter Switch Layout Drawing 1

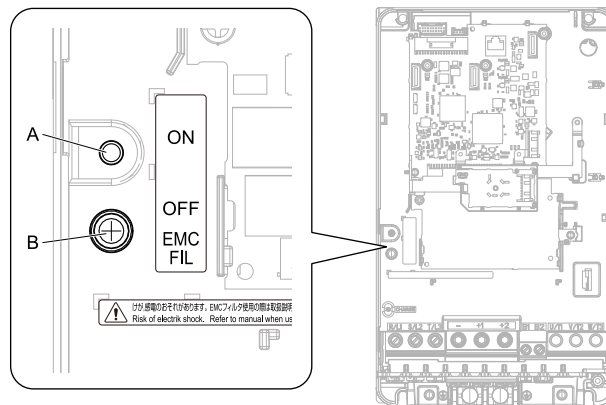

A - SW (ON)

B - Screw (OFF)

Figure 1.9 EMC Filter Switch Layout Drawing 2

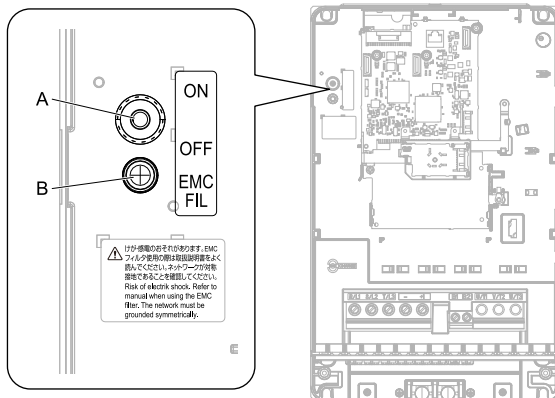

A - SW (ON)

B - Screw (OFF)

Figure 1.10 EMC Filter Switch Layout Drawing 3

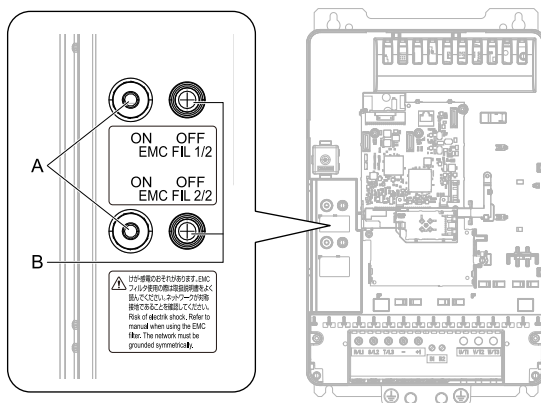

A - SW (ON)

B - Screw (OFF)

Figure 1.11 EMC Filter Switch Layout Drawing 4

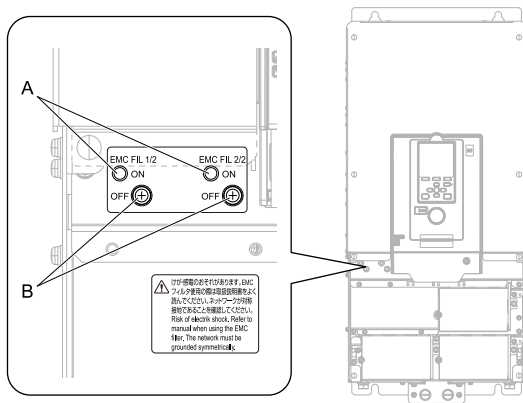

A - SW (ON)

B - Screw (OFF)

Figure 1.12 EMC Filter Switch Layout Drawing 5

If the screw of the EMC filter switch is lost, use a new one and tighten it to the specified tightening torque according the following table.

NOTICE Use only the screws specified in this manual. Do not use different screws than what is recommended. Failure to comply could damage the drive.

Table 1.10 Screw Sizes and Tightening Torques

Model	Screw Size	Tightening Torque N-m
2004 - 2042, 4002 - 4023	M4 × 20	1.0 - 1.3
2056, 2070, 2082, 4031 - 4038, 4044, 4060	M4 × 20	1.0 - 1.3

Model	Screw Size	Tightening Torque N·m
2110 - 2211, 4075 - 4168	M4 × 25	1.0 - 1.3
2257 - 2415, 4208 - 4675	M5 × 25	2.0 - 2.5

◆ External EMC Filter

Install the external EMC filter to the drive input side when using models 2xxxA and 4xxxA to comply with EN 61800-3:2004+A1:2012. *Refer to External EMC Filter Installation on page 24* for the selection of the EMC filters.

■ External EMC Filter Installation

⚠ WARNING *Electrical Shock Hazard. Ground the drive to comply with EMC guidelines. Ground the power supply line neutral for 400 V class drives. Failure to comply could cause death or serious injury.*

Refer to [Figure 1.13](#) for instruction on wiring the external EMC filter and the drive.

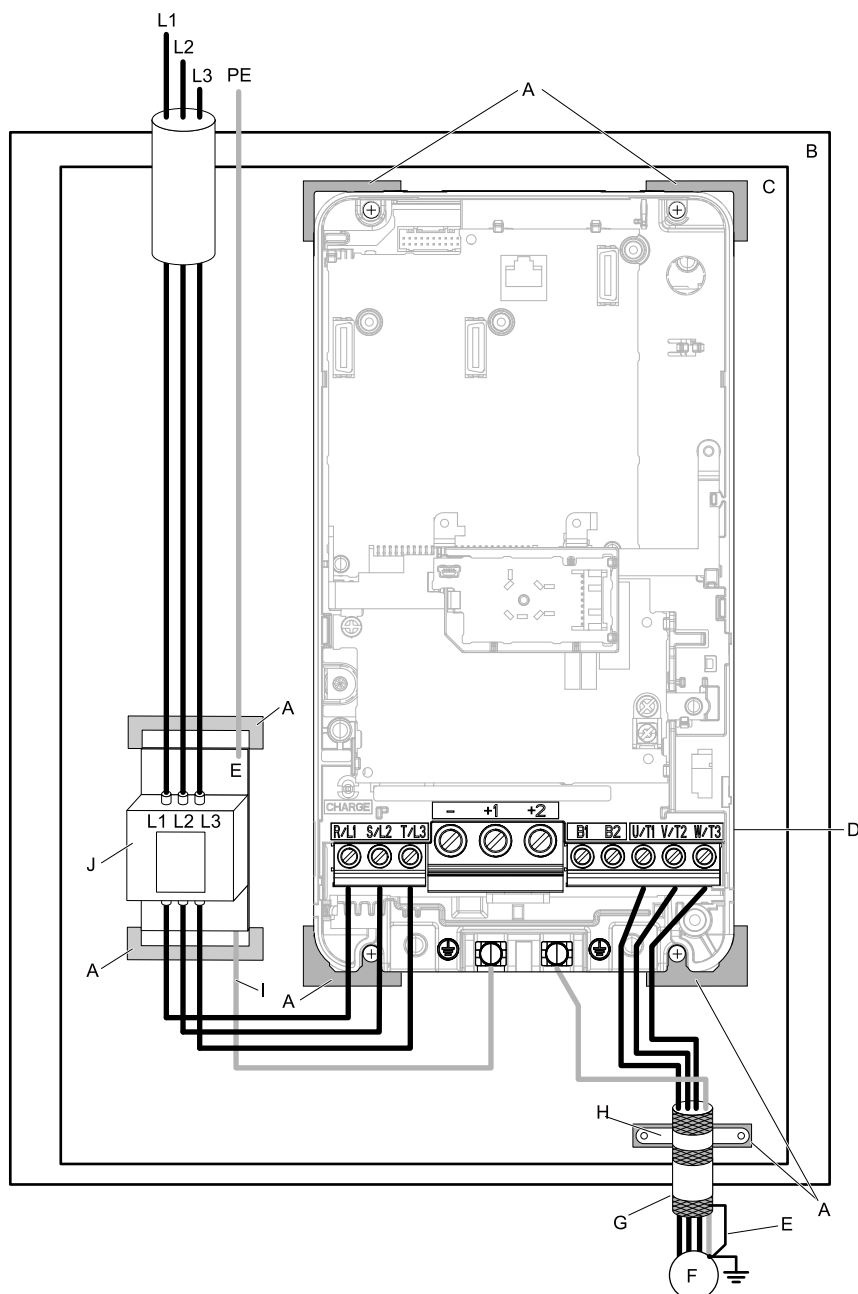

- A - Grounding surface (remove any paint or sealant)**
B - Enclosure panel
C - Metal plate
D - Drive
E - Cable shield ground
F - Motor
G - Motor cable (braided shield cable, max. 10 m (32.8 ft.))
H - Cable clamp
I - Ground wire
J - External EMC filter

Figure 1.13 External EMC Filter and Drive Installation for CE Compliance

◆ DC Reactor

Install a DC reactor for drive models 2004, 2006, 4002, and 4004 when using an internal or external EMC filter to comply with IEC/EN 61000-3-2. Refer to [Table 1.11](#) to select a DC reactor.

Table 1.11 DC Reactors for Harmonic Suppression (Manufacturer: Yaskawa Electric)

Drive Model	DC Reactor Model	DC Reactor Rating
2004	UZDA-B	5.4 A, 8 mH
2006	UZDA-B	5.4 A, 8 mH

Drive Model	DC Reactor Model	DC Reactor Rating
4002	UZDA-B	3.2 A, 28 mH
4004	UZDA-B	3.2 A, 28 mH

2 UL Standards



Figure 2.1 UL/cUL Mark

The UL/cUL Mark indicates that this product satisfies stringent safety standards. This mark appears on products in the United States and Canada. It shows UL approval, indicating that it has been determined that the product complies with safety standards after undergoing strict inspection and assessment. UL-approved parts must be used for all major components that are built into electrical appliances that obtain UL approval.

This product has been tested in accordance with UL standard UL61800-5-1, and has been verified to be in compliance with UL standards.

Machines and devices integrated with this product must satisfy the following conditions for compliance with UL standards.

◆ Area of Use

Install and use this product in a location of overvoltage category III and pollution degree 2 (UL standard) or less.

■ Ambient Temperature Setting

Maintain the ambient temperature within the following ranges according to the enclosure type.

- Enclosed wall-mounted type (UL Type 1): -10 °C to +40 °C (14 °F to 104 °F)
- Open chassis type (IP20): -10 °C to +50 °C (14 °F to 122 °F)

◆ Main Circuit Terminal Wiring

Follow the instructions in this manual when wiring the main circuit terminals.

Read through the following notes before wiring the screw clamp terminal blocks.

■ Notes on Wiring the Main Circuit Terminal Block

Note:

- Use copper wire. Non-copper wire such as aluminum wire cannot be used.
- Be sure remove any foreign objects on the wire connections for the terminal block.
- Remove the insulator from the connection wires to the wire stripping lengths listed in the manual.
- Do not use a wire with bent or crushed conductor. If a deformed wire is used for connection, cut off the bent end of the wire before using it.
- When using stranded wire, do not solder the conductor portion.
- When stranded wire is used, wire it so that no wire fibers protrude out of the connection. Do not excessively twist the stranded wire.
- Insert the wire until it is completely inside the terminal block. Once the insulator from the wire is removed to the suggested wire stripping length, the insulator will fit within the plastic housing.
- The tightening torque is different for each terminal. Tighten the screws to the specified tightening torque.
- Use a torque driver, torque ratchet or torque wrench that is designed for the screws. A flat end driver or a hex tool will be needed when wiring the screw clamp terminal. Refer to the recommended conditions listed in the product manual and provide tools accordingly.
- When using an electric driver to tighten, be especially careful and tighten at low speed, 300 to 400 r/min.
- Wiring tools can be purchased from Yaskawa. Contact Yaskawa or your nearest sales representative for details.
- When replacing your existing drive with this one, the existing wires may have wire gauges that are out of range of some of the gauges applicable to the new drive. For the usable and unusable wire gauges, contact Yaskawa or your nearest sales representative.
- After connecting the wires, gently pull on the wires to check that they do not pull out.
- Cut off an appropriate section of the wiring cover to facilitate the wiring.
- Regularly tighten any loose terminal block screws to their specified tightening torques.
- To protect the wiring connections from strain forces, be sure to secure wires near wiring parts using some sort of strain relief system. Refer to the following diagram.

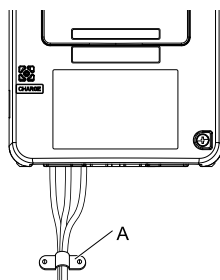

A - Strain relief

Figure 2.2 Wiring Example Using Strain Relief

Table 2.1 Recommended Wiring Tools

Screw Size	Screw Shape	Adapter	Bit		Torque Driver Model (Tightening Torque)	Torque Wrench
			Model	Manufacturer		
M4	Slot (-)	Bit	SF-BIT-SL 1,0X4,0-70	PHOENIX CONTACT	TSD-M 3NM (1.2 - 3 N·m)	-
M5 *1	Slot (-)	Bit	SF-BIT-SL 1,2X6,5-70	PHOENIX CONTACT	Wire Gauge ≤ 25 mm ² (AWG 10): TSD-M 3NM (1.2 - 3 N·m)	Wire Gauge ≤ 25 mm ² (AWG 10): -
					Wire Gauge ≥ 30 mm ² (AWG 8): -	Wire Gauge ≥ 30 mm ² (AWG 8): 4.1 - 4.5 N·m *2 *3
M6	Hex socket cap (WAF: 5 mm)	Bit	SF-BIT-HEX 5-50	PHOENIX CONTACT	-	5 - 9 N·m *2 *3
M8	Hex socket cap (WAF: 6 mm)	Bit	SF-BIT-HEX 6-50	PHOENIX CONTACT	-	8 - 12 N·m *2 *3
M10	Hex socket cap (WAF: 8 mm)	Bit	SF-BIT-HEX 8-50	PHOENIX CONTACT	-	12 - 14 N·m *2 *3

*1 When wiring the drive models 2056 and 4089 or below, select tools correctly based on the wire gauges.

*2 Use 6.35 mm bit socket holder.

*3 Use torque wrench that its torque measurement range includes this value.

■ Main Circuit Wire Gauges and Tightening Torques

Refer to [Table 2.2](#) and [Table 2.3](#) for the recommended wire gauges and tightening torques of the main circuit terminals.

Comply with the local regulations applicable to the drive with regard to the correct wire gauges.

Note:

- Wire gauge recommendations based on drive continuous current ratings using 75 °C (167 °F) 600 V class 2 heat resistant indoor PVC wire. Assume the following usage conditions:
 - Ambient temperature: 40 °C (104 °F) or lower
 - Wiring distance: 100 m (3281 ft.) or shorter
 - Rated current (ND) value
- Use terminals +1, +2, +3, -, B1, and B2 to connect peripheral options such as a DC reactor or a braking resistor. Do not connect anything other than optional devices.
- When connecting peripheral devices or options to terminals +1, +2, +3, -, B1, and B2, refer to the specific instruction manual of each device for wire gauges. Contact Yaskawa or your nearest sales representative if the wire gauge recommended for the peripheral device or optional recommended gauge is out of the range of the applicable gauge for the drive.
- Use UL approved closed-loop crimp terminals for wires that connect to the main circuit terminal of drive models 2257 to 2415 and 4208 to 4675. Crimp the crimp terminal using a tool that is recommended by the manufacturer of the terminal.

Three-Phase 200 V Class

Table 2.2 Main Circuit Wire Gauges and Tightening Torques (Three-phase 200 V Class)

Model	Terminal	Recommended Gauge AWG, kcmil	Applicable Gauge AWG, kcmil	Wire Stripping Length ^{*1} mm	Terminal Screw		Tightening Torque N·m (lb·in)
					Terminal Screw Size	Shape	
2004	R/L1, S/L2, T/L3	14	14 - 6	10	M4	Slot (-)	1.5 - 1.7 (13.5 - 15)
	U/T1, V/T2, W/T3	14	14 - 6	10	M4	Slot (-)	1.5 - 1.7 (13.5 - 15)
	-, +1, +2	14	14 - 3	18	M5	Slot (-)	2.3 - 2.5 (19.8 - 22) ^{*2}
	B1, B2	14	14 - 10	10	M4	Slot (-)	1.5 - 1.7 (13.5 - 15)
	⊕	10	14 - 10	-	M4	Phillips/slot combo	1.2 - 1.5 (10.6 - 13.3)
2006	R/L1, S/L2, T/L3	14	14 - 6	10	M4	Slot (-)	1.5 - 1.7 (13.5 - 15)
	U/T1, V/T2, W/T3	14	14 - 6	10	M4	Slot (-)	1.5 - 1.7 (13.5 - 15)
	-, +1, +2	14	14 - 3	18	M5	Slot (-)	2.3 - 2.5 (19.8 - 22) ^{*2}
	B1, B2	14	14 - 10	10	M4	Slot (-)	1.5 - 1.7 (13.5 - 15)
	⊕	10	14 - 10	-	M4	Phillips/slot combo	1.2 - 1.5 (10.6 - 13.3)
2010	R/L1, S/L2, T/L3	12	14 - 6	10	M4	Slot (-)	1.5 - 1.7 (13.5 - 15)
	U/T1, V/T2, W/T3	14	14 - 6	10	M4	Slot (-)	1.5 - 1.7 (13.5 - 15)
	-, +1, +2	12	14 - 3	18	M5	Slot (-)	2.3 - 2.5 (19.8 - 22) ^{*2}
	B1, B2	14	14 - 10	10	M4	Slot (-)	1.5 - 1.7 (13.5 - 15)
	⊕	10	14 - 10	-	M4	Phillips/slot combo	1.2 - 1.5 (10.6 - 13.3)

Model	Terminal	Recommended Gauge AWG, kcmil	Applicable Gauge AWG, kcmil	Wire Stripping Length ^{*/} mm	Terminal Screw		Tightening Torque N·m (lb·in)
					Terminal Screw Size	Shape	
2012	R/L1, S/L2, T/L3	10	14 - 6	10	M4	Slot (-)	1.5 - 1.7 (13.5 - 15)
	U/T1, V/T2, W/T3	12	14 - 6	10	M4	Slot (-)	1.5 - 1.7 (13.5 - 15)
	-, +1, +2	10	14 - 3	18	M5	Slot (-)	2.3 - 2.5 (19.8 - 22) ^{*2}
	B1, B2	14	14 - 10	10	M4	Slot (-)	1.5 - 1.7 (13.5 - 15)
	⊕	10	14 - 10	-	M4	Phillips/slot combo	1.2 - 1.5 (10.6 - 13.3)
2018	R/L1, S/L2, T/L3	10	14 - 6	10	M4	Slot (-)	1.5 - 1.7 (13.5 - 15)
	U/T1, V/T2, W/T3	10	14 - 6	10	M4	Slot (-)	1.5 - 1.7 (13.5 - 15)
	-, +1, +2	8	14 - 3	18	M5	Slot (-)	2.3 - 2.5 (19.8 - 22) ^{*2}
	B1, B2	14	14 - 10	10	M4	Slot (-)	1.5 - 1.7 (13.5 - 15)
	⊕	10	14 - 10	-	M4	Phillips/slot combo	1.2 - 1.5 (10.6 - 13.3)
2021	R/L1, S/L2, T/L3	8	14 - 6	10	M4	Slot (-)	1.5 - 1.7 (13.5 - 15)
	U/T1, V/T2, W/T3	10	14 - 6	10	M4	Slot (-)	1.5 - 1.7 (13.5 - 15)
	-, +1, +2	8	14 - 3	18	M5	Slot (-)	2.3 - 2.5 (19.8 - 22) ^{*2}
	B1, B2	14	14 - 10	10	M4	Slot (-)	1.5 - 1.7 (13.5 - 15)
	⊕	10	12 - 10	-	M4	Phillips/slot combo	1.2 - 1.5 (10.6 - 13.3)
2030	R/L1, S/L2, T/L3	6	14 - 6	10	M4	Slot (-)	1.5 - 1.7 (13.5 - 15)
	U/T1, V/T2, W/T3	8	14 - 6	10	M4	Slot (-)	1.5 - 1.7 (13.5 - 15)
	-, +1, +2	6	14 - 3	18	M5	Slot (-)	2.3 - 2.5 (19.8 - 22) ^{*2}
	B1, B2	12	14 - 10	10	M4	Slot (-)	1.5 - 1.7 (13.5 - 15)
	⊕	8	10 - 8	-	M5	Phillips/slot combo	2.0 - 2.5 (17.7 - 22.1)

Model	Terminal	Recommended Gauge AWG, kcmil	Applicable Gauge AWG, kcmil	Wire Stripping Length *1 mm	Terminal Screw		Tightening Torque N-m (lb-in)
					Terminal Screw Size	Shape	
2042	R/L1, S/L2, T/L3	6	14 - 6	10	M4	Slot (-)	1.5 - 1.7 (13.5 - 15)
	U/T1, V/T2, W/T3	6	14 - 6	10	M4	Slot (-)	1.5 - 1.7 (13.5 - 15)
	-, +1, +2	3	14 - 3	18	M5	Slot (-)	2.3 - 2.5 (19.8 - 22) *2
	B1, B2	10	14 - 10	10	M4	Slot (-)	1.5 - 1.7 (13.5 - 15)
	⊕	8	10 - 8	-	M5	Phillips/slot combo	2.0 - 2.5 (17.7 - 22.1)
2056	R/L1, S/L2, T/L3	3	8 - 3	18	M5	Slot (-)	2.3 - 2.5 (19.8 - 22) *2
	U/T1, V/T2, W/T3	4	10 - 4	18	M5	Slot (-)	2.3 - 2.5 (19.8 - 22) *2
	-, +1, +2	1	8 - 1	20	M6	Hex socket cap (WAF: 5 mm)	5 - 5.5 (45 - 49)
	B1, B2	8	14 - 8	10	M4	Slot (-)	1.5 - 1.7 (13.5 - 15)
	⊕	6	8 - 6	-	M6	Phillips/slot combo	5.4 - 6.0 (47.8 - 53.1)
2070	R/L1, S/L2, T/L3	1	6 - 1	20	M6	Hex socket cap (WAF: 5 mm)	5 - 5.5 (45 - 49)
	U/T1, V/T2, W/T3	3	6 - 3	20	M6	Hex socket cap (WAF: 5 mm)	5 - 5.5 (45 - 49)
	-, +1, +2	1/0	4 - 1/0	20	M6	Hex socket cap (WAF: 5 mm)	5 - 5.5 (45 - 49)
	B1, B2	8	14 - 8	10	M4	Slot (-)	1.5 - 1.7 (13.5 - 15)
	⊕	6	6 - 4	-	M6	Phillips/slot combo	5.4 - 6.0 (47.8 - 53.1)
2082	R/L1, S/L2, T/L3	1/0	6 - 1/0	20	M6	Hex socket cap (WAF: 5 mm)	5 - 5.5 (45 - 49)
	U/T1, V/T2, W/T3	2	6 - 2	20	M6	Hex socket cap (WAF: 5 mm)	5 - 5.5 (45 - 49)
	-, +1, +2	2/0	4 - 2/0	20	M6	Hex socket cap (WAF: 5 mm)	5 - 5.5 (45 - 49)
	B1, B2	6	14 - 6	10	M4	Slot (-)	1.5 - 1.7 (13.5 - 15)
	⊕	6	6 - 4	-	M6	Phillips/slot combo	5.4 - 6.0 (47.8 - 53.1)

Model	Terminal	Recommended Gauge AWG, kcmil	Applicable Gauge AWG, kcmil	Wire Stripping Length ^{*1} mm	Terminal Screw		Tightening Torque N·m (lb·in)
					Terminal Screw Size	Shape	
2110	R/L1, S/L2, T/L3	1/0	6 - 1/0	27	M6	Hex socket cap (WAF: 5 mm)	8 - 9 (71 - 80)
	U/T1, V/T2, W/T3	1/0	6 - 1/0	27	M6	Hex socket cap (WAF: 5 mm)	8 - 9 (71 - 80)
	-, +1	2/0	6 - 2/0	27	M8	Hex socket cap (WAF: 6 mm)	10 - 12 (89 - 107)
	B1, B2	4	10 - 4	21	M6	Hex socket cap (WAF: 5 mm)	3 - 3.5 (27 - 31)
	⊕	6	6 - 4	-	M6	Hex bolt (cross-slotted)	5.4 - 6.0 (47.8 - 53.1)
2138	R/L1, S/L2, T/L3	2/0	2 - 2/0	27	M6	Hex socket cap (WAF: 5 mm)	8 - 9 (71 - 80)
	U/T1, V/T2, W/T3	2/0	2 - 2/0	27	M6	Hex socket cap (WAF: 5 mm)	8 - 9 (71 - 80)
	-, +1	4/0	2 - 4/0	27	M8	Hex socket cap (WAF: 6 mm)	10 - 12 (89 - 107)
	B1, B2	3	10 - 3	21	M6	Hex socket cap (WAF: 5 mm)	3 - 3.5 (27 - 31)
	⊕	4	4	-	M6	Hex bolt (cross-slotted)	5.4 - 6.0 (47.8 - 53.1)
2169	R/L1, S/L2, T/L3	4/0	2/0 - 250	37	M10	Hex socket cap (WAF: 8 mm)	12 - 14 (107 - 124)
	U/T1, V/T2, W/T3	4/0	3/0 - 300	37	M10	Hex socket cap (WAF: 8 mm)	12 - 14 (107 - 124)
	-, -, +1, +1 ^{*3}	1 ^{*4}	1/0 - 2/0	28	M6	Hex socket cap (WAF: 5 mm)	8 - 9 (71 - 80)
	+3	1/0	1 - 2/0	28	M8	Hex socket cap (WAF: 6 mm)	8 - 9 (71 - 80)
	⊕	4	4 - 2	-	M8	Hex bolt (slotted)	9.0 - 11 (79.7 - 97.4)
2211	R/L1, S/L2, T/L3	250	2/0 - 250	37	M10	Hex socket cap (WAF: 8 mm)	12 - 14 (107 - 124)
	U/T1, V/T2, W/T3	300	3/0 - 300	37	M10	Hex socket cap (WAF: 8 mm)	12 - 14 (107 - 124)
	-, -, +1, +1 ^{*3}	2/0	1/0 - 2/0	28	M6	Hex socket cap (WAF: 5 mm)	8 - 9 (71 - 80)
	+3	2/0	1 - 2/0	28	M8	Hex socket cap (WAF: 6 mm)	8 - 9 (71 - 80)
	⊕	4	4 - 1/0	-	M8	Hex bolt (slotted)	9.0 - 11 (79.7 - 97.4)

Model	Terminal	Recommended Gauge AWG, kcmil	Applicable Gauge AWG, kcmil	Wire Stripping Length *1 mm	Terminal Screw		Tightening Torque N-m (lb-in)
					Terminal Screw Size	Shape	
2257	R/L1, S/L2, T/ L3	2/0 × 2P	2/0 - 4/0 × 2P	-	M10	Hex self- locking nut	20 (177)
	U/T1, V/T2, W/ T3	2/0 × 2P	2/0 - 4/0 × 2P	-	M10	Hex self- locking nut	20 (177)
	-, +1	4/0 × 2P	4/0 - 250 × 2P	-	M10	Hex self- locking nut	20 (177)
	+3	1 × 2P *4	1/0 - 2/0 × 2P	-	M10	Hex self- locking nut	20 (177)
	⊕	3	3 - 300	-	M10	Hex bolt (slotted)	18 - 23 (159 - 204)
2313	R/L1, S/L2, T/ L3	4/0 × 2P	2/0 - 4/0 × 2P	-	M10	Hex self- locking nut	20 (177)
	U/T1, V/T2, W/ T3	3/0 × 2P	2/0 - 4/0 × 2P	-	M10	Hex self- locking nut	20 (177)
	-, +1	250 × 2P	4/0 - 250 × 2P	-	M10	Hex self- locking nut	20 (177)
	+3	1/0 × 2P	1/0 - 2/0 × 2P	-	M10	Hex self- locking nut	20 (177)
	⊕	2	2 - 300	-	M10	Hex bolt (slotted)	18 - 23 (159 - 204)
2360	R/L1, S/L2, T/ L3	Preparing					
	U/T1, V/T2, W/ T3						
	-, +1						
	+3						
	⊕						
2415	R/L1, S/L2, T/ L3	Preparing					
	U/T1, V/T2, W/ T3						
	-, +1						
	+3						
	⊕						

*1 Remove the insulator from the tips of wires to the length shown in "Wire Stripping Length."

*2 When using wire with AWG 8 or higher, tighten to a tightening torque of 4.1 to 4.5 N·m (36 to 40 lb-in.).

*3 Terminals - and + have two screws. Recommended Gauge indicates the wire gauge per one terminal.

*4 Use cables in the range of applicable gauges to meet the IP20 protective level.

Three-Phase 400 V Class

Table 2.3 Main Circuit Wire Gauges and Tightening Torques (Three-phase 400 V Class)

Model	Terminal	Recommended Gauge AWG, kcmil	Applicable Gauge AWG, kcmil	Wire Stripping Length *7 mm	Terminal Screw		Tightening Torque N-m (lb-in)
					Size	Shape	
4002	R/L1, S/L2, T/ L3	14	14 - 6	10	M4	Slot (-)	1.5 - 1.7 (13.5 - 15)
	U/T1, V/T2, W/ T3	14	14 - 6	10	M4	Slot (-)	1.5 - 1.7 (13.5 - 15)
	-, +1, +2	14	14 - 3	18	M5	Slot (-)	2.3 - 2.5 (19.8 - 22) *2
	B1, B2	14	14 - 10	10	M4	Slot (-)	1.5 - 1.7 (13.5 - 15)
	⊕	12	14 - 12	-	M4	Phillips/slot combo	1.2 - 1.5 (10.6 - 13.3)
4004	R/L1, S/L2, T/ L3	14	14 - 6	10	M4	Slot (-)	1.5 - 1.7 (13.5 - 15)
	U/T1, V/T2, W/ T3	14	14 - 6	10	M4	Slot (-)	1.5 - 1.7 (13.5 - 15)
	-, +1, +2	14	14 - 3	18	M5	Slot (-)	2.3 - 2.5 (19.8 - 22) *2
	B1, B2	14	14 - 10	10	M4	Slot (-)	1.5 - 1.7 (13.5 - 15)
	⊕	12	14 - 12	-	M4	Phillips/slot combo	1.2 - 1.5 (10.6 - 13.3)
4005	R/L1, S/L2, T/ L3	14	14 - 6	10	M4	Slot (-)	1.5 - 1.7 (13.5 - 15)
	U/T1, V/T2, W/ T3	14	14 - 6	10	M4	Slot (-)	1.5 - 1.7 (13.5 - 15)
	-, +1, +2	14	14 - 3	18	M5	Slot (-)	2.3 - 2.5 (19.8 - 22) *2
	B1, B2	14	14 - 10	10	M4	Slot (-)	1.5 - 1.7 (13.5 - 15)
	⊕	10	14 - 10	-	M4	Phillips/slot combo	1.2 - 1.5 (10.6 - 13.3)
4007	R/L1, S/L2, T/ L3	14	14 - 6	10	M4	Slot (-)	1.5 - 1.7 (13.5 - 15)
	U/T1, V/T2, W/ T3	14	14 - 6	10	M4	Slot (-)	1.5 - 1.7 (13.5 - 15)
	-, +1, +2	14	14 - 3	18	M5	Slot (-)	2.3 - 2.5 (19.8 - 22) *2
	B1, B2	14	14 - 10	10	M4	Slot (-)	1.5 - 1.7 (13.5 - 15)
	⊕	10	14 - 10	-	M4	Phillips/slot combo	1.2 - 1.5 (10.6 - 13.3)

Model	Terminal	Recommended Gauge AWG, kcmil	Applicable Gauge AWG, kcmil	Wire Stripping Length *1 mm	Terminal Screw		Tightening Torque N-m (lb-in)
					Size	Shape	
4009	R/L1, S/L2, T/L3	14	14 - 6	10	M4	Slot (-)	1.5 - 1.7 (13.5 - 15)
	U/T1, V/T2, W/T3	14	14 - 6	10	M4	Slot (-)	1.5 - 1.7 (13.5 - 15)
	-, +1, +2	12	14 - 3	18	M5	Slot (-)	2.3 - 2.5 (19.8 - 22) *2
	B1, B2	14	14 - 10	10	M4	Slot (-)	1.5 - 1.7 (13.5 - 15)
	⊕	10	14 - 10	-	M4	Phillips/slot combo	1.2 - 1.5 (10.6 - 13.3)
4012	R/L1, S/L2, T/L3	12	14 - 6	10	M4	Slot (-)	1.5 - 1.7 (13.5 - 15)
	U/T1, V/T2, W/T3	14	14 - 6	10	M4	Slot (-)	1.5 - 1.7 (13.5 - 15)
	-, +1, +2	10	14 - 3	18	M5	Slot (-)	2.3 - 2.5 (19.8 - 22) *2
	B1, B2	14	14 - 10	10	M4	Slot (-)	1.5 - 1.7 (13.5 - 15)
	⊕	10	14 - 10	-	M4	Phillips/slot combo	1.2 - 1.5 (10.6 - 13.3)
4018	R/L1, S/L2, T/L3	10	14 - 6	10	M4	Slot (-)	1.5 - 1.7 (13.5 - 15)
	U/T1, V/T2, W/T3	10	14 - 6	10	M4	Slot (-)	1.5 - 1.7 (13.5 - 15)
	-, +1, +2	8	14 - 3	18	M5	Slot (-)	2.3 - 2.5 (19.8 - 22) *2
	B1, B2	14	14 - 10	10	M4	Slot (-)	1.5 - 1.7 (13.5 - 15)
	⊕	10	14 - 10	-	M5	Phillips/slot combo	2.0 - 2.5 (17.7 - 22.1)
4023	R/L1, S/L2, T/L3	8	14 - 6	10	M4	Slot (-)	1.5 - 1.7 (13.5 - 15)
	U/T1, V/T2, W/T3	10	14 - 6	10	M4	Slot (-)	1.5 - 1.7 (13.5 - 15)
	-, +1, +2	8	14 - 3	18	M5	Slot (-)	2.3 - 2.5 (19.8 - 22) *2
	B1, B2	12	14 - 10	10	M4	Slot (-)	1.5 - 1.7 (13.5 - 15)
	⊕	10	12 - 10	-	M5	Phillips/slot combo	2.0 - 2.5 (17.7 - 22.1)

Model	Terminal	Recommended Gauge AWG, kcmil	Applicable Gauge AWG, kcmil	Wire Stripping Length *1 mm	Terminal Screw		Tightening Torque N-m (lb-in)
					Size	Shape	
4031	R/L1, S/L2, T/L3	6	8 - 3	18	M5	Slot (-)	2.3 - 2.5 (19.8 - 22) *2
	U/T1, V/T2, W/T3	8	10 - 4	18	M5	Slot (-)	2.3 - 2.5 (19.8 - 22) *2
	-, +1, +2	6	8 - 1	20	M6	Hex socket cap (WAF: 5 mm)	5 - 5.5 (45 - 49)
	B1, B2	10	14 - 8	10	M4	Slot (-)	1.5 - 1.7 (13.5 - 15)
	⊕	8	10 - 8	-	M6	Phillips/slot combo	5.4 - 6.0 (47.8 - 53.1)
4038	R/L1, S/L2, T/L3	6	8 - 3	18	M5	Slot (-)	2.3 - 2.5 (19.8 - 22) *2
	U/T1, V/T2, W/T3	8	10 - 4	18	M5	Slot (-)	2.3 - 2.5 (19.8 - 22) *2
	-, +1, +2	4	8 - 1	20	M6	Hex socket cap (WAF: 5 mm)	5 - 5.5 (45 - 49)
	B1, B2	10	14 - 8	10	M4	Slot (-)	1.5 - 1.7 (13.5 - 15)
	⊕	6	10 - 6	-	M6	Phillips/slot combo	5.4 - 6.0 (47.8 - 53.1)
4044	R/L1, S/L2, T/L3	4	10 - 4	18	M5	Slot (-)	2.3 - 2.5 (19.8 - 22) *2
	U/T1, V/T2, W/T3	6	10 - 6	18	M5	Slot (-)	2.3 - 2.5 (19.8 - 22) *2
	-, +1, +2	3	10 - 3	18	M5	Slot (-)	2.3 - 2.5 (19.8 - 22) *2
	B1, B2	8	14 - 8	10	M4	Slot (-)	1.5 - 1.7 (13.5 - 15)
	⊕	6	8 - 6	-	M6	Phillips/slot combo	5.4 - 6.0 (47.8 - 53.1)
4060	R/L1, S/L2, T/L3	4	10 - 4	18	M5	Slot (-)	2.3 - 2.5 (19.8 - 22) *2
	U/T1, V/T2, W/T3	4	10 - 4	18	M5	Slot (-)	2.3 - 2.5 (19.8 - 22) *2
	-, +1	3	10 - 3	18	M5	Slot (-)	2.3 - 2.5 (19.8 - 22) *2
	B1, B2	8	14 - 8	10	M4	Slot (-)	1.5 - 1.7 (13.5 - 15)
	⊕	6	8 - 6	-	M6	Phillips/slot combo	5.4 - 6.0 (47.8 - 53.1)

2 UL Standards

Model	Terminal	Recommended Gauge AWG, kcmil	Applicable Gauge AWG, kcmil	Wire Stripping Length *1 mm	Terminal Screw		Tightening Torque N-m (lb-in)
					Size	Shape	
4075	R/L1, S/L2, T/L3	3	12 - 3	18	M5	Slot (-)	2.3 - 2.5 (19.8 - 22) *2
	U/T1, V/T2, W/T3	3	12 - 3	18	M5	Slot (-)	2.3 - 2.5 (19.8 - 22) *2
	-, +1	2	10 - 2	18	M5	Slot (-)	2.3 - 2.5 (19.8 - 22) *2
	B1, B2	6	14 - 6	10	M4	Slot (-)	1.5 - 1.7 (13.5 - 15)
	⊕	6	6	-	M6	Hex bolt (cross-slotted)	5.4 - 6.0 (47.8 - 53.1)
4089	R/L1, S/L2, T/L3	2	10 - 2	18	M5	Slot (-)	2.3 - 2.5 (19.8 - 22) *2
	U/T1, V/T2, W/T3	2	10 - 2	18	M5	Slot (-)	2.3 - 2.5 (19.8 - 22) *2
	-, +1	1/0	6 - 1/0	20	M6	Hex socket cap (WAF: 5 mm)	5 - 5.5 (45 - 49)
	B1, B2	6	14 - 6	18	M5	Slot (-)	2.3 - 2.5 (19.8 - 22) *2
	⊕	4	6 - 4	-	M6	Hex bolt (cross-slotted)	5.4 - 6.0 (47.8 - 53.1)
4103	R/L1, S/L2, T/L3	1/0	2 - 2/0	27	M6	Hex socket cap (WAF: 5 mm)	8 - 9 (71 - 80)
	U/T1, V/T2, W/T3	1	2 - 2/0	27	M6	Hex socket cap (WAF: 5 mm)	8 - 9 (71 - 80)
	-, +1	2/0	2 - 4/0	27	M8	Hex socket cap (WAF: 6 mm)	10 - 12 (89 - 107)
	B1, B2	3	10 - 3	21	M6	Hex socket cap (WAF: 5 mm)	3 - 3.5 (27 - 31)
	⊕	4	6 - 4	-	M6	Hex bolt (cross-slotted)	5.4 - 6.0 (47.8 - 53.1)
4140	R/L1, S/L2, T/L3	3/0	2/0 - 250	37	M10	Hex socket cap (WAF: 8 mm)	12 - 14 (107 - 124)
	U/T1, V/T2, W/T3	2/0 *3	3/0 - 300	37	M10	Hex socket cap (WAF: 8 mm)	12 - 14 (107 - 124)
	-, -, +1, +1 *4	2 *3	1/0 - 2/0	28	M6	Hex socket cap (WAF: 5 mm)	8 - 9 (71 - 80)
	B1, B2	1	1 - 2/0	28	M8	Hex socket cap (WAF: 6 mm)	8 - 9 (71 - 80)
	⊕	4	4	-	M8	Hex bolt (slotted)	9.0 - 11 (79.7 - 97.4)

Model	Terminal	Recommended Gauge AWG, kcmil	Applicable Gauge AWG, kcmil	Wire Stripping Length *7 mm	Terminal Screw		Tightening Torque N-m (lb-in)
					Size	Shape	
4168	R/L1, S/L2, T/L3	4/0	2/0 - 250	37	M10	Hex socket cap (WAF: 8 mm)	12 - 14 (107 - 124)
	U/T1, V/T2, W/T3	4/0	3/0 - 300	37	M10	Hex socket cap (WAF: 8 mm)	12 - 14 (107 - 124)
	-, -, +1, +1 *4	1/0	1/0 - 2/0	28	M6	Hex socket cap (WAF: 5 mm)	8 - 9 (71 - 80)
	B1, B2	1/0	1 - 2/0	28	M8	Hex socket cap (WAF: 6 mm)	8 - 9 (71 - 80)
	⊕	4	4 - 2	-	M8	Hex bolt (slotted)	9.0 - 11 (79.7 - 97.4)
4208	R/L1, S/L2, T/L3	1/0 × 2P *3	2/0 - 4/0 × 2P	-	M10	Hex self-locking nut	20 (177)
	U/T1, V/T2, W/T3	1/0 × 2P *3	2/0 - 4/0 × 2P	-	M10	Hex self-locking nut	20 (177)
	-, +1	3/0 × 2P *3	4/0 - 250 × 2P	-	M10	Hex self-locking nut	20 (177)
	+3	1 × 2P *3	1/0 - 2/0 × 2P	-	M10	Hex self-locking nut	20 (177)
	⊕	4	4 - 300	-	M10	Hex bolt (slotted)	18 - 23 (159 - 204)
4250	R/L1, S/L2, T/L3	2/0 × 2P	2/0 - 4/0 × 2P	-	M10	Hex self-locking nut	20 (177)
	U/T1, V/T2, W/T3	2/0 × 2P	2/0 - 4/0 × 2P	-	M10	Hex self-locking nut	20 (177)
	-, +1	3/0 × 2P *3	4/0 - 250 × 2P	-	M10	Hex self-locking nut	20 (177)
	+3	1 × 2P *3	1/0 - 2/0 × 2P	-	M10	Hex self-locking nut	20 (177)
	⊕	2	2 - 350	-	M10	Hex bolt (slotted)	18 - 23 (159 - 204)
4296	R/L1, S/L2, T/L3	3/0 × 2P	2/0 - 3/0 × 2P	-	M10	Hex self-locking nut	20 (177)
	U/T1, V/T2, W/T3	3/0 × 2P	2/0 - 3/0 × 2P	-	M10	Hex self-locking nut	20 (177)
	-, +1	4/0 × 2P	4/0 - 250 × 2P	-	M10	Hex self-locking nut	20 (177)
	+3	1/0 × 2P	1/0 - 2/0 × 2P	-	M10	Hex self-locking nut	20 (177)
	⊕	2	2 - 350	-	M10	Hex bolt (slotted)	18 - 23 (159 - 204)
4371	R/L1, S/L2, T/L3	Preparing					
	U/T1, V/T2, W/T3						
	-, +1						
	+3						
	⊕						

Model	Terminal	Recommended Gauge AWG, kcmil	Applicable Gauge AWG, kcmil	Wire Stripping Length *1 mm	Terminal Screw		Tightening Torque N-m (lb-in)
					Size	Shape	
4389	R/L1, S/L2, T/L3						
	U/T1, V/T2, W/T3						
	-, +1						
	+3						
	⊕						
4453	R/L1, S/L2, T/L3 R1/L11, S1/L21, T1/L31						
	U/T1, V/T2, W/T3						
	-, +1						
	+3						
	⊕						
4568	R/L1, S/L2, T/L3 R1/L11, S1/L21, T1/L31						
	U/T1, V/T2, W/T3						
	-, +1						
	+3						
	⊕						
4675	R/L1, S/L2, T/L3 R1/L11, S1/L21, T1/L31						
	U/T1, V/T2, W/T3						
	-, +1						
	+3						
	⊕						

- *1 Remove the insulator from the tips of wires to the length shown in “Wire Stripping Length.”
- *2 When using wire with AWG 8 or higher, tighten to a tightening torque of 4.1 to 4.5 N·m (36 to 40 lb·in.).
- *3 Use cables in the range of applicable gauges to meet the IP20 protective level.
- *4 Terminals - and + have two screws. Recommended Gauge indicates the wire gauge per one terminal.

■ Closed-Loop Crimp Terminals

Yaskawa recommends closed-loop crimp terminals from J.S.T.MFG. Co., Ltd., and insulation caps from Tokyo DIP Co., Ltd.

Contact Yaskawa or your nearest sales representative for details on selection of closed-loop crimp terminals and insulation caps.

Follow local standards concerning appropriate wire gauges in the region where the drive is used.

Note:

Use only insulated crimp terminals or crimp terminals with insulation tubing to comply with UL standards. Use UL-Listed, vinyl-coated insulated copper wires for operation with a continuous maximum allowable temperature of 75 °C at 600 V.

■ Factory Recommended Branch Circuit Protection

To maintain compliance with UL61800-5-1, execute branch circuit protection when a short occurs in the internal circuit. Yaskawa recommends connecting a semiconductor protective type fuses to the input side for branch circuit protection. Refer to [Table 2.4](#) to [Table 2.7](#) for the recommended fuses.

NOTICE Do not energize or operate equipment soon after a fuse blows or RCM/RCD trips. Check the condition of cable wiring and peripheral devices to identify the root cause. If the root cause cannot be determined, do not turn on the power or operate equipment. Contact Yaskawa Support immediately.

- 200 V class
The drive is suitable for use on a circuit capable of delivering not more than 100,000 RMS symmetrical amperes and 240 Vac during short circuit of the power supply, when protected by fuses as specified in this document.
- 400 V class
The drive is suitable for use on a circuit capable of delivering not more than 100,000 RMS symmetrical amperes and 480 Vac during short circuit of the power supply, when protected by fuses as specified in this document.

Drive's built-in short circuit protection does not provide branch circuit protection. Branch circuit protection must be provided in accordance with the NEC (National Electric Code) the CEC (Canadian Electric Code, Part I), and any additional local codes.

Three-Phase 200 V Class

Table 2.4 Factory Recommended Drive Branch Circuit Protection (Normal Duty)

Drive Model	Maximum Applicable Motor Output kW (HP)	Input Current Rating A	Semiconductor Protection Fuse Rated Current Manufacturer: EATON/ Bussmann
2004	0.75 (0.75)	4.8	FWH-45B
2006	1.1 (1.5)	6.7	FWH-45B
2010	2.2 (3)	12.7	FWH-45B
2012	3 (4)	17	FWH-100B
2018	3.7 (5)	20.7	FWH-100B
2021	5.5 (7.5)	30	FWH-100B
2030	7.5 (10)	40.3	FWH-125B
2042	11 (15)	52	FWH-150B
2056	15 (20)	78.4	FWH-200B
2070	18.5 (25)	96	FWH-225A
2082	22 (30)	114	FWH-225A FWH-250A *2
2110	30 (40)	111	FWH-225A FWH-250A *2
2138	37 (50)	136	FWH-275A FWH-300A *2
2169 *1	45 (60)	164	FWH-275A FWH-350A *2
2211 *1	55 (75)	200	FWH-325A FWH-450A *2
2257 *1	75 (100)	271	FWH-600A
2313 *1	90 (125)	324	FWH-800A
2360 *1	110 (150)	394	FWH-1000A
2415 *1	-	-	FWH-1400A

*1 Approval pending. Contact Yaskawa or your nearest sales representative.

*2 We recommend a fuse with a large rated current for applications involving repeated loads.

Table 2.5 Factory Recommended Drive Branch Circuit Protection (Heavy Duty)

Drive Model	Maximum Applicable Motor Output kW (HP)	Input Current Rating A	Semiconductor Protection Fuse Rated Current Manufacturer: EATON/ Bussmann
2004	0.55 (0.5)	3.6	FWH-45B
2006	0.75 (1)	4.8	FWH-45B
2010	1.5 (2)	8.9	FWH-45B
2012	2.2 (3)	12.7	FWH-50B
2018	3 (4)	17	FWH-80B
2021	3.7 (5)	20.7	FWH-80B
2030	5.5 (7.5)	30	FWH-125B
2042	7.5 (10)	40.3	FWH-150B
2056	11 (15)	58.2	FWH-200B
2070	15 (20)	78.4	FWH-225A
2082	18.5 (25)	96	FWH-225A FWH-250A *2
2110	22 (30)	82	FWH-225A FWH-250A *2
2138	30 (40)	111	FWH-275A FWH-300A *2
2169 *1	37 (50)	136	FWH-275A FWH-350A *2
2211 *1	45 (60)	164	FWH-325A FWH-450A *2
2257 *1	55 (75)	200	FWH-600A
2313 *1	75 (100)	271	FWH-800A
2360 *1	90 (125)	324	FWH-1000A
2415 *1	110 (150)	394	FWH-1400A

*1 Approval pending. Contact Yaskawa or your nearest sales representative.

*2 We recommend a fuse with a large rated current for applications involving repeated loads.

Three-Phase 400 V Class

Table 2.6 Factory Recommended Drive Branch Circuit Protection (Normal Duty)

Drive Model	Maximum Applicable Motor Output kW (HP)	Maximum Applicable Motor Output kW (HP)	Input Current Rating A	Semiconductor Protection Fuse Rated Current Manufacturer: EATON/ Bussmann
	Input Voltage < 460 V	Input Voltage ≥ 460 V		
4002	0.75 (1)	0.75 (1)	2.5	FWH-50B
4004	1.5 (2)	1.5 (2)	4.7	FWH-50B
4005	2.2 (3)	2.2 (3)	6.7	FWH-50B
4007	3.0 (4)	3 (4)	8.9	FWH-60B
4009	3.7 (5)	4.0 (5)	11.7	FWH-60B
4012	5.5 (7.5)	5.5 (7.5)	15.8	FWH-60B
4018	7.5 (10)	7.5 (10)	21.2	FWH-80B
4023	11 (15)	11 (15)	30.6	FWH-90B
4031	15 (20)	15 (20)	41.3	FWH-150B
4038	18.5 (25)	18.5 (25)	50.5	FWH-200B
4044	22 (30)	22 (30)	59.7	FWH-200B

Drive Model	Maximum Applicable Motor Output kW (HP) Input Voltage < 460 V	Maximum Applicable Motor Output kW (HP) Input Voltage ≥ 460 V	Input Current Rating A	Semiconductor Protection Fuse Rated Current Manufacturer: EATON/ Bussmann
4060	30 (40)	30 (40)	58.3	FWH-225A
4075	37 (50)	37 (50)	71.5	FWH-250A
4089	45 (60)	45 (60)	86.5	FWH-275A
4103	55 (75)	55 (75)	105	FWH-275A
4140	75 (100)	75 (100)	142	FWH-300A
4168	90 (125)	90 (125)	170	FWH-325A FWH-400A *2
4208	110 (150)	110 (150)	207	FWH-500A
4250	150 (200)	132 (175)	248	FWH-600A
4296	185 (250)	160 (200)	300	FWH-700A
4371 *1	220 (300)	200 (250)	373	FWH-800A
4389 *1	260 (350)	220 (300)	410	FWH-1000A
4453 *1	300 (400)	250 (335)	465	FWH-1200A
4568 *1	335 (450)	315 (400)	584	FWH-1200A
4675 *1	450 (600)	355 (450)	657	FWH-1400A FWH-1600A *2

*1 Approval pending. Contact Yaskawa or your nearest sales representative.

*2 We recommend a fuse with a large rated current for applications involving repeated loads.

Table 2.7 Factory Recommended Drive Branch Circuit Protection (Heavy Duty)

Drive Model	Maximum Applicable Motor Output kW (HP) Input Voltage < 460 V	Maximum Applicable Motor Output kW (HP) Input Voltage ≥ 460 V	Input Current Rating A	Semiconductor Protection Fuse Rated Current Manufacturer: EATON/ Bussmann
4002	0.55 (0.75)	0.55 (0.75)	1.9	FWH-50B
4004	0.75 (1)	1.1 (1.5)	3.5	FWH-50B
4005	1.5 (2)	1.5 (2)	4.7	FWH-50B
4007	2.2 (3)	2.2 (3)	6.7	FWH-60B
4009	3 (4)	3 (4)	8.9	FWH-60B
4012	3.7 (5)	4.0 (5)	11.7	FWH-60B
4018	5.5 (7.5)	5.5 (7.5)	15.8	FWH-80B
4023	7.5 (10)	7.5 (10)	21.2	FWH-90B
4031	11 (15)	11 (15)	30.6	FWH-150B
4038	15 (20)	15 (20)	41.3	FWH-200B
4044	18.5 (25)	18.5 (25)	50.5	FWH-200B
4060	22 (30)	22 (30)	43.1	FWH-225A
4075	30 (40)	30 (40)	58.3	FWH-250A
4089	37 (50)	37 (50)	71.5	FWH-275A
4103	45 (60)	45 (60)	86.5	FWH-275A
4140	55 (75)	55 (75)	105	FWH-300A
4168	75 (100)	75 (100)	142	FWH-325A FWH-400A *2
4208	90 (125)	90 (125)	170	FWH-500A
4250	110 (150)	110 (150)	207	FWH-600A

Drive Model	Maximum Applicable Motor Output kW (HP) Input Voltage < 460 V	Maximum Applicable Motor Output kW (HP) Input Voltage ≥ 460 V	Input Current Rating A	Semiconductor Protection Fuse Rated Current Manufacturer: EATON/Bussmann
4296	150 (200)	132 (175)	248	FWH-700A
4371 *1	185 (250)	160 (200)	300	FWH-800A
4389 *1	220 (300)	200 (250)	373	FWH-1000A
4453 *1	260 (350)	220 (300)	410	FWH-1200A
4568 *1	300 (400)	250 (335)	465	FWH-1200A
4675 *1	370 (500)	315 (400)	584	FWH-1400A FWH-1600A *2

*1 Approval pending. Contact Yaskawa or your nearest sales representative.

*2 We recommend a fuse with a large rated current for applications involving repeated loads.

◆ Low Voltage Wiring for Control Circuit Terminals

Low voltage wiring must be provided in accordance with the NEC (National Electric Code), the CEC (Canadian Electric Code, Part I), and any additional local codes. The NEC class 1 circuit conductor is recommended. Use the UL approved class 2 power supply for external power supply.

Table 2.8 Power Supply Used for Control Circuit Terminals

Input/Output	Terminal sign	Power supply specifications
Digital inputs	S1 to S8, SN, SC, SP	The LVLC power supply in the drive is used. Use the UL approved class 2 power supply for external power supply.
Analog input	A1 to A3, AC, +V, -V	The LVLC power supply in the drive is used. Use the UL approved class 2 power supply for external power supply.
Analog output	FM, AM, AC	The LVLC power supply in the drive is used.
Pulse Train Output	MP, AC	The LVLC power supply in the drive is used. Use the UL approved class 2 power supply for external power supply.
Pulse train input	RP, AC	The LVLC power supply in the drive is used. Use the UL approved class 2 power supply for external power supply.
Safe Disable input	H1, H2, HC	The LVLC power supply in the drive is used. Use the UL approved class 2 power supply for external power supply.
Serial communication input/output	D+, D-, AC	The LVLC power supply in the drive is used. Use the UL approved class 2 power supply for external power supply.
24 V external power supply	PS, AC	Use the UL approved class 2 power supply.

◆ Drive Motor Overload and Overheat Protection

The drive motor overload and overheat protection function complies with the NEC (National Electric Code) and the CEC (Canadian Electric Code, Part I).

Set the *Motor Rated Current* and L1-01 through L1-04 [*Motor Overload Protection Select*] properly to enable motor overload and overheat protection.

Set the motor rated current according to the control method using E2-01 [*Motor Rated Current (FLA)*], E5-03 [*PM Motor Rated Current (FLA)*], or E9-06 [*Motor Rated FLA*].

■ E2-01: Motor Rated Current (FLA)

No. (Hex.)	Name	Description	Default Setting (Range)
E2-01 (030E)	Motor Rated Current	Sets the motor rated current in amps.	Determined by o2-04 and C6-01 (10% to 200% of the drive rated current)

Note:

- If parameter $E2-01 < E2-03$ [Motor No-Load Current] is set, oPE02 [Parameter Range Setting Error] will be detected.
- The units for the default setting and setting range vary depending on the model of the drive.
 –2004 to 2042, 4002 to 4023: 0.01 A units
 –2056 to 2415, 4031 to 4675: 0.1 A units

The value set in $E2-01$ becomes the base value for motor protection, the torque limit, and torque control. Enter the motor rated current as written on the motor nameplate. The value of $E2-01$ is automatically set to the value input for “Motor Rated Current” by the Auto-Tuning process.

■ E5-03: PM Motor Rated Current (FLA)

No. (Hex.)	Name	Description	Default Setting (Range)
E5-03 (032B)	PM Motor Rated Current (FLA)	Sets the motor rated current (FLA) for PM motors.	Determined by E5-01 (10 to 200% of the drive rated current)

The value of $E5-03$ is automatically set to the value input for [PM Motor Rated Current] by the Auto-Tuning process when the following types of Auto-Tuning processes are performed.

- PM Motor Parameter Settings
- PM Stationary Auto-Tuning
- PM StaTun for Stator Resistance
- PM Rotational Auto-Tuning

Note:

- Display is in the following units:
- 2004 to 2042, 4002 to 4023: 0.01 A units
 - 2056 to 2415, 4031 to 4675: 0.1 A units

■ E9-06: Motor Rated Current

No. (Hex.)	Name	Description	Default Setting (Range)
E9-06 (11E9)	Motor Rated Current	Sets the motor rated current in amperes.	Determined by E9-01 and o2-04 (10% to 200% of the drive rated current)

Note:

- Values appear in the following units.
- 2004 to 2042, 4002 to 4023: 0.01 A units
 - 2056 to 2415, 4031 to 4675: 0.1 A units

The setting value of $E9-06$ is the reference value for motor protection. Enter the motor rated current as written on the motor nameplate. The value of $E9-06$ is automatically set to the value input for [Motor Rated Current] by the Auto-Tuning process for motor parameter settings.

■ L1-01: Motor Overload Protection Select

No. (Hex.)	Name	Description	Default Setting (Range)
L1-01 (0480)	Motor Overload (oL1) Protection	Sets the motor overload protection function that uses electronic thermal protectors.	Determined by A1-02 (0 - 6)

Enables or disables the motor overload protection using electronic thermal protectors.

Cooling capability varies depending on the speed control range of the motor. Select motor protection using an electronic thermal protector that matches the allowable load characteristics of the motor being used.

The drive has overload protection for the motor using an electronic thermal protector. The electronic thermal protector of the drive calculates motor overload tolerance based on output current, output frequency, motor thermal characteristics, and time characteristics to provide overload protection for the motor. The drive triggers an *oL1* [Motor Overload] and shuts off the drive output when the drive detects motor overload.

It is also possible to set a motor overload alarm. Set *H2-01 = 1F* [Terminal M1-M2 Function Selection = Motor overload alarm (*oL1*)] to set a motor overload alarm. When the motor overload level rises above 90% of the *oL1* detection level, the output terminal switches ON and triggers an overload alarm.

Note:

Set *L1-01 = 1 to 6* [Enabled] when only one motor is connected to a drive. External thermal relays are not necessary in such cases.

0 : Disabled

Disable motor protection when motor overload protection is not required or when the drive is operating more than one motor.

The following diagram shows an example of the circuit configuration when connecting multiple motors to a single drive.

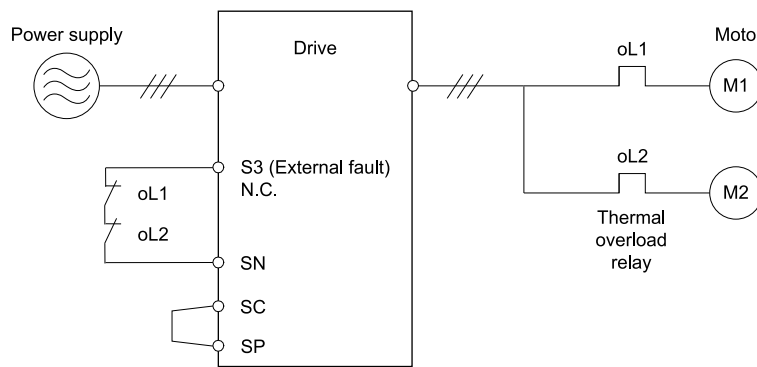

Figure 2.3 Protection Circuit Configuration when Connecting Multiple Motors to Single Drive

NOTICE The motor cannot be protected by electronic thermal protection when one drive is running two or more motors simultaneously or the motor has a rated current significantly larger than that of standard motors (underwater motors, for example). Add thermal relays to each motor after setting *L1-01 = 0* [Motor Overload Protection Select = Disabled] and configure circuits to protect each motor. The motor may fail if handled improperly.

1 : Variable Torque

Use this setting for general-purpose motors with a base frequency of 60 Hz.

The motor has less cooling capability in the low speed range because the cooling fan slows down and there is lower overload tolerance as the speed drops. Therefore, there is lower overload tolerance as the speed drops. The trigger point for the electronic thermal protector changes according to the overload tolerance characteristics of the motor. This provides motor overheat protection from low speed to high speed across the entire speed range.

Load tolerance	Cooling Ability	Overload Characteristics (at 100% motor load)
	<p>This motor is designed to operate using commercial line power. The motor has maximum cooling capability when operating at a 60 Hz base frequency.</p>	<p>The drive detects <i>oL1</i> when operating at frequencies lower than 60 Hz. The drive triggers a fault relay output and the motor coasts to stop.</p>

2 : Constant Torque 10:1 Speed Range

Use this setting for drive dedicated motors with a speed range for constant torque of 1:10.

The speed control for this motor is 10% to 100% when at 100% load. Operating slower than 10% speed at 100% load will trigger motor overload.

Load tolerance	Cooling Ability	Overload Characteristics (at 100% motor load)
	<p>This motor is designed to withstand increasing temperature during continuous operation even in the low speed range (10% base frequency).</p>	<p>The motor operates continuously at 10% to 100% base frequency.</p>

3 : Constant Torque 100:1 SpeedRange

Use this setting for vector motors with a speed range for constant torque of 1:100.

The speed control for this motor is 1 % to 100% when at 100% load. Operating slower than 1% speed at 100% load will trigger motor overload.

Load tolerance	Cooling Ability	Overload Characteristics (at 100% motor load)
	<p>This motor is designed to withstand increasing temperature during continuous operation even in the low speed range (1% base frequency).</p>	<p>The motor operates continuously at 1% to 100% base frequency. Motor overload is triggered when operating slower than 1% speed at 100% load.</p>

4 : PM Variable Torque

Use this setting for PM motors with derated torque characteristics.

The motor has less cooling capability in the low speed range because the cooling fan slows down and there is lower overload tolerance as the speed drops. Therefore, there is lower overload tolerance as the speed drops. The trigger point for the electronic thermal protector changes according to the overload tolerance characteristics of the motor. This provides motor overheat protection from low speed to high speed across the entire speed range.

Load tolerance	Cooling Ability	Overload Characteristics (at 100% motor load)
	<p>This motor is designed to withstand increasing temperature during continuous operation at both rated speed and rated torque.</p>	<p>The drive detects <i>oLL</i> when the motor operates continuously at lower speed than rated rotation speed at over 100% torque. The drive triggers a fault relay output and the motor coasts to stop.</p>

5 : PM Constant Torque

Use this setting with a PM motor for constant torque that has a speed range for constant torque of 1:500.

The speed control for this motor is 0.2 % to 100% when at 100% load. Operating slower than 0.2% speed at 100% load will trigger motor overload.

Load tolerance	Cooling Ability	Overload Characteristics (at 100% motor load)
<p>The graph plots Torque (%) on the y-axis (ranging from 67 to 150) against Motor speed relative to rated speed (%) on the x-axis (ranging from 0.2 to 150). Two curves are shown: a solid line for '60 s short time rating' and a dashed line for 'Continuous rating'. Both curves show torque increasing with speed up to 100%, then decreasing. The 60s short time rating curve reaches 150% torque at 100% speed, while the continuous rating curve reaches approximately 100% torque at 100% speed.</p>	<p>This motor is designed to withstand increasing temperature during continuous operation even in the low speed range (0.2% base frequency).</p>	<p>The motor operates continuously at 0.2% to 100% rated speed. Motor overload is triggered when operating slower than 0.2% speed at 100% load.</p>

6 : Variable Torque (50Hz)

Use this setting for general-purpose motors with a base frequency of 50 Hz.

The motor has less cooling capability in the low speed range because the cooling fan slows down and there is lower overload tolerance as the speed drops. Therefore, there is lower overload tolerance as the speed drops. The trigger point for the electronic thermal protector changes according to the overload tolerance characteristics of the motor. This provides motor overheat protection from low speed to high speed across the entire speed range.

Load tolerance	Cooling Ability	Overload Characteristics (at 100% motor load)
<p>The graph plots Torque (%) on the y-axis (ranging from 60 to 150) against Motor speed (%) on the x-axis (ranging from 5 to 200). A solid line represents the '60 s short time' rating, and a dashed line represents the 'Continuous' rating. The rated speed is marked at 100% speed. Specific maximum speeds are indicated for different motor frames: Max. speed over frame # 200LJ, Max. speed frame # 160MJ to 180LJ, and Max. speed under frame # 132MHJ.</p>	<p>This motor is designed to operate using commercial line power. The motor has maximum cooling capability when operating at a 50 Hz base frequency.</p>	<p>The drive detects <i>oLI</i> when operating at frequencies lower than commercial line power. The drive triggers a fault relay output and the motor coasts to stop.</p>

■ L1-02: Motor Overload Protection Time

No. (Hex.)	Name	Description	Default Setting (Range)
L1-02 (0481)	Motor Overload Protection Time	Sets the motor thermal overload protection (<i>oLI</i>) time. Usually it is not necessary to change this setting.	1.0 min (0.1 - 5.0 min)

Set the overload tolerance time to the length of time that the motor is allowed to operate at 150% load from continuous operation at 100% load.

The default setting triggers the electronic thermal protector after the motor operates at 150% load continuously for 1 minute after continuous operation at 100% load (hot start).

The following diagram is an example of the electronic thermal protector operation time. Motor overload protection operates in the range between a cold start and a hot start.

This example shows a general-purpose motor operating at the base frequency with *L1-02* set to 1.0 min.

- Cold start
Shows the motor protection operation time characteristics when the overload occurs immediately after starting operation from a complete stop.
- Hot start
Shows the motor protection operation time characteristics when overload occurs from continuous operation below the motor rated current.

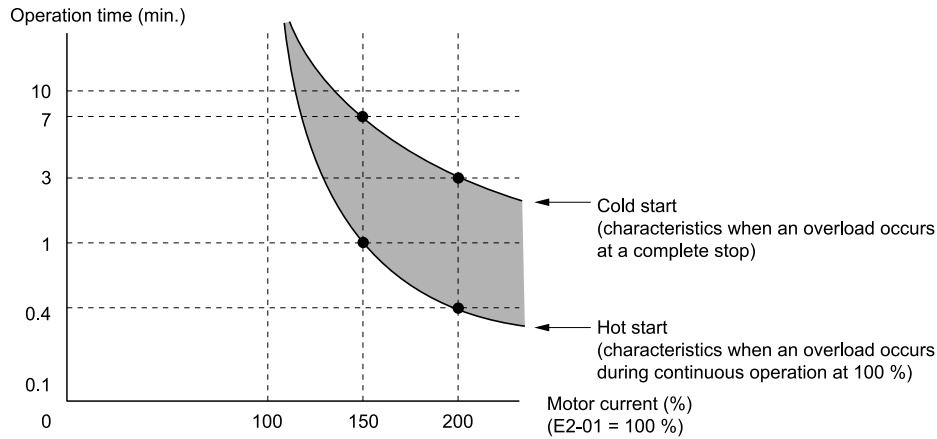

Figure 2.4 Protection Operation Time for a General-purpose Motor at Rated Output Frequency

■ L1-03: Motor OH Alarm Operation Select

No. (Hex.)	Name	Description	Default Setting (Range)
L1-03 (0482)	Motor OH Alarm Operation Select	Selects the drive operation when the PTC input signal input into the drive reaches the detection level of <i>oH3</i> [Motor Overheat Alarm].	3 (0 - 3)

0 : Ramp to Stop

The drive ramps the motor to stop according to the deceleration time. Fault relay output terminal MA-MC will turn on, and MB-MC will turn off.

1 : Baseblock (motor coasts)

The output shuts off and the motor coasts to stop. Fault relay output terminal MA-MC will turn on, and MB-MC will turn off.

2 : Fast Stop (use C1-09)

The drive stops the motor using the deceleration time set in *C1-09* [Fast Stop Time]. Fault relay output terminal MA-MC will turn on, and MB-MC will turn off.

3 : Alarm Only

oH3 appears on the keypad, and operation continues. The output terminal set for Minor Fault (*H2-01* to *H2-04* = 10) switches ON.

■ L1-04: Motor OH Fault Operation Select

No. (Hex.)	Name	Description	Default Setting (Range)
L1-04 (0483)	Motor OH Fault Operation Select	Selects the drive operation when the PTC input signal input into the drive reaches the detection level of <i>oH4</i> [Motor Overheat Failure].	1 (0 - 2)

0 : Ramp to stop

The drive ramps the motor to stop according to the deceleration time. Fault relay output terminal MA-MC will turn on, and MB-MC will turn off.

1 : Coast to stop

The drive shuts off output and the motor coasts to stop. Fault relay output terminal MA-MC will turn on, and MB-MC will turn off.

2 : Fast Stop

The drive stops the motor using the deceleration time set in *C1-09* [Fast Stop Time]. Fault relay output terminal MA-MC will turn on, and MB-MC will turn off.

3 Safe Disable Input



Figure 3.1 TUV Mark

The TUV mark indicates that the product complies with the safety standards.

This section describes precautions for supporting the Safe Disable input. Contact us for more information.

The safety function complies with the standards shown in [Table 3.1](#).

Table 3.1 Safety Standards and Unified Standards Applied

Safety Standards	Unified Standards Applied ^{*1}
Functional Safety	IEC/EN 61508:2010 (SIL3)
	IEC 62061:2012 / EN 62061:2013 (SILCL3)
	IEC/EN 61800-5-2:2007 (SIL3)
Machine Safety	ISO 13849-1:2006 (Cat.III, PL e) / EN ISO 13849-1/AC:2009 (Cat.III, PL e)
EMC	IEC 61000-6-7:2014/FprEN 61000-6-7:2014, IEC/EN61326-3-1:2008

*1 Approval pending for models 2169 to 2415, 4371 to 4675.

Note:

SIL is an abbreviation of Safety Integrity Level.

◆ Specification

The Safe Disable input provides the stop function compliant to “Safe Torque Off” defined in IEC/EN 61800-5-2:2007. The Safe Disable input is designed to meet the requirements of EN ISO 13849-1 and IEC/EN 61508. It is also equipped with the safety status monitor to detect safety circuit errors.

The following table lists the specifications for the safety function.

Table 3.2 Specifications for the Safety Function

Item	Description
Input/output	<ul style="list-style-type: none"> Input: 2 Safe Disable input (H1, H2) Signal ON level: 18 Vdc to 28 Vdc Signal OFF level: -4 Vdc to +4 Vdc Output: 1 Safety monitor output EDM (MFDO)
Response time from opening the input to stopping the drive output	3 ms or less
Response time from opening H1 and H2 terminal inputs to operating the EDM signal	20 ms or less
Failure probability	Less frequent operation request mode PFD = 4.65E-6
	Frequent operation request mode or continuous mode PFH = 1.11E-9
Performance level	The Safe Disable input complies with the performance level requirements of EN ISO 13849-1 in consideration of the self-diagnostic function.
HFT (hardware fault tolerance)	N = 1
Type of subsystem	Type B

Note:

EDM = External Device Monitoring

PFD = Probability of Failure on Demand

PFH = Probability of Dangerous Failure per Hour

◆ Notes

⚠ DANGER Sudden Movement Hazard. Make sure the whole system or machinery in which the Safe Disable function is used complies with safety requirements. When implementing the Safe Disable function into the safety system of a machine, perform a thorough risk assessment for the entire system to assure compliance with relevant safety norms. Improper use of the Safe Disable function will cause serious injury or even death.

⚠ DANGER Sudden Movement Hazard. An external holding brake and dynamic brake are not considered to be safety components for drives. Even when using an external holding brake or dynamic brake with a drive output signal (including EDM), it is still not considered a safe system because the drive output signal is not a safety component. A system is required that satisfies safety requirements. Failure to comply will cause death or serious injury.

⚠ DANGER Sudden Movement Hazard. Connect the Safe Disable inputs to the devices in compliance with safety requirements. Failure to comply will cause death or serious injury.

⚠ WARNING Sudden Movement Hazard. When using a PM motor, even if the drive output is shut off by the Safe Disable function, a breakdown of two output transistors can cause current to flow through the motor winding, resulting in a motor output axis movement for a maximum angle of 180 degrees (electrically). Make sure such a situation would have no effect on the safety of the application when using the Safe Disable function. Failure to comply could cause serious injury or death.

⚠ WARNING Electrical Shock Hazard. The Safe Disable function can switch off the drive output, but does not cut the drive power supply and cannot electrically isolate the drive output from the input. Always shut off the drive power supply when performing maintenance or installations on the drive input side as well as the drive output side. Failure to comply could cause serious injury or death.

⚠ WARNING Sudden Movement Hazard. The motor will move when an external gravitational force in the vertical axis is applied even if the Safe Disable function is in operation. Failure to comply could cause serious injury or death.

⚠ WARNING Sudden Movement Hazard. When using the Safe Disable inputs, make sure to remove the wire links between terminals H1, H2, and HC that were installed prior to shipment. Failure to do so will keep the Safe Disable circuit from operating properly and could cause death or serious injury.

⚠ WARNING Sudden Movement Hazard. All safety features (including Safe Disable) should be inspected daily and periodically. If the system is not operating normally, this could cause death or serious injury.

⚠ WARNING Sudden Movement Hazard. Only a qualified technician with a thorough understanding of the drive, the instruction manual, and safety standards should be permitted to wire, inspect, and maintain the Safe Disable input. Failure to comply could cause death or serious injury.

NOTICE From the moment terminal inputs H1 and H2 have opened, it takes up to 3 ms for drive output to shut off completely. The sequence set up to trigger terminals H1 and H2 should make sure that both terminals remain open for at least 3 ms in order to properly interrupt drive output.

NOTICE The Safe Disable Monitor (multi-function output terminal assigned to the EDM function) should not be used for any other purpose than to monitor the Safe Disable status or to discover a malfunction in the Safe Disable inputs. The monitor output is not considered a safe output.

NOTICE Replace drives with a built-in safety function 10 years after its first used.

◆ Using the Safe Disable Function

■ Safe Disable Circuit

The Safe Disable circuit is comprised of two independent channels (terminals H1 and H2) that block the output transistors. The input can use the internal power supply of the drive.

Set the EDM function to one of the multifunction digital output terminals [$H2-xx = 21$ or 121] to monitor the status of the Safe Disable function. This is called the “Safe Disable monitor output function.”

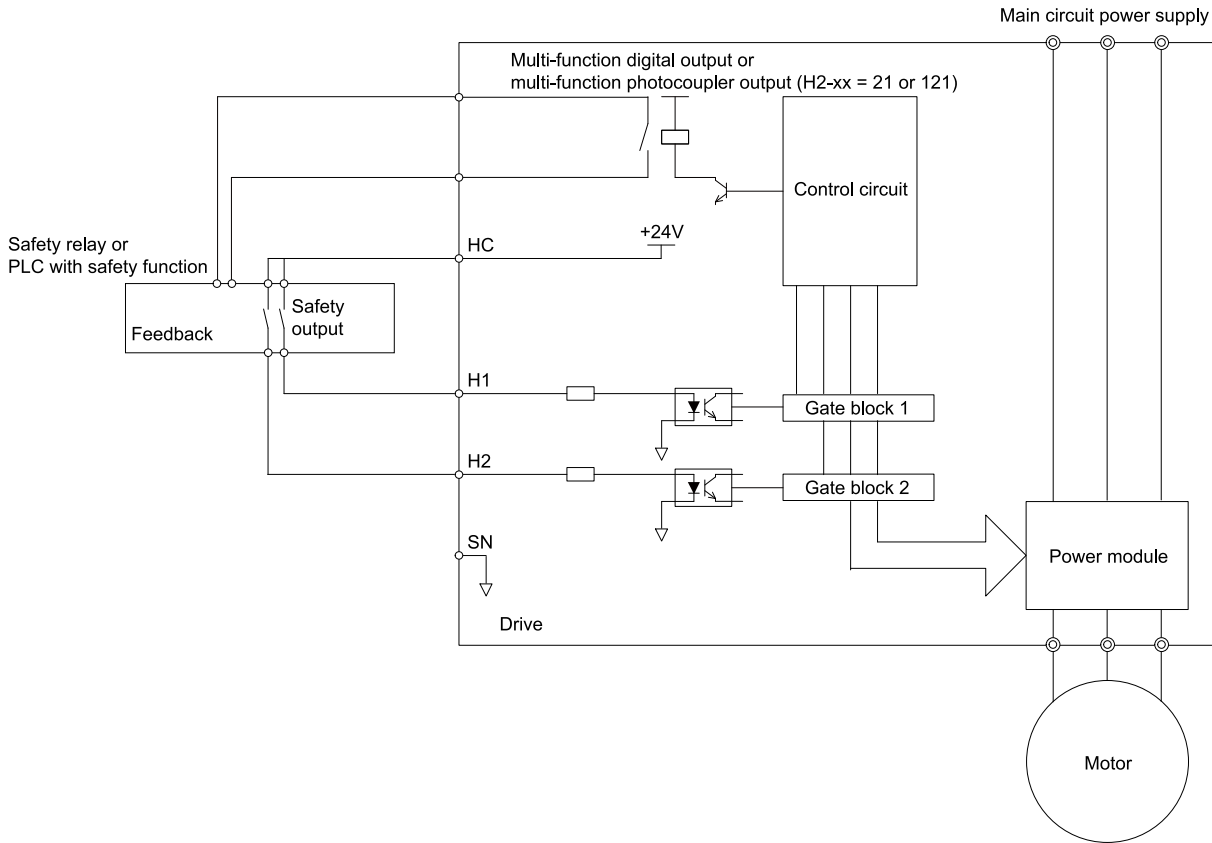

Figure 3.2 Safe Disable Function Wiring Example

■ Disabling and Enabling the Drive Output (“Safe Torque Off”)

Refer to Figure 3.3 for an example of drive operation when switching from the “Safe Torque Off” status until reaching normal operation.

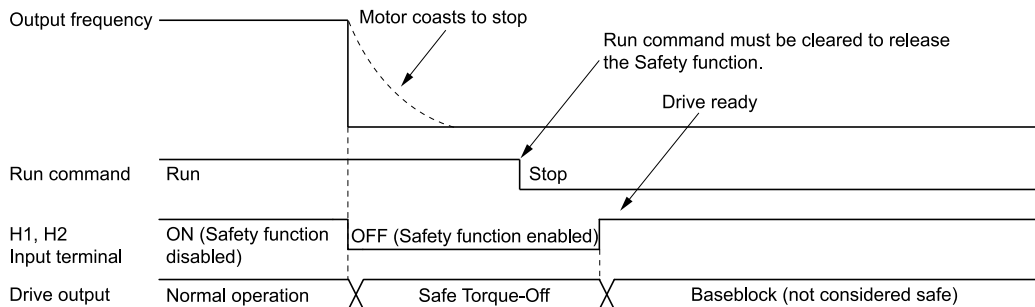

Figure 3.3 Safe Disable operation

Switching from Normal Operation to “Safe Torque Off”

Turning OFF (opening) either safety input terminal H1 or H2 will enable the Safe Disable function. Triggering the Safe Disable function while the motor is running will shut off the drive output and motor torque and the motor will coast to stop regardless of the *b1-03 [Stopping Method Selection]* setting value.

The “Safe Torque Off” status is only possible when using the Safe Disable function. Clear the Run command to stop the drive. Shutting off the drive output, as in a baseblock condition, is not the same as “Safe Torque Off”.

Note:

- A maximum of 3 ms will elapse from when terminals H1 or H2 shut off until the drive switches to the "Safe Torque Off" status. Set the OFF status for terminals H1 and H2 to hold for at least 2 ms. The drive may not be able to switch to the “Safe Torque Off” status if terminals H1 and H2 are only open for less than 2 ms.
- Switch OFF terminals H1 and H2 after the motor has come to a complete stop to prevent the motor from coasting to stop during normal operation.

Returning to Normal Operation from “Safe Torque Off”

The safety input releases only when the Run command is not present.

- During Stop:

Place one short circuit between terminals H1-HC and one between terminals H2-HC to disable "Safe Torque Off" when the Safe Disable function is triggered during stop. Enter the Run command after the drive stops normally.

- During run:
Place one short circuit between terminals H1-HC and one between terminals H2-HC to disable "Safe Torque Off" after clearing the Run command when the Safe Disable function is triggered during stop. Enter the Run command after entering the STOP command regardless of whether terminals H1 and H2 are ON.

■ Safe Disable Monitor Output Function and Keypad Display

Refer to [Table 3.3](#) for information on the relationship between each status of the input channel, Safety monitor output, and drive output.

Table 3.3 Safe Disable Input and EDM Terminal Status

Input Channel Status		Safety Monitor Output		Drive Output Status	Keypad Display	LED Status Ring
Input 1 (H1 - HC)	Input 2 (H2 - HC)	Multi-function Digital Output Terminal (H2-xx = 21)	Multi-function Digital Output Terminal (H2-xx = 121)			
ON (Short circuit)	ON (Short circuit)	OFF	ON	Baseblock (Drive ready)	Normally displayed	Ready: Lit
OFF (Open)	ON (Short circuit)	OFF	ON	Safety status (STo)	SToF (Flashing)	ALM/ERR: Flashing
ON (Short circuit)	OFF (Open)	OFF	ON	Safety status (STo)	SToF (Flashing)	ALM/ERR: Flashing
OFF (Open)	OFF (Open)	ON	OFF	Safety status (STo)	STo (Flashing)	Ready: Flashing

Safety Function Status Monitor

The drive Safety monitor output sends a feedback signal regarding the Safety function status. The Safety monitor output is one of the possible settings available for the multi-function digital output terminals. A controller (PTC or safety relay) must read this signal as an input signal to maintain the "Safe Torque Off" status in the event that the Safe Disable circuit is damaged. Refer to the manual for the safety device for more information on the Safety function.

It is possible to switch polarity of the Safety monitor output signal using the multi-function digital output functions settings. Refer to [Table 3.3](#) for setting instructions.

Keypad Display

The keypad will flash *STo* [*Safe Disable Signal Input*] when both input channels are OFF (Open).

The keypad flashes *SToF* [*Safe Disable Signal Fault*] when one input channel is OFF (Open), and the other is ON (Short circuit) to indicate that either the Safe disable circuit or the drive are damaged. The keypad will never display *SToF* when the Safe disable circuit is used correctly. Refer to the chapter on Troubleshooting for more information.

The keypad displays *SCF* [*Safe Circuit Fault*] when the drive detects a fault in the Safe disable circuit to indicate that the drive is damaged. Refer to the chapter on Troubleshooting for more information.

■ Validating Safe Disable Function

Perform the following Safe Disable input test when replacing parts or performing maintenance after completing all necessary wiring to start the drive. Keep a record of the test results.

- Ensure that the keypad flashes *STo* [*Safe Disable Signal Input*] when both input channels are OFF (Open) and confirm that the motor is not running. Also check that the motor is not running.
- Monitor the ON/OFF status of the input channels and ensure that multi-function digital output assigned to the EDM function operates as shown in [Table 3.3](#).
The ON/OFF status of the multi-function digital output may not display correctly on the keypad if one or more of the following are true:
 - Incorrect parameter settings
 - A problem with an external device
 - There is a short or disconnection in the external wiring.

– The device is damaged.

Identify the cause and fix the problem to display the status properly.

- Ensure that the EDM signal operates during normal operation as described in [Table 3.3](#).

4 Disposal and Environmental Compatibility

- Dispose or recycle electronic waste in accordance with local laws and regulations.
- Do not dispose electronic waste with household waste.

YASKAWA AC Drive GA700

High Performance General Applications Drive
Standards Compliance

YASKAWA EUROPE GmbH

Hauptstraße 185, 65760 Eschborn, Germany

Phone: +49-6196-569-500

E-mail: support@yaskawa.eu.com

Internet: <http://www.yaskawa.eu.com>

DRIVE CENTER (INVERTER PLANT)

2-13-1, Nishimiyaichi, Yukuhashi, Fukuoka, 824-8511, Japan

Phone: +81-930-25-2548 Fax: +81-930-25-3431

Internet: <http://www.yaskawa.co.jp>

YASKAWA AMERICA, INC.

2121, Norman Drive South, Waukegan, IL 60085, U.S.A.

Phone: +1-800-YASKAWA (927-5292) or +1-847-887-7000 Fax: +1-847-887-7310

Internet: <http://www.yaskawa.com>

YASKAWA

YASKAWA ELECTRIC CORPORATION

In the event that the end user of this product is to be the military and said product is to be employed in any weapons systems or the manufacture thereof, the export will fall under the relevant regulations as stipulated in the Foreign Exchange and Foreign Trade Regulations. Therefore, be sure to follow all procedures and submit all relevant documentation according to any and all rules, regulations and laws that may apply.

Specifications are subject to change without notice for ongoing product modifications and improvements.

© 2016 YASKAWA Electric Corporation



TOEPC71061718

www.nicsanat.com

021-87700210



MANUAL NO. TOEP C710617 18B <1>-0
Tokyo, Japan September 2016

J
uctions