

Start-Up 01/2002 Edition



www.nicsanat.com

021-87700210

sinumerik

SINUMERIK 802C

SIEMENS

www.nicsanat.com

021-87700210



SIEMENS

SINUMERIK 802C

Start-Up

Valid for

Control
SINUMERIK 802C

Software Version
3

01.2002 Edition

www.nicsanat.com

021-87700210



Numerical Control System	1
Installing the Control System	2
Installing the Drives	3
Start-Up	4
Update	5
Technical Appendix	6
Manual Machine	7
Index	

SINUMERIK® Documentation

Printing history

Brief details of this edition and previous editions are listed below.

The status of each edition is shown by the code in the "Remarks" column.

Status code in the "Remarks" column:

A New documentation.

B Unrevised reprint with new Order No.

C Revised edition with new status.

If actual changes have been made on the page since the last edition, this is indicated by a new edition coding in the header on the page.

Edition	Order-No.	Remark
04.00	6FC5597-3AA20-0BP2	A
01.02	6FC5597-3AA20-0BP2	C

This Manual is included on the documentation on CD-ROM (**DOCONCD**)

Edition	Order-No.	Remark
11.02	6FC5298-6CA00-0AG3	C

Trademarks

SIMATIC®, SIMATIC HMI®, SIMATIC NET®, SIROTEC®, SINUMERIK® and SIMODRIVE® are registered trademarks of Siemens. Third parties using for their own purposes any other names in this document which refer to trademarks might infringe upon the rights of trademark owners.

Other functions not described in this documentation might be executable in the control. This does not, however, represent an obligation to supply such functions with a new control or when servicing.

This publication was produced with Interleaf V 7

The reproduction, transmission or use of this document or its contents is not permitted without express written authority. Offenders will be liable for damages. All rights, including rights created by patent grant or registration of utility model or design, are reserved.

© Siemens AG 2002. All rights reserved.

We have checked that the contents of this document correspond to the hardware and software described. Nonetheless, differences might exist and therefore we cannot guarantee that they are completely identical. The information contained in this document is, however, reviewed regularly and any necessary changes will be included in the next edition. We welcome suggestions for improvement.

Subject to change without prior notice.

Safety notices

This Manual contains notices intended to ensure your personal safety and to avoid material damage. The notices are highlighted by a warning triangle and, depending on the degree of hazard, represented as shown below:



Danger

indicates that loss of life, severe personal injury or substantial material damage **will** result if the appropriate precautions are not taken.



Warning

indicates that loss of life, severe personal injury or substantial material damage **may** result if the appropriate precautions are not taken.



Caution

indicates that minor personal injury or material damage may result if the appropriate precautions are not taken.

Caution

without a warning triangle means that a material damage **can** occur if the appropriate precautions are not taken.

Attention

means that an undesired event or status **can** occur if the appropriate note is not observed.

Note

is used to draw your special attention to an important information on the product, the handling of the product or the corresponding part of the documentation.

Qualified personnel

Start-up and operation of a device may only be carried out by **qualified personnel**. Qualified personnel as referred to in the safety notices provided in this Manual are persons who are authorized to start up, ground and tag devices, systems and circuits according to the relevant safety standards.

Usage as per intended purpose

Please observe the following:



Warning

The device may only be used for the cases of application, as intended by the Catalog, and only in conjunction with third-party devices and components recommended or approved by Siemens.

The proper and safe operation of the product requires transport, storage and installation according to the relevant instructions and qualified operation and maintenance at the prescribed intervals.

Table of Contents

1	SINUMERIK 802C Control System	1-9
1.1	Components of the SINUMERIK 802C	1-9
1.2	Technical data	1-12
2	Installing the Control System	2-15
2.1	Installing and removing the SINUMERIK 802C	2-15
2.2	Interfaces and cables	2-18
2.3	Connecting the individual components	2-21
2.3.1	Connecting the operator panel	2-21
2.3.2	Connecting the feed drives and the spindle (X7)	2-23
2.3.3	Connecting the measuring systems (X3 ... X6)	2-26
2.3.4	Configuration of the RS232 interface connection (X8)	2-27
2.3.5	Connecting handwheels (X10)	2-29
2.3.6	Connecting NCREADY (X20)	2-30
2.3.7	Connecting the digital inputs and outputs (X2003 ... X2006)	2-31
2.4	ENC and operator panel power supply (X1)	2-35
2.5	Grounding	2-36
2.6	LEDs and operating elements on the ENC	2-38
3	Installing the Drives	3-39
4	Start-Up	4-41
4.1	General	4-41
4.1.1	Access levels	4-42
4.1.2	Structure of machine data (MD) and setting data (SD)	4-43
4.1.3	Handling machine data	4-44
4.1.4	Data saving	4-44
4.2	Turning on and booting the control system	4-46
4.2.1	Boot messages	4-48
4.3	Starting up the PLC	4-49
4.3.1	Commissioning of the PLC	4-49
4.3.2	Start-up modes of the PLC	4-51
4.3.3	PLC alarms	4-52
4.3.4	Machine control panel (MCP) layout	4-56
4.3.5	PLC programming	4-57
4.3.6	Instruction set	4-61
4.3.7	Programm organization	4-68
4.3.8	Data organization	4-69
4.3.9	Interface to the control system	4-69
4.3.10	Testing and monitoring the user program	4-69
4.4	PLC applications "Download/Upload/Copy/Compare"	4-70
4.5	User Interface	4-72
4.6	Technology Setting	4-72
4.7	Commissioning	4-73
4.7.1	Entering the general machine data	4-73
4.7.2	Starting up the axes	4-75
4.7.3	Starting up the spindle	4-85
4.7.4	Completing the Start-Up	4-87
4.7.5	Cycle start-up	4-88
4.8	Series machine start-up	4-89

5	Software Update	5-91
5.1	Updating the system software using a PC/PG	5-91
5.2	Updating the system software incl. user data without using a PC/PG	5-92
5.3	Update errors	5-93
6	Technical Appendix	6-94
6.1	List of machine and setting data	6-94
6.1.1	Display machine data	6-94
6.1.2	General machine data	6-96
6.1.3	Channel-specific machine data	6-96
6.1.4	Axis-specific machine data	6-97
6.1.5	Setting data	6-103
6.2	PLC user interface signals	6-105
6.2.1	Address ranges	6-105
6.2.2	Retentive data area	6-106
6.2.3	NCK signals	6-107
6.2.4	Channel signals	6-108
6.2.5	Axis/spindle signals	6-113
6.2.6	Signals from/to MMC	6-116
6.2.7	Machine control panel signals (MCP signals)	6-118
6.2.8	PLC machine data	6-119
6.2.9	User alarm	6-120
6.3	Application note: unipolar spindle control	6-123
7	Manual Machine	7-125
7.1	Hardware and software requirements for the installation	7-125
7.2	Loading the software	7-126
7.3	Switching the user interface	7-128
7.4	Switching the language	7-128
7.5	Additional machine data	7-129
7.6	Input limitations with regard to the user interface	7-129
7.7	Operation without machine control panel (MCP)	7-130
7.8	I/O assignment in the standard PLC program	7-130
7.8.1	Assignment of the digital inputs:	7-130
7.8.2	Assignment of the digital outputs:	7-132
7.9	Default assignment of special data for the "Manual machine"	7-133

SINUMERIK 802C Control System

1.1 Components of the SINUMERIK 802C

What is SINUMERIK?

The SINUMERIK 802C is a microprocessor–controlled numerical control system for simple machine tools with stepper motor drives .

Hardware components

It consists of the following hardware components:

- ENC: Control component for a maximum of 3 analog axes and an analog interface for a main spindle drive (ENC = Economical Numerical Control)
- OP020: NC operator panel with graphics display and keyboard
- MCP: machine control panel
- DI/O16: 16 binary inputs/outputs each extendable to max. 64 by using 4 modules

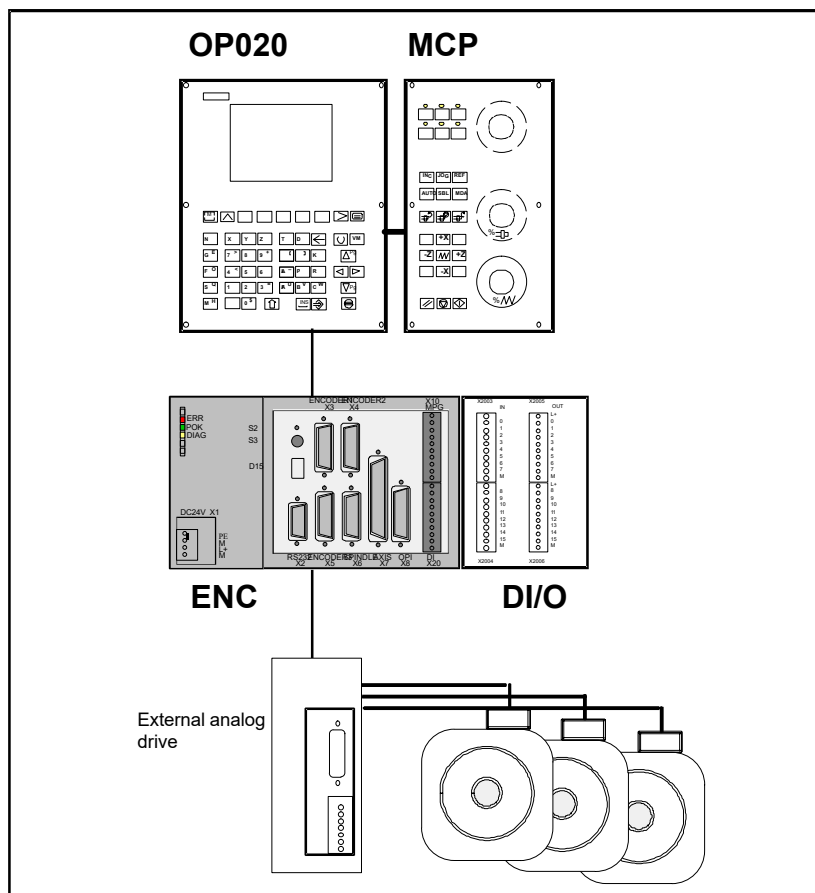

Fig. 1-1 SINUMERIK 802C hardware components (example configuration)

Software components

The SINUMERIK 802C comprises the following software components, which can be ordered:

- System software on the permanent flash memory of the ENC
 - Boot software, loads the remaining system software from the permanent memory into the user memory (DRAM) and starts the system.
 - MMC software (Man Machine Communication), implements all operating functions
 - NCK software (NC Kernel) implements all NC functions. This software controls an NC channel with a maximum of 3 movement axes and a spindle.
 - PLC software (Programmable Logic Control), executes the integrated PLC user program cyclically.
 - Integrated PLC user program intended to adjust the SINUMERIK 802C to the machine functions (see also Description of Functions “Integrated User Program for SINUMERIK 802C”).

- Toolbox
 - WinPCIN transfer program for a PC/PG (programming device) to transfer user data and programs
 - Text manager
 - Cycle kit for loading into the control system using WinPCIN
 - User program library
 - Technological machine data files
 - Programming tool
- Update diskettes
 - Update program with operator prompting system
 - 802C system software, packed, for loading and programming the SINUMERIK 802C via an update program.

User data

User data are:

- Machine data
- Setting data
- Tool data
- R parameters
- Zero offsets
- Compensation data
- Part programs
- Standard cycles

Data saving

Modified user data are saved for at least 50 h after power off or power failure. After then, they might get lost.



Warning

To avoid data loss, the operator must carry out data saving (see Section 4.1.4).

1.2 Technical data

Connected load

Table 1-1 Connected load

Parameter	Min.	Typ.	Max.	Unit	
Supply voltage	20.4		28.8	V	
Ripple			3.6	V _{ss}	
Current consumption from 24 V		1		A	*
Power dissipation of ENC		15		W	
Power dissipation of OP020		7		W	
Power dissipation of MCP		-			
Power dissipation of DI/O16		7		W	**
Start-up current			2.6	A	

* Basic configuration of ENC, OP020, MCP and DI/O16, all outputs open, current consumption for any

further DI/O16 connected will increase by 0.05 A each.
** at nominal load

Weight

Table 1-2 Weight

Component	Weight [g]
ENC component	900 g
DI/O16 component	350 g
OP020 component	1,800 g
MCP component	1,200 g

Dimensions

Table 1-3 Component dimensions

Component	Dimensions HxWxD [mm]
ENC component	125 x 200 x 118
DI/O component	125 x 80 x 118
OP020 component	300 x 250 x 50
MCP component	300 x 170 x 50

Environmental operating conditions

Table 1-4 Environmental operating conditions

Parameter	
Temperature range	0...55 °C
Permissible relative humidity	5...95 % without condensation
Air pressure	700...1,060 hPa

The operating conditions comply with IEC 1131-2.
Installation in a housing (e.g. cubicle) is absolutely necessary for operation.

Transport and storage conditions

Table 1-5 Transport and storage conditions

Parameter	
Temperature range	Transport: -40...70 °C Storage: -20 ... 55 °C
Permissible relative air humidity	5...95 % without condensation
Air pressure	700...1,060 hPa
Transport height	-1,000...3,000 m
Free fall in transport package	≤ 1,200 mm

Protective quality and degree of protection

Class of protection I to IEC 536.

No PE terminal required.

Foreign matter and water protection to IEC 529.

- for ENC and DI/O16: IP 20
- for OP020 and MCP: IP 54 front
IP 00 rear

www.nicsanat.com

021-87700210



SINUMERIK 802C
6FC5 597-3AA20-0BP2 (01.02)

Installing the Control System

2.1 Installing and removing the SINUMERIK 802C



Warning

Before performing any installation work, always first make sure that the system is disconnected from the mains!

The modules contain electrostatically sensitive devices.

It must be ensured that persons without ESD protection never touch printed circuit boards or components when handling operator and machine control panels.

Approach

Prior to installation, the machine control panel can be provided with a spindle override switch and an emergency stop button. If these are not required, the openings must be covered with the supplied self-adhesive covers.

1. Mount the spindle override switch.
2. Install the operator panel and the machine control panel.
3. Connect the panel using ribbon cable.
4. Install the DIN rail.
5. Connect the ENC and DI/O components.

Note

If you want to connect several DI/O16 components, it may be necessary to remove the right-hand connector from the housing.

6. Slide the components onto the DIN rail, tilt it down and screw it tight.

Removing the control system

The control components are removed as described above in the reverse order.



Warning

Before removing the control components, always first make sure that the system is disconnected from the mains!

Mounting dimensions

The dimensions shown below are important for installing the control components:

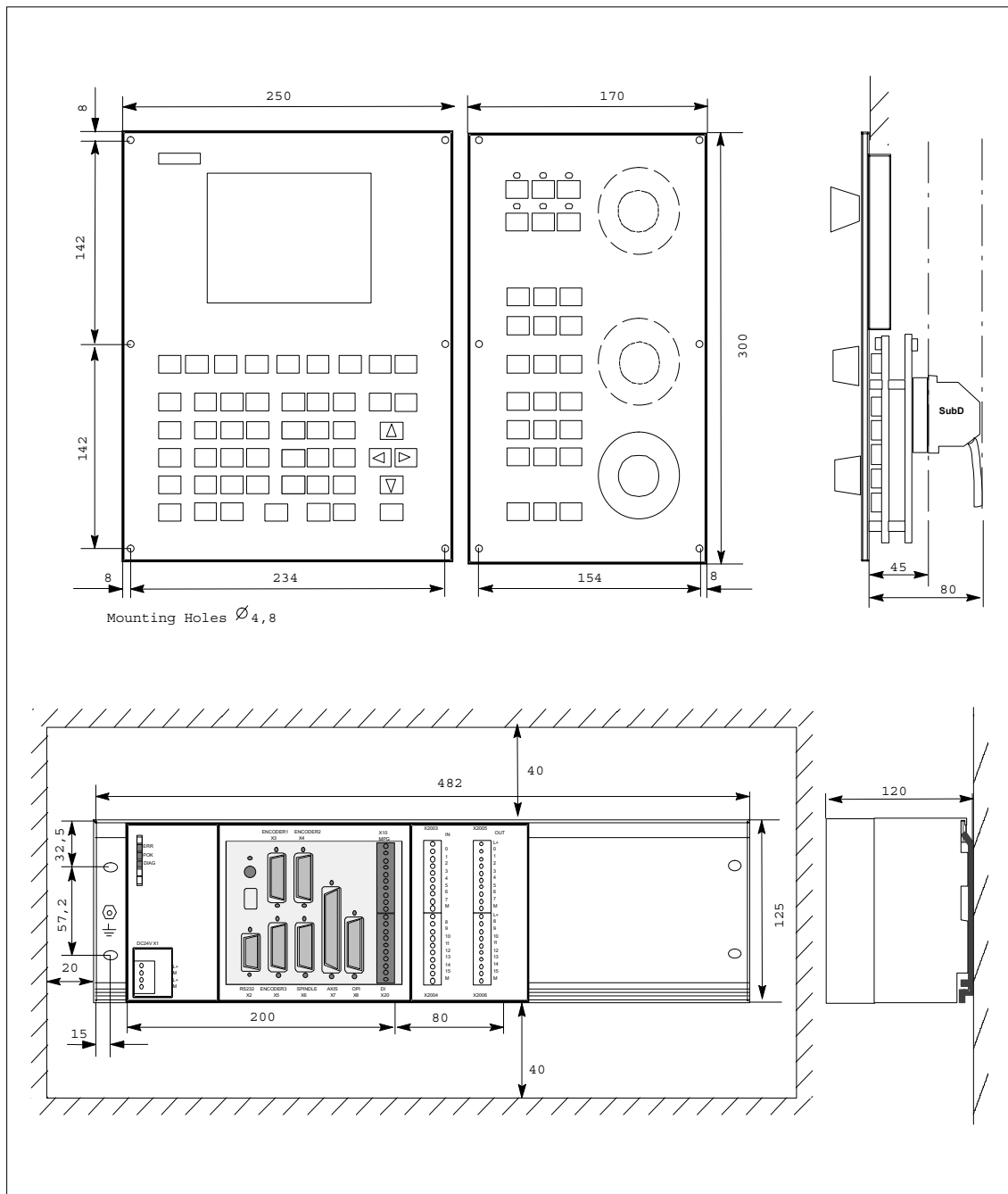

Fig. 2-1 Mounting dimensions for SINUMERIK 802C

2.2 Interfaces and cables

Position of the interfaces and front panel elements

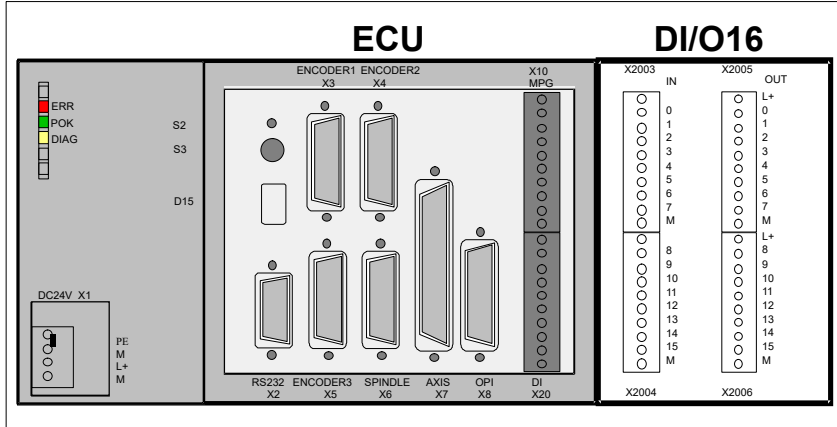

Fig. 2-2 User interfaces

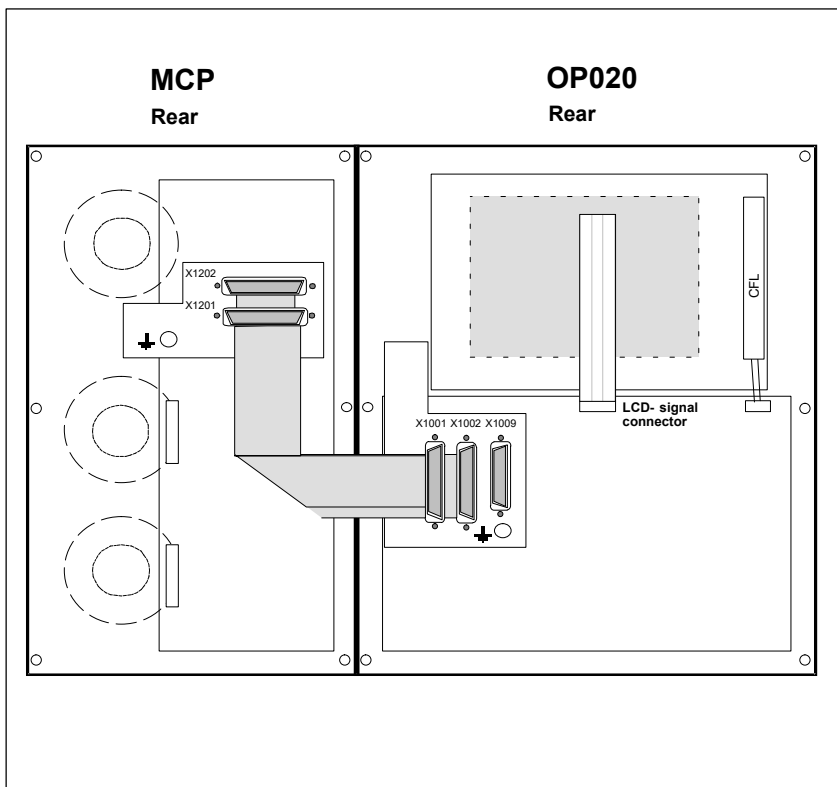

Fig. 2-3 Rear of machine control panel and operator panel

Interfaces

ENC

- **X1 power supply terminals (DC24V)**
4-pin screw-type terminal block for connecting the 24 V load power supply
- **X2 RS232 interface (V24)**
9-pin sub-D plug connector
- **X3 to X5 measuring system interfaces (ENCODER)**
three 15-pin sub-D plug connectors for connecting incremental position encoders (RS422)
- **X6 spindle interface (SPINDLE)**
9-pin sub-D socket for connecting a spindle drive with analog interface
- **X7 drive interface (AXIS)**
50-pin sub-D socket connector for connecting the power sections for a maximum of four analog drives including spindle
- **X8 operator terminal interface (OPI)**
25-pin D-Sub female connector for connecting the operator terminal
- **X10 handwheel interface (MPG)**
10-pin front connector for connecting the handwheels
- **X20 digital inputs (DI)**
10-pin front connector for connecting the NC READY relay

DI/O

- **X2003 and X2004**
10-pin front connector for connecting digital inputs
- **X2005 and X2006**
10-pin front connector for connecting digital outputs

LEDs

3 LEDs for fault and status displays

Operating elements

Start-up switch **S**

Connecting cables

The components are wired up as shown in the Connection Diagram 2-4. For the cables required, please refer to the diagram below.

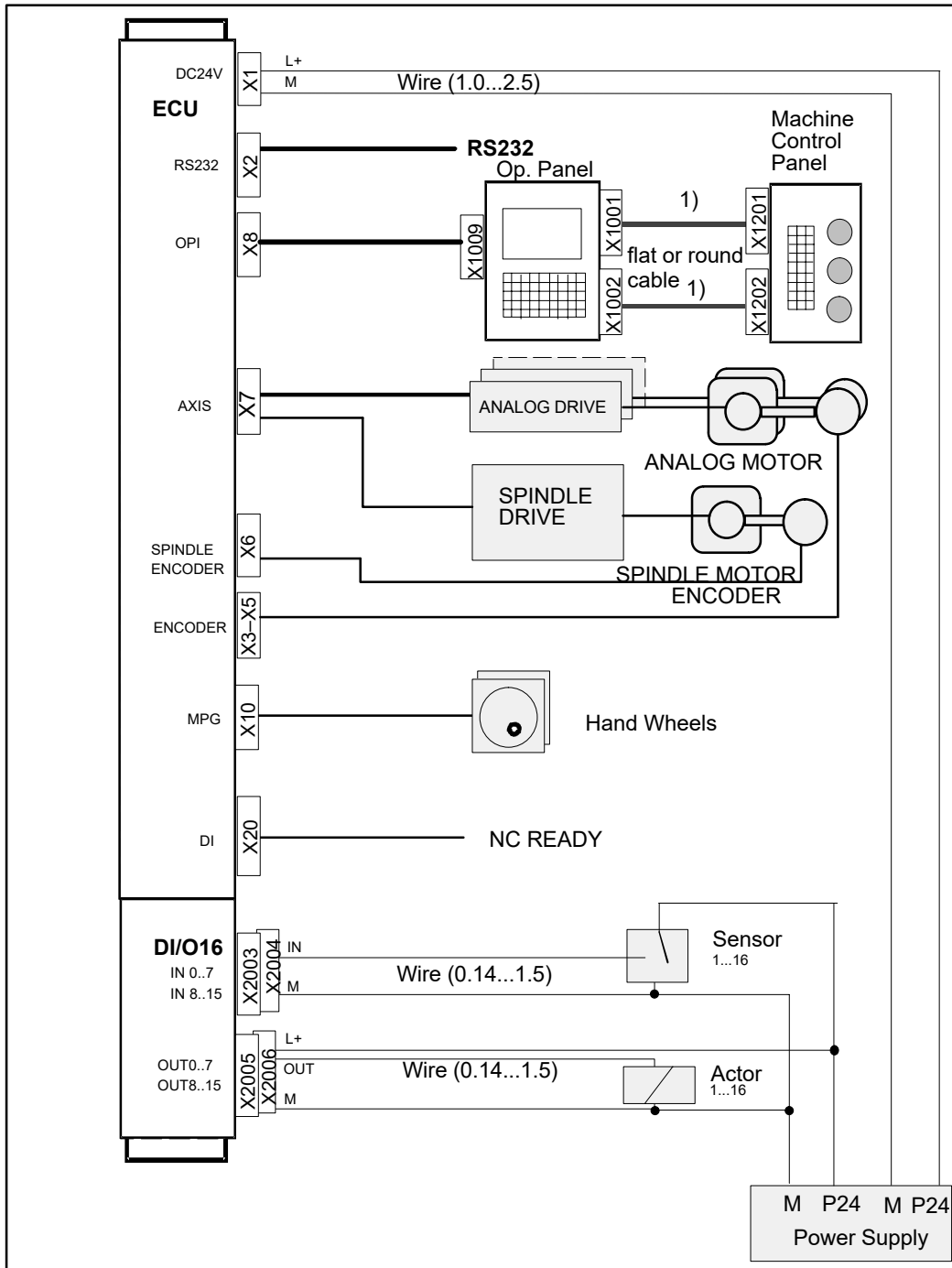

Fig. 2-4 SINUMERIK 802C connection diagram

1) Ribbon cable (included in scope of supply)

2.3 Connecting the individual components

Connecting the components

Note

Use only shielded cable and make sure that the shield is connected to the metal or metal plated connector casing on the control side. For the purpose of isolating the analog setpoint signal from low-frequency interference, we recommend not to ground the shield on the drive side.

The preassembled cable offered as accessories provides optimum protection against interference.

General procedure:

Proceed as follows to connect the individual components:

1. Connect the cables to the components as shown in Fig. 2-4.
2. Fix the sub-D connector in place using the knurled screws.

2.3.1 Connecting the operator panel

Connector pin assignment on the ENC side

Operator panel interface

Connector designation:	X8
	OP020
Connector type:	25-pin sub-D plug connector

2.3 Connecting the individual components

Table 2-1 Pin assignment of connector X8

X8					
Pin	Signal	Type	Pin	Signal	Type
1			14	P24_OP	VO
2	M_OP	VO	15	OPD0_N	O
3	OPD0	O	16	OPD1_N	O
4	OPD1	O	17	OPD2_N	O
5	OPD2	O	18	OPD3_N	O
6	OPD3	O	19	OPCP1_N	O
7	OPCP1	O	20	OPCP2_N	O
8	OPCP2	O	21	OPS_N	O
9	OPS	O	22	ENRXD_N	I
10	ENRXD	I	23	ENTXD_N	O
11	ENTXD	O	24	ENRTS_N	O
12	ENRTS	O	25	P24_OP	VO
13	M_OP	VO			

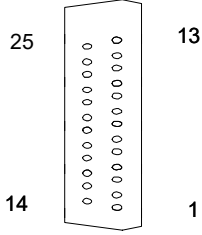

Connector pin assignment on the OP side

Operator panel interface

Connector designation: **X1009**
 OP020
 Connector type: 25-pin sub-D plug connector

Table 2-2 Pin assignment of connector X1009

X1009					
Pin	Signal	Type	Pin	Signal	Type
1			14	P24_OP	VI
2	M_OP	VI	15	OPD0_N	I
3	OPD0	I	16	OPD1_N	I
4	OPD1	I	17	OPD2_N	I
5	OPD2	I	18	OPD3_N	I
6	OPD3	I	19	OPCP1_N	I
7	OPCP1	I	20	OPCP2_N	I
8	OPCP2	I	21	OPS_N	I
9	OPS	I	22	OPTXD_N	O
10	OPTXD	O	23	OPRXD_N	I
11	OPRXD	I	24	OPCTS_N	I
12	OPCTS	I	25	P24_OP	VI
13	M_OP	VI			

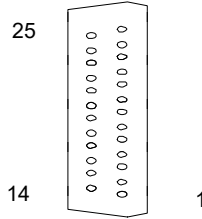

Signal names

OPD[0...3]	LCD Data 0...3
OPCP1	LCD Latch
OPS	LCD Frame
OPCP2	LCD Clock
OPRXD	OP Receive Data
OPTXD	OP Transmit Data
OPCTS	OP Clear to Send
ENRXD	ECU Receive Data
ENTXD	ECU Transmit Data
ENRTS	ECU Request to Send
P24_OP	DC24V
M_OP	Ground

Signal level

RS422 / LVDS

Signal type

VO	Voltage output
VI	Voltage input
O	Output
I	Input

2.3.2 Connecting the feed drives and the spindle (X7)**Connector pin assignment on the ENC side****Feed drive interface**

Connector designation: **X7**
 AXIS 1-4
 Connector type: 50-pin sub-D plug connector

Table 2-3 Pin assignment of connector X7

X7								
Pin	Signal	Type	Pin	Signal	Type	Pin	Signal	Type
1	SW1	VO	18			34	BS1	VO
2	BS2	VO	19			35	SW2	VO
3	SW3	VO	20			36	BS3	VO
4	BS4	VO	21			37	SW4	VO
5			22			38		
6			23			39		
7			24			40		
8			25			41		
9			26			42		
10			27			43		

2.3 Connecting the individual components

11			28			44		
12			29			45		
13			30			46		
14	RF1.1	K	31			47	RF1.2	K
15	RF2.1	K	32			48	RF2.2	K
16	RF3.1	K	33			49	RF3.2	K
17	RF4.1	K				50	RF4.2	K

Signal names

SWn Setpoint
 BSn Reference potential for setpoint
 RFn.1, RFn.2 Servo enable contact

Signal level

RS422

Signal type

O Signal output

Axis assignment

1 X axis
 2 Y axis
 3 Z axis
 4 Spindle

Table 2-4 Cable assignment (for type 6FX2 002–3AD01)

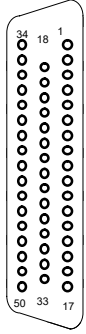
NC Side		Cable	Drive Side	
	PIN	Core Color	Signal Name	PIN
	14	black	1st axis	1.9
	47	brown		1.65
	34	red		1.4
	1	orange		1.56
	15	yellow	2nd axis	2.9
	48	green		2.65
	2	blue		2.14
	35	purple	2.56	3rd axis
	16	gray	3.9	
	49	pink	3.65	
	36	white/black	3.14	
	3	white/brown	3.56	Spindle
	17	white/red	4.9	
	50	white/orange	4.65	
	4	white/yellow	4.14	
	37	white/green	4.56	

Drives with analog interface Signals

One voltage and one enable signal each is output.

- **SWn (SETPOINT)**

Analog voltage signal in the range ± 10 V to output a speed setpoint

- **Sn (REFERENCE SIGNAL)**

Reference potential (analog ground) for the setpoint signal, internally connected to logic ground.

- **RFn (SERVO ENABLE)**

Relay contact pair controlling the enable of the power section, e.g. of a SIMODRIVE drive unit controlled via a PLC program.

Signal parameters

The setpoint is output as an analog differential signal.

Table 2-5 Electrical parameters of the signal outputs for step-switching drives

Parameter	Min	Max	Unit
Voltage range	-10.5	10.5	V
Output current	-3	3	mA

2.3 Connecting the individual components

Relay contact

Table 2-6 Electrical parameters of the relay contacts RFn.1 and RFn.2

Parameter	Max.	Unit
Switching voltage	50	V
Switching current	1	A
Switching power	30	VA

Cable length: max. 35 m

2.3.3 Connecting the measuring systems (X3 ... X6)

Pin assignment of the connector on the ENC side

Measuring system interface (incremental encoder)

Connector designation: **X3 ... X6**

ENCODER

Connector type: 15-pin sub-D plug connector

Table 2-7 Pin assignment of the female connector X3 ... X6

X3 ... X6					
Pin	Signal	Type	Pin	Signal	Type
1			9	M	VO
2			10	N	I
3			11	N_N	I
4	P5_MS	VO	12	B_N	I
5		VO	13	B	I
6	P5_MS	VO	14	A_N	I
7	M	VO	15	A	I
8					

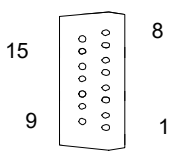

Signal names

A, A_N Track A (true and negated)
 B, B_N Track B (true and negated)
 N, N_N Zero mark (true and negated)
 P5_MS +5.2 V supply
 M Supply ground

Signal level

RS422

Signal type

VO Voltage output (supply)
 I 5V input (5V signal)

Connectable encoder types

Incremental 5 V encoders can be connected directly.

Characteristics

The encoders must meet the following requirements:

Transmission method:	Differential transmission with 5 V square-wave signals Output signals: Track A as true and negated signal ($U_{a1}, \overline{U_{a1}}$) Track B as true and negated signal ($U_{a2}, \overline{U_{a2}}$) Zero signal N as true and negated signal ($U_{a0}, \overline{U_{a0}}$)
Max. output frequency:	1.5 MHz
Phase offset between tracks A and B:	$90^\circ \pm 30^\circ$
Current consumption:	max. 300 mA

Cable lengths

The maximum cable length depends on the specifications of the encoder power supply and on the transmission frequency.

To provide fault-free operation, make sure that the following values are not exceeded when using preassembled interconnecting cables from SIEMENS:

Table 2-8 Maximum cable lengths depending on the encoder power supply

Supply Voltage	Tolerance	Current Consumption	Max. Cable Length
5 V DC	4.75 V...5.25 V	≤ 300 mA	25 m
5 V DC	4.75 V...5.25 V	≤ 220 mA	35 m

Table 2-9 Maximum cable lengths depending on the transmission frequency

Encoder Type	Frequency	Max. Cable Length
incremental	1 MHz	10 m
	500 kHz	35 m

2.3.4 Configuration of the RS232 interface connection (X8)

Pin assignment of the connector on the ENC side

RS232 interface

Connector designation:	X2
	RS232
Connector type:	9-pin sub-D plug connector

2.3 Connecting the individual components

Table 2-10 Pin assignment of connector X2

X8					
Pin	Name	Type	Pin	Name	Type
1			6	DSR	I
2	RxD	I	7	RTS	O
3	TxD	O	8	CTS	I
4	DTR	O	9		
5	M	VO			

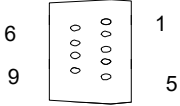

Signal description:

RxD	Receive data
TxD	Send data
RTS	Request to send
CTS	Send enable
DTR	Standby output
DSR	Standby input
M	Ground

Signal level

RS232 (± 12 V)

Signal type

I	Input
O	Output
VO	Voltage output

Cable for WinPCIN

Table 2-11 Cable for WinPCIN: Pin assignment of the Sub-D connector

9-Pin	Name	25-Pin
1	Shield	1
2	RxD	2
3	TxD	3
4	DTR	6
5	M	7
6	DSR	20
7	RTS	5
8	CTS	4
9		

2.3.5 Connecting handwheels (X10)

Pin assignment of the connector on the ENC side

Handwheel interface

Connector designation: **X10**
MPG
 Connector type: 10-pin mini-Combicon plug connector

Table 2-12 Pin assignment of connector
X10

X10		
Pin	Name	Type
1	A1	I
2	A1_N	I
3	B1	I
4	B1_N	I
5	P5_MS	VO
6	M5_MS	VO
7	A2	I
8	A2_N	I
9	B2	I
10	B2_N	I

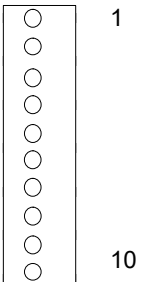

Signal names

A1, A1_N Track A, true and negated (handwheel 1)
 B1, B1_N Track B, true and negated (handwheel 1)
 A2, A2_N Track A, true and negated (handwheel 2)
 B2, B2_N Track B, true and negated (handwheel 2)
 P5_MS 5.2 V supply voltage for handwheels
 M Supply ground

Signal level

RS422

Signal type

VO Voltage output
 I Input (5 V signal)

Handwheels

Two electronic handwheels can be connected which must meet the following requirements:

Transmission method: 5 V square-wave (TTL level or RS422)

Signals: Track A as true and negated signal (U_{a1} , $\overline{U_{a1}}$)
 Track B as true and negated signal (U_{a2} , $\overline{U_{a2}}$)

2.3 Connecting the individual components

Max. output frequency: 500 kHz

Phase offset between tracks A and B: $90^\circ \pm 30^\circ$

Supply: 5 V, max. 250 mA

2.3.6 Connecting NCREADY (X20)

Pin assignment of the connector on the ENC side

BERO input interface

Connector designation: **X20**
DI

Connector type: 10-pin plug connector

Table 2-13 Pin assignment of connector X20

X20		
Pin	Name	Type
11	NCRDY_1	K
12	NCRDY_2	K
13	reserved	DI
14	reserved	DI
15	reserved	DI
16	reserved	DI
17	reserved	DI
18	reserved	DI
19	reserved	VI
20	reserved	VI

Signal names

NCRDY_1...2 NC Ready (NCREADY contacts 1...2)

Signal type

K Switching contact

NC-READY output

Readiness in the form of a relay contact (NO); must be integrated into the EMERGENCY STOP circuit.

Table 2-14 Electrical parameters of the NCREADY relay contact

Parameter	Max.	Unit
DC switching voltage	50	V
Switching current	1	A
Switching power	30	VA

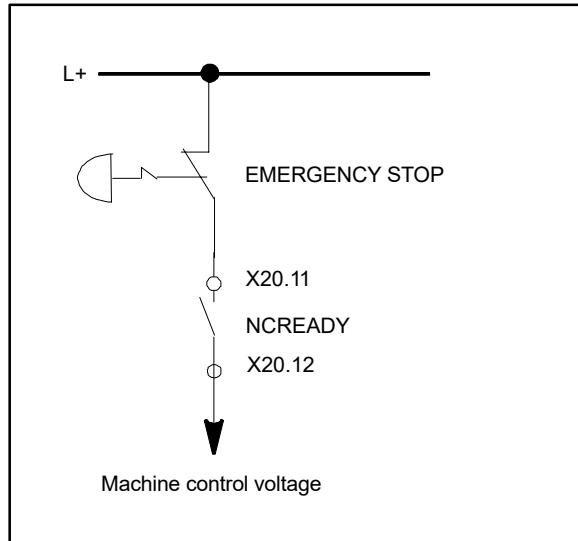

Fig. 2-5

The NCREADY contact will switch off the control voltage in case of danger.

2.3.7 Connecting the digital inputs and outputs (X2003 ... X2006)

Connector pin assignment

Interface for the digital inputs

Connector designation: **X2003, X2004**
IN
 Connector type: 10-pin plug connector

2.3 Connecting the individual components

Table 2-15 Connector pin assignment

X2003		
Pin	Name	Type
1		
2	DI0	I
3	DI1	I
4	DI2	I
5	DI3	I
6	DI4	I
7	DI5	I
8	DI6	I
9	DI7	I
10	M24	V

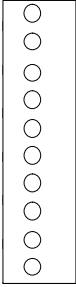

X2004		
Pin	Name	Type
1		
2	DI8	I
3	DI9	I
4	DI10	I
5	DI11	I
6	DI12	I
7	DI13	I
8	DI14	I
9	DI15	I
10	M24	V

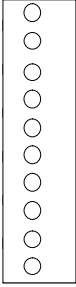

Signal names

DI0...15 24 V digital inputs

Signal type

V Voltage input
 I Input (24 V signal)

Table 2-16 Electrical parameters of the digital inputs

Parameter	Value	Unit	Note
"1" signal, voltage range	15...30	V	
"1" signal, current consumption	2...15	mA	
"0" signal, voltage range	-3...5	V	or input open
Signal delay 0 → 1	0.5...3	ms	
Signal delay 1 → 0	0.5...3	ms	

Connector pin assignment

Interface for digital outputs

Connector designation: **X2005, X2006**
OUT

Connector type: 10-pin plug connector

Table 2-17 Connector pin assignment

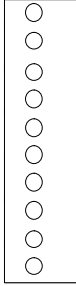
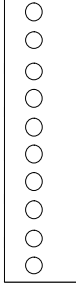
X2005			
Pin	Name	Type	
1	1P24	V	
2	DO0	O	
3	DO1	O	
4	DO2	O	
5	DO3	O	
6	DO4	O	
7	DO5	O	
8	DO6	O	
9	DO7	O	
10	1M24	V	
X2006			
Pin	Name	Type	
1	2P24	V	
2	DO8	O	
3	DO9	O	
4	DO10	O	
5	DO11	O	
6	DO12	O	
7	DO13	O	
8	DO14	O	
9	DO15	O	
10	2M24	V	

2.3 Connecting the individual components

Signal names

DO0...15 Digital outputs 24V/0.5A

Signal type

V Voltage input
 O Output (24 V signal)

Table 2-18 Electrical parameters of the digital outputs

Parameter	Value	Unit	Note
"1" signal, nominal voltage	24	V	
Voltage drop	max. 3	V	
"1" signal, output current	0.5	A	Simultaneity factor 0.5 per 16 outputs
"0" signal, leakage current	max. 2	mA	

Connecting sensors and actuators

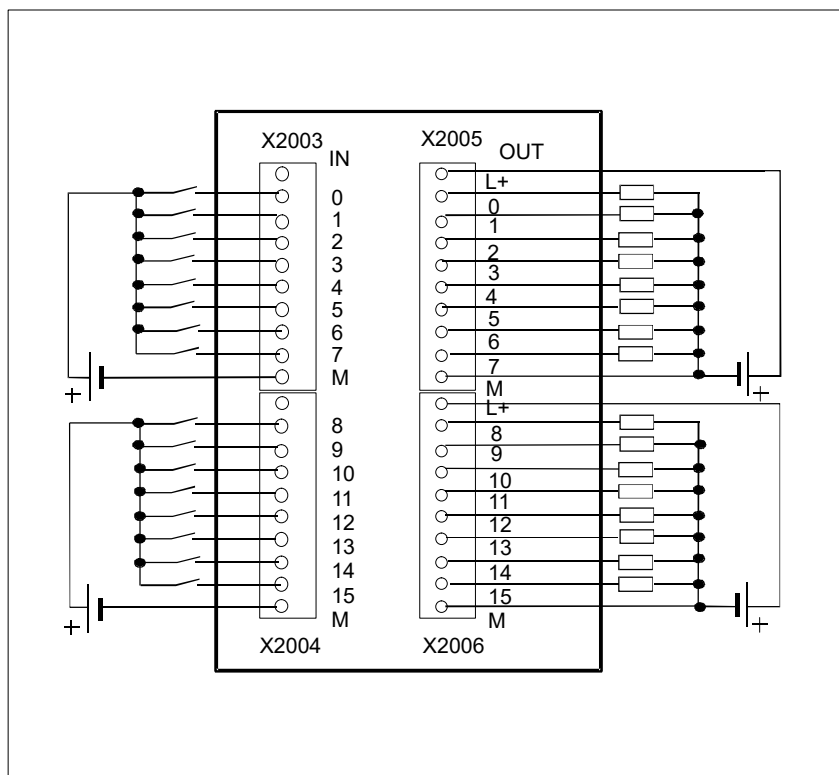

Fig. 2-6 Connecting the digital inputs and outputs

2.4 ENC and operator panel power supply (X1)

Screw-type terminal block

The 24 V DC load power supply unit required for supplying ENC and operator terminal is connected to screw-type terminal block X1.

Characteristics of the load power supply

The 24 V DC voltage must be generated as a functional extra-low voltage with safe electrical isolation (to IEC 204-1, Section 6.4, PELV).

Table 2-19 Electrical parameters of the load power supply

Parameter	Min.	Max.	Units	Conditions
Voltage range mean value	20.4	28.8	V	
Ripple		3.6	V _{ss}	
Non-periodic overvoltage		35	V	500 ms cont. 50 s recovery
Rated current consumption		1	A	
Starting current		2.6	A	

Pin connector assignment on the ENC side

Table 2-20 Pin connector assignment of screw-type terminal block X1

Terminal		
1	PE	PE
2	M	Ground
3	L+	DC 24 V
4	M	Ground

The contacts 2/4 are connected internally in the device.

Operator panel

The operator panel does not possess a separate power supply connection. It is powered from the ENC via the signal cables.

2.5 Grounding

Ground connections

The following ground connections must be implemented:

- Busbar for ENC, DI/O
- OP020 operator panel
- Machine control panel (MCP)

The ground connections for the MCP/OP020 must take into account installation in the machine or a panel.

In the case of cubicle installation, the grounding points must be connected to the grounding bar (see Fig. 2-7).

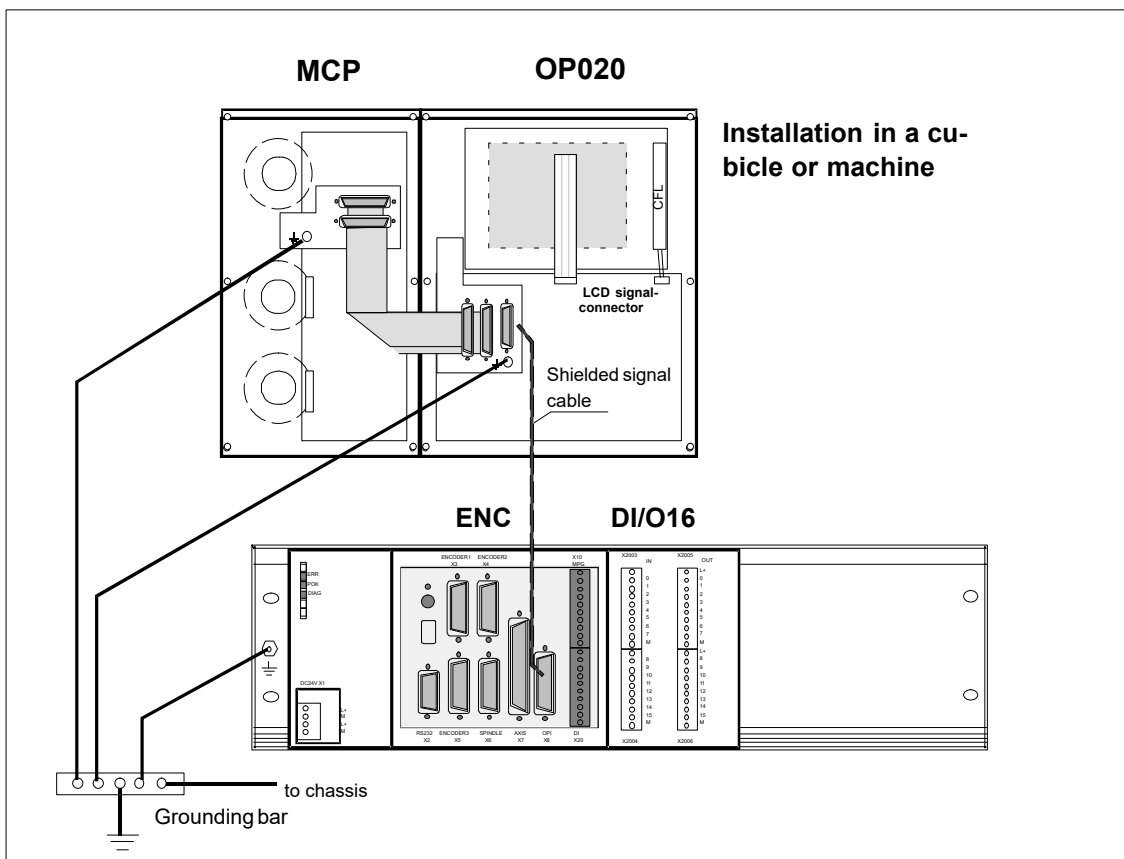

Fig. 2-7 Grounding diagram for MCP/OP020 installation in a cubicle or machine

Panel installation requires that the ground connections on the MCP and OP020 are connected together and to the panel frame. The panel frame is grounded centrally (see Fig. 2-8).

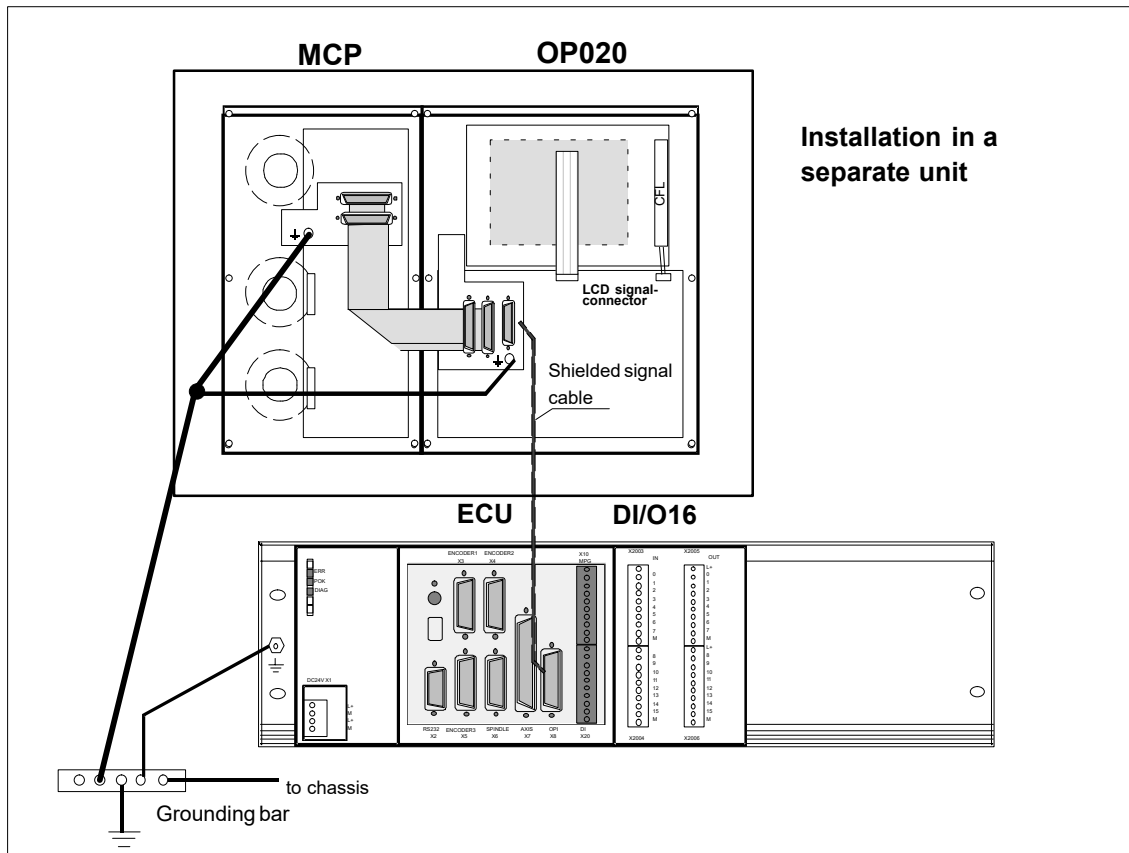

Fig. 2-8 Grounding diagram for MCP/OP020 installation in a panel

2.6 LEDs and operating elements on the ENC

Error and status LEDs

There are three LEDs on the front panel of the ENC.

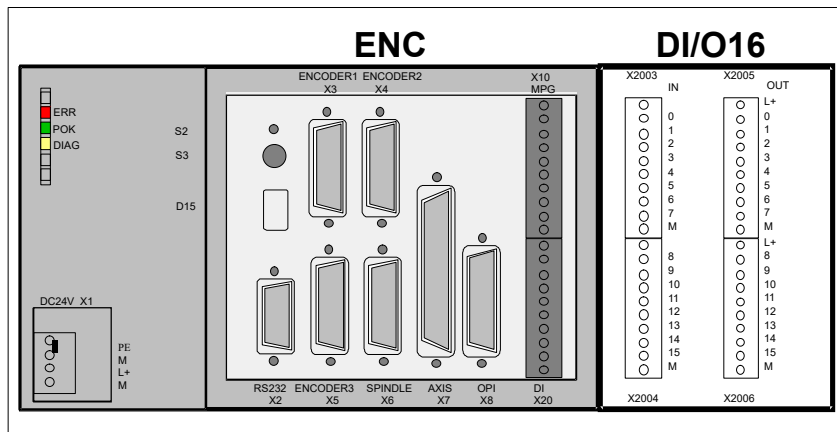

Fig. 2-9 User interfaces

ERR (red)

Group error

This LED indicates an error condition of the ENC.

POK (green)

Power OK

The power supply is ready.

DIAG (yellow)

Diagnostics

This LED indicates various diagnosis states. Under normal operating conditions, this LED flashes 1:1.

Start-up switch (S3)

This rotary switch is intended to assist start-up.

Position 0: Normal operation

Positions 1-4: Start-up

cf. also Section 4.2, Table 4-2

Installing the Drives



Lesehinweis

Manufacturer documentation of the drives

www.nicsanat.com

021-87700210



SINUMERIK 802C
6FC5 597-3AA20-0BP2 (01.02)

Start-Up

4.1 General

Start-up requirements

- The following is required:
 - User's Guide: "Operation and Programming, SINUMERIK 802C"
 - **PC/PG** (programming device) only for data saving and series start-up
 - **Toolbox** on CD. The CD is either supplied with the control system or can be ordered separately.
Contents: see also p. 1–11
- The mechanical and electrical installation of the equipment must be completed.

Note

Installation notes are to be found in Chapter LEERER MERKER.

- The control system with its components has powered up without errors.

Start-up sequence

The SINUMERIK 802C can be started up as follows:

1. Check whether the ENC has powered up.
2. PLC start-up
3. Technology setting
4. Set general machine data.
5. Set axis/machine-specific machine data.
 - Match encoder with spindle
 - Match setpoint with spindle
6. Dry run for axes and spindle(s)
7. Drive optimization
8. Complete start-up, data saving

4.1.1 Access levels

Protection levels

The SINUMERIK 802C provides a protection level concept for enabling data areas. The protection levels range from 0 to 7 whereby **0** is the highest and **7** the lowest level.

The control system comes with default passwords for protection levels 2 and 3. If necessary these passwords can be changed by the appropriate authorized person.

Table 4-1 Protection level concept

Protection Level	Disabled via	Data Area
0		Siemens, reserved
1		Siemens, reserved
2	Password: EVENING (default)	Machine manufacturer
3	Password: CUSTOMER (default)	Authorized operator, setter
4	No password or user IS from PLC → NCK	Authorized operator, setter
5	User IS from PLC → NCK	
6	User IS from PLC → NCK	
7	User IS from PLC → NCK	

Protection levels 2 ... 3

The protection levels 2 and 3 require a password. The passwords can be changed after activation. For example, if the passwords are no longer known, the control system must be reinitialized (booting in Start-Up Switch position 1). This will reset all passwords to the default settings for this software version.

If the password is deleted, protection level 4 is applicable.

The password remains set until it is reset using the **Delete password** softkey; **POWER ON** will not reset the password.

Protection levels 4 ... 7

Protection level 4 is automatically set when no password is entered. If required, the protection levels 4 ... 7 can be set from the user program via the user interface.

See Section 6.1.1 "Display Machine Data".

Note

How to set the access levels is described in the User's Guide "Operation and Programming".

4.1.2 Structure of machine data (MD) and setting data (SD)

Number and name

Machine data (MD) and setting data (SD) are differed either by numbers or names. Both the number and the name are displayed on the screen.

Parameters:

- Activation
- Protection level
- Unit
- Standard value
- Range of values

Activation

The activation levels are listed according to their priority. Any data changes come into effect after:

- POWER ON (po) switching on/off the SINUMERIK 802S
- NEW_CONF (cf)
 - **Activate MD** softkey on the operator panel
 - **RESET** key on machine control panel (MCP)
 - Modifications at the block limits are possible while the program is running.
- RESET (re) **RESET** key on the machine control panel (MCP) or M2/m30 at the end of the program
- IMMEDIATELY (im) after entering a value

Protection level

To display machine data, protection level 4 (or higher) must be activated.

Start-up or machine data input generally requires protection level 2 or higher (password "EVENING").

Unit

Depending on the MD SCALING_SYSTEM_IS_METRIC, the physical units of the MD are set as follows:

MD10240 = 1	MD10240 = 0
mm	in
mm/min	in/min
m/s ²	in/s ²
m/s ³	in/s ³
mm/rev	in/rev

If no physical units are applicable to the MD, the field contains a "-".

Note

The default setting of the machine data is MD10240 SCALING_SYSTEM IS METRIC = 1 (metric).
With the INCH scaling system MD10240=0, MD203=4 (display unit after the decimal).

Default data

This is the default value for the machine or setting data.

Range of values (minimum and maximum values)

... specifies the input limits. If no range of values is specified, then the input limits are defined by the data type, and the field is marked with "***".

4.1.3 Handling machine data

Handling methods

- Display
- Input via keys and V24 interface
- Making backup copies and reading in/reading out data via the V24 interface

These back-up copies contain

- machine data
- line check sums and
- machine data numbers.

Aborting when loading MD

If incorrect machine data files are read into the control system, an alarm is output.

At the end of reading, an alarm with the number of errors is displayed.

4.1.4 Data saving

Saving data internally

The data in the memory backed up for a limited period can be saved internally in the permanent memory of the control system.

An internal data backup should be carried out if the control system has been switched off for more than 50 hours (at least 10 min/day with controller ON).

It is recommended to carry out internal data saving whenever important data changes have been made.

Note

During the internal data backup, a memory copy of the memory backed up for a limited time is made and stored in the permanent memory. Selective data backup (e.g. only the machine data and not the part programs) is not possible.

Saving data internally:

Use the **ETC key** to extend the menu in the **Diagnosis/Start-up** menu and press the **Save data** softkey.

Loading data from an internal data backup:

Boot the control system using the start-up switch, position 3

If the data in the backed-up memory area are lost, on **POWER ON** the data saved in the permanent memory area are automatically reloaded into the memory.

Note

The note "4062 Data backup copy has been loaded" appears.

Saving data externally

In addition to the internal data backup, the user data of the control system can and must also be saved internally.

External data saving requires a PC/PG (programming device) with V24 interface and the **WinPCIN** tool (included in the tool box).

External data saving should be performed whenever substantial changes in the data have been made, as well as always at the end of start-up.

External data backup variants:

1. The data record is read out completely, creating the **series start-up file**. This is intended for series start-up or to restore the control system status after replacing hardware components or after data loss.
2. Files are read in or read out by areas. The following user data can be selected as individual files:

Data

- Machine data
- Setting data
- Tool data
- R parameters
- Zero offset
- Compensation data (LEC)

Part programs

Standard cycles

4.2 Turning on and booting the control system

Saving data externally:

Use the **Services/Data outp.** menu to transfer the following user data as individual files to an external PC via the V24 interface.

Loading data from an external data backup into the control system:

Press the **Start data inp.** softkey in the **Services** menu.

4.2 Turning on and booting the control system

Approach

- Inspect the system visually for:
 - proper mechanical installation with tight electrical connections
 - supply voltages
 - connections for shielding and grounding.
- Turn on the control system.

Note

Providing memory and start-up switch **S1** are set correctly (see Fig.2-9), the control system boots.

Start-up switch S1 (hardware)

The ENC is provided with a start-up switch to assist start-up of the control system. This switch can be actuated using a screw driver.

Table 4-2 Start-up switch settings

Position	Meaning
0	Normal power-up
1	Power-up with default machine data (user data determined by the software version)
2	System software update
3	Power-up with saved data
4	PLC stop
5	Reserve
6	Assigned
7	Assigned

The switch position comes into effect with next power-up and is displayed on the screen when the control system powers up.

Start-up switch(software)

In addition to the hardware start-up switch, the following functions can also be carried out in the **Diagnosis/Start-up/Start-up switch** menu:

- Normal power-up (Start-up switch position 0)
- Power-up with default machine data (Start-up switch position 1)
- Power-up with saved data (Start-up switch position 3)

These power-up functions have a higher priority than the hardware start-up switch.

Booting the control system

When the control system is turned on for the first time, an initial state of the control system is established automatically. All memory areas are initialized and are loaded with previously stored default data.

The PLC area of retentive bit memories is explicitly erased.

The control system changes to the **JOG/Ref.point approach** mode and the yellow **LED DIAG** flashes (see Fig. 2-9).

This initial state is the precondition for error-free start-up of the control system.

When the control system is already turned on, start-up is also possible in the **Diagnosis** menu (see User Manual).

Normal booting (Start-up switch position 0)

Result	
User data exist, no boot error	Control system changes to JOG/Ref.point approach mode, yellow LED DIAG (see Fig. 4-1) flashes.
Data in user memory faulty	Backed-up user data are loaded from the permanent memory into the user memory (as in start-up switch position 3). If no valid user data are in the permanent memory, the default data are loaded (as in start-up switch position 1). Any deviations from normal booting are displayed on the screen.

Booting with default machine data(Start-up switch position 1)

Result
The user memory area not loaded with default data is erased, and the default machine data are loaded from the permanent memory into the user memory.

Booting with saved data (Start-up switch position 3)

Result
The user data backed-up on the permanent memory are loaded into the user memory.

Contrast control

See User's Guide "Operation and Programming"

4.2.1 Boot messages

Displays on the screen

When the control system is booting, test patterns or boot information are displayed on the screen as progress displays.

After the control system has booted without errors, it changes to the **JOG/Ref.point approach** mode, and the yellow **DIAG** LED (see Fig. 4-1) flashes.

Boot errors

Boot errors are displayed either on the screen or via the LED (see Fig. 4-1 in the following).

The **ERR** flashes, and the **DIAG** LED does not flash.

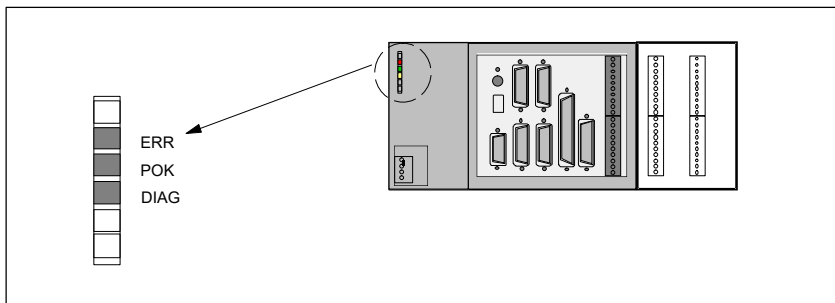

Fig. 4-1 LED

Table 4-3 Boot errors

Error Message	Remedial Action
ERROR EXCEPTION	<ol style="list-style-type: none"> 1. Check the connections of the plugged or connected modules (PLC D/IO modules). 2. Switch off the control system and back on again (POWER ON). 3. Carry out a software update. 4. Replace the hardware components. 5. Inform the hotline if necessary.
ERROR DRAM	
ERROR BOOT	
ERROR NO BOOT2	
ERROR NO SYSTEM	
ERROR LOAD NC NO SYSTEM-LOADER	
ERROR LOAD NC CHECKSUM-ERROR	
ERROR LOAD NC DECOMPRESS-ERROR	
ERROR LOAD NC INTERNAL-ERROR 1	

4.3 Starting up the PLC

General

The PLC is a store-programmable logic controller for simple machines. It has no hardware of its own and is used as a software PLC in the SINUMERIK 802C control system.

The task of the PLC is to control machine-related functional sequences.

The PLC executes the user program cyclically. A PLC cycle is always executed in the same sequence of order.

- Update process image (inputs, outputs, user interface, timers)
- Process communication requests (Operator Panel, PLC 802 Programming Tool)
- Execute user program
- Evaluate alarms
- Output process image (outputs, user interface)

The PLC executes the user program cyclically, starting from the first up to the final operation. Access from user program is only carried out via the process image and not directly to the hardware inputs or outputs. The hardware inputs and outputs are updated by the PLC at the beginning and at the end of program execution. The signals are thus stable over a PLC cycle.

The user program can be created by means of the PLC 802 Programming Tool using the programming language S7-200 in conjunction with ladder diagrams (LAD). A ladder diagram is a graphical programming language to represent electrical circuit diagrams.

This Documentation describes the program structure and the instruction set of the PLC in detail.

4.3.1 Commissioning of the PLC

The SINUMERIK 802C comes to the user with a simulation program included.

The SAMPLE user program is stored in the permanent memory. This sample program and the documentation are included in the SINUMERIK 802SC Toolbox component "PLC802SC Library".

The simulation program is intended for the first function test of the control system after assembling the control.

Internal simulation program

The simulation program is integral part of the 802C system software. The simulation program allows operation of the control system without digital input and output modules. The user program processes all firmly defined keys and the default setting of the axis keyboard (default).

Axes and spindle are switched to simulation mode. No real axis movement is carried out. The Axis/Spindle Disable user signal is set for each axis. For this reason, the movements of the axes and of the spindle are simulated virtually. The user can use this program to test the interrelation of the components Operator Panel / Machine Control Panel / ENC.

Approach

- Set MD20700 to zero.
- Use the **Diagnosis/StartUp switch/PLC** softkey to select Simulation. You can check the current setting via **Diagnosis/Service display/Version/PLC application**.
- Select the desired key and check your setting by pressing the key.

Supported keys

- Mode selection

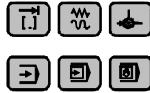

- Axis keys

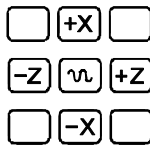

- NC keys



Note

- The **Increment** key is only active in the **JOG** mode. The toggle function can be used to set increments in the range between 1 and 1,000. Check the response by pressing the axis direction keys.
 - **Reference Point** is not supported.
-

Standard user program

The control system comes with the SAMPLE user program for simple turning machines, which is stored in the permanent memory.

4.3.2 Start-up modes of the PLC

The PLC can activate its start-up modes from two places.

Table 4-4 Start-up modes

Start-Up Switch	Operator Panel Start Up Menu	PLC Program Selection	Program Status	Retentive Data (Backed-Up)	MD for the PLC in the User Interface
	<u>NCK start-up *</u>				
Normal power-up Position 0	Normal power-up	User program	Run	Unchanged	Accept active PLC MD
Power-up with default values Position 1	Power-up with default values	User program	Run	Deleted	Standard PLC MD
Power-up with saved data Position 3	Power-up with saved data	User program	Run	Saved data	Saved PLC MD
PLC Stop after POWER ON Position 4		Unchanged	Stop	Unchanged	Accept active PLC MD
	<u>PLC start up **</u>				
	Restart	User program	Run	Unchanged	Accept active PLC MD
	Restart and debug mode	User program	Stop	Unchanged	Accept active PLC MD
	Restart with simulation	Simulation program	Run	Unchanged	Accept active PLC MD
	Overall reset	User program	Run	Deleted	Accept active PLC MD
	Overall reset and debug mode	User program	Stop	Deleted	Accept active PLC MD

* Diagnosis/Start up / Start up switch / NCK softkey

** Diagnosis/Start up / Start up switch / PLC softkey

The start-up switch PLC Stop can be activated either during operation or power-up.

The debug mode (see “Operation and Programming”, Chapter 7) causes the PLC to remain in PLC Stop after the control system has powered up. All power-up modes that have been set either via softkeys or via hardware start-up switches will only come into effect after the next power-up of the control system. The hardware start-up switch “PLC STOP” (position 4) is active immediately. The priority of the power-up modes activated via the softkeys on the operator panel is higher than that of the hardware start-up switches.

Example:

- Hardware start-up switch position 3
- Restart from operator panel

=> Restart is active from next power-up of the control system

The Run mode activates the cyclic mode.

In the Stop mode, the following actions are initiated:

- All hardware outputs are disabled.
- The NC Ready relay is inactive.
- No cyclic operation (active user program is not executed)
- Process image is no longer updated ("frozen")
- Emergency Stop active

The user can also use the PLC 802 Programming Tool to start the Stop or Run modes.

A corrected or new project can only be loaded into the control system in the Stop mode. The user program comes only into effect with next power-up or when the Run mode is active.

4.3.3 PLC alarms

The control system displays a maximum of 8 PLC alarms (system alarms or user alarms).

The PLC manages the alarm information per PLC cycle. It stores or deletes the alarms in the alarm list according to their occurrence. The first alarm in the list is generally the alarm last occurred.

If more than 8 alarms occur, the first seven alarms occurred are displayed, and the last one with the highest cancel priority is displayed.

Alarm response and cancel criterion

Furthermore, the PLC manages the alarm responses. The alarm responses are always active, irrespective of the number of active alarms. Depending on the type of the alarm response, the PLC triggers an appropriate response.

Each alarm requires a cancel criterion to be defined. The PLC uses the SELF-CLEARING criterion as default criterion.

Cancel criteria are:

- POWERONCLEAR: The alarm is canceled by switching off/switching on the control system.
- CANCELCLEAR: The alarm is canceled by pressing the Cancel key or the Reset key (analogously to NCK alarms).
- SELF-CLEARING: The alarm is cleared because the cause resulting in the alarm has been eliminated or does not exist any longer.

Desired alarm responses are defined for each alarm in the PLC. By default, the PLC uses the SHOWALARM response (bit0 – bit5 = 0).

Possible alarm responses are:

- PLC Stop : The user program is no longer executed, the NC Ready relay drops out, and the hardware outputs are disabled (OUTDS).
- EMERGENCY STOP: The PLC provides the EMERGENCY STOP signal to the NCK in the user interface after the user program has been executed.
- Feed disable: The PLC provides the Feed Disable signal to the NCK in the user interface after the user program has been executed.
- Read-in disable: The NCK provides the Read-in Disable signal to the NCK in the user interface after the user program has been executed.
- NC Start inhibited: The PLC provides the NC Start Inhibited signal to the NCK after the user program has been executed.
- SHOWALARM : This alarm has no alarm response (bit0 – bit5 =0).

Priority of cancel conditions

The cancel conditions have the following priority:

- POWER ON CLEAR – system alarms (highest priority)
- CANCEL CLEAR – system alarms
- SELF-CLEARING – system alarms
- POWER-ON CLEAR – user alarms
- CANCEL CLEAR – user alarms
- SELF-CLEARING – user alarm (lowest priority)

System alarms

see Diagnostics Guide

User alarms

The user interface “1600xxxx” provides the user with two sub-ranges for setting a user alarm.

- Sub-range 0: 4 x 8 bits to set user alarms (0 → 1 edge)
 Byte 0 : Bit0 => 1st user alarm “ 700000 ”
 Byte 3 : Bit7 => 32nd user alarm “ 700031 ”
- Sub-range 1: User alarm variables

The respective bit (sub-range 0) with a 0/1 edge change will activate a new user alarm.

Sub-range 1 is intended for additional user information.

Sub-range 2 can be used to analyze the active alarm responses.

Sub-range 1 can only be read or written as a double word. Sub-range 2 can only be read.

You can delete self-clearing alarms by resetting the respective bit in the variable range “1600xxxx” in sub-range 0 (1 → 0 edge).

The remaining user alarms are cleared by the PLC after detecting the respective cancel condition. If the alarm is still present, the alarm occurs again.

User alarm activation

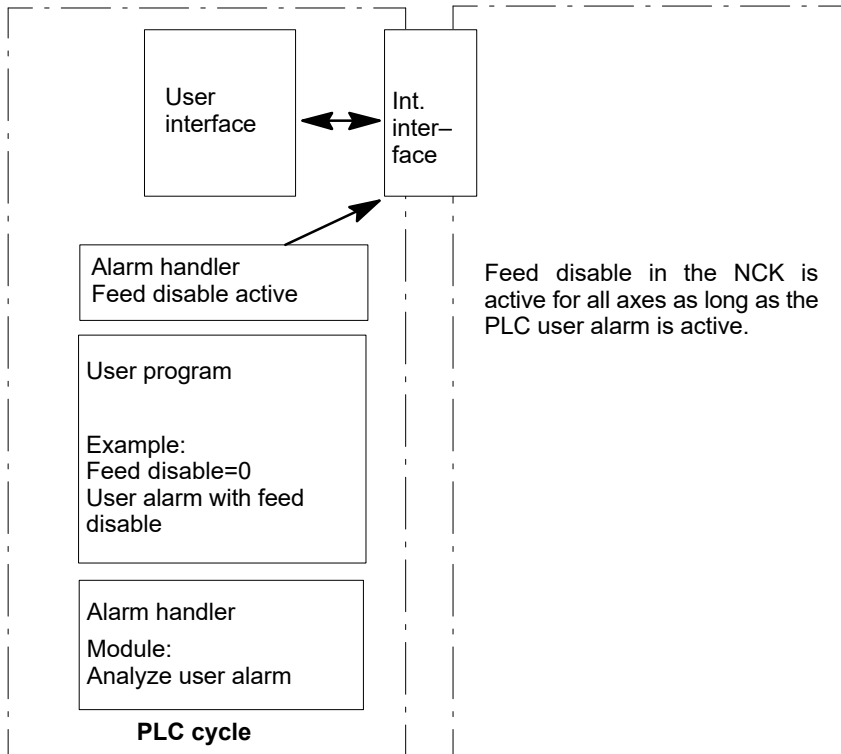

Fig. 4-2 User alarm with Feed Disable alarm response

Configuring user alarms

Each alarm is assigned a configuration byte. The user alarms can be configured by the user in machine data **14516_MN_USER_DATA_PLC_ALARM**.

Default setting MD 14516: 0 => SHOW ALARM/SELF-CLEARING user alarm

Configuration byte structure:

- Bit0 – bit5 : Alarm responses
- Bit6 – bit7 : Cancel criterion

Alarm responses: Bit0 – bit 5 = 0: Showalarm (default)

- Bit0 = 1: NC Start inhibited
- Bit1 = 1: Read-in disable
- Bit2 = 1: Feed disable for all axes
- Bit3 = 1: EMERGENCY STOP
- Bit4 = 1: PLC Stop
- Bit5 = Reserved

Cancel criteria: Bit6 + bit7 = 0: SELF-CLEARING alarm (default)

- Bit6 = 1 : CANCELCLEAR alarm
- Bit7 = 1 : POWERONCLEAR alarm

The following variable types are possible:

- %D ... Integer decimal number
- %I ... Integer decimal number
- %U ... Unsigned decimal number
- %O ... Integer octal number
- %X ... Integer hexadecimal number
- %B ... Binary representation of 32-bit value
- %F... 4 byte floating point number

User alarm text examples

- 700000 " " // Only user alarm number
- 700001 " Hardware limit switch X + axis
- 700002 " %D " // Only variable as an integer decimal number
- 700003 " Alarm number with fixed alarm text and variable %X "
- 700004 " %U Alarm number with variable and fixed alarm text "
- 700005 "Rotation monitoring of axis active : %U"

Operator panel display : 700005 Rotation monitoring of axis active : 1

or 700005 Rotation monitoring of axis active : 3

4.3.4 Machine control panel (MCP) layout

The machine control panel in the standard version has been configured for simple turning machines (2 axes and one spindle).

The user can use the keys 1 – 6 and the associated LEDs (the same applies to keys 1 ... 6) for his own purposes.

The keys 16–24 should be used as axis keys (see sample program SAMPLE). The programmer can assign the axis keys depending on his particular machine type.

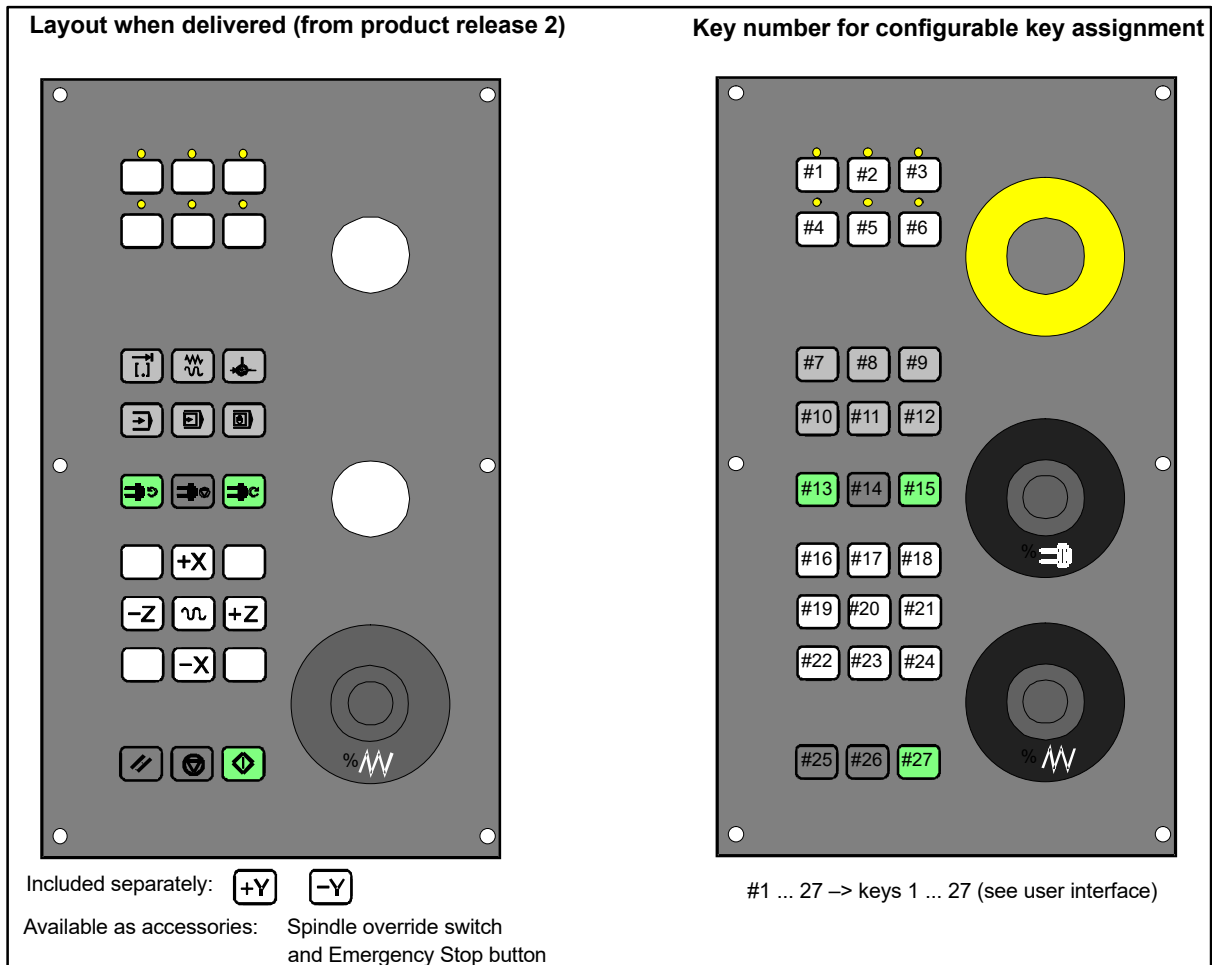

Fig. 4-3 Layout of the machine control panel

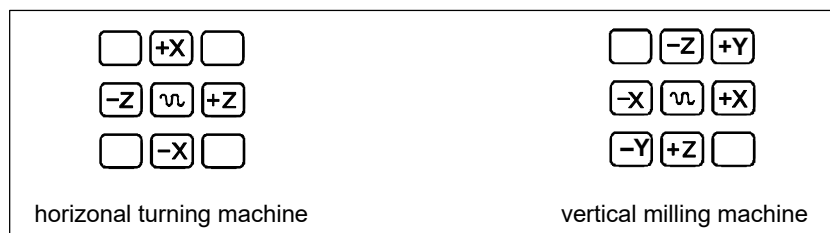

Fig. 4-4 Examples for the assignment of the axis keyboard

4.3.5 PLC programming

The PLC user program is created using the PLC 802 Programming Tool.

The Documentation “S7–200 Automation System, System Manual” describes how this tool is operated for S7–200. The PLC 802 Programming Tool is to be understood as a subset of this Documentation.

4.3 Starting up the PLC

Compared with the S7–200 MicroWin basic system, please note the following:

- The PLC 802 Programming Tool is delivered in the English language version.
- The user program can only be programmed using ladder diagram.
- Only a subset of the S7–200 programming language is supported.
- The compilation of the user program is carried out either offline on a programming device (PG)PC or semi–automatically when downloading into the control system.
- The project can be loaded into the control system (download).
- It is also possible to load the project from the control system (upload).
- Direct data addressing is not possible; therefore, no programming errors will result during the operation.
- The data/process information must be managed by the user in accordance with the particular type.

Example:

Information 1 T value DWord memory size (32–bit)
 Information 2 Override Byte memory size (8–bit)

User data

Byte 0 DWord (Information 1)
 Byte 4 Byte (Information 2)

The user is not allowed to access both of these data at the same time; otherwise, the relevant data access rules must be observed.

- Furthermore, the data direction in the memory model (alignment) and the data type must be observed for all data.

Example:

Flag bit MB0.1,MB3.5
 Flag byte MB0,MB1,MB2
 Flag word MW0,MW2,MW4
MW3, MW5 ... are not permissible
 Flag double–word MD0,MD4,MD8
MD1,MD2,MD3, MD5 ... are not permissible

Table 4-6 PLC data types permitted in the control system

Data Type	Size	Address Alignment	Range for Logic Operations	Range for Arithmetical Operations
BOOL	1 bit	1	0, 1	–
BYTE	1 byte	1	00 ... FF	0 ... +255
WORD	2 bytes	2	0000 ... FFFF	–32 768 ... + 32 767
DWORD (Double Word)	4 bytes	4	0000 0000 ... FFFF FFFF	–2 147 483 648 ... +2 147 483 647
REAL	4 bytes	4	–	$\pm 10^{-37} \dots \pm 10^{38}$

PLC project

In any case, the PLC 802 Programming tool manages one project (logic operations, symbols and comments). The download function is intended to store all important information of a project in a control system.

The control system is able to store max. 4,000 instructions and 1,000 symbols. The required PLC memory is influenced by the following components:

- Number of instructions
- Number and length of the symbol names
- Number and length of the comments

S7-200 ladder diagram

A ladder diagram is a graphical programming language similar to electric circuit diagrams. When creating a program using the ladder diagram form, then you will work with graphical components to create the networks of your logics. To create your program, you can use the following elements:

- Contacts constitute a switch through which the current can flow. Current, however, will only flow through a normally open contact if the contact is closed (logical value 1). Current will flow through a normally closed contact or a negated contact (NOT) if the contact is open (logical value 0).
- Coils constitute a relay or an output which is updated by the signal flow.
- Boxes constitute a function (e.g. a timer, counter or arithmetic operation) which is carried out at the moment when the signal flow reaches the box.

A network consists of the elements mentioned above, forming a closed circuit. The current flows from the left conductor bar (in the ladder diagram symbolized by a vertical line at the left window) through the closed contacts, enabling coils or boxes.

Overview of commands

Table 4-7 Operand identifiers

Operand ID	Description	Range
V	Data	V0.0 to V79999999.7 (see Table 4-8)
T	Timers	T0 to T15
C	Counters	C0 to C31
I	Map of digital inputs	I0.0 to I7.7
Q	Map of digital outputs	Q0.0 to Q7.7
M	Flags	M0.0 to M127.7
SM	Special flags	SM0.0 to SM 0.6 (see Table 4-10)
AC	ACCU	AC0 ... AC3

Table 4-8 Generating the addresses for the V range (see user interface)

Type Code (DB No.)	Range No. (Channel/ Axis No.)	Subrange	Offset	Addressing
00 (00-79)	00 (00-99)	0 (0-9)	000 (000-999)	symbolic (8-digit)

Table 4-9 S802C ranges of operands

Accessed by:	Memory Type	SINUMERIK 802SC	
Bit (Byte.bit)	V	14000000.0–79999999.7	
	I	0.0 – 7.7	
	Q	0.0 – 7.7	
	M	0.0 – 127.7	
	SM	0.0 – 0.6	
	T	0 – 15	
	C	0 – 31	
	L	0.0 – 59.7	
	Byte	VB	14000000–79999999
		IB	0 – 7
QB		0 – 7	
MB		0 – 127	
SMB		0	
LB		0 – 59	
AC		0 – 3	
Word	VW	14000000–79999998	
	IW	0 – 6	
	QW	0 – 6	
	MW	0 – 126	
	T	0 – 15	
	C	0 – 31	
	LW	0 – 58	
	AC	0 – 3	
	Double Word	VD	14000000–79999994
ID		0 – 4	
QD		0 – 4	
MD		0 – 124	
LD		0 – 56	
AC		0 – 3	

Table 4-10 Special Flag SM Bit Definition

SM Bits	Description
SM 0.0	Flags with defined ONE signal
SM 0.1	Initial position: first PLC cycle '1', following cycles '0'
SM 0.2	Buffered data lost – applicable only to the first PLC cycle ('0' data o.k., '1' – data lost)

Table 4-10 , FortsetzungSpecial Flag SM Bit Definition



SM Bits	Description
SM 0.3	POWER ON: first PLC cycle '1', following cycles '0'
SM 0.4	60 s cycle (alternating '0' for 30 s, then '1' for 30 s)
SM 0.5	1 s cycle (alternating '0' for 0.5 s, then '1' for 0.5 s)
SM 0.6	PLC cycle (alternating, one "0" cycle, then one "1" cycle)

4.3.6 Instruction set

A detailed description of the instructions is to be found in the help system of the PLC 802 Programming Tool (Help > Contents and Index, "SIMATIC LAD Instructions") and in the Documentation "S7-200 Automation System, CPU22x System Manual.

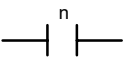
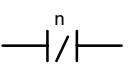
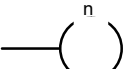
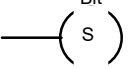
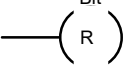
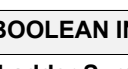
Table 4-11 Instruction set

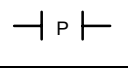
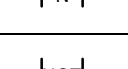
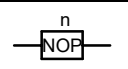

BASIC BOOLEAN INSTRUCTIONS		
Instruction	Ladder Symbol	Valid Operands
Load normal open		n: V, I, Q, M, SM, T, C, L
And n=1 close		n: V, I, Q, M, SM, T, C, L
Or n=0 open		
Load Not normal close		n: V, I, Q, M, SM, T, C, L
And Not n=0 close		
Or Not n=1 open		
Output prior 0, n=0 prior 1, n=1		n: V, I, Q, M, T, C, L
Set (1 Bit) prior 0, not set prior 1 or ↗		S_Bit: V, I, Q, M, T, C, L n=1
Reset (1 Bit) prior 0, no reset prior 1 or ↗		S_Bit: V, I, Q, M, T, C, L n=1

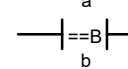
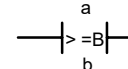
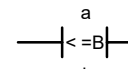
OTHER BOOLEAN INSTRUCTIONS		
Instruction	Ladder Symbol	Valid Operands
Edge Up prior ↗ close (1 PLC cycle)		
Edge Down prior ↘ close (1 PLC cycle)		
Logical Not prior 0, later 1 prior 1, later 0		
No operation		n = 0 ... 255

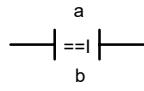
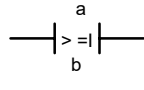
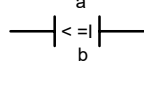
BYTE COMPARES (Unsigned)		
Instruction	Ladder Symbol	Valid Operands
Load Byte = a = b close		a: VB, IB, QB, MB, SMB, AC, Constant, LB b: VB, IB, QB, MB, SMB, AC, Constant, LB
And Byte = a ≠ b open		
Or Byte =		
Load Byte ≥ a ≥ b close		
And Byte ≥ a < b open		
Or Byte ≥		
Load Byte ≤ a ≤ b close		
And Byte ≤ a > b open		
Or Byte ≤		

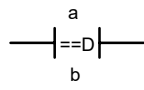
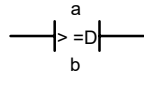
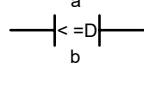
WORD COMPARES (Signed)		
Instruction	Ladder Symbol	Valid Operands
Load Word = a = b close And Word = a ≠ b open Or Word =		a: VW, T, C, IW, QW, MW, AC, Constant, LW b: VW, T, C, IW, QW, MW, AC, Constant, LW
Load Word ≥ a ≥ b close And Word ≥ a < b open Or Word ≥		
Load Word ≤ a ≤ b close And Word ≤ a > b open Or Word ≤		

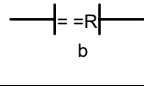
DOUBLE WORD COMPARES (Signed)		
Instruction	Ladder Symbol	Valid Operands
Load DWord = a = b close And DWord = a ≠ b open Or DWord =		a: VD, ID, QD, MD, AC, Constant, LD b: VD, ID, QD, MD, AC, Constant, LD
Load DWord ≥ a ≥ b close And DWord ≥ a < b open Or DWord ≥		
Load DWord ≤ a ≤ b close And DWord ≤ a > b open Or DWord ≤		

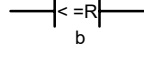
REAL WORD COMPARES (Signed)		
Instruction	Ladder Symbol	Valid Operands
Load RWord = a = b close And RWord = a ≠ b open Or RWord =		a: VD, ID, QD, MD, AC, Constant, LD b: VD, ID, QD, MD, AC, Constant, LD
Load RWord ≥ a ≥ b close And RWord ≥ a < b open Or RWord ≥		
Load RWord ≤ a ≤ b close And RWord ≤ a > b open Or RWord ≤		

TIMER		
Instruction	Ladder Symbol	Valid Operands
Timer Retentive On Delay EN=1, Start EN=0, Stop If $T_{Value} \geq PT$, $T_{bit}=1$		Enable: (IN) S0 Txxx: T0 – T15 Preset: (PT) VW, T, C, IW, QW, MW, AC, Constant 100 ms T0 – T15
Timer On Delay EN=1, Start EN=0, Stop If $T_{Value} \geq PT$, $T_{bit}=1$		Enable: (IN) S0 Txxx: T0 – T15 Preset: (PT) VW, T, C, IW, QW, MW, AC, Constant 100 ms T0 – T15
Timer Of Delay If $T_{Value} < PT$, $T_{bit}=1$		Enable: (IN) S0 Txxx: T0 – T15 Preset: (PT) VW, T, C, IW, QW, MW, AC, Constant 100 ms T0 – T15

COUNTER		
Instruction	Ladder Symbol	Valid Operands
Count Up CU ↗, Value+1 R=1, Reset If $C_{Value} \geq PV$, $C_{bit}=1$		Cnt Up: (CU) S1 Reset: (R) S0 Cxxx: C0 – 31 Preset: (PV) VW, T, C, IW, QW, MW, AC, Constant, LW
Count Up/Down CU ↗, Value+1 CD ↘, Value-1 R=1, Reset If $C_{Value} \geq PV$, $C_{bit}=1$		Cnt Up: (CU) S2 Cnt Dn: (CD) S1 Reset: (R) S0 Cxxx: C0 – 31 Preset: (PV) VW, T, C, IW, QW, MW, AC, Constant, LW
Count Down If $C_{Value} = 0$, $C_{bit}=1$		Cnt Down: (CD) S2 Reset: (R) S0 Cxxx: C0 – 31 Preset: (PV) VW, T, C, IW, QW, MW, AC, Constant, LW

MATH OPERATIONS		
Instruction	Ladder Symbol	Valid Operands
Word Add If EN = 1, Word Subtract $b = a + b$ $b = b - a$		Enable: EN In: VW, T, C, IW, QW, MW, AC, Constant, LW Out: VW, T, C, IW, QW, MW, AC, LW
DWord Add If EN = 1, DWord Subtract $b = a + b$ $b = b - a$		Enable: EN In: VD, ID, QD, MD, AC, Constant, LD Out: VD, ID, QD, MD, AC, LD
Multiply If EN = 1, $b = a \times b$		Enable: EN In: VW, T, C, IW, QW, MW, AC, Constant, LW Out: VD, ID, QD, MD, AC, LD
Divide If EN = 1, $b = b \div a$ Out: 16 bit remainder Out+2: 16 bit quotient		Enable: EN In: VW, T, C, IW, QW, MW, AC, Constant, LW Out: VD, ID, QD, MD, LD
Add If EN = 1, Subtract $b = a + b$ Real Numbers $b = b - a$		Enable: EN In: VD, ID, QD, MD, AC, Constant, LD Out: VD, ID, QD, MD, AC, LD
Multiply If EN = 1, Divide $b = a \times b$ Real Numbers $b = b \div a$		Enable: EN In: VD, ID, QD, MD, AC, Constant, LD Out: VD, ID, QD, MD, AC, LD

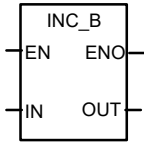
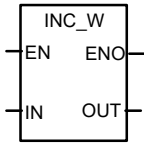
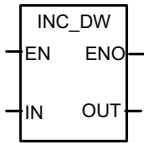
INCREMENT, DECREMENT		
Instruction	Ladder Symbol	Valid Operands
Increment If EN = 1, Decrement $a = a + 1$ Byte $a = a - 1$		Enable: EN In: VB, IB, QB, MB, AC, Constant LB Out: VB, IB, QB, MB, AC, LB
Increment If EN = 1, Decrement $a = a + 1$ Word $a = a - 1$ $a = /a$		Enable: EN In: VW, T, C, IW, QW, MW, AC, Constant, LW Out: VW, T, C, IW, QW, MW, AC, LW
Increment If EN = 1, Decrement. $a = a + 1$ $a = a - 1$		Enable: EN In: VD, ID, QD, MD, AC, Constant, LD Out: VD, ID, QD, MD, AC, LD

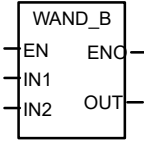
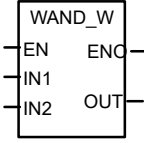
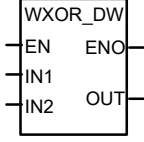
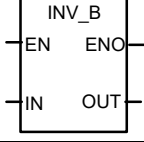
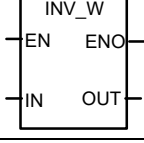
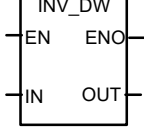
LOGIC OPERATIONS		
Instruction	Ladder Symbol	Valid Operands
Byte AND If EN = 1, Byte OR $b = a \text{ AND } b$ Byte XOR $b = a \text{ OR } b$ $b = a \text{ XOR } b$		Enable: EN In: VB, IB, QB, MB, AC, Constant, LB Out: VB, IB, QB, MB, AC, LB
Word AND If EN = 1, Word OR $b = a \text{ AND } b$ Word XOR $b = a \text{ OR } b$ $b = a \text{ XOR } b$		Enable: EN In: VW, T, C, IW, QW, MW, AC, Constant, LW Out: VW, T, C, IW, QW, MW, AC, LW
DWord AND If EN = 1, DWord OR $b = a \text{ AND } b$ DWord XOR $b = a \text{ OR } b$ $b = a \text{ XOR } b$		Enable: EN In: VD, ID, QD, MD, AC, Constant, LD Out: VD, ID, QD, MD, AC, LD
Invert Byte If EN = 1, $a = /a$		Enable: EN In: VB, IB, QB, MB, AC, Constant, LB Out: VB, IB, QB, MB, AC, LB
Invert Word If EN = 1, $a = /a$		Enable: EN In: VW, T, C, IW, QW, MW, AC, Constant, LW Out: VW, T, C, IW, QW, MW, AC, LW
Invert DWord If EN = 1, $a = /a$		Enable: EN In: VD, ID, QD, MD, AC, Constant, LD Out: VD, ID, QD, MD, AC, LD

SHIFT AND ROTATE OPERATIONS		
Instruction	Ladder Symbol	Valid Operands
Shift Right Shift Left If EN = 1, a = a SR c bits a = a SL c bits		Enable: EN In: VB, IB, QB, MB, AC, Constant, LB Out: VB, IB, QB, MB, AC Count: VB, IB, QB, MB, AC, Constant, LB
Shift Right Shift Left If EN = 1, a = a SR c bits a = a SL c bits		Enable: EN In: VW, T, C, IW, QW, MW, AC, Constant, LW Out: VW, T, C, IW, QW, MW, AC, LW Count: VB, IB, QB, MB, AC, Constant, LB
DWord Shift R DWord Shift L If EN = 1, a = a SR c bits a = a SL c bits		Enable: EN In: VD, ID, QD, MD, AC, Constant, LD Out: VD, ID, QD, MD, AC, LD Count: VB, IB, QB, MB, AC, Constant, LB

CONVERSION OPERATIONS		
Instruction	Ladder Symbol	Valid Operands
Convert Double Word Integer to a Real If EN = 1, convert the double word integer i to a real number o.		Enable: EN In: VD, ID, QD, MD, AC, Constant, LD Out: VD, ID, QD, MD, AC, LD
Convert a Real to a Double Word Integer If EN = 1, convert the real number i to a double word integer o.		Enable: EN In: VD, ID, QD, MD, AC, Constant, LD Out: VD, ID, QD, MD, AC, LD

PROGRAM CONTROL FUNCTIONS		
Instruction	Ladder Symbol	Valid Operands
Jump to Label If EN = 1, go to label n.		Enable: EN Label: WORD: 0-127
Label Label marker for the jump.		Label: WORD: 0-127
Conditional Return from Subroutine If EN = 1, exit the subroutine.		Enable: EN
Conditional End If EN = 1, END terminates the main scan.		Enable: EN

PROGRAM CONTROL FUNCTIONS		
Instruction	Ladder Symbol	Valid Operands
Subroutine If EN \nearrow , go to sub-routine n.		Label: Constant : 0–63

MOVE, FILL AND FIND OPERATIONS		
Instruction	Ladder Symbol	Valid Operands
Move Byte If EN = 1, copy i to o.		Enable: EN In: VB, IB, QB, MB, AC, Constant, LB Out: VB, IB, QB, MB, AC, LB
Move Word If EN = 1, copy i to o.		Enable: EN In: VW, T, C, IW, QW, MW, AC, Constant, LW Out: VW, T, C, IW, QW, MW, AC, LW
Move DWord If EN = 1, copy i to o.		Enable: EN In: VD, ID, QD, MD, AC, Constant, LD Out: VD, ID, QD, MD, AC, LD
Move Real If EN = 1, copy i to o.		Enable: EN In: VD, ID, QD, MD, AC, Constant, LD Out: VD, ID, QD, MD, AC, LD
Swap Bytes If EN = 1, exchange MSB and LSB of w.		Enable: EN In: VW, IW, QW, MW, T, C, AC, LW

4.3.7 Programm organization

Each programmer should divide the user program into several closed program sections (sub-routines). The S7–200 programming language allows the user to create structured user programs. There are two program types – main programs and subroutines. Eight program levels are possible.

A PLC cycle can be a multiple of the control–internal interpolation cycle (IPO cycle). The machine manufacturer must set the PLC cycle according to his/her own requirements (see machine data “PLC_IPO_TIME_RATIO”). The ratio IPO/ PLC of 1:1 is the fastest possible cyclic processing.

Example: The programmer programs a sequence control in the main program using his own defined cycle counter. The sequence control defines all cyclic signals in the subroutine (UP0); UP1/UP2 is called every two cycles, and UP 3 controls all signals in steps of three cycles.

4.3.8 Data organization

The data can be divided into three areas:

- non-retentive data
- retentive data
- machine data for the PLC (All these machine data are active after POWER ON.)

Most data, such as process map, timers and counters, are non-retentive data and deleted with each power-up.

The user has a certain area available for the retentive data (data range 14000000 –140000xx). All data that are wished to remain their validity even after POWER ON can be stored in this area.

The user can use the PLC MD (see user interface) to load his program with default data or to parameterize various program sections.

4.3.9 Interface to the control system

This interface can be selected on the operator panel using the softkeys **Diagnosis \ Start-up \ STEP7 connect**.

The V24 interface remains active even after restart or normal power-up. The connection (STEP7 connect active) to the control system can be checked in the PLC 802 Programming Tool menu "PLC/Information". If the interface is active, e.g. the active PLC mode (Run/Stop) is displayed in this window.

4.3.10 Testing and monitoring the user program

The user program can be analyzed or checked for errors using the following methods:

- PLC Status menu (PCU)
- Status list menu (PCU)
- PLC 802 Programming Tool (see Help menu > Contents and Index, "Debugging" or documentation "S7-200 Automation System", Section "Testing and Monitoring Your Program")

4.4 PLC applications “Download/Upload/Copy/Compare”

The user can save or copy PLC applications in the control system or overwrite them by another PLC project.

This is possible using the

- Programming Tool 802
- WinPCIN (binary file)

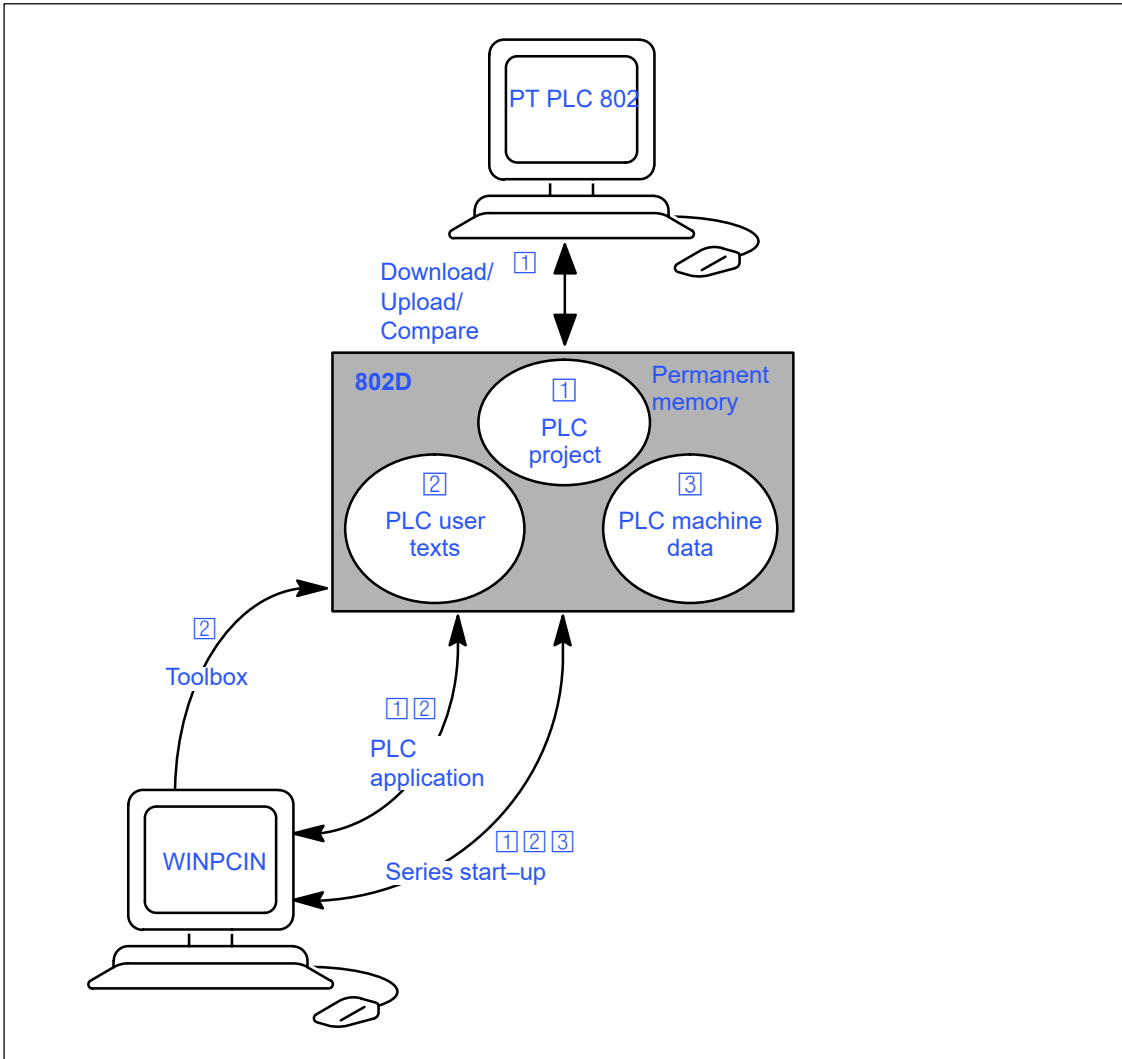

Fig. 4-5 PLC applications in the control system

Download

This function is used to write the transferred data to the permanent memory (load memory) of the control system.

- Download the PLC project using the PLC 802 Programming Tool (Step 7 connect on)
- Series start-up using the WinPCIN tool (PLC MD, PLC project and user alarm texts) Data In

The loaded PLC user program is transferred from the permanent memory to the user memory when the control is booted next time; it will be active from this moment.

Upload

The PLC applications can be saved using the PLC 802 Programming Tool or the tool PCIN.

- Upload PLC project using the PLC 802 Programming Tool (Step 7 connect on)
Read out the project from the control system to reconstruct the current project in the PLC 802 Programming Tool.
- Series start-up "Start-up Data" using the tool PCIN (PLC MD, PLC Project and user alarm texts) Data Out
- Read out PLC applications using the Tool PCIN (PLC Project information and user alarm texts) Data Out

Compare

The project in the PLC 802 Programming Tool is compared with the project contained in the permanent memory (load memory) of the CNC.

Versions display

Calling via the softkey **Diagnosis / Service Display / Version**

- **Project**
The transmitted project including user program, which is active in the PLC after the control system has powered up.

The programmer can use the first comment line in the program title of the PLC 802 Programming Tool for his own additional information in the version display (see "View Properties").

4.5 User Interface

This interface includes all signals between NCK/PLC and HMI/PLC. In addition, the PLC decodes the auxiliary function commands for straightforward further processing in the user program.

4.6 Technology Setting

Overview

The SINUMERIK 802C is supplied with the default machine data as a control system for turning machines (2 axes, 1 spindle). If you wish to set another technology (e.g. milling), the relevant machine data file must be loaded from the tool box into the control system.

The file with the technology machine data must be loaded after the control system has booted successfully, but prior to commissioning.

Sequence of operations

To change the technology setting, proceed as follows:

- Make a V24 link between PG/PC and the control system.
- Turn on the control system and wait until it has booted without errors.
- Press the **Start data inp.** softkey in the Services menu (use the V24 default interface settings).
- Select the technology machine data file techmill.ini (included in the toolbox) required for milling and transfer it to the PG/PC using WinPCIN.
- After the file has been transferred correctly, carry out POWER ON.
- The SINUMERIK 802S is now preset to the desired technology.

Example: techmill. ini

Default: 3 axes (X, Y and Z), 1 spindle, no transversal axis, G17 etc.

If you wish to reconfigure a SINUMERIK 802S control system to turning, carry out POWER ON with the default machine data (start-up switch position 1).

Note

All memory areas are initialized or loaded with stored default values (machine data).

The basic configuration of the SINUMERIK 802C must be carried out during the commissioning prior to the general configuration (MD input).

This need not to be done when series start-up is carried out. The configured machine data are contained in the series start-up file.

4.7 Commissioning

Initializing the control system

- Turn on the control system.
- The SINUMERIK 802C will load the standard machine data automatically.

4.7.1 Entering the general machine data

Overview

To make your work easier, the most important machine data of the individual subranges are listed. If more detailed information is required, the user is referred to the relevant chapters/ sections of this manual. The machine data and interface signals are described in detail in the descriptions of functions to which reference is made in the relevant lists.

Note

The general machine data are selected such (default values) that only a few machine data parameters have to be modified.

Entering the machine data (MD)

Before the machine data can be entered, the password for protection level 2 or 3 must be entered.

The following machine data ranges must be selected and modified (if necessary) using the appropriate softkeys:

- General machine data
- Axis machine data
- Other machine data
- Display machine data

Once entered, these data are immediately written to the data memory.

The machine data are activated depending on the Activation setting of the appropriate machine data, Section 4.1.2.

Note

Since these data are only stored in the memory backed up for a limited period of time, a data backup is necessary (see Section 4.1.4).

Machine data

The following machine data list contains all general and other machine data and setting data, which can be changed if necessary.

Number	Description	Default Value
10074	Division ratio of the PLC task factor for main run	2
11100	Number of auxiliary function groups	1
11200	Standard machine data loaded on next Power On	OH
11210	MD backup of changed MD only	0FH
11310	Threshold for direction change of handwheel	2
11320	Handwheel pulses per detent position (handwheel number): 0...1	1
20210	Maximum angle for compensation blocks with TRC	100
20700	NC-Start disable without reference point	1
21000	Circle end point monitoring constant	0.01
22000	Auxiliary function group (aux. fct. no. in channel): 0...49	1
22010	Auxiliary function type (aux. fct. no. in channel): 0...49	""
22030	Auxiliary function value (aux. fct. no. in channel): 0...49	0
22550	New tool compensation for M function	0

Setting data

Number	Explanation	Default-Value
41110	Jog feedrate	0
41200	Spindle speed	0
42000	Start angle	0
42100	Dry run feedrate	5000

4.7.2 Starting up the axes

Overview

The SINUMERIK 802C has up to three stepper motor feedrate axes (X, Y and Z). The stepper motor drive signals are output at connector **X7** for the:

- X axis at pins 1–3 (PULS1, DIR1 and EN1)
- Y axis at pins 4–6 (PULS2, DIR2 and EN2) and for the
- Z axis at pins 7–9 (PULS3, DIR3 and EN3).

Simulation/stepper motor drive

Setpoint output and pulse feedback can be switched between simulation and drive operation using the axis MD **30130_CRTLOUT_TYPE** and **30240_ENC_TYPE**.

Table 4-12

MD	Simulation	Normal Operation
30130	Value = 0 To test the axis, the actual value is fed back internally as an actual value. No setpoint output at connector X7 .	Value = 2 The setpoint signals for stepper motor operation are output at connector X7 . Real axis traversal is possible using a stepper motor.
30240	Value = 0	Value = 3 Internal pulse feedback from setpoint output to actual value input "ON"

Machine data for axes and spindle

Number	Explanation	Default Value
30130	Output type of setpoint (setpoint branch):	0
30200	Number of encoders	1
30240	Type of actual value acquisition (actual position value) (encoder no.) 0: Simulation 2: Square-wave generator, standard encoder (pulse multiplication)	0
30350	Output of axis signals with simulation axes	0
31020	Encoder markings per revolution (encoder no.)	2048
31030	Pitch of leadscrew	10
31040	Encoder mounted directly to the machine (encoder no:)	0
31050	Denominator load gearbox (control parameter no.): 0...5	1

Number	Explanation	Default Value
31060	Numerator load gearbox (control parameter set no.): 0...5	1
31070	Denominator resolver gearbox (encoder no.)	1
31080	Numerator resolver gearbox (encoder no.)	1
32100	Traversing direction (not control direction)	1
32110	Sign actual value (control direction) (encoder no.)	1
32200	Servo gain factor (control parameter set no.): 0...5	1
32250	Rated output voltage	80
32260	Rated motor speed (setpoint branch): 0	3000
32700	Interpolatory compensation (encoder no.): 0,1	0
33050	Traversing distance for lubrication from PLC	100 000 000
35010	Gear change possible. Spindle has several gear steps	0
35040	Own spindle reset	0
35100	Maximum spindle speed	10000
35110	Maximum speed for gear change (gear stage no.): 0..5	500,...
35120	Minimum speed for gear change (gear stage no.): 0..5	50,...
35130	Maximum speed of gear stage (gear stage no.): 0...5	500,...
35140	Minimum speed of gearsetp (gear stage no.): 0...5	5,...
35150	Spindle speed tolerance	0.1
35160	Spindle speed limitation from PLC	1000
35220	Speed for reduced acceleration	1.0
35230	Reduced acceleration	0.0
35300	Position control switch-on speed	500
35350	Direction of rotation when positioning	3
35400	Reciprocation speed	500
35410	Acceleration during reciprocating	16
35430	Starting direction during reciprocation	0
35440	Reciprocation time for M3 direction	1
35450	Reciprocation time for M4 direction	0,5
35510	Feedrate enable for spindle stopped	0
36000 (only SPOS)	Exact positioning coarse	0.04
36010 (only SPOS)	Exact positioning fine	0.01
36020 (only SPOS)	Delay exact positioning fine	1

Number	Explanation	Default Value
36030 (only SPOS)	Zero-speed tolerance	0.2
36040 (only SPOS)	Delay zero-speed monitoring	0.4
36050 (only SPOS)	Clamping tolerance	0.5
36060 (only SPOS)	Maximum velocity/speed "axis/spindle stopped"	5 (axis); 0.0138 (spindle)
36200	Threshold value for velocity monitoring (control parameter set no.): 0...5	11500 (axis); 31,94 (spindle)
36300	Encoder limit frequency	300000
36302	Encoder limit frequency at which encoder is switched on again. (Hysteresis)	99.9
36310	Zero mark monitoring (encoder no.): 0,1 0: Zero mark monitoring off, encoder HW monitoring on 1-99, >100: Number of recognized zero mark errors during monitoring 100: Zero mark monitoring off, encoder HW monitoring off	0
36400	Contour Tol	1
36610	Duration of the deceleration ramp for error states	0.05
36620	Cutout delay servo enable	0.1
36700	Automatic drift compensation	0
36710	Drift limit value for automatic drift compensation	1
36720	Drift basic value	0

Matching encoder to axis/spindle

Machine data for encoder adjustment

Number	Description	Spindle	
31040	Encoder mounted directly to the machine (encoder no.)	0	1
31020	Encoder markings per revolution (encoder no.)	Incr. /rev.	Incr. /rev.
31080	Numerator resolver gearbox (encoder no.)	Motor revs	Load rev.
31070	Denominator resolver gearbox (encoder no.)	Enc. revs	Enc. revs
31060	Numerator load gearbox (control parameter set no.): 0...5	Motor revs	Motor revs
31050	Denominator load gearbox (control parameter no.): 0...5	Load revs	Load revs

Example 1 for encoder matching:

Axis with rotary encoder (500 pulses) mounted directly on the motor. The internal multiplication factor is 4. The internal computational resolution amounts to 1,000 increments per degree.

	360 degrees	MD31080	1
Inter-	MD	M	0
nal	310	D	0
reso-	20	3	0
lution	4	1	
=		0	
		7	
		0	

	$360 \cdot 1 \cdot 1000$	=
Inter-	5	1
nal	0	8
reso-	0	0
lution	.	
=	4	
	.	
	1	

One encoder increment corresponds to 180 internal increments. One encoder increment corresponds to 0.18 degrees (minimum positioning step).

Example 2 for encoder matching:

Spindle with rotary encoder on motor (2,048 pulses), internal multiplication = 4, 2 speed stages exist:

Gear stage 1: Motor/spindle = 2.5/1

Gear stage 2: Motor/spindle = 1/1

Gear stage 1

$$\text{Internal resolution} = \frac{360 \text{ degrees}}{\text{MD} \cdot \text{MD31080} \cdot \text{MD31050}} \cdot 1$$

MD	M	M	1 , 0 0 0 i n c r/ d e g
310	D	D	
20	3	3	
4	1	1	
	0	0	
	7	6	
	0	0	

$$\text{Internal resolution} = \frac{360 \text{ degrees}}{4 \cdot 1 \cdot 1} = 1,0000 \text{ pulses}$$

One encoder increment corresponds to 43.945 internal increments. One encoder increment corresponds to 0.043945 degrees (minimum positioning step).

Machine data default settings for analog motor axes

The machine data list below contains the default machine data with their recommended settings with the analog motor axes connected.

After they have been set, the axis are ready to be traversed, as far as the machine data are concerned, and only fine settings have to be done.

Number	Description	Default Value	Setting or Remark
30130	Output type of setpoint (setpoint branch): 0	0	1
30240	Type of actual value acquisition (actual position value) (encoder no.) 0: Simulation 2: Encoder external	0	2
31020	Encoder markings per revolution (encoder no.)	2048	Steps per encoder revolution
31030	Pitch of leadscrew	10	Leadscrew pitch
31050	Denominator load gearbox (control parameter no.): 0...5	1	Load gear transmission ratios

Number	Description	Default Value	Setting or Remark
31060	Nominator load gearbox (control parameter no.) 0...5	1	Load gear transmission ratios (MD31080:MD31050)
31070	Denominator resolver gearbox (control parameter no.): 0...5	1	Load gear transmission ratios
31080	Nominator resolver gearbox (control parameter no.): 0...5	1	Load gear transmission ratios (MD31080:MD31050)
32000	Maximum axis velocity	10000	30,000 (max. axis velocity)
32100	Traversing direction (not control direction)	0	Reversal of direction of movement
32110	Sign actual value (control direction) (encoder no.)	0	Measuring system reversal
32200	Servo gain factor (control parameter set no.): 0...5	1,0	1.0 (position controller gain)
32250	Rated output voltage	80%	The speed defined in MD32260 is reached at the setpoint of 8 V
32260	Rated motor speed (setpoint branch): 0	3000	Motor speed
34070	Reference point positioning velocity	300	Positioning velocity when referencing
34200	Type of position measuring system 1: Zero pulse (on encoder track)	1	Zero pulse
36200	Threshold value for velocity monitoring (control parameter set no.): 0...5	11500	Threshold monitoring for velocity monitoring in the axis
		31,94	Threshold value for speed monitoring in the spindle

To solve monitoring problems, the following machine data must be set.

Number	Description	Default Value	Setting or Remark
36000	Exact positioning coarse	0.04	Exact stop coarse
36010	Exact positioning fine	0.01	Exact stop fine
36020	Delay exact positioning fine	1.0	Positioning delay time
36060	Maximum velocity/speed "axis/spindle stopped"	5.0	Threshold velocity for "Axis at standstill"
		0.013889	Threshold velocity for "Spindle at standstill"

Parameterization example

Encoder:	2500 [10,000 pulses per motor revolution]
Load gear:	1:1
Leadscrew pitch:	10 mm
Motor speed:	1,200 rpm
MD 30130	=1
MD 30240	=2
MD 31020	=2500
MD 32250	=80%
MD 32260	=1,200 rpm
MD 32000	=12,000 mm/min

The hardware of the drive must be set such that it will reach exactly 1,200 rpm at 8 V.

Servo gain

The servo gain default setting is $K_v=1$ (corresponds to 1mm following error at a velocity of 1m/min).

The servo gain can or has to be adapted according to the particular mechanical conditions. Too high gain will result in vibrations, too low gain in a too high following error. It is imperative that the drive observes the set speed characteristic (MD32250, MD32260). In addition, the continuous characteristic of the speed when passing zero is also imperative.

Service display of the axis behavior

Servo Trace

To provide axis service, the **Servo Trace** function is integrated in the Diagnosis menu, which can be used for graphical representation of the axis setpoint speed.

The Trace function is selected in the **Diagnosis/Service display/Servo Trace** operating area (cf. User Manual "Operation..").

Dynamic adaptation for thread G331/G332

Function

The dynamic response of spindle and involved axis for the function G331/G332– thread interpolation – can be adapted to the "slower" control loop. Usually, this concerns the Z axis, which is adapted to the more inert response of the spindle.

If an exact adjustment is carried out, it is possible to sacrifice of a compensating chuck for tapping. At least, higher spindle speeds/smaller compensation paths can be achieved.

Activation

The values for the adaptation are entered in MD 32910 DYN_MATCH_TIME [n], usually for the axis. The adaptation is only possible if MD 32900 DYN_MATCH_ENABLE =1 has been set for the axis/spindle.

With active function G331/G332, parameter block n (0...5) of the axis of MD 32910 becomes automatically active, which acts corresponding to the gear stage for the spindle. The gear stage is dependent on the spindle speed with M40 or is directly set by M41...M45 (see also Section 4.5.3 Start-up of the spindle).

Number	Explanation	Default Value
32900	Dynamic response adaptation	0
32910	Time constant of dynamic adaption (control parameter set no): 0...5	0.0

Determination of value

The dynamic value of the spindle is stored for each individual stage in MD 32200 POSCTRL_GAIN[n] as closed-loop gain. An adaptation of the axis to these values must be made in MD 32910 DYN_MATCH_TIME [n] in accordance with the following instruction:

$$MD\ 32910\ DYN_MATCH_TIME\ [n] = \frac{1}{K_v[n]_{spindle}} - \frac{1}{K_v[n]_{axis}}$$

The entry to be made in MD 32910 requires the time unit s. The values of MD 32200 POSCTRL_GAIN[n] for spindle and axis must be converted accordingly:

$$K_v[n]_{spindle} = POSCTRL_GAIN[n]_{spindle} \frac{1000}{60}$$

$$K_v[n]_{axis} = POSCTRL_GAIN[n]_{axis} \frac{1000}{60}$$

When using further gear stages with G331/G332, the adaptation must also be carried out in these parameter blocks.

Example for adaptation of the dynamic response of the Z axis/spindle:

1st gear stage → parameter block[1],
 for spindle–K_v, MD 32200 POSCTRL_GAIN[1] = 0.5 is entered,
 for axis Z–K_v, MD 32200 POSCTRL_GAIN[1] = 2.5 is entered.,

The searched entry for the Z axis in

$$\begin{aligned} \text{MD 32910 DYN_MATCH_TIME [1]} &= \frac{1}{K_{v[1]\text{spindle}}} - \frac{1}{K_{v[1]z}} \\ &= \left(\frac{1}{0.5} - \frac{1}{2.5} \right) * \frac{60}{1000} \end{aligned}$$

$$\text{MD 32910 DYN_MATCH_TIME [1]} = \underline{0.0960} \text{ s}$$

If necessary, for fine adaptation, in practice a more exact value must be determined.

When traversing axis (e.g. Z axis) and spindle, the exact value for POSCTRL_GAIN is displayed on the service display.

MD 32900 DYN_MATCH_ENABLE must be set to = 1.

Example: service display for Z axis with POSCTRL_GAIN : 2.437 in 1,000/min

Exact calculation:

$$\text{MD 32910 DYN_MATCH_TIME [1]} = \left(\frac{1}{0.5} - \frac{1}{2.437} \right) * \frac{60}{1000} = \underline{0.0954} \text{ s}$$

In practice, this value can be optimized. To this aim, the thread is first tested with compensating chuck and the calculated values. Then the values should be modified sensitively such that the difference path in the compensating chuck approximates to zero.

Now, the POSCTRL_GAIN values displayed on the service display for axis and spindle should be identical.

Note

If MD 32900 DYN_MATCH_ENABLE has been set to “1” for the drilling axis, it should also be set to “1” for all interpolating axes. This increases the traversing accuracy along the contour. However, the entries for these axes in MD 32910 DYN_MATCH_TIME [n] must be left at the value “0”.

Backlash compensation**Overview**

The falsification of axis travel due to mechanical backlash can be compensated (cf. Technical Manual “Description of Functions”).

Funktion

The axis-specific actual value is corrected by the backlash compensation value (MD32450 BACKLASH) with each change of the traversing direction.

Activation

The backlash compensation is active in all operating modes only after referencing.

Leadscrew error compensation (LEC)**Overview**

The compensation values are determined by means of the measured error curve and entered in the control system using special system variables during start-up. The compensation tables (cf. Technical Manual "Description of Functions") must be created in the form of NC programs.

Function

The leadscrew error compensation (LEC) changes the axis-specific actual position by the associated compensation value.

If the compensation values are too high, an alarm message can be output (e.g. contour monitoring, speed setpoint limitation).

Activation

The LEC is only activated in all operating modes if the following requirements are met:

- The number of compensation intermediate points must be defined. They are only active after Power ON (MD: MM_ENC_MAX_POINTS).

**Caution**

Changing the MD: MM_CEC_MAX_POINTS[t] or MM_ENC_COMP_MAX_POINTS automatically reorganizes the NC user memory when the control system is booting. All user data stored in the user memory (e.g. drive and MMC machine data, tool offsets, part programs, compensation tables etc.) are deleted.

- Enter the compensation value for the intermediate point N in the compensation value table (ENC_COMP_[0,N,Axi]).
- Select the distance between the individual intermediate points (ENC_COMP_STEP [0,Axi]).
- Select the start position (ENC_COMP_MIN [0,Axi]).
- Define the end position (ENC_COMP_MAX [0,Axi]).
- In the NC, set MD: ENC_COMP_ENABLE(0)=0. This is the only way to load the compensation table.
- The compensation values for the machine axes are entered into the NC memory by means of a part program (see also example in the Manual "Description of Functions")

- Approach the reference points in the axes. Then start the NC program with the leadscrew error compensation table. The reference points must then be approached once more to set the LEC active. The LEC function is activated by setting the MD: ENC_COMP_ENABLE(0)=1 for each machine axis.
 - Another possibility to create the LEC compensation table is by reading out the LEC file from the NC via the V24 interface.

MD: MM_ENC_MAX_POINTS must be set depending on the number of axes to be compensated. Select Service using the softkey, put the cursor to Data, and press the **Show** softkey. Then select “Leadscrew Error” using the cursor and press the **Data Out** softkey.

Enter compensation values, intermediate point distance, start and end position in the received file _N_COMPLETE_EEC by means of the editor (e.g. in the PCIN/OUT program). Then re-read the edited file into the control system. Approach the reference point in the axes and set MD: ENC_COMP_ENABLE(0)=1. The LEC is thus activated.

4.7.3 Starting up the spindle

Overview

With the SINUMERIK 802C, the spindle is a subfunction of the entire axis functionality. The machine data of the spindle are therefore to be found under the axis machine data (from MD35000). For this reason, data have to be entered for the spindle, too; these data are described for axis start-up.

Note

With SINUMERIK 802C, the 4th machine axis (SP) is fixed for the spindle.

The spindle settings for the 4th machine axis are contained in the default machine data.

The spindle setpoint (± 10 V analog voltage signal) is output to **X7**. The spindle measuring system must be connected to **X6**.

Spindle modes

The following modes are possible for the spindle:

- Control mode (M3, M4, M5)
- Oscillating mode (to assist gearbox change)
- Positioning mode (SPOS)

MD for spindle

see MD for axis and spindle

SD for spindle

Number	Description	Default Value
43210	Progr. spindle speed limitation G25	0
43220	Progr. spindle speed limitation G26	1000
43230	Spindle speed limitation with G96	100

Spindle MD parameterization

Spindle machine data are entered depending on the gear stages. Each gear stage is assigned a parameter record.

The set of parameters corresponding to the current gear stage is selected.

Example: 1st gear stage → set of parameters [1]

Note

The field containing the parameter "0" is **not** used for the spindle machine data..

Machine data for setpoint and actual values**Setpoints:**

MD 30130 CTRLOUT_TYPE [AX4] = 1

Actual values:

MD 30200 NUM_ENC[AX4] = 0 ;Spindle without encoder

MD 30200 NUM_ENC[AX4] = 1 ;Spindle with encoder

MD 30240 ENC_TYPE[AX4] = 2

Interface signals of the spindle

	Interface signals
	"Speed change" 39032000 Bit 3
	"Actual gear stage" 38032000 bits 0 to 2
	"No speed monitoring on gear change" 38032000 bit 6
	"Speed is changed" 38032000 Bit 3
	"Set gear stage" 39032000 bits 0 to 2
	"Positioning mode" 39032002 bit 5
	"Oscillating through PLC" 38032002 bit 4
	"Oscillating mode" 39032002 bit 6
	"Control mode" 39032002 bit 7

	Interface signals
	“Traversing minus” 39030004 bit 6
	“Traversing plus” 39030004 bit 7

Reciprocation mode for gear change

The reciprocation mode of the spindle is intended to facilitate the gear change. For reciprocation mode, the following axis MD and interface signals are relevant:

Number	Description
Machine data	
35400	Reciprocation speed
35410	Acceleration when reciprocating
35430	Start direction in reciprocation
35440	Reciprocation time for M3 direction
35450	Reciprocation time for M4 direction
Interface signals	
	“Change gear” 39032000 bit 3
	“Reciprocation speed” 38032002 bit 5
	“Reciprocating by PLC” 38032002 bit 4
	“Set direction of rotation CCW” 38032002 bit 7

4.7.4 Completing the Start-Up

After start-up of the control system by the machine manufacturer, the following should be observed prior to delivery to the final customer:

1. Change the default password for access level 2 from “EVENING” to your own password.

If the machine manufacturer uses the password “EVENING” for access level 2 during the start-up work, the password must be changed.

- Press the softkey **Change passw.**
- Enter the new password and press OK to confirm.
- Note the password in the Manufacturer Documentation.

4.7 Commissioning

2. Reset the access level.

To save the data which have been set during the start-up, an internal data saving is required. To this aim, set access level 7 (final customer); otherwise, access level 2 will also be saved.

- Press the softkey **Delete passw.**
- The access level will be reset.

3. Carry out internal data saving.

- Press the softkey **Save data.**

4.7.5 Cycle start-up

Sequence of operations

When loading cycles into the control system, adhere to the following sequence of operations:

1. Save tool offset data and zero offsets either on the FLASH or on the PG (programming device).
These data can be selected in the **Services** menu by pressing the **Data outp./data...** softkey.
2. Load all files of the selected technology path from the toolbox diskette into the control system via the V24 interface.
3. Carry out POWER ON.
4. Reload the recovered data.

4.8 Series machine start-up

Functionality

The objective of series machine start-up is:

- after commissioning, in order to bring another control system connected to the same machine type with minimum effort to the condition as after commissioning;
- or
- under service conditions (after replacing hardware components), to bring a new control system to the initial state with minimum effort.

Precondition

To carry out commissioning, a PC/PG provided with a V24 interface for data transfer from/to the control system is necessary.

In the PC/PG, the **PCIN** tool must be used.

Sequence of operations

1. Create the series machine start-up file (transfer from the control system to the PC/PG).:
 - Make a V24 cable connection between the PC/PG (COM port) and the SINUMERIK 802S (X8).
 - Make the following settings in the WinPCIN tool:
 - Binary format
 - Receive data
 - Select the path where you want to save your data
 - SaveThe PC/PG will set itself to “Receive” and will wait for data from the control system.
 - Enter the password for protection level 2 in the control system.
 - Call the **Services/RS232 setting** menu.
 - Select the **Start-up data** line from the **Services** menu and press **Start data outp.** to output the series machine start-up file.
2. Reading in the series machine start-up file into the SINUMERIK 802S:
 - Enter the V24 interface settings as described under 1).
 - Press the **Data In Start** button in the **Service** menu. The control system is thus ready to receive data.
 - Use the PCIN tool in the PC/PG to select the series start-up file from the **DATA_OUT** menu and start data transfer.
 - The control system is brought to “RESET with rebooting” three times during and at the end of data transfer. On completion of error-free data transfer, the control system is completely configured and ready to operate.

Series machine start-up file

The series machine start-up file contains:

- machine data
- R parameters
- display and alarm text files
- display machine data
- PLC user program
- main programs
- subroutines
- cycles

Software Update

5.1 Updating the system software using a PC/PG

General

The following reasons may require a system software update:

- You wish to install new system software (new software version).
- After hardware replacement, if software versions other than the supplied are to be loaded.

Note

In addition to the update procedure description below, the update diskette also contains a description of the update procedure in the readme.txt file.

Preconditions

To change the system software of the SINUMERIK 802S, you will need the following:

- Update software (2 diskettes)
- A PG/PC with V24 interface (COM1 or COM2) and an appropriate cable.

Update procedure

As far as not yet done, carry out external data saving before you update your updating system software (see Section 4.1.4 "Data Saving").

1. Turn the hardware start-up switch to position "2" (software update on permanent memory).
2. Start the update file on your PC/PG by calling UPD_802.BAT on your diskette.

The installation is menu-assisted.

3. After the software has been prepared in the PC/PG completely, the message "Transfer the selected ..." appears on the display.
4. **Power On** ---> control system changes to the update condition.
Various patterns appear on the screen.
5. After the patterns on the display of the SINUMERIK 802S have disappeared, start the transfer on the PC/PG.

5.2 Updating the system software incl. user data without using a PC/PG

The progress and the end of the update (and errors if any) are displayed on the PG/PC.

6. At the end of the update --> switch off the control system.
7. Turn the start-up switch to position "1" ---> switch on the control system
8. Booting with default values
9. Prior to next POWER ON ---> start-up switch to 0 position.

Note

Reload the externally saved user standard data via V24.

5.2 Updating the system software incl. user data without using a PC/PG

General

It is possible to transfer the entire contents of the memory of the control system including user data from one control system directly to another control system.

This can be necessary after updating the system software of a CNC and subsequent reloading the recovered user data (series start-up file) into this control system in order to bring further control systems to the same condition.

This reduces the time needed for the transfer.

Precondition

Cable connection from master control system (source control) to slave control (control system to be updated) via V24 interface.

Update sequence

1. Turn the hardware start-up switch of both control systems to position "2" (software update on permanent memory).
2. Carry out **POWER ON** for slave control system —> control system changes to the update condition.
Various patterns appear on the screen.
3. After the patterns on the screen have disappeared, switch on the master control system on the slave control.
3 data blocks are transferred.

5.3 Update errors

Table 5-1 Update errors

Error Text	Explanation	Remedial Action
ERROR UPDATE	Error when updating the system software via V24 <ul style="list-style-type: none"> Data already in receive buffer (send from PC side started too early) Error when erasing the FLASH memory Error when writing to the FLASH memory Inconsistent data (incomplete or faulty) 	<ul style="list-style-type: none"> Repeat update Check link between control system and PC/PG Check diskette
SINUMERIK 802S UPDATE NO DATA	Update without programming the code FLASH completed (no data received, transfer not started)	

Technical Appendix

6.1 List of machine and setting data

Data type

BOOLEAN	Machine data bit (1 or 0)
BYTE	Integer values (from -128 to 127)
DOUBLE	Real and integer values (from $\pm 4.19 \cdot 10^{-307}$ to $\pm 1.67 \cdot 10^{308}$)
DWORD	Integer values (from $-2.147 \cdot 10^9$ to $2.147 \cdot 10^9$)
STRING	Character string (max. 16 characters) consisting of upper-case letters with digits and underscore
UNSIGNED WORD	Integer values (from 0 to 65536)
SIGNED WORD	Integer values (from -32768 to 32767)
UNSIGNED DWORD	Integer values (from 0 to 4294967300)
SIGNED DWORD	Integer values (from -2147483650 to 2147483649)
WORD	Hex values (from 0000 to FFFF)
DWORD	Hex values (from 00000000 to FFFFFFFF)
FLOAT DWORD	Real values (from $\pm 8.43 \cdot 10^{-37}$ to $\pm 3.37 \cdot 10^{38}$)

6.1.1 Display machine data

Number	MD Name			Activated	User Class w/r
Representation	Name, Miscellaneous				
Unit	Standard value	Minimum value	Maximum value	Data type	
202	\$MM_FIRST_LANGUAGE				
Decimal	Foreground language			Power On	2/3
0	1	1	2	Byte	
203	\$MM_DISPLAY_RESOLUTION				
Decimal	Display resolution			Power On	2/3
0	3	0	5	Byte	
206	\$MM_USER_CLASS_WRITE_TOA_GEO				
Decimal	User class Write tool geometry			Immediately	2/3
0	3	0	7	Byte	
207	\$MM_USER_CLASS_WRITE_TOA_WEAR				
Decimal	User class Write tool wear data			Immediately	2/3
0	3	0	7	Byte	

6.1 List of machine and setting data

208	\$MM_USER_CLASS_WRITE_ZOA				
Decimal	User class Write settable zero offset			Immediately	2/3
0	3	0	7	Byte	
210	\$MM_USER_CLASS_WRITE_SEA				
Decimal	User class Write setting data			Immediately	2/3
0	3	0	7	Byte	
216	\$MM_USER_CLASS_WRITE_RPA				
Decimal	User class Write R parameters			Immediately	2/3
0	3	0	7	Byte	
217	\$MM_USER_CLASS_SET_V24				
Decimal	User class Set V24			Immediately	2/3
0	3	0	7	Byte	
219	\$MM_USER_CLASS_DIR_ACCESS				
Decimal	User class access directory			Immediately	2/3
0	3	0	7	Byte	
277	\$MM_USER_CLASS_PLC_ACCESS				
Decimal	User class access PLC project			Immediately	2/3
0	3	0	7	Byte	
278	\$MM_NCK_SYSTEM_FUNC_MASK				
Decimal	Option data to enable system-specific functions			POWER ON	2/2
0	0	0	15	Byte	
280	\$MM_V24_PPI_ADDR_PLC				
Decimal	PPI address of the PLC			POWER ON	3/3
0	2	0	126	BYTE	
281	\$MM_V24_PPI_ADDR_NCK				
Decimal	PPI address of the NCK			POWER ON	3/3
0	3	0	126	BYTE	
282	\$MM_V24_PPI_ADDR_MMC				
Decimal	PPI address of the HMI			POWER ON	3/3
0	4	0	126	BYTE	
283	\$MM_V24_PPI_MODEM_ACTIVE				
Decimal	Modem active			Immediately	3/3
0	0	0	1	BYTE	
284	\$MM_V24_PPI_MODEM_BAUD				
Decimal	Modem baud rate			Immediately	3/3
0	7	5	9	BYTE	
285	\$MM_V24_PPI_MODEM_PARITY				
Decimal	Modem parity			Immediately	3/3
0	0	0	2	BYTE	

6.1 List of machine and setting data

6.1.2 General machine data

Number	MD Name					
Unit	Name, Miscellaneous			Activated		
HW / function	Standard value	Minimum value	Maximum value	D type	User class	
10074	PLC_IPO_TIME_RATIO					
-	PLC task factor for main run			POWER ON		
	2	1	50	DWORD	2/7	
10240	SCALING_SYSTEM_IS_METRIC					
-	Basic system metric			POWER ON		
_always	1	***	***	BOOLEAN	2/7	
11100	AUXFU_MAXNUM_GROUP_ASSIGN					
-	Number of auxiliary functions distr. amongst aux. fct. groups			POWER ON		
_always	1	1	50	BYTE	2/7	
11200	INIT_MD					
HEX	Standard machine data loaded on next Power On			POWER ON		
_always	0x0F	-	-	BYTE	2/7	
11210	UPLOAD_MD_CHANGE_ONLY					
HEX	Saving only of modified MD (value=0: complete= no difference)			RESTART		
-	0x0F	-	-	BYTE	2/7	
11310	HANDWH_REVERSE					
-	Threshold for direction change handwheel			POWER ON		
_always	2	0.0	plus	BYTE	2/7	
11320	HANDWH_IMP_PER_LATCH					
-	Handwheel pulses per detent position (handwheel number): 0...1			POWER ON		
_always	1., 1.	-	-	DOUBLE	2/7	
14510	USER_DATA_INT [n]					
kB	User data (INT) 0 ... 31			POWER ON		
_always	-	0	-	DWORD	2/7	
14512	USER_DATA_HEX [n]					
kB	User data (Hex) 0 ... 31			POWER ON		
-	0	0	0xFF	BYTE	2/7	
14514	USER_DATA_FLOAT [n]					
-	User data (Float) 0 ... 7			POWER ON		
-	0.0	DOUBLE	2/7	
14516	USER_DATA_PLC_ALARM [n]					
-	User data (Hex) Alarm bit 0 ... 31			POWER ON		
-	0	0	0xFF	BYTE	2/7	

6.1.3 Channel-specific machine data

Number	MD Name					
Unit	Name, Miscellaneous			Activated		
HW / function	Standard value	Minimum value	Maximum value	D type	User class	

20210	CUTCOM_CORNER_LIMIT					
Degrees	Maximum angle for compensation blocks with TRC			POWER ON		
_always	100	0.0	150.		DOUBLE	2/7
20700	REFP_NC_START_LOCK					
-	NC-Start disable without reference point			RESET		
_always	1	0	1		BOOLEAN	2/7
21000	CIRCLE_ERROR_CONST					
mm	Circle end point monitoring constant			POWER ON		
_always	0.01	0.0	plus		DOUBLE	2/7
22000	AUXFU_ASSIGN_GROUP					
-	Auxiliary function group (aux. fct. no. in channel): 0...49			POWER ON		
_always	1	1	15		BYTE	2/7
22010	AUXFU_ASSIGN_TYPE					
-	Auxiliary function type (aux. fct. no. in channel): 0...49			POWER ON		
_always	, ,	-	-		STRING	2/7
22030	AUXFU_ASSIGN_VALUE					
-	Auxiliary function value (aux. fct. no. in channel): 0...49			POWER ON		
_always	0	-	-		DWORD	2/7
22550	TOOL_CHANGE_MODE					
-	New tool compensation for M function			POWER ON		
_always	0	0	1		BYTE	2/7
27800	TECHNOLOGY_MODE					
-	Technology in the channel (value=0: milling, value=1: turning)			NEW CONF		
	1	0	1		BYTE	2/7

6.1.4 Axis-specific machine data

Number	MD Name					
Unit	Name, Miscellaneous			Activated		
HW / function	Standard value	Minimum value	Maximum value		D type	User class
30130	CTRLOUT_TYPE					
-	Output type of setpoint (setpoint branch): 0			POWER ON		
_always	0	0	2		BYTE	2/7
30200	NUM_ENCS					
-	Anzahl der Geber (1 oder kein Geber für die Spindel)			RESTART		
	1	0	1		BYTE	2/7
30240	ENC_TYPE					
-	Type of actual value acquisition (actual position value) (encoder no.) 0: Simulation 2: Square-wave generator, standard encoder (pulse multiplication) 3: Encoder for stepper motor			POWER ON		
_always	0, 0	0	4		BYTE	2/7
30350	SIMU_AX_VDI_OUTPUT					
-	Output of axis signals with simulation axes			POWER ON		
_always	0	***	***		BOOLEAN	2/7
30600	FIX_POINT_POS					
mm, de- grees	Fixed-value positions of axis with G75 (position no.)			POWER ON		
_always	0.0	-	-		DOUBLE	2/7

6.1 List of machine and setting data

31000	ENC_IS_LINEAR				
-	Direct measuring system (linear scale) (encoder no.)			POWER ON	
_always	0	***	***	BOOLEAN	2/7
31010	ENC_GRID_POINT_DIST				
mm	Division period for linear scales (encoder no.)			POWER ON	
_always	0.01	0.0	plus	DOUBLE	2/7
31020	ENC_RESOL				
-	Encoder markings per revolution (encoder no.)			POWER ON	
_always	2048	0.0	plus	DWORD	2/7
31030	LEADSCREW_PITCH				
mm	Pitch of leadscrew			POWER ON	
_always	10.0	0.0	plus	DOUBLE	2/7
31040	ENC_IS_DIRECT				
-	Encoder mounted directly to the machine (encoder no.)			POWER ON	
_always	0	***	***	BOOLEAN	2/7
31050	DRIVE_AX_RATIO_DENOM				
-	Denominator load gearbox (control parameter no.): 0...5			POWER ON	
_always	1, 1, 1, 1, 1, 1	1	2147000000	DWORD	2/7
31060	DRIVE_AX_RATIO_NUMERA				
-	Numerator load gearbox (control parameter set no.): 0...5			POWER ON	
_always	1, 1, 1, 1, 1, 1	1	2147000000	DWORD	2/7
31070	DRIVE_ENC_RATIO_DENOM				
-	Denominator resolver gearbox (encoder no.)			POWER ON	
_always	1	1	2147000000	DWORD	2/7
31080	DRIVE_ENC_RATIO_NUMERA				
-	Numerator resolver gearbox (encoder no.)			POWER ON	
_always	1	1	2147000000	DWORD	2/7
31090	JOG_INCR_WEIGHT				
mm, degrees	Evaluation of an increment with INC/handwheel			RESET	
32000	MAX_AX_VELO				
mm/min, rev/min	Maximum axis velocity			NEW CONF	
_always	10000.	0.0	plus	DOUBLE	2/7
32010	JOG_VELO_RAPID				
mm/min, rev/min	Rapid traverse in jog mode			RESET	
_always	10000.	0.0	plus	DOUBLE	2/7
32020	JOG_VELO				
mm/min, rev/min	Jog axis velocity			RESET	
_always	2000.	0.0	plus	DOUBLE	2/7
32070	CORR_VELO				
%	Axis velocity for handwheel override, ext. ZO, cont. dressing, distance control			RESET	
_always	50	0.0	plus	DWORD	2/7
32100	AX_MOTION_DIR				
-	Traversing direction (not control direction)			POWER ON	
_always	1	-1	1	DWORD	2/7

6.1 List of machine and setting data

32110	ENC_FEEDBACK_POL					
-	Sign actual value (control direction) (encoder no.)			POWER ON		
_always	1	-1	1		DWORD	2/7
32200	POSCTRL_GAIN					
1000/min	Servo gain factor (control parameter set no.): 0...5			NEW CONF		
_always	(2,5; 2,5; 2,5; 1), ...	0.0	plus		DOUBLE	2/7
32250	RATED_OUTVAL					
%	Ratedoutput voltage (setprint brauch):0			NEW CONF		
_always	80	0.0	10		DOUBLE	2/7
32260	RATED_VELO					
rev/min	Rated motor speed (setpoint branch): 0			NEW CONF		
_always	3000	0.0	plus		DOUBLE	2/7
32300	MAX_AX_ACCEL					
mm/s ² , rev/s ²	Axis acceleration			NEW CONF		
_always	1	0	***		DOUBLE	2/7
32450	BACKLASH					
mm	Backlash			NEW CONF		
_always	0.000	*	*		DOUBLE	2/7
32700	ENC_COMP_ENABLE					
-	Interpolatory compensation (encoder no.): 0,1			POWER ON		
_always	0	***	***		BOOLEAN	2/7
32900	DYN_MATCH_ENABLE					
-	Dynamic response adaptation			NEW_CONF		
	0	0	1		BYTE	2/7
32910	DYN_MATCH_TIME					
-	Time constant of dynamic adaption (control parameter set no): 0...5			NEW_CONF		
	0	0.0	plus		DOUBLE	2/7
32920	AC_FILTER_TIME					
s	Smoothing factor time constant for adaptive control			POWER ON		
_always	0.0	0.0	plus		DOUBLE	2/7
33050	LUBRICATION_DIST					
mm, deg.	Traversing distance for lubrication from PLC			NEW CONF		
_always	100000000	0.0	plus		DOUBLE	2/7
34000	REFP_CAM_IS_ACTIVE					
-	Axis with reference point cam			RESET		
_always	1	***	***		BOOLEAN	2/7
34010	REFP_CAM_DIR_IS_MINUS					
-	Approach reference point in minus direction			RESET		
_always	0	***	***		BOOLEAN	2/7
34020	REFP_VELO_SEARCH_CAM					
mm/min, rev/min	Reference point approach velocity			RESET		
_always	5000.0	0.0	plus		DOUBLE	2/7
34030	REFP_MAX_CAM_DIST					
mm, deg.	Maximum distance to reference cam			RESET		
_always	10000.0	0.0	plus		DOUBLE	2/7

6.1 List of machine and setting data

34040	REFP_VELO_SEARCH_MARKER					
mm/min, rev/min	Creep speed (encoder no.)			RESET		
_always	300.0	0.0	plus	DOUBLE	2/7	
34050	REFP_SEARCH_MARKER_REVERSE					
-	Direction reversal to reference cams (encoder no.)			RESET		
_always	0	***	***	BOOLEAN	2/7	
34060	REFP_MAX_MARKER_DIST					
mm, deg.	Maximum distance to reference mark. Max. distance to 2 reference marks for distance-coded measuring systems.			RESET		
_always	20.0	0.0	plus	DOUBLE	2/7	
34070	REFP_VELO_POS					
mm/min, rev/min	Reference point positioning velocity			RESET		
_always	1000.0	0.0	plus	DOUBLE	2/7	
34080	REFP_MOVE_DIST					
mm, deg.	Reference point distance/target point for distance-coded system			RESET		
_always	-2.0	-	-	DOUBLE	2/7	
34090	REFP_MOVE_DIST_CORR					
mm, deg.	Reference point offset/absolute offset distance-coded			POWER ON		
_always	0.0	-	-	DOUBLE	2/7	
34092	REFP_CAM_SHIFT					
mm, deg.	Electr. cam offset of incremental measuring systems with equidistant zero marks			RESET		
_always	0.0	0.0	plus	DOUBLE	2/7	
34100	REFP_SET_POS					
mm, deg.	Reference point value/irrelevant for distance-coded system: 0 ... 3			RESET		
_always	0., 0., 0., 0.	-	-	DOUBLE	2/7	
34110	REFP_CYCLE_NR					
-	Sequence of axes in channel-specific referencing -1: No obligatory reference point for NC Start 0: No channel-specific reference-point approach 1-15: Sequence in channel-specific reference point approach			RESET		
_always	1	-1	31	DWORD	2/7	
34200	ENC_REFP_MODE					
-	Type of position measuring system 0: No ref. point appr.; if an absolute encoder exists: REFP_SET_POS accepted 1: Zero pulse (on encoder track)			POWER ON		
_always	1	0	6	BYTE	2/7	
35010	GEAR_STEP_CHANGE_ENABLE					
-	Gear change possible. Spindle has several gear steps			POWER ON		
_always	0	***	***	BOOLEAN	2/7	
35040	SPIND_ACTIVE_AFTER_RESET					
-	Own spindle reset			POWER ON		
_always	0	***	***	BOOLEAN	2/7	
35100	SPIND_VELO_LIMIT					
rev/min	Maximum spindle speed			POWER ON		
_always	10000	0.0	plus	DOUBLE	2/7	
35110	GEAR_STEP_MAX_VELO					
rev/min	Maximum speed for gear change (gear stage no.): 0..5			NEW CONF		
_always	500, 500, 1000, 2000, 4000, 8000	0.0	plus	DOUBLE	2/7	

6.1 List of machine and setting data

35120	GEAR_STEP_MIN_VELO					
rev/min	Minimum speed for gear change (gear stage no.): 0..5			NEW CONF		
_always	50, 50, 400, 800, 1500, 3000	0.0	plus		DOUBLE	2/7
35130	GEAR_STEP_MAX_VELO_LIMIT					
rev/min	Maximum speed of gear stage (gear stage no.): 0...5			NEW CONF		
_always	500, 500, 1000, 2000, 4000, 8000	0.0	plus		DOUBLE	2/7
35140	GEAR_STEP_MIN_VELO_LIMIT					
rev/min	Minimum speed of gearsetp (gear stage no.): 0...5			NEW CONF		
_always	5, 5,10, 20, 40, 80	0.0	plus		DOUBLE	2/7
35150	SPIND_DES_VELO_TOL					
Factor	Spindle speed tolerance			RESET		
_always	0.1	0.0	1.0		DOUBLE	2/7
35160	SPIND_EXTERN_VELO_LIMIT					
rev/min	Spindle speed limitation from PLC			NEW CONF		
_always	1000	0.0	plus		DOUBLE	2/7
35200	GEAR_STEP_SPEEDCTRL_ACCEL					
rev/s^2	Acceleration in speed control mode [gear stage no.]: 0...5			NEW CONF		
_always	30, 30, 25, 20, 15, 10	2	***		DOUBLE	2/7
35210	GEAR_STEP_POSCTRL_ACCEL					
rev/s^2	Acceleration in position control mode (gear stage no.): 1...5			NEW CONF		
_always	30, 30, 25, 20, 15, 10	2	***		DOUBLE	2/7
35220	ACCEL_REDUCTION_SPEED_POINT					
Factor	Speed for reduced acceleration			RESET		
_always	1.0	0.0	1.0		DOUBLE	2/7
35230	ACCEL_REDUCTION_FACTOR					
Factor	Reduced acceleration			RESET		
_always	0.0	0.0	0.95		DOUBLE	2/7
35240	ACCEL_TYPE_DRIVE					
-	Type of acceleration			RESET		
	0	0	1		BOOLEAN	2/7
35300	SPIND_POSCTRL_VELO					
rev/min	Position control switch-on speed			NEW CONF		
_always	500	0.0	plus		DOUBLE	2/7
35350	SPIND_POSITIONING_DIR					
-	Direction of rotation when positioning			RESET		
_always	3	3	4		BYTE	2/7
35400	SPIND_OSCILL_DES_VELO					
rev/min	Reciprocation speed			NEW CONF		
_always	500	0.0	plus		DOUBLE	2/7
35410	SPIND_OSCILL_ACCEL					
rev/s^2	Acceleration during reciprocating			NEW CONF		
_always	16	2	***		DOUBLE	2/7
35430	SPIND_OSCILL_START_DIR					
-	Starting direction during reciprocation 0-2: As last direction of rotation (zero-speed M3) 3: M3 direction 4: M4 direction			RESET		
_always	0	0	4		BYTE	2/7

6.1 List of machine and setting data

35440	SPIND_OSCILL_TIME_CW					
s	Reciprocation time for M3 direction			NEW CONF		
_always	1.0	0.0	plus	DOUBLE	2/7	
35450	SPIND_OSCILL_TIME_CCW					
s	Reciprocation time for M4 direction			NEW CONF		
_always	0.5	0.0	plus	DOUBLE	2/7	
35510	SPIND_STOPPED_AT_IPO_START					
-	Feedrate enable for spindle stopped			RESET		
_always	0	***	***	BOOLEAN	2/7	
36000	STOP_LIMIT_COARSE					
mm, deg.	Exact positioning coarse			NEW CONF		
_always	0.04	0.0	plus	DOUBLE	2/7	
36010	STOP_LIMIT_FINE					
mm, deg.	Exact positioning fine			NEW CONF		
_always	0.01	0.0	plus	DOUBLE	2/7	
36020	POSITIONING_TIME					
s	Delay exact positioning fine			NEW CONF		
_always	1.0	0.0	plus	DOUBLE	2/7	
36030	STANDSTILL_POS_TOL					
mm, deg.	Zero-speed tolerance			NEW CONF		
_always	0.2	0.0	plus	DOUBLE	2/7	
36040	STANDSTILL_DELAY_TIME					
s	Delay zero-speed monitoring			NEW CONF		
_always	0.4	0.0	plus	DOUBLE	2/7	
36050	CLAMP_POS_TOL					
mm, deg.	Clamping tolerance			NEW CONF		
_always	0.5	0.0	plus	DOUBLE	2/7	
36060	STANDSTILL_VELO_TOL					
mm/min, rev/min	Maximum velocity/speed "axis/spindle stopped"			NEW CONF		
_always	5 (0.014)	0.0	plus	DOUBLE	2/7	
36100	POS_LIMIT_MINUS					
mm, deg.	1st software limit switch minus			RESET		
_always	-100000000	-	-	DOUBLE	2/7	
36110	POS_LIMIT_PLUS					
mm, deg.	1st software limit switch plus			RESET		
_always	100000000	-	-	DOUBLE	2/7	
36120	POS_LIMIT_MINUS2					
mm, deg.	2nd software limit switch minus			RESET		
_always	-100000000	-	-	DOUBLE	2/7	
36130	POS_LIMIT_PLUS2					
mm, deg.	2nd software limit switch plus			RESET		
_always	100000000	-	-	DOUBLE	2/7	
36200	AX_VELO_LIMIT					
mm/min, rev/min	Threshold value for velocity monitoring (control parameter set no.): 0...5			NEW CONF		
_always	11500., 11500., 11500., 11500., ...	0.0	plus	DOUBLE	2/7	

6.1 List of machine and setting data

36300	ENC_FREQ_LIMIT					
Hz	Encoder limit frequency			POWER ON		
_always	300000	0	plus	DOUBLE	2/7	
36302	ENC_FREQ_LIMIT_LOW					
%	Encoder limit frequency at which encoder is switched on again. (Hysteresis)			NEW CONF		
_always	99.9	0	100	DOUBLE	2/7	
36310	ENC_ZERO_MONITORING					
-	Zero mark monitoring (encoder no.): 0,1 0: Zero mark monitoring off, encoder HW monitoring on 1-99, >100: Number of recognized zero mark errors during monitoring 100: Zero mark monitoring off, encoder HW monitoring off			NEW CONF		
_always	0, 0	0.0	plus	DWORD	2/7	
36400	CONTOU_TOL					
mm, deg.	Contour monitoring tolerance band			NEW CONF		
_always	1.0	***	***	DOUBLE	2/2	
36500	ENC_CHANGE_TOL					
mm, deg	Portion of distance for backlash working			NEW CONF		
_always	0,1	0.0	plus	DOUBLE	2/7	
36610	AX_EMERGENCY_STOP_TIME					
s	Duration of the deceleration ramp for error states			NEW CONF		
_always	0.05	0.0	plus	DOUBLE	2/7	
36620	SERVO_DISABLE_DELAY_TIME					
s	Cutout delay servo enable			NEW CONF		
_always	0.1	0.0	plus	DOUBLE	2/7	
36700	DRIFT_ENABLE					
-	Automatic drift compensation			NEW CONF		
_always	0	***	***	BOOLEAN	2/7	
36710	DRIFT_LIMIT					
%	Drift limit value for automatic drift compensation			NEW CONF		
_always	1.000	0.0	plus	DOUBLE	2/7	
36720	DRIFT_VALUE					
%	Drift basic value			NEW CONF		
_always	0.0			DOUBLE	2/7	
38000	MM_ENC_COMP_MAX_POINTS					
-	Number of intermediate points for interpolatory compensation (SRAM)			POWER ON		
_always	0, 0	0	5000	DWORD	2/7	

6.1.5 Setting data

Number	MD Name					
Unit	Name, Miscellaneous			Activated		
HW / function	Standard value	Minimum value	Maximum value		D type	User class
41110	JOG_SET_VELO					
mm/min	Axis speed for JOG			Immediately		
_always	0.0	0.0	plus	DOUBLE	4/4	
41200	JOG_SPIND_SET_VELO					
rev/min	Speed for spindle JOG mode			Immediately		
_always	0.0	0.0	plus	DOUBLE	4/4	

6.1 List of machine and setting data

43210	SPIND_MIN_VELO_G25				
rev/min	Progr. spindle speed limitation G25			Immediately	
_always	0.0	0.0	plus	DOUBLE	4/4
43220	SPIND_MAX_VELO_G26				
rev/min	Progr. spindle speed limitation G26			Immediately	
_always	1000	0.0	plus	DOUBLE	4/4
43230	SPIND_MAX_VELO_LIMS				
rev/min	Spindle speed limitation with G96			Immediately	
_always	100	0.0	plus	DOUBLE	4/4
52011	STOP_CUTCOM_STORE				
	Alarm response for TRC and feedforward stop			Immediately	
-	1	0	1	BOOLEAN	4/4

6.2 PLC user interface signals

The following tables of the user interface signals between PLC and NC (and vice versa) are handled by the integrated fixed user program.

These signals can be displayed using PLC Status in the **Diagnosis/Start-Up/PLC Status** menu.

6.2.1 Address ranges

Operand Identifier	Description	Range
V	Data	V0.0 to V79999999.7 (see below)
T	Timers	T0 to T15
C	Counters	C0 to C31
I	Image of digital inputs	I0.0 to I7.7
Q	Image of digital outputs	Q0.0 to Q7.7
M	Flags	M0.0 to M127.7
SM	Special flags	SM0.0 to SM 0.6 (see below)
AC	ACCU	AC0 ... AC3

Generating the V address range

Type Identifier (DB No.)	Range No. (Channel / Axis No.)	Subrange	Offset	Addressing
10 (10-79)	00 (00-99)	0 (0-9)	000 (000-999)	symbolic (8-digit)

Definition of special flag bits (SM) (read-only)

SM Bits	Description
SM 0.0	Flags with a defined ONE signal
SM 0.1	Initial position: first PLC cycle '1', following cycles '0'
SM 0.2	Buffered data lost - only valid in the first PLC cycle ('0' - data o.k., '1' - data lost)
SM 0.3	Power On: first PLC cycle '1', following cycles '0'
SM 0.4	60 s clock (alternating '0' for 30 s, then '1' for 30 s)
SM 0.5	1 s clock (alternating '0' for 0.5 s, then '1' for 0,5 s)
SM 0.6	PLC cycle clock (alternating one cycle '0', then one cycle '1')

Note

All empty user interface fields in the following tables are **Reserved for SIEMENS** and may neither be written, nor evaluated by the user!

All fields with a "0" contain the value "logic =".

Variable access rights

[r] is used to mark a read-only range
 [r/w] is used to mark a read/write range

6.2.2 Retentive data area

1400		Retentive Data [r/w]						
Data block		Interface NCK ———> PLC						
Byte	Bit 7	Bit 6	Bit 5	Bit 4	Bit 3	Bit 2	Bit 1	Bit 0
14000000	User Data							
14000001	User Data							
14000002	User Data							
	...							
	...							
	...							
14000062	User Data							
14000063	User Data							

6.2.3 NCK signals

2600		General signals to NCK [r/w]							
Data block		Interface PLC → NCK							
Byte	Bit 7	Bit 6	Bit 5	Bit 4	Bit 3	Bit 2	Bit 1	Bit 0	
26000000	Protection level						Acknowl. EMER- GENCY STOP	EMER- GENCY STOP	
	4	5	6	7					
26000001						Request distances to go by the axes	Request actual dis- tances to go by the axes		
26000002									
26000003									

2700		General signals from NCK [r]						
Data block		Interface NCK → PLC						
Byte	Bit 7	Bit 6	Bit 5	Bit 4	Bit 3	Bit 2	Bit 1	Bit 0
27000000							EMER- GENCY STOP active	
27000001								
27000002		Drive ready						
27000003		Ambient tempera- ture alarm						NCK alarm present

3000		Mode signals to NCK [r/w]						
Data block			Interface PLC —> NCK					
Byte	Bit 7	Bit 6	Bit 5	Bit 4	Bit 3	Bit 2	Bit 1	Bit 0
30000000	Reset			Mode Change lock		JOG	MDA	AUTOM.
30000001						REF		TEACH IN
30000002								
30000003								

3100		Mode signals from NCK [r]						
Data block			Interface NCK —> PLC					
Byte	Bit 7	Bit 6	Bit 5	Bit 4	Bit 3	Bit 2	Bit 1	Bit 0
31000000					READY	JOG	MDA	AUTOM.
31000001						REF		TEACH IN

6.2.4 Channel signals

Control signals to NC channel

3200		Signals to NCK channel [r/w]						
Data block			Interface PLC —> NCK					
Byte	Bit 7	Bit 6	Bit 5	Bit 4	Bit 3	Bit 2	Bit 1	Bit 0
32000000		Activate dry run feed	Activate M01	Activate Single Block ⁴⁾				
32000001	Activate Program Test							Activate Referencing
32000002								Activate Skip Block
32000003								

32000004	Feed override ²⁾							
	H	G	F	E	D	C	B	A
32000005	Rapid traverse override ³⁾							
	H	G	F	E	D	C	B	A
32000006	Feed ¹⁾ override enabled	Rapid traverse override enabled		Program level abortion		Delete distance to go	Read-in disabled	Feed lock
32000007				NC stop axes plus spindle	NC stop	NC stop to block limit	NC start	NC start inhibited

Notes:

- 1)+ Feed override enabled Even if the feed override is not enabled (=100%), the 0% position is active.
- 2)+ Feed override 31 positions (Gray code) with 31 MD for % weighting
- 3)+ Rapid traverse override 31 positions (Gray code) with 31 MD for % weighting
- 4)+ Single Block Use the softkey to select Single Block Type Preselection (SBL1/SBL2) see "User Manual"

Control signals to axes in the WCS

3200		Signals to NCK Channel [r/w]						
Data block		Interface PLC ———> NCK						
Byte	Bit 7	Bit 6	Bit 5	Bit 4	Bit 3	Bit 2	Bit 1	Bit 0
32001000	Axis 1 in WCS							
	Traversing keys + -		Rapid traverse override	Traversing key lock	Feed stop	Activate handwheel		
32001001	Axis 1 in WCS							
		contin-uous			1000 INC	100 INC	10 INC	1 INC
32001002								
32001003								
32001004	Axis 2 in WCS							
	Traversing keys + -		Rapid traverse override	Traversing key lock	Feed Stop	Activate handwheel		
32001005	Axis 2 in WCS							
		contin-uous			1000 INC	100 INC	10 INC	1 INC
32001006								
32001007								

6.2 PLC user interface signals

32001008	Traversing keys + -		Rapid traverse override	Traversing key lock	Feed stop	Activate handwheel 2 1		
32001009	contin- ous		Axis 3 in WCS Machine function		1000 INC	100 INC	10 INC	1 INC
32001010								
32001011								

Status signals from NC channel

3300		Signals from NCK channel [r]						
Data block		Interface NCK —> PLC						
	Bit 7	Bit 6	Bit 5	Bit 4	Bit 3	Bit 2	Bit 1	Bit 0
33000000			M0 / M1 active					
33000001	Program test active		M2 / M30 active	Block search active		Revolu- tional feed active		Referenc- ing active
33000002								
33000003	Channel state			Program state				
	Reset	inter- rupted	active	aborted	inter- rupted	stopped	waiting	running
33000004	NCK alarm with stop of ma- chining present	NCK alarm channel- specific present			All axes stopped	All axes refer- enced		
33000005								
33000006								
33000007								

Status signals: Axes in WCS

3300		Signals from NCK channel [r]						
Data block		Interface NCK —> PLC						
Byte	Bit 7	Bit 6	Bit 5	Bit 4	Bit 3	Bit 2	Bit 1	Bit 0
33001000	Traversing command plus minus		Axis 1 in WCS				Handwheel active 2 1	
33001001	contin- ous		Axis 1 in WCS				Machine function 1000 INC 100 INC 10 INC 1 INC	
33001002								
33001003								
33001004	Traversing command plus minus		Axis 2 in WCS				Handwheel active 2 1	
33001005	contin- ous		Axis 2 in WCS				Active machine function 1000 INC 100 INC 10 INC 1 INC	
33001006								
33001007								
33001008	Traversing command plus minus		Axis 3 in WCS				Handwheel active 2 1	
33001009	contin- ous		Axis 3 in WCS				Active machine function 1000 INC 100 INC 10 INC 1 INC	
33001010								
33001011								

Transfer of auxiliary functions from the NC channel

2500		Auxiliary functions from NCK channel [r]						
Data block		Interface PLC						
Byte	Bit 7	Bit 6	Bit 5	Bit 4	Bit 3	Bit 2	Bit 1	Bit 0
25000000								Modify de-coded M functions 0–99
25000001				Modify T funct. 1				
25000002								
25000003								

Decoded M signals (M0 – M99)

2500		M functions from NCK channel [r]						
Data block		Interface NCK						
Byte	Bit 7	Bit 6	Bit 5	Bit 4	Bit 3	Bit 2	Bit 1	Bit 0
25001000	Dynamic M functions							
	M7	M6	M5	M4	M3	M2	M1	M0
25001001	Dynamic M functions							
	M15	M14	M13	M12	M11	M10	M9	M8
25001002	Dynamic M functions							
	M23	M22	M21	M20	M19	M18	M17	M16
				...				
				...				
				...				
25001012	Dynamic M functions							
					M99	M98	M97	M96
25001013								

25001014								
25001015								

Notes:

- + Static M functions must be generated by the PLC user from the dynamic M functions.
- + Dynamic M functions are decoded by the basic program (M00 to M99).

Transferred T functions

2500		T functions from NCK channel [r]						
Data block		Interface PLC						
Byte	Bit 7	Bit 6	Bit 5	Bit 4	Bit 3	Bit 2	Bit 1	Bit 0
25002000	T function 1 (DINT)							
25002004								
25002008								
25002012								

6.2.5 Axis/spindle signals

Signals to axis/spindle

Common signals to axis/spindle

3800...3803		Signals to axis/spindle [r/w]						
Data block		Interface PLC → NCK						
Byte	Bit 7	Bit 6	Bit 5	Bit 4	Bit 3	Bit 2	Bit 1	Bit 0
380x0000	Feed override							
	H	G	F	E	D	C	B	A
380x0001	Override enabled		Position encoder 1	Follow-up mode	Axes/spindle lock			

6.2 PLC user interface signals

380x0002					Clamping process running	Delete distance to go/spindle reset	Servo enable	
380x0003		Speed/spindle speed limitation						
380x0004	Traversing keys plus minus		Rapid traverse override	Traversing key lock	Feed stop Spindle stop		Activate handwheel 2 1	
380x0005		continuous			1000 INC	100 INC	10 INC	1 INC
380x0006	Machine function							
380x0007								

Signals to axis

3800...3802		Signals to axis [r/w]						
Data block		Interface PLC —> NCK						
Byte	Bit 7	Bit 6	Bit 5	Bit 4	Bit 3	Bit 2	Bit 1	Bit 0
380x1000 (axis)	Delay Ref.-point approach				2nd software limit switch plus minus		Hardware limit switch plus minus	
380x1001 (axis)								
380x1002 (axis)								
380x1003 (axis)								

Signals to spindle

3803		Signals to spindle [r/w]						
Data block		Interface PLC —> NCK						
Byte	Bit 7	Bit 6	Bit 5	Bit 4	Bit 3	Bit 2	Bit 1	Bit 0
38032000 (spindle)					Gear is changed	Actual gear stage C B A		
								Spindle feed

38032001 (spindle)		Invert M3/M4						override valid
38032002 (spindle)	Set direction of rotation		Recipro- cating speed	Recipro- cating by PLC				
	CCW	CW						
38032003 (spindle)	Spindle override							
	H	G	F	E	D	C	B	A

General signals from axis/spindle

3900...3903			Signals from axis/spindle [r]					
Data block			Interface NCK ———> PLC					
Byte	Bit 7	Bit 6	Bit 5	Bit 4	Bit 3	Bit 2	Bit 1	Bit 0
390x0000	Position reached with exact pos. fine	with exact pos., coarse		Refer- enced/ synchro- nized 1		Encoder limit fre- quency exceeded 1		Spindle/ no axis
390x0001	Current controller active	Speed controller active	Position controller active	Axis/spindle stopped ($n < n_{min}$)	Follow-up active			
390x0002								
390x0003								
390x0004	Motion command						Handwheel active	
	plus	minus					2	1
390x0005	Active machine function				1000 INC	100 INC	10 INC	1 INC
390x0006		continu- ous						
390x0007								

Signals from axis

3900...3903			Signals from axis [r]					
Data block			Interface NCK ———> PLC					
Byte	Bit 7	Bit 6	Bit 5	Bit 4	Bit 3	Bit 2	Bit 1	Bit 0
390x1000 (axis)								

6.2 PLC user interface signals

390x1001 (axis)								
390x1002 (axis)								Lubrication pulse
390x1003 (axis)								

Signals from spindle

3903		Signals from spindle [r]						
Data block		Interface NCK —> PLC						
Byte	Bit 7	Bit 6	Bit 5	Bit 4	Bit 3	Bit 2	Bit 1	Bit 0
39032000 (spindle)					Change gear	Set gear stage		
						C	B	A
39032001 (spindle)	Actual direction of rotation CW		Spindle within set range			Set speed increased	Set speed limited	Speed limit exceeded
39032002 (spindle)	Active spindle mode				Tapping without compensating chuck			
	Control mode	Reciprocating mode	Positioning mode					
39032003 (spindle)								

6.2.6 Signals from/to MMC

Program control signals from MMC (retentive area)

(see also signals to channel V32000000)

1700		MMC signals [r]						
Data block		Interface MMC —> PLC						
DBB	Bit 7	Bit 6	Bit 5	Bit 4	Bit 3	Bit 2	Bit 1	Bit 0
17000000 (MMC —> PLC)		Dry run feed selected	M01 selected					
17000001 (MMC —> PLC)	Program test selected				Feed override for rapid traverse selected			
17000002								Select Skip

(MMC → PLC)									Block
17000003 (MMC → PLC)									

Dynamic mode signals from MMC

1800		Signals from MMC [r]							
Data block		Interface MMC → PLC							
Byte	Bit 7	Bit 6	Bit 5	Bit 4	Bit 3	Bit 2	Bit 1	Bit 0	
18000000									
18000001						Machine function		TEACH IN	
18000002									
18000003									

General selection/status signals from MMC (retentive area)

1900		MMC Signals [r]							
Data block		Interface MMC → PLC							
Byte	Bit 7	Bit 6	Bit 5	Bit 4	Bit 3	Bit 2	Bit 1	Bit 0	
19001000 (MMC → PLC)									
19001001 (MMC → PLC)									
19001002 (MMC → PLC)									
19001003 (MMC → PLC)	Machine axis					Axis number for handwheel 1 B A			
19001004 (MMC → PLC)	Machine axis					Axis number for handwheel 2 B A			
19001005 (MMC → PLC)									
19001006 (MMC → PLC)									

Control signals to operator panel (retentive range)

1900		Signals to operator panel [r/w]						
Data block		Interface PLC —> MMC						
Byte	Bit 7	Bit 6	Bit 5	Bit 4	Bit 3	Bit 2	Bit 1	Bit 0
19005000						OP key lock		
19005001								
19005002								
19005003								

6.2.7 Machine control panel signals (MCP signals)

Status signals from MCP

1000		Signals from MCP [r]						
		Interface MCP —> PLC						
Byte	Bit 7	Bit 6	Bit 5	Bit 4	Bit 3	Bit 2	Bit 1	Bit 0
10000000	#8 JOG	#7 INC	#6 free	#5 free	#4 free	#3 free	#2 free	#1 free
10000001	#16 Axis key	#15 Spindle start	#14 Spindle stop	#13 Spindle start +	#12 MDA	#11 SBL	#10 AUTO	#9 REF
10000002	#24 Axis key	#23 Axis key	#22 Axis key	#21 Axis key	#20 Axis key	#19 Axis key	#18 Axis key	#17 Axis key
10000003	"0"	"0"	"0"	"0"	"0"	#27 NC START	#26 NC STOP	#25 NC RE-SET
10000004	"0"	"0"	"0"	Feed override				
				E	D	C	B	A
10000005	"0"	"0"	"0"	Spindle override				
				E	D	C	B	A

Control signals to MCP

1100		Signals to MCP [r/w]						
		Interface PLC —> MCP						
Byte	Bit 7	Bit 6	Bit 5	Bit 4	Bit 3	Bit 2	Bit 1	Bit 0

11000000			L6	L5	L4	L3	L2	L1
11000001								

6.2.8 PLC machine data

**INT values (MD 14510
USER_DATA_INT)**

4500		Signals from NCK [r]						
Data block		Interface NCK ———> PLC						
Byte								
45000000	Int value (WORD/ 2 bytes)							
45000002	Int value (WORD/ 2 bytes)							
45000004	Int value (WORD/ 2 bytes)							
45000006	Int value (WORD/ 2 bytes)							
45000060	Int value (WORD/ 2 bytes)							
45000062	Int value (WORD/ 2 bytes)							

HEX values (MD 14512 USER_DATA_HEX)

4500		Signals from NCK [r]						
Data block		Interface NCK ———> PLC						
Byte								
45001000	Hex value (BYTE)							
45001001	Hex value (BYTE)							
45001002	Hex value (BYTE)							
45001003	Hex value (BYTE)							
45001030	Hex value (BYTE)							
45001031	Hex value (BYTE)							

FLOAT values (MD 14514 USER_DATA_FLOAT)

4500		Signals from NCK [r]						
Data block		Interface NCK ———> PLC						
Byte								
45002000	Float value (REAL/ 4 bytes)							
45002004	Float value (REAL/ 4 bytes)							
45002008	Float value (REAL/ 4 bytes)							
45002012	Float value (REAL/ 4 bytes)							
45002016	Float value (REAL/ 4 bytes)							
45002020	Float value (REAL/ 4 bytes)							
45002024	Float value (REAL/ 4 bytes)							
45002028	Float value (REAL/ 4 bytes)							

HEX-BYTE values (MD 14516 USER_DATA_PLC_ALARM)

4500		Signals from NCK [r]						
Data block		Interface NCK ———> PLC						
Byte								
45003000	Alarm reaction / clear criterion of alarm 700000							
45003001	Alarm reaction / clear criterion of alarm 700001							
45003002	Alarm reaction / clear criterion of alarm 700002							
45003031	Alarm reaction / clear criterion of alarm 700031							

6.2.9 User alarm

Alarm activation

1600		Alarm activation [r/w]						
Data block		Interface PLC ———> MMC						
Byte	Bit 7	Bit 6	Bit 5	Bit 4	Bit 3	Bit 2	Bit 1	Bit 0
16000000	Activation of alarm no.							
	700007	700006	700005	700004	700003	700002	700001	700000
16000001	Activation of alarm no.							

	700015	700014	700013	700012	700011	700010	700009	700008
16000002	Activation of alarm no.							
	700023	700022	700021	700020	700019	700018	700017	700016
16000003	Activation of alarm no.							
	700031	700030	700029	700028	700027	700026	700025	700024

Variable for alarm

1600		Variable for alarm [r/w]						
Data block		Interface PLC ———> MMC						
Byte								
16001000	Variable for alarm 700000							
16001004	Variable for alarm 700001							
16001008	Variable for alarm 700002							
	...							
16001116	Variable for alarm 700029							
16001120	Variable for alarm 700030							
16001124	Variable for alarm 700031							

Active alarm response

1600		Active alarm response [r]						
Data block		Interface PLC ———> MMC						
Byte	Bit 7	Bit 6	Bit 5	Bit 4	Bit 3	Bit 2	Bit 1	Bit 0
16002000				PLC-STOP	NOT-AUS	Feed lock of all axes	Read-in disable	NC start inhibited
16002001								
16002002								
16002003								

Axis actual value and distances to go

5700 ... 5704			Signals from axis/spindle [r]					
Data block			Interface PLC → MMC					
Byte	Bit 7	Bit 6	Bit 5	Bit 4	Bit 3	Bit 2	Bit 1	Bit 0
570x0000	Axis actual value (REAL)							
570x0004	Axis distance to go (REAL)							

Technical Appendix

6.3 Application note: unipolar spindle control

General

With SINUMERIK 802C, the spindle speed setpoint is generally output in the range from –10V through +10V (S... M3 or M4). A setpoint output with positive polarity only (0V through +10V) and an additional direction signal, as it is required for unipolar frequency converters, can be realized via appropriate programming in the NC part program and in the PLC user program (additionally, two M commands for switching the direction signal and M3 for starting rotation). A direction reversal may only be carried out with setpoint zero (spindle at standstill). It should be taken into account that the setpoint output is provided by the NC, but switching of the direction signal is provided by the PLC. In other words: It must be ensured by the user program that the new direction signal is only provided if the spindle has stopped. A new rotation start may only be provided after the direction signal has been output by the PLC.

Position-controlled spindle mode (SPOS= , G331,G332, LCYC84) is not possible with unipolar spindle control.

NC programming

```
N10 M5 ;Spindle stop
N20 G4 F15 ;Dwelling if necessary, spindle must have stopped safely
      what can also be provided by the PLC user program
N30 M23 ;M23 will be the new direction signal
N40 S200 M3 ;New spindle speed and start of rotation
N100 M5 ;Spindle stop
```

PLC programming

according to the particular conditions and requirements, taking into account what was mentioned below;

M23 and M24, for example, are the M commands for the direction signals and must be evaluated accordingly by the user program; then, the direction signal must be set.

Manual Machine

This description should be understood as an addition to the “Start-up Guide for the Sinumerik 802S”. Therefore, only the special features of the Sinumerik 802S with regard to the “Manual machine” user interface will be described here.

7.1 Hardware and software requirements for the installation

Hardware:

Notice

To ensure that the software is installed successfully when installing the software both for the first time and whenever installing new software in the future if the “Manufacturer protection level” is not enabled in the control system, the 802C standard operator panel (OP 020) is required, in addition to the machine control panel (because of the keys for entering the password).

The following components are required to install the Sinumerik 802S/C MM software:

- PG, PC or laptop with CD-ROM drive and serial interface (V24)
- V24 data cable
- OP 020 operator panel (standard operator panel); not always required with subsequent installations (provided that the “Manufacturer protection level” is still enabled in the control)
- Jumper on connector X1002, pin 24 → pin 5 if no machine control panel (MCP) is connected.

Software:

The following requirements must be fulfilled, and the following components must be provided:

- PG, PC or laptop with operative WinPCIN program (if not yet installed, install it from the Toolbox)
- CD ROM with up-to-date toolbox for Sinumerik 802S/C MM
- At least software version 03.01.06–802S/C or higher must be installed on the Sinumerik 802S/C (otherwise, the operating system must be updated).

7.2 Loading the software

Preparatory work:



- If an operator panel other than the standard operator panel (OP 020) is installed on the machine and an initial or subsequent installation is carried out with which not the “Manufacturer protection level” is set in the control system, then the currently installed operator panel must be replaced by the standard operator panel (OP 020).
- If no machine control panel (MCP) is connected to the installed operator panel, then connect a jumper (pin 24 → pin 5) to the connector X1002 of the operator panel; otherwise, the control system will not power up.
- Use an appropriate cable to connect PG, PC or laptop on which an operative WinPCIN program is installed to the V24 interface of the Sinumerik (connector X2).

Supplementary installation conditions:

If a language other than the first language is installed, switch to the second language English to install the “Manual machine”.

Installing the software:

To ensure successful installation, it is imperative to observe the sequence described below:

- Start the WinPCIn software on your PG, PC or laptop.
- Use an appropriate interface cable to connect the X2 interface of the Sinumerik (V24 interface) to COM 1 on the PG, PC or laptop.
- Turn on the control system.
- Use the  key to switch to the “Data” area.
- Press the “Diagnosis” function key.
- Press the “Start-up” function key.
- Use the  key to extend the menu range.
- Press the “Set passw.” function key.
- Type “EVENING” and press the “OK” function key. Make sure that the message “Access level: Manufacturer” is displayed; otherwise, repeat the password input.
- Select the  key to switch back to the “Data” area.
- Press the “Services” function key.
- Press the “Settings” function key.
- Press the “V24 binary” function key. Accept the settings displayed in the WinPCIN software (V24_ini) (19200 Bd, 1 stop bit, no parity, 8 data bits, Handshake RTS/CTS).
- Press the “OK” function key to accept the Sinumerik settings.
- Use the WinPCIN software to start the transfer of the file “manmach.arc” from the Toolbox CD ROM (in some cases, first the file has to be copied to the hard disk, as not every WinPCIN version can access a CD ROM drive).

- Press the “Input start” function key to start the data transfer on the control system.
- A box with the following question will appear on the control system: “Read in start-up data?”. If you wish to start this process, press the “OK” function key to confirm.
- If the data transfer has been started successfully, the message “V24 input running” is displayed. The data transfer will take approx. 15 minutes; during this time, it is imperative to prevent a power failure or an interruption of the data transfer. If sometimes the message “No text management available!” is displayed, this is normal and can therefore be ignored.

Note



Under no circumstances may a power failure or an interruption of the data transfer occur while the data transfer is running! Otherwise, a new power-up of the control system can be suppressed due to an uncontrolled interruption of the data saving (in the flash memory). In this case, it is not possible to try to transfer the data once more; the operating system must be re-installed.

- After the transfer has been completed, press the “Error log” function key to check whether the “OK” message has been set for all data.
- Carry out Power ON. The user interface for the manual machine is installed.

The installation of the “Manual Machine” user interface is now completed. Now, however, the relevant default data are not yet set for machine data, tool data, MGUDs,..., and for the PLC program.

These data / default data must be loaded into the control system by transferring an appropriately adapted “initial.ini”. To this end, either use the “initial.ini” adapted by the machine manufacturer or load (when starting the project) the default machine data record included in the file “manmach.cnf” on the supplied CD ROM.

How to load the file “manmach.cnf” (default data record) is explained in the following:

- After the control system has powered up, press the  key to call the interactive password screenform.
- Enter the password “1111” and press the  key to confirm.
- Press the  once more and use the “OK” function key to switch to the standard user interface.

The further sequence corresponds to that as described for the installation of the user interface for the “Manual Machine” (see above). The individual difference is that the file “MM_2.ser” must be transferred from the Toolbox.

During the transfer, the control system reboots sometimes. The whole process takes approx. 5 minutes (depending on the amount of data).

At the completion of this process, the relevant machine data and – in some cases – also the standard PLC program must be adapted accordingly, depending on the hardware configuration.



Two PLC projects are contained in the Toolbox:

- ManMach_MCP.ptp: designed for use on the standard machine control panel
- ManMach_3DIO.ptp: designed as described in Section 7.8 (with I/O modules)

7.3 Switching the user interface



From “Manual Machine” to Siemens standard:

To switch to the Siemens standard user interface, proceed as follows (always start from the 2nd extension of the basic menu):

- Press the  key to call the password input screenform.
- Enter the password “1111” and press the  key to confirm.
- Press the  key once more and then press the “OK” function key to switch to the standard user interface.

From Siemens standard to “Manual Machine”:

To switch back to the “Manual Machine” screenform, proceed as follows:



- Press the  key to switch to the main selection screenform.
- Press the  to extend the function key bar.
- Press the “Man. Mach” function key to switch to the “manual Machine” screenform area.

7.4 Switching the language

In the “Manual Machine” operating area:

How to switch the language in the “Manual Machine” operating area is described in detail in the “Operator’s Guide Sinumerik 802S/C, Manal Machine” in the Chapter “Service Functions”.

In the Siemens standard user interface:

- Press the  key to call the main selection screenform.
- Press the “Diagnosis” function key.
- Press the  key to extend the function key bar.
- Press the “Language changeover” function key to switch to the alternative language.

7.5 Additional machine data**Limitations:**

MD 14514 [0]	\$MN_USER_DATA_FLOAT [0]	Max. input value for “Cut meters”
--------------	--------------------------	-----------------------------------

Lubrication:

MD 14510 [1]	\$MN_USER_DATA_INT [1]	Lubrication time (x 100ms)
MD 14510 [2]	\$MN_USER_DATA_INT [2]	Lubrication pause (x 100ms)

Spindle shutdown in “Chuck key position”:

MD 14510 [0]	\$MN_USER_DATA_INT [0]	Time monitoring Spindle positioning (x 100ms)
MD 14514 [1]	\$MN_USER_DATA_FLOAT [1]	Starting speed Spindle positioning
MD 14514 [2]	\$MN_USER_DATA_FLOAT [2]	Tolerance window Spindle positioning
MD 35160 [4]	\$MA_SPIND_EXTERN_VELO_LIMIT [2]	Spindle speed limitation from PLC Spindle positioning

7.6 Input limitations with regard to the user interface

Spindle:	0 < speed	< MD 35100 [4]	\$MA_SPIND_VELO_LIMIT [4]
	0 < cut meters	< MD 14514 [0]	\$MN_USER_DATA_FLOAT [4]
Feedrate:	0 < Time feedrate	< MD 32020 [1]	\$MA_JOG_VELO [1]
	0 < Revolutional feedrate	< MD 32050 [1]	\$MA_JOG_REV_VELO [1]

7.7 Operation without machine control panel (MCP)

7.7 Operation without machine control panel (MCP)

If you wish to run the control system without machine control panel (MCP), then connect a jumper between pin 24 and pin 5 to connector X1002 on the installed operator panel; otherwise, the control system will not power up.

7.8 I/O assignment in the standard PLC program

The standard PLC program supplied with the Toolbox is designed for subsequent I/O assignments where currently only modules of the DI/O16 type can be used.

7.8.1 Assignment of the digital inputs:

1st module:

I 0.0 *	Reference switch X axis	X2003	Pin 2	DI 0
I 0.1 *	Reference switch Z axis	X2003	Pin 3	DI 1
I 0.2	Limit position X axis	X2003	Pin 4	DI 2
I 0.3	Limit position Z axis (tailstock collision switch)	X2003	Pin 5	DI 3
I 0.4		X2003	Pin 6	DI 4
I 0.5	Chuck guard closed	X2003	Pin 7	DI 5
I 0.6	Lubrication filling level	X2003	Pin 8	DI 6
I 0.7	Lubrication pressure	X2003	Pin 9	DI 7
I 1.0		X2004	Pin 2	DI 8
I 1.1	Protective door closed	X2004	Pin 3	DI 9
I 1.2	Drive ready	X2004	Pin 4	DI 10
I 1.3 *	I2t monitoring of drive tripped	X2004	Pin 5	DI 11
I 1.4		X2004	Pin 6	DI 12
I 1.5		X2004	Pin 7	DI 13
I 1.6	Spindle jogging key	X2004	Pin 8	DI 14
I 1.7		X2004	Pin 9	DI 15

2nd module:

I 2.0	Retract axis (bypass limit switch)	X2003	Pin 2	DI 0
I 2.1 *	Q21 230V power supply missing	X2003	Pin 3	DI 1
I 2.2		X2003	Pin 4	DI 2
I 2.3 *	Q4 Motor circuit-breaker coolant pump tripped	X2003	Pin 5	DI 3
I 2.4 *	Q2 Motor circuit-breaker spindle external ventilation tripped	X2003	Pin 6	DI 4
I 2.5	Coolant pump is ON	X2003	Pin 7	DI 5
I 2.6	Single block active	X2003	Pin 8	DI 6
I 2.7 *	EMERGENCY STOP	X2003	Pin 9	DI 7
I 3.0		X2004	Pin 2	DI 8
I 3.1		X2004	Pin 3	DI 9
I 3.2		X2004	Pin 4	DI 10
I 3.3		X2004	Pin 5	DI 11
I 3.4	Spindle CCW rotation	X2004	Pin 6	DI 12
I 3.5	Spindle CW rotation	X2004	Pin 7	DI 13
I 3.6	Handwheel evaluation bit 1	X2004	Pin 8	DI 14
I 3.7	Handwheel evaluation bit 2	X2004	Pin 9	DI 15

3rd module:

I 4.0	Spindel override bit 1	X2003	Pin 2	DI 0
I 4.1	Spindel override bit 2	X2003	Pin 3	DI 1
I 4.2	Spindel override bit 3	X2003	Pin 4	DI 2
I 4.3	Spindel override bit 4	X2003	Pin 5	DI 3
I 4.4	Feed override bit 1	X2003	Pin 6	DI 4
I 4.5	Feed override bit 2	X2003	Pin 7	DI 5
I 4.6	Feed override bit 3	X2003	Pin 8	DI 6
I 4.7	Feed override bit 4	X2003	Pin 9	DI 7
I 5.0	Star handle axis direction X+	X2004	Pin 2	DI 8
I 5.1	Star handle axis direction X-	X2004	Pin 3	DI 9
I 5.2	Star handle axis direction Z+	X2004	Pin 4	DI 10
I 5.3	Star handle axis direction Z-	X2004	Pin 5	DI 11
I 5.4	Rapid traverse override axes	X2004	Pin 6	DI 12
I 5.5	Star handle 0 position	X2004	Pin 7	DI 13
I 5.6	Cycle start key	X2004	Pin 8	DI 14
I 5.7 *	Cycle stop key	X2004	Pin 9	DI 15

All inputs marked with a * possess an inverted logics, i.e. their meanings refer to the signal status "LOW", and with all of the remaining inputs to the signal status "HIGH".

7.8.2 Assignment of the digital outputs:

1st module:

O 0.0		X2005	Pin 2	DO 0
O 0.1	Pulse enable drive I/RF module	X2005	Pin 3	DO 1
O 0.2	Pulse enable drive	X2005	Pin 4	DO 2
O 0.3	Coolant pump ON	X2005	Pin 5	DO 3
O 0.4	Secondary power ON	X2005	Pin 6	DO 4
O 0.5	Fault general	X2005	Pin 7	DO 5
O 0.6	Fault lubrication	X2005	Pin 8	DO 6
O 0.7		X2005	Pin 9	DO 7
O 1.0	Ready	X2006	Pin 2	DO 8
O 1.1		X2006	Pin 3	DO 9
O 1.2		X2006	Pin 4	DO 10
O 1.3	Lubrication axes	X2006	Pin 5	DO 11
O 1.4		X2006	Pin 6	DO 12
O 1.5		X2006	Pin 7	DO 13
O 1.6		X2006	Pin 8	DO 14
O 1.7		X2006	Pin 9	DO 15

2nd module:

O 2.0	Spindle contactor (control)	X2005	Pin 2	DO 0
O 2.1		X2005	Pin 3	DO 1
O 2.2	Bypass axis limit switch	X2005	Pin 4	DO 2
O 2.3		X2005	Pin 5	DO 3
O 2.4		X2005	Pin 6	DO 4
O 2.5		X2005	Pin 7	DO 5
O 2.6		X2005	Pin 8	DO 6
O 2.7		X2005	Pin 9	DO 7
O 3.0		X2006	Pin 2	DO 8
O 3.1		X2006	Pin 3	DO 9
O 3.2		X2006	Pin 4	DO 10
O 3.3		X2006	Pin 5	DO 11
O 3.4		X2006	Pin 6	DO 12
O 3.5		X2006	Pin 7	DO 13
O 3.6		X2006	Pin 8	DO 14
O 3.7		X2006	Pin 9	DO 15

7.9 Default assignment of special data for the “Manual machine”

3rd module:

O 4.0		X2005	Pin 2	DO 0
O 4.1	PLC cycle time	X2005	Pin 3	DO 1
O 4.2		X2005	Pin 4	DO 2
O 4.3		X2005	Pin 5	DO 3
O 4.4		X2005	Pin 6	DO 4
O 4.5		X2005	Pin 7	DO 5
O 4.6		X2005	Pin 8	DO 6
O 4.7		X2005	Pin 9	DO 7
O 5.0		X2006	Pin 2	DO 8
O 5.1		X2006	Pin 3	DO 9
O 5.2		X2006	Pin 4	DO 10
O 5.3		X2006	Pin 5	DO 11
O 5.4		X2006	Pin 6	DO 12
O 5.5		X2006	Pin 7	DO 13
O 5.6		X2006	Pin 8	DO 14
O 5.7		X2006	Pin 9	DO 15

7.9 Default assignment of special data for the “Manual machine”

Machine data:

MD 12010	\$MN_OVR_FACTOR_AX_SPEED[1]	0.1
MD 12010	\$MN_OVR_FACTOR_AX_SPEED[2]	0.2
MD 12010	\$MN_OVR_FACTOR_AX_SPEED[3]	0.3
MD 12010	\$MN_OVR_FACTOR_AX_SPEED[4]	0.4
MD 12010	\$MN_OVR_FACTOR_AX_SPEED[5]	0.5
MD 12010	\$MN_OVR_FACTOR_AX_SPEED[6]	0.6
MD 12010	\$MN_OVR_FACTOR_AX_SPEED[7]	0.7
MD 12010	\$MN_OVR_FACTOR_AX_SPEED[8]	0.8
MD 12010	\$MN_OVR_FACTOR_AX_SPEED[9]	0.9
MD 12010	\$MN_OVR_FACTOR_AX_SPEED[10]	0.95
MD 12010	\$MN_OVR_FACTOR_AX_SPEED[11]	1
MD 12010	\$MN_OVR_FACTOR_AX_SPEED[12]	1.05
MD 12010	\$MN_OVR_FACTOR_AX_SPEED[13]	1.1
MD 12010	\$MN_OVR_FACTOR_AX_SPEED[14]	1.2
MD 12010	\$MN_OVR_FACTOR_AX_SPEED[15]	1.2
MD 12010	\$MN_OVR_FACTOR_AX_SPEED[16]	1.2
MD 12010	\$MN_OVR_FACTOR_AX_SPEED[17]	1.2
MD 12010	\$MN_OVR_FACTOR_AX_SPEED[18]	1.2

7.9 Default assignment of special data for the "Manual machine"

MD 12010	\$MN_OVR_FACTOR_AX_SPEED[19]	1.2
MD 12010	\$MN_OVR_FACTOR_AX_SPEED[20]	1.2
MD 12010	\$MN_OVR_FACTOR_AX_SPEED[21]	1.2
MD 12030	\$MN_OVR_FACTOR_FEEDRATE[1]	0.1
MD 12030	\$MN_OVR_FACTOR_FEEDRATE[2]	0.2
MD 12030	\$MN_OVR_FACTOR_FEEDRATE[3]	0.3
MD 12030	\$MN_OVR_FACTOR_FEEDRATE[4]	0.4
MD 12030	\$MN_OVR_FACTOR_FEEDRATE[5]	0.5
MD 12030	\$MN_OVR_FACTOR_FEEDRATE[6]	0.6
MD 12030	\$MN_OVR_FACTOR_FEEDRATE[7]	0.7
MD 12030	\$MN_OVR_FACTOR_FEEDRATE[8]	0.8
MD 12030	\$MN_OVR_FACTOR_FEEDRATE[9]	0.9
MD 12030	\$MN_OVR_FACTOR_FEEDRATE[10]	0.95
MD 12030	\$MN_OVR_FACTOR_FEEDRATE[11]	1
MD 12030	\$MN_OVR_FACTOR_FEEDRATE[12]	1.05
MD 12030	\$MN_OVR_FACTOR_FEEDRATE[13]	1.1
MD 12030	\$MN_OVR_FACTOR_FEEDRATE[14]	1.2
MD 12030	\$MN_OVR_FACTOR_FEEDRATE[15]	1.2
MD 12030	\$MN_OVR_FACTOR_FEEDRATE[16]	1.2
MD 12030	\$MN_OVR_FACTOR_FEEDRATE[17]	1.2
MD 12030	\$MN_OVR_FACTOR_FEEDRATE[18]	1.2
MD 12030	\$MN_OVR_FACTOR_FEEDRATE[19]	1.2
MD 12030	\$MN_OVR_FACTOR_FEEDRATE[20]	1.2
MD 12030	\$MN_OVR_FACTOR_FEEDRATE[21]	1.2
MD 12050	\$MN_OVR_FACTOR_RAPID_TRA[1]	0.1
MD 12050	\$MN_OVR_FACTOR_RAPID_TRA[2]	0.2
MD 12050	\$MN_OVR_FACTOR_RAPID_TRA[3]	0.3
MD 12050	\$MN_OVR_FACTOR_RAPID_TRA[4]	0.4
MD 12050	\$MN_OVR_FACTOR_RAPID_TRA[5]	0.5
MD 12050	\$MN_OVR_FACTOR_RAPID_TRA[6]	0.6
MD 12050	\$MN_OVR_FACTOR_RAPID_TRA[7]	0.7
MD 12050	\$MN_OVR_FACTOR_RAPID_TRA[8]	0.8
MD 12050	\$MN_OVR_FACTOR_RAPID_TRA[9]	0.9
MD 12050	\$MN_OVR_FACTOR_RAPID_TRA[10]	0.95
MD 12050	\$MN_OVR_FACTOR_RAPID_TRA[11]	1
MD 12050	\$MN_OVR_FACTOR_RAPID_TRA[12]	1
MD 12050	\$MN_OVR_FACTOR_RAPID_TRA[13]	1
MD 12050	\$MN_OVR_FACTOR_RAPID_TRA[14]	1
MD 12050	\$MN_OVR_FACTOR_RAPID_TRA[15]	1
MD 12050	\$MN_OVR_FACTOR_RAPID_TRA[16]	1
MD 12050	\$MN_OVR_FACTOR_RAPID_TRA[17]	1
MD 12202	\$MN_PERMANENT_FEED[0]	350
MD 12202	\$MN_PERMANENT_FEED[1]	1000

7.9 Default assignment of special data for the "Manual machine"

MD 12202	\$MN_PERMANENT_FEED[2]	2000
MD 12202	\$MN_PERMANENT_FEED[3]	3500
MD 14510	\$MN_USER_DATA_INT[0]	300
MD 14510	\$MN_USER_DATA_INT[1]	20
MD 14510	\$MN_USER_DATA_INT[2]	600
MD 14514	\$MN_USER_DATA_FLOAT[0]	1000
MD 14514	\$MN_USER_DATA_FLOAT[1]	22
MD 14514	\$MN_USER_DATA_FLOAT[2]	15
MD 18118	\$MN_MM_NUM_GUD_MODULES	2
MD 18120	\$MN_MM_NUM_GUD_NAMES_NCK	14
MD 18150	\$MN_MM_GUD_VALUES_MEM	30
MD 20150	\$MC_GCODE_RESET_VALUES[7]	2
MD 20150	\$MC_GCODE_RESET_VALUES[14]	2
MD 20150	\$MC_GCODE_RESET_VALUES[27]	1
MD 31090	\$MA_JOG_INCR_WEIGHT[AX1]	0.0005
MD 32084	\$MA_HANDWH_STOP_COND[AX1]	H2ff
MD 32084	\$MA_HANDWH_STOP_COND[AX3]	H2ff
MD 35040	\$MA_SPIND_ACTIVE_AFTER_RESET[AX4]	1
MD 35160	\$MA_SPIND_EXTERN_VELO_LIMIT[AX4]	18

Setting data:

MD 41110	\$SN_JOG_SET_VELO	500
MD 41120	\$SN_JOG_REV_SET_VELO	0.2
MD 41130	\$SN_JOG_ROT_AX_SET_VELO	100
MD 41200	\$SN_JOG_SPIND_SET_VELO	100
MD 42100	\$SC_DRY_RUN_FEED	10
MD 42440	\$SC_FRAME_OFFSET_INCR_PROG	0
MD 42442	\$SC_TOOL_OFFSET_INCR_PROG	0
MD 43300	\$SA_ASSIGN_FEED_PER_REV_SOURCE[AX4]	0

R parameters:

R[4]	1
------	---

www.nicsanat.com

021-87700210



SINUMERIK 802C
6FC5 597-3AA20-0BP2 (01.02)

Index

A

Access levels, 4-42

B

Boot messages, 4-48

C

Configuration of the RS232 interface connection (X8), 2-27
 Connecting handwheels (X10), 2-29
 Connecting NCREADY (X20), 2-30
 Connecting the digital inputs and outputs (X2003 ... X2006), 2-31
 Connecting the Feed Drives (X2), 2-23
 Connecting the individual components, 2-21
 Connecting the Operator Panel, 2-21
 Connecting the spindle drive (X3), 2-26
 Connection diagram, 2-20

E

ENC and operator panel power supply (X1), 2-35
 Encoder matching to spindles, 4-77

G

Grounding, 2-36
 Grounding diagram, 2-36

I

Installing and Dismantling the SINUMERIK 802C, 2-15

Interfaces and cables, 2-18

L

LEDs and operating elements on the ENC unit, 2-38

M

Machine and Setting Data, Unit, 4-43
 Manual machine, 7-125
 Default assignment, 7-133
 I/O assignment, 7-130
 Installation, 7-125
 Machine data, 7-129
 Switching the language, 7-128
 Switching the user interface, 7-128

P

Protection levels, 4-42

S

Spindel data, Spindle modes, 4-85

U

Updating the System Software, 5-91

SIEMENS AG
A&D MC BMS
Postfach 3180
D-91050 Erlangen

(Tel. +49 180 / 5050 – 222 [Hotline]
Fax +49 9131 / 98 – 2176 [Documentation]
Mailto: motioncontrol.docu@erlf.siemens.de)

Suggestions

Corrections

for Publication/Manual:

SINUMERIK 802C

Manufacturer Documentation

Start-Up

Order No.: 6FC5597-3AA20-0BP2

Edition: 01.02

Should you come across any printing errors when reading this publication, please notify us on this sheet.

Suggestions for improvement are also welcome.

From

Name

Company/dept.

Street

Zip code: City:

Telephone: /

Telefax: /

Suggestions and/or corrections

www.nicsanat.com

021-87700210



www.nicsanat.com

021-87700210



SINUMERIK 802S and 802C Document Structure

General Documentation: **Catalog**



User Manual: **Operation and Programming**



User Manual: **Diagnostics Guide**



Technical Manual: **Start-Up**

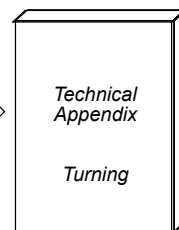
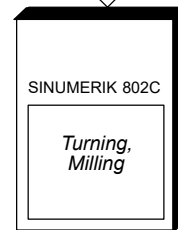
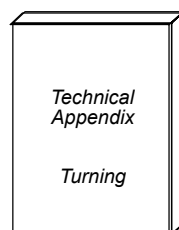

Technical Manual: **Description of Functions**

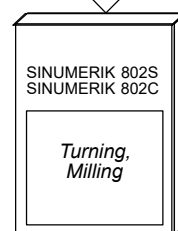



www.nicsanat.com

021-87700210

Siemens AG

Automatisierungs- und Antriebstechnik
Motion Control Systems
Postfach 3180, D – 91050 Erlangen
Bundesrepublik Deutschland

www.ad.siemens.de

© Siemens AG 2002
Subject to change without prior notice
Order No.: 6FC5597-3AA20-0BP2

Printed in the Federal Republic of Germany