

sinumerik & sinamics



SINUMERIK 802D sl with
SINAMICS S120



NIC SANAT
انیک صنعت

www.nicsanat.com

021-87700210

SIEMENS

Related catalogs

SITRAIN

Training for Automation and Industrial Solutions

Order No.:

Paper: E86060-K6850-A101-B5

CD-ROM: E86060-D6850-A100-C2-7400

ITC



A&D Mall

Internet:

www.siemens.com/automation/mall



Offline Mall for Automation and Drives

CA 01



Order No.:

CD-ROM: E86060-D4001-A110-C3-7600

CD-ROM for catalog NC 802D sl

In the supplied CD-ROM for catalog NC 802D sl · 2005 you will find:

- Information about planning/configuring based on the technical documentation; further technical documentation can be found at: www.siemens.com/automation/doconweb
- Dimension drawings of our motors (PDF/DXF format)
- Glossary explaining terms and functions
- Catalog NC 802D sl in electronic form (PDF format)

Hardware and software requirements

- Intel Pentium 333 MHz (or higher)
- Minimum 128 MB of RAM
- Screen resolution 1024 x 768 pixels
- 4x CD-ROM drive
- Windows 98 SE/NT 4.x/2000/XP
- Acrobat Reader
- MS Internet Explorer 5.5 and newer

Start

Insert the CD-ROM into the CD-ROM drive. The program starts automatically. If the AutoRun function is not activated in your system, start file "start.hta" from the CD-ROM using the Windows Explorer.

Note

Installation is not necessary to view the information on this CD-ROM. This does not apply, however, when using the dimension drawings in DXF format.

Hotline

Please send any questions or suggestions to: motioncontrol.docu@erlf.siemens.de



Trademarks

All product designations may be trademarks or product names of Siemens AG or supplier companies whose use by third parties for their own purposes could violate the rights of the owners.

www.nicsanat.com

021-87700210



SINUMERIK 802D sl

Catalog

NC 802D sl · 2005



The products described in this catalog also appear in CD-ROM catalog CA 01

Contact your local Siemens representative for further information

© Siemens AG 2005



The products and systems described in this catalog are marketed on the basis of a certified quality management system in accordance with DIN EN ISO 9001 (Certificate Registration No. 001258 QM) and DIN EN ISO 14001 (Certificate Registration No. 081342 UM). The certificates are recognized in all IQNet countries.

SIEMENS

Introduction

Welcome to Automation and Drives
Topology
Configuration tool

1

Overview of functions

2

SINUMERIK 802D sl

3

SINAMICS S120

Line-side power components
Line/Motor Modules
DC link components
Encoder system connections

4

AC motors

Synchronous motors
Asynchronous motors
Gear units
Selection guide

5

Connection system

MOTION-CONNECT
DRIVE-CLiQ
Power cables
Signal cables

6

Appendix

Service & Support
A&D online services
Directories
Conditions of sale and delivery
Export regulations

7

Welcome to Automation and Drives

We would like to welcome you to Automation and Drives and our comprehensive range of products, systems, solutions and services for production and process automation and building technology worldwide.

With Totally Integrated Automation and Totally Integrated Power, we deliver solution platforms based on standards that offer you a considerable savings potential.

Discover the world of our technology now. If you need more detailed information, please contact one of your regional Siemens partners.

They will be glad to assist you.





Topology SINUMERIK 802D sl



Compact operator panel control for turning and milling applications

The SINUMERIK 802D "solution line" constitutes the ideal control for applications ranging from simple turning and milling tasks to complex turning jobs such as face and peripheral surface machining or complex milling operations like three-axis "mold making". Thanks to its modular design and simple start-up procedure, the control is ideal for machines in the lower and medium power range.

Operation of the SINUMERIK 802D sl, based on ShopMill/ ShopTurn, completes the SINUMERIK product range with the required "simplicity" of control.

Modularity of drives

The control has been optimally coordinated with the new drives from the SINAMICS S120 range. In this combination, the strengths of both control system and drive can be fully exploited. As ever, the modular drive system is the option with the greatest potential for achieving the right balance between performance and cost. It is possible to choose between Single or Double Motor Modules from the SINAMICS range, enabling you to configure the optimum system for your needs.

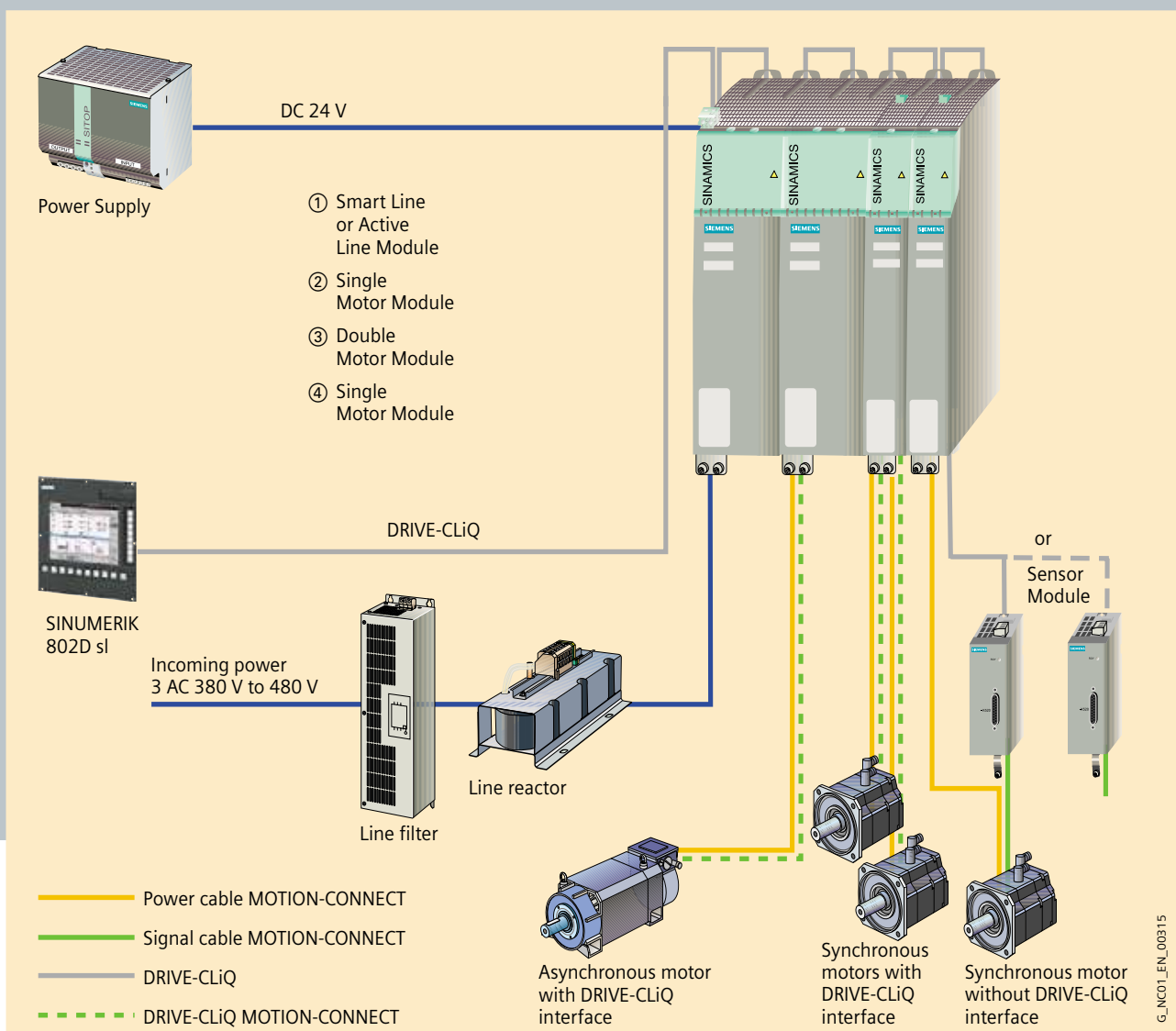

Topology

SINUMERIK 802D sl



DRIVE-CLiQ – the digital interface between all components

All components of the SINUMERIK 802D sl and SINAMICS S120 systems, as well as the motors and encoders, are now interconnected via a shared serial interface – DRIVE-CLiQ. A standardized connector system reduces the multiplicity of connection components and eases stockkeeping. Cable connections are simpler and easier to install.

Integrated closed-loop control

With the closed-loop control for up to 6 drives that is now integrated in the control system, the SINUMERIK 802D sl is forging a new path. It is no longer necessary to exchange data between the CNC and drive control in order to implement motion control tasks. This is now performed directly as an internal cross-drive function, saving the time and effort previously required to configure the connections. An ever increasing number of tasks relating to the drive can be solved directly in the control, making the start-up process even easier.



The configuration tool SINAMICS MICROMASTER SIZER

The SIZER tool is a fast and simple mechanism for configuring the **SINAMICS S120** drives and the **SINUMERIK 802D sl** control.

The tool helps you with the technical configuring of components needed to implement a drive application. SIZER guides you through every stage of the configuration, from the mains supply to the drive components and motors. Motors are configured by means of standardized load characteristics, pulse drives or free load cycles. The drive components needed (e.g. power sections, infeds) are determined by calculation. The configuration completes the drive system with supplementary components (e.g. sensor modules, terminal expansion, cables, reactor and filters).

The guided configuring process helps beginners to use the tool. Status information keeps them up to date with their progress and the online help displays configuring tips. Apart from the calculation data, characteristics are also displayed to facilitate optimization and highlight spare capacity. The parts list can be downloaded to the SAP-VSR ordering system by the export function.

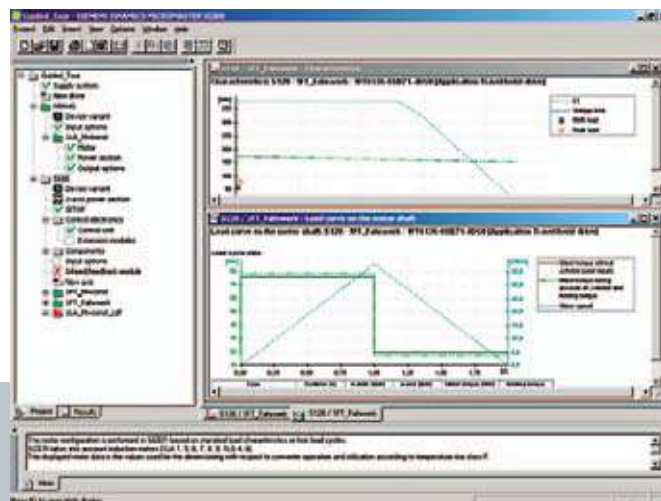

Minimum hardware and software requirements:

- PG or PC with Pentium II 400 MHz (2000), Pentium III 500 MHz (XP)
- 256 MB RAM
- At least 600 MB free hard disk capacity
- Additional 100 MB free hard disk capacity on Windows system drive
- Monitor resolution 1024 x 768 pixels
- Windows 2000/SP2, XP/SP1
- Microsoft Internet Explorer 5.5/SP2

Use

The SINAMICS MICROMASTER SIZER can be used free of charge. A token charge is made for order handling.

The user interface languages are German/English. You can obtain your SINAMICS MICROMASTER SIZER configuring tool from your local Siemens sales office, quoting order number: **6SL3070-0AA00-0AG0**.

Overview of functions



2/2	SINUMERIK 802D sl CNC system
2/2	Control structure/application
2/2	Measuring systems that can be connected
2/3	CNC functionality <ul style="list-style-type: none"> - Program functions - Axis functions - Spindle functions - Interpolations
2/4	CNC functionality <ul style="list-style-type: none"> - Transformations - Measuring - Motion-synchronous actions - Language - Cycles
2/5	CNC programming <ul style="list-style-type: none"> - Programming support
2/5	Parameters
2/5	Simulation
2/5	Operating modes
2/6	Tools
2/6	Communication and data management
2/6	Operation
2/7	Axis monitoring functions
2/7	Compensations
2/8	PLC area
2/8	Monitoring functions
2/8	Start-up
2/8	Diagnostic functions

Overview of functions SINUMERIK 802D sl CNC system

2

- Standard (basic functionality)
- Option
- Not available

Order No.

SINUMERIK 802D sl

T/M
plus

T/M
pro

Control structure/application

Panel-based design			
Drives	See Drive System		
• SINAMICS S120 Motor Module linked via DRIVE-CLiQ		●	●
Channels/mode groups (MGs)		1	1
• Maximum configuration		1	1
CNC <u>main</u> memory (buffered) for programs and data in MB		1	10
CNC <u>main</u> memory, maximum configuration		1	10
Axes/spindles		● 1)	● 1)
• Maximum configuration of axes		● 1)	● 1)
• Maximum configuration of spindles		● 1)	● 1)
• Maximum configuration of axes and spindles		● 1)	● 1)
• Configuration per channel axes incl. spindles		● 1)	● 1)
PLC-controlled axis		● 4)	● 4)

Measuring systems that can be connected

Max. number		2)	2)
Incremental rotary measuring systems with RS 422 (TTL)		● 3)	● 3)
Linear scale LMS with sin/cos 1 V _{pp}			
• via SINAMICS Sensor Module SMC/SME		–	–
Linear scale LMS with distance-coded reference marks			
• via SINAMICS Sensor Module SMC/SME		–	–
Linear scale LMS with EnDat			
• via SINAMICS Sensor Module SMC/SME		–	–
Rotary measuring systems with distance-coded reference marks			
• via SINAMICS Sensor Module SMC/SME		–	–
Absolute encoder connection with EnDat linear/rotary			
• via SINAMICS Sensor Module SMC/SME		–	–
Absolute/incremental encoder installed in 1FT6/1FK			
• integrated in motor via SINAMICS S120 + Sensor Module		●	●
Incremental encoder with sin/cos 1 V _{pp}			
• via SINAMICS Sensor Module SMC/SME		–	–
Resolver integrated in 1FT6/1FK via SINAMICS S120 with Sensor Module SMC/SME/motor-integrated		–	–

- 1) 4 axes + 1 spindle or 3 axes + 1 spindle + 2nd spindle for rotating tool.
- 2) One measuring system per axis.
- 3) SINAMICS SMC Sensor Module required for max. one measuring system (spindle).
- 4) Available soon.

Overview of functions SINUMERIK 802D sl CNC system

2

	Order No.	SINUMERIK 802D sl	
		T/M plus	T/M pro
<ul style="list-style-type: none"> ● Standard (basic functionality) ○ Option – Not available 			

CNC functionality: Program functions

Dynamic preprocessing memory (FIFO)		●	●
Look ahead		50	100
Frame system		●	●

CNC functionality: Axis functions

Feedrate override of 0 ... 200%		●	●
Traversing range ± 9 decades		●	●
Rotary axis, turning endlessly		–	–
Velocity, max. 300 m/s		●	●
Acceleration with jerk limitation		●	●
Programmable acceleration		●	●
Follow-up mode		●	●
Separate path feed for corners and chamfers		●	●
Traversing to fixed stop		● 1)	● 1)

CNC functionality: Spindle functions

Digital spindle speed		●	●
Spindle speed, max. programmable value range: REAL ±3.4028 ex 38 (display: ± 999 999 999.9999)		●	●
Spindle override of 0 ... 200%		●	●
5 gear stages		●	●
Automatic gear stage selection		●	●
Oriented spindle stop		●	●
Spindle speed limitation (min. and max.)		●	●
Constant cutting rate		●	●
Spindle control via PLC (positioning, oscillation)		–	–
Changeover to axis mode		●	●
Thread cutting with constant or variable pitch		●	●
Tapping with compensating chuck/rigid tapping		●	●

CNC functionality: Interpolations

Linear interpolation axes		● 4	● 4
• Maximum		4	4
Circle via center point and end point		●	●
Circle via interpolation point		●	●
Helical interpolation		2D+2	2D+2

1) Available soon.

Overview of functions SINUMERIK 802D sl CNC system

2

- Standard (basic functionality)
- Option
- Not available

Order No.

SINUMERIK 802D sl

T/M
plus

T/M
pro

CNC functionality: Transformations

TRANSMIT/peripheral surface transformation

●

●

CNC functionality: Measuring

Measuring Stage 1
Probe (touch trigger)

●

●

CNC functionality: Motion-synchronous actions

High-speed CNC inputs/outputs

- Digital inputs onboard
- Digital inputs or outputs onboard

–

–

–

–

CNC programming: Language

Programming language (DIN 66025 and high-level language expansion)

●

●

Subroutine levels and interrupt routines, max.

8/0

8/0

Number of subroutine repetitions ≤ 9999

●

●

Number of levels for skippable blocks (/0 to /...)

1

1

Polar coordinates

●

●

1/2/3-point contours

●

●

Dimensions metric/inch, changeover manually or via program

●

●

Auxiliary function output

- Via M word, max. programmable value range: INT $2^{31} - 1$
- Via H word, max. programmable value range:
REAL $\pm 3.4028 \times 38$ (display: $\pm 999\,999\,999.9999$) INT -2^{31} to $2^{31} - 1$

●

●

●

●

High-level language CNC with

- Predefined user variables (arithmetic parameters)
- Indirect programming
- Program jumps and branches
- Arithmetic and trigonometric functions
- Comparing operations and logic combinations
- Control structures IF-ELSE-ENDIF

●

●

●

●

●

●

●

●

●

●

●

●

Online ISO dialect interpreter

●

●

Program/workpiece management

- Number of part programs on NC, max.
on supplementary CF card
on network drive

99

99

●

●

–

●

1)

CNC programming: Cycles

Process-oriented cycles for drilling/milling and turning

●

●

Access protection for cycles

●

●

1) Available soon.

Overview of functions SINUMERIK 802D sl CNC system

<ul style="list-style-type: none"> ● Standard (basic functionality) ○ Option – Not available 	Order No.	SINUMERIK 802D sl	
		T/M plus	T/M pro

CNC programming: Programming support

Program editor			
• Text editor with editing functions: Marking, copying, deleting, ...		●	●
Programming support for geometry entries			
• Screens for 1/2/3-point contours		●	●
Programming support for cycles			
• Screens and stationary auxiliary displays		●	●
• Programming support expandable (e.g. customer cycles)		1)	1)

Parameters

Number of basic frames, max.		1	1
Number of settable offsets, max.		6	6
Scratching, determining work offset		●	●

Simulation

Drilling/milling (toolholder vertical to the workpiece)			
• Single-sided 2D view, dynamic		●	●
Turning (toolholder vertical to the workpiece)			
• Traverse path simulation without model (broken-line graphics)		●	●

Operating modes

JOG		●	●
• Handwheel selection		●	●
• Inch/metric changeover		●	●
• Manual measurement of work offset		●	●
• Manual measurement of tool compensation		●	●
• Automatic tool measurement		●	●
• Reference point approach, automatic/via CNC program		●	●
MDA		●	●
• Input in text editor		●	●
• Save MDA program		●	●
Teach In		●	●
• Teach positions in MDA buffer		●	●
		2)	2)
Automatic		●	●
• Execute from internal memory and/or CF card		●	●
• Execute from RS 232 C interface		–	–
• Execute from network drive		–	●
			2)
• Program control		●	●
• Program editing		●	●
• Block search with/without calculation		●	●

(02/05)

1) On request.
2) Available soon.

Overview of functions SINUMERIK 802D sl CNC system

2

- Standard (basic functionality)
- Option
- Not available

Order No.

SINUMERIK 802D sl

T/M
plus

T/M
pro

Operating modes (continued)

Repos (repositioning on the contour)

- With operator command/semi-automatically
- Program-controlled

Tools

Tool types:

- Turning
- Drilling/milling

Tool radius compensations in plane

- With transition circle/ellipse on outer edges

Tool change via T number

Look-ahead detection of contour violations

Operation without tool management

- Editing of tool data
- Tool compensation selection via T and D numbers
- Number of tools/cutting edges in tool list

Monitoring of tool life and workpiece count

Communication and data management

Serial interfaces RS 232 C

Ethernet connection

I/O interfacing via PROFIBUS DP

Save data to internal memory and/or CF card

Save data via RS 232 C interface

Save data to network drive (Ethernet)

Operation

SINUMERIK 802D sl operator panel, 10.4", color

Handheld units

- Mini handheld unit with coiled connecting lead
- Mini handheld unit with straight connecting lead

Machine control panels

- Machine Control Panel MCP
- Machine Control Panel MCP 802D sl ¹⁾

1) Available soon.

Overview of functions SINUMERIK 802D sl CNC system

2

- Standard (basic functionality)
- Option
- Not available

Order No.

SINUMERIK 802D sl

T/M
plus

T/M
pro

Operation (continued)

Connection of electronic handwheels		2	2
• with 120 mm x 120 mm front panel, 5 V operating voltage	6FC9320-5DB00	○	○
• with 76 mm x 76 mm front panel, 5 V operating voltage	6FC9320-5DC00	○	○
Keyboards			
• Full CNC keyboard 802D sl, horizontal format	6FC5303-0DM13-1AA0	○	○
• Full CNC keyboard 802D sl, vertical format	6FC5303-0DT12-1AA0	○	○
CNC program messages		●	●
Online help for programming, alarms and machine data (expandable)		●	●
Access protection, 8 levels		●	●
Operating software languages			
• 2 languages switchable online		●	●
• Chinese Simplified, German, English		●	●
• Chinese Traditional, Korean		● 2)	● 2)
• Other languages		○ 1)	○ 1)

Axis monitoring

Working area limitation		●	●
Software and hardware limit switch monitoring		●	●
Position monitoring		●	●
Standstill monitoring		●	●
Clamping monitoring		●	●
Contour monitoring		●	●

Compensations

Backlash compensation		●	●
Leadscrew error compensation		●	●
Measuring system error compensation		●	●
Feedforward control, speed-dependent		–	●
Friction compensation		●	●

- 1) On request.
2) Available soon.

Overview of functions SINUMERIK 802D sl CNC system

2

- Standard (basic functionality)
- Option
- Not available

Order No.

SINUMERIK 802D sl

T/M
plus

T/M
pro

PLC area

SIMATIC S7-200 (integrated)		●	●
Machining time, typically in ms/KI for bit operations ¹⁾		0.1	0.1
Machining time, typically in ms/KI for word operations ¹⁾		0.2	0.2
Ladder steps memory configuration		6000	6000
• LAD ladder diagram		●	●
PLC programming tool, PLC program examples, standard machine data and alarm text editor on Toolbox		●	●
PP 72/48 I/O module max. number	6FC5611-0CA01-0AA0	○ 3	○ 3
Digital inputs, maximum		216	216
Digital outputs, maximum		144	144
Bit memories, max. number		3072	3072
Timers, max. number		40	64
Counters, max. number		32	64
Subroutines		64	64
Cyclic function block		●	●
Equipment for PLC programming and program test with PG/PC		○	○
User machine data for configuring the PLC user program		●	●

Monitoring functions

Spindle speed limitation		●	●
--------------------------	--	---	---

Start-up

Start-up software integrated for SINAMICS S120 drive system		●	●
Series start-up via a serial interface		●	●
Series start-up via CF card		●	●
PLC samples library (PLC templates)		●	●
Starter start-up tool for SINAMICS	6SL3072-0AA00-0AG0	●	●

Diagnostic functions

Alarms and Messages		●	●
Trip recorder can be activated for diagnostic purposes		● 2) 5)	● 2) 5)
PLC status		●	●
LAD display		●	●
PLC remote diagnostics via modem		○ 3) 5)	○ 3) 5)
PLC remote diagnostics via Ethernet		–	● 4) 5)
RCS 802 (Remote Control System, remote diagnostics for SINUMERIK 802D sl)		○ 5)	○ 5)

1) 1 KI = 1024 instructions, corresponds to approx. 3 KB.

2) Logbook for alarms/keys.

3) RCS 802 and modem required.

4) RCS 802 required.

5) Available soon.

CNC control

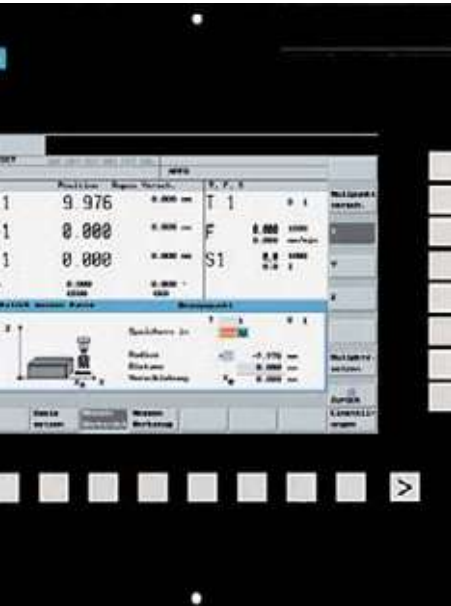

3/2	SINUMERIK 802D sl
3/4	Operator Components
3/4	Machine control panel MCP 802D sl
3/5	Machine control panel MCP
3/6	I/Os
3/6	PP 72/48 I/O module
3/7	Ordering example



SINUMERIK 802D sl

Overview

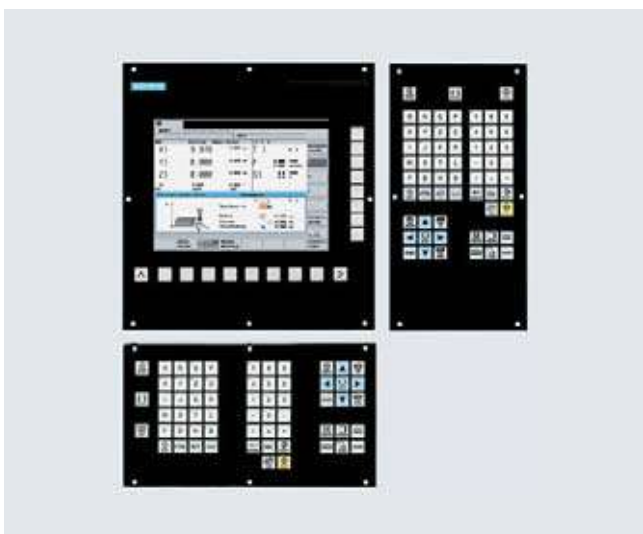

The SINUMERIK 802D sl is an operator panel control which combines all the components of a CNC (NC, PLC, HMI) in one unit. 5 digital drives can be connected via a DRIVE-CLiQ link.

Of these, up to 2 axes can be declared as spindles. The I/Os are easy to operate via the PROFIBUS DP system. This design is conceived to ensure very simple and robust installation with minimum wiring. In combination with the modular structure of the drive system, the control is designed to offer maximum flexibility.

The scope of functions of the control system makes it ideal for use on standardized turning and milling machines, and applications ranging from one-off production to 3-axis mold-making applications. The availability of an additional PLC-controlled axis in the drive group adds an independent, non-interpolating axis to the range of potential applications.

Benefits

- Easy to operate thanks to DIN programming and ISO code
- High reliability
- Compact control with very simple, interference-immune wiring
- Components delivered for individual configurations
- Comprehensive programming aids with cycles and contour definitions
- Ethernet onboard (pro version) ensures integrability
- Digital drive technology via DRIVE-CLiQ
- Maintenance-free: Without battery and fan

Function

- 5 digital feed drives and one positioning axis (4 feed axes + 1 spindle or 3 feed axes + 2 spindles)
- A bipolar analog spindle can be used
- Turning or milling are freely selectable
- RS 232 C interface
- Ethernet onboard (pro version) (available soon)
- Pre-assigned machine data
- Sample program and PLC library included in scope of supply
- Simple PLC (S7-200) "Ladder" programming
- 216 digital inputs and 144 digital outputs (0.25 A)

Technical data

SINUMERIK 802D sl	
Input voltage	24 V DC +20%/-15%
Power consumption	50 W
Degree of protection to DIN EN 60529 (IEC 60529)	
• Front	IP65
• Rear	IP00
Humidity rating in accordance with DIN EN 60721-3-3	Class 3K5 condensation and icing excluded. Low air temperature 0 °C.
Permissible ambient temperature	
• Storage and transport	-20 ... +60 °C
• Operation	0 ... +50 °C
Weight, approx.	
• PCU	4.9 kg
• Full CNC keyboards	1.7 kg
Dimensions (W x H x D)	
• PCU	309.4 mm x 330 mm x 70 mm
• Full CNC keyboard, vertical format	172 mm x 330 mm x 24 mm
• Full CNC keyboard, horizontal format	309.4 mm x 175 mm x 24 mm

Selection and ordering data

Designation	Order No.
Hardware components	
SINUMERIK 802D sl operator panel CNC (PCU)	
• Version T/M plus	6FC5370-0AA00-2AA0
• Version T/M pro	6FC5370-0AA00-3AA0
Full CNC keyboard, vertical format for mounting on the side of the PCU incl. connecting cable Length: 1.5 m	6FC5303-ODT12-1AA0
Full CNC keyboard, horizontal format for mounting under the PCU incl. connecting cable Length: 1.5 m	6FC5303-ODM13-1AA0
Terminal strip converter 50-pole	6EP5406-5AA00
Cable set 6 m ribbon cable, 50-pole 8 insulation displacement connectors, 50-pole	6EP5306-5BG00
CF card for series start-up and program memory/program execution	
• 32 MB	6FC5313-1AG00-0AA0
• 64 MB	6FC5313-2AG00-0AA0
Software	
SINUMERIK 802D sl Toolbox on CD-ROM incl.	6FC5810-0CY10-0YU8
• Cycles	
• Languages	
• Alarm text editor	
• Starter (stand alone)	
• PLC 802 programming tool	
• RS 802	
• PLC library	
• Adobe-Reader	

Integration

The following components can be connected to the SINUMERIK 802D sl:

- Full CNC keyboard (vertical or horizontal format)
- Up to 2 electronic handwheels
- One mini handheld unit (contains one handwheel)
- One machine control panel (MCP) via a PP 72/48 I/O module or an MCP 802D sl machine control panel via an MCPA module (available soon)
- Up to 3 PP 72/48 I/O modules
- SINAMICS S120 drive system via DRIVE-CLiQ

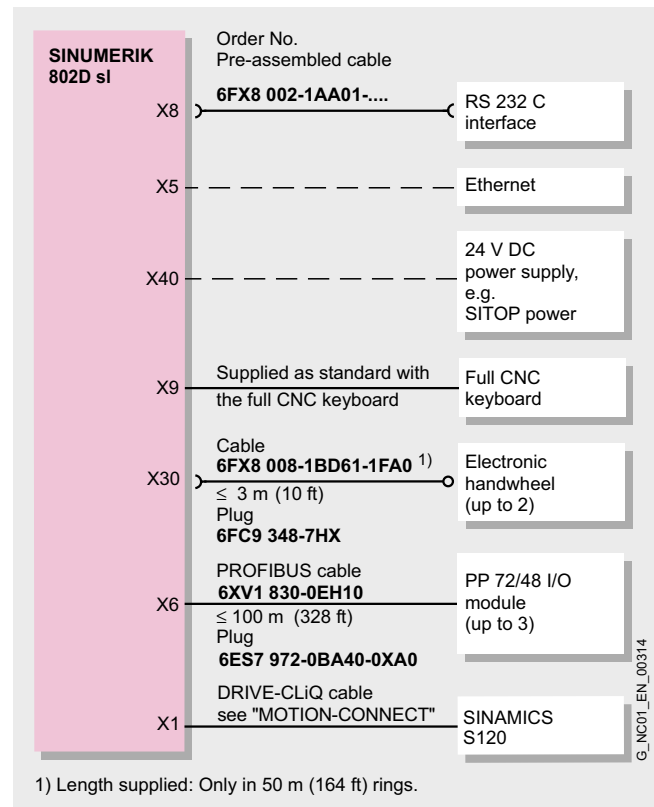

Connection overview for SINUMERIK 802D sl

Please note the maximum permissible cable lengths (e.g. ≤ 25 m). Malfunctions can occur if longer cables are used.

CNC control Operator Components

Machine control panel MCP 802D sl

Overview



The machine control panel MCP 802D sl with plastic front for the SINUMERIK 802D sl offers a simple solution for turning and milling machines. The panel includes all the keys required to operate the machine.

Benefits

- Simple connection via ribbon cables and post links on the MCPA module (available soon)
- Suitable dimensions for the SINUMERIK 802D sl
- Fully equipped with all the necessary function elements

Function

- Can be adapted to turning and milling applications by means of replaceable keys
- User-assignable keys with LED indicator
- Emergency stop mushroom pushbutton with NO and NC contacts
- 2 override rotary knobs for feedrate and spindle drive
- ± 10 V interface for an analog spindle drive on the MCPA module

Integration

The MCP 802D sl machine control panel can be used with CNC system:

- SINUMERIK 802D sl

Die MCP 802D sl can be mounted to the right or left next to the PCU on the SINUMERIK 802D sl. The connection is made with a ribbon cable on the MCPA module mounted on the rear panel of the PCU on the SINUMERIK 802D sl.

Technical data

MCP 802D sl	
Input voltage	5 V DC +20%/-15%
Power consumption	5 W
Inputs/outputs	Connectors in accordance with MIL-C-83-503/DIN 41-651
Degree of protection to DIN EN 60529 (IEC 60529)	
• Front	IP54
• Rear	IP00
Condensation	not permissible
Permissible ambient temperature	
• Storage and transport	-20 ... +60 °C
• Operation	0 ... +50 °C
Weight, approx.	1.5 kg
Dimensions (W x H x D)	170 mm x 330 mm x 60 mm

Selection and ordering data

Designation	Order No.
Machine control panel MCP 802D sl Vertical format for side mounting on PCU incl. ribbon cable (available soon)	6FC5303-0AF30-1AA0
MCPA module for MCP 802D sl connection and with ± 10 V interface (available soon)	6FC5312-0AD01-0AA0
Accessories	
2nd switching element for Emergency Off with 2 contacts 1 NO + 1 NC, 2-pole screw terminal	3SB3400-0A

Overview

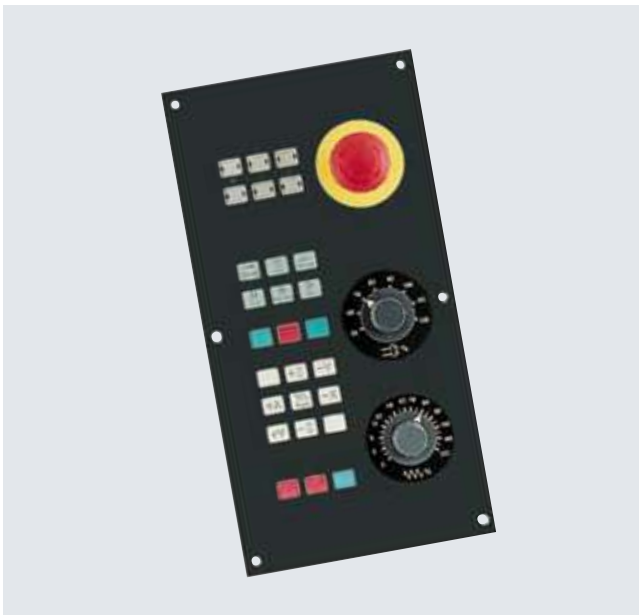

The machine control panel MCP with metal front for the SINUMERIK 802D controls offers a simple solution for turning and milling machines. This panel includes all the keys required to operate the machine; these can be connected directly to the PP 72/48 I/O module by means of a ribbon cable. The connections are at the 24 V DC level for easier implementation.

Benefits

- Simple connection via ribbon cables and post links
- Suitable dimensions for the SINUMERIK 802D controls
- Fully equipped with all the necessary function elements

Function

- 24 V DC supply level
- Can be adapted to turning and milling applications by means of replaceable keys
- User-assignable keys with LED indicator
- Emergency stop mushroom pushbutton with NO and NC contacts
- 2 override rotary knobs for feedrate and spindle drive

Integration

The machine control panel MCP can be used with the following CNC systems:

- SINUMERIK 802D base line
- SINUMERIK 802D
- SINUMERIK 802D sl

Technical data

MCP	
Input voltage	24 V DC +20%/-15%
Power consumption	5 W
Inputs/outputs	Connectors in accordance with MIL-C-83-503/DIN 41-651
Degree of protection to DIN EN 60529 (IEC 60529)	
• Front	IP54
• Rear	IP00
Condensation	not permissible
Permissible ambient temperature	
• Storage and transport	-20 ... +60 °C
• Operation	0 ... +50 °C
Weight, approx.	1.5 kg
Dimensions (W x H x D)	170 mm x 330 mm x 60 mm

Selection and ordering data

Designation	Order No.
Machine control panel MCP for SINUMERIK 802D controls	6FC5603-0AD00-0AA1

Accessories

2nd switching element for Emergency Off with 2 contacts 1 NO + 1 NC, 2-pole screw terminal	3SB3400-0A
---	-------------------

PP 72/48 I/O module

Overview

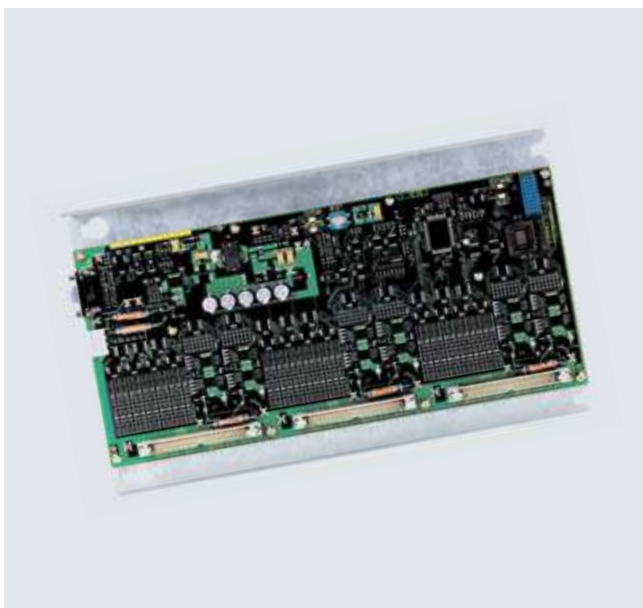

The I/O module PP 72/48 is connected to the PROFIBUS DP and provides 72 digital inputs and 48 digital outputs. The 3 connectors for the inputs and outputs are 50-pole post links for the connection of ribbon cables.

Benefits

- Connection via PROFIBUS DP
- 3 post links with 24 digital inputs and 16 digital outputs each with 24 V DC, 0.25 A
- With mounting plate for easy mounting
- Integral 24 V DC power supply with electrical isolation between inputs and outputs and PROFIBUS

Integration

The PP 72/48 I/O module can be used for the following CNC controls:

- SINUMERIK 802D sl
- SINUMERIK 802D base line
- SINUMERIK 802D
- SINUMERIK 840Di

A power supply (+24 V DC) is required for the module and the digital outputs.

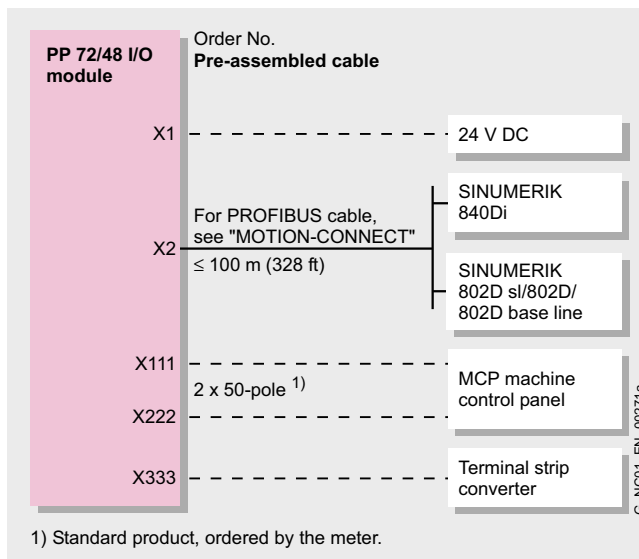

Connection overview for PP 72/48

Please note the maximum permissible cable lengths (e.g. ≤ 25 m). Malfunctions can occur if longer cables are used.

Technical data

PP 72/48	
Input voltage	24 V DC +20%/-15%
Power consumption	11 W
Inputs/outputs	Connectors in accordance with MIL-C-83-503/DIN 41-651
Degree of protection to DIN EN 60529 (IEC 60529)	IP00
Condensation	not permissible
Permissible ambient temperature	
• Storage and transport	-20 ... +60 °C
• Operation	0 ... +50 °C
Weight, approx.	1.2 kg
Dimensions (W x H x D)	325 mm x 194 mm x 35 mm

Selection and ordering data

Designation	Order No.
PP 72/48 I/O module for 72 digital inputs and 48 digital outputs	6FC5611-0CA01-0AA0
Accessories	
Terminal strip converter 50-pole	6EP5406-5AA00
Cable set comprising: 6 m ribbon cable 50-pole 8 insulation displacement connectors 50-pole	6EP5306-5BG00
PROFIBUS cable	6XV1830-0EH10
PROFIBUS connectors	6ES7972-0BA40-0XA0

G_NC01_EN_00271a

Equipment is required for a simple turning machine with 2 servo axes X and Z, and 1 spindle for a belt drive plus additional encoders:

- SINUMERIK 802D sl
- SINAMICS S120
- SIMODRIVE motors
- Cables

Designation	Number	Order No.
SINUMERIK		
SINUMERIK 802D sl PCU T/M plus	1	6FC5370-0AA00-2AA0
SINUMERIK 802D sl, full CNC keyboard, vertical format	1	6FC5303-ODT12-1AA0
SINUMERIK 802D sl machine control panel MCP 802D sl	1	6FC5303-0AF30-1AA0
SINUMERIK 802D sl MCPA module (available soon)	1	6FC5312-0DA01-0AA0
PP 72/48 I/O module; 72 inputs 24 V, 48 outputs 24 V, 0.25 A	2	6FC5611-0CA01-0AA0
Repair service contract 0-4 measuring circuits, regional groups 1-3	1	6FC8506-2RX01-0AA0
SINAMICS		
SINAMICS Active Line Module; 16 kW; internal air cooling including DRIVE-CLiQ cable	1	6SL3130-7TE21-6AA0
SINAMICS Single Motor Module; 30 A, internal air cooling including DRIVE-CLiQ cable	1	6SL3120-1TE23-0AA1
SINAMICS Double Motor Module; 5 A/5 A, internal air cooling including DRIVE-CLiQ cable	1	6SL3120-2TE15-0AA0
SINAMICS Sensor Module SMC30	1	6SL3055-0AA00-5CA0
HF reactor, 16 kW (if a SINAMICS line filter is not required)	1	6SN1111-0AA00-0BA1
HF reactor, 16 kW together with a SINAMICS 16 kW line filter	1	6SL3000-0FE21-6AA0
SINAMICS DRIVE-CLiQ cable; IP20/IP20 Length: 0.60 m	1	6SL3060-4AU00-0AA0
PROFIBUS DP bus cable, 2-core	5	6XV1830-0EH10
Warning labels	4	6SL3166-3AB00-0AA0
Motors		
1FK7 Compact servo motor, 6.0 Nm, 3000 rev/min; with DRIVE-CLiQ interface	2	1FK7060-5AF71-1DG0
1PH7 spindle motor, 9 kW, with DRIVE-CLiQ interface	1	1PH7107-2QF02-0CA0
Power cable MOTION-CONNECT 800 for servo motors	2	6FX8002-5CS01-1AH0
Signal cable MOTION-CONNECT 800 for motors	3	6FX8002-2DC10-1AH0
Accessories		
SITOP POWER module, 24 V DC/10 A	1	6EP1434-2BA00
Connector for PROFIBUS up to 12 Mbit/s, without PG socket	3	6ES7972-0BA41-0XA0
Shaft encoder with TTL; 1024 pulses	1	6FX2001-2CB02
Spring disk coupling 6/6 mm	1	6FX2001-7KF10
Clamps for shaft encoder	3	6FX2001-7KP01

CNC control

Notes

3

Drive system SINAMICS S120 Servo

4



4/2	System data
4/2	General technical data
4/3	Overload capability
4/4	Line-side power components
4/4	Line filters
4/6	Line reactors
4/8	Assignment overview
4/9	Line Modules
4/9	Smart Line Modules
4/11	Active Line Modules
4/13	Motor Modules
4/13	Single Motor Modules
4/17	Double Motor Modules
4/18	DC link components
4/19	Braking Module
4/20	Braking resistors
4/21	Capacitor Module
4/22	Encoder system connection
4/23	SMC30 Sensor Module Cabinet-mounted

SINAMICS S120 Servo Drive System

System Data

General technical data

Technical data



Unless explicitly specified otherwise, the following technical data are valid for all components of the SINAMICS S120 drive system described here.

Electrical data

Line connection voltage	3 AC 380 ... 480 V $\pm 10\%$ (-15% < 1 min)
Line frequency	50/60 Hz, -6/+6%
Electronic power supply	24 V DC, -15/+20%
Radio interference suppression	
• Standard	No radio interference suppression
• With line filter	Class A1 to EN 55011 possible
Overvoltage category	Class III to EN 60664-1

Mechanical data

Vibration stressing	
• Transport	EN 60721-3-2, Class 2M3
• Operation	EN 60721-3-3, Class 3M4
Shock stressing	
• Transport	EN 60721-3-2, Class 2M3
• Operation	EN 60721-3-3, Class 3M4

Ambient conditions

Degree of protection	IP20 to EN 60529
Protection class	Class I (with protective conductor system) and Class III (PELV) to EN 61800-5-1
Cooling method	Internal ventilation, power sections with forced air cooling with integrated cooling fan

Ambient conditions

Permissible ambient and coolant temperature (air) during operation for line-side components, Line Modules and Motor Modules	0 ... +40 °C without derating, > 40 ... +55 °C see derating characteristics
Permissible ambient and coolant temperature (air) during operation for control units, additional system components, DC link components and Sensor Modules	0 ... +55 °C
Climatic ambient conditions	
• Storage	Class 1K3 to EN 60721-3-1 Temperature -25 ... +55 °C
• Transport	Class 2K4 to EN 60721-3-2 Temperature -40 ... +70 °C Max. humidity 95% at 40 °C
• Operation	Class 3K3 to EN 60721-3-3 Relative humidity 5 ... 65% annual average, ≤ 80% max. 2 months per year, condensation, splashwater and ice formation not permitted (EN 60204, Part 1)
Environmental class/harmful chemical substances	
• Storage	Class 1C2 to EN 60721-3-1
• Transport	Class 2C2 to EN 60721-3-2
• Operation	Class 3C2 to EN 60721-3-3
Organic/biological influences	
• Storage	Class 1B1 to EN 60721-3-1
• Transport	Class 2B1 to EN 60721-3-2
• Operation	Class 3B1 to EN 60721-3-3
Degree of pollution	2 to EN 60664-1
Installation altitude	Up to 1000 m above sea level no derating, > 1000 m to 5000 m above sea level see derating characteristics

Approvals

Certification	CE (low-voltage and EMC Directives), cULus (file nos.: E192450, E164110 and E70122)
Safety Integrated – safe standstill (SH) and safe brake control (SBC)	Safety Integrity Level (SIL) 2 to IEC 61508, control category 3 to EN 954-1

Modules

Line Modules in Booksize format	
• Rated supply voltage	3 AC 380 ... 480 V
Active Line Modules in Booksize format	
• Rated pulse frequency	8 kHz
Motor Modules in Booksize format	
• DC link connection voltage	510 ... 750 V DC
• Rated pulse frequency	4 kHz

Technical data (continued)

Overload capability

Line Modules in Booksize format

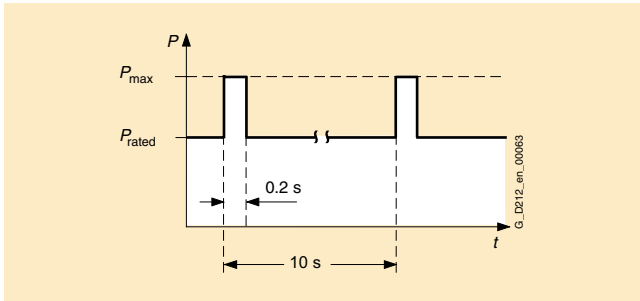

Load cycle with preloading

Motor Modules in Booksize format

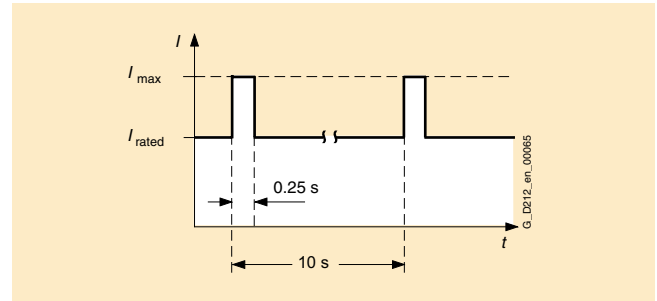

Load cycle with preloading

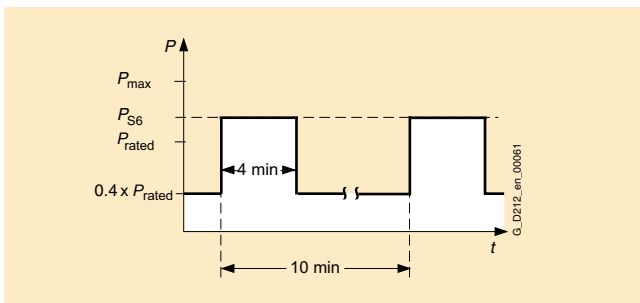

S6 load cycle with preloading

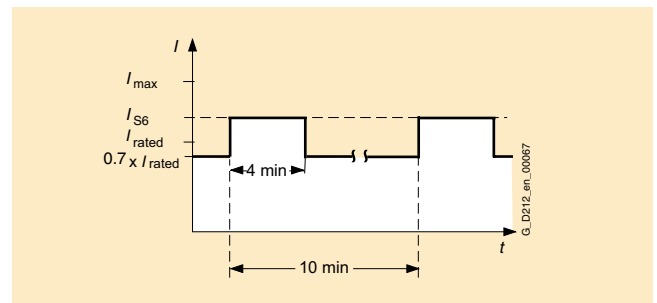

S6 load cycle with preloading

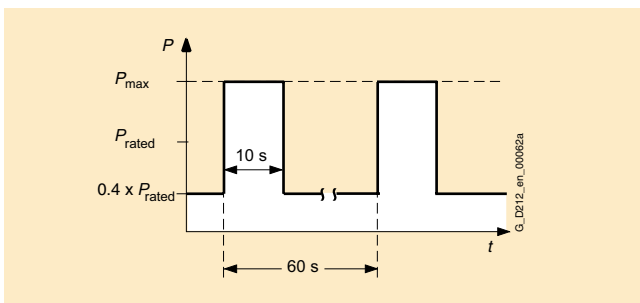

S6 load cycle with preloading

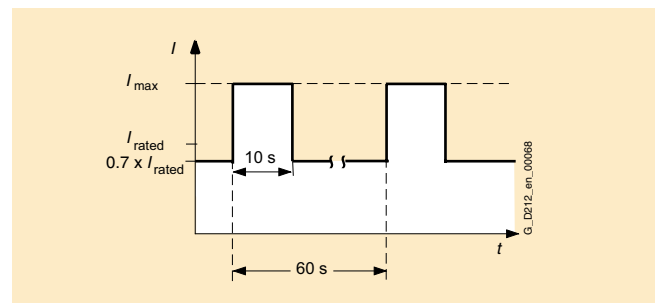

S6 load cycle with preloading

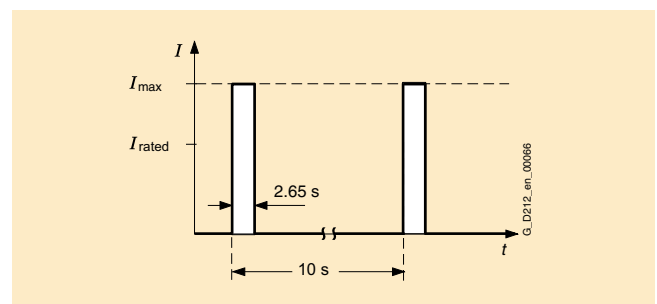

Load cycle without preloading

SINAMICS S120 Servo Drive System

Line-side power components

Line filters

Overview

Line-side power components are used to protect the connected components against transient or continuous overvoltages and ensure that prescribed limit values are adhered to.



When combined with line reactors and a consistent system structure, line filters limit the conducted interference emitted by the power modules to permissible values for industrial supplies (Class A1 to EN 61800-3) at the installation site. Line filters are only suitable for direct connection to TN systems.

Selection and ordering data

Line filters can only be ordered together with the appropriate line reactor. The order number comprises the line filter and the line reactor.

Line filters and line reactors	For Smart Line Modules	Order No. Line filters and line reactors
5 kW	6SL3130-6AE15-0AA0	6SL3000-0GE15-0AA0
10 kW	6SL3130-6AE21-0AA0	6SL3000-0GE21-0AA0

Line filters and line reactors	For Active Line Modules	Order No. Line filters and line reactors
16 kW	6SL3130-7TE21-6AA1	6SL3000-0FE21-6AA0
36 kW	6SL3130-7TE23-6AA1	6SL3000-0FE23-6AA0
55 kW	6SL3130-7TE25-5AA1	6SL3000-0FE25-5AA0
80 kW	6SL3130-7TE28-0AA0	6SL3000-0FE28-0AA0
120 kW	6SL3130-7TE31-2AA0	6SL3000-0FE31-2AA1

Accessories

Adapter sets are available for very compact installation. They enable line filters and line reactors to be installed compactly one above the other in the control cabinet.

Adapter set for line filter and line reactor	Active Line Module power output	Order No. Adapter set
6SL3000-0FE21-6AA0	16 kW	6SL3060-1FE21-6AA0
6SL3000-0FE23-6AA0	36 kW	6SN1162-0GA00-0CA0

SINAMICS S120 Servo Drive System

Line-side power components

Line filters

Technical data

		Line filters	
For Smart Line Module	Type	6SL3130-6AE15-0AA0	6SL3130-6AE21-0AA0
Rated power supply of the Smart Line Module	kW	5	10
Rated current	A	12	24
Power loss	kW	0.005	0.009
Line/power connection L1, L2, L3/U, V, W		Screw-type terminals 10 mm ²	Screw-type terminals 10 mm ²
PE connection		On housing with M6 bolt	On housing with M6 bolt
Width	mm	60	60
Height	mm	285	285
Depth	mm	122	122
Weight, approx.	kg	2.0	2.4

		Line filters				
For Active Line Module	Type	6SL3130-7TE21-6AA1	6SL3130-7TE23-6AA1	6SL3130-7TE25-5AA1	6SL3130-7TE28-0AA0	6SL3130-7TE31-2AA0
Rated power supply of the Active Line Module	kW	16	36	55	80	120
Rated current	A	30	67	103	150	225
Power loss	kW	0.17	0.25	0.35	0.45	0.59
Line/power connection L1, L2, L3/U, V, W		Screw-type terminals 10 mm ²	Screw-type terminals 50 mm ²	Screw-type terminals 50 mm ²	Screw-type terminals 95 mm ²	M10 connecting lugs
PE connection		On housing with M5 bolt	On housing with M8 bolt	On housing with M8 bolt	On housing with M8 bolt	On housing with M8 bolt
Width	mm	130	130	130	200	300
Height	mm	480	480	480	480	480
Depth	mm	150	245	260	260	260
Weight, approx.	kg	9	16	19	22	32

SINAMICS S120 Servo Drive System

Line-side power components

Line reactors

Overview



Line reactors limit low-frequency line harmonics to permissible values. For this reason, line reactors must always be used.

Selection and ordering data

Line reactor	For Smart Line Modules	Order No. Line reactor
5 kW	6SL3130-6AE15-0AA0	6SL3000-0CE15-0AA0
10 kW	6SL3130-6AE21-0AA0	6SL3000-0CE21-0AA0

Line reactor	For Active Line Modules	Order No. Line reactor
16 kW	6SL3130-7TE21-6AA1	6SN1111-0AA00-0BA1
36 kW	6SL3130-7TE23-6AA1	6SN1111-0AA00-0CA1
55 kW	6SL3130-7TE25-5AA1	6SN1111-0AA00-0DA1
80 kW	6SL3130-7TE28-0AA0	6SN1111-0AA00-1EA0
120 kW	6SL3130-7TE31-2AA0	6SL3000-0DE31-2BA0

SINAMICS S120 Servo Drive System

Line-side power components

Line reactors

Technical data

		Line reactor	
		6SL3000-0CE15-0AA0	6SL3000-0CE21-0AA0
For Smart Line Module	Type	6SL3130-6AE15-0AA0	6SL3130-6AE21-0AA0
Rated power infeed supply of the Smart Line Module	kW	5	10
Rated current	A	14	28
Power loss	kW	0.062	0.116
Line/power connection 1U1, 1V1, 1W1/ 1U2, 1V2, 1W2		Screw-type terminals 4 mm ²	Screw-type terminals 10 mm ²
PE connection		Screw-type terminals 4 mm ²	Screw-type terminals 10 mm ²
Degree of protection		IP00	IP00
Width	mm	90	110
Height	mm	150	180
Depth	mm	170	197
Weight, approx.	kg	3.7	7.5

		Line reactor				
		6SN1111-0AA00-0BA1	6SN1111-0AA00-0CA1	6SN1111-0AA00-0DA1	6SN1111-0AA00-1EA0	6SL3000-0DE31-2BA0
For Active Line Module	Type	6SL3130-7TE21-6AA1	6SL3130-7TE23-6AA1	6SL3130-7TE25-5AA1	6SL3130-7TE28-0AA0	6SL3130-7TE31-2AA0
Rated power infeed supply of the Active Line Module	kW	16	36	55	80	120
Rated current	A	30	67	103	150	225
Power loss	kW	0.17	0.25	0.35	0.45	0.59
Line/power connection 1U1, 1V1, 1W1/ 1U2, 1V2, 1W2		Screw-type terminals 16 mm ²	Screw-type terminals 35 mm ²	Screw-type terminals 70 mm ²	M10 connecting lugs	M10 connecting lugs
PE connection		Screw-type terminals 16 mm ²	Screw-type terminals 35 mm ²	Screw-type terminals 70 mm ²	M10 connecting lugs	M10 connecting lugs
Degree of protection		IP00	IP00	IP00	IP00	IP00
Width	mm	150	150	150	222	225
Height	mm	330	330	330	330	330
Depth	mm	145	230	280	200	300
Weight, approx.	kg	8.5	13	18	40	50

SINAMICS S120 Servo Drive System

Line-side power components

Assignment overview

Overview

Suitable line-side power components are assigned depending on the power rating of the Smart or Active Line Modules.

Assignment of line-side power components to Smart Line Modules

Rated power infeed kW	Assignment to Smart Line Modules Type 6SL3130-...	Main switch		Fuse switch disconnecter		Switch disconnecter with fuse holders		NH fuse (gL/gG)		
		Order No.		Order No.		Order No.		Order No.	Rated current	Size
5	6AE15-0AA0	3LD2003-0TK51		3NP4010-0CH01		3KL5030-1EB01		3NA3805	16 A	000
10	6AE21-0AA0	3LD2203-0TK51		3NP4010-0CH01		3KL5030-1EB01		3NA3814	35 A	000

Rated power infeed kW	Assignment to Smart Line Modules Type 6SL3130-...	Circuit-breaker		Main contactor		Line filter and line reactor		Line reactor	
		Order No.		Order No.		Order No.		Order No.	
5	6AE15-0AA0	3RV1031-4BA10		3RT1023-1BB40		6SL3000-0GE15-0AA0		6SL3000-0CE15-0AA0	
10	6AE21-0AA0	3RV1031-4FA10		3RT1026-1BB40		6SL3000-0GE21-0AA0		6SL3000-0CE21-0AA0	

Assignment of line-side power components to Active Line Modules

Rated power infeed kW	Assignment to Active Line Modules Type 6SL3130-...	Main switch		Leading auxiliary circuit switch for main switch		Fuse switch disconnecter		Switch disconnecter with fuse holders		Leading auxiliary switch for switch disconnecter with fuse holders	
		Order No.		Order No.		Order No.		Order No.		Order No.	
16	7TE21-6AA1	3LD2504-0TK51		3LD9250-3B		3NP4010-0CH01		3KL5030-1EB01		3KX3552-3EA01	
36	7TE23-6AA1	3LD2704-0TK51		3LD9250-3B		3NP4010-0CH01		3KL5230-1EB01		3KX3552-3EA01	
55	7TE25-5AA1	3KA5330-1EE01		3KX3552-3EA01		3NP4270-0CA01		3KL5530-1EB01		3KX3552-3EA01	
80	7TE28-0AA0	3KA5330-1EE01		3KX3552-3EA01		3NP4270-0CA01		3KL5530-1EB01		3KX3552-3EA01	
120	7TE31-2AA0	3KA5730-1EE01		3KX3552-3EA01		3NP5360-0CA00		3KL5730-1EB01		3KX3552-3EA01	

Rated power infeed kW	Assignment to Active Line Modules Type 6SL3130-...	NEOZED fuse (gL/gG)			DIAZED fuse (gL/gG)			NH fuse (gL/gG)			UL/CSA fuse, Class J		
		Order No.	Rated current	Size	Order No.	Rated current	Size	Order No.	Rated current	Size	Reference No.	Rated current	Size
16	7TE21-6AA1	5SE2335	35 A	D02	5SB411	35 A	DIII	3NA3814	35 A	000	AJT35	35 A	27x60
36	7TE23-6AA1				5SC211	80 A	DIVH	3NA3824	80 A	000	AJT80	80 A	29x117
55	7TE25-5AA1							3NA3132	125 A	1	AJT125	125 A	41x146
80	7TE28-0AA0							3NA3136	160 A	1	AJT175	175 A	41x146
120	7TE31-2AA0							3NA3144	250 A	1	AJT250	250 A	54x181

Available from:
Ferraz Shawmut
<http://www.ferrazshawmut.com>

Rated power infeed kW	Assignment to Active Line Modules Type 6SL3130-...	Circuit-breaker		Main contactor		Output interface for main switch		Line filter and line reactor		Line reactor	
		Order No.		Order No.		Order No.		Order No.		Order No.	
16	7TE21-6AA1	3RV1031-4FA10		3RT1035-1AC24		3TX7004-1LB00		6SL3000-0FE21-6AA0		6SN1111-0AA00-0BA1	
36	7TE23-6AA1	3RV1041-4LA10		3RT1045-1AP04		3TX7004-1LB00		6SL3000-0FE23-6AA0		6SN1111-0AA00-0CA1	
55	7TE25-5AA1	3VF3211-3FU41-0AA0		3RT1054-1AP36		3TX7004-1LB00		6SL3000-0FE25-5AA0		6SN1111-0AA00-0DA1	
80	7TE28-0AA0	3VF3211-3FW41-0AA0		3RT1056-6AP36		3TX7004-1LB00		6SL3000-0FE28-0AA0		6SN1111-0AA00-1EA0	
120	7TE31-2AA0	3VF4211-3DM41-0AA0		3RT1065-6AP36		3TX7004-1LB00		6SL3000-0FE31-2AA1		6SL3000-0DE31-2BA0	

SINAMICS S120 Servo Drive System

Line Modules

Line Modules

Overview

The drives group is connected to the power supply network by means of a line module. The Smart Line Module and the Active Line Modules supply power to the DC link.

The line modules are suitable for direct operation on TN, TT (grounded) and IT (ungrounded) systems.

When the Smart and Active Line Modules are in regenerative feedback mode, the power supplied to the DC link from the drives is fed back into the line. On a line, which does not support regenerative feedback, the regenerative feedback function of the line module must be deactivated.

Smart Line Modules

Overview



Smart Line Modules are non-regulated rectifier/regenerative units (diode bridge for incoming supply; stable, line-commutated feedback via IGBTs) with 100% regenerative feedback power. The regenerative feedback capability of the modules can be deactivated by means of a digital input.

Design

Smart Line Modules feature the following interfaces as standard:

- 1 x line connection via plug-in screw-type terminal with integrated shield connection plate
- 1 x connection for the electronics power supply via the 24 V terminal adapter included in the scope of supply
- 2 x DC link connections via integrated DC link busbars
- 2 digital inputs
- 1 x digital output
- 2 x PE (protective earth) connections

The status of the Smart Line Modules is indicated via two multi-color LEDs.

The signal line shield can be connected to the Line Module via a shield connection terminal, e. g. Weidmüller type KLBÜ 3-8 SC. The shield connection terminal must not be used for strain relief.

Selection and ordering data

Description	Order No.
Smart Line Module 5 kW	6SL3130-6AE15-0AA0
Smart Line Module 10 kW	6SL3130-6AE21-0AA0

Accessories

Description	Order No.
Warning labels in foreign languages This set of foreign language warning labels can be placed over the standard German or English signs. One label in each of the following languages is provided in each set: Chinese, Danish, Dutch, Finnish, French, Greek, Italian, Japanese, Korean, Portuguese, Spanish and Swedish.	6SL3166-3AB00-0AA0

SINAMICS S120 Servo Drive System

Line Modules

Smart Line Modules

Technical data

Smart Line Modules		6SL3130-6AE15-0AA0	6SL3130-6AE21-0AA0
Rated infeed/regenerative power P_{rated}	kW	5	10
Infeed/regenerative power for S6 duty (40%) P_{S6}	kW	6.5	13
Max. infeed/regenerative power P_{max}	kW	10	20
Rated DC link infeed current	A	8.3	16.6
DC link infeed current for S6 duty (40%)	A	11	22
Max. DC link infeed current	A	16.6	33.2
Rated input current	A	12	24
Input current for S6 duty (40%)	A	on request	on request
Max. input current	A	on request	on request
Max. current requirements (at 24 V DC)	A	1.0	1.3
24 V DC busbar current capacity	A	20	20
DC link capacitance	μ F	220	330
Max. DC link capacitance of drive group	μ F	6000	6000
DC link busbar current capacity	A	100	100
Efficiency	η	0.95	0.95
Power loss	kW	on request	on request
Cooling air requirement	m^3/s	0.008	0.008
Sound pressure level	dB (A)	< 60	< 60
Power connection U1, V1, W1		Screw-type terminals 2.5 ... 6 mm ² (X1)	Screw-type terminals 2.5 ... 6 mm ² (X1)
PE connection		On housing with M5 screw	On housing with M5 screw
Max. cable length (total of all motor power cables and DC link)	m	350 (shielded) 560 (unshielded)	350 (shielded) 560 (unshielded)
Width	mm	50	50
Height	mm	380	380
Depth	mm	270	270
Weight, approx.	kg	4.7	4.8

SINAMICS S120 Servo Drive System

Line Modules

Active Line Modules

Overview



The self-controlled rectifier/regenerative units (with IGBTs in in-feed and regenerative direction) with step-up converters generate an increased, regulated DC link voltage, meaning that the connected motor modules are not dependent on Line tolerances.

Design

Active Line Modules feature the following interfaces as standard:

- 1 x power connection via screw terminals with integrated shield connection plate (up to and including 16 kW rated power supply)
- 1 x connection for the electronics power supply via the 24 V terminal adapter included in the scope of supply
- 1 x DC link connection via integrated DC link busbars
- 3 x DRIVE-CLiQ sockets
- 2 x PE (protective earth) connections

The status of the Active Line Modules is indicated via two multi-color LEDs.

The shield for the power supply cable can be connected to the integrated shield connection plate of the 100 mm wide Active Line Module via a shield connection terminal or hose clamp, e. g. Weidmüller type KLBÜ CO 4. The shield connection terminal must not be used for strain relief. A shield connection plate can be supplied for 150 mm, 200 mm and 300 mm wide modules.

The signal line shield can be connected to the line module via a shield connection terminal, e. g. Weidmüller type KLBÜ 3-8 SC. The shield connection terminal must not be used for strain relief.

Selection and ordering data

Description	Order No.
Active Line Module	
• 16 kW	6SL3130-7TE21-6AA1
• 36 kW	6SL3130-7TE23-6AA1
• 55 kW	6SL3130-7TE25-5AA1
• 80 kW	6SL3130-7TE28-0AA0
• 120 kW	6SL3130-7TE31-2AA0

Accessories

Description	Order No.
Shield connection plate for 150 mm Line/Motor Modules	6SL3162-1AF00-0AA1
Shield connection plate for 200 mm Line/Motor Modules	6SL3162-1AH01-0AA0
Shield connection plate for 300 mm Line/Motor Modules	6SL3162-1AH00-0AA0
Warning labels in foreign languages	6SL3166-3AB00-0AA0

This set of foreign language warning labels can be placed over the standard German or English signs.
One label in each of the following languages is provided in each set:
Chinese, Danish, Dutch, Finnish, French, Greek, Italian, Japanese, Korean, Portuguese, Spanish and Swedish.

SINAMICS S120 Servo Drive System

Line Modules

Active Line Modules

Technical data

Active Line Module		6SL3130-7TE21-6AA1	6SL3130-7TE23-6AA1	6SL3130-7TE25-5AA1	6SL3130-7TE28-0AA0	6SL3130-7TE31-2AA0
Rated infeed/ regenerative power P_{rated}	kW	16	36	55	80	120
Infeed/regener- ative power for S6 duty (40%) P_{S6}	kW	21	47	71	106	158
Max. infeed/ regenerative power P_{max}	kW	35	70	91	131	175
Rated DC link power supply	A	27	60	92	134	200
DC link infeed current for S6 duty (40%)	A	35	79	121	176	244
Max. DC link infeed current	A	59	117	152	195	292
Rated input current	A	26	58	88	128	192
Input current for S6 duty (40%)	A	35	79	121	176	244
Max. input cur- rent	A	59	117	152	195	292
Max. current requirements (at 24 V DC)	A	1.1	1.5	1.9	2.0	2.5
24 V DC bus- bar current capacity	A	20	20	20	20	20
DC link capacitance	μF	710	1410	1880	2820	3760
Max. DC link capacitance of drive group	μF	20000	20000	20000	20000	20000
DC link busbar current capacity	A	100	100	200	200	200
Efficiency	η	0.95	0.95	0.95	0.95	0.95
Power loss	kW	0.26	0.63	0.90	1.35	2.20
Cooling air requirement	m^3/s	0.016	0.031	0.044	0.144	0.144
Sound pres- sure level	dB (A)	< 60	< 65	< 60	< 75	< 75
Power connec- tion U1, V1, W1		Screw-type terminals 2.5 ... 10 mm ² (X1)	Screw studs for ring terminal ends, M6, 2.5 ... 50 mm ² (X1)	Screw studs for ring terminal ends, M8, 2.5 ... 95 mm ² , 2x35 mm ² (X1)	Screw studs for ring terminal ends, M8 2.5 ... 120 mm ² , 2x50 mm ² (X1)	Screw studs for ring terminal ends, M8, 2.5 ... 120 mm ² , 2x50 mm ² (X1)
PE connection		On housing with M5 screw	On housing with M6 screw	On housing with M6 screw	On housing with M8 screw	On housing with M8 screw
Max. cable length (total of all motor power cables and DC link)	m	350 (shielded) 560 (unshielded)	350 (shielded) 560 (unshielded)	350 (shielded) 560 (unshielded)	350 (shielded) 560 (unshielded)	350 (shielded) 560 (unshielded)
Width	mm	100	150	200	300	300
Height	mm	380	380	380	380 (629 with fan)	380 (629 with fan)
Depth	mm	270	270	270	270	270
Weight, approx.	kg	7	10.3	17	23	23

SINAMICS S120 Servo Drive System

Motor Modules

Motor Modules

Overview

A wide range of single axis and double axis Motor Modules with various current/power ratings are available:

- Single Motor Modules: Single axis module in booksize format with rated output currents of 3 A to 200 A

- Double Motor Modules: Two-axis module in booksize format with rated output currents of 3 A to 18 A

In principle, all Single Motor and Double Motor Modules can be operated on Smart or Active Line Modules.

Single Motor Modules

Design



Single Motor Modules feature the following interfaces as standard:

- 2 x DC link connections via integrated DC link busbars
- 1 x electronics power supply connection via integrated 24 V DC bars
- 3 x DRIVE-CLiQ sockets
- 1 x motor connection, plug-in (not included in scope of supply) or screw-stud depending on rated output current
- 2 x safe standstill input terminals (enable pulses)
- 1 x safe motor brake control
- 1 x temperature sensor input (KTY84-130)
- 2 x PE (protective earth) connections

The status of the Motor Modules is indicated via two multi-color LEDs.

The motor cable shield of the 50 mm and 100 mm modules is inside the connector. A shield connection plate can be supplied for the 150 mm, 200 mm and 300 mm wide modules. On these modules, the motor cable shield can be connected using a hose-clamp.

The signal line shield can be connected to the Motor Module via a shield connection terminal, e. g. Weidmüller type KLBÜ 3-8 SC. The shield connection terminal must not be used for strain relief.

Selection and ordering data

Single Motor Module		Order No.
Rated output current	Rated power	
A	kW	
3	1.6	6SL3120-1TE13-0AA0
5	2.7	6SL3120-1TE15-0AA0
9	4.8	6SL3120-1TE21-0AA1
18	9.7	6SL3120-1TE21-8AA1
30	16	6SL3120-1TE23-0AA1
45	24	6SL3120-1TE24-5AA1
60	32	6SL3120-1TE26-0AA1
85	46	6SL3120-1TE28-5AA1
132	71	6SL3120-1TE31-3AA0
200	107	6SL3120-1TE32-0AA0

SINAMICS S120 Servo Drive System

Motor Modules

Single Motor Modules

Accessories

Description	Order No.	Description	Order No.
Shield connection plate for 150 mm Line/Motor Modules	6SL3162-1AF00-0AA1	DC link adapters (2x) for multi-tier configuration	6SL3162-2BM01-0AA0
Shield connection plate for 200 mm Line/Motor Modules	6SL3162-1AH01-0AA0	Screw-type terminals 35 ... 95 mm ² for all Line/Motor Modules in booksize format	
Shield connection plate for 300 mm Line/Motor Modules	6SL3162-1AH00-0AA0	24 V terminal adapter	6SL3162-2AA00-0AA0
DC link supply adapter for direct infeed of DC link voltage Screw-type terminals 0.5 ... 10 mm ² for 50 mm and 100 mm Line/Motor Modules	6SL3162-2BD00-0AA0	Warning labels in foreign languages This set of foreign language warning labels can be placed over the standard German or English signs. One label in each of the following languages is provided in each set: Chinese, Danish, Dutch, Finnish, French, Greek, Italian, Japanese, Korean, Portuguese, Spanish and Swedish.	6SL3166-3AB00-0AA0
DC link power supply adapter for direct infeed of DC link voltage Screw-type terminals 35 ... 95 mm ² for 150 mm, 200 mm and 300 mm Line/Motor Modules	6SL3162-2BM00-0AA0	Plug-in motor brake connector for Line/Motor Modules with a rated output current ≥ 45 A Wago http://www.wago.com	Item No.: 231-102/037-000 (Wago)

SINAMICS S120 Servo Drive System

Motor Modules

Single Motor Modules

Technical data

Single Motor Module	6SL3120-1TE13-0AA0	6SL3120-1TE15-0AA0	6SL3120-1TE21-0AA1	6SL3120-1TE21-8AA1	6SL3120-1TE23-0AA1
Rated output current I_{rated}	A 3	5	9	18	30
Output current for S6 duty (40%) I_{S6}	A 3.5	6	10	24	40
Max. output current I_{max}	A 6	10	18	36	56
Rated power at 600 V DC DC link voltage	kW 1.6	2.7	4.8	9.7	16.0
DC link voltage range	V 510 ... 750	510 ... 750	510 ... 750	510 ... 750	510 ... 750
DC link overvoltage tripping	V 820 ($\pm 2\%$)	820 ($\pm 2\%$)	820 ($\pm 2\%$)	820 ($\pm 2\%$)	820 ($\pm 2\%$)
DC link busbar current capacity	A 100	100	100	100	100
DC link capacitance	μF 110	110	110	220	710
Max. current requirement (at 24 V DC)	A 0.8	0.8	0.85	0.85	0.9
24 V DC busbar current capacity	A 20	20	20	20	20
	If, due to a number of Line and Motor Modules being mounted side-by-side, the current carrying capacity exceeds 20 A, an additional 24 V DC connection using a 24 V terminal adapter is required (max. cross-section 6 mm ² , max. fuse protection 20 A).				
Efficiency η	0.97	0.97	0.97	0.97	0.97
Power loss	kW 0.035	0.055	0.080	0.165	0.290
Cooling air requirement	m ³ /s 0.008	0.008	0.008	0.008	0.016
Sound pressure level	dB(A) < 60	< 60	< 60	< 60	< 60
Motor connection U2, V2, W2	Plug-in connector (X1), max. 30 A	Plug-in connector (X1), max. 30 A	Plug-in connector (X1), max. 30 A	Plug-in connector (X1), max. 30 A	Plug-in connector (X1), max. 30 A
PE connection	On housing with M5 screw	On housing with M5 screw	On housing with M5 screw	On housing with M5 screw	On housing with M5 screw
Motor brake connection	Integrated in the plug-in motor connector (X1), 24 V DC, 2 A	Integrated in the plug-in motor connector (X1), 24 V DC, 2 A	Integrated in the plug-in motor connector (X1), 24 V DC, 2 A	Integrated in the plug-in motor connector (X1), 24 V DC, 2 A	Integrated in the plug-in motor connector (X1), 24 V DC, 2 A
Max. motor power cable length	m 50 (shielded) 75 (unshielded)	50 (shielded) 75 (unshielded)	50 (shielded) 75 (unshielded)	50 (shielded) 75 (unshielded)	50 (shielded) 75 (unshielded)
Width	mm 50	50	50	50	100
Height	mm 380	380	380	380	380
Depth	mm 270	270	270	270	270
Weight, approx.	kg 5.1	5.1	5	5	6,9

SINAMICS S120 Servo Drive System

Motor Modules

Single Motor Modules

Technical data (continued)

Single Motor Module		6SL3120-1TE24-5AA1	6SL3120-1TE26-0AA1	6SL3120-1TE28-5AA1	6SL3120-1TE31-3AA0	6SL3120-1TE32-0AA0
Rated output current I_{rated}	A	45	60	85	132	200
Output current at S6 duty (40%) I_{S6}	A	60	80	110	150	250
Max. output current I_{max}	A	85	113	141	210	282
Rated power at 600 V DC DC link voltage	kW	24	32	46	71	107
DC link voltage range	V	510 ... 750	510 ... 750	510 ... 750	510 ... 750	510 ... 750
DC link overvoltage tripping	V	820 ($\pm 2\%$)	820 ($\pm 2\%$)	820 ($\pm 2\%$)	820 ($\pm 2\%$)	820 ($\pm 2\%$)
DC link busbar current capacity	A	100	100	200	200	200
DC link capacitance	μF	1175	1410	1880	2820	3995
Max. current requirement (at 24 V DC)	A	1.2	1.2	1.5	1.5	1.5
24 V DC busbar current capacity	A	20	20	20	20	20
		If, due to a number of Line and Motor Modules being mounted side-by-side, the current carrying capacity exceeds 20 A, an additional 24 V DC connection using a 24 V terminal adapter is required (max. cross-section 6 mm ² , max. fuse protection 20 A).				
Efficiency	η	0.97	0.97	0.97	0.97	0.97
Power loss	kW	on request	on request	0.75	on request	2.05
Cooling air requirement	m ³ /s	0.031	0.031	0.044	0.144	0.144
Sound pressure level	dB(A)	< 65	< 65	< 60	< 75	< 75
Motor connection U2, V2, W2		M6 screw studs, 2.5 ... 50 mm ² (X1)	M6 screw studs, 2.5 ... 50 mm ² (X1)	M8 screw studs, 2.5 ... 95 mm ² , 2x35 mm ² (X1)	M8 screw studs, 2.5 ... 120 mm ² , 2x50 mm ² (X1)	M8 screw studs, 2.5 ... 120 mm ² , 2x50 mm ² (X1)
PE connection		On housing with M6 screw	On housing with M6 screw	On housing with M6 screw	On housing with M8 screw	On housing with M8 screw
Motor brake connection		Plug-in connector (X11), 24 V DC, 2 A	Plug-in connector (X11), 24 V DC, 2 A	Plug-in connector (X11), 24 V DC, 2 A	Plug-in connector (X11), 24 V DC, 2 A	Plug-in connector (X11), 24 V DC, 2 A
Max. motor power cable length	m	100 (shielded) 150 (unshielded)	100 (shielded) 150 (unshielded)	100 (shielded) 150 (unshielded)	100 (shielded) 150 (unshielded)	100 (shielded) 150 (unshielded)
Width	mm	150	150	200	300	300
Height	mm	380	380	380	380 (629 with fan)	380 (629 with fan)
Depth	mm	270	270	270	270	270
Weight, approx.	kg	9	9	15	21	21

SINAMICS S120 Servo Drive System

Motor Modules

Double Motor Modules

Design



Double Motor Modules feature the following interfaces as standard:

- 2 x DC link connections via integrated DC link busbars
- 2 x electronics power supply connections via integrated 24 V DC bars
- 4 x DRIVE-CLiQ sockets
- 2 x plug-in motor connections (not included in scope of supply)
- 4 x safe standstill input terminals (1 input per axis)
- 2 x safe motor brake control
- 2 x temperature sensor inputs (KTY84-130)
- 3 x PE (protective earth) connections

The status of the Motor Modules is indicated via two multi-color LEDs.

On Double Motor Modules, the motor cable shield can be connected in the connector.

The signal line shield can be connected to the Motor Module via a shield connection terminal, e. g. Weidmüller type KLBÜ 3-8 SC. The shield connection terminal must not be used for strain relief.

Selection and ordering data

Double Motor Module	Rated power	Order No.
Rated output current		
A	kW	
3	1.6	6SL3120-2TE13-0AA0
5	2.7	6SL3120-2TE15-0AA0
9	4.8	6SL3120-2TE21-0AA0
18	9.7	6SL3120-2TE21-8AA0

Accessories

Description	Order No.
DC link power supply adapter for direct infeed of DC link voltage Screw-type terminals 0.5 ... 10 mm ² for 50 mm and 100 mm Line/Motor Modules	6SL3162-2BD00-0AA0
DC link power supply adapter for direct infeed of DC link voltage Screw-type terminals 35 ... 95 mm ² for 150 mm, 200 mm and 300 mm Line/Motor Modules	6SL3162-2BM00-0AA0
DC link adapters (2x) for multi-tier configuration Screw-type terminals 35 ... 95 mm ² for all Line/Motor Modules in booksize format	6SL3162-2BM01-0AA0
24 V terminal adapter	6SL3162-2AA00-0AA0
Warning labels in foreign languages This set of foreign language warning labels can be placed over the standard German or English signs. One label in each of the following languages is provided in each set: Chinese, Danish, Dutch, Finnish, French, Greek, Italian, Japanese, Korean, Portuguese, Spanish and Swedish.	6SL3166-3AB00-0AA0
Plug-in motor brake connector Wago http://www.wago.com	Item No.: 231-102/037-000 (Wago)

SINAMICS S120 Servo Drive System

Motor Modules

Double Motor Modules

Technical data

Double Motor Module		6SL3120-2TE13-0AA0	6SL3120-2TE15-0AA0	6SL3120-2TE21-0AA0	6SL3120-2TE21-8AA0
Rated output current I_{rated}	A	2×3	2×5	2×9	2×18
Output current for S6 duty (40%) I_{S6}	A	2×3.5	2×6	2×10	2×24
Max. output current I_{max}	A	2×6	2×10	2×18	2×36
Rated power at 600 V DC DC link voltage	kW	2×1.6	2×2.7	2×4.8	2×9.7
DC link voltage range	V	510 ... 750	510 ... 750	510 ... 750	510 ... 750
DC link overvoltage tripping	V	820 (± 2%)	820 (± 2%)	820 (± 2%)	820 (± 2%)
DC link busbar current capacity	A	100	100	100	100
DC link capacitance	μF	110	220	220	710
Max. current requirement (at 24 V DC)	A	0.8	1.0	1.0	1.0
24 V DC busbar current capacity	A	20	20	20	20
		If, due to a number of Line and Motor Modules being mounted side-by-side, the current carrying capacity exceeds 20 A, an additional 24 V DC connection using a 24 V terminal adapter is required (max. cross-section 6 mm ² , max. fuse protection 20 A).			
Efficiency	η	0.97	0.97	0.97	0.97
Power loss	kW	0.06	0.085	0.16	0.32
Cooling air requirement	m ³ /s	0.008	0.008	0.008	0.016
Sound pressure level	dB(A)	< 70	< 70	< 70	< 70
Motor connection U2, V2, W2		2×plug-in connector (X1, X2), max. 30 A	2×plug-in connector (X1, X2), max. 30 A	2×plug-in connector (X1, X2), max. 30 A	2×plug-in connector (X1, X2), max. 30 A
PE connection		On housing with M5 screw	On housing with M5 screw	On housing with M5 screw	On housing with M5 screw
Motor brake connection		Integrated in the plug-in motor connector (X1, X2), 24 V DC, 2 A	Integrated in the plug-in motor connector (X1, X2), 24 V DC, 2 A	Integrated in the plug-in motor connector (X1, X2), 24 V DC, 2 A	Integrated in the plug-in motor connector (X1, X2), 24 V DC, 2 A
Max. motor power cable length	m	50 (shielded) 75 (unshielded)	50 (shielded) 75 (unshielded)	50 (shielded) 75 (unshielded)	50 (shielded) 75 (unshielded)
Width	mm	50	50	50	100
Height	mm	380	380	380	380
Depth	mm	270	270	270	270
Weight, approx.	kg	5.1	5.1	5.1	6.6

SINAMICS S120 Servo Drive System

DC link components

Braking Module

Overview



A Braking Module (and an external braking resistor) is required to bring drives to a controlled stop in the event of a line failure (e. g. emergency retraction) or to limit the DC link voltage during short-time regeneration if, for example, the regenerative feedback capability of the Line Module has been deactivated or has not been dimensioned sufficiently. The Braking Module houses the power electronics and the associated control circuit. During operation, the DC link power is converted into heat loss in an external braking resistor located outside the control cabinet. The Braking Module functions autonomously. The Braking Modules can be operated in parallel. Braking Modules can also be used for rapid discharge of the DC link.

Design

The Braking Module features the following interfaces as standard:

- 2 x DC link connections via integrated DC link busbars
- 2 x electronics power supply connections via integrated 24 V DC bars
- 2 x braking resistor connection terminals
- 2 x digital inputs (disable Braking Module/acknowledge faults and rapid discharge of DC link)
- 2 x digital outputs (Braking Module disabled and prewarning – I_{xt} monitoring)
- 2 x PE (protective earth) connections

The status of the Braking Module is indicated via two 2-color LEDs.

Technical data

Braking Module	
Rated power	1.5 kW
Peak power	100 kW
Max. current requirement (at 24 V DC)	0.2 A
Digital inputs	
Voltage	-3 ... +30 V
• Low level (an open digital input is interpreted as "low")	-3 ... +5 V
• High level	15 ... 30 V
• Current consumption (typ. at 24 V DC)	10 mA
• Max. connectable cross-section	1.5 mm ²
Digital outputs (continuously-short-circuit-proof)	
• Voltage	24 V DC
• Max. load current per digital output	100 mA
• Max. connectable cross-section	1.5 mm ²
24 V DC busbar current capacity	20 A
DC link busbar current capacity	100 A
PE connection	On housing with M5 screw
Width	50 mm
Height	380 mm
Depth, with spacer (included in scope of supply)	270 mm
Weight, approx.	4.1 kg

Selection and ordering data

Description	Order No.
Braking Module	6SL3100-1AE31-0AA0

Accessories

Description	Order No.
Warning labels in foreign languages	6SL3166-3AB00-0AA0
This set of foreign language warning labels can be placed over the standard German or English signs. One label in each of the following languages is provided in each set: Chinese, Danish, Dutch, Finnish, French, Greek, Italian, Japanese, Korean, Portuguese, Spanish and Swedish.	

SINAMICS S120 Servo Drive System

DC link components

Braking resistors

Overview

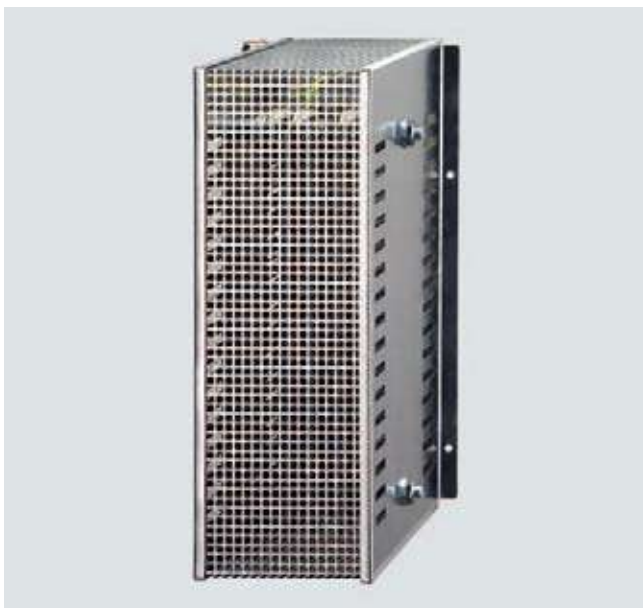

Excess power in the DC link is dissipated via the braking resistor.

The braking resistor is connected to a Braking Module. This means that the resulting heat loss can be dissipated outside of the control cabinet.

Two braking resistors with different rated and peak powers are available.

Technical data

		Braking resistor 0.3 kW/25 kW	Braking resistor 1.5 kW/100 kW
Rated power P_{rated}	kW	0.3	1.5
Peak power P_{max}	kW	25	100
In-service period for peak power	s	0.4	2
Braking duty cycle T duration	s	33	133
Degree of protec- tion		IP54	IP20
Width	mm	80	193
Height	mm	210	410
Depth	mm	53	240
Weight, approx.	kg	3.4	5.6

Selection and ordering data

Description	Order No.
Braking resistor 0.3 kW/25 kW	6SN1113-1AA00-0DA0
Braking resistor 1.5 kW/100 kW	6SL3100-1BE31-0AA0

4

SINAMICS S120 Servo Drive System

DC link components

Capacitor Module

Overview



Capacitor Modules are used to increase the DC link capacitance to bridge momentary power losses.

Capacitor Modules are connected to the DC link voltage via the integrated DC link busbars. Capacitor Modules function autonomously.

Capacitor Modules can be operated in parallel.

Design

The Capacitor Module features the following interfaces as standard:

- 2 x DC link connections via integrated DC link busbars
- 2 x PE (protective earth) connections

Technical data

Capacitor Module	
Capacitance	4000 μ F
24 V DC busbar current capacity	20 A
DC link busbar current capacity	100 A
PE connection	On housing with M5 screw
Width	100 mm
Height	380 mm
Depth, with spacer (included in scope of supply)	270 mm
Weight, approx.	7.2 kg

Selection and ordering data

Description	Order No.
Capacitor Module	6SL3100-1CE14-0AA0

Accessories

Description	Order No.
Warning labels in foreign languages	6SL3166-3AB00-0AA0
This set of foreign language warning labels can be placed over the standard German or English signs. One label in each of the following languages is provided in each set: Chinese, Danish, Dutch, Finnish, French, Greek, Italian, Japanese, Korean, Portuguese, Spanish and Swedish.	

SINAMICS S120 Servo Drive System

Encoder system connection

Encoder system connection

Overview

The encoder system can only be connected to SINAMICS S120 via DRIVE-CLiQ.

Motors with DRIVE-CLiQ interfaces can be ordered for this purpose, for example 1FK7 and 1FT6 synchronous motors and 1PH7 asynchronous motors. Each of these motors can be supplied as standard with one DRIVE-CLiQ interface.

These motors with DRIVE-CLiQ interfaces can be connected to the corresponding Motor Module directly via the MOTION-CONNECT DRIVE-CLiQ cables available. This connection route is used to transmit motor encoder and temperature signals as well as electronic rating plate data such as unique ID numbers, rated data (voltage, current, torque) directly to the Control Unit. These motors make start-up and diagnostics much easier, as the motor and encoder type can be identified automatically.

Motors without DRIVE-CLiQ interface

The encoder and temperature signals of motors without DRIVE-CLiQ interfaces, as well as those of external encoders, must be connected via Sensor Modules. Sensor Modules Cabinet-mounted with IP20 degree of protection are currently available for direct installation in control cabinets.

Only one encoder can be connected to each Sensor Module Cabinet-mounted.

Technical data

	Motors with DRIVE-CLiQ interface and resolver (2-pole/multi-pole)	Motors with DRIVE-CLiQ interface and incremental encoder sin/cos 1 V _{pp} , absolute encoder EnDat (512 S/R, 2048 S/R) or single absolute encoder
Max. current requirement at 24 V DC (via Motor Module and MOTION-CONNECT DRIVE-CLiQ cable)	500 mA	500 mA
Max. DRIVE-CLiQ cable length between motor and Motor Modules	<ul style="list-style-type: none"> • 100 m when using MOTION-CONNECT 500 DRIVE-CLiQ cables • 50 m when using MOTION-CONNECT 800 DRIVE-CLiQ cables 	

Further information

If possible, motor encoder and temperature signals should be connected to the corresponding Motor Module and external encoders to the Control Unit.

SINAMICS S120 Servo Drive System

Encoder system connection

SMC30 Sensor Module Cabinet-mounted

Overview



SMC30 Sensor Modules Cabinet-mounted are required when a motor with a DRIVE-CLiQ interface is not available and when external sensors are required in addition to the motor encoder.

TTL/HTL incremental encoders with and without cable-break detection are supported.

The motor temperature can also be detected using KTY84-130 temperature sensors.

Design

The SMC30 Sensor Module Cabinet-mounted features the following interfaces as standard:

- 1 x DRIVE CLiQ interface
- 1 x encoder connection including motor temperature detection (KTY84-130) via SUB-D connector or terminals
- 1 x connection for the electronics power supply via the 24 V DC power supply connector
- 1 x PE (protective earth) connection

The status of the SMC30 Sensor Module Cabinet-mounted is indicated via a multi-color LED.

SMC30 Sensor Modules Cabinet-mounted can be snapped onto a 35x15/7.5 DIN rail to EN 50022.

The maximum encoder cable length between SMC30 modules and encoders is 100 m. For HTL encoders, this length can be increased to 300 m if signals A+/A- and B+/B- are evaluated and the power supply cable has a minimum cross-section of 0.75 mm².

The signal line shield can be connected to the SMC30 Sensor Module Cabinet-mounted via a shield connection terminal, e. g. Phoenix Contact type SK8 or Weidmüller type KLBU CO 1. The shield connection terminal must not be used for strain relief.

Technical data

SMC30 Sensor Module Cabinet-mounted	
Max. current requirement (at 24 V DC) without taking account of encoder	0.6 A
Max. connectable cross-section	2.5 mm ²
Max. fuse protection	20 A
Power loss	< 10 W
PE connection	On housing with M4 screw
Width	50 mm
Height	150 mm
Depth	111 mm
Weight, approx.	0.8 kg

Selection and ordering data

Description	Order No.
SMC30 Sensor Module Cabinet-mounted (without DRIVE-CLiQ cable)	6SL3055-0AA00-5CA0

SINAMICS S120 Servo Drive System

Notes

4

AC motors











5/3	Synchronous motors
5/2	Selection guide Type of construction Degree of protection
5/3	1FK7 motors
5/6	Asynchronous motors
5/6	1PH7 motors with forced ventilation
5/10	Gear units
5/10	Planetary gear units for 1FK7 motors

AC motors

Selection guide

Type

Type	Designation	Type	Designation	Type	Designation
	IM B3		IM B5 IM B14		IM B35
	IM V5		IM V1 IM V18		IM V15
	IM V6		IM V3 IM V19		IM V36

Degree of protection

Degree of protection designation according to EN 60034-5 and IEC 60034-5 is made using the letters "IP" and two digits (e.g. IP64). The second digit in the degree of protection designation represents the protection against water, the first digit the protection against penetration of foreign matter.

Since coolants are used for machine tools and transfer machines which contain oil, are able to creep, and may also be corrosive, protection against water alone is insufficient. The designation for the degree of protection should only be considered here as a guideline. Our sealing systems are based on many years of practical experience, exceed the IEC definitions by far, and are appropriate for the requirements of machine tools.

The table can serve as a decision aid for selecting the proper degree of protection for servomotors. With the IM V3/IM V19 designs, permanent liquid on the flange is only permissible with IP 67/IP 68.

Liquids	General workshop environment	Water; gen. coolant (95% water, 5% oil); oil	Creep oil; petroleum; aggressive coolants
Effect			
Dry	IP64	-	
Humid/moist environment	-	IP64	IP67 ¹⁾
Mist		IP65	IP67
Spray	-	IP65	IP68
Jet	-	IP67	IP68
Splash, brief immersion; constant immersion	-	IP67	IP68

1) IP64 with dry run at shaft exit.

Overview



1FK7 motors are extremely compact permanent-magnet synchronous motors. The available options, gear units and encoders, together with the expanded product range, mean that 1FK7 motors can be optimized to meet the requirements of any application. They therefore also satisfy the permanently increasing demands of state-of-the-art machine generations.

1FK7 motors can be combined with the SINAMICS S drive system to create a powerful system with high functionality. The built-in encoder systems for speed and position control can be selected depending on the application.

The motors are designed for operation without external cooling and the heat is dissipated through the motor surface. 1FK7 motors have a high overload capability.

Benefits

1FK7 Compact motors offer the following benefits:

- Space-saving installation thanks to very high power density
- Can be used universally for numerous applications
- Wide motor spectrum

1FK7 High Dynamic motors offer the following benefits:

- Extremely high dynamic response due to low moment of inertia of rotor

Application

- Machine tools
- Robots and manipulators
- Wood, glass, ceramics and stone working
- Packaging, plastics and textile machines
- Auxiliary axes

Technical data

Type of motor	Permanent-magnet synchronous motor
Magnetic material	Rare-earth magnetic material
Insulation of the stator winding in accordance with EN 60034-1 (IEC 60034-1)	Temperature class F for a winding temperature rise of $\Delta T = 100 \text{ K}$ at an ambient temperature of $+40 \text{ °C}$
Type according to EN 60034-7 (IEC 60034-7)	IM B5 (IM V1, IM V3)
Degree of protection according to EN 60034-5 (IEC 60034-5)	IP64
Cooling	Natural cooling
Temperature monitoring	KTY 84 temperature sensor in stator winding
Paint finish	Unpainted
Shaft end on the drive end in accordance with DIN 748-3 (IEC 60072-1)	Smooth shaft
2 nd rating plate 3 rd rating plate	Applied to end shield Supplied separately packed
Radial eccentricity, concentricity, and axial eccentricity in accordance with DIN 42955 (IEC 60072-1)	Tolerance N (normal)
Vibration severity according to EN 60034-14 (IEC 60034-14)	Level N (normal)
Sound pressure level, max. acc. to DIN EN ISO 1680	1FK702: 55 dB (A) 1FK703: 55 dB (A) 1FK704: 55 dB (A) 1FK706: 65 dB (A) 1FK708: 70 dB (A) 1FK710: 70 dB (A)
Encoder systems, built-in, for motors with/without DRIVE-CLiQ interface	<ul style="list-style-type: none"> • Incremental encoder sin/cos 1 V_{pp} 2048 S/R • Absolute encoder, multiturn, 2048 S/R on 1FK704 to 1FK710. 512 S/R on 1FK702 and 1FK703 and traversing range 4096 revolutions with EnDat interface • Simple absolute encoder, multiturn, 32 S/R and traversing range 4096 revolutions with EnDat interface • Multipole resolver ¹⁾ (number of pole pairs corresponds to number of pole pairs of the motor) • Resolver 2-pole
Connection	Connectors for signals and power can be rotated (270°)
Options	<ul style="list-style-type: none"> • Shaft end on the drive end with featherkey and keyway (half-key balancing) • Built-in holding brake • Degree of protection IP65, additional IP67 drive end flange • Planetary gear unit (requires smooth shaft end) • Anthracite paint finish

1) A max. operating frequency of 470 Hz must be observed with SINAMICS.

AC motors

Synchronous motors

Core type 1FK7 Compact motors with natural cooling

Selection and ordering data

Rated speed	Shaft height SH	Rated power	Static torque	Rated torque ¹⁾	Rated current	1FK7 Compact synchronous motor with natural cooling	No. of pole pairs	Rotor moment of inertia (without brake)	Weight (without brake)
n_{rated}		P_{rated} at $\Delta T=100$ K	M_0 at $\Delta T=100$ K	M_{rated} at $\Delta T=100$ K	I_{rated} at $\Delta T=100$ K	Order No. Core type		J	m
rpm		kW	Nm	Nm	A			10^{-4} kgm ²	kg
2000	100	7.75	48	37	16	1FK7105 - 5AC71 - 1 ■ ■ ■ ■	4	156	39
3000	48	0.82	3	2.6	1.95	1FK7042 - 5AF71 - 1 ■ ■ ■ ■	4	3.01	4.9
		63	1.48	6	4.7	3.7	1FK7060 - 5AF71 - 1 ■ ■ ■ ■	4	7.95
		2.29	11	7.3	5.6	1FK7063 - 5AF71 - 1 ■ ■ ■ ■	4	15.1	11.5
	80	2.14	8	6.8	4.4	1FK7080 - 5AF71 - 1 ■ ■ ■ ■	4	15	10
		3.3	16	10.5	7.4	1FK7083 - 5AF71 - 1 ■ ■ ■ ■	4	27.3	14
	100	3.77	18	12	8	1FK7100 - 5AF71 - 1 ■ ■ ■ ■	4	55.3	19
		4.87	27	15.5	11.8	1FK7101 - 5AF71 - 1 ■ ■ ■ ■	4	79.9	21
		5.37 ²⁾	36	20.5 ²⁾	16.5 ²⁾	1FK7103 - 5AF71 - 1 ■ ■ ■ ■	4	105	29
8.17		48	26	18	1FK7105 - 5AF71 - 1 ■ ■ ■ ■	4	156	39	
4500	63	1.74	6	3.7	4.1	1FK7060 - 5AH71 - 1 ■ ■ ■ ■	4	7.95	7
		2.09 ³⁾	11	5 ³⁾	6.1 ³⁾	1FK7063 - 5AH71 - 1 ■ ■ ■ ■	4	15.1	11.5
	80	2.39	8	5.7	5.6	1FK7080 - 5AH71 - 1 ■ ■ ■ ■	4	15	10
		3.04 ⁴⁾	16	8.3 ⁴⁾	9 ⁴⁾	1FK7083 - 5AH71 - 1 ■ ■ ■ ■	4	27.3	14
6000	28	0.4	0.85	0.6	1.4	1FK7022 - 5AK71 - 1 ■ ■ ■ ■	3	0.28	1.8
		36	0.5	1.1	0.8	1.4	1FK7032 - 5AK71 - 1 ■ ■ ■ ■	3	0.61
	48	0.69	1.6	1.1	1.7	1FK7040 - 5AK71 - 1 ■ ■ ■ ■	4	1.69	3.5
		1.02 ⁵⁾	3	2 ⁵⁾	3.1 ⁵⁾	1FK7042 - 5AK71 - 1 ■ ■ ■ ■	4	3.01	4.9

• Encoder systems for motors without DRIVE-CLiQ interface: Incremental encoder sin/cos 1 V_{pp} 2048 S/R
 Absolute encoder EnDat 2048 S/R ¹⁾ (not for 1FK702/1FK703)
 Absolute encoder EnDat 512 S/R ¹⁾ (for 1FK702/1FK703 only)
 Single absolute encoder EnDat 32 S/R ¹⁾ (not for 1FK702/1FK703)
 Multipole resolver ⁶⁾
 2-pole resolver

• Encoder systems for motors with DRIVE-CLiQ interface: Incremental encoder sin/cos 1 V_{pp} 2048 S/R
 Absolute encoder EnDat 2048 S/R ¹⁾ (not for 1FK702/1FK703)
 Absolute encoder EnDat 512 S/R ¹⁾ (for 1FK702/1FK703 only)
 Multipole resolver ⁶⁾
 2-pole resolver

• Shaft end: Radial eccentricity tolerance: Holding brake:
 With featherkey and keyway N Without
 With featherkey and keyway N With
 Smooth shaft N Without
 Smooth shaft N With

• Degree of protection: IP64
 IP65 and additional IP67 drive end flange
 IP64, anthracite paint finish
 IP65 and additional IP67 drive end flange, anthracite paint finish
 IP65 and additional IP67 drive end flange, anthracite paint finish and metal rating plate on motor

A
E
G
S
T

D
F
L
U
P

A
B
G
H

0
2
3
5
8

Selection of degree of protection and type, see "Selection guide".

Selection and ordering data

Motor type (continued)	Static current I_0 at M_0 $\Delta T=100$ K A	Calculated power $P_{calc} = \frac{M_0 \times n_{rated}}{9550}$ P_{calc} for M_0 $\Delta T=100$ K kW	SINAMICS Motor Module Rated output current		Power cable with complete shield Motor connection (and brake connection) via power connector		
			I_{rated} at M_0 $\Delta T=100$ K A	Order No.	Power con- nector Size	Motor cable cross-section ⁸⁾ mm ²	Order No. Prefabricatd cable
1FK7 105 - 5AC71...	20	10	30	6SL3120 - 1TE23 - 0AA0	1.5	4 x 2.5	6FX 002 - 5S31 - ■ ■ ■ 0
1FK7 042 - 5AF71...	2.2	0.9	3	6SL3120 - ■TE13 - 0AA0	1	4 x 1.5	6FX 002 - 5S01 - ■ ■ ■ 0
1FK7 060 - 5AF71...	4.5	1.9	5	6SL3120 - ■TE15 - 0AA0	1	4 x 1.5	6FX 002 - 5S01 - ■ ■ ■ 0
1FK7 063 - 5AF71...	8	3.5	9	- ■TE21 - 0AA0	1	4 x 1.5	- 5S01 - ■ ■ ■ 0
1FK7 080 - 5AF71...	4.8	2.5	5	6SL3120 - ■TE15 - 0AA0	1	4 x 1.5	6FX 002 - 5S01 - ■ ■ ■ 0
1FK7 083 - 5AF71...	10.4	5.0	9 ⁷⁾	- ■TE21 - 0AA0	1	4 x 1.5	- 5S01 - ■ ■ ■ 0
1FK7 100 - 5AF71...	11.2	5.7	18	6SL3120 - ■TE21 - 8AA0	1	4 x 1.5	6FX 002 - 5S01 - ■ ■ ■ 0
1FK7 101 - 5AF71...	19	8.5	18 ⁷⁾	- ■TE21 - 8AA0	1.5	4 x 2.5	- 5S31 - ■ ■ ■ 0
1FK7 103 - 5AF71...	27.5	11.3	30	- 1TE23 - 0AA0	1.5	4 x 4	- 5S41 - ■ ■ ■ 0
1FK7 105 - 5AF71...	31	15	30 ⁷⁾	- 1TE23 - 0AA0	1.5	4 x 10	- 5S61 - ■ ■ ■ 0
1FK7 060 - 5AH71...	6.2	2.8	9	6SL3120 - ■TE21 - 0AA0	1	4 x 1.5	6FX 002 - 5S01 - ■ ■ ■ 0
1FK7 063 - 5AH71...	12	5.2	18	- ■TE21 - 8AA0	1	4 x 1.5	- 5S01 - ■ ■ ■ 0
1FK7 080 - 5AH71...	7.4	3.8	9	6SL3120 - ■TE21 - 0AA0	1	4 x 1.5	6FX 002 - 5S01 - ■ ■ ■ 0
1FK7 083 - 5AH71...	15	7.5	18	- ■TE21 - 8AA0	1	4 x 1.5	- 5S01 - ■ ■ ■ 0
1FK7 022 - 5AK71...	1.8	0.5	3	6SL3120 - ■TE13 - 0AA0	1	4 x 1.5	6FX 002 - 5S01 - ■ ■ ■ 0
1FK7 032 - 5AK71...	1.7	0.7	3	6SL3120 - ■TE13 - 0AA0	1	4 x 1.5	6FX 002 - 5S01 - ■ ■ ■ 0
1FK7 040 - 5AK71...	2.25	1.0	3	6SL3120 - ■TE13 - 0AA0	1	4 x 1.5	6FX 002 - 5S01 - ■ ■ ■ 0
1FK7 042 - 5AK71...	4.4	1.9	5	6SL3120 - ■TE15 - 0AA0	1	4 x 1.5	6FX 002 - 5S01 - ■ ■ ■ 0
• Single Motor Module				1			
• Double Motor Module				2			
Type of power cable							
• MOTION-CONNECT 800						8	
• MOTION-CONNECT 500						5	
• Without brake conductors							C
• With brake conductors							D
See "MOTION-CONNECT connection system" for length code as well as power and signal cables.							

- 1) If the absolute encoder is used, M_{rated} is reduced by 10%.
- 2) These values refer to $n = 2500$ rpm.
- 3) These values refer to $n = 4000$ rpm.
- 4) These values refer to $n = 3500$ rpm.
- 5) These values refer to $n = 5000$ rpm.
- 6) A max. operating frequency of 470 Hz must be observed with SINAMICS S.
- 7) With the specified Motor Module, the motor cannot be fully utilized according to $\Delta T = 100$ K winding temperature rise. If a Motor Module with a higher rating is used, you must check whether the specified power cable can be connected to it.
- 8) The current carrying capacity of the power cables corresponds to IEC 60204-1 for type of routing C under continuous operating conditions with an ambient air temperature of +40 °C, designed for I_0 (100 K), PVC/PUR-insulated cable.

AC motors

Asynchronous motors

1PH7 motors

Overview



1PH7 motor (SH 100 to SH 160)

Air-cooled 1PH7 motors are rugged and low-maintenance 4-pole squirrel-cage asynchronous motors. A fan for providing separate ventilation is mounted axially on the rear side of the motor. The normal direction of air flow is from the drive end to the non-drive end in order to keep the exhaust heat of the motor away from the machine. The inverse air direction can be ordered as an option. The motors are equipped with a built-in encoder system for sensing the motor speed and indirect position. On machine tools, the encoder system is capable of C-axis operation as standard. An additional encoder is not required for C-axis operation.

Benefits

- Short overall length of motor
- Minimized noise curve due to the integrated terminal box (SH 100 to SH 160)
- Maximum speeds of up to 9000 rpm (option: 12000 rpm)
- Full rated torque is continually available - even at standstill
- Optimum matching to the power levels SINAMICS S

Application

- Small compact machine tools
- Complex machining centers and lathes
- Special machines
- Printing industry:
 - Single drives for printing units
- Rubber, plastic, wire and glass manufacturing:
 - Drives for extruders, calenders, rubber injection molding, film machines, non woven textile machines
 - Wire-drawing machines, wire-stranding machines, etc.
- General applications such as coiler and winder drives.

Technical data (general)

Insulation of the stator winding in accordance with EN 60034-1 (IEC 60034-1)	Temperature class F for a coolant inlet temperature of up to +40 °C
Motor fan ratings	3 AC 400 V ±10%, 50/60 Hz 3 AC 480 V +5% -10%, 60 Hz
Encoder systems, built-in, for motors with/without DRIVE-CLiQ interface	Incremental encoder sin/cos 1 V _{pp} 2048 S/R
Terminal box connection type	Terminals in terminal box
• Motor	Terminals in terminal box
• Fans	12/17-pole circular socket (without mating connector)
• Motor encoder and PTC thermistor	IM B3 IM B35
Type acc. to EN 60034-7 (IEC 60034-7)	
Rating plates	1 supplied separately packed in terminal box
Permissible coolant temperature	-15 ... +40 °C
Temperature monitoring	KTY 84 temperature sensor in stator winding
Sound pressure level acc. to DIN EN ISO 1680 (tolerance +3 dB)	From DE to NDE (with the fan operating on a 50 Hz supply system) 1PH710.: 70 dB (A) 1PH713.: 70 dB (A) 1PH716.: 75 dB (A) ¹⁾

Technical data (core type)

Type ²⁾ acc. to EN 60034-7 (IEC 60034-7)	1PH710: IM B5 (IM V1, IM V3) 1PH713: IM B5 (IM V1, IM V3) 1PH716: IM B35 (IM V15, IM V36)
Terminal box location (facing drive end ³⁾)	Top, cable entry from right
Bearing arrangement at drive end ⁴⁾	Bearing for belt or coupling output
Vibration severity acc. to EN 60034-14 (IEC 60034-14)	Stage S
Shaft and flange accuracy acc. to DIN 42955 (IEC 60072-1)	Tolerance R (reduced)
Degree of protection acc. to EN 60034-5 (IEC 60034-5)	Motor IP55, fan IP54
Paint finish	Unpainted

1) The sound pressure level can be reduced if the fan is operating on a 60 Hz supply system with option K44.

2) For type, see "Selection guide".

3) DE is the drive end with shaft. NDE is the non-drive end.

4) For permissible loads, see the 1PH Motors Planning Guide.

Characteristics

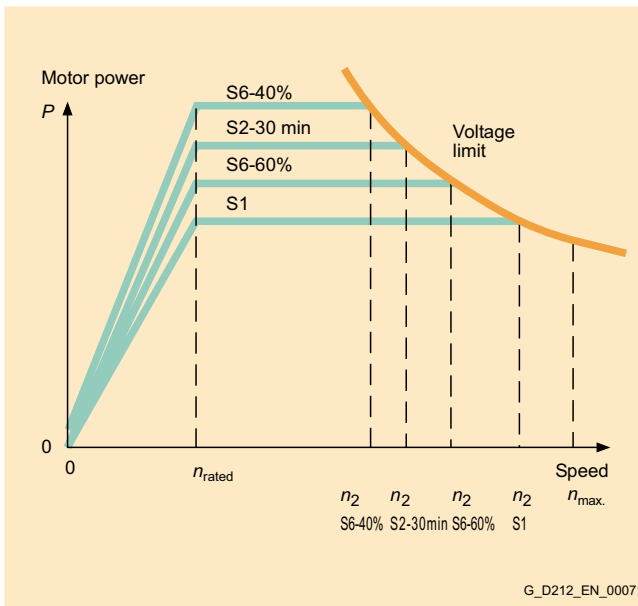

Typical power-speed diagram for AC motors ¹⁾

The diagram shows the typical ratio between motor speed and drive power for 1PH7 motors in the following duty types (according to IEC 60034-1):

- S1: Continuous duty
- S6: Continuous duty with intermittent loading and a relative ON period of 60% (S6-60%) or 40% (S6-40%) with a maximum duty cycle time of 10 min.
- S2: Short-time operation with an ON period of 30 min (S2-30 min) followed by standstill.

Motor Type	Rated speed n_{rated} rpm	Attainable speed for rated power in duty type (according to IEC 60034-1)			
		n_2 ²⁾ rpm	S6-60% rpm	S6-40% rpm	S2-30 min rpm
1PH7101-..F	1500	8200	7000	6000	6500
1PH7103-..D	1000	3750	3750	3100	3350
1PH7103-..F	1500	5000	4600	3900	4500
1PH7103-..G	2000	9000	7500	6400	6900
1PH7105-..F	1500	7900	6750	5750	6150
1PH7107-..D	1000	5800	4800	4100	4650
1PH7107-..F	1500	6500	6200	5250	5650
1PH7107-..G	2000	7000	7000	6900	7000
1PH7131-..F	1500	6700	5500	4500	5000
1PH7133-..D	1000	4700	3700	2800	3450
1PH7133-..F	1500	6800	5600	4500	5100
1PH7133-..G	2000	6500	6500	5900	6450
1PH7135-..F	1500	7500	6200	5200	5650
1PH7137-..D	1000	5400	4500	3600	4100
1PH7137-..F	1500	7000	7000	6200	6800
1PH7137-..G	2000	6000	6000	5800	6000
1PH7163-..B	500	2500	1900	1500	1730
1PH7163-..D	1000	5800	4800	4000	4400
1PH7163-..F	1500	5500	5500	5500	5500
1PH7163-..G	2000	3500	3500	3500	3500
1PH7167-..B	500	2100	1600	1250	1400
1PH7167-..D	1000	6250	5200	4300	4700
1PH7167-..F	1500	4500	4500	4500	4500
1PH7167-..G	2000	3250	3250	3250	3250

1) For further planning information refer to the 1PH Motors Planning Guide.

2) Values from the power-speed diagram based on using an Active Line Module on a 3 AC 400 V supply system. If you are using the Smart Line Module, proceed in accordance with the 1PH Motor Planning Guide.

AC motors

Asynchronous motors

Core type 1PH7 motors

Selection and ordering data

Shaft height SH	Rated speed	Max. permanent speed		Max. speed ²⁾		Rated power for duty type (according to IEC 60034-1)				1PH7 asynchronous motor Order No. Core type	
	n_{rated}	$n_{S1 cont.}^{3)}$	$n_{S1 cont.}^{4)}$	n_{max}	$n_{max}^{5)}$	P_{rated}	S1	S6-60%	S6-40%		S2-30 min
	rpm	rpm	rpm	rpm	rpm	kW	kW	kW	kW		
100	2000	5500	–	9000	–	7	8.5	10	9.25	1PH7103 - ■ ■ G02 - 0C ■ 0	
	1500	5500	–	9000	–	9	11	13	12	1PH7107 - ■ ■ F02 - 0C ■ 0	
132	1000	4500	–	8000	–	12	15	18.5	16	1PH7133 - ■ ■ D02 - 0C ■ 0	
	2000					20	25	30	27.5	1PH7133 - ■ ■ G02 - 0C ■ 0	
	1000	4500	–	8000	–	17	20.5	25	22.5	1PH7137 - ■ ■ D02 - 0C ■ 0	
	2000					28	35	43	39	1PH7137 - ■ ■ G02 - 0C ■ 0	
160	1000	3700	–	6500	–	22	27	33	30	1PH7163 - ■ ■ D03 - 0C ■ 0	
	1500					30	37	45	41	1PH7163 - ■ ■ F03 - 0C ■ 0	
	1500	3700	–	6500	–	37	46	56	51	1PH7167 - ■ ■ F03 - 0C ■ 0	
• Fans:		External fan unit and PG cable entry in terminal box								2	A
		External fan unit and metric cable entry in terminal box								7	
• Encoder systems for motors without DRIVE-CLiQ interface:		Incremental encoder sin/cos 1 V _{pp} (no C or D track)								N	J
• Encoder systems for motors with DRIVE-CLiQ interface:		Incremental encoder sin/cos 1 V _{pp} (no C or D track)								Q	
• Type: ¹⁾		IM B5 (IM V1, IM V3)								2	J
		IM B35 (IM V15, IM V36)								3	
• Drive end shaft extension: ¹⁾		• Balancing:		• Direction of air flow (fan):		• Exhaust direction:				A	
Featherkey		Half-key		DE → NDE		Axial					
Smooth shaft		–		DE → NDE		Axial					

For type, see "Selection guide".

Selection and ordering data

Motor type (continued)	Rated torque M_{rated} Nm	Moment of inertia J kgm^2	Weight approx. m kg	Rated current for duty type (according to IEC 60034-1)				SINAMICS Motor Module Rated output current	
				I_{rated} S1 A	S6-60% A	S6-40% A	S2-30 min A	I_{rated} S1 A	Order No.
1PH7103 - ..G02 -...	33.4	0.017	40	17.5	20.5	23.5	21.5	18	6SL3120 - 1TE21 - 8AA0
1PH7107 - ..F02 -...	57.3	0.029	63	23.5	27.5	31	29	30	6SL3120 - 1TE23 - 0AA0
1PH7133 - ..D02 -...	114.6	0.076	90	30	36	43	37.5	30	6SL3120 - 1TE23 - 0AA0
1PH7133 - ..G02 -...	95.5	0.076	90	45	54	63	59	45	- 1TE24 - 5AA0
1PH7137 - ..D02 -...	162.3	0.109	130	43	50	60	54	45	6SL3120 - 1TE24 - 5AA0
1PH7137 - ..G02 -...	133.7	0.109	130	60	73	87	80	60	- 1TE26 - 0AA0
1PH7163 - ..D03 -...	210.1	0.19	180	55	65	77	71	60	6SL3120 - 1TE26 - 0AA0
1PH7163 - ..F03 -...	191.0	0.19	180	72	86	102	94	85	- 1TE28 - 5AA0
1PH7167 - ..F03 -...	235.5	0.23	228	82	97	115	104	85	6SL3120 - 1TE28 - 5AA0
Single Motor Module									1
Double Motor Module									2



1PH7 motor (SH 100 to SH 160)

- The following motor versions are required for "ZF gearbox mounting prepared" (see "Gear units" for gear selection):
 - Types IM B5 or IM B35
 - Shaft with featherkey and full-key balancing
- For continuous duty (with 30% n_{max} , 60% $\frac{2}{3} n_{max}$, 10% standstill) for a duty cycle time of 10 min. For bearing replacement intervals, see the 1PH Motors Planning Guide.
- Bearing version for coupling/belt drive.
- Bearing version for increased maximum speed.
- Version for increased maximum speed only in conjunction with vibration severity grade SR. The following options are not possible:
 - ZF gearbox mounting prepared
 - Shaft seal

AC motors

Gear units

LP planetary gear units for 1FK7 motors

Overview



LP planetary gear unit

1FK7 motors can easily be combined with planetary gear units to form compact coaxial drive units. The gear units are flanged directly to the drive end of the motors.

When selecting the gear units, ensure that the permissible speed of the gear unit is not exceeded by the maximum speed of the motor. In the case of high operating frequencies, allowance must be made for the withstand ratio f_2 (see Planning Guide). The frictional losses of the gear unit must always be taken into account when planning.

The gear units are only available in non-balanced design and with featherkey.

Benefits

- High efficiency (> 97%)
- Circumferential backlash: Single-stage ≤ 12 arcmin
- Power transmission from the central sun gear via planetary gears
- No shaft deflections in the planetary gear set due to the symmetrical force distribution
- The enclosed gear units, which are filled with grease before leaving the factory, are attached to the shaft by means of an integral clamping hub. This requires a smooth motor shaft extension with rotational accuracy tolerance N according to DIN 42955. The motor flange is fitted by means of adapter plates.
- Oil seal on motor side included in the gear unit
- Output shaft of gear unit exactly coaxial with the motor
- The gear units are suitable for all mounting positions.
- The gear units are filled with grease before leaving the factory. They are lubricated and sealed for life (service life 20000 hours).
- Degree of protection IP64
- Small dimensions
- Low weight

Integration

The gear units assigned to the individual motors and gear ratios i available for these motor/gear combinations are listed in the following selection table. When making a selection, the maximum permissible input speed of the gear unit must be observed (this is the same as the maximum motor speed).

The motor/gear combinations listed in the selection table are mainly intended for positioning duty (S5). At the rated speed and rated torque, continuous duty is permissible. The gear unit temperature must not exceed +90 °C.

Selection and ordering data

Ordering data: **1FK7** ■■■■ - **A** ■71 - **1** ■■■■ - **Z** Order No. of the motor with codes "**Z**" and
V ■ ■ ■ Code for mounting the planetary gear assigned to the specific motor
G Precondition: Smooth motor shaft
H

Motor natural cooling	Planetary gear unit single-stage		Available gear ratios $i =$		Maximum permissible input speed ¹⁾	Maximum permissible output torque ¹⁾		Max. perm. radial force on output shaft ²⁾	Moment of inertia of gear unit	
	Type	Circumferential play ≤ 12 arcmin	Gear unit weight approx. kg	5		10	M_{G2} at $i = 5$			M_{G2} at $i = 10$
1FK7022	LP 050-M01		0.77	✓	–	8000	11.5	10.5	650	J_G at $i = 5/10$ 10^{-4} kgm ²
1FK7022	LP 070-M01		1.9	–	✓	6000	32	29	1450	0.28
1FK7032				✓	✓					
1FK7033				✓	✓					
1FK7040	LP 090-M01		4.1	✓	✓	6000	80	72	2400	1.77
1FK7042				✓	✓					
1FK7043				✓	✓					
1FK7044				✓	✓					
1FK7060	LP 120-M01		9	✓	✓	4800	200	180	4600	5.42
1FK7061				✓	✓					
1FK7063				✓	✓					
1FK7064				✓	–					
1FK7080	LP 155-M01		17.5	✓	✓	3600	400	320	7500	25.73
1FK7082				✓	✓					
1FK7083				✓	✓					
1FK7085				✓	–					
1FK7100				✓	–					
1FK7101			✓	–						
1FK7103			✓	–						

Code

• Gear shaft with featherkey

V40 **V42**

Continuous duty S1

At the rated speed and rated torque, continuous duty is permissible. The gear unit temperature must not exceed +90 °C.

Planetary gear unit single-stage	Rated input speed	Rated output torque	
Circumferential play ≤ 12 arcmin			
Type	n_{rated1}	M_{rated2} at $i = 5$	M_{rated2} at $i = 10$
	rpm	Nm	Nm
LP 050-M01	4000	5.7	5.2
LP 070-M01	3700	16	15
LP 090-M01	3400	40	35
LP 120-M01	2600	100	90
LP 155-M01	2000	290	170

1) Values for positioning duty S5.

2) Referred to the center of the output shaft at 100 rpm.

AC motors

Notes

5

6

Connection system MOTION-CONNECT



6/2	General information
6/2	Technical data
6/4	Power cables
6/5	Extensions
6/6	Signal cables
6/9	Extensions
6/10	Length code

Connection system MOTION-CONNECT

General information

Overview

MOTION-CONNECT cables are suitable for use on all types of machine tools and production machines.

Power, signal and DRIVE-CLiQ cables can be ordered as prefabricated cables.

MOTION-CONNECT comprises the following types of cables:

- **MOTION-CONNECT 500**, the solution for mainly fixed routing.
- **MOTION-CONNECT 800** meets all requirements for use in cable carriers on machine tools and production machines.

Benefits

The use of prefabricated MOTION-CONNECT cables will provide you with high-quality and system-tested problem-free operation. The cables can be supplied to the meter. Intermediate lengths are also available on request.

Application

The degree of protection of the prefabricated power and signal cables and their extensions outside the control cabinet when closed and connected is IP67.



Technical data

Cables	DRIVE-CLiQ	DRIVE-CLiQ MOTION-CONNECT 500	DRIVE-CLiQ MOTION-CONNECT 800	MOTION-CONNECT 500	MOTION-CONNECT 800
Type	6FX2...-1DC...-....	6FX5...-DC...-....	6FX8...-DC...-....	6FX500-.....-....	6FX800-.....-....

Certification

Power/signal cables

• VDE ¹⁾	Yes	Yes	Yes	Yes	Yes
• cUL or UL/CSA	UL STYLE 2502/ CSA-N.210.2-M90	UL STYLE 2502/ CSA-N.210.2-M90	UL STYLE 2502/ CSA-N.210.2-M90	UL758-CSA-C22.2- N210.2-M90	UL758-CSA-C22.2- N210.2-M90
• UL-CSA File No. ²⁾	Yes	Yes	Yes	Yes	Yes

Electrical data to DIN VDE 0472

Rated voltage

• Power cable U_0/U					
- Supply cores	-	-	-	600 V/1000 V	600 V/1000 V
- Signal cores	-	-	-	24 V (VDE) 1000 V (UL/CSA)	24 V (VDE) 1000 V (UL/CSA)
• Signal cable	30 V	30 V	30 V	30 V	30 V

Test voltage (rms)

• Power cable					
- Supply cores	-	-	-	4 kV	4 kV
- Signal cores	-	-	-	2 kV	2 kV
• Signal cable	500 V	500 V	500 V	500 V	500 V

Operating temperature

On the surface

• Fixed installation	-20 ... +80 °C	-20 ... +80 °C	-50 ... +80 °C	-20 ... +80 °C	-50 ... +80 °C
• Flexible installation	-	0 ... +60 °C	-20 ... +60 °C	0 ... +60 °C	-20 ... +60 °C

1) The respective registration number is printed on the cable sheath (only valid for power cables).

2) The File Number is printed on the cable sheath.

Connection system MOTION-CONNECT

General information

Technical data (continued)

Cables	DRIVE-CLiQ	DRIVE-CLiQ MOTION-CONNECT 500	DRIVE-CLiQ MOTION-CONNECT 800	MOTION-CONNECT 500	MOTION-CONNECT 800
Type	6FX2...-1DC...-....	6FX5...-DC...-....	6FX8...-DC...-....	6FX500...-.....-....	6FX800...-.....-....
Mechanical data					
Max. tensile stress on power/signal cables					
• Fixed installation	45 N/mm ²	50 N/mm ²	50 N/mm ²	50 N/mm ²	50 N/mm ²
• Flexible installation	–	20 N/mm ²	20 N/mm ²	20 N/mm ²	20 N/mm ²
Minimum permissible bending radius					
• Power cable					
- Fixed installation	–	–	–	5 × D _{max}	6 × D _{max}
- Flexible installation	–	–	–	See "Power cables"	See "Power cables"
• Signal cable					
- Fixed installation	50 mm	35 mm	60 mm	60 mm	60 mm
- Flexible installation	–	125 mm	100 mm	100 mm	100 mm
Torsional stress	–	Absolute 30°/m	Absolute 30°/m	Absolute 30°/m	Absolute 30°/m
Bending					
• Power cables					
- 1.5 ... 6 mm ²	–	–	10 mill.	100,000	10 mill.
- 10 ... 185 mm ²	–	–	3 mill.	100,000	3 mill.
• Signal cables	–	100,000	10 mill.	2 mill.	10 mill.
Traversing velocity					
• Power cables					
- 1.5 ... 6 mm ²	–	–	–	30 m/min	180 m/min
- 10 ... 50 mm ²	–	–	–	30 m/min	100 m/min
• Signal cables	–	30 m/min	180 m/min	180 m/min	180 m/min
Acceleration					
• Power cables	–	–	–	2 m/s ²	5 m/s ² (5 m); 10 m/s ² (2.5 m)
• Signal cables	–	2 m/s ²	5 m/s ² (5 m); 10 m/s ² (10 m)	5 m/s ²	5 m/s ² (5 m); 10 m/s ² (2.5 m)
Chemical data					
Insulation material	CFC/silicone-free	CFC/silicone-free	CFC/halogen/ silicone-free DIN 472815/ IEC 60754-1	CFC/silicone-free	CFC/halogen/ silicone-free DIN 472815/ IEC 60754-1
Oil resistance	DIN EN 60811-1-1/2-1	DIN EN 60811-1-1/2-1	VDE 0472, Part 803 Test mode B	VDE 0472, Part 803 Test mode B (mineral oils only)	VDE 0472, Part 803 Test mode B
Outer sheath	PVC	PVC	PUR, DIN VDE 0282, Part 10	PVC	PUR, DIN VDE 0282, Part 10
• Power cable	–	–	DESINA color orange RAL 2003	DESINA color orange RAL 2003	DESINA color orange RAL 2003
• Signal cable	Gray RAL 7032	DESINA color green RAL 6018	DESINA color green RAL 6018	DESINA color green RAL 6018	DESINA color green RAL 6018
Flame-retardant	IEC 60332.1	IEC 60332.1	IEC 60332.1	IEC 60332.1	IEC 60332.1

The technical data for these cables apply only for simple bends with horizontal traverse paths up to 5 m.

Connection system MOTION-CONNECT

Power cables

Selection and ordering data

MOTION-CONNECT power cables *without brake cores*

Connection method, Motor Module side	No. of cores x cross-section mm ²	Connector size, motor side	Prefabricated cable for 1FK/1PH motors ²⁾ Order No.	D _{max.}		Cable (sold by meter) ³⁾ for 1PH motors Order No.	Weight (without connector)		Smallest perm. bending radius ¹⁾		
				6FX5 mm	6FX8 mm		6FX5 kg/m	6FX8 kg/m	6FX5 mm	6FX8 mm	
Connector	4x1.5	1	6FX 002-5CS01-■■■■0	8.4	10.4	6FX 008-1BB11-■■■■0	0.18	0.16	155	100	
		1.5	6FX 002-5CS21-■■■■0								
		o. A. ²⁾	6FX5002-5CS02-■■■■0								
Connector	4x2.5	1	6FX 002-5CS11-■■■■0	10.0	12.1	6FX 008-1BB21-■■■■0	0.24	0.24	180	120	
		1.5	6FX 002-5CS31-■■■■0								
		o. A. ²⁾	6FX5002-5CS12-■■■■0								
Connector	4x4	1.5	6FX 002-5CS41-■■■■0	11.4	13.2	6FX 008-1BB31-■■■■0	0.27	0.31	210	130	
		o. A. ²⁾	6FX5002-5CS42-■■■■0								
Connector	4x6	1.5	6FX 002-5CS51-■■■■0	13.6	16.0	6FX 008-1BB41-■■■■0	0.46	0.43	245	170	
		o. A. ²⁾	6FX5002-5CS52-■■■■0								
Connector	4x10	1.5	6FX 002-5CS61-■■■■0	20.0	19.4	6FX 008-1BB51-■■■■0	0.73	0.63	360	210	
		3	6FX 002-5CS13-■■■■0								
		o. A. ²⁾	6FX5002-5CS62-■■■■0								
Ring terminal ends	4x6	1.5	6FX 002-5CS54-■■■■0	15.6	16.0	6FX 008-1BB41-■■■■0	0.46	0.43	285	170	
	4x10	1.5	6FX 002-5CS64-■■■■0	20.0	19.4	6FX 008-1BB51-■■■■0	0.73	0.63	360	210	
	4x16	3	6FX 002-5CS23-■■■■0	24.2	23.6	6FX 008-1BB61-■■■■0	1.10	0.95	440	260	
	4x25	3	–	28	6FX 008-1BB25-■■■■0	1.42	–	505	–		
	4x35	–	–	31.5	6FX 008-1BB35-■■■■0	1.87	–	570	–		
	4x50	–	–	38	6FX 008-1BB50-■■■■0	3.42	–	685	–		
	4x70	–	–	42.6	6FX 008-1BB70-■■■■0	4.12	–	770	–		
	4x95	–	–	51.7	6FX 008-1BB05-■■■■0	4.48	–	935	–		
	4x120	–	–	56	6FX 008-1BB12-■■■■0	6.11	–	1010	–		
	4x150	–	–	63	6FX 008-1BB15-■■■■0	7.75	–	1135	–		
	4x185	–	–	66.2	6FX 008-1BB18-■■■■0	9.45	–	1195	–		
	Type of power cable										
	• MOTION-CONNECT 500			5		5					
• MOTION-CONNECT 800			8		8						

1) Valid for installation in cable carrier.

2) o. A. = Open core ends; suitable for motors with terminal box, e.g. 1PH motors.

3) Power cables of 1.5 mm² and 2.5 mm² are supplied in 50 m, 100 m, 200 m and 500 m rings or disposable drums. Power cables with cross-section of 4 mm² or greater can be ordered by the meter up to 100 m.

Selection and ordering data

MOTION-CONNECT power cables with brake cores

Connection method, Motor Module side	No. of cores x cross-section mm ²	Connector size, motor side	Prefabricated cable for 1FK motors Order No.	D _{max.}		Cable (sold by meter) ¹⁾ for 1PH7 motors Order No.	Weight (without connector)		Smallest perm. bending radius ¹⁾	
				6FX5 mm	6FX8 mm		6FX5 kg/m	6FX8 kg/m	6FX5 mm	6FX8 mm
Connector	4x1.5+2x1.5	1	6FX 002-5DS01-■■■■0	10.8	12.9	6FX 008-1BA11-■■■■0	0.22	0.25	195	125
		1.5	6FX 002-5DS21-■■■■0							
Connector	4x2.5+2x1.5	1	6FX 002-5DS11-■■■■0	12.4	14.2	6FX 008-1BA21-■■■■0	0.28	0.31	225	140
		1.5	6FX 002-5DS31-■■■■0							
Connector	4x4+2x1.5	1.5	6FX 002-5DS41-■■■■0	14.0	15.3	6FX 008-1BA31-■■■■0	0.36	0.40	255	150
Connector	4x6+2x1.5	1.5	6FX 002-5DS51-■■■■0	16.1	17.8	6FX 008-1BA41-■■■■0	0.54	0.53	290	195
Connector	4x10+2x1.5	1.5	6FX 002-5DS61-■■■■0	21.7	20.8	6FX 008-1BA51-■■■■0	0.75	0.74	395	230
		3	6FX 002-5DS13-■■■■0							
Ring terminal ends	4x6+2x1.5	1.5	6FX 002-5DS54-■■■■0	16.1	17.8	6FX 008-1BA41-■■■■0	0.54	0.53	290	195
	4x10+2x1.5	1.5	6FX 002-5DS64-■■■■0	21.7	20.8	6FX 008-1BA51-■■■■0	0.75	0.74	395	230
	4x16+2x1.5	3	6FX5002-5DS23-■■■■0	25.0	24.7	6FX 008-1BA61-■■■■0	1.10	1.10	450	275
	4x25+2x1.5	3	6FX5002-5DS33-■■■■0	29.4	27.9	6FX 008-1BA25-■■■■0	1.56	1.46	530	325
	4x35+2x1.5	3	6FX5002-5DS43-■■■■0	32.6	32.0	6FX 008-1BA35-■■■■0	2.01	2.10	590	380
	4x50+2x1.5	3	6FX5002-5DS53-■■■■0	38.0	35.8	6FX 008-1BA50-■■■■0	3.30	2.75	685	420
Type of power cable										
• MOTION-CONNECT 500			5			5				
• MOTION-CONNECT 800			8			8				

1) Power cables of 1.5 mm² and 2.5 mm² are supplied in 50 m, 100 m, 200 m and 500 m rings or disposable drums. Power cables with cross-section of 4 mm² or greater can be ordered by the meter up to 100 m.

Connection system MOTION-CONNECT

Power cables Extensions

Selection and ordering data

Prefabricated MOTION-CONNECT power cables for 1PH7 motors

Motor type	PG 2)	No. of cores x cross-section mm ²	Prefabricated cable for 1PH7 motors Order No.	Weight (without connector)		Smallest perm. bending radius ¹⁾	
				6FX5 kg/m	6FX8 kg/m	6FX5 mm	6FX8 mm
1PH710	PG29	4x10	6FX 002-5CB10-...0	0.73	0.63	20	19.4
		4x16	6FX 002-5CB16-...0	1.10	0.95	24.2	23.6
1PH713	PG36	4x16	6FX 002-5CC16-...0	1.10	0.95	24.2	23.6
		4x25	6FX 002-5CC25-...0	1.42	-	28.0	-
		4x25	6FX 8 002-5DC25-...0	-	1.46	-	27.9
		4x35	6FX 5 002-5CC35-...0	1.87	-	31.5	-
1PH716	PG42	4x35	6FX 8 002-5DC35-...0	-	2.10	-	32
		4x25	6FX 5 002-5CD25-...0	1.42	-	28.0	-
		4x25	6FX 8 002-5DD25-...0	-	1.46	-	27.9
		4x35	6FX 5 002-5CD35-...0	1.87	-	31.5	-
4x35			6FX 8 002-5DD35-...0	-	2.10	-	32

- MOTION-CONNECT 500 **5**
- MOTION-CONNECT 800 **8**

Note:

1PH7 motors do not have a brake as standard and therefore do not require power cables with brake cores.

If a brake is used, it must be supplied through a separate cable via the terminal box.

The MOTION-CONNECT 800 power cables with cross-sections 25 mm² and 35 mm² are available only with brake cores.

Single Motor Modules of 45 A and higher have screw-type terminals and therefore require cables with open cores at both ends. With lower module currents, cables with connectors at the module end must be used for 1PH7 motors.

Power cable extensions

No. of cores x cross-section mm ²	Basic cable for 1FK motors Type	Connector size	Extension	Connector size
			Order No.	
4x1.5	6FX . 002-5 . S01- . . . 0	1	6FX 002-5 A05- . . . 0	1
4x2.5	6FX . 002-5 . S11- . . . 0	1	6FX 002-5 A15- . . . 0	1
4x1.5	6FX . 002-5 . S21- . . . 0	1.5	6FX 002-5 A28- . . . 0	1.5
4x2.5	6FX . 002-5 . S31- . . . 0	1.5	6FX 002-5 A38- . . . 0	1.5
4x4	6FX . 002-5 . S41- . . . 0	1.5	6FX 002-5 A48- . . . 0	1.5
4x6	6FX . 002-5 . S51- . . . 0	1.5	6FX 002-5 A58- . . . 0	1.5
4x10	6FX . 002-5 . S61- . . . 0	1.5	6FX 002-5 A68- . . . 0	1.5
4x10	6FX . 002-5 . S13- . . . 0	3	6FX 002-5 X18- . . . 0	3
4x16	6FX . 002-5 . S23- . . . 0	3	6FX 002-5 X28- . . . 0	3
4x25	6FX . 002-5DS33- . . . 0	3	6FX 002-5DX38- . . . 0	3

Type of power cable

- MOTION-CONNECT 500 **5**
- MOTION-CONNECT 800 **8**

- Without brake cores **C**
- With brake cores **D**

The combinations of power cable extensions shown are only provided by way of example.

1) Valid for installation in cable carrier.
2) Conduit thread.

Overview



Signal cables are prefabricated and are sold by the meter for the connection of a variety of components.

The following different types of cable are available:

- DRIVE-CLiQ cables
- MOTION-CONNECT DRIVE-CLiQ cables
- MOTION-CONNECT prefabricated cables

Application

DRIVE-CLiQ cables

are used to connect components with DRIVE-CLiQ connections, which have a separate or external 24 V DC power supply.

DRIVE-CLiQ cables for connecting Line/Motor Modules with a control unit are part of the scope of supply of the relevant Line/Motor Modules.

MOTION-CONNECT DRIVE-CLiQ cables

are used whenever components with DRIVE-CLiQ connections must meet high requirements such as mechanical stress and oil resistance, e. g. in the event of a connection outside the cabinet between

- Motor Modules and Sensor Modules
- Motor Modules and motors with DRIVE-CLiQ interface

MOTION-CONNECT DRIVE-CLiQ cables feature 24 V DC cores.

MOTION-CONNECT prefabricated cables

are used whenever motor encoders on motors without DRIVE-CLiQ interface are connected to Sensor Modules.

Connection system MOTION-CONNECT

Signal cables

Overview of connections for Line Modules and Motor Modules

The DRIVE-CLiQ cables type 6SL3060-4A..00-0AA0 required for the standard configuration are part of the scope of supply of

the Line Modules and Motor Modules. In this case, the modules should be mounted directly adjacent to one another in a row.

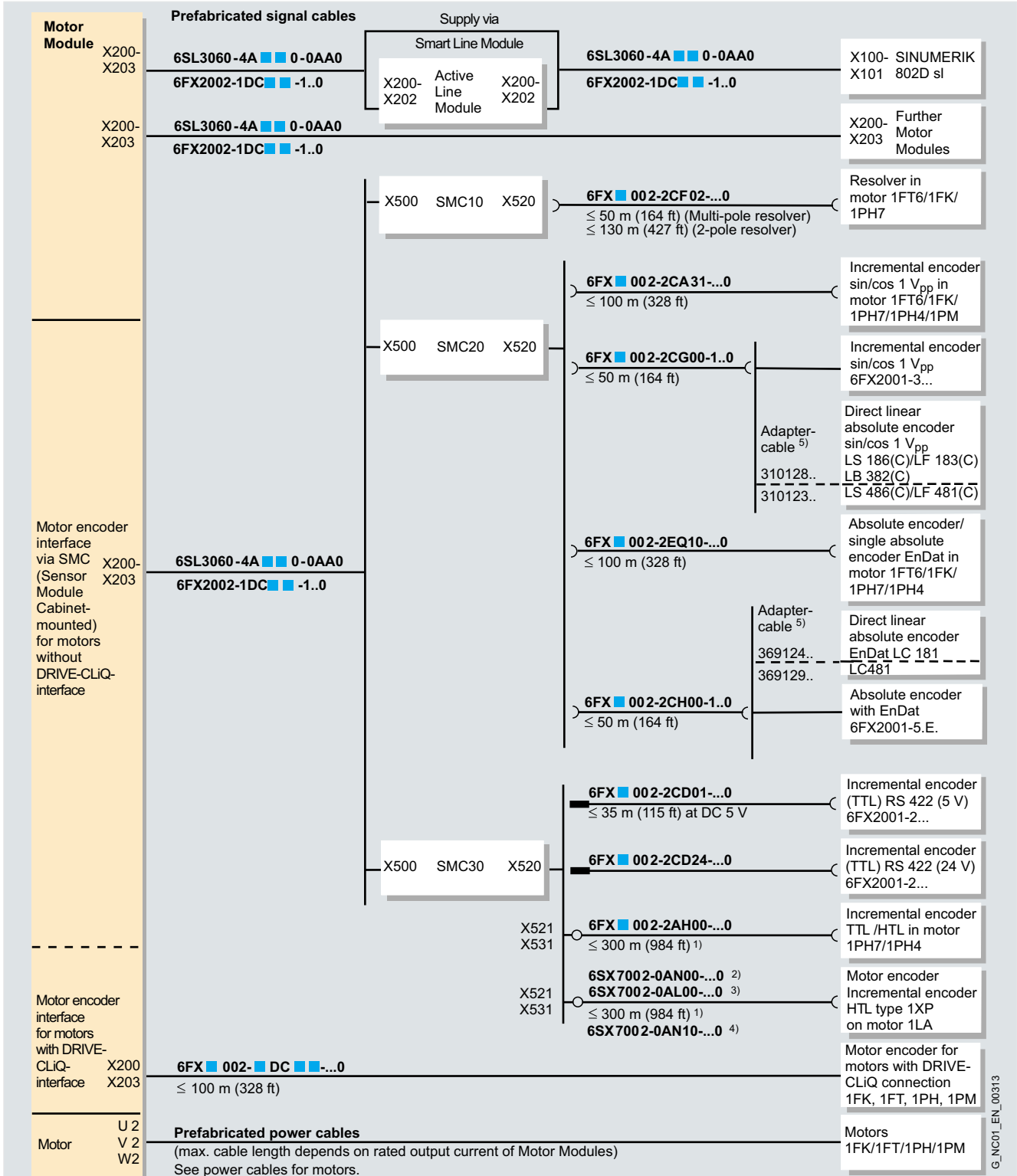

G_NC01_EN_00313



Connection system MOTION-CONNECT

Signal cables

Selection and ordering data

Signal cable	Length	Degree of protection (connector)	Order No.
DRIVE-CLiQ prefabricated cables (without 24 V DC cores)			
In specific lengths	0.11 m	IP20/IP20	6SL3060-4AB00-0AA0
	0.16 m		6SL3060-4AD00-0AA0
	0.21 m		6SL3060-4AF00-0AA0
	0.26 m		6SL3060-4AH00-0AA0
	0.31 m		6SL3060-4AK00-0AA0
	0.36 m		6SL3060-4AM00-0AA0
	0.60 m		6SL3060-4AU00-0AA0
	0.95 m		6SL3060-4AA10-0AA0
	1.20 m		6SL3060-4AW00-0AA0
	1.45 m		6SL3060-4AF10-0AA0
	2.80 m		6SL3060-4AJ20-0AA0
	5.00 m		6SL3060-4AA50-0AA0
By the meter	max. 70 m	IP20/IP20	6FX2002-1DC00- 1 ■ ■ ■ 0
	max. 70 m	IP67/IP67	6FX2002-1DC20- 1 ■ ■ ■ 0
MOTION-CONNECT 500 DRIVE-CLiQ cables (with 24 V DC cores)			
By the meter	max. 100 m	IP20/IP20	6FX5002-2DC00- ■ ■ ■ ■ 0
	max. 100 m	IP20/IP67	6FX5002-2DC10- ■ ■ ■ ■ 0
	max. 100 m	IP67/IP67	6FX5002-2DC20- ■ ■ ■ ■ 0
MOTION-CONNECT 800 DRIVE-CLiQ cables (with 24 V DC cores)			
By the meter	max. 50 m	IP20/IP20	6FX8002-2DC00- 1 ■ ■ ■ 0
	max. 50 m	IP20/IP67	6FX8002-2DC10- 1 ■ ■ ■ 0
	max. 50 m	IP67/IP67	6FX8002-2DC20- 1 ■ ■ ■ 0
MOTION-CONNECT prefabricated cables			
Resolver in 1FK/1PH7 motor (for SMC10)			6FX ■ 002-2CF02- ■ ■ ■ ■ 0
• multi-pole	max. 50 m	IP20/IP67	
• 2-pole	max. 130 m	IP20/IP67	
Incremental encoder sin/cos 1 V _{pp} in 1FK/1PH motor (for SMC20)	max. 100 m	IP20/IP67	6FX ■ 002-2CA31- ■ ■ ■ ■ 0
Incremental encoder sin/cos 1 V _{pp} 6FX2001-3... (for SMC20)	max. 50 m	IP20/IP67	6FX ■ 002-2CG00- ■ ■ ■ ■ 0
Single/Absolute encoder with EnDat in 1FK/1PH motor (for SMC20)	max. 100 m	IP20/IP67	6FX ■ 002-2EQ10- ■ ■ ■ ■ 0
Absolute encoder with EnDat 6FX2001-5.E. (for SMC20)	max. 100 m	IP20/IP67	6FX ■ 002-2CH00- ■ ■ ■ ■ 0
Incremental encoder (TTL) RS 422 (5 V) 6FX2001-2... (for SMC30)	max. 35 m	IP20/IP67	6FX ■ 002-2CD01- ■ ■ ■ ■ 0
Incremental encoder (TTL) RS 422 (24 V) 6FX2001-2... (for SMC30)	max. 35 m	IP20/IP67	6FX ■ 002-2CD24- ■ ■ ■ ■ 0
Incremental encoder in 1PH7 motor (for SMC30)			6FX ■ 002-2AH00- ■ ■ ■ ■ 0
• TTL encoder	max. 100 m	IP20/IP67	
• HTL encoder	max. 300 m	IP20/IP67	
Incremental encoder HTL type 1XP on motor (for SMC30)			
• Track A, B	max. 300 m	IP20/IP67	6SX7002-0AL00- ■ ■ ■ ■ 0
• Track A, B, N and A*, B*, N*	max. 300 m	IP20/IP67	6SX7002-0AN00- ■ ■ ■ ■ 0
• Track A, B, N and A*, B*, N* and right-angled connector	max. 300 m	IP20/IP67	6SX7002-0AN10- ■ ■ ■ ■ 0
Type of power cable			
• MOTION-CONNECT 500			5
• MOTION-CONNECT 800			8

Connection system MOTION-CONNECT

Signal cables Extensions

Length code

Selection and ordering data

Signal cable extensions

Basic cable Type	Extension Order No.
6FX . 002-2AH00-	6FX ■ 002-2AH04- ■ ■ ■ 0
6FX . 002-2CA31-	6FX ■ 002-2CA34- ■ ■ ■ 0
6FX . 002-2CD01-	6FX ■ 002-2CB54- ■ ■ ■ 0
6FX . 002-2CD24-	6FX ■ 002-2CB54- ■ ■ ■ 0
6FX . 002-2CF02-	6FX ■ 002-2CF04- ■ ■ ■ 0
6FX . 002-2CG00-	6FX ■ 002-2CB54- ■ ■ ■ 0
6FX . 002-2CH00-	6FX ■ 002-2AD04- ■ ■ ■ 0
6FX . 002-2EQ10-	6FX ■ 002-2EQ14- ■ ■ ■ 0

Type of power cable

• MOTION-CONNECT 500	5
• MOTION-CONNECT 800	8

The combinations of power cable extensions shown are only provided by way of example.

Overview

Length codes for prefabricated cables

Prefabricated cables Length code	6FX.....-.....-	6SX.....-.....-
0 m	■ ■ ■ 0	■ ■ ■ 0
100 m	■ ■ ■ 0	■ ■ ■ 0
200 m	■ ■ ■ 0	■ ■ ■ 0
300 m	■ ■ ■ 0	■ ■ ■ 0
0 m		1
10 m		2
20 m		3
30 m		4
40 m		A
50 m		B
60 m		C
70 m		D
80 m		E
90 m		F
		G
		H
		J
		K
0 m		A
1 m		B
2 m		C
3 m		D
4 m		E
5 m		F
6 m		G
7 m		H
8 m		J
9 m		K

Examples:	1.0 m:	1 A B 0
	2.0 m:	1 A C 0
	8.0 m:	1 A J 0
	299.0 m:	3 K K 0

Length definition for prefabricated cables

The cable length specified does not include the connector.

- Tolerance for a cable length of up to 10 m: $\pm 2\%$
- Tolerance for a cable length of more than 10 m: $\pm 1\%$

Selection and ordering data

Designation	Order No.
Power/signal cables (sold by meter)¹⁾	
• 50 m	6FX. 008-.....-1FA0
• 100 m	6FX. 008-.....-2AA0
• 200 m	6FX. 008-.....-3AA0
• 500 m	6FX. 008-.....-6AA0

1) Power cables of 1.5 mm² and 2.5 mm² are supplied in 50 m, 100 m, 200 m and 500 m rings or disposable drums. Power cables with cross-section of 4 mm² or greater can be ordered by the meter up to 100 m.

Appendix



7/2	Service & Support
7/3	Repair service contract RSV
7/5	Siemens contacts worldwide
7/6	Information and ordering in the Internet and on CD-ROM
7/6	A&D on the WWW
7/6	Product selection using the interactive catalog
7/6	Easy shopping with the A&D Mall
7/7	Subject index
7/8	Order number index
7/9	Conditions of sale and delivery



Appendix Service & Support

General information

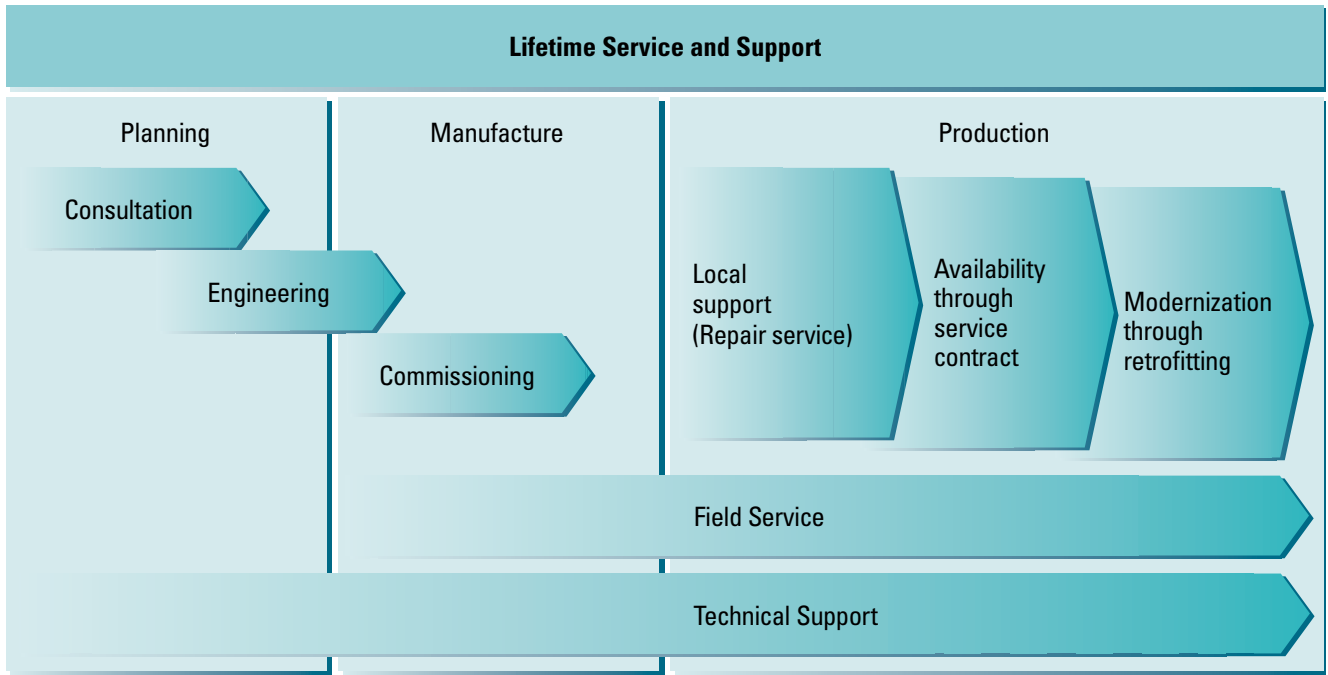

G_NC01_EN_00155

Overview

Our customer support provides all services required throughout the life cycle of your machine – covering the planning phase, retrofitting and even modernization.

Competent consulting and engineering

Simply contact our experts; they will be pleased to help you. Our experts not only develop application-specific programs and graphical user interfaces, they can also match the CNC functionality to your specific technology. The advantages gained compared to your competitors simultaneously reduce the implementation requirements for your projects.

Start-up

It is a matter of course for us that we support you during commissioning and start-up of the produced applications. We also run in your machines, independent of whether prototype or series machine.

Local support (repair service)

With our repair service contract, you as a machine manufacturer or dealer can guarantee local support for your customers at low cost. The contract covers the repair of components delivered by Siemens at the machine location. For details, refer to the "Repair service contract RSV".

Field Service

Our qualified field service personnel are of course also available if you have not agreed on a service contract. Our personnel will eliminate faults, supply any required spare parts, and arrange the necessary repairs.

Technical support

You require help when using our products? We offer consulting by telephone and also online support.

For many products, online support offers technical information concerning:

- FAQs, tips and tricks, downloads
- Manuals
- Helpful programs and software products

Further information

If you are looking for a contact for our wide range of service and support activities, then you have come to the right place!

Technical Support
Phone: +49 (0) 180 50 50 222
Fax: +49 (0) 180 50 50 223

Online support:



<http://www.siemens.com/automation/support>

Field Service for Germany
Phone: +49 (0) 180 50 50 444

Worldwide service centers on the Internet:



<http://www.siemens.com/automation/partner>

It goes without saying that our field service is also ready to provide you with service and support for engineering, installation, repairs, service contracts, modernization and spare parts/repairs.

Overview

RSV description of performance

Siemens eliminates the faults on the Siemens Automation & Drives components (with the exception of complete motor spindles) specified in the contract at the machine location for the machine tool manufacturer and dealer in the context of the repair service contract (RSV).

RSV services

- Provision of servicing personnel
- Fault diagnostics on site
- Troubleshooting on site
- Proof of troubleshooting

Fault diagnostics refers to the components specified in the parts list of the final destination memo. Diagnostics is carried out on the basis of a technically preclarified fault message by the manufacturer or dealer with specification of the contract number.

Fault correction is carried out by repairing and/or replacing faulty components. In the event of a machine standstill, fault correction is carried out with the response time specified for the country group. Within the agreed contract period, faulty components which were not older than 12 months at the beginning of the RSV will be replaced free-of-charge.

Siemens provides qualified personnel for fault diagnostics and fault correction on our products. If mechanical work is also necessary, this must be provided or arranged by the manufacturer/dealer. Example: dismantling/mounting of motors or other mechanical components.

The services are provided during the usual working hours in the country of installation.

Spare parts are provided either from our central warehouse or from regional warehouses using our worldwide spare part logistics. Our central warehouse contains all important spare parts. Regional warehouses are adapted to include the components referred to in the final destination memo.¹⁾

The following components are not defined as spare parts :

- Motors ²⁾
- Cables ³⁾
- Special or customer-specific modules and components which are not available from Siemens as spare parts.

Faulty components ⁴⁾ are replaced free-of-charge within the agreed contract period.

Contract prerequisites

- Final destination memo
- Data saved at the user

The manufacturer/dealer provides the final destination memo early enough prior to commencement of the contract, and guarantees that all data of the machine are stored and available at the user. Particular data for the final destination memo are: machine number, machine type, processing technology, control system, drive system, number of measuring circuits, type of data storage, data storage medium, data on OEM application, date of commissioning at end user, country of end user, parts list of components used.

RSV certificate

The manufacturer or dealer as the RSV contract partner is provided with a certificate following handing over of the final destination memo (prerequisite for provision of services at the end customer). This certificate contains the contract number and the important contract data such as machine number, machine type, start of contract, end of contract, and address for provision of the services.

Period of applicability

The RSV commences with the date registered with us for completion of the 2nd commissioning at the end customer, and ceases following expiry of the selected period for the RSV.

Contract periods

The RSV is offered for the limitation period (warranty period) of our customers (manufacturer/dealer) compared to their end customers. Various RSV periods permit you to satisfy different market requirements. In the case of RSV periods exceeding the originally selected limitation period for the Siemens A&D components, the limitation period is extended with respect to claims for subsequent fulfillment, with the exception of further rights and claims, in line with the extended RSV period. An existing RSV can be extended once by ½ year or 1 year. The extension must be ordered during the period of the basic RSV.

Contract versions

Two versions of the RSV are available:

- The **master contract** is for machine manufacturers who agree to order one RSV for all machines with Siemens equipment.
- The **individual contract** is for machine manufacturers who order an RSV only for certain machines equipped by Siemens.

Service exclusions

The contract service is excluded in all cases of Point VIII./7 Article deficiencies of the "General conditions of supply and delivery for the electrical industry" ⁴⁾. In the case of parts subject to wear (e. g. motor bearings and fans or cables), replacement will be provided free-of-charge within 12 months following commencement of the RSV in the case of proper use, and independent of the actual RSV duration.

Export license

Fulfillment of the service call may be subject to authorization due to the purpose of use or due to the type of spare parts, equipment and documentation required. The service call is therefore subject to the granting of the necessary export licenses and absence of any other obstacles due to German or other applicable export regulations.

- 1) Since the export of standard versions (components/system) is subject to a time-consuming official approval procedure, which applies in equal measure to the supply of such components for the purpose of servicing and spare parts supply, we recommend **supply of the export version** wherever possible. This applies in particular in cases where the control can be exported without official approval after the machine manufacturer has installed it in a machine tool.
- 2) For selected motors, we centrally stock components for fast delivery within Germany and the U.S.A. These motors can be manufactured and delivered within a few working days. You can obtain the current list from your Siemens partner.
- 3) The delivery times known to you usually apply.
- 4) Examples of service exclusions:
Failure to comply with "Siemens Planning and User Rules"
- Contamination likely to cause malfunction (e. g. oil, conductive materials, rust)
- Mechanical damage
- Electrical interference
- Malicious damage.

Appendix Service & Support

Repair service contract RSV

Overview (continued)

Reaction time

The following response times apply to RSV implementation in the case of a machine standstill:

Country group	
LG 1	Next working day
LG 2	Within two working days
LG 3	Depending on country-specific circumstances
LG 4	Depending on country-specific circumstances, only for customers with master contract for the price of the individual contract

We define the response time as the time from reception of your clarified order up till our service engineer begins the journey to the site stated in the order, or until commencement of troubleshooting using Teleservice. The listed response times apply to "Technically clarified fault messages" within the usual working hours of the region (e. g. Monday to Friday 8 a.m. to 5 p.m.) excluding public holidays.

Country list

The repair service is offered for the following countries:

Continent	Country/region
Country group 1	
America	Brazil, Canada, Mexico, USA
Asia	China, India, Japan, Singapore, South Korea, Taiwan, Thailand
Australia	Australia
Europe	Austria, Belgium, Czech Republic, Denmark, Finland, France, Germany, Great Britain, Holland, Italy, Liechtenstein, Luxembourg, Portugal, Sweden, Switzerland, Spain, Turkey
Country group 2	
America	Argentina
Asia	Indonesia, Malaysia
Australia	New Zealand
Europe	Andorra, Estonia, Hungary, Ireland, Latvia, Lithuania, Norway, Poland, Slovak Republic, Slovenia
Country group 3	
Africa	Egypt, South Africa
Asia	Iran, Israel, Pakistan, Philippines, Saudi Arabia, Vietnam
Europe	Belarus, Bulgaria, Croatia, Greece, Rumania, Russia, Ukraine
Country group 4	
	Remaining countries

OEM service levels

To guarantee repair service for OEM applications, an assessment is necessary on the basis of the OEM service guideline. The assessment grades the OEM service application from 0 to 4. A surcharge will be levied for OEM service grades 1 to 4.

Selection and ordering data

Designation	Order No.
Repair service contract (RSV) for Siemens A&D components on machine tools for countries in country groups 1 to 3	
<ul style="list-style-type: none"> • 1 year contract period ¹⁾ • 2 year contract period ²⁾ • Master contract • Individual contract • 0 to 4 measuring circuits • 5 to 6 measuring circuits • 7 to 8 measuring circuits • ≥ 9 measuring circuits (basic RSV for ≥ 9 measuring circuits) • > 9 measuring circuits (measuring circuit surcharge for RSV > 9 measuring circuits) ³⁾ 	6FC8506-1 ■ X0 ■ -0AA0 6FC8506-2 ■ X0 ■ -0AA0 R E 1 2 3 8 0
Repair service contract Contract extension by 6 or 12 months for Siemens A&D components on machine tools for countries in country groups 1 to 3	
<ul style="list-style-type: none"> • Basic RSV 1 year • Basic RSV 2 years • Master contract • Individual contract • 0 to 4 measuring circuits • 5 to 6 measuring circuits • 7 to 8 measuring circuits • ≥ 9 measuring circuits (basic RSV for ≥ 9 measuring circuits) • > 9 measuring circuits (measuring circuit surcharge for RSV > 9 measuring circuits) ³⁾ Contract extension (possible once per RSV)	6FC8506-0 ■ X0 ■ - AA1 6FC8506-0 ■ X0 ■ - AA2 R E 1 2 3 8 0 6 1
OEM service levels Surcharge for repair service contract for Siemens components on machine tools with OEM applications. Measuring circuits 1 to n for countries in country groups 1 to 4	
<ul style="list-style-type: none"> • Surcharge for OEM service level 1 • Surcharge for OEM service level 2 • Surcharge for OEM service level 3 • Surcharge for OEM service level 4 	6FC8506-3SX01-0AA0 6FC8506-3SX02-0AA0 6FC8506-3SX03-0AA0 6FC8506-3SX04-0AA0

- 1) Max. 24 months from passage of risk (delivery of components).
- 2) Max. 36 months from passage of risk (delivery of components).
- 3) Example for 17 measuring circuits: (basic RSV for ≥ 9 measuring circuits) plus 8 x (measuring circuit surcharge for RSV > 9 measuring circuits).

Appendix

Siemens contacts worldwide

At

www.siemens.com/automation/partner

you can find details of Siemens contact partners worldwide responsible for particular technologies.

You can obtain in most cases a contact partner for

- Technical Support,
- Spare parts/repairs,
- Service,
- Training,
- Sales or
- Consultation/engineering.

You start by selecting a

- Country,
- Product or
- Sector.

By further specifying the remaining criteria you will find exactly the right contact partner with his/her respective expertise.



Appendix A&D online services

Information and Ordering in the Internet and on CD-ROM

A&D on the WWW



A detailed knowledge of the range of products and services available is essential when planning and configuring automation systems. It goes without saying that this information must always be fully up-to-date.

The Siemens Automation and Drives Group (A&D) has therefore built up a comprehensive range of information in the World Wide Web, which offers quick and easy access to all data required.

Under the address

<http://www.siemens.com/automation>

you will find everything you need to know about products, systems and services.

Product selection using the interactive catalog

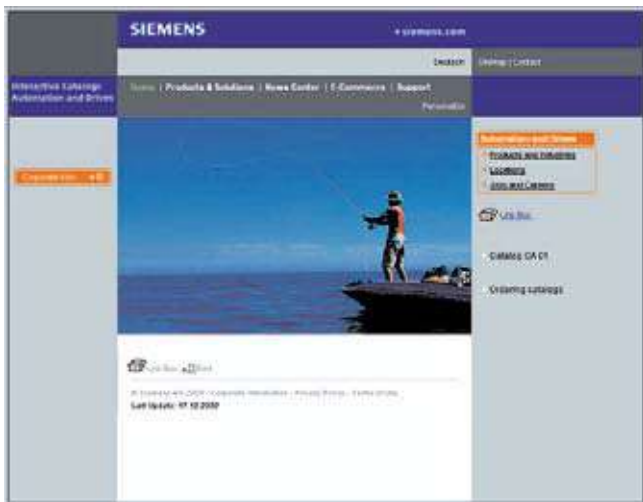

Detailed information together with convenient interactive functions:

The interactive catalog CA 01 covers more than 80,000 products and thus provides a full summary of the Siemens Automation and Drives product base.

Here you will find everything that you need to solve tasks in the fields of automation, switchgear, installation and drives. All information is linked into a user interface which is easy to work with and intuitive.

After selecting the product of your choice you can order at the press of a button, by fax or by online link.

Information on the interactive catalog CA 01 can be found in the Internet under

<http://www.siemens.com/automation/ca01>

- or on CD-ROM or DVD.

Easy shopping with the A&D Mall



The A&D Mall is the virtual department store of Siemens AG in the Internet. Here you have access to a huge range of products presented in electronic catalogs in an informative and attractive way.

Data transfer via EDIFACT allows the whole procedure from selection through ordering to tracking of the order to be carried out online via the Internet.

Numerous functions are available to support you.

For example, powerful search functions make it easy to find the required products, which can be immediately checked for availability. Customer-specific discounts and preparation of quotes can be carried out online as well as order tracking and tracing.

Please visit the A&D Mall on the Internet under:

<http://www.siemens.com/automation/mall>

7

Numerics

1FK7 motors	5/3
1PH7 motors	5/6
24 V terminal adapter	4/9, 4/11, 4/14, 4/17
2nd switching element	3/4, 3/5

A

A&D on the WWW	7/6
Active Line Module	4/11
Adapter set	4/4
Axis monitoring	2/7

B

Braking Module	4/19
Braking resistor	4/20

C

Cable set	3/2, 3/6
Capacitor Module	4/21
CF card	3/2
Circuit-breaker	4/8
CNC functionality	2/3
– Axis functions	2/3
– Interpolations	2/3
– Measuring	2/4
– Motion-synchronous actions	2/4
– Program functions	2/3
– Spindle functions	2/3
– Transformations	2/4
CNC programming	2/4
– Cycles	2/4
– Language	2/4
– Programming support	2/5
Communication and data management	2/6
Compensations	2/7
Competent consulting and engineering	7/2
Contract periods	7/3
Contract prerequisites	7/3
Contract versions	7/3
Control structure/application	2/2
Conversion table	7/10

D

DC link adapter	4/14, 4/17
DC link power supply adapter	4/14, 4/17
Degree of protection	5/2
Diagnostic functions	2/8
DIAZED fuse	4/8
Double Motor Module	4/17
DRIVE-CLiQ	1/5
DRIVE-CLiQ cable	6/7, 6/9
DRIVE-CLiQ interface	4/22

E

Easy shopping	7/6
Encoder system	4/22
Export license	7/3

F

Field Service	7/2
Full CNC keyboard	3/2
Fuse switch disconnecter	4/8

I

I/O module	3/6
------------	-----

L

Leading auxiliary circuit switch for main switch	4/8
Leading auxiliary switch for switch disconnecter with fuse holder	4/8
Length codes	6/10
Length definition	6/10
Line filter	4/4, 4/8
Line Module	4/7, 4/9
Line reactor	4/6, 4/8
Local support (repair service)	7/2

M

Machine control panel	3/4
Machine control panel MCP	3/5
Main contactor	4/8
Main switch	4/8
MCP	3/5
MCP 802D sl	3/4
MCPA module	3/4
Measuring systems	2/2
Monitoring functions	2/8
MOTION-CONNECT	6/2
Motor Module	4/13

N

NH fuse	4/8
NEOZED fuse	4/8

O

Operating modes	2/5
Operation	2/6
Ordering example	3/7
Output interface for main switch	4/8
Overload capability	4/3

P

Parameters	2/5
Period of applicability	7/3
Planetary gear unit	5/10
PLC area	2/8
Power cables	6/4
Power cable extensions	6/6
PP 72/48	3/6
Prefabricated MOTION-CONNECT power cables	6/6
Product selection	7/6
PROFIBUS cable	3/6
PROFIBUS connector	3/6

R

Repair service contract RSV	7/3, 7/4
-----------------------------	----------

S

Service exclusions	7/3
Shield connection plate	4/11, 4/14
Siemens contact partners	7/5
Signal cable	6/7
Signal cable extensions	6/10
Simulation	2/5
SINAMICS MICROMASTER SIZER	1/6
SINAMICS S120	4/2
Single Motor Module	4/13
SINUMERIK 802D sl	3/2
SINUMERIK 802D sl Toolbox	3/3
Smart Line Module	4/9
SMC30 Sensor Module Cabinet-mounted	4/23
Start-up	2/8, 7/2
Switch disconnecter with fuse holder	4/8

T

Technical support	7/2
Terminal adapter 24 V	4/9, 4/11, 4/14, 4/17
Terminal strip converter	3/2, 3/6
Terms and conditions of sale and delivery	7/11
Tools	2/6
Topology SINUMERIK 802D sl	1/6
Type	5/2

U

UL/CSA fuse	4/8
-------------	-----

W

Warning labels	4/9, 4/11, 4/14, 4/17, 4/19, 4/21
----------------	-----------------------------------

Appendix

Order number index

Type	Page	Type	Page
1FK70 ...		5SE2 ...	
1FK7022-...	5/4	5SE2335	4/8
1FK7032-...	5/4	6EP5 ...	
1FK7040-...	5/4	6EP5306-5BG00	3/2, 3/6
1FK7042-...	5/4	6EP5406-5AA00	3/2, 3/6
1FK7060-...	5/4	6ES7 ...	
1FK7063-...	5/4	6ES7972-0BA40-0XA0	3/3, 3/6
1FK7080-...	5/4	6FC5 ...	
1FK7083-...	5/4	6FC5303-0AF30-1AA0	2/6, 3/4
1FK71 ...		6FC5303-0DM13-1AA0	2/7, 3/2
1FK7100-...	5/4	6FC5303-0DT12-1AA0	2/7, 3/2
1FK7101-...	5/4	6FC5312-0AD01-0AA0	3/4
1FK7103-...	5/4	6FC5313-1AG00-0AA0	3/2
1FK7105-...	5/4	6FC5313-2AG00-0AA0	3/2
1PH71 ...		6FC5370-0AA00-2AA0	3/2
1PH7103-...G02-....	5/8	6FC5370-0AA00-3AA0	3/2
1PH7107-...F02-....	5/8	6FC5603-0AD00-0AA1	2/6, 3/5
1PH7133-...D02-....	5/8	6FC5611-0CA01-0AA0	2/8, 3/6
1PH7133-...G02-....	5/8	6FC5810-0CY10-0YU8	3/3
1PH7137-...D02-....	5/8	6FC8506-...	
1PH7137-...G02-....	5/8	6FC8506-0.X0-..AA1	7/4
1PH7163-...D03-....	5/8	6FC8506-0.X0-..AA2	7/4
1PH7163-...F03-....	5/8	6FC8506-1.X0-0AA0	7/4
1PH7167-...F03-....	5/8	6FC8506-2.X0-0AA0	7/4
3KA5 ...		6FC8506-3SX01-0AA0	7/4
3KA5330-1EE01	4/8	6FC8506-3SX02-0AA0	7/4
3KA5730-1EE01	4/8	6FC8506-3SX03-0AA0	7/4
3KL5 ...		6FC8506-3SX04-0AA0	7/4
3KL5030-1EB01	4/8	6FC9 ...	
3KL5230-1EB01	4/8	6FC9320-5DB00	2/7
3KL5530-1EB01	4/8	6FC9320-5DC00	2/7
3KL5730-1EB01	4/8	6FC9348-7HX	3/3
3KX3 ...		6FX.002-...	
3KX3552-3EA01	4/8	6FX.002-5.S01-....	5/5
3LD2 ...		6FX.002-5.S31-....	5/5
3LD2003-0TK51	4/8	6FX.002-5.S41-....	5/5
3LD2203-0TK51	4/8	6FX.002-5.S61-....	5/5
3LD2504-0TK51	4/8	6FX.002-2AD04-....	6/10
3LD2704-0TK51	4/8	6FX.002-2AH-....	6/8, 6/9, 6/10
3LD9250-3B	4/8	6FX.002-2CA-....	6/8, 6/9, 6/10
3NA3 ...		6FX.002-2CB54-....	6/10
3NA3132	4/8	6FX.002-2CD-....	6/8, 6/9
3NA3136	4/8	6FX.002-2CF-....	6/8, 6/9, 6/10
3NA3144	4/8	6FX.002-2CG00-....	6/8, 6/9
3NA3805	4/8	6FX.002-2CH00-....	6/8, 6/9
3NA3814	4/8	6FX.002-2EQ-....	6/8, 6/9, 6/10
3NA3824	4/8	6FX.002-5.A-....	6/6
3NP4 ...		6FX.002-5.X-....	6/6
3NP4010-0CH01	4/8	6FX.002-5CB-....	6/6
3NP4270-0CA01	4/8	6FX.002-5CC16-....	6/6
3NP5360-0CA00	4/8	6FX.002-5CS-....	6/4
3RT10 ...		6FX.002-5DS-....	6/5
3RT1023-1BB40	4/8	6FX.002-5DX38-....	6/6
3RT1026-1BB40	4/8	6FX.008-...	
3RT1035-1AC24	4/8	6FX.008-1BA-....	6/5
3RT1045-1AP04	4/8	6FX.008-1BB-....	6/4
3RT1054-1AP36	4/8	6FX.008-.....1FA0	6/10
3RT1056-6AP36	4/8	6FX.008-.....2AA0	6/10
3RT1065-6AP36	4/8	6FX.008-.....3AA0	6/10
3RV10 ...		6FX.008-.....6AA0	6/10
3RV1031-4BA10	4/8	6FX2 ...	
3RV1031-4FA10	4/8	6FX2002-1DC-....	6/8, 6/9
3RV1041-4LA10	4/8	6FX2007-1AD01	2/6
3SB3 ...		6FX2007-1AD11	2/6
3SB3400-0A	3/4, 3/5	6FX5 ...	
3TX7 ...		6FX5002-2DC-....	6/9
3TX7004-1LB00	4/8	6FX5002-5CC-....	6/6
3VF3 ...		6FX5002-5CD-....	6/6
3VF3211-3FU41-0AA0	4/8	6FX5002-5CS-....	6/4
3VF3211-3FW41-0AA0	4/8	6FX5002-5DS-....	6/5
3VF4 ...		6FX8 ...	
3VF4211-3DM41-0AA0	4/8	6FX8002-2DC-....	6/9
5SB4 ...		6FX8002-5DC-....	6/6
5SB411	4/8	6FX8002-5DD-....	6/6
5SC2 ...		6FX8008-1BD61-1FA0	3/3
5SC211	4/8		

Appendix

Order number index

Type	Page	Type	Page
6SL30 ...		6SL316.-...	
6SL3000-0CE15-0AA0	4/6, 4/8	6SL3162-1AF00-0AA1	4/11, 4/14
6SL3000-0CE21-0AA0	4/6, 4/8	6SL3162-1AH00-0AA0	4/11, 4/14
6SL3000-0DE31-2BA0	4/6, 4/8	6SL3162-1AH01-0AA0	4/11, 4/14
6SL3000-0FE21-6AA0	4/4, 4/8	6SL3162-2AA00-0AA0	4/14, 4/17
6SL3000-0FE23-6AA0	4/4, 4/8	6SL3162-2BD00-0AA0	4/14, 4/17
6SL3000-0FE25-5AA0	4/4, 4/8	6SL3162-2BM00-0AA0	4/14, 4/17
6SL3000-0FE28-0AA0	4/4, 4/8	6SL3162-2BM01-0AA0	4/14, 4/17
6SL3000-0FE31-2AA1	4/4, 4/8	6SL3166-3AB00-0AA0	4/9, 4/11, 4/14, 4/17, 4/19, 4/21
6SL3000-0GE15-0AA0	4/4, 4/8	6SN11 ...	
6SL3000-0GE21-0AA0	4/4, 4/8	6SN1111-0AA00-0BA1	4/6, 4/8
6SL3055-0AA00-5CA0	4/23	6SN1111-0AA00-0CA1	4/6, 4/8
6SL3060-1FE21-6AA0	4/4	6SN1111-0AA00-0DA1	4/6, 4/8
6SL3060-4A...-....	6/8, 6/9	6SN1111-0AA00-1EA0	4/6, 4/8
6SL3070-0AA00-0AG0	1/6	6SN1113-1AA00-0DA0	4/20
6SL3072-0AA00-0AG0	2/8	6SN1162-0GA00-0CA0	4/4
6SL3100-...		6SX7 ...	
6SL3100-1AE31-0AA0	4/19	6SX7002-0AL00-....	6/8, 6/9
6SL3100-1BE31-0AA0	4/20	6SX7002-0AN.0-....	6/9
6SL3100-1CE14-0AA0	4/21	6XV1 ...	
6SL3120-...		6XV1830-0EH10	3/3, 3/6
6SL3120-1TE13-0AA0	4/13, 5/5	Item No. – Wago	
6SL3120-1TE15-0AA0	4/13, 5/5	231-102/037-000	4/14, 4/17
6SL3120-1TE21-0AA1	4/13, 5/5	Weidmüller type	
6SL3120-1TE21-8AA1	4/13, 5/5, 5/9	KLBÜ 3-8 SC	4/9, 4/11, 4/13, 4/17
6SL3120-1TE23-0AA1	4/13, 5/5, 5/9	KLBÜ CO 1	4/23
6SL3120-1TE24-5AA1	4/13, 5/9	KLBÜ CO 4	4/11
6SL3120-1TE26-0AA1	4/13, 5/9	LP ...	
6SL3120-1TE28-5AA1	4/13, 5/9	LP 050-M01	5/11
6SL3120-1TE31-3AA0	4/13	LP 070-M01	5/11
6SL3120-1TE32-0AA0	4/13	LP 090-M01	5/11
6SL3120-2TE13-0AA0	4/17, 5/5	LP 120-M01	5/11
6SL3120-2TE15-0AA0	4/17, 5/5	LP 155-M01	5/11
6SL3120-2TE21-0AA0	4/17, 5/5	310 ...	
6SL3120-2TE21-8AA0	4/17, 5/5, 5/9	310123...	6/8
6SL3130-...		310128...	6/8
6SL3130-6AE15-0AA0	4/9	369 ...	
6SL3130-6AE21-0AA0	4/9	369124...	6/8
6SL3130-7TE21-6AA1	4/11	369129...	6/8
6SL3130-7TE23-6AA1	4/11	Short codes	
6SL3130-7TE25-5AA1	4/11	V40	5/11
6SL3130-7TE28-0AA0	4/11	V42	5/11
6SL3130-7TE31-2AA0	4/11		

Appendix

Conversion tables

Rotary inertia

A \ B	lb-in ²	lb-ft ²	lb-in-s ²	lb-ft-s ² slug-ft ²	kg-cm ²	kg-cm-s ²	gm-cm ²	gm-cm-s ²	oz-in ²	oz-in-s ²
lb-in ²	1	6.94×10^{-3}	2.59×10^{-3}	2.15×10^{-4}	2.926	2.98×10^{-3}	2.92×10^3	2.984	16	4.14×10^{-2}
lb-ft ²	144	1	0.3729	3.10×10^{-2}	421.40	0.4297	4.21×10^5	429.71	2304	5.967
lb-in-s ²	386.08	2.681	1	8.33×10^{-2}	1.129×10^{-3}	1.152	1.129×10^6	1.152×10^3	6.177×10^3	16
lb-ft-s ² slug-ft ²	4.63×10^3	32.17	12	1	1.35×10^{-4}	13.825	1.355×10^7	1.38×10^4	7.41×10^{-4}	192
kg-cm ²	0.3417	2.37×10^{-3}	8.85×10^{-4}	7.37×10^{-5}	1	1.019×10^{-3}	1000	1.019	5.46	1.42×10^{-2}
kg-cm-s ²	335.1	2.327	0.8679	7.23×10^{-2}	980.66	1	9.8×10^5	1000	5.36×10^3	13.887
gm-cm ²	3.417×10^{-4}	2.37×10^{-6}	8.85×10^{-7}	7.37×10^{-8}	1×10^{-3}	1.01×10^{-6}	1	1.01×10^{-3}	5.46×10^{-3}	1.41×10^{-5}
gm-cm-s ²	0.335	2.32×10^{-3}	8.67×10^{-4}	7.23×10^{-5}	0.9806	1×10^{-3}	980.6	1	5.36	1.38×10^{-2}
oz-in ²	0.0625	4.34×10^{-4}	1.61×10^{-4}	1.34×10^{-5}	0.182	1.86×10^{-4}	182.9	0.186	1	2.59×10^{-3}
oz-in-s ²	24.13	0.1675	6.25×10^{-2}	5.20×10^{-3}	70.615	7.20×10^{-2}	7.09×10^4	72.0	386.08	1

Torque

A \ B	lb-in	lb-ft	oz-in	N-m	kg-cm	kg-m	gm-cm	dyne-cm
lb-in	1	8.333×10^{-2}	16	0.113	1.152	1.152×10^{-2}	1.152×10^3	1.129×10^6
lb-ft	12	1	192	1.355	13.825	0.138	1.382×10^4	1.355×10^7
oz-in	6.25×10^{-2}	5.208×10^{-3}	1	7.061×10^{-3}	7.200×10^{-2}	7.200×10^{-4}	72.007	7.061×10^7
N-m	8.850	0.737	141.612	1	10.197	0.102	1.019×10^4	1×10^7
kg-cm	0.8679	7.233×10^{-2}	13.877	9.806×10^{-2}	1	10^{-2}	1000	9.806×10^5
kg-m	86.796	7.233	1.388×10^3	9.806	100	1	1×10^5	9.806×10^7
gm-cm	8.679×10^{-4}	7.233×10^{-5}	1.388×10^{-2}	9.806×10^{-5}	1×10^{-3}	1×10^{-5}	1	980.665
dyne-cm	8.850×10^{-7}	7.375×10^{-8}	1.416×10^{-5}	10^{-7}	1.0197×10^{-6}	1.019×10^{-8}	1.019×10^{-3}	1

Length

A \ B	inches	feet	cm	yd	mm	m
inches	1	0.0833	2.54	0.028	25.4	0.0254
feet	12	1	30.48	0.333	304.8	0.3048
cm	0.3937	0.03281	1	1.09×10^{-2}	10	0.01
yd	36	3	91.44	1	914.4	0.914
mm	0.03937	0.00328	0.1	1.09×10^{-3}	1	0.001
m	39.37	3.281	100	1.09	1000	1

Mass

A \ B	lb	oz	gm	slug
lb	1	16	453.6	0.0311
oz	6.25×10^{-2}	1	28.35	1.93×10^{-3}
gm	2.205×10^{-3}	3.527×10^{-3}	1	6.852×10^{-5}
slug	32.17	514.8	1.459×10^4	1

Power

A \ B	H.P.	Watts
H.P. (English)	1	745.7
(lb-in)(deg./sec)	2.645×10^{-6}	1.972×10^{-3}
(lb-in)(RPM)	1.587×10^{-5}	1.183×10^{-2}
(lb-ft)(deg./sec)	3.173×10^{-5}	2.366×10^{-2}
(lb-ft)(RPM)	1.904×10^{-4}	0.1420
Watts	1.341×10^{-3}	1

Rotation

A \ B	RPM	rad/sec.	degrees/sec.
RPM	1	0.105	6.0
rad/sec.	9.55	1	57.30
degrees/sec.	0.167	1.745×10^{-2}	1

Temperature conversion

°F	°C	°C	°F
0	-17.8	-10	14
32	0	0	32
50	10	10	50
70	21.1	20	68
90	32.2	30	86
98.4	37	37	98.4
212	100	100	212
subtract 32 and multiply by $\frac{5}{9}$		multiply by $\frac{9}{5}$ and add 32	

Force

A \ B	lb	oz	gm	dyne	N
lb	1	16	453.6	4.448×10^{-5}	4.4482
oz	0.0625	1	28.35	2.780×10^{-4}	0.27801
gm	2.205×10^{-3}	0.03527	1	1.02×10^{-3}	N.A.
dyne	2.248×10^{-6}	3.59×10^{-5}	890.7	1	0.00001
N	0.22481	3.5967	N.A.	100.000	1

To convert from A to B, multiply by entry in table.

Conditions of sale and delivery

Terms and Conditions of Sale and Delivery

By using this catalog you can acquire hardware and software products described therein from the Siemens AG subject to the following terms. Please note! The scope, the quality and the conditions for supplies and services, including software products, by any Siemens entity having a registered office outside of Germany, shall be subject exclusively to the General Terms and Conditions of the respective Siemens entity.

for customers with a seat or registered office in the Federal Republic of Germany

The General Terms of Payment as well as the General Conditions for the Supply of Products and Services of the Electrical and Electronics Industry shall apply.

For software products, the General License Conditions for Software Products for Automation and Drives for Customers with Seat or registered Office in Germany shall apply.

for customers with a seat or registered office outside of Germany

The General Terms of Payment as well as the General Conditions for Supplies of Siemens, Automation and Drives for Customers with a Seat or registered Office outside of Germany shall apply.

For software products, the General License Conditions for Software Products for Automation and Drives for Customers with Seat or registered Office outside of Germany shall apply.

General

The prices are in € (Euro) ex works, exclusive packaging.

The sales tax (value added tax) is not included in the prices. It shall be debited separately at the respective rate according to the applicable legal regulations.

In addition to the prices of products which include silver and/or copper, surcharges may be calculated if the respective limits of the notes are exceeded.

Prices are subject to change without prior notice. We will debit the prices valid at the time of delivery.

The dimensions are in mm. Illustrations are not binding.

Insofar as there are no remarks on the corresponding pages, - especially with regard to data, dimensions and weights given - these are subject to change without prior notice.

Comprehensive Terms and Conditions of Sale and Delivery are available free of charge from your local Siemens business office under the following Order Nos.:

- 6ZB5310-0KR30-0BA0
(for customers based in the Federal Republic of Germany)
- 6ZB5310-0KS53-0BA0
(for customers based outside of the Federal Republic of Germany)

or download them from the Internet:

www.siemens.com/automation/mall

(Germany: A&D Mall Online-Help System)

Export regulations

The products listed in this catalog / price list may be subject to European / German and/or US export regulations.

Therefore, any export requiring a license is subject to approval by the competent authorities.

According to current provisions, the following export regulations must be observed with respect to the products featured in this catalog / price list:

AL	Number of the <u>German Export List</u> . Products marked other than "N" require an export license. In the case of software products, the export designations of the relevant data medium must also be generally adhered to. Goods labeled with an " <u>AL not equal to N</u> " are subject to a European or German export authorization when being exported out of the EU.
ECCN	<u>Export Control Classification Number</u> . Products marked other than "N" are subject to a reexport license to specific countries. In the case of software products, the export designations of the relevant data medium must also be generally adhered to. Goods labeled with an " <u>ECCN not equal to N</u> " are subject to a US re-export authorization.

Even without a label or with an "AL: N" or "ECCN: N", authorization may be required due to the final destination and purpose for which the goods are to be used.

The deciding factors are the AL or ECCN export authorization indicated on order confirmations, delivery notes and invoices.

Errors excepted and subject to change without prior notice.

A&D/VuL/En 14.11.03

Appendix

Notes

7

Editors:
Siemens AG, A&D PT5, Erlangen

Siemens AG
Automation and Drives
Motion Control Systems
Postfach 31 80
91050 ERLANGEN
FEDERAL REPUBLIC OF GERMANY

Order No.
E86060-K4460-E112-A1-7600
KG K 02.05 3.0 BD 80 En/ 522 298
Printed in the Federal Republic of Germany

Catalogs of the Automation and Drives Group (A&D)

Further information can be obtained from our branch offices listed in the appendix or at www.siemens.com/automation/partner

Automation and Drives Interactive catalog on CD-ROM • The Offline Mall of Automation and Drives	<i>Catalog</i>	CA 01
Automation Systems for Machine Tools SINUMERIK & SIMODRIVE		NC 60
Drive Systems <u>Variable-Speed Drives</u> SINAMICS G130 Drive Converter Chassis Units, SINAMICS G150 Drive Converter Cabinet Units SINAMICS G110 Inverter Chassis Units SINAMICS S120 Servo Control Drive System SINAMICS S150 Drive Converter Cabinet Units DC Motors SIMOREG DC MASTER 6RA70 Digital Chassis Converters SIMOREG K 6RA22 Analog Chassis Converters SIMOREG DC MASTER 6RM70 Digital Converter Cabinet Units SIMOVERT PM Modular Converter Systems SIEMOSYN Motors MICROMASTER 410/420/430/440 Inverters MICROMASTER 411/COMBIMASTER 411 SIMOVERT MV Medium-Voltage Drives SIMOVERT MASTERDRIVES Vector Control SIMOVERT MASTERDRIVES Motion Control Synchronous and asynchronous servomotors for SIMOVERT MASTERDRIVES SIMODRIVE 611 universal and POSMO <u>Low-Voltage Three-Phase-Motors</u> Squirrel-Cage Motors, Totally Enclosed, Fan-Cooled <u>Automation Systems for Machine Tools SIMODRIVE</u> • Main Spindle Motors • Feed Motors • Converter Systems SIMODRIVE 611/POSMO <u>Drive and Control Components for Hoisting Equipment</u>		D 11 D 11.1 D 21.2 D 21.3 DA 12 DA 21.1 DA 21.2 DA 22 DA 45 DA 48 DA 51.2 DA 51.3 DA 63 DA 65.10 DA 65.11 DA 65.3 DA 65.4 M 11 NC 60 HE 1
Electrical Installation Technology ALPHA Small Distribution Boards and Distribution Boards ALPHA FIX Terminal Blocks BETA Modular Installation Devices DELTA Switches and Outlets GAMMA Building Management Systems		ET A1 ET A5 ET B1 ET D1 ET G1
Factory Automation Sensors		FS 10
Human Machine Interface Systems SIMATIC HMI		ST 80
Industrial Communication for Automation and Drives		IK PI
Low-Voltage Controls and Distribution Low-Voltage Switchgear – Controlgear for Industry Power Distribution – Products and Systems for Low-Voltage Power Distribution SIDAC-D reactors and SIDAC-F filters SIVACON 8PS Busbar trunking systems CD, BD01, BD2 up to 1250 A SIVACON 8PS Busbar trunking systems LDA/LDC 1100 A to 5000 A SIVACON 8PS Busbar trunking systems LXA/LXC over 800 A Low-Voltage Controlgear, Switchgear and Systems SENTRON WL	<i>Catalog</i>	LV 10 LV 30 LV 63 LV 70 LV 71 LV 72 LV 90 NS WL
Motion Control System SIMOTION		PM 10
Process Instrumentation and Analytics Field Instruments for Process Automation Measuring Instruments for Pressure, Differential Pressure, Flow, Level and Temperature, Positioners and Liquid Meters <i>PDF: Indicators for panel mounting</i> SIREC Recorders and Accessories SIPART, Controllers and Software SIWAREX Weighing Systems Continuous Weighing and Process Protection Gas Analysis Equipment for the Process Industry <i>PDF: Process Analytics, Components for the System Integration</i> SIPAN Liquid Analysis		FI 01 MP 12 MP 20 MP 31 WT 01 WT 02 PA 10 PA 11 PA 20
SIMATIC Industrial Automation Systems SIMATIC PCS Process Control System <i>PDF: SIMATIC S5/505 Automation Systems</i> Products for Totally Integrated Automation and Micro Automation SIMATIC PCS 7 Process Control System <i>PDF: Add-ons for the SIMATIC PCS 7 Process Control System</i> pc-based Automation SIMATIC Control Systems		ST 45 ST 50 ST 70 ST PCS 7 ST PCS 7.A ST PC ST DA
SIPOS Electric Actuators Electric Rotary, Linear and Part-turn Actuators Electric Rotary Actuators for Nuclear Plants		MP 35 MP 35.1/.2
Systems Engineering Power supplies SITOP power System cabling SIMATIC TOP connect		KT 10.1 KT 10.2
System Solutions Applications and Products for Industry are part of the interactive catalog CA 01		
TELEPERM M Process Control System AS 235, AS 235H and AS 235K automation systems <i>PDF: AS 488/TM automation systems</i> Operating and monitoring with WinCC/TM CS 275 bus system		PLT 111 PLT 112 PLT 123 PLT 130

PDF: These catalogs are only available as pdf files.

www.nicsanat.com
021-87700210



A&D/3U/En 21.12.04



www.nicsanat.com

021-87700210

The information provided in this catalog contains descriptions or characteristics of performance which in case of actual use do not always apply as described or which may change as a result of further development of the products. An obligation to provide the respective characteristics shall only exist if expressly agreed in the terms of contract. Availability and technical specifications are subject to change without notice.

Token fee 3.00 €

Siemens AG

Automation and Drives
Motion Control Systems

www.siemens.com/sinumerik

Order No. E86060-K4460-E112-A1-7600