

# SIEMENS

## SINUMERIK 802D sl

### Lists



[www.nicsanat.com](http://www.nicsanat.com)

021-87700210

Valid for

*Control system*

SINUMERIK 802D sl

*Software version*

1

Machine / Setting Data

Explanations

1

Machine Data

Overview

2

Setting Data

Overview

3

Machine Data

Description

4

Setting Data

Description

5

Interface Signals

6

PLC User Interface -

7

SINAMICS Parameters

8

02.06 Edition

6FC5397-5CP10-0BA0

## Safety-related information

This manual contains important information related to your personal safety and the protection of equipment. The notices referring to your personal safety are highlighted in the manual by a triangular safety alert symbol, notices referring to property damage only have no safety alert symbol. These notices shown below are graded according to the degree of danger:



### Danger

indicates that death or severe personal injury **will** result if proper precautions are not taken.



### Warning

indicates that death or severe personal injury **may** result if proper precautions are not taken.



### Caution

with a safety alert symbol, indicates that minor personal injury can result if proper precautions are not taken.

### Caution

without a safety alert symbol, indicates that property damage **can** result if proper precautions are not taken.

### Notice

indicates that an undesirable event or state **may** arise if the relevant note is not observed.

If more than one degree of danger is present, the warning notice representing the highest degree of danger will be used. A notice warning of injury to persons with a warning symbol may also include a warning relating to property damage.

## Qualified personnel

The device/system may only be set up and used in conjunction with this documentation. Commissioning and operation of a device/system may only be performed by **qualified personnel**. Qualified persons as far as the safety instructions given in this documentation are concerned are those who have the necessary authorization to commission, ground and identify equipment, systems and circuits in accordance with the relevant safety standards.

## Use as prescribed

Note the following:



### Warning

This device and its components may only be used for the applications described in the catalog or in the technical descriptions, and only in combination with third-party devices and components which have been approved or recommended by Siemens. This product can only function correctly and safely if it is transported, stored, set up, and installed correctly, and operated and maintained as recommended.

## Trademarks

All designations with the trademark symbol ® are registered trademarks of Siemens AG. Other designations in this documentation may be trademarks whose use by third parties for their own purposes may infringe the rights of the owner.

## Disclaimer of liability

We have checked the contents of this manual for agreement with the hardware and software described. Since discrepancies cannot be precluded entirely, we cannot guarantee full agreement. The information given in this publication is reviewed at regular intervals and any corrections that might be necessary are made in the subsequent editions.

# Preface

## SINUMERIK Documentation

The SINUMERIK Documentation is organized in 3 levels:

- General Documentation:
- User Documentation
- Manufacturer/Service Documentation:

A monthly overview of publications with specification of the available languages can be found on the Internet at:

<http://www.siemens.com/motioncontrol>

Follow the menu items "Support"/"Technical Documentation"/"Overview of Publications".

The Internet edition of DOConCD – DOConWEB – can be found at:

<http://www.automation.siemens.com/doconweb>

Information of our training offer and answers to frequently asked questions ("FAQs") can be found on the Internet at:

<http://www.siemens.com/motioncontrol> and there under the menu option "Support".

## Target group

The present publication is aimed at planning engineers, programmers and start-up engineers.

## Utility value

The present Lists Manual provides knowledge in respect of parameters and their effects on the system.

## Standard scope

The present documentation describes the functionality of the standard scope. Any amendments made by the machine manufacturer are documented by the machine manufacturer.

Other functions not described in this documentation can possibly also be performed on the control system. However, the customer is not entitled to demand these functions when the new equipment is supplied or servicing is carried out.

For reasons of clarity, this documentation does not contain all detailed information on all types of the product and can thus not consider any conceivable case of installation, operation and maintenance.

## Technical Support

If you have any questions, do not hesitate to call our hotline:

### Time zones Europe and Africa

A&D Technical Support  
Tel.: +49 (0) 180 / 5050 – 222  
Fax: +49 (0) 180 / 5050 – 223  
Internet: <http://www.siemens.com/automation/support-request>  
E-mail: <mailto:adsupport@siemens.com>

### Time zones Asia and Australia

A&D Technical Support  
Tel.: +86 1064 719 990  
Fax: +86 1064 747 474  
Internet: <http://www.siemens.com/automation/support-request>  
E-mail: <mailto:adsupport@siemens.com>

### Time zone America

A&D Technical Support  
Tel.: +1 423 262 2522  
Fax: +1 423 262 2289  
Internet: <http://www.siemens.com/automation/support-request>  
E-mail: <mailto:adsupport@siemens.com>

### Questions regarding the Manual

If you have any questions (suggestions, corrections) regarding the Documentation, please send a fax to the following number or an e-mail to the following address:

Fax: +49 (0) 9131 / 98 – 63315  
E-mail: <mailto:motioncontrol.docu@siemens.com>  
Fax form: see return fax form at the end of this publication

### Internet address for SINUMERIK

<http://www.siemens.com/sinumerik>

### EU Declaration of Conformity

The EU Declaration of Conformity in respect of the EMC Guideline can be obtained

- on the Internet:  
<http://www.ad.siemens.de/csinfo>  
under the product order number 15257461
- and from the appropriate regional office of the business area A&D MC of Siemens AG.

# Table of Contents

<b>1</b>	<b>Machine and Setting Data – Explanations</b> .....	<b>1-17</b>
1.1	Specifications in the list .....	1-17
1.2	Overview of the machine and setting data areas .....	1-22
<b>2</b>	<b>List of Machine Data</b> .....	<b>2-23</b>
2.1	Display machine data .....	2-23
2.2	General machine data .....	2-29
2.3	Channel-specific machine data .....	2-38
2.4	Axis-specific machine data .....	2-49
<b>3</b>	<b>Setting Data – Overview</b> .....	<b>3-65</b>
3.1	Setting data .....	3-65
3.2	Channel-specific setting data .....	3-67
3.3	Axis-specific setting data .....	3-71
<b>4</b>	<b>Machine Data – Description</b> .....	<b>4-75</b>
4.1	Display machine data .....	4-75
4.2	General machine data .....	4-78
4.3	Channel-specific machine data .....	4-82
4.4	Axis-specific machine data .....	4-90
<b>5</b>	<b>Setting Data – Description</b> .....	<b>5-119</b>
5.1	General setting data .....	5-119
5.2	Channel-specific setting data .....	5-121
5.3	Spindle-specific setting data .....	5-123
<b>6</b>	<b>Interface Signals</b> .....	<b>6-127</b>
6.1	General .....	6-127
6.2	Signals from/to HMI .....	6-129
6.2.1	Program-control signals from HMI .....	6-129
6.2.2	Signals from HMI .....	6-130
6.2.3	Signals from operator panel .....	6-131
6.2.4	General selection/status signals from HMI .....	6-131
6.2.5	General selection/status signals to HMI .....	6-132
6.3	Auxiliary function transfer from NC channel .....	6-134
6.4	NCK signals .....	6-137
6.4.1	General signals to NCK .....	6-137
6.4.2	General signals from NCK .....	6-138
6.5	Mode signals .....	6-140
6.6	Channel-specific signals .....	6-143
6.6.1	Signals to channel .....	6-143
6.6.2	Signals from the channel .....	6-154
6.7	Axis/spindle-specific signals .....	6-162
6.7.1	Transferred axis-specific M and S functions .....	6-162
6.7.2	Signals to axis/spindle .....	6-163
6.7.3	Signals from axis/spindle .....	6-174

6.8	Tool management functions from NC channel .....	6-182
<b>7</b>	<b>PLC User Interface .....</b>	<b>7-183</b>
7.1	Address ranges .....	7-183
7.2	User data .....	7-185
7.2.1	User data 1 .....	7-185
7.2.2	User data2 .....	7-185
7.2.3	Signals from MCP (connected to the MCPA module) .....	7-185
7.2.4	Signals to MCP (connected to the MCPA module) .....	7-186
7.2.5	Reading/writing NC data: Job [F20.6] .....	7-186
7.2.6	Read/write NC data: Result [F20.6] .....	7-186
7.3	Retentive data area .....	7-187
7.4	User alarm .....	7-188
7.4.1	User alarm: Activation .....	7-188
7.4.2	Variable for alarm .....	7-188
7.4.3	Active alarm reaction .....	7-189
7.5	Signals from/to HMI .....	7-189
7.5.1	Program control signals from HMI (retentive area) .....	7-189
7.5.2	Program selection from PLC (retentive area) .....	7-190
7.5.3	Checkback signal "Program selection from HMI (retentive area) .....	7-190
7.5.4	Signals from HMI .....	7-190
7.5.5	Signals from PLC .....	7-191
7.5.6	Signals from operator panel (retentive area) .....	7-191
7.5.7	General selection/status signals from HMI (retentive area) .....	7-191
7.5.8	General selection/status signals to HMI (retentive area) .....	7-192
7.6	Auxiliary function transfer from NC channel .....	7-193
7.6.1	Decoded M signals: (M0-M99) .....	7-194
7.6.2	Transferred T functions .....	7-194
7.6.3	Transferred M functions .....	7-195
7.6.4	Transferred S functions .....	7-195
7.6.5	Transferred D functions .....	7-195
7.6.6	Transferred H functions .....	7-196
7.7	NCK signals .....	7-197
7.7.1	General signals to NCK .....	7-197
7.7.2	General signals from NCK .....	7-197
7.7.3	Signals to fast inputs and outputs .....	7-198
7.7.4	Signal from fast inputs and outputs .....	7-199
7.7.5	Operating mode signals .....	7-200
7.8	Channel signals .....	7-201
7.8.1	Signals to NC channel .....	7-201
7.8.2	Signals from NC channel .....	7-204
7.9	Axis/spindle signals .....	7-207
7.9.1	Transferred M/S functions, axis-specific .....	7-207
7.9.2	Signals to axis/spindle .....	7-207
7.9.3	Signals from axis/spindle .....	7-211
7.10	PLC machine data .....	7-214
7.10.1	INT values (MD 14510 USER_DATA_INT) .....	7-214
7.10.2	HEX values (MD 14512 USER_DATA_HEX) .....	7-214
7.10.3	FLOAT values (MD 14514 USER_DATA_FLOAT) .....	7-214
7.10.4	User alarm: Configuration (MD 14516 USER_DATA_PLC_ALARM) .....	7-215
7.11	Reading and writing PLC variables .....	7-215
7.12	Tool management functions from NC channel .....	7-216
<b>8</b>	<b>SINAMICS Parameters .....</b>	<b>8-217</b>

## List of Machine and Setting Data

10000, <b>4-78</b>	10814  EXTERN_M_NO_MAC_CYCLE, 2-32
10000  AXCONF_MACHAX_NAME_TAB, 2-29	10815  EXTERN_M_NO_MAC_CYCLE_NAME, 2-32
10074, <b>4-78</b>	10816  EXTERN_G_NO_MAC_CYCLE, 2-32
10074  PLC_IPO_TIME_RATIO, 2-29	10817  EXTERN_G_NO_MAC_CYCLE_NAME, 2-32
10088  REBOOT_DELAY_TIME, 2-29	10818  EXTERN_INTERRUPT_NUM_ASUP, 2-32
10200  INT_INCR_PER_MM, 2-29	10820  EXTERN_INTERRUPT_NUM_RETRAC, 2-33
10210  INT_INCR_PER_DEG, 2-29	10880  MM_EXTERN_CNC_SYSTEM, 2-33
10240, <b>4-79</b>	10881  MM_EXTERN_GCODE_SYSTEM, 2-33
10240  SCALING_SYSTEM_IS_METRIC, 2-29	10882  NC_USER_EXTERN_GCODES_TAB, 2-33
10350  FASTIO_DIG_NUM_INPUTS, 2-29	10884  EXTERN_FLOATINGPOINT_PROG, 2-33
10360  FASTIO_DIG_NUM_OUTPUTS, 2-29	10886  EXTERN_INCREMENT_SYSTEM, 2-33
10366  HW_ASSIGN_DIG_FASTIN, 2-30	10888  EXTERN_DIGITS_TOOL_NO, 2-33
10368  HW_ASSIGN_DIG_FASTOUT, 2-30	10890  EXTERN_TOOLPROG_MODE, 2-33
10450  SW_CAM_ASSIGN_TAB, 2-30	10900  INDEX_AX_LENGTH_POS_TAB_1, 2-33
10460  SW_CAM_MINUS_LEAD_TIME, 2-30	10910  INDEX_AX_POS_TAB_1, 2-33
10461  SW_CAM_PLUS_LEAD_TIME, 2-30	10920  INDEX_AX_LENGTH_POS_TAB_2, 2-34
10470  SW_CAM_ASSIGN_FASTOUT_1, 2-30	10930  INDEX_AX_POS_TAB_2, 2-34
10480  SW_CAM_TIMER_FASTOUT_MASK, 2-30	11100, <b>4-79</b>
10485  SW_CAM_MODE, 2-30	11100  AUXFU_MAXNUM_GROUP_ASSIGN, 2-34
10710  PROG_SD_RESET_SAVE_TAB, 2-30	11160  ACCESS_EXEC_CST, 2-34
10713  M_NO_FCT_STOPRE, 2-31	11161  ACCESS_EXEC_CMA, 2-34
10714  M_NO_FCT_EOP, 2-31	11162  ACCESS_EXEC_CUS, 2-34
10715  M_NO_FCT_CYCLE, 2-31	11165  ACCESS_WRITE_CST, 2-34
10716  M_NO_FCT_CYCLE_NAME, 2-31	11166  ACCESS_WRITE_CMA, 2-34
10717  T_NO_FCT_CYCLE_NAME, 2-31	11167  ACCESS_WRITE_CUS, 2-34
10718  M_NO_FCT_CYCLE_PAR, 2-31	11170  ACCESS_WRITE_SACCESS, 2-34
10719  T_NO_FCT_CYCLE_MODE, 2-31	11171  ACCESS_WRITE_MACCESS, 2-34
10735  JOG_MODE_MASK, 2-31	11172  ACCESS_WRITE_UACCESS, 2-35
10760  G53_TOOLCORR, 2-31	11210, <b>4-79</b>
10804  EXTERN_M_NO_SET_INT, 2-31	11210  UPLOAD_MD_CHANGES_ONLY, 2-35
10806  EXTERN_M_NO_DISABLE_INT, 2-31	11240, <b>4-80</b>
10808  EXTERN_INTERRUPT_BITS_M96, 2-32	11240  PROFIBUS_SDB_NUMBER, 2-35
10810  EXTERN_MEAS_G31_P_SIGNAL, 2-32	11250  PROFIBUS_SHUTDOWN_TYPE, 2-35
10812  EXTERN_DOUBLE_TURRET_ON, 2-32	11310, <b>4-80</b>

11310  HANDWH_REVERSE, 2-35	20080, <b>4-82</b>
11320, <b>4-80</b>	20080  AXCONF_CHANAX_NAME_TAB, 2-38
11320  HANDWH_IMP_PER_LATCH, 2-35	20090, <b>4-83</b>
11346, <b>4-80</b>	20090  SPIND_DEF_MASTER_SPIND, 2-38
11346  HANDWH_TRUE_DISTANCE, 2-35	20094  SPIND_RIGID_TAPPING_M_NR, 2-38
11516  USER_DATA_PLC_ALARM, 2-36	20095  EXTERN_RIGID_TAPPING_M_NR, 2-38
11717  D_NO_FCT_CYCLE_NAME, 2-35	20106  PROG_EVENT_IGN_SINGLEBLOCK, 2-38
13060, <b>4-81</b>	20107  PROG_EVENT_IGN_INHIBIT, 2-38
13060  DRIVE_TELEGRAM_TYPE, 2-35	20108  PROG_EVENT_MASK, 2-39
13070  DRIVE_FUNCTION_MASK, 2-35	20140, <b>4-83</b>
13080  DRIVE_TYPE_DP, 2-35	20140  TRAFO_RESET_VALUE, 2-39
13120  CONTROL_UNIT_LOGIC_ADDRESS, 2-35	20172  COMPRESS_VELO_TOL, 2-39
13200  MEAS_PROBE_LOW_ACTIVE, 2-35 , <b>4-81</b>	202, <b>4-75</b>
13220  MEAS_PROBE_DELAY_TIME, 2-36	202  FIRST_LANGUAGE, 2-23
14510, <b>4-81</b>	20204  WAB_CLEARANCE_TOLERANCE, 2-39
14510  USER_DATA_INT, 2-36	203, <b>4-75</b>
14512, <b>4-81</b>	203  DISPLAY_RESOLUTION, 2-23
14512  USER_DATA_HEX, 2-36	20310  TOOL_MANAGEMENT_MASK, 2-39
14514, <b>4-81</b>	20320  TOOL_TIME_MONITOR_MASK, 2-39
14514  USER_DATA_FLOAT, 2-36	20360, <b>4-83</b>
14516, <b>4-81</b>	20360  TOOL_PARAMETER_DEF_MASK, 2-39
15700  LANG_SUB_NAME, 2-36	204, <b>4-75</b>
15702  LANG_SUB_PATH, 2-36	204  DISPLAY_RESOLUTION_INCH, 2-23
17400  OEM_GLOBAL_INFO, 2-36	20450  LOOKAH_RELIEVE_BLOCK_CYCLE, 2-39
17530  TOOL_DATA_CHANGE_COUNTER, 2-36	20460  LOOKAH_SMOOTH_FACTOR, 2-39
18030  HW_SERIAL_NUMBER, 2-36	205, <b>4-75</b>
18040  VERSION_INFO, 2-36	205  DISPLAY_RESOLUTION_SPINDLE, 2-23
18080  MM_TOOL_MANAGEMENT_MASK, 2-37	20500  CONST_VELO_MIN_TIME, 2-39
18102  MM_TYPE_OF_CUTTING_EDGE, 2-37	20550  EXACT_POS_MODE, 2-39
18120  MM_NUM_GUD_NAMES_NCK, 2-37	20552  EXACT_POS_MODE_G0_TO_G1, 2-40
18130  MM_NUM_GUD_NAMES_CHAN, 2-37	20610  ADD_MOVE_ACCEL_RESERVE, 2-40
18150  MM_GUD_VALUES_MEM, 2-37	20624  HANDWH_CHAN_STOP_COND, 2-40
20050, <b>4-82</b>	207  USER_CLASS_READ_TOA, 2-23
20050  AXCONF_GEOAX_ASSIGN_TAB, 2-38	20700, <b>4-83</b>
20070, <b>4-82</b>	20700  REFP_NC_START_LOCK, 2-40
20070  AXCONF_MACHAX_USED, 2-38	20730 G0_LINEAR_MODE, 2-40

20732  EXTERN_G0_LINEAR_MODE, 2-40	22256  AUXFU_ASSOC_M1_VALUE, 2-42
20734  EXTERN_FUNCTION_MASK, 2-40	223  USER_CLASS_WRITE_PWA, 2-24
208  USER_CLASS_WRITE_TOA_GEO, 2-23	22400  S_VALUES_ACTIVE_AFTER_RESET, 2-42
209  USER_CLASS_WRITE_TOA_WEAR, 2-23	22410  F_VALUES_ACTIVE_AFTER_RESET, 2-42
210  USER_CLASS_WRITE_ZOA, 2-23	22534, <b>4-85</b>
21000, <b>4-84</b>	22534  TRAFO_CHANGE_M_CODE, 2-42
21000  CIRCLE_ERROR_CONST, 2-40	22550, <b>4-85</b>
21010  CIRCLE_ERROR_FACTOR, 2-40	22550  TOOL_CHANGE_MODE, 2-42
21020, <b>4-84</b>	22910  WEIGHTING_FACTOR_FOR_SCALE, 2-42
21020  WORKAREA_WITH_TOOL_RADIUS, 2-40	22914  AXES_SCALE_ENABLE, 2-42
21190  TOFF_MODE, 2-40	22920  EXTERN_FIXED_FEEDRATE_F1_ON, 2-42
21194  TOFF_VELO, 2-40	22930  EXTERN_PARALLEL_GEOAX, 2-42
21196  TOFF_ACCEL, 2-41	24020  FRAME_SUPPRESS_MODE, 2-42
212  USER_CLASS_WRITE_SEA, 2-23	24100, <b>4-85</b>
213  USER_CLASS_READ_PROGRAM, 2-24	24100  TRAFO_TYPE_1, 2-43
214  USER_CLASS_WRITE_PROGRAM, 2-24	24110, <b>4-85</b>
215  USER_CLASS_SELECT_PROGRAM, 2-24	24110  TRAFO_AXES_IN_1, 2-43
217  USER_CLASS_WRITE_CYCLES, 2-24	24120, <b>4-86</b>
218  USER_CLASS_WRITE_RPA, 2-24	24120  TRAFO_GEOAX_ASSIGN_TAB_1, 2-43
219  USER_CLASS_SET_V24, 2-24	24130  TRAFO_INCLUDES_TOOL_1, 2-43
22000, <b>4-84</b>	24200, <b>4-86</b>
22000  AUXFU_ASSIGN_GROUP, 2-41	24200  TRAFO_TYPE_2, 2-43
22010, <b>4-84</b>	24210, <b>4-86</b>
22010  AUXFU_ASSIGN_TYPE, 2-41	24210  TRAFO_AXES_IN_2, 2-43
22020, <b>4-85</b>	24220, <b>4-86</b>
22020  AUXFU_ASSIGN_EXTENSION, 2-41	24220  TRAFO_GEOAX_ASSIGN_TAB_2, 2-43
22030, <b>4-85</b>	24230  TRAFO_INCLUDES_TOOL_2, 2-43
22030  AUXFU_ASSIGN_VALUE, 2-41	247  V24_PG_PC_BAUD, 2-24
22035  AUXFU_ASSIGN_SPEC, 2-41	24700  TRAANG_ANGLE_1, 2-44
22040  AUXFU_PREDEF_GROUP, 2-41	24710  TRAANG_BASE_TOOL_1, 2-44
22050  AUXFU_PREDEF_TYPE, 2-41	24720  TRAANG_PARALLEL_VELO_RES_1, 2-44
22060  AUXFU_PREDEF_EXTENSION, 2-41	24721  TRAANG_PARALLEL_ACCEL_RES_1, 2-44
22070  AUXFU_PREDEF_VALUE, 2-41	24750  TRAANG_ANGLE_2, 2-44
221  USER_CLASS_DIR_ACCESS, 2-24	24760  TRAANG_BASE_TOOL_2, 2-44
222  USER_CLASS_PLG_ACCESS, 2-24	24770  TRAANG_PARALLEL_VELO_RES_2, 2-44
22254  AUXFU_ASSOC_M0_VALUE, 2-42	24771  TRAANG_PARALLEL_ACCEL_RES_2, 2-44

24800, <b>4-86</b>	26018  NIBBLE_PRE_START_TIME, 2-47
24800  TRACYL_ROT_AX_OFFSET_1, 2-44	26020  NIBBLE_SIGNAL_CHECK, 2-47
24805  TRACYL_ROT_AX_FRAME_1, 2-44	27100  ABSBLOCK_FUNCTION_MASK, 2-47
24808  TRACYL_DEFAULT_MODE_1, 2-45	27400  OEM_CHAN_INFO, 2-48
24810, <b>4-86</b>	27800, <b>4-87</b>
24810  TRACYL_ROT_SIGN_IS_PLUS_1, 2-45	27800  TECHNOLOGY_MODE, 2-48
24820, <b>4-86</b>	27860, <b>4-88</b>
24820  TRACYL_BASE_TOOL_1, 2-45	27860  PROCESSTIMER_MODE, 2-48
24850  TRACYL_ROT_AX_OFFSET_2, 2-45	27880, <b>4-89</b>
24855  TRACYL_ROT_AX_FRAME_2, 2-45	27880  PART_COUNTER, 2-48
24858  TRACYL_DEFAULT_MODE_2, 2-45	27882, <b>4-89</b>
24860  TRACYL_ROT_SIGN_IS_PLUS_2, 2-45	27882  PART_COUNTER_MCODE, 2-48
24870  TRACYL_BASE_TOOL_2, 2-45	280  V24_PPI_ADDR_PLC, 2-24
24900, <b>4-87</b>	281  V24_PPI_ADDR_NCK, 2-24
24900  TRANSMIT_ROT_AX_OFFSET_1, 2-45	28400  MM_ABSBLOCK, 2-48
24905  TRANSMIT_ROT_AX_FRAME_1, 2-45	28402  MM_ABSBLOCK_BUFFER_CONF, 2-48
24910, <b>4-87</b>	289, <b>4-76</b>
24910  TRANSMIT_ROT_SIGN_IS_PLUS_1, 2-46	289  CTM_SIMULATION_TIME_NEW_POS, 2-24
24911, <b>4-87</b>	290, <b>4-76</b>
24911  TRANSMIT_POLE_SIDE_FIX_1, 2-46	290  CTM_POS_COORDINATE_SYSTEM, 2-24
24920, <b>4-87</b>	291, <b>4-76</b>
24920  TRANSMIT_BASE_TOOL_1, 2-46	291  CTM_CROSS_AX_DIAMETER_ON, 2-25
24950  TRANSMIT_ROT_AX_OFFSET_2, 2-46	292, <b>4-76</b>
24955  TRANSMIT_ROT_AX_FRAME_2, 2-46	292  CTM_G91_DIAMETER_ON, 2-25
24960  TRANSMIT_ROT_SIGN_IS_PLUS_2, 2-46	30100  CTRLOUT_SEGMENT_NR, 2-49
24961  TRANSMIT_POLE_SIDE_FIX_2, 2-46	30110, <b>4-90</b>
24970  TRANSMIT_BASE_TOOL_2, 2-46	30110  CTRLOUT_MODULE_NR, 2-49
26000  PUNCHNIB_ASSIGN_FASTIN, 2-46	30120, <b>4-90</b>
26002  PUNCHNIB_ASSIGN_FASTOUT, 2-46	30120  CTRLOUT_NR, 2-49
26004  NIBBLE_PUNCH_OUTMASK, 2-47	30130, <b>4-90</b>
26006  NIBBLE_PUNCH_INMASK, 2-47	30130  CTRLOUT_TYPE, 2-49
26008  NIBBLE_PUNCH_CODE, 2-47	30134, <b>4-90</b>
26010  PUNCHNIB_AXIS_MASK, 2-47	30134  IS_UNIPOLAR_OUTPUT, 2-49
26012  PUNCHNIB_ACTIVATION, 2-47	30200, <b>4-90</b>
26014  PUNCH_PATH_SPLITTING, 2-47	30200  NUM_ENCS, 2-49
26016  PUNCH_PARTITION_TYPE, 2-47	30220, <b>4-90</b>

30220  ENC_MODULE_NR, 2-50	31050  DRIVE_AX_RATIO_DENOM, 2-51
30230, <b>4-91</b>	31060, <b>4-93</b>
30230  ENC_INPUT_NR, 2-50	31060  DRIVE_AX_RATIO_NUMERA, 2-51
30240, <b>4-91</b>	31064  DRIVE_AX_RATIO2_DENOM, 2-51
30240  ENC_TYPE, 2-50	31066  DRIVE_AX_RATIO2_NUMERA, 2-51
30270  ENC_ABS_BUFFERING, 2-50	31070, <b>4-93</b>
30300, <b>4-91</b>	31070  DRIVE_ENC_RATIO_DENOM, 2-51
30300  IS_ROT_AX, 2-50	31080, <b>4-93</b>
30310, <b>4-91</b>	31080  DRIVE_ENC_RATIO_NUMERA, 2-51
30310  ROT_IS_MODULO, 2-50	311  FG_GROUP2, 2-25
30320, <b>4-92</b>	31122, <b>4-93</b>
30320  DISPLAY_IS_MODULO, 2-50	31122  BERO_DELAY_TIME_PLUS, 2-51
30350, <b>4-92</b>	31123, <b>4-93</b>
30350  SIMU_AX_VDI_OUTPUT, 2-50	31123  BERO_DELAY_TIME_MINUS, 2-52
30465  AXIS_LANG_SUB_MASK, 2-50	312  FG_GROUP3, 2-25
305  G_GROUP1, 2-25	313  FG_GROUP4, 2-25
30500  INDEX_AX_ASSIGN_POS_TAB, 2-50	314  FG_GROUP5, 2-25
306  G_GROUP2, 2-25	32000, <b>4-94</b>
30600, <b>4-92</b>	32000  MAX_AX_VELO, 2-52
30600  FIX_POINT_POS, 2-50	32010, <b>4-94</b>
307  G_GROUP3, 2-25	32010  JOG_VELO_RAPID, 2-52
308  G_GROUP4, 2-25	32020, <b>4-94</b>
309  G_GROUP5, 2-25	32020  JOG_VELO, 2-52
310  FG_GROUP1, 2-25	32100, <b>4-94</b>
31000, <b>4-92</b>	32100  AX_MOTION_DIR, 2-52
31000  ENC_IS_LINEAR, 2-51	32110, <b>4-95</b>
31010, <b>4-92</b>	32110  ENC_FEEDBACK_POL, 2-52
31010  ENC_GRID_POINT_DIST, 2-51	32200, <b>4-95</b>
31020, <b>4-92</b>	32200  POSCTRL_GAIN, 2-52
31020  ENC_RESOL, 2-51	32210  POSCTRL_INTEGR_TIME, 2-52
31030, <b>4-93</b>	32220  POSCTRL_INTEGR_ENABLE, 2-52
31030  LEADSCREW_PITCH, 2-51	32230  POSCTRL_CONFIG, 2-53
31040, <b>4-93</b>	32300  MAX_AX_ACCEL, 2-53, <b>4-95</b>
31040  ENC_IS_DIRECT, 2-51	32301  JOG_MAX_ACCEL, 2-53
31044  ENC_IS_DIRECT2, 2-51	32320  DYN_LIMIT_RESET_MASK, 2-53
31050, <b>4-93</b>	32420  JOG_AND_POS_JERK_ENABLE, 2-53, <b>4-95</b>

32430  JOG_AND_POS_MAX_JERK, 2-53 , <b>4-95</b>	34030, <b>4-98</b>
32431, <b>4-96</b>	34030  REFP_MAX_CAM_DIST, 2-55
32431  MAX_AX_JERK, 2-53	34040, <b>4-98</b>
32432, <b>4-96</b>	34040  REFP_VELO_SEARCH_MARKER, 2-55
32432  PATH_TRANS_JERK_LIM, 2-53	34050, <b>4-98</b>
32436  JOG_MAX_JERK, 2-53	34050  REFP_SEARCH_MARKER_REVERSE, 2-55
32440  LOOKAH_FREQUENCY, 2-53	34060, <b>4-98</b>
32450, <b>4-96</b>	34060  REFP_MAX_MARKER_DIST, 2-55
32450  BACKLASH, 2-53	34070, <b>4-99</b>
32490  FRICT_COMP_MODE, 2-54	34070  REFP_VELO_POS, 2-56
32500  FRICT_COMP_ENABLE, 2-54	34080, <b>4-99</b>
32510  FRICT_COMP_ADAPT_ENABLE, 2-54	34080  REFP_MOVE_DIST, 2-56
32520  FRICT_COMP_CONST_MAX, 2-54	34090, <b>4-99</b>
32530  FRICT_COMP_CONST_MIN, 2-54	34090  REFP_MOVE_DIST_CORR, 2-56
32540  FRICT_COMP_TIME, 2-54	34092, <b>4-100</b>
32610  VELO_FFW_WEIGHT, 2-54	34092  REFP_CAM_SHIFT, 2-56
32630, <b>4-96</b>	34093, <b>4-100</b>
32630  FFW_ACTIVATION_MODE, 2-54	34093  REFP_CAM_MARKER_DIST, 2-56
32640  STIFFNESS_CONTROL_ENABLE, 2-54	34100, <b>4-100</b>
32642  STIFFNESS_CONTROL_CONFIG, 2-54	34100  REFP_SET_POS, 2-56
32644  STIFFNESS_DELAY_TIME, 2-54	34110, <b>4-101</b>
32700, <b>4-96</b>	34110  REFP_CYCLE_NR, 2-56
32700  ENC_COMP_ENABLE, 2-55	34120  REFP_BERO_LOW_ACTIVE, 2-56
32810, <b>4-97</b>	34200, <b>4-101</b>
32810  EQUIV_SPEEDCTRL_TIME, 2-55	34200  ENC_REFP_MODE, 2-56
330  CMM_POS_COORDINATE_SYSTEM, 2-26	34210 , <b>4-102</b>
33050, <b>4-97</b>	34210  ENC_REFP_STATE, 2-56
33050  LUBRICATION_DIST, 2-55	34220 , <b>4-102</b>
331  CONTOUR_MASK, 2-26	34220  ENC_ABS_TURNS_MODULO, 2-57
332  TOOL_LIST_PLACE_NO, 2-26	343  V24_PPI_ADDR_MMC, 2-26
34000, <b>4-97</b>	344  V24_PPI_MODEM_ACTIVE, 2-26
34000  REFP_CAM_IS_ACTIVE, 2-55	345  V24_PPI_MODEM_BAUD, 2-26
34010, <b>4-97</b>	346  V24_PPI_MODEM_PARITY, 2-26
34010  REFP_CAM_DIR_IS_MINUS, 2-55	34990  ENC_ACTVAL_SMOOTH_TIME, 2-57
34020, <b>4-97</b>	35000, <b>4-103</b>
34020  REFP_VELO_SEARCH_CAM, 2-55	35000  SPIND_ASSIGN_TO_MACHAX, 2-57

35010, <b>4-103</b>	35400  SPIND_OSCILL_DES_VELO, 2-59
35010  GEAR_STEP_CHANGE_ENABLE, 2-57	35410, <b>4-107</b>
35012  GEAR_STEP_CHANGE_POSITION, 2-57	35410  SPIND_OSCILL_ACCEL, 2-59
35014  GEAR_STEP_USED_IN_AXISMODE, 2-57	35430, <b>4-107</b>
35020  SPIND_DEFAULT_MODE, 2-57	35430  SPIND_OSCILL_START_DI, 2-59
35030  SPIND_DEFAULT_ACT_MASK, 2-57	35440, <b>4-107</b>
35040, <b>4-103</b>	35440  SPIND_OSCILL_TIME_CW, 2-59
35040  SPIND_ACTIVE_AFTER_RESET, 2-57	35450, <b>4-107</b>
35100, <b>4-104</b>	35450  SPIND_OSCILL_TIME_CCW, 2-59
35100  SPIND_VELO_LIMIT, 2-57	35500, <b>4-108</b>
35110, <b>4-104</b>	35500  SPIND_ON_SPEED_AT_IPO_START, 2-59
35110  GEAR_STEP_MAX_VELO, 2-57	35510, <b>4-108</b>
35112  GEAR_STEP_MAX_VELO2, 2-58	35510  SPIND_STOPPED_AT_IPO_START, 2-59
35120, <b>4-104</b>	35550  DRILL_VELO_LIMIT, 2-59
35120  GEAR_STEP_MIN_VELO, 2-58	356  HMI_COL_TITLE_FOCUS_FORE, 2-26
35122  GEAR_STEP_MIN_VELO2, 2-58	357  HMI_COL_TITLE_FOCUS_BACK, 2-26
35130, <b>4-104</b>	360  SPINDLE_LOAD_DISPL1, 2-26
35130  GEAR_STEP_MAX_VELO_LIMIT, 2-58	36000  STOP_LIMIT_COARSE, 2-59 , <b>4-108</b>
35140, <b>4-105</b>	36010, <b>4-109</b>
35140  GEAR_STEP_MIN_VELO_LIMIT, 2-58	36010  STOP_LIMIT_FINE, 2-59
35150, <b>4-105</b>	36020  POSITIONING_TIME, 2-60 , <b>4-109</b>
35150  SPIND_DES_VELO_TOL, 2-58	36030  STANDSTILL_POS_TOL, 2-60 , <b>4-109</b>
35160, <b>4-105</b>	36040  STANDSTILL_DELAY_TIME, 2-60 , <b>4-109</b>
35160  SPIND_EXTERN_VELO_LIMIT, 2-58	36050, <b>4-109</b>
35200, <b>4-106</b>	36050  CLAMP_POS_TOL, 2-60
35200  GEAR_STEP_SPEEDCTRL_ACCEL, 2-58	36060, <b>4-110</b>
35210, <b>4-106</b>	36060  STANDSTILL_VELO_TOL, 2-60
35210  GEAR_STEP_POSCTRL_ACCEL, 2-58	361, <b>4-76</b>
35212  GEAR_STEP_POSCTRL_ACCEL2, 2-58	361  USER_MEAS_TOOL_CHANGE, 2-27
35300, <b>4-106</b>	36100  POS_LIMIT_MINUS, 2-60 , <b>4-110</b>
35300  SPIND_POSCTRL_VELO, 2-58	36110  POS_LIMIT_PLUS, 2-60 , <b>4-110</b>
35310, <b>4-106</b>	36120  POS_LIMIT_MINUS2, 2-60 , <b>4-110</b>
35310  SPIND_POSIT_DELAY_TIME, 2-59	36130  POS_LIMIT_PLUS2, 2-60 , <b>4-110</b>
35350, <b>4-106</b>	362  SPINDLE_LOAD_DISPL2, 2-27
35350  SPIND_POSITIONING_DIR, 2-59	36200  AX_VELO_LIMIT, 2-60 , <b>4-111</b>
35400, <b>4-106</b>	36210, <b>4-111</b>

36210  CTRLOUT_LIMIT, 2-60	37040, <b>4-116</b>
363  SPINDLE_LOAD_BAR_LIM2, 2-27	37040  FIXED_STOP_BY_SENSOR, 2-62
36300  ENC_FREQ_LIMIT, 2-61 , <b>4-111</b>	37050, <b>4-116</b>
36302, <b>4-111</b>	37050  FIXED_STOP_ALARM_MASK, 2-62
36302  ENC_FREQ_LIMIT_LOW, 2-61	37060, <b>4-116</b>
36310  ENC_ZERO_MONITORING, 2-61 , <b>4-112</b>	37060  FIXED_STOP_ACKN_MASK, 2-63
364  SPINDLE_LOAD_BAR_LIM3, 2-27	371  TOOL_REF_PROBE_AXIS2, 2-27
36400  CONTOUR_TOL, 2-61 , <b>4-112</b>	372  TOOL_REF_PROBE_AXIS3, 2-27
365  SPINDLE_LOAD_BAR_MAX, 2-27	373, <b>4-77</b>
36500, <b>4-112</b>	373  MEAS_SAVE_POS_LENGTH2, 2-27
36500  ENC_CHANGE_TOL, 2-61	374  TOOL_WEAR_LIMIT_VALUE, 2-27
366  SPINDLE_LOAD_BAR_COL1, 2-27	37400, <b>4-116</b>
36600  BRAKE_MODE_CHOICE, 2-61 , <b>4-112</b>	37400  EPS_TLIFT_TANG_STEP, 2-63
36610  AX_EMERGENCY_STOP_TIME, 2-61 , <b>4-113</b>	37402, <b>4-117</b>
36620, <b>4-114</b>	37402  TANG_OFFSET, 2-63
36620  SERVO_DISABLE_DELAY_TIME, 2-61	375  USER_CLASS_READ_CUS_DIR, 2-28
367  SPINDLE_LOAD_BAR_COL2, 2-27	376  USER_CLASS_WRITE_CUS_DIR, 2-28
36710  DRIFT_LIMIT, 2-61	37610  PROFIBUS_CTRL_CONFIG, 2-63
36720, <b>4-114</b>	37620  PROFIBUS_TORQUE_RED_RESOL, 2-63
36720  DRIFT_VALUE, 2-61	377  USER_CLASS_WRITE_TO_MON_DAT, 2-28
368  SPINDLE_LOAD_BAR_COL3, 2-27	378  USER_CLASS_LADDER_VIEW, 2-28
369  PROBE_MODE, 2-27	37800  OEM_AXIS_INFO, 2-63
370  TOOL_REF_PROBE_AXIS1, 2-27	379  SPINDLE_DISP_MODE, 2-28
37000, <b>4-114</b>	38000, <b>4-117</b>
37000  FIXED_STOP_MODE, 2-61	38000  MM_ENC_COMP_MAX_POINTS, 2-63
37002, <b>4-114</b>	383  V24_PPI_ADDR_DRV1, 2-28
37002  FIXED_STOP_CONTROL, 2-62	41010, <b>5-119</b>
37010, <b>4-115</b>	41010  JOG_VAR_INCR_SIZE, 3-65
37010  FIXED_STOP_TORQUE_DEF, 2-62	41110, <b>5-119</b>
37012, <b>4-115</b>	41110  JOG_SET_VELO, 3-65
37012  FIXED_STOP_TORQUE_RAMP_TIME, 2-62	41130, <b>5-119</b>
37014  FIXED_STOP_TORQUE_FACTOR, 2-62	41130  JOG_ROT_AX_SET_VELO, 3-65
37020, <b>4-115</b>	41200, <b>5-120</b>
37020  FIXED_STOP_WINDOW_DEF, 2-62	41200  JOG_SPIND_SET_VELO, 3-65
37030, <b>4-115</b>	41500  SW_CAM_MINUS_POS_TAB_1, 3-65
37030  FIXED_STOP_THRESHOLD, 2-62	41501  SW_CAM_PLUS_POS_TAB_1, 3-65

41520  SW_CAM_MINUS_TIME_TAB_1, 3-66	42520  CORNER_SLOWDOWN_START, 3-69
41521  SW_CAM_PLUS_TIME_TAB_1, 3-66	42522  CORNER_SLOWDOWN_END, 3-69
42000, <b>5-121</b>	42524  CORNER_SLOWDOWN_OVR, 3-69
42000  THREAD_START_ANGLE, 3-67	42526  CORNER_SLOWDOWN_CRIT, 3-69
42010, <b>5-121</b>	42528  CUTCOM_DECEL_LIMIT, 3-70
42010  THREAD_RAMP_DISP, 3-67	42940, <b>5-122</b>
42100, <b>5-121</b>	42940  TOOL_LENGTH_CONST, 3-70
42100  DRY_RUN_FEED, 3-67	42950, <b>5-122</b>
42101  DRY_RUN_FEED_MODE, 3-67	42950  TOOL_LENGTH_TYPE, 3-70
42110, <b>5-121</b>	42990  MAX_BLOCKS_IN_IPOBUFFER, 3-70
42110  DEFAULT_FEED, 3-67	42995  CONE_ANGLE, 3-70
42120  APPROACH_FEED, 3-67	43120  DEFAULT_SCALE_FACTOR_AXIS, 3-71
42140  DEFAULT_SCALE_FACTOR_P, 3-67	43200  SPIND_S, 3-71
42150  DEFAULT_ROT_FACTOR_R, 3-67	43202  SPIND_CONSTCUT_S, 3-71
42160  EXTERN_FIXED_FEEDRATE_F1_F9, 3-67	43206  SPIND_SPEED_TYPE, 3-71
42162  EXTERN_DOUBLE_TURRET_DIST, 3-68	43210, <b>5-123</b>
42200  SINGLEBLOCK2_STOPRE, 3-68	43210  SPIND_MIN_VELO_G25, 3-71
42400  PUNCH_DWELLTIME, 3-68	43220, <b>5-123</b>
42402  NIBPUNCH_PRE_START_TIME, 3-68	43220  SPIND_MAX_VELO_G26, 3-71
42404  MINTIME_BETWEEN_STROKES, 3-68	43230, <b>5-123</b>
42440  FRAME_OFFSET_INCR_PROG, 3-68	43230  SPIND_MAX_VELO_LIMS, 3-71
42442  TOOL_OFFSET_INCR_PROG, 3-68	43240  M19_SPOS, 3-71
42444  TARGET_BLOCK_INCR_PROG, 3-68	43250  M19_SPOSMODE, 3-71
42450  CONTPREC, 3-68	43400, <b>5-124</b>
42465  SMOOTH_CONTUR_TOL, 3-68	43400  WORKAREA_PLUS_ENABLE, 3-71
42470  CRIT_SPLINE_ANGLE, 3-68	43410, <b>5-124</b>
42471  MIN_CURV_RADIUS, 3-68	43410  WORKAREA_MINUS_ENABLE, 3-72
42475  COMPRESS_CONTUR_TOL, 3-69	43420, <b>5-124</b>
42480  STOP_CUTCOM_STOPRE, 3-69	43420  WORKAREA_LIMIT_PLUS, 3-72
42490  CUTCOM_G40_STOPRE, 3-69	43430, <b>5-124</b>
42494  CUTCOM_ACT_DEACT_CTRL, 3-69	43430  WORKAREA_LIMIT_MINUS, 3-72
42496  CUTCOM_CLSD_CONT, 3-69	43500, <b>5-124</b>
42500  SD_MAX_PATH_ACCEL, 3-69	43500  FIXED_STOP_SWITCH, 3-72
42502  IS_SD_MAX_PATH_ACCEL, 3-69	43510, <b>5-125</b>
42510  SD_MAX_PATH_JERK, 3-69	43510  FIXED_STOP_TORQUE, 3-72
42512  IS_SD_MAX_PATH_JERK, 3-69	43700  OSCILL_REVERSE_POS1, 3-72

43710 |OSCILL\_REVERSE\_POS2, 3-72

43720 |OSCILL\_DWELL\_TIME1, 3-72

43730 |OSCILL\_DWELL\_TIME2, 3-72

43740 |OSCILL\_VELO, 3-72

43750 |OSCILL\_NUM\_SPARK\_CYCLES, 3-73

43760 |OSCILL\_END\_POS, 3-73

43770 |OSCILL\_CTRL\_MASK, 3-73

43780 |OSCILL\_IS\_ACTIVE, 3-73

43790 |OSCILL\_START\_POS, 3-73

# Machine and Setting Data – Explanations

## 1.1 Specifications in the list

The machine and setting data are listed in the form of tables.

MD number	MD identifier				Cross reference
Unit	Brief description				Activation
Display filter				Attributes	Data type
System	Dimension	Default value	Minimum value	Maximum value	Protection

The following information are specified:

### Number and identifier

MD and SD are addressed via their numbers or their names (identifiers). The number and the name, as well as the activation type and the unit are displayed on the screen of the control system.

### Cross reference

For a detailed description of the appropriate data, please refer to the description of functions or manual/guide specified.

Example: [F-S1]                      Description of Functions 802D sl, Chapter "Spindle (S1)"

### Unit/unit system

Depending on MD 10240 SCALING\_SYSTEM\_IS\_METRIC, the physical units of the machine data (MD) differ as follows:

MD 10240 = 1	MD 10240 = 0
mm	inch
mm/min	inch/min
m/s <sup>2</sup>	inch/s <sup>2</sup>
m/s <sup>3</sup>	inch/s <sup>3</sup>
mm/rev.	inch/rev.

If there are machine data with no physical unit assigned, a hyphen ("-") can be found in the relevant field.

**Note**

The default setting is MD 10240 SCALING\_SYSTEM\_IS\_METRIC = 1 (metric).

**Activation**

The activation stages are listed according to their priority. If any data is changed, it comes into effect after:

- POWER ON (po) Turning off / turning on the SINUMERIK 802D sl
- NEW\_CONF (cf) With **RESET** at the PLC interface (V3000 0000.7)
- RESET (re) With **RESET** at the PLC interface (V3000 0000.7) or at the end of the program M2/M30
- IMMEDIATELY (im) After input of the value

**Display filter**

The number of machine data displayed in a specific area can be reduced thanks to a display filter.

Display filters are offered for the following machine data areas:

- General machine data
- Channel-specific machine data
- Axis-specific machine data

To parameterize the display filter for a machine data area, use the **Select group** softkey to call the relevant machine data area.

**Note for reader**

SINUMERIK 802D sl, "Operation and Programming...", Chapter "System"

Table 1-1 Display filters in the individual data areas

Code	Display filter
	<b>General machine data</b>
N01	Configuration / scaling
N02	Memory configuration
N03	PLC machine data
N04	Drive control
N05	Status data / diagnosis
N06	Monitoring functions / limitations
N07	Auxiliary functions
N08	Corrections / compensations

Table 1-1 Display filters in the individual data areas, cont'd

Code	Display filter
N09	Technological functions
N10	I/O configuration
N11	Standard machine
	<b>Channel-specific machine data</b>
C01	Configuration
C02	Memory configuration
C03	Default settings
C04	Auxiliary functions
C05	Speeds/velocities
C06	Monitoring functions / limitations
C07	Transformations
C08	Corrections / compensations
C09	Technological functions
C10	Standard machine
	<b>Axis-specific machine data</b>
A01	Configuration (including memory)
A02	Measuring system
A03	Machine geometry
A04	Speeds, velocities / accelerations / jerk
A05	Monitoring functions / limitations
A06	Spindle
A07	Controller data
A08	Status data
A09	Corrections / compensations
A10	Technological functions
A11	Standard machine

**Data type**

BOOLEAN	Boolean value: 1 (TRUE) or 0 (FALSE)
BYTE	8-bit value, as an INTEGER value: -128 ... 127, as a hexadecimal value: 00 ... FF as a character as per ASCII character set, e.g. "a"
STRING	Sequence of characters (max. 16)
WORD	16-bit value, as an INTEGER value: -32768 ... 32767, as a hexadecimal value: 0000 ... FFFF
UNSIGNED WORD	16-bit value, as an INTEGER value: 0 ... 65535, as a hexadecimal value: 0000 ... FFFF
INTEGER	16-bit value (here defined locally), INTEGER value: -32768 ... 32767
DWORD	32-bit value, as an INTEGER value: -2147483648 ... 2147483647, as a hexadecimal value: 0000 0000 ... FFFF
UNSIGNED WORD	32-bit value, as an INTEGER value: 0 ... 4294967295, as a hexadecimal value: 0000 0000 ... FFFF FFFF
DOUBLE	64-bit value, floating point value: $\pm 4.19 \cdot 10^{-307} \dots \pm 1.67 \cdot 10^{308}$

**System**

Specifies the control system for which the data with the entered values applies. The following entries are possible:

- default  
The entered values apply for all SINUMERIK 802D sl.  
Any deviations in the range of values must be entered in the following lines of the table. If **no** "default" entry exists, the data only applies for the control variants specified.
- tm1 Turning/milling value
- tm2 Turning/milling plus
- tm3 Turning/milling pro
- ng2 Nibbling/grinding plus
- ng3 Nibbling/grinding pro

## Default values

This value is used to specify a default value for the machine data. If the default values for the channels are different, this is marked by a ", ".

## Range of values (minimum/maximum value)

Specifies the input limits. If no range of values is specified, the data type determines the input limits, and the field is marked with "\*\*\*".

## Protection levels

The SINUMERIK 802D sl provides a concept of protection levels for enabling data areas. There are the protection levels 0 to 7 whereby **0** is the highest and **7** the lowest level.

The protection levels can be set for certain function areas (e.g. program editor) using the display machine data (USER\_CLASS...).

When the control system is delivered, certain default passwords are already set for the protection levels 1 to 3. If necessary, the appropriate authorized person can change these passwords.

Table 1-2 Protection level concept

Protection level	Locked by	Area
0		Siemens, reserved
1	Password: SUNRISE (default)	Expert mode (OEM HIGH)
2	Password: EVENING (default)	Machine manufacturer (OEM LOW)
3	Password: CUSTOMER (default)	Authorized operator, setter
4 to 7	No password and user interface from PLC → NCK	Authorized operator, setter or appropriate graduations as desired

### Protection levels 1 ... 3

The protection levels 1 to 3 require a password. The passwords can be changed after activation. For example, if the passwords are no longer known, the control system must be reinitialized (booting with default machine data). This will reset all passwords to their defaults according to the software release you have acquired.

The password remains set until it is reset by selecting the **Delete password** softkey. **POWER ON** will **not** reset the password.

### Protection levels 4 ... 7

Protection level 7 is set automatically if no password is set and no protection level interface signal is set. The protection levels 4 to 7 can be set from the PLC user program even without a password by setting the bits in the user interface.

## 1.2 Overview of the machine and setting data areas

The machine and setting data are divided into the following areas:

Table 1-3 Overview of the machine and setting data areas

Area		Designation
from	to	
200	400	Display machine data
1 000	19 999	General machine data
20 000	29 999	Channel-specific machine data
30 000	39 999	Axis-specific machine data
41 000	41 999	General setting data
42 000	42 999	Channel-specific setting data
43 000	43 999	Axis-specific setting data

## List of Machine Data

### 2.1 Display machine data

Number	MD identifier				Cross reference
Schematic view	Name, miscellaneous			Activation	Read/write protection level
Unit	Default value	Minimum value	Maximum value	Data type	
<b>202</b>	<b>FIRST_LANGUAGE</b>				<b>F-T3</b>
decimal	Foreground language			<b>POWER ON</b>	2/3
0	2	1	2	BYTE	
<b>203</b>	<b>DISPLAY_RESOLUTION</b>				<b>F-T3</b>
decimal	Display resolution			<b>immediately</b>	2/3
0	3	0	5	BYTE	
<b>204</b>	<b>DISPLAY_RESOLUTION_INCH</b>				<b>F-T3</b>
decimal	Display resolution			<b>immediately</b>	2/3
0	4	0	5	BYTE	
<b>205</b>	<b>DISPLAY_RESOLUTION_SPINDLE</b>				<b>F-T3</b>
decimal	Display resolution			<b>immediately</b>	2/3
0	1	0	5	BYTE	
<b>207</b>	<b>USER_CLASS_READ_TOA</b>				
decimal	Protection level for "Read tool offsets, general"			<b>immediately</b>	3/3
0	3	0	7	BYTE	
<b>208</b>	<b>USER_CLASS_WRITE_TOA_GEO</b>				
decimal	Protection level for "Write tool geometry"			<b>immediately</b>	3/3
0	3	0	7	BYTE	
<b>209</b>	<b>USER_CLASS_WRITE_TOA_WEAR</b>				
decimal	Protection level for "Write wear data"			<b>immediately</b>	3/3
0	3	0	7	BYTE	
<b>210</b>	<b>USER_CLASS_WRITE_ZOA</b>				
decimal	Protection level for "Write settable work offset"			<b>immediately</b>	3/3
0	3	0	7	BYTE	
<b>212</b>	<b>USER_CLASS_WRITE_SEA</b>				
decimal	Protection level for "Write setting data"			<b>immediately</b>	3/3
0	7	0	7	BYTE	

## 2.1 Display machine data

<b>213</b>	<b>USER_CLASS_READ_PROGRAM</b>			
decimal	Protection level for "Read part program"			<b>immediately</b>
0	7	0	7	BYTE
<b>214</b>	<b>USER_CLASS_WRITE_PROGRAM</b>			
decimal	Protection level for "Enter part program"			<b>immediately</b>
0	3	0	7	BYTE
<b>215</b>	<b>USER_CLASS_SELECT_PROGRAM</b>			
decimal	Protection level for program selection			<b>immediately</b>
0	3	0	7	BYTE
<b>217</b>	<b>USER_CLASS_WRITE_CYCLES</b>			
decimal	Protection level for "Write cycles"			<b>immediately</b>
0	3	0	7	BYTE
<b>218</b>	<b>USER_CLASS_WRITE_RPA</b>			
decimal	Protection level for "Write R parameters"			<b>immediately</b>
0	3	0	7	BYTE
<b>219</b>	<b>USER_CLASS_SET_V24</b>			
decimal	Protection level for "Set V24"			<b>immediately</b>
0	3	0	7	BYTE
<b>221</b>	<b>USER_CLASS_DIR_ACCESS</b>			
decimal	Protection level for directory access			<b>immediately</b>
0	3	0	7	BYTE
<b>222</b>	<b>USER_CLASS_PLC_ACCESS</b>			
decimal	Protection level for PLC project			<b>immediately</b>
0	3	0	7	BYTE
<b>223</b>	<b>USER_CLASS_WRITE_PWA</b>			
decimal	Protection level for protected working area			<b>immediately</b>
0	7	0	7	BYTE
<b>247</b>	<b>V24_PG_PC_BAUD</b>			
Bit pattern	PG: Baud rate (300, 600, 1200, 2400, 4800, 9600, 19200, 38400)			<b>immediately</b>
0	7	0	7	BYTE
<b>280</b>	<b>V24_PPI_ADDR_PLC</b>			
	PLC station address			<b>POWER ON</b>
	2	0	126	BYTE
<b>281</b>	<b>V24_PPI_ADDR_NCK</b>			
	NCK station address			<b>POWER ON</b>
	3	0	126	BYTE
<b>289</b>	<b>CTM_SIMULATION_TIME_NEW_POS</b>			<b>F-K1</b>
decimal	Simulation of actual-value refresh rate			<b>immediately</b>
0	100	0	4000	INTEGER
<b>290</b>	<b>CTM_POS_COORDINATE_SYSTEM</b>			<b>F-K1</b>
decimal	Position of the coordinate system			<b>immediately</b>
0	2	0	7	BYTE

<b>291</b>	<b>CTM_CROSS_AX_DIAMETER_ON</b>			<b>F-K1</b>	
decimal	Diameter for "Transverse axis active"			<b>immediately</b>	3/4
0	1	0	1	BYTE	
<b>292</b>	<b>CTM_G91_DIAMETER_ON</b>			<b>F-K1</b>	
decimal	Incremental feed			<b>immediately</b>	3/7
0	1	0	1	BYTE	
<b>305</b>	<b>G_GROUP1</b>				
decimal	User-oriented G group for position display			<b>immediately</b>	3/7
0	1	1	1000	INTEGER	
<b>306</b>	<b>G_GROUP2</b>				
decimal	User-oriented G group for position display			<b>immediately</b>	3/7
0	2	1	1000	INTEGER	
<b>307</b>	<b>G_GROUP3</b>				
decimal	User-oriented G group for position display			<b>immediately</b>	3/7
0	8	1	1000	INTEGER	
<b>308</b>	<b>G_GROUP4</b>				
decimal	User-oriented G group for position display			<b>immediately</b>	3/7
0	9	1	1000	INTEGER	
<b>309</b>	<b>G_GROUP5</b>				
decimal	User-oriented G group for position display			<b>immediately</b>	3/7
0	10	1	1000	INTEGER	
<b>310</b>	<b>FG_GROUP1</b>				
decimal	User-oriented G group for position display (external language)			<b>immediately</b>	3/7
0	1	1	1000	INTEGER	
<b>311</b>	<b>FG_GROUP2</b>				
decimal	User-oriented G group for position display (external language)			<b>immediately</b>	3/7
0	2	1	1000	INTEGER	
<b>312</b>	<b>FG_GROUP3</b>				
decimal	User-oriented G group for position display (external language)			<b>immediately</b>	3/7
0	8	1	1000	INTEGER	
<b>313</b>	<b>FG_GROUP4</b>				
decimal	User-oriented G group for position display (external language)			<b>immediately</b>	3/7
0	9	1	1000	INTEGER	
<b>314</b>	<b>FG_GROUP5</b>				
decimal	User-oriented G group for position display (external language)			<b>immediately</b>	3/7
0	10	1	1000	INTEGER	

2.1 Display machine data

330	CMM_POS_COORDINATE_SYSTEM			
decimal	Coordinate position of machine *)			immediately
0	0	0	7	BYTE

\*) Explanation:

Both the position and the size of the representation are handed over during initialization. The position of the coordinate system can be influenced by the "Axis direction" parameter in the header of the file.

The following positions are possible:

	Position	X+	Z+
0	up	to the right	
1	up	to the left	
2	down	to the right	
3	down	to the left	
4	<b>to the right</b>	<b>top</b>	
5	to the left	up	
6	to the right	down	
7	to the left	down	

The positions of the elements must be specified in position 4 (mathematic coordinate system). The simulation will then automatically convert the representation to the relevant system.

331	CONTOUR_MASK			
decimal	Activating the 802 contour definition programming			immediately
0	1	0	1	BYTE

332	TOOL_LIST_PLACE_NO			
decimal	Activate location number in tool list			immediately
0	0	0	1	INTEGER

343	V24_PPI_ADDR_MMC			
decimal				POWER ON
0	4	0	126	

344	V24_PPI_MODEM_ACTIVE			
decimal				immediately
0	0	0	1	Byte

345	V24_PPI_MODEM_BAUD			
decimal	Baud rate for modem connection			immediately
0	7	5	9	Byte

346	V24_PPI_MODEM_PARITY			
decimal	Parity for modem connection			immediately
0	0	0	2	Byte

356	HMI_COL_TITLE_FOCUS_FORE			
decimal	Color settings title bar focus window foreground			immediately
	15	0	15	Byte

357	HMI_COL_TITLE_FOCUS_BACK			
decimal	Color settings title bar focus window background			immediately
	2	0	15	Byte

360	SPINDLE_LOAD_DISPL1			
decimal	Activate utilization display for spindle 1			immediately
	0	0	1	INTEGER

<b>361</b>	<b>USER_MEAS_TOOL_CHANGE</b>				
decimal	Input enable for T/D no. in the "Tool gauging" window			<b>immediately</b>	3/3
	0	0	1	Byte	
<b>362</b>	<b>SPINDLE_LOAD_DISPL2</b>				
decimal	Activate utilization display for spindle 2			<b>immediately</b>	3/3
	1	0	1	INTEGER	
<b>363</b>	<b>SPINDLE_LOAD_BAR_LIM2</b>				
decimal	Activate utilization display for the spindle, limit value 2			<b>immediately</b>	2/2
	100	0	9999999	INTEGER	
<b>364</b>	<b>SPINDLE_LOAD_BAR_LIM3</b>				
decimal	Activate utilization display for the spindle, limit value 3			<b>immediately</b>	2/2
	100	0	9999999	INTEGER	
<b>365</b>	<b>SPINDLE_LOAD_BAR_MAX</b>				
decimal	Utilization display for the spindle, maximum			<b>immediately</b>	2/2
	120	0	120	INTEGER	
<b>366</b>	<b>SPINDLE_LOAD_BAR_COL1</b>				
decimal	Utilization display color for the spindle, range 1			<b>immediately</b>	3/3
	10	0	15	Byte	
<b>367</b>	<b>SPINDLE_LOAD_BAR_COL2</b>				
decimal	Utilization display color for the spindle, range 2			<b>immediately</b>	3/3
	9	0	15	Byte	
<b>368</b>	<b>SPINDLE_LOAD_BAR_COL3</b>				
decimal	Utilization display color for the spindle, range 3			<b>immediately</b>	3/3
	9	0	15	Byte	
<b>369</b>	<b>PROBE_MODE</b>				
decimal	Measuring system type: 1: Probe, 2: Opt. measuring technique			<b>immediately</b>	3/3
	1	0	2	INTEGER	
<b>370</b>	<b>TOOL_REF_PROBE_AXIS1</b>				
decimal	Absolute position of probe X			<b>immediately</b>	2/2
	0	-999999.999	999999.999	DOUBLE	
<b>371</b>	<b>TOOL_REF_PROBE_AXIS2</b>				
decimal	Absolute position of probe Y			<b>immediately</b>	2/2
	0	-999999.999	999999.999	DOUBLE	
<b>372</b>	<b>TOOL_REF_PROBE_AXIS3</b>				
decimal	Absolute position of probe Z			<b>immediately</b>	2/2
	9	-999999.999	999999.999	DOUBLE	
<b>373</b>	<b>MEAS_SAVE_POS_LENGTH2</b>				
decimal	Activate tool gauging; select "Save Pos" softkey for all values			<b>immediately</b>	2/2
	0	0	1	Byte	
<b>374</b>	<b>TOOL_WEAR_LIMIT_VALUE</b>				
decimal	Limit value for wear control during input			<b>immediately</b>	2/2
	9.999	0	9.999	DOUBLE	

## 2.1 Display machine data

375		USER_CLASS_READ_CUS_DIR			
decimal	Protection level for "Read user cycles"			<b>immediately</b>	2/3
0	7	0	7	Byte	
376		USER_CLASS_WRITE_CUS_DIR			
decimal	Protection level for "Write user cycles"			<b>immediately</b>	2/2
0	2	0	7	Byte	
377		USER_CLASS_WRITE_TO_MON_DAT			
decimal	Protection level for "Tool monitoring"			<b>immediately</b>	2/3
0	3	0	7	Byte	
378		USER_CLASS_LADDER_VIEW			
decimal	Protection level for "Select user ladder view"			<b>immediately</b>	2/2
0	2	0	7	Byte	
379		SPINDLE_DISP_MODE			
decimal	0: Default mode, display of spindle speed 1: Constant cutting rate, display with G96 set 2: Mixed display			<b>immediately</b>	3/3
0	0	0	2	Byte	
383		V24_PPI_ADDR_DRV1			
decimal	Station address for the drives			<b>POWER ON</b>	3/3
0	5	0	126	Byte	

## 2.2 General machine data

MD number	MD identifier				
Unit	Brief description				Activation
Display filter					Data type
System *	Dimension	Default value	Minimum value	Maximum value	Protection

\* Values other than those in the default system

### Note regarding the value definition:

TRUE corresponds to 1

FALSE corresponds to 0

10000	AXCONF_MACHAX_NAME_TAB				
-	Machine axis name				POWER ON
N01, N11					STRING
Default	6	"X1", "Y1", "Z1", "SP", "A1", "PLCX1"	-	-	2/2
ng2	6	"X1", "Z1", "C1", "A1", "B1", "PLCX1"	-	-	2/2
ng3	6	"X1", "Z1", "C1", "A1", "B1", "PLCX1"	-	-	2/2
tm1	4	"X1", "Y1", "Z1", "SP"	-	-	2/2

10074	PLC_IPO_TIME_RATIO				
-	Factor of the PLC task for main run				POWER ON
N01, N05					DWORD
Default	-	1	1	50	2/2

10088	REBOOT_DELAY_TIME				
s	Reboot delay				immediately
EXP					DOUBLE
Default	-	0.2	0.0	1.0	2/2

10200	INT_INCR_PER_MM				
-	Computational resolution for linear positions				POWER ON
N01					DOUBLE
Default	-	1000.0	1.0	1.0e9	2/2
ng2	-	100000.0	1.0	1.0e9	2/2
ng3	-	100000.0	1.0	1.0e9	2/2

10210	INT_INCR_PER_DEG				
-	Computational resolution for angular positions				POWER ON
N01					DOUBLE
Default	-	1000.0	1.0	1.0e9	2/2
ng2	-	100000.0	1.0	1.0e9	2/2
ng3	-	100000.0	1.0	1.0e9	2/2

10240	SCALING_SYSTEM_IS_METRIC				
-	Metric basic system				POWER ON
N01					BOOLEAN
Default	-	TRUE	-	-	2/2

10350	FASTIO_DIG_NUM_INPUTS				
-	Number of active digital NCK input bytes				POWER ON
N10					BYTE
Default	-	2	1	MAXNUM_DIG_FASTIN_BYTES	2/2

10360	FASTIO_DIG_NUM_OUTPUTS				
-	Number of active digital NCK output bytes				POWER ON
N10					BYTE
Default	-	2	0	MAXNUM_DIG_FASTOUT_BYTES	2/2

## 2.2 General machine data

<b>10366</b>	<b>HW_ASSIGN_DIG_FASTIN</b>				
-	Hardware assignment of external digital NCK inputs				POWER ON
N10					DWORD
Default	1	0x0	0x0	0x00010101	2/2
ng2	1	0x00010101	0x0	0x00010101	2/2
ng3	1	0x00010101	0x0	0x00010101	2/2
<b>10368</b>	<b>HW_ASSIGN_DIG_FASTOUT</b>				
-	Hardware assignment of external digital NCK outputs				POWER ON
N10					DWORD
Default	1	0x0	0x0	0x00010101	2/2
ng2	1	0x00010101	0x0	0x00010101	2/2
ng3	1	0x00010101	0x0	0x00010101	2/2
<b>10450</b>	<b>SW_CAM_ASSIGN_TAB</b>				
-	Assignment software cams to machine axes				POWER ON
N09					BYTE
ng2	8	0, 0, 0, 0, 0, 0, 0, 0	0	6	2/2
ng3	8	0, 0, 0, 0, 0, 0, 0, 0	0	6	2/2
<b>10460</b>	<b>SW_CAM_MINUS_LEAD_TIME</b>				
s	Lead or delay time at minus cams 1-16				POWER ON
N09					DOUBLE
ng2	8	0.0, 0.0, 0.0, 0.0, 0.0, 0.0, 0.0, 0.0	0	-	3/3
ng3	8	0.0, 0.0, 0.0, 0.0, 0.0, 0.0, 0.0, 0.0	0	-	3/3
<b>10461</b>	<b>SW_CAM_PLUS_LEAD_TIME</b>				
s	Lead or delay time at plus cams 1-16				POWER ON
N09					DOUBLE
ng2	8	0.0, 0.0, 0.0, 0.0, 0.0, 0.0, 0.0, 0.0	0	-	3/3
ng3	8	0.0, 0.0, 0.0, 0.0, 0.0, 0.0, 0.0, 0.0	0	-	3/3
<b>10470</b>	<b>SW_CAM_ASSIGN_FASTOUT_1</b>				
-	Hardware assignment for output of cams 1-8 to NCK I/Os				POWER ON
N09					DWORD
ng2	-	0	-	-	2/2
ng3	-	0	-	-	2/2
<b>10480</b>	<b>SW_CAM_TIMER_FASTOUT_MASK</b>				
-	Screenform for output of cam signals via timer interr. to NCU				POWER ON
N09					DWORD
ng2	-	0	-	-	2/2
ng3	-	0	-	-	2/2
<b>10485</b>	<b>SW_CAM_MODE</b>				
-	Behavior of SW cams				POWER ON
N09					DWORD
ng2	-	0	-	-	2/2
ng3	-	0	-	-	2/2
<b>10710</b>	<b>PROG_SD_RESET_SAVE_TAB</b>				
-	Setting data to be updated				POWER ON
EXP, N01					DWORD
ng2	30	0, 0, 0...	-	-	2/2
ng3	30	0, 0, 0...	-	-	2/2
tm2	30	0, 0, 0...	-	-	2/2
tm3	30	0, 0, 0...	-	-	2/2

<b>10713</b>	<b>M_NO_FCT_STOPRE</b>				
-	M function with preprocessing stop				POWER ON
EXP, N12, N07					DWORD
Default	15	-1, -1, -1, -1, -1, -1, -1, -1, -1, -1, -1, -1, -1, -1, -1	-	-	2/2
<b>10714</b>	<b>M_NO_FCT_EOP</b>				
-	M function active for spindle after reset				POWER ON
EXP, N07					DWORD
Default	-	-1	-	-	2/2
<b>10715</b>	<b>M_NO_FCT_CYCLE</b>				
-	M function to be replaced by a subroutine				POWER ON
EXP, N12, N07					DWORD
Default	10	-1, -1, -1, -1, -1, -1, -1, -1, -1, -1, -1, -1, -1, -1, -1	-	-	2/2
<b>10716</b>	<b>M_NO_FCT_CYCLE_NAME</b>				
-	Subroutine name for replacement of an M function				POWER ON
EXP, N12, N07					STRING
Default	10		-	-	2/2
<b>10717</b>	<b>T_NO_FCT_CYCLE_NAME</b>				
-	Subroutine name for replacement of a T function				POWER ON
EXP, N12, N07					STRING
Default	-1		-	-	2/2
<b>10718</b>	<b>M_NO_FCT_CYCLE_PAR</b>				
-	M function replacement by parameters				POWER ON
EXP, N12, N07					DWORD
Default	-	-1	-	-	2/2
<b>10719</b>	<b>T_NO_FCT_CYCLE_MODE</b>				
-	Parameterization of the T function replacement				POWER ON
EXP, N12, N07					DWORD
Default	-	0	0	1	2/2
<b>10735</b>	<b>JOG_MODE_MASK</b>				
-	Enable jogging in the AUTOMATIC mode				POWER ON
EXP, N01					DWORD
Default	-	0	0	0x1	2/2
<b>10760</b>	<b>G53_TOOLCORR</b>				
-	Effect with G53, G153 and SUPA				POWER ON
N12					BOOLEAN
tm1	-	FALSE	-	-	2/2
tm2	-	FALSE	-	-	2/2
tm3	-	FALSE	-	-	2/2
<b>10804</b>	<b>EXTERN_M_NO_SET_INT</b>				
-	M function to activate ASUB				POWER ON
EXP, N12					DWORD
tm1	-	96	-	-	2/2
tm2	-	96	-	-	2/2
tm3	-	96	-	-	2/2
<b>10806</b>	<b>EXTERN_M_NO_DISABLE_INT</b>				
-	M function to deactivate ASUB				POWER ON
EXP, N12					DWORD
tm1	-	97	-	-	2/2
tm2	-	97	-	-	2/2
tm3	-	97	-	-	2/2

## 2.2 General machine data

<b>10808</b>	<b>EXTERN_INTERRUPT_BITS_M96</b>				
-	Activate interrupt program (ASUB)				POWER ON
EXP, N12					DWORD
tm1	-	0	-	-	2/2
tm2	-	0	-	-	2/2
tm3	-	0	-	-	2/2
<b>10810</b>	<b>EXTERN_MEAS_G31_P_SIGNAL</b>				
-	Assignment of the measuring inputs for G31 P..				POWER ON
EXP, N12					BYTE
tm1	4	1, 1, 1, 1	0	3	2/2
tm2	4	1, 1, 1, 1	0	3	2/2
tm3	4	1, 1, 1, 1	0	3	2/2
<b>10812</b>	<b>EXTERN_DOUBLE_TURRET_ON</b>				
-	Double-resolver head with G68				POWER ON
EXP, N12					BOOLEAN
tm1	-	FALSE	-	-	2/2
tm2	-	FALSE	-	-	2/2
tm3	-	FALSE	-	-	2/2
<b>10814</b>	<b>EXTERN_M_NO_MAC_CYCLE</b>				
-	Macro call via M function				POWER ON
EXP, N12					DWORD
tm1	10	-1, -1, -1, -1, -1, -1, -1, -1, -1, -1	-	-	2/2
tm2	10	-1, -1, -1, -1, -1, -1, -1, -1, -1, -1	-	-	2/2
tm3	10	-1, -1, -1, -1, -1, -1, -1, -1, -1, -1	-	-	2/2
<b>10815</b>	<b>EXTERN_M_NO_MAC_CYCLE_NAME</b>				
-	Name of subroutine for M function macro call				POWER ON
EXP, N12					STRING
tm1	10		-	-	2/2
tm2	10		-	-	2/2
tm3	10		-	-	2/2
<b>10816</b>	<b>EXTERN_G_NO_MAC_CYCLE</b>				
-	G function for macro call				POWER ON
EXP, N12					DOUBLE
tm1	50	-1, -1, -1, -1, -1, -1, -1, -1, -1, -1 ....	-	-	2/2
tm2	50	-1, -1, -1, -1, -1, -1, -1, -1, -1, -1 ....	-	-	2/2
tm3	50	-1, -1, -1, -1, -1, -1, -1, -1, -1, -1 ....	-	-	2/2
<b>10817</b>	<b>EXTERN_G_NO_MAC_CYCLE_NAME</b>				
-	Name of subroutine for G function macro call				POWER ON
EXP, N12					STRING
tm1	50		-	-	2/2
tm2	50		-	-	2/2
tm3	50		-	-	2/2
<b>10818</b>	<b>EXTERN_INTERRUPT_NUM_ASUP</b>				
-	Interrupt number for ASUB start (M96)				POWER ON
EXP, N12					BYTE
tm1	-	1	1	8	2/2
tm2	-	1	1	8	2/2
tm3	-	1	1	8	2/2

<b>10820</b>	<b>EXTERN_INTERRUPT_NUM_RETRAC</b>				
-	Interrupt number f. rapid retraction (G10.6)				POWER ON
EXP, N12					BYTE
tm1	-	2	1	8	2/2
tm2	-	2	1	8	2/2
tm3	-	2	1	8	2/2
<b>10880</b>	<b>MM_EXTERN_CNC_SYSTEM</b>				
-	Def. of control system to be adapted				POWER ON
N01, N12					DWORD
tm1	-	1	1	3	2/2
tm2	-	1	1	3	2/2
tm3	-	1	1	3	2/2
<b>10881</b>	<b>MM_EXTERN_GCODE_SYSTEM</b>				
-	ISO_3 Mode: GCodeSystem				POWER ON
N01, N12					DWORD
Default	-	0	0	2	2/2
<b>10882</b>	<b>NC_USER_EXTERN_GCODES_TAB</b>				
-	List of user-specific G commands, ext. language				POWER ON
N12					STRING
Default	60		-	-	2/2
<b>10884</b>	<b>EXTERN_FLOATINGPOINT_PROG</b>				
-	Evaluation of progr. values without decimal point				POWER ON
N12					BOOLEAN
Default	-	TRUE	-	-	2/2
<b>10886</b>	<b>EXTERN_INCREMENT_SYSTEM</b>				
-	Increment system				POWER ON
N12					BOOLEAN
Default	-	FALSE	-	-	2/2
<b>10888</b>	<b>EXTERN_DIGITS_TOOL_NO</b>				
-	Number of digits for T number				POWER ON
N12					BYTE
Default	-	2	0	8	2/2
<b>10890</b>	<b>EXTERN_TOOLPROG_MODE</b>				
-	Tool change program with ext. language				POWER ON
N12					DWORD
Default	-	0	-	-	2/2
<b>10900</b>	<b>INDEX_AX_LENGTH_POS_TAB_1</b>				
-	Number of positions for indexing axis table 1				RESET
N09					DWORD
ng2	-	0	0	60	2/2
ng3	-	0	0	60	2/2
tm2	-	0	0	60	2/2
tm3	-	0	0	60	2/2
<b>10910</b>	<b>INDEX_AX_POS_TAB_1</b>				
mm/inch, degrees	Indexing position table 1				RESET
N09					DOUBLE
ng2	60	0.0, 0.0, 0.0, 0.0, 0.0 ....	-	-	2/2
ng3	60	0.0, 0.0, 0.0, 0.0, 0.0 ....	-	-	2/2
tm2	60	0.0, 0.0, 0.0, 0.0, 0.0 ....	-	-	2/2
tm3	60	0.0, 0.0, 0.0, 0.0, 0.0 ....	-	-	2/2

## 2.2 General machine data

<b>10920</b>	<b>INDEX_AX_LENGTH_POS_TAB_2</b>				
-	Number of positions for indexing axis table 2				RESET
N09					DWORD
ng2	-	0	0	60	2/2
ng3	-	0	0	60	2/2
tm2	-	0	0	60	2/2
tm3	-	0	0	60	2/2
<b>10930</b>	<b>INDEX_AX_POS_TAB_2</b>				
-	Indexing position table 2				RESET
N09					DOUBLE
ng2	60	0.0, 0.0, 0.0, 0.0....	-	-	2/2
ng3	60	0.0, 0.0, 0.0, 0.0....	-	-	2/2
tm2	60	0.0, 0.0, 0.0, 0.0....	-	-	2/2
tm3	60	0.0, 0.0, 0.0, 0.0....	-	-	2/2
<b>11100</b>	<b>AUXFU_MAXNUM_GROUP_ASSIGN</b>				
-	Number of auxiliary functions in AuxF groups				POWER ON
N01, N07, N02					DWORD
Default	-	1	1	255	2/2
<b>11160</b>	<b>ACCESS_EXEC_CST</b>				
-	Right of execution for /_N_CST_DIR				POWER ON
N01					BYTE
Default	-	7	-	-	2/2
<b>11161</b>	<b>ACCESS_EXEC_CMA</b>				
-	Right of execution for /_N_CMA_DIR				POWER ON
N01					BYTE
Default	-	7	-	-	2/2
<b>11162</b>	<b>ACCESS_EXEC_CUS</b>				
-	Right of execution for /_N_CUS_DIR				POWER ON
N01					BYTE
Default	-	7	-	-	3/3
<b>11165</b>	<b>ACCESS_WRITE_CST</b>				
-	Write protection for /_N_CST_DIR				POWER ON
N01					DWORD
Default	-	-1	-	-	2/2
<b>11166</b>	<b>ACCESS_WRITE_CMA</b>				
-	Write protection for directory /_N_CMA_DIR				POWER ON
N01					DWORD
Default	-	-1	-	-	2/2
<b>11167</b>	<b>ACCESS_WRITE_CUS</b>				
-	Write protection for directory /_N_CUS_DIR				POWER ON
N01					DWORD
Default	-	-1	-	-	3/3
ng2	-	-1	-	-	2/2
ng3	-	-1	-	-	2/2
<b>11170</b>	<b>ACCESS_WRITE_SACCESS</b>				
-	Write protection for _N_SACCESS_DEF				POWER ON
N01					BYTE
Default	-	7	-	-	2/2
<b>11171</b>	<b>ACCESS_WRITE_MACCESS</b>				
-	Write protection for _N_MACCESS_DEF				POWER ON
N01					BYTE
Default	-	7	-	-	2/2

<b>11172</b>	<b>ACCESS_WRITE_UACCESS</b>			
-	Write protection for _N_UACCESS_DEF			POWER ON
N01			-	BYTE
Default	-	7	-	3/3
<b>11210</b>	<b>UPLOAD_MD_CHANGES_ONLY</b>			
-	MD backup only for changed MD			immediately
N01, N05			-	BYTE
Default	-	0x0F	-	2/2
<b>11240</b>	<b>PROFIBUS_SDB_NUMBER</b>			
-	SDB1000 number			POWER ON
N01, N05			-	DWORD
Default	4	0, -1, 0, -1	-1	7
<b>11250</b>	<b>PROFIBUS_SHUTDOWN_TYPE</b>			
-	Profibus Shutdown handling			POWER ON
EXP, N01			-	BYTE
Default	-	0	0	2
<b>11310</b>	<b>HANDWH_REVERSE</b>			
-	Threshold for handwheel direction reversal			POWER ON
N09			-	BYTE
Default	-	2	-	2/2
<b>11320</b>	<b>HANDWH_IMP_PER_LATCH</b>			
-	Handwheel pulses per locking position			POWER ON
N09			-	DOUBLE
Default	6	1., 1., 1., 1., 1., 1.	-	2/2
<b>11346</b>	<b>HANDWH_TRUE_DISTANCE</b>			
-	Handwheel travel or speed specification			POWER ON
N01			-	BYTE
Default	-	0	0	3
<b>11717</b>	<b>D_NO_FCT_CYCLE_NAME</b>			
-	Name of subroutine for D code substitution			POWER ON
EXP, N12, N07			-	STRING
Default	-1		-	2/2
<b>13060</b>	<b>DRIVE_TELEGRAM_TYPE</b>			
-	Default message frame type for Profibus DP			POWER ON
N04, N10			-	DWORD
Default	31	102, 102, 102...	-	2/2
<b>13070</b>	<b>DRIVE_FUNCTION_MASK</b>			
-	Used DP functions			POWER ON
N04, N10			-	DWORD
Default	6	2, 2, 2, 2, 2, 2	-	2/2
<b>13080</b>	<b>DRIVE_TYPE_DP</b>			
-	Drive type with Profibus			POWER ON
EXP			-	BYTE
Default	31	0, 0, 0...	0	4
<b>13120</b>	<b>CONTROL_UNIT_LOGIC_ADDRESS</b>			
-	SINAMICS-CU logic address			POWER ON
N04, N10			-	DWORD
Default	7	6500	0	8191
<b>13200</b>	<b>MEAS_PROBE_LOW_ACTIVE</b>			
-	Polarity change of the probe			POWER ON
N10, N09			-	BOOLEAN
Default	2	FALSE, FALSE	-	3/3

## 2.2 General machine data

<b>13220</b>	<b>MEAS_PROBE_DELAY_TIME</b>				
s	Detection of probe deflection delay time				POWER ON
N10, N09					DOUBLE
Default	2	0.0, 0.0	0	0.1	3/3
<b>14510</b>	<b>USER_DATA_INT</b>				
-	User data (INT)				POWER ON
N03					DWORD
Default	32	0, 0, 0...	-32768	32767	7/3
<b>14512</b>	<b>USER_DATA_HEX</b>				
-	User data (HEX)				POWER ON
N03					DWORD
Default	32	0, 0, 0...	0	0x0FF	7/3
<b>14514</b>	<b>USER_DATA_FLOAT</b>				
-	User data (FLOAT)				POWER ON
N03					DOUBLE
Default	8	0.0, 0.0, 0.0, 0.0, 0.0, 0.0, 0.0, 0.0	-3.40e38	3.40e38	7/3
<b>11516</b>	<b>USER_DATA_PLC_ALARM</b>				
-	User data (HEX)				POWER ON
N03					BYTE
Default	64	0, 0, 0...	-	-	7/3
<b>15700</b>	<b>LANG_SUB_NAME</b>				
-	Name of subroutine for substitution				POWER ON
N01					STRING
Default	-1		-	-	2/2
<b>15702</b>	<b>LANG_SUB_PATH</b>				
-	Path of subroutine for substitution				POWER ON
N01					BYTE
Default	-	0	0	2	2/2
<b>17400</b>	<b>OEM_GLOBAL_INFO</b>				
-	OEM version info				POWER ON
-					STRING
Default	5		-	-	2/2
<b>17530</b>	<b>TOOL_DATA_CHANGE_COUNTER</b>				
-	Mark tool data change for HMI				POWER ON
EXP, N01					DWORD
Default	-	0	0	0xF	2/2
<b>18030</b>	<b>HW_SERIAL_NUMBER</b>				
-	to be defined				POWER ON
N05					STRING
Default	1		-	-	2/2
<b>18040</b>	<b>VERSION_INFO</b>				
-	Version and (if necessary) date of PCMCIA card				POWER ON
N05					STRING
ng2	4	"802D sl-NG2"	-	-	2/2
ng3	4	"802D sl-NG3"	-	-	2/2
tm1	4	"802D sl-TM1"	-	-	2/2
tm2	4	"802D sl-TM2"	-	-	2/2
tm3	4	"802D sl-TM3"	-	-	2/2

<b>18080</b>	<b>MM_TOOL_MANAGEMENT_MASK</b>				
-	Reserved memory for the tool management (SRAM)				POWER ON
N02, N09					DWORD
ng2	-	0x0	0	0xFFFF	2/2
ng3	-	0x0	0	0xFFFF	2/2
tm2	-	0x0	0	0xFFFF	2/2
tm3	-	0x0	0	0xFFFF	2/2
<b>18102</b>	<b>MM_TYPE_OF_CUTTING_EDGE</b>				
-	Type of D number programming (SRAM)				POWER ON
N02, N09					DWORD
Default	-	0	0	1	2/2
<b>18120</b>	<b>MM_NUM_GUD_NAMES_NCK</b>				
-	Number of global GUD definitions (SRAM)				POWER ON
N02					DWORD
Default	-	50	-	-	2/2
<b>18130</b>	<b>MM_NUM_GUD_NAMES_CHAN</b>				
-	Number of channel GUD definitions (SRAM)				POWER ON
N02					DWORD
Default	-	150	-	-	2/2
<b>18150</b>	<b>MM_GUD_VALUES_MEM</b>				
-	Memory space for GUD values (SRAM)				POWER ON
N02					DWORD
Default	-	32	-	-	2/2

## 2.3 Channel-specific machine data

MD number	MD identifier				
Unit	Brief description				Activation
Display filter					Data type
System	Dimension	Default value	Minimum value	Maximum value	Protection

### Note regarding the value definition:

TRUE corresponds to 1

FALSE corresponds to 0

20050	AXCONF_GEOAX_ASSIGN_TAB				
-	Assignment 'geometry/channel axis'				POWER ON
C01, C10					BYTE
Default	3	1, 2, 3	0	6	2/2
ng2	3	1, 0, 2	0	6	2/2
ng3	3	1, 0, 2	0	6	2/2

20070	AXCONF_MACHAX_USED				
-	Machine axis number valid in channel				POWER ON
C01, C10					BYTE
Default	6	1, 2, 3, 4, 5, 0	0	6	2/2
tm1	4	1, 2, 3, 4	0	6	2/2

20080	AXCONF_CHANAX_NAME_TAB				
-	Name of channel axis in the channel				POWER ON
C01, C11, C10					STRING
Default	6	"X", "Y", "Z", "SP", "A", "PLCX"	-	-	2/2
ng2	6	"X", "Z", "C", "A", "B", "PLCX"	-	-	2/2
ng3	6	"X", "Z", "C", "A", "B", "PLCX"	-	-	2/2
tm1	4	"X", "Y", "Z", "SP"	-	-	2/2

20090	SPIND_DEF_MASTER_SPIND				
-	Number of master spindle				POWER ON
C01, C03					BYTE
tm2	-	1	1	2	2/2
tm3	-	1	1	2	2/2

20094	SPIND_RIGID_TAPPING_M_NR				
-	M function for axis mode (Siemens mode)				POWER ON
C01, C03, C10					DWORD
tm2	-	70	-	-	2/2
tm3	-	70	-	-	2/2

20095	EXTERN_RIGID_TAPPING_M_NR				
-	M function for axis mode (external mode)				POWER ON
C01, C11, C03, C10					DWORD
tm2	-	29	-	-	2/2
tm3	-	29	-	-	2/2

20106	PROG_EVENT_IGN_SINGLEBLOCK				
-	Prog events ignore single block				POWER ON
N01					DWORD
Default	-	0x0	0	0x1F	2/2

20107	PROG_EVENT_IGN_INHIBIT				
-	Prog events ignore read-in disable				POWER ON
N01					DWORD
Default	-	0x0	0	0x1F	2/2

<b>20108</b>	<b>PROG_EVENT_MASK</b>				
-	Event-controlled program calls				POWER ON
N01					DWORD
Default	-	0x0	0	0xF	7/2
<b>20140</b>	<b>TRAFO_RESET_VALUE</b>				
-	Active transformation in case of RESET				RESET
C03					BYTE
ng2	-	0	0	8	2/2
ng3	-	0	0	8	2/2
tm2	-	0	0	8	2/2
tm3	-	0	0	8	2/2
<b>20172</b>	<b>COMPRESS_VELO_TOL</b>				
mm/min	Max. permissible deviation of path feedrate during compression				POWER ON
C09					DOUBLE
tm3	-	60000.0	-	-	2/2
<b>20204</b>	<b>WAB_CLEARANCE_TOLERANCE</b>				
mm	Direction reversal with SAR				POWER ON
C06					DOUBLE
Default	-	0.01	-	-	2/2
<b>20310</b>	<b>TOOL_MANAGEMENT_MASK</b>				
-	Activate tool management functions				POWER ON
C09					DWORD
ng2	-	0x0	0	0xFFFFFFFF	2/2
ng3	-	0x0	0	0xFFFFFFFF	2/2
tm2	-	0x0	0	0xFFFFFFFF	2/2
tm3	-	0x0	0	0xFFFFFFFF	2/2
<b>20320</b>	<b>TOOL_TIME_MONITOR_MASK</b>				
-	Time monitoring for the tool in the toolholder				POWER ON
C06, C09					DWORD
Default	-	0x1	-	-	2/2
tm1	-	0x0	-	-	2/2
<b>20360</b>	<b>TOOL_PARAMETER_DEF_MASK</b>				
-	Definition of the tool parameters				POWER ON
C09					DWORD
Default	-	0x0	0	0xFFFF	2/2
<b>20450</b>	<b>LOOKAH_RELIEVE_BLOCK_CYCLE</b>				
-	Block cycle time relief factor				POWER ON
EXP, C05					DOUBLE
Default	-	0.0	-	-	2/2
<b>20460</b>	<b>LOOKAH_SMOOTH_FACTOR</b>				
%	Smoothing factor for Look Ahead				NEW CONF
EXP, C05					DOUBLE
Default	-	0.0	0.	500.0	2/2
<b>20500</b>	<b>CONST_VELO_MIN_TIME</b>				
s	Minimum time with constant velocity				POWER ON
EXP, C05					DOUBLE
Default	-	0.0	0.0	0.1	2/2
<b>20550</b>	<b>EXACT_POS_MODE</b>				
-	Exact stop conditions with G00 and G01				NEW CONF
EXP					BYTE
Default	-	0	0	33	2/2

## 2.3 Channel-specific machine data

<b>20552</b>	<b>EXACT_POS_MODE_G0_TO_G1</b>				
-	Exact stop conditions with the transition G00→G01				NEW CONF
EXP					BYTE
Default	-	0	0	5	2/2
<b>20610</b>	<b>ADD_MOVE_ACCEL_RESERVE</b>				
-	Acceleration margin for overlaid movements				POWER ON
C05					DOUBLE
ng2	-	.2	0.	0.9	2/2
ng3	-	.2	0.	0.9	2/2
<b>20624</b>	<b>HANDWH_CHAN_STOP_COND</b>				
-	Def. of response of handwheel travel to channel-specific VDI ISs				POWER ON
EXP, C09					DWORD
ng3	-	0x13FF	0	0xFFFF	2/2
<b>20700</b>	<b>REFP_NC_START_LOCK</b>				
-	NC start disable without reference point				RESET
C01, C03					BOOLEAN
Default	-	TRUE	-	-	2/2
<b>20730</b>	<b>G0_LINEAR_MODE</b>				
-	Interpolation behavior with G0				POWER ON
C09					BOOLEAN
Default	-	TRUE	-	-	2/2
<b>20732</b>	<b>EXTERN_G0_LINEAR_MODE</b>				
-	Interpolation behavior with G00				POWER ON
N12					BOOLEAN
tm1	-	TRUE	-	-	2/2
tm2	-	TRUE	-	-	2/2
tm3	-	TRUE	-	-	2/2
<b>20734</b>	<b>EXTERN_FUNCTION_MASK</b>				
-	Function mask for external language				RESET
N12					DWORD
tm1	-	0	0	0xFFFF	2/2
tm2	-	0	0	0xFFFF	2/2
tm3	-	0	0	0xFFFF	2/2
<b>21000</b>	<b>CIRCLE_ERROR_CONST</b>				
mm	Circle end point monitoring constant				POWER ON
C06					DOUBLE
Default	-	0.01	-	-	2/2
<b>21010</b>	<b>CIRCLE_ERROR_FACTOR</b>				
-	Circle end point monitoring factor				POWER ON
C06					DOUBLE
Default	-	0.001	-	-	2/2
<b>21020</b>	<b>WORKAREA_WITH_TOOL_RADIUS</b>				
-	Tool radius with working area limitation				RESET
C03, C06					BOOLEAN
Default	-	FALSE	-	-	2/2
<b>21190</b>	<b>TOFF_MODE</b>				
-	Mode of correction in tool direction				RESET
C03, C06					BYTE
ng3	-	0	-	-	2/2
<b>21194</b>	<b>TOFF_VELO</b>				
mm/min	Feedrate for online correction in tool dir.				NEW CONF
C08					DOUBLE
ng3	3	0., 0., 0.	-	-	2/2



## 2.3 Channel-specific machine data

<b>22254</b>	<b>AUXFU_ASSOC_M0_VALUE</b>				
-	Additional M functions for program stop				POWER ON
C01, C03, C10				-	DWORD
Default	-	-1	-	-	2/2
<b>22256</b>	<b>AUXFU_ASSOC_M1_VALUE</b>				
-	Additional M functions for conditional stop				POWER ON
C01, C03, C10				-	DWORD
Default	-	-1	-	-	2/2
<b>22400</b>	<b>S_VALUES_ACTIVE_AFTER_RESET</b>				
-	S function active even after RESET				POWER ON
C04, C03, C05				-	BOOLEAN
Default	-	FALSE	-	-	2/2
<b>22410</b>	<b>F_VALUES_ACTIVE_AFTER_RESET</b>				
-	F function active even after RESET				POWER ON
C04, C03, C05				-	BOOLEAN
Default	-	FALSE	-	-	2/2
<b>22534</b>	<b>TRAFO_CHANGE_M_CODE</b>				
-	M code when switching the transformation type				POWER ON
C04				-	DWORD
Default	-	0	0	99999999	2/2
<b>22550</b>	<b>TOOL_CHANGE_MODE</b>				
-	New tool offset with T or M function				POWER ON
C01, C11, C04, C09				-	BYTE
Default	-	0	0	1	2/2
<b>22910</b>	<b>WEIGHTING_FACTOR_FOR_SCALE</b>				
-	Input resolution for scaling factor				POWER ON
EXP, C01, C11				-	BOOLEAN
tm1	-	FALSE	-	-	2/2
tm2	-	FALSE	-	-	2/2
tm3	-	FALSE	-	-	2/2
<b>22914</b>	<b>AXES_SCALE_ENABLE</b>				
-	Activation for axial scaling factor G51				POWER ON
EXP, C01, C11				-	BOOLEAN
tm1	-	FALSE	-	-	2/2
tm2	-	FALSE	-	-	2/2
tm3	-	FALSE	-	-	2/2
<b>22920</b>	<b>EXTERN_FIXED_FEEDRATE_F1_ON</b>				
-	Activate fixed feedrate F1 - F9				POWER ON
EXP, C01, C11				-	BOOLEAN
tm1	-	FALSE	-	-	2/2
tm2	-	FALSE	-	-	2/2
tm3	-	FALSE	-	-	2/2
<b>22930</b>	<b>EXTERN_PARALLEL_GEOAX</b>				
-	Assignment of parallel channel geometry axis				POWER ON
EXP, C01, C11				-	BYTE
tm1	3	0	0	6	2/2
tm2	3	0	0	6	2/2
tm3	3	0	0	6	2/2
<b>24020</b>	<b>FRAME_SUPPRESS_MODE</b>				
-	Positions with frame suppression				POWER ON
C03				-	DWORD
Default	-	0x0	0	0x0000003	2/2

## 2.3 Channel-specific machine data

24100	TRAFO_TYPE_1				
-	Transformation 1 in the channel				NEW CONF
C07					DWORD
ng2	-	0	-	-	2/2
ng3	-	0	-	-	2/2
tm2	-	0	-	-	2/2
tm3	-	0	-	-	2/2

24110	TRAFO_AXES_IN_1				
-	Axis assignment for transformation 1				NEW CONF
C07					BYTE
ng2	6	1, 2, 3, 4, 5, 0	0	6	2/2
ng3	6	1, 2, 3, 4, 5, 0	0	6	2/2
tm2	6	1, 2, 3, 4, 5, 0	0	6	2/2
tm3	6	1, 2, 3, 4, 5, 0	0	6	2/2

24120	TRAFO_GEOAX_ASSIGN_TAB_1				
-	GEO/channel axis assignment for transformation 1				NEW CONF
C07					BYTE
ng2	3	0	0	6	2/2
ng3	3	0	0	6	2/2
tm2	3	0	0	6	2/2
tm3	3	0	0	6	2/2

24130	TRAFO_INCLUDES_TOOL_1				
-	Tool handling with active 1st transformation				NEW CONF
C07					BOOLEAN
ng2	-	TRUE	-	-	2/2
ng3	-	TRUE	-	-	2/2
tm2	-	TRUE	-	-	2/2
tm3	-	TRUE	-	-	2/2

24200	TRAFO_TYPE_2				
-	Transformation 2 in the channel				NEW CONF
C07					DWORD
ng2	-	0	-	-	2/2
ng3	-	0	-	-	2/2
tm2	-	0	-	-	2/2
tm3	-	0	-	-	2/2

24210	TRAFO_AXES_IN_2				
-	Axis assignment for transformation 2				NEW CONF
C07					BYTE
ng2	6	1, 2, 3, 4, 5, 0	0	6	2/2
ng3	6	1, 2, 3, 4, 5, 0	0	6	2/2
tm2	6	1, 2, 3, 4, 5, 0	0	6	2/2
tm3	6	1, 2, 3, 4, 5, 0	0	6	2/2

24220	TRAFO_GEOAX_ASSIGN_TAB_2				
-	GEO/channel axis assignment for transformation 2				NEW CONF
C07					BYTE
ng2	3	0, 0, 0	0	6	2/2
ng3	3	0, 0, 0	0	6	2/2
tm2	3	0, 0, 0	0	6	2/2
tm3	3	0, 0, 0	0	6	2/2

24230	TRAFO_INCLUDES_TOOL_2				
-	Tool handling with active 2nd transformation				NEW CONF
C07					BOOLEAN
ng2	-	TRUE	-	-	2/2
ng3	-	TRUE	-	-	2/2
tm2	-	TRUE	-	-	2/2
tm3	-	TRUE	-	-	2/2

## 2.3 Channel-specific machine data

<b>24700</b>	<b>TRAANG_ANGLE_1</b>				
degrees	Angle between Cartesian axis and real (inclined) axis				NEW CONF
C07					DOUBLE
ng2	-	0.0	-	-	2/2
ng3	-	0.0	-	-	2/2
<b>24710</b>	<b>TRAANG_BASE_TOOL_1</b>				
mm	Vector of base tool for 1st TRAANG transformation				NEW CONF
C07					DOUBLE
ng2	3	0.0, 0.0, 0.0	-	-	2/2
ng3	3	0.0, 0.0, 0.0	-	-	2/2
<b>24720</b>	<b>TRAANG_PARALLEL_VELO_RES_1</b>				
-	Velocity margin of parallel axis for the 1st TRAANG transf.				NEW CONF
C07					DOUBLE
ng2	-	0.0	0.0	1.0	2/2
ng3	-	0.0	0.0	1.0	2/2
<b>24721</b>	<b>TRAANG_PARALLEL_ACCEL_RES_1</b>				
-	Acceleration margin of parallel axis for the 1st TRAANG transf.				NEW CONF
C07					DOUBLE
ng2	-	0.0	0.0	1.0	2/2
ng3	-	0.0	0.0	1.0	2/2
<b>24750</b>	<b>TRAANG_ANGLE_2</b>				
degrees	Angle between Cartesian axis and real (inclined) axis				NEW CONF
C07					DOUBLE
ng2	-	0.0	-	-	2/2
ng3	-	0.0	-	-	2/2
<b>24760</b>	<b>TRAANG_BASE_TOOL_2</b>				
mm	Vector of base tool for 2nd TRAANG transformation				NEW CONF
C07					DOUBLE
ng2	3	0.0, 0.0, 0.0	-	-	2/2
ng3	3	0.0, 0.0, 0.0	-	-	2/2
<b>24770</b>	<b>TRAANG_PARALLEL_VELO_RES_2</b>				
-	Velocity margin of parallel axis for the 2nd TRAANG transform.				NEW CONF
C07					DOUBLE
ng2	-	0.0	0.0	1.0	2/2
ng3	-	0.0	0.0	1.0	2/2
<b>24771</b>	<b>TRAANG_PARALLEL_ACCEL_RES_2</b>				
-	Acceler. margin of parallel axis for the 2nd TRAANG transform.				NEW CONF
C07					DOUBLE
ng2	-	0.0	0.0	1.0	2/2
ng3	-	0.0	0.0	1.0	2/2
<b>24800</b>	<b>TRACYL_ROT_AX_OFFSET_1</b>				
degrees	Rotary axis offset TRACYL 1				NEW CONF
C07					DOUBLE
tm2	-	0.0	-	-	2/2
tm3	-	0.0	-	-	2/2
<b>24805</b>	<b>TRACYL_ROT_AX_FRAME_1</b>				
-	Rotary axis offset TRACYL 1				NEW CONF
C07					BYTE
tm2	-	0	0	2	2/2
tm3	-	0	0	2	2/2

<b>24808</b>	<b>TRACYL_DEFAULT_MODE_1</b>				
-	Selection of the TRACYL mode				NEW CONF
C07					BYTE
tm2	-	0	0	1	2/2
tm3	-	0	0	1	2/2
<b>24810</b>	<b>TRACYL_ROT_SIGN_IS_PLUS_1</b>				
-	Sign of the rotary axis				NEW CONF
C07					BOOLEAN
tm2	-	TRUE	-	-	2/2
tm3	-	TRUE	-	-	2/2
<b>24820</b>	<b>TRACYL_BASE_TOOL_1</b>				
mm	Base tool vector				NEW CONF
C07					DOUBLE
tm2	3	0.0, 0.0, 0.0	-	-	2/2
tm3	3	0.0, 0.0, 0.0	-	-	2/2
<b>24850</b>	<b>TRACYL_ROT_AX_OFFSET_2</b>				
degrees	Rotary axis offset TRACYL 2				NEW CONF
C07					DOUBLE
tm2	-	0.0	-	-	2/2
tm3	-	0.0	-	-	2/2
<b>24855</b>	<b>TRACYL_ROT_AX_FRAME_2</b>				
-	Rotary axis offset TRACYL 2				NEW CONF
C07					BYTE
tm2	-	0	0	2	2/2
tm3	-	0	0	2	2/2
<b>24858</b>	<b>TRACYL_DEFAULT_MODE_2</b>				
-	Selection of the TRACYL mode				NEW CONF
C07					BYTE
tm2	-	0	0	1	2/2
tm3	-	0	0	1	2/2
<b>24860</b>	<b>TRACYL_ROT_SIGN_IS_PLUS_2</b>				
-	Sign of the rotary axis				NEW CONF
C07					BOOLEAN
tm2	-	TRUE	-	-	2/2
tm3	-	TRUE	-	-	2/2
<b>24870</b>	<b>TRACYL_BASE_TOOL_2</b>				
mm	Base tool vector				NEW CONF
C07					DOUBLE
tm2	3	0.0, 0.0, 0.0	-	-	2/2
tm3	3	0.0, 0.0, 0.0	-	-	2/2
<b>24900</b>	<b>TRANSMIT_ROT_AX_OFFSET_1</b>				
degrees	Rotary axis offset TRANSMIT 1				NEW CONF
C07					DOUBLE
tm2	-	0.0	-	-	2/2
tm3	-	0.0	-	-	2/2
<b>24905</b>	<b>TRANSMIT_ROT_AX_FRAME_1</b>				
-	Rotary axis offset TRANSMIT 1				NEW CONF
C07					BYTE
tm2	-	0	0	2	2/2
tm3	-	0	0	2	2/2

## 2.3 Channel-specific machine data

<b>24910</b>	<b>TRANSMIT_ROT_SIGN_IS_PLUS_1</b>				
-	Sign of the rotary axis				NEW CONF
C07					BOOLEAN
tm2	-	TRUE	-	-	2/2
tm3	-	TRUE	-	-	2/2
<b>24911</b>	<b>TRANSMIT_POLE_SIDE_FIX_1</b>				
-	Limiting of working area in front of / after the pole				NEW CONF
C07					BYTE
tm2	-	0	0	2	2/2
tm3	-	0	0	2	2/2
<b>24920</b>	<b>TRANSMIT_BASE_TOOL_1</b>				
mm	Base tool vector				NEW CONF
C07					DOUBLE
tm2	3	0.0, 0.0, 0.0	-	-	2/2
tm3	3	0.0, 0.0, 0.0	-	-	2/2
<b>24950</b>	<b>TRANSMIT_ROT_AX_OFFSET_2</b>				
degrees	Rotary axis offset TRANSMIT 2				NEW CONF
C07					DOUBLE
tm2	-	0.0	-	-	2/2
tm3	-	0.0	-	-	2/2
<b>24955</b>	<b>TRANSMIT_ROT_AX_FRAME_2</b>				
-	Rotary axis offset TRANSMIT 2				NEW CONF
C07					BYTE
tm2	-	0	0	2	2/2
tm3	-	0	0	2	2/2
<b>24960</b>	<b>TRANSMIT_ROT_SIGN_IS_PLUS_2</b>				
-	Sign of the rotary axis				NEW CONF
C07					BOOLEAN
tm2	-	TRUE	-	-	2/2
tm3	-	TRUE	-	-	2/2
<b>24961</b>	<b>TRANSMIT_POLE_SIDE_FIX_2</b>				
-	Limitation of the working area in front of/after the pole				NEW CONF
C07					BYTE
tm2	-	0	0	2	2/2
tm3	-	0	0	2	2/2
<b>24970</b>	<b>TRANSMIT_BASE_TOOL_2</b>				
mm	Base tool vector				NEW CONF
C07					DOUBLE
tm2	3	0.0, 0.0, 0.0	-	-	2/2
tm3	3	0.0, 0.0, 0.0	-	-	2/2
<b>26000</b>	<b>PUNCHNIB_ASSIGN_FASTIN</b>				
-	Hardware assignment for input byte for stroke control				POWER ON
C01, C09					DWORD
ng2	-	0	-	-	2/2
ng3	-	0	-	-	2/2
<b>26002</b>	<b>PUNCHNIB_ASSIGN_FASTOUT</b>				
-	Hardware assignment for output byte for stroke control				POWER ON
C01, C09					DWORD
ng2	-	0	-	-	2/2
ng3	-	0	-	-	2/2

<b>26004</b>	<b>NIBBLE_PUNCH_OUTMASK</b>				
-	Screenform for fast output bits				POWER ON
C01, C09			-		BYTE
ng2	8	1, 0, 0, 0, 0, 0, 0, 0	-	-	2/2
ng3	8	1, 0, 0, 0, 0, 0, 0, 0	-	-	2/2
<b>26006</b>	<b>NIBBLE_PUNCH_INMASK</b>				
-	Screenform for fast input bits				POWER ON
C01, C09			-		BYTE
ng2	8	1, 0, 0, 0, 0, 0, 0, 0	-	-	2/2
ng3	8	1, 0, 0, 0, 0, 0, 0, 0	-	-	2/2
<b>26008</b>	<b>NIBBLE_PUNCH_CODE</b>				
-	Definition of M functions				POWER ON
C09			-		DWORD
ng2	8	0, 23, 22, 25, 26, 0, 0, 0	-	-	2/2
ng3	8	0, 23, 22, 25, 26, 0, 0, 0	-	-	2/2
<b>26010</b>	<b>PUNCHNIB_AXIS_MASK</b>				
-	Definition of punching and nibbling axes				POWER ON
C09			-		DWORD
ng2	-	7, 0, 0...	-	-	2/2
ng3	-	7, 0, 0...	-	-	2/2
<b>26012</b>	<b>PUNCHNIB_ACTIVATION</b>				
-	Activation of punching and nibbling functions				POWER ON
C09			-		DWORD
ng2	-	0	-	-	2/2
ng3	-	0	-	-	2/2
<b>26014</b>	<b>PUNCH_PATH_SPLITTING</b>				
-	Activation of automatic path segmentation				POWER ON
C09			-		DWORD
ng2	-	2	-	-	2/2
ng3	-	2	-	-	2/2
<b>26016</b>	<b>PUNCH_PARTITION_TYPE</b>				
-	Behavior of individual axes with automatic path segmentation				POWER ON
C09			-		DOUBLE
ng2	-	0.	-	-	2/2
ng3	-	0.	-	-	2/2
<b>26018</b>	<b>NIBBLE_PRE_START_TIME</b>				
s	Delay time for nibbling/punching with G603				POWER ON
C09			-		DWORD
ng2	-	0, 0, 0...	-	-	2/2
ng3	-	0, 0, 0...	-	-	2/2
<b>26020</b>	<b>NIBBLE_SIGNAL_CHECK</b>				
-	Alarm on chattering punching signal				POWER ON
C09			-		DWORD
ng2	-	0	-	-	2/2
ng3	-	0	-	-	2/2
<b>27100</b>	<b>ABSBLOCK_FUNCTION_MASK</b>				
-	Block display parameterized with absolute values				POWER ON
N01			-		DWORD
ng2	-	0x0	0	0x1	2/2
ng3	-	0x0	0	0x1	2/2
tm2	-	0x0	0	0x1	2/2
tm3	-	0x0	0	0x1	2/2

## 2.3 Channel-specific machine data

27400 OEM_CHAN_INFO					
-	OEM version info				POWER ON
-					STRING
Default	3	'''' '''' ''''	-	-	2/2
27800 TECHNOLOGY_MODE					
-	Technology in the channel				NEW CONF
C09					BYTE
Default	-	0	-	-	2/2
ng2	-	21	-	-	2/2
ng3	-	21	-	-	2/2
27860 PROCESSTIMER_MODE					
-	Activating the program runtime measurement				RESET
C09					DWORD
ng2	-	0x07	0	0x0FF	2/2
ng3	-	0x07	0	0x0FF	2/2
tm2	-	0x07	0	0x0FF	2/2
tm3	-	0x07	0	0x0FF	2/2
27880 PART_COUNTER					
-	Activate workpiece counter				RESET
C09					DWORD
ng2	-	0x0	0	0x0FFFF	3/2
ng3	-	0x0	0	0x0FFFF	3/2
tm2	-	0x0	0	0x0FFFF	3/2
tm3	-	0x0	0	0x0FFFF	3/2
27882 PART_COUNTER_MCODE					
-	Workpiece counting using a user-defined M command				POWER ON
C09					BYTE
ng2	3	2, 2, 2	0	99	3/2
ng3	3	2, 2, 2	0	99	3/2
tm2	3	2, 2, 2	0	99	3/2
tm3	3	2, 2, 2	0	99	3/2
28400 MM_ABSBLOCK					
-	Activate block display with absolute values				POWER ON
EXP, C02					DWORD
Default	-	0, 0, 0, 0 ...	-	-	2/2
28402 MM_ABSBLOCK_BUFFER_CONF					
-	Dimension size of upload buffer				POWER ON
EXP, C02					DWORD
Default	2	0, 0 ...	-	-	2/2

## 2.4 Axis-specific machine data

MD number	MD identifier				
Unit	Brief description				Activation
Display filter				Attributes	Data type
System *	Dimension	Default value	Minimum value	Maximum value	Protection

\* Values other than those in the standard system

### Note regarding the value definition:

TRUE corresponds to 1

FALSE corresponds to 0

30100	CTRLOUT_SEGMENT_NR				
-	Setpoint assignment: bus segment number				POWER ON
EXP, -				-	BYTE
Default	1	5	0	5	2/2

30110	CTRLOUT_MODULE_NR				
-	Setpoint: Drive no./module no.				POWER ON
- , -				-	BYTE
Default	1	1, 2, 3, 4, 5, 6, 7, 8, 9, 10, 11, 12, 13, 14, 15, 16, 17, 18, 19, 20, 21, 22, 23, 24, 25, 26, 27, 28, 29, 30, 31	1	31	2/2
tm1	1	2, 3, 4, 1, 5, 6, 7, 8, 9, 10, 11, 12, 13, 14, 15, 16, 17, 18, 19, 20, 21, 22, 23, 24, 25, 26, 27, 28, 29, 30, 31	1	31	2/2
tm2	1	2, 3, 4, 1, 5, 6, 7, 8, 9, 10, 11, 12, 13, 14, 15, 16, 17, 18, 19, 20, 21, 22, 23, 24, 25, 26, 27, 28, 29, 30, 31	1	31	2/2
tm3	1	2, 3, 4, 1, 5, 6, 7, 8, 9, 10, 11, 12, 13, 14, 15, 16, 17, 18, 19, 20, 21, 22, 23, 24, 25, 26, 27, 28, 29, 30, 31	1	31	2/2

30120	CTRLOUT_NR				
-	Setpoint: Output to module				POWER ON
EXP, -				-	BYTE
Default	1	1	1	3	2/2

30130	CTRLOUT_TYPE				
-	Setpoint output type				POWER ON
- , -				-	BYTE
Default	1	0	0	3	2/2

30134	IS_UNIPOLAR_OUTPUT				
-	Setpoint output is unipolar				POWER ON
-				-	BYTE
Default	1	0	0	2	2/2

30200	NUM_ENCS				
-	Number of encoders				POWER ON
- , -				-	BYTE
Default	-	1	0	1	2/2

## 2.4 Axis-specific machine data

<b>30220</b>	<b>ENC_MODULE_NR</b>				
-	Actual value: Drive no./measuring circuit no.				POWER ON
-,-,-					BYTE
ng2	1	1, 2, 3, 4, 5, 6	1	31	7/2
ng3	1	1, 2, 3, 4, 5, 6	1	31	7/2
tm1	1	2, 3, 4, 1	1	31	7/2
tm2	1	2, 3, 4, 1, 5, 6	1	31	7/2
tm3	1	2, 3, 4, 1, 5, 6	1	31	7/2
<b>30230</b>	<b>ENC_INPUT_NR</b>				
-	Actual value: Input number on module/measuring circuit board				POWER ON
-,-,-					BYTE
Default	1	1	1	2	2/2
<b>30240</b>	<b>ENC_TYPE</b>				
-	Actual value: Encoder type				POWER ON
-,-,-					BYTE
Default	1	0	0	5	2/2
<b>30270</b>	<b>ENC_ABS_BUFFERING</b>				
-	Absolute encoder: Traversing range extension				POWER ON
EXP,-,-					BYTE
Default	1	0	0	1	2/2
<b>30300</b>	<b>IS_ROT_AX</b>				
-	Rotary axis/spindle				POWER ON
-,-,-					SCAL, CTEQ
Default	-	FALSE	-	-	2/2
<b>30310</b>	<b>ROT_IS_MODULO</b>				
-	Modulo conversion for rotary axis/spindle				POWER ON
-,-,-					CTEQ
Default	-	FALSE	-	-	2/2
<b>30320</b>	<b>DISPLAY_IS_MODULO</b>				
-	Display modulo 360 degrees for rotary axis				POWER ON
-,-,-					CTEQ
Default	-	FALSE	-	-	2/2
<b>30350</b>	<b>SIMU_AX_VDI_OUTPUT</b>				
-	Axis signals for simulation axis				POWER ON
-,-					CTEQ
Default	-	FALSE	-	-	2/2
<b>30465</b>	<b>AXIS_LANG_SUB_MASK</b>				
-	Substitution of NC language commands				POWER ON
N01					DWORD
Default	-	0	0	3	2/2
<b>30500</b>	<b>INDEX_AX_ASSIGN_POS_TAB</b>				
-	Axis is indexing axis				RESET
-,-					BYTE
ng2	-	0	0	3	2/2
ng3	-	0	0	3	2/2
tm2	-	0	0	3	2/2
tm3	-	0	0	3	2/2
<b>30600</b>	<b>FIX_POINT_POS</b>				
mm, degrees	Axis position with G75				POWER ON
-,-					DOUBLE
Default	2	0.0, 0.0	-	-	2/2

<b>31000</b>	<b>ENC_IS_LINEAR</b>				
-	Linear scale				POWER ON
-,-					BOOLEAN
Default	1	FALSE	-	-	2/2
<b>31010</b>	<b>ENC_GRID_POINT_DIST</b>				
mm	Scale division with linear scales				POWER ON
-,-					DOUBLE
Default	1	0.01	-	-	2/2
<b>31020</b>	<b>ENC_RESOL</b>				
-	Encoder lines per revolution				POWER ON
-,-					DWORD
Default	1	2048	-	-	2/2
<b>31030</b>	<b>LEADSCREW_PITCH</b>				
mm	Lead of the ballscrew				POWER ON
-,-					DOUBLE
Default	-	10.0	-	-	2/2
<b>31040</b>	<b>ENC_IS_DIRECT</b>				
-	Encoder mounted directly on the machine				POWER ON
-,-					BOOLEAN
Default	1	FALSE	-	-	2/2
<b>31044</b>	<b>ENC_IS_DIRECT2</b>				
-	Encoders installed at the attached gearbox				NEW CONF
-					BOOLEAN
Default	1	FALSE	-	-	2/2
<b>31050</b>	<b>DRIVE_AX_RATIO_DENOM</b>				
-	Load gearbox denominator				POWER ON
-,-					DWORD
Default	6	1, 1, 1, 1, 1, 1	1	2147000000	2/2
<b>31060</b>	<b>DRIVE_AX_RATIO_NUMERA</b>				
-	Load gearbox numerator				POWER ON
-,-					DWORD
Default	6	1, 1, 1, 1, 1, 1	-2147000000	2147000000	2/2
<b>31064</b>	<b>DRIVE_AX_RATIO2_DENOM</b>				
-	Denominator of attached gearbox				NEW CONF
-					DWORD
Default	-	1	1	2147000000	2/2
<b>31066</b>	<b>DRIVE_AX_RATIO2_NUMERA</b>				
-	Numerator of attached gearbox				NEW CONF
-					DWORD
Default	-	1	-2147000000	2147000000	2/2
<b>31070</b>	<b>DRIVE_ENC_RATIO_DENOM</b>				
-	Measuring gearbox denominator				POWER ON
-,-					DWORD
Default	1	1	1	2147000000	2/2
<b>31080</b>	<b>DRIVE_ENC_RATIO_NUMERA</b>				
-	Measuring gearbox numerator				POWER ON
-,-					DWORD
Default	1	1	1	2147000000	2/2
<b>31122</b>	<b>BERO_DELAY_TIME_PLUS</b>				
s	BERO delay time				NEW CONF
-,-					DOUBLE
Default	1	0.000110	-	-	2/2

## 2.4 Axis-specific machine data

<b>31123</b>	<b>BERO_DELAY_TIME_MINUS</b>				
s	BERO delay time				NEW CONF
- , -					DOUBLE
Default	1	0.000078	-	-	2/2
<b>32000</b>	<b>MAX_AX_VELO</b>				
mm/min, rev/min	Maximum axis velocity				NEW CONF
- , -					CTEQ
Default	-	10000.	1.e <sup>-9</sup>	-	7/2
<b>32010</b>	<b>JOG_VELO_RAPID</b>				
mm/min, rev/min	Rapid traverse in the JOG mode				RESET
- , -					CTEQ
Default	-	10000.	-	-	7/2
<b>32020</b>	<b>JOG_VELO</b>				
mm/min, rev/min	JOG axis velocity				RESET
- , -					CTEQ
Default	-	2000.	-	-	7/2
<b>32100</b>	<b>AX_MOTION_DIR</b>				
-	Traversing direction (not control direction)				POWER ON
- , - , -					DWORD
ng2	-	1	-1	1	2/2
tm1	-	1	-1	1	2/2
tm2	-	1	-1	1	2/2
tm3	-	1	-1	1	2/2
<b>32110</b>	<b>ENC_FEEDBACK_POL</b>				
-	Sign of actual value (control direction)				POWER ON
- , - , -					DWORD
Default	1	1	-1	1	2/2
<b>32200</b>	<b>POSCTRL_GAIN</b>				
1,000 r.p.m.	Servo gain factor				NEW CONF
- , -					CTEQ
Default	6	16.66666667, 16.66666667, 16.66666667, 16.66666667, 16.66666667, 16.66666667	0	2000.	7/2
<b>32210</b>	<b>POSCTRL_INTEGR_TIME</b>				
s	Integral action time of the position controller				NEW CONF
-					DOUBLE
ng2	-	1.0	0	10000.0	2/2
tm1	-	1.0	0	10000.0	2/2
tm2	-	1.0	0	10000.0	2/2
tm3	-	1.0	0	10000.0	2/2
<b>32220</b>	<b>POSCTRL_INTEGR_ENABLE</b>				
-	Activation of the integral portion of the position controller				POWER ON
-					BOOLEAN
ng2	-	FALSE	-	-	2/2
tm1	-	FALSE	-	-	2/2
tm2	-	FALSE	-	-	2/2
tm3	-	FALSE	-	-	2/2

<b>32230</b>	<b>POSCTRL_CONFIG</b>				
-	Configuration of the position controller structure				POWER ON
-					BYTE
Default	-	0	0	17	7/2
<b>32300</b>	<b>MAX_AX_ACCEL</b>				
m/s <sup>2</sup> , rev/s <sup>2</sup>	Axis acceleration				NEW CONF
- , -					DOUBLE
Default	5	1.0, 1.0, 1.0, 1.0, 1.0	1.0e-3	-	7/2
<b>32301</b>	<b>JOG_MAX_ACCEL</b>				
m/s <sup>2</sup> , rev/s <sup>2</sup>	maximum axis acceleration in jog movement				NEW CONF
- , -					DOUBLE
Default	-	0.0	0.0	-	7/2
<b>32320</b>	<b>DYN_LIMIT_RESET_MASK</b>				
-	to be defined				RESET
- , -					DWORD
Default	-	0	0	0x01	2/2
<b>32420</b>	<b>JOG_AND_POS_JERK_ENABLE</b>				
-	Enable axial jerk limitation				RESET
-					BOOLEAN
Default	-	FALSE	-	-	2/2
<b>32430</b>	<b>JOG_AND_POS_MAX_JERK</b>				
m/s <sup>3</sup> , degrees/s <sup>3</sup>	Axial jerk				RESET
-					DOUBLE
Default	-	1000.0	1.e-9	-	2/2
<b>32431</b>	<b>MAX_AX_JERK</b>				
m/s <sup>3</sup> , degrees/s <sup>3</sup>	Maximum axial jerk when traveling along the path				NEW CONF
-					DOUBLE
tm1	5	1.e3, 1.e3, 1.e3, 1.e3, 1.e3	1.e-9	-	3/3
tm2	5	1.e3, 1.e3, 1.e3, 1.e3, 1.e3	1.e-9	-	3/3
tm3	5	1.e3, 1.e3, 1.e3, 1.e3, 1.e3	1.e-9	-	3/3
<b>32432</b>	<b>PATH_TRANS_JERK_LIM</b>				
m/s <sup>3</sup> , degrees/s <sup>3</sup>	Max. axial jerk when traveling along the path with block transition				NEW CONF
-					DOUBLE
tm1	5	1.e3, 1.e3, 1.e3, 1.e3, 1.e3	-	-	3/3
tm2	5	1.e3, 1.e3, 1.e3, 1.e3, 1.e3	-	-	3/3
tm3	5	1.e3, 1.e3, 1.e3, 1.e3, 1.e3	-	-	3/3
<b>32436</b>	<b>JOG_MAX_JERK</b>				
m/s <sup>3</sup> , degrees/s <sup>3</sup>	Maximum axial jerk for jog movement				NEW CONF
-					DOUBLE
Default	-	0.0	0.0	-	2/2
<b>32440</b>	<b>LOOKAH_FREQUENCY</b>				
-	Smoothing frequency with LookAhead				NEW CONF
EXP, -					DOUBLE
Default	-	10.	-	-	2/2
<b>32450</b>	<b>BACKLASH</b>				
mm, de- grees	Backlash on reversal				NEW CONF
-					DOUBLE
Default	1	0.0, 0.0	-	-	2/2

## 2.4 Axis-specific machine data

<b>32490</b>	<b>FRICT_COMP_MODE</b>				
-	Type of friction compensation				POWER ON
-					BYTE
Default	1	1	0	2	2/2
<b>32500</b>	<b>FRICT_COMP_ENABLE</b>				
-	Friction compensation active				NEW CONF
-					BOOLEAN
Default	-	FALSE	-	-	2/2
<b>32510</b>	<b>FRICT_COMP_ADAPT_ENABLE</b>				
-	Friction compensation adaptation active				NEW CONF
EXP, -					BOOLEAN
Default	1	FALSE	-	-	2/2
<b>32520</b>	<b>FRICT_COMP_CONST_MAX</b>				
mm/min, rev/min	Maximum friction compensation value				NEW CONF
EXP, -					DOUBLE
Default	1	0.0	-	-	2/2
<b>32530</b>	<b>FRICT_COMP_CONST_MIN</b>				
mm/min, rev/min	Minimum friction compensation value				NEW CONF
EXP, -					DOUBLE
Default	1	0.0	-	-	2/2
<b>32540</b>	<b>FRICT_COMP_TIME</b>				
s	Friction compensation time constant				NEW CONF
EXP, -					DOUBLE
Default	1	0.015	-	-	2/2
<b>32610</b>	<b>VELO_FFWEIGHT</b>				
-	Feedforward factor for speed feedforward control				NEW CONF
-,-					DOUBLE
ng3	6	1.0, 1.0, 1.0, 1.0, 1.0, 1.0	-	-	2/2
tm3	6	1.0, 1.0, 1.0, 1.0, 1.0, 1.0	-	-	2/2
<b>32630</b>	<b>FFW_ACTIVATION_MODE</b>				
-	Feedforward control can be activated from the program				RESET
-,-					CTEQ
ng3	-	1	-	-	2/2
tm3	-	1	-	-	2/2
<b>32640</b>	<b>STIFFNESS_CONTROL_ENABLE</b>				
-	Dynamic stiffness control				NEW CONF
-,-					CTEQ
Default	1	FALSE	-	-	2/2
<b>32642</b>	<b>STIFFNESS_CONTROL_CONFIG</b>				
-	Configure dynamic stiffness control				POWER ON
-,-					CTEQ
Default	1	0	0	1	2/2
<b>32644</b>	<b>STIFFNESS_DELAY_TIME</b>				
s	Dyn. stiffness control: Delay				POWER ON
-,-					CTEQ
Default	1	0.0	-0.02	0.02	2/2
tm1	1	-0.0015	-0,02	0,02	2/2
tm2	1	-0.0015	-0,02	0,02	2/2
tm3	1	-0.0015	-0,02	0,02	2/2

<b>32700</b>	<b>ENC_COMP_ENABLE</b>			
-	Encoder/lead error compensation			NEW CONF
-				BOOLEAN
Default	1	FALSE	-	2/2
<b>32810</b>	<b>EQUIV_SPEEDCTRL_TIME</b>			
s	Equivalent time constant for the speed control loop			NEW CONF
- , -				DOUBLE
Default	6	0.008, 0.008, 0.008, 0.008, 0.008, 0.008	-	2/2
tm1	6	0.003, 0.003, 0.003, 0.003, 0.003, 0.003	-	2/2
tm2	6	0.003, 0.003, 0.003, 0.003, 0.003, 0.003	-	2/2
tm3	6	0.003, 0.003, 0.003, 0.003, 0.003, 0.003	-	2/2
<b>33050</b>	<b>LUBRICATION_DIST</b>			
mm, de-grees	Travel for the lubrication pulse PLC signal			NEW CONF
- , -				DOUBLE
Default	-	1.0e8	-	3/3
<b>34000</b>	<b>REFP_CAM_IS_ACTIVE</b>			
-	Axis with reference point cam			RESET
- , -				BOOLEAN
Default	-	TRUE	-	2/2
<b>34010</b>	<b>REFP_CAM_DIR_IS_MINUS</b>			
-	Reference point approach in the negative direction			RESET
- , -				BOOLEAN
Default	-	FALSE	-	2/2
<b>34020</b>	<b>REFP_VELO_SEARCH_CAM</b>			
mm/min, rev/min	Cam approach velocity			RESET
- , - , -				DOUBLE
Default	-	5000.00	-	2/2
<b>34030</b>	<b>REFP_MAX_CAM_DIST</b>			
mm, de-grees	Max. distance to reference cam			RESET
- , -				DOUBLE
Default	-	10000.0	-	2/2
<b>34040</b>	<b>REFP_VELO_SEARCH_MARKER</b>			
mm/min, rev/min	Velocity when searching for the reference mark			RESET
- , - , -				DOUBLE
Default	1	300.00	-	2/2
<b>34050</b>	<b>REFP_SEARCH_MARKER_REVERSE</b>			
-	Direction reversal on reference cam			RESET
- , -				BOOLEAN
Default	1	FALSE	-	2/2
<b>34060</b>	<b>REFP_MAX_MARKER_DIST</b>			
mm, de-grees	Max. distance to reference mark			RESET
- , -				DOUBLE
Default	1	20.0	-	2/2

2.4 Axis-specific machine data

<b>34070</b>	<b>REFP_VELO_POS</b>				
mm/min, rev/min	Reference point approach velocity				RESET
-,-,-					DOUBLE
Default	-	10000.00	-	-	2/2
tm1	-	1000.00	-	-	2/2
tm2	-	1000.00	-	-	2/2
tm3	-	1000.00	-	-	2/2
<b>34080</b>	<b>REFP_MOVE_DIST</b>				
mm, de- grees	Reference point distance				NEW CONF
-,-					DOUBLE
Default	1	-2.0	-1e <sup>15</sup>	1e <sup>15</sup>	2/2
<b>34090</b>	<b>REFP_MOVE_DIST_CORR</b>				
mm, de- grees	Reference point offset				NEW CONF
-,-,-,-					DOUBLE
Default	1	0.0	-1e <sup>15</sup>	1e <sup>15</sup>	2/2
<b>34092</b>	<b>REFP_CAM_SHIFT</b>				
mm, de- grees	Electr. cam offset of incremental measuring systems				RESET
-,-					DOUBLE
Default	1	0.0	-	-	2/2
<b>34093</b>	<b>REFP_CAM_MARKER_DIST</b>				
mm, de- grees	Reference cam/marker distance				POWER ON
-,-					DOUBLE
Default	1	0.0	-	READ	2/2
<b>34100</b>	<b>REFP_SET_POS</b>				
mm, de- grees	Reference point position				RESET
-,-					DOUBLE
Default	4	0.0, 0.0, 0.0, 0.0	-45000000	45000000	2/2
<b>34110</b>	<b>REFP_CYCLE_NR</b>				
-	Order of axes when referencing				POWER ON
-					DWORD
Default	-	1, 2, 3, 4, 5, 6, 7, 8, 9, 10, 11, 12, 13, 14, 15, 16, 17, 18, 19, 20, 21, 22, 23, 24, 25, 26, 27, 28, 29, 30, 31, 32, 33, 34, 35, 36, 37, 38, 39, 40, 41, 42, 43, 44, 45, 46, 47, 48, 49, 50, 51, 52, 53, 54, 55, 56, 57, 58, 59, 60, 61, 62, 63, 64	-1	31	2/2
<b>34120</b>	<b>REFP_BERO_LOW_ACTIVE</b>				
-	Polarity change of the BERO cam				POWER ON
-					BOOLEAN
Default	-	FALSE	-	-	2/2
<b>34200</b>	<b>ENC_REFP_MODE</b>				
-	Referencing mode				POWER ON
-,-					BYTE
Default	1	1	0	8	2/2
<b>34210</b>	<b>ENC_REFP_STATE</b>				
-	Absolute encoder adjusting status				immediately
-,-,-					BYTE
Default	1	0	0	2	2/2

<b>34220</b>	<b>ENC_ABS_TURNS_MODULO</b>				
-	Modulo range of the rotary absolute encoder				POWER ON
-,-					DWORD
Default	1	4096	1	100000	2/2
<b>34990</b>	<b>ENC_ACTVAL_SMOOTH_TIME</b>				
s	Smoothing time constant for actual values				RESET
-					DOUBLE
Default	1	0.0	0.0	0.5	3/3
<b>35000</b>	<b>SPIND_ASSIGN_TO_MACHAX</b>				
-	Assignment 'spindle - machine axis'				POWER ON
-,-,-					BYTE
ng2	-	0	0	2	2/2
ng3	-	0	0	3	2/2
tm1	-	0	0	1	2/2
tm2	-	0	0	2	2/2
tm3	-	0	0	2	2/2
<b>35010</b>	<b>GEAR_STEP_CHANGE_ENABLE</b>				
-	Gear stage change possible				RESET
-,-					DWORD
Default	-	0x00	0	0x2B	2/2
<b>35012</b>	<b>GEAR_STEP_CHANGE_POSITION</b>				
mm, de- grees	Gear stage change position				NEW CONF
-,-					DOUBLE
Default	6	0.0, 0.0, 0.0, 0.0, 0.0, 0.0	-	-	2/2
<b>35014</b>	<b>GEAR_STEP_USED_IN_AXISMODE</b>				
-	Gear stage for axis mode with M70				NEW CONF
-,-,-					DWORD
Default	-	0	0	5	2/2
<b>35020</b>	<b>SPIND_DEFAULT_MODE</b>				
-	Spindle park position				RESET
-,-					BYTE
Default	-	0	0	3	2/2
<b>35030</b>	<b>SPIND_DEFAULT_ACT_MASK</b>				
-	Activate spindle park position				RESET
-,-					BYTE
Default	-	0x00	0	0x03	2/2
<b>35040</b>	<b>SPIND_ACTIVE_AFTER_RESET</b>				
-	Own spindle RESET				POWER ON
-,-					BYTE
Default	-	0	0	2	2/2
<b>35100</b>	<b>SPIND_VELO_LIMIT</b>				
rev/min	Maximum spindle speed				POWER ON
-,-,-					DOUBLE
Default	-	10000.0	1.0e-3	-	7/2
<b>35110</b>	<b>GEAR_STEP_MAX_VELO</b>				
rev/min	Maximum speed for gear stage change				NEW CONF
-,-,-					DOUBLE
Default	6	500.0, 500.0, 1000.0, 2000.0, 4000.0, 8000.0	-	-	2/2

2.4 Axis-specific machine data

<b>35112</b>	<b>GEAR_STEP_MAX_VELO2</b>				
rev/min	to be defined				NEW CONF
- , - , -					DOUBLE
Default	6	500.0, 500.0, 1000.0, 2000.0, 4000.0, 8000.0	0	-	2/2
<b>35120</b>	<b>GEAR_STEP_MIN_VELO</b>				
rev/min	Minimum speed for gear stage change				NEW CONF
- , - , -					DOUBLE
Default	6	50.0, 50.0, 400.0, 800.0, 1500.0, 3000.0	-	-	2/2
<b>35122</b>	<b>GEAR_STEP_MIN_VELO2</b>				
rev/min	to be defined				NEW CONF
- , - , -					DOUBLE
Default	6	50.0, 50.0, 400.0, 800.0, 1500.0, 3000.0	0	-	2/2
<b>35130</b>	<b>GEAR_STEP_MAX_VELO_LIMIT</b>				
rev/min	Maximum speed of gear stage				NEW CONF
- , - , -					DOUBLE
Default	6	500.0, 500.0, 1000.0, 2000.0, 4000.0, 8000.0	1.0e-3	-	2/2
<b>35140</b>	<b>GEAR_STEP_MIN_VELO_LIMIT</b>				
rev/min	Minimum speed of gear stage				NEW CONF
- , - , -					DOUBLE
Default	6	5.0, 5.0, 10.0, 20.0, 40.0, 80.0	-	-	2/2
<b>35150</b>	<b>SPIND_DES_VELO_TOL</b>				
-	Spindle speed tolerance				RESET
- , - , - , - , -					DOUBLE
Default	-	0.1	0.0	1.0	2/2
<b>35160</b>	<b>SPIND_EXTERN_VELO_LIMIT</b>				
rev/min	Spindle speed limitation from PLC				NEW CONF
- , -					DOUBLE
Default	-	1000.0	1.0e-3	-	2/2
<b>35200</b>	<b>GEAR_STEP_SPEEDCTRL_ACCEL</b>				
rev/s <sup>2</sup>	Acceleration in the control mode				NEW CONF
- , - , -					DOUBLE
Default	6	30.0, 30.0, 25.0, 20.0, 15.0, 10.0	1.0e-3	-	2/2
<b>35210</b>	<b>GEAR_STEP_POSCTRL_ACCEL</b>				
rev/s <sup>2</sup>	Acceleration in the position-controlled mode				NEW CONF
- , - , -					DOUBLE
Default	6	30.0, 30.0, 25.0, 20.0, 15.0, 10.0	1.0e-3	-	2/2
<b>35212</b>	<b>GEAR_STEP_POSCTRL_ACCEL2</b>				
rev/s <sup>2</sup>	to be defined				NEW CONF
- , - , -					DOUBLE
Default	6	30.0, 30.0, 25.0, 20.0, 15.0, 10.0	1.0e-3	-	2/2
<b>35300</b>	<b>SPIND_POSCTRL_VELO</b>				
rev/min	Position controller starting speed				NEW CONF
- , -					DOUBLE
Default	-	500.0	-	-	2/2

<b>35310</b>	<b>SPIND_POSIT_DELAY_TIME</b>				
s	Positioning delay time				NEW CONF
- , -					CTEQ
Default	6	0.0, 0.05, 0.1, 0.2, 0.4, 0.8	-	-	DOUBLE 2/2
<b>35350</b>	<b>SPIND_POSITIONING_DIR</b>				
-	Direction of rotation when positioning				RESET
-					CTEQ
Default	-	3	3	4	BYTE 2/2
<b>35400</b>	<b>SPIND_OSCILL_DES_VELO</b>				
rev/min	Reciprocating speed				NEW CONF
- , -					CTEQ
Default	-	500.0	-	-	DOUBLE 2/2
<b>35410</b>	<b>SPIND_OSCILL_ACCEL</b>				
rev/s <sup>2</sup>	Acceleration when reciprocating				NEW CONF
- , -					CTEQ
Default	-	16.0	1.0e-3	-	DOUBLE 2/2
<b>35430</b>	<b>SPIND_OSCILL_START_DIR</b>				
-	Starting direction when reciprocating				RESET
-					CTEQ
Default	-	0	0	4	BYTE 2/2
<b>35440</b>	<b>SPIND_OSCILL_TIME_CW</b>				
s	Reciprocation time for M3 direction				NEW CONF
-					CTEQ
Default	-	1.0	-	-	DOUBLE 2/2
<b>35450</b>	<b>SPIND_OSCILL_TIME_CCW</b>				
s	Reciprocation time for M4 direction				NEW CONF
-					CTEQ
Default	-	0.5	-	-	DOUBLE 2/2
<b>35500</b>	<b>SPIND_ON_SPEED_AT_IPO_START</b>				
-	Feed enable with spindle in setpoint range				RESET
- , - , -					CTEQ
Default	-	1	0	2	BYTE 2/2
<b>35510</b>	<b>SPIND_STOPPED_AT_IPO_START</b>				
-	Feed enable with the spindle stopped				RESET
- , - , -					CTEQ
Default	-	FALSE	-	-	BOOLEAN 2/2
<b>35550</b>	<b>DRILL_VELO_LIMIT</b>				
rev/min	Maximum speeds for tapping				NEW CONF
- , - , -					CTEQ
Default	6	10000.0, 10000.0, 10000.0, 10000.0, 10000.0, 10000.0	1	-	DOUBLE 2/2
<b>36000</b>	<b>STOP_LIMIT_COARSE</b>				
mm, degrees	Exact stop coarse				NEW CONF
-					DOUBLE
Default	-	0.04	-	-	2/2
<b>36010</b>	<b>STOP_LIMIT_FINE</b>				
mm, de- grees	Exact stop fine				NEW CONF
-					DOUBLE
Default	-	0.01	-	-	2/2

List of Machine Data

2.4 Axis-specific machine data

<b>36020</b>	<b>POSITIONING_TIME</b>			
s	Exact stop fine delay time			NEW CONF
-				DOUBLE
Default	-	1.0	-	2/2
<b>36030</b>	<b>STANDSTILL_POS_TOL</b>			
mm, de- grees	Standstill tolerance			NEW CONF
-				DOUBLE
Default	-	0.2	-	2/2
<b>36040</b>	<b>STANDSTILL_DELAY_TIME</b>			
s	Standstill monitoring delay time			NEW CONF
-				DOUBLE
Default	-	0.4	-	2/2
<b>36050</b>	<b>CLAMP_POS_TOL</b>			
mm, degrees	Clamping tolerance			NEW CONF
-				DOUBLE
Default	-	0.5	-	2/2
<b>36060</b>	<b>STANDSTILL_VELO_TOL</b>			
mm/min, rev/min	Threshold velocity for axis stopped			NEW CONF
-, -				DOUBLE
Default	-	5.00	-	2/2
<b>36100</b>	<b>POS_LIMIT_MINUS</b>			
mm, de- grees	1st software limit switch minus			NEW CONF
-, -, -				CTEQ
Default	-	-1.0e8	-	2/2
<b>36110</b>	<b>POS_LIMIT_PLUS</b>			
mm, de- grees	1st software limit switch, plus			NEW CONF
-, -, -				CTEQ
Default	-	1.0e8	-	2/2
<b>36120</b>	<b>POS_LIMIT_MINUS2</b>			
mm, de- grees	2nd software limit switch minus			NEW CONF
-, -				CTEQ
Default	-	-1.0e8	-	2/2
<b>36130</b>	<b>POS_LIMIT_PLUS2</b>			
mm, de- grees	2nd software limit switch, plus			NEW CONF
-, -				CTEQ
Default	-	1.0e8	-	2/2
<b>36200</b>	<b>AX_VELO_LIMIT</b>			
mm/min, rev/min	Velocity monitoring threshold value			NEW CONF
-, -, -				CTEQ
Default	6	11500.0, 11500.0, 11500.0, 11500.0, 11500.0, 11500.0	-	2/2
<b>36210</b>	<b>CTRLOUT_LIMIT</b>			
%	Maximum speed setpoint			NEW CONF
EXP, -				CTEQ
Default	1	110.0	0	200 7/2

<b>36300</b>	<b>ENC_FREQ_LIMIT</b>				
-	Encoder limit frequency				POWER ON
EXP, -, -, -					DOUBLE
Default	1	3.0e5	-	-	2/2
<b>36302</b>	<b>ENC_FREQ_LIMIT_LOW</b>				
%	Encoder limit frequency resynchronization				NEW CONF
EXP, -, -, -					DOUBLE
Default	1	99.9	0	100	2/2
<b>36310</b>	<b>ENC_ZERO_MONITORING</b>				
-	Zero mark monitoring				NEW CONF
EXP, -, -					DWORD
Default	1	0	-	-	2/2
<b>36400</b>	<b>CONTOUR_TOL</b>				
mm, degrees	Contour monitoring tolerance band				NEW CONF
-, -					DOUBLE
Default	-	1.0	-	-	2/2
<b>36500</b>	<b>ENC_CHANGE_TOL</b>				
mm, degrees	Position actual-value switching tolerance				NEW CONF
-, -					DOUBLE
Default	-	0.1	-	-	2/2
<b>36600</b>	<b>BRAKE_MODE_CHOICE</b>				
-	Brake behavior at hardware limit switch				POWER ON
EXP, -					CTEQ BYTE
Default	-	0	0	1	2/2
<b>36610</b>	<b>AX_EMERGENCY_STOP_TIME</b>				
s	Time of braking ramp in case of errors				NEW CONF
-					DOUBLE
Default	-	0.05	-	-	2/2
<b>36620</b>	<b>SERVO_DISABLE_DELAY_TIME</b>				
s	Cutout delay controller enable				NEW CONF
-					DOUBLE
Default	-	0.1	-	-	2/2
<b>36710</b>	<b>DRIFT_LIMIT</b>				
%	Limit value for automatic drift compensation				NEW CONF
EXP, -, -					DOUBLE
Default	1	1.0	0	1.e9	3/3
<b>36720</b>	<b>DRIFT_VALUE</b>				
%	Drift base value				NEW CONF
EXP, -, -					DOUBLE
Default	1	0.0	-	-	2/2
<b>37000</b>	<b>FIXED_STOP_MODE</b>				
-	Mode "Traversing to fixed stop"				POWER ON
-					CTEQ BYTE
ng2	-	0	0	3	2/2
ng3	-	0	0	3	2/2
tm2	-	0	0	3	2/2
tm3	-	0	0	3	2/2

## 2.4 Axis-specific machine data

37002		FIXED_STOP_CONTROL			
-		Sequence control when traveling to fixed stop			POWER ON
-				-	BYTE
ng2	-	0	0	3	2/2
ng3	-	0	0	3	2/2
tm2	-	0	0	3	2/2
tm3	-	0	0	3	2/2
37010		FIXED_STOP_TORQUE_DEF			
%		Fixed stop clamping torque default setting			POWER ON
-				CTEQ	DOUBLE
ng2	-	5.0	0.0	100.0	2/2
ng3	-	5.0	0.0	100.0	2/2
tm2	-	5.0	0.0	100.0	2/2
tm3	-	5.0	0.0	100.0	2/2
37012		FIXED_STOP_TORQUE_RAMP_TIME			
s		Time until the changed torque limit is reached			NEW CONF
-				-	DOUBLE
tm2	-	0.0	-	-	2/2
tm3	-	0.0	-	-	2/2
37014		FIXED_STOP_TORQUE_FACTOR			
-		Torque limit adaptation factor			NEW CONF
-				-	DOUBLE
tm2	-	1.0	-	-	2/2
tm3	-	1.0	-	-	2/2
37020		FIXED_STOP_WINDOW_DEF			
mm, de- grees		Fixed stop monitoring window default setting			POWER ON
- , -				CTEQ	DOUBLE
ng2	-	1.0	-	-	2/2
ng3	-	1.0	-	-	2/2
tm2	-	1.0	-	-	2/2
tm3	-	1.0	-	-	2/2
37030		FIXED_STOP_THRESHOLD			
mm, de- grees		Threshold for fixed stop detection			NEW CONF
-				-	DOUBLE
ng2	-	2.0	-	-	2/2
ng3	-	2.0	-	-	2/2
tm2	-	2.0	-	-	2/2
tm3	-	2.0	-	-	2/2
37040		FIXED_STOP_BY_SENSOR			
-		Fixed stop detection via sensor			immediately
-				CTEQ	BYTE
ng2	-	0	0	3	2/2
ng3	-	0	0	3	2/2
tm2	-	0	0	3	2/2
tm3	-	0	0	3	2/2
37050		FIXED_STOP_ALARM_MASK			
-		Enabling of the fixed-stop alarms			NEW CONF
- , -				-	BYTE
ng2	-	1	0	15	2/2
ng3	-	1	0	15	2/2
tm2	-	1	0	15	2/2
tm3	-	1	0	15	2/2

37060		FIXED_STOP_ACKN_MASK			
-		Masking of PLC acknowledgments			POWER ON
-				CTEQ	BYTE
ng2	-	0	0	3	2/2
ng3	-	0	0	3	2/2
tm2	-	0	0	3	2/2
tm3	-	0	0	3	2/2
37400		EPS_TLIFT_TANG_STEP			
mm, de- grees		Angle of tangent for corner recognition			RESET
-				CTEQ	DOUBLE
ng3	-	5.0	-	-	2/2
tm3	-	5.0	-	-	2/2
37402		TANG_OFFSET			
mm, de- grees		Default angle for tangential correction			RESET
-				CTEQ	DOUBLE
ng3	-	0.0	-	-	2/2
tm3	-	0.0	-	-	2/2
37610		PROFIBUS_CTRL_CONFIG			
-		Profibus control bit configuration			POWER ON
EXP, -				-	BYTE
Default	-	0	0	2	7/2
37620		PROFIBUS_TORQUE_RED_RESOL			
%		Resolution of Profibus torque reduction			NEW CONF
EXP, -				-	DOUBLE
Default	-	1.0	0.005	10.0	2/2
37800		OEM_AXIS_INFO			
-		OEM version info			POWER ON
-, -				-	STRING
Default	2	'''' , ''''	-	-	7/2
38000		MM_ENC_COMP_MAX_POINTS			
-		Intermediate points for encoder/spindle compensation			POWER ON
-, -, -				-	DWORD
Default	1	125	0	5000	7/0



## Setting Data – Overview

### 3.1 Setting data

MD number	SD identifier				as of version
Unit	Brief description				Activation
Display filter				Attributes	Data type
System *	Dimension	Default value	Minimum value	Maximum value	Protection

\* Values other than those in the Default system

#### Note regarding the value definition:

TRUE corresponds to 1

FALSE corresponds to 0

41010	JOG_VAR_INCR_SIZE				
-	JOG mode: Size of variable increment				IMMEDIATELY
-				-	DOUBLE
Default	-	0.	-	-	7/7

41110	JOG_SET_VELO				
mm/min	Axis velocity in the JOG mode				IMMEDIATELY
-				-	DOUBLE
Default	-	0.0	-	-	7/7

41130	JOG_ROT_AX_SET_VELO				
rev/min	Axis velocity of the rotary axes in the JOG mode				IMMEDIATELY
-				-	DOUBLE
Default	-	0.0	-	-	7/7

41200	JOG_SPIND_SET_VELO				
rev/min	Speed for spindle jog mode				IMMEDIATELY
-				-	DOUBLE
Default	-	0.0	-	-	7/7

41500	SW_CAM_MINUS_POS_TAB_1				
mm/inch, degrees	Switching points with falling edge of cams 1-8				IMMEDIATELY
-				-	DOUBLE
ng2	8	0.0, 0.0, 0.0, 0.0, 0.0, 0.0, 0.0, 0.0	-	-	7/7
ng3	8	0.0, 0.0, 0.0, 0.0, 0.0, 0.0, 0.0, 0.0	-	-	7/7

41501	SW_CAM_PLUS_POS_TAB_1				
mm/inch, degrees	Switching points with rising edge of cams 1-8				IMMEDIATELY
-				-	DOUBLE
ng2	8	0.0, 0.0, 0.0, 0.0, 0.0, 0.0, 0.0, 0.0	-	-	7/7
ng3	8	0.0, 0.0, 0.0, 0.0, 0.0, 0.0, 0.0, 0.0	-	-	7/7

3.1 Setting data

<b>41520 SW_CAM_MINUS_TIME_TAB_1</b>					
mm/inch, degrees	Lead times for the '-' switching points of cams 1-8				IMMEDIATELY
-				-	DOUBLE
ng2	8	0.0, 0.0, 0.0, 0.0, 0.0, 0.0, 0.0, 0.0, 0.0	-	-	7/7
ng3	8	0.0, 0.0, 0.0, 0.0, 0.0, 0.0, 0.0, 0.0, 0.0	-	-	7/7
<b>41521 SW_CAM_PLUS_TIME_TAB_1</b>					
mm/inch, degrees	Lead times for the '+' switching points of cams 1-8				IMMEDIATELY
-				-	DOUBLE
ng2	8	0.0, 0.0, 0.0, 0.0, 0.0, 0.0, 0.0, 0.0, 0.0	-	-	7/7
ng3	8	0.0, 0.0, 0.0, 0.0, 0.0, 0.0, 0.0, 0.0, 0.0	-	-	7/7

## 3.2 Channel-specific setting data

MD number	SD identifier				as of version
Unit	Brief description				Activation
Display filter				Attributes	Data type
System	Dimension	Default value	Minimum value	Maximum value	Protection

### Note regarding the value definition:

TRUE corresponds to 1  
FALSE corresponds to 0

42000	THREAD_START_ANGLE				
degrees	Thread start angle [deg]				IMMEDIATELY
-				-	DOUBLE
tm1	-	0	-	-	3/3
tm2	-	0	-	-	3/3
tm3	-	0	-	-	3/3

42010	THREAD_RAMP_DISP				
mm	Acceleration pattern of the axis when thread cutting				IMMEDIATELY
-				-	DOUBLE
tm1	2	-1.0, -1.0	-1.0	999999.	3/3
tm2	2	-1.0, -1.0	-1.0	999999.	3/3
tm3	2	-1.0, -1.0	-1.0	999999.	3/3

42100	DRY_RUN_FEED				
mm/min	At least the programmed velocity with active dry run				IMMEDIATELY
-				-	DOUBLE
Default	-	5000	-	-	7/7

42101	DRY_RUN_FEED_MODE				
-	Mode for dry run velocity				IMMEDIATELY
-				-	BYTE
Default	-	0	0	12	7/7

42110	DEFAULT_FEED				
mm/min	Default value for path feedrate				IMMEDIATELY
-				-	DOUBLE
Default	-	0	-	-	7/7

42120	APPROACH_FEED				
mm/min	Path feed in approach blocks				IMMEDIATELY
-				-	DOUBLE
Default	-	0	-	-	2/2

42140	DEFAULT_SCALE_FACTOR_P				
-	Default scaling factor for address P				IMMEDIATELY
-				-	DWORD
Default	-	1	-	-	7/7

42150	DEFAULT_ROT_FACTOR_R				
-	Default rotation factor for address R				IMMEDIATELY
-				-	DOUBLE
Default	-	0.	-	-	7/7

42160	EXTERN_FIXED_FEEDRATE_F1_F9				
-	Fixed feedrates F1 - F9				IMMEDIATELY
-				-	DOUBLE
Default	10	0.0, 0.0, 0.0, 0.0, 0.0, 0.0, 0.0, 0.0, 0.0, 0.0	-	-	7/7

## 3.2 Channel-specific setting data

<b>42162</b>	<b>EXTERN_DOUBLE_TURRET_DIST</b>				
-	Tool distance of dual resolver head				IMMEDIATELY
-					DOUBLE
Default	-	0.	-	-	7/7
<b>42200</b>	<b>SINGLEBLOCK2_STOPRE</b>				
-	Activate debug mode for SBL2				IMMEDIATELY
-					BOOLEAN
Default	-	FALSE	-	-	7/7
<b>42400</b>	<b>PUNCH_DWELLTIME</b>				
s	Dwell time for punching and nibbling				IMMEDIATELY
-					DOUBLE
ng2	-	1.0	-	-	3/3
ng3	-	1.0	-	-	3/3
<b>42402</b>	<b>NIBPUNCH_PRE_START_TIME</b>				
s	Delay time (punch/nibble) with G603				IMMEDIATELY
-					DOUBLE
ng2	-	.02	-	-	3/3
ng3	-	.02	-	-	3/3
<b>42404</b>	<b>MINTIME_BETWEEN_STROKES</b>				
s	Minimum time between 2 strokes in seconds				IMMEDIATELY
-					DOUBLE
ng3	-	0.0	-	-	3/3
<b>42440</b>	<b>FRAME_OFFSET_INCR_PROG</b>				
-	Work offset in frames				IMMEDIATELY
-					BOOLEAN
Default	-	TRUE	-	-	7/7
<b>42442</b>	<b>TOOL_OFFSET_INCR_PROG</b>				
-	Tool length compensations				IMMEDIATELY
-					BOOLEAN
Default	-	TRUE	-	-	7/7
<b>42444</b>	<b>TARGET_BLOCK_INCR_PROG</b>				
-	Incremental programming with block search				IMMEDIATELY
-					BOOLEAN
Default	-	TRUE	-	-	7/7
<b>42450</b>	<b>CONTPREC</b>				
mm	Contour accuracy				IMMEDIATELY
-					DOUBLE
tm3	-	0.1	0.000001	999999.	3/3
<b>42465</b>	<b>SMOOTH_CONTUR_TOL</b>				
mm	Maximal contour tolerance on smoothing				IMMEDIATELY
-					DOUBLE
tm3	-	0.05	0.000001	999999.	3/3
<b>42470</b>	<b>CRIT_SPLINE_ANGLE</b>				
degrees	Critical angle of spline and polynomial interpol. and compressor				IMMEDIATELY
-					DOUBLE
tm3	-	36.0	0.0	89.0	3/3
<b>42471</b>	<b>MIN_CURV_RADIUS</b>				
mm	Minimum radius of curvature				IMMEDIATELY
EXP, C09					DOUBLE
tm3	-	3.0	-	-	3/3

<b>42475</b>	<b>COMPRESS_CONTUR_TOL</b>				
mm	Maximal contour deviation with compressor				IMMEDIATELY
-					DOUBLE
tm3	-	0.05	0.000001	999999.	3/3
<b>42480</b>	<b>STOP_CUTCOM_STOPRE</b>				
-	Alarm response with TRC and preprocessing stop				IMMEDIATELY
-					BOOLEAN
Default	-	TRUE	-	-	3/3
<b>42490</b>	<b>CUTCOM_G40_STOPRE</b>				
-	Retraction behavior of TRC with preprocessing stop				IMMEDIATELY
-					BOOLEAN
Default	-	FALSE	-	-	3/3
<b>42494</b>	<b>CUTCOM_ACT_DEACT_CTRL</b>				
-	Approach/retraction behavior with 2-1/2D TRC				IMMEDIATELY
-					DWORD
Default	-	2222	-	-	3/3
<b>42496</b>	<b>CUTCOM_CLSD_CONT</b>				
-	Behavior of the TRC with closed contour				IMMEDIATELY
-					BOOLEAN
Default	-	FALSE	-	-	3/3
<b>42500</b>	<b>SD_MAX_PATH_ACCEL</b>				
m/s <sup>2</sup>	Max. path acceleration				IMMEDIATELY
-					DOUBLE
tm3	-	10000.	1.0e-3	-	3/3
<b>42502</b>	<b>IS_SD_MAX_PATH_ACCEL</b>				
-	Evaluate SD SC_SD_MAX_PATH_ACCEL				IMMEDIATELY
-					BOOLEAN
tm3	-	FALSE	-	-	3/3
<b>42510</b>	<b>SD_MAX_PATH_JERK</b>				
m/s <sup>2</sup>	Max. path-related jerk as SD				IMMEDIATELY
-					DOUBLE
tm3	-	100000.	1.0e-9	-	3/3
<b>42512</b>	<b>IS_SD_MAX_PATH_JERK</b>				
-	Evaluate SD SD_MAX_PATH_JERK				IMMEDIATELY
-					BOOLEAN
tm3	-	FALSE	-	-	3/3
<b>42520</b>	<b>CORNER_SLOWDOWN_START</b>				
mm	Start of feed reduction at G62.				IMMEDIATELY
-					DOUBLE
tm3	-	0.	-	-	3/3
<b>42522</b>	<b>CORNER_SLOWDOWN_END</b>				
mm	End of feed reduction at G62.				IMMEDIATELY
-					DOUBLE
tm3	-	FALSE	-	-	3/3
<b>42524</b>	<b>CORNER_SLOWDOWN_OVR</b>				
%	Feed override reduction at G62				IMMEDIATELY
-					DOUBLE
tm3	-	0.	-	-	3/3
<b>42526</b>	<b>CORNER_SLOWDOWN_CRIT</b>				
degrees	Corner detection at G62				IMMEDIATELY
-					DOUBLE
tm3	-	0.	-	-	3/3

## 3.2 Channel-specific setting data

<b>42528</b>	<b>CUTCOM_DECEL_LIMIT</b>				
-	Feedrate reduction at circles with TRC				IMMEDIATELY
-					DOUBLE
tm3	-	0.	0.	1.	3/3
<b>42940</b>	<b>TOOL_LENGTH_CONST</b>				
-	Tool length component when changing the plane				IMMEDIATELY
-					DWORD
Default	-	0	-	-	3/3
<b>42950</b>	<b>TOOL_LENGTH_TYPE</b>				
-	Tool length component not depending on tool type				IMMEDIATELY
-					DWORD
Default	-	0	-	-	3/3
<b>42990</b>	<b>MAX_BLOCKS_IN_IPOBUFFER</b>				
-	Max. number of blocks in the IPO buffer				IMMEDIATELY
-					DWORD
ng3	-	-1	-	-	2/2
tm3	-	-1	-	-	2/2
<b>42995</b>	<b>CONE_ANGLE</b>				
-	Cone angle				IMMEDIATELY
-					DOUBLE
Default	-	0	-90	90	7/7

### 3.3 Axis-specific setting data

MD number	SD identifier				
Unit	Brief description				Activation
Display filter				Attributes	Data type
System	Dimension	Default value	Minimum value	Maximum value	Protection

**Note regarding the value definition:**

TRUE corresponds to 1  
FALSE corresponds to 0

43120	DEFAULT_SCALE_FACTOR_AXIS				
-	Default scaling factor with active G51				IMMEDIATELY
-				-	DWORD
tm1	-	1	-	-	7/7
tm2	-	1	-	-	7/7
tm3	-	1	-	-	7/7

43200	SPIND_S				
rev/min	Speed for spindle start through virtual interface				IMMEDIATELY
-				-	DOUBLE
Default	-	0.0	-	-	7/7

43202	SPIND_CONSTCUT_S				
m/min	Cutting rate for spindle start through virtual interface				IMMEDIATELY
-				-	DOUBLE
Default	-	0.0	-	-	7/7

43206	SPIND_SPEED_TYPE				
-	Speed type for spindle start by VDI				IMMEDIATELY
-				-	DOUBLE
Default	-	94	93	972	7/7

43210	SPIND_MIN_VELO_G25				
rev/min	Limits the spindle speed to the specified minimum value				IMMEDIATELY
-				-	DOUBLE
Default	-	0.0	-	-	7/7

43220	SPIND_MAX_VELO_G26				
rev/min	Limits the spindle speed to the specified maximum value				IMMEDIATELY
-				-	DOUBLE
Default	-	1000.0	-	-	7/7

43230	SPIND_MAX_VELO_LIMS				
rev/min	Limits the spindle speed to the specified maximum value				IMMEDIATELY
-				-	DOUBLE
Default	-	100.0	-	-	7/7

43240	M19_SPOS				
degrees	Spindle position with M19				IMMEDIATELY
-, -				-	DOUBLE
Default	-	0.0	-10000000.0	10000000.0	7/7

43250	M19_SPOSMODE				
-	Spindle position approach mode for spindle positioning with M19.				IMMEDIATELY
-, -				-	DWORD
Default	-	0	0	5	7/7

43400	WORKAREA_PLUS_ENABLE				
-	Working area limitation active in the positive direction				IMMEDIATELY
-				CTEQ	BOOLEAN
Default	-	FALSE	-	-	7/7

## 3.3 Axis-specific setting data

<b>43410</b>	<b>WORKAREA_MINUS_ENABLE</b>				
-	Working area limitation active in the negative direction				IMMEDIATELY
-	CTEQ				BOOLEAN
Default	-	FALSE	-	-	7/7
<b>43420</b>	<b>WORKAREA_LIMIT_PLUS</b>				
mm, de- grees	Axial working area limitation active in the positive direction				IMMEDIATELY
-	-				DOUBLE
Default	-	1.0e+8	-	-	7/7
<b>43430</b>	<b>WORKAREA_LIMIT_MINUS</b>				
mm, de- grees	Axial working area limitation active in the negative direction				IMMEDIATELY
-	-				DOUBLE
Default	-	-1.0e+8	-	-	7/7
<b>43500</b>	<b>FIXED_STOP_SWITCH</b>				
-	Selection "Travel to fixed stop"				IMMEDIATELY
-	-				BYTE
ng2	-	0	0	1	2/2
ng3	-	0	0	1	2/2
tm2	-	0	0	1	2/2
tm3	-	0	0	1	2/2
<b>43510</b>	<b>FIXED_STOP_TORQUE</b>				
%	Fixed stop clamping torque				IMMEDIATELY
-	-				DOUBLE
tm2	-	5.0	0.0	800.0	2/2
tm3	-	5.0	0.0	800.0	2/2
<b>43700</b>	<b>OSCILL_REVERSE_POS1</b>				
mm, de- grees	Oscillation reversal point 1				IMMEDIATELY
-	-				DOUBLE
ng2	-	0.0	-	-	7/7
ng3	-	0.0	-	-	7/7
<b>43710</b>	<b>OSCILL_REVERSE_POS2</b>				
mm, de- grees	Oscillation reversal point 2				IMMEDIATELY
-	-				DOUBLE
ng2	-	0.0	-	-	7/7
ng3	-	0.0	-	-	7/7
<b>43720</b>	<b>OSCILL_DWELL_TIME1</b>				
s	Hold time at oscillation reversal point 1				IMMEDIATELY
-	-				DOUBLE
ng2	-	0.0	-	-	7/7
ng3	-	0.0	-	-	7/7
<b>43730</b>	<b>OSCILL_DWELL_TIME2</b>				
s	Hold time at oscillation reversal point 2				IMMEDIATELY
-	-				DOUBLE
ng2	-	0.0	-	-	7/7
ng3	-	0.0	-	-	7/7
<b>43740</b>	<b>OSCILL_VELO</b>				
mm/min, rev/min	Feedrate of reciprocating axis				IMMEDIATELY
-	-				DOUBLE
ng2	-	0.0	-	-	7/7
ng3	-	0.0	-	-	7/7

<b>43750</b>	<b>OSCILL_NUM_SPARK_CYCLES</b>				
-	Number of spark-out strokes				IMMEDIATELY
-					DWORD
ng2	-	0	-	-	7/7
ng3	-	0	-	-	7/7
<b>43760</b>	<b>OSCILL_END_POS</b>				
mm, de-grees	End position of the reciprocating axis				IMMEDIATELY
-					DOUBLE
ng2	-	0.0	-	-	7/7
ng3	-	0.0	-	-	7/7
<b>43770</b>	<b>OSCILL_CTRL_MASK</b>				
-	Oscillation sequence control screenform				IMMEDIATELY
-					DWORD
ng2	-	0	-	-	7/7
ng3	-	0	-	-	7/7
<b>43780</b>	<b>OSCILL_IS_ACTIVE</b>				
-	Activate oscillation movement				IMMEDIATELY
-					BOOLEAN
ng2	-	FALSE	-	-	7/7
ng3	-	FALSE	-	-	7/7
<b>43790</b>	<b>OSCILL_START_POS</b>				
mm, de-grees	to be defined				IMMEDIATELY
-					DOUBLE
ng2	-	0.0	-	-	7/7
ng3	-	0.0	-	-	7/7



## Machine Data – Description

This Chapter describes machine data which are of general importance but for which there are no specific chapters in this description of functions.

### 4.1 Display machine data

202 MD number	<b>FIRST_LANGUAGE</b> Foreground language
Meaning:	The language (1 or 2) which is to be automatically active after each system startup is set in the machine data. Two languages are available simultaneously in SINUMERIK 802D. Languages other than those included in the control ex works can be loaded. It is possible to temporarily switch to a second language using a softkey in the Diagnosis area. After power ON the predefined language set in MD is again active.
References	"Operation and Programming"
203 MD number	<b>DISPLAY_RESOLUTION</b> Display resolution
Meaning:	This machine data defines the number of places after the decimal point in the position display for linear axes in metric systems as well as in general for rotary axes. Spindle positions are treated as rotary axis positions. The position is displayed with 10 symbols max. including the plus/minus sign and the decimal point. A plus sign is not displayed. All 3 positions after the decimal point are displayed per default.⇒ MD value=3: Display resolution = $10^{-3}$ [mm] or [degrees].
Related to ....	MD 10200: INT_INCR_PER_MM or MD 10210: INT_INCR_PER_DEG
204 MD number	<b>DISPLAY_RESOLUTION_INCH</b> Display resolution for the INCH dimension system
Meaning:	This machine data specifies the number of places after the decimal point for linear axes for Inch dimension systems. The position is displayed with max. 10 characters including the plus/minus sign and the decimal point. A plus sign is not displayed. All 4 positions after the decimal point are displayed per default.⇒ MD value=4: Display resolution = $10^{-4}$ [inch] The display is retained according to MD 203 for rotary axes and spindle positions
Related to ....	MD 10200: INT_INCR_PER_MM, MD 203: DISPLAY_RESOLUTION
205 MD number	<b>DISPLAY_RESOLUTION_SPINDLE</b> Display resolution for spindle values
Meaning:	This machine data specifies the number of places after the decimal point of the spindle speed display. The values are displayed with 10 symbols max. including the plus/minus sign and the decimal point. A plus sign is not displayed. 1 position after the decimal point is displayed per default.⇒ MD value=1: Display resolution = $10^{-1}$

## 4.1 Display machine data

289 MD number	<b>CTM_SIMULATION_TIME_NEW_POS</b> Simulation updating rate of actual value
Meaning:	This MD is set to specify the time intervals at which the simulation graphic must be updated in accordance with the current machining process on the machine tool. Value = 0 means no update.
Note for the reader:	SINUMERIK 802D sl Description of Functions: K1

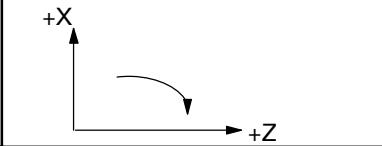
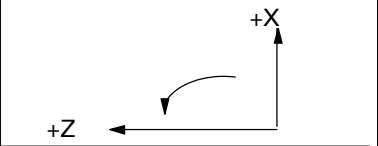
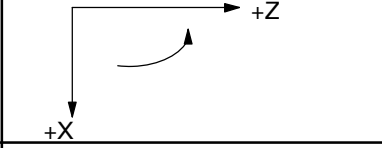
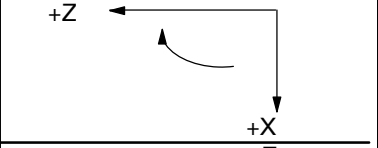
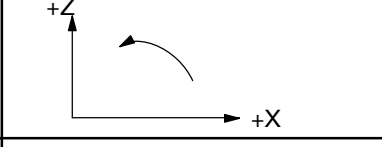
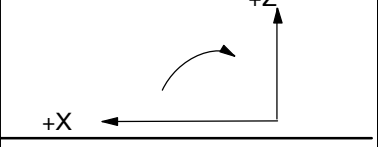
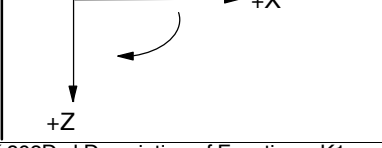
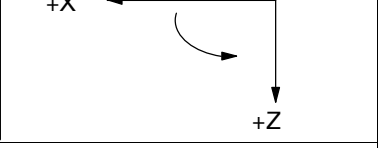
290 MD number	<b>CTM_POS_COORDINATE_SYSTEM</b> Simulation of actual-value refresh rate			
Meaning:	The position of the coordinate system can be altered as follows:			
	0		1	
	2		3	
	4		5	
	6		7	
Note for the reader:	SINUMERIK 802D sl Description of Functions: K1			

291 MD number	<b>CTM_CROSS_AX_DIAMETER_ON</b> Diameter display for active transverse axes
Meaning:	<b>0:</b> Inputs for absolute values as radius value. Zero offsets always as radius, tool lengths always as radius, tool wear always as radius <b>1:</b> Position display as diameter, distance to go as diameter absolute distances as diameter
Note for the reader:	SINUMERIK 802D sl Description of Functions: K1

292 MD number	<b>CTM_G91_DIAMETER_ON</b> Incremental infeed
Meaning:	<b>0:</b> Input in radius <b>1:</b> Input in diameter
Note for the reader:	SINUMERIK 802D sl Description of Functions: K1

361 MD number	<b>MEAS_TOOL_CHANGE</b> Input enable for T/D no. for tool measuring
Meaning:	<b>0:</b> T/D number input blocked <b>1:</b> T/D number input enabled
Note for the reader:	SINUMERIK 802D sl Description of Functions: M5

373	MEAS_SAVE_POS_LENGTH2
MD number	Enable tool measuring SK "Save Pos" for all values.
Meaning:	Controls "Save/Pos" softkey for "Manual tool measuring" function: 0: The SK "Save Pos" is only active when measuring length 1 1: SK "Save Pos" is generally active
Note for the reader:	SINUMERIK 802D sl Description of Functions: M5

## 4.2 General machine data

10000 MD number	<b>AXCONF_MACHAX_NAME_TAB[0]...[4]</b> Machine axis name
Meaning:	<p>The name of the machine axis is entered in this MD</p> <ul style="list-style-type: none"> <li>The preferred axis label (name) should be used comprising a valid address letter (A, B, C, Q, U, V, W, X, Y, Z), followed by an optional, numerical expansion (1–99).</li> <li>The selected machine axis label (name) must differ from the label (name) of geometry axes (X, Y, Z) and additional channel axes (MD 20080: AXCONF_CHANAX_NAME_TAB if a transformation is planned (e.g.: TRANSMITT)).</li> </ul> <p><b>Comment:</b> Transformation for SINUMERIK 802D, SW release P1, transformations are not available.</p> <ul style="list-style-type: none"> <li>A “free” entered machine axis label (axis name) may not be a name, address, keyword or predefined label or name that is already being used in the control or is reserved for other functions (e.g.: SPOS, DIAMON, ...).</li> </ul> <p><b>Note:</b> Not all the SINUMERIK control system functions are documented for 802D. Use of a free axis identifier is therefore conditional.</p>
Special cases, errors, ... ..	We recommend the following for machine axis identifiers: X1, Y1, Z1, U1, V1, W1, Q1 for linear axes, A1, B1, C1 for rotary axes
Related to ....	MD 20060: AXCONF_GEOAX_NAME_TAB (geometry axis identifier) MD 20080 :AXCONF_CHANAX_NAME_TAB (channel axis identifier)

10074 MD number	<b>PLC_IPO_TIME_RATIO</b> PLC task factor for main run (IPO)
Meaning:	<p>Division ratio between IPO and PLC tasks.</p> <p>A value of 2 means, for example, that the PLC task is processed in every second IPO cycle only. The PLC cycle time therefore equals 2 IPO times. More runtime is therefore available for the other tasks.</p> <p>The PLC runtime must not exceed this PLC cycle time, or a PLC STOP alarm will be triggered.</p>
Application example(s)	

10200 MD number	<b>INT_INCR_PER_MM</b> Calculation resolution for linear positions
Meaning:	The number of internal increments per millimeter is defined in this MD. The precision of the linear position input is limited to the calculation resolution by rounding-off the product of the programmed value and the calculation resolution to an integer value. To make the rounding clear, powers of 10 should be used for the calculation resolution.
Application example(s)	The calculation resolution can be increased to > 1000 incr./mm for linear axes operating to high accuracy requirements.
Note for the reader:	SINUMERIK 802D sl Description of Functions: G2

10210 MD number	<b>INT_INCR_PER_DEG</b> Computational resolution for angular positions
Meaning:	The number of internal increments per degree is defined in this MD. The precision of the angular position input is limited to the calculation resolution by rounding-off the product of the programmed value and the calculation resolution to an integer value. To make the rounding clear, powers of 10 should be used for the calculation resolution.
Application example(s)	The calculation resolution can be changed to > 1000 incr./degrees for a high-resolution rotary axis.
Note for the reader:	SINUMERIK 802D sl Description of Functions: G2

10240 MD number	<b>SCALING_SYSTEM_IS_METRIC</b> Basic system metric						
Meaning:	<p>The MD defines the basic system used by the control to scale length-dependent physical quantities during data input/output.</p> <p>All related data are stored internally in the basic units 1 mm, 1 degree and 1 sec.</p> <p>When accessing a part program via the operator panel or from an external device, scaling is in the following units:</p> <p>SCALING_SYSTEM_IS_METRIC = 1: normalized to: mm, mm/min, m/s<sup>2</sup>, m/s<sup>3</sup>mm/rev</p> <p>SCALING_SYSTEM_IS_METRIC = 0: normalized to: inch, inch/min, inch/s<sup>2</sup>inch/s<sup>3</sup>: inch/rev</p> <p>The selection of the basic system also specifies the interpretation of the programmed F value for linear axes:</p> <table style="margin-left: 40px;"> <tr> <td style="padding-right: 20px;">metric</td> <td>inch</td> </tr> <tr> <td>G94 mm/min</td> <td>inch/min</td> </tr> <tr> <td>G95 mm/rev</td> <td>inch/rev</td> </tr> </table> <p>A power-up is necessary after changing this machine data, as associated machine data that have physical units will otherwise be normalized incorrectly.</p> <p>Perform the following steps:</p> <ul style="list-style-type: none"> <li>• MD change by manual input <ul style="list-style-type: none"> <li>⇒ First perform start-up and then enter the physical units in the related machine data.</li> </ul> </li> <li>• MD change via machine data file <ul style="list-style-type: none"> <li>⇒ First perform start-up and then reload the machine data file so that the new physical units are activated.</li> </ul> </li> </ul> <p>If the machine data are altered, alarm 4070 "Scaling machine data altered" is output.</p>	metric	inch	G94 mm/min	inch/min	G95 mm/rev	inch/rev
metric	inch						
G94 mm/min	inch/min						
G95 mm/rev	inch/rev						
Application example(s)	Installation in the metric system and then conversion to inch system.						
Note for the reader:	SINUMERIK 802D sl Description of Functions: G2						

11100 MD number	<b>AUXFU_MAXNUM_GROUP_ASSIGN</b> Number of auxiliary functions distributed among the AUXFU groups
Meaning:	The number of the auxiliary functions that have been distributed to the groups must be entered in the MD. This number only includes the customer-specific auxiliary functions, not the predefined auxiliary functions.
Application example(s)	
Related to ....	MD 22010: AUXFU_ASSIGN_TYPE [n] (auxiliary function type)
Note for the reader:	SINUMERIK 802D sl Description of Functions: H2

11210 MD number	<b>UPLOAD_MD_CHANGES_ONLY</b> MD backup of changed MD only
Meaning:	<p>Selection of differential MD upload:</p> <p><b>Bit0(LSB)</b> Effectiveness of the differential upload for TEA files (machine data files) 0: All data are output 1: only the values changed as compared to the compiled MD are output</p> <p><b>Bit1</b> Effectiveness of the differential upload for INI files 0: All data are output 1: only the values changed as compared to the compiled MD are output</p> <p><b>Bit2</b> change of a field element 0: complete arrays are output 1: only changed field elements of an array are output</p> <p><b>Bit3</b> R parameter (for INI files only) 0: All R parameters are output 1: only R parameters unequal to '0' are output</p> <p><b>Bit4</b> frames (for INI files only) 0: All frames are output 1: only frames are output which are not zero frames.</p> <p><b>Bit5</b> tool data (cutting edge parameter) (for INI files only) 0: All tool data are output 1: only tool data unequal to '0' are output.</p>

## 4.2 General machine data

11240 MD number	<b>PROFIBUS_SDB_NUMBER</b> SDB1000 number
Meaning:	<p><b>BUS_SDB_NUMBER [0] = 0</b> Digital inputs and outputs via I/O modules (PP modules) The assignment is provided via DIL switches. Max. 3 modules with the addresses 9, 8 and 7 are possible.</p> <p><b>PROFIBUS_SDB_NUMBER [2] = X</b> Number of the system module you are using for configuring the hardware I/Os. SINUMERIK 802D sl offers the following options to choose from:</p> <p><b>0:</b> 2 SINAMICS drives with SLM <b>1:</b> 3 SINAMICS drives with SLM <b>2:</b> 4 SINAMICS drives with SLM <b>3:</b> 5 SINAMICS drives with SLM</p> <p><b>4:</b> 3 SINAMICS drives with ALM <b>5:</b> 4 SINAMICS drives with ALM <b>6:</b> 5 SINAMICS drives with ALM</p> <p>Note: With the SDB reloaded from the toolbox, PROFIBUS_SDB_NUMBER[2] = 0 must be set. This activates the module. The machine data PROFIBUS_SDB_NUMBER[1] and PROFIBUS_SDB_NUMBER[3] are reserved internally for Siemens.</p>
Note for the reader:	SINUMERIK 802D sl Description of Functions: G2
11310 MD number	<b>MN_HANDWH_REVERSE</b> Threshold for change in handwheel direction
Meaning:	<p><b>0:</b> No immediate movement in the opposite direction <b>&gt; 0:</b> Immediate movement in the opposite direction if the handwheel is turned in the opposite direction by at least the number of pulses indicated</p>
Note for the reader:	SINUMERIK 802D sl Description of Functions: H1
11320 MD number	<b>HANDWH_IMP_PER_LATCH[0]...[2]</b> Handwheel pulses per detent position [handwheel index]:
Meaning:	<p>This adapts the connected handwheels to the control system. The number of pulses generated by the handwheel for each handwheel detent position is entered. The handwheel pulse weighting may be defined for each connected handwheel (1 to 2) separately. When adapted to the control, each handwheel detent position has the same effect as one press of the traverse key in incremental jogging mode. If a negative value is entered, the handwheel is active in the reverse direction.</p>
Related to ....	MD: JOG_INCR_WEIGHT (weighting of an increment of a machine axis for INC/manual).
Note for the reader:	SINUMERIK 802D sl Description of Functions: H1
11346 MD number	<b>HANDWH_TRUE_DISTANCE</b> Handwheel path or velocity values
Meaning:	<p><b>0:</b> The settings from the handwheel are velocity settings. When the handwheel is stationary, braking is realized along the shortest path. <b>1:</b> The settings from the handwheel are distance settings. No pulses are lost. Limiting the velocity to the maximum permissible value can cause the axes to overtravel. <b>2:</b> Effect as for value=0, however, with a longer braking travel when the handwheel is stationary. <b>3:</b> Effect as for value=1, however, with a longer braking travel when the handwheel is stationary.</p>
Related to ....	
Note for the reader:	SINUMERIK 802D sl Description of Functions: H1

13060 MD number	<b>DRIVE_TELEGRAM_TYPE[n]</b> Default message frame type for drives connected to PROFIBUS DP
Meaning:	The message frame type: <b>102:</b> must be specified for each drive. Standard message frame for SINAMICS actual-value assignment <b>103:</b> SINAMICS– Spindle with second direct measuring system Index [n] of the machine data has the following code: [drive index]: n=0: Drive number 1 n=1: Drive number 2, etc.
Note for the reader:	SINUMERIK 802D sl Description of Functions: G2
13200 MD number	<b>MEAS_PROBE_LOW_ACTIVE[0]</b> Switching characteristics of probe
Meaning:	<b>0:</b> non-deflected status 0 V      deflected status 24 V <b>1:</b> non-deflected status 24 V      deflected status 0 V
Note for the reader:	SINUMERIK 802D sl Description of Functions: M5
14510 MD number	<b>USER_DATA_INT[0]...[31]</b> User data (INT)
Meaning:	User machine data, evaluation in PLC (displayed as whole number, decimal)
14512 MD number	<b>USER_DATA_HEX[0]...[31]</b> User data (HEX)
Meaning:	User machine data, evaluation in PLC (display in HEX format) 1)
14514 MD number	<b>USER_DATA_FLOAT[0]...[7]</b> User data (FLOAT)
Meaning:	User machine data, evaluation in PLC (floating point format, restricted to 32Bit IEEE format in PLC)
14516 MD number	<b>USER_DATA_PLC_ALARM[0]...[31]</b> User data (HEX)
Meaning:	User data, evaluation in PLC (display in HEX format) 1)
18080 ** MD number	<b>MM_TOOL_MANAGEMENT_MASK</b> Memory reservation for the tool monitoring
Meaning:	Value = 0: no memory is reserved, tool monitoring not possible Value = 0x2: Monitoring data/memory is made available (only possible if "Tool monitoring" option is present)
Related to ....	MD 20310: TOOL_MANAGEMENT_MASK
Note for the reader:	SINUMERIK 802D sl Description of Functions: W1

\*\* This machine data is **not** available with 802D sl value.

## 4.3 Channel-specific machine data

20050 MD number	<b>AXCONF_GEOAX_ASSIGN_TAB[0]...[2]</b> Assignment between geometry axis and channel axis
Meaning:	This MD assigns a geometry axis to a channel axis. The assignment must be made for all 3 geometry axes (X,Y,Z). If a geometry axis is not assigned, the value 0 should be entered. The geometry axis is therefore not available and cannot be programmed, e.g. if the second geometry axis is not required for the "turning" technology Y → entry: value 0 (see default setting for turning).
Special cases, errors, ... ..	It is advisable to assign the first channel axes to the geometry axes.

20070 MD number	<b>AXCONF_MACHAX_USED[0]...[4]</b> Machine axis number valid in channel
Meaning:	This MD assigns a machine axis to a channel axis. SINUMERIK 802D has 5 channel axes. Channel axis identifiers for the axes activated in the channel must be specified in MD 20080: AXCONF_CHANAX_NAME_TAB. The axes can be programmed.  A machine axis that has not been assigned to a channel axis is not active i.e. no axis control, no display on the screen.
Special cases, errors, ... ..	A channel axis and therefore indirectly a machine axis must be assigned to each geometry axis to be programmed. The remaining axes (besides the geometry axes) in the channel are additional axes – also programmable.
Application example(s)	Example of assigning the machine axis (MA) to the channel axes: AXCONF_MACHAX_USED [0] = 3                   ;3rd MA is 1st axis in the channel AXCONF_MACHAX_USED [1] = 1                   ;1st MA is 2nd axis in the channel AXCONF_MACHAX_USED [2] = 5                   ;5th MA is 3rd axis in the channel AXCONF_MACHAX_USED [3] = 0                   ; no assignment Note: Leave no spaces!, Example of programming error: AXCONF_MACHAX_USED [0] = 1                   ;1st MA is 1st axis in the channel AXCONF_MACHAX_USED [1] = 2                   ;2nd MA is 2nd axis in the channel AXCONF_MACHAX_USED [2] = 0                   ;space in list ... AXCONF_MACHAX_USED [3] = 3                   ;... of the channel axes
Related to ....	MD 20080: AXCONF_CHANAX_NAME_TAB[0]...[4] (channel axis identifier)

20080 MD number	<b>AXCONF_CHANAX_NAME_TAB[0]...[4]</b> Channel axis name
Meaning:	In this MD you can set the name of the channel axis. The channel axis is displayed with this identifier in the WCS. This identifier is also written in the program. Generally, the first two or three channel axes are used as geometry axes (see also MD 20050: AXCONF_GEOAX_ASSIGN_TAB). The remaining channel axes are defined as special axes. SINUMERIK 802D has 5 channel axes.
Special cases, errors, ... ..	We recommend the following for the channel axis identifiers: X, Y, Z, U, V, W, Q           for linear axes, A, B, C                       for rotary axes If you decide to use names other than those recommended, follow the rules for creating axis identifiers (see MD 10000: AXCONF_MACHAX_NAME_TAB).

20090 MD number	<b>SPIND_DEF_MASTER_SPIND</b>
Meaning:	Definition of the master spindle default setting (in channel). The spindle number is entered. A series of functions are linked to the master spindle which are not possible for a different spindle. Note: The SETMS(n) language command can be used to declare the spindle number n as master spindle. The spindle defined as master spindle in this MD is declared as master spindle again with SETMS. At the program end or program termination, the spindle defined in this MD is also declared as master spindle.
Further references	
Note for the reader:	SINUMERIK 802D sl Description of Functions: S1

20140 MD number	<b>TRAF0_RESET_VALUE</b> Active transformation following RESET
Meaning:	Definition of the transformation data set selected during booting and for a reset or an end of the part program. (In conjunction with machine data \$MC_RESET_MODE_MASK and for a part program start in conjunction with machine data \$MC_START_MODE_MASK)
Note for the reader:	SINUMERIK 802D sl Description of Functions: M1

20310 ** MD number	<b>TOOL_MANAGEMENT_MASK</b> Activation of the tool monitoring
Meaning:	Value = 0: no tool monitoring Value = 0x2: Tool monitoring activated (only possible if "Tool monitoring" option is present)
Related to ....	MD 18080: MM_TOOL_MANAGEMENT_MASK
Note for the reader:	SINUMERIK 802D sl Description of Functions: W1

\*\* This machine data is **not** available with 802D sl value.

20360 MD number	<b>TOOL_PARAMETER_DEF_MASK</b> Definition of tool parameters
Meaning:	Bit 0 = 0: For turning tools the wear parameter of the transverse axis X is applied as a radius value. Bit 0 = 1: For turning tools the wear parameter of the transverse axis X is applied as a diameter value.
Special cases, errors, ... ..	
Note for the reader:	SINUMERIK 802D sl Description of Functions: W1

20700 MD number	<b>REFP_NC_START_LOCK</b> NC start disable without reference point
Meaning:	<b>0:</b> The "NC start" interface signal (V3200 0007.1) for starting part programs or part program blocks (MDA) is also possible if none or not all channel axes are referenced. To ensure that the axes move to the correct position after NC Start, the workpiece coordinate system (WCS) must be set to a correct value by other methods (scratching method). <b>1:</b> The NC only starts if all of the axes have been referenced.
Note for the reader:	SINUMERIK 802D sl Description of Functions: R1

## 4.3 Channel-specific machine data

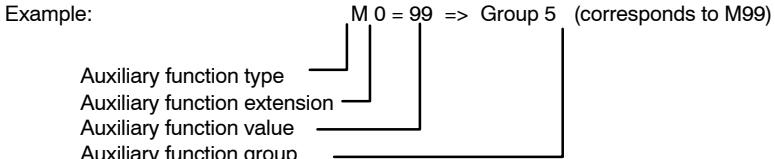
21000 MD number	<b>CIRCLE_ERROR_CONST</b> Circle end point monitoring constant
Meaning:	This machine data identifies the permissible absolute circle difference. In circle programming, the radii from the programmed center point to the starting point and to the end point are usually not equal (the circle is "overdefined"). The maximum permissible difference between these two radii which is accepted without an alarm being triggered is defined by the <b>larger value</b> in the following data: – MD: CIRCLE_ERROR_CONST – Start radius multiplied by 0.001 I.e. for small circles the tolerance is a fixed value (MD: CIRCLE_ERROR_CONST) and for large circles it is proportional to the start radius.
Application example	MD 21000: CIRCLE_ERROR_CONST = 0.01 mm With these MD and a radius $\leq 10$ mm, the constant has an effect, with $> 10$ mm, the proportional factor has an effect.
Note for the reader:	SINUMERIK 802D sl Description of Functions: K1
21020 MD number	<b>WORKAREA_WITH_TOOL_RADIUS</b> Allowance for tool radius with working area limiting
Meaning:	<b>0:</b> The tool radius is not taken into account. <b>1:</b> The tool radius is taken into account with respect to the working area limit.
Note for the reader:	SINUMERIK 802D sl Description of Functions: A3
22000 MD number	<b>AUXFU_ASSIGN_GROUP[n]</b> Auxiliary function group [aux. func. no. in channel]: 0 ... 63
Meaning:	see MD 22010: AUXFU_ASSIGN_TYPE [n] (auxiliary function type)
Application example(s)	
Note for the reader:	SINUMERIK 802D sl Description of Functions: H2
22010 MD number	<b>AUXFU_ASSIGN_TYPE[n]</b> Auxiliary function type [aux. func. no. in channel]: 0 ... 63
Meaning:	This MD (auxiliary function type) and MD 22020: AUXFU_ASSIGN_EXTENSION[n] (auxiliary function extension) and MD 22030: AUXFU_ASSIGN_VALUE[n] (auxiliary function value) and MD 22000: AUXFU_ASSIGN_GROUP[n] (auxiliary function group) are used to allocate an auxiliary function type (M, H, T, D, S), the related extension and the auxiliary function value to an auxiliary function group. Example:  <p>⇒ MD: AUXFU_ASSIGN_TYPE[0] = M MD: AUXFU_ASSIGN_EXTENSION[0] = 0 ; other values only for type H MD: AUXFU_ASSIGN_VALUE[0] = 99 MD: AUXFU_ASSIGN_GROUP[0] = 5 ; (Group 5)</p> <p>M00, M01, M02, (M17 and M30) are assigned to Group 1 by default. M3, M4, M5 are assigned to Group 2 by default.</p> <p>The machine data index [n] indicates the auxiliary function number in the channel: 0–63 All auxiliary functions that are assigned to auxiliary function groups must be numbered in ascending order. [0] ≠ 1st auxiliary function [1] ≠ 2. ,, ...</p> <p>The machine data for the allocation of an auxiliary function to an auxiliary function group must be provided with the same index [n].</p>
Special cases, errors, ... ..	If the auxiliary function value of an auxiliary function is less than 0, then all auxiliary functions of this type and extension are assigned to a group.
Related to ....	MD 11100: AUXFU_MAXNUM_GROUP_ASSIGN
Note for the reader:	SINUMERIK 802D sl Description of Functions: H2

22020 MD number	<b>AUXFU_ASSIGN_EXTENSION[n]</b> Auxiliary function extension [aux. func. no. in channel]: 0 ... 63
Meaning:	see MD 22010: AUXFU_ASSIGN_TYPE [n] (auxiliary function type)
Application example(s)	
22030 MD number	<b>AUXFU_ASSIGN_VALUE[n]</b> Auxiliary function value [aux. func. no. in channel]: 0 ... 63
Meaning:	If the value in this MD is smaller than 0 all auxiliary functions of this type and this address extension are assigned to this group. See MD 22010: AUXFU_ASSIGN_TYPE [n] (auxiliary function type)
Note for the reader:	SINUMERIK 802D sl Description of Functions: H2
22534 MD number	<b>TRAF0_CHANGE_M_CODE</b> M code for transformation changeover
Meaning:	Number of M code that is output at the VDI interface in the case of a transformation changeover on the geometry axes. No M code is output if this MD is set to one of the values 0 to 6, 17 or 30. It is not monitored whether an M code created in this way will conflict with other functions.
Note for the reader:	SINUMERIK 802D sl Description of Functions: M1
22550 MD number	<b>TOOL_CHANGE_MODE</b> New tool offset for M function
Meaning:	The T function is used to select a tool in a program. The setting in this machine data determines whether the new tool is loaded immediately on execution of the T function:  <b>1:</b> The new tool is prepared for changing with the T function. This setting is used mainly on milling machines with a tool magazine, in order to bring the new tool into the tool change position without interrupting the machining process. The old tool is removed from the spindle with an M function and the new tool is loaded into the spindle. According to DIN 66025, this tool change is programmed using the M function <b>M6</b> .
Related to ....	
Note for the reader:	SINUMERIK 802D sl Description of Functions: W1
24100 MD number	<b>TRAF0_TYPE_1</b> Type of 1st transformation
Meaning:	Transformation type of 1st transformation: 0 no transformation 256 TRANSMIT transformation 512 TRACYL transformation 513 TRACYL transformation with X-Y-Z-C kinematics  further transformations are not available with SINUMERIK 802D.
MD irrelevant for ... ..	No transformations
Related to ....	TRAF0_TYPE_2
Note for the reader:	SINUMERIK 802D sl Description of Functions: M1
24110 MD number	<b>TRAF0_AXES_IN_1[i]</b> Axis assignment for transformation 1 [axis index]: 0 ... 4
Meaning:	Axis assignment at input of 1st transformation Example for Transmit: Index i assumes the values 0,1, 2 with TRANSMIT. \$MC_TRAFO_AXES_IN_1[0]= channel axis number of axis perpendicular to rotary axis \$MC_TRAFO_AXES_IN_1[1]= channel axis number of rotary axis \$MC_TRAFO_AXES_IN_1[2]= channel axis number of axis parallel to rotary axis Example for TRACYL: see TRACYL section
MD irrelevant for ... ..	No transformation
Related to ....	TRAF0_AXES_IN_2
Note for the reader:	SINUMERIK 802D sl Description of Functions: M1

## 4.3 Channel-specific machine data

24120 MD number	<b>TRAFO_GEOAX_ASSIGN_TAB_1[i]</b> Assignment of geometry axes to channel axes with transformation 1 [geometry axis number]: 0 ... 2
Meaning:	This MD specifies the channel axes on which the axes of the Cartesian coordinate system are mapped when transformation 1 is active. Index i assumes the values 0, 1, 2 with TRANSMIT. It refers to the first, second and third geometry axis.
MD irrelevant for ... ..	No transformation
Application example(s)	\$MC_TRAFO_GEOAX_ASSIGN_TAB_1[0]= 2 ; 2nd channel axis
Related to ....	\$MC_AXCONF_GEOAX_ASSIGN_TAB, if no transformation is active.
Note for the reader:	SINUMERIK 802D sl Description of Functions: M1

24200 MD number	<b>TRAFO_TYPE_2</b> Type of transformation
Meaning:	Same as TRAFO_TYPE_1, but for transformation 2
Note for the reader:	SINUMERIK 802D sl Description of Functions: M1

24210 MD number	<b>TRAFO_AXES_IN_2[i]</b> Axis assignment for transformation 2/3/4/5/6/7/8 [axis index]: 0 ... 4
Meaning:	Axis assignment at input of 2nd transformation. Same meaning as for TRAFO_AXES_IN_1.
Note for the reader:	SINUMERIK 802D sl Description of Functions: M1

24220 MD number	<b>TRAFO_GEOAX_ASSIGN_TAB_2[i]</b> Assignment of geometry axes to channel axes with transformation 2 [geometry axis number]: 0 ... 2
Meaning:	The channel axes on which the axes of the Cartesian coordinate system are mapped when transformation 2 is active are set in this MD. The meaning otherwise corresponds to TRAFO_GEOAX_ASSIGN_TAB_1.
Note for the reader:	SINUMERIK 802D sl Description of Functions: M1

24800 MD number	<b>TRACYL_ROT_AX_OFFSET_1</b> Offset of rotary axis for the TRACYL transformation
Meaning:	Specifies the offset of the rotary axis in degrees in relation to the zero position while TRACYL is active for the first declared TRACYL transformation for each channel.
MD irrelevant for ... ..	No TRACYL active
Application example(s)	\$MC_TRACYL_ROT_AX_OFFSET_1=15.0
Note for the reader:	SINUMERIK 802D sl Description of Functions: M1

24810 MD number	<b>TRACYL_ROT_SIGN_IS_PLUS_1</b> Sign of rotary axis for the TRACYL transformation
Meaning:	Specifies the sign which is applied to the rotary axis during the TRACYL transformation for the TRACYL transformation.
MD irrelevant for ... ..	No TRACYL transformation
Application example(s)	\$MC_TRACYL_ROT_SIGN_IS_PLUS_1 = 1
Note for the reader:	SINUMERIK 802D sl Description of Functions: M1

24820 MD number	<b>TRACYL_BASE_TOOL_1[i]</b> Vector of base tool for TRACYL transformation, [Geo-Axis-Index]: 0 ... 2
Meaning:	MD specifies the distance of the tool zero point referred to the appropriate geometry axes valid with TRACYL active and without tool length offset selected for the TRACYL transformation. Programmed length compensations are added to the base tool. Index i assumes values 0, 1, 2 for the 1st to 3rd geometry axes.
MD irrelevant for ... ..	No TRACYL transformation
Application example(s)	\$MC_TRACYL_BASE_TOOL_1[0]=tx
Note for the reader:	SINUMERIK 802D sl Description of Functions: M1

24900 MD number	<b>TRANSMIT_ROT_AX_OFFSET_1</b> Position offset of rotary axis
Meaning:	Specifies the offset of the rotary axis in degrees in relation to the zero position – while TRANSMIT is active – for the TRANSMIT transformation.
MD irrelevant for ... ..	No TRANSMIT active
Application example(s)	\$MC_TRANSMIT_ROT_AX_OFFSET_1=15.0
Note for the reader:	SINUMERIK 802D sl Description of Functions: M1

24910 MD number	<b>TRANSMIT_ROT_SIGN_IS_PLUS_1</b> Sign of rotary axis
Meaning:	Specifies the sign which is applied to the rotary axis during the TRANSMIT transformation for the TRANSMIT transformation.
MD irrelevant for ... ..	No TRANSMIT transformation
Application example(s)	\$MC_TRANSMIT_ROT_SIGN_IS_PLUS_1= 1
Note for the reader:	SINUMERIK 802D sl Description of Functions: M1

24911 MD number	<b>TRANSMIT_POLE_SIDE_FIX_1</b> Restriction of working range in front of/behind pole
Meaning:	Restriction of working range in front of/behind pole or no restrictions, i.e. traversal through pole. The setpoints have the following meanings: <b>0:</b> No restrictions of working range. Traversal through pole.  1: Working range of linear axis for positions $\geq 0$ , (if tool length compensation parallel to linear axis equals 0) 2: Working range of linear axis for positions $\leq 0$ , (if tool length compensation parallel to the linear axis equals 0)
Note for the reader:	SINUMERIK 802D sl Description of Functions: M1

24920 MD number	<b>TRANSMIT_BASE_TOOL_1[i]</b> Vector of base tool on activation of transformation, [Geo-Axis-Index]: 0 ... 2
Meaning:	MD specifies the distance of the tool zero point referred to the appropriate geometry axes valid with TRANSMIT active and without tool length offset selected for the TRANSMIT transformation. Programmed length compensations are added to the base tool. Index i assumes values 0, 1, 2 for the 1st to 3rd geometry axes.
MD irrelevant for ... ..	No TRANSMIT transformation
Application example(s)	\$MC_TRANSMIT_BASE_TOOL_1[0]=20.0
Note for the reader:	SINUMERIK 802D sl Description of Functions: M1

27800 MD number	<b>TECHNOLOGY_MODE</b> Technology in channel
Meaning:	Selection of the technology for display and operating purposes (HMI) <b>0:</b> Milling <b>1:</b> Turning This makes technology-dependent displays and softkeys available in the HMI.
Special cases, errors, ... ..	

## 4.3 Channel-specific machine data

27860 MD number	<b>PROCESSTIMER_MODE</b> Activating the program runtime measurement
Meaning:	<p>The channel-specific timers can be activated/deactivated through this machine data.</p> <p>Meaning:</p> <p>Bit 0 = 0      No measurement of the total runtime for all part programs          Bit 0 = 1      The measurement of the total runtime for all part programs is active ( \$AC_OPERATING_TIME )</p> <p>Bit 1 = 0      No measurement of the current program runtime          Bit 1 = 1      The measurement of the current program runtime is active ( \$AC_CYCLE_TIME )</p> <p>Bit 2 = 0      No measurement of the tool cutting time          Bit 2 = 1      The measurement of the tool cutting time is active ( \$AC_CUTTING_TIME )</p> <p>Bit 3            Reserved</p> <p>Further bits only for Bit 0, 1, 2 = 1:</p> <p>Bit 4 = 0      No measurement with active dry run feedrate          Bit 4 = 1      Measurement also with active dry run feed          Bit 5 = 0      No measurement in program test          Bit 5 = 1      Measurement also in program test          Bit 6, 7       Reserved</p>
Application example	
Special cases, errors, ...	It is recommended that timers that are never used are deactivated. This helps the free-up computational time other user applications.
Note for the reader:	SINUMERIK 802D sl Description of Functions: K1

27880 MD number	<b>PART_COUNTER</b> Activation of the workpiece counters
Meaning:	<p>The workpiece counters can be set with this machine data. Meaning of the individual Bits:</p> <p>Bit 0 – 3: Activation \$AC_REQUIRED_PARTS</p> <p>-----</p> <p>Bit 0 = 1: Counter \$AC_REQUIRED_PARTS is active Further meaning Bit 1–3 only when bit 0 = 1:</p> <p>Bit 1 = 0: Alarm IS output when \$AC_ACTUAL_PARTS matches \$AC_REQUIRED_PARTS Bit 1 = 1: Alarm IS output when \$AC_SPECIAL_PARTS matches \$AC_REQUIRED_PARTS Bit 2, 3 Reserved</p> <p>Bit 4 – 7: Activation \$AC_TOTAL_PARTS</p> <p>-----</p> <p>BBit 4 = 1: Counter \$AC_TOTAL_PARTS is active Further meaning Bit 5–7 only when Bit 4 = 1:</p> <p>Bit 5 = 0: Counter \$AC_TOTAL_PARTS is incremented by 1 on output of M2/M30. Bit 5 = 1: Counter \$AC_TOTAL_PARTS is incremented by 1 on the M command from MD 27882: PART_COUNTER_MCODE[0]</p> <p>Bit 6 = 0: Counter \$AC_TOTAL_PARTS also active in program test/block search Bit 6 = 1: no processing \$AC_TOTAL_PARTS in program test/block search Bit 7 Reserved</p> <p>Bit 8 – 11: Activation \$AC_ACTUAL_PARTS</p> <p>-----</p> <p>Bit 8 = 1: Counter \$AC_ACTUAL_PARTS is active Further meaning Bit 9–11 only when Bit 8 = 1:</p> <p>Bit 9 = 0: Counter \$AC_ACTUAL_PARTS is incremented by 1 on output of M2/M30. Bit 9 = 1: Counter \$AC_ACTUAL_PARTS is incremented by 1 on the M command from MD 27882: PART_COUNTER_MCODE[1]</p> <p>Bit 10 = 0: Counter \$AC_ACTUAL_PARTS also active in program test/block search Bit 10 = 1: no processing \$AC_ACTUAL_PARTS in program test/block search Bit 11 Reserved</p> <p>Bit 12 – 15: Activation \$AC_SPECIAL_PARTS</p> <p>-----</p> <p>Bit 12 = 1: Counter \$AC_SPECIAL_PARTS is active Further meaning Bit 13–15 only when Bit 12 = 1:</p> <p>Bit 13 = 0: Counter \$AC_SPECIAL_PARTS is incremented by 1 on output of M2/M30 Bit 13 = 1: Counter \$AC_SPECIAL_PARTS is incremented by 1 on output of the M command from MD 27882: PART_COUNTER_MCODE[2]</p> <p>Bit 14, 15 Reserved</p>
Application example	
Related to ....	MD 27882: PART_COUNTER_MCODE IS "Required number of workpieces reached" (V3300 40001.1)
Note for the reader:	SINUMERIK 802D sl Description of Functions: K1

27882 MD number	<b>PART_COUNTER_MCODE[n]</b> n = 0 ... 2 , index for counter assignment Workpiece counting via M command
Meaning:	<p>On activation of workpiece counting through MD 27880: PART_COUNTER the counting pulse can be triggered by a special M command. Only in this case are the values defined here observed. Meaning: The workpiece counters are incremented by 1 at the IS signal output of the described M command. The following applies:</p> <p style="padding-left: 40px;">\$PART_COUNTER_MCODE[0] for \$AC_TOTAL_PARTS \$PART_COUNTER_MCODE[1] for \$AC_ACTUAL_PARTS \$PART_COUNTER_MCODE[2] for \$AC_SPECIAL_PARTS</p>
Application example	
Related to ....	MD 27880: PART_COUNTER
Note for the reader:	SINUMERIK 802D sl Description of Functions: K1

## 4.4 Axis-specific machine data

30110 MD number	<b>CTRLOUT_MODULE_NR[n]</b> Setpoint: Drive number/module number
Meaning:	For a standard axis, the drive number must be entered.  Index [n] of the machine data is coded as follows: [setpoint branch]: 0
Note for the reader:	SINUMERIK 802D sl Description of Functions: G2

30120 MD number	<b>CTRLOUT_NR[n]</b> Setpoint: Output to module:
Meaning:	The number of the output on a module via which the setpoint output is addressed is entered here.  Index[n] of the machine data is coded as follows: [setpoint branch]: 0
Note for the reader:	SINUMERIK 802D sl Description of Functions: G2

30130 MD number	<b>CTRLOUT_TYPE[n]</b> Output type of setpoint
Meaning:	The speed setpoint output type is entered in the MD: <b>0:</b> Simulation (no HW required) <b>1:</b> Setpoint output active The index [n] of the machine data has the following code: [setpoint branch]: 0
Application example(s)	Simulation: Machine functions can be simulated even if there is no drive system.
Note for the reader:	SINUMERIK 802D sl Description of Functions: G2

30134 MD number	<b>IS_UNIPOLAR_OUTPUT[0]</b> Setpoint output is unipolar
Meaning:	
Application example(s)	Unipolar output driver (for unipolar, analog drive actuator) → <b>analog spindle:</b> For unipolar setting, only positive speed setpoints are supplied to the drive; the sign of the speed setpoint value is output separately in its own digital control signal.  <b>0:</b> Bipolar output ( $\pm 10V$ ) with pos./neg. speed setpoint value, controller enable (regular case) <b>1:</b> Unipolar output 0...+10V with enabling and direction signal (controller enable, neg. direction of travel) <b>2:</b> unipolar output 0...+10V with linkage of enabling and direction of travel signals (controlling pos. direction of travel, controller enabling neg. direction of travel)
Note for the reader:	SINUMERIK 802D sl Description of Functions: S1

30200 MD number	<b>NUM_ENCS</b> Number of encoders
Meaning:	<b>1:</b> Spindle/axis with measuring system (in the motor or direct) <b>0:</b> No measuring system (possible for spindles)
Note for the reader:	SINUMERIK 802D sl Description of Functions: G2

30220 MD number	<b>ENC_MODULE_NR[n]</b> Actual value: Drive number/measuring circuit number
Meaning:	For a standard axis, the drive number must be entered.  Index [n] of the machine data is coded as follows: [encoder no.]: 0
Note for the reader:	SINUMERIK 802D sl Description of Functions: G2

30230 MD number	<b>ENC_INPUT_NR[n]</b> Actual value: Input number on module/ measuring circuit board
Meaning:	The number of the input on a module via which the encoder is addressed is entered here.  The index[n] of the machine data has the following code: [encoder no.]: 0
Application example(s)	Simulation: Machine functions can be simulated even if there is no measuring system.
Note for the reader:	SINUMERIK 802D sl Description of Functions: G2

30240 MD number	<b>ENC_TYPE[n]</b> Actual value: Encoder type
Meaning:	The encoder type used is entered in the MD: <b>0:</b> Simulation <b>1:</b> Raw signal generator (1VPP, sin, cos) <b>4:</b> Absolute encoder with EnDat interface 2, 3, 5: reserved The index[n] of the machine data has the following code: [encoder no.]: 0
Application example(s)	Simulation: Machine functions can be simulated even if there is no measuring system.
Note for the reader:	SINUMERIK 802D sl Description of Functions: G2

30300 MD number	<b>IS_ROT_AX</b> Rotary axis
Meaning:	<b>1:</b> Axis: The axis is defined as a "rotary axis". The units of the axis-specific machine data/setting data are interpreted by the control in default setting as follows: <ul style="list-style-type: none"> <li>• position in degrees</li> <li>• velocity in rev/min</li> <li>• acceleration in rev/s<sup>2</sup></li> <li>• jerk limiting in rev/s<sup>3</sup></li> </ul> Spindle: For a spindle the machine data should always be set to "1", or alarm 4210 "Rotary axis declaration missing" is sent. <b>0:</b> The axis is defined as a linear axis.
Special cases, errors, ... ..	For axis: alarm 4200 if the axis is already defined as a geometry axis. For spindle: Alarm 4210
Related to ....	The subsequent machine data only become effective after activating the MD 30300:IS_ROT_AX = 1: <ul style="list-style-type: none"> <li>• MD 30310:ROT_IS_MODULO (modulo conversion for rotary axis)</li> <li>• MD 30320:DISPLAY_IS_MODULO (position display is modulo)</li> <li>• MD 10210:INT_INCR_PER_DEG (calculation resolution for angular positions)</li> </ul>
References	Tab. 2.2 Combination options for machine data
Note for the reader:	SINUMERIK 802D sl Description of Functions: R2

30310 MD number	<b>ROT_IS_MODULO</b> Modulo conversion for rotary axis
Meaning:	<b>1:</b> A modulo conversion is performed on the setpoints for the rotary axis.. The software limit switches and the working area limits are <b>inoperative</b> ; the traversing range is therefore unlimited in both directions. ROT_IS_AX must be set to "1"  <b>0:</b> no modulo conversion
MD irrelevant for ... ..	MD 30300: IS_ROT_AX = 0 (linear axis)
Application example(s)	Continuously rotating axes (e.g. for eccentric rotation, grinding, winding)
Related to ....	MD 30320: DISPLAY_IS_MODULO (position display is modulo 360°) MD 30300: IS_ROT_AX = 1 (rotary axis) MD 36100: POS_LIMIT_MINUS (software limit switch minus) MD 36110: POS_LIMIT_PLUS (software limit switch plus) SD 43430: WORKAREA_LIMIT_MINUS (working area, limiting minus) SD 43420: WORKAREA_LIMIT_PLUS (working area, limiting plus)
Note for the reader:	SINUMERIK 802D sl Description of Functions: R2

## 4.4 Axis-specific machine data

30320 MD number	<b>DISPLAY_IS_MODULO</b> Position display "Modulo 360°"
Meaning:	<p><b>1:</b> Position display "Modulo 360 degree" is active: The position display of the rotary axis or spindle (for basic or machine coordinate system) is defined as "Modulo 360 degree". In the positive direction of rotation, the control periodically resets the position display internally to 0.000 degrees after 359.999 degrees. The display range is always positive and is always between 0 and 359.999 degrees</p> <p><b>0:</b> Absolute position display is active: Contrary to the modulo 360 degree position display, for the absolute position display – e.g. for a positive direction of rotation – after 1 revolution +360 degrees is displayed; after 2 revolutions, +720 degrees etc. Here, the display range is limited corresponding to the linear axes.</p>
MD irrelevant for ... ..	Linear axes MD 30300: IS_ROT_AX = 0
Application example(s)	<ul style="list-style-type: none"> <li>For endlessly rotating rotary axes (MD 30310:ROT_IS_MODULO = 1) we recommend that the position display is activated with modulo 360 degrees.</li> <li>For spindles, the position display should always be activated with 360 degrees.</li> </ul>
Related to ....	MD 30300: IS_ROT_AX (axis is rotary axis)
Note for the reader:	SINUMERIK 802D sl Description of Functions: R2

30350 MD number	<b>SIMU_AX_VDI_OUTPUT</b> Output of axis signals for simulation axes
Meaning:	<p>The machine data specifies whether axis-specific interface signals are output to the PLC during the simulation of an axis.</p> <p><b>1:</b> The axis-specific interface signals of a simulated axis are output to the PLC. The PLC user program can thus be tested even if the drives are not available.</p> <p><b>0:</b> The axis-specific interface signals of a simulated axis are not output to the PLC. All axis-specific interface signals are set to "0".</p>
MD irrelevant for ... ..	MD 30130: CTRLOUT_TYPE (output type of setpoint value) = 1
Application example(s)	MD: SIMU_AX_VDI_OUTPUT = 0 For instance, this prevents the brake from being opened during the simulation of an axis.
Note for the reader:	SINUMERIK 802D sl Description of Functions: G2

30600 MD number	<b>FIX_POINT_POS</b> Fixed value positions of axes with G75
Meaning:	This machine data is used to specify the fixed point position for an axis that is approached when G75 is programmed.
Application example(s)	Travel to fixed point: G75 X1=0 The machine axis identifier is programmed here! A dummy value, here 0, must be defined for the axis.
References	"Operation and Programming"1

31000 MD number	<b>ENC_IS_LINEAR</b> Direct measuring system (linear scale)
Meaning:	Value 1: Encoder is a linear scale
Note for the reader:	SINUMERIK 802D sl Description of Functions: G2

31010 MD number	<b>ENC_GRID_POINT_DIST</b> Distance between reference marks on linear scales
Meaning:	Distance of marks with linear encoders
Note for the reader:	SINUMERIK 802D sl Description of Functions: G2

31020 MD number	<b>ENC_RESOL[n]</b> Encoder pulses per revolution
Meaning:	The encoder lines per encoder revolution should entered in the MD. The index[n] of the machine data has the following code: [encoder no.]: 0
Note for the reader:	SINUMERIK 802D sl Description of Functions: G2

31030 MD number	<b>LEADSCREW_PITCH</b> Leadscrew pitch
Meaning:	The pitch of the leadscrew is entered in this MD.
Note for the reader:	SINUMERIK 802D sl Description of Functions: G2
31040 MD number	<b>ENC_IS_DIRECT[n]</b> Encoder is connected directly to the machine
Meaning:	<b>1:</b> Encoder for actual-value assignment is mounted directly at the machine. <b>0:</b> Encoder for actual-value assignment is mounted on the motor. The index[n] of the machine data has the following code: [encoder no.]: 0
Special cases, errors, ... ..	Entering the wrong information can cause an incorrect encoder resolution, because, for example, the wrong gear ratios are used for calculation.
Note for the reader:	SINUMERIK 802D sl Description of Functions: G2
31050 MD number	<b>DRIVE_AX_RATIO_DENOM[n]</b> Load gearbox, denominator
Meaning:	The denominator of the load gearbox should entered in the MD. The index[n] of the machine data has the following code: [closed-loop control set of parameters set no.]: 0–5
Note for the reader:	SINUMERIK 802D sl Description of Functions: G2
31060 MD number	<b>DRIVE_AX_RATIO_NUMERA[n]</b> Load gearbox, numerator
Meaning:	The numerator of the load gearbox should entered in the MD. The index[n] of the machine data has the code: Closed-loop control set of parameters set no.: 0–5
Note for the reader:	SINUMERIK 802D sl Description of Functions: G2
31070 MD number	<b>DRIVE_ENC_RATIO_DENOM[n]</b> Measuring gearbox denominator
Meaning:	The denominator of the measuring gearbox should entered in the MD. The index[n] of the machine data has the following code: [encoder no.]: 0
Note for the reader:	SINUMERIK 802D sl Description of Functions: G2
31080 MD number	<b>DRIVE_ENC_RATIO_NUMERA[n]</b> Measuring gearbox numerator
Meaning:	The numerator of the measuring gearbox should entered in the MD. The index[n] of the machine data has the following code: [encoder no.]: 0
Note for the reader:	SINUMERIK 802D sl Description of Functions: G2
31122 MD number	<b>BERO_DELAY_TIME_PLUS[0]</b> BERO delay time plus
Meaning:	In conjunction with the setting MD 34200: ENC_REFP_MODE = 7, the MD causes a signal propagation delay compensation in the positive direction of motion when a Bero (zero mark) is used for defining position.
Related to ....	MD 34200: ENC_REFP_MODE
Note for the reader:	SINUMERIK 802D sl Description of Functions: R1
31123 MD number	<b>BERO_DELAY_TIME_MINUS[0]</b> BERO delay time minus
Meaning:	In conjunction with the setting MD 34200: ENC_REFP_MODE = 7, the MD causes a signal propagation delay compensation in the negative direction of motion when a Bero (zero mark) is used for defining position.
Related to ....	MD 34200: ENC_REFP_MODE
Note for the reader:	SINUMERIK 802D sl Description of Functions: R1

## 4.4 Axis-specific machine data

32000 MD number	<b>MAX_AX_VELO</b> Maximum axis velocity
Meaning:	The limit velocity to which the axis can accelerate (rapid traverse limit) is entered in this MD. This velocity is used for traversing when rapid traverse G0 is programmed. The maximum linear or rotary axis velocity should be entered in the MD in accordance with MD 30300: IS_ROT_AX. The maximum permissible axis velocity depends on the machine and drive dynamics and the limit frequency of the actual-value acquisition.
Note for the reader:	SINUMERIK 802D sl Description of Functions: G2

32010 MD number	<b>JOG_VELO_RAPID</b> Rapid traverse in JOG mode
Meaning:	The axis velocity entered here applies when the rapid traverse override key is operated in JOG mode and when the feedrate override switch is set to 100%. The value entered may not exceed the maximum permissible axis velocity (MD 32000: MAX_AX_VELO). MD 32010 will <b>not</b> be used for the programmed rapid traverse G0.
MD irrelevant for ... ..	Operating modes AUTOMATIC and MDA
Related to ....	MD 32000: MAX_AX_VELO (maximum axis velocity) IS "Rapid traverse override" (V3200 1000.5, V3200 1004.5, V3200 1008.5, V380x 0004.5), IS "Feedrate override" (VB380x 0000) – axis-specific IS "Rapid traverse override" (VB3200 0005) – for geom. axes
Note for the reader:	SINUMERIK 802D sl Description of Functions: H1

32020 MD number	<b>JOG_VELO</b> Axis velocity in JOG mode
Meaning:	The velocity entered applies to traversing <b>axes</b> in JOG mode when the feedrate override switch is at position 100%. The velocity of MD 32020: JOG_VELO is only used when general setting data is SD 41110: JOG_SET_VELO = 0 for linear axes or SD 41130: JOG_ROT_AX_SET_VELO = 0 for rotary axes. If this is the case, the axis velocity is active for – Continuous jogging – Incremental traversing (INC1, ..., INCvar) The value entered may not exceed the maximum permissible axis velocity (MD 32000: MAX_AX_VELO).  <b>Spindle</b> in JOG mode: This can also be used to define the traverse velocity in JOG mode for specific spindles if SD 41200: JOG_SPIND_SET_VELO = 0. The velocity is influenced by the spindle speed override switch.
MD irrelevant for ... ..	Operating modes AUTOMATIC and MDA
Application example(s)	If different velocities have to be set for the individual axes traversing in JOG mode, this can be done for specific axes in this MD. SD 41110: JOG_SET_VELO (or equivalent) may be set to 0!
Related to ....	MD 32000: MAX_AX_VELO (maximum axis velocity) SD 41110: JOG_SET_VELO (JOG velocity for G94, linear axis) SD 41130: JOG_ROT_AX_SET_VELO (JOG velocity for rotary axes) SD 41200: JOG_SPIND_SET_VELO (JOG speed for spindle), which applies to all spindles, Axis-specific IS "Feedrate override" (VB380x 0000) Axis-specific IS "Spindle override" (VB380x 2003) Channel-specific IS "Feedrate override" (VB3200 0004) for geom. axes
Note for the reader:	SINUMERIK 802D sl Description of Functions: H1

32100 MD number	<b>AX_MOTION_DIR</b> Traversing direction
Meaning:	The traversing direction of the machine axis can be reversed with this MD. The control direction is not reversed, i.e. closed-loop control remains stable. <b>0 or 1:</b> Direction not reversed <b>-1:</b> Direction reversed

32110 MD number	<b>ENC_FEEDBACK_POL[n]</b> Sign of actual value (control direction)
Meaning:	The direction of evaluation of the rotary encoder signals is entered in this MD. <b>0 or 1:</b> Direction not reversed <b>-1:</b> Direction reversed If the direction is reversed, the control direction is also reversed if the encoder is used for position control. The index[n] of the machine data has the following code: [encoder no.]: 0 0
Special cases, errors, ...	If the wrong control direction is entered, the axis may go out of control. One of the following alarms is output, depending on the settings of the associated limit values: Alarm 25040 "Zero-speed monitoring" Alarm 25050 "Contour monitoring" Alarm 25060 "Speed setpoint limit" The associated limit values are described in: <b>References:</b> Chapter "Axis monitoring functions" The control direction selected might be incorrect if an uncontrolled setpoint jump occurs when a drive is connected.
Note for the reader:	SINUMERIK 802D sl Description of Functions: G2

32200 MD number	<b>POSCTRL_GAIN[n]</b> Servo gain factor
Meaning:	Position controller gain, so-called servo gain factor The input/output unit for the user is [(m/min)/mm]. That is, MD: POSCTRL_GAIN[n] = 1 corresponds to 1 mm following error at V = 1m/min.  If the value "0" is entered the position controller is opened. When entering the servo gain factor it is important to check that the gain factor of the whole position control loop is still dependent on other parameters of the controlled system. A distinction should be made between a "desired servo gain factor" (MD: POSCTRL_GAIN) and the "actual servo gain" (produced by the machine). Only when all the parameters of the control loop are matched will these servo gain factors be the same. <b>Note:</b> Axes which interpolate with one another for a machining operation must either have the same gain setting (i.e. an identical following error at the same velocity). The real servo gain factor can be checked with the following error in the service displays. The index[n] of the machine data has the following code: [closed-loop control set of parameters set no.]: 0-5
Note for the reader:	SINUMERIK 802D sl Description of Functions: G2

32300 MD number	<b>MAX_AX_ACCEL</b> Axis acceleration
Meaning:	The acceleration defines a change in velocity of the axis against time. Different axes do not have to have the same acceleration. The lowest acceleration value of all the axes involved in interpolation is taken into account. In the case of rotary axes, the entered value corresponds to the angular acceleration. The machine manufacturer should determine for which continuous deceleration and acceleration the machine is suitable. This value is entered in the machine data. The acceleration value is active for every type of acceleration and delay operation.
MD irrelevant for ...	Error states that lead to rapid stop.
Note for the reader:	SINUMERIK 802D sl Description of Functions: B2

32420 MD number	<b>JOG_AND_POS_JERK_ENABLE</b> Enabling axis-specific jerk limitation
Meaning:	Enables the axis-specific jerk limitation function for JOG and REF modes and positioning axis operation.
Related to ....	MD 32430: JOG_AND_POS_MAX_JERK (axis-specific jerk)
Note for the reader:	SINUMERIK 802D sl Description of Functions: B2

32430 MD number	<b>JOG_AND_POS_MAX_JERK</b> Axis-specific jerk
Meaning:	The jerk limitation restricts changes to axis acceleration in JOG mode.
MD irrelevant for ...	Path interpolation and error states that lead to rapid stop.
Related to ....	MD 32420: JOG_AND_POS_JERK_ENABLE (enabling of axis-specific jerk limitation)
Note for the reader:	SINUMERIK 802D sl Description of Functions: B2

## 4.4 Axis-specific machine data

32431	<b>MAX_AX_JERK</b>
MD number	Maximum axis-specific jerk during path motion (in AUTO, MDA mode)
Meaning:	This maximum axis-specific jerk is active for path motion. Path motion is possible in AUTO, MDA modes.
Related to ....	MD 32432: PATH_TRANS_JERK_LIM acts at block transition We recommend setting equal values for both MD.
Note for the reader:	SINUMERIK 802D sl Description of Functions: B2

32432	<b>PATH_TRANS_JERK_LIM</b>
MD number	Maximum axis-specific jerk during path movement at the block transition
Meaning:	The control limits the jerk (acceleration jump) at a block transition between contour sections of different curvature to the value set.
MD irrelevant for ... ..	Exact stop
Application example(s)	
Related to ....	Continuous path mode, SOFT type of acceleration MD 32431: MAX_AX_JERK (maximum axis-specific jerk with path movement) It is recommended to set both MD to the same values.
Note for the reader:	SINUMERIK 802D sl Description of Functions: B1

32450	<b>BACKLASH[n]</b>
MD number	Backlash
Meaning:	Backlash between the positive and the negative direction of travel. The compensation value input is <ul style="list-style-type: none"> <li>• positive if the encoder leads the machine part (normal case)</li> <li>• negative if the encoder lags behind the machine part.</li> </ul> If zero is entered backlash compensation is deactivated. Backlash compensation is always activated after reference point approach in all modes. The index [n] has the following coding: [encoder no.]: 0
Special cases, errors, ... ..	
Related to ....	MD 36500: ENC_CHANGE_TOL (backlash compensation partial section)
Note for the reader:	SINUMERIK 802D sl Description of Functions: K3

32630	<b>FFW_ACTIVATION_MODE</b>
MD number	Feedforward control can be activated from program
Meaning:	This MD can be used to define whether the feedforward control for this axis/spindle can be switched on and off in the part program. <b>0:</b> Feedforward control <b>cannot</b> be switched on/off with FFWON or FFWOF. <b>1:</b> Feedforward control can be switched on/off with FFWON or FFWOF in the part program. The last condition to be active remains active even after Reset (and therefore with JOG). Because the feedforward control for all axes of a channel is switched on/off with FFWON or FFWOF, this MD should therefore have identical settings for axes that interpolate with each other.
Related to ....	
References	"Operation and Programming"
Note for the reader:	SINUMERIK 802D sl Description of Functions: K3

32700	<b>ENC_COMP_ENABLE[n]</b>
MD number	Encoder/spindle error compensation (LEC)
Meaning:	<b>1:</b> 'LEC' is activated for the axis/measuring system. With LEC, leadscrew errors and measuring system errors can be compensated. The function is only enabled internally if the measuring system has been referenced (IS: "Referenced/synchronized 1" = 1). Write protection function (compensation values) active. <b>0:</b> 'LEC' is not active for the axis/measuring system.  Index [n] has the following coding: [encoder no.]: 0
Related to ....	IS "Referenced/synchronized 1"
Note for the reader:	SINUMERIK 802D sl Description of Functions: K3

32810 MD number	<b>EQUIV_SPEEDCTRL_TIME[n]</b> Equivalent time constant of speed control loop n= control parameter set no.: 0 to 5
Meaning:	This equivalent time constant is required for the "speed feedforward control" function. The value must correspond with the equivalent time constant of the closed speed control loop. Setting aid: Guide value is the time constant of the setpoint value smoothing in the drive.
Related to ....	
Note for the reader:	SINUMERIK 802D sl Description of Functions: K3

33050 MD number	<b>LUBRICATION_DIST</b> Path for lubrication pulse PLC signal
Meaning:	Path for triggering the lubrication pulse. The status of the axis-specific IS: "Lubrication pulse" (V390x 1002.0) is changed according to the specified path of the respective axis. This enables travel-dependent control of a lubrication device for one axis by the PLC user program. The path is added up after POWER ON.
Related to ....	IS: "Lubrication pulse" (V390x 1002.0)

34000 MD number	<b>REFP_CAM_IS_ACTIVE</b> Axis with reference point cam
Meaning:	Machine axes with only one zero mark across their entire traversing range or rotary axes with only one zero mark per revolution are not identified as a machine axis with reference cam by the MD: REF_CAM_IS_ACTIVE. A machine axis identified as a machine axis with reference cam accelerates, when the plus/minus travel key is pressed, to the velocity defined in MD 34040: REFP_VELO_SEARCH_MARKER (reference point creep velocity).
MD irrelevant for ... ..	
Note for the reader:	SINUMERIK 802D sl Description of Functions: R1

34010 MD number	<b>REFP_CAM_DIR_IS_MINUS</b> Reference point approach in minus direction
Meaning:	<b>0: Reference point approach in the positive direction</b> <b>1: Reference point approach in negative direction</b> Approach with incremental measuring systems: Starting via the traverse key is only possible in the specified direction. If the wrong travel key is pressed, reference point approach does not start.  If the machine axis is positioned before the reference cam, it accelerates to the velocity specified in MD 34020: REFP_VELO_SEARCH_CAM (reference point creep velocity). If the machine axis is on the reference cam, it accelerates to the velocity specified in MD 34020: REFP_VELO_SEARCH_CAM and travels initially <b>away from</b> the preset direction, away from the cam.  Note for absolute encoders: The direction of the traversing key is also significant for calibrating the absolute encoders: Approach the direction for fixed position and update values in MD 34090 and MD 34210.
Note for the reader:	SINUMERIK 802D sl Description of Functions: R1

34020 MD number	<b>REFP_VELO_SEARCH_CAM</b> Reference point approach velocity
Meaning:	The reference point approach velocity is the velocity at which the machine axis travels in the direction of the reference cam when the travel key is pressed (phase 1). This value should be set at a magnitude large enough for the axis to be stopped before it reaches a hardware limit switch.
MD irrelevant for ... ..	
Note for the reader:	SINUMERIK 802D sl Description of Functions: R1

## 4.4 Axis-specific machine data

34030 MD number	<b>REFP_MAX_CAM_DIST</b> Maximum distance to reference cam
Meaning:	If the machine axis travels a path defined in this MD from the starting position in the direction of the reference cam without reaching the reference cam ("Reference point approach delay" interface signal is not set), the axis stops and alarm 20000 "Reference cam not reached" is signaled
MD irrelevant for ... ..	
Note for the reader:	SINUMERIK 802D sl Description of Functions: R1

34040 MD number	<b>REFP_VELO_SEARCH_MARKER[n]</b> Reference point creep speed [encoder number]: 0
Meaning:	<p>1) For incremental measuring systems: This is the velocity at which the axis travels between initial detection of the reference cam and synchronization with the first zero mark (phase 2). Traversing direction: opposite to the direction specified for cam detection (MD 34010: REFP_CAM_DIR_IS_MINUS) If MD 34050: REFP_SEARCH_MARKER_REVERSE (direction reversal at the reference cam) is set, then for synchronization with a rising reference cam edge, at the cams, the axis travels at the velocity defined in MD 34020: REFP_VELO_SEARCH_CAM.</p> <p>2) Indirect measurement system with BERO on the load-side (preferred for spindles) At this velocity, the zero mark associated with the BERO is searched for. The zero mark is accepted if the actual velocity is within the tolerance range defined by MD 35150: SPIND_DES_VELO_TOL, from the velocity specified in MD 34040: MD 34040: REFP_VELO_SEARCH_MARKER[n].</p>
Note for the reader:	SINUMERIK 802D sl Description of Functions: R1

34050 MD number	<b>REFP_SEARCH_MARKER_REVERSE[n]</b> Change of direction on reference cam [encoder number]: 0
Meaning:	<p>This can be used to set the search direction for the zero mark:</p> <p>0: Synchronization with falling reference cam edge The machine axis accelerates to the velocity defined in MD 34040: REFP_VELO_SEARCH_MARKER (reference point creep velocity) in the opposite direction to that defined in MD 34010: REFP_CAM_DIR_IS_MINUS (approach reference point in minus direction). If the reference cam is exited ("Reference point approach delay" interface signal is reset), the control synchronizes itself with the first zero mark.</p> <p>1: Synchronization with rising reference cam edge The machine axis accelerates to the velocity defined in MD 34020: REFP_VELO_SEARCH_MARKER (reference point creep velocity) in the opposite direction to that specified in the MD: REFP_CAM_DIR_IS_MINUS. When the axis leaves the reference cam ("Reference point approach delay" interface signal is reset), the machine axis decelerates to a stop and accelerates in the opposite direction towards the reference cam at the velocity defined in MD: REFP_VELO_SEARCH_MARKER. When the reference cam is reached ("Reference point approach delay" interface signal is enabled), the control is synchronizing with the first zero mark.</p>
MD irrelevant for ... ..	
Note for the reader:	SINUMERIK 802D sl Description of Functions: R1

34060 MD number	<b>REFP_MAX_MARKER_DIST[n]</b> Maximum distance to reference mark [encoder no.]: 0
Meaning:	For incremental measuring systems: If, after leaving the reference cam ("Reference point approach delay" interface signal is reset), the machine axis travels a distance defined in MD: REFP_MAX_MARKER_DIST without detecting the reference mark, the axis stops and alarm 20002 "Zero mark missing" is signaled.
Application example(s)	If, on incremental measurement systems, the control is required to detect reliably that the same zero mark is always used for synchronization (to avoid detection of an incorrect machine zero), the maximum value in this MD must not exceed the distance between two reference marks.
Note for the reader:	SINUMERIK 802D sl Description of Functions: R1

34070 MD number	<b>REFP_VELO_POS</b> Reference point positioning velocity
Meaning:	With incremental measuring systems: The axis travels at this velocity between the time of synchronization with the first zero mark and arrival at the reference point.
Note for the reader:	SINUMERIK 802D sl Description of Functions: R1

34080 MD number	<b>REFP_MOVE_DIST[n]</b> Reference point distance/target point with distance-coded system [encoder number]: 0
Meaning:	<p>With incremental measuring systems</p> <p>Following synchronization with the first zero mark, the machine accelerates to the velocity defined in MD 34070: REFP_VELO_POS (reference point positioning velocity) and travels a distance calculated from the addition of MD: REFP_MOVE_DIST and MD 34090: REFP_MOVE_DIST_CORR (reference point offset). This distance precisely matches the distance between the zero mark detected in phase 2 and the reference point.</p>
	<p>MD 34100: REFP_SET_POS[0]</p> <p>Velocity</p> <p>MD: REFP_MOVE_DIST + MD: REFP_SET_POS_CORR</p> <p>MD 34020: REFP_VELO_SEARCH_CAM (Reference point approach velocity)</p> <p>MD 34040: REFP_VELO_SEARCH_MARKER (reference point creep velocity)</p> <p>Zero mark</p> <p>Reference point approach dela</p> <p>Reference point cam</p>
Note for the reader:	SINUMERIK 802D sl Description of Functions: R1

34090 MD number	<b>REFP_MOVE_DIST_CORR[n]</b> Reference point offset/absolute offset, distance-coded, n: [encoder number]: 0
Meaning:	<ul style="list-style-type: none"> <li>Incremental encoder with zero mark(s): After detecting the zero mark, the axis is positioned away from the zero mark through the distance specified by MD 34080: REFP_MOVE_DIST + REFP_MOVE_DIST_CORR. Once the axis has traveled this distance, it has reached the reference point. MD 34100: REFP_SET_POS is included in the actual value. Override switches are effective during the traversing motion through REFP_MOVE_DIST+REFP_MOVE_DIST_CORR.</li> <li>Absolute value encoder: REFP_MOVE_DIST_CORR is effective as absolute offset. It defines the offset between machine zero and the zero mark of the absolute measuring system. <b>Note:</b> this MD is changed by the control during calibration and modulo correction in conjunction with the absolute encoders!</li> </ul>
Note for the reader:	SINUMERIK 802D sl Description of Functions: R1

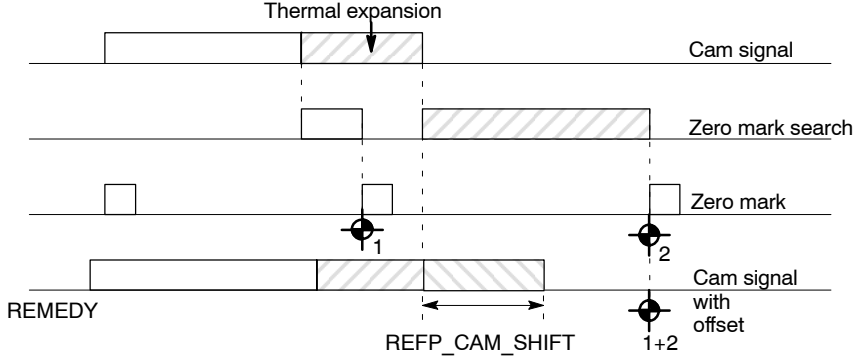
34092 MD number	<b>REFP_CAM_SHIFT</b> Electronic reference cam offset for incremental measuring systems with equidistant zero marks
Meaning:	<p>When the reference cam signal occurs, the zero mark search is not started immediately, but with a delay after the distance of REFP_CAM_SHIFT. The reproducibility of the zero mark search can thus be ensured even in the case of temperature-dependent expansion of the reference cam through defined selection of a zero mark. As the control calculates the reference cam offset in the interpolation cycle, the actual cam offset is at least REFP_CAM_SHIFT and maximum REFP_CAM_SHIFT+(MD 34040: REFP_VELO_SEARCH_MARKER * interpolation cycle)</p> <p>The reference cam offset acts in the direction of zero mark search. The reference cam offset is active only if the cam MD 34000: REFP_CAM_IS_ACTIVE=1 is present.</p>  <p>REMEDY</p>
Note for the reader:	SINUMERIK 802D sl Description of Functions: R1

34093 MD number	<b>REFP_CAM_MARKER_DIST</b> Reference cam/reference mark distance
Meaning:	<p>The indicated value is equivalent to the distance between departure from the reference cam and detection of the reference mark. If the values are too small, there is a risk that the determination of the reference point will be non-deterministic, due to temperature effects or fluctuations in the operating time of the cam signal. The path covered can be used as a guide for setting the electronic reference cam offset. The machine data is read only.</p>
Related to ....	REFP_CAM_IS_ACTIVE, REFP_SHIFT_CAM
Note for the reader:	SINUMERIK 802D sl Description of Functions: R1

34100 MD number	<b>REFP_SET_POS[0]</b> Reference point for an incremental system
Meaning:	<ul style="list-style-type: none"> <li>Incremental encoder with zero mark(s): The position value which is set as the current position after detecting the zero mark and traveling through the distance REFP_MOVE_DIST + REFP_MOVE_DIST_CORR (relative to the zero mark).</li> <li>Absolute value encoder: REFP_SET_POS corresponds to the correct actual value at the calibration position. The reaction on the machine depends on the status of MD34210: ENC_REFP_STATE: When MD 34210: ENC_REFP_STATE = 1, the value of REFP_SET_POS is transferred as the absolute value. When MD 34210: ENC_REFP_STATE = 2 and MD 34330: REFP_STOP_AT_ABS_MARKER=0, the axis approaches the target position defined in REFP_SET_POS. The value from REFP_SET_POS is used.</li> </ul> <p>Note: MD: REFP_SET_POS[1]...[3] reserved – do not use.</p>
Related to ....	
Note for the reader:	SINUMERIK 802D sl Description of Functions: R1

34110 MD number	<b>REFP_CYCLE_NR</b> Axis sequence for channel-specific referencing
Meaning:	<p><b>0:</b> Axis-specific referencing Axis-specific referencing is started separately for each machine axis with the "plus/minus travel keys" interface signal. All axes can be referenced at the same time. If the machine axes are to be referenced in a particular order, the following options are available:</p> <ul style="list-style-type: none"> <li>• The operator must follow the order himself after starting.</li> <li>• The PLC must check the order after starting or define the order itself.</li> </ul> <p>The machine axis is not started via channel-specific referencing. The NC cannot be started without first referencing this axis.</p> <p><b>-1:</b> The machine axis is started using channel-specific referencing. NC start is possible <b>without</b> referencing this axis. Note: The effect of inputting -1 for all axes of a channel can be achieved by setting the channel-specific MD 20700: REFP_NC_START_LOCK (NC start disable without reference point) to zero.</p> <p><b>&gt; 0:</b> Channel-specific referencing Channel specific referencing is started with the "activate referencing" interface signal (V3200 0001.0). The control acknowledges a successful start with the "referencing active" interface signal. Each machine axis assigned to the channel can be referenced with channel-specific referencing (this is achieved internally on the control by simulating the plus/minus travel keys).</p> <p>MD: REFP_CYCLE_NR can be used to define the sequence in which machine data is referenced:</p> <p><b>1:</b> The machine axis is started using channel-specific referencing.</p> <p><b>2:</b> The machine axis is started using channel-specific referencing if all of the machine axes designated in MD: REFP_CYCLE_NR with a <b>1</b> are referenced.</p> <p><b>3:</b> The machine axis is started using channel-specific referencing if all of the machine axes designated in MD: REFP_CYCLE_NR with a <b>2</b> are referenced.</p> <p><b>4:</b> The machine axis is started using channel-specific referencing if all of the machine axes designated in MD: REFP_CYCLE_NR with a <b>3</b> are referenced.</p>
MD irrelevant for ... ..	Axis-specific referencing
Related to ....	"Activate referencing" interface signal "Referencing active" interface signal
Note for the reader:	SINUMERIK 802D sl Description of Functions: R1

34200 MD number	<b>ENC_REFP_MODE[n]</b> Referencing mode [encoder no.]: 0
Meaning:	<p>All mounted position measuring systems can be subdivided as follows for referencing:</p> <p><b>0:</b> if absolute encoder exists: transfer of MD 34100: REFP_SET_POS Other encoders: no reference point travel possible</p> <p><b>1:</b> referencing with incremental measuring systems: Incremental rotary measuring system Incremental linear measuring system (position measuring system) Zero pulse on encoder track (not with absolute encoders)</p> <p>2, 3, 4, 5, 6: not available</p> <p><b>7:</b> synchronize spindle with BERO, configured approach velocity (MD 34040)</p>
Related to ....	
Note for the reader:	SINUMERIK 802D sl Description of Functions: R1

## 4.4 Axis-specific machine data

34210 MD number	<b>ENC_REFP_STATE[n]</b> Status of absolute value encoder [encoder number]: 0
Meaning:	<ul style="list-style-type: none"> <li>• Absolute value encoder: <ul style="list-style-type: none"> <li><b>0:</b> Default when installing for the first time: encoder is not calibrated.</li> <li><b>1:</b> encoder calibration enabled, encoder not yet calibrated</li> <li><b>2:</b> encoder is calibrated</li> </ul> </li> <li>• Incremental encoder: <ul style="list-style-type: none"> <li><b>0:</b> default: no auto referencing</li> <li><b>1:</b> auto referencing enabled, but encoder not yet referenced or not in exact stop</li> <li><b>2:</b> encoder is referenced and in exact stop auto referencing effective next time the encoder is activated.</li> </ul> </li> </ul>
Application example(s)	<p>The MD ENC_REFP_STATE can be altered by the person installing and by the operating system:</p> <ul style="list-style-type: none"> <li>• Absolute value encoder: <ul style="list-style-type: none"> <li>– Alteration by the installer: The data must be set to "1" by the commissioning engineer encoder is required.</li> <li>– Alteration by the operating system: on successful adjustment from 1 ==&gt; 2 if adjustment from 2 ==&gt; 0 or 1 has become invalid gear speed changes with change of ratio are identified by the operating system. <b>Changes to the mechanical components of the machine (e.g. encoder change, motor and encoder change, etc.) are not detected.</b></li> </ul> </li> <li>• Incremental encoder: <ul style="list-style-type: none"> <li>– Alteration by the installer: The data must be set to "1" by the commissioning engineer if automatic referencing is to be carried out.</li> <li>– Alteration by the operating system: for referenced axis and "axis at exact stop" from 1 ==&gt; 2 if the reference position has become invalid or if the axis is not at exact stop from 2==&gt; 1 Unlike the absolute value encoder, changes in position here are <b>not</b> detected during power OFF or when the encoder is inactive.</li> </ul> </li> </ul>
MD irrelevant for ... ..	
Note for the reader:	SINUMERIK 802D sl Description of Functions: R1

34220 MD number	<b>ENC_ABS_TURNS_MODULO[0]</b> Range, rotary absolute value encoders
Meaning:	<p>Number of encoder revolutions that a rotary value encoder can resolve 0 degrees &lt;= position &lt;= n * 360 degrees, (with n = ENC_ABS_TURNS_MODULO) <b>Note:</b> With control disabled the encoder may be turned by half this value max.</p>
Special cases, errors, ... ..	<p>Only powers of two are allowed as values ( 1, 2, 4, 8, 16, ..., 4096). If other values are entered, they are "rounded off". Rounding off is shown in the machine data; the change is displayed in alarm 26025. <b>The MD is only relevant for rotary encoders (with linear and rotary axes).</b></p> <p><b>Important information:</b> When using an encoder with smaller multi-turn information, or when using single-turn encoders, the value must be decreased accordingly. In any case, for multi-turn absolute encoders the value should be changed to the maximum quantity supported by the encoder so that the unambiguous traversing range that is increased as a result can be utilized (Note: This value also influences the permissible position offset when the encoder or power supply is switched off).</p>
Related to ....	
Note for the reader:	SINUMERIK 802D sl Description of Functions: R2

35000 MD number	<b>SPIND_ASSIGN_TO_MACHAX</b> Assignment of spindle to machine axis
Meaning:	The machine axis that is to be used as a spindle is entered into this MD.
Application example(s)	An example of a milling machine with 3 machine axes (X1, Y1, Z1) and a spindle: SPIND_ASSIGN_TO_MACHAX[AX1] = 0 ----> X1 SPIND_ASSIGN_TO_MACHAX[AX2] = 0 ----> Y1 SPIND_ASSIGN_TO_MACHAX[AX3] = 0 ----> Z1 SPIND_ASSIGN_TO_MACHAX[AX4] = 1 ----> Spindle no. 1 is the 4th machine axis
Related to ....	MD 30300: IS_ROT_AX (rotary axis/spindle) MD 30310: ROT_IS_MODULO (modulo conversion for rotary axis/spindle) This machine data must be set; otherwise, the alarms 4210 "Rotary axis declaration missing" and 4215 "Modulo axis declaration missing" are output. MD 30320: DISPLAY_IS_MODULO (display modulo 360 degrees) IS "Spindle/no axis" (V390x 0000.0)
Note for the reader:	SINUMERIK 802D sl Description of Functions: S1

35010 MD number	<b>GEAR_STEP_CHANGE_ENABLE</b> Gear stage change possible
Meaning:	If the spindle motor is mounted to the spindle directly (1:1) or with a non-adjustable gear ratio, GEAR_STEP_CHANGE_ENABLE (gear stage change is possible) must be set to zero. It is not possible to change the gear stage with M40 to M45. If the spindle motor is mounted to the spindle via a gearbox with changeable gear stages, GEAR_STEP_CHANGE_ENABLE must be set to one. The gear can have up to 5 gear stages, which can be selected using M40, M41 to M45.
Related to ....	MD 35110: GEAR_STEP_MAX_VELO (maximum speed for gear stage change) MD 35120: GEAR_STEP_MIN_VELO (min. speed for gear stage change) GEAR_STEP_MAX_VELO and GEAR_STEP_MIN_VELO must cover the whole speed range.
Note for the reader:	SINUMERIK 802D sl Description of Functions: S1

35040 MD number	<b>SPIND_ACTIVE_AFTER_RESET</b> Spindle active after reset
Meaning:	This MD defines the response of the spindle after reset (V3200 0000.7) and program end (M2, M30). It is only active in the spindle control mode. <b>0:</b> Open-loop control mode: – Spindle stops; applies to M2/M30 and Reset – Program is aborted; applies to M2/M30  Oscillation mode: – Alarm 10640 "Stop not possible during gear change" – Oscillation is not aborted – Axes are stopped – Program is aborted after gear change or spindle reset, the alarm is cleared.  Positioning mode: – Is stopped Axis mode: – Is stopped  ----- <b>1:</b> Open-loop control mode: – Spindle does not stop – Program is aborted  Oscillation mode: – Alarm 10640 "Stop not possible during gear change" – Oscillation is not aborted – Axes are stopped – Program is aborted after gear change, the alarm is cleared and the spindle continues rotating at the programmed M and S value.  Positioning mode: – Is stopped Axis mode: – Is stopped  The IS "Spindle reset" (V380x 0002.2) is always active irrespective of SPIND_ACTIVE_AFTER_RESET
MD irrelevant for ... ..	All spindle modes except control mode
Related to ....	IS "Reset" (V3200 0000.7) IS "Spindle reset" (V380x 0002.2)
Note for the reader:	SINUMERIK 802D sl Description of Functions: S1

## 4.4 Axis-specific machine data

35100 MD number	<b>SPIND_VELO_LIMIT</b> Maximum spindle speed
Meaning:	The maximum spindle speed is defined in this MD, which the spindle (the spindle chuck with the workpiece or the tool) must not exceed. The NCK limits an excessive spindle speed setpoint to this value. If the maximum spindle actual speed is exceeded, even allowing for the spindle speed tolerance (MD 35150: SPIND_DES_VELO_TOL, there is a fault in the drive and the IS "Speed limit exceeded" (V390x 2001.0) is enabled. Alarm 22050 "Maximum speed reached" is also output and all of the axes and spindles on the channel brought to a standstill (provided the encoder is still functioning correctly).
Related to ....	MD 35150: SPIND_DES_VELO_TOL (spindle speed tolerance) IS "Speed limit exceeded" (V390x 2001.0) Alarm 22050 "Maximum speed reached"
Note for the reader:	SINUMERIK 802D sl Description of Functions: S1

35110 MD number	<b>GEAR_STEP_MAX_VELO[n]</b> Maximum speed for gear stage change [gear stage number]: 0...5 (index 0 is irrelevant for spindles)
Meaning:	The maximum speed of the gear stage for automatic gear stage change (M40) is defined. The gear stages must be defined by this MD and MD 35120: GEAR_STEP_MIN_VELO_LIMIT in a way that avoids gaps in the programmable spindle speed range between the gear stages. <b>Incorrect</b> GEAR_STEP_MAX_VELO [gear stage1] =1000 GEAR_STEP_MIN_VELO [gear stage2] =1200 <b>Correct</b> GEAR_STEP_MAX_VELO [gear stage1] =1000 GEAR_STEP_MIN_VELO [gear stage2] =950
Related to ....	MD 35010: GEAR_STEP_CHANGE_ENABLE (gear stage change is possible) MD 35120: GEAR_STEP_MIN_VELO (minimum speed for gear stage change) MD 35140: GEAR_STEP_MIN_VELO_LIMIT (minimum speed for gear stage) MD 35130: GEAR_STEP_MAX_VELO_LIMIT (maximum speed for gear stage)
Note for the reader:	SINUMERIK 802D sl Description of Functions: S1

35120 MD number	<b>GEAR_STEP_MIN_VELO[n]</b> Minimum speed for gear stage change [gear stage number]: 0 ... 5
Meaning:	The minimum speed of the gear stage for automatic gear stage change (M40) is defined. Refer to MD 35120: GEAR_STEP_MAX_VELO for more information.
Related to ....	MD 35110: GEAR_STEP_MAX_VELO (maximum speed for gear stage change) MD 35010: GEAR_STEP_CHANGE_ENABLE (gear stage change is possible) MD 35140: GEAR_STEP_MIN_VELO_LIMIT (minimum speed for gear stage) MD 35130: GEAR_STEP_MAX_VELO_LIMIT (maximum speed for gear stage)
Note for the reader:	SINUMERIK 802D sl Description of Functions: S1

35130 MD number	<b>GEAR_STEP_MAX_VELO_LIMIT[n]</b> Maximum speed for gear stage [gear stage number]; 0 ... 5
Meaning:	The maximum speed for the gear stage is defined. This speed can never be exceeded in the currently engaged gear stage.
Special cases, errors, ... ..	<ul style="list-style-type: none"> <li>When the closed-loop position control is enabled, then a limit is set to 90% of the value (control margin)</li> <li>If an S value is programmed, that lies above the max. speed of the gearbox stage selected, the reference (setpoint) speed is limited to the maximum speed of the gear stage (for gear stage selection – M41 to M45); further, the IS: "Programmed speed too high" is set.</li> <li>If an S value is programmed that lies above the max. speed for gear stage change, a new gear stage is specified (for automatic gear stage selection M40).</li> <li>If an S value is programmed, that lies above the max. speed of the highest gear stage, the speed is limited to the max. speed of the gear stage (for automatic gear stage selection – M40).</li> <li>If an S value is programmed for which there is no matching gear stage, then a gear stage change is not made.</li> </ul>
Related to ....	MD 35010: GEAR_STEP_CHANGE_ENABLE (gear stage change is possible) MD 35110: GEAR_STEP_MAX_VELO (maximum speed for gear stage change) MD 35120: GEAR_STEP_MIN_VELO (minimum speed for gear stage change) MD 35140: GEAR_STEP_MIN_VELO_LIMIT (min. speed of gear stage) IS "Setpoint speed limited" (V390x 2001.1)
Note for the reader:	SINUMERIK 802D sl Description of Functions: S1

35140 MD number	<b>GEAR_STEP_MIN_VELO_LIMIT[n]</b> Minimum speed for gear stage [gear stage number]: 0 ... 5
Meaning:	The minimum gear stage speed is entered. The speed cannot drop to below this value, even if a very low S value is programmed. The speed can only drop to below this minimum value as a result of the signals/commands/states listed in "Minimum/maximum speed for the gear stage".
MD irrelevant for ... ..	Spindle mode, oscillation mode, positioning mode
Application example(s)	Smooth operation of the motor is not assured below the minimum speed.
Related to ....	MD 35010: GEAR_STEP_CHANGE_ENABLE (gear stage change is possible) MD 35110: GEAR_STEP_MAX_VELO (maximum speed for gear stage change) MD 35120: GEAR_STEP_MIN_VELO (minimum speed for gear stage change) MD 35130: GEAR_STEP_MAX_VELO_LIMIT (max. speed of gear stage) IS "Setpoint speed increased" (V390x 2001.2)
Note for the reader:	SINUMERIK 802D sl Description of Functions: S1

35150 MD number	<b>SPIND_DES_VELO_TOL</b> Spindle speed tolerance
Meaning:	Factor for spindle speed for determining the tolerance in the spindle mode control mode.  The set speed (programmed speed x spindle override, allowing for limits) is compared with the actual speed. <ul style="list-style-type: none"> <li>• If the actual speed deviates from the setpoint speed by more than the SPIND_DES_VELO_TOL, IS "spindle in setpoint range" (V390x 2001.5) is set to zero.</li> <li>• If the actual speed exceeds the maximum spindle speed (MD 35100: SPIND_VELO_LIMIT) by more than SPIND_DES_VELO_TOL, the IS "Speed limit exceeded" is set (V390x 2001.0) and alarm 22050 "Maximum speed reached" is output. All axes and spindles of the channel are brought to a standstill.</li> </ul>
MD irrelevant for ... ..	Spindle mode oscillation mode Spindle mode positioning mode
Fig. 4-1	<p>The graph shows spindle speed (rev/min) on the y-axis and Time (t) on the x-axis. A horizontal line represents the 'Set speed'. Two dashed lines above and below the set speed represent the 'Upper Spindle speed tolerance' and 'Lower Spindle speed tolerance' respectively. The vertical distance between these two dashed lines is labeled 'SPIND_DES_VELO_TOL'. A solid curve labeled 'Actual speed' starts at the origin, rises linearly, and then levels off, staying within the tolerance range.</p>
Related to ....	MD 35500: SPIND_ON_SPEED_AT_IPO_START MD 35100: SPIND_VELO_LIMIT (maximum spindle speed) IS "Spindle in setpoint range" (V390x 2001.5) IS "Speed limit exceeded" (V390x 2001.0) Alarm 22050 "Maximum speed reached"
Note for the reader:	SINUMERIK 802D sl Description of Functions: S1

35160 MD number	<b>SPIND_EXTERN_VELO_LIMIT</b> Spindle speed limiting via PLC
Meaning:	A limit for the spindle speed is entered, which is taken into account when the IS "Velocity/speed limiting" (V380x 0003.6) is enabled. The control limits an excessive spindle speed setpoint to this value.
Note for the reader:	SINUMERIK 802D sl Description of Functions: S1

## 4.4 Axis-specific machine data

35200 MD number	<b>GEAR_STEP_SPEEDCTRL_ACCEL[n]</b> Acceleration in control mode [gear stage number]: 0 ... 5
Meaning:	If the spindle is in <b>control mode</b> , the acceleration in GEAR_STEP_SPEEDCTRL_ACCEL. is entered.
Special cases, errors, ... ..	Thus the acceleration in speed control mode can be set so that the current limit is reached.
Related to ....	MD 35210: GEAR_STEP_POSCTRL_ACCEL (acceleration in position control mode)
Note for the reader:	SINUMERIK 802D sl Description of Functions: S1

35210 MD number	<b>GEAR_STEP_POSCTRL_ACCEL[n]</b> Acceleration in position control mode [gear stage number]: 0 ... 5
Meaning:	The acceleration in <b>position control mode</b> must be set so that the current limit is not reached.
Related to ....	MD 35200: GEAR_STEP_SPEEDCTRL_ACCEL
Note for the reader:	SINUMERIK 802D sl Description of Functions: S1

35300 MD number	<b>SPIND_POSCTRL_VELO</b> Position control activation speed
Meaning:	When positioning a spindle that is not in position control mode, the position control is not activated until the spindle has reached the speed defined in MD: SPIND_POSCTRL_VELO. Please refer to Chapter "Spindle mode, positioning mode" for a description of spindle operating characteristics under various supplementary conditions (positioning from movement, positioning from standstill).
Related to ....	MD 35350: SPIND_POSITIONING_DIR (direction of rotation during positioning from standstill), if no synchronization is available.
Note for the reader:	SINUMERIK 802D sl Description of Functions: S1

35310 MD number	<b>SPIND_POSIT_DELAY_TIME[n]</b> Positioning delay time [gear stage number]: 0 ... 5
Meaning:	After reaching the positioning end (exact stop fine) the time delay for <b>block search</b> is activated at output of a collected positioning block (SPOS).
Related to ....	
Note for the reader:	SINUMERIK 802D sl Description of Functions: S1

35350 MD number	<b>SPIND_POSITIONING_DIR</b> Positioning direction of rotation for a nonsynchronized spindle
Meaning:	When SPOS is programmed, the spindle is switched to position control mode and accelerates with the acceleration defined in MD 35210: GEAR_STEP_POSCTRL_ACCEL (acceleration in position control mode) if the spindle is not synchronized. The direction of rotation is defined by MD 35350: SPIND_POSITIONING_DIR (direction of rotation for positioning from standstill). SPIND_POSITIONING_DIR = 3 ---> Clockwise rotation SPIND_POSITIONING_DIR = 4 ---> Counterclockwise rotation
Related to ....	MD 35300: SPIND_POSCTRL_VELO (position control activation speed)
Note for the reader:	SINUMERIK 802D sl Description of Functions: S1

35400 MD number	<b>SPIND_OSCILL_DES_VELO</b> Oscillation speed
Meaning:	During oscillation, the IS "Oscillation speed" (V380x 2002.5) is used to select a motor speed for the spindle motor. The motor speed is defined here. This motor speed is independent of the current gear stage. In the AUTOMATIC and MDA displays, the oscillation speed is displayed in the "spindle setpoint" window until the gear is changed.
MD irrelevant for ... ..	All spindle modes except oscillation mode
Application example(s)	The to and fro oscillation of the spindle motor makes it easier to engage a new gear stage because the teeth on the gear wheels can mesh with each other better.
Special cases, errors, ... ..	The oscillation acceleration defined in MD 35410: SPIND_OSCILL_ACCEL is valid for the oscillation speed defined in this MD.
Related to ....	MD 35410: SPIND_OSCILL_ACCEL (acceleration in oscillation mode) MD 35130: GEAR_STEP_MAX_VELO_LIMIT[n] (maximum speed of the gear stage) IS "Oscillation via PLC" (V380x 2002.4) IS "Oscillation speed" (V380x 2002.5)
Note for the reader:	SINUMERIK 802D sl Description of Functions: S1

35410 MD number	<b>SPIND_OSCILL_ACCEL</b> Oscillation acceleration
Meaning:	The acceleration specified is only effective for the output of the oscillation speed (MD 35400: SPIND_OSCILL_DES_VELO) to the spindle motor. The oscillation speed is selected using the IS "Oscillation speed".
MD irrelevant for ... ..	All spindle modes except oscillation mode
Related to ....	MD 35400: SPIND_OSCILL_DES_VELO (Oscillation speed) IS "Oscillation speed" (V380x 2002.5) IS "Oscillation via PLC" (V380x 2002.4)
Note for the reader:	SINUMERIK 802D sl Description of Functions: S1

35430 MD number	<b>SPIND_OSCILL_START_DIR</b> Oscillation start direction
Meaning:	With the IS "Oscillation speed", the spindle motor accelerates to the speed specified in MD 35400: SPIND_OSCILL_DES_VELO. <b>The start direction</b> is defined by this MD: SPIND_OSCILL_START_DIR if IS "Oscillation via PLC" is not enabled. <b>0:</b> start direction corresponding with the last direction of rotation <b>1:</b> start direction in opposite direction of last rotation <b>2:</b> start direction in opposite direction of last rotation <b>3:</b> start direction is M3 <b>4:</b> start direction is M4
MD irrelevant for ... ..	All spindle modes except oscillation mode
Related to ....	MD 35400: SPIND_OSCILL_DES_VELO (Oscillation speed) IS "Oscillation speed" (V380x 2002.5) IS "Oscillation via PLC" (V380x 2002.4)
Note for the reader:	SINUMERIK 802D sl Description of Functions: S1

35440 MD number	<b>SPIND_OSCILL_TIME_CW</b> Oscillation time for M3 direction
Meaning:	The oscillation time defined here acts in direction of M3.
MD irrelevant for ... ..	<ul style="list-style-type: none"> <li>All spindle modes except oscillation mode</li> <li>Oscillation set by the PLC (IS "Oscillation via PLC" (V380x 2002.4))</li> </ul>
Related to ....	MD 35450: SPIND_OSCILL_TIME_CCW (Oscillation time for M4 direction) IS "Oscillation speed" (V380x 2002.5) IS "Oscillation via PLC" (V380x 2002.4)
Note for the reader:	SINUMERIK 802D sl Description of Functions: S1

35450 MD number	<b>SPIND_OSCILL_TIME_CCW</b> Oscillation time for M4 direction
Meaning:	The oscillation time defined here acts in direction of M4.
MD irrelevant for ... ..	<ul style="list-style-type: none"> <li>All spindle modes except oscillation mode</li> <li>Oscillation set by the PLC (IS "Oscillation via PLC" (V380x 2002.4))</li> </ul>
Fig. 4-2	
Related to ....	MD 35440: SPIND_OSCILL_TIME_CW (Oscillation time for M3 direction) IS "Oscillation speed" (V380x 2002.5) IS "Oscillation via PLC" (V380x 2002.4)
Note for the reader:	SINUMERIK 802D sl Description of Functions: S1

## 4.4 Axis-specific machine data

35500 MD number	<b>SPIND_ON_SPEED_AT_IPO_START</b> Feed enable with spindle in setpoint range
Meaning:	<b>0:</b> path interpolation is not influenced <b>1:</b> path interpolation is only enabled when the spindle has reached the specified speed (tolerance band is set via MD35150). <b>2:</b> function as for value =1, in addition: Traveling path axes are also stopped before machining. e.g. continuous path mode (G64) and change of rapid traverse (G60) in one machining block (G1, G2,...). The path is stopped at the last G0 block and does not start moving until the spindle has reached the speed setpoint range.
Application example(s)	see MD 35510
Related to ....	MD 35150: SPIND_DES_VELO_TOL (spindle speed tolerance) IS "Spindle in setpoint range" (V390x 2001.5)
Note for the reader:	SINUMERIK 802D sl Description of Functions: S1

35510 MD number	<b>SPIND_STOPPED_AT_IPO_START</b> Feed enable with stationary spindle
Meaning:	When a spindle is stopped (M5), the path feed is disabled if this MD is enabled and the spindle is in control mode. When the spindle has come to a standstill (IS, "axis/spindle stationary" (V390x 0001.4) is enabled), the path feed is enabled.
Application example(s)	The MD 35500 and this MD 35510 can be used to control the path feed according to the actual spindle speed (control mode): <ul style="list-style-type: none"> <li>• If the spindle is in the acceleration phase (programmed setpoint not yet reached), the path feed is disabled.</li> <li>• If the actual speed deviates from the speed setpoint by less than the spindle speed tolerance (MD 35150: SPIND_DES_VELO_TOL), the path feed is enabled..</li> <li>• If the spindle is in the braking phase, the path feed is disabled.</li> <li>• If the spindle is signaled to be stationary (IS: "Axis/spindle stationary" V390x 0001.4) path feed is enabled.</li> <li>• In blocks with G0, the modification is not active.</li> </ul>
Related to ....	MD 35500: SPIND_ON_SPEED_AT_IPO_START (feed enable for spindle in setpoint range)
Note for the reader:	SINUMERIK 802D sl Description of Functions: S1

36000 MD number	<b>STOP_LIMIT_COARSE</b> Exact stop coarse
Meaning:	An NC block has been completed when the distance in between the actual position of the path axes and the setpoint (reference) position is the exact stop limit that has been entered. If the actual position of a path axis is not within these limits, the NC block is not considered complete and continued part program processing is not possible. Transition to the next block can be influenced by the value entered. The larger the value, the earlier block change can be initiated. If the defined exact stop limit is not reached, <ul style="list-style-type: none"> <li>– the block is not considered completed,</li> <li>– it is not possible to continue traversing the axis,</li> <li>– alarm 25080 positioning monitoring is triggered after the time in MD 36020: POSITIONING_TIME (monitoring time exact stop fine) has elapsed,</li> <li>– the direction of movement +/- is displayed for the axis in the positioning display. The exact stop window is also evaluated for spindles in position control mode.</li> </ul>
Special cases, errors, ... ..	This MD may not be smaller than the setting in MD 36010: STOP_LIMIT_FINE (exact stop fine). In order to achieve the same block change behavior as for exact stop, the exact stop coarse window can be the same as that for exact stop fine. This MD may not be equal to or larger than the setting in MD 36030: STANDSTILL_POS_TOL (zero-speed tolerance).
Related to ....	MD 36020: POSITIONING_TIME (exact stop fine delay time)
Note for the reader:	SINUMERIK 802D sl Description of Functions: A3

36010 MD number	<b>STOP_LIMIT_FINE</b> Exact stop fine
Meaning:	See MD 3600: STOP_LIMIT_COARSE (exact stop coarse)
Special cases, errors, ... ..	This MD must not be greater than the setting in MD 36000: STOP_LIMIT_COARSE (exact stop coarse). This MD must not be equal to or greater than the setting in MD 36030: STANDSTILL_POS_TOL (zero-speed tolerance).
Related to ....	MD 36020: POSITIONING_TIME (exact stop fine delay time)
Note for the reader:	SINUMERIK 802D sl Description of Functions: A3

36020 MD number	<b>POSITIONING_TIME</b> Time delay exact stop fine
Meaning:	This MD defines the time after which the following error must have reached the limit value for exact stop fine when approaching a position (position setpoint has reached the target). If this is not the case, alarm 25080 "Positioning monitoring" is set and the relevant axis is stopped. The MD setting should be large enough that the monitoring function does not respond during normal operation, as the complete traversing operation (acceleration, constant travel, deceleration) is monitored by other functions.
Related to ....	MD 36010: STOP_LIMIT_FINE (exact stop fine)
Note for the reader:	SINUMERIK 802D sl Description of Functions: A3

36030 MD number	<b>STANDSTILL_POS_TOL</b> Zero-speed tolerance
Meaning:	At the end of a motion block (position setpoint has reached the target), monitoring checks whether the axis is not more than the distance specified in MD 36040: STANDSTILL_DELAY_TIME (zero-speed monitoring delay time) from its setpoint after the configurable delay time in MD 36060: STANDSTILL_POS_TOL (zero-speed tolerance) has expired. If the setpoint position zero-speed tolerance has been violated in any direction, alarm 25040 "Zero-speed monitoring" is triggered and the axis is brought to a standstill.
Special cases, errors, ... ..	The zero-speed tolerance must be greater than the "Exact stop limit coarse".
Related to ....	MD 36040: STANDSTILL_DELAY_TIME (zero-speed monitoring delay time)
Note for the reader:	SINUMERIK 802D sl Description of Functions: A3

36040 MD number	<b>STANDSTILL_DELAY_TIME</b> Zero-speed monitoring delay time
Meaning:	See MD 36030: STANDSTILL_POS_TOL (zero-speed tolerance)
Related to ....	MD 36030: STANDSTILL_POS_TOL (zero-speed tolerance)
Note for the reader:	SINUMERIK 802D sl Description of Functions: A3

36050 MD number	<b>CLAMP_POS_TOL</b> Clamping tolerance with interface signal "Clamping active"
Meaning:	The clamping monitor is activated by "Clamping active" interface signal (V380x 0002.3). If the monitored axis has been pushed out of the setpoint position (exact stop limit) by more than the clamping tolerance, alarm 26000 "Clamping monitoring" is triggered and the axis is stopped.
Special cases, errors, ... ..	The clamping tolerance must be larger than the "Exact stop limit coarse".
Related to ....	IS "Clamping in progress"
Note for the reader:	SINUMERIK 802D sl Description of Functions: A3

## 4.4 Axis-specific machine data

36060 MD number	<b>STANDSTILL_VELO_TOL</b> Maximum velocity/speed "Axis/spindle stationary"
Meaning:	The zero-speed range for the axis velocity and spindle speed is set in this machine data. If the actual velocity of the axis or the actual speed of the spindle is smaller than the value entered, and if no more setpoints are being output to the axis/ spindle, interface signal "Axis/spindle stationary" (V390x 0001.4) is set.
Application example(s)	The pulse enable should not be removed until the axis/spindle is stationary to ensure that the axis/spindle is stopped in a controlled manner. Otherwise the axis will coast to rest.
Related to ....	"Axis/ spindle stationary" interface signal (V390x 0001.4)
Note for the reader:	SINUMERIK 802D sl Description of Functions: A3
36100 MD number	<b>POS_LIMIT_MINUS</b> 1st software limit, switch minus
Meaning:	Same meaning as 1st software limit switch but applies to the traversing limit in the negative direction. The MD is effective after reference point approach if PLC interface signal "2nd software limit switch minus" is not set.
MD irrelevant for ... ..	If axis is not referenced.
Related to ....	"2nd software limit switch minus" interface signal
36110 MD number	<b>POS_LIMIT_PLUS</b> 1. Software limit, switch plus
Meaning:	A software limit switch can be activated in addition to a hardware limit switch. The absolute position, in the machine coordinate system, of the positive range limit is entered for each axis. The MD is effective after reference point approach if interface signal "2nd software limit switch plus" is not enabled.
MD irrelevant for ... ..	If axis is not referenced.
Related to ....	"2nd software limit switch plus" interface signal
Note for the reader:	SINUMERIK 802D sl Description of Functions: A3
36120 MD number	<b>POS_LIMIT_MINUS2</b> 2nd software limit, switch minus
Meaning:	Same meaning as 2nd software limit switch plus, but applies to the traversing limit in the negative direction. An interface signal can be used to select from the PLC which of the software limit switches 1 or 2 is to apply. e.g. V380x 1000 Bit 2 = 0 "1st software limit switch minus" active for 1st axis Bit 2 = 1 "2nd software limit switch minus" active for 1st axis
MD irrelevant for ... ..	If axis is not referenced.
Related to ....	"2nd software limit switch minus" interface signal
Note for the reader:	SINUMERIK 802D sl Description of Functions: A3
36130 MD number	<b>POS_LIMIT_PLUS2</b> 2nd software limit, switch plus
Meaning:	This machine data can be used to specify a 2nd software limit switch position in the positive direction in the machine axis system. An interface signal can be used to select from the PLC which of the software limit switches 1 or 2 is to apply. e.g.: V380x 1000 Bit 3 = 0 "1st software limit switch plus" active for 1st axis Bit 3 = 1 "2nd software limit switch plus" active for 1st axis.
MD irrelevant for ... ..	If axis is not referenced.
Related to ....	"2nd software limit switch plus" interface signal
Note for the reader:	SINUMERIK 802D sl Description of Functions: A3

36200 MD number	<b>AX_VELO_LIMIT[0]...[5]</b> Threshold value for velocity monitoring
Meaning:	The threshold value for the actual velocity monitoring function is entered in this MD. If the axis has at least one active encoder and this is operating below its limit frequency, alarm 25030 "Actual velocity alarm limit" is activated and the axes brought to a standstill when the threshold value is exceeded. Settings <ul style="list-style-type: none"> <li>• For axes, a value that lies 10–15% above MD 32000: MAX_AX_VELO (maximum axis velocity) should be chosen.</li> <li>• For spindles, a value should be selected for each gear stage which is 10–15% higher than MD 35110: GEAR_STEP_MAX_VELO_LIMIT[n] (maximum speed of gear stage).</li> </ul> Machine data index has the following code: [control parameter set number]: 0–5 Please refer to the following for the effect of control parameters sets: <b>References:</b> Chapter "Velocities, Setpoint/Actual-Value Systems, Closed-Loop Control"
36210 MD number	<b>CTRLOUT_LIMIT[n]</b> Maximum speed setpoint
Meaning:	The maximum speed setpoint is defined as a percentage in this MD. The value refers to the speed (100%) at which the axis velocity of MD 32000: MAX_AX_VELO is reached. A value larger than 100% contains the required control reserve for digital drives. If settings beyond the limit are made, the MD value is used as the limiter, an alarm is emitted and the axes brought to a halt.  With an analog spindle the maximum speed that can be output is limited by the maximum setpoint output voltage of 10V. The value in this MD should not be greater than the speed value that is reached at this voltage (100%).  Index[n] of the machine data is coded as follows: [setpoint branch]: 0
References	See Chapter "Axis monitoring functions".
Note for the reader:	SINUMERIK 802D sl Description of Functions: G2
36300 MD number	<b>ENC_FREQ_LIMIT[0]</b> Encoder limit frequency
Meaning:	The encoder frequency is entered into this MD.  The active encoder is defined via the "Position measuring system 1" interface signal (V380x 0001.5).
Related to ....	MD 36302: ENC_FREQ_LIMIT_LOW
Note for the reader:	SINUMERIK 802D sl Description of Functions: A3
36302 MD number	<b>ENC_FREQ_LIMIT_LOW</b> Encoder limit frequency resynchronization
Meaning:	The encoder frequency monitoring function operates with a hysteresis. MD 36300: ENC_FREQ_LIMIT defines the encoder limit frequency at which the encoder is switched off, MD: ENC_FREQ_LIMIT_LOW the frequency at which the encoder is switched back on again. MD: ENC_FREQ_LIMIT_LOW is a fraction of MD: ENC_FREQ_LIMIT in percent. Normally the default of MD: ENC_FREQ_LIMIT_LOW is enough. However, the limit frequency of the absolute track on absolute value encoders with En-Dat interface is significantly lower than the limit frequency of the incremental track. By setting a low value in MD: ENC_FREQ_LIMIT, it is possible to ensure that the encoder is not switched on again until the frequency is lower than the limit frequency of the absolute track and is thus not referenced until permitted by the absolute track. This referencing takes place automatically for spindles. Example EQN 1325: Limit frequency of incremental track electronics: 430 kHz ==>MD 36300: ENC_FREQ_LIMIT = 430000 Hz Limit frequency of absolute track: approx. 2000 encoder rev/min with 2048 marks, i.e. limit frequency (2000/60) * 2048 Hz = 68 kHz ==>MD 36302: ENC_FREQ_LIMIT_LOW = 68/430 = 15 %
Related to ....	
Note for the reader:	SINUMERIK 802D sl Description of Functions: R1

## 4.4 Axis-specific machine data

36310 MD number	<b>ENC_ZERO_MONITORING[0]</b> Zero-mark monitoring
Meaning:	This machine data activates the zero-mark monitoring and determines the number of inadmissible zero marks. <b>0:</b> Zero-mark monitoring OFF, encoder hardware monitoring ON <b>1–99, &gt; 100:</b> Number of identified zero-mark errors at which the monitoring should be activated <b>100:</b> Zero-mark monitoring OFF, encoder hardware monitoring OFF
Examples:	MD value = 1: monitoring is activated at the 1st error. MD value = 2: the 1st error is tolerated. Monitoring is activated at the 2nd error. MD value = 3: the 1st and 2nd errors are tolerated. Monitoring is activated at the 3rd error. The error count always begins at zero when the encoder is switched on.
Special cases, errors, ... ..	The zero-mark monitoring on absolute value encoders must be switched off with value = 0!
Note for the reader:	SINUMERIK 802D sl Description of Functions: A3

36400 MD number	<b>CONTOUR_TOL</b> Contour monitoring tolerance band
Meaning:	Tolerance band for max. contour deviation. The maximum difference between the real and expected actual value is entered in this MD. The input of a tolerance band is designed to prevent the contour monitoring function from responding erroneously due to slight fluctuations in speed resulting from normal control procedures (e.g. during first cut). This MD must be adapted to the position controller gain and, in the case of feedforward control, to the accuracy of the loop model MD 32810: EQUIV_SPEEDCTRL_TIME (equivalent time constant for speed loop feedforward control) and to the permissible acceleration rates and velocities.
Note for the reader:	SINUMERIK 802D sl Description of Functions: A3

36500 MD number	<b>ENC_CHANGE_TOL</b> Backlash compensation partial section/tolerance for position actual value changeover
Meaning:	Partial section when applying backlash compensation. This MD is used to manage large backlash compensation values. It ensures that the backlash is not switched through to the actual value all at once, but in n steps with an increment size as set in MD: ENC_CHANGE_TOL. Calculation of the backlash thus takes n servo cycles. If it takes too long to complete computation of the backlash, zero speed monitoring alarms may be generated. This MD only becomes effective if the MD: ENC_CHANGE_TOL is set higher than MD: BACK_LASH.
Related to ....	MD 32450: BACKLASH[0] (backlash compensation)
Note for the reader:	SINUMERIK 802D sl Description of Functions: K3

36600 MD number	<b>BRAKE_MODE_CHOICE</b> Deceleration behavior on hardware limit switch
Meaning:	If a rising signal edge is detected at the axis-specific hardware limit switch, the axis is decelerated immediately. The type of deceleration is specified via machine data: <b>0:</b> controlled deceleration according to the acceleration ramp defined by MD 32300: MAX_AX_ACCEL (axis acceleration). <b>1:</b> fast deceleration (setpoint default = 0) with reduction of following error.
Related to ....	"Hardware limit switch plus or minus" interface signal (V380x 1000.1 or V380x 1000.0)
Note for the reader:	SINUMERIK 802D sl Description of Functions: A3

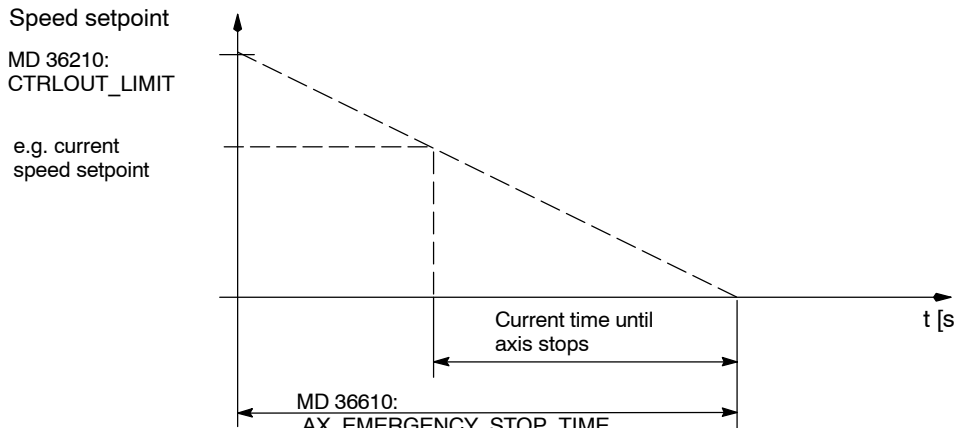
36610 MD number	<b>AX_EMERGENCY_STOP_TIME</b> Length of the braking ramp for error states
Meaning:	<p>For <b>axis</b>: when the following monitoring functions respond, the affected axis is brought to a standstill with rapid stop (with open position control loop) along a braking ramp of the speed setpoint:</p> <ul style="list-style-type: none"> <li>• EMERGENCY STOP</li> <li>• Following error monitoring</li> <li>• Positioning monitoring</li> <li>• Zero-speed monitoring</li> <li>• Clamping monitoring</li> <li>• Speed setpoint monitoring</li> <li>• Actual velocity monitoring</li> <li>• Encoder limit frequency monitoring (except on speed-controlled spindles)</li> <li>• Zero-mark monitoring</li> <li>• Contour tunnel monitoring</li> </ul> <p>If the encoder limit frequency is exceeded, the speed setpoint is displayed as the actual value in the basic NC display.</p> <p>The time for the reduction of the speed setpoint from the maximum speed setpoint to setpoint = 0 should be entered in MD 36610. The time taken to stop the axis depends on the actual speed setpoint at the time the monitoring responds.</p> <div style="text-align: center;">  </div> <p>Fig. 4-1 Braking ramp for error states</p> <p>For <b>spindle</b>: In the case of spindles without an active position control, the speed-controlled spindle may continue to rotate with no rapid stop braking response when the encoder frequency monitoring function responds (i.e. no valid actual value information available). The speed setpoint monitor is active, but not the actual velocity monitor (MD 36200) when the encoder is active. The spindle speed setpoint limit is just limited (no alarm); the setpoint is limited to the max. chuck speed (MD 35100) and displayed in IS "Programmed speed too high". The current speed is not displayed as no valid actual value is available at this point in time</p>
Meaning:	<p>Where interpolating axes are involved, maintenance of the contour during the deceleration phase cannot be guaranteed.</p> <p>Notice: If the value for the duration of the braking ramp for error states has been set too high, controller enable is canceled even though the axis/spindle is still traversing. It is then stopped abruptly with speed setpoint 0. The time set in MD 36610: AX_EMERGENCY_STOP_TIME should therefore be less than the time set in MD 36620: SERVO_DISABLE_DELAY_TIME (shutdown delay controller enable).</p>
Related to ....	<p>MD 36620: SERVO_DISABLE_DELAY_TIME Shutdown delay servo enable MD 36210: CTRL0UT_LIMIT Maximum speed setpoint</p>
Note for the reader:	SINUMERIK 802D sl Description of Functions: A3

## 4.4 Axis-specific machine data

36620 MD number	<b>SERVO_DISABLE_DELAY_TIME</b> Cutout delay servo enable
Meaning:	Maximum delay time for removal of "controller enable" after a fault. If the axis/spindle is still moving the speed enable (controller enable) of the drive is removed by the control at the latest after the delay time set. The entered delay time is activated in the following events: <ul style="list-style-type: none"> <li>• For faults which cause the axes to stop immediately</li> <li>• If IS "controller enable" is removed by the PLC</li> </ul> As soon as the actual speed has reached the zero speed range (MD 36060: STANDSTILL_VELO_TOL) "Servo enable" is removed for the drive. The time set must be long enough to allow the axis/spindle to be brought to zero speed from maximum traversing velocity/speed. If the axis/spindle is stationary, "controller enable" is removed for the drive immediately.
Application example(s)	The drive speed control should be maintained long enough for the axis/spindle to come to a standstill from maximum traversing speed. Removal of "controller enable" for a moving axis/spindle must be delayed until this has happened.
Special cases, errors, ... ..	<b>Caution:</b> If the setting for the controller enable shutdown delay is too small the servo enable will be removed even though the axis/spindle is still moving. The axis/spindle is then stopped abruptly with setpoint 0. The time in this MD should therefore be greater than the duration of the brake ramp in error states (MD 36610: AX_EMERGENCY_STOP_TIME).
Related to ....	IS "controller enable" (V380x 0002.1) MD 36610: AX_EMERGENCY_STOP_TIME (Time for braking ramp when an error occurs)
Note for the reader:	SINUMERIK 802D sl Description of Functions: N2

36720 MD number	<b>DRIFT_VALUE</b> Basic drift value <span style="float: right;">for analog spindles only</span>
Meaning:	The basic drift value entered here is always applied as an additional speed setpoint value for the analog spindle.
MD irrelevant for ... ..	
Note for the reader:	SINUMERIK 802D sl Description of Functions: S1

37000 MD number	<b>FIXED_STOP_MODE</b> Travel to fixed stop mode
Meaning:	The machine data specifies how the "Travel to fixed stop" function can be started. Value =0: Travel to fixed stop not available. = 1: Travel to fixed stop may be started from the NC program using the command FXS[x]=1.
Note for the reader:	SINUMERIK 802D sl Description of Functions: F1

37002 MD number	<b>FIXED_STOP_CONTROL</b> Special function when traveling to fixed stop
Meaning:	Bit 0: Response for pulse inhibit at limit =0: Travel to fixed stop is canceled. = 1: Travel to fixed stop is interrupted, i.e. the drive is rendered powerless. As soon as the pulse block is canceled once more, the drive applies pressure again with the limited torque. The torque is applied abruptly.
Note for the reader:	SINUMERIK 802D sl Description of Functions: F1

37010 MD number	<b>FIXED_STOP_TORQUE_DEF</b> Default for clamping torque
Meaning:	The clamping torque is entered in this machine data as a percentage of the maximum motor torque (for FSD, corresponds with percentage of max. current setpoint)  The clamping torque becomes operative as soon as the fixed stop is reached or IS "Acknowledge fixed stop" has been set.  The entered value is a default and is effective only on the condition that <ul style="list-style-type: none"> <li>no clamping torque has been programmed with command FXST[x].</li> <li>the clamping torque set in SD 43510: FIXED_STOP_TORQUE has not been changed (after fixed stop was reached).</li> </ul>
Related to ....	SD 43510: FIXED_STOP_TORQUE (clamping torque for travel to fixed stop)
Note for the reader:	SINUMERIK 802D sl Description of Functions: F1

37012 MD number	<b>FIXED_STOP_TORQUE_RAMP_TIME</b> Virtual time until reaching the new clamping torque when traveling to fixed stop
Meaning:	Virtual time until reaching the modified torque limit.  The subdivision is measured in the position controller cycle and applied abruptly. The value 0.0 deactivates the ramp function.
Note for the reader:	SINUMERIK 802D sl Description of Functions: F1

37020 MD number	<b>FIXED_STOP_WINDOW_DEF</b> Default for fixed stop monitoring window
Meaning:	The default setting for the fixed stop monitoring window is set in this machine data.  The fixed stop monitoring window becomes operative as soon as the fixed stop is reached, i.e. IS "Fixed stop reached" is set.  If the axis/spindle leaves the position at which the fixed stop has been detected by more than the tolerance specified in MD: FIXED_STOP_WINDOW_DEF, then alarm 20093 "Fixed stop monitoring has responded" is output and the "FXS" function deselected.  The entered value is a default and is effective only on the condition that <ul style="list-style-type: none"> <li>no fixed stop monitoring window has been programmed with command FXSW[x]</li> <li>the fixed stop monitoring window set via SD 43520: FIXED_STOP_WINDOW has not been changed (after fixed stop was reached).</li> </ul>
Related to ....	SD 43520: FIXED_STOP_WINDOW (fixed stop monitoring window)
Note for the reader:	SINUMERIK 802D sl Description of Functions: F1

37030 MD number	<b>FIXED_STOP_THRESHOLD</b> Threshold for fixed stop detection
Meaning:	The contour monitoring threshold for fixed stop detection is entered in this machine data.  This machine data is effective only if MD: FIXED_STOP_BY_SENSOR is set to 0.  IS "Fixed stop reached" is set if the axis-specific contour deviation exceeds the threshold set in MD: FIXED_STOP_THRESHOLD.
MD irrelevant for ... ..	MD 37040: FIXED_STOP_BY_SENSOR = 1
Related to ....	IS "Fixed stop reached"
Note for the reader:	SINUMERIK 802D sl Description of Functions: F1

## 4.4 Axis-specific machine data

37040 MD number	<b>FIXED_STOP_BY_SENSOR</b> Fixed stop detection via sensor
Meaning:	The machine data specifies how the "Fixed stop reached" criterion is determined. Value =0: The "Fixed stop reached" criterion is determined internally based on the axis-specific contour deviation (threshold specified by MD: FIXED_STOP_THRESHOLD). = 1: The "Fixed stop reached" criterion is determined via an external sensor and the NC is notified via IS "Fixed stop sensor". =2: The "Fixed stop reached" criterion is accepted provided either the contour monitoring function (setting = 0) <b>or</b> the signal from the external sensor (setting = 1) has responded.
Related to ....	MD 37030: FIXED_STOP_THRESHOLD (threshold for fixed stop detection) IS "Sensor for fixed stop"
Note for the reader:	SINUMERIK 802D sl Description of Functions: F1

37050 MD number	<b>FIXED_STOP_ALARM_MASK</b> Enabling the fixed stop alarms
Meaning:	The machine data specifies whether the alarm 20091 "Fixed stop not reached" and 20094 "Fixed stop aborted" will be generated. Value = 0: suppress alarm 20091 "Fixed stop not reached" = 2: suppress alarms 20091 "Fixed stop not reached" <b>and</b> 20094 "Fixed stop aborted" = 3: suppress alarm 20094 "Fixed stop aborted"  All other permissible values of $\leq 7$ do <b>not</b> suppress any alarms.
Note for the reader:	SINUMERIK 802D sl Description of Functions: F1

37060 MD number	<b>FIXED_STOP_ACKN_MASK</b> Monitoring of PLC acknowledgments for travel to fixed stop
Meaning:	This machine data determines whether or not the NC waits for acknowledgment messages from the PLC when the "Travel to fixed stop" function is active.  Bit 0 = 0: Once the NC has transmitted IS "Activate travel to fixed stop" to the PLC, it starts the programmed travel motion.  Bit 0 = 1: After the NC has transferred IS "Activate travel to fixed stop" to the PLC, it waits for the PLC to acknowledge with IS "Enable travel to fixed stop" and then starts the programmed travel motion.  Bit 1 = 0: Once the NC has transferred IS "Fixed stop reached" to the PLC, the program advances to the next block.  Bit 1 = 1: After the NC has transferred IS "Fixed stop reached" to the PLC, it waits for the PLC to acknowledge with IS "Acknowledge fixed stop reached", outputs the programmed torque and then executes a block change.
Related to ....	IS "Activate travel to fixed stop" IS "Enable travel to fixed stop" IS "Fixed stop reached" IS "Acknowledge fixed stop reached"
Note for the reader:	SINUMERIK 802D sl Description of Functions: F1

37400 MD number	<b>EPS_TLIFT_TANG_STEP</b> Tangential angle for corner recognition
Meaning:	If TLIFT has been programmed and the axis is under tangential follow-up control (tracking), a step change in the position setpoint which is larger than the value of this MD causes an intermediate block to be inserted. The intermediate block moves the axis to the position corresponding to the initial tangent in the next block.
MD irrelevant for ... ..	TLIFT not activated
Related to ....	TLIFT instruction
Note for the reader:	SINUMERIK 802D sl Description of Functions: T3

37402 MD number	<b>TANG_OFFSET</b> Default angle for tangential follow-up control
Meaning:	Default offset (angle) which the following axis forms with the tangent. The angle acts additively to the angle programmed in the TANGON block.
MD irrelevant for ... ..	if no tangential follow-up control
Related to ....	TANGON instruction
Note for the reader:	SINUMERIK 802D sl Description of Functions: T3

38000 MD number	<b>MM_ENC_COMP_MAX_POINTS[n]</b> (MD can only be displayed!) Interpolation points for encoder/spindle compensation (LEC )
Meaning:	For leadscrew error compensation, the maximum number of interpolation points per axis/measuring system is 125. The required number k can be calculated as follows using the defined parameters: $k = \frac{\$AA\_ENC\_COMP\_MAX - \$AA\_ENC\_COMP\_MIN}{\$AA\_ENC\_COMP\_STEP} + 1$ <p>           \$AA_ENC_COMP_MIN            Initial position            (system variable)            \$AA_ENC_COMP_MAX        End position                (system variable)            \$AA_ENC_COMP_STEP        Distance betw. interpolation points (system variable)         </p> Index[n] has the following coding: [encoder no.]: 0
Related to ....	MD 32700: ENC_COMP_ENABLE[n] Interpolatory compensation active
Note for the reader:	SINUMERIK 802D sl Description of Functions: K3



## Setting Data – Description

### 5.1 General setting data

41010 SD number	<b>JOG_VAR_INCR_SIZE</b> Size of variable increment for INC/handwheel
Meaning:	This setting data defines the number of increments when variable increment (INCvar) is selected. This increment size is traversed by the axis in JOG mode whenever the traverse key is pressed or the handwheel is turned one detent position and variable increment is selected ("Active machine function: INC variable" interface signal for machine or geometry axes is set to 1). <b>Note:</b> Please note that the increment size is active for incremental jogging <b>and</b> handwheel jogging.
SD irrelevant for ... ..	If INCvar not active
Related to ....	IS "Active machine function: INCvariable" (V3200 1001.5, V3200 1005.5, V3200 1009.5, V380x 0005.5)
Note for the reader:	SINUMERIK 802D sl Description of Functions: H1

41110 SD number	<b>JOG_SET_VELO</b> JOG velocity for linear axes (for G94)
Meaning:	<b>Value &gt; 0:</b> The velocity entered applies to all linear axes in JOG mode if they are traversed manually using the "traversing keys plus and minus". The axis velocity setting is active for: <ul style="list-style-type: none"> <li>- Continuous traversing</li> <li>- Incremental traversing (INC1, ..., INCvar)</li> </ul> The value entered may not exceed the maximum permissible axis velocity (MD 32000: MAX_AX_VELO).  <b>Value = 0:</b> The feedrate in JOG mode is the corresponding axis-specific MD 32020: JOG_VELO "JOG axis velocity". In this way, it is possible to define a separate JOG velocity for every axis.
SD irrelevant for ... ..	- For rotary axes (SD 41130: JOG_ROT_AX_SET_VELO) applies
Related to ....	Axis-specific MD 32020: JOG_VELO (JOG axis velocity) Axis-specific MD 32000: MAX_AX_VELO (maximum axis velocity) SD 41130: JOG_ROT_AX_SET_VELO (JOG velocity for rotary axes)
Note for the reader:	SINUMERIK 802D sl Description of Functions: H1

41130 SD number	<b>JOG_ROT_AX_SET_VELO</b> JOG velocity for rotary axes
Meaning:	As for SD 41110: JOG_AX_SET_VELO – but for <b>all rotary axes</b> instead of linear axes
Application example(s)	The operator can define a JOG velocity for a particular application.
Related to ....	MD 32020: JOG_VELO (JOG axis velocity) MD 32000: MAX_AX_VELO (maximum axis velocity)
Note for the reader:	SINUMERIK 802D sl Description of Functions: H1

## 5.1 General setting data

41200 SD number	<b>JOG_SPIND_SET_VELO</b> JOG speed for spindles
Meaning:	<p><b>Value &gt; 0:</b> The velocity entered applies to spindles in JOG mode if they are traversed manually using the "traversing keys plus and minus". The velocity setting is active for:</p> <ul style="list-style-type: none"> <li>- Continuous jogging</li> <li>- Incremental jogging (INC1, ..., INCvar)</li> </ul> <p>The value entered must not exceed the maximum permissible velocity (MD 32000: MAX_AX_VELO).</p> <p><b>Value = 0:</b> If 0 has been entered in the setting data, the active JOG velocity is MD 32020: JOG_VELO (JOG axis velocity). Each axis can be given its own JOG velocity with this MD (axis-specific MD). When the spindle is traversed in JOG mode, the maximum velocity of the active gear stage (MD 35130: GEAR_STEP_MAX_VELO_LIMIT) is taken into account.</p>
SD irrelevant for ... ..	Axes
Related to ....	MD 32020: JOG_VELO (JOG axis velocity) MD 35130: GEAR_STEP_MAX_VELO_LIMIT (maximum velocity of gear stages)
Note for the reader:	SINUMERIK 802D sl Description of Functions: H1, S1

## 5.2 Channel-specific setting data

42000 SD number	<b>THREAD_START_ANGLE</b> Start angle for thread G33
Meaning:	This setting data can be used to program the offset of the individual threads when cutting multiple threads. This SD can be changed from the part program by the SF=... command. If no SF=... is written in the G33 block of the part program, then the setting data applies.
Further references	"Operation and Programming"
Note for the reader:	SINUMERIK 802D sl Description of Functions: K1

42010 SD number	<b>THREAD_RAMP_DISP[n]</b> (Index n = 0: run-up distance, n=1: Deceleration path) Starting and deceleration behavior of feed axis in thread cutting G33
Meaning:	The SD is effective for thread cutting with G33, G34, G35. It provides two elements that determine the behavior during the <b>starting</b> of the thread axis (1st element = index 0) and during the <b>braking</b> with rounding (2nd element = index 1). The values possess the same properties for the thread run-in and run-out: -1: Starting/braking of the thread axis is carried out with the configured acceleration. Jerk according to current BRISK/SOFT programming.  0: Abrupt starting/braking of the feedrate axis during thread cutting. > 0: The maximum thread starting/braking distance is defined. The defined distance may cause an acceleration overload of the axis. The SD is defined during the programming of DITR (Displacement Thread Ramp) from the block.  The default values (-1) for both elements of the SD are set with NC reset and at the end of the part program. Example: \$SC_THREAD_RAMP_DISP[0]=2 ; run-in path 2 mm  The SD is defined during the programming of DITS (index 0) and DITE (index 1) from the block.
SD irrelevant for ... ..	no G33, G34, G35
Related to ....	With the DITS and DITE (Displacement Thread Start/End) part program instructions.
Note for the reader:	SINUMERIK 802D sl Description of Functions: K1, V1

42100 SD number	<b>DRY_RUN_FEED</b> Dry run feedrate
Meaning:	To check a part program with regard to the traversing path (without workpiece to be machined) the operator can activate the dry run feed function on the operator interface (Program control softkey). The value of this setting data is then taken instead of the programmed feed value. Rapid traverse feed values are not changed. The dry run feedrate value can be entered in the Setting data menu. The function is effective only in the AUTOMATIC and MDA modes.
SD irrelevant for ... ..	Dry run feedrate function not activated
Application example(s)	Checking traversing distances with new part programs
Special cases, errors, ... ..	The function may not be activated if a workpiece should be machined. The maximum cutting speed of the tool might be exceeded by the activated dry run feedrate. The destruction of the workpiece and of the tool could be the consequence.
Note for the reader:	SINUMERIK 802D sl Description of Functions: K1

42110 SD number	<b>DEFAULT_FEED</b> Default value for path feedrate
Meaning:	The setting date is evaluated during the start of the part program with consideration of the switch-on position of the feedrate type. Switch-on positions: Turning: G95 – feedrate in mm/rev. of the spindle Milling: G94 – feedrate in mm/min If no F word is written at G1, G2, G2, ... for the applicable feedrate type and if the SD value is not zero, the feedrate from this SD is used. Otherwise, an alarm indicating the missing feedrate is issued.
SD irrelevant for ... ..	Turning: G94 programmed Milling: G95 programmed
Note for the reader:	SINUMERIK 802D sl Description of Functions: V1

## 5.2 Channel-specific setting data

42940 SD number	<b>TOOL_LENGTH_CONST</b> Retain the assignment of tool lengths 1 to 3 to the geo-axes when changing the machining plane (G17 to G19)																																																								
Meaning:	<p>If this setting data is not zero, the allocation of the tool lengths 1 to 3 (length, wear) to the geometry axes is not changed if the machining plane (G17 to G19) changes. The allocation of tool length components to the geometry axes results from the value of the setting data according to the following tables. With respect to the allocation, a distinction is made between turning tools (tool types 500 to 599) and other tools (drilling/milling tools). For the representation in the tables it is assumed that geometry axes 1 to 3 are named X, Y, Z. However, the geometry axis sequence, and not the axis identifier, is the determining factor in the assignment of an offset to an axis.</p> <p>The assignment of the tool lengths to the geometry axes for <b>turning tools</b> (tool types 500 to 599) results from the value of setting data SD 42940 in accordance with the following table:</p> <table border="1"> <thead> <tr> <th>Plane/value</th> <th>Length 1</th> <th>Length 2</th> <th>Length 3</th> </tr> </thead> <tbody> <tr> <td>17</td> <td>Y</td> <td>X</td> <td>Z</td> </tr> <tr> <td>18*)</td> <td>X</td> <td>Z</td> <td>Y</td> </tr> <tr> <td>19</td> <td>Z</td> <td>Y</td> <td>X</td> </tr> <tr> <td>-17</td> <td>X</td> <td>Y</td> <td>Z</td> </tr> <tr> <td>-18</td> <td>Z</td> <td>X</td> <td>Y</td> </tr> <tr> <td>-19</td> <td>Y</td> <td>Z</td> <td>X</td> </tr> </tbody> </table> <p>The following table shows the allocation of the tool lengths 1 to 3 to the geometry axes for <b>drills/milling cutters</b> (tool types 100 to 299):</p> <table border="1"> <thead> <tr> <th>Plane/value</th> <th>Length 1</th> <th>Length 2</th> <th>Length 3</th> </tr> </thead> <tbody> <tr> <td>17*)</td> <td>Z</td> <td>Y</td> <td>X</td> </tr> <tr> <td>18</td> <td>Y</td> <td>X</td> <td>Z</td> </tr> <tr> <td>19</td> <td>X</td> <td>Z</td> <td>Y</td> </tr> <tr> <td>-17</td> <td>Z</td> <td>X</td> <td>Y</td> </tr> <tr> <td>-18</td> <td>Y</td> <td>Z</td> <td>X</td> </tr> <tr> <td>-19</td> <td>X</td> <td>Y</td> <td>Z</td> </tr> </tbody> </table>	Plane/value	Length 1	Length 2	Length 3	17	Y	X	Z	18*)	X	Z	Y	19	Z	Y	X	-17	X	Y	Z	-18	Z	X	Y	-19	Y	Z	X	Plane/value	Length 1	Length 2	Length 3	17*)	Z	Y	X	18	Y	X	Z	19	X	Z	Y	-17	Z	X	Y	-18	Y	Z	X	-19	X	Y	Z
Plane/value	Length 1	Length 2	Length 3																																																						
17	Y	X	Z																																																						
18*)	X	Z	Y																																																						
19	Z	Y	X																																																						
-17	X	Y	Z																																																						
-18	Z	X	Y																																																						
-19	Y	Z	X																																																						
Plane/value	Length 1	Length 2	Length 3																																																						
17*)	Z	Y	X																																																						
18	Y	X	Z																																																						
19	X	Z	Y																																																						
-17	Z	X	Y																																																						
-18	Y	Z	X																																																						
-19	X	Y	Z																																																						
Related to ....	SD 42950: TOOL_LENGTH_TYPE																																																								
Note for the reader:	SINUMERIK 802D sl Description of Functions: W1																																																								

42950 SD number	<b>TOOL_LENGTH_TYPE</b> Allocation of the tool length compensation independent of tool type
Meaning:	<b>0:</b> The assignment is performed by default. A distinction is made between turning tools (tool type 500 to 599) and drilling/milling tools (tool type 100 to 299).
Related to ....	SD 42940: TOOL_LENGTH_CONST
Note for the reader:	SINUMERIK 802D sl Description of Functions: W1

### 5.3 Spindle-specific setting data

43210 SD number	<b>SPIND_MIN_VELO_G25</b> Programmable lower spindle speed limiting for G25
Meaning:	The spindle speed is not permitted to drop below the minimum spindle speed limit entered in this SD. The NCK limits an excessively small spindle speed setpoint to this value. The spindle speed can only fall below the minimum limit through: <ul style="list-style-type: none"> <li>• Spindle override 0%</li> <li>• M5</li> <li>• S0</li> <li>• IS "Spindle stop" (V380x 0004.3)</li> <li>• IS "Controller enable" (V380x 0002.1)</li> <li>• IS "Reset" (V3000 0000.7)</li> <li>• IS "Spindle reset" (V380x 0002.2)</li> <li>• IS "Oscillation speed" (V380x 2002.5)</li> </ul>
SD irrelevant for ... ..	All spindle modes except control mode
Special cases, errors, ... ..	The value in SD: SPIND_MIN_VELO_G25 can be altered by means of: <ul style="list-style-type: none"> <li>• G25 S .... in the part program</li> <li>• Operator commands from the HMI</li> </ul> The value in SD: SPIND_MIN_VELO_G25 is retained after reset or power off.
Related to ....	SD 43220: SPIND_MAX_VELO_G26 SD 43230: SPIND_MAX_VELO_LIMS (progr. Spindle speed limiting with G96)
Note for the reader:	SINUMERIK 802D sl Description of Functions: S1

43220 SD number	<b>SPIND_MAX_VELO_G26</b> Programmable upper spindle speed limiting for G26
Meaning:	The spindle speed is not permitted to exceed the maximum spindle speed limit entered in this SD. The NCK limits an excessive spindle speed setpoint to this value.
SD irrelevant for ... ..	All spindle modes except control mode.
Special cases, errors, ... ..	The value in this SD: SPIND_MIN_VELO_G26 can be altered by means of: <ul style="list-style-type: none"> <li>• G26 S .... in the part program</li> <li>• Operator commands from the HMI</li> </ul> The value in SD: SPIND_MIN_VELO_G26 is retained after reset or power off.
Related to ....	SD 43210: SPIND_MIN_VELO_G25 (progr. spindle speed limiting G25) SD 43230: SPIND_MAX_VELO_LIMS (progr. Spindle speed limiting with G96)
Note for the reader:	SINUMERIK 802D sl Description of Functions: S1

43230 SD number	<b>SPIND_MAX_VELO_LIMS</b> progr. Spindle speed limiting G96
Meaning:	At constant cutting rate (G96 and G97) an extra limits entered in SPIND_MAX_VELO_LIMS is operative in addition to the continually applied limits. Furthermore this can be described with SPIND_MAX_VELO_LIMS in the part program with LIMS=... .
SD irrelevant for ... ..	All spindle functions except for G96 and G97 (constant cutting speed)
Application example(s)	When cutting-off and for very small diameters of the workpiece to be machined, the spindle with the workpiece (lathe) accelerates higher and higher at a constant cutting rate (G96), theoretically reaching an infinitely high set speed in the position of the traverse axis X=0. In cases such as this, the spindle rotates up to its maximum spindle speed in the current gear stage (limited, where applicable, by G26). If, especially for G96, the spindle is to be limited to a lower speed, then this can be defined using LIMS=.... SPIND_MAX_VELO_LIMS.
Special cases, errors, ... ..	The value SD 43210: SPIND_MIN_VELO_LIMS can be changed using: <ul style="list-style-type: none"> <li>• LIMS S .... in the part program</li> <li>• Operator commands from the HMI</li> </ul> The value SD SPIND_MIN_VELO_LIMS is retained after reset or power down.
Related to ....	SD 43220: SPIND_MAX_VELO_G26 (maximum spindle speed) SD 43210: SPIND_MIN_VELO_G25 (minimum spindle speed)
Note for the reader:	SINUMERIK 802D sl Description of Functions: S1

## 5.3 Spindle-specific setting data

43400 SD number	<b>WORKAREA_PLUS_ENABLE</b> Working area limiting active in positive direction
Meaning:	<b>0:</b> The working area limit of the axis is deactivated in the positive direction. <b>1:</b> The working area limit of the axis is active in the positive direction. The setting data is parameterized using the operator panel in the "Parameter" area by activating/deactivating the working area limitation.
SD irrelevant for ... ..	G-Code: WALIMOF
Note for the reader:	SINUMERIK 802D sl Description of Functions: A3

43410 SD number	<b>WORKAREA_MINUS_ENABLE</b> Working area limiting active in negative direction
Meaning:	<b>0:</b> The working area limit of the axis is deactivated in the negative direction. <b>1:</b> The working area limit of the axis is active in the negative direction. The setting data is parameterized using the operator panel in the "Parameter" area by activating/deactivating the working area limitation.
SD irrelevant for ... ..	G-Code: WALIMOF
Note for the reader:	SINUMERIK 802D sl Description of Functions: A3

43420 SD number	<b>WORKAREA_LIMIT_PLUS</b> Working area, limiting plus
Meaning:	The working area limits can be used to restrict the working area in the MCS in the positive direction of the corresponding axis. The setting data can be changed via the operator panel in the "Parameter" operating area. The positive working area limit can be changed in the program with G26.
SD irrelevant for ... ..	G-Code: WALIMOF
Related to ....	SD 43400: WORKAREA_PLUS_ENABLE
Note for the reader:	SINUMERIK 802D sl Description of Functions: A3

43430 SD number	<b>WORKAREA_LIMIT_MINUS</b> Working area, limiting minus
Meaning:	The working area limitation can be used to restrict the working area in the MCS in the negative direction of the corresponding axis. The setting data can be changed via the operator panel in the "Parameter" operating area. The negative working area limit can be changed in the program with G25.
SD irrelevant for ... ..	G code: WALIMOF
Related to ....	SD 43410: WORKAREA_MINUS_ENABLE
Note for the reader:	SINUMERIK 802D sl Description of Functions: A3

43500 SD number	<b>FIXED_STOP_SWITCH</b> Selection of travel to fixed stop
Meaning:	This setting data allows the "Travel to fixed stop" function to be checked.  Value =0: Deselect "Travel to fixed stop" function =1: Select "Travel to fixed stop" function  The setting data can be overwritten by the part program using the command FXS[x]=1/0.
Note for the reader:	SINUMERIK 802D sl Description of Functions: F1

43510 SD number	<b>FIXED_STOP_TORQUE</b> Clamping torque for travel to fixed stop
Meaning:	<p>The clamping torque is entered in this setting data as a percentage of the maximum motor torque (for FSD, corresponds with percentage of max. current setpoint)</p> <p>Please note that a clamping torque greater than 100% may only be present for a short time; otherwise, the motor will be damaged</p> <p>When selecting the function "Travel to fixed stop" through programming FXS[.] the default setting of the MD 37010: FIXED_STOP_TORQUE_DEF applies until it is programmed with FXST[.].</p> <p>The FXST[x] command acts like a block-synchronous change of this setting data. The setting data can be modified by the operator. The SD is already operative as the stop is approached.</p> <p>The <b>fixed stop is considered reached</b> if: FIXED_STOP_ACKN_MASK,  bit 1 = 0, with MD37060: (no acknowledgment required) IS "Fixed stop reached" is set by the NC.  Bit 1 = 1: (acknowledgment required) IS "Fixed stop reached" is set by the NC <b>and</b> acknowledged by IS "Acknowledge fixed stop reached".</p>
Related to ....	MD 37010: FIXED_STOP_TORQUE_DEF (default setting for clamping torque)
Note for the reader:	SINUMERIK 802D sl Description of Functions: F1



## Interface Signals

### 6.1 General

#### Interfaces

The exchange of signals and data between the PLC user program and

- NCK (core of numerical control)
- HMI (display unit)

takes place through various data areas. The PLC user program does not have to handle the exchange of data and signals. From the users point of view, this takes place automatically.

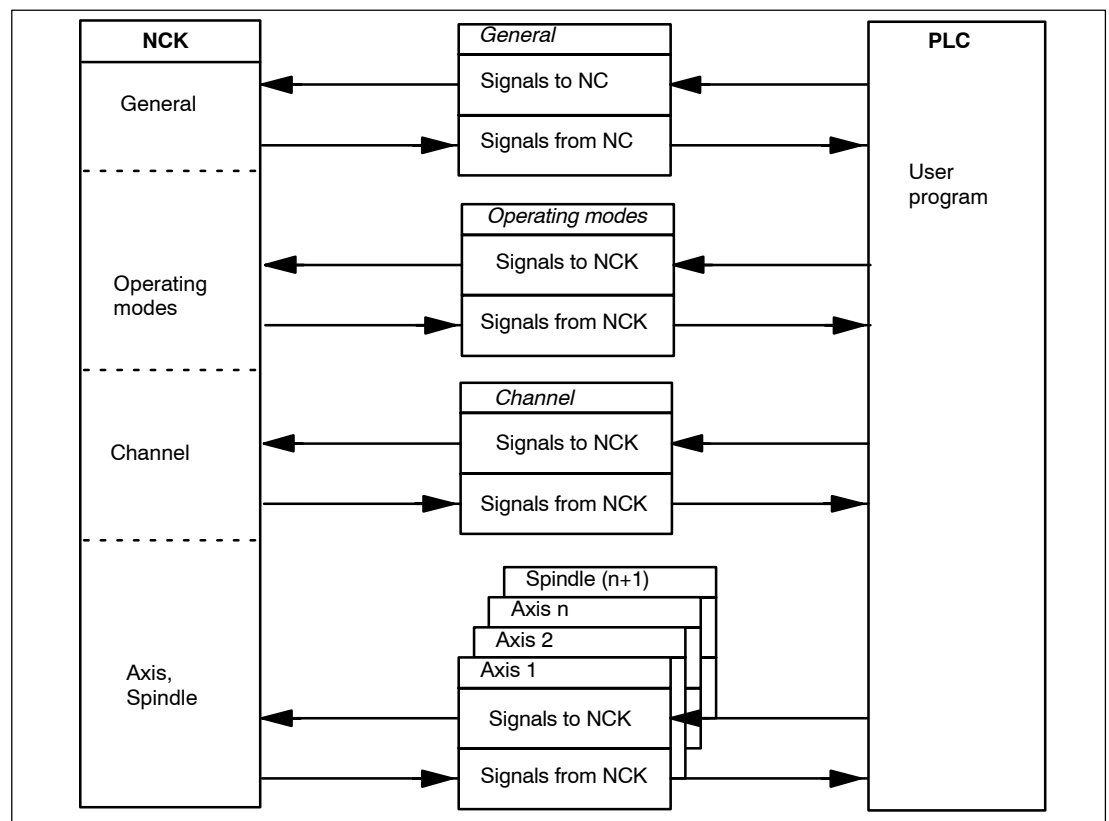

Fig. 6-1 PLC/NCK interface

### Cyclical signal exchange

The control and status signals of the PLC/NCK interface are updated cyclically.

The signals can be subdivided into the following groups (see Fig. 6-1):

- General signals
- Operating mode signals
- Channel signals
- Axis/spindle signals

## 6.2 Signals from/to HMI

### 6.2.1 Program-control signals from HMI

V1700 0000.5 Interface signal	M01 selected Signal(s) from HMI ----> PLC
Edge evaluation: no	Signal(s) updated: cyclic Signal(s) valid from SW:
Signal state 1 or signal transition 0 ----> 1	Program control Activate M1 has been selected on the operator interface. This does not activate the function.
Signal state 0 or signal transition 1 ----> 0	Program control Activate M1 has not been selected via the operator interface.
Related to ....	IS "Activate M01" IS "M0/M1 active"
Note for the reader:	802D sl Description of Functions: K1

V1700 0000.6 Interface signal	Dry run feedrate selected Signal(s) from HMI ----> PLC
Edge evaluation: no	Signal(s) updated: cyclic Signal(s) valid from SW:
Signal status 1 or edge transition 0 ----> 1	Dry run feedrate is selected. Instead of the programmed feedrate, the dry run feedrate entered in SD 42100: DRY_RUN_FEED is effective. When activating the dry run feedrate, the signal is automatically entered in the PLC interface and transferred by the PLC basic program to the PLC interface signal "Activate dry run feedrate".
Signal status 0 or edge transition 1 ----> 0	Dry run feedrate is not selected. The programmed feedrate is effective.
Related to ....	IS "Activate dry run feedrate" (V3200 0000.6) SD: DRY_RUN_FEED (dry run feedrate)
Note for the reader:	802D sl Description of Functions: V1, K1

V1700 0001.3 Interface signal	Feed override for rapid traverse selected Signal(s) from HMI ----> PLC
Edge evaluation: no	Signal(s) updated: cyclic Signal(s) valid from SW:
Signal status 1 or edge transition 0 ----> 1	The feedrate override switch is also to act as a rapid traverse override switch. Overrides more than 100 % are limited to the maximum value of 100 % rapid traverse override. The interface signal (IS) "Feedrate override selected for rapid traverse" is automatically entered in the PLC interface by the operator panel and transferred by the PLC basic program to the PLC interface signal "Rapid traverse override effective". Furthermore, the IS "Feedrate override" (VB3200 0004) is copied by the PLC basic program into the IS "Rapid traverse override" (VB3200 0005).
Signal state 0 or signal transition 1 ----> 0	Program control -Feed override for rapid traverse- has not been selected via the operator interface.
Application example(s)	This signal is used if no separate rapid traverse override switch exists.
Note for the reader:	802D sl Description of Functions: V1

V1700 0001.7 Interface signal	Program test selected Signal(s) from HMI ----> PLC
Edge evaluation: no	Signal(s) updated: cyclic Signal(s) valid from SW:
Signal state 1 or signal transition 0 ----> 1	Program control Program test has been selected via the operator interface. This does not activate the function.
Signal state 0 or signal transition 1 ----> 0	Program control Program test has not been selected via the operator interface.
Related to ....	IS "Activate program test" IS "Program test active"
Note for the reader:	802D sl Description of Functions: K1

## 6.2 Signals from/to HMI

V1700 0002 V1700 0003.0 to .1 Interface signal	Skip block selectedrogram test selected" <sup>m</sup> # Signal(s) from HMI ----> PLC
Edge evaluation: no	Signal(s) updated: cyclic Signal(s) valid from SW:
Signal state 1 or signal transition 0 ----> 1	Program control –skip block– has been selected via the operator interface. This does not activate the function.
Signal state 0 or signal transition 1 ----> 0	Program control –skip block– has not been selected via the operator interface.
Related to ....	IS "Activate skip block"
Note for the reader:	802D sl Description of Functions: K1

V1700 0003.7 *** Interface signal	Measuring in JOG active Signal(s) to PLC (HMI ----> PLC)
Edge evaluation: no	Signal(s) updated: cyclic Signal(s) valid from SW: 1.1
Signal state 1 or signal transition 0 ----> 1	The "Tool measuring in JOG" function is activated by HMI. <b>Note:</b> This signal remains set when changing to AUTOMATIC mode in this function. The HMI maintains the JOG image in the display. Only the active mode display changes.
Signal state 0 or signal transition 1 ----> 0	The "Tool measuring" function is not active.
Note for the reader:	802D sl Description of Functions: M5

## 6.2.2 Signals from HMI

V1800 0000.0 Interface signal	AUTOMATIC mode Signal(s) to PLC (HMI ----> PLC)
Edge evaluation: yes	Signal(s) updated: cyclic Signal(s) valid from SW: 1.1
Signal state 1 or signal transition 0 ----> 1	AUTOMATIC mode has been selected by the HMI. The signal status 1 is active for only one PLC cycle.
Signal state 0	AUTOMATIC mode is not selected by the HMI.
Signal irrelevant for ... ..	if "Change mode disable" signal
Note for the reader:	802D sl Description of Functions: M5

V1800 0000.1 Interface signal	MDA mode Signal(s) to PLC (HMI ----> PLC)
Edge evaluation: yes	Signal(s) updated: cyclic Signal(s) valid from SW: 1.1
Signal state 1 or signal transition 0 ----> 1	MDA mode has been selected by the HMI. The signal status 1 is active for only one PLC cycle.
Signal state 0	MDA mode is not selected by the HMI.
Signal irrelevant for ... ..	if "Change mode disable" signal
Note for the reader:	802D sl Description of Functions: M5

V1800 0000.2 Interface signal	JOG mode Signal(s) to PLC (HMI ----> PLC)
Edge evaluation: yes	Signal(s) updated: cyclic Signal(s) valid from SW: 1.1
Signal state 1 or signal transition 0 ----> 1	JOG mode has been selected by the HMI. The signal status 1 is active for only one PLC cycle.
Signal state 0	JOG mode is not selected by the HMI.
Signal irrelevant for ... ..	if "Change mode disable" signal
Note for the reader:	802D sl Description of Functions: M5

V1800 0000.4 Interface signal	Mode group changeover disable Signal(s) to PLC (HMI ----> PLC)
Edge evaluation: yes	Signal(s) updated: cyclic Signal(s) valid from SW: 1.1
Signal state 1 or signal transition 0 ----> 1	Request by MMC: The current active mode (JOG, MDA or AUTOMATIC) should not be changed. The signal status is active for only one PLC cycle.
Signal state 0	The mode can be changed.
Note for the reader:	802D sl Description of Functions: M5

V1800 0000.6 *** Interface signal	Start measuring in JOG Signal(s) to PLC (HMI ----> PLC)
Edge evaluation: yes	Signal(s) updated: cyclic Signal(s) valid from SW: 1.1
Signal state 1 or signal transition 0 ----> 1	Request to PLC by HMI to start the measuring program with NC start. The signal status 1 is active for only one PLC cycle only.
Signal state 0	
Note for the reader:	802D sl Description of Functions: M5

V1800 0001.2 Interface signal	Machine function REF Signal(s) to PLC (HMI ----> PLC)
Edge evaluation: yes	Signal(s) updated: cyclic Signal(s) valid from SW: 1.1
Signal state 1 or signal transition 0 ----> 1	The REF machine function is selected from within JOG mode. The signal status 1 is active for only one PLC cycle only.
Signal state 0	Machine function REF is not selected.
Signal irrelevant for ... ..	if JOG mode is not active.
Note for the reader:	802D sl Description of Functions: M5

### 6.2.3 Signals from operator panel

V1900 0000.6 Interface signal	Simulation active Signal(s) from HMI ----> PLC
Edge evaluation: no	Signal(s) updated: cyclic Signal(s) valid from SW:
Signal state 1 or signal transition 0 ----> 1	The -simulation- function has been selected via the operator interface.
Signal state 0 or signal transition 1 ----> 0	The -simulation- function has not been selected via the operator interface.
Related to ....	
Note for the reader:	802D sl Description of Functions: K1

### 6.2.4 General selection/status signals from HMI

V1900 0003.7 V1900 0004.7 Interface signal	Machine axis for handwheel 1 for handwheel 2 Signal(s) from NC (HMI -> PLC)
Edge evaluation: no	Signal(s) updated: cyclic Signal(s) valid from SW:
Signal state 1 or signal transition 0 ----> 1	The operator has assigned an axis to the handwheel (1, 2, 3) directly on the operator panel. This axis is a <b>machine axis</b> – not a geometry axis (axis in the WCS). For further information see IS "Axis number".
Signal state 0 or signal transition 1 ----> 0	The operator has assigned an axis to the handwheel (1, 2, 3) directly on the operator panel. This axis is a <b>geometry axis</b> (axis in the WCS). For further information see IS "Axis number".
Related to ....	IS "Axis number" (V1900 0003.0 to .4, ff)
Note for the reader:	802D sl Description of Functions: H1

6.2 Signals from/to HMI

V1900 1003.0 to .2 V1900 1004.0 to .2	Axis number for handwheel 1 for handwheel 2																												
Interface signal	Signal(s) from NC (HMI -> PLC)																												
Edge evaluation: no	Signal(s) updated: cyclic Signal(s) valid from SW:																												
Significance of signal	<p>The operator can assign an axis to every handwheel directly via the operator panel. To do so, he defines the required axis (e.g. X).</p> <p>The PLC user interface provides the number of the axis plus the information 'machine axis or geometry axis' ('machine axis' interface signal) as HMI interface signals.</p> <p>The "Activate handwheel" interface signal for the defined axis must be set from the PLC user program.</p> <p>Depending on the setting in the HMI interface signal "machine axis", either the interface for the geometry axis or for the machine axis is used.</p> <p>The following must be noted when assigning the axis designation to the axis number:</p> <ul style="list-style-type: none"> <li>• IS "Machine axis" = 1; i.e. machine axis – not geometry axis: The assignment is made via MD 10000: AXCONF_MACHAX_NAME_TAB[n] (machine axis name).</li> <li>• IS "Machine axis" = 0; i.e. geometry axis (axis in WCS): The assignment is made via MD 20060: AXCONF_GEOAX_NAME_TAB[n] (geometry axis name in channel). IS "Channel number geometry axis handwheel n" defines the channel assigned to the handwheel.</li> </ul> <p>The following coding applies to the axis number:</p> <table border="1"> <thead> <tr> <th>Bit 2</th> <th>Bit 1</th> <th>Bit 0</th> <th>axis number</th> </tr> </thead> <tbody> <tr> <td>0</td> <td>0</td> <td>0</td> <td>-</td> </tr> <tr> <td>0</td> <td>0</td> <td>1</td> <td>1</td> </tr> <tr> <td>0</td> <td>1</td> <td>0</td> <td>2</td> </tr> <tr> <td>0</td> <td>1</td> <td>1</td> <td>3</td> </tr> <tr> <td>1</td> <td>0</td> <td>0</td> <td>4</td> </tr> <tr> <td>1</td> <td>0</td> <td>1</td> <td>5</td> </tr> </tbody> </table> <p>Note: Bit 3 and bit 4 must always be left with value =0.</p>	Bit 2	Bit 1	Bit 0	axis number	0	0	0	-	0	0	1	1	0	1	0	2	0	1	1	3	1	0	0	4	1	0	1	5
Bit 2	Bit 1	Bit 0	axis number																										
0	0	0	-																										
0	0	1	1																										
0	1	0	2																										
0	1	1	3																										
1	0	0	4																										
1	0	1	5																										
Related to ....	<p>IS "Machine axis" (V1900 1003.7 ff)</p> <p>IS "Activate handwheel" 1 to 3 /geometry axes 1, 2, 3 (V3200 1000.0 to .2, V3200 1004.0 to .2, V3200 1008.0 to .2)</p> <p>IS "Activate handwheel" 1 to 3 /machine axes (V380x 0004.0 to .2)</p> <p>MD 10000: AXCONF_MACHAX_NAME_TAB [n] (machine axis name)</p> <p>MD 20060: AXCONF_GEOAX_NAME_TAB[n] (name of the geometry axis in the channel)</p>																												
Note for the reader:	802D sI Description of Functions: H1																												

6.2.5 General selection/status signals to HMI

V1900 5001.0 Interface signal	Update the tool list Signal(s) from channel (PLC ---> HMI)
Edge evaluation: yes	Signal(s) updated: cyclic Signal(s) valid from SW:
Signal state 1 or signal transition 0 ---> 1	Tool display is updated
Signal state 0 or signal transition 1 ---> 0	No effect
Note for the reader:	802D sI Description of Functions: W1

V1900 5002.0 Interface signal	Enabling machine tool measuring in JOG Signal(s) from NCK (PLC → HMI)
Edge evaluation: no	Signal(s) updated: cyclic Signal(s) valid from SW: 2
Signal state 1 or signal transition 0 ---> 1	Measuring in JOG function can be activated.
Signal state 0 or signal transition 1 ---> 0	Measuring in JOG is not possible.
Note for the reader:	802D sI Description of Functions: M5

VD1900 5004 Interface signal	Tool number for tool measuring in JOG Signal(s) to HMI (PLC ----> HMI)		
Edge evaluation: no	Signal(s) updated: cyclic	Signal(s) valid from SW: 1.1	
Value > 0 (DWORD)	Input of T number from PLC for entering measurement results to HMI. The number entered in the HMI screen is used as offset number D.		
Value = 0	No specification of the T no. by PLC		
Signal irrelevant for ... ..	if IS "Measuring in JOG active" (V1700 0003.7) is not set.		
Note for the reader:	802D sl Description of Functions: M5		

## 6.3 Auxiliary function transfer from NC channel

V2500 0004.0 to .4 V2500 0006.0 V2500 0008.0 V2500 0010.0 V2500 0012.0 to .2 Interface signal	M function Change 1 to 5 S function Change 1 T function Change 1 D function Change 1 H function Change 1 to 3 Signal(s) from channel (NCK → PLC)	
Edge evaluation: no	Signal(s) updated: cyclic	Signal(s) valid from SW:
Signal state 1	An M, S, T, D or H function has been output to the interface with a new value together with the associated change signal. In this case, the change signal indicates that the appropriate value is valid. The change signals are only valid for one PLC cycle! That means that there is a pending change for this cycle if the signal is 1.	
Signal state 0	The value of the data concerned is not valid.	
Note for the reader:	802D sl Description of Functions: H2	

VB2500 1000 to VB2500 1012 Interface signal	Decoded M signals: M0 – M99 Signal(s) from channel (NCK → PLC)	
Edge evaluation: no	Signal(s) updated: cyclic	Signal(s) valid from SW:
Signal state 1	The dynamic M signal bits are set by decoded M functions.	
Signal state 0	With a general auxiliary function output, dynamic M signal bits are acknowledged by the PLC system program after the complete AWP routine has been executed once.	
Application example(s)	Spindle clockwise/counter-clockwise rotation, switch coolant ON/OFF	
Related to ....	IS "M function for the spindle (DINT), axis-specific" (VD370x 0000)	
Note for the reader:	802D sl Description of Functions: H2	

VD2500 2000 Interface signal	T function 1 Signal(s) from channel (NCK → PLC)	
Edge evaluation: no	Signal(s) updated: Job controlled by NCK	Signal(s) valid from SW:
Signal state 1	The T function programmed in an NC block is made available here as soon as the T change signal is applied. Value range of T function: 0–32000; integer The T function remains valid until it is overwritten by a new T function.	
Signal state 0	<ul style="list-style-type: none"> <li>After PLC power-up.</li> <li>All auxiliary functions are deleted before a new function is entered.</li> </ul>	
Application example(s)	Control of automatic tool selection.	
Special cases, errors, ... ..	When T0 is selected, the current tool is removed from the tool holder but not replaced by a new tool (default configuration by machine manufacturer).	
Note for the reader:	802D sl Description of Functions: H2	

## 6.3 Auxiliary function transfer from NC channel

VD2500 3000	M function 1
VD2500 3008	M function 2
VD2500 3016	M function 3
VD2500 3024	M function 4
VD2500 3032	M function 5
VB2500 3004	Extended address M function 1
VB2500 3012	Extended address M function 2
VB2500 3020	Extended address M function 3
VB2500 3028	Extended address M function 4
VB2500 3036	Extended address M function 5
Interface signal	Signal(s) from channel (NCK -> PLC)
Edge evaluation: no	Signal(s) updated: Job controlled by NCK      Signal(s) valid from SW:
Signal state 1	Up to 5 M functions programmed in an NC block are made available here simultaneously as soon as the M change signals are applied. Value range of the M functions: 0 to 99; integer Value range of extended address: 1-2; integer (spindle number) The M functions remain valid until they are overwritten by new M functions.
Signal state 0	<ul style="list-style-type: none"> <li>• After PLC power-up.</li> <li>• All auxiliary functions are deleted before a new function is entered.</li> </ul>
Related to ....	IS "M function for the spindle (DINT), axis-specific" (VD370x 0000)
Note for the reader:	802D sl Description of Functions: H2

VD2500 4000	S function 1
VD2500 4008	S function 2
VB2500 4004	Extended address S function 1
VB2500 4012	Extended address S function 2
Interface signal	Signal(s) from channel (NCK -> PLC)
Edge evaluation: no	Signal(s) updated: Job controlled by NCK      Signal(s) valid from SW:
Signal state 1	The S function programmed in an NC block (speed or cutting value with G96) is made available here as soon as the S change signal is applied. Value range of the S function: : Floating point (REAL format/4-byte) Value range of extended address: 1-2; integer (spindle number) The S function remains valid until it is overwritten by a new S function.
Signal state 0	<ul style="list-style-type: none"> <li>• After PLC power-up.</li> <li>• All auxiliary functions are deleted before a new function is entered.</li> </ul>
Related to ....	IS "S function for the spindle (REAL), axis-specific" (VD370x 0004)
Note for the reader:	802D sl Description of Functions: H2

VD2500 5000	D function 1
Interface signal	Signal(s) from channel (NCK -> PLC)
Edge evaluation: no	Signal(s) updated: Job controlled by NCK      Signal(s) valid from SW:
Signal state 1	The D function programmed in an NC block is made available here as soon as the D change signal is applied. Value range of D function: 0-9; integer The D function remains valid until it is overwritten by a new D function.
Signal state 0	<ul style="list-style-type: none"> <li>• After PLC power-up.</li> <li>• All auxiliary functions are deleted before a new function is entered.</li> </ul>
Application example(s)	
Special cases, errors, ... ..	D0 is reserved for deselecting the current tool offset.
Note for the reader:	802D sl Description of Functions: H2

6.3 Auxiliary function transfer from NC channel

VD2500 6000	H function 1
VD2500 6008	H function 2
VD2500 6016	H function 3
VW2500 6004	Extended address H function 1
VW2500 6012	Extended address H function 2
VW2500 6020	Extended address H function 3
Interface signal	Signal(s) from channel (NCK -> PLC)
Edge evaluation: no	Signal(s) updated: Job controlled by NCK
	Signal(s) valid from SW:
Signal state 1	Up to 3 H functions programmed in an NC block are made available here simultaneously as soon as the H change signals are applied. Value range of the H functions: Floating point (REAL format/4-byte) Value range of extended address: 0 to 99; integer The H functions remain valid until they are overwritten by new H functions.
Signal state 0	<ul style="list-style-type: none"> <li>• After PLC power-up.</li> <li>• All auxiliary functions are deleted before a new function is entered.</li> </ul>
Application example(s)	Switching functions on the machine.
Note for the reader:	802D sl Description of Functions: H2

## 6.4 NCK signals

### 6.4.1 General signals to NCK

V2600 0000.1 Interface signal	EMERGENCY STOP Signal(s) to NC (PLC ----> NC)
Edge evaluation: no	Signal(s) updated: cyclic Signal(s) valid from SW:
Signal state 1 or signal transition 0 ----> 1	The NC is switched to the EMERGENCY STOP state and the EMERGENCY STOP procedure is started on the NC.
Signal state 0 or signal transition 1 ----> 0	<ul style="list-style-type: none"> <li>The NC is not in the EMERGENCY STOP state.</li> <li>The EMERGENCY STOP state is (still) active but can be reset with IS "Acknowledge EMERGENCY STOP" and IS "reset".</li> </ul>
Related to ....	IS "Acknowledge EMERGENCY STOP" (V2600 0000.2) IS "EMERGENCY STOP active" (V2700 0000.1)

V2600 0000.2 Interface signal	Acknowledge EMERGENCY STOP Signal(s) to NC (PLC ----> NC)
Edge evaluation: no	Signal(s) updated: cyclic Signal(s) valid from SW:
Signal state 1 or signal transition 0 ----> 1	<p>The EMERGENCY STOP state is reset only if IS "Acknowledge EMERGENCY STOP" followed by IS "Reset" (V3000 0000.7) are set. It must be noted in this respect that IS "Acknowledge EMERGENCY STOP" and IS "Reset" must be set (together) for a long enough period for IS "EMERGENCY STOP active" (V2600 0000.1) to be reset.</p> <p>By resetting the EMERGENCY STOP state:</p> <ul style="list-style-type: none"> <li>the "EMERGENCY STOP active" interface signal is reset</li> <li>the controller enable is switched in</li> <li>IS "Position control active" is set</li> <li>the IS "802-Ready" is set</li> <li>Alarm 3000 is canceled</li> <li>the part program is no longer processed</li> </ul>
Related to ....	IS "EMERGENCY STOP" (V2600 0000.1) IS "EMERGENCY STOP active" (V2700 0000.1) IS "Reset" (V3000 0000.7)

V2600 0001.0 Interface signal	INC inputs in mode group range active Signal(s) to NCK (PLC -> NCK)
Edge evaluation: no	Signal(s) updated: cyclic Signal(s) valid from SW:
Signal state 1 or signal transition 0 ----> 1	The IS "INC1", "INC10", ..., "continuous" in the operating mode range are used as input signals (V3000 0002.0 to .6).
Signal state 0 or signal transition 1 ----> 0	The IS "INC1", "INC10", ..., "continuous" in the axis and geometry axis range are used as input signals.
Related to ....	<p>IS "Machine function INC1 to continuous" in operating mode range (V3000 0002.0 to .6)</p> <p>IS "Machine function INC1,....,continuous"</p> <p style="padding-left: 100px;">for geometry axis 1 (V3200 1001.0 to .6)</p> <p style="padding-left: 100px;">for geometry axis 2 (V3200 1005.0 to .6)</p> <p style="padding-left: 100px;">for geometry axis 3 (V3200 1009.0 to .6)</p> <p>IS "Machine function INC1,....,continuous" in axis range (V380x 0005.0 to .6)</p>
Note for the reader:	802D sl Description of Functions: H1

## 6.4.2 General signals from NCK

V2700 0000.1 Interface signal	EMERGENCY STOP active Signal(s) to NC (PLC ----> NC)		
Edge evaluation: no	Signal(s) updated: cyclic	Signal(s) valid from SW:	
Signal state 1 or signal transition 0 ----> 1	The NC is in the EMERGENCY STOP state.		
Related to ....	IS "EMERGENCY STOP" (V2600 0000.1) IS "Acknowledge EMERGENCY STOP" (V2600 0000.2)		

V2700 0001.0 Interface signal	Probe 1 is actuated Signal(s) from NCK (NCK → PLC)		
Edge evaluation: no	Signal(s) updated: cyclic	Signal(s) valid from SW:	
Signal state 1 or signal transition 0 ----> 1	Probe 1 is actuated		
Signal state 0 or signal transition 1 ----> 0	Probe 1 is not actuated		
Note for the reader:	802D sl Description of Functions: M5		

V2700 0001.7 Interface signal	INCH dimension system Signal(s) to NC (PLC ----> NC)		
Edge evaluation: no	Signal(s) updated: cyclic	Signal(s) valid from SW:	
Signal state 1	The NC works with the inch dimension system.		
Signal state 0	The NC works with the metric dimension system.		
Note for the reader:	802D sl Description of Functions: G2		

V2700 0004.0 to .7 Interface signal	Minus cam signals 1–32 Signal(s) from NCK (NCK----> PLC)		
Edge evaluation: no	Signal(s) updated: cyclically	Signal(s) valid from SW release: 2.1	
Signal status 1 or edge transition 0 ----> 1	The switching edges of the minus cam signals 1–32 are created independently of the direction of traversing of the (rotary) axis and transferred to the PLC interface at the IPO clock. Linear axis: – The minus cam signal switches from 0 to 1 when the axis overtravels the minus cam in the negative axis direction. Modulo rotary axis: – The minus cam signal changes the levels at each positive edge of the plus cam signal.		
Signal status 0 or edge transition 1 ----> 0	Linear axis: – The minus cam signal switches from 1 to 0 when the axis overtravels the minus cam in the positive axis direction. Modulo rotary axis: – The minus cam signal changes the levels at each positive edge of the plus cam signal.		

V2700 0008.0 to .7 Interface signal	Plus cam signal 1–32 Signal(s) from NCK (NCK---> PLC)		
Edge evaluation: no	Signal(s) updated: cyclically	Signal(s) valid from SW release: 2.1	
Signal status 1 or edge transition 0 ---> 1	<p>The switching edges of the plus cam signals 1–32 are created independently of the direction of traversing of the (rotary) axis and transferred to the PLC interface at the IPO clock.</p> <p>Linear axis: – The plus cam signal switches from 0 to 1 when the axis overtravels the plus cam in the positive direction. Modulo rotary axis: – The plus cam signal switches from 0 to 1 when the axis overtravels the minus cam in the positive axis direction.</p> <p>The described behavior of the plus cam applies under the following condition: Plus cam – minus cam &lt; 180 degrees If this condition is not fulfilled or the minus cam is greater than the plus cam, the behavior of the plus cam signal is inverted. The behavior of the minus cam signal remains unchanged.</p>		
Signal status 0 or edge transition 1 ---> 0	<p>Linear axis: – The plus cam signal switches from 1 to 0 when the axis overtravels the plus cam in the negative direction. Modulo rotary axis: – The plus cam signal switches back from 1 to 0 when the axis overtravels the plus cam in the positive axis direction.</p> <p>The described behavior of the plus cam applies under the following condition: Plus cam – minus cam &lt; 180 degrees If this condition is not fulfilled or the minus cam is greater than the plus cam, the behavior of the plus cam signal is inverted. The behavior of the minus cam signal remains unchanged.</p>		

## 6.5 Mode signals

V3000 0000.0	AUTOMATIC mode		
Interface signal	Signal(s) to NCK (PLC ----> NCK)		
Edge evaluation: no	Signal(s) updated: cyclic	Signal(s) valid from SW:	
Signal state 1 or signal transition 0 ----> 1	AUTOMATIC mode is selected by the PLC program.		
Signal state 0 or signal transition 1 ----> 0	AUTOMATIC mode is not selected by the PLC program.		
Signal irrelevant for ... ..	if "Mode group changeover disable" signal		
Related to ....	IS "Active mode AUTOMATIC"		
Note for the reader:	802D sl Description of Functions: K1		

V3000 0000.1	MDA mode		
Interface signal	Signal(s) to NCK (PLC ----> NCK)		
Edge evaluation: no	Signal(s) updated: cyclic	Signal(s) valid from SW:	
Signal state 1 or signal transition 0 ----> 1	MDA mode is selected by the PLC program.		
Signal state 0 or signal transition 1 ----> 0	MDA mode is not selected by the PLC program.		
Signal irrelevant for ... ..	if "Mode group changeover disable" signal		
Related to ....	IS "Active mode MDA"		
Note for the reader:	802D sl Description of Functions: K1		

V3000 0000.2	JOG mode		
Interface signal	Signal(s) to NCK (PLC ----> NCK)		
Edge evaluation: no	Signal(s) updated: cyclic	Signal(s) valid from SW:	
Signal state 1 or signal transition 0 ----> 1	JOG mode is selected by the PLC program.		
Signal state 0 or signal transition 1 ----> 0	JOG mode is not selected by the PLC program.		
Signal irrelevant for ... ..	if "Mode group changeover disable" signal		
Related to ....	IS "Active mode JOG"		
Note for the reader:	802D sl Description of Functions: K1		

V3000 0000.4	Mode group changeover disable		
Interface signal	Signal(s) to NCK (PLC ----> NCK)		
Edge evaluation: no	Signal(s) updated: cyclic	Signal(s) valid from SW:	
Signal state 1 or signal transition 0 ----> 1	The currently active mode (JOG, MDA or AUTOMATIC) cannot be changed.		
Signal state 0	The mode can be changed.		
Note for the reader:	802D sl Description of Functions: K1		

V3000 0000.7	Reset		
Interface signal	Signal(s) to NCK (PLC ----> NCK)		
Edge evaluation: yes	Signal(s) updated: cyclic	Signal(s) valid from SW:	
Signal state 1 or signal transition 0 ----> 1	The channel must change to the "RESET" status. The current program is then in program status "aborted". All moving axes and spindles are decelerated to zero speed according to their acceleration ramp without contour violation. The initial settings are set (e.g. for G functions). The alarms are cleared if they are not POWER ON alarms.		
Signal state 0 or signal transition 1 ----> 0	Channel status and program run are not affected by this signal.		
Related to ....	IS "Channel reset" IS "All channels in reset state"		
Special cases, errors, ... ..	An alarm which cancels IS "802 ready" ensures that the channel is no longer in the Reset state. In order to switch to another operating mode, a "reset" must then be initiated.		
Note for the reader:	802D sl Description of Functions: K1		

V3000 0001.2 Interface signal	Machine function REF Signal(s) to NCK (PLC ----> NCK)		
Edge evaluation: no	Signal(s) updated: cyclic	Signal(s) valid from SW:	
Signal state 1 or signal transition 0 ----> 1	Machine function REF is activated in JOG mode.		
Signal state 0 or signal transition 1 ----> 0	Machine function REF is not activated.		
Signal irrelevant for ... ..	if JOG mode is not active.		
Note for the reader:	802D sl Description of Functions: K1		

V3000 0000.0 to .6 Interface signal	Machine function INC1, INC10, INC100, INC1000, INC10000, INCvar, continuous Signal(s) to modes (PLC -> NCK)		
Edge evaluation: no	Signal(s) updated: cyclic	Signal(s) valid from SW:	
Signal state 1 or signal transition 0 ----> 1	This input range is only used if the "INC inputs in mode group range active" interface signal (V2600 0001.0) is <b>set</b> . The signals then apply to all axes and geometry axes.  IS "INC..." defines how many increments the axis traverses when the traversing key is pressed or the handwheel turned one detent position. JOG mode must be active. With "INCvar" the value in the general SD 41010: JOG_VAR_INCR_SIZE applies. In "continuous mode" the associated axis can be traversed with the plus or minus traversing key according to how the traverse key is pressed. As soon as the selected machine function becomes active, this is signaled to the PLC interface (IS "Active machine function INC1; ..."). If several machine function signals (INC1, INC... or "Continuous jogging") are selected at the interface simultaneously, no machine function is activated by the control. Note: The input IS "INC..." or "continuous" for changing an active machine function must be active for at least one PLC cycle. A static application is not required.		
Signal state 0 or signal transition 1 ----> 0	The machine function in question is not selected. No change to the active machine function is required. If an axis is currently traversing an increment, this movement is also aborted if this machine function is deselected or changed over.		
Related to ....	IS "INC inputs in mode group range active" (V2600 0001.0) IS "Machine function INC1, ..., continuous" for geometry axis 1 (V3200 1001.0 to .6) for geometry axis 2 (V3200 1005.0 to .6) for geometry axis 3 (V3200 1009.0 to .6) IS "Machine function INC1, ..., continuous" in axis range (V380x 0005.0 to .6) IS "Active machine function INC1, ..., continuous" for geometry axis 1 (V3300 1001.0 to .6) for geometry axis 2 (V3300 1005.0 to .6) for geometry axis 3 (V3300 1005.0 to .6) IS "Active machine function INC1, ..., continuous" in axis range (V390x 0005.0 to .6)		
Note for the reader:	802D sl Description of Functions: H1		

V3100 0000.0 Interface signal	Active mode AUTOMATIC Signal(s) from NCK (NCK ----> PLC)		
Edge evaluation: no	Signal(s) updated: cyclic	Signal(s) valid from SW:	
Signal state 1 or signal transition 0 ----> 1	AUTOMATIC mode is active.		
Signal state 0 or signal transition 1 ----> 0	AUTOMATIC mode is not active.		
Note for the reader:	802D sl Description of Functions: K1		

V3100 0000.1 Interface signal	Active mode MDA Signal(s) from NCK (NCK ----> PLC)		
Edge evaluation:	Signal(s) updated: cyclic	Signal(s) valid from SW:	
Signal state 1 or signal transition 0 ----> 1	MDA mode is active.		
Signal state 0 or signal transition 1 ----> 0	MDA mode is not active.		
Note for the reader:	802D sl Description of Functions: K1		

## 6.5 Mode signals

V3100 0000.2	Active mode JOG
Interface signal	Signal(s) from NCK (NCK ----> PLC)
Edge evaluation: no	Signal(s) updated: cyclic
Signal state 1 or signal transition 0 ----> 1	JOG mode is active.
Signal state 0 or signal transition 1 ----> 0	JOG mode is not active.
Note for the reader:	802D sl Description of Functions: K1

V3100 0000.3	802 READY
Interface signal	Signal(s) from NCK (NCK ----> PLC)
Edge evaluation: no	Signal(s) updated: cyclic
Signal state 1 or signal transition 0 ----> 1	This signal is set after POWER ON when all voltages are present. The mode group is now ready and part programs can be processed and axes traversed in the channel.
Signal state 0 or signal transition 1 ----> 0	The mode group/channel is not ready. Possible causes of this are: <ul style="list-style-type: none"> <li>- A serious axis or spindle alarm is active</li> <li>- Hardware fault</li> <li>- Mode group incorrectly configured (machine data)</li> </ul> <p>If the mode group ready signal changes to the "0" state</p> <ul style="list-style-type: none"> <li>- the axis and spindle drives are decelerated with max. braking current to zero speed,</li> <li>- the signals from the PLC to the NCK are switched to the inactive state (initial setting).</li> </ul>
Special cases, errors, ... ..	An alarm which cancels IS "802 READY" ensures that the channel is no longer in the Reset state. In order to switch to another operating mode, a "reset" must then be initiated. (V3000 0000.7)
Note for the reader:	802D sl Description of Functions: K1

V3100 0001.2	Active machine function REF
Interface signal	Signal(s) from NCK (NCK ----> PLC)
Edge evaluation: no	Signal(s) updated: cyclic
Signal state 1 or signal transition 0 ----> 1	Machine function REF is active in JOG.
Signal state 0 or signal transition 1 ----> 0	Machine function REF is not active.
Note for the reader:	802D sl Description of Functions: K1

## 6.6 Channel-specific signals

### 6.6.1 Signals to channel

V3200 0000.4 Interface signal	Activate single block Signal(s) to channel (PLC ----> NCK)
Edge evaluation: no	Signal(s) updated: cyclic Signal(s) valid from SW:
Signal state 1 or signal transition 0 ----> 1	In the AUTOMATIC mode the program is processed in the single-block mode; in MDA only 1 block can be entered in any case.
Signal state 0 or signal transition 1 ----> 0	No effect
Application example(s)	A new program can first be tested in single block mode in order to monitor the individual program steps more exactly.
Special cases, errors, ... ..	<ul style="list-style-type: none"> <li>Intermediate blocks can be inserted if tool radius compensation (G41,G42) is selected.</li> <li>In a series of G33 blocks single block is effective only if "dry run feedrate" is selected.</li> <li>Pure calculation blocks are not processed in the single step in "Single block coarse" but only in "Single block fine". The preselection is made via softkey "Program control".</li> </ul>
Related to ....	IS "Single-block selected" IS "Program status stopped"
References	Subsection LEERER MERKER
Note for the reader:	802D sl Description of Functions: K1

V3200 000.5 Interface signal	Activate M1 Signal(s) to channel (PLC ----> NCK)
Edge evaluation: no	Signal(s) updated: cyclic Signal(s) valid from SW:
Signal state 1 or signal transition 0 ----> 1	M1 programmed in the part program leads to a programmed stop when processed in AUTOMATIC or MDA mode.
Signal state 0 or signal transition 1 ----> 0	M1 programmed in the part program does not lead to a programmed stop.
Related to ....	IS "M01 selected" (V1700 0000.5) IS "M0/M1 active" (V3300 0000.5)
Note for the reader:	802D sl Description of Functions: K1

V3200 0000.6 Interface signal	Activate dry run feedrate Signal(s) to channel (PLC → NCK)
Edge evaluation: no	Signal(s) updated: cyclic Signal(s) valid from SW:
Signal state 1 or signal transition 0 ----> 1	Instead of the programmed feedrate (for G1, G2, G3, CIP, CT), the dry run feedrate defined in SD 42100: DRY_RUN_FEED is used if the dry run feedrate is larger than the programmed feedrate. This interface signal is evaluated on an NC start when the channel is in the "Reset" state. When selected on the PLC, the "Activate dry run feedrate" interface signal is required to be set by the PLC user program.
Signal state 0 or signal transition 1 ----> 0	The programmed feedrate is used for traversing. Active after Reset.
Application example(s)	Testing a workpiece program with an increased feedrate.
Related to ....	IS "Dry run feedrate selected" (V1700 0000.6) SD 42100: DRY_RUN_FEED (Dry run feedrate)
Note for the reader:	802D sl Description of Functions: V1

## 6.6 Channel-specific signals

V3200 0001.0 Interface signal	Activate referencing Signal(s) to channel (PLC → NCK)
Edge evaluation: yes	Signal(s) updated: cyclic      Signal(s) valid from SW:
Signal state 1 or signal transition 0 → 1	Channel-specific referencing is started with the "Activate referencing" interface signal. The control acknowledges a successful start with the "Referencing active" interface signal. Each machine axis assigned to the channel can be referenced with channel-specific referencing (this is achieved internally on the control by simulating the plus/minus travel keys). The axis-specific MD 34110: REFP_CYCLE_NR (axis sequence for channel-specific referencing) can be used to define the sequence in which the machine data are referenced. If all axes entered in MD: REFP_CYCLE_NR have reached their reference point, the "all axes referenced" interface signal (V3300 0004.2) is enabled.
Application example(s)	If the machine axes are to be referenced in a particular sequence, the following options are available: <ul style="list-style-type: none"> <li>• The operator must observe the correct sequence on start-up</li> <li>• The PLC must check the sequence when starting or define it itself.</li> <li>• The channel-specific referencing function is used.</li> </ul>
Related to ....	"Referencing active" interface signal (V3300 0001.0) "All axes referenced" interface signal (V3300 0004.2)
Note for the reader:	802D sl Description of Functions: R1
V3200 0001.7 Interface signal	Activate program test Signal(s) to channel (PLC → NCK)
Edge evaluation: no	Signal(s) updated: cyclic      Signal(s) valid from SW:
Signal state 1 or signal transition 0 → 1	Axis disable is set internally for all axes (not spindle). Therefore the machine axes do not move when a part program block or a part program is being processed. The axis movements are simulated on the operator interface with changing axis position values. The axis position values for the display are generated from the calculated setpoints. The part program is processed in the normal way.
Signal state 0 or signal transition 1 → 0	Part program processing is not affected by the function program test
Related to ....	IS "Program test selected" IS "Program test active"
Note for the reader:	802D sl Description of Functions: K1
V3200 0002.0 Interface signal	Skip block Signal(s) to channel (PLC → NCK)
Edge evaluation: no	Signal(s) updated: cyclic      Signal(s) valid from SW:
Signal state 1 or signal transition 0 → 1	Blocks marked in the part program with an oblique (/) are skipped. If there is a series of skip blocks, this signal is only active if it is pending before decoding of the first block of the series, ideally <b>before NC start</b> .
Signal state 0 or signal transition 1 → 0	The marked part program blocks are not skipped.
Related to ....	IS "Skip block selected"
Note for the reader:	802D sl Description of Functions: K1
V3200 0003.0 Interface signal	Stroke disable Signal(s) to the channel (PLC → NCK)
Edge evaluation:	Signal(s) updated:      Signal(s) valid from SW release: 3
Signal status 1 or edge transition 0 → 1	This signal is used to enable the punching strokes via the PLC. 1-signal: The stroke is disabled; no punching stroke must be initiated by the NC.
Signal status 0 or edge transition 1 → 0	0-signal: Stroke enable is provided; if no enable signal is set, no punching stroke can be executed by the NC.
V3200 0003.1 Interface signal	Stroke initiated manually Signal(s) to the channel (PLC → NCK)
Edge evaluation:	Signal(s) updated:      Signal(s) valid from SW release: 3
Signal status 1 or signal transition 0 → 1	This signal can be used to initiate a single stroke in the manual mode. 1-signal: A manual stroke is executed.
Signal status 0 or signal transition 1 → 0	0-signal: No effect

V3200 0003.2 Interface signal	Stroke suppressed Signal(s) to the channel (PLC→NCK)
Edge evaluation:	Signal(s) updated:      Signal(s) valid from SW release: 3
Signal status 1 or edge transition 0 ----> 1	The signal merely prevents the stroke. The machine will nevertheless traverse. If the automatic path distribution is active, it also remains active. Merely the "Initiate stroke" signal is suppressed. The machine will traverse in the "stop and go" mode. The step length is defined by the path segmentation. 1-signal: The stroke suppression is active.
Signal status 0 or signal transition 1 ----> 0	0-signal: The stroke suppression is not active.

V3200 0003.3 Interface signal	Stroke does not run Signal(s) to the channel (PLC→NCK)
Edge evaluation:	Signal(s) updated:      Signal(s) valid from SW release: 3
Signal status 1 or edge transition 0 ----> 1	The NC reacts to this signal with immediate motion stop. If a motion or another action is interrupted due to this signal, an alarm is issued. Physically, the signal for the manual stroke is identically to the "Stroke active" signal, i.e. the system is switched such that the two signals are connected to the same NC input via an AND operation. 1-signal: Stroke does not run (corresponds to the "Stroke enable" signal)
Signal status 0 or signal transition 1 ----> 0	0-signal: Stroke running (corresponds to the "Stroke enable" signal)

V3200 0003.4 Interface signal	Delayed stroke Signal(s) to the channel (PLC→NCK)
Edge evaluation:	Signal(s) updated:      Signal(s) valid from SW release: 3
Signal status 1 or edge transition 0 ----> 1	This signal can be used to activate a "Delayed stroke". In respect of its function, this signal corresponds to a programming of PDELAYON. Any further PLC signals not complying with the standard are not evaluated by the NCK. Except for the manual stroke initiation, the evaluation of the signals is limited to PON active. 1-signal: Delayed stroke is active
Signal status 0 or edge transition 1 ----> 0	0-signal: Delayed stroke is not active

V3200 0003.5 Interface signal	Manual stroke initiation Signal(s) to the channel (PLC→NCK)
Edge evaluation:	Signal(s) updated:      Signal(s) valid from SW release: 6.4
Signal status 1 or edge transition 0 ----> 1	This signal "Manual stroke initiation" can be used to initiate punching by the operator even without part program machining. Thus, the punch initiation is controlled from the PLC. A performed stroke initiation is indicated to the PLC via the NCK → PLC IS "Manual stroke initiation acknowledgment" (DB21, ... DBX38.1). 1-signal: Manual stroke initiation is active
Signal status 0 or edge transition 1 ----> 0	0-signal: Manual stroke initiation is not active

6.6 Channel-specific signals

VB3200 0004	Feedrate override																																																																																																		
Interface signal	Signal(s) to channel (PLC → NCK)																																																																																																		
Edge evaluation: no	Signal(s) updated: cyclic	Signal(s) valid from SW:																																																																																																	
Signal state 1 or signal transition 0 ---> 1	<p>Table 6-1 Gray coding for feedrate override</p> <table border="1"> <thead> <tr> <th>Switch position</th> <th>Code</th> <th>Feedrate override factor</th> </tr> </thead> <tbody> <tr><td>1</td><td>00001</td><td>0.0</td></tr> <tr><td>2</td><td>00011</td><td>0.01</td></tr> <tr><td>3</td><td>00010</td><td>0.02</td></tr> <tr><td>4</td><td>00110</td><td>0.04</td></tr> <tr><td>5</td><td>00111</td><td>0.06</td></tr> <tr><td>6</td><td>00101</td><td>0.08</td></tr> <tr><td>7</td><td>00100</td><td>0.10</td></tr> <tr><td>8</td><td>01100</td><td>0.20</td></tr> <tr><td>9</td><td>01101</td><td>0.30</td></tr> <tr><td>10</td><td>01111</td><td>0.40</td></tr> <tr><td>11</td><td>01110</td><td>0.50</td></tr> <tr><td>12</td><td>01010</td><td>0.60</td></tr> <tr><td>13</td><td>01011</td><td>0.70</td></tr> <tr><td>14</td><td>01001</td><td>0.75</td></tr> <tr><td>15</td><td>01000</td><td>0.80</td></tr> <tr><td>16</td><td>11000</td><td>0.85</td></tr> <tr><td>17</td><td>11001</td><td>0.90</td></tr> <tr><td>18</td><td>11011</td><td>0.95</td></tr> <tr><td>19</td><td>11010</td><td>1.00</td></tr> <tr><td>20</td><td>11110</td><td>1.05</td></tr> <tr><td>21</td><td>11111</td><td>1.10</td></tr> <tr><td>22</td><td>11101</td><td>1.15</td></tr> <tr><td>23</td><td>11100</td><td>1.20</td></tr> <tr><td>24</td><td>10100</td><td>1.20</td></tr> <tr><td>25</td><td>10101</td><td>1.20</td></tr> <tr><td>26</td><td>10111</td><td>1.20</td></tr> <tr><td>27</td><td>10110</td><td>1.20</td></tr> <tr><td>28</td><td>10010</td><td>1.20</td></tr> <tr><td>29</td><td>10011</td><td>1.20</td></tr> <tr><td>30</td><td>10001</td><td>1.20</td></tr> <tr><td>31</td><td>10000</td><td>1.20</td></tr> </tbody> </table>			Switch position	Code	Feedrate override factor	1	00001	0.0	2	00011	0.01	3	00010	0.02	4	00110	0.04	5	00111	0.06	6	00101	0.08	7	00100	0.10	8	01100	0.20	9	01101	0.30	10	01111	0.40	11	01110	0.50	12	01010	0.60	13	01011	0.70	14	01001	0.75	15	01000	0.80	16	11000	0.85	17	11001	0.90	18	11011	0.95	19	11010	1.00	20	11110	1.05	21	11111	1.10	22	11101	1.15	23	11100	1.20	24	10100	1.20	25	10101	1.20	26	10111	1.20	27	10110	1.20	28	10010	1.20	29	10011	1.20	30	10001	1.20	31	10000	1.20
Switch position	Code	Feedrate override factor																																																																																																	
1	00001	0.0																																																																																																	
2	00011	0.01																																																																																																	
3	00010	0.02																																																																																																	
4	00110	0.04																																																																																																	
5	00111	0.06																																																																																																	
6	00101	0.08																																																																																																	
7	00100	0.10																																																																																																	
8	01100	0.20																																																																																																	
9	01101	0.30																																																																																																	
10	01111	0.40																																																																																																	
11	01110	0.50																																																																																																	
12	01010	0.60																																																																																																	
13	01011	0.70																																																																																																	
14	01001	0.75																																																																																																	
15	01000	0.80																																																																																																	
16	11000	0.85																																																																																																	
17	11001	0.90																																																																																																	
18	11011	0.95																																																																																																	
19	11010	1.00																																																																																																	
20	11110	1.05																																																																																																	
21	11111	1.10																																																																																																	
22	11101	1.15																																																																																																	
23	11100	1.20																																																																																																	
24	10100	1.20																																																																																																	
25	10101	1.20																																																																																																	
26	10111	1.20																																																																																																	
27	10110	1.20																																																																																																	
28	10010	1.20																																																																																																	
29	10011	1.20																																																																																																	
30	10001	1.20																																																																																																	
31	10000	1.20																																																																																																	
Related to ....	IS "Feedrate override active" (V3200 0006.7)																																																																																																		
Note for the reader:	802D sl Description of Functions: V1																																																																																																		

VB3200 0005	Rapid traverse override																																																																																																	
Interface signal	Signal(s) to channel (PLC → NCK)																																																																																																	
Edge evaluation: no	Signal(s) updated: cyclic	Signal(s) valid from SW:																																																																																																
Special cases, errors, ... ..	The feed disable is inactive when G33 is active.																																																																																																	
Signal state 1 or signal transition 0 ---> 1	<p style="text-align: center;">Table 6-2 Gray coding for rapid traverse override</p> <table border="1" style="margin-left: auto; margin-right: auto;"> <thead> <tr> <th>Switch position</th> <th>Code</th> <th>Rapid traverse override factor</th> </tr> </thead> <tbody> <tr><td>1</td><td>00001</td><td>0.0</td></tr> <tr><td>2</td><td>00011</td><td>0.01</td></tr> <tr><td>3</td><td>00010</td><td>0.02</td></tr> <tr><td>4</td><td>00110</td><td>0.04</td></tr> <tr><td>5</td><td>00111</td><td>0.06</td></tr> <tr><td>6</td><td>00101</td><td>0.08</td></tr> <tr><td>7</td><td>00100</td><td>0.10</td></tr> <tr><td>8</td><td>01100</td><td>0.20</td></tr> <tr><td>9</td><td>01101</td><td>0.30</td></tr> <tr><td>10</td><td>01111</td><td>0.40</td></tr> <tr><td>11</td><td>01110</td><td>0.50</td></tr> <tr><td>12</td><td>01010</td><td>0.60</td></tr> <tr><td>13</td><td>01011</td><td>0.70</td></tr> <tr><td>14</td><td>01001</td><td>0.75</td></tr> <tr><td>15</td><td>01000</td><td>0.80</td></tr> <tr><td>16</td><td>11000</td><td>0.85</td></tr> <tr><td>17</td><td>11001</td><td>0.90</td></tr> <tr><td>18</td><td>11011</td><td>0.95</td></tr> <tr><td>19</td><td>11010</td><td>1.00</td></tr> <tr><td>20</td><td>11110</td><td>1.00</td></tr> <tr><td>21</td><td>11111</td><td>1.00</td></tr> <tr><td>22</td><td>11101</td><td>1.00</td></tr> <tr><td>23</td><td>11100</td><td>1.00</td></tr> <tr><td>24</td><td>10100</td><td>1.00</td></tr> <tr><td>25</td><td>10101</td><td>1.00</td></tr> <tr><td>26</td><td>10111</td><td>1.00</td></tr> <tr><td>27</td><td>10110</td><td>1.00</td></tr> <tr><td>28</td><td>10010</td><td>1.00</td></tr> <tr><td>29</td><td>10011</td><td>1.00</td></tr> <tr><td>30</td><td>10001</td><td>1.00</td></tr> <tr><td>31</td><td>10000</td><td>1.00</td></tr> </tbody> </table>		Switch position	Code	Rapid traverse override factor	1	00001	0.0	2	00011	0.01	3	00010	0.02	4	00110	0.04	5	00111	0.06	6	00101	0.08	7	00100	0.10	8	01100	0.20	9	01101	0.30	10	01111	0.40	11	01110	0.50	12	01010	0.60	13	01011	0.70	14	01001	0.75	15	01000	0.80	16	11000	0.85	17	11001	0.90	18	11011	0.95	19	11010	1.00	20	11110	1.00	21	11111	1.00	22	11101	1.00	23	11100	1.00	24	10100	1.00	25	10101	1.00	26	10111	1.00	27	10110	1.00	28	10010	1.00	29	10011	1.00	30	10001	1.00	31	10000	1.00
Switch position	Code	Rapid traverse override factor																																																																																																
1	00001	0.0																																																																																																
2	00011	0.01																																																																																																
3	00010	0.02																																																																																																
4	00110	0.04																																																																																																
5	00111	0.06																																																																																																
6	00101	0.08																																																																																																
7	00100	0.10																																																																																																
8	01100	0.20																																																																																																
9	01101	0.30																																																																																																
10	01111	0.40																																																																																																
11	01110	0.50																																																																																																
12	01010	0.60																																																																																																
13	01011	0.70																																																																																																
14	01001	0.75																																																																																																
15	01000	0.80																																																																																																
16	11000	0.85																																																																																																
17	11001	0.90																																																																																																
18	11011	0.95																																																																																																
19	11010	1.00																																																																																																
20	11110	1.00																																																																																																
21	11111	1.00																																																																																																
22	11101	1.00																																																																																																
23	11100	1.00																																																																																																
24	10100	1.00																																																																																																
25	10101	1.00																																																																																																
26	10111	1.00																																																																																																
27	10110	1.00																																																																																																
28	10010	1.00																																																																																																
29	10011	1.00																																																																																																
30	10001	1.00																																																																																																
31	10000	1.00																																																																																																
Related to ....	IS "Rapid traverse override active" (V3200 0006.6)																																																																																																	
Note for the reader:	802D sl Description of Functions: V1																																																																																																	

V3200 0006.0	Feed disable	
Interface signal	Signal(s) to channel (PLC → NCK)	
Edge evaluation: no	Signal(s) updated: cyclic	Signal(s) valid from SW:
Signal state 1 or signal transition 0 ---> 1	<p>The signal is active on a channel in all operating modes.</p> <ul style="list-style-type: none"> <li>The signal disables all axes interpolating relative to each other as long as G33 (thread) is not active. All axes are brought to a standstill with adherence to the path contour. When the feed disable is canceled (0 signal), the interrupted part program is continued.</li> <li>The position control is retained, i.e. the following error is eliminated.</li> <li>If a travel request is issued for an axis with an active "Feed disable", The pending travel request is executed immediately when the "Feed disable" is canceled.</li> </ul> <p>If the axis is interpolating in relation to others, this also applies to these axes.</p>	
Signal state 0 or signal transition 1 ---> 0	<ul style="list-style-type: none"> <li>The feedrate is enabled for all axes on the channel.</li> <li>If a travel request ("Travel command") exists for an axis or group of axes when the "Feed disable" is canceled, this is executed immediately.</li> </ul>	
Special cases, errors, ... ..	The feed disable is inactive when G33 is active.	
Note for the reader:	802D sl Description of Functions: V1	

6.6 Channel-specific signals

V3200 0006.1	Read-in disable		
Interface signal	Signal(s) to channel (PLC ----> NCK)		
Edge evaluation: no	Signal(s) updated: cyclic	Signal(s) valid from SW:	
Signal state 1 or signal transition 0 ----> 1	Data transfer of the next block into the interpolator is disabled. This signal is only active in modes AUTOMATIC and MDA.		
Signal state 0 or signal transition 1 ----> 0	Data transfer of the next block into the interpolator is enabled. This signal is only active in modes AUTOMATIC and MDA.		
Application example(s)	<p>In a case where an auxiliary function has to have been executed before the next block can be processed (e.g. for a tool change), automatic block change must be inhibited with read-in disable.</p> <p>                 1 Reading into buffer                  2 Block processed                  3 Read-in disable signal                  4 Data transfer                  5 Contents of the interpolator                  6 Output of the auxiliary function                  7 Data transfer into the interpolator                  8 Read-in disable for tool change                  9 Query point of the read-in enable                  ► Remove read-in disable             </p>		
Related to ....	IS "Program status running"		
Note for the reader:	802D sl Description of Functions: K1		

V3200 0006.4	Program level abort		
Interface signal	Signal(s) to channel (PLC ----> NCK)		
Edge evaluation: yes	Signal(s) updated: cyclic	Signal(s) valid from SW:	
Signal state 1 or signal transition 0 ----> 1	On each signal transition 0 -> 1 the current program level being processed (subroutine level) is immediately aborted. Processing of the part program continues one level higher after the exit point.		
Signal state 0 or signal transition 1 ----> 0	No effect		
Special cases, errors, ... ..	The main program level cannot be aborted with this IS, only with IS "Reset".		
Note for the reader:	802D sl Description of Functions: K1		

V3200 0006.6	Rapid traverse override active
Interface signal	Signal(s) to channel (PLC → NCK)
Edge evaluation: no	Signal(s) updated: cyclic
Signal state 1 or signal transition 0 ----> 1	The rapid traverse override between 0 and a maximum of 100% entered in the PLC interface is channel-specific.
Signal state 0 or signal transition 1 ----> 0	The rapid traverse override entered in the PLC interface is ignored. If the rapid traverse override is not active, an override factor of 100% is used internally on the NC. <b>Note:</b> The 1st switch position of the gray-coded interface for the value represents an exception. In this case, this override factor is also used with "Rapid traverse override inactive" and 0% is issued as the override value for axes.
Special cases, errors, ...	The rapid traverse override is inactive if G33 is active.
Related to ....	IS "Rapid traverse override" (V3200 0005)
Note for the reader:	802D sl Description of Functions: V1

V3200 0006.7	Feedrate override active
Interface signal	Signal(s) to channel (PLC → NCK)
Edge evaluation: no	Signal(s) updated: cyclic
Signal state 1 or signal transition 0 ----> 1	The feedrate override between 0 and a maximum of 120% entered in the PLC interface is active for the path feedrate and therefore automatically for the related axes. In JOG mode, the feedrate override acts directly on the axes.
Signal state 0 or signal transition 1 ----> 0	The feedrate override entered in the PLC interface is ignored. If the feedrate override is not active, an override factor of 100% is used internally on the NC. <b>Note:</b> The 1st switch position of the gray-coded interface for the value represents an exception. In this case, this override factor is also used with "Feedrate override inactive" and 0% is issued as the override value for axes (acts the same as "Feed disable").
Special cases, errors, ...	The feedrate override is inactive if G33 is active.
Related to ....	IS "Feedrate override" (V3200 0004)
Note for the reader:	802D sl Description of Functions: V1

V3200 0007.0	NC start disable
Interface signal	Signal(s) to channel (PLC ----> NCK)
Edge evaluation: no	Signal(s) updated: cyclic
Signal state 1 or signal transition 0 ----> 1	IS "NC Start" is ineffective
Signal state 0 or signal transition 1 ----> 0	IS "NC Start" is effective.
Application example(s)	This signal is used to suppress renewed program processing because, for example, there is no lubricant.
Related to ....	IS "NC Start"
Note for the reader:	802D sl Description of Functions: K1

V3200 0007.1	NC Start
Interface signal	Signal(s) to channel (PLC ----> NCK)
Edge evaluation: yes	Signal(s) updated: cyclic
Signal state 1 or signal transition 0 ----> 1	AUTOMATIC mode: The selected NC program is started or resumed. If data are transferred from the PLC to the NC in the "Program interrupted" state, the data are calculated immediately on NC Start.  MDA mode: The entered part program blocks are released for execution or continued.
Signal state 0 or signal transition 1 ----> 0	No effect
Related to ....	IS "NC Start disable"
Note for the reader:	802D sl Description of Functions: K1

6.6 Channel-specific signals

V3200 0007.2 Interface signal	NC Stop at block limit Signal(s) to channel (PLC ----> NCK)
Edge evaluation: no	Signal(s) updated: cyclic Signal(s) valid from SW:
Signal state 1 or signal transition 0 ----> 1	The current NC program is stopped after the current part program block has been processed. Otherwise as for IS "NC Stop".
Signal state 0 or signal transition 1 ----> 0	No effect
Related to ....	IS "NC Stop" IS "NC Stop axes plus spindles" IS "Program status stopped" IS "Channel status interrupted"
Note for the reader:	802D sl Description of Functions: K1

V3200 0007.3 Interface signal	NC stop Signal(s) to channel (PLC ----> NCK)
Edge evaluation: no	Signal(s) updated: cyclic Signal(s) valid from SW:
Signal state 1 or signal transition 0 ----> 1	The current NC program is stopped immediately, the current block is not completed. Only the axes without contour violation are stopped. Distances to go are traversed only after a renewed start. The program status changes to "stopped", the channel status changes to "interrupted".
Signal state 0 or signal transition 1 ----> 0	No effect
Application example(s)	<p>On NC start the program is continued at the point of interruption.</p> <p>IS "NC Stop"</p> <p>IS "NC Start"</p> <p>Program running</p> <p>Axis running</p> <p>Block processed</p>
Special cases, errors, ... ..	The signal NC stop must be active for at least one PLC cycle.
Related to ....	IS "NC Stop at block limit" IS "NC Stop axes plus spindles" IS "Program status stopped" IS "Channel status interrupted"
Note for the reader:	802D sl Description of Functions: K1

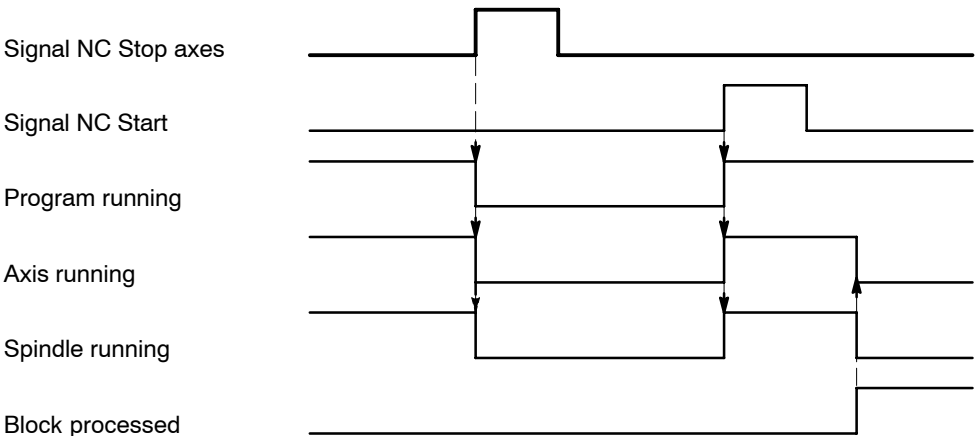
V3200 0007.4	NC Stop axes plus spindles
Interface signal	Signal(s) to channel (PLC ----> NCK)
Edge evaluation: no	Signal(s) updated: cyclic
	Signal(s) valid from SW:
Signal state 1 or signal transition 0 ----> 1	The current NC program is stopped immediately, the current block is not completed. Distances-to-go are not completed until a start signal is given. The axes and the spindle are stopped. They are brought to a controlled standstill, however. The program status changes to stopped, the channel status changes to interrupted.
Signal state 0 or signal transition 1 ----> 0	No effect
Signal irrelevant for ... ..	Channel status Reset Program status aborted
Special cases, errors, ... ..	All axes and spindles that were not caused to move by a program or program block (e.g. axes are moved by pressing the travel keys on the machine control panel) are <b>not</b> decelerated to zero speed with "NC stop axes plus spindles".  The program is continued at the interrupted place with NC Start.  The signal "NC stop axes plus spindles" must be pending for at least one PLC cycle.  
Related to ....	IS "NC Stop at block limit" IS "NC Stop" IS "Program status stopped" IS "Channel status interrupted"
Note for the reader:	802D sl Description of Functions: K1

V3200 0013.5	Deactivate workpiece counter
Interface signal	Signal(s) to channel (PLC ----> NCK)
Edge evaluation: no	Signal(s) updated: cyclic
	Signal(s) valid from SW:
Signal state 1 or signal transition 0 ----> 1	The workpiece count monitoring is turned off with activated tool monitoring.
Signal state 0 or signal transition 1 ----> 0	No effect
Related to ....	
Note for the reader:	802D sl Description of Functions: W1

6.6 Channel-specific signals

V3200 1000.0 to .1 V3200 1004.0 to .1 V3200 1008.0 to .1 Interface signal	Activate handwheel (1 to 3) for geometry axis 1 for geometry axis 2 for geometry axis 3 Signal(s) to channel (PLC → NCK)
Edge evaluation: no	Signal(s) updated: cyclic Signal(s) valid from SW:
Signal state 1 or signal transition 0 → 1	These machine data determine whether this geometry axis is assigned to handwheel 1, 2, 3 or no handwheel. Only one handwheel can be assigned to an axis at any one time. If several "Activate handwheel" interface signals are set, priority "Handwheel 1" before "Handwheel 2" before "Handwheel 3" applies. <b>Note:</b> Three geometry axes can be traversed simultaneously with handwheels 1 to 3!
Signal state 0 or signal transition 1 → 0	Neither handwheel 1, 2 nor 3 is assigned to this geometry axis.
Application example(s)	The PLC user program can use this interface signal to disable the influence of turning the handwheel on the geometry axis.
Related to ....	IS "Handwheel active" 1 to 3 for geometry axis 1: V3300 1000.0 to .2 for geometry axis 2: V3300 1004.0 to .2 for geometry axis 3: V3300 1008.0 to .2
Note for the reader:	802D sl Description of Functions: H1

V3200 1000.3 V3200 1004.3 V3200 1008.3 Interface signal	Feed stop Geo-axes (axes in the WCS) Signal(s) to channel (PLC → NCK)
Edge evaluation: no	Signal(s) updated: cyclic Signal(s) valid from SW:
Signal state 1 or signal transition 0 → 1	The signal is only active in JOG mode (axes traversed in the WCS). <ul style="list-style-type: none"> <li>The signal triggers a feed stop for the axis. Traversing axes are brought to a standstill under controlled braking (ramp stop). No alarm is output.</li> <li>The position control is retained, i.e. the following error is eliminated.</li> <li>If a travel request is issued for an axis with an active "Feed stop", the request is retained. This pending travel request is executed immediately after the "Feed stop" is canceled.</li> </ul>
Signal state 0 or signal transition 1 → 0	<ul style="list-style-type: none"> <li>The feedrate is enabled for the axis.</li> <li>If a travel request ("Travel command") is active when the "Feed stop" is canceled, this is executed immediately.</li> </ul>
Note for the reader:	802D sl Description of Functions: V1

V3200 1000.4 V3200 1004.4 V3200 1008.4 Interface signal	Traverse key disable for geometry axis 1 for geometry axis 2 for geometry axis 3 Signal(s) to channel (PLC → NCK)
Edge evaluation: no	Signal(s) updated: cyclic Signal(s) valid from SW:
Signal state 1 or signal transition 0 → 1	The traverse keys plus and minus have no effect on the geometry axes in question. It is thus not possible to traverse the geometry axis in JOG with the traverse keys on the machine control panel. If the traverse key disable is activated during a traverse movement, the geometry axis is stopped.
Signal state 0	Traverse keys plus and minus are enabled.
Application example(s)	It is thus possible, depending on the operating mode, to disable manual traverse of the geometry axis in JOG mode with the traverse keys from the PLC user program.
Related to ....	IS "Traverse key plus" and " ... minus" for geometry axis 1 (V3200 1000.7 and .6) for geometry axis 2 (V3200 1004.7 and .6) for geometry axis 3 (V3200 1008.7 and .6)
Note for the reader:	802D sl Description of Functions: H1

V3200 1000.5 V3200 1004.5 V3200 1008.5 Interface signal	Rapid traverse override for geometry axis 1 for geometry axis 2 for geometry axis 3 Signal(s) to channel (PLC → NCK)
Edge evaluation: no	Signal(s) updated: cyclic Signal(s) valid from SW: 1.1
Signal state 1 or signal transition 0 → 1	If the PLC interface signal "Rapid traverse override" is set together with "Traverse key plus" and "Traverse key minus", the geometry axis in question traverses at rapid traverse set for JOG on the assigned machine axis (e.g.: X → X1). The rapid traverse velocity is defined in MD 32010: JOG_VELO_RAPID. Rapid traverse override is active in the following JOG modes: – Continuous traversing – Incremental traversing If rapid traverse override is active, the velocity can be modified with the rapid traverse override switch.
Signal state 0 or signal transition 1 → 0	The geometry axis traverses at the defined JOG velocity (SD: JOG_SET_VELO or MD: JOG_VELO).
Note for the reader:	802D sl Description of Functions: H1, V1

V3200 1000.7 and .6 V3200 1004.7 and .6 V3200 1008.7 and .6 Interface signal	Traverse keys plus and minus for geometry axis 1 for geometry axis 2 for geometry axis 3 Signal(s) to channel (PLC → NCK)
Edge evaluation: yes	Signal(s) updated: cyclic Signal(s) valid from SW:
Signal state 1 or signal transition 0 → 1	The selected axis can be traversed in both directions in JOG mode with the traverse keys plus and minus. <b>Incremental traversing</b> With signal 1 the axis starts to traverse at the set increment. If the signal changes to the 0 state before the increment is traversed, the traversing movement is interrupted. When the signal state changes to 1 again the movement is continued. The axis can be stopped and started several times as described above until the increment has been completely traversed. <b>Continuous traversal</b> If no INC measure is selected, and "continuous" is, the axis travels for as long as the traverse key is pressed. If both traverse signals (plus and minus) are set at the same time, no movement occurs, or any current movement is aborted! The effect of the traverse keys can be disabled for every axis individually with the PLC interface signal "Traverse key disable". <b>Notice!</b> In contrast to machine axes, for geometry axes, only one geometry axis can be traversed at any one time using the traversing keys. Alarm 20062 is triggered if an attempt is made to traverse more than one axis with the traverse keys.
Signal state 0 or signal transition 1 → 0	No traverse
Signal irrelevant for ...	Operating modes AUTOMATIC and MDA
Special cases, errors, ...	The geometry axis cannot be traversed in JOG mode: – If it is already being traversed via the axis-specific PLC interface (as a machine axis). – If another geometry axis is already being traversed with the traverse keys. Alarm 20062 "Axis already active" is output.
Related to ....	IS "Traverse key plus" and "Traverse key minus" for the machine axes (V380x 0004.7 and .6) IS "Traverse key disable" for geometry axis 1 (V3200 1000.4) for geometry axis 2 (V3200 1004.4) for geometry axis 3 (V3200 1008.4)
Note for the reader:	802D sl Description of Functions: H1

## 6.6 Channel-specific signals

V3200 1001.0 to .6 V3200 1005.0 to .6 V3200 1009.0 to .6 Interface signal	for geometry axis 1 for geometry axis 2 for geometry axis 3 Signal(s) to channel (PLC → NCK)
Edge evaluation: no	Signal(s) updated: cyclic
Signal state 1 or signal transition 0 → 1	Signal(s) valid from SW:
Signal state 1 or signal transition 0 → 1	This input range is only used if IS "INC inputs in mode group range active" (V2600 0001.0) is <b>not set</b> . The interface signals INC... define how many increments the geometry axis traverses when the traverse key is pressed or the handwheel is turned one detent position. JOG mode must be active.  With "INCvar" the value in the general SD 41010: JOG_VAR_INCR_SIZE applies. In mode "continuous" the associated geometry axis can be traversed with the plus or minus traversing key according to how the traverse key is pressed. As soon as the selected machine function becomes active, this is signaled to the PLC interface (interface signal "Active machine function INC1;..."). If several machine function signals (INC1, INC... or "Continuous jogging") are selected at the interface simultaneously, no machine function is activated by the control. Note: The input IS "INC..." or "continuous" for changing an active machine function must be active for at least one PLC cycle. A static application is not required.
Signal state 0 or signal transition 1 → 0	The machine function in question is not selected. No change to the active machine function is requested. If an axis is currently traversing an increment, this movement is also aborted if this machine function is deselected or changed over.
Related to ....	IS "Active machine function INC1, ..." for geometry axis 1 (V3300 1001.0 ... .6) for geometry axis 2 (V3300 1005.0 ... .6) for geometry axis 3 (V3300 1005.0 ... .6) IS "INC inputs in the mode group area active" (V2600 0001.0)
Note for the reader:	802D sl Description of Functions: H1

## 6.6.2 Signals from the channel

V3300 0000.3 Interface signal	Action block active Signal(s) from channel (NCK → PLC)
Edge evaluation: no	Signal(s) updated: cyclic
Signal state 1 or signal transition 0 → 1	Signal(s) valid from SW:
Application example(s)	Block search: Output with accumulated auxiliary function outputs in progress (see Subsection LEERER MERKER)
Note for the reader:	802D sl Description of Functions: K1

V3300 0000.4 Interface signal	Approach block active Signal(s) from channel (NCK → PLC)
Edge evaluation: no	Signal(s) updated: cyclic
Signal state 1 or signal transition 0 → 1	Signal(s) valid from SW:
Application example(s)	Block search with calculation/on contour: Start block in progress (see Subsection LEERER MERKER)
Note for the reader:	802D sl Description of Functions: K1

V3300 0000.5	M0/M1 active
Interface signal	Signal(s) from channel (NCK ----> PLC)
Edge evaluation: no	Signal(s) updated: cyclic
Signal state 1 or signal transition 0 ----> 1	The part program block has been processed, the auxiliary functions have been output and - M0 is stored in the working memory - M1 is stored in the working memory and IS "Activate M01" is active The program status changes to stopped.
Signal state 0 or signal transition 1 ----> 0	- With IS "NC Start" - On program abort as a result of Reset
Related to ....	IS "Activate M01" IS "M01 selected"
Note for the reader:	802D sl Description of Functions: K1

V3300 0000.6	Last action block active
Interface signal	Signal(s) from channel (NCK ----> PLC)
Edge evaluation: no	Signal(s) updated: cyclic
Signal state 1 or signal transition 0 ----> 1	Block search: Last block of the output with collected auxiliary function outputs in progress (see Subsection LEERER MERKER)
Application example(s)	
Note for the reader:	802D sl Description of Functions: K1

V3300 0001.0	Referencing active
Interface signal	Signal(s) from channel (NCK -> PLC)
Edge evaluation: yes	Signal(s) updated: cyclic
Signal state 1 or signal transition 0 ----> 1	Channel-specific referencing has been started with the "Activate referencing" interface signal and successful start acknowledged with the "Referencing active" interface signal. Channel-specific referencing is operational.
Signal state 0 or signal transition 1 ----> 0	<ul style="list-style-type: none"> <li>Channel-specific referencing has been completed</li> <li>Axis-specific referencing running</li> <li>No referencing active</li> </ul>
Signal irrelevant for ... ..	Spindles
Related to ....	"Activate referencing" interface signal (V3200 0001.0)
Note for the reader:	802D sl Description of Functions: R1

V3300 0001.2	Revolutional feedrate active
Interface signal	Signal(s) from channel (NCK → PLC)
Edge evaluation: no	Signal(s) updated: cyclic
Signal state 1 or signal transition 0 ----> 1	When programming G95 (revolutional feedrate) in the AUTOMATIC mode.
Application example(s)	
Related to ....	
Note for the reader:	802D sl Description of Functions: V1

6.6 Channel-specific signals

V3300 0001.4 Interface signal	Block search active Signal(s) from channel (NCK ----> PLC)
Edge evaluation: no	Signal(s) updated: cyclic Signal(s) valid from SW:
Signal state 1 or signal transition 0 ----> 1	The Block search function is active. It was selected and started on the operator interface.
Signal state 0 or signal transition 1 ----> 0	The block search function is not active.
Application example(s)	The block search function makes it possible to jump to a certain block within a part program and to start processing the part program at this block.
Note for the reader:	802D sl Description of Functions: K1

V3300 0001.5 Interface signal	M2/M30 active Signal(s) from channel (NCK ----> PLC)
Edge evaluation: no	Signal(s) updated: cyclic Signal(s) valid from SW:
Signal state 1 or signal transition 0 ----> 1	NC block with M2 is completely processed. If traversing motions are also programmed in this block, the signal is not output until the target position is reached.
Signal state 0 or signal transition 1 ----> 0	<ul style="list-style-type: none"> <li>- No program end or abort</li> <li>- Status after power-up of control system</li> <li>- Start of an NC program</li> </ul>
	<p>Data transfer to working memory</p> <p>Block processed</p> <p>NC block with M2</p> <p>M change signal (1 PLC cycle time)</p> <p>IS "M2/M30 active"</p> <p>The diagram shows five horizontal lines representing different signals over time. 1. 'Data transfer to working memory' shows a pulse that occurs before the block is processed. 2. 'Block processed' shows a pulse that occurs during the execution of the NC block. 3. 'NC block with M2' shows a rectangular pulse representing the duration of the NC block. 4. 'M change signal (1 PLC cycle time)' shows a pulse that occurs at the end of the NC block. 5. 'IS "M2/M30 active"' shows a pulse that occurs at the end of the M change signal. Vertical dashed lines indicate the timing relationships between these events.</p>
Application example(s)	The PLC can detect the end of program processing with this signal and react appropriately.
Special cases, errors, ... ..	<ul style="list-style-type: none"> <li>- The functions M2 and M30 have equal priority. Only M2 should be used.</li> <li>- IS "M2/M30 active" is applied statically at the end of a program.</li> <li>- Not suitable for automatic follow-on functions such as workpiece counting, bar feed, etc. M2 must be programmed in a separate block and the word M2 or the decoded M signal used for these functions.</li> <li>- No auxiliary functions leading to read-in stop may be written in the last block of a program.</li> </ul>
Note for the reader:	802D sl Description of Functions: K1

V3300 0001.6 Interface signal	Transformation active Signal(s) from NCK channel (NCK->PLC)
Edge evaluation: no	Signal(s) updated: cyclic Signal(s) valid from SW: 2.0
Signal state 1 or signal transition 0 ----> 1	The NC command TRANSMIT or TRACYL is programmed in the part program. The corresponding block has been processed by the NC and a transformation is now active.
Signal state 0 Edge change 1---->0	No transformation is active.
Note for the reader:	802D sl Description of Functions: M1

V3300 0001.7	Program test active
Interface signal	Signal(s) from channel (NCK ----> PLC)
Edge evaluation: no	Signal(s) updated: cyclic   Signal(s) valid from SW:
Signal state 1 or signal transition 0 ----> 1	Program control "Program test" is active. Axis disable is set internally for all axes (not spindles). Therefore the machine axes do not move when a part program block or a part program is being processed. The axis movements are simulated on the operator interface with changing axis position values. The axis position values for the display are generated from the calculated setpoints. The part program is processed in the normal way.
Signal state 0 or signal transition 1 ----> 0	Program control Program test is not active.
Related to ....	IS "Activate program test" IS "Program test selected"
Note for the reader:	802D sl Description of Functions: K1

V3300 0003.0	Program status running
Interface signal	Signal(s) from channel (NCK ----> PLC)
Edge evaluation: no	Signal(s) updated: cyclic   Signal(s) valid from SW:
Signal state 1 or signal transition 0 ----> 1	The part program has been started with IS "NC start" and is running.
Signal state 0 or signal transition 1 ----> 0	<ul style="list-style-type: none"> <li>- Program stopped by M00/M01 or NC Stop or mode change.</li> <li>- The block is executed in single-block mode.</li> <li>- End of program reached (M2)</li> <li>- Program abort by Reset</li> <li>- Current block cannot be processed</li> </ul>
Special cases, errors, ... ...	The IS "Program status running" does not change to 0 if workpiece machining is stopped by the following events: <ul style="list-style-type: none"> <li>- Output of feed disable or spindle disable</li> <li>- IS "Read-in disable"</li> <li>- Feed override to 0%</li> <li>- Response of the spindle and axis monitoring</li> </ul>
Note for the reader:	802D sl Description of Functions: K1

V3300 0003.2	Program status stopped
Interface signal	Signal(s) from channel (NCK ----> PLC)
Edge evaluation: no	Signal(s) updated: cyclic   Signal(s) valid from SW:
Signal state 1 or signal transition 0 ----> 1	The NC part program has been stopped by "NC stop", "NC stop axes plus spindles", "NC stop at block limit", programmed M0 or M1 or single block mode.
Signal state 0 or signal transition 1 ----> 0	Program status "stopped" is not active.
Related to ....	IS "NC Stop" IS "NC Stop axes plus spindles" IS "NC Stop at block limit"
Note for the reader:	802D sl Description of Functions: K1

V3300 0003.3	Program status interrupted
Interface signal	Signal(s) from channel (NCK ----> PLC)
Edge evaluation: no	Signal(s) updated: cyclic   Signal(s) valid from SW:
Signal state 1 or signal transition 0 ----> 1	When changing from AUTOMATIC or MDA mode (when program has stopped) after JOG the program status switches to "interrupted". The program can be continued at the point of interruption in AUTOMATIC or MDA mode when "NC start" is operated.
Signal state 0 or signal transition 1 ----> 0	Program status interrupted is not active.
Special cases, errors, ... ...	IS "Program status interrupted" signifies that the part program can be continued after an NC start.
Note for the reader:	802D sl Description of Functions: K1

## 6.6 Channel-specific signals

V3300 0003.4 Interface signal	Program status aborted Signal(s) from channel (NCK ---> PLC)
Edge evaluation: no	Signal(s) updated: cyclic   Signal(s) valid from SW:
Signal state 1 or signal transition 0 ---> 1	The program has been selected but not started or the current program was aborted with Reset.
Signal state 0 or signal transition 1 ---> 0	Program status interrupted is not active.
Related to ....	IS "Reset"
Note for the reader:	802D sl Description of Functions: K1

V3300 0003.5 Interface signal	Channel status active Signal(s) from channel (NCK ---> PLC)
Edge evaluation: no	Signal(s) updated: cyclic   Signal(s) valid from SW:
Signal state 1 or signal transition 0 ---> 1	In this channel – a part program or block is currently being processed in AUTOMATIC or MDA mode or – at least one axis is being traversed in JOG mode.
Signal state 0 or signal transition 1 ---> 0	"Channel status interrupted" or "Channel status Reset" is active.
Note for the reader:	802D sl Description of Functions: K1

V3300 0003.6 Interface signal	Channel status interrupted Signal(s) from channel (NCK ---> PLC)
Edge evaluation: no	Signal(s) updated: cyclic   Signal(s) valid from SW:
Signal state 1 or signal transition 0 ---> 1	The NC part program in AUTOMATIC or MDA mode can be stopped by "NC stop", "NC stop axes plus spindles", "NC stop at block limit", programmed M0 or M1 or single block mode. With NC start the part program or the interrupted traversing movement can be continued.
Signal state 0 or signal transition 1 ---> 0	"Channel status active" or "Channel status Reset" is active.
Note for the reader:	802D sl Description of Functions: K1

V3300 0003.7 Interface signal	Channel status reset Signal(s) from channel (NCK ---> PLC)
Edge evaluation: no	Signal(s) updated: cyclic   Signal(s) valid from SW:
Signal state 1 or signal transition 0 ---> 1	The signal changes to 1 as soon as the channel goes into Reset status, i.e. no processing taking place.
Signal state 0 or signal transition 1 ---> 0	The signal changes to 0 if processing is taking place in the channel, e.g. execution of a part program or block search
Note for the reader:	802D sl Description of Functions: K1

V3300 0004.2 Interface signal	All axes referenced Signal(s) from channel (PLC -> NCK)
Edge evaluation: no	Signal(s) updated: cyclic   Signal(s) valid from SW: 1.1
Signal state 1 or signal transition 0 ---> 1	All axes referenced. (Note for axes requiring referencing: MD 34110: REFP_CYCLE_NR, MD 20700: REFP_NC_START_LOCK )
Signal state 0 or signal transition 1 ---> 0	One or more axes on the channel have not been referenced.
Special cases, errors, ... ..	The spindles of the channel have no effect on this interface signal.
Related to ....	"Referenced/synchronizing 1" interface signal (V390x 0000.4)
Note for the reader:	802D sl Description of Functions: R1

V3300 00004.3 Data block	All axes stationary Signal(s) from channel (NCK -> PLC)
Edge evaluation: no	Signal(s) updated: cyclic   Signal(s) valid from SW:
Signal state 1 or signal transition 0 ---> 1	All axes assigned to the channel are stationary with interpolator end. No other traversing movements are active.
Note for the reader:	802D sl Description of Functions: B1

V3300 0006.0 Interface signal	Stroke initiation active Signal(s) from the channel (NCK → PLC)
Edge evaluation:	Signal(s) updated: Signal(s) valid from SW release: 3
Signal status 1 or signal transition 0 → 1	This signal indicates an active stroke initiation. 1-signal: The stroke initiation is active.
Signal status 0 or signal transition 1 → 0	0-signal: The stroke initiation is not active.

V3300 0006.1 Interface signal	Acknowledgment of manual stroke initiation Signal(s) from the channel (NCK → PLC)
Edge evaluation:	Signal(s) updated: Signal(s) valid from SW release: 3
Signal status 1 or signal transition 0 → 1	This signal indicates whether a manual stroke was initiated. 1-signal: A manual stroke was initiated.
Signal status 0 or signal transition 1 → 0	0-signal: No manual stroke was initiated.

V3300 0008 V3300 0009 Interface signal	Machine-related protection zone 1 (...10) preactivated Signal(s) from the channel (NCK → PLC)
Edge evaluation: no	Signal(s) updated: cyclically
Signal status 1 or edge transition → 0 ? 1	The machine-related protection zone 1 (...10) is preactivated in the current block. (The preactivation was performed in the part program.) Thus, the protection zone can be activated or deactivated in the PLC user program using the interface signal DB21, ... DBX8.0 – DBX9.1 ("Activate machine-related protection zone 1 (...10)").
Signal status 0 or edge transition → 1 ? 0	The machine-related protection zone 1 (...10) is deactivated in the current block. (The deactivation was performed in the part program.) Thus, the protection zone can be deactivated or set inactive in the PLC user program using the interface signal DB21, ... DBX8.0 – DBX9.1 ("Activate machine-related protection zone 1 (...10)").
Related to ....	DB21, ... DBX8.0 – DBX9.1 ("Activate machine-related protection zone 1 (...10)").

V3300 0010 V3300 0011 Interface signal	Channel-specific protection zone 1 (...10) preactivated Signal(s) from the channel (NCK → PLC)
Edge evaluation: no	Signal(s) updated: cyclically
Signal status 1 or edge transition → 0 ? 1	The channel-specific protection zone 1 (...10) is preactivated in the current block. (The preactivation was performed in the part program.) Thus, the protection zone can be activated or deactivated in the PLC user program using the interface signal DB21, ... DBX10.0 – DBX11.1 ("Activate channel-specific protection zone 1 (...10)").
Signal status 0 or edge transition → 1 ? 0	The channel-specific protection zone 1 (...10) is deactivated in the current block. (The deactivation was performed in the part program.) Thus, the protection zone can be deactivated or set inactive in the PLC user program using the interface signal DB21, ... DBX10.0 – DBX11.1 ("Activate channel-specific protection zone 1 (...10)").
Related to ... with ....	DB21, ... DBX10.0 – DBX11.1 ("Activate channel-specific protection zone 1 (...10)").

V3300 0012 V3300 0013 Interface signal	Machine-related protection zone 1 (...10) violated Signal(s) from the channel (NCK → PLC)
Edge evaluation: no	Signal(s) updated: cyclically
Signal status 1 or edge transition → 0 ? 1	The activated, machine-related protection zone 1 (...10) is violated in the current block or in the current JOG motion. The preactivated, machine-related protection zone 1 (...10) would be violated in the current block if it would be set active by the PLC.
Signal status 0 or edge transition → 1 ? 0	The activated, machine-related protection zone 1 (...10) is not violated in the current block. The preactivated, machine-related protection zone 1 (...10) would not be violated in the current block if it would be set active by the PLC.
Application example(s)	This interface signal (IS) can be used to check before swinging parts into the work space whether the tool or the workpiece is in the machine-related protection zone of the part to be swung in.

## 6.6 Channel-specific signals

V3300 0014 V3300 0015 Interface signal	Channel-specific protection zone 1 (...10) violated  Signal(s) from the channel (NCK ----> PLC)
Edge evaluation: no	Signal(s) updated: cyclically
Signal status 1 or edge transition --> 0 ? 1	The activated, channel-specific protection zone 1 (...10) is violated in the current block. The preactivated, channel-specific protection zone 1 (...10) would be violated in the current block if it would be set active by the PLC.
Signal status 0 or edge transition --> 1 ? 0	The activated, channel-specific protection zone 1 (...10) is not violated in the current block. The preactivated, channel-specific protection zone 1 (...10) would not be violated in the current block if it would be set active by the PLC.
Application example(s)	This interface signal (IS) can be used to check before swinging parts into the work space whether the tool or the workpiece is in the channel-specific protection zone of the part to be swung in.

V3300 1000.0 bis .1 V3300 1004.0 to .1 V3300 1008.0 to .1 Interface signal	Handwheel active (1 to 2) for geometry axis 1 for geometry axis 2 for geometry axis 3  Signal(s) from channel (NCK -> PLC)
Edge evaluation: no	Signal(s) updated: cyclic      Signal(s) valid from SW:
Signal state 1 or signal transition 0 ----> 1	These PLC interface signals report whether this geometry axis is assigned to handwheel 1, 2 or 3 or to no handwheel. Only one handwheel can be assigned to an axis at any one time. If several "Activate handwheel" interface signals are set, priority "Handwheel 1" before "Handwheel 2" before "Handwheel 3" applies. If the assignment is active, the geometry axis can be traversed with the handwheel in JOG mode.
Signal state 0 or signal transition 1 ----> 0	Neither handwheel 1, 2 nor 3 is assigned to this geometry axis.
Related to ....	IS "Activate handwheel" (V3200 1000.0 to .2, V3200 1004.0 to .2, V3200 1008.0 to .2)
Note for the reader:	802D sl Description of Functions: H1

V3300 1000.7 and .6 V3300 1004.7 and .6 V3300 1008.7 and .6 Interface signal	Travel command plus and minus for geometry axis      for geometry axis 1 for geometry axis 2 for geometry axis 3  Signal(s) from channel (NCK -> PLC)
Edge evaluation: no	Signal(s) updated: cyclic      Signal(s) valid from SW:
Signal state 1 or signal transition 0 ----> 1	A traverse movement of the axis is to be executed in one or the other direction. Depending on the mode selected, the command is triggered in different ways: <ul style="list-style-type: none"> <li>- JOG mode: with the plus or minus traverse key</li> <li>- REF submode: with the traverse key that takes the axis to the reference point</li> <li>- AUTO/MDA mode: the program block containing a coordinate value for the axis in question is executed.</li> </ul>
Signal state 0 or signal transition 1 ----> 0	A travel command in the relevant axis direction has not been given or a traverse movement has been completed. <ul style="list-style-type: none"> <li>• JOG mode: <ul style="list-style-type: none"> <li>- Cancellation of traverse key</li> <li>- While ending traversing with the handwheel.</li> </ul> </li> <li>• REF submode: <ul style="list-style-type: none"> <li>When the reference point is reached</li> </ul> </li> <li>• AUTO/MDA mode: <ul style="list-style-type: none"> <li>- The program block has been executed (and the next block does not contain any coordinate values for the axis in question)</li> <li>- Abort with "RESET", etc.</li> <li>- IS "Axis disable" is active</li> </ul> </li> </ul>
Application example(s)	To release clamping of axes with clamping <b>Note:</b> If the clamping is not released until the travel command is given, these axes cannot be operated under continuous path control!
Related to ....	IS "Traverse key plus" and " ... minus"      for geometry axis 1 (V3200 1000.7 and .6) for geometry axis 2 (V3200 1004.7 and .6) for geometry axis 3 (V3200 1008.7 and .6)
Note for the reader:	802D sl Description of Functions: H1

V3300 1001.0, ..., .6 V3300 1005.0, ..., .6 V3300 1009.0, ..., .6 Interface signal	Active machine function INC1, ..., continuous for geometry axis 1 for geometry axis 2 for geometry axis 3 Signal(s) from channel (NCK → PLC)		
Edge evaluation: no	Signal(s) updated: cyclic	Signal(s) valid from SW:	
Signal state 1 or signal transition 0 ----> 1	The PLC interface receives a signal stating which JOG mode machine function is active for the geometry axes.		
Signal state 0 or signal transition 1 ----> 0	The machine function in question is not active.		
Related to ....	IS "Machine function INC1, ..., continuous" for geometry axis 1 (V3200 1001.0 ... .6) for geometry axis 2 (V3200 1005.0 ... .6) for geometry axis 3 (V3200 1009.0 ... .6)		
Note for the reader:	802D sl Description of Functions: H1		

V3300 4001.1 Interface signal	Workpiece setpoint reached Signal(s) from channel (NCK ----> PLC)		
Edge evaluation: no	Signal(s) updated: cyclic	Signal(s) valid from SW:	
Signal state 1 or signal transition 0 ----> 1	The required number of workpieces is reached.  According to setting in MD 27880: PART_COUNTER: Bit 1 = 0: when \$AC_REQUIRED_PARTS equal to \$AC_ACTUAL_PARTS Bit 1 = 1: when \$AC_REQUIRED_PARTS equal to \$AC_SPECIAL_PARTS		
Signal state 0 or signal transition 1 ----> 0	The required number of workpieces is not reached.		
Note for the reader:	802D sl Description of Functions: K1		

## 6.7 Axis/spindle-specific signals

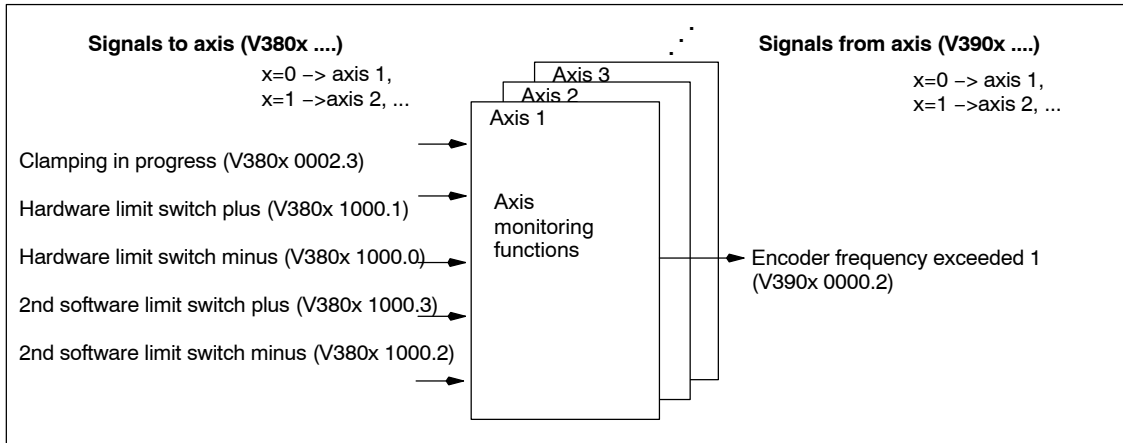

Fig. 6-2 PLC interface signals for axis monitoring functions

### 6.7.1 Transferred axis-specific M and S functions

VD370x 0000	M function for spindle	
Interface signal	Signals from axis/spindle (NCK -> PLC), axis-specific	
Edge evaluation:	Signal(s) updated: cyclic	Signal(s) valid from SW:
	Generally the M functions are output in V2500... channel-specific. In the V25001... range these only remain valid for one PLC cycle; in V25003... until a new function is output. In this IS "M function for spindle" <b>selected spindle M functions</b> are available to the PLC as a current integer value.	
	<ul style="list-style-type: none"> <li>• M3 &gt; value: 3</li> <li>• M4 &gt; value: 4</li> <li>• M5 &gt; value: 5</li> </ul>	
Related to ....	IS "S function for spindle" (VD370x 0004), axis-specific IS auxiliary function transfer from NC channel (V2500...)	
Note for the reader:	802D sl Description of Functions: S1	

VD370x 0004	S function for spindle	
Interface signal	Signals from axis/spindle (NCK -> PLC), axis-specific	
Edge evaluation:	Signal(s) updated: cyclic	Signal(s) valid from SW:
	Generally the S function is transferred to the PLC channel-specific in VD2500 4000 as a floating point value. In this IS "S function for spindle" the floating point value is output to the PLC on an axis-specific basis:	
	<ul style="list-style-type: none"> <li>• S... as the spindle speed in rpm (programmed value)</li> <li>• S... as the constant cutting speed in m/min or ft/min for G96</li> </ul> <p>The following S functions are <b>not</b> output here:</p> <ul style="list-style-type: none"> <li>• S... as the programmed Spindle speed limiting G25</li> <li>• S... as the programmed Spindle speed limiting G26</li> <li>• S... as the dwell time in spindle revolutions</li> </ul>	
Related to ....	IS "M function for the spindle" (VD370x 0000), axis-specific IS "Transferred S function" (VD2500 4000), channel-specific	
Note for the reader:	802D sl Description of Functions: S1	

## 6.7.2 Signals to axis/spindle

VB380x 0000	Feedrate override (axis-specific)																																																																																																		
Interface signal	Signal(s) to axis (PLC → NCK)																																																																																																		
Edge evaluation: no	Signal(s) updated: cyclic	Signal(s) valid from SW:																																																																																																	
Signal state 1 or signal transition 0 ---> 1	The axis-specific feedrate override is defined via the PLC in gray coding.																																																																																																		
	<table border="1"> <thead> <tr> <th>Switch position</th> <th>Code</th> <th>Axial feedrate override factor</th> </tr> </thead> <tbody> <tr><td>1</td><td>00001</td><td>0.0</td></tr> <tr><td>2</td><td>00011</td><td>0.01</td></tr> <tr><td>3</td><td>00010</td><td>0.02</td></tr> <tr><td>4</td><td>00110</td><td>0.04</td></tr> <tr><td>5</td><td>00111</td><td>0.06</td></tr> <tr><td>6</td><td>00101</td><td>0.08</td></tr> <tr><td>7</td><td>00100</td><td>0.10</td></tr> <tr><td>8</td><td>01100</td><td>0.20</td></tr> <tr><td>9</td><td>01101</td><td>0.30</td></tr> <tr><td>10</td><td>01111</td><td>0.40</td></tr> <tr><td>11</td><td>01110</td><td>0.50</td></tr> <tr><td>12</td><td>01010</td><td>0.60</td></tr> <tr><td>13</td><td>01011</td><td>0.70</td></tr> <tr><td>14</td><td>01001</td><td>0.75</td></tr> <tr><td>15</td><td>01000</td><td>0.80</td></tr> <tr><td>16</td><td>11000</td><td>0.85</td></tr> <tr><td>17</td><td>11001</td><td>0.90</td></tr> <tr><td>18</td><td>11011</td><td>0.95</td></tr> <tr><td>19</td><td>11010</td><td>1.00</td></tr> <tr><td>20</td><td>11110</td><td>1.05</td></tr> <tr><td>21</td><td>11111</td><td>1.10</td></tr> <tr><td>22</td><td>11101</td><td>1.15</td></tr> <tr><td>23</td><td>11100</td><td>1.20</td></tr> <tr><td>24</td><td>10100</td><td>1.20</td></tr> <tr><td>25</td><td>10101</td><td>1.20</td></tr> <tr><td>26</td><td>10111</td><td>1.20</td></tr> <tr><td>27</td><td>10110</td><td>1.20</td></tr> <tr><td>28</td><td>10010</td><td>1.20</td></tr> <tr><td>29</td><td>10011</td><td>1.20</td></tr> <tr><td>30</td><td>10001</td><td>1.20</td></tr> <tr><td>31</td><td>10000</td><td>1.20</td></tr> </tbody> </table>			Switch position	Code	Axial feedrate override factor	1	00001	0.0	2	00011	0.01	3	00010	0.02	4	00110	0.04	5	00111	0.06	6	00101	0.08	7	00100	0.10	8	01100	0.20	9	01101	0.30	10	01111	0.40	11	01110	0.50	12	01010	0.60	13	01011	0.70	14	01001	0.75	15	01000	0.80	16	11000	0.85	17	11001	0.90	18	11011	0.95	19	11010	1.00	20	11110	1.05	21	11111	1.10	22	11101	1.15	23	11100	1.20	24	10100	1.20	25	10101	1.20	26	10111	1.20	27	10110	1.20	28	10010	1.20	29	10011	1.20	30	10001	1.20	31	10000	1.20
Switch position	Code	Axial feedrate override factor																																																																																																	
1	00001	0.0																																																																																																	
2	00011	0.01																																																																																																	
3	00010	0.02																																																																																																	
4	00110	0.04																																																																																																	
5	00111	0.06																																																																																																	
6	00101	0.08																																																																																																	
7	00100	0.10																																																																																																	
8	01100	0.20																																																																																																	
9	01101	0.30																																																																																																	
10	01111	0.40																																																																																																	
11	01110	0.50																																																																																																	
12	01010	0.60																																																																																																	
13	01011	0.70																																																																																																	
14	01001	0.75																																																																																																	
15	01000	0.80																																																																																																	
16	11000	0.85																																																																																																	
17	11001	0.90																																																																																																	
18	11011	0.95																																																																																																	
19	11010	1.00																																																																																																	
20	11110	1.05																																																																																																	
21	11111	1.10																																																																																																	
22	11101	1.15																																																																																																	
23	11100	1.20																																																																																																	
24	10100	1.20																																																																																																	
25	10101	1.20																																																																																																	
26	10111	1.20																																																																																																	
27	10110	1.20																																																																																																	
28	10010	1.20																																																																																																	
29	10011	1.20																																																																																																	
30	10001	1.20																																																																																																	
31	10000	1.20																																																																																																	
	Table 6-3 Gray coding for axis-specific feedrate override																																																																																																		
Related to ....	IS "Override active" (V380x 0001.7)																																																																																																		
Note for the reader:	802D sl Description of Functions: V1																																																																																																		

6.7 Axis/spindle-specific signals

V380x 0001.1 Interface signal	Acknowledge fixed stop reached Signal(s) to axis/spindle (PLC → NCK)
Edge evaluation: no	Signal(s) updated: cyclic Signal(s) valid from SW: 2.0
Signal state 1 or signal transition 0 ----> 1	Meaning after the fixed stop has been reached IS "Fixed stop reached" = 1 → The axis pushes against the fixed stop with the clamping torque → The fixed stop monitoring window is activated → A block change is performed.
Signal state 0  Edge change 1---->0	Meaning after the fixed stop has been reached IS "Fixed stop reached" = 1 → The axis pushes against the fixed stop with the clamping torque → The fixed stop monitoring window is activated → <b>No</b> block change is performed and channel alarm "Wait: Auxiliary function acknowledgment missing" is displayed.  Meaning once the fixed stop has been reached: IS "Fixed stop reached" = 1 The function is aborted, the alarm "20094 axis %1 Function aborted" is displayed. Meaning when function is deselected "FXS = 0" via part program: Torque limiting and monitoring of the fixed stop window are canceled.
IS irrelevant for ....	MD 37060: FIXED_STOP_ACKN_MASK (monitoring of PLC acknowledgments for travel to fixed stop) = 0 or 1 (for values >1, however)
Related to ....	MD 37060: FIXED_STOP_ACKN_MASK (monitoring of PLC acknowledgments for travel to fixed stop) IS "Fixed stop reached"
Note for the reader:	802D sl Description of Functions: F1

V380x 0001.2 Interface signal	Sensor for fixed stop Signal(s) to axis/spindle (PLC → NCK)
Edge evaluation: no	Signal(s) updated: cyclic Signal(s) valid from SW: 2.0
Signal state 1 or signal transition 0 ----> 1	Fixed stop is reached.
Signal state 0 or signal transition 1 ----> 0	Fixed stop is not reached.
Related to ....	The signal is effective only if MD 37040: FIXED_STOP_BY_SENSOR is set to 1.
Note for the reader:	802D sl Description of Functions: F1

V380x 0001.7 Interface signal	Override active Signal(s) to axis/spindle (PLC → NCK)
Edge evaluation: no	Signal(s) updated: cyclic Signal(s) valid from SW:
Signal state 1 or signal transition 0 ----> 1	Feedrate override active (for axes): • The axis-specific feedrate override between 0 and a maximum of 120% entered in the PLC interface is used.  Spindle override active (for spindle): • The spindle override of 50 to a maximum of 120% is used.
Signal state 0 or signal transition 1 ----> 0	The existing axis-specific feedrate override or spindle override is not active. If the feedrate override is inactive, 100% is used as the internal override factor. <b>Note:</b> The 1st switch position of the gray-coded interface for the value represents a special case. In this case, the override factor of the 1st switch position is also used with "Override inactive" and 0% is issued as the override value for axes (acts the same as "Feed disable"); accordingly 50%, is issued for the spindle.
Special cases, errors, ... ..	• The spindle override is always accepted with 100% in the spindle "Oscillation mode". • The spindle override acts on the programmed values before the limits (e.g. G26) intervene. • The feedrate override is inactive if G33 is active.
Related to ....	IS "Feedrate override" and IS "Spindle override"
Note for the reader:	802D sl Description of Functions: V1

V380x 0002.0 Interface signal	Cam activation Signal(s) to axis/spindle (PLC --> NCK)	
Edge evaluation: no	Signal(s) updated: cyclically	Signal(s) valid from SW release: 2.1
Signal status 1 or signal transition 0 ----> 1	The output of the minus and plus cam signals of an axis to the general PLC interface is activated. The activation comes immediately into effect after processing of the IS "Cam activation" in the NCK.	
Signal status 0 or signal transition 1 ----> 0	The minus and plus cam signals of an axis are <b>not</b> output to the general PLC interface.	
Related to ....	IS "Minus cam signal 1-32" (V2700 0004.0 bis .7) IS "Plus cam signal 1-32" (V2700 0008.0 to .7)	

V380x 0002.2 Interface signal	Spindle reset/Delete distance-to-go Signal(s) to axis/spindle (PLC -> NCK)	
Edge evaluation: yes	Signal(s) updated: cyclic	Signal(s) valid from SW:
Edge change 0 ----> 1	Independent of MD 35040: SPIND_ACTIVE_AFTER_RESET, spindle reset has the following effects for the different spindle modes: Open-loop control mode: <ul style="list-style-type: none"> <li>- Spindle stops</li> <li>- Program continues running</li> <li>- Spindle continues to run with subsequent M and S program commands</li> </ul> Oscillation mode: <ul style="list-style-type: none"> <li>- Oscillation is aborted</li> <li>- Axes continue to run</li> <li>- Program is continued with current gear stage</li> <li>- With a subsequent M value and a higher S value, IS "Setpoint speed limited" (V390x 2001.1) is set if necessary.</li> </ul> Positioning mode: <ul style="list-style-type: none"> <li>- is stopped</li> </ul>	
Signal state 0 or signal transition 1 ----> 0	No effect	
Related to ....	MD 35040: SPIND_ACTIVE_AFTER_RESET (own spindle reset) IS "Reset" (V300 00000.7) IS "Delete distance-to-go" (V380x 0002.2) is another name for the same signal; however, it applies to each axis.	
Note for the reader:	802D sl Description of Functions: S1	

V380x 0002.3 Data block	Clamping in progress Signal(s) to axis/spindle (PLC ----> NCK)	
Edge evaluation: no	Signal(s) updated: cyclic	Signal(s) valid from SW:
Signal state 1 or signal transition 0 ----> 1	Clamping in progress The clamping monitoring function is activated.	
Signal state 0 or signal transition 1 ----> 0	Clamping terminated. The zero-speed monitoring function takes over from the clamping monitoring function.	
Related to ....	MD 36050: CLAMP_POS_TOL (clamping tolerance)	
Note for the reader:	802D sl Description of Functions: A3	

6.7 Axis/spindle-specific signals

V380x 0003.1 Interface signal	Enable travel to fixed stop Signal(s) to axis/spindle (PLC → NCK)
Edge evaluation: no	Signal(s) updated: cyclic Signal(s) valid from SW: 2.0
Signal state 1 or signal transition 0 ----> 1	Meaning when "FXS" function is selected via part program, (IS "Activate travel to fixed stop" = 1): Travel to fixed stop is enabled and the axis traverses from the start position at the programmed velocity to the programmed target position.
Signal state 0	Meaning when "FXS" function is selected via part program, (IS "Activate travel to fixed stop" = 1): → Travel to fixed stop is disabled. → The axis is at the start position with reduced torque. → Channel alarm "Wait: Auxiliary function acknowledgment missing" is displayed.
Edge change 1---->0	Meaning <b>before</b> the fixed stop has been reached IS "Fixed stop reached" = 0 → Travel to fixed stop is aborted → Alarm "20094: axis%1 Function aborted" is displayed  Meaning <b>once</b> fixed stop has been reached IS "Fixed stop reached" = 1. Torque limiting and the monitoring of the fixed stop monitoring window are canceled.
IS irrelevant for ....	MD 37060: FIXED_STOP_ACKN_MASK (monitoring of PLC acknowledgments for travel to fixed stop) = 0 or 2
Related to ....	MD 37060: FIXED_STOP_ACKN_MASK (monitoring of PLC acknowledgments for travel to fixed stop) IS "Activate travel to fixed stop"
Note for the reader:	802D sl Description of Functions: F1

V380x 0003.6 Data block	Velocity/spindle speed limitation Signal(s)
Edge evaluation: no	Signal(s) updated: cyclic Signal(s) valid from SW:
Signal state 1 or signal transition 0 ----> 1	The NCK limits the velocity/spindle speed to the limit value set in MD 35160: SPIND_EXTERN_VELO_LIMIT.
Signal state 0 or signal transition 1 ----> 0	No limiting active.
Related to ....	MD 35100: SPIND_VELO_LIMIT (max. spindle speed) SD 43220: SPIND_MAX_VELO_G26 (prog. spindle speed limiting G26) SD 43230: SPIND_MAX_VELO_LIMIT (prog. spindle speed limiting G96)
Note for the reader:	802D sl Description of Functions: A3

V380x 0004.0 to .2 Interface signal	Activate handwheel (1 to 3) Signal(s) to axis/spindle (PLC → NCK)
Edge evaluation: no	Signal(s) updated: cyclic Signal(s) valid from SW:
Signal state 1 or signal transition 0 ----> 1	This PLC interface signal defines whether this machine axis is assigned to handwheel 1, 2, 3 or no handwheel. Only one handwheel can be assigned to an axis at any one time. If several "Activate handwheel" interface signals are set, priority "Handwheel 1" before "Handwheel 2" before "Handwheel 3" applies. If the assignment is active, the machine axis can be traversed with the handwheel in JOG mode.
Signal state 0 or signal transition 1 ----> 0	Neither handwheel 1, 2 nor 3 is assigned to this geometry axis.
Application example(s)	The PLC user program can use this interface signal to disable the influence of turning the handwheel on the axis.
Related to ....	IS "Handwheel active" 1 to 3 (V390x 0004.0 to .2)
Note for the reader:	802D sl Description of Functions: H1

V380x 0004.3 Interface signal	Feed stop/Spindle stop (axis-specific) Signal(s) to axis/spindle (PLC → NCK)
Edge evaluation: no	Signal(s) updated: cyclic Signal(s) valid from SW:
Signal state 1 or signal transition 0 ----> 1	The signal is active in all modes. Feed stop: <ul style="list-style-type: none"> <li>The signal triggers a feed stop for the axis. Traversing axes are brought to a standstill under controlled braking (ramp stop). No alarm is output.</li> <li>The signal triggers a feed stop for all path axes interpolating relative to each other when the "Feed stop" is activated for any one of these axes. In this case, <b>all the axes</b> are brought to a stop with adherence to the path contour. When the feed stop signal is canceled, execution of the interrupted part program is resumed.</li> <li>The position control is retained, i.e. the following error is eliminated.</li> <li>If a travel request is issued for an axis with an active "Feed stop", the request is retained. This pending travel request is executed immediately when "Feed stop" is canceled. If the axis is interpolating in relation to others, this also applies to these axes.</li> </ul> Spindle stop: <ul style="list-style-type: none"> <li>The spindle is brought to a standstill along the acceleration characteristic.</li> <li>In positioning mode, activation of the "Spindle stop" signal interrupts the positioning process. The above response applies with respect to individual axes.</li> </ul>
Signal state 0 or signal transition 1 ----> 0	Feed stop: <ul style="list-style-type: none"> <li>The feedrate is enabled for the axis.</li> <li>If a travel request ("Travel command") is active when the "Feed stop" is canceled, this is executed immediately.</li> </ul> Spindle stop: <ul style="list-style-type: none"> <li>The speed is enabled for the spindle.</li> <li>The spindle is accelerated to the previous speed setpoint with the acceleration characteristic or, in positioning mode, positioning is resumed.</li> </ul>
Application example(s)	Feed stop: <ul style="list-style-type: none"> <li>The traversing motion in the machine axes is not started when "Feed stop" is active, if, for example, certain operating states that do not permit axis motion (e.g. door not closed) prevail.</li> </ul> Spindle stop: <ul style="list-style-type: none"> <li>Change a tool</li> </ul>
Special cases, errors, ... ..	
Note for the reader:	802D sl Description of Functions: V1

V380x 0004.4 Interface signal	Traverse key disable Signal(s) to axis/spindle (PLC → NCK)
Edge evaluation: no	Signal(s) updated: cyclic Signal(s) valid from SW:
Signal state 1 or signal transition 0 ----> 1	The traverse keys plus and minus have no effect on the machine axes in question. It is thus not possible to traverse the machine axis in JOG with the traverse keys on the machine control panel. If the traverse key disable is activated during a traverse movement, the machine axis is stopped.
Signal state 0 or signal transition 1 ----> 0	Traverse keys plus and minus are enabled.
Application example(s)	It is thus possible, depending on the operating mode, to disable manual traverse of the machine axis in JOG mode with the traverse keys from the PLC user program.
Related to ....	IS "Traverse key plus" and "Traverse key minus" (V380x 0004.7 and .6)
Note for the reader:	802D sl Description of Functions: H1

V380x 0004.5 Interface signal	Rapid traverse override Signal(s) to axis/spindle (PLC → NCK)
Edge evaluation: no	Signal(s) updated: cyclic Signal(s) valid from SW:
Signal state 1 or signal transition 0 ----> 1	If interface signal "Rapid traverse override" is set together with "Traverse key plus" and "Traverse key minus", the machine axis in question traverses at rapid traverse. The rapid traverse velocity is defined in MD 32010: JOG_VELO_RAPID. Rapid traverse override is active in the following JOG modes: <ul style="list-style-type: none"> <li>Continuous jogging</li> <li>Incremental jogging</li> </ul> If rapid traverse override is active, the velocity can be modified with the axis-specific feedrate override switch.
Signal state 0 or signal transition 1 ----> 0	The machine axis traverses at the defined JOG velocity (SD 41110: JOG_SET_VELO or SD 41130, or MD 32020: JOG_VELO).
Signal irrelevant for ... ..	<ul style="list-style-type: none"> <li>Operating modes AUTOMATIC and MDA</li> <li>Reference point approach (JOG mode)</li> </ul>
Related to ....	IS "Traverse key plus" and "Traverse key minus" (V380x 0004.7 and .6) IS axis-specific "Feedrate override" (VB380x 0000)
Note for the reader:	802D sl Description of Functions: H1

6.7 Axis/spindle-specific signals

V380x 0004.7 and .6 Interface signal	Plus and minus traverse keys Signal(s) to axis/spindle (PLC → NCK)
Edge evaluation: yes	Signal(s) updated: cyclic Signal(s) valid from SW:
Signal state 1 or signal transition 0 → 1	The selected axis can be traversed in both directions in JOG mode with the traverse keys plus and minus. <b>Incremental traversing</b> With signal 1 the axis starts to traverse at the set increment. If the signal changes to the 0 state before the increment is traversed, the traversing movement is interrupted. When signal state 1 occurs again, the traverse motion is restarted. The traversing motion of the axis can be stopped and restarted multiple times as described above until the increment has been fully traversed. <b>Continuous traversing</b> If no INC measure is selected but "continuous" is, the axis travels for as long as the traverse key is actuated.  If both traverse signals (plus and minus) are set at the same time there is no movement or a current movement is aborted. The effect of the traverse keys can be disabled for every axis individually with the PLC interface signal "Traverse key disable".
Signal state 0 or signal transition 1 → 0	No traverse
Signal irrelevant for ...	Operating modes AUTOMATIC and MDA
Application example(s)	The machine axis cannot be traversed in JOG mode if it is already being traversed via the channel-specific PLC interface (as a geometry axis). Alarm 20062 is signaled.
Special cases, .....	Indexing axes
Related to ....	IS "Traverse key plus" and " ... minus" for geometry axis 1 (V3200 1000.7 and .6) for geometry axis 2 (V3200 1004.7 and .6) for geometry axis 3 (V3200 1008.7 and .6)  IS "Traverse key disable" (V380x 0004.4 )
Note for the reader:	802D sl Description of Functions: H1

V380x 0005.0 to .6 Interface signal	Machine functions INC1, INC10, INC100, INC1000, INC10000, INCvar, continuous Signal(s) to axis/spindle (PLC → NCK)
Edge evaluation: no	Signal(s) updated: cyclic Signal(s) valid from SW:
Signal state 1 or signal transition 0 → 1	This input range is only used if IS "INC inputs in mode group range active" (V2600 0001.0) is <b>not set</b> . The interface signals "INC..." define how many increments the machine axis traverses when the traverse key is pressed or the handwheel is turned one detent position. JOG must be active. With "INCvar" the value in the general SD 41010: JOG_VAR_INCR_SIZE applies. In "continuous" mode the associated axis can be traversed with the plus or minus traversing key according to how the traverse key is pressed.  As soon as the selected machine function becomes active, this is signaled to the PLC interface (IS "Active machine function INC1..."). If several machine function signals (INC1, INC... or "Continuous jogging") are selected at the interface simultaneously, no machine function is activated by the control. Note: The input IS "INC..." or "continuous" for changing an active machine function must be active for at least one PLC cycle. A static application is not required.
Signal state 0 or signal transition 1 → 0	The machine function in question is not selected. No change to the active machine function is requested. If an axis is currently traversing an increment, this movement is also aborted if this machine function is deselected or changed over.
Related to ....	IS "Active machine function INC1, ..." (V390x 0005.0 ... .6) IS "INC inputs in the mode group area active" (V2600 0001.0)
Note for the reader:	802D sl Description of Functions: H1

V380x 1000.1 and .0 Data block	Hardware limit switches plus and minus Signal(s) to axis/spindle (PLC ----> NCK)	
Edge evaluation: no	Signal(s) updated: cyclic	Signal(s) valid from SW:
Signal state 1 or signal transition 0 ----> 1	A switch can be mounted at each end of the travel range of a machine axis which will cause a signal "Hardware limit switch plus or minus" to be signaled to the NC via the PLC if it is approached. If the signal is recognized as set, alarm 021614 "Hardware limit switch + or -" is output and the axis is decelerated immediately. The braking mode is defined in MD 36600: BRAKE_MODE_CHOICE (deceleration behavior on hardware limit switch).	
Signal state 0 or signal transition 1 ----> 0	Normal condition, hardware limit switch not triggered.	
Related to ....	MD 36600: BRAKE_MODE_CHOICE (deceleration behavior on hardware limit switch)	
Note for the reader:	802D sl Description of Functions: A3	

V380x1000.3 or .2 Data block	2nd software limit switch plus or minus Signal(s) to axis/spindle (PLC ----> NCK)	
Edge evaluation: no	Signal(s) updated: cyclic	Signal(s) valid from SW:
Signal state 1 or signal transition 0 ----> 1	2nd software limit switch for the plus or minus direction is active. 1st software limit switch for the plus or minus direction is not active. The 2nd software limit switches (plus and minus) can be activated in addition to the 1st software limit switches (plus and minus) via this interface signal. The position is defined by MD 36130: POS_LIMIT_PLUS2, MD 36120: POS_LIMIT_MINUS2 (2nd software limit switch plus, 2nd software limit switch minus).	
Signal state 0 or signal transition 1 ----> 0	1st software limit switch for the plus or minus direction is active. 2nd software limit switch for the plus or minus direction is not active.	
Related to ....	MD 36110: POS_LIMIT_PLUS, MD 36130: POS_LIMIT_PLUS2, MD 36100: POS_LIMIT_MINUS, MD 36120: POS_LIMIT_MINUS2, (software limit switch plus, software limit switch minus)	
Note for the reader:	802D sl Description of Functions: A3	

V380x1000.7 Interface signal	Reference point approach delay Signal(s) to axis/spindle (PLC -> NCK)	
Edge evaluation: no	Signal(s) updated: cyclic	Signal(s) valid from SW:
Signal state 1 or signal transition 0 ----> 1	The machine axis is positioned at the reference cam.	
Signal state 0 or signal transition 1 ----> 0	The machine axis is positioned in front of the reference cam. A reference cam of appropriate length (to the end of the traversing range) has been used to prevent the machine axis from being positioned behind the referencing cam.	
Related to ....		
Note for the reader:	802D sl Description of Functions: R1	

## 6.7 Axis/spindle-specific signals

V380x 2000.0 to .2 Interface signal	Actual gear stage A to C Signal(s) to axis/spindle (PLC → NCK)																												
Edge evaluation: yes	Signal(s) updated: cyclic																												
Signal state 1 (level-operated)	Signal(s) valid from SW: When the new gear is engaged, the IS "Actual gear stage A to C" and "Gear changed" are enabled by the PLC user. This informs the NCK that the correct gear stage has been successfully engaged. The gear change is complete (spindle oscillation mode is deselected), the spindle accelerates in the new gear stage to the last programmed spindle speed and the next block in the part program can be executed. The actual gear stage is specified in coded format (ABC values). A parameter set is used for each of the 5 gear stages and is assigned as follows:  <table border="1"> <thead> <tr> <th>Parameter set no.</th> <th>VDI code CBA</th> <th>Data in data set</th> <th>contents</th> </tr> </thead> <tbody> <tr> <td>0</td> <td>-</td> <td>Data for axis mode</td> <td>Servo gain factor Monitoring functions</td> </tr> <tr> <td>1</td> <td>000 001</td> <td>Data for 1st gear stage</td> <td>M40 speed Min/max speed Acceleration etc.</td> </tr> <tr> <td>2</td> <td>010</td> <td>Data for 2nd gear stage</td> <td></td> </tr> <tr> <td>3</td> <td>011</td> <td>Data for 3rd gear stage</td> <td></td> </tr> <tr> <td>4</td> <td>100</td> <td>Data for 4th gear stage</td> <td></td> </tr> <tr> <td>5</td> <td>101 110 111</td> <td>Data for 5th gear stage</td> <td></td> </tr> </tbody> </table>	Parameter set no.	VDI code CBA	Data in data set	contents	0	-	Data for axis mode	Servo gain factor Monitoring functions	1	000 001	Data for 1st gear stage	M40 speed Min/max speed Acceleration etc.	2	010	Data for 2nd gear stage		3	011	Data for 3rd gear stage		4	100	Data for 4th gear stage		5	101 110 111	Data for 5th gear stage	
Parameter set no.	VDI code CBA	Data in data set	contents																										
0	-	Data for axis mode	Servo gain factor Monitoring functions																										
1	000 001	Data for 1st gear stage	M40 speed Min/max speed Acceleration etc.																										
2	010	Data for 2nd gear stage																											
3	011	Data for 3rd gear stage																											
4	100	Data for 4th gear stage																											
5	101 110 111	Data for 5th gear stage																											
Special cases, errors, ... ..	If the PLC user reports back to the NCK with a different actual gear stage than issued by the NCK as the set gear stage, the gear change is still treated as having been successfully completed and the actual gear stage A to C is activated.																												
Related to ....	IS "Set gear stage A" to "...C" (V390x 2000.0 to .2) IS "Change gear" (V390x 2000.3) IS "Gear changed" (V380x 2000.3) IS "Oscillation speed" (V380x 2002.5) Parameter sets (MD) for gear stages.																												
Note for the reader:	802D sI Description of Functions: S1																												

V380x 2000.3 Interface signal	Gear changed Signal(s) to axis/spindle (PLC → NCK)
Edge evaluation: yes	Signal(s) updated: cyclic
Signal state 1 or signal transition 0 → 1	Signal(s) valid from SW: When the new gear is engaged, the IS "Actual gear stage A to C" and "Gear changed" are enabled by the PLC user. This informs the NCK that the correct gear stage has been successfully engaged. The gear stage change is complete (spindle oscillation mode is deselected), the spindle accelerates in the new gear stage to the last programmed spindle speed and the next block in the part program can be executed. The IS "Change gear" is reset by the NCK, which causes the PLC user to reset the IS "Gear changed".
Signal state 0 or signal transition 1 → 0	No effect
Signal irrelevant for ... ..	All spindle modes except oscillation mode
Special cases, errors, ... ..	If the PLC user reports back to the NCK with a different actual gear stage than issued by the NCK as the set gear stage, the gear change is still treated as having been successfully completed and the actual gear stage A to C is activated.
Related to ....	IS "Actual gear stage A" to "C" (V380x 2000.0 to .2) IS "Set gear stage A" to "...C" (V390x 2000.0 to .2) IS "Change gear" (V390x 2000.3) IS "Oscillation speed" (V380x 2002.5)
Note for the reader:	802D sI Description of Functions: S1

V380x 2001.0 Interface signal	Feedrate override for spindle valid (instead of spindle override) Signal(s) from axis/spindle (PLC → NCK)	
Edge evaluation: yes	Signal(s) updated: cyclic	Signal(s) valid from SW:
Signal state 1 or signal transition 0 → 1	The "Feedrate override" value (VB380x 0000) is used for the spindle instead of the "Spindle override" value.	
Signal state 0 or signal transition 1 → 0	The "Spindle override" value is used.	
Related to ....	IS "Spindle override" (V380x 2003) IS "Feedrate override" (V380x 0000) IS "Override active" (V380x 0001.7)	
Note for the reader:	802D sl Description of Functions: V1	

V380x 2001.4 Interface signal	Resynchronize spindle during positioning 1 Signal(s) to axis/spindle (PLC → NCK)	
Edge evaluation: yes	Signal(s) updated: cyclic	Signal(s) valid from SW:
Signal state 1	The spindle must be resynchronized during positioning.	
Signal state 0 or signal transition 1 → 0	No effect	
Signal irrelevant for ... ..	All spindle modes except for positioning mode	
Application example(s)	The spindle has an indirect measuring system and slipping may occur between the motor and the clamp. If the signal=1 when the positioning process is started, the old reference is deleted and the zero mark searched for again before the end position is approached.	
Related to ....	"Referenced/synchronizing 1" interface signal (V390x 0000.4)	
Note for the reader:	802D sl Description of Functions: S1	

V380x 2001.6 Interface signal	Invert M3/M4 Signal(s) to axis/spindle (PLC → NCK)	
Edge evaluation: yes	Signal(s) updated: cyclic	Signal(s) valid from SW:
Signal state 1 or signal transition 0 → 1	The direction of rotation of the spindle motor changes with the following functions: <ul style="list-style-type: none"> <li>• M3</li> <li>• M4</li> <li>• M5</li> <li>• SPOS from movement; not active for SPOS from standstill.</li> </ul>	
Application example(s)	The machine has a selector switch for a vertical and horizontal spindle. The mechanical design incorporates <b>one gear wheel more</b> on the horizontal spindle than on the vertical spindle. The direction of rotation must therefore be changed on the horizontal spindle if the spindle is always to rotate clockwise with M3.	
Note for the reader:	802D sl Description of Functions: S1	

V380x 2002.4 Interface signal	Oscillation via PLC Signal(s) to axis/spindle (PLC → NCK)	
Edge evaluation: yes	Signal(s) updated: cyclic	Signal(s) valid from SW:
Signal state 1 or signal transition 0 → 1	If the IS "Oscillation via PLC" is <b>enabled</b> , the IS "Oscillation speed" effects output of a speed only in conjunction with the IS "Direction of rotation setpoint counter-clockwise and clockwise". The oscillation, i.e. the continuous change of the direction of rotation, is performed by the PLC user with the IS "Direction of rotation setpoint counter-clockwise and clockwise" (oscillation via PLC).	
Signal state 0 or signal transition 1 → 0	If the IS "Oscillation via PLC" is <b>not enabled</b> , the IS "Oscillation speed" triggers automatic oscillation on the NCK. The two times for the directions of rotation are entered in MD 35440: SPIND_OSCILL_TIME_CW (oscillation time for M3 direction) SPIND_OSCILL_TIME_CW (oscillation time for M3 direction) and MD 35450: SPIND_OSCILL_TIME_CCW (oscillation time for M4 direction).	
Application example(s)	If the new gear stage cannot be engaged in spite of several attempts by the NCK, the system can be switched to oscillation via PLC. Both of the times can then be altered by the PLC user. This assures a reliable change of the gear stage, even with unfavorable gear wheel positions.	
Related to ....	MD 35440: SPIND_OSCILL_TIME_CW (oscillation time for direction M3) MD 35450: SPIND_OSCILL_TIME_CCW (oscillation time for M4 direction) IS "Oscillation speed" (V380x 2002.5) IS "Set direction of rotation counterclockwise" (V380x 2002.7) IS "Set direction of rotation clockwise" (V380x 2002.6)	
Note for the reader:	802D sl Description of Functions: S1	

## 6.7 Axis/spindle-specific signals

V380x 2002.5 Interface signal	Oscillation speed Signal(s) to axis/spindle (PLC -> NCK)
Edge evaluation: no	Signal(s) updated: cyclic Signal(s) valid from SW: 1.1
Signal state 1 or signal transition 0 ---> 1	<p>If the gear stage must be changed (IS "Change gear" (V390x 2000.3) is enabled), the spindle changes to oscillation mode.</p> <p>The spindle decelerates to a standstill with different acceleration levels, according to the point when the IS "Oscillation speed" (V380x 2002.5) was enabled:</p> <ol style="list-style-type: none"> <li>1. The IS "Oscillation speed" is enabled <b>before</b> the IS "Change gear" is enabled by the NCK. The spindle is brought to a standstill with the acceleration during oscillation (MD: SPIND_OSCILL_ACCEL). Once the spindle is stationary, oscillation is immediately initiated.</li> <li>2. The IS "Oscillation speed" is enabled <b>after</b> the IS "Change gear" is enabled by the NCK and when the spindle is stationary. The position controller is disabled. The spindle decelerates with the deceleration rate in speed controlled mode. After the IS "Oscillation speed" is set, the spindle starts to oscillate with the oscillation acceleration (MD: SPIND_OSCILL_ACCEL).</li> </ol> <p>If the IS "Oscillation via PLC" (V380x 2002.4) is <b>not enabled</b>, the IS "Oscillation speed" triggers automatic oscillation on the NCK. The two times for the directions of rotation are entered in MD: in SPIND_OSCILL_TIME_CW (oscillation time for M3 direction) and SPIND_OSCILL_TIME_CCW (oscillation time for M4 direction).</p> <p>If the IS "Oscillation via PLC" is <b>enabled</b>, the IS "Oscillation speed" effects output of a speed only in conjunction with the IS "Direction of rotation setpoint counter-clockwise and clockwise". The oscillation, i.e. the continuous change of the direction of rotation, is performed by the PLC user with the IS "Direction of rotation setpoint counter-clockwise and clockwise" (oscillation via PLC).</p>
Signal state 0 or signal transition 1 ---> 0	The spindle does not oscillate.
Signal irrelevant for ... ..	All spindle modes except oscillation mode
Application example(s)	The oscillation speed is used to facilitate the engagement of a new gear stage.
Related to ....	IS "Oscillation via the PLC" (V380x 2002.4) IS "Set direction of rotation counterclockwise" (V380x 2002.7) IS "Set direction of rotation clockwise" (V380x 2002.6)
Note for the reader:	802D sI Description of Functions: S1

V380x 2002.7 / .6 Interface signal	Setpoint direction of rotation, counter-clockwise/setpoint direction of rotation, clockwise Signal(s) to axis/spindle (PLC -> NCK)
Edge evaluation: yes	Signal(s) updated: cyclic Signal(s) valid from SW: 1.1
Signal state 1 or signal transition 0 ---> 1	<p>When the IS "Oscillation via PLC" is enabled, the two IS "Direction of rotation setpoint counterclockwise" and "Direction of rotation setpoint clockwise" can be used to set the direction of rotation for the oscillation speed. The times for the oscillation movement of the spindle motor are defined by enabling the IS "Direction of rotation setpoint counterclockwise and clockwise" for a corresponding length of time.</p>
Signal irrelevant for ... ..	All spindle modes except oscillation mode
Application example(s)	See IS "Oscillation via PLC"
Special cases, errors, ... ..	<ul style="list-style-type: none"> <li>• If both of the IS are enabled simultaneously, no oscillation speed is output.</li> <li>• If no IS are set, then an oscillation speed is not output.</li> </ul>
Related to ....	IS "Oscillation via the PLC" (V380x 2002.4) IS "Oscillation speed" (V380x 2002.5)
Note for the reader:	802D sI Description of Functions: S1

VB380x 2003	Spindle override																																																																																																		
Interface signal	Signal(s) to spindle (PLC → NCK)																																																																																																		
Edge evaluation: no	Signal(s) updated: cyclic	Signal(s) valid from SW:																																																																																																	
Signal state 1 or signal transition 0 ---> 1	<p>The spindle override is defined via the PLC in gray coding. The override value determines the percentage of the programmed speed setpoint that is issued to the spindle.</p> <table border="1"> <thead> <tr> <th>Switch position</th> <th>Code</th> <th>Spindle override factor</th> </tr> </thead> <tbody> <tr><td>1</td><td>00001</td><td>0.5</td></tr> <tr><td>2</td><td>00011</td><td>0.55</td></tr> <tr><td>3</td><td>00010</td><td>0.60</td></tr> <tr><td>4</td><td>00110</td><td>0.65</td></tr> <tr><td>5</td><td>00111</td><td>0.70</td></tr> <tr><td>6</td><td>00101</td><td>0.75</td></tr> <tr><td>7</td><td>00100</td><td>0.80</td></tr> <tr><td>8</td><td>01100</td><td>0.85</td></tr> <tr><td>9</td><td>01101</td><td>0.90</td></tr> <tr><td>10</td><td>01111</td><td>0.95</td></tr> <tr><td>11</td><td>01110</td><td>1.00</td></tr> <tr><td>12</td><td>01010</td><td>1.05</td></tr> <tr><td>13</td><td>01011</td><td>1.10</td></tr> <tr><td>14</td><td>01001</td><td>1.15</td></tr> <tr><td>15</td><td>01000</td><td>1.20</td></tr> <tr><td>16</td><td>11000</td><td>1.20</td></tr> <tr><td>17</td><td>11001</td><td>1.20</td></tr> <tr><td>18</td><td>11011</td><td>1.20</td></tr> <tr><td>19</td><td>11010</td><td>1.20</td></tr> <tr><td>20</td><td>11110</td><td>1.20</td></tr> <tr><td>21</td><td>11111</td><td>1.20</td></tr> <tr><td>22</td><td>11101</td><td>1.20</td></tr> <tr><td>23</td><td>11100</td><td>1.20</td></tr> <tr><td>24</td><td>10100</td><td>1.20</td></tr> <tr><td>25</td><td>10101</td><td>1.20</td></tr> <tr><td>26</td><td>10111</td><td>1.20</td></tr> <tr><td>27</td><td>10110</td><td>1.20</td></tr> <tr><td>28</td><td>10010</td><td>1.20</td></tr> <tr><td>29</td><td>10011</td><td>1.20</td></tr> <tr><td>30</td><td>10001</td><td>1.20</td></tr> <tr><td>31</td><td>10000</td><td>1.20</td></tr> </tbody> </table> <p>Table 6-4 Gray coding for spindle override</p>			Switch position	Code	Spindle override factor	1	00001	0.5	2	00011	0.55	3	00010	0.60	4	00110	0.65	5	00111	0.70	6	00101	0.75	7	00100	0.80	8	01100	0.85	9	01101	0.90	10	01111	0.95	11	01110	1.00	12	01010	1.05	13	01011	1.10	14	01001	1.15	15	01000	1.20	16	11000	1.20	17	11001	1.20	18	11011	1.20	19	11010	1.20	20	11110	1.20	21	11111	1.20	22	11101	1.20	23	11100	1.20	24	10100	1.20	25	10101	1.20	26	10111	1.20	27	10110	1.20	28	10010	1.20	29	10011	1.20	30	10001	1.20	31	10000	1.20
Switch position	Code	Spindle override factor																																																																																																	
1	00001	0.5																																																																																																	
2	00011	0.55																																																																																																	
3	00010	0.60																																																																																																	
4	00110	0.65																																																																																																	
5	00111	0.70																																																																																																	
6	00101	0.75																																																																																																	
7	00100	0.80																																																																																																	
8	01100	0.85																																																																																																	
9	01101	0.90																																																																																																	
10	01111	0.95																																																																																																	
11	01110	1.00																																																																																																	
12	01010	1.05																																																																																																	
13	01011	1.10																																																																																																	
14	01001	1.15																																																																																																	
15	01000	1.20																																																																																																	
16	11000	1.20																																																																																																	
17	11001	1.20																																																																																																	
18	11011	1.20																																																																																																	
19	11010	1.20																																																																																																	
20	11110	1.20																																																																																																	
21	11111	1.20																																																																																																	
22	11101	1.20																																																																																																	
23	11100	1.20																																																																																																	
24	10100	1.20																																																																																																	
25	10101	1.20																																																																																																	
26	10111	1.20																																																																																																	
27	10110	1.20																																																																																																	
28	10010	1.20																																																																																																	
29	10011	1.20																																																																																																	
30	10001	1.20																																																																																																	
31	10000	1.20																																																																																																	
Related to ....	IS "Override active" (V380x 0001.7) IS "Feedrate override for spindle valid" (V380x 2001.0)																																																																																																		
Note for the reader:	802D sl Description of Functions: V1																																																																																																		

## 6.7.3 Signals from axis/spindle

V390x 0000.0 Interface signal	Spindle/no axis Signal(s) from axis/spindle (NCK → PLC)	
Edge evaluation: yes	Signal(s) updated: cyclic	Signal(s) valid from SW:
Signal state 1 or signal transition 0 → 1	<p>The machine axis is operated as a spindle in the following spindle modes:</p> <ul style="list-style-type: none"> <li>• Control mode</li> <li>• Oscillation mode</li> <li>• Positioning mode</li> <li>• Thread drilling (tapping) without compensating chuck (rigid tapping)</li> </ul> <p>The IS to axis (V380x 1000 to V380x 1003) and from axis (V390x 1000 to V390x 1003) are invalid. The IS to spindle (V380x 2000 to V380x 2003) and from spindle (V380x 2000 to V380x 2003) are valid.</p>	
Signal state 0 or signal transition 1 → 0	<p>The machine axis is operated as an axis The IS to axis (V380x 1000 to V380x 1003) and from axis (V390x 1000 to V390x 1003) are valid. The IS to spindle (V380x 2000 to V380x 2003) and from spindle (V380x 2000 to V380x 2003) are invalid.</p>	
Application examples	If a spindle is sometimes also used as a rotary axis on a machine tool (turning machine with spindle/C axis or milling machine with spindle/rotary axis for rigid tapping), the "Spindle/no axis" signal can be used to determine whether the machine axis is in axis mode or spindle mode.	
Note for the reader:	802D sl Description of Functions: S1	

V390x 0000.2 Data block	Encoder limit frequency exceeded 1 Signal(s) from axis/spindle (NCK → PLC)	
Edge evaluation: no	Signal(s) updated: cyclic	Signal(s) valid from SW:
Signal state 1 or signal transition 0 → 1	<p>The axis velocity defined in MD 36300: ENC_FREQ_LIMIT (encoder limit frequency) has been exceeded. The reference point for the position measuring system concerned has been lost (IS: Referenced/synchronized is in signal state 0). Proper position closed loop control is no longer possible. The spindles continue to run with speed control. The axes are brought to a standstill with rapid stop (with open position control loop) along a speed setpoint ramp.</p>	
Signal state 0 or signal transition 1 → 0	<p>The axis velocity defined in MD 36300: ENC_FREQ_LIMIT is no longer exceeded. For the edge change 1 → 0, the encoder frequency must have dropped below the setting in MD 36302: ENC_FREQ_LIMIT_LOW (% value of MD 36300: ENC_FREQ_LIMIT).</p>	
Note for the reader:	802D sl Description of Functions: A3	

V390x 0000.4 Interface signal	Referenced/synchronizing 1 Signal(s) from axis/spindle (NCK → PLC)	
Edge evaluation:	Signal(s) updated:	Signal(s) valid from SW:
Signal state 1 or signal transition 0 → 1	<p><b>Axes:</b> When, during a reference point approach, the machine axis has reached the reference point (incremental measurement systems) or target point (linear measuring system with distance-coded reference marks), the machine axis is deemed to have been referenced and the "referenced/synchronizing 1" interface signal (depending on which position measurement system is active during referencing) is enabled.</p> <p><b>Spindles:</b> A spindle is synchronized (zero mark crossed or BERO responded) after Power On after one spindle revolution at the latest.</p>	
Signal state 0 or signal transition 1 → 0	The machine axis/spindle with position measurement system 1 is not referenced/synchronizing.	
Related to ....	"Position measuring system 1" interface signal (V380x 0000.5)	
Note for the reader:	802D sl Description of Functions: R1, S1	

V390x 0000.6 Data block	Position reached with exact stop coarse Signal(s) from axis/spindle (NCK → PLC)
Edge evaluation: no	Signal(s) updated: cyclic Signal(s) valid from SW:
Signal state 1 or signal transition 0 → 1	The axis is in the appropriate exact stop and no interpolator is active for the axis and <ul style="list-style-type: none"> <li>- The control system is in the Reset mode (Reset key or end of program).</li> <li>- The axis was last programmed as a positioning spindle.</li> <li>- The path movement was stopped with NC Stop.</li> <li>- The spindle is in position-controlled mode and is stationary.</li> <li>- The axis is switched from speed-controlled to position-controlled mode with IS "Position measuring system".</li> </ul>
Signal state 0 or signal transition 1 → 0	The axis is not in the appropriate exact stop or the interpolator is active for the axis or <ul style="list-style-type: none"> <li>- The path movement was stopped with NC Stop.</li> <li>- The spindle is in the speed-controlled mode.</li> <li>- "Parking mode" is active for the axis.</li> <li>- The axis is switched from the position-controlled to the speed-controlled mode with using the IS "Position measuring system".</li> </ul>
Signal irrelevant for ... ..	
Related to ....	MD 36000: STOP_LIMIT_COARSE (exact stop coarse)
Note for the reader:	802D sl Description of Functions: B1

V390x 0000.7 Data block	Position reached with exact stop fine Signal(s) from axis/spindle (NCK → PLC)
Edge evaluation: no	Signal(s) updated: cyclic Signal(s) valid from SW:
Signal state 1 or signal transition 0 → 1	See IS "Position reached with exact stop coarse"
Signal state 0 or signal transition 1 → 0	See IS "Position reached with exact stop coarse"
Signal irrelevant for ... ..	
Related to ....	MD 36010: STOP_LIMIT_FINE (exact stop fine)
Note for the reader:	802D sl Description of Functions: B1

V390x 0002.3 Interface signal	Measurement active Signal(s) from axis/spindle (NCK → PLC)
Edge evaluation: no	Signal(s) updated: cyclic Signal(s) valid from SW:
Signal state 1 or signal transition 0 → 1	The "Measuring" function is active.  This displays the current measurement status of the axis (measuring block with this axis is running).
Signal state 0 or signal transition 1 → 0	The "Measuring" function is not active.
Note for the reader:	802D sl Description of Functions: M5

V390x 0002.4 Interface signal	Activate travel to fixed end stop Signal(s) from axis/spindle (NCK → PLC)
Edge evaluation: no	Signal(s) updated: cyclic Signal(s) valid from SW: 2.0
Signal state 1 or signal transition 0 → 1	The "Travel to fixed stop function" is active.
Signal state 0 or signal transition 1 → 0	The "Travel to fixed stop function" is not active.
Note for the reader:	802D sl Description of Functions: F1

V390x 0002.5 Interface signal	Fixed stop reached Signal(s) from axis/spindle (NCK → PLC)
Edge evaluation: no	Signal(s) updated: cyclic Signal(s) valid from SW: 2.0
Signal state 1 or signal transition 0 → 1	The fixed stop was reached after selection of the "FXS" function.
Signal state 0 or signal transition 1 → 0	The fixed stop has still not been reached after selection of the "FXS" function.
Note for the reader:	802D sl Description of Functions: F1

## 6.7 Axis/spindle-specific signals

V390x 0004.0 to .2 Interface signal	Handwheel active (1 to 3) Signal(s) from axis/spindle (NCK → PLC)
Edge evaluation: no	Signal(s) updated: cyclic Signal(s) valid from SW: 1.1
Signal state 1 or signal transition 0 → 1	These PLC interface signals provide feedback whether the machine axis is assigned to handwheel 1, 2, 3 or no handwheel. Only one handwheel can be assigned to an axis at any one time. If several "Activate handwheel" interface signals are set, priority "Handwheel 1" before "Handwheel 2" before "Handwheel 3" applies. If the assignment is active, the machine axis can be traversed with the handwheel in JOG mode.
Signal state 0 or signal transition 1 → 0	Neither handwheel 1, 2 nor 3 is assigned to this geometry axis.
Related to ....	IS "Activate handwheel" (V380x 0004.0 to .2) IS "Handwheel selected" from HMI (V1900 0003, ff)
Note for the reader:	802D sl Description of Functions: H1

V390x 0004.7 and .6 Interface signal	Plus and minus traverse keys Signal(s) from axis/spindle (NCK → PLC)
Edge evaluation: no	Signal(s) updated: cyclic Signal(s) valid from SW:
Signal state 1 or signal transition 0 → 1	A traverse movement of the axis is to be executed in one or the other direction. Depending on the mode selected, the command is triggered in different ways: <ul style="list-style-type: none"> <li>- JOG mode: with the plus or minus traverse key</li> <li>- REF submode: with the traverse key that takes the axis to the reference point</li> <li>- AUT/MDA mode: the program block containing a coordinate value for the axis in question is executed.</li> </ul>
Signal state 0 or signal transition 1 → 0	A travel command in the relevant axis direction has not been given or a traverse movement has been completed. <ul style="list-style-type: none"> <li>• JOG mode: <ul style="list-style-type: none"> <li>- Cancellation of traverse key.</li> <li>- While ending traversing with the handwheel.</li> <li>- REF submode: When the reference point is reached</li> </ul> </li> <li>• AUT/MDA mode: <ul style="list-style-type: none"> <li>- The program block has been executed (and the next block does not contain any coordinate values for the axis in question)</li> <li>- Abort with "RESET", etc.</li> <li>- IS "Axis disable" is active</li> </ul> </li> </ul>
Application example(s)	To release clamping of axes with clamping (e.g. on a rotary table). <b>Note:</b> If the clamping is not released until the travel command is given, these axes cannot be operated under continuous path control!
Related to ....	IS "Traverse key plus" and "Traverse key minus" (V380x 0004.7 and .6)
Note for the reader:	802D sl Description of Functions: H1

V390x 0005.0, ..., .6 Interface signal	Active machine function INC1, ..., continuous Signal(s) from axis/spindle (NCK → PLC)
Edge evaluation: no	Signal(s) updated: cyclic Signal(s) valid from SW: 1.1
Signal state 1 or signal transition 0 → 1	The PLC interface receives a signal stating which JOG mode machine function is active for the machine axes.
Signal state 0 or signal transition 1 → 0	The machine function in question is not active.
Related to ....	IS "Machine function INC1, ..., continuous" (V380x 0005.0, ..., .6)
Note for the reader:	802D sl Description of Functions: H1

V390x 2000.0 to .2 Interface signal	Set gear stage A to C Signal(s) from axis/spindle (NCK → PLC)																	
Edge evaluation: yes	Signal(s) updated: cyclic	Signal(s) valid from SW:																
Signal state 1 or signal transition 0 ----> 1	<p>A gear stage can be defined as follows:</p> <ul style="list-style-type: none"> <li>• Permanent definition in the part program (M41 to M45)</li> <li>• Automatic definition by the programmed spindle speed (M40)</li> </ul> <p>M41 to M45:</p> <ul style="list-style-type: none"> <li>• The gear stage can be permanently defined in the part program with M41 to M45. If the M41 to M45 commands select a gear stage which is not the same as the current (actual) gear stage, the IS "Change gear" and the IS "Set gear stage A to C" are enabled.</li> </ul> <p>M40:</p> <ul style="list-style-type: none"> <li>• M40 in the part program causes the gear stage to be selected automatically by the control. The control checks which gear stage is possible for the programmed spindle speed (S function). If a gear stage is identified that is not equal to the current (actual) gear stage, the "Change gear" and "Set gear stage A" to "...C" interface signals are set.</li> </ul> <p>The set gear stage is output in coded format:</p> <table border="0"> <tr><td>1st gear stage</td><td>0 0 0 (C B A)</td></tr> <tr><td>1st gear stage</td><td>0 0 1</td></tr> <tr><td>2nd gear stage</td><td>0 1 0</td></tr> <tr><td>3rd gear stage</td><td>0 1 1</td></tr> <tr><td>4th gear stage</td><td>1 0 0</td></tr> <tr><td>5th gear stage</td><td>1 0 1</td></tr> <tr><td>Invalid value</td><td>1 1 0</td></tr> <tr><td>Invalid value</td><td>1 1 1</td></tr> </table>		1st gear stage	0 0 0 (C B A)	1st gear stage	0 0 1	2nd gear stage	0 1 0	3rd gear stage	0 1 1	4th gear stage	1 0 0	5th gear stage	1 0 1	Invalid value	1 1 0	Invalid value	1 1 1
1st gear stage	0 0 0 (C B A)																	
1st gear stage	0 0 1																	
2nd gear stage	0 1 0																	
3rd gear stage	0 1 1																	
4th gear stage	1 0 0																	
5th gear stage	1 0 1																	
Invalid value	1 1 0																	
Invalid value	1 1 1																	
Signal irrelevant for ... ..	Other spindle modes except oscillation mode																	
Related to ....	IS "Change gear" (V390x 2000.3) IS "Actual gear stage A" to "...C" (V380x 2000.0 to .2) IS "Gear changed" (V380x 2000.3)																	
Note for the reader:	802D sl Description of Functions: S1																	

V390x 2000.3 Interface signal	Change gear stage Signal(s) from axis/spindle (NCK → PLC)	
Edge evaluation: yes	Signal(s) updated: cyclic	Signal(s) valid from SW:
Signal state 1 or signal transition 0 ----> 1	<p>A gear stage can be defined as follows:</p> <ul style="list-style-type: none"> <li>• Permanent definition in the part program (M41 to M45)</li> <li>• Automatic definition by the programmed spindle speed (M40)</li> </ul> <p>M41 to M45:</p> <ul style="list-style-type: none"> <li>• The gear stage can be permanently defined in the part program with M41 to M45. If the M41 to M45 commands select a gear stage which is not the same as the current (actual) gear stage, the IS "Change gear" and the IS "Set gear stage A to C" are enabled.</li> </ul> <p>M40:</p> <ul style="list-style-type: none"> <li>• M40 in the part program causes the gear stage to be selected automatically by the control. The control checks which gear stage is possible for the programmed spindle speed (S function). If a gear stage is identified that is not equal to the current (actual) gear stage, the "Change gear" and "Set gear stage A" to "...C" interface signals are set.</li> <li>• While the signal = 1, the text "Wait for gear stage change" is displayed in the channel operating message".</li> </ul>	
Special cases, errors, ... ..	The IS "Change gear" is only enabled when a new gear stage is selected that is <b>not equal</b> to the current actual gear stage.	
Related to ....	IS "Set gear stage A" to C" (V390x 2000.0 to .2) IS "Actual gear stage A" to "...C" (V380x 2000.0 to .2) IS "Gear changed" (V380x 2000.3)	
Note for the reader:	802D sl Description of Functions: S1	

6.7 Axis/spindle-specific signals

V390x 2001.0 Interface signal	Speed limit exceeded Signal(s) from axis/spindle (NCK → PLC)
Edge evaluation: yes	Signal(s) updated: cyclic   Signal(s) valid from SW:
Signal state 1 or signal transition 0 → 1	If the actual speed exceeds the maximum spindle speed MD 35100: SPIND_VELO_LIMIT by more than the spindle speed tolerance MD 35150: SPIND_DES_VELO_TOL the IS "Speed limit exceeded" is enabled and alarm 22050 "Maximum speed reached" is output. All axes and spindles of the channel are brought to a standstill.
Related to ....	MD 35150: SPIND_DES_VELO_TOL (spindle speed tolerance) MD 35100: SPIND_VELO_LIMIT (maximum spindle speed) Alarm 22050 "Maximum speed reached"
Note for the reader:	802D sl Description of Functions: S1

V390x 2001.1 Interface signal	Setpoint speed limited (programmed speed too high) Signal(s) from axis/spindle (NCK → PLC)
Edge evaluation: yes	Signal(s) updated: cyclic   Signal(s) valid from SW:
Signal state 1 or signal transition 0 → 1	If a spindle speed (rev/min) or a constant cutting speed (m/min or ft/min) is programmed, the value is <b>exceeded</b> one of the following limits: <ul style="list-style-type: none"> <li>• Max. speed of specified gear stage</li> <li>• Maximum spindle speed</li> <li>• Speed limited by the PLC interface signal</li> <li>• Progr. Spindle speed limiting G26</li> <li>• Progr. Spindle speed limiting for G96</li> </ul> The spindle speed is limited to the maximum limit.
Signal state 0 or signal transition 1 → 0	If a spindle speed (1/min) or a constant cutting speed (m/min) or ft/min) is programmed, none of the limit values have been exceeded.
Application example(s)	The IS "Setpoint speed limited" can be used to detect that the programmed speed cannot be achieved. The PLC user can recognize this condition as not permissible and block path feed, or he can block the path feed or the entire channel. IS "Spindle in set range" is processed.
Note for the reader:	802D sl Description of Functions: S1

V390x 2001.2 Interface signal	Setpoint speed increased (programmed speed too low) Signal(s) from axis/spindle (NCK → PLC)
Edge evaluation: yes	Signal(s) updated: cyclic   Signal(s) valid from SW:
Signal state 1 or signal transition 0 → 1	If a spindle speed (rev/min) or a constant cutting speed (m/min or ft/min) is programmed, the value is <b>below</b> one of the following limits: <ul style="list-style-type: none"> <li>• Minimum speed of the specified gear stage</li> <li>• Min. spindle speed</li> <li>• Speed limited by the PLC</li> <li>• Progr. Spindle speed limiting G25</li> <li>• Progr. spindle speed limit for G96</li> </ul> The spindle speed is limited to the minimum limit.
Signal state 0 or signal transition 1 → 0	If a spindle speed (1/min) or a constant cutting speed (m/min or ft/min) is programmed, the value has not fallen below any of the limits.
Application example(s)	The IS "Setpoint speed increased" can be used to detect that the programmed speed cannot be achieved. The PLC user can recognize this condition as not permissible and block path feed, or he can block the path feed or the entire channel. IS "Spindle in set range" is processed.
Note for the reader:	802D sl Description of Functions: S1

V390x 2001.5 Interface signal	Spindle in setpoint range Signal(s) from axis/spindle (NCK → PLC)	
Edge evaluation: yes	Signal(s) updated: cyclic	Signal(s) valid from SW:
Signal state 1 or signal transition 0 ----> 1	The IS "Spindle in setpoint range" reports whether the programmed, and possibly limited spindle speed has been reached. In the spindle "control mode", the speed setpoint (programmed speed + spindle override including limits) is compared with the actual speed. If the actual speed deviates from the set speed by <b>less</b> than the spindle speed tolerance in MD 35150: SPIND_DES_VELO_TOL, the IS "Spindle in setpoint range" is enabled.	
Signal state 0 or signal transition 1 ----> 0	The IS "Spindle in setpoint range" reports whether the spindle is still in the acceleration or braking phase. In the spindle control mode, the speed setpoint (programmed speed * spindle override) is compared with the actual value. If the actual speed deviates from the set speed by <b>more</b> than the spindle speed tolerance in SPIND_DES_VELO_TOL, the IS "Spindle in setpoint range" is reset.	
Signal irrelevant for ... ..	all spindle modes except for speed mode (control mode).	
Application example(s)	The path feed must generally be disabled when the spindle is in the acceleration phase (programmed speed setpoint not yet reached). This can be performed as follows: <ul style="list-style-type: none"> <li>• The IS "Spindle in setpoint range" is evaluated and the IS "Feed disable" (V3200 0006.0) is enabled.</li> <li>• MD 35500: SPIND_ON_SPEED_AT_IPO_START (feed enable with spindle in setpoint range) is enabled and the NCK then internally evaluates whether the spindle is in the setpoint range. The path feed is only enabled if the spindle is within the setpoint range. The positioning axes are never stopped by this function.</li> </ul>	
Related to ....	MD 35500: SPIND_DES_VELO_TOL (spindle speed tolerance)	
Note for the reader:	802D sl Description of Functions: S1	

V390x 2001.7 Interface signal	Actual direction of rotation clockwise Signal(s) from axis/spindle (NCK → PLC)	
Edge evaluation: yes	Signal(s) updated: cyclic	Signal(s) valid from SW:
Signal state 1 or signal transition 0 ----> 1	When the spindle is rotating, "Actual direction of rotation clockwise" = 1 signals that the direction of rotation is CLOCKWISE. The actual direction of rotation is derived from the spindle position measurement encoder.	
Signal state 0 or signal transition 1 ----> 0	When the spindle is rotating, "Actual direction of rotation clockwise" = 0 signals that the direction of rotation is COUNTERCLOCKWISE.	
Signal irrelevant for ... ..	<ul style="list-style-type: none"> <li>• Spindle stationary, IS "Axis/spindle stationary" = 1 (at standstill it is not possible to evaluate a direction of rotation)</li> <li>• Spindles without a position measuring encoder</li> </ul>	
Related to ....	IS "Spindle stationary" (V390x 0001.4)	
Note for the reader:	802D sl Description of Functions: S1	

V390x 2002.0 Interface signal	Constant cutting rate active Signal(s) from axis/spindle (NCK → PLC)	
Edge evaluation: yes	Signal(s) updated: cyclic	Signal(s) valid from SW:
Signal state 1 or signal transition 0 ----> 1	For programming G96 S... the constant cutting rate function is carried out. The S word is now the cutting value.	
Related to ....		
Note for the reader:	802D sl Description of Functions: S1	

## 6.7 Axis/spindle-specific signals

V390x 2002.3 Interface signal	Rigid tapping active (no compensation) Signal(s) from axis/spindle (NCK → PLC)
Edge evaluation: yes	Signal(s) updated: cyclic      Signal(s) valid from SW:
Signal state 1 or signal transition 0 → 1	The spindle is running in the rigid tapping function [no compensating chuck] (thread interpolation G331/G332). The spindle speed is also programmed with S... in rev/min for rigid tapping, however the direction of rotation is stored in the sign for the pitch. There is <b>no</b> reaction or updating of all spindle-specific interface signals such as: IS "Spindle reset" IS "Synchronize spindle" IS "Invert M3/M4" IS "Spindle in setpoint range" IS "Programmable speed too high"
Application example(s)	Certain functions should not be used during rigid tapping (no compensating chuck), such as: <ul style="list-style-type: none"> <li>Reset IS "Controller enable" (V380x 0002.1)</li> <li>IS "Set feed stop" (V380x 0004.3)</li> <li>Reset</li> <li>When activating the EMERGENCY STOP during rigid tapping, it should be remembered that the tool and workpiece are locked together.</li> </ul>
Related to ....	
Note for the reader:	802D sl Description of Functions: S1

V390x 2002.5 Interface signal	Active spindle positioning mode Signal(s) from axis/spindle (NCK → PLC)
Edge evaluation: yes	Signal(s) updated: cyclic      Signal(s) valid from SW:
Signal state 1 or signal transition 0 → 1	When programming SPOS=..... the spindle is in positioning mode.
Related to ....	IS "Active spindle mode control mode" (V390x 2002.7) IS "Active spindle mode oscillation mode" (V390x 2002.6)
Note for the reader:	802D sl Description of Functions: S1

V390x 2002.6 Interface signal	Active spindle mode oscillation mode Signal(s) from axis/spindle (NCK → PLC)
Edge evaluation: yes	Signal(s) updated: cyclic      Signal(s) valid from SW:
Signal state 1 or signal transition 0 → 1	The spindle is in oscillation mode if a new gear stage was defined using the automatic gear stage selection (M40) or M41 to M45 (IS "Change gear" is enabled). The IS "Change gear" is only enabled when a new gear stage is selected that is <b>not equal</b> to the current actual gear stage.
Related to ....	IS "Active spindle mode control mode" (V390x 2002.7) IS "Active spindle mode positioning mode" (V390x 2002.5) IS "Change gear" (V390x 2000.3)
Note for the reader:	802D sl Description of Functions: S1

V390x 2002.7 Interface signal	Active spindle control mode Signal(s) from axis/spindle (NCK → PLC)
Edge evaluation: yes	Signal(s) updated: cyclic      Signal(s) valid from SW:
Signal state 1 or signal transition 0 → 1	The spindle is in control mode with the following functions: Spindle direction of rotation input M3/M4 or spindle stop M5
Related to ....	IS "Active spindle mode oscillation mode" (V390x 2002.6) IS "Active spindle mode positioning mode" (V390x 2002.5)
Note for the reader:	802D sl Description of Functions: S1

V390x5004.2 Interface signal	Reciprocation reversal active Signal(s) from axis/spindle
Edge evaluation: no	Signal(s) updated: cyclically      Signal(s) valid from SW release: 7.2
Signal status 1 or signal transition 0 → 1	The braking phase after reciprocation reversal from external (DB31, ...DBX28.0) is active.
Signal status 0 or signal transition 1 → 0	No braking after reciprocation reversal from external is active.

V390x5004.3 Interface signal	Reciprocation cannot be started. Signal(s) from axis/spindle	
Edge evaluation: no	Signal(s) updated: cyclically	Signal(s) valid from SW release: 2.1
Signal status 1 or signal transition 0 ----> 1	The reciprocating axis cannot be started; faulty programming. This state can also occur if the traversing motion has already been performed.	
Signal status 0 or signal transition 1 ----> 0	The reciprocating motion can be started.	

V390x5004.4 Interface signal	Error during the reciprocating motion Signal(s)	
Edge evaluation:	Signal(s) updated:	Signal(s) valid from SW release: 2.1
Signal status 1 or signal transition 0 ----> 1	The reciprocating motion was canceled.	
Signal status 0 or signal transition 1 ----> 0	The reciprocating motion is performed without errors.	

V390x5004.5 Interface signal	Sparking-out active Signal(s) from axis/spindle	
Edge evaluation: no	Signal(s) updated: cyclically	Signal(s) valid from SW release: 2.1
Signal status 1 or signal transition 0 ----> 1	The axis performs sparking-out strokes.	
Signal status 0 or signal transition 1 ----> 0	The axis is currently not performing any sparking-out strokes.	
Related to ....	DBX100.7	

V390x5004.6 Interface signal	Reciprocating motion active Signal(s) from axis/spindle	
Edge evaluation: no	Signal(s) updated: cyclically	Signal(s) valid from SW release: 2.1
Signal status 1 or signal transition 0 ----> 1	The axis performs a reciprocating motion between 2 reversal points.	
Signal status 0 or signal transition 1 ----> 0	The axis is currently not reciprocating.	
Signal not relevant with .....	DBX100.7 = 0	
Related to ....	DBX100.7	

V390x5004.7 Interface signal	Reciprocation active Signal(s) from axis/spindle	
Edge evaluation: no	Signal(s) updated: cyclically	Signal(s) valid from SW release: 2.1
Signal status 1 or signal transition 0 ----> 1	The axis is currently traversed as a reciprocating axis.	
Signal status 0 or signal transition 1 ----> 0	The axis is a positioning axis.	
Related to ....	DBX100.5, DBX100.6	

V390x5008.0 to .5 Interface signal	Active infeed axes Signal(s) from axis/spindle	
Edge evaluation: no	Signal(s) updated: cyclically	Signal(s) valid from SW release: 2.1
Signal status 1 or signal transition 0 ----> 1	The axis that issues the signal is currently the reciprocating axis and reports its active infeed axes (104.0 axis 1 is infeed axis, 104.1 axis 2 is infeed axis, etc.) in this field.	
Signal status 0 or signal transition 1 ----> 0	The appropriate axis is not an infeed axis.	
Related to ....	DBX100.7	

## 6.8 Tool management functions from NC channel

V5300 0000.0 Interface signal	Tool prewarning limit reached Signal(s) from channel (NCK ----> PLC)		
Edge evaluation: yes	Signal(s) updated: Job controlled by NCK	Signal(s) valid from SW:	
Signal state 1/ value	The prewarning limit for a tool to be monitored was reached. The T number is provided in VD5300 1000.		
Signal state 0	No prewarning limit reached		
Note for the reader:	802D sl Description of Functions: W1		

V5300 0000.1 Interface signal	Tool limit value reached Signal(s) from channel (NCK ----> PLC)		
Edge evaluation: yes	Signal(s) updated: Job controlled by NCK	Signal(s) valid from SW:	
Signal state 1/ value	The limit for a tool to be monitored was reached. The T number is provided in VD5300 1004.		
Signal state 0	Limit value reached		
Note for the reader:	802D sl Description of Functions: W1		

VD5300 1000 Interface signal	T number for tool prewarning limit Signal(s) from channel (NCK ----> PLC)		
Edge evaluation: yes	Signal(s) updated: Job controlled by NCK	Signal(s) valid from SW:	
Signal state 1/ value	The T number for which the tool prewarning limit is set is provided.		
Signal state 0	No tool number reported		
Note for the reader:	802D sl Description of Functions: W1		

VD5300 1004 Interface signal	T number for tool limit value Signal(s) from channel (NCK ----> PLC)		
Edge evaluation: yes	Signal(s) updated: Job controlled by NCK	Signal(s) valid from SW:	
Signal state 1/ value	The T number for which the tool limit value is set is provided.		
Signal state 0	No tool number reported		
Note for the reader:	802D sl Description of Functions: W1		

## PLC User Interface

### 7.1 Address ranges

Operand identifiers	Description	Area
V	Data	V0.0 to V79999999.7 (see below)
T	Timers	T0 to T39
C	Counters	C0 to C31
I	Figure: digital inputs	I0.0 to I17.7
Q	Figure: digital outputs	Q0.0 to Q11.7
M	Flag	M0.0 to M383.7
SM	Special flag	SM0.0 to SM 0.6 (see below)
O	ACCU (logic)	AC0, AC1 (UDword)
O	ACCU (arithmetic)	AC2, AC3 (Dword)

#### Structure of V-range addresses:

Type identifier (DB no.)	Range No. (channel and axis No.)	Subarea	Offset	addressing
10 (10–79)	00 (00–99)	0 (0–9)	000 (000–999)	symbolic (8-digit)

#### Special flag – SM bit definition (read-only):

SM bits	Description
SM0.0	Flag with defined ONE signal
SM0.1	Initial setting: first PLC cycle '1', following cycles '0'
SM0.2	Buffered data lost – only valid in first PLC cycle ('0' data ok, '1' data lost)
SM0.3	Power On: first PLC cycle '1', following cycles '0'
SM 0.4	60 s cycle (alternating '0' for 30 s, then '1' for 30 s)
SM 0.5	1 s cycle (alternating '0' for 0.5 s, then '1' for 0.5 s)
SM 0.6	PLC cycle (alternating one cycle '0', then one cycle '1')

---

**Note**

All empty fields in the user interface are “Reserved for Siemens” and must not be written in or evaluated!

Fields marked with “0” always receive the value “logical 0”.

References to the description of the interface signals refer to the corresponding chapters of the description of functions and are specified by [F “Chapter number”].

---

**Variable access rights:**

[r] labels the range “read only” allowed

[r/w] labels the range “read/ write” allowed

additionally data format specification:

1: BIT

8: BYTE

16: INT/WORD

32: DINT/DWORD/REAL

without data format specification: all named data formats are readable and writable

## 7.2 User data

### 7.2.1 User data 1

1000		Data 1 [r/w]							
Data Block		Bit 7	Bit 6	Bit 5	Bit 4	Bit 3	Bit 2	Bit 1	Bit 0
1000 0000	up to	User data							
1000 0011		User data							

### 7.2.2 User data2

1100		Data 2 [r/w]							
Data Block		Bit 7	Bit 6	Bit 5	Bit 4	Bit 3	Bit 2	Bit 1	Bit 0
1100 0000	up to	User data							
1100 0007		User data							

### 7.2.3 Signals from MCP (connected to the MCPA module)

1000		Data 1 [r/w]							
Data block		Bit 7	Bit 6	Bit 5	Bit 4	Bit 3	Bit 2	Bit 1	Bit 0
1000 1000		Key 8 JOG	Key 7 Var. INC	Key 6 User key 6	Key 5 User key 5	Key 4 User key 4	Key 3 User key 3	Key 2 User key 2	Key 1 User key 1
1000 1001		Key 16 4th axis -	Key 15 Spindle CCW	Key 14 Spindle STOP	Key 13 Spindle CW	Key 12 mode	Key 11 Single block	Key 10 mode	Key 9 LOG REF
1000 1002		Key 24 4th axis +	Key 23 1st axis -	Key 22 2nd axis -	Key 21 3rd axis +	Key 20 Rapid tra- verse over- ride	Key 19 3rd axis -	Key 18 2nd axis +	Key 18 1st axis +
1000 1003							Key 27 START	Key 26 STOP	Key 25 RESET
1000 1004					E	D	C	B	A
1000 1005					E	D	C	B	A

**7.2.4 Signals to MCP (connected to the MCPA module)**

<b>1000</b>		<b>Data 1 [r/w]</b>						
Data block								
Byte	Bit 7	Bit 6	Bit 5	Bit 4	Bit 3	Bit 2	Bit 1	Bit 0
1100 1000			LED 6	LED 5	LED 4	LED 3	LED 2	LED 1

**7.2.5 Reading/writing NC data: Job [F20.6]**

<b>1200</b>		<b>NC data I/s [r/w]</b>						
Data Block		PLC interface -----> NCK						
Byte	Bit 7	Bit 6	Bit 5	Bit 4	Bit 3	Bit 2	Bit 1	Bit 0
1200 0000							Write variable	Start
1200 0001	Number of variables							

<b>1200 ... 1207</b>		<b>NC data I/s [r/w]</b>						
Data Block		PLC interface -----> NCK						
Byte	Bit 7	Bit 6	Bit 5	Bit 4	Bit 3	Bit 2	Bit 1	Bit 0
120x1000	Variable index							
120x1001	Area number							
120x1002	Line index for the NCK variable x (WORD)							
120x1004	Column index for the NCK variable x (WORD)							
120x1006								
120x1008	Writing: Data to NCK variable x (data type of the variables: 1...4 bytes)							

**7.2.6 Read/write NC data: Result [F20.6]**

<b>1200</b>		<b>NC data I/s [r/w]</b>						
Data Block		NCK interface -----> PLC						
Byte	Bit 7	Bit 6	Bit 5	Bit 4	Bit 3	Bit 2	Bit 1	Bit 0
1200 2000							Error in job	Request completed
1200 2001								
1200 2002								

1200 ... 1207		NC data l/s [r/w]						
Data Block		NCK interface -----> PLC						
Byte	Bit 7	Bit 6	Bit 5	Bit 4	Bit 3	Bit 2	Bit 1	Bit 0
120x3000								Invalid variable
120x3001	Access result							
120x3002								
120x3004	Reading: Data from NCK variable x (data type of the variables: 1...4 bytes)							

Access result:

- 0 No error
- 3 Illegal access to object
- 5 Invalid address
- 10 Object does not exist

### 7.3 Retentive data area

1400		Retentive data [r/w]						
Data Block								
Byte	Bit 7	Bit 6	Bit 5	Bit 4	Bit 3	Bit 2	Bit 1	Bit 0
1400 0000	User data							
up to								
1400 0127	User data							

## 7.4 User alarm

**Note:** Information on PLC alarms, including configuring user alarms, can be found in:

**References:** “Operating Instructions”, Chapter “PLC alarms”

### 7.4.1 User alarm: Activation

1600		Activating alarm [r/w]						
Data Block		PLC interface -----> HMI						
Byte	Bit 7	Bit 6	Bit 5	Bit 4	Bit 3	Bit 2	Bit 1	Bit 0
1600 0000	700007	700006	700005	700004	700003	700002	700001	700000
1600 0001	700015	700014	700013	700012	700011	700010	700009	700008
1600 0002	700023	700022	700021	700020	700019	700018	700017	700016
1600 0003	700031	700030	700029	700028	700027	700026	700025	700024
1600 0004	700039	700038	700037	700036	700035	700034	700033	700032
1600 0005	700047	700046	700045	700044	700043	700042	700041	700040
1600 0006	700055	700054	700053	700052	700051	700050	700049	700048
1600 0007	700063	700062	700061	700060	700059	700058	700057	700056

### 7.4.2 Variable for alarm

1600		Variable for alarm [r32/w32]						
Data Block		PLC interface -----> HMI						
Start byte								
1600 1000	Variable for alarm 700000 (4 bytes)							
1600 1004	Variable for alarm 700001 (4 bytes)							
1600 1008	Variable for alarm 700002 (4 bytes)							
...	...							
1600 1244	Variable for alarm 700061 (4 bytes)							
1600 1248	Variable for alarm 700062 (4 bytes)							
1600 1252	Variable for alarm 700063 (4 bytes)							

### 7.4.3 Active alarm reaction

1600		Active alarm reaction [r]						
Data Block		PLC interface -----> HMI						
Byte	Bit 7	Bit 6	Bit 5	Bit 4	Bit 3	Bit 2	Bit 1	Bit 0
1600 2000				PLC STOP	EMERGENCY STOP	Feed disable on all axes	Read-in disable	NC start disable
1600 2001								
1600 2002								
1600 2003								

## 7.5 Signals from/to HMI

### 7.5.1 Program control signals from HMI (retentive area)

1700		HMI signals [r]						
Data Block		HMI interface -----> PLC						
Byte	Bit 7	Bit 6	Bit 5	Bit 4	Bit 3	Bit 2	Bit 1	Bit 0
1700 0000		Test run feedrate selected [F-K1]	M01 selected [F-K1]					
1700 0001	Program test selected [F-K1]				Feedrate override for rapid traverse selected [[F-K1] [F-V1]			
1700 0002	Skip block 7 selected	Skip block 6 selected	Skip block 5 selected	Skip block 4 selected	Skip block 3 selected	Skip block 2 selected	Skip block 1 selected	Skip block 0 selected [F-K1]
1700 0003	Measuring in JOG active [F-M5]						Skip block 9 selected	Skip block 8 selected

### 7.5.2 Program selection from PLC (retentive area)

1700		HMI signals [r/w]						
Data Block		PLC interface -----> HMI						
Byte	Bit 7	Bit 6	Bit 5	Bit 4	Bit 3	Bit 2	Bit 1	Bit 0
1700 1000	Program selection from PLC: Program number [F-A2]							
1700 1001	Command job from PLC: Command [F-A2]							
1700 1002 to 1700 1003								

### 7.5.3 Checkback signal "Program selection from HMI (retentive area)

1700		HMI signals [r]						
Data Block		HMI interface -----> PLC						
Byte	Bit 7	Bit 6	Bit 5	Bit 4	Bit 3	Bit 2	Bit 1	Bit 0
1700 2000							Error Program selection [F-A2]	Program selected [F-A2]
1700 2001							Error Command execution [F-A2]	Execute command [F-A2]
1700 2002 to 1700 2003								

### 7.5.4 Signals from HMI

1800		HMI signals [r]						
Data Block		HMI interface -----> PLC						
Byte	Bit 7	Bit 6	Bit 5	Bit 4	Bit 3	Bit 2	Bit 1	Bit 0
1800 0000		Start measuring in JOG [F-M5]		Mode group changeover disable [F-M5]		JOG mode [[F-M5]	MDA mode [F-M5]	AUTO mode [F-M5]
1800 0001						Machine function REF [F-M5]		

### 7.5.5 Signals from PLC

1800		Signals from PLC [r]						
Data Block		PLC interface						
Byte	Bit 7	Bit 6	Bit 5	Bit 4	Bit 3	Bit 2	Bit 1	Bit 0
1800 1000	MCPA exists						Power-up with saved data [F-A2]	Power-up with default values [F-A2]
1800 1001								
1800 1002								
1800 1003								

### 7.5.6 Signals from operator panel (retentive area)

1900		HMI signals [r/w]						
Data Block		HMI interface -----> PLC						
Byte	Bit 7	Bit 6	Bit 5	Bit 4	Bit 3	Bit 2	Bit 1	Bit 0
1900 0000		Simulation active [F-K1]						
1900 0001								
1900 0002								
1900 0003								

### 7.5.7 General selection/status signals from HMI (retentive area)

1900		HMI signals [r]						
Data Block		HMI interface -----> PLC						
Byte	Bit 7	Bit 6	Bit 5	Bit 4	Bit 3	Bit 2	Bit 1	Bit 0
1900 1000								
1900 1001								
1900 1002								
1900 1003	Machine axis [F-H1]				Axis number for handwheel 1			
					C [F-H1]	B [F-H1]	A [F-H1]	
1900 1004	Machine axis [F-H1]				Axis number for handwheel 2			
					C [F-H1]	B [F-H1]	A [F-H1]	
1900 1005								
1900 1006								
1900 1007								

**7.5.8 General selection/status signals to HMI (retentive area)**

1900		Signals to operator panel [r/w]						
Data Block		PLC interface -----> HMI						
Byte	Bit 7	Bit 6	Bit 5	Bit 4	Bit 3	Bit 2	Bit 1	Bit 0
1900 5000						OP key disable [F-A2]		
1900 5001								Update tool list [F-W1]
1900 5002								Enable tool measuring in JOG [F-M5]
1900 5003								
1900 5004	T number for tool measuring in JOG (DINT) [F-M5]							
...								
1900 5007								

## 7.6 Auxiliary function transfer from NC channel

2500		Auxiliary functions from NCK channel[r]						
Data Block		NCK interface -----> PLC						
Byte	Bit 7	Bit 6	Bit 5	Bit 4	Bit 3	Bit 2	Bit 1	Bit 0
2500 0000 up to 2500 0003								
2500 0004				M fcts. 5 Change [F-H2]	M fcts. 4 Change [F-H2]	M fcts. 3 Change [F-H2]	M fcts. 2 Change [F-H2]	M fcts. 1 Change [F-H2]
2500 0005								
2500 0006								S fcts. 1 change [F-H2]
2500 0007								
2500 0008								T function 1 change [F-H2]
2500 0009								
2500 0010								D function 1 change [F-H2]
2500 0011								
2500 0012						H fcts. 3 change [F-H2]	H fcts. 2 change [F-H2]	H fcts. 1 change [F-H2]
2500 0013 up to 2500 0019								

7.6 Auxiliary function transfer from NC channel

7.6.1 Decoded M signals: (M0–M99)

2500		M functions from NCK channel[r]						
Data Block		NCK interface -----> PLC						
Byte	Bit 7	Bit 6	Bit 5	Bit 4	Bit 3	Bit 2	Bit 1	Bit 0
2500 1000	M7	M6	M5	M4	M3	M2	M1	M0
2500 1001	M15	M14	M13	M12	M11	M10	M9	M8
2500 1002	M23	M22	M21	M20	M19	M18	M17	M16
				...				
2500 1012					M99	M98	M97	M96
2500 1013 up to 2500 1015								

Remarks: The signals are output for the duration of a PLC cycle.

7.6.2 Transferred T functions

2500		T functions from NCK channel[r]						
Data Block		NCK interface -----> PLC						
Start byte	Bit 7	Bit 6	Bit 5	Bit 4	Bit 3	Bit 2	Bit 1	Bit 0
2500 2000	T function 1 (DINT) [F–H2]							
2500 2004 to 2500 2007								

### 7.6.3 Transferred M functions

2500		M functions from NCK channel[r]						
Data Block		NCK interface -----> PLC						
Start byte	Bit 7	Bit 6	Bit 5	Bit 4	Bit 3	Bit 2	Bit 1	Bit 0
2500 3000	M function 1 (DINT) [F-H2]							
2500 3004	Extended address of M function 1 (byte)							
2500 3008	M function 2 (DINT) [F-H2]							
2500 3012	Extended address of M function 2 (byte)							
2500 3016	M function 3 (DINT) [F-H2]							
2500 3020	Extended address of M function 3 (byte)							
2500 3024	M function 4 (DINT) [F-H2]							
2500 3028	Extended address of M function 4 (byte)							
2500 3032	M function 5 (DINT) [F-H2]							
2500 3036	Extended address of M function 5 (byte)							

### 7.6.4 Transferred S functions

2500		S functions from NCK channel[r]						
Data Block		NCK interface -----> PLC						
Start byte	Bit 7	Bit 6	Bit 5	Bit 4	Bit 3	Bit 2	Bit 1	Bit 0
2500 4000	S function 1 (REAL) [F-H2]							
2500 4004	Extended address of S function 1 (byte)							
2500 4008	S function 2 (REAL) [F-H2]							
2500 4012	Extended address of S function 2 (byte)							

### 7.6.5 Transferred D functions

2500		D functions from NCK channel[r]						
Data Block		NCK interface -----> PLC						
Start byte	Bit 7	Bit 6	Bit 5	Bit 4	Bit 3	Bit 2	Bit 1	Bit 0
2500 5000	D function 1 (DINT) [F-H2]							
2500 5004								

### 7.6.6 Transferred H functions

2500		H functions from NCK channel[r]						
Data Block		NCK interface -----> PLC						
Start byte	Bit 7	Bit 6	Bit 5	Bit 4	Bit 3	Bit 2	Bit 1	Bit 0
2500 6000	H function 1 (REAL) [F-H2]							
2500 6004	Extended address for H function 1 (INT) [F-H2]							
2500 6008	H function 2 (REAL)							
2500 6012	Extended address for H function 2 (INT) [F-H2]							
2500 6016	H function 3 (REAL) [F-H2]							
2500 6020	Extended address for H function 3 (INT) [F-H2]							

## 7.7 NCK signals

### 7.7.1 General signals to NCK

2600		General signals to NCK [r/w]						
Data Block		PLC interface -----> NCK						
Byte	Bit 7	Bit 6	Bit 5	Bit 4	Bit 3	Bit 2	Bit 1	Bit 0
2600 0000	Protection level [F-A2]					Acknowledge EMERGENCY STOP [F-N2]	EMERGENCY STOP [F-N2]	Braking at contour in case of EMERGENCY STOP
	4	5	6	7				
2600 0001						Request axis distances- to-go	Request axis actual va- lues	INC inputs in mode group range ac- tive 1) [F-H1]
2600 0002								
2600 0003								

Remarks: 1) see operating mode signals

### 7.7.2 General signals from NCK

2700		General signals from NCK [r]						
Data Block		NCK interface -----> PLC						
Byte	Bit 7	Bit 6	Bit 5	Bit 4	Bit 3	Bit 2	Bit 1	Bit 0
2700 0000							EMERGENCY STOP active [F-N2]	
2700 0001	INCH dimension system [F-G2]						Probe 2 actuated [F-M5]	Probe 1 actuated [F-M5]
2700 0002		Drive ready [F-A2]	Drives in cyclical operation [F-A2]					
2700 0003		Air temperature alarm [F-A2]						NCK alarm is active [F-A2]
2700 0004	Software cam MI- NUS 7	Software cam MI- NUS 6	Software cam MI- NUS 5	Software cam MI- NUS 4	Software cam MI- NUS 3	Software cam MI- NUS 2	Software cam MI- NUS 1	Software cam MI- NUS 0
2700 0005								

7.7 NCK signals

2700 0006								
2700 0007								
2700 0008	Software cam PLUS 7	Software cam PLUS 6	Software cam PLUS 5	Software cam PLUS 4	Software cam PLUS 3	Software cam PLUS 2	Software cam PLUS 1	Software cam PLUS 0
2700 0009								
2700 0010								
2700 0011								
2700 0012	Modification counter for motions of handwheel 1							
2700 0013	Modification counter for motions of handwheel 2							
2700 0014								
2700 0015	Modification counter, inch/metric unit system							

7.7.3 Signals to fast inputs and outputs

<b>2800</b>	<b>Signals to fast inputs and outputs [r/w]</b>							
Data block	Interface PLC -----> NCK							
Byte	Bit 7	Bit 6	Bit 5	Bit 4	Bit 3	Bit 2	Bit 1	Bit 0
2800 0000	Disable digital NCK inputs							
	Input 8	Input 7	Input 6	Input 5	Input 4	Input 3	Input 2	Input 1
2800 0001	Values from the PLC for the NCK inputs							
	Input 8	Input 7	Input 6	Input 5	Input 4	Input 3	Input 2	Input 1
2800 0004	Disable digital NCK outputs							
	Output 8	Output 7	Output 6	Output 5	Output 4	Output 3	Output 2	Output 1
2800 0005	Overwrite screenform for digital NCK outputs							
	Output 8	Output 7	Output 6	Output 5	Output 4	Output 3	Output 2	Output 1
2800 0006	Value from the PLC for the digital NCK outputs							
	Output 8	Output 7	Output 6	Output 5	Output 4	Output 3	Output 2	Output 1
2800 0007	Setpoint screenform for the NCK outputs							
	Output 8	Output 7	Output 6	Output 5	Output 4	Output 3	Output 2	Output 1

<b>2800</b>		<b>Signals to fast inputs and outputs [r/w]</b>						
Data block		Interface PLC -----> NCK						
Byte	Bit 7	Bit 6	Bit 5	Bit 4	Bit 3	Bit 2	Bit 1	Bit 0
2800 1000	Disable external digital NCK inputs							
	Input 16	Input 15	Input 14	Input 13	Input 12	Input 11	Input 10	Input 9
2800 1001	Values from the PLC for the external NCK inputs							
	Input 16	Input 15	Input 14	Input 13	Input 12	Input 11	Input 10	Input 9
2800 1008	Disable external digital NCK outputs							
	Output 16	Output 15	Output 14	Output 13	Output 12	Output 11	Output 10	Output 9
2800 1009	Overwrite screenform for the external digital NCK outputs							
	Output 16	Output 15	Output 14	Output 13	Output 12	Output 11	Output 10	Output 9
2800 1010	Value from the PLC for the external digital NCK outputs							
	Output 16	Output 15	Output 14	Output 13	Output 12	Output 11	Output 10	Output 9
2800 1011	Setpoint screenform for the external digital NCK outputs							
	Output 16	Output 15	Output 14	Output 13	Output 12	Output 11	Output 10	Output 9

### 7.7.4 Signal from fast inputs and outputs

<b>2900</b>		<b>Signals from fast inputs and outputs [r/w]</b>						
Data block		Interface PLC -----> NCK						
Byte	Bit 7	Bit 6	Bit 5	Bit 4	Bit 3	Bit 2	Bit 1	Bit 0
2900 0000	Actual values of the digital NCK inputs							
	Input 8	Input 7	Input 6	Input 5	Input 4	Input 3	Input 2	Input 1
2900 0004	Setpoints of the digital NCK outputs							
	Output 8	Output 7	Output 6	Output 5	Output 4	Output 3	Output 2	Output 1

<b>2900</b>		<b>Signals to fast inputs and outputs [r/w]</b>						
Data block		Interface PLC -----> NCK						
Byte	Bit 7	Bit 6	Bit 5	Bit 4	Bit 3	Bit 2	Bit 1	Bit 0
2900 1000	Actual values of the external digital NCK inputs							
	Input 16	Input 15	Input 14	Input 13	Input 12	Input 11	Input 10	Input 9
2900 1004	NCK setpoint for the external digital NCK outputs							
	Output 16	Output 15	Output 14	Output 13	Output 12	Output 11	Output 10	Output 9

### 7.7.5 Operating mode signals

3000		Operating mode signals to NCK [r/w]						
Data Block		PLC interface -----> NCK						
Byte	Bit 7	Bit 6	Bit 5	Bit 4	Bit 3	Bit 2	Bit 1	Bit 0
3000 0000	Reset [F-K1]			Mode group changeover disable [F-K1]		Operating mode		
						JOG [F-K1]	MDI [F-K1]	AUTOM. [F-K1]
3000 0001						Machine function		
						REF [F-K1]		Teach In
3000 0002	Machine function <sup>1)</sup> [F-H1]							
		Continuous traversal	INCvar	INC10 000	INC1000	INC100	INC10	INC1
3000 0003								

Remarks:

- <sup>1)</sup> Machine function                    in order to use machine function signals in VB3000 0002, signal "INC inputs in mode group range active" (V2600 0001.0) must be set to "1"  
Machine function INC10 000 is not supported by all machine control panels.

3100		Operating mode signals from NCK [r]						
Data Block		NCK interface -----> PLC						
Byte	Bit 7	Bit 6	Bit 5	Bit 4	Bit 3	Bit 2	Bit 1	Bit 0
3100 0000					802- READY [F-K1]	Active mode		
						JOG [F-K1]	MDI [F-K1]	AUTOM. [F-K1]
3100 0001						Active machine function		
						REF [F-K1]		Teach In
3100 0002		Continuous traversing active	var. INC active	10000 INC active	1000 INC active	100 INC active	10 INC active	1 INC active
3100 0003								

## 7.8 Channel signals

### 7.8.1 Signals to NC channel

#### Control signals to NC channel

3200		Signals to NCK channel [r/w]						
Data Block		PLC interface -----> NCK						
Byte	Bit 7	Bit 6	Bit 5	Bit 4	Bit 3	Bit 2	Bit 1	Bit 0
3200 0000		Activate dry run feed [F-V1]	M01 Activate [F-K1]	Single block <sup>4)</sup> Activate [F-K1]	DRF Activate	Forward travel Activate	Reverse travel Activate	
3200 0001	Activate program test [F-K1]						Enable protection zones	Activate referencing [F-R1]
3200 0002	Activate "Skip block 7"	Activate "Skip block 6"	Activate "Skip block 5"	Activate "Skip block 4"	Activate "Skip block 3"	Activate "Skip block 2"	Activate "Skip block 1"	Activate "Skip block 0" [F-K1]
3200 0003	Nibbling and punching							
			Stroke initiated manually 2	Delayed stroke	Stroke does not run	Stroke suppressed	Stroke initiated manually	Stroke disable
3200 0004	Feedrate override <sup>2)</sup> [F-V1]							
	H	G	F	E	D	C	B	O
3200 0005	Rapid traverse override <sup>3)</sup> [F-V1]							
	H	G	F	E	D	C	B	O
3200 0006	Feedrate override <sup>1)</sup> active [F-V1]	Rapid traverse override active [F-V1]	Limited path velocity	Program level abort [F-K1]	Delete number of subroutine cycles	Delete distance-to-go [F-A2]	Read-in disable [F-K1]	Feedrate disable [F-V1]
3200 0007			Suppress Start Lock	NC stop axes plus spindle [F-K1]	NC stop [F-K1]	NC Stop at block limit [F-K1]	NC Start [F-K1]	NC Start disable [F-K1]
3200 0008	Activate machine-related protection zone							
	Area 8	Area 7	Area 6	Area 5	Area 4	Area 3	Area 2	Area 1
3200 0009	Activate machine-related protection zone							
							Area 10	Area 9
3200 0010	Activate channel-specific protection zone							
	Area 8	Area 7	Area 6	Area 5	Area 4	Area 3	Area 2	Area 1
3200 0011	Activate channel-specific protection zone							
							Area 10	Area 9
3200 0012								

7.8 Channel signals

3200 0013	Do not disable tool [F-W1]		Deactivate workpiece counter [F-W1]					
3200 0014			Activate associated M01	Neg. direction for sim. contour handwheel	Sim. contour handwheel ON	Activate contour handwheel (bit-/binary-coded) Handwheel 2   Handwheel 1		
3200 0015	Activate "Skip block 9"	Activate "Skip block 8"						

Remarks:

- 1)+ Feedrate override active Even if the feedrate override is not active, (=100%) the 0% position still functions.
- 2)+ Feedrate override 31 positions (Gray code)
- 3)+ Rapid override 31 positions (Gray code)
- 4)+ Single block Select single block type selection (SBL coarse/SBL fine) via softkey (see "User's Guide")

## Control signals to geometry axes (axes in WCS)

3200		Signals to NCK channel [r/w]						
Data Block		PLC interface -----> NCK						
Byte	Bit 7	Bit 6	Bit 5	Bit 4	Bit 3	Bit 2	Bit 1	Bit 0
3200 1000	<b>Geometry axis 1 (axis 1 in WCS)</b>							
	Traversing keys + [F-H1]		- [F-H1]	Rapid traverse override [F-H1]	Traversing key lock [F-H1]	Feedrate stop [F-H1]	Activate handwheel 2 [F-H1]	
3200 1001	<b>Geometry axis 1 (axis 1 in WCS)</b>							
	Machine function <sup>1)</sup> [F-H1]							
3200 1002		Continuous traversal	INCvar	INC10 000	INC1000	INC100	INC10	INC1 [
3200 1003								
3200 1004	<b>Geometry axis 2 (axis 2 in WCS)</b>							
	Traversing keys + [F-H1]		- [F-H1]	Rapid traverse override [F-H1]	Traversing key lock [F-H1]	Feedrate stop [F-H1]	Activate handwheel 2 [F-H1]	
3200 1005	<b>Geometry axis 2 (axis 2 in WCS)</b>							
	Machine function <sup>1)</sup> [F-H1]							
3200 1006		Continuous traversal	INCvar	INC10 000	INC1000	INC100	INC10	INC1
3200 1007								
3200 1008	<b>Geometry axis 3 (axis 3 in WCS)</b>							
	Traversing keys + [F-H1]		- [F-H1]	Rapid traverse override [F-H1]	Traversing key lock [F-H1]	Feedrate stop [F-H1]	Activate handwheel 2 [F-H1]	
3200 1009	<b>Geometry axis 3 (axis 3 in WCS)</b>							
	Machine function <sup>1)</sup> [F-H1]							
3200 1010		Continuous traversal	INCvar	INC10 000	INC1000	INC100	INC10	INC1
3200 1011								

## Remarks:

1) Machine function specification of machine function in VB3200 1001, VB3200 1005, VB3200 1009, only if signal "INC inputs in mode group range active" (V2600 0001.0) is not set.

Machine function INC10 000 is not supported by all machine control panels.

### 7.8.2 Signals from NC channel

#### Status signals from NC channel

3300		Signals from NCK channel [r]							
Data Block		NCK interface -----> PLC							
Byte	Bit 7	Bit 6	Bit 5	Bit 4	Bit 3	Bit 2	Bit 1	Bit 0	
3300 0000		Last action block active [F-K1]	M0/M1 active [F-K1]	Approach block active [F-K1]	Action block active [F-K1]	Forward travel active	Reverse travel active	Program execution from ext. active	
3300 0001	Program test active [F-K1]	Transform. active [F-M1]	M2 / M30 active [F-K1]	Block search active [F-K1]	Handwheel override active	Rev. feedrate active [F-V1]		Referencing active [F-R1]	
3300 0002									
3300 0003	Channel status			Program status					
	Reset [F-K1]	interrupted [F-K1]	active [F-K1]	Aborted [F-K1]	interrupted [F-K1]	Stopped [F-K1]		Running [F-K1]	
3300 0004	NCK alarm with processing stop present [F-A2]	Channel-specific NCK alarm is active [F-A2]			all axes stationary [F-B1]	all axes referenced [F-R1]	Stop request	Start request	
3300 0005						Contour handwheel active (bit-/binary-coded)			
						Handwheel 2	Handwheel 1		
3300 0006	Nibbling and punching							Acknowl. of manual stroke initiation	Stroke initiation
3300 0007								Protection zones no longer guaranteed	
3300 0008	Machine-related protection zones preactivated								
		Area 7	Area 6	Area 5	Area 4	Area 3	Area 2	Area 1	
3300 0009	Machine-related protection zones preactivated							Area 10	Area 9
3300 0010	Channel-specific protection zones preactivated								
		Area 7	Area 6	Area 5	Area 4	Area 3	Area 2	Area 1	
3300 0011	Channel-specific protection zones preactivated							Area 10	Area 9
3300 0012	Machine-related protection zones violated								
		Area 7	Area 6	Area 5	Area 4	Area 3	Area 2	Area 1	
3300 0013	Machine-related protection zones violated							Area 10	Area 9
3300 0014	Channel-specific protection zones violated								
		Area 7	Area 6	Area 5	Area 4	Area 3	Area 2	Area 1	
3300 0015	Channel-specific protection zones violated							Area 10	Area 9

## Status signals to geometry axes (axes in WCS)

3300		Signals from NCK channel [r]						
Data Block		NCK interface -----> PLC						
Byte	Bit 7	Bit 6	Bit 5	Bit 4	Bit 3	Bit 2	Bit 1	Bit 0
<b>Geometry axis 1 (axis 1 in WCS)</b>								
3300 1000	Motion command plus [F-H1]    minus [F-H1]		Travel request plus    minus				Handwheel active 2 [F-H1]    1 [F-H1]	
3300 1001	Active machine function [F-H1]							
		Continuous traversal	INCvar	INC10 000	INC1000	INC100	INC10	INC1
3300 1002								
3300 1003								
<b>Geometry axis 2 (axis 2 in WCS)</b>								
3300 1004	Motion command plus [F-H1]    minus [F-H1]		Travel request plus    minus				Handwheel active 2 [F-H1]    1 [F-H1]	
3300 1005	Active machine function [F-H1]							
		Continuous traversal	INCvar	INC10 000	INC1000	INC100	INC10	INC1
3300 1006								
3300 1007								
<b>Geometry axis 3 (axis 3 in WCS)</b>								
3300 1008	Motion command plus [F-H1]    minus [F-H1]		Travel request plus    minus				Handwheel active 2 [F-H1]    1 [F-H1]	
3300 1009	Active machine function [F-H1]							
		Continuous traversal	INCvar	INC10 000	INC1000	INC100	INC10	INC1
3300 1010								
3300 1011								

## Further status signals from the NC channel

3300		Signals from NCK channel [r]						
Data Block		NCK interface -----> PLC						
Byte	Bit 7	Bit 6	Bit 5	Bit 4	Bit 3	Bit 2	Bit 1	Bit 0
3300 4000								G00 active
3300 4001				Travel request for drive test present			Workpiece setpoint reached [F-K1]	External language mode active [F-A2]
3300 4002								
3300 4003		DELAY FST SUP-PRESS		DELAY FST				

**G functions from NC channel**

<b>3500</b>		<b>Signals from NCK channel [r]</b>						
Data Block		NCK interface -----> PLC						
Byte	Bit 7	Bit 6	Bit 5	Bit 4	Bit 3	Bit 2	Bit 1	Bit 0
3500 0000	Active G function of group 1							
3500 0001	Active G function of group 2							
3500 00..	Active G function of group ...							
3500 0063	Active G function of group 64							

**Note:**

With SINUMERIK 802D, G group 2 is transferred in VB3500 0001 with values

0: – no group 2 G command is active,

1: G4,      2: G63,      3: G74,      4: G75,      11: G147,      12: G247,      13: G347,  
 14: G148,      15: G248,      16: G348      (other values: not available in SINUMERIK 802D)

Other settings are possible with MD 22510: see Section 21.3

When the NC program terminates or is aborted, the last status of the groups is retained. The meaning of the G commands is explained in

**References:** “Operation and Programming”, Section “Overview of instructions”

**Note:** It cannot be guaranteed that a PLC user program will have a block-synchronous connection between the active NC block and the applied G codes at any given time. The connection does not exist, for instance, if temporally short blocks are used with continuous path mode (G64).

## 7.9 Axis/spindle signals

### 7.9.1 Transferred M/S functions, axis-specific

<b>3700 ... 3704</b>		<b>M/S functions [r]</b>						
Data block		PLC interface -----> NCK						
Start byte	Bit 7	Bit 6	Bit 5	Bit 4	Bit 3	Bit 2	Bit 1	Bit 0
370x 0000	M function for spindle (DINT) [F-S1]							
370x 0004	S function for spindle (REAL) [F-S1]							

### 7.9.2 Signals to axis/spindle

#### Common signals to axis/spindle

<b>3800 ... 3804</b>		<b>Signals to axis/spindle [r/w]</b>						
Data block		PLC interface -----> NCK						
Byte	Bit 7	Bit 6	Bit 5	Bit 4	Bit 3	Bit 2	Bit 1	Bit 0
380x 0000	Feedrate override [F-V1]							
	H	G	F	E	D	C	B	A
380x 0001	Override active [F-V1]		Position measuring system 1 [F-A2]	Follow-up mode [F-A2]	Axis/spindle disable [F-A2]	Sensor for fixed stop [F-F1]	Acknowledge fixed stop reached [F-F1]	
380x 0002					Clamping in progress [F-A3]	Distance-to-go/spindle reset [F-S1]	Controller enable [F-A2]	Cam activation
380x 0003	Axis/spindle enable program test	Velocity/spindle speed limiting [F-A3]					Enable approach to fixed stop [F-F1]	
380x 0004	Traversing keys		Rapid traverse override [F-H1]	Traversing key lock [F-H1]	Feedrate stop Spindle stop [F-V1]	Activate handwheel		
	plus [F-H1]	minus [F-H1]				2 [F-H1]	1 [F-H1]	
380x 0005	Machine function <sup>1)</sup> [F-H1]							
		Continuous traversal	INCvar	INC10 000	INC1000	INC100	INC10	INC1
380x 0006 up to 380x 0011								

Remarks: 1) Machine function Specification of machine function in VB380x 0005, only if signal "INC inputs in mode group range active" (V2600 0001.0) is not set. Machine function INC10 000 is not supported by all machine control panels.

**Signals to axis**

3800 ... 3804		Signals to axis [r/w]						
Data block		PLC interface -----> NCK						
Byte	Bit 7	Bit 6	Bit 5	Bit 4	Bit 3	Bit 2	Bit 1	Bit 0
380x 1000 (axis)	Delay. Ref. pt. approach [F-R1]			Modulo Limit Enabled	2nd software limit switch		Hardware limit switch	
					plus [F-A3]	minus [F-A3]	plus [F-A3]	minus [F-A3]
380x 1001 up to 380x 1003								

**Signals to spindle**

3800 ... 3804		Signals to spindle [r/w]						
Data block		PLC interface -----> NCK						
Byte	Bit 7	Bit 6	Bit 5	Bit 4	Bit 3	Bit 2	Bit 1	Bit 0
380x 2000 (Spindle)	Clear S value	Spindle: No speed monitoring when switching the gear stage; resynchronize 2	Spindle: Resynchronize 2	Spindle: Resynchronize 1	Gear changed [F-S1]	Actual gear stage		
						C [F-S1]	B [F-S1]	A [F-S1]
380x 2001 (spindle)		Invert M3/M4 [F-S1]		Resynchronize spindle during positioning 1 [F-S1]				Feedrate override valid for spindle [F-V1]
380x 2002 (Spindle)	Setpoint direction of rotation		Oscillation speed [F-S1]	Oscillation via PLC [F-S1]				
	Left [F-S1]	Right [F-S1]						
380x 2003 (Spindle)	Spindle override [F-V1]							
	H	G	F	E	D	C	B	A

### Signals to PLC axis

3800 ... 3805		Signals to PLC axis [r/w]						
Data block		Interface PLC -----> NCK						
Byte	Bit 7	Bit 6	Bit 5	Bit 4	Bit 3	Bit 2	Bit 1	Bit 0
380x 3000	Start positioning axis							
380x 3001								
380x 3002						Traversing dimension: Inch (not metric)	G function: Shortest path (DC)	G function: incremental (IC)
380x 3003	Indexing position						G function: Abs. pos. direction (ACP)	G function: Abs. neg. direction (ACN)
380x 3004	Position (REAL, with indexing axis: DWORD)							
380x 3005								
380x 3006								
380x 3007								
380x 3008								
380x 3009	Feedrate (REAL), if = 0, value is taken from machine data POS_AX_VELO							
380x 3010								
380x 3011								
380x 3011								

### Signals to drive

3800 ... 3805		Signals to axis/spindle [r/w]						
Data block		PLC interface -----> NCK						
Byte	Bit 7	Bit 6	Bit 5	Bit 4	Bit 3	Bit 2	Bit 1	Bit 0
380x 4000					Speed set-point smoothing			
380x 4001	Pulse enable [F-A2]	Speed controller integrator disable [F-A2]				Parameter set selection [F-A2]		
						C	B	A
380x 4002								
380x 4003								

**Signals to technology functions**

<b>3800 ... 3805</b> Data block		<b>Signals to axis/spindle [r/w]</b> Interface PLC -----> NCK						
Byte	Bit 7	Bit 6	Bit 5	Bit 4	Bit 3	Bit 2	Bit 1	Bit 0
380x 5000								
380x 5001								
380x 5002								
380x 5003	Stop HIAxMove	Stop Corr	Stop DEPBCS	Stop DEPMCS	Resume HIAxMove	Resume Corr	Resume DEPBCS	Resume DEPMCS
380x 5004 (grinding) (reciproca- ting)	PLC con- trols axis	AxStop, stop	Stop at next rever- sal point	Change re- versal point	Set rever- sal point	AxResume	AxReset	OscillAxExt Reversal
380x 5005 (grinding)								
380x 5006 (spindle)				Positioning the spindle	Automatic gear stage change	Specified direction of rotation CCW	Specified direction of rotation CW	Spindle STOP

### 7.9.3 Signals from axis/spindle

#### General signals from axis/spindle

3900 ... 3905		Signals from axis/spindle [r]						
Data block		NCK interface -----> PLC						
Byte	Bit 7	Bit 6	Bit 5	Bit 4	Bit 3	Bit 2	Bit 1	Bit 0
390x 0000	Position reached with exact stop, fine [F-B1]	Position reached with exact stop, coarse [F-B1]		Referenced/synchronized 1 [F-R1]		Encoder limit frequency exceeded 1 [F-A3]		Spindle/no axis [F-S1]
390x 0001	Current controller active [F-A2]	Speed control loop active [F-A2]	Position controller active [F-A2]	Axis/spindle stationary (n < n <sub>min</sub> ) [F-A2]	Follow up mode active [F-A2]			
390x 0002		Power Fixed stop limited	Fixed stop reached [F-F1]	Activate travel to fixed stop [F-F1]	Measurement active [F-M5]			Cam active
390x 0003								
390x 0004	Motion command plus [F-H1]	Motion command minus [F-H1]	Travel request plus	Travel request minus			Handwheel active 2 [F-H1]	Handwheel active 1 [F-H1]
390x 0005		Continuous	INCvar	INC10 000	INC1000	INC100	INC10	INC1
390x 0006 up to 390x 0011	PLC axis assigned firmly							

#### Signals from axis

3900 ... 3905		Signals from axis [r]						
Data block		NCK interface -----> PLC						
Byte	Bit 7	Bit 6	Bit 5	Bit 4	Bit 3	Bit 2	Bit 1	Bit 0
390x 1000				Modulo Limit Enabled active				
390x 1001								
390x 1002	Rotary axis in position	Indexing axis in position	Positioning axis	Path axis				Lubrication pulse [F-A2]
390x 1003								

**Signals from spindle**

3900 ... 3905		Signals from spindle [r]						
Data block		NCK interface -----> PLC						
Byte	Bit 7	Bit 6	Bit 5	Bit 4	Bit 3	Bit 2	Bit 1	Bit 0
390x 2000 (Spindle)					Gearbox changeover [F-S1]	Set gear stage C [F-S1]   B [F-S1]   A [F-S1]		
390x 2001 (Spindle)	Actual direction of rotation clockwise [F-S1]	Speed mo- nitoring	Spindle In the setpoint range [F-S1]	Supporting range limit violated	Geometry monitoring	Setpoint speed increased [F-S1]	Setpoint speed limited [F-S1]	Speed limit exceeded [F-S1]
390x 2002 (Spindle)	Active spindle mode Control mode [F-S1]   Oscillation mode [F-S1]   Positioning mode [F-S1]				Rigid tapping [F-S1]		SUG active	Const. cutting velocity active [F-S1]
390x 2003			Spindle in position					

**Signals from PLC axis**

3900 ... 3905		Signals from spindle [r]						
Data block		Interface NCK -----> PLC						
Byte	Bit 7	Bit 6	Bit 5	Bit 4	Bit 3	Bit 2	Bit 1	Bit 0
390x 3000	Positioning axis active	Position reached					Error during traversing	Axis cannot be started
390x 3001								
390x 3002								
390x 3003	Error number							

**Signals from drive**

3900 ... 3905		Signals from axis/spindle [r]						
Data block		NCK interface -----> PLC						
Byte	Bit 7	Bit 6	Bit 5	Bit 4	Bit 3	Bit 2	Bit 1	Bit 0
390x 4000								
390x 4001	Pulses enabled [F-A2]	Speed controller integrator disabled [F-A2]	Drive ready [F-A2]			Active parameter set [F-A2] C   B   A		
390x 4002		$n_{act} = n_{set}$ [F-A2]	$n_{act} < n_x$ [F-A2]	$n_{act} < n_{min}$ [F-A2]	$Md < Mdx$ [F-A2]	Ramp-up completed [F-A2]	Temperature prewarning Heat sink [F-A2]	Motor [F-A2]
390x 4003								$Uzk < Uzkx$

**Signals from technology functions**

3900 ... 3905		Signals from axis/spindle [r]						
Data block		Interface NCK -----> PLC						
Byte	Bit 7	Bit 6	Bit 5	Bit 4	Bit 3	Bit 2	Bit 1	Bit 0
390x 5000								
390x 5001								
390x 5002	ESR reaction initiated	Acceleration warning threshold reached	Velocity warning threshold reached	Overlaid movement				
390x 5003		Max. acceleration reached	Max. velocity reached	Synchronization running	Axis accelerated			
390x 5004 (grinding) (reciprocating)	Reciprocation active	Reciprocating motion active	Sparking-out active	Error during the reciprocating motion	Reciprocation cannot be started.	OscillAxExt Reversal active		
390x 5005								
390x 5006								
390x 5007								
390x 5008	Active additional axis							
			Axis 6	Axis 5	Axis 4	Axis 3	Axis 2	Axis 1

## 7.10 PLC machine data

### 7.10.1 INT values (MD 14510 USER\_DATA\_INT)

<b>4500</b>	<b>Signals from NCK [r16]</b>						
Data block	NCK interface -----> PLC						
Start byte							
4500 0000	Int values (WORD/ 2 Byte)						
4500 0002	Int values (WORD/ 2 Byte)						
4500 0004	Int values (WORD/ 2 Byte)						
up to							
4500 0062	Int values (WORD/ 2 Byte)						

### 7.10.2 HEX values (MD 14512 USER\_DATA\_HEX)

<b>4500</b>	<b>Signals from NCK [r8]</b>						
Data block	NCK interface -----> PLC						
Byte							
4500 1000	Hex value (BYTE)						
4500 1001	Hex value (BYTE)						
up to							
4500 1031	Hex value (BYTE)						

### 7.10.3 FLOAT values (MD 14514 USER\_DATA\_FLOAT)

<b>4500</b>	<b>Signals from NCK [r32]</b>						
Data block	NCK interface -----> PLC						
Start byte							
4500 2000	Float value (REAL/ 4 Byte)						
4500 2004	Float value (REAL/ 4 Byte)						
up to							
4500 2028	Float value (REAL/ 4 Byte)						

### 7.10.4 User alarm: Configuration (MD 14516 USER\_DATA\_PLC\_ALARM)

4500		Signals from NCK [r8]					
Data block		NCK interface -----> PLC					
Byte							
4500 3000		Alarm reaction/ deletion criterion Alarm 700000					
4500 3001		Alarm reaction/ deletion criterion Alarm 700001					
up to							
4500 3031		Alarm reaction/ deletion criterion Alarm 700031					

**Note:** Information on PLC alarms, including configuring user alarms, can be found in:

**References:** “Installation and Start-Up Guide”, Section “PLC alarms”

## 7.11 Reading and writing PLC variables

4900		PLC variables [r/w]					
Data block		PLC interface					
Byte							
4900 0000		Offset[0]					
4900 0001		Offset[1]					
up to							
4900 1021		...					
4900 1022		Offset[1022]					
4900 1023		Offset[1023]					

**Note:** The application programmers of NCK and PLC themselves are responsible for the organization of this data area. Data type, position offset and meaning of the variables must be agreed. The memory range limits per data type must be observed (1, 2 or 4 byte types). Further information can be found in:

**References:** “Operation and Programming”, Section “Reading and writing PLC variables”

## 7.12 Tool management functions from NC channel

### Change signals for tool management functions

<b>5300</b>		<b>Tool management functions [r]</b>						
Data block		NCK interface NCK PLC -----> PLC						
Byte	Bit 7	Bit 6	Bit 5	Bit 4	Bit 3	Bit 2	Bit 1	Bit 0
5300 0000							Tool limit value reached [F-W1]	Tool warning limit reached [F-W1]

### Transferred tool management functions

<b>5300</b>		<b>Tool management functions [r32]</b>						
Data block		NCK interface -----> PLC						
Byte								
5300 1000	T number for tool warning limit (DINT) [F-W1]							
5300 1004	T number for tool limit value (DINT) [F-W1]							

### Axis actual values and distances-to-go

<b>5700 ... 5704</b>		<b>Signals from axis/spindle [r32]</b>						
Data block		NCK interface -----> PLC						
Byte								
570x 0000	Axis actual value (REAL)							
570x 0004	Axis distance-to-go (REAL)							

**Note:** Axis actual values and distances-to-go can each be requested separately:  
 – V2600 0001.1 Request for axis actual values  
 – V2600 0001.2 Request for axis distances-to-go

Once the respective request has been set, these values are provided by NCK for all axes.

# SINAMICS Parameters



---

**Note for reader**

For the SINAMICS parameters, please refer to the documentation "SINAMICS S, Lists Manual".

---



# Index

## A

Acceleration (B2)|MD for axial jerk, 4-95  
 Acceleration (B2)|MD for the default setting of the axial  
 jerk limitation, 4-95  
 Address ranges, 7-183  
 Auxiliary function transfer from NC channel, 6-134  
 Axis-/spindle-specific setting data, 5-123  
 Axis-/spindle-specific signals, 6-162  
 Axis-specific machine data, 1-49 , 4-90

## C

Channel-specific machine data, 1-38 , 4-82  
 Channel-specific setting data, 5-121  
 Channel-specific signals, 6-143  
 Compensations (K3)|MD for activating feedforward  
 control from the program, 4-96  
 Compensations (K3)|MD for the equivalent time con-  
 stant of the speed control loop, 4-97  
 Continuous-path control mode, exact stop and LookA-  
 head (B1)|MD for exact stop coarse, 4-108  
 Continuous-path control mode, exact stop and LookA-  
 head (B1)|MD for exact stop fine, 4-109  
 Cross reference, 1-17  
 Cyclic signal exchange, 6-128

## D

Data description  
 channel-specific machine data, 4-82  
 general machine data, 4-78  
 Setting data, 5-119  
 Data types, 1-20  
 Default values, 1-21  
 Display machine data, 4-75

## G

General machine data, 1-29 , 4-78  
 General selection/status signals to HMI, 6-132  
 General setting data, 5-119  
 General signals, 6-137  
 General signals from NC, 6-138  
 General signals to NC, 6-137

## I

Identifier, 1-17

Interface signals, 6-127

Activate referencing, 6-144  
 Active spindle control mode, 6-180  
 Active spindle mode oscillation mode, 6-180  
 Active spindle positioning mode, 6-180  
 Actual direction of rotation clockwise, 6-179  
 Actual gear stage A to C, 6-170  
 All axes referenced, 6-158  
 Change gear stage, 6-177  
 Clamping in progress, 6-165  
 Encoder limit frequency exceeded, 6-174  
 Gear switchover, 6-170  
 Hardware limit switches plus and minus, 6-169  
 Invert M3/M4, 6-171  
 Oscillation speed, 6-172  
 Oscillation via PLC, 6-171  
 Probe activated, 6-138  
 Reference point approach delay, 6-169  
 Referencing active, 6-155  
 Resynchronize spindle during positioning, 6-171  
 Revolutional feedrate active, 6-155  
 Rigid tapping active (no compensation), 6-180  
 Second software limit switch plus or minus, 6-169  
 Set gear stage A to C, 6-177  
 Setpoint direction of rotation, counter-clockwise/  
 setpoint direction of rotation, clockwise, 6-172  
 Setpoint speed increased, 6-178  
 Setpoint speed limited, 6-178  
 Speed limit exceeded, 6-178  
 Spindle in setpoint range, 6-179  
 Spindle reset/Delete distance-to-go, 6-165  
 Spindle/no axis, 6-174  
 Velocity/spindle speed limiting, 6-166

## M

Machine and setting data, Explanations, 1-17  
 Machine data  
 axis-specific, 1-49  
 channel-specific, 1-38  
 Display, 1-23  
 General, 1-29  
 list, 1-23  
 Machine data, setting data  
 activation, 1-18  
 areas, 1-22  
 Manual traversing and handwheel traversing (H1)|MD  
 for axis velocity in JOG mode, 4-94  
 Manual traversing and handwheel traversing (H1)|MD  
 for rapid traverse in JOG mode, 4-94

Manual traversing and handwheel traversing (H1)|SD  
for JOG speed for the spindle, 5-120  
Manual traversing and handwheel traversing (H1)|SD  
for JOG velocity for linear axes (for G94), 5-119  
Manual traversing and handwheel traversing (H1)|SD  
for JOG velocity for rotary axes, 5-119  
Manual traversing and handwheel traversing (H1)|SD  
for the size of the variable increment with INC/  
handwheel, 5-119  
Mode group, channel, program operation (K1)|MD for  
circle end position constant, 4-84  
Mode group, channel, program operation (K1)|SD for  
dry run feedrate, 5-121  
Mode signals, 6-140

## N

Number, 1-17

## P

PLC user interface, 7-183  
Axis/spindle signals, 7-207  
Channel signals, 7-201  
PLC machine data, 7-214  
User alarm, 7-188  
User data, 7-185  
PLC/NCK interface, 6-127  
Program-control signals from HMI, 6-129  
Protection levels, 1-21

## R

Range of values, 1-21

## S

Setting data, 2-65 , 5-119  
axis-specific, 2-71  
channel-specific, 2-67  
overview, 2-65  
Signals from axis/spindle, 6-174  
Signals from HMI, 6-130  
Signals from NC, 6-131  
Signals from operator panel, 6-131  
Signals from the channel, 6-154  
Signals from/to HMI, 6-129  
Signals to axis/spindle, 6-163  
Signals to channel, 6-143  
SINAMICS parameters, 8-217

## T

Tool management functions from NC channel, 6-182  
Transferred axis-specific M and S functions, 6-162

## U

Unit, 1-17  
Unit system, 1-17

To:  
SIEMENS AG  
A&D MC MS  
Postfach 3180  
D-91050 Erlangen  
(Tel. +49 (0) 180 5050 – 222 [hotline]  
Fax +49 (0) 9131 98 – 63315 [documentation]  
E-mail: motioncontrol.docu@siemens.com)

**Suggestions**

**Corrections**

For publication/manual:

SINUMERIK 802D sl

Manufacturer Documentation

**From:**

Name

Company/Dept.

Address

Zip code: City:

Telephone: /

Telefax: /

**Lists**

Order No.: 6FC5397-5CP10-0BA0  
Edition 02.2006

Should you come across any printing errors when reading this publication, please notify us on this sheet. Suggestions for improvement are also welcome.

**Suggestions and/or corrections**



[www.nicsanat.com](http://www.nicsanat.com)

021-87700210