

SIEMENS



www.nicsanat.com

021-87700210

Motion Control

SINUMERIK 808







Equipment for Machine Tools

Catalog
NC 81.1

Edition
2018

siemens.com/sinumerik

Related catalogs

Motion Control SINUMERIK 840 Equipment for Machine Tools E86060-K4462-A101-A2-7600	NC 62	
Motion Control SINUMERIK 828 Equipment for Machine Tools E86060-K4482-A101-A5-7600	NC 82	
Motion Control Drives SINAMICS Inverters for Single-Axis Drives Built-In Units E86060-K5531-A111-A1-7600	D 31.1	
Motion Control Drives SINAMICS Inverters for Single-Axis Drives Distributed Inverters E86060-K5531-A121-A1-7600	D 31.2	
SITRAIN Training for Industry www.siemens.com/sitrain		
Products for Automation and Drives Interactive Catalog DVD-ROM E86060-D4001-A510-D8-7600	CA 01	
Industry Mall Information and Ordering Platform in the Internet: www.siemens.com/industrymall		

SINUMERIK 808

Equipment for Machine Tools

Motion Control



Catalog NC 81.1 · 2018

Supersedes:
Catalog NC 81.1 · 2017

Refer to the Industry Mall for current updates of
this catalog:

www.siemens.com/industrymall

The products contained in this catalog can also be found
in the Interactive Catalog CA 01.

Article No.: E86060-D4001-A510-D8-7600

Please contact your local Siemens branch.

NEW

Click on an Article No. in the catalog PDF to call it up in the
Industry Mall and to obtain all the information.

Article No.

6SL3070-0AA00-0AG0
6SL3072-0AA00-0AG0



Or directly on the Internet, e.g.
www.siemens.com/product?6SL3070-0AA00-0AG0



The products and systems described in
this catalog are distributed under application
of a certified quality management system in
accordance with DIN EN ISO 9001 (Certified
Registration No. 001258 UM). The certificate
is recognized by all IQNet countries.

Introduction

1

Overview of functions SINUMERIK 808D family

2

SINUMERIK 808D system SINUMERIK 808D PPU 141.3 Operator components Feed axis solutions MOTION-CONNECT connection systems Example packages

3

SINUMERIK 808D ADVANCED system SINUMERIK 808D ADVANCED PPU 15x.3/PPU 16x.3 Operator components Feed axis solutions Spindle solutions MOTION-CONNECT connection systems Example packages

4

Accessories Operator components Supplementary components Direct spindle encoder

5

Services and training Services Training Documentation

6

Appendix Certificates of suitability Subject index Conversion tables Metal surcharges Conditions of sale and delivery Export regulations

7

www.nicsanat.com
021-87700210



Integrated Drive Systems

Faster on the market and in the black with Integrated Drive Systems

SINAMICS is an important element of a Siemens Integrated Drive System, contributing significantly to increased efficiency, productivity, and availability in industrial production processes.

Integrated Drive Systems are Siemens' trendsetting answer to the high degree of complexity that characterizes drive and automation technology today. The world's only true one-stop solution for entire drive systems is characterized in particular by its threefold integration: Horizontal, vertical,

and lifecycle integration ensure that every drive system component fits seamlessly into the whole system, into any automation environment, and even into the entire lifecycle of a plant.

The outcome is an optimal workflow – from engineering all the way to service that entails more productivity, increased efficiency, and better availability. That's how Integrated Drive Systems reduce time to market and time to profit.

Horizontal integration

Integrated drive portfolio: The core elements of a fully integrated drive portfolio are frequency converters, motors, couplings, and gear units. At Siemens, they're all available from a single source. Perfectly integrated, perfectly interacting. For all power and performance classes. As standard solutions or fully customized. No other player in the market can offer a comparable portfolio. Moreover, all Siemens drive components are perfectly matched, so they are optimally interacting.

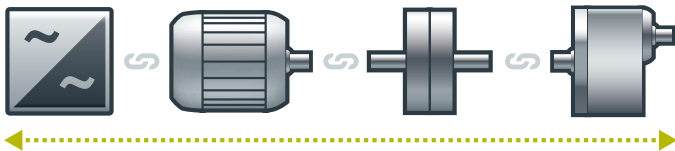

You can boost the availability of your application or plant to up to



Vertical integration

Thanks to **vertical integration**, the complete drive train is seamlessly integrated in the entire automation environment – an important prerequisite for production with maximum value added. Integrated Drive Systems are part of Totally Integrated Automation (TIA), which means that they are perfectly embedded into the system architecture of the entire industrial production process. This enables optimal processes through maximum communication and control.

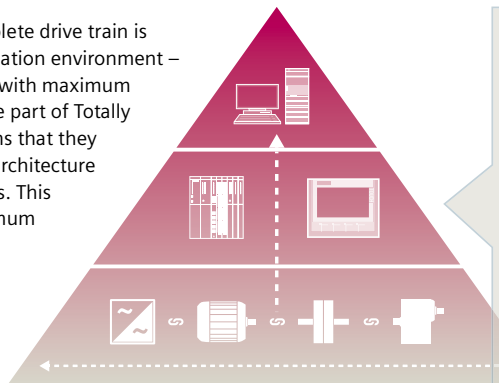

With TIA Portal you can cut your engineering time by up to



Lifecycle integration

Lifecycle integration adds the factor of time: Software and service are available for the entire lifecycle of an Integrated Drive System. That way, important optimization potential for maximum productivity, increased efficiency, and highest availability can be leveraged throughout the system's lifecycle – from planning, design, and engineering to operation, maintenance, and all the way even to modernization.

With Integrated Drive Systems, assets become important success factors. They ensure shorter time to market, maximum productivity and efficiency in operation, and shorter time to profit.

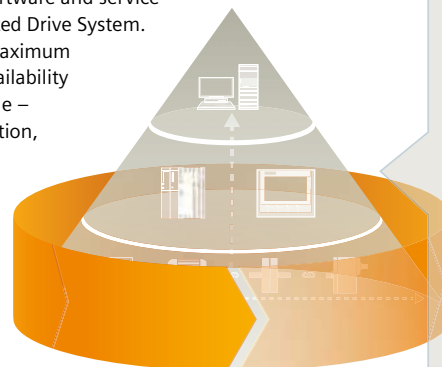

With Integrated Drive Systems you can reduce your maintenance costs by up to



Introduction



1/2	How to use this catalog
1/3	The system
1/4	SINUMERIK 808D/808D ADVANCED
1/5	Feed and spindle drive solutions
1/6	MOTION-CONNECT connection systems

Introduction

How to use this catalog

1

Overview

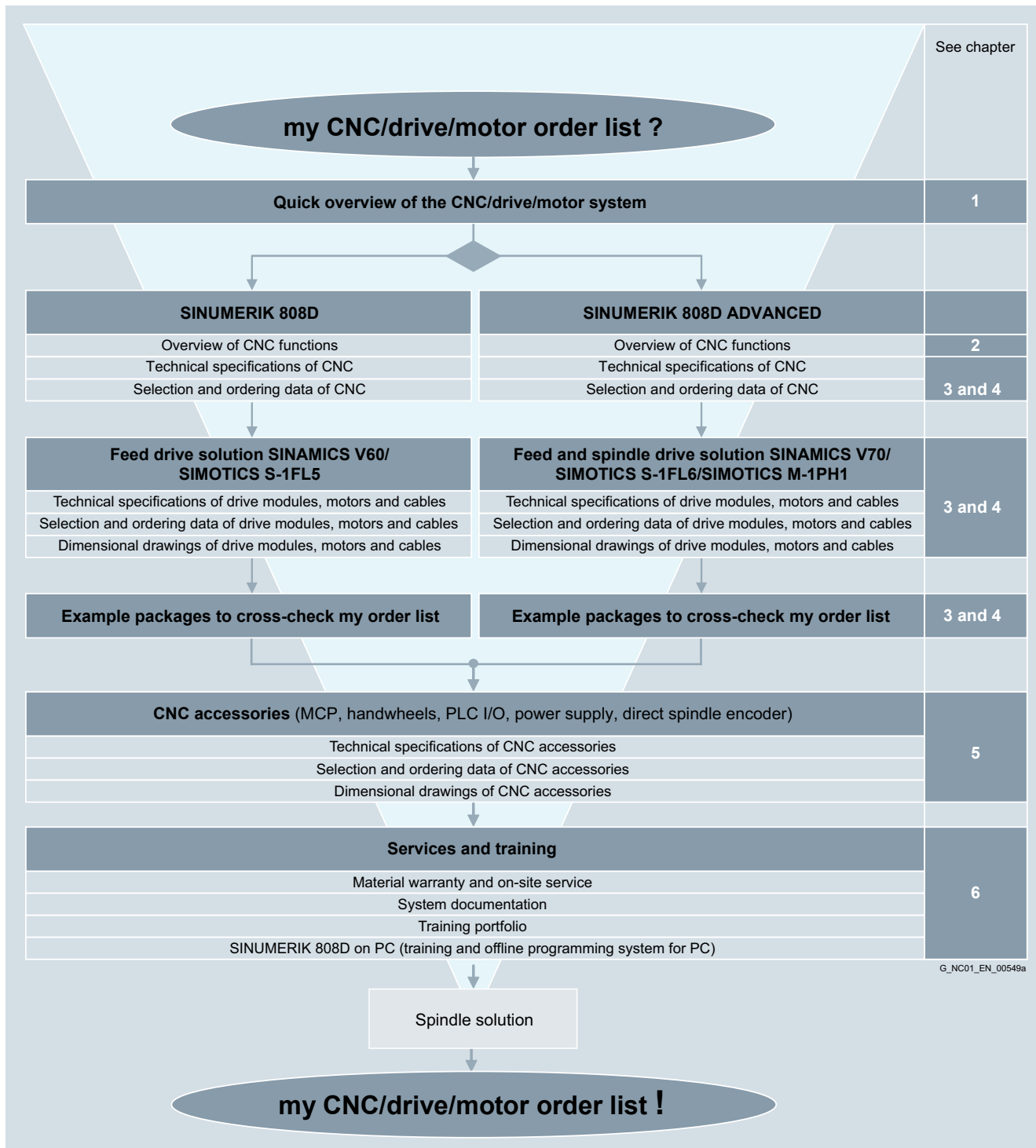

G_NC01_EN_00549a

Overview

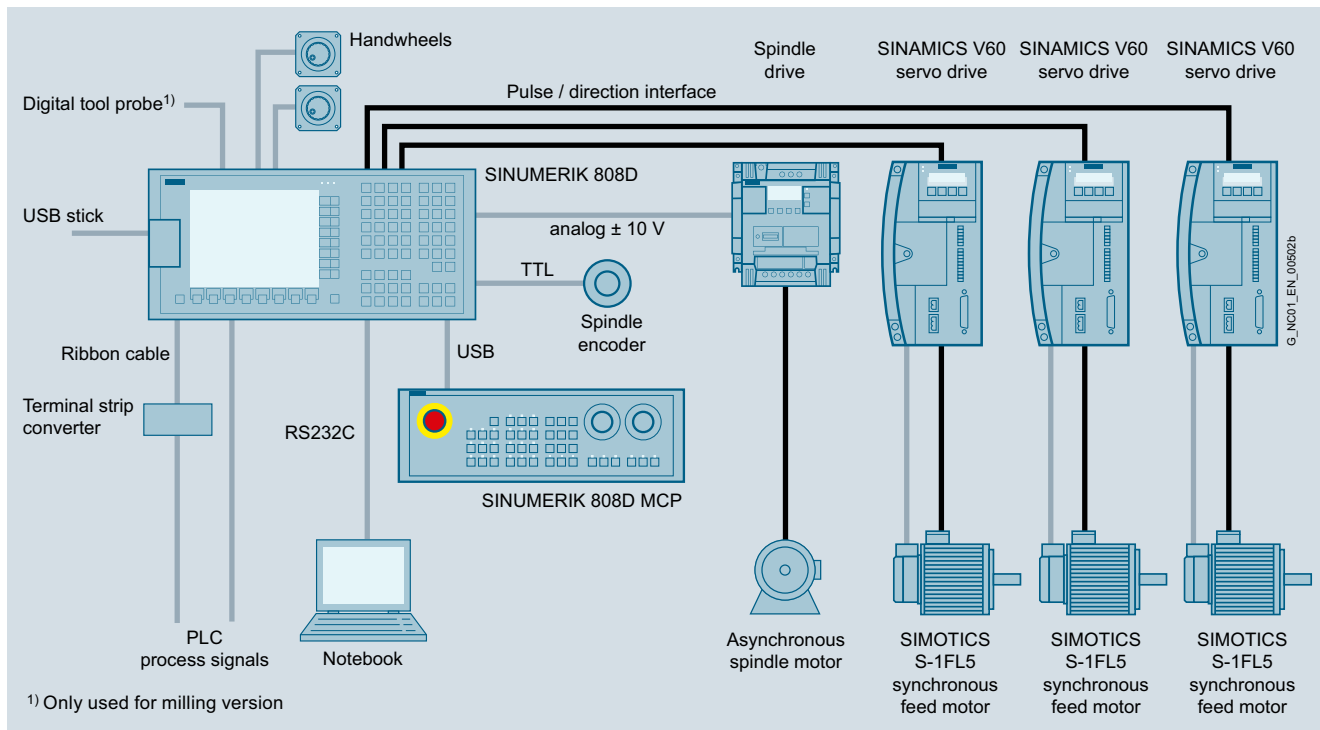

SINUMERIK 808D system

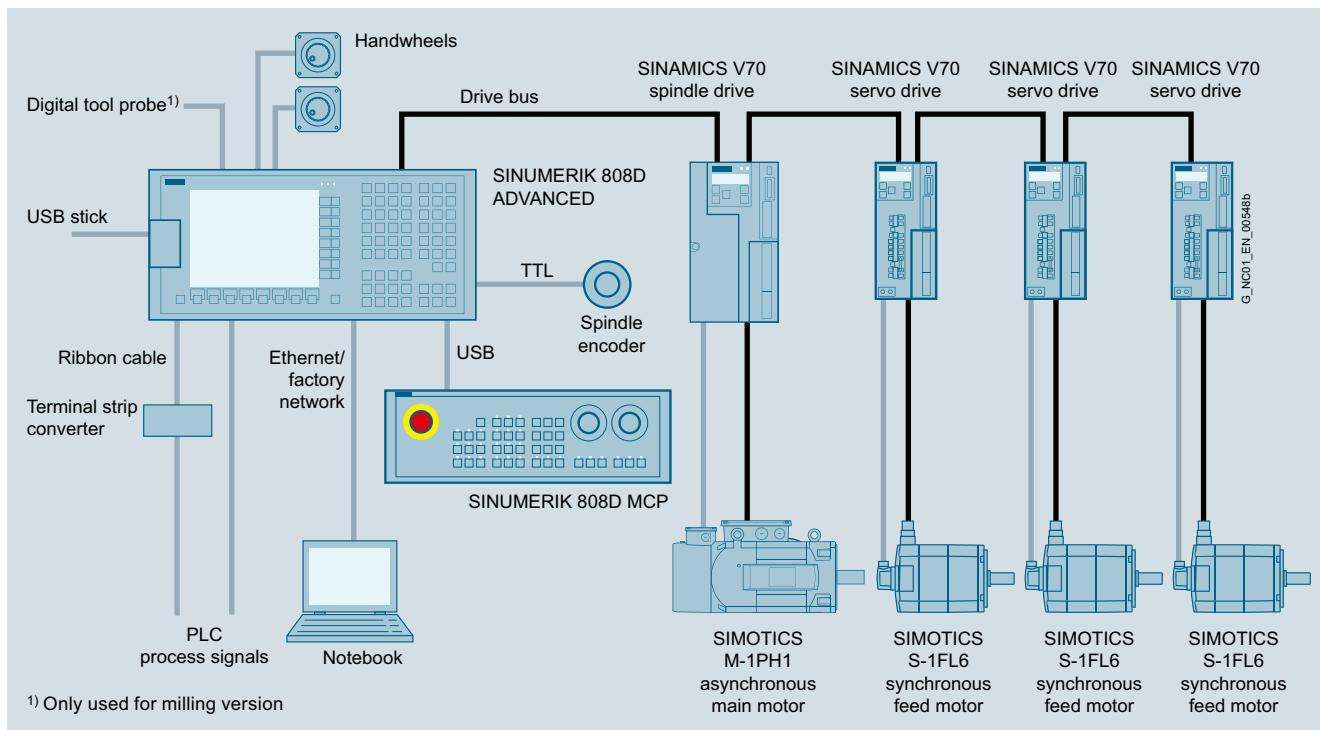

SINUMERIK 808D ADVANCED system

Introduction

SINUMERIK 808D/808D ADVANCED

1

Overview

Small, robust, easy, simply smart

The operator-panel-based CNCs SINUMERIK 808D and SINUMERIK 808D ADVANCED are extremely compact, rugged and very easy to maintain. SINUMERIK 808D is suitable for machines needed for economic CNC solutions. With variable software options and high-dynamic servo drive systems, the SINUMERIK 808D ADVANCED system is offering the latest CNC solution for high-performance basic machines.



Preconfigured for basic standard turning machines ...

The SINUMERIK 808D Turning/SINUMERIK 808D ADVANCED T CNC is perfectly preconfigured to meet the requirements of modern standard turning machines. Intelligent CNC features such as full servo controlled rigid tapping or the flying switch-over between spindle and C axis enable most precise and fast-turning operation.

Perfectly preconfigured for:

- SINUMERIK 808D Turning:
Up to 4 axes/spindles in one machining channel;
- SINUMERIK 808D ADVANCED T:
Up to 5 axes/spindles in one machining channel with/without a driven tool
- Preconfigured system software for inclined bed fully automated lathes and flat bed semi-automatic lathes

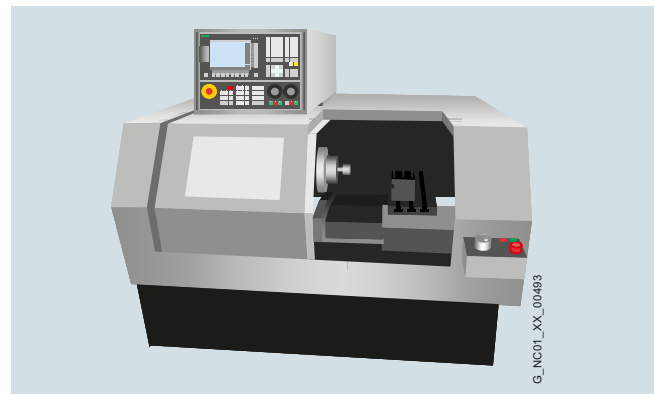

... and basic standard milling machines

The SINUMERIK 808D Milling/SINUMERIK 808D ADVANCED M CNC is perfectly preconfigured to meet the requirements of modern standard milling machines.

- SINUMERIK 808D Milling:
Up to 4 axes/spindles in one machining channel
- SINUMERIK 808D ADVANCED M:
Up to 5 axes/spindles in one machining channel
- Preconfigured system software for vertical machining centers

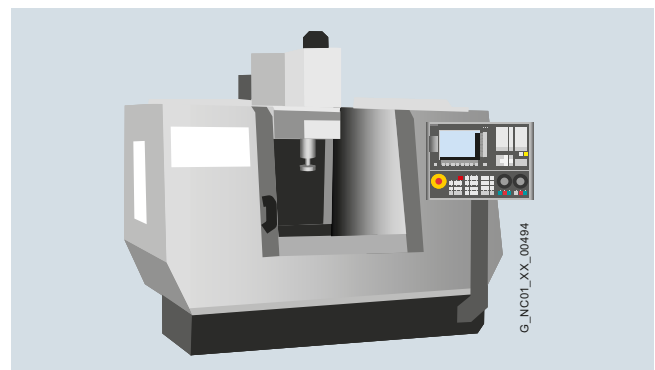

Overview



SINAMICS V60 and SIMOTICS S-1FL5

SINAMICS V60 servo drives and SIMOTICS S-1FL5 feed motors are the perfect partners as an economic solution to achieve maximum dynamics and accuracy for feed axes in standard turning and milling machine tool applications with SINUMERIK 808D.

With its closed-loop speed and current control, SINAMICS V60 is perfectly tailored for economic but powerful feed axes and guarantees easiest commissioning without any PC tools.

With a robust design, SINAMICS V60 together with SIMOTICS S-1FL5 feed motors are perfectly prepared for maximum availability even in harsh environments.



SINAMICS V70, SIMOTICS S-1FL6 and SIMOTICS M-1PH1

SINAMICS V70 servo drives, SIMOTICS S-1FL6 feed motors and SIMOTICS M-1PH1 main motors are designed for the maximum cutting performance for the basic turning and milling machine tool applications. The bus communication with the SINUMERIK 808D ADVANCED CNC system, threefold overload capacity and the 20 bit high-resolution absolute encoder installed in SIMOTICS S-1FL6 feed motors and SIMOTICS M-1PH1 main motors allow to increase the precision and efficiency of the machines.

With a robust design, SINAMICS V70 together with SIMOTICS S-1FL6 feed motors and SIMOTICS M-1PH1 main motors are perfectly prepared for maximum availability even in harsh environments.

Up to 36 months material warranty and on-site service

Siemens offers a standard material warranty and free on-site service period of 24 months for the SINUMERIK 808D, SINUMERIK 808D ADVANCED and the associated components. Warranty can be easily extended up to 36 months by end user registration.

Moreover, Siemens ensures elimination of any defects on the components free of cost on site during the warranty period.

Further information about the conditions and the scope of the warranty and the on-site service can be found at:

www.siemens.com/automation/oss

Introduction

MOTION-CONNECT connection systems

1

Overview

MOTION-CONNECTION 300 connection system

The MOTION-CONNECT 300 cables in this catalog are suitable for use with standard turning and milling machines.

The use of pre-assembled MOTION-CONNECT 300 cables ensures high quality and system-tested, problem-free operation.

Degree of protection of pre-assembled power and signal cables and their extensions is IP65 when closed and connected unless otherwise stated.

MOTION-CONNECT 300 cables are not suitable for outdoor use.

MOTION-CONNECT cables are approved for a maximum horizontal traverse path of 5 m.

To maximize the service life of the cable carrier and cables, cables in the carrier made from different materials must be separated in the cable carrier using spacers. The spacers must be filled evenly to ensure that the position of the cables does not change during operation. The cables should be distributed as symmetrically as possible according to their weights and dimensions. Cables with different outer diameters should be separated by spacers as well.

When inserting pre-assembled cables into the cable carrier, do not pull at the connector, as this may damage the strain relief or cable clamping.

The cables must not be fixed in the cable carrier. They must be freely movable.

The cables must be able to be moved without applying force, specifically in the bending radii of the carrier. The specified minimum bending radii must be adhered to.

The cable fixings must be attached at both ends at an appropriate distance from the end points of the moving parts in a dead zone.

Cables must be installed in accordance with the instructions supplied by the cable carrier manufacturer.

In case of vibration load and with horizontal or vertical cable entries, we recommend that the cable is additionally fixed if between the cable strain relief on the cable carrier and the terminal at the motor part of the cable is hanging loose or is not routed. To prevent machine vibrations being transmitted to the connectors, the cable should be fixed at the moving part where the motor is mounted.

The cables must be unwound without twisting.

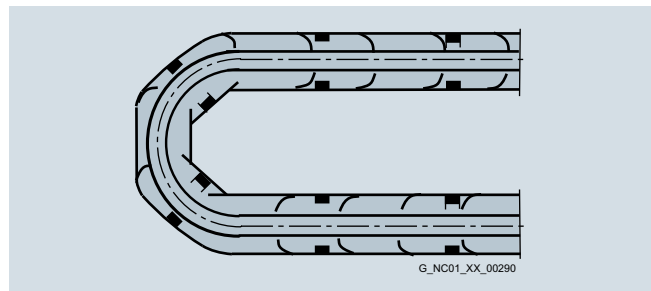
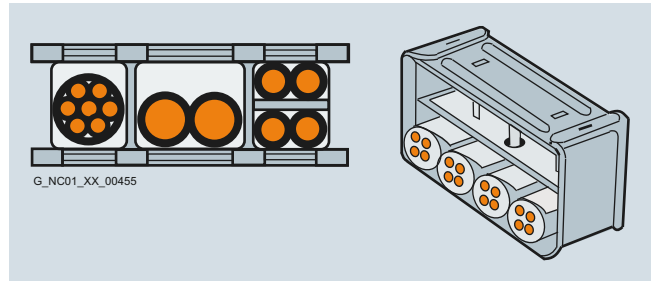

Derating factors for power and signal cables

Ambient air temperature °C (°F)	Derating factor according to EN 60204-1 Table D.1
30 (86)	1.15
35 (95)	1.08
40 (104)	1.00
45 (113)	0.91
50 (122)	0.82
55 (131)	0.71
60 (140)	0.58

Overview of functions



2/2	SINUMERIK 808D family
2/2	Control structure and configuration
2/2	Drives
2/2	Connectable measuring systems
2/3	Connectable CNC accessories
2/3	Axis functions
2/4	Spindle functions
2/4	Interpolations
2/4	Measuring functions
2/4	Motion-synchronous actions
2/5	Open Architecture
2/5	CNC programming
2/6	Technology cycles
2/6	Canned cycles
2/7	Program and workpiece management
2/7	Programming support
2/7	Simulation
2/8	Operating modes
2/8	Tools
2/9	Communication and data management
2/10	HMI functions
2/10	Monitoring functions
2/10	Compensations
2/11	PLC area
2/12	Commissioning and serial production
2/12	Diagnostic functions
2/12	Service and maintenance
2/12	Training and offline programming

The functionality of the SINUMERIK 808D family (SINUMERIK 808D, SINUMERIK 808D ADVANCED) complies with the export list restrictions. Accordingly, these CNC controls do not require official approval in accordance with EU or German law.

The information in the overview of functions of SINUMERIK 808D and SINUMERIK 808D ADVANCED controls is based on the following software version:

Control system	Software version
SINUMERIK 808D PPU 141.3	4.8 SP1
SINUMERIK 808D ADVANCED PPU 15x.3/PPU 16x.3	4.8 SP1

Overview of functions

SINUMERIK 808D family

Control structure and configuration/Drives/Connectable measuring systems

✓ Basic version ○ Option – Not available	Article No.	SINUMERIK 808D		SINUMERIK 808D ADVANCED			
		PPU 141.3		PPU 15x.3		PPU 16x.3	
		Turning	Milling	Turning	Milling	Turning	Milling
Control structure and configuration							
Panel-based control system comprising:							
• Compact operator panel		✓	✓	✓	✓	✓	✓
• CNC/PLC Control Unit		✓	✓	✓	✓	✓	✓
• Onboard digital PLC inputs/outputs		✓	✓	✓	✓	✓	✓
• CF card with system software Export version		Turning	Milling	Turning	Milling	Turning	Milling
SINUMERIK operator panel CNC:							
• Operator panel layout horizontal/vertical		✓/–	✓/–	✓/✓	✓/✓	✓/✓	✓/✓
• Color display		8.4"	8.4"	8.4"	8.4"	8.4"	8.4"
• Display resolution		800 × 600	800 × 600	800 × 600	800 × 600	800 × 600	800 × 600
• Integrated CNC keyboard with hard keys		✓	✓	✓	✓	✓	✓
• Specific CNC keyboard layout for		Turning	Milling	Turning	Milling	Turning	Milling
• Operator panel with Simplified Chinese layout		✓	✓	✓	✓	✓	✓
• Operator panel with English layout		✓	✓	✓	✓	✓	✓
SINUMERIK Operate BASIC							
Quantity of pulse/direction interfaces for feed axis converter		3	3	–	–	–	–
Quantity of bus interfaces for axis converter		–	–	1	1	1	1
Quantity of analog ±10 V interfaces for spindle converter		1	1	1	1	1	1
Channels/mode groups MG:							
• Maximum configuration		1	1	1	1	1	1
CNC user memory (buffered) for CNC part programs	The 1.25 MB memory is for storing and editing the user program. There is another 500 MB memory for NC program storage.	1.25 MB	1.25 MB	1.25 MB	1.25 MB	1.25 MB	1.25 MB
Axes/spindles:							
• Basic quantity of axes/spindles		3	4	3	4	3	4
• Maximum configuration axes/spindles		4	4	4	4	5	5
• Axis/spindle, each additional	6FC5800-0AK70-0YB0	0	–	0	–	0	0
Drives							
Feed drives:							
• SINAMICS V60 via pulse/direction interface		0	0	–	–	–	–
• SINAMICS V70 via bus interface		–	–	0	0	0	0
• 3rd-party feed axis converter via pulse/direction interface		0	0	–	–	–	–
Spindles:							
• Analog Drive Interface		0	0	0	0	0	0
SINAMICS V70 spindle via bus interface		–	–	0	0	0	0
Connectable measuring systems							
Number of measuring systems per axis, max.		1	1	1	1	1	1
Encoder installed in SIMOTICS S-1FL5 feed motors		✓	✓	–	–	–	–
Encoder installed in SIMOTICS S-1FL6 feed motors		–	–	✓	✓	✓	✓
Encoder installed in SIMOTICS M-1PH1 main motors		–	–	✓	✓	✓	✓
RS422 (TTL) direct incremental spindle encoder	6FX2001-2EB02	0	0	0	0	0	0

Connectable CNC accessories/Axis functions

✓ Basic version ○ Option – Not available	Article No.	SINUMERIK 808D		SINUMERIK 808D ADVANCED			
		PPU 141.3		PPU 15x.3		PPU 16x.3	
		Turning	Milling	Turning	Milling	Turning	Milling
Connectable CNC accessories							
Machine Control Panel:							
• SINUMERIK 808D MCP horizontal:							
- English layout	6FC5303-0AF35-0AA0	○	○	○	○	○	○
- Simplified Chinese layout	6FC5303-0AF35-0CA0	○	○	○	○	○	○
• SINUMERIK 808D MCP vertical:							
- English layout	6FC5303-0AF35-2AA0	○	○	○	○	○	○
- Simplified Chinese layout	6FC5303-0AF35-2CA0	○	○	○	○	○	○
• SINUMERIK 808D MCP vertical: with handwheel slot							
- English layout	6FC5303-0AF35-3AA0	○	○	○	○	○	○
- Simplified Chinese layout	6FC5303-0AF35-3CA0	○	○	○	○	○	○
• 3rd-party MCP via onboard digital PLC inputs/outputs							
		○	○	○	○	○	○
Number of digital tool probes, max.		–	1	–	1	–	1
Number of electronic handwheels RS422 5 V DC, max.		2	2	2	2	2	2
Electronic handwheels 5 V DC:							
• With 120 mm × 120 mm front panel	6FC9320-5DB01	○	○	○	○	○	○
• With 76.2 mm × 76.2 mm front panel	6FC9320-5DC01	○	○	○	○	○	○
• Without front panel, without setting wheel	6FC9320-5DF01	○	○	○	○	○	○
• Without front panel, with setting wheel	6FC9320-5DM00	○	○	○	○	○	○
Axis functions							
Feedrate override		0 ... 200 %	0 ... 200 %	0 ... 200 %	0 ... 200 %	0 ... 200 %	0 ... 200 %
Feedrate override axis-specific		0 ... 200 %	0 ... 200 %	0 ... 200 %	0 ... 200 %	0 ... 200 %	0 ... 200 %
Traversing range decades		± 9	± 9	± 9	± 9	± 9	± 9
Rotary axis, turning endlessly		✓	✓	✓	✓	✓	✓
Velocity, max.		300 m/s	300 m/s	300 m/s	300 m/s	300 m/s	300 m/s
Acceleration with jerk limitation		✓	✓	✓	✓	✓	✓
Programmable acceleration		✓	✓	✓	✓	✓	✓
Feedrate interpolation		✓	✓	✓	✓	✓	✓
Separate path feed for corners and chamfers		✓	✓	✓	✓	✓	✓
Velocity-dependent feed forward control		✓	✓	✓	✓	✓	✓
Friction compensation		✓	✓	✓	✓	✓	✓
Auto Servo Tuning AST		–	–	✓	✓	✓	✓
Direct Servo Control DSC		–	–	✓	✓	✓	✓
TRANSMIT/TRACYL Transformation without Y axis	6FC5800-0AS50-0YB0	○	○	–	–	○	○
Pair of synchronized axes (gantry axes), basic	6FC5800-0AS51-0YB0	–	–	–	–	○	○
Contour handwheel	6FC5800-0AM08-0YB0	○	○	○	○	○	○

Overview of functions

SINUMERIK 808D family

Spindle functions/Interpolations/Measuring functions/Motion-synchronous actions

✓ Basic version ○ Option – Not available	Article No. Note	SINUMERIK 808D		SINUMERIK 808D ADVANCED			
		PPU 141.3		PPU 15x.3		PPU 16x.3	
		Turning	Milling	Turning	Milling	Turning	Milling
Spindle functions							
Spindle speed, analog		✓	✓	✓	✓	✓	✓
Spindle speed, max. programmable value range (display ± 999999999.9999)		10 ⁶ ... 10 ⁻⁴	10 ⁶ ... 10 ⁻⁴	10 ⁶ ... 10 ⁻⁴	10 ⁶ ... 10 ⁻⁴	10 ⁶ ... 10 ⁻⁴	10 ⁶ ... 10 ⁻⁴
Spindle override		0 ... 200 %	0 ... 200 %	0 ... 200 %	0 ... 200 %	0 ... 200 %	0 ... 200 %
Gear stages		5	5	5	5	5	5
Intermediate gear		✓	✓	✓	✓	✓	✓
Automatic gear stage selection		✓	✓	✓	✓	✓	✓
Oriented spindle stop	Requires direct spindle encoder.	✓	✓	✓	✓	✓	✓
Spindle speed limitation min./max.		✓	✓	✓	✓	✓	✓
Constant cutting rate		✓	✓	✓	✓	✓	✓
Spindle control via PLC (positioning, oscillation)		✓	✓	✓	✓	✓	✓
Changeover to axis mode	Requires servo spindle and direct encoder.	✓	✓	✓	✓	✓	✓
Axis synchronization on-the-fly	Requires servo spindle and direct encoder.	✓	✓	✓	✓	✓	✓
Thread run-in and run-out programmable		✓	✓	✓	✓	✓	✓
Thread cutting with constant or variable pitch		✓	✓	✓	✓	✓	✓
Tapping with compensating chuck/rigid tapping	Requires servo spindle and direct encoder.	✓	✓	✓	✓	✓	✓
Interpolations							
Linear interpolation axes, max.		3	3	3	3	3	4
Circle via center point and end point		✓	✓	✓	✓	✓	✓
Circle via interpolation point		✓	✓	✓	✓	✓	✓
Helical interpolation		✓	✓	✓	✓	✓	✓
Continuous-path mode with programmable rounding clearance		✓	✓	✓	✓	✓	✓
Advanced Surface look ahead, velocity control and CNC block compression		–	–	–	–	–	✓
High-speed setting cycle CYCLE832		–	–	–	–	–	✓
Look ahead (number of blocks)		1	50	1	50	1	150
Measuring functions							
Measuring in JOG:							
• Number of probes (switching) with/without deletion of distance-to-go		–	1	–	1	–	1
Motion-synchronous actions							
CNC inputs/outputs, high-speed:							
• Digital inputs CNC onboard		3	3	3	3	3	3
- Digital inputs cycle time		0.2 ms	0.2 ms	0.2 ms	0.2 ms	0.2 ms	0.2 ms
• Digital outputs CNC onboard		1	1	1	1	1	1
- Digital outputs cycle time		0.3 ms	0.3 ms	0.3 ms	0.3 ms	0.3 ms	0.3 ms
Synchronized actions and high-speed auxiliary function output incl. 3 synchronous functions		✓	✓	✓	✓	✓	✓
Positioning axes and spindles via synchronized actions (command axes)		✓	✓	✓	✓	✓	✓

Overview of functions

SINUMERIK 808D family

Open Architecture/CNC programming

<ul style="list-style-type: none"> ✓ Basic version ○ Option - Not available 	Article No.	SINUMERIK 808D		SINUMERIK 808D ADVANCED			
		PPU 141.3		PPU 15x.3		PPU 16x.3	
		Turning	Milling	Turning	Milling	Turning	Milling
Open Architecture							
Customizable HMI:							
• Customizable screens in the HMI		✓	✓	✓	✓	✓	✓
• Input screens for customized user cycles		✓	✓	✓	✓	✓	✓
CNC programming							
Programming methods:							
• SINUMERIK style programming language (DIN 66025 and high-level language expansion)		✓	✓	✓	✓	✓	✓
• ISO code		✓	✓	✓	✓	✓	✓
Main program call from main program and subroutine		✓	✓	✓	✓	✓	✓
Subprogram levels, max.		11	11	11	11	11	11
Number of subprogram passes		≤ 9999	≤ 9999	≤ 9999	≤ 9999	≤ 9999	≤ 9999
Number of levels for skip blocks		1	1	1	1	1	1
Polar coordinates		✓	✓	✓	✓	✓	✓
Dimensions metric/inch, changeover:							
• Manually		✓	✓	✓	✓	✓	✓
• Via program		✓	✓	✓	✓	✓	✓
Inverse-time feedrate		✓	✓	✓	✓	✓	✓
Auxiliary function output:							
• Via M word, max. programmable value range		INT 231 ⁻¹	INT 231 ⁻¹	INT 231 ⁻¹	INT 231 ⁻¹	INT 231 ⁻¹	INT 231 ⁻¹
• Via H word, max. programmable value range REAL ± 3.4028 ex 38 (display ± 999999999.9999)		INT -231 ... 231 ⁻¹	INT -231 ... 231 ⁻¹	INT -231 ... 231 ⁻¹	INT -231 ... 231 ⁻¹	INT -231 ... 231 ⁻¹	INT -231 ... 231 ⁻¹
Basic frames, max. number		1	1	1	1	1	1
Settable offsets, max. number		6	6	6	6	6	6
Work offsets, programmable (frames)		✓	✓	✓	✓	✓	✓
Global and local user data		✓	✓	✓	✓	✓	✓
Global program user data		✓	✓	✓	✓	✓	✓
SINUMERIK high-level CNC language with:							
• Frame concept TRANS/ROT/SCALE/MIRROR		✓	✓	✓	✓	✓	✓
• User variables, configurable		✓	✓	✓	✓	✓	✓
• Predefined user variables (arithmetic parameters)		✓	✓	✓	✓	✓	✓
• Predefined user variables (arithmetic parameters), configurable		✓	✓	✓	✓	✓	✓
• Read/write system variables		✓	✓	✓	✓	✓	✓
• Indirect programming		✓	✓	✓	✓	✓	✓
• Program jumps and branches		✓	✓	✓	✓	✓	✓
• Arithmetic and trigonometric functions		✓	✓	✓	✓	✓	✓
• Compare operations and logic combinations		✓	✓	✓	✓	✓	✓
• Macro techniques		✓	✓	✓	✓	✓	✓
• Control structures IF-ELSE-ENDIF		✓	✓	✓	✓	✓	✓
• Control structures WHILE, FOR, REPEAT, LOOP		✓	✓	✓	✓	✓	✓
• STRING functions		✓	✓	✓	✓	✓	✓

Overview of functions

SINUMERIK 808D family

Technology cycles/Canned cycles

✓ Basic version ○ Option – Not available	Article No.	SINUMERIK 808D		SINUMERIK 808D ADVANCED			
		PPU 141.3		PPU 15x.3		PPU 16x.3	
		Turning	Milling	Turning	Milling	Turning	Milling
Technology cycles							
Technology cycles for SINUMERIK style programming language:							
• Drilling, centering – CYCLE81		✓	✓	✓	✓	✓	✓
• Drilling, counterboring – CYCLE82		✓	✓	✓	✓	✓	✓
• Deep-hole drilling – CYCLE83		✓	✓	✓	✓	✓	✓
• Rigid tapping – CYCLE84		✓	✓	✓	✓	✓	✓
• Tapping with compensating chuck – CYCLE840		✓	✓	✓	✓	✓	✓
• Reaming 1 – CYCLE85		✓	✓	✓	✓	✓	✓
• Boring – CYCLE86		✓	✓	✓	✓	✓	✓
• Position pattern: Row of holes – HOLES1		–	✓	–	✓	–	✓
• Position pattern: Circle of holes – HOLES2		–	✓	–	✓	–	✓
• Cutoff - CYCLE92		✓	–	✓	–	✓	–
• Groove – CYCLE93		✓	–	✓	–	✓	–
• Undercut (forms E and F according to DIN) – CYCLE94		✓	–	✓	–	✓	–
• Contour cutting with relief cut – CYCLE95		✓	–	✓	–	✓	–
• Thread undercut – CYCLE96		✓	–	✓	–	✓	–
• Thread chaining – CYCLE98		✓	–	✓	–	✓	–
• Thread cutting – CYCLE99		✓	–	✓	–	✓	–
• Face milling – CYCLE71		–	✓	–	✓	–	✓
• Contour milling – CYCLE72		–	✓	–	✓	–	✓
• Milling a rectangular spigot – CYCLE76		–	✓	–	✓	–	✓
• Milling a circular spigot – CYCLE77		–	✓	–	✓	–	✓
• Long holes located on a circle – LONGHOLE		–	✓	–	✓	–	✓
• Slots on a circle – SLOT1		–	✓	–	✓	–	✓
• Circumferential slot – SLOT2		–	✓	–	✓	–	✓
• Milling a rectangular pocket – POCKET3		–	✓	–	✓	–	✓
• Milling a circular pocket – POCKET4		–	✓	–	✓	–	✓
• Thread milling – CYCLE90		–	✓	–	✓	–	✓
• High-speed settings – CYCLE832		–	✓	–	✓	–	✓
Canned cycles							
Canned cycles for ISO code milling:							
• High-speed deep hole drilling cycle with chip breakage (G73)		–	✓	–	✓	–	✓
• Drilling a left-hand thread without any compensating chuck cycle (G74)		–	✓	–	✓	–	✓
• Fine drilling cycle (G76)		–	✓	–	✓	–	✓
• Deselection of a fixed cycle (G80)		–	✓	–	✓	–	✓
• Drilling cycle, counterboring (G81)		–	✓	–	✓	–	✓
• Countersink drilling cycle (G82)		–	✓	–	✓	–	✓
• Deep hole drilling cycle with chip removal (G83)		–	✓	–	✓	–	✓
• Drilling a right-hand thread without any compensating chuck cycle (G84)		–	✓	–	✓	–	✓
• Boring cycle (G85)		–	✓	–	✓	–	✓
• Boring cycle, retraction with G00 (G86)		–	✓	–	✓	–	✓
• Boring cycle, reverse countersinking (G87)		–	✓	–	✓	–	✓
• Boring cycle, retraction with machining feedrate (G89)		–	✓	–	✓	–	✓

2

Canned cycles/Program and workpiece management/Programming support/Simulation

✓ Basic version ○ Option – Not available	Article No.	SINUMERIK 808D		SINUMERIK 808D ADVANCED			
		PPU 141.3		PPU 15x.3		PPU 16x.3	
		Turning	Milling	Turning	Milling	Turning	Milling
Canned cycles (continued)							
Canned cycles for ISO code turning (G code system A):							
• Thread cutting with constant lead (G32)		✓	–	✓	–	✓	–
• Thread cutting with variable lead (G34)		✓	–	✓	–	✓	–
• Finishing cycle (G70)		✓	–	✓	–	✓	–
• Stock removal cycle longitudinal axis (G71)		✓	–	✓	–	✓	–
• Stock removal cycle transverse axis (G72)		✓	–	✓	–	✓	–
• Closed cutting cycle (G73)		✓	–	✓	–	✓	–
• Multiple repetitive grooving cycles in the longitudinal axis (G74)		✓	–	✓	–	✓	–
• Deep hole drilling and recessing in facing axis (G75)		✓	–	✓	–	✓	–
• Multiple thread cutting (G76)		✓	–	✓	–	✓	–
• Axial cutting (G90)		✓	–	✓	–	✓	–
• Thread cutting (G92)		✓	–	✓	–	✓	–
• Radial cutting (G94)		✓	–	✓	–	✓	–
Program and workpiece management							
Part programs on PPU, max. number		255	255	255	255	255	255
Readable part program names		✓	✓	✓	✓	✓	✓
Sub-folders for part programs with readable names		✓	✓	✓	✓	✓	✓
Programming support							
Background editing		✓	✓	✓	✓	✓	✓
Program editor:							
• Full screen CNC editor with cut, copy and paste functionality		✓	✓	✓	✓	✓	✓
• Programming support programGUIDE BASIC for SINUMERIK technology cycles		✓	✓	✓	✓	✓	✓
• Contour computer with programming graphics/free contour input (contour calculator)		✓	✓	✓	✓	✓	✓
Simulation							
2D simulation		✓	✓	✓	✓	✓	✓
Real-time simulation of current machining operation		✓	✓	✓	✓	✓	✓

Overview of functions

SINUMERIK 808D family

Operating modes/Tools

✓ Basic version ○ Option – Not available	Article No.	SINUMERIK 808D		SINUMERIK 808D ADVANCED				
		PPU 141.3		PPU 15x.3		PPU 16x.3		
		Turning	Milling	Turning	Milling	Turning	Milling	
Operating modes								
	Manual Machine plus for manual controlled semi-CNC lathes	6FC5800-0AP07-0YB0	○	–	○	–	○	–
	JOG:							
	• T, S, M screen for quick activation of machine functions		✓	✓	✓	✓	✓	✓
	• Face milling cycle for workpiece preparation		–	✓	–	✓	–	✓
	• Handwheel selection		✓	✓	✓	✓	✓	✓
	• Switchover: inch/metric		✓	✓	✓	✓	✓	✓
	• Manual measurement of work offset		✓	✓	✓	✓	✓	✓
	• Manual measurement of tool offset		✓	✓	✓	✓	✓	✓
	• Semi-automatic tool measurement with tool probe		–	✓	–	✓	–	✓
	MDI:							
	• Input in text editor		✓	✓	✓	✓	✓	✓
	Automatic:							
	• Execution from memory stick connected to USB interface on operator panel front		✓	✓	✓	✓	✓	✓
	• Program control (dry-run feed, block skip etc.)		✓	✓	✓	✓	✓	✓
	• Program editing		✓	✓	✓	✓	✓	✓
	• Block search with/without calculation		✓	✓	✓	✓	✓	✓
	Repos (repositioning on the contour):							
	• With operator command/semi-automatically		✓	✓	✓	✓	✓	✓
	• Program-controlled		✓	✓	✓	✓	✓	✓
	Preset:							
	• Set actual value		✓	✓	✓	✓	✓	✓
Tools								
	Tools/cutting edges, max.		64/128	64/128	64/128	64/128	64/128	64/128
	Tool types:							
	• Turning		✓	–	✓	–	✓	–
	• Drilling		✓	✓	✓	✓	✓	✓
	• Milling		✓	✓	✓	✓	✓	✓
	Tool radius compensations in plane:							
	• With approach and retract strategies		✓	✓	✓	✓	✓	✓
	• With transition circle/ellipse on outer edges		✓	✓	✓	✓	✓	✓
	Tool offset selection via T and D numbers		✓	✓	✓	✓	✓	✓
	Look-ahead detection of contour violations		✓	✓	✓	✓	✓	✓

2

Communication and data management

✓ Basic version ○ Option – Not available	Article No.	SINUMERIK 808D		SINUMERIK 808D ADVANCED			
		PPU 141.3		PPU 15x.3		PPU 16x.3	
		Turning	Milling	Turning	Milling	Turning	Milling
Communication and data management							
USB interface on panel front for memory stick and USB PC keyboard:							
• Transfer of:		✓	✓	✓	✓	✓	✓
- Machine and setting data		✓	✓	✓	✓	✓	✓
- PLC data		✓	✓	✓	✓	✓	✓
- Compensation data		✓	✓	✓	✓	✓	✓
- Tool and work offset data		✓	✓	✓	✓	✓	✓
- R parameter		✓	✓	✓	✓	✓	✓
- HMI data		✓	✓	✓	✓	✓	✓
- User cycles		✓	✓	✓	✓	✓	✓
- Part programs		✓	✓	✓	✓	✓	✓
- PLC program (*.pte)		✓	✓	✓	✓	✓	✓
• Execute part program		✓	✓	✓	✓	✓	✓
Ethernet interface:							
• Transfer of:		✓	✓	✓	✓	✓	✓
- Machine and setting data		✓	✓	✓	✓	✓	✓
- PLC data		✓	✓	✓	✓	✓	✓
- Compensation data		✓	✓	✓	✓	✓	✓
- Tool and work offset data		✓	✓	✓	✓	✓	✓
- R parameter		✓	✓	✓	✓	✓	✓
- HMI data		✓	✓	✓	✓	✓	✓
- User cycles		✓	✓	✓	✓	✓	✓
- Part programs		✓	✓	✓	✓	✓	✓
• Execute part program		✓	✓	✓	✓	✓	✓
• Part program send/receive		✓	✓	✓	✓	✓	✓
• PLC program upload/download		✓	✓	✓	✓	✓	✓
• PLC status monitoring		✓	✓	✓	✓	✓	✓

Overview of functions

SINUMERIK 808D family

HMI functions/Monitoring functions/Compensations

✓ Basic version ○ Option – Not available	Article No. Note	SINUMERIK 808D		SINUMERIK 808D ADVANCED			
		PPU 141.3		PPU 15x.3		PPU 16x.3	
		Turning	Milling	Turning	Milling	Turning	Milling
HMI functions							
CNC lock function	6FC5800-0AS71-0YB0	○	○	○	○	○	○
SINUMERIK 808D startGUIDE:							
• Startup assistant Built-in graphical interactive assistant for 1st commissioning of machines with SINUMERIK 808D		✓	✓	✓	✓	✓	✓
• Series startup assistant Built-in graphical interactive assistant for the series production of machines with SINUMERIK 808D		✓	✓	✓	✓	✓	✓
• Sales assistant Built-in viewer for bitmaps with sales arguments for SINUMERIK 808D, extendable by customer-specific sales arguments for the machine		✓	✓	✓	✓	✓	✓
Online help for programming, alarms and machine data		✓	✓	✓	✓	✓	✓
CNC program messages		✓	✓	✓	✓	✓	✓
Screen saver		✓	✓	✓	✓	✓	✓
Access protection level support		✓	✓	✓	✓	✓	✓
Chinese input method editor for part program names, sub-directory names and CNC comments		✓	✓	✓	✓	✓	✓
Operating software languages:							
• Chinese Simplified, Czech, English, French, German, Italian, Korean, Polish, Portuguese, Russian, Spanish, Turkey, Hungary		✓	✓	✓	✓	✓	✓
• Language switchover online		✓	✓	✓	✓	✓	✓
Monitoring functions							
Working area limitation		✓	✓	✓	✓	✓	✓
Limit switch monitoring		✓	✓	✓	✓	✓	✓
Software and hardware limit switches		✓	✓	✓	✓	✓	✓
Position monitoring		✓	✓	✓	✓	✓	✓
Standstill (zero-speed) monitoring		✓	✓	✓	✓	✓	✓
Clamping monitoring		✓	✓	✓	✓	✓	✓
Contour monitoring		✓	✓	✓	✓	✓	✓
Axis limitation from the PLC		✓	✓	✓	✓	✓	✓
Spindle speed limitation		✓	✓	✓	✓	✓	✓
Compensations							
Backlash compensation		✓	✓	✓	✓	✓	✓
Leadscrew error compensation		✓	✓	✓	✓	✓	✓
Bidirectional leadscrew error compensation	6FC5800-0AM54-0YB0	○	○	○	○	○	○

2

✓ Basic version ○ Option – Not available	Article No.	SINUMERIK 808D		SINUMERIK 808D ADVANCED			
		PPU 141.3		PPU 15x.3		PPU 16x.3	
		Turning	Milling	Turning	Milling	Turning	Milling
PLC area							
Integrated PLC		✓	✓	✓	✓	✓	✓
Style of PLC program:							
• Prepared and ready to run PLC program on board		✓	✓	✓	✓	✓	✓
• Fully customized PLC programs by offline PLC programming tool		✓	✓	✓	✓	✓	✓
Fixed cycle time for PLC		12 ms	12 ms	12 ms	12 ms	12 ms	12 ms
Maximum number of ladder steps		6000	6000	6000	6000	6000	6000
PLC programming language:							
• LAD ladder diagram		✓	✓	✓	✓	✓	✓
Offline PLC programming tool	6FC5811-0CY00-0YA8 On toolbox DVD-ROM	○	○	○	○	○	○
PLC Ladder Viewer on PPU		✓	✓	✓	✓	✓	✓
PLC I/O:							
• On-board digital PLC:	Connection via screw-clamp connector on PPU.						
- Inputs 24 V		24	24	24	24	24	24
- Outputs 24 V, 0.2 A		16	16	16	16	16	16
• On-board digital PLC:	Connection via 50-pole ribbon cable connector.						
- Inputs 24 V		48	48	48	48	48	48
- Outputs 24 V, 0.2 A		32	32	32	32	32	32
Connection via 50-pole ribbon cable connector to PPU:							
• Terminal strip converter	6EP5406-5AA00	○	○	○	○	○	○
• Cable set	6EP5306-5BG00	○	○	○	○	○	○
PLC alarms/messages, max. number		128	128	128	128	128	128
Bit memories, number		256 bytes	256 bytes	256 bytes	256 bytes	256 bytes	256 bytes
Timers, number		64	64	64	64	64	64
Counters, number		64	64	64	64	64	64
Subroutines		64	64	64	64	64	64
User machine data for configuring the PLC user program		✓	✓	✓	✓	✓	✓

Overview of functions

SINUMERIK 808D family

Commissioning and serial production/Diagnostic functions/Service and maintenance/Training and offline programming

✓ Basic version ○ Option – Not available	Article No. Note	SINUMERIK 808D		SINUMERIK 808D ADVANCED			
		PPU 141.3		PPU 15x.3		PPU 16x.3	
		Turning	Milling	Turning	Milling	Turning	Milling
Commissioning and serial production							
SINUMERIK 808D startGUIDE							
• Startup assistant Built-in graphical interactive assistant for 1st commissioning of machines with SINUMERIK 808D family		✓	✓	✓	✓	✓	✓
• Series startup assistant Built-in graphical interactive assistant for the series production of machines with SINUMERIK 808D family		✓	✓	✓	✓	✓	✓
Backup/restore of system software via USB memory stick		✓	✓	✓	✓	✓	✓
Cloning of serial startup files for serial production via USB memory stick		✓	✓	✓	✓	✓	✓
SINUMERIK 808D family toolbox with:	6FC5811-0CY00-0YA8 On toolbox DVD-ROM.	○	○	○	○	○	○
• Offline PLC programming tool		○	○	○	○	○	○
• Sample PLC program		○	○	○	○	○	○
• MCP strip template		○	○	○	○	○	○
• MCP icon library		○	○	○	○	○	○
• User manuals		○	○	○	○	○	○
• Access My Machine AMM		✓	✓	✓	✓	✓	✓
Diagnostic functions							
Alarms and messages		✓	✓	✓	✓	✓	✓
Action log can be activated for diagnostic purposes		✓	✓	✓	✓	✓	✓
PLC status		✓	✓	✓	✓	✓	✓
LAD display		✓	✓	✓	✓	✓	✓
Service and maintenance							
Integrated service planner for monitoring of service intervals		✓	✓	✓	✓	✓	✓
One touch system backup (Ctrl + S)		✓	✓	✓	✓	✓	✓
CNC memory buffering via battery		✓	✓	✓	✓	✓	✓
Training and offline programming							
SINUMERIK 808D on PC	6FC5870-0YC40-0YT0 Free download of trial version from: www.cnc4you.com	○	○	○	○	○	○

SINUMERIK 808D system



3/2	CNC control
3/2	SINUMERIK 808D PPU 141.3
3/5	Operator components
3/5	SINUMERIK 808D MCP
3/7	Feed axis solutions
3/7	SINAMICS V60 servo drive
3/10	SIMOTICS S-1FL5 feed motor
3/13	MOTION-CONNECT connection systems
3/13	MOTION-CONNECT cables for SINUMERIK 808D
3/15	MOTION-CONNECT cables for SINAMICS V60 servo drive
3/17	Example packages
3/17	Example package for Turning
3/18	Example package for Milling

SINUMERIK 808D system

CNC control

SINUMERIK 808D PPU 141.3

Overview



SINUMERIK 808D Turning PPU 141.3 horizontal



SINUMERIK 808D Milling PPU 141.3 horizontal

The SINUMERIK 808D PPU 141.3 is an operator-panel-based CNC, preconfigured for use in modern basic standard turning and milling machines.

Benefits

- Compact, rugged, and maintenance-friendly operator-panel CNC with dedicated system software for turning and milling technologies
- Intelligent clamp mounting without drilling holes into the cabinet
- Minimum commissioning efforts due to plug and play machine control panel connected via USB interface
- Maximum performance and accuracy due to most modern CNC features
- SINUMERIK 808D startGUIDE: assists all process steps of the machine – from engineering to production, from sales to operation and programming at the push of a button
- SINUMERIK Operate BASIC: maximum operator convenience similar to SINUMERIK 828D and 840D sl
- SINUMERIK programGUIDE BASIC: wide range of technology cycles for turning, milling and drilling with graphical input screens
- Manual Machine plus: easy semi-automatic machining with handwheel controlled flat-bed lathes¹⁾
- Easy data transmission via USB stick and Ethernet interface

Function

- IP65 protection for CNC front panel and machine control panel
- Integrated CNC keyboard with mechanical keys
- English panel layout
- 8.4" color LCD display
- USB user interface on the operator panel front
- Ethernet interface
- Pulse/direction interface for feed drives
- Analog ± 10 V interface for spindle drive
- NV-RAM technology needs no battery
- Pre-configured system software for turning and milling technologies
- 1 machining channel/mode group
- Up to 4 axes/spindles
- Graphically guided SINUMERIK CNC programming and standard ISO-code programming with canned cycles
- Graphical CNC simulation
- Integrated contour computer
- Integrated PLC based on the SIMATIC S7-200 command set with ladder logic programming
- Integrated/distributed PLC I/O concept with 72 digital PLC inputs and 48 digital PLC outputs
- CNC options subject to license
- Customized user screens
- Machine maintenance tasks are accomplished by integrated service planner.

Integration

The following components can be connected to the SINUMERIK 808D PPU 141.3:

- Up to 2 electronic handwheels
- Up to 72 digital PLC inputs and 48 digital PLC outputs
- 1 TTL direct spindle encoder
- SINUMERIK 808D MCP via USB interface
- SINAMICS V60 drive system for feed axes
- Spindle drives via ± 10 V analog output
- PC via Ethernet interface

¹⁾ Only for turning.

Technical specifications

Article No.	6FC5370-1A.03-0AA0
Product name	SINUMERIK 808D PPU 141.3 horizontal
Input voltage	24 V DC + 20 %/- 15 %
Power consumption, max.	50 W
Mains buffering time	3 ms (20 ms with SITOP smart)
Degree of protection according to EN 60529 (IEC 60529)	
• Operator panel front, with closed front cover	IP65
• PPU, rear	IP20
Relative humidity	
• Storage	5 ... 95 % at 25 °C
• Transport	5 ... 95 % at 25 °C
• Operation	5 ... 90 % at 25 °C (no condensation)
Ambient temperature	
• Storage	-20 ... +60 °C
• Transport	-20 ... +60 °C
• Operation	
- Front	0 ... 45 °C
- Rear	0 ... 50 °C
Dimensions	
• Width	420 mm
• Height	200 mm
• Depth	104 mm
Panel cutout	
• Width	406 mm
• Height	186 mm
• Tolerance	+ 1 mm
Weight, approx.	3.06 kg
Certificate of suitability	CE, EAC

Selection and ordering data

Description	Article No.
<i>Hardware components</i>	
SINUMERIK 808D Turning PPU 141.3 horizontal	6FC5370-1AT03-0AA0
English layout	
SINUMERIK 808D Milling PPU 141.3 horizontal	6FC5370-1AM03-0AA0
English layout	
<i>Software components</i>	
SINUMERIK 808D T/M toolbox	6FC5811-0CY00-0YA8
On DVD-ROM	

Options

Description	Article No.
Additional NC axis¹⁾	6FC5800-0AK70-0YB0
Manual Machine plus (MM+)¹⁾	6FC5800-0AP07-0YB0
Bidirectional leadscrew error compensation	6FC5800-0AM54-0YB0
TRANSMIT/TRACYL Transformation without Y axis	6FC5800-0AS50-0YB0
Contour handwheel	6FC5800-0AM08-0YB0
CNC lock function	6FC5800-0AS71-0YB0

¹⁾ Only for turning.

Overview



SINUMERIK 808D MCP

The SINUMERIK 808D MCP machine control panel with mechanical keys is designed to permit user-friendly, well-structured operation of the machine functions. It is suitable for machine level operation of turning and milling machines. Customized keys can be individually labeled using slide-in strips.

The machine control panel can be mounted from the rear using special clamps without drilling holes into the cabinet.

Design

Operator controls:

- Mode and function keys
 - 39 keys, of which 30 keys with LEDs
 - Direction keys for machines with rapid traverse override (MCP is pre-assembled with turning slide-in strips. Milling slide-in strips are supplied in the included accessories pack)
 - Pre-defined MCP keys for common functions, such as handwheel selection, tool change, coolant control or program test
- Spindle control with spindle override (rotary switch with 15 positions)
- Feedrate control with feedrate/rapid traverse override (rotary switch with 18 positions)
- 7-segment display for tool number

Layout:

- English or Chinese Simplified

Key type:

- Mechanical keys with protection foil

Interface to CNC:

- USB

Expansion options:

- 1 slot for emergency stop button ($d = 22$ mm)
- 3 slots for control devices ($d = 16$ mm)

Integration

The SINUMERIK 808D MCP machine control panel can be used for:

- SINUMERIK 808D
- SINUMERIK 808D ADVANCED

Technical specifications

Article No.	6FC5303-0AF35-0.A0
Product name	SINUMERIK 808D MCP machine control panel
Input voltage	5 V DC provided by PPU 141.3 via USB interface
Power consumption, max.	5 W
Degree of protection according to EN 60529 (IEC 60529)	<ul style="list-style-type: none"> • Front IP65 • Rear IP20
Humidity rating based on EN 60721-3-3	Class 3K5 condensation and icing excluded. Low air temperature 0 °C.
Relative humidity	<ul style="list-style-type: none"> • Storage 5 ... 95 % at 25 °C • Transport 5 ... 95 % at 25 °C • Operation 5 ... 90 % at 25 °C
Ambient temperature	<ul style="list-style-type: none"> • Storage -20 ... +60 °C • Transport -20 ... +60 °C • Operation <ul style="list-style-type: none"> - Front 0 ... 45 °C - Rear 0 ... 50 °C
Distance	0.5 m
Dimensions	<ul style="list-style-type: none"> • Width 420 mm • Height 120 mm • Depth 58 mm
Panel cutout	<ul style="list-style-type: none"> • Width 406 mm • Height 106 mm • Tolerance + 1 mm
Weight, approx.	0.86 kg
Certificate of suitability	CE, EAC

Selection and ordering data

Description	Article No.
SINUMERIK 808D MCP machine control panel	
With USB cable	
• English layout	6FC5303-0AF35-0AA0
• Simplified Chinese layout	6FC5303-0AF35-0CA0

The scope of supply of the SINUMERIK 808D MCP includes:

- USB cable 0.5 m
- Mounting clamps
- Slide-in strips for turning application (already inserted)
- Slide-in strips for milling application
- Blank slide-in strip for individual labeling

SINUMERIK 808D system

Operator components

SINUMERIK 808D MCP

Dimensional drawings

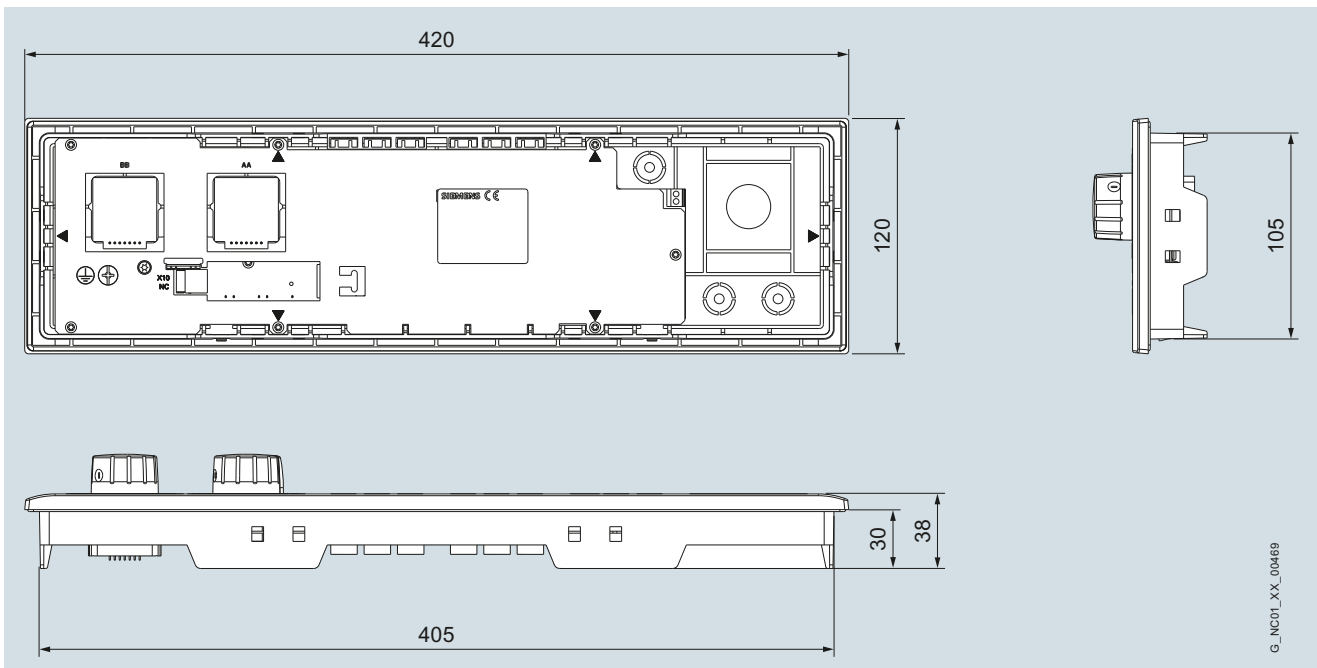

SINUMERIK 808D MCP

G_NC01_XX_00469

Overview



SINAMICS V60 servo drives

The SINAMICS V60 servo drive is specially designed to control the feed axes in standard machine tool applications. The system is designed primarily for applications where cost effectiveness is the primary consideration. The key performance data of the drive are aligned to perfectly fit to the solution provided by the SINUMERIK 808D.

Benefits

- Compact module with integrated infeed, inverter and closed-loop position control for one feed axis
- No cooling fans needed thanks to large heat sink made of die-cast aluminum
- Coated electronic modules
- Commissioning and configuring without PC-based tools
- Very simple commissioning using keys/7-segment display
- Faster commissioning thanks to pre-configured motor data stored in the drive.
- CE certified

Function

- 4 versions with output currents of 4 A, 6 A, 7 A and 10 A
- Supply voltage 220 V to 240 V 3 AC
- 200 % overload capability
- Pulse/direction interface (5 V difference signals) to the SINUMERIK 808D
- Integrated motor brake switch
- Alarm relay contact

Integration

The following components can be connected to the SINAMICS V60:

- SINUMERIK 808D Turning PPU 141.3 horizontal
- SINUMERIK 808D Milling PPU 141.3 horizontal
- SIMOTICS S-1FL5 feed motor
- TTL encoder in SIMOTICS S-1FL5 feed motor
- Brake in SIMOTICS S-1FL5 feed motor

Selection and ordering data

SINAMICS V60 servo drive		SIMOTICS S-1FL5 feed motor
Rated output current		Static torque
I_{rated} A	Article No.	M_0 at $\Delta T = 100$ K Nm
4	6SL3210-5CC14-0UA0	4
6	6SL3210-5CC16-0UA0	6
7	6SL3210-5CC17-0UA0	7.7
10	6SL3210-5CC21-0UA0	10

SINUMERIK 808D system

Feed axis solutions

SINAMICS V60 servo drive**Technical specifications**

Article No.	6SL3210-5CC14-0UA0	6SL3210-5CC16-0UA0	6SL3210-5CC17-0UA0	6SL3210-5CC21-0UA0
Product name	SINAMICS V60 servo drive			
Input voltage	220 ... 240 V 3 AC - 15 %/+ 10 %			
Input frequency	50 ... 60 Hz ± 10 %			
Infeed	Non-stabilized			
Electronics power supply	24 V DC - 15 %/+ 20 %			
24 V DC supply	0.8 A (1.4 A) combined with motors without brake (with brake)			
Input voltage				
Pulse/direction interface				
• Rated value	5 V DC			
• Frequency range	≤ 333 kHz			
Cooling	Natural cooling			
Ambient temperature				
• Storage	-20 ... +80 °C			
• Transport	-20 ... +80 °C			
• Operation	0 ... 45 °C without derating, > 45 ... 55 °C derating to 70 %			
Air humidity	< 95 %			
Site altitude	Up ... 1000 m without derating, > 1000 ... 2000 m derating to 80 %			
Conductor cross-section, max.	2.5 mm ²			
Connectable motors	SIMOTICS S-1FL5			
Degree of protection	IP20			
Encoder evaluation	TTL encoder with 2500 S/R (13 bit resolution through electronic multiplication)			
Output current				
• Rated current I_{rated}	4 A	6 A	7 A	10 A
• Peak current I_{max}	8 A	12 A	14 A	20 A
Rated power P_{rated}	0.8 kW	1.2 kW	1.4 kW	2 kW
Power loss	36 W	47 W	54 W	70 W
Cooling air required	0.005 m ³ /s	0.005 m ³ /s	0.005 m ³ /s	0.005 m ³ /s
Sound pressure level L_{pA} (1 m)	< 45 dB	< 45 dB	< 45 dB	< 45 dB
Dimensions ¹⁾				
• Width	106 mm	106 mm	106 mm	123 mm
• Height	226 mm	226 mm	226 mm	226 mm
• Depth	200 mm	200 mm	200 mm	200 mm
Weight	2.63 kg	2.63 kg	2.63 kg	3.44 kg
Certificate of suitability	CE			

S/R = Signals/Revolution

¹⁾ Minimum distances: 25 mm between drive modules, 100 mm from other control cabinet components.

Dimensional drawings

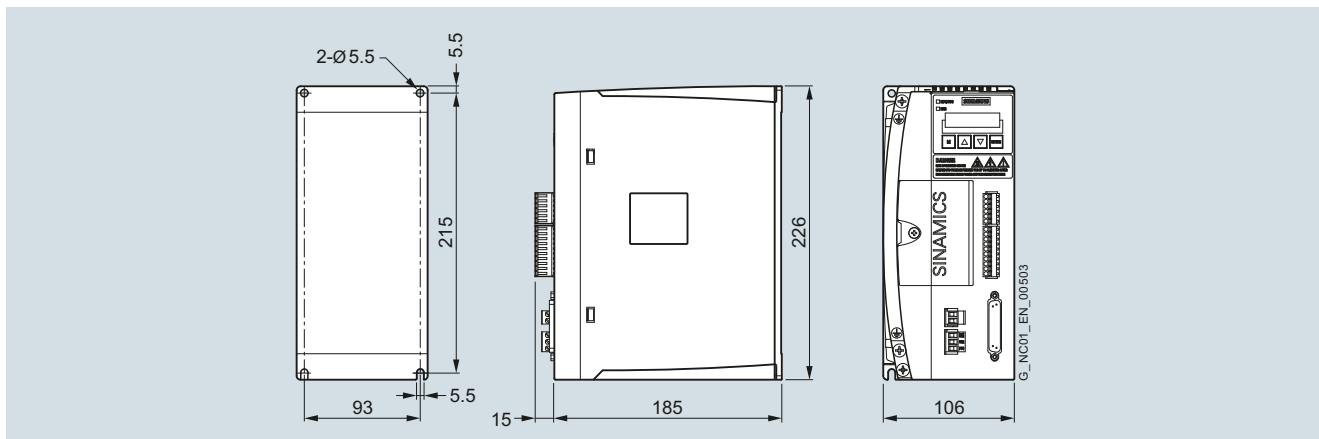

SINAMICS V60 4 A/6 A/7 A

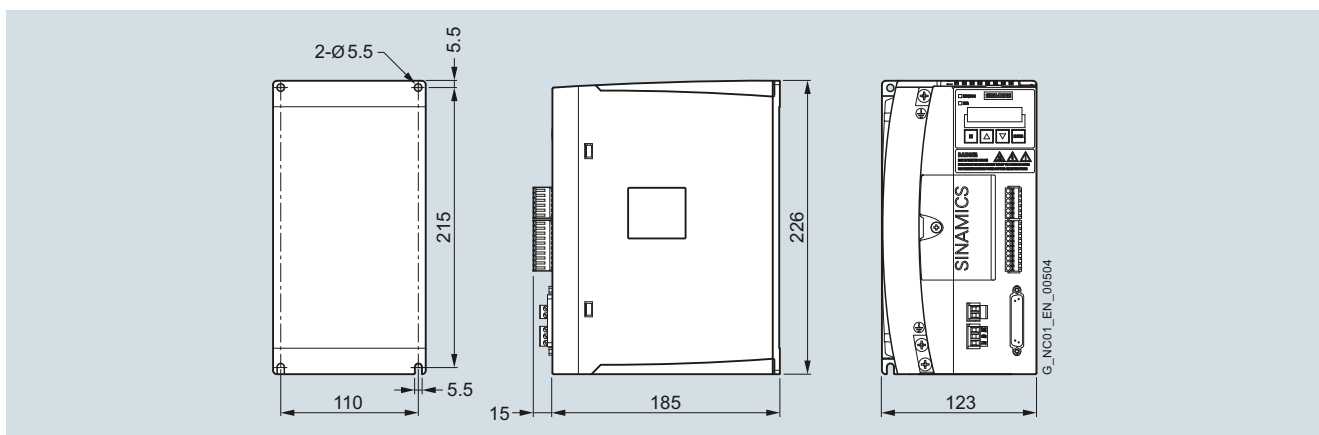

SINAMICS V60 10 A

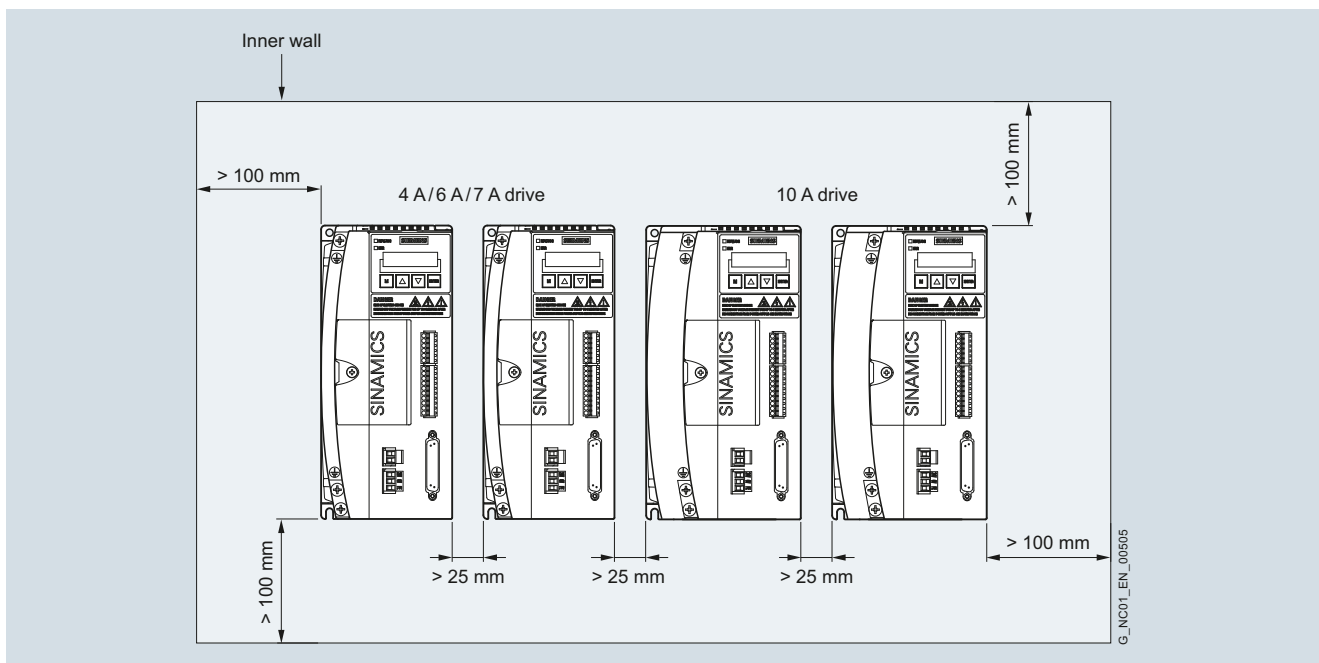

Mounting clearance

3

SINUMERIK 808D system

Feed axis solutions

SIMOTICS S-1FL5 feed motor**Overview**

SIMOTICS S-1FL5 feed motors

The SIMOTICS S-1FL5 feed motor is optimized for operation with the SINAMICS V60 servo drive and provides the dynamic performance required by machine tools.

Benefits

- High performance rare earth magnet material
- Rugged design with IP54 degree of protection and military style connectors
- Maximum flexibility due to variants with/without brake and plain shaft/feather key

Function

- 4 motor types with 4 Nm, 6 Nm, 7.7 Nm and 10 Nm
- Rated speed of 2000 rpm
- Integrated TTL encoder with 2500 S/R (13 bit resolution through electronic multiplication of the SINAMICS V60 Controlled Power Module CPM60.1)
- Degree of protection IP54, natural cooling
- Optional holding brake
- With plain shaft or feather key, half-key balancing

3

SINUMERIK 808D system

Feed axis solutions

SIMOTICS S-1FL5 feed motor**Selection and ordering data**

SIMOTICS S-1FL5 feed motors			SINAMICS V60 servo drive
Static torque M_0 at $\Delta T = 100$ K Nm	Rated speed n_{rated} rpm	Article No.	Rated output current I_{rated} A
4	2000	1FL5060-0AC21-0A ■ 0	4
6	2000	1FL5062-0AC21-0A ■ 0	6
7.7	2000	1FL5064-0AC21-0A ■ 0	7
10	2000	1FL5066-0AC21-0A ■ 0	10

Shaft extension:	Holding brake:	
Feather key and keyway (half-key balancing)	Without	A
Feather key and keyway (half-key balancing)	With	B
Plain shaft	Without	G
Plain shaft	With	H

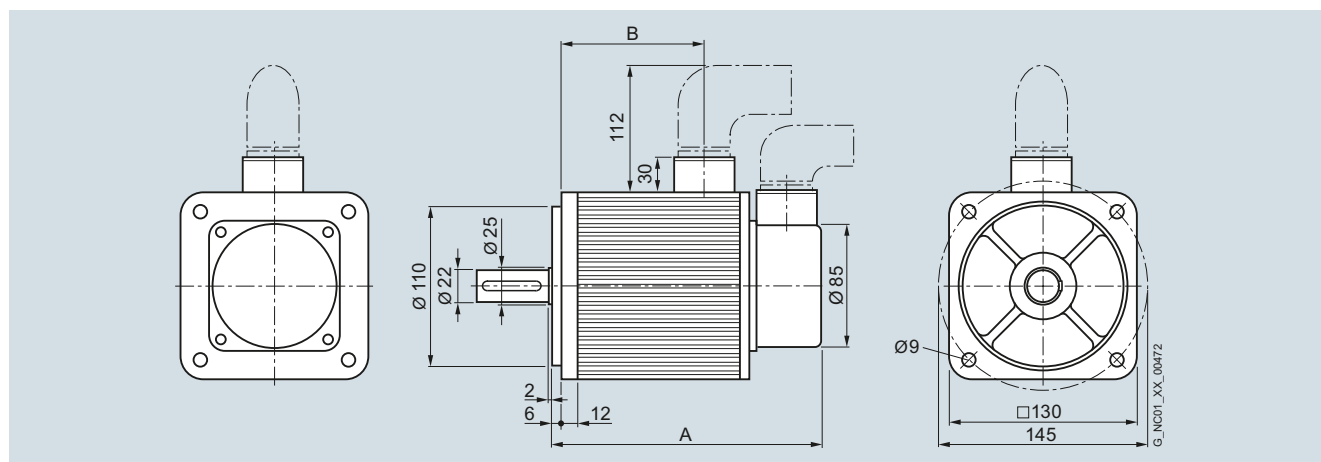
Dimensional drawings

SIMOTICS S-1FL5 feed motor

Motor Type	Dimensions in mm		
	A without brake	A with brake	B
1FL5060	163	205	80
1FL5062	181	223	98
1FL5064	195	237	112
1FL5066	219	261	136

Technical specifications

Article No.	1FL5060-...	1FL5062-...	1FL5064-...	1FL5066-...
Product brand name	SIMOTICS			
Product type designation	S-1FL5			
Product designation	Feed motors			
Type of motor	Synchronous motor			
Rated speed	2000 rpm			
Encoder	TTL encoder with 2500 S/R			
Infeed	Non-stabilized			
Type of construction in accordance with EN 60034-7 (IEC 60034-7)	IM B5 (IM V1, IM V3)			
Degree of protection in accordance with EN 60034-5 (IEC 60034-5)	IP54			
Cooling	Natural cooling			
Shaft end in accordance with DIN 748-3 (IEC 60072-1)	Plain shaft/Shaft key (C type)			
Paint finish	Black			
Insulation of the stator winding in accordance with EN 60034-1 (IEC 60034-1)	Temperature class 130 (B)			
Ambient temperature				
• Storage	-20 ... +80 °C			
• Transport	-20 ... +80 °C			
• Operation	0 ... 45 °C without derating, > 45 ... 55 °C derating to 70 %			
Torque				
• Static torque M_{rated}	4 Nm	6 Nm	7.7 Nm	10 Nm
• Torque, max. M_{max} (converter)	8 Nm	12 Nm	15.4 Nm	20 Nm
Rated power	0.8 kW	1.2 kW	1.5 kW	2 kW
Static current	4 A	6 A	7 A	10 A
Rated speed	2000 rpm	2000 rpm	2000 rpm	2000 rpm
Efficiency η	91.1 %	93.3 %	92.0 %	93.7 %
Moment of inertia without brake	$11.01 \times 10^{-4} \text{ kgm}^2$	$15.44 \times 10^{-4} \text{ kgm}^2$	$20.17 \times 10^{-4} \text{ kgm}^2$	$25.95 \times 10^{-4} \text{ kgm}^2$
Moment of inertia with brake	$12.68 \times 10^{-4} \text{ kgm}^2$	$17.11 \times 10^{-4} \text{ kgm}^2$	$21.84 \times 10^{-4} \text{ kgm}^2$	$27.62 \times 10^{-4} \text{ kgm}^2$
Shaft height	65 mm	65 mm	65 mm	65 mm
Dimensions				
• Edge dimension	130 mm	130 mm	130 mm	130 mm
• Length				
- Without brake	221 mm	239 mm	253 mm	277 mm
- With brake	263 mm	281 mm	295 mm	319 mm
Weight				
• Without brake	6 kg	7.6 kg	8.6 kg	10.6 kg
• With brake	8.6 kg	10.2 kg	11.2 kg	13.2 kg
Certificate of suitability	CE			

S/R = Signals/Revolution

Integration

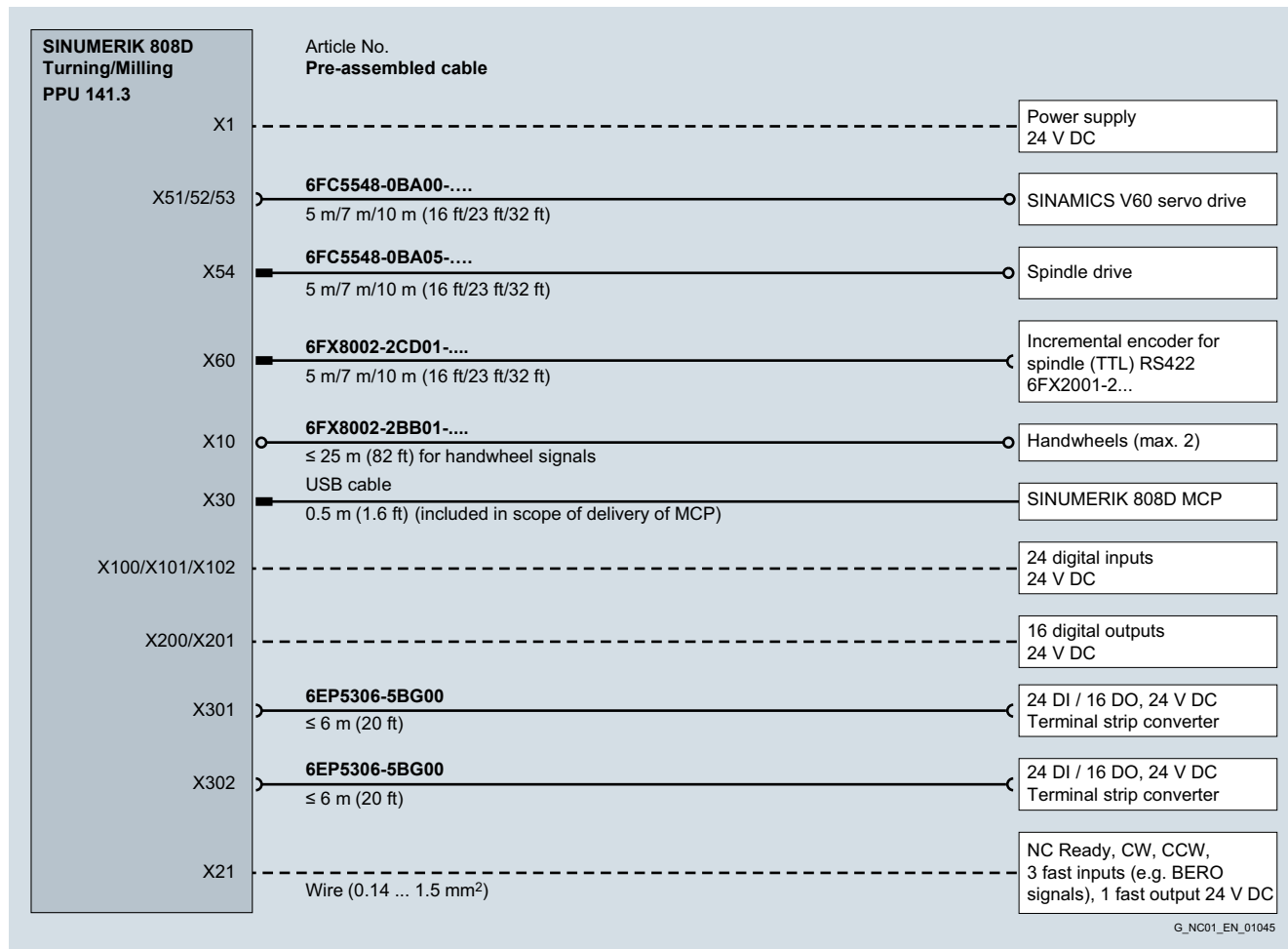

Connection overview of SINUMERIK 808D Turning/Milling PPU 141.3

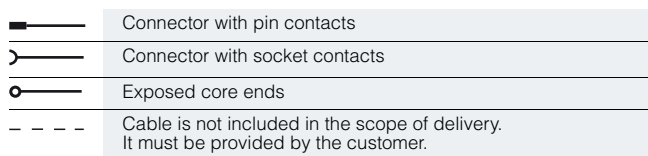

3

SINUMERIK 808D system

MOTION-CONNECT connection systems

MOTION-CONNECT cables for SINUMERIK 808D

Technical specifications

Article No.	6FC5548-0BA00-....	6FC5548-0BA05-....
Product name	Setpoint cable PPU 141.3 - SINAMICS V60 servo drive	Setpoint cable PPU 141.3 - analog spindle drive
No. of cores	15	4
Certificate of suitability • cURus or UR/CSA ¹⁾ • RoHS conformity	UL20276 Yes	UL2576 Yes
Rated voltage	30 V	30 V
Test voltage, rms	500 V	500 V
Operating temperature on the surface • Fixed installation • Flexible installation	-20 ... +80 °C 0 ... 60 °C	-20 ... +80 °C 0 ... 60 °C
Smallest bending radius • Fixed installation • Flexible installation	100 mm 200 mm	60 mm 120 mm
Insulation material, incl. jacket	PVC	PVC
Oil resistance	70 °C X 4hr	70 °C X 4hr
Outer jacket	PVC Gray	PVC Gray
Flame-retardant	VW-1	VW-1

Article No.	6FX8002-2CD01-....	6FX8002-2BB01-....
Product name	Signal cable PPU 141.3 - incremental encoder for spindle (TTL)	Signal cable PPU 141.3 - handwheel
Certificate of suitability • cURus or UR/CSA ¹⁾ • RoHS conformity	UL758-CSA-C22.2-N.210.2-M90 Yes	UL758-CSA-C22.2-N.210.2-M90 Yes
Rated voltage	30 V	30 V
Test voltage, rms	500 V	500 V
Operating temperature on the surface • Fixed installation • Flexible installation	-50 ... +80 °C -20 ... +60 °C	-50 ... +80 °C -20 ... +60 °C
Tensile stress, max. • Fixed installation • Flexible installation	50 N/mm ² 20 N/mm ²	50 N/mm ² 20 N/mm ²
Smallest bending radius • Fixed installation • Flexible installation	35 mm 70 mm	35 mm 70 mm
Torsional stress	Absolute 30°/m	Absolute 30°/m
Bending	10 million	10 million
Traversing velocity	300 m/min	300 m/min
Acceleration	5 m/s ²	5 m/s ²
Insulation material, incl. Jacket	CFC/silicone-free IEC 60754-1/DIN VDE 0472-815	CFC/silicone-free IEC 60754-1/DIN VDE 0472-815
Oil resistance	EN 60811-2-1	EN 60811-2-1
Outer jacket	PVC DESINA color green RAL 6018	PVC DESINA color green RAL 6018
Flame-retardant	EN 60332-1-1 to 1-3	EN 60332-1-1 to 1-3

For general information about MOTION-CONNECT please refer to Introduction.

¹⁾ The respective registration number is printed on the cable jacket.

Selection and ordering data

Description	Article No.
Pre-assembled setpoint cable PPU 141.3 - SINAMICS V60 Length • 5 m • 7 m • 10 m	6FC5548-0BA00-1AF0 6FC5548-0BA00-1AH0 6FC5548-0BA00-1BA0
Pre-assembled setpoint cable PPU 141.3 - analog spindle drive Length • 5 m • 7 m • 10 m	6FC5548-0BA05-1AF0 6FC5548-0BA05-1AH0 6FC5548-0BA05-1BA0
Pre-assembled signal cable PPU 141.3 - incremental encoder for spindle (TTL) Length • 5 m • 7 m • 10 m	6FX8002-2CD01-1AF0 6FX8002-2CD01-1AH0 6FX8002-2CD01-1BA0

Description	Article No.
Pre-assembled signal cable PPU 141.3 - handwheel Length • 1 m • 5 m • 7 m • 10 m	6FX8002-2BB01-1AB0 6FX8002-2BB01-1AF0 6FX8002-2BB01-1AH0 6FX8002-2BB01-1BA0

MOTION-CONNECT cables for SINAMICS V60 servo drive

Integration

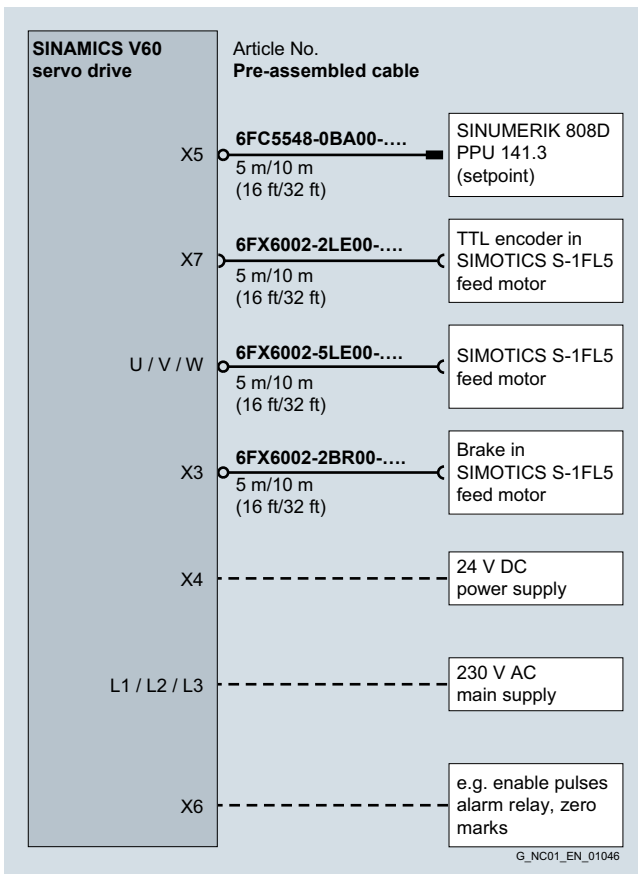

Connection overview of SINAMICS V60 servo drive

—●—	Connector with pin contacts
—○—	Connector with socket contacts
—○—	Exposed core ends
- - - -	Cable is not included in the scope of delivery. It must be provided by the customer.

SINUMERIK 808D system

MOTION-CONNECT connection systems

MOTION-CONNECT cables for SINAMICS V60 servo drive

Technical specifications

Article No.	6FX6002-2LE00-....	6FX6002-5LE00-....	6FX6002-2BR00-....
Product name	Encoder cable SINAMICS V60 - TTL encoder in SIMOTICS S-1FL5 feed motor	Power cable SINAMICS V60 - SIMOTICS S-1FL5 feed motor	Brake cable SINAMICS V60 - brake in SIMOTICS S-1FL5 feed motor
Degree of protection (when closed and connected)	IP54	IP54	IP54
Certificate of suitability • VDE ¹⁾ /RoHS conformity	Yes RoHS	Yes RoHS	Yes RoHS
Rated voltage U0/U	30 V/30 V	300 V/500 V	30 V/30 V
Test voltage, rms	500 V	2 kV	500 V
Operating temperature on the surface • Fixed installation	-20 ... +80 °C	-20 ... +80 °C	-20 ... +80 °C
Tensile stress, max. • Fixed installation • Flexible installation	50 N/mm ² 20 N/mm ²	50 N/mm ² 20 N/mm ²	50 N/mm ² 20 N/mm ²
Smallest bending radius • Fixed installation • Flexible installation	40 mm 160 mm	50 mm 200 mm	25 mm 100 mm
Torsional stress	Absolute 30°/m	Absolute 30°/m	Absolute 30°/m
Bending	100000	100000	100000
Insulation material, incl. Jacket	PVC	PVC	PVC
Oil resistance	EN 60811-2-1 (mineral oil only)	EN 60811-2-1 (mineral oil only)	EN 60811-2-1 (mineral oil only)
Outer jacket	PVC	PVC	PVC
Flame-retardant	FT1	FT1	FT1

For general information about MOTION-CONNECT please refer to Introduction.

Selection and ordering data

Description	Article No.
Pre-assembled encoder cable SINAMICS V60 - TTL encoder in SIMOTICS S-1FL5 feed motor	
Length	
• 5 m	6FX6002-2LE00-1AF0
• 10 m	6FX6002-2LE00-1BA0
Pre-assembled power cable SINAMICS V60 - SIMOTICS S-1FL5 feed motor	
Length	
• 5 m	6FX6002-5LE00-1AF0
• 10 m	6FX6002-5LE00-1BA0
Pre-assembled brake cable SINAMICS V60 - brake in SIMOTICS S-1FL5 feed motor	
Length	
• 5 m	6FX6002-2BR00-1AF0
• 10 m	6FX6002-2BR00-1BA0

¹⁾ The respective registration number is printed on the cable jacket.

Overview

The following composition of an equipment package is an example of an inclined bed lathe with:

- 2 machining axes (X, Z)
- 1 main spindle with direct spindle encoder
- 24 digital PLC input signals and 16 digital PLC output signals

Designation	Quantity	Article No.
SINUMERIK CNC		
SINUMERIK 808D Turning PPU 141.3 horizontal, English layout	1	6FC5370-1AT03-0AA0
SINUMERIK 808D MCP, English layout	1	6FC5303-0AF35-0AA0
Electronic handwheel with front panel 120 mm × 120 mm, with setting wheel 5 V DC, RS422	1	6FC9320-5DB01
Stabilized power supply, SITOP PSU200M 24 V, 5 A	1	6EP1333-3BA10
RS422 (TTL) incremental encoder, 1024 S/R	1	6FX2001-2EB02
Spring disk coupling, shaft diameter 6 mm/6 mm	1	6FX2001-7KF10
Clamp strap (1 unit), for encoders with Synchro flange	3	6FX2001-7KP01
Pre-assembled setpoint cable PPU 141.3 - SINAMICS V60, length 5 m	2	6FC5548-0BA00-1AF0
Pre-assembled setpoint cable PPU 141.3 - analog spindle drive, length 5 m	1	6FC5548-0BA05-1AF0
Pre-assembled signal cable PPU 141.3 - handwheel, length 1 m	1	6FX8002-2BB01-1AB0
Pre-assembled signal cable PPU 141.3 - incremental spindle encoder (TTL), length 5 m	1	6FX8002-2CD01-1AF0
SINAMICS V60		
SINAMICS V60, I_{rated} 4 A	1	6SL3210-5CC14-0UA0
SINAMICS V60, I_{rated} 6 A	1	6SL3210-5CC16-0UA0
SIMOTICS S-1FL5		
SIMOTICS S-1FL5 feed motor, 4 Nm, 2000 rpm, plain shaft, without holding brake	1	1FL5060-0AC21-0AG0
SIMOTICS S-1FL5 feed motor, 6 Nm, 2000 rpm, plain shaft, with holding brake	1	1FL5062-0AC21-0AH0
Pre-assembled encoder cable SINAMICS V60 - TTL encoder in SIMOTICS S-1FL5 feed motor, length 5 m	2	6FX6002-2LE00-1AF0
Pre-assembled power cable SINAMICS V60 - SIMOTICS S-1FL5 feed motor, length 5 m	2	6FX6002-5LE00-1AF0
Pre-assembled brake cable SINAMICS V60 - brake in SIMOTICS S-1FL5 feed motor, length 5 m	1	6FX6002-2BR00-1AF0

SINUMERIK 808D system

Example packages

Example package for Milling

Overview

The following composition of an equipment package is an example of a vertical machining center with:

- 3 machining axes (X, Y, Z)
- 1 main spindle with direct spindle encoder
- 35 digital PLC input signals and 22 digital PLC output signals

Designation	Quantity	Article No.
SINUMERIK CNC		
SINUMERIK 808D Milling PPU 141.3 horizontal, English layout	1	6FC5370-1AM03-0AA0
SINUMERIK 808D MCP, English layout	1	6FC5303-0AF35-0AA0
Electronic handwheel with front panel 120 mm × 120 mm, with setting wheel 5 V DC, RS422	1	6FC9320-5DB01
Terminal strip converter 50-pole	1	6EP5406-5AA00
Cable set ribbon cable, 50-pole, with connectors, 50-pole	1	6EP5306-5BG00
Stabilized power supply, SITOP PSU200M 24 V, 5 A	1	6EP1333-3BA10
RS422 (TTL) incremental encoder, 1024 S/R	1	6FX2001-2EB02
Spring disk coupling, shaft diameter 6 mm/6 mm	1	6FX2001-7KF10
Clamp strap (1 unit), for encoders with Synchro flange	3	6FX2001-7KP01
Pre-assembled setpoint cable PPU 141.3 - SINAMICS V60, length 5 m	3	6FC5548-0BA00-1AF0
Pre-assembled setpoint cable PPU 141.3 - analog spindle drive, length 5 m	1	6FC5548-0BA05-1AF0
Pre-assembled signal cable PPU 141.3 - handwheel, length 1 m	1	6FX8002-2BB01-1AB0
Pre-assembled signal cable PPU 141.3 - incremental spindle encoder (TTL), length 7 m	1	6FX8002-2CD01-1AH0
SINAMICS V60		
SINAMICS V60, I_{rated} 7 A	2	6SL3210-5CC17-0UA0
SINAMICS V60, I_{rated} 10 A	1	6SL3210-5CC21-0UA0
SIMOTICS S-1FL5		
SIMOTICS S-1FL5 feed motor, 7.7 Nm, 2000 rpm, plain shaft, without holding brake	2	1FL5064-0AC21-0AG0
SIMOTICS S-1FL5 feed motor, 10 Nm, 2000 rpm, plain shaft, with holding brake	1	1FL5066-0AC21-0AH0
Pre-assembled encoder cable SINAMICS V60 - TTL encoder in SIMOTICS S-1FL5 feed motor, length 10 m	3	6FX6002-2LE00-1BA0
Pre-assembled power cable SINAMICS V60 - SIMOTICS S-1FL5 feed motor, length 10 m	3	6FX6002-5LE00-1BA0
Pre-assembled brake cable SINAMICS V60 - brake in SIMOTICS S-1FL5 feed motor, length 10 m	1	6FX6002-2BR00-1BA0

SINUMERIK 808D ADVANCED system



4/2	CNC control
4/2	SINUMERIK 808D ADVANCED PPU 15x.3/PPU 16x.3
4/5	Operator components
4/5	SINUMERIK 808D MCP horizontal/vertical
4/8	Feed axis solutions
4/8	SINAMICS V70 servo drive
4/12	SIMOTICS S-1FL6 feed motor
4/16	Spindle solutions
4/16	SINAMICS V70 spindle drive
4/20	SIMOTICS M-1PH1 main motor
4/26	MOTION-CONNECT connection systems
4/26	MOTION-CONNECT cables for SINUMERIK 808D ADVANCED
4/29	MOTION-CONNECT cables for SINAMICS V70 servo drive
4/31	MOTION-CONNECT cables for SINAMICS V70 spindle drive
4/33	Example packages
4/33	Example package for Turning with SINUMERIK 808D ADVANCED T
4/34	Example package for Milling with SINUMERIK 808D ADVANCED M

SINUMERIK 808D ADVANCED system

CNC control

SINUMERIK 808D ADVANCED PPU 15x.3/PPU 16x.3

Overview



SINUMERIK 808D ADVANCED PPU 151.3/PPU 161.3 horizontal



SINUMERIK 808D ADVANCED PPU 150.3/PPU 160.3 vertical

The SINUMERIK 808D ADVANCED PPU 15x.3/PPU 16x.3 is an operator-panel-based CNC, preconfigured for use in modern basic standard turning and milling machines.

There are two variants of SINUMERIK 808D ADVANCED PPU's – PPU 15x.3 and PPU 16x.3 – with same appearance and different functionalities. The differences are described between PPU 15x.3 and PPU 16x.3 in chapter 2 - Overview of functions.

Benefits

- Compact, rugged, and maintenance-friendly operator-panel CNC
- Actual position feedback to CNC
- Intelligent clamp mounting without drilling holes into the cabinet
- Minimum commissioning efforts due to plug and play machine control panel connected via USB interface
- Direct commissioning on HMI for feed drives and automatic servo tuning (AST)
- Maximum performance and accuracy due to most modern CNC features
- SINUMERIK 808D startGUIDE: assists all process steps of the machine – from engineering to production, from sales to operation and programming at the push of a button

- SINUMERIK Operate BASIC: maximum operator convenience similar to SINUMERIK 828D and SINUMERIK 840D sl
- SINUMERIK programGUIDE BASIC: wide range of technology cycles for turning, milling and drilling with graphical input screens
- Manual Machine plus: easy semi-automatic machining with handwheel controlled flat-bed lathes¹⁾
- Fast data transmission via USB stick and high-speed Ethernet interface
- More software options can cover more applications and enhance the machine performance
- Maximum performance and accuracy due to the Advanced Surface function²⁾

Function

- 2 operator panel variants for horizontal and vertical operator panel housings
- IP65 protection for CNC front panel and machine control panel
- Integrated CNC keyboard with mechanical keys
- Simplified Chinese or English panel layout
- 8.4" color LCD display
- USB user interface on the operator panel front
- Drive bus interface for feed drives and spindle
- Analog ± 10 V interface for spindle drive
- Data buffering without battery
- Pre-configured system software for turning and milling technologies
- Up to 5 axes/spindles³⁾
- Automatic servo tuning AST
- Ethernet interface for commissioning and data transfer
- Graphically guided SINUMERIK CNC programming and standard ISO-code programming with canned cycles
- Graphical CNC simulation
- Integrated contour computer
- Integrated PLC based on the SIMATIC S7-200 command set with ladder logic programming
- Integrated/distributed PLC I/O concept with 72 digital PLC inputs and 48 digital PLC outputs
- CNC options subject to license
- Customized user screens
- Machine maintenance tasks are accomplished by integrated service planner

Integration

The following components can be connected to the SINUMERIK 808D ADVANCED PPU 15x.3/PPU 16x.3:

- Up to 2 electronic handwheels
- Up to 72 digital PLC inputs and 48 digital PLC outputs
- 1 TTL direct spindle encoder
- SINUMERIK 808D MCP via USB interface
- SINAMICS V70 drive system for feed axes and spindle
- Spindle drives via ± 10 V analog output
- PC via Ethernet interface
- 1 digital tool probe⁴⁾

1) Only for turning

2) Only for PPU 16x.3 milling

3) Up to 4 axes/spindle for PPU 15x.3

4) Only for milling

Technical specifications

Article No.	6FC5370-.B.03-0.A0	6FC5370-.A.03-0.A0
Product name	SINUMERIK 808D ADVANCED PPU 150.3/PPU 160.3 vertical	SINUMERIK 808D ADVANCED PPU 151.3/PPU 161.3 horizontal
Input voltage	24 V DC + 20 %/- 15 %	
Power consumption, max.	50 W	
Mains buffering time	3 ms (20 ms with SITOP smart)	
Degree of protection according to EN 60529 (IEC 60529)	<ul style="list-style-type: none"> • Operator panel front, with closed front cover • PPU, rear 	
Relative humidity	<ul style="list-style-type: none"> • Storage • Transport • Operation 	
Ambient temperature	<ul style="list-style-type: none"> • Storage • Transport • Operation - Front - Rear 	
Dimensions	<ul style="list-style-type: none"> • Width • Height • Depth 	
Panel cutout	<ul style="list-style-type: none"> • Width • Height • Tolerance 	
Weight, approx.		
Certificate of suitability		

Selection and ordering data

Description	Article No.	Description	Article No.
<i>Hardware components</i>		<i>Hardware components (continued)</i>	
SINUMERIK 808D ADVANCED T PPU 160.3 vertical		SINUMERIK 808D ADVANCED M PPU 150.3 vertical	
• English layout	6FC5370-2BT03-0AA0	• English layout	6FC5370-3BM03-0AA0
• Simplified Chinese layout	6FC5370-2BT03-0CA0	• Simplified Chinese layout	6FC5370-3BM03-0CA0
SINUMERIK 808D ADVANCED T PPU 161.3 horizontal		SINUMERIK 808D ADVANCED M PPU 151.3 horizontal	
• English layout	6FC5370-2AT03-0AA0	• English layout	6FC5370-3AM03-0AA0
• Simplified Chinese layout	6FC5370-2AT03-0CA0	• Simplified Chinese layout	6FC5370-3AM03-0CA0
SINUMERIK 808D ADVANCED M PPU 160.3 vertical		<i>Software components</i>	
• English layout	6FC5370-2BM03-0AA0	SINUMERIK 808D T/M toolbox	6FC5811-0CY00-0YA8
• Simplified Chinese layout	6FC5370-2BM03-0CA0	On DVD-ROM	
SINUMERIK 808D ADVANCED M PPU 161.3 horizontal		Options	
• English layout	6FC5370-2AM03-0AA0	Description	Article No.
• Simplified Chinese layout	6FC5370-2AM03-0CA0	Additional NC axis¹⁾	6FC5800-0AK70-0YB0
SINUMERIK 808D ADVANCED T PPU 150.3 vertical		Manual Machine plus (MM+)²⁾	6FC5800-0AP07-0YB0
• English layout	6FC5370-3BT03-0AA0	TRANSMIT/TRACYL Transformation without Y axis	6FC5800-0AS50-0YB0
• Simplified Chinese layout	6FC5370-3BT03-0CA0	Pair of synchronized axes (gantry axes), basic³⁾	6FC5800-0AS51-0YB0
SINUMERIK 808D ADVANCED T PPU 151.3 horizontal		Bidirectional leadscrew error compensation	6FC5800-0AM54-0YB0
• English layout	6FC5370-3AT03-0AA0	Contour handwheel	6FC5800-0AM08-0YB0
• Simplified Chinese layout	6FC5370-3AT03-0CA0	CNC lock function	6FC5800-0AS71-0YB0

1) Only for PPU 15x.3 turning and PPU 16x.3

2) Only for turning

3) Only for PPU 16x.3

SINUMERIK 808D ADVANCED system

CNC control

SINUMERIK 808D ADVANCED PPU 15x.3/PPU 16x.3

Dimensional drawings

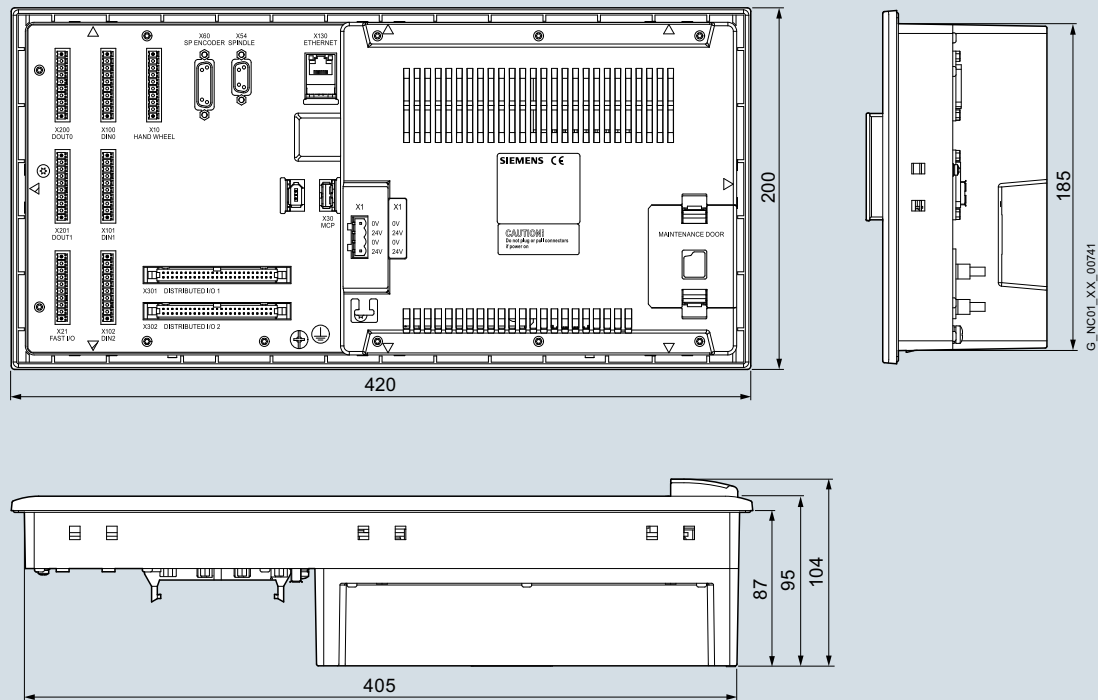

SINUMERIK 808D ADVANCED T/M horizontal

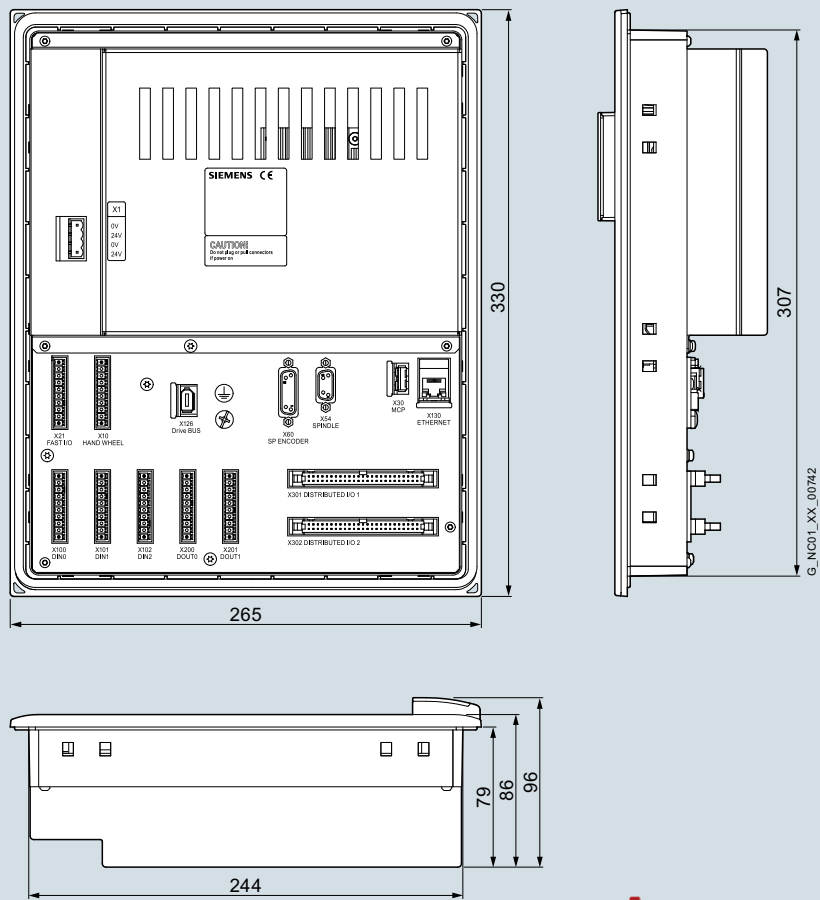

SINUMERIK 808D ADVANCED T/M vertical



SINUMERIK 808D ADVANCED system

Operator components

SINUMERIK 808D MCP horizontal/vertical

Overview



SINUMERIK 808D MCP horizontal



SINUMERIK 808D MCP vertical



SINUMERIK 808D MCP vertical, with handwheel slot

The SINUMERIK 808D MCP machine control panel with mechanical keys is designed to permit user-friendly, well-structured operation of the machine functions. It is suitable for machine level operation of milling and turning machines. Customized keys can be individually labeled using slide-in strips.

The machine control panel is available as vertical and horizontal version for different machine designs. Depending on the design of the machine, the SINUMERIK 808D MCP can also be ordered with a handwheel slot.

The machine control panel is mounted from the rear using special clamps without drilling holes into the cabinet.

Design

Operator controls:

- Mode and function keys
 - 39 keys (horizontal version: 30 keys with LEDs, vertical version: 39 keys with LEDs)
 - Direction keys for machines with rapid traverse override (MCP is pre-assembled with turning slide-in strips. Milling slide-in strips are supplied in the included accessories pack)
 - Pre-defined MCP keys for common functions, such as handwheel selection, turret skip, coolant control or program test
- Horizontal version and vertical version without handwheel slot: Spindle control with spindle override (rotary switch with 15 positions)
- Feedrate control with feedrate/rapid traverse override (rotary switch with 18 positions)
- 7-segment display for tool number

Layout:

- English or Chinese Simplified

Key type:

- Mechanical keys with protection foil

Interface to CNC:

- USB

Expansion options:

- 1 slot for emergency stop button ($d = 22$ mm)
- Horizontal version: 3 slots for control devices ($d = 16$ mm)
- Vertical version: 4 slots for control devices ($d = 16$ mm)
- 1 slot for handwheel ($d = 44$ mm), only for the vertical version with handwheel slot. The handwheel with a diameter of 44 mm must be ordered separately

Selection and ordering data

Description	Article No.
SINUMERIK 808D MCP machine control panel, horizontal With USB cable	
• English layout	6FC5303-0AF35-0AA0
• Simplified Chinese layout	6FC5303-0AF35-0CA0
SINUMERIK 808D MCP machine control panel, vertical with rotary switch for spindle override With USB cable	
• English layout	6FC5303-0AF35-2AA0
• Simplified Chinese layout	6FC5303-0AF35-2CA0
SINUMERIK 808D MCP machine control panel, vertical with handwheel slot With USB cable	
• English layout	6FC5303-0AF35-3AA0
• Simplified Chinese layout	6FC5303-0AF35-3CA0

The scope of supply of the SINUMERIK 808D MCP includes:

- USB cable 0.5 m
- Mounting clamps
- Slide-in strips for turning application (already inserted)
- Slide-in strips for milling application
- Blank slide-in strip for individual labeling

SINUMERIK 808D ADVANCED system

Operator components

SINUMERIK 808D MCP horizontal/vertical**Integration**

The SINUMERIK 808D MCP machine control panel can be used for:

- SINUMERIK 808D Turning
- SINUMERIK 808D Milling
- SINUMERIK 808D ADVANCED T
- SINUMERIK 808D ADVANCED M

Technical specifications

Article No.	6FC5303-0AF35-0.A0	6FC5303-0AF35-...A0
Product name	SINUMERIK 808D MCP machine control panel horizontal version	SINUMERIK 808D MCP machine control panel vertical version
Input voltage	5 V DC provided by PPU via USB interface	
Power consumption, max.	5 W	
Degree of protection according to EN 60529 (IEC 60529)		
• Front	IP65	
• Rear	IP20	
Humidity rating based on EN 60721-3-3	Class 3K5 condensation and icing excluded. Low air temperature 0 °C.	
Relative humidity		
• Storage	5 ... 95 % at 25 °C	
• Transport	5 ... 95 % at 25 °C	
• Operation	5 ... 90 % at 25 °C	
Ambient temperature		
• Storage	-20 ... +60 °C	
• Transport	-20 ... +60 °C	
• Operation		
- Front	0 ... 45 °C	
- Rear	0 ... 50 °C	
Distance	0.5 m	
Dimensions		
• Width	420 mm	265 mm
• Height	120 mm	230 mm
• Depth	58 mm	58 mm
Panel cutout		
• Width	406 mm	245 mm
• Height	106 mm	211 mm
• Tolerance	+ 1 mm	+ 1 mm
Weight, approx.	0.86 kg	
• With handwheel slot	-	0.79 kg
• With rotary switch	-	0.93 kg
Certificate of suitability	CE, EAC	

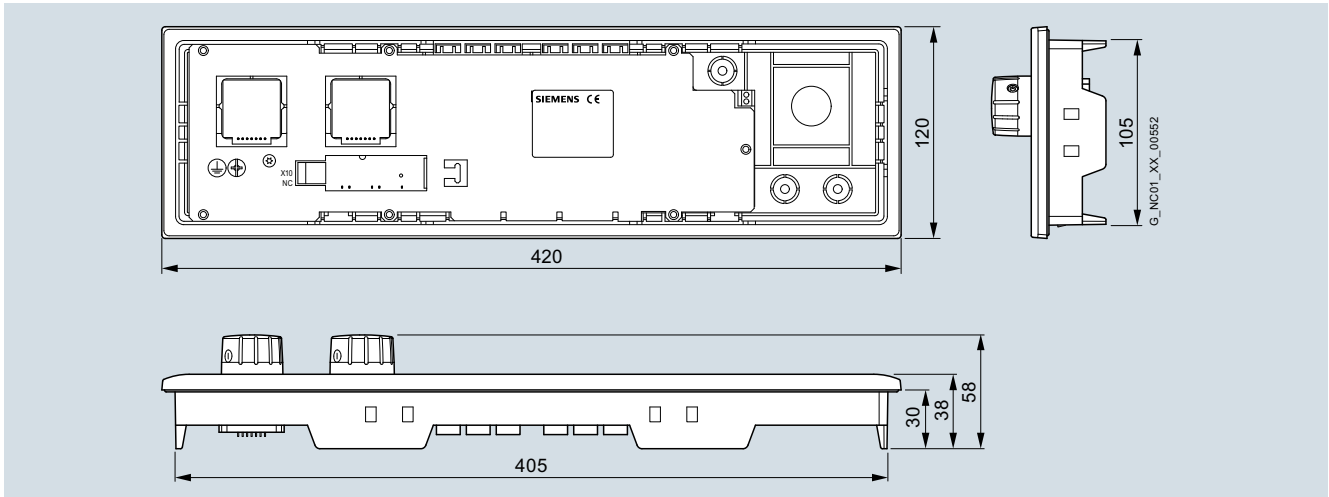
Dimensional drawings

SINUMERIK 808D MCP horizontal

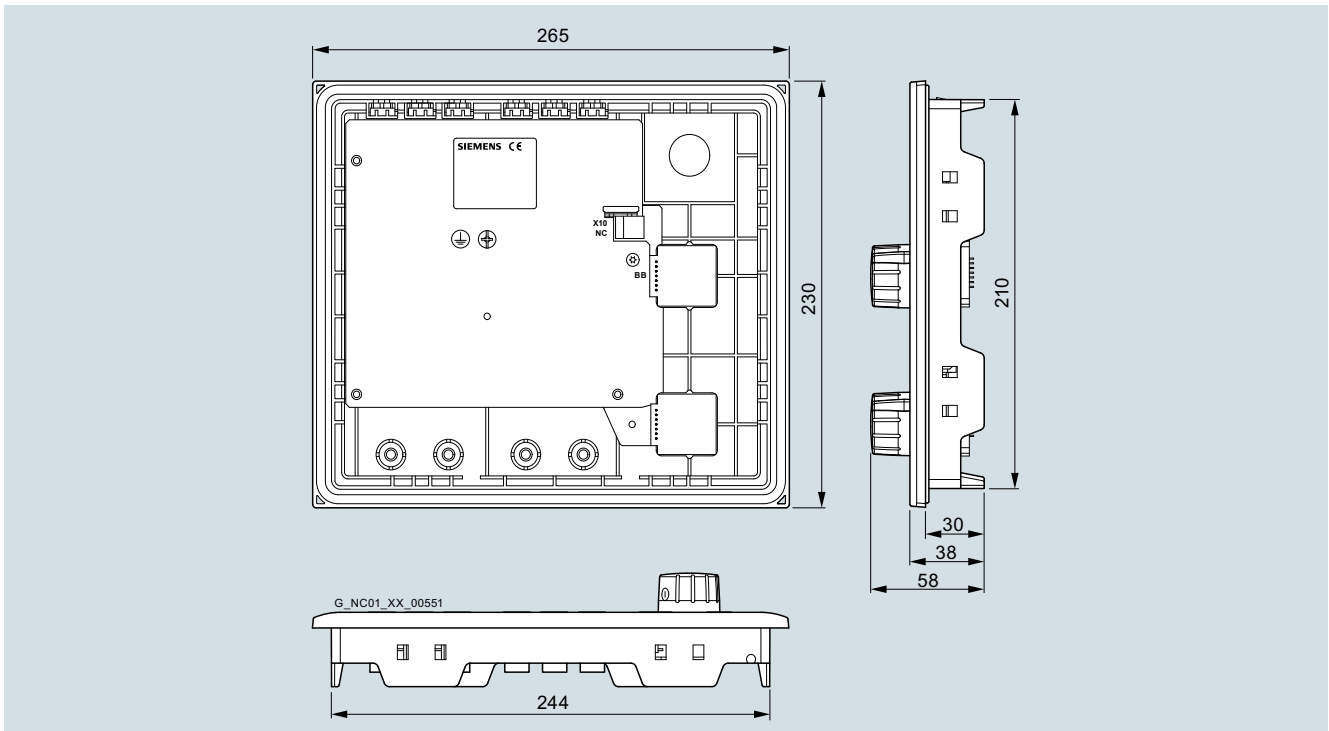

SINUMERIK 808D MCP vertical with handwheel slot/without handwheel slot

SINUMERIK 808D ADVANCED system

Feed axis solutions

SINAMICS V70 servo drive

Overview



SINAMICS V70, frame sizes FSC/FSB/FSA

The SINAMICS V70 servo drive is specially designed to control the feed axes in standard machine tool applications. The system is designed essentially for applications where cost effectiveness is the primary consideration. The key performance data of the drive are aligned to perfectly fit to the solution provided by the SINUMERIK 808D ADVANCED.

Benefits

- Compact module with integrated infeed, inverter and closed-loop position control for one feed axis
- Coated electronic modules
- Commissioning on CNC directly
- Faster commissioning thanks to pre-configured motor data stored in the drive.
- CE certified

Function

- 7 versions cover power range from 0.4 kW to 7 kW
- Supply voltage 380 V to 480 V 3 AC
- 300 % overload capability
- Drive bus communication to the SINUMERIK 808D ADVANCED
- Integrated motor brake switch
- Safe Torque Off (STO)

Integration

The following components can be connected to the SINAMICS V70:

- SINUMERIK 808D ADVANCED PPU 15x.3/PPU 16x.3
- SIMOTICS S-1FL6 feed motor
- Encoder in SIMOTICS S-1FL6 feed motor
- Brake in SIMOTICS S-1FL6 feed motor

Selection and ordering data

Rated output current A	Frame size	SINAMICS V70 servo drive Article No.
1.2	FSA	6SL3210-5DE12-4UA0
3.0	FSA	6SL3210-5DE13-5UA0
4.6	FSB	6SL3210-5DE16-0UA0
5.3	FSB	6SL3210-5DE17-8UA0
7.8	FSB	6SL3210-5DE21-0UA0
11	FSC	6SL3210-5DE21-4UA0
13.2	FSC	6SL3210-5DE21-8UA0

Description	Article No.
-------------	-------------

Spare parts

SINAMICS V70/V90 fan kits	
• Frame size FSB	6SL3200-0WF00-0AA0
• Frame size FSC	6SL3200-0WF01-0AA0
SINAMICS V70 drive bus terminator	6FC5548-0BA21-0AA0

Technical specifications

Article No.	6SL3210-5DE12-4UA0	6SL3210-5DE13-5UA0	6SL3210-5DE16-0UA0	6SL3210-5DE17-8UA0	6SL3210-5DE21-0UA0	6SL3210-5DE21-4UA0	6SL3210-5DE21-8UA0
Product name	SINAMICS V70 servo drive						
Frame size	FSA		FSB			FSC	
Input voltage	380 ... 480 V 3 AC -15 %/+10 %						
Input frequency	50 ... 60 Hz ± 10 %						
Infeed	Non-stabilized						
Electronics power supply	24 V DC ± 10 %						
24 V DC supply	2.0 A (4.0 A) combined with motors without brake (with brake)						
Cooling	Natural cooling			Forced ventilation			
Ambient temperature	-40 ... +70 °C						
• Storage/transport	0 ... 45 °C without derating,						
• Operation	> 45 ... 55 °C with derating (derating by 0 % at 45 °C up to 20 % at 55 °C)						
Air humidity	90 % (non-condensing)						
• Storage/transport	< 90 % (non-condensing)						
• Operation							
Ambient conditions	Indoor (without sunshine), without corrosive gas, combustible gas, oil gas, nor dust						
Installation altitude	Up to 1000 m without derating						
Connectable motors	SIMOTICS S-1FL6						
Degree of protection	IP20						
Encoder evaluation	Absolute encoder 20 bit/incremental encoder with 2500 S/R (13 bit resolution through electronic multiplication)						
Output current							
• Rated current I_{rated}	1.2 A	3.0 A	4.6 A	5.3 A	7.8 A	11.0 A	13.2 A
• Peak current I_{max}	3.6 A	9.0 A	13.8 A	15.9 A	23.4 A	33.0 A	39.6 A
Rated output power P_{rated}	0.4 kW	1 kW	1.5 kW	1.75 kW	2.5 kW	3.5 kW	7 kW
Power loss	36 W	47 W	54 W	70 W	47 W	54 W	70 W
Cooling air required	0.005 m ³ /s	0.005 m ³ /s	0.005 m ³ /s	0.005 m ³ /s	0.005 m ³ /s	0.005 m ³ /s	0.005 m ³ /s
Conductor cross-section, max.	1.5 mm ²		2.5 mm ²				
Dimensions ¹⁾							
• Width	80 mm		100 mm			140 mm	
• Height	180 mm		180 mm			260 mm	
• Depth	200 mm		200 mm			240 mm	
Weight, approx.	1.85 kg		2.45 kg			5.65 kg	
Certificate of suitability	CE, EAC						

S/R = Signals/Revolution

¹⁾ Minimum distance between drive modules: 10 mm.

SINUMERIK 808D ADVANCED system

Feed axis solutions

SINAMICS V70 servo drive

Dimensional drawings

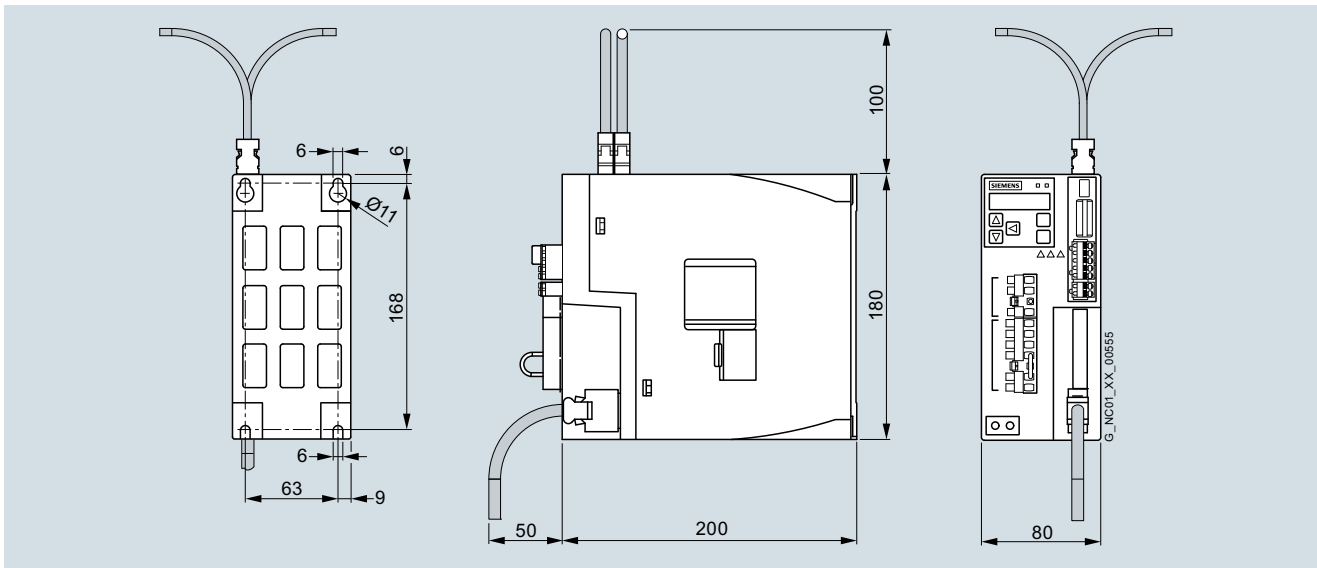

SINAMICS V70, frame size FSA

4

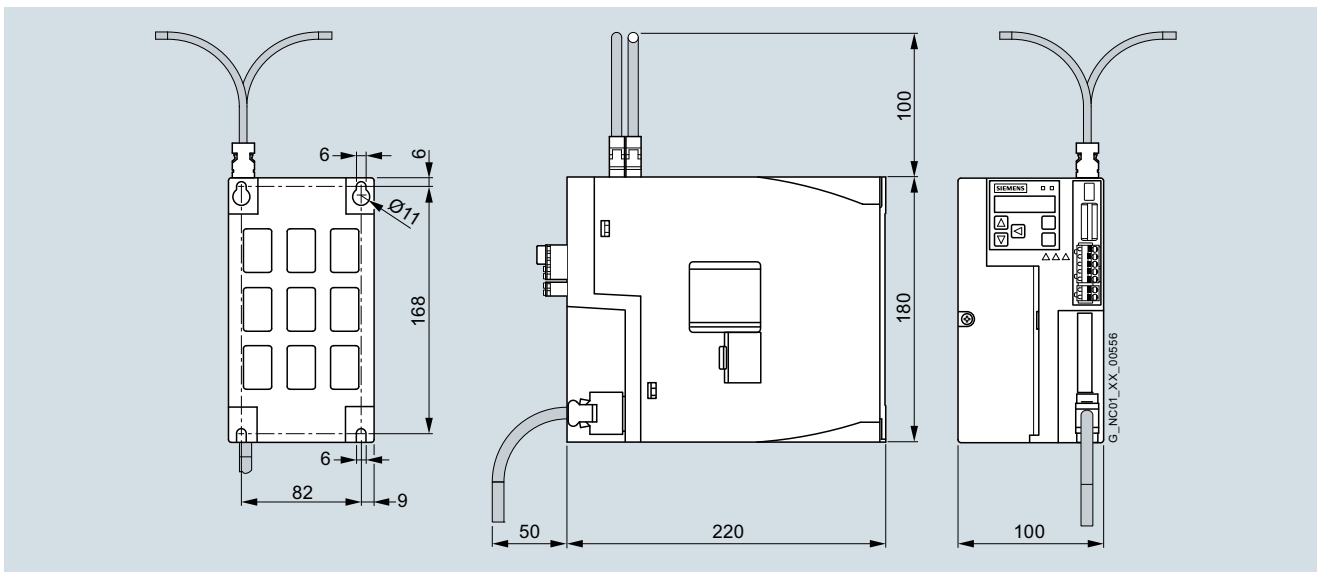

SINAMICS V70, frame size FSB

Dimensional drawings (continued)

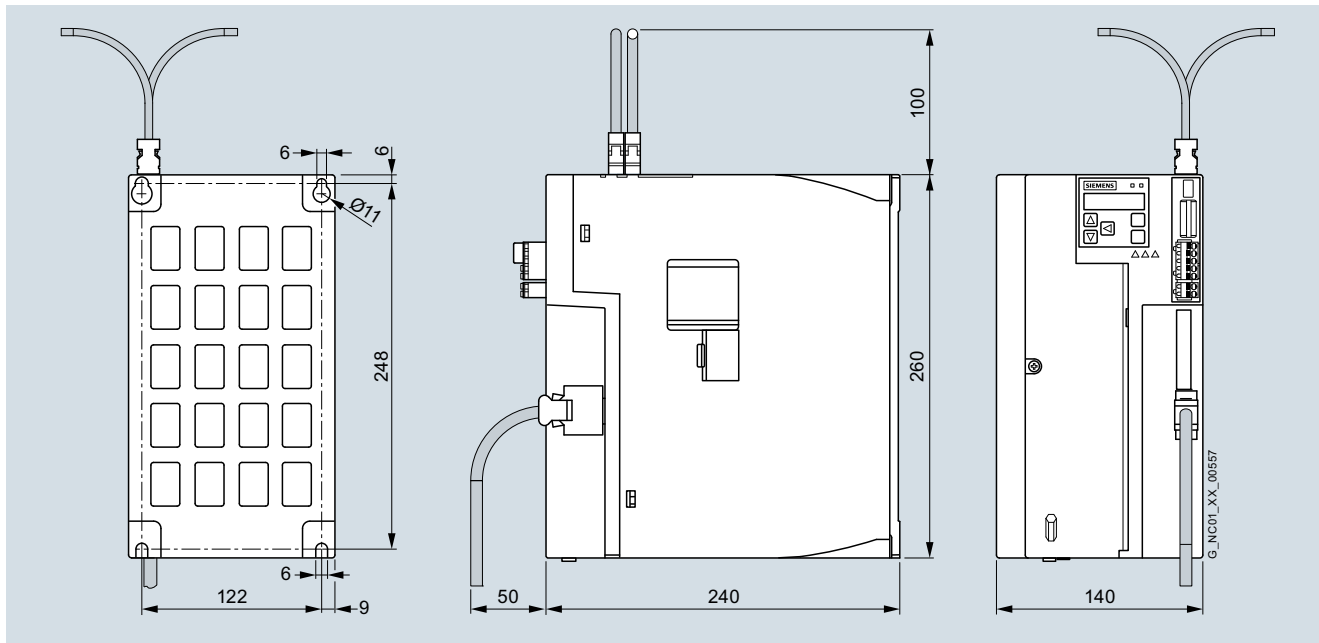

SINAMICS V70, frame size FSC

4

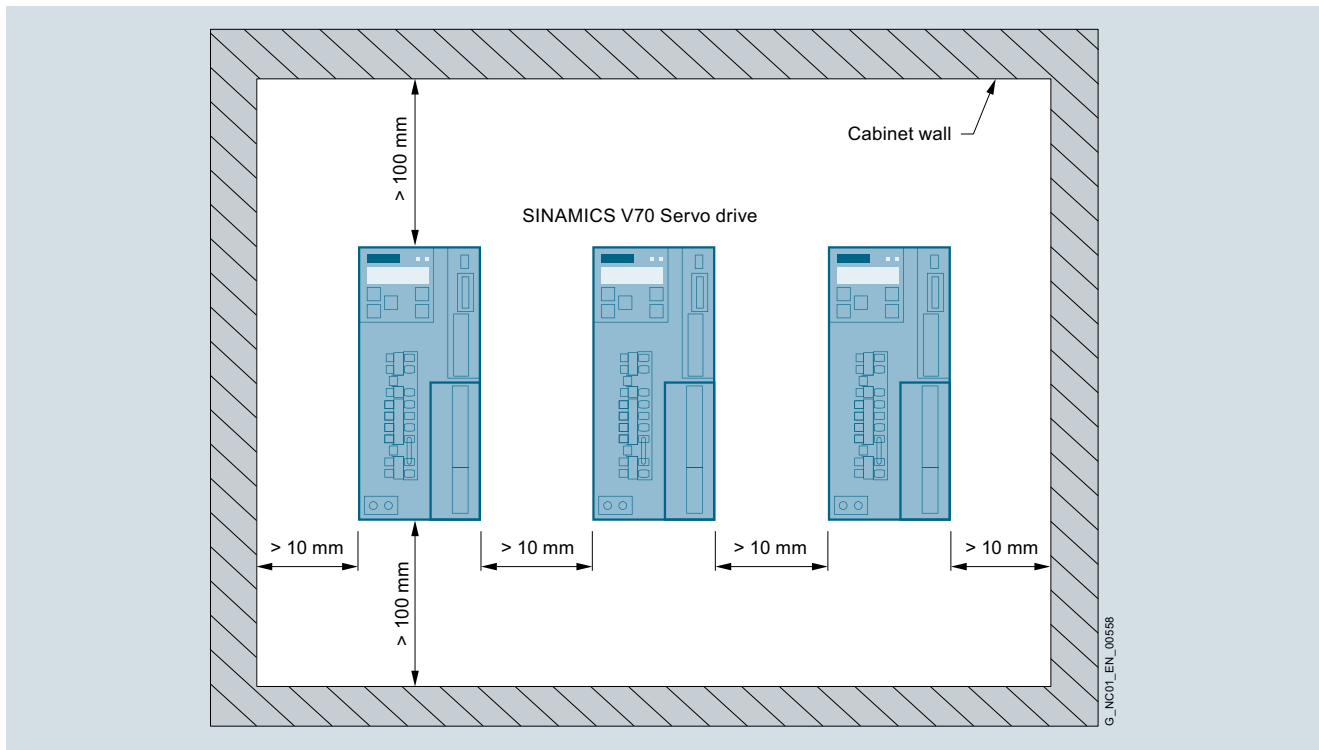

Mounting clearance

SINUMERIK 808D ADVANCED system

Feed axis solutions

SIMOTICS S-1FL6 feed motor

Overview

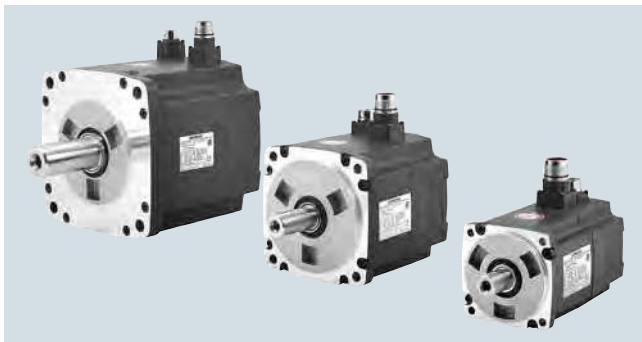

SIMOTICS S-1FL6 motors

SIMOTICS S-1FL6 motors are permanent-magnet synchronous motors and designed for operation without external cooling. The heat is dissipated through the motor surface. Thanks to the quick-lock connectors, quick and easy mounting of the motors is possible. Together with the SINAMICS V70, the SIMOTICS S-1FL6 feed motors provide a highly dynamic solution for the machine tool application.

Benefits

- High-performance magnet material
- Rugged design with IP65 degree of protection for complete motor including connectors
- Smooth running quality thanks to low torque ripple
- High rated speed for some variants
- High acceleration due to the 300 % overload capacity
- Rotatable and fast-release connectors
- Maximum flexibility due to variants with incremental encoder/20 bit absolute encoder, with/without brake and plain shaft/feather key, half-key balancing

Function

- 3 motor shaft heights: SH 45, SH 65 and SH 90
- Rated speed of 2000 rpm/3000 rpm
- Max. speed up to 4000 rpm
- 300 % overload capacity
- Integrated 20 bit absolute encoder or incremental encoder with 2500 S/R (13 bit resolution through electronic multiplication of the V70 drive)
- Degree of protection IP65, natural cooling
- Optional holding brake
- With plain shaft or feather key, half-key balancing

Technical specifications

Article No.	1FL6...
Product brand name	SIMOTICS
Product type designation	S-1FL6
Product designation	Feed motor
Type of motor	Synchronous motor
Type of motor	Permanent-magnet synchronous motor
Magnet material	High-performance magnet material
Cooling	Natural cooling
Insulation of the stator winding in accordance with EN 60034-1 (IEC 60034-1)	Temperature class 130 (B)
Thermal class	B
Type of construction in accordance with EN 60034-7 (IEC 60034-7)	IM B5 (IM V1, IM V3)
Degree of protection in accordance with EN 60034-5 (IEC 60034-5)	IP65, with oil seal
Shaft extension in accordance with IEC 60072-1	Plain shaft/feather key (C type, motors with a keyway are balanced with a half-fitted key by the manufacturer)
Sound pressure level, max.	
• 1FL604	65 dB
• 1FL606	70 dB
• 1FL609	70 dB
Ambient temperature	
• Storage/transport	-15 ... +65 °C
• Operation	0 ... 40 °C without derating
Humidity	
• Storage/transport	90 % at 30 °C
• Operation	90 % at 30 °C
Installation altitude	Up to 1000 m above sea level without derating > 1000 m ... 5000 m with derating
Paint finish	Anthracite
Certificate of suitability	CE, EAC

www.nicsanat.com

021-87700210



NIC SANAT
دنیک صنعت

SINUMERIK 808D ADVANCED system

Feed axis solutions

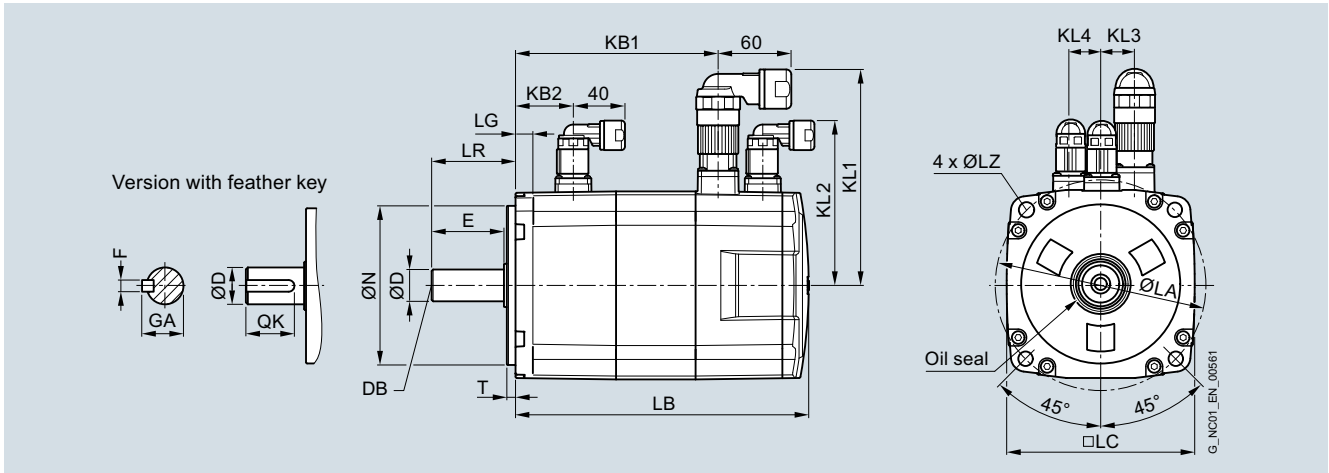
SIMOTICS S-1FL6 feed motor**Dimensional drawings**

SIMOTICS S-1FL6 feed motor with incremental encoder

For motor		Dimensions in mm																						
Shaft height	Type	DE shaft extension										<u>Encoder system:</u>												
		LC	LA	LZ	N	LR	T	LG	D	DB	E	QK	GA	F	LB	KB1	KB2	LB	KB1	KB2	KL1	KL2	KL3	KL4
1FL6 natural cooling without/with brake																								
45	1FL6042	90	100	7	80	35	4	10	19	M6 x 16	30	25	21.5	6	154.5	93.5	-	201	140	31.5	136	92	-	-
	1FL6044														201.5	140.5	-	248	187					
65	1FL6061	130	145	9	110	58	6	12	22	M8 x 16	50	44	25	8	148	85.5	-	202.5	140	39.5	158	115	23	22
	1FL6062														181	118.5	-	235.5	173					
	1FL6064														181	118.5	-	235.5	173					
	1FL6066														214	151.5	-	268.5	206					
	1FL6067														247	184.5	-	301.5	239					
90	1FL6090	180	200	13.5	114.3	80	3	18	35	M12 x 25	75	60	38	10	189.5	140	-	255	206	44.5	184	149	34	34
	1FL6092														211.5	162	-	281	232					
	1FL6094														237.5	188	-	307	258					
	1FL6096														289.5	240	-	359	310					

4

Dimensional drawings (continued)

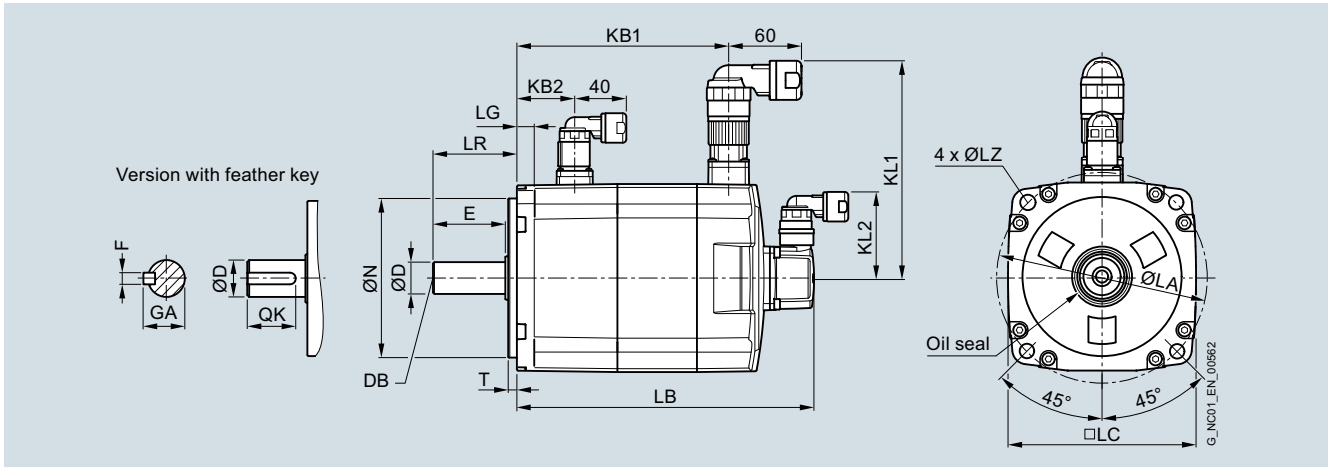

SIMOTICS S-1FL6 feed motor with absolute encoder

Shaft height	Type	Dimensions in mm														Encoder system:								
		LC	LA	LZ	N	LR	T	LG	D	DB	E	QK	GA	F	LB	KB1	KB2	LB	KB1	KB2	KL1	KL2	KL3	KL4
1FL6 natural cooling without/with brake																								
45	1FL6042	90	100	7	80	35	4	10	19	M6 × 16	30	25	21.5	6	157	100	-	203.5	147	31.5	136	60	-	-
	1FL6044														204	147	-	250.5	194					
65	1FL6061	130	145	9	110	58	6	12	22	M8 × 16	50	44	25	8	151	92	-	205.5	147	39.5	158	60	-	-
	1FL6062														184	125	-	238.5	180					
	1FL6064														184	125	-	238.5	180					
	1FL6066														217	158	-	271.5	213					
	1FL6067														250	191	-	304.5	246					
90	1FL6090	180	200	13.5	114.3	80	3	18	35	M12 × 25	75	60	38	10	197	135	-	263	201	44.5	184	60	-	-
	1FL6092														223	161	-	289	227					
	1FL6094														249	187	-	315	253					
	1FL6096														301	239	-	367	305					

SINUMERIK 808D ADVANCED system

Spindle solutions

SINAMICS V70 spindle drive

Overview



SINAMICS V70 spindle drive, frame sizes FSD/FSC/FSB

The SINAMICS V70 spindle drive controls the spindle in standard machine tool applications. The system is designed essentially for applications where cost effectiveness is the primary consideration. The key performance data of the drive are aligned to perfectly fit to the solution provided by the SINUMERIK 808D ADVANCED.

Benefits

- Compact module with integrated infeed, inverter and closed-loop for spindle
- Coated electronic modules
- Commissioning on CNC directly
- Faster commissioning thanks to pre-configured motor data stored in the drive
- CE certified

Function

- Power range from 3.7 kW to 15 kW
- Supply voltage 380 V to 480 V 3 AC
- Drive bus communication to the SINUMERIK 808D ADVANCED
- Safe Torque Off (STO)

Integration

The following components can be connected to the SINAMICS V70 spindle drive:

- SINUMERIK 808D ADVANCED PPU 15x.3/PPU 16x.3
- SIMOTICS M-1PH1 main motor
- Encoder in SIMOTICS M-1PH1 main motor

Technical specifications

Article No.	6SL3210-5DE21-1UA0	6SL3210-5DE21-3UA0	6SL3210-5DE22-0UA0	6SL3210-5DE23-0UA0	6SL3210-5DE24-0UA0
Product brand name	SINAMICS				
Product type designation	V70				
Product designation	Spindle drive				
Frame size	FSB	FSC		FSD	
Rated output current	10.5 A	12.9 A	19.6 A	29.8 A	37.6 A
Max. output current	21 A	24.6 A	39.2 A	59.6 A	75.2 A
Max. supported motor power	3.7 kW	3.7 kW	7.5 kW	11 kW	15 kW
Output frequency	0 Hz to 400 Hz				
Power supply	<ul style="list-style-type: none"> • Voltage/frequency 380 V ... 480 V 3 AC, 50/60 Hz • Permissible voltage fluctuation -15 % ... +10 % • Permissible frequency fluctuation -10 % ... +10 % 				
• Rated input current	13.2 A	16.2 A	24.5 A	37.3 A	47 A
• Power supply capacity	8.7 kVA	10.7 kVA	16.1 kVA	24.5 kVA	30.9 kVA
• Inrush current	4 A	2.5 A	2.5 A	2.5 A	2.5 A
24 V DC power supply	<ul style="list-style-type: none"> • Voltage 24 V (-15 % ... +20 %) • Maximum current 3 A 				
Overload capability	The overload capability is 150 % by default. It can be set up to 200 % via p0640, but the corresponding overload duration might be reduced under the circumstances.				
Control system	Servo control				
Braking resistor	Braking resistor is not included in the standard system package. Choose an external braking resistor according to the technical specifications as listed below from Siemens product portfolio or from 3rd party.				
• Resistance	70 Ω	27 Ω		18 Ω	
• Max. power	9.1 kW	23.7 kW		37.4 kW	
• Rated power	229 W	1185 W		1870 W	
• Max. energy	18.3 kJ	189.6 kJ		299.2 kJ	
Protective functions	<ul style="list-style-type: none"> • Earthing fault protection • Output short-cut protection • Overvoltage/undervoltage protection • I²t detection • IGBT overtemperature protection 				

Technical specifications (continued)

Article No.	6SL3210-5DE21-1UA0	6SL3210-5DE21-3UA0	6SL3210-5DE22-0UA0	6SL3210-5DE23-0UA0	6SL3210-5DE24-0UA0
Product brand name	SINAMICS				
Product type designation	V70				
Product designation	Spindle drive				
Cooling method	Fan-cooled				
Degree of protection	IP20				
Degree of pollution	Class 2				
Operating environment	Indoor (without direct sunlight), free from corrosive gas, combustible gas, oil gas, or dust				
Relative humidity, during					
• storage	90 % (non-condensing)				
• operation	< 90 % (non-condensing)				
Ambient temperature, during					
• storage	-40 °C ... +70 °C				
• operation	0 °C ... 45 °C without power derating 45 °C ... 55 °C with power derating				
Installation altitude	< 1000 m above sea level (without derating)				
Vibration					
• transport and storage	5 Hz ... 9 Hz: 3.5 mm deflection 9 Hz ... 200 Hz: 1 g vibration Ambient Classification: 1M2				
• operation	Operational area II/3M2 10 Hz ... 58 Hz: 0.075 mm deflection 58 Hz ... 200 Hz: 1 g vibration				
Shock					
• transport and storage	Covered by vibration test				
• operation	Operational area: II Ambient classification: 3M2 Peak acceleration: 5 g + 15 g Duration: 30 ms + 11 ms Quantity of shocks: 3 Summed shocks: 18 Cycle time: 1 s				
Width	100 mm	140 mm	140 mm	190 mm	190 mm
Height	180 mm	260 mm	260 mm	350 mm	350 mm
Depth	220 mm	240 mm	240 mm	185 mm	185 mm
Net weight	2.35 kg	5.05 kg	5.05 kg	8.05 kg	8.3 kg
Certificate of suitability	CE, EAC, RCM				

Selection and ordering data

Motor output power kW	Frame size	SINAMICS V70 spindle drive Article No.
<i>Line voltage 380 V... 480 V 3 AC</i>		
3.7	FSB	6SL3210-5DE21-1UA0
3.7	FSC	6SL3210-5DE21-3UA0
7.5	FSC	6SL3210-5DE22-0UA0
11	FSD	6SL3210-5DE23-0UA0
15	FSD	6SL3210-5DE24-0UA0

Accessories

A shield plate can be ordered as an option for FSD devices.

Description	Article No.
Shield plate for V70 spindle drive Frame size FSD	6SL3266-1ED00-0VA0

SINUMERIK 808D ADVANCED system

Spindle solutions

SINAMICS V70 spindle drive

Dimensional drawings

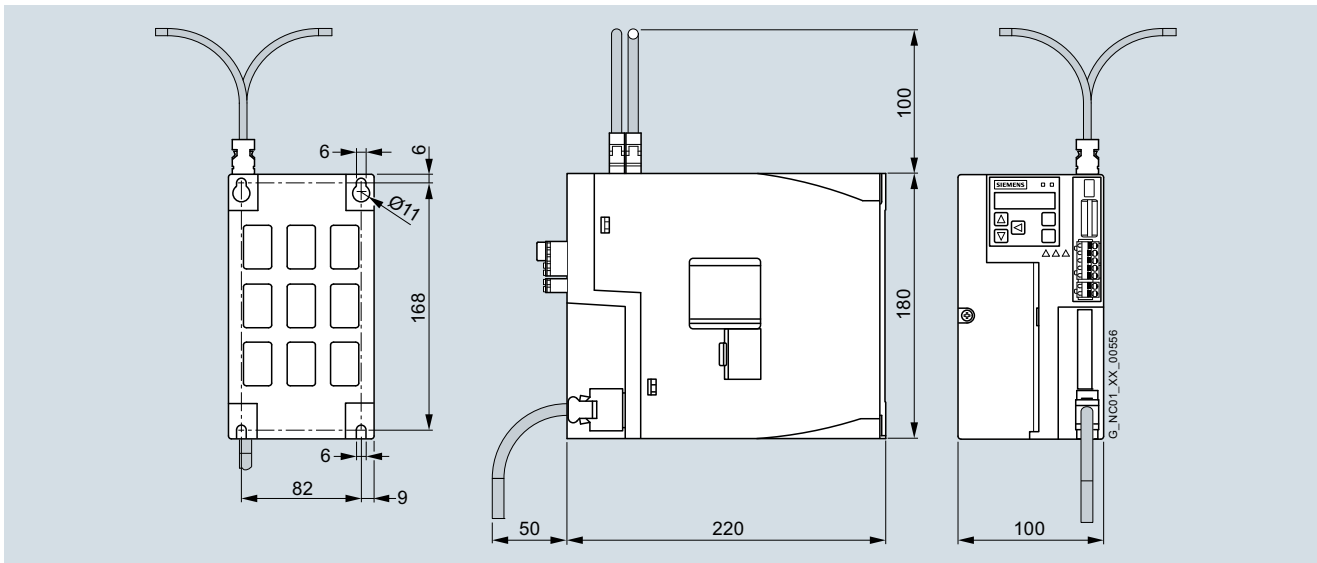

SINAMICS V70 spindle drive, frame size FSB

4

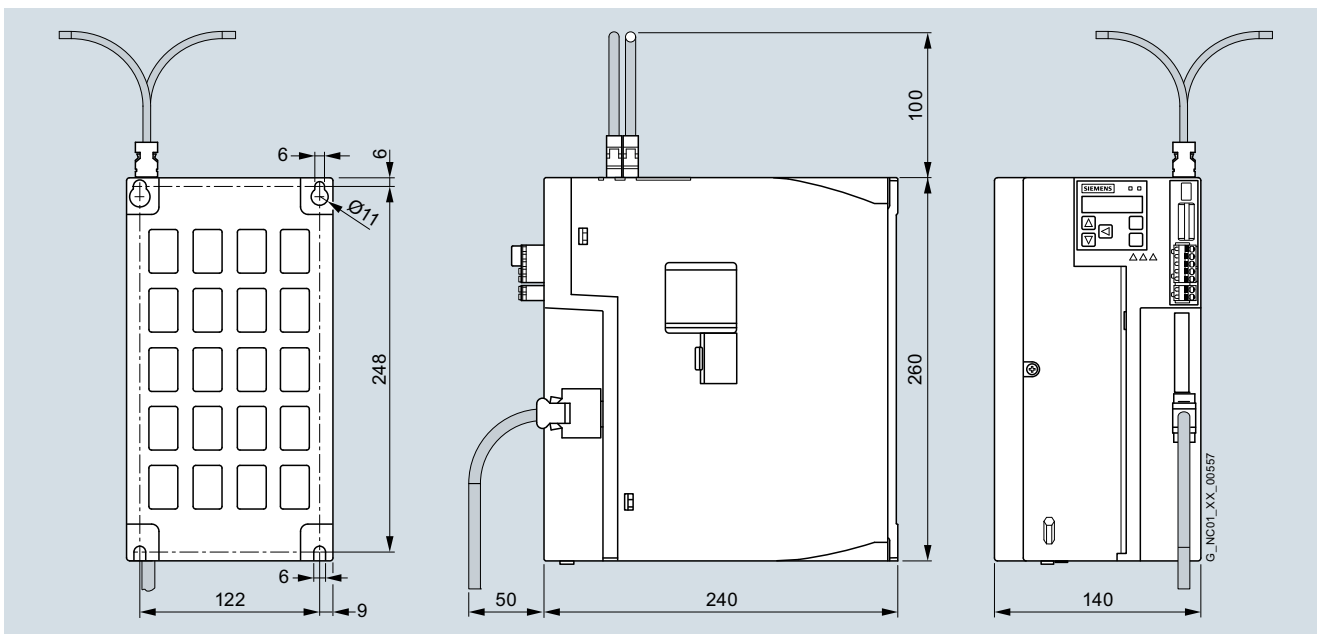

SINAMICS V70 spindle drive, frame size FSC

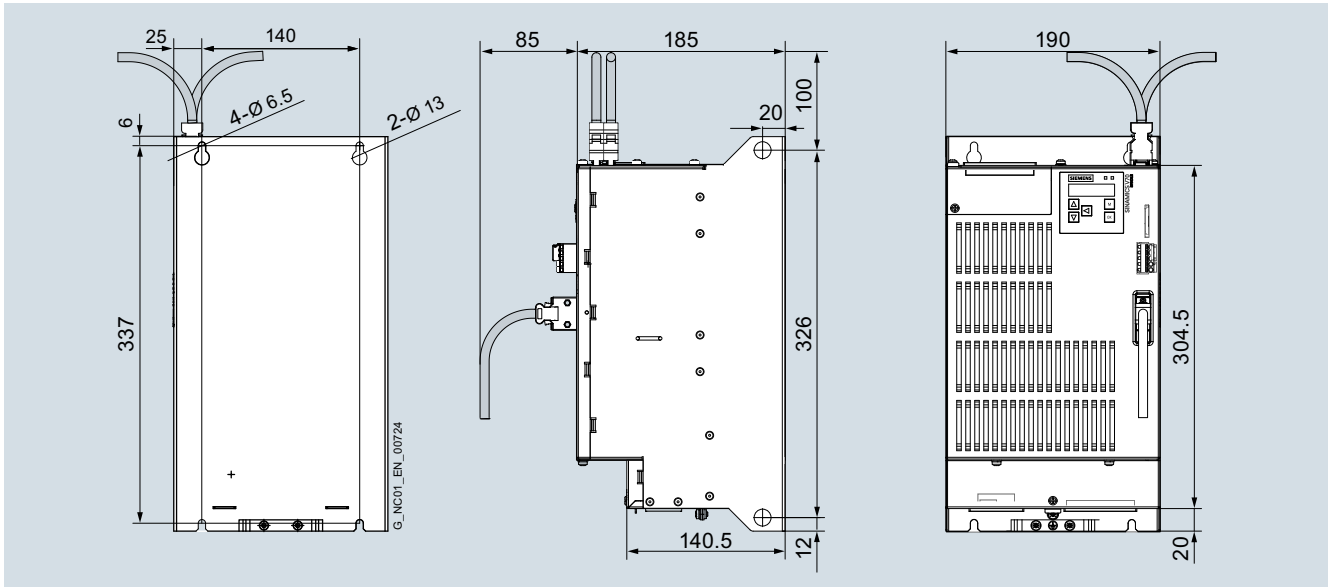
Dimensional drawings (continued)

SINAMICS V70 spindle drive, frame size FSD

SINUMERIK 808D ADVANCED system

Spindle solutions

SIMOTICS M-1PH1 main motor

Overview

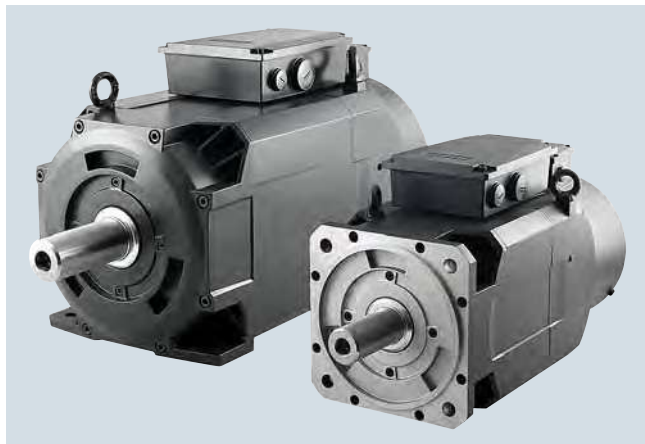

SIMOTICS M-1PH1 main motors SH 132/SH 100

1PH1 main motors have been especially designed for use as main drives in machine tools. These motors are available as asynchronous version with forced fan cooling. Together with the SINAMICS V70 spindle drive, a dynamic and powerful main drive system with high performance is created.

Technical specifications

Article No.	1PH1...
Product brand name	SIMOTICS
Product type designation	M-1PH1
Product designation	Main motor
Type of motor	Squirrel-cage asynchronous motor
Cooling	Forced ventilation
Ambient temperature, admissible	
• Storage	-20 ... +65 °C
• Operation	-15 ... +40 °C without power derating
Relative humidity, during	
• Storage	≤ 95 %
• Operation	≤ 90 %
Installation altitude	Up to 1000 m above sea level without power derating
Maximum noise level	72 dB
Thermal class	F
Vibration severity grade	
• 1PH11...-1.F	Grade B is maintained up to 1800 rpm Grade S is maintained from 1800 rpm to 10000 rpm
• 1PH11...-1.D	Grade B is maintained up to 1800 rpm Grade R is maintained from 1800 rpm to 6000 rpm
Shock resistance	2.25 m/s ² (continuous in axial direction); 10 m/s ² (continuous in radial direction)
Static bearing lifetime	> 20000 h ¹⁾
Oil seal lifetime	> 20000 h
Encoder lifetime	> 20000 h
Motor lifetime	20000 h
Degree of protection	IP54 (dust-tight and splash-proof during motor operation)
Type of construction	IM B5, IM B3, IM V1, and IM V5
Paint finish	Anthracite
Certificate of suitability	CE, EAC

Benefits

- High productivity
 - Short ramp up and ramp down time
 - High overload capability
 - Low moment of motor inertia
- Better cutting performance
 - High vibration resistance (R/S)
 - Low torque ripple
- Compact design
- Easy commissioning together with drive
 - Easy wiring via drive bus communication
 - Easy parameter setting and monitor servo status in HMI
- Easy service
 - Fan design optimized for easy replacement
- High robustness
 - Optimized bearing concept for high transverse force

Function

- Robust, cost optimized design
- Shaft height: SH 100/SH 132
- Rated speed: 1000 rpm/1500 rpm
- Max. speed: up to 10000 rpm
- Rated output: 3.7 kW to 15 kW
- Rated torque 24 Nm to 105 Nm
- 2 times overload capability for high dynamic response
- Foot mounting and flange mounting available
- Degree of protection IP54
- Incremental encoder TTL 2500 S/R / Absolute encoder single-turn 20-bit
- Plain shaft or with key

S/R = Signals/Revolution

¹⁾ This lifetime is only for reference. When a motor keeps running at rated speed under rated load, replace its bearing after 20000 hours to 30000 hours of service time. Even if the time is not reached, the bearing must be replaced when unusual noise, vibration, or faults are found.

Selection and ordering data

Rated speed	Maximum speed ¹⁾	Shaft height	Rated power S1 duty	Rated torque S1 duty	SIMOTICS M-1PH1 Main motors Asynchronous motors Forced ventilation NDE → DE	Rated current for S1 duty	SINAMICS V70 spindle drive			
n_{rated}	$n_{max.}$	SH	P_{rated}	M_{rated}			Rated output current for S1 duty	Frame size		
rpm	rpm		kW	Nm		Article No.	I_{rated} A	I_{rated} A	Article No. 6SL3210-...	
1000	6000	100	3.7	35	1PH1103-1 ■ D 1 ■ - ■ GA0	12.9	12.9	5DE21-3UA0	FSC	
	6000		5.5	53		1PH1105-1 ■ D 1 ■ - ■ GA0	18.8	19.6	5DE22-0UA0	FSC
1500	10000	100	3.7	24	1PH1101-1 ■ F 1 ■ - ■ GA0	10.3	10.5	5DE21-1UA0	FSB	
	10000		5.5	35		1PH1103-1 ■ F 1 ■ - ■ GA0	16.9	19.6	5DE22-0UA0	FSC
	10000		7.5	48		1PH1105-1 ■ F 1 ■ - ■ GA0	19.6	19.6	5DE22-0UA0	FSC
1000	6000	132	7.5	72	1PH1131-1 ■ D 1 ■ - ■ GA0	26.6	29.8	5DE23-0UA0	FSD	
	6000		11	105		1PH1133-1 ■ D 1 ■ - ■ GA0	28.3	29.8	5DE23-0UA0	FSD
1500	8000	132	11	70	1PH1131-1 ■ F 1 ■ - ■ GA0	28.8	29.8	5DE23-0UA0	FSD	
	8000		15	96		1PH1133-1 ■ F 1 ■ - ■ GA0	36.7	37.6	5DE24-0UA0	FSD

Encoder type

Incremental encoder TTL 2500 S/R

L

Absolute encoder, single-turn, 20 bit

H

Type of construction

IM B3/IM V5, foot mounting

0

IM B5/IM V1, flange mounting

2

Shaft extension DE
Balancing

Plain shaft

-

0

Feather key

Full-key

1

Feather key

Half-key

2

S/R = Signals/Revolution

¹⁾ Maximum speed that must not be exceeded.

SINUMERIK 808D ADVANCED system

Spindle solutions

SIMOTICS M-1PH1 main motor

Dimensional drawings

Mounting position

The SIMOTICS M-1PH1 main motor supports flange mounting and foot mounting as shown below:

Mounting method	Standard type of construction	Rotated type of construction
Foot mounting	IM B3	IM V5
Flange mounting	IM B5	IM V1

Minimum clearance between a fan and parts/components mounted by the customer

The minimum clearance between a fan and parts/components mounted by the customer or the air discharge opening, and the minimum clearance S between the air intake/air discharge opening and adjacent components must be maintained.

Shaft height	Fan mounting	Minimum clearance between a fan and parts/components	Minimum clearance S
SH 100	Non-drive end axial, can be rotated through 180°	30 mm	30 mm

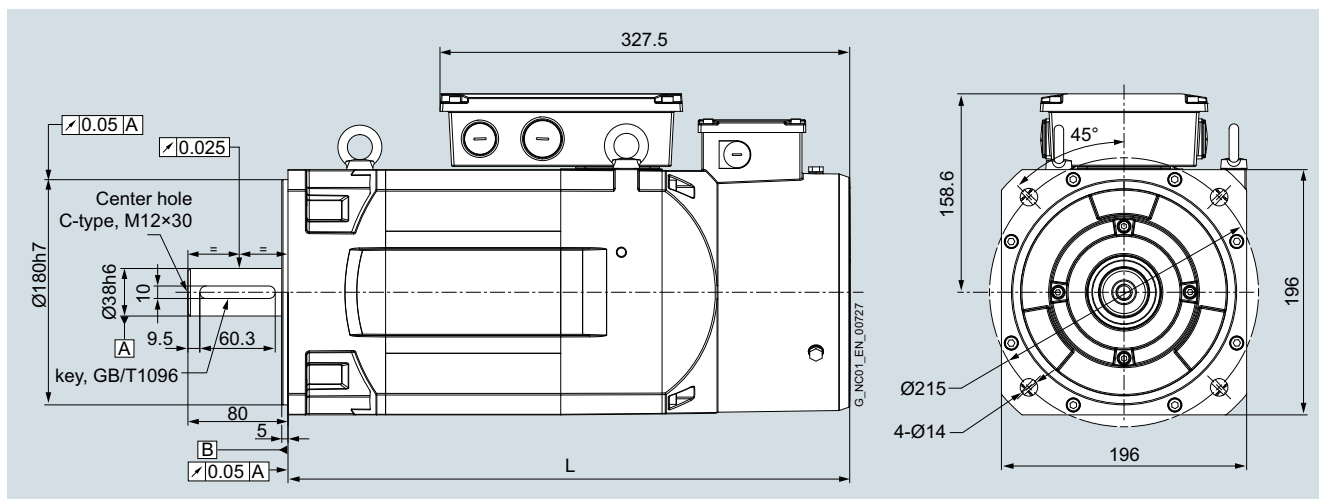

For motor Dimensions in mm

Shaft height	Type	L
--------------	------	---

1PH1, type of construction IM B5/IM V1

100	1PH1101-1.F12-.GA0	419
	1PH1103-1.F12-.GA0	449
	1PH1103-1.D12-.GA0	449
	1PH1105-1.F12-.GA0	499
	1PH1105-1.D12-.GA0	499

Dimensional drawings (continued)

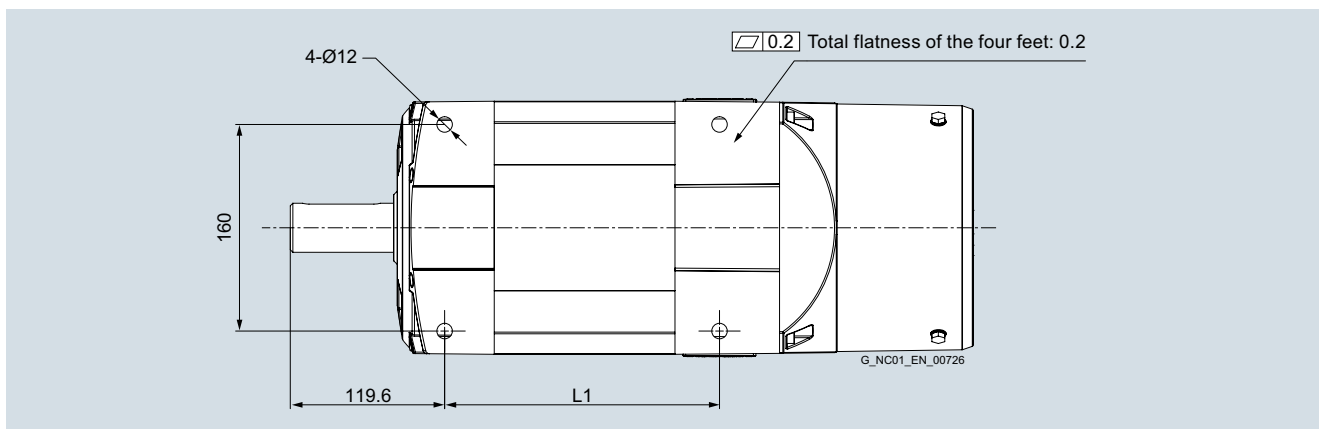
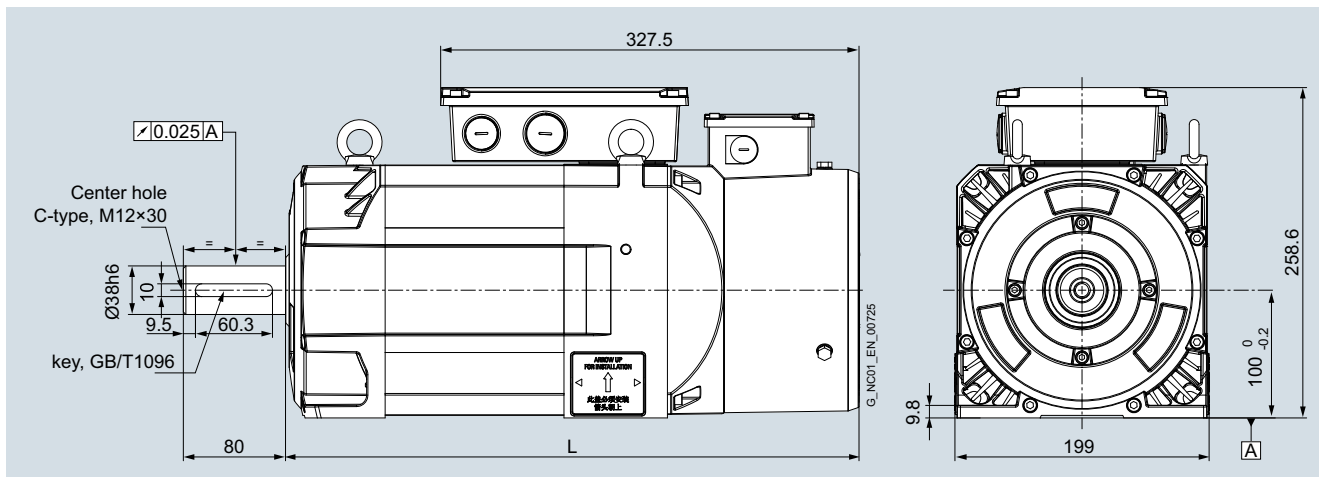

For motor Shaft height Type
Dimensions in mm L L1

1PH1, type of construction IM B3/IM V5

Shaft height	Type	L	L1
100	1PH1101-1.F10-.GA0	419	183
	1PH1103-1.F10-.GA0	449	213
	1PH1103-1.D10-.GA0	449	213
	1PH1105-1.F10-.GA0	499	263
	1PH1105-1.D10-.GA0	499	263

4

SINUMERIK 808D ADVANCED system

Spindle solutions

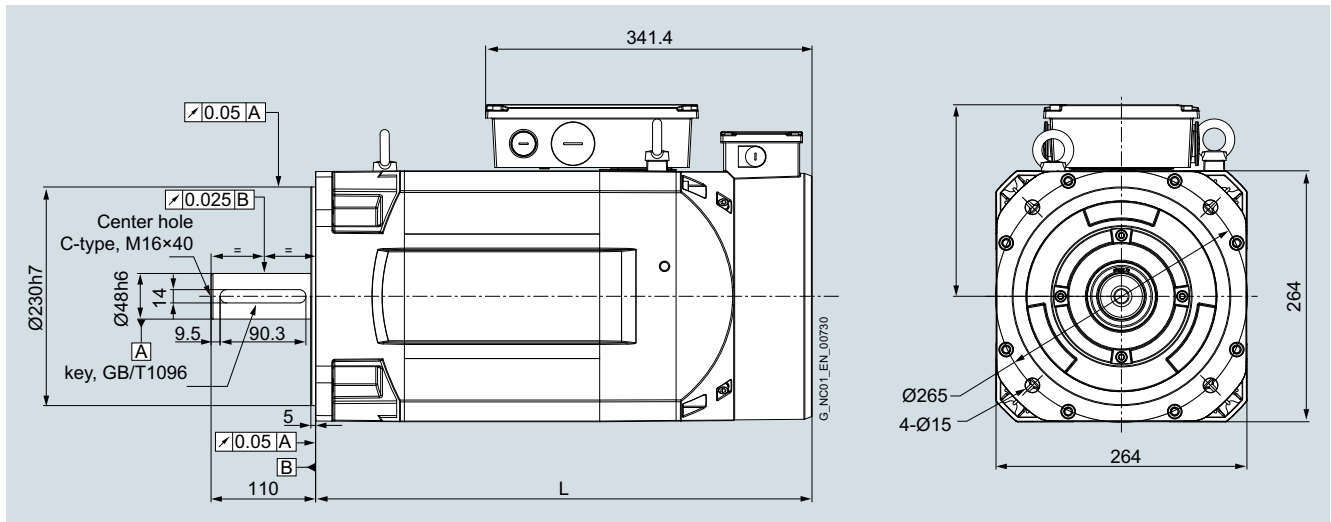
SIMOTICS M-1PH1 main motor**Dimensional drawings** (continued)

For motor Dimensions in mm

Shaft height	Type	L
--------------	------	---

1PH1, type of construction IM B5/IM V1

132	1PH1131-1.F12-.GA0	475
	1PH1131-1.D12-.GA0	465
	1PH1133-1.F12-.GA0	525
	1PH1133-1.D12-.GA0	525

4

Dimensional drawings (continued)

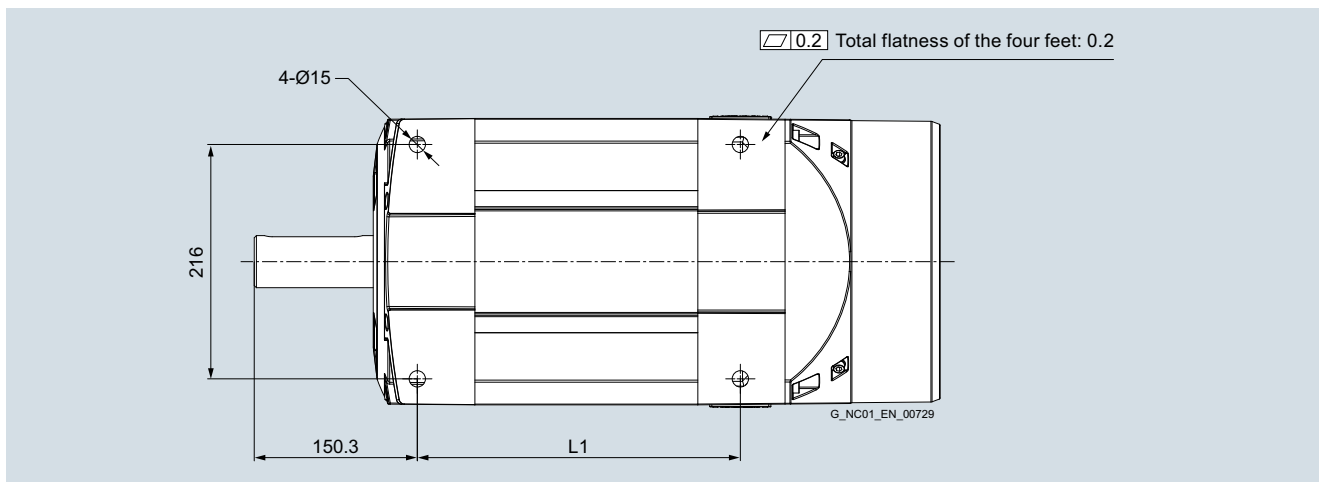
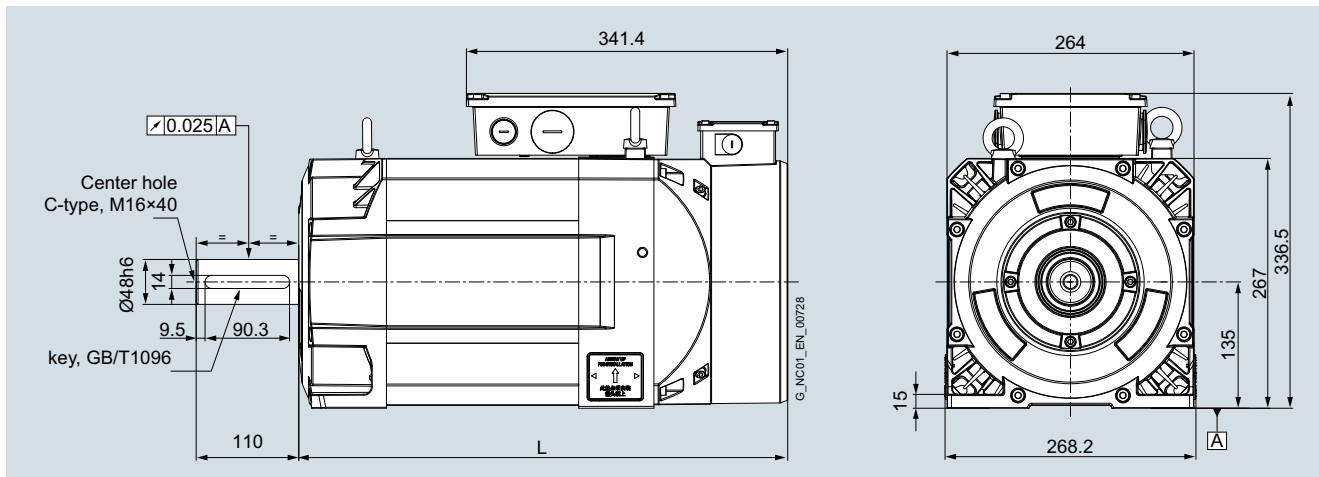

For motor		Dimensions in mm	
Shaft height	Type	L	L1
1PH1, type of construction IM B3/IM V5			
132	1PH1131-1.F10-.GA0	475	251.8
	1PH1131-1.D10-.GA0	465	241.8
	1PH1133-1.F10-.GA0	525	301.8
	1PH1133-1.D10-.GA0	525	301.8

4

SINUMERIK 808D ADVANCED system

MOTION-CONNECT connection systems

MOTION-CONNECT cables for SINUMERIK 808D ADVANCED

Integration

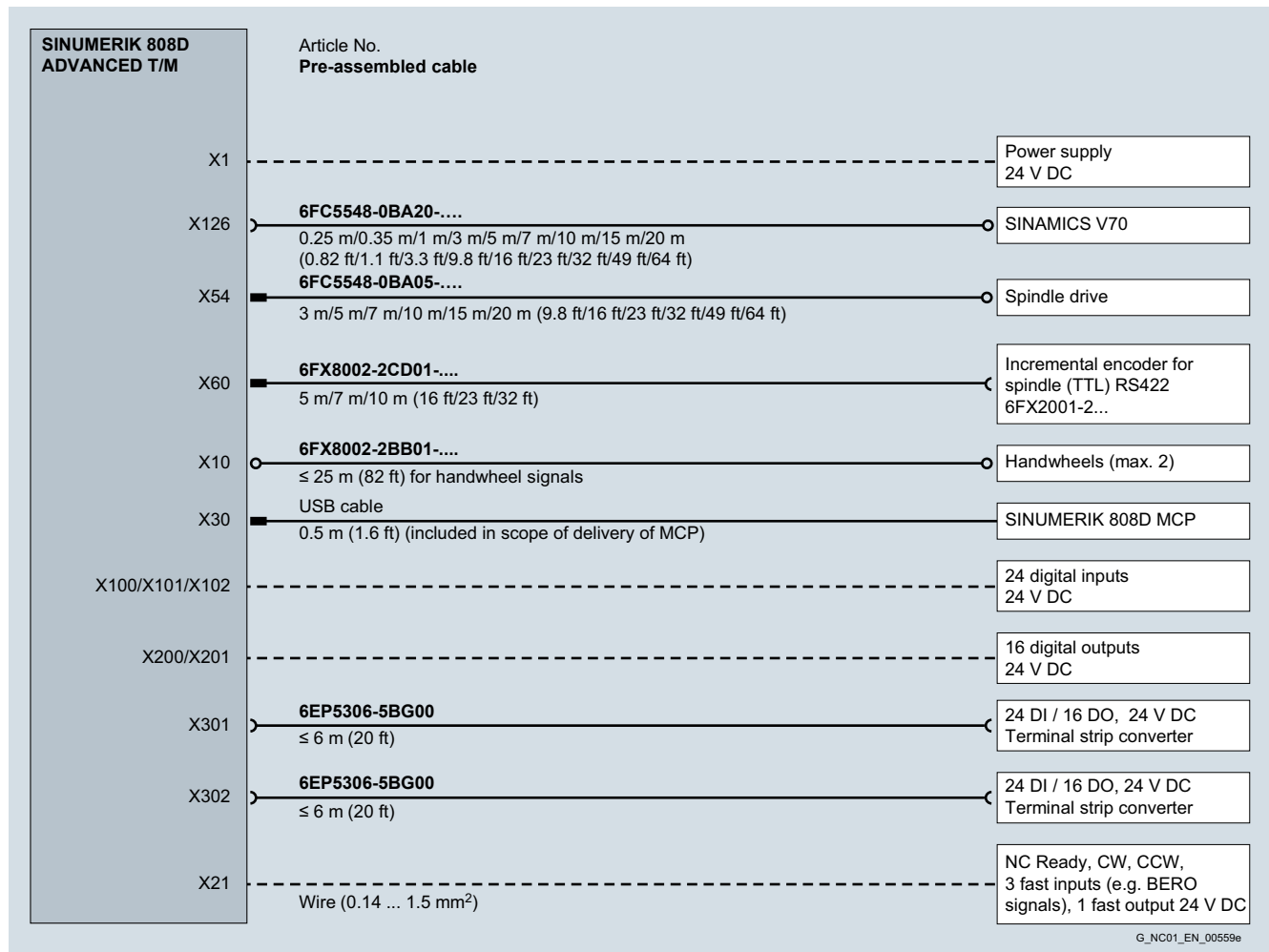

Connection overview of SINUMERIK 808D ADVANCED T/M

—■—	Connector with pin contacts
—○—	Connector with socket contacts
—○—	Exposed core ends
---	Cable is not included in the scope of delivery. It must be provided by the customer.

SINUMERIK 808D ADVANCED system

MOTION-CONNECT connection systems

MOTION-CONNECT cables for SINUMERIK 808D ADVANCED

Technical specifications

Article No.	6FC5548-0BA20-....	6FC5548-0BA05-....
Product name	Drive bus cable PPU 15x.3/PPU 16x.3 – SINAMICS V70 SINAMICS V70 – SINAMICS V70	Setpoint cable PPU 15x.3/PPU 16x.3 – spindle drive
No. of cores	2	4
Certificate of suitability • cURus or UR/CSA ¹⁾ • RoHS conformity	UL1581 Yes	UL2576 Yes
Operating voltage	100 V	30 V
Test voltage, rms	3600 V	500 V
Operating temperature on the surface • Fixed installation • Flexible installation	-40 ... +80 °C -40 ... +60 °C	-20 ... +80 °C 0 ... 60 °C
Smallest bending radius • Fixed installation • Flexible installation	75 mm 150 mm	60 mm 120 mm
Insulation material, incl. jacket	PVC	PVC
Oil resistance	Limited mineral oil and fats resistance	70 °C × 4 h
Outer jacket	PVC Gray	PVC Gray
Flame-retardant	IEC 60332-3-24	VW-1
Article No.	6FX8002-2CD01-....	6FX8002-2BB01-....
Product name	Signal cable PPU 15x.3/PPU 16x.3 – Incremental encoder for spindle (TTL)	Signal cable PPU 15x.3/PPU 16x.3 – handwheel
Certificate of suitability • cURus or UR/CSA ¹⁾ • RoHS conformity	UL758-CSA-C22.2-N.210.2-M90 Yes	UL758-CSA-C22.2-N.210.2-M90 Yes
Rated voltage	30 V	30 V
Test voltage, rms	500 V	500 V
Operating temperature on the surface • Fixed installation • Flexible installation	-50 ... +80 °C -20 ... +60 °C	-50 ... +80 °C -20 ... +60 °C
Tensile stress, max. • Fixed installation • Flexible installation	50 N/mm ² 20 N/mm ²	50 N/mm ² 20 N/mm ²
Smallest bending radius • Fixed installation • Flexible installation	35 mm 70 mm	35 mm 70 mm
Torsional stress	Absolute 30°/m	Absolute 30°/m
Bending	10 million	10 million
Traversing velocity	300 m/min	300 m/min
Acceleration	5 m/s ²	5 m/s ²
Insulation material, incl. Jacket	CFC/silicone-free IEC 60754-1/DIN VDE 0472-815	CFC/silicone-free IEC 60754-1/DIN VDE 0472-815
Oil resistance	EN 60811-2-1	EN 60811-2-1
Outer jacket	PVC DESINA color green RAL 6018	PVC DESINA color green RAL 6018
Flame-retardant	EN 60332-1-1 to 1-3	EN 60332-1-1 to 1-3

For general information about MOTION-CONNECT please refer to Introduction.

¹⁾ The respective registration number is printed on the cable jacket.

SINUMERIK 808D ADVANCED system

MOTION-CONNECT connection systems

MOTION-CONNECT cables for SINUMERIK 808D ADVANCED

Selection and ordering data

Description	Article No.
Pre-assembled bus cable PPU PPU 15x.3/PPU 16x.3 – SINAMICS V70 and SINAMICS V70 – SINAMICS V70 Length • 0.25 m • 0.35 m • 1 m • 3 m • 5 m • 7 m • 10 m • 15 m • 20 m	6FC5548-0BA20-1AA2 6FC5548-0BA20-1AA3 6FC5548-0BA20-1AB0 6FC5548-0BA20-1AD0 6FC5548-0BA20-1AF0 6FC5548-0BA20-1AH0 6FC5548-0BA20-1BA0 6FC5548-0BA20-1BF0 6FC5548-0BA20-1CA0
Pre-assembled setpoint cable PPU PPU 15x.3/PPU 16x.3 – spindle drive Length • 3 m • 5 m • 7 m • 10 m • 15 m • 20 m	6FC5548-0BA05-1AD0 6FC5548-0BA05-1AF0 6FC5548-0BA05-1AH0 6FC5548-0BA05-1BA0 6FC5548-0BA05-1BF0 6FC5548-0BA05-1CA0
Pre-assembled signal cable PPU PPU 15x.3/PPU 16x.3 – incremental encoder for spindle (TTL) Length • 5 m • 7 m • 10 m	6FX8002-2CD01-1AF0 6FX8002-2CD01-1AH0 6FX8002-2CD01-1BA0
Pre-assembled signal cable PPU PPU 15x.3/PPU 16x.3 – handwheel Length • 1 m • 5 m • 7 m • 10 m	6FX8002-2BB01-1AB0 6FX8002-2BB01-1AF0 6FX8002-2BB01-1AH0 6FX8002-2BB01-1BA0

SINUMERIK 808D ADVANCED system

MOTION-CONNECT connection systems

MOTION-CONNECT cables for SINAMICS V70 servo drive

Integration

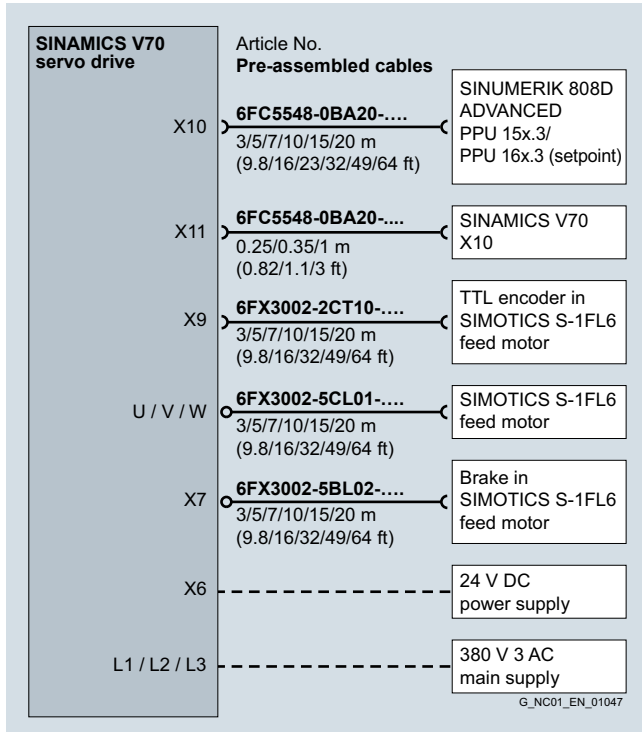

Connection overview of SINAMICS V70 servo drive

	Connector with pin contacts
	Connector with socket contacts
	Exposed core ends
	Cable is not included in the scope of delivery. It must be provided by the customer.

Selection and ordering data

Description	Article No.
Pre-assembled signal cable SINAMICS V70 – SIMOTICS S-1FL6 feed motor with absolute encoder	
Length	
• 3 m	6FX3002-2DB10-1AD0
• 5 m	6FX3002-2DB10-1AF0
• 7 m	6FX3002-2DB10-1AH0
• 10 m	6FX3002-2DB10-1BA0
• 15 m	6FX3002-2DB10-1BF0
• 20 m	6FX3002-2DB10-1CA0
Pre-assembled signal cable SINAMICS V70 – SIMOTICS S-1FL6 feed motor with incremental encoder	
Length	
• 3 m	6FX3002-2CT10-1AD0
• 5 m	6FX3002-2CT10-1AF0
• 7 m	6FX3002-2CT10-1AH0
• 10 m	6FX3002-2CT10-1BA0
• 15 m	6FX3002-2CT10-1BF0
• 20 m	6FX3002-2CT10-1CA0
Pre-assembled power cable 4 × 1.5 mm² SINAMICS V70, frame size FSA – SIMOTICS S-1FL6 feed motor	
Length	
• 3 m	6FX3002-5CL01-1AD0
• 5 m	6FX3002-5CL01-1AF0
• 7 m	6FX3002-5CL01-1AH0
• 10 m	6FX3002-5CL01-1BA0
• 15 m	6FX3002-5CL01-1BF0
• 20 m	6FX3002-5CL01-1CA0
Pre-assembled power cable 4 × 2.5 mm² SINAMICS V70, frame size FSB/FSC – SIMOTICS S-1FL6 feed motor	
Length	
• 3 m	6FX3002-5CL11-1AD0
• 5 m	6FX3002-5CL11-1AF0
• 7 m	6FX3002-5CL11-1AH0
• 10 m	6FX3002-5CL11-1BA0
• 15 m	6FX3002-5CL11-1BF0
• 20 m	6FX3002-5CL11-1CA0
Pre-assembled brake cable SINAMICS V70 – SIMOTICS S-1FL6 feed motor with brake	
Length	
• 3 m	6FX3002-5BL02-1AD0
• 5 m	6FX3002-5BL02-1AF0
• 7 m	6FX3002-5BL02-1AH0
• 10 m	6FX3002-5BL02-1BA0
• 15 m	6FX3002-5BL02-1BF0
• 20 m	6FX3002-5BL02-1CA0

SINUMERIK 808D ADVANCED system

MOTION-CONNECT connection systems

MOTION-CONNECT cables for SINAMICS V70 servo drive

Technical specifications

Article No.	6FX3002-2DB10-.... 6FX3002-2CT10-....	6FX3002-5CL01-.... 6FX3002-5CL11-....	6FX3002-5BL02-....
Product name	Signal cable SINAMICS V70 – Encoder in SIMOTICS S-1FL6 feed motor	Power cable SINAMICS V70 – SIMOTICS S-1FL6 feed motor	Signal cable SINAMICS V70 – brake in SIMOTICS S-1FL6 feed motor
No. of cores	10	4	2
Degree of protection (when closed and connected)	IP65	IP65	IP65
Certificate of suitability			
• RoHS	Yes	Yes	Yes
• UL	Yes	Yes	Yes
• CE	No	Yes	No
Rated voltage U_0/U	30 V/30 V	600 V/1000 V	30 V/30 V
Test voltage, rms	500 V	4 kV	500 V
Operating temperature on the surface			
• Fixed installation	-15 ... +80 °C	-15 ... +80 °C	-15 ... +80 °C
Tensile stress, max.			
• Fixed installation	50 N/mm ²	50 N/mm ²	50 N/mm ²
• Flexible installation	20 N/mm ²	20 N/mm ²	20 N/mm ²
Smallest bending radius			
• Fixed installation	6 × diameter	6 × diameter	6 × diameter
• Flexible installation	155 mm	155 mm	155 mm
Torsional stress	Absolute 30°/m	Absolute 30°/m	Absolute 30°/m
Bending	1000000	1000000	1000000
Insulation material, incl. jacket	PVC	PVC	PVC
Oil resistance	EN 60811-2-1	EN 60811-2-1	EN 60811-2-1
Outer jacket	PVC	PVC	PVC
Flame-retardant	FT1	FT1	FT1

For general information about MOTION-CONNECT please refer to Introduction.

Integration

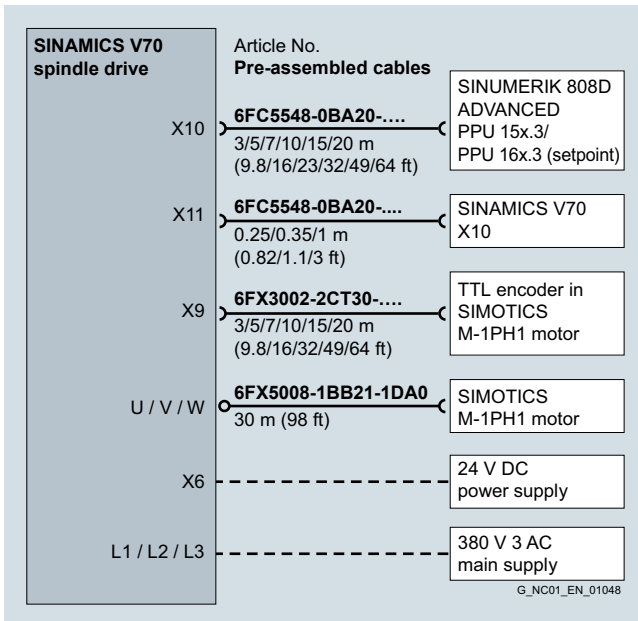

Connection overview for SINAMICS V70 spindle drive

—	Connector with pin contacts
⌋	Connector with socket contacts
○	Exposed core ends
- - - -	Cable is not included in the scope of delivery. It must be provided by the customer.

SINUMERIK 808D ADVANCED system

MOTION-CONNECT connection systems

MOTION-CONNECT cables for SINAMICS V70 spindle drive

Technical specifications

Article No.	6FX5008-1BB21-1DA0 6FX5008-1BB31-1DA0 6FX5008-1BB51-1DA0 6FX5008-1BB61-1DA0	6FX3002-2CT30-.... 6FX3002-2DB30-....
Product name	MOTION-CONNECT 500 power cable	MOTION-CONNECT 300 signal cable
No. of cores	4	10
Degree of protection (motor side only)	–	IP20
Certificate of suitability • RoHS • CE	Yes Yes	Yes No
Rated voltage	1000 V	30 V
Operating temperature on the surface	-20 ... +80 °C	-30 ... +90 °C
Smallest bending radius • Fixed installation • Flexible installation	5 × outer diameter 180 mm, 210 mm	5 × outer diameter 20 × outer diameter
Bending	100000	100000
Shielding	Yes (coverage ≥ 80 %)	Yes
Oil resistance	DIN VDE 472-803 Part B	EN 60811-2-1
Outer jacket	PVC	PVC
Flame-retardant	IEC 332.1	EN 60332-1-1 to 1-3

For general information about MOTION-CONNECT please refer to Introduction.

Selection and ordering data

Description	Article No.	Description	Article No.
MOTION-CONNECT 500 power cable 4 × 2.5 mm ² , sold by the meter, for SIMOTICS M-1PH1 motor 3.7 kW Length • 30 m	6FX5008-1BB21-1DA0	MOTION-CONNECT 500 power cable 4 × 16 mm ² , sold by the meter, for SIMOTICS M-1PH1133-1.D... motor and for SIMOTICS M-1PH1133-1.F... motor Length • 30 m	6FX5008-1BB61-1DA0
MOTION-CONNECT 500 power cable 4 × 4 mm ² , sold by the meter, for SIMOTICS M-1PH1 motor 5.5 kW to 7.5 kW Length • 30 m	6FX5008-1BB31-1DA0	MOTION-CONNECT 300 pre-assembled signal cable SINAMICS V70 spindle drive – SIMOTICS M-1PH1 motor with incremental encoder Length • 3 m • 5 m • 7 m • 10 m • 15 m • 20 m	6FX3002-2CT30-1AD0 6FX3002-2CT30-1AF0 6FX3002-2CT30-1AH0 6FX3002-2CT30-1BA0 6FX3002-2CT30-1BF0 6FX3002-2CT30-1CA0
MOTION-CONNECT 500 power cable 4 × 10 mm ² , sold by the meter, for SIMOTICS M-1PH1131-1.F... motor Length • 30 m	6FX5008-1BB51-1DA0	MOTION-CONNECT 300 pre-assembled signal cable SINAMICS V70 spindle drive – SIMOTICS M-1PH1 motor with absolute encoder Length • 3 m • 5 m • 7 m • 10 m • 15 m • 20 m	6FX3002-2DB30-1AD0 6FX3002-2DB30-1AF0 6FX3002-2DB30-1AH0 6FX3002-2DB30-1BA0 6FX3002-2DB30-1BF0 6FX3002-2DB30-1CA0

Overview

The following composition of an equipment package is an example of an inclined bed lathe with:

- 2 machining axes (X, Z)
- 1 digital spindle with direct spindle encoder
- 24 digital PLC input signals and 16 digital PLC output signals

Designation	Quantity	Article No.
SINUMERIK CNC		
SINUMERIK 808D ADVANCED T PPU 160.3 vertical, English layout	1	6FC5370-2BT03-0AA0
SINUMERIK 808D MCP vertical, with handwheel slot, English layout	1	6FC5303-0AF35-3AA0
Stabilized power supply, SITOP PSU200M 24 V, 5 A	1	6EP1333-3BA10
RS422 (TTL) incremental encoder, 1024 S/R	1	6FX2001-2EB02
Spring disk coupling, shaft diameter 6 mm/6 mm	1	6FX2001-7KF10
Clamp strap for encoders with Synchro flange	3	6FX2001-7KP01
Pre-assembled bus cable PPU 160.3 – SINAMICS V70, length 5 m	1	6FC5548-0BA20-1AF0
Pre-assembled bus cable SINAMICS V70 – SINAMICS V70, length 0.25 m	2	6FC5548-0BA20-1AA2
Pre-assembled signal cable PPU 160.3 – handwheel, length 1 m	1	6FX8002-2BB01-1AB0
Pre-assembled signal cable PPU 160.3 – incremental spindle encoder (TTL), length 5 m	1	6FX8002-2CD01-1AF0
SINAMICS V70		
SINAMICS V70, I_{rated} 3.0 A	1	6SL3210-5DE13-5UA0
SINAMICS V70, I_{rated} 5.3 A	1	6SL3210-5DE17-8UA0
SINAMICS V70 spindle ¹⁾ , I_{rated} 19.6 A	1	6SL3210-5DE22-0UA0
Pre-assembled signal cable SINAMICS V70 – absolute encoder in SIMOTICS S-1FL6 feed motor, length 5 m	2	6FX3002-2DB10-1AF0
Pre-assembled power cable $4 \times 1.5 \text{ mm}^2$ SINAMICS V70 – SIMOTICS S-1FL6 feed motor, length 5 m	1	6FX3002-5CL01-1AF0
Pre-assembled power cable $4 \times 2.5 \text{ mm}^2$ SINAMICS V70 – SIMOTICS S-1FL6 feed motor, length 5 m	1	6FX3002-5CL11-1AF0
Pre-assembled brake cable SINAMICS V70 – brake in SIMOTICS S-1FL6 feed motor with holding brake, length 5 m	1	6FX3002-5BL02-1AF0
Pre-assembled signal cable SINAMICS V70 – incremental encoder for spindle, length 5 m	1	6FX3002-2CT30-1AF0
Power cable $4 \times 4 \text{ mm}^2$, sold by the meter, (optional) ²⁾ SINAMICS V70 – SIMOTICS M-1PH1 main motor, length 30 m	1	6FX5008-1BB31-1DA0
SIMOTICS motors		
SIMOTICS S-1FL6 feed motor, 4 Nm, 2000 rpm, absolute encoder, plain shaft, without holding brake	1	1FL6061-1AC61-0LG1
SIMOTICS S-1FL6 feed motor, 11 Nm, 2000 rpm, absolute encoder, plain shaft, with holding brake	1	1FL6066-1AC61-0LH1
SIMOTICS M-1PH1 main motor, 53 Nm, 1000 rpm, incremental encoder, plain shaft	1	1PH1105-1LD10-0GA0

¹⁾ For braking resistor selection, please refer to page 4/16.

²⁾ The 30 m power cables (raw cables) listed above could be selected for use with 1PH1 motors. You must assemble the power cable with connectors by yourself. You could also select the third party power cable by yourselves according to the system configuration.

SINUMERIK 808D ADVANCED system

Example packages

Example package for Milling with SINUMERIK 808D ADVANCED M

Overview

The following composition of an equipment package is an example of a vertical machining center with:

- 3 machining axes (X, Y, Z)
- 1 digital spindle without direct spindle encoder
- 35 digital PLC input signals and 22 digital PLC output signals

Designation	Quantity	Article No.
SINUMERIK CNC		
SINUMERIK 808D ADVANCED M PPU 161.3 horizontal, English layout	1	6FC5370-2AM03-0AA0
SINUMERIK 808D MCP, English layout	1	6FC5303-0AF35-0AA0
Electronic handwheel with front panel 120 mm × 120 mm, with setting wheel 5 V DC, RS422	1	6FC9320-5DB01
Terminal strip converter 50-pole	1	6EP5406-5AA00
Cable set, 50-pole ribbon cable, with insulation displacement connectors, 50-pole	1	6EP5306-5BG00
Stabilized power supply, SITOP PSU200M 24 V, 5 A	1	6EP1333-3BA10
Pre-assembled bus cable PPU 161.3 – SINAMICS V70, length 5 m	1	6FC5548-0BA20-1AF0
Pre-assembled bus cable SINAMICS V70 – SINAMICS V70, length 0.25 m	2	6FC5548-0BA20-1AA2
Pre-assembled bus cable SINAMICS V70 – SINAMICS V70, length 1 m	1	6FC5548-0BA20-1AB0
Pre-assembled signal cable PPU 161.3 – handwheel, length 1 m	1	6FX8002-2BB01-1AB0
Pre-assembled signal cable PPU 161.3 – incremental spindle encoder (TTL), length 7 m	1	6FX8002-2CD01-1AH0
SINAMICS V70		
SINAMICS V70, I_{rated} 4.6 A	2	6SL3210-5DE16-0UA0
SINAMICS V70, I_{rated} 7.8 A	1	6SL3210-5DE21-0UA0
SINAMICS V70 spindle ¹⁾ , I_{rated} 19.6 A	1	6SL3210-5DE22-0UA0
Pre-assembled signal cable SINAMICS V70 – incremental encoder in SIMOTICS S-1FL6 feed motor, length 10 m	3	6FX3002-2CT10-1BA0
Pre-assembled power cable 4 × 2.5 mm ² SINAMICS V70 – SIMOTICS S-1FL6 feed motor, length 10 m	3	6FX3002-5CL11-1BA0
Pre-assembled brake cable SINAMICS V70 – brake in SIMOTICS S-1FL6 feed motor, length 10 m	1	6FX3002-5BL02-1BA0
Pre-assembled signal cable SINAMICS V70 – incremental encoder for spindle, length 10 m	1	6FX3002-2CT30-1BA0
Power cable 4 × 4 mm ² , sold by the meter, (optional) ²⁾ SINAMICS V70 – SIMOTICS M-1PH1 main motor, length 30 m	1	6FX5008-1BB31-1DA0
SIMOTICS motors		
SIMOTICS S-1FL6 feed motor, 8 Nm, 2000 rpm, incremental encoder, plain shaft, without holding brake	2	1FL6064-1AC61-0AG1
SIMOTICS S-1FL6 feed motor, 15 Nm, 2000 rpm, incremental encoder, plain shaft, with holding brake	1	1FL6067-1AC61-0AH1
SIMOTICS M-1PH1 main motor, 48 Nm, 1500 rpm, incremental encoder, plain shaft	1	1PH1105-1LF12-0GA0

¹⁾ For braking resistor selection, please refer to page 4/16.

²⁾ The 30 m power cables (raw cables) listed above could be selected for use with 1PH1 motors. You must assemble the power cable with connectors by yourself. You could also select the third party power cable by yourselves according to the system configuration.

Accessories



5/2	Operator components
5/2	Electronic handwheel
5/5	Supplementary components
5/5	Terminal strip converter
5/6	SITOP power supply
5/8	Direct spindle encoder

Accessories

Operator components

Electronic handwheel

Overview



Electronic handwheel

This handwheel generates signals which correspond to the movements of the handwheel as it is turned. The axis selected via the control can be positioned. The handwheels are equipped with a magnetic latching mechanism that supports traversing with incremental accuracy. The front panel can be removed.

Selection and ordering data

Description	Article No.
Electronic handwheel 5 V DC, RS422	
• With front panel 120 mm × 120 mm, with setting wheel	6FC9320-5DB01
• With front panel 76.2 mm × 76.2 mm, with setting wheel	6FC9320-5DC01
• Without front panel, with small setting wheel	6FC9320-5DM00
• Without front panel, without setting wheel, for installation	6FC9320-5DF01
Adapter set For installation in front panel with 3-hole fixing	6FC9320-5DN00

Technical specifications

Article No.	6FC9320-5DB01	6FC9320-5DC01/ 6FC9320-5DF01/ 6FC9320-5DM00
Product name	Electronic handwheel	
Rated voltage	5 V DC ± 5 %	5 V DC ± 5 %
Rated current, max.	60 mA	60 mA
Interface	RS422 (TTL)	RS422 (TTL)
Phase angle of pulse sequence A to B	90° electrical	90° electrical
Pulses	2 × 100 S/R	2 × 100 S/R
Actuating force	8 Ncm	4 Ncm
Output frequency, max.	2 kHz	2 kHz
Distance to PPU, max.	25 m	25 m
Degree of protection according to EN 60529 (IEC 60529)		
• Front	IP65	IP65
• Rear	IP50	IP50
Relative humidity		
• Storage	10 ... 95 % at 25 °C	10 ... 95 % at 25 °C
• Transport	10 ... 95 % at 25 °C	10 ... 95 % at 25 °C
• Operation	5 ... 80 % at 25 °C	5 ... 80 % at 25 °C
Ambient temperature		
• Storage	-40 ... +85 °C	-40 ... +85 °C
• Transport	-40 ... +85 °C	-40 ... +85 °C
• Operation	0 ... 70 °C	0 ... 70 °C
Weight, approx.	0.6 kg	0.4 kg
Approvals, according to	cULus	cULus

S/R = Signals/Revolution

Dimensional drawings

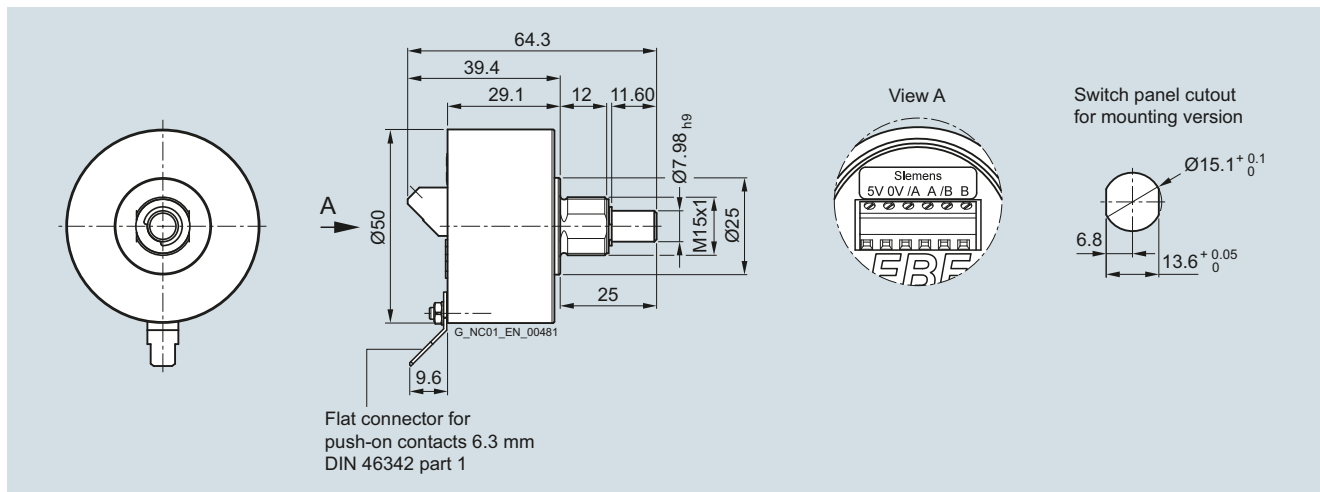

Electronic handwheel without front panel without setting wheel

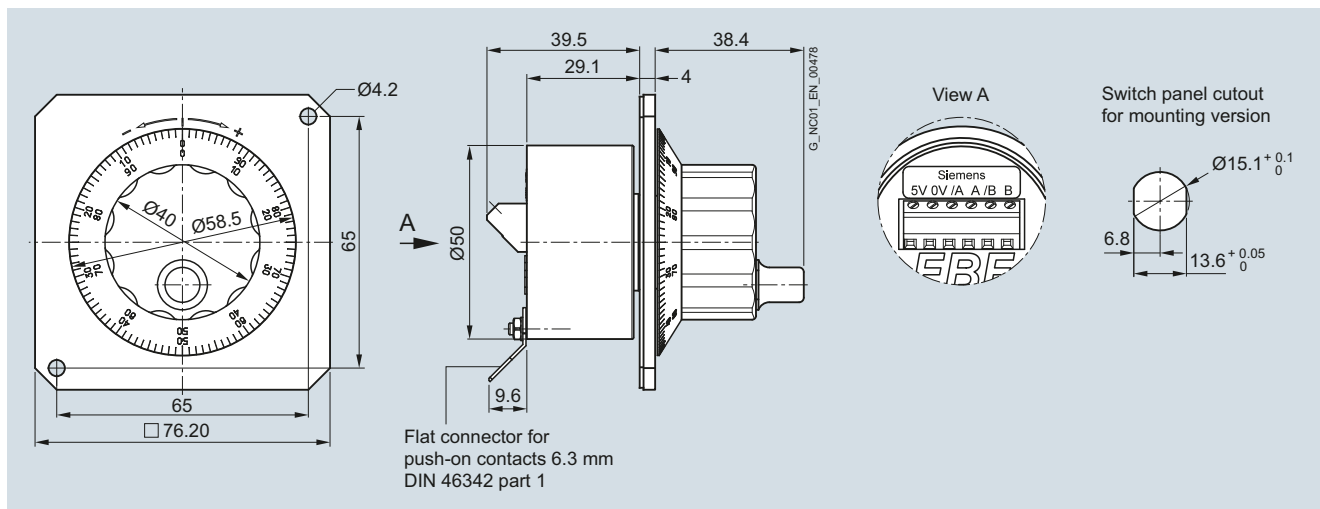

Electronic handwheel with front panel 76.2 mm × 76.2 mm

Accessories

Operator components

Electronic handwheel

Dimensional drawings (continued)

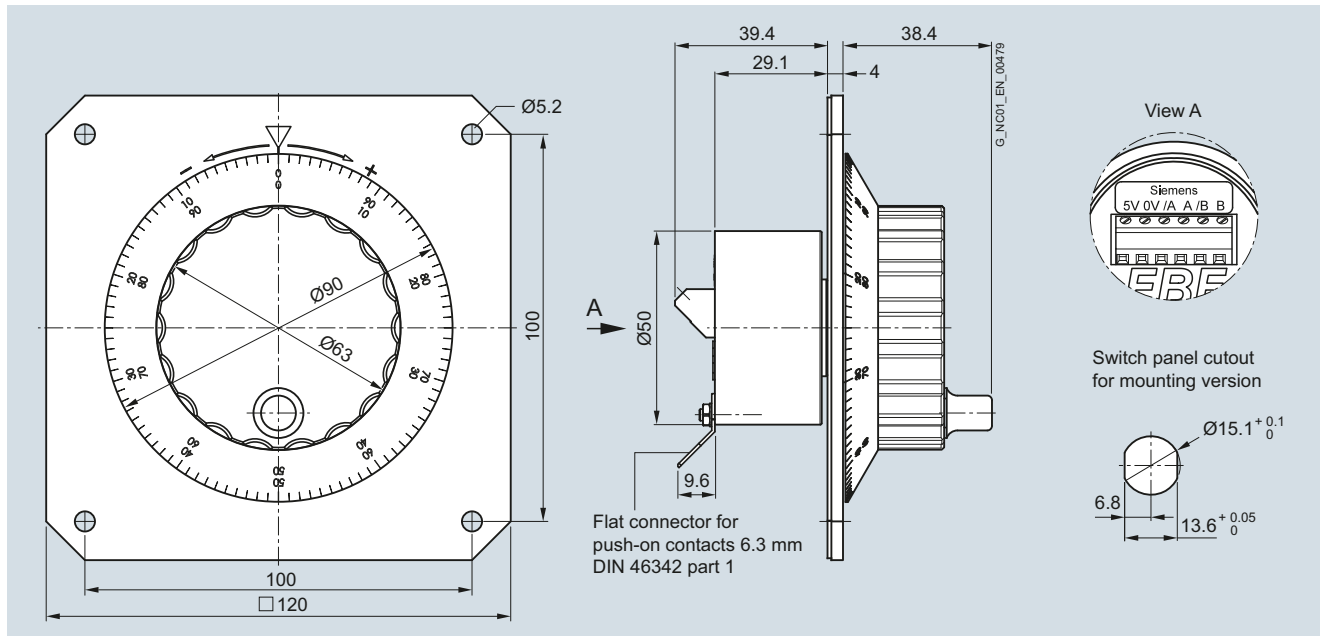

Electronic handwheel with front panel 120 mm x 120 mm

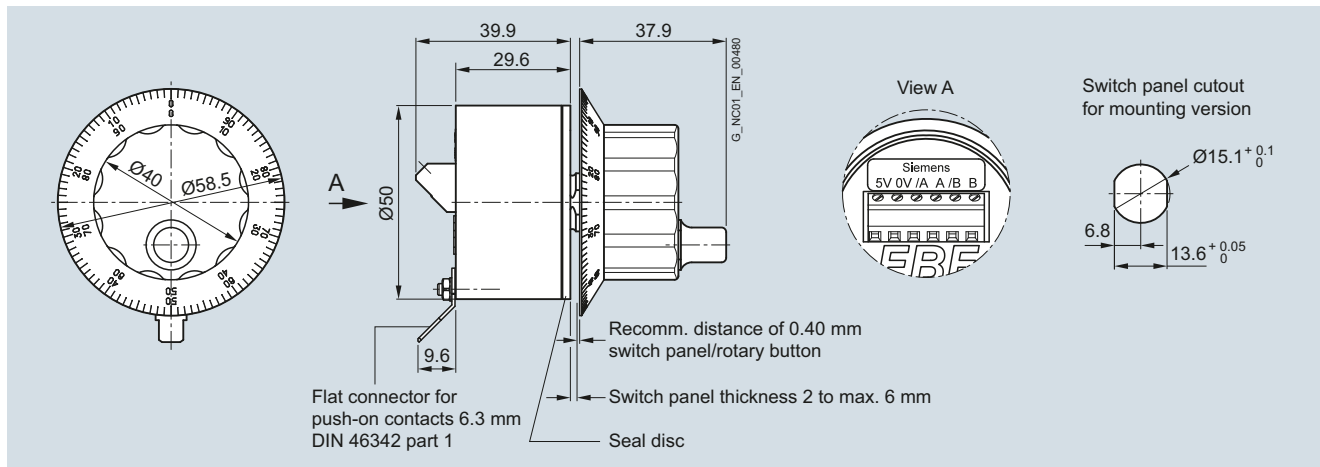

Electronic handwheel without front panel with small setting wheel

Overview

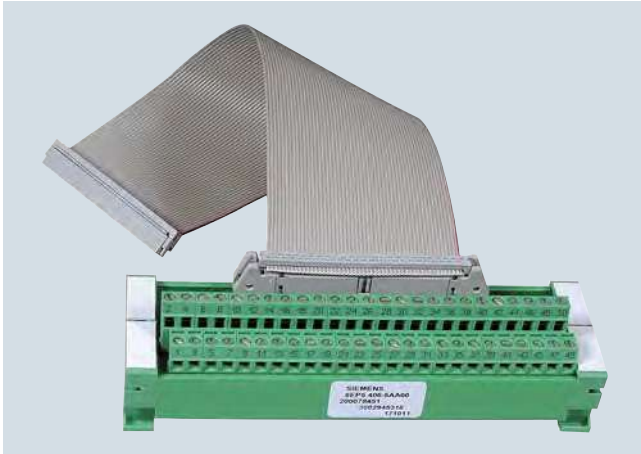

Terminal strip converter

The SINUMERIK 808D PPU 141.3/SINUMERIK 808D ADVANCED PPU 15x.3/PPU 16x.3 feature 24 digital PLC inputs and 16 digital PLC outputs which can be connected directly using screw-clamps on the PPU.

In addition, the PPU 141.3/PPU 15x.3/PPU 16x.3 feature 48 digital PLC inputs and 32 digital PLC outputs which can be connected via 2 terminal strip converters.

This allows the connection of process signals directly in the cabinet with significantly reduced wiring efforts.

Design

Connection of PLC process signals

- Screw-clamps
 - 24 digital inputs
 - 16 digital outputs

Connection to PPU

- Ribbon cable, 50-pole
- Insulation displacement connectors

Cabinet mounting

- Standard mounting rails

Selection and ordering data

Description	Article No.
Terminal strip converter	6EP5406-5AA00
50-pole	
Cable set	6EP5306-5BG00
Ribbon cable, 50-pole, length: 6 m 8 insulation displacement connectors, 50-pole	

Dimensional drawings

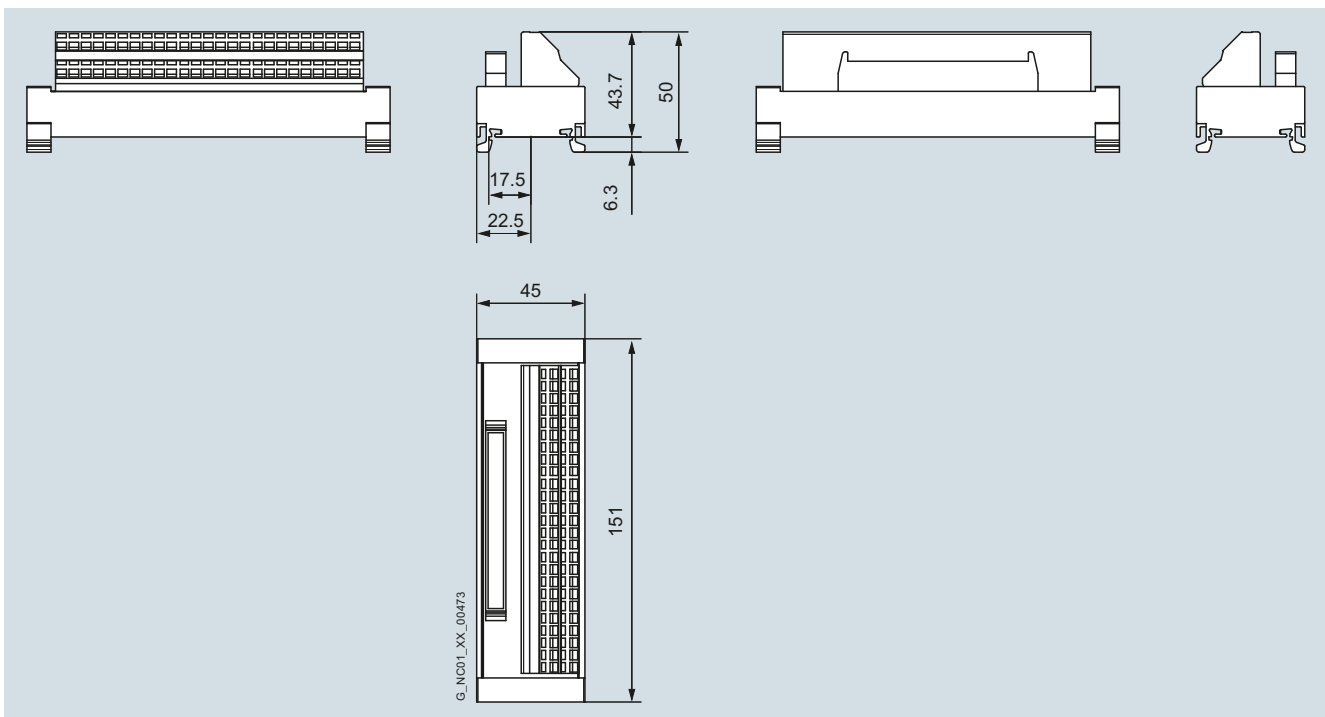

Terminal strip converter

Accessories

Supplementary components

SITOP power supply

Overview

Stabilized power supply units



SITOP modular power supply unit

The 24 V power supply units from the SITOP range are optimized for industrial use and operate on the switched-mode principle. Due to the precisely regulated output voltage, the devices are even suitable for the connection of sensitive sensors.

SITOP smart/modular

Slimline dimensions, strong performance. SITOP smart/modular requires little space on the mounting rail and offers high performance at a reasonable price. With its tolerant overload response, even loads with a high inrush current can be smoothly switched on.

If required, 50 % extra power is made available for 5 seconds.

Benefits

- High efficiency
- Low space requirements and easy installation
- Exact output voltage and low residual ripple
- Integrated short-circuit protection and safe electrical separation
- National and international approvals
- No release of silicone

Selection and ordering data

Description	Article No.
Stabilized power supply SITOP modular SITOP PSU200M 24 V DC/5 A Input voltage: 120 V/230 V AC (85 ... 264 V/176 ... 550 V AC) Output voltage: 24 V DC \pm 3 % Approvals: cULus, CSA	6EP1333-3BA10
Stabilized power supply SITOP smart PSU100S 24 V DC/10 A Input voltage: 120 V/230 V AC (85 ... 132 V/170 ... 264 V AC) Output voltage: 24 V DC \pm 3 % Approvals: cULus, CSA	6EP1334-2BA20

More information

You can find additional information in Catalog KT 10.1 or on the Internet at:

www.siemens.com/sitop

www.siemens.com/industrymall

Dimensional drawings

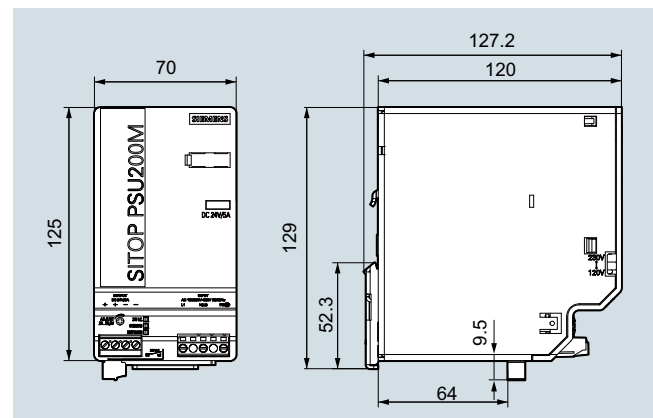

Stabilized power supply SITOP modular 5 A

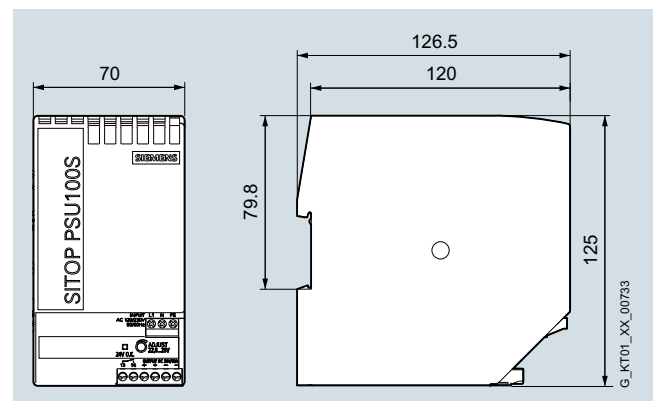

Stabilized power supply SITOP smart 10 A

Application



RS422 (TTL) incremental encoder

The optoelectronic incremental TTL encoders are tailored for the use as direct spindle encoders in conjunction with the SINUMERIK 808D CNCs.

Design

The direct incremental spindle encoder features a Synchro flange and can be attached to the machine with 3 clamp straps and a spring disk coupling.

The encoder supply voltage of 5 V DC is provided by the SINUMERIK 808D CNC.

The direct incremental spindle encoder delivers specific pulses per revolution according to your selection which are multiplied by the factor of 4 internally to reach the precision level suitable for standard lathes and milling machines.

Incremental encoders operate on the principle of optoelectronic scanning of dividing disks with the transmitted light principle. With an appropriate arrangement of the line pattern on the dividing disk connected to the shaft and the fixed aperture, the optoelectronic elements provide two trace signals A and B at 90° to one another, as well as a reference signal R. The encoder electronics amplify these signals and convert them into different output levels.

Accessories

Direct spindle encoder

Direct spindle encoder

Technical specifications

Article No.	6FX2001-2E...
Product name	RS422 (TTL) incremental encoder for spindle
Operating voltage U_p on encoder	5 V DC \pm 10 %
Scanning frequency, max.	300 kHz
No-load current consumption, max.	150 mA
Signal level	RS422 (TTL)
Outputs protected against short-circuit to 0 V	Yes
Switching time (10 ... 90 %) (1 m cable and recommended input circuit)	Rise/fall time $t_r/t_f \leq 50$ ns
Phase angle, signal A to B	90°
Edge spacing, min.	
• At 300 kHz	≥ 0.45 μ s
Cable length to downstream electronics, max. ¹⁾	100 m
LED failure monitoring	High-resistance driver
Resolution, max.	5000 S/R
Accuracy (in angular seconds)	± 18 mech. \times 3600/ number of signals/revolution z
Speed, max.	
• Mechanical	12000 rpm
Starting torque (at 20 °C)	≤ 0.01 Nm
Shaft loading capacity	
• $n \leq 6000$ rpm	
- Axial	40 N
- Radial at shaft extension	60 N
• $n > 6000$ rpm	
- Axial	10 N
- Radial at shaft extension	20 N
Shaft diameter	6 mm
Shaft length	10 mm
Angular acceleration, max.	10^5 rad/s ²
Moment of inertia of rotor	2.9×10^{-6} kgm ²
Vibration (55 ... 2000 Hz) to EN 60068-2-6	≤ 300 m/s ²
Shock to EN 60068-2-27	
• 2 ms	≤ 2000 m/s ²
Degree of protection to EN 60529 (IEC 60529)	
• At housing	IP67
• At shaft input	IP64
Ambient temperature	
Operation	
• Flange outlet	
- At $U_p = 5$ V \pm 10 %	-40 ... +100 °C
Weight, approx.	0.3 kg
EMC	EMC guideline 2004/108/EG and regulations of the EMC guide- lines (generic standards)
Certificate of suitability	CE, CSA, UL

S/R = Signals/Revolution

Technical specifications (continued)

Article No.	6FX2001-7KF10
Product name	Spring disk coupling
Transferable torque, max.	0.8 Nm
Shaft diameter	6 mm both ends
Center offset of shafts, max.	0.4 mm
Axial displacement	± 0.4 mm
Angular displacement of shafts, max.	3°
Torsional rigidity	150 Nm/rad
Lateral spring stiffness	6 N/mm
Moment of inertia	19 gcm ²
Speed, max.	12000 rpm
Ambient temperature	
• Operation	-40 ... +150 °C
Weight, approx.	16 g

Selection and ordering data

Description	Article No.
RS422 (TTL) incremental encoder	
Synchro flange 5 V DC supply voltage Radial flange outlet	
• 500 S/R	6FX2001-2EA50
• 1000 S/R	6FX2001-2EB00
• 1024 S/R	6FX2001-2EB02
• 1250 S/R	6FX2001-2EB25
• 1500 S/R	6FX2001-2EB50
• 2000 S/R	6FX2001-2EC00
• 2048 S/R	6FX2001-2EC04
• 2500 S/R	6FX2001-2EC50
• 3600 S/R	6FX2001-2ED60
• 5000 S/R	6FX2001-2EF00
Spring disk coupling	6FX2001-7KF10
For shaft diameter 6 mm/6 mm	
Clamp strap (1 unit)	6FX2001-7KP01
For encoders with Synchro flange (3 units are required)	

S/R = Signals/Revolution

¹⁾ With recommended cable and input circuitry of the downstream electronics, observe max. permissible cable length of module to be evaluated.

Dimensional drawings

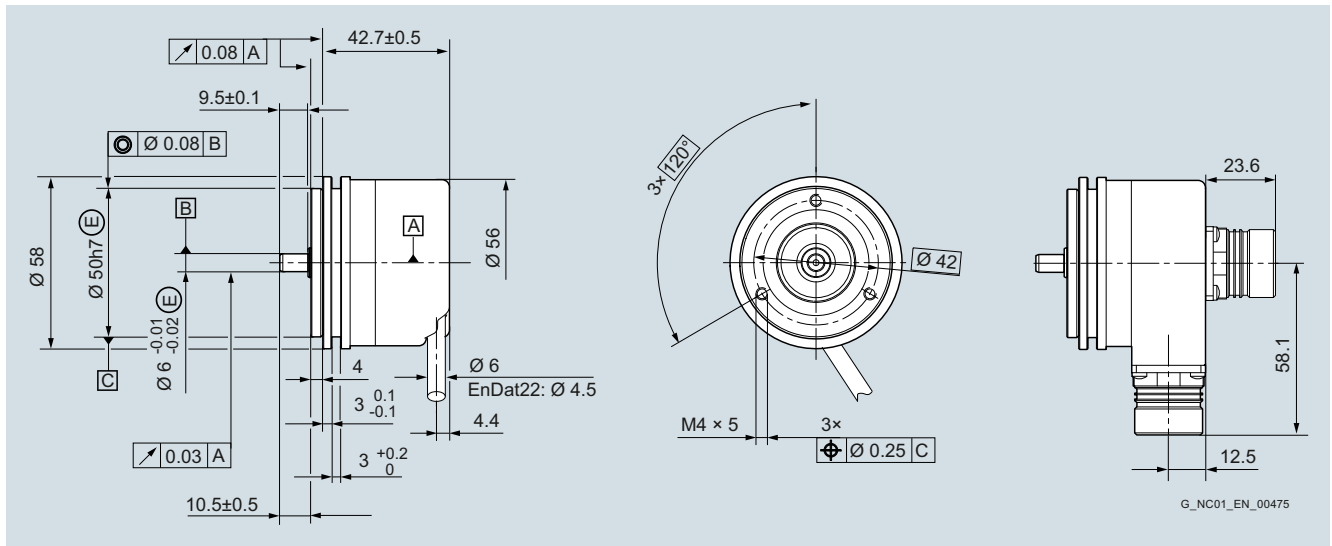

RS422 (TTL) incremental encoder

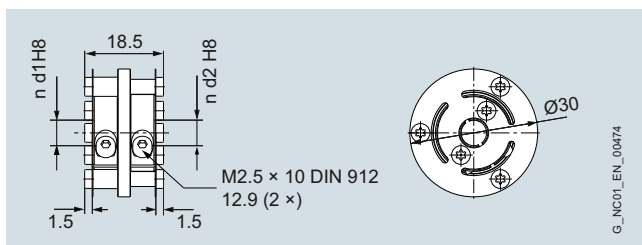

Spring disk coupling, $d1 = d2 = 6$ mm

Accessories

Notes

Services and training



6/2	Services
6/2	Material warranty and on-site service
6/3	Training
6/3	Training services
6/4	SINUMERIK 808D on PC
6/5	Siemens Automation Cooperates with Education
6/5	Automation and drive technology training made easy
6/7	Documentation
6/7	Specific documentation for SINUMERIK 808D
6/8	Specific documentation for SINUMERIK 808D ADVANCED

Services and training

Services

Material warranty and on-site service

Overview



Equipment package SINUMERIK 808D ADVANCED T, PPU 161.3, horizontal with MCP - SINAMICS V70 FSA ... FSD, 400 V 3 AC – SIMOTICS S-1FL6 servomotors - SIMOTICS M-1PH1 main motor – MOTION-CONNECT 300 cables

For the SINUMERIK 808D/SINUMERIK 808D ADVANCED and the associated components¹⁾ by Siemens DF & PD you will receive a material warranty and free on-site service of up to 36 months²⁾.

More information

For the material warranty and on-site support the same scope as for Repair Service Contracts applies. Further information can be found at:

www.siemens.com/automation/oss

¹⁾ Not applicable to complete motor spindles.

²⁾ Standard warranty period: 24 months from 1st delivery of equipment package from Siemens factory.
Extended warranty period: 36 months from 1st delivery of equipment package from Siemens factory. When registration completed within standard warranty period.

Overview

Siemens offers training directly from the manufacturer and thus first-hand know-how. The training courses comprise Siemens' entire product and system range in the area of automation and drive technology as well as further training regarding branch and system solutions.



Benefits

- Training centers in more than 60 countries.
- Standardized or individual training courses.
- Teaching of basic knowledge, advanced and special knowledge.
- Training makes optimum use and adjustment of products and systems possible.



More information

You can find additional information on the Internet at:

<https://support.automation.siemens.com/WW/view/en/24486113>

Services and training

Training

SINUMERIK 808D on PC

Overview



SINUMERIK 808D on PC is a PC-based CNC training/CNC programming software package. SINUMERIK 808D on PC enables completely identical CNC operation and CNC programming as on the SINUMERIK 808D or SINUMERIK 808D ADVANCED. SINUMERIK 808D on PC can be used for the following applications:

- Self-study or professional training of SINUMERIK 808D/SINUMERIK 808D ADVANCED operation and CNC programming
- Offline CNC program creation and simulation
- Professional presentation of SINUMERIK 808D/SINUMERIK 808D ADVANCED operation and CNC programming

Benefits

- User-friendly, control-identical simulation of operation and CNC programming of SINUMERIK controls on the PC
- Maximum compatibility thanks to integrated original SINUMERIK CNC software
- Accurate simulation of machine operation with inexpensive virtual machine control panel
- Optimum training software for the most common CNC programming styles – ISO code and SINUMERIK style CNC programming
- Easy CNC program exchange via PC and CNC of machine via USB memory stick
- The full version of SINUMERIK 808D on PC can be downloaded free of charge

Function

Technologies and machine types

SINUMERIK 808D on PC can be used for the following most common machine types:

- Vertical machining centers or milling machines with geometry axes X, Y, Z and a main spindle
- Turning machines with geometry axes X, Z and a main spindle

If the SINUMERIK 808D/SINUMERIK 808D ADVANCED of the target machine has been configured with the standard parameters, CNC programs created with SINUMERIK 808D on PC can be executed on the machine without any program adaptations.

Accurate simulation of real operator control on the machine

With its fully-fledged virtual machine control panel, SINUMERIK 808D on PC offers functions such as CNC Start, CNC Stop, feedrate and spindle override or direction keys and can therefore be operated just like a real machine.

Online help

Like a SINUMERIK 808D/SINUMERIK 808D ADVANCED, SINUMERIK 808D on PC also offers a context-based online help.

Languages

The following languages are available:

- English
- Chinese Simplified
- Russian
- Portuguese

Free download

SINUMERIK 808D on PC can be downloaded free of charge at: www.cnc4you.siemens.com

Integration

SINUMERIK 808D on PC can be used for:

- SINUMERIK 808D Turning
- SINUMERIK 808D Milling
- SINUMERIK 808D ADVANCED T
- SINUMERIK 808D ADVANCED M

Preconditions

Hardware

- PC with 1.5 GHz processor (single core)
- RAM: 1 GB
- Hard disk: 2 GB of free memory space
- DVD drive for installation from DVD
- Graphics card: Minimum resolution 640 × 480 pixels
- USB interface
- Mouse, keyboard

Software

- Operating system Windows XP SP3 32 bit Professional/Home Edition
- Operating system Windows 7 32 bit/64 bit
- Adobe Acrobat Reader

Selection and ordering data

Description	Article No.
SINUMERIK 808D on PC on DVD-ROM	6FC5870-0YC40-0YT0

www.nicsanat.com

021-87700210



Unique support for educators and students in educational institutions

Cooperates
with Education

Automation

SIEMENS

Siemens Automation Cooperates with Education (SCE)

SCE offers a global system for sustained support of technical skills. SCE supports educational institutions in their teaching assignment in the industrial automation sector and offers added value in the form of partnerships, technical expertise, and know-how. As the technological leader, our comprehensive range of services can support you in the knowledge transfer for Industry 4.0.

Our services at a glance

- Training curriculums for your lessons
- Trainer packages for hands-on learning
- Courses convey up-to-date, specialist knowledge
- Support for your projects/textbooks
- Complete didactic solutions from our partners for your lessons
- Personal contact for individual support

Training curriculums for your lessons



Use our profound industrial know-how for practice-oriented and individual design of your course. We offer you more than 100 didactically prepared training curriculums on the topics of automation and drives technology free of charge. These materials are perfectly matched to your curricula and syllabuses, and optimally suited for use with our trainer packages. This takes into account all aspects of a modern industrial solution: installation, configuration, programming, and commissioning. All documents, including projects, can be individually matched to your specific requirements.

Particular highlights:

- The new SIMATIC PCS 7 curriculums and trainer packages. Using plant simulation, you can pass on basic, practice-oriented PCS 7 knowledge at universities within about 60 hours (= 1 semester).
- The new TIA Portal training materials for SIMATIC S7-1500/S7-1200/S7-300 are available in English, German, French, Italian, Spanish, Portuguese and Chinese for download.

www.siemens.com/sce/curriculums

Trainer packages for hands-on learning



Our SCE trainer packages offer a specific combination of original industrial components which are perfectly matched to your requirements and can be conveniently used in your course. These price-reduced bundles available exclusively to schools include innovative and flexible hardware and software packages.

SCE currently offers more than 80 SCE trainer packages including related equipment e.g. Micro Memory. These cover both the factory and process automation sectors. You can use them to impart the complete course contents on industrial automation at a very low cost.

Trainer packages are available for:

- Introduction to automation technology with LOGO! logic module
- PLC engineering with SIMATIC S7 hardware and STEP 7 software (S7-1500/S7-1200/S7-300 and TIA Portal)
- Operator control and monitoring with SIMATIC HMI
- Industrial networking over bus systems with SIMATIC NET (PROFINET, PROFIBUS, IO-Link)
- Sensor systems with VISION, RFID and SIWAREX
- Process automation with SIMATIC PCS 7
- Networked drive and motion technologies with SINAMICS/SIMOTION
- Power Monitoring Devices SENTRON PAC4200
- Motor Management SIMOCODE
- CNC programming with SinuTrain

Important ordering notes:

Only the following institutions are authorized to obtain trainer packages: vocational schools, Colleges and Universities, in-house vocational training departments, non commercial research institutions and non commercial training departments.

To purchase a trainer package, you require a specific end-use certificate, which you can obtain from your regional sales office.

www.siemens.com/sce/tp

Services and training

Siemens Automation Cooperates with Education

Automation and drive technology training made easy

Unique support for educators and students in educational institutions (continued)

Courses convey up-to-date specialist knowledge



Profit from our excellent know-how as the leader in industrial technologies. We offer you specific courses for automation and drive technology worldwide. These support you in the practice-oriented transferring of product and system know-how, are in conformance with curriculums, and derived from the training fields. Compact technical courses especially for use at universities are also available.

Our range of courses comprises a wide variety of training modules based on the principle of Totally Integrated Automation (TIA). The focus is on the same subject areas as with the SCE trainer packages.

Every PLC and drive course is oriented on state-of-the-art technology. Your graduates can thus be prepared optimally for their future professional life.

In some countries we are offering classes based on our training curriculums. Please inquire with your SCE contact partner.

www.siemens.com/sce/courses

Support for your projects/textbooks



Automation and drive technology is characterized by continuous and rapid developments. Service and Support therefore play an important role.

We can provide you with consulting for selected projects and support from your personal SCE contact as well as our web-based and regional Customer Support.

As a particular service, SCE supports technical authors with our know-how as well as with intensive technical consulting. Siemens library of special textbooks covering the industrial automation sector provides an additional resource for you and your students. These can be found at the SCE web site.

www.siemens.com/sce/contact
www.siemens.com/sce/books

Complete didactic solutions from our partners



Our partners for learning systems offer a wide range of training systems and solutions for use in your courses or laboratory.

These models have been designed based on our trainer packages and thus save you the time and cost of self-construction of individual components. The Partner systems provide you with simple and effective help in the fulfillment of your teaching assignment.

www.siemens.com/sce/partner

Contact for individual support

You can find your personal SCE contact on our Internet site. Your local SCE Promoter will answer all your questions concerning the complete SCE offering, and provide you with timely and competent information about innovations. When you encounter challenges, you can profit from our global team of excellence.

If a direct SCE contact is not listed for your country, please contact your local Siemens office.

www.siemens.com/sce/contact

SCE Support Finder for your Internet request

You are an educator and need support on the topic of industry automation? Send us your request:

www.siemens.com/sce/supportfinder



Overview

Comprehensive documentation is available for the SINUMERIK 808D and SINUMERIK 808D ADVANCED CNC controls, including the SINAMICS V60 and SINAMICS V70 drive system. This documentation includes Operator's Guides, Programming Guides or Configuration Guides, as well as Installation Guides.

Information is available in the following formats:

- Paper version, printed copy

<https://support.industry.siemens.com/cs/ww/en/view/108464614>

- PDF file available for download on the Internet at:

www.siemens.com/automation/support

You will find further information on the Internet at:

www.siemens.com/motioncontrol/docu

Selection and ordering data

Description	Article No.
<i>Specific documentation for SINUMERIK 808D for machine tool manufacturers</i>	
SINUMERIK 808D Operating Instructions¹⁾	
• English	6FC5397-2EP10-0BA0
• Chinese Simplified	6FC5397-2EP10-0RA0
<i>Specific documentation for SINUMERIK 808D for users</i>	
SINUMERIK 808D Diagnostics Manual	
• English	6FC5398-6DP10-0BA0
• Chinese Simplified	6FC5398-6DP10-0RA0
SINUMERIK 808D Turning Programming and Operating Manual	
• English	6FC5398-5DP10-0BA0
• Chinese Simplified	6FC5398-5DP10-0RA0
• Polish	6FC5398-5DP10-0NA0
• Portuguese	6FC5398-5DP10-0KA0
• Russian	6FC5398-5DP10-0PA0
SINUMERIK 808D Milling Programming and Operating Manual	
• English	6FC5398-4DP10-0BA0
• Chinese Simplified	6FC5398-4DP10-0RA0
• Polish	6FC5398-4DP10-0NA0
• Portuguese	6FC5398-4DP10-0KA0
• Russian	6FC5398-4DP10-0PA0
SINUMERIK 808D Manual Machine plus (Turning) Programming and Operating Manual	
• English	6FC5398-3DP10-0BA0
• Chinese Simplified	6FC5398-3DP10-0RA0
SINUMERIK 808D Commissioning Manual	
• English	6FC5397-4EP10-0BA0
• Chinese Simplified	6FC5397-4EP10-0RA0

¹⁾ Includes:
 - Mechanical Installation Manual
 - Electrical Installation Manual
 - Function Manual
 - Parameter List Manual
 - Diagnostics Manual
 - PLC subroutines

Services and training

Documentation

Specific documentation for SINUMERIK 808D ADVANCED

Selection and ordering data

Description	Article No.	Description	Article No.
<i>Specific documentation for SINUMERIK 808D ADVANCED for machine tool manufacturers</i>		<i>Specific documentation for SINUMERIK 808D ADVANCED for users</i>	
SINUMERIK 808D ADVANCED Commissioning Manual <ul style="list-style-type: none"> English Chinese Simplified 	6FC5397-4EP10-0BA6 6FC5397-4EP10-0RA6	SINUMERIK 808D ADVANCED Diagnostics Manual <ul style="list-style-type: none"> English Chinese Simplified 	6FC5398-6DP10-0BA4 6FC5398-6DP10-0RA4
SINUMERIK 808D ADVANCED Function Manual <ul style="list-style-type: none"> English Chinese Simplified 	6FC5397-7EP40-0BA2 6FC5397-7EP40-0RA2	SINUMERIK 808D ADVANCED T Programming and Operating Manual <ul style="list-style-type: none"> English Chinese Simplified 	6FC5398-5DP10-0BA5 6FC5398-5DP10-0RA5
SINUMERIK 808D ADVANCED Parameter Manual <ul style="list-style-type: none"> English Chinese Simplified 	6FC5397-8EP40-0BA2 6FC5397-8EP40-0RA2	SINUMERIK 808D ADVANCED M Programming and Operating Manual <ul style="list-style-type: none"> English Chinese Simplified 	6FC5398-4DP10-0BA5 6FC5398-4DP10-0RA5
		SINUMERIK 808D ADVANCED Manual Machine plus (Turning) Programming and Operating Manual <ul style="list-style-type: none"> English Chinese Simplified 	6FC5398-3DP10-0BA3 6FC5398-3DP10-0RA3
		SINUMERIK 808D ADVANCED Programming and Operating Manual ISO dialects (Turning and Milling) <ul style="list-style-type: none"> English Chinese Simplified 	6FC5398-0DP40-0BA2 6FC5398-0DP40-0RA2

Appendix



7/2	Certificates of suitability
7/4	Partner at Siemens
7/5 7/5	Partner at Industry Siemens Partner Program
7/6 7/6 7/7	Online Services Information and Ordering Options on the Internet and DVD Information and Download Center Social Media, Mobile Media
7/8 7/8 7/10	Notes on software Software licenses Setup texts and software update services
7/11	Subject index
7/13	Conversion tables
7/15	Metal surcharges
7/18 7/18	Conditions of sale and delivery Export regulations

SINUMERIK 808D system

Certificates of suitability







Overview

Many of the products in this Catalog fulfill requirements, e.g. for UL, CSA or FM and are labeled with the corresponding approval designation.





All of the certificates of suitability, approvals, certificates, declarations of conformity, test certificates, e.g. CE, UL, Safety Integrated etc. have been performed with the associated system components as they are described in the Configuration Manuals.

The certificates are only valid if the products are used with the described system components, are installed according to the Installation Guidelines and used for their intended purpose.

In other cases, the vendor of these products is responsible for arranging for the issue of new certificates.

Test symbol	Tested by	Device series/ component	Test standard	Product category/ File No.
UL: Underwriters Laboratories <i>Independent public testing body in North America</i>				
	UL according to UL standard	SINUMERIK	Standard UL 508, CSA C22.2 No. 142	NRAQ/7.E164110 NRAQ/7.E217227
		SIMOTION	Standard UL 508, CSA C22.2 No. 142	NRAQ/7.E164110
	UL according to CSA standard	SINAMICS	Standard UL 508, 508C, 61800-5-1 CSA C22.2 No. 142, 274	NRAQ/7.E164110, NMMS/2/7/8.E192450, NMMS/2/7/8.E203250, NMMS/7.E214113, NMMS/7.E253831
				NMMS/2/7/8.E121068 NMMS/7.E355661 NMMS/7.E323473
	UL according to UL and CSA standards			
	UL according to UL standard	SIMODRIVE	Standard UL 508C, CSA C22.2 No. 274	NMMS/2/7/8.E192450 NMMS/7.E214113
	UL according to CSA standard	SIMOTICS	Standard UL 1004-1, 1004-6, 1004-8, CSA C22.2 No. 100	PRGY2/8.E227215 PRH2/8.E93429 PRH2/8.E342747 PRGY2/8.E253922 PRH2/8.E342746
	UL according to UL and CSA standards			
		Line/motor reactors	Standard UL 508, 506, 5085-1, 5085-2, 1561, CSA C22.2 No. 14, 47, 66.1-06, 66.2-06	XQNX2/8.E257859 NMTR2/8.E219022 NMMS2/8.E333628 XPTQ2/8.E257852 XPTQ2/8.E103521 NMMS2/8.E224872 XPTQ2/8.E354316 XPTQ2/8.E198309 XQNX2/8.E475972
		Line filters, dv/dt filters, sine-wave filters	UL 1283, CSA C22.2 No. 8	FOKY2/8.E70122
		Resistors	UL 508, 508C, CSA C22.2 No. 14, 274	NMTR2/8.E224314 NMMS2/8.E192450 NMTR2/8.E221095 NMTR2/8.E226619
TUV: TÜV Rheinland of North America Inc. <i>Independent public testing body in North America, Nationally Recognized Testing Laboratory (NRTL)</i>				
TÜV: TÜV SÜD Product Service <i>Independent public testing body in Germany, Nationally Recognized Testing Laboratory (NRTL) for North America</i>				
	TUV according to UL and CSA standards	SINAMICS	NRTL listing according to standard UL 508C	U7V 12 06 20078 013 U7 11 04 20078 009 U7 11 04 20078 010 U7 11 04 20078 011
		SIMOTION	NRTL listing according to standard UL 508	U7V 13 03 20078 01
		SIMODRIVE	NRTL listing according to standard UL 508C, CSA C22.2. No. 14	CU 72090702
		Motion Control Encoders	NRTL listing according to UL 61010-1 CSA C22.2 No. 61010-1	U8V 10 06 20196 024

Overview (continued)

Test symbol	Tested by	Device series/ component	Test standard	Product category/ File No.
CSA: Canadian Standards Association <i>Independent public testing body in Canada</i>				
	CSA according to CSA standard	SINUMERIK	Standard CSA C22.2 No. 142	2252-01 : LR 102527
FMRC: Factory Mutual Research Corporation <i>Independent public testing body in North America</i>				
	FM according to FM standard	SINUMERIK	Standard FMRC 3600, FMRC 3611, FMRC 3810, ANSI/ISA S82.02.1	–
EAC: Ivanovo-Certificate <i>Independent public testing body in the Russian Federation</i>				
	EAC in accordance with the EAC Directive	SINAMICS SINUMERIK SIMOTION	Standard IEC 61800-5-1/-2, IEC 61800-3	–
RCM: Australian Communications and Media Authority <i>Independent public testing body in Australia</i>				
	RCM according to EMC standard	SINAMICS SINUMERIK SIMOTION	Standard IEC AS 61800-3, EN 61800-3	–
KC: National Radio Research Agency <i>Independent public testing body in South Korea</i>				
	KC according to EMC standard	SINAMICS SINUMERIK SIMOTION	Standard KN 11	–
BIA <i>Federal Institute for Occupational Safety</i>				
–	Functional safety	SINAMICS SINUMERIK SIMOTION	Standard EN 61800-5-2	–
TÜV SÜD Rail				
–	Functional safety	SINAMICS SINUMERIK SIMOTION	Standard EN 61800-5-2	–

More information about certificates can be found online at:

<https://support.industry.siemens.com/cs/ww/en/ps/cert>

SINUMERIK 808D system

Partner at Siemens

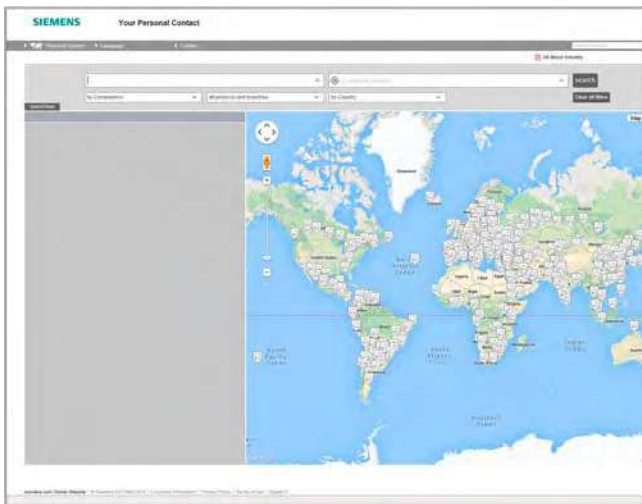

At Siemens we are resolutely pursuing the same goal: long-term improvement of your competitive ability. We are committed to this goal. Thanks to our commitment, we continue to set new standards in automation and drive technology. In all industries – worldwide.

At your service locally, around the globe for consulting, sales, training, service, support, spare parts on the entire portfolio of Digital Factory and Process Industries and Drives.

Your partner can be found in our Personal Contacts Database at: www.siemens.com/automation-contact

You start by selecting

- the required competence,
- products and branches,
- a country,
- a city

or by a

- location search or
- person search.

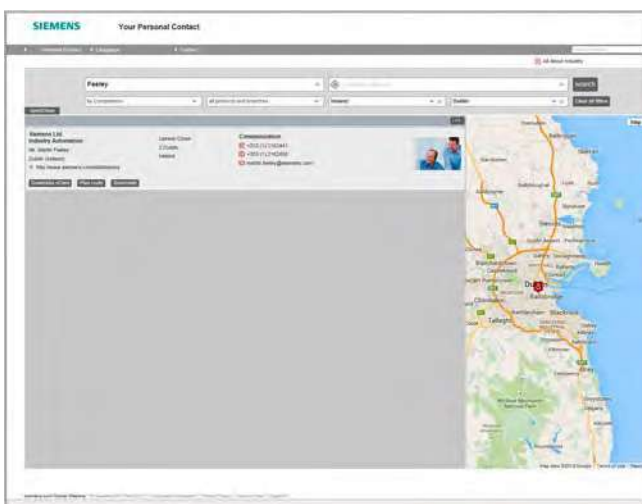

7

Overview

Siemens Solution and Approved Partners



Highest competence in automation and drive technology as well as power distribution

Siemens works closely together with selected partner companies around the world in order to ensure that customer requirements for all aspects of automation and drives, as well as power distribution, are fulfilled as best as possible – wherever you are, and whatever the time. It is for this reason that we systematically train and keep our partners well prepared, in addition to certifying them in specific technologies. It is our declared intention and goal to train and prepare our partners to the same standards as our own employees.

This approach is based on contractually agreed quality criteria as well as optimum support for our partners by providing clearly-defined processes. This ensures that they possess all the qualities to meet customer requirements optimally. The partner emblem is the guarantee and indicator of proven quality.

Solution Partners and Approved Partners

The Siemens Partner Program distinguishes between Solution Partners and Approved Partners.

At present we are working with more than 1,400 Solution Partners worldwide. They represent countless tailored and future-proof automation and drive solutions in the most diverse industries.

With their extensive technical product knowledge, Siemens Approved Partners offer a combination of goods and services that include specialist technologies, customized modifications and the provision of high-quality system and product packages. They also provide qualified technical support and assistance

Partner Finder



In the Siemens global Solution Partner program, customers are certain to find the optimum partner for their specific requirements - with no great effort. The Partner Finder is basically a comprehensive database that showcases the profiles of all our solution partners.

Easy selection:

Set filters in the search screen form according to the criteria that are relevant to you. You can also directly enter the name of an existing partner.

Skills at a glance:

Gain a quick insight into the specific competencies of any particular partner with the reference reports.

Direct contact option:

Use our electronic query form:

www.siemens.com/partnerfinder

Additional information on the Siemens Solution Partner Program is available online at:

www.siemens.com/partner-program

SINUMERIK 808D system

Online Services

Information and ordering options on the Internet and DVD

The Future of Manufacturing on the Internet



Detailed knowledge of the range of products and services available is essential when planning and engineering automation systems. It goes without saying that this information must always be as up-to-date as possible.

Industry is on the threshold of the fourth industrial revolution as digitization now follows after the automation of production. The goals are to increase productivity and efficiency, speed, and quality. In this way, companies can remain competitive on the path to the future of industry.

You will find everything you need to know about products, systems and services on the internet at:

www.siemens.com/industry

Product Selection Using the Interactive CA 01 Automation and Drives Catalog



Detailed information together with user-friendly interactive functions:

The CA 01 interactive catalog covers more than 100,000 products, thus providing a comprehensive overview of the product range provided by Siemens.

You will find everything you need here for solving tasks in the fields of automation, switching, installation and drives. All information is provided over a user interface that is both user-friendly and intuitive.

You can order the CA 01 product catalog from your Siemens sales contact or in the Information and Download Center:

www.siemens.com/industry/infocenter

Information about the CA 01 interactive catalog can be found on the Internet at:

www.siemens.com/automation/ca01

or on DVD.

Easy Shopping with the Industry Mall

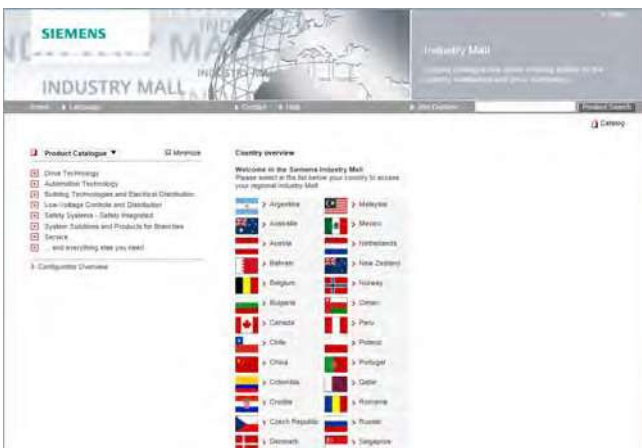

The Industry Mall is the electronic ordering platform of Siemens AG on the Internet. Here you have online access to a huge range of products presented in an informative and attractive way.

Data transfer via EDIFACT allows the whole procedure, from selection through ordering to tracking and tracing, to be carried out online. Availability checks, customer-specific discounts and bid creation are also possible.

Numerous additional functions are provided for your support. For example, powerful search functions make it easy to select the required products. Configurators enable you to configure complex product and system components quickly and easily. CAx data types are also provided here.

You can find the Industry Mall on the Internet at:

www.siemens.com/industrymall

Downloading Catalogs

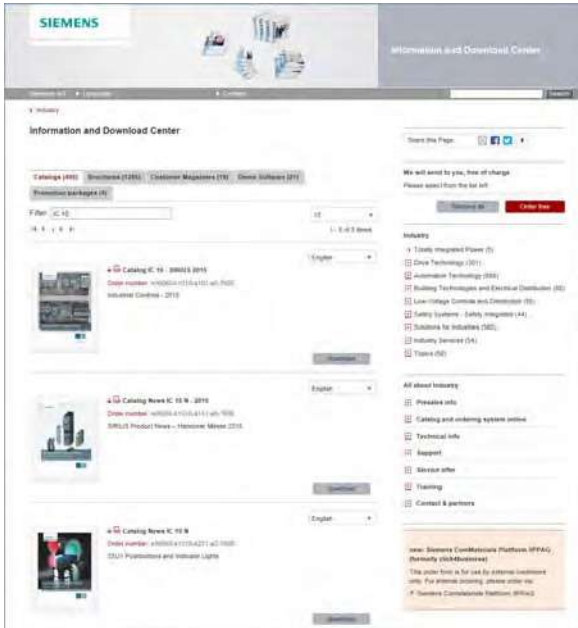

In addition to numerous other useful documents, you can also find the catalogs listed on the back inside cover of this catalog in the Information and Download Center. You can download these catalogs in PDF format without having to register.

The filter dialog above the first catalog displayed makes it possible to carry out targeted searches. If you enter "MD 3" for example, you will find both the MD 30.1 and MD 31.1 catalogs. If you enter "IC 10", both the IC 10 catalog and the associated news or add-ons are displayed.

Visit us at:

www.siemens.com/industry/infocenter

Social and Mobile Media

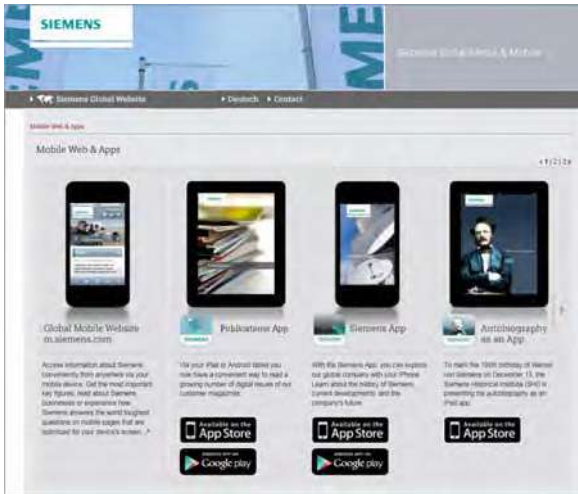

Connect with Siemens through social media: visit our social networking sites for a wealth of useful information, demos on products and services, the opportunity to provide feedback, to exchange information and ideas with customers and other Siemens employees, and much, much more. Stay in the know and follow us on the ever-expanding global network of social media.

To find out more about Siemens' current social media activities, visit us at:

www.siemens.com/socialmedia

Or via our product pages at:

www.siemens.com/automation or www.siemens.com/drives

Here you can read all the news on the future of the industry, watch current videos and obtain information about all the latest industry developments.

www.siemens.com/future-of-manufacturing

Discover the world of Siemens.

We are also constantly expanding our offering of cross-platform apps for smartphones and tablets. You will find the current Siemens apps at the App Store (iOS) or at Google Play (Android):

<https://itunes.apple.com/en/app/siemens/id452698392?mt=8>

<https://play.google.com/store/search?q=siemens>

The Siemens app, for example, tells you all about the history, latest developments and future plans of the company – with informative pictures, fascinating reports and the most recent press releases.

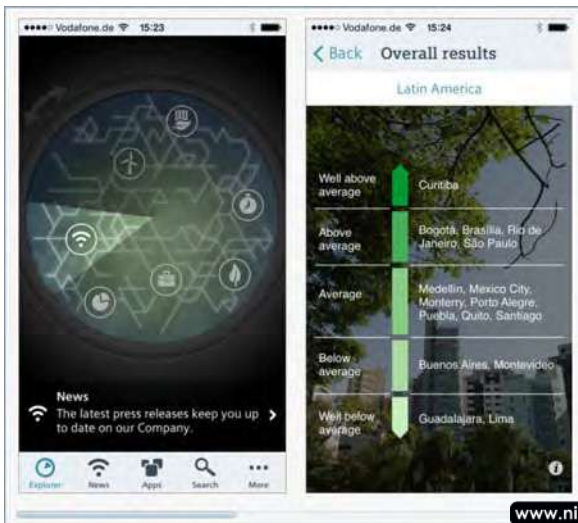

SINUMERIK 808D system

Notes on software

Software licenses

Overview

Software types

Software requiring a license is categorized into types. The following software types have been defined:

- Engineering software
- Runtime software

Engineering software

This includes all software products for creating (engineering) user software, e.g. for configuring, programming, parameterizing, testing, commissioning or servicing.

Data generated with engineering software and executable programs can be duplicated for your own use or for use by third-parties free-of-charge.

Runtime software

This includes all software products required for plant/machine operation, e.g. operating system, basic system, system expansions, drivers, etc.

The duplication of the runtime software and executable programs created with the runtime software for your own use or for use by third-parties is subject to a charge.

You can find information about license fees according to use in the ordering data (e.g. in the catalog). Examples of categories of use include per CPU, per installation, per channel, per instance, per axis, per control loop, per variable, etc.

Information about extended rights of use for parameterization/configuration tools supplied as integral components of the scope of delivery can be found in the readme file supplied with the relevant product(s).

License types

- Floating license
- Single license
- Rental license
- Rental floating license
- Trial license
- Demo license
- Demo floating license

Floating license

The software may be installed for internal use on any number of devices by the licensee. Only the concurrent user is licensed. The concurrent user is the person using the program. Use begins when the software is started. A license is required for each concurrent user.

Single license

Unlike the floating license, a single license permits only one installation of the software per license.

The type of use licensed is specified in the ordering data and in the Certificate of License (CoL). Types of use include for example per instance, per axis, per channel, etc.

One single license is required for each type of use defined.

Rental license

A rental license supports the sporadic use of engineering software. Once the license key has been installed, the software can be used for a specific period of time (the operating hours do not have to be consecutive).

One license is required for each installation of the software.

Rental floating license

The rental floating license corresponds to the rental license, except that a license is not required for each installation of the software. Rather, one license is required per object (for example, user or device).

Trial license

A trial license supports short-term use of the software in a non-productive context, e.g. for testing and evaluation purposes. It can be transferred to another license.

Demo license

The demo license support the sporadic use of engineering software in a non-productive context, for example, use for testing and evaluation purposes. It can be transferred to another license. After the installation of the license key, the software can be operated for a specific period of time, whereby usage can be interrupted as often as required.

One license is required per installation of the software.

Demo floating license

The demo floating license corresponds to the demo license, except that a license is not required for each installation of the software. Rather, one license is required per object (for example, user or device).

Certificate of License (CoL)

The CoL is the licensee's proof that the use of the software has been licensed by Siemens. A CoL is required for every type of use and must be kept in a safe place.

Downgrading

The licensee is permitted to use the software or an earlier version/release of the software, provided that the licensee owns such a version/release and its use is technically feasible.

Delivery versions

Software is constantly being updated. The following delivery versions

- PowerPack
- Upgrade

can be used to access updates.

Existing bug fixes are supplied with the ServicePack version.

PowerPack

PowerPacks can be used to upgrade to more powerful software. The licensee receives a new license agreement and CoL (Certificate of License) with the PowerPack. This CoL, together with the CoL for the original product, proves that the new software is licensed.

A separate PowerPack must be purchased for each original license of the software to be replaced.

Overview**Upgrade**

An upgrade permits the use of a new version of the software on the condition that a license for a previous version of the product is already held.

The licensee receives a new license agreement and CoL with the upgrade. This CoL, together with the CoL for the previous product, proves that the new version is licensed.

A separate upgrade must be purchased for each original license of the software to be upgraded.

ServicePack

ServicePacks are used to debug existing products.

ServicePacks may be duplicated for use as prescribed according to the number of existing original licenses.

License key

Software products with and without license keys are supplied.

The license key serves as an electronic license stamp and is also the switch for activating the software (floating license, rental license, etc.).

The complete installation of software products requiring license keys includes the program to be licensed (the software) and the license key (which represents the license).

Software Update Service (SUS)

As part of the SUS contract, all software updates for the respective product are made available to you free of charge for a period of one year from the invoice date. The contract will automatically be extended for one year if it is not canceled three months before it expires.

The possession of the current version of the respective software is a basic condition for entering into an SUS contract.

You can download explanations concerning license conditions from:

www.siemens.com/automation/salesmaterial-as/catalog/en/terms_of_trade_en.pdf

SINUMERIK 808D system

Notes on software

Setup texts and software update services

Overview

For supplies and deliveries of software products see also Conditions of sale and delivery.

Legal notes during setup for new software products

All software products feature a uniform reference to the license conditions. The license conditions are enclosed either with the documentation or in the software pack. When software is downloaded from the Internet, the license contract is displayed before the ordering procedure and must be accepted by the user before downloading can continue.

Notice:

This software is protected by German and/or US copyright laws and the regulations of international agreements. Unauthorized reproduction or sale of this software or parts of it is a criminal offense. This will lead to criminal and civil prosecution, and may result in significant fines and/or claims for damages. Prior to installing and using the software, please read the applicable license conditions for this software. You will find these in the documentation or packaging.

If you have received this software on a CD-ROM that is marked Trial version, or accompanying software that is licensed for your use, the software is only permitted to be used for test and validation purposes in accordance with the accompanying conditions for the trial license. To this end, it is necessary for programs, software libraries, etc. are installed on your computer. We therefore urgently recommend that installation is performed on a single-user computer or on a computer that is not used in the production process or for storing important data, since it cannot be completely excluded that existing files will be modified or overwritten. We accept no liability whatsoever for damage and/or data losses that result from this installation or the non-observance of this warning. Every other type of use of this software is only permitted if you are in possession of a valid license from Siemens is obtained.

If you are not in possession of a valid license that can be proven by presenting an appropriate Certificate of License/software product certificate, please abort installation immediately and contact a Siemens office without delay to avoid claims for damages.

Overview (continued)

Software update services

Order

To order the software update service, an article number must be specified. The software update service can be ordered when the software products are ordered or at a later date. Subsequent orders require that the ordering party is in possession at least of a single license.

Note:

It is recommended that the software update service is ordered as early as possible. If a new software version of a software product is released for delivery by Siemens, only those customers will receive it automatically who are entered in the appropriate delivery list at Siemens at this time. Previous software versions, or the current software version are not supplied when the software update service is ordered. The software update service requires that the software product is up-to-date at the time of completion of the contract for the software update service.

Delivery

When a software update service is ordered, you will be sent the contractual conditions of this service and the price is due for payment. At the same time, you will be included in a delivery list for the software product to be updated. If Siemens releases a new software version for the corresponding software product for general sale (function version or product version), it will be delivered automatically to the goods recipient specified in the delivery address within the contract period.

More information

Security information

Siemens provides products and solutions with industrial security functions that support the secure operation of plants, systems, machines and networks. In order to protect plants, systems, machines and networks against cyber threats, it is necessary to implement – and continuously maintain – a holistic, state-of-the-art industrial security concept. Siemens' products and solutions constitute one element of such a concept. Customer are responsible for preventing unauthorized access to their plants, systems, machines and networks. Such systems, machines and components should only be connected to an enterprise network or the internet if and to the extent such a connection is necessary and only when appropriate security measures (e.g. firewalls and/or network segmentation) are in place.

For additional information on industrial security measures that may be implemented, please visit:

www.siemens.com/industrialsecurity

Siemens' products and solutions undergo continuous development to make them more secure. Siemens strongly recommends that product updates are applied as soon as they are available and that the latest product versions are used. Use of product versions that are no longer supported, and failure to apply the latest updates may increase customer's exposure to cyber threats.

To stay informed about product updates, subscribe to the Siemens Industrial Security RSS Feed under

www.siemens.com/industrialsecurity

<i>Numerics</i>	Page	<i>D (continued)</i>	Page
1FL5 feed motors	1/5, 2/2, 3/10	Dimensional drawings (continued)	
1FL6 feed motors	1/5, 2/2, 4/12	• SINUMERIK 808D ADVANCED T/M	4/4
1PH1 main motors	1/5, 2/2, 4/20	• SINUMERIK 808D MCP	3/6
A		• SINUMERIK 808D MCP horizontal/vertical	4/7
Absolute encoder	1/5, 4/9, 4/12, 4/13, 4/20, 4/21	• SINUMERIK 808D PPU 141.3	3/4
Accessories	2/3, 4/17, 5/1	• SITOP power supply	5/6
Adapter set	5/2	• Terminal strip converter	5/5
Additional NC axis	2/2, 3/3, 4/3	Direct spindle encoder	2/2, 5/7
Advanced Surface	2/4, 4/2	Documentation	6/7
Approvals	7/2	Download Center	7/7
Apps	7/7	Downloading Catalogs	7/7
Axis functions	2/3	Drive bus terminator	4/8
Axis/spindle, each additional	2/2, 3/3, 4/3	Drives	2/2
B		E	
Battery	2/12, 3/2, 4/2	Electronic handwheel	2/3, 5/2
Bidirectional leadscrew error compensation	2/10, 3/3, 4/3	Encoder	2/2, 3/11, 4/8, 4/16, 5/8
Brake cable	3/16, 4/29	Encoder cable	3/16
Bus cable	4/27	Equipment package examples	3/17, 3/18, 4/33, 4/34
C		Example packages	3/17, 3/18, 4/33, 4/34
Cable set	2/11, 5/5	Export regulations	7/18
Cables, pre-assembled	3/13, 3/15, 3/16, 4/26, 4/28, 4/29, 4/31, 4/32	F	
Canned cycles	2/6, 3/2, 4/2	Fan kits	4/8
Certificates of suitability	7/2	Feed axis solutions	1/5, 3/7, 4/8
Clamp strap	5/8	Feed motor	3/10, 4/12
CNC control	3/2, 4/2	Free on-site service	1/5, 6/2
CNC lock function	2/10, 3/3, 4/3	H	
CNC programming	2/5	HMI functions	2/10
CNC user memory	2/2	I	
Commissioning	2/12	Incremental encoder	2/2
Communication	2/9	Industry Mall	7/6
Compensations	2/10	Information and Ordering on the Internet	7/6
Conditions of sale and delivery	7/18	Interactive Catalog CA 01	7/6
Configuration	2/2	Interpolations	2/4
Connectable CNC accessories	2/3	L	
Connectable measuring systems	2/2	License key	7/9
Connection of PLC process signals	5/5	License types	7/8
Connection overview		M	
• SINAMICS V60 servo drive	3/15	Machine control panel	2/3, 3/5, 4/5
• SINAMICS V70 servo drive	4/29	Main motors	2/2, 4/20
• SINAMICS V70 spindle drive	4/31	Maintenance	2/12
• SINUMERIK 808D ADVANCED T/M	4/26	Manual	6/7, 6/8
• SINUMERIK 808D Turning/Milling PPU 141.3	3/13	Manual Machine plus	2/8, 3/2, 3/3, 4/2, 4/3
Connection system	1/6	Material warranty	1/5, 6/2
Control configuration	2/2	Measuring functions	2/4
Control structure	2/2	Measuring systems	2/2
Contour handwheel	2/3, 3/3, 4/3	Metal surcharges	7/15
Conversion tables	7/13	MM+	2/8, 3/2, 3/3, 4/2, 4/3
Cycles	2/6	Mobile Media	7/7
D		Mode groups	2/2
Data management	2/9	Monitoring functions	2/10
Derating factors for power and signal cables	1/6	MOTION-CONNECT	1/6, 3/13, 4/26
Diagnostic functions	2/12	MOTION-CONNECT cables	
Dimensional drawings		• for SINAMICS V60 servo drive	3/15
• Direct spindle encoder	5/9	• for SINAMICS V70 servo drive	4/21
• Electronic handwheel	5/3	• for SINAMICS V70 spindle drive	4/31
• SIMOTICS M-1PH1 main motor	4/22	• for SINUMERIK 808D	3/13
• SIMOTICS S-1FL5 feed motor	3/12	• for SINUMERIK 808D ADVANCED	4/26
• SIMOTICS S-1FL6 feed motor	4/14	MOTION-CONNECT connection systems	1/6, 3/13, 4/26
• SINAMICS V60 servo drive	3/9	Motion-synchronous actions	2/4
• SINAMICS V70 servo drive	4/10		
• SINAMICS V70 spindle drive	4/18		

SINUMERIK 808D system

Subject index

O	Page	S (continued)	Page
Offline PLC programming tool	2/11	SINUMERIK 808D MCP	2/3, 3/5, 4/5
Offline programming	2/12	SINUMERIK 808D MCP horizontal/vertical	4/5
On-site service	1/5, 6/2	SINUMERIK 808D MCP machine control panel	3/5, 4/5
Open Architecture	2/5	SINUMERIK 808D MCP machine control panel, horizontal	4/5
Operating modes	2/8	SINUMERIK 808D MCP machine control panel, vertical	4/5
Operating software languages	2/10	SINUMERIK 808D MCP machine control panel, vertical with handwheel slot	4/5
Operator components	3/5, 4/5, 5/2	SINUMERIK 808D Milling	1/4, 3/3
Operator-panel-based CNCs	1/4	SINUMERIK 808D Milling PPU 141.3 horizontal	3/3
Options	3/3, 4/3	SINUMERIK 808D on PC	2/12, 6/4
P		SINUMERIK 808D startGUIDE	2/10, 2/12, 3/2, 4/2
Pair of synchronized axes (gantry axes), basic	2/3, 4/3	SINUMERIK 808D system	1/3, 3/1
Partner at Siemens	7/4, 7/5	SINUMERIK 808D T/M toolbox	2/11, 2/12, 3/3, 4/3
PC-based CNC training	6/4	SINUMERIK 808D Turning	1/4, 3/2
PLC area	2/11	SINUMERIK 808D Turning PPU 141.3 horizontal	3/3
Power cable	3/16, 3/29, 4/32	SINUMERIK Operate BASIC	2/2, 3/2, 4/2
Power supply	5/6	SINUMERIK programGUIDE BASIC	2/7, 3/2, 4/2
Program and workpiece management	2/7	SITOP power supply	5/6
Programming support	2/7	Slot for handwheel	4/5
R		Social Media	7/7
RS422 (TTL) incremental encoder	2/2, 5/7, 5/8	Software licenses	7/8
S		Software Update Service	7/9, 7/10
Security information	7/10	Software version	2/1
Serial production	2/12	Solution Partner	7/5
Service	2/12, 6/1, 6/2	Spindle functions	2/4
Servo drive	3/7, 4/8	Spring disk coupling	5/7, 5/8, 5/9
Setpoint cable	3/15, 4/28	Supplementary components	5/5
Setup texts	7/10	Support, on-site.....	1/5, 6/2
Shield plate	4/17	SUS	7/9
Siemens Automation Cooperates with Education	6/5	T	
Siemens Solution Partner	7/5	Teaching support	6/5
Signal cable	3/15, 4/28, 4/29, 4/32	Technology cycles	2/6, 3/2, 4/2
SIMOTICS M-1PH1 main motor	1/5, 4/20	Terminal strip converter	2/11, 5/5
SIMOTICS S-1FL5 feed motor	1/5, 3/10	Tools	2/8
SIMOTICS S-1FL6 feed motor	1/5, 4/12	Training	2/12, 6/3
Simulation	2/7	TRANSMIT/TRACYL Transformation without Y axis	2/3, 3/3, 4/3
SINAMICS V60	1/5, 3/7	U	
SINAMICS V70	1/5, 4/8	Upgrade	7/8, 7/9
SINAMICS V70 spindle	4/16	W	
SINUMERIK 808D	1/4, 2/1	Workpiece management	2/7
SINUMERIK 808D ADVANCED	1/4, 2/1		
SINUMERIK 808D ADVANCED M	1/4, 4/3		
SINUMERIK 808D ADVANCED PPU 150.3/160.3 vertical	4/2		
SINUMERIK 808D ADVANCED PPU 151.3/161.3 horizontal	4/2		
SINUMERIK 808D ADVANCED system	1/3, 4/1		
SINUMERIK 808D ADVANCED T	1/4, 4/3		
SINUMERIK 808D family			
• Overview of functions	2/1		
• Toolbox	2/11, 2/12		

Rotary inertia (to convert from A to B, multiply by entry in table)

A \ B	lb-in ²	lb-ft ²	lb-in-s ²	lb-ft-s ² slug-ft ²	kg-cm ²	kg-cm-s ²	gm-cm ²	gm-cm-s ²	oz-in ²	oz-in-s ²
lb-in ²	1	6.94×10^{-3}	2.59×10^{-3}	2.15×10^{-4}	2.926	2.98×10^{-3}	2.92×10^3	2.984	16	4.14×10^{-2}
lb-ft ²	144	1	0.3729	3.10×10^{-2}	421.40	0.4297	4.21×10^5	429.71	2304	5.967
lb-in-s ²	386.08	2.681	1	8.33×10^{-2}	1.129×10^3	1.152	1.129×10^6	1.152×10^3	6.177×10^3	16
lb-ft-s ² slug-ft ²	4.63×10^3	32.17	12	1	1.35×10^4	13.825	1.355×10^7	1.38×10^4	7.41×10^4	192
kg-cm ²	0.3417	2.37×10^{-3}	8.85×10^{-4}	7.37×10^{-5}	1	1.019×10^{-3}	1000	1.019	5.46	1.41×10^{-2}
kg-cm-s ²	335.1	2.327	0.8679	7.23×10^{-2}	980.66	1	9.8×10^5	1000	5.36×10^3	13.887
gm-cm ²	3.417×10^{-4}	2.37×10^{-6}	8.85×10^{-7}	7.37×10^{-8}	1×10^{-3}	1.01×10^{-6}	1	1.01×10^{-3}	5.46×10^{-3}	1.41×10^{-5}
gm-cm-s ²	0.335	2.32×10^{-3}	8.67×10^{-4}	7.23×10^{-5}	0.9806	1×10^{-3}	980.6	1	5.36	1.38×10^{-2}
oz-in ²	0.0625	4.34×10^{-4}	1.61×10^{-4}	1.34×10^{-5}	0.182	1.86×10^{-4}	182.9	0.186	1	2.59×10^{-3}
oz-in-s ²	24.13	0.1675	6.25×10^{-2}	5.20×10^{-3}	70.615	7.20×10^{-2}	7.09×10^4	72.0	386.08	1

Torque (to convert from A to B, multiply by entry in table)

A \ B	lb-in	lb-ft	oz-in	N-m	kg-cm	kg-m	gm-cm	dyne-cm
lb-in	1	8.333×10^{-2}	16	0.113	1.152	1.152×10^{-2}	1.152×10^3	1.129×10^6
lb-ft	12	1	192	1.355	13.825	0.138	1.382×10^4	1.355×10^7
oz-in	6.25×10^{-2}	5.208×10^{-3}	1	7.061×10^{-3}	7.200×10^{-2}	7.200×10^{-4}	72.007	7.061×10^4
N-m	8.850	0.737	141.612	1	10.197	0.102	1.019×10^4	1×10^7
kg-cm	0.8679	7.233×10^{-2}	13.877	9.806×10^{-2}	1	10^{-2}	1000	9.806×10^5
kg-m	86.796	7.233	1.388×10^3	9.806	100	1	1×10^5	9.806×10^7
gm-cm	8.679×10^{-4}	7.233×10^{-5}	1.388×10^{-2}	9.806×10^{-5}	1×10^{-3}	1×10^{-5}	1	980.665
dyne-cm	8.850×10^{-7}	7.375×10^{-8}	1.416×10^{-5}	10^{-7}	1.0197×10^{-6}	1.019×10^{-8}	1.019×10^{-3}	1

Length (to convert from A to B, multiply by entry in table)

A \ B	inches	feet	cm	yd	mm	m
inches	1	0.0833	2.54	0.028	25.4	0.0254
feet	12	1	30.48	0.333	304.8	0.3048
cm	0.3937	0.03281	1	1.09×10^{-2}	10	0.01
yd	36	3	91.44	1	914.4	0.914
mm	0.03937	0.00328	0.1	1.09×10^{-3}	1	0.001
m	39.37	3.281	100	1.09	1000	1

Power (to convert from A to B, multiply by entry in table)

A \ B	hp	Watts
hp (English)	1	745.7
(lb-in) (deg./s)	2.645×10^{-6}	1.972×10^{-3}
(lb-in) (rpm)	1.587×10^{-5}	1.183×10^{-2}
(lb-ft) (deg./s)	3.173×10^{-5}	2.366×10^{-2}
(lb-ft) (rpm)	1.904×10^{-4}	0.1420
Watts	1.341×10^{-3}	1

Force (to convert from A to B, multiply by entry in table)

A \ B	lb	oz	gm	dyne	N
lb	1	16	453.6	4.448×10^5	4.4482
oz	0.0625	1	28.35	2.780×10^4	0.27801
gm	2.205×10^{-3}	0.03527	1	1.02×10^{-3}	N.A.
dyne	2.248×10^{-6}	3.59×10^{-5}	980.7	1	0.00001
N	0.22481	3.5967	N.A.	100000	1

Mass (to convert from A to B, multiply by entry in table)

A \ B	lb	oz	gm	kg	slug
lb	1	16	453.6	0.4536	0.0311
oz	6.25×10^{-2}	1	28.35	0.02835	1.93×10^{-3}
gm	2.205×10^{-3}	3.527×10^{-2}	1	10^{-3}	6.852×10^{-5}
kg	2.205	35.27	10^3	1	6.852×10^{-2}
slug	32.17	514.8	1.459×10^4	14.59	1

Rotation (to convert from A to B, multiply by entry in table)

A \ B	rpm	rad/s	degrees/s
rpm	1	0.105	6.0
rad/s	9.55	1	57.30
degrees/s	0.167	1.745×10^{-2}	1

SINUMERIK 808D system

Conversion tables

Temperature Conversion

°F	°C	°C	°F
0	-17.8	-10	14
32	0	0	32
50	10	10	50
70	21.1	20	68
90	32.2	30	86
98.4	37	37	98.4
212	100	100	212
subtract 32 and multiply by $\frac{5}{9}$		multiply by $\frac{9}{5}$ and add 32	

Mechanism Efficiencies

Acme-screw with brass nut	~0.35–0.65
Acme-screw with plastic nut	~0.50–0.85
Ball-screw	~0.85–0.95
Chain and sprocket	~0.95–0.98
Preloaded ball-screw	~0.75–0.85
Spur or bevel-gears	~0.90
Timing belts	~0.96–0.98
Worm gears	~0.45–0.85
Helical gear (1 reduction)	~0.92

Friction Coefficients

Materials	μ
Steel on steel (greased)	~0.15
Plastic on steel	~0.15–0.25
Copper on steel	~0.30
Brass on steel	~0.35
Aluminum on steel	~0.45
Steel on steel	~0.58
Mechanism	μ
Ball bushings	<0.001
Linear bearings	<0.001
Dove-tail slides	~0.2++
Gibb ways	~0.5++

Material Densities

Material	lb-in ³	gm-cm ³
Aluminum	0.096	2.66
Brass	0.299	8.30
Bronze	0.295	8.17
Copper	0.322	8.91
Hard wood	0.029	0.80
Soft wood	0.018	0.48
Plastic	0.040	1.11
Glass	0.079–0.090	2.2–2.5
Titanium	0.163	4.51
Paper	0.025–0.043	0.7–1.2
Polyvinyl chloride	0.047–0.050	1.3–1.4
Rubber	0.033–0.036	0.92–0.99
Silicone rubber, without filler	0.043	1.2
Cast iron, gray	0.274	7.6
Steel	0.280	7.75

Wire Gauges¹⁾

Cross-section mm ²	Standard Wire Gauge (SWG)	American Wire Gauge (AWG)
0.2	25	24
0.3	23	22
0.5	21	20
0.75	20	19
1.0	19	18
1.5	17	16
2.5	15	13
4	13	11
6	12	9
10	9	7
16	7	6
25	5	3
35	3	2
50	0	1/0
70	000	2/0
95	00000	3/0
120	0000000	4/0
150	–	6/0
185	–	7/0

¹⁾ The table shows approximate SWG/AWG sizes nearest to standard metric sizes; the cross-sections do not match exactly.

Explanation of the raw material/metal surcharges¹⁾

Surcharge calculation

To compensate for variations in the price of the raw materials silver, copper, aluminum, lead, gold, dysprosium²⁾ and/or neodym²⁾, surcharges are calculated on a daily basis using the so-called metal factor for products containing these raw materials. A surcharge for the respective raw material is calculated as a supplement to the price of a product if the basic official price of the raw material in question is exceeded.

The surcharges are calculated in accordance with the following criteria:

- Basic official price of the raw material
Basic official price from the day prior to receipt of the order or prior to release order (daily price) for³⁾
 - Silver (sales price, processed)
 - Gold (sales price, processed)
- and for⁴⁾
 - Copper (lower DEL notation + 1 %)
 - Aluminum (aluminum in cables)
 - Lead (lead in cables)
- Metal factor of the products
Certain products are displayed with a metal factor. The metal factor determines the official price (for those raw materials concerned) as of which the metal surcharges are applied and the calculation method used (weight or percentage method). An exact explanation is given below.

Structure of the metal factor

The metal factor consists of several digits; the first digit indicates whether the percentage method of calculation refers to the list price or a possible discounted price (customer net price) (L = list price / N = customer net price).

The remaining digits indicate the method of calculation used for the respective raw material. If no surcharge is added for a raw material, a "-" is used.

1st digit	List or customer net price using the percentage method
2nd digit	for silver (AG)
3rd digit	for copper (CU)
4th digit	for aluminum (AL)
5th digit	for lead (PB)
6th digit	for gold (AU)
7th digit	for dysprosium (Dy) ²⁾
8th digit	for neodym (Nd) ²⁾

Weight method

The weight method uses the basic official price, the daily price and the raw material weight. In order to calculate the surcharge, the basic official price must be subtracted from the daily price. The difference is then multiplied by the raw material weight.

The basic official price can be found in the table below using the number (1 to 9) of the respective digit of the metal factor. The raw material weight can be found in the respective product descriptions.

Percentage method

Use of the percentage method is indicated by the letters A-Z at the respective digit of the metal factor.

The surcharge is increased - dependent on the deviation of the daily price compared with the basic official price - using the percentage method in "steps" and consequently offers surcharges that remain constant within the framework of this "step range". A higher percentage rate is charged for each new step. The respective percentage level can be found in the table below.

Metal factor examples

L E A - - - -	<ul style="list-style-type: none"> Basis for % surcharge: List price Silver Basis 150 €, Step 50 €, 0.5 % Copper Basis 150 €, Step 50 €, 0.1 % No surcharge for aluminum No surcharge for lead No surcharge for gold No surcharge for dysprosium No surcharge for neodym
N - A 6 - - -	<ul style="list-style-type: none"> Basis for % surcharge: Customer net price No surcharge for silver Copper Basis 150 €, Step 50 €, 0.1 % Aluminum acc. to weight, basic offic. price 225 € No surcharge for lead No surcharge for gold No surcharge for dysprosium No surcharge for neodym
- - 3 - - - -	<ul style="list-style-type: none"> No basis necessary No surcharge for silver Copper acc. to weight, basic official price 150 € No surcharge for aluminum No surcharge for lead No surcharge for gold No surcharge for dysprosium No surcharge for neodym

¹⁾ Refer to the separate explanation on the next page regarding the raw materials dysprosium and neodym (= rare earths).
²⁾ For a different method of calculation, refer to the separate explanation for these raw materials on the next page.
³⁾ Source: Umicore, Hanau (www.metalsmanagement.umicore.com).
⁴⁾ Source: Schutzvereinigung DEL-Notiz e.V. (www.del-notiz.org).

SINUMERIK 808D system

Metal surcharges

Explanation of the raw material/metal surcharges for dysprosium and neodym (rare earths)

Surcharge calculation

To compensate for variations in the price of the raw materials silver¹⁾, copper¹⁾, aluminum¹⁾, lead¹⁾, gold¹⁾, dysprosium and/or neodym, surcharges are calculated on a daily basis using the so-called metal factor for products containing these raw materials. The surcharge for dysprosium and neodym is calculated as a supplement to the price of a product if the basic official price of the raw material in question is exceeded.

The surcharge is calculated in accordance with the following criteria:

- Basic official price of the raw material²⁾
Three-month basic average price (see below) in the period before the quarter in which the order was received or the release order took place (= average official price) for
- dysprosium (Dy metal, 99 % min. FOB China; USD/kg)
- neodym (Nd metal, 99 % min. FOB China; USD/kg)
- Metal factor of the products
Certain products are displayed with a metal factor. The metal factor indicates (for those raw materials concerned) the basic official price as of which the surcharges for dysprosium and neodym are calculated using the weight method. An exact explanation of the metal factor is given below.

Three-month average price

The prices of rare earths vary according to the foreign currency, and there is no freely accessible stock exchange listing. This makes it more difficult for all parties involved to monitor changes in price. In order to avoid continuous adjustment of the surcharges, but to still ensure fair, transparent pricing, an average price is calculated over a three-month period using the average monthly foreign exchange rate from USD to EUR (source: European Central Bank). Since not all facts are immediately available at the start of each month, a one-month buffer is allowed before the new average price applies.

Examples of calculation of the average official price:

Period for calculation of the average price:	Period during which the order/release order is effected and the average price applies:
Sep 2016 - Nov 2016	Q1 in 2017 (Jan - Mar)
Dec 2016 - Feb 2017	Q2 in 2017 (Apr - Jun)
Mar 2017 - May 2017	Q3 in 2017 (Jul - Sep)
Jun 2017 - Aug 2017	Q4 in 2017 (Oct - Dec)

Structure of the metal factor

The metal factor consists of several digits; the first digit is not relevant to the calculation of dysprosium and neodym.

The remaining digits indicate the method of calculation used for the respective raw material. If no surcharge is added for a raw material, a "-" is used.

1st digit	List or customer net price using the percentage method
2nd digit	for silver (AG) ¹⁾
3rd digit	for copper (CU) ¹⁾
4th digit	for aluminum (AL) ¹⁾
5th digit	for lead (PB) ¹⁾
6th digit	for gold (AU) ¹⁾
7th digit	for dysprosium (Dy)
8th digit	for neodym (Nd)

Weight method

The weight method uses the basic official price, the average price and the raw material weight. In order to calculate the surcharge, the basic official price must be subtracted from the average price. The difference is then multiplied by the raw material weight.

The basic official price can be found in the table below using the number (1 to 9) of the respective digit of the metal factor. Your Sales contact can inform you of the raw material weight.

Metal factor examples

-----71	No basis necessary
	No surcharge for silver
	No surcharge for copper
	No surcharge for aluminum
	No surcharge for lead
	No surcharge for gold
	Dysprosium acc. to weight, basic official price 300 €
	Neodym acc. to weight, basic official price 50 €

¹⁾ For a different method of calculation, refer to the separate explanation for these raw materials on the previous page.

²⁾ Source: Asian Metal Ltd (www.asianmetal.com)

Values of the metal factor

Percentage method	Basic official price in €	Step range in €	% surcharge 1st step	% surcharge 2nd step	% surcharge 3rd step	% surcharge 4th step	% surcharge per additional step	
			Price in €	Price in €	Price in €	Price in €		
A	150	50	0.1	0.2	0.3	0.4	0.1	
B	150	50	0.2	0.4	0.6	0.8	0.2	
C	150	50	0.3	0.6	0.9	1.2	0.3	
D	150	50	0.4	0.8	1.2	1.6	0.4	
E	150	50	0.5	1.0	1.5	2.0	0.5	
F	150	50	0.6	1.2	1.8	2.4	0.6	
G	150	50	1.0	2.0	3.0	4.0	1.0	
H	150	50	1.2	2.4	3.6	4.8	1.2	
I	150	50	1.6	3.2	4.8	6.4	1.6	
J	150	50	1.8	3.6	5.4	7.2	1.8	
			175.01 - 225.00	225.01 - 275.00	275.01 - 325.00	325.01 - 375.00		
O	175	50	0.1	0.2	0.3	0.4	0.1	
P	175	50	0.2	0.4	0.6	0.8	0.2	
R	175	50	0.5	1.0	1.5	2.0	0.5	
			225.01 - 275.00	275.01 - 325.00	325.01 - 375.00	375.01 - 425.00		
S	225	50	0.2	0.4	0.6	0.8	0.2	
U	225	50	1.0	2.0	3.0	4.0	1.0	
V	225	50	1.0	1.5	2.0	3.0	1.0	
W	225	50	1.2	2.5	3.5	4.5	1.0	
			150.01 - 175.00	175.01 - 200.00	200.01 - 225.00	225.01 - 250.00		
Y	150	25	0.3	0.6	0.9	1.2	0.3	
			400.01 - 425.00	425.01 - 450.00	450.01 - 475.00	475.01 - 500.00		
Z	400	25	0.1	0.2	0.3	0.4	0.1	
Price basis (1st digit)								
L	Calculation based on the list price							
N	Calculation based on the customer net price (discounted list price)							
Weight method	Basic official price in €							
1	50	Calculation based on raw material weight						
2	100							
3	150							
4	175							
5	200							
6	225							
7	300							
8	400							
9	555							
Miscellaneous								
-	No metal surcharge							

SINUMERIK 808D system

Conditions of sale and delivery/Export regulations

1. General Provisions

By using this catalog you can acquire hardware and software products described therein from Siemens AG subject to the following Terms and Conditions of Sale and Delivery (hereinafter referred to as "T&C"). Please note that the scope, the quality and the conditions for supplies and services, including software products, by any Siemens entity having a registered office outside Germany, shall be subject exclusively to the General Terms and Conditions of the respective Siemens entity. The following T&C apply exclusively for orders placed with Siemens Aktiengesellschaft, Germany.

1.1 For customers with a seat or registered office in Germany

For customers with a seat or registered office in Germany, the following applies subordinate to the T&C:

- the "General Terms of Payment"¹⁾ and,
- for software products, the "General License Conditions for Software Products for Automation and Drives for Customers with a Seat or Registered Office in Germany"¹⁾ and,
- for other supplies and services, the "General Conditions for the Supply of Products and Services of the Electrical and Electronics Industry"¹⁾.

1.2 For customers with a seat or registered office outside Germany

For customers with a seat or registered office outside Germany, the following applies subordinate to the T&C:

- the "General Terms of Payment"¹⁾ and,
- for software products, the "General License Conditions for Software Products for Automation and Drives for Customers with a Seat or Registered Office outside of Germany"¹⁾ and
- for other supplies and/or services, the "General Conditions for Supplies of Siemens Industry for Customers with a Seat or Registered Office outside of Germany"¹⁾.

2. Prices

The prices are in € (Euro) ex point of delivery, exclusive of packaging.

The sales tax (value added tax) is not included in the prices. It shall be charged separately at the respective rate according to the applicable statutory legal regulations.

Prices are subject to change without prior notice. We will charge the prices valid at the time of delivery.

To compensate for variations in the price of raw materials (e.g. silver, copper, aluminum, lead, gold, dysprosium and neodym), surcharges are calculated on a daily basis using the so-called metal factor for products containing these raw materials. A surcharge for the respective raw material is calculated as a supplement to the price of a product if the basic official price of the raw material in question is exceeded.

The metal factor of a product indicates the basic official price (for those raw materials concerned) as of which the surcharges on the price of the product are applied, and with what method of calculation.

You will find a detailed explanation of the metal factor on the page headed "Metal surcharges".

To calculate the surcharge (except in the cases of dysprosium and neodym), the official price from the day prior to that on which the order was received or the release order was effected is used.

To calculate the surcharge applicable to dysprosium and neodym ("rare earths"), the corresponding three-month basic average price in the quarter prior to that in which the order was received or the release order was effected is used with a one-month buffer (details on the calculation can be found in the explanation of the metal factor).

3. Additional Terms and Conditions

The dimensions are in mm. In Germany, according to the German law on units in measuring technology, data in inches apply only to devices for export.

Illustrations are not binding.

Insofar as there are no remarks on the individual pages of this catalog – especially with regard to data, dimensions and weights given – these are subject to change without prior notice.

4. Export regulations

We shall not be obligated to fulfill any agreement if such fulfillment is prevented by any impediments arising out of national or international foreign trade or customs requirements or any embargoes and/or other sanctions.

Export of goods listed in this catalog may be subject to licensing requirements. We will indicate in the delivery details whether licenses are required under German, European and US export lists. Goods labeled with "AL" not equal to "N" are subject to European or German export authorization when being exported out of the EU. Goods labeled with "ECCN" not equal to "N" are subject to US re-export authorization.

The export indications can be viewed in advance in the description of the respective goods on the Industry Mall, our online catalog system. Only the export labels "AL" and "ECCN" indicated on order confirmations, delivery notes and invoices are authoritative.

Even without a label, or with label "AL:N" or "ECCN:N", authorization may be required i.a. due to the final disposition and intended use of goods.

If you transfer goods (hardware and/or software and/or technology as well as corresponding documentation, regardless of the mode of provision) delivered by us or works and services (including all kinds of technical support) performed by us to a third party worldwide, you must comply with all applicable national and international (re-)export control regulations.

If required for the purpose of conducting export control checks, you (upon request by us) shall promptly provide us with all information pertaining to the particular end customer, final disposition and intended use of goods delivered by us respectively works and services provided by us, as well as to any export control restrictions existing in this relation.

The products listed in this catalog may be subject to European/German and/or US export regulations. Any export requiring approval is therefore subject to authorization by the relevant authorities.

Errors excepted and subject to change without prior notice.



1) The text of the Terms and Conditions of Siemens AG can be downloaded at:
www.siemens.com/automation/salesmaterial-as/catalog/en/terms_of_trade_en.pdf

Further information can be obtained from our branch offices listed at www.siemens.com/automation-contact

Interactive Catalog on DVD	<i>Catalog</i>	Process Instrumentation and Analytics	<i>Catalog</i>
Products for Automation and Drives	CA 01	<i>Digital: Field Instruments for Process Automation</i>	FI 01
Building Control		<i>Digital: Display Recorders SIREC D</i>	MP 20
GAMMA Building Control	ET G1	<i>Digital: SIPART Controllers and Software</i>	MP 31
Drive Systems		Products for Weighing Technology	WT 10
SINAMICS G130 Drive Converter Chassis Units	D 11	<i>Digital: Process Analytical Instruments</i>	AP 01
SINAMICS G150 Drive Converter Cabinet Units		<i>Digital: Process Analytics, Components for Continuous Emission Monitoring</i>	AP 11
SINAMICS GM150, SINAMICS SM150 Medium-Voltage Converters	D 12	Low-Voltage Power Distribution and Electrical Installation Technology	
SINAMICS PERFECT HARMONY GH180 Medium-Voltage Air-Cooled Drives (Germany Edition)	D 15.1	SENTRON · SIVACON · ALPHA Protection, Switching, Measuring and Monitoring Devices, Switchboards and Distribution Systems	LV 10
SINAMICS G180 Converters – Compact Units, Cabinet Systems, Cabinet Units Air-Cooled and Liquid-Cooled	D 18.1	Standards-Compliant Components for Photovoltaic Plants	LV 11
SINAMICS S120 Chassis Format Units and Cabinet Modules	D 21.3	Electrical Components for the Railway Industry	LV 12
SINAMICS S150 Converter Cabinet Units		Power Monitoring Made Simple	LV 14
SINAMICS S120 and SIMOTICS	D 21.4	Components for Industrial Control Panels according to UL Standards	LV 16
SINAMICS DCM DC Converter, Control Module	D 23.1	3WT Air Circuit Breakers up to 4000 A	LV 35
SINAMICS Inverters for Single-Axis Drives · Built-In Units	D 31.1	3VT Molded Case Circuit Breakers up to 1600 A	LV 36
SINAMICS Inverters for Single-Axis Drives · Distributed Inverters	D 31.2	<i>Digital: SIVACON System Cubicles, System Lighting and System Air-Conditioning</i>	LV 50
<i>Digital: SINAMICS G120P and SINAMICS G120P Cabinet pump, fan, compressor converters</i>	D 35	<i>Digital: ALPHA Distribution Systems</i>	LV 51
LOHER VARIO High Voltage Motors Flameproof, Type Series 1PS4, 1PS5, 1MV4 and 1MV5 Frame Size 355 to 1000, Power Range 80 to 7100 kW	D 83.2	ALPHA FIX Terminal Blocks	LV 52
Three-Phase Induction Motors	D 84.1	SIVACON S4 Power Distribution Boards	LV 56
SIMOTICS HV, SIMOTICS TN		SIVACON 8PS Busbar Trunking Systems	LV 70
High Voltage Three-phase Induction Motors	D 84.9	<i>Digital: DELTA Switches and Socket Outlets</i>	ET D1
SIMOTICS HV Series A-compact PLUS		Vacuum Switching Technology and Components for Medium Voltage	HG 11.01
<i>Digital: Modular Industrial Generators SIGENTICS M</i>	D 85.1	Motion Control	
Three-Phase Induction Motors SIMOTICS HV, Series H-compact	D 86.1	SINUMERIK 840 Equipment for Machine Tools	NC 62
Synchronous Motors with Permanent-Magnet Technology, HT-direct	D 86.2	SINUMERIK 808 Equipment for Machine Tools	NC 81.1
DC Motors	DA 12	SINUMERIK 828 Equipment for Machine Tools	NC 82
SIMOREG DC MASTER 6RA70 Digital Chassis Converters	DA 21.1	SIMOTION Equipment for Production Machines	PM 21
SIMOREG K 6RA22 Analog Chassis Converters	DA 21.2	<i>Digital: Drive and Control Components for Cranes</i>	CR 1
<i>Digital: SIMOREG DC MASTER 6RM70 Digital Converter Cabinet Units</i>	DA 22	Power Supply	
SIMOVERT PM Modular Converter Systems	DA 45	SITOP Power supply	KT 10.1
MICROMASTER 420/430/440 Inverters	DA 51.2	Safety Integrated	
MICROMASTER 411/COMBIMASTER 411	DA 51.3	Safety Technology for Factory Automation	SI 10
Low-Voltage Three-Phase-Motors		SIMATIC HMI / PC-based Automation	
SIMOTOCS S-1FG1 Servo geared motors	D 41	Human Machine Interface Systems/ PC-based Automation	ST 80/ ST PC
SIMOTICS Low-Voltage Motors	D 81.1	SIMATIC Ident	
SIMOTICS FD Low-Voltage Motors	D 81.8	Industrial Identification Systems	ID 10
LOHER Low-Voltage Motors	D 83.1	SIMATIC Industrial Automation Systems	
<i>Digital: MOTOX Geared Motors</i>	D 87.1	Products for Totally Integrated Automation	ST 70
SIMOGEAR Geared Motors	MD 50.1	SIMATIC PCS 7 Process Control System System components	ST PCS 7
SIMOGEAR Electric-monorail geared motors Light-load and heavy-load applications	MD 50.8	SIMATIC PCS 7 Process Control System Technology components	ST PCS 7 T
SIMOGEAR Gearboxes with adapter	MD 50.11	Add-ons for the SIMATIC PCS 7 Process Control System	ST PCS 7 AO
Mechanical Driving Machines		SIMATIC S7-400 advanced controller	ST 400
FLENDER Standard Couplings	MD 10.1	SIMATIC NET	
FLENDER High Performance Couplings	MD 10.2	Industrial Communication	IK PI
FLENDER Backlash-free Couplings	MD 10.3	SIRIUS Industrial Controls	
FLENDER SIP Standard industrial planetary gear units	MD 31.1	SIRIUS Industrial Controls	IC 10

www.nicsanat.com
021-87700210



Digital: These catalogs are only available as a PDF.

Information and Download Center

Digital versions of the catalogs are available on the Internet at:
www.siemens.com/industry/infocenter
There you'll find additional catalogs in other languages.

Please note the section "Downloading catalogs" on page "Online services" in the appendix of this catalog.

Get more information

SINUMERIK automation systems for machine tools:
www.siemens.com/sinumerik

The SINAMICS drives family:
www.siemens.com/sinamics

Motion Control Systems and Solutions for production machine and machine tool equipment:
www.siemens.com/motioncontrol

Local partners worldwide:
www.siemens.com/automation-contact

Siemens AG
Digital Factory Division
Motion Control
Postfach 3180
91050 ERLANGEN
GERMANY

© Siemens AG 2017
Subject to change without prior notice
Article No. E86060-K4481-A111-A4-7600
V1.MKKATA.MTS.111 / Dispo 09400
KG 1117 0.6 HOF/DPG 108 En
Printed in Germany

The information provided in this catalog contains merely general descriptions or characteristics of performance which in case of actual use do not always apply as described or which may change as a result of further development of the products. An obligation to provide the respective characteristics shall only exist if expressly agreed in the terms of contract. Availability and technical specifications are subject to change without notice.

All product designations may be trademarks or product names of Siemens AG or supplier companies whose use by third parties for their own purposes could violate the rights of the owners.

Token fee: 2.00 €

Security information

Siemens provides products and solutions with industrial security functions that support the secure operation of plants, systems, machines and networks.

In order to protect plants, systems, machines and networks against cyber threats, it is necessary to implement – and continuously maintain – a holistic, state-of-the-art industrial security concept. Siemens' products and solutions constitute one element of such a concept.

Customers are responsible for preventing unauthorized access to their plants, systems, machines and networks. Such systems, machines and components should only be connected to an enterprise network or the internet if and to the extent such a connection is necessary and only when appropriate security measures (e.g. firewalls and/or network segmentation) are in place.

For additional information on industrial security measures that may be implemented, please visit:
www.siemens.com/industrialsecurity

Siemens' products and solutions undergo continuous development to make them more secure. Siemens strongly recommends that product updates are applied as soon as they are available and that the latest product versions are used. Use of product versions that are no longer supported, and failure to apply the latest updates may increase customer's exposure to cyber threats.

To stay informed about product updates, subscribe to the Siemens Industrial Security RSS Feed under:
www.siemens.com/industrialsecurity



www.nicsanat.com

021-87700210