

# SIEMENS

## SINUMERIK 810D

### Configuration CCU

Equipment Manual



[www.nicsanat.com](http://www.nicsanat.com)

021-87700210

Valid for

*Control*

SINUMERIK 810D powerline

SINUMERIK 810DE powerline

Edition 03/2006

System Overview	1
Connection Conditions	2
Design and Installation	3
Description	4
Axis Expansion	5
I/O Modules	6
NCU Terminal Block	7
DMP Compact Modules	8
Maintenance and Service	9
Abbreviations	A

Index

## SINUMERIK® Documentation

### Printing history

Brief details of this edition and previous editions are listed below.

The status of each edition is shown by the code in the “Remarks” column.

*Status code in the “Remarks” column:*

- A** . . . . . New documentation.
- B** . . . . . Unrevised reprint with new order no.
- C** . . . . . Revised edition with new status.

Edition	Order No.	Remarks
12.95	6FC5297-1AD10-0BP0	A
07.96	6FC5297-1AD10-0BP1	C
08.97	6FC5297-2AD10-0BP0	C
12.98	6FC5297-3AD10-0BP0	C
08.99	6FC5297-3AD10-0BP1	C
04.00	6FC5297-3AD10-0BP2	C
10.00	6FC5297-4AD10-0BP0	C
12.01	6FC5297-4AD10-0BP1	C
03.02	6FC5297-6AD10-0BP0	C
11.02	6FC5297-6AD10-0BP1	C
03.05	6FC5297-6AD10-0BP2	C
03.06	6FC5297-7AD10-0BP0	C

### Trademarks

All product names mentioned may be trademarks or product designations of Siemens AG or their suppliers, whose use by third parties for their own purposes may infringe the rights of the trademark owners.

Further information is available in the Internet under:  
<http://www.siemens.com/motioncontrol>

This publication was produced with Interleaf V 7.

Copyright© Siemens AG 2006

Other functions not described in this documentation might be executable in the control. However, no claim can be made regarding the availability of these functions when the equipment is first supplied or in the event of servicing.

We have checked that the contents of this document correspond to the hardware and software described. Nevertheless, differences might exist and therefore we cannot guarantee that they are completely identical. The information given in this publication is reviewed at regular intervals and any corrections that might be necessary are made in the subsequent printings. Suggestions for improvement are also welcome.

Subject to change without prior notice.

# Preface

## SINUMERIK Documentation

The SINUMERIK documentation is subdivided into 3 parts:

- General Documentation
- User documentation
- Manufacturer/Service documentation

A list of documents with the respective available languages is updated on a monthly basis and is available on the Internet at:

<http://www.siemens.com/motioncontrol>

Select "Support" → "Technical Documentation" → "Overview of Documents".

The Internet version of the DOConCD (DOConWEB) is available at:

<http://www.automation.siemens.com/doconweb>

Information on the training offerings and on FAQs (frequently asked questions) can be found in the Internet under:

<http://www.siemens.com/motioncontrol> and menu item "Support".

## Target group

This documentation is intended for:

- Project engineers, electricians and installers
- Maintenance and service personnel

## Benefits

The information in this manual enables installation of the SINUMERIK 810D Numerical Control and measures for maintenance and service.

## Standard version

This documentation only describes the functionality of the standard version. Extensions or changes made by the machine tool manufacturer are documented by the machine tool manufacturer. Other functions not described in this documentation might be executable in the control. This does not, however, represent an obligation to supply such functions with an initial delivery or when servicing.

For the sake of simplicity, this documentation does not contain all detailed information about all types of the product and cannot cover every conceivable case of installation, operation, or maintenance.

## Technical Support

If you have any questions about the control, please contact the hotline:

### Europe and Africa time zone

A&D Technical Support

Tel.: +49 (0) 180 / 5050 222

Fax: +49 (0) 180 / 5050-223

Internet: <http://www.siemens.com/automation/support-request>

E-Mail: <mailto:adsupport@siemens.com>

**Asia and Australia time zone**

A&D Technical Support  
 Tel.: +86 1064 719 990  
 Fax: +86 1064 747 474  
 Internet: <http://www.siemens.com/automation/support-request>  
 E-Mail: <mailto:adsupport@siemens.com>

**America time zone**

A&D Technical Support  
 Tel.: +1 423 262 2522  
 Fax: +1 423 262 2289  
 Internet: <http://www.siemens.com/automation/support-request>  
 E-Mail: <mailto:adsupport@siemens.com>

**Note**

Country-specific telephone numbers for technical support are provided under the following internet address:

Enter <http://www.siemens.com/automation/service&support>

**Questions about the manual**

For questions on the documentation (suggestions, corrections), please send a fax or e-mail to the following address:

Fax: +49 (0) 9131 / 98 – 63315  
 E-Mail: <mailto:motioncontrol.docu@siemens.com>

Fax form: see the reply form at the end of the brochure

**SINUMERIK Internet address**

<http://www.siemens.com/sinumerik>

**EC Conformity Declaration**

The EC conformity declarations on EMC are to be found at/can be obtained from:

- in the Internet:  
<http://www.ad.siemens.de/csinfo>  
 under the product/order no. 15257461
- at the relevant branch office of the A&D MC group of Siemens AG.

**Safety instructions**

This manual contains information which you should observe in order to ensure your own personal safety, as well to avoid material damage. Notices which are relevant to your own personal safety are highlighted by a safety alert symbol; notices which are relevant only to equipment and property damage have no safety alert symbol. The warnings appear in decreasing order of risk as given below.

**Danger**

indicates that death or serious injury **will** result if proper precautions are not taken.



---

**Warning**

indicates that death or serious injury **may** result if proper precautions are not taken.

---



---

**Caution**

with a safety alert symbol, indicates that minor personal injury **may** result if proper precautions are not taken.

---



---

**Caution**

without a safety alert symbol, indicates that property damage **can** result if proper precautions are not taken.

---



---

**Notice**

indicates that an undesirable event or state **may** arise if the relevant notes are not observed.

---

If several hazards of different degrees occur, the hazard with the highest degree must always be given priority. If a warning note with a warning triangle warns of personal injury, the same warning note can also contain a warning of material damage.

**Qualified personnel**

Commissioning and operation of the device/equipment/system in question must only be performed using this documentation. Only **qualified personnel** should be allowed to commission and operate the device/system. Qualified persons are defined as persons who are authorized to commission, to ground, and to tag circuits, equipment, and systems in accordance with established safety practices and standards.

**Intended use**

Please note the following:

---



---

**Warning**

The equipment may only be used for single purpose applications explicitly described in the catalog and in the technical description and it may only be used along with third-party devices and components recommended by Siemens. To ensure trouble-free and safe operation of the product, it must be transported, stored and installed as intended and maintained and operated with care.

---

## Danger notices

Should it be necessary to test or take measurements on live equipment, then the specifications and procedures defined in Accident Prevention Regulation of the Berufsgenossenschaft BGV A3 (German employer's liability insurance association) must be adhered to, in particular § 8 "Permissible deviations when working with live components". Suitable electric tools should be used.



### Danger

Operating electrical equipment has parts and components that are at hazardous voltage levels.

After disconnecting all the supply voltages, a hazardous voltage will be present in the DC link of all SIMODRIVE modules for another 5 minutes!  
See Operating Guide



### Danger

- Repairs to devices that have been supplied by our company must only be carried out by **SIEMENS Customer Service** or by repair centers **authorized by SIEMENS**. When replacing parts or components, only use those parts that are included in the spare parts list.
- Before opening the equipment, always ensure that the power is off.
- EMERGENCY STOP devices complying with EN 60204 (VDE 0113 Part 1) must remain effective in all automation equipment modes. Resetting the EMERGENCY STOP device must not cause an uncontrolled or undefined restart.
- Anywhere in the automation equipment where faults might cause major material damage or even physical injury, in other words, where faults could be dangerous, additional external precautions must be taken, or facilities must be provided, that guarantee or enforce a safe operational state, even when there is a fault (e.g. using an independent limit value switch, mechanical interlocks etc.)



### Warning

Connecting cables and signal cables should be installed so that inductive and capacitive interference does not in any way impair the automation functions.



### Warning

The modules contain electrostatically sensitive devices. Discharge yourself of electrostatic energy before touching the components. The easiest way to do this is to touch a conductive, grounded object immediately beforehand (for example, the bare metal part of control cabinet or the protective ground contact of a socket outlet).

## ESD notices

### Electrostatically Sensitive Devices

---



#### Important

Handling of modules containing devices sensitive to electrostatic discharge:

- When handling components which can be destroyed by electrostatic discharge, it must be ensured that personnel, the workstation and packaging are well grounded.
  - Generally, electronic modules must not be touched unless work has to be carried out on them. Only touch electronic modules after you have grounded yourself.
  - Touch components only if:
    - you are constantly grounded via an ESD arm band,
    - ESD-shoes or ESD-shoe grounding strips if there is an ESD floor.
  - Modules may be placed only on electrically conductive surfaces (table with ESD top, conductive ESD foam plastic, ESD packing bags, ESD transport containers).
  - Keep modules away from visual display units, monitors or TV sets (minimum distance from screen 10 cm).
  - Do not bring ESD-sensitive modules into contact with chargeable and highly-insulating materials, such as plastic, insulating table tops or clothing made of synthetic materials.
  - Measurements on modules are allowed only if
    - the measuring instrument is properly grounded (e.g. equipment grounding conductor), or
    - before measuring with a potential-free measuring instrument, the probe is briefly discharged (e.g. touch the unpainted metal parts of the control housing).
- 

## Other information



#### Important

This notice indicates important facts that must be taken into consideration.

---

#### Note

This note contains additional important information.

---



## Contents

<b>1</b>	<b>System overview</b> .....	<b>1-11</b>
1.1	SINUMERIK 810D powerline .....	1-11
1.2	System configuration .....	1-12
1.3	Labels .....	1-21
<b>2</b>	<b>Connection Conditions</b> .....	<b>2-23</b>
2.1	Supplementary electrical conditions .....	2-23
2.1.1	Power supply .....	2-24
2.1.2	Safe isolation to EN 61800-5-1 .....	2-26
2.1.3	Grounding Concept .....	2-28
2.1.4	RI suppression measures .....	2-29
2.2	Climatic and mechanical environmental conditions .....	2-31
2.2.1	Transport and storage conditions .....	2-31
2.2.2	Operating conditions .....	2-32
2.3	Technical data of the individual components .....	2-34
2.4	MPI/OPI network rules .....	2-35
<b>3</b>	<b>Design and Installation of the 810D</b> .....	<b>3-37</b>
3.1	Structure of the SINUMERIK 810D .....	3-37
3.2	Assembly of the SINUMERIK 810D .....	3-38
3.2.1	Alteration for external heat dissipation, 2-axis CCU box .....	3-43
3.3	Power supply .....	3-45
<b>4</b>	<b>Description of the SINUMERIK 810D</b> .....	<b>4-47</b>
4.1	Components of the SINUMERIK 810D .....	4-47
4.1.1	Overview .....	4-47
4.2	Interfaces .....	4-50
4.2.1	Overview .....	4-50
4.2.2	Description of the interfaces, operating and display elements .....	4-52
4.2.3	Cable distributor .....	4-60
4.3	Measuring system .....	4-63
4.3.1	Assignment of measuring systems and motor connection .....	4-63
4.3.2	Encoder systems that can be evaluated .....	4-64
4.3.3	Measuring channels, indirect and direct measuring system .....	4-66
4.4	Integrated power modules: 3-axis CCU box .....	4-71
4.5	Integrated power modules: 2-axis CCU box .....	4-74
4.6	PLC module .....	4-75
4.7	PCMCIA card (memory card) .....	4-76

<b>5</b>	<b>Axis expansion</b> .....	<b>5-77</b>
5.1	Axis expansion plug-in unit .....	5-77
5.2	Axis expansion with SIMODRIVE 611D control plug-in unit .....	5-80
<b>6</b>	<b>I/O Modules</b> .....	<b>6-83</b>
6.1	Single I/O module .....	6-83
<b>7</b>	<b>NCU terminal block</b> .....	<b>7-91</b>
<b>8</b>	<b>DMP compact modules</b> .....	<b>8-97</b>
8.1	DMP compact module 16I (6FC5111-0CA01-0AA0) .....	8-97
8.2	DMP compact module 16O (6FC5111-0CA02-0AA2) .....	8-99
8.3	DMP compact module 8O (6FC5111-0CA03-0AA2) .....	8-101
8.4	DMP compact module 1I analog (6FC5111-0CA04-0AA0) .....	8-103
8.5	DMP compact module 1I NC analog (6FC5211-0AA10-0AA0) .....	8-106
8.6	DMP compact module 1O analog (6FC5111-0CA05-0AA0) .....	8-109
<b>9</b>	<b>Maintenance and Service</b> .....	<b>9-111</b>
9.1	Battery replacement (6FC5247-0AA18-0AA0) .....	9-111
<b>A</b>	<b>Abbreviations</b> .....	<b>A-113</b>
<b>B</b>	<b>Index</b> .....	<b>B-115</b>

# System Overview

# 1

## 1.1 SINUMERIK 810D powerline

Since 03.2002

- SINUMERIK 810D powerline and
- SINUMERIK 810DE powerline

have been available. The following powerline module with improved performance is now available:

Table 1-1 powerline module for SINUMERIK 810D/810DE

Module	Description
CCU3	with additional pulse interface and 2 machining channels
CCU3.4	like CCU3, but with increased NC performance and PLC 314C-2DP

---

### Note

SINUMERIK 810D powerline and SINUMERIK 810DE powerline are delivered with software version 6.

Earlier software versions of SINUMERIK 810D cannot be run on SINUMERIK 810D powerline and SINUMERIK 810DE powerline.

---

## 1.2 System configuration

**Components** A fully equipped SINUMERIK 810D consists of different components. These are listed below.

Table 1-2 Components of the 810D in the maximum configuration (without motors)

Component	MLFB	Description
Mains supply module (MS)	See <b>References:</b> /PJU/ Configuration Manual Converters	Power supply module for powering the electronics and drives. Either unstabilized (OI 5 kW to 28 kW) or stabilized as infeed/regenerative feedback module (I/R module) as from 16 kW to 120 kW; optional filter modules.
SINUMERIK 810D – CCU box (3 axes) – CCU box (2 axes)	6FC5447-0AA00-0AA1 6FC5447-0AA01-0AA0	Module racks for CCU integrated power modules: 1 x 18/36A (FSD) or 24/32A (MSD) and 2 x 6/12A (FSD), internal heat dissipation only Module rack for the CCU integrated power modules: 2 x 9/18/A (FSD), internal/external heat dissipation
– CCU3.4	6FC5410-0AY03-1AA0	like CCU3 but with PLC 314C-2DP
– CCU3	6FC5410-0AY03-0AA1 6FC5410-0AY03-0AA2	CPU of the 810D contains: NCK, PLC 315-2DP, communication functions, digital standard control Additional functions: – 16 MB DRAM, 2.5 MB SRAM – Handling with 6 axes – 2nd channel with 6 axes
Operator panel front <sup>1)</sup>		Display, keyboard and operation of the 810D
PCU 20/50/70 <sup>1)</sup>		Makes communication between operator and machine possible
Machine control panel <sup>1)</sup>		Operation of PLC-controlled machine functions of 810D
ISA adapter <sup>1)</sup>		Permits use of AT modules in conjunction with the PCU
Full CNC keyboard <sup>1)</sup>		Full keyboard connectable to PCU
Memory card (PCMCIA)		Slot for PCMCIA card on the CCU. PCMCIA card for software update (not 810DE).
Floppy disk unit <sup>1)</sup>		Built-in unit for connection to PCU
Cable distributor	6FX2006-1BA02	Connection of two handwheels and two probes to the CCU
Cable		<b>References:</b> Catalog NC Z
Axis expansion plug-in unit left	6FC5412-0FA12-0AA0	For installation in a SIMODRIVE 611 D power module (1-axis) for axis expansion, place between I/R module and 810D <b>References:</b> /PJU/, Configuration Manual Converters
Axis expansion plug-in unit	6FC5412-0FA10-0AA0	For installation in a SIMODRIVE 611 power module (1-axis or 2-axis), <b>References:</b> /PJU/, Configuration Manual Converters
SIMATIC components		See <a href="http://www.siemens.com/automation/simatic">http://www.siemens.com/automation/simatic</a>
Single I/O module	6FC5411-0AA00-0AA0	PLC I/O module with 64 inputs and 32 short-circuit-proof outputs
NCU terminal block <sup>1)</sup>	6FC5211-0AA00-0AA0	Rapid digital and analog NC I/Os on the drive bus of the SINUMERIK 810D
Handheld unit <sup>1)</sup>	6FX2007-1AC..	Handheld unit with handwheel, EMERGENCY STOP button, key-switch, override, enabling buttons, display, free keys, connection via MPI bus and cable distributor

Component	MLFB	Description
Handheld terminal (HT 6) <sup>1)</sup>	6FC5403-0AA10-0AA0	Handheld unit combining the functions of operator panel front and MCP, with <ul style="list-style-type: none"> <li>– Display,</li> <li>– Keyboard, enabling buttons, EMERGENCY STOP and override button</li> <li>– RS 232 C interface for archiving programs and data</li> <li>– Connection via cables and distributors to SINUMERIK 810D/840Di/840D and FM357-2H</li> </ul>
Distributor box <sup>1)</sup>	6FX2006-1BC00	For linking the hand-held unit to the MPI bus. Connection for EMERGENCY STOP circuit, enable keys, handwheel, 24 V DC
Mini Handheld Unit <sup>1)</sup>	6FX2006-1BG00	Small handheld unit for setup and operation on simple machines for job shop or similar applications. Use with 810D, 840C, 840D, and FM-NC possible.

The components marked with <sup>1)</sup> are described in:

**References:** /BH/, Operator Components Manual

1 System Overview

1.2 System configuration

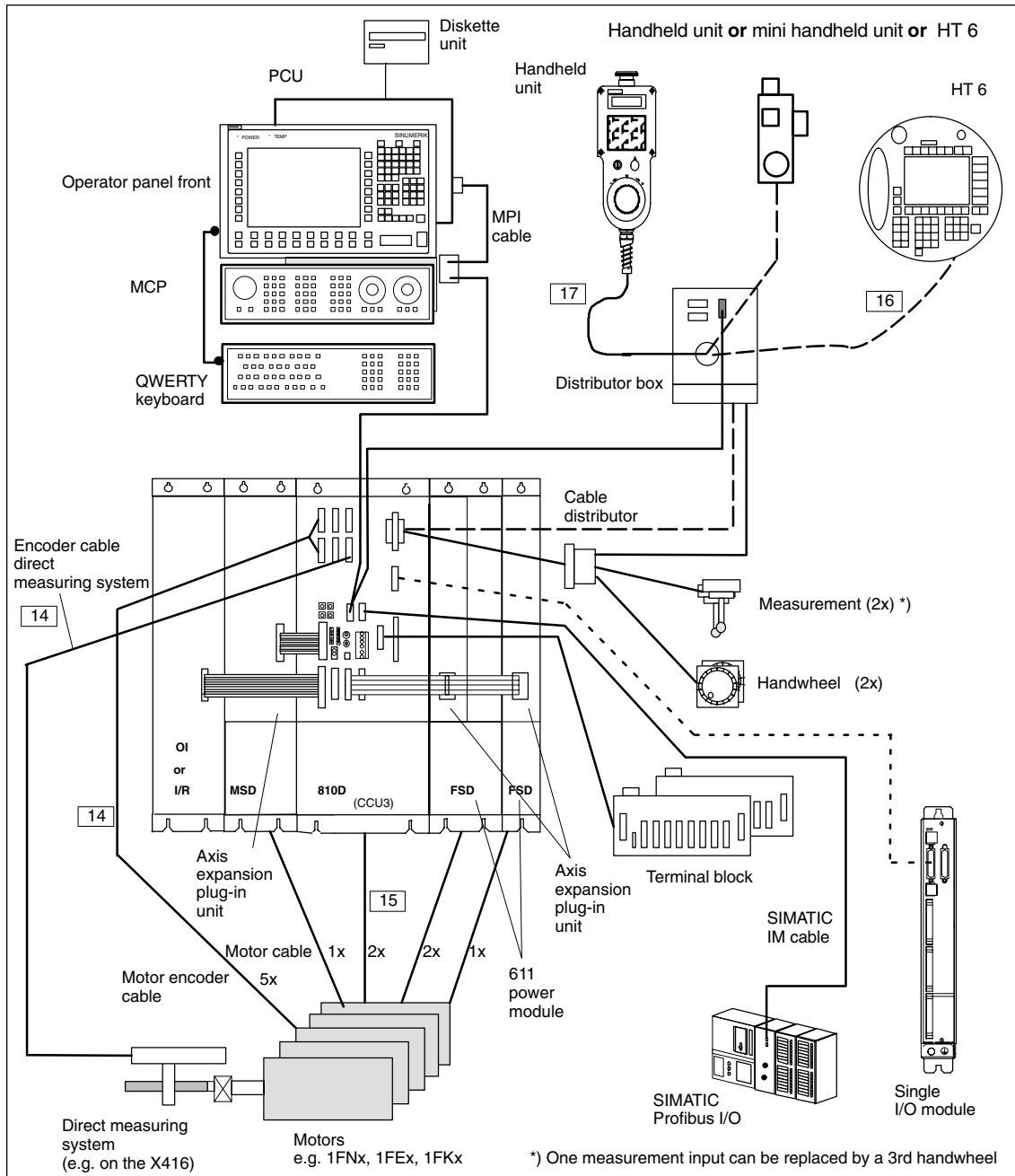

Fig. 1-1 System of the SINUMERIK 810D, for example, the CCU3



1 System Overview

1.2 System configuration

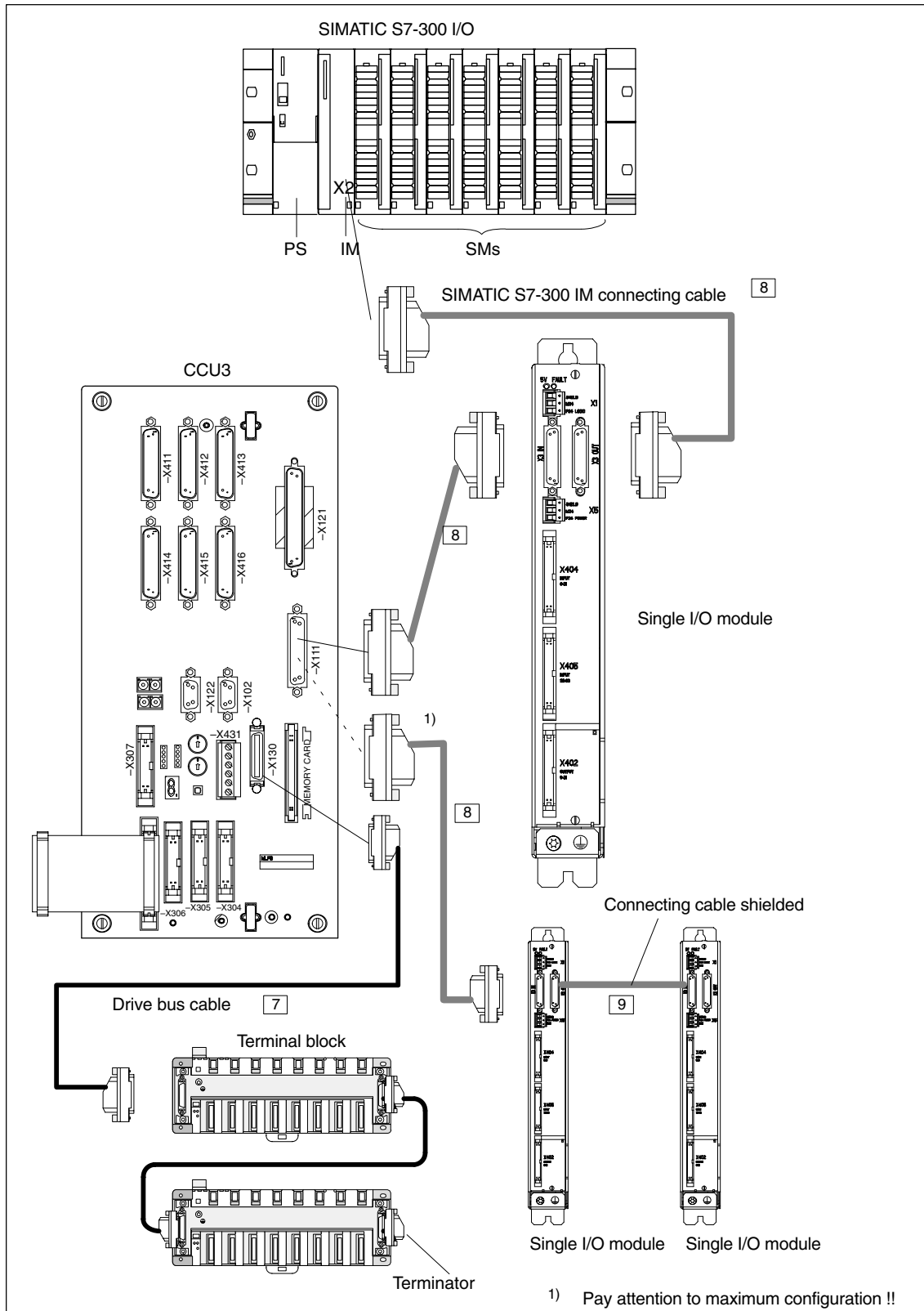

Fig. 1-3 Interface configuration of the SINUMERIK 810D for PLC I/Os and NCU terminal block

## Connecting cables

The following connecting cables are used for the SINUMERIK 810D

Table 1-3 Connecting cables for SINUMERIK 810D

No.	MLFB	Description
1	6FX2002-4EA0-1-1-1-1 <sup>1)</sup>	MPI bus cable from the operator panel front to the MCP and to the CCU
2	6ES7901-0BF00-0AA0	MPI bus cable from the distributor box (HHU) to the CCU
3	6FX2002-4AA21-1-1-1-1 <sup>1)</sup>	Connecting cable from distributor box to cable distributor on the CCU (for the handwheel pulses from the HHU)
4	Included in the scope of supply of the PG740	MPI bus cable to the PG
5	6FX2002-4AA41-1AB0	Probe connection cable to cable distributor, length: 5 m
6	6FX2002-4AA21-1-1-1-1 <sup>1)</sup>	Connecting cable for the electronic handwheel to the cable distributor on the CCU
7	6FX2002-1CB01-1AB0	Drive bus cable (1 m) for connection of the NCU terminal block
8	6ES7368-3-1-1-1-1-1-1 <sup>1)</sup>	Connecting cable for the Step7-300 I/Os (IM361 or single I/O module)
9	6FC5411-0AA80-0AA0	Connecting cable shield for single-tier configuration with several single I/O modules
10	6FC5412-0FA80-0AA0	Cable set for external SIMODRIVE 611 control, for connecting the device bus and drive bus
11	6FX2003-0DA00-0AA0	Terminator for drive bus (only if the drive bus is used)
12	<sup>1)</sup>	Ribbon cable for terminal strip converter
13	<sup>2)</sup>	Motor encoder cable – incremental – absolute
14	6FX2002-2CG00-1AA0 6FX2002-2CH00-1AA0	Cable for connection of direct measuring system to the CCU – incremental – absolute
15	<sup>2)</sup>	Power cables for motor
16	6FX2002-1AA-3-1-1-1-1	Round cable from HT6 to the distributor box
17	<sup>2)</sup>	Round cable from HHU to the distributor box

A number is assigned to each cable.  
You will find these numbers (1 to 17) in the figures above.

1) For length code, see **Reference:** Catalog NC Z

2) see **References:** /PJU/, Configuration Manual Converters

## PCU 50/70, MCP and HHU/HT 6

There are 4 possible variants:

- HHU/HT 6 without PCU 50/70/MCP
- PCU 50/70/20 + MCP                      MPI bus cable with cable no. 1
- PCU 50/70/20                                MPI bus cable with cable no. 2
- MCP    MPI bus cable with cable no. 2

<b>Axis expansion on 810D</b>	<p>On the SINUMERIK 810D, the number of axes can be expanded to six axes, including spindles.</p> <p>There are two possibilities:</p> <p><b>either</b> Connect axis expansion plug-in unit and SIMODRIVE 611 power module at axis expansion interface,</p> <p><b>or</b> Connect SIMODRIVE 611D control plug-in unit with SIMODRIVE 611 power module on drive bus/device bus.</p>
<b>Axis expansion plug-in unit</b>	<p>The axis expansion plug-in units are used whenever no more than six measuring channels are required for the SINUMERIK 810D. This plug-in unit is plugged into a SIMODRIVE 611 power module. The axis expansion plug-in units are designed for 1-axis and 2-axis power modules. The ribbon cables are part of the plug-in unit.</p>
<b>Axis expansion control plug-in unit</b>	<p>If the six measuring channels of the SINUMERIK 810D are insufficient, SIMODRIVE 611 controller plug-ins must be inserted into the SIMODRIVE 611 power modules to connect further measuring systems (connection via drive bus with drive bus terminator). If 611D control modules are used, it may be necessary to connect the NCU terminal block to the free drive bus connector of the 611D control.</p> <p>See Chapter 5, Axis expansion</p>
<b>Power modules</b>	<p>The CCU can control up to 6 axes onboard. For this purpose there is a new expansion plug-in in addition to the existing axis expansion plug-in modules.</p> <p>All power modules of the 611D series can be connected as external power modules for axis expansion.</p>
<b>Combinations</b>	<p>As from SW 6.3, the limitation to six drives applies.</p> <p>Expansion levels 1 to 6 can be achieved by many combinations. To operate the spindle to the internal power module, connect it to the 24A/32A power module (A1).</p>

Table 1-4 Possible combinations for 1 to 6 drives on SINUMERIK 810D

Number of drives	Internal drives 1 x 18/36A (FSD) *or 24/32A (MSD) 2x9/18 / 2 x 6/12A		Drives via axis expansion
	3 power modules	2 power modules	
1	1	1	0
	0	0	1
2	2	2	0
	1	1	1
	0	0	2
3	3	–	0
	2	2	1
	1	1	2
	0	0	3
4	3	–	1
	2	2	2
	1	1	3
5	3	–	2
	2	2	3
6	3	–	3
	2	2	4

CCU 3 with 3 axis CCU box plus  
2 axis power module to right of CCU  
1 axis power module to right of CCU

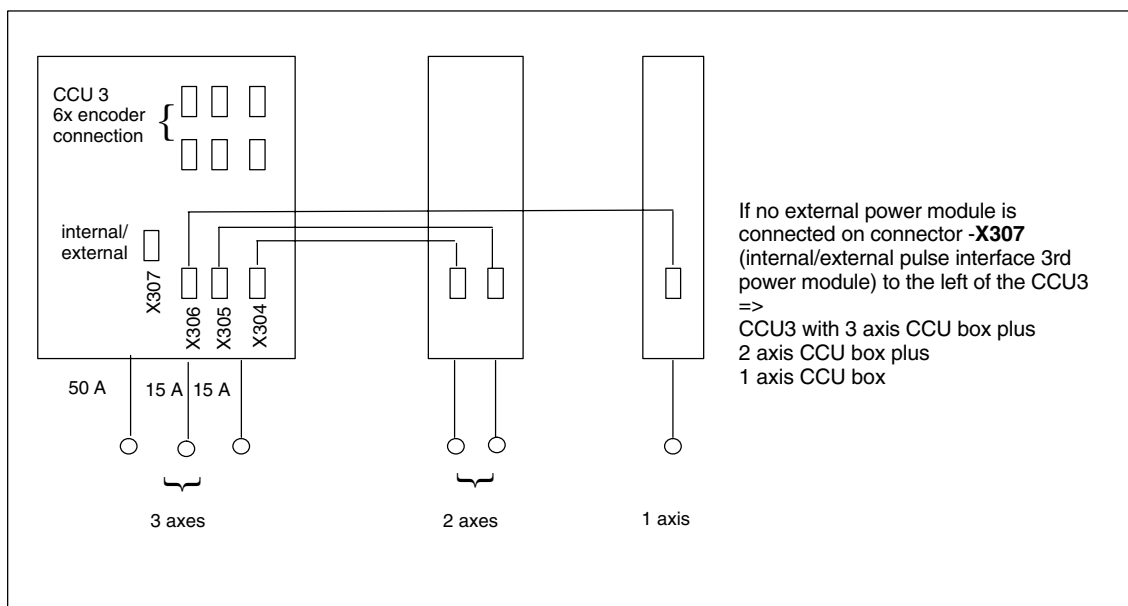

Fig. 1-4 First way of operating 6 axes on CCU3 with internal 3 axis CCU box

## 1 System Overview

### 1.2 System configuration

CCU 3 with 3 axis CCU box or 2 axis CCU box plus  
 2 axis power module to the right of CCU  
 1 axis power module to the right of CCU  
 1 axis power module to the left of CCU

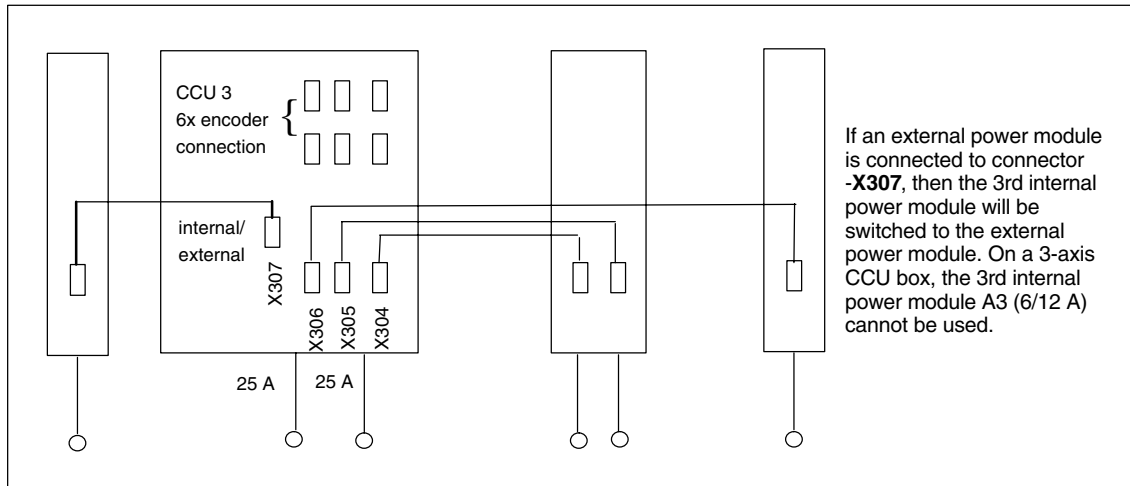

Fig. 1-5 Second way of operating 6 axes on CCU 3 with 2 axis CCU box

### Restrictions

- Power supply:  $\leq 120$  kW.
- The DC link busbar of the 810D is capable of an effective load of 200 A.
- The length of the ribbon cable of the axis expansion plug-in unit left for connecting the SIMODRIVE 611 power module is 300 mm.
- The length of the ribbon cable of the axis expansion plug-in unit right is sufficient for a module width of 150 mm.
- The length of the cable set for the axis expansion with 611D control plug-in unit is:  
 62 mm for the drive bus and 150 mm for the device bus.

## 1.3 Labels

In case of technical queries or service, please quote all data on the rating plate to the local SIEMENS office responsible for your equipment.

One of the following labels is attached to the components and modules:

### PCBs with screen printing

Example: Component number: 570 573.9001.00  
Product version: B (last cross)

SIEMENS	<input checked="" type="checkbox"/>	<input checked="" type="checkbox"/>	C	D	E
570 573.9001.00					

### CCU3.4 module

Example: Component name: CCU3.4  
MLFB: 6FC5410-0AY03-1AA0  
Component number: A5E00377496

CCU3.4	6FC5410-0AY03-1AA0	A5E00377496	A B C
--------	--------------------	-------------	-------

### CCU box

Example: Component name: SINUMERIK 810D  
Power module 2x15A+1x50A  
MLFB: 6FC5447-0AA00-0AA1  
Product version: A (last cross)

SIEMENS					
SINUMERIK 810D					
Power module 2x15A + 1x50A					
6FC5 447-0AA00-0AA1					
Made in Germany					
		<input checked="" type="checkbox"/>	A	<input type="checkbox"/>	B
				<input type="checkbox"/>	C





# Connection Conditions

# 2

## 2.1 Supplementary electrical conditions

### Compliance with the connection conditions

The controller is tested for compliance with the ambient conditions specified below. Fault-free operation is only ensured if:

- These environmental conditions are maintained when storing, transporting and operating the equipment.
- Original components and spare parts are used. This applies in particular to the use of specified cables and plug connectors.
- The equipment has been correctly mounted/installed.



---

### Danger

The equipment may not be commissioned until it has been clearly identified that the machine in which the controller is installed is in full conformance with the specifications in EC Machinery Directive 98/37/EC.

---

### Assistance and support

The connection conditions must be carefully maintained for the complete system. Please contact your local Siemens office or representative for any assistance.

### 2.1.1 Power supply

#### Demands on DC power supplies



#### Warning

- The DC power supply is always referenced to ground and must be generated by a safety transformer.
- Final user interfaces are powered via a DC power supply with protective separation per EN 61800-5-1.
- In the case of supply cables > 10 m, protective elements must be fitted at the device input in order to protect against lightning (surge voltage).
- The DC power supply must be connected to the ground/shield of the NC for EMC and/or functional reasons. For EMC reasons, this connection should only be made at one point. As a rule, the connection is provided as standard in the S7-300 I/Os. If this is not the case in exceptional circumstances, the ground connection should be made to the grounding rail of the NC cabinet; also refer to /EMC/ EMC Configuring Guidelines.

Table 2-1 Requirements of the DC supply

<b>Rated voltage</b>	In accordance with EN 61131-2 <ul style="list-style-type: none"> <li>• Voltage range (average value)</li> <li>• Voltage ripple peak-to-peak</li> <li>• Ramp-up time at power-on</li> </ul>	24 V DC 20.4 V DC to 28.8 V DC 5 % (unfiltered 6-pulse rectification) Any
<b>Non-cyclic overvoltages</b>	<ul style="list-style-type: none"> <li>• Duration</li> <li>• Restoration time</li> <li>• Events per hour</li> </ul>	$\leq 35$ V $\leq 500$ ms $\geq 50$ s $\leq 10$
<b>Transient voltage interruptions</b>	<ul style="list-style-type: none"> <li>• Outage time</li> <li>• Restoration time</li> <li>• Events per hour</li> </ul>	$\leq 3$ ms $\geq 10$ s $\leq 10$

#### Configuration 810D power consumption

The EP and CP points for the power modules only apply in conjunction with the SINUMERIK 810D (axis expansion). The EP and CP points from Catalog NC 60 apply when SIMODRIVE 611D modules with control plug-in units are used.

Table 2-2 EP and CP points for 810D components

Component	Electronics points (EP)	Control points (CP)
810D	2	4.5
EnDat encoder	0	0.3
Power module $\leq 50$ A	0.6	0.5
Power module $> 50$ A $\leq 80$ A	0.75	1.0
Power module $> 80$ A, $\leq 120$ A	1.5	1.5
611D module MSD or FSD	See Catalog NC 60	See Catalog NC 60

Table 2-3 Example of calculation of the supply power for 4 axes/1 spindle for 810D

Module	Electronics points (EP)			Control points (CP)		
	Assessment factor, individual module	Number of modules	Product	Assessment factor, individual module	Number of modules	Product
810D	2	1	2	4.5	1	4.5
EnDat encoder	0	2	0	0.3	2	0.6
LTM 50A	0.6	1	0.6	0.5	1	0.5
LTM 80A	0.75	1	0.75	1	1	1
		Total for products	3.35		Total for products	6.6
	For I/R unit 16 kW		$\leq 7.5$	For I/R unit 16 kW		$\leq 16.50$

### 2.1.2 Safe isolation to EN 61800-5-1

The complete system includes end user interfaces (UIs) and interfaces for servicing, commissioning and maintenance.

#### End user interfaces (UI)

UIs are all the interfaces that are freely accessible to the machine operator without the need for tools or aids. These user interfaces are designed with safe isolation to EN 61800-5-1.

#### Interfaces for servicing, commissioning and maintenance



#### Danger

The interfaces for servicing, commissioning and maintenance purposes are provided **without** safe isolation.

If necessary, these interfaces can be isolated safely using a supplementary adapter (insulation voltage 230 V AC). These adapters are not included in the Siemens scope of delivery. You can buy these parts from your local dealer who will help you to make the proper choice.

Table 2-4 Service interfaces

Component	Interface name	Function
CCU module	X341, X342, X351, X352	DAC socket for analog signals



#### Danger

Safe isolation can only be ensured if the system configuration specified below is strictly adhered to. When mounting additional components (e.g. S7-300 FM, IP) with an end user interface, please make sure that the end user interface has a basic insulation for at least 230 V AC.

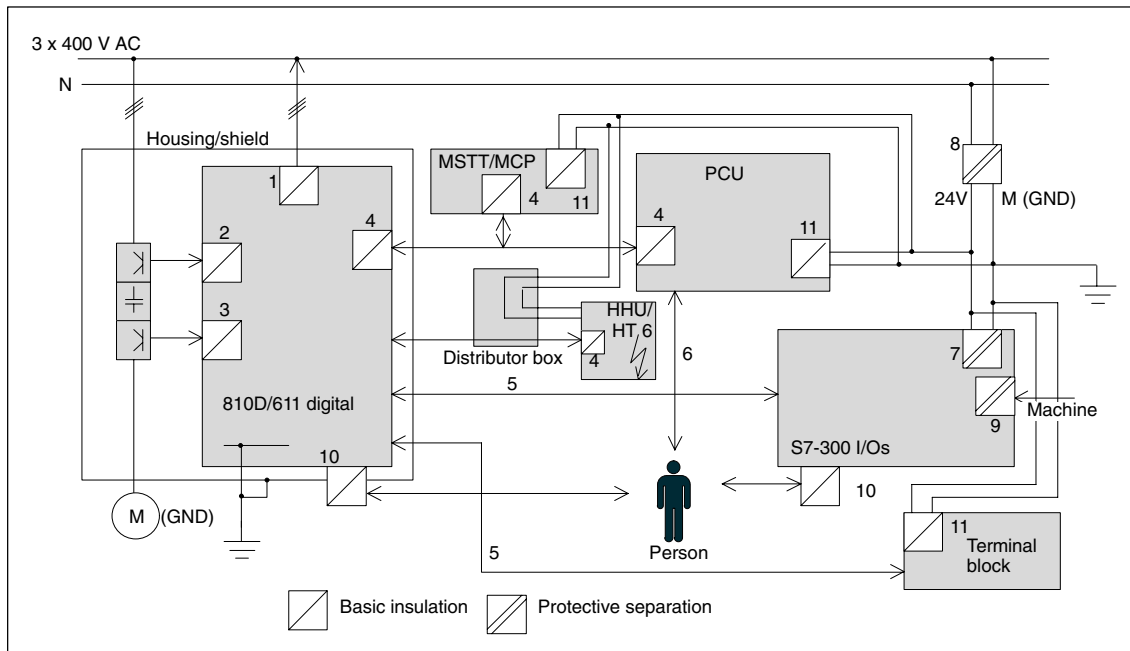

Fig. 2-1 Protective separation as per EN 61800-5-1

Fig. 2-1 shows the potential balance of the 810D/611D/S7-300 system. Legend:

1. Floating power supply of the SIMODRIVE electronics unit with 230 V AC basic insulation.
2. Floating transistor triggers for the three-phase rectifier bridge with 230 V AC basic insulation.
3. Floating transistor triggers for each axis of the three-phase inverter bridge with 230 V AC basic insulation.
4. Floating signal connection from the CCU to the PCU or HHU/HT 6 with 230 V AC basic insulation.
5. Non-floating signal line between CCU and I/O devices.
6. Non-floating end user interface with protective separation for 230 VAC through interfaces 1 to 4 and 7.
7. Protectively separated 5 V DC power supply, fed from a protectively separated 24 V DC supply.
8. 24 V DC power supply unit for external devices and for the machine adaptation control according to applicable standards in the form of a PELV (Protective Extra Low Voltage) circuit featuring safe isolation.
9. Floating interfaces to the machine (not accessible to the end user).
10. Floating signal interfaces directly accessible to the end user (e.g. V.24). For these interfaces, you must always make sure that there is either safe isolation with respect to the line supply voltage or that there are two basic insulation levels, for 230 V AC each.
11. 5 V DC power supply with basic insulation, fed from a safely-isolated 24 V DC supply.

### 2.1.3 Grounding Concept

The SINUMERIK 810D system consists of a number of individual components, each of which must comply with the appropriate EMC and safety standards. The individual system components are:

- CCU box
- Machine control panel MCP
- Keyboard
- Operator panels (operator panel front + PCU/TCU)
- NCU terminal block
- Distributor box and handheld unit
- S7-300 I/O with IM 361 interface module
- Single I/O module

CCU box and SIMODRIVE components are fixed to a metal cabinet plate with screws. Make sure that near the screws a low-impedance contact of the CCU box with the cabinet panel can be made. Insulating varnishes must be removed where possible. The connection must be kept free of corrosion.

The electronics grounds of the modules are interconnected via the unit and control bus and also routed to terminal X151 of the NE module.

The ground and module ground M should be connected at the power supply terminal of the IM 361. Further, for the EFP, "SHIELD" and "M24" must be connected in connector X1.

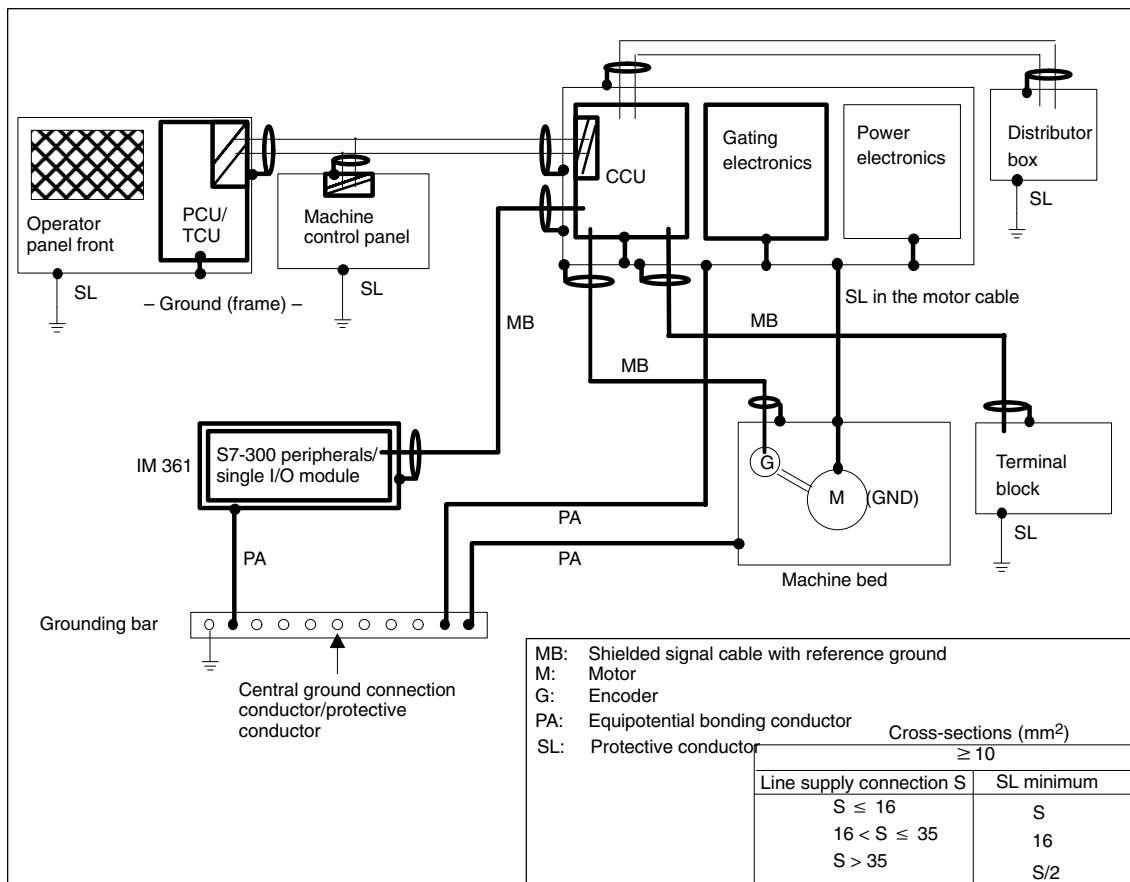

Fig. 2-2 Grounding concept

**References:** /EMV/, EMC Configuring Guidelines

## 2.1.4 RI suppression measures

In addition to the protective grounding of system components, special precautions must be taken to ensure safe, fault-free operation of the system. These measures include shielded signal cables, special equipotential bonding, isolation, and shielding measures.

### Shielded signal cables

To ensure safe, interference-free operation of the installation, it is essential to use the cables specified in the individual diagrams.

For digital signal transmission, the shield must have a conductive connection at both sides of the housing.

#### Exception:

Standard shielded cables grounded on only one side can be used for devices from other manufacturers (printers, programming devices, etc.).

## 2 Connection Conditions

### 2.1 Supplementary electrical conditions

These external devices may not be connected to the control during normal operation. However, if the system cannot be operated without them, then the cable shields must be connected at both ends. Furthermore, the external device must be connected to the control via an equipotential bonding cable.

#### Cable definitions

Definition:

- Signal cables (e.g.)
  - Data cables (MPI, sensor cables, etc.)
  - Binary inputs and outputs
  - Emergency Stop cables
- Load cables (e.g.)
  - Low-voltage supply cables (230 V AC, +24 V DC etc.)
  - Supply cables to contactors (primary and secondary circuit)

#### Rules for routing cables

In order to achieve the best possible noise immunity of the complete system (control, power module, machine), the following EMC measures must be carefully observed:

- Signal cables and load cables must be routed at the greatest possible distance from one another.
- If necessary, signal and load cables may cross one another (if possible, at an angle of 90°), but must never be laid close or parallel to one another.
- Only cables provided by the manufacturer should be used as signal cables from and to the CCU.
- Signal cables may not be routed close to strong external magnetic fields (e.g. motors and transformers).
- Pulse-carrying HC/HV cables must always be laid completely separately from all other cables.
- If signal lines cannot be routed a sufficient distance away from other cables, they must be installed in grounded cable ducts (metal).
- The clearance (surface through which interference can be coupled-in) between the following cables must be kept to a minimum:
  - Signal cable and electrical circuit signal cable (twisted)
  - Signal cable and associated equipotential bonding conductor
  - Equipotential bonding conductor and PE conductor (routed together)



#### Important

For further notes on interference suppression measures and the connection of shielded cables, please refer to

**References:** /EMV/, EMC Configuring Guidelines.

## 2.2 Climatic and mechanical environmental conditions

<b>Test standards</b>	Vibration load:	EN 60068-2-6
	Shock load:	EN 60068-2-27
	Climate:	EN 60068-2-1/EN 60068-2-2/EN 60068-2-14 EN 60068-2-30/EN 60068-2-31/EN 60068-2-32/ EN 60068-2-33/EN 60068-2-34
<b>Requirement standards</b>	Long-term storage:	EN 60721-3-1
	Transport:	EN 60721-3-2
	Stationary operation:	EN 60721-3-3

### 2.2.1 Transport and storage conditions

#### Components in original packaging

The following specifications apply to components in transport packaging:

Table 2-5 Ambient climatic conditions per EN 60721-3-1/-3-2, class 1K3/2K4

	Transportation	Storage	
<b>Ambient temperature range</b>	-40 ... 70 °C	-25 ... 55 °C	
<b>Rate of temperature change</b>	<18 K	<18 K	Within one hour
<b>Relative humidity</b>	10 ... 95 %	10 ... 95 %	
<b>Permissible change in relative air humidity</b>	max 0.1 %	max 0.1 %	Within 1 minute

Table 2-6 Test limits for mechanical environmental conditions

<b>Vibration</b> to EN 60068-2-6	Frequency range	5 ... 9 Hz
	Constant deflection	7.5 mm
	Acceleration amplitude	9 ... 200 Hz: 2g
<b>Shock resistance</b> to EN 60068-2-27	Acceleration	30g
	Duration of nominal shock	6 ms
	Number of nominal shocks	18 shocks
	Shock form	Half-sine

$g \approx 9.81 \text{ m/s}^2$  (acceleration due to gravity)

## 2 Connection Conditions

### 2.2 Climatic and mechanical environmental conditions

#### Shipment of backup batteries

Backup batteries must only be transported in the original packaging. No special approval is needed for transporting backup batteries. The lithium content is approximately 300 mg.

#### Note

The backup battery is classified as a hazardous substance, Class 9, in accordance with the relevant air-freight transportation regulations.



#### Danger

Incorrect handling of backup batteries can lead to a risk of ignition, explosion and combustion. The stipulations of EN 60086-4, in particular regarding avoidance of mechanical or electrical tampering of any kind, must be complied with.

For more information on handling batteries, see section 9.1.

## 2.2.2 Operating conditions

#### Climatic environmental conditions

If the specified values cannot be maintained, then a heat exchanger or air conditioner must be provided.

Table 2-7 Climatic environmental conditions to EN 60721-3-3, Class 3K3

<b>Ambient temperature range</b>	0 ... 55 °C	
<b>Rate of temperature change</b>	max. 0.5 K	Within 1 minute
<b>Relative humidity</b>	5 ... 90 %	
<b>Permissible change in the relative air humidity</b>	Max. 0.1 %	Within 1 minute
<b>Moisture condensation and ice formation</b>	not permissible	
<b>Dripping water, spray, splash water, water jets</b>	not permissible	
<b>Air inlet</b>	Without caustic gases, dusts and oils	
<b>Atmospheric pressure</b>	1060 to 920 kPa	0 to 1000 meters above mean sea level
<b>Derating</b>	At altitudes of 1000 to 4000 m above SL, the upper limit temperature is to be lowered by 3.5 °C/500 m.	

## Mechanical environmental conditions

Table 2-8 Test limits for mechanical environmental conditions

<b>Vibration</b> to EN 60068-2-6	Frequency range	10 ... 58 Hz
	Constant deflection	0.075 mm
	Acceleration amplitude	58 ... 200 Hz: 1g
<b>Shock resistance</b> to EN 60068-2-27	Acceleration	5g
	Duration of nominal shock	30 ms
	Number of nominal shocks	18 shocks
	Shock form	Half-sine

$g \approx 9.81 \text{ m/s}^2$  (acceleration due to gravity)

## Gases that can adversely affect the function

Degree of severity 3C2 as per EN 60721-3-3

## Dust that can adversely affect the function

When working in areas where gases, dust and oils may be hazardous to functionality, the controller must be operated in a control cabinet with a heat exchanger or with suitable supply air.

Maximum permissible dust contents in the air circulating in the cabinet:

- Suspended solids 0.2 mg/m<sup>3</sup>
- Deposits 1.5 mg/m<sup>2</sup>/h

### Note

The dust precipitate must be removed at appropriate time intervals.

## Radio interference

Relevant standards: EN 61000-6-3 and -4

Table 2-9 Limit values for radio interference suppression in industrial environments

	Limit class as per EN 61000-6-4
Conducted radio interference	A (Industry)
Radio interference	A (Industry)

### Note

The user must consider interference radiation for the complete system. Particular attention should be paid to cabling. Please contact your sales representative for assistance and support.

If compliance with limit value class B (residential areas) is required, please contact your local Siemens office or representative.

## 2.3 Technical data of the individual components

Table 2-10 General technical data

<b>Security</b>	
Protection class	I (protective conductor) as per EN 61800-5-1
Degree of protection per EN 60529	IP20 or IPXXB
Approvals	CE / cULus
Degree of contamination	2
Cooling	Open circuit ventilation
<b>Mechanical environmental conditions</b>	
Transport (in transport packaging)	2M2 according to EN 60721-3-2
Storage	1M2 according to EN 60721-3-1

Table 2-11 Mechanical data

<b>Component</b>	<b>Dimensions width x height x depth in mm</b>	<b>Weight in kg (approx.)</b>
CCU box	150 x 490 x 268	
3 axes	Internal heat dissipation	11.3
2 axes	Internal and external heat dissipation	11.4
CCU	150 x 307 x 220	1.6
Single I/O module	50 x 374 x 153	1.7
NCU terminal block	257 x 100 x 40	0.5

Table 2-12 Electrical data

<b>Components</b>	<b>Rated voltage</b>	<b>Max. power loss at rated voltage</b>	<b>Max. current</b>
CCU box	Power supply via SIMODRIVE 611 power supply (I/R or OI module). Power supply via other devices is not permitted.	Approx. 350 W internal/external/total 69/ 111 /180 W	Refer to table 2-3
3 axes			
2 axes			
CCU		Approx. 25 W	Refer to table 2-3
Single I/O module	24 V for logic supply, 24 V for load supply,		0.3 A 12 A
NCU terminal block	24 V for logic supply, load supply directly on the DMP module		0.5 A

## 2.4 MPI/OPI network rules

### Application

The following devices can be interconnected across the MPI bus:

- CCU
- PCU
- HT 6
- HHU
- MSTT/MCP

The MPI interconnecting cables are available in different lengths.

### Network installations

When installing a network, observe the following basic rules:

1. The MPI connection can be routed from one user to the next by plugging the MPI connector of the outgoing cable onto the MPI connector of the incoming cable.
2. The bus line must be terminated at **both ends**. To do this, enable the terminating resistor in the MPI connector of the first and last node and disable the remaining terminating resistors (see figure 2-3).

---

#### Note

- Only two inserted terminating resistors are permitted.
- In the case of the HHU/HT 6, bus terminating resistors are **permanently** integrated in the device.

- 
3. **At least 1** terminal must be supplied with **5 V**. This is done by connecting an MPI connector with the terminating resistor connected to an energized device.

---

#### Notice

The CCU must be located at the end of the connection.

- 
4. Stubs (feeder cable from bus segment to node) should be as short as possible.

---

#### Note

Unused stubs must be removed.

- 
5. Every MPI node must **first** be connected and then activated. When disconnecting an MPI node, **first** deactivate the connection and then remove the connector.
  6. A maximum of two of the HHU and HT 6 components can be connected for each bus segment.

## 2 Connection Conditions

### 2.4 MPI/OPI network rules

Another possibility is two identical components, provided they have different node addresses.

For setting the addresses (also see corresponding component section):

- HHU: Via DIP switch or display (see “Handheld unit” section),
- For HT 6, by adapting the address before commissioning (refer to Operating Components “Handheld Terminal HT 6”).

**No** bus terminating resistors may be inserted at the distributor boxes of an HHU or HT 6 (refer to the note on item 2.)

If required, more than one HHU/HT 6 can be connected to a bus segment using intermediate repeaters.

7. The following cable lengths for MPI or OPI for standard use without repeater may not be exceeded:

MPI (187.5 kbaud): Max. total cable length is 1000 m

OPI (1.5 Mbaud): Max. total cable length is 200 m.

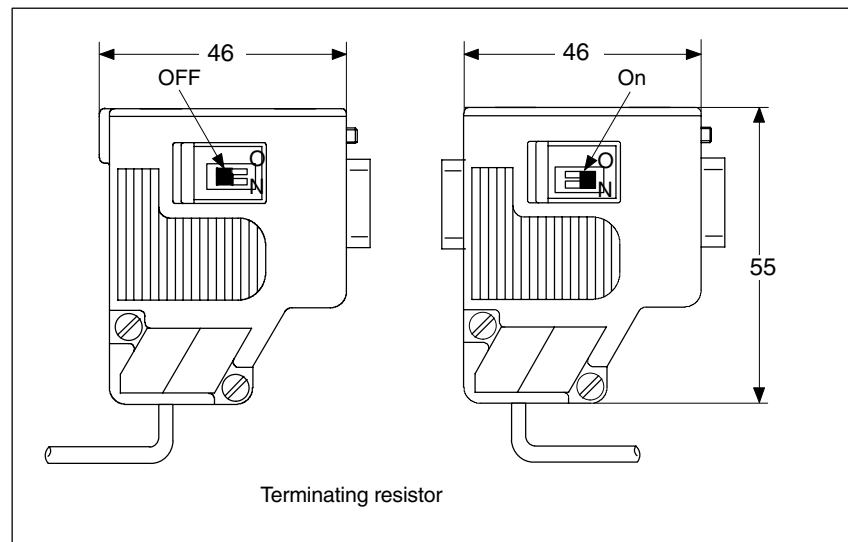

Fig. 2-3 MPI connector

**Reference:** Catalog IK PI – Industrial Communication for Automation and Drives



# 3

## Design and Installation of the 810D

### 3.1 Structure of the SINUMERIK 810D

The SINUMERIK 810D consists of two components:

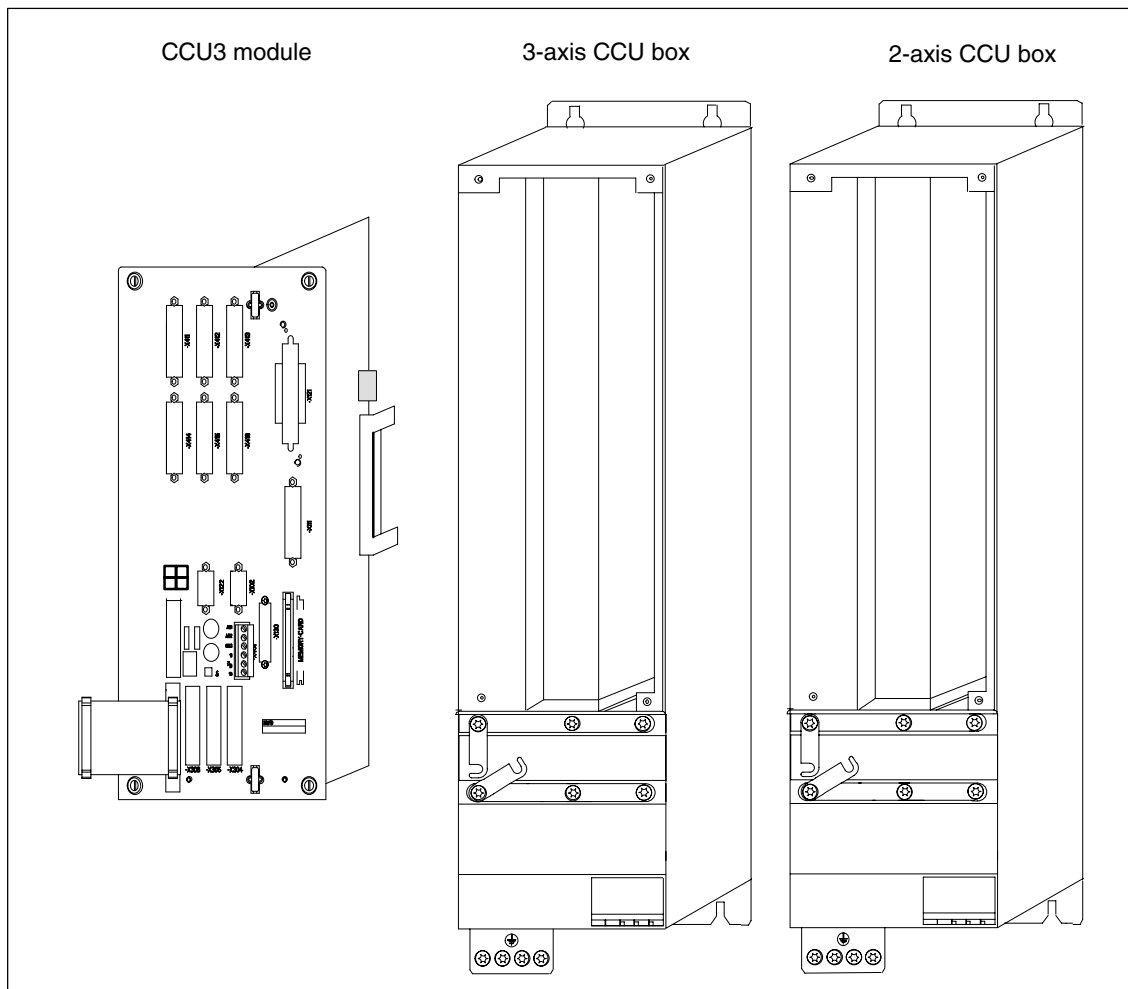

Fig. 3-1 Components of the SINUMERIK 810D

1. CCU module (Compact Control Unit)
2. 3-axis CCU box (sheet-metal housing with 3 integrated power modules for fitting the CCU module) with internal heat dissipation or
3. 2-axis CCU box with external and internal heat dissipation (sheet-metal housing with 2 integrated power modules for fitting the CCU module).  
As-delivered state: internal heat dissipation.  
Alteration: Unscrew mounting bracket with screwdriver (Torx for M6) and plug in the 4 ground springs (see Installation Guide).

**Open equipment** These modules are open equipment. This means they may only be installed in housings, cabinets, or in electrical equipment rooms that can only be entered or accessed with a key or tool. Housings, cabinets, or electrical equipment rooms may only be accessed by trained or authorized personnel. An external fire protection casing is required.

## 3.2 Assembly of the SINUMERIK 810D

**Preparing for installation** You require the following tool to assemble the SINUMERIK 810D:

- Screwdriver for slot-head screws sizes 0 and 1
- Screwdriver for Torx screws M4 and M5

**Position in the overall assembly** The CCU box must be installed to the right of the SIMODRIVE power supply module. It is possible to mount a further power module to the left of the box.

**Installation of the CCU box** The CCU box is fitted to the right of the power supply. 4 M5 screws are recommended for fixing.

1. Remove the plastic cover over the DC link bars by loosening it with a flat screwdriver in the gap on the top and then folding it forward and down.
2. With two M4 Torx screws, connect the DC link bars of the power supply unit and CCU box and possibly the next module also. Ensure that all the DC link connecting screws are securely fastened.
3. Place the cover into the matching cut-outs with the plastic lugs facing downward and close the DC link by folding the cover backward until the topside latch clicks.

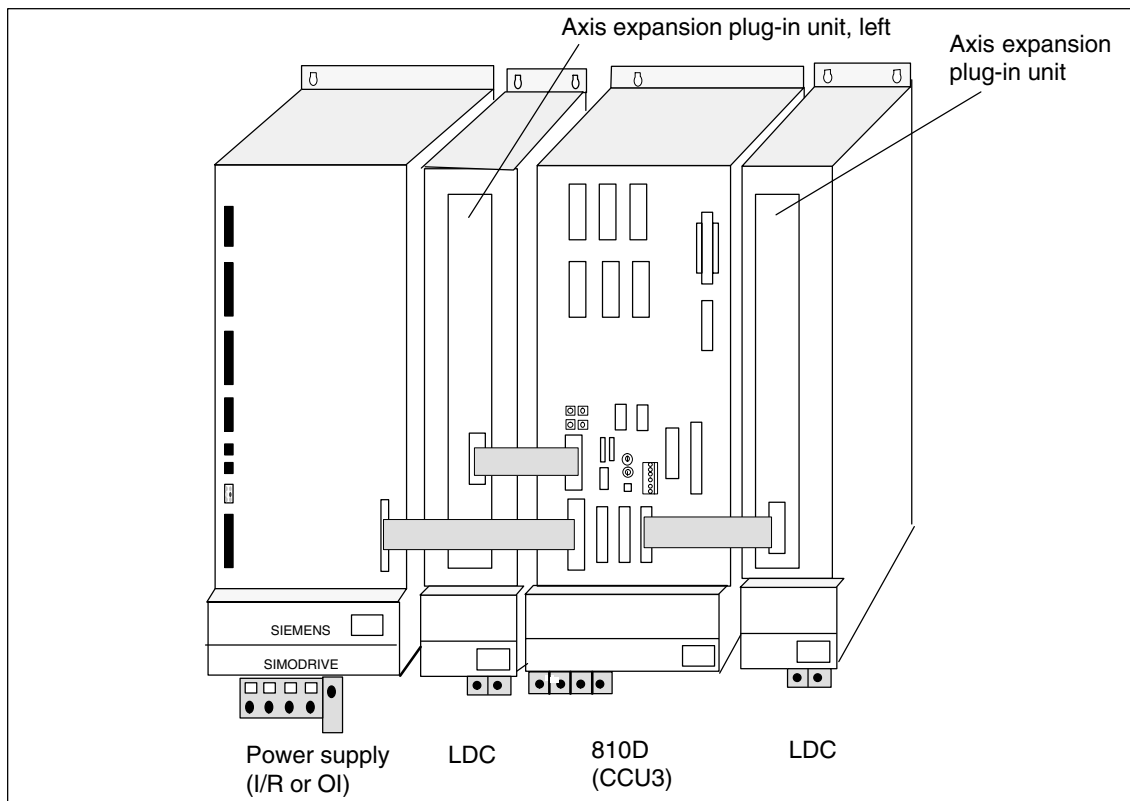

Fig. 3-2 Overall assembly SINUMERIK 810D with SIMODRIVE 611 power module

### Installation of the CCU

Sequence:

1. Connect the battery on the CCU module
2. Insert and fix the CCU module into the guide rails of the CCU box

To be able to ensure compliance with the EMC conditions and resistance to vibrations, it is necessary to tighten the slot-head screws (1) (see figure 3-3).

3 Design and Installation of the 810D  
3.2 Assembly of the SINUMERIK 810D

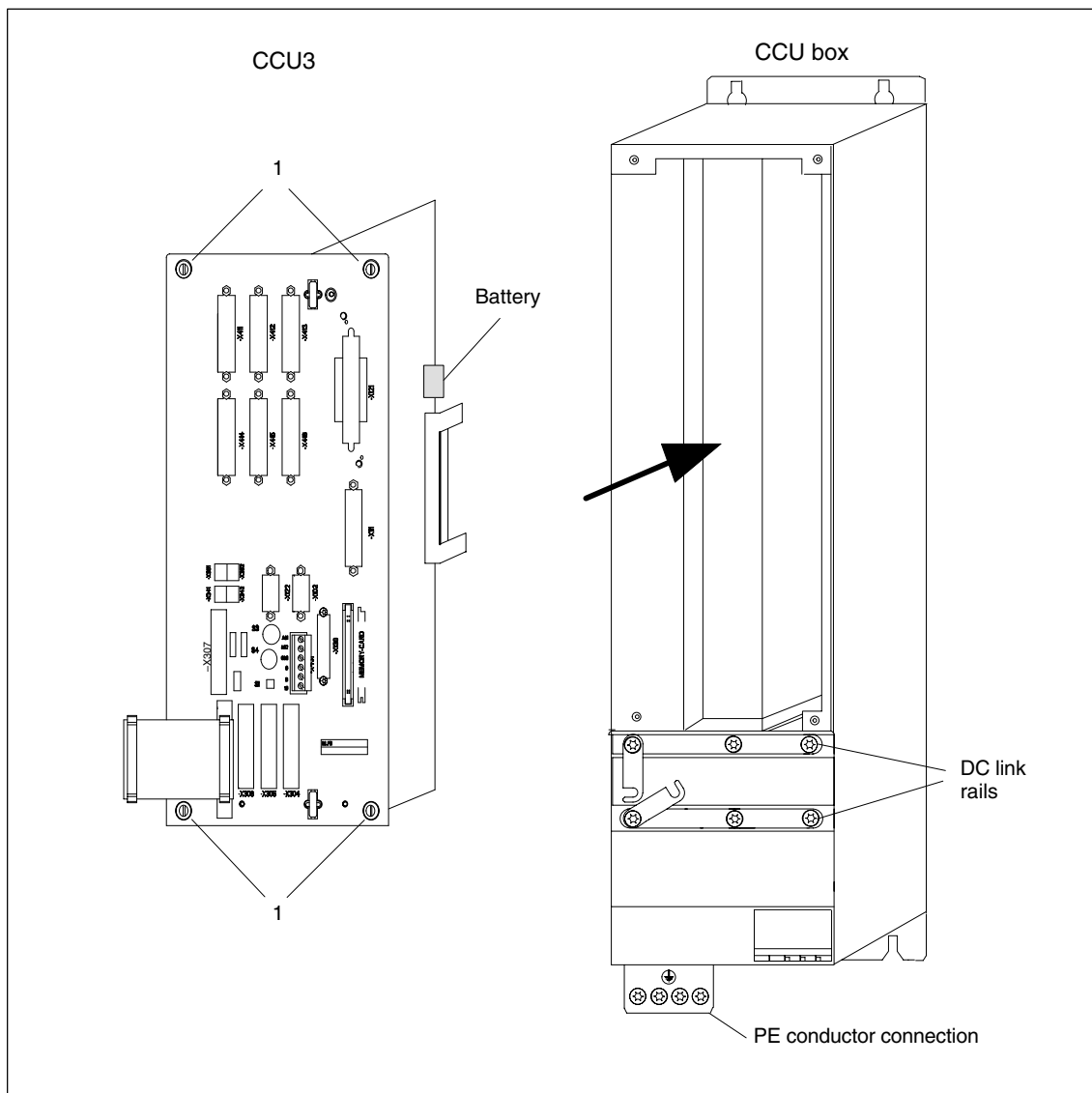

Fig. 3-3 Assembly of the SINUMERIK 810D

**Installation instructions**

Pay attention to the following when installing the SINUMERIK 810D:

1. Cooling clearance top and bottom, approx. 100 mm
2. The shields of the motor cables must be connected after mounting the shield sheet, see section 2.1.3.
3. The equipotential bonding conductor must be connected for each motor.
4. Additional mounting depth is required for mounting the connector.
5. The tightening torque of the screws must be complied with.
6. The screws of the DC link busbars must all be tightened.

### Mounting the shielding plate

The metal sheet is mounted on the 3-axis CCU box with the 3 screws on the underside (2-axis CCU box, see figure Mounting the shielding plate). The shielding plate is supplied in the box. The tube clip for connecting the shield is contained in the scope of supply of the ready-assembled SIEMENS motor cable.

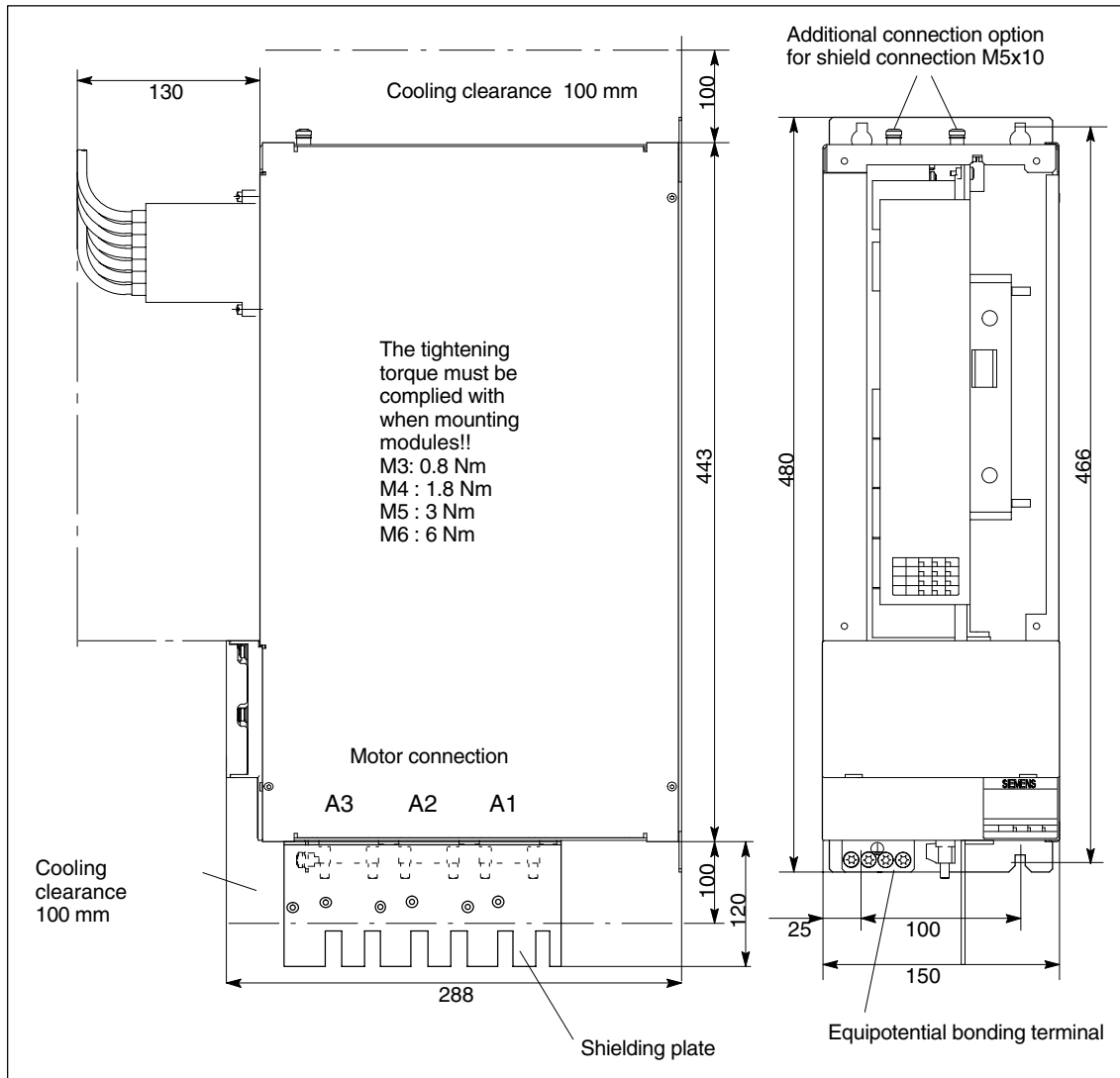

Fig. 3-4 Dimension drawing of the 3-axis CCU box

3 Design and Installation of the 810D  
3.2 Assembly of the SINUMERIK 810D

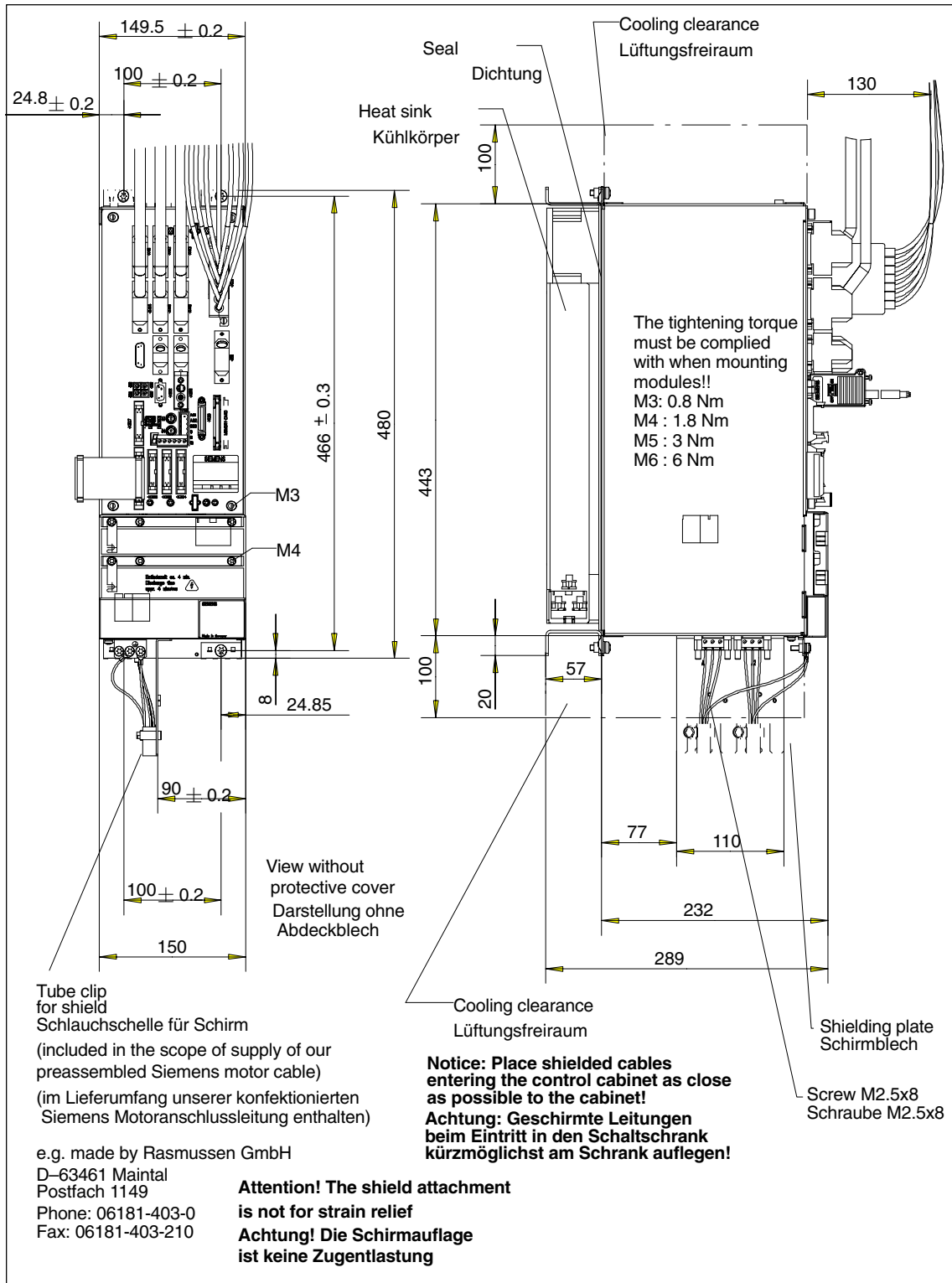

Fig. 3-5 Dimension drawing of the 2-axis CCU box

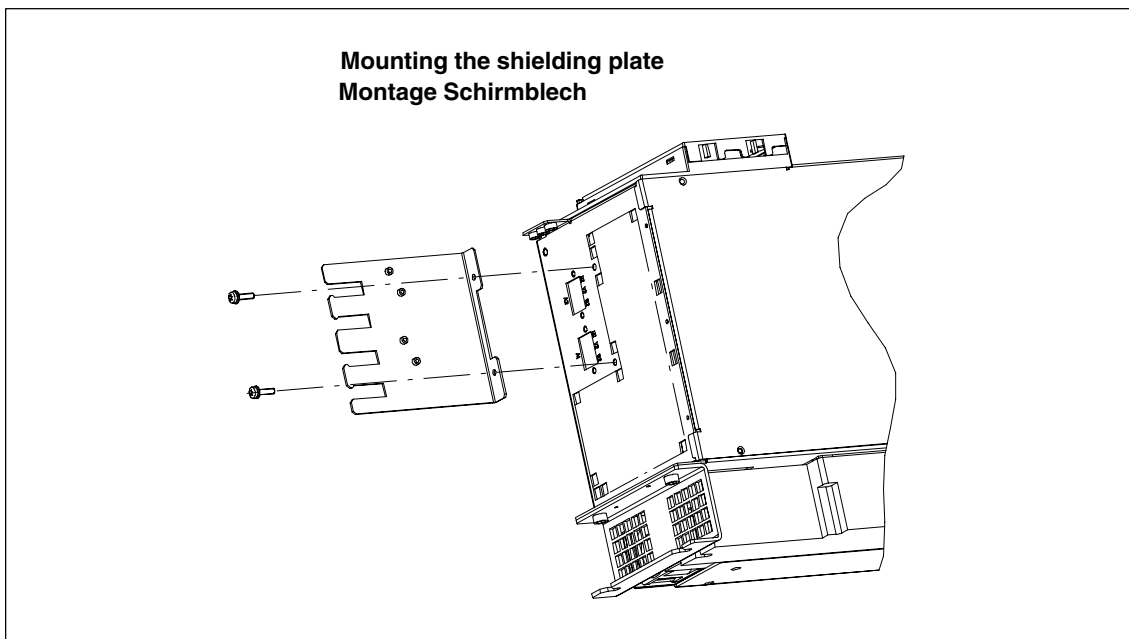

Fig. 3-6 2-axis CCU box: Mounting the shielding plate

### 3.2.1 Alteration for external heat dissipation, 2-axis CCU box

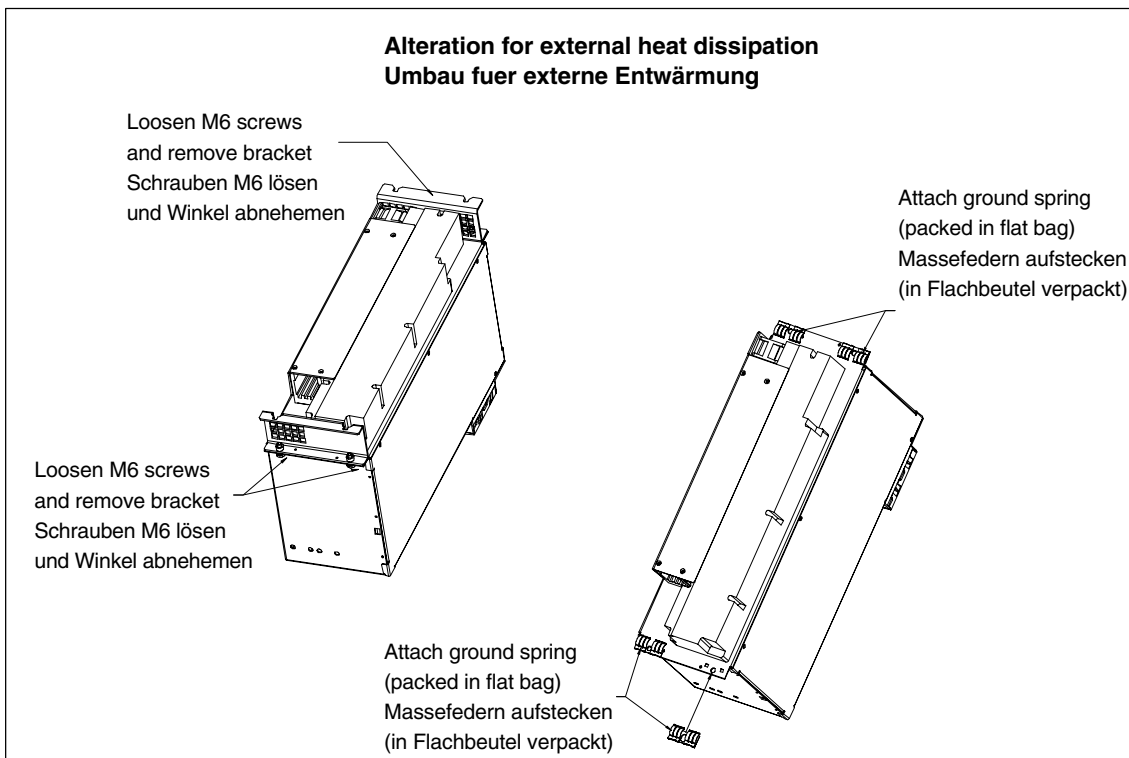

Fig. 3-7 2-axis CCU box: Alteration for external heat dissipation

3 Design and Installation of the 810D  
3.2 Assembly of the SINUMERIK 810D

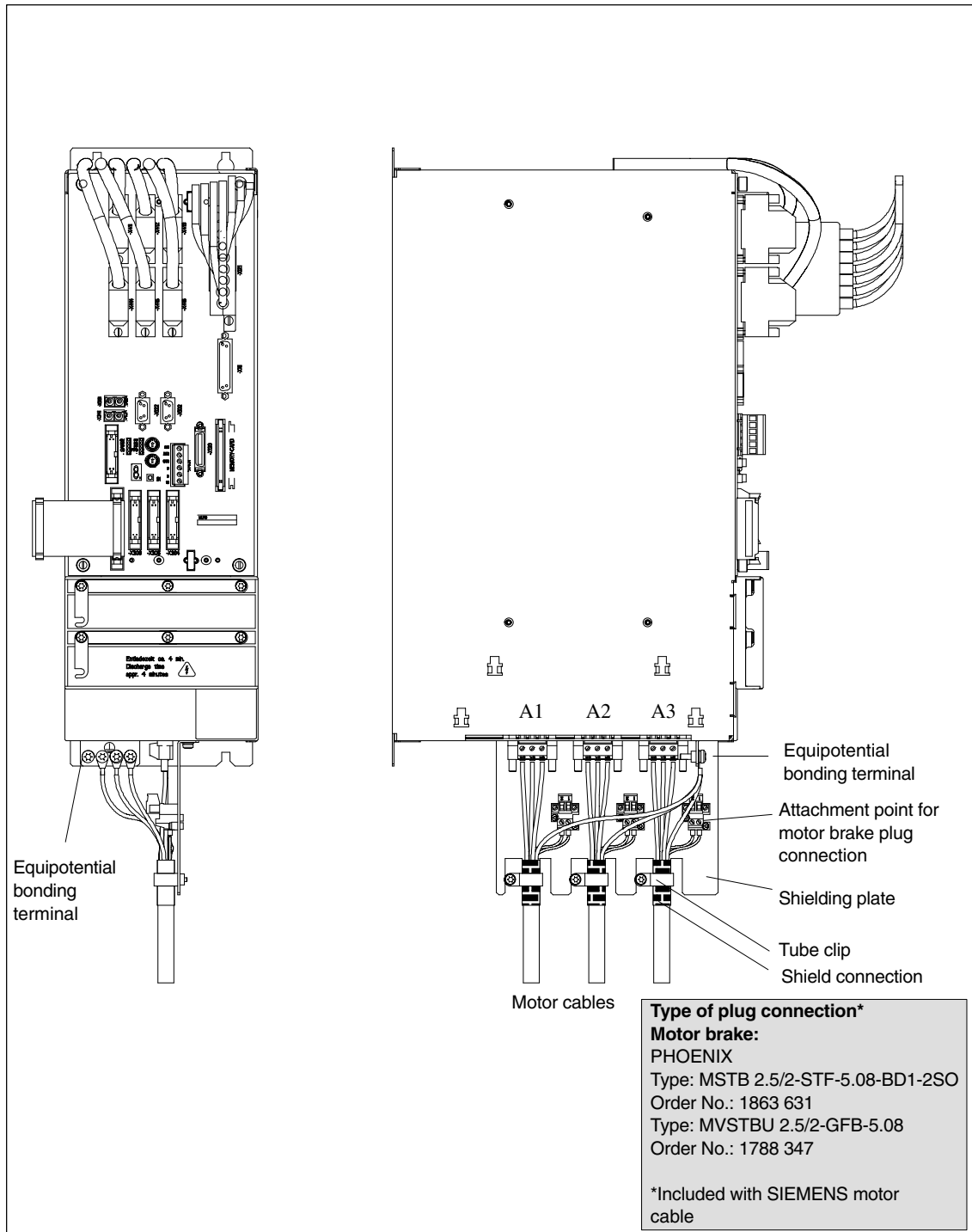

Fig. 3-8 Terminal for motor and encoder cables (3-axis CCU box)

### 3.3 Power supply

Power supplies are available as a stabilized infeed/regenerative feedback module (I/R module) and as an open-loop control infeed module (OI). They provide the necessary operating voltages and the necessary power for the system in different power ranges.

The I/R modules can feed excess DC link energy (e.g. in braking operation) back into the network. OI modules dissipate the braking energy in a pulsed resistor.

The power supply module is the first module on the left in the sequence of modules.

Line filters must be used to comply with the EMC rules of the CE standard.

#### Terminals 72, 73, 74

“Ready” message from NC and drive.

Terminals 72 and 73 are closed in the fault-free condition.

#### Permissible modules

- Power supply module: OI 5 kW, OI 10 kW, OI 28 kW,  
I/R 16 kW, I/R 36 kW, I/R 55 kW; I/R 80 kW;  
I/R 120 kW
- SIMODRIVE filter modules or commutation reactors

---

#### Note

The power supply and filter modules/reactors are described in the Configuration Manual Converters SIMODRIVE 611 digital (settings, technical data, circuit suggestions).

---



---

#### Danger

A hazardous voltage will be present for a further 5 minutes after the system has been shut down.

---





# 4

## Description of the SINUMERIK 810D

### 4.1 Components of the SINUMERIK 810D

#### 4.1.1 Overview

The structure of the SINUMERIK 810D is compatible with the SIMODRIVE 611 digital module series. The SINUMERIK 810D is operated with the SIMODRIVE 611 power supply modules (OI or I/R modules).

**3-axis CCU box** Basic housing with fans for fitting the CCU module with three integrated power modules 1x18A/36A (FSD) or 24A/32A (MSD) and 2x6A/12A (FSD) and slot for CCU module (internal heat dissipation).

**2-axis CCU box** Basic housing with fan for fitting the CCU module with two integrated power modules 9A/18A (FSD) and slot for CCU module (internal and external heat dissipation).

**CCU module** The CCU module (Compact Control Unit) of the SINUMERIK 810D performs all CNC, PLC, communication, and closed-loop control tasks. The CCU has 6 measuring channels. Each drive requires one measuring channel for the motor measuring system. If measuring channels of the basic unit are left over, they can be assigned freely as direct measuring channels, e.g. for the spindle.

Additional measuring channels are obtained by using a 611D closed-loop control module (1- or 2-axis control module) with or without a direct measuring system (DMS). The 611D closed-loop control module performs closed-loop control of the drive. The unused measuring channels can be freely assigned.

## 4 Description of the SINUMERIK 810D

### 4.1 Components of the SINUMERIK 810D

**PCMCIA card (NC card)** The NC card with the system software **must remain inserted during operation.**

---

#### Note

For a software upgrade, the export software can be copied onto the internal flash EPROM.

---

In addition to the software upgrade, the PCMCIA card can also be used for series commissioning; see

**References:** /IAC/, Commissioning Manual 810D

#### Closed-loop control

The closed-loop control complies with the 611D standard control with the following restrictions as compared with SINUMERIK 840D:

- 5-axis transformation
- Safety integrated
- Analog axis
- Hydraulic drives
- Drive-independent stop/retract
- 3D clearance control

### Drive functions of SIMODRIVE 611D

The following table shows drive functions and values, which differ from module to module.

Table 4-1 Function differences for SIMODRIVE 611 digital

Function	Standard 2		Performance 1		Performance 2 (2-axis)	CCU3/CCU3.4 (6-axis/810D)
	1-axis	2-axis (FSD only)	1-axis	2-axis (FSD only)		
Disabling of pulses via NCK (safety)	No		No		Yes	Yes
Encoder limit frequency, direct measuring system	200 kHz		300 kHz		350 kHz	300 kHz
Motor data sets, expansion from 2 to 4 for MSD	No		No		Yes	Yes
Speed actual-value filter for analog 611U	No		No		Yes	Yes
i <sup>2</sup> t power module limitation	No		No		Yes	Yes
Minimum current controller cycle	125 μs		62,5 μs	125 μs	62,5 μs 31,25 μs <sup>1)</sup>	Standard 156.5 μs (option 125 μs)
Minimum speed controller cycle	125 μs	500 μs	62,5 μs	125 μs	62,5 μs 31,25 μs <sup>1)</sup>	Standard 312 μs (option 125 μs)
Minimum position controller cycles	2 ms	4 ms	0.5 ms	1 ms	0.5 ms	1.5 ms to 3 axes; as from 3 axes 2.5 ms (standard 2.5 ms)
Speed controller rise time	1.4 ms	4 ms	0.8 ms	1.4 ms	0.8 ms	approx. 1.4 ms
Rated frequency of closed speed control loop	550 Hz	160 Hz	1 kHz	550 Hz	1 kHz	approx. 550 Hz for 125 μs; approx. 300 Hz for 312 μs
Max. motor speed (4-pole)	18000 rpm		36000 rpm	18000 rpm	42000 rpm	18000 rpm
Max. electrical fundamental frequency for motor	666 Hz		1333 Hz	666 Hz	1400 Hz	666 Hz for 125 μs Current controller cycle
Smooth running	0.2 μm	1.5 μm	0.1 μm	0.2 μm	0.1 μm	approx. 1.5 μm
Pulse multiplication factor	128		2048		2048	128
1)	As from drive software version 6.4.2 for FSD 1-axis					

## 4.2 Interfaces

### 4.2.1 Overview

#### Brief description

The modules have the following interfaces:

- Optical encoder (up to six measuring systems for unconditioned voltage signal encoder, 1 V<sub>pp</sub>, incremental/absolute with EnDat interface )
- Three axis expansion connections for up to three ext. power modules
- Drive bus for axis expansion with 611D modules and connection from NCU terminal block
- PCMCIA slot
- Backup battery on board
- Connection for cable distributor (handwheel, probe)
- MPI interface for operator panel front, programming device, ...
- PLC I/O bus (P/K bus)
- PROFIBUS DP
- External pulse enable common for all drives
- Start disable terminals AS1, AS2
- BERO input for ext. zero mark (spindle)
- Displays for errors, status, power up
- Operating elements for commissioning, general reset, reset
- Four measuring sockets for diagnostics
- Device bus terminal

Table 4-2 Overview of hardware interfaces

	<b>Interface</b>	<b>CCU</b>
Closed-loop control	Pulse interfaces (6 axes)	4 **)
	Optical encoder	6
	DAC test sockets	Yes
	BERO input	Yes
	Terminals (AS1, AS2, 663, 9,19)	Yes
NCK/PLC	PBus/KBus	Yes
	MPI interface	Yes
	Drive bus (611D interface)	Yes
	Connection for diff. handwheel	Yes
	Two measuring pulse inputs	Yes
	PCMCIA interface	Yes
Miscellaneous	PROFIBUS DP	Yes
	Electronic PS (backplane)	Yes

\*\*) incl. 2 spindles

4 Description of the SINUMERIK 810D

4.2 Interfaces

4.2.2 Description of the interfaces, operating and display elements

Overview

Location of the interfaces, operating and display elements

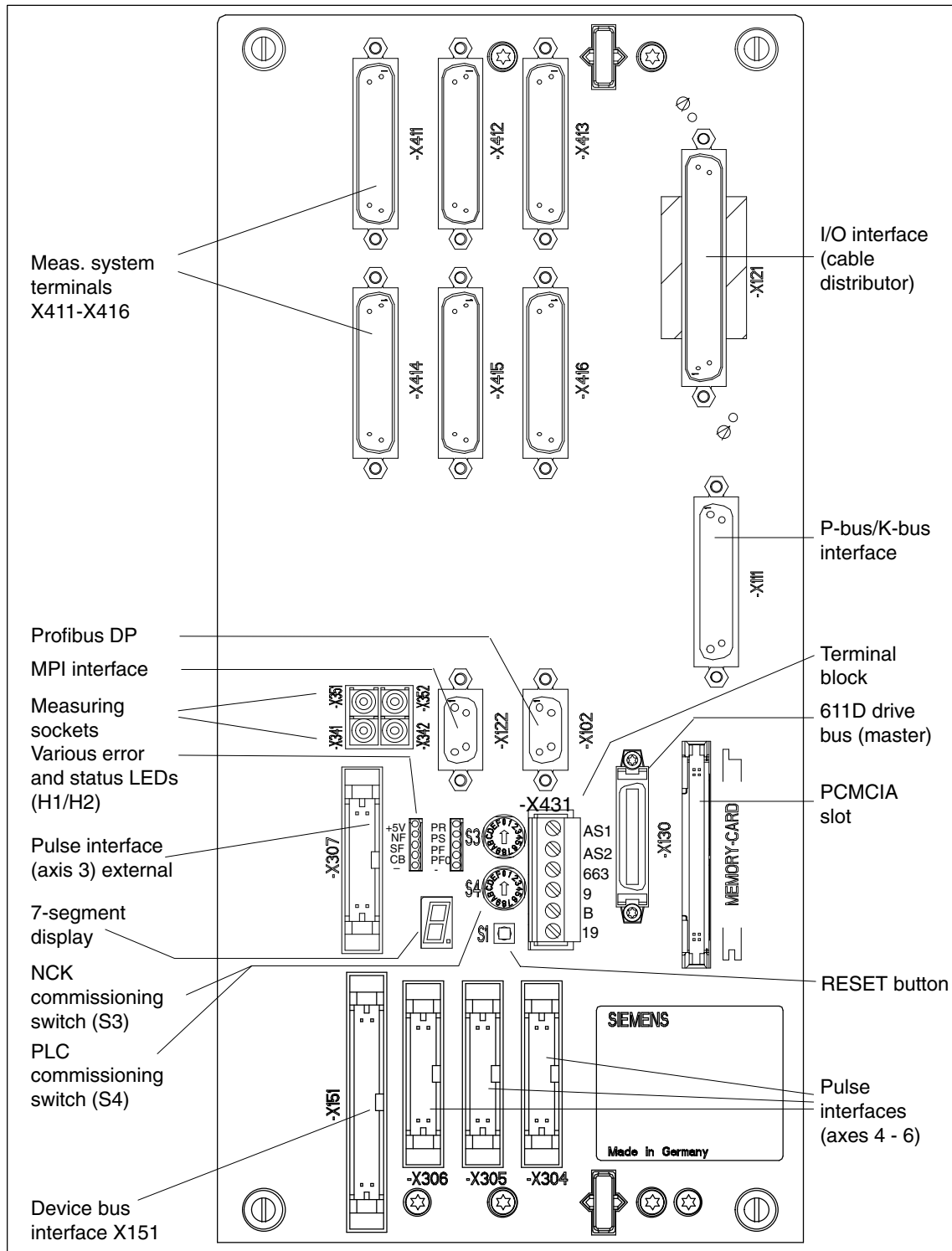

Fig. 4-1 SINUMERIK 810D with CCU 3, position of the interfaces, operating and display elements

**Signal names**

The signal names in the following tables mean:

P5	Logic power supply 5 V
GND	Logic reference potential ground
P5EXT	Logic power supply 5 V isolated
M5EXT	Logic reference potential for P5EXT

**Signal types**

The signal types in the following tables mean:

B	Bidirectional
I	Input
O	Output
V	Voltage
OC	Open Collector

**X102****PROFIBUS DP interface**

Connector name:	<b>X102</b>
Connector type:	9-pole D-Sub socket connector
Maximum cable length:	200 m
Special features:	isolation (safe isolation) 12 MBaud

Table 4-3 X102 pin assignments

X102					
Pin	Name	Type	Pin	Name	Type
1	Not assigned		6	P5EXT	VO
2	M24EXT *)	VO	7	P24EXT *)	VO
3	RS_L2DP	B	8	XRS_L2DP	B
4	ORTSAS_L2DP	O	9	IRTSPG_L2DP	I
5	M5EXT	VO			

\*) 24 V only present if 24 V is fed to X121 (cable distributor).

**Signal names**

RS, XRS	RS485 data
ORTSAS	Request to Send programmable controller
IRTSPG	Request to Send programming device

**X111****P-bus/K-bus****Connection of S7-300 I/O and single I/O module**

Connector name:	<b>X111</b>
Connector type:	25-pole D-Sub socket connector
Maximum cable length:	10 m
Special features:	non-isolated (no safe isolation)

## 4 Description of the SINUMERIK 810D

## 4.2 Interfaces

Table 4-4 Assignment of the P-bus/K-bus terminal X111

X111					
Pin	Name	Type	Pin	Name	Type
1	RS_ALARM_N	I	14	RS_ALARM	I
2	IM_ADR0_N	O	15	IM_ADR0	O
3	IM_ADR1_N	O	16	IM_ADR1	O
4	IM_ADR2_N	O	17	IM_ADR2	O
5	M (GND)	VO	18	K<2>	O
6	KBUS_B_N	B	19	KBUS_B	B
7	RS_OD_N	O	20	RS_OD	O
8	RS_DIDO_N	B	21	RS_DIDO	B
9	RS_CLK_N	O	22	RS_CLK	O
10	RS_COM_N	O	23	RS_COM	O
11	RS_LAT_N	O	24	RS_LAT	O
12	RS_READY_N	O	25	RS_READY	I
13	Not assigned	–			

**Signal names**

RS_ALARM, RS_ALARM_N	
IM_ADRi, IM_ADRi_N	P-bus line number
KBUS_B, KBUS_B_N	
RS_OD, RS_OD_N	
RS_DIDO, RS_DIDO_N	P-bus data
RS_CLK, RS_CLK_N	P-bus cycle
RS_COM, RS_COM_N	P-bus command
RS_LAT, RS_LAT_N	
RS_READY, RS_READY_N	P-bus ready signal

**X121****I/O interface (cable distributor for handwheel and probe)**

Connector name:	<b>X121</b>
Connector type:	37-pole D-Sub male connector
Maximum cable length:	25 m for all functions
Special features:	Handwheels non-isolated

Table 4-5 Pin assignment of the cable distributor interface X121

X121					
Pin	Name	Type	Pin	Name	Type
1/2	M24_EXT	VI	18	MPG0 *B	I
3	OUTPUT_1	O	19	Not assigned	–
4	OUTPUT_0	O	20/21	P24_EXT	VI
5	INPUT_3	I	22	OUTPUT_3	O
6	INPUT_2	I	23	OUTPUT_2	O
7	INPUT_1	I	24-27	MEXT	VI
8	INPUT_0	I	28	MEPUS 1	I
9	MEPUS 0	I	29	MEPUC 1	I
10	MEPUC 0	I	30	MPG1 A	I
11	MPG1 *A	I	31/32	M (GND)	VO
12/13	PENC1	VO	33	MPG1 B	I
14	MPG1 *B	I	34	MPG0 A	I
15	MPG0 *A	I	35/36	M (GND)	VO
16/17	PENC2	VO	37	MPG0 B	I

The terminals with a gray background are not assigned.

#### Signal names

PENC1	P5 power handwheel 1
PENC2	P5 power handwheel 2
MPGi_B	Meas. pulse encoder (handwheel encoder) track B (i={1..0})
MPGi_*B	Meas. pulse encoder (handwheel encoder) track B inverted (i={1..0})
MPGi_A	Meas. pulse encoder (handwheel encoder) track A (i={1..0})
MPGi_*A	Meas. pulse encoder (handwheel encoder) track A inverted (i={1..0})
MEPUCi	Meas. pulse
MEPUSi	Meas. pulse

## X122

### MPI interface (187.5 kBaud)

Connector name:	<b>X122</b>
Connector type:	9-pole D-Sub socket connector
Maximum cable length:	200 m

Table 4-6 X122 pin assignments

X122					
Pin	Name	Type	Pin	Name	Type
1	Not assigned	–	6	P5EXT	VO
2	M24EXT	VO	7	P24EXT	VO
3	RS	B	8	XRS	B
4	ORTSAS	O	9	IRTSPG	I
5	M5EXT	VO			

#### Signal names

Analogous to X102 (table 4-3)

## 4 Description of the SINUMERIK 810D

### 4.2 Interfaces

#### X130

#### SIMODRIVE 611D-Drive bus interface and I/O extension

Connector name: **X130**  
 Connector type: 36-pole Micro Ribbon  
 Maximum cable length: 10 m  
 Special features: non-isolated (no safe isolation)

#### X151

#### Device bus interface (power supply)

Connector name: **X151**  
 Connector type: 34-pole ribbon cable connector, male

#### X304, X305, X306

#### Connection for axis expansion plug-in unit

Connector name: **X304, X305, X306**  
 Connector type: 20-pole ribbon cable connector, male

#### X307

#### Pulse interface for axis 3

Connector name: **X307**  
 Connector type: 20-pole ribbon cable connector, male

#### X341, X342, X351, X352

#### Measuring sockets for output of 3 analog signals. The measuring values that are output are assigned in the software.

Connector name: **X341, X342, X351, X352**  
 Connector type: Measuring socket 2 mm

Table 4-7 Assignment of the measuring sockets X341 to X352

Measuring socket	Position on the CCU	Meaning	Section
X351	⊗ ⊙ ⊙ ⊙	DAC 1	0– 5V
X352	⊙ ⊗ ⊙ ⊙	DAC 2	0– 5V
X341	⊙ ⊙ ⊗ ⊙	DAC 3	0 – 5V
X342	⊙ ⊙ ⊙ ⊗	Ground for all DACs	

#### X411-X416

#### 6 x measuring system connection for indirect and direct position sensing

Connector name: **X411-X416**  
 Connector type: 25-pole, D-Sub male connector  
 Signals with a gray background are not required for a direct measuring system.

Table 4-8 Assignment of the measuring system terminal X411-X416

X411-X416					
Pin	Name	Type	Pin	Name	Type
1	PENC1/2	VO	14	PENC1/2	VO
2	M (GND)	V	15	ENCDAT <sub>i</sub>	B
3	AP <sub>i</sub>	I	16	M (GND)	V
4	AN <sub>i</sub>	I	17	RP <sub>i</sub>	I
5	M (GND)	V	18	RN <sub>i</sub>	I
6	BP <sub>i</sub>	I	19	CP <sub>i</sub>	I
7	BN <sub>i</sub>	I	20	CN <sub>i</sub>	I
8	M (GND)	V	21	DP <sub>i</sub>	I
9	Not assigned	–	22	DN <sub>i</sub>	I
10	ENCCLK	O	23	XENCDAT <sub>i</sub>	B
11	Not assigned	–	24	M (GND)	V
12	XENCCLK	O	25	THMOTCOM	I
13	THMOT <sub>i</sub>	I			

Signals with a gray background are not assigned when connecting direct measuring systems.

### Signal names

<Signal name><sub>i</sub> means signal of the measuring system *i* with *i* = 1, ..., 6

PENC1/2	Encoder power supply (PENC1: X411-X413, PENC2: X414-X416)		
AP <sub>i</sub>	Incremental signal A	BP <sub>i</sub>	Incremental signal B
AN <sub>i</sub>	Incremental signal $\bar{A}$	BN <sub>i</sub>	Incremental signal $\bar{B}$
ENCCLK	BMI clock signal	RP <sub>i</sub>	Incremental signal R
XENCCLK	BMI clock signal	RN <sub>i</sub>	Incremental signal $\bar{R}$
THMOT <sub>i</sub>	Motor temperature	CP <sub>i</sub>	Incremental signal C
ENCDAT <sub>i</sub>	BMI data signal	CN <sub>i</sub>	Incremental signal $\bar{C}$
XENCDAT <sub>i</sub>	BMI data signal		
DP <sub>i</sub>	Incremental signal D		
DN <sub>i</sub>	Incremental signal $\bar{D}$ (not for direct meas. system)		
XB MIDAT	BMI data signal		
THMOTCOM	Motor temperature		

### Note

The encoder power supply is not stabilized; that means: no remote/sense operation. This limits the encoder cable length.

- EQN 1325:  $\leq 18$  m
- ERN 1387:  $\leq 25$  m
- Non-Siemens encoder with power consumption  $\leq 300$  mA:  $\leq 18$  m

## 4 Description of the SINUMERIK 810D

### 4.2 Interfaces

#### X431

#### Terminal block for connection of starting lockout, pulse release (all drives) and external zero mark (BERO)

Connector name: **X431**  
 Connector type: 6-pole Combicon terminal (Phoenix connector), for 1.5 mm<sup>2</sup> conductor cross-section

Table 4-9 Terminal signals drive X431

Terminal	Signal	Front panel labeling	Function	Type
1	EN-	19	Reference ground for enable potential	V
2	BERO	B	Input for external zero mark (BERO)	I
3	EN+	9	Enable potential + 24 V, reference terminal is terminal 19	V
4	T663	T663	Pulse enable for all drives (FSD and MSD)	I
5	AS2	AS2	Relay starting lockout (feedback terminal 663)	
6	AS1	AS1	Relay starting lockout (feedback terminal 663)	

#### Signal names

AS1 Feedback drive enable (NC)  
 AS2 Feedback drive enable (NC)  
 T663 Control SH relay  
 BERO BERO input  
 EN+ Enable voltage (+24 V)  
 EN- Enable voltage (24 V reference)

#### Note

The “starting lockout” relay is operated with terminal 663. If opened, the control pulses are blocked and the motors are switched torque-free.

## Operating and display elements

Fig. 4-1 shows the position of the operating and display elements on the front panel.

Table 4-10 Operating and display elements on the CCU module

Description	Type	Meaning
RESET (S1)	Button	Triggering a hardware reset to reset the control and drive followed by a complete restart.
S3	Rotary switch	NCK commissioning switch Position 0: Normal operation Position 1: Clear and reset NCK Position 2: Software update NCK of memory card Position 3...7: not used
S4	Rotary switch	PLC mode switch Position 0: PLC-RUN Position 1: PLC-RUN-P Position 2: PLC-STOP Position 3: MRES
LEDs (left row)	green LED	<b>+5V:</b> lit when the supply voltage is within the tolerance range.
	red LED	<b>NF:</b> lit if the NCK or PLC watchdog has responded
	red LED	<b>SF:</b> lit in the event of drive error. No longer lit following system power up in the fault-free condition.
	yellow LED	<b>CB:</b> lit when data transmission is in progress via the MPI interface.
	yellow LED	<b>P24:</b> lit on failure of the 24V power supply
LEDs (right row)	green LED	<b>PR:</b> PLC-RUN state
	red LED	<b>PS:</b> PLC-STOP state
	red LED	<b>PF:</b> lit on PLC error
	yellow LED	<b>PFO:</b> PLC-FORCE state
	yellow LED	<b>RST:</b> lit briefly on reset.
H3	7 segment	Software-assisted output of test and diagnostics messages

## DAC measuring sockets

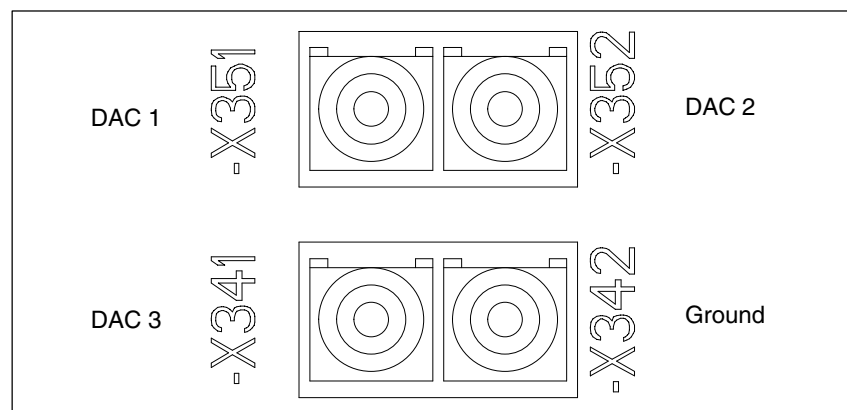

Fig. 4-2 DAC measuring sockets on CCU modules

### 4.2.3 Cable distributor

#### Cable distributor (I/O interface) X121

The cable distributor splits the X121 interface of the CCU into

- two connections of differential handwheel,
- two connections of meas. pulse input,

in max. seven single cables.

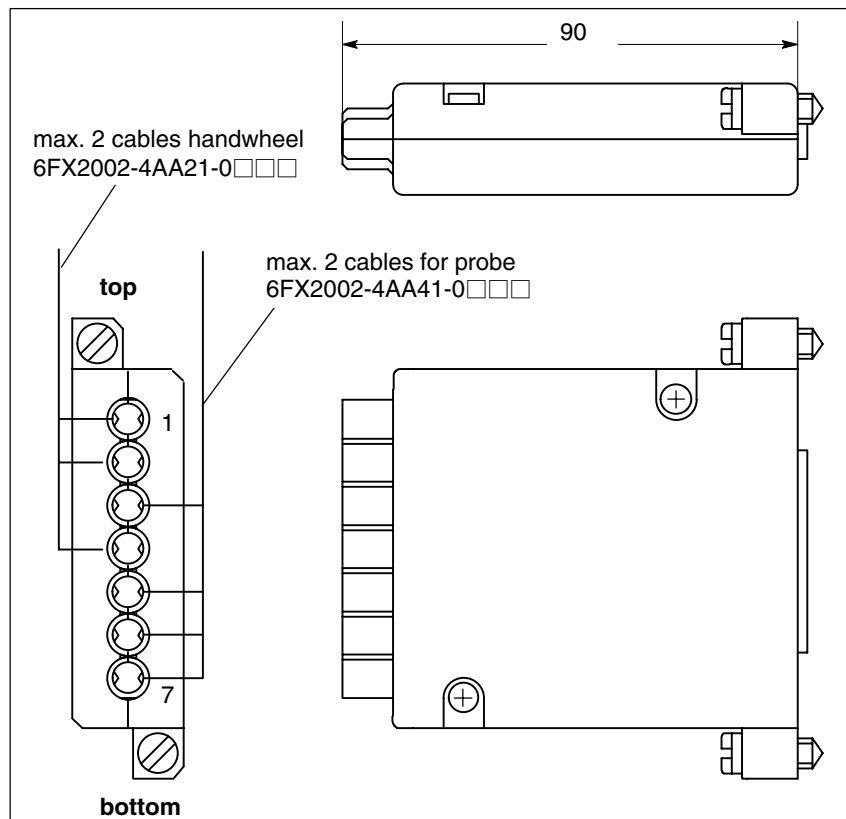

Fig. 4-3 Cable distributor

The cable distributor (37-pole) consists of connector housing (SINUMERIK version) for a 37-pole D-Sub connector with an enlarged interior. The rear contains seven cable inputs where the cables must be attached as shown in table 4-12.

Plug the cables into connectors X1 to X10 in the opened cable distributors and route the cable into the cable entry. Make sure that the shield jackets that became free have a large conductive connection to the metallic contact areas as shown in figure 4-4. Locate the upper terminal bar in such a way that its “teeth” are facing the “teeth” of the lower terminal bar and then secure the upper housing section.

This will reliably press the cable shields between the contact areas of the contact springs and contact them. Fixing to the front panel of the CCU routes the shield potential via the contact springs of the cable distributor.

The DIP-FIX switches inside the cable distributor 6FX 2006-1BA01 must be set as follows:

Table 4-11 Setting the DIP-FIX switches (S1 to S6) in the cable distributor

Switches	S1	S2	S3	S4	S5	S6
Open	x	x	x	x		
Closed					x	x

### Location of interfaces

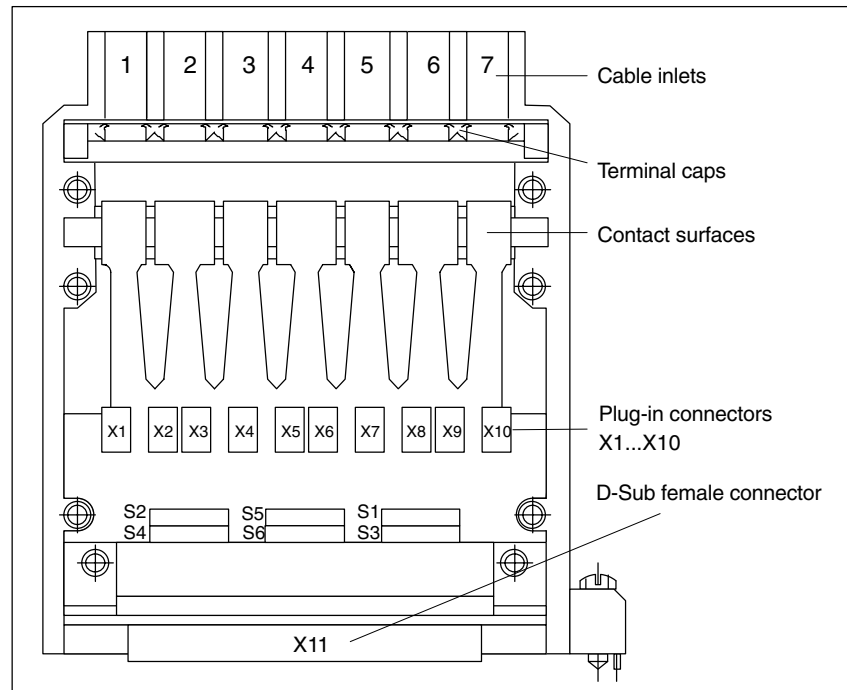

Fig. 4-4 Position of the interfaces of the cable distributor

### Connector X1-X10

Table 4-12 Connector assignments

Connector No.	Cable routing	Peripherals
X1	1 (top)	1st handwheel
X2		
X3	2	2nd handwheel
X4		
X5	3	2nd measuring probe
X6	4	Reserved
X7		
X8	5	Reserved
X9	6	Reserved
X10	7 (bottom)	1st measuring probe

4 Description of the SINUMERIK 810D

4.2 Interfaces

**Pin assignment** Connector designation: **X1...X10**  
Connector type: DU-BOX plug connectors

Table 4-13 Cable distributor pin assignment

Pin no. 37-pole connector	Signal name	DU BOX connector no./pin	Cable routing	Cable Order No. 6FX2002-4AA	Core color	I/Os	Terminal
9 10	– MEPUS 0 – MEPUC 0	X10/2 X10/1 X10/4 X10/3	7	41-0□□□	rd or bn bk shield	1st probe 1st probe	Signal +24V Reference signal
1 20 2 21		X9/2 X9/1 X9/4 X9/3	6	41-0□□□		Reserved	
3 22 4 23		X8/2 X8/1 X8/4 X8/3	5	41-0□□□		Reserved	
5 24 6 25 7 26 8 27		X7/2 X7/1 X7/4 X7/3 X6/2 X6/1 X6/4 X6/3	4	21-0□□□		Reserved	
28 29	– MEPUS 1 – MEPUC 1	X5/2 X5/1 X5/4 X5/3	3	41-0□□□	rd or bn bk shield	2nd probe 2nd probe	Signal +24V Reference signal
11 30 12 31 13 32 14 33	MPG1 $\bar{A}$ MPG1 A MPG1 5V MPG1 0V MPG1 5V MPG1 0V MPG1 $\bar{B}$ MPG1 B	X4/2 X4/1 X4/4 X4/3 X3/2 X3/1 X3/4 X3/3	2	21-0□□□	rd or bn bk gn ye vt bu shield	2nd handwheel 6FC9320-5DB	$\bar{A}$ A 5 V 0 V 5 V 0 V $\bar{B}$ B
15 34 16 35 17 36 18 37	MPG0 $\bar{A}$ MPG0 A MPG0 5V MPG0 0V MPG0 5V MPG0 0V MPG0 $\bar{B}$ MPG0 B	X2/2 X2/1 X2/4 X2/3 X1/2 X1/1 X1/4 X1/3	1	21-0□□□	rd or bn bk gn ye vt bu shield	1st handwheel 6FC9320-5DB	$\bar{A}$ A 5 V 0 V 5 V 0 V $\bar{B}$ B

**Signal names**

MPG0/1 5V	Supply voltage handwheel 0/1, 5 V <sup>1)</sup>
MPG0/1 0V	Supply voltage handwheel 0/1, 0 V
MPG0/1 A/ $\bar{A}$	Differential handwheel input 0/1 A/ $\bar{A}$
MPG0/1 B/ $\bar{B}$	Differential handwheel input 0/1 B/ $\bar{B}$
MEPUS 0/1	Meas. pulse signal 0/1
MEPUC 0/1	Meas. pulse common (reference ground) 0/1

1) total of max. 1 A, i.e. max. 500 mA per handwheel

## 4.3 Measuring system

### 4.3.1 Assignment of measuring systems and motor connection

#### Motor measuring system and motor connection

A certain motor connection is permanently assigned to each measuring system

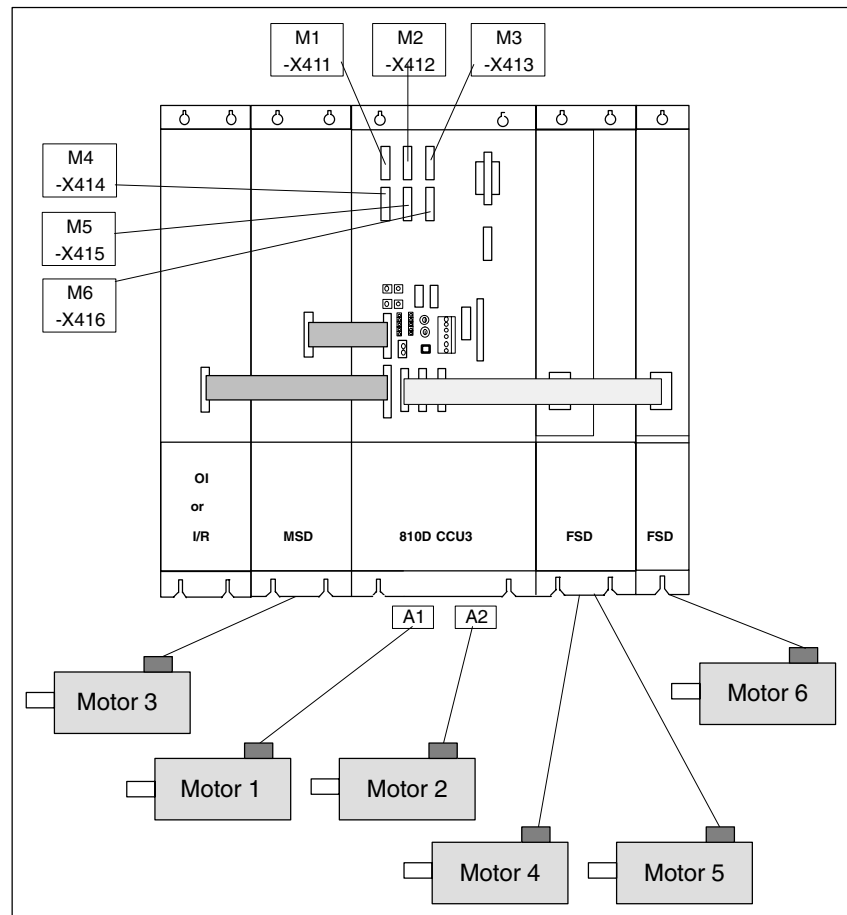

Fig. 4-5 Assignment of measuring system to motor connection

Table 4-14 Assignment of measuring system to motor connection or axis expansion

Connection of measuring system	Motor connection	Connection of axis expansion
X411	A1 internal	–
X412	A2 internal	–
X413 alternatively	A3 internal A3 external	– X307
X414	–	X304
X415	–	X305
X416	–	X306

### 4.3.2 Encoder systems that can be evaluated

#### Incremental measuring systems

Incremental systems with two 90-degree offset sinusoidal voltages signals A, B and a reference mark R.

E.g. ERN 1387 (motor measuring system)

Transfer:	Differential signals A, $\bar{A}$ ; B, $\bar{B}$ and R, $\bar{R}$
Amplitude A – $\bar{A}$	typ. 1 Vpp
Amplitude B – $\bar{B}$	typ. 1 Vpp
Amplitude R – $\bar{R}$	typ. 0.5 Vpp...1 Vpp
Power supply:	5 V $\pm$ 5 %
Maximum supply current:	300 mA
Max. encoder signal frequency that can be evaluated:	350 kHz

#### Note

For the above frequency, the signal amplitude must be  $\geq 60\%$  of the typical amplitude and the deviation of the phase offset from the ideal  $90^\circ$  between track A and B must be  $\leq \pm 30^\circ$ .

Pay attention to the frequency characteristic of the encoder signals.

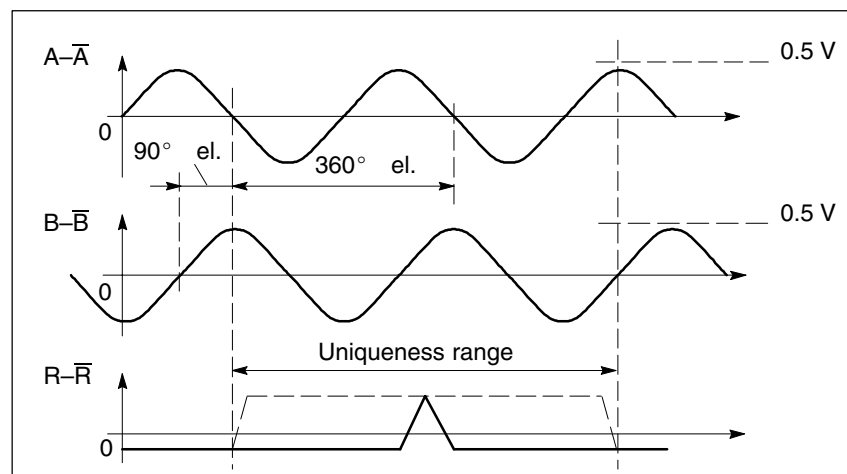

Fig. 4-6 Signal curve of incremental encoders for clockwise rotation

### Absolute (EnDat) measuring systems

Single-turn, multi-turn, and linear absolute measuring systems with two 90° offset sinusoidal voltage signals A, B, and EnDat interface, e.g. multi-turn encoder EQN 1325, single-turn encoder ECN 1313 or linear absolute measurement system LC181.

Transfer incremental signals:	Differential signals A, $\bar{A}$ and B, $\bar{B}$
Amplitude A – $\bar{A}$	typ. 1 Vpp
Amplitude B – $\bar{B}$	typ. 1 Vpp
Transfer serial signals:	Differential signals Data, $\bar{\text{Data}}$ and Clock, $\bar{\text{Clock}}$
Level:	acc. to EIA 485
Power supply:	5 V $\pm$ 5 %
Maximum supply current:	300 mA
Max. encoder signal frequency that can be evaluated:	350 kHz

#### Note

For the above frequency, the signal amplitude must be  $\geq 60\%$  of the typical amplitude and the deviation of the phase offset from the ideal 90° between track A and B must be  $\leq \pm 30^\circ$ .

Pay attention to the frequency characteristic of the encoder signals.

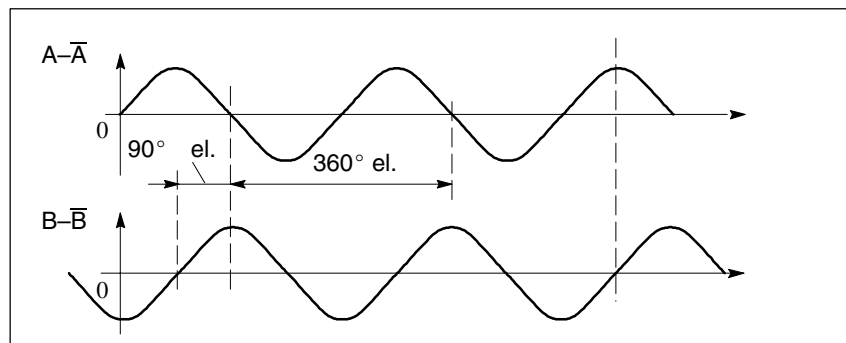

Fig. 4-7 Signal curve for incremental tracks for a clockwise rotation

### 4.3.3 Measuring channels, indirect and direct measuring system

#### Measuring channels for SINUMERIK 810D

The six measuring channels on the SINUMERIK 810D can be used both for indirect and for direct position sensing. A free measuring channel can, for example, be used for a direct spindle measuring system. Additional measuring channels can be obtained by using a 611D standard control module with/without direct measuring system.

#### Connecting cables

The following connecting cables are used for the SINUMERIK 810D:

Table 4-15 Connecting cables for SINUMERIK 810D

No.	MLFB	Description
1	6FX2002-2CA31-1□□0 <sup>1)</sup>	Motor measuring system cable incremental, 25-pole connector
2	6FX2002-2CG00-1□□0 <sup>1), 2)</sup>	Connecting cable for direct measuring system, 25-pole connector (for connection to CCU only)
3	6FX2002-2CH00-1□□0 <sup>1), 2)</sup>	Connecting cable for Multiturn absolute EnDat encoder, 25-pole connector (for connection to CCU only)
4	6FX2002-2CA11-1□□0 <sup>1)</sup>	Connecting cable for direct measuring system, 15-pole connector (for connection to 611D control only)
5	6FX2002-2AD00-1□□0 <sup>1)</sup>	Connecting cable for Multiturn absolute EnDat encoder, 15-pole connector (for connection to 611 control only)
6	6FX2002-2EQ00-1□□0 <sup>1)</sup>	Motor measuring system cable absolute, 25-pole connector
7	6FX2002-2EQ10-1□□0 <sup>1)</sup>	Motor measuring system cable absolute, 25-pole connector

1) Length code, refer to Catalog NC Z

2) Measuring system end circular connector

A number is assigned to each cable.  
You will find these numbers (1-7) in the following figures.

#### Indirect measuring system FSD

The motor measuring system is also used for position sensing.

Two encoder systems are available:

- Incremental encoder
- Absolute encoder



<p style="text-align: center;"><b>Indirect position (motor rotor position) and motor speed sensing</b></p> <p style="text-align: center;"><b>FSD</b></p>	<p><b>M: Max. possible measuring steps</b>  <b>G: Accuracy of the encoder system</b></p>
	<p>M = 128 x Z per 360 degr. mech.            Z...Increments            Z = 2048</p> <p>G = 0.006 deg.</p>
	<p>M = 128 x Z per 360 degr. mech.            Z...Increments            Z = 2048</p> <p>G = 0.006 deg.</p> <p>multiturn absolute:            4096 revolutions</p>
	<p>M = 128 x Z per 360 degr. mech.            Z...Increments            Z = 2048</p> <p>G = 0.006 deg.</p> <p>multiturn absolute:            4096 revolutions</p>

Fig. 4-8 Indirect position sensing with digital closed-loop control FSD

4 Description of the SINUMERIK 810D

4.3 Measuring system

**Direct measuring system FSD**

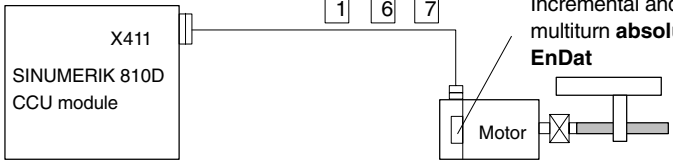
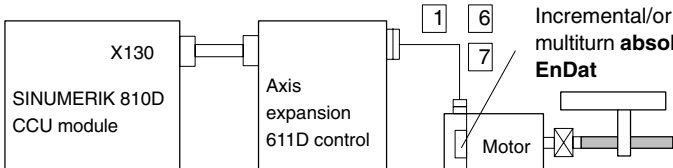
The motor measurement system is used for sensing the motor position. A second measuring system, e.g. a scale, can be used for load-side position sensing if necessary. Incremental encoders, distance-coded incremental encoders, or EnDat absolute value encoders can be used (voltage signals).

<p><b>Direct position sensing with free CCU measuring channel FSD</b></p>	<p><b>M: Max. possible measuring steps G: Accuracy of the encoder system</b></p>
	<p>M = 128 per encoder signal period or lattice pitch</p> <p>G is a function of the accuracy of the load-side encoder system.</p>
<p><b>Direkt position sensing for axis expansion with external 611D control</b></p>	
	<p>M = 128 or 2048 for 611D convenience control per encoder signal period or lattice pitch</p> <p>G is a function of the accuracy of the load-side encoder system.</p>
	<p>M = 128 per encoder signal period or lattice pitch</p> <p>G is a function of the accuracy of the optional encoder system.</p>

Fig. 4-9 Direct position sensing with digital closed-loop control FSD

\*) e.g. 1FK7

### Indirect measuring system MSD

The motor measuring system is also used for position sensing.

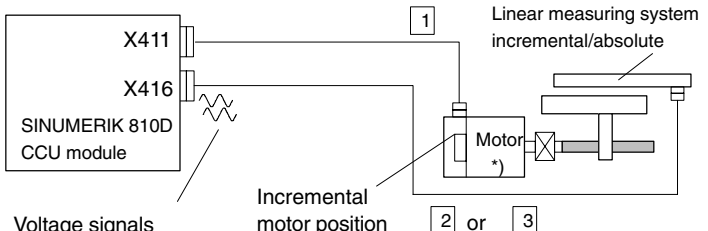
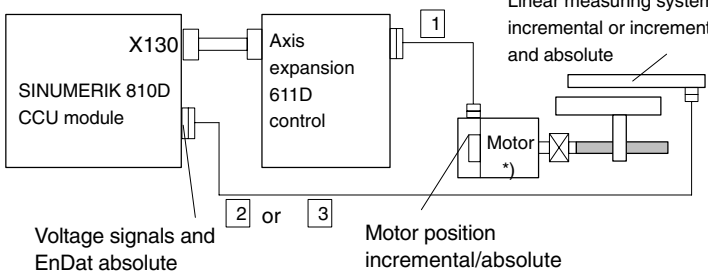
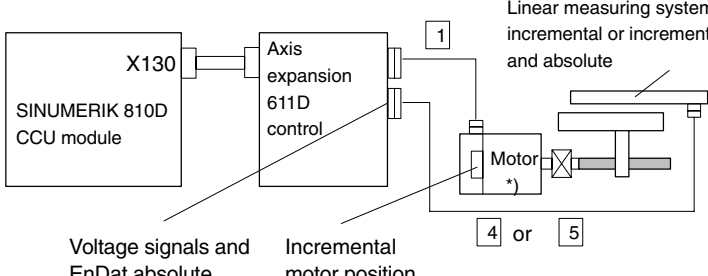
An encoder system is available:

- optical/incremental (1PH motor)

Indirect position (motor rotor position) and motor speed sensing MSD	M: Max. possible measuring steps G: Accuracy of the encoder system
 <p>The diagram shows a box labeled 'X411 SINUMERIK 810D CCU module' connected to a motor labeled 'Motor *'. A line labeled 'Incremental' with a '1' in a box above it connects the module to the motor. The motor is shown with a gear and a shaft.</p>	<p>M = 128 x Z per 360 degr. mech.            Z...Increments            Z = 2048            G = 0.006 deg.</p>
 <p>The diagram shows a box labeled 'X130 SINUMERIK 810D CCU module' connected to a box labeled 'Axis expansion 611D control'. This box is then connected to a motor labeled 'Motor *'. A line labeled 'Incremental' with a '1' in a box above it connects the axis expansion box to the motor. The motor is shown with a gear and a shaft.</p>	<p>M = 128 x Z per 360 degr. mech.            Z...Increments            Z = 2048            G = 0.006 deg.</p>

Fig. 4-10 Indirect position sensing with digital closed-loop control MSD

\*) e.g. 1PH7

4 Description of the SINUMERIK 810D

4.3 Measuring system

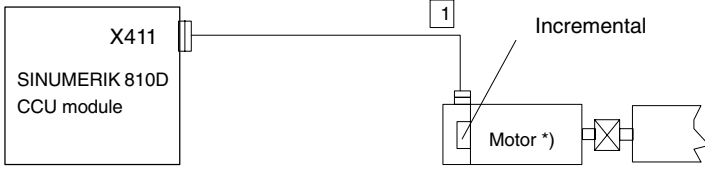
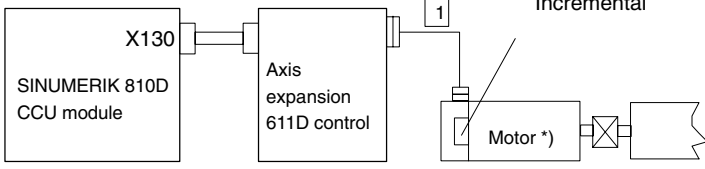
**Direct measuring system MSD**

The motor measurement system is used for sensing the motor position. A second measuring system, e.g. a rotary transducer, can be used for load-side position sensing if necessary.  
In the case of SINUMERIK 810D only encoders with voltage signals can be used.

Direct position sensing with free CCU measuring channel MSD	<b>M: Max. possible measuring steps</b> <b>G: Accuracy of the encoder system</b>
	<p>M = 128 per encoder signal period or lattice pitch</p> <p>G is a function of the accuracy of the optional encoder system.</p>
	<p>M = 128 x Z per 360 deg. mech.</p> <p>Z...Increments Z = 2048</p> <p>G = 0.006 deg.</p>
Direkt position sensing for axis expansion with external 611D control	
	<p>M = 128 x Z per 360 degr. mech.</p> <p>Z...Increments Z = 2048</p> <p>G = 0.006 deg.</p>
	<p>M = 128 x Z per 360 degr. mech.</p> <p>Z...Increments Z = 2048</p> <p>G = 0.006 deg.</p>

Fig. 4-11 Direct position sensing for MSD

\*) e.g. 1PH7

## 4.4 Integrated power modules: 3-axis CCU box

### Description

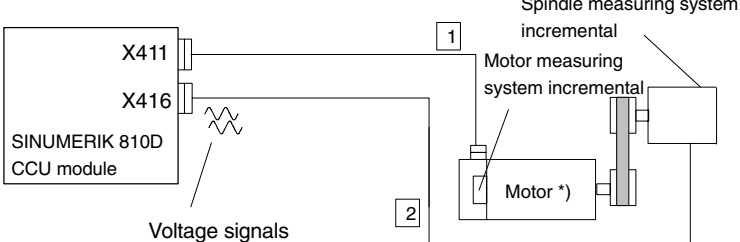
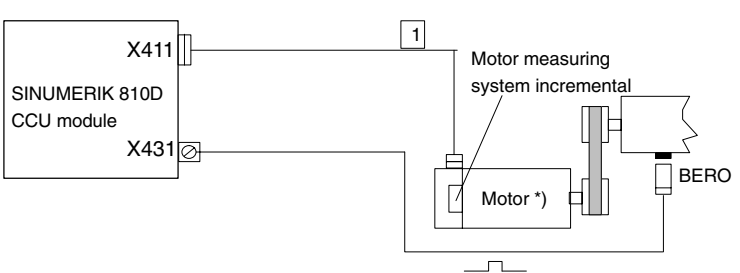
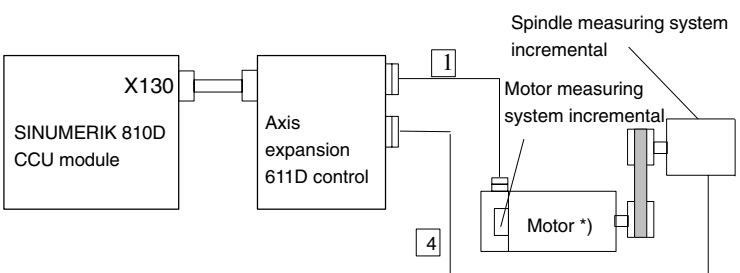
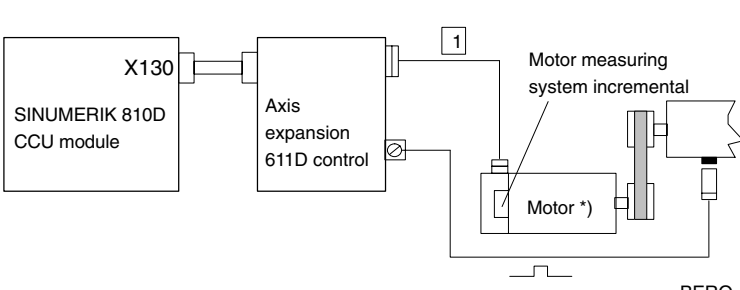
On the SINUMERIK 810D, three integrated power modules are fitted on one heat sink in the 3-axis CCU box:

- Power module for 2 x 6A/12A (FSD)
- Power module for 1 x 18A/36A (FSD) or 24A/32A (MSD)
- Heat sink temperature sensor

Table 4-16 Assignment between motor connection and power module

Motor connection	Power module	Rated current (sine, rms)
A1 (rear)	18A/36A (FSD) or 24 A/32A /MSD)	24 A
A2 (center)	6A/12A (only as FSD)	6 A
A3 (front)	6A/12A (only as FSD)	6 A

### Note

The spindle can only be used on "A1" on the integrated power module.

### Current derating as a function of the ambient temperature

All the technical details apply for ambient temperatures up to max. 40 °C. At ambient temperatures > 40°, linear current derating is necessary, as in the case of the OI power supply. At maximum ambient temperature 55 °C: Current derating to 60 % of the 40 °C value.

### Current derating as a function of the installation altitude

All power ratings apply up to an installation altitude of 1000 m. At an installation altitude of > 1000 m, the load currents must be reduced according to the derating factor.

The diagram is given in Subsection 4.3.3 Installation altitude

**References:** /PJU/, Configuration Manual Converters

## 4 Description of the SINUMERIK 810D

## 4.4 Integrated power modules: 3-axis CCU box

## Permissible duty cycles FSD

For use as FSD power module (A1 – A3)

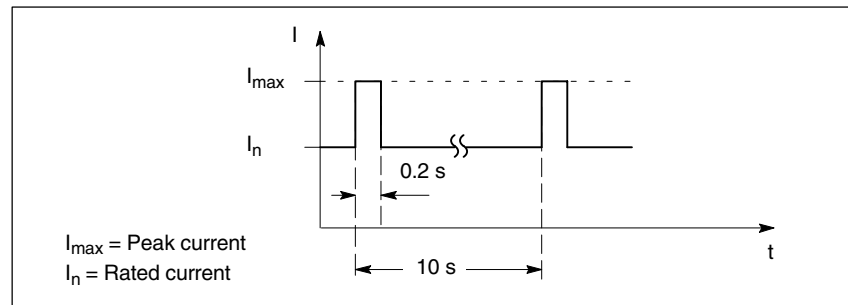

Fig. 4-12 Peak current duty cycle with previous load for FSD

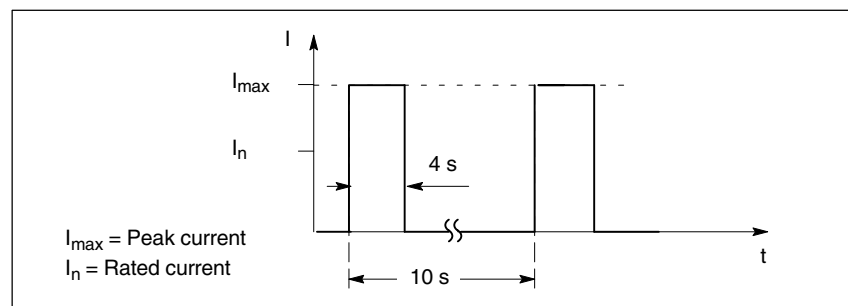

Fig. 4-13 Peak current duty cycle without previous load for FSD

## Permissible duty cycles FSD

For MSD power module only with 24A/32A

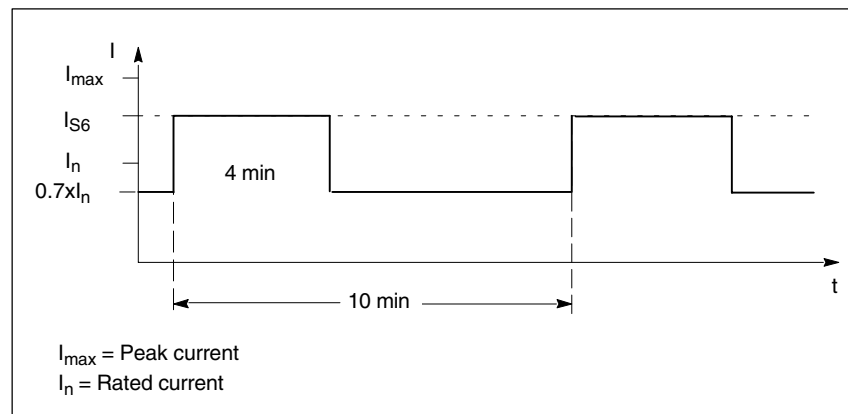

Fig. 4-14 S6 duty cycle with previous load for MSD

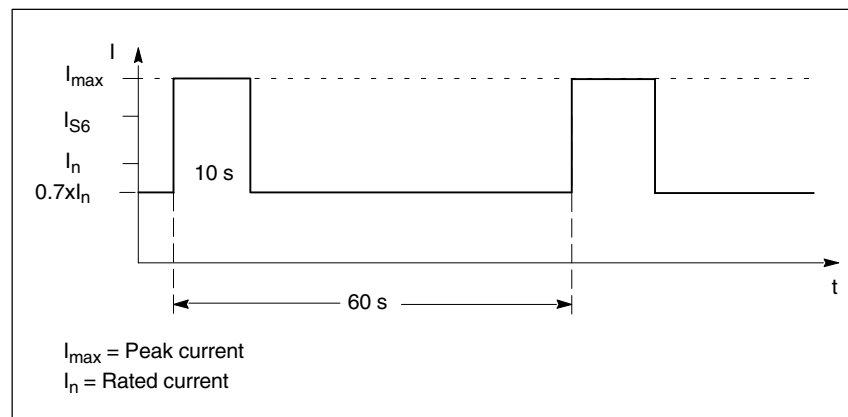

Fig. 4-15 S6 duty cycle with previous load for MSD

**Coincidence factor**

The power modules A2 and A3 may only be operated in simultaneous continuous duty at 63 % of their rated current on average. No coincidence restrictions apply to A1.

## 4.5 Integrated power modules: 2-axis CCU box

### Description

On the SINUMERIK 810D, 2 integrated power modules are fitted on one heat sink in the 2-axis CCU box:

- Power module for 9A/18A (FSD)
- Heat sink temperature sensor

The 2-axis CCU box can be mounted with internal or external heat dissipation.

Table 4-17 Assignment between motor connection and power module

Motor connection	Power module	Rated current (sine, rms)
A1 (rear)	9A/18A (only as FSD)	9 A
A2 (front)	9A/18A (only as FSD)	9 A

### Note

The 3rd drive number "A3" can be used for an axis in "Axis expansion plug-in unit left".

### Current derating as a function of the ambient temperature

All the technical details apply for ambient temperatures up to max. 40 °C. At ambient temperatures > 40°, linear current derating is necessary, as in the case of the OI power supply. At maximum ambient temperature 55 °C: Current derating to 60 % of the 40 °C value.

### Current derating as a function of the installation altitude

All power ratings apply up to an installation altitude of 1000 m. At an installation altitude > 1000 m, the load currents must be derated according to the diagram for the OI power supply.

The diagram is given in Subsection 4.3.3 Installation altitude

**References:** /PJU/, Configuration Manual Converters

### Permissible duty cycles FSD

For use as FSD power module (A1 – A2)

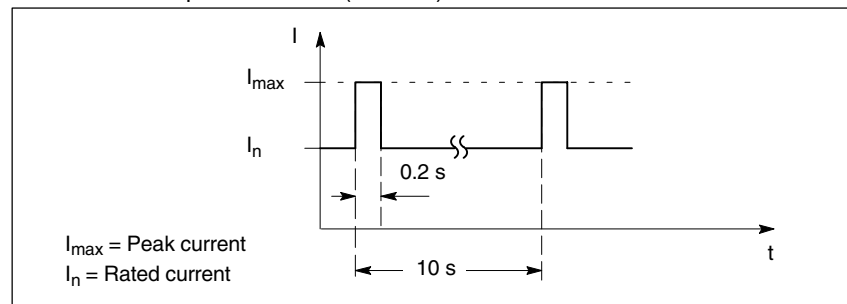

Fig. 4-16 Peak current duty cycle with previous load for FSD

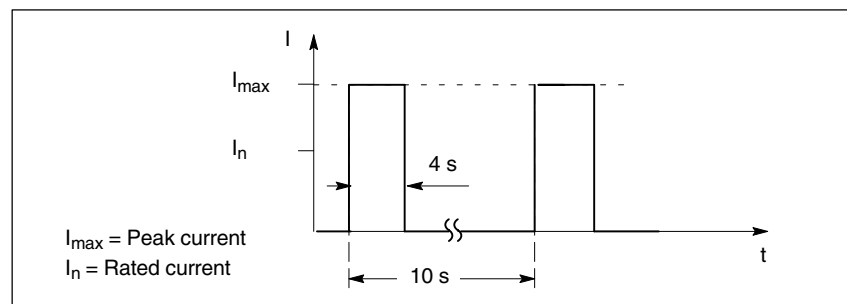

Fig. 4-17 Peak current duty cycle without previous load for FSD

**References:** /PJU/, Configuration Manual Converters

## 4.6 PLC module

### PLC module

The PLC module represents a PLC-CPU that is compatible with the S7-300 product range. Via the PK bus X111, three external chains with eight S7-300 I/O modules each can be connected. It is also possible to connect up three single I/O modules. Mixing IM 361s and single I/O modules is permissible.

## 4.7 PCMCIA card (memory card)

The CCU contains a plug-in unit for standard PC cards with which all type II flash cards with up to 8 Mbytes storage capacity can be operated.

**Recommendation:** Use Siemens PC cards.

- The PCMCIA card is used for software upgrading or for standard software.
- In addition to the software upgrade, the PC card can also be used for series commissioning; see  
**References:** /IAC/, Commissioning Manual 810D
- The PCMCIA card with the system software **must remain inserted during operation.**

---

### Caution

Inserting and removing the PCMCIA card while energized will cause data to be lost!

---



# 5

## Axis Expansion

### 5.1 Axis expansion plug-in unit

#### Application

The axis expansion plug-in unit is installed in a SIMODRIVE 611 power module and then connected to the X304-X306 axis expansion terminal of the SINUMERIK 810D. The plug-in unit is designed for 1-axis and 2-axis power modules.

There is also an axis expansion plug-in unit left with terminals for connectors X307 (CCU) und X301 (expansion plug-in unit) at the same height.

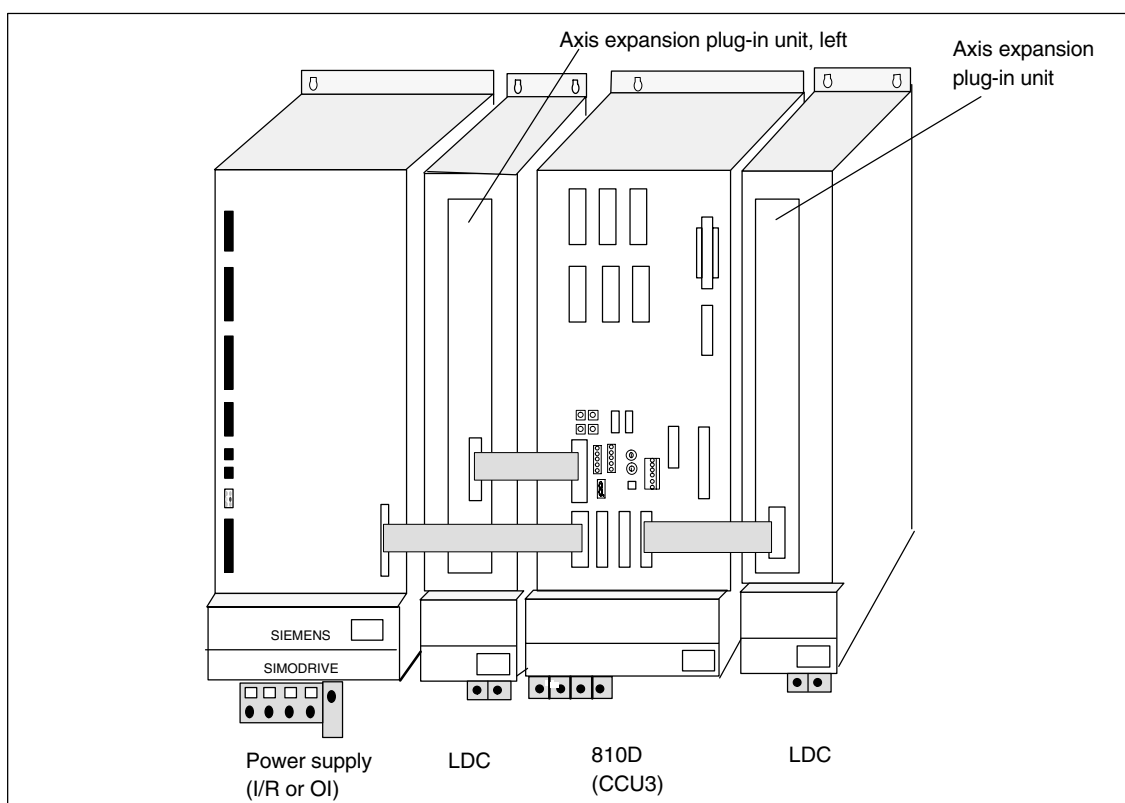

Fig. 5-1 Axis expansion plug-in unit, left and right, for the SINUMERIK 810D with SIMODRIVE 611 power modules

## 5 Axis Expansion

### 5.1 Axis expansion plug-in unit

#### Note

On LT modules more than 50 mm wide and a permanently mounted device bus, the free end of the device bus must be fixed to the 34-pole device bus connector on the module.

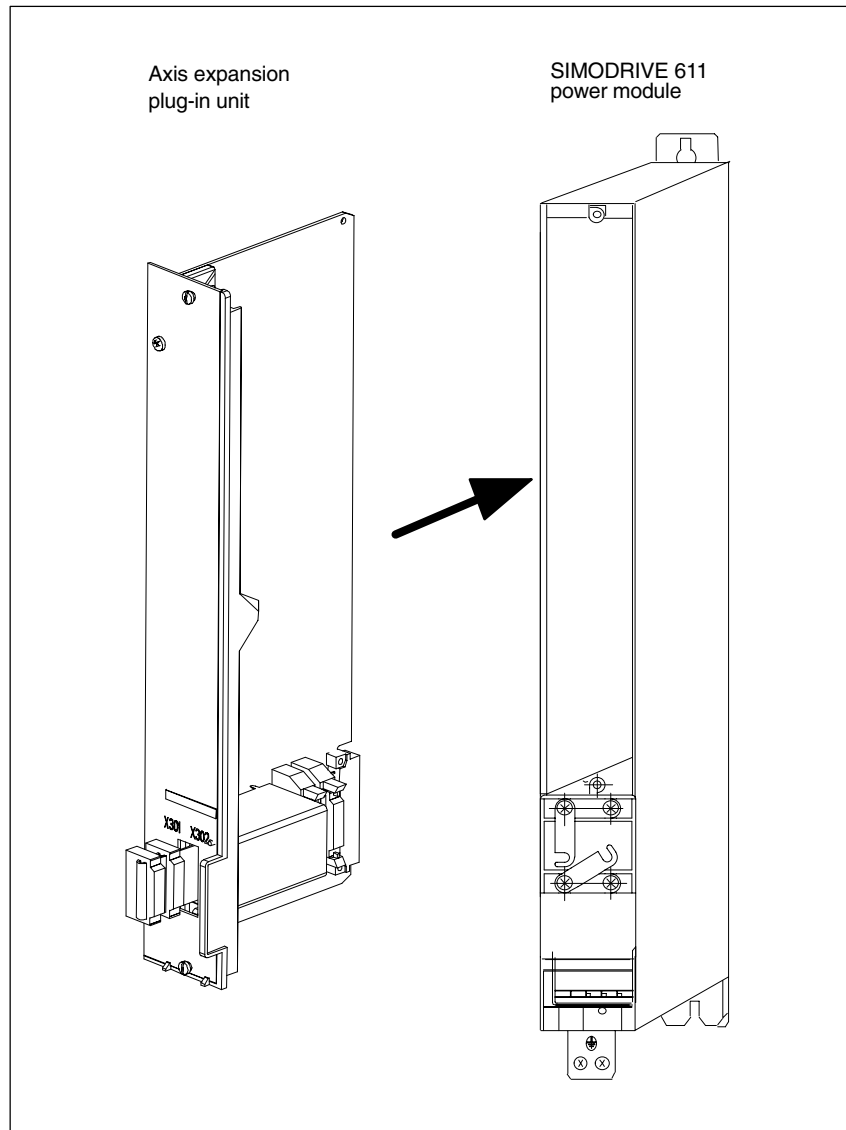

Fig. 5-2 Mounting the axis expansion plug-in unit in the power module

#### Connecting the ribbon cable connector

The axis expansion plug-in module has two connectors X301 and X302. Connector X301 must be connected to a 1-axis power module when used. If a 2-axis power module is used, connector X301 must be assigned to the first axis and connectors X302, to the second axis.

Table 5-1 Connection of the ribbon cable connector to the axis expansion plug-in unit

Ribbon cable connector	1-axis power module	2-axis power module
X301	1st axis	1st axis
X302	Unassigned	2nd axis

## Installation

1. Bring in and connect the ribbon cable for connector X301 through the slot in the front panel with the notch facing forward.
2. If applicable, also attach the ribbon cable for connector X302 accordingly (for 2nd axis).

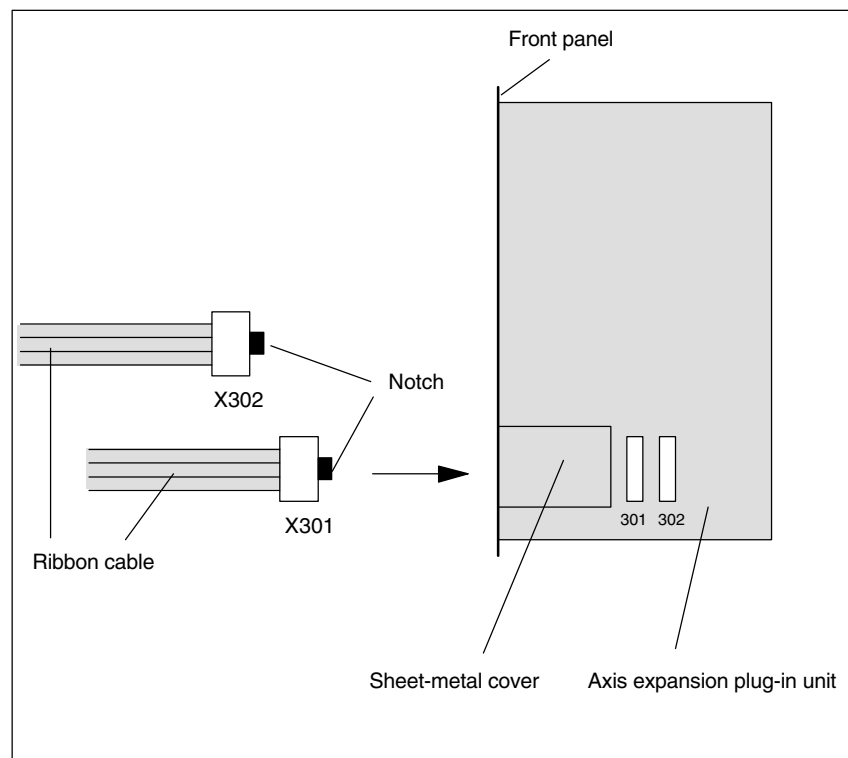

Fig. 5-3 Connection of the ribbon cables to the axis expansion

3. After plugging in the axis expansion plug-in unit and connecting to the CCU, you should push the excess cable length in the space provided for that purpose under the sheet-metal cover of the axis expansion plug-in unit.

## 5.2 Axis expansion with SIMODRIVE 611D control plug-in unit

**Application** Axis expansion with SIMODRIVE 611D control plug-in unit is only used if the number of measuring channels of the SINUMERIK 810D is insufficient, or higher performance is required.

**Mounting** The SIMODRIVE 611D module must be inserted as the first module to the right of the SINUMERIK 810D. If DC link busbars are connected, all screws must be tightened firmly (comply with tightening torque, see figure 3-4).

**Connection** A special set of cables is required to connect the SIMODRIVE 611D control module. This cable set contains the connection with the drive bus and another device bus cable.

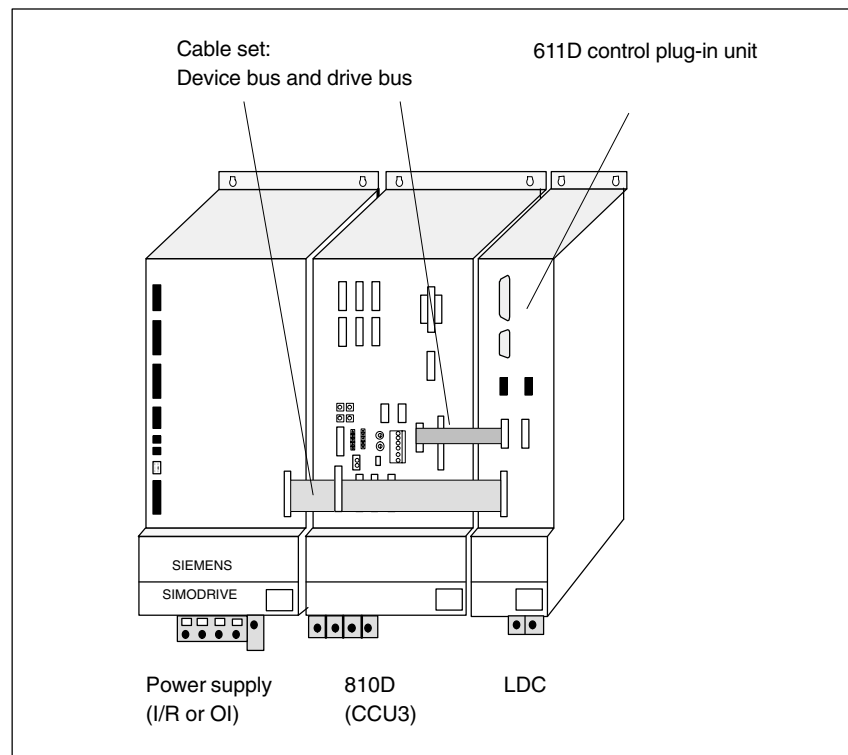

Fig. 5-4 Axis expansion for SINUMERIK 810D with the SIMODRIVE 611D module

**Note**

For EMC-compliant assembly, shielded motor cables must be used in conjunction with the shielding contact plates available for SIMODRIVE power modules; see

**References:** /PJU/, Configuration Manual Converters  
/EMV/, EMC Configuring Guidelines

**Cable set for axis expansion**

For connection of the SIMODRIVE 611D control plug-in unit that is located immediately to the right of the 810D.

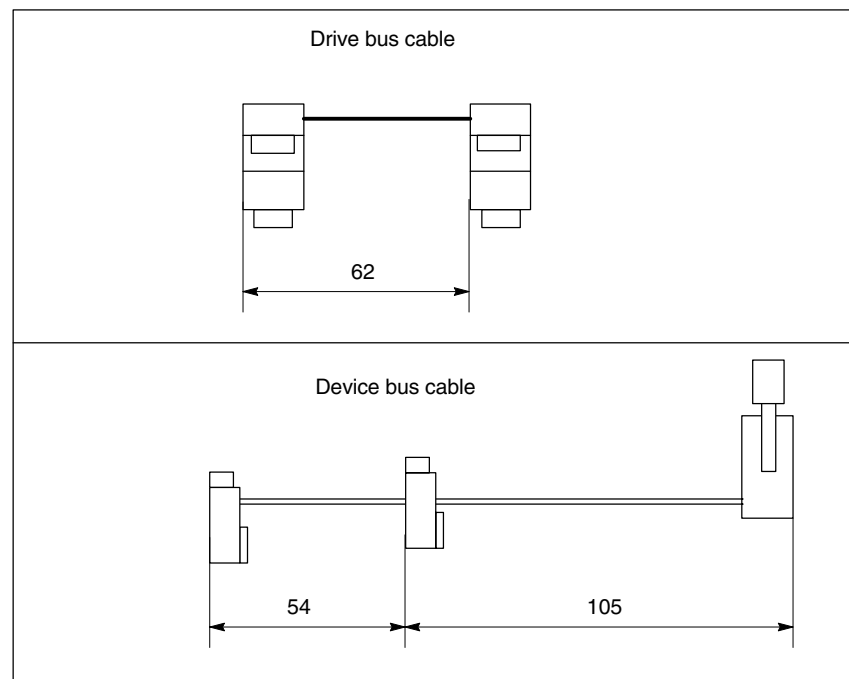

Fig. 5-5 Cable set for axis expansion with SIMODRIVE 611D module

Table 5-2 Recommendation for length selection of the drive bus cable

Order no.	Module width to be bridged in mm	Comment
6SN1161-1CA00-0BA1	50	Drive bus cable round cable, shielded
6FC5247-0AA28-0AA0 GWE: 462008006403	50 50	Device bus cable Device bus cable
6SN1161-1AA00-0BA0	<50	Device bus cable 400 mm
NC60 Catalog: Select length + 50 mm	<50	Drive bus cable round cable, shielded





# 6

## I/O Modules

### 6.1 Single I/O module

**Brief description** The single I/O module has 64 inputs and 32 short-circuit-proof outputs (isolated). Each output can be loaded with 0.5 A. The coincidence factor is 75 %.

Up to three single I/O modules can be attached to the SINUMERIK 810D; combinations with SIMATIC S7-300 chains are possible.

**Connection to 810D** The single I/O module (connector X3 IN) is connected to the SINUMERIK 810D (connector X111). The max. cable length is 10 m. Two cable variants are available for the connection from one single I/O module to the next:

- For single mounting: 6ES7368-3□□□0-0AA0
- For single-tier configuration with several single I/O modules: 6FC5411-0AA80-0AA0, length 150 mm.

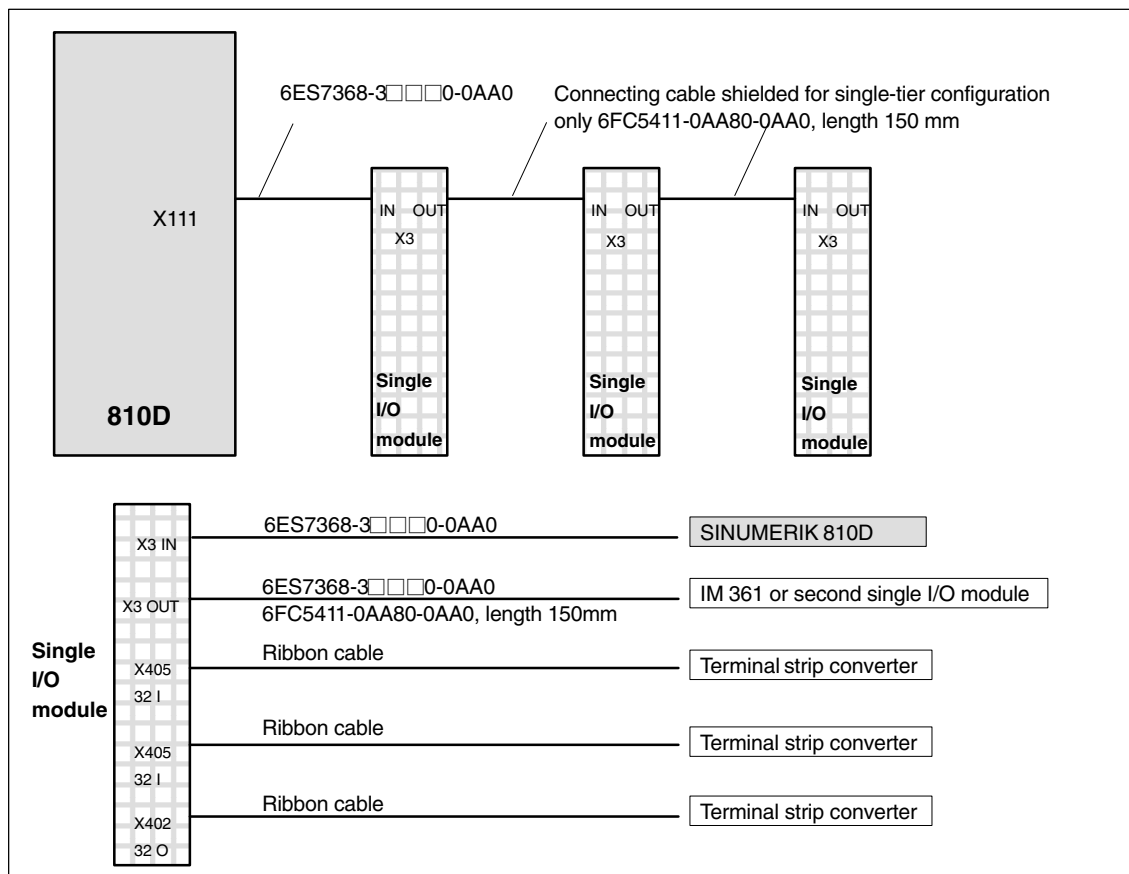

Fig. 6-1 Overview of terminals, single I/O modules on the SINUMERIK 810D

6 I/O Modules

6.1 Single I/O module

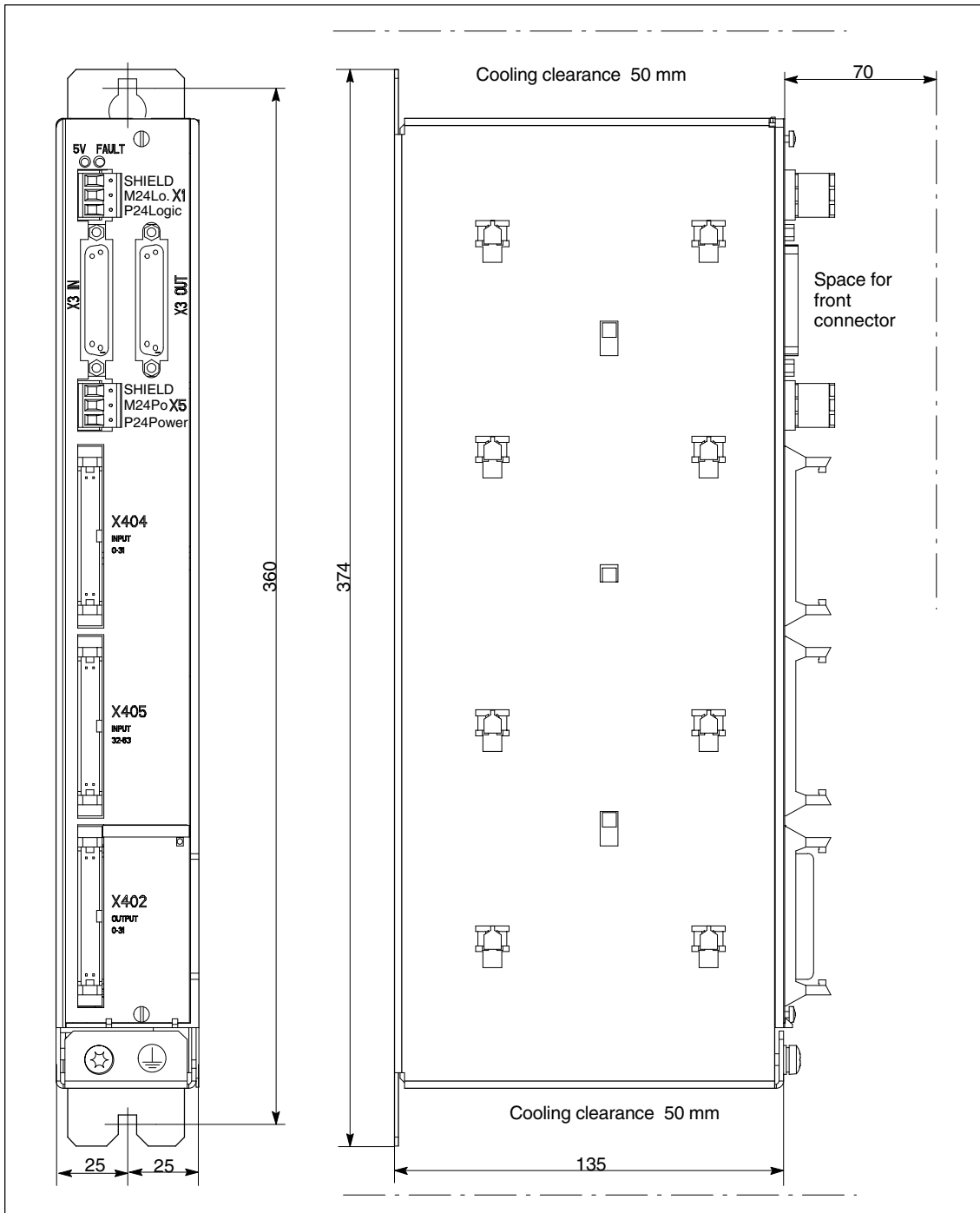

Fig. 6-2 Dimension drawing of single I/O module

**EMC measures**

The single I/O module has an equipotential bonding terminal. To conduct interference currents away, a low-resistance finely stranded bonding conductor to the ground bus is required (see subsection 2.1.3) with a cross-section of at least 10 mm<sup>2</sup>. The connection must be as short as possible. When the PE and interference conductors are in common, the PE conductor rules in EN 61800-5-1 must be followed.

## Technical data

Table 6-1 Technical data of the single I/O module

Power supply for LOGIC (X1) and POWER (X5)	<ul style="list-style-type: none"> <li>– rated value</li> <li>– perm. range</li> <li>– ripple</li> <li>– polarity reversal protection</li> <li>– fuse-protection</li> </ul>	24 V DC 18.5 ... 30.2 V 3.6 Vpp yes LOGIC: 1 A/250 V POWER: no
Current consumption	<ul style="list-style-type: none"> <li>– LOGIC</li> <li>– POWER</li> </ul>	Type: 0.3 A, max. 1 A max: 12 A
Power loss	<ul style="list-style-type: none"> <li>– LOGIC</li> <li>– POWER</li> </ul>	Type: 7.2 VA, max. 30.2 VA max. 362 VA
Inputs	<ul style="list-style-type: none"> <li>Number of inputs</li> <li>Signal level for signal "0"</li> <li>Signal level for signal "1"</li> <li>Isolation</li> <li>Input current 1-signal</li> <li>Input current 0-signal</li> <li>Delay time <math>T_{PHL}</math></li> <li>Delay time <math>T_{PLH}</math></li> <li>Voltage strength</li> <li>Cable length terminal block</li> </ul>	64 digital inputs –3 V to + 5 V + 15 V to + 30 V yes (optocoupler) 2 – 15 mA, type: 6 mA –9 mA to 1 mA 0.5 to 3 ms 0.5 to 3 ms 2 kV max. 3 m
Outputs	<ul style="list-style-type: none"> <li>Number of outputs</li> <li>Signal level for signal "0"</li> <li>Signal level for signal "1"</li> <li>Isolation</li> <li>Short-circuit-proof</li> <li>Max. output current</li> <li>Switching frequency</li> <li>Voltage strength</li> <li>Cable length terminal block</li> </ul>	32 digital outputs open $U_{Power} - 0.5 V$ yes (optocoupler) yes resistive: 0.6 A inductive: 0.6 A Lamp: 6 W ohmic load: 100 Hz inductive load: 2 Hz Lamp load: 11 Hz 2 kV max. 3 m
Overtemperature protection		Block specific
Coincidence factor		75 %
Total of all rated currents each within group of 0.5 A		

**Connection of the electronics power supply**

The 24 V DC power supply is connected to X1 via a 3-way angled Phoenix screw terminal connector (2.5 mm<sup>2</sup>).



Table 6-2 X1 pin assignment

X1 LOGIC power supply		
Pin	Name	Type
3	SHIELD	
2	M24	VI
1	P24 Logic	VI

**Signal names**

P24 Logic + 24 V electronics power supply external  
M24 Electronics power supply ground external

**Signal type**

VI Voltage Input

**Note**

SHIELD and M24 must be bridged.

**Connecting the load power supply**

The 24 V DC load power supply is connected to X5 via a 3-way angled Phoenix screw terminal connector (2.5 mm<sup>2</sup>).

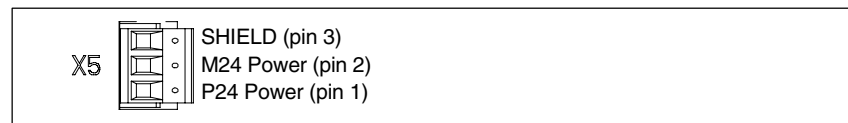

Table 6-3 X5 pin assignment

X5 POWER power supply		
Pin	Name	Type
3	SHIELD	
2	M24	VI
1	P24 Power	VI

**Signal names**

P24 Power + 24 V load power supply external  
M24 Load power supply ground external

**Signal type**

VI Voltage Input

**Connection of the inputs/outputs**

The inputs/outputs are connected via ribbon cables (max. 3 m length). The following 34-way terminal strip converters can be used for this purpose:

see **References:**

Terminal strip converter without LED: 6FC9302-2AA  
 Terminal strip converter with LED red: 6FC9302-2AB (0.5A)  
 6FC9302-2AL (2 A)

Terminal strip converter with LED green: 6FC9302-2BB01

Assignment of the ribbon cable is compatible with the I/O modules (logic modules) of the SINUMERIK 810.

**Meaning of the LEDs**

The module status of the single I/O module is indicated via two LEDs.

LED green: 5 V Power OK

LED red: Group error

**X402 outputs 0-31**

Connecting the outputs

Connector name: X402 OUTPUT 0–31

Connector type: 34-way DIN ribbon cable connection

Length of the ribbon cable: Max. 3 m to the terminal strip converter

**Note**

The outputs must be protected externally against voltage surges by inductive loads. (free-wheeling diodes, RC elements, . . .)

1	Not assigned		2	Not assigned	
3	OUT0[0]	0	4	OUT0[1]	0
5	OUT0[2]	0	6	OUT0[3]	0
7	OUT0[4]	0	8	OUT0[5]	0
9	OUT0[6]	0	10	OUT0[7]	0
11	OUT1[0]	0	12	OUT1[1]	0
13	OUT1[2]	0	14	OUT1[3]	0
15	OUT1[4]	0	16	OUT1[5]	0
17	OUT1[6]	0	18	OUT1[7]	0
19	OUT2[0]	0	20	OUT2[1]	0
21	OUT2[2]	0	22	OUT2[3]	0
23	OUT2[4]	0	24	OUT2[5]	0
25	OUT2[6]	0	26	OUT2[7]	0
27	OUT3[0]	0	28	OUT3[1]	0
29	OUT3[2]	0	30	OUT3[3]	0
31	OUT3[4]	0	32	OUT3[5]	0
33	OUT3[6]	0	34	OUT3[7]	0

## 6 I/O Modules

## 6.1 Single I/O module

**Signal names**OUT<sub>i</sub>[j]            Output j of output byte i**Signal type**

O                    Output

**X404  
Inputs 0 to 31**

Connecting inputs 0 to 31

Connector name:                    X404 INPUT 0–31  
 Connector type:                    34-way DIN ribbon cable connection length  
 of the ribbon cable:                Max. 3 m to the terminal block

1	Not assigned		2	Not assigned	
3	INP0[0]	I	4	INP0[1]	I
5	INP0[2]	I	6	INP0[3]	I
7	INP0[4]	I	8	INP0[5]	I
9	INP0[6]	I	10	INP0[7]	I
11	INP1[0]	I	12	INP1[1]	I
13	INP1[2]	I	14	INP1[3]	I
15	INP1[4]	I	16	INP1[5]	I
17	INP1[6]	I	18	INP1[7]	I
19	INP2[0]	I	20	INP2[1]	I
21	INP2[2]	I	22	INP2[3]	I
23	INP2[4]	I	24	INP2[5]	I
25	INP2[6]	I	26	INP2[7]	I
27	INP3[0]	I	28	INP3[1]	I
29	INP3[2]	I	30	INP3[3]	I
31	INP3[4]	I	32	INP3[5]	I
33	INP3[6]	I	34	INP3[7]	I

**Signal names**INP<sub>i</sub>[j]            Input j of input byte i**Signal type**

I                    Input

**X405**  
**Inputs 32 to 63**

Connecting inputs 32 to 63

Connector name: X405 INPUT 32–63  
 Connector type: 34-way DIN ribbon cable connection length  
 of the ribbon cable: Max 3 m to the terminal block

1	Not assigned		2	Not assigned	
3	INP4[0]	I	4	INP4[1]	I
5	INP4[2]	I	6	INP4[3]	I
7	INP4[4]	I	8	INP4[5]	I
9	INP4[6]	I	10	INP4[7]	I
11	INP5[0]	I	12	INP5[1]	I
13	INP5[2]	I	14	INP5[3]	I
15	INP5[4]	I	16	INP5[5]	I
17	INP5[6]	I	18	INP5[7]	I
19	INP6[0]	I	20	INP6[1]	I
21	INP6[2]	I	22	INP6[3]	I
23	INP6[4]	I	24	INP6[5]	I
25	INP6[6]	I	26	INP6[7]	I
27	INP7[0]	I	28	INP7[1]	I
29	INP7[2]	I	30	INP7[3]	I
31	INP7[4]	I	32	INP7[5]	I
33	INP7[6]	I	34	INP7[7]	I

**Signal names**

INPi[j] Input j of input byte i

**Signal type**

I Input

**Address space**

From the PLC's viewpoint, the 810D single I/O is equivalent to a S7-300 I/O chain with the following configuration:

- P-bus interface IM-R
- 2 x 32-bit input module
- 1 x 32-bit output module

6 I/O Modules

6.1 Single I/O module

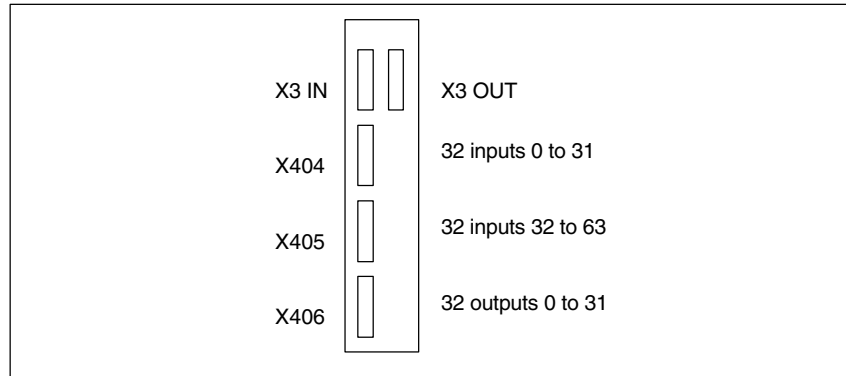

This results in the following address space:

1. Input range  
Input byte (chain number \*32) to (chain number \*32) +7, i.e. from input byte 32 to input byte 39 for operation in chain 1
2. Output range  
Output byte (chain number \*32) +8 to (chain number \*32) +11, i.e. from output byte 40 to output byte 44 for operation in chain 1

Only one I/O module is possible per chain.

The address range is assigned automatically during startup. Parameterization is not required.

In HW Config, it is possible to treat the 810D I/Os as the equivalent arrangement of S7-300 modules.

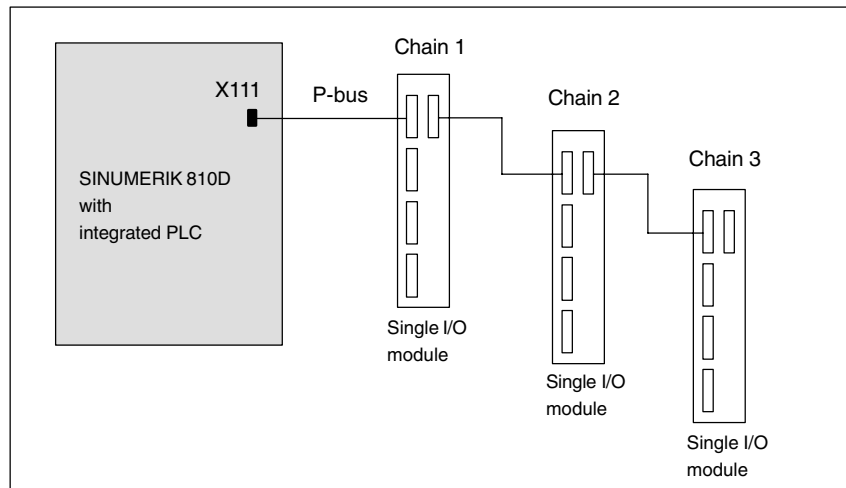

Fig. 6-3 SINUMERIK 810D with 3 I/O chains (max. configuration)



# NCU Terminal Block

# 7

## 6FC5211-0AA00-0AA0

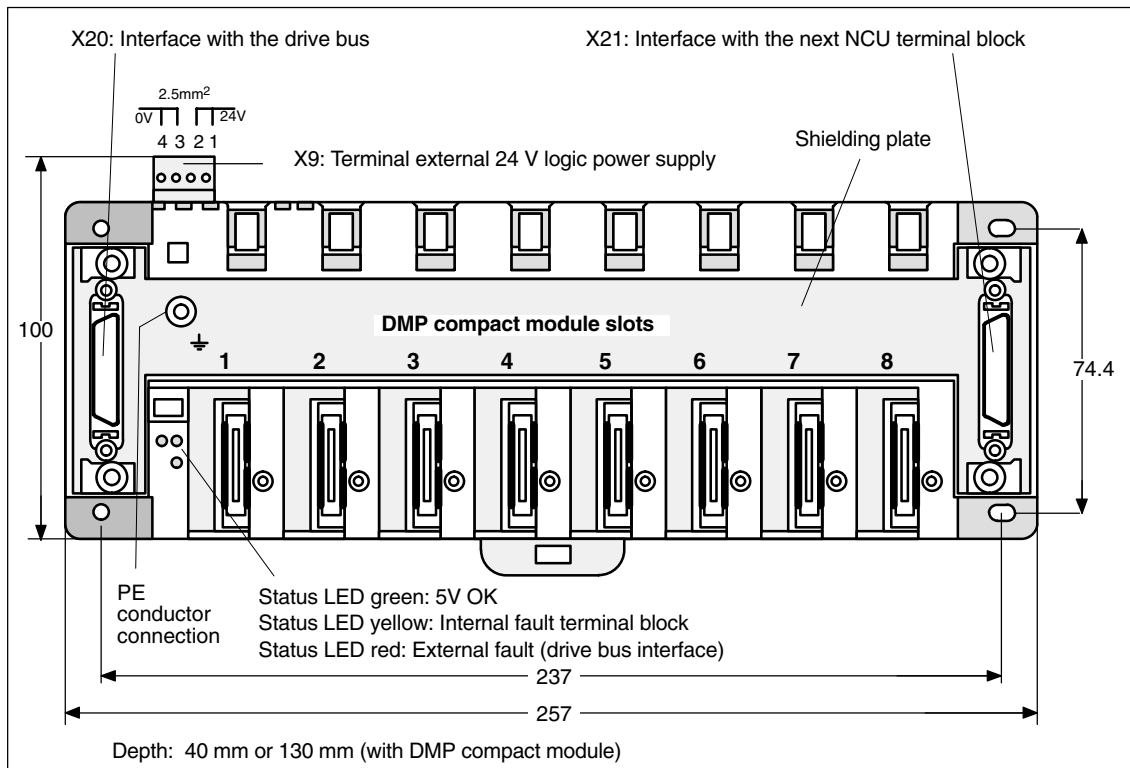

Fig. 7-1 Front view of NCU terminal block

### Mounting

In order to ensure optimum heat dissipation of the DMP compact module, the terminal block should be secured horizontally, so that the modules can be suspended vertically.

### Connection to the drive bus

The terminal block is connected to connector X20 on the drive bus of the last drive module via round cables. These cables are available in different lengths. (cable lengths 1, 2, 5, and 10 m). Up to 2 terminal blocks can be operated (in accordance with the available NCK addresses for rapid analog and digital I/Os). The round cables are also used in conjunction with individual terminal blocks.



### Important

Please make sure that the total length of the cable connections does not exceed 10 m.

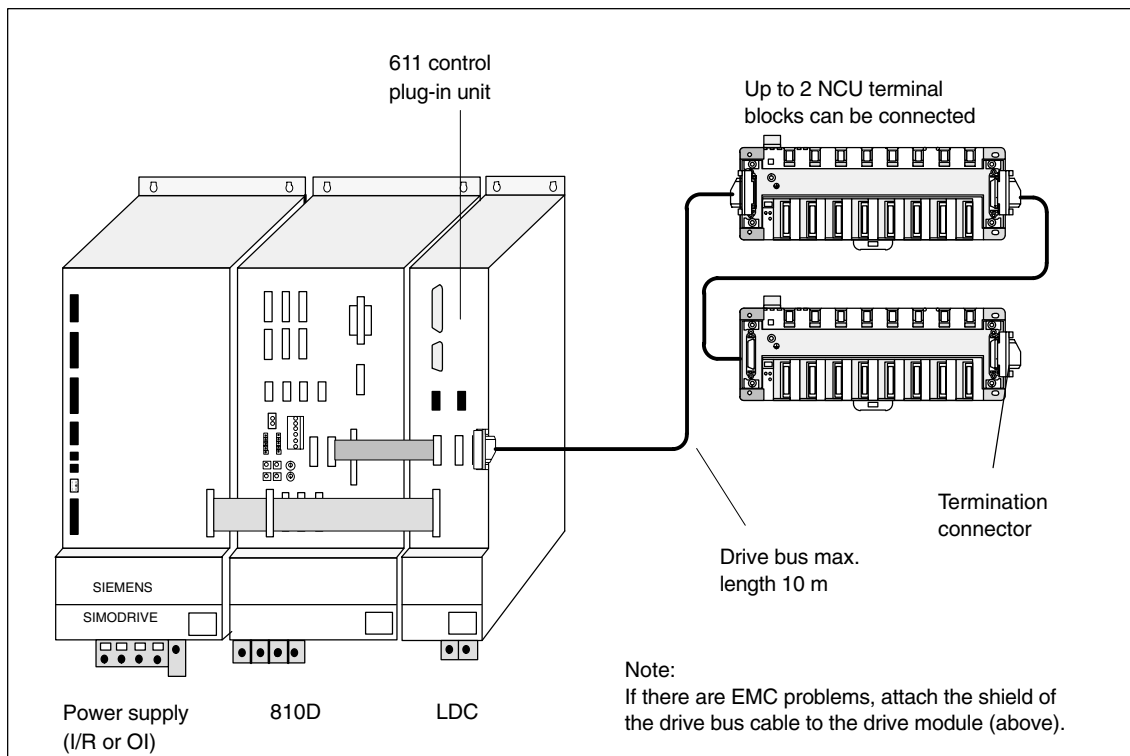

Fig. 7-2 Connection of NCU terminal block

### Terminator

The drive bus terminator must be plugged into slot X21 on the last NCU terminal block.

### PE conductor

When the PE and interference conductors are in common, the PE conductor rules in EN 61800-5-1 must be followed. PE conductor connection, see fig. 7-1.

## EMC measures

The PE conductor connection is also used to conduct interference currents away from:

- the shields of the DMP casing,
- the DMP compact plug-in modules,
- the 24 V logic power supply.

To ensure that these interference suppression measures are effective, there must be a low-resistance connection between the shielding plate and ground potential.

The low-resistance bonding conductor should be a stranded cable with a cross-section of at least 10 mm<sup>2</sup> and a length of less than < 30 cm, if possible.

## DMP compact modules

A maximum of 8 DMP compact modules can be connected per NCU terminal block.

Module type	Max. number	Variation
DMP compact module 16 I	2	Digital inputs
DMP compact module 16 O	2	Digital outputs 0,5 A
DMP compact module 8 O	4	Digital outputs 2.0 A
DMP compact module 1I analog	8	Analog input 13 bits
DMP compact module 1I NC analog IN	4	Rapid analog input 75 μs, 12 bits
DMP compact module 1O analog	4	Analog output 14 bits

Equipment in max. 2 terminal blocks of a control:

Peripherals	Number
Digital inputs	32
Digital outputs	32
Analog inputs	8
Analog outputs	8



### Important

A maximum of 4 analog outputs and 4 analog inputs can be plugged in at the same time for each NCU terminal block.



### Caution

After the load supply voltage for the DMP compact modules has been switched off during operation, the outputs do not reliably reestablish through-connection when the load supply voltage is switched on again. If switch-off during operation cannot be avoided, the DMP outputs have to be reset via the PLC program when the load supply voltage is switched off. The outputs are set again after the voltage has been switched on again.

**Monitoring functions**

- +5 V monitoring
- Temperature monitoring 60 °C ± 3 °C
- Configuration monitoring
- Sign-of-life monitoring (watchdog) of the microcontroller
- Sign-of-life monitoring of the NC

Fault	Acquisition	Effect
Undervoltage (< 4.75 V)	Limit monitor	Disabling of the NC outputs, LED (green) off
Ambient temperature	Temperature sensor	Status signal to NC, screen display
Sign of life CCU	Cyclic signaling	Disabling of the NC outputs, LED (red) on
Watchdog	Time acquisition	Disabling of the NC outputs, LED (red) on
Hardware combination	Hardware configuration	Disabling of the NC outputs, LED (red, yellow) on, status signal to NC

The digital and analog outputs are switched to a safe state (0 V at the output) with the XOUTDS signal in the event of disturbances or faults in the CCU, the microcontroller, and power failure.

**Power supply**

DC 24 V (20.4 V DC to 28.8 V DC)  
Connector designation: X9  
Connector type: 4-pole terminal block, 2.5 mm<sup>2</sup> Terminal

Table 7-1 X9 pin assignments

X9		
Pin	Name	Type
1	P24 ext	VI
2	P24 ext	VI
3	M24 ext	VI
4	M24 ext	VI

**Note**

Pins 1 and 2 or 3 and 4 are bridged in a group on the module.

**Signal names**

P24 ext +24 V power supply external  
M24 ext Power supply ground external

**Signal type**

VI Voltage Input

**X20/X21**

Drive bus interface

Connector name: X20 (IN) X21 (OUT)

Connector type: 36-pole micro ribbon

Special features: Non-isolated, no protective separation

Caution: Max. length of the drive bus is 10 m

**X11–X18**

Module connector

Connector name: X11 ... X18 (slots 1 ... 8)

Connector type: 30-pole male connector ELCO Microleaf

Table 7-2 Technical data of the NCU terminal block

<b>Mechanical data</b>			
Dimensions	Height	Width	Depth
	100 mm	257 mm	40 mm
Weight	Approx. 0.5 kg		
<b>Ambient conditions</b>			
Degree of protection	IP20 or IPXXB		
<b>Power consumption (24 V)</b>			
During operation	150 –500 mA		





# 8

## DMP Compact Modules

### Mounting

The following dimensions must be observed when mounting:

Table 8-1 Dimensions of the DMP compact modules

Width	25 mm
Height	90 mm
	115 mm with plugged in connecting plugs
	130 mm with terminal block
Depth	108 mm
Degree of protection	IP20 or IPXXB

### 8.1 DMP compact module 16I (6FC5111-0CA01-0AA0)

The DMP compact module 16I is an encapsulated module. It can be plugged into a slot of the NCU terminal block as a plug-in module.

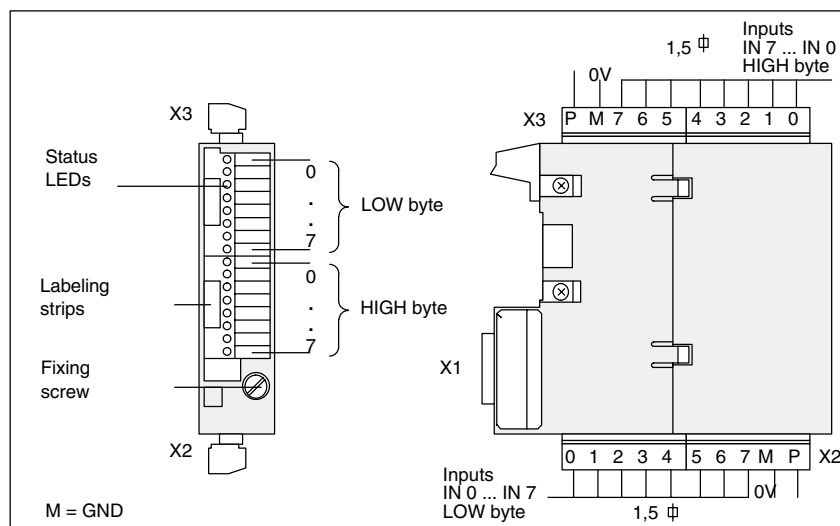

Fig. 8-1 Front view and side view of a DMP compact module 16I

## 8 DMP Compact Modules

### 8.1 DMP compact module 16I (6FC5111-0CA01-0AA0)

#### Interfaces

- A 30-pole connector X1 for connection to the NCU terminal block.
- Two 10x terminals X2 and X3 (Phoenix, Type MC1.5/10-ST-3.81 GREY, order no. for X3 and X2: 18 28 171) for connecting the 16 inputs and the load power supply.
- The terminals are pluggable and can be mechanically coded by the customer.
- The 24 V terminal P is not used

#### Display elements

16 LEDs as a status display for the logical states of the inputs.

LEDs lit:            Input on.

Table 8-2            Technical data of DMP compact module 16I

Number of inputs		16 digital inputs
Galvanic isolation		Yes
Power supply $V_{LOAD}$	<ul style="list-style-type: none"> <li>– Rated value</li> <li>– Perm. range</li> <li>– Ripple</li> </ul>	24 V DC 20.4 V to 28.8 V 3.6 Vpp
Input voltage	<ul style="list-style-type: none"> <li>– Rated value</li> <li>– For signal “0”</li> <li>– For signal “1”</li> </ul>	24 V DC –3 to +5 V +13 V to +33 V
Input current for signal “1”		+ 2 mA to + 5 mA
Delay time	for $t_{pLH}$	$t_{pLH}$ = type 1 ms
Delay time	for $t_{pHL}$	$t_{pHL}$ = type 1 ms
Length for cables	max.	30 m
Weight	about	125 g

## 8.2 DMP compact module 16O (6FC5111-0CA02-0AA2)

The DMP compact module 16O is an encapsulated module. It can be plugged into a slot of the NCU terminal block as a plug-in module.

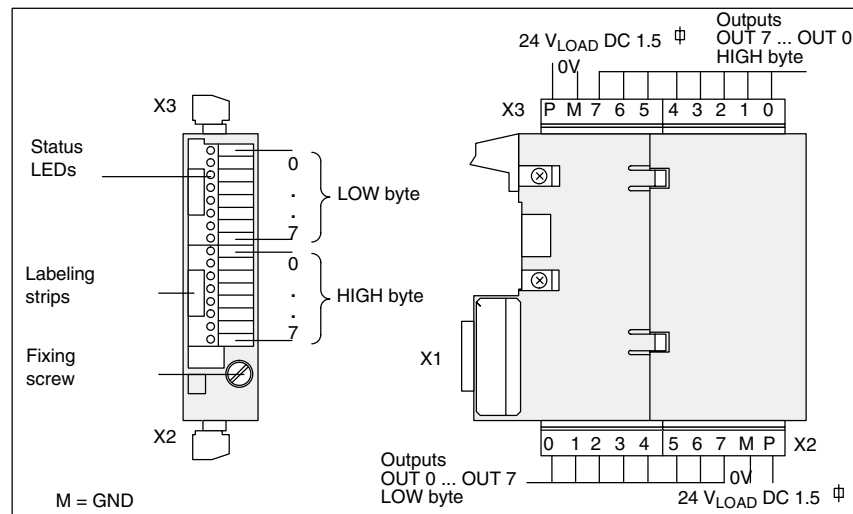

Fig. 8-2 Front view and side view of a DMP compact module 16A

### Interfaces

- A 30-pole connector X1 for connection to the NCU terminal block.
- 10-terminal X2 and X3 (Phoenix, Type MC1.5/10-ST-3.81 GREY, order no. for X3 and X2: 18 28 171) for connecting the 16 outputs and the load power supply.
- The terminals are pluggable and can be mechanically coded by the customer.

### Display elements

16 LEDs as a status display for the logical states of the outputs.  
As from product version B, the LEDs go out when the load voltage fails.

LEDs lit: Output on.

Table 8-3 Technical data of DMP compact module 16O

Number of outputs	16 digital outputs
Galvanic isolation	Yes
Power supply $V_{LOAD}$	
– Rated value	24 V DC
– Perm. range	20.4 V to 28.8 V
– Ripple	3.6 Vpp
Signal level of the outputs (typically)	
– For signal “0”	Open
– For signal “1”	$V_{load} - 250 \text{ mV}$

Table 8-3 Technical data of DMP compact module 16O

Output load for signal "1" (rated value)		
– Ohmic load		500 mA
– Lamp load		5 W
– Inductive load		500 mA
Short-circuit protection		Yes
Power loss at 30 V		Max. 3.8 W
Operating frequency for		
– Ohmic load		100 Hz
– Lamps		11 Hz
– Inductive load (for rated current, higher values are permissible for lower currents)		2 Hz
Total load capability at 55 °C (relative to the total rated current of all outputs)		50 %
Delay time	for t <sub>PLH</sub>	t <sub>PLH</sub> = max. 0.5 ms
Delay time	for t <sub>PHL</sub>	t <sub>PHL</sub> = max. 0.5 ms
Length for cables	Max.	50 m
Weight	about	160 g

**Important**

As of version C, a new output driver is used for the DMP compact module 16A. The following behavior is to be observed:

In the event of a fault triggered by overcurrent or short-circuit, the outputs automatically reconnect after the fault has been rectified. (previously: latching disable until the output is reactivated by the PLC user program).

If one output is short-circuited, the three other outputs of the same half-byte can also be disabled. In normal operation with currents < 0.7 A, there is no mutual influence.

---

8 outputs each are powered by a power supply. For each group of 8 outputs (2 x outputs 0 ... 7), the total of the output currents must not be greater than 2 A. (This corresponds to a coincidence factor of 50 % if each output is under full load). All 16 outputs can be loaded simultaneously with 0.25 A for example.

---

**Important**

If inductive loads are used, switching voltage peaks must be limited by external free-wheeling diodes or RC connections.

---

### 8.3 DMP compact module 8O (6FC5111-0CA03-0AA2)

The DMP compact module 8O is an encapsulated module. It can be plugged into a slot of the NCU terminal block as a plug-in module.

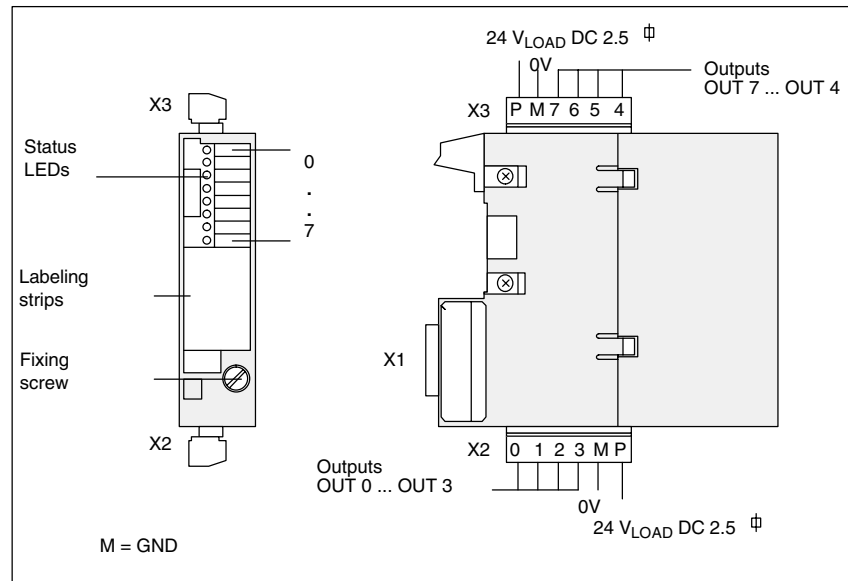

Fig. 8-3 Front view and side view of a DMP compact module 8A

Terminal	P	M (GND)	7/3	6/2	5/1	4/0
X3	24 V	0 V	OUT 7	OUT 6	OUT 5	OUT 4
X2	24 V	0 V	OUT 3	OUT 2	OUT 1	OUT 0

#### Interfaces

- A 30-pole connector X1 for connection to the NCU terminal block.
- 6-way terminals X3 and X2 (Phoenix, type MSTB2.5/6-ST-5.08 GRAY, order no. for X3:18 28 647 and for X2: 18 28 168) for connecting the 8 outputs and the load power supply.
- The terminals are pluggable and can be mechanically coded by the customer.

#### Display elements

8 LEDs as a status display for the logical states of the outputs. As from product version B, the LEDs go out when the load voltage fails.

LEDs lit:            Output on

Table 8-4 Technical data of DMP compact module 80

Number of outputs		8 digital outputs
Galvanic isolation		Yes
Power supply $V_{LOAD}$	<ul style="list-style-type: none"> <li>– Rated value</li> <li>– Perm. range</li> <li>– Ripple</li> </ul>	24 V DC 20.4 V to 28.8 V 3.6 Vpp
Signal level of the outputs (typically)	<ul style="list-style-type: none"> <li>– For signal “0”</li> <li>– For signal “1”</li> </ul>	Open $V_{load} - 80 \text{ mV}$
Output load for signal “1” (rated value)	<ul style="list-style-type: none"> <li>– Ohmic load</li> <li>– Lamp load</li> <li>– Inductive load</li> </ul>	2000 mA 25 W 2000 mA
Short-circuit protection		Yes
Power loss at 30 V		Max. 3.1 W
Operating frequency for	<ul style="list-style-type: none"> <li>– Ohmic load</li> <li>– Lamps</li> <li>– Inductive load (for rated current, higher values are permissible for lower currents)</li> </ul>	100 Hz 11 Hz 2 Hz
Total load capability at 55 °C (relative to the total rated current of all outputs)		50 %
Delay time	for $t_{pLH}$	$t_{pLH} = \text{max. } 0.5 \text{ ms}$
Delay time	for $t_{pHL}$	$t_{pHL} = \text{max. } 0.5 \text{ ms}$
Length for cables	max.	50 m
Weight	about	145 g

**Important**

As of product version B, a new output driver is used for the DMP compact module 80. It behaves as follows:

In the event of a fault triggered by overcurrent or short-circuit, the outputs automatically reconnect after the fault has been rectified.

---

4 outputs each are powered by a power supply. For each group of 4 outputs (outputs 0 to 3 and 4 to 7), the total of the output currents must not be greater than 4 A. (This corresponds to a coincidence factor of 50 % if each output is under full load). All 8 outputs can be loaded simultaneously with 1 A for example.

---

**Important**

If inductive loads are used, switching voltage peaks must be limited by external free-wheeling diodes or RC connections.

---

## 8.4 DMP compact module 1I analog (6FC5111-0CA04-0AA0)

The DMP compact module 1I analog is an encapsulated module. It can be plugged into a slot of the NCU terminal block as a plug-in module. (Maximum of 4 modules per terminal block) The conversion time is a max. of 60 ms in the rated range and a max. of 80 ms in the overshoot range.

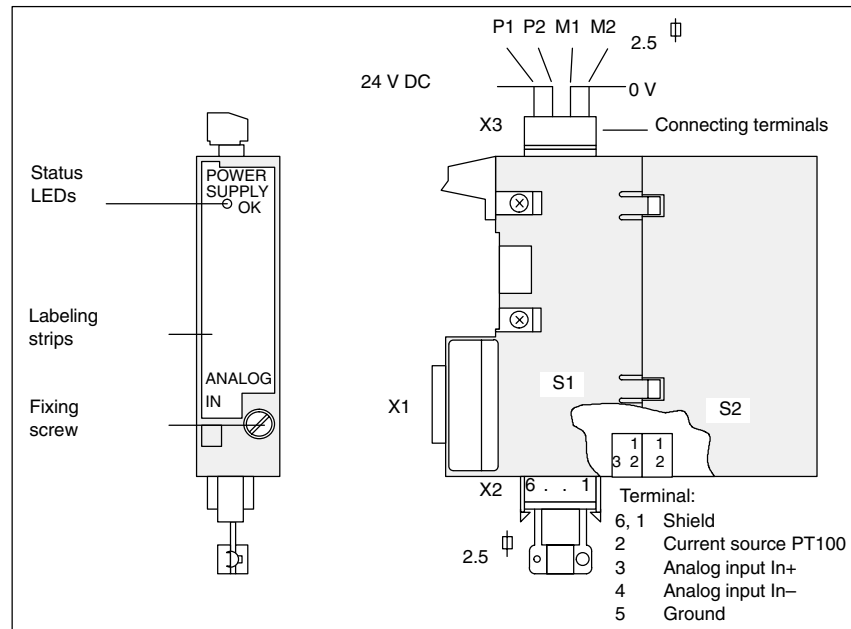

Fig. 8-4 Front view and side view of a DMP compact module 1E analog

### Interfaces

- A 30-pole connector X1 for connection to the NCU terminal block.
- 4-way terminal X3 (Phoenix, Type MSTB2.5/4-ST-5.08 GREY, order no. for X3: 18 48 407) for connecting the power supply for the analog part and 6x terminal X2 (Phoenix, Type MSTB2.5/6-ST-5.08 GREY, order no. for X2: 17 87 076) for connecting the analog input.
- The terminals are pluggable and can be mechanically coded by the customer.

### Display elements

1 LED as a status display for the power supply.

LED lit: internal power supply OK

### Jumpering

S1: Setting of the measurement range

1–2 closed: +10 V

1–3 closed: +500 mV

S2: Setting the line frequency

closed: for 50 Hz systems

open: for 60 Hz systems

8 DMP Compact Modules

8.4 DMP compact module 1I analog (6FC5111-0CA04-0AA0)

**Analog value representation**

The DMP compact module 1I analog is used to input and digitize an analog voltage value. This voltage value is measured by an isolated differential input.

In conjunction with the installed constant current source (2.5 mA), it is possible to connect PT100 resistance thermometers.

**Conversion time**

The conversion time depends on the level of the input voltage.  
Input voltage in the dimensioning range → conversion time < 60 ms.

Input voltage in the overshoot range → conversion time < 80 ms.

The integration time is included in the conversion time, which determines the noise suppression:

S 2 closed → Integration time 20 ms 50 Hz noise suppression.

S 2 open → Integration time 16 2/3 ms 60 Hz noise suppression.

Table 8-5 Digital analog value representation for DMP compact module 1I analog

Input word	IB m								IB m+1						Analog input voltage			
	7	6	5	4	3	2	1	0	7	6	5	4	3	2	1	0	10 V range	500 mV range
Significance	SG	2 <sup>11</sup>	2 <sup>10</sup>	2 <sup>9</sup>	2 <sup>8</sup>	2 <sup>7</sup>	2 <sup>6</sup>	2 <sup>5</sup>	2 <sup>4</sup>	2 <sup>3</sup>	2 <sup>2</sup>	2 <sup>1</sup>	2 <sup>0</sup>	0	OR	PF		
Digital value	0	1	1	1	1	1	1	1	1	1	1	1	1	0	0	0	19.995 V	999.76 mV
	:																	
	0	1	0	0	0	0	0	0	0	0	0	0	1	0	0	0	10.005 V	500.24 mV
	0	1	0	0	0	0	0	0	0	0	0	0	0	0	0	0	10 V	500 mV
	0	0	1	1	1	1	1	1	1	1	1	1	1	0	0	0	9.995 V	499.76 mV
	:																	
	0	0	0	0	0	0	0	0	0	0	0	0	1	0	0	0	0.005 V	0.24 mV
	0	0	0	0	0	0	0	0	0	0	0	0	0	0	0	0	0 V	0 mV
	1	1	1	1	1	1	1	1	1	1	1	1	1	0	0	0	-0.005 V	-0.24 mV
	:																	
	1	1	0	0	0	0	0	0	0	0	0	0	1	0	0	0	-9.995 V	-499.76 mV
	1	1	0	0	0	0	0	0	0	0	0	0	0	0	0	0	-10 V	-500 mV
	1	0	1	1	1	1	1	1	1	1	1	1	1	0	0	0	-10.005 V	-500.24 mV
	:																	
1	0	0	0	0	0	0	0	0	0	0	0	1	0	0	0	-19.995 V	-999.76 mV	

0 = always 0

OR= Overflow bit, input voltage is greater than 20 V or 1 V (double input range)

PF = Power supply failure of the analog part

### Example circuits

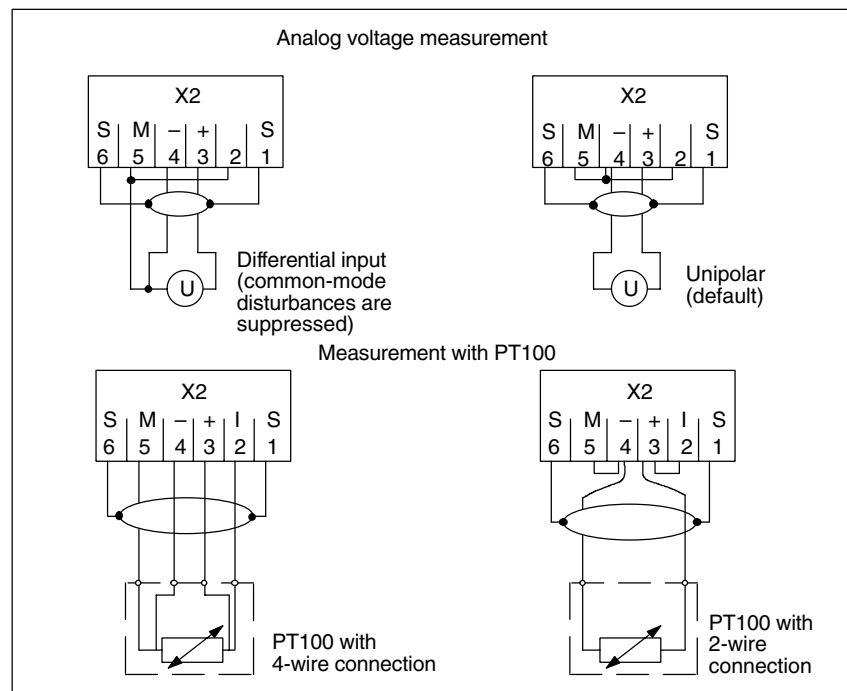

Fig. 8-5 Example circuits for DMP compact module 11 analog

### Note

If the power source is not required, it must be short-circuited.

Table 8-6 Technical data DMP compact module 11 analog

Number of inputs		1 analog input
Galvanic isolation		Yes
Power supply $V_{LOAD}$	<ul style="list-style-type: none"> <li>– Rated value</li> <li>– Perm. range</li> <li>– Ripple</li> </ul>	24 V DC 20.4 V to 28.8 V 3.6 Vpp
Input voltage	<ul style="list-style-type: none"> <li>– Rated range</li> <li>– Overshoot range</li> </ul>	$\pm 10$ V or $\pm 500$ mV+ $\pm 20$ V or $\pm 1$ V
Current consumption (24 V)		45 mA
$I_{const}$ for PT100		2.5 mA
Connection of signal generators		see below
Digital representation of the input signal		12 bits + sign
Error message (input voltage in the overshoot range)		Yes
Basic error limits		$\pm 0.2$ %
Operational limits (0 °C to 60 °C)		$\pm 0.5$ %
Length of cables (shielded)	max.	30 m
Weight	about	150 g

## 8.5 DMP compact module 1I NC analog (6FC5211-0AA10-0AA0)

The DMP compact module 1I NC analog is an encapsulated rapid analog input module with 75  $\mu$ s access time. It can be plugged into a slot of the NCU terminal block as a plug-in module (maximum 4 modules per terminal block).

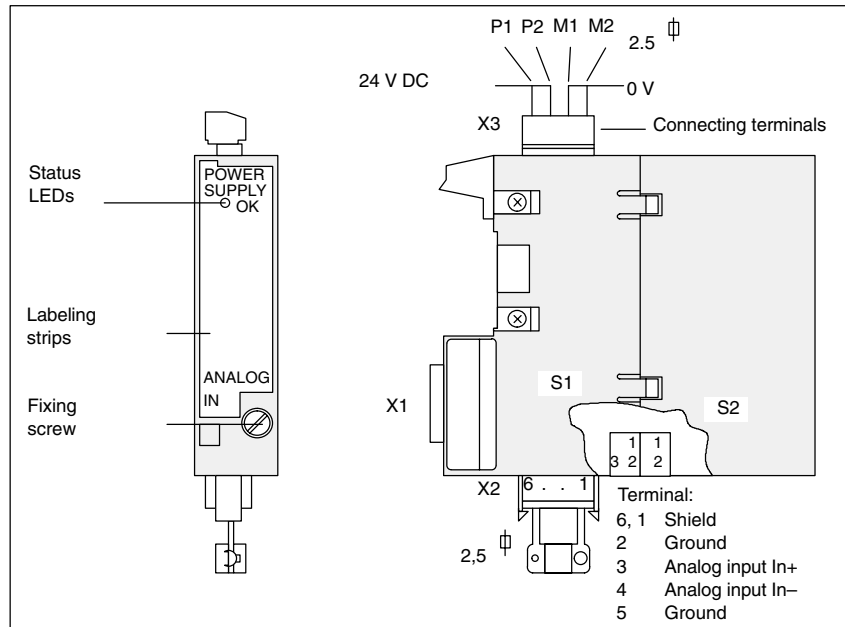

Fig. 8-6 Front view and side view of a DMP compact module 1E NC analog

### Interfaces

- A 30-pole connector X1 for connection to the NCU terminal block.
- 4-way terminal X3 (Phoenix, Type MSTB2.5/4-ST-5.08 GREY, order no. for X3: 18 48 407) for connecting the power supply for the analog part and 6x terminal X2 (Phoenix, Type MSTB2.5/6-ST-5.08 GREY, order no. for X2: 17 87 076) for connecting the analog input.
- The terminals are pluggable and can be mechanically coded by the customer.

### Display elements

1 LED as a status display for the power supply.

LED lit: internal power supply OK

### Analog value representation

The DMP compact module 11 NC analog is used to input and digitize an analog voltage value. This voltage value is measured by an isolated differential input.

The converter result is available to the user in the form of two's complement. The resolution is 4.88 mV for one bit. The duration for a converter cycle (from triggering of conversion to the time at which the result can be read out) is max. 75  $\mu$ s.

Table 8-7 Digital analog value representation for DMP compact module 11 NC analog

Input word	IB m								IB m+1				Analog input voltage				
Significance	7	6	5	4	3	2	1	0	7	6	5	4	3	2	1	0	Range +/- 10 V
	SG	$2^{10}$	$2^9$	$2^8$	$2^7$	$2^6$	$2^5$	$2^4$	$2^3$	$2^2$	$2^1$	$2^0$	0	0	0	PF	
Digital value	0	1	1	1	1	1	1	1	1	1	1	1	0	0	0	0	9.995 V
	:								:				:				
	0	0	0	0	0	0	0	0	0	0	0	1	0	0	0	0	0.005 V
	0	0	0	0	0	0	0	0	0	0	0	0	0	0	0	0	0 V
	1	1	1	1	1	1	1	1	1	1	1	1	0	0	0	0	-0.005 V
	:								:				:				
1	0	0	0	0	0	0	0	0	0	0	1	0	0	0	0	-9.995 V	
1	0	0	0	0	0	0	0	0	0	0	0	0	0	0	0	-10 V	

0 = always 0

PF = Power supply failure of the analog part

### Example circuits

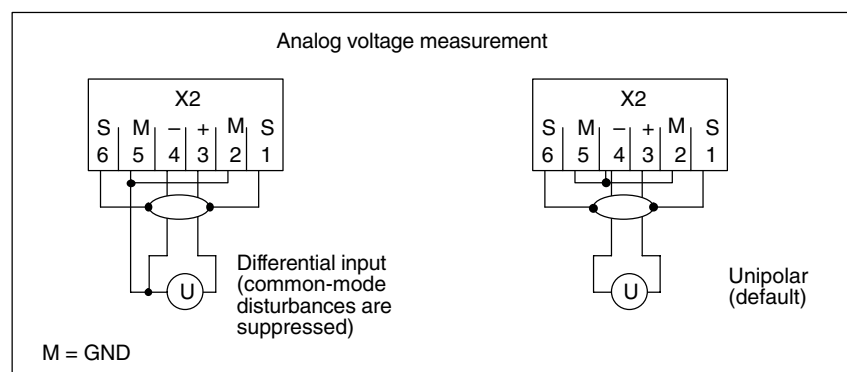

Fig. 8-7 Example circuits for DMP compact module 11 NC analog

## 8 DMP Compact Modules

## 8.5 DMP compact module 11 NC analog (6FC5211-0AA10-0AA0)

Table 8-8 Technical data DMP compact module 11 NC analog

Number of inputs		1 analog input
Galvanic isolation		Yes
Power supply $V_{LOAD}$	<ul style="list-style-type: none"> <li>– Rated value</li> <li>– Perm. range</li> <li>– Ripple</li> </ul>	24 V DC 20.4 V to 28.8 V 3.6 Vpp
Input voltage	– Rated range	$\pm 10$ V
Current consumption (24 V)		85 mA
Connection of signal generators		see below
Digital representation of the input signal		11 bits + sign
Total error over temperature range 0 to 55 °C including zero error		$\pm 0.6$ %
Length of cables (shielded)	max.	30 m
Weight	approx.	160 g

## 8.6 DMP compact module 1O analog (6FC5111-0CA05-0AA0)

The DMP compact module 1O analog is an encapsulated module. It can be plugged into a slot of the NCU terminal block as a plug-in module. (Maximum 4 modules per terminal block)

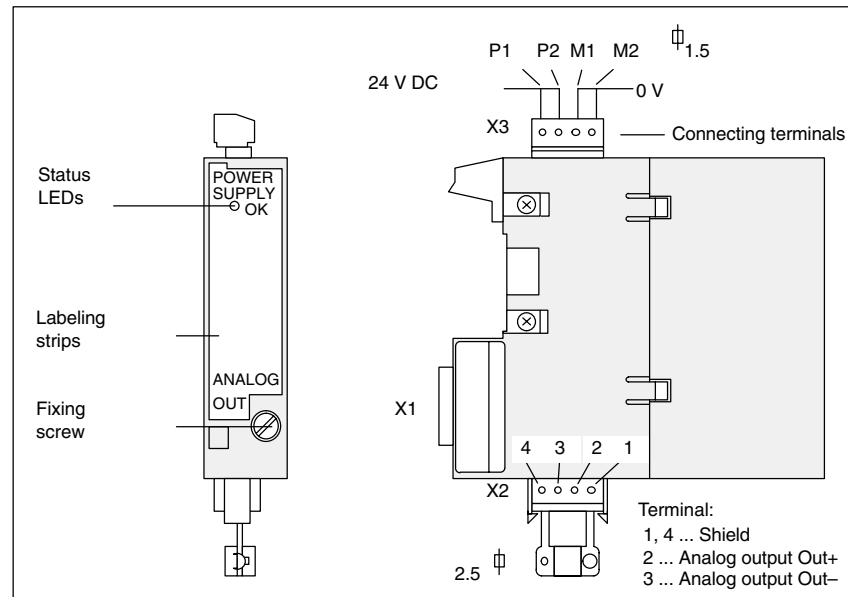

Fig. 8-8 Front view and side view of a DMP compact module 1A analog

### Interfaces

- A 30-pole connector X1 for connection to the NCU terminal block.
- 4-way terminal X3 (Phoenix, Type MC1.5/4-ST-3.81, order no. for X3: 1828126) for connecting the power supply for the analog part and X2 (Phoenix, Type MSTB2.5/4-ST-5.08 GREY, order no. for X2: 18 40 942) for connecting the analog output.
- The terminals are pluggable and can be mechanically coded by the customer.

### Conversion time

The pure conversion time is a max. of 10  $\mu$ s. Because the analog signal is smoothed by an RC element, its time constant determines the total conversion time:

- Product version A: 100  $\mu$ s
- As of product version B: 330  $\mu$ s

### Display elements

1 LED as a status display for the power supply.

LED lit: internal power supply OK

8 DMP Compact Modules

8.6 DMP compact module 1O analog (6FC5111-0CA05-0AA0)

Table 8-9 Digital analog value representation DMP compact module 1O analog

Output word	QB m								QB m+1								Analog output voltage
	7	6	5	4	3	2	1	0	7	6	5	4	3	2	1	0	
Significance	SG	2 <sup>12</sup>	2 <sup>11</sup>	2 <sup>10</sup>	2 <sup>9</sup>	2 <sup>8</sup>	2 <sup>7</sup>	2 <sup>6</sup>	2 <sup>5</sup>	2 <sup>4</sup>	2 <sup>3</sup>	2 <sup>2</sup>	2 <sup>1</sup>	2 <sup>0</sup>	1	0	always 0
Digital value	0	1	1	1	1	1	1	1	1	1	1	1	1	1	0	0	+9.9988 V
	0	0	0	0	0	0	0	0	0	0	0	0	0	1	0	0	+1.22 mV
	0	0	0	0	0	0	0	0	0	0	0	0	0	0	0	0	0 V
	1	1	1	1	1	1	1	1	1	1	1	1	1	1	0	0	-1.22 mV
	1	0	0	0	0	0	0	0	0	0	0	0	0	0	0	0	-10 V

Table 8-10 Technical data DMP compact module 1O analog

Number of outputs	1 analog output
Galvanic isolation	Yes
Power supply V <sub>LOAD</sub>	
– Rated value	24 V DC
– Perm. range	20.4 V to 28.8 V
– Ripple	3.6 Vpp
Power consumption (24 V)	60 mA
Output voltage	– Rated range
	± 10 V DC
Output current	± 3 mA
Load resistance at voltage outputs	min. 3.3 kΩ
Digital representation of the input signal	13 bits + sign
Short-circuit protection	Yes
Length of cables (shielded)	max. 30 m
Weight	about 140 g



# 9

## Maintenance and Service

### 9.1 Battery replacement (6FC5247-0AA18-0AA0)

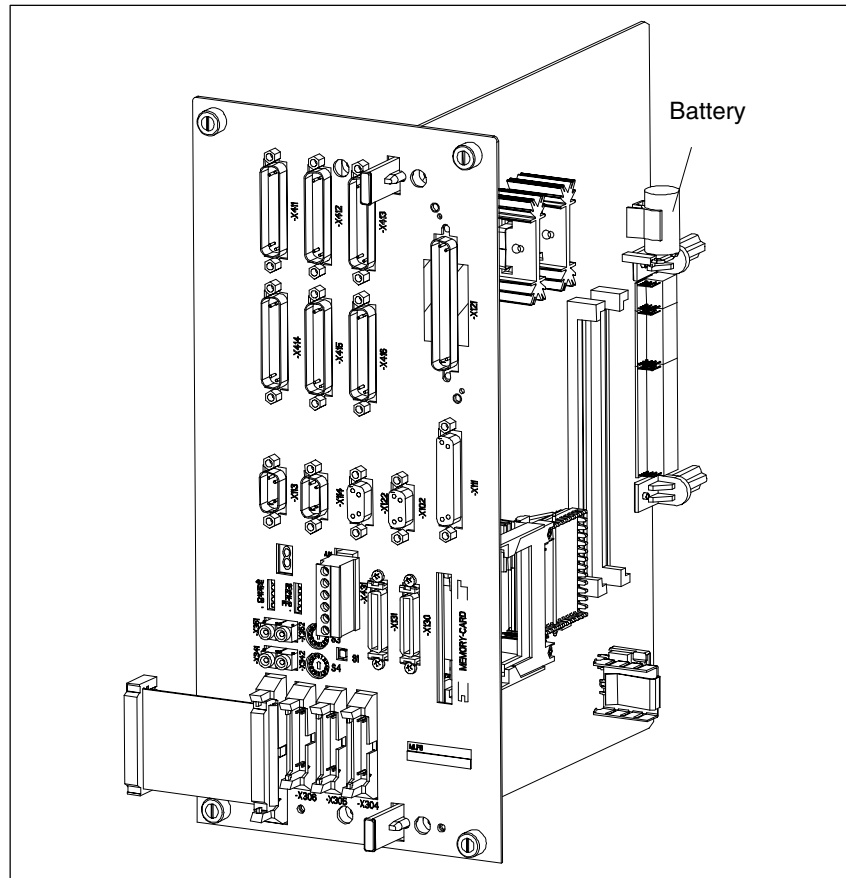

Fig. 9-1 CCU module: Location of battery



#### Danger

Do not attempt to reactivate discharged batteries with heat or by any other means. The batteries must not be recharged because this could cause leakage and/or explosion.

Non-compliance can cause injury to people or damage to property.

## 9 Maintenance and Service

### 9.1 Battery replacement (6FC5247-0AA18-0AA0)

The CCU module features battery-backed SRAMs and clock modules. The back-up voltage is monitored by the control and a monitoring signal is output. The battery must be replaced within 6 weeks of the monitoring responding. The battery can be replaced after the controller has been switched off without any loss of data, as data is retained for approximately 15 minutes.

#### **Backup time**

The service life of the batteries used is a minimum of 3 years.  
The battery must be removed before the module is put into storage.

#### **Replacement of the battery on the CCU module**

The battery is located on the CCU module (see figure 9-1). Before removing the CCU module, please comply with the ESD measures in the Preface and the transportation and storage conditions specified in section 2.2.1 of this manual.

1. Switch off the control.
2. Follow the ESD rules!
3. Remove all connectors, first labeling them if necessary.
4. Loosen the 4 fixing screws of the CCU module and pull it out.
5. Remove the battery and pull out the battery connector. Data backup is ensured for about 15 min by a capacitor.
6. Connect the new battery (ensuring correct polarity) and press it into its holder.
7. Reinsert the CCU module and screw it tight.
8. Plug in all connectors correctly.



# A

## Abbreviations

<b>AC</b>	Alternating Current
<b>AT</b>	Advanced Technology
<b>C-bus</b>	Communication Bus
<b>CCU</b>	Compact Control Unit
<b>CE</b>	Communauté Européenne – European Community
<b>CNC</b>	Computerized Numerical Control
<b>COM</b>	Communication module
<b>CPU</b>	Central Processor Unit
<b>DC</b>	Direct Current
<b>DMP</b>	Distributed Machine Peripherals (I/Os)
<b>DP</b>	Distributed I/Os
<b>DRAM</b>	Dynamic RAM: Dynamic memory (volatile)
<b>EMC</b>	Electromagnetic Compatibility
<b>EnDat</b>	Absolute encoder interface, Heidenhain
<b>ESD</b>	Electrostatic Sensitive Device
<b>EUI</b>	End User Interface
<b>FSD</b>	Feed Drive
<b>HHU</b>	Handheld Unit
<b>HMI</b>	Human Machine Interface: Operating functions of SINUMERIK for operation, programming, and simulation.
<b>HT</b>	Handheld Terminal
<b>HW Config</b>	SIMATIC S7 tool for configuring and parameterizing S7 hardware within an S7 project
<b>I/R</b>	Infeed/regenerative feedback module
<b>IM</b>	Interface Module (SIMATIC S7-300)
<b>ISA</b>	Industry Standard Architecture
<b>LDC</b>	Power Section (power module)

<b>LED</b>	Light Emitting Diode
<b>MCP</b>	Machine Control Panel
<b>MLFB</b>	Machine-Readable Product Designation (order no.)
<b>MPI</b>	Multi Point Interface: Multi-point serial interface
<b>MS</b>	Mains Supply
<b>MSD</b>	Main Spindle Drive
<b>NC</b>	Numerical Control
<b>NCK</b>	Numerical Control Kernel: NC kernel with block preparation, traversing range, etc.
<b>NCU</b>	Numerical Control Unit: NCK hardware unit (SINUMERIK 840D)
<b>OI</b>	Unstabilized power supply
<b>OP</b>	Operator Panel
<b>OPI</b>	Operator Panel Interface
<b>P-bus</b>	Peripherals Bus
<b>PCMCIA</b>	Personal Computer Memory Card International Association
<b>PCU</b>	Personal Computer Unit: NC controller component which allows the operator to communicate with the machine and vice versa.
<b>PG</b>	Programming device
<b>PLC</b>	Programmable Logic Control
<b>PROFIBUS</b>	Process Field Bus: Serial data bus
<b>PS</b>	Power Supply (SIMATIC S7-300)
<b>RAM</b>	Random Access Memory: Program memory that can be read and written to.
<b>SM</b>	SIMATIC S7-300 Signal Module, e.g. I/O modules
<b>SRAM</b>	Static RAM: Static memory (battery-backed)
<b>VGA</b>	Video graphics adapter



# Index

# B

## Numbers

2-axis CCU box, 4-74

3-axis CCU box, 4-71

## A

Alteration for external mounting, 2-axis CCU box, 3-43

Assembly of the 810D, 3-40

Assembly of the SINUMERIK 810D, 3-38

Axis expansion, 1-18

Plug-in unit, 5-77

with SIMODRIVE 611D control plug-in unit, 5-80

## B

Backup battery, transportation, 2-32

Battery replacement, 9-111

## C

Cable distributor, 4-60

Connector, 4-61

DIP FIX switches, 4-61

Location of the ports, 4-61

Pin assignments, 4-62

Cable set for 611D control plug-in unit, 5-81

CCU

Interfaces, 4-51

Mounting, 3-39

Operating and display elements, 4-59

CCU box, installation, 3-38

Climatic environmental conditions, 2-31

Operation, 2-32, 2-33

Transport and storage, 2-31

Coincidence factor, 4-73

Combinations, 1-18

Components of the SINUMERIK 810D, 1-12, 4-47

Connecting cables, 1-17

Conversion time

DMP compact module 1I analog, 8-103, 8-104

DMP compact module 1O analog, 8-109

Current derating, 4-71, 4-74

## D

DAC measuring sockets, 4-59

DC power supplies, 2-24

Device bus, X151, 4-56

Dimension drawing

2-axis CCU box, 3-42

3-axis CCU box, 3-41

Display elements, 4-59

DMP compact module, 8-97

16I, 8-97

16O, 8-99

1I analog, 8-103

1I, NC analog, 8-106

1O analog, 8-109

8O, 8-101

Drive bus, X130, 4-56

Drive functions of SIMODRIVE 611D, 4-49

Dust that can adversely affect function, 2-33

Duty cycles

FSD, 4-72, 4-75

MSD, 4-72

## E

Encoder cables, terminal, 3-44

## F

Function-impairing gases, 2-33

## G

Gases, function-impairing, 2-33

General view of the 810D, 1-14

Grounding concept, 2-28

## H

Heat sink temperature sensor, 4-71

**I**

- I/O interface, X121, 4-54
- Installation altitude, 4-71, 4-74
- Interface configuration,
  - for MPI bus, HHU, HT 6, 1-15
  - with PLC I/Os and NCU terminal block, 1-16
- Interfaces, 4-50
  - Description, 4-52

**K**

- K-bus, X111, 4-53

**L**

- L2-DP interface, X102, 4-53
- Labeling, 1-21
- Labels, 1-21
- Location of the ports, 4-52

**M**

- Maintenance, 9-111
- Measuring channels, 4-66
- Measuring system, 4-63
  - direct, 4-66
  - direct, FSD, 4-68
  - direct, MSD, 4-70
  - indirect, 4-66
  - indirect, FSD, 4-66
  - indirect, MSD, 4-69
- Measuring systems
  - Absolute (EnDat), 4-65
  - Connecting cables, 4-66
  - Incremental, 4-64
- Mechanical data, 2-34
- Mechanical environmental conditions
  - Operation, 2-33
  - Transport and storage, 2-31
- Motor cables, terminal, 3-44
- Motor connection, 4-63
- Motor measuring system, 4-63
- Mounting the shielding plate, 2-axis CCU box, 3-43
- MPI interface, X122, 4-55
- MPI/OPI network rules, 2-35

**N**

- NCU terminal block, 7-91
  - DMP compact modules, 7-93
  - EMC measures, 7-93
  - Monitoring, 7-94
  - Power supply, 7-94
  - Terminal, 7-92
  - Terminator, 7-92
  - X11-X18, 7-95
  - X20/X21, 7-95
- Noise immunity of the complete system, 2-30

**O**

- Operating conditions, 2-32
- Operator controls, 4-59

**P**

- P-bus, X111, 4-53
- PCMCIA card (memory card), 4-76
- PLC module, 4-75
- PLCCPU, 4-75
- Position sensing
  - direct, FSD, 4-68
  - direct, MSD, 4-70
  - indirect, FSD, 4-67
  - indirect, MSD, 4-69
- Power consumption, 2-24
- Power modules, 1-18
- Power modules, integrated
  - 2-axis CCU box, 4-74
  - 3-axis CCU box, 4-71
- Power supply, 2-24
- Power supply module, 3-45
- powerline modules, SINUMERIK 810D/810DE, 1-11
- Protective separation, 2-26
- Pulse interface (axis 3), 4-56

**R**

- Radio interference, 2-33
- RI suppression measures, 2-29
- Ribbon cable, 5-79
  - Connector, 5-78

**S**

Sensor systems, 4-64  
Service, 9-111  
Shielded signal cables, 2-29  
Shielding plate, mounting, 3-41  
Siemens PC card, 4-76  
Signal curve of incremental encoders, 4-64  
Single I/O, address space, 6-89  
Single I/O module, 6-83  
    Dimension drawing, 6-84  
    Electronics power supply, 6-86  
    EMC, 6-84  
    Inputs/outputs, 6-87  
    LED, 6-87  
    Load power supply, 6-86  
    Technical data, 6-85  
    Terminal, 6-83  
    X402, 6-87  
    X404, 6-88  
    X405, 6-89  
Storage conditions, 2-31  
Structure of the SINUMERIK 810D, 3-37  
Supplementary conditions, electrical, 2-23  
Supplementary electrical conditions, 2-23  
System configuration, 1-12

**T**

Technical data of the individual components, 2-34  
Terminal block, X431, 4-58  
Transport conditions, 2-31

**X**

X102, 4-53  
X111, 4-53  
X121, 4-54  
X122, 4-55  
X130, 4-56  
X151, 4-56  
X304, X305, X306, 4-56  
X307, 4-56  
X341, X342, X351, X352, 4-56  
X411-X416, 4-56  
X431, 4-58



To  
 SIEMENS AG  
 A&D MC MS  
 Postfach 3180

D-91050 Erlangen

Phone: +49 (0) 180 5050 – 222 [Hotline]

Fax: +49 (0) 9131 98 – 63315 [Documentation]

<mailto:motioncontrol.docu@siemens.com>

<p><b>From</b></p> <p>Name _____</p> <p>Company/Dept. _____</p> <p>Address _____</p> <p>Zip code: _____ City: _____</p> <p>Telephone: _____ / _____</p> <p>Fax: _____ / _____</p>	<p><b>Suggestions</b></p> <p><b>Corrections</b></p> <p>For publication/manual:</p> <p>SINUMERIK 810D          Configuration CCU</p> <p>Manufacturer/service documentation</p> <p>Equipment Manual</p> <p>Order No.: 6FC5297-7AD10-0BP0          Edition: 03/06</p> <p>Should you come across any printing errors when reading this publication, please notify us on this sheet.          Suggestions for improvement are also welcome.</p>
---	--

**Suggestions and/or corrections**

# Documentation overview SINUMERIK 840D/840Di/810D (03/2006)

## General documentation

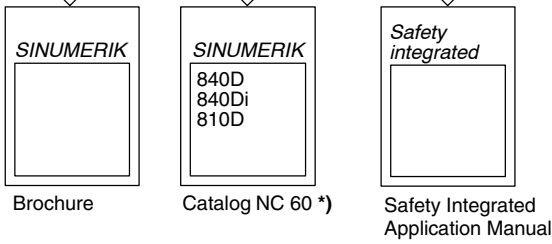

## User documentation

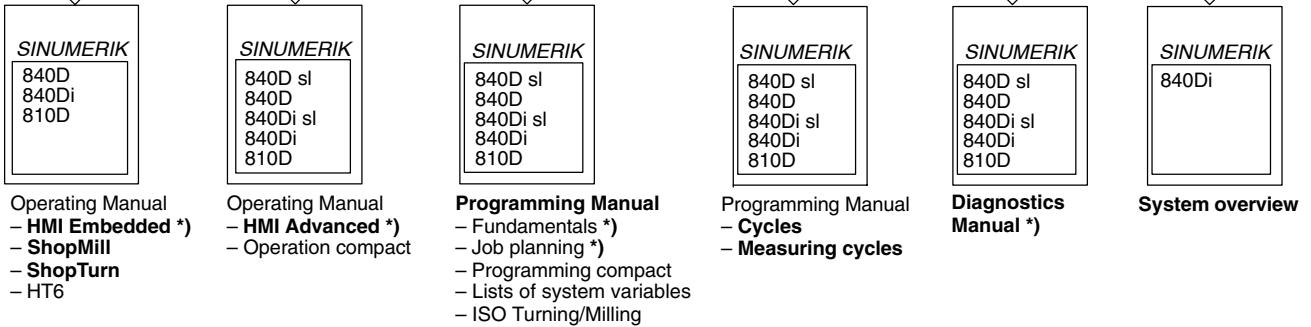

## Manufacturer/service documentation

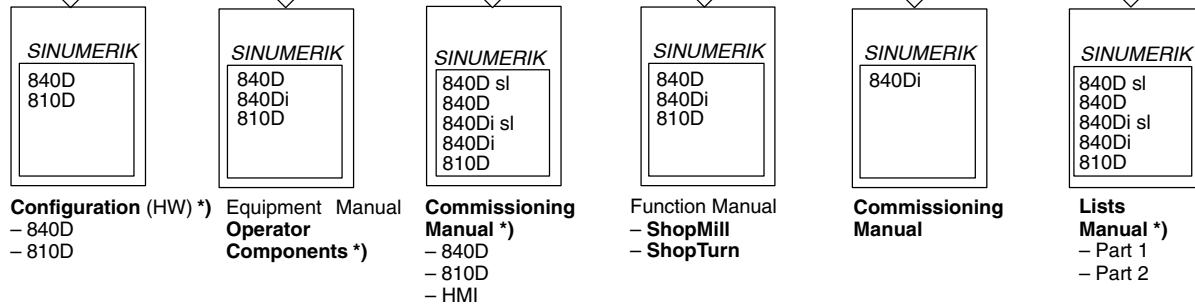

## Manufacturer/service documentation

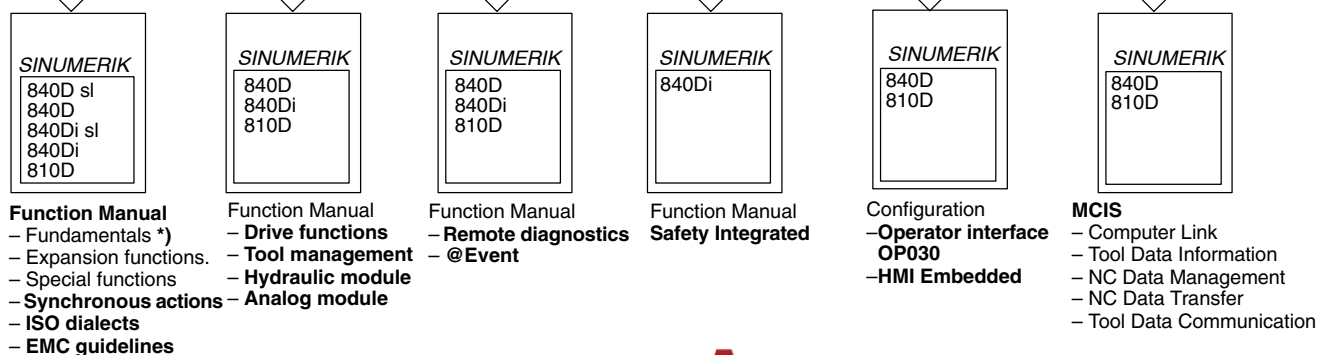

## Electronic Documentation



\*) Recommended minimum scope of documentation