

SIEMENS



www.nicsanat.com

021-87700210



Motion Control

SINUMERIK 828

Equipment for Machine Tools

Catalog
NC 82

Edition
2018

siemens.com/sinumerik

Motion Control
SINUMERIK 840
Equipment for Machine Tools

NC 62



E86060-K4462-A101-A3-7600

SITRAIN
Training for Industry

ITC



www.siemens.com/sitrain

Products for Automation and Drives CA 01
Interactive Catalog
Download



www.siemens.com/ca01download

Industry Mall
Information and Ordering Platform
on the Internet:



www.siemens.com/industrymall

Scan the QR code to download
the SINUMERIK 828 Glossary
as a PDF file to your tablet or
smartphone.



Via the Siemens Industry Mall:

<https://mall.industry.siemens.com/mall/en/en/catalog/products/10229786>



Catalog NC 82 · 2018

Supersedes:
Catalog NC 82 · 2017

Refer to the Industry Mall for current updates of this catalog:

www.siemens.com/industrymall

The products contained in this catalog can also be found in the Interactive Catalog CA 01.

Article No.: E86060-D4001-A510-D8-7500

Please contact your local Siemens branch.

NEW

Click on an Article No. in the catalog PDF to call it up in the Industry Mall and to obtain all the information.

Article No.

6SL3070-0AA00-0AG0
6SL3072-0AA00-0AG0



Or directly on the Internet, e.g.
www.siemens.com/product?6SL3070-0AA00-0AG0



The products and systems described in this catalog are distributed under application of a certified quality management system in accordance with DIN EN ISO 9001. The certificate is recognized by all IQNet countries.

Introduction

Overview of functions
CNC controls SINUMERIK 828

SINUMERIK CNC controls
SINUMERIK 828D

SINAMICS S120 drive system
SINAMICS S120 Combi
SINAMICS S120

SIMOTICS motors
SIMOTICS S-1FK7 feed motors
SIMOTICS M-1PH8 spindle motors

Motion Control Encoder measuring systems
Incremental encoders
Absolute encoders

MOTION-CONNECT connection systems
Connection overviews
Power cables
Signal cables

Services and training
Services
Documentation · Training
Engineering software · Applications

Product Partner SINUMERIK Systems

Appendix
Certificates of suitability
Conversion tables
Metal surcharges
Conditions of sale and delivery/Export regulations

Digital Enterprise

The building blocks that ensure everything works together perfectly in the digital enterprise

Digitalization is already changing all areas of life and existing business models. It is placing greater pressure on industry while at the same time creating new business opportunities. Today, thanks to scalable solutions from Siemens, companies can already become a digital enterprise and ensure their competitiveness.



Industry faces tremendous challenges



Reduce time-to-market

Today manufacturers have to bring products to market at an ever-increasing pace despite the growing complexity of these products. In the past, a major manufacturer would push aside a small one, but now it is a fast manufacturer that overtakes a slow one.



Boost flexibility

Consumers want customized products, but at a price they would pay for a mass-produced item. That only works if production is more flexible than ever before.



Improve quality

To ensure a high level of quality while meeting legal requirements, companies have to establish closed quality loops and enable the traceability of products.

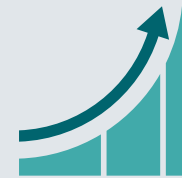

Boost efficiency

Today the product itself needs to be sustainable and environmentally friendly, while energy efficiency in production has become a competitive advantage.



Increase security

Increasing networking escalates the threat to production facilities of cyberattacks. Today more than ever, companies need suitable security measures.



The digital enterprise has already become a reality

To fully benefit from all the advantages of digitalization, companies first have to achieve complete consistency of their data. Fully digitally integrated business processes, including those of suppliers, can help to create a digital representation of the entire value chain. This requires

- the integration of industrial software and automation,
- expansion of the communication networks,
- security in automation,
- and the use of business-specific industrial services.

MindSphere

The cloud-based open IoT operating system from Siemens

With MindSphere, Siemens offers a cost-effective and scalable cloud platform as a service (PaaS) for the development of applications. The platform, designed as an open operating system for the Internet of Things, makes it possible to improve the efficiency of plants by collecting and analyzing large volumes of production data.

Totally Integrated Automation (TIA)

Where digitalization becomes reality

Totally Integrated Automation (TIA) ensures the seamless transition from the virtual to the real world. It already encompasses all the necessary conditions for transforming the benefits of digitalization into true added value. The data that will form the digital twin for actual production is generated from a common base.

Digital Plant

Learn more about the digital enterprise for the process industry
www.siemens.com/digitalplant

Digital Enterprise Suite

Learn more about the digital enterprise for the discrete industry
www.siemens.com/digital-enterprise-suite

Integrated Drive Systems

Faster on the market and in the black with Integrated Drive Systems

Integrated Drive Systems are Siemens' trendsetting answer to the high degree of complexity that characterizes drive and automation technology today. The world's only true one-stop solution for entire drive systems is characterized in particular by its threefold integration: Horizontal, vertical, and lifecycle integration ensure that every drive system component fits seamlessly into the whole system, into any automation environment, and even into the entire lifecycle of a plant.

The outcome is an optimal workflow – from engineering all the way to service that entails more productivity, increased efficiency, and better availability. That's how Integrated Drive Systems reduce time to market and time to profit.

Horizontal integration

Integrated drive portfolio: The core elements of a fully integrated drive portfolio are frequency converters, motors, couplings, and gear units. At Siemens, they're all available from a single source. Perfectly integrated, perfectly interacting. For all power and performance classes. As standard solutions or fully customized. No other player in the market can offer a comparable portfolio. Moreover, all Siemens drive components are perfectly matched, so they are optimally interacting.

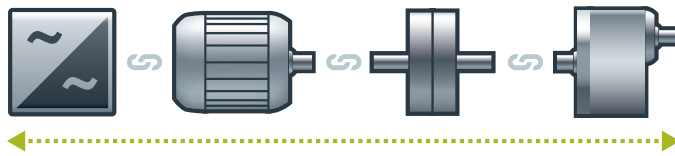

You can boost the availability of your application or plant to up to

99%*
*e.g., conveyor application

Vertical integration

Thanks to **vertical integration**, the complete drive train is seamlessly integrated in the entire automation environment – an important prerequisite for production with maximum value added. Integrated Drive Systems are part of Totally Integrated Automation (TIA), which means that they are perfectly embedded into the system architecture of the entire industrial production process. This enables optimal processes through maximum communication and control.

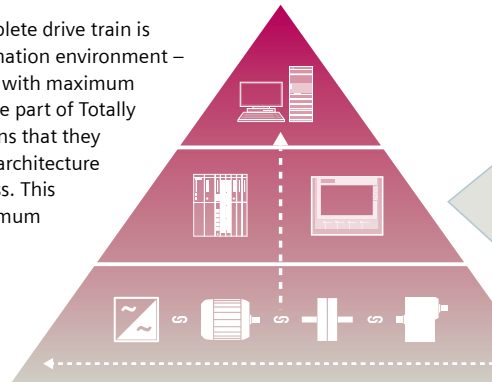

With TIA Portal you can cut your engineering time by up to

30%

Lifecycle integration

Lifecycle integration adds the factor of time: Software and service are available for the entire lifecycle of an Integrated Drive System. That way, important optimization potential for maximum productivity, increased efficiency, and highest availability can be leveraged throughout the system's lifecycle – from planning, design, and engineering to operation, maintenance, and all the way even to modernization.

With Integrated Drive Systems, assets become important success factors. They ensure shorter time to market, maximum productivity and efficiency in operation, and shorter time to profit.

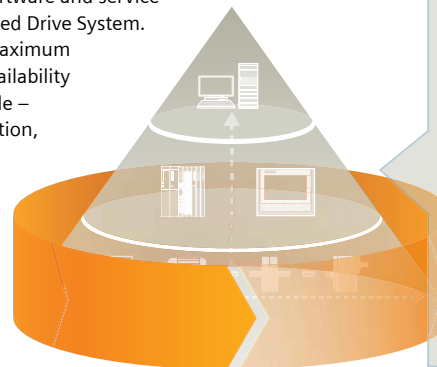

With Integrated Drive Systems you can reduce your maintenance costs by up to

15%

www.siemens.com/ids



1/2	SINUMERIK CNC controls
1/2	SINUMERIK – the CNC portfolio for the global machine tool market
1/3	SINUMERIK 828
1/6	SINAMICS S120 drive system
1/7	SIMOTICS motors
1/8	The overall system
1/8	SINUMERIK 828D with SINAMICS S120 SIMOTICS motors
1/9	Drive Based Safety Integrated
1/11	Energy efficiency



Overview

SINUMERIK – the CNC portfolio for the global machine tool market

From basic, standard CNC machines through standard machine tools up to modular, high-end machine concepts – SINUMERIK CNCs offer the optimum solution for each and every machine concept.

Whether individual part or mass production, basic or complex workpieces – SINUMERIK is the highly productive automation solution across all production domains. These extend from prototype and tool building through moldmaking up to large series production.

<https://siemens.com/sinumerik>

SINUMERIK 808	SINUMERIK 828	SINUMERIK 840
<p>The entry-level CNC for simple standard machines</p> <p>The SINUMERIK 808D ADVANCED control is a panel-based CNC for the lower performance range. The compact and user-friendly entry-level solution is used for basic turning and milling applications. Features such as simple operation, commissioning and maintenance, in conjunction with an optimum cost position, represent the perfect basis for equipping entry-level CNC machines.</p>	<p>The compact CNC for standard machines</p> <p>SINUMERIK 828 control systems are optimally suited for standard machines that are produced in high unit quantities with a low degree of modularity. The powerhouse SINUMERIK 828D in the compact class is the ideal solution for cost-sensitive markets, where high CNC performance and easy commissioning are demanded.</p>	<p>The open CNC for modular machine concepts</p> <p>The SINUMERIK 840D sl offers the absolute maximum in terms of openness and flexibility. This makes the SINUMERIK 840D sl the optimum CNC for machine tools whose mechanical design should be individually adapted to address the requirements of individual users.</p>
		
<ul style="list-style-type: none"> • Panel-based compact CNC • Up to 6 axes/spindles • 1 machining channel • 8.4"-color display • SIMATIC S7-200-based PLC 	<ul style="list-style-type: none"> • Panel-based compact CNC • Up to 10 axes/spindles and 2 auxiliary axes • Up to 2 machining channels T, M, G • 15.6" touch display • SIMATIC S7-200-based PLC 	<ul style="list-style-type: none"> • Drive-based modular CNC • Multi-technology CNC • Up to 93 axes/spindles and any number of PLC axes • Up to 30 machining channels • Modular concept, up to 24" color display • SIMATIC S7-300-based PLC
<p>SINAMICS V70 SIMOTICS S-1FL6</p>	<p>SINAMICS S120 Combi SINAMICS S120 Booksize SIMOTICS</p>	<p>SINAMICS S120 Booksize SINAMICS S120 Chassis SINAMICS S120 Combi SIMOTICS</p>
<p>SINUMERIK 808D ADVANCED</p>	<p>SINUMERIK 828D</p>	<p>SINUMERIK 840D sl</p>

Overview

SINUMERIK 828D – the powerhouse in the compact class of CNCs

With their unique CNC performance, SINUMERIK 828D controls set productivity benchmarks when it comes to milling and turning on standard machines as well as functions to simply automate grinding machines.

Rugged and maintenance-free

Their die-cast magnesium operator panel fronts, the panel-based CNC design with just a few interfaces, as well as a high degree of protection, make SINUMERIK 828D controls a dependable partner even in harsh environments.

Designed without a fan or hard disk, with NVRAM memory technology and no back-up battery, SINUMERIK 828D controls are completely maintenance-free CNCs.

User-friendly

The SINUMERIK 828D CNCs are very easy to operate thanks to a full QWERTY CNC keyboard with short-stroke keys and high-resolution 10.4" TFT color display or 15.6" touch display.

CNC data are quickly and easily transferred via USB, CF card (for 10.4") and RJ45 interfaces on the operator panel front.

Optimum scalability

Based on the three CNC performance versions SW24x, SW26x and SW28x of the SINUMERIK 828D CNCs, favorably-priced compact as well as more complex machines with additional axes/spindles and 2 machining channels can be implemented.



Preconfigured technology for use in standard turning and milling machines

SINUMERIK 828D is perfectly adapted for use in standard machines and provides optimum support for turning and milling technology. With two preconfigured system software variants for machining technology, the SINUMERIK 828D CNC systems are ready for use in turning and milling machines on dispatch from the factory.

An ideal basis for implementing a compact grinding machine

The G-Tech technology variant provides grinding machine manufacturers with a perfect platform on which to design grinding machines – it also supports cylindrical and surface grinding machines.

Since grinding machine manufacturers want to fully incorporate their specific process know-how so that it is even reflected in the operating philosophy of the CNC, the G-Tech variant of the SINUMERIK 828D offers a number of sophisticated grinding and dressing cycles for this purpose. Additionally, SINUMERIK Run MyScreens provides manufacturers with the option of designing their own HMI.

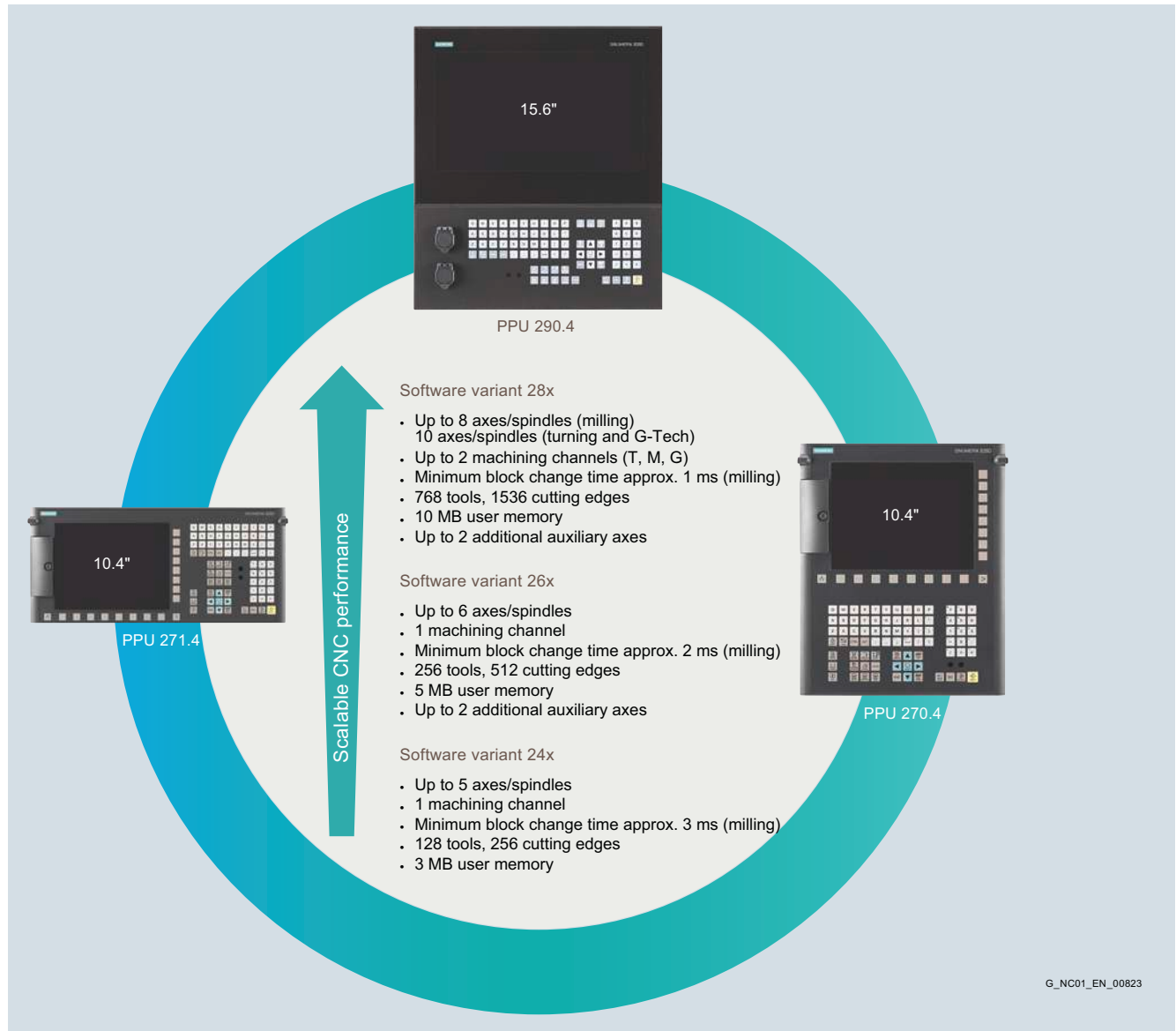

Overview (continued)*The right performance for the relevant technology – scalable by selection of appropriate software*

The SINUMERIK 828D supports three technology variants:

- Turning
- Milling
- G-Tech

The name of the technology variant is added to the end of the software designation. The full software designation is formed in conjunction with the performance variant: SW 2xx Turning for a lathe.

SINUMERIK 828D offers the right performance level for any compact machine. One of three different performance variants can be used depending on the requirements of the application in terms of channels, axis quantity structures, and the cycle times of the interpolator and position controller.

The following variants are available:

- SW 24x
- SW 26x
- SW 28x

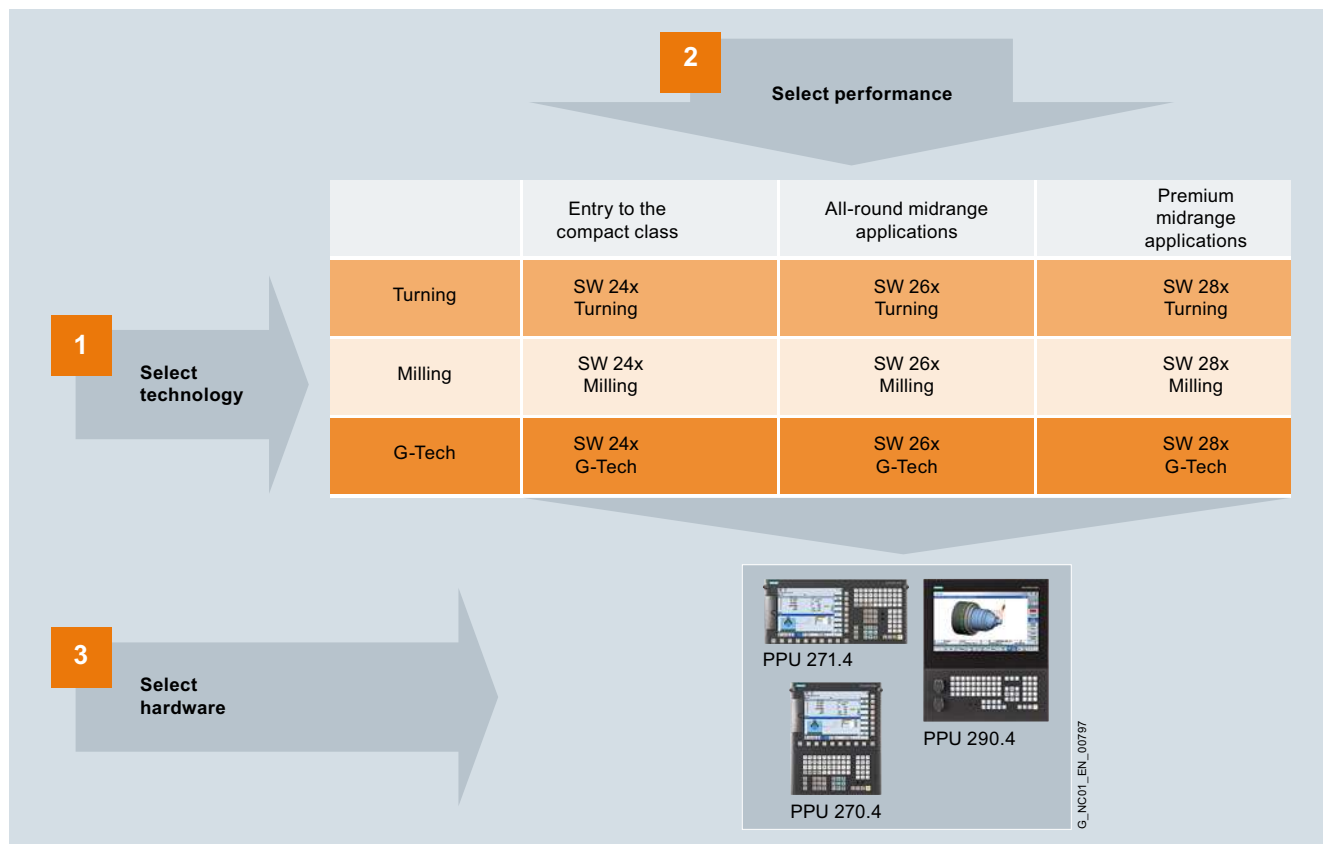
Bundling of software and hardware

The bundling process for software and hardware is completed by selection of a suitable CNC (PPU). Two vertical PPUs 2x0.4 and a horizontal PPU 271.4 are available for selection.

Example 1:

Software package SW 24x Turning is required for a lathe with 4 axes/spindles. It must then be decided whether the vertical or horizontal variant of the CNC will be used.

The horizontal variant is the better option for lathes so that PPU 271.4 is selected for this application example.

Example 2:

Software package SW 26x Milling is required for a milling machine with 6 axes/spindles. It must then be decided whether the vertical or horizontal variant of the CNC will be used.

The vertical variant is the better option for milling machines so that PPU 270.4 is selected for this application example.

Overview

The rugged drive class for compact machine concepts

The SINAMICS S120 Combi drive system offers the usual SINAMICS functionality in a multi-axis drive module tailored for compact turning and milling machines. With a host of technical highlights, the SINAMICS S120 Combi sets new standards in this drive class.

SINAMICS S120 Combi integrates a line infeed with regenerative feedback capability as well as 3 or 4 Motor Modules for spindle and feed motors in one Power Module. The power spectrum extends up to 16 kW spindle power (S1) and up to 12 A current (S1) for feed motors.

SINAMICS S120 Combi thus covers the typical range of power ratings of compact standard turning and milling machines and is the perfect drive partner for the SINUMERIK 828D CNCs.

The solution for machines with more axes and higher power ratings

The SINAMICS S120 Combi Power Module can be extended by the SINAMICS S120 Motor Modules in booksize compact format if the machine has more axes.

For machine concepts beyond the performance limit of the SINAMICS S120 Combi, the SINAMICS S120 modular drive system is available as an alternative for the SINUMERIK 828D CNCs.

The SIZER for Siemens Drives engineering tool will provide you with support for configuring the equipment, or seek advice from your Siemens sales representative.

You will find further information in the Siemens Industry Mall:

www.siemens.com/industrymall



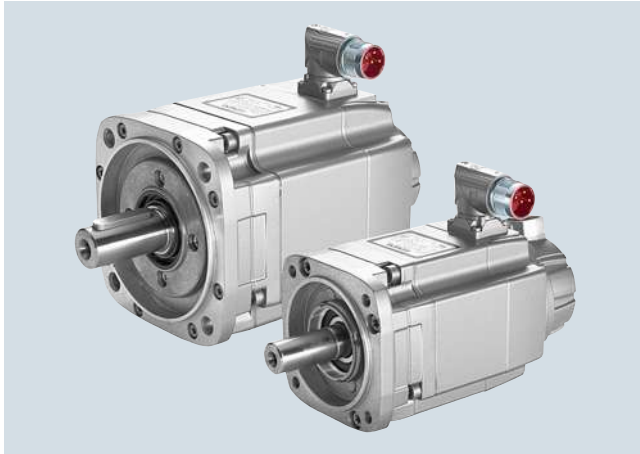

SIMOTICS S-1FK7 feed motors – maximum precision in the machine

The performance and accuracy of the CNC control and drive are useful only if they can be transferred to the machine axes. Thanks to their unique dynamic response and accuracy, SIMOTICS S-1FK7 feed motors are exactly suited for this purpose.

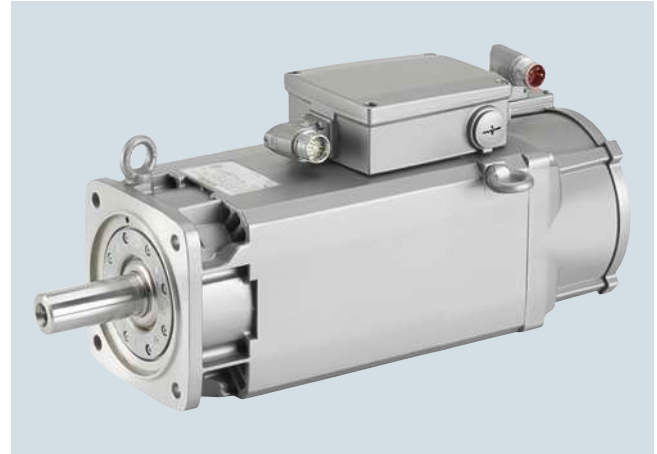

SIMOTICS M-1PH8 spindle motors – peak performance for the spindle

With the SIMOTICS M-1PH8 spindle motors we offer the perfect solution for this purpose. Very fast acceleration times and a wide speed range with high output guarantee maximum productivity of the machine – with speeds of up to 24000 rpm.

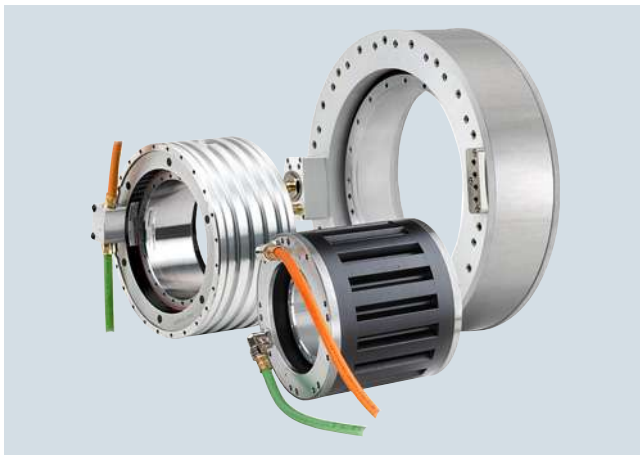

SIMOTICS T-1FW6 torque motors

The torque motors satisfy the most exacting demands in precision, performance and dynamic response. Permanent-magnet synchronous motors with a high number of poles are fully integrated in the machine, and mechanical transmission elements such as gear units are omitted, so you benefit from greater flexibility with regard to installation, easier servicing, higher availability and minimal space requirements.

We can also provide customized solutions

In addition to the range of motors described, we offer a comprehensive range of solutions for feed and spindle applications. Your Siemens sales representative will be happy to advise you on how to configure your individual equipment.

You will find further information, as well as the full range of available motors, in our Catalog NC 62 or on the Siemens Industry Mall at:

www.siemens.com/industrymall

Overview

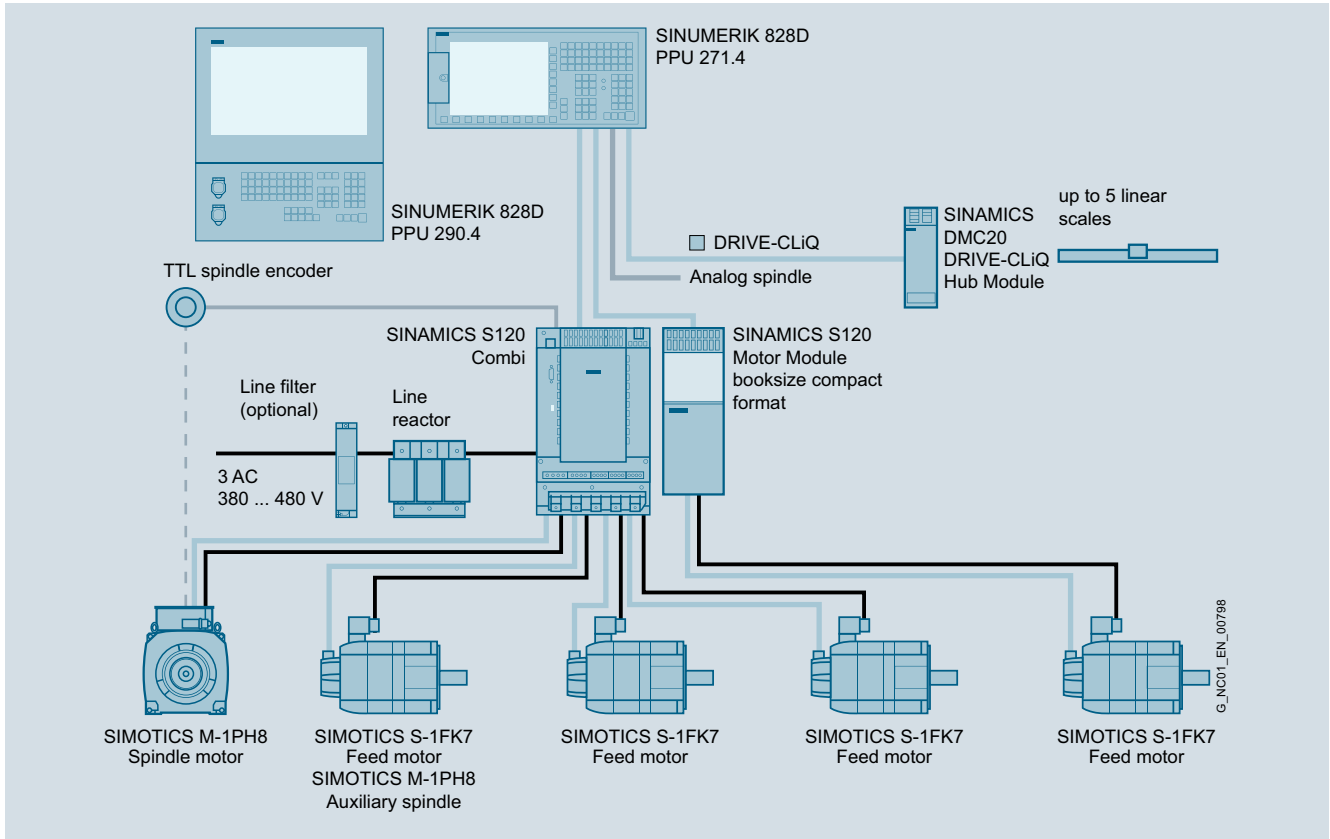

Configuration example

The perfect basis for safe machine concepts

With Safety Integrated, the SINUMERIK 828 CNCs offer an optimum platform for the implementation of safe machine concepts. Operation when protective doors are open? A safe speed monitoring function makes it possible to manage requirements of this type.

The Safety Integrated functions of the SINUMERIK 828D conform to Machinery Directive 2006/42/EC. As a result, it is possible to comply cheaply and efficiently with the machine safety regulations applicable in Europe or other countries.

Material warranty and on-site service

For the worst-case scenario, you will receive a free on-site service contract for a period of 24 months (72 months maximum) for the SINUMERIK 828D and the associated components (except for complete motor spindles) from Siemens DF & PD.

Your benefit: We eliminate any defects on our components free of charge on site, i.e. directly at the site of installation of your machine.

Further information about the conditions and the scope of the warranty and on-site service contract can be found in section Services.

Overview

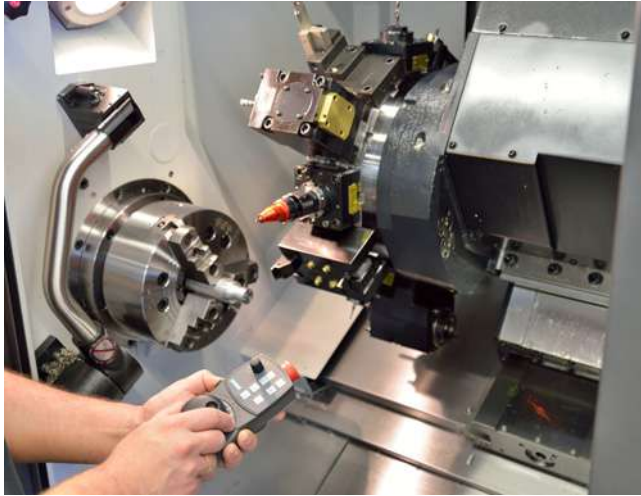

Drive Based Safety Integrated provides integrated safety functions that support the implementation of highly effective personnel and machine protection.

The safety functions comply with the requirements of Category 3 as well as Performance Level PL d according to DIN EN ISO 13849-1 and safety integrity level SIL 2 according to DIN EN 61508. Consequently, important functional safety requirements can be implemented easily and economically.

The functional scope includes, for example:

- Functions for safe monitoring of standstill
- Functions for safe monitoring of speed

Benefits

- High degree of safety:
Full implementation of the safety functions in Category 3/ SIL 2/PL d
- Outstanding flexibility:
Application of practical safety and operating concepts
- Faster commissioning:
Integrated safety functions

Application

For the CNC axes of the SINUMERIK 828D, both the Safety Integrated basic functions (STO, SS1, SBC) and the extended Safety Integrated functions of SINAMICS can be used. The Safety Integrated basic functions are directly controlled via terminals. A SINAMICS S120 TM54F Terminal Module is required for controlling the extended Safety Integrated functions.

For simple positioning tasks, e.g. revolvers, loading systems or tool magazines that require no coordination with the CNC part program, it is possible to connect two auxiliary axes to the SINUMERIK 828D via the I/O interface based on PROFINET using a SINAMICS S120 CU310-2 PN or CU320-2 PN.

The Safety Integrated basic functions of the SINAMICS system can be utilized for these CNC auxiliary axes. The Safety Integrated basic functions are selected by hardware and in 2 channels via terminals on the CU310-2 PN/CU320-2 PN and the Motor Module.

A partially automated acceptance test is provided in SINUMERIK Operate for acceptance testing Safety Integrated functions. All measured data and traces are logged and can be printed out in an acceptance report.

Design

We recommend the following safety relays for the configuration of the safe control logic for individual safety functions:

- SIRIUS 3SK safety relays for configuring a hardware circuit
- SIRIUS 3RK3 Modular Safety System for a graphically parameterizable solution

You will find further information about SIRIUS in Catalog SI 10 or in the Siemens Industry Mall at:

www.siemens.com/industrymall

Mode of operation

Clearly structured screen forms are provided in SINUMERIK Operate to assist with the commissioning of Safety Integrated functions.

Safety status information such as, for example, the name of the currently active Safety Integrated function, is transferred to the CNC via the safety info channel (SIC).

The NCK and drive can exchange signals in the opposite direction via the safety control channel (SCC) for the purpose of conducting the safe brake test, for example.

This solution significantly reduces the wiring outlay for the machine manufacturer.

Function

The safety functions are available in all modes and can communicate with the process using safety-oriented input/output signals. They can be implemented for each individual axis and spindle.

The following Safety Integrated functions are available (terms in accordance with IEC 61800-5-2):

Safety Integrated basic functions (basic version):

- Safe Torque Off (STO)
Suppression of drive pulses, providing safe electronic interruption of the energy supply
- Safe Brake Control (SBC)
Safe brake control of holding brakes which are active in the de-energized state, e.g. motor holding brakes
- Safe Stop 1 (SS1) time-controlled
Safe shutdown of a drive, with subsequent transition into the STO state

The Safety Integrated basic functions are license-free.

The basic functions of Safety Integrated are activated via the terminals of the SINAMICS S120 Combi Power Modules or the SINAMICS S120 Motor Modules in booksize compact format and SINUMERIK 828D.

Extended Safety Integrated functions (option):

- Safe Torque Off (STO)
Suppression of drive pulses, providing safe electronic interruption of the energy supply
- Safe Stop 1 (SS1) time-controlled or speed-controlled
Safe shutdown of a drive, with subsequent transition into the STO state
- Safe Stop 2 (SS2)
Safe stopping of the drive with subsequent monitoring for standstill (SOS)
- Safe Operating Stop (SOS)
Monitors drives for standstill – the drives remain fully functional in the position control
- Safely-Limited Speed (SLS)
Monitoring of 4 configurable velocity limit values, e.g. during setup
- Safe Acceleration Monitor (SAM) / Safe Brake Ramp (SBR)
Safe monitoring of the braking process
- Safe Speed Monitor (SSM)
Safe checkback signal when a value falls below a settable speed limit, e.g. for enabling a protective door
- Safely-Limited Position (SLP)
Selectable traversing range limitation (2 ranges)
- Safe Direction (SDI)
Safe monitoring of the direction of motion
- Safe Brake Management (SBM)
 - Safe Brake Control (SBC)
2-channel braking signal – integrated in the SINAMICS S120 Motor Module
 - Safe Brake Test (SBT) → diagnostic function
Cyclic brake test

The extended Safety Integrated functions require a software license in the form of a CNC option per axis/spindle with Safety functions.

A SINAMICS TM54F Terminal Module is required for controlling the extended Safety Integrated functions.

Function (continued)

Commissioning support:

- Graphical commissioning with SINUMERIK Operate
For each Safety function there is a clear, graphical display available for fast commissioning
- Integrated acceptance test with SINUMERIK Operate
Partially automated acceptance test for all safety-related functions. Simple operation of the test process, automatic configuration of trace functions and automatic generation of an acceptance record.

Integration

- SINUMERIK 828D
- SINAMICS S120 Combi Power Module or SINAMICS S120 Motor Module in booksize compact format
- Motors with encoders that comply with the Safety Integrated specification: SIMOTICS M-1PH8 or SIMOTICS S-1FK7 motors
- Encoder system: If you require information about the use of suitable encoder systems with SINUMERIK Safety Integrated, contact your local Siemens office or regional company.
- Signal cables that comply with the SINAMICS S120 specification: MOTION-CONNECT connection systems
- Controlling the extended Safety Integrated functions: SINAMICS S120 TM54F Terminal Module
- CNC option with software license per axis/spindle with the extended Safety Integrated functions
- 3TK28, 3SK or 3RK3 safety relays

More information

For further information about standards, SINUMERIK Safety Integrated functions and safety function calculations, see:

<https://support.industry.siemens.com/cs/document/109478083>

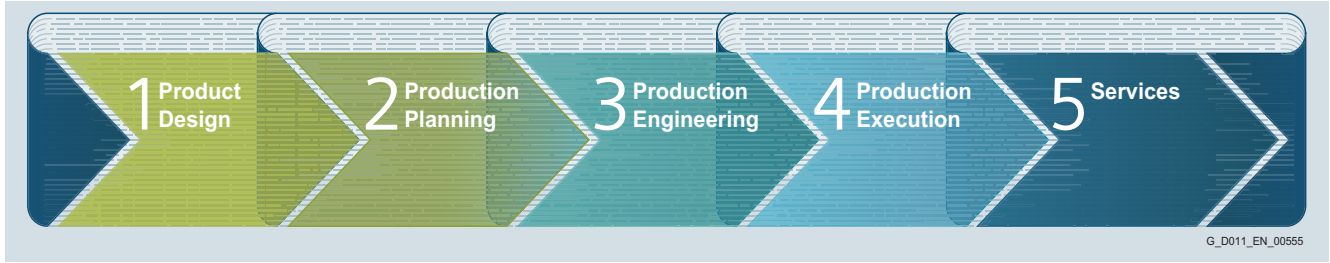

Gerät	Aktuelle Leistung [kW]	Eingespeiste Energie [kWh]	Rückgespeiste Energie [kWh]	Summe Energie [kWh]
Achse X11	-0.065	0.001	0.000	0.001
Achse Y11	-0.085	0.002	0.001	0.001
Achse Z11	-0.017	0.001	0.000	0.001
Achse A11	2.653	0.014	0.010	0.004
Achse C11	0.000	0.000	0.000	-0.000
Achse SP1	-0.000	0.000	0.000	0.000
Achse TM111	0.000	0.000	0.000	-0.000
Achse X12	-0.095	0.001	0.000	0.001
Achse A12	4.326	0.015	0.009	0.006
Achse A21	1.934	0.013	0.011	0.002
Achse A22	3.142	0.015	0.009	0.006
Achse TM112	0.000	0.000	0.000	0.000
Achse TM113	-0.000	0.000	0.000	-0.000
Summe Antriebe	11.083	0.061	0.040	0.021
Sentron PAC	0.000	0.000	0.000	0.000
Summe Maschine	11.083	0.061	0.040	0.021

Representation for a quick overview of the current power and energy consumption



Graphical comparison of two measurements for qualitative evaluation of the energy consumed by a machine tool.

Energy is one of the most important cost factors in industry. Operators can, of course, always make savings here and there, but the full potential for saving energy can only be exploited by taking a holistic view of the entire value chain of a system.

As an innovative partner, we offer industry energy-efficient solutions with products and services for all phases in the product development and production process.

5 steps toward higher energy efficiency

Exploit the full potential of energy efficiency in your production with our comprehensive range of products, systems and solutions, that cover all phases of the product development and production process.

Our energy efficiency concept aims to continuously and comprehensively reduce the energy usage of machines and plants and so increase the competitiveness of our customers.

To achieve this, as a leading technology partner, we accompany all phases of the product development and production process – from product design through production planning and engineering – up to the production itself, and all the associated services.

Only the perfect interaction of all components can achieve maximum energy efficiency in production. Our continual innovations ensure that your investments in energy efficiency pay off more quickly.

Energy monitoring with SENTRON PAC

SETRON PAC measuring devices ensure precise, reproducible and reliable measurement of energy values for infeed, outgoing feeders or individual loads.

Overview of defined energy saving profiles for a machine tool – pre-warning window in the foreground

Energy efficiency with SINUMERIK Ctrl-Energy

Siemens machine tool systems set the standard for energy efficiency in the machine tool: SINUMERIK Ctrl-Energy covers a wide range of highly efficient drive/motor components, CNC/ drive functions, software solutions and services.

SINUMERIK Ctrl-Energy thus offers energy-efficient solutions for the complete machine lifecycle – from the design phase to full operation. For example, intelligent functions, such as the analysis of the energy costs of the workpiece, are available to the user: Pressing the shortcut Ctrl + E helps the SINUMERIK save energy.





2/2	SINUMERIK 828D CNC controls
2/2	Control structure and configuration
2/4	Connectable drives
2/5	Connectable measuring systems
2/5	Connectable motors
2/6	Axis functions
2/6	Spindle functions
2/7	Interpolations
2/8	Couplings
2/9	Transformations
2/10	Measuring functions and measuring
2/10	Technologies
2/11	Motion-synchronous actions
2/11	Engineering
2/12	CNC programming language
2/14	Programming support
2/16	Simulations
2/16	Operating modes
2/18	Tools
2/19	Tool management
2/20	Communication and data management
2/21	Operation
2/22	Monitoring functions
2/23	Compensations
2/23	PLC area
2/25	Safety functions
2/25	Commissioning
2/26	Diagnostic functions
2/26	Remote control of other systems
2/26	Service and maintenance
2/26	SINUMERIK Ctrl-Energy
2/27	<u>Overview of CNC options</u>
2/27	Manufacturer options
2/29	User options
2/32	System overview

The functionality of SINUMERIK 828D CNCs complies with the export list restrictions. Accordingly, these CNCs do not require official approval in accordance with German law as a result of their type.

The following overview lists all the functions that are available with SINUMERIK 828D CNCs. The information in the overview of SINUMERIK 828D functions is based on the following software version:

CNC	Software version
SINUMERIK 828D	4.8

Siemens NC 82 · 2018

Description ✓ Basic version O Option – Not available	Article No. Notes	SINUMERIK 828D		
		SW 24x	SW 26x	SW 28x
Control structure and configuration				
Panel-based compact CNC comprising:		✓	✓	✓
• Compact operator-panel CNC		✓	✓	✓
• CNC/PLC control unit		✓	✓	✓
• Closed-loop control for drives		5	6	6
Design, drive-based/PC-based		–	–	–
Operator-panel CNC:				
• Horizontal		✓	✓	✓
• Vertical		✓	✓	✓
• Color display		10.4"/15.6"	10.4"/15.6"	10.4"/15.6"
• Integrated QWERTY keyboard with short-stroke keys		✓	✓	✓
SINUMERIK operator panels with TCU		–	–	–
SINUMERIK operator panels with PCU		–	–	–
SINUMERIK 828D:				
• PPU 270.4	6FC5370-6AA40-0AA0	O	O	O
• PPU 271.4	6FC5370-5AA40-0AA0	O	O	O
• PPU 290.4	6FC5370-8AA40-0BA0	O	O	O
System software, export version, on CF card, with license				
• SINUMERIK 828D with PPU 270/PPU 271/PPU 290:				
- Turning	6FC5835-1GY40-5YA0	O	–	–
- Milling	6FC5835-2GY40-5YA0	O	–	–
- G-Tech Cylindrical/G-Tech Surface	6FC5835-3GY40-5YA0	O	–	–
- Turning	6FC5834-1GY40-5YA0	–	O	–
- Milling	6FC5834-2GY40-5YA0	–	O	–
- G-Tech Cylindrical/G-Tech Surface	6FC5834-3GY40-5YA0	–	O	–
- Turning	6FC5836-1GY40-5YA0	–	–	O
- Milling	6FC5836-2GY40-5YA0	–	–	O
- G-Tech Cylindrical/G-Tech Surface	6FC5836-3GY40-5YA0	–	–	O
SINUMERIK Operate Embedded HMI		✓	✓	✓
Windows-based HMI		–	–	–
DRIVE-CLiQ drive interface		✓	✓	✓
Numeric Control Extension NX10.3 for applications with up to 8 axes or for reducing the current controller cycle clock to 62.5 µs:	6SL3040-1NC00-0AA0			
• Turning		–	–	O
• Milling		–	O	O
• G-Tech Cylindrical/G-Tech Surface		–	–	O
Numeric Control Extension NX15.3 for applications with up to 10 axes or for reducing the current controller cycle clock to 62.5 µs:	6SL3040-1NB00-0AA0			
• Turning		–	–	O
• Milling		–	–	O
• G-Tech Cylindrical/G-Tech Surface		–	–	O

Description ✓ Basic version O Option – Not available	Article No. Notes	SINUMERIK 828D		
		SW 24x	SW 26x	SW 28x
Control structure and configuration (continued)				
Machining channel, each additional	6FC5800-0AC10-0YB0	–	–	0
Machining channel, maximum:				
• Turning	Basic configuration: 1 machining channel	1	1	2
• Milling	Basic configuration: 1 machining channel	1	1	2
• G-Tech Cylindrical/G-Tech Surface	Basic configuration: 1 machining channel	1	1	2
Mode group, maximum:				
• Turning	Basic configuration: 1 MODE GROUP	1	1	2
• Milling	Basic configuration: 1 MODE GROUP	1	1	1
• G-Tech Cylindrical/G-Tech Surface	Basic configuration: 1 MODE GROUP	1	1	2
Mode group, each additional:	6FC5800-0AC00-0YB0			
• Turning		–	–	0
• Milling		–	–	–
• G-Tech Cylindrical/G-Tech Surface		–	–	0
CNC user memory (buffered) for CNC part programs:				
• Turning		3 MB	5 MB	10 MB
• Milling		3 MB	5 MB	10 MB
• G-Tech Cylindrical/G-Tech Surface		3 MB	5 MB	10 MB
CNC user memory expanded for programs	6FC5800-0AP77-0YB0	–	0 100 MB	0 100 MB
Execution from external storage EES Only limited by the available memory with the following options: Execution from external storage EES (6FC5800-0AP75-0YB0) or expansion of the CNC user memory (6FC5800-0AP77-0YB0)	6FC5800-0AP75-0YB0 Contains the option: CNC user memory expanded for programs 6FC5800-0AP77-0YB0	–	0	0
CNC user memory additionally on user CompactFlash card	CompactFlash card must be ordered separately	✓	✓	✓
HMI user memory additional 256 MB on CompactFlash card of the PPU		–	–	–
Axes/spindles or positioning axis/auxiliary spindle:				
• Basic configuration of axes/spindles:				
- Turning		3	3	3
- Milling		4	4	4
- G-Tech Cylindrical/G-Tech Surface		3	3	3
• Maximum configuration axes/spindles + PLC positioning axes:				
- Turning		5	6 + 2	10 + 2
- Milling		5	6 + 2	8 + 2
- G-Tech Cylindrical/G-Tech Surface		5	6 + 2	10 + 2
Axis/spindle, each additional	6FC5800-0AC20-0YB0	0	0	0
Positioning axis/auxiliary spindle, each additional	6FC5800-0AC30-0YB0	0	0	0
PLC-controlled axis		✓	✓	✓
PLC positioning axis, e.g. CU310-2 PN via I/O interface based on PROFINET, maximum		–	2	2
Systems and number of the TOOLCARRIER:				
• Turning		–	–	–
• Milling		1	1	1
• G-Tech Cylindrical/G-Tech Surface		2	2	4
CNC lock function	6FC5800-0AP76-0YB0	0	0	0

Description ✓ Basic version ○ Option – Not available	Article No. Notes	SINUMERIK 828D		
		SW 24x	SW 26x	SW 28x
Connectable drives				
SINAMICS S120 Motor Modules via DRIVE-CLiQ	See Catalog NC 62	✓	✓	✓
SINAMICS S120 DRIVE-CLiQ on motor	See Motion Control Encoder measuring systems	✓	✓	✓
SINAMICS S120 Sensor Module Cabinet:	See Catalog NC 62			
• SMC20	6SL3055-0AA00-5BA3	○	○	○
• SMC30	6SL3055-0AA00-5CA2	○	○	○
• SMC40	6SL3055-0AA00-5DA0	○	○	○
SINAMICS S120 Sensor Module External:	See Catalog NC 62			
• SME20	6SL3055-0AA00-5EA3	○	○	○
• SME25	6SL3055-0AA00-5HA3	○	○	○
• SME120	6SL3055-0AA00-5JA3	○	○	○
• SME125	6SL3055-0AA00-5KA3	○	○	○
SINAMICS S120, supplementary system components:				
• DMC20 DRIVE-CLiQ Hub Module	6SL3055-0AA00-6AA1	○	○	○
• DME20 DRIVE-CLiQ Hub Module	6SL3055-0AA00-6AB0	○	○	○
SINAMICS S120 Combi	See SINAMICS S120 drive system	○	○	○
SINAMICS S120 Motor Modules Booksize format	See SINAMICS S120 drive system			
• Internal air cooling	6SL3120-...	○	○	○
• External air cooling	6SL3121-...	○	○	○
SINAMICS S120 Active Line Modules Booksize format	See SINAMICS S120 drive system			
• Internal air cooling	6SL3130-...	○	○	○
• External air cooling	6SL3131-...	○	○	○
SINAMICS S120 Smart Line Modules Booksize format	See SINAMICS S120 drive system			
• Internal air cooling	6SL3130-...	○	○	○
• External air cooling	6SL3131-...	○	○	○
SINAMICS S120 Motor Modules Booksize compact format only as expansion axes for SINAMICS S120 Combi:	See SINAMICS S120 drive system			
• Internal air cooling	3SL3420-...	○	○	○
SINAMICS S120 Motor Modules Chassis format Internal air cooling	Rated pulse frequency 2 kHz On request	○	○	○
Analog Drive Interface for 4 axes ADI 4	6FC5211-0BA01-0AA4	–	–	–

Description ✓ Basic version ○ Option – Not available	Article No. Notes	SINUMERIK 828D		
		SW 24x	SW 26x	SW 28x
Connectable measuring systems				
Number of measuring systems per axis, maximum	Not valid for PLC drives	2	2	2
Absolute encoders installed in the motors:				
• SIMOTICS S-1FT7		○	○	○
• SIMOTICS S-1FK7		○	○	○
• SIMOTICS M-1PH8		○	○	○
Incremental encoders installed in the motors:				
• SIMOTICS S-1FT7		○	○	○
• SIMOTICS S-1FK7		○	○	○
• SIMOTICS M-1PH8		○	○	○
Resolvers installed in SIMOTICS S-1FK7 motors		○	○	○
Rotary measuring systems with:				
	See Motion Control Encoder measuring systems			
• sin/cos 1 V _{pp}	6FX2001-3...	○	○	○
• RS422 (TTL)	6FX2001-2...	○	○	○
• Distance-coded reference marks		○	○	○
• EnDat 2.1/EnDat 2.2		○	○	○
• DRIVE-CLiQ	6FX2001-5...	○	○	○
Linear measuring systems LMS with:				
	See Catalog NC 62			
• sin/cos 1 V _{pp}		○	○	○
• Distance-coded reference marks RS422 (TTL)		○	○	○
• EnDat 2.1		○	○	○
Absolute encoder connection with SSI interface		○	○	○
Certified DQI encoders (DQI 100)	See Motion Control Encoder measuring systems	○	○	○
Connectable motors (preferred versions)				
SIMOTICS S-1FK7 servomotor		○	○	○
SIMOTICS S-1FT7 servomotor		○	○	○
SIMOTICS M-1PH8 spindle motor		○	○	○
SIMOTICS M-1FE1 built-in motor	Not with SINAMICS S120 Combi	○	○	○
SIMOTICS L-1FN3 linear motor		○	○	○
SIMOTICS T-1FW6 built-in torque motor		○	○	○
Hybrid spindle/motor spindle 2SP1	www.siemens.com/spindles	○	○	○
Non-Siemens motor	On request	○	○	○

2

2

Description ✓ Basic version O Option – Not available	Article No. Notes	SINUMERIK 828D		
		SW 24x	SW 26x	SW 28x
Axis functions				
Feedrate override		0 ... 200 %	0 ... 200 %	0 ... 200 %
Feedrate override, axis-specific		0 ... 200 %	0 ... 200 %	0 ... 200 %
Traversing range, decades		± 9	± 9	± 9
Rotary axis, turning endlessly		✓	✓	✓
Velocity, maximum		300 m/s	300 m/s	300 m/s
Acceleration with jerk limitation		✓	✓	✓
Programmable acceleration		✓	✓	✓
Follow-up mode		✓	✓	✓
Measuring systems 1 and 2, selectable		✓	✓	✓
Feedrate interpolation		✓	✓	✓
Separate path feedrate for roundings and chamfers		✓	✓	✓
Travel to fixed stop		✓	✓	✓
Travel to fixed stop with Force Control	6FC5800-0AM01-0YB0	0	0	0
Analog axes/spindles				
• Basic configuration		1	1	1
• Maximum configuration via analog axis module (retrofit solution) with two analog axes per HLA module and 1 axis/spindle on the PPU	For further information, go to: https://support.industry.siemens.com/cs/ww/en/view/109475900	5	5	5
Analog axis module (retrofit solution)	6FC5300-0BA01-0AA0 Limited function – only for analog axis	2	2	2
Setpoint exchange		–	–	–
Tangential control:	6FC5800-0AM06-0YB0			
• Turning		–	–	–
• Milling		–	–	–
• G-Tech Cylindrical/G-Tech Surface		0	0	0
Position switching signals/cam controller		–	–	–
Advanced Position Control APC ECO	6FC5800-0AM12-0YB0	0	0	0
Advanced Position Control APC		–	–	–
Spindle functions				
Spindle speed, analog setpoint	Connection to PPU See Analog axes/spindles	1	1	1
Spindle speed, digital setpoint		✓	✓	✓
Spindle speed, max. programmable value range	Display: ± 999999999.9999	10 ⁶ ... 10 ⁻⁴	10 ⁶ ... 10 ⁻⁴	10 ⁶ ... 10 ⁻⁴
Spindle override		0 ... 200 %	0 ... 200 %	0 ... 200 %
Gear stages		5	5	5
Intermediate gear		✓	✓	✓
Gear stage selection, automatic		✓	✓	✓
Oriented spindle stop		✓	✓	✓
Spindle speed limitation min./max.		✓	✓	✓
Constant cutting speed		✓	✓	✓
Spindle control via PLC (positioning, oscillation)		✓	✓	✓
Changeover to axis mode		✓	✓	✓
Axis synchronization on-the-fly		✓	✓	✓
Thread run-in and run-out, programmable		✓	✓	✓
Thread cutting with constant or variable pitch		✓	✓	✓
Tapping with compensating chuck/rigid tapping		✓	✓	✓

Description ✓ Basic version O Option – Not available	Article No. Notes	SINUMERIK 828D		
		SW 24x	SW 26x	SW 28x
Interpolations				
Linear interpolating axes, maximum	Simultaneously interpolating	4	4	4
Circle via center point and end point		✓	✓	✓
Circle via intermediate point		✓	✓	✓
Helical interpolation:		✓	✓	✓
Universal interpolator NURBS (non-uniform rational B splines)		✓	✓	✓
Continuous-path mode with programmable rounding clearance		✓	✓	✓
Multi-axis interpolation > 4 interpolating axes		–	–	–
Advanced Surface:	6FC5800-0AS07-0YB0			
• Turning		–	–	–
• Milling		✓	✓	✓
• G-Tech Cylindrical/G-Tech Surface		–	–	–
Top Surface:	6FC5800-0AS17-0YB0			
	Requirement: Advanced Surface			
• Turning		–	–	–
• Milling		O	O	O
• G-Tech Cylindrical/G-Tech Surface		–	–	–
Nodding compensation ECO	6FC5800-0AS20-0YB0	O	O	O
• A compensation axis can process one influence quantity				
• Adaptive compensation via 3 interpolation points	No rotary axis possible			
Nodding compensation ADVANCED	6FC5800-0AS21-0YB0	O	O	O
• Each compensation axis can process 3 influence quantities				
• Adaptive compensation via 3 interpolation points	No rotary axis possible			
• Unlimited number of compensation axes				
Spline interpolation (A, B and C splines)	6FC5800-0AS16-0YB0	O	O	O
Compressor for 3-axis machining COMPCAD:				
• Turning		–	–	–
• Milling		✓	✓	✓
• G-Tech Cylindrical/G-Tech Surface	Without CYCLE832	✓	✓	✓
Polynomial interpolation		–	–	–
Involute interpolation		–	–	–
Crank interpolation CRIP		–	–	–

Description ✓ Basic version O Option – Not available	Article No. Notes	SINUMERIK 828D		
		SW 24x	SW 26x	SW 28x
Couplings				
Pair of synchronized axes (gantry axes), Basic:	6FC5800-0AS51-0YB0	O	O	O
• Turning		1	1	1
• Milling		1	1	2
• G-Tech Cylindrical/G-Tech Surface		1	1	1
Master-slave Basic for drives	6FC5800-0AS52-0YB0	O	O	O
• Turning		1	1	2
• Milling		1	1	2
• G-Tech Cylindrical/G-Tech Surface		1	1	2
Generic coupling, CP-Static, e.g. counterspindle:	6FC5800-0AM75-0YB0			
• 1 x basic synchronous spindle, coupling ratio 1:1, no multi-edge machining:				
- Turning		–	–	O
- Milling		O	O	O
- G-Tech Cylindrical/G-Tech Surface		O	O	O
Generic coupling, CP-Basic, e.g. multi-edge turning:	6FC5800-0AM72-0YB0			
• 4 axis pairs in simultaneous coupled motion:				
- Turning		O	O	O
- Milling		–	–	–
- G-Tech Cylindrical/G-Tech Surface		O	O	O
• 1 x synchronous spindle/multi-edge turning:				
- Turning		O	O	O
- Milling		–	–	–
- G-Tech Cylindrical/G-Tech Surface		O	O	O
• Master-value coupling/curve table interpolation		–	–	–
Generic coupling CP-Comfort, e.g. electronic gear:	6FC5800-0AM73-0YB0			
• 4 axis pairs in simultaneous coupled motion:				
- Turning		O	O	O
- Milling		–	–	–
- G-Tech Cylindrical/G-Tech Surface		O	O	O
• 1 x synchronous spindle/multi-edge turning:				
- Turning		O	O	O
- Milling		–	–	–
- G-Tech Cylindrical/G-Tech Surface		O	O	O
• Electronic gear for 3 leading axes, without curve table, without cascading:				
- Turning		O	O	O
- Milling		–	–	–
- G-Tech Cylindrical/G-Tech Surface		O	O	O
• Axial coupling in the machine coordinate system		–	–	–
• Master-value coupling/curve table interpolation		–	–	–

Description ✓ Basic version ○ Option – Not available	Article No. Notes	SINUMERIK 828D		
		SW 24x	SW 26x	SW 28x
Transformations				
Cartesian point-to-point travel PTP		✓	✓	✓
TRANSMIT/cylinder surface transformation	6FC5800-0AM27-0YB0	○	○	○
TRANSMIT/TRACYL Transformation without Y axis	6FC5800-0AS50-0YB0	○	○	○
Inclined axis:	6FC5800-0AM28-0YB0			
• Turning	For non-orthogonal Y axis	–	–	○
• Milling		–	–	–
• G-Tech Cylindrical	For non-orthogonal X axis	○	○	○
• G-Tech Surface		–	–	–
Inclined axis Basic, fixed angle:	6FC5800-0AS54-0YB0			
• Turning		–	–	–
• Milling		–	–	–
• G-Tech Cylindrical/G-Tech Surface	For non-orthogonal X axis	○	○	○
Simple oscillation function, modal:				
• Turning		–	–	–
• Milling		–	–	–
• G-Tech Cylindrical/G-Tech Surface		✓	✓	✓
Oscillation function, non-modal, modal and asynchronous:	6FC5800-0AM34-0YB0			
• Turning		–	–	–
• Milling		–	–	–
• G-Tech Cylindrical/G-Tech Surface	CYCLE4071-CYCLE4079	○	○	○
Concatenated transformations inclined axis TRAANG after cardanic milling head/TRANSMIT/TRACYL:				
• Turning		–	–	✓
• Milling		–	–	–
• G-Tech Cylindrical		✓	✓	✓
• G-Tech Surface		–	–	–

Description ✓ Basic version ○ Option – Not available	Article No. Notes	SINUMERIK 828D		
		SW 24x	SW 26x	SW 28x
Measuring functions and measuring cycles				
Measuring stage 1 Two probes switching with/without deletion of distance-to-go		✓	✓	✓
Measuring stage 2 Axial measurement, measurements from synchronized actions, cyclic measurement	6FC5800-0AM32-0YB0			
• Turning		–	–	–
• Milling		–	–	–
• G-Tech Cylindrical/G-Tech Surface		–	○	○
Measuring cycles for drilling/milling and turning Calibration of workpiece probe, workpiece measurement, tool measurement:	6FC5800-0AP28-0YB0			
• Turning		○	○	○
• Milling		○	○	○
• G-Tech Cylindrical/G-Tech Surface		–	–	–
Measure kinematics Determine transformation data of rotary axes:	6FC5800-0AP18-0YB0			
• Turning		–	–	–
• Milling		○	○	○
• G-Tech Cylindrical/G-Tech Surface		–	–	–
Logging of measurement results		✓	✓	✓
Technologies				
Handwheel override		✓	✓	✓
Contour handwheel	6FC5800-0AM08-0YB0	○	○	○
Multiple feedrates in one block:				
• Turning		–	–	–
• Milling		–	–	–
• G-Tech Cylindrical/G-Tech Surface		✓	✓	✓
Continuous dressing, parallel dressing Online modification of tool offset:				
• Turning/milling		–	–	–
• G-Tech Cylindrical/G-Tech Surface		✓	✓	✓
SINUMERIK MDynamics:				
• Advanced Surface:	6FC5800-0AS07-0YB0			
- Turning		–	–	–
- Milling		✓	✓	✓
- G-Tech Cylindrical/G-Tech Surface		–	–	–
• Top Surface:	6FC5800-0AS17-0YB0			
- Turning		–	–	–
- Milling		○	○	○
- G-Tech Cylindrical/G-Tech Surface		–	–	–
• High Speed Settings				
- Turning		–	–	–
- Milling		✓	✓	✓
- G-Tech Cylindrical/G-Tech Surface		–	–	–
• Expansion of user memory using user CompactFlash card:	CompactFlash card must be ordered separately.			
- Turning		–	–	–
- Milling		✓	✓	✓
- G-Tech Cylindrical/G-Tech Surface		✓	✓	✓
Easy connection of robots and handling systems SINUMERIK Run MyRobot /EasyConnect		✓	✓	✓
SINUMERIK Run MyRobot /Handling	6FC5800-0AP72-0YB0	–	–	–
SINUMERIK Run MyRobot /Handling (package)	6FC5800-0AP71-0YB0	–	–	–
SINUMERIK Run MyRobot /Direct control (Run MyCC /ROBX/AR)	6FC5800-0AR05-0YB0	–	–	–

Description ✓ Basic version ○ Option – Not available	Article No. Notes	SINUMERIK 828D		
		SW 24x	SW 26x	SW 28x
Motion-synchronous actions				
CNC inputs/outputs, high-speed:				
• Digital inputs drives onboard		12	12	12
• Digital inputs or outputs drives onboard, parameterizable		8	8	8
• Digital inputs CNC onboard		8	8	8
• Digital outputs CNC onboard		8	8	8
Synchronized actions and fast auxiliary function output incl. 3 synchronous functions		✓	✓	✓
Positioning axes and spindles via synchronized actions (command axes)		✓	✓	✓
Analog value control in the IPO cycle		–	–	–
Evaluation of internal drive variables, Basic	6FC5800-0AS53-0YB0	○	○	○
Asynchronous subprograms ASUB		✓	✓	✓
Interrupt routines with fast retraction from the contour (with subprogram/ASUB/LIFTFAST)		✓	✓	✓
Cross-mode actions (ASUBs and synchronized actions in all operating modes)		✓	✓	✓
Online tool correction:				
• Turning		–	–	–
• Milling		–	–	–
• G-Tech Cylindrical/G-Tech Surface		✓	✓	✓
Display active synchronized actions in HMI:	Included in option: Extended operator functions 6FC5800-0AP16-0YB0			
• Turning		○	○	✓
• Milling		○	○	✓
• G-Tech Cylindrical/G-Tech Surface		○	○	✓
Engineering				
Integrate screens in SINUMERIK Operate SINUMERIK Run MyScreens				
• Free screens		5	5	5
• > 5 screens, extended functions:	6FC5800-0AP64-0YB0			
- Turning		○	○	○
- Milling		○	○	○
- G-Tech Cylindrical/G-Tech Surface		✓	✓	✓
Easy XML:				
• Turning		✓	✓	✓
• Milling		✓	✓	✓
• G-Tech Cylindrical/G-Tech Surface		✓	✓	✓

Description ✓ Basic version ○ Option – Not available	Article No. Notes	SINUMERIK 828D		
		SW 24x	SW 26x	SW 28x
CNC programming language				
Programming language DIN 66025 and high-level language expansion		✓	✓	✓
Main program call from main program and subprogram		✓	✓	✓
Subprogram levels, maximum		11	11	11
Interrupt routines, maximum		4	4	4
Number of subprogram passes		≤ 9999	≤ 9999	≤ 9999
Number of levels for skip blocks		2	2	2
Number of levels for skip blocks, maximum:	Included in option: Extended operator functions 6FC5800-0AP16-0YB0	10	10	10
• Turning		○	○	✓
• Milling		○	○	✓
• G-Tech Cylindrical/G-Tech Surface		○	○	✓
Polar coordinates		✓	✓	✓
1/2/3-point contours		✓	✓	✓
Dimensions metric/inch, changeover via operator action or program		✓	✓	✓
Inverse-time feedrate		✓	✓	✓
Auxiliary function output via:				
• M word, max. programmable value range: INT $2^{31} - 1$... 2^{31}		✓	✓	✓
• H word, max. programmable value range: REAL $\pm 3.4028 \text{ ex}38$, INT $-2^{31} \dots 2^{31} - 1$	Display: ± 999999999.9999	✓	✓	✓
CNC high-level language with:				
• User variables, GUD, configurable		✓	✓	✓
• Predefined user variables (R parameters), commentable		300	300	300
• Predefined global user variables (global R parameters), commentable:				
- Turning		–	–	100
- Milling		–	–	100
- G-Tech Cylindrical/G-Tech Surface		–	–	100
• Predefined user variables LUD (R parameters), configurable		✓	✓	✓
• Read/write system variables		✓	✓	✓
• Indirect programming		✓	✓	✓
• Program jumps and branches		✓	✓	✓
• Dynamic jumps RETB		✓	✓	✓
• Program coordination with WAIT, START, INIT:				
- Turning		–	–	✓
- Milling		–	–	✓
- G-Tech Cylindrical/G-Tech Surface		–	–	✓
• Arithmetic and trigonometric functions		✓	✓	✓
• Comparison operations and logic combinations		✓	✓	✓
• Macro techniques		✓	✓	✓
• Control structures IF-ELSE-ENDIF		✓	✓	✓
• Control structures WHILE, FOR, REPEAT, LOOP		✓	✓	✓
• Commands to HMI		✓	✓	✓
• STRING functions		✓	✓	✓

Description ✓ Basic version O Option – Not available	Article No. Notes	SINUMERIK 828D		
		SW 24x	SW 26x	SW 28x
CNC programming language (continued)				
Program functions:				
• Dynamic preprocessing memory (FIFO)		✓	✓	✓
• Look Ahead, recorded part program blocks:				
- Turning		1	1	1
- Milling with MDynamics Advanced Surface	COMPCAD active	150	300	450
- Milling with MDynamics Top Surface	COMPSURF active	600	600	600
- G-Tech Cylindrical		1	1	1
- G-Tech Surface		150	300	450
• Look Ahead, IPO blocks, buffered:				
- Turning		1	1	1
- Milling with MDynamics Advanced Surface	COMPCAD active	50	100	150
- Milling with MDynamics Top Surface	COMPSURF active	200	200	200
- G-Tech Cylindrical		1	1	1
- G-Tech Surface		50	100	150
• Frame concept		✓	✓	✓
• Inclined-surface machining with swivel cycle:				
- Turning		–	–	–
- Milling		✓	✓	✓
- G-Tech Cylindrical/G-Tech Surface		✓	✓	✓
• Axis/spindle replacement		✓	✓	✓
• Geometry axes, switchable online in the CNC program		✓	✓	✓
• Program preprocessing		✓	✓	✓
Online ISO dialect interpreter:				
• Turning		✓	✓	✓
• Milling		✓	✓	✓
• G-Tech Cylindrical/G-Tech Surface		–	–	–
Program/workpiece management:				
• Part programs on PPU, maximum number Only limited by the available memory with the following options: Execution from external storage EES (6FC5800-0AP75-0YB0) or expansion of the CNC user memory (6FC5800-0AP77-0YB0)	In total maximum 512 files per directory	750	750	750
• Workpieces on PPU, maximum number Only limited by the available memory with the following options: Execution from external storage EES (6FC5800-0AP75-0YB0) or expansion of the CNC user memory (6FC5800-0AP77-0YB0)	In total, maximum 256 directories	250	250	250
• On additional plug-in CompactFlash card		✓	✓	✓
• On USB storage medium, e.g. USB flash drive	Hard disk not possible	✓	✓	✓
• On network drive (Windows Share/FTP)	Included in option: Network drive management via Ethernet 6FC5800-0AP01-0YB0	O	O	O
• Templates for workpieces, programs and INI files		✓	✓	✓
• Job lists		✓	✓	✓
Basic frames, maximum number		1	1	1
Settable offsets, maximum number		50	100	100
Work offsets, programmable (frames)		✓	✓	✓
Work offsets, fit-dependent:	Fit-dependent corrections			
• Turning		–	–	–
• Milling		–	–	–
• G-Tech Cylindrical/G-Tech Surface		✓	✓	✓

Description ✓ Basic version O Option – Not available	Article No. Notes	SINUMERIK 828D		
		SW 24x	SW 26x	SW 28x
CNC programming language (continued)				
Scratching, determining work offset		✓	✓	✓
Work offsets, external via PLC		✓	✓	✓
Global and local user data		✓	✓	✓
Global program user data		✓	✓	✓
Display and log system variables also via online configurable display		–	–	–
Programming support				
Program editor:				
• Programming support for cycles, programGUIDE		✓	✓	✓
• CNC editor with editing functions: select, copy, delete		✓	✓	✓
• Geometry processor with programming graphics/free contour input (contour calculator)		✓	✓	✓
• Screens for 1/2/3-point contours (contour definition programming)		–	–	–
• ShopTurn/ShopMill machining step programming:	6FC5800-0AP17-0YB0			
- Turning		O	O	O
- Milling		O	O	O
- G-Tech Cylindrical/G-Tech Surface		–	–	–
• programSYNC – multi-channel step sequence programming:	6FC5800-0AP05-0YB0			
- Turning		–	–	O
- Milling		–	–	O
- G-Tech Cylindrical/G-Tech Surface		–	–	–
• Manual Machine functions:	Included in option: ShopTurn/ShopMill machining step programming 6FC5800-0AP17-0YB0			
- Turning		O	O	O
- Milling		O	O	O
- G-Tech Cylindrical/G-Tech Surface		–	–	–
• Backup workpiece setup data:	Included in option: Extended operator functions 6FC5800-0AP16-0YB0			
- Turning		O	O	O
- Milling		O	O	O
- G-Tech Cylindrical/G-Tech Surface		O	O	O
• Multiple clamping of various workpieces:	Included in option: ShopTurn/ShopMill machining step programming 6FC5800-0AP17-0YB0			
- Turning		–	–	–
- Milling		O	O	O
- G-Tech Cylindrical/G-Tech Surface		–	–	–

Description ✓ Basic version ○ Option – Not available	Article No. Notes	SINUMERIK 828D		
		SW 24x	SW 26x	SW 28x
Programming support (continued)				
Technology cycles for drilling/milling:	Basic scope			
• Turning		✓	✓	✓
• Milling		✓	✓	✓
• G-Tech Cylindrical/G-Tech Surface		–	–	–
Technology cycles for turning:	Basic scope			
• Turning		✓	✓	✓
• Milling		–	–	–
• G-Tech Cylindrical/G-Tech Surface		–	–	–
Technology cycles for grinding Grinding basic		–	–	–
Extended functions for grinding Grinding advanced:	6FC5800-0AS35-0YB0			
• Dressing (paraxial form-truing) with stock removal cycles (Basic CYCLE95)				
• Cylinder error compensation				
- Turning		–	–	–
- Milling		–	–	–
- G-Tech Cylindrical/G-Tech Surface		○	○	○
Advanced technology functions (expansion of the technology cycles for turning and milling):	6FC5800-0AP58-0YB0			
• Pocket milling with free contour definition and islands:				
- Turning		○	✓	✓
- Milling		○	✓	✓
- G-Tech Cylindrical/G-Tech Surface		–	–	–
• Stock removal cycles with free contour definition:				
- Turning		○	✓	✓
- Milling		–	–	–
- G-Tech Cylindrical/G-Tech Surface		–	–	–
Residual material detection and machining for contour pockets and stock removal:	6FC5800-0AP13-0YB0 Requirement: Advanced technology functions option 6FC5800-0AP58-0YB0			
• Turning		○	○	○
• Milling		○	○	○
• G-Tech Cylindrical/G-Tech Surface		–	–	–
Access protection for cycles	6FC5800-0AP54-0YB0	○	○	○
Programming support can be extended, e.g. customer cycles		✓	✓	✓
DXF Reader for PC integrated in SINUMERIK Operate	6FC5800-0AP56-0YB0	○	○	○
Balance cutting:	6FC5800-0AS05-0YB0			
• Turning		–	–	○
• Milling		–	–	–
• G-Tech Cylindrical/G-Tech Surface		–	–	–
Monitoring for maximum tool speed/acceleration	6FC5800-0AS08-0YB0			
• Turning		○	○	○
• Milling		○	○	○
• G-Tech Cylindrical/G-Tech Surface		○	○	○

Description ✓ Basic version O Option – Not available	Article No. Notes	SINUMERIK 828D		
		SW 24x	SW 26x	SW 28x
Simulations				
Simulation of program X, while program Y is being executed (simulation parallel to machining)		–	–	–
Simulation (finished part) in 2D representation		✓	✓	✓
Simulation 1 (finished part) in 3D representation:	6FC5800-0AP25-0YB0			
• Turning		O	O	O
• Milling		O	O	O
• G-Tech Cylindrical/G-Tech Surface		–	–	–
Simulation finished part and working area in 3D representation		–	–	–
Simulation finished part with collision check in 3D representation		–	–	–
Simultaneous recording (Real-time simulation of current machining operation)	6FC5800-0AP22-0YB0	O	O	O
Operating modes				
JOG:				
• Handwheel selection		✓	✓	✓
• Inch/metric changeover		✓	✓	✓
• Manual measurement of work offset:				
- Turning		✓	✓	✓
- Milling		✓	✓	✓
- G-Tech Cylindrical/G-Tech Surface		–	–	–
• Additional measuring version beyond standard scope: Standard scope workpiece zero: Set edge, align edge, right-angled corner, 1 hole, 1 circular spigot and rectangular spigot Expansion of the measurement screens via combo box	Included in option: Extended operator functions 6FC5800-0AP16-0YB0			
- Turning		–	–	–
- Milling		O	O	O
- G-Tech Cylindrical/G-Tech Surface		–	–	–
• Manual measurement of tool offset:				
- Turning		✓	✓	✓
- Milling		✓	✓	✓
- G-Tech Cylindrical/G-Tech Surface	Manual dresser setup	✓	✓	✓
• Automatic tool/workpiece measurement:				
- Turning		✓	✓	✓
- Milling		✓	✓	✓
- G-Tech Cylindrical/G-Tech Surface	Manual workpiece setup	✓	✓	✓
• Reference point approach, automatic/via CNC program		✓	✓	✓
MDI:				
• Input in text editor		✓	✓	✓
• Load/save MDI program:	Included in option: Extended operator functions 6FC5800-0AP16-0YB0			
- Turning		O	O	O
- Milling		O	O	O
- G-Tech Cylindrical/G-Tech Surface		O	O	O
• Input screen forms for technology and positioning, cycle support		✓	✓	✓

Description ✓ Basic version ○ Option – Not available	Article No. Notes	SINUMERIK 828D		
		SW 24x	SW 26x	SW 28x
Operating modes (continued)				
Teach-in:	Included in option: Extended operator functions 6FC5800-0AP16-0YB0			
• Turning		○	○	○
• Milling		○	○	○
• G-Tech Cylindrical/G-Tech Surface		○	○	○
Automatic:				
• Execution from storage medium connected to CompactFlash card Interface on the operator panel front		✓	✓	✓
• Execution from storage medium connected to the front USB interface of the operator panel, e.g. card reader, USB flash drive	Hard disk not possible	✓	✓	✓
• Execution from storage medium connected to the rear USB interface of the operator panel, e.g. card reader, USB flash drive	Hard disk not possible	✓	✓	✓
• Execution from network drive	Included in option: Network drive management via Ethernet 6FC5800-0AP01-0YB0	○	○	○
• Program control		✓	✓	✓
• Program editing		✓	✓	✓
• Overstore:	Included in option: Extended operator functions 6FC5800-0AP16-0YB0			
- Turning		○	○	○
- Milling		○	○	○
- G-Tech Cylindrical/G-Tech Surface		○	○	○
• DRF offset:	Included in option: Extended operator functions 6FC5800-0AP16-0YB0			
- Turning		○	○	○
- Milling		○	○	○
- G-Tech Cylindrical/G-Tech Surface		○	○	○
• Block search with/without calculation		✓	✓	✓
• Extended block search Program, search pointer, step up and down, interrupt function:	Included in option: Extended operator functions 6FC5800-0AP16-0YB0			
- Turning		○	○	○
- Milling		○	○	○
- G-Tech Cylindrical/G-Tech Surface		○	○	○
Repos (repositioning on the contour):				
• Via operator input/semi-automatically		✓	✓	✓
• Program		✓	✓	✓
Preset:				
• Set actual value		✓	✓	✓

Description ✓ Basic version O Option – Not available	Article No. Notes	SINUMERIK 828D		
		SW 24x	SW 26x	SW 28x
Tools				
Tool types:				
• Turning:				
- Turning		✓	✓	✓
- Milling		–	–	–
- G-Tech Cylindrical/G-Tech Surface		–	–	–
• Drilling/milling:				
- Turning		✓	✓	✓
- Milling		✓	✓	✓
- G-Tech Cylindrical/G-Tech Surface		–	–	–
• Groove sawing:				
- Turning		✓	✓	✓
- Milling		✓	✓	✓
- G-Tech Cylindrical/G-Tech Surface		–	–	–
• Grinding/dressing:				
- Turning		–	–	–
- Milling		–	–	–
- G-Tech Cylindrical/G-Tech Surface		✓	✓	✓
• Multi-tool:				
- Turning		✓	✓	✓
- Milling		✓	✓	✓
- G-Tech Cylindrical/G-Tech Surface		–	–	–
Tool radius compensations in plane with:				
• Approach and retract strategies		✓	✓	✓
• Transition circle/ellipse on outer edges		✓	✓	✓
Configurable intermediate blocks with tool radius compensation active		✓	✓	✓
Tool radius compensation in 3D representation		–	–	–
Tool carrier with orientation capability:				
• Turning		–	–	–
• Milling		✓	✓	✓
• G-Tech Cylindrical/G-Tech Surface		✓	✓	✓
Look-ahead detection of contour violations		✓	✓	✓
Constant grinding wheel peripheral speed GWPS:				
• Turning		–	–	–
• Milling		–	–	–
• G-Tech Cylindrical/G-Tech Surface		✓	✓	✓

Description ✓ Basic version O Option – Not available	Article No. Notes	SINUMERIK 828D		
		SW 24x	SW 26x	SW 28x
Tool management				
Operation with tool management:				
• Real magazines, maximum number:				
- Turning		1	1	2
- Milling		1	1	2
- G-Tech Cylindrical/G-Tech Surface		1	2	2
• Tool list		✓	✓	✓
• Expandable tool list		–	–	–
• Tools in tool list:				
- Turning		128	256	768
- Milling		128	256	768
- G-Tech Cylindrical/G-Tech Surface		128	256	768
• Cutting edges in tool list:				
- Turning		256	512	1536
- Milling		256	512	1536
- G-Tech Cylindrical/G-Tech Surface		256	512	1536
• Tool offset selection via T and D numbers		✓	✓	✓
• Magazine list		✓	✓	✓
• Configurable magazine list		✓	✓	✓
• Magazine data		✓	✓	✓
• Empty location search and location positioning		✓	✓	✓
• Convenient empty location search using softkeys		✓	✓	✓
• Loading and unloading of tools		✓	✓	✓
• Tool cabinet and tool catalog		–	–	–
• Loading and unloading via code carrier system		–	–	–
• Adapter data:				
- Turning		✓	✓	✓
- Milling		–	–	–
- G-Tech Cylindrical/G-Tech Surface		–	✓	✓
• Location-dependent offsets, reference point on wheel:				
- Turning		–	–	–
- Milling		–	–	–
- G-Tech Cylindrical/G-Tech Surface		✓	✓	✓
• Tool life monitoring and workpiece count		✓	✓	✓
• Replacement tools for tool management:	6FC5800-0AM78-0YB0			
- Turning		O	O	O
- Milling		O	O	O
- G-Tech Cylindrical/G-Tech Surface		–	–	–
• Multi-tool tool holder		–	–	–
Manage tools SINUMERIK Manage MyTools		–	–	–

Description ✓ Basic version ○ Option – Not available	Article No. Notes	SINUMERIK 828D		
		SW 24x	SW 26x	SW 28x
Communication and data management				
Transfer data to storage medium on front USB interface of operator panel, e.g. card reader, USB flash drive	Hard disk not possible	✓	✓	✓
Transfer data to the front CF card interface of the operator panel		✓	✓	✓
Transfer process data (WRITE ISOPRINT) to the CF card, USB flash drive or via RS232C interface		✓	✓	✓
Manage additional drives via:				
• Ethernet (Windows Share/Linux/FTP), maximum	6FC5800-0AP01-0YB0	○ 21	○ 21	○ 21
• 2 × USB 3.0 interface rear	1 × reserved for machine control panel	✓	✓	✓
• CF card interface on the operator panel front	Only with PPU 270.4 and PPU 271.4	✓	✓	✓
RS232C serial interface		✓	✓	✓
Data backup of the system software and user data (backup/restore) on the user CF card		✓	✓	✓
Peripheral connection via I/O interface based on PROFINET	Only via PP 72/48D PN or PP 72/48D 2/2A PN I/O modules	✓	✓	✓
Connection to an external PROFINET network with SIMATIC PN/PN coupler	6ES7158-3AD10-0XA0	○	○	○
SIMATIC ET 200SP bus adapter BA 2 × RJ45 2 × RJ45 sockets for PROFINET	6ES7193-6AR00-0AA0	○	○	○
SINUMERIK Create MyInterface		–	–	–
SINUMERIK Access MyBackup		–	–	–
Production data evaluation:				
• SINUMERIK Analyze MyPerformance		–	–	–
Host computer connection Server for OPC UA in SINUMERIK Operate SINUMERIK Access MyMachine:				
• Access MyMachine /OPC UA Variables, maximum number	6FC5800-0AP67-0YB0	○ 100	○ 100	○ 100

Description ✓ Basic version O Option – Not available	Article No. Notes	SINUMERIK 828D		
		SW 24x	SW 26x	SW 28x
Operation				
SINUMERIK operator panels with PCU/TCU		–	–	–
SINUMERIK PCU 50.5 Windows 7		–	–	–
Connection for:				
• Standard monitor (DVI), VGA via ext. adapter, as for PCU 50.5		–	–	–
• SIMATIC OPs		–	–	–
Control unit management:				
• One operator panel per CNC		✓	✓	✓
• Combinations of several operator panels and several CNC controls		–	–	–
Handheld units:				
• SINUMERIK HT 2/HT 8 handheld terminal		–	–	–
• Mini handheld unit with coiled connecting cable	6FX2007-1AD03	O	O	O
• Mini handheld unit with straight cable	6FX2007-1AD13	O	O	O
• Connection kit for mini handheld unit, non-assembled without Industrial Ethernet	6FX2006-1BG03	O	O	O
• Connection kit for mini handheld unit, assembled with PROFINET	6FX2006-1BG20	O	O	O
• 90° angle socket	6FX2006-1BG56	O	O	O
• Holder for mini handheld unit	6FX2006-1BG70	O	O	O
Machine control panels:				
• SINUMERIK MCP 310C PN	6FC5303-0AF23-0AA1	O	O	O
• SINUMERIK MCP 310 USB	6FC5303-0AF33-0AA0	O	O	O
• SINUMERIK MCP 416 USB	6FC5303-0AF34-0AA0	O	O	O
• SINUMERIK MCP 483C PN	6FC5303-0AF22-0AA1	O	O	O
• SINUMERIK MCP 483 USB	6FC5303-0AF32-0AA0	O	O	O
• SINUMERIK MCP Interface PN for customer-specific machine control panel	6FC5303-0AF03-0AA0	O	O	O
• SINUMERIK MPP Machine Push Button Panel		–	–	–
Electronic handwheels:				
• With 120 mm × 120 mm front panel, 5 V DC	6FC9320-5DB01	O	O	O
• With 76.2 mm × 76.2 mm front panel, 5 V DC	6FC9320-5DC01	O	O	O
• With 76.2 mm × 76.2 mm front panel, 24 V DC	6FC9320-5DH01	–	–	–
• Without front panel, without setting wheel, 5 V DC	6FC9320-5DF01	O	O	O
• Without front panel, with setting wheel, 5 V DC	6FC9320-5DM00	O	O	O
• Portable in housing, coiled cable	6FC9320-5DE02	O	O	O
• Flange socket for portable handwheel	6FC9341-1AQ	O	O	O
Connection for electronic handwheels to, max.:		3	3	3
• SINUMERIK PPU		2	2	2
• SINUMERIK MCP Interface PN	Use: Manual machine	1	1	1
Keyboards:				
• Integrated QWERTY keyboard with short-stroke keys		✓	✓	✓
• SINUMERIK keyboards		–	–	–
• KBPC CG US standard PC keyboard		–	–	–
Connection for external storage devices via USB:				
• Card reader USB 2.0 for memory media CF/SD/MMC:	6FC5335-0AA00-0AA0	O	O	O
- 2 GB CompactFlash card	6FC5313-5AG00-0AA2	O	O	O
• USB Flash drive 32 GB including SIMATIC IPC-BIOS-Manager	6AV6881-0AS42-0AA0	O	O	O

Description ✓ Basic version ○ Option – Not available	Article No. Notes	SINUMERIK 828D		
		SW 24x	SW 26x	SW 28x
Operation (continued)				
Extended operator functions	6FC5800-0AP16-0YB0	○	○	○
Plain text display of user variables		✓	✓	✓
Multi-channel display:				
• Turning		–	–	✓
• Milling		–	–	✓
• G-Tech Cylindrical/G-Tech Surface		–	–	✓
2D representation of the 3D protection/working areas		✓	✓	✓
Workpiece-related actual value system		✓	✓	✓
Menu selection via the PLC		✓	✓	✓
CNC program messages		✓	✓	✓
Online help for programming, alarms and machine data, expandable		✓	✓	✓
Screen blanking		✓	✓	✓
Access protection		8 levels	8 levels	8 levels
Operating software languages:				
• Chinese Simplified, Chinese Traditional, English, French, German, Italian, Korean, Korean, Portuguese, Spanish		✓	✓	✓
• Additional languages, use of language extensions		✓	✓	✓
• Language extensions on DVD-ROM: e.g. Bulgarian, Croatian, Czech, Danish, Dutch, Finnish, Greek, Hindi, Hungarian, Indonesian, Japanese, Malaysian, Polish, Romanian, Russian, Slovakian, Slovenian, Swedish, Tamil, Thai, Turkish, Vietnamese - SINUMERIK Operate operating software - SINUMERIK 828	6FC5860-0YC40-0YA8	○	○	○
Monitoring functions				
Working area limitation		✓	✓	✓
Limit switch monitoring software and hardware limit switches		✓	✓	✓
Position monitoring		✓	✓	✓
Standstill monitoring		✓	✓	✓
Clamping monitoring		✓	✓	✓
2D/3D protection areas		✓	✓	✓
Collision avoidance ECO (machine, working area)	6FC5800-0AS03-0YB0 Only single-channel	○	○	○
Collision avoidance (machine, working area)	6FC5800-0AS02-0YB0	–	–	–
Collision avoidance ADVANCED (machine, working area)	6FC5800-0AS04-0YB0	–	–	–
Kinematic chain		✓	✓	✓
Contour monitoring		✓	✓	✓
Contour monitoring with tunnel function		–	–	–
Path length evaluation		–	–	–
Axis limitation from the PLC		✓	✓	✓
Spindle speed limitation		✓	✓	✓
Generator operation		✓	✓	✓
Extended stop and retract ESR, incl. generator operation	6FC5800-0AM61-0YB0	–	–	–
Drive-autonomous extended stop and retract ESR incl. generator operation	6FC5800-0AM60-0YB0	○	○	○
IDM integrated tool monitoring and diagnostics		–	–	–

Description ✓ Basic version ○ Option – Not available	Article No. Notes	SINUMERIK 828D		
		SW 24x	SW 26x	SW 28x
Compensations				
Backlash compensation		✓	✓	✓
Leadscrew error compensation		✓	✓	✓
Leadscrew error compensation, bidirectional	6FC5800-0AM54-0YB0 The correctable tolerance band is restricted to 1 mm.	○	○	○
Measuring system error compensation		✓	✓	✓
Sag compensation, multi-dimensional	6FC5800-0AM55-0YB0 The correctable tolerance band is restricted to 1 mm.	○	○	○
Quadrant error compensation:				
• Conventional		✓	✓	✓
• With neural networks		✓	✓	✓
Graphic monitoring of the quadrant error compensation using circularity test		✓	✓	✓
Friction compensation with adaptive characteristics	6FC5800-0AS06-0YB0	○	○	○
Temperature compensation		✓	✓	✓
Feedforward control, velocity-dependent		✓	✓	✓
Feedforward control, acceleration-dependent				
• Turning		✓	✓	✓
• Milling		✓	✓	✓
• G-Tech Cylindrical/G-Tech Surface		–	–	–
Backlash compensation, dynamic		✓	✓	✓
Cogging torque compensation for 1 axis/spindle	6FC5800-0AD50-0YB0	○	○	○
Cylinder error compensation	Included in option: Technology cycles for grinding Grinding advanced 6FC5800-0AS35-0YB0			
• Turning		–	–	–
• Milling		–	–	–
• G-Tech Cylindrical/G-Tech Surface		○	○	○
PLC area				
SIMATIC S7-300		–	–	–
SIMATIC S7-200 based (integrated)		✓	✓	✓
Cycle time for PLC		9 ms	6 ms	6 ms
Reaction time to process events, terminal to terminal:				
• Turning		7.5 ms	7.5 ms	4.5 ms
• Milling		7.5 ms	7.5 ms	7.5 ms
• G-Tech Cylindrical		7.5 ms	7.5 ms	4.5 ms
• G-Tech Surface		7.5 ms	7.5 ms	7.5 ms
Memory expansion Ladder Steps, maximum	Basic configuration: 24000	32000	32000	32000
Memory expansion to 32000 Ladder Steps	6FC5800-0AD40-0YB0	○	○	○
PLC programming language:				
• Ladder diagram LAD		✓	✓	✓
• Function block diagram FBD		–	–	–
• Statement list STL		–	–	–
PLC programming tool for integrated PLC	On toolbox DVD-ROM	○	○	○
PLC Ladder Viewer in SINUMERIK Operate		✓	✓	✓
PLC re-wire Editor in SINUMERIK Operate	INT100/101 only	✓	✓	✓
PLC Ladder Editor in SINUMERIK Operate	PLC program editor	✓	✓	✓

Description ✓ Basic version ○ Option – Not available	Article No. Notes	SINUMERIK 828D		
		SW 24x	SW 26x	SW 28x
PLC area (continued)				
I/O modules:				
• PP 72/48D PN digital I/O module, maximum number:	6FC5311-0AA00-0AA0	0	0	0
- Turning		3	4	5
- Milling		3	4	5
- G-Tech Cylindrical/G-Tech Surface		3	5	5
• PP 72/48D 2/2A PN I/O module digital/analog, maximum number:	6FC5311-0AA00-1AA0	0	0	0
- Turning		3	4	5
- Milling		3	4	5
- G-Tech Cylindrical/G-Tech Surface		3	5	5
• General I/Os via PROFIBUS/PROFINET		–	–	–
• General SIMATIC PROFINET PLC I/Os		–	–	–
• Analog Drive Interface for 4 axes ADI 4	Replaced by retrofit solution: 6FC5300-0BA01-0AA0	–	–	–
Digital inputs, maximum		216	288	360
Digital outputs, maximum		144	192	240
Analog inputs, maximum:				
• Turning		6	8	10
• Milling		6	8	10
• G-Tech Cylindrical/G-Tech Surface		6	8	10
Analog outputs, maximum:				
• Turning		6	8	10
• Milling		6	8	10
• G-Tech Cylindrical/G-Tech Surface		6	8	10
PLC alarms/messages, maximum number		248	248	248
Extended PLC alarms/messages, maximum number		1000	1000	1000
Bit memories, number		512 bytes	512 bytes	512 bytes
Timers, number		256	256	256
Counters, number		256	256	256
Subroutines		256	256	256
FB, FC		–	–	–
DB, highest number, max. number		64	64	64
Cyclic block		✓	✓	✓
Cyclic block, servo-synchronous		✓	✓	✓
User machine data for configuring the PLC user program		✓	✓	✓
NCVar selector		✓	✓	✓
Import and export of PLC projects PLC file handling via archives		✓	✓	✓
Freely configurable PLC interface		✓	✓	✓

Description ✓ Basic version O Option – Not available	Article No. Notes	SINUMERIK 828D		
		SW 24x	SW 26x	SW 28x
Safety functions				
Drive-based Safety Integrated Safety functions for personnel and machine protection:				
• Safe Torque Off (STO)		✓	✓	✓
• Safe Brake Control (SBC)		✓	✓	✓
• Safe Stop 1 (SS1)		✓	✓	✓
Extended Safety Integrated functions:	6FC5800-0AC50-0YB0	O	O	O
• Safe Torque Off (STO)				
• Safe Stop 1 (SS1)				
• Safe Stop 2 (SS2)				
• Safe Operating Stop (SOS)				
• Safely-Limited Speed (SLS)				
• Safe Acceleration Monitor (SAM) / Safe Brake Ramp (SBR)				
• Safe Speed Monitor (SSM)				
• Safely-Limited Position (SLP)				
• Safe Direction (SDI)				
• Safe Brake Management (SBM) - Safe Brake Control (SBC) - Safe Brake Test (SBT)				
	For one CNC axis/spindle			
SINAMICS S120 Terminal Module Cabinet TM54F for controlling extended Safety Integrated functions	6SL3055-0AA00-3BA0 Required for each PPU and NX.	O	O	O
Commissioning				
Commissioning software for the drive system integrated:				
• SINAMICS S120		✓	✓	✓
Auto Servo Tuning AST Fully automatic speed and position controller optimization		✓	✓	✓
Commissioning trace integrated Drive optimization without an additional oscilloscope		✓	✓	✓
Standard commissioning via:				
• RS232C serial interface		–	–	–
• USB interface with storage medium, e.g. USB flash drive	Hard disk not possible Import/export INI file	✓	✓	✓
• Network drive		✓	✓	✓
• User CompactFlash card		✓	✓	✓
• SINUMERIK Access MyMachine /P2P for PC/PG	6FC5860-7YC00-0YA0 Product-ID: MCS31401	O	O	O
STARTER commissioning tool for PC/PG for SINAMICS S120	On toolbox DVD-ROM	O	O	O
SinuCom commissioning/service tools for SINUMERIK 840D sl		–	–	–

Description ✓ Basic version ○ Option – Not available	Article No. Notes	SINUMERIK 828D		
		SW 24x	SW 26x	SW 28x
Diagnostic functions				
Alarms and messages		✓	✓	✓
Action log can be activated for diagnostic purposes		✓	✓	✓
PLC status		✓	✓	✓
LAD display		✓	✓	✓
PLC remote diagnostics via modem		✓	✓	✓
PLC remote diagnostics via Ethernet		✓	✓	✓
Integrated spindle monitor (S-Monitor):	6FC5800-0AP55-0YB0			
• Turning		–	○	○
• Milling		–	○	○
• G-Tech Cylindrical/G-Tech Surface		–	–	–
Easy Message Machine status transfer using text messages (SMS) requires a telecontrol system with antenna and modem cable:				
• MODEM MD720 GSM/GPRS, 2G	6NH9720-3AA01-0XX0	○	○	○
• ANT 794-4MR antenna	6NH9860-1AA00	○	○	○
• Modem cable	6NH7701-5AN	○	○	○
Remote diagnostics and data transfer:				
• SINUMERIK Access MyMachine /P2P	6FC5800-0AP30-0YB0 Product-ID: MCS3140	○	○	○
	Connection of a modem router to X127			
• SINUMERIK Access MyMachine /P2P for PC/PG – data transfer between PC/PG and CNCs	6FC5860-7YC00-0YA0 Product-ID: MCS31401	○	○	○
Remote control of other systems				
Remote desktop control with VNC Viewer		✓	✓	✓
Service and maintenance				
Integrated service planner for the monitoring of service intervals		✓	✓	✓
Easy Extend Simply extends optional machine components		✓	✓	✓
SINUMERIK Ctrl-Energy				
Intelligent standby control of the machine Ctrl-E profiles		✓	✓	✓
Measurement and evaluation of the total energy consumption of the machine and the drive system Ctrl-E analysis:				
• Transfer of manual values from the PLC		✓	✓	✓
• SENTRON PAC3200 measuring device for front panel mounting records 50 measured values	7KM2112-0BA00-3AA0	○	○	○
• SENTRON PAC4200 measuring device for front panel mounting records 200 measured values	7KM4212-0BA00-3AA0	○	○	○
Flux reduction:				
• Turning		✓	✓	✓
• Milling		✓	✓	✓
• G-Tech Cylindrical/G-Tech Surface		–	–	–
Reactive-current compensation	Only with SINAMICS S120 Active Line Module	–	–	–

Description ✓ Basic version ○ Option – Not available	Article No. Notes	SINUMERIK 828D		
		SW 24x	SW 26x	SW 28x
Manufacturer options				
Axis/spindle, each additional	6FC5800-0AC20-0YB0	○	○	○
Positioning axis/auxiliary spindle, each additional	6FC5800-0AC30-0YB0	○	○	○
Machining channel, each additional	6FC5800-0AC10-0YB0	–	–	○
Mode group, each additional:	6FC5800-0AC00-0YB0			
• Turning		–	–	○
• Milling		–	–	–
• G-Tech Cylindrical/G-Tech Surface		–	–	○
TRANSMIT/cylinder surface transformation	6FC5800-0AM27-0YB0	○	○	○
TRANSMIT/TRACYL Transformation without Y axis	6FC5800-0AS50-0YB0	○	○	○
Inclined axis:	6FC5800-0AM28-0YB0			
• Turning	For non-orthogonal Y axis	–	–	○
• Milling		–	–	–
• G-Tech Cylindrical	For non-orthogonal X axis	○	○	○
• G-Tech Surface		–	–	–
Inclined axis Basic, fixed angle:	6FC5800-0AS54-0YB0			
• Turning		–	–	–
• Milling		–	–	–
• G-Tech Cylindrical/G-Tech Surface	For non-orthogonal X axis	○	○	○
Oscillation function, non-modal, modal and asynchronous:	6FC5800-0AM34-0YB0			
• Turning		–	–	–
• Milling		–	–	–
• G-Tech Cylindrical/G-Tech Surface	CYCLE4071-CYCLE4079	○	○	○
Measuring stage 2 Axial measurement, measurements from synchronized actions, cyclic measurement	6FC5800-0AM32-0YB0			
• Turning		–	–	–
• Milling		–	–	–
• G-Tech Cylindrical/G-Tech Surface		–	○	○
Pair of synchronized axes (gantry axes), Basic:	6FC5800-0AS51-0YB0	○	○	○
• Turning		1	1	1
• Milling		1	1	2
• G-Tech Cylindrical/G-Tech Surface		1	1	1
Travel to fixed stop with Force Control	6FC5800-0AM01-0YB0	○	○	○
Tangential control:	6FC5800-0AM06-0YB0			
• Turning		–	–	–
• Milling		–	–	–
• G-Tech Cylindrical/G-Tech Surface		○	○	○
Generic coupling, CP-Static, e.g. counterspindle:	6FC5800-0AM75-0YB0			
• 1 x basic synchronous spindle, coupling ratio 1:1, no multi-edge machining:				
- Turning		–	–	○
- Milling		○	○	○
- G-Tech Cylindrical/G-Tech Surface		○	○	○
Generic coupling, CP-Basic, e.g. multi-edge turning:	6FC5800-0AM72-0YB0			
• 4 axis pairs in simultaneous coupled motion:				
- Turning		○	○	○
- Milling		–	–	–
- G-Tech Cylindrical/G-Tech Surface		○	○	○
• 1 x synchronous spindle/multi-edge turning:				
- Turning		○	○	○
- Milling		–	–	–
- G-Tech Cylindrical/G-Tech Surface		○	○	○
• Master-value coupling/curve table interpolation		–	–	–

Description ✓ Basic version ○ Option – Not available	Article No. Notes	SINUMERIK 828D		
		SW 24x	SW 26x	SW 28x
Manufacturer options (continued)				
Generic coupling CP-Comfort, e.g. electronic gear:	6FC5800-0AM73-0YB0			
• 4 axis pairs in simultaneous coupled motion:				
- Turning		○	○	○
- Milling		–	–	–
- G-Tech Cylindrical/G-Tech Surface		○	○	○
• 1 x synchronous spindle/multi-edge turning:				
- Turning		○	○	○
- Milling		–	–	–
- G-Tech Cylindrical/G-Tech Surface		○	○	○
• Electronic gear for 3 leading axes, without curve table, without cascading:				
- Turning		○	○	○
- Milling		–	–	–
- G-Tech Cylindrical/G-Tech Surface		○	○	○
• Axial coupling in the machine coordinate system		–	–	–
• Master-value coupling/curve table interpolation		–	–	–
Leadscrew error compensation, bidirectional	6FC5800-0AM54-0YB0 The correctable tolerance band is restricted to 1 mm.	○	○	○
Sag compensation, multi-dimensional	6FC5800-0AM55-0YB0 The correctable tolerance band is restricted to 1 mm.	○	○	○
Master-slave Basic for drives	6FC5800-0AS52-0YB0	○	○	○
• Turning		1	1	2
• Milling		1	1	2
• G-Tech Cylindrical/G-Tech Surface		1	1	2
Evaluation of internal drive variables, Basic	6FC5800-0AS53-0YB0	○	○	○
SINUMERIK Operate Runtime license OA Easy Screen SINUMERIK Run MyScreens				
> 5 screens, extended functions	6FC5800-0AP64-0YB0			
• Turning		○	○	○
• Milling		○	○	○
• G-Tech Cylindrical/G-Tech Surface		✓	✓	✓
Extended Safety Integrated functions for one CNC axis/spindle	6FC5800-0AC50-0YB0	○	○	○
Access protection for cycles	6FC5800-0AP54-0YB0	○	○	○
Drive-autonomous extended stop and retract ESR incl. generator operation	6FC5800-0AM60-0YB0	○	○	○
Integrated spindle monitor (S-Monitor):	6FC5800-0AP55-0YB0			
• Turning		–	○	○
• Milling		–	○	○
• G-Tech Cylindrical/G-Tech Surface		–	–	–
Memory expansion to 32000 Ladder Steps	6FC5800-0AD40-0YB0	○	○	○
Balance cutting:	6FC5800-0AS05-0YB0			
• Turning		–	–	○
• Milling		–	–	–
• G-Tech Cylindrical/G-Tech Surface		–	–	–
Friction compensation with adaptive characteristics	6FC5800-0AS06-0YB0	○	○	○
CNC lock function	6FC5800-0AP76-0YB0	○	○	○

Description ✓ Basic version ○ Option – Not available	Article No. Notes	SINUMERIK 828D		
		SW 24x	SW 26x	SW 28x
Manufacturer options (continued)				
Advanced Position Control APC ECO	6FC5800-0AM12-0YB0	○	○	○
Collision avoidance ECO (machine, working area)	6FC5800-0AS03-0YB0 Only single-channel	○	○	○
Collision avoidance (machine, working area)	6FC5800-0AS02-0YB0	–	–	–
Collision avoidance ADVANCED (machine, working area)	6FC5800-0AS04-0YB0	–	–	–
Nodding compensation ECO • A compensation axis can process one influence quantity • Adaptive compensation via 3 interpolation points	6FC5800-0AS20-0YB0 No rotary axis possible	○	○	○
Nodding compensation ADVANCED • Each compensation axis can process 3 influence quantities • Adaptive compensation via 3 interpolation points • Unlimited number of compensation axes	6FC5800-0AS21-0YB0 No rotary axis possible	○	○	○
User options				
Extended functions for grinding Grinding advanced:	6FC5800-0AS35-0YB0			
• Dressing (paraxial form-truing) with stock removal cycles (Basic CYCLE95)				
• Cylinder error compensation				
- Turning		–	–	–
- Milling		–	–	–
- G-Tech Cylindrical/G-Tech Surface		○	○	○
Advanced technology functions ¹⁾ (expansion of the technology cycles for turning and milling):	6FC5800-0AP58-0YB0			
• Pocket milling with free contour definition and islands:				
- Turning		○	✓	✓
- Milling		○	✓	✓
- G-Tech Cylindrical/G-Tech Surface		–	–	–
• Stock removal cycles with free contour definition:				
- Turning		○	✓	✓
- Milling		–	–	–
- G-Tech Cylindrical/G-Tech Surface		–	–	–
Extended operator functions ²⁾	6FC5800-0AP16-0YB0	○	○	○

¹⁾ The CNC option Advanced technology functions provides you with technology cycles for the following additional machining operations:

- Asymmetric grooves (turning only)
- Drill and thread milling
- Thread milling
- Multi-edge milling
- Engraving
- Extended stock removal along contour with segmentation of blank (turning only)
- Contour grooving and plunge turning (turning only)
- Milling of contour pockets and spigots with up to 12 islands
- Position pattern - hide position
- Asymmetrically turn a shoulder
- DIN thread undercut

²⁾ The operator functions in the basic scope of the SINUMERIK 828D are designed for standard applications.

- The CNC option Extended operator functions enables the following additional operator functions:
- Overstore:
 - Teach-in:
 - DRF function
 - Extended block search
 - Extended skip levels > 2
 - Backup workpiece setup data
 - Additional measuring version beyond standard scope (only milling)
 - Standard scope workpiece zero: Set edge, align edge, right-angled corner, 1 hole, 1 circular spigot and rectangular spigot
 - Expansion of the measurement screens via combo box
 - Synchronized actions softkey
 - MDI load/save

Description ✓ Basic version ○ Option – Not available	Article No. Notes	SINUMERIK 828D		
		SW 24x	SW 26x	SW 28x
User options (continued)				
Program editor:				
• ShopTurn/ShopMill machining step programming:	6FC5800-0AP17-0YB0			
- Turning		○	○	○
- Milling		○	○	○
- G-Tech Cylindrical/G-Tech Surface		–	–	–
• programSYNC – multi-channel step sequence programming:	6FC5800-0AP05-0YB0			
- Turning		–	–	○
- Milling		–	–	○
- G-Tech Cylindrical/G-Tech Surface		–	–	–
Residual material detection and machining for contour pockets and stock removal:	6FC5800-0AP13-0YB0 Requirement: Advanced technology functions option 6FC5800-0AP58-0YB0			
• Turning		○	○	○
• Milling		○	○	○
• G-Tech Cylindrical/G-Tech Surface		–	–	–
Simulation 1 (finished part) in 3D representation:	6FC5800-0AP25-0YB0			
• Turning		○	○	○
• Milling		○	○	○
• G-Tech Cylindrical/G-Tech Surface		–	–	–
Simultaneous recording (Real-time simulation of current machining operation)	6FC5800-0AP22-0YB0	○	○	○
Measuring cycles for drilling/milling and turning Calibration of workpiece probe, workpiece measurement, tool measurement:	6FC5800-0AP28-0YB0			
• Turning		○	○	○
• Milling		○	○	○
• G-Tech Cylindrical/G-Tech Surface		–	–	–
Manage additional drives via:				
• Ethernet (Windows Share/Linux/FTP), maximum	6FC5800-0AP01-0YB0	○ 21	○ 21	○ 21
Operation with tool management:				
• Replacement tools for tool management:	6FC5800-0AM78-0YB0			
- Turning		○	○	○
- Milling		○	○	○
- G-Tech Cylindrical/G-Tech Surface		–	–	–
Remote diagnostics and data transfer:				
• SINUMERIK Access MyMachine /P2P	6FC5800-0AP30-0YB0 Product-ID: MCS3140	○	○	○
Contour handwheel	6FC5800-0AM08-0YB0	○	○	○

Description ✓ Basic version ○ Option – Not available	Article No. Notes	SINUMERIK 828D		
		SW 24x	SW 26x	SW 28x
User options (continued)				
SINUMERIK MDynamics:				
• Advanced Surface:	6FC5800-0AS07-0YB0			
- Turning		–	–	–
- Milling		✓	✓	✓
- G-Tech Cylindrical/G-Tech Surface		–	–	–
• Top Surface:	6FC5800-0AS17-0YB0			
- Turning		–	–	–
- Milling		○	○	○
- G-Tech Cylindrical/G-Tech Surface		–	–	–
Spline interpolation (A, B and C splines)	6FC5800-0AS16-0YB0	○	○	○
Measure kinematics Determine transformation data of rotary axes:	6FC5800-0AP18-0YB0			
• Turning		–	–	–
• Milling		○	○	○
• G-Tech Cylindrical/G-Tech Surface		–	–	–
Host computer connection Server for OPC UA in SINUMERIK Operate SINUMERIK Access MyMachine:				
• Access MyMachine /OPC UA Variables, maximum number	6FC5800-0AP67-0YB0	○ 100	○ 100	○ 100
DXF Reader for PC integrated in SINUMERIK Operate	6FC5800-0AP56-0YB0	○	○	○
CNC user memory expanded for programs	6FC5800-0AP77-0YB0	–	○ 100 MB	○ 100 MB
Execution from external storage EES	6FC5800-0AP75-0YB0 Contains the option: CNC user memory expanded for programs 6FC5800-0AP77-0YB0	–	○	○
Monitoring for maximum tool speed/acceleration	6FC5800-0AS08-0YB0			
• Turning		○	○	○
• Milling		○	○	○
• G-Tech Cylindrical/G-Tech Surface		○	○	○

Product name	SINUMERIK 828D		
	SW 24x	SW 26x	SW 28x
Number of DRIVE-CLiQ ports	3	3	3
Number of axes/spindles (basic scope)			
• Turning	3	3	3
• Milling	4	4	4
• G-Tech Cylindrical/G-Tech Surface	3	3	3
Number of axes/spindles + PLC positioning axis, maximum			
• Turning	5	6 + 2	10 + 2 ²⁾
• Milling	5	6 + 2	8 + 2 ¹⁾
• G-Tech Cylindrical/G-Tech Surface	5	6 + 2	10 + 2 ²⁾
Number of axes with drive-based Safety Integrated, maximum (Extended Safety Integrated functions)			
• Turning	5	6	6 / 10 ²⁾
• Milling	5	6	6 / 8 ¹⁾
• G-Tech Cylindrical/G-Tech Surface	5	6	6 / 10 ²⁾
IPO cycle for max. configuration			
• Turning	9 ms	6 ms	6 ms
• Milling	9 ms	6 ms	3 ms
• G-Tech Cylindrical/G-Tech Surface	9 ms	6 ms	3 ms
Minimum block change time, approx.			
• Turning	9 ms	6 ms	6 ms
• Milling	9 ms	6 ms	3 ms
• G-Tech Cylindrical/G-Tech Surface	9 ms	6 ms	3 ms
Minimum block change time with compressor, approx.			
• Turning	9 ms	6 ms	6 ms
• Milling	3 ms	2 ms	1 ms
• G-Tech Cylindrical/G-Tech Surface	–	–	–
Position control cycle³⁾			
• Turning	3 ms (125 µs)	3 ms (125 µs)	1.5 ms (125 µs)
• Milling	3 ms (125 µs)	3 ms (125 µs)	3 ms (125 µs)
• G-Tech Cylindrical/G-Tech Surface	3 ms (125 µs)	3 ms (125 µs)	3 ms (125 µs)
PLC cycle time	9 ms	6 ms	6 ms
Velocity and current controller clock cycle	125 µs	125 µs	125 µs
Velocity and current controller clock cycle for a high-speed spindle			
Mixed operation without NX: 4 × 125 µs and 1 × 62.5 µs, max. number of axes = 5			
• Turning	–	–	–
• Milling	62.5 µs	62.5 µs	62.5 µs
• G-Tech Cylindrical/G-Tech Surface	62.5 µs	62.5 µs	62.5 µs
Non-Volatile Random-Access Memory (NVRAM) for:			
• OEM	512 KB	512 KB	512 KB
• User data	3 MB	5 MB	10 MB
Number of Numeric Control Extensions NX10.3			
• Turning	–	–	1
• Milling	–	1	1
• G-Tech Cylindrical/G-Tech Surface	–	–	1
Number of Numeric Control Extensions NX15.3			
• Turning	–	–	1
• Milling	–	–	–
• G-Tech Cylindrical/G-Tech Surface	–	–	1
Number of I/O modules PP 72/48D PN or PP 72/48D 2/2A PN			
• Turning	3	4	5
• Milling	3	4	5
• G-Tech Cylindrical/G-Tech Surface	3	5	5

1) The maximum number of axes/spindles can be increased to 8, 6 of which can be connected to the PPU 270.4/271.4 or PPU 290.4, and 2 to the NX10.3.

2) The maximum number of axes/spindles can be increased to 10, 6 of which can be connected to the PPU 270.4/271.4 or PPU 290.4, and 4 to the NX15.3.

3) With active Dynamic Servo Control (DSC), the position controller clock cycle corresponds to the current controller clock cycle of 125 µs.



3/2	SINUMERIK 828D
3/2	PPU 271.4/PPU 270.4
3/8	PPU 290.4
3/13	Operator components
3/13	SINUMERIK MCP 310 USB
3/14	SINUMERIK MCP 416 USB
3/15	SINUMERIK MCP 483 USB
3/16	SINUMERIK MCP Interface PN
3/17	Mini handheld unit
3/19	Electronic handwheel
3/21	SINUMERIK I/O
3/21	SINUMERIK I/O modules PP 72/48D PN and PP 72/48D 2/2A I
3/23	Supplementary components
3/23	SIMATIC PN/PN coupler
3/24	MD720 GSM/GPRS, 2G modem
3/25	SITOP power supply
3/26	SETRON PAC measuring devices
	CAD CREATOR Dimensional drawing and 2D/3D CAD generator www.siemens.com/cadcreator
	Drive Technology Configurator Guided product selection through to exact article number www.siemens.com/dt-configurator
	Siemens NC 82 · 2018

Overview

3



SINUMERIK 828D PPU 271.4, horizontal



SINUMERIK 828D PPU 270.4, vertical

The SINUMERIK 828D is an operator-panel CNC which combines all the components of a CNC in one unit:

- CNC, PLC, HMI
- 10.4" TFT color display
- Full CNC keyboard
- Closed-loop control for 6 drives

The motors can easily be connected to the digital drive system via DRIVE-CLiQ. In combination with the modular structure of the SINAMICS S120 drive system, this design is conceived to ensure very simple and rugged installation with minimum wiring overhead.

The performance range of the CNC has been precisely selected to meet the requirements of standard turning, milling and grinding machines – from one-off production runs to industrial scale manufacture. Thanks to the technology-specific variants for turning, milling and grinding, the system parameters are optimized for the machine, making the commissioning process much quicker and easier.

The operator-panel CNC is mounted from the rear using special clamps included in the scope of supply.

Benefits

Benefits for the machine operator

- High-quality, rugged, magnesium die-cast operator panels with degree of protection IP65
- Maintenance-free operator panel front, e.g. no fan, battery or hard disk
- Extremely user-friendly operation through integrated QWERTY keyboard with short-stroke keys
- Easy data exchange thanks to USB and Ethernet interfaces on the operator panel front
- Simple operation using ShopTurn and ShopMill software
- Advanced Surface and Top Surface: Innovative, high-performance CNC functions provide top quality of workpiece surface with minimum machining times
- Unique spectrum of technology cycles – ranging from the machining of any turning and milling contour with residual material detection to in-process measurements and balance cutting
- G-Tech is a grinding package with an extensive scope of CNC functions ranging from the low-cost entry-level model up to highly productive machines
- Animated Elements: Optimum operator guidance thanks to CNC input screens with animated elements
- Easy input via CNC direct keys on the CNC keyboard
- SINUMERIK Access MyMachine /Ethernet permits remote diagnostics from anywhere in the world
- Easy Message: Integrated mobile radio modem for optimum process monitoring and maximum machine availability via text messages (SMS)
- Easy Extend: Flexible handling of machine units, e.g. an A axis/parts machine
- Maintenance scheduler: Signaling of pending maintenance tasks in accordance with specified maintenance intervals

Benefits for the machine manufacturer

- High system quality through reduction in hardware interfaces
- Drive-based Safety Integrated for compliance with the machinery directive
- Less complex system thanks to technology-specific system software
- Faster, easier commissioning thanks to preset system parameters
- Automatic system configuration by means of single PLC I/Os
- Service Planner: Integrated planner for machine maintenance intervals
- Easy Archive: Integrated archiving procedure for optimum handling of commissioning updates
- Easy Extend: Integrated wizard for optional machine units
- Simple PLC programming with symbols and comments on the CNC
- No outlay required by dealers and machine manufacturers thanks to free PLC programming tool
- Faults will be remedied for a period of 24 months following 2nd commissioning for all system components in accordance with the OSS service description for 36 months

Function

- Operator-panel CNC with dedicated system software variants for turning, milling and grinding technologies
- Proximity/clearance sensor for smart display control
- Operator panel variants for horizontal or vertical operator panel housings
- Integrated QWERTY full CNC keyboard with short-stroke keys
- CompactFlash card, USB and Ethernet interfaces on the operator panel front
- Additional Ethernet interface at the rear of the CNC for connection to factory network
- Additional USB interface at the rear of the CNC for machine control panel
- Integrated PLC based on the SIMATIC S7-200 command set with ladder logic programming
- I/O interface based on PROFINET for the connection of PLC I/O devices and a machine control panel
- Connection of a GSM/GPRS modem: Easy Message (option)
- Integrated PLC editor in SINUMERIK Operate makes it possible to edit the PLC program quickly without any additional PC tools
- CNC options subject to license
- Up to 6 axes/spindles
- Up to 8 axes/spindles with SINAMICS NX10.3
- Up to 10 axes/spindles with SINAMICS NX15.3
- 1 analog spindle
- 1 machining channel, 2 machining channels with SW 28xA
- 1 mode group, 2 mode groups with SW 28x for turning and G-Tech
- EES function – unlimited expansion of CNC memory
- Integrated tool management with tool life monitoring
- Graphical machining step programming ShopTurn/ShopMill (option)
- Top Surface
- User interface SINUMERIK Operate – same look and feel as SINUMERIK 840D sl
- Configurable user screens with SINUMERIK Run MyScreens (Easy Screen)
- SINUMERIK Run MyRobot /EasyConnect for simple interfacing of robots and handling systems
- Integrated data archiving procedure for simple data updates

Integration

The following components can be connected to the SINUMERIK 828D PPU 27x.4:

- 2 electronic handwheels¹⁾
- Mini handheld unit with handwheel
- 3 to 5 PP 72/48D PN or PP 72/48D 2/2A PN I/O modules
- SIMATIC PN/PN coupler
- SINUMERIK MCP 310 USB or MCP 483 USB machine control panels
- SINUMERIK MCP Interface PN
- GSM/GPRS modem
- SENTRON PAC measuring devices
- SINAMICS S120 drive system via DRIVE-CLiQ
- SINAMICS Numeric Control Extension NX10.3 (only with SW 26x for milling and SW 28x for turning, milling and G-Tech)
- SINAMICS Numeric Control Extension NX15.3 (only with SW 28x for turning and G-Tech)
- Expansion of the SINUMERIK 828D system by additional auxiliary axes for loading axes, parts catchers or other auxiliary modules

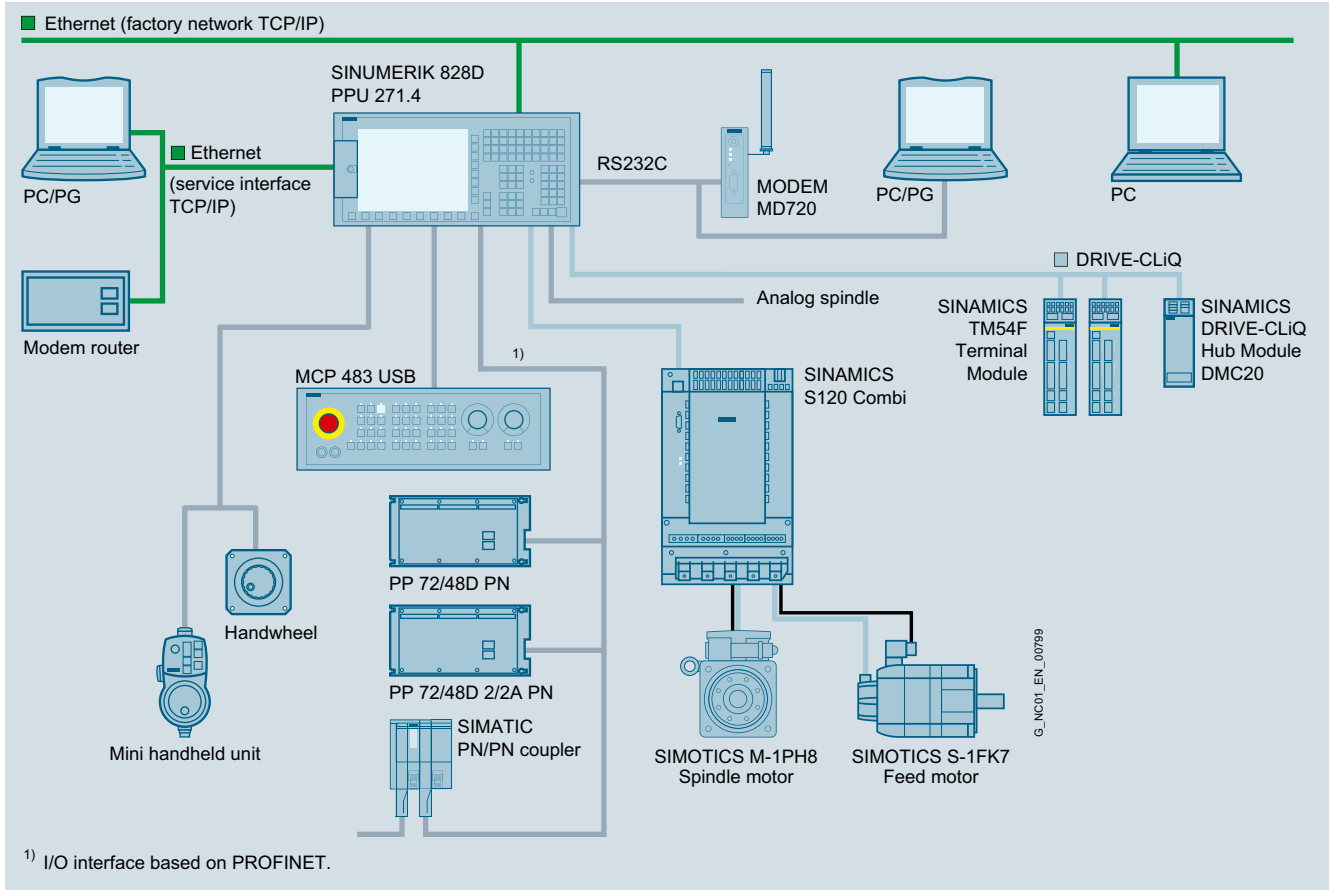

SINUMERIK 828D PPU 271.4 configuration example with SINAMICS S120 Combi

¹⁾ Third handwheel can be connected via MCP Interface PN. Use: Manual machine.

Integration (continued)

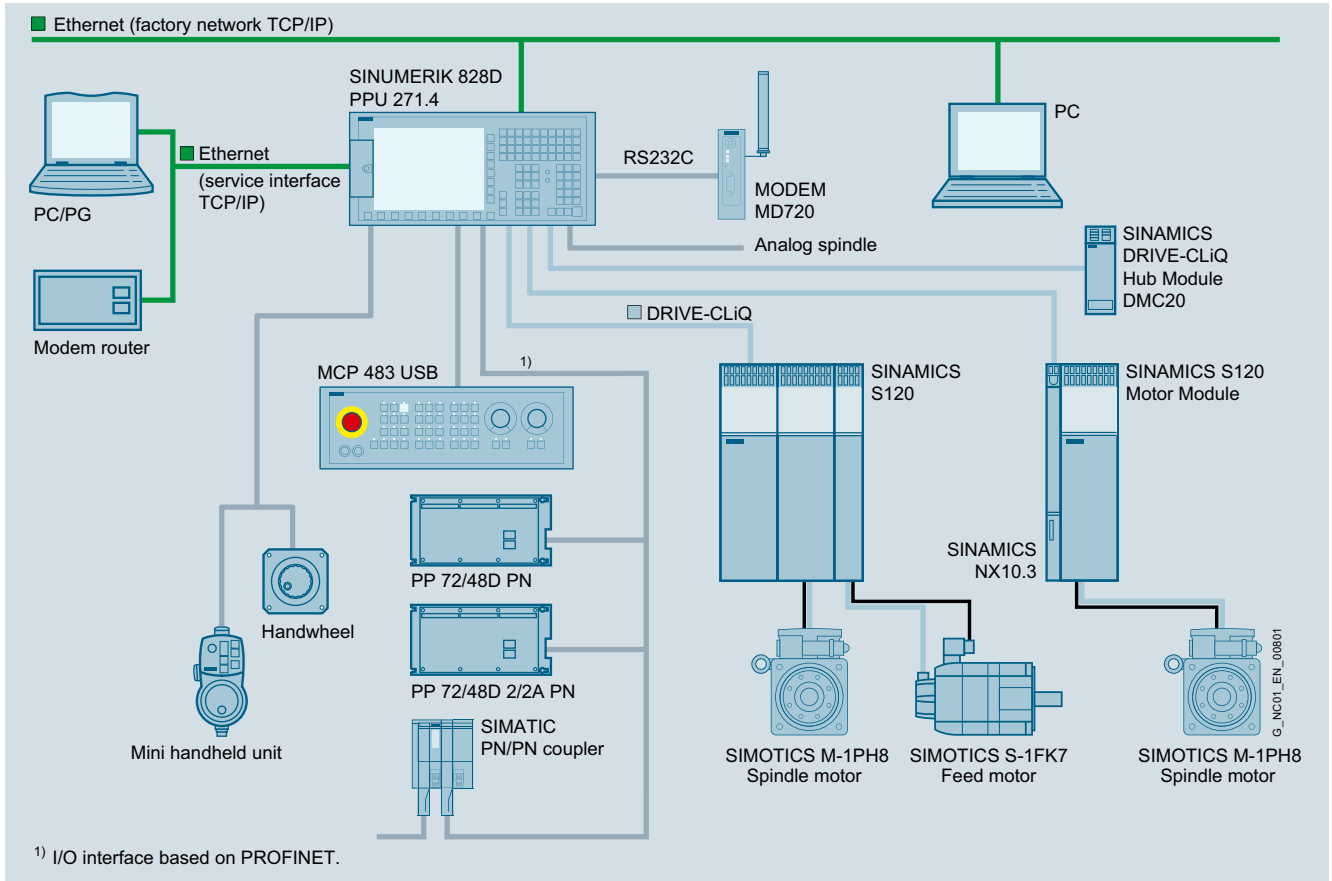

SINUMERIK 828D PPU 271.4 configuration example with SINAMICS S120

Technical specifications

Article No.		6FC5370-5AA40-0AA0	6FC5370-6AA40-0AA0
Product brand name		SINUMERIK	SINUMERIK
Product type designation		828D	828D
Product short term		PPU 271.4	PPU 270.4
Product designation		CNC control	CNC control
Screen diagonal	in	10.4	10.4
Design of display		TFT color	TFT color
Display resolution	Pixels	800 × 600	800 × 600
Design of operator panel		Horizontal	Vertical
Mounting position of operator panel		Vertical	Vertical
Supply voltage at DC	V	24	24
• Relative negative tolerance at 24 V	%	15	15
• Relative positive tolerance at 24 V	%	20	20
Active power consumption maximum	W	60	60
Buffering time in the event of power failure	ms	3	3
• Note		20 ms with SITOP smart power supply	20 ms with SITOP smart power supply
Environmental category acc. to IEC 60721-3-3		Condensation and icing excluded. Low air temperature 0 °C.	Condensation and icing excluded. Low air temperature 0 °C.
Degree of protection			
• front		IP65	IP65
- Note		With the front cover closed	With the front cover closed
• rear		IP20	IP20
Relative humidity at 25 °C, during			
• storage	%	10 ... 100	10 ... 100
• transport	%	5 ... 95	5 ... 95
• operation	%	5 ... 90	5 ... 90
Ambient temperature, during			
• storage	°C	-25 ... +55	-25 ... +55
• transport	°C	-20 ... +60	-20 ... +60
• operation			
- front	°C	0 ... 45	0 ... 45
- rear	°C	0 ... 55	0 ... 55
Width	mm	483	310
Height	mm	220	380
Depth	mm	105	105
Net weight	kg	4.5	4.5
Certificate of suitability		CE, cULus, EAC	CE, cULus, EAC

Selection and ordering data

Description	Article No.
Hardware components	
SINUMERIK 828D PPU 271.4 horizontal¹⁾ Without system software	6FC5370-5AA40-0AA0
SINUMERIK 828D PPU 270.4 vertical¹⁾ Without system software	6FC5370-6AA40-0AA0
Software components	
System software SW 24x¹⁾ On CompactFlash card with license software version 4.8 SP4, Export	
• Turning	6FC5835-1GY40-5YA0
• Milling	6FC5835-2GY40-5YA0
• G-Tech Cylindrical/G-Tech Surface	6FC5835-3GY40-5YA0
System software SW 26x¹⁾ On CompactFlash card with license software version 4.8 SP4, Export	
• Turning	6FC5834-1GY40-5YA0
• Milling	6FC5834-2GY40-5YA0
• G-Tech Cylindrical/G-Tech Surface	6FC5834-3GY40-5YA0
System software SW 28x¹⁾ On CompactFlash card with license software version 4.8 SP4, Export	
• Turning	6FC5836-1GY40-5YA0
• Milling	6FC5836-2GY40-5YA0
• G-Tech Cylindrical/G-Tech Surface	6FC5836-3GY40-5YA0
SINUMERIK 828D toolbox On DVD-ROM	6FC5830-0CY40-0YA8
SINUMERIK Access MyMachine /P2P For PC/PG on CD-ROM current software version	6FC5860-7YC00-0YA0 Product-ID: MCS31401
Language extensions On DVD-ROM without license	6FC5860-0YC40-0YA8
• For SINUMERIK 828D up to software version 4.5	
• For SINUMERIK Operate up to software version 2.7	
SIZER for Siemens Drives engineering tool For SINAMICS and MICROMASTER on DVD-ROM Languages: English, French, German, Italian	6SL3070-0AA00-0AG0

Description	Article No.
Additional hardware components	
SINAMICS Numeric Control Extension	
• NX10.3	6SL3040-1NC00-0AA0
• NX15.3	6SL3040-1NB00-0AA0
SINAMICS S120 TM54F Terminal Module	6SL3055-0AA00-3BA0
SIMATIC PN/PN coupler For deterministic data exchange between max.4 PN controllers per subnet	6ES7158-3AD10-0XA0
DRIVE-CLiQ signal cable, pre-assembled For PROFINET connection Connector degree of protection IP20	
• In fixed lengths ²⁾	6SL3060-4A..0-0AA0
• In precise decimeter lengths ²⁾	6FX2002-1DC00-....
Accessories	
CompactFlash card, 2 GB, empty To expand user memory and replace a defective system CompactFlash card	6FC5313-5AG00-0AA2
Front cover for PPU With fixture (included in scope of delivery)	6FC5348-2AA00-0AA0
Logbook and license certificate SINUMERIK Edition 06.09 Languages: English, German	6FC5095-0AA10-0AP1

More information

The following hardware components are only available in a package and cannot be ordered individually:

- SINUMERIK 828D PPU 271.4/ PPU 270.4

When the package is delivered, the CompactFlash card containing the system software is already installed in the SINUMERIK.

For more information, please contact your local Siemens office.

¹⁾ Not available individually, see More information.

²⁾ For complete Article No. and length code, see MOTION-CONNECT connection systems.

Overview



SINUMERIK 828D PPU 290.4 vertical

The SINUMERIK 828D is an operator-panel CNC which combines all the components of a CNC in one unit:

- CNC, PLC, HMI
- 15.6" multi-touch display in 16:9 format
- Full CNC keyboard
- Closed-loop control for 6 drives

The motors can easily be connected to the digital drive system via DRIVE-CLiQ. In combination with the modular structure of the SINAMICS S120 drive system, this design is conceived to ensure very simple and rugged installation with minimum wiring overhead.

The performance range of the CNC has been precisely selected to meet the requirements of standard turning, milling and grinding machines – from one-off production runs to industrial scale manufacture. Thanks to the technology-specific variants for turning, milling and grinding, the system parameters are optimized for the machine, making the commissioning process much quicker and easier.

The operator-panel CNC is mounted from the rear using special clamps included in the scope of supply.

Benefits

Benefits for the machine operator

- High-quality, rugged, magnesium die-cast operator panels with degree of protection IP65
- Maintenance-free operator panel front, e.g. no fan, battery or hard disk
- Extremely user-friendly operation through integrated QWERTY keyboard with short-stroke keys
- Easy data exchange thanks to USB and Ethernet interfaces on the operator panel front
- Simple operation using ShopTurn and ShopMill software
- Advanced Surface and Top Surface: Innovative, high-performance CNC functions provide top quality of workpiece surface with minimum machining times
- Unique spectrum of technology cycles – ranging from the machining of any turning and milling contour with residual material detection to in-process measurements and balance cutting
- G-Tech is a grinding package with an extensive scope of CNC functions ranging from the low-cost entry-level model up to highly productive machines
- Animated Elements: Optimum operator guidance thanks to CNC input screens with animated elements
- Easy input via CNC direct keys on the CNC keyboard
- SINUMERIK Access MyMachine /Ethernet permits remote diagnostics from anywhere in the world
- Easy Message: Integrated mobile radio modem for optimum process monitoring and maximum machine availability via text messages (SMS)
- Easy Extend: Flexible handling of machine units, e.g. an A axis/parts machine
- Maintenance scheduler: Signaling of pending maintenance tasks in accordance with specified maintenance intervals

Benefits for the machine manufacturer

- High system quality through reduction in hardware interfaces
- Drive-based Safety Integrated for compliance with the machinery directive
- Less complex system thanks to technology-specific system software
- Faster, easier commissioning thanks to preset system parameters
- Automatic system configuration by means of single PLC I/Os
- Service Planner: Integrated planner for machine maintenance intervals
- Easy Archive: Integrated archiving procedure for optimum handling of commissioning updates
- Easy Extend: Integrated wizard for optional machine units
- Simple PLC programming with symbols and comments on the CNC
- No outlay required by dealers and machine manufacturers thanks to free PLC programming tool
- Faults will be remedied for a period of 24 months following 2nd commissioning for all system components in accordance with the OSS service description for 36 months

Function

- Operator-panel CNC with dedicated system software variants for turning, milling and grinding technologies
- Proximity/clearance sensor for smart display control
- Integrated QWERTY full CNC keyboard with short-stroke keys
- USB and Ethernet interfaces on the operator panel front
- Additional Ethernet interface at the rear of the CNC for connection to factory network
- Additional USB interface at the rear of the CNC for machine control panel
- Integrated PLC based on the SIMATIC S7-200 command set with ladder logic programming
- I/O interface based on PROFINET for the connection of PLC I/O devices and a machine control panel
- Connection of a GSM/GPRS modem: Easy Message (option)
- Integrated PLC editor in SINUMERIK Operate makes it possible to edit the PLC program quickly without any additional PC tools
- CNC options subject to license
- Up to 6 axes/spindles
- Up to 8 axes/spindles with SINAMICS NX10.3
- Up to 10 axes/spindles with SINAMICS NX15.3
- 1 analog spindle
- 1 machining channel, 2 machining channels with SW 28x
- 1 mode group, 2 mode groups with SW 28x for turning and G-Tech
- EES function – unlimited expansion of CNC memory
- Integrated tool management with tool life monitoring
- Graphical machining step programming ShopTurn/ShopMill (option)
- Top Surface
- User interface SINUMERIK Operate – same look and feel as SINUMERIK 840D sl
- Configurable user screens with SINUMERIK Run MyScreens (Easy Screen)
- SINUMERIK Run MyRobot /EasyConnect for simple interfacing of robots and handling systems
- Integrated data archiving procedure for simple data updates

Integration

The following components can be connected to the SINUMERIK 828D PPU 290.4:

- 2 electronic handwheels¹⁾
- Mini handheld unit with handwheel
- 3 to 5 PP 72/48D PN or PP 72/48D 2/2A PN I/O modules
- SIMATIC PN/PN coupler
- SINUMERIK MCP 416 USB machine control panel
- SINUMERIK MCP Interface PN
- GSM/GPRS modem
- SENTRON PAC measuring devices
- SINAMICS S120 drive system via DRIVE-CLiQ
- SINAMICS Numeric Control Extension NX10.3 (only with SW 26x for milling and SW 28x for turning, milling and G-Tech)
- SINAMICS Numeric Control Extension NX15.3 (only with SW 28x for turning, milling and G-Tech)
- Expansion of the SINUMERIK 828D system by additional auxiliary axes for loading axes, parts catchers or other auxiliary modules

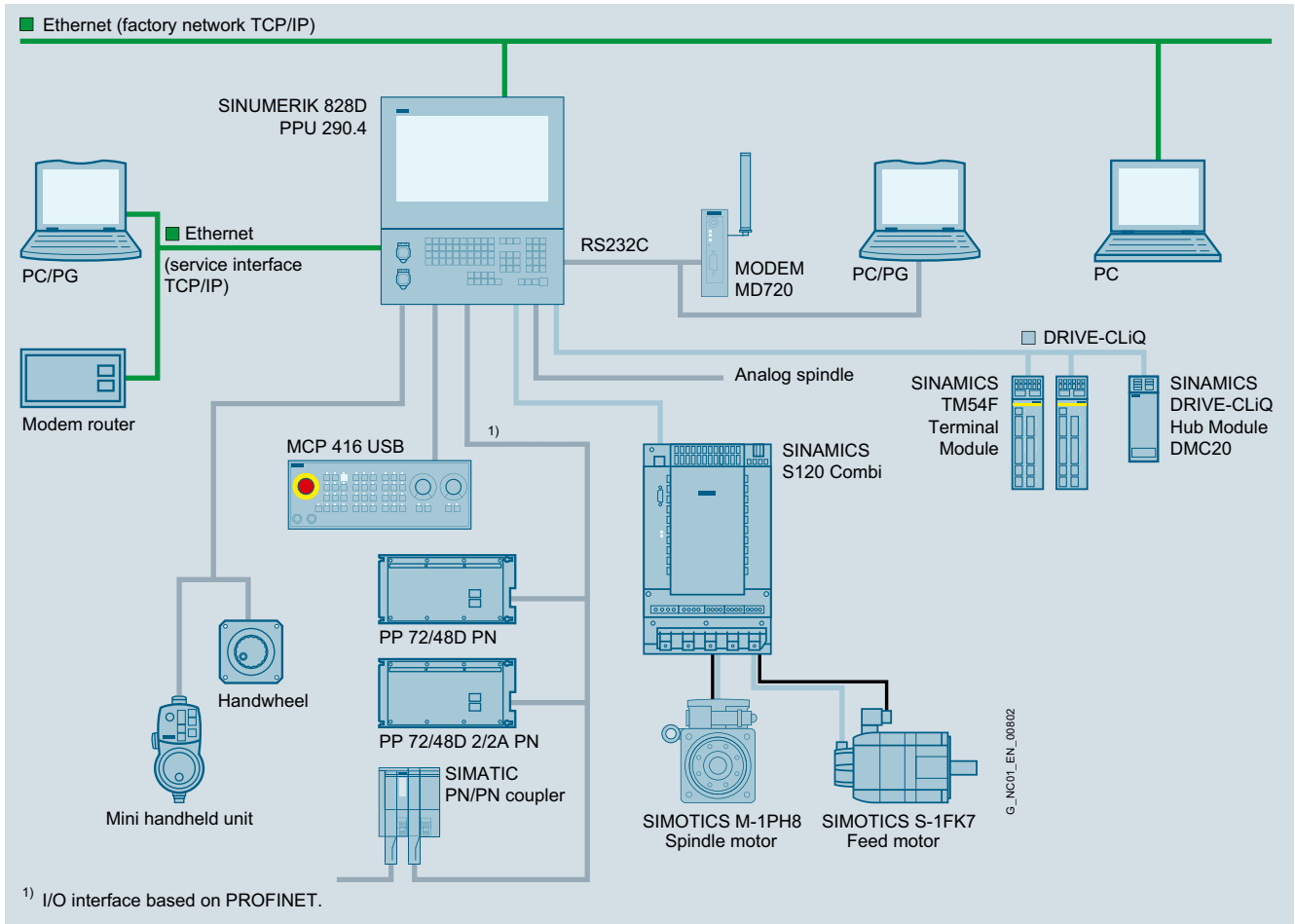

SINUMERIK 828D PPU 290.4 configuration example with SINAMICS S120 Combi

¹⁾ Third handwheel can be connected via MCP Interface PN. Use: Manual machine.

Integration (continued)

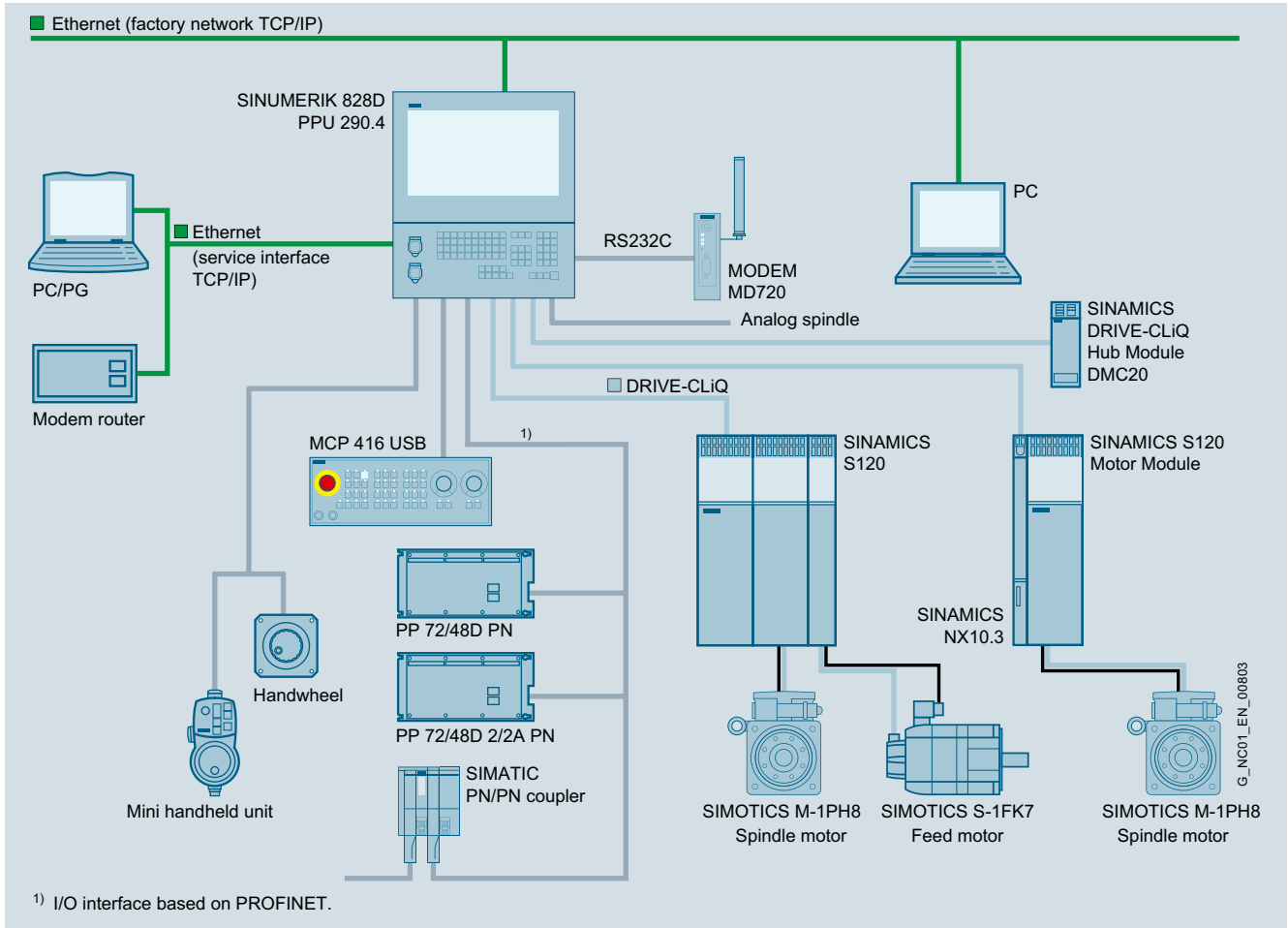

SINUMERIK 828D PPU 290.4 configuration example with SINAMICS S120

Technical specifications

Article No.	6FC5370-8AA40-0BA0
Product brand name	SINUMERIK
Product type designation	828D
Product short term	PPU 290.4
Product designation	CNC control
Screen diagonal	15.6 in
Design of display	TFT color
Display resolution	1366 × 768 pixels
Design of operator panel	Vertical
Mounting position of operator panel	Vertical
Supply voltage at DC	24 V
• Relative negative tolerance at 24 V	15 %
• Relative positive tolerance at 24 V	20 %
Active power consumption maximum	60 W
Buffering time in the event of power failure	3 ms
• Note	20 ms with SITOP smart power supply
Environmental category acc. to IEC 60721-3-3	Condensation and icing excluded. Low air temperature 0 °C.
Degree of protection	
• front	IP65
• rear	IP20

Article No.	6FC5370-8AA40-0BA0
Product brand name	SINUMERIK
Product type designation	828D
Product short term	PPU 290.4
Product designation	CNC control
Relative humidity at 25 °C, during	
• storage	10 ... 100 %
• transport	5 ... 95 %
• operation	5 ... 90 %
Ambient temperature, during	
• storage	-25 ... +55 °C
• transport	-20 ... +60 °C
• operation	
- front	0 ... 45 °C
- rear	0 ... 55 °C
Width	416 mm
Height	470 mm
Depth	105 mm
Net weight	8.9 kg
Certificate of suitability	CE, cULus, EAC

Selection and ordering data

Description	Article No.
Hardware components	
SINUMERIK 828D PPU 290.4 vertical¹⁾ Without system software	6FC5370-8AA40-0BA0
Software components	
System software SW 24x¹⁾ On CompactFlash card with license software version 4.8 SP4, Export	
• Turning	6FC5835-1GY40-5YA0
• Milling	6FC5835-2GY40-5YA0
• G-Tech Cylindrical/G-Tech Surface	6FC5835-3GY40-5YA0
System software SW 26x¹⁾ On CompactFlash card with license software version 4.8 SP4, Export	
• Turning	6FC5834-1GY40-5YA0
• Milling	6FC5834-2GY40-5YA0
• G-Tech Cylindrical/G-Tech Surface	6FC5834-3GY40-5YA0
System software SW 28x¹⁾ On CompactFlash card with license software version 4.8 SP4, Export	
• Turning	6FC5836-1GY40-5YA0
• Milling	6FC5836-2GY40-5YA0
• G-Tech Cylindrical/G-Tech Surface	6FC5836-3GY40-5YA0
SINUMERIK 828D toolbox On DVD-ROM	6FC5830-0CY40-0YA8
SINUMERIK Access MyMachine /P2P For PC/PG on CD-ROM current software version	6FC5860-7YC00-0YA0 Product-ID: MCS31401
Language extensions On DVD-ROM without license	6FC5860-0YC40-0YA8
• For SINUMERIK 828D up to software version 4.5	
• For SINUMERIK Operate up to software version 2.7	
SIZER for Siemens Drives engineering tool For SINAMICS and MICROMASTER on DVD-ROM Languages: English, French, German, Italian	6SL3070-0AA00-0AG0

Description	Article No.
Additional hardware components	
SINAMICS Numeric Control Extension	
• NX10.3	6SL3040-1NC00-0AA0
• NX15.3	6SL3040-1NB00-0AA0
SINAMICS S120 TM54F Terminal Module	6SL3055-0AA00-3BA0
SIMATIC PN/PN coupler For deterministic data exchange between max.4 PN controllers per subnet	6ES7158-3AD10-0XA0
DRIVE-CLiQ signal cable, pre-assembled For PROFINET connection Connector degree of protection IP20	
• In fixed lengths ²⁾	6SL3060-4A..0-0AA0
• In precise decimeter lengths ²⁾	6FX2002-1DC00-....
Accessories	
CompactFlash card, 2 GB, empty To expand user memory and replace a defective system CompactFlash card	6FC5313-5AG00-0AA2
Logbook and license certificate SINUMERIK Edition 06.09 Languages: English, German	6FC5095-0AA10-0AP1

More information

The following hardware components are only available in a package and cannot be ordered separately:

- SINUMERIK 828D PPU 290.4

When the package is delivered, the CompactFlash card containing the system software is already installed in the SINUMERIK.

For more information, please contact your local Siemens office.

¹⁾ Not available individually, see More information.

²⁾ For complete Article No. and length code, see MOTION-CONNECT connection systems.

Overview



SINUMERIK MCP 310 USB machine control panel with emergency stop pushbutton (accessory)

The SINUMERIK MCP 310 USB machine control panel enables user-friendly operation of the machine functions. It can be used with a SINUMERIK 828D CNC for machine-related operation of turning, grinding and milling machines. The machine-specific keys have replaceable slide-in labels so that they can be adapted.

The machine control panel is mounted from the rear with special clamps supplied with the panel. The emergency stop mushroom pushbutton can be ordered as an accessory.

Design

Operator control and display elements:

- Mode selectors and function keys:
 - 39 keys with LEDs
 - Predefined keys for common functions, e.g. reset key, program control
 - Key group for operating as milling or turning machine. The slide-in labels for keys for milling or turning machines are included in the accessories pack.
 - Keys for individual use
- Spindle control with spindle override (rotary switch with 15 positions)
- Feedrate control with feedrate/rapid traverse override (rotary switch with 18 positions)
- 2-digit, 7-segment display for the tool number

Key type:

- Membrane keys with protective film

Interface:

- USB 2.0 for communication with the SINUMERIK PPU:
 - Transmission rate 12 Mbit/s

Expansion options:

- 1 slot for emergency stop button, e.g. switch ($d = 22$ mm)
- 4 slots for control devices, e.g. switches ($d = 16$ mm)

Integration

The SINUMERIK MCP 310 USB machine control panel can be used with:

- SINUMERIK 828D
 - PPU 270.4

Technical specifications

Article No.	6FC5303-0AF33-0AA0
Product brand name	SINUMERIK
Product short term	MCP 310 USB
Product designation	Machine control panel
Supply voltage at DC	5 V
Active power consumption maximum	2.5 W
Degree of protection	
• front	IP65
- Note	With mounted emergency stop pushbutton
• rear	IP20
Environmental category acc. to IEC 60721-3-3	Condensation and icing excluded. Low air temperature 0 °C.
Relative humidity at 25 °C, during	
• storage	5 ... 95 %
• transport	5 ... 95 %
• operation	5 ... 85 %
Ambient temperature, during	
• storage	-40 ... +70 °C
• transport	-40 ... +70 °C
• operation	
- front	0 ... 45 °C
- rear	0 ... 55 °C
Width	310 mm
Height	230 mm
Depth	49 mm
Net weight	1.1 kg
Certificate of suitability	CE, cULus, EAC, KCC, RCM

Selection and ordering data

Description	Article No.
SINUMERIK MCP 310 USB machine control panel USB 2.0, width 310 mm, with membrane keys including USB cable length 0.8 m	6FC5303-0AF33-0AA0
Accessories	
Emergency stop mushroom pushbutton, 22 mm Plastic, round, red, positive latching, rotate to unlatch, complete with holder	3SB3000-1HA20
Contact block with 2 contacts 1 NO + 1 NC, 2-pin, screw terminal	3SB3400-0A

Overview

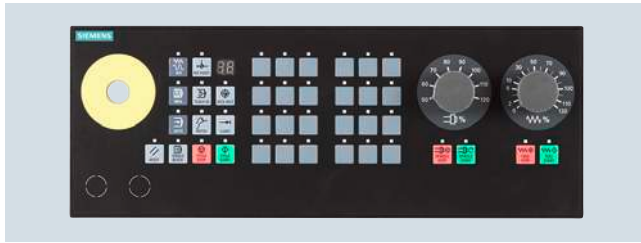

The SINUMERIK MCP 416 USB machine control panel enables user-friendly operation of the machine functions. It can be used with a SINUMERIK 828D CNC for machine-related operation of turning, grinding and milling machines. The machine-specific keys have replaceable slide-in labels so that they can be adapted.

The machine control panel is mounted from the rear with special clamps supplied with the panel. The emergency stop mushroom pushbutton can be ordered as an accessory.

Design

Operator control and display elements:

- Mode selectors and function keys:
 - 40 keys with LEDs
 - Predefined keys for common functions, e.g. reset key, program control
 - Key group for operating as milling or turning machine. The slide-in labels for keys for milling or turning machines are included in the accessories pack.
 - Keys for individual use.

- Spindle control with spindle override (rotary switch with 15 positions)
- Feedrate control with feedrate/rapid traverse override (rotary switch with 18 positions)
- 2-digit, 7-segment display for the tool number

Key type:

- Membrane keys with protective film

Interface:

- USB 2.0 for communication with the SINUMERIK PPU: Transmission rate 12 Mbit/s

Expansion options:

- 1 slot for emergency stop button ($d = 16$ mm)
- 2 slots for control devices, e.g. switches ($d = 16$ mm)

Integration

The SINUMERIK MCP 416 USB machine control panel can be used with:

- SINUMERIK 828D
 - PPU 290.4

Technical specifications

Article No.	6FC5303-0AF34-0AA0
Product brand name	SINUMERIK
Product short term	MCP 416 USB
Product designation	Machine control panel
Supply voltage at DC	5 V
Active power consumption maximum	2.5 W
Degree of protection	
• front	IP65
- Note	With mounted emergency stop pushbutton
• rear	IP20
Environmental category acc. to IEC 60721-3-3	Condensation and icing excluded. Low air temperature 0 °C.
Relative humidity at 25 °C, during	
• storage	5 ... 95 %
• transport	5 ... 95 %
• operation	5 ... 85 %
Ambient temperature, during	
• storage	-40 ... +70 °C
• transport	-40 ... +70 °C
• operation	
- front	0 ... 45 °C
- rear	0 ... 55 °C
Width	416.5 mm
Height	155 mm
Depth	58.5 mm
Net weight	1.2 kg
Certificate of suitability	CE, cULus, EAC, KCC, RCM

Selection and ordering data

Description	Article No.
SINUMERIK MCP 416 USB machine control panel USB 2.0, width 416.5 mm, with membrane keys including USB cable length 0.8 m	6FC5303-0AF34-0AA0
Accessories	
Emergency stop mushroom pushbutton, 16 mm Plastic, round, red, positive latching, rotate to unlatch	3SB2000-1AC01
Holder For contact block, flat connector	3SB2908-0AA
Contact block with 2 contacts 1 NO + 1 NC, 2-pin, solder pin connection	3SB2455-0J

Overview

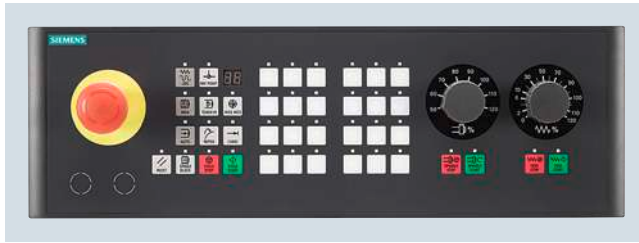

SINUMERIK MCP 483 USB machine control panel with emergency stop pushbutton (accessory)

The SINUMERIK MCP 483 USB machine control panel enables user-friendly operation of the machine functions. It can be used with a SINUMERIK 828D CNC for machine-related operation of turning, grinding and milling machines. The machine-specific keys have replaceable slide-in labels so that they can be adapted.

The machine control panel is mounted from the rear with special clamps supplied with the panel. The emergency stop mushroom pushbutton can be ordered as an accessory.

Design

Operator control and display elements:

- Mode selectors and function keys:
 - 40 keys with LEDs
 - Predefined keys for common functions, e.g. reset key, program control
 - Key group for operating as milling or turning machine. The slide-in labels for keys for milling or turning machines are included in the accessories pack.
 - Keys for individual use
- Spindle control with spindle override (rotary switch with 15 positions)
- Feedrate control with feedrate/rapid traverse override (rotary switch with 18 positions)
- 2-digit, 7-segment display for the tool number

Key type:

- Membrane keys with protective film

Interface:

- USB 2.0 for communication with the SINUMERIK PPU: Transmission rate 12 Mbit/s

Expansion options:

- 1 slot for emergency stop button, e.g. switch ($d = 22$ mm)
- 2 slots for control devices, e.g. switches ($d = 16$ mm)

Integration

The SINUMERIK MCP 483 USB machine control panel can be used with:

- SINUMERIK 828D
- PPU 271.4

Technical specifications

Article No.	6FC5303-0AF32-0AA0
Product brand name	SINUMERIK
Product short term	MCP 483 USB
Product designation	Machine control panel
Supply voltage at DC	5 V
Active power consumption maximum	2.5 W
Degree of protection	
• front	IP65
- Note	With mounted emergency stop pushbutton
• rear	IP20
Environmental category acc. to IEC 60721-3-3	Condensation and icing excluded. Low air temperature 0 °C.
Relative humidity at 25 °C, during	
• storage	5 ... 95 %
• transport	5 ... 95 %
• operation	5 ... 85 %
Ambient temperature, during	
• storage	-40 ... +70 °C
• transport	-40 ... +70 °C
• operation	
- front	0 ... 45 °C
- rear	0 ... 55 °C
Width	483 mm
Height	155 mm
Depth	49 mm
Net weight	1.22 kg
Certificate of suitability	CE, cULus, EAC, KCC, RCM

Selection and ordering data

Description	Article No.
SINUMERIK MCP 483 USB machine control panel USB 2.0, width 483 mm, with membrane keys including USB cable length 0.8 m	6FC5303-0AF32-0AA0
Accessories	
Emergency stop mushroom pushbutton, 22 mm Plastic, round, red, positive latching, rotate to unlatch, complete with holder	3SB3000-1HA20
Contact block with 2 contacts 1 NO + 1 NC, 2-pin, screw terminal	3SB3400-0A

Overview

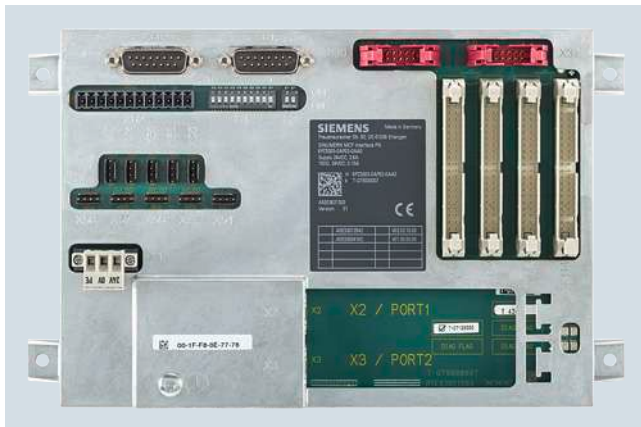

The SINUMERIK MCP Interface PN enables customer-specific machine control panels to be connected via PROFINET.

On the SINUMERIK MCP Interface PN, digital inputs, outputs, connections for rotary override switches and handwheels are provided as well as two Industrial Ethernet interfaces for communication.

Design

You can connect the following operator controls to the SINUMERIK MCP Interface PN:

- 80 single keys
- 64 LEDs
- 2 handwheels
- 2 rotary override switches

The following inputs/outputs are also available:

- 9 digital inputs (5 V)
- 6 digital inputs (24 V)
- 15 digital outputs (24 V each 0.15 A)

Integration

The SINUMERIK MCP Interface PN can be used for:

- SINUMERIK 828D

Technical specifications

Article No.	6FC5303-0AF03-0AA0
Product brand name	SINUMERIK
Product short term	MCP Interface PN
Product designation	Machine control panel interface for PROFINET
Supply voltage at DC	24 V
Active power consumption maximum	62.4 W
• Note	Of all connectable operator controls, own requirement 2.4 W
Degree of protection	IP00
Environmental category acc. to IEC 60721-3-3	Condensation and icing excluded. Low air temperature 0 °C.
Relative humidity at 25 °C, during	
• storage	5 ... 95 %
• transport	5 ... 95 %
• operation	5 ... 95 %
Ambient temperature, during	
• storage	-25 ... +55 °C
• transport	-40 ... +70 °C
• operation	
- front	0 ... 45 °C
- rear	0 ... 55 °C
Width	242 mm
Height	152 mm
Depth	36 mm
Net weight	557 g
Certificate of suitability	CE, cULus, EAC

Selection and ordering data

Description	Article No.
SINUMERIK MCP Interface PN For connection of customer-specific machine control panels over PROFINET	6FC5303-0AF03-0AA0
Accessories	
Feedrate/rapid traverse override electronic rotary switch 1 × 23G, T=32, cap, button, pointer, and rapid traverse and feedrate dials ¹⁾	6FC5247-0AF13-1AA0
Spindle/rapid traverse override electronic rotary switch 1 × 16G, T=24, cap, button, pointer, and rapid traverse and spindle dials ²⁾	6FC5247-0AF12-1AA0
Cable set (1 set = 60 units) For additional control devices Length 500 mm	6FC5247-0AA35-0AA0

¹⁾ 23G: Latching at position 23; T=32: 32 positions for 360°

²⁾ 16G: Latching at position 16; T=24: 24 positions for 360°

Overview



The convenient, ergonomically designed mini handheld unit with rugged metal connector is suitable for setting up and operating standard machines in the Jobshop area.

Benefits

- Mobile positioning of axes
- Easy graduation of coarse, medium and fine infeed facilitates fast, increment-precise positioning
- Rugged and compact design

Design

- Emergency stop implemented in 2 channels with 4-wire connection
- 3-position enabling button implemented in 2 channels with 3-wire connection
- Rapid traverse key and 2 ± keys
- 1 handwheel to traverse the axes in jog mode
- Facility to connect rotary switches for selecting up to 5 axes
- 3 function keys for customized applications – user-assignable with slide-in labels for inscribing
- Interface for connection kit (accessory)
- Optional angle socket for a cable outlet direction rotated through 90° (accessory). The angle socket can only be used in conjunction with the non-assembled connection kit.
- Mounting with integrated magnetic clamp or a holder (accessory)

Integration

The mini handheld unit can be used for:

- SINUMERIK 828D

Selection and ordering data

Description	Article No.
Mini handheld unit 3-step enabling button incl. magnetic clamps and connecting cable with metal connector	
<ul style="list-style-type: none"> • Coiled connecting cable Length 2.1 m, stretches to 3.5 m 	6FX2007-1AD03
<ul style="list-style-type: none"> • Straight cable Length 5 m 	6FX2007-1AD13
Accessories	
Connection kit for mini handheld unit, non-assembled Connection socket for self-assembly Version with metal connector for connection to machine control panel <u>without</u> Industrial Ethernet, with terminator	6FX2006-1BG03
Connection kit for mini handheld unit, assembled Version with metal connector for connection to machine control panel <u>with</u> PROFINET, with terminator for SINUMERIK 828D	6FX2006-1BG20
90° angle socket For connection kit, non-assembled 6FX2006-1BG03 Metal version	6FX2006-1BG56
Holder For mini handheld units 6FX2007-1AD.3 and electronic handwheel in housing 6FC9320-5DE02	6FX2006-1BG70

Technical specifications

Article No.		6FX2007-1AD03	6FX2007-1AD13
Product brand name		SINUMERIK	SINUMERIK
Product designation		Mini handheld unit	Mini handheld unit
Product feature		With coiled cable	With straight cable
Supply voltage at DC	V	24	24
Supply voltage at DC			
• for handwheel	V	5	5
- Note		For emergency stop button, enabling buttons and switching signals	For emergency stop button, enabling buttons and switching signals
Design of the interface		RS422	RS422
Number of pulses per revolution maximum		100	100
Transmission link to PPU maximum	m	25	25
Transmission link to the NCU/PCU maximum	m	25	25
• Note		When using the handwheel	When using the handwheel
Degree of protection without shaft input		IP65	IP65
Environmental category acc. to IEC 60721-3-3		Condensation and icing excluded. Low air temperature 0 °C.	Condensation and icing excluded. Low air temperature 0 °C.
Relative humidity at 25 °C, during			
• storage	%	5 ... 95	5 ... 95
• transport	%	5 ... 95	5 ... 95
• operation	%	5 ... 95	5 ... 95
Ambient temperature, during			
• storage	°C	-20 ... +60	-20 ... +60
• transport	°C	-20 ... +60	-20 ... +60
• operation	°C	0 ... 55	0 ... 55
Width	mm	90	90
Height	mm	67	67
Depth	mm	180	180
• Note		With emergency stop button	With emergency stop button
Net weight	g	500	500
• Note		Without connecting cable	Without connecting cable
Certificate of suitability		CE	CE

Overview



Electronic handwheels with front panel and handwheel portable in housing

The electronic handwheels enable an axis to be traversed manually. The axis selected via the CNC can be positioned so that the axes are parallel.

The portable electronic handwheel is intended for use directly at the machine.

Benefits

- Positioning of axes
- Rugged and compact housing variant

Design

- Handwheels for installation by user – with or without front panel (the front panel can be removed)
- Portable handwheel in housing:
 - Connection by means of a spiral cable
 - Mounting with integrated magnetic clamp or a holder (accessory)

Function

The electronic handwheels feature a magnetic latching facility which enables increment-precise traversing.

The handwheels generate 5 V DC TTL signals.

Integration

The electronic handwheel can be used for:

- SINUMERIK 828D

Selection and ordering data

Description	Article No.
Electronic handwheel <ul style="list-style-type: none"> • With front panel 120 mm × 120 mm, with setting wheel, 5 V DC, RS422 • With front panel 76.2 mm × 76.2 mm, with setting wheel 5 V DC, RS422 • Without front panel, with small setting wheel 5 V DC, RS422 • Without front panel, without setting wheel, for installation, 5 V DC, RS422 • Portable in housing, with setting wheel, 5 V DC, RS422 spiral cable, length 2.5 m 	6FC9320-5DB01 6FC9320-5DC01 6FC9320-5DM00 6FC9320-5DF01 6FC9320-5DE02
Adapter set For installation in front panel with 3-hole fixing	6FC9320-5DN00
Flange socket Installation socket, 9-pin, socket for portable handwheel	6FC9341-1AQ
Holder For mini handheld units 6FX2007-1AD.3 and electronic handwheel in housing 6FC9320-5DE02	6FX2006-1BG70
Signal cable, pre-assembled For connecting an electronic handwheel to the PPU Length max. 3 m ¹⁾	6FX8002-2BB01-1A..

¹⁾ For complete Article No. and length code, see MOTION-CONNECT connection systems

Technical specifications

Article No. Product brand name Product designation Product feature		6FC9320-5DB01 SINUMERIK Electronic handwheel With front panel 120 mm x 120 mm	6FC9320-5DC01 SINUMERIK Electronic handwheel With front panel 76.2 mm x 76.2 mm	6FC9320-5DM00 SINUMERIK Electronic handwheel Without front panel, with setting wheel	6FC9320-5DF01 SINUMERIK Electronic handwheel Without front panel, without setting wheel	6FC9320-5DE02 SINUMERIK Electronic handwheel Portable in housing with spiral cable
Supply voltage at DC	V	5	5	5	5	5
Consumed current maximum	mA	60	60	60	60	80
Design of the interface		RS422 (TTL)	RS422 (TTL)	RS422 (TTL)	RS422 (TTL)	RS422 (TTL)
Phase displacement angle between signal A and signal B	°	90	90	90	90	90
Number of pulses per revolution maximum		100	100	100	100	100
Minimum actuating torque in activation direction	Nm	0.08	0.04	0.04	0.04	0.04
Electrical output frequency maximum	kHz	2	2	2	2	2
Transmission link to PPU maximum	m	25	25	25	25	20
Degree of protection		-	-	-	-	IP65
Degree of protection						
• front		IP65	IP65	IP65	IP65	-
• rear		IP50	IP50	IP50	IP50	-
Environmental category acc. to IEC 60721-3-3		Condensation and icing excluded. Low air temperature 0 °C.				
Relative humidity at 25 °C, during						
• storage	%	5 ... 95	5 ... 95	5 ... 95	5 ... 95	5 ... 95
• transport	%	5 ... 95	5 ... 95	5 ... 95	5 ... 95	5 ... 95
• operation	%	5 ... 95	5 ... 95	5 ... 95	5 ... 95	5 ... 95
Ambient temperature, during						
• storage	°C	-25 ... +55	-25 ... +55	-25 ... +55	-25 ... +55	-25 ... +55
• transport	°C	-40 ... +70	-40 ... +70	-40 ... +70	-40 ... +70	-40 ... +70
• operation	°C	0 ... 55	0 ... 55	0 ... 55	0 ... 55	0 ... 55
Outer diameter of the housing	mm	-	-	58.5	50	-
Width	mm	120	76.2	-	-	85
Height	mm	120	76.2	-	-	160
Depth	mm	81.8	81.8	83.8	64.3	67
Net weight	g	700	400	300	200	300
• Note		-	-	-	-	Without connecting cable
Certificate of suitability		CE, cULus	CE, cULus	CE, cULus	CE, cULus	CE, cULus

Overview

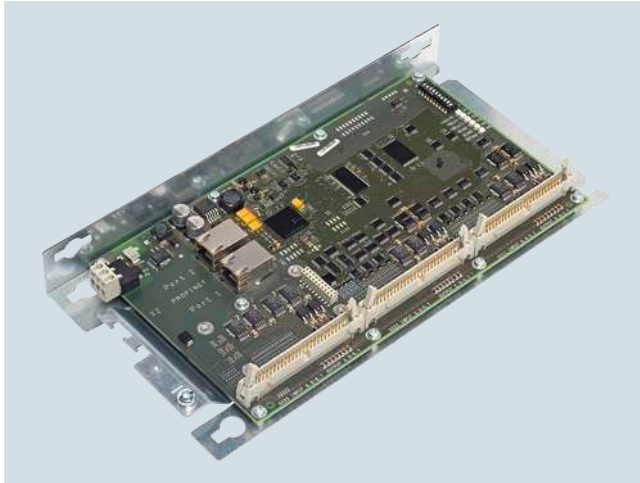

SINUMERIK PP 72/48D PN I/O module

The SINUMERIK PP 72/48D PN I/O module is available in a digital variant with 72 inputs and 48 outputs, and in a digital/analog variant PP 72/48D 2/2A PN with 2 analog inputs and 2 analog outputs in addition.

The I/O modules are connected to the CNC via a PROFINET-based I/O interface. The digital inputs and outputs are connected by means of three 50-pin ribbon cables. Terminal strip converters can be used or the direct connection of distribution boards, for example, is possible.

Benefits

- Easy connection via PROFINET-based I/O interface
- Mounting plate for easy module installation in the control cabinet
- Automatic module detection by the CNC, no complex configuring required
- Easy connection of terminal strip converters to plug connectors
- Integrated 24 V DC power supply with electrical isolation between the inputs and outputs and PROFINET

Integration

The PP 72/48D PN and PP 72/48D 2/2A PN I/O modules can be used for the following CNC:

- SINUMERIK 828D

Selection and ordering data

Description	Article No.
SINUMERIK PP 72/48D PN I/O module 72 digital inputs and 48 digital outputs	6FC5311-0AA00-0AA0
SINUMERIK PP 72/48D 2/2A PN I/O module 72 digital inputs and 48 digital outputs 2 analog inputs and 2 analog outputs	6FC5311-0AA00-1AA0
Accessories	
Terminal strip converter 50-pin	6EP5406-5AA00
Cable set Ribbon cable 50-pin, length 6 m, 8 insulation displacement connectors, 50-pin	6EP5306-5BG00
DRIVE-CLiQ signal cable, pre-assembled For PROFINET connection Connector degree of protection IP20 • In fixed lengths ¹⁾ • In precise decimeter lengths ¹⁾	6SL3060-4A..0-0AA0 6FX2002-1DC00-...

¹⁾ For complete Article No. and length code, see MOTION-CONNECT connection systems

Technical specifications

Article No. Product brand name Product short term Product designation	6FC5311-0AA00-0AA0 SINUMERIK PP 72/48D PN PROFINET I/O module	6FC5311-0AA00-1AA0 SINUMERIK PP 72/48D 2/2A PN PROFINET I/O module with additional analog inputs and outputs
Supply voltage at DC	V 24	24
Active power consumption maximum • Note	W 17 -	19 Without digital outputs
Number of digital inputs	72	72
Number of digital outputs	48	48
Number of analog inputs	-	2
Number of analog outputs	-	2
Degree of protection	IP00	IP00
Environmental category acc. to IEC 60721-3-3	Condensation and icing excluded. Low air temperature 0 °C.	Condensation and icing excluded. Low air temperature 0 °C.
Relative humidity at 25 °C, during		
• storage	% 5 ... 95	5 ... 95
• transport	% 5 ... 95	5 ... 95
• operation	% 5 ... 95	5 ... 95
Ambient temperature, during		
• storage	°C -40 ... +70	-40 ... +70
• transport	°C -40 ... +70	-40 ... +70
• operation	°C 0 ... 55	0 ... 55
Width	mm 150	150
Height	mm 300	300
Depth	mm 35	35
Net weight	g 900	900
Certificate of suitability	CE, cULus	CE, cULus

Overview



The SIMATIC PN/PN coupler is used whenever easy-to-configure, fast (deterministic) data exchange between PROFINET controllers is required. Data transmission can be performed both beyond network boundaries as well as within a single network side.

Benefits

- Fast deterministic data exchange between CPUs with PROFINET controller, even beyond network boundaries
- Configuration with two PROFINET devices completely independent of the communication technology
- Very simple configuration of the data exchange via virtual IO modules or alternatively via data records for larger amounts of data
- Simultaneous data transfer to up to 3 CPUs on own network side and/or up to 4 CPUs on opposite network side
- Easy to integrate into any PROFINET network with 2 ports per network side

Design

The SIMATIC PN/PN coupler features an enclosure and is snapped onto a DIN rail (7.5 mm or 15 mm). 2 galvanically isolated plug-in connections are available for the power supply.

Accessories (not included in the PN/PN coupler scope of supply):

- SIMATIC BusAdapter
- Labelling strips
- Strain relief
- Connector

Function

The SIMATIC PN/PN coupler provides the output data of the writing CPU as input data to the receiving CPUs within a PN cycle. Both fail-safe data (via F_SendDP/F_ReceiveDP of a SIMATIC F-CPU only) and standard data can be transmitted.

2 basically different methods are available for data transmission:

- Data exchange via virtual I/O modules (coupling modules)
- Data record transfer

The PN/PN coupler provides extensive diagnostic information about LEDs, interrupts and status bytes. In this way, errors can be quickly located and commissioning and downtimes minimized.

The PN/PN coupler supports a variety of SIMATIC BusAdapters for flexible connection to PROFINET.

Integration

The SIMATIC PN/PN coupler can be used for the following CNC:

- SINUMERIK 828D

Technical specifications

Article No.	6ES7158-3AD10-0XA0
Product brand name	SIMATIC
Product type designation	PN/PN coupler
Product designation	PN/PN coupler
Supply voltage for DC	24 V
Current consumption, max.	360 mA
Power loss, typ.	4 W
Mains/voltage failure stored energy time	10 ms
Transmission rate, max.	100 Mbit/s
Degree of protection	IP20
Ambient temperature, during	
• operation	
- for horizontal installation	0 ... 60 °C
- for vertical installation	0 ... 50 °C
Width	100 mm
Height	117 mm
Depth	74 mm
• Note	With mounting rail
Net weight	200 g
Certificate of suitability	Network loading class 3 / Security Level 1 Test Cases V1.1.4

Selection and ordering data

Description	Article No.
SIMATIC PN/PN coupler	6ES7158-3AD10-0XA0
For deterministic data exchange between max. 4 PN controllers per subnet	

More information

Additional information is available on the Internet in the Siemens Industry Mall at:

www.siemens.com/industrymall

Overview



MD720 GSM/GPRS, 2G modem

The MD720 GSM/GPRS, 2G modem transmits the text messages into the GSM network of the mobile radio operator. By inserting any SIM card into the MD720 GSM/GPRS, 2G modem, it is possible to freely select the required mobile radio operator.

With Easy Message the SINUMERIK 828D CNCs provide a means of transmitting process data using text messages (SMS). This makes it possible to send messages to various mobile phones of the operating and maintenance personnel to notify them, for example, of the workpiece counter reading or the fact that a tool has reached its wear limit.

Benefits

- Rugged GSM modem for industrial use
- High-quality signal transmission thanks to powerful external antenna
- Simple mounting on standard mounting rails in the control cabinet or operator panel housing

Design

The MD720 GSM/GPRS, 2G modem features the following interfaces as standard:

- 9-pin Sub-D socket for connection to the CNC (RS232C interface)
- 4-pin screw terminal for connection to a 24 V DC supply voltage
- SMA antenna connection socket for GSM/GPRS antenna
- Slot for inserting a GSM-SIM card

The MD720 GSM/GPRS, 2G modem has diagnostic LEDs for modem status, field strength and connection control.

Easy Message provides the following functions:

- Input of PIN number
- Configuration of user profiles
- Display of modem status and field strength
- Generation of outgoing text messages (SMS)
- Processing of incoming text messages (SMS)
- Visualization of transmission protocol

Integration

The MD720 GSM/GPRS, 2G modem can be used for the following CNC:

- SINUMERIK 828D

The following components can be connected:

- Modem cable for RS232C interface
- ANT 794-4MR antenna

Technical specifications

Article No.	6NH9720-3AA01-0XX0
Product short term	MD720
Product designation	Mobile network modem GSM/GPRS, 2G
Supply voltage at DC	24 V
Power loss, typical	5 W
Transfer rate with GSM transmission	9600 bit/s
• With downlink maximum	54 kbit/s
• With uplink maximum	42 kbit/s
Operating frequency with GSM transmission	850/900/1800/1900 MHz
Interfaces	
• RS232C	9-pin Sub-D socket
• Antenna	SMA antenna socket (50 Ω)
• Power supply	4-pin terminal strip
Degree of protection	IP30
Maximum relative humidity at 25 °C	95 %
Ambient temperature, during	
• storage	-25 ... +85 °C
• transport	-25 ... +85 °C
• operation	-20 ... +60 °C
Width	30 mm
Height	100 mm
Depth	90 mm
Net weight	150 g
Certificate of suitability	CE, CSA, UL
Wireless approvals	Current approvals can be found on the Internet at www.siemens.com/mobilenetwork-approvals

Selection and ordering data

Description	Article No.
MD720 GSM/GPRS, 2G modem	6NH9720-3AA01-0XX0
Mobile network modem with RS232 interface	
ANT 794-4MR antenna	6NH9860-1AA00
Modem cable	6NH7701-5AN
For RS232C interface Length 2.5 m	

More information

You can find additional information on the Internet at:

www.siemens.com/industrymall

Overview



The 24 V power supply units from the SITOP range are optimized for industrial use and operate on the switched-mode principle. Due to the precisely regulated output voltage, the devices are even suitable for the connection of sensitive sensors. Different versions are available depending on the output current and field of application.

SITOP does not require much space on the standard mounting rail and offers a high level of functionality.

Thanks to the extra power, 1.5 times the rated current for 5 seconds, large loads can also be switched on without any problems.

Benefits

- High efficiency
- Narrow width and easy installation
- Exact output voltage and low residual ripple
- Integrated short-circuit protection and safe electrical separation
- National and international approvals
- No release of silicone

Selection and ordering data

Description	Article No.
SITOP PSU100S 24 V DC, 1-phase Input voltage: 120 V/230 V AC • 10 A • 20 A	6EP1334-2BA20 6EP1336-2BA10
SITOP PSU300S 24 V DC, 3-phase Input voltage: 400 ... 500 V 3 AC • 10 A • 20 A	6EP1434-2BA12 6EP1436-2BA10

More information

You can find additional information in Catalog KT 10.1, in the Siemens Industry Mall or on the Internet at:

www.siemens.com/industrymall
www.siemens.com/sitop

Technical specifications

Article No.		6EP1334-2BA20	6EP1336-2BA10	6EP1434-2BA20	6EP1436-2BA10
Product brand name		SITOP	SITOP	SITOP	SITOP
Product short term		PSU100S	PSU100S	PSU300S	PSU300S
Product designation		Stabilized power supply 1-phase	Stabilized power supply 1-phase	Stabilized power supply 3-phase	Stabilized power supply 3-phase
Voltage range for AC	V	85 ... 132 170 ... 264	85 ... 132 176 ... 264	340 ... 550	340 ... 550
Line frequency range	Hz	47 ... 63	47 ... 63	47 ... 63	47 ... 63
Rated output current for DC	A	10	20	10	20
Rated output voltage for DC	V	24	24	24	24
Total tolerance, static	%	±3	±3	±3	±3
Mains buffering at $I_{out rated}$, min.	ms	20 (at $V_{in} = 120$ V or 230 V)	20 (at $V_{in} = 120$ V or 230 V)	6 (at $V_{in} = 400$ V)	6 (at $V_{in} = 400$ V)
Degree of protection		IP20	IP20	IP20	IP20
Humidity class according to EN 60721		Climate class 3K3, without condensation	Climate class 3K3, without condensation	Climate class 3K3, without condensation	Climate class 3K3, without condensation
Ambient temperature, during					
• storage	°C	-40 ... +85	-40 ... +85	-40 ... +85	-40 ... +85
• transport	°C	-40 ... +85	-40 ... +85	-40 ... +85	-40 ... +85
• operation	°C	-25 ... +70	0 ... 70	-25 ... 70	0 ... 70
Width	mm	70	115	70	90
Height	mm	125	145	125	145
Depth	mm	120	150	120	150
Net weight	kg	0.8	2.4	0.7	1.6
Certificate of suitability		CB, CE, cCSAus, cULus	CB, CE, cCSAus, cULus	CB, CE, cCSAus, cULus	CB, CE, cCSAus, cULus

Overview



SENTRON PAC3200 measuring device



SENTRON PAC4200 measuring device

The 7KM PAC measuring devices enable precise, reproducible and reliable measurement of energy values for infeed, outgoing feeders or individual loads. They not only provide comprehensive information about your electrical installations and power distribution, but also key measured values for assessing the system state and quality of the power supply. For further processing of the measured data, the devices are equipped with a wide range of communication options for easy integration into higher-level automation and energy management systems.

The devices can be used for both single-phase and multi-phase measurements in 3- and 4-conductor power supply systems (TN, TT, IT).

Benefits

- Simple mounting and commissioning
- High IP65 degree of protection (front side, when installed) permits usage in extremely dusty and wet environments
- Intuitive operation using 4 function buttons and multilingual plain text displays
- Easy to adapt to different systems using integrated and optional
 - Digital inputs and outputs
 - Communication interfaces
- Global application
 - At least 8 languages
 - International approvals
 - Developed and tested in accordance with European and international standards
- Low mounting depth

Selection and ordering data

Description	Article No.
SENTRON PAC3200 measuring device With screw terminals Records 50 measured values	7KM2112-0BA00-3AA0
SENTRON PAC4200 measuring device With screw terminals Records 200 measured values	7KM4212-0BA00-3AA0

More information

More information is available in the Siemens Industry Mall or on the Internet at:

www.siemens.com/industrymall
www.siemens.com/lowvoltage/powermonitoring

Technical specifications

Article No.		7KM2112-0BA00-3AA0	7KM4212-0BA00-3AA0
Product brand name		SETRON	SETRON
Product short term		PAC3200	PAC4200
Product designation		Measuring device	Measuring device
Type of measured value acquisition		Seamless	Seamless
Measuring inputs for voltage at 3 AC maximum	V	690/400	690/400
Wide-range power supply			
• At AC	V	95 ... 240	95 ... 240
• At DC	V	110 ... 340	110 ... 340
Measurable frequency	Hz	45 ... 65	45 ... 65
Protection class when mounted		II	II
Degree of pollution		2	2
Degree of protection			
• front		IP65	IP65
• rear		IP20	IP20
Relative humidity at 25 °C, during operation	%	5 ... 95	5 ... 95
Ambient temperature, during			
• storage	°C	-25 ... +70	-25 ... +70
• transport	°C	-25 ... +70	-25 ... +70
• operation	°C	-10 ... +55	-10 ... +55
Width	mm	96	96
Height	mm	96	96
Depth	mm	56	82
Mounting depth	mm	51	77
Net weight	g	540	460
Certificate of suitability		CB, CE, EAC, RCM, UL	CB, CE, EAC, RCM, UL

3

3



4/2	SINAMICS S120 Combi
4/2	Power Modules
4/8	External fan module, Reinforcement plates
4/9	Line reactors
4/10	Line filters
4/11	SINAMICS S120 in booksize compact format
4/11	<u>Motor Modules</u>
4/12	Single Motor Modules
4/13	Double Motor Modules
4/14	SINAMICS S120 in booksize format
4/14	<u>Line Modules</u>
4/14	Smart Line Modules
4/17	Line reactors
4/18	Line filters
4/19	Recommended line-side components
4/20	Active Line Modules
4/24	Active Interface Modules
4/26	Basic Line Filters
4/27	Recommended line-side components
4/28	Basic Line Modules
4/32	Line reactors
4/33	Line filters
4/34	Recommended line-side components
4/35	<u>Motor Modules</u>
4/35	Single Motor Modules
4/40	Double Motor Modules
4/43	Series motor reactors
4/44	<u>DC link components</u>
4/44	Braking Module
4/45	Braking resistors
4/46	Capacitor Module
4/47	Control Supply Module
4/48	DC link rectifier adapter
4/48	DC link adapter
4/49	Supplementary system components
4/49	DMC20 DRIVE-CLiQ Hub Module
4/50	DME20 DRIVE-CLiQ Hub Module
4/51	TM54F Terminal Module
4/53	<u>Encoder system connection</u>
4/53	SMC20 Sensor Module Cabinet-Mounted
4/54	SMC30 Sensor Module Cabinet-Mounted
4/55	SMC40 Sensor Module Cabinet-Mounted
4/56	SME125 Sensor Module External
	CAD CREATOR
	Dimensional drawing and 2D/3D CAD generator www.siemens.com/cadcreator
	Drive Technology Configurator
	Guided product selection through to exact article number www.siemens.com/dt-configurator
	Siemens NC 82 · 2018

Overview



SINAMICS S120 Combi Power Module

SINAMICS S120 Combi is a very compact and rugged drive concept tailored for compact turning and milling machines. SINAMICS S120 Combi integrates a line infeed with regenerative feedback capability, power units for spindle and feed motors as well as a TTL encoder interface into a single Power Module.

The SINAMICS S120 Combi Power Modules are optimized as a drive for 3 to 6 axes in machine tools. The Power Modules are available with external air cooling. SINAMICS Motor Modules in booksize compact format are used as expansion axes.

Benefits

- Compact multi-axis module with line infeed with regenerative feedback capability and power units for 3 or 4 axes
- Customized drive system for compact standard turning and milling machines
- Requires very little mounting space in control cabinet incl. fan unit, shield terminals and ventilation clearances
- Optimized for weak supply networks with frequent under-voltage, network imbalances and large frequency fluctuations
- Optimized for harsh operating conditions with increased cabinet temperature and increased humidity
- Rugged Power Modules resistant to short circuits, overvoltage and ground faults
- Rugged and easy-to-fit screw-type terminals with integrated shield connection for the power cables
- Perfectly designed for expansion using additional Motor Modules in booksize compact format
- Low energy consumption thanks to state-of-the-art 400-V technology
- Excellent dynamic response and machining precision thanks to Dynamic Servo Control (DSC)
- Simple cabling due to intelligent DRIVE-CLiQ interface
- Very simple commissioning thanks to predefined topologies

Function

- Power Module with 3 or 4 integrated power units
- Integrated line infeed with regenerative feedback capability
- Integrated TTL encoder interface
- Integrated motor brake control for one axis
- Integrated fan power supply
- Line supply voltage 380 to 480 V 3 AC
- Supply types TT, TN and IT
- Integrated shield terminals
- Heat dissipation concept with external heatsink for extremely low power losses in the control cabinet
- Easy-to-mount fan module optimized for harsh environments
- Increased availability thanks to fan monitoring
- Derating only from 45 °C cabinet temperature
- Power cables are connected by means of screw-type terminals

Integration

The following components can be connected to the SINAMICS S120 Combi drive system:

- SINUMERIK 828D
 - Numeric Control Extension NX10.3
 - Numeric Control Extension NX15.3
- 3 or 4 spindle/feed motors
- 3 or 4 motor encoders
- 3 or 4 direct encoders via DMC20
- Direct spindle encoder directly to TTL or sin/cos via SMC20
- External fan module
- Up to two additional SINAMICS S120 Motor Modules in booksize compact format via DC link connection and 24 V DC busbars
- Braking Module with braking resistor via DC link connection
- Control Supply Module via DC link connection and 24 V DC busbars
- One safe motor brake control
- 5 or 6 DRIVE-CLiQ sockets
- 24 V electronics power supply via connector
- 1 safe standstill input for the infeed (Enable Pulses)
- 1 safe standstill input for the spindle and feeds (Enable Pulses)
- 1 temperature sensor input for the spindle
- PE connections

The scope of supply of the SINAMICS S120 Combi Power Modules includes:

- SINAMICS S120 Combi Power Module
- Accessories pack consisting of:
 - 4 DRIVE-CLiQ dust protection blanking plugs
 - Connector X224 for the electronics power supply
 - Connector X11 for motor brake control
 - Connector X21 Enable Pulses infeed
 - Connector X22 Enable Pulses temperature sensor – axes
 - 5 shield terminals for power cables
 - Shield terminal for signal cable

Selection and ordering data

SINAMICS S120 Combi Power Module with external air cooling

Rated power Infeed kW	Rated output current Spindle A	Rated output current Feedrate 1 A	Rated output current Feedrate 2 A	Rated output current Feedrate 3 A	Article No.
3-axis Power Module					
16	18	5	5	–	6SL3111-3VE21-6FA1
16	24	9	9	–	6SL3111-3VE21-6EA1
20	30	9	9	–	6SL3111-3VE22-0HA1
4-axis Power Module					
10	24 ¹⁾	12	12	12	6SL3111-4VE21-0EA1
16	18	9	5	5	6SL3111-4VE21-6FA1
16	24	9	9	9	6SL3111-4VE21-6EA1
20	30	12	9	9	6SL3111-4VE22-0HA1

Technical specifications

Article No.	6SL3111-3VE2-..... 6SL3111-4VE2-.....
Product brand name	SINAMICS
Product type designation	S120 Combi
Product designation	Power Module
DC link voltage ²⁾	1.35 × line voltage
Output voltage	0 ... 0.7 × DC link voltage
Line power factor at rated power	
• Fundamental $\cos \varphi_1$	> 0.96
• Total λ	0.64 ... 0.90
Radio interference suppression	
• Standard	No radio interference suppression
• With line filter	Category C2 to EN 61800-3
Degree of protection	IP20
Installation altitude	Up to 1000 m above sea level without derating > 1000 ... 4000 m with derating
Certificate of suitability	CE, cURus
Safety Integrated	Safety Integrity Level 2 (SIL 2) according to IEC 61508 Performance Level d (PLd) according to ISO 13849-1 Control Category 3 according to ISO 13849-1

¹⁾ Pulse frequency 4 kHz/8 kHz.

²⁾ The DC link voltage adjusts itself to the mean value of the rectified line voltage.

Technical specifications (continued)

Article No.		6SL3111-3VE21-6FA1	6SL3111-3VE21-6EA1	6SL3111-3VE22-0HA1
Product brand name		SINAMICS		
Product type designation		S120 Combi		
Product designation		3-axis Power Module with <u>external</u> air cooling		
Infeed				
• Rated power P_{rated} (S1)	kW	16	16	20
• Infeed power P_{S6} (40 %)	kW	21	21	26.5
• Peak infeed power P_{max}	kW	35	35	40
Regenerative feedback				
• Rated power P_{rated} (S1)	kW	16	16	20
• Peak regenerative feedback power P_{max}	kW	35	35	40
Supply voltages				
• Line voltage 3 AC	V	380 ... 480 ± 10 %		
• Line frequency	Hz	45 ... 66		
• Electronics power supply DC	V	24 (20.4 ... 28.8)		
Rated input current				
• At 400 V 3 AC	A	28	28	34
• At 380 V/480 V 3 AC	A	29/25	29/25	35/30
• At 400 V 3 AC I_{S6} (40 %)	A	35.5	35.5	44
• At 400 V 3 AC peak current	A	56	56	63.5
Pulse frequency	kHz	4	4	4
Output voltage AC	V	0 ... 0.7 × DC link voltage		
Spindle				
• Rated output current AC I_{rated}	A	18	24	30
• Base-load current AC I_H	A	15.3	20.4	25.5
• Intermittent-duty operating current AC I_{S6} (40 %)	A	24	32	40
• Peak current AC I_{max}	A	36	48	56
Rated power				
• At 540 V DC link voltage	kW	8.7	11.7	14.4
• At 600 V DC link voltage	kW	9.7	13	16
Feedrate 1/Feedrate 2				
• Rated output current AC I_{rated}	A	5	9	9
• Base-load current AC I_H	A	4.3	7.7	7.7
• Intermittent-duty operating current AC I_{S6} (40 %)	A	6.5	12	12
• Peak current AC I_{max}	A	10	18	18
Rated power				
• At 540 V DC link voltage	kW	2.4	4.3	4.3
• At 600 V DC link voltage	kW	2.7	4.8	4.8
Output for expansion axis				
• DC link output current DC I_{rated}	A	40	40	40
• DC link voltage DC	V	460 ... 720	460 ... 720	460 ... 720
• Electronics output current for expansion axis 24 V DC	A	20	20	20
Electronics current consumption at 24 V DC				
• Without external fan module	A	1.5	1.5	1.5
• With external fan module	A	2.3	2.3	2.3
Total power loss, incl. electronics losses				
• Internal	W	81	91	102
• External	W	344	446	532

Technical specifications (continued)

Article No.	6SL3111-3VE21-6FA1	6SL3111-3VE21-6EA1	6SL3111-3VE22-0HA1
Product brand name	SINAMICS		
Product type designation	S120 Combi		
Product designation	3-axis Power Module with <u>external</u> air cooling		
Ambient temperature, maximum			
• Without derating	°C 45	45	45
• With derating	°C 55	55	55
DC link voltage DC	V 460 ... 720		
• Overvoltage trip DC	V 820 ± 2 %		
• Undervoltage trip DC	V 380 ± 2 %		
DC link capacitance	µF 1645	1880	2115
Circuit breaker (UL)			
• Type	3VL2505-2KN30-....	3VL2505-2KN30-....	3VL2506-2KN30-....
• Rated current	A 35	35	60
• Short-circuit current rating SCCR at 480 V 3 AC, resulting	kA 65	65	65
Safety fuses (UL)			
• Type	AJT35	AJT35	AJT60
• Rated current	A 35	35	60
• Short-circuit current rating SCCR, resulting			
- At 480 V 3 AC	kA 65	65	65
- At 600 V 3 AC	kA 200	200	200
Cooling air requirement	m ³ /h 160	160	160
Width	mm 260	260	260
Height	mm 380	380	380
Depth	mm 304	304	304
Net weight	kg 18.4	18.4	18.5

Technical specifications (continued)

Article No.	6SL3111-4VE21-0EA1	6SL3111-4VE21-6FA1	6SL3111-4VE21-6EA1	6SL3111-4VE22-0HA1	
Product brand name	SINAMICS				
Product type designation	S120 Combi				
Product designation	4-axis Power Module with <u>external</u> air cooling				
Infeed					
• Rated power P_{rated} (S1)	kW	10	16	16	20
• Infeed power P_{S6} (40 %)	kW	13	21	21	26.5
• Peak infeed power P_{max}	kW	35	35	35	40
Regenerative feedback					
• Rated power P_{rated} (S1)	kW	10	16	16	20
• Peak regenerative feedback power P_{max}	kW	35	35	35	40
Supply voltages					
• Line voltage 3 AC	V	380 ... 480 ± 10 %			
• Line frequency	Hz	45 ... 66			
• Electronics power supply DC	V	24 (20.4 ... 28.8)			
Rated input current					
• At 400 V 3 AC	A	16.2	28	28	34
• At 380 V/480 V 3 AC	A	17/12.8	29/25	29/25	35/30
• At 400 V 3 AC I_{S6} (40 %)	A	21.1	35.5	35.5	44
• At 400 V 3 AC peak current	A	56.7	56	56	63.5
Pulse frequency	kHz	4 (8) ¹⁾	4	4	4
Output voltage AC	V	0 ... 0.7 × DC link voltage			
Spindle					
• Rated output current AC I_{rated}	A	24	18	24	30
• Base-load current AC I_H	A	20.4	15.3	20.4	25.5
• Intermittent-duty operating current AC I_{S6} (40 %)	A	32 at 4 kHz (19.2 at 8 kHz) ¹⁾	24	32	40
• Peak current AC I_{max}	A	60	36	48	56
Rated power					
• At 540 V DC link voltage	kW	11.7	8.7	11.7	14.4
• At 600 V DC link voltage	kW	13	9.7	13	16
Feedrate 1					
• Rated output current AC I_{rated}	A	12	9	9	12
• Base-load current AC I_H	A	10.8	7.7	7.7	10.3
• Intermittent-duty operating current AC I_{S6} (40 %)	A	16	12	12	16
• Peak current AC I_{max}	A	36	18	18	24
Rated power					
• At 540 V DC link voltage	kW	5.8	4.3	4.3	5.8
• At 600 V DC link voltage	kW	6.5	4.8	4.8	6.5
Feedrate 2/Feedrate 3					
• Rated output current AC I_{rated}	A	12	5	9	9
• Base-load current AC I_H	A	10.8	4.3	7.7	7.7
• Intermittent-duty operating current AC I_{S6} (40 %)	A	16	6.5	12	12
• Peak current AC I_{max}	A	36	10	18	18
Rated power					
• At 540 V DC link voltage	kW	5.8	2.4	4.3	4.3
• At 600 V DC link voltage	kW	6.5	2.7	4.8	4.8
Output for expansion axis					
• DC link output current DC I_{rated}	A	18.5	40	40	40
• DC link voltage DC	V	510 ... 720	510 ... 720	510 ... 720	510 ... 720
• Electronics output current for expansion axis 24 V DC	A	5	20	20	20

¹⁾ Changeover to 8 kHz only possible for the spindle.

Technical specifications (continued)

Article No.	6SL3111-4VE21-0EA1	6SL3111-4VE21-6FA1	6SL3111-4VE21-6EA1	6SL3111-4VE22-0HA1
Product brand name	SINAMICS			
Product type designation	S120 Combi			
Product designation	4-axis Power Module with <u>external</u> air cooling			
Electronics current consumption at 24 V DC				
• Without external fan module	A	1.6	1.6	1.6
• With external fan module	A	2.4	2.4	2.4
Total power loss, incl. electronics losses	W	770	492	607
• Internal	W	115	87	100
• External	W	655	405	507
Ambient temperature, maximum				
• Without derating	°C	45	45	45
• With derating	°C	55	55	55
DC link voltage DC	V	460 ... 720		
• Overvoltage trip DC	V	820 ± 2 %		
• Undervoltage trip DC	V	380 ± 2 %		
DC link capacitance	µF	2520	1645	2115
Circuit breaker (UL)				
• Type		3VL2505-2KN30-....	3VL2505-2KN30-....	3VL2505-2KN30-....
• Rated current	A	50	50	60
• Short-circuit current rating SCCR at 480 V 3 AC, resulting	kA	65	65	65
Safety fuses (UL)				
• Type		AJT35	AJT35	AJT35
• Rated current	A	35	35	60
• Short-circuit current rating SCCR, resulting				
- At 480 V 3 AC	kA	65	65	65
- At 600 V 3 AC	kA	200	200	200
Cooling air requirement	m ³ /h	160	160	160
Width	mm	260	260	260
Height	mm	380	380	380
Depth	mm	304	304	304
Net weight	kg	19.4	18.9	19

Overview



External fan module

The external fan module combined with the reinforcement plates is employed to provide perfect cooling of a SINAMICS S120 Combi Power Module.

To cool the SINAMICS S120 Combi Power Modules, a volumetric flow of air through the heatsink of at least 160 m³/h is required.

The external fan module delivers a maximum volumetric flow rate of 290 m³/h. This dimensioning ensures an adequate air flow rate, even with a lower supply voltage or with a slightly soiled heatsink.

Due to the encapsulated electronics and the ball-bearing-mounted closed rotor, the fan module can be used even under exacting environmental conditions. The fans are equipped with electronic reverse-polarity, blocking and overload protection systems. To ensure maximum machine availability, the fan speed is monitored. A user alarm is displayed if the fan stops.

Technical specifications

Article No.	6SL3161-0EP00-0AA0
Product brand name	SINAMICS
Product type designation	S120 Combi
Product designation	External fan module
Rated voltage DC	24 V
Voltage range DC	20.4 ... 28.8 V
Volumetric flow maximum	290 m ³ /h
Current consumption	0.8 A
Power consumption	18 W
Ambient temperature, maximum	-20 ... +70 °C
Service life	
• At 55 °C	50000 h
• At 70 °C	20000 h
Degree of protection	IP54
Height	258 mm
Width	104 mm
Depth	86 mm
Net weight	1.5 kg
Certificate of suitability	CSA, UL, VDE

Overview

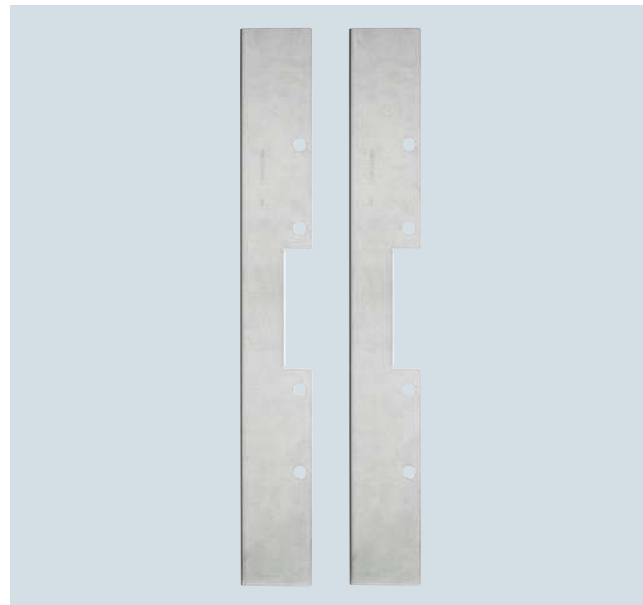

Reinforcement plates

It is essential to ensure that the air actually flows through the heatsink. The gap between the fan module and heatsink must therefore be closed. The reinforcement plates must be used for this purpose where possible.

The reinforcement plates

- Close the gap between the fan module and heatsink
- Reinforce the rear wall of the control cabinet for sealed installation
- Guarantee ideal ventilation spaces

Technical specifications

Article No.	6SL3161-1LP00-0AA0
Product brand name	SINAMICS
Product type designation	S120 Combi
Product designation	Reinforcement plates
Height	575 mm
Width	15 mm
Depth	75 mm
Net weight	0.75 kg

Selection and ordering data

Description	Article No.
SINAMICS S120 Combi External fan module	6SL3161-0EP00-0AA0
Accessories	
SINAMICS S120 Combi Reinforcement plates (2 units)	6SL3161-1LP00-0AA0

Overview



Line reactor

SINAMICS S120 Combi Power Modules cannot operate without line reactors.

The use of other makes of line reactor can lead to malfunctions or irreparable damage to equipment.

Selection and ordering data

Suitable for
SINAMICS S120 Combi

Rated power Infeed	Power Module Type	Rated power kW	Article No.
16	6SL3111-3VE21-6FA1	16	6SL3100-0EE21-6AA0
16	6SL3111-3VE21-6EA1		
10	6SL3111-4VE21-0EA1		
16	6SL3111-4VE21-6FA1		
16	6SL3111-4VE21-6EA1		
20	6SL3111-3VE22-0HA1	20	6SL3100-0EE22-0AA0
20	6SL3111-4VE22-0HA1		

SINAMICS line reactor

Technical specifications

Article No.	6SL3100-0EE21-6AA0	6SL3100-0EE22-0AA0
Product brand name	SINAMICS	SINAMICS
Product designation	Line reactor	Line reactor
Rated power	kW 16	20
Rated current	A 28	33
Power loss	W 75	98
Line/load connection 1U1, 1V1, 1W1/1U2, 1V2, 1W2	Screw-type terminals	Screw-type terminals
• Conductor cross-section	mm ² 4	10
PE connection	Screw-type terminals	Screw-type terminals
• Conductor cross-section	mm ² 4	10
Degree of protection	IP20	IP20
Width	mm 219	219
Height	mm 176	176
Depth	mm 120	130
Net weight	kg 10.7	10.9
Certificate of suitability	cURus	cURus

Overview



Line filter

In plants with strict EMC requirements, line filters work together with line reactors to restrict the conducted interference emanating from the Power Modules to the limit values of Class A1 as defined in EN 55011 and Category C2 as defined in EN 61800-3. Line filters are suitable only for direct connection to TN systems.

The use of other makes of line filter can lead to malfunctions or irreparable damage to equipment.

Note:

According to product standard IEC 61800-3, RFI suppression commensurate with the relevant rated conditions must be provided and is a legal requirement in the EU (EMC Directive). Line filters and line reactors are required for this purpose.

The machine manufacturer must provide verification that the machinery to be operated with the drive products and the installed suppression elements, e.g. line filters, are CE-EMC-compliant.

Technical specifications

Article No.	6SL3000-0BE21-6DA0		
Product brand name	SINAMICS		
Product designation	Line filter		
Rated current	36 A		
Rated infeed power	10 kW	16 kW	20 kW
Power loss in rated operation	12 W	15 W	16 W
Line/load connection L1, L2, L3/U, V, W	Screw-type terminals		
• Conductor cross-section	10 mm ²		
PE connection	M6 screw stud		
Degree of protection	IP20		
Width	50 mm		
Height	429 mm		
Depth	226 mm		
Net weight	5 kg		
Certificate of suitability	cURus		

Selection and ordering data

Suitable for SINAMICS S120 Combi		SINAMICS line filter
Rated power Infeed kW	Power Module Type	
16	6SL3111-3VE21-6FA1	6SL3000-0BE21-6DA0
16	6SL3111-3VE21-6EA1	
20	6SL3111-3VE22-0HA1	
10	6SL3111-4VE21-0EA1	
16	6SL3111-4VE21-6FA1	
16	6SL3111-4VE21-6EA1	
20	6SL3111-4VE22-0HA1	

Overview

The SINAMICS S120 Combi Power Module can be extended by the S120 Motor Modules in booksize compact format.

Benefits

- Simple addition of supplementary machine components when using the SINAMICS S120 Combi drive system
- Expansion axes can interpolate freely with the SINAMICS S120 Combi axes
- Connection of the Motor Modules by simple connection of DC link busbars and 24 V busbars
- Motor Modules are supplied via the infeed integrated in the SINAMICS S120 Combi
- Energy exchange between Motor Modules and the SINAMICS S120 Combi Power Module through a shared DC link
- Simple connection to the DRIVE-CLiQ interface

Function

Connection of up to 2 SINAMICS S120 Motor Modules in booksize compact format to the integrated line infeed of the SINAMICS S120 Combi Power Modules¹⁾.

Integration

The Motor Modules receive their control information via DRIVE-CLiQ from:

- SINUMERIK 828D
 - Numeric Control Extension NX10.3
 - Numeric Control Extension NX15.3

Technical specifications

Article No. Product designation	6SL3420-1TE... Single Motor Module in booksize compact format
Article No. Product designation	6SL3420-2TE... Double Motor Module in booksize compact format
Product brand name	SINAMICS
DC link voltage DC Up to 2000 m above sea level	510 ... 720 V (line voltage 380 ... 480 V 3 AC)
Electronics power supply DC	24 V -15 %/+20 %
Cooling method	Internal air cooling Power units with increased air cooling by built-in fan
Ambient or coolant temperature (air) During operation for line-side components, Line Modules and Motor Modules	0 ... 40 °C without derating > 40 ... 55 °C with derating
Installation altitude	Up to 1000 m above sea level without derating > 1000 ... 4000 m above sea level with derating
Degree of protection	IP20
Certificate of suitability	CE, cULus, cURus
Safety Integrated	Safety Integrity Level 2 (SIL 2) according to IEC 61508 Performance Level d (PLd) according to ISO 13849-1 Control category 3 according to ISO 13849-1 or EN 954-1

¹⁾ The simultaneity factor of the axis grouping for the infeed power of the SINAMICS S120 Combi Power Module must be observed.

Design



Single Motor Modules in booksize compact format

The Single Motor Modules in booksize compact format feature the following connections and interfaces as standard:

- 2 DC link connections via integrated DC link busbars
- 1 electronics power supply connection via integrated 24 V DC busbars
- 3 DRIVE-CLiQ sockets
- 1 motor connection via connector
- 1 safe standstill input
- 1 safe motor brake control
- 1 temperature sensor input
- 2 PE (protective earth) connections

Design (continued)

The status of the Motor Modules is indicated via two multi-color LEDs.

The shield of the motor cable is routed over the connector to the motor connection.

The signal cable shield can be connected to the Motor Module by means of a shield connection clamp, e.g. Weidmüller type KLBÜ 3-8 SC.

The scope of supply of the Motor Modules includes:

- DRIVE-CLiQ cable appropriate to the width of the Motor Module for connection to the adjacent Motor Module, length 0.11 m for Motor Modules with a width of 50 mm or length 0.16 m for Motor Modules with a width of 75 mm.
- 2 dust protection blanking plugs for sealing unused DRIVE-CLiQ sockets
- Jumper for connecting the 24 V DC busbar to the adjacent Motor Module
- Connector X21
- Connector X11 for motor brake connection
- Connector X1 for motor connection
- 1 set of warning labels in 30 languages

Selection and ordering data

SINAMICS S120 Single Motor Modules in booksize compact format		
Rated output current	Rated power	Internal air cooling
A	kW	Article No.
DC link voltage 510 ... 720 V DC		
3	1.6	6SL3420-1TE13-0AA1
5	2.7	6SL3420-1TE15-0AA1
9	4.8	6SL3420-1TE21-0AA1
18	9.7	6SL3420-1TE21-8AA1

Technical specifications

Article No.	6SL3420-1TE13-0AA1	6SL3420-1TE15-0AA1	6SL3420-1TE21-0AA1	6SL3420-1TE21-8AA1
Product brand name	SINAMICS			
Product type designation	S120			
Product designation	Single Motor Modules in booksize compact format with internal air cooling			

DC link voltage 510 ... 720 V DC

Output current		3	5	9	18
• Rated current I_{rated}	A	3	5	9	18
• I_{max}	A	9	15	27	54
Rated power	kW	1.6	2.7	4.8	9.7
DC link current $I_d^{1)}$	A	3.6	6	11	22
Current requirement at 24 V DC, maximum	A	0.85	0.85	0.85	0.85
Power loss ²⁾					
• With internal air cooling in control cabinet	W	70	100	100	180
Width	mm	50	50	50	75
Height	mm	270	270	270	270
Depth	mm	226	226	226	226
Net weight	kg	2.7	2.7	2.7	3.4

1) Rated DC link current for dimensioning an external DC connection.

2) Power loss of Motor Module at rated power including losses of 24 V DC electronics power supply.

Design



Double Motor Modules in booksize compact format

The Double Motor Modules in booksize compact format feature the following connections and interfaces as standard:

- 2 DC link connections via integrated DC link busbars
- 2 electronics power supply connections via integrated 24 V DC busbars
- 4 DRIVE-CLiQ sockets
- 2 motor connections via connector
- 2 safe standstill inputs (1 input per axis)
- 2 safe motor brake controls
- 2 temperature sensor inputs
- 3 PE (protective earth) connections

Design (continued)

The status of the Motor Modules is indicated via two multi-color LEDs.

The shield of the motor cables is routed over the connectors to the motor connection.

The signal cable shield can be connected to the Motor Module by means of a shield connection clamp, e.g. Weidmüller type KLBÜ 3-8 SC.

The scope of supply of the Motor Modules includes:

- DRIVE-CLiQ cable for connection to the adjacent Motor Module, length 0.16 m
- 2 dust protection blanking plugs for sealing unused DRIVE-CLiQ sockets
- Jumper for connecting the 24 V DC busbar to the adjacent Motor Module
- Connectors X21 and X22
- Connectors X1 and X2 for motor connection
- 1 set of warning labels in 30 languages

Selection and ordering data

SINAMICS S120 Double Motor Modules in booksize compact format		
Rated output current	Rated power	Internal air cooling
A	kW	Article No.
DC link voltage 510 ... 720 V DC		
2 × 1.7	2 × 0.9	6SL3420-2TE11-7AA1
2 × 3	2 × 1.6	6SL3420-2TE13-0AA1
2 × 5	2 × 2.7	6SL3420-2TE15-0AA1

Technical specifications

Article No.	6SL3420-2TE11-7AA1	6SL3420-2TE13-0AA1	6SL3420-2TE15-0AA1
Product brand name	SINAMICS		
Product type designation	S120		
Product designation	Double Motor Modules in booksize compact format with internal air cooling		
DC link voltage DC 510 ... 720 V			
Output current			
• Rated current I_{rated}	A	2 × 1.7	2 × 3
• I_{max}	A	2 × 5.1	2 × 9
Rated power	kW	2 × 0.9	2 × 1.6
DC link current $I_d^{1)}$	A	4.1	7.2
Power loss ²⁾			
• With internal air cooling in control cabinet	W	110	130
Width	mm	75	75
Height	mm	270	270
Depth	mm	226	226
Net weight	kg	3.4	3.4

¹⁾ Rated DC link current for dimensioning an external DC connection.

²⁾ Power loss of Motor Module at rated power including losses of 24 V DC electronics power supply.

Overview



Smart Line Module in booksize format

Smart Line Modules are stall-protected, line-commutated feed/regenerative feedback units (diode bridge for incoming supply; stall-protected, line-commutated regenerative feedback via IGBTs) with 100 % continuous regenerative feedback power. The regenerative feedback capability of the modules can be deactivated by means of a digital input (Smart Line Modules 5 kW and 10 kW) or by means of parameterization (Smart Line Modules 16 kW, 36 kW and 55 kW).

Smart Line Modules are designed for connection to grounded TN and TT and non-grounded IT supply systems.

The DC link is pre-charged by means of integrated pre-charging resistors.

The associated line reactor is absolutely essential for operating a Smart Line Module.

Design

The Smart Line Modules in booksize format feature the following connections and interfaces as standard:

- 1 power connection via screw-type terminals
- 1 connection for the 24 V DC electronics power supply via the 24 V terminal adapter included in the scope of supply
- 1 DC link connection via integrated DC link busbars
- 2 PE (protective earth) connections
- 2 digital inputs (only for 5 kW and 10 kW Smart Line Modules)
- 1 digital output (only for 5 kW and 10 kW Smart Line Modules)
- 3 DRIVE-CLiQ sockets (only for 16 kW, 36 kW and 55 kW Smart Line Modules)
- 1 temperature sensor input

The status of the Smart Line Modules is indicated via two multi-color LEDs.

The signal cable shield can be connected to the Line Module by means of a shield connection clamp, e.g. Weidmüller type KLBU 3-8 SC.

¹⁾ The DC link voltage is regulated to the mean value of the rectified line voltage.

Design (continued)

The scope of supply of the Smart Line Modules includes:

- DRIVE-CLiQ cable for connection to the adjacent Control Unit on the left for drive control, length 0.11 m (only for 16 kW, 36 kW and 55 kW Smart Line Modules)
- 2 dust protection blanking plugs for sealing unused DRIVE-CLiQ sockets (only for Smart Line Modules 16 kW, 36 kW and 55 kW)
- DRIVE-CLiQ cable (length depends on Smart Line Module width) for connection to the adjacent Motor Module, length = width of Smart Line Module + 0.11 m
- Jumper for connecting the 24 V DC busbar to the adjacent Motor Module
- 24 V terminal adapter (X24)
- Connector X21 for digital inputs and outputs
- Connector X22 for digital inputs and outputs (only for 5 kW and 10 kW Smart Line Modules)
- Connector X1 for line connection (only for 5 kW and 10 kW Smart Line Modules)
- 1 set of warning labels in 30 languages

Technical specifications

Article No.	6SL313-6....-....
Product brand name	SINAMICS
Product type designation	S120
Product designation	Smart Line Modules in booksize format
Line voltage 3 AC Up to 2000 m above sea level	380 ... 480 V $\pm 10\%$ (in operation $-15\% < 1$ min)
Line frequency	47 ... 63 Hz
SCCR (short circuit current rating)	65 kA in conjunction with the recommended fuses Class J or circuit breakers in accordance with UL489/CSA 22.2 No. 5-02 see recommended line-side components
Line power factor At rated power	<ul style="list-style-type: none"> • Fundamental $\cos \varphi_1$ > 0.96 • Total λ 0.65 ... 0.90
Overvoltage category according to EN 60664-1	Class III
DC link voltage approx.	$1.35 \times \text{line voltage}^1$
Electronics power supply DC	24 V $-15\%/+20\%$
Radio interference suppression	<ul style="list-style-type: none"> • Standard No radio interference suppression • With line filter Category C2 to EN 61800-3 up to overall cable length 350 m (shielded)
Cooling method	Internal air cooling Power units with increased air cooling by built-in fan
Ambient or coolant temperature (air) During operation for line-side components, Line Modules and Motor Modules	0 ... 40 °C without derating > 40 ... 55 °C with derating
Installation altitude	Up to 1000 m above sea level without derating > 1000 ... 4000 m above sea level with derating
Certificate of suitability	CE, cULus

Technical specifications (continued)

Article No.	6SL3130-6AE15-0AB1	6SL3130-6AE21-0AB1	6SL3130-6TE21-6AA4	6SL3130-6TE23-6AA3	6SL3130-6TE25-5AA3
Product designation	Smart Line Module in booksize format with <u>internal</u> air cooling				
Product brand name	SINAMICS				
Product type designation	S120				

Line voltage 380 ... 480 V 3 AC

Infeed/regenerative feedback power						
• Rated power P_{rated} at 380 V 3 AC	kW	5	10	16	36	55
• For S6 duty (40 %)	kW	6.5	13	21	47	71
• P_{max}	kW	10	20	35	70	91
DC link current						
• At 540 V/600 V DC	A	9.3/8.3	18.5/16.6	30/27	67/60	105/92
• For S6 duty (40 %)	A	11	22	35	79	138
• Maximum	A	16.6	33.2	59	117	178
Input current						
• Rated current at 380 V/400 V/480 V 3 AC	A	8.6/8.1/6.7	17/16.2/12.8	29/27.5/24.5	62/59/51	94/90/77
• For S6 duty (40 %) at 400 V	A	10.6	21.1	35	76	106
• Maximum at 400 V	A	15.7	31.2	57.5	112	130
Current requirement, maximum 24 V DC electronics power supply	A	0.8	0.9	0.95	1.5	1.9
Current carrying capacity						
• 24 V DC busbars	A	20	20	20	20	20
• DC link busbars	A	100	100	100	200	200
DC link capacitance						
• Smart Line Module	μF	220	330	710	1410	1880
• Drive line-up, maximum	μF	6000	6000	20000	20000	20000
Power loss ¹⁾	W	80	140	190	406	665
Cooling air requirement	m^3/s	0.008	0.008	0.016	0.031	0.044
Sound pressure level L_{pA} (1 m)	dB	< 60	< 60	< 60	< 60	< 60
Line connection U1, V1, W1		Screw-type terminals (X1)	Screw-type terminals (X1)	Screw-type terminals (X1)	M6 screw studs (X1)	M6 screw studs (X1)
• Conductor cross-section	mm^2	2.5 ... 6	2.5 ... 6	2.5 ... 10	2.5 ... 50	2.5 ... 95
Shield connection		Shield connection plate integrated into the connector			See Accessories	See Accessories
PE connection		M5 screw	M5 screw	M5 screw	M6 screw	M6 screw
Cable length, max. Total of all motor cables and DC link						
• Shielded	m	350	350	630	630	1000
• Unshielded	m	560	560	850	850	1500
Degree of protection		IP20	IP20	IP20	IP20	IP20
Width	mm	50	50	100	150	200
Height	mm	380	380	380	380	380
Depth	mm	270	270	270	270	270
Net weight	kg	4.7	4.7	7.2	10.7	16

¹⁾ Power loss of Smart Line Module at rated power including losses of 24 V DC electronics power supply.

Selection and ordering data

SINAMICS S120 Smart Line Module in booksize format	
Rated power	Internal air cooling
kW	Article No.
5	6SL3130-6AE15-0AB1
10	6SL3130-6AE21-0AB1
16	6SL3130-6TE21-6AA4
36	6SL3130-6TE23-6AA3
55	6SL3130-6TE25-5AA3

Description	Article No.
Accessories	
Shield connection plate For Line Modules and Motor Modules in booksize format with a width of: • 150 mm • 200 mm	6SL3162-1AF00-0AA1 6SL3162-1AH01-0AA0
DC link rectifier adapter For direct infeed of DC link voltage For Line Modules and Motor Modules in booksize format with a width of: • 50 mm and 100 mm Screw-type terminals 0.5 ... 10 mm ² • 150 mm, 200 mm and 300 mm Screw-type terminals 35 ... 95 mm ²	6SL3162-2BD00-0AA0 6SL3162-2BM00-0AA0
DC link adapter (2 units) For multi-tier configuration For all Line Modules and Motor Modules in booksize format Screw-type terminals 35 ... 95 mm ²	6SL3162-2BM01-0AA0

Description	Article No.
Accessories for re-ordering	
SINAMICS S120 Terminal Kit Plug-in terminals, DRIVE-CLiQ jumper (length = Module width + 60 mm), dust protection blanking plugs for DRIVE-CLiQ port For Smart Line Modules with a width of: • 50 mm • 100 mm • 150 mm • 200 mm	6SL3163-8KB00-0AA1 6SL3163-8FD00-0AA0 6SL3163-8GF00-0AA0 6SL3163-8HH00-0AA0
24 V terminal adapter For all Line Modules and Motor Modules in booksize format	6SL3162-2AA00-0AA0
24 V jumper For connection of the 24 V busbars for booksize format	6SL3162-2AA01-0AA0
Warning labels in 30 languages This label set can be glued over the standard German or English labels to provide warnings in other languages. One set of labels is supplied with the devices. One sign in each of the following languages is provided in each set: BG, CN, CZ, DE, DK, EE, ES, FI, FR, GB, GR, HU, IE, IS, IT, JP, KR, LT, LV, MT, NL, NO, PL, PT, RO, RU, SE, SI, SK, TR	6SL3166-3AB00-0AA0
SINAMICS/SINUMERIK/SIMOTION dust protection blanking plugs For DRIVE-CLiQ port • 50 units	6SL3066-4CA00-0AA0

Overview

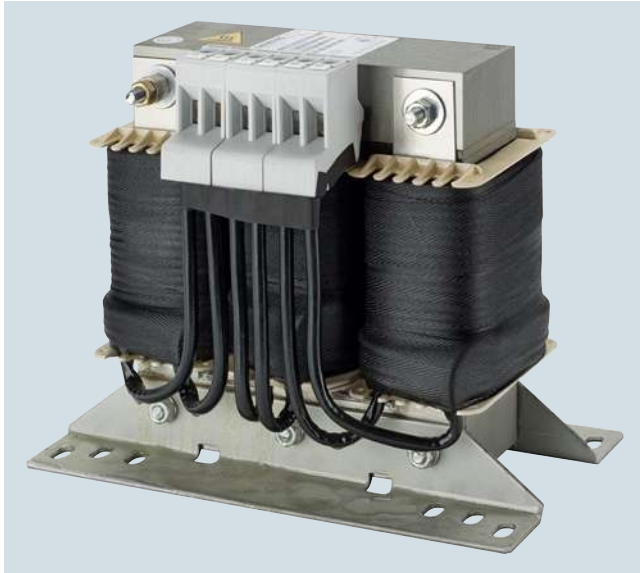

Line reactor

Smart Line Modules are not warranted to operate without the specified line reactors.

The use of other makes of line reactor can lead to malfunctions or irreparable damage to equipment.

Selection and ordering data

Suitable for Smart Line Module		SINAMICS line reactor	
Rated power Smart Line Module	Booksize format Internal air cooling	Rated current	Article No.
kW	Type	A	
5	6SL3130-6AE15-0AB1	14	6SL3000-0CE15-0AA0
10	6SL3130-6AE21-0AB1	28	6SL3000-0CE21-0AA0
16	6SL3130-6TE21-6AA4	35	6SL3100-0EE21-6AA0
36	6SL3130-6TE23-6AA3	69	6SL3000-0CE23-6AA0
55	6SL3130-6TE25-5AA3	103	6SL3000-0CE25-5AA0

Technical specifications

Article No.	6SL3000-0CE15-0AA0	6SL3000-0CE21-0AA0	6SL3100-0EE21-6AA0	6SL3000-0CE23-6AA0	6SL3000-0CE25-5AA0	
Product brand name	SINAMICS	SINAMICS	SINAMICS	SINAMICS	SINAMICS	
Product designation	Line reactor	Line reactor	Line reactor	Line reactor	Line reactor	
Line voltage 380 ... 480 V 3 AC						
Rated current	A	14	28	28	69	103
Power loss	W	62	116	75	170	190
Line/load connection 1U1, 1V1, 1W1/ 1U2, 1V2, 1W2		Screw-type terminals	Screw-type terminals	Screw-type terminals	Screw-type terminals	Screw-type terminals
• Conductor cross-section	mm ²	4	10	4	35	70
PE connection		M4 screw	M4 screw	M6 screw stud according to DIN 46234	M6 screw stud according to DIN 46234	M8 screw stud according to DIN 46234
Degree of protection		IP20	IP20	IP20	IP20	IP20
Width	mm	150	177	219	225	300
Height	mm	175	196	176	235	280
Depth	mm	66.5	86	120	224	290
Net weight	kg	3.7	7.5	10.9	17	37
Certificate of suitability		cURus	cURus	cURus	cURus	cURus

Overview



Line filter

In plants with strict EMC requirements, line filters work together with line reactors to restrict the conducted interference emanating from the Power Modules to the limit values of Class A1 as defined in EN 55011 and Category C2 as defined in EN 61800-3.

Line filters are suitable only for direct connection to TN systems. The use of other makes of line filter can lead to malfunctions or irreparable damage to equipment.

Selection and ordering data

Suitable for Smart Line Module		SINAMICS line filter	
Rated power Smart Line Module	Booksized format Internal air cooling	Rated current	Article No.
kW	Type	A	
5	6SL3130-6AE15-0AB1	12	6SL3000-0HE15-0AA0
10	6SL3130-6AE21-0AB1	25	6SL3000-0HE21-0AA0
16	6SL3130-6TE21-6AA4	36	6SL3000-0BE21-6DA0
36	6SL3130-6TE23-6AA3	74	6SL3000-0BE23-6DA1
55	6SL3130-6TE25-5AA3	105	6SL3000-0BE25-5DA0

Technical specifications

Article No.	6SL3000-0HE15-0AA0	6SL3000-0HE21-0AA0	6SL3000-0BE21-6DA0	6SL3000-0BE23-6DA1	6SL3000-0BE25-5DA0	
Product brand name	SINAMICS	SINAMICS	SINAMICS	SINAMICS	SINAMICS	
Product designation	Line filter	Line filter	Line filter	Line filter	Line filter	
Line voltage 380 ... 480 V 3 AC						
Rated current	A	12	25	36	74	105
Power loss	W	20	20	16	26	43
Line/load connection L1, L2, L3/U, V, W		Screw-type terminals	Screw-type terminals	Screw-type terminals	Screw-type terminals	Screw-type terminals
• Conductor cross-section	mm ²	10	10	10	35	50
PE connection		M6 screw stud according to DIN 46234	M6 screw stud according to DIN 46234	M6 screw stud according to DIN 46234	M6 screw stud according to DIN 46234	M8 screw stud according to DIN 46234
Degree of protection		IP20	IP20	IP20	IP20	IP20
Width	mm	60	60	50	75	100
Height	mm	285	285	429	433	466
Depth	mm	122	122	226	226	226
Net weight	kg	2.1	2.3	5.0	7.5	11.5
Certificate of suitability		cURus	cURus	cURus	cURus	cURus

Overview

Suitable line-side power components are assigned depending on the power rating of the Smart Line Module.

Additional information about the line-side power components can be found in Catalogs LV 10, IC 10 and IC 10 AO as well as the Industry Mall.

The tables below list recommended components.

Assignment of line-side power components to Smart Line Modules in booksize format

Suitable for Smart Line Module		Line contactor	Circuit breaker IEC 60947	Circuit breaker UL489/CSA C22.2 No. 5-02	Main switch
Rated power	Booksize format Internal air cooling		Article No.		
kW	Type	Type	Type	Type	Article No.
5	6SL3130-6AE15-0AB1	3RT1023-...	3RV2021-4BA10	3VL1102-2KM30-....	3LD2003-0TK51
10	6SL3130-6AE21-0AB1	3RT1026-...	3RV1031-4FA10	3VL1135-2KM30-....	3LD2203-0TK51
16	6SL3130-6TE21-6AA4	3RT1035-...	3RV1031-4FA10	3VL2505-2KN30-....	3LD2504-0TK51
36	6SL3130-6TE23-6AA3	3RT1045-...	3RV1041-4LA10	3VL2508-2KN30-....	3LD2704-0TK51
55	6SL3130-6TE25-5AA3	3RT1054-...	3VL2712-1DC33-....	3VL2512-2KN30-....	3KA5330-1GE01

Suitable for Smart Line Module		Fuse-switch disconnecter	Switch disconnecter with fuse holders	LV HRC fuse (gL/gG)			UL/CSA fuse, Class J Available form: Mersen www.ep.mersen.com		
Rated power	Booksize format Internal air cooling			Rated current	Size	Article No.	Rated current	Size	Reference No.
kW	Type	Article No.	Article No.	A			A	mm	
5	6SL3130-6AE15-0AB1	3NP1123-1CA20	3KL5030-1GB01	16	000	3NA3805	17.5	21 × 57	AJT17-1/2
10	6SL3130-6AE21-0AB1	3NP1123-1CA20	3KL5030-1GB01	35	000	3NA3814	35	27 × 60	AJT35
16	6SL3130-6TE21-6AA4	3NP1123-1CA20	3KL5030-1GB01	35	000	3NA3814	35	27 × 60	AJT35
36	6SL3130-6TE23-6AA3	3NP1123-1CA20	3KL5230-1GB01	80	000	3NA3824	80	27 × 117	AJT80
55	6SL3130-6TE25-5AA3	3NP1143-1DA20	3KL5530-1GB01	125	000	3NA3132	125	41 × 146	AJT125

Overview



Active Line Module in booksize format

Active Line Modules are self-commutated infeed/regenerative feedback units (with IGBTs in the infeed and regenerative feedback directions) that generate a controlled DC link voltage. This means that the connected Motor Modules are decoupled from the line voltage. Line voltage fluctuations within the permissible supply tolerances have no effect on the motor voltage. Active Line Modules are designed for connection to grounded, star (TN, TT) and non-grounded, symmetrical IT systems.

The DC link is pre-charged via integrated pre-charging resistors.

In order to operate an Active Line Module, it is absolutely essential to use the appropriate Active Interface Module.

Design

The Active Line Modules in booksize format feature the following connections and interfaces as standard:

- 1 power connection via screw-type terminals
- 1 connection for the 24 V DC electronics power supply via the 24 V terminal adapter included in the scope of supply
- 1 DC link connection via integrated DC link busbars
- 3 DRIVE-CLiQ sockets
- 2 PE (protective earth) connections
- 1 temperature sensor input

The status of the Active Line Modules is indicated via two multi-color LEDs.

For the Active Line Module with a width of 100 mm, the shield of the power connection cable can be connected to the integrated shield connection plate by means of a shield connection clamp or hose clip, e.g. Weidmüller type KLBÜ CO 4. The shield connection clamp must not be used as a strain relief mechanism. Shield connection sets are available for the 150 mm, 200 mm and 300 mm wide Active Line Modules.

The signal cable shield can be connected to the Motor Module by means of a shield connection clamp, e.g. Weidmüller type KLBÜ 3-8 SC.

Design (continued)

The scope of supply of the Active Line Modules includes:

- DRIVE-CLiQ cable for connection to the adjacent Control Unit on the left for drive control, length 0.11 m
- DRIVE-CLiQ cable (length depends on Active Line Module width) for connection to the adjacent Motor Module, length = width of Active Line Module + 0.11 m
- 2 dust protection blanking plugs for sealing unused DRIVE-CLiQ sockets
- Jumper for connecting the 24 V DC busbar to the adjacent Motor Module
- 24 V terminal adapter (X24)
- Connector X21 for digital inputs
- Fan insert for Active Line Modules of 80 kW and 120 kW (the voltage for the fan unit is supplied by the Active Line Module)
- 1 set of warning labels in 30 languages

Integration

The Active Line Module receives its control information via DRIVE-CLiQ from:

- SINUMERIK 828D
 - Numeric Control Extension NX10.3
 - Numeric Control Extension NX15.3

Technical specifications

Article No.	6SL3130-7TE...
Product brand name	SINAMICS
Product type designation	S120
Product designation	Active Line Modules in booksize format
Line voltage 3 AC Up to 2000 m above sea level	380 ... 480 V $\pm 10\%$ -15 % < 1 min
SCCR (short circuit current rating)	65 kA in conjunction with the recommended fuses Class J or circuit breakers in accordance with UL489/CSA 22.2 No. 5-02 see recommended line-side components
Line frequency	47 ... 63 Hz
Line power factor	<ul style="list-style-type: none"> • Active Mode <ul style="list-style-type: none"> - Fundamental $\cos \varphi_1$ - Total λ • Smart Mode <ul style="list-style-type: none"> - Fundamental $\cos \varphi_1$ - Total
Efficiency	98 %
Overvoltage category according to EN 60664-1	Class III

Technical specifications (continued)

Article No.	6SL3130-7TE...	Article No.	6SL3130-7TE...
Product brand name	SINAMICS	Product brand name	SINAMICS
Product type designation	S120	Product type designation	S120
Product designation	Active Line Modules in booksize format	Product designation	Active Line Modules in booksize format
DC link voltage U_d		Radio interference suppression	
• Active Mode	The DC link voltage is regulated and can be adjusted as a voltage decoupled from the line voltage. Factory setting 380 ... 400 V 3 AC: 600 V 400 ... 415 V 3 AC: 625 V	• Standard Active Line Module + Active Interface Module	Category C3 to EN 61800-3 up to 350 m total cable length
• Smart Mode	The DC link voltage is regulated in proportion to the line voltage to the mean rectified line voltage value. Factory setting 416 ... 480 V 3 AC: 1.35 × line voltage ¹⁾	• With line filter	Category C2 to EN 61800-3 up to 350 m total cable length Category C3 to EN 61800-3 up to 350 ... 1000 m total cable length
Electronics power supply DC	24 V, -15 %/+20 %	Cooling method	Internal air cooling Power units with increased air cooling by built-in fan
		Ambient or coolant temperature (air) During operation for line-side components, Line Modules and Motor Modules	0 ... 40 °C without derating > 40 ... 55 °C with derating
		Installation altitude	Up to 1000 m above sea level without derating > 1000 ... 4000 m above sea level with derating
		Certificate of suitability	CE, cULus

Article No.	6SL3130-7TE21-6AA4	6SL3130-7TE23-6AA3	6SL3130-7TE25-5AA3	6SL3130-7TE28-0AA3	6SL3130-7TE31-2AA3
Product designation	Active Line Module in booksize format with <u>internal air cooling</u>				
Product brand name	SINAMICS				
Product type designation	S120				

Line voltage 380 ... 480 V 3 AC

Infeed/regenerative feedback power						
• Rated power P_{rated} at 380 V 3 AC	kW	16	36	55	80	120
• For S6 duty (40 %)	kW	21	47	71	106	145
• P_{max}	kW	35	70	91 (110 ²)	131	175
DC link current						
• At 600 V DC	A	27	60	92	134	200
• For S6 duty (40 %)	A	35	79	121	176	244
• Maximum	A	59	117	152 (176 ²)	218	292
Input current						
• Rated current at 380 V/400 V/480 V 3 AC	A	26/25/21	58/55/46	88/84/70	128/122/102	192/182/152
• For S6 duty (40 %) at 400 V	A	32	71	108	161	220
• Maximum at 400 V	A	54	107	139 (168 ²)	200	267
Current requirement, max. 24 V DC electronics power supply	A	1.1	1.5	1.9	2.0	2.5
Current carrying capacity						
• 24 V DC busbars	A	20	20	20	20	20
• DC link busbars	A	100	200	200	200	200

¹⁾ Active Mode can also be selected if the connected motors are suitable for > 650 V DC.

²⁾ Higher peak power is possible in combination with the Active Interface Module 6SL3100-0BE25-5AB0 (for operating cycle constraints, see SINAMICS S120 Manual).

Technical specifications (continued)

Article No.	6SL3130-7TE21-6AA4	6SL3130-7TE23-6AA3	6SL3130-7TE25-5AA3	6SL3130-7TE28-0AA3	6SL3130-7TE31-2AA3
Product designation	Active Line Module in booksize format with <u>internal</u> air cooling				
Product brand name	SINAMICS				
Product type designation	S120				

Line voltage 380 ... 480 V 3 AC (continued)

DC link capacitance						
• Active Line Module	μF	710	1410	1880	2820	3995
• Drive line-up, maximum	μF	20000	20000	20000	20000	20000
Power loss ¹⁾	W	280	670	950	1380	2240
Cooling air requirement	m ³ /s	0.016	0.031	0.044	0.144	0.144
Sound pressure level <i>L</i> _{pA} (1 m)	dB	< 60	< 65	< 60	< 73	< 73

Line voltage 380 ... 480 V 3 AC

Line connection U1, V1, W1		Screw-type terminals (X1)	M6 screw studs (X1)	M8 screw studs (X1)	M8 screw studs (X1)	M8 screw studs (X1)
• Conductor cross-section, maximum	mm ²	2.5 ... 10	2.5 ... 50	2.5 ... 95, 2 × 35	2.5 ... 120, 2 × 50	2.5 ... 120, 2 × 50
Shield connection		Integrated in the connector	See Accessories	See Accessories	See Accessories	See Accessories
PE connection		M5 screw	M6 screw	M6 screw	M8 screw	M8 screw
Cable length, maximum Total of all motor cables and DC link						
• Shielded	m	630 ²⁾	630 ²⁾	1000	1000	1000
• Unshielded	m	850 ²⁾	850 ²⁾	1500	1500	1500
Degree of protection		IP20	IP20	IP20	IP20	IP20
Width	mm	100	150	200	300	300
Height	mm	380	380	380	380	380
• With fan ³⁾	mm	–	–	–	629	629
Depth	mm	270	270	270	270	270
Net weight	kg	7	10	16	23	23

¹⁾ Power loss of Active Line Module at rated power including losses of 24 V DC electronics power supply.

²⁾ Max. cable lengths in combination with Active Interface Module and Basic Line Filter (category C3 to EN 61800-3).

³⁾ The fan is supplied together with the Active Line Module and must be installed before the Active Line Module is commissioned.

Selection and ordering data

SINAMICS S120 Active Line Module in booksize format	
Rated power kW	Internal air cooling Article No.
16	6SL3130-7TE21-6AA4
36	6SL3130-7TE23-6AA3
55	6SL3130-7TE25-5AA3
80	6SL3130-7TE28-0AA3
120	6SL3130-7TE31-2AA3
Description	Article No.
Accessories	
Shield connection plate For Line Modules and Motor Modules in booksize format with a width of:	
• 150 mm	6SL3162-1AF00-0AA1
• 200 mm	6SL3162-1AH01-0AA0
• 300 mm	6SL3162-1AH00-0AA0
DC link rectifier adapter For direct infeed of DC link voltage For Line Modules and Motor Modules in booksize format with a width of:	
• 50 mm and 100 mm Screw-type terminals 0.5 ... 10 mm ²	6SL3162-2BD00-0AA0
• 150 mm, 200 mm and 300 mm Screw-type terminals 35 ... 95 mm ²	6SL3162-2BM00-0AA0
DC link adapter (2 units) For multi-tier configuration For all Line Modules and Motor Modules in booksize format Screw-type terminals 35 ... 95 mm ²	6SL3162-2BM01-0AA0

Description	Article No.
Accessories for re-ordering	
SINAMICS S120 Terminal Kit Plug-in terminals, DRIVE-CLiQ jumper (length = Module width + 60 mm), dust protection blanking plugs for DRIVE-CLiQ port For Active Line Modules with a width of:	
• 100 mm	6SL3163-8FD00-0AA0
• 150 mm	6SL3163-8GF00-0AA0
• 200 mm	6SL3163-8HH00-0AA0
• 300 mm	6SL3163-8JM00-0AA0
24 V terminal adapter For all Line Modules and Motor Modules in booksize format	6SL3162-2AA00-0AA0
24 V jumper For connection of the 24 V busbars for booksize format	6SL3162-2AA01-0AA0
Warning labels in 30 languages This label set can be glued over the standard German or English labels to provide warnings in other languages. One set of labels is supplied with the devices. One sign in each of the following languages is provided in each set: BG, CN, CZ, DE, DK, EE, ES, FI, FR, GB, GR, HU, IE, IS, IT, JP, KR, LT, LV, MT, NL, NO, PL, PT, RO, RU, SE, SI, SK, TR	6SL3166-3AB00-0AA0
SINAMICS/SINUMERIK/SIMOTION dust protection blanking plugs For DRIVE-CLiQ port	
• 50 units	6SL3066-4CA00-0AA0

Overview



Active Interface Modules for 16 kW, 36 kW, 55 kW and 80 kW/120 kW

The Active Interface Modules combine with the Active Line Modules to form a functional unit and are essential for operation of the associated Active Line Module. The Active Interface Modules contain a Clean Power Filter and basic interference suppression to ensure compliance with Category C3 in accordance with EN 61800-3 with respect to emitted interference.

The Clean Power Filter protects the line supply from switching-frequency harmonics. The drive system therefore draws a sinusoidal current from the supply and causes almost no harmonics.

The Active Line Modules in combination with the Active Interface Module can also be operated on supply systems with an isolated star point (IT supply systems).

Design

The scope of supply of the Active Interface Modules includes:

- Connector X21 for temperature evaluation and fan control
- Connector X24 for connecting the 24 V supply for the integrated fan
- DRIVE-CLiQ cable for connecting the Control Unit to the Active Line Module; length of the DRIVE-CLiQ cable = width of the Active Interface Modules + 0.11 m
- Shield connection plate for Active Interface Module 16 kW
- 1 set of warning labels in 30 languages

Integration

Depending on the position of the Active Interface Module in the drive system, additional DRIVE-CLiQ cables may be required. If it is separately installed on the left next to the Control Unit and Active Line Module, no additional DRIVE-CLiQ cables are required. If the Active Interface Module is placed between the Control Unit and Active Line Module, the DRIVE-CLiQ cables supplied with the Active Line Modules are suitable for setting up a line topology, i.e. Active Line Module and all Motor Modules in series on one DRIVE-CLiQ line.

If the Active Line Module is connected over a separate DRIVE-CLiQ line, the DRIVE-CLiQ cable marked with (1) must be ordered. A DRIVE-CLiQ cable suitable for connection (2) is included in the scope of supply of the Active Line Module.

For DRIVE-CLiQ cables for different configurations, see [MOTION-CONNECT connection systems](#).

Integration (continued)

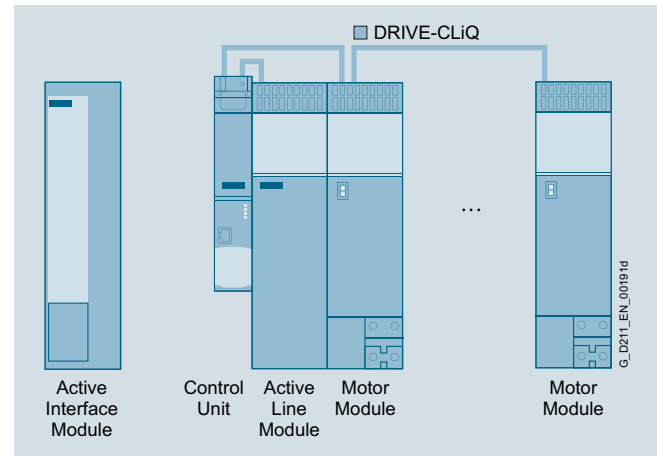

Separate Active Interface Module

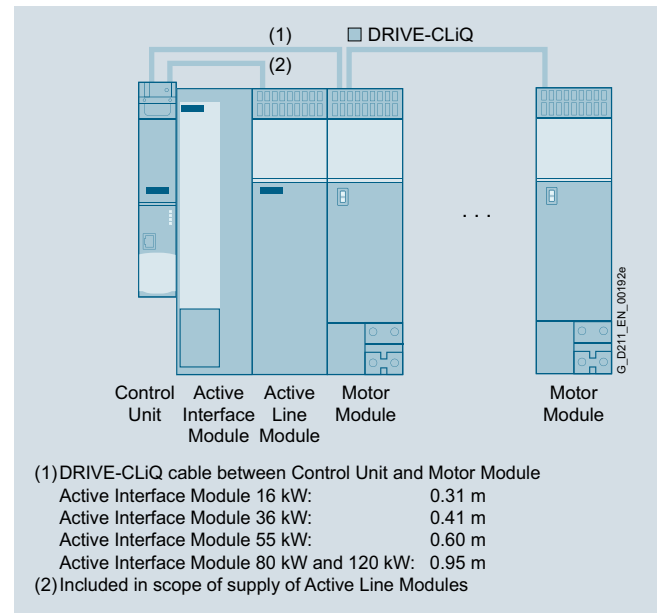

Active Interface Module integrated in the drive line-up

The Active Interface Module requires a 24 V DC supply for operation of the integral fan.

The fan rotates after the 24 V DC supply is applied and can, if necessary (service life, noise), be disconnected from the Control Unit over the "Fan off" input. It is only permissible to switch off the fan when the infeed of the drive system is not operating, otherwise the Active Interface Module will overheat.

The thermostatic switch installed in the Active Interface Module is evaluated over the connected Active Line Module.

The power cables between the Active Interface Module and Active Line Module must be shielded if limit values for interference suppression are to be complied with.

The cable shield can be routed over the shield connection plate (accessories) to the Active Interface Module or Active Line Module.

Technical specifications

Article No.	6SL3100-0BE21-6AB0	6SL3100-0BE23-6AB0	6SL3100-0BE25-5AB0	6SL3100-0BE28-0AB0	6SL3100-0BE31-2AB0	
Product brand name	SINAMICS					
Product designation	Active Interface Module with internal air cooling					
Line voltage 380 ... 480 V 3 AC						
Rated current	A	26	58	88	128	192
Current requirement, max. 24 V DC electronics power supply	A	0.25	0.6	0.6	1.2	1.2
Internal resistance Digital input Fan off (X21/pin 4)	Ω	1440 \pm 10 %	1440 \pm 10 %	1440 \pm 10 %	1440 \pm 10 %	1440 \pm 10 %
Power loss	W	300	390	450	575	800
Cooling air requirement	m ³ /s	0.03	0.04	0.075	0.15	0.15
Sound pressure level L_{pA} (1 m)	dB	57	60	66	68	68
Line/load connection L1, L2, L3/U2, V2, W2		Screw-type terminals	Screw-type terminals	Screw-type terminals	M8 screw studs	M8 screw studs
• Conductor cross-section	mm ²	16	50	50	2.5 ... 120 or 2 x 50	2.5 ... 120 or 2 x 50
Thermostatic switch		NC contact	NC contact	NC contact	NC contact	NC contact
• Switching capacity AC		250 V/1.6 A	250 V/1.6 A	250 V/1.6 A	250 V/1.6 A	250 V/1.6 A
• Switching capacity DC		60 V/0.75 A	60 V/0.75 A	60 V/0.75 A	60 V/0.75 A	60 V/0.75 A
PE connection		M5 screw	M6 screw	M6 screw	M8 screw	M8 screw
Degree of protection		IP20	IP20	IP20	IP20	IP20
Width x height x depth	mm	100 x 380 x 270	150 x 380 x 270	200 x 380 x 270	300 x 380 x 270	300 x 380 x 270
Net weight	kg	13.0	18.5	23.2	31.9	36.6
Certificate of suitability		cURus	cURus	cURus	cURus	cURus

Selection and ordering data

Suitable for Active Line Module		SINAMICS Active Interface Module	
Rated power Active Line Module kW	Booksize format Internal air cooling Type	Rated current A	Article No.
16	6SL3130-7TE21-6AA4	26	6SL3100-0BE21-6AB0
36	6SL3130-7TE23-6AA3	58	6SL3100-0BE23-6AB0
55	6SL3130-7TE25-5AA3	88	6SL3100-0BE25-5AB0
80	6SL3130-7TE28-0AA3	128	6SL3100-0BE28-0AB0
120	6SL3130-7TE31-2AA3	192	6SL3100-0BE31-2AB0

Description	Article No.
Accessories	
Shield connection plate For Active Interface Modules: • 16 kW • 36 kW • 55 kW • 80 kW and 120 kW	Included in the scope of supply 6SL3163-1AF00-0AA0 6SL3163-1AH00-0AA0 6SL3163-1AM00-0AA0

Description	Article No.
Accessories (continued)	
DRIVE-CLiQ signal cable, pre-assembled Connectors with degree of protection IP20/IP20 For Active Interface Module • 16 kW, length 0.31 m • 36 kW, length 0.41 m • 55 kW, length 0.60 m • 80 kW and 120 kW, length 0.95 m	6SL3060-4AK00-0AA0 6SL3060-4AP00-0AA0 6SL3060-4AU00-0AA0 6SL3060-4AA10-0AA0
Accessories for re-ordering	
SINAMICS S120 Terminal Kit Plug-in terminals, DRIVE-CLiQ jumper For Active Interface Modules with a width of: • 100 mm • 150 mm • 200 mm • 300 mm	6SL3160-8CD10-0AA0 6SL3160-8DF10-0AA0 6SL3160-8EH10-0AA0 6SL3160-8FM10-0AA0
Warning labels in 30 languages This label set can be glued over the standard German or English labels to provide warnings in other languages. One set of labels is supplied with the devices. One sign in each of the following languages is provided in each set: BG, CN, CZ, DE, DK, EE, ES, FI, FR, GB, GR, HU, IE, IS, IT, JP, KR, LT, LV, MT, NL, NO, PL, PT, RO, RU, SE, SI, SK, TR	6SL3166-3AB00-0AA0

Overview



Basic Line Filter

Basic Line Filters are used on machines on which conducted interference emissions in the frequency range between 150 kHz and 30 MHz need to be damped in accordance with the requirements of CE-EMC legislation.

With the Basic Line Filters in combination with the Active Interface Modules, the limits for the interference voltages can be extended to Category C2 as defined in IEC 61800-3 or, maintaining compliance with Category C3, longer total cable lengths may be used in the configuration.

Selection and ordering data

Suitable for Active Line Module		SINAMICS Basic Line Filter	
Rated power Active Line Module	Booksized format Internal air cooling	Rated current	Article No.
kW	Type	A	
16	6SL3130-7TE21-6AA4	36	6SL3000-0BE21-6DA0
36	6SL3130-7TE23-6AA3	74	6SL3000-0BE23-6DA1
55	6SL3130-7TE25-5AA3	105	6SL3000-0BE25-5DA0
80	6SL3130-7TE28-0AA3	132	6SL3000-0BE28-0DA0
120	6SL3130-7TE31-2AA3	192	6SL3000-0BE31-2DA0

Technical specifications

Article No.	6SL3000-0BE21-6DA0	6SL3000-0BE23-6DA1	6SL3000-0BE25-5DA0	6SL3000-0BE28-0DA0	6SL3000-0BE31-2DA0
Product brand name	SINAMICS				
Product designation	Basic Line Filter	Basic Line Filter	Basic Line Filter	Basic Line Filter	Basic Line Filter
Line voltage 380 ... 480 V 3 AC					
Rated current	A 36	74	105	132	192
Power loss	W 16	26	43	56	73
Line/load connection L1, L2, L3/U, V, W	Screw-type terminals	Screw-type terminals	Screw-type terminals	Screw-type terminals	Screw-type terminals
• Conductor cross-section	mm ² 10	35	50	95	95
PE connection	M6 screw stud to DIN 46234	M6 screw stud to DIN 46234	M8 screw stud to DIN 46234	M10 screw stud to DIN 46234	M10 screw stud to DIN 46234
Degree of protection	IP20	IP20	IP20	IP20	IP20
Width	mm 50	75	100	150	150
Height	mm 429	433	466	479	479
Depth	mm 226	226	226	226	226
Net weight	kg 5	7.5	11.5	17.5	18.5
Certificate of suitability	cURus	cURus	cURus	cURus	cURus

Overview

Suitable line-side power components are assigned depending on the power rating of the Active Line Modules.

Additional information about the line-side power components can be found in Catalogs LV 10, IC 10 and IC 10 AO as well as the Industry Mall

The tables below list recommended components.

Assignment of line-side power components to Active Line Modules in booksize format

Suitable for Active Line Module		Line contactor	Output coupling device for line contactor		Main switch		Leading auxiliary switch for main switch	
Rated power	Booksize format Internal air cooling							
kW	Type	Type	Article No.		Article No.		Article No.	
16	6SL3130-7TE21-6AA4	3RT1035-...	3TX7004-1LB00		3LD2504-0TK51		3LD9200-5B	
36	6SL3130-7TE23-6AA3	3RT1045-...	3TX7004-1LB00		3LD2704-0TK51		3LD9200-5B	
55	6SL3130-7TE25-5AA3	3RT1054-...	3TX7004-1LB00		3KA5330-1GE01		3KX3552-3EA01	
80	6SL3130-7TE28-0AA3	3RT1056-...	3TX7004-1LB00		3KA5330-1GE01		3KX3552-3EA01	
120	6SL3130-7TE31-2AA3	3RT1065-...	3TX7004-1LB00		3KA5730-1GE01		3KX3552-3EA01	

Suitable for Active Line Module		Circuit breaker IEC 60947		Circuit breaker UL489/ CSA C22.2 No. 5-02		Fuse-switch disconnecter		Switch disconnecter with fuse holders		Leading auxiliary switch for switch disconnecter with fuse holders	
Rated power	Booksize format Internal air cooling										
kW	Type	Article No.		Type		Article No.		Article No.		Article No.	
16	6SL3130-7TE21-6AA4	3RV1031-4FA10		3VL2505-2KN30-....		3NP1123-1CA20		3KL5230-1GB01		3KX3552-3EA01	
36	6SL3130-7TE23-6AA3	3RV1041-4LA10		3VL2508-2KN30-....		3NP1123-1CA20		3KL5230-1GB01		3KX3552-3EA01	
55	6SL3130-7TE25-5AA3	3VL2712-1DC33-....		3VL2512-2KN30-....		3NP1143-1DA20		3KL5530-1GB01		3KX3552-3EA01	
80	6SL3130-7TE28-0AA3	3VL3720-1DC33-....		3VL3517-2KN30-....		3NP1143-1DA20		3KL5530-1GB01		3KX3552-3EA01	
120	6SL3130-7TE31-2AA3	3VL3725-1DC36-....		3VL3525-2KN30-....		3NP1153-1DA20		3KL5730-1GB01		3KX3552-3EA01	

Suitable for Active Line Module		NEOZED fuse (gL/gG)			DIAZED fuse (gL/gG)			LV HRC fuse (gL/gG)			UL/CSA fuse, Class J ¹⁾ Available from: Mersen www.ep.mersen.com		
Rated power	Booksize format Internal air cooling	Rated current	Size	Article No.	Rated current	Size	Article No.	Rated current	Size	Article No.	Rated current	Size	Ref.-No.
kW	Type	A			A			A			A	mm	
16	6SL3130-7TE21-6AA4	35	D02	5SE2335	35	DIII	5SB411	35	000	3NA3814	35	27x60	AJT35
36	6SL3130-7TE23-6AA3	-	-	-	80	DIV	5SC211	80	000	3NA3824	80	29x117	AJT80
55	6SL3130-7TE25-5AA3	-	-	-	-	-	-	125	1	3NA3132	125	41x146	AJT125
80	6SL3130-7TE28-0AA3	-	-	-	-	-	-	160	1	3NA3136	175	41x146	AJT175
120	6SL3130-7TE31-2AA3	-	-	-	-	-	-	250	1	3NA3144	250	54x181	AJT250

¹⁾ Not suitable for 3NP and 3KL switch disconnectors.

Overview



20 kW, 40 kW and 100 kW Basic Line Modules in booksize format

Basic Line Modules are available for applications in which no energy is returned to the supply or where the energy exchange between motor and generator axes takes place in the DC link. Basic Line Modules can only feed energy from the supply system into the DC link, energy cannot be fed back into the supply system. The DC link voltage is directly derived from the 3-phase line voltage via a 6-pulse bridge circuit.

Basic Line Modules are designed for connection to grounded, star (TN, TT) and non-grounded, symmetrical IT supply systems. The connected Motor Modules are pre-charged over the integrated pre-charging resistors (20 kW and 40 kW) or through activation of the thyristors (100 kW).

Basic Line Modules 20 kW and 40 kW are equipped with an integrated brake chopper and can be directly used for applications in generating mode after connecting an external braking resistor.

A Braking Module is only required with a 100 kW Basic Line Module in generating mode.

Design

The Basic Line Modules in booksize format feature the following connections and interfaces as standard:

- 1 power connection
- 1 connection for the 24 V DC electronics power supply
- 1 DC link connection
- 3 DRIVE-CLiQ sockets
- 1 connection for braking resistor (only 20 kW and 40 kW Basic Line Modules)
- 1 temperature sensor input

The status of the Basic Line Modules is indicated via two multi-color LEDs.

The scope of supply of the Basic Line Modules includes:

- DRIVE-CLiQ cable for connection to the adjacent Control Unit on the left for drive control, length 0.11 m
- DRIVE-CLiQ cable (length depends on Basic Line Module width) for connection to the adjacent Motor Module, length = width of Basic Line Module + 0.11 m
- Jumper for connecting the 24 V DC busbar to the adjacent Motor Module
- 24 V terminal adapter (X24)
- Connector X21
- 2 dust protection blanking plugs for sealing unused DRIVE-CLiQ sockets
- 1 set of warning labels in 30 languages

Note:

The thermostatic switch built into the braking resistor must be looped into the shutdown chain of the drive to prevent thermal overloading of the system in the event of a fault. If a braking resistor is not connected, a jumper must be connected between X21.1 and X21.2.

Integration

The Basic Line Module receives its control information via DRIVE-CLiQ from:

- SINUMERIK 828D
 - Numeric Control Extension NX10.3
 - Numeric Control Extension NX15.3

Technical specifications

Article No.	6SL3130-1TE...	Article No.	6SL3130-1TE...
Product brand name	SINAMICS	Product brand name	SINAMICS
Product type designation	S120	Product type designation	S120
Product designation	Basic Line Modules in booksize format	Product designation	Basic Line Modules in booksize format
Line voltage Up to 2000 m above sea level	380 ... 480 V 3 AC $\pm 10\%$ -15 % < 1 min ¹⁾	Radio interference suppression	
SCCR (short circuit current rating)	65 kA in conjunction with the recommended fuses Class J or circuit breakers in accordance with UL489/CSA 22.2 No. 5-02 see recommended line-side components	<ul style="list-style-type: none"> • Standard <ul style="list-style-type: none"> - 20 kW and 40 kW Basic Line Modules - 100 kW Basic Line Module • With line filter 	No radio interference suppression Category C3 to EN 61800-3 Total cable length up to 350 m (shielded) Category C2 to EN 61800-3 Total cable length up to 350 m (shielded)
Line frequency	47 ... 63 Hz	Cooling method	Internal air cooling Power units with increased air cooling by built-in fan
Line power factor At rated power		Ambient or coolant temperature (air) During operation for line-side components, Line Modules and Motor Modules	0 ... 40 °C without derating > 40 ... 55 °C with derating
<ul style="list-style-type: none"> • Fundamental $\cos \varphi_1$ • Total λ 	<ul style="list-style-type: none"> > 0.96 0.75 ... 0.93 	Installation altitude	Up to 1000 m above sea level without derating > 1000 ... 4000 m above sea level with derating
Overvoltage category according to EN 60664-1	Class III	Certificate of suitability	CE, cULus
DC link voltage, approx.	1.35 × line voltage ²⁾		
Electronics power supply DC	24 V -15 %/+20 %		

Article No.	6SL3130-1TE22-0AA0	6SL3130-1TE24-0AA0	6SL3130-1TE31-0AA0
Product brand name	SINAMICS		
Product type designation	S120		
Product designation	Basic Line Module in booksize format with <u>internal</u> air cooling		

Line voltage 380 ... 480 V 3 AC

Power				
<ul style="list-style-type: none"> • Rated power P_{rated} at 380 V 3 AC • For S6 duty (40 %) • P_{max} 	kW kW kW	20 26 60	40 52 120	100 130 175
Braking power With external braking resistor				
<ul style="list-style-type: none"> • $P_{Bmax.}$ ($= 2 \times P_{rated}$) • Continuous braking power P_d ($= 0.25 \times P_{rated}$) 	kW kW	40 5	80 10	– –
DC link current				
<ul style="list-style-type: none"> • At 600 V DC • For S6 duty (40 %) • Maximum 	A A A	34 43 100	67 87 200	167 217 292
Input current				
<ul style="list-style-type: none"> • Rated current at 380 V 3 AC • Maximum 	A A	35 100	70 199	172 290
Activation threshold Braking chopper	V	774	774	–

1) Can also be operated on supply systems with 200 ... 240 V 3 AC $\pm 10\%$ with appropriate parameter assignment and reduced output.

2) The DC link voltage is unregulated and load-dependent.

Technical specifications (continued)

Article No.	6SL3130-1TE22-0AA0	6SL3130-1TE24-0AA0	6SL3130-1TE31-0AA0	
Product brand name	SINAMICS			
Product type designation	S120			
Product designation	Basic Line Module in booksize format with <u>internal</u> air cooling			
Line voltage 380 ... 480 V 3 AC				
Resistance value External braking resistor	Ω	≥ 14.8	≥ 7.4	–
Cable length, maximum To braking resistor	m	15	15	–
Connection for braking resistor (X2)		Screw-type terminals	Screw-type terminals	–
• Conductor cross-section, maximum	mm^2	0.5 ... 4	0.5 ... 10	–
Current requirement, maximum 24 V DC electronics power supply	A	1	1.4	2
Current carrying capacity				
• 24 V DC busbars	A	20	20	20
• DC link busbars	A	100	200	200
DC link capacitance				
• Basic Line Module	μF	940	1880	4100
• Drive line-up, maximum	μF	20000	20000	50000
Internal air cooling				
• Power loss ¹⁾	W	144	284	628
• Cooling air requirement	m^3/s	0.016	0.031	0.05
• Sound pressure level L_{pA} (1 m)	dB	< 60	< 65	< 65
Line connection U1, V1, W1		Screw-type terminals	Screw-type terminals	M8 screw studs
• Conductor cross-section, maximum	mm^2	0.5 ... 16	10 ... 50	1 × 35 ... 120 or 2 × 50
Shield connection		Integrated into the power plug	See Accessories	See Accessories
PE connection		M5 screw	M6 screw	M6 screw
Cable length, maximum Total of all motor power cables and DC link				
• Shielded	m	630	630	1000
• Unshielded	m	850	850	1500
Degree of protection		IP20	IP20	IP20
Width	mm	100	150	200
Height	mm	380	380	380
Depth	mm	270	270	270
Net weight	kg	6.8	11.3	15.8

¹⁾ Power loss of Basic Line Modules at rated power including losses of 24 V DC electronics power supply.

Selection and ordering data

Description	Article No.
SINAMICS S120 Basic Line Module in booksize format with internal air cooling Rated power: <ul style="list-style-type: none"> • 20 kW • 40 kW • 100 kW 	6SL3130-1TE22-0AA0 6SL3130-1TE24-0AA0 6SL3130-1TE31-0AA0
Accessories	
Shield connection plate For Line Modules and Motor Modules in booksize format with internal air cooling and a width of: <ul style="list-style-type: none"> • 150 mm • 200 mm 	6SL3162-1AF00-0AA1 6SL3162-1AH01-0AA0
DC link rectifier adapter For direct infeed of DC link voltage For Line Modules and Motor Modules in booksize format with a width of: <ul style="list-style-type: none"> • 50 mm and 100 mm Screw-type terminals 0.5 ... 10 mm² • 150 mm, 200 mm and 300 mm Screw-type terminals 35 ... 95 mm² 	6SL3162-2BD00-0AA0 6SL3162-2BM00-0AA0
DC link adapter (2 units) For multi-tier configuration For all Line Modules and Motor Modules in booksize format Screw-type terminals 35 ... 95 mm ²	6SL3162-2BM01-0AA0

Description	Article No.
Accessories for re-ordering	
SINAMICS S120 Terminal Kit Plug-in terminals, DRIVE-CLiQ jumper (length = Module width + 60 mm), dust protection blanking plugs for DRIVE-CLiQ port For Basic Line Modules with a width of: <ul style="list-style-type: none"> • 100 mm • 150 mm • 200 mm 	6SL3163-8LD00-0AA0 6SL3163-8GF00-0AA0 6SL3166-3AB00-0AA0
24 V terminal adapter For all Line Modules and Motor Modules in booksize format	6SL3162-2AA00-0AA0
24 V jumper For connection of the 24 V busbars for booksize format	6SL3162-2AA01-0AA0
Warning labels in 30 languages This label set can be glued over the standard German or English labels to provide warnings in other languages. One set of labels is supplied with the devices. One sign in each of the following languages is provided in each set: BG, CN, CZ, DE, DK, EE, ES, FI, FR, GB, GR, HU, IE, IS, IT, JP, KR, LT, LV, MT, NL, NO, PL, PT, RO, RU, SE, SI, SK, TR	6SL3166-3AB00-0AA0
SINAMICS/SINUMERIK/SIMOTION dust protection blanking plugs For DRIVE-CLiQ port <ul style="list-style-type: none"> • 50 units 	6SL3066-4CA00-0AA0

Overview

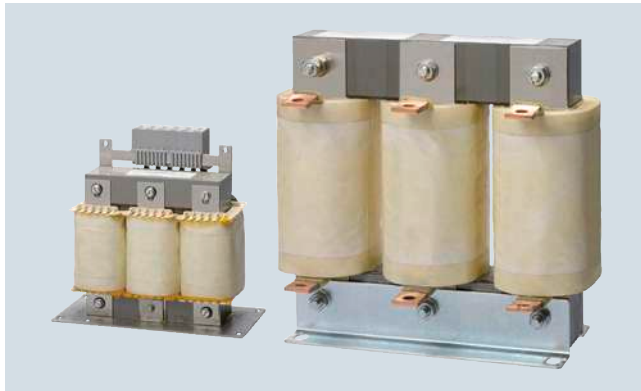

20 kW and 100 kW line reactors

Line reactors reduce low-frequency line harmonic distortions and offload the semiconductors of the Basic Line Module.

The use of other makes of line reactor can lead to malfunctions or irreparable damage to equipment.

Selection and ordering data

Suitable for Basic Line Module		SINAMICS line reactor	
Rated power Basic Line Module	Booksized format	Rated current	Article No.
kW	Type	A	
20	6SL3130-1TE22-0AA0	37	6SL3000-OCE22-0AA0
40	6SL3130-1TE24-0AA0	74	6SL3000-OCE24-0AA0
100	6SL3130-1TE31-0AA0	185	6SL3000-OCE31-0AA0

Technical specifications

Article No.	6SL3000-OCE22-0AA0	6SL3000-OCE24-0AA0	6SL3000-OCE31-0AA0
Product brand name	SINAMICS	SINAMICS	SINAMICS
Product designation	Line reactor	Line reactor	Line reactor
Line voltage 380 ... 480 V 3 AC			
Rated current	A	37	74
Power loss			
• At 50 Hz	W	130	270
• At 60 Hz	W	154	320
Line/load connection		Screw-type terminals	Screw-type terminals
• Conductor cross-section	mm ²	0.5 ... 16	2.5 ... 35
Degree of protection		IP20	IP20
Width	mm	178	210
Height	mm	165	239
Depth	mm	100	105
Net weight	kg	5.2	11.2
Certificate of suitability		cURus	cURus

Overview



Line filter

In plants with strict EMC requirements, line filters work together with line reactors to restrict the conducted interference emanating from the Power Modules to the limit values of Class A1 as defined in EN 55011 and Category C2 as defined in EN 61800-3. Line filters are suitable only for direct connection to TN systems.

The use of other makes of line filter can lead to malfunctions or irreparable damage to equipment.

Selection and ordering data

Suitable for Basic Line Module		SINAMICS line filter	
Rated power Basic Line Module	Booksize format	Rated current	Article No.
kW	Type	A	
20	6SL3130-1TE22-0AA0	36	6SL3000-0BE21-6DA0
40	6SL3130-1TE24-0AA0	74	6SL3000-0BE23-6DA1
100	6SL3130-1TE31-0AA0	192	6SL3000-0BE31-2DA0

Technical specifications

Article No.	6SL3000-0BE21-6DA0	6SL3000-0BE23-6DA1	6SL3000-0BE31-2DA0
Product brand name	SINAMICS	SINAMICS	SINAMICS
Product designation	Line filter	Line filter	Line filter
Line voltage 380 ... 480 V 3 AC			
Rated current	A 36	74	192
Power loss	W 16	26	73
Line/load connection L1, L2, L3/U, V, W	Screw-type terminals	Screw-type terminals	Screw-type terminals
• Conductor cross-section	mm ² 10	35	95
PE connection	M6 screw stud	M6 screw stud	M10 screw stud
Degree of protection	IP20	IP20	IP20
Width	mm 50	75	150
Height	mm 429	433	479
Depth	mm 226	226	226
Net weight	kg 5	7.5	18.5
Certificate of suitability	cURus	cURus	cURus

Overview

Suitable line-side power components are assigned depending on the power rating of the Basic Line Module.

Additional information about the line-side power components can be found in Catalogs LV 10, IC 10 and IC 10 AO as well as the Industry Mall.

The tables below list recommended components.

Assignment of line-side power components to Basic Line Modules in booksize format

Suitable for Basic Line Module		Line contactor	Output coupling device for line contactor			Main switch		
Rated power	Booksize format							
kW	Type	Type	Article No.			Article No.		
20	6SL3130-1TE22-0AA0	3RT1035-...	3RQ3018-1AB00			3LD2504-0TK51		
40	6SL3130-1TE24-0AA0	3RT1045-...	3RQ3018-1AB00			3LD2704-0TK51		
100	6SL3130-1TE31-0AA0	3RT1056-...	3RQ3018-1AB00			3KA5530-1GE01		

Suitable for Basic Line Module		Circuit breaker IEC 60947	Circuit breaker UL489/CSA C22.2 No. 5-02			Fuse-switch disconnecter		
Rated power	Booksize format							
kW	Type	Article No.	Type			Article No.		
20	6SL3130-1TE22-0AA0	3RV1041-4JA10	3VL2506-2KN30-....			3NP1123-1CA20		
40	6SL3130-1TE24-0AA0	3VL2710-1DC33-....	3VL2510-2KN30-....			3NP1123-1CA20		
100	6SL3130-1TE31-0AA0	3VL3725-1DC36-....	3VL3525-2KN30-....			3NP1143-1DA20		

Suitable for Basic Line Module		Switch disconnecter with fuse holders	LV HRC fuse (gL/gG)			UL/CSA fuse, Class J ¹⁾ Available from: Mersen www.ep.mersen.com		
Rated power	Booksize format		Rated current	Size	Article No.	Rated current	Size	Reference No.
kW	Type	Article No.	A			A	mm	
20	6SL3130-1TE22-0AA0	3KL5230-1GB01	63	000	3NA3822	60	27 × 60	AJT60
40	6SL3130-1TE24-0AA0	3KL5230-1GB01	100	000	3NA3830	100	27 × 117	AJT100
100	6SL3130-1TE31-0AA0	3KL5730-1GB01	250	1	3NA3144	250	54 × 181	AJT250

¹⁾ Not suitable for 3NP and 3KL switch disconnectors.

Design



Single Motor Module in booksize format C/D type, 3 A to 30 A (left)
Single Motor Module in booksize format C type, 45 A and 60 A, with optional shield connection plate (right)

The Single Motor Modules in booksize format feature the following connections and interfaces as standard:

- 2 DC link connections via integrated DC link busbars
- 1 electronics power supply connection via integrated 24 V DC busbars
- 3 DRIVE-CLiQ sockets
- 1 motor connection
- 1 safe standstill input
- 1 safe motor brake control
- 1 temperature sensor input
- 2 PPE (protective earth) connections – a PE connection is integrated in the connector for C/D types 3 A to 30 A

The status of the Motor Modules is indicated via two multi-color LEDs.

Motor Modules 3 A to 30 A are supplied with a mounted shield connection plate. The associated shield connection clamp can be found in the Terminal Kit supplied.

A shield connection plate is optionally available for Motor Modules 45 A to 200 A. On these modules, the motor cable shield can be connected using a shield connection clamp or a hose clip.

The signal cable shield can be connected to the Motor Module by means of a shield connection clamp, e.g. Weidmüller type KLBÜ 3-8 SC.

Design (continued)

The scope of supply of the Motor Modules includes:

- DRIVE-CLiQ cable appropriate to the width of the Motor Module for connection to the adjacent Motor Module, length = width of Motor Module + 0.06 m
- Jumper for connecting the 24 V DC busbar to the adjacent Motor Module
- Connector X21
- Connector X11 for the motor brake connection for Motor Modules with a rated output current of 45 A to 200 A
- 2 dust protection blanking plugs for sealing unused DRIVE-CLiQ sockets
- Fan insert for the 132 A and 200 A Motor Modules (the voltage for the fan insert is supplied by the Motor Module)
- 1 shield connection plate with shield connection clamp (for Motor Modules 3 A to 30 A)
- 1 set of warning labels in 30 languages

Integration

The Single Motor Module communicates via DRIVE-CLiQ with:

- SINUMERIK 828D
 - Numeric Control Extension NX10.3
 - Numeric Control Extension NX15.3

Technical specifications

Article No.	6SL3120-1TE...
Product brand name	SINAMICS
Product type designation	S120
Product designation	Single Motor Module in booksize format
DC link voltage DC	510 ... 720 V (line voltage 380 ... 480 V 3 AC)
Output frequency	0 ... 650 Hz ¹⁾²⁾
Electronics power supply DC	24 V -15 %/+20 %
Cooling method	Internal air cooling Power units with increased air cooling by built-in fan
Permissible ambient and coolant temperature (air) During operation for line-side components, Line Modules and Motor Modules	0 ... 40 °C without derating > 40 ... 55 °C with derating
Installation altitude	Up to 1000 m above sea level without derating > 1000 ... 4000 m above sea level with derating
Certificate of suitability	CE, cULus
Safety Integrated	Safety Integrity Level 2 (SIL 2) according to IEC 61508, Performance Level d (PLd) according to ISO 13849-1 and Control category 3 according to ISO 13849-1

¹⁾ At rated output current (max. output frequency 1300 Hz for 62.5 µs current control cycle, 8 kHz pulse frequency, 60 % permissible output current). Note the correlation between max. output frequency, pulse frequency and current derating.

²⁾ The output frequency is currently limited to 550 Hz. The specified values apply to systems with license for high output frequency.

For further information, refer to:
<https://support.industry.siemens.com/cs/ww/en/view/104020669>

Technical specifications (continued)

Article No.	–	–	–	6SL3120-1TE21-8AC0	6SL3120-1TE22-4AC0	6SL3120-1TE23-0AC0
Product designation	Single Motor Module in booksize format with <u>internal</u> air cooling <u>C type</u>					
Article No.	6SL3120-1TE13-0AD0	6SL3120-1TE15-0AD0	6SL3120-1TE21-0AD0	6SL3120-1TE21-8AD0	6SL3120-1TE22-4AD0	6SL3120-1TE23-0AD0
Product designation	Single Motor Module in booksize format with <u>internal</u> air cooling <u>D type</u>					
Product brand name	SINAMICS					
Product type designation	S120					

DC link voltage 510 ... 720 V DC

Output current							
• Rated current I_{rated}	A	3	5	9	18	24	30
• Base-load current I_H	A	2.6	4.3	7.7	15.3	20.4	25.5
• I_{S6} (40 %)							
- C type	A	–	–	–	24	32	40
- D type	A	4	6.7	12	24	32	40
• I_{max}							
- C type	A	–	–	–	36	48	56
- D type	A	9	15	27	54	72	90
Type rating ¹⁾							
• Based on I_{rated}	kW	1.6	2.7	4.8	9.7	12.9	16
• Based on I_H	kW	1.4	2.3	4.1	8.2	10.9	13.7
Rated pulse frequency	kHz	4	4	4	4	4	4
DC link current $I_d^{2)}$	A	3.6	6	11	22	29	36
Current carrying capacity							
• DC link busbars	A	100 ³⁾	100 ³⁾	100 ³⁾	100 ³⁾	100 ³⁾	100 ³⁾
• 24 V DC busbars ⁴⁾	A	20	20	20	20	20	20
DC link capacitance	µF	110	110	110	220	390	705
Current requirement at 24 V DC, maximum	A	0.75	0.75	0.75	0.75	1.0	0.8
Power loss ⁵⁾ typical/maximum	W	30 ⁶⁾ /50	40 ⁶⁾ /70	60 ⁶⁾ /100	140 ⁶⁾ /190	190 ⁶⁾ /200	260 ⁶⁾ /310
Cooling air requirement	m ³ /s	0.009	0.009	0.009	0.009	0.0147	0.0155
Sound pressure level L_{pA} (1 m)	dB	< 60	< 60	< 60	< 60	< 88	< 60
Motor connection U2, V2, W2		Plug-in connector (X1) ⁷⁾ , 1.5 ... 6 mm ²	Plug-in connector (X1) ⁷⁾ , 1.5 ... 6 mm ²	Plug-in connector (X1) ⁷⁾ , 1.5 ... 6 mm ²	Plug-in connector (X1) ⁷⁾ , 1.5 ... 6 mm ²	Plug-in connector (X1) ⁷⁾ , 1.5 ... 6 mm ²	Plug-in connector (X1) ⁷⁾ , 1.5 ... 6 mm ²
PE connection		M5 screw	M5 screw	M5 screw	M5 screw	M5 screw	M5 screw
Motor brake connection		Integrated into the plug-in motor connector (X1), 24 V DC, 2 A					
Motor cable length, maximum							
• Shielded	m	50	50	50	70	50	100
• Unshielded	m	75	75	75	100	75	150
Degree of protection		IP20	IP20	IP20	IP20	IP20	IP20
Width	mm	50	50	50	50	50	100
Height	mm	380	380	380	380	380	380
Depth	mm	270	270	270	270	270	270
Net weight	kg	4.6	4.6	4.6	4.6	4.7	7.9

1) Rated power of a typical standard asynchronous (induction) motor at 600 V DC link voltage.

2) Rated DC link current for dimensioning an external DC connection.

3) With reinforced DC link bridges, (Article No. 6SL3162-2BB00-0AA0) 200 A is possible (see Accessories).

4) If, due to a number of Line Modules and Motor Modules being mounted side by side, the current carrying capacity exceeds 20 A, an additional 24 V DC connection using a 24 V terminal adapter is required (max. cross-section 6 mm², max. fuse protection 20 A).

5) Power loss of Motor Module at rated power including losses of 24 V DC electronics power supply.

6) At max. motor cable length 30 m, pulse frequency 4 kHz and DC link voltage 540 ... 600 V.

7) Connector not included in scope of delivery (see Accessories).

Technical specifications (continued)

Article No.	6SL3120-1TE24-5CA0	6SL3120-1TE26-OCA0	–	–	–
Product designation	Single Motor Module in booksize format with <u>internal</u> air cooling C type				
Article No.	–	–	6SL3120-1TE28-5AA3	6SL3120-1TE31-3AA3	6SL3120-1TE32-0AA4
Product designation	Single Motor Module in booksize format with <u>internal</u> air cooling				
Product brand name	SINAMICS				
Product type designation	S120				

DC link voltage 510 ... 720 V DC

Output current						
• Rated current I_{rated}	A	45	60	85	132	200
• Base-load current I_H	A	38	51	68	105	141
• I_{S6} (40 %)	A	60	80	110	150	230
• I_{max}	A	90	120	141	210	282
Type rating ¹⁾						
• Based on I_{rated}	kW	24	32	46	71	107
• Based on I_H	kW	21	28	37	57	76
Rated pulse frequency	kHz	4	4	4	4	4
DC link current $I_d^{2)}$	A	54	72	102	158	200
Current carrying capacity						
• DC link busbars	A	200	200	200	200	200
• 24 V DC busbars ³⁾	A	20	20	20	20	20
DC link capacitance	µF	1230	1410	1880	2820	3995
Current requirement at 24 V DC, maximum	A	0.9	0.9	1.5	1.5	1.5
Power loss ⁴⁾ typical/maximum	W	340 ⁵⁾ /360	460 ⁵⁾ /480	770 ⁵⁾ /790	1260 ⁵⁾ /1290	2030 ⁵⁾ /2090
Cooling air requirement	m ³ /s	0.0233	0.0233	0.044	0.144	0.144
Sound pressure level L_{pA} (1 m)	dB	< 71	< 71	< 60	< 73	< 73
Motor connection U2, V2, W2		M6 screw studs (X1)	M6 screw studs (X1)	M8 screw studs (X1)	M8 screw studs (X1)	M8 screw studs (X1)
• Conductor cross-section, maximum	mm ²	2.5 ... 50	2.5 ... 50	2.5 ... 95, 2 × 35	2.5 ... 120, 2 × 50	2.5 ... 120, 2 × 50
Shield connection		See Accessories	See Accessories	See Accessories	See Accessories	See Accessories
PE connection		M5 screw	M5 screw	M6 screw	M8 screw	M8 screw
Motor brake connection		Plug-in connector (X11), 24 V DC, 2 A	Plug-in connector (X11), 24 V DC, 2 A	Plug-in connector (X11), 24 V DC, 2 A	Plug-in connector (X11), 24 V DC, 2 A	Plug-in connector (X11), 24 V DC, 2 A
Motor cable length, maximum						
• Shielded	m	100	100	100	100	100
• Unshielded	m	150	150	150	150	150
Degree of protection		IP20	IP20	IP20	IP20	IP20
Width	mm	100	100	200	300	300
Height	mm	380	380	380	380	380
• With fan ⁶⁾	mm	–	–	–	629	629
Depth	mm	270	270	270	270	270
Net weight		8.5	8.6	14.8	21	21

1) Rated power of a typical standard asynchronous (induction) motor at 600 V DC link voltage.

2) Rated DC link current for dimensioning an external DC connection.

3) If, due to a number of Line Modules and Motor Modules being mounted side-by-side, the current carrying capacity exceeds 20 A, an additional 24 V DC connection using a 24 V terminal adapter is required (max. cross-section 6 mm², max. fuse protection 20 A).

4) Power loss of Motor Module at rated power including losses of 24 V DC electronics power supply.

5) At max. motor cable length 30 m, pulse frequency 4 kHz and DC link voltage 540 ... 600 V.

6) The fan is supplied with the Motor Module and must be installed before the Motor Module is commissioned.

Configuration

Motor Modules in booksize format C/D types, 3 A to 60 A

Rated current	3 A	5 A	9 A	18 A	24 A	30 A	45 A	60 A
D types								
Single Motor Modules	3 A / 9 A 50 mm (1.97 in)	5 A / 15 A 50 mm (1.97 in)	9 A / 27 A 50 mm (1.97 in)	18 A / 54 A 50 mm (1.97 in)	24 A / 72 A 50 mm (1.97 in)	30 A / 90 A 100 mm (3.94 in)	–	–
Double Motor Modules	2 x 3 A / 2 x 9 A 50 mm (1.97 in)	2 x 5 A / 2 x 15 A 50 mm (1.97 in)	2 x 9 A / 2 x 27 A 50 mm (1.97 in)	2 x 18 A / 2 x 54 A 100 mm (3.94 in)	–	–	–	–
C types								
Single Motor Modules	–		18 A / 36 A 50 mm (1.97 in)	24 A / 48 A 50 mm (1.97 in)	30 A / 56 A 100 mm (3.94 in)	45 A / 90 A 100 mm (3.94 in)	60 A / 120 A 100 mm (3.94 in)	–
Double Motor Module	–		2 x 18 A / 2 x 36 A 100 mm (3.94 in)	–	–	–	–	–
Rated current / maximum current in A 50 mm (1.97 in) or 100 mm (3.94 in) widths								

G_PM21_EN_00266a

Overview of available Single Motor Modules in booksize format C/D types

- C type:
Optimized for continuous load with up to 200 % overload
- D type:
Optimized for highly dynamic, intermittent duty cycles with up to 300 % overload

Devices in booksize format C/D types are optimized for multi-axis applications and are mounted next to one another. The connection for the common DC link is an integral feature. The device is internally air cooled.

The booksize format Motor Modules C/D types have been developed to be fully compatible with the booksize series regarding spare parts. They offer the following advantages:

- The amount of space required beneath the Motor Modules has been reduced thanks to improvements in the design and a new motor plug connector
- With the new motor plug connector design, the brake conductors and the PE connection are integrated directly in the plug connector
- The motor connections on the Double Motor Module are located side by side, resulting in a significantly improved level of accessibility
- The fan can be simply replaced without having to remove the Motor Module

Selection and ordering data

**SINAMICS S120
Single Motor Module in booksize format**

Rated output current	Type rating	Internal air cooling	Internal air cooling	Internal air cooling
A	kW	Article No.	C type	D type
DC link voltage 510 ... 720 V DC				
3	1.6	–	–	6SL3120-1TE13-0AD0
5	2.7	–	–	6SL3120-1TE15-0AD0
9	4.8	–	–	6SL3120-1TE21-0AD0
18	9.7	–	6SL3120-1TE21-8AC0	6SL3120-1TE21-8AD0
24	12.9	–	6SL3120-1TE22-4AC0	6SL3120-1TE22-4AD0
30	16	–	6SL3120-1TE23-0AC0	6SL3120-1TE23-0AD0
45	24	–	6SL3120-1TE24-5AC0	–
60	32	–	6SL3120-1TE26-0AC0	–
85	46	6SL3120-1TE28-5AA3	–	–
132	71	6SL3120-1TE31-3AA3	–	–
200	107	6SL3120-1TE32-0AA4	–	–

Selection and ordering data (continued)

Description	Article No.	Description	Article No.
Accessories		Accessories for re-ordering	
Power connector (X1) At Motor Module end, with spring-loaded terminals 1.5 ... 6 mm ² For Motor Modules in booksize format C/D types with rated output current of 3 ... 30 A <ul style="list-style-type: none"> • Screw-type terminal • Push-in connection with snap-in actuators 	6SL3162-2MA00-0AC0 6SL3162-2MB00-0AC0	SINAMICS S120 Terminal Kit 24 V jumper, plug-in terminals, DRIVE-CLiQ jumper (length = Module width + 60 mm), shield connection clamp with pressure plate, dust protection blanking plugs for DRIVE-CLiQ port, coding plug for X1 For Motor Modules C/D types with rated output current of 3 ... 30 A and a width of: <ul style="list-style-type: none"> • 50 mm • 100 mm 	6SL3162-8AC00-0AA0 6SL3162-8BE00-0AA0
Shield connection plate For Line Modules and Motor Modules in booksize format with a width of: <ul style="list-style-type: none"> • 100 mm • 200 mm • 300 mm 	6SL3162-1AD00-0AA0 6SL3162-1AH01-0AA0 6SL3162-1AH00-0AA0	SINAMICS S120 Terminal Kit 24 V jumper, plug-in terminals, DRIVE-CLiQ jumper (length = Module width + 60 mm), dust protection blanking plugs for DRIVE-CLiQ port For Motor Modules C type with rated output current of 45 ... 60 A and a width of: <ul style="list-style-type: none"> • 100 mm 	6SL3162-8BG00-0AA0
Shield connection clamp For Motor Modules in booksize format C type with rated output current of 45 A/60 A <ul style="list-style-type: none"> • Diameter 3 ... 14 mm • Diameter 20 ... 35 mm 	8WH9130-0MA00 8WH9130-0PA00	For Motor Modules with rated output current of 85 ... 200 A and a width of: <ul style="list-style-type: none"> • 200 mm • 300 mm 	6SL3162-8DH00-0AA0 6SL3162-8EM00-0AA0
DC link rectifier adapter¹⁾ For direct infeed of DC link voltage For Line Modules and Motor Modules in booksize format with a width of: <ul style="list-style-type: none"> • 50 mm and 100 mm Screw-type terminals 0.5 ... 10 mm² • 200 mm and 300 mm Screw-type terminals 35 ... 95 mm² 	6SL3162-2BD00-0AA0 6SL3162-2BM00-0AA0	24 V jumper For connection of the 24 V busbars for booksize format	6SL3162-2AA01-0AA0
24 V terminal adapter For all Line Modules and Motor Modules in booksize format	6SL3162-2AA00-0AA0	Shield connection clamp For Single Motor Modules in booksize format C/D types with rated output current of 3 A ... 30 A	6SL3162-0AQ00-0AA0
DC link adapter (2 units) For multi-tier configuration For all Line Modules/Motor Modules in booksize format Screw-type terminals 35 ... 95 mm ²	6SL3162-2BM01-0AA0	Warning labels in 30 languages This label set can be glued over the standard German or English labels to provide warnings in other languages. One set of labels is supplied with the devices. One sign in each of the following languages is provided in each set: BG, CN, CZ, DE, DK, EE, ES, FI, FR, GB, GR, HU, IE, IS, IT, JP, KR, LT, LV, MT, NL, NO, PL, PT, RO, RU, SE, SI, SK, TR	6SL3166-3AB00-0AA0
Reinforced DC link bridge 6 mm For replacement of the DC link bridge in Single Motor Modules 3 A ... 24 A Double Motor Modules 2 x 3 A ... 2 x 9 A For booksize format C/D types with a width of 50 mm 1 package with 10 pieces for 5 modules	6SL3162-2BB00-0AA0	SINAMICS/SINUMERIK/SIMOTION dust protection blanking plugs For DRIVE-CLiQ port <ul style="list-style-type: none"> • 50 units 	6SL3066-4CA00-0AA0
		Replacement fan For Motor Modules in booksize format C/D types with a width of: <ul style="list-style-type: none"> • 50 mm • 100 mm 	6SL3162-0AN00-0AA0 6SL3162-0AP00-0AA0

¹⁾ The DC link rectifier adapter must not be used for Motor Modules C type, 45 A and 60 A.

Design



Double Motor Module in booksize format C/D type

Double Motor Modules feature the following connections and interfaces as standard:

- 2 DC link connections via integrated DC link busbars
- 2 electronics power supply connections via integrated 24 V DC busbars
- 4 DRIVE-CLiQ sockets
- 2 motor connections via connectors X1 and X2 (not included in the scope of delivery)
- 2 safe standstill inputs (1 input per axis)
- 2 safe motor brake controls
- 2 temperature sensor inputs
- 1 PE (protective earth) connection

The status of the Motor Modules is indicated via two multi-color LEDs.

The Motor Modules are supplied with a mounted shield connection plate. The associated shield connection clamp can be found in the Terminal Kit supplied.

The signal cable shield can be connected to the Motor Module by means of a shield connection clamp, e.g. Weidmüller type KLBÜ 3-8 SC.

The scope of supply of the Motor Modules includes:

- DRIVE-CLiQ cable appropriate to the width of the Motor Module for connection to the adjacent Motor Module, length = width of Motor Module + 0.06 m
- 2 dust protection blanking plugs for sealing unused DRIVE-CLiQ sockets
- Jumper for connecting the 24 V DC busbar to the adjacent Motor Module
- Connectors X21 and X22
- Device fans supplied from the internal voltage levels for cooling the power unit
- 1 shield connection plate with shield connection clamp
- 1 set of warning labels in 30 languages

Integration

The Double Motor Module communicates via DRIVE-CLiQ with:

- SINUMERIK 828D
 - Numeric Control Extension NX10.3
 - Numeric Control Extension NX15.3

Technical specifications

Article No.	6SL3120-2TE...
Product brand name	SINAMICS
Product type designation	S120
Product designation	Double Motor Modules in booksize format
DC link voltage DC	510 ... 720 V (line voltage 3 AC 380 ... 480 V)
Output frequency	0 ... 650 Hz ¹⁾²⁾
Electronics power supply DC	24 V -15 %/+20 %
Cooling method	Internal air cooling Power units with increased air cooling by built-in fan
Permissible ambient and coolant temperature (air) During operation for line-side components, Line Modules and Motor Modules	0 ... 40 °C without derating > 40 ... 55 °C with derating
Installation altitude	Up to 1000 m above sea level without derating > 1000 ... 4000 m above sea level with derating
Certificate of suitability	CE, cULus
Safety Integrated	Safety Integrity Level 2 (SIL 2) according to IEC 61508, Performance Level d (PLd) according to ISO 13849-1 Control category 3 according to ISO 13849-1/EN 954-1

¹⁾ Note the correlation between max. output frequency, pulse frequency and current derating.

²⁾ The output frequency is currently limited to 550 Hz. The specified values apply to systems with license for high output frequency.
For further information, refer to:
<https://support.industry.siemens.com/cs/ww/en/view/104020669>

Technical specifications (continued)

Article No.	–	–	–	6SL3120-2TE21-8AC0
Product designation	Double Motor Module in booksize format <u>internal</u> air cooling <u>C type</u>			
Article No.	6SL3120-2TE13-0AD0	6SL3120-2TE15-0AD0	6SL3120-2TE21-0AD0	6SL3120-2TE21-8AD0
Product designation	Double Motor Module in booksize format <u>internal</u> air cooling <u>D type</u>			
Product brand name	SINAMICS			
Product type designation	S120			

DC link voltage 510 ... 720 V DC

Output current					
• Rated current I_{rated}	A	2 × 3	2 × 5	2 × 9	2 × 18
• I_{S6} (40 %)					
- C type	A	–	–	–	2 × 24
- D type	A	2 × 4	2 × 6.7	2 × 12	2 × 24
• Base-load current I_H	A	2 × 2.6	2 × 4.3	2 × 7.7	2 × 15.3
• I_{max}					
- C type	A	–	–	–	2 × 36
- D type	A	2 × 9	2 × 15	2 × 27	2 × 54
Type rating ¹⁾					
• Based on I_{rated}	kW	2 × 1.6	2 × 2.7	2 × 4.8	2 × 9.7
• Based on I_H	kW	2 × 1.4	2 × 2.3	2 × 4.1	2 × 8.2
DC link current $I_d^{(2)}$	A	7.2	12	22	43
Current carrying capacity					
• DC link busbars	A	100	100	100	100
• 24 V DC busbars ³⁾	A	20	20	20	20
DC link capacitance	µF	220	220	220	705
Current requirement at 24 V DC, maximum	A	0.9	0.9	0.9	1.1
Power loss ⁴⁾ typical ⁶⁾ /maximum	W	50/100	80/130	150/190	280/350
Cooling air requirement	m ³ /s	0.009	0.009	0.009	0.0155
Sound pressure level L_{pA} (1 m)	dB	<60	<60	<60	<60
Motor connection U2, V2, W2		2 × plug connector (X1, X2) ⁵⁾ , 2 × (1.5 ... 6 mm ²)	2 × plug connector (X1, X2) ⁵⁾ , 2 × (1.5 ... 6 mm ²)	2 × plug connector (X1, X2) ⁵⁾ , 2 × (1.5 ... 6 mm ²)	2 × plug connector (X1, X2) ⁵⁾ , 2 × (1.5 ... 6 mm ²)
PE connection		M5 screw	M5 screw	M5 screw	M5 screw
Motor brake connection		Integrated into the plug-in motor connector (X1, X2), 24 V DC, 2 A			
Motor cable length, maximum					
• Shielded	m	50	50	50	70
• Unshielded	m	75	75	75	100
Degree of protection		IP20	IP20	IP20	IP20
Width	mm	50	50	50	100
Height	mm	380	380	380	380
Depth	mm	270	270	270	270
Net weight	kg	4.7	4.7	4.7	7.7

1) Rated power of a typical standard asynchronous motor at 600 V DC link voltage.

2) Rated DC link current for dimensioning an external DC connection.

3) If, due to a number of Line Modules and Motor Modules being mounted side-by-side, the current carrying capacity exceeds 20 A, an additional 24 V DC connection using a 24 V terminal adapter is required (max. cross-section 6 mm², max. fuse protection 20 A).

4) Power loss of Motor Module at rated power including losses of 24 V DC electronics power supply.

5) Connector not included in scope of supply (see Accessories).

6) At max. motor cable length 30 m, pulse frequency 4 kHz and DC link voltage 540 ... 600 V.

Selection and ordering data

SINAMICS S120 Double Motor Module in booksize format			
Rated output current	Type rating	Internal air cooling C type	Internal air cooling D type
A	kW	Article No.	Article No.
DC link voltage 510 ...720 V DC			
2 × 3	2 × 1.6	–	6SL3120-2TE13-0AD0
2 × 5	2 × 2.7	–	6SL3120-2TE15-0AD0
2 × 9	2 × 4.8	–	6SL3120-2TE21-0AD0
2 × 18	2 × 9.7	6SL3120-2TE21-8AC0	6SL3120-2TE21-8AD0

Description	Article No.
Accessories	
Power connector (X1/X2) At Motor Module end, with spring-loaded terminals 1.5 ... 6 mm ² For Motor Modules in booksize format C/D type with rated output current of 3 ... 30 A <ul style="list-style-type: none">• Screw-type terminal• Push-in connection with snap-in actuators	6SL3162-2MA00-0AC0 6SL3162-2MB00-0AC0
DC link rectifier adapter For direct infeed of DC link voltage For Line Modules and Motor Modules in booksize format with a width of 50 mm and 100 mm Screw-type terminals 0.5 ... 10 mm ²	6SL3162-2BD00-0AA0
DC link adapter (2 units) For multi-tier configuration For all Line Modules and Motor Modules in booksize format Screw-type terminals 35 ... 95 mm ²	6SL3162-2BM01-0AA0
24 V terminal adapter For all Line Modules and Motor Modules in booksize format	6SL3162-2AA00-0AA0
Reinforced DC link bridge 6 mm For replacement of the DC link bridge in Single Motor Modules 3 A ... 24 A Double Motor Modules 2 × 3 A ... 2 × 9 A For booksize format C/D types with a width of 50 mm 1 package with 10 pieces for 5 modules	6SL3162-2BB00-0AA0

Description	Article No.
Accessories for re-ordering	
SINAMICS S120 Terminal Kit 24 V jumper, plug-in terminals, DRIVE-CLiQ jumper (length = Module width + 60 mm), shield connection clamp with pressure plate, dust protection blanking plugs for DRIVE-CLiQ port, coding plug for X1 and X2 For Motor Modules C/D types with a width of: <ul style="list-style-type: none">• 50 mm• 100 mm	6SL3162-8AD00-0AA0 6SL3162-8BF00-0AA0
24 V jumper For connection of the 24 V busbars for booksize format	6SL3162-2AA01-0AA0
Shield connection clamp For Double Motor Modules in booksize format C/D types	6SL3162-0AR00-0AA0
Warning labels in 30 languages This label set can be glued over the standard German or English labels to provide warnings in other languages. One set of labels is supplied with the devices. One sign in each of the following languages is provided in each set: BG, CN, CZ, DE, DK, EE, ES, FI, FR, GB, GR, HU, IE, IS, IT, JP, KR, LT, LV, MT, NL, NO, PL, PT, RO, RU, SE, SI, SK, TR	6SL3166-3AB00-0AA0
SINAMICS/SINUMERIK/SIMOTION dust protection blanking plugs For DRIVE-CLiQ port <ul style="list-style-type: none">• 50 units	6SL3066-4CA00-0AA0
Replacement fan For Motor Modules in booksize format C/D types with a width of: <ul style="list-style-type: none">• 50 mm• 100 mm	6SL3162-0AN00-0AA0 6SL3162-0AP00-0AA0

4 4

Overview



Series motor reactor

A series reactor in the form of a three-limb iron-cored reactor may be required in the case of special motors with low leakage inductance (for which the controller settings are insufficient). Motors with a low leakage inductance are, from experience, motors that can achieve high stator frequencies > 300 Hz or motors with a high rated current > 85 A.

The series motor reactors are designed for a pulse frequency of 4 kHz or 8 kHz output from the Motor Module. Higher pulse frequencies are not permissible.

The series motor reactor must be installed as close as possible to the Motor Module

The voltage drop across a series reactor depends on the motor current and the motor frequency. If an unregulated infeed is used, the maximum rated motor voltage depends on the connected line supply voltage. If these guide values are observed, lower reductions in power in the upper speed range of the motor can be achieved.

The surface temperature of the series motor reactor can reach up to 100 °C. This additional heat source must be taken into account in the system.

The notes in the Configuration Manual for the motors used must be observed.

Selection and ordering data

Suitable for Motor Module in booksize format Internal air cooling	Series motor reactor		
	Rated current	Rated inductance	Article No.
Type	A	mH	
6SL3120-...	108	0.1	4EU3951-0AR00-4B

Technical specifications

Article No.	4EU3951-0AR00-4B
Product designation	Series motor reactor
Input voltage 380 ... 480 V 3 AC (DC link voltage 510 ... 720 V DC)	
Rated current	108 A
Rated inductance	0.1 mH
Power loss	454 W
Continuous current I_{thmax} thermally permissible	120 A
Continuous frequency thermally permissible	1400 Hz
Pulse frequency maximum	8 kHz
Relative voltage drop at the series motor reactor	38 %
At I_{thmax} and U_{rated}	
Ambient temperature	40 °C
Connection to Motor Module/motor	Flat-type terminal
PE connection	M8 screw
Degree of protection	IP00
Width	410 mm
Height	385 mm
Depth	174 mm
Net weight	68 kg
Certificate of suitability	cURus

Overview



Braking Module in booksize format

A Braking Module and the matching external braking resistor are required to bring drives to a controlled standstill in the event of a power failure (e.g., emergency retraction or EMERGENCY OFF category 1) or limit the DC link voltage for brief periods of generator operation, e.g., when the regenerative feedback capability of the Line Module is deactivated. The Braking Module includes the power electronics and the associated control circuit. During operation, the DC link power is converted into heat loss in an external braking resistor. Braking Modules function autonomously.

Braking modules in booksize format can also be used for rapid discharge of the DC link.

Design

The Braking Module in booksize format features the following connections and interfaces as standard:

- 2 DC link connections via integrated DC link busbars
- 2 electronics power supply connections via integrated 24 V DC busbars
- Terminals for connecting the braking resistor
- 2 digital inputs (disable Braking Module/acknowledge faults and rapid discharge of DC link)
- 2 digital outputs (Braking Module disabled and prewarning $I \times t$ monitoring)
- 2 PE (protective earth) connections

The status of the Braking Module is indicated via two 2-color LEDs.

¹⁾ Connecting Braking Modules in the booksize format in parallel should be avoided, as it cannot be guaranteed that the power will be evenly divided between the modules.

Technical specifications

Article No.	6SL3100-1AE31-0AB1
Product brand name	SINAMICS
Product type designation	S120
Product designation	Braking Module in booksize format with internal air cooling

DC link voltage 510 ... 720 V DC

Rated power P_{DB}	1.5 kW ¹⁾
Peak power P_{max}	100 kW ¹⁾
Activation threshold	770 V
Cable length, maximum to braking resistor	10 m
DC link capacitance	110 μ F
Current requirement at DC 24 V, maximum	0.5 A
Digital inputs in accordance with IEC 61131-2 Type 1	
• Voltage	-3 ... +30 V
• Low level an open digital input is interpreted as "low"	-3 ... +5 V
• High level	15 ... 30 V
• Current consumption at 24 V DC, typical	10 mA
• Conductor cross-section, maximum	1.5 mm ²
Digital outputs	Continuously short-circuit- proof
• Voltage DC	24 V
• Load current per digital output, maximum	100 mA
• Conductor cross-section, maximum	1.5 mm ²
Current carrying capacity	
• 24 V DC busbars	20 A
• DC link busbars	100 A
PE connection	M5 screw
Width	50 mm
Height	380 mm
Depth with spacer	270 mm
Net weight	4.1 kg
Certificate of suitability	cURus

Selection and ordering data

Description	Article No.
SINAMICS Braking Module in booksize format	6SL3100-1AE31-0AB1
Internal air cooling, including spacers	

Accessories for re-ordering

Warning labels in 30 languages	6SL3166-3AB00-0AA0
---------------------------------------	---------------------------

This label set can be glued over the standard German or English labels to provide warnings in other languages.

One set of labels is supplied with the devices.

One sign in each of the following languages is provided in each set: BG, CN, CZ, DE, DK, EE, ES, FI, FR, GB, GR, HU, IE, IS, IT, JP, KR, LT, LV, MT, NL, NO, PL, PT, RO, RU, SE, SI, SK, TR

Overview



Braking resistor

Excess energy in the DC link is dissipated via the braking resistor.

The corresponding braking resistor is connected to a Braking Module or Basic Line Module. Positioning the braking resistor outside the control cabinet or switchgear room allows the power losses to be dissipated, thereby allowing a corresponding reduction in the level of air conditioning required.

Selection and ordering data

Suitable for Braking Module in booksize format	Braking resistor		
	Rated power P_{DB} kW	Peak power P_{max} kW	Article No.
Type 6SL3100-1AE31-0AB1	0.3	25	6SN1113-1AA00-0DA0
	1.5	100	6SL3100-1BE31-0AA0

Suitable for Basic Line Module in booksize format	Braking resistor		
	Rated power P_{DB} kW	Peak power P_{max} kW	Article No.
Type 6SL3130-1TE22-0AA0	5	30	6SE7023-2ES87-2DC0
	12.5	75	6SE7028-0ES87-2DC0

Technical specifications

Article No.	6SN1113-1AA00-0DA0	6SL3100-1BE31-0AA0	6SE7023-2ES87-2DC0	6SE7028-0ES87-2DC0
Product designation	Braking resistor for Braking Module in booksize format		Braking resistor for Basic Line Module in booksize format	

DC link voltage 510 V ... 720 V DC

	Ω	17	5.7	20	8		
Resistance	Ω	17	5.7	20	8		
Rated power P_{DB}	kW	0.3	1.5	5	12.5		
Peak power P_{max}	kW	25	100	30	75		
Load duration t_a for peak power	s	0.1	0.4	1	2	15	15
Cycle duration t of braking duty cycle	s	11.5	210	68	460	90	90
Power connections		–	–	M6 screw stud	M6 screw stud		
PE connection		–	–	M6 screw stud	M6 screw stud		
Thermostatic switch (NC contact)		–	–	Screw-type terminals	Screw-type terminals		
• Switching capacity AC		–	–	250 V/max. 10 A	250 V/max. 10 A		
• Switching capacity DC		–	–	42 V/0.2 A	42 V/0.2 A		
• Conductor cross-section	mm ²	–	–	2.5	1.5		
Degree of protection		IP54 ¹⁾	IP20	IP20	IP20		
Width	mm	80	193	430	740		
Height	mm	210	410	485	485		
Depth	mm	53	240	305	305		
Net weight	kg	3.4	5.6	17	27		
Certificate of suitability		cULus	–	UL, CSA	UL, CSA		

¹⁾ Braking resistor with connected 1.5 mm² shielded cable, length 3 m.

Overview



Capacitor Module in booksize format

The Capacitor Module is used to increase the DC link capacitance to bridge momentary power losses.

The Capacitor Module is connected to the DC link voltage via the integrated DC link busbars. The Capacitor Module functions autonomously.

Several Capacitor Modules can be operated in parallel.

Design

Capacitor Modules feature the following connections and interfaces as standard:

- 2 DC link connections via integrated DC link busbars
- 2 PE (protective earth) connections

Technical specifications

Article No.	6SL3100-1CE14-0AA0
Product brand name	SINAMICS
Product designation	Capacitor Module in booksize format

DC link voltage 510 ... 720 V DC

Capacitance	4100 μ F
Current carrying capacity	
• 24 V DC busbars	20 A
• DC link busbars	100 A
PE connection	M5 screw
Width	100 mm
Height	380 mm
Depth with spacer	270 mm
Net weight	7.3 kg
Certificate of suitability	cULus

Selection and ordering data

Description	Article No.
SINAMICS Capacitor Module in booksize format Internal air cooling, incl. spacers	6SL3100-1CE14-0AA0
Accessories for re-ordering	
Warning labels in 30 languages This label set can be glued over the standard German or English labels to provide warnings in other languages. One set of labels is supplied with the devices. One sign in each of the following languages is provided in each set: BG, CN, CZ, DE, DK, EE, ES, FI, FR, GB, GR, HU, IE, IS, IT, JP, KR, LT, LV, MT, NL, NO, PL, PT, RO, RU, SE, SI, SK, TR	6SL3166-3AB00-0AA0

Overview



Control Supply Module in booksize format

The Control Supply Module in booksize format provides a 24 V to 28.8 V DC power supply that can be set using an integrated potentiometer via the line or DC link. The Control Supply Module can either be operated individually or in a parallel connection with a maximum of 10 devices.

A DIP switch on the top of the module is used to change over between single and parallel mode in the de-energized state (details of connection for parallel operation are given in the Manual for booksize modules).

Using the Control Supply Module, it is possible, for example, to make emergency retraction movements in the event of a supply failure, provided that the DC link voltage is available.

Design

Control Supply Modules feature the following connections and interfaces as standard:

- 1 line connection
- 2 DC link connections via integrated DC link busbars
- 2 electronics power supply connections via integrated 24 V DC busbars
- 1 connection for the electronics power supply for Control Units, Terminal Modules, Sensor Modules, etc., via the 24 V terminal adapter provided in the scope of supply (max. cross-section 6 mm², max. fuse protection 20 A)
- 1 integrated potentiometer for setting the output voltage
- 1 digital output to signal the error-free state
- 1 DIP switch to change over between single and parallel mode
- 2 PE (protective earth) connections

The status of the Control Supply Modules is indicated via two multi-color LEDs.

Technical specifications

Article No.	6SL3100-1DE22-0AA1
Product brand name	SINAMICS
Product designation	Control Supply Module in booksize format

DC link voltage 510 ... 720 V DC Line voltage 380 ... 480 V 3 AC

Rated input current	
• At 400 V 3 AC	≤ 2 A
• At 600 V DC	1.1 A
DC link voltage range DC	300 ... 882 V Operation in 300 ... 430 V range is permitted briefly for < 1 min
Radio interference suppression (standard)	Category C2 to EN 61800-3
Rated output voltage DC	24 ... 28.8 V adjustable using potentiometer
Rated output current	20 A
Current carrying capacity	
• 24 V DC busbars	20 A
• DC link busbars	100 A
Line connection L1, L2, L3 (X1)	Screw-type terminals
• Conductor cross-section	0.2 ... 4.0 mm ²
PE connection	M5 screw
Width	50 mm
Height	380 mm
Depth with spacer	270 mm
Net weight	4.8 kg
Certificate of suitability	cULus

Selection and ordering data

Description	Article No.
SINAMICS Control Supply Module in booksize format	6SL3100-1DE22-0AA1
Internal air cooling incl. spacers	
Accessories for re-ordering	
Warning labels in 30 languages	6SL3166-3AB00-0AA0
This label set can be glued over the standard German or English labels to provide warnings in other languages. One set of labels is supplied with the devices.	
One sign in each of the following languages is provided in each set: BG, CN, CZ, DE, DK, EE, ES, FI, FR, GB, GR, HU, IE, IS, IT, JP, KR, LT, LV, MT, NL, NO, PL, PT, RO, RU, SE, SI, SK, TR	

Overview



DC link rectifier adapter for unit widths of 50 and 100 mm



DC link rectifier adapter for unit widths of 150 to 300 mm

If the internal DC link busbars of the Motor Modules are not used, the DC link voltage must be supplied externally through a DC link rectifier adapter, e.g. when devices of booksize format are coupled with devices of chassis format over an external DC busbar. The DC link rectifier adapter is mounted on the DC link busbars of the Motor Module. The DC link cables are routed from above.



DC link adapter (multi-tier) for all unit widths

If a multi-tier Motor Module configuration is used, a DC link adapter can be provided for linking the DC links of two drive lineups. The DC link adapter is mounted sideways on the DC link busbars of the Motor Module. Installation is possible on the right or left side of the Motor Module. The marking of the poles (DCN and DCP) at the DC link adapter match the side chosen for installation. The DC link cables are routed from behind. The DC link adapter (multi-tier) cannot be used in combination with the reinforced DC link busbars for the Motor Modules ≤ 100 mm in width.

Selection and ordering data

Description	Article No.
SINAMICS DC link rectifier adapter For direct infeed of DC link voltage For Line Modules and Motor Modules in booksize and booksize compact formats with a width of: <ul style="list-style-type: none"> • 50 mm and 100 mm • 150 mm, 200 mm and 300 mm 	6SL3162-2BD00-0AA0 6SL3162-2BM00-0AA0
SINAMICS DC link adapter set (2 units) For multi-tier configuration <ul style="list-style-type: none"> • For all Line Modules and Motor Modules in booksize and booksize compact formats • For all Line Modules and Motor Modules in booksize format 50 mm and 100 mm wide with reinforced DC links 	6SL3162-2BM01-0AA0 6SL3162-2BM10-0AA0

Technical specifications

Article No.	6SL3162-2BD00-0AA0	6SL3162-2BM00-0AA0	6SL3162-2BM01-0AA0	6SL3162-2BM10-0AA0
Product brand name	SINAMICS	SINAMICS	SINAMICS	SINAMICS
Product designation	DC link rectifier adapter	DC link rectifier adapter	DC link adapter	DC link adapter
Connection	Screw-type terminals	Screw-type terminals	Screw-type terminals	Screw-type terminals
• Conductor cross-section	mm ² 0.5 ... 10	35 ... 95	35 ... 95	35 ... 95
Current carrying capacity	A 43	240	240	240
Net weight	kg 0.06	0.48	0.76	0.76
Certificate of suitability	cURus	cURus	cURus	cURus

Overview

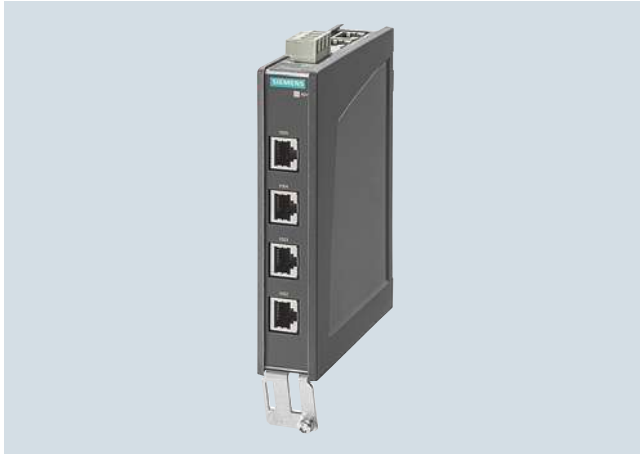

DMC20 DRIVE-CLiQ Hub Module

The DMC20 DRIVE-CLiQ Hub Module is used to implement a star-shaped topology of a DRIVE-CLiQ line. Two DMC20 DRIVE-CLiQ Hub Modules can be connected in series (cascaded).

Design

The DMC20 DRIVE-CLiQ Hub Module in degree of protection IP20 is designed for mounting in control cabinets.

The following are located on the DMC20 DRIVE-CLiQ Hub Module:

- 6 DRIVE-CLiQ sockets for connecting 5 DRIVE-CLiQ devices
- 1 connection for the electronics power supply via the 24 V DC supply connector

The status of the DMC20 DRIVE-CLiQ Hub Module is indicated via a multi-color LED.

The DMC20 DRIVE-CLiQ Hub Module can be snapped onto a TH 35 top-hat rail in accordance with EN 60715 (IEC 60715).

Technical specifications

Article No.	6SL3055-0AA00-6AA1
Product brand name	SINAMICS
Product designation	DMC20 DRIVE-CLiQ Hub Module
Current requirement at 24 V DC, maximum without DRIVE-CLiQ supply	0.15 A
• Conductor cross-section, maximum	2.5 mm ²
Degree of protection	IP20
Width	30 mm
Height	151 mm
Depth	110 mm
Net weight	0.36 kg
Certificate of suitability	cULus

Selection and ordering data

Description	Article No.
SINAMICS DMC20 DRIVE-CLiQ Hub Module Without DRIVE-CLiQ cable	6SL3055-0AA00-6AA1
Accessories for re-ordering	
SINAMICS/SINUMERIK/SIMOTION dust protection blanking plugs For DRIVE-CLiQ port	
• 50 units	6SL3066-4CA00-0AA0

Integration

Signals from more than one encoder can be collected with one DRIVE-CLiQ Hub Module and forwarded to the Control Unit through a single DRIVE-CLiQ cable.

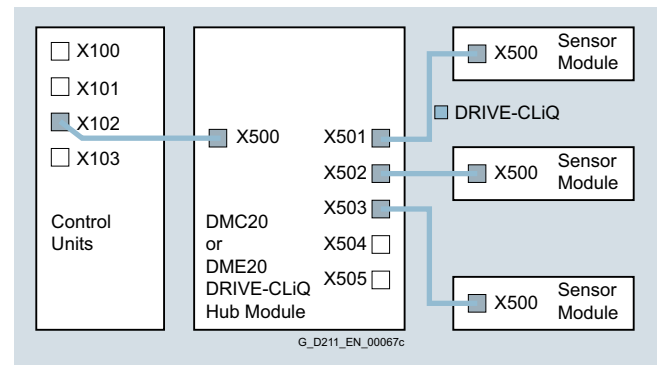

Connection overview for DMC20 DRIVE-CLiQ Hub Module

Overview



DME20 DRIVE-CLiQ Hub Module

The DME20 DRIVE-CLiQ Hub Module is used to implement a star-shaped topology of a DRIVE-CLiQ line. Two DME20 DRIVE-CLiQ Hub Modules can be connected in series (cascaded).

Selection and ordering data

Description	Article No.
SINAMICS DME20 DRIVE-CLiQ Hub Module Without DRIVE-CLiQ cable; without electronics power supply cable and circular connector for 24 V DC	6SL3055-0AA00-6AB0
Accessories	
24 V DC power supply cable	Ordering and delivery Phoenix Contact www.phoenixcontact.com Art. No. 1508365 Art. No. 1521601
Accessories for re-ordering	
SINAMICS dust protection blanking plugs Degree of protection IP67 For DRIVE-CLiQ port	6SL3066-4CA01-0AA0
• 6 units	

Design

The following are located on the DME20 DRIVE-CLiQ Hub Module:

- 6 DRIVE-CLiQ sockets for connecting 5 DRIVE-CLiQ devices
- 1 connection for the electronics power supply via the 24 V DC circular supply connector with conductor cross-section $4 \times 0.75 \text{ mm}^2$ (pins 1+2 internally bridged; pins 3+4 internally bridged)

The scope of supply of the DME20 DRIVE-CLiQ Hub Modules includes:

- 6 dust protection blanking plugs for sealing unused DRIVE-CLiQ sockets

Technical specifications

Article No.	6SL3055-0AA00-6AB0
Product brand name	SINAMICS
Product designation	DME20 DRIVE-CLiQ Hub Module
Current requirement at 24 V DC, maximum without DRIVE-CLiQ supply	0.15 A
• Conductor cross-section, maximum	$4 \times 0.75 \text{ mm}^2$
Degree of protection	IP67
Width	99 mm
Height	149 mm
Depth without connector	55.7 mm
Net weight	0.8 kg
Certificate of suitability	cULus

Integration

Signals from more than one encoder can be collected with one DRIVE-CLiQ Hub Module and forwarded to the Control Unit through a single DRIVE-CLiQ cable.

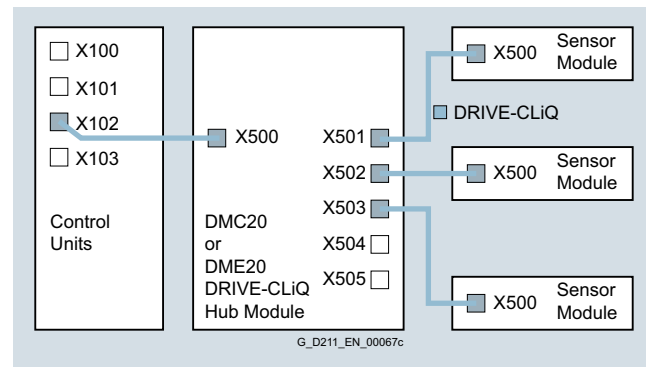

Connection overview for DME20 DRIVE-CLiQ Hub Module

Overview



TM54F Terminal Module

The TM54F Terminal Module is a dual-processor I/O interface with 4 fail-safe digital outputs and 10 fail-safe digital inputs for utilization of the Safety Integrated functions of the SINAMICS S120 drive system via external actuators and sensors.

Every available safety function integrated in the drive can be controlled via the fail-safe digital inputs on the TM54F Terminal Module. In the event that the parameterized safety functions of several drives operated together on a Control Unit are to be executed together, then these drives can be grouped in the TM54F Terminal Module. The advantage of this approach is that only one fail-safe digital input needs to be connected for these drives.

The fail-safe digital inputs and outputs have two channels and are redundantly configured with an internal data cross-check using the two processors. A fail-safe digital output consists of one P-switching and one M-switching output as well as one digital input to read back the switching state. A fail-safe digital input consists of two digital inputs.

Safety sensors can be connected over two switchable 24 V sensor supplies and can be evaluated over the fail-safe digital inputs. The switchable 24 V sensor supply ensures that the fail-safe digital inputs can be dynamized to detect dormant errors (this dynamization is used to check the shutdown paths). An unswitchable 24 V sensor supply is additionally provided by the TM54F Terminal Module for connecting undynamizable safety sensors.

The TM54F Terminal Module must be directly connected to a Control Unit via a DRIVE-CLiQ cable. Only one TM54F Terminal Module can be assigned to each Control Unit. It is not permissible to make the TM54F connection via another DRIVE-CLiQ device, e.g. a Motor Module or a Line Module.

Design

The following are located on the TM54F Terminal Module:

- 4 fail-safe digital outputs
- 10 fail-safe digital inputs
- 4 LEDs, single color for indicating the status of the read back channel of the fail-safe digital outputs
- 4 LEDs, dual-color for indicating the status of the fail-safe digital outputs
- 20 LEDs, dual-color for indicating the status of the fail-safe digital inputs
- 3 LEDs, single color for indicating the status of the 24 V sensor supplies
- 2 DRIVE-CLiQ sockets
- 2 connections for 24 V sensor supply, switchable
- 1 connection for 24 V sensor supply, not switchable
- 1 connection for the electronics power supply via the 24 V DC power supply connector
- 1 connection for the 24 V power supply to digital outputs and sensors
- 1 PE (protective earth) connection

The status of the TM54F Terminal Module is indicated via a multi-color LED.

The TM54F Terminal Module can be snapped onto a TH 35 standard mounting rail in accordance with EN 60715 (IEC 60715).

The signal cable shield can be attached to the TM54F Terminal Module via a shield connection clamp, e.g. type SK8 supplied by Phoenix Contact or type KLBÜ CO 1 supplied by Weidmüller. The shield connection clamp must not be used as a strain relief mechanism.

Pins for connector coding are included in the TM54F Terminal Module scope of supply.

Integration

The TM54F Terminal Module can communicate via DRIVE-CLiQ with the following Control Units:

- SINUMERIK 828D
 - Numeric Control Extension NX10.3
 - Numeric Control Extension NX15.3

Selection and ordering data

Description	Article No.
SINAMICS S120 TM54F Terminal Module	6SL3055-0AA00-3BA0
With pins for connector coding without DRIVE-CLiQ cable	
Accessories for re-ordering	
SINAMICS/SINUMERIK/SIMOTION dust protection blanking plugs	
For DRIVE-CLiQ port	
• 50 units	6SL3066-4CA00-0AA0

Technical specifications

Article No.	6SL3055-0AA00-3BA0
Product brand name	SINAMICS
Product type designation	S120
Product designation	Terminal Module TM54F
Current requirement at 24 V DC (X524) without DRIVE-CLiQ supply	0.2 A
<ul style="list-style-type: none"> • Conductor cross-section, maximum • Fuse protection, maximum 	2.5 mm ² 20 A
Current requirement, external at 24 V DC, maximum	4 A
For supplying the digital outputs and 24 V sensor supply (X514 at 24 V DC)	
<ul style="list-style-type: none"> • Conductor cross-section, maximum • Fuse protection, maximum 	2.5 mm ² 20 A
I/O	
<ul style="list-style-type: none"> • Number of fail-safe digital inputs • Number of fail-safe digital outputs • 24 V sensor supply 	10 4 3, of which 2 can be temporarily shut down using an internal test routine for dynamizing fail-safe digital inputs, current carrying capacity 0.5 A each
<ul style="list-style-type: none"> • Connection method • Conductor cross-section, maximum 	Plug-in screw-type terminals 1.5 mm ²
Digital inputs	In accordance with IEC 61131-2 Type 1, with galvanic isolation
<ul style="list-style-type: none"> • Voltage • Low level an open digital input is interpreted as "low" • High level • Current consumption, typical • Delay time of digital inputs, approx.¹⁾ • Safe state 	-3 ... +30 V -3 ... +5 V 15 ... 30 V > 3.2 mA 30 µs 60 µs Low level For inputs that can be inverted: without inversion

Article No.	6SL3055-0AA00-3BA0
Product brand name	SINAMICS
Product type designation	S120
Product designation	Terminal Module TM54F
Digital outputs	Sustained-short-circuit-proof
<ul style="list-style-type: none"> • Voltage DC • Load current per fail-safe digital output, maximum²⁾ • Delay times at resistive load¹⁾ - L → H typical - H → L typical • Safe state 	24 V 0.5 A 300 µs 350 µs Output switched off
Scanning cycle t _{SI}	4 ... 25 ms adjustable
For fail-safe digital inputs or fail-safe digital outputs	
Power loss at 24 V DC, maximum	4.5 W
PE connection	M4 screw
Width	50 mm
Height	151 mm
Depth	110 mm
Net weight	0.9 kg
Certificate of suitability	cULus
Safety Integrated	According to IEC 61508 SIL 2 and EN ISO 13849-1 PL d and category 3

1) The specified delay times refer to the hardware. The actual reaction time depends on the time slot in which the digital input/output is processed.
2) The total current of all fail-safe digital outputs must not exceed 5.33 A.

Overview



SMC20 Sensor Module Cabinet-Mounted

The SMC20 Sensor Module Cabinet-Mounted is required to evaluate the encoder signals of motors without a DRIVE-CLiQ interface. External encoders can also be connected via the SMC20.

The following encoder signals can be evaluated:

- Incremental encoder sin/cos 1 V_{pp}
- Absolute encoder EnDat 2.1
- SSI encoder with incremental signals sin/cos 1 V_{pp} (firmware version V2.4 and later)

The motor temperature can also be sensed using a PTC thermistor KTY84-130, Pt1000 or PTC.

Design

The SMC20 Sensor Module Cabinet-Mounted features the following connections and interfaces as standard:

- 1 encoder connection including motor temperature sensing (KTY84-130, Pt1000 or PTC) via SUB-D connector
- 1 DRIVE-CLiQ interface
- 1 connection for the electronics power supply via the 24 V DC power supply connector
- 1 PE (protective earth) connection

The status of the SMC20 Sensor Module Cabinet-Mounted is indicated via a multi-color LED.

The SMC20 Sensor Module Cabinet-Mounted can be snapped onto a TH 35 standard mounting rail in accordance with EN 60715 (IEC 60715).

The signal cable shield is connected via the encoder system connector and can also be connected to the SMC20 Sensor Module Cabinet-Mounted via a shield connection clamp, e.g. Phoenix Contact type SK8 or Weidmüller type KLBÜ CO 1.

The shield connection clamp must not be used as a strain relief mechanism.

Integration

SMC20 Sensor Modules Cabinet-Mounted communicate with a Control Unit via DRIVE-CLiQ.

Technical specifications

Article No.	6SL3055-0AA00-5BA3
Product brand name	SINAMICS
Product type designation	S120
Product designation	SMC20 Sensor Module Cabinet-Mounted
Current requirement at 24 V DC, maximum without taking encoder into account	0.2 A
• Conductor cross-section, maximum	2.5 mm ²
• Fuse protection, maximum	20 A
Power loss, maximum	10 W
Encoders which can be evaluated	<ul style="list-style-type: none"> • Incremental encoder sin/cos 1 V_{pp} • Absolute encoder EnDat 2.1 • SSI encoder with incremental signals sin/cos 1 V_{pp} (firmware version V2.4 and later)
• Encoder supply DC	5 V/0.35 A
• Encoder frequency incremental signals, maximum	500 kHz
• Signal subdivision (interpolation), maximum	16384 times (14 bit)
• SSI baud rate	100 ... 1000 kBaud
Cable length to encoder, maximum	100 m
PE connection	M4 screw
Width	30 mm
Height	150 mm
Depth	111 mm
Net weight	0.45 kg
Certificate of suitability	cULus

Selection and ordering data

Description	Article No.
SINAMICS S120 SMC20 Sensor Module Cabinet-Mounted Without DRIVE-CLiQ cable	6SL3055-0AA00-5BA3
Accessories for re-ordering	
SINAMICS/SINUMERIK/SIMOTION dust protection blanking plugs For DRIVE-CLiQ port	
• 50 units	6SL3066-4CA00-0AA0

Overview



SMC30 Sensor Module Cabinet-Mounted

The SMC30 Sensor Module Cabinet-Mounted is required to evaluate the encoder signals of motors without a DRIVE-CLiQ interface. External encoders can also be connected via the SMC30.

The following encoder signals can be evaluated:

- Incremental encoders TTL/HTL with/without open-circuit detection (open-circuit detection is only available with bipolar signals)
- SSI encoder with TTL/HTL incremental signals
- SSI encoder without incremental signals

The motor temperature can also be sensed using a PTC thermistor KTY84-130, Pt1000 or PTC.

Design

The SMC30 Sensor Module Cabinet-Mounted features the following connections and interfaces as standard:

- 1 encoder connection including motor temperature sensing (KTY84-130, Pt1000 or PTC) either via SUB-D connector or via terminals
- 1 DRIVE-CLiQ interface
- 1 connection for the electronics power supply via the 24 V DC supply connector
- 1 PE (protective earth) connection

The status of the SMC30 Sensor Module Cabinet-Mounted is indicated using a multi-color LED.

The SMC30 Sensor Module Cabinet-Mounted can be snapped onto a TH 35 standard mounting rail in accordance with EN 60715 (IEC 60715).

The maximum encoder cable length between SMC30 modules and encoders is 100 m. For HTL encoders, this length can be increased to 300 m if the A+/A- and B+/B- signals are evaluated and the power supply cable has a minimum cross-section of 0.5 mm².

The signal cable shield can be connected to the SMC30 Sensor Module Cabinet-Mounted via a shield connection clamp, e.g., Phoenix Contact type SK8 or Weidmüller type KLBÜ CO 1.

The shield connection clamp must not be used as a strain relief mechanism.

Integration

SMC30 Sensor Modules Cabinet-Mounted communicate with a Control Unit via DRIVE-CLiQ.

Technical specifications

Article No.	6SL3055-0AA00-5CA2
Product brand name	SINAMICS
Product type designation	S120
Product designation	SMC30 Sensor Module Cabinet-Mounted
Current requirement at 24 V DC, maximum without taking encoder into account	0.2 A
• Conductor cross-section, maximum	2.5 mm ²
• Fuse protection, maximum	20 A
Power loss, maximum	10 W
Encoders which can be evaluated	<ul style="list-style-type: none"> • Incremental encoder TTL/HTL • SSI encoder with TTL/HTL incremental signals • SSI encoder without incremental signals
• Input current range TTL/HTL	4 ... 20 mA (typ. 10 mA)
• Encoder supply DC	24 V/0.35 A or 5 V/0.35 A
• Encoder frequency, maximum	300 kHz
• SSI baud rate	100 ... 1000 kBaud
• Resolution absolute position SSI	30 bit
Cable length, maximum	
• TTL encoder	100 m only bipolar signals permitted ¹⁾
• HTL encoder	100 m for unipolar signals 300 m for bipolar signals ¹⁾
• SSI encoder	100 m
PE connection	M4 screw
Width	30 mm
Height	150 mm
Depth	111 mm
Net weight	0.45 kg
Certificate of suitability	cULus

Selection and ordering data

Description	Article No.
SINAMICS S120 SMC30 Sensor Module Cabinet-Mounted Without DRIVE-CLiQ cable	6SL3055-0AA00-5CA2
Accessories for re-ordering	
SINAMICS/SINUMERIK/SIMOTION dust protection blanking plugs For DRIVE-CLiQ port	
• 50 units	6SL3066-4CA00-0AA0

¹⁾ Signal cables twisted in pairs and shielded.

Overview



SMC40 Sensor Module Cabinet-Mounted

The SMC40 Sensor Module Cabinet-Mounted is required to evaluate the encoder signals of motors without a DRIVE-CLiQ interface. External encoders can also be connected via the SMC40.

The following encoder signals can be evaluated:

- Absolute encoder EnDat 2.2

Design

The SMC40 Sensor Module Cabinet-Mounted features the following connections and interfaces as standard:

- 2 encoder system interfaces
- 2 DRIVE-CLiQ interfaces
- 1 connection for the electronics power supply via the 24 V DC supply connector
- 1 PE (protective earth) connection

The status of the SMC40 Sensor Module Cabinet-Mounted is indicated using a multi-color LED.

The SMC40 Sensor Module Cabinet-Mounted can be snapped onto a TH 35 standard mounting rail in accordance with EN 60715 (IEC 60715).

The maximum encoder cable length between SMC40 modules and encoder systems is 100 m. The specified supply voltage of the encoder must be observed. The maximum cable length for DRIVE-CLiQ cables is 30 m.

The signal cable shield can be connected to the SMC40 Sensor Module Cabinet-Mounted via a shield connection clamp, e.g., Phoenix Contact type SK8 or Weidmüller type KLBÜ CO 1.

The shield connection clamp must not be used as a strain relief mechanism.

Integration

SMC40 Sensor Modules Cabinet-Mounted communicate with a Control Unit via DRIVE-CLiQ.

Technical specifications

Article No.	6SL3055-0AA00-5DA0
Product brand name	SINAMICS
Product type designation	S120
Product designation	SMC40 Sensor Module Cabinet-Mounted
Current requirement at 24 V DC, maximum without taking encoder into account	0.1 A
• Conductor cross-section, maximum	2.5 mm ²
• Fuse protection, maximum	20 A
Power loss, maximum	4 W
Encoders which can be evaluated	Absolute encoder EnDat 2.2
PE connection	M4 screw
Width	30 mm
Height	150 mm
Depth	111 mm
Net weight	0.45 kg
Certificate of suitability	cULus

Selection and ordering data

Description	Article No.
SINAMICS S120 SMC40 Sensor Module Cabinet-Mounted Without DRIVE-CLiQ cable	6SL3055-0AA00-5DA0
Accessories for re-ordering	
SINAMICS/SINUMERIK/SIMOTION dust protection blanking plugs For DRIVE-CLiQ port • 50 units	6SL3066-4CA00-0AA0

Overview



SME125 Sensor Module External

The SME125 Sensor Modules External are encoder evaluation units with degree of protection IP67, especially suitable for use in linear and torque motor applications. They can be installed close to the motor systems and encoders in the machine.

Sensor Modules External evaluate the encoder signals and motor temperature sensors specifically and convert the information obtained for DRIVE-CLiQ. The motor temperature signals are safely electrically separated.

Neither motor nor encoder data are saved in the SME125. The SME 125 can be operated on Control Units with firmware release V2.4 and later.

The following encoder signals can be evaluated:

- Absolute encoder EnDat 2.1
- SSI absolute encoder¹⁾ with sin/cos $1 V_{pp}$ incremental signals, but without reference signal

The motor temperature can also be sensed using a PTC thermistor KTY84-130, Pt1000 or PTC.

Design

SME125 Sensor Modules External feature the following connections and interfaces as standard:

- 1 DRIVE-CLiQ interface with integrated 24 V DC electronics power supply from the Control Unit or Motor Module
- 1 encoder connection via circular connector
- 1 temperature sensor connection via circular connector
- 1 PE (protective earth) connection

Technical specifications

Article No.	6SL3055-0AA00-5KA3
Product brand name	SINAMICS
Product type designation	S120
Product designation	SME125 Sensor Module External
Current requirement at 24 V DC, maximum without taking encoder into account	0.16 A
• Current carrying capacity of the encoder supply, for measuring system at 5 V DC	0.35 A
• Conductor cross-section, maximum	Acc. to connector contacts
• Fuse protection, maximum	Via DRIVE-CLiQ power supply source
Power loss	≤ 4.5 W
Encoders which can be evaluated	<ul style="list-style-type: none"> • Absolute encoder EnDat 2.1 with 5 V voltage supply • SSI absolute encoder with incremental signals sin/cos $1 V_{pp}$ with 5 V voltage supply
• Encoder frequency that can be evaluated, maximum	≤ 500 kHz
• Signal subdivision (interpolation)	≤ 16384 times (14 bit)
• SSI/EnDat 2.1 baud rate	100 kHz
Measuring system interface	17-pin M23 circular connector
Temperature sensor input	6-pin M17 circular connector
Output	IP67 DRIVE-CLiQ connector
Cable length, maximum	
• To measuring system ²⁾ / temperature sensor	3 m
• To automatic speed control	100 m
PE connection	M4 screw/1.8 Nm
Degree of protection	IP67
Width	117.6 mm
Height	43.1 mm
Depth	127 mm
Net weight	0.7 kg
Certificate of suitability	cULus

Selection and ordering data

Description	Article No.
SINAMICS SME125 Sensor Module External For absolute encoders Without DRIVE-CLiQ cable	6SL3055-0AA00-5KA3
Accessories	
Signal connector For temperature sensor input connector kit, 6+1-pole	6FX2003-0SU07
Signal connector For SME125 encoder system interface connector kit, 17-pole	6FX2003-0SA17

¹⁾ Only SSI encoders with 5 V supply voltage.

²⁾ The maximum cable length for the encoder system interface depends on the current consumption of the encoder system and the cross-section of the wires in the cable. However, the maximum length is 10 m.

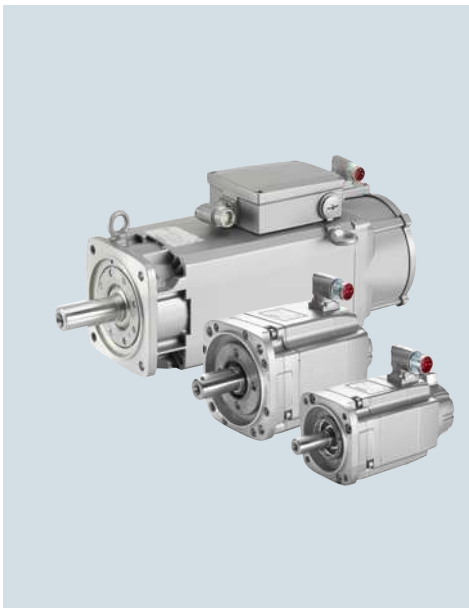

5/2	Feed motors for SINAMICS S120 Combi/S120
5/2	SIMOTICS S-1FK7 Compact/ 1FK7 High Inertia synchronous motor Natural cooling
5/6	Spindle motors for SINAMICS S120 Combi
5/8	SIMOTICS M-1PH8 asynchronous motor SH 80 – Forced ventilation
5/10	SIMOTICS M-1PH8 asynchronous motor SH 100 – Forced ventilation
5/12	SIMOTICS M-1PH8 asynchronous motor SH 100 – Forced ventilation – Star-delta circuit
5/14	SIMOTICS M-1PH8 asynchronous motor SH 132 – Forced ventilation
5/16	SIMOTICS M-1PH8 Premium Performance asynchronous motors SH 80 – Forced ventilation
5/18	Dimensional drawings
5/18	SIMOTICS S-1FK7 Compact synchronous motors with DRIVE-CLiQ – Natural cooling
5/19	SIMOTICS S-1FK7 High Inertia synchronous motors with DRIVE-CLiQ – Natural cooling
5/20	SIMOTICS M-1PH8 asynchronous motor SH 80 – Forced ventilation
5/21	SIMOTICS M-1PH8 asynchronous motor SH 100 – Forced ventilation
5/22	SIMOTICS M-1PH8 asynchronous motor SH 132 – Forced ventilation
5/23	SIMOTICS M-1PH8 Premium Performance asynchronous motors SH 80 – Forced ventilation – Solid shaft
5/24	SIMOTICS M-1PH8 Premium Performance asynchronous motors SH 80 – Forced ventilation – Hollow shaft
	CAD CREATOR
	Dimensional drawing and 2D/3D CAD generator www.siemens.com/cadcreator
	Drive Technology Configurator
	Guided product selection through to exact article number www.siemens.com/dt-configurator
	Siemens NC 82 · 2018

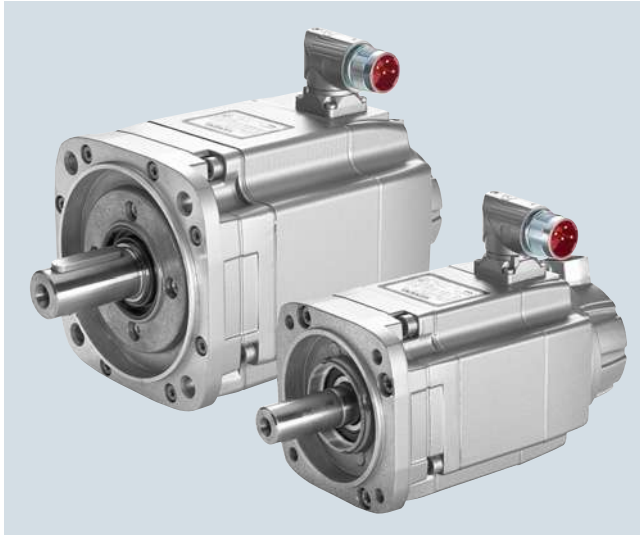
Overview**5**

SIMOTICS S-1FK7 feed motors in SH 63/SH 48 with DQI encoder

SIMOTICS S-1FK7 motors are compact permanent-magnet synchronous motors. 1FK7 motors can be combined with the SINAMICS S120 drive system to create a powerful system with high functionality. The motors are designed for operation without external cooling and the heat is dissipated through the motor surface. 1FK7 motors have a high overload capability.

The SIMOTICS S-1FK7 feed motors are perfectly adapted to the SINAMICS S120 Combi drive system.

Benefits

- Maximum machine dynamics thanks to optimum relation between torque and motor moment of inertia
- Very high torque even at high speeds as a result of the special field weakening concept
- Excellent machine precision thanks to high resolution of motor encoder and high-precision shaft and flange mounting
- Very fast acceleration thanks to triple electrical overload capability
- High degree of ruggedness because encoder is mechanically decoupled from the motor shaft
- Maintenance-free absolute encoders without battery
- High energy efficiency

SIMOTICS S-1FK7 Compact motors

- Space-saving installation due to extremely high power density
- For universal applications
- Wide range of motors

SIMOTICS S-1FK7 High Inertia motors

- Robust closed-loop control properties for high or variable load moment of inertia
- Minimal optimization and commissioning overhead for the compensation of disturbances

Function

- Compact synchronous servomotors
- Torque M_0 : 3 Nm to 48 Nm
- Shaft heights: 48 to 100
- Rated speeds: 2000 rpm to 6000 rpm
- Easily replaceable encoders with 20 bit resolution
- Electronic rating plate in motor encoder
- Naturally-cooled type of construction without fan
- Plug connection for power cable
- DRIVE-CLiQ interface for signal cable
- IP65 degree of protection

Technical specifications

Article No.	1FK7...
Product brand name	SIMOTICS
Product type designation	S-1FK7 Compact S-1FK7 High Inertia
Product designation	Feed motor
Type of motor	Permanent-magnet synchronous motor
Magnet material	Rare-earth magnet material
Cooling	Natural cooling
Temperature monitoring	Temperature sensor in the stator winding
Insulation of the stator winding in accordance with EN 60034-1 (IEC 60034-1)	Temperature class 155 (F) for a winding temperature rise of $\Delta T = 100$ K at an ambient temperature of 40 °C
Type of construction in accordance with EN 60034-7 (IEC 60034-7)	IM B5 (IM V1, IM V3)
Degree of protection in accordance with EN 60034-5 (IEC 60034-5)	IP65
Shaft extension on the drive end in accordance with DIN 748-3 (IEC 60072-1)	Plain shaft/ Feather key and keyway (half-key balancing)
Shaft and flange accuracy in accordance with DIN 42955 (IEC 60072-1) ¹⁾	Tolerance N
Vibration severity in accordance with EN 60034-14 (IEC 60034-14)	Grade A is maintained up to rated speed
Sound pressure level L_{pA} (1 m) in accordance with DIN EN ISO 1680, maximum	
• 1FK704	55 dB
• 1FK706	65 dB
• 1FK708/1FK710	70 dB
Connection	Connectors for signals and power, can be rotated
Paint finish	Anthracite RAL 7016
2nd rating plate	Enclosed separately
Holding brake	With/without
Certificate of suitability	cURus

Options

Order code	Description
K23	Special paint finish for "Worldwide" climate group: Primer and paint finish: Anthracite RAL 7016

When ordering a motor with options, **-Z** should be added to the Article No.

¹⁾ Shaft extension run-out, concentricity of centering ring and shaft, and perpendicularity of flange to shaft.

Selection and ordering data

Static torque M_0 at $\Delta T = 100\text{ K}$ Nm	Rated speed n_{rated} rpm	Shaft height SH	Rated power P_{rated} at $\Delta T = 100\text{ K}$ kW	SIMOTICS S-1FK7 synchronous motors Natural cooling Article No.	Moment of inertia of rotor		Weight, approx.	
					Without brake J	With brake J	Without brake m	With brake m
					10^{-4} kgm^2	10^{-4} kgm^2	kg	kg
1FK7 Compact								
6	3000	63	1.5	1FK7060-2AF71-1 ■■■ 1	7.7	8.7	7.1	8.5
8	3000	80	2.1	1FK7080-2AF71-1 ■■■ 1	14.2	17.5	10.3	13.3
8.5	3000	63	1.9	1FK7062-2AF71-1 ■■■ 1	11.2	12.2	9.1	10.5
11	2000	63	1.9	1FK7063-2AC71-1 ■■■ 1	14.7	15.7	11.1	12.5
	3000	63	2.3	1FK7063-2AF71-1 ■■■ 1	14.7	15.7	11.1	12.5
12	2000	80	2.1	1FK7081-2AC71-1 ■■■ 1	20	23.5	12.9	15.9
	3000	80	2.7	1FK7081-2AF71-1 ■■■ 1	20	23.5	12.9	15.9
16	2000	80	2.6	1FK7083-2AC71-1 ■■■ 1	26	29.5	15.6	18.6
	3000	80	3.3	1FK7083-2AF71-1 ■■■ 1	26	29.5	15.6	18.6
18	2000	100	3.0	1FK7100-2AC71-1 ■■■ 1	54	62	17.6	21
	3000	100	3.8	1FK7100-2AF71-1 ■■■ 1	54	62	17.6	21
20	2000	80	3.1	1FK7084-2AC71-1 ■■■ 1	32.5	35.5	18.3	21.3
	3000	80	3.1	1FK7084-2AF71-1 ■■■ 1	32.5	35.5	18.3	21.3
27	2000	100	4.3	1FK7101-2AC71-1 ■■■ 1	79	87	23.0	27.5
36	2000	100	5.2	1FK7103-2AC71-1 ■■■ 1	104	112	28.5	33.0
48	2000	100	7.7	1FK7105-2AC71-1 ■■■ 1	154	162	39.0	43.5
1FK7 High Inertia								
3	6000	48	0.9	1FK7042-3BK71-1 ■■■ 1	5.1	5.4	5.1	5.8
6	3000	63	1.5	1FK7060-3BF71-1 ■■■ 1	12.5	13.5	7.9	9.3
8.5	3000	63	1.9	1FK7062-3BF71-1 ■■■ 1	23.5	24.5	10.7	12.1
12	3000	80	2.7	1FK7081-3BF71-1 ■■■ 1	49	52	15.2	18.2
18	2000	100	3.0	1FK7100-3BC71-1 ■■■ 1	87	95	19.4	22.8
20	2000	80	3.1	1FK7084-3BC71-1 ■■■ 1	99	102	23.0	26.0
	3000	80	3.1	1FK7084-3BF71-1 ■■■ 1	99	102	23.0	26.0
27	2000	100	4.3	1FK7101-3BC71-1 ■■■ 1	127	136	25.7	30.2
	3000	100	4.9	1FK7101-3BF71-1 ■■■ 1	127	136	25.7	30.2
36	2000	100	5.2	1FK7103-3BC71-1 ■■■ 1	168	176	32.1	36.6
	3000	100	4.4	1FK7103-3BF71-1 ■■■ 1	168	176	32.1	36.6
48	2000	100	7.7	1FK7105-3BC71-1 ■■■ 1	249	258	44.4	48.9

Encoder system for motors with DRIVE-CLiQ interface

- 20 bit absolute encoder single-turn (AS20DQI encoder)
- 20 bit absolute encoder single-turn + 12 bit multi-turn (AM20DQI encoder)

Shaft extension	Shaft and flange accuracy	Holding brake	
Feather key and keyway	Tolerance N	Without	Q R
Feather key and keyway	Tolerance N	With	
Plain shaft	Tolerance N	Without	A B G H
Plain shaft	Tolerance N	With	



Motor type (repeated)	Efficiency ¹⁾	Stall current I_0 at M_0 at $\Delta T = 100$ K A	SINAMICS S120 Combi Power Module	SINAMICS S120 Motor Module Booksize compact format	Power cable with complete shield Motor connection and brake connection via power connector	
	η		Rated output current I_{rated}	Rated output current I_{rated}	Power connector	Cable cross-section ²⁾
	%		A	A	A	Size
1FK7060-2AF71-...	90	4.45	5	5	1	4 × 1.5
1FK7080-2AF71-...	92	4.9	5	5	1	4 × 1.5
1FK7062-2AF71-...	91	5.3	5	5	1	4 × 1.5
1FK7063-2AC71-...	91	5.3	5	5	1	4 × 1.5
1FK7063-2AF71-...	91	8.0	9	9	1	4 × 1.5
1FK7081-2AC71-...	93	5.0	5	5	1	4 × 1.5
1FK7081-2AF71-...	93	8.7	9	9	1	4 × 1.5
1FK7083-2AC71-...	93	7.5	9	9	1	4 × 1.5
1FK7083-2AF71-...	93	10.1	12	18	1	4 × 1.5
1FK7100-2AC71-...	92	8.4	9	9	1	4 × 1.5
1FK7100-2AF71-...	92	11.1	12	18	1	4 × 1.5
1FK7084-2AC71-...	93	8.5	9	9	1	4 × 1.5
1FK7084-2AF71-...	93	12.1	12	18	1	4 × 1.5
1FK7101-2AC71-...	93	12.3	12	18	1.5	4 × 1.5
1FK7103-2AC71-...	93	14.4	–	18	1.5	4 × 1.5
1FK7105-2AC71-...	93	20.0	–	18	1.5	4 × 2.5
1FK7042-3BK71-...	89	4.4	5	5	1	4 × 1.5
1FK7060-3BF71-...	90	4.45	5	5	1	4 × 1.5
1FK7062-3BF71-...	91	5.3	5	5	1	4 × 1.5
1FK7081-3BF71-...	93	8.7	9	9	1	4 × 1.5
1FK7100-3BC71-...	92	8.4	9	9	1	4 × 1.5
1FK7084-3BC71-...	93	8.5	9	9	1	4 × 1.5
1FK7084-3BF71-...	93	12.1	12	18	1	4 × 1.5
1FK7101-3BC71-...	93	12.3	12	18	1.5	4 × 1.5
1FK7101-3BF71-...	93	18.8	–	18	1.5	4 × 2.5
1FK7103-3BC71-...	93	14.4	–	18	1.5	4 × 1.5
1FK7103-3BF71-...	93	26.0	–	30	1.5	4 × 4
1FK7105-3BC71-...	93	20.0	–	30	1.5	4 × 2.5

For more
components refer to
SINAMICS S120
drive system

For information on the cables
refer to MOTION-CONNECT
connection systems

¹⁾ Optimum efficiency in continuous duty.

²⁾ The current carrying capacity of the power cables complies with EN 60204-1 for installation type C, for continuous duty at an ambient air temperature of 40 °C.

Overview

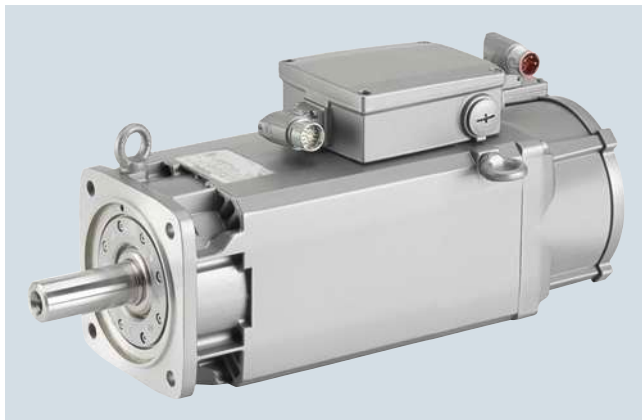

SIMOTICS M-1PH808 spindle motor with forced ventilation

SIMOTICS M-1PH8 motors are compact squirrel-cage asynchronous motors with degree of protection IP55. SIMOTICS M-1PH8 motors have been designed specifically for use in conjunction with the SINAMICS S120 drive system. Depending on the control requirements, appropriate encoder systems are available for the motors for sensing the motor speed and indirect position.

The SIMOTICS M-1PH8 spindle motors are perfectly adapted to the SINAMICS S120 Combi drive system.

Benefits

- Maximum power over an extremely wide speed range as a result of intelligent winding design and optimized field-weakening and heat dissipation concept
- Very fast spindle acceleration rates and maximum cutting forces thanks to special lamination structure and high overload factor
- Long-lasting motor bearings for high radial forces with belt drives
- High degree of protection, including motor fan

Function

- Compact asynchronous spindle motors
- Spindle power: 2.8 kW to 12 kW
- Shaft heights: 80 to 132
- Maximum speed: 24000 rpm
- Electronic rating plate in motor encoder
- Integrated, easily replaceable fan
- Integrated terminal box for power cable
- DRIVE-CLiQ interface for signal cable
- IP55 degree of protection (including fan)
- Vibration severity grade S/A and Special/B
- High rotational accuracy
- Optimized bearing design for high cantilever forces

Application

- Main spindles for standard milling and turning machines
- Driven tools for standard turning machines

Design

Terminal box assignment, max. connectable conductor cross-sections

1PH8 motor Forced ventilation	Terminal box	Cable entry		Outer cable diameter, max. ¹⁾	Number of main terminals	Cross-section per terminal, max.	Rated current, max. ²⁾
		Power	External signals				
Type	Type			mm		mm ²	A
1PH808	gk803	1 × M25 × 1.5	1 × Ø 22 mm ³⁾	20	Phases: 3 × M5 Grounding: 2 × M5	1 × 10	50
1PH810	gk813	1 × M32 × 1.5	1 × Ø 22 mm ³⁾	24.2	Phases: 3 × M5 Grounding: 2 × M5	1 × 16	66
1PH810 Star/ Delta	gk826	1 × M32 × 1.5	1 × Ø 22 mm ³⁾	24.2	Phases: 6 × M5 Grounding: 2 × M5	1 × 10	50
1PH813	gk833	1 × M40 × 1.5	1 × Ø 22 mm ³⁾	32	Phases: 3 × M6 Grounding: 2 × M6	1 × 35	104

¹⁾ Dependent on the design of the metric cable gland.

²⁾ Current-carrying capacity based on EN 60204-1 and IEC 60364-5-52 according to installation type C.

³⁾ Hole with Ø 22 mm, 90° to signal connection.

Technical specifications

Article No.	1PH8...
Product brand name	SIMOTICS
Product type designation	M-1PH8
Product designation	Spindle motor
Type of motor	Asynchronous motor
Cooling	Forced ventilation
Ambient temperature, permissible	-15 ... +40 °C
Temperature monitoring	Temperature sensor in the stator winding
Insulation of the stator winding in accordance with EN 60034-1 (IEC 60034-1)	For an ambient temperature of up to 40 °C
<ul style="list-style-type: none"> • 1PH808/1PH810/1PH813 	Temperature class 180 (H)
Motor fan ratings	
<ul style="list-style-type: none"> • 1PH808 	230 V 1 AC ± 10 %, 50 Hz 265 V 1 AC ± 10 %, 60 Hz
<ul style="list-style-type: none"> • 1PH810/1PH813 	400 V 3 AC ± 10 %, 50 Hz 480 V 3 AC ± 10 %, 60 Hz
Encoder system, built-in	DRIVE-CLiQ interface
<ul style="list-style-type: none"> • 1PH8...-1D... for speeds up to 12000 rpm 	22 bit incremental encoder (resolution 4194304, internal 2048 S/R) + commutation position 11 bit (IC22DQ encoder)
<ul style="list-style-type: none"> • 1PH8...-1U... for speeds up to 15000 rpm 	20 bit incremental encoder (resolution 1048576, internal 512 S/R) without commutation position (IN20DQ encoder)
<ul style="list-style-type: none"> • 1PH8...-1S... for speeds up to 24000 rpm 	19 bit incremental encoder (resolution 524288, internal 256 S/R) without commutation position (IN19DQ encoder)
Sound pressure level L_{pA} (1 m) in accordance with EN ISO 1680 Tolerance + 3 dB	Rated pulse frequency of 4 kHz and speed range up to 5000 rpm
<ul style="list-style-type: none"> • 1PH808/1PH810/1PH813 	70 dB
Connection	
<ul style="list-style-type: none"> • 1PH808/1PH810/1PH813 	Terminal box top/cable entry from right/signal connection DE
<ul style="list-style-type: none"> • Fan 	
<ul style="list-style-type: none"> - 1PH808 	Power connector
<ul style="list-style-type: none"> - 1PH810/1PH813 	Terminals in terminal box
<ul style="list-style-type: none"> • Encoder system 	Connector for signals (without mating connector) or DRIVE-CLiQ
Vibration severity	In accordance with Siemens/EN 60034-14 (IEC 60034-14)
Shaft and flange accuracy ¹⁾	In accordance with Siemens/DIN 42955 (IEC 60072-1)
Degree of protection in accordance with EN 60034-5 (IEC 60034-5)	
<ul style="list-style-type: none"> • 1PH808/1PH810/1PH813 	IP55
<ul style="list-style-type: none"> • Fan 	IP55
Rating plate	1 unit attached to motor 1 unit supplied loose in terminal box
Paint finish	Anthracite RAL 7016
Certificate of suitability	cURus

Options

Order code	Description
K23	Special paint finish for "Worldwide" climate group: Primer and paint finish: Anthracite RAL 7016

When ordering a motor with options, **-Z** should be added to the Article No.

¹⁾ Shaft extension run-out, concentricity of centering ring and shaft, and perpendicularity of flange to shaft.

Selection and ordering data

Rated speed	Continuous speed, max.	Rated power S1 duty	Rated torque	Static torque	SIMOTICS M-1PH8 asynchronous motor Forced ventilation DE → NDE Terminal box top	Efficiency	Moment of inertia	Weight, approx.
n_{rated} rpm	n_{max1} rpm	P_{rated} kW	M_{rated} Nm	M_0 Nm	Article No.	η %	J kgm ²	m kg
Shaft height SH 80 – Line voltage 400 V 3 AC								
1500	10000	2.8	18	21	1PH8083-1DF0 ■ - ■ HA1	80.9	0.0064	32
	12000	2.8	18	21	1PH8083-1DF0 ■ - ■ DA1-Z L37	80.9	0.0064	32
	12000	2.8	18	21	1PH8083-1DF0 ■ - ■ LA1	80.9	0.0064	32
2000	10000	3.7	18	21	1PH8083-1DG0 ■ - ■ HA1	83.2	0.0064	32
	12000	3.7	18	21	1PH8083-1DG0 ■ - ■ DA1-Z L37	83.2	0.0064	32
	15000	3.7	18	21	1PH8083-1UG0 ■ - ■ LA1	83.2	0.0064	32
	17000	3.7	18	21	1PH8083-1SG0 ■ - ■ MA1	83.2	0.0064	32
3000	10000	4.1	13	21	1PH8083-1DM0 ■ - ■ HA1	86.9	0.0064	32
	12000	4.1	13	21	1PH8083-1DM0 ■ - ■ DA1-Z L37	86.9	0.0064	32
	15000	4.1	13	21	1PH8083-1UM0 ■ - ■ LA1	86.9	0.0064	32
	20000	4.1	13	21	1PH8083-1SM0 ■ - ■ MA1	86.9	0.0064	32
4500	10000	4.8	10	19	1PH8083-1DN0 ■ - ■ HA1	86.4	0.0064	32
	12000	4.8	10	19	1PH8083-1DN0 ■ - ■ DA1-Z L37	86.4	0.0064	32
	15000	4.8	10	19	1PH8083-1UN0 ■ - ■ LA1	86.4	0.0064	32
	20000	4.8	10	19	1PH8083-1SN0 ■ - ■ MA1	86.4	0.0064	32
1500	10000	3.7	24	27	1PH8087-1DF0 ■ - ■ HA1	81.7	0.0089	39
	12000	3.7	24	27	1PH8087-1DF0 ■ - ■ DA1-Z L37	81.7	0.0089	39
	14000	3.7	24	27	1PH8087-1UF0 ■ - ■ LA1	81.7	0.0089	39
2000	10000	4.9	23	27	1PH8087-1DG0 ■ - ■ HA1	85.3	0.0089	39
	12000	4.9	23	27	1PH8087-1DG0 ■ - ■ DA1-Z L37	85.3	0.0089	39
	15000	4.9	23	27	1PH8087-1UG0 ■ - ■ LA1	85.3	0.0089	39
	18000	4.9	23	27	1PH8087-1SG0 ■ - ■ MA1	85.3	0.0089	39
3000	10000	4.8	15	27	1PH8087-1DM0 ■ - ■ HA1	87.1	0.0089	39
	12000	4.8	15	27	1PH8087-1DM0 ■ - ■ DA1-Z L37	87.1	0.0089	39
	15000	4.8	15	27	1PH8087-1UM0 ■ - ■ LA1	87.1	0.0089	39
	20000	4.8	15	27	1PH8087-1SM0 ■ - ■ MA1	87.1	0.0089	39
4500	10000	5.8	12	25	1PH8087-1DN0 ■ - ■ HA1	86.8	0.0089	39
	12000	5.8	12	25	1PH8087-1DN0 ■ - ■ DA1-Z L37	86.8	0.0089	39
	15000	5.8	12	25	1PH8087-1UN0 ■ - ■ LA1	86.8	0.0089	39
	20000	5.8	12	25	1PH8087-1SN0 ■ - ■ MA1	86.8	0.0089	39

Type of construction

IM B3 (IM V5, IM V6)
IM B5 (IM V1, IM V3)

Shaft extension DE

Plain shaft

Feather key

Feather key

Balancing

–

Full-key

Half-key

L37 Increased continuous speed, max. from 10000 to 12000 rpm

Bearing version

0 D Standard with fixed bearing**1 H** Standard**2 L** Performance**M** High PerformanceVibration severity acc. to Siemens¹⁾/ EN 60034-14

SR/A

S/A

SPECIAL/B

SPECIAL/B

Shaft and flange accuracy

R

R

SPECIAL

SPECIAL

¹⁾ For definition of the vibration severity according to Siemens, see the 1PH8 Configuration Manual.

Motor type (repeated)	Rated current for S1 duty	Stall current	SINAMICS S120 Combi						
			Rated output current for S1 duty	3-axis Power Modules			4-axis Power Modules		
				Article No.	Article No.	Article No.	Article No.	Article No.	Article No.
	I_{rated} A	I_0 A	I_{rated} A	6SL3111- 3VE21-6FA1	6SL3111- 3VE21-6EA1	6SL3111- 3VE22-0HA1	6SL3111- 4VE21-6FA1	6SL3111- 4VE21-6EA1	6SL3111- 4VE22-0HA1
1PH8083-1.F...	7.5	8	9	0	O/●	O/●	O/●	O/●	O/●
	7.5	8	9	0	O/●	O/●	O/●	O/●	O/●
	7.5	8	9	0	O/●	O/●	O/●	O/●	O/●
1PH8083-1.G...	11.6	12	12	0	0	0	0	0	O/●
	11.6	12	12	0	0	0	0	0	O/●
	11.6	12	12	0	0	0	0	0	O/●
	11.6	12	12	0	0	0	0	0	O/●
1PH8083-1.M...	13.6	17	18	0	0	0	0	0	O/● ²⁾
	13.6	17	18	0	0	0	0	0	O/● ²⁾
	13.6	17	18	0	0	0	0	0	O/● ²⁾
	13.6	17	18	0	0	0	0	0	O/● ²⁾
1PH8083-1.N...	17	23	18	✓	0	0	✓	0	0
	17	23	18	✓	0	0	✓	0	0
	17	23	18	✓	0	0	✓	0	0
	17	23	18	✓	0	0	✓	0	0
1PH8087-1.F...	10	11	12	0	O/● ²⁾	O/● ²⁾	O/● ²⁾	O/● ²⁾	O/●
	10	11	12	0	O/● ²⁾	O/● ²⁾	O/● ²⁾	O/● ²⁾	O/●
	10	11	12	0	O/● ²⁾	O/● ²⁾	O/● ²⁾	O/● ²⁾	O/●
1PH8087-1.G...	14.1	15	18	0	0	0	0	0	0
	14.1	15	18	0	0	0	0	0	0
	14.1	15	18	0	0	0	0	0	0
	14.1	15	18	0	0	0	0	0	0
1PH8087-1.M...	17.3	23	18	✓	0	0	✓	0	0
	17.3	23	18	✓	0	0	✓	0	0
	17.3	23	18	✓	0	0	✓	0	0
	17.3	23	18	✓	0	0	✓	0	0
1PH8087-1.N...	19.5	28	30	✓ ²⁾	0	0	✓ ²⁾	0	0
	19.5	28	30	✓ ²⁾	0	0	✓ ²⁾	0	0
	19.5	28	30	✓ ²⁾	0	0	✓ ²⁾	0	0
	19.5	28	30	✓ ²⁾	0	0	✓ ²⁾	0	0

- ✓ Perfectly suited as main spindle
- Suitable as main spindle
- Perfectly suited as driven tool
- Not suitable

²⁾ With derating.

Selection and ordering data

Rated speed	Continu-ous speed, max.	Rated power S1 duty	Rated torque	Static torque	SIMOTICS M-1PH8 asynchronous motor Forced ventilation DE → NDE IP55 degree of protection Terminal box top	Efficiency	Moment of inertia	Weight, approx.
n_{rated} rpm	n_{max1} rpm	P_{rated} kW	M_{rated} Nm	M_0 Nm	Article No.	η %	J kgm ²	m kg
Shaft height SH 100 – Line voltage 400 V 3 AC								
1500	9000	3.7	24	29	1PH8101-1DF0 ■ - ■ HA1	83.5	0.0138	42
	10000	3.7	24	29	1PH8101-1DF0 ■ - ■ DA1-Z L37	83.5	0.0138	42
	12000	3.7	24	29	1PH8101-1DF0 ■ - ■ LA1	83.5	0.0138	42
1000	9000	3.7	35	38	1PH8103-1DD0 ■ - ■ HA1	81.4	0.0172	51
	10000	3.7	35	38	1PH8103-1DD0 ■ - ■ DA1-Z L37	81.4	0.0172	51
	12000	3.7	35	38	1PH8103-1DD0 ■ - ■ LA1	81.4	0.0172	51
1500	9000	5.5	35	38	1PH8103-1DF0 ■ - ■ HA1	85.2	0.0172	51
	10000	5.5	35	38	1PH8103-1DF0 ■ - ■ DA1-Z L37	85.2	0.0172	51
	12000	5.5	35	38	1PH8103-1DF0 ■ - ■ LA1	85.2	0.0172	51
2000	9000	7	33	38	1PH8103-1DG0 ■ - ■ HA1	87.7	0.0172	51
	10000	7	33	38	1PH8103-1DG0 ■ - ■ DA1-Z L37	87.7	0.0172	51
	12000	7	33	38	1PH8103-1DG0 ■ - ■ LA1	87.7	0.0172	51
3000	9000	8.4	27	38	1PH8103-1DM0 ■ - ■ HA1	90.0	0.0172	51
	10000	8.4	27	38	1PH8103-1DM0 ■ - ■ DA1-Z L37	90.0	0.0172	51
	12000	8.4	27	38	1PH8103-1DM0 ■ - ■ LA1	90.0	0.0172	51
1500	9000	7	45	52	1PH8105-1DF0 ■ - ■ HA1	86.7	0.0252	65
	10000	7	45	52	1PH8105-1DF0 ■ - ■ DA1-Z L37	86.7	0.0252	65
	12000	7	45	52	1PH8105-1DF0 ■ - ■ LA1	86.7	0.0252	65
1000	9000	6.3	60	63	1PH8107-1DD0 ■ - ■ HA1	83.4	0.0289	73
	10000	6.3	60	63	1PH8107-1DD0 ■ - ■ DA1-Z L37	83.4	0.0289	73
	12000	6.3	60	63	1PH8107-1DD0 ■ - ■ LA1	83.4	0.0289	73
1500	9000	9	57	63	1PH8107-1DF0 ■ - ■ HA1	86.9	0.0289	73
	10000	9	57	63	1PH8107-1DF0 ■ - ■ DA1-Z L37	86.9	0.0289	73
	12000	9	57	63	1PH8107-1DF0 ■ - ■ LA1	86.9	0.0289	73
2000	9000	10.5	50	63	1PH8107-1DG0 ■ - ■ HA1	89.7	0.0289	73
	10000	10.5	50	63	1PH8107-1DG0 ■ - ■ DA1-Z L37	89.7	0.0289	73
	12000	10.5	50	63	1PH8107-1DG0 ■ - ■ LA1	89.7	0.0289	73

Type of construction

IM B3 (IM V5, IM V6)
IM B5 (IM V1, IM V3)

0
2

Shaft extension DE

Balancing

Plain shaft
Feather key
Feather key

–
Full-key
Half-key

L37 Increased continuous speed, max. from 9000 to 10000 rpm

Bearing version

Vibration severity acc. to Siemens¹⁾/ EN 60034-14

Shaft and flange accuracy

0 D	Standard with fixed bearing	SR/A	R
1 H	Standard	S/A	R
2 L	Performance	SPECIAL/B	SPECIAL
M	High Performance	SPECIAL/B	SPECIAL

¹⁾ For definition of the vibration severity according to Siemens, see the 1PH8 Configuration Manual.

Motor type (repeated)	Rated current for S1 duty	Stall current	SINAMICS S120 Combi						
			Rated output current for S1 duty	3-axis Power Modules			4-axis Power Modules		
				Article No.	Article No.	Article No.	Article No.	Article No.	Article No.
I_{rated} A	I_0 A	I_{rated} A	6SL3111- 3VE21-6FA1	6SL3111- 3VE21-6EA1	6SL3111- 3VE22-0HA1	6SL3111- 4VE21-6FA1	6SL3111- 4VE21-6EA1	6SL3111- 4VE22-0HA1	
1PH8101-1.F...	12.5	14	12	○	○	○	○	○	○/●
	12.5	14	12	○	○	○	○	○	○/●
	12.5	14	12	○	○	○	○	○	○/●
1PH8103-1.D...	10	11	12	○	○/● ²⁾	○/● ²⁾	○/● ²⁾	○/● ²⁾	○/●
	10	11	12	○	○/● ²⁾	○/● ²⁾	○/● ²⁾	○/● ²⁾	○/●
	10	11	12	○	○/● ²⁾	○/● ²⁾	○/● ²⁾	○/● ²⁾	○/●
1PH8103-1.F...	13.5	14	18	○	○	○	○	○	○/● ²⁾
	13.5	14	18	○	○	○	○	○	○/● ²⁾
	13.5	14	18	○	○	○	○	○	○/● ²⁾
1PH8103-1.G...	17.5	19	18	✓	○	○	✓	○	○
	17.5	19	18	✓	○	○	✓	○	○
	17.5	19	18	✓	○	○	✓	○	○
1PH8103-1.M...	25.7	31	30	–	✓ ²⁾	○	–	✓ ²⁾	○
	25.7	31	30	–	✓ ²⁾	○	–	✓ ²⁾	○
	25.7	31	30	–	✓ ²⁾	○	–	✓ ²⁾	○
1PH8105-1.F...	17.5	20	18	✓	○	○	✓	○	○
	17.5	20	18	✓	○	○	✓	○	○
	17.5	20	18	✓	○	○	✓	○	○
1PH8107-1.D...	17.5	25	18	✓	○	○	✓	○	○
	17.5	25	18	✓	○	○	✓	○	○
	17.5	25	18	✓	○	○	✓	○	○
1PH8107-1.F...	23.5	25	24	–	✓	○	–	✓	○
	23.5	25	24	–	✓	○	–	✓	○
	23.5	25	24	–	✓	○	–	✓	○
1PH8107-1.G...	26	29	30	–	✓ ²⁾	✓	–	✓ ²⁾	✓
	26	29	30	–	✓ ²⁾	✓	–	✓ ²⁾	✓
	26	29	30	–	✓ ²⁾	✓	–	✓ ²⁾	✓

- ✓ Perfectly suited as main spindle
- Suitable as main spindle
- Perfectly suited as driven tool
- Not suitable

²⁾ With derating.

Selection and ordering data

Rated speed	Continu- ous speed, max.	Rated power S1 duty	Rated torque	Static torque	SIMOTICS M-1PH8 asynchronous motor Forced ventilation DE → NDE IP55 degree of protection Terminal box top	Efficiency	Moment of inertia	Weight, approx.
n_{rated} rpm	n_{max1} rpm	P_{rated} kW	M_{rated} Nm	M_0 Nm	Article No.	η %	J kgm ²	m kg
Shaft height SH 100 – Line voltage 400 V 3 AC – Star-delta circuit								
1500/4000	9000	3.7/3.7	24/9	29/19	1PH8101-1DS0 ■ - ■ HA1	83.0/89.0	0.0138	42
	10000	3.7/3.7	24/9	29/19	1PH8101-1DS0 ■ - ■ DA1-Z L37	83.0/89.0	0.0138	42
	12000	3.7/3.7	24/9	29/19	1PH8101-1DS0 ■ - ■ LA1	83.0/89.0	0.0138	42
	18000	3.7/3.7	24/9	29/19	1PH8101-1SS0 ■ - ■ MA1	83.0/89.0	0.0138	42
1500/4000	9000	7.5/7.5	48/18	55/36	1PH8105-1DS0 ■ - ■ HA1	86.4/90.7	0.0252	65
	10000	7.5/7.5	48/18	55/36	1PH8105-1DS0 ■ - ■ DA1-Z L37	86.4/90.7	0.0252	65
	12000	7.5/7.5	48/18	55/36	1PH8105-1DS0 ■ - ■ LA1	86.4/90.7	0.0252	65
	18000	7.5/7.5	48/18	55/36	1PH8105-1SS0 ■ - ■ MA1	86.4/90.7	0.0252	65
1500/4000	9000	8.5/8.5	54/20	63/42	1PH8107-1DS0 ■ - ■ HA1	86.1/89.8	0.0289	73
	10000	8.5/8.5	54/20	63/42	1PH8107-1DS0 ■ - ■ DA1-Z L37	86.1/89.8	0.0289	73
	12000	8.5/8.5	54/20	63/42	1PH8107-1DS0 ■ - ■ LA1	86.1/89.8	0.0289	73
	18000	8.5/8.5	54/20	63/42	1PH8107-1SS0 ■ - ■ MA1	86.1/89.8	0.0289	73

Type of construction

IM B3 (IM V5, IM V6)
IM B5 (IM V1, IM V3)

0
2

L37 Increased continuous speed, max.
from 9000 to 10000 rpm

Shaft extension DE

Plain shaft

Feather key

Feather key

Balancing

–

Full-key

Half-key

Bearing version

0 D Standardwith
fixed bearing
1 H Standard
2 L Performance
M High Performance

Vibration severity
acc. to Siemens¹⁾/
EN 60034-14

SR/A

S/A

SPECIAL/B

SPECIAL/B

Shaft and
flange
accuracy

R

R

SPECIAL

SPECIAL

¹⁾ For definition of the vibration severity according to Siemens, see the 1PH8 Configuration Manual.

Motor type (repeated)	Rated current for S1 duty	Stall current	SINAMICS S120 Combi						
			Rated output current for S1 duty	3-axis Power Modules			4-axis Power Modules		
				Article No.	Article No.	Article No.	Article No.	Article No.	Article No.
I_{rated} A	I_0 A	I_{rated} A	6SL3111- 3VE21-6FA1	6SL3111- 3VE21-6EA1	6SL3111- 3VE22-0HA1	6SL3111- 4VE21-6FA1	6SL3111- 4VE21-6EA1	6SL3111- 4VE22-0HA1	
1PH8101-1.S...	13.2/13.5	15/20	18	○	○	○	○	○	○
	13.2/13.5	15/20	18	○	○	○	○	○	○
	13.2/13.5	15/20	18	○	○	○	○	○	○
	13.2/13.5	15/20	18	○	○	○	○	○	○
1PH8105-1.S...	23/24	25/35	24	–	○	○	–	○	○
	23/24	25/35	24	–	○	○	–	○	○
	23/24	25/35	24	–	○	○	–	○	○
	23/24	25/35	24	–	○	○	–	○	○
1PH8107-1.S...	27/28	30/40	30	–	–	○	–	–	○
	27/28	30/40	30	–	–	○	–	–	○
	27/28	30/40	30	–	–	○	–	–	○
	27/28	30/40	30	–	–	○	–	–	○

- ✓ Perfectly suited as main spindle
- Suitable as main spindle
- Perfectly suited as driven tool
- Not suitable

²⁾ With derating.

Selection and ordering data

Rated speed	Continuous speed, max.	Rated power S1 duty	Rated torque	Static torque	SIMOTICS M-1PH8 asynchronous motor Forced ventilation DE → NDE IP55 degree of protection Terminal box top	Efficiency	Moment of inertia	Weight, approx.
n_{rated} rpm	n_{max1} rpm	P_{rated} kW	M_{rated} Nm	M_0 Nm	Article No.	η %	J kgm ²	m kg
Shaft height SH 132 – Line voltage 400 V 3 AC								
1500	8000	11	70	96	1PH8131-1DF0 ■ - ■ HA1	89.9	0.059	89
	10000	11	70	96	1PH8131-1DF0 ■ - ■ LA1	89.9	0.059	89
1000	8000	12	115	128	1PH8133-1DD0 ■ - ■ HA1	87.1	0.076	106
	10000	12	115	128	1PH8133-1DD0 ■ - ■ LA1	87.1	0.076	106
Type of construction								
IM B3 (IM V5, IM V6)					0			
IM B5 (IM V1, IM V3)					2			
Shaft extension DE				Balancing		Bearing version		Vibration severity acc. to Siemens¹⁾/ EN 60034-14
Plain shaft				–		0 H Standard	S/A	Shaft and flange accuracy
Feather key				Full-key		1 L Performance	SPECIAL/B	R
Feather key				Half-key		2 M High Performance	SPECIAL/B	SPECIAL

¹⁾ For definition of the vibration severity according to Siemens, see the 1PH8 Configuration Manual.

Motor type (repeated)	Rated current for S1 duty	Stall current	SINAMICS S120 Combi						
			Rated output current for S1 duty	3-axis Power Modules			4-axis Power Modules		
	I_{rated} A	I_0 A	I_{rated} A	Article No.			Article No.		
				6SL3111- 3VE21-6FA1	6SL3111- 3VE21-6EA1	6SL3111- 3VE22-0HA1	6SL3111- 4VE21-6FA1	6SL3111- 4VE21-6EA1	6SL3111- 4VE22-0HA1
1PH8131-1.F...	24	30	24	–	✓	○	–	✓	○
	24	30	24	–	✓	○	–	✓	○
1PH8133-1.D...	30	32	30	–	–	✓	–	–	✓
	30	32	30	–	–	✓	–	–	✓

- ✓ Perfectly suited as main spindle
- Suitable as main spindle
- Perfectly suited as driven tool
- Not suitable

²⁾ With derating.

Selection and ordering data

Rated speed	Maximum speed	Rated power S1 duty	Rated torque	SIMOTICS M-1PH8 Premium Performance asynchronous motor Forced ventilation DE → NDE IP55 degree of protection Terminal box top	Efficiency	Moment of inertia	Weight, approx. Motor with solid shaft
n_{rated} rpm	n_{max} rpm	P_{rated} kW	M_{rated} Nm	Article No.	η %	J kgm ²	m kg
Shaft height SH 80 – Line voltage 400 V 3 AC							
9000	24000	2.8	3.0	1PH8081-1SU0 2- NA1-Z Q12+Q52	88.5	0.0045	24
	24000	2.8	3.0	1PH8081-1SW0 2- NA1-Z Q12+Q52	84.3	0.0045	24
	24000	3.5	3.7	1PH8081-1SV0 2- NA1-Z Q12+Q52	95.0	0.0045	24
5200	24000	4.5	8.3	1PH8083-1SW0 2- NA1-Z Q12+Q52	86.6	0.0064	29.5
12000	24000	4.5	3.6	1PH8083-1SV0 2- NA1-Z Q12+Q52	93.9	0.0064	29.5
	24000	6.5	5.2	1PH8087-1SV0 2- NA1-Z Q12+Q52	94.7	0.0089	37

Type of construction

IM B5 (IM V1, IM V3)

2

Shaft extension DE

Solid shaft

0

Hollow shaft

Order code **Y64** required.
Prepared for rotary union without bearing¹⁾

3

Bearing version

Vibration severity
acc. to Siemens²⁾
EN 60034-14Shaft and
flange
accuracyPremium
Performance

SPECIAL/B

SPECIAL

N

Q52 DE flange with additional 4 × M8 thread for one
adapter plate for alignment of motor shaft with
spindle shaft**Q12** M5 sealing air connection on terminal box¹⁾

¹⁾ For further details on interfaces and sealing air conditioning, see the 1PH8 Configuration Manual.

²⁾ For definition of the vibration severity according to Siemens, see the 1PH8 Configuration Manual.

Motor type (repeated)	Rated current for S1 duty I_{rated} A	Pulse frequency kHz	SINAMICS S120 Combi					
			3-axis Power Modules			4-axis Power Modules		
			Article No.			Article No.		
			6SL3111- 3VE21-6FA1	6SL3111- 3VE21-6EA1	6SL3111- 3VE22-0HA1	6SL3111- 4VE21-6EA1	6SL3111- 4VE22-0HA1	6SL3111- 4VE21-0EA1
1PH8081-1SU02-....	12.5	4	–	–	–	✓	✓	○
1PH8081-1SW02-....	12.5	8	–	–	–	–	–	✓
1PH8081-1SV02-....	15.5	8	–	–	–	–	–	✓
1PH8083-1SW02-....	15.5	8	–	–	–	–	–	✓
1PH8083-1SV02-....	15.5	8	–	–	–	–	–	✓
1PH8087-1SV02-....	19.0	8	–	–	–	–	–	✓

- ✓ Perfectly suited as main spindle
- Suitable as main spindle
- Perfectly suited as driven tool
- Not suitable

Dimensional drawings

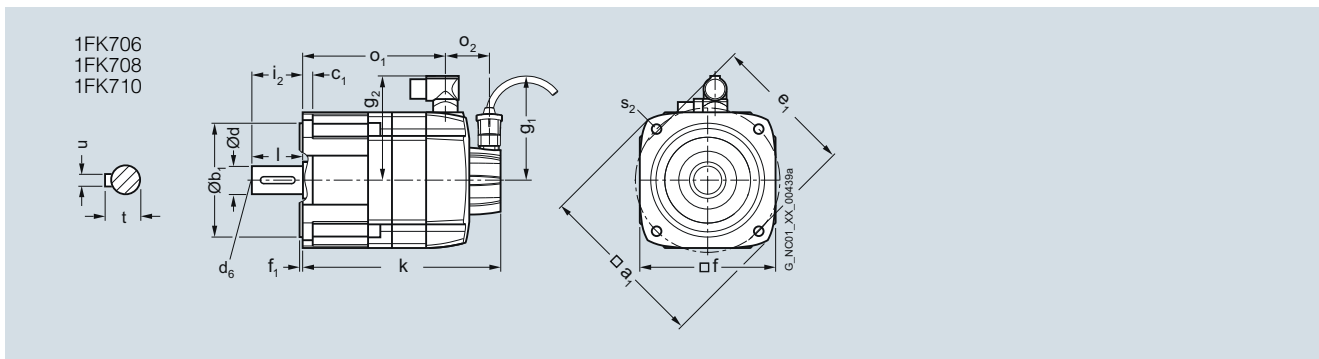

For motor Dimensions in mm (inches)

Shaft height	Type	DIN IEC	a ₁ P	b ₁ N	c ₁ LA	e ₁ M	f AB	f ₁ T	i ₂ -	s ₂ S	Shaft extension DE				
											d D	d ₆ -	l E	t GA	u F
1FK7 Compact, natural cooling, DQI encoder with DRIVE-CLiQ, with/without brake															
63	1FK706.-2A		155 (6.10)	110 (4.33)	10 (0.39)	130 (5.12)	126 (4.96)	3.5 (0.14)	50 (1.97)	9 (0.35)	24 (0.94)	M8	50 (1.97)	27 (1.06)	8 (0.31)
80	1FK708.-2A		194 (7.64)	130 (5.12)	11.5 (0.45)	165 (6.50)	155 (6.10)	3.5 (0.14)	58 (2.28)	11 (0.43)	32 (1.26)	M12	58 (2.28)	35 (1.38)	10 (0.39)
100	1FK710.-2A		245 (9.65)	180 (7.09)	13 (0.51)	215 (8.46)	192 (7.56)	4 (0.16)	80 (3.15)	14 (0.55)	38 (1.50)	M12	80 (3.15)	41 (1.61)	10 (0.39)

Shaft height	Type	DIN IEC	g ₁ -	g ₂ -	DQI encoder with DRIVE-CLiQ				
					o ₂ -	k LB	o ₁ -	k LB	o ₁ -
63	1FK7060-2A		104.5 (4.11)	104 (4.09)	50 (1.97)	168 (6.61)	106 (4.17)	203 (7.99)	141 (5.55)
	1FK7062-2A					190 (7.48)	128 (5.04)	226 (8.90)	163 (6.42)
	1FK7063-2A					213 (8.39)	151 (5.94)	248 (9.76)	186 (7.32)
80	1FK7080-2A		104.5 (4.11)	119 (4.69)	48 (1.89)	171 (6.73)	111 (4.37)	223 (8.78)	163 (6.42)
	1FK7081-2A					190 (7.48)	130 (5.12)	242 (9.53)	182 (7.17)
	1FK7083-2A					209 (8.23)	149 (5.87)	261 (10.28)	201 (7.91)
	1FK7084-2A					229 (9.02)	168 (6.61)	281 (11.06)	221 (8.70)
100	1FK7100-2A		104.5 (4.11)	137 (5.39)	53 (2.09)	183 (7.20)	118 (4.65)	220 (8.66)	170 (6.69)
	1FK7101-2A					209 (8.23)	144 (5.67)	261 (10.28)	196 (7.72)
	1FK7103-2A					235 (9.25)	170 (6.69)	287 (11.30)	222 (8.74)
	1FK7105-2A					287 (11.30)	222 (8.74)	339 (13.35)	274 (10.79)

Dimensional drawings

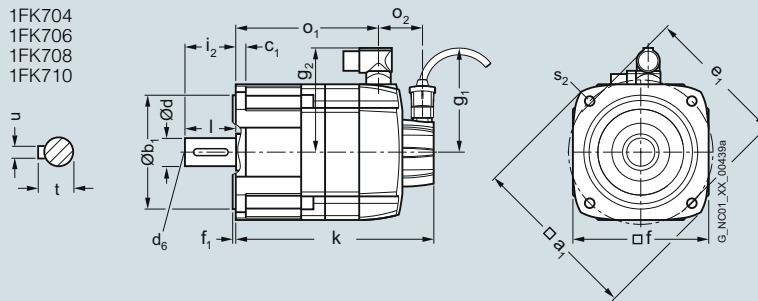

For motor		Dimensions in mm (inches)										Shaft extension DE			
Shaft height	Type	DIN IEC	a ₁ P	b ₁ N	c ₁ LA	e ₁ M	f AB	f ₁ T	i ₂ -	s ₂ S	d D	d ₆ -	l E	t GA	u F
1FK7 High Inertia, natural cooling, DQI encoder with DRIVE-CLiQ, with/without brake															
48	1FK704.-3B	120 (4.72)	80 (3.15)	10 (0.39)	100 (3.94)	96 (3.78)	3 (0.12)	40 (1.57)	6.5 (0.26)	19 (0.75)	M6	40 (1.57)	21.5 (0.85)	6 (0.24)	
63	1FK706.-3B	155 (6.10)	110 (4.33)	10 (0.39)	130 (5.12)	126 (4.96)	3.5 (0.14)	50 (1.97)	9 (0.35)	24 (0.94)	M8	50 (1.97)	27 (1.06)	8 (0.31)	
80	1FK708.-3B	194 (7.64)	130 (5.12)	11.5 (0.45)	165 (6.50)	155 (6.10)	3.5 (0.14)	58 (2.28)	11 (0.43)	32 (1.26)	M12	58 (2.28)	35 (1.38)	10 (0.38)	
100	1FK710.-3B	245 (9.65)	180 (7.09)	13 (0.51)	215 (8.46)	192 (7.56)	4 (0.16)	80 (3.15)	14 (0.55)	38 (1.50)	M12	80 (3.15)	41 (1.61)	10 (0.39)	

Shaft height	Type	DIN IEC	g ₁ -	g ₂ -	DQI encoder with DRIVE-CLiQ			
					o ₂ -	k LB	o ₁ -	k LB
48	1FK7042-3B	104.5 (4.11)	90 (3.54)	50 (1.97)	187 (7.36)	125 (4.92)	219 (8.62)	157 (6.18)
63	1FK7060-3B	104.5 (4.11)	104 (4.09)	50 (1.97)	182 (7.17)	120 (4.72)	217 (8.54)	155 (6.10)
	1FK7062-3B				216 (8.50)	153 (6.02)	251 (9.88)	189 (7.44)
80	1FK7081-3B	104.5 (4.11)	119 (4.69)	48 (1.89)	211 (8.31)	151 (5.94)	264 (10.39)	203 (7.99)
	1FK7084-3B				270 (10.63)	209 (8.23)	322 (12.68)	262 (10.31)
100	1FK7100-3B	104.5 (4.11)	137 (5.39)	53 (2.09)	183 (7.20)	118 (4.65)	220 (8.66)	170 (6.69)
	1FK7101-3B		158 (6.22)		209 (8.23)	144 (5.67)	261 (10.28)	196 (7.72)
	1FK7103-3B		158 (6.22)		235 (9.25)	170 (6.69)	287 (11.30)	222 (8.74)
	1FK7105-3B		158 (6.22)		287 (11.30)	222 (8.74)	339 (13.35)	274 (10.79)

Dimensional drawings

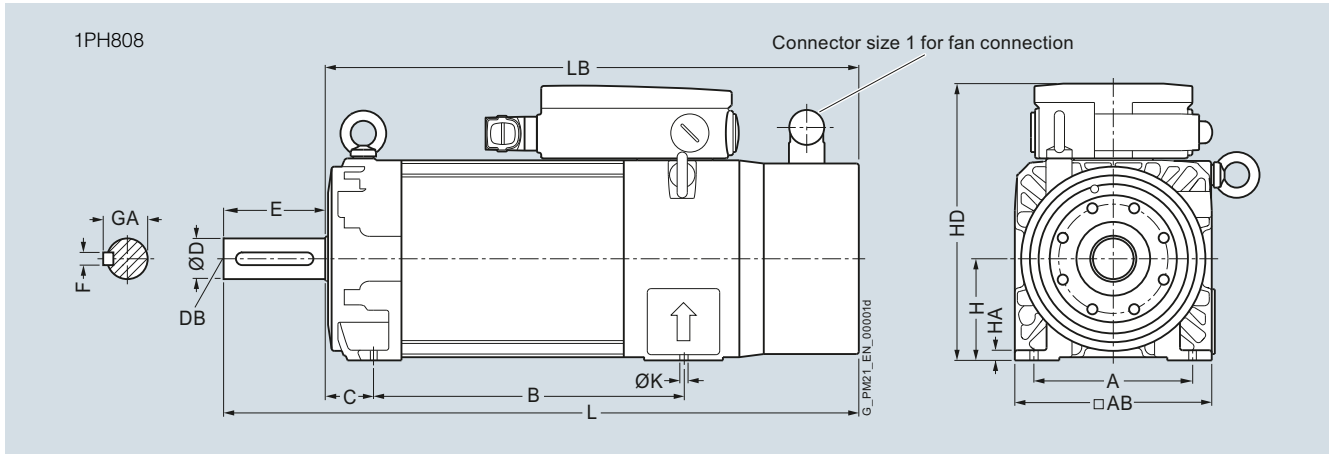

For motor Dimensions in mm (inches)

Shaft height	Type	IEC	Dimensions in mm (inches)										Shaft extension DE				
			A	AB	B	C	H	HA	HD	L	LB	K	D	DB	E	F	GA
1PH8, type of construction IM B3, forced ventilation																	
80	1PH8083		125 (4.92)	155 (6.10)	194 (7.64)	38 (1.50)	80 (3.15)	8 (0.31)	216 (8.50)	455 (17.91)	375 (14.76)	10 (0.39)	32 (1.26)	M12	80 (3.15)	10 (0.39)	35 (1.38)
	1PH8087				244 (9.61)					505 (19.88)	425 (16.73)						

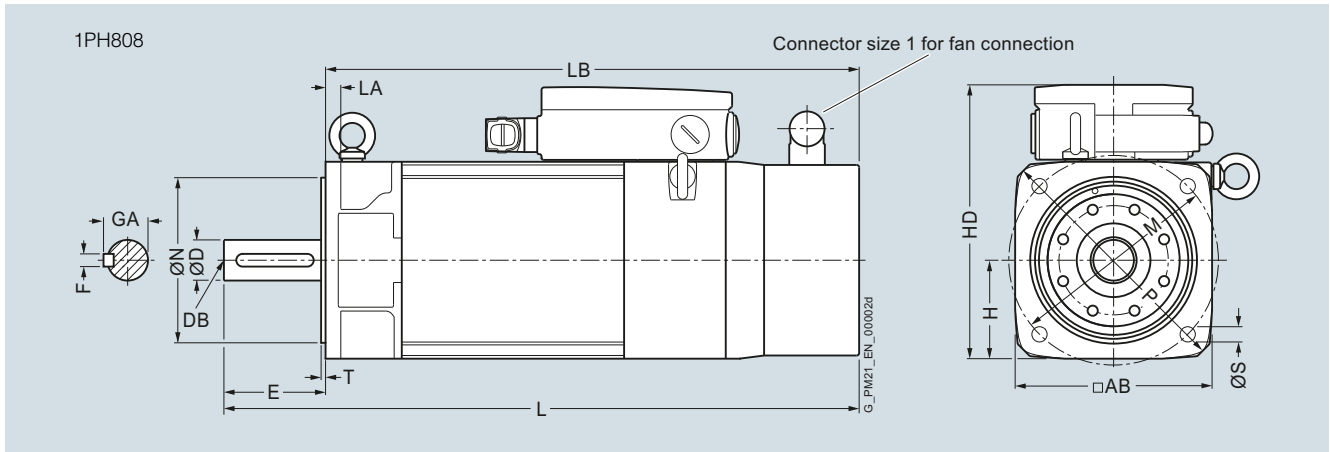

For motor Dimensions in mm (inches)

Shaft height	Type	IEC	Dimensions in mm (inches)											Shaft extension DE				
			AB	H	HD	L	LA	LB	M	N	P	S	T	D	DB	E	F	GA
1PH8, type of construction IM B5, forced ventilation																		
80	1PH8083		155 (6.10)	77.5 (3.05)	213.5 (8.41)	455 (17.91)	12 (0.47)	375 (14.76)	165 (6.50)	130 (5.12)	200 (7.87)	12 (0.47)	3.5 (0.14)	32 (1.26)	M12	80 (3.15)	10 (0.39)	35 (1.38)
	1PH8087					505 (19.88)		425 (16.73)										

Dimensional drawings

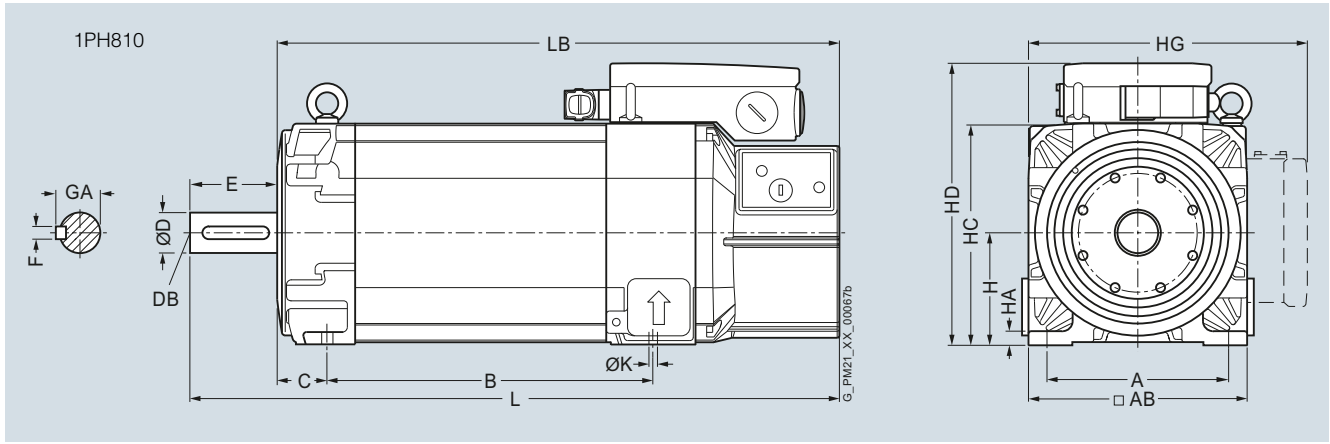

For motor Dimensions in mm (inches)

Shaft height	Type	Dimensions in mm (inches)													Shaft extension DE				
		IEC A	AB	C	B	H	HA	HC	HD	HG	K	L	LB	D	DB	E	F	GA	
1PH8, type of construction IM B3, forced ventilation																			
100	1PH8101	160 (6.30)	196 (7.72)	43 (1.69)	167 (6.57)	100 (3.94)	11 (0.43)	198 (7.80)	252 (9.92)	276.5 (10.89)	12 (0.47)	449.5 (17.70)	369.5 (14.55)	38 (1.50)	M12	80 (3.15)	10 (0.39)	41 (1.61)	
	1PH8103				202.5 (7.97)							485 (19.09)	405 (15.94)						
	1PH8105				262 (10.31)							544.5 (21.44)	464.5 (18.29)						
	1PH8107				297.5 (11.71)							580 (22.83)	500 (19.69)						

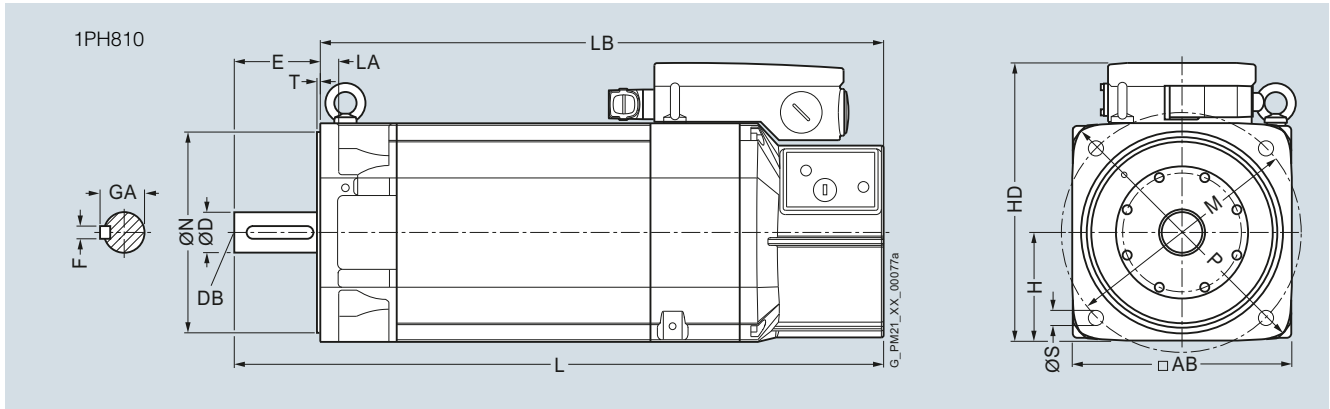

For motor Dimensions in mm (inches)

Shaft height	Type	Dimensions in mm (inches)													Shaft extension DE				
		IEC AB	H	HD	L	LA	LB	M	N	P	S	T	D	DB	E	F	GA		
1PH8, type of construction IM B5, forced ventilation																			
100	1PH8101	196 (7.72)	98 (3.86)	250 (9.84)	449.5 (17.70)	16 (0.63)	369.5 (14.55)	215 (8.46)	180 (7.09)	250 (9.84)	14 (0.55)	4 (0.16)	38 (1.50)	M12	80 (3.15)	10 (0.39)	41 (1.61)		
	1PH8103				485 (19.09)		405 (15.94)												
	1PH8105				544.5 (21.44)		464.5 (18.29)												
	1PH8107				580 (22.83)		500 (19.69)												

Dimensional drawings

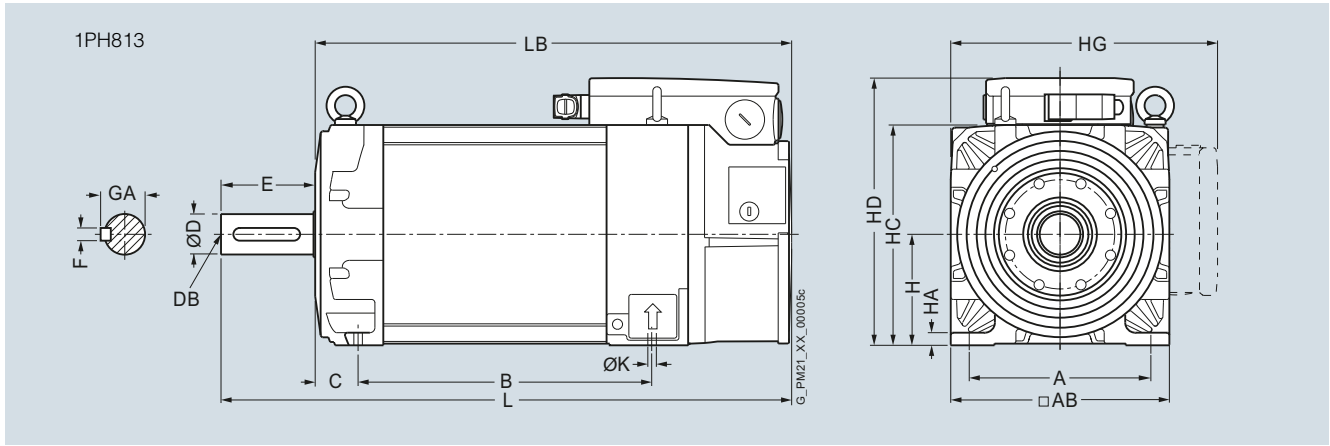

For motor Dimensions in mm (inches)

Shaft height	Type	Dimensions in mm (inches)													Shaft extension DE				
		IEC A	AB	B	C	H	HA	HC	HD	HG	K	L	LB	D	DB	E	F	GA	
1PH8, type of construction IM B3, forced ventilation																			
132	1PH8131	216 (8.50)	260 (10.24)	220.5 (8.68)	53 (2.09)	132 (5.20)	15 (0.59)	262 (10.31)	317.5 (12.50)	357.5 (14.07)	12 (0.47)	549 (21.61)	439 (17.28)	48 (1.89)	M16	110 (4.33)	14 (0.55)	51.5 (2.03)	
	1PH8133			265.5 (10.45)								594 (23.39)	484 (19.06)						

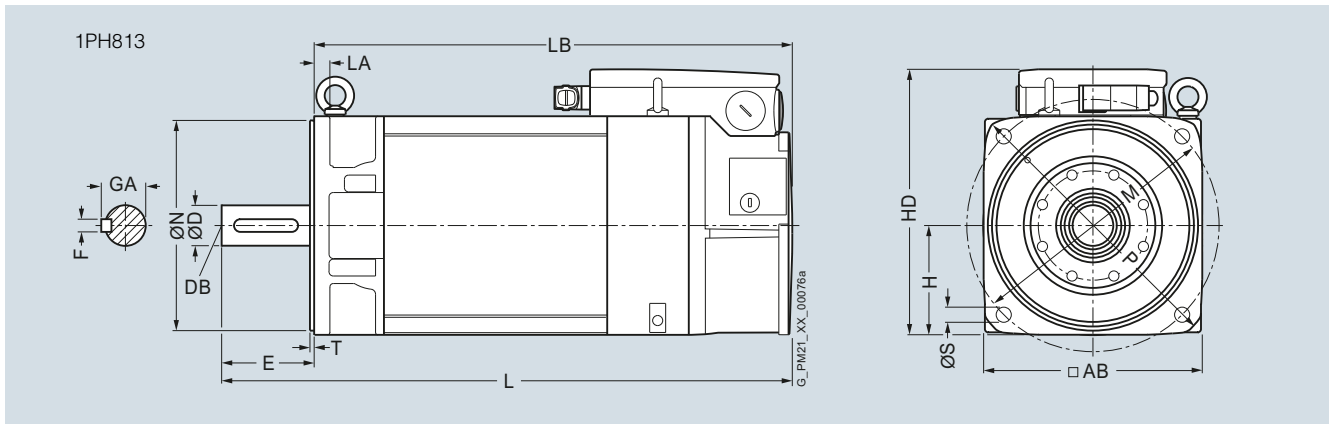

For motor Dimensions in mm (inches)

Shaft height	Type	Dimensions in mm (inches)													Shaft extension DE				
		IEC AB	H	HD	L	LA	LB	M	N	P	S	T	D	DB	E	F	GA		
1PH8, type of construction IM B5, forced ventilation																			
132	1PH8131	260 (10.24)	130 (5.12)	315.5 (12.42)	549 (21.61)	18 (0.71)	439 (17.28)	300 (11.81)	250 (9.84)	340 (13.39)	18 (0.71)	5 (0.20)	48 (1.89)	M16	110 (4.33)	14 (0.55)	51.5 (2.03)		
	1PH8133				594 (23.39)		484 (19.06)												

Dimensional drawings

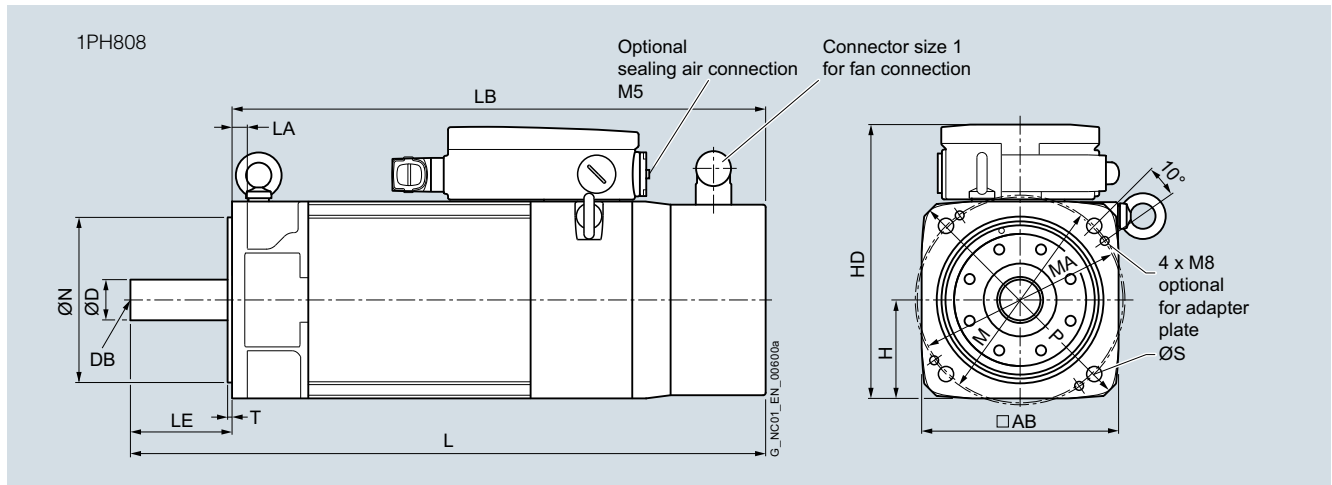

For motor Dimensions in mm (inches)

Shaft height	Type	Dimensions in mm (inches)													Shaft extension DE		
		IEC AB	H	HD	L	LA	LB	M	MA	N	P	S	T	D	DB	LE	
1PH8 Premium Performance, type of construction IM B5, forced ventilation, solid shaft																	
80	1PH8081	155 (6.10)	77.5 (3.05)	213.5 (8.41)	375 (14.75)	12 (0.45)	325 (12.80)	165 (6.50)	162 (6.38)	130 (5.12)	200 (7.87)	12 (0.47)	3.5 (0.14)	24 (0.94)	M6	50 (1.97)	
	1PH8083				425 (16.73)		375 (14.75)										
	1PH8087				475 (18.70)		425 (16.73)										



6/2	Built-on optoelectronic rotary encoder
6/2	<u>Introduction</u>
6/3	<u>Incremental encoders</u>
6/3	Incremental encoder with sin/cos 1 V
6/3	Incremental encoder with RS422 (TT)
6/6	<u>Absolute encoders</u>
6/6	Absolute encoder with DRIVE-CLiQ
6/7	<u>Accessories</u>
6/7	Couplings
6/7	Clamps
6/7	Signal connector as mating connector
6/7	MOTION-CONNECT
6/7	DRIVE-CLiQ signal cables



CAD CREATOR

Dimensional drawing and
2D/3D CAD generator

www.siemens.com/cadcreator

Siemens NC 82 · 2018

Overview

Motion control encoder	Interface	Built-on encoder usable for Safety Integrated	Resolution	Accuracy	Cable length	Degree of protection at housing (at shaft input)
Incremental encoders						
	sin/cos 1 V _{pp}	Yes	1000 ... 2500 S/R	± 18 mech. × 3600/PPR count z	150	IP67 (IP64)
	RS422 (TTL)	1)	500 ... 5000 S/R	± 18 mech. × 3600/PPR count z	100	IP67 (IP64)
Absolute encoders						
	DRIVE-CLiQ	Yes	Single-turn 24 bit Multi-turn 36 bit (2 ²⁴ steps × 4096 revolutions)	± 20	100	IP67 (IP64)

Accessories for measuring systems

Couplings
Clamps
Signal connector as mating connector
MOTION-CONNECT DRIVE-CLiQ signal cables

6

Motion control encoders are optoelectronic built-on encoders that detect the traversing distances, angles of rotation, speeds or positions of machine axes. Motion control encoders are direct measuring systems that are built-on to shafts, axes or motors. They can be used in conjunction with numerical and programmable logic controllers, drives and position displays. Motion control encoders are system-tested, certified components that have been harmonized for use with the following systems:

- SINUMERIK CNC controls
- SIMOTION Motion Control Systems
- SIMATIC programmable logic controllers
- SINAMICS drive systems

Application

Motion control encoders are used with machine tools and production machines as additional external measuring systems. They are available as incremental or absolute encoders.

Incremental encoders

In the case of incremental encoders, the machine must travel to a reference point after each power-off state, as the position is not usually stored in the control. Movements of the machine while the power is off are not recorded.

Incremental encoders are suitable for use in simple machine concepts with mostly small dimensions.

Absolute encoders

Absolute encoders, on the other hand, also record movements while the power is off and return the actual position after power on. Travel to a reference point is not necessary.

Absolute encoders are suitable for complex machines or machines with large dimensions.

Design

All motion control encoders are available in Synchro flange and clamp flange versions. The absolute encoders are also available with a hollow shaft and torque arm.

The motion control encoders are driven via a plug-in coupling or spring disk coupling. Alternatively, pulleys can also be used.

The motion control encoder supply voltage is 5 V DC or alternatively 10 V to 30 V DC. The 10 V to 30 V DC version supports longer cable lengths. Most control systems supply the voltage directly at the measuring circuit connector. With SINAMICS, the measuring systems are provided with power via the Sensor Modules.

For motion control encoders with cables, the cable length including the connector is 1 m.

The following bending radii must be observed for the cable to the built-on encoder:

- One-time bending: ≥ 20 mm
- Continuous bending: ≥ 75 mm

More information

Power supply

The measuring systems only fulfill the requirements stipulated in the standard IEC 61010-1 if the power is supplied from a secondary circuit with limited power according to IEC 61010-1^{3rd Ed.} Section 9.4 or with limited power according to IEC 60950-1^{2nd Ed.} Section 2.5, or from a secondary circuit Class 2 according to UL1310.

You can also use the corresponding sections of the standards DIN EN 61010-1, EN 61010-1, U 61010-1 and CAN/CSA-C22.2 No. 61010-1 instead of the standard IEC 61010-1^{3rd Ed.}, Section 9.4, respectively the corresponding sections of the standards DIN EN 60950-1, EN 60950-1, UL 60950-1 and CAN/CSA-C22.2 No. 60950-1 instead of the standard IEC 60950-1^{2nd Ed.}, Section 2.5.

1) If you require information about the usability of measuring systems Motion Control Encoder for Safety Integrated please contact your local Siemens office.

Function

Incremental encoders detect relative movement and deliver a defined number of electrical pulses per revolution, which represent the measurement of the traveled distance or angle.

Incremental encoders operate on the principle of optoelectronic scanning of dividing discs with the transmitted light principle. The light source is a light emitting diode (LED). The light-dark modulation generated as the encoder shaft rotates is picked up by photoelectronic elements. With an appropriate arrangement of the line pattern on the dividing disk connected to the shaft and the fixed aperture, the photoelectronic elements provide two trace signals A and B at 90° to one another, as well as a reference signal R.

The encoder electronics amplify these signals and convert them to different output levels.

The following signal levels are available:

- Analog signals sin/cos with level $1 V_{pp}$
The analog signal allows the digitization of the trace signals. In order to obtain a fine resolution, the signals are interpolated in the higher-level control.
- RS422 differential signals (TTL)
The resolution can be quadrupled by means of edge evaluation.



Incremental encoder with sin/cos $1 V_{pp}$ and clamp flange incl. cable with connector as well as incremental encoder with RS422 and Synchro flange

Technical specifications

Article No.		6FX2001-3.... Motion Control Encoder Incremental encoder with sin/cos $1 V_{pp}$	6FX2001-2.... Motion Control Encoder Incremental encoder with RS422 (TTL)
Product name			
Product designation			
Operating voltage DC V_p on encoder	V	$5 \pm 10 \%$	$5 \pm 10 \%$ or 10 ... 30
Limit frequency, typical	kHz	≥ 180 (- 3 dB) ≥ 450 (- 6 dB)	–
Scanning frequency, maximum	kHz	–	300
No-load current consumption, maximum	mA	150	150
Resolution, maximum	S/R	2500	5000
Signal level		Sinusoidal $1 V_{pp}$	RS422 (TTL)
Outputs protected against short circuit to 0 V		Yes short-time	Yes
Switching time (10 ... 90 %) rise/fall t_r/t_f (for 1 m cable and recommended input circuit)	ns	–	≤ 50
Phase angle signal A to B Edge spacing	Degrees	90 ± 10	90
• At 300 kHz	μs	–	≥ 0.45
Cable length to downstream electronics, ¹⁾	m	150	100 without error signal 50 with error signal
Accuracy	arcsec	± 18 mech. \times 3600/PPR count z	± 18 mech. \times 3600/PPR count z
LED failure monitoring		–	High-resistance driver
Speed, mechanical, maximum	rpm	12000	12000
Starting torque at 20 °C	Nm	≤ 0.01	≤ 0.01

S/R = signals/revolution

¹⁾ With recommended cable and input circuitry of the downstream electronics, observe max. permissible cable length of module to be evaluated.

Technical specifications (continued)

Article No. Product name Product designation		6FX2001-3... Motion Control Encoder Incremental encoder with sin/cos 1 V _{pp}	6FX2001-2... Motion Control Encoder Incremental encoder with RS422 (TTL)
Shaft loading capacity			
• $n \leq 6000$ rpm			
- Axial	N	40	40
- Radial at shaft extension	N	60	60
• $n > 6000$ rpm			
- Axial	N	10	10
- Radial at shaft extension	N	20	20
Shaft diameter			
• Synchro flange	mm	6	6
• Clamp flange	mm	10	10
Shaft length			
• Synchro flange	mm	10	10
• Clamp flange	mm	20	20
Angular acceleration, maximum	rad/s ²	10 ⁵	10 ⁵
Moment of inertia of rotor	kgm ²	$\leq 2.9 \times 10^{-6}$	$\leq 2.9 \times 10^{-6}$
Vibration (55 ... 2000 Hz) according to EN 60068-2-6	m/s ²	≤ 300	≤ 300
Shock according to EN 60068-2-27			
• 6 ms	m/s ²	≤ 2000	≤ 2000
Degree of protection			
• At housing		IP67	IP67
• At shaft input		IP64	IP64
Ambient temperature, during <u>Operation</u>			
• Flange outlet or fixed cable			
- At V _p = 5 V ± 10 %	°C	-40 ... +100	-40 ... +100
- At V _p = 10 ... 30 V	°C	-	-40 ... +70
• Flexible cable			
- At V _p = 5 V ± 10 %	°C	-10 ... +100	-10 ... +100
- At V _p = 10 ... 30 V	°C	-	-10 ... +70
Net weight	kg	0.3	0.3
EMC		EMC Directive 2014/30/EC and regulations of EMC directives (applicable basic standards)	
Certificate of suitability		CE, CSA, UL	CE, CSA, UL

Selection and ordering data

Description	Article No.	Description	Article No.
Incremental encoder with sin/cos 1 V_{pp}		Incremental encoder with RS422 (TTL)	
<u>5 V DC supply voltage</u>		<u>5 V DC supply voltage</u>	
• Synchro flange and connection via		• Synchro flange and connection via	
- Axial flange outlet	6FX2001-3G	- Axial flange outlet	6FX2001-2G
- Radial flange outlet	6FX2001-3E	- Radial flange outlet	6FX2001-2E
- Cable 1 m with connector ¹⁾	6FX2001-3C	- Cable 1 m with connector ¹⁾	6FX2001-2C
<u>Resolution</u>		• Clamp flange and connection via	
1000 S/R	B 0 0	- Axial flange outlet	6FX2001-2R
1024 S/R	B 0 2	- Radial flange outlet	6FX2001-2P
2500 S/R	C 5 0	- Cable 1 m with connector ¹⁾	6FX2001-2M
		<u>10 ... 30 V DC supply voltage</u>	
		• Synchro flange and connection via	
		- Axial flange outlet	6FX2001-2H
		- Radial flange outlet	6FX2001-2F
		- Cable 1 m with connector ¹⁾	6FX2001-2D
		• Clamp flange and connection via	
		- Axial flange outlet	6FX2001-2S
		- Radial flange outlet	6FX2001-2Q
		- Cable 1 m with connector ¹⁾	6FX2001-2N
		<u>Resolution</u>	
		500 S/R	A 5 0
		1000 S/R	B 0 0
		1024 S/R	B 0 2
		1250 S/R	B 2 5
		1500 S/R	B 5 0
		2000 S/R	C 0 0
		2048 S/R	C 0 4
		2500 S/R	C 5 0
		3600 S/R	D 6 0
		5000 S/R	F 0 0
		S/R = signals/revolution	

¹⁾ Universal integrated cable outlet for axial and radial outlet direction.

Function



Absolute encoder with DRIVE-CLiQ

Absolute encoders output an absolute angular position between 0° and 360°. They operate on the same scanning principle as incremental encoders, but have a greater number of tracks. For example, if there are 13 tracks, then $2^{13} = 8192$ steps are coded in the case of single-turn encoders. The code used is a one-step code (gray code). This prevents any scanning errors from occurring. After switching on the machine, the position value is transferred immediately to the controller, travel to a reference point is not necessary.

All absolute encoders are available in single-turn and multi-turn versions.

Single-turn encoders

Single-turn encoders divide one rotation (360 degrees mechanical) into a specific number of steps, e.g. 8192. A unique code word is assigned to each position. After 360° the position values are repeated.

Multi-turn encoders

Multi-turn encoders record the number of revolutions in addition to the absolute position within one revolution. To do this, further code discs which are coupled via gear steps with the encoder shaft are scanned. When evaluating 12 additional tracks, this means that an additional $2^{12} = 4096$ revolutions can be coded.

Interface	Benefits
DRIVE-CLiQ	<ul style="list-style-type: none"> • Very high data transfer rates possible • Advantages in time-critical applications • Simple and quick automatic configuration using electronic rating plates • Fast and easy diagnostics with a single tool • One interface for connecting drives as well as indirect and direct measurement systems to the CNC.

Technical specifications

Article No.	6FX2001-5.D.-1AA0
Product name	Motion Control Encoder
Product designation	Absolute encoder with DRIVE-CLiQ
Operating voltage DC V_p on encoder	24 V - 15 % + 20 %
Current consumption, approx.	
• Single-turn	37 mA
• Multi-turn	43 mA
Interface	DRIVE-CLiQ
Data output	DRIVE-CLiQ
Short-circuit strength	Yes
Transfer rate	100 Mbit/s
Speed, maximum	
• Electrical	14000 rpm
- At ± 12 bit accuracy	12000 rpm
• Mechanical	
- Single-turn	15000 rpm
- Multi-turn	12000 rpm
Cable length to downstream electronics, maximum ¹⁾	100 m
Connection	Flange outlet M12 radial
Resolution	
• Single-turn	24 bit
• Multi-turn	36 bit (2^{24} steps × 4096 revolutions)
Incremental track	2048 S/R, 1 V_{pp} (internal only)
Code type	
• Transfer	DRIVE-CLiQ
Accuracy	± 20°
Starting torque at 20 °C	≤ 0.01 Nm
Shaft loading capacity of solid shaft	
• $n \leq 6000$ rpm	
- Axial	40 N
- Radial at shaft extension	60 N
• $n > 6000$ rpm	
- Axial	10 N
- Radial at shaft extension	20 N
Shaft diameter	
• Synchro flange	6 mm with flat face
• Clamp flange	10 mm with flat face
• Torque arm hollow shaft	10 or 12 mm
Shaft length	
• Synchro flange	10 mm
• Clamp flange	20 mm
Angular acceleration, maximum	10^5 rad/s ²
Moment of inertia of rotor	
• Solid shaft	2.9×10^{-6} kgm ²
• Hollow shaft	4.6×10^{-6} kgm ²
S/R = signals/revolution	

¹⁾ Observe the max. permissible cable length of the connected module.

Technical specifications

Article No.	6FX2001-5.D.-1AA0
Product name	Motion Control Encoder
Product designation	Absolute encoder with DRIVE-CLiQ
Vibration (55 ... 2000 Hz) according to EN 60068-2-6	
• Solid shaft	≤ 300 m/s ²
• Hollow shaft	≤ 150 m/s ²
Shock according to EN 60068-2-27	
• 6 ms	
- Solid shaft	≤ 2000 m/s ²
- Hollow shaft	≤ 1000 m/s ²
Degree of protection	
• At housing	IP67
• At shaft input	IP64
Ambient temperature, during	
• Operation	-30 ... +100 °C
Net weight	
• Single-turn	0.35 kg
• Multi-turn	0.35 kg
EMC	EMC Directive 2014/30/EC and regulations of EMC directives (applicable basic standards)
Certificate of suitability	CE, CSA, UL

Selection and ordering data

Description	Article No.
Absolute encoders with DRIVE-CLiQ	
<u>24 V DC supply voltage</u>	
• Radial connection	
- Synchro flange Solid shaft	6FX2001-5FD -1AA0
- Clamp flange Solid shaft	6FX2001-5QD -1AA0
- Torque arm Hollow shaft diameter 10 mm	6FX2001-5VD -1AA0
- Torque arm Hollow shaft diameter 12 mm	6FX2001-5WD -1AA0
<u>Resolution</u>	
• Single-turn 24 bit	1 3
• Multi-turn 36 bit	2 5

More information

Since the DRIVE-CLiQ interface has been disclosed, it is possible to use absolute encoders with integrated DRIVE-CLiQ interface from a range of different manufacturers.

You can find additional information on the Internet at:

<https://support.industry.siemens.com/cs/document/65402168>

Accessories

Overview

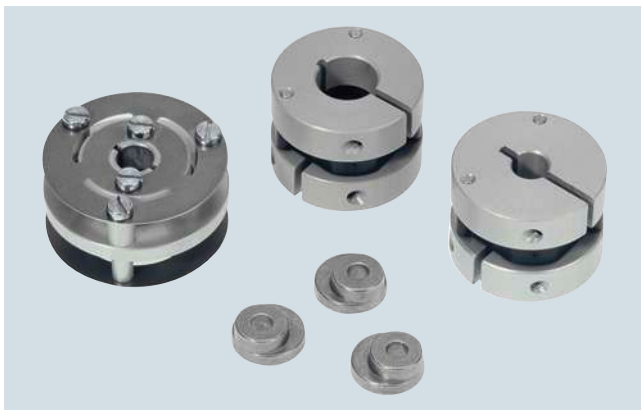

Couplings and clamps

Couplings

The motion control encoders are driven via a plug-in coupling or spring disk coupling. Alternatively, pulleys can also be used.

Clamps

Motion control encoders with Synchro flange can be axially mounted on the machine with screws or secured with 3 clamps.

Signal connector as mating connector

A signal connector is available as a mating connector for motion control encoders with flange outlet or with cable and connector.

The mating connector with 12 contacts is suitable for all incremental encoders.

Signal connector

A signal connector is available as a replacement for motion control encoders with cable and connector.

MOTION-CONNECT DRIVE-CLiQ signal cables

Pre-assembled MOTION-CONNECT DRIVE-CLiQ signal cables with M12 plug are available as basic cables and extensions for connecting motion control encoders with DRIVE-CLiQ interface.

For further information about the signal cables, refer to MOTION-CONNECT connection systems.

Technical specifications

Article No.		6FX2001-7KF06	6FX2001-7KF10	6FX2001-7KS06	6FX2001-7KS10
Product name		Motion Control Encoder			
Product designation		Spring disk coupling	Spring disk coupling	Plug-in coupling	Plug-in coupling
Diameter					
• 1st shaft diameter	mm	6	6	6	10
• 2nd shaft diameter	mm	5	6	6	10
Transferable torque, maximum	Nm	0.8	0.8	0.7	0.7
Mechanical speed, maximum	rpm	12000	12000	12000	12000
Center offset of shafts, maximum	mm	0.4	0.4	0.5	0.5
Axial displacement	mm	0.4	0.4	0.5	0.5
Angular displacement of shafts, maximum	°	3	3	1	1
Rigidity					
• Radial	Nm/rad	150	150	31	31
• Axial	N/mm	6	6	10	10
Moment of inertia	kgcm ²	0.019	0.019	0.02	0.02
Ambient temperature, during					
• Operation	°C	-40 ... +150	-40 ... +150	-40 ... +80	-40 ... +80
Outer diameter	mm	30	30	25	25
Length	mm	18.3	18.3	19	19
Net weight	g	16	16	20	20
Article No.		6FX2001-7KP01			
Product name		Motion Control Encoder			
Product designation		Clamp			
Outer diameter					
• 1st clamp diameter	mm	9			
• 2nd clamp diameter	mm	12			
Clamp hole diameter	mm	3.2			
Height	mm	5.5			
Net weight	g	3			

Selection and ordering data

Description	Article No.	Description	Article No.
Spring disk coupling For shaft diameter: • 6 mm/6 mm • 6 mm/5 mm	6FX2001-7KF10 6FX2001-7KF06	Signal connector with cap nut (1 unit) Mating connector for incremental encoder with sin/cos 1 V _{pp} and RS422 (TTL) and absolute encoder with SSI 12-pole, insulator each with 12 socket contacts 0.08 ... 0.22 mm ² and 0.20 ... 0.56 mm ² 2 × cable clamping for diameters of 6.5 ... 10 mm and 10.1 ... 13 mm	6FX2003-0SU12
Plug-in coupling For shaft diameter: • 6 mm/6 mm • 10 mm/10 mm	6FX2001-7KS06 6FX2001-7KS10	Signal connector with external thread for encoders with cable (1 unit) Replacement connector for incremental encoder with sin/cos 1 V _{pp} and RS422 (TTL) 12-pole, insulator with 12 pin contacts 0.20 ... 0.56 mm ² 2 × cable clamping for diameters of 6.5 ... 10 mm and 10.1 ... 13 mm	6FX2003-0SA12
Clamp (1 unit) For built-on encoders with Synchro flange (3 units are required.)	6FX2001-7KP01	MOTION CONNECT DRIVE-CLiQ signal cable¹⁾ For encoder systems with DRIVE-CLiQ and M12 connection	6FX.002-2DC3.-1..0

¹⁾ For complete Article No. and length code, see MOTION-CONNECT connection systems.



7/2	Introduction
7/2	General information
7/4	Connection overviews
7/4	SINUMERIK 828D
7/5	SINUMERIK PP 72/48D PN and PP 72/48D 2/2A PN I/O modules
7/6	SINAMICS S120 Combi Power Modules
7/7	SINAMICS S120 Motor Modules, booksize compact and booksize form
7/8	SINAMICS S120 Sensor Modules Cabinet-Mounted SMC20/SMC30/SM
7/9	Power cables
7/10	Power cables for SIMOTICS S-1FK7 with SPEED-CONNECT connector
7/11	Power cables for SIMOTICS M-1PH8 with terminal box
7/12	Signal cables
7/14	Pre-assembled DRIVE-CLiQ signal c without 24 V DC cores
7/14	Pre-assembled MOTION-CONNECT DRIVE-CLiQ signal cables with 24 V DC cores
7/15	Signal cables for direct or external measuring systems with full-thread connector
7/16	Length code
Siemens NC 82 · 2018	

Overview

MOTION-CONNECT cables are suitable for use with many different types of machine tools and production machinery.

The following variants of MOTION-CONNECT cable are available as fully-assembled power and signal cables or sold by the meter:

- **MOTION-CONNECT 500**
 - Cost-effective solution for predominantly fixed installation
 - Suitable for low mechanical loading
 - Tested for travel distances of up to 5 m
- **MOTION-CONNECT 800PLUS**
 - Meets requirements for use in cable carriers
 - Suitable for high mechanical loading
 - Oil resistance
 - Tested for travel distances of up to 50 m

Benefits

Pre-assembled MOTION-CONNECT cables provide high quality and perfect, system-tested functionality.

SPEED-CONNECT

Fast, stable and reliable connections can be made with the new, pre-assembled cables with SPEED-CONNECT connectors. With a short rotation as far as the stop, the cap nut of the connector secures the connection.

The cables with SPEED-CONNECT connectors supplement the established range of MOTION-CONNECT cables with full-thread connectors.

Application

MOTION-CONNECT cables are intended for use in machines. They are not suitable for building technology applications or outdoor installation.

MOTION-CONNECT cables are tested in a cable carrier with horizontal travel distance and are also designed for cable carrier installation. They are not self-supporting.

The pre-assembled cables can be ordered in length units of 10 cm and can be extended, if necessary.

When cable lengths (basic cables and extensions) are determined for the systems and applications described in this catalog, the technically permissible maximum cable lengths (e.g. 25 m) specified in the catalog must be observed. Malfunctions can occur if longer cables are used.

Siemens assumes no liability for correct transmission of signals or power in this case.

Compatibility between SPEED-CONNECT and full-thread connectors:

Connector on motor with external thread	Connector with cap nut on cable	Compatibility
SPEED-CONNECT	SPEED-CONNECT	✓
SPEED-CONNECT	Full thread	✓
Full thread	Full thread	✓
Full thread	SPEED-CONNECT	–

Function

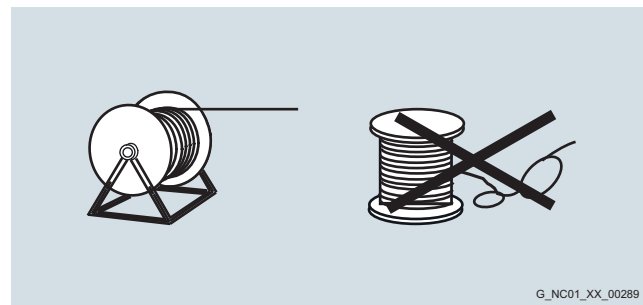

The cables must be removed from the drum without twisting, i.e. the cables must be unwound and must never be lifted over the drum flange in loops.

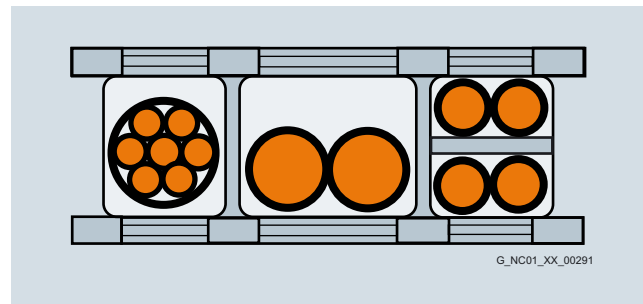

To maximize the service life of the cable carrier and cables, cables in the carrier made from different materials must be separated by spacers in the cable carrier. The spacers must be filled evenly to ensure that the position of the cables does not change during operation. The cables should be distributed as symmetrically as possible according to their weights and dimensions. Cables with very different outer diameters should also be separated by spacers.

When inserting pre-assembled cables into the cable carrier, do not pull at the connector, as this may damage the strain relief or cable clamping.

The cables must not be fixed in the cable carrier. They must be freely movable.

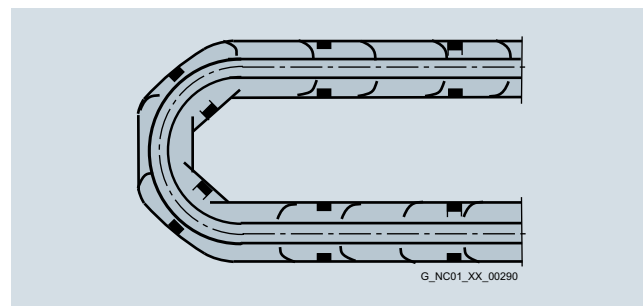

The cables must be able to be moved without application of force in particular in the bending radii of the carrier. The specified minimum bending radii must be adhered to.

The cable fixings must be attached at both ends at an appropriate distance away from the end points of the moving parts in a dead zone.

7

Function (continued)

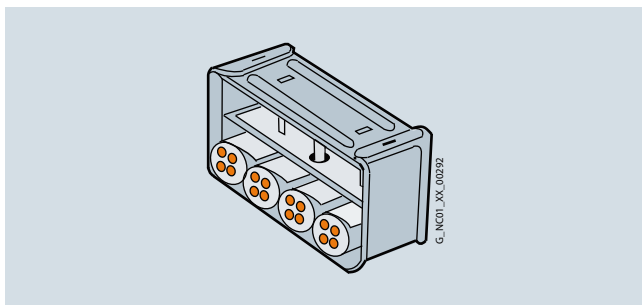

MOTION-CONNECT cables are tested in a cable carrier. The cables are attached at one end by means of strain relief to the moving ends of the cable carrier. Strain relief is applied over a wide area of the cable jacket surface without crimping the cable.

Cables must be installed in accordance with the instructions supplied by the cable carrier manufacturer.

Notes:

If, for example, pre-assembled cables are installed in a cable carrier in such a way that the connector would inhibit assembly, pre-assembled cables without assembled connector can also be supplied (power and signal cables¹⁾). In this case, the contacts of the cables are crimped and the connector enclosure is supplied separately. After installing the cables, the customer assembles the connector enclosure.

In case of vibration load and with horizontal or vertical cable entries, we recommend that the cable is additionally fixed if between the cable strain relief on the cable carrier and the terminal at the motor part of the cable is hanging loose or is not routed. To prevent machine vibrations being transmitted to the connectors, the cable should be fixed at the moving part where the motor is mounted.

Representation in connection overviews

Symbol	Explanation
	Connector with pin contacts
	Connector with socket contacts
	Exposed core ends
	Cable not included in the scope of delivery. Cable must be supplied by the customer.

More information

Current carrying capacity for power and signal cables

The current carrying capacity of PVC/PUR-insulated copper cables is specified for installation type C under continuous operating conditions in the table with reference to an ambient air temperature of 40 °C. For other ambient temperatures, the values must be corrected by the derating factors from the table.

Current-carrying capacity of cables with copper cores according to EN 60204-1

rms 50/60 Hz AC or DC in amps for installation type C

Multi-core cables, vertically or horizontally on walls/open, without protection tubes and installation ducts/with contact

Cross-section mm ²	Current A
----------------------------------	--------------

Electronics (one control circuit pair)

0.20	4.4
0.50	7.5
0.75	9.5

Power (one symmetrically loaded AC cable)

0.75	9.8
1.00	11.7
1.50	15.2
2.50	21
4	28
6	36

Derating factors for power and signal cables

Ambient air temperature °C	Derating factor accord. to EN 60204-1, Table D.1
30	1.15
35	1.08
40	1.00
45	0.91
50	0.82
55	0.71
60	0.58

¹⁾ Not applicable to DRIVE-CLiQ signal cables.

Integration

Connection overview of SINUMERIK 828D PPU 271.4/PPU 270.4/PPU 290.4

SINUMERIK 828D PPU 271.4/PPU 270.4 PPU 290.4		Article No. Pre-assembled cable	
DRIVE-CLiQ	X100 X101 X102	DRIVE-CLiQ cable ≤ 50 m (164 ft)	SINAMICS S120 SINAMICS S120 Terminal Module TM54F SINAMICS NX10.3 SINAMICS NX15.3
	Digital I Digital I/O	X122 X132	Drive: 12 digital inputs 8 digital inputs/outputs
Digital I/O	X242 X252	≤ 30 m (98 ft)	CNC: 8 digital inputs 8 digital outputs Analog spindle (X252)
24 V DC	X1	≤ 10 m (32 ft)	Power supply
Ethernet PPU front	X127	Ethernet cable ≤ 100 m (328 ft)	Programming device, PC Modem router (remote diagnostics)
	X130	Ethernet cable ≤ 100 m (328 ft)	Factory network
Ethernet PPU rear	X140	6NH7701-5AN (length: 2.5 m (8.2 ft)) ≤ 3 m (9.8 ft)	MODEM MD720 GSM/GPRS, 2G
	RS232C		SINUMERIK MCP Interface PN
PLC I/O	Port 1 / PN 1 Port 2 / PN 2	6SL3060-4A..0-0AA0 (in fixed lengths) ≤ 5 m (1.64 ft)	SINUMERIK I/O module PP 72/48D PN/ PP 72/48D 2/2A PN
		6FX2002-1DC00-.... (by the decimeter) ≤ 70 m (230 ft)	SIMATIC PN/PN coupler PLC auxiliary axes e.g. SINAMICS S120 CU310-2/CU320-2
Handwheels	X143	6FX8002-2BB01-1A.. ≤ 3 m (9.8 ft)	Electronic handwheel (up to 2)
USB PPU front	X125	USB cable ≤ 3 m (9.8 ft)	USB memory device Card reader
	USB PPU rear	X135	USB cable 0.8 m (2.6 ft) (included in scope of delivery of MCP)
		X145	USB cable ≤ 3 m (9.8 ft)
CF card PPU front ¹⁾			

G_NC01_EN_00752a

- 1) CompactFlash card for user data. Only for PPU 271.4/PPU 270.4.
 2) Only for PPU 271.4/PPU 270.4.
 3) Only for PPU 290.4.

Integration (continued)

Connection overview of SINUMERIK PP 72/48D PN and PP 72/48D 2/2A PN I/O modules

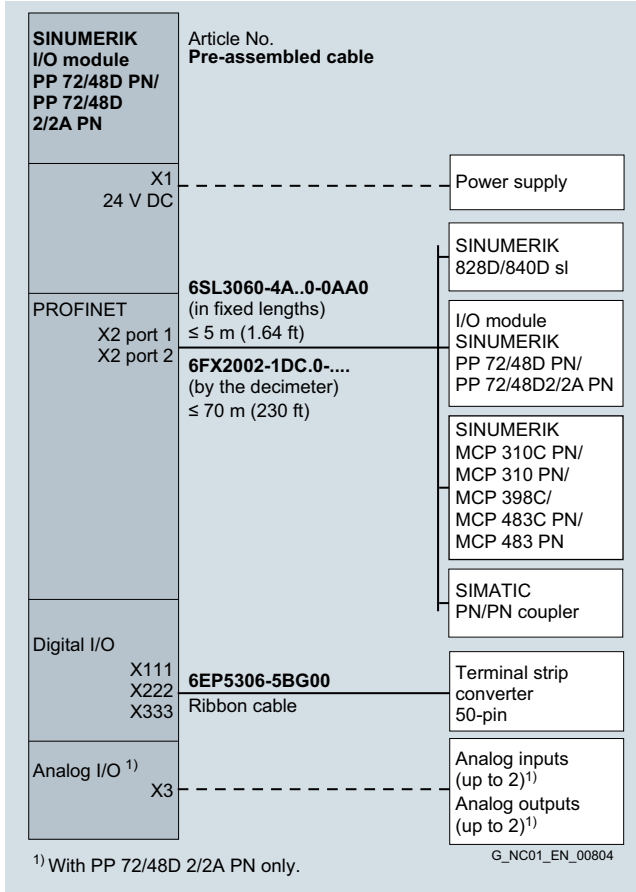

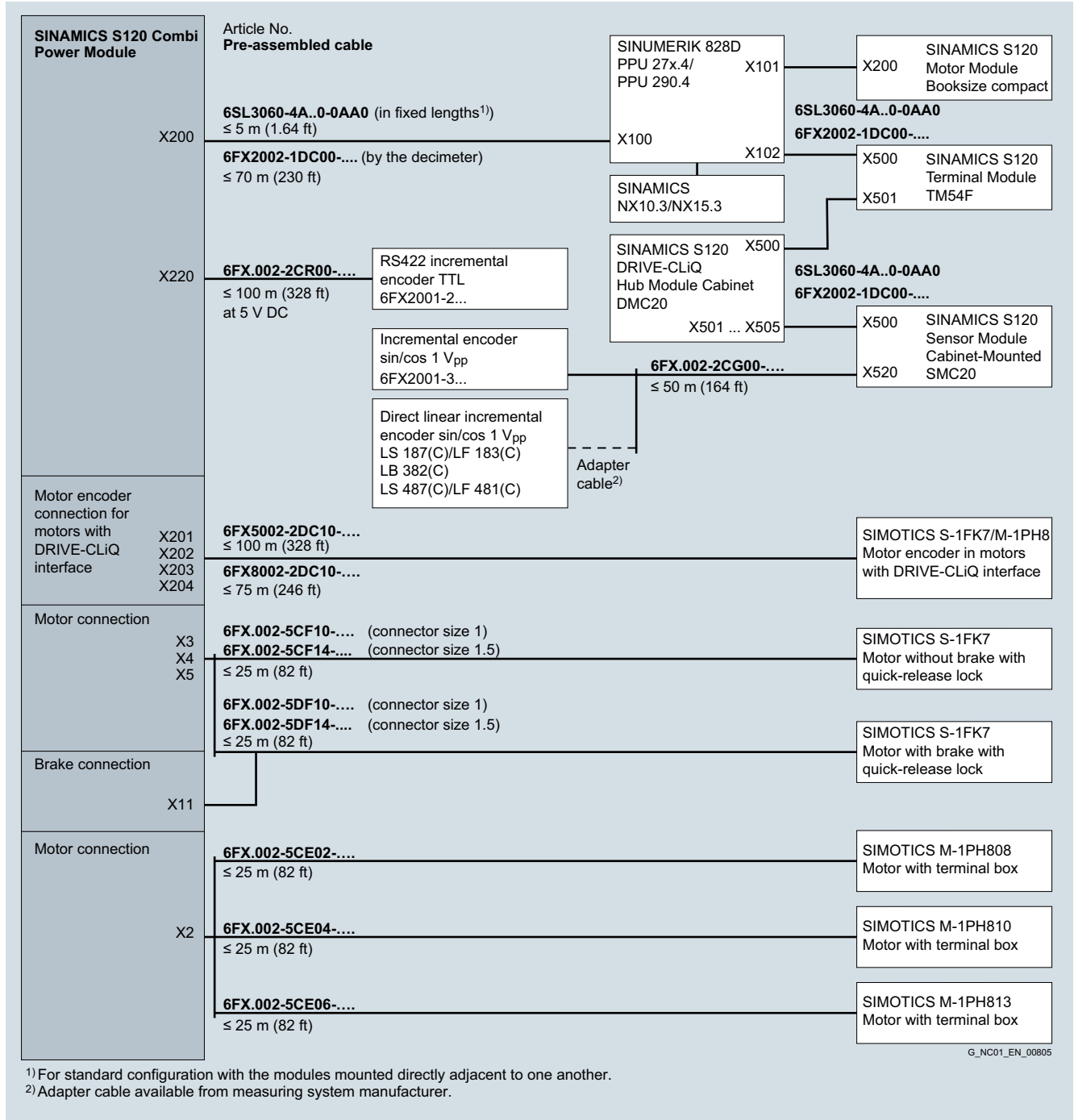

Integration (continued)

Connection overview of SINAMICS S120 Motor Modules, booksize compact and booksize formats

The DRIVE-CLiQ signal cables of type 6SL3060-4A..0-0AA0 required for the standard configuration are part of the scope of supply of the Motor Modules. In this case, the modules must be mounted directly adjacent to one another in a row.

SINAMICS S120 Motor Module Booksize compact and booksize formats X200-X203 ¹⁾	Article No. Pre-assembled cable 6SL3060-4A..0-0AA0 (in fixed lengths ²⁾ ≤ 5 m (1.64 ft)	X200- X202 SINAMICS S120 Smart Line Module X200- X202 SINAMICS S120 Active Line Module
	6FX2002-1DC00-.... (by the decimeter) ≤ 70 m (230 ft)	X200- X203 ¹⁾ SINAMICS S120 Motor Module X100 SINUMERIK 828D SINAMICS NX10.3/NX15.3
X200- X203 ¹⁾	6SL3060-4A..0-0AA0 (in fixed lengths ²⁾ ≤ 5 m (1.64 ft)	Further SINAMICS S120 Motor Modules
	6FX2002-1DC00-.... (by the decimeter) ≤ 70 m (230 ft)	
Motor encoder connection via SMC for motors <u>without</u> DRIVE-CLiQ interface X200- X203 ¹⁾	6SL3060-4A..0-0AA0 (in fixed lengths ²⁾ ≤ 5 m (1.64 ft)	X500 SINAMICS SMC20
	6FX2002-1DC00-.... (by the decimeter) ≤ 70 m (230 ft)	X500 SINAMICS SMC30 X500 SINAMICS SMC40
Motor encoder connection for motors <u>with</u> DRIVE-CLiQ interface X200- X203 ¹⁾	6FX5002-2DC10-.... ≤ 100 m (328 ft)	SIMOTICS S-1FK7/M-1PH8 Motor encoder in motors with DRIVE-CLiQ interface
	6FX8002-2DC10-.... ≤ 75 m (246 ft)	
Motor connection	Pre-assembled power cables, see power cables for motors (max. cable length, see technical specifications of Motor Modules)	SIMOTICS motors

G_NC01_EN_00579c

1) For Single Motor Module: X200-X202
 For Double Motor Module: X200-X203

2) For standard configuration with the modules mounted directly adjacent to one another.

Connection overview of SINAMICS S120 Sensor Module Cabinet-Mounted SMC20

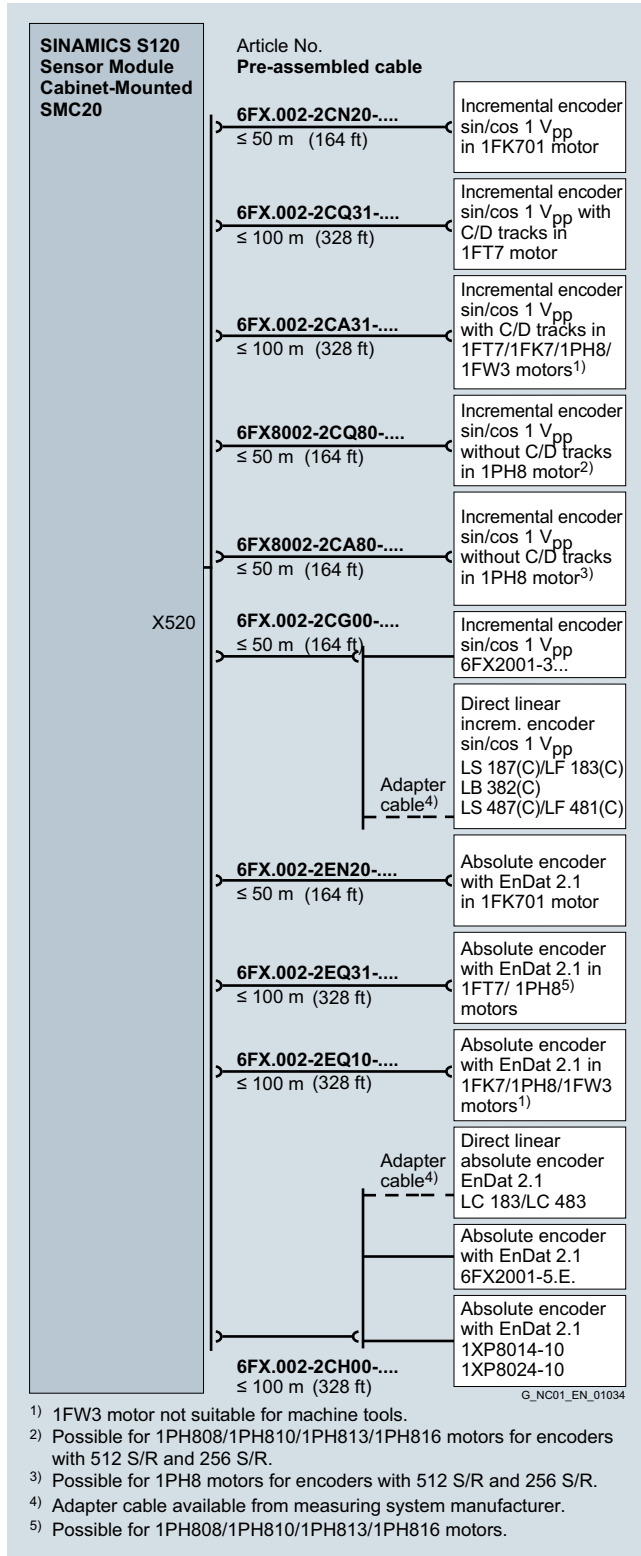

Connection overview of SINAMICS S120 Sensor Module Cabinet-Mounted SMC30

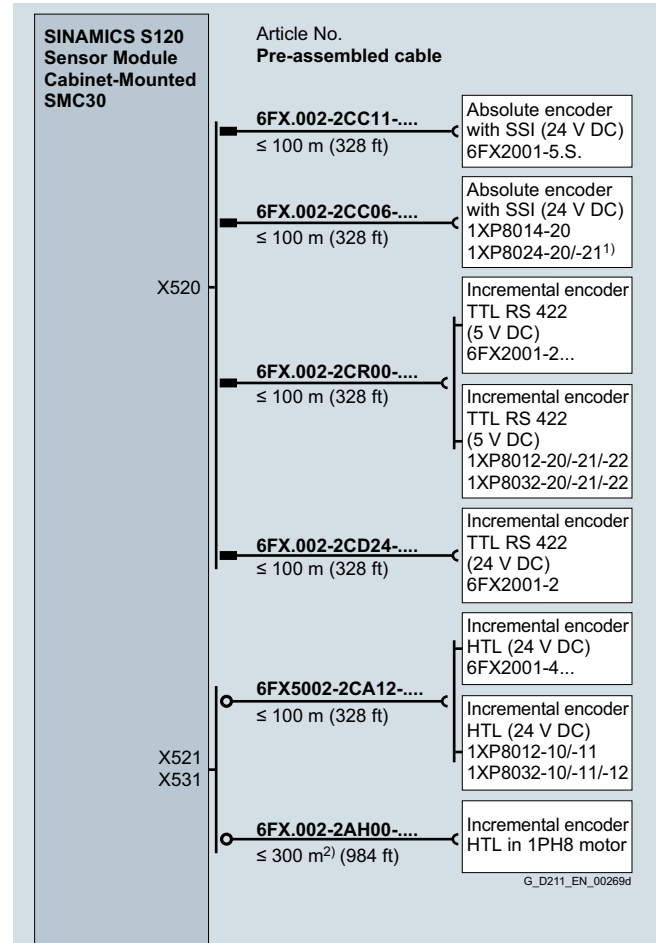

¹⁾For position control only.
²⁾Applies to HTL encoders with bipolar signal evaluation or for evaluation of difference signals A*, A and B*, B; for HTL encoders with unipolar signal evaluation the permissible cable length is reduced to 100 m (328 ft).

Connection overview of SINAMICS S120 Sensor Module Cabinet-Mounted SMC40

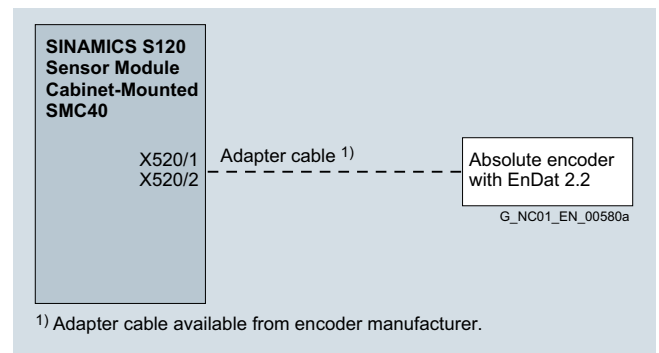

Overview

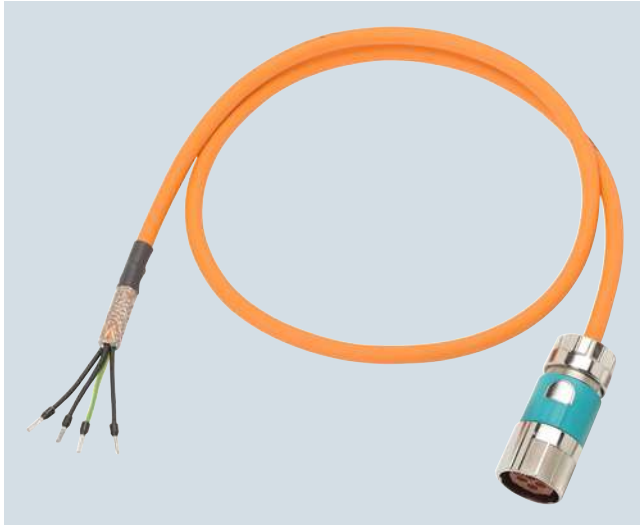

Power cable for connecting a SIMOTICS S-1FK7 motor with SPEED-CONNECT connector to a SINAMICS S120 Combi Power Module

The synchronous and asynchronous motors are connected to the Motor Modules or Power Modules by means of MOTION-CONNECT power cables.

The pre-assembled MOTION-CONNECT power cables are of high quality and offer safety with problem-free functioning.

Type of delivery	Cross-section	Length
Pre-assembled power cables		
• Variable length, in exact decimeter lengths	1.5 mm ² to 6 mm ²	0.1 m to 299.8 m
Power cables sold by the meter		
• Fixed lengths	1.5 mm ² and 2.5 mm ²	50 m, 100 m, 200 m, 500 m
• Variable length, in exact meter lengths	4 mm ² and 6 mm ²	1 m to 500 m

The cables are supplied on reels up to 30 kg or 100 m. Above 30 kg or 100 m, cable drums are used instead of reels. This applies to both pre-assembled power cables and cables sold by the meter.

Technical specifications

Article No.	6FX500-.....	6FX800-.....
Product name	MOTION-CONNECT 500	MOTION-CONNECT 800PLUS
Product designation	Power cable	Power cable
Certificate of suitability		
• CE	Yes	Yes
• RoHS conformity	Yes	Yes
• cURus or UR/CSA ¹⁾	UL758-CSA-C22.2-N.210.2-M90	UL758-CSA-C22.2-N.210.2-M90
Rated voltage U_0/U		
• Power conductors	600 V/1000 V	600 V/1000 V
• Signal conductors	24 V (EN) 1000 V (UL/CSA)	24 V (EN) 1000 V (UL/CSA)
Test voltage, rms		
• Power conductors	4 kV	4 kV
• Signal conductors	2 kV	2 kV
Operating temperature on the surface		
• Fixed installation	-20 ... +80 °C	-50 ... +80 °C
• Flexible installation	0 ... 60 °C	-20 ... +60 °C
Tensile stress, max.		
• Fixed installation	50 N/mm ²	50 N/mm ²
• Flexible installation	20 N/mm ²	20 N/mm ²
Smallest bending radius		
• Fixed installation	$5 \times D_{\max}$	$4 \times D_{\max}$
• Flexible installation	See Selection and ordering data	See Selection and ordering data
Torsional stress	Absolute 30°/m	Absolute 30°/m
Bending	100000	10 million
Traversing velocity	30 m/min	Up to 300 m/min
Acceleration	2 m/s ²	Up to 50 m/s ²
Insulation material, incl. jacket	FCKW/silicone-free	FCKW/halogen/silicone-free IEC 60754-1/DIN VDE 0472-815
Oil resistance	EN 60811-2-1 (mineral oil only)	EN 60811-2-1
Outer jacket	PVC DESINA color orange RAL 2003	PUR, HD22.10 S2 (VDE 0282, Part 10) DESINA color orange RAL 2003
Flame-retardant	EN 60332-1-1 to 1-3	EN 60332-1-1 to 1-3

Degree of protection of the pre-assembled power cables and their extensions when closed and connected: IP67.

¹⁾ The UR-CSA File No. is printed on the cable jacket.

Selection and ordering data

Power cables for SIMOTICS S-1FK7 motors with SPEED-CONNECT connector

Connection method, Power/Motor Module end	Number of cores x cross-section mm ²	Connector size, motor end	Pre-assembled cable with SPEED-CONNECT connector	Cable sold by the meter ¹⁾	D _{max}		Weight (cable sold by the meter)		Smallest bending radius ²⁾	
			Article No.	Article No.	6FX5 mm	6FX8 mm	6FX5 kg/m	6FX8 kg/m	6FX5 mm	6FX8 mm
SIMOTICS S-1FK7 motors without holding brake on SINAMICS S120 Combi Power Modules										
Exposed core ends ³⁾	4 x 1.5	1	6FX 002-5CF10-....	6FX 008-1BB11-....	8.4	9.5	0.12	0.15	155	75
		1.5	6FX 002-5CF14-....							
SIMOTICS S-1FK7 motors with holding brake on SINAMICS S120 Combi Power Modules										
Exposed core ends ³⁾	4 x 1.5+2 x 1.5	1	6FX 002-5DF10-....	6FX 008-1BA11-....	10.8	12.0	0.22	0.23	195	90
		1.5	6FX 002-5DF14-....							
SIMOTICS S-1FK7 motors without holding brake on SINAMICS S120 Motor Modules in booksize compact format										
Exposed core ends	4 x 1.5	1	6FX 002-5CG10-....	6FX 008-1BB11-....	8.4	9.5	0.12	0.15	155	75
		1.5	6FX 002-5CG22-....							
	4 x 2.5	1	6FX 002-5CG12-....	6FX 008-1BB21-....	10.0	11.0	0.21	0.20	180	90
		1.5	6FX 002-5CG32-....							
SIMOTICS S-1FK7 motors with holding brake on SINAMICS S120 Motor Modules in booksize compact format										
Exposed core ends	4 x 1.5+2 x 1.5	1	6FX 002-5DG10-....	6FX 008-1BA11-....	10.8	12.0	0.22	0.23	195	90
		1.5	6FX 002-5DG22-....							
	4 x 2.5+2 x 1.5	1	6FX 002-5DG12-....	6FX 008-1BA21-....	12.4	13.8	0.25	0.30	225	105
		1.5	6FX 002-5DG32-....							
SIMOTICS S-1FK7 motors without holding brake on SINAMICS S120 Motor Modules in booksize format										
Connector ⁴⁾	4 x 1.5	1	6FX 002-5CN01-....	6FX 008-1BB11-....	8.4	9.5	0.12	0.15	155	75
		1.5	6FX 002-5CN21-....							
	4 x 2.5	1	6FX 002-5CN11-....	6FX 008-1BB21-....	10.0	11.0	0.21	0.20	180	90
		1.5	6FX 002-5CN31-....							
SIMOTICS S-1FK7 motors with holding brake on SINAMICS S120 Motor Modules in booksize format										
Connector ⁴⁾	4 x 1.5+2 x 1.5	0.5	6FX 002-5DN20-....	6FX 008-1BA11-....	10.8	12.0	0.22	0.23	195	90
		1	6FX 002-5DN01-....							
		1.5	6FX 002-5DN21-....							
	4 x 2.5+2 x 1.5	1	6FX 002-5DN11-....	6FX 008-1BA21-....	12.4	13.8	0.25	0.30	225	105
		1.5	6FX 002-5DN31-....							
SIMOTICS S-1FK7 motors without holding brake on SINAMICS S120 Motor Modules C/D types in booksize format										
Connector ⁴⁾	4 x 1.5	1	6FX 002-5CN06-....	6FX 008-1BB11-....	8.4	9.5	0.12	0.15	155	75
		1.5	6FX 002-5CN26-....							
	4 x 2.5	1	6FX 002-5CN16-....	6FX 008-1BB21-....	10.0	11.0	0.21	0.20	180	90
		1.5	6FX 002-5CN36-....							
SIMOTICS S-1FK7 motors with holding brake on SINAMICS S120 Motor Modules C/D types in booksize format										
Connector ⁴⁾	4 x 1.5+2 x 1.5	0.5	6FX 002-5DN27-....	6FX 008-1BA11-....	10.8	12.0	0.22	0.23	195	90
		1	6FX 002-5DN06-....							
		1.5	6FX 002-5DN26-....							
	4 x 2.5+2 x 1.5	1	6FX 002-5DN16-....	6FX 008-1BA21-....	12.4	13.8	0.25	0.30	225	105
		1.5	6FX 002-5DN36-....							
MOTION-CONNECT 500			5		5					
MOTION-CONNECT 800PLUS			8		8					
Length code							

1) Note type of delivery.

2) Valid for installation in a cable carrier.

3) Length of core ends for power is 55 mm and length of brake core ends is 250 mm.

4) For SINAMICS S120 Motor Modules and Motor Modules C/D types 3 A to 30 A in booksize format.

Selection and ordering data

Power cables for SIMOTICS M-1PH8 motors with terminal box

Motor	Thread	Number of cores × cross-section	Connection method Power/Motor Module end	Pre-assembled cable	Cable sold by the meter ¹⁾	D_{max}		Weight (cable sold by the meter)		Smallest bending radius ²⁾	
						6FX5	6FX8	6FX5	6FX8	6FX5	6FX8
Type		mm ²		Article No.	Article No.	mm	mm	kg/m	kg/m	mm	mm
SIMOTICS M-1PH8 motors with terminal box on SINAMICS S120 Combi Power Modules											
M-1PH808	M25	4 × 2.5	Exposed core ends ³⁾	6FX8002-5CE02-....	6FX8008-1BB21-....	11.0	11.0	0.21	0.20	180	90
M-1PH810	M32	4 × 4	Exposed core ends ³⁾	6FX8002-5CE04-....	6FX8008-1BB31-....	11.4	12.3	0.27	0.31	210	100
M-1PH813	M40	4 × 6	Exposed core ends ³⁾	6FX8002-5CE06-....	6FX8008-1BB41-....	20.0	15.1	0.37	0.42	245	120
SIMOTICS M-1PH8 motors with terminal box on SINAMICS S120 Motor Modules in booksize compact format											
M-1PH808	M25	4 × 2.5	Exposed core ends ⁴⁾	6FX8002-5CR10-....	6FX8008-1BB21-....	–	11.0	–	0.20	–	90
M-1PH810	M32	4 × 2.5	Exposed core ends ⁴⁾	6FX8002-5CR11-....	6FX8008-1BB21-....	–	11.0	–	0.20	–	90
SIMOTICS M-1PH8 motors with terminal box on SINAMICS S120 Motor Modules in booksize format											
M-1PH808	M25	4 × 2.5	Connector ⁵⁾	6FX8002-5CP10-....	6FX8008-1BB21-....	–	11.0	–	0.20	–	90
M-1PH810	M32	4 × 2.5	Connector ⁵⁾	6FX8002-5CP11-....	6FX8008-1BB21-....	–	11.0	–	0.20	–	90
SIMOTICS M-1PH8 motors with terminal box on SINAMICS S120 Motor Modules C/D types in booksize format											
M-1PH808	M25	4 × 2.5	Connector ⁵⁾	6FX8002-5CP17-....	6FX8008-1BB21-....	–	11.0	–	0.20	–	90
M-1PH810	M32	4 × 2.5	Connector ⁵⁾	6FX8002-5CP16-....	6FX8008-1BB21-....	–	11.0	–	0.20	–	90
MOTION-CONNECT 500				5							
MOTION-CONNECT 800PLUS				8		8					
Length code										

1) Note type of delivery.

2) Valid for installation in a cable carrier.

3) Length of core ends for power is 55 mm and length of brake core ends is 250 mm.

4) Length of core ends: 300 mm. 4 M8 cable lugs and 4 M6 cable lugs are also included in the scope of supply of the cables.

5) For SINAMICS S120 Motor Modules and Motor Modules C/D types 3 A to 30 A in booksize format.

Overview



MOTION-CONNECT DRIVE-CLiQ signal cable with IP20/IP67 connector
Signal cables are pre-assembled and are sold by the meter for the connection of a variety of components.

The following different types of cable are available:

- DRIVE-CLiQ signal cables
- MOTION-CONNECT DRIVE-CLiQ signal cables
- MOTION-CONNECT pre-assembled signal cables

Application

DRIVE-CLiQ signal cables

DRIVE-CLiQ signal cables are used to connect components with DRIVE-CLiQ connections which have a separate or external 24 V DC power supply.

MOTION-CONNECT DRIVE-CLiQ signal cables

MOTION-CONNECT DRIVE-CLiQ signal cables with 24 V DC cores are used whenever components with DRIVE-CLiQ connections must meet high requirements such as mechanical stress and oil resistance, e.g. where a connection is made outside the cabinet between Power Modules/Motor Modules and SIMOTICS S-1FK7/ SIMOTICS M-1PH8 motors with DRIVE-CLiQ interface.

MOTION-CONNECT pre-assembled signal cables

MOTION-CONNECT pre-assembled signal cables are used whenever motor encoders on motors without DRIVE-CLiQ interface are connected to Sensor Modules.

Type of delivery for pre-assembled signal cables

Pre-assembled signal cables are available in units of 10 cm.

The cables are supplied on reels up to 30 kg or 100 m. Above 30 kg or 100 m, cable drums are used instead of reels.

Technical specifications

Article No.	6FX2...-1DC...-....	6FX5...-DC...-....	6FX8...-DC...-....
Product name		MOTION-CONNECT 500	MOTION-CONNECT 800PLUS
Product designation	DRIVE-CLiQ signal cable	DRIVE-CLiQ signal cable	DRIVE-CLiQ signal cable
Certificate of suitability			
• CE	Yes	Yes	Yes
• RoHS conformity	Yes	Yes	Yes
• cURus or UR/CSA ¹⁾	UL STYLE 2502/CSA-N.210.2-M90	UL STYLE 2502/CSA-N.210.2-M90	UL STYLE 2502/CSA-N.210.2-M90
Rated voltage according to EN 50395	30 V	30 V	30 V
Test voltage, rms	500 V	500 V	500 V
Operating temperature on the surface			
• Fixed installation	-20 ... +80 °C	-20 ... +80 °C	-20 ... +80 °C
• Flexible installation	-	0 ... 60 °C	-20 ... +60 °C
Tensile stress, max.			
• Fixed installation	45 N/mm ²	80 N/mm ²	50 N/mm ²
• Flexible installation	-	30 N/mm ²	20 N/mm ²
Smallest bending radius			
• Fixed installation	50 mm	35 mm	35 mm
• Flexible installation	-	125 mm	75 mm
Torsional stress	-	Absolute 30°/m	Absolute 30°/m
Bending	-	100000	10 million
Traversing velocity	-	30 m/min	300 m/min
Acceleration	-	2 m/s ²	Up to 50 m/s ²
Insulation material, incl. jacket	FCKW/silicone-free	FCKW/silicone-free	FCKW/halogen/silicone-free IEC 60754-1/DIN VDE 0472-815
Oil resistance	EN 60811-2-1	EN 60811-2-1 (mineral oil only)	EN 60811-2-1
Outer jacket	PVC	PVC	PUR, HD22.10 S2 (VDE 0282, Part 10)
	Gray RAL 7032	DESINA color green RAL 6018	DESINA color green RAL 6018
Flame-retardant	EN 60332-1-1 to 1-3	EN 60332-1-1 to 1-3	EN 60332-1-1 to 1-3

Degree of protection of the pre-assembled signal cables and their extensions when closed and connected: IP67.

¹⁾ The UR-CSA File No. is printed on the cable jacket.



Technical specifications (continued)

Article No.	6FX500-.....-....	6FX800-.....-....
Product name	MOTION-CONNECT 500	MOTION-CONNECT 800PLUS
Product designation	Signal cable	Signal cable
Certificate of suitability		
• CE	Yes	Yes
• RoHS conformity	Yes	Yes
• cURus or UR/CSA ¹⁾	UL758-CSA-C22.2-N.210.2-M90	UL758-CSA-C22.2-N.210.2-M90
Rated voltage according to EN 50395	30 V	30 V
Test voltage, rms	500 V	500 V
Operating temperature on the surface		
• Fixed installation	-20 ... +80 °C	-50 ... +80 °C
• Flexible installation	0 ... 60 °C	-20 ... +60 °C
Tensile stress, max.		
• Fixed installation	50 N/mm ²	50 N/mm ²
• Flexible installation	20 N/mm ²	20 N/mm ²
Smallest bending radius		
• Fixed installation	60 mm	4 × D _{max}
• Flexible installation	100 mm	70 mm
Torsional stress	Absolute 30°/m	Absolute 30°/m
Bending	2 million	10 million
Traversing velocity	180 m/min	Up to 300 m/min
Acceleration	5 m/s ²	Up to 50 m/s ²
Insulation material, incl. jacket	FCKW/silicone-free	FCKW/halogen/silicone-free IEC 60754-1/DIN VDE 0472-815
Oil resistance	EN 60811-2-1 (mineral oil only)	EN 60811-2-1
Outer jacket	PVC DESINA color green RAL 6018	PUR, HD22.10 S2 (VDE 0282, Part 10) DESINA color green RAL 6018
Flame-retardant	EN 60332-1-1 to 1-3	EN 60332-1-1 to 1-3

Degree of protection of the pre-assembled signal cables and their extensions when closed and connected: IP67.

¹⁾ The UR-CSA File No. is printed on the cable jacket.

Selection and ordering data

Type	Length	D_{max}	Connector module end motor end	Degree of protection module end motor end	DRIVE-CLiQ signal cable without 24 V DC cores
	m	mm			Article No.
	Fixed lengths	0.11	RJ45	IP20	6SL3060-4AB00-0AA0
		0.16			6SL3060-4AD00-0AA0
		0.21			6SL3060-4AF00-0AA0
		0.26			6SL3060-4AH00-0AA0
		0.31			6SL3060-4AK00-0AA0
		0.36			6SL3060-4AM00-0AA0
		0.41			6SL3060-4AP00-0AA0
		0.60			6SL3060-4AU00-0AA0
		0.95			6SL3060-4AA10-0AA0
		1.20			6SL3060-4AW00-0AA0
		1.45			6SL3060-4AF10-0AA0
		2.10			6SL3060-4AB20-0AA0
		2.40			6SL3060-4AE20-0AA0
		2.80			6SL3060-4AJ20-0AA0
	5.00	6SL3060-4AA50-0AA0			
To the decimeter	max. 70	7.0	RJ45	IP20	6FX2002-1DC00-....
					
Length code				

Pre-assembled MOTION-CONNECT DRIVE-CLiQ signal cables with 24 V DC cores

Selection and ordering data

Type	Application	Length, max.	D_{max}	Connector module end motor end	Degree of protection module end motor end	MOTION-CONNECT DRIVE-CLiQ signal cable with 24 V DC cores
		m	mm			Article No.
	For built-in or built-on encoder systems with DRIVE-CLiQ interface. For example, for making the connection between SIMOTICS motors and SINAMICS S120 Motor Modules or Power Modules.	75	7.1	RJ45	IP67	6FX8002-2DC10-....
		100	7.1	RJ45	IP67	6FX5002-2DC10-....
MOTION-CONNECT 500						5
MOTION-CONNECT 800PLUS						8
Length code					

Selection and ordering data

Encoder system	Motor	Connection via	Length, max.	D_{max}	Degree of protection Connector 1)	Basic cable	Extension
						Article No.	Article No.
	SIMOTICS	SINAMICS	m	mm			
Absolute encoder with EnDat 2.1	M-1PH8	SMC20	100	9.8	IP20/IP67	6FX002-2EQ10-....	6FX002-2EQ14-....
Absolute encoder with EnDat 2.1 6FX2001-5.E..		SMC20	100	9.2	IP20/IP67	6FX002-2CH00-....	6FX002-2AD04-....
Absolute encoder with SSI 24 V DC 6FX2001-5.S.. Clock-pulse rate 100 ... 250 kHz		SMC30	100	9.3	IP20/IP67	6FX002-2CC11-....	6FX002-2CB54-....
Incremental encoder sin/cos 1 V _{pp} 2048 S/R, with C and D tracks	M-1PH8	SMC20	100	9.8	IP20/IP67	6FX002-2CA31-....	6FX002-2CA34-....
Incremental encoder sin/cos 1 V _{pp} 256 and 512 S/R, without C and D tracks	M-1PH8	SMC20	50	9.2	IP20/IP67	6FX8002-2CA80-....	6FX002-2CA34-....
Incremental encoder sin/cos 1 V _{pp} without C and D tracks 6FX2001-3		SMC20	50	9.3	IP20/IP67	6FX002-2CG00-....	6FX002-2CB54-....
HTL incremental encoder	M-1PH8	SMC30	300 ²⁾	9.3	-/IP67	6FX002-2AH00-....	6FX002-2AH04-....
HTL incremental encoder 24 V DC 6FX2001-4		SMC30	100	9.3	-/IP67	6FX5002-2CA12-....	6FX002-2CB54-....
TTL incremental encoder RS422 6FX2001-2							
• 5 V DC		SMC30	100	9.3	IP20/IP67	6FX002-2CR00-....	6FX002-2CB54-....
• 24 V DC		SMC30	100	9.3	IP20/IP67	6FX002-2CD24-....	6FX002-2CB54-....
MOTION-CONNECT 500						5	5
MOTION-CONNECT 800PLUS						8	8
Length code					

The combinations of signal cable extensions shown are only provided by way of example.

The maximum specified cable length (basic cable and extensions) must not be exceeded.
The permissible total maximum length is reduced by 2 m for each interruption point.

1) The specified degree of protection refers to the basic cable.

2) Applicable to HTL encoders with bipolar signal evaluation or for evaluation of the difference signals A*, A and B*, B;
for HTL encoders with unipolar signal evaluation, the permissible cable length is reduced to 100 m.

Overview

Length Article No. supplement

Length code for pre-assembled cables

Length	Article No.	supplement
6FX.....-.....- ■ ■ ■ ■ ■		
0 m	1	A
100 m	2	B
200 m	3	K
0 m		A
10 m		B
20 m		C
30 m		D
40 m		E
50 m		F
60 m		G
70 m		H
80 m		J
90 m		K
0 m		A
1 m		B
2 m		C
3 m		D
4 m		E
5 m		F
6 m		G
7 m		H
8 m		J
9 m		K
0 m		0
0.1 m		1
0.2 m		2
0.3 m		3
0.4 m		4
0.5 m		5
0.6 m		6
0.7 m		7
0.8 m		8
Examples:	1.0 m	1 A B 0
	2.2 m	1 A C 2
	8.0 m	1 A J 0
	299.0 m	3 K K 0

Length Article No. supplement

Length code for power and signal cables, sold by the meter¹⁾

Length	Article No.	supplement
6FX.008-.....- ■ ■ A 0		
50 m	1	F
100 m	2	A
200 m	3	A
500 m	6	A

More information

Definition of lengths for pre-assembled cables

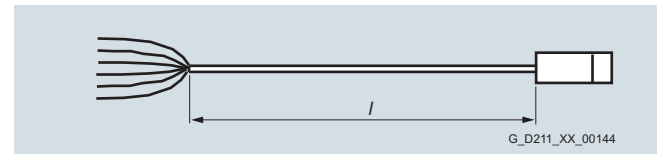

Cable with exposed core ends and pre-assembled connector

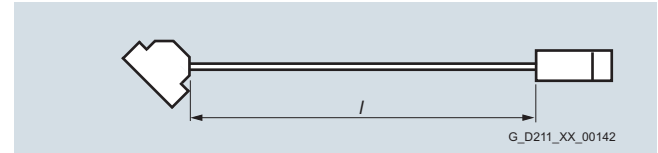

Cable with pre-assembled connectors at both ends

Tolerances:

- Cable lengths up to 10 m: $\pm 2\%$
- Cable lengths of 10 m and longer: $\pm 1\%$

¹⁾ Note type of delivery (up to 2.5 mm² in fixed lengths, above in exact meter lengths).

Overview



SINUMERIK 828D automation system, SINAMICS S120 Combi and SIMOTICS M-1PH8 as well as SIMOTICS S-1FK7 motors

On-site service

For the SINUMERIK 828D and the associated components¹⁾, you will receive a free on-site service contract for a period of 24 months from Siemens DF & PD.

The control is automatically registered on dispatch from the factory and the 24-month contract period begins. When arrival at the final destination or second commissioning is registered online (identSNAPSHOT) within 24 months following dispatch, the on-site service contract period is extended to 36 months.

On-site service includes:

- Provision of servicing personnel
- On-site diagnostics
- Fault correction on site
- Proof of fault correction

The fault correction is carried out by repairing and/or replacing faulty components.

Selection and ordering data

Description	Article No.
Extension of on-site service	6FC8520-0RX00 - AA2
For SINUMERIK 828D and the associated components from Siemens DF & PD on machine tools	
• Contract extension by 6 months	0
• Contract extension by 12 months	1
• Contract extension by 24 months	2
• Contract extension by 36 months	3

More information

Further information about the conditions and the scope of the on-site service contract can be found at:

www.siemens.com/automation/oss

For further information about online registration with identSNAPSHOT, visit:

www.siemens.com/identsnapshot

8

Benefits

- You benefit because the contract period for on-site service is extended to 36 months when final acceptance by your customer (second commissioning) is registered.
- You can contractually extend the period for on-site service by an additional 6, 12, 24 or 36 months.
- This contract extension is effective from expiry of the 36-month on-site service and must be purchased before it expires.

¹⁾ Not applicable to complete motor spindles.

Overview

Comprehensive documentation is available for the SINUMERIK 828D CNCs, as well as the SINAMICS S120 and SINAMICS S120 Combi drive systems, ranging from the Operating Manual, Programming Manual or Configuration Manual up to the Commissioning Manual.

The documents are available in hardcopy form or as a PDF file for downloading from the Internet.

You can find additional information on the Internet at: <https://support.industry.siemens.com/cs/de/en/view/108464614>

PDF versions of the catalogs are available on the Internet at: www.siemens.com/automation/infocenter

Selection and ordering data

Description	Article No.
<i>User, manufacturer and service documentation</i>	
User license for SINUMERIK documentation	6FC5395-0AP00-0XB0
Provision of documentation for further processing	
Valid for use on a control	
Supply of a license	
License conditions see: www.siemens.com/docu-licence	
DOConCD	6FC5398-0AC10-1YA5
SINUMERIK 840D sl/828D	
SINAMICS S120	
SIMOTICS Motors	
SIMATIC	
User, manufacturer and service documentation on DVD-ROM	
Version: V4.8 SP2	
Languages: English, German	
• Delivery of current edition	6FC5298-0CD00-0YG0
• Update service	6FC5298-0CD00-0YG2
Decentralization with PROFIBUS DP/DPV1	Orderable via book retailers
• German	ISBN: 978-3-89578-189-6
• English	ISBN: 978-3-89578-218-3

Overview

Siemens offers training directly from the manufacturer and thus first-hand know-how. The training courses comprise Siemens' entire product and system range in the area of automation and drive technology as well as further training regarding branch and system solutions.



Siemens offers a comprehensive range of further training for practice-orientated teaching of the technologies by Siemens Industry:

Training Services SITRAIN

Inform yourself of our SITRAIN training offer, which covers Siemens' entire product and system range in the area of automation and drive technology with more than 300 different courses. Find out how to perfectly adjust the training to your wishes: The individual training requirement is jointly determined for your company and a further training program is then specifically developed for these requirements.

Training-related Services

Here, you receive information on a series of further services which supplement SITRAIN's comprehensive training offer.

Benefits

- Training centers in more than 60 countries.
- Standardized or individual training courses.
- Teaching of basic knowledge, advanced and special knowledge.
- Training makes optimum use and adjustment of products and systems possible.

More information

You can find additional information on the Internet at:

<https://support.industry.siemens.com/cs/ww/en/sc/2226>

Overview



SinuTrain for SINUMERIK Operate is a PC-based CNC programming software package, based on the original CNC kernel.

SinuTrain for SINUMERIK Operate enables completely identical operator control and CNC programming as on SINUMERIK CNCs that are equipped with the graphical user interface SINUMERIK Operate.

Application

SinuTrain for SINUMERIK Operate can be used for the following applications:

In the work preparation

- Higher machine availability through work preparation on the CNC programming station and security through offline verification of the programs
- Operation and programming are identical 1:1 to that on the machine, so no new operating or programming knowledge is required.
- Enhanced productivity thanks to integrated program and tool management as on a real CNC control, integration into the company network, and external data storage media, e.g. USB stick

In training

- Simple learning and professional training through preconfigured machines, and no additional hardware costs
- Learning as on the CNC, with additional tutorials and programming guides
- Perfectly tailored training packages¹⁾ directly from: www.siemens.com/sce

Application (continued)

At the machine manufacturer

- Adaptation of SinuTrain to the specific machine
- The real machine and the machine-manufacturer-specific SinuTrain delivered together to the end users
- Another sales argument thanks to the CNC programming station supplied

For the presentation

- Present always and everywhere
- Live demonstration of (new) SINUMERIK functions instead of slides

Function

The SinuTrain offline programming station brings SINUMERIK Operate to the PC to create realistic conditions, including animated machine control panels. This facilitates the easy transition of know-how from a training situation into a practical environment. This powerful tool enables practice-oriented offline programming on the PC based on the DIN 66025 programming language, the ShopMill and ShopTurn options, type SINUMERIK 828D and 840D sl commands, and the direct transfer of CNC programs to the CNC. Using SINUMERIK Operate and the original SINUMERIK CNC kernel, all operating and programming operations can be used and CNC programs executed.

Integration

SinuTrain for SINUMERIK Operate Version 4.8 is based on SINUMERIK 840D sl CNC software with software version 4.8 SP3, and can be used for:

- SINUMERIK 828D (see Compatibility)
- SINUMERIK 840D sl

Requirements:

Hardware:

- PC with 2 GHz processor
- RAM: 4 GB of free memory space
- Hard disk:
 - 1.2 GB of free memory space for the minimum installation in English
 - 3.3 GB of free memory space for the complete installation in all languages
- DVD drive for installation from DVD-ROM

Software:

- Operating system
 - Windows 7 SP1 (32-bit/64-bit – Starter, Web Edition and Embedded are not supported)
 - Windows 8.1 (32-bit/64-bit – the RT Edition is not supported)
 - Windows 10 (64-bit – Mobile and Mobile Enterprise are not supported)
- Adobe Acrobat Reader

¹⁾ For schools and universities only, not for in-house vocational training.

Selection and ordering data

Description	Article No.
SinuTrain for SINUMERIK Operate Version 4.8 SINUMERIK 840D sl with CNC software 4.8 SP3	
<ul style="list-style-type: none"> • Single-user license 	6FC5870-4YC45-0YA0
<ul style="list-style-type: none"> • Upgrade for single-user license¹⁾ 	6FC5870-4YC45-0YC0
<ul style="list-style-type: none"> • Multi-user/classroom license (18) 	6FC5870-8YC45-0YA0
<ul style="list-style-type: none"> • Upgrade for multi-user/classroom license (18)¹⁾ 	6FC5870-8YC45-0YC0
<ul style="list-style-type: none"> • Basic version 	6FC5870-0YC45-0YA0
Machine adaptation for SinuTrain for SINUMERIK Operate	
<ul style="list-style-type: none"> • Machine adaptation by Siemens²⁾ 	6FC5088-4AA22-4AB1
<ul style="list-style-type: none"> • Importing the start-up archive (option) 	6FC5870-0CC45-0YA0
Training packages³⁾	
<ul style="list-style-type: none"> • Trainer package <ul style="list-style-type: none"> - 6 × single-user licenses - 40 × student licenses 	6FC5870-1TC45-0YA0
<ul style="list-style-type: none"> • Trainer package XL <ul style="list-style-type: none"> - 1 × classroom license (18) - 40 × student licenses 	6FC5870-2TC45-0YA0
<ul style="list-style-type: none"> • 300-h-student license 	6FC5870-1YC45-0YA0
<ul style="list-style-type: none"> • Student package <ul style="list-style-type: none"> - 20 × 300-h-student license 	6FC5870-1SC45-0YA0

More information

The basic version of SinuTrain for SINUMERIK Operate is available for download on the Internet.

You can find additional information on the Internet at:

www.siemens.com/sinustrain

3

8

- ¹⁾ With the upgrade license, you can upgrade an existing SinuTrain Complete, SinuTrain ShopTurn or SinuTrain ShopMill to SinuTrain for SINUMERIK Operate V4.8. Prerequisite for the upgrade license is an existing, valid ALM license key for the running period of SinuTrain versions 6.3, 7.3, 7.5, 2.6, 4.4, 4.5 or 4.7. This excludes SinuTrain Trial/Promotion and SinuTrain BASIC
- ²⁾ Services for machine adaptation:
You provide a complete file for CNC series commissioning archive by email. You will then receive a file for importing into SinuTrain by email. For more information, please contact your local Siemens sales office or Regional Company.
- ³⁾ For schools and universities only, not for in-house vocational training departments, at:
www.siemens.com/sce

Overview



SINUMERIK 828D training case

The SINUMERIK 828D training case is used for the realistic practice of operating, programming, installation and service tasks.

Design

The SINUMERIK 828D training case contains:

- SINUMERIK 828D PPU 281.3 including system software and software options
- SINUMERIK MCP 483 PN machine control panel
- SINUMERIK PP 72/48D PN I/O module
- SITOP 24 V/10 A power supply
- Industrial Ethernet Switch SCALANCE XB005 unmanaged

The SINUMERIK 828D training case is designed for table set-up and is supplied in a PELI protector case with integrated rigid foam inlay. The extendable handle and the rollers in the base make the case easy to transport.

Technical specifications

Article No.	6AG1067-1AA13-0AA0
Product brand name	SINUMERIK
Product designation	SINUMERIK 828D training case
Supply voltage for 1 AC	230 V
Degree of protection	IP00
Ambient temperature, during	
• storage	-20 ... +60 °C
• transport	-20 ... +60 °C
• operation	5 ... 40 °C
Width	650 mm
Height	500 mm
Depth	250 mm
Net weight	30 kg

Selection and ordering data

Description	Article No.
SINUMERIK 828D training case	6AG1067-1AA13-0AA0

Knowledge & technology – the keystones to success in digitalization



Digitalization is quickly and radically changing our world. What does this mean for education?

In the world of Industrie 4.0, companies can expect a host of new opportunities and challenges. New systems are verified on the spot through simulations. Automated mass production processes can make every product on the conveyor belt a unique product.

New products are now market-ready much faster. Siemens is shaping this transformation as a technology leader in the field of automation and process lifecycle management (PLM).

These new digitalization processes are changing the know-how requirements for employees. Many educational institutions are facing the challenge of conveying Industrie 4.0 know-how as part of their teaching and training. The Siemens Automation Co-operates with Education (SCE) program is supporting educators on the way to Industrie 4.0.

The SCE digitalization concept for educators

The SCE digitalization concept presented here shows how digitalization can be implemented in educational institutions – from vocational schools to universities.

Digitalization (or Industrie 4.0) know-how is now introduced through CAx and cloud technologies. It is founded on the basics of automation, such as digital technologies, PLC and information technologies, and on advanced automation and industrial communication technologies.

The level of digitalization knowledge can be weighted, depending on the vocational field or branch of study – e.g. mechanical engineering, automation engineering or computer science.

3 8

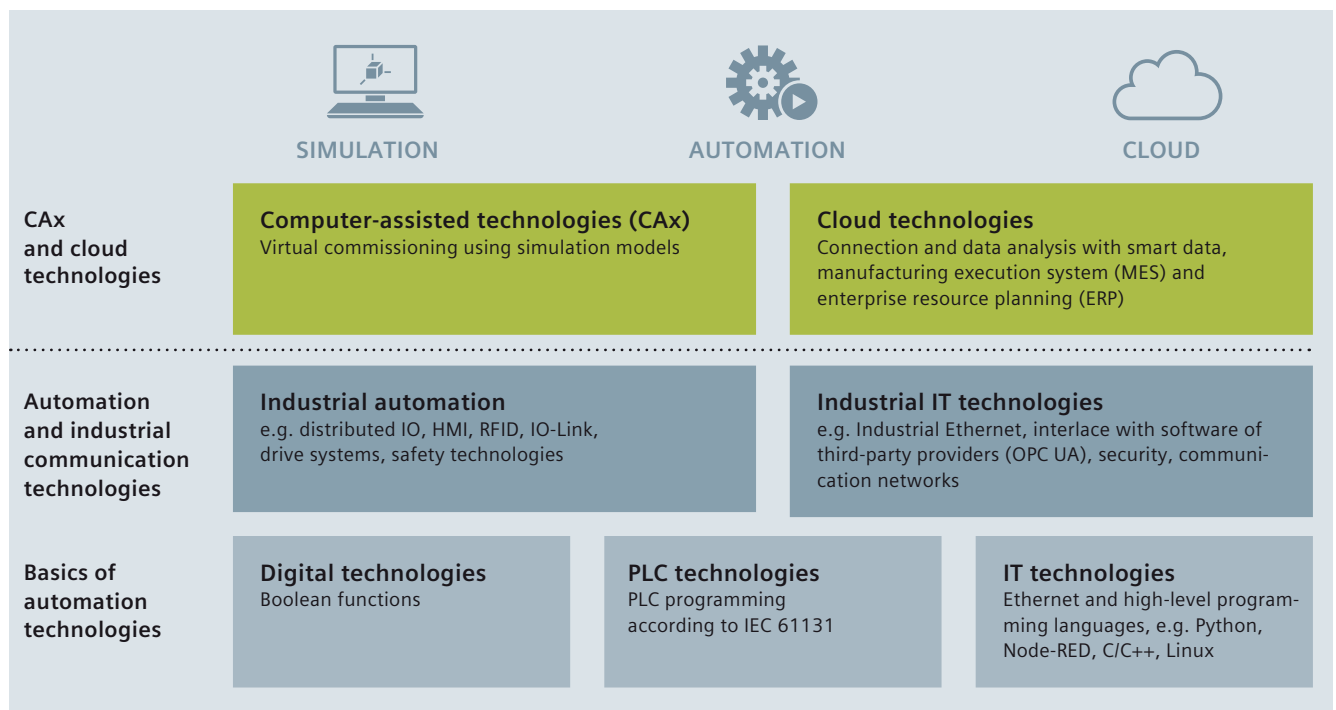

The SCE digitalization concept for educators (continued)

As part of their project work, students at Vocational School 2 in Wolfsburg, Germany, have implemented the three levels of the SCE Industrie 4.0 concept. A virtual twin created with the Siemens NX Mechatronics Designer (MCD) CAD software was used for the design and virtual commissioning. This enables fast and efficient assembly of the real automation system, e.g. with SIMATIC S7-1500/ET 200SP/RFID, for use in classes. Production data, such as the number of bottles filled, production date and system parameters, are uploaded to a cloud using SIMATIC IOT2000.

[siemens.com/iot2020](https://www.siemens.com/iot2020)

[siemens.com/nx](https://www.siemens.com/nx)

The SCE offers**Learning and training documents**

More than 100 didactically prepared learning and training documents are available through SCE and incorporate the digitalization concept. They are designed for use in classes, but can also be customized or used for individual study. These documents are available for free download, most of them in 7 languages.

[siemens.com/sce/documents](https://www.siemens.com/sce/documents)

Educator courses

Excellent teaching content is needed to introduce students to digitalization. For this purpose, SCE holds educator courses in certain regions. Based on our learning and training documents and through practical exercises, educators acquire the latest Industrie 4.0 know-how.

[siemens.com/sce/courses](https://www.siemens.com/sce/courses)

**Trainer packages**

The 90 SCE trainer packages help educators teaching and implementing the SCE digitalization concept. Trainer packages comprise specially compiled, genuine Siemens hardware and software products. The trainer packages are based on the learning and training documents and are offered to schools, colleges and universities at special terms.

[siemens.com/sce/tp](https://www.siemens.com/sce/tp)

Support for your projects / textbooks

We support you on selected projects with advice and assistance from SCE contact partners.

As a special service, we support textbook authors. We maintain a list of textbooks on the SCE website.

[siemens.com/sce/contact](https://www.siemens.com/sce/contact)

[siemens.com/sce/books](https://www.siemens.com/sce/books)

Partnerships for proliferation of Industrie 4.0 in education



Partnership with WorldSkills

As a technology powerhouse, we support vocational training of students around the world. Since 2010, we have partnered with WorldSkills as a Global Industry Partner in order to amplify this cause.

WorldSkills is an international organization whose mission is to raise the profile and recognition of skilled people, and show how important vocational skills are in achieving economic growth and personal success. Every two years, WorldSkills hosts the world championships of skills.

Siemens provides the competitors with automation products, such as SIMATIC S7-1500 and LOGO!, for the disciplines: industrial control, electrical installations, Polymechanics/Automation and manufacturing technology.

The next international skill competitions are scheduled for Kazan/Russia, in 2019 and Shanghai/China, in 2021. Additionally, we support selected continental and regional competitions.

siemens.com/worldskills

Partnerships with educators

We provide support to educators and educational organizations in the form of one-on-one advice through SCE contact partners and Siemens experts as well as long-term cooperation.

siemens.com/sce/contact

Partnerships with producers of learning systems

For practical training in classrooms and labs, numerous producers of learning systems offer a wide range of complete didactic solutions based on SCE trainer packages.

siemens.com/sce/partner

Information portal



To facilitate your teaching assignment and/or for selfstudy, we offer educators and students a comprehensive SCE information portal. At this portal you have quick access to all SCE offers, e.g. learning and training documents including projects, Getting Started information, videos, manuals, trial software and newsletters.

siemens.com/sce

SIEMENS

Global Industry
Partner of
WorldSkills
International



Overview

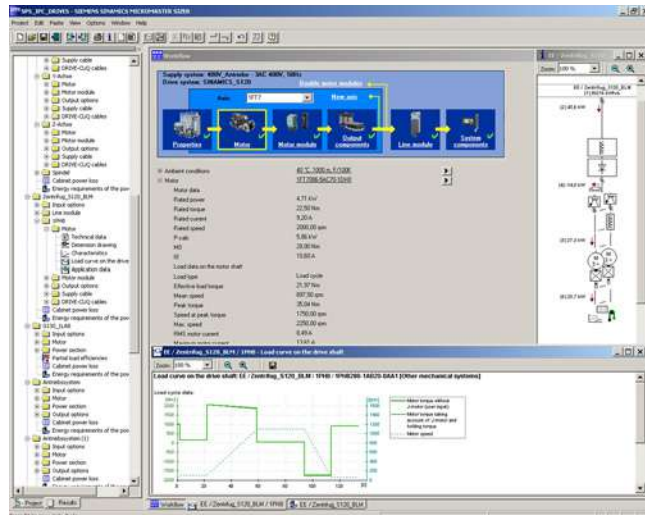

The following drives and controls can be engineered in a user-friendly way using the SIZER for Siemens Drives engineering tool:

- SIMOTICS low-voltage motors, including servo geared motors
- SINAMICS low-voltage drive systems
- Motor starters
- SINUMERIK CNC
- SIMOTION Motion Control controller
- SIMATIC controller

It provides support when selecting the technologies involved in the hardware and firmware components required for a drive task. SIZER for Siemens Drives covers the full range of operations required to configure a complete drive system, from basic single drives to demanding multi-axis applications.

SIZER for Siemens Drives supports all of the engineering steps in one workflow:

- Configuring the power supply
- Designing the motor and gearbox, including calculation of mechanical transmission elements
- Configuring the drive components
- Compiling the required accessories
- Selecting the line-side and motor-side power options, e.g. cables, filters, and reactors

When SIZER for Siemens Drives was being designed, particular importance was placed on a high degree of usability and a universal, function-based approach to the drive application. The extensive user guidance makes it easy to use the tool. Status information keeps you continually informed about the progress of the configuration process.

The drive configuration is saved in a project. In the project, the components and functions used are displayed in a hierarchical tree structure.

The project view permits the configuration of drive systems and the copying/inserting/modifying of drives already configured.

Overview (continued)

The configuration process produces the following results:

- A parts list of the required components (export to Excel, use of the Excel data sheet for import to SAP)
- Technical specifications of the system
- Characteristic curves
- Comments on system reactions
- Mounting arrangement of drive and control components and dimensional drawings of motors
- Energy requirements of the configured application

These results are displayed in a results tree and can be reused for documentation purposes.

Support is provided by the technological online help menu:

- Detailed technical specifications
- Information about the drive systems and their components
- Decision-making criteria for the selection of components
- Online help in English, French, German, Italian, Chinese and Japanese

Integration

System requirements

- PG or PC with Pentium III min. 800 MHz (recommended > 1 GHz)
- 512 MB RAM (1 GB RAM recommended)
- At least 4.1 GB of free hard disk space
- An additional 100 MB of free hard disk space on Windows system drive
- Screen resolution 1024 × 768 pixels (1280 × 1024 pixels recommended)
- Operating system:
 - Windows 7 Professional (32/64-bit)
 - Windows 7 Enterprise (32/64-bit)
 - Windows 7 Ultimate (32/64-bit)
 - Windows 7 Home (32/64-bit)
 - Windows 8.1 Professional (32/64-bit)
 - Windows 8.1 Enterprise (32/64-bit)
- Microsoft Internet Explorer V5.5 SP2

Selection and ordering data

Description	Article No.
SIZER for Siemens Drives engineering tool on DVD-ROM	6SL3070-0AA00-0AG0
English, French, German, Italian	

More information

The SIZER for Siemens Drives engineering tool is available free on the Internet at www.siemens.com/sizer

Overview

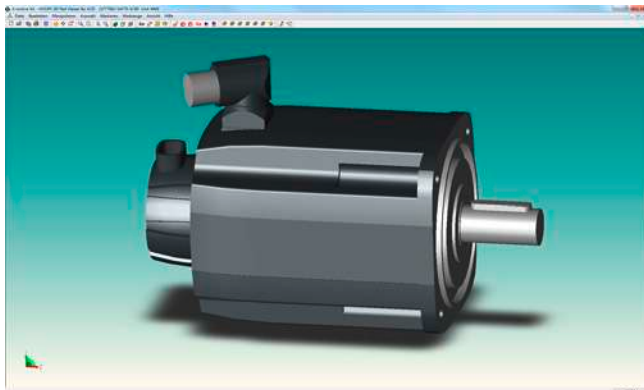
**CAD CREATOR –
Dimensional drawing and 2D/3D CAD generator**

Thanks to its intuitive user interface, CAD CREATOR allows you to quickly create product-specific dimensional drawings and 2D/3D CAD models. The CAD CREATOR assists the machine manufacturer's designers, drafting engineers and project engineers when creating plant documentation.

The data for motors, drives and CNC controls is currently available in the online version:

- SIMOTICS motors for Motion Control
- SINAMICS S110, SINAMICS S120
- SINUMERIK
- SIMOTION
- MOTION-CONNECT connection systems
- Measuring systems

Performance features

- Provision of dimensional drawings as 2D/3D CAD models
- Display of 2D/3D CAD models and dimensional drawings on integrated viewers
- With the online version, 3D models and dimensional drawings can also be displayed in the form of a downloadable PDF
- Support for all general geometry interfaces STEP, IGES, Parasolid, SAT, VDA, and for special interfaces such as Ideas, NX, Solid Edge, Pro/Engineer, Autocad, Inventor, Mechanical Desktop, Catia and Solidworks

The CAD CREATOR offers a variety of options for configuring, and different methods for searching for a product:

- The entry point is the **Product selection**
- Selection according to **Technical description**

After successful configuration of the product, the dimensional drawings and models are displayed with the integrated viewers and made available for export.

Selection and ordering data

Description	Article No.
CAD CREATOR	6SL3075-0AA00-0AG0
Dimensional drawing and 2D/3D CAD generator on DVD-ROM	
English, French, German, Italian, Spanish	

More information

The CAD CREATOR is available on DVD-ROM and as an Internet application.

More information is available on the Internet at www.siemens.com/cadcreator

Overview

The Drive Technology Configurator (DT Configurator) helps you to configure the optimum drive technology products for your application – starting with gear units, motors, converters as well as the associated options and components and ending with controllers, software licenses and connection systems. Whether with little or detailed knowledge of products: preselected product groups, deliberate navigation through selection menus and direct product selection through entry of the article number support quick, efficient and convenient configuration.

In addition, comprehensive documentation comprising technical data sheets, 2D dimensional drawings/3D CAD models, operating instructions, certificates, etc. can be selected in the DT Configurator. Immediate ordering is possible by simply transferring a parts list to the shopping cart of the Industry Mall.



Drive Technology Configurator for efficient drive configuration with the following functions

- Quick and easy configuration of drive products and associated components – gear units, motors, converters, controllers, connection systems
- Configuration of drive systems for pumps, fans and compressor applications from 1 kW to 2.6 MW
- Retrievable documentation for configured products and components, such as
 - Data sheets in up to 9 languages in PDF or RTF format
 - 2D dimensional drawings/3D CAD models in various formats
 - Terminal box drawing and terminal connection diagram
 - Operating instructions
 - Certificates
 - Start-up calculation for SIMOTICS motors
 - EPLAN macros
- Support with retrofitting in conjunction with Spares On Web (www.siemens.com/sow)
- Ability to order products directly through the Siemens Industry Mall

Access to the Drive Technology Configurator

The Drive Technology Configurator can be called up without registration and without a login:
www.siemens.com/dt-configurator

Selection and ordering data

Description	Article No.
Interactive catalog CA 01 including Drive Technology Configurator	
• German (DVD-ROM – Edition Germany)	E86060-D4001-A500-D8
• English, French, German, Spanish (Download – without prices)	E86060-D4001-A510-D8-7500

More information

[Online access to the Drive Technology Configurator](#)

More information about the Drive Technology Configurator is available on the Internet at
www.siemens.com/dtconfigurator

[Offline access to the Drive Technology Configurator in the Interactive Catalog CA 01](#)

In addition, the Drive Technology Configurator is also included in the Interactive Catalog CA 01 – the offline version of the Siemens Industry Mall.

The Interactive Catalog CA 01 can be ordered from the relevant Siemens sales office or via the Internet:
www.siemens.com/automation/CA01

Overview

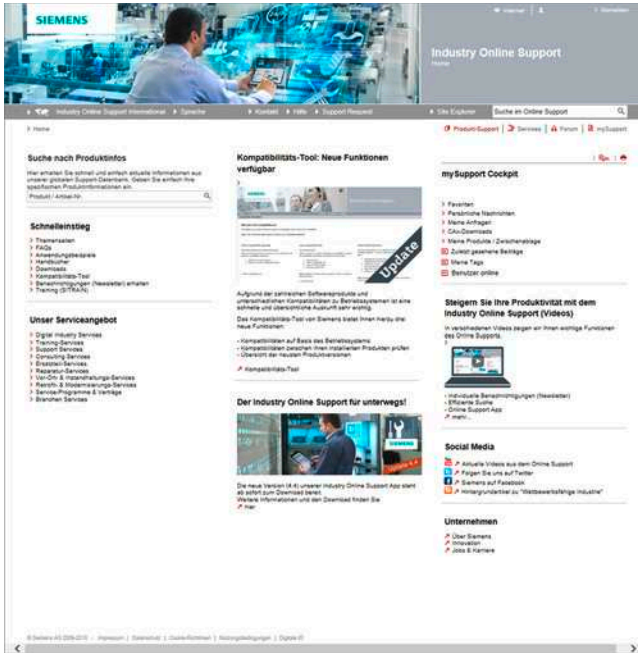

Application examples

Descriptions of real, functioning and sector-neutral solutions, comprising a solution path, performance/power data, configuring instructions and the tested program code.

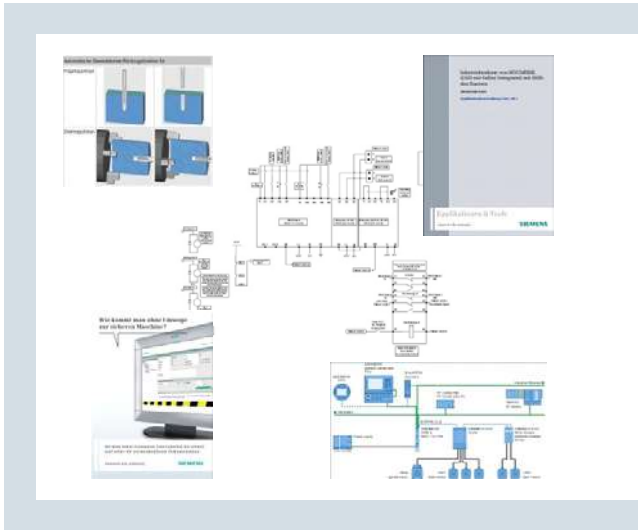

Benefits

The application examples show you solutions for typical automation tasks as example. You can use this as a suggestion or basis for your own solutions.

More information

You can find application examples on the Internet at:

www.siemens.com/automation/support

Or contact your Siemens representative.

3

8



- 9/2 Hofmann Mess- und Auswuchttechnik GmbH & Co. KG
AB 9000 ring balancing system
- 9/3 MARPOSS S.p.A.
Laser Tool Setter
- 9/4 MCU GmbH & Co. KG
Toolinspect II
- 9/5 PROMETEC GmbH
PROSIN^{PLUS}
- 9/6 Dr.-Ing. Paul Christiani GmbH & Co.
- 9/6 CNC crash course
- 9/6 ShopMill CNC crash course
- 9/7 ShopTurn CNC crash course
- 9/7 CNC technology telecourse

Under the name Product Partner SINUMERIK Systems, leading companies present acknowledged know-how in specific fields. Their products and solutions, that they develop, produce and sell themselves, are a useful complement to our comprehensive portfolio.

Our partner network also makes a crucial contribution toward you benefiting from maximally complete, high quality and efficient solutions, enabling you to sustainably improve your competitiveness.

This partnership allows intensive cooperation, and ensures a high degree of compatibility and reliability in production use with SINUMERIK CNCs.

The systems supplied by our partners are in many cases available for earlier SINUMERIK software versions and can be installed retrospectively.

For further information, please contact the partner directly.

You can find additional information on the Internet at:

www.siemens.com/product-partner

Siemens NC 82 · 2018

Overview



AB 9000 ring balancing system

The AB 9000 ring balancing system is based on a brilliantly simple concept. The vibrations generated on rotating systems due to imbalance are actively and quickly eliminated as the system rotates. Two balancing rotors are permanently mounted on the tool spindle via thin ring bearings. A fast, intelligent controller uses sensors to detect the imbalance in the spindle, calculates and adjusts the position of the two balancing rotors electromagnetically until they are ideally positioned to compensate the imbalance.

Benefits

- Automatic (active) balancing of all kinds of rotors
- Balancing during operation without machine shutdown
- Implementation of test imbalance for the purpose of system identification
- Generation of unbalance for acceptance tests

Function

- Automatic (active) balancing of rotors (e.g. grinding wheels, grinding spindles, turning chucks, fans) in one or two planes with imbalance monitoring
- Active balancing during operation without machine shutdown
- Ring-shaped balancing unit for efficient, space-saving integration into the rotor
- Very fast balancing even at high rotational speeds by electro-magnetic actuator and adaptive balancing process
- Non-contact, wear-free transmission of actuator energy between stator and balancing ring
- Pre-balancing software for manual correction of basic unbalance - AB 9000 then only balances the new operational unbalances
- Balancing unit can be neutralized, e.g. for pre-balancing.
- Indication of remaining balancing capacity
- PC operating software

Integration

The AB 9000 can be used for the following CNC:

- SINUMERIK 828D:
with separate PC

More information

Hofmann Mess- und Auswuchttechnik GmbH & Co. KG

Werner-von-Siemens-Straße 21
64319 PFUNGSTADT
GERMANY

Tel. +49 6157 949-0
E-mail: hofmann@hofmann-global.com
Internet: www.hofmann-global.com

Overview



Laser Tool Setter – Automatic non-contact tool setting, part probing, machine and tool monitoring on machine tools

Marposs provides measuring cycles for part probing and tool setting which work in synergy with Marposs Probing Systems. The specific user interface makes programming easy.

All the necessary measurements can be performed on the part and on the tool for rapid setup of the machine. High-speed monitoring of the part, before and after the machining cycle as well as continuous monitoring of the machining conditions, can be performed by Marposs Probing and Monitoring Systems.

Benefits

- Fast, automatic and precise workpiece setup
- Tool presetting in machine condition to compensate axes thermal drift
- Tool and process verification to keep high production quality
- Part inspection on machine to avoid repositioning

Function

Tool measurements with Mida laser:

- Length and diameter of the tool
- Axial breakage
- Cutters integrity
- Cutters radius
- Compensation of the thermal drift of the machine axes

Part measurements with Mida spindle probes:

- Part positioning
- Measuring of drilled holes, pins, pockets and shoulders
- Single surface measurement
- Measuring the internal and external cross-arm

Machine and tool monitoring with MMS:

- Performance (tool breakage and wear)
- Force (cutting force optimization)
- Vibrations (machine condition and tool unbalancing)
- Temperature (overheating of bearings)
- Displacement (spindle growth)

Integration

Laser Tool Setter and probing systems can be used for the following CNC:

- SINUMERIK 828D

More information

MARPOSS S.p.A.

Via Saliceto 13
40010 BENTIVOGLIO (BO)
ITALY

Tel.: +39 051 899534
E-mail: marposs4partner@marposs.com
Internet: www.marposs.com

Overview

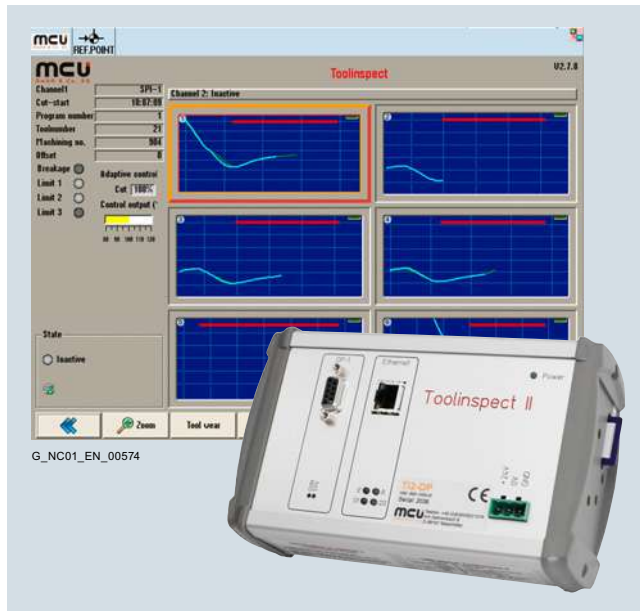

Toolinspect II - Tool and process monitoring

The Toolinspect II module communicates with the SINUMERIK CNC via PROFINET or PROFIBUS DP. Visualization on the operator panel of the CNC is implemented with the module via a TCP/IP interface.

Benefits

- Easy operation using 3 function keys
- Tool damage detected immediately (real time system)
- Machine cycle time is not increased
- Automatic adaptation to any type of machining without intervention by the machine operator
- Rugged flash memory

Function

- Control-integrated tool, process and machine analysis
- 19 languages available online and selectable at any time
- Adaptive control for roughing operations to reduce machining times (option)
- Automatic system and data backup on 4 GB SD card
- Read out of torque and path actual data
- Monitoring of up to 6 channels (6 simultaneous machining operations)
- Monitoring after tool change
- Integrated process analysis and process reports in PDF/Excel files (option)
- Process analysis with evaluation capability for technologists and export function of the actual values and display of the data in Excel
- Evaluation of MDE production data and up to 250 faults (option)
- Link to SINUMERIK Integrate

Integration

Toolinspect II can be used for the following CNC:

- SINUMERIK 828D

More information

MCU GmbH & Co. KG
Sales Office

Berglenstraße 11
71364 WINNENDEN
GERMANY

Tel.: +49 7195 1375-38
E-mail: vertrieb@mcu-gmbh.de
Internet: www.mcu-gmbh.de

Overview

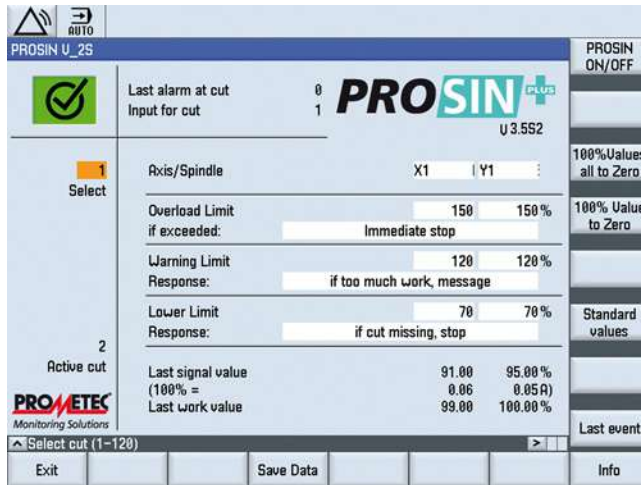

PROSIN^{PLUS} tool breakage and tool wear monitoring

The low-cost PROSIN^{PLUS} software permits direct access to the current values of the digital drives of the machine tool. If a tool breaks, the current of the associated drive changes; this value is increased in the case of a blunt tool. With PROSIN^{PLUS}, additional sensors and even complete monitoring units can be omitted.

A particular highlight of PROSIN^{PLUS} is the reliable detection of wear on rough-machining tools. This assumes mass production in which the batch size is significantly larger than the number of working tools.

PROSIN^{PLUS} is patented according to EP 1 276 027 and its derivations.

Benefits

- Break detection for drills, from approx. 2 mm (depending on rated spindle power)
- Protects machine, tool holder and tool from overload
- Reduces secondary damage resulting from tool breakage, tool wear, incorrect CNC parameter entries, incorrect clamping of the workpieces, etc.
- Suitable for mass production as well as small batch sizes

Function

- Operator control using SINUMERIK operator panels
- No additional hardware required
- Only one operator side and extremely easy to operate
- Very easy to retrofit
- Up to 120 different cuts of a CNC program can be monitored with 3 thresholds for missing tool, tool in contact with workpiece, tool wear, and tool overload

Integration

PROSIN^{PLUS} can be used for the following CNC:

- SINUMERIK 828D

More information

PROMETEC Gesellschaft für Produktions-, Mess- und Automatisierungstechnik mbH

Jülicher Straße 338
52070 AACHEN
GERMANY

Tel.: +49 241 16609-0
E-mail: prometec-de@prometec.com
Internet: www.prometec.com

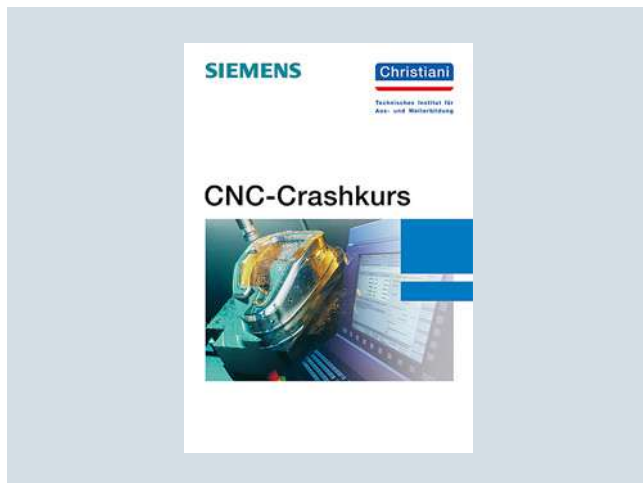
Overview**CNC crash course**

The CNC crash course technical manual is intended for readers who want to thoroughly study the subject of CNC technology. The thematic composition of this technical manual is designed so that CNC beginners, in particular, are also well catered for, systematically leading trainees to a specified level of proficiency.

All the course examples in this technical manual are based on SINUMERIK Operate, software version 4.4 and higher.

Benefits

- Learning the fundamentals of CNC technology
- Programming in accordance with DIN 66025
- CNC milling
- CNC turning

Function

- 6 programming exercises on the subject of CNC milling, with solutions
- 4 programming exercises on the subject of CNC turning, with solutions
- Use of free SINUMERIK Operate demo software version 4.4
- Color design of pages

Integration

The CNC Crash Course technical manual can be used for the following CNC:

- SINUMERIK 828D

More information**Dr.-Ing. Paul Christiani GmbH & Co. KG**

Hermann-Hesse-Weg 2
78464 KONSTANZ
GERMANY

Tel.: +49 7531 5801-100
E-mail: info@christiani.de
Internet: www.christiani-north-america.com

Overview**ShopMill CNC crash course**

The CNC Crash Course ShopMill technical manual describes the construction and operation of the SINUMERIK CNC ShopMill user interface. In addition to the description of functions for programming, two workpieces are programmed by way of example. Basic knowledge of the CNC technology is required. This technical manual shall provide an entry into programming.

The SinuTrain version for SINUMERIK Operate software version 4.5 Basic refers to practical applications.

Benefits

- Structure of operator controls
- Creating tools
- Programming with ShopMill

Function

- 2 programming exercises on the subject of ShopMill
- Use of the free SINUMERIK Operate software version 4.5 Ed. 3 Basic
- Color design of pages

Integration

The CNC Crash Course ShopMill technical manual can be used for the following CNC:

- SINUMERIK 828D

More information**Dr.-Ing. Paul Christiani GmbH & Co. KG**

Hermann-Hesse-Weg 2
78464 KONSTANZ
GERMANY

Tel.: +49 7531 5801-100
E-mail: info@christiani.de
Internet: www.christiani-north-america.com

Overview**ShopTurn CNC crash course**

The CNC Crash Course ShopTurn technical manual describes the configuration and handling of the SINUMERIK CNC user interface ShopTurn. In addition to the description of functions for programming, three workpieces are programmed by way of example. Basic knowledge of the CNC technology is required. This technical manual shall provide an entry into programming.

The SinuTrain version for SINUMERIK Operate software version 4.5 Basic refers to practical applications.

Benefits

- Structure of operator controls
- Creating tools
- Programming with ShopTurn

Function

- Three programming exercises on the subject of ShopTurn
- Use of the free SinuTrain for SINUMERIK Operate 4.5 Basic version
- Color design of pages

Integration

The CNC Crash Course ShopTurn technical manual can be used for the following CNC:

- SINUMERIK 828D

More information**Dr.-Ing. Paul Christiani GmbH & Co. KG**

Hermann-Hesse-Weg 2
78464 KONSTANZ
GERMANY

Tel.: +49 7531 5801-100
E-mail: info@christiani.de
Internet: www.christiani-north-america.com

Overview**CNC technology telecourse**

The CNC technology telecourse offers a comprehensive and practical introduction to the techniques of CNC programming. In order to ensure the greatest possible learning success, participants receive six sets of easily understandable, well structured tutorial notes, an extensive software package and professional supervision by an experienced course coach.

Benefits

- Advanced training without loss of earnings
- Maximum flexibility and free time allocation
- Efficient learning
- Quick attainment of learning targets
- Practice-oriented learning

Function

- Fundamentals of CNC technology
- Well-founded insights into process-related modes of operation and operation of the programming software
- CNC programming in accordance with DIN 66025
- Technology training for creating work plans and setup specifications
- Practical set up and equipping of CNC turning and milling machines
- Error checking of the programs created with realistic simulation software

Integration

The CNC technology telecourse can be used for the following CNC:

- SINUMERIK 828D

More information**Dr.-Ing. Paul Christiani GmbH & Co. KG**

Hermann-Hesse-Weg 2
78464 KONSTANZ
GERMANY

Tel.: +49 7531 5801-100
E-mail: info@christiani.de
Internet: www.christiani-north-america.com

9

9



10/2	Certificates of suitability
10/4	Partner · Industry Mall and Interactive Catalog
10/5	Information and Download Center
10/6	Notes on software
10/6	Software licenses
10/8	Setup texts and software update ser
10/10	Conversion tables
10/12	Metal surcharges
10/15	Conditions of sale and delivery/ Export regulations







Overview

Many of the products in this Catalog fulfill requirements, e.g. for UL, CSA or FM and are labeled with the corresponding approval designation.

All of the certificates of suitability, approvals, certificates, declarations of conformity, test certificates, e.g. CE, UL, Safety Integrated etc. have been performed with the associated system components as they are described in the Catalogs and Configuration Manuals.

The certificates are only valid if the products are used with the described system components, are installed according to the Installation Guidelines and used for their intended purpose.

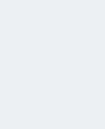
In other cases, the vendor of these products is responsible for arranging for the issue of new certificates.

Test code	Tested by	Device series/ Component	Test standard	Product category/ File-No.
UL: Underwriters Laboratories <i>Independent public testing body in North America</i>				
	UL according to UL standard	SINUMERIK	Standard UL 508, CSA C22.2 No. 142	NRAQ/7.E164110 NRAQ/7.E217227
		SIMOTION	Standard UL 508, CSA C22.2 No. 142	NRAQ/7.E164110
	UL according to CSA standard	SINAMICS	Standard UL 508, 508C, 61800-5-1 CSA C22.2 No. 142, 274	NRAQ/7.E164110, NMMS/2/7/8.E192450, NMMS/2/7/8.E203250, NMMS/7.E214113, NMMS/7.E253831
				NMMS/2/7/8.E121068 NMMS/7.E355661 NMMS/7.E323473
	UL according to UL standard	SIMODRIVE	Standard UL 508C, CSA C22.2 No. 274	NMMS/2/7/8.E192450 NMMS/7.E214113
	UL according to CSA standard	SIMOTICS	Standard UL 1004-1, 1004-6, 1004-8, CSA C22.2 No. 100	PRGY2/8.E227215 PRHZ2/8.E93429 PRHJ2/8.E342747 PRGY2/8.E253922 PRHZ2/8.E342746
	UL according to UL and CSA standards	Line/motor reactors	Standard UL 508, 506, 5085-1, 5085-2, 1561, CSA C22.2 No. 14, 47, 66.1-06, 66.2-06	XQNX2/8.E257859 NMTR2/8.E219022 NMMS2/8.E333628 XPTQ2/8.E257852 XPTQ2/8.E103521 NMMS2/8.E224872 XPTQ2/8.E354316 XPTQ2/8.E198309 XQNX2/8.E475972
	Line filters, dv/dt filters, sine-wave filters		UL 1283, CSA C22.2 No. 8	FOKY2/8.E70122
	Resistors		UL 508, 508C, CSA C22.2 No. 14, 274	NMTR2/8.E224314 NMMS2/8.E192450 NMTR2/8.E221095 NMTR2/8.E226619
TUV: TÜV Rheinland of North America Inc. <i>Independent public testing body in North America, Nationally Recognized Testing Laboratory (NRTL)</i>				
TÜV: TÜV SÜD Product Service <i>Independent public testing body in Germany, Nationally Recognized Testing Laboratory (NRTL) for North America</i>				
	TUV according to UL and CSA standards	SINAMICS	NRTL listing according to standard UL 508C	U7V 12 06 20078 013 U7 11 04 20078 009 U7 11 04 20078 010 U7 11 04 20078 011
		SIMOTION	NRTL listing according to standard UL 508	U7V 13 03 20078 01
		SIMODRIVE	NRTL listing according to standard UL 508C, CSA C22.2. No. 14	CU 72090702
		Motion Control Encoder	NRTL listing according to UL 61010-1 CSA C22.2 No. 61010-1	U8V 10 06 20196 024

10

10/2

Siemens NC 82 · 2018

Overview (continued)

Test code	Tested by	Device series/ Component	Test standard	Product category/ File-No.
CSA: Canadian Standards Association <i>Independent public testing body in Canada</i>				
	CSA according to CSA standard	SINUMERIK	Standard CSA C22.2 No. 142	2252-01 : LR 102527
FMRC: Factory Mutual Research Corporation <i>Independent public testing body in North America</i>				
	FM according to FM standard	SINUMERIK	Standard FMRC 3600, FMRC 3611, FMRC 3810, ANSI/ISA S82.02.1	-
EAC: Ivanovo-Certificate <i>Independent public testing body in the Russian Federation</i>				
	EAC in accordance with the EAC Directive	SINAMICS SINUMERIK SIMOTION	Standard IEC 61800-5-1/-2, IEC 61800-3	-
RCM: Australian Communications and Media Authority <i>Independent public testing body in Australia</i>				
	RCM according to EMC standard	SINAMICS SINUMERIK SIMOTION	Standard IEC AS 61800-3, EN 61800-3	-
KC: National Radio Research Agency <i>Independent public testing body in South Korea</i>				
	KC according to EMC standard	SINAMICS SINUMERIK SIMOTION	Standard KN 11	-
BIA <i>Federal Institute for Occupational Safety</i>				
-	Functional safety	SINAMICS SINUMERIK SIMOTION	Standard EN 61800-5-2	-
TÜV SÜD Rail				
-	Functional safety	SINAMICS SINUMERIK SIMOTION	Standard EN 61800-5-2	-

More information about certificates can be found online at:
<https://support.industry.siemens.com/cs/ww/en/ps/cert>

Partner at Siemens

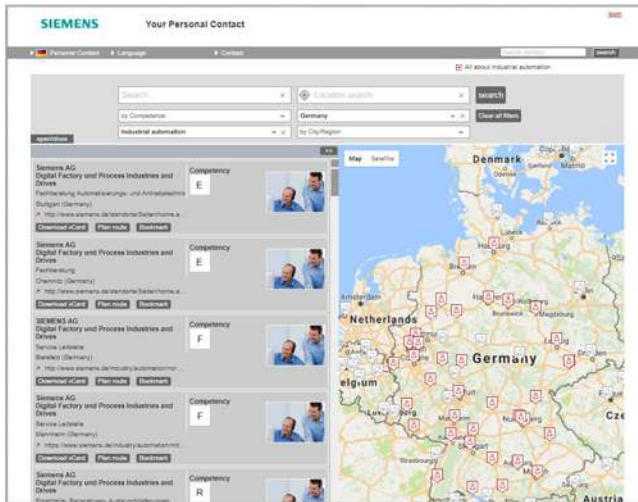

At your service locally, around the globe for consulting, sales, training, service, support, spare parts on the entire portfolio of Digital Factory and Process Industries and Drives.

Your partner can be found in our Personal Contacts Database at: www.siemens.com/automation-contact

You start by selecting

- the required competence,
 - products and branches,
 - a country and a city
- or by a
- location search or free text search.

Easy product selection and ordering in the Industry Mall and with the Interactive Catalog CA 01

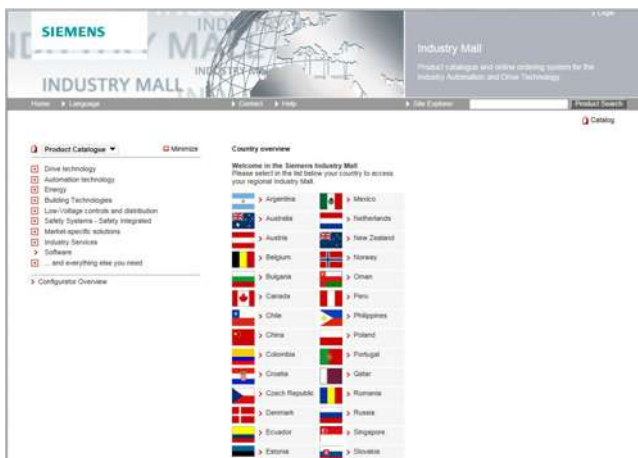

Industry Mall

The Industry Mall is a Siemens Internet ordering platform. Here you have a clear and informative online access to a huge range of products.

Powerful search functions make it easy to select the required products. Configurators enable you to configure complex product and system components quickly and easily. CAx data types are also provided here.

Data transfer allows the whole procedure, from selection through ordering to tracking and tracing, to be carried out online. Availability checks, customer-specific discounts and bid creation are also possible.

www.siemens.com/industrymall



Interactive Catalog CA 01 - Products for Automation and Drives

The Interactive Catalog CA 01 combined with the Siemens Industry Mall unites the benefits of offline and online media in one application – the performance of an offline catalog with the availability of manifold and up-to-date information on the Internet.

Select products and assemble orders with the CA 01, determine the availability of the selected products and track & trace via the Industry Mall.

More information and download: www.siemens.com/automation/ca01

0 10

Downloading catalogs

The screenshot displays the Siemens Information and Download Center interface. At the top, there is a navigation bar with the Siemens logo and the text 'Information and Download Center'. Below this, there are tabs for 'Catalogs (282)', 'Brochures (510)', 'Customer Magazines (8)', and 'Demo Software (15)'. A search filter is set to '10' and the language is 'English'. The main content area shows a list of catalogs, including 'Catalog D 11 - 2015 (13 MB)' and 'Catalog D 12 - 2017 with dimension drawings'. On the right side, there is a sidebar with a 'Text Size' selector and a 'Share this Page' button. Below that, a message states 'We will send to you, free of charge. Please select from the list left.' followed by a list of product categories such as 'Building Technologies (2)', 'Drive technology (294)', 'Energy (11)', 'Industrial automation (922)', 'Low-voltage control and distribution (32)', 'Safety systems - Safety Integrated (31)', 'Services (8)', and 'Software (1)'. At the bottom of the sidebar, there is a section titled 'All about Products & Services' with links for 'Pressure info', 'Catalog and ordering system online', 'Technical info', 'Support', and 'Service offer'.

In the Information and Download Center you can download catalogs and brochures in PDF format without having to register.

The filter dialog makes it possible to carry out targeted searches.

www.siemens.com/industry/infocenter

Overview**Software types**

Software requiring a license is categorized into types. The following software types have been defined:

- Engineering software
- Runtime software

Engineering software

This includes all software products for creating (engineering) user software, e.g. for configuring, programming, parameterizing, testing, commissioning or servicing.

Data generated with engineering software and executable programs can be duplicated for your own use or for use by third-parties free-of-charge.

Runtime software

This includes all software products required for plant/machine operation, e.g. operating system, basic system, system expansions, drivers, etc.

The duplication of the runtime software and executable programs created with the runtime software for your own use or for use by third-parties is subject to a charge.

You can find information about license fees according to use in the ordering data (e.g. in the catalog). Examples of categories of use include per CPU, per installation, per channel, per instance, per axis, per control loop, per variable, etc.

Information about extended rights of use for parameterization/configuration tools supplied as integral components of the scope of delivery can be found in the readme file supplied with the relevant product(s).

License types

- Floating license
- Single license
- Rental license
- Rental floating license
- Trial license
- Demo license
- Demo floating license

Floating license

The software may be installed for internal use on any number of devices by the licensee. Only the concurrent user is licensed. The concurrent user is the person using the program. Use begins when the software is started. A license is required for each concurrent user.

Single license

Unlike the floating license, a single license permits only one installation of the software per license.

The type of use licensed is specified in the ordering data and in the Certificate of License (CoL). Types of use include for example per instance, per axis, per channel, etc.

One single license is required for each type of use defined.

Rental license

A rental license supports the sporadic use of engineering software. Once the license key has been installed, the software can be used for a specific period of time (the operating hours do not have to be consecutive).

One license is required for each installation of the software.

Rental floating license

The rental floating license corresponds to the rental license, except that a license is not required for each installation of the software. Rather, one license is required per object (for example, user or device).

Trial license

A trial license supports short-term use of the software in a non-productive context, e.g. for testing and evaluation purposes. It can be transferred to another license.

Demo license

The demo license support the sporadic use of engineering software in a non-productive context, for example, use for testing and evaluation purposes. It can be transferred to another license. After the installation of the license key, the software can be operated for a specific period of time, whereby usage can be interrupted as often as required.

One license is required per installation of the software.

Demo floating license

The demo floating license corresponds to the demo license, except that a license is not required for each installation of the software. Rather, one license is required per object (for example, user or device).

Certificate of License (CoL)

The CoL is the licensee's proof that the use of the software has been licensed by Siemens. A CoL is required for every type of use and must be kept in a safe place.

Downgrading

The licensee is permitted to use the software or an earlier version/release of the software, provided that the licensee owns such a version/release and its use is technically feasible.

Delivery versions

Software is constantly being updated. The following delivery versions

- PowerPack
- Upgrade

can be used to access updates.

Existing bug fixes are supplied with the ServicePack version.

PowerPack

PowerPacks can be used to upgrade to more powerful software. The licensee receives a new license agreement and CoL (Certificate of License) with the PowerPack. This CoL, together with the CoL for the original product, proves that the new software is licensed.

A separate PowerPack must be purchased for each original license of the software to be replaced.

Upgrade

An upgrade permits the use of a new version of the software on the condition that a license for a previous version of the product is already held.

The licensee receives a new license agreement and CoL with the upgrade. This CoL, together with the CoL for the previous product, proves that the new version is licensed.

A separate upgrade must be purchased for each original license of the software to be upgraded.

Overview

ServicePack

ServicePacks are used to debug existing products. ServicePacks may be duplicated for use as prescribed according to the number of existing original licenses.

License key

Software products with and without license keys are supplied.

The license key serves as an electronic license stamp and is also the switch for activating the software (floating license, rental license, etc.).

The complete installation of software products requiring license keys includes the program to be licensed (the software) and the license key (which represents the license).

Software Update Service (SUS)

As part of the SUS contract, all software updates for the respective product are made available to you free of charge for a period of one year from the invoice date. The contract will automatically be extended for one year if it is not canceled three months before it expires.

The possession of the current version of the respective software is a basic condition for entering into an SUS contract.

You can download explanations concerning license conditions from www.siemens.com/automation/salesmaterial-as/catalog/en/terms_of_trade_en.pdf

Overview

For supplies and deliveries of software products see also Conditions of sale and delivery.

Legal notes during setup for new software products

All software products feature a uniform reference to the license conditions. The license conditions are enclosed either with the documentation or in the software pack. When software is downloaded from the Internet, the license contract is displayed before the ordering procedure and must be accepted by the user before downloading can continue.

Notice:

This software is protected by German and/or US copyright laws and the regulations of international agreements. Unauthorized reproduction or sale of this software or parts of it is a criminal offense. This will lead to criminal and civil prosecution, and may result in significant fines and/or claims for damages. Prior to installing and using the software, please read the applicable license conditions for this software. You will find these in the documentation or packaging.

If you have received this software on a CD-ROM that is marked Trial version, or accompanying software that is licensed for your use, the software is only permitted to be used for test and validation purposes in accordance with the accompanying conditions for the trial license. To this end, it is necessary for programs, software libraries, etc. are installed on your computer. We therefore urgently recommend that installation is performed on a single-user computer or on a computer that is not used in the production process or for storing important data, since it cannot be completely excluded that existing files will be modified or overwritten. We accept no liability whatsoever for damage and/or data losses that result from this installation or the non-observance of this warning. Every other type of use of this software is only permitted if you are in possession of a valid license from Siemens is obtained.

If you are not in possession of a valid license that can be proven by presenting an appropriate Certificate of License/software product certificate, please abort installation immediately and contact a Siemens office without delay to avoid claims for damages.

Overview (continued)**Software update services****Order**

To order the software update service, an article number must be specified. The software update service can be ordered when the software products are ordered or at a later date. Subsequent orders require that the ordering party is in possession at least of a single license.

Note:

It is recommended that the software update service is ordered as early as possible. If a new software version of a software product is released for delivery by Siemens, only those customers will receive it automatically who are entered in the appropriate delivery list at Siemens at this time. Previous software versions, or the current software version are not supplied when the software update service is ordered. The software update service requires that the software product is up-to-date at the time of completion of the contract for the software update service.

Delivery

When a software update service is ordered, you will be sent the contractual conditions of this service and the price is due for payment. At the same time, you will be included in a delivery list for the software product to be updated. If Siemens releases a new software version for the corresponding software product for general sale (function version or product version), it will be delivered automatically to the goods recipient specified in the delivery address within the contract period.

More information**Security information**

Siemens provides products and solutions with industrial security functions that support the secure operation of plants, systems, machines and networks. In order to protect plants, systems, machines and networks against cyber threats, it is necessary to implement – and continuously maintain – a holistic, state-of-the-art industrial security concept. Siemens' products and solutions only form one element of such a concept. Customer is responsible to prevent unauthorized access to its plants, systems, machines and networks. Systems, machines and components should only be connected to the enterprise network or the internet if and to the extent necessary and with appropriate security measures (e.g. use of firewalls and network segmentation) in place. Additionally, Siemens' guidance on appropriate security measures should be taken into account.

For more information about industrial security, please visit:

www.siemens.com/industrialsecurity

Siemens' products and solutions undergo continuous development to make them more secure. Siemens strongly recommends to apply product updates as soon as available and to always use the latest product versions. Use of product versions that are no longer supported, and failure to apply latest updates may increase customer's exposure to cyber threats.

To stay informed about product updates, subscribe to the Siemens Industrial Security RSS Feed under

www.siemens.com/industrialsecurity

Rotary inertia (to convert from A to B, multiply by entry in table)

A \ B	lb-in ²	lb-ft ²	lb-in-s ²	lb-ft-s ² slug-ft ²	kg-cm ²	kg-cm-s ²	gm-cm ²	gm-cm-s ²	oz-in ²	oz-in-s ²
lb-in ²	1	6.94×10^{-3}	2.59×10^{-3}	2.15×10^{-4}	2.926	2.98×10^{-3}	2.92×10^3	2.984	16	4.14×10^{-2}
lb-ft ²	144	1	0.3729	3.10×10^{-2}	421.40	0.4297	4.21×10^5	429.71	2304	5.967
lb-in-s ²	386.08	2.681	1	8.33×10^{-2}	1.129×10^3	1.152	1.129×10^6	1.152×10^3	6.177×10^3	16
lb-ft-s ² slug-ft ²	4.63×10^3	32.17	12	1	1.35×10^4	13.825	1.355×10^7	1.38×10^4	7.41×10^4	192
kg-cm ²	0.3417	2.37×10^{-3}	8.85×10^{-4}	7.37×10^{-5}	1	1.019×10^{-3}	1000	1.019	5.46	1.41×10^{-2}
kg-cm-s ²	335.1	2.327	0.8679	7.23×10^{-2}	980.66	1	9.8×10^5	1000	5.36×10^3	13.887
gm-cm ²	3.417×10^{-4}	2.37×10^{-6}	8.85×10^{-7}	7.37×10^{-8}	1×10^{-3}	1.01×10^{-6}	1	1.01×10^{-3}	5.46×10^{-3}	1.41×10^{-5}
gm-cm-s ²	0.335	2.32×10^{-3}	8.67×10^{-4}	7.23×10^{-5}	0.9806	1×10^{-3}	980.6	1	5.36	1.38×10^{-2}
oz-in ²	0.0625	4.34×10^{-4}	1.61×10^{-4}	1.34×10^{-5}	0.182	1.86×10^{-4}	182.9	0.186	1	2.59×10^{-3}
oz-in-s ²	24.13	0.1675	6.25×10^{-2}	5.20×10^{-3}	70.615	7.20×10^{-2}	7.09×10^4	72.0	386.08	1

Torque (to convert from A to B, multiply by entry in table)

A \ B	lb-in	lb-ft	oz-in	N-m	kg-cm	kg-m	gm-cm	dyne-cm
lb-in	1	8.333×10^{-2}	16	0.113	1.152	1.152×10^{-2}	1.152×10^3	1.129×10^6
lb-ft	12	1	192	1.355	13.825	0.138	1.382×10^4	1.355×10^7
oz-in	6.25×10^{-2}	5.208×10^{-3}	1	7.061×10^{-3}	7.200×10^{-2}	7.200×10^{-4}	72.007	7.061×10^4
N-m	8.850	0.737	141.612	1	10.197	0.102	1.019×10^4	1×10^7
kg-cm	0.8679	7.233×10^{-2}	13.877	9.806×10^{-2}	1	10^{-2}	1000	9.806×10^5
kg-m	86.796	7.233	1.388×10^3	9.806	100	1	1×10^5	9.806×10^7
gm-cm	8.679×10^{-4}	7.233×10^{-5}	1.388×10^{-2}	9.806×10^{-5}	1×10^{-3}	1×10^{-5}	1	980.665
dyne-cm	8.850×10^{-7}	7.375×10^{-8}	1.416×10^{-5}	10^{-7}	1.0197×10^{-6}	1.019×10^{-8}	1.019×10^{-3}	1

Length (to convert from A to B, multiply by entry in table)

A \ B	inches	feet	cm	yd	mm	m
inches	1	0.0833	2.54	0.028	25.4	0.0254
feet	12	1	30.48	0.333	304.8	0.3048
cm	0.3937	0.03281	1	1.09×10^{-2}	10	0.01
yd	36	3	91.44	1	914.4	0.914
mm	0.03937	0.00328	0.1	1.09×10^{-3}	1	0.001
m	39.37	3.281	100	1.09	1000	1

Force (to convert from A to B, multiply by entry in table)

A \ B	lb	oz	gm	dyne	N
lb	1	16	453.6	4.448×10^5	4.4482
oz	0.0625	1	28.35	2.780×10^4	0.27801
gm	2.205×10^{-3}	0.03527	1	1.02×10^{-3}	N.A.
dyne	2.248×10^{-6}	3.59×10^{-5}	980.7	1	0.00001
N	0.22481	3.5967	N.A.	100000	1

Power (to convert from A to B, multiply by entry in table)

A \ B	hp	Watts
hp (English)	1	745.7
(lb-in) (deg./s)	2.645×10^{-6}	1.972×10^{-3}
(lb-in) (rpm)	1.587×10^{-5}	1.183×10^{-2}
(lb-ft) (deg./s)	3.173×10^{-5}	2.366×10^{-2}
(lb-ft) (rpm)	1.904×10^{-4}	0.1420
Watts	1.341×10^{-3}	1

Mass (to convert from A to B, multiply by entry in table)

A \ B	lb	oz	gm	kg	slug
lb	1	16	453.6	0.4536	0.0311
oz	6.25×10^{-2}	1	28.35	0.02835×10^{-3}	1.93×10^{-5}
gm	2.205×10^{-3}	3.527×10^{-2}	1	10^{-3}	6.852×10^{-5}
kg	2.205	35.27	10^3	1	6.852×10^{-2}
slug	32.17	514.8	1.459×10^4	14.59	1

Rotation (to convert from A to B, multiply by entry in table)

A \ B	rpm	rad/s	degrees/s
rpm	1	0.105	6.0
rad/s	9.55	1	57.30
degrees/s	0.167	1.745×10^{-2}	1

Temperature Conversion

°F	°C	°C	°F
0	-17.8	-10	14
32	0	0	32
50	10	10	50
70	21.1	20	68
90	32.2	30	86
98.4	37	37	98.4
212	100	100	212
subtract 32 and multiply by $\frac{5}{9}$		multiply by $\frac{9}{5}$ and add 32	

Mechanism Efficiencies

Acme-screw with brass nut	~0.35–0.65
Acme-screw with plastic nut	~0.50–0.85
Ball-screw	~0.85–0.95
Chain and sprocket	~0.95–0.98
Preloaded ball-screw	~0.75–0.85
Spur or bevel-gears	~0.90
Timing belts	~0.96–0.98
Worm gears	~0.45–0.85
Helical gear (1 reduction)	~0.92

Friction Coefficients

Materials	μ
Steel on steel (greased)	~0.15
Plastic on steel	~0.15–0.25
Copper on steel	~0.30
Brass on steel	~0.35
Aluminum on steel	~0.45
Steel on steel	~0.58
Mechanism	μ
Ball bushings	<0.001
Linear bearings	<0.001
Dove-tail slides	~0.2++
Gibb ways	~0.5++

Material Densities

Material	lb-in ³	gm-cm ³
Aluminum	0.096	2.66
Brass	0.299	8.30
Bronze	0.295	8.17
Copper	0.322	8.91
Hard wood	0.029	0.80
Soft wood	0.018	0.48
Plastic	0.040	1.11
Glass	0.079–0.090	2.2–2.5
Titanium	0.163	4.51
Paper	0.025–0.043	0.7–1.2
Polyvinyl chloride	0.047–0.050	1.3–1.4
Rubber	0.033–0.036	0.92–0.99
Silicone rubber, without filler	0.043	1.2
Cast iron, gray	0.274	7.6
Steel	0.280	7.75

Wire Gauges¹⁾

Cross-section mm ²	Standard Wire Gauge (SWG)	American Wire Gauge (AWG)
0.2	25	24
0.3	23	22
0.5	21	20
0.75	20	19
1.0	19	18
1.5	17	16
2.5	15	13
4	13	11
6	12	9
10	9	7
16	7	6
25	5	3
35	3	2
50	0	1/0
70	000	2/0
95	00000	3/0
120	0000000	4/0
150	–	6/0
185	–	7/0

¹⁾ The table shows approximate SWG/AWG sizes nearest to standard metric sizes; the cross-sections do not match exactly.

Explanation of the raw material/metal surcharges¹⁾

Surcharge calculation

To compensate for variations in the price of the raw materials silver, copper, aluminum, lead, gold, dysprosium²⁾ and/or neodym²⁾, surcharges are calculated on a daily basis using the so-called metal factor for products containing these raw materials. A surcharge for the respective raw material is calculated as a supplement to the price of a product if the basic official price of the raw material in question is exceeded.

The surcharges are calculated in accordance with the following criteria:

- Basic official price of the raw material
Basic official price from the day prior to receipt of the order or prior to release order (daily price) for³⁾
 - Silver (sales price, processed)
 - Gold (sales price, processed)
 and for⁴⁾
 - Copper (lower DEL notation + 1 %)
 - Aluminum (aluminum in cables)
 - Lead (lead in cables)
- Metal factor of the products
Certain products are displayed with a metal factor. The metal factor determines the official price (for those raw materials concerned) as of which the metal surcharges are applied and the calculation method used (weight or percentage method). An exact explanation is given below.

Structure of the metal factor

The metal factor consists of several digits; the first digit indicates whether the percentage method of calculation refers to the list price or a possible discounted price (customer net price) (L = list price / N = customer net price).

The remaining digits indicate the method of calculation used for the respective raw material. If no surcharge is added for a raw material, a "-" is used.

1st digit	List or customer net price using the percentage method
2nd digit	for silver (AG)
3rd digit	for copper (CU)
4th digit	for aluminum (AL)
5th digit	for lead (PB)
6th digit	for gold (AU)
7th digit	for dysprosium (Dy) ²⁾
8th digit	for neodym (Nd) ²⁾

Weight method

The weight method uses the basic official price, the daily price and the raw material weight. In order to calculate the surcharge, the basic official price must be subtracted from the daily price. The difference is then multiplied by the raw material weight.

The basic official price can be found in the table below using the number (1 to 9) of the respective digit of the metal factor. The raw material weight can be found in the respective product descriptions.

Percentage method

Use of the percentage method is indicated by the letters A-Z at the respective digit of the metal factor.

The surcharge is increased - dependent on the deviation of the daily price compared with the basic official price - using the percentage method in "steps" and consequently offers surcharges that remain constant within the framework of this "step range". A higher percentage rate is charged for each new step. The respective percentage level can be found in the table below.

Metal factor examples

L E A - - - -	Basis for % surcharge: List price Silver Basis 150 €, Step 50 €, 0.5 % Copper Basis 150 €, Step 50 €, 0.1 % No surcharge for aluminum No surcharge for lead No surcharge for gold No surcharge for dysprosium No surcharge for neodym
N - A 6 - - - -	Basis for % surcharge: Customer net price No surcharge for silver Copper Basis 150 €, Step 50 €, 0.1 % Aluminum acc. to weight, basic offic. price 225 € No surcharge for lead No surcharge for gold No surcharge for dysprosium No surcharge for neodym
- - 3 - - - -	No basis necessary No surcharge for silver Copper acc. to weight, basic official price 150 € No surcharge for aluminum No surcharge for lead No surcharge for gold No surcharge for dysprosium No surcharge for neodym

¹⁾ Refer to the separate explanation on the next page regarding the raw materials dysprosium and neodym (= rare earths).

²⁾ For a different method of calculation, refer to the separate explanation for these raw materials on the next page.

³⁾ Source: Umicore, Hanau (www.metalsmanagement.umicore.com).

⁴⁾ Source: Schutzvereinigung DEL-Notiz e.V. (www.del-notiz.org).

Explanation of the raw material/metal surcharges for dysprosium and neodym (rare earths)

Surcharge calculation

To compensate for variations in the price of the raw materials silver¹⁾, copper¹⁾, aluminum¹⁾, lead¹⁾, gold¹⁾, dysprosium and/or neodym, surcharges are calculated on a daily basis using the so-called metal factor for products containing these raw materials. The surcharge for dysprosium and neodym is calculated as a supplement to the price of a product if the basic official price of the raw material in question is exceeded.

The surcharge is calculated in accordance with the following criteria:

- Basic official price of the raw material²⁾
Three-month basic average price (see below) in the period before the quarter in which the order was received or the release order took place (= average official price) for
- dysprosium (Dy metal, 99 % min. FOB China; USD/kg)
- neodym (Nd metal, 99 % min. FOB China; USD/kg)
- Metal factor of the products
Certain products are displayed with a metal factor. The metal factor indicates (for those raw materials concerned) the basic official price as of which the surcharges for dysprosium and neodym are calculated using the weight method. An exact explanation of the metal factor is given below.

Three-month average price

The prices of rare earths vary according to the foreign currency, and there is no freely accessible stock exchange listing. This makes it more difficult for all parties involved to monitor changes in price. In order to avoid continuous adjustment of the surcharges, but to still ensure fair, transparent pricing, an average price is calculated over a three-month period using the average monthly foreign exchange rate from USD to EUR (source: European Central Bank). Since not all facts are immediately available at the start of each month, a one-month buffer is allowed before the new average price applies.

Examples of calculation of the average official price:

Period for calculation of the average price:	Period during which the order/release order is effected and the average price applies:
Sep 2016 - Nov 2016	Q1 in 2017 (Jan - Mar)
Dec 2016 - Feb 2017	Q2 in 2017 (Apr - Jun)
Mar 2017 - May 2017	Q3 in 2017 (Jul - Sep)
Jun 2017 - Aug 2017	Q4 in 2017 (Oct - Dec)

Structure of the metal factor

The metal factor consists of several digits; the first digit is not relevant to the calculation of dysprosium and neodym.

The remaining digits indicate the method of calculation used for the respective raw material. If no surcharge is added for a raw material, a "-" is used.

1st digit	List or customer net price using the percentage method
2nd digit	for silver (AG) ¹⁾
3rd digit	for copper (CU) ¹⁾
4th digit	for aluminum (AL) ¹⁾
5th digit	for lead (PB) ¹⁾
6th digit	for gold (AU) ¹⁾
7th digit	for dysprosium (Dy)
8th digit	for neodym (Nd)

Weight method

The weight method uses the basic official price, the average price and the raw material weight. In order to calculate the surcharge, the basic official price must be subtracted from the average price. The difference is then multiplied by the raw material weight.

The basic official price can be found in the table below using the number (1 to 9) of the respective digit of the metal factor. Your Sales contact can inform you of the raw material weight.

Metal factor examples

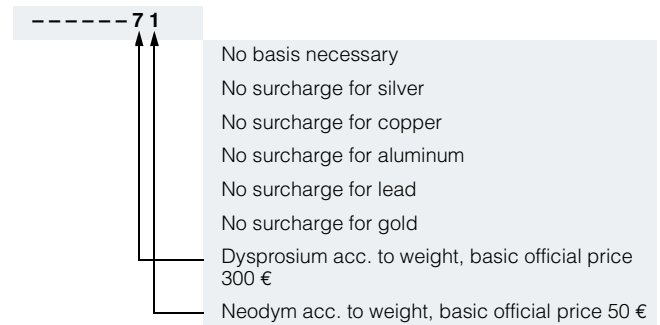

¹⁾ For a different method of calculation, refer to the separate explanation for these raw materials on the previous page.

²⁾ Source: Asian Metal Ltd (www.asianmetal.com)

Values of the metal factor

Percentage method	Basic official price in €	Step range in €	% surcharge 1st step	% surcharge 2nd step	% surcharge 3rd step	% surcharge 4th step	% surcharge per additional step	
			Price in €	Price in €	Price in €	Price in €		
A	150	50	0.1	0.2	0.3	0.4	0.1	
B	150	50	0.2	0.4	0.6	0.8	0.2	
C	150	50	0.3	0.6	0.9	1.2	0.3	
D	150	50	0.4	0.8	1.2	1.6	0.4	
E	150	50	0.5	1.0	1.5	2.0	0.5	
F	150	50	0.6	1.2	1.8	2.4	0.6	
G	150	50	1.0	2.0	3.0	4.0	1.0	
H	150	50	1.2	2.4	3.6	4.8	1.2	
I	150	50	1.6	3.2	4.8	6.4	1.6	
J	150	50	1.8	3.6	5.4	7.2	1.8	
			175.01 - 225.00	225.01 - 275.00	275.01 - 325.00	325.01 - 375.00		
O	175	50	0.1	0.2	0.3	0.4	0.1	
P	175	50	0.2	0.4	0.6	0.8	0.2	
R	175	50	0.5	1.0	1.5	2.0	0.5	
			225.01 - 275.00	275.01 - 325.00	325.01 - 375.00	375.01 - 425.00		
S	225	50	0.2	0.4	0.6	0.8	0.2	
U	225	50	1.0	2.0	3.0	4.0	1.0	
V	225	50	1.0	1.5	2.0	3.0	1.0	
W	225	50	1.2	2.5	3.5	4.5	1.0	
			150.01 - 175.00	175.01 - 200.00	200.01 - 225.00	225.01 - 250.00		
Y	150	25	0.3	0.6	0.9	1.2	0.3	
			400.01 - 425.00	425.01 - 450.00	450.01 - 475.00	475.01 - 500.00		
Z	400	25	0.1	0.2	0.3	0.4	0.1	
Price basis (1st digit)								
L	Calculation based on the list price							
N	Calculation based on the customer net price (discounted list price)							
Weight method	Basic official price in €							
1	50	Calculation based on raw material weight						
2	100							
3	150							
4	175							
5	200							
6	225							
7	300							
8	400							
9	555							
Miscellaneous								
-	No metal surcharge							

0 10

1. General Provisions

By using this catalog you can acquire hardware and software products described therein from Siemens AG subject to the following Terms and Conditions of Sale and Delivery (hereinafter referred to as "T&C"). Please note that the scope, the quality and the conditions for supplies and services, including software products, by any Siemens entity having a registered office outside Germany, shall be subject exclusively to the General Terms and Conditions of the respective Siemens entity. The following T&C apply exclusively for orders placed with Siemens Aktiengesellschaft, Germany.

1.1 For customers with a seat or registered office in Germany

For customers with a seat or registered office in Germany, the following applies subordinate to the T&C:

- for installation work the "General Conditions for Erection Works – Germany"¹⁾ ("Allgemeine Montagebedingungen – Deutschland" (only available in German at the moment)) and/or
- for Plant Analytics Services the "Standard Terms and Conditions for Plant Analytics Services – for Customer in Germany"¹⁾ ("Allgemeine Geschäftsbedingungen für das Plant Analytics Services – für Kunden in Deutschland" (only available in German at the moment)) and/or
- for stand-alone software products and software products forming a part of a product or project, the "General License Conditions for Software Products for Automation and Drives for Customers with a Seat or registered Office in Germany"¹⁾ and/or
- for other supplies and/or services the "General Conditions for the Supply of Products and Services of the Electrical and Electronics Industry"¹⁾.

In case such supplies and/or services should contain Open Source Software, the conditions of which shall prevail over the "General Conditions for the Supply of Products and Services of the Electrical and Electronics Industry"¹⁾. A notice will be contained in the scope of delivery in which the applicable conditions for Open Source Software are specified. This shall apply mutatis mutandis for notices referring to other third party software components.

1.2 For customers with a seat or registered office outside Germany

For customers with a seat or registered office outside Germany, the following applies subordinate to the T&C:

- for Plant Analytics Services the "Standard Terms and Conditions for Plant Analytics Services"¹⁾ and/or
- for services the "International Terms & Conditions for Services"¹⁾ supplemented by "Software Licensing Conditions"¹⁾ and/or
- for other supplies of hard- and/or software the "International Terms & Conditions for Products"¹⁾ supplemented by "Software Licensing Conditions"¹⁾

1.3 For customers with master or framework agreement

To the extent our supplies and/or services offered are covered by an existing master or framework agreement, the terms and conditions of that agreement shall apply instead of T&C.

2. Prices

The prices are in € (Euro) ex point of delivery, exclusive of packaging.

The sales tax (value added tax) is not included in the prices. It shall be charged separately at the respective rate according to the applicable statutory legal regulations.

Prices are subject to change without prior notice. We will charge the prices valid at the time of delivery.

To compensate for variations in the price of raw materials (e.g. silver, copper, aluminum, lead, gold, dysprosium and neodym), surcharges are calculated on a daily basis using the so-called metal factor for products containing these raw materials. A surcharge for the respective raw material is calculated as a supplement to the price of a product if the basic official price of the raw material in question is exceeded.

The metal factor of a product indicates the basic official price (for those raw materials concerned) as of which the surcharges on the price of the product are applied, and with what method of calculation.

You will find a detailed explanation of the metal factor on the page headed "Metal surcharges".

To calculate the surcharge (except in the cases of dysprosium and neodym), the official price from the day prior to that on which the order was received or the release order was effected is used.

To calculate the surcharge applicable to dysprosium and neodym ("rare earths"), the corresponding three-month basic average price in the quarter prior to that in which the order was received or the release order was effected is used with a one-month buffer (details on the calculation can be found in the explanation of the metal factor).

3. Additional Terms and Conditions

The dimensions are in mm. In Germany, according to the German law on units in measuring technology, data in inches apply only to devices for export.

Illustrations are not binding.

Insofar as there are no remarks on the individual pages of this catalog - especially with regard to data, dimensions and weights given - these are subject to change without prior notice.

¹⁾ The text of the Terms and Conditions of Siemens AG can be downloaded at www.siemens.com/automation/salesmaterial-as/catalog/en/terms_of_trade_en.pdf

4. Export regulations

We shall not be obligated to fulfill any agreement if such fulfillment is prevented by any impediments arising out of national or international foreign trade or customs requirements or any embargoes and/or other sanctions.

Export may be subject to license. We shall indicate in the delivery details whether licenses are required under German, European and US export lists.

Our products are controlled by the U.S. Government (when labeled with "ECCN" unequal "N") and authorized for export only to the country of ultimate destination for use by the ultimate consignee or end-user(s) herein identified. They may not be resold, transferred, or otherwise disposed of, to any other country or to any person other than the authorized ultimate consignee or end-user(s), either in their original form or after being incorporated into other items, without first obtaining approval from the U.S. Government or as otherwise authorized by U.S. law and regulations.

The export indications can be viewed in advance in the description of the respective goods on the Industry Mall, our online catalog system. Only the export labels "AL" and "ECCN" indicated on order confirmations, delivery notes and invoices are authoritative.

Products labeled with "AL" unequal "N" are subject to European / national export authorization. Products without label, with label "AL:N" / "ECCN:N", or label "AL:9X9999" / "ECCN: 9X9999" may require authorization from responsible authorities depending on the final end-use, or the destination.

If you transfer goods (hardware and/or software and/or technology as well as corresponding documentation, regardless of the mode of provision) delivered by us or works and services (including all kinds of technical support) performed by us to a third party worldwide, you must comply with all applicable national and international (re-)export control regulations.

If required for the purpose of conducting export control checks, you (upon request by us) shall promptly provide us with all information pertaining to the particular end customer, final disposition and intended use of goods delivered by us respectively works and services provided by us, as well as to any export control restrictions existing in this relation.

The products listed in this catalog may be subject to European/German and/or US export regulations. Any export requiring approval is therefore subject to authorization by the relevant authorities.

Errors excepted and subject to change without prior notice.

Interactive Catalog	<i>Catalog</i>	
Products for Automation and Drives	CA 01	
Building Control		
GAMMA Building Control	ET G1	
Drive Systems		
SINAMICS G130 Drive Converter Chassis Units	D 11	
SINAMICS G150 Drive Converter Cabinet Units		
<i>Digital: SINAMICS PERFECT HARMONY GH180 Medium-Voltage Air-Cooled Drives (Germany Edition)</i>	D 15.1	
SINAMICS G180 Converters – Compact Units, Cabinet Systems, Cabinet Units Air-Cooled and Liquid-Cooled	D 18.1	
SINAMICS S120 Chassis Format Converter Units	D 21.3	
SINAMICS S120 Cabinet Modules		
SINAMICS S150 Converter Cabinet Units		
SINAMICS S120 and SIMOTICS	D 21.4	
SINAMICS DCM DC Converter, Control Module	D 23.1	
SINAMICS Inverters for Single-Axis Drives · Built-In Units	D 31.1	
SINAMICS Inverters for Single-Axis Drives · Distributed Inverters	D 31.2	
<i>Digital: SINAMICS Converters for Single-Axis Drives · SINAMICS G120X</i>	D 31.5	
<i>Digital: SINAMICS S210 Servo Drive System</i>	D 32	
<i>Digital: SINAMICS V90 Basic Servo Drive System</i>	D 33	
<i>Digital: SINAMICS G120P and SINAMICS G120P Cabinet pump, fan, compressor converters</i>	D 35	
LOHER VARIO High Voltage Motors Flameproof, Type Series 1PS4, 1PS5, 1MV4 and 1MV5 Frame Size 355 to 1000, Power Range 80 to 7100 kW	D 83.2	
<i>Digital: Three-Phase Induction Motors SIMOTICS HV, SIMOTICS TN</i>	D 84.1	
<i>Digital: Three-Phase Induction Motors SIMOTICS HV</i>	D 84.3	
High Voltage Three-phase Induction Motors SIMOTICS HV Series A-compact PLUS	D 84.9	
<i>Digital: Modular Industrial Generators SIGENTICS M</i>	D 85.1	
Synchronous Motors with Permanent-Magnet Technology, HT-direct	D 86.2	
DC Motors	DA 12	
SIMOVERT PM Modular Converter Systems	DA 45	
MICROMASTER 420/430/440 Inverters	DA 51.2	
MICROMASTER 411/COMBIMASTER 411	DA 51.3	
<u>Low-Voltage Three-Phase-Motors</u>		
SIMOTOCS S-1FG1 Servo geared motors	D 41	
SIMOTICS Low-Voltage Motors	D 81.1	
SIMOTICS FD Low-Voltage Motors	D 81.8	
LOHER Low-Voltage Motors	D 83.1	
<i>Digital: MOTOX Geared Motors</i>	D 87.1	
SIMOGEAR Geared Motors	MD 50.1	
SIMOGEAR Electric-monorail geared motors Light-load and heavy-load applications	MD 50.8	
SIMOGEAR Gearboxes with adapter	MD 50.11	
<u>Mechanical Driving Machines</u>		
FLENDER Standard Couplings	MD 10.1	
FLENDER High Performance Couplings	MD 10.2	
FLENDER Backlash-free Couplings	MD 10.3	
FLENDER SIP Standard industrial planetary gear units	MD 31.1	
Motion Control		
SINUMERIK 840 Equipment for Machine Tools	NC 62	
SINUMERIK 808 Equipment for Machine Tools	NC 81.1	
SINUMERIK 828 Equipment for Machine Tools	NC 82	
SIMOTION Equipment for Production Machines	PM 21	
<i>Digital: Drive and Control Components for Cranes</i>	CR 1	
Process Instrumentation and Analytics	<i>Catalog</i>	
<i>Digital: Field Instruments for Process Automation</i>	FI 01	
<i>Digital: Display Recorders SIREC D</i>	MP 20	
<i>Digital: SIPART Controllers and Software</i>	MP 31	
Products for Weighing Technology	WT 10	
<i>Digital: Process Analytical Instruments</i>	AP 01	
<i>Digital: Process Analytics, Components for Continuous Emission Monitoring</i>	AP 11	
Low-Voltage Power Distribution and Electrical Installation Technology		
SETRON · SIVACON · ALPHA	LV 10	
Protection, Switching, Measuring and Monitoring Devices, Switchboards and Distribution Systems		
Electrical Components for the Railway Industry	LV 12	
Power Monitoring Made Simple	LV 14	
Components for Industrial Control Panels according to UL Standards	LV 16	
<i>Digital: Air circuit breakers and molded case circuit breakers with UL certification</i>	LV 18	
3WT Air Circuit Breakers up to 4000 A	LV 35	
3VT Molded Case Circuit Breakers up to 1600 A	LV 36	
<i>Digital: SIVACON System Cubicles, System Lighting and System Air-Conditioning</i>	LV 50	
<i>Digital: ALPHA Distribution Systems</i>	LV 51	
ALPHA FIX Terminal Blocks	LV 52	
SIVACON S4 Power Distribution Boards	LV 56	
SIVACON 8PS Busbar Trunking Systems	LV 70	
<i>Digital: DELTA Switches and Socket Outlets</i>	ET D1	
Vacuum Switching Technology and Components for Medium Voltage	HG 11.01	
Power Supply		
SITOP Power supply	KT 10.1	
Safety Integrated		
Safety Technology for Factory Automation	SI 10	
SIMATIC HMI / PC-based Automation		
Human Machine Interface Systems/ PC-based Automation	ST 80/ ST PC	
SIMATIC Ident		
Industrial Identification Systems	ID 10	
SIMATIC Industrial Automation Systems		
Products for Totally Integrated Automation	ST 70	
SIMATIC PCS 7 Process Control System	ST PCS 7	
System components		
SIMATIC PCS 7 Process Control System Technology components	ST PCS 7 T	
Add-ons for the SIMATIC PCS 7 Process Control System	ST PCS 7 AO	
SIMATIC S7-400 advanced controller	ST 400	
SIMATIC NET		
Industrial Communication	IK PI	
SIRIUS Industrial Controls		
<i>Digital: SIRIUS Industrial Controls</i>	IC 10	

Digital: These catalogs are only available as a PDF.

Information and Download Center

Digital versions of the catalogs are available on the Internet at:
www.siemens.com/industry/infocenter
There you'll find additional catalogs in other languages.

SINUMERIK automation systems for machine tools:

www.siemens.com/sinumerik

The SINAMICS drives family:

www.siemens.com/sinamics

Motion Control Systems and Solutions for production machine and machine tool equipment:

www.siemens.com/motioncontrol

Local partners worldwide:

www.siemens.com/automation-contact

Siemens AG
Digital Factory Division
Motion Control
Postfach 3180
91050 ERLANGEN
GERMANY

© Siemens AG 2018

Subject to change without prior notice

PDF (E86060-K4482-A101-A6-7600)

V1.MKKATA.MTS.121

KG 1118 HOF 218 En

Produced in Germany

The information provided in this catalog contains merely general descriptions or characteristics of performance which in case of actual use do not always apply as described or which may change as a result of further development of the products. An obligation to provide the respective characteristics shall only exist if expressly agreed in the terms of contract. Availability and technical specifications are subject to change without notice.

All product designations may be trademarks or product names of Siemens AG or supplier companies whose use by third parties for their own purposes could violate the rights of the owners.

Siemens provides products and solutions with industrial security functions that support the secure operation of plants, systems, machines and networks.

In order to protect plants, systems, machines and networks against cyber threats, it is necessary to implement – and continuously maintain – a holistic, state-of-the-art industrial security concept. Siemens' products and solutions only form one element of such a concept.

Customers are responsible for preventing unauthorized access to their plants, systems, machines and networks. Such systems, machines and components should only be connected to an enterprise network or the internet if and to the extent such a connection is necessary and only when appropriate security measures (e.g. firewalls and/or network segmentation) are in place.

For additional information on industrial security measures that may be implemented, please visit <https://www.siemens.com/industrialsecurity>

Siemens' products and solutions undergo continuous development to make them more secure. Siemens strongly recommends that product updates are applied as soon as they are available and that the latest product versions are used. Use of product versions that are no longer supported, and failure to apply the latest updates may increase customer's exposure to cyber threats.

To stay informed about product updates, subscribe to the Siemens Industrial Security RSS Feed under <https://www.siemens.com/industrialsecurity>



www.nicsanat.com

021-87700210