

Modicon Premium PLCs

TSX 57

User Manual

Edition October 2003

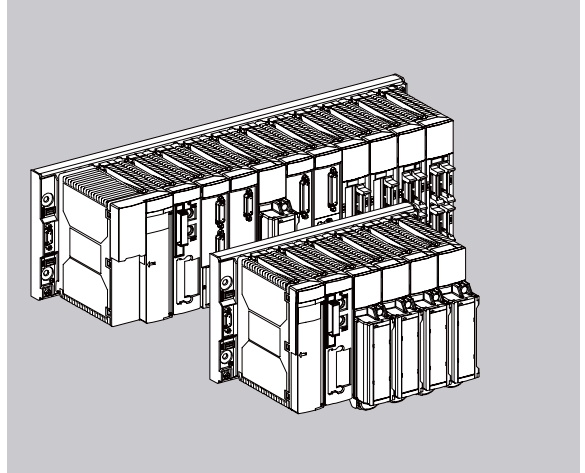

www.nicsanat.com

021-87700210



Telemecanique

1 General

This manual is intended for personnel technically qualified to install, operate and maintain the products which are described herein. It contains all the necessary information for correct use of the products. However, for advanced use of our products please contact your nearest sales office for additional information.

The contents of this manual are not contractual and cannot under any circumstance extend or restrict contract warranty clauses.

2 Qualification of personnel

Only **qualified personnel** are authorized to install, operate or maintain the products. Any work performed by a unqualified person or non-observance of the safety instructions in this document or attached to the equipment may risk the safety of personnel and/or cause irreparable damage to equipment. The following personnel may be regarded as being "**Qualified**" :

- those involved with application design. Design office personnel familiar with control system safety concepts (for example, design engineers, etc),
- those involved with equipment installation. Individuals who are familiar with the installation, connection and startup of control system equipment (for example installers or wiring technicians working during the installation phase, technicians setting up the equipment, etc),
- those involved with operation. Personnel trained to operate and manage control system equipment (for example, operators, etc),
- those performing preventive or corrective maintenance. Personnel who are trained and experienced in the adjustment and repair of control system equipment (for example, installation engineers, after sales service engineers, etc).

3 Warnings

Warnings serve to prevent specific risks encountered by personnel and/or equipment. They are indicated in the documentation and on the products by different warning symbols, according to the severity of the risk :

Danger or Caution or Attention

Indicates that not following instructions or ignoring the warning may cause serious personal injury, death and/or serious damage to equipment.

Warning or Important or

Indicates that not following a specific instruction may lead to minor injury and/or damage to equipment.

Note or Comment

Highlights important information relating to the product, its operation or its accompanying documentation.

4 Conformity of use

The products described in this manual **conform to the European Directives** (*) to which they are subject (CE marking). However, they can only be used correctly in the context of the applications for which they are intended (described in the various documents) and when connected to approved third party products.

As a general rule, if all handling, transport and storage specifications are observed, and all instructions for installation, operation and maintenance are followed, the products will be used correctly, with no danger to personnel or equipment.

(*) DEMC and DLV Directives, concerning Electromagnetic Compatibility and Low Voltage.

5 Installing and setting up equipment

It is important to observe the following rules when installing and starting up equipment. In addition, if the installation includes digital links, it is essential to follow the basic wiring rules given in the user's guide, **reference TSX DG GND**, or in manual **TSX DR NET**, part C.

- safety instructions must be followed meticulously. These instructions are in the documentation or on the equipment being installed and set up.
- the type of equipment defines the way in which it should be installed :
 - a flush-mountable device (for example, a process control terminal or a cell controller) must be flush-mounted,
 - a device which is to be built in (for example, PLC) must be placed in a cabinet or enclosure,
 - the casing of a laptop or portable device (for example, a programming terminal or a notebook) must remain closed,
- if the device is permanently connected, its electrical installation must include a device to isolate it from the power supply and a circuit-breaker to protect it against overcurrents and isolation faults. If this is not the case, the power socket must be grounded and be easily accessed. **In all cases, the device must be connected to the protective mechanical ground PG using green/yellow wires (NFC 15 100).**
- low voltage circuits (even though they are low voltage) must be connected to the protective ground so that dangerous voltages can be detected.
- before a device is powered up, its nominal voltage must be checked to ensure that it has been adjusted to conform with the supply voltage.
- if the device is supplied with 24 or 48 VDC, the low voltage circuits must be protected. Only use power supplies which conform to the standards currently in force.
- check that the supply voltages remain within the tolerance ranges defined in the technical characteristics of the devices.
- all measures must be taken to ensure that any power return (immediate, warm or cold) does not lead to a dangerous state which may risk personnel or the installation.
- emergency stop devices must remain effective in all the device's operating modes, even those which are abnormal (for example, when a wire becomes disconnected). Resetting these devices must not cause uncontrolled or improper restarts.
- cables which carry signals must be located where they do not cause interference with the control system functions by capacitive, inductive or electromagnetic interference.
- control system equipment and their control devices must be installed in such a way as to ensure that they are protected against unintentional operation.
- appropriate safety measures must be taken for the inputs and outputs, to prevent improper states in the control system device, if no signal is received.

6 Equipment operation

The operational safety and availability of a device is its ability to avoid the appearance of faults and to minimize their effects if they occur.

A system is said to be fail-safe if the appearance of faults **never** causes a dangerous situation.

A fault inside the control system is known as :

- passive, if it results in an open output circuit (no command is sent to the actuators).
- active, if it results in a closed output circuit (an command is sent to the actuators).

From the safety point of view, a given fault is dangerous or not depending on the type of command given during normal operation. A passive fault is dangerous if the normal command is the operation of an alarm. An active fault is dangerous if it maintains or activates an undesirable command.

It is important to note the basic difference between the behavior of an electromechanical relay and an electronic component (for example a transistor) :

- there is a high probability, approximately 90%, that the failure of a relay will cause an open circuit (control circuit powered off).
- there is a 50% probability that the failure of a transistor will cause either an open circuit or a closed circuit.

This is why it is important to correctly estimate the types and consequences of faults when automating a system using electronic products such as PLCs, including when relay output modules are used on PLCs.

The system designer must **use devices external to the PLC** to protect against active faults inside the PLC, which are not indicated and are judged to be dangerous to the application. This may require solutions from various different technologies such as mechanical, electromechanical, pneumatic or hydraulic devices (for example, directly wiring a limit switch and emergency stop switches to the coil of a movement control contactor).

To protect against dangerous faults which may occur on output circuits or preactuators, it is sometimes beneficial to resort to general principles and use the large processing capacity of PLCs, for example by using "inputs to check the correct execution of commands requested by the program".

7 Electrical and thermal characteristics

Details of the electrical and thermal characteristics of devices are given in the associated technical documents (installation manuals, service instructions).

8 Environmental conditions

In industry, the micro-environmental conditions of electronic devices can vary greatly. For this reason, programmable controllers and associated modules must conform to the following two types of installation :

- installation in an enclosure with IP54 protection for protecting devices from metallic dust amongst other things. Two guidelines are associated with this enclosure type of installation :
 - direct access to electronic modules should be strictly reserved to maintenance staff (see section 2), with access keys,
 - the selection of a metallic enclosure must be considered, since it serves as extra screening against the latent risk of electromagnetic interference.
- direct installation without protection for TSX Premium PLCs and associated systems (power supply modules, etc) which themselves have IP20 protection.
This type of installation applies to areas with restricted access and low pollution levels (not exceeding 2), for example stations or control rooms which have neither machines nor any activity generating metallic dust or other metallic particles. The external walls hence serve as the PLC enclosure.

9 Preventive or corrective maintenance

Availability

The availability of a system is its ability, in terms of its combined reliability, maintainability and maintenance logistics, to be in a state to perform a required function, at a given moment and within a defined time period.

Availability is therefore specific to each application, since it is a combination of :

- the architecture of the automatic system,
- the reliability and maintainability : intrinsic characteristics of the equipment (PLCs, sensors, machine, etc),
- maintenance logistics : characteristic intrinsic to the user of the control system (software structure, fault indication, process, on-site replacement parts, training of personnel).

Troubleshooting procedure

- control system equipment should only be repaired by qualified personnel (after sales service engineer, or technician approved by Schneider Automation S.A.). Only certified replacement parts or components should be used.
- before performing any operation on equipment (for example opening an enclosure), always cut the power supply off (disconnect the power plug or open the power isolation switch).
- before performing any "mechanical" operation on equipment on site, cut the power supply off and mechanically lock any moving parts.
- before removing a module, a memory cartridge, a PCMCIA card, etc, check in the manual whether this should be done with the power off or if it is possible while the device is powered up. Meticulously follow the instructions given in the manual.
- on positive logic outputs or negative logic inputs, take all necessary precautions to prevent a disconnected wire from coming into contact with the mechanical ground (risk of undesirable command).

Replacement and recycling of used batteries

- if these are replaced, use batteries of the same type and dispose of defective batteries in the same way as toxic waste.
Do not throw lithium or mercury batteries into a fire, open or recharge them, or attempt to solder them.

Installation

Analog : TSX AEY ●●● / ASY ●●● modules

Communication : TSX SCY 21600 module and PCMCIA cards

Counting : TSX CTY 2A / CTY 4A modules

Axis control : TSX CAY 21/ CAY 41 modules

Stepper control : TSX CFY 11/ CFY 21 modules

Startup/Diagnostics/Maintenance

Standards and installation conditions

Process supplies

-

-

-

-

-

C

D

E

F

G

H

I

J



C

D

E

F

G

H

I

J

K

L

M

N

O

General presentation

Part A1

Section	Page
1 Presentation	1/1
1.1 Component parts	1/1
1.1-1 Basic elements	1/1
1.1-2 Discrete I/O	1/2
1.1-3 Analog I/O	1/3
1.1-4 Counting	1/3
1.1-5 Axis control	1/4
1.1-6 Stepper control	1/4
1.1-7 Communication	1/5
1.1-8 Weighing	1/6
1.1-9 Fan modules	1/6
1.2 The various types of station	1/7
2 TSX RKY●● standard racks & TSX RKY●● E extendable racks	2/1
2.1 Presentation	2/1
2.1-1 General	2/1
2.1-2 Physical description	2/2
2.2 Installation / mounting	2/3
2.3 Functions	2/4
2.3-1 Composition of a PLC station	2/4
2.3-2 Addressing racks in a PLC station	2/5
2.3-3 Module addresses	2/6
2.3-4 Installing power supplies, processors and other modules	2/7
2.4 Accessories	2/8
2.4-1 TSX CBY ●●0K BusX extension cables	2/8
2.4-2 TSX TLY line terminator	2/9
2.4-3 TSX RKA 02 protective cover for an unoccupied position	2/9
2.4-4 Marking	2/10

General presentation

Part A1

Section	Page
3 TSX P57-10 / P57-20 processors	3/1
3.1 Presentation	3/1
3.1-1 General	3/1
3.1-2 Physical description	3/2
3-2 Catalog	3/3
3.3 Installation/mounting	3/4
3.3-1 Installation	3/4
3.3-2 Mounting	3/4
3.4 Auxiliary functions	3/5
3.4-1 Terminal port	3/5
3.4-2 Slot for PCMCIA communication card	3/5
3.4-3 Memories	3/6
3.4-4 Processor RESET pushbutton	3/7
3.4-5 Display	3/8
3.4-6 Realtime clock	3/9
3.5 Characteristics	3/11
3.5-1 General characteristics	3/11
3.5-2 Electrical characteristics	3/12
4 TSX PSY●●● power supplies	4/1
4.1 Presentation	4/1
4.1-1 General	4/1
4.1-2 Physical description	4/2
4-2 Catalog	4/3
4.3 Auxiliary functions	4/4

General presentation

Part A1

Section	Page
4.4 Installation / insertion	4/6
4.4-1 Installation	4/6
4.4-2 Insertion / connections	4/6
4.5 Characteristics	4/7
4.5-1 Characteristics of AC power supplies	4/7
4.5-2 Characteristics of DC power supplies	4/8
4.5-3 Characteristics of the alarm relay contact	4/10
4.6 Power consumption table for selecting a power supply module	4/11
4.7 Definition of protection devices at the head of the line	4/15
5 Mounting	5/1
5.1 Installation rules	5/1
5.1-1 Positioning the racks	5/1
5.2 Dimensions	5/2
5.3 Mounting/fixing racks	5/3
5.3-1 Mounting on a 35 mm wide DIN rail	5/3
5.3-2 Mounting on panel or Telequick pre-slotted plate	5/4
5.4 Mounting modules and terminal blocks	5/5
5.4-1 Inserting a module in a rack	5/5
5.4-2 Fitting a screw terminal block on a module	5/6
5.5 Fitting/removing the RAM memory backup battery	5/7
5.6 Inserting/removing the PCMCIA memory card	5/8

General presentation

Part A1

Section	Page
6 Connections	6/1
6.1 Ground connections	6/1
6.1-1 Grounding the racks	6/1
6.1-2 Grounding the modules	6/1
6.2 Connection of power supplies	6/2
6.2-1 Rules for connection	6/2
6.2-2 Connection of AC power supply modules	6/4
6.2-3 Connecting DC power supply modules via an AC supply	6/6
6.2-4 Sensor and preactuator power supply interlocking	6/10
7 Functions	7/1
7.1 Addressing discrete I/O channels	7/1
7.2 Setting the PLC to RUN/STOP	7/2
7.3 Single task application structure	7/3
7.3-1 Cyclic execution	7/3
7.3-2 Periodic execution	7/5
7.4 Multitask application structure	7/7
7.4-1 Control tasks	7/8
7.4-2 Event-triggered tasks	7/10
7.5 User memory structure	7/12
7.5-1 Application memory	7/12

General presentation

Part A1

Section	Page
7.6 Operating modes of the PLC on start-up	7/15
7.6-1 Cold start	7/15
7.6-2 Warm restart	7/16
7.6-3 Operation following power supply failure and return	7/16
7.6-4 Operation after insertion/removal of a PCMCIA memory card	7/18
7.6-5 Operation after pressing the processor RESET button	7/18
7.6-6 Operation after pressing the power supply RESET button	7/18
7.6-7 PLC response to cold start	7/19
7.7 Behavior on insertion/removal of a module when powered-up	7/20
7.8 Behavior of the I/O on downgraded operating mode	7/20
7.8-1 Safety value of discrete and analog outputs	7/20
7.8-2 Discrete and analog outputs switching to fallback mode	7/21
7.8-3 I/O faults	7/21
7.9 Loading the operating system (OS)	7/22
8 Appendix	8/1
8.1 Fan modules	8/1
8.1-1 General presentation	8/1
8.1-2 Physical presentation	8/2
8.1-3 Catalog	8/2
8.1-4 Dimensions	8/3
8.1-5 Mounting	8/4
8.1-6 Installation rules for racks with fan modules	8/5
8.1-7 Connections	8/6
8.1-8 Characteristics	8/7



General presentation

Part A1

Section	Page
8.2 Performance	8/8
8.2-1 MAST task scan time	8/8
8.2-2 FAST task scan time	8/14
8.2-3 Response time to an event	8/14

1.1 Component parts

1.1-1 Basic elements

TSX Premium PLCs are entirely modular. A PLC station is constructed around the following basic elements :

- **Standard racks** with 6, 8 and 12 positions (see part A1 - section 2). They can make up a PLC station **limited to a single rack**.
- **Extendable racks** with 6, 8 and 12 positions (see part A1 - section 2). They can make up a PLC station **containing a maximum of 8 racks**, distributed on the bus (known as BusX). Bus continuity between the various racks is provided by bus extension cables whose total length should not exceed 50 meters.

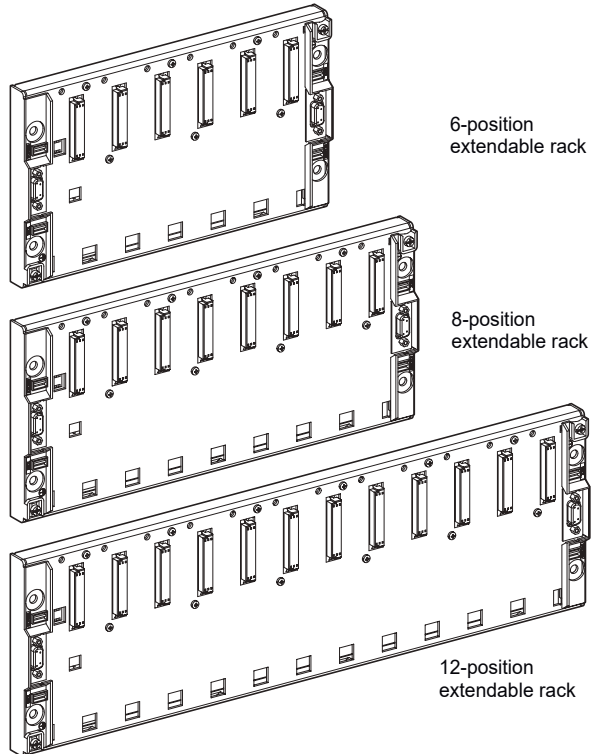

- **Power supply modules** (see part A1 - section 4)
Each rack requires a power supply module determined according to the distributed supply (AC or DC) and the power required at rack level (standard format module or double format module)

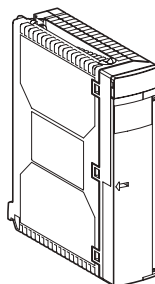

standard format power supply

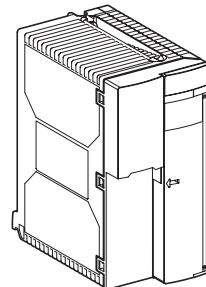

double format power supply

• **Processor modules** (see part A1 - section 3)

Each station has a processor, which is selected according to the processing power required :

- TSX P57-10 processor

This can run a PLC station comprising a maximum of 1 standard rack or 2 extendable racks, 512 discrete I/O, 24 analog I/O, 2 application-specific modules (counter, axis control, etc).

- TSX P57-20 processor

This can run a PLC station comprising a maximum of 1 standard rack or 8 extendable racks, 1024 discrete I/O, 80 analog I/O, 6 application-specific modules (counter, axis control, etc).

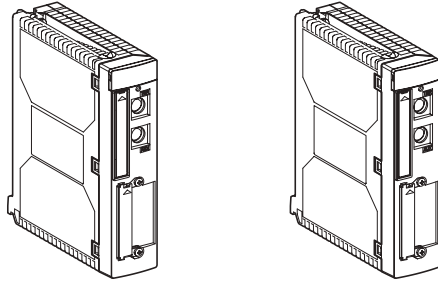

1.1-2 Discrete I/O (see part B)

A wide range of discrete I/O modules enables users to match their particular requirements. These modules vary in :

- Modularity : 8, 16, 32 and 64 channels.
- Type of inputs :
 - modules with DC inputs (24VDC, 48VDC).
 - modules with AC inputs (24VAC, 48VAC, 110VAC, 240VAC).
- Type of outputs :
 - modules with relay outputs.
 - modules with DC solid state outputs (24VDC / 0.1A - 0.5A - 2A, 48VDC / 0.25A - 1A).
 - modules with AC solid state outputs (24VAC / 130VAC / 1A, 48VAC / 240VAC / 2A).
- Type of connections : screw terminal connections and HE10 type connectors, for connection to sensors and preactuators by means of the TELEFAST 2 prewiring system.

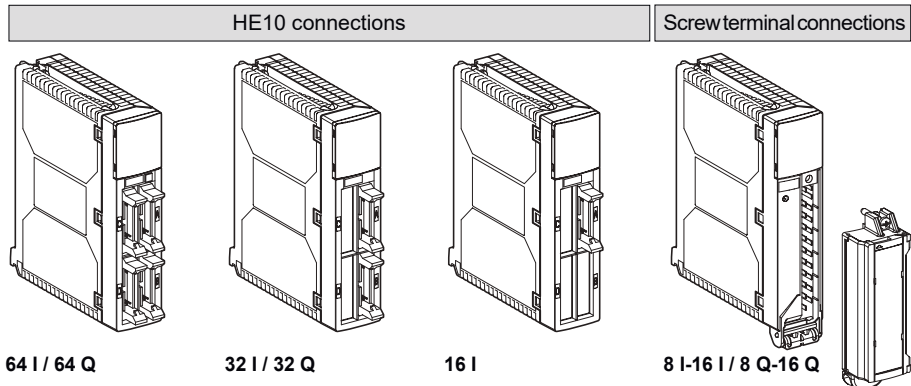

1.1-3 Analog I/O (see part C)

The range of analog I/O modules covers the majority of requirements. These modules vary in :

- Modularity : 4, 8, 16 channels.
- Performance and signal ranges on offer : voltage/current, multirange (thermocouple, temperature probe, voltage/current).
- Type of connections :
 - screw terminal connections,
 - 25-pin SUB D type connectors, for connection to sensors by means of the TELEFAST 2 prewiring system.

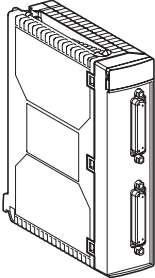
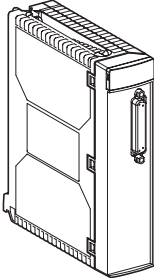
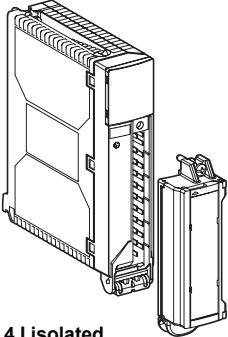
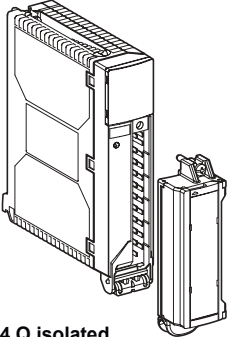
25-pin SUB D connections		Screw terminal connections	
			
16 I non-isolated between channels	8 I non-isolated between channels	4 I isolated between channels	4 Q isolated between channels
Voltage / Current 0...10 V, ± 10 V 0...5V, 1...5V 0...20 mA, 4...20 mA	Voltage / Current 0...10 V, ± 10 V 0...5V, 1...5V 0...20 mA, 4...20 mA	Multirange 0...10 V, ± 10 V 0...5V, 1...5V 0...20 mA, 4...20 mA Temperature probe Thermocouple	Voltage / Current ± 10 V 0...20 mA 4...20 mA
12 bits	12 bits	16 bits	11 bits + sign

1.1-4 Counting (see part E)

TSX Premium PLCs offer the principal counting functions (downcounting, upcounting, up/down counting) using "counter" modules.

There are two modules :

- 1 module containing 2 channels,
- 1 module containing 4 channels.

These modules can be used to count pulses at a maximum frequency of 40 kHz on 24 bits + sign.

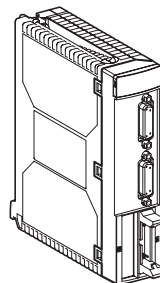

2-channel module

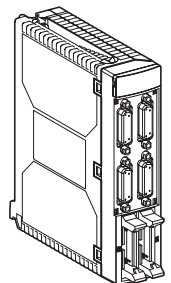

4-channel module

1.1-5 Axis control (see part F)

By means of "axis control" modules, TSX Premium PLCs can be used to manage movement control applications, controlled by servomotors where the speed reference is an analog value (± 10 V)

There are two modules :

- a 2-channel module which can be used for servo loop positioning with two independent axes (limited linear).
- a 4-channel module which can be used for servo loop positioning with four independent axes (limited linear).

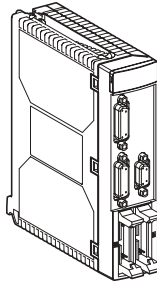

2-channel module

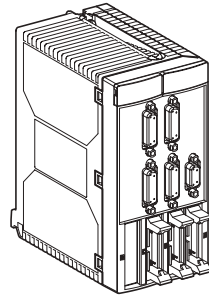

4-channel module

1.1-6 Stepper control (see part G)

By means of "stepper control" modules, TSX Premium PLCs can be used to manage movement control applications, controlled by transporters where the speed reference is a frequency.

There are two modules :

- a single channel module which can be used to control a transporter.
- a 2-channel module which can be used to control two transporters.

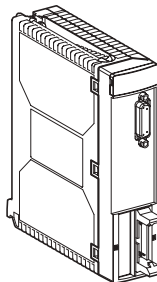

Single channel module

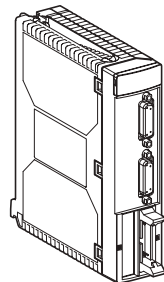

2-channel module

1.1-7 Communication (see parts A2 & D)

TSX Premium PLCs can be used for a number of communication modes :

- **Communication via terminal ports** (see part A2)

TSX Premium PLC processors have two terminal ports, (TER) and (AUX), RS 485 non-isolated serial link, UNI-TELWAY or character mode protocol. These terminal ports can be used for connecting :

- a programming terminal and/or a man-machine interface terminal (UNI-TELWAY master mode),
- the station to a UNI-TELWAY multidrop link (UNI-TELWAY master or slave mode),
- a printer or a terminal in character mode.

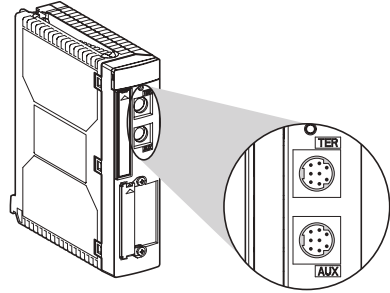

Note : the user-defined communication protocol is identical for both ports.

- **Communication via a communication module** (see part D)

This module, which can be integrated in all TSX Premium rack PLCs, has :

- an integrated communication channel (1), isolated RS 485 serial link, multiprotocol (UNI-TELWAY, MODBUS/JBUS, character mode).
- a slot (2), which can take a PCMCIA format communication card (see below).

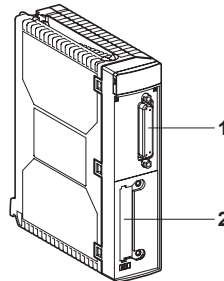

- **Communication via PCMCIA cards which can be integrated in the processor or the communication module** (see part D)

The processors and the communication module both have a slot which can take a PCMCIA format communication card :

- multiprotocol cards (UNI-TELWAY, MODBUS/JBUS, character mode) :
- non isolated RS 232 D serial link
- isolated RS 485 serial link
- current loop link,
- FIPWAY network card
- FIPIO Agent bus card (1)

(1) only on the processor.

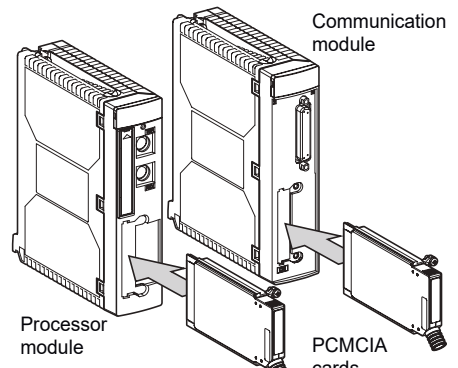

1.1-8 Weighing (see manual TSX DM ISP Y100E)

By means of the "weighing" module, TSX Premium PLCs can be used to manage weighing applications : batching, multiproduct batching, sorting by weight, flow control, weight totalizing, etc.

This module has a measurement input for 8 sensors maximum, 2 fast discrete outputs and a serial link for an extension display.

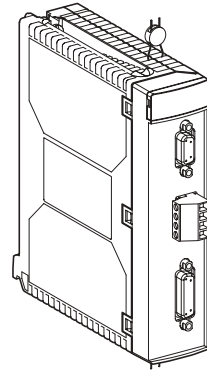

1.1-9 Fan modules (see part A1- section 8)

Depending on the rack modularity (6, 8 or 12 positions), one, two or three fan modules can be installed on top of each rack in order to help cool the various modules by forced convection.

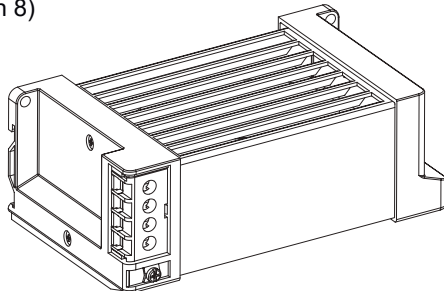

These fan units should be used in the following cases :

- **Ambient temperature in the range 25°C...60°C** : forced ventilation increases the lifetime of the various TSX Premium PLC components (25% increase in MTBF),
- **Ambient temperature in the range 60°C...70°C**: since the ambient temperature is limited to 60°C without ventilation, forced ventilation is used to decrease the temperature inside the modules by 10°C, bringing the internal module temperature to the equivalent of an ambient temperature of 60°C.

There are three types of fan module :

- fan module with 110 VAC power supply,
- fan module with 220 VAC power supply,
- fan module with 24 VDC power supply.

1.2 The various types of station

The maximum capacities of a TSX Premium PLC station are defined according to the type of rack (standard or extendable) and the type of processor (TSX P57 10 or TSX P57 20) selected.

- **TSX 57-10 stations** : based on a TSX P57 10 processor

Station with standard rack

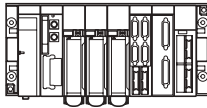

Maximum configuration :

- 1 standard rack with 6, 8 or 12 positions
- 1 TSX P57 10 processor, processing capacity :
 - 512 discrete I/O,
 - 24 analog I/O,
 - 2 application-specific modules (counter, axis control, etc).

Station with extendable racks

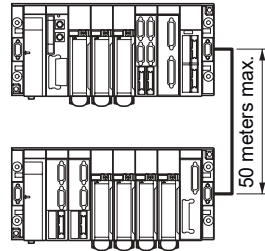

Maximum configuration :

- 2 extendable racks with 6, 8 or 12 positions
- 1 TSX P57 10 processor, processing capacity :
 - 512 discrete I/O,
 - 24 analog I/O,
 - 2 application-specific modules (counter, axis control, etc).
- Maximum length of bus extension cable to the second rack limited to 50 meters.

- **TSX 57-20 stations** : based on a TSX P57 20 processor

**Station with
standard rack**

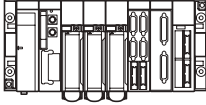

**Station with
extendable racks**

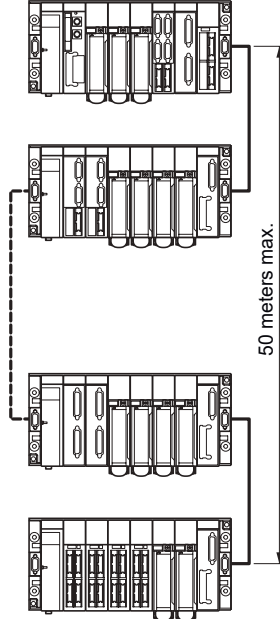

Maximum configuration :

- 1 standard rack with 6, 8, or 12 positions.
- 1 TSX P57 20 processor, processing capacity :
 - 1024 discrete I/O,
 - 80 analog I/O,
 - 6 application-specific modules (counter, axis control, etc).

Maximum configuration :

- 8 extendable racks with 6, 8, or 12 positions.
- 1 TSX P57 20 processor, processing capacity :
 - 1024 discrete I/O,
 - 80 analog I/O,
 - 6 application-specific modules (counter, axis control, etc).
- Total length of bus extension cables limited to 50 meters.

2.1 Presentation

2.1-1 General

TSX RKY ... racks constitute the basic element of TSX Premium PLCs.

These racks provide the following functions :

- mechanical function :
They are used for fitting all PLC station modules (power supply modules, processor, discrete/analog I/O, application-specific modules).
They can be fitted in enclosures, on the machine frame or on panels.
- electrical function :
The racks have an integral bus, called BusX which distributes :
 - the power supplies required for each module in the same rack,
 - the service signals and data for the whole PLC station if it comprises a number of racks.

So as to match user requirements more closely, there are two families of racks, each available in 3 versions (6, 8 and 12 positions).

- **Standard racks** : These are used to make up a PLC station limited to a single rack.
- **Extendable racks** : These are used to make up a PLC station which can contain a maximum of 8 racks. These racks are distributed on a bus known as BusX, whose maximum length is limited to 50 meters.

Bus continuity from one rack to another is provided by a bus extension cable, with special characteristics.

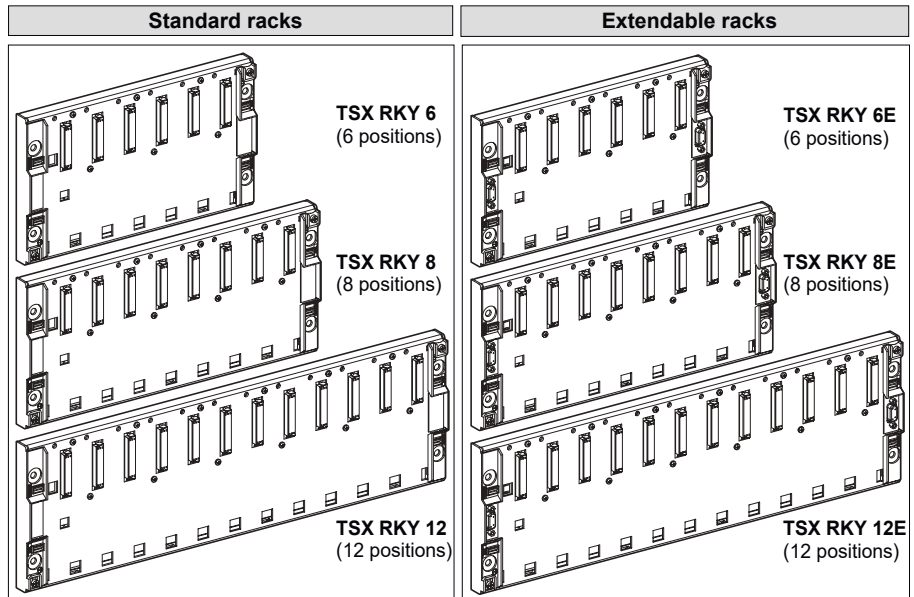

2.1-2 Physical description

• Standard racks

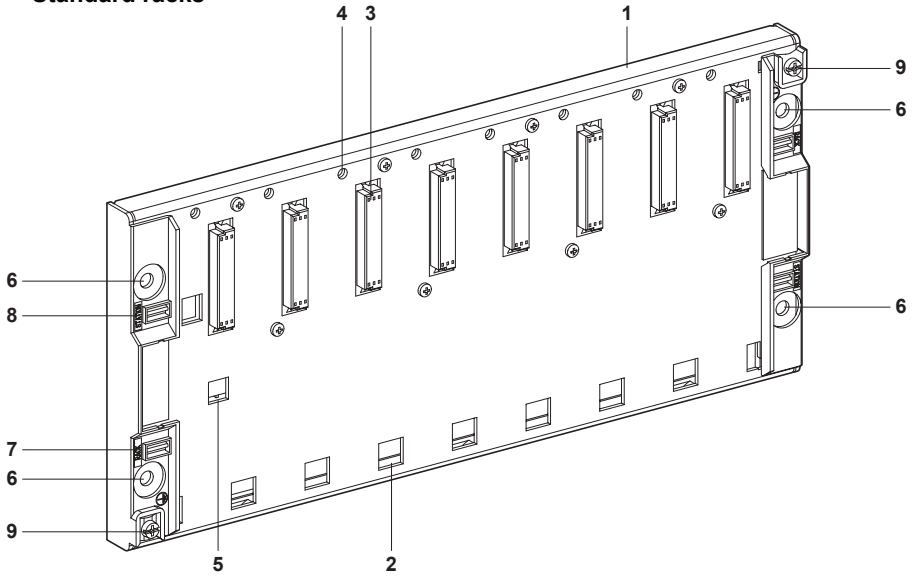

• Extendable racks

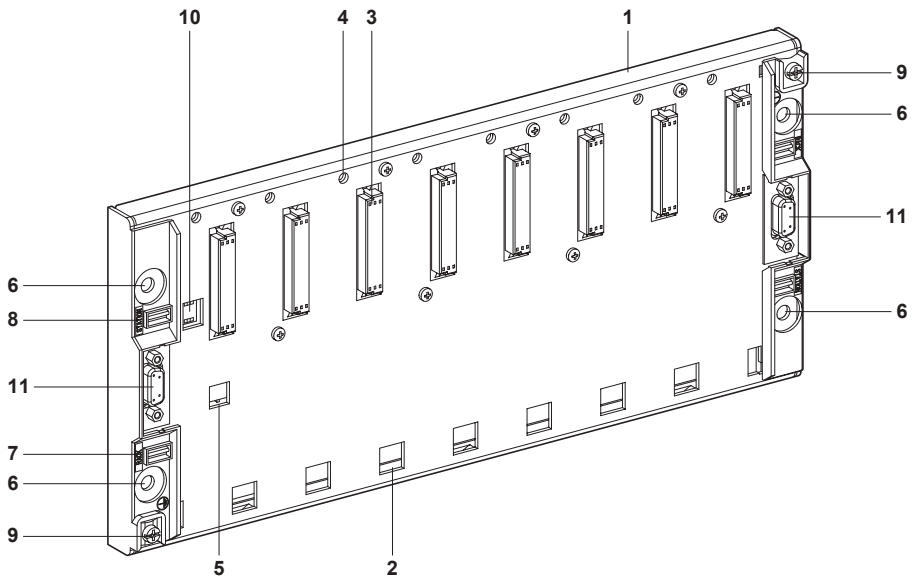

-
- 1 Metal plate acting as :
 - support for the BusX electronic card and protection for the bus against EMI and ESD interference,
 - module support,
 - mechanical reinforcement for the rack.
 - 2 Apertures for anchoring the module pins,
 - 3 48-pin female 1/2 DIN connectors for connecting the rack to each module.
When the rack is supplied these connectors are protected by covers which should be removed before the modules are installed.
The connector located furthest to the left and marked PS is always dedicated to the rack power supply module; the other connectors marked 00 to ..can take all the other types of module.
 - 4 Tapped holes for the module fixing screw.
 - 5 Aperture which ensures correct location when a power supply module is fitted.
Since the power supply modules have a boss on the rear panel, it is impossible to mount this module in any other position.
 - 6 Holes for fitting the rack on a support large enough to take M6 screws.
 - 7 Location for marking the rack address.
 - 8 Location for marking the station network address.
 - 9 Ground terminals for grounding the rack.
 - 10 Micro-switches for encoding the rack address (on extendable racks only).
 - 11 9-pin female SUB D connectors for connecting BusX to another rack (on extendable racks only).

2.2 Installation / mounting

The procedure for installing and mounting racks is explained in section 5 of this part.

- Installation : section 5.1
- Mounting : section 5.3

2.3 Functions

2.3-1 Composition of a PLC station

- **Based on standard racks : TSX RKY 6/8/12**

standard racks are used to make up a TSX 57-10 or TSX 57-20 PLC station limited to a single rack.

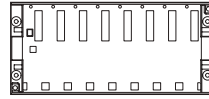

- **Based on extendable racks : TSX RKY 6E/8E/12E**

By using extendable racks, it is possible to make up a PLC station containing a maximum of 2 racks for a TSX 57-10 station and 8 racks for a TSX 57-20 station.

The racks can have the same product reference or different product references, and are connected by BusX extension cables (1). BusX should have a line terminator (2) fitted at each end.

- BusX extension cables

The racks are interconnected by TSX CBY ..0K BusX extension cables connected to the 9-pin SUB D connector to be found on the right and left-hand side of each extendable rack.

As the concept of inlet and outlet does not apply to 9-pin SUB D connectors, it does not matter whether the cable coming in from a rack or the cable going out to another rack is connected to the right or left connector.

- line terminator

The two extendable racks at the end of the daisy chain **must** be fitted with a TSX TLY line terminator on the unused 9-pin SUB D connector.

- maximum cable length

The total length of all the TSX CBY ..0K cables used in a PLC station must never exceed 50 meters.

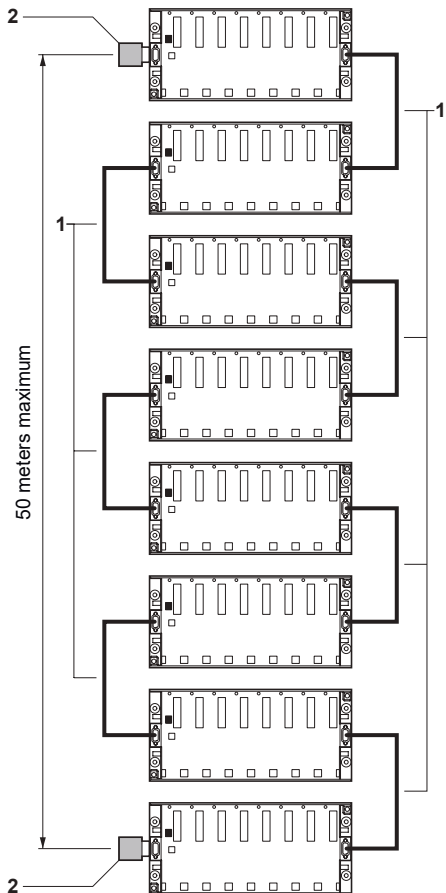

2.3-2 Addressing racks in a PLC station

- **Station made up of standard racks**

The station is always limited to a single rack; the rack address is therefore implicit and has the value 0 (no micro-switches).

- **Station made up of extendable racks**

Each station rack must have an address assigned to it. This address is encoded via 4 micro-switches located on the rack.

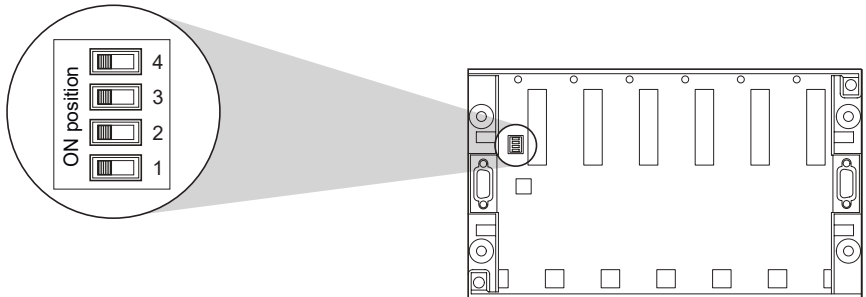

Rack addresses		0	1	2	3	4	5	6	7
Position of micro-switches	4								
	3								
	2								
	1								
		ON OFF	ON OFF	ON OFF	ON OFF	ON OFF	ON OFF	ON OFF	ON OFF

Note :

- it makes no difference which position micro-switch 4 is in. In the above drawing, micro-switch 4 is always in the ON position.
- at the time of supply, the micro-switches are in the ON position (address 0).

Assigning addresses to the various racks

Address 0 : This address is always assigned to the rack which holds the processor, as this rack can be in any position in the daisy chain.

Addresses 1 to 7 : These can be assigned to all the other extendable station racks, in any order.

Note :

The rack address must be encoded before the power supply module is mounted.

2.3-3 Module addresses

For all standard and extendable racks, a module address is geographical and will depend on the position of the module in the rack. The address of each position is indicated above each connector; the connector marked PS is always dedicated to the rack power supply.

Module addresses according to the type of rack

- TSX RKY 6/6E racks : addresses 00 to 04
- TSX RKY 8/8E racks : addresses 00 to 06
- TSX RKY 12/12E racks : addresses 00 to 10

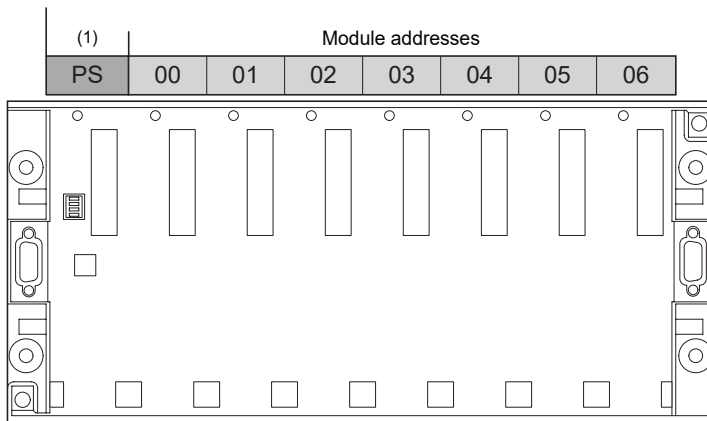

Example : module addresses on TSX RKY 8E rack

(1) PS = Marks the power supply module connector

2.3-4 Installing power supplies, processors and other modules

• On a standard or extendable rack with address 0

The rack with address 0 must hold a power supply module and the processor module. Since TSX Premium PLCs can have two types of power supply (standard format or double format), the position of the processor will depend on the type of power supply being used.

Using a standard format power supply module :

- the power supply module always occupies position PS,
- the processor may be inserted in position 0 (preferred position) or position 1 (in this case slot 0 is not available),
- the other modules should be installed from position 01 onwards.

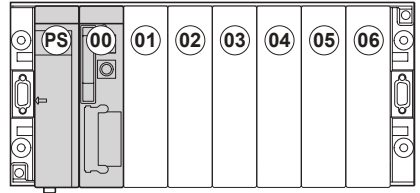

Using a double format power supply module :

- the power supply module always occupies positions PS and 00,
- the processor module **must** be installed in position 01,
- the other modules should be installed from position 02 onwards.

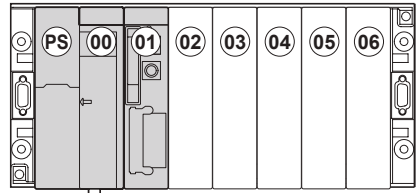

• On an extendable rack with addresses 1 to 7

Each rack must have a power supply module, whether standard or double format.

Using a standard format power supply module :

- the power supply module always occupies position PS,
- the other modules should be installed from position 00 onwards.

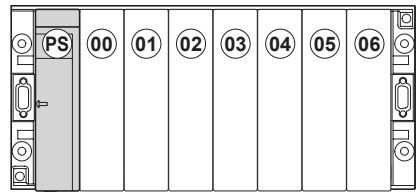

Using a double format power supply module :

- the power supply module always occupies positions PS and 00,
- the other modules should be installed from position 01 onwards.

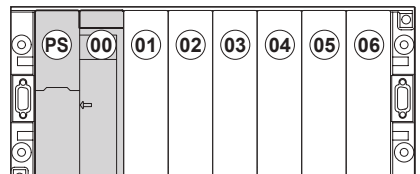

2.4 Accessories

2.4-1 TSX CBY ..0K BusX extension cables

These cables are used to daisy-chain TSX RKY ..E extendable racks and carry the various BusX signals. They are fitted with 9-pin male SUB D connectors at each end, which connect to the 9-pin female SUB D connectors on the extendable rack.

Note :

These cables do not carry any supply voltage, as each rack has its own power supply module.

7 cable lengths are available for the various types of use :

Product references	Length
TSX CBY 010K	1 meter
TSX CBY 030K	3 meters
TSX CBY 050K	5 meters
TSX CBY 120K	12 meters
TSX CBY 180K	18 meters
TSX CBY 280K	28 meters
TSX CBY 380K	38 meters

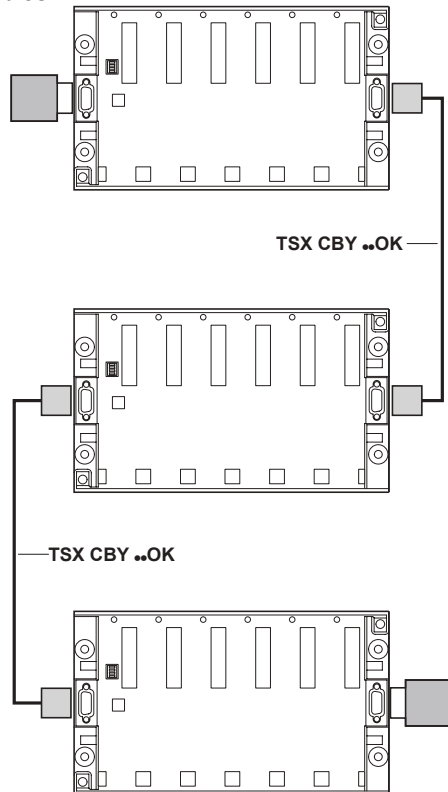

The total length of all the cables used in a PLC station is limited to 50 meters.

All the station racks **MUST** be powered down prior to inserting or removing a TSX CBY ...0K cable.

2.4-2 TSX TLY line terminator

When using extendable racks, in order to ensure correct data transmission on BusX, the bus should be fitted with a line terminator at each end (see outline diagram in section 2.3-1).

A line terminator is made up of a 9-pin SUB D connector and a cover containing the adaptor elements. It fits onto the 9-pin SUB D connectors on the extendable racks located at the end of the line.

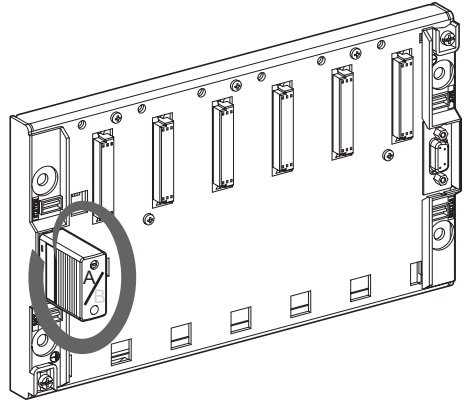

TSX TLY line terminators are sold in lots of 2 and marked A and B. Each end of the bus must, without fail, have an A line terminator or a B line terminator (see diagrams below).

⚠ All the station racks MUST be powered down prior to inserting or removing a line terminator.

Positioning of line terminators (A and B)

- On a PLC station with several TSX RKY●●E extendable racks

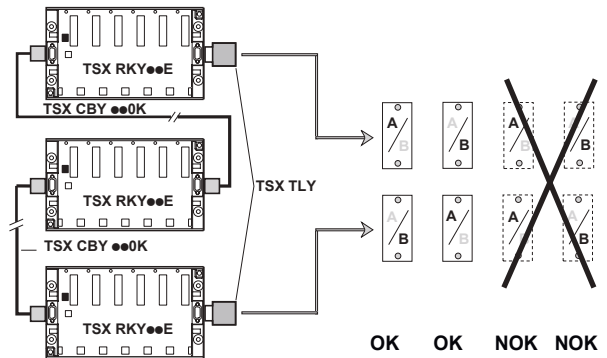

- On a PLC station with a single TSX RKY●●E extendable rack

Note:

When using a single extendable rack, a line terminator must be fitted to each 9-pin SUB D connector on the rack.

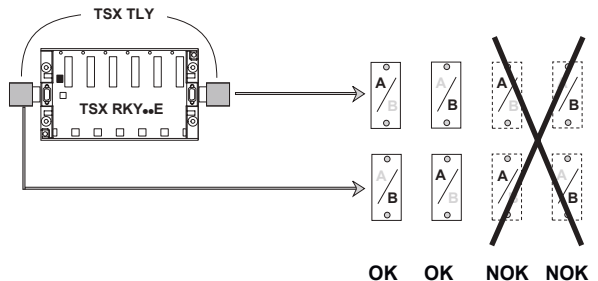

2.4-3 TSX RKA 02 protective cover for an unoccupied position

If there are any unoccupied positions on a rack, it is advisable to fit a TSX RKA 02 cover in this position, which is available for this purpose. This cover fits on the rack in the same way as a shallow version of a module.

TSX RKA 02 covers are sold in lots of 5.

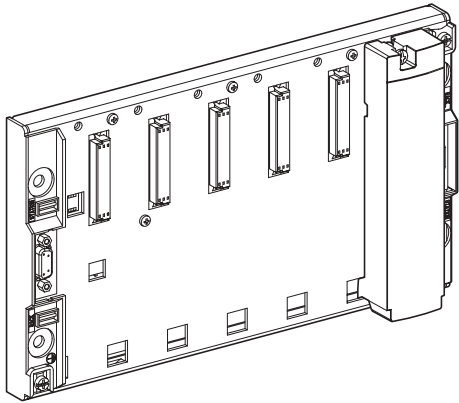

2.4-4 Marking

• Marking module positions on the rack

When the module is in place on the rack, it hides the position marker which is screen-printed on the rack. So that a module position can still be identified quickly, each rack comes with a sheet of self-adhesive labels which can be used to mark the position of each module. These self-adhesive labels can be stuck on top of the module when it is in place on the rack.

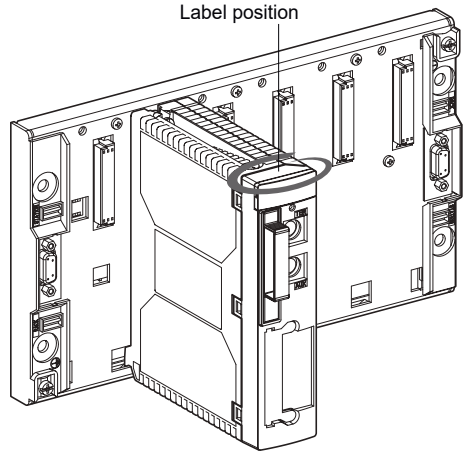

Sheet of labels

PS	00	01	02	03	04	05	06
07	08	09	10	11	12	13	14

Example : processor module marking

• Marking racks

Each rack is supplied with a pack of clip-on markers on a strip. These can be used to mark each rack with :

- the address of the rack in the station,
- the network address of the station, if this is connected to a communication network.

Each rack therefore has two slots to take these markers.

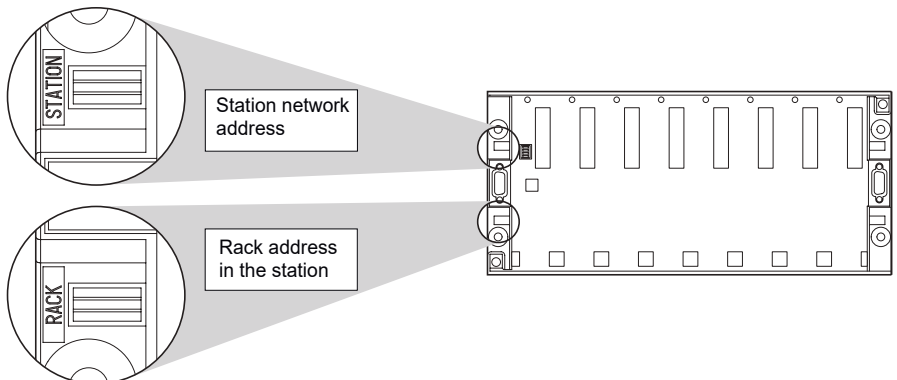

3.1 Presentation

3.1-1 General

TSX Premium PLC processors manage an entire PLC station comprising discrete I/O modules, analog I/O modules and application-specific modules which can be distributed over one or more racks connected on BusX.

Two types of processor are available to meet users' varying needs :

- TSX P57 10 processor :

This can be used to manage a PLC station comprising a maximum of 2 TSX RKY 10E racks containing a maximum of 512 discrete I/O, 24 analog I/O, 2 application-specific modules (eg counter, axis control, stepper control, communication or weighing).

- TSX P57 20 processor :

This can be used to manage a PLC station comprising a maximum of 8 TSX RKY 20E racks containing a maximum of 1024 discrete I/O, 80 analog I/O, 6 application-specific modules (eg counter, axis control, stepper control, communication or weighing).

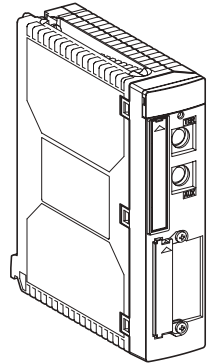

Moreover, each processor integrates :

- A protected internal RAM memory which can accept the complete application and which can be extended by a PCMCIA memory card (RAM or flash EPROM),
- A realtime clock,
- Various modes of communication :
 - communication via terminal ports (UNI-TELWAY mode or character mode) :
2 terminal ports (TER and AUX) enable simultaneous connection of two devices (typically a programming terminal and a man-machine interface terminal).
 - communication via PCMCIA card :
a slot is able to receive a number of communication cards, so that a communication channel (FIPWAY, FIPIO Agent, UNI-TELWAY, serial links) can be connected directly to the processor.

The application is designed using PL7 Junior software under Windows, which offers :

- Four programming languages :
Grafcet, Ladder, Structured text and List languages,
- A multitasking software structure :
master task, fast task, event processing,
- Modification of currently running programs,
- etc.

3.1-2 Physical description

1 Display block comprising 4 indicator lamps :

- RUN indicator lamp (green) : lit if the processor is operating (program running),
- ERR indicator lamp (red) : when lit, this indicates faults relating to the processor and its installed devices (PCMCIA memory card and PCMCIA communication card)
- I/O indicator lamp (red) : when lit, this indicates faults originating from another station module or a configuration fault,
- TER indicator lamp (yellow) : when lit, this indicates activity on the terminal port.

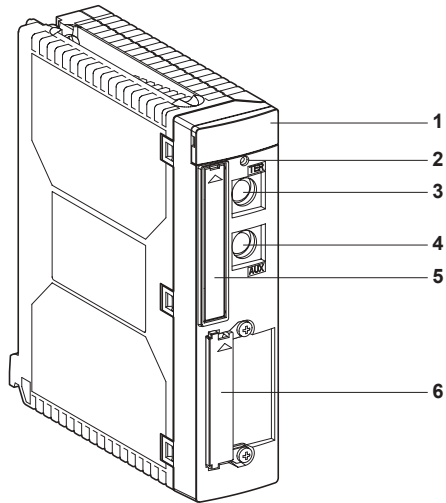

2 Pencil-point RESET button which causes the PLC to perform a cold start when pressed.

3 Terminal port (TER connector) : enables a peripheral device (with or without its own power supply) to be connected : programming or adjustment terminal, man-machine interface terminal, printer, etc.

4 Terminal port (AUX connector) : enables a peripheral device (with or without its own power supply) to be connected : programming or adjustment terminal, man-machine interface terminal, printer, etc.

5 Slot for a PCMCIA type 1 format memory extension card. **If no card is present, this slot is fitted with a cover which MUST remain in place; if removed, the processor will stop.**

6 Slot for a PCMCIA type 3 format communication card which enables a FIPWAY, FIPIO Agent, UNI-TELWAY, or serial link communication channel to be connected to the processor.

If no communication card is present, this slot is fitted with a cover.

3.2 Catalog

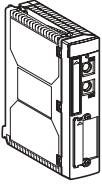
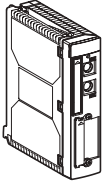
Module type	Processors	
		
Station characteristics (1) TSX RKY..E racks	2	8
Module slots (2)	24	96
No. of discrete I/O	512	1024
No. of analog I/O channels	24	80
Application-specific modules (3)	2	6
Slots for PCMCIA communication cards	1 (on processor) + 1 via each communication module	
FIPWAY network connection	1	
FIPIO Agent bus connection	1	
Application-specific functions Counting,	via applic.-specific module (2/4 channels dep. on module, frequency 40 kHz)	
Axis control,	via application-specific module (2 or 4 axes dep. on module)	
Stepper control	via application-specific module (1 or 2 channels dep. on module),	
Communication	Unitelway bus : via terminal port, PCMCIA card, application-specific module Fipio Agent : via PCMCIA card Modbus : via application-specific module, PCMCIA card Character mode : via terminal port, PCMCIA card, application-specific module	
Weighing	via application-specific module (1 measurement input, 50 measurements/second)	
Network	FIPWAY : via PCMCIA card	
Product references	TSX P 57 10	TSX P 57 20

(1) Maximum characteristics for the station managed by the processor

(2) For standard format modules

(3) Counter (TSX CTY **), axis control (TSX CAY **), stepper control (TSX CFY **).

3.3 Installation/mounting

3.3-1 Installation

A TSX P 57 .. processor module is installed in a TSX RKY ... rack in position 00 or 01 depending on whether the rack is equipped with a standard or double format power supply module.

- Rack with TSX PSY 2600/1610 standard format power supply module :

In this instance, the TSX P 57 ..processor module is installed in position 00.

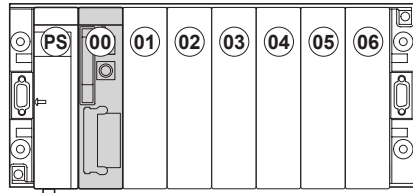

- Rack with TSX PSY 3610/5500/5520 double format power supply module :

In this instance, since the power supply module takes up two positions (PS and 00), the TSX P 57 ..processor has to be installed in position 01.

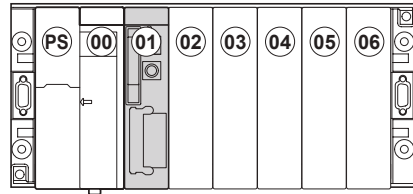

Note :

The rack where the processor is installed is always address 0

3.3-2 Mounting

The procedure for mounting modules is defined in section 5.4-1.



The rack power supply must always be powered down prior to mounting a TSX P 57 .. processor module.

3.4 Auxiliary functions

3.4-1 Terminal port

Each processor has a terminal port (non-isolated RS 485 link), with two 8-pin mini-DIN connectors, used to physically connect two devices on the processor front panel :

- **TER connector :**

This is used to connect an FTX type or PC compatible terminal, or to connect the PLC to the UNI-TELWAY bus by means of the TSX P ACC 01 isolator box. This port enables power of 5V to be supplied to the connected accessory (within the limits of the current available from the power supply unit).

- **AUX connector :**

This is used to connect a peripheral device ,with or without its own power supply, (terminal, man-machine interface terminal or printer) (no voltage supplied to this connector).

The default communication mode for the TER and AUX connectors is UNI-TELWAY master at 19200 bauds and, by configuration, UNI-TELWAY slave mode or ASCII character mode.

Note : The various connection possibilities and the different operating modes for these terminal ports are explained in part A2 - Terminal port.

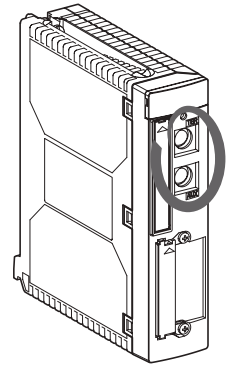

3.4-2 Slot for PCMCIA communication card

Each processor has a slot on the front panel for inserting a type 3 PCMCIA format communication card.

This slot can take any card which conforms to the internal interface standard, such as :

- **TSX SCP111** : RS 232 D multiprotocol card, 9 non isolated signals
- **TSX SCP112** : current loop multiprotocol card (20 mA CL)
- **TSX SCP114** : RS 485 multiprotocol card, compatible with isolated RS 422,
- **TSX FPP 10/20** : FIPIO Agent/FIPWAY cards

⚠ Do not insert or remove a communication card when the processor is powered up.

Note :

Further information on how to install the various communication cards is provided in this manual - part D.

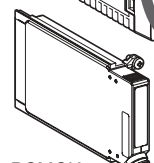
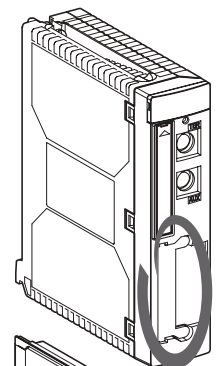

PCMCIA
communication

3.4-3 Memories

- **Internal RAM memory**

Each processor has an internal RAM memory of the following size :

- 32 Kwords for a TSX P 57 10 processor,
- 48 Kwords for a TSX P 57 20 processor.

This memory can receive the whole application. If this is too large, the memory can be extended by a PCMCIA memory card.

The processor internal RAM memory can be protected by an optional battery located in the power supply module. This protection is obviously only effective if the power supply and processor modules are in place on the rack. If either of these modules is removed, the RAM memory is no longer protected.

Note : Organization of the application memory (internal RAM + PCMCIA memory card) is described in this part - section 7.4

- **PCMCIA memory cards**

The slot located on the processor front panel, protected by a cover, can be used to insert an optional type 1 PCMCIA format memory card. This card can be used to extend the processor internal memory in order to store the application program and the constants.

Note : before inserting a PCMCIA memory card, the protective cover must first be removed.

There are three types of memory card :

- **protected RAM type memory card :**

used predominantly during creation and debugging of the application program, this can be used for all online functions for transferring and modifying the application. The memory is protected by a removable battery integrated in the memory card.

- **Flash Eprom type memory card :**

used once the application program has been debugged, this can only be used to perform a global transfer of the application and to bypass the problems of battery backup.

- **BACKUP type memory card :**

with the application program, this can be used to reload the application program into the processor internal RAM memory without needing to use a programming terminal.

This card cannot be used unless the application is only in the processor internal RAM memory and if the total size (program + constants) is less than 32 Kwords.

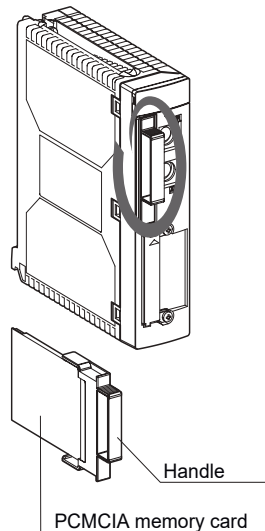

Handling PCMCIA memory cards with the power on

A PCMCIA memory card can be inserted or removed with the power on. To become operational, the memory card handle must be fitted; if this is missing, the processor will not start (processor faulty, ERR indicator lamp on).

When a memory card complete with handle is inserted, this causes the processor to cold-start.

Product references

Product references	Type	Capacity	Processor compatibility	
			TSX P 57 10	TSX P 57 20
TSX MRP 032P	RAM	32 Kwords	Yes	Yes
TSX MRP 064P	RAM	64 Kwords	Yes	Yes
TSX MRP 0128P	RAM	128 Kwords	No	Yes
TSX MFP 032P (1)	Flash Eprom	32 Kwords	Yes	Yes
TSX MFP 064P	Flash Eprom	64 Kwords	Yes	Yes
TSX MFP 0128P	Flash Eprom	128 Kwords	No	Yes
TSX MFP BAK032P	BACKUP	32 Kwords	Yes	Yes

(1) PCMCIA memory cards TSX MFP 032P for use on TSX P57 10/20 processors must be version II \geq 02

Note :

- Memory capacity : Kwords = K16 (word of 16 bits)
- Organization of the application memory (internal RAM + PCMCIA memory card) is described in this part - section 7.4

3.4-4 Processor RESET pushbutton

Using a pencil to push this button on the processor front panel causes the application to cold-start :

- processor running normally :
cold start while stopped or running, according to procedure defined at the time of configuration,
- processor faulty :
forced starting while stopped.

Note :

The operating modes which are effective after a cold start are described in this part - section 7.5

3.4-5 Display

Four indicator lamps on the processor front panel enable rapid diagnostics of the PLC status :

RUN indicator lamp (green) : shows the application status

- On : application running normally, program execution,
- Flashing : application stopped or executing incorrectly,
- Off : application missing or invalid.

ERR indicator lamp (red) : signals faults relating to the processor and its ancillary equipment (memory card and PCMCIA communication card)

- On : blocking fault (malfunction, system fault or power supply),
- Flashing : non-blocking fault arising from :
 - the application (missing, invalid or execution error),
 - the PCMCIA memory card : (malfunction, incompatible type, battery fault),
 - the PCMCIA communication card (malfunction, incompatible type, internal fault),
- Off : normal status, no internal fault.

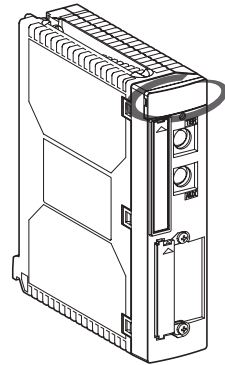

I/O indicator lamp (red) : signals configuration faults and faults arising from other station modules :

- On : external fault arising from :
 - a station module (internal, external fault),
 - configuration fault.
- Flashing : self-test running,
- Off : normal status, no internal fault.

TER indicator lamp (yellow) : signals activity on the terminal port TER

- On : exchange in progress.
If there is traffic on the terminal port, this may give the impression that this indicator lamp is flashing.
- Off : no exchange in progress

3.4-6 Realtime clock

Each processor has a battery-backed realtime clock which manages :

- the current date and time,
- the date and time of the last application stop

The date and time are still managed when the processor is powered down, so long as it is mounted on the rack with its power supply module in place, and protected by a battery.

 **If the processor is removed, the date and time information is lost**

• Current date and time

The processor updates the current date and time in system words %SW49 to %SW53. This data is encoded in BCD format.

System words	High order byte	Low order byte
%SW49	00	Days of the week (1 to 7)
%SW50	Seconds (0 to 59)	00
%SW51	Hours (0 to 23)	Minutes (0 to 59)
%SW52	Month (1 to 12)	Days of the month (1 to 31)
%SW53	Century (0 to 99)	Year (0 to 99)

• Access to the date and time :

- via the processor debug screen,
- via the program :

reads : system words %SW49 to %SW53 if system bit %S50 = 0

immediate updating : writes system words %SW49 to %SW53 if system bit %S50 = 1

incremental updating : system words %SW59 are used to adjust the date and time field by field starting from the current value if system bit %S59 = 1

bit 0 = 1 increments the day of the week	bit 8 = 1 decrements the day of the week
bit 1 = 1 increments the seconds	bit 9 = 1 decrements the seconds
bit 2 = 1 increments the minutes	bit 10 = 1 decrements the minutes
bit 3 = 1 increments the hours	bit 11 = 1 decrements the hours
bit 4 = 1 increments the days	bit 12 = 1 decrements the days
bit 5 = 1 increments the month	bit 13 = 1 decrements the month
bit 6 = 1 increments the years	bit 14 = 1 decrements the years
bit 7 = 1 increments the centuries	bit 15 = 1 decrements the centuries

Note : the processor does not manage the changeover from winter to summer time automatically

- **Date and time of the last application stop**

The date and time of the last application stop are stored in BCD format in system words %SW54 to %SW58.

System words	High order byte	Low order byte
%SW54	Seconds (0 to 59)	00
%SW55	Hours (0 to 23)	Minutes (0 to 59)
%SW56	Month (1 to 12)	Days of the month (1 to 31)
%SW57	Century (0 to 99)	Year (0 to 99)
%SW58	Day of the week (1 to 7)	Cause of the last application stop

- access to the date and time of the last application stop :

By reading system words %SW54 to %SW58

- cause of the last application stop :

By reading the low order byte of system word %SW58 (value stored in BCD format)

%SW58 = 1 application changes to STOP mode,

%SW58 = 2 stops the application after a software fault,

%SW58 = 4 power break or the power supply RESET button pressed

%SW58 = 5 stop due to hardware fault

%SW58 = 6 application stop after HALT instruction

3.5 Characteristics

3.5-1 General characteristics

Processors		TSX P 57 10	TSX P 57 20	
Maximum configuration	No. of TSX RKY ..E racks (6/8/12 positions)	2	8	
	Maximum no. of module slots	24	96	
Functions	Maximum no. of discrete I/O channels	512	1024	
	Maximum no. of analog I/O channels	24	80	
	Maximum no. of application-specific modules (1)	2	6	
	No. of integrated UNI-TELWAY connections (terminal port)	1	1	
	No. of FIPWAY network connections	1	1	
	No. of FIPIO agent bus connections	1	1	
	Realtime clock	Yes	Yes	
Memory (2)	Internal RAM (can be protected)	32 Kwords	48 Kwords	
	PCMCIA memory card	32/64 Kwords	32/64/128Kwords	
	Max. memory size	96 Kwords	176 Kwords	
Application structure	Master task	1	1	
	Fast task	1	1	
	Event processing	32	64 (1 of which takes priority)	
Execution time for 1K instructions	Internal Ram	100% Boolean	0.72 ms	0.31 ms
		100% numeric	1.18 ms	0.44 ms
	PCMCIA card	65% Boolean/35% numeric	1.39 ms	0.78 ms
System overhead	MAST task	cyclic operation	2 ms	1.4 ms
		periodic operation	1.7 ms	1.2 ms
	FAST task		0.57 ms	0.5 ms
Programming software		PL7 Junior under Windows		
Programming languages		Ladder language, Grafcet language, structured text language, List language		

(1) Counter (TSX CTY ..), axis control (TSX CAY ..), stepper control (TSX CFY ..), communication (TSX SCY 21600). weihina (TSX ISP Y100).

3.5-2 Electrical characteristics

Since the processors can accept certain devices without their own power supply, the power consumption of these devices must be taken into account when calculating the global power consumption.

- Devices without their own power supply which can be connected to the terminal port
 - Adjustment terminal : T FTX 117 ADJUST,
 - TSX P ACC01 box for connection to the UNI-TELWAY bus.
- Devices without their own power supply which can be integrated in the processor :
 - TSX FPP 10/20 PCMCIA communication cards
 - TSX SCP 111/112/114 PCMCIA communication card

Consumption on 5V power supply		Typical	Maximum
Processors + PCMCIA memory card	TSX P 57 10	440 mA	600 mA
	TSX P 57 20	450 mA	650 mA
Devices without their own power supply which connect to the terminal port (TER)	T FTX 117 ADJUST	310 mA	340 mA
	TSX P ACC01	150 mA	250 mA
PCMCIA communication cards which can be integrated in the processor	TSX FPP 10	330 mA	360 mA
	TSX FPP 20	330 mA	360 mA
	TSX SCP 111	140 mA	300 mA
	TSX SCP 112	120 mA	300 mA
	TSX SCP 114	150 mA	300 mA

4.1 Presentation

4.1-1 General

TSX PSY ●●● power supply modules are designed to supply power to each TSX RKY ●●● rack and its modules. The power supply module is selected according to the distributed supply (DC or AC) and the required power (standard format or double format version).

Moreover, each power supply module has auxiliary functions such as :

- a display block, an alarm relay,
- a slot which takes a battery for backing up the data in the processor RAM memory,
- a pencil-point type pushbutton which, when pressed, simulates a power break, causing a warm restart of the application,
- a 24 VDC sensor power supply (only on versions powered by an AC supply).

Power supply modules for AC supply

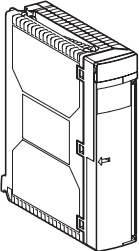
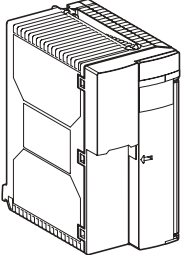
Standard format model	Double format model
 <p data-bbox="219 975 350 995">TSX PSY 2600</p>	 <p data-bbox="684 975 815 995">TSX PSY 5500</p>
100...240 VAC	100...120 / 200...240 VAC

Power supply modules for DC supply

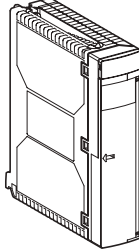
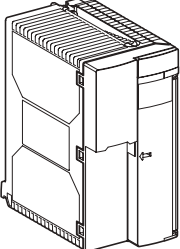
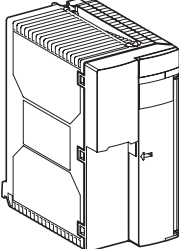
Standard format model	Double format model	
 <p data-bbox="202 1439 333 1460">TSX PSY 1610</p>	 <p data-bbox="524 1439 655 1460">TSX PSY 3610</p>	 <p data-bbox="838 1439 969 1460">TSX PSY 5520</p>
24 VDC non-isolated	24 48 VDC isolated	

4.1-2 Physical description

Power supplies take the form of the following modules :

- standard format, for TSX PSY 2600 and TSX PSY 1610 modules,
- double format, for TSX PSY 5500/3610/5520 modules.

1 Display block comprising :

- an OK indicator lamp (green), on if the voltages are present and correct,
- a BAT indicator lamp (red), on when the battery is defective or missing,
- a 24V indicator lamp (green), on when the sensor voltage is present. This indicator lamp is only found on TSX PSY 2600/5500 AC power supplies.

2 Pencil-point RESET button which, when pressed, causes a warm restart of the application.

3 Slot which takes a battery for backing up the processor internal RAM memory.

4 Cover which protects the module front panel.

5 Screw terminal block for connection :

- to the power supply network,
- of the alarm relay contact,
- of the sensor power supply for TSX PSY 2600/5500 AC power supplies.

6 Hole for a cable clamp,

7 Fuse located under the module which protects :

- the 24 VR voltage on the TSX PSY 3610 non-isolated DC power supply,
- the primary voltage on the other power supplies.

8 110/220 voltage selector, present only on the TSX PSY 5500 AC power supply. When delivered, the selector is set to 220.

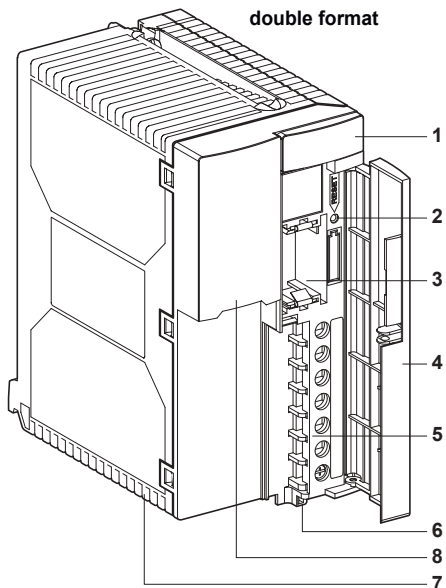
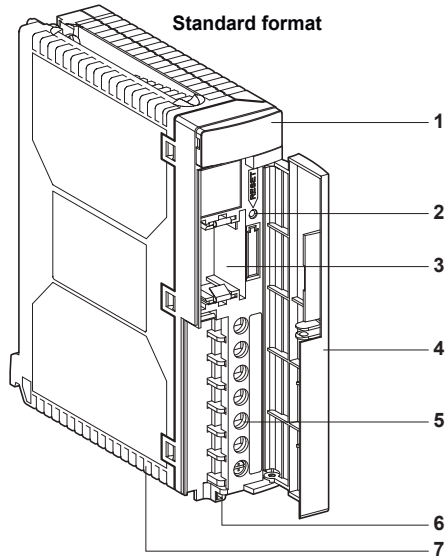

4-2 Catalog

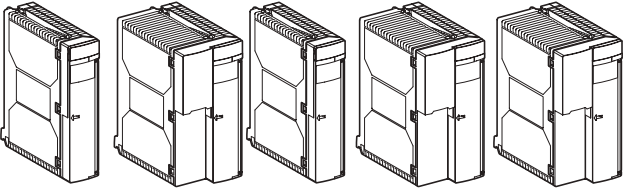
Module type	Power supplies				
					
Input characteristics					
Nominal voltages	100...240 VAC	100...120 VAC 200...240 VAC	24 VDC non-isolated	24...48 VDC isolated	
Limit values	85...264 VAC	85...140 VAC 190...264 VAC	19.2 ... 30 VDC	19.2...60 VDC	
Limit frequency	47...63 Hz				
Accepted duration of AC supply micro-cuts	≤ 10 ms		≤ 1ms		
Apparent power	50 VA	150 VA			
Nominal input current	0.5A/100V 0.3A/240V	1.7A/100V 0.5A/240V	≤ 1.5 A	≤ 2.7A	≤ 3 A /24V ≤ 1.5A/48V
Output characteristics					
Total useful power	26 W	50 W	26 W	50 W	50 W
Output voltages ---	5V, 24VR (1), 24VC (2)		5V, 24VR (1)		
Nominal current 5V ---	5 A	7 A	3 A	7 A	7 A
24VR ---	0.6 A	0.9 A	0.6 A	0.8 A	0.8 A
24VC ---	0.6 A	0.9 A			
Auxiliary functions					
Alarm relay	yes (1 NO, volt-free, contact on terminal block)				
Display	yes via indicator lamps on the front panel				
Backup battery	yes (status monitoring via indicator lamp on the module front panel)				
Conformity to standards	IEC 1131-2				
References	TSX PSY 2600	TSX PSY 5500	TSX PSY 1610	TSX PSY 3610	TSX PSY 5520

(1) 24 V --- voltage for supplying power to the relays, installed on "relay output" modules.

(2) 24 V --- voltage for supplying power to the sensors.

4.3 Auxiliary functions

• Alarm relay

This relay, which is included in every power supply module, has a volt-free contact which can be accessed on the module screw terminal block

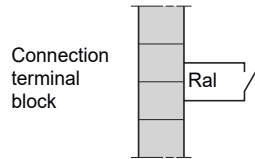

Principle

- Alarm relay of the module located on the rack supporting the processor (rack 0)

During normal operation, with the PLC running, the alarm relay is activated and its contact is closed (state 1). If the application stops, even partially, such as when a "blocking" fault appears, the output voltages are incorrect, or the supply voltage disappears, this relay is de-energized and its associated contact opens (state 0).

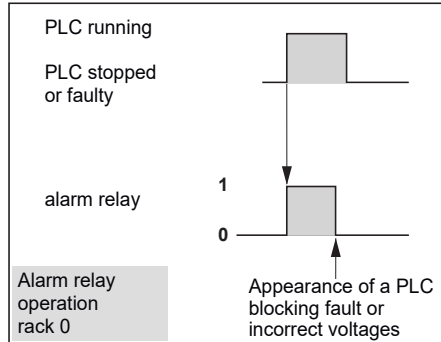

- Alarm relay of modules located on the other racks (racks 1 to 7):

Once the module is powered up and the output voltages are correct, the alarm relay is activated and its contact is closed (state 1).

When the supply voltage disappears or if the output voltages are incorrect, the relay is de-energized (state 0).

These operating modes enable these contacts to be used in external safety circuits such as, for example, interlocking of preactuator power supplies, data feedback.

• Backup battery

Each power supply module has a slot to take a battery which supplies power to the internal RAM memory located in the processors, and therefore protects the data when the PLC is powered down. This battery, supplied in the same packaging as the power supply module, should be installed by the user, taking care to respect the polarity.

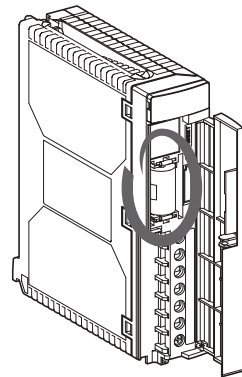

- **Battery characteristics** : thionyl lithium chloride battery, 3.6 V / 0.8 Ah, size 1 / 2AA.

- **Replacement part reference** : TSX PLP 01

- **Data backed up for** : 1 year,

- **Monitoring the state of the battery** : When powered up, the power supply module monitors the state of the battery. In the event of a problem, the user receives a visual warning from the BAT indicator lamp (red), which comes on; if this happens, the battery must be changed immediately.

- **Changing the battery** : The battery should be changed with the power supply module powered up or immediately after it is powered down. In this last instance, the time for this operation is limited to 10 minutes, after which the data in the RAM memory may be lost.

As a preventive measure, the battery should be changed once a year.

- **Display**

Every power supply module has a display block comprising :

- Three indicator lamps (OK, BAT, 24V) for TSX PSY 2600 / 5500 AC power supplies,
- Two indicator lamps (OK, BAT) for TSX PSY 1610 / 3610 / 5520 DC power supplies,



OK indicator lamp (green) :

- on during normal operation,
- off when the output voltages are below the thresholds,

BAT indicator lamp (red) :

- off during normal operation,
- on if battery missing, run down, wrong way round, or incompatible type

24V indicator lamp (green) :

- on during normal operation,
- off if the 24V sensor voltage delivered by the power supply is no longer in the monitoring range.

- **RESET pushbutton**

Action on this pushbutton results in a sequence of service signals identical to that for :

- a power break when pressed,
- a power-up when released.

These actions (press and release) effect a warm restart of the application (see section 7.5-2 - Part A1)

- **Sensor power supply**

TSX PSY 2600/5500 AC power supplies have an integrated power supply which delivers a 24 VDC voltage to supply the sensors.

This sensor power supply is accessible on the module screw terminal block.

4.4 Installation / insertion

4.4-1 Installation

- TSX PSY 2600/1610 standard format power supply modules :

These are installed in the first slot of each TSX RKY ... rack and occupy position PS.

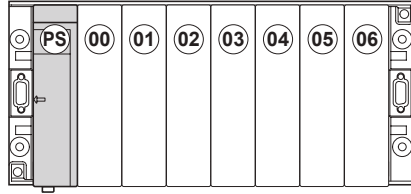

- TSX PSY 3610/5500/5520 double format power supply modules :

These are installed in the first two slots of each TSX RKY ... rack and occupy positions PS and 00.

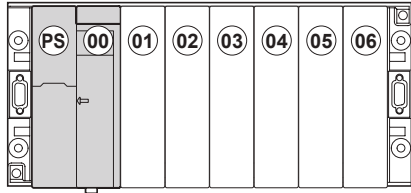

Note :

Every power supply module has a locating system which ensures that it can only be installed in the slots designated above.

4.4-2 Insertion / connections

Inserting modules : see section 5.4-1 of this part.

Connections : see section 6.2 of this part.



When inserting or removing a TSX PSY power supply module, the external power supplies must be powered down.

Important:

The PLC internal 0V is connected to the machine ground. The machine ground itself must be connected to the earth ground.

4.5 Characteristics

4.5-1 Characteristics of AC power supplies

References		TSX PSY 2600	TSX PSY 5500	
Primary	Nominal voltages	100...240 VAC	100..120/200...240VAC	
	Limit voltages	85...264 VAC	85...140/ 190...264VAC	
	Nominal/limit frequencies	50-60 / 47-63 Hz	50-60 Hz / 47-63 Hz	
	Apparent power	50 VA	150 VA	
	Nominal current drawn : Irms	≤ 0.5 A at 100 V ≤ 0.3 A at 240 V	≤ 1.7 A at 100 V ≤ 0.5 A at 240 V	
	Initial power-up	I inrush	≤ 37 A at 100 V ≤ 75 A at 240 V	≤ 38 A at 100 V ≤ 38 A at 240 V
		I ² t on energization	0.63 A ² s at 100 V 2.6 A ² s at 100 V	4 A ² s at 100 V 2 A ² s at 100 V
	25°C (1)	I ² t on energization	0.034 As at 100V 0.067 As at 240V	0.11 As at 100V 0.11 As at 240V
	Accepted duration of micro-cuts		≤ 10 ms	≤ 10 ms
	Integrated phase protection (fuse located under the module)		via 5x20 fuse, time-delay type 4 A	4 A
Secondary	Total useful power		26 W	50W
	5 VDC output	Nominal voltage	5.1 V	5.1 V
		Nominal current	5 A	7 A
		Power (typical)	25 W	35 W
	24 VR output (2) (24V relay)	Nominal voltage	24 VDC	24 VDC
		Nominal current	0.6 A	0.8A
		Power (typical)	15 W	19 W
	24VC output (3) (24V sensor)	Nominal voltage	24 VDC	24 VDC
		Nominal current	0.5 A	0.8A
		Power (typical)	12 W	19 W
Outputs protected against		overloads/short-circuits/overvoltages		
Conformity to standards		IEC 1131-2	IEC 1131-2	
Isolation	Dielectric withstand	primary / secondary	2000 Vrms - 50/60 Hz - 1 min	
		primary / ground	2000 Vrms - 50/60 Hz - 1 min	
Insulation resistance	primary / secondary	≥ 100 MΩ		
		primary / ground	≥ 100 MΩ	

- (1) These values should be taken into account when starting several devices simultaneously or when calculating the size of protective devices.
- (2) 24V ∩∩∩ output for supplying power to the "relay output" module relays.
- (3) 24V ∩∩∩ output for supplying power to the sensors. This cannot be placed in parallel with an

4.5-2 Characteristics of DC power supplies

• Non-isolated power supplies

References		TSX PSY 1610	TSX PSY 3610	
Primary	Nominal voltages	24 VDC	24 VDC	
	Limit voltages (including ripple) (1)	19.2...30 VDC (possible up to 34V for 1H in 24 H)	19.2...30 VDC	
	Nominal input current : I _{rms} at 24 VDC	≤ 1.5 A	≤ 2.7 A	
	Initial I inrush power-up	≤ 100 A at 24 VDC	≤ 150 A at 24 VDC	
	at I ² t on power-up	12.5 A ² s	20 A ² s	
	25°C (2) It on power-up	0.2 As	0.5 As	
	Accepted duration of AC supply micro-cuts	≤ 1 ms	≤ 1 ms	
	Integrated protection on + input (fuse located under the module)	via fuse 5x20, time-delay, 3.5 A	no	
Secondary	Total useful power (typical)	30 W	50 W	
	5VDC output	Nominal voltage	5V	5.1
		Nominal current	3 A	7 A
		Power (typical)	15 W	35 W
	24VR output (3) (24 VDC relay)	Nominal voltage	U supply — 0.6V	U supply — 0.6V
		Nominal current	0.6 A	0.8A
		Power (typical)	15 W	19 W
	Integrated protection on outputs against (4)	Overloads	yes	yes
		Short-circuits	yes	yes
		Overvoltages	yes	yes
Conformity to standards		IEC 1131-2	IEC 1131-2	

(1) When supplying power to modules with "relay outputs", the range limit is reduced to 21.6V...26.4V.

(2) These values should be taken into account when starting several devices simultaneously or when calculating the size of protective devices.

(3) 24 V \approx output for supplying power to the "relay output" module relays.

(4) The 24VR output voltage cannot be accessed by the user and is protected by a fuse located below the module (5x20, 4A, Medium).

• Isolated power supply

References		TSX PSY 5520	
Primary	Nominal voltages		24...48 VDC
	Limit voltages (including ripple)		19.2...60 VDC
	Nominal input current : Irms		≤ 3 A at 24 VDC ≤ 1.5 A at 48 VDC
	Initial power-up	I inrush	≤ 15 A at 24 VDC ≤ 15 A at 48 VDC
		I ² t on power-up	50 A ² s at 24 VDC 55 A ² s at 48 VDC
	at 25°C		
	(1)	I _t on power-up	7 As at 24 VDC 6 As at 48 VDC
	Accepted duration of AC supply micro-cuts		≤ 1 ms
	Integrated protection on + input (fuse located under the module)		via fuse 5x20, time-delay type, 5 A
	Secondary	Total useful power (typical)	
5VDC output		Nominal voltage	5.1 V
		Nominal current	7 A
		Power (typical)	35 W
24VR output (2) (24 VDC relay)		Nominal voltage	24 V
		Nominal current	0.8 A
		Power (typical)	19 W
Integrated protection on outputs against		Overloads	yes
		Short-circuits	yes
		Overvoltages	yes
Conformity to standards		IEC 1131-2	
Isolation	Dielectric withstand	primary / secondary	2000 Vrms - 50/60 Hz - 1 min
		primary / ground	2000 Vrms - 50/60 Hz - 1 min
	Insulation resistance	primary / secondary	≥ 10 MΩ
		primary / ground	≥ 10 MΩ

(1) These values should be taken into account when starting several devices simultaneously or when calculating the size of protective devices.

(2) 24V --- output for supplying power to the "relay output" module relays.

4.5-3 Characteristics of the alarm relay contact

Characteristics		Alarm relay contact				
Limit operating voltage	AC	19...264 V				
	DC	10...30 V (possible up to 34V for 1 hour in 24 hours)				
Thermal current		3 A				
AC load	Resistive load AC12	Voltage	~ 24 V	~ 48 V	~ 110 V	~ 220 V
		Power	50 VA (5)	50 VA (6) 110 VA (4)	110 VA (6) 220 VA (4)	220 VA (6)
AC load	Inductive load AC14 and AC15	Voltage	~ 24 V	~ 48 V	~ 110 V	~ 220 V
		Power	24 VA (4)	10VA (10) 24 VA (8)	10 VA (11) 50 VA (7) 110 VA (2)	10 VA (11) 50 VA (9) 110 VA (6) 220 VA (1)
DC load	Resistive load DC12	Voltage	--- 24 V			
		Power	24 W (6) 40 W (3)			
	Inductive load DC13 (L/R = 60 ms)	Voltage	--- 24 V			
		Power	10 W (8) 24 W (6)			
	Min. switchable load	1 mA / 5 V				
Response time	Energization	< 10 ms				
	De-energization	< 10 ms				
Type of contact		Normally open				
Integrated protection	Against overloads and short-circuits	None, a quick-blow fuse must be fitted				
	Against inductive overvoltages in ~	None, an RC circuit or MOV peak limiter (ZNO) suitable for the voltage must be fitted in parallel across the terminals of each preactuator				
	Against inductive overvoltages in ---	None, a discharge diode must be fitted across the terminals of each preactuator				
Isolation (test voltage)	Contact/ground	2000 V rms 50/60 Hz for 1 min				
	Insulation resistance	> 10 MΩ at 500 VDC				

- | | | |
|---------------------------------------|---------------------------------------|---------------------------------------|
| (1) 0.1 x 10 ⁶ operations | (5) 0.7 x 10 ⁶ operations. | (9) 3 x 10 ⁶ operations. |
| (2) 0.15 x 10 ⁶ operations | (6) 1 x 10 ⁶ operations. | (10) 5 x 10 ⁶ operations. |
| (3) 0.3 x 10 ⁶ operations | (7) 1.5 x 10 ⁶ operations. | (11) 10 x 10 ⁶ operations. |
| (4) 0.5 x 10 ⁶ operations | (8) 2 x 10 ⁶ operations. | |

4.6 Power consumption table for selecting a power supply module

The power required to supply a rack depends on the types of module installed on it. It is therefore necessary to draw up a power consumption table in order to define which power supply module should be inserted in the rack (standard or double format module). The tables on the following pages show the typical consumption of each module and can be used to calculate the consumption of each rack and on each output according to which modules have been installed.

Power available on each power supply module

Power supply modules Power (typical)	Standard format		Double format		
	TSX PSY 1610	TSX PSY 2600	TSX PSY 3610	TSX PSY 5520	TSX PSY 5500
Total useful power (all outputs mixed up) (1)	30 W (30W)	26 W (30W)	50 W (55W)	50 W (55W)	50 W (55W)
Power available on 5 VDC output	15 W	25 W	35 W	35 W	35 W
Power available on 24 VR output	15 W	15 W	19 W	19 W	19 W
Power available on 24 VC output (sensor power supply on front panel terminal block)	not supplied	12 W	not supplied	not supplied	19 W

(1) The values in brackets are the maximum values which can be held for 1 out of every 10 minutes. These values must not be included when calculating the consumption requirement.

Caution :

When drawing up the power requirement, the total power drawn on each output (5 VDC, 24 VR and 24 VC) must not exceed the total useful power of the module.

Power consumption table

Rack number :								
Module type	References	No.	Consumption in mA (typical value) (1)					
			On 5VDC		On 24VR		On 24VC (2)	
			Module	Total	Module	Total	Module	Total
Processor + PCMCIA memory card	TSX P57-10		440					
	TSX P57-20		450					
Discrete inputs	TSX DEY 08D2		55			80		
	TSX DEY 16A2		80					
	TSX DEY 16A3		80					
	TSX DEY 16A4		80					
	TSX DEY 16A5		80					
	TSX DEY 16D2		80			135		
	TSX DEY 16D3		80					
	TSX DEY 16FK		250			75		
	TSX DEY 32D2K		135			160		
	TSX DEY 64D2K		155			315		
	Discrete outputs	TSX DSY 08R4D		55		80		
TSX DSY 08R5			55		70			
TSX DSY 08R5A			55		80			
TSX DSY 08S5			125					
TSX DSY 08T2			55					
TSX DSY 08T22			55					
TSX DSY 08T31			55					
TSX DSY 16R5			80		135			
TSX DSY 16S4			220					
TSX DSY 16T2			80					
TSX DSY 16T3			80					
TSX DSY 32T2K			140					
TSX DSY 64T2K			155					
Total								

(1) The module consumption is given for 100% of inputs or outputs at state 1.

(2) If using an external 24 V sensor power supply, do not take the consumption on this output into account when selecting the rack power supply.

Power consumption table (continued)

Rack number :								
Module type	References	No.	Consumption in mA (typical value) (1)					
			On 5VDC		On 24V _R		On 24V _C (2)	
			Module	Total	Module	Total	Module	Total
Report								
Analog	TSX AEY 414		660					
	TSX AEY 800		270					
	TSX AEY 1600		270					
	TSX ASY 410		990					
Counter	TSX CTY 2A		280			30		
	TSX CTY 4A		330			60		
Axis control	TSX CAY 21		1100			15		
	TSX CAY 41		1500			30		
Stepper control	TSX CFY 11		510			50		
	TSX CFY 21		650			100		
Weighing	TSX AWY 001		150	145				
Communication	TSX SCY 21600		350					
	TSX SCP 111		140					
	TSX SCP 112		120					
	TSX SCP 114		150					
	TSX FPP 10		330					
	TSX FPP 20		330					
Other (devices without their own power supply which can be connected on the terminal port)	TSX P ACC01		150					
	TSX FTX 117		310					
Grand total								

(1) The module consumption is given for 100% of inputs or outputs at state 1.

(2) If using an external --- 24 V sensor power supply, do not take the consumption on this output into account when selecting the rack power supply.

Power requirement

The power requirement for a rack should be calculated on the basis of the consumption table drawn up using the tables defined on the preceding pages. The currents which apply to each output (5 VDC, 24 VR and 24 VC) are those which appear on the grand total line of the preceding table.

Rack number :				
1	Power required on 5 VDC output :	$\times 10^{-3} \text{ A} \times 5 \text{ V}$	= W
2	Power required on 24 VR output :	$\times 10^{-3} \text{ A} \times 24 \text{ V}$	= W
3	Power required on 24 VC output :	$\times 10^{-3} \text{ A} \times 24 \text{ V}$	= W
4	Total power required :			= W
Caution : The power calculated must be compared to the power supplies in the table below.				
• Power required on each output \leq power available on each output :				
$1 \leq 1a, 2 \leq 2a, 3 \leq 3a$				
• Sum of the power required on each output \leq total power available :				
$4 \leq 4a$				

Power available (at each output and total)

Power available / Modules	On 5 VDC output 1a	On 24 VR output 2a	On 24 VC output 3a	Total 4a
TSX PSY 1610	15 W	15 W	—	30 W
TSX PSY 2600	25 W	15 W	12 W	26 W
TSX PSY 3610	35 W	19 W	—	50 W
TSX PSY 5520	35 W	19 W	—	50 W
TSX PSY 5500	35 W	19 W	19 W	50 W

4.7 Definition of protection devices at the head of the line

It is recommended that a protective device such as a circuit-breaker or a fuse be installed on the power supply at the head of the line.

The information below shows the minimum rating for the circuit-breaker and line fuse for a given power supply module.

• Selecting a line circuit-breaker

When selecting the rating for the circuit-breaker, the following three characteristics, which are given for each power supply, should be taken into account:

- nominal input current : I_{rms} ,
- inrush current : I ,
- I_t .

The minimum rating for the circuit-breaker is selected as follows :

- circuit-breaker rating $I_N > I_{rms}$ power supply,
- I_{max} circuit-breaker $> I$ inrush power supply,
- I_t circuit-breaker at point A on the curve $> I_t$ power supply.

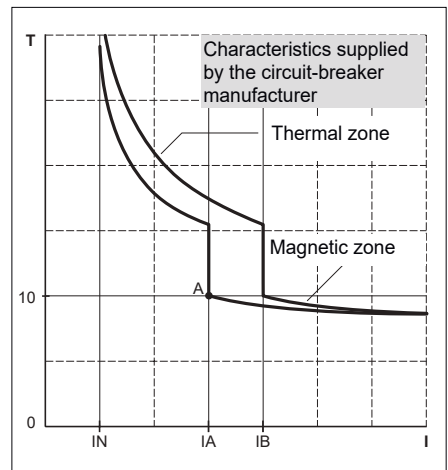

• Selecting the line fuse

When selecting the rating for the line fuse, the following two characteristics, which are given for each power supply, should be taken into account:

- nominal input current : I_{rms} ,
- I^2t .

The minimum rating for the fuse is selected as follows :

- fuse rating $I_N > 3 \times I_{rms}$ power supply,
- I^2t of the fuse $> 3 \times I^2t$ power supply

Note:

A reminder of the power supply characteristics (I_{rms} , I inrush, I_t , I^2t) is given on the following page.

Reminder of the I_{rms}, I_{inrush}, I_t and I²_t characteristics of each supply module

Modules	TSX	PSY 2600	PSY 5500	PSY 1610	PSY 3610	PSY 5520
I_{rms}	at 24 VDC	–	–	1.5 A	2.7 A	3 A
	at 48 VDC	–	–	–	–	1.5 A
	at 100 VAC	0.5 A	1.7 A	–	–	–
	at 240 VAC	0.3 A	0.5 A	–	–	–
I_{inrush} (1)	at 24 VDC	–	–	100 A	150 A	15 A
	at 48 VDC	–	–	–	–	15 A
	at 100 VAC	37 A	38 A	–	–	–
	at 240 VAC	75 A	38 A	–	–	–
I_t (1)	at 24 VDC	–	–	0.2 As	0.5 As	7 As
	at 48 VDC	–	–	–	–	6 As
	at 100 VAC	0.034 As	0.11 As	–	–	–
	at 240 VAC	0.067 As	0.11 As	–	–	–
I²_t (1)	at 24 VDC	–	–	12.5 A ² s	20 A ² s	50 A ² s
	at 48 VDC	–	–	–	–	55 A ² s
	at 100 VAC	0.63 A ² s	4 A ² s	–	–	–
	at 240 VAC	2.6 A ² s	2 A ² s	–	–	–

(1) Values on initial power-up at 25°C.

5.1 Installation rules

5.1-1 Positioning the racks

When mounting TSX RKY... racks certain installation rules must be respected :

- 1 As the various modules (power supply, processors, discrete I/O, etc) are cooled by natural convection, **the various racks must be installed horizontally and on a vertical plane.**

Note :

If fan modules are being used, see section 8 of this part.

- 2 If several racks are installed in the same enclosure, it is recommended that the following positioning guidelines are respected :
 - leave a space of at least 150 mm between two superposed racks, to allow for the cable ducts and to facilitate air circulation.
 - it is advisable to install equipment which generates heat (transformers, process power supplies, power contactors, etc) above the racks.
 - leave a space of at least 100 mm on each side of a rack to allow room for the cables and to facilitate air circulation.

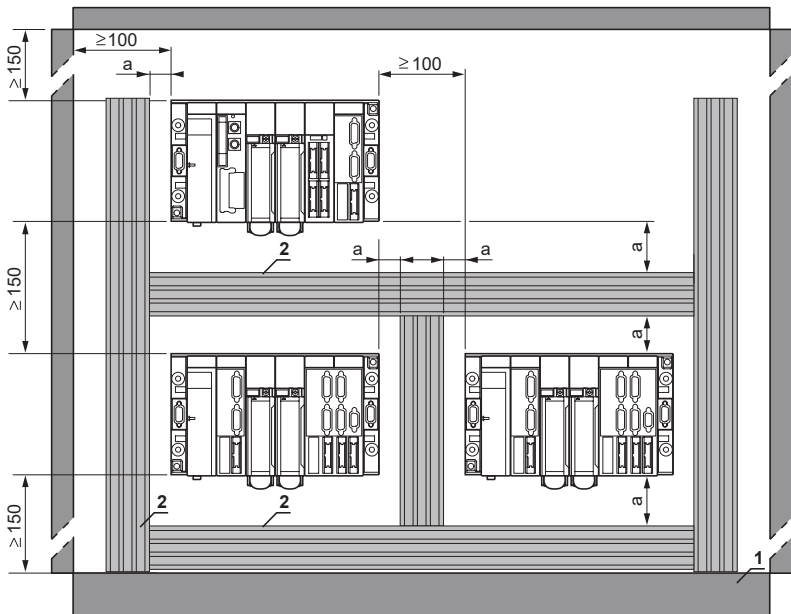

$a \geq 50 \text{ mm}$

- 1 Housing or enclosure.
- 2 Cable duct or clip.

5.2 Dimensions

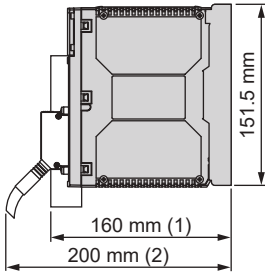

TSX RKY 6/6E

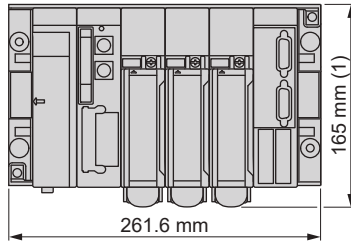

- (1) Modules with screw terminal blocks
- (2) Maximum depth with all types of module and associated connections

TSX RKY 8/8E

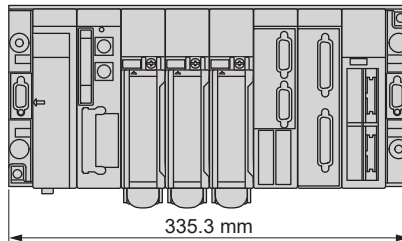

TSX RKY 12/12E

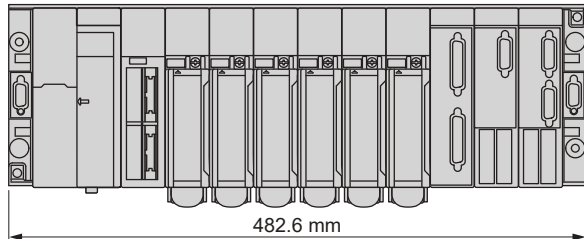

Note :

If using fan modules, see section 8 of this part.

5.3 Mounting/fixing racks

TSX RKY●● and TSX RKY●●E racks can be mounted :

- on a 35 mm wide DIN rail fixed with M6x25 screws
- on a Telequick pre-slotted mounting plate or on a panel,

The installation rules described in section 5.1 should be adhered to, whatever the type of mounting.

Note :

If using fan modules, see section 8 of this part.

5.3-1 Mounting on a 35 mm wide DIN rail

Fix with 4 M6x25 screws + washers and AF1-CF56 1/4 turn sliding nuts.

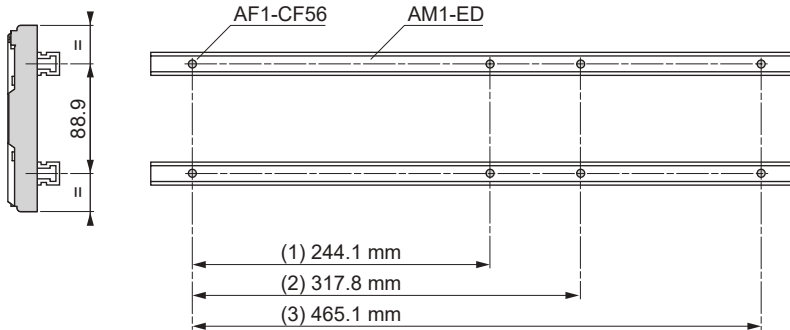

- (1) TSX RKY6 and TSX RKY 6E
- (2) TSX RKY8 and TSX RKY 8E
- (3) TSX RKY 12 and TSX RKY 12E

5.3-2 Mounting on panel or Telequick pre-slotted mounting plate

- Mounting on panel : cut-out (dimensions in mm)

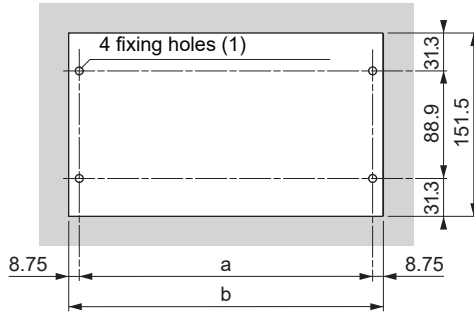

(1) The fixing hole diameter must be large enough for M6 screws.

- Mounting on AM1-PA Telequick pre-slotted mounting plate (dimensions in mm)

Fix the rack with 4 M6x25 screws + washer and AF1-EA6 clip nuts

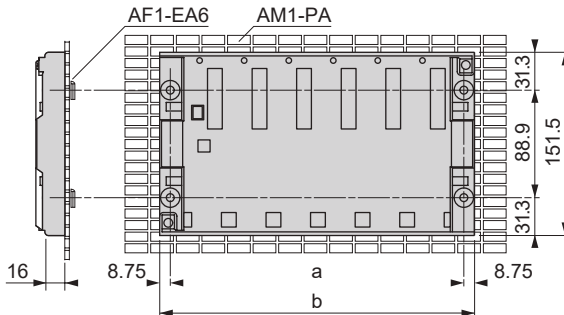

Racks	a	b	Thickness
TSX RKY 6/6E	244.1 mm	261.6 mm	16 mm
TSX RKY 8/8E	317.8 mm	335.3 mm	16 mm
TSX RKY 12/12E	465.1 mm	482.6 mm	16 mm

5.4 Mounting modules and terminal blocks

Modules can be inserted and removed while powered up **with the exception of the processor and PCMCIA communication cards.**

To insert/remove powered-up modules, they must be manually screwed and unscrewed to ensure that the signals on BusX are connected/disconnected in the correct sequence. This sequence cannot be assured if an electric screwdriver is used.

-  powered-up modules must be removed/installed with the terminal block or connector HE10 disconnected, having taken care to cut the sensor/preactuator power supply if it is greater than 48V.

5.4-1 Inserting a module in a rack

- 1 Locate the pins on the rear of the module in the centering holes at the bottom of the rack (①).

- 2 Swivel the module, bringing it into contact with the rack (②).

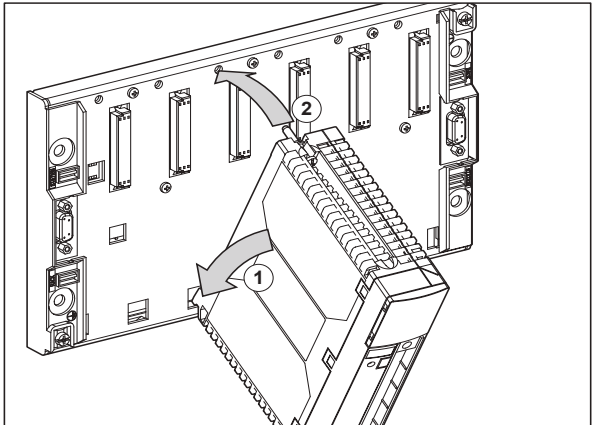

- 3 Fit the module firmly onto the rack by tightening the screw at the top of the module (③).

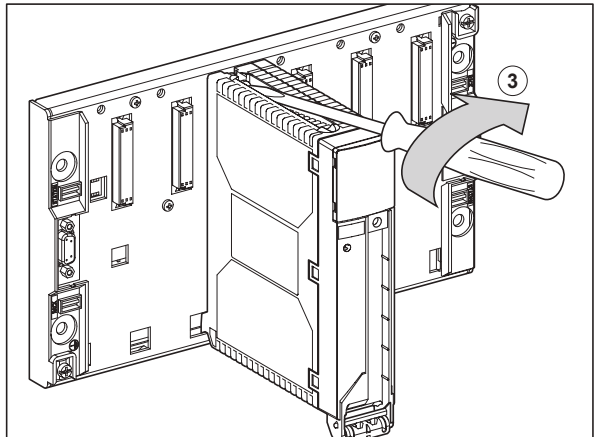

5.4-2 Fitting a screw terminal block on a module

The first time a screw terminal block is mounted on a module which takes this type of connection, the terminal block has to be coded with the type of module on which it is mounted. This is done by transferring 2 physical coding devices from the module onto the screw terminal. This mechanical code prohibits any subsequent mounting of the terminal block with this code on any other type of module.

1 With the module already in place on the rack, mount the terminal block as shown opposite (1). The code is transferred automatically during this initial operation.

2 Swivel the screw terminal into position to plug onto the module (2).

3 Lock the screw terminal on the module by tightening the appropriate screw (3).

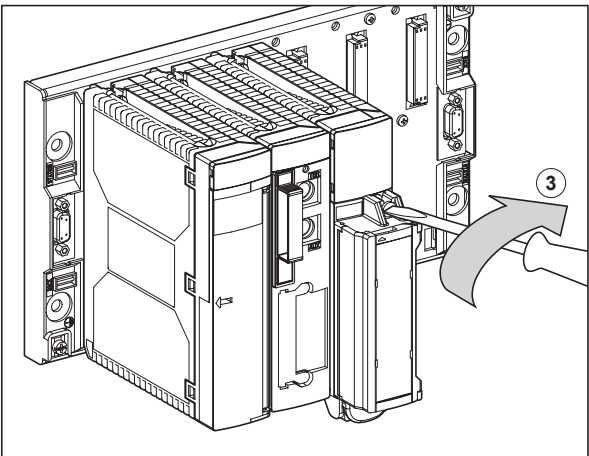
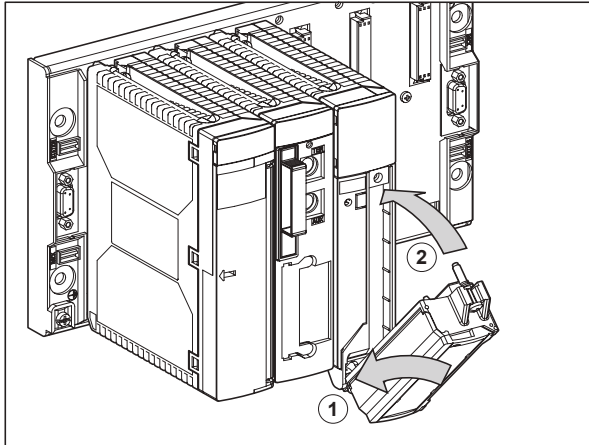

Note :

When replacing a module in position on the rack with another module, the screw terminal block on the old module already has physical coding devices which relate to that module.

There are two possible options :

- Replace the module with a module of the same type : in order to install the coded terminal block on the new module, it will first be necessary to remove the physical coding devices on the new module before installing the terminal block,
- Replace the module with another type of module : it will first be necessary to remove the old physical coding devices on the terminal block before installing it as described above.

5.5 Fitting/removing the RAM memory backup battery

This battery, located on the power supply module TSX PSY backs up the processor internal RAM memory in the event of a mains power supply failure. Supplied in the same packaging as the power supply module, it should be installed by the user.

Fitting the battery

- 1 Open the access cover located on the front panel of the power supply module,
- 2 Position the battery in its compartment, taking care to respect the polarity, as shown on the plate,
- 3 Close the access cover.

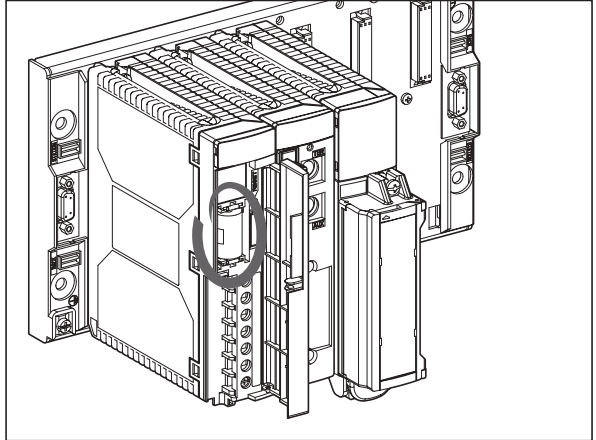

Changing the battery

The battery should be changed **once a year**, as a preventive measure, or when the BAT indicator lamp lights up. Follow the same procedure as for installation :

- 1 Open the cover which accesses the battery,
- 2 Take the defective battery out of its compartment,
- 3 Insert the new battery, taking care to respect the polarity,
- 4 Close and lock the access cover.

This operation must be performed with the power on. If there is a loss of power supply while changing the battery, the RAM memory backup operates for a maximum of 10 minutes.

Important :

So as not to forget to change the battery every year, it is advisable to note the date of the next change due on the special label inside the access cover.

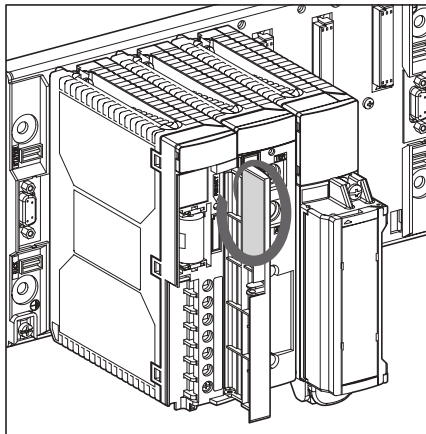

Next change	
BATTERY	
LITHIUM	
Thionyl	
chloride	
1/2AA	
FUSE 5x20 UL	
PSY2600	4A T
PSY5500	4A T
PSY5520	5A T
PSY1610	3.5A T
PSY3610	4A M

5.6 Inserting/removing the PCMCIA memory card

A handle is required to insert the memory card in its slot.

Fitting the handle onto the card

- 1 Position the end of the memory card (opposite end from the connector) at the handle opening.

The triangular-shaped markers on both the handle and the label of the card should be on the same side.

- 2 Slide the memory card into the handle until it stops. It then forms an integral part of the handle.

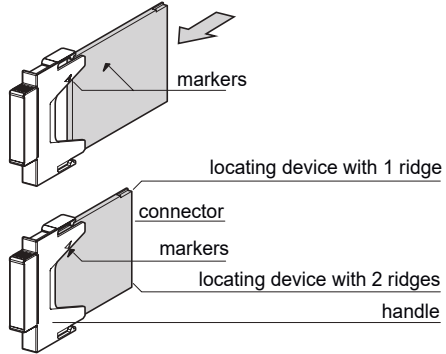

Inserting the memory card

To install the memory card in the processor, proceed as follows :

- 1 Remove the protective cover by unlocking and then pulling it towards the front of the PLC,
- 2 Position the PCMCIA card with its handle into the slot which is now vacant. Slide in until the card stops, then push the handle to connect the card.

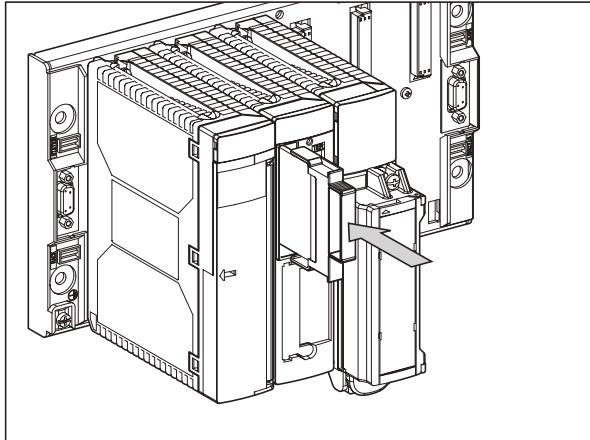

Note :

When installing the PCMCIA card in its slot, make sure that the physical locating devices are correctly positioned :

- 1 ridge towards the top,
- 2 ridges towards the bottom

Installing / changing the battery on a RAM type PCMCIA memory card

PCMCIA RAM memory cards (TSX MRP) must be fitted with a battery (reference TSX BAT M01), which has to be changed (see table below). To do this :

- 1 Remove the card from its slot by pulling the handle towards the front of the PLC.
- 2 Separate the PCMCIA card from its handle by pulling them apart.
- 3 Hold the PCMCIA card so as to allow access to the battery slot at the non-connector end of the card.
- 4 Unlock the battery holder, located at the non-connector end of the card. To do this, press the clip towards the bottom of the card (in the opposite direction to the write-protect micro-switch) while pulling it towards the back.
- 5 Remove the battery with holder from its slot.
- 6 Replace the defective battery with an identical 3 V battery. The polarities must be respected by placing the + markers on the holder and the battery on the same side.
- 7 Put the battery with holder back in its slot and lock it in place. To do this, simply reverse the removal procedure.
- 8 Fix the PCMCIA card in its handle.
- 9 Replace the card with its handle in the PLC.

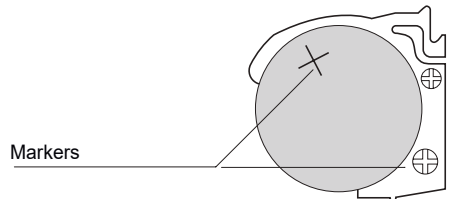
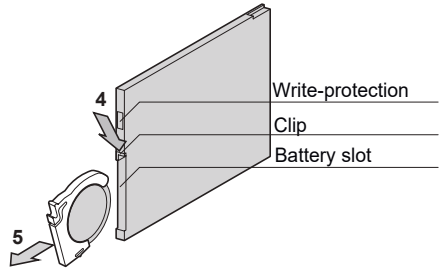

Battery service life

PCMCIA card stored in normal conditions (-20 °C to 70 °C)	12 months
PCMCIA card installed in an operating PLC (0 °C to 60 °C)	36 months

Note :

During operation, when the PCMCIA card battery is faulty, the processor ERR lamp flashes.

6.1 Ground connections

6.1-1 Grounding the racks

The functional grounding of racks is provided by the rear panel, which is metal. This ensures that PLCs meet environmental standards, provided that the racks are fixed to a metal support which is correctly grounded. The various racks which may constitute a TSX 57 PLC station must be fitted either on the same support or on different supports which must however be correctly interconnected.

To protect personnel, the \perp terminals of each rack **must, without exception**, be connected to the protective earth ground. To do this, use a green/yellow wire with a cross-section of at least 2.5 mm² and as short as possible.

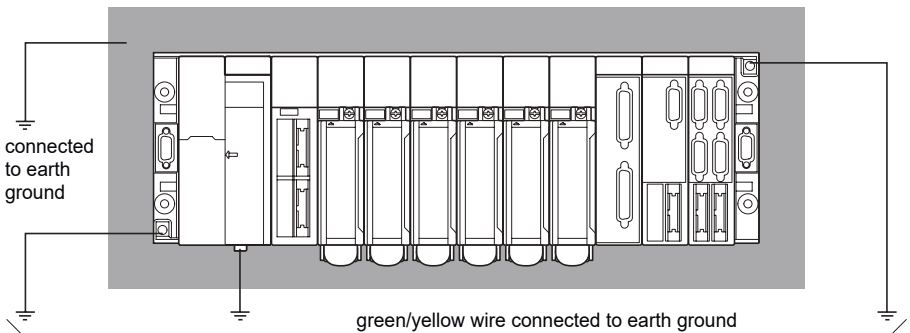

Important

The PLC internal 0V is connected to the machine ground. The machine ground itself must be connected to the earth ground.

6.1-2 Grounding the modules

The modules are grounded by metal plates located on the module rear panel. When the module is in position, these metal plates are in contact with the rack metal-work, thus providing the connection to ground.

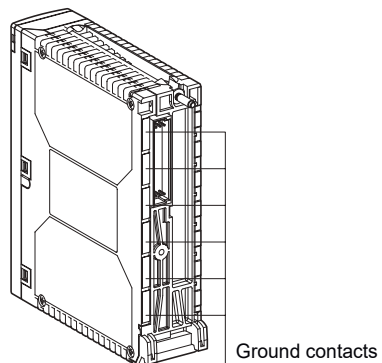

6.2 Connection of power supplies

6.2-1 Rules for connection

The TSX PSY.... power supply modules on each rack have a non-removable terminal block, protected by a cover, which is used to connect the mains supply, the alarm relay, the protective ground and, for AC power supplies, the power supply for the 24 VDC sensors.

This terminal block is fitted with captive screw clamp terminals with a maximum connection capacity of 2 wires with a cross-section of 2.5 mm². The wires exit vertically downwards, and can be secured with a cable clamp.

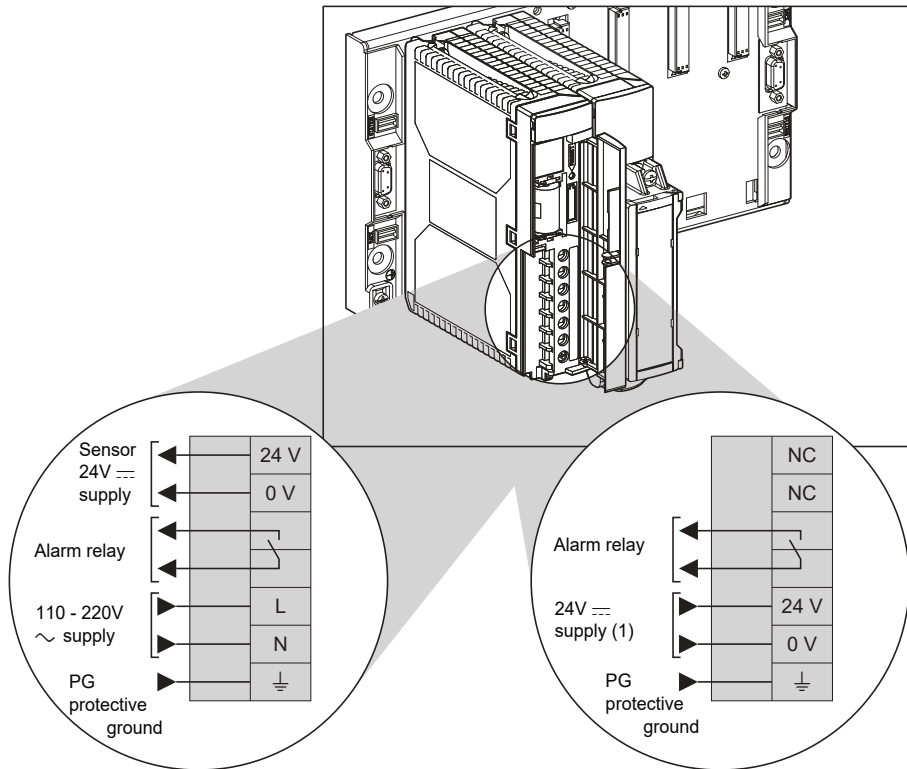

AC power supply TSX PSY 2600/5500

DC power supplies TSX PSY 1610/3610/5520

 For the TSX PSY 5500 power supply module, set the voltage selector position according to the mains voltage being used (110 - 220V AC).

(1) 24V...48V for the TSX PSY 5520 power supply

Be sure to install a device for protecting and breaking the power supply upstream of the PLC station.

When choosing protection devices, the user should take account of the inrush currents defined in the table of characteristics for each power supply (see section 4.5).

Note :

Given that the TSX PSY 1610/2610/5520 DC power supplies have a very strong inrush current, it is not advisable to use them on DC supplies with return current protection (fold back).

When a power supply module is connected on a DC supply, in order to avoid line losses, it is essential to limit the length of the power supply cable :

- TSX PSY 1610 power supply module :
 - length limited to 30 meters each way (60 meters in total) with copper wires, cross-section 2.5mm²
 - length limited to 20 meters each way (40 meters in total) with copper wires, cross-section 1.5mm²
- TSX PSY 3610 and TSX PSY 5520 power supply modules :
 - length limited to 15 meters each way (30 meters in total) with copper wires, cross-section 2.5mm²
 - length limited to 10 meters each way (20 meters in total) with copper wires, cross-section 1.5mm²

Warning :

Interconnection of several PLCs which are powered by a secure DC supply not connected to ground.

The 0V and the mechanical ground are connected inside the PLCs, the network wiring accessories and some operator panels.

Special connection arrangements must be made for specific applications which use a free-floating mounting. These depend on the installation mode used. In this case, it is compulsory to use an isolated DC supply. Please contact us when defining the electrical installation.

6.2-2 Connection of AC power supply modules

Connecting a PLC station comprising a single rack

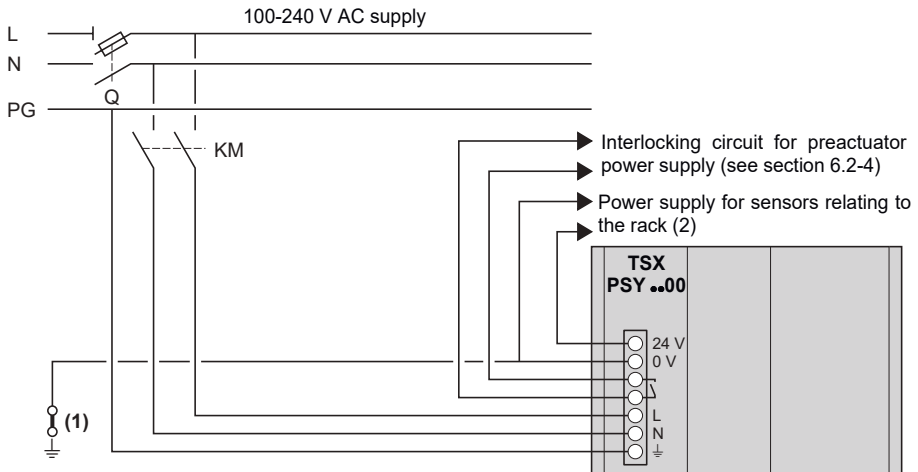

Q : general isolator,

KM : line contactor or circuit-breaker,

Protective fuse :

AC power supplies are fitted as standard with a protective fuse located under the module and in series on the L input :

- TSX PSY 2600 power supply : 4 A fuse, 5x20, time-delayed,
- TSX PSY 5500 power supply : 4 A fuse, 5x20, time-delayed

(1) isolation strip for locating ground fault.

(2) available current :

- 0.6 A with TSX PSY 2600 power supply module, (see characteristics section 4.5-1)
- 0.9 A with TSX PSY 5500 power supply module, (see characteristics section 4.5-1)

Connection of a PLC station comprising a number of racks

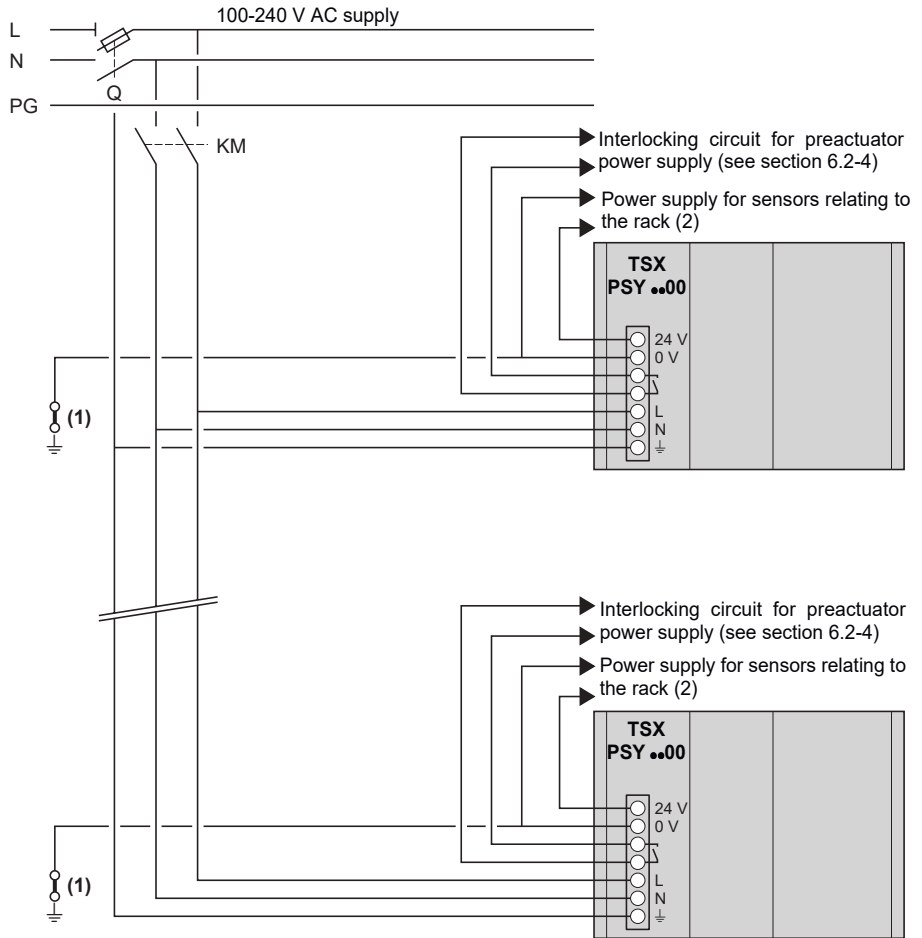

Note :

When there are a number of PLC stations, all powered from a single supply, the connection principle is identical.

Q : general isolator,
KM : line contactor or circuit-breaker,

Protective fuse :

AC power supplies are fitted as standard with a protective fuse located under the module and in series on the L input :

- TSX PSY 2600 power supply : 4 A fuse, 5x20, time-delayed,
- TSX PSY 5500 power supply : 4 A fuse, 5x20, time-delayed

(1) isolation strip for locating ground fault.

(2) available current :

- 0.6 A with TSX PSY 2600 power supply module. (see characteristics section 4.5.1)

6.2-3 Connecting DC power supply modules via an AC supply

• TSX PSY 1610/3610 non-isolated power supply modules

- Connection of a PLC station comprising a single rack, with AC supply referenced to ground

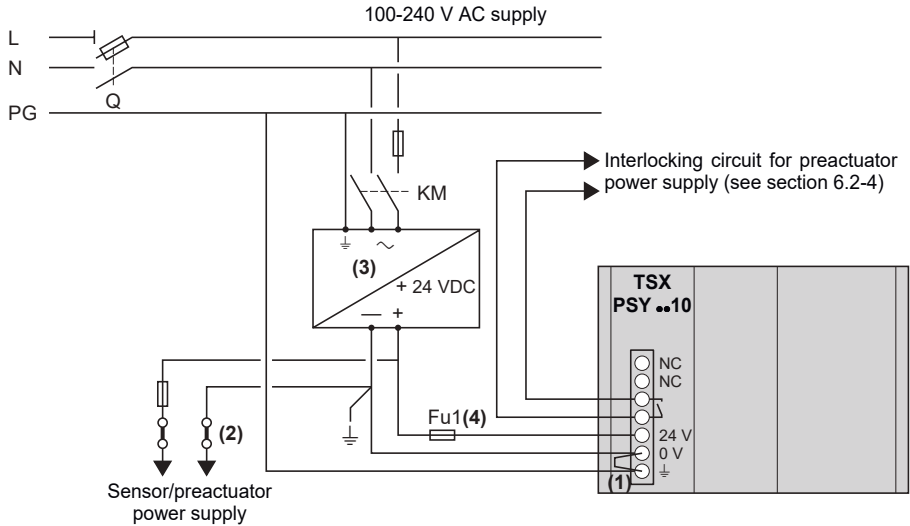

Q : general isolator,

KM : line contactor or circuit-breaker,

(1) : external shunt supplied with the power supply module

(2) : isolation strip for locating ground fault. In this instance the power supply needs to be unplugged in order to disconnect the AC supply from the ground.

(3) : it is possible to use a process power supply (to be defined according to the power required, see part J).

(4) : protective fuse, (4 A, time-delayed) which is only necessary with a TSX PSY 3610 power supply module.

The TSX PSY 1610 power supply module is fitted as standard with a protective fuse located under the module and in series on the 24V input (3.5 A fuse, 5x20, time-delayed).

- Connection of a PLC station comprising a number of racks, with AC supply referenced to ground

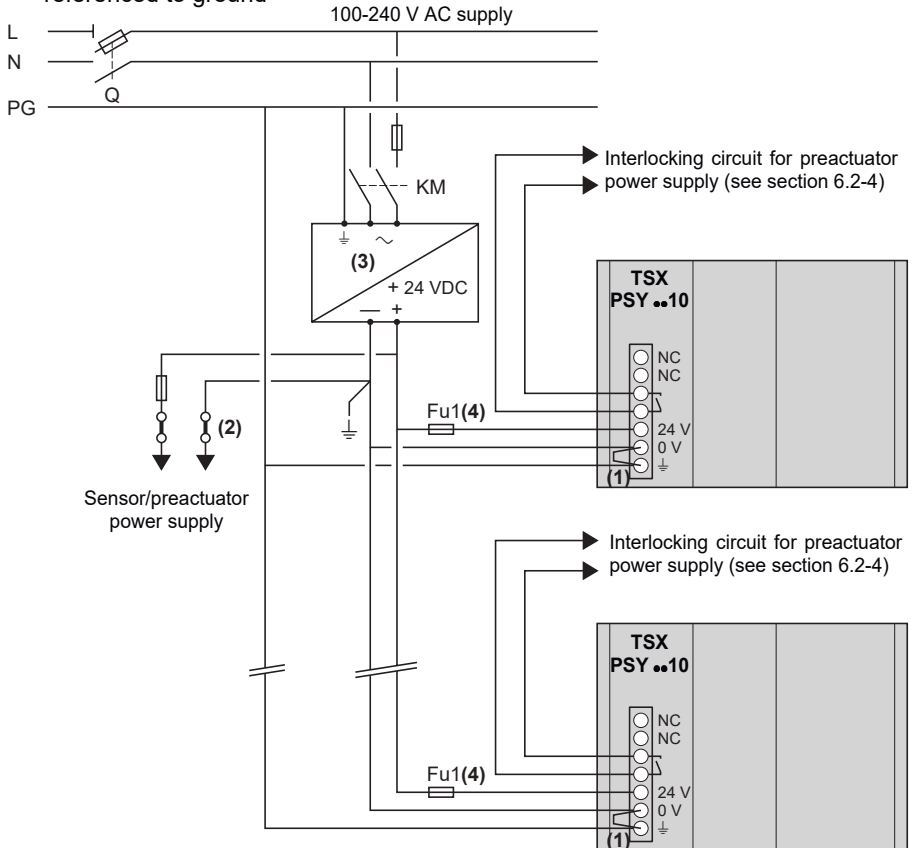

- Q : general isolator,
 KM : line contactor or circuit-breaker,
 (1) : external shunt supplied with the power supply module
 (2) : isolation strip for locating ground fault. In this instance the power supply needs to be unplugged in order to disconnect the AC supply from the ground.
 (3) : it is possible to use a process power supply (to be defined according to the power required, see part J).
 (4) : protective fuse, (4A, time-delayed) which is only necessary with a TSX PSY 3610 power supply module.
 The TSX PSY 1610 power supply module is fitted as standard with a protective fuse located under the module and in series on the 24V input (3.5 A fuse, 5x20, time-delayed).

Note :

- When there are a number of PLC stations, all powered from a single supply, the connection principle is identical.

• TSX PSY 5520 isolated power supply

- Connecting a PLC station comprising a single rack, with AC supply referenced to ground

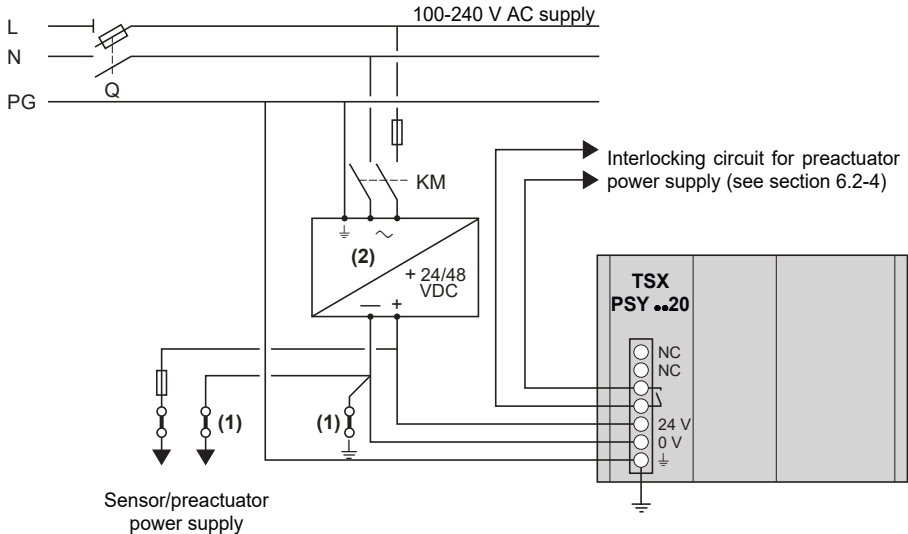

Q : general isolator,

KM : line contactor or circuit-breaker,

Protective fuse :

The TSX PSY 5520 power supply module is fitted as standard with a protective fuse located under the module and in series on the 24V input : 5 A fuse, 5x20, time-delayed,

(1) : isolation strip for locating ground fault.

(2) : it is possible to use a process power supply (to be defined according to the power required, see part J).

- Connecting a PLC station comprising a number of racks, with AC supply referenced to ground

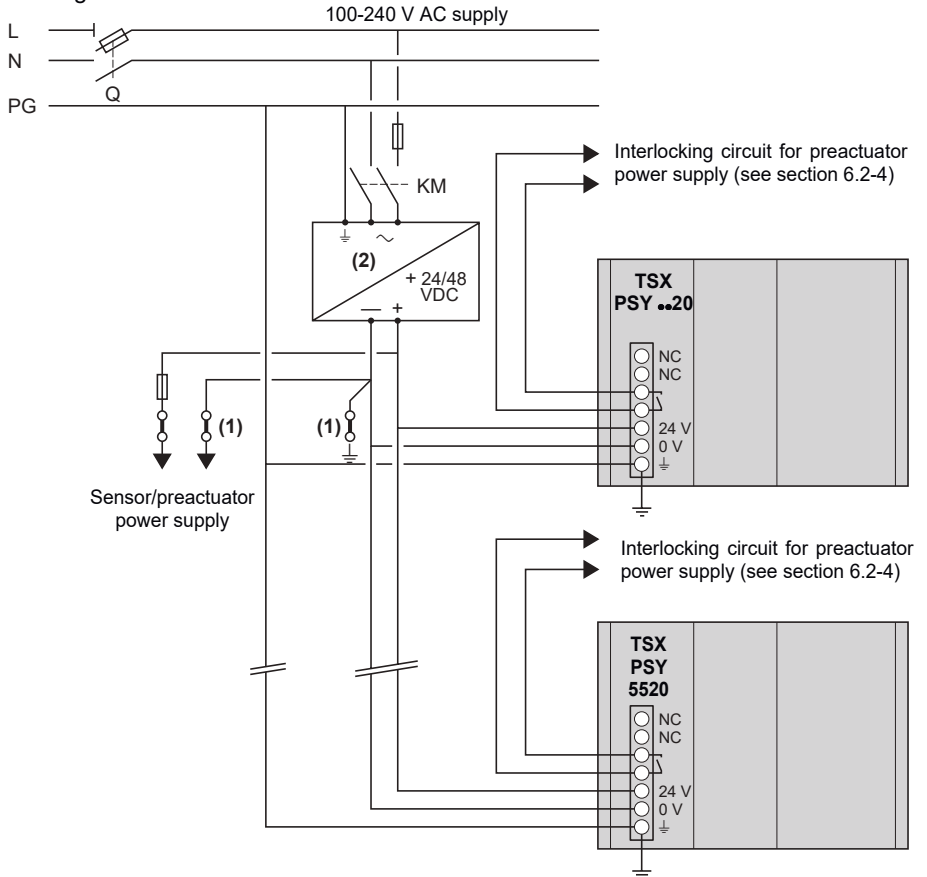

Q : general isolator,
KM : line contactor or circuit-breaker,
Protective fuse :

The TSX PSY 5520 power supply module is fitted as standard with a protective fuse located under the module and in series on the 24V input : 5 A fuse, 5x20, time-delayed,

(1) : isolation strip for locating ground fault.

(2) : it is possible to use a process power supply (to be defined according to the power required, see part J).

Note :

- When there are a number of PLC stations, all powered from a single supply, the connection principle is identical.

6.2-4 Sensor and preactuator power supply interlocking

It is advisable to interlock the various power supplies in the following sequence :

- 1 Power up the PLC and input (sensor) power supply via the KM contactor (see previous circuit diagrams),
- 2 If the PLC is running in AUTO mode, power up the output (preactuator) power supply via the KA contactor. This is interlocked with the alarm relay contact of each power supply.

In addition, safety standards require authorization to be given by an operator before restarting the installation after a stop (caused by a power failure or use of the emergency stop button). The following interlocking circuit diagrams take account of these standards. The MANU/AUTO switch gives the option of forcing the outputs from a programming terminal, when the PLC is stopped.

Example 1 : PLC station supplied with AC

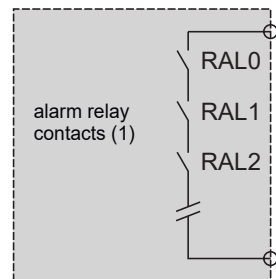
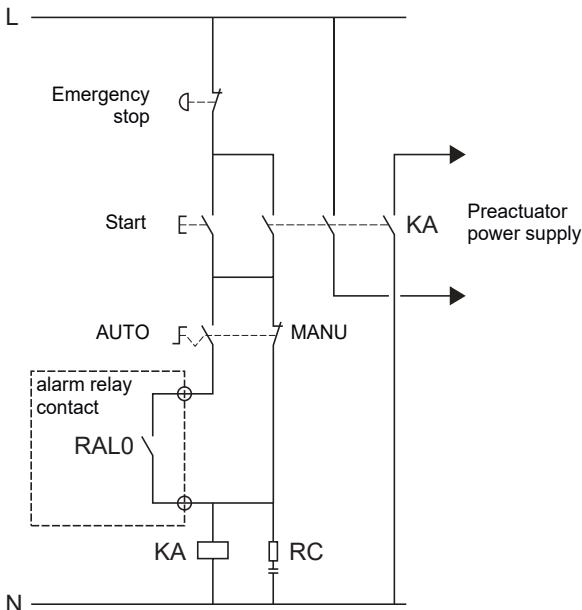

KA : contactor interlocked with the alarm relay of the power supply in AUTO operation.

- (1) If the PLC station comprises a number of racks :
connect all the power supply "alarm relay" contacts (RAL0, RAL1, RAL2, ...)

Example 2 : PLC station supplied with DC

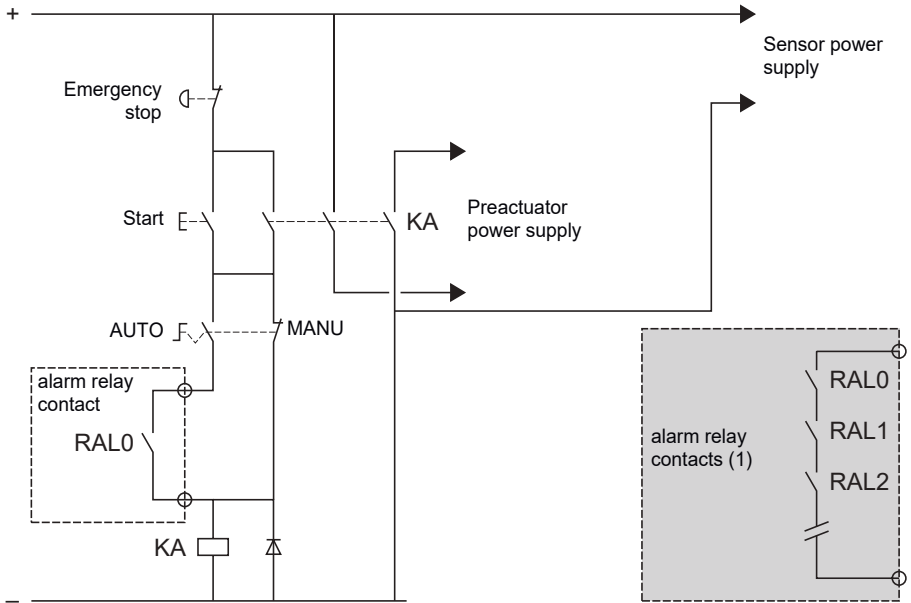

KA : contactor interlocked with the alarm relay of the power supply in AUTO operation.

- (1) If the PLC station comprises a number of racks :
connect all the power supply "alarm relay" contacts (RAL0, RAL1, RAL2, etc) in series.

7.1 Addressing discrete I/O channels

The addressing for all TSX Premium PLC bit and word objects is defined in the PL7 Junior reference manual, part A1, section 1.2. This section only covers the addressing principle for discrete I/O.

Channel addressing is **geographical**; ie. it depends on :

- the rack address,
- the physical position of the module in the rack,

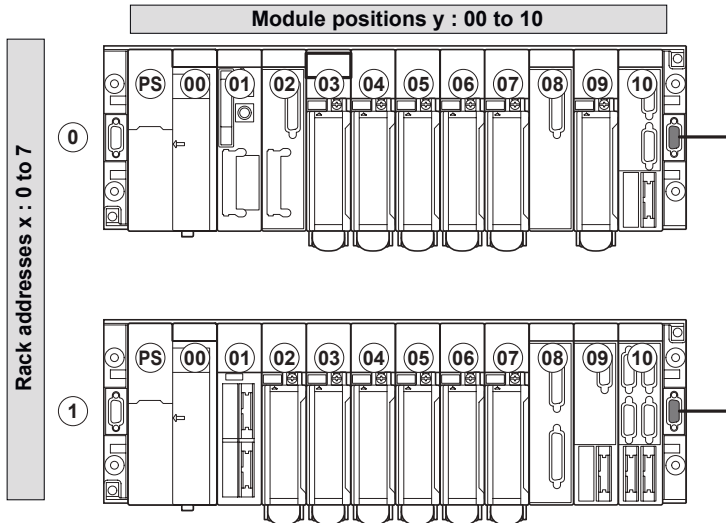

The address syntax for discrete I/O is as follows :

%	I or Q	rack address x	module position y	.	channel number
Symbol	I = input Q = output	x = 0 to 7	y = 00 to 10	Point	i = 0 to 63

Examples

(1) %Q7.3 means : module output 3 located in position 07 in rack 0

(2) %I102.5 means : module input 5 located in position 02 in rack at address 1

Rack addresses (x) and module positions (y)

TSX racks	RKY 6	RKY 8	RKY 12	RKY 6E	RKY 8E	RKY 12E
Rack address : x	0	0	0	0 to 7	0 to 7	0 to 7
Module position : y	00 to 04	00 to 06	00 to 10	00 to 04	00 to 06	00 to 10

Note : the rack containing the processor is always at address 0

Channel numbers (i)

TSX DEY / DSY..... modules	64 I/O	32 I/O	16 I/O	8 I/O
---------------------------------	--------	--------	--------	-------

7.2 Setting the PLC to RUN/STOP

Principle

The RUN/STOP function is used to start (RUN) or stop (STOP) execution of the application program.

This function can be performed from :

- A programming or adjustment terminal,
- A discrete physical input which will previously have been dedicated to this function during the application configuration stage.

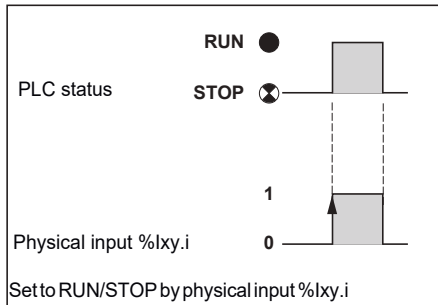

Setting the PLC to STOP using this physical input has priority over setting it to RUN from a terminal or network.

Operating modes of the physical RUN/STOP input

- Operation of the physical RUN/STOP input (%Ixy.i)
 - At state 0, this input forces the application to stop (STOP state),
 - A rising edge on this input causes the application to start up (RUN state),
 - At state 1, the application can be controlled freely from a terminal,
 - If there is a fault on the RUN/STOP input, the application stops. Once the fault has disappeared, and if the input is at state 1, the application restarts in RUN mode.
- Processing on a restart
 - the cold start is performed in RUN if :
 - the RUN/STOP input is at state 1,
 - there is no fault on this input at the time of the start.
 - the warm restart is performed in RUN if :
 - the RUN/STOP input is at state 1,
 - there is no fault on this input at the time of the start,
 - the PLC has not received a STOP command before the break.

Summary of the PLC status during a warm restart

(depending on the state of the RUN/STOP input before the break and on return of power)

RUN/STOP input state before power break	RUN/STOP input state on return of power	
	State 1	State 0 or faulty
State 1, PLC in RUN mode	PLC in RUN mode	PLC in STOP mode
State 1, PLC in STOP mode	PLC in STOP mode	PLC in STOP mode
State 0	PLC in RUN mode	PLC in STOP mode
Faulty	PLC in RUN mode	PLC in STOP mode

7.3 Single task application structure

The application comprises only the master (MAST) task, which may be executed either cyclically or periodically, depending on the selection at the time of configuration.

7.3-1 Cyclic execution

This type of operation corresponds to the normal execution of the PLC scan (default selection). It consists of sequencing the scans of the main task (MAST), one after another.

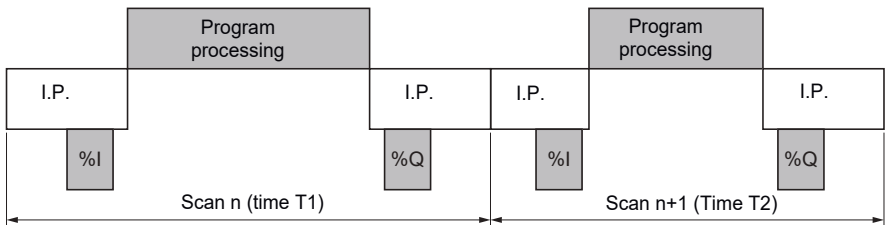

I.P. (internal processing) : the system implicitly monitors the PLC (managing the system bits and words, updating the realtime clock current values, updating the status indicator lamps, detecting changes to RUN/STOP, etc) and processing requests originating from the programming terminal or the communication system,

%I (reading the inputs) : writing the status of information on the inputs to the memory,

Program processing : execution of the application program, written by the user,

%Q (updating outputs) : assigning physical outputs of discrete, analog and application-specific modules according to the status calculated by the application program.

Operating cycle

PLC running : the processor performs internal processing, reading of inputs, application program processing and updating of outputs. Reading of inputs and updating of outputs occur in parallel with the internal processing.

PLC stopped : the processor only performs internal processing and reading of inputs. The output values are handled by the module according to the fallback mode configured for each channel or group of channels.

- fallback to 0 or 1: the physical outputs are forced to the fallback value (the image memory is not changed),
- maintain status : the module physical outputs are maintained at their last value.

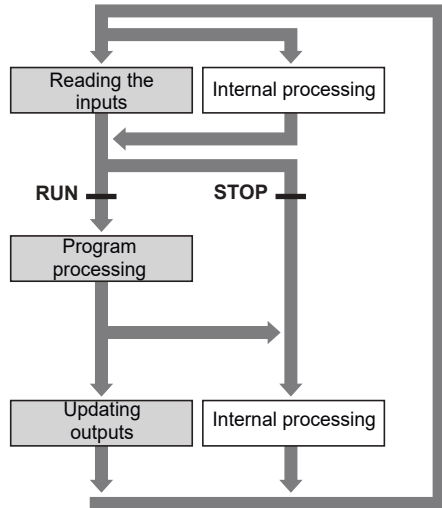

Watchdog overrun

The application scan time is monitored by the PLC (watchdog) and must not exceed the value defined at the time of configuration.

In the event of an overrun, system bit %S11 is set to 1 and the application is declared to be faulty, which causes the PLC to stop immediately (the processor ERR and RUN indicator lamps flash).

Comment

To avoid tripping the watchdog when making a modification in RUN mode, it is necessary to leave approximately 50 ms time available between the maximum duration of the MAST task and duration of the watchdog.

7.3-2 Periodic execution

In this operating mode, the internal processing, reading of inputs, application program processing and updating of outputs are performed periodically according to a time defined during configuration (from 1 to 255 ms) which can be adjusted by system word %SW0.

At the start of a PLC scan, a timer, initialized with the current configured value, starts to count down. The PLC scan must finish before expiry of this countdown, which at 0 starts a new scan.

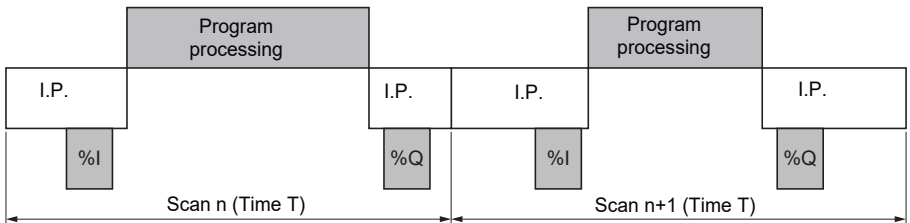

I.P. (internal processing) : the system implicitly monitors the PLC (managing the system bits and words, updating the realtime clock current values, updating the status indicator lamps, detecting changes to RUN/STOP, etc) and processing requests originating from the programming terminal or the communication system,

%I (reading of inputs) : writing the status of information on the inputs to the memory,

Program processing : execution of the application program, written by the user,

%Q (updating of outputs) : assigning the physical outputs of discrete, analog and application-specific modules according to the status calculated by the application program.

Operating cycle

PLC running : the processor performs internal processing, reading of inputs, application program processing and updating of outputs. Reading of inputs and updating of outputs occur in parallel with the internal processing.

If the period is not yet over, the processor completes its operating cycle with "system" tasks or background tasks until the end of the period.

PLC stopped : the processor only performs internal processing and reading of inputs. The output values are managed by the module according to the fallback mode configured for each channel or group of channels.

- fallback to 0 or 1: the physical outputs are forced to the fallback value (the image memory is not changed),
- maintain status : the module physical outputs are maintained at their last value.

Period overrun : if the operating time exceeds that assigned to the period, the PLC indicates a period overrun by setting system bit %S19 of the task to 1; processing continues and is executed in its entirety (it should not exceed the watchdog time limit).

The next scan is sequenced after implicit writing of the outputs of the current scan.

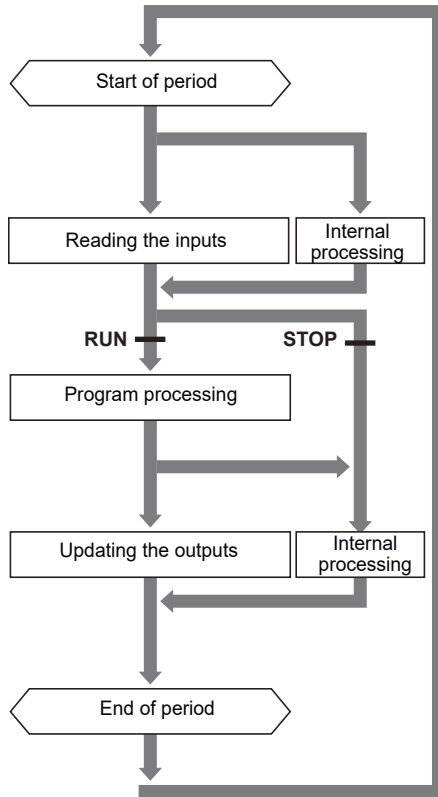

Watchdog overrun

The application scan time is monitored by the PLC (watchdog) and must not exceed the value defined during configuration.

In the event of an overrun, system bit %S11 is set to 1 and the application is declared to be faulty, which causes the PLC to stop immediately (the processor ERR and RUN indicator lamps flash). The duration of the watchdog must, without exception, be longer than the duration of the period.

Comment

To avoid tripping the watchdog when making a modification in RUN mode, it is necessary to leave approximately 50 ms time available between the maximum duration of the period and the duration of the watchdog.

7.3 Multitask application structure

The application structure of a TSX 57-10 or TSX 57-20 PLC can be single task or multitask. In a single task structure, only the main MAST task is used in cyclic or periodic operation (see previous section). In a multitask structure, 2 command tasks (MAST and FAST) and event-triggered tasks are offered and executed according to their priority. When one of these tasks is triggered (occurrence of an event or start of scan), the task interrupts the execution of less important tasks in progress. The interrupted task recommences when the priority task is complete. The structure of this kind of application is as follows :

- the main MAST task, low priority, is always present. It can be cyclic or periodic,
- the FAST task, medium priority, is optional. It is always periodic,
- the event-triggered tasks EVT_i, highest priority, are called by the system when an event occurs. These tasks are optional and are useful for applications requiring short software response times. There can be no more than 32 on a TSX 57-10 PLC and 64 on a TSX 57-20 PLC.

In TSX 57-10/20 PLCs, the event-triggered task EVT0 has higher priority than the other event-triggered tasks (EVT1 to EVT63).

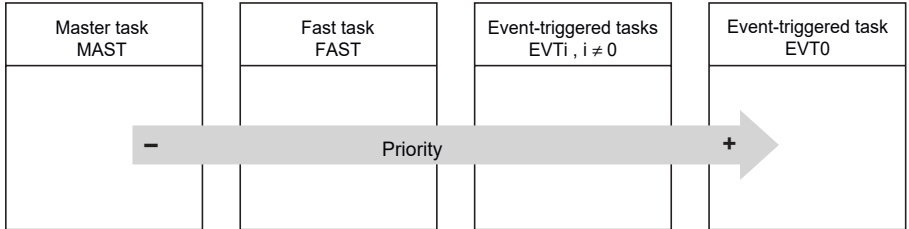

Example of multitask processing :

- cyclic master task (MAST),
- fast task with 20 ms period (FAST),
- event-triggered task.

Key

- I : reading of inputs
- P : program processing
- Q : updating outputs

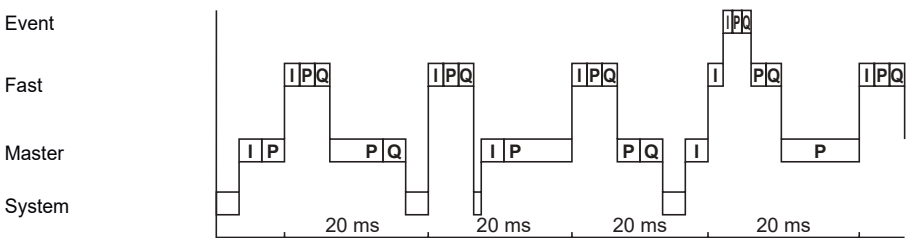

7.3-1 Control tasks

- **MAST master task**

This task has the lowest priority and controls the majority of the application program. It can be configured to execute cyclically (default mode) or periodically. With periodic execution, the period duration can be configured in the PL7 Junior program and can be adjusted by system word %SW0 (%SW0 = 0 : cyclic execution).

The MAST task is organized according to the model described in the previous section : implicit reading of inputs, execution of the application program and implicit writing of outputs.

- **FAST task**

This task has a higher priority than the MAST task and is periodic in order to allow the lower priority time to be executed.

The period duration can be configured in the PL7 Junior program and adjusted by system word %SW1. This can be higher than that of the MAST task in order to adapt to slow periodic processing. The program executed must nevertheless remain short in order not to penalize the main task (MAST).

Note

When the FAST task is empty (no program), it does not exist in the PLC and the system bits and words associated with it are not significant. Hence the channels associated with the task are not exchanged.

- **Period overrun**

With periodic execution (MAST and FAST task), if the operating time exceeds that assigned to the period, the PLC signals a period overrun by setting system bit %S19 of the task to state 1; processing continues and is executed in its entirety (it must not exceed the watchdog time limit). The next scan is sequenced after implicit writing of the outputs of the current scan.

- **Watchdog overrun**

With cyclic or periodic execution, the application scan time is monitored by the PLC (watchdog) and must not exceed the value defined during configuration. In the event of an overrun, system bit %S11 is set to 1 and the application is declared to be faulty, which causes the PLC to stop immediately (the processor ERR and RUN indicator lamps flash). The duration of the watchdog must, without exception, be longer than the duration of the period.

- **Assigning channels to control tasks**

In addition to the application program, the tasks execute "system" functions related to managing their associated implicit I/O. Associating a channel or group of channels with a task is defined in the configuration screen of the corresponding module; the task associated by default is the MAST task.

Discrete I/O module channels :

The modularity of the discrete I/O modules being 8 successive channels (channels 0 to 7, channels 8 to 15, etc), the I/O can be assigned in groups of 8 channels, to either the MAST or FAST task. For example, it is possible to assign the channels of a 32-input module as follows :

- inputs 0 to 7 assigned to the MAST task,
- inputs 8 to 15 assigned to the FAST task,
- inputs 16 to 23 assigned to the MAST task,
- inputs 24 to 31 assigned to the FAST task.

Counter and axis control module channels :

Each channel of a counter or axis control module can be assigned to either the MAST or FAST task. For example, for a 2-channel counter module, it is possible to assign : channel 0 to the MAST task and channel 1 to the FAST task.

Analog module channels :

Each channel (TSXAEY 414 and TSXASY 410 modules) or group of 4 channels (TSXAEY 800 and TSXAEY 1600 modules) can be assigned to either the MAST or FAST task (MAST task by default).

Note

In order to maximize performance, the module channels should ideally be grouped in a single task.

• Task monitoring

In RUN mode, tasks can be enabled or inhibited by writing a system bit. When a task is inhibited, it exchanges its I/O but does not execute its application program.

MAST task monitoring : system bit %S30 (0 = task inhibited, 1 = task enabled)

FAST task monitoring : system bit %S31 (0 = task inhibited, 1 = task enabled)

By default, the MAST and FAST tasks are active.

7.4-2 Event-triggered tasks

Event-triggered tasks allow control events to be taken into account and processed as quickly as possible (for example, the event inputs of the TSX DEY 16FK discrete module, exceeding the threshold on a counter module, etc).

Control events

These are **external events** which can be triggered by, for example :

- the event inputs of the TSX DEY 16FK discrete module, on a rising or falling edge,
- the counter channel(s) on counter modules,
- the reception of telegrams in a PLC equipped with a TSX FPP 20 or TSX SCY 21600 module.
- etc.

It is possible to configure up to 32 events in a TSX 57-10 PLC and up to 64 events in a TSX 57-20 PLC; the association between a channel and an event number is made in the channel configuration screen.

The appearance of a control event diverts the application program towards the processing which is associated with the I/O channel or with the reception of a telegram, which caused the event :

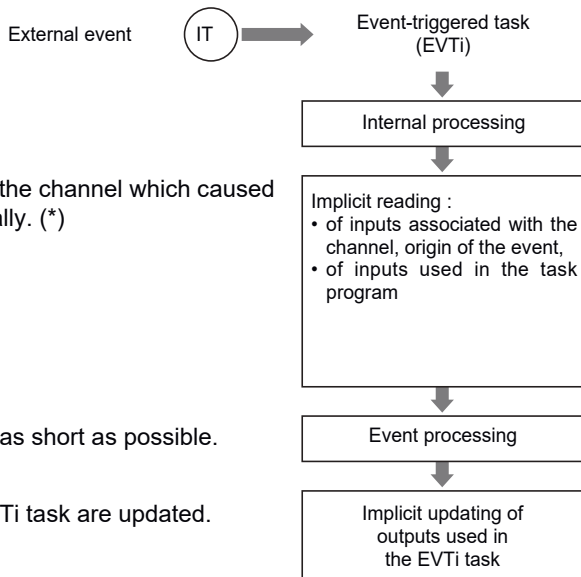

All the inputs associated with the channel which caused the event are read automatically. (*)

The processing time must be as short as possible.

All the outputs used in the EVTi task are updated.

Notes :

The EVTi task I/O are also exchanged in the MAST or FAST task (in each period or scan), which can cause inconsistencies linked to the input chronology (loss of edge, for example).

(*) In the case of telegrams, data reading is performed by the RCV_TLG function (see PL7 Junior programming manual, communication, part L)

Enabling and inhibiting event-triggered tasks

Event-triggered tasks can be globally enabled or inhibited by the application program, via system bit %S38. If one or more events take place while the event-triggered tasks are inhibited, the associated processing is lost.

Masking and unmasking control events

Two PL7 language instructions, available to the application program, allow both global masking and unmasking of control events. If one or more events take place during masking, they are memorized by the system and the associated processing in the event-triggered tasks will only be performed after unmasking; the order of appearance is maintained.

The masking of event-triggered tasks must be short so that :

- there is not too long a delay in taking account of events,
- events are not lost (memorization capacity overrun).

Priority of control events

In a TSX 57 PLC, there are 2 levels of priority for control events : event 0 (EVT0) has higher priority than the other events (EVT1 to EVT31 or EVT63 depending on the processor).

When an event occurs, if an event-triggered task of the same or higher priority level is being executed, it is memorized in a stack and the processing associated with this new event will only be performed after the processing in progress. If the stack overflows, events will be lost; an error is indicated by system bit %S39 being set to 1.

Maximum number of channels used in event-triggered tasks

The number of channels associated with the total number of control events is limited (see table below).

Type of channel	Processor TSX P57-10 (32 EVT)	Processor TSX P57-20 (64 EVT)
Maximum number of discrete I/O channels	32	128
Maximum number of analog channels	8	16
Max. no. of app.-specific module channels	4	16

Notes

- I/O exchanges of the EVT_i task are performed by channel (for some analog and application-specific modules) or by group of channels (for discrete modules and some analog modules). For this reason, if the processing modifies, for example, outputs 2 and 3 of a discrete module, it is the image (PLC memory) of outputs 0 to 7 which will be transferred to the module.
- any exchange of an input/output in an event-triggered task can cause loss of rising edge information, concerning processing performed on this channel (or group of channels), in the task where it has been declared : MAST or FAST.

7.5 User memory structure

TSX 57 PLC memory consists of an internal RAM memory designed to take the application program, with a capacity of :

- 32 Kwords for a TSX 57-10 PLC,
- 48 Kwords for a TSX 57-20 PLC.

Furthermore, this internal RAM memory can be extended with a PCMCIA memory card with a capacity of :

- 32 Kwords or 64 Kwords, RAM or FLASH EPROM type for a TSX 57-10 PLC.
- 32 Kwords, 64 Kwords or 128 Kwords, RAM or FLASH EPROM type for a TSX 57-20 PLC.

7.5-1 Application memory

The application memory can be divided into memory zones, physically shared between the RAM internal memory and the PCMCIA memory card (if the TSX 57 is equipped with a memory card):

- the application data zone is always in internal RAM,
- the application program zone (application descriptors and executable task code) is in internal RAM or in the PCMCIA memory card
- the constants, initial values and configuration zone is in internal RAM or in the PCMCIA card,

With respect to these different zones, 2 types of application memory organization are possible depending on whether or not the PLC is equipped with a PCMCIA memory card.

TSX 57-10 or TSX 57-20
(without PCMCIA card)

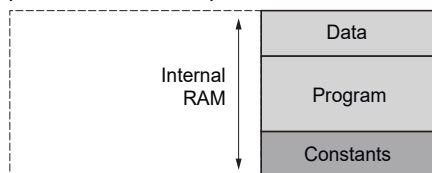

TSX 57-10 or TSX 57-20
(with PCMCIA card)

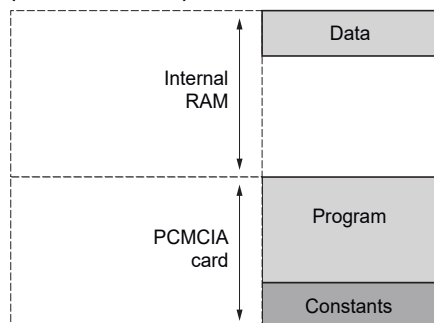

- Data** : application data,
Program : descriptors and executable task code,
Constants : constant words, initial values and configuration.

Application in Internal RAM

So that the application is loaded entirely in the protected internal RAM (*) of the PLC (TSX 57-10 or TSX 57-20 without PCMCIA memory card), its size must be compatible with that of the RAM memory :

- 32 Kwords (TSX 57-10), split for example into 7.5 Kwords of application data and 24.5 Kwords of program and constants,
- 48 Kwords (TSX 57-20), split for example into 10 Kwords of application data and 38 Kwords of program and constants.

(*) The internal RAM is protected by an optional battery of 3.6 V located on the power supply module which has an autonomy of 1 year (see section 4.3 of this part).

Application in the PCMCIA card

In this case, the memory card contains the executable program, the constants, the configuration etc; the internal RAM is reserved exclusively for data.

In the creation and debugging phases of the program, it is necessary to use a protected RAM type PCMCIA card. Once the program is operational, it will be able to be executed in this same memory card or transferred to a FEPROM type PCMCIA card, to ensure protection in the event of failure of the RAM type memory card battery.

Note

When an application has been configured for execution in the internal RAM memory of a TSX 57 PLC (no PCMCIA memory card defined in the processor configuration screen), the presence of this card must first be declared (in the processor configuration screen) before transferring this application to a PLC equipped with a PCMCIA memory card.

Application protection

Whatever the structure of the PLC memory : whether the application is situated in the internal RAM or in the PCMCIA card, the application can be protected in order to inhibit access under PL7 Junior (program reading and debugging) when the terminal is online. To "remove" the protection of such an application, it must be transferred again, without protection, from the terminal to the PLC. This operation requires the source program of the application to have been previously loaded into the terminal.

A protected application in a PCMCIA card can be executed by another PLC, but never duplicated.

In addition to the protection offered by PL7 Junior, PCMCIA cards have a lock which inhibits any write access (program loading or modification).

Application backup

With TSX Premium PLCs, it is possible to back up the application (program and constants) on a Backup memory card (reference TSX MFP BAK 032P). The internal RAM memory can thus be reloaded with the contents of this Backup memory card.

Note : This Backup function is not available when the application is being executed on a RAM or FLASH EPROM PCMCIA memory card.

- **Loading an application "backup" from the PLC internal RAM memory.**

This operation is used to transfer the application program from the PLC internal RAM memory to a Backup PCMCIA memory card (reference TSX MFP BAK 032P). To do this perform the following steps.

- 1 insert the Backup memory card into its slot with the write-protection tab WP in the OFF position,
- 2 transfer the application from the PLC internal RAM to the Backup card (PLC/ Backup menu, RAM -> Backup option),
- 3 at the end of this operation, remove the Backup card and set the WP switch to ON (protecting the backup).

⚠ If the application in the PLC is protected, inserting the Backup memory card reinitializes the PLC internal RAM memory. In this case, the procedure for loading the Backup memory card is as follows :

- 1 ensure that the application program to be saved is available in the terminal. If it is not, transfer this program to the terminal,
- 2 insert the Backup memory card into its slot with the write-protection tab WP in the OFF position,
- 3 transfer the application from the terminal to the PLC internal RAM (PLC/Backup menu, Terminal -> PLC option),
- 4 transfer the application from the PLC internal RAM to the Backup card (PLC/Backup menu, Terminal -> PLC option),
- 5 at the end of this operation, remove the Backup card and set the WP switch to ON (protecting the backup).

Note :

These various transfers are executed from a terminal with PL7 Junior software (see "Operating modes" manual TLX DM PL7J 12E - part C - section 3.9.

- **Retrieving an application "backup" from a preloaded memory card**

This operation, using a preloaded memory card (reference TSX MFP BAK 032P), enables the application program to be updated without using a terminal.

The write-protection tab on this memory card must be in the ON position.

When this type of card is inserted in a TSX 57 PLC, its contents are automatically transferred into the PLC internal RAM memory. At the end of the transfer, the PLC is placed in forced STOP (whatever the configured RUN AUTO option).

As long as the "backup" card is in the PLC, a power break / power return always causes its start-up in forced STOP.

Removal of the card causes the PLC to cold start, in RUN or STOP according to the RUN AUTO configuration.

7.6 Operating modes of the PLC on start-up

7.6-1 Cold start

When one of the following operations takes place :

- loading an application,
- return of the power supply after a break with loss of context,
- pressing the RESET button on the processor,
- manipulating the handle of the PCMCIA memory card on the processor,
- initialization from PL7 Junior,
- forcing bit %S0 from a terminal,

the PLC performs a **cold start** which involves :

- resetting the I/O bits and internal bits to zero,
- initialization of the data zone and the function blocks from the configuration data,
- setting internal words to zero if no save was requested during configuration,
- canceling bit forcing and step blocking,
- sending the configuration parameters (1) to all the application-specific modules (analog, counter, axis control, communication, etc) and to the PCMCIA communication card.

Cold starting is performed in RUN (the PLC places itself in RUN automatically) or in STOP (the PLC places itself in STOP), depending on the status of the "automatic start-up in RUN" bit defined in the configuration or on the state of the RUN/STOP input. If an application is loaded via the terminal port or a RESET is carried out (processor RESET button) following a blocking fault, the cold start is forced to STOP.

For example, when a PCMCIA memory card containing an application with the "automatic start-up in RUN" bit is plugged into a TSX 57-10/20 PLC, this automatically performs a cold start in RUN.

Processing the cold start

A cold start is signaled by system bit %S0 being set to 1.

If the user wishes specific processing vis à vis the application when a cold start occurs, at the start of the MAST task he should test the status of this system bit %S0 which remains in state 1 during the first MAST task scan.

(1) If bit %S0 is forced to 1 from a programming terminal or during initialization from PL7 Junior, this causes a cold start without reinitialization of the application-specific modules (analog, counter, communication, etc).

7.6-2 Warm restart

During a restart after a power failure, and if the application context has not changed, this does not cause a cold start, but a warm restart which restarts execution of the program from the line where the failure occurred, without updating the outputs at the end of the restart cycle. At the end of this restart cycle, the system :

- initializes the message stacks,
- sends the configuration parameters to all the application-specific modules (analog, counter, axis control, etc) and to the PCMCIA format communication module.
- deactivates the event-triggered and FAST tasks until the end of the first MAST task scan,
- empties the event stacks,
- restarts execution of the MAST task.

Processing the warm restart

A warm restart is signaled by system bit %S1 being set to 1.

If the user wishes a specific processing vis à vis the application when a warm restart occurs, at the start of the MAST task he should test the status of this system bit %S1 which remains at state 1 during the first MAST task scan.

7.6-3 Operation following power supply failure and return

- **Power supply failure on one or more racks including the one holding the processor (rack 0):**

The system memorizes the application context and the time of the failure, then sets all the outputs to state 0 for the racks concerned. Should the other racks remain powered up, the corresponding outputs change to fallback mode (0 or 1 or maintain state according to the choice defined at the time of configuration).

When the power supply returns, the saved context is compared to the current one, which defines the type of start which will be executed :

- if the application context has changed (loss of system context or new application), the PLC performs a **cold start** and initializes the application,
 - if the application context is identical, the PLC performs a **warm restart** without initializing the data.
- **Power supply failure on a rack other than rack 0:**
All the channels on this rack are seen as faulty by the processor but the other racks are not affected, and the values of the faulty inputs cease to be updated in the application memory. In the case of a discrete input module they are set to 0, unless they have been forced, in which case they keep their forced value.

If the duration of the failure is less than 10 ms for AC power supplies or 1 ms for DC power supplies, it is not seen by the program which runs normally.

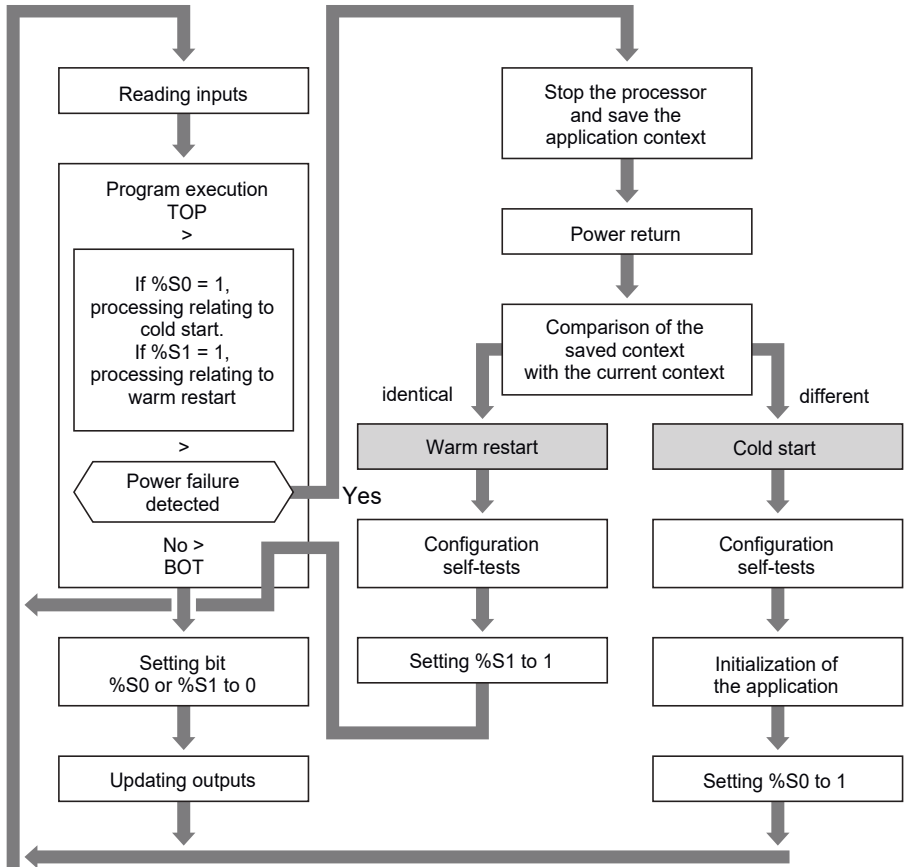

7.6-4 Operation after insertion/removal of a PCMCIA memory card

TSX 57-10/20 processors are equipped with a cover on the front panel which must be removed in order to insert a PCMCIA memory card. Removing the cover causes the PLC to stop without saving the application context. The module outputs change to fallback mode.

Insertion of the memory card fitted with its handle causes the PLC to cold start. Similarly, removing the memory card causes the PLC to stop without saving the application context.

7.6-5 Operation after pressing the processor RESET button

The processor has a RESET button on the front panel which can be pressed in order to trigger a cold start of the PLC in RUN or in STOP (1), on the application contained in the memory card (or in the internal RAM).

RESET following a PLC blocking fault (see definition of a blocking fault, section 3.1 - part H)

When a blocking fault appears, the rack 0 alarm relay is deactivated (open contact) and the module outputs change to the fallback position or their state is maintained, according to the choice made at the time of configuration. Pressing the RESET button causes the PLC to cold start, forced into STOP.

Other example

Pressing the RESET button causes the PLC to cold start, in RUN or in STOP (1), on the application contained in the memory card (or in the internal RAM).

(1) Starting in RUN or in STOP is defined during configuration.

Note :

When the RESET button is used, and during the PLC cold start, the terminal links ceases to be active.

7.6-6 Operation after pressing the power supply RESET button

The power supply module in each rack has a RESET button on the front panel, which can be pressed to trigger an initialization sequence for the modules in the rack it is supplying.

If this button is pressed on the power supply module in the rack containing the processor

7.6-7 PLC response to cold start

When the PLC starts after the power supply returns with loss of context, pressing the processor RESET button or manipulating the handle, it responds differently depending on the status of its memory :

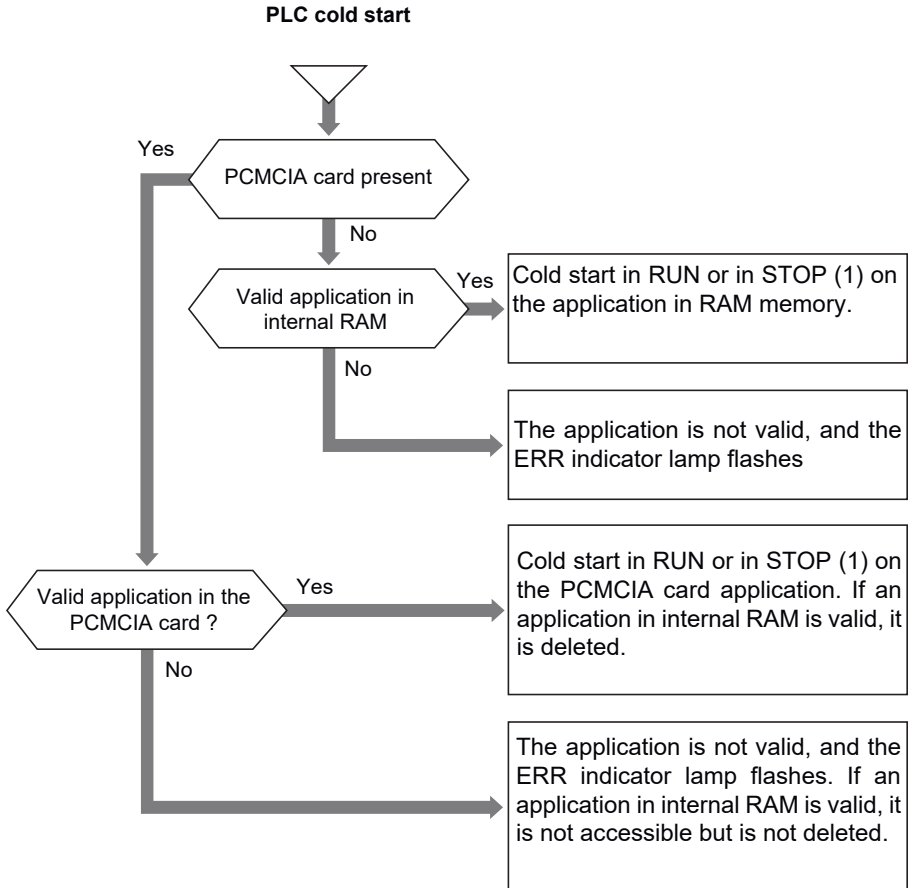

(1) Starting in RUN or in STOP is defined during configuration

7.7 Behavior on insertion/removal of a module when powered-up

All modules can be inserted when powered-up, with the exception of the processor module and PCMCIA communication cards.

Insertion and removal of modules when powered-up means that a module can be replaced without stopping the application.

The removal of a module activates system bits associated with the I/O, and the faults associated with the module and its channels. Inputs are no longer updated in the application memory and are set to 0 in the case of a discrete input module, unless they have been forced, in which case they keep their forced value while the module is missing. The processor I/O indicator lamp comes on.

When the new module is inserted, the system tries to configure it with the configuration of the module it is replacing.

If this configuration is successful (module with the same reference), the channels are once again taken into account by the application, and the faults caused by the absence of the module disappear. The processor I/O indicator lamp goes off.

If this reconfiguration fails (module with a different reference), the channels are not taken into account by the application, the system bits associated with the I/O and the faults associated with the module and its channels remain active, and the processor I/O indicator lamp stays on.

7.8 Behavior of the I/O on downgraded operating mode

7.8-1 Safety value of discrete and analog outputs

- **Situations :**

- the PLC is not configured
- the PLC is in STOP mode without previously having been in RUN mode (for example after loading the application, or on a cold start in STOP mode),
- the PLC is in RUN mode but the task which manages the output module is in STOP mode and has never been in RUN mode,
- power break on the rack where the output module is positioned,
- output module does not conform to the configuration.

- **Behavior :**

Outputs are set to the safety value : 0 for discrete and analog outputs.

7.8-2 Discrete and analog outputs switching to fallback mode

- **Situations:**

These occur as soon as the application ceases to function normally

- the PLC switches to STOP mode,
- the PLC switches to "error" (processor fault) or to "HALT or software fault" (application blocking fault),
- the task which manages these outputs switches to STOP mode,
- insertion of a breakpoint in the task which manages these outputs,
- command to switch outputs to fallback mode by system bit %S9 or the debug screen,
- communication fault detected by the output module (output not updated by the processor).

- **Behavior :**

The output values are managed by the module depending on the fallback mode for each channel or group of channels :

- fallback : the module physical outputs are forced to the fallback value configured (0 or 1). (The image memory is not modified),
 - maintain state: the module physical outputs are maintained at their last value.
- The default operating mode is fallback to 0.

7.8-3 I/O faults

- **Situations :**

- channel fault,
- module fault,
- module missing or does not conform to the configuration,
- communication fault detected by the processor.

- **Behavior :**

- faulty discrete input channel : the value in the application memory is set to 0, unless it is forced, in which case it is maintained at the forced value,
- other types of faulty input : in the case of a communication fault, the value in the application memory is not updated (the value is maintained),
- faulty output channel : the value of the output continues to be managed by the application and is only sent to the module if the latter conforms to the configuration.

The fault is indicated by the system bits associated with the I/O and the fault information associated with the module and its channels. The processor I/O indicator lamp is lit.

7.9 Loading the operating system (OS)

The TSX Premium PLC operating system can be updated by downloading via the processor terminal port.

The operating system updating procedure is explained in the manual TLX DM PL7 J12E - part E - section 8.

8.1 Fan modules

8.1-1 General presentation

The fan modules installed above the TSX Premium PLC racks ensure forced air convection in order to ensure that the ambient temperature is evenly distributed inside the unit and thus eliminate the different hot spots which may exist.

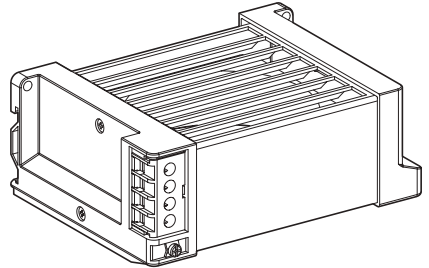

A temperature probe integrated into every fan module is used to inform the user that the ambient temperature has reached its maximum value.

The use of fan modules is advised in the following cases :

- **Ambient temperature in the range 25°C...60°C** : this increases the lifetime of the various TSX Premium PLC components (25% increase in MTBF).
- **Ambient temperature in the range 60°C...70°C** : since the ambient temperature is limited to 60°C without ventilation, forced ventilation is used to decrease the temperature inside the modules by 10°C, bringing the internal module temperature to the equivalent of an ambient temperature of 60°C.

Three fan modules are available for adaptation to the main power supplies : fan modules with 24 VDC, 110 VAC or 220 VAC supply voltage.

Depending on the rack modularity (6, 8 or 12 positions), 1, 2 or 3 fan modules must be installed above each rack :

- racks with 12 positions
TSX RKY 12 / 12E :
3 fan modules,
- racks with 8 positions
TSX RKY 8 / 8E :
2 fan modules,
- racks with 6 positions
TSX RKY 6 / 6E :
1 fan module

TSX RKY 12/12E

TSX RKY 8/8E

TSX RKY 6/6E

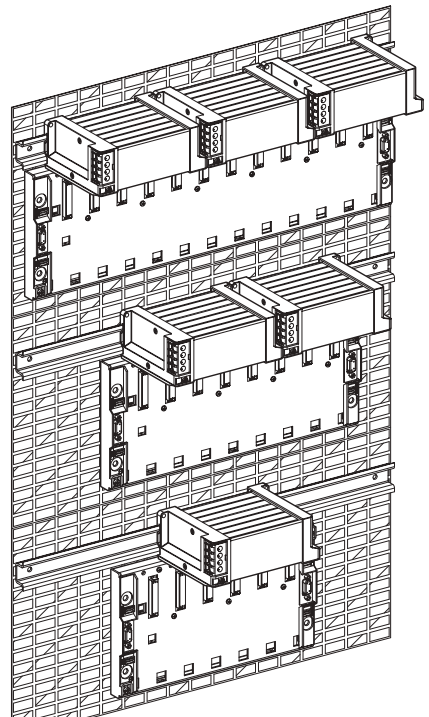

8.1-2 Physical presentation

1 Terminal block for connecting :

- the module power supply voltage,
- the power supply for the temperature probe and the associated indicator lamp or preactuator.

Each terminal can receive one 1.5 mm² wire without a cable end or two 1 mm² wires with cable ends.

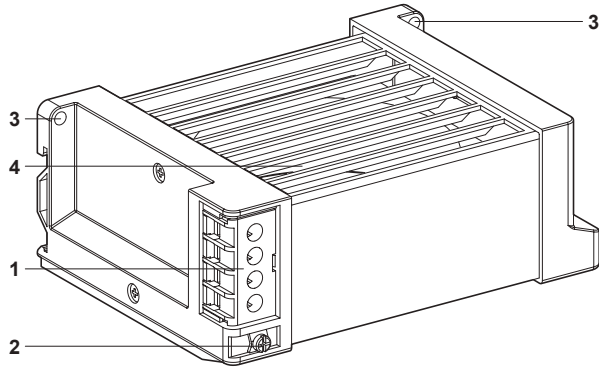

2 Terminal for grounding the module.

3 Holes for fixing the module (M4 x 12 screws). When using these modules with TSX Premium PLCs, the fan modules must be fixed on a 35 x 15 AM1-ED... type rail

4 Tilted shutters which enable the air to be directed to the front.

8.1-3 Catalog

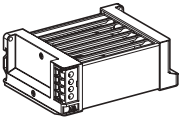
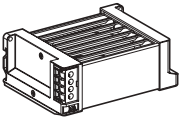
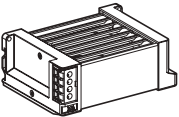
Type of module	Fan		
			
Characteristics			
Power supply voltage	24 VDC	110 VAC	220 VAC
Temperature probe	Yes (temperature detection $\geq 80^{\circ}\text{C} \pm 5^{\circ}\text{C}$), open on alarm		
No. of modules per rack	1 module on a rack with 6 positions (TSX RKY 6/6E) 2 modules on a rack with 8 positions (TSX RKY 8/8E) 3 modules on a rack with 12 positions (TSX RKY 12/12E)		
References	TSX FAN D2 P	TSX FAN A4 P	TSX FAN A5 P

8.1-4 Dimensions

• Single fan module (measurements in millimeters)

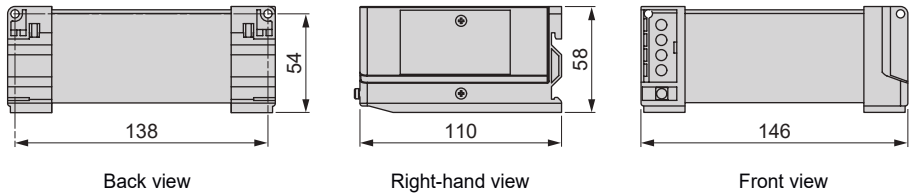

• Fan module + rack (measurements in millimeters)

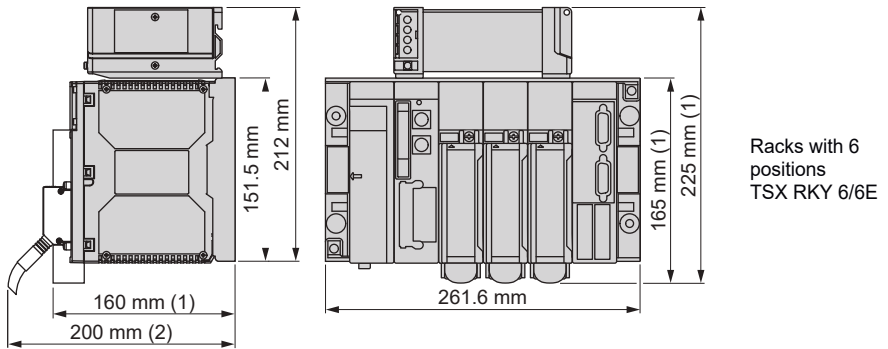

- (1) with screw terminal module
- (2) Maximum depth associated with all types of modules and their connectors

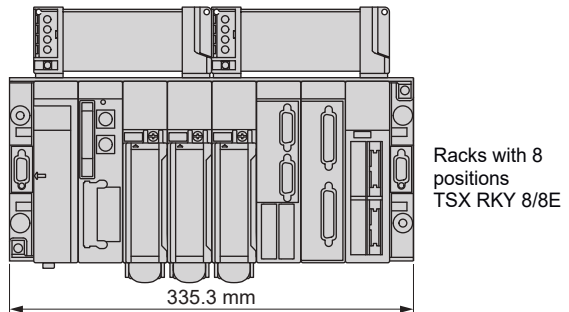

Racks with 12 positions
TSX RKY 8/8E

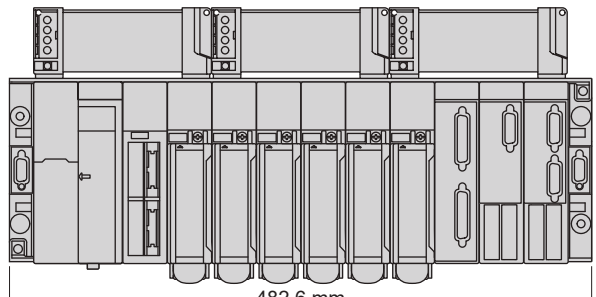

8.1-5 Mounting

Fan modules associated with TSX Premium PLCs must be mounted on 35 mm x 15 mm rails (type AM1-ED...) to compensate for the thickness of the rack.

Note :

The fixing distances for TSX RKY .. Racks are defined in part A1 - section 5.3

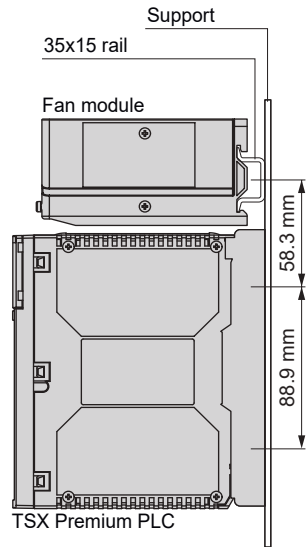

Mounting positions for the fan modules depending on the type of rack

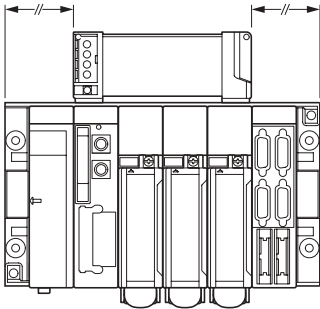

Racks with 6 positions (TSX RKY 6/6E)

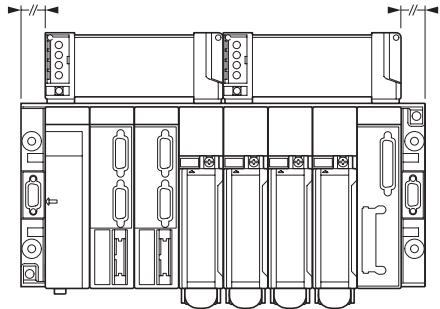

Racks with 8 positions (TSX RKY 8/8E)

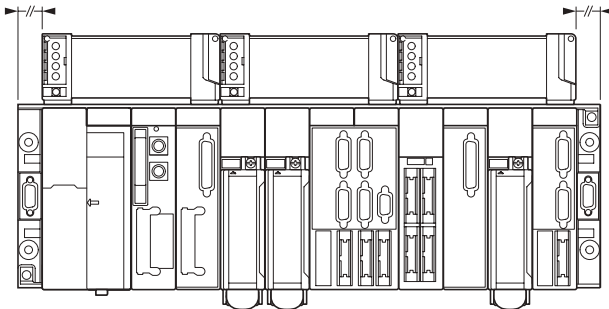

8.1-6 Installation rules for racks with fan modules

(see general rules on positioning racks which are not fan-cooled, part A1 - section 5.1).

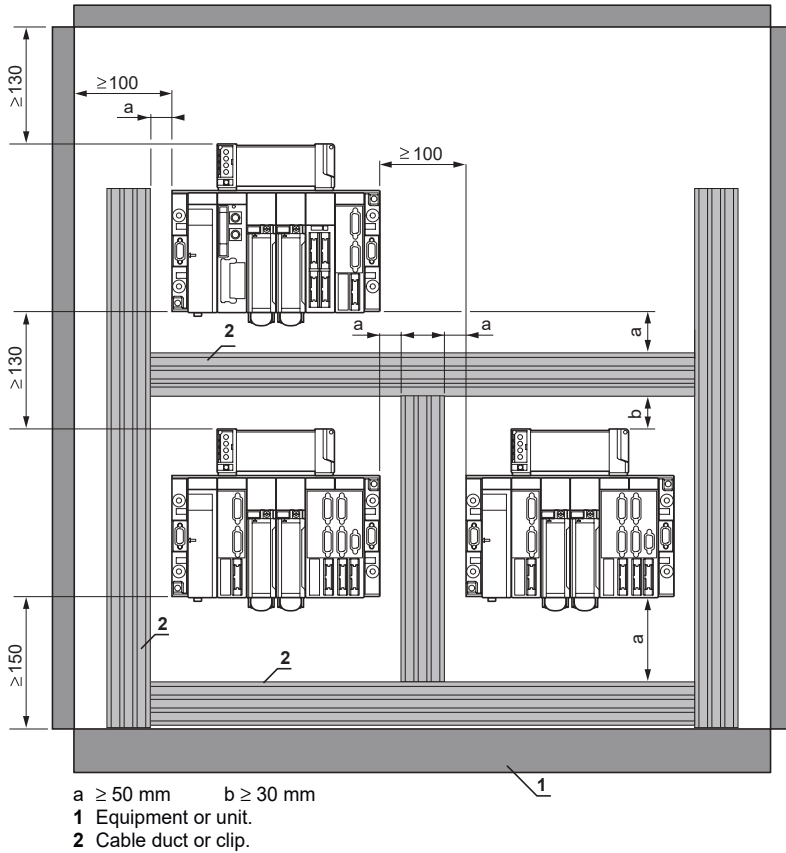

8.1-7 Connections

• Connecting the fan module power supply

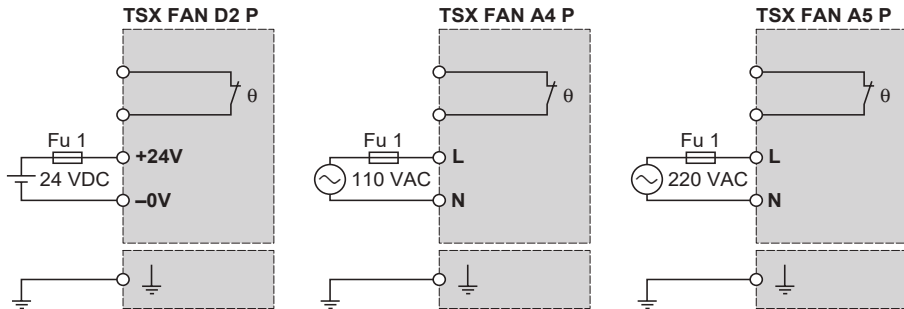

Note : when using several fan modules of the same type, use one common power supply for all the fan modules.

• Connecting the temperature probe power supply

The temperature probe can be power supplied either in AC or DC and connected to an indicator lamp, a PLC input, etc.

DC power supply

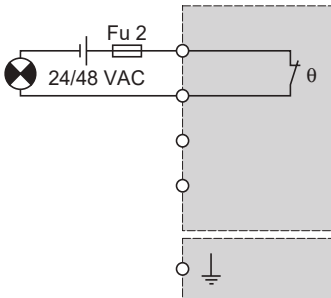

AC power supply

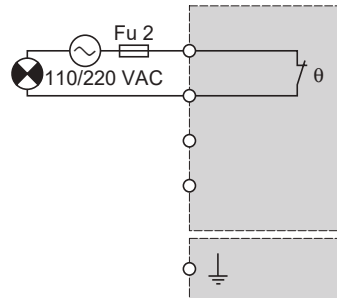

Note : when using several fan modules, the probe contacts will be placed in series.

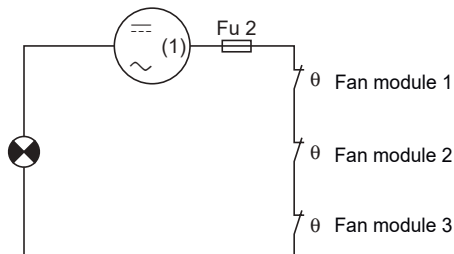

(1) — 24 / 48 V or ~ 110 / 220 V

8.1-8 Characteristics

Type of module		TSX FAN D2 P	TSX FAN A4 P	TSX FAN A5 P
Power supply voltage	Nominal	24 VDC	110 VAC	220 VAC
	Limit	20...27.6 VDC	90...120 VAC	180...260 VAC
Current drawn at nominal voltage		180 mA	180 mA	100 mA
Temperature probe	Power supply voltage	: --- 24 / 48 VDC or ~ 110 / 220 VAC		
	Breaking capacity (on resistive load)	1 A at 24 VDC / 10 000 operations 1 A at 48 VDC / 30 000 operations 1 A at 110 VAC / 30 000 operations 0.5 A at 220 VAC 10 000 operations		
	Activation	Temperature $\geq 75\text{ }^{\circ}\text{C} \pm 5^{\circ}\text{C}$		
	Status	closed if temperature $\leq 75^{\circ}\text{C} \pm 5^{\circ}\text{C}$ open if temperature $\geq 75^{\circ}\text{C} \pm 5^{\circ}\text{C}$		

8.2 Performance

8.2-1 MAST task scan time

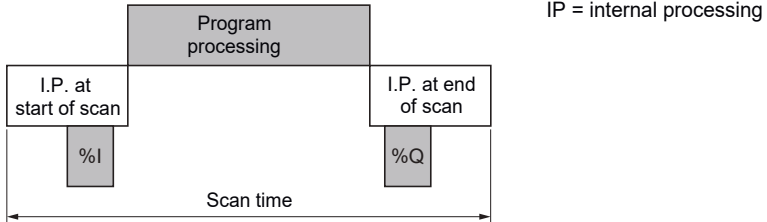

$$\text{MAST scan time} = \text{Program processing time (Ttp)} + \text{Internal processing time at start and end of scan (Tti)}$$

• Definition of the program processing time Ttp

$$\text{Ttp} = \text{Application code execution time (Texca)} + \text{Grafcet overhead time (ToG7)}$$

- Application code execution time (Texca)

Texca = Σ of the time of each instruction executed by the application program on each scan

The execution times for each instruction as well as the typical application used to verify these are given in the manual TLX DR PL7 12E - part B - section 8.

By way of indication, the table below gives the execution time in milliseconds (ms), for 1K instruction (1).

Type of processor		TSX P 57 10		TSX P 57 20	
		Internal Ram	Memory card	Internal Ram	Memory card
Program execution					
Application code execution time (Texca)	100% Boolean instructions	0.72 ms	0.72 ms	0.31 ms	0.47 ms
	65% Boolean instructions + 35% numeric instructions	1.39 ms	1.39 ms	0.78 ms	0.98 ms

Note : not all application program instructions need to be executed on each PLC scan.

(1) 1K instruction = 1024 instructions

- Grafcet overhead time (ToG7)

$$\text{ToG7} = \left[\begin{array}{c} \text{TGF} \\ + \\ (\text{TEA} \times \text{number of steps active at the same time}) \\ + \\ (\text{TTP} \times \text{number of transitions which are true at the same time}). \end{array} \right]$$

Type of processor	TSX P 57 10	TSX P 57 20
TGF	0.332 ms	0.291 ms
TEA	0.121 ms	0.106 ms
TTP	0.491 ms	0.431 ms

• Definition of the internal processing time at the start and end of the scan (Tti)

$$\text{Tti} = \begin{array}{c} \text{MAST task system overhead time (TosM)} \\ + \\ \max [\text{System time for communication in reception (Tcomr);} \\ \text{management time at start of scan for implicit I/O \%I (Tge\%I)}] \\ + \\ \max [\text{System time for communication in transmission (Tcome);} \\ \text{management time at end of scan for implicit I/O \%Q (Tgs\%Q)}] \end{array}$$

- MAST task system overhead time (TosM)

Type of processor	TSX P 57 10	TSX P 57 20
Cyclic execution time	2 ms	1.4 ms
Periodic execution time	1.7 ms	1.2 ms

- Management time of implicit I/O (%I and %Q) at the start and end of the scan

$$\mathbf{Tge\%I} = 60 \mu\text{s} + \Sigma \text{ of IN times for each module (see below)}$$

$$\mathbf{Tgs\%Q} = 60 \mu\text{s} + \Sigma \text{ of OUT times for each module (see below)}$$

Input (IN) and output (OUT) management times for each module :

Discrete I/O, analog, counter, axis control and stepper control modules.

Type of module	Management times		
	Input (IN)	Output (OUT)	Total (IN + OUT)
8-channel discrete inputs	27 μs	–	27 μs
16-channel discrete inputs (all modules except TSX DEY 16FK)	27 μs	–	27 μs
32-channel discrete inputs	48 μs	–	48 μs
64-channel discrete inputs	96 μs	–	96 μs
Fast discrete inputs (8 channels used) (TSX DEY 16FK module)	29 μs	16 μs	45 μs
Fast discrete inputs (16 channels used) (TSX DEY 16FK module)	37 μs	22 μs	59 μs
8-channel discrete outputs	26 μs	15 μs	41 μs
16-channel discrete outputs	33 μs	20 μs	53 μs
32-channel discrete outputs	47 μs	30 μs	77 μs
64-channel discrete outputs	94 μs	60 μs	154 μs
Analog inputs (per group of 4 channels)	84 μs	–	84 μs
Analog outputs (4 channels)	59 μs	59 μs	118 μs
Counter (TSX CTY **), per channel	55 μs	20 μs	75 μs
Stepper control (TSX CFY **), per channel	75 μs	20 μs	95 μs
Axis control (TSX CAY **), per channel	85 μs	22 μs	107 μs

Note :

The times given for discrete I/O modules assume that all the module channels are assigned to the same task.

Example : using a TSX DEY 32 D2 K module

- if the 32 channels are assigned to the same task, take the "32-channel discrete inputs" time.
- if only 16 channels are assigned to the same task, take the "16-channel discrete inputs" time, not the "32-channel discrete inputs" time divided by 2.

- Communication system time

Communication (excluding telegram) is managed during the MAST task "Internal Processing" phases :

- at the start of the scan for message reception (Tcomr)
- at the end of the scan for message transmission (Tcome)

The MAST task scan time is therefore affected by communication traffic. The communication time per scan varies considerably depending on :

- the traffic generated by the processor : number of communication OFs which are active simultaneously,
- the traffic generated by other devices in the direction of the processor or devices for which the processor as master, acts as a router.

This time is only spent in scans where there is a new message to be managed.

Examples of communication system times :

- PL7 Junior software with terminal connected and animation table open

Type of processor	TSX P 57 10	TSX P 57 20
Average scan time	2.5 ms	1.8 ms
Maximum scan time	3.4 ms	2.4 ms

- 1 SEND_RQ OF (mirror request, 100 characters)

Instruction execution time : 2 ms (for a TSX P 57 20 processor) to be included in the application code execution time for scans where the OF is actually executed.

Communication system time

Type of processor	TSX P 57 10	TSX P 57 20
Time during transmission	1.4 ms	1 ms
Time during reception	1.4 ms	1 ms

All these times cannot occur in the same scan. Transmission occurs in the same scan as execution of the instruction as long as the communication traffic is low but not in the same scan as reception of the response.

Example of calculating MAST task scan times in the following conditions :

For an application with the following characteristics :

- TSX P 57 20 processor,
- Task execution : cyclic,
- Program execution in PLC internal RAM,
- 10 K instructions, 65% Boolean + 35 % numeric,
- 1 communication OF of the SEND_REQ type,
- 128 discrete inputs distributed on : seven TSX DEY 16D2 modules + one TSX DEY 16FK module
- 80 discrete outputs, distributed on : five TSX DSY 16T2 modules,
- 32 analog inputs distributed on : two TSX AEY 1600 modules,
- 16 analog outputs distributed on : four TSX ASY 410 modules,
- 2 counter channels distributed on : one TSX CTY 2A module,

Application code execution time (Texca) :

- Without communication OF : $10 \times 0.78 = 7.8 \text{ ms}$
- With 1 communication OF of the SEND_REQ type = $(10 \times 0.78) + 2 = 9.8 \text{ ms}$

System overhead time (TosM) = 1.4 ms

Management time for implicit I/O (%I and %Q) at the start and end of the scan :

Module reference	Type of module	Number of modules	Management time at start (IN)	Management time at end (OUT)
TSX DEY 16 D2	16-channel discrete inputs	7	238 μs	–
TSX DEY 16 FK	16-channel discrete inputs (fast inputs)	1	37 μs	22 μs
TSX DSY 16T2	16-channel discrete outputs	5	165 μs	100 μs
TSX AEY 1600	Analog inputs	2 (32 channels)	672 μs	–
TSX ASY 410	Analog outputs	4 (16 channels)	236 μs	236 μs
TSX CTY 2A	Counter	1 (2 channels)	110 μs	40 μs

Total management time	1458 μs	398 μs
------------------------------	--------------------	-------------------

- Management time at start of scan : $T_{ge\%I} = 60\mu\text{s} + 1458 \mu\text{s} = 1518 \mu\text{s} = 1.52 \text{ ms}$
- Management time at end of scan : $T_{gs\%Q} = 60\mu\text{s} + 398 \mu\text{s} = 458 \mu\text{s} = 0.46 \text{ ms}$

Communication system time :

- Sending the request : $T_{come} = 1 \text{ ms}$
- Receiving the response : $T_{comr} = 1 \text{ ms}$

Scan time without execution of the communication OF

$$\begin{aligned} T_{cyM} &= T_{exca} + T_{osM} + T_{ge\%I} + T_{gs\%Q} \\ &= 7.8 \text{ ms} + 1.4 \text{ ms} + 1.52 \text{ ms} + 0.46 \text{ ms} &= & \boxed{11.18 \text{ ms}} \end{aligned}$$

Scan time with execution of the communication OF and transmission of the request

$$\begin{aligned} T_{cyM} &= T_{exca} + T_{osM} + T_{ge\%I} + \max [\text{request transmission time } (T_{come}), T_{gs\%Q}] \\ &= 9.8 \text{ ms} + 1.4 \text{ ms} + 1.52 \text{ ms} + \max [1 \text{ ms}; 0.46 \text{ ms}] &= & \boxed{13.72 \text{ ms}} \end{aligned}$$

Scan time with receipt of the response

$$\begin{aligned} T_{cyM} &= T_{exca} + T_{osM} + \max [\text{response receipt time } (T_{comr}), T_{ge\%I}] + T_{gs\%Q} \\ &= 7.8 \text{ ms} + 1.4 \text{ ms} + \max [1 \text{ ms}; 1.52 \text{ ms}] + 0.46 \text{ ms} &= & \boxed{11.18 \text{ ms}} \end{aligned}$$

8.2-2 FAST task scan time

$$\text{FAST scan time} = \text{Program processing time (Ttp)} + \text{Internal processing time at start and end of scan (Tti)}$$

- **Definition of the program processing time Ttp**

$$\text{Ttp} = \text{Execution time of application code with respect to the FAST task (Texca)}$$

- Application code execution time (Texca) : see definition section 8.2-1

- **Definition of the internal processing time at the start and end of the scan (Tti)**

$$\text{Tti} = \text{FAST task overhead system time (TsoF)} + \text{Management time for implicit I/O (%I and %Q) at start and end of scan}$$

- FAST task overhead system time (TosF)

Type of processor	TSX P 57 10	TSX P 57 20
FAST task overhead system time	0.57 ms	0.5 ms

- Management time of implicit I/O (%I and %Q) at start and end of the scan : see section 8.2-1

8.2-3 Response time to an event

Time between a rising or falling edge on an event-triggered input and the corresponding edge on an output set by the event-triggered task program.

Example : program with 100 Boolean instructions and input module TSX DEY 16 FK

Type of processor		TSX P 57 10			TSX P 57 20		
		Min.	Typ.	Max.	Min.	Typ.	Max.
Response time	Minimum, typical, maximum						
	TSX DSY 08T22 output module	1.2 ms	1.3 ms	2.8 ms	1 ms	1.1 ms	2.2 ms
	TSX DSY 32T2K output module	1.9 ms	2.4 ms	4.2 ms	1.8 ms	2.2 ms	3.7 ms

Section	Page
1 Terminal port	1/1
1.1 Preface	1/1
1.2 Presentation	1/1
1.2-1 Communication with a programming or adjustment terminal	1/2
1.2-2 Communication with an operator panel	1/2
1.2-3 UNI-TELWAY master/slave communication	1/3
1.2-4 Character string communication	1/3
1.3 Connections	1/4
1.3-1 Programming / adjustment terminal	1/5
1.3-2 Operator panel	1/6
1.3-3 Programming / adjustment terminal and operator panel	1/6
1.3-4 Modem on terminal port	1/7
1.3-5 UNI-TELWAY master	1/9
1.3-6 UNI-TELWAY slave	1/10
1.3-7 UNI-TELWAY inter-PLC	1/11
1.3-8 UNI-TELWAY inter-device	1/12
1.3-9 TSX model 40 master PLC type	1/13
1.3-10 Character string	1/14
1.3-11 Terminal port connection summary table	1/15
1.4 Appendix	1/16
1.4-1 Characteristics	1/16
1.4-2 Terminal port pin connection	1/17
2 TSX P ACC 01 box	2/1
2.1 Presentation	2/1
2.1-1 Functions	2/1
2.1-2 External appearance	2/1

Section	Page
2.2 Hardware installation	2/2
2.2-1 Dimensions and fixing	2/2
2.2-2 Internal view	2/2
2.2-3 Connection to the UNI-TELWAY bus	2/3
2.2-4 Connection to TSX 57-●● PLCs	2/3
2.2-5 Configuration of switches	2/4
2.3 Examples of topology	2/5
2.3-1 Connectable devices	2/5
2.3-2 Master mode	2/6
2.3-3 Slave mode	2/7
2.3-4 Connection between two PLCs	2/8
2.4 TSX P ACC01 box connectors	2/9

1.1 Preface

Since the terminal port refers to the UNI-TELWAY master, UNI-TELWAY slave and character string communication modes it will be necessary to consult the following documentation for the installation (hardware and software) of these communication modes.

- TSX DG UTW E : UNI-TELWAY communication Bus (User guide),
- TSX DR NET E : X-WAY communication (Reference manual),
- TLX DS COM PL7 13E : TSX Micro / Premium PLC communication (installation manual)

1.2 Presentation

The terminal port on TSX Premium PLCs is an RS 485 non-isolated link consisting of two 8-pin mini DIN connectors. These two connectors, which are functionally identical, located on the processor and marked TER and AUX, enable physical and simultaneous connection of two devices such as a programming/adjustment terminal and an operator panel.

The TER connector is also able to supply power to a device which does not have its own supply (FTX 117, RS 485/RS 232 converter cable, TSX P ACC 01 isolation box, etc).

The terminal port functions in UNI-TELWAY master mode by default. By configuration, it is possible to switch to UNI-TELWAY slave character mode.

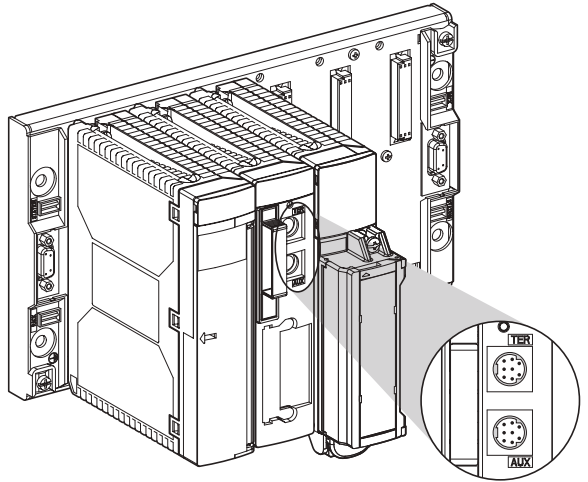

Note

The communication mode (UNI-TELWAY master, UNI-TELWAY slave or character mode) is identical on the two connectors TER and AUX

The drawings presented in the following sections 1.2-1, 1.2-2, 1.2-3 and 1.2-4 are simplified schematics. Connections for the various elements on the terminal port are presented in section 1.3.

1.2-1 Communication with a programming or adjustment terminal

Configured as the UNI-TELWAY master (default function), the terminal port is used to connect a programming and adjustment terminal.

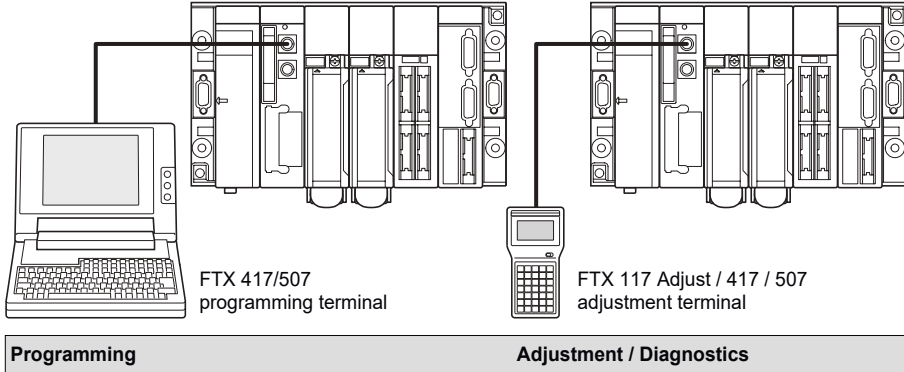

1.2-2 Communication with an operator panel

Configured as the UNI-TELWAY master (default function), the terminal port enables an operator panel to be connected. The man-machine interface uses UNI-TE protocol to communicate with the local PLC and other stations on the network.

In order to free the TER connector for possible connection of a programming or adjustment terminal, the operator panel will be connected to the AUX connector.

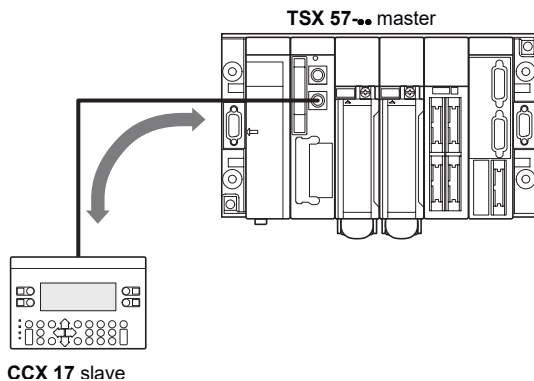

1.2-3 UNI-TELWAY master/slave communication

The default communication mode of the terminal port is UNI-TELWAY master. It principally enables the connection of a slave programming terminal and an operator panel.

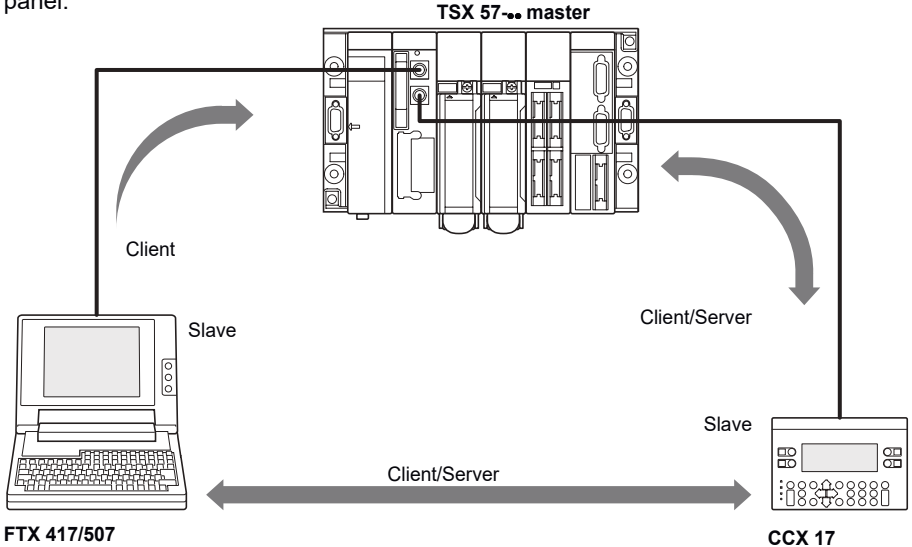

1.2-4 Character string communication

This mode is used when connecting a printer or a specialized man-machine interface (monitor, panel mounted controller, etc) to a TSX Premium PLC.

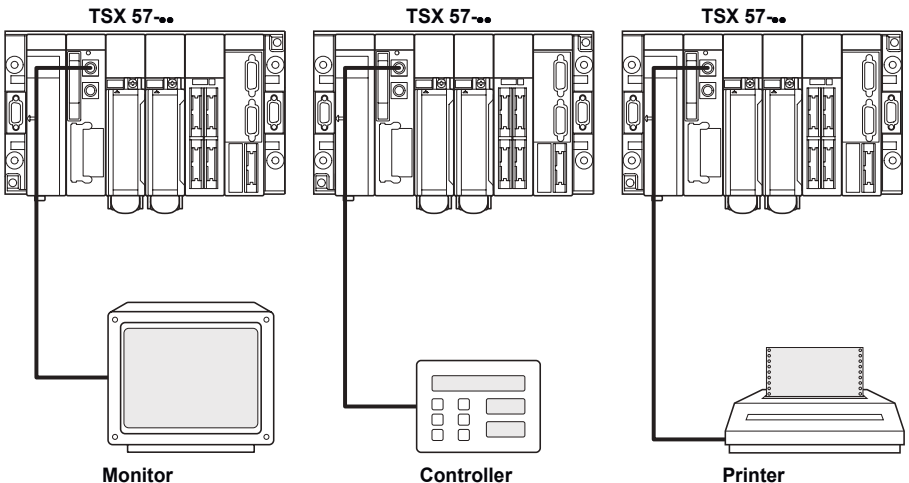

1.3 Connections

The connector (marked TER) can be used to connect any device supporting the UNI-TELWAY protocol, and in particular devices which do not have their own power supply (FTX 117 programming terminal, RS 485/RS 232 converter cable, TSX P ACC 01 isolation box, etc).

The connector (marked AUX) can only be used to connect devices which have their own power supply (operator panel, PLC, third-party equipment, etc).

The terminal port enables three operating modes :

- UNI-TELWAY master (default configuration),
- UNI-TELWAY slave,
- Character string.

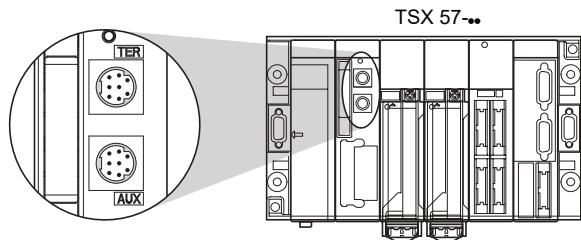

Note

The operating mode defined during configuration (UNI-TELWAY master, UNI-TELWAY slave, character mode) is identical for both connectors.

Depending on the operating mode selected during configuration, the terminal port can be used to connect :

- a programming and adjustment terminal,
- a man-machine interface,
- another PLC,
- UNI-TELWAY devices (sensor / actuator, variable speed drive, etc),
- a printer or monitor (character string mode link).
- a modem.

The use of an isolation box, reference TSX P ACC 01, provides 2 connectors, enabling, for example, a programming terminal and two slave devices to be connected simultaneously. This box is also necessary to connect a TSX 57-.. PLC on a UNI-TELWAY link when the distance between the devices is greater than 10 meters. Slave mode can be forced by using this box, which is described in section 2.

Note

The TSX P ACC 01 box must be used to connect a TSX 57-.. slave PLC on a UNI-TELWAY bus.

1.3-1 Programming / adjustment terminal

Because it does not have its own supply, the FTX 117 Adjust terminal must be connected to the TER connector of the processor of type TSX 57 type PLCs. Terminals with their own supply, (FTX 417, FTX 507), can be connected to the AUX terminal port.

The programming terminal uses UNI-TE protocol for programming, adjusting or performing diagnostics on the local PLC and all the station devices.

If the PLC is connected on a network architecture, network transparency enables the programming terminal to reach all the devices on the network.

The references for the various connection cables are :

Connection examples

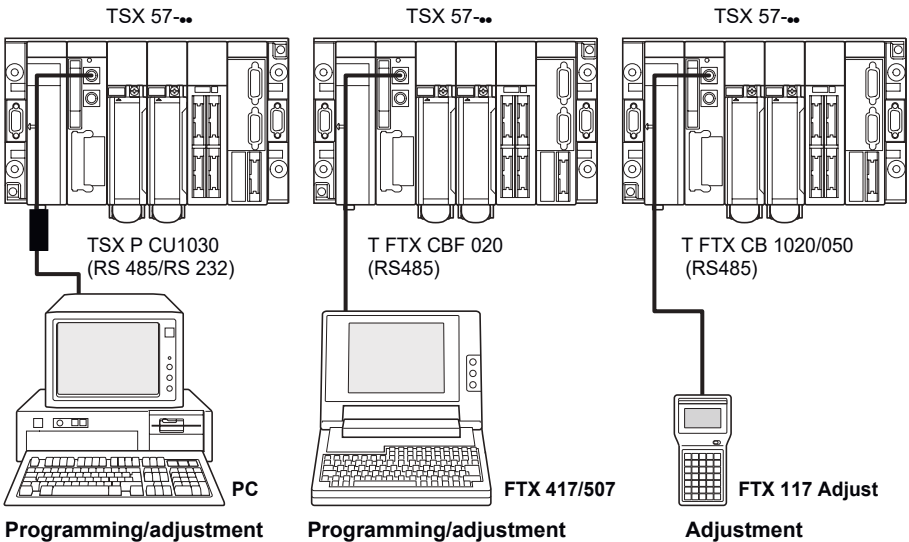

Note :

The TSX P CU1030 cable does not operate on the AUX terminal port

1.3-2 Operator panel

The operator interface equipment uses UNI-TE protocol to communicate with the local PLC and other stations on the network.

In the case of a TSX 57 PLC, the operator panel has its own power supply and must be connected to the AUX terminal port in order to leave the TER port available for a terminal which requires a power supply (FTX 117 Adjust for example).

Connection example

The references of the connection cables between the terminal port and a CCX 17 operator panel are shown opposite.

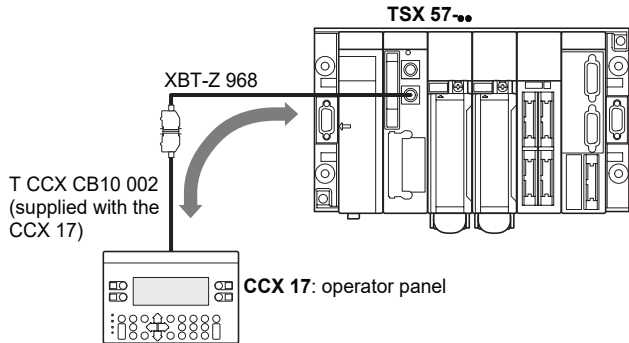

1.3-3 Programming / adjustment terminal and operator panel

The PLC terminal port can handle two devices in multidrop mode : the programming / adjustment terminal and an operator panel.

TSX 57 .. PLCs have two connectors, and therefore each connector can accept one of these devices. Because the FTX 117 adjustment terminal does not have its own supply, it must be connected to the TER connector.

Connection example

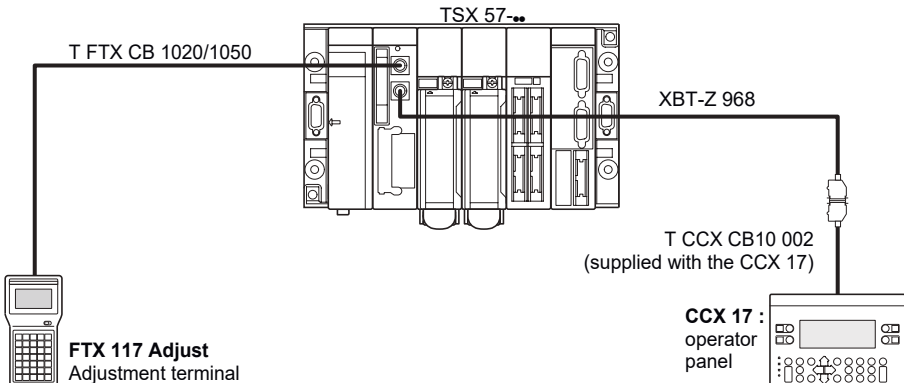

Note:

1.3-4 Modem on terminal port

The terminal port of TSX Micro PLCs version \geq V1.5 and of TSX Premium PLCs is compatible with a modem connection in the following protocols : UNI-TELWAY Master, UNI-TELWAY Slave and Character string.

The modem to be connected must have the following characteristics :

- 1- Support a 10 or 11 bits per character format if the terminal port is used in UNI-TELWAY mode : 1 Start, 8 Data, 1 Stop, Odd, or No Parity,
- 2- operate without any data compression if the terminal port is used in UNI-TELWAY mode,
- 3- be able to be configured with "DTR signal forced" on the RS 232 serial port (in cases where the modem is used in response mode), since this signal is not connected by the cable,
- 4- operate without flow control (no -RTS/CTS- hardware or -XON/XOFF- software) on the RS 232 serial port, since the cable to be used on the terminal port side can only carry TX, RX and GND signals.
- 5- operate without carrier control. Warning : this operating mode also uses RTS and CTS control signals,
- 6- accept a telephone call entry while its characters arrive on the RS 232 serial port (in cases where a modem/telephone network is used in response mode on a terminal port configured as a UNI-TELWAY master).

Warning : it is strongly recommended to check with the modem supplier that the above characteristics are available on the selected modem.

Connection diagram :

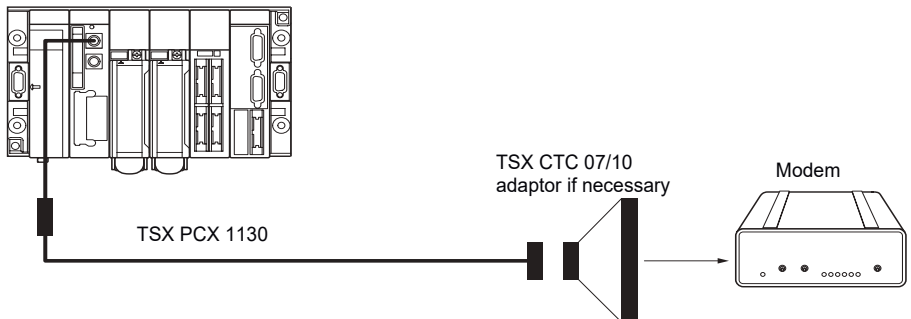

Example 1 : for a terminal port in UNI-TELWAY master mode connected to a modem/telephone network in response mode, numbers 1 to 6 of the above characteristics are required.

Example 2 : for a terminal port in character string mode connected to a modem via a dedicated line, numbers 3 to 5 of the above characteristics are required.

Configuration of the terminal port in UNI-TELWAY mode :

The waiting time is between 100 and 250 ms.

In master mode, the number of slaves configured must correspond to the real number of slaves on the bus.

In slave mode, the number of addresses must correspond to those used..

The TSX Micro PLC terminal port is configured using PL7 Micro or PL7 Micro / Junior software.

Example of configuration screen :

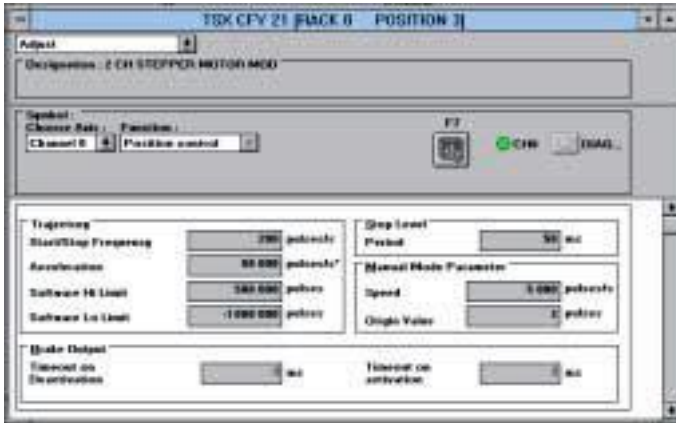

For further details refer to the TLX DS COM PL7 communication manual.

1.3-5 UNI-TELWAY master

This is the default operating mode of the terminal port. It principally enables the connection of a programming terminal and an operator panel.

Connection example

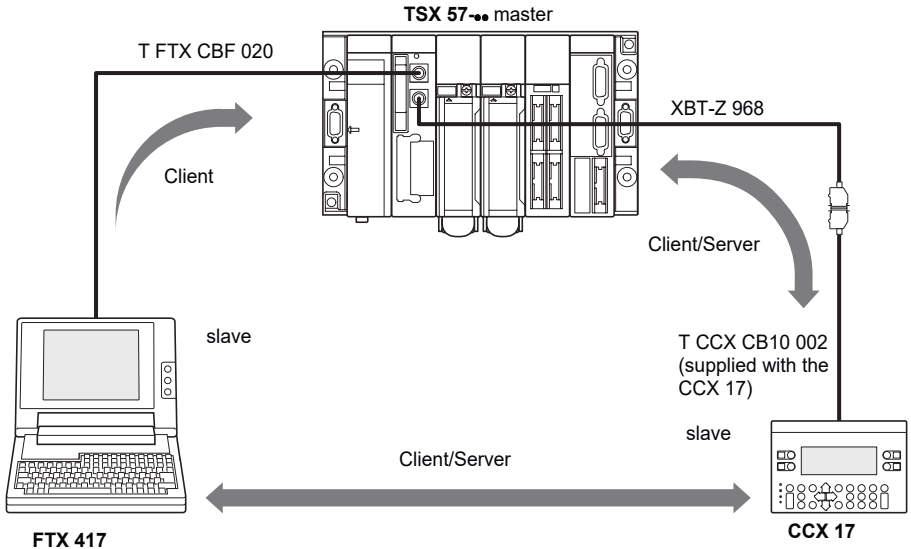

Important

The master can scan up to eight link addresses. Link addresses 1, 2 and 3 are reserved for the programming terminal, the five other addresses can be used to connect a man-machine interface, slave PLC, sensors/actuators or any other slave device which supports the UNI-TE slave protocol. If a CCX 17 operator panel is used, addresses 4 and 5 are reserved (addresses forced by using XBT-Z 968 cables).

This operating mode is operational immediately, and consequently, within the limits of the default configuration, no other installation phase is necessary to connect a device on this type of link.

1.3-6 UNI-TELWAY slave

The terminal port UNI-TELWAY slave protocol enables, for example, a slave TSX 57 .. PLC to be integrated on a UNI-TELWAY bus managed by a TSX 57 .. master PLC (PCMCIA communication card or terminal port) or a model 40 TSX/PMX PLC. For this connection to be possible, a TSX P ACC 01 connection box must be used. The different ways of connecting this box are shown in section 2.

Connection example

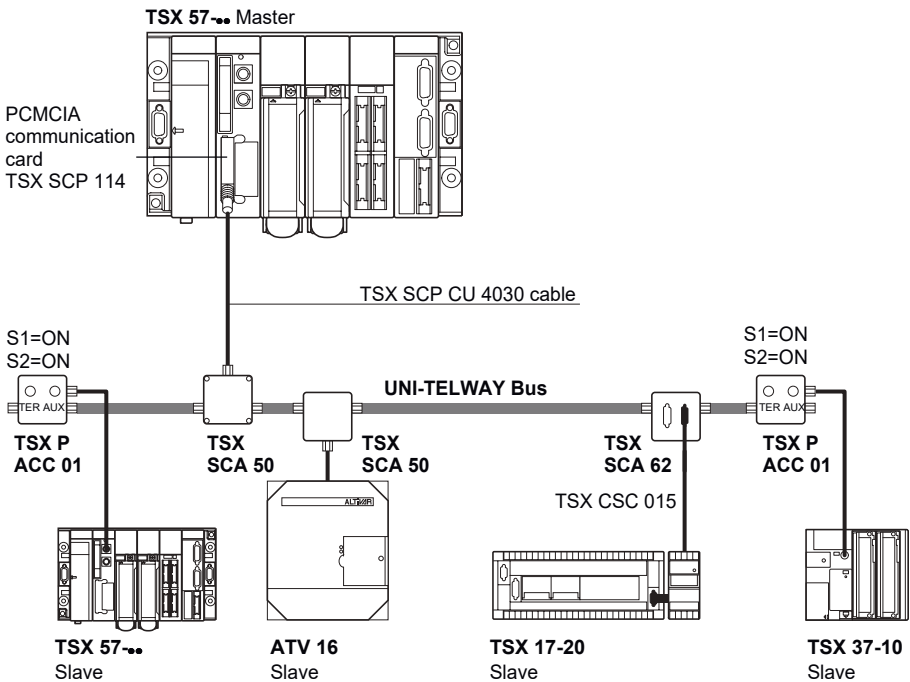

A slave PLC manages up to three consecutive link addresses :

- Ad0 (system address),
- Ad1 (client application address),
- Ad2 (listen application address).

Note:

When setting up TSX SCA 50 and TSX SCA 62 boxes, consult the TSX DG UTW manual : UNI-TELWAY Bus Communication (User guide),

1.3-7 UNI-TELWAY inter-PLC

The terminal port enables the connection of two PLCs, one of which is the master and the other the slave.

A connection box TSX P ACC 01 is essential for this type of connection. The various means of connecting this box are given in section 2.

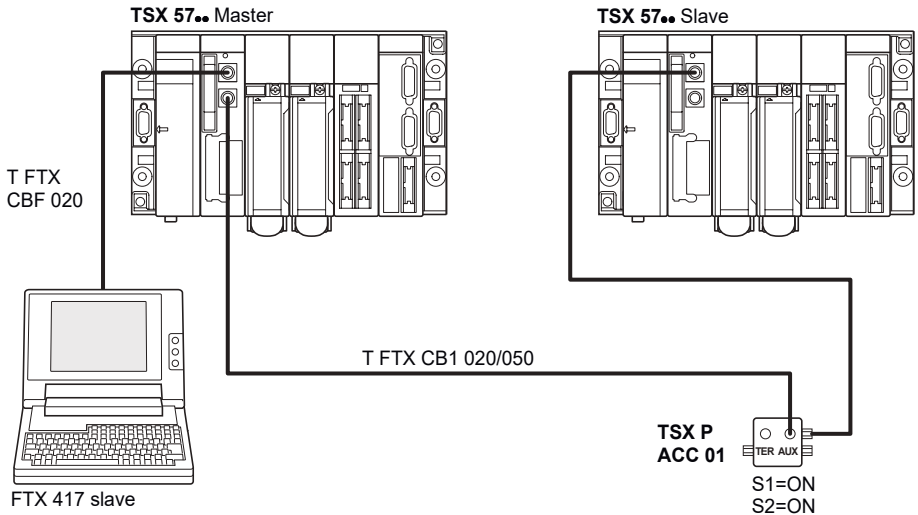

1.3-8 UNI-TELWAY inter-device

The terminal port on TSX Premium PLCs provides a means of connection to a UNI-TELWAY bus for communication with devices such as variable speed drives, sensors/actuators or with other PLCs.

When connecting a TSX 57 ..PLC (master or slave) to a UNI-TELWAY bus, it is essential that a TSX P ACC 01 box is used. For more details, refer to section 2.

Connection example

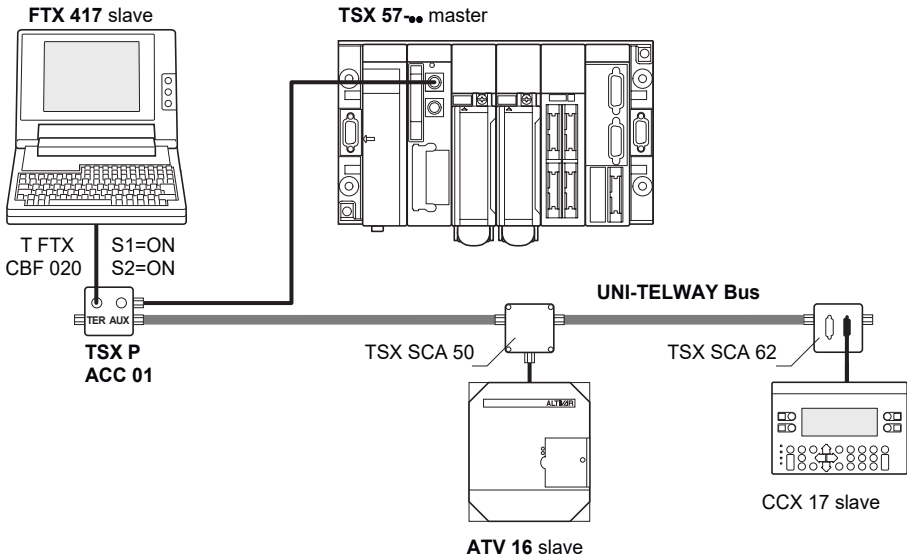

The connected devices communicate with the PLC using UNI-TE protocol.

The various devices can also communicate between themselves.

The programming terminal can access all devices directly to perform adjustment and diagnostic functions.

Note:

When setting up TSX SCA 50 and TSX SCA 62 boxes, consult the TSX DG UTW manual : UNI-TELWAY Bus Communication (User guide),

1.3-9 TSX model 40 master PLC type

A TSX/PMX model 40 type PLC can also be configured as the UNI-TELWAY bus master and can control the TSX 57 .. PLC slaves.

Connection example

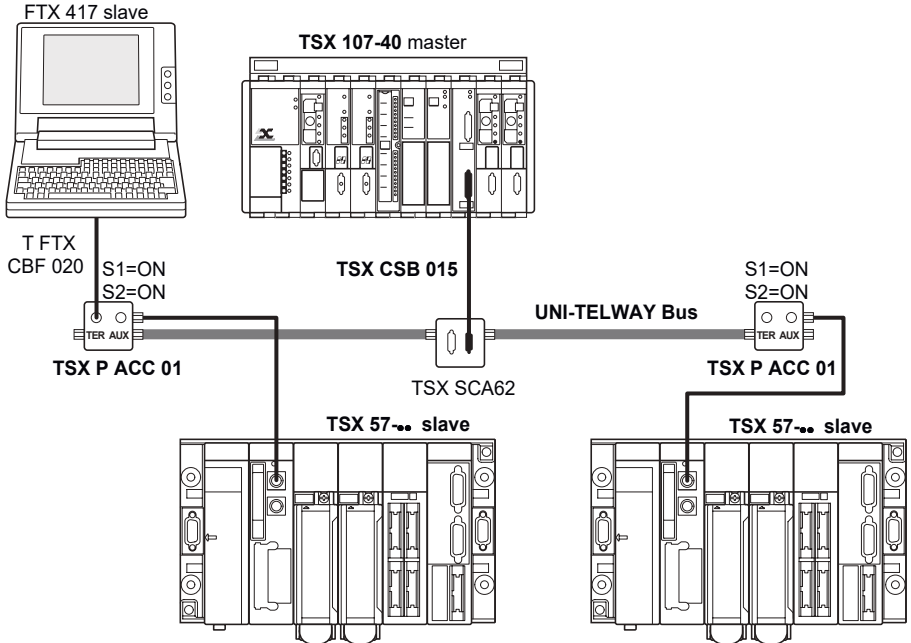

Note:

When setting up TSX SCA 50 and TSX SCA 62 boxes, consult the TSX DG UTW manual : UNI-TELWAY Bus Communication (User guide)

1.3-10 Character string

When configured in character mode, the terminal port can be used to connect a device such as a printer, monitor, or specialized panel (panel mounted controller for example, etc).

Connection example

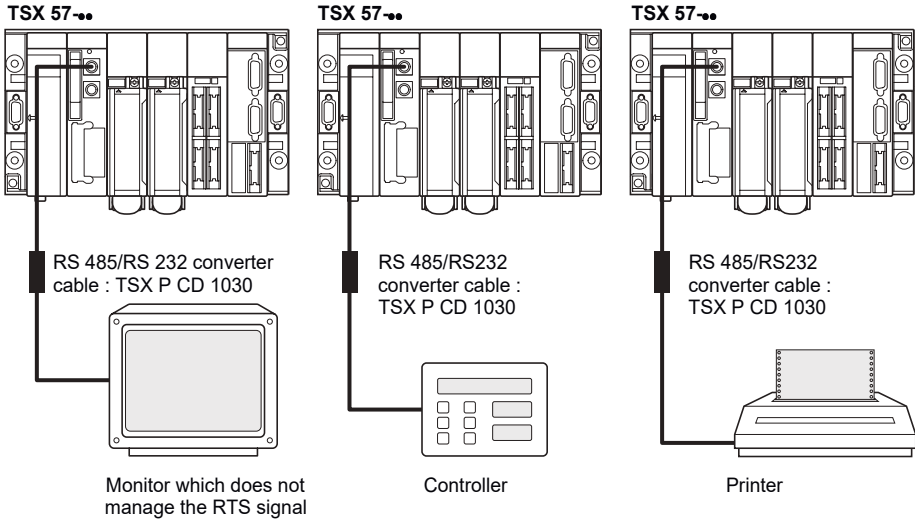

Note :

The TSX PCD 1030 cable provides the RS485 / RS232 conversion, and supplies "slave peripheral" information to the printer. It does not operate on the AUX terminal port of the TSX 37-20 and **the connected device must manage the RTS signal.**

Warning :

The TSX PCX 1030 and TSX PCX 1130 cables should only be connected to the PLC TER port to supply the RS485 / RS 232 conversion electronics. To avoid conflicting signals, devices must not be connected to the PLC AUX port.

To ensure all types of connection, cables are supplied with adaptors.

The TSX PCX 1030 cable is supplied with two adaptors / converters :

TSX CTC 07 : 9-pin male to 25-pin female,

TSX CTC 10 : 9-pin male to 25-pin male.

The TSX PCX 1130 cable is supplied with one adaptor / converter :

TSX CTC 09 : 9-pin male to 25-pin male.

1.3-11 Terminal port connection summary table

The table below defines the cable linking the connectors of a TSX 57 terminal port to the peripheral equipment.

Connection cable	PLC terminal ports		Example of connected devices
	TER	AUX	
T FTX CB 1020 or T FTX CB 1050	X		FTX 117 TSX P ACC 01
T FTX CBF 020	X	X	FTX 507, FTX 417
TSX P CU 1030	X		RS 232 programming and adjustment terminals
TSX P CD 1030	X		Graphics terminals, printers, managing the RTS signal
XBT-Z 968	X	X	CCX 17, XBT
TSX P ACC 01	X		UNI-TELWAY connection
TSX PCX 1030	X		devices which do not manage the RTS signal, type DTE <--> DTE : programming terminals, RS 232 printers
TSX PCX 1130	X		devices which do not manage the RTS signal, type DTE <--> DCE : Modem

The two TSX PCX 1030 and TSX PCX 1130 cables ensure the conversion of the RS 485 signals to RS 232. They permit connection of the terminal port to RS 232 devices which do not manage the RTS signal.

They are both fitted with a switch for setting the PLC to Master or slave mode. The switch can be accessed internally by removing the metal cover containing the electronics. The switch is managed as follows :

	PL7 configuration UTW master	PL7 configuration UTW slave	PL7 configuration Character mode
Switch position M	UTW master with PL7 conf	UTW master with default conf	UTW master with default conf
Switch position E	UTW slave with default conf	UTW slave with PL7 conf	Character mode with PL7 conf

Switch setting :

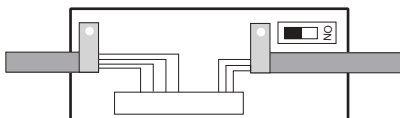

Master mode M

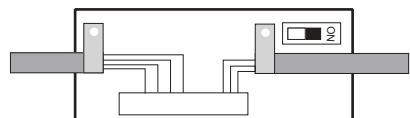

Slave mode S

1.4 Appendix

1.4-1 Characteristics

The terminal port characteristics are given in the table below :

		UNI-TELWAY mode master or slave	Character mode
Structure	Physical interface	RS 485 non isolated.	RS 485 non isolated.
	Protocol	Multidrop master/slave.	No protocol.
Transmission	Bit rate	19200 bits/s by default modifiable from 1200 to 19200 b/s 1 start bit, 8 data bits, even, odd or no parity, 1 stop bit	9600 bits/s by default modifiable from 1200 to 19200 bits/s. 7 or 8 data bits, even, odd or no parity, with or without echo.
	Configuration	Number of devices	Maximum of eight (8 addresses handled by the master). In slave mode the addresses 4,5,6 are selected by default In master mode, the reserved addresses are : 1,2,3 for the programming terminal, 4,5 if CCX 17 present, the others are available.
	Length	10 m maximum.	10 m maximum.
Services	UNI-TE	Requests in point to point with confirmation of 128 bytes maximum initiated by any connected device. No broadcasting initiated by the master.	Character strings of 120 bytes max. The messages must end with \$0D (carriage return)
	Other functions	Transparency of communicat- ion with any device in a network architecture via the master.	
	Safety	One control character on each frame, acknowledgment and repetition possible.	No error feedback.
	Monitoring	Bus status table, status of devices, error counters are accessible by the slaves.	No flow control.

Note :

Use of a TSX P ACC 01 cable connector enables the RS485 link to be used in isolated mode. See section 2.

1.4-2 Terminal port pin connection

The terminal port has 8-pin mini-DIN lockable connectors marked TER and AUX.

The signals are given below :

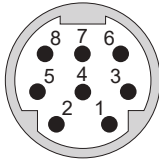

TER

- 1 D (B)
- 2 D (A)
- 3 not connected
- 4 /DE
- 5 /DPT (1 = master)
- 6 not connected
- 7 0 volt
- 8 5 volts

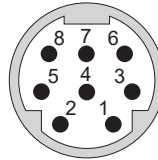

AUX

- 1 D (B)
- 2 D (A)
- 3 not connected
- 4 /DE
- 5 /DPT (1 = master)
- 6 not connected
- 7 0 volt
- 8 not connected

Note

The operation of the terminal port is dependent on two parameters:

- the state of the signal / DPT (0 or 1), fixed by the wiring accessory (lead, TSX P ACC 01),
- the software configuration of the terminal port defined under PL7 Junior.

The table below defines the operating mode of the terminal port as a function of these two parameters.

Signal /DPT value Configuration under PL7 Junior	0	1
UNI-TELWAY master	Terminal port in UTW slave mode (by default)	Terminal port in UTW master mode
UNI-TELWAY slave	Terminal port in UTW slave mode	Terminal port in UTW master mode (by default)
Character mode	Terminal port in character mode	Terminal port in UTW master mode (by default)

2.1 Presentation

2.1-1 Functions

The TSX P ACC 01 box is a wiring accessory which connects to the TER connector on the processor of TSX Premium PLCs via a rigid cable, equipped with a mini-DIN connector at one end.

It is used to :

- connect several devices to the TSX Premium PLC terminal port. For this purpose, it has with two mini-DIN connectors, marked TER and AUX, which are functionally identical to the TER and AUX connectors of TSX 57-.. PLCs,
- isolate UNI-TELWAY signals so that the TSX Premium terminal port link can be extended to more than 10 meters to connect the PLC on a UNI-TELWAY bus,
- provide line termination when the box is connected to one end of the UNI-TELWAY bus,
- determine the operating mode of the terminal port :
 - UTW master,
 - UTW slave or character mode.

Note :

The two terminal ports of the TSX P AC01 box, TER and AUX, are not isolated from each other nor from the TER port of the PLC to which they are connected.

2.1-2 External appearance

The box is made of zamak, the same as for the UNI-TELWAY terminal or connection box (TSX SCA50 and TSX SCA62). It is designed to be mounted in a cabinet (see dimensions section 2.2-1). Its protection index is IP 20.

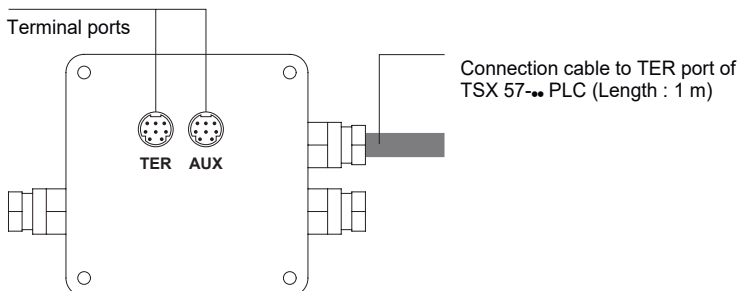

2.2 Hardware installation

2.2-1 Dimensions and fixing

The TSX P ACC 01 box is installed on an AM1 PA... pre-slotted plate or on an AM1-DE/DP type DIN rail with an LA9 D09976 fixing plate.

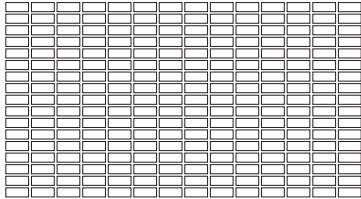

AM1-PA...

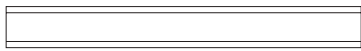

AM1 DE/EP

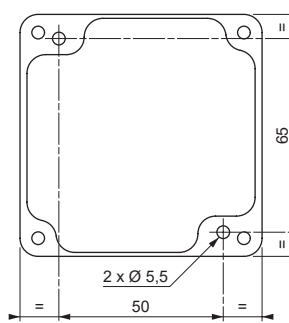

2.2-2 Internal view

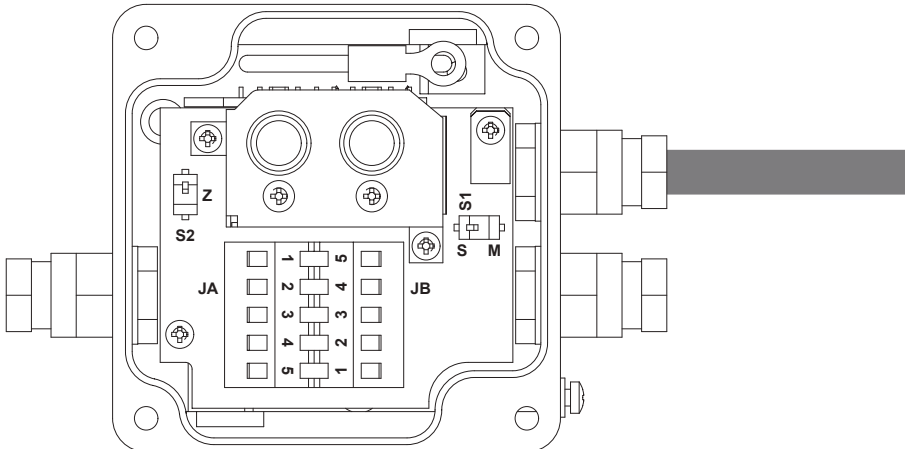

- S1 Selection of operating mode (master or slave),
- S2 Line terminator,
- JA and JB UNI-TELWAY bus connection terminals.

2.2-3 Connection to the UNI-TELWAY bus

The TSX P ACC 01 box is connected to the UNI-TELWAY bus via the JA and JB connection terminals as shown opposite.

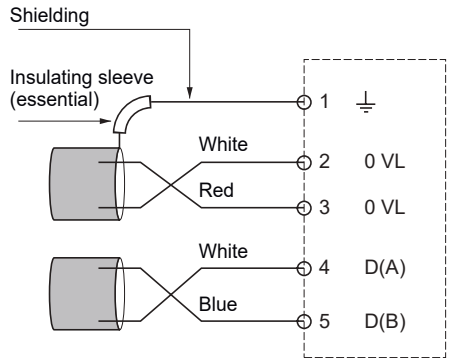

2.2-4 Connection to TSX 57-.. PLCs

As the TSX P ACC 01 box has to be supplied, it must be connected by its integral cable to the TER connector of the PLC processor.

The box can be connected or disconnected while the PLC is powered up.

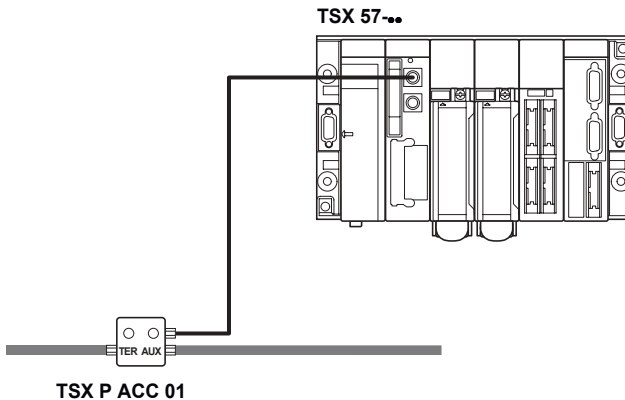

Note :

Only one TSX P ACC01 box can be connected to a TSX 57-.. PLC.

2.2-5 Configuration of switches

Line terminator configuration

End of line adaptation performed by switch S2 as indicated below :

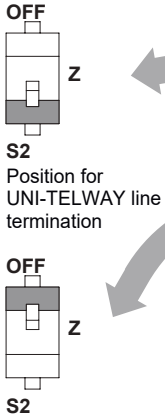

Other positions

Operating mode configuration

The choice of operating mode is determined via switch S1 as indicated below :

Note : the operating mode selected only concerns the connection cable for the TER connector of the PLC processor

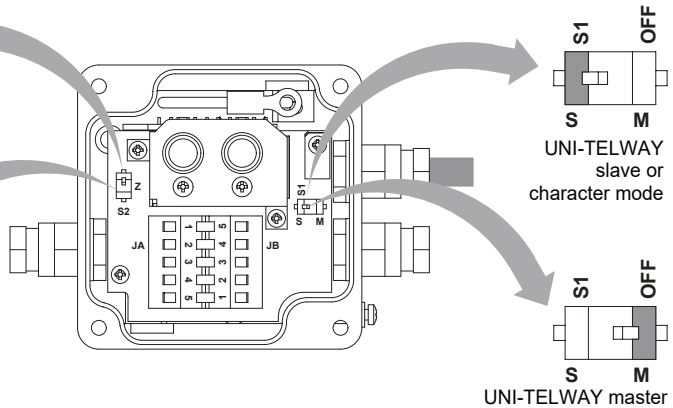

2.3 Examples of topology

2.3-1 Connectable devices

The functions of the two TER and AUX connectors of the TSX P ACC 01 box are identical to those of the TER and AUX connectors of the processor on TSX Premium PLCs :

- the TER connector on the box can be used to connect any device supporting UNI-TELWAY protocol, and in particular devices which do not have their own power supply (FTX 117 Adjust terminal, RS 485/RS 232 converter cable, etc),
- the AUX connector on the box can only be used to connect devices which have their own supply (operator panel, PLCs, third-party equipment, etc).

Important

The TSX P ACC 01 box is supplied by the TER connector of the PLC to which it is connected. The TER port on the box can therefore be used to connect devices with their own power supply (CCX 17, etc) or without their own supply (FTX 117 Adjust terminal, RS 485/RS 232 converter cable, etc).

In the event that the user wishes to connect the terminal port of a second PLC to one of the connectors on the TSX P ACC 01 box, it is essential that the AUX connector (on the box and the PLC) is used in order to avoid conflict between the two PLC power supplies.

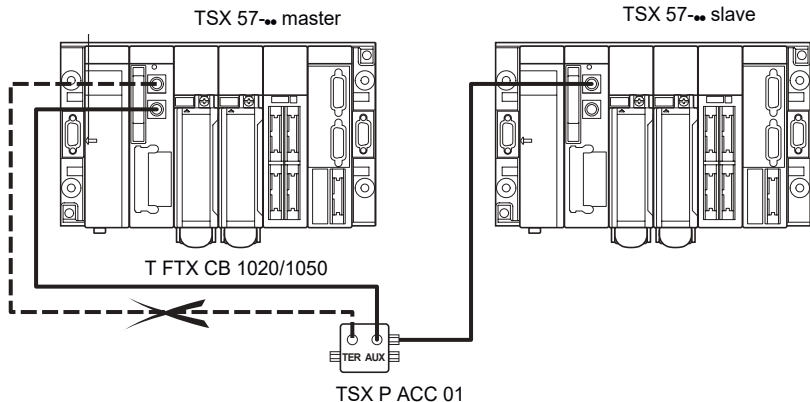

2.3-2 Master mode

A TSX P ACC 01 box is connected to a master PLC on the UNI-TELWAY link as shown in the example below.

Switches S1 and S2 must be set to OFF (master mode and other position).

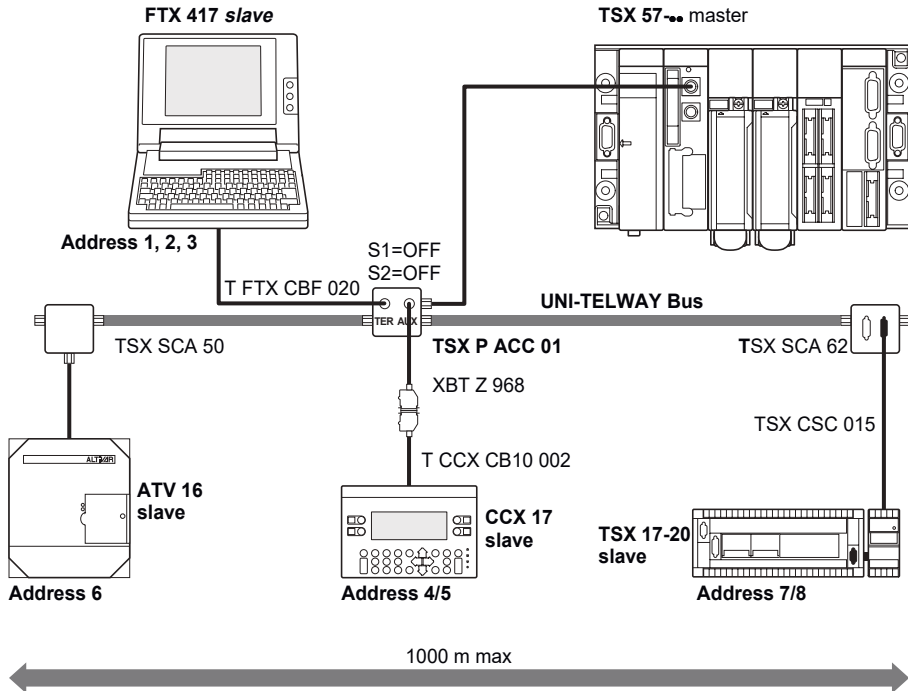

2.3-3 Slave mode

A TSX P ACC 01 box is connected to a slave PLC on the UNI-TELWAY link as shown below.

In this example, switches S1 and S2 on both boxes must be set to ON (slave mode and line termination boxes).

Important

For a PLC to function in slave mode, it must be connected to a TSX P ACC 01 box by the box integral cable.

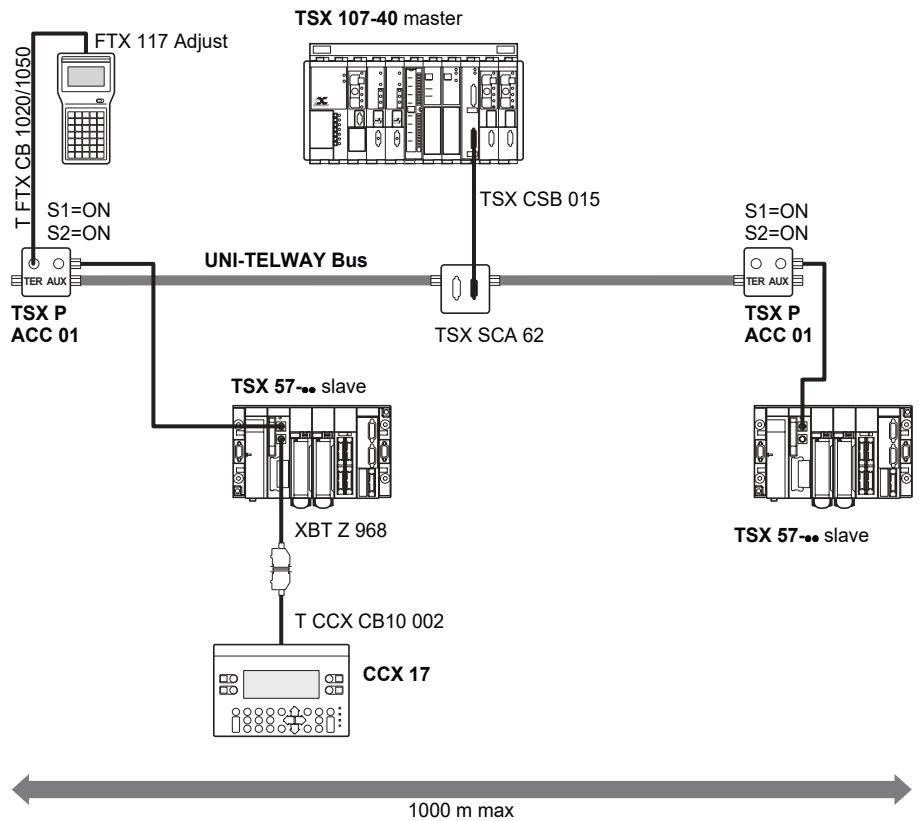

2.3-4 Connection between two PLCs

Reminder

If the user wishes to connect the terminal port of a second PLC to one of the TSX P ACC 01 box ports, the AUX port must be used in order to avoid conflict between the power supplies of the two PLCs.

For a PLC to function in slave mode, it must be connected to a TSX P ACC 01 box by the box integral cable.

In the example below, the TSX P ACC 01 box must be connected to the UNI-TELWAY slave PLC by the box integral cable. Switch S1 must be set to ON.

As the box is not situated on a UNI-TELWAY bus, the position of switch S2 is not important.

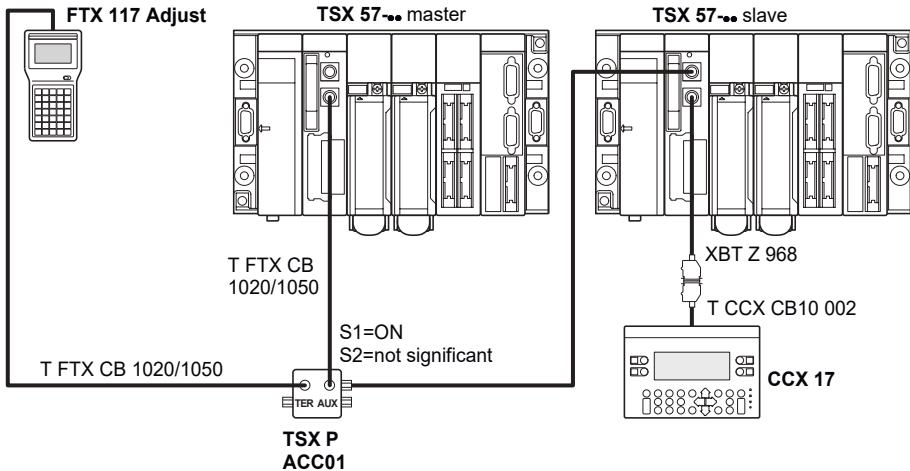

2.4 TSX P ACC01 box connectors

The TSX P ACC 01 box has two parallel connectors, marked TER and AUX.

The signals are given below :



TER

- 1 D (B)
- 2 D (A)
- 3 not connected
- 4 not connected
- 5 not connected
- 6 not connected
- 7 0 volt
- 8 5 volts

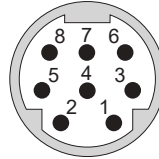

AUX

- 1 D (B)
- 2 D (A)
- 3 not connected
- 4 not connected
- 5 not connected
- 6 not connected
- 7 not connected
- 8 not connected

Index

A

AUX connector A2 1/1

D

Devices which can be connected
to TSX P ACC01 A2 2/5

M

Modem on terminal port A2 1/7

T

TER connector A2 1/1

Terminal port characteristics A2 1/16

Terminal port, communication

Character string A2 1/3

Modem connection A2 1/7

UNI-TELWAY master/slave A2 1/3

With an operator panel A2 1/2

Terminal port connections A2 1/4

Character string A2 1/14

Operator panel A2 1/6

Programming/adjustment terminal A2 1/5

Programming/adjustment terminal
and operator panel A2 1/6

TSX model 40 master PLC type A2 1/13

UNI-TELWAY inter-device A2 1/12

UNI-TELWAY inter-PLC A2 1/11

UNI-TELWAY master A2 1/9

UNI-TELWAY slave A2 1/10

Terminal port pin connection A2 1/17

TSX P ACC 01 box A2 2/1

TSX P ACC01 box connectors A2 2/9

TSX P ACC01 configuration A2 2/4

TSX P ACC01 connection between
two PLCs A2 2/8

TSX P ACC01 connections A2 2/3

To the UNI-TELWAY bus A2 2/3

To TSX 57-ii PLCs A2 2/3

TSX P ACC01 dimensions A2 2/2

TSX P ACC01 fixing A2 2/2

TSX P ACC01 master mode A2 2/6

TSX P ACC01 slave mode A2 2/7

Section	Page
1 Introduction	
1.1 Description	1/1
1.1-1 General description	1/1
1.1-2 Physical description	1/2
1.2 Catalog	1/3
1.3 Installing, inserting and removing modules	1/9
1.3-1 Installation	1/9
1.3-2 Inserting/removing modules	1/9
1.4 Labelling	1/10
1.4-1 Modules with screw terminal block	1/10
1.4-2 Module with HE10 connectors	1/11
1.5 Channel addressing	1/12
2 Discrete I/O functions	2/1
2.1 General functions	2/1
2.1-1 Constant current inputs	2/1
2.1-2 Protecting DC transistor outputs	2/1
2.1-3 Reactivating outputs	2/1
2.1-4 Output fallback state	2/2
2.1-5 Sharing the I/O	2/2
2.2 Specific functions of the TSX DEY 16FK module	2/3
2.2-1 Programmable input filtering	2/3
2.2-2 Latching inputs	2/4
2.2-3 Event management	2/5
2.3 Diagnostic functions	B1 2/6
2.3-1 Module diagnostics	B1 2/6
2.3-2 Process diagnostics	B1 2/6

Section	Page
2.4 Protection	2/8
2.4-1 Built-in protection for 24 VDC transistor output modules	2/8
2.4-2 Fuse protection	2/8
2.4-3 Protection of relay output contacts	2/9
3 General installation rules	3/1
3.1 Recommendations for use	3/1
3.2 General wiring rules and recommendations	3/2
3.3 Compatibility of sensors → inputs and preactuators → outputs	3/5
3.3-1 Compatibility of sensors with inputs	3/5
3.3-2 Compatibility of preactuators with outputs	3/7
3.3-3 Using negative logic (24 VDC)	3/8
3.4 Software installation and associated language objects	3/10
3.5 Discrete I/O display and diagnostics	3/10
4 Characteristics	4/1
4.1 Characteristics of input modules with screw terminal	4/1
4.1-1 Input modules 24 - 48 VDC	4/1
4.1-2 24 VDC negative logic input module	4/2
4.1-3 AC voltage input modules with screw terminal	4/3
4.2 Characteristics of input modules with connectors	4/4
4.2-1 Fast input module	4/4
4.2-2 32 and 64 channel input modules	4/5
4.2-3 Temperature derating	4/6

Section	Page
4.3	Characteristics of outputs with screw terminal 4/7
4.3-1	Transistor output modules 4/7
4.3-2	Relay output modules 50 VA 4/8
4.3-3	Relay output module 100 VA : TSX DSY 08R4D 4/9
4.3-4	Relay output module 100 VA : TSX DSY 08R5A 4/10
4.3-5	Triac output modules 4/11
4.4	Characteristics of transistor output modules with connector 4/12
5 Connections	5/1
5.1	Connection equipment 5/1
5.1-1	Connection to modules with screw terminal block 5/1
5.1-2	Connection to modules with HE10 connectors 5/2
5.2	Module connections 5/4
5.2-1	TSX DEY 08D2 / 16D2 modules 5/4
5.2-2	TSX DEY 16D3 module 5/7
5.2-3	TSX DEY 16A2 / 16A3 / 16A4 / 16A5 modules 5/8
5.2-4	TSX DEY 16FK module 5/9
5.2-5	TSX DEY 32D2K / 64D2K modules 5/11
5.2-6	TSX DSY 08T2 / 16T2 / 16T3 / 08T22 / 08T31 modules 5/14
5.2-7	Relay modules 50 VA : TSX DSY 08R5 / 16R5 5/17
5.2-8	Relay modules 100 VA : TSX DSY 08R5A / 08R4D 5/19
5.2-9	TSX DSY 08S5 / 16S4 modules 5/21
5.2-10	TSX DSY 32T2K / 64T2K modules 5/23
6 TELEFAST 2 connection interfaces for discrete I/O	6/1
6.1	Presentation 6/1
6.2	TSX Micro I/O module and sub-base compatibility 6/6

Section

Page

6.3	TSX Premium I/O module and sub-base compatibility	6/7
6.4	Module → interface sub-base connection principle	6/8
6.5	Sensor or preactuator connection to sub-bases	6/10
6.5-1	ABE-7H08R10/R11, ABE-7H16R10/R11 sub-bases	6/10
6.5-2	ABE-7H12R10/R11 sub-bases	6/11
6.5-3	ABE-7H08R21, ABE-7H16R20/21/23 sub-bases	6/12
6.5-4	ABE-7H12R20/21 sub-bases	6/13
6.5-5	ABE-7H08S21, ABE-7H16S21 sub-bases	6/14
6.5-6	ABE-7H12S21 sub-base	6/15
6.5-7	ABE-7H16R30/31 sub-bases	6/16
6.5-8	ABE-7H12R50 sub-base	6/17
6.5-9	ABE-7H116R50 sub-base	6/18
6.5-10	ABE-7H16F43 sub-base	6/19
6.5-11	ABE-7H16S43 sub-base	6/20
6.5-12	Fixed relay output adaptor sub-bases : ABE-7R08S111, ABE-7R16S111, ABE-7R16S210/212	6/21
6.5-13	Fixed solid state relay input adaptor sub-bases : ABE-7S16E2B1/E2E1/E2E0/E2F0/E2M0	6/24
6.5-14	Fixed solid state relay output adaptor sub-bases : ABE-7S16S2B0 and ABE-7S16S2B2 ABE-7S08S2B0 and ABE-7S08S2B1	6/25
6.5-15	Removable solid state or electromechanical relay output sub-bases, relay 10mm wide ABE-7R16T210, ABE-7P16T210 ABE-7R16T212, ABE-7P16T212 ABE-7R16T230 ABE-7R16T231 ABE-7P16T214 ABE-7P16T215	6/28 6/29 6/30 6/31 6/32 6/33

Section	Page
6.5-16 Removable electromechanical or solid state relay input or output sub-bases, relay 12.5 mm wide	
ABE-7R16T330, ABE-7P16T330	6/34
ABE-7R16T332, ABE-7P16T332	6/35
ABE-7R16T370	6/36
ABE-7P16T334	6/37
ABE-7P16T318	6/38
ABE-7P16F310	6/39
ABE-7P16F312	6/40
<hr/> 6.6 Compatibility table for relays and sub-bases	6/41
<hr/> 6.7 Accessories	6/42
<hr/> 6.8 Sub-base electrical characteristics	6/43
6.8-1 Fixed input adaptor sub-bases	6/43
6.8-2 Fixed solid state output adaptor sub-bases	6/44
6.8-3 Fixed relay output adaptor sub-bases	6/45
6.8-4 Removable output electromechanical relays	6/46
6.8-5 Removable input solid state relays	6/47
6.8-6 Fixed output solid state relays	6/48
<hr/> 6.9 Dimensions and mounting	6/49

1.1 Description

1.1-1 General description

Inputs : these receive signals from sensors and perform the acquisition, adaptation, electrical isolation and filtering functions and protect against interference signals.

Outputs : these store instructions given by the processor in order to control preactuators via decoupling and amplifying circuits.

A wide range of discrete inputs and outputs meet requirements encountered on the following levels :

- functional : AC or DC I/O, positive or negative logic,
- connection via screw terminal blocks or HE 10 connectors,
- modularity : 8, 16, 32 or 64 channels/module.

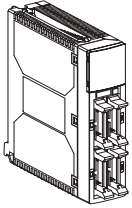
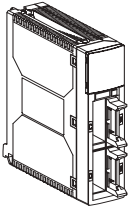
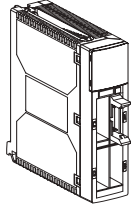
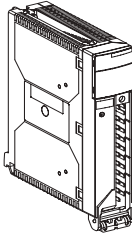
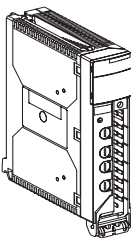
Modularity Connection	64 I or 64 Q	32 I or 32 Q	16 I	8 I or 8 Q
HE10 connectors				
Modularity Connection	64 I or 64 Q	32 I or 32 Q	16 I or 16 Q	8 I or 8 Q
Screw terminal blocks (Terminal blocks not shown)				

1.1-2 Physical description

I/O modules are standard format (1 slot), and are incorporated in a plastic case which provides IP20 protection for all the electronics.

The internal screening elements are connected to the protected ground for the rack via contacts located at the back of the modules (see part A1 section 6.1-2).

Modules with connection via screw terminal block

- 1 Module display and diagnostic block.
- 2 Removable screw terminal block for direct connection of the I/O to sensors and preactuators.
Reference : **TSX BLY 01**.
- 3 Pivoting door providing access to terminal block screws and also acting as a reference label holder.
- 4 Rotating support containing the locating device.

Note : The terminal blocks are supplied separately.

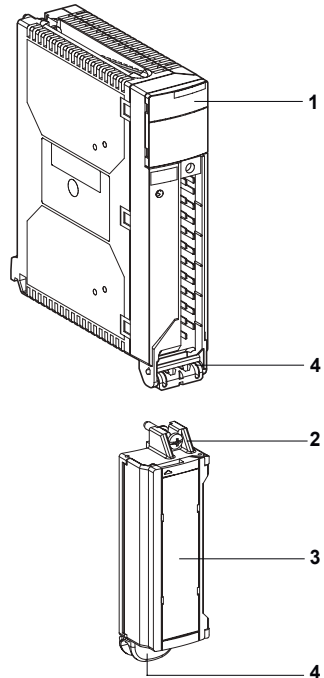

Modules with connection via HE10 connectors

Each module is composed of the following elements :

- 1 Module display and diagnostic block.
- 2 HE10 connectors, protected by a cover. They enable connection of the I/O to sensors and preactuators either directly or via TELEFAST 2 connection sub-bases.

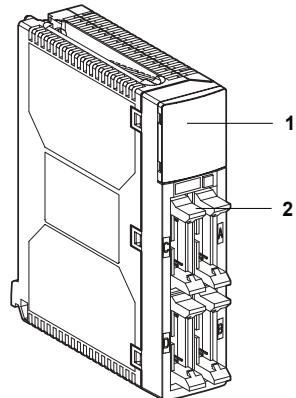

1.2 Catalog

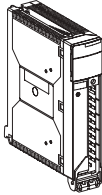
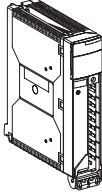
Module type	Inputs with terminal block						
							
Modularity	8 inputs		16 inputs				
Voltage	24 VDC		48 VDC	24 VAC 24 VDC	48 VAC	100..120 VAC	200..240 VAC
Isolation	Isolated inputs						
IEC 1131-2 conformity	Type 2 (1)						
Logic	Positive			Positive Negative			
Proximity sensor compatibility	2 and 3-wire proximity sensors (IEC 947-5-2)				2-wire AC proximity sensors (IEC 947-5-2)		
Filtering	Integrated 4 ms			Integrated, 50 or 60 Hz supply			
Connection	Screw terminal block						
References	TSX DEY 08D2	TSX DEY 16D2	TSX DEY 16D3	TSX DEY 16A2	TSX DEY 16A3	TSX DEY 16A4	TSX DEY 16A5

(1) For module TSX DEY 16A2, type 2 conformity only applies to the 24 VAC version

Catalog (continued)

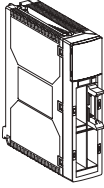
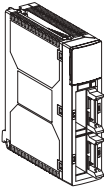
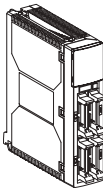
Module type	Inputs with connectors		
			
Modularity	16 fast inputs	32 inputs	64 inputs
Voltage	24 VDC		
Isolation	Isolated inputs		
IEC 1131-2 conformity	Type 1		
Logic	Positive		
Proximity sensor compatibility	2-wire proximity sensor see characteristics section 4 3-wire proximity sensor		
Filter	(0.1.. 7.5 ms in steps of 0.5)	fixed 4 ms	fixed 4 ms
Programmable filter	Yes		
Latching	Yes		
Event	Yes		
Connection	HE 10 connectors		
References	TSX DEY 16FK	TSX DEY 32D2K	TSX DEY 64D2K

Catalog (continued)

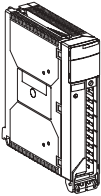
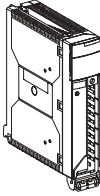
Module type	Transistor outputs with terminal block				
					
Modularity	8 outputs			16 outputs	
Voltage	24 VDC	48 VDC		24 VDC	48 VDC
Isolation	Isolated outputs				
Current	0.5 A	2 A	1 A	0.5 A	0.25 A
IEC 1131-2 conformity	Yes				
Automatic protection	Outputs protected against short-circuits and overloads with automatic or controlled reactivation with a rapid electromagnet demagnetization circuit				
Fallback	Configurable output fallback. Continuous monitoring of output control and outputs set to 0 if an internal fault is detected				
Logic	Positive				
Response time	1 ms	0.2 ms	0.3 ms	1 ms	1 ms
Connection	Screw terminal block				
References	TSX DSY 08T2	TSX DSY 08T22	TSX DSY 08T31	TSX DSY 16T2	TSX DSY 16T3

Catalog (continued)

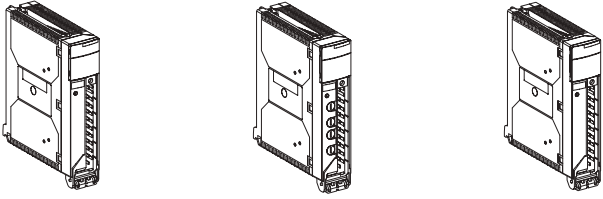
Module type	Relay outputs with terminal block			
				
Modularity	8 outputs		16 outputs	
Voltage	12..24 VDC or 24..240 VAC	24..130 VDC	24..48 VDC or 24..240 VAC	12..24 VDC or 24..240 VAC
Isolation	Isolated outputs between contact and ground			
Current	3 A	5 A		3 A
IEC 1131-2 conformity	Yes			
Protection	No protection	Protection by interchangeable fuses Outputs set to 0 on detection of a fault, reactivated after fuse replacement		No protection
Fallback	Configurable output fallback.			
Unlocking terminal block	Automatic output cut-off facility when the terminal block is unlocked			
Logic	Positive/negative			
Connection	Screw terminal block			
References	TSX DSY 08R5	TSX DSY 08R4D	TSX DSY 08R5A	TSX DSY 16R5

Catalog (continued)

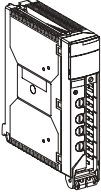
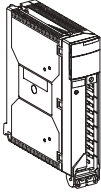
Module type	Triac outputs with terminal block	
		
Modularity	8 outputs	16 outputs
Voltage	48..240 VAC	24..120 VAC
Isolation	Isolated outputs	
Current	2 A	1 A
IEC 1131-2 conformity	Yes	
Protection	Protection by interchangeable fuses	Outputs not protected against short-circuits or overloads. Anti-flame protection by non-interchangeable fuses.
Fallback	Configurable output fallback	
Unlocking terminal block	Automatic output cut-off facility when the terminal block is unlocked	
Connection	Screw terminal	
References	TSX DSY 08S5	TSX DSY 16S4

Catalog (continued)

Module type

Solid state outputs with connectors

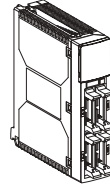
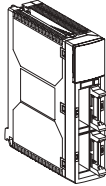

Modularity	32 outputs	64 outputs
Voltage	24 VDC	
Isolation	Isolated outputs	
Current	0.1 A	
IEC 1131-2 conformity	Yes	
Protection	Outputs protected against short-circuits and overload with automatic or controlled reactivation	
Fallback	Configurable output fallback. Continuous monitoring of output control and outputs set to 0 if an internal fault is detected	
Logic	Positive	
Connection	HE 10 connectors	
References	TSX DSY 32T2K	TSX DSY 64T2K

1.3 Installing, inserting and removing modules

1.3-1 Installation

All TSX Premium discrete I/O modules are standard format.

They are supplied by the backplane bus and include a display on the front panel (see section 3.5).

The modules can be placed in either a standard rack or an extendable rack. They can be moved safely without switching off the power supply to the rack.

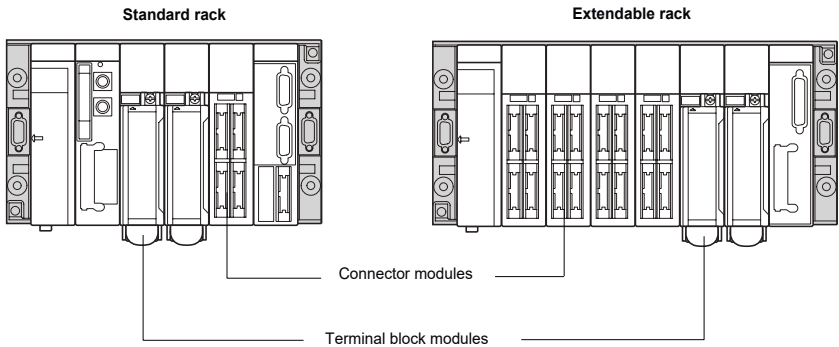

1.3-2 Inserting/removing modules

Discrete I/O modules should be inserted in the rack as follows :

- Position the two pins at the bottom of the card in the corresponding slots in the rack.
- Tilt the module upwards and plug in the backplane connector.
- Tighten the fixing screw at the top of the module (See part A1, section 5.4 Inserting modules).

Warning

If this screw is not tightened, the module will not stay in position in the rack.

⚠ Reminder :

Modules must be inserted and removed with the sensor and preactuator supply off and **the terminal block disconnected**.

1.4 Labelling

1.4-1 Modules with screw terminal block

The module has three-fold labelling :

1 on the display block,
the module reference,

2 under the display block,
the module characteristics

3 on the terminal block,
a removable label, to be placed inside
the door, printed on both sides with the
following information :

external view (door closed) :

- module reference,
- type of channels,
- a box for writing in the module position number (address),
- description of each channel (symbol),
- internal view (door open) :
- I/O wiring diagram with channel numbers and connection terminal numbers.

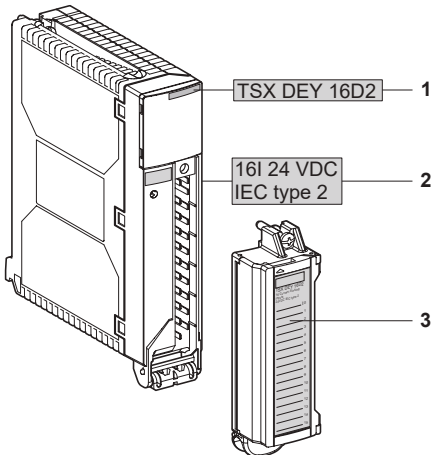

View with door closed



View with door open

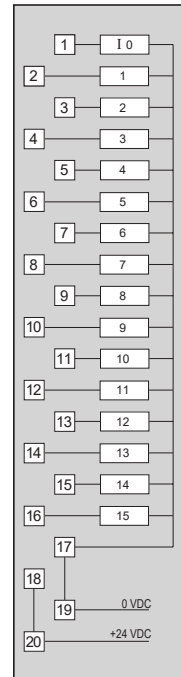

Note :

1.4-2 Module with HE10 connectors

The module labelling is laser-engraved :

- 1 **Marking** on the display block shows :
 - the module reference,
- 2 **Marking of module characteristics**
- 3 **Marking (A)** of addresses of corresponding channels :
 - module channels 0 to 15,
- 4 **Marking (B)** of addresses of corresponding channels :
 - module channels 16 to 31,
- 5 **Marking (C)** of addresses of corresponding channels :
 - module channels 32 to 47,
- 6 **Marking (D)** of addresses of corresponding channels :
 - module channels 48 to 63,

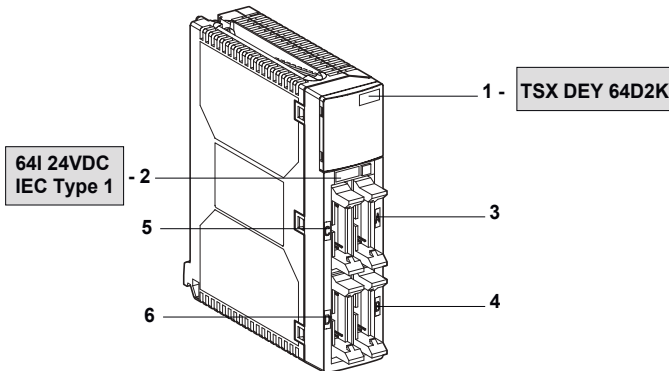

1.5 Channel addressing

Channel addressing is geographical ; in other words it depends on :

- the rack address (0 to 7),
- the physical position of the module in the rack :
 - 00 to 04 for a rack with 6 slots,
 - 00 to 06 for a rack with 8 slots,
 - 00 to 10 for a rack with 12 slots.

The syntax for a discrete I/O address is as follows :

%	I or Q	Address Rack	Module position	.	channel number
Symbol	I = Input Q = Output	0 to 7	00 to 10	Point	0 to 63

Example :

%I102.5 indicates : input bit 5 of the module in position 2 of rack 1.

For more information see part A1 section 7.1 in this document, and part G - section 4.2 - Discrete I/O of manual TLX DS 57 PL7 12E (PL7 Junior, TSX Premium Application-specific functions)

2-1 General functions

2.1-1 Constant current inputs

24 and 48 VDC inputs are "constant current" type. Although the input voltage may be higher than 11 V (for 24 VDC inputs) or 20 V (for 48 VDC inputs), the input current is constant.

This characteristic has the following advantages :

- it ensures minimum current when energized on conforming to the IEC standard,
- it limits the current used when the input voltage increases, thus avoiding unnecessary temperature rise in the module,
- it reduces the current used on the power supply sensor, whether provided by the PLC power supply or a process supply.

2.1-2 Protecting DC transistor outputs

All transistor outputs (except those which are specifically marked "Unprotected"), have a protection device which detects the appearance of an overload or short-circuit when an output is active. Any such fault deactivates the output (tripping) and the fault is signalled on the front panel display. The LED for the faulty channel flashes, and the I/O fault LED lights up.

The fault is also indicated to the system. Language interface objects and debug screens are used to display the fault.

To use an output after tripping, it must be reactivated (see section 2.1-3).

2.1-3 Reactivating outputs

When an output is tripped following a fault, it can be reactivated so that it is active again. Reactivation may be either automatic or controlled, depending on the option selected during configuration. This applies to modules with **DC transistor outputs** and to **modules with relay and triac outputs** protected by interchangeable fuses. (See software installation document TLX DS 57 PL7 12E section 2.5)

- If the automatic option has been selected, reactivation is executed by the module. There is a delay of about 10 seconds, and if the fault persists, the reactivation is repeated every 10 seconds until the fault disappears.
- If the controlled option has been selected, reactivation is executed after a command from the application program or from the terminal, via the debug screen. The minimum time between two reactivations is 10 seconds, and the module incorporates a delay to prevent repeated reactivations occurring very close together.

Reactivation affects one group of 8 channels at a time, but has no effect on channels

2.1-4 Output fallback state

All TSX Premium discrete module outputs can be placed in a state determined by the user when there is an fault on the PLC bus (base rack or extension rack), or if the processor stops. This state, known as the fallback position, is selected during configuration.

Several options are available :

- Fallback strategy configured per group of 8 channels with :
 - either channel states maintained (last state given by the module),
 - or switch to fallback position.
- Fallback value : if switching to fallback position is requested, all 8 channels in the same group will take the fallback value (0 or 1) set during configuration. The fallback value is determined channel by channel.

2.1-5 Sharing the I/O

Each module is split functionally into groups of 8 channels. Each group of channels can be assigned to a specific application task. This is most useful for modules with a large number of channels (eg TSX DEY 64D2K) where, for example, 48 channels could be assigned to the Master task (Mast), 8 channels to a Fast task and 8 channels would not be used for any task.

This property can be accessed in the PL7 Junior programming workshop configuration.

Note :

Inputs belonging to a single group (of channels) can easily be used by different tasks. When sharing the output channels of the same group, it is wise to take a certain number of precautions.

The channels of a single group have consecutive numbers, the first channel of each group always being a multiple of 8, (eg channels 0 to 7, 8 to 15, ... 24 to 31, ... 56 to 63).

Operating modes are common to channels in a group, and some functions are handled in common for all the channels in a group.

Example :

- Fallback strategy.
- Reactivating outputs after tripping.

2.2 Specific functions of the TSX DEY 16FK module

2.2-1 Programmable input filtering

The input filter time for the **TSX DEY 16FK** module can be modified in configuration mode.

Input filtering is performed by :

- a fixed analog filter which provides maximum immunity for 0.1 ms to filter out line interference,
- a digital filter which can be configured in increments of 0.5 ms. This filtering can be modified in configuration mode via the terminal.

Configurable filter times (in ms)																
0.1		1		2		3		4		5		6		7		7.5
	0.5		1.5		2.5		3.5		4.5		5.5		6.5		7.5	

The default filter time is 4 ms.

Note

- To avoid signals due to contact bounce when mechanical contacts are closed, it is advisable to use filter times of more than 3ms.
- In order to comply with standard IEC1131-2, the filter time must be set to ≥ 3.5 ms

2.2-2 Latching inputs

Principle

Use the latch function to recognize particularly short pulses and those which are shorter than the PLC scan time.

This function recognizes the pulse so that it may be processed in the master (MAST) or fast (FAST) task during the next scan without interrupting the PLC scan.

The pulse is recognized when the input changes state. This may be either :

- change from state 0 → to state 1,
- change from state 1 → to state 0,

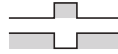

Example of processing a latch on pulse 0 → 1

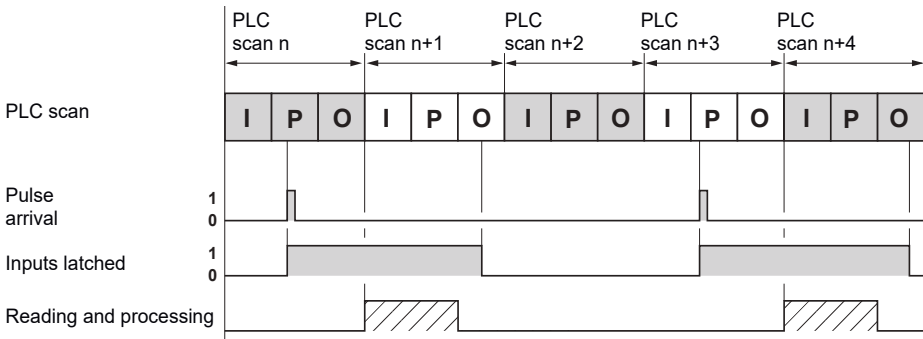

Example of processing a latch on pulse 1 → 0

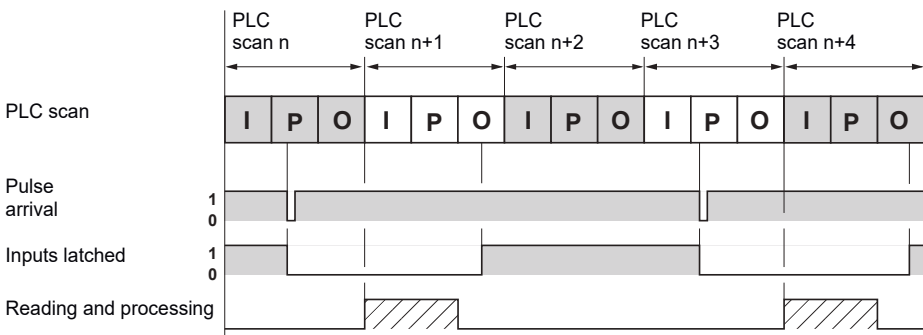

Key

I = read inputs, P = process program, O = update outputs

Note

The time which separates the arrival of two pulses on the same input must be greater than or equal to the time of two PLC scans.

The minimum duration of the pulse should be greater than the filter time selected.

2.2-3 Event management

Principle

The **TSX DEY 16FK** module can be used to configure up to 16 event-triggered inputs. These inputs enable acceptance of events and ensure their immediate processing (interrupt processing). Event-triggered processing **priority** is given to the number **0**. Event 0 is only associated with channel 0.

These inputs can be associated with event-triggered processing (Evti) and are defined in configuration mode by :

- $i = 0$ to 31 for the TSX P5710 processor
- $i = 0$ to 63 for the TSX P5720 processor

Event-triggered processing is initiated on a rising edge ($0 \rightarrow 1$) or falling edge ($1 \rightarrow 0$) of the associated input or simply on an edge : an EVT status (see Language interface) enables it to be differentiated during processing.

When two edges are detected on a module simultaneously, the events are processed in ascending order of channel number.

The principle of event-triggered processing is defined in part A, section 1.6-5 of the reference manual.

The recursion time of the edges on each input or the pulse width on an input programmed as RE + FE must correspond to the following diagram :

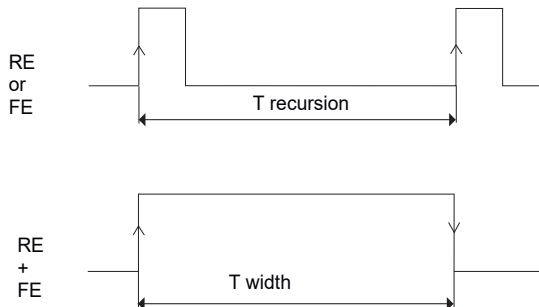

$$T \text{ recursion or } T \text{ width} > 0.25 \text{ ms} + 0.25 \times \text{module event number}$$

2.3 Diagnostic functions

2.3-1 Module diagnostics

Dialog fault

Any communication fault, hindering normal operation of an output module or the fast input module, is indicated on the front panel by the red "ERR" lamp (module) flashing, and by the %@ module.ERR fault bit.

A communication fault can be caused by a hardware fault on the backplane bus, by a processor fault or by a faulty extension cable.

Internal Module Fault

Any internal fault which the module is able to detect is indicated on the front panel by the red "ERR" lamp coming on and the green "RUN" lamp going off.

Some instances of total module malfunction cannot be detected but are characterized by all lamps going off (as with a power supply fault).

2.3-2 Process diagnostics

Monitoring sensor/preactuator voltage

All input modules and transistor output modules have a device for monitoring the sensor and preactuator voltage.

When the sensor or preactuator voltage is below a certain threshold at which correct module operation cannot be ensured, the red I/O lamp lights up, and the "External voltage" fault is also indicated in the language objects.

- For an input module, when the sensor voltage is correct, the state perceived by the input is indeed that of the sensor, whatever type of sensor is being used (within the recommended range).
- For an output module, when the preactuator voltage is correct, the state determined for the preactuator is the state determined by the application. **However, it is up to the user to check that the preactuator supply voltage is within the range accepted by the preactuators being used** (bear in mind the residual output voltage).

This monitoring is unique to terminal block modules. On connector modules with 32 or 64 channels, there is one monitoring device per connector (or one for every 16 channels).

A sensor or actuator voltage fault causes all inputs and outputs affected by the fault to switch to fault mode, that is all channels for a terminal block module, and the group(s) of 16 channels, on a connector module of 32 or 64 channels.

Note :

Relay and triac output modules do not monitor preactuator voltage.

Monitoring presence of the terminal block

All terminal block modules include a facility for monitoring that the terminal block is on the module. If the terminal block is missing or if it is not properly attached to the module, the "I/O" lamp flashes and a "Terminal block" fault is indicated in the language interface. Connector modules do not have a facility for monitoring the **presence** of connectors. The module **power supply monitoring performs this function**.

Monitoring Short-circuit and Overload

Transistor output modules include a load state monitoring facility. If there is a short-circuit or an overload on one or more outputs, they trip. The faults are indicated on the front panel by the lamps of the faulty channels flashing, and by the red "I/O" lamp lighting up.

The faults are indicated in the language interface by the "Short-circuit fault" bit on each channel and by the "Tripping" bit of channel groups per module.

The tripping of a channel is indicated by :

- I/O indicator lamp ON (I/O fault),
- channel lamp flashing,
- channel fault bit being set to 1 (%lx.i.ERR =1)
- a fault code in the module status word

Monitoring sensor voltage

All input modules include a facility for monitoring the sensor voltage for all module channels. This facility monitors that the supply voltage for the sensors and the module is at a sufficient level to ensure correct operation of the module input channels (see section 4 for the various characteristics of each module).

If the sensor voltage is lower than or equal to a defined threshold, it is signalled by :

- I/O indicator lamp ON (I/O fault),
- channel fault bit %lx.i.ERR =1
- a fault code in the module status word and in the channel status word.

Note : The sensor supply should be protected by a fast blow fuse.

Monitoring preactuator voltage

All modules with 24/48 VDC transistor outputs include a facility for monitoring the preactuator supply voltage for all module channels. This facility monitors that the supply voltage for the preactuator and the module is at a sufficient level to ensure correct operation of the module output channels.

This voltage should be greater than 18 V (24 VDC power supply), 36 V (48 VDC power supply) for modules with DC transistor outputs. If the preactuator voltage is less than or equal to this threshold, the outputs change to state 0 and the fault is indicated by :

- I/O indicator lamp ON (I/O fault),
- channel fault bit %lx.i.ERR =1
- a fault bit in the module status word and in the channel status word.

2.4 Protection

2.4-1 Built-in protection for 24 VDC transistor output modules

Protection of each channel against short-circuits and overload

All channels incorporate a protection facility providing protection against this type of fault.

Protection against polarity reversal

Modules have a device which causes the power supply to short-circuit, without damaging the module, to protect against polarity reversal.

In order for this protection to function in optimum conditions, it is essential to place a fast-blow fuse on the power supply upstream of the preactuators.

Note :

As a general rule it is advisable to fit one fuse for all the module output channels ; see section 4.3 for a table of characteristics.

Protection against inductive overvoltages

Each output is individually protected against inductive overvoltages and is equipped with a zener diode fast demagnetization circuit for electromagnets which enables a reduction in the mechanical cycle time of certain fast machines.

2.4-2 Fuse protection

TSX DSY 08R5A/08R4D modules and **TSX DSY 08S5** output modules are equipped with interchangeable fuses which can be accessed on the front panel of the modules when the terminal block is removed.

If there is a fault, the front panel displays the module diagnostics.

The I/O indicator lamp is ON ; the channel fault bit %Ix.i.ERR =1.

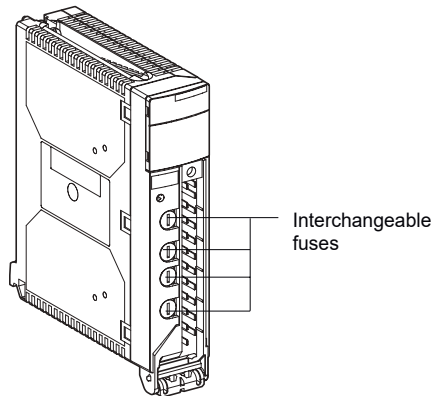

The fuses can be accessed once the terminal block has been removed.

2.4-3 Protection of relay output contacts (TSX DSY 08R5/16R5)

These relay outputs do not include a contact protection facility to enable control of :

- electrically isolated inputs, with a low energy level which require zero leakage current,
- power circuits, by eliminating induced overvoltages at source.

For this reason, it is imperative to connect the following to the terminals of the preactuator coils :

- an RC circuit or an MOV (ZNO) peak limiter, for use with AC supply,
- a flywheel diode for use with DC supply.

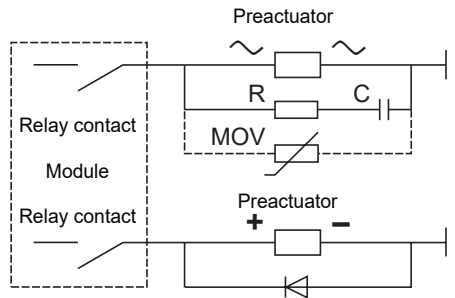

Note : A relay output, used on an AC load, must not then be used on a DC load and vice versa.

3.1 Recommendations for use

Installation/removal of screw terminal blocks or HE10 connectors

Screw terminal blocks or HE10 connectors are installed or removed with the power supply to the preactuators and sensors off.

Inserting and removing modules

The terminal block must be disconnected when modules are inserted and removed, however, this can be done while the PLC is powered up.

Locking modules into their slot

In order to ensure that the contacts and electrical ground are securely connected, the fixing lock on the modules should be pushed in as far as possible.

Choice of DC power supplies for sensors and preactuators

Regulated or rectified power supplies with filtering

When using external 24 VDC power supplies, it is advisable to use :

- either regulated power supplies,
- or non regulated power supplies with filtering of :
 - 1000 μ F/A for full wave single phase rectification and 500 μ F/A for 3-phase rectification,
 - Maximum ripple (peak to peak) : 5%
 - Maximum voltage variation : - 20% to + 25% of the nominal voltage (ripple included)

Note :

Unfiltered rectified power supplies must not be used.

Cadmium/nickel battery power supply

This type of power supply may be used for supplying sensors and preactuators as well as the associated I/O. In normal operation, the latter tolerate a maximum voltage of 30 VDC.

When this type of battery is being charged, the battery voltage may reach 34 VDC for a duration of 1 hour. For this reason, all I/O modules operating on 24 VDC tolerate a voltage of 34 VDC, limited to 1 hour in 24 hours.

This type of operation has the following restrictions :

- the maximum current at 34 VDC tolerated by the outputs must never exceed the current defined for a voltage of 30 VDC,
- a derating in temperature which limits to :
 - 80% of the I/O at state 1 up to 30°C,
 - 50% of the I/O at state 1 at 60°C.

3.2 General wiring rules and recommendations

Discrete I/O contain protection circuits ensuring excellent immunity to industrial conditions. However, certain rules must be observed :

External power supplies for sensors and preactuators

These power supplies must be protected against short-circuits and overloads by fast blow fuses.

Attention

If the 24 VDC installation does not conform to VLSF standards (very low safety voltage), the 0V of the 24 VDC power supplies must be connected to the mechanical ground, this being taken to ground as near to the power supply unit as possible. This is necessary for the safety of personnel in the event of one of the AC supply phases coming into contact with the 24 VDC.

Note :

If an I/O module with a screw terminal block or HE10 connector is present in the PLC, the sensor or preactuator voltage must be connected to it, otherwise an "external power supply" fault will be displayed with the I/O LED on.

For connector modules, the sensor/preactuator power supply must be connected to each connector, except if the corresponding channels are not used and have not been assigned to **any** task (see part G, section 2 "Discrete I/O", in the PL7 Junior User's Manual).

Inputs

- Usage recommendations for the fast input module (TSX DEY 16 FK)
 - when using 24 VDC inputs, it is advisable to set the filter time for the required function.
 - if the filter time is reduced to less than 3 ms, use of sensors with mechanical contact outputs is not recommended in order to avoid the effect of contact bounce when the contact is closed
 - in order to achieve optimal operation, the use of DC inputs and sensors is recommended as AC inputs have a much longer response time.
- 24 VDC inputs and line coupling with AC supply
Close coupling between cables carrying AC and cables carrying DC input signals may interfere with operation.
(see simplified schematic on the next page)

24 VDC inputs and line coupling with an AC supply (continued)

Simplified schematic

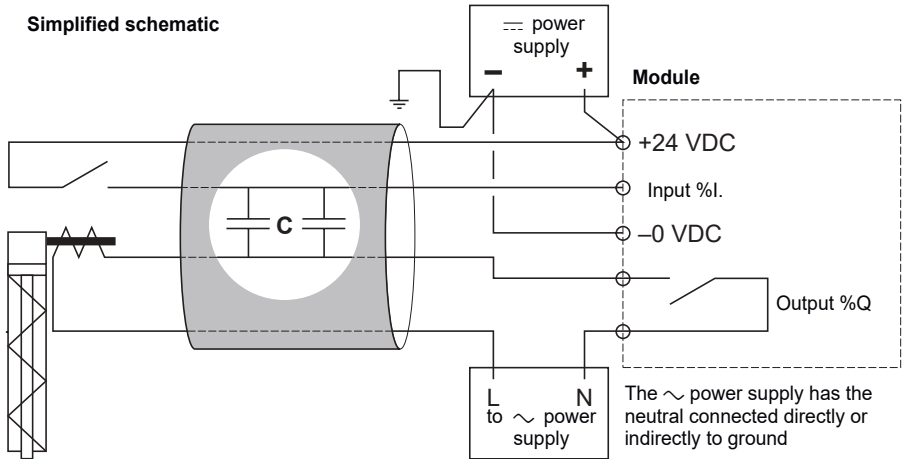

When the contact at the input is open, AC crossing the parasitic capacitance of the cable may generate a current in the input which may cause it to change to state 1.

Line capacitance not to be exceeded.

The following values are given for coupling with a 240 VAC/50 Hz line.

For coupling with a different voltage, apply the following formula :

$$\text{Permissible capacitance} = \frac{\text{Capacitance at 240 VAC} \times 240}{\text{line voltage}}$$

Modules	Max. permissible coupling capacitance with 240 VAC/50 Hz line		
TSX DEY 32/64D2K			25 nF
TSX DEY 16D2			45 nF
TSX DEY 16FK	10 nF	30 nF	60 nF
Filtering	0.1 ms	3.5 ms	7.5 ms

Note :

By way of an example, a standard 1 meter cable has a coupling capacitance of 100 to 150 pF.

- 24 to 240 VAC inputs and line coupling
In this case, when the line controlling the input is open, current circulates due to the capacitance of the cable coupling.

Simplified schematic

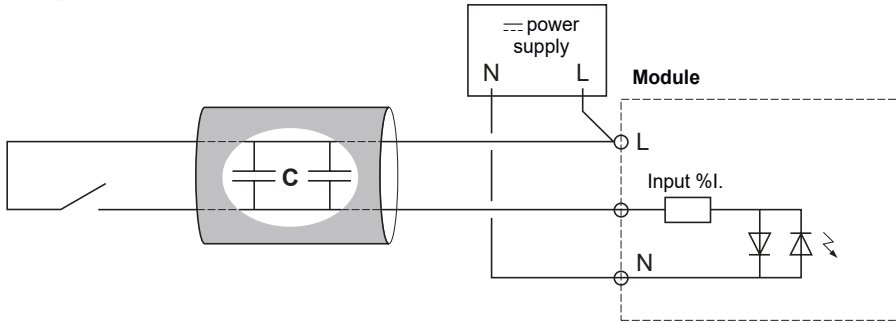

Line capacitance not to be exceeded :

Module	Maximum coupling capacitance
TSX DEY 16A2	50 nF
TSX DEY 16A3	60 nF
TSX DEY 16A4	70 nF
TSX DEY 16A5	85 nF

Outputs

- for high currents, it is advisable to segment the terminal connections by protecting each one with a fast blow fuse,
- use wire of sufficient cross-section to avoid voltage drops and temperature rises.

Cable routing

- inside and outside the equipment,
In order to limit the AC coupling, power circuit cables (power supply, power contactors, etc) must be separated from the input cables (sensors) and the output cables (preactuators).
- outside the equipment,
I/O cables must be placed in a sheath separate to that used for power cables and placed in separate metal ducting, itself connected to ground. These cables must be separated by a minimum distance of 100 mm.

3.3 Compatibility of sensors → inputs and preactuators → outputs

3.3-1 Compatibility of sensors with inputs

Compatibility between 3-wire sensors and 24 and 48 VDC inputs

- 3-wire sensors and positive logic inputs (sink) IEC 1131-2 type 1 and type 2, All inductive or capacitive proximity sensors, 3-wire PNP type photoelectric detectors, operating at 24 and 48 VDC, are compatible with all positive logic inputs.

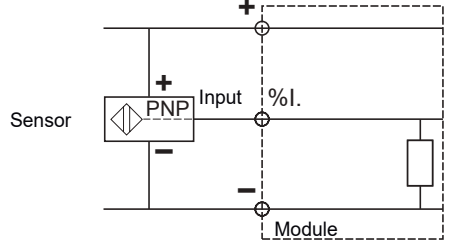

Compatibility between 2-wire sensors and 24 VDC inputs

- 2-wire sensors and positive logic inputs (sink) IEC 1131-2 type 1. All proximity sensors or other 2-wire sensors, operating at 24 VDC and having the characteristics listed below, are compatible with all 24 VDC positive logic type 1 inputs.
Residual voltage at closed state: $\leq 7\text{ V}$
Minimum switching current : $\leq 2.5\text{ mA}$
Residual current at open state : $\leq 1.4\text{ mA}$.

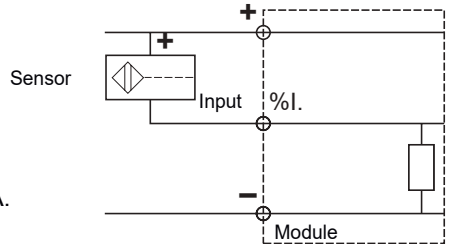

- 2-wire sensors and positive logic inputs (sink) IEC 1131 type 2. All 2-wire proximity sensors, operating at 24 and 48 VDC and conforming to CENELEC standards, are compatible with all 24 and 48 VDC positive logic type 2 inputs.

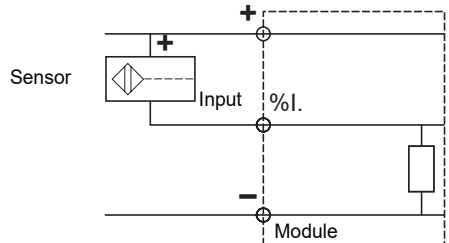

Compatibility between 2-wire sensors and 110/120 VAC inputs

All 2-wire AC proximity sensors conforming to IEC 947-5-2 standards and other 110/120 VAC contacts, are compatible with all 110/120 VAC IEC inputs 1131-2 type 2.

Summary table

Type of input Type of proximity sensor	24 VDC Type 1 positive logic	24 VDC Type 2 positive logic	24 VAC Type 2	48 VAC Type 2	115 VAC Type 2	200/240 VAC Type 2
All 3-wire prox. sensor (DC), PNP				48 VDC		
All 3-wire prox. sensor (DC), NPN				48 VDC		
Telemecanique or other 2-wire proximity sensors DC with the following characteristics: Residual voltage at closed state $\leq 7V$ Minimum switching current $\leq 2.5 \text{ mA}$ Resid. current at open state $\leq 1.4 \text{ mA}$						
2-wire proximity sensor (AC/DC)				48 VDC		(1)
2-wire proximity sensor (AC)						(1)

Key

DC : operates at --- voltage

AC : operates at \sim voltage

AC/DC : operates at \sim or --- voltage

48 VDC : compatibility

(1) : see operation in negative logic

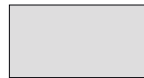

Compatibility

3.3-2 Compatibility of preactuators with outputs

Compatibility between DC preactuators and outputs

- Respect the maximum current and output switching frequency specified in the characteristics tables.
- In the case of low consumption preactuators, the output leakage current at rest state must be taken into account such that :
I nominal \geq 50 x I leakage,
I nominal = current drawn by the preactuator,
I leakage = leakage current in the output at rest state.

Compatibility between tungsten filament lamps and transistor outputs (constant current)

- For outputs with protection against short-circuits, respect the maximum power of the tungsten filament lamps specified in the characteristics tables otherwise, there is the risk of tripping the outputs due to the lamp pull-in current at the moment of illumination.

Compatibility between AC preactuators and relay outputs

- Preactuators with inductive AC have a pull-in current which may exceed the holding current by ten times during a maximum time of 2/F seconds (F= AC frequency). For this reason, the relay outputs are designed to withstand this duty cycle (AC14 and AC15). The characteristics table for relay outputs specifies the maximum permitted holding power (in VA) as a function of the number of operations.

Reminder of thermal current definition

The current which may continuously flow through a closed relay, with an acceptable rise in temperature. **Under no circumstances should this current be switched by the relay.**

Compatibility between filament lamp and triac outputs

- respect the maximum power equal to U x I max.

Compatibility between AC preactuators and triac outputs

- respect the maximum specified current,
- In the case of low consumption preactuators, the output leakage current at rest state must be taken into account such that :
0,1 x I nominal \geq 5 x I leakage,
I nominal = current drawn by the preactuator,
I leakage = leakage current in the output at rest state.

3.3-3 Using negative logic (24 VDC)

Negative logic (Source inputs / Sink outputs) can be used with the following modules :

- for the inputs :
 - TSX DEY16A2 (this module intended for use with AC, can also be used with DC : positive or negative logic).

Warning :

The filter time for the inputs of module TSX DEY 16A2 is between 10 and 20 ms.

- for the outputs :
 - relay outputs modules : TSX DSY 16R5 or TSX DSY 08R4D.

Wiring diagram :

Input module : **TSX DEY 16A2**

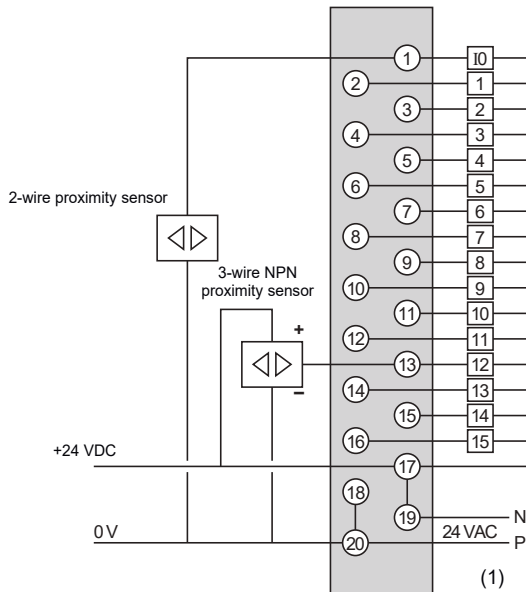

(1) : label identification for AC wiring (most common type of module operation).

Comment:

It is not advisable to use negative logic when the 0V sensor is connected to ground. This is because if one of the wires were to be accidentally disconnected and come into contact with the mechanical ground, the input might be set to state 1. This would

Relay output module : TSX DSY 16R5

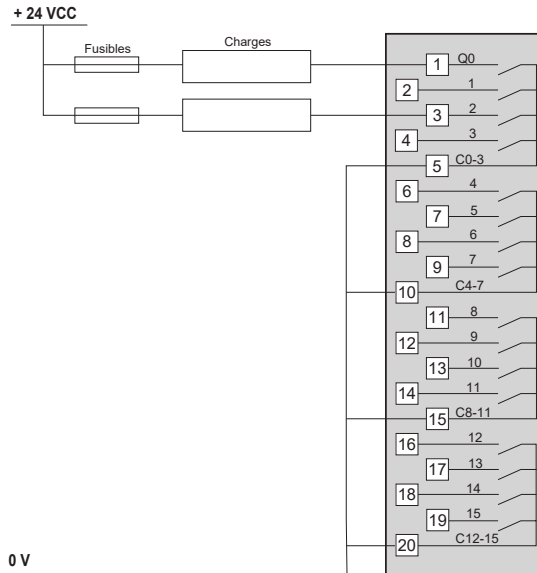

Relay output module : TSX DSY 08R4D

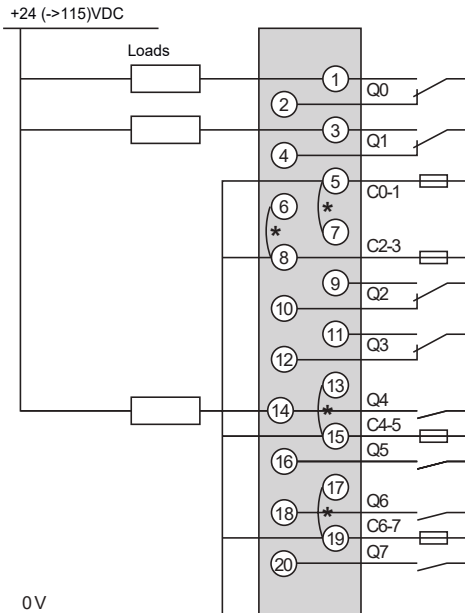

(*) : Strap required for the 24 V

3.4 Software installation and associated language objects

Discrete I/O used in the application program should be software configured using a configuration editor:

- declaration of the various modules in their respective position (in the rack),
- definition of the channel parameters for each module :
 - filter time for fast inputs,
 - assignment of channels to a task,
 - type of output reactivation,
 - fallback mode of channel outputs,
 - etc.

The software installation and language objects associated with the discrete I/O are described in the PL7 Junior TLX DS PL7 J 12E software installation manual, part G "Discrete I/O".

3.5 Discrete I/O display and diagnostics

The use and operation of display blocks is described in this manual in part H, "Maintenance/Diagnostics".

The discrete I/O diagnostics are based on 3 indicator lamps :

- RUN green,
- ERR red,
- I/O red,

on the front panel of each module as shown in the diagram opposite.

The zone below the diagnostic indicator lamps contains the lamps which relate to the input or output channels.

The channel is active when the corresponding lamp is on.

64-channel modules also have a +32 indicator lamp.

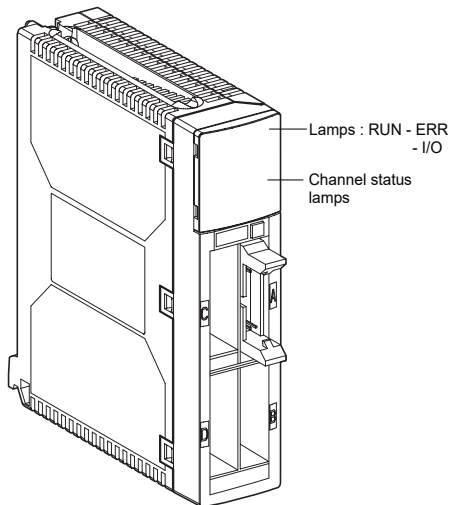

There are 3 types of display block depending on the module :

- 8 channel modules have :
 - 3 module status lamps,
 - 8 channel status lamps,

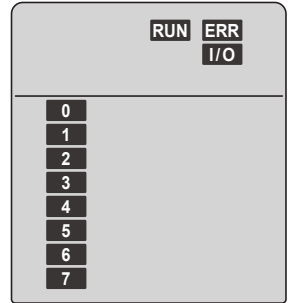

- 16 channel modules have :
 - 3 module status lamps,
 - 16 channel status lamps,

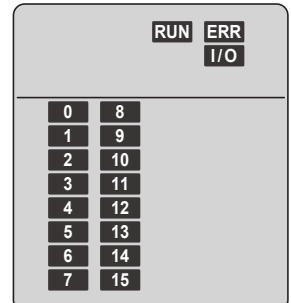

- 32 and 64 channel modules have :
 - 3 module status lamps,
 - 1 lamp + 32, displaying channels 32 to 63,
 - 32 channel status lamps.

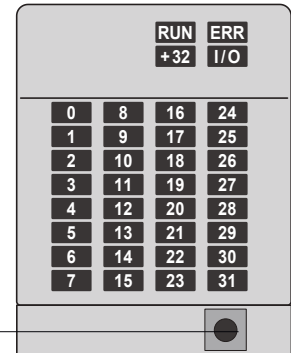

Switch for displaying channels higher than 31

Example : displaying channel 41
Lamps 9 and +32 lit.

4.1 Characteristics of input modules with screw terminal

4.1-1 Input modules 24 - 48 VDC

Module reference		TSX DEY 08D2 / 16D2	TSX DEY 16D3	
Nominal input values	Voltage	24 VDC	48 VDC	
	Current	7 mA	7 mA	
Input limit values	at state 1	Voltage	≥ 11 V	
		Current	≥ 6.5 mA (for U = 11V)	
	at state 0	Voltage	≤ 5 V	
		Current	≤ 2 mA	
	Sensor supply (ripple included)		19...30 V (possible up to 34 V, limited to 1 hour per 24 hours)	38...60 V
	Input impedance at state 1 for 24 V		4 kΩ	7 kΩ
Filter time	typical	4 ms	4 ms	
	maximum	7 ms	7 ms	
IEC 1131-2 conformity		Yes type 2	Yes type 2	
Compatibility	2-wire/3-wire prox. sensors	IEC 947-5-2	IEC 947-5-2	
Dielectric strength		1500 V rms, 50/60 Hz for 1 min		
Insulation resistance		10 MΩ	10 MΩ	
Type of input		current sink	current sink	
Paralleling of inputs (1)		Yes	Yes	
Consumption 5V	typical	55/80 mA	80 mA	
	maximum	65/90 mA	90 mA	
Consumption 24V sensor	typical	25/25 mA	25 mA	
	maximum	33/33 mA	33 mA	
Dissipated power	No. = Number of channels (1 + 0.15 x No.) W	(1 + 0.3 x No.) W		
Temperature derating (2)	The characteristics at 60°C are ensured for 60% of the inputs at state 1 (this characteristic is not relevant to module TSX DEY 08D2).			

(1) This characteristic enables several inputs to be wired in parallel on the same module, or on different modules if redundant inputs are required.

(2) See section 4.2-3.

4.1-2 24 VDC negative logic input module

Module reference		TSX DEY 16A2
Nominal input values	Voltage	24 VDC
	Current	16 mA (on exit)
Input limit values	at state 1	
	Voltage	$\geq U_{sup} - 14 \text{ V}$
	Current	$\geq 6.5 \text{ mA}$ (on exit)
	at state 0	
	Voltage	$\geq U_{sup} - 5 \text{ V}$
	Current	$\leq 2 \text{ mA}$ (on exit)
	Sensor supply (ripple included)	19...30 V (possible up to 34 V, limited to 1 hour per 24 hours)
Input impedance at state 1 for 24 V		1.6 k Ω
Filter time	typical	10 ms
	maximum	20 ms
Compatibility	proximity sensor	2-wire (Telemecanique) 3-wire (IEC 947-5-2)
Dielectric strength		1500 V rms, 50/60 Hz for 1 min
Insulation resistance		10 M Ω
Type of input		resistive
Paralleling of inputs		No
Consumption 5V	typical	80 mA
	maximum	90 mA
Consumption 24V	typical	15 mA
	maximum	19 mA
Dissipated power		$1 + 0.4 \times \text{Number of channels} \text{ W}$
Temperature derating (1)	The characteristics at 60°C are ensured for 60% of the inputs at state 1	

(1) See section 4.2-3.

4.1-3 AC voltage input modules with screw terminal

Module reference		TSX DEY 16A2	TSX DEY 16A3	TSX DEY 16A4	TSX DEY 16A5
Nominal input values	Voltage	24 VAC	48 VAC	100..120 VAC	200..240 VAC
	Current	15 mA	16 mA	12 mA	15 mA
Input limit values	at state 1 Voltage	10 V	29 V	74 V	159 V
	Current	6 mA (U=10V)	6 mA (U=29V)	6 mA (U=74V)	6 mA (U=159V)
	at state 0 Voltage	5 V	10 V	20 V	40 V
	Current	3 mA	4 mA	4 mA	4 mA
	Frequency	47...63 Hz			
	Sensor supply	20...26 V	40...52 V	87...132 V	170...264V
Input impedance		1.6 kΩ	3.2 kΩ	9.2 kΩ	20 kΩ
Type of input		Resistive	Capacitive	Capacitive	Capacitive
Typical filter time	Switch on	15 ms	10 ms	10 ms	10 ms
	Switch off	20 ms	20 ms	20 ms	20 ms
IEC 1131-2 conformity		type 2	type 2	type 2	type 1
Compatibility		2-/ 3-wire prox. sensors		IEC 947-5-2	
Consumption 5V	typical	80 mA	80 mA	80 mA	80 mA
	maximum	90 mA	90 mA	90 mA	90 mA
Consumption 24V sensor	typical	15 mA	16 mA	15 mA	12 mA
	maximum	19 mA	20 mA	19 mA	16 mA
Nominal dissipated power (1) per channel		0.89 W	0.86 W	0.83 W	0.97 W
Dielectric strength		1500 Vrms 1500 Vrms 1500 Vrms 2000 Vrms			
Input/ground or Input/internal logic		(50/60 Hz for 1 minute)			
Insulation resistance		> 10 MΩ at 500 VDC			
Temperature derating (1)		The characteristics at 60°C are ensured for 60% of the inputs at state 1			

(1) See section 4.2-3.

4.2 Characteristics of input modules with connectors

4.2-1 Fast input module

Reference		TSX DEY 16FK	
Nominal input values	Voltage	24 VDC	
	Current	3.5 mA	
Input limit values	at state 1	Voltage	≥ 11 V
		Current	≥ 3 mA
	at state 0	Voltage	≤ 5 V
		Current	≤ 1.5 mA
Sensor supply (ripple included)		19...30 V (possible up to 34 V, limited to 1 hour per 24 hours)	
Filter time	default	4 ms	
	Configurable filtering	0.1...7.5 ms (in increments of 0.5)	
Type of input		current sink	
Paralleling of inputs (1)		Yes	
IEC 1131-2 conformity		Yes type 1	
Compatibility	2-wire proximity sensor	Yes (Telemecanique sensor and leakage current < 1.5 mA)	
	3-wire proximity sensor	Yes	
Consumption 5V	typical	250 mA	
	maximum	300 mA	
Consumption 24V sensor	typical	20 mA	
	maximum	30 mA	
Dissipated power		1.2 W + 0.1 W x No. of inputs at 1	
Dielectric strength Input / ground or Input / internal logic		1500 V rms, 50/60 Hz for 1 minute	
Insulation resistance		> 10 M Ω at 500 VDC	
Temperature derating (2)		The characteristics at 60°C are ensured for 60 % of inputs at state 1	

(1) This characteristic enables several inputs to be wired in parallel on the same module, or on different modules if redundant inputs are required.

(2) See section 4.2-3.

4.2-2 32 and 64 channel input modules

Reference		TSX DEY 32D2K	TSX DEY 64D2K	
Nominal input values	Voltage	24 VDC	24 VDC	
	Current	3.5 mA	3.5 mA	
Input limit values	at state 1	Voltage	≥ 11 V	
		Current	≥ 3 mA	
	at state 0	Voltage	≤ 5 V	
		Current	≤ 1.5 mA	
	Sensor supply (ripple included)		19...30 V (possible up to 34 V, limited to 1 hour per 24 hours)	
	Typical filter time		4 ms	4 ms
Maximum filter time		7 ms	7 ms	
IEC 1131-2 conformity		Yes type 1	Yes type 1	
Compatibility	2-wire proximity sensor	Yes with leakage current < 1.5 mA		
	3-wire proximity sensor	Yes	Yes	
Type of input		current sink	current sink	
Power consumption	5 V	Typical	135 mA	
		Maximum	155 mA	
	24 V	Typical	30 mA	
		Maximum	40 mA	
Dissipated power		1 + 0.1 W x No. of channels	1.5 + 0.1 W x No. of channels	
Operating temperature		0°...60°C		
Dielectric strength Input/ground or Input/internal logic		1500 V rms, 50/60 Hz for 1 min		
Insulation resistance		> 10 MΩ at 500 VDC		
Temperature derating (1)		The characteristics at 60°C are ensured for 60 % of inputs at state 1		

(1) See section 4.2-3.

4.2-3 Temperature derating

All the characteristics of the various discrete modules are given for a simultaneous loading of 60% of the channels at state 1. For operation with a higher loading, see the following derating curve.

Percentage of inputs at state 1

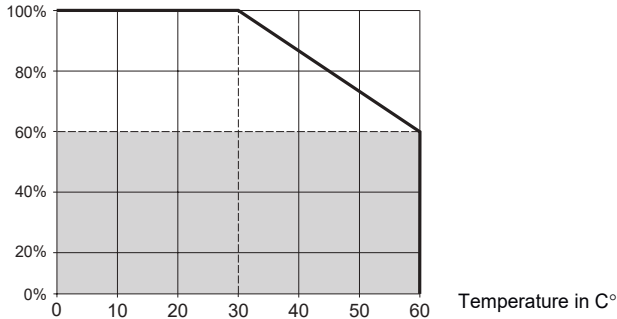

Notes :

There is no derating for relay output modules, the user must check that the overall consumption on the 24 V relay power supply is sufficient.

For transistor outputs, temperature derating is on the maximum current used by the active outputs.

Example 1 : a module with sixteen 24 VDC/0.5 A transistor outputs, each switching 0.5 A.

At 60°C, the maximum permitted current at the outputs is $16 \times 0.5 \times 60\% = 4.8$ which corresponds to about 10 outputs active simultaneously.

Example 2 : the same module (sixteen 24 VDC/0.5 A transistor outputs) each switching 0.3 A.

At 60°C, the maximum permitted current at the outputs is $16 \times 0.3 \times 60\% = 2.9$ A, which corresponds to 16 outputs active simultaneously. In this case, there is no derating on the outputs ; the maximum permitted current maximum of the module is not exceeded.

4.3 Characteristics of outputs with screw terminal

4.3-1 Transistor output modules

Module reference		TSX DSY 08T2 / 16T2	TSX DSY 08T22	TSX DSY 08T31	TSX DSY 16T3
Nominal output values	Voltage	24 VDC	24 VDC	48 VDC	48 VDC
	Current	500 mA	2 A	1 A	250 mA
Output limit values	Voltage	19...30 V (1)		38...60 V	38...60 V
	Current/channel	0.5 A	2 A	1 A	0.25 A
	Current/module	4 A / 7 A	14 A	7 A	4 A
Leakage current	at state 0	< 1 mA			
Residual voltage		< 1.2 V	< 0.5 V	< 1 V	< 1.5 V
Min load impedance		48 Ω	12 Ω	48 Ω	192 Ω
Response time (2)		1.2 ms	200 μs	200 μs	1.2 ms
Switching frequency on inductive load		0.5 / L ² Hz			
Built-in protection	Against overvoltages	Yes, by transil diode			
	Against reverse polarity	Yes, by reverse mounted diode. Provide a fuse on the + 24 V or + 48 V of the preactuators.			
	Against short-circuits and overloads	15 ms			
Preactuator voltage detection threshold		16 V	16 V	34 V	34 A
Maximum filament lamp power		6 W	10 W	10 W	6 W
Consumption 5V	typical	55/80 mA	55 mA	55 mA	80 mA
	maximum	65/90 mA	65 mA	65 mA	90 mA
Consumption 24V preactuator	typical	30/40 mA	30 mA	30 mA	40 mA
	maximum	40/60 mA	50 mA	50 mA	60 mA
Nominal power	dissipated	1 / 1.1 W	1.3 W	2.2 W	2.4 W
	per output x module current	+ (0.75 W)	+ (0.2 W)	+ (0.55 W)	+ (0.85 W)
Dielectric strength	Input/ground or Input/internal logic	1500 V rms, 50/60 Hz for 1 min			
Insulation resistance		> 10 MΩ at 500 VDC			
Temperature derating		The characteristics at 60°C are ensured for 60% of the max. module current			

(1) 34 V permissible for 1 hour per 24 hours.

(2) All outputs have fast demagnetization circuits for electromagnets.

Electromagnet discharge time < L/R.

4.3-2 Relay output modules 50 VA

Modules		TSX DSY 08R5 / 16R5				
Operating voltage DC		12..24 V/10..34 V				
(nominal / limit)	AC	24..240 V/20..264 V				
Thermal current		3 A				
AC load	Resistive	Voltage	~ 24 V	~ 48 V	~100..120V	~200..240V
		Power	50 VA (5)	50 VA (6)	110 VA (6)	220 VA (6)
	AC12 duty			110 VA (4)	220 VA (4)	
	Inductive	Voltage	~ 24 V	~ 48 V	~100..120V	~200..240V
Power		24 VA (4)	10VA (10)	10 VA (11)	10 VA (11)	
AC14 and AC15 duty			24 VA (8)	50 VA (7)	50 VA (9)	
				110 VA (2)	110 VA (6)	
					220 VA (1)	
DC load	Resistive	Voltage	--- 24 V			
		Power	24 W (6) 40 W (3)			
	Inductive	Voltage	--- 24 V			
		Power	10 W (8) 24 W (6)			
	DC13 duty (L/R = 60 ms)					
Min switchable load		1 mA / 5 V				
Response time	Switch on	< 8 ms				
	Switch off	< 10 ms				
Type of contact		Normally open				
Built-in protection	Against overloads and short-circuits	None, a fast blow fuse must be fitted to each channel or group of channels				
	Against inductive overvoltages for ~	None, an RC circuit or MOV (ZNO) peak limiter appropriate for the voltage must be fitted in parallel to the terminals of each preactuator				
	Against inductive overvoltages for ---	None, a flywheel diode must be fitted across the terminals of each preactuator				
Isolation (test voltage)	Outputs/ground	2000 V rms 50/60 Hz for 1 min				
	Outputs/internal logic					
	Insulation resistance	> 10 MΩ at 500 VDC				
Power consumption	5 V internal	Typ. 55/80 mA		Max. 65/90 mA		
	24 V relay per channel at 1	Typ. 8.5 mA		Max. 10 mA		
Nominal dissipated power		0.25 W + (0.2 W x No. of outputs at 1)				

(1) 0.1 x 10⁶ operations

(5) 0.7 x 10⁶ operations.

(9) 3 x 10⁶ operations.

(2) 0.15 x 10⁶ operations

(6) 1 x 10⁶ operations.

(10) 5 x 10⁶ operations.

(3) 0.3 x 10⁶ operations

(7) 1.5 x 10⁶ operations.

(11) 10 x 10⁶ operations.

4.3-3 Relay output module 100 VA : TSX DSY 08R4D

Module reference		TSX DSY 08R4D			
Operating voltage (nominal/limit)	DC	24..130V/19..143 V			
	AC	not allowed			
Thermal current		5 A (Max 6 A per common)			
DC load	Resistive	Voltage	--- 24 V	--- 48 V	--- 100...130 V
		DC12 duty Power	50 W (6) 100 W (3)	100 W(6) 200 W (3)	220 W (6) 440 W (3)
	Inductive	Voltage	---24V	---48V	--- 110V
		DC13 duty (L/R = 60 ms) Power	20 W (8) 50 W (6)	50 W(8) 100 W(6)	110 W (8) 220 W (6)
Response time	Switch on	< 10 ms			
	Switch off	< 15 ms			
Type of contact		2x2 N/C - N/O (1) 2x2 N/O			
Isolation between contacts and ground		2000 V at 50 to 60 Hz			
Built-in protection	against overvoltages	R-C circuit and Ge-Mov			
	against overloads and short-circuits	Interchangeable fast blow fuse per common 6.3 A			
Power consumption	5 V	Typical	55 mA		
		Maximum	65 mA		
	24 V	Typical	10 mA per channel at 1		
		Relay	Maximum	12 mA per channel at 1	
Nominal dissipated power (2)		0.25 W + (0.24 W x No. of outputs at 1)			

(1) N/C = normally closed - N/O = Normally open

(2) 60 % of active outputs.

(6) 1 x 10⁶ operations.

(3) 0.3 x 10⁶ operations

(8) 2 x 10⁶ operations.

4.3-4 Relay output module 100 VA : TSX DSY 08R5A

Module reference		TSX DSY 08R5A				
Operating voltage DC		24..48V/19..60 V				
(nominal/limit)	AC	24..240V/20..264V				
Thermal current		5 A (Max 6 A per common)				
AC	Resistive	Voltage	~ 24 V	~ 48 V	~100..120V	~200..240V
	load	AC12 duty	Power	100 VA (5)	100 VA (6)	220 VA (6)
				200 VA (4)	440 VA (4)	
DC	Resistive	Voltage	~ 24 V	~ 48 V	~100..120V	~200..240V
		AC14 and AC15 duty	Power	50 VA (4)	20 VA (10)	20 VA (11)
				50 VA (8)	110 VA (7)	110 VA (9)
					220 VA (2)	220 VA (6)
					440 VA (1)	
DC	Resistive	Voltage	== 24 V	== 48 V		
		load	DC12 duty	Power	24 W (6)	50 W (6)
				50 W (3)	100 W (3)	
DC	Inductive	Voltage	== 24 V	== 48 V		
		DC13 duty (L/R = 60 ms)	Power	10 W (8)	24 W (8)	
			24 W (6)	50 W (6)		
Response time	Switch on		< 10 ms			
	Switch off		< 15 ms			
Type of contact		2x2 N/C - N/O (1)				
		2x2 N/O				
Isolation between contacts and ground		2000 V at 50 to 60 Hz				
Built-in protection	against overvoltages	R-C circuit and Ge-Mov				
	against overloads and short-circuits	Interchangeable fast blow fuse per common 6.3 A				
Power consumption	5 V	Typical	55 mA			
		Maximum	65 mA			
	24 V	Typical	10 mA	per channel at 1		
		Relay	Maximum	12 mA	per channel at 1	
Dissipated power		0.25 W + (0.24 W x No. of outputs at 1)				
(1)	0.1 x 10 ⁶ operations	(5)	0.7 x 10 ⁶ operations.	(9)	3 x 10 ⁶ operations.	
(2)	0.15 x 10 ⁶ operations	(6)	1 x 10 ⁶ operations.	(10)	5 x 10 ⁶ operations.	
(3)	0.3 x 10 ⁶ operations	(7)	1.5 x 10 ⁶ operations.	(11)	10 x 10 ⁶ operations.	
(4)	0.5 x 10 ⁶ operations	(8)	2 x 10 ⁶ operations.			

4.3-5 Triac output modules

Module reference		TSX DSY 08S5	TSX DSY 16S4
Operating voltage	DC	not allowed	
	(nominal/limit) AC	48..240V/41..264V	24..120V/20..132V
Permissible current (1)		2 A / channel - 12A/module	1 A / channel - 12A/module
Response time	Switch on	≤ 10 ms	
	Switch off	≤ 10 ms	
Isolation between contacts and gnd.		2000 V at 50...60 Hz	
Build-in protection	against overvoltages	Ge-Mov	
	against overloads and short-circuits	Fast blow fuse per common ≤ 6.3 A	Anti-flame protection non interchangeable per common de 10 A
Power consumption 5 V	Typical	125 mA	220 mA
	Maximum	135 mA	230 mA
Dissipated power		0.5 W + 1 W/A per output	0.85 W + 1 W/A per output

Important:

When using TSX DSY 08S5 modules at 220 VAC, it is essential not to use different phases between groups of channels on the same module.

(1) temperature derating is as shown on graph below

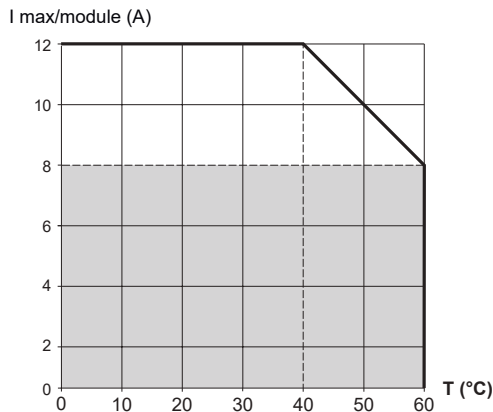

4.4 Characteristics of transistor output modules with connector

Module reference		TSX DSY 32T2K	TSX DSY 64T2K
Type of output		positive logic	
Operating voltage (nominal/limit)	DC	24V / 19...30 V (ripple included), possible up to 34 V, limited to 1 hour per 24 hours).	
	AC	not allowed	
Permissible current		0.1 A/chann. - 3.2 A / module	0.1 A/chann.- 5 A/module
Permissible lamp power		0.2 A	
Residual voltage		< 1.5 V for I = 0.1 A	
Response time		1.2 ms	
Paralleling of outputs	Yes : 3 max		
Leakage current		< 0.4 mA for U = 30 V	
Compatibility of DC inputs with IEC1 and IEC12		Yes	
Built-in protection	against overvoltages	Yes, Transil diode	
	against overloads and short-circuits	Automatic cut-out after 15 ms	
	against reversed polarity	Reverse mounted diode place a 3 A fuse across the 24 V	
Load impedance at state 1		> 220 Ω	
Dielectric strength		1500 V rms 50...60 Hz for 1 minute	
Consumption 5V	typical	135 mA	135 mA
	maximum	155	175 mA
Consumption 24V	typical	30 mA	60 mA
	maximum	40 mA	80 mA
Dissipated power		1.6 W + 0.1 W / output	2.4 W + 0.1 W / output

5.1 Connection equipment

5.1-1 Connection to modules with screw terminal block

The terminal blocks of the I/O modules have an automatic transfer coding device for when they are first used. This avoids handling errors while a module is being replaced. The coding ensures electrical compatibility for each type of module. See part A1 section 5.4.

Each terminal can accept bare wires or wires fitted with cable ends, or open lugs.

The capacity of each terminal is :

- minimum : 1 wire, 0.2 mm² (AWG 24) without cable end,
- maximum : 1 wire, 2 mm² without cable end or,
1 wire, 1.5 mm² with cable end.



1 5.5 mm maximum

The screw terminals have a recess for screwdrivers with the following heads :

- Pozidrive N°1 cruciform,
- flat, Ø 5 mm diameter

The screw terminal connection blocks are fitted with captive screws. They are supplied unscrewed. The maximum capacity of the terminal block is 16 wires, 1 mm² (AWG) + 4 wires 1.5 mm² (AWG).

Opening the cover

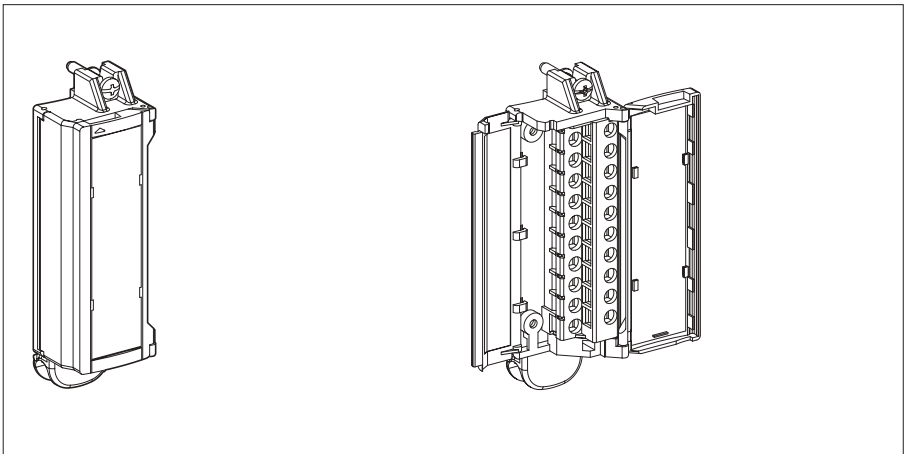

5.1-2 Connection to modules with HE10 connectors

20 wire preformed cable, 22 gauge (0.34 mm²),

Used for simple and direct wire to wire connection of the I/O on modules with HE10 connectors to sensors, preactuators or terminals.

This preformed cable comprises :

- at one end, an HE10 moulded connector carrying 20 wires, 0.34 mm² cross-section within a sheath,
- at the other end, flying leads color coded conforming to DIN 47100 standard.

Note : A nylon cord inside the cable enables the sheath to be stripped easily.

There are two product references : **TSX CDP 301** : 3 meters.

TSX CDP 501 : 5 meters.

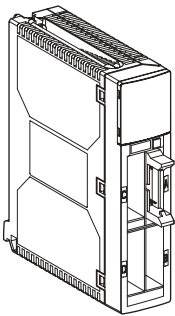

Module

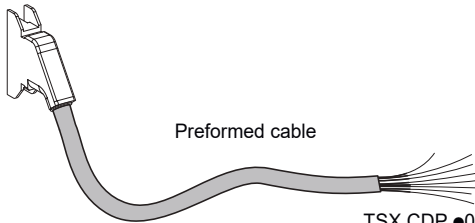

Preformed cable

TSX CDP ●01

Correspondence between wire color and the HE10 connector pin number

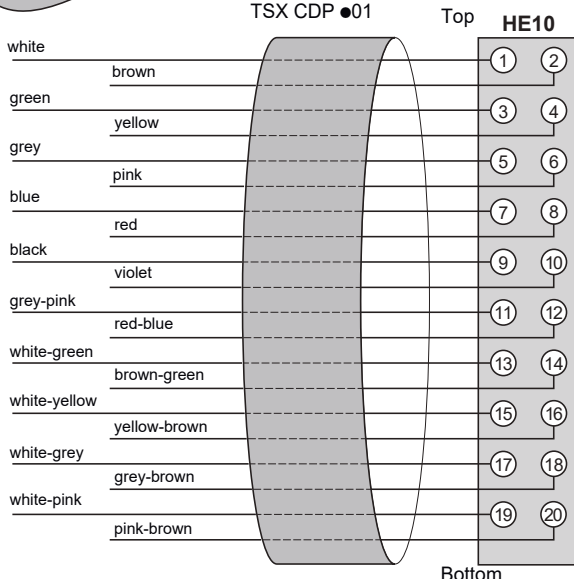

Preformed stranded sheathed connection cable 28 gauge (0.08 mm²)

Used to connect the I/O from modules with HE10 connectors to TELEFAST 2 rapid connection and wiring interfaces. This preformed cable comprises 2 HE10 connectors and a sheathed rolled ribbon cable with 0.08 mm² cross-section wires.

Bearing in mind the small cross-section of the wires, it is recommended that they be used only for low current inputs or outputs (≤ 100 mA per input or output).

There are three product references :

- TSX CDP 102** : length 1 meter
- TSX CDP 202** : length 2 meters
- TSX CDP 302** : length 3 meters

Connection cable 22 gauge (0.34 mm²)

Used to connect the I/O of modules with HE10 connectors to TELEFAST 2 rapid connection and wiring interfaces. This preformed cable comprises 2 HE10 moulded connectors and a cable with 0.34 mm² cross-section wires used for carrying higher currents (≤ 500 mA).

There are five product references :

- TSX CDP 053** : length 0.50 meters.
- TSX CDP 103** : length 1 meter.
- TSX CDP 203** : length 2 meters.
- TSX CDP 303** : length 3 meters.
- TSX CDP 503** : length 5 meters.

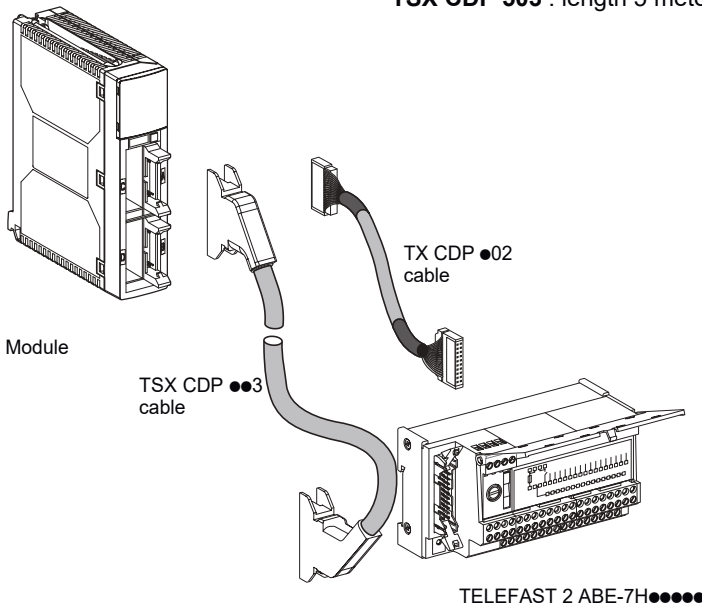

5.2 Module connections

5.2-1 TSX DEY 08D2 / 16D2 modules

Presentation

TSX DEY 08D2 / 16D2 modules comprise :

- 8 inputs 24 VDC, positive logic type 2 for the TSX DEY 08D2 modules,
- 16 inputs 24 VDC, positive logic type 2 for the TSX DEY 16D2 module,

The inputs are connected via a removable screw terminal block on the module.

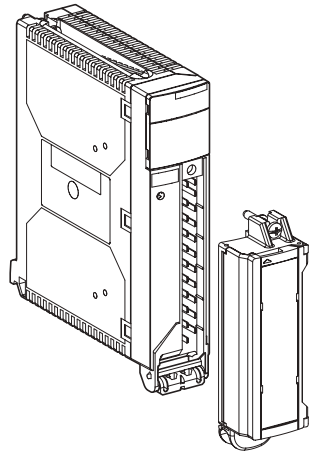

Simplified input schematic

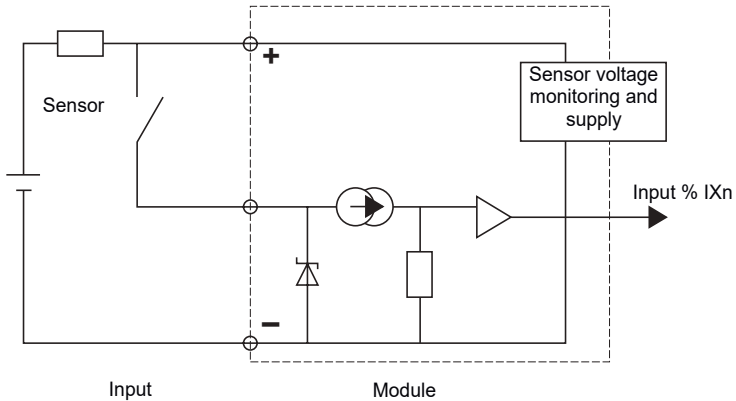

TSX DEY 08D2 module connections

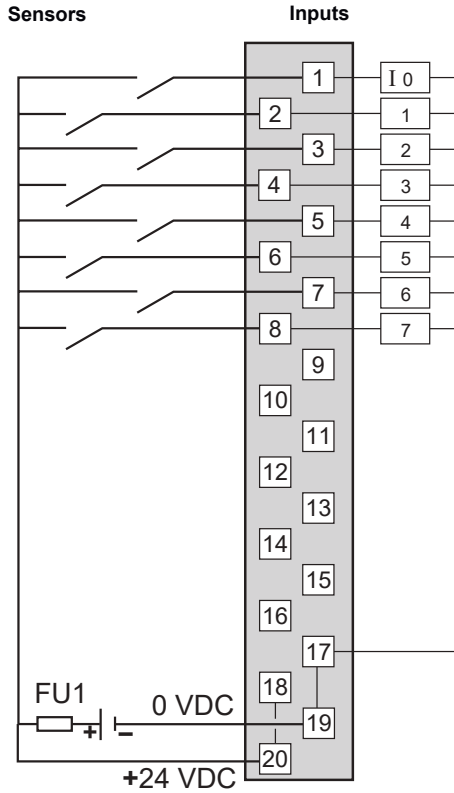

FU1 = 0.5 A fast blow fuse

TSX DEY 16D2 module connection

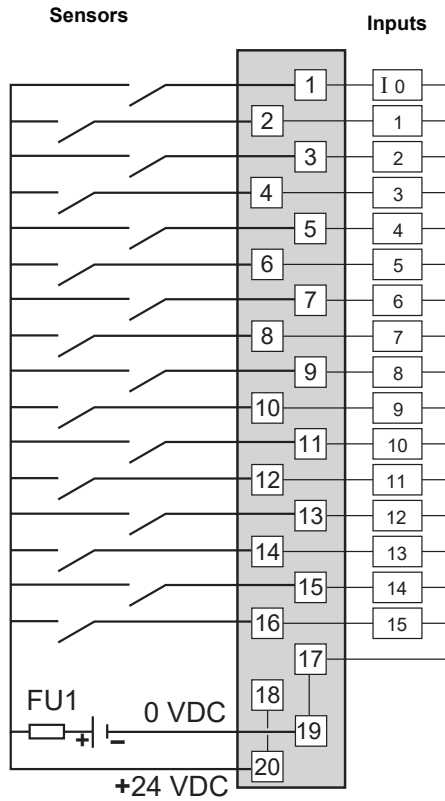

FU1 = 0.5 A fast blow fuse

5.2-2 TSX DEY 16D3 module

Presentation

The TSX DEY 16D3 module has 16 inputs, 48 VDC.

This module is connected to a 20-pin screw terminal block. Inputs are type 2, positive logic.

Module TSX DEY 16D3 connections

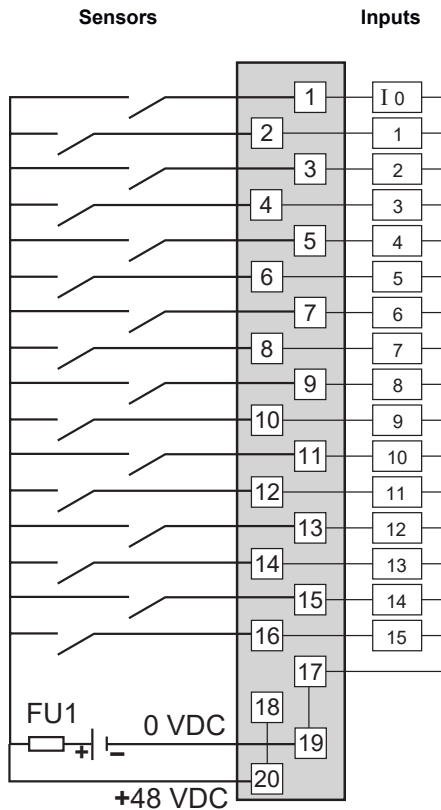

FU1 = 0.5 A fast blow fuse

5.2-3 TSX DEY 16A2 / 16A3 / 16A4 / 16A5 modules

Presentation

TSX DEY 16A2 / 16A3 / 16A4 and 16A5 modules have AC inputs, type 2. They are connected to the 20-pin screw terminal block.

Simplified input schematic

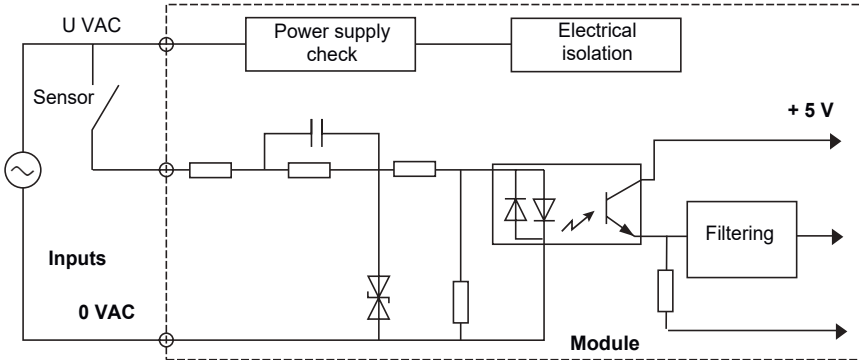

TSX DEY 16A2 / 16A3 / 16A4 / 16A5 module connections

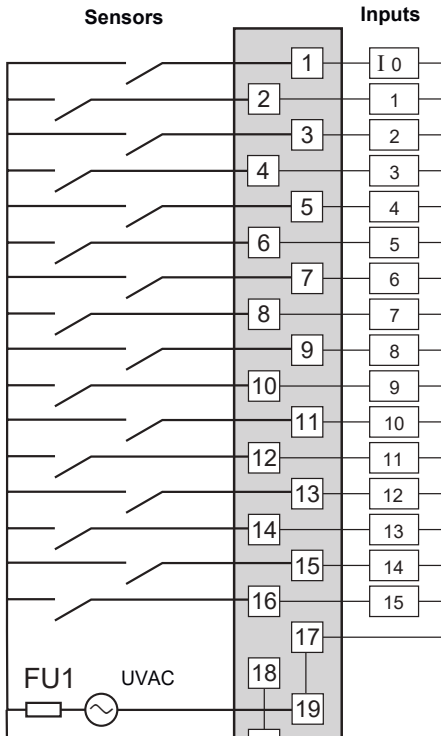

UVAC = 24 V for TSX DEY 16A2
48 V for TSX DEY 16A3
115 V for TSX DEY 16A4
230 V for TSX DEY 16A5

FU1 = 0.5 A fast
blow fuse

5.2-4 TSX DEY 16FK module

Presentation

This module has 16 fast input channels, 24 VDC. They are type 1 inputs, proximity sensor compatible conforming to the characteristics in section 4.

The module is fitted with an HE10 male connector :

- connector A addresses 0 to 15

The connector can accept :

- either a TSX CDP•01 preformed cable for direct connection to the sensor terminal,
- or a TSX CDP•02 cable or a TSX CDP••3 cable for connection to a TELEFAST 2 interface.

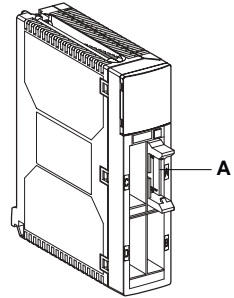

Simplified schematic

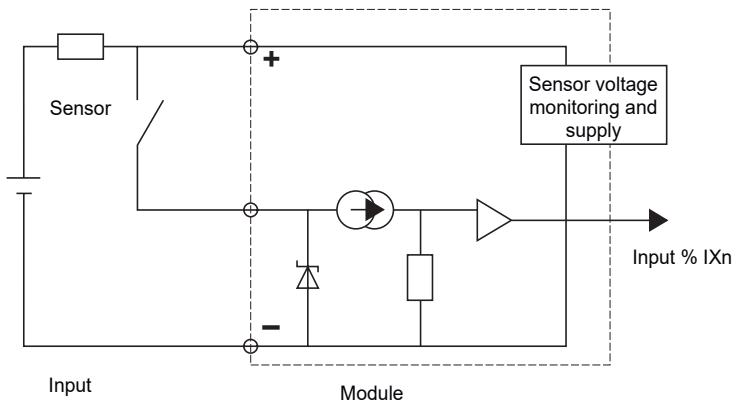

TSX DEY 16FK module connections

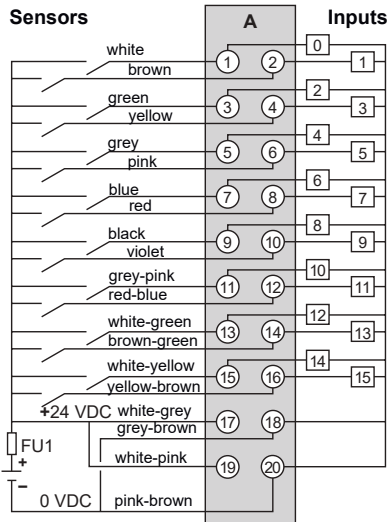

FU1 = 0.5 A fast blow fuse

Note :

The colors are used to show the correspondence between the HE10 connector pins and the flying leads of a TSX CDP*01 preformed cable.

5.2-5 TSX DEY 32D2K / 64D2K modules

Presentation

TSX DEY 32D2K and 64D2K modules have 24 VDC inputs. These are type 1 proximity sensor compatible inputs conforming to the characteristics in section 4.

The TSX DEY 32D2K module is fitted with 2 HE10 male connectors:

- connectors A and B are used to connect inputs :
 - A (0 to 15)
 - B (16 to 31)

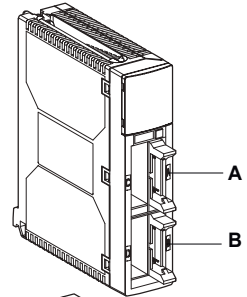

The TSX DEY 64D2K module is fitted with 4 HE10 male connectors :

- connectors A and B for connecting channels :
 - A (0 to 15)
 - B (16 to 31)
- connectors C and D for connecting channels :
 - C (32 to 47)
 - D (48 to 63)

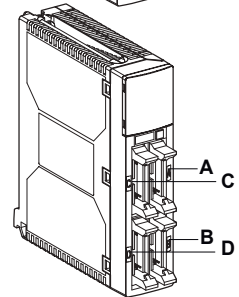

Each connector can accept :

- either a TSX CDP•01 preformed cable for connecting to a sensor terminal,
- or a TSX CDP•02 cable or a TSX CDP••3 cable for connecting to a TELEFAST 2 interface.

Simplified input schematic

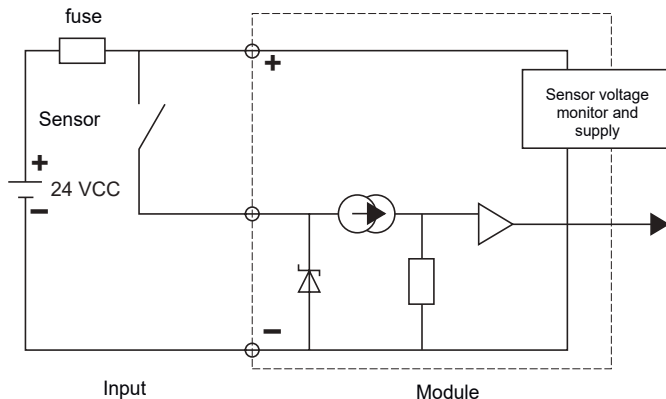

TSX DEY 32D2K module connections

FU1 = 0.5 A fast
blow fuse

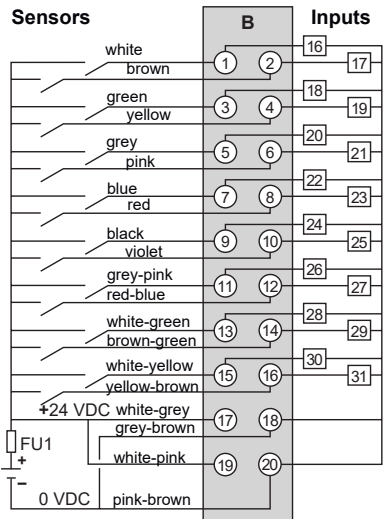
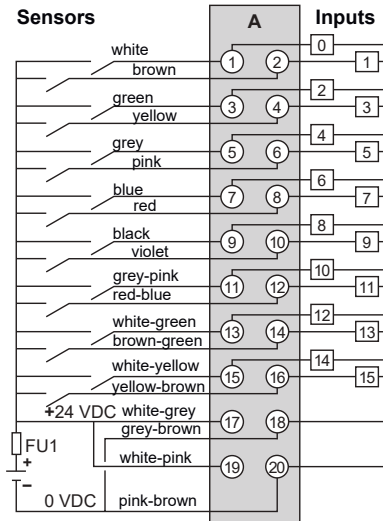

TSX DEY 64D2K module connections

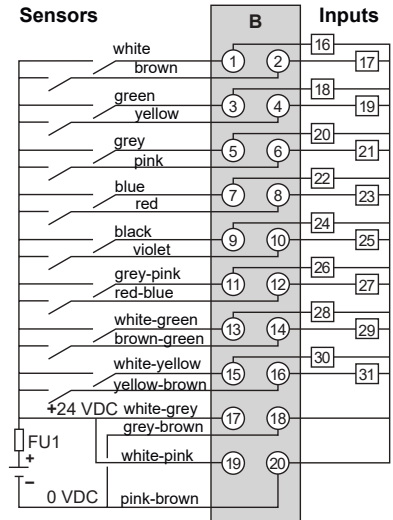
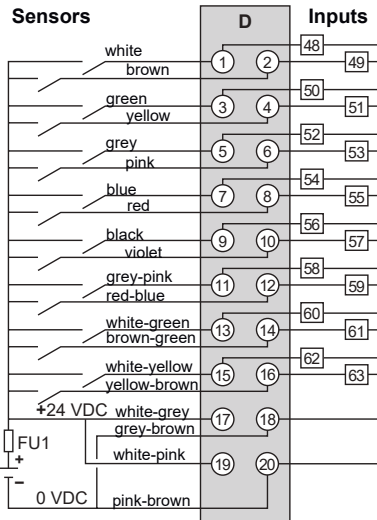
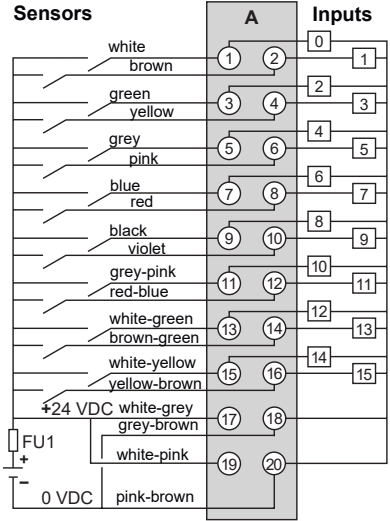
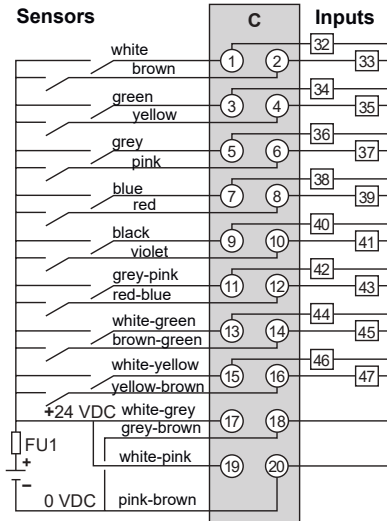

FU1 = 0.5 A fast blow fuse

5.2-6 TSX DSY 08T2 / 16T2 / 16T3 / 08T22 / 08T31 modules

Presentation

TSX DSY 08T2 / 16T2 and 08T22 modules have protected 24 VDC transistor outputs, TSX DSY 16T3/08T31 modules have 48 VDC protected transistor outputs.

These five modules are fitted with a 20-pin screw terminal block, which can be removed in order to connect the outputs.

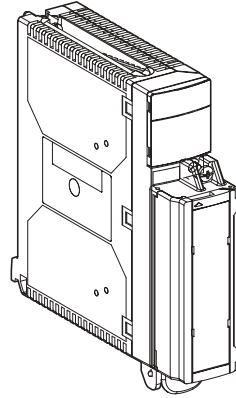

Simplified output schematic

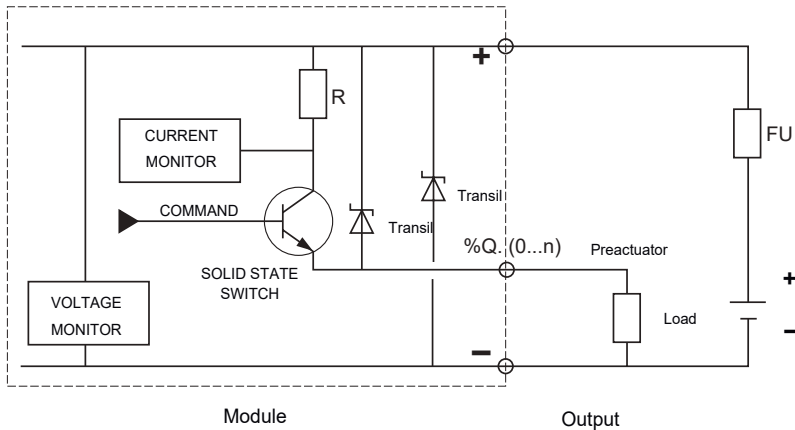

TSX DSY 08T2/08T22 module connections

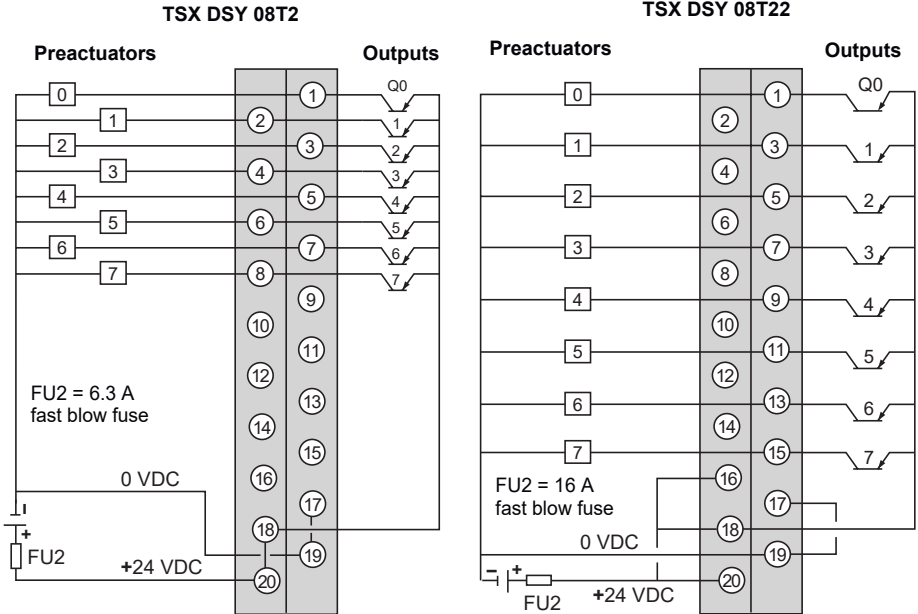

TSX DSY 16T2 module connection

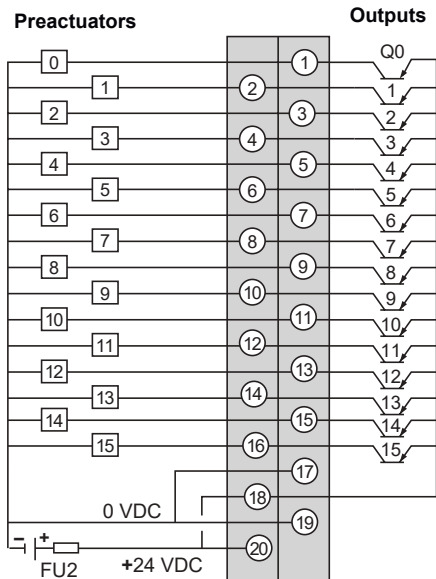

FU2 = 6.3 A fast blow fuse

TSX DSY 16T3 module connections : 48 VDC supply

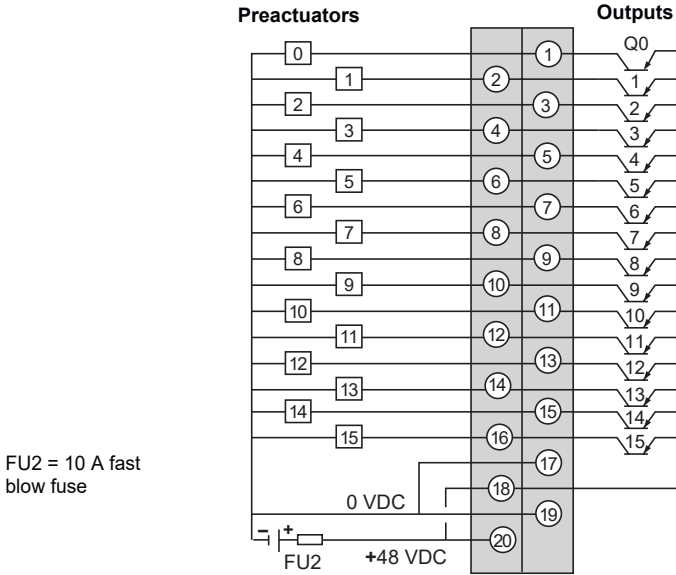

FU2 = 10 A fast
blow fuse

TSX DSY 08T31 module connection

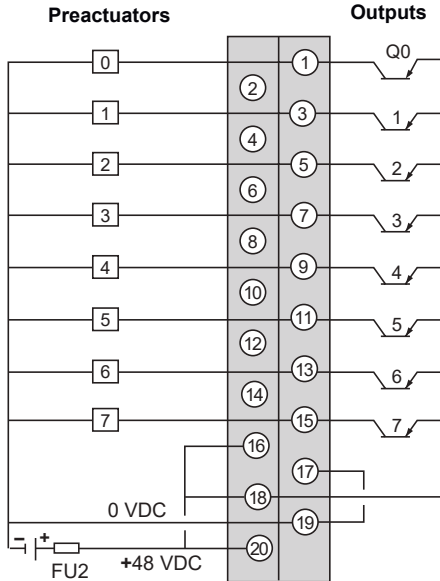

FU2 = 10 A fast blow fuse

5.2-7 Relay modules 50 VA : TSX DSY 08R5 / 16R5

Presentation

TSX DSY 08R5 and 16R5 modules have 8 relay outputs and 16 relay outputs respectively.

They are fitted with a 20-pin screw terminal block, which can be removed in order to connect the outputs.

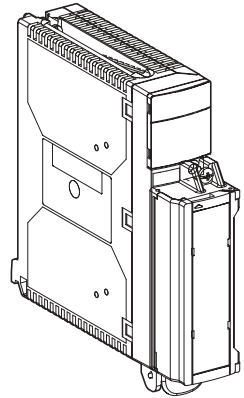

Simplified output schematic

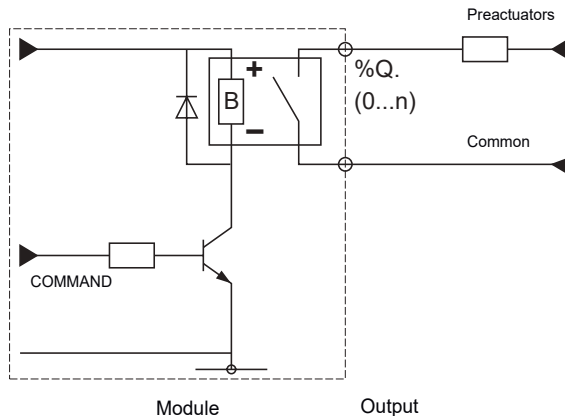

Warning :

- The relay contact must be protected by placing across the preactuator terminals :
- either an RC circuit or MOV (ZNO) peak limiter when using AC,
 - or a flywheel diode when using DC.

TSX DSY 08R5 module connections

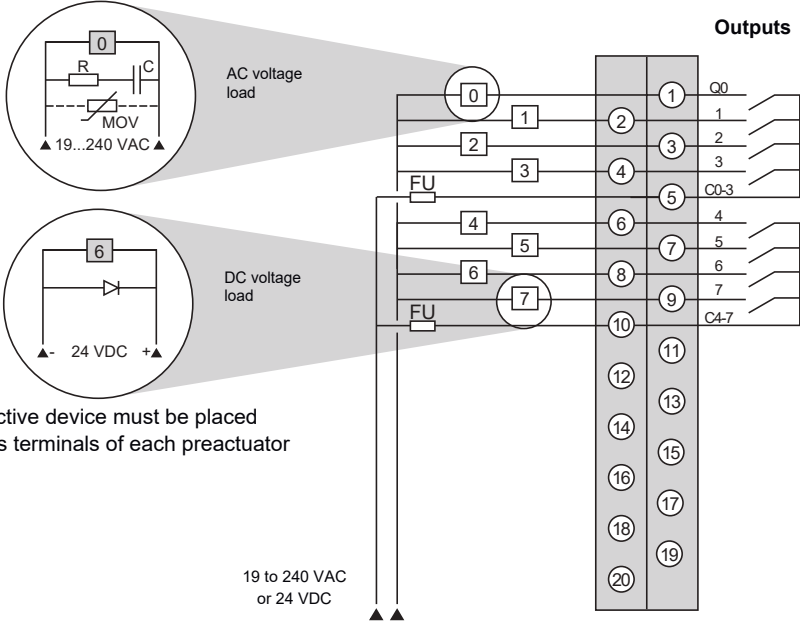

TSX DSY 16R5 module connections

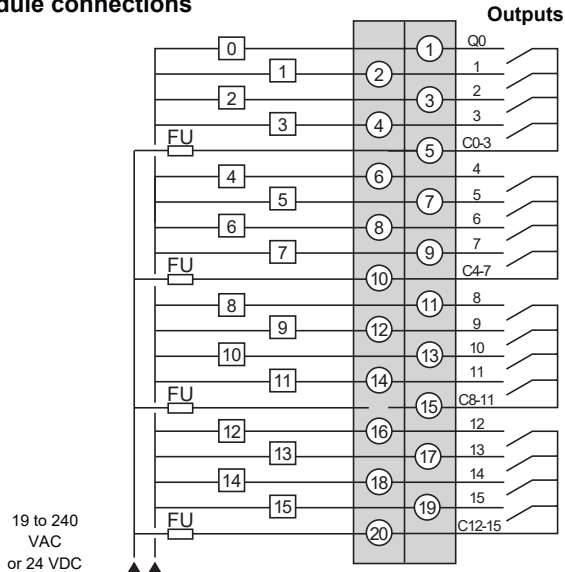

Note :

When the supply voltage for the preactuators is from a 3-phase supply which is equal to or greater

5.2-8 Relay modules 100 VA : TSX DSY 08R5A / 08R4D

Presentation

TSX DSY 08R5A and 08R4D modules each have 8 protected relay outputs. They are fitted with a 20-pin screw terminal block, which can be removed in order to connect the outputs.

Simplified N/O - N/C output schematic

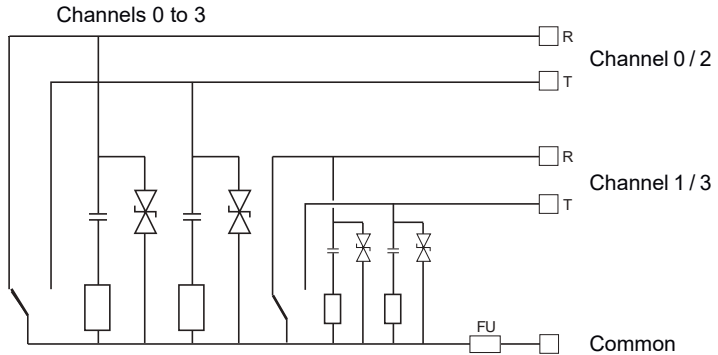

R : Normally closed - T : Normally open

FU = interchangeable 6.3 A fast blow fuse. 1 fuse per common

Simplified N/O output schematic

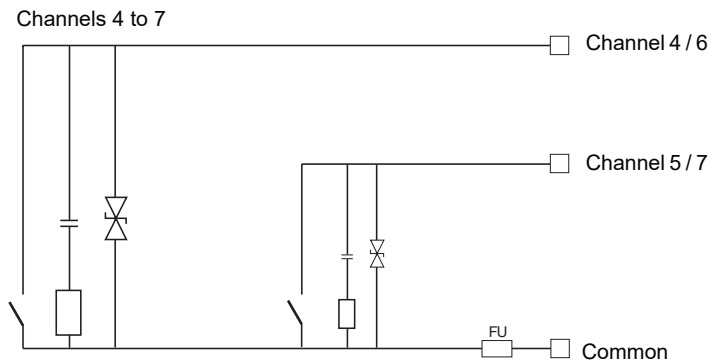

FU = 6.3 A - interchangeable fast blow fuse. 1 fuse per common.

TSX DSY 08R5A module connections

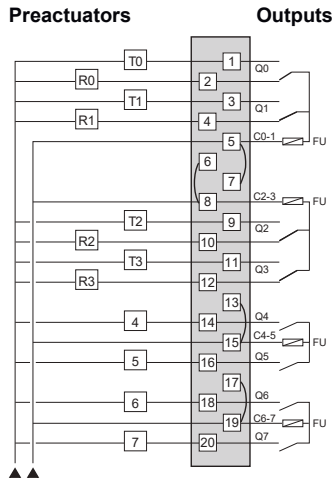

19 to 240 VAC
or 19 to 60 VDC (nominal = 48 VDC)

= strap 24 V

must be connected when using
24 V AC or DC.

FU = 6.3 A fast blow fuse

TSX DSY 08R4D module connections

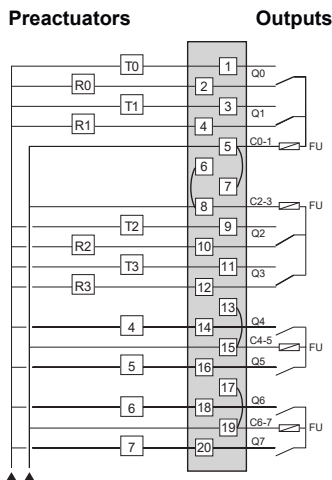

24 to 130 VDC

= strap 24 V

must be connected when using
24 V AC or DC.

FU = 6.3 A fast blow fuse

5.2-9 TSX DSY 08S5 / 16S4 modules

Presentation

TSX DSY 08S5 and 16S4 modules have 8 and 16 triac outputs respectively. They must be fitted with a removable 20-pin screw terminal block.

Simplified output schematic for a TSX DSY 08S5 module

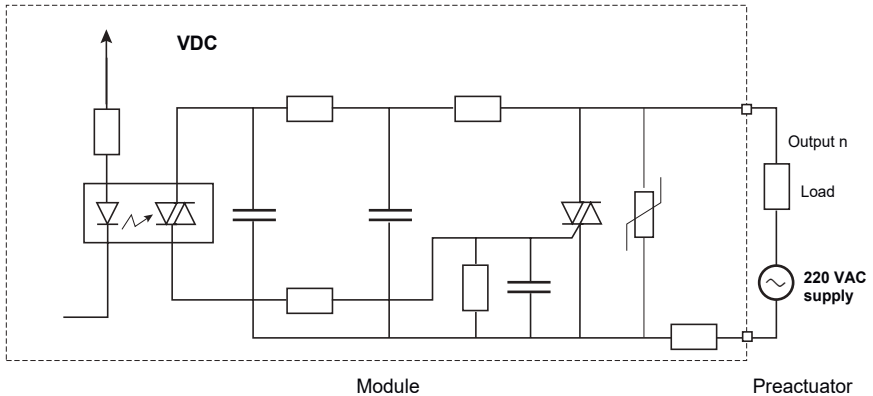

Simplified output schematic for a TSX DSY 16S4 module

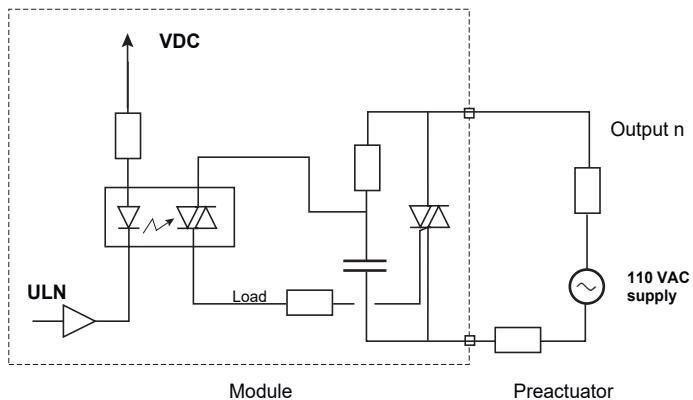

Note :

Protect the module outputs against short-circuits at the load, by means of a 6.3 A fast blow fuse.

TSX DSY 08S5 module connections

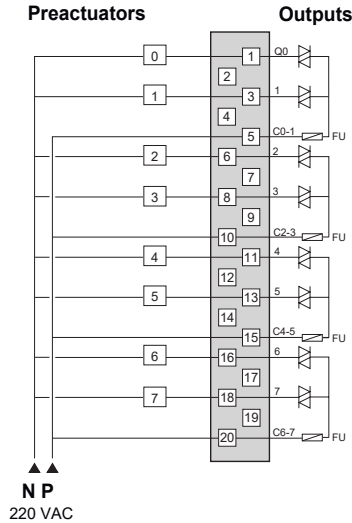

FU = interchangeable 6.3 A fast blow fuse

TSX DSY 16S4 module connections

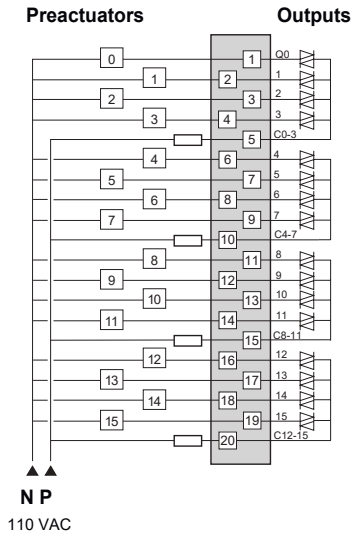

Note :

Place a 6.3 A fast blow fuse at the load

5.2-10 TSX DSY 32T2K / 64T2K modules

Presentation

TSX DSY 32T2K and 64T2K modules have positive logic source type transistor outputs.

These modules are fitted with HE10 male connectors :

- 2 connectors A and B for module TSX DSY 32T2K
 - connector A for outputs 0 to 15
 - connector B for outputs 16 to 31
- 4 connectors A, B, C and D for module TSX DSY 64T2K
 - connector A for outputs 0 to 15
 - connector B for outputs 16 to 31
 - connector C for outputs 32 to 47
 - connector D for outputs 48 to 63

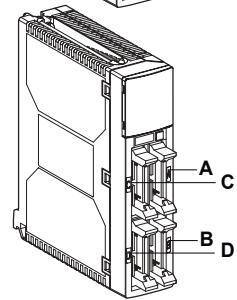
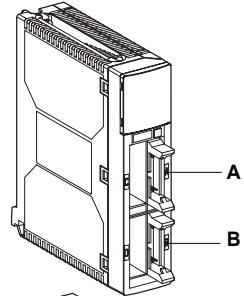

The connectors can accept :

- either a TSX CDP•01 preformed cable for direct connection to the preactuator terminal,
- or a TSX CDP••3 cable or TSX CDP•02 preformed cable for connection to a TELEFAST 2 wiring interface.

Simplified output schematic

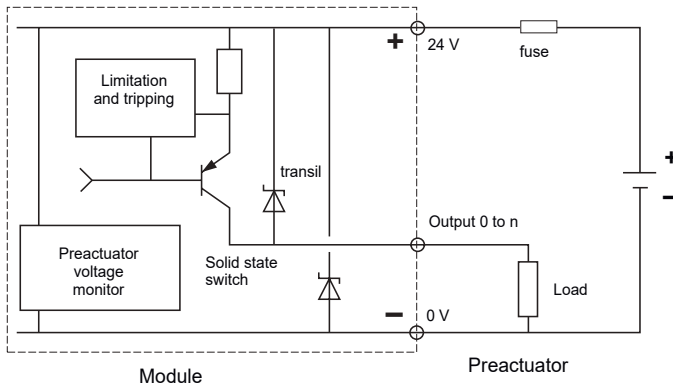

TSX DSY 32T2K module connections

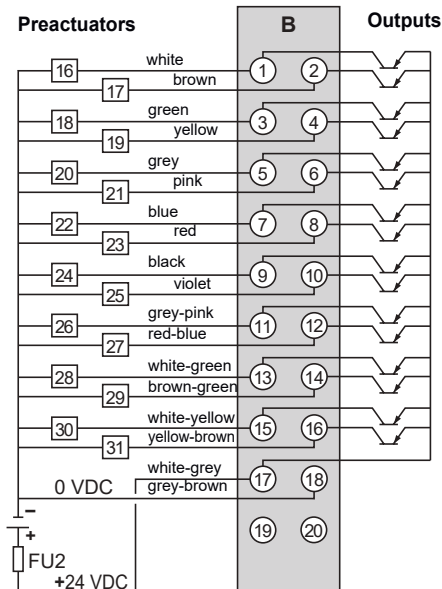
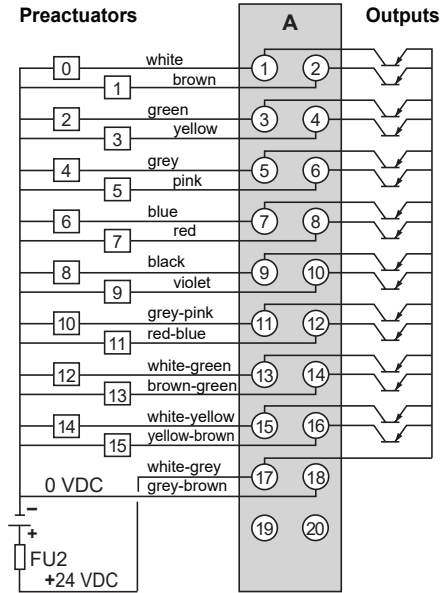

FU2 = 2 A fast
blow fuse

Note :

The colors are used to show the correspondence between the HE10 connector pins and the flying

TSX DSY 64T2K module connections

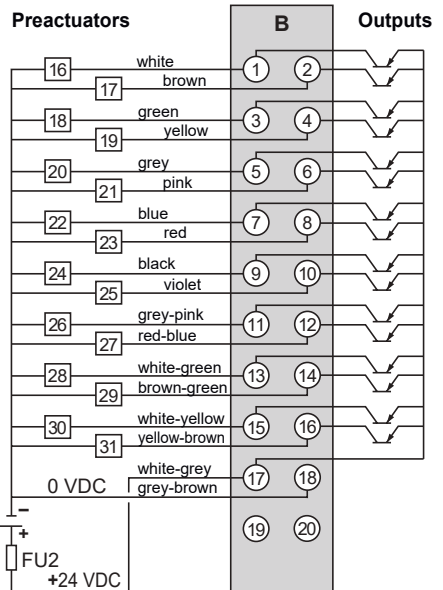
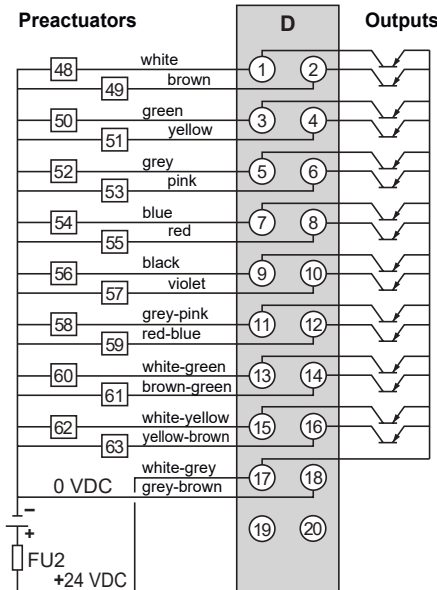
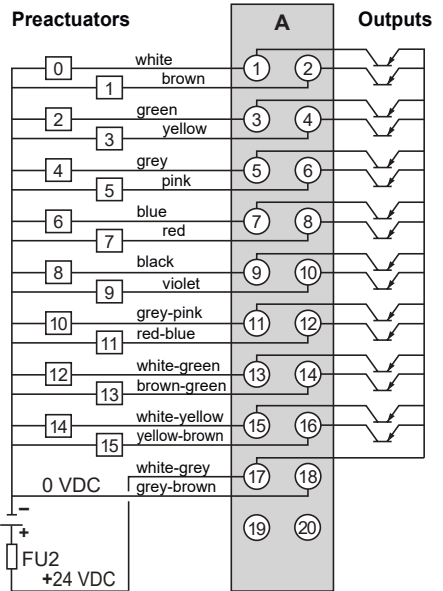
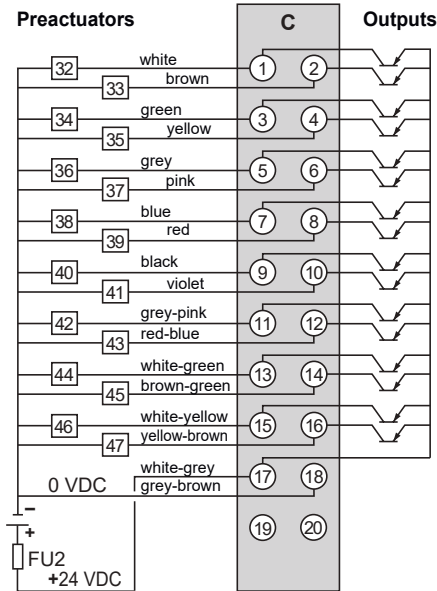

Note :

FU2 = 2 A fast blow fuse

The colors are used to show the correspondence between the HE10 connector pins and the flying

6.1 Presentation

The TELEFAST 2 system is a range of products for rapid connection of discrete I/O modules to the application. It replaces screw terminal blocks, and provides remote location of single-wire termination.

The TELEFAST 2 system can only be connected to modules equipped with HE10 connectors. It is composed of interface sub-bases and connecting cables. Several types of sub-base exist :

• Connection interface sub-bases for discrete I/O, 8/12/16 channels :

- 8 channel sub-base :

- ABE-7H08R10, ABE-7H08R11,
ABE-7H08R21
• with 1 isolator/channel
ABE-7H08S21

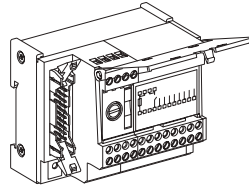

- 12 and 16 channel compact sub-bases :

- ABE-7H12R50*,
ABE-7H16R50.

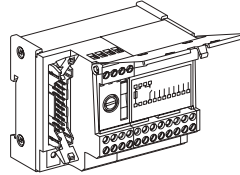

- 12 and 16 channel sub-bases :

- ABE-7H12R10 (1), ABE-7H12R11 (1),
ABE-7H12R20 (1), ABE-7H12R21 (1),
ABE-7H16R10, ABE-7H16R11,
ABE-7H16R20, ABE-7H16R21/23,
ABE-7H16R30, ABE-7H16R31,
• with 1 isolator/channel
ABE-7H12S21 (1), ABE7-H16S21
• with 1 fuse + 1 isolator/channel
ABE-7H16S43 (for Inputs)
ABE-7H16F43 (for Outputs)

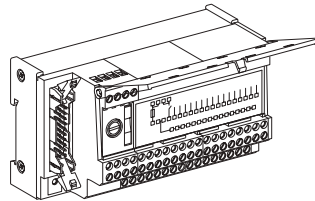

Identification of the various discrete I/O connection sub-bases

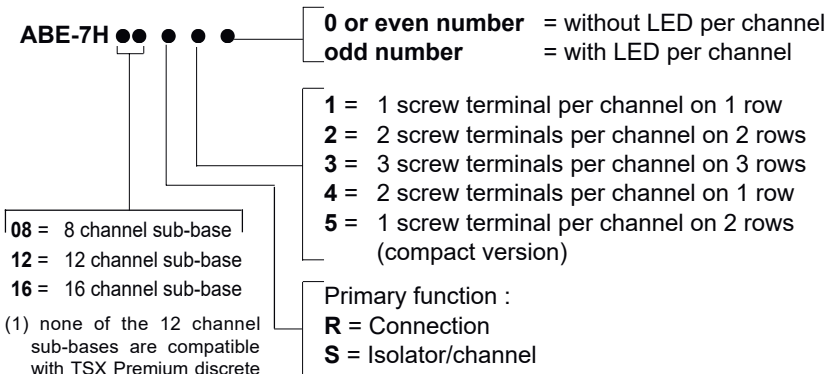

• **Connection interface and input adaptor sub-bases, 16 isolated channels**

- ABE-7S16E2B1 : 16 inputs 24 VDC,
- ABE-7S16E2E1 : 16 inputs 48 VDC,
- ABE-7S16E2E0 : 16 inputs 48 VAC,
- ABE-7S16E2F0 : 16 inputs
110/120 VAC,
- ABE-7S16E2M0 : 16 inputs
220/240 VAC.

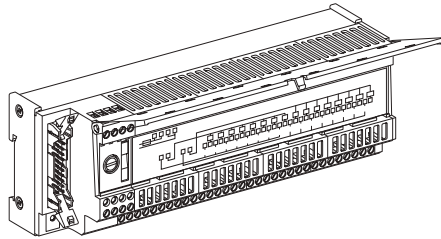

• **Connection interface and solid state output adaptor sub-bases, 8 and 16 channels :**

8 channel sub-bases

- ABE-7S08S2B0 : 8 solid state outputs
24VDC/0.5 A, with
fault detection feed-
back to the PLC.
- ABE-7S08S2B1 : 8 solid state outputs
24VDC/2A, with
fault detection feed-
back to the PLC.

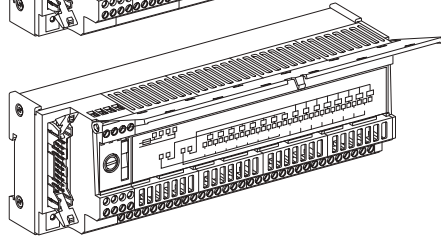
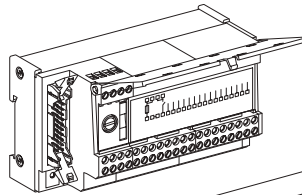

16 channel sub-base

- ABE-7S16S2B0 : 16 solid state out-
puts 24VDC/0.5A,
with fault detection
feedback to the
PLC,
- ABE-7S16S2B2 : 16 solid state out-
puts 24VDC/0.5A,
without fault detec-
tion feedback to the
PLC.

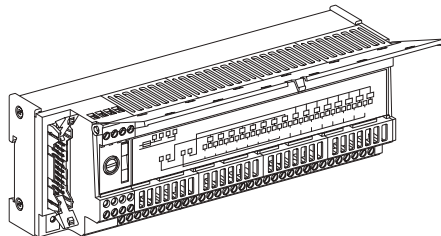

- **Connection interface and relay output adaptor sub-bases, 8 and 16 channels :**

- **8 channel sub-base**

- ABE-7R08S111: 8 relay outputs, 1 "N/O" with distribution of "+" or "~" poles.

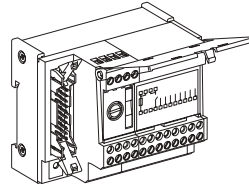

- ABE-7R08S210: 8 relay outputs, 1 "N/O", volt-free contact.

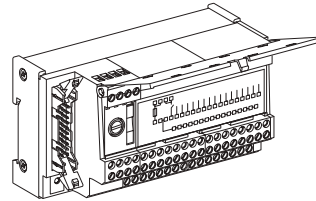

- **16 channel sub-base**

- ABE-7R16S111: 16 relay outputs, 1 "N/O", 2x8 commons "+" or "~".

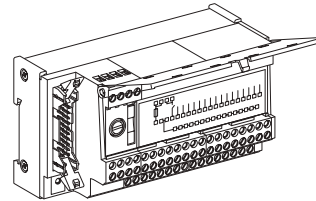

- ABE-7R16S210: 16 relay outputs, 1 "N/O", volt-free contact,

- ABE-7R16S212: 16 relay outputs, 1 "N/O" with distribution of 2 poles per group of 8 channels.

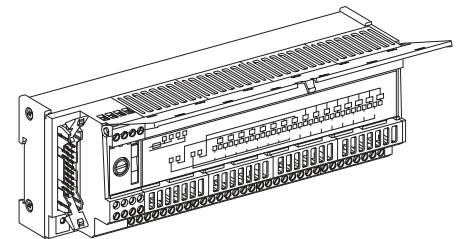

- **Adaptor sub-base 16 channels → 2 x 8 channels**

- ABE-7ACC02 : enables the distribution of :
 - 16 channels in 2 x 8 channels,
 - 12 channels in 8 channels + 4 channels.

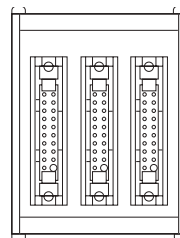

- Input or output adaptor interface sub-bases, with or without removable electromechanical or solid state relays, 16 channels

Output sub-bases

1"N/O", volt-free contact

- ABE-7R16T210 : with 10 mm wide electromechanical relay,
- ABE-7P16T210 : 10 mm wide relays, not supplied,
- ABE-7P16T214 : as above but with 1 fuse per channel.

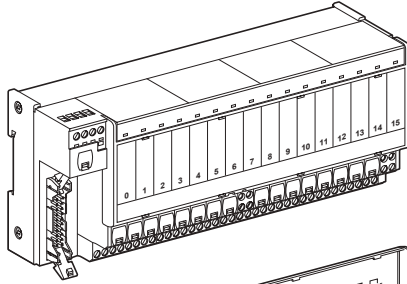

1"N/O", with distribution of 2 poles per group of 8 channels

- ABE-7R16T212 : with 10 mm wide electromechanical relay,
- ABE-7P16T212 : 10 mm wide relays, not supplied,
- ABE-7P16T215 : as above but with 1 fuse per channel.

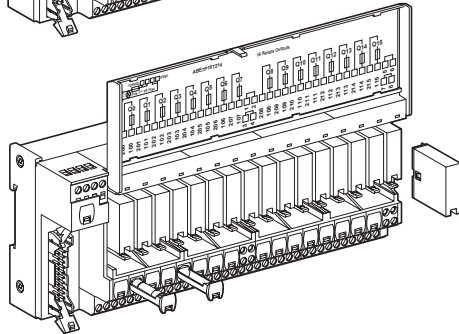

1"N/O", with distribution of 2 poles per group of 4 channels

- ABE-7P16T318 : without 12.5mm wide electromechanical relay,
1 fuse +
1 isolator/channel

1"C/O", volt-free contact

- ABE-7R16T230 : with 10 mm wide electromechanical relay,
- ABE-7R16T330 : with 12.5 mm wide electromechanical relay,
- ABE-7P16T330 : 12.5 mm wide relays, not supplied,
- ABE-7P16T334 : as above but with 1 fuse per channel.

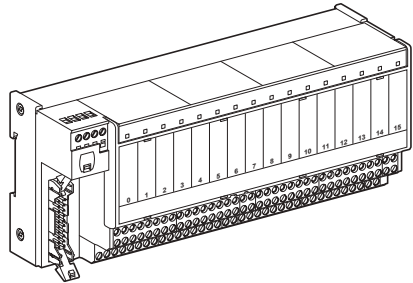

1"C/O", common per group of 8 channels

- ABE-7R16T231 : with 10 mm wide electromechanical relay.

1"C/O", with distribution of 2 poles per group of 8 channels

- ABE-7R16T332 : with 12.5 mm wide electromechanical relay,
- ABE-7P16T332 : 12.5 mm wide relays, not supplied.

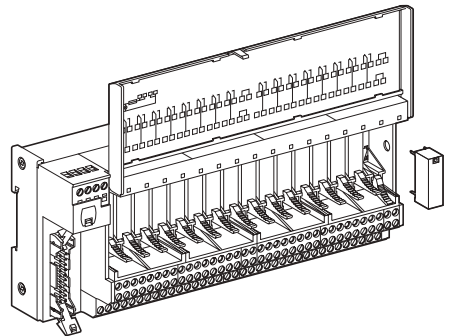

2 "C/O", volt-free contact

- ABE-7R16T370 : with 12.5 mm wide electromechanical relay.

• **Input sub-bases for 12.5 mm wide solid state relays**

- ABE-7P16F310 : volt-free,
- ABE-7P16F312 : distribution of 2 poles per group of 8 channels.

6.2 TSX Micro I/O module and sub-base compatibility

Discrete I/O modules	TSX	DMZ 28DTK		DMZ64DTK		DEZ 12D2K	DSZ 08T2K
Modularity		1x16I	1x12Q	2x16I	2x16Q	1x12I	1x8Q

Connection sub-bases

8 channels

ABE-7H08R●●	(1)		(1)	(1)			
ABE-7H08S21	(1)		(1)	(1)			

12 channels

ABE-7H12R●●							
ABE-7H12S21							

16 channels

ABE-7H16R●●							
ABE-7H16S21							
ABE-7H16R23							
ABE-7H16F43							
ABE-7H16S43							

Input adaptor sub-bases

16 channels

ABE-7S16S2●●							
ABE-7P16F3●●							

Output adaptor sub-bases

8 channels

ABE-7S08S2●●				(1)		(2)	
ABE-7R08S●●●				(1)			

16 channels

ABE-7R16S●●●		(3)					
ABE-7R16T●●●		(3)					
ABE-7P16T●●●		(3)					

(1) with adaptor 16 → 2x8 channels ABE-7ACC02

(2) except ABE-7S08S2B0

(3) caution : the 4 unused outputs are at state 1

 Combination possible

6.3 TSX Premium I/O module and sub-base compatibility

Discrete I/O modules	TSX	DEY 16FK	DEY : 32D2K - 64D2K		DSY : 32T2K - 64T2K	
Modularity		1x16I	2x16I	4x16I	2x16Q	4x16Q

Connection sub-bases

8 channels

ABE-7H08R●●	(1)	(1)	(1)	(1)	(1)	(1)
ABE-7H08S21	(1)	(1)	(1)	(1)	(1)	(1)

12 channels

ABE-7H12R●●						
ABE-7H12S21						

16 channels

ABE-7H16R●●						
ABE-7H16S21						
ABE-7H16R23						
ABE-7H16F43						
ABE-7H16S43						

Input adaptor sub-bases

16 channels

ABE-7S16E2●●						
ABE-7P16F3●●						

Output adaptor sub-bases

8 channels

ABE-7S08S2●●				(1)	(1)
ABE-7R08S●●●				(1)	(1)

16 channels

ABE-7R16S●●●					
ABE-7R16T●●●					
ABE-7P16T●●●					

(1) with adaptor 16 → 2x8 channels ABE-7ACC02



Combination possible

6.4 Module → interface sub-base connection principle

The connection between an HE 10 connector located on a discrete I/O module and a connection sub-base is made using a pre-formed stranded sheathed connection cable (TSX CDP ●02) or a cable (TSX CDP ●●3) equipped with 20-pin HE 10 connectors at each end,

- Pre-formed stranded sheathed connection cables, 28 gauge : 0.08 mm² (see description section 5.1-2).

Given the small cross section of the wires, it is recommended that they be used for the connection of I/O with low currents (≤ 100 mA per channel).

There are three product references :

- TSX CDP 102 : 1 meter long,
- TSX CDP 202 : 2 meters long,
- TSX CDP 302 : 3 meters long.

- Connection cables, 22 gauge : 0.34 mm² (see description section 5.1-2)

Used to connect any I/O with a current of ≤ 500 mA per channel.

There are five product references :

- TSX CDP 053 : 0.5 meters long,
- TSX CDP 103 : 1 meter long,
- TSX CDP 203 : 2 meters long,
- TSX CDP 303 : 3 meters long,
- TSX CDP 503 : 5 meters long,

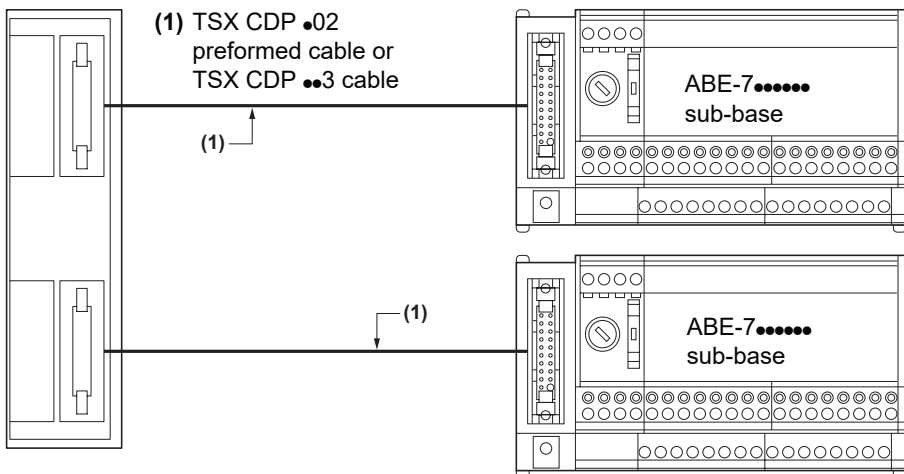

Module with HE10 connector
(16 channels per connector)

Connection of 16 channels (2 x 8) using an ABE-7ACC02 adaptor sub-base.
Example 1 : Connection of 16 channels (2 x 8)

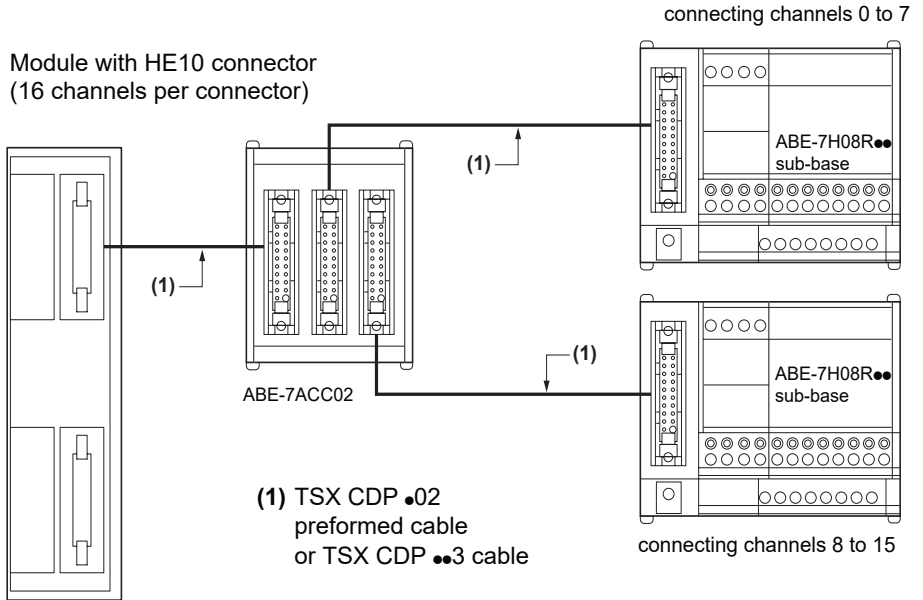

6.5 Sensor or preactuator connection to sub-bases

6.5-1 ABE-7H08R10, ABE-7H08R11, ABE-7H16R10, ABE-7H16R11 sub-bases

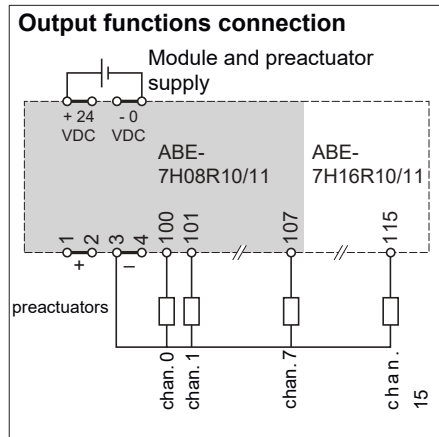
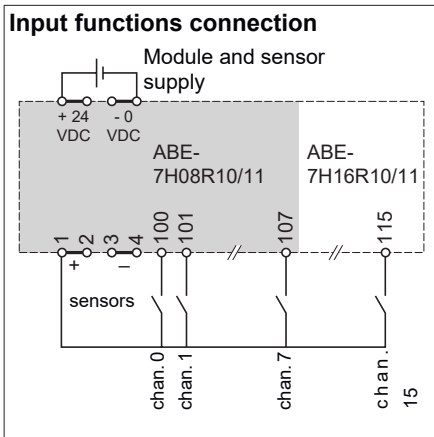
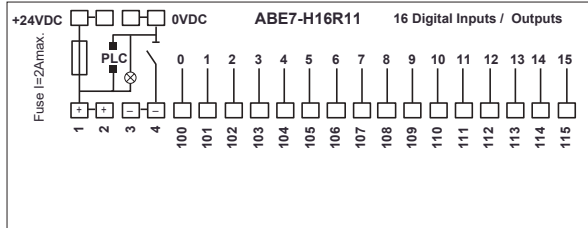
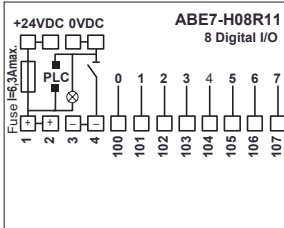

Connection of sensor common :

- on terminals 1 or 2 : sensors connected to supply "+" (positive logic inputs),

Connection of preactuator common :

- on terminals 3 or 4 : preactuators connected to supply "-" (positive logic outputs).



Sub-bases are supplied with a general purpose 2A fast blow fuse. In order to ensure optimum protection, this fuse should be rated according to the application (connection to input or output functions) and the maximum permissible current in the sub-base. Type and rating of fuse to be used :

- for input functions : 0.5 A fast blow fuse,
- for output functions :
 - 2 A fast blow fuse on ABE-7H16R●● sub-base
 - 6.3 A fast blow fuse on ABE-7H08R●● sub-base

6.5-2 ABE-7H12R10, ABE-7H12R11 sub-bases

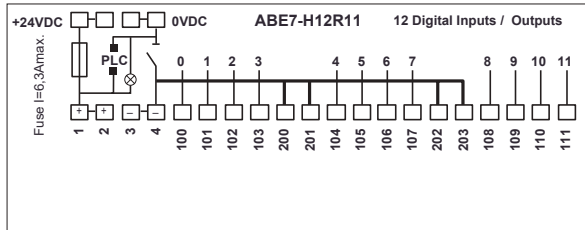

Input functions connection

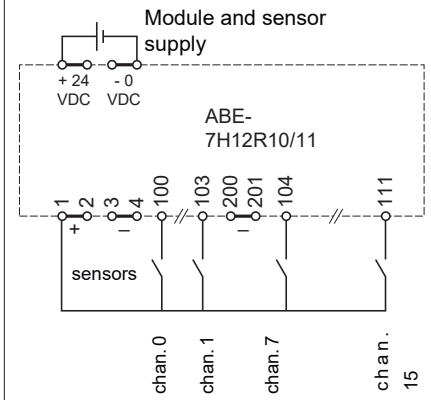

Output functions connection

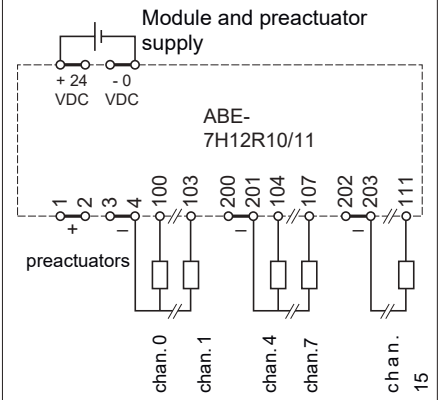

Connection of sensor common :

- on terminals 1 or 2 : sensors connected to the supply "+" (positive logic inputs).



Terminals 200/201/202 and 203 are connected to the "-" pole.

Connection of preactuator common :

The use of a number of terminals connected to the "-" pole (3, 4, 200, 201, 202 and 203) creates commons for each group of 4 or 2 channels (positive logic outputs)



Sub-bases are supplied with a general purpose 6.3 A fast blow fuse. In order to ensure optimum protection, this fuse should be rated according to the application (connection to input or output functions) and the maximum permissible current in the sub-base. Type and rating of fuse to be used :

- for input functions : 0.5 A fast blow fuse,
- for output functions :
- 6.3 A fast blow fuse on ABE-7H12R●● sub-base

6.5-3 ABE-7H08R21, ABE-7H16R20, ABE-7H16R21, ABE-7H16R23 sub-bases for type 2 inputs

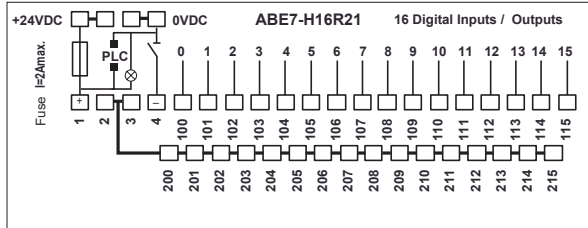
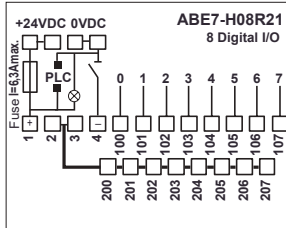

Input functions connection

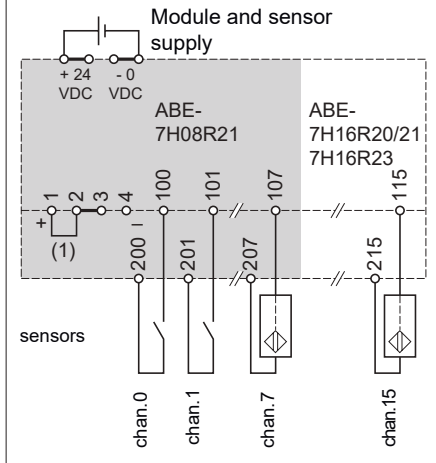

Output functions connection

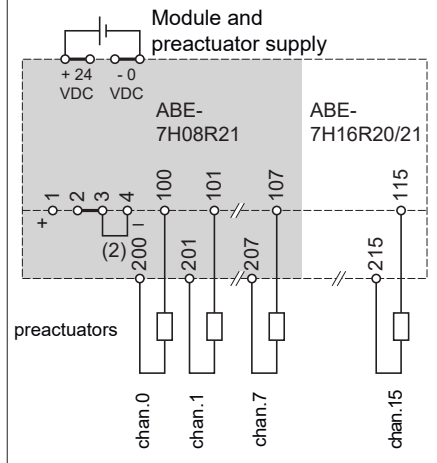

Connection of sensor common :

In order to create the sensor supply common, place the jumper (1) across terminals 1 & 2 : terminals 200 to 215 should be connected to the supply "+" (positive logic input).

Connection of preactuator common :

In order to create the preactuator supply common, place the jumper (2) across terminals 3 & 4 : terminals 200 to 215 should be connected to the supply "+" (positive logic outputs).



Sub-bases are supplied with a general purpose 2 A fast blow fuse. In order to ensure optimum protection, this fuse should be rated according to the application (connection to input or output functions) and the maximum permissible current in the sub-base. Type and rating of fuse to be used :

- for input functions : 0.5 A fast blow fuse,
- for output functions :
 - 2 A fast blow fuse on ABE-7H16R●● sub-base
 - 6.3 A fast blow fuse on ABE-7H08R●● sub-base

6.5-4 ABE-7H12R20, ABE-H12R21 sub-bases

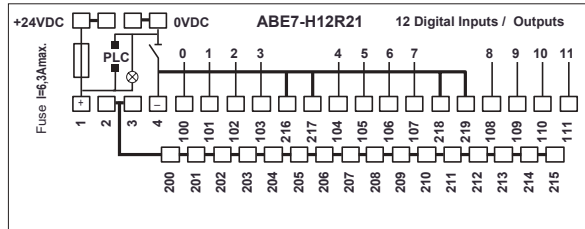

Input functions connection

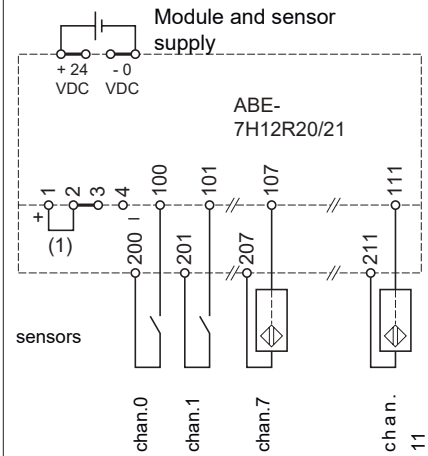

Output functions connection

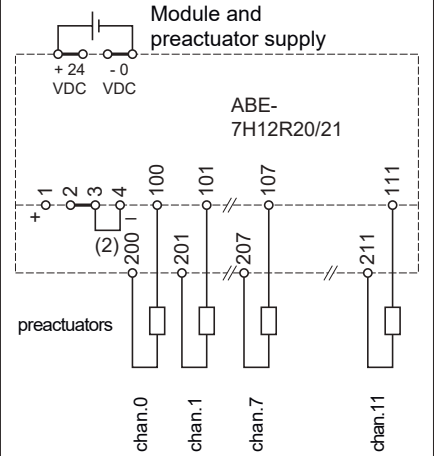

Connection of sensor common :

In order to create the sensor supply common, place the jumper (1) across terminals 1 & 2 : terminals 200 to 215 should be connected to the supply "+" (positive logic input).

⚠ Terminals 216, 217, 218 and 219 are connected to the "-" pole.

Connection of preactuator common :

In order to create the preactuator supply common, place the jumper (2) across terminals 3 & 4 : terminals 200 to 215 should be connected to the supply "-" (positive logic outputs).

⚠ Terminals 216, 217, 218 and 219 are connected to the "-" pole.



The sub-base is supplied with a general purpose 6.3 A fast blow fuse. In order to ensure optimum protection, this fuse should be rated according to the application (connection to input or output functions) and the maximum permissible current in the sub-base. Type and rating of fuse to be used :

- for input functions : 0.5 A fast blow fuse,
- for output functions :
 - 6.3 A fast blow fuse on ABE-7H12R●● sub-base

6.5-5 ABE-7H08S21, ABE-7H16S21 sub-bases with 1 isolator per channel

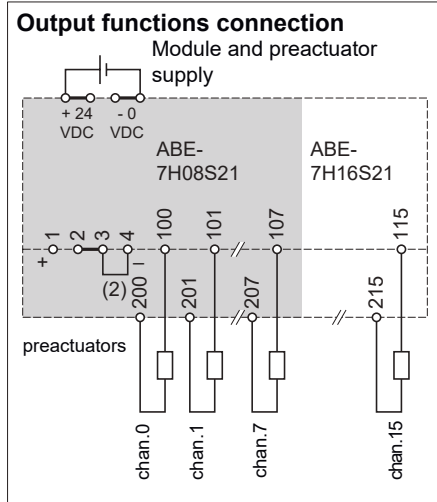
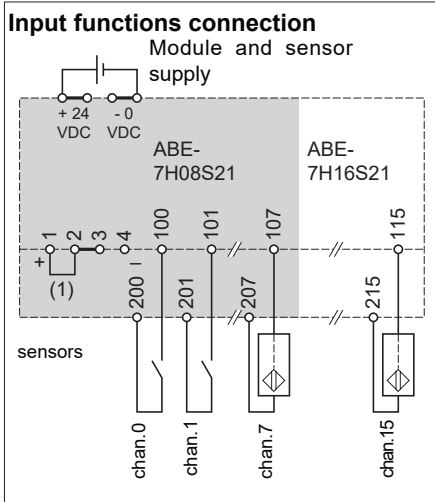
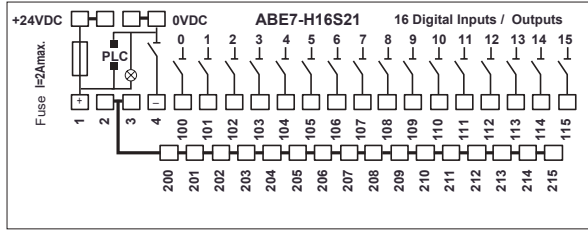
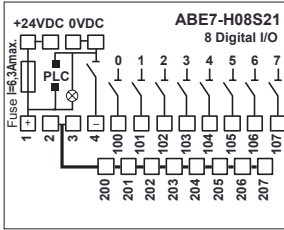

Connection of sensor common :
In order to create the sensor supply common, place the jumper (1) across terminals 1 & 2 : terminals 200 to 215 should be connected to the supply "+" (positive logic input).

Connection of preactuator common :
In order to create the preactuator supply common, place the jumper (2) across terminals 3 & 4 : terminals 200 to 215 should be connected to the supply "-" (positive logic outputs).

⚠ Sub-bases are supplied with a general purpose 2 A fast blow fuse. In order to ensure optimum protection, this fuse should be rated according to the application (connection to input or output functions) and the maximum permissible current in the sub-base. Type and rating of fuse to be used :

- for input functions : 0.5 A fast blow fuse,
- for output functions :
 - 2 A fast blow fuse on ABE-7H16S21 sub-base
 - 6.3 A fast blow fuse on ABE-7H08S21 sub-base

6.5-6 ABE-7H12S21 sub-base with 1 isolator per channel

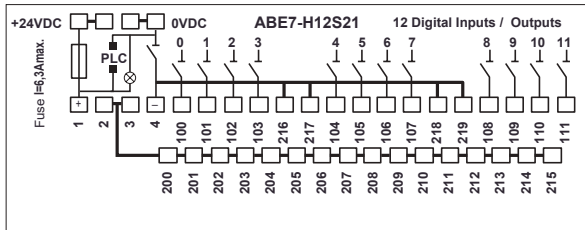

Input functions connection

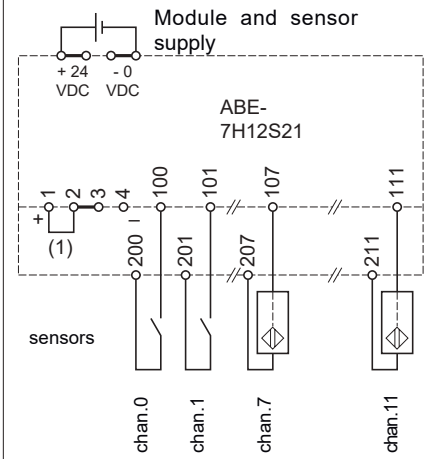

Output functions connection

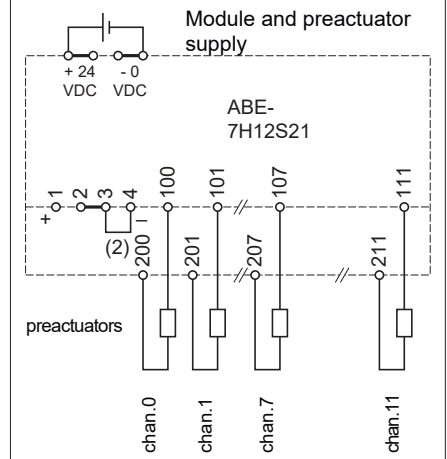

Connection of sensor common :

In order to create the sensor supply common, place the jumper (1) across terminals 1 & 2 : terminals 200 to 215 should be connected to the supply "+" (positive logic input).

⚠ Terminals 216, 217, 218 and 219 are connected to the "-" pole.

Connection of preactuator common :

In order to create the preactuator supply common, place the jumper (2) across terminals 3 & 4 : terminals 200 to 215 should be connected to the supply "-" (positive logic outputs).

⚠ Terminals 216, 217, 218 and 219 are connected to the "-" pole.

⚠ The sub-base is supplied with a general purpose 6.3 A fast blow fuse. In order to ensure optimum protection, this fuse should be rated according to the application (connection to input or output functions) and the maximum permissible current in the sub-base. Type and rating of fuse to be used :

- for input functions : 0.5 A fast blow fuse,
- for output functions :
- 6.3 A fast blow fuse on ABE-7H12S21 sub-base

6.5-7 ABE-7H16R30, ABE-7H16R31 sub-bases

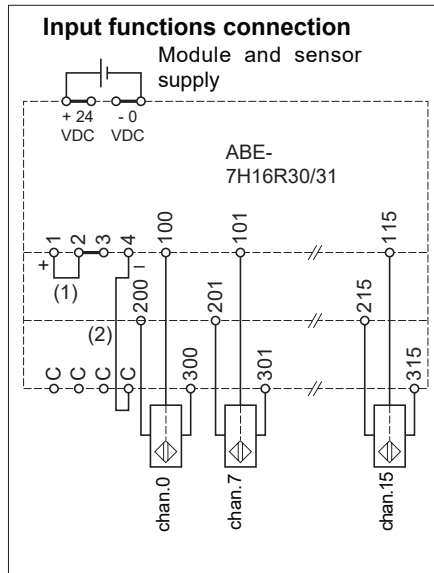
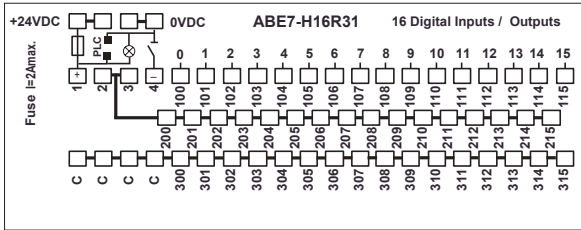

Connection of sensor common :

In order to create the sensor supply common :

- place the jumper (1) across terminals 1 & 2 : terminals 200 to 215 should be connected to the supply "+",
- connect terminal 4 to one of the "C" terminals on the third row (2) : terminals 300 to 315 should be connected to the supply "-".



Sub-bases are supplied with a general purpose 2 A fast blow fuse. In order to ensure optimum protection, this fuse should be rated according to the application (connection to input or output functions) and the maximum permissible current in the sub-base. Type and rating of fuse to be used :

- for input functions : 0.5 A fast blow fuse.

6.5-8 ABE-7H12R50 sub-base

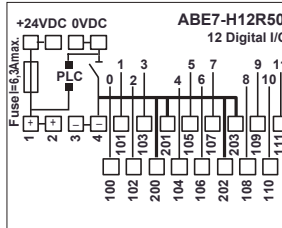

Input functions connection

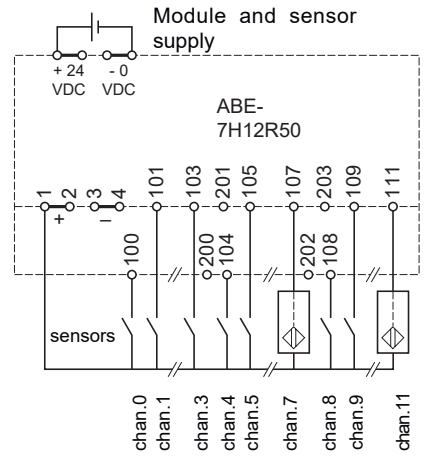

Output functions connection

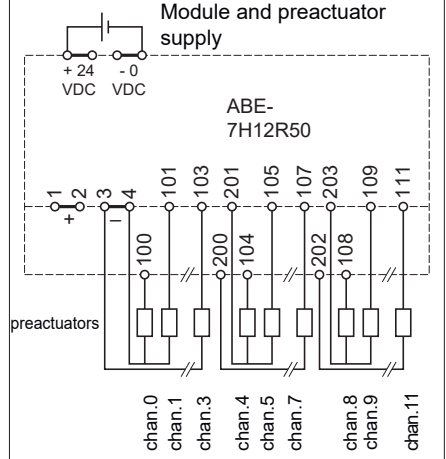

Connection of sensor common :

- on terminals 1 or 2 : sensors connected to the supply "+" (positive logic input).

⚠ Terminals 200/201/202 and 203 are connected to the "-" pole.

Connection of preactuator common :

The use of a number of terminals connected to the "-" pole (3, 4, 200, 201, 202 and 203) creates commons for each group of 4 or 2 channels (positive logic outputs)

⚠ The sub-base is supplied with a general purpose 6.3 A fast blow fuse. In order to ensure optimum protection, this fuse should be rated according to the application (connection to input or output functions) and the maximum permissible current in the sub-base. Type and rating of fuse to be used :

- for input functions : 0.5 A fast blow fuse,
- for output functions :
- 6.3 A fast blow fuse on ABE-7H12R50 sub-base

6.5-9 ABE-7H16R50 sub-base

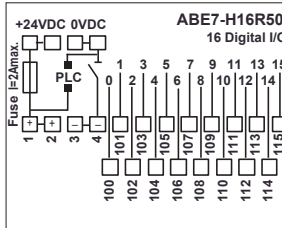

Input functions connection

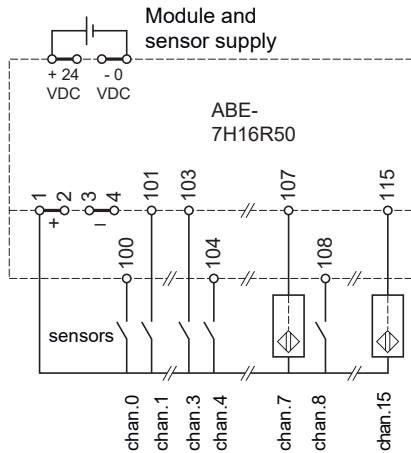

Output functions connection

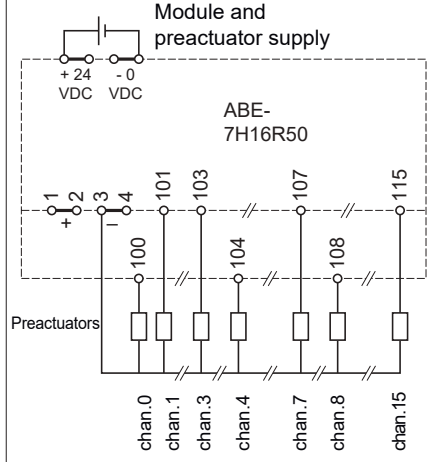

Connection of sensor common :

- on terminals 1 or 2 : sensors connected to the supply "+" (positive logic input).

Connection of preactuator common :

- on terminals 3 or 4 : preactuators connected to supply "-" (positive logic output).



The sub-base is supplied with a general purpose 6.3 A fast blow fuse. In order to ensure optimum protection, this fuse should be rated according to the application (connection to input or output functions) and the maximum permissible current in the sub-base. Type and rating of fuse to be used :

- for input functions : 0.5 A fast blow fuse,
- for output functions :
- 2 A fast blow fuse on ABE-7H16R50 sub-base

6.5-10 ABE-7H16F43 output sub-base with 1 fuse and 1 isolator per channel

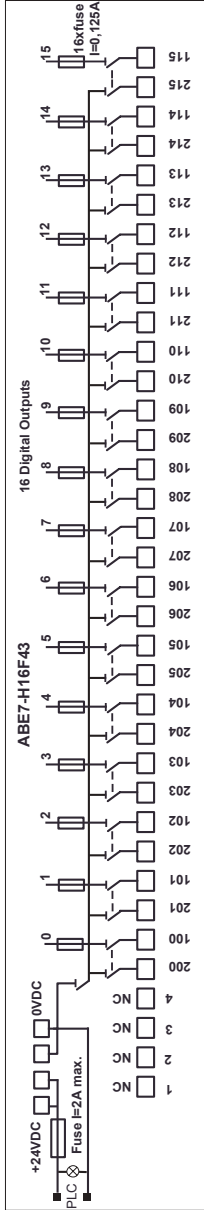

Output function connection

Type and rating of fuse supplied with the sub-base :
2 A fast blow fuse

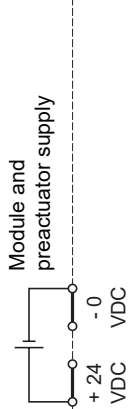

ABE-7H16F43

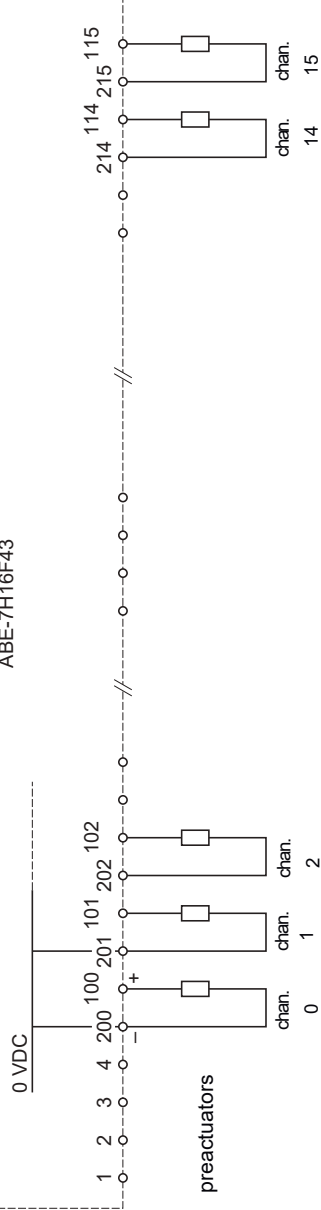

Each channel has :

- a 0.125 A fuse fitted as standard
- an isolator which breaks the "c" and the channel signal simultaneously



Terminals 200, 201, 202, ..., 214, 215 are connected to the supply "c"

6.5-11 ABE-7H16S43 input sub-base with 1 fuse and 1 isolator per channel

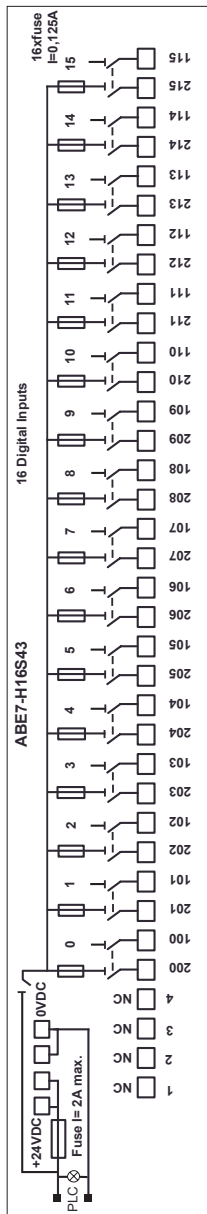

Input function connection

Type and rating of fuse supplied with the sub-base :
2 A fast blow fuse

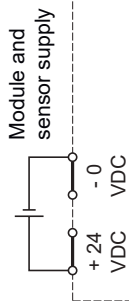

ABE-7H16S43

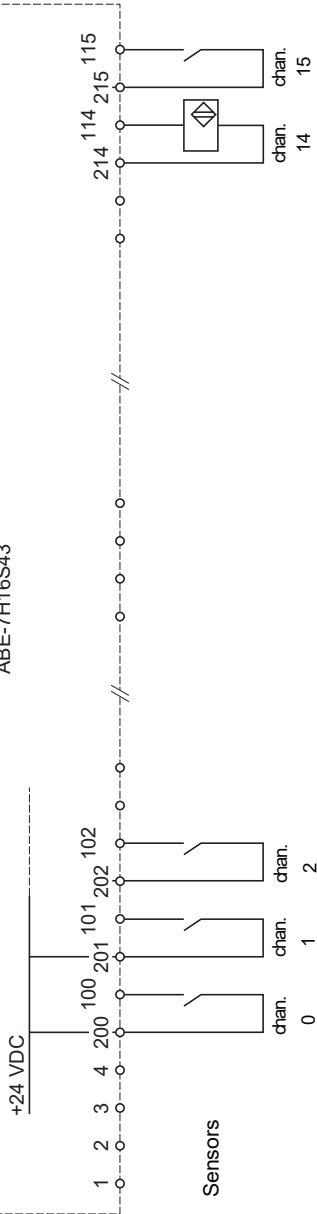

Each channel has :

- a 0.125 A fuse fitted as standard
- an isolator which breaks the "0" and the channel signal simultaneously



Terminals 200, 201, 202, ..., 214, 215 are connected to the supply "0"

6.5-12 Fixed relay output adaptor sub-bases : ABE-7R08S111, ABE-7R16S111, ABE-7R16S210, ABE-7R16S212

- **ABE-7R08S111 sub-bases** : 8 relay outputs, 1"N/O" twice 4 commons "+ or ~"
- **ABE-7R16S111** : 16 relay outputs, 1"N/O" twice 8 commons "+ or ~"

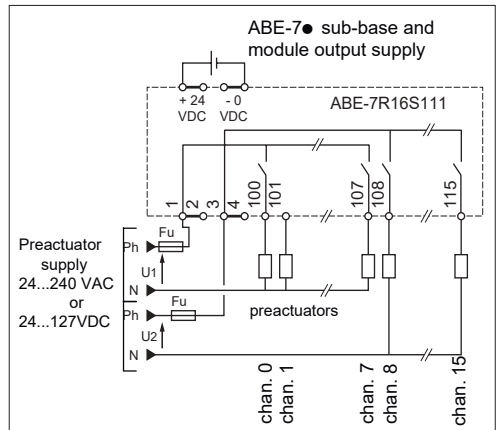
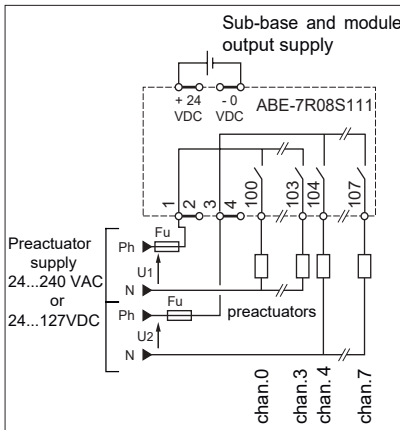
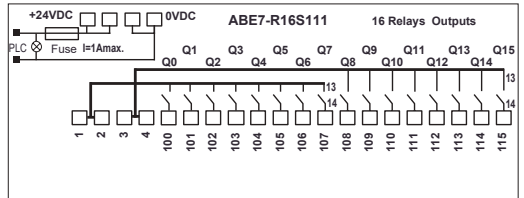
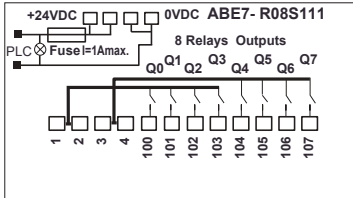

Type and rating of fuse supplied with the sub-base :
1 A fast blow fuse.

Fu : fuse to be rated according to the load



Protection of relay contacts :

Protection circuit must be placed across the preactuator terminals :

- RC or MOV circuit for AC,
- flywheel diode for DC

- **ABE-7R16S210 sub-base** : 16 relay outputs, 1 "N/O", volt-free contacts

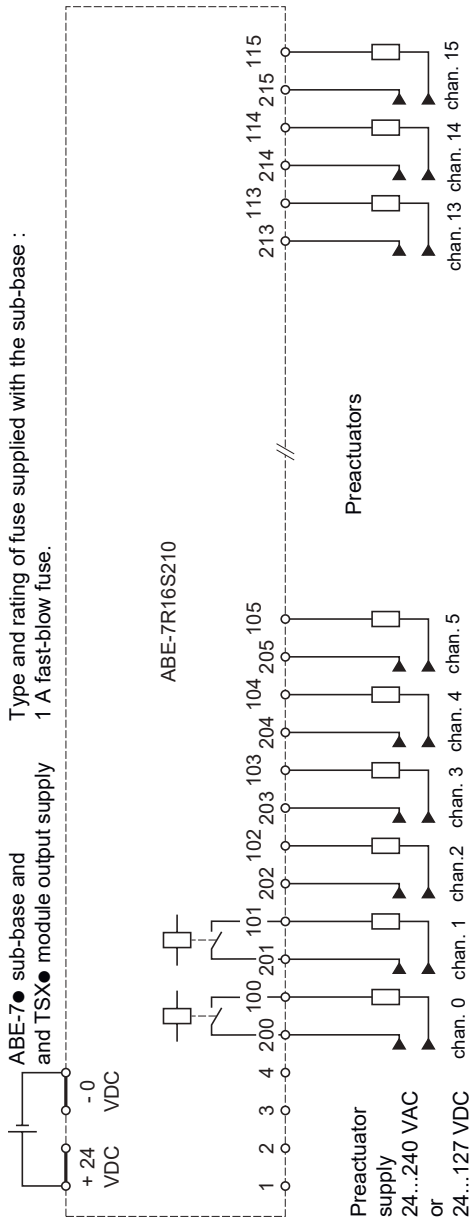
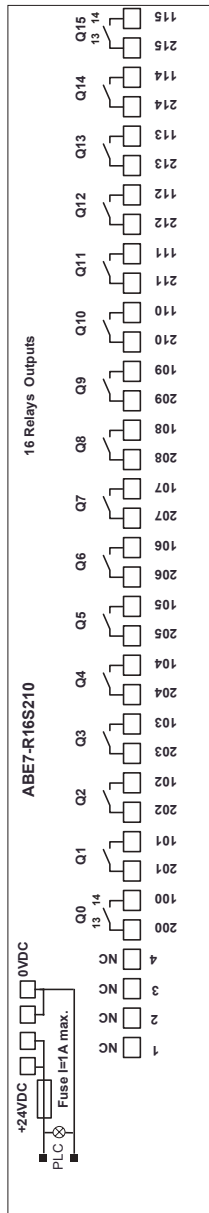

Protection of relay contacts :

A protection circuit must be placed across the terminals of each preactuator :

- RC or MOV circuit for AC,
- flywheel diode for DC

Provide one protection fuse per preactuator or per group if they are supplied with the same voltage.

- **ABE-7R16S212 sub-base** : 16 relay outputs, 1 "N/O", with distribution of 2 poles per group of 8 channels

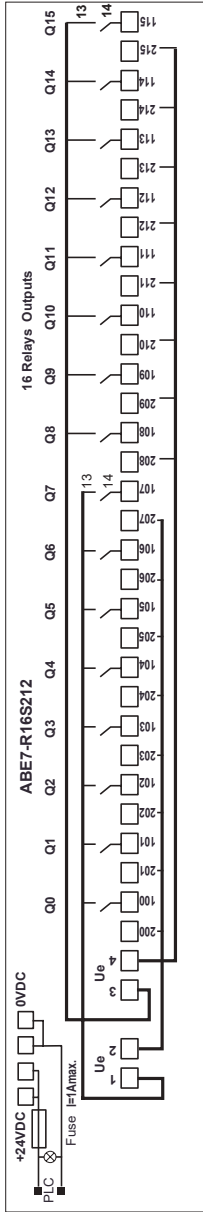

Type and rating of fuse supplied with the sub-base :
1 A fast blow fuse

ABE-7● sub-base and
TSX● module output supply

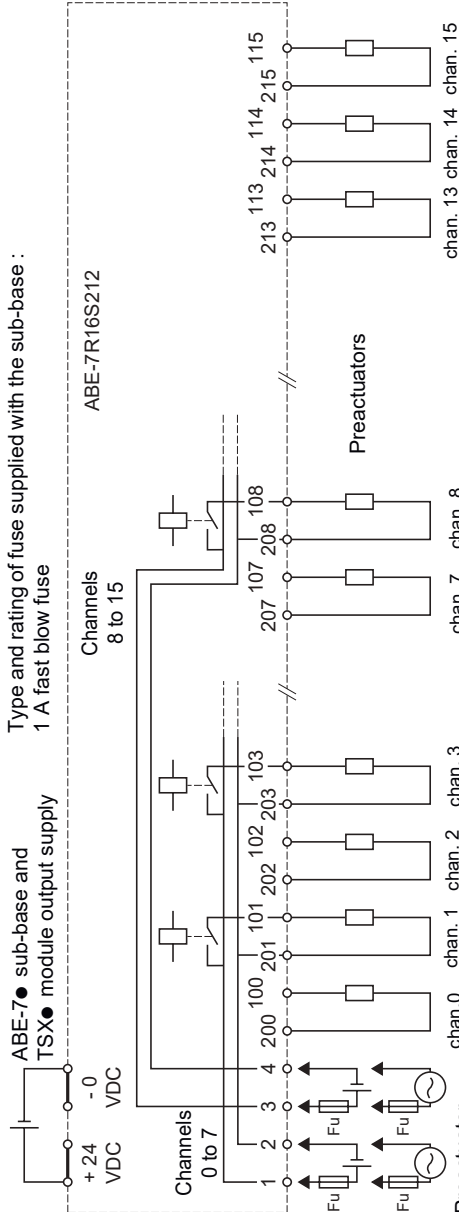

Protection of relay contacts :
A protection circuit must be placed across the terminals of each preactuator :

- RC or MOV circuit for AC,
- flywheel diode for DC

Fu : fuse to be rated according to the load

6.5-13 Fixed solid state relay input adaptor sub-bases : ABE-7S16E2B1, ABE-7S16E2E1, ABE-7S16E2E0, ABE-7S16E2F0, ABE-7S16E2M0

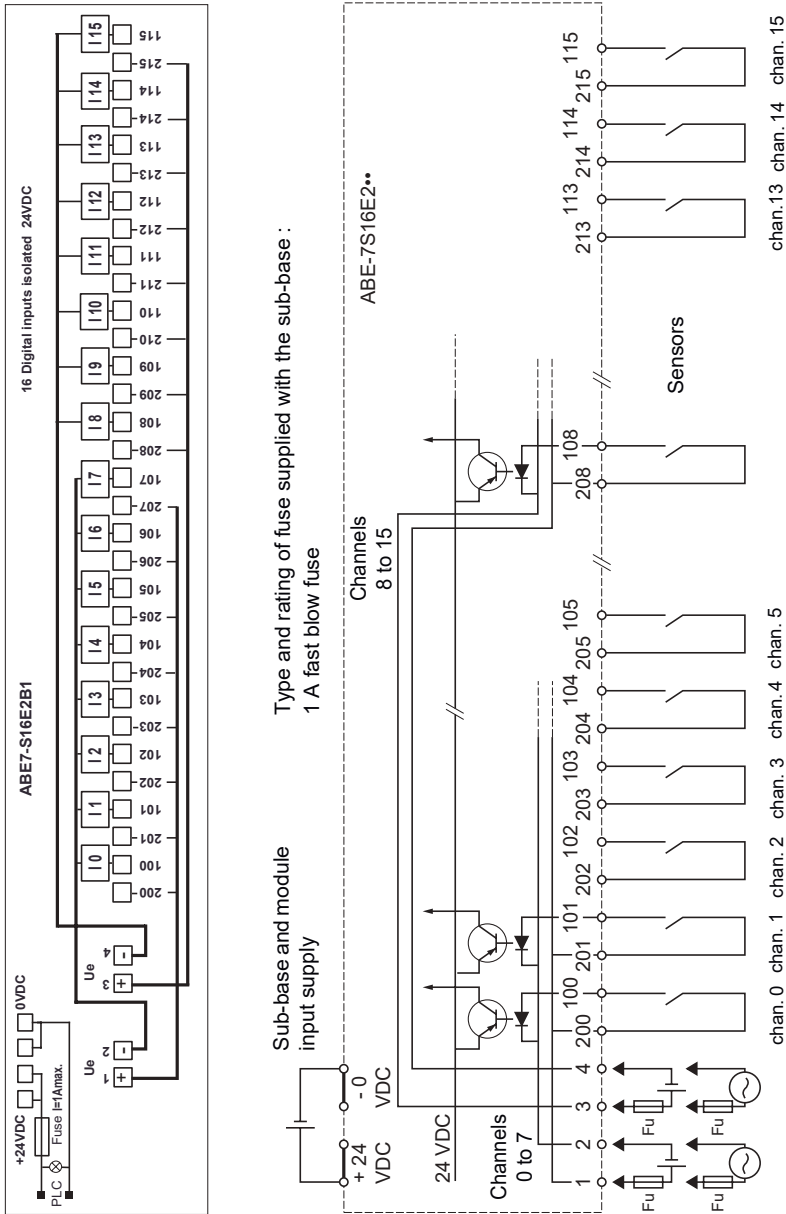

Fu : fuse to be rated according to the load

Sensor supply
--- or ~
depending on the type of sub-base

6.5-14 Solid state output adaptor sub-bases : ABE-7S16S2B0, ABE-7S16S2B2 and ABE-7S08S2B0, ABE-7S08S2B1

- **ABE-7S16S2B0 and ABE-7S16S2B2 sub-bases** : 16 solid state outputs/24VDC / 0.5A

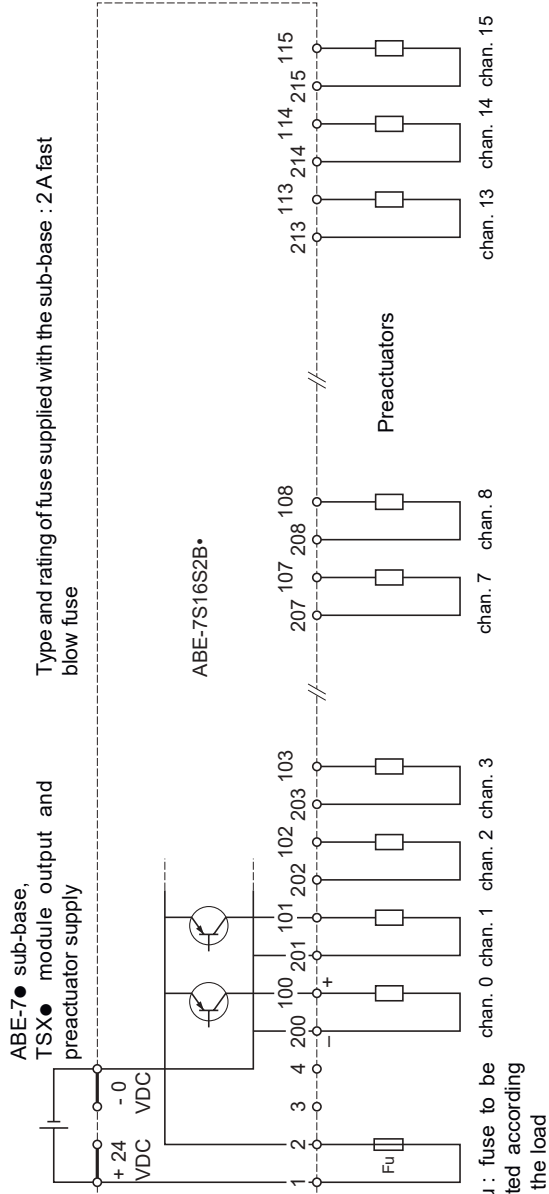
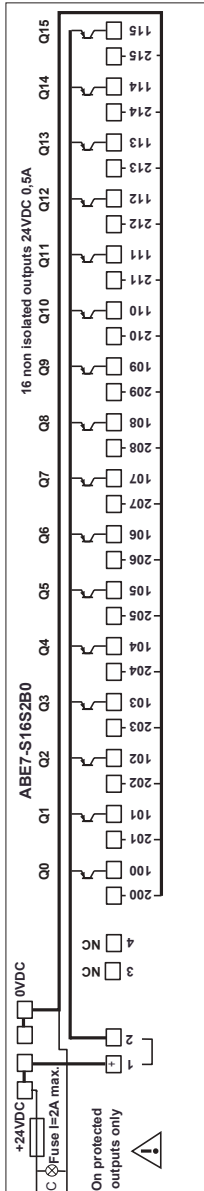

- **ABE-7S08S2B1 sub-base** : 8 solid state outputs / 24 VDC / 2A

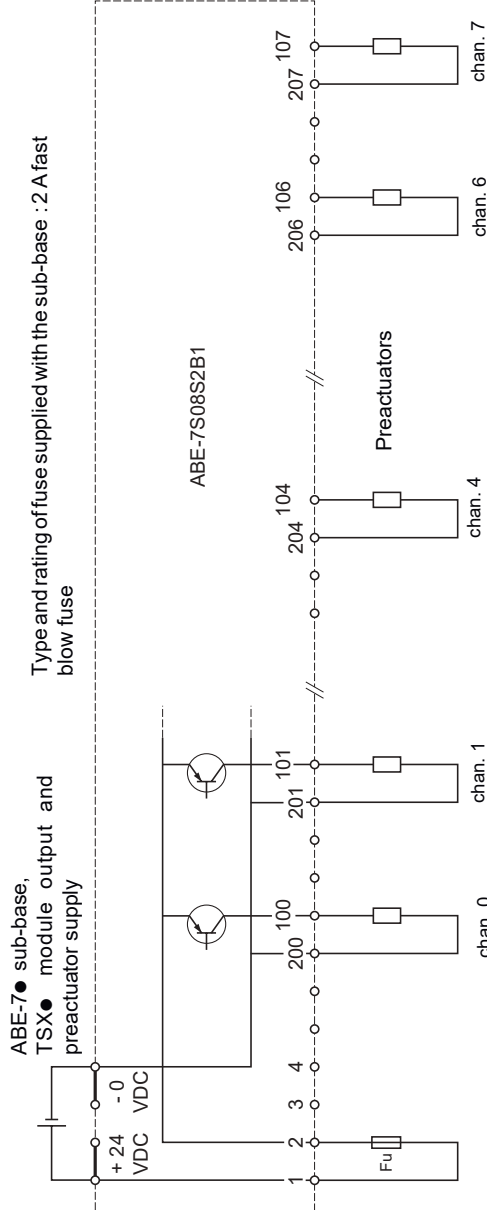
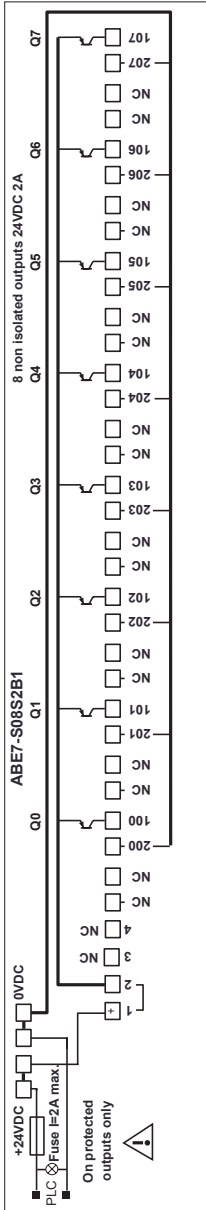

Fu : fuse to be
rated according
to the load

⚠ Filament lamps must not be connected

- **ABE-7S08S2B0 sub-base** : 8 solid state outputs / 24 VDC / 0.5A

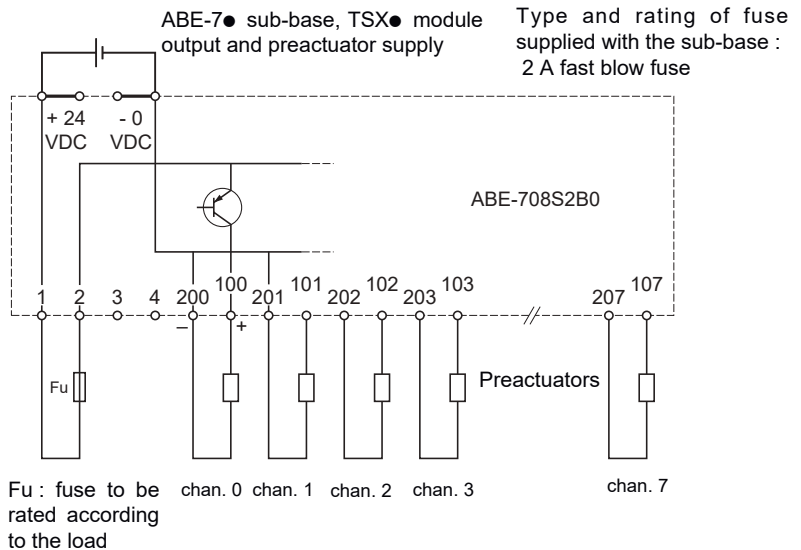
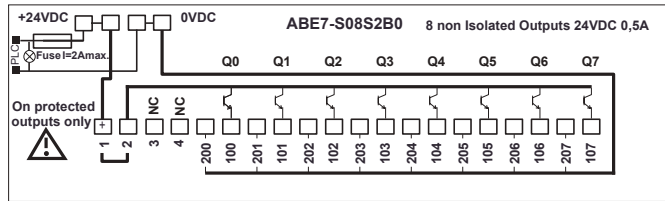

6.5-15 Solid state or electromechanical relay output sub-bases, relay 10mm wide

• 1"N/O" sub-bases, volt-free contact

- ABE-7R16T210 with electromechanical relays
- ABE-7P16T210 relays not supplied

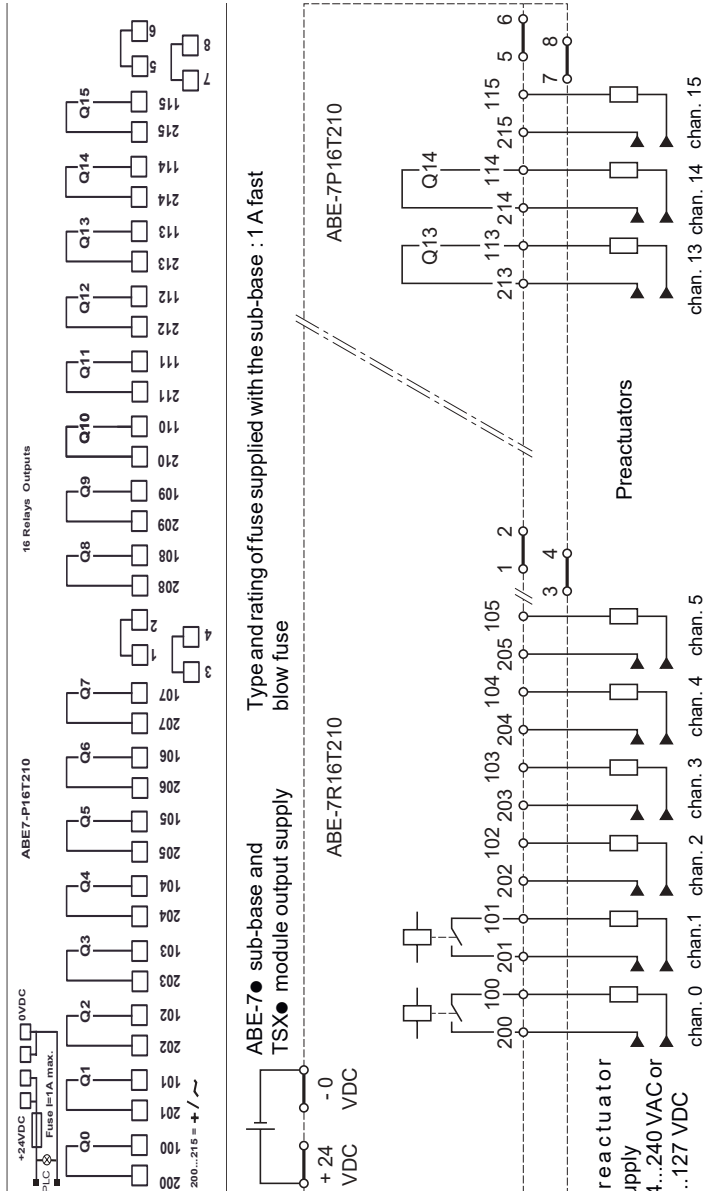

Protection of relay contacts :

- A protection circuit must be placed across the terminals of each preactuator :
- RC or MOV circuit for AC
 - flywheel diode for DC

Provide one protection fuse per preactuator or per group if they are supplied with the same voltage

- 1"N/O" sub-bases, with distribution of 2 poles per group of 8 channels
- ABE-7R16T212 with electromechanical relays
- ABE-7P16T212 relays not supplied

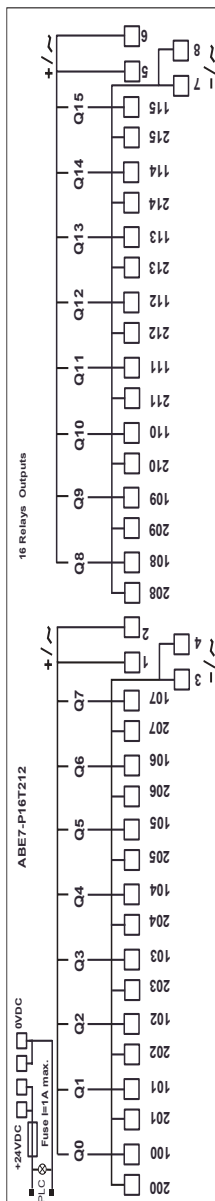

ABE-7● sub-base and
TSX● module output supply
Type and rating of fuse supplied with the sub-base : 1 A fast
blow fuse

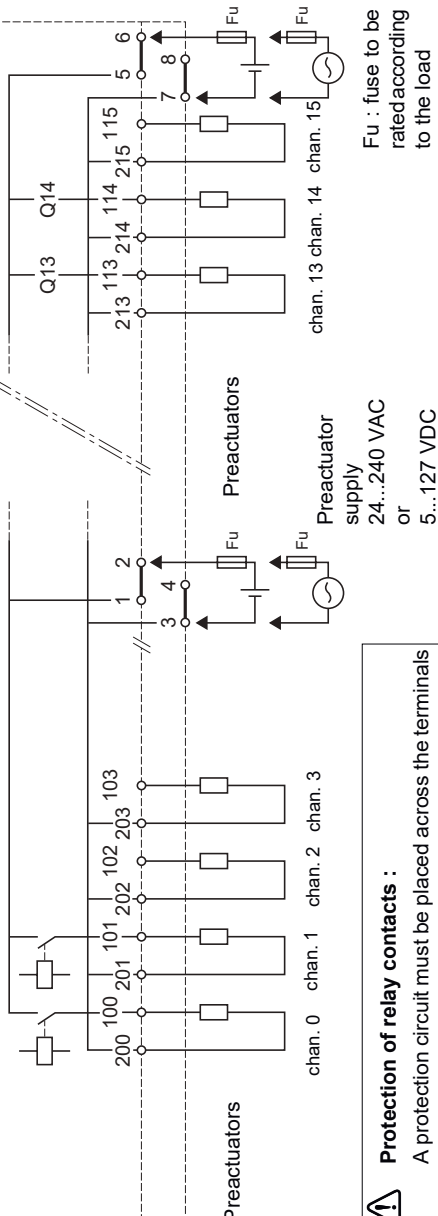

Protection of relay contacts :
A protection circuit must be placed across the terminals of each preactor :

- RC or MOV circuit for AC
- flywheel diode for DC

• ABE-7R16T230 sub-base with electromechanical relays (1 "C/O"), volt-free contact

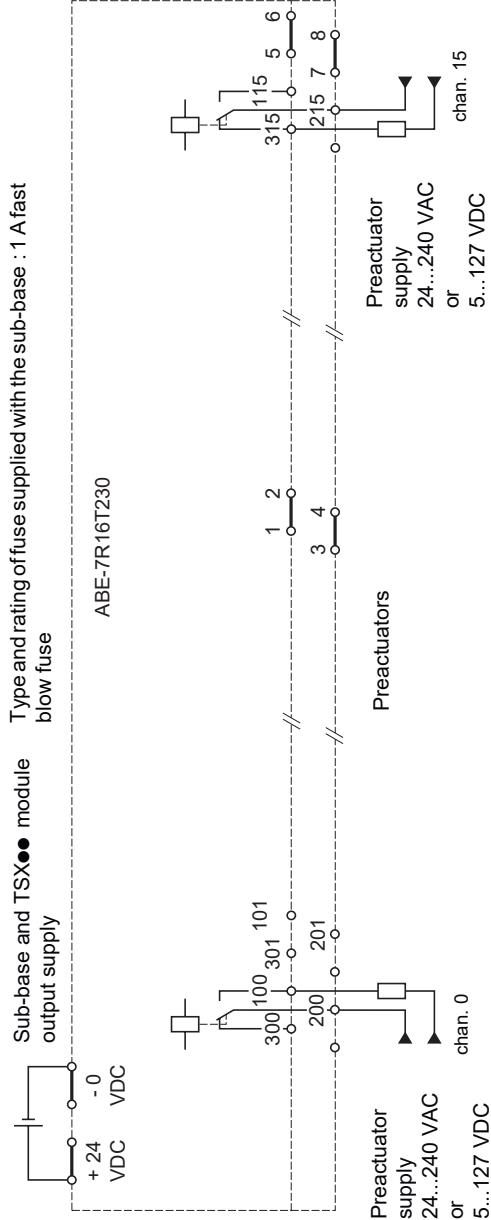
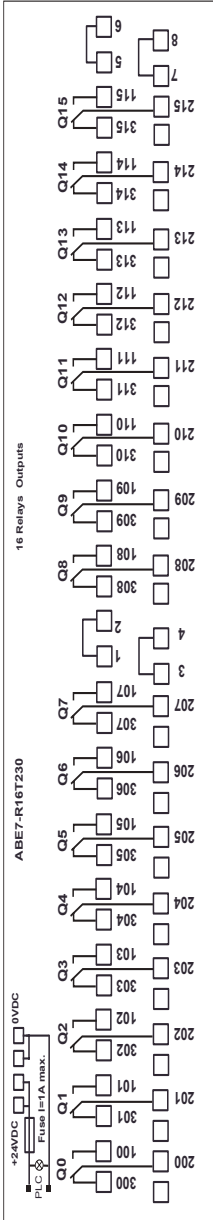

Protection of relay contacts :

A protection circuit must be placed across the terminals of each preactuator :

- RC or MOV circuit for AC
- flywheel diode for DC

Provide one protection fuse per preactuator or per group if they are supplied with the same voltage

- **ABE-7R16T231 sub-base, with electromechanical relay (1"C/O"), distribution of one common per group of 8 channels**

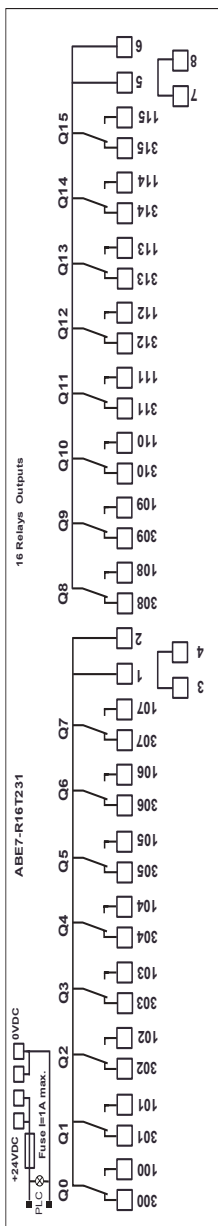

Sub-base and TSX●● module
Type and rating of fuse supplied with the sub-base : 1 A fast
blow fuse

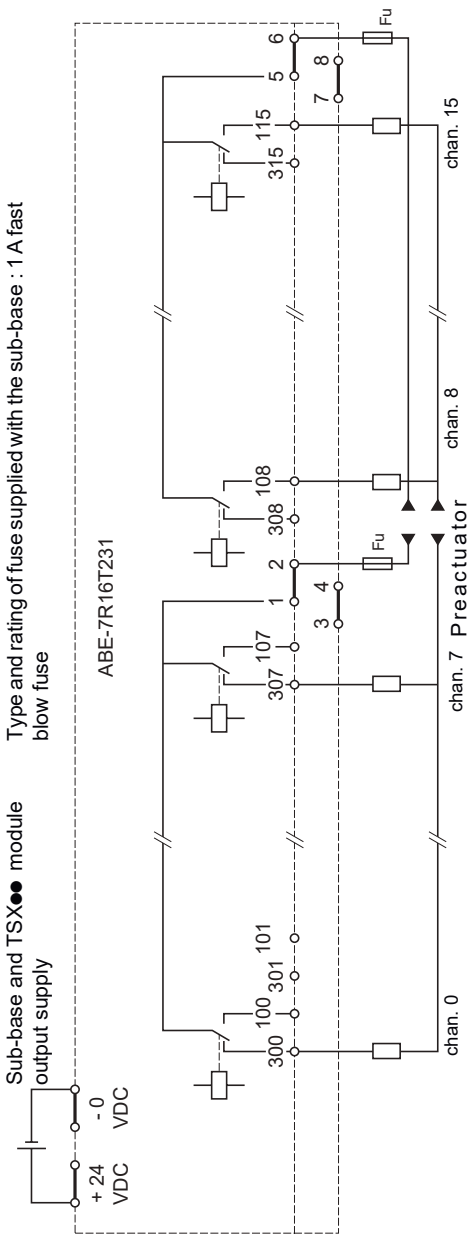

Protection of relay contacts :

A protection circuit must be placed across the terminals of each pre-actuator :

- RC or MOV circuit for AC
- flywheel diode for DC

Fu : fuse to be rated according to the load

- ABE-7P16T214 sub-base relays not supplied
1"N/O", volt-free contact
1 fuse per channel

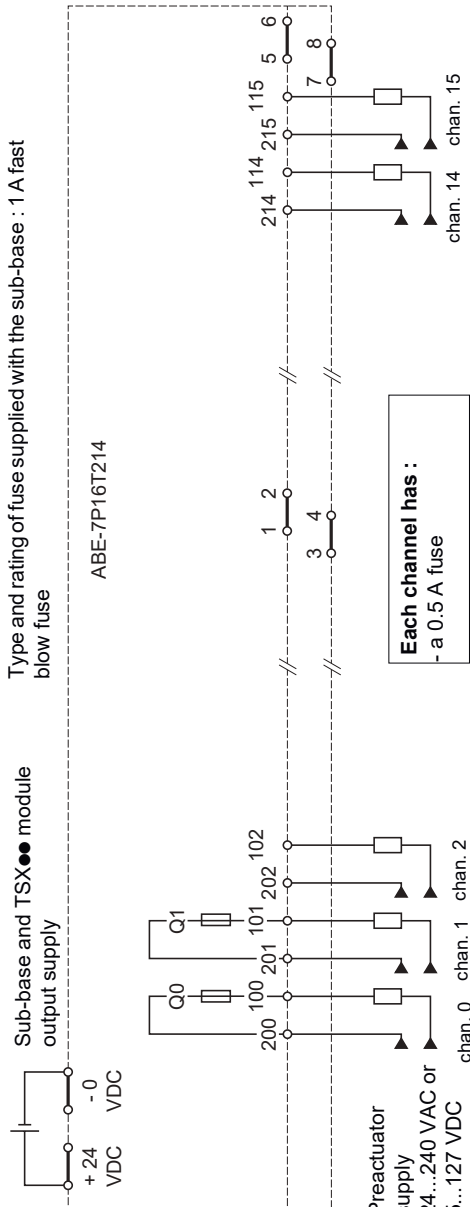
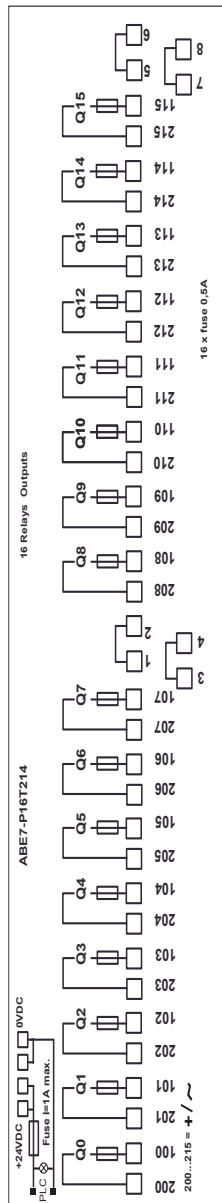

Protection of relay contacts :
A protection circuit must be placed across the terminals of each preactuator :

- RC or MOV circuit for AC
- flywheel diode for DC

Provide one protection fuse per reactor or per group if they are supplied with the same voltage

- **ABE-7P16T215 sub-base relays not supplied**
1"N/O", distribution of 2 poles per group of 8 channels
1 fuse per channel

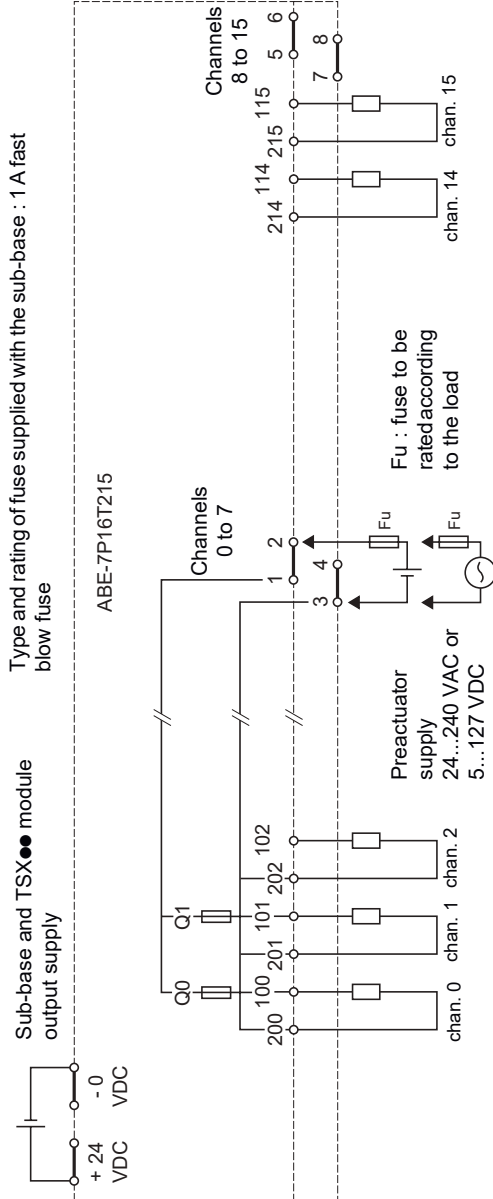
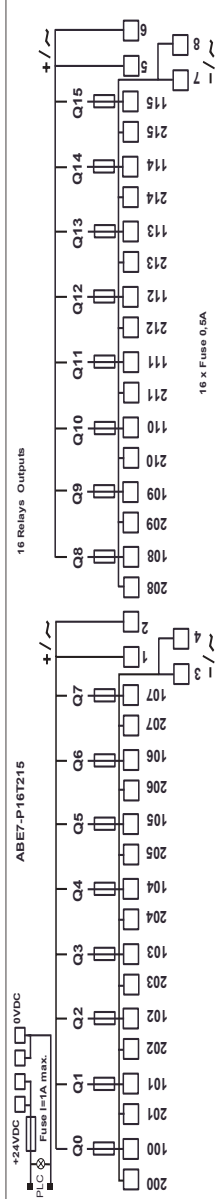

Protection of relay contacts :
A protection circuit must be placed across the terminals of each pre-actuator :

- RC or MOV circuit for AC
- flywheel diode for DC

Each channel has :
- a 0.5 A fuse

6.5-16 Electromechanical or solid state relay input or output sub-bases, relay 12.5 mm wide

- 1"C/O" sub-bases, volt-free contact
 - ABE-7R16T330 with electromechanical relays
 - ABE-7P16T330 relays not supplied

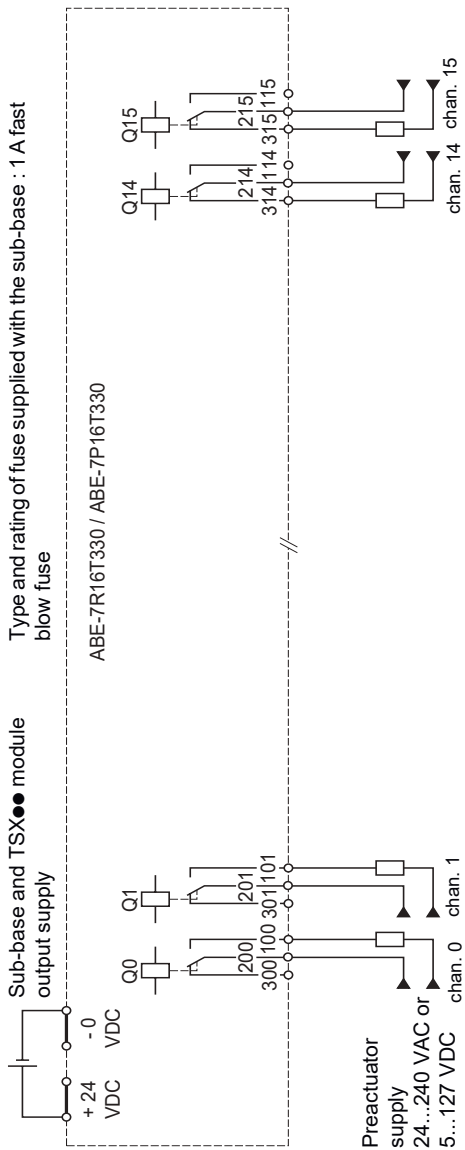
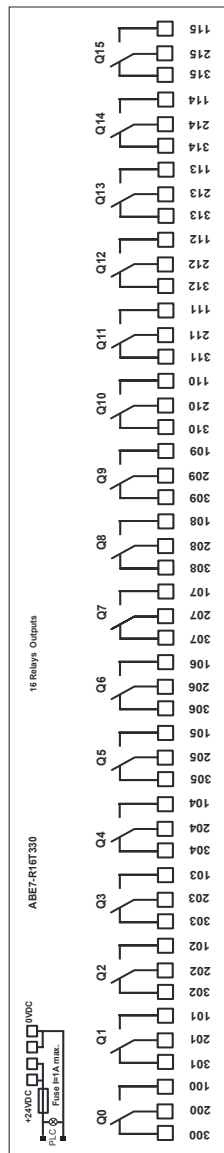

Protection of relay contacts :

A protection circuit must be placed across the terminals of each preactuator :

- RC or MOV circuit for AC
- flywheel diode for DC

Provide one protection fuse per preactuator or per group if they are supplied with the same voltage

- 1"C/O" sub-bases, distribution of 2 poles per group of 4 channels
- ABE-7R16T332 with electromechanical relays
- ABE-7P16T332 relays not supplied

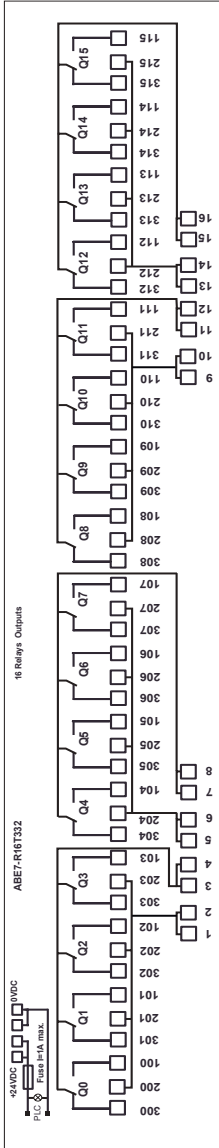

Type and rating of fuse supplied with the sub-base : 1 A fast
blow fuse

Sub-base and TSX module
output supply

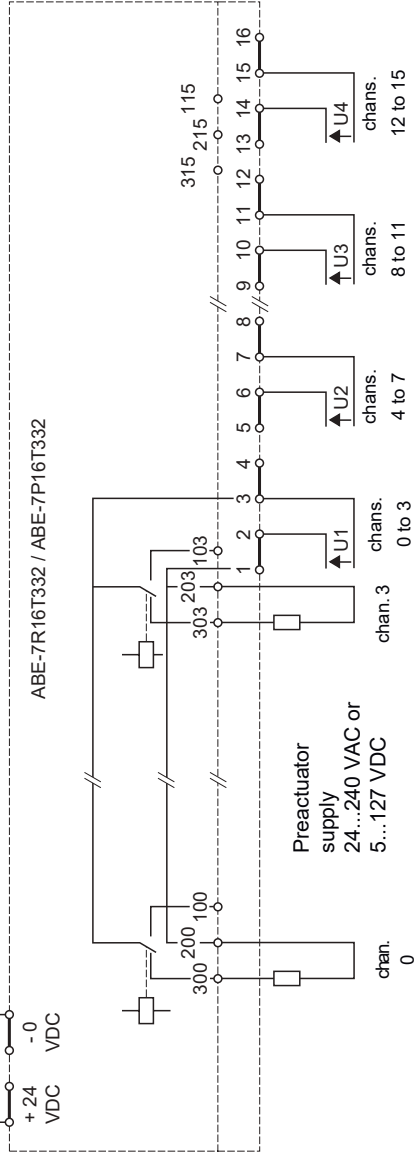

Protection of relay contacts :
A protection circuit must be placed across the terminals of each preactuator :

- RC or MOV circuit for AC
- flywheel diode for DC

Provide a protection fuse on the preactuator supply.

- ABE-7R16T370 sub-bases, with electromechanical relay (2 "C/O"), volt-free contact

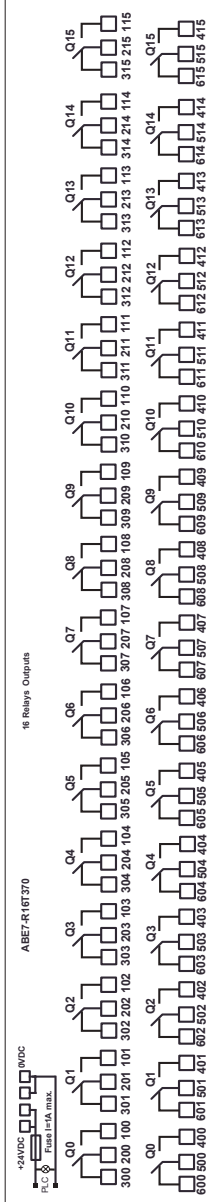

Sub-base and TSX●● module
output supply

Type and rating of fuse supplied with the sub-base : 1 A fast
blow fuse

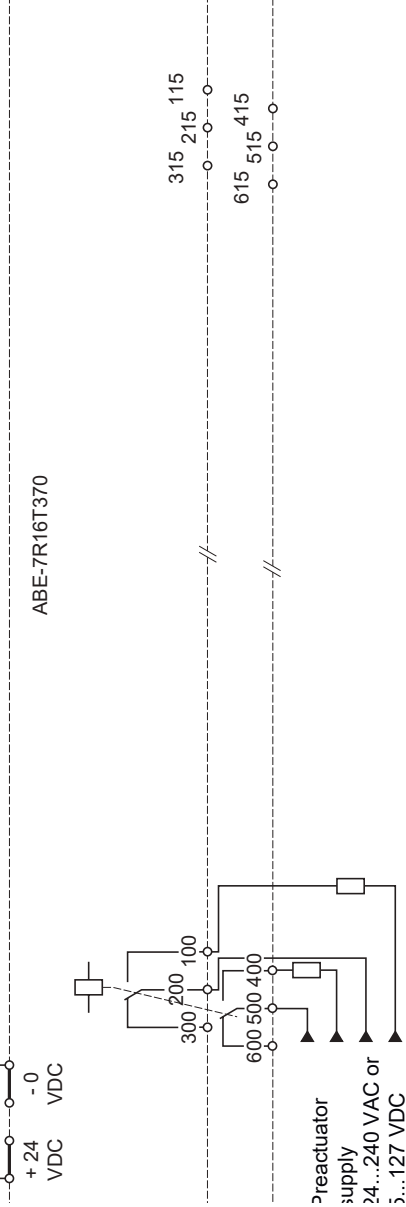

Protection of relay contacts :

A protection circuit must be placed across the terminals of each preactuator :

- RC or MOV circuit for AC
- flywheel diode for DC

Provide one protection fuse per reactor or per group if they are supplied with the same voltage

• ABE-7P16T334 sub-base, relay not supplied (1"C/O"), volt-free contact

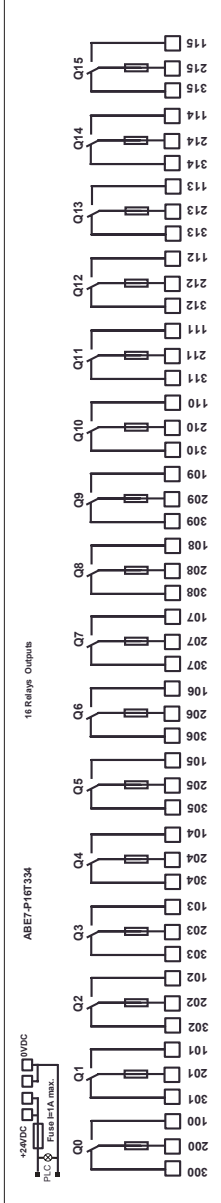

Sub-base and TSX module
output supply

Type and rating of fuse supplied with the sub-base : 1 A fast
blow fuse

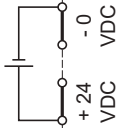

ABE-7P16T334

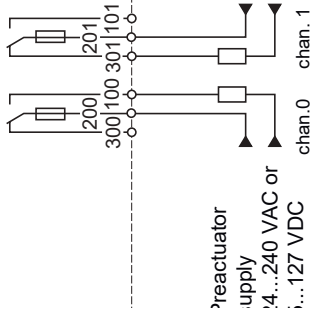

Each channel has:
- a 2 A fuse

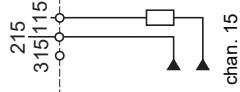

Protection of relay contacts :

A protection circuit must be placed across the terminals of each preactuator :

- RC or MOV circuit for AC
- flywheel diode for DC

Provide one protection fuse per preactuator or per group if they are supplied with the same voltage

- ABE-7P16T318 sub-base relays not supplied
- 1 "C/O" distribution of 2 poles per group of 4 channels
- 1 fuse and 1 isolator per channel

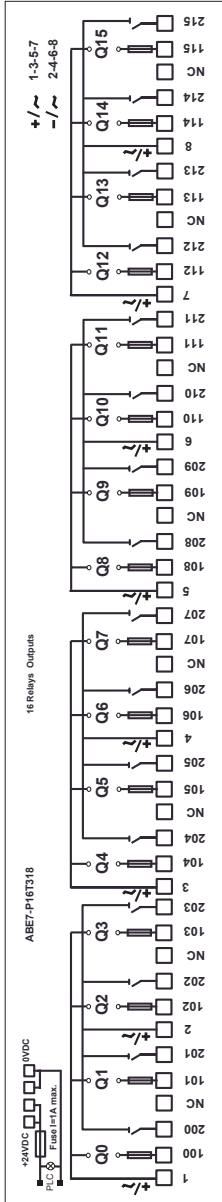

Type and rating of fuse supplied with the sub-base : 1 A fast
blow fuse

Sub-base and TSX module
output supply

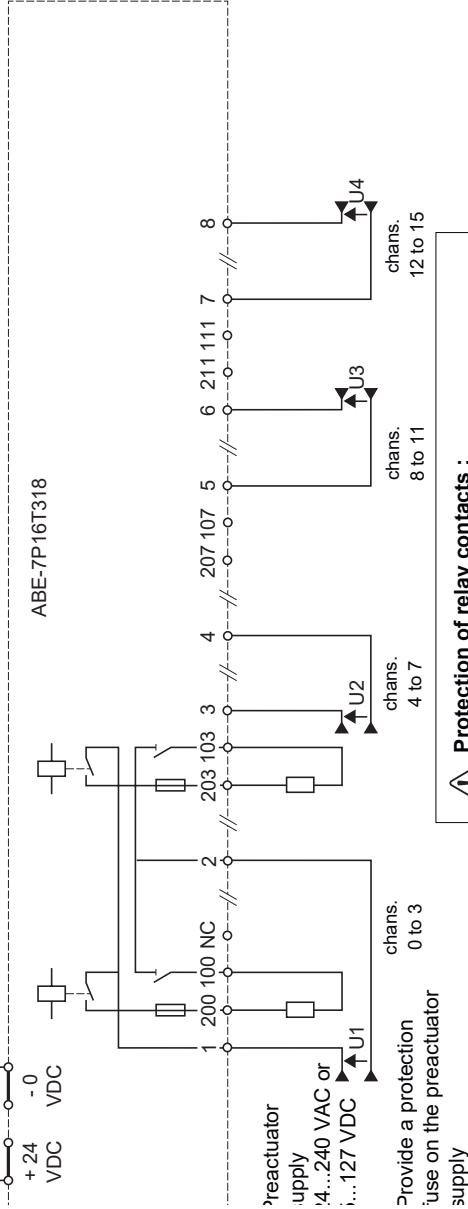

Protection of relay contacts :

- A protection circuit must be placed across the terminals of each preactuator :
- RC or MOV circuit for AC
- flywheel diode for DC

Each channel has :

- a 2 A fuse
- isolated common

• ABE-7P16F310 solid state relay input sub-base (relays not supplied), volt-free

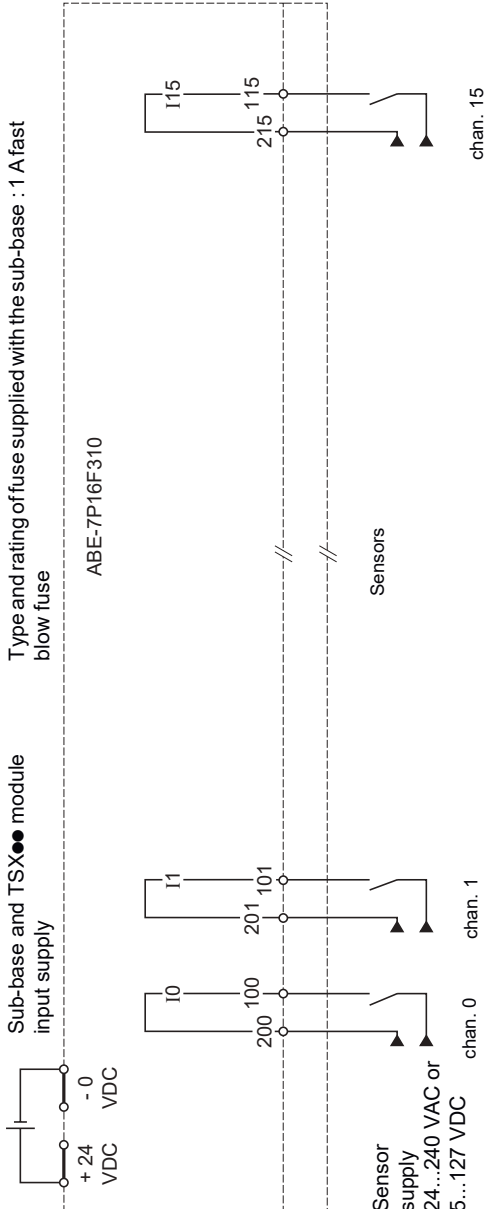
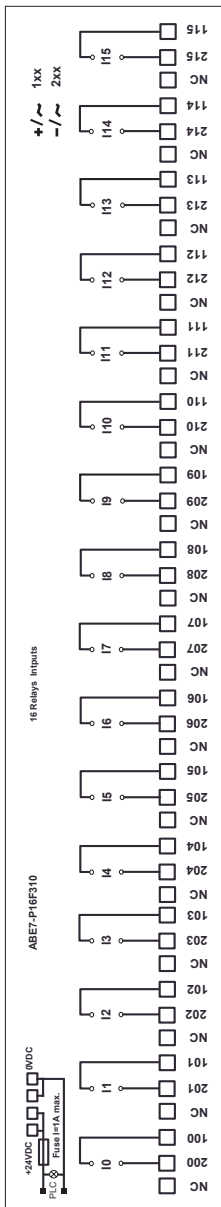

Provide one protection fuse per group of sensors if they are supplied with the same voltage

- ABE-7P16F312 solid state relay input sub-base (relays not supplied), distribution of 2 poles per group of 8 channels

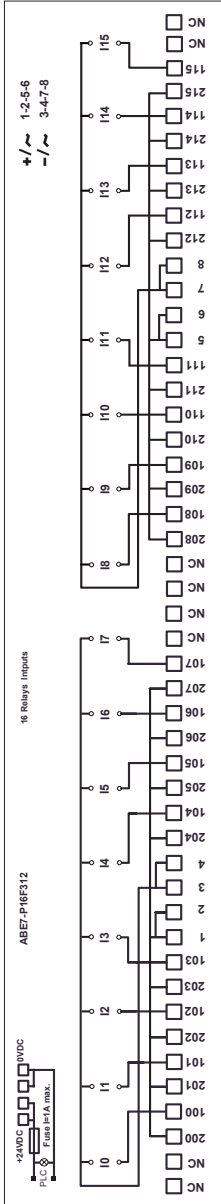

Sub-base and TSX●●● module
output supply

Type and rating of fuse supplied with the sub-base : 1 A fast
blow fuse

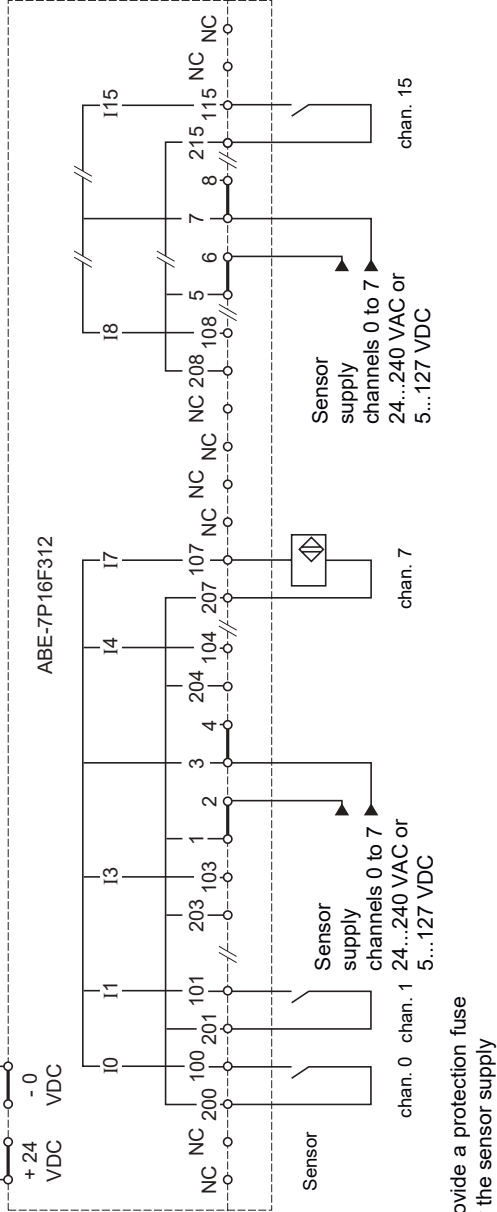

6.6 Compatibility table for relays and ABE-7R16T●●●, ABE-7P16T●●●, ABE-7P16F●●● sub-bases

Sub-bases ABE-7	Equipped with electromechanical relays				not equipped with relays			
	R16T21●	R16T23●	R16T33●	R16T370	P16T21●	P16T33●	P16T318	P16F31●
Electromechanical relay (output) (1) compatible relays (2) except ABE-7P16T334								
10mm	ABR-7S21 1"N/O"							
	ABR-7S23 1"C/O"	(1)						
12.5mm	ABR-7S33 1"C/O"							
	ABR-7S37 2"C/O"							
Solid state relay (output)								
10mm	ABS-7SC2E	(1)						
	ABS-7SA2M	(1)						
12.5mm	ABS-7SC3BA		(1)			(2)		
	ABS-7SC3E		(1)					
	ABS-7SA3M		(1)					
Solid state relay (input)								
12.5mm	ABS-7EC3AL							
	ABS-7EC3B2							
	ABS-7EC3E2							
	ABS-7EA3E5							
	ABS-7EA3F5							
	ABS-7EA3F6							
	ABS-7EA3M5							
	ABS-7EA3M6							
Continuity block								
10 mm	ABE-7ACC20							
12.5 mm	ABE-7ACC21							

6.7 Accessories

- **Add-on shunt terminal block :**

ABE-7BV10 : terminal block with 10 screw terminals
ABE-7BV20 : terminal block with 20 screw terminals

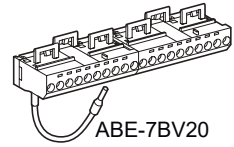

ABE-7BV20

- **Adaptor sub-base :**

ABE-7ACC02 : used to switch from 16 channels to 2x8 channels

- **Mounting kit :**

ABE-7ACC01 : is used to fix sub-bases to full plates

- **Dust and damp-proof cable bushing :**

ABE-7ACC84 : is used to feed through the enclosure without isolating the leads

- **Enclosure feed through :**

ABE-7ACC83 : HE10 connectors for 8/12 channels → M23 cylindrical connector.

ABE-7ACC82 : HE10 connector for 16 channels → M23 cylindrical connector.

ABE-7ACC80 : HE10 connectors for 32 channels → "HARTING" type connector.

ABE-7ACC81 : plug-in connector for ABE-7ACC80

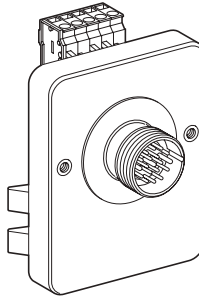

ABE-7ACC82

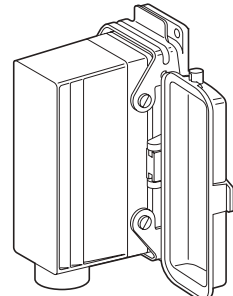

ABE-7ACC80

- **Removable continuity module :**

ABE-7ACC20 : 10 mm wide
ABE-7ACC21 : 12.5 mm wide

- **Software for marking customer labels :**

ABE-7LOGV10

- **Glass 5 x 20 fast blow fuse :**

ABE-7FU012	0.125 A	ABE-7FU200	2 A
ABE-7F7050	0.5 A	ABE-7FU630	6.3 A
ABE-7FU100	1 A		

- **Self-adhesive label holder :**

AR1-SB3 for AB1-R. / AB1-G. type labels

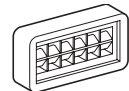

- **Relays for ABE-7R16T●●●, ABE-7P16T●●● and ABE-7P16F●●● sub-bases :**

ABR-7S●●● : electromechanical output relays
(see page 6/41)

ABS-7S●●● : solid state output relays
(see page 6/41)

ABS-7E●●● : solid state input relays
(see page 6/41)

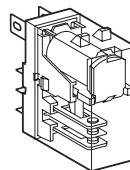

ABR-7S●●●

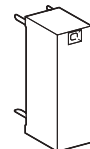

ABS-7S●●●

6.8 Sub-base electrical characteristics

6.8-1 Fixed input adaptor sub-bases

Types of sub-base		ABE-7 S16E2B1	ABE-7 S16E2E1	ABE-7 S16E2E0	ABE-7 S16E2F0	ABE-7 S16E2M0	
Number of channels		16	16	16	16	16	
Control circuit characteristics (application inputs)							
Nominal values	Voltage	24VDC	48VDC	48VAC	110/ 130VAC	230/ 240VAC	
	Current	12 mA	13 mA	12 mA	8.3 mA	8 mA	
	Frequency	-	-	50/60 Hz	50/60 Hz	50/60 Hz	
Input limit values	At state 1	Voltage	≥ 13.7 V	≥ 30 V	≥ 32 V	≥ 79 V	≥ 164 V
		Current	≥ 5 mA	≥ 6 mA	≥ 5 mA	≥ 5 mA	≥ 4.5 mA
	At state 0	Voltage	≤ 5 V	≤ 10 V	≤ 10 V	≤ 30 V	≤ 40 V
		Current	≤ 2 mA	≤ 2 mA	≤ 1.5 mA	≤ 2 mA	≤ 2 mA
	Frequency	-	-	47...63 Hz	47...63 Hz	47...63 Hz	
	Sensor supply (ripple included)	19..30 V	38.4...60 V	38.4...53 V	96...143 V	184...264 V	
IEC 1131-2 conformity		type 1	type 2	type 1	type 1	type 1	
Response time	State 0 to 1	0.05 ms	0.05 ms	20 ms	20 ms	20 ms	
	State 1 to 0	0.4 ms	0.4 ms	20 ms	20 ms	20 ms	
Maximum switching frequency		1000 Hz	1000 Hz	25 Hz	25 Hz	25 Hz	
Nominal insulation voltage	I/O		300 V				
Nominal impulse withstand voltage (1.2 / 50)	I/O		2.5 kV				

6.8-2 Fixed solid state output adaptor sub-bases

Types of sub-base		ABE-7 S08S2B0	ABE-7 S16S2B2	ABE-7 S08S2B1	
Number of channels		8 / 16	16	8	
Output circuit characteristics					
DC load	Resistive, DC12 duty	Voltage	24 VDC	24 VDC	24 VDC
		Current	0.5 A	0.5 A	2 A (1)
	Inductive, DC13 duty	Voltage	24 VDC	24 VDC	24 VDC
		Current	0.25 A	0.25 A	0.5 A (1)
	Filament lamp	10 W	10 W	no	
Limit values		Voltage	19...30 VDC	19...30 VDC	19...30 VDC
Leakage current at state 0			≤ 0.3 mA	≤ 0.3 mA	≤ 0.5 mA
Residual voltage at state 1			≤ 0.6 V	≤ 0.6 V	≤ 0.5 V
Minimum current per channel			1 mA	1 mA	1 mA
Response	State 0 to 1		0.1 ms	0.1 ms	0.1 ms
	State 1 to 0		0.02 ms	0.02 ms	0.02 ms
Built-in protection	Against overloads and short-circuits		Yes by current limiter and circuit-breaker Id > 0.75 A	Id > 0.75 A	Id > 2.6 A
	Against inductive overvoltages		Yes by integrated zener diode		
	Against reversed polarity		Yes by peak limiter		
Switching frequency on inductive load			< 0.6 LI ²	< 0.6 LI ²	< 0.5 LI ²
Fault detection feedback			Yes	No	Yes
Nominal insulation voltage	I/O		300 V		
Nominal impulse withstand voltage (1.2 / 50)	I/O		2.5 kV		

(1) from 50°C to + 60°C alternating between channels

6.8-3 Fixed relay output adaptor sub-bases

Types of sub-base		ABE-7 R●●S111	ABE-7 R●●S210	ABE-7 R16S212	
Number of channels		8 / 16	8 / 16	16	
Contact characteristics					
Limit operating voltage	AC ~	250 V	250 V	250 V	
	DC ---	30 V	125 V	125 V	
Thermal current		3 A	5A	5A	
AC load	Resistive, AC12 duty	Voltage	230 VAC	230 VAC	230 VAC
		Current (1)	0.6 A	1.5 A	1.5 A
	Inductive, AC15 duty	Voltage	230 VAC	230 VAC	230 VAC
		Current (1)	0.4 A	0.9 A	0.9 A
DC load	Resistive, DC12 duty	Voltage	24 VDC	24 VDC	24 VDC
		Current (1)	0.6 A	1.5 A	1.5 A
	Inductive, DC13 duty	Voltage	24 VDC	24 VDC	24 VDC
		L/R = 10 ms Current (1)	0.2A	0.6 A	0.6 A
Minimum switching	Current	1 mA	10 mA	10 mA	
	Voltage	5 V	5 V	5 V	
Response time	State 0 to 1	10 ms	10 ms	10 ms	
	State 1 to 0	6 ms	5 ms	5 ms	
Maximum rate of on-load operation		0.5 Hz	0.5 Hz	0.5 Hz	
Built-in protection	Against overloads and short-circuits	None, fit a fast blow fuse per channel or group of channels			
	Against inductive overvoltages in AC	None, an RC circuit or an MOV (ZNO) peak limiter appropriate to the voltage must be placed across the terminals of each preactuator			
	Against inductive overvoltages in DC	None, a flywheel diode must be placed across the terminals of each preactuator			
Nominal insulation voltage	Coil/contact	300 V			
Nominal impulse withstand voltage (1.2 / 50)	Coil/contact	2.5 kV			

(1) for 0.5 x 10⁶ operations

6.8-4 Removable output electromechanical relays

Relay references	ABR-7	→	S21	S23	S33	S37
Relay width			10 mm	10 mm	12.5 mm	12.5 mm
Contact characteristics						
Contact type			1"N/O"	1"C/O"	1"C/O"	2"C/O"
Max operating voltage	AC ~		250 V	250 V	264 V	264 V
(in line with IEC 947-5-1)	DC ---		125 V	125 V	125 V	125 V
Thermal current			4 A	4 A	5 A	5 A
Frequency of the usage current			50/60 Hz			
AC load	Resistive,	Voltage	230 VAC	230 VAC	230 VAC	230 VAC
	AC12 duty	Current (1)	1.5 A	1.2 A	3 A	2.5 A
	Inductive,	Voltage	230 VAC	230 VAC	230 VAC	230 VAC
	AC15 duty	Current (1)	0.9 A	0.7 A	1.7 A	1.3 A
DC load	Resistive,	Voltage	24 VDC	24 VDC	24 VDC	24 VDC
	DC12 duty	Current (1)	1.5 A	1.2 A	3 A	2.5 A
	Inductive,	Voltage	24 VDC	24 VDC	24 VDC	24 VDC
	DC13 duty					
	L/R = 10 ms	Current (1)	0.6 A	0.45 A	1.4 A	1 A
Minimum switching		Current	10 mA	10 mA	100 mA	100 mA
		Voltage	5 V	5 V	5 V	5 V
Response time		State 0 to 1	10 ms	10 ms	13 ms	15 ms
		State 1 to 0	5 ms	5 ms	13 ms	20 ms
Maximum rate of on-load operation			0.5 Hz	0.5 Hz	0.5 Hz	0.5 Hz
Nominal insulation voltage	Coil/contact		300 V			
Nominal impulse withstand voltage	Coil/contact		2.5 kV			
(1.2 / 50)						

6.8-5 Removable input solid state relays

References	ABS-7	→	EC3AL	EC3B2	EC3E2	EA3E5	EA3F5	EA3M5
Relay width			12.5mm	12.5mm	12.5mm	12.5mm	12.5mm	12.5mm
Control characteristics								
Nominal operating voltage (Us)	DC	—	5V	24V	48V	—	—	—
	AC	~				48V	110/130V	230/240V
Maximum operating voltage (ripple included)			6V	30 V	60 V	53 V	143 V	264 V
Max Us current			13.6 mA	15 mA	15 mA	12 mA	8.3 mA	8 mA
State 1 guaranteed	Voltage		3.75 V	11 V	30 V	32 V	79 V	164 V
	Current		4.5 mA	6 mA	6 mA	5 mA	5 mA	4.5 mA
State 0 guaranteed	Voltage		2 V	5 V	10 V	10 V	30 V	40 V
	Current		0.09 mA	2 mA	2 mA	1.5 mA	2 mA	2 mA
Maximum switching frequency (cyclic ratio 50%)			1000 Hz	1000 Hz	1000 Hz	25 Hz	25 Hz	25 Hz
IEC 1131-2 conformity			—	Type 2	Type 2	Type 1	Type 1	Type 1
Response time	State 0 to 1		0.05 ms	0.05 ms	0.05 ms	20 ms	20 ms	20 ms
	State 1 to 0		0.4 ms	0.4 ms	0.4 ms	20 ms	20 ms	20 ms
Nominal insulation voltage	I/O			300 V				
Nominal impulse withstand voltage (1.2 / 50)	I/O			2.5 kV				

6.8-6 Fixed output solid state relays

References	ABS-7	→	SC2E	SA2M	SC3BA	SC3E	SA3M
Relay width			10mm	10mm	12.5mm	12.5mm	12.5mm
Output circuit characteristics							
Nominal operating voltage	DC	⎓	5..48V	—	24V	5..48V	—
	AC	~	—	24..240V	—	—	24..240V
Maximum voltage			57.6VDC	264 VAC	30 VDC	60 VDC	264 VAC
AC load	Resistive, AC12 duty	Current	—	0.5 A	—	—	2 A
DC load	Resistive, DC12 duty	Current	0.5 A	—	2 A	1.5 A	—
	Inductive, DC13 duty	Current	—	—	—	0.3 A	—
	Filament lamp DC6 duty		—	—	—	10 W	—
Leakage current at state 0			≤ 0.5 mA	≤ 2 mA	≤ 0.3 mA	≤ 0.3 mA	≤ 2 mA
Residual voltage at state 1			≤ 1 V	≤ 1.1 V	≤ 0.3 V	≤ 1.3 V	≤ 1.3 V
Minimum current per channel			1 mA	10 mA	1 mA	1 mA	10 mA
Response time	State 0 to 1		0.1 ms	10 ms	0.1 ms	0.1 ms	10 ms
	State 1 to 0		0.6 ms	10 ms	0.02 ms	0.6 ms	10 ms
Switching frequency on inductive load			—	—	< 0.5 L ²	—	—
Nominal insulation voltage	I/O			300 V			
Nominal impulse withstand voltage (1.2 / 50)	I/O			2.5 kV			

6.9 Dimensions and mounting

• Dimensions

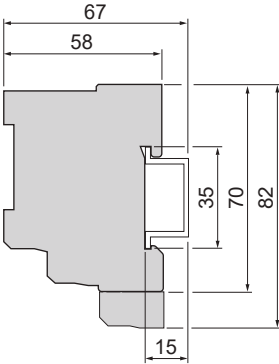

(1) Dimension with add-on shunt terminal block ABE-7BV20 or ABE-7BV10

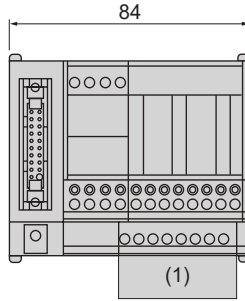

ABE-7H08R1●
ABE-7H08R2●
ABE-7H12R50
ABE-7H16R50
ABE-7R08S111
ABE-7H08S21

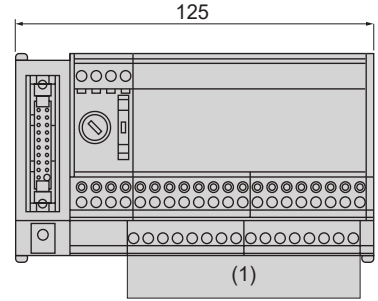

ABE-7H12R1● , ABE-7H12R2●
ABE-7H12S21 , ABE-7H16R1●
ABE-7H16R2● , ABE-7H16R3●
ABE-7H16S21 , ABE-7R16S111
ABE-7R08S210 , ABE-7S08S2B0

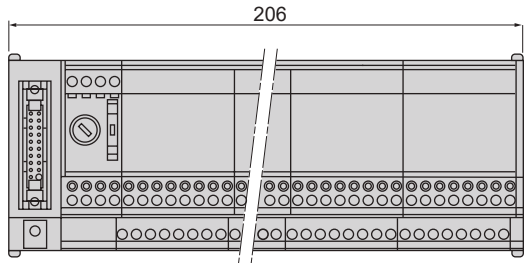
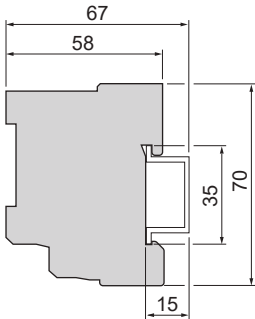

ABE-7H16F43 ABE-7S16E2B1 ABE-7S08S2B1
ABE-7H16S43 ABE-7S16E2E1 ABE-7S16S2B0
ABE-7S16E2E0 ABE-7S16S2B2
ABE-7S16E2F0 ABE-7R16S210
ABE-7S16E2M0 ABE-7R16S212

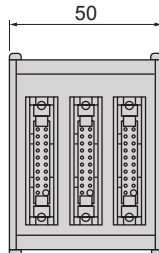
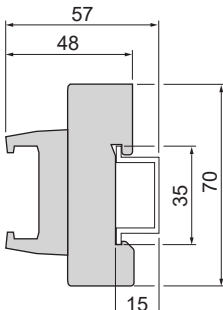

ABE-7ACC02

• Dimensions (cont)

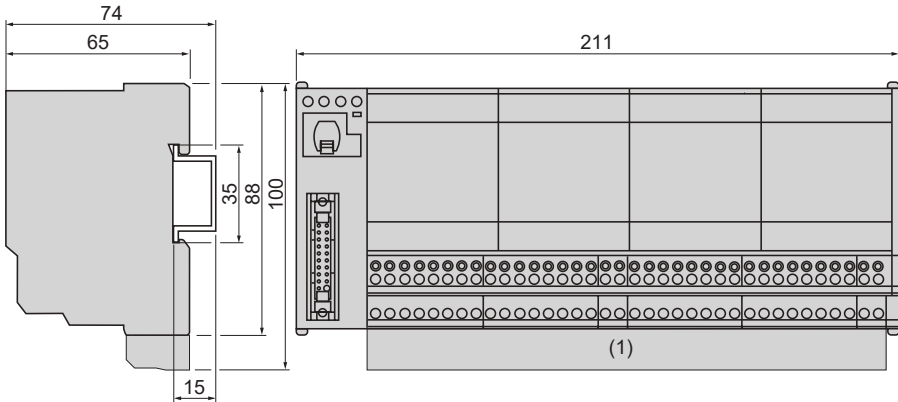

Reference with dimensions of 211x88 mm (product pictured with removable relays and screws not mounted)

ABE-7R16T210
ABE-7R16T212
ABE-7R16T231
ABE-7R16T230

ABE-7P16T210
ABE-7P16T212
ABE-7P16T214
ABE-7P16T215

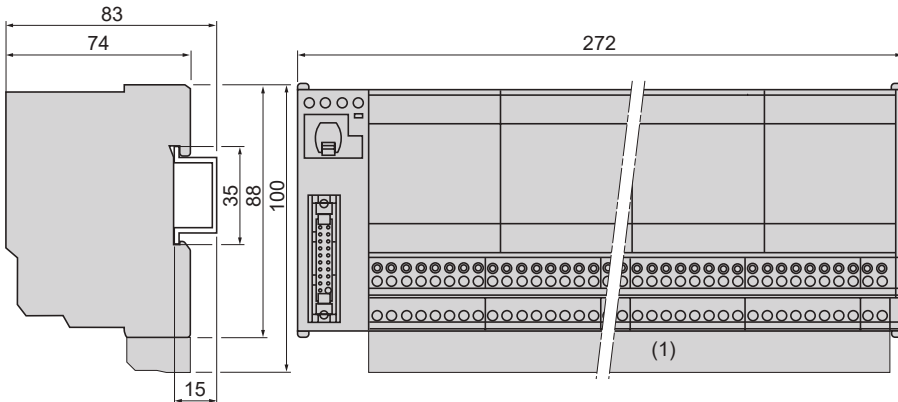

Reference with dimensions of 272x88 mm (product pictured with removable relays and screws not mounted)

ABE-7R16T330
ABE-7R16T332
ABE-7R16T370

ABE-7P16T330
ABE-7P16T332
ABE-7P16T334
ABE-7P16T318

(1) Dimension with add-on shunt terminal block ABE-7BV20 or ABE-7BV10

- **Mounting**

TELEFAST 2 connection sub-bases are mounted on 35 mm DIN rails.



Special mounting requirements for certain sub-bases

The following sub-bases must be mounted on a vertical plane and in a horizontal position :

- input adaptor sub-bases : ABE-7S16E2E1
- solid state output adaptor sub-bases : ABE-7S●●S2B●

Section	Page
1 General introduction	1/1
1.1 Description	1/1
1.1-1 General	1/1
1.1-2 Physical description	1/1
1.2 Catalog	1/2
1.3 Labeling	1/3
2 General installation rules	2/1
2.1 Installation recommendations	2/1
2.1-1 Module and terminal block installation	2/1
2.2 Wiring recommendations	2/1
3 TSX AEY 800 / TSX AEY 1600 modules	3/1
3.1 Presentation	3/1
3.2 Input processing	3/3
3.2-1 Measurement sampling	3/3
3.2-2 Range selection and overshoot monitoring	3/4
3.2-3 Measurement filtering	3/4
3.2-4 Measurement display	3/6
3.2-5 Sensor alignment	3/7
3.2-6 Recalibration	3/8
3.3 Fault processing	3/9
3.3-1 External faults	3/9
3.3-2 Internal faults	3/9
3.3-3 Other faults	3/9
3.3-4 Fault display	3/10

Part C

C

Section	Page
3.4 Characteristics	3/11
3.4-1 Input characteristics	3/11
3.5 Connections	3/12
3.5-1 Connector pinout	3/12
3.5-2 Wiring accessories	3/13
3.5-3 TELEFAST pinout	3/14
4 TSX AEY 414 module	4/1
4.1 Presentation	4/1
4.2 Input processing	4/3
4.2-1 Measurement sampling	4/3
4.2-2 Range selection and overshoot monitoring	4/3
4.2-3 Sensor link monitoring	4/5
4.2-4 Measurement filtering	4/5
4.2-5 Measurement display	4/6
4.2-6 Sensor alignment	4/7
4.2-7 Recalibration	4/8
4.3 Fault processing	4/8
4.3-1 External faults	4/8
4.3-2 Internal faults	4/9
4.3-3 Other faults	4/9
4.3-4 Fault display	4/10
4.4 Characteristics	4/11
4.4-1 General characteristics	4/11
4.4-2 Detailed input characteristics	4/12
4.5 Connections	4/23
4.5-1 Terminal block pinout	4/23
4.5-2 External resistors (0..20 mA and 4..20 mA range)	4/24
4.5-3 Sensor connection	4/24
4.5-4 Recommendations for installing thermocouples	4/25

Section	Page
5 TSX ASY 410 module	5/1
5.1 Presentation	5/1
5.2 Output processing	5/3
5.2-1 Writing to the outputs	5/3
5.2-2 Behavior of outputs when the program is in STOP or absent	5/3
5.2-3 Forcing outputs	5/3
5.2-4 Overshoot monitoring	5/3
5.2-5 Digital/analog conversion	5/4
5.2-6 Updating the outputs	5/4
5.3 Fault processing	5/4
5.3-1 External faults	5/4
5.3-2 Internal faults	5/5
5.3-3 Fallback / Maintain outputs or set outputs to 0	5/5
5.3-4 Other faults	5/6
5.3-5 Fault display	5/6
5.4 Characteristics	5/7
5.4-1 Output characteristics	5/7
5.5 Connections	5/8
5.5-1 Terminal block pinout	5/8

Part C

C

1.1 Description

1.1-1 General

The analog I/O modules in the TSX 57 range are standard format modules (occupying a single position), equipped with one 25-pin SubD connector (TSX AEY 800), two 25-pin SubD connectors (TSX AEY 1600), or a screw terminal block (TSX AEY 414 and TSX ASY 410). They can be installed in any position in TSX RKY.. racks, except for the first position which is reserved for the rack's power supply.

The maximum number of analog modules which can be used in a TSX 57 configuration must be such that :

- the total number of analog I/O does not exceed 24 in a TSX 57-10 configuration,
- the total number of analog I/O does not exceed 80 in a TSX 57-20 configuration.

1.1-2 Physical description

- 1 Rigid casing which provides support and protection for the electronic card.
- 2 Module reference markings (visible on the right side of the module).
- 3 Display block showing operating modes and errors.
- 4 Connector for the screw terminal block.
- 5 Module encoder.
- 6 25-pin SubD connector(s), for connecting sensors or preactuators.
- 7 Removable screw terminal block, for connecting sensors or preactuators. This terminal block is supplied separately under reference TSX BLY 01.
- 8 Cover providing access to screw terminals. Also holds the terminal wiring and channel identification label.
- 9 Terminal encoder.

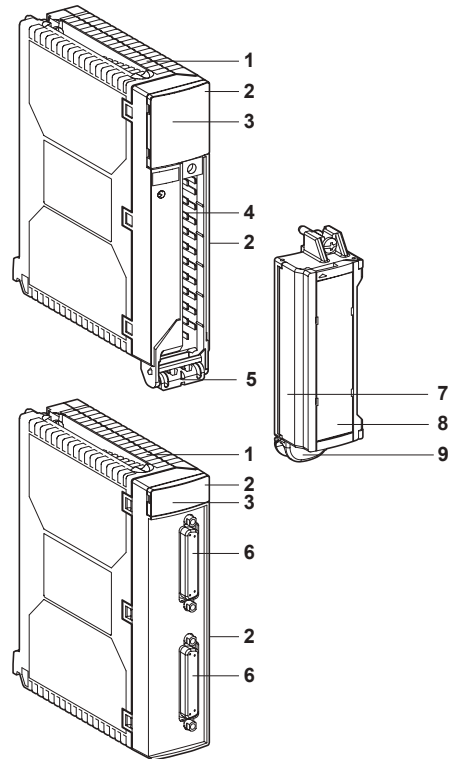

1.2 Catalog

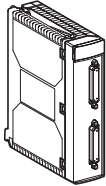
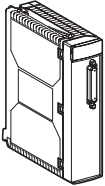
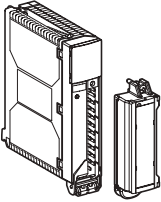
Module type	Inputs			Outputs
				
Number of channels	16	8	4	4
Range	± 10 V 0..10 V 0..5 V 1..5 V 0..20 mA 4..20 mA	± 10 V 0..10 V 0..5 V 1..5 V 0..20 mA 4..20 mA	± 10 V 0..10 V ± 5 V 0.5 V (0..20 mA) 1.5 V (4..20 mA) -13.. + 63 mV 0..400 Ω 0..3850 Ω Temperature probe Thermocouple	± 10 V 0..20 mA 4..20 mA
Current consumed on 24 VR	0 mA	0 mA	0 mA	0 mA
Current consumed on 5 V	270 mA (typ.) 380 mA (max)	270 mA (typ.) 380 mA (max)	660 mA (typ.) 940 mA (max)	990 mA (typ.) (*) 1220 mA (max) (*)
Channel isolation	Common point		1500 Vrms isolation	
Resolution	12 bits		16 bits	11 bits + sign
Connections	2 x 25-pin SubD	1 x 25-pin SubD	20-pin screw terminal block	
TSX reference	AEY 1600	AEY 800	AEY 414	ASY 410

(*) + 20 mA per active channel

1.3 Labeling

The module is identified by laser-engraved markings on the cover, accessible on the front panel and the right-hand side of the module :

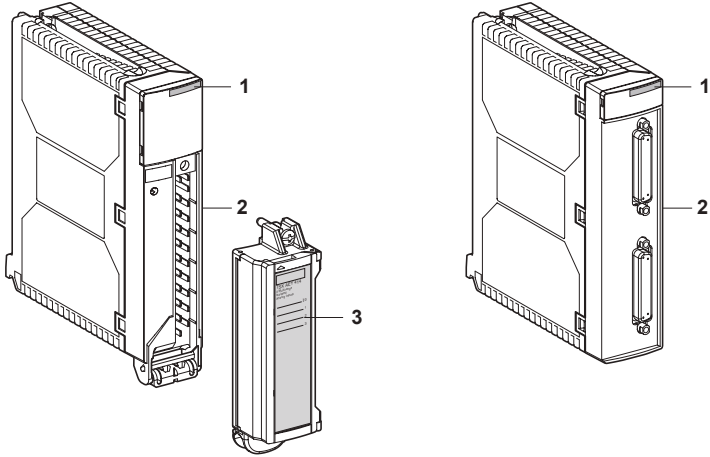

- module marking **1**, which indicates the module reference,
- module marking **2**, which indicates the module reference and type,
- removable terminal block label **3**, located inside the cover, displaying the module reference and type and the terminal wiring. Additional information may be added to this double-sided label by the user.

2.1 Installation recommendations

2.1-1 Module and terminal block installation

Inserting/removing modules

Analog modules and terminal blocks can be inserted and removed when the PLC is **powered up** (without risk of damage to the modules or interference to the PLC).

The presence of the terminal block is detected using a shunt positioned in the upper part of the terminal block, which should **always be tightened to its maximum**.

The terminal block should **always be removed before removing the module**. This avoids leading voltage on to the terminal block inputs (up to 1700 V) in the event of a module isolation fault.

Encoding the screw terminal block

The first time a screw terminal block is fitted onto a module, the coding is transferred from the module to the terminal block which becomes specific to the module type (for more information about encoding the terminal block, please refer to section 5 of part A1).

2.2 Wiring recommendations

To protect the signal against serial mode and common mode noise, it is advisable to take the following precautions :

Conductor type

Use shielded twisted pairs with a minimum cross-section of 0.28 mm² (AWG24 gauge).

Cable shielding

- **for modules fitted with a screw terminal block (TSX AEY 414 / TSX ASY 410)**

Connect the shielding at each end of the cable to the shielding connection terminals (ground terminals). See the paragraph on the following page concerning referencing of sensors and preactuators to ground.

- **for modules fitted with SubD connector(s) (TSX AEY 800 / 1600)**

As there is a large number of channels, a minimum 13-pair twisted cable will be used with general shielding (external diameter 15 mm maximum), fitted with a 25-pin male SubD connector for linking with the module.

Connect the shielding of the cable to the cover of the male SubD connector. It is connected to the PLC ground via the SubD connector retention screws (for this reason, it is therefore compulsory to screw the male SubD connector onto its female base).

Grouping of conductors in cables

Signals of the same type with the same reference to ground can be grouped together in multipair cables.

Cable routing

Keep the discrete I/O cables (especially those for relay outputs) as far away as possible from the power cables.

Sensors referenced to ground

For modules with non-isolated channels (TSX AEY 800 and TSX AEY 1600), sensors **which are not referenced to ground** are preferred.

To ensure correct operation of the measurement system, the following precautions are advised :

- sensors should be located near to each other (few meters),
- all the sensors should be referenced to the same point, which is connected to the module ground.

Use of sensors referenced to ground

If the sensors are referenced to ground, this can, in certain cases, lead to a ground voltage at the terminal block or SubD connector(s). It is therefore **essential** that the following rules are observed :

- this voltage must be less than the safety voltage,
- when a reference voltage is taken to a sensor it can cause leakage current. It should therefore be checked that any leakage current generated does not interfere with the system.

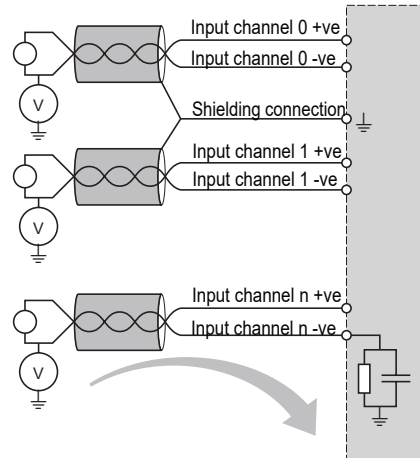

For safety reasons, the modules are fitted with an RC network ($>30 \text{ M}\Omega$, 4.7 nF), which grounds the reference voltage of the channels.

Use of preactuators referenced to ground

There is no technical restriction for referencing preactuators to ground. For safety reasons, however, it is preferable to avoid a ground voltage occurring at the terminal block, as this may vary significantly from the nearby ground voltage.

3.1 Presentation

General

TSX AEY 800 and TSX AEY 1600 modules are analog input modules with 8 /16 high level inputs. Linked to sensors or transmitters, they perform monitoring, measurement and continuous process control functions.

The TSX AEY 800 or TSX AEY 1600 module offers the range $\pm 10\text{ V}$, $0..10\text{ V}$, $0..5\text{ V}$, $1..5\text{ V}$, $0..20\text{ mA}$ or $4..20\text{ mA}$ for each of its inputs, depending on the choice made during configuration.

TSX AEY 800 / AEY 1600

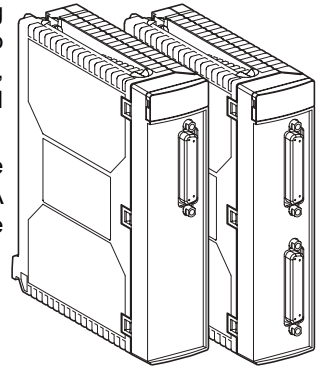

Functions

These input modules perform the following functions :

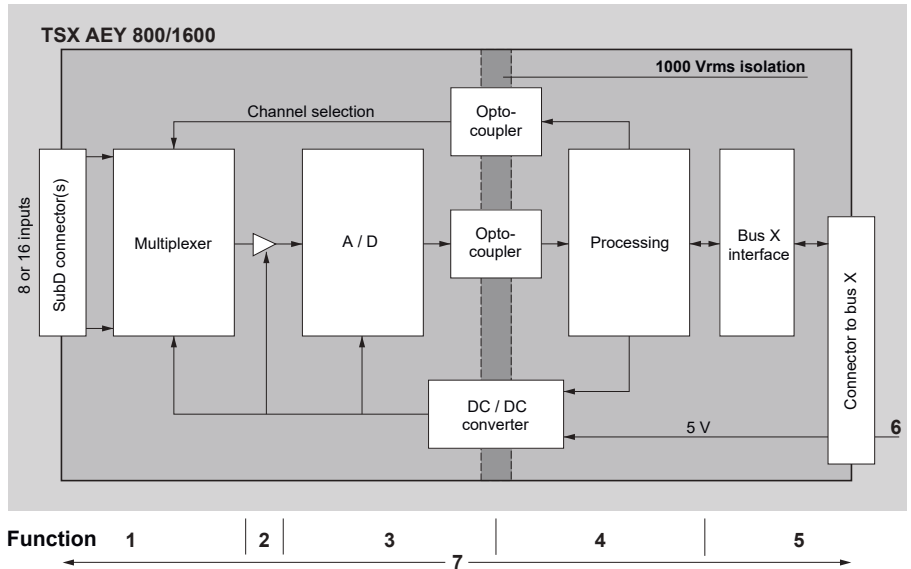

1 Connection to the process and scanning of input channels

- physical connection to the process, via SubD connector(s),
- protection of the module against overvoltages (peak limiting diodes),
- adaptation of input signals by analog filtering,
- scanning of input channels, by solid state multiplexing (it is possible to scan only those channels defined as being used : **fast cycle**).

2 Adaptation to input signals

- gain selection, according to the characteristics of the input signals, defined during configuration (unipolar or bipolar voltage or current range),
- compensation for drift in the amplifier circuits.

3 Digitalization of input measurement analog signals (12-bit analog/digital converter).

4 Converting input measurements to a unit which can be handled by the user

- acceptance of recalibration and alignment coefficients to be applied to the measurements, as well as the autocalibration coefficients of the module,
- measurement filtering (digital filter), according to the configuration parameters,
- measurement scaling, according to the parameters set during configuration.

5 Interface and communication with the application

- management of exchanges via bus X,
- geographical addressing,
- reception of module and channel configuration parameters,
- transmission of measured values, as well as the module status, to the application.

6 Module power supply

7 Monitoring the module and indicating possible faults to the application

- test of conversion circuit,
- test for range overshoot on the channels,
- test for the presence of the terminal block,
- test of watchdog.

3.2 Input processing

3.2-1 Measurement sampling

Measurement sampling depends on the cycle used, defined during configuration : normal cycle or fast cycle.

In **normal cycle**, the input scan cycle is fixed, irrespective of the number of inputs used :

- 27 ms for a TSX AEY 800 module.
- 51 ms for a TSX AEY 1600 module.

In **fast cycle**, only the channels defined as used are scanned, even if they are not consecutive. This improves the module scan time. The module scan time is represented by the following formula :

$$Ct \text{ (ms)} = 3 (N + 1), \text{ where } N = \text{number of channels used}$$

For example, if 6 channels are used the scan time is $3 (6 + 1) = 21 \text{ ms}$

Filtering is inhibited in fast mode.

The scan cycle of the channels used is as follows :

• normal cycle

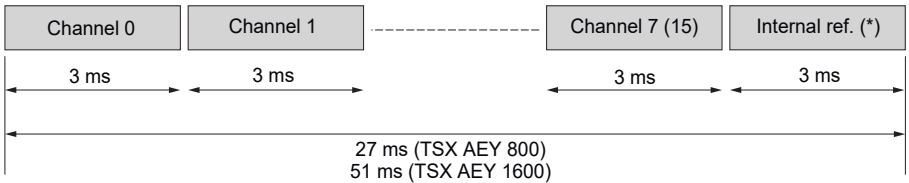

• fast cycle (for example, channels 3, 5 and 6 used)

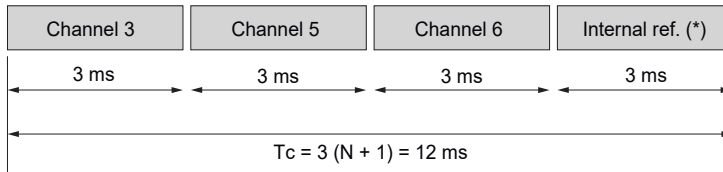

(*) corresponds to the acquisition of voltage references integrated in the module, to enable its periodic autocalibration.

Note

The module scan is not synchronous with the PLC scan (application). At the start of each PLC cycle, the channel values are taken into account, which means that some values will not have changed if the scan of the MAST task is shorter than that of the module.

3.2-2 Range selection and overshoot monitoring

Each module has the choice of 6 ranges for each of its inputs : ± 10 V, 0..10 V, 0..5 V, 1..5 V, 0..20 mA and 4..20 mA.

The module monitors overshoot for the chosen range, ie. it checks that the measurement is between the upper and lower limits defined in the table below. Outside these limits, the analog measurement system risks saturation and an overshoot fault is signalled by a bit which can be used by the program (error bit `%Imodule.channel.ERR = 1` indicates a channel fault and status word bit `%MWmodule.channel.2:X1 = 1` indicates a range overshoot on the channel).

Modules generally allow a 5% range overshoot of the positive electrical range (for example, 5% of 10 V for the range ± 10 V). The 0-5 V and 0-20 mA ranges will not tolerate a negative overshoot. As soon as the measured value becomes negative, a range overshoot fault is signalled.

AEY 800 AEY 1600	Lower Limit	Upper Limit	Values available by default. Standard format	Min. limit in User (1) format	Max. limit in User (1) format
Range					
± 10 V	- 10.5 V	+ 10.5 V	± 10500	Min - 5% (max-min)/2	Max + 5% (max-min)/2
0..10 V	- 0.5 V	+ 10.5 V	- 500..10500	Min - 5% (max-min)	Max + 5% (max-min)
0.5 V	0 V	+ 5.25 V	0..10500	Min (2)	Max + 5% (max-min)
1..5 V	0.8 V	+ 5.2 V	- 500..10500	Min - 5% (max-min)	Max + 5% (max-min)
0..20 mA	0 mA	+ 21 mA	0..10500	Min (2)	Max + 5% (max-min)
4..20 mA	+ 3.2 mA	+ 20.8 mA	- 500..10500	Min - 5% (max-min)	Max + 5% (max-min)

Min / Max : minimum / maximum values entered in USER format configuration.

(1) See section 3.2-4

(2) Range overshoot is signalled for an overshoot of approximately :

-10 mV for the range 0..5 V,

-40 μ A for the range 0..20 mA.

3.2-3 Measurement filtering

First order filtering is performed with a filtering coefficient which can be modified via a programming terminal or by the program. The mathematical formula used is :

$$Mes_{fn} = \alpha \times Mes_{fn-1} + (1 - \alpha) \times Val_{bn}$$

where :

α = filter efficiency,

Mes_{fn} = filtered measurement at moment n,

Mes_{fn-1} = filtered measurement at moment n-1,

Val_{bn} = "raw" value measured at moment n

During configuration, the user selects the filter value from 7 possible values (0 to 6). This value may be subsequently modified, even when the application is in RUN.

TSX AEY 800

Efficiency required	Value to select	Corresponding α	Filter response time at 63%	Cut off frequency (Hz)
No filter	0	0	0	-
Low level of filtering	1	0.750	100 ms	1.591
	2	0.875	202 ms	0.788
Medium level of filtering	3	0.937	419 ms	0.379
	4	0.969	851 ms	0.187
High level of filtering	5	0.984	1.714 s	0.093
	6	0.992	3.442 s	0.046

TSX AEY 1600

Efficiency required	Value to select	Corresponding α	Filter response time at 63%	Cut off frequency (Hz)
No filter	0	0	0	-
Low level of filtering	1	0.750	178 ms	0.894
	2	0.875	382 ms	0.416
Medium level of filtering	3	0.937	791 ms	0.201
	4	0.969	1.607 s	0.099
High level of filtering	5	0.984	3.239 s	0.049
	6	0.992	6.502 s	0.024

Note

Filtering is inhibited in fast cycle

3.2-4 Measurement display

The measurement supplied to the application can be used directly by the operator, who can choose between :

- using the 0..10000 standard display (or ± 10000 for the range ± 10 V),
- entering the parameters for the display format by indicating the desired minimum and maximum values.

Standard display. The values are displayed in standard units :

- for a unipolar range of 0-10 V, 0-5 V, 0-20 mA or 4-20 mA, they are displayed from 0 to 10000 (0 ‰_{000} to 10000 ‰_{000}),
- for the bipolar range of ± 10 V, they are displayed from - 10000 to + 10000 ($- 10000 \text{ ‰}_{000}$ to $+ 10000 \text{ ‰}_{000}$).

User display. The user may select the range of values in which the measurements are expressed, by choosing :

- the lower limit corresponding to the minimum of the range 0 ‰_{000} (or $- 10000 \text{ ‰}_{000}$),
- the upper limit corresponding to the maximum of the range $+ 10000 \text{ ‰}_{000}$.

These upper and lower limits are integers between - 30000 and + 30000.

For example, suppose a conditioning unit indicates information about pressure on a 4-20 mA loop, with 4 mA corresponding to 3200 mB and 20 mA corresponding to 9600 mB. The user can then select the User format, by defining the following upper and lower limits :

- $0 \text{ ‰}_{000} \Leftrightarrow 3200$ as lower limit,
- $10000 \text{ ‰}_{000} \Leftrightarrow 9600$ as upper limit.

The values transmitted to the program will vary between 3200 (= 4 mA) and 9600 (= 20 mA).

For more information about standard or user display, refer to the installation manual for application-specific functions, reference TLX DS 57 PL7 12E.

3.2-5 Sensor alignment

Alignment consists of eliminating a systematic shift observed by a given sensor, around a given operating point. An error linked to the process will be compensated but not an error linked to the control system. For this reason, replacing a module does not require a new alignment. On the other hand, replacing the sensor or changing the operating point of that sensor will require a new alignment.

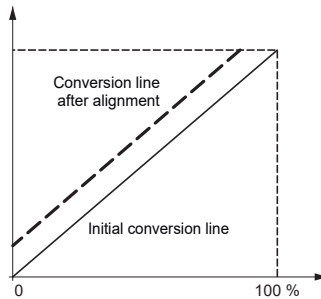

For example, suppose that a pressure sensor, linked to a conditioning unit (1mV/mB), indicates 3200 mB, while the actual pressure is 3210 mB. The value measured by the module in standard scale will be 3200 (3.20 V). The user can align the measurement to the value 3210 (required value). After this alignment procedure, the measurement channel will apply a systematic offset of +10 to any new measurement.

The alignment value which should be entered is 3210.

The alignment value can be modified via a programming terminal, even when the program is in RUN. For each input channel, the user can :

- display and modify the required measurement value,
- save the alignment value,
- know if the channel already has an alignment.

The alignment offset can also be modified via the program.

Alignment is performed when the channel is in normal operation, without affecting the operating modes of the module channel.

The maximum deviation between the measured value and the required value (aligned value) should not exceed ± 1000 .

3.2-6 Recalibration

As TSX AEY 800 and TSX AEY 1600 modules are common point modules, it is only necessary to recalibrate channel 0 in order to recalibrate the whole module.

It is recommended that the module should be recalibrated outside the application.

Recalibration can be performed with the PLC task linked to the channel, in RUN or in STOP.

In recalibration mode, the measurements of all the module channels are declared invalid (bit %Ixy.i.ERR = 1), filtering and alignment are inhibited, the acquisition cycles of the channels can be extended.

As inputs other than channel 0 are not read during recalibration, the value transmitted to the application for these other channels is the last value measured before recalibration.

Recalibration is performed from the calibration screen and is performed for the whole module only on channel 0. To do this :

- click on a channel to go to recalibration mode (a confirmation message signals the change to this mode),
- connect a voltage reference to **the voltage input** of channel 0, according to the range to be recalibrated :

- reference = 10 V \pm 20 ppm, to recalibrate the module for the ranges \pm 10 V and 0..10 V,
- reference = 5 V \pm 20 ppm, to recalibrate the module for the ranges 0..5 V, 1..5 V, 0..20 mA and 4..20 mA.

Warning : the 5 V reference recalibrates the whole **measurement system** for the ranges 0..20 mA and 4..20 mA, but does not take into account the **250 Ω current shunt** integrated in the module and located on the current input,

- select in the calibration screen the connected reference (for example 10 V). Wait the necessary time for the voltage reference to stabilize, then confirm the selection. Recalibration of the ranges linked to this reference (for example, \pm 10 V and 0..10 V) is performed automatically. The displayed value of channel 0 should therefore be 10000 \pm 10.
- the user can then connect another external voltage reference (for example 5 V), then repeat the previous procedure up to the automatic recalibration of the ranges linked to that reference (0..5 V, 1..5 V, 0..20 mA and 4..20 mA).

Recalibration is not accepted until it has been saved in the module ("**save**" button). The "**Return to factory parameters**" button cancels all recalibrations and reverts to the initial recalibration (performed in the factory). Pressing the "Return to factory parameters" button triggers a confirmation message. However, after confirmation, it is immediately accepted and does not require saving.

If the user exits the screen without saving, a message is displayed which reminds the user that it has not been saved. If the user still chooses to exit the screen, the new calibration coefficients will be lost (it will revert to the old coefficients).

3.3 Fault processing

3.3-1 External faults

Range overshoot

At the time of measurement range overshoot, the following bits are set to 1 :

- fault bit %**lxy.i.ERR**, associated with the channel (for example, %**I2.0.ERR** for channel 0 of the module located in slot 2),
- bit 1 (range overshoot) of status word associated with the channel (for example, %**MW2.0.2:X1** for channel 0 of the module located in slot 2).

The **I/O indicator lamp is permanently on** during the fault.

3.3-2 Internal faults

Each module carries out a series of self-tests (watchdog, memory, analog/digital conversion circuit). When an error occurs during these tests, an internal fault is signalled. The channels change to 0 and the **ERR indicator lamp is permanently on**. If a module is inoperative and can no longer communicate with the processor, the latter will still be informed as it detects a module which is absent or inoperative.

Self-test performed	Status of ERR indicator lamp during a fault	Feedback of fault to the processor
Watchdog test	Permanently on	no
Checksum of REEPROM memory	Permanently on	no
Test of bus X interface	Permanently on	no
Test of external RAM	Permanently on	no
Test of EEPROM memory	Permanently on	no
Test of internal references	Permanently on	yes

3.3-3 Other faults

Communication fault

When a communication fault occurs with the processor, the channels are frozen at the last value before the fault.

Terminal block fault (user definable)

If the terminal block fault is configured, it occurs when at least one channel is used, while the corresponding SubD connector is absent. When such a fault occurs, the following bits are set to 1 :

- fault bit **%Ixy.i.ERR**, associated with the channel (for example, %I2.0.ERR for channel 0 of the module located in slot 2),
- bit 2 (terminal block fault) of the status word associated with the channel (for example, %MW2.0.2:X2 for channel 0 of the module located in slot 2).

The **I/O indicator lamp flashes** during the fault.

3.3-4 Fault display

Modules TSX AEY 800 and TSX AEY 1600 are fitted with a display block comprising 3 indicator lamps which display the module operating modes and possible faults : RUN, ERR and I/O indicator lamps.

Module status	Status indicator lamps		
	RUN	ERR	I/O
Normal operation	●	○	○
External fault (range overshoot)	●	○	●
Internal fault (module failure)			
• communication with CPU possible	●	●	○
• communication with CPU not possible	○	●	○
Other fault (communication fault)	●	○	○
Other fault (terminal block fault)	●	○	⊗

Note

When a range overshoot fault occurs at the same time as a terminal block fault, the indicator lamps behave as for a range overshoot (I/O lamp is on).

- Indicator lamp off
- ⊗ Indicator lamp flashing
- Indicator lamp on

3.4 Characteristics

3.4-1 Input characteristics

Module	TSX AEY 800	TSX AEY 1600	
Number of channels	8	16	
Analog/digital conversion	12 bits (3719 points for voltage / 3836 points for current)		
Configuration of acquisition scan	Fast : periodic acquisition of channels used Normal : periodic acquisition of all channels		
Conversion time	3 ms / channel	3 ms / channel	
Channels / ground dielectric voltage	1000 V rms	1000 V rms	
Isolation between channels	Common point	Common point	
Isolation between bus and channels	1000 V rms	1000 V rms	
Maximum permissible overvoltage on inputs	± 30 V for voltage ± 30 mA for current	± 30 V for voltage ± 30 mA for current	
Standards	IEC 1131	IEC 1131	
Electrical range	± 10 V 0..10 V	0..5 V 1..5 V	0..20 mA 4..20 mA
Full scale (FS)	10 V	5 V	20 mA
Resolution	5.38 mV	1.34 mV	5.21 μA
Maximum error at 25 °C Max. error at 0 to 60 °C	0.19% FS 0.22% FS	0.15% FS 0.22% FS	0.25% FS 0.41% FS
Temperature drift	20 ppm / °C	20 ppm / °C	45 ppm / °C
Range overshoot	± 10.5 V (range ± 10 V) -0.5..10.5 V (range 0..10 V)	0..5.25 V (range 0.. 5 V) 0.8..5.2 V (range 1..5 V)	0..21 mA (range 0.. 20 mA) 3.2..20.8 mA (range 4..20 mA)
Precision of internal conversion resistance	/	/	0.1% - 25 ppm / °C

3.5 Connections

3.5-1 Connector pinout

TSX AEY 800

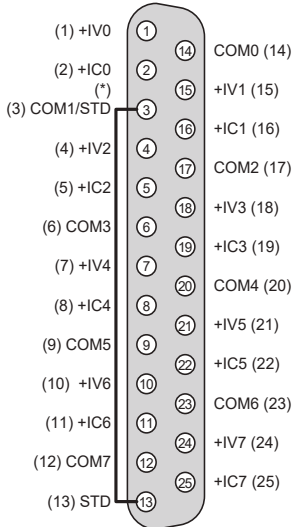

TSX AEY 1600

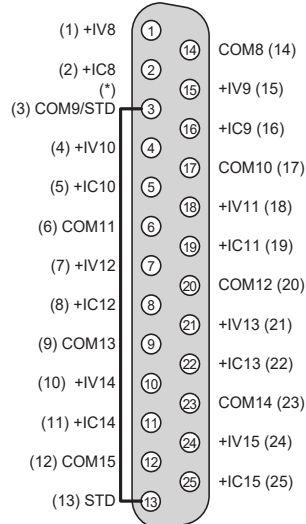
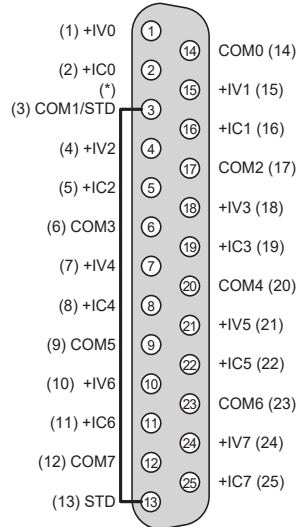

+IVx : +ve voltage input of channel x
+ICx : +ve current input of channel x
COMx: -ve input of channel x (voltage or current)
STD : Strap (*) to detect removal.

3.5-2 Wiring accessories

Using TELEFAST wiring accessories facilitates the installation of TSX AEY 800 and TSX AEY 1600 analog modules, by giving access to the inputs via the screw terminals. The analog module is connected to the TELEFAST accessories via a 3 meter shielded cable, reference TSX CAP 030 which has 25-pin SubD connectors fitted at both ends.

There are two types of TELEFAST analog wiring accessories :

- TELEFAST accessory, reference ABE 7 CP A02, distributes the 8 channels coming from a 25-pin SubD connector, onto the screw terminals,
- TELEFAST accessory, reference ABE 7 CP A 03, distributes the 8 channels coming from a 25-pin SubD connector, onto the screw terminals; but also :
 - supplies, channel by channel, the 2 and 4-wire sensors with a 24 V protected and current-limited voltage (to 30 mA),
 - maintains the continuity of the current loops when the 25-pin SubD connector is removed,
 - protects the current shunt contained in the modules against overvoltages.

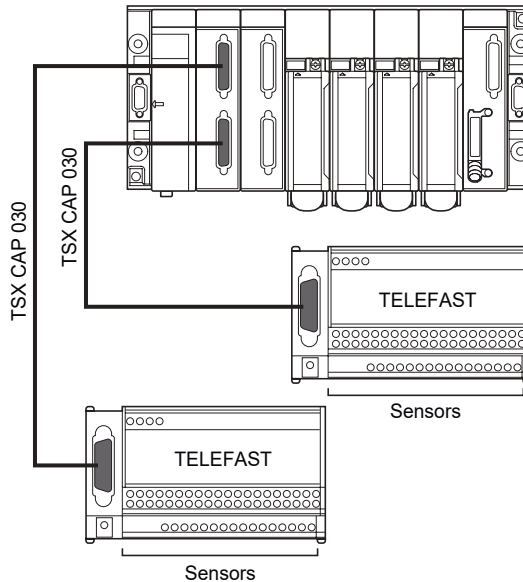

Note

The TELEFAST wiring accessory, reference ABE 6 SD 2520, can be used instead of the TELEFAST ABE 7 CP A02, as it has the same functions (the only difference between the 2 wiring accessories is that the TELEFAST ABE 6 SD 2520 belongs to the TELEFAST first-generation range)

3.5-3 TELEFAST pinout

After connecting the analog module to a TELEFAST accessory, via cable TSX CAP 030, the distribution of the analog channels on the TELEFAST terminals is as follows :

TELEFAST, reference ABE 7 CP A02

TELEFAST terminal no.	25-pin SubD connector pin no.	Type of signal	TELEFAST terminal no.	25-pin SubD connector pin no.	Type of signal
1	/	Ground	Supp1	/	Ground
2	/	Ground	Supp2	/	Ground
3	/	Ground	Supp3	/	Ground
4	/	Ground	Supp4	/	Ground
100	1	+IV0 or +IV8	200	14	COM0 or COM8
101	2	+IC0 or +IC8	201	/	Ground
102	15	+IV1 or +IV9	202	3	COM1 or COM9
103	16	+IC1 or +IC9	203	/	Ground
104	4	+IV2 or +IV10	204	17	COM2 or COM10
105	5	+IC2 or +IC10	205	/	Ground
106	18	+IV3 or +IV11	206	6	COM3 or COM11
107	19	+IC3 or +IC11	207	/	Ground
108	7	+IV4 or +IV12	208	20	COM4 or COM12
109	8	+IC4 or +IC12	209	/	Ground
110	21	+IV5 or +IV13	210	9	COM5 or COM13
111	22	+IC5 or +IC13	211	/	Ground
112	10	+IV6 or +IV14	212	23	COM6 or COM14
113	11	+IC6 or +IC14	213	/	Ground
114	24	+IV7 or +IV15	214	12	COM7 or COM15
115	25	+IC7 or +IC15	215	/	Ground

TELEFAST, reference ABE 7 CP A03

TELEFAST terminal no	25-pin SubD connector pin no.	Type of signal	TELEFAST terminal no	25-pin SubD connector pin no.	Type of signal
1	/	0 V	Supp1	/	24 V (sensor supply)
2	/	0 V	Supp2	/	24 V (sensor supply)
3	/	0 V	Supp3	/	0 V (sensor supply)
4	/	0 V	Supp4	/	0 V (sensor supply)
100	/	IS1 or IS9 (*)	200	/	IS0 or IS8 (*)
101	15	+IV1 or +IV9	201	1	+IV0 or +IV8
102	16	+IC1 or +IC9	202	2	+IC0 or +IC8
103	/	Ground	203	14 / 3	COM0 / COM1 or COM8 / COM9
104	/	IS3 or IS11 (*)	204	/	IS2 or IS10 (*)
105	18	+IV3 or +IV11	205	4	+IV2 or +IV10
106	19	+IC3 or +IC11	206	5	+IC2 or +IC10
107	/	Ground	207	17 / 6	COM2 / COM3 or COM10 / COM11
108	/	IS5 or IS13 (*)	208	/	IS4 or IS12 (*)
109	21	+IV5 or +IV13	209	7	+IV4 or +IV12
110	22	+IC5 or +IC13	210	8	+IC4 or +IC12
111	/	Ground	211	20 / 9	COM4 / COM5 or COM12 / COM13
112	/	IS7 or IS15	212	/	IS6 or IS14 (*)
113	24	+IV7 or +IV15	213	10	+IV6 or +IV14
114	25	+IC7 or +IC15	214	11	+IC6 or +IC14
115	/	Ground	215	23 / 12	COM6 / COM7 or COM14 / COM15

(*) ISx : 24 Vsupply on channel x

4.1 Presentation

General

The TSX AEY 414 is a multirange input module, with 4 inputs isolated from each other. This module provides for each of its inputs, according to the selection made during configuration, the range :

- B, E, J, K, L, N, R, S, T, U thermocouple or electrical range $-13..+63$ mV,
- 2 or 4-wire Pt100, Pt1000, Ni1000 temperature probes, or ohmic range : $0..400 \Omega$, $0..3850 \Omega$,
- high level ± 10 V, $0..10$ V, ± 5 V, $0..5$ V ($0..20$ mA with an external shunt) or $1..5$ V ($4..20$ mA with an external shunt). Note that external shunts are delivered with the product.

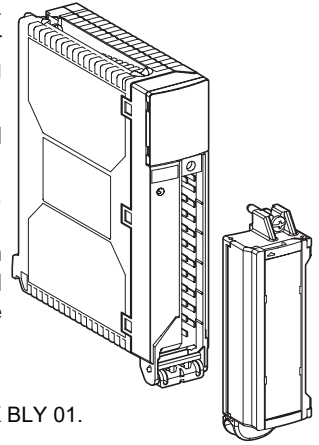

Note

The terminal block is supplied separately under reference TSX BLY 01.

Functions

This input module performs the following functions :

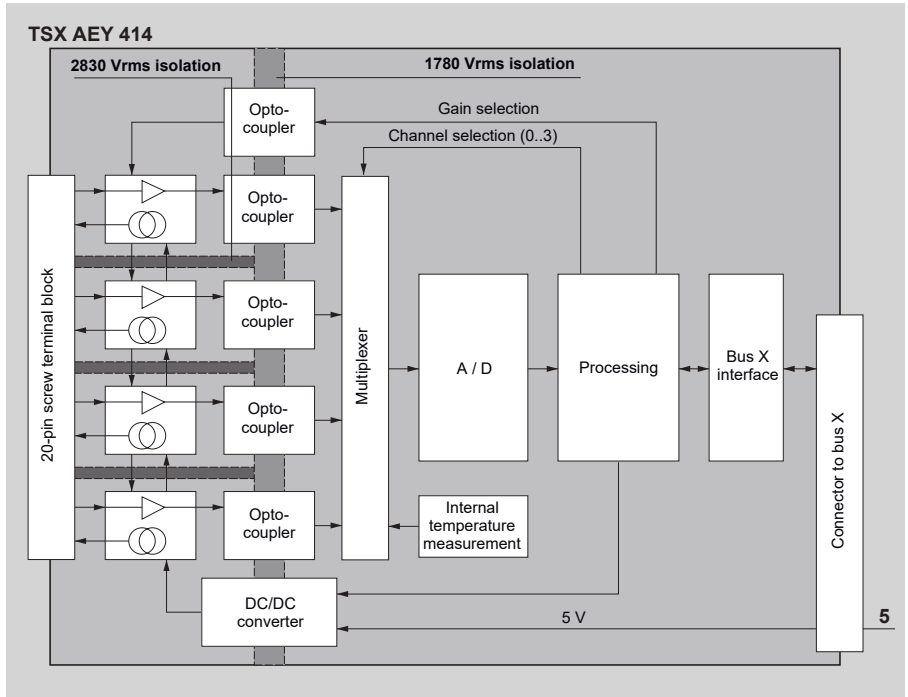

Function

1

2

3

4

1 Connection to the process and scanning of input channels

- physical connection to the process, via screw terminal block,
- gain selection, according to the characteristics of the input signals, defined for each channel during configuration (high level, thermocouple or temperature probe range).
- multiplexing

2 Digitalization of input measurement analog signals

3 Converting input measurements to a unit which can be handled by the user

- acceptance of recalibration and alignment coefficients to be applied to the measurements (channel by channel and range by range), as well as the autocalibration coefficients of the module,
- linearization of the measurement provided by Pt or Ni temperature probes,
- linearization of the measurement and acceptance of the internal or external cold junction compensation, in the case of thermocouples,
- measurement scaling, according to the parameters set during configuration (physical units or user range).

4 Interface and communication with the application

- management of exchanges via bus X,
- geographical addressing,
- reception of module and channel configuration parameters,
- transmission of measured values, as well as the module status, to the application.

5 Module power supply

6 Monitoring the module and indicating possible faults to the application

- test for the conversion circuit,
- test for range overshoot on the channels,
- test for the presence of the terminal block,
- test of the sensor link (except on ranges $\pm 10\text{ V}$, $0..10\text{ V}$, $\pm 5\text{ V}$, $0..5\text{ V}$ and $0..20\text{ mA}$),
- test for the watchdog.

4.2 Input processing

4.2-1 Measurement sampling

The TSXA EY 414 module scan time and consequently the sampling rate are independent of the AC supply frequency (50 Hz or 60 Hz).

The measurements are linked together in the following way : channel 0, channel 1, channel 2, channel 3 and internal selection. Internal selection corresponds to the internal temperature or internal references for module autocalibration or to the line compensation for the temperature probe ranges.

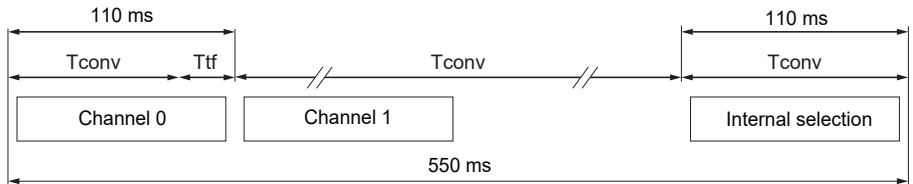

T_{conv} is the time taken to convert a channel : T_{conv} = 106 ms,

T_{tf} is the time taken for the wiring test : T_{tf} = 4 ms.

Internal selection does not require a wiring test, except for line compensation.

The scan is always executed in the same way and lasts 550 ms.

4.2-2 Range selection and overshoot monitoring

Using the software, the user can choose one of the following ranges for each channel : ± 10 V, 0..10 V, ± 5 V, 0..5 V (0..20 mA), 1..5 V (4..20 mA), -13..+63 mV, 0..400 Ω , 0..3850 Ω , Pt100, Pt1000, Ni1000, B, E, J, K, L, N, R, S, T and U thermocouple.

For thermocouple ranges, cold junction compensation is performed by the module. However, the cold junction temperature can be measured via the module terminal block (by an internal probe in the module) or remotely via a Pt100 Class A external probe (not supplied), connected to channel 0 of the module.

Whatever the selected range, the module monitors overshoot; that is, it checks that the measurement is between the upper and lower limits defined by the following table. Outside these limits, saturation of the analog measurement system is likely and an overshoot fault is signalled by a bit which can be used by the program (error bit %Ixy.i.ERR = 1 signals a fault on the channel and status word bit %MWxy.i.2:X1 = 1 indicates a range overshoot on the channel).

For ranges ± 10 V, 0..10 V, ± 5 V, 0..5 V, 1..5 V, 0..20 mA and 4..20 mA :
modules generally allow a 5% positive overshoot of the electrical range.

For temperature ranges :

the range overshoot corresponds to an overshoot of the input range, an overshoot of the standard sensor measurement zone or an overshoot of the compensation temperature range (-5 °C to +85 °C). The use of internal compensation in a normal environment (0 °C to +60 °C) is compatible with thresholds -5 °C to +85 °C.

Overshoot values

TSX AEY 414 Range	Lower limit	Upper limit	Default values	Min. limit in User mode	Max. limit in User mode
± 10 V	-10.5 V	+10.5 V	± 10500	Min - 5%(max-min)/2	Max + 5%(max-min)/2
0..10 V	-0.5 V	+10.5 V	-500..+10500	Min - 5%(max-min)	Max + 5%(max-min)
± 5 V	-5.25 V	+5.25 V	± 10500	Min - 5%(max-min)	Max + 5%(max-min)
0..5 V	-0.25 V	+5.25 V	-500..+10500	Min - 5%(max-min)	Max + 5%(max-min)
1..5 V	+0.8 V	+5.2 V	-500..+10500	Min - 5%(max-min)	Max + 5%(max-min)
0..20 mA	-1 mA	+21 mA	-500..+10500	Min - 5%(max-min)	Max + 5%(max-min)
4..20 mA	+3.2 mA	+20.8 mA	-500..+10500	Min - 5%(max-min)	Max + 5%(max-min)
B	0 °C (32 °F)	+1802 °C (+3276 °F)	d°C or d°F	0	+10000
E	-270 °C (-454 °F)	+812 °C (+1495 °F)	d°C or d°F	0	+10000
J	-210 °C (-346 °F)	+1065 °C (+1953 °F)	d°C or d°F	0	+10000
K	-270 °C (-454 °F)	+1372 °C (+2502 °F)	d°C or d°F	0	+10000
L	-200 °C (-328 °F)	+900 °C (+1652 °F)	d°C or d°F	0	+10000
N	-270 °C (-454 °F)	+1300 °C (+2372 °F)	d°C or d°F	0	+10000
R	-50 °C (-58 °F)	+1769 °C (+3216 °F)	d°C or d°F	0	+10000
S	-50 °C (-58 °F)	+1769 °C (+3216 °F)	d°C or d°F	0	+10000
T	-270 °C (-454 °F)	+400 °C (+752 °F)	d°C or d°F	0	+10000
U	-200°C (-328 °F)	+600 °C (+1112 °F)	d°C or d°F	0	+10000
Pt100	-200 °C (-328 °F)	+850 °C (+1562 °F)	d°C or d°F	-500	+10000
Pt1000	-200 °C (-328 °F)	+800 °C (+1472 °F)	d°C or d°F	-500	+10000
Ni1000	-60 °C (-76 °F)	+240 °C (+464 °F)	d°C or d°F	-500	+10000
-13..+63 mV	-13 mV	+63 mV	-2064..10000	Min	Max
0..400 Ω	0	400 Ω	0..10000	Min	Max
0..3850 Ω	0	3850 Ω	0..10000	Min	Max

4.2-3 Sensor link monitoring

Sensor link monitoring imposes a maximum value on the resistance, R_s , of the sensors connected to the module inputs. This maximum R_s value is compatible with normal operation of TSX AEY 414 module (refer to the following table).

A sensor link fault can correspond to a short-circuit (S.C.) or an open circuit (O.C.) according to the type of sensor used. However, report is global and makes no distinction between a short-circuit and an open circuit.

Notes

- the module manages the coherence between the terminal block fault and the sensor link fault.
- the sensor link fault is not detected in the 0-5 V / 0-20 mA range (this function is not offered to the user and the wiring test is not performed).
- in the 1-5 V / 4-20 mA range, the wiring test is only effective if the 250 Ω shunt is connected. If the shunt is not connected, the wiring test may not detect a fault, even if the cables are cut.
- in the case of temperature probes, the sensor link fault caused by a line compensation anomaly can appear or disappear with a maximum delay of 12 s, in relation to the occurrence of the anomaly.

Sensor	Pt1000 / Ni1000 temperature probes	Pt100 temperature probe	Thermocouples -15/60 mV, B, E, J, K, L, N, R, S, T, U
Max R_s	-	-	100 Ω
O.C.	> 3850 Ω	> 400 Ω	100000 Ω
S.C.	150 Ω	15 Ω	not detectable

4.2-4 Measurement filtering

First order filtering is performed with a filtering coefficient which can be modified from a programming terminal or by the program. The mathematical formula used is as follows :

$$\mathbf{Mes}_{fn} = \alpha \times \mathbf{Mes}_{fn-1} + (1-\alpha) \times \mathbf{Val}_{bn}$$

where :

- α = filter efficiency,
- \mathbf{Mes}_{fn} = filtered measurement at moment n,
- \mathbf{Mes}_{fn-1} = filtered measurement at moment n-1,
- \mathbf{Val}_{bn} = "raw" value measured at moment n.

During configuration the user selects a filter value from 7 possible values (0 to 6).
This value may be subsequently modified, even when the application is in RUN.

Efficiency required	Value to select	Corresponding α	Filter response time at 63%	Cut off frequency (Hz)
No filtering	0	0	0	-
Low level of filtering	1	0.750	1.91 s	0.083
	2	0.875	4.12 s	0.039
Medium level of filtering	3	0.937	8.45 s	0.019
	4	0.969	17.5 s	0.0091
High level of filtering	5	0.984	34.1 s	0.0046
	6	0.992	68.5 s	0.0022

4.2-5 Measurement display

This processing enables the choice of the display format in which the measurements are supplied to the user program. It is necessary to differentiate between electrical ranges and thermocouple or temperature probe ranges.

Electrical ranges

The measurement supplied to the application can be used directly by the operator who can choose between :

- using 0..10000 standard display (or ± 10000 for the range ± 10 V),
- setting his own display format parameters by indicating his required minimum and maximum values.

Standard display (default). Values are displayed in standard units :

- for a unipolar range 0..10 V, 0..5 V, 0..20 mA or 4..20 mA, they are displayed from 0 to 10000 ($0^{0/000}$ to $10000^{0/000}$),
- for ± 10 V and ± 5 V bipolar ranges, they are displayed from -10000 to +10000 ($-10000^{0/000}$ to $+10000^{0/000}$).

User display. The user by choose the range of values in which the measurements are expressed, by choosing :

- the lower limit corresponding to the minimum of the range : $0^{0/000}$ (or $-10000^{0/000}$),
- the upper limit corresponding to the maximum of the range : $+10000^{0/000}$.

These upper and lower limits are integers between -30000 and +30000.

Thermocouple and temperature probe ranges

The user has the choice of two types of display :

- **Temperature display.** Values are supplied by default in tenths of a degree :
 - tenths of a degree Celsius, if the unit chosen during configuration is °C,
 - tenths of a degree Fahrenheit, if the unit chosen during configuration is °F.
- **Standard display.** The user can choose a 0..10000 standard display (0 to 10000^{0/1000}), by specifying the minimum and maximum temperatures corresponding to 0 and 10000.

4.2-6 Sensor alignment

Alignment consists of eliminating a systematic shift observed by a given sensor, around a given operating point. An error linked to the process will be compensated but not an error linked to the control system. For this reason, replacing a module does not require a new alignment. On the other hand, replacing the sensor or changing the operating point of that sensor will require a new alignment.

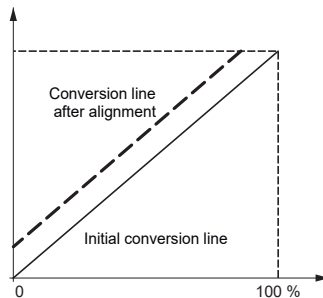

For example, suppose that a Pt100 probe, plunged into melting ice (probe adjustment procedure) displays 10 °C after measurement (and not 0 °C). The user can align the measurement to the value 0 (required value). After this alignment procedure, the measurement channel will apply a systematic offset of -10 to any new measurement.

The alignment value can be modified via a programming terminal, even if the program is in RUN. For each input channel, the user can :

- display and modify the required measurement value,
- save the alignment value,
- know if the channel already has an alignment.

Alignment is performed when the channel is in normal operation, without affecting the operating modes of the module channel.

The maximum deviation between the measured value and the required value (aligned value) should not exceed ± 1000 .

4.2-7 Recalibration

Recalibrating a module :

- corrects long-term drifts on the module,
- improves precision at an ambient temperature other than 25 °C (recommended).

The recalibration range is limited to between $\pm 1\%$ of the full scale, since beyond that range the module will consider there to be an analog input circuit anomaly.

Recalibration (full scale) is performed on each of the channels and in each of the ranges, by placing a calibration source directly on the input terminals. The following table indicates the calibration value to be supplied, according to the user range :

User range	$\pm 10\text{ V}$, $0..10\text{ V}$, $\pm 5\text{ V}$, $0..5\text{ V}$, $1..5\text{ V}$, $0..20\text{ mA}$ & $4..20\text{ mA}$	Pt100, Pt1000 and Ni1000	-13..63 mV, B, E, J, K, L, N, R, S, T and U
Calibration voltage	$10\text{ V} \pm 0.018\%$	$2.5\text{ V} \pm 0.016\%$	$60\text{ mV} \pm 0.028\%$
Measurement current	/	$2.5\text{ mA} \pm 0.0328\%$	/

- In the case of temperature probes, recalibration of the current source takes place channel by channel. This consists of reading the value supplied by each of the current sources (only in 2.5 mA) to within 0.0328% and supplying the value in units of 100 nA. The recalibration procedure is available via the PL7 Junior software debug screens (refer to the installation manual for analog applications).
- for the calibration voltages 10 V and 2.5 V, the expected value read after calibration is 10000 ± 2 . For a calibration voltage of 60 mV, the value read is expected to be 9523 ± 2 (10000 corresponding to full scale, ie 63 mV).

4.3 Fault processing

4.3-1 External faults

Range overshoot

At the time of measurement range overshoot, the following bits are set to 1 :

- fault bit **%Ixy.i.ERR**, associated with the channel (for example, %I2.0.ERR for channel 0 of the module located in slot 2),
- bit 1 (rage overshoot) of status word associated with the channel (for example, %MW2.0.2:X1 channel 0 of the module located in slot 2).

The **I/O indicator lamp is permanently on** during the fault.

Sensor link fault (user definable)

When a sensor link fault occurs (refer to section 4.2-3, sensor link monitoring), the following bits are set to 1 :

- fault bit **%Ixy.i.ERR**, associated with the channel (for example, %I2.0.ERR for channel 0 of the module located in slot 2),
- bit 0 (sensor link fault) of status word associated with the channel (for example, %MW2.0.2:X1 channel 0 of the module located in slot 2).

4.3-2 Internal faults

Each module carries out a series of self-tests (watchdog, memory, analog/digital conversion circuit). When an error occurs during these tests, an internal fault is signalled : the channels are reset to 0 (%IWxy.i) and the **ERR indicator lamp is permanently on**. If a module is inoperative and can no longer communicate with the processor, the latter will still be informed as it detects a module which is absent or inoperative.

Self-test performed	Status of ERR indicator lamp during a fault	Feedback of fault to the processor
Watchdog test	Permanently on	no
Checksum of REEPROM memory	Permanently on	no
Test of bus X interface	Permanently on	no
Test of external RAM	Permanently on	no
Test of EEPROM memory	Permanently on	no
Test of converters	Permanently on	yes
Test of internal references	Permanently on	yes

4.3-3 Other faults

Communication fault

When a fault of communication with the processor occurs the channels are frozen at the last value before the fault.

Terminal block fault (user-definable)

If the terminal block fault is configured, it occurs when the terminal block is absent. When such a fault occurs, the following bits are set to 1 :

- fault bit **%Ixy.i.ERR**, associated with the channel (for example, %I2.0.ERR for the channel 0 of the module located in slot 2),
- bit 2 (terminal block fault) of the status word associated with the channel (for example, %MW2.0.2:X2 for the channel 0 of the module located in slot 2).

The **I/O indicator lamp flashes** during the fault.

4.3-4 Fault display

The TSX AEY 414 module is fitted with a display block comprising 3 indicator lamps which display the module operating modes and possible faults : RUN, ERR and I/O indicator lamps.

Module status	Status indicator lamps		
	RUN	ERR	I/O
Normal operation	●	○	○
External fault (range overshoot or sensor link fault)	●	○	●
Internal fault (module failure)			
• communication with CPU possible	●	●	○
• communication with CPU not possible	○	●	○
Other fault (communication fault)	●	○	○
Other fault (terminal block fault)	●	○	⊗

- Indicator lamp off
- ⊗ Indicator lamp flashing
- Indicator lamp on

4.4 Characteristics

4.4-1 General characteristics

Number of channels	4									
Analog/digital conversion	0..65535 points / 16 bits									
Acquisition scan time	550 ms									
Digital filter	1st order / User-definable time constant									
Channel / ground dielectric voltage	1780 Vrms									
Dielectric voltage between channels	2830 Vrms									
Permissible common mode voltage betw. channels and ground during operation	240 VAC or 100 VDC									
Permissible common mode voltage between channels during operation	415 VAC or 200 VDC									
Overtoltage permitted in differential mode on inputs	±30 VDC (powered on, without 250Ω external resistors) ±15 VDC (powered off, without 250Ω external resistors)									
Overcurrent permitted on inputs	±25 mA (powered on/off, with 250Ω external shunts)									
Linearization	Automatic									
Cold junction compensation	Internal and automatic External by Pt100 class A on channel 0, between -5 °C and +85 °C									
Temperature probe current	2.5 mA DC for 100 Ω and 559 μA DC for 1000 Ω									
PLC standards	UL508, UL94, IEC1131, IEC68, IEC801									
Sensor standards	IEC584, IEC751, DIN 43760, DIN 43710, NF C 42-330									
Electrical ranges	±10 V	0..10 V	±5 V (1)	0.5 V (1)	1.5 V (1)	0..20 mA (1)	4..20 mA	-13..63 mV	0..400Ω	0..3850Ω
Full Scale	10 V	10 V	5 V	5 V	5 V	20 mA	20 mA	63 mV	400Ω	3850Ω
Max. error at 25 °C (2)	0.27% FS	0.16% FS	0.27% FS	0.22% FS	0.27% FS	0.36% FS	0.45% FS	0.19% FS	0.13% FS	0.22% FS
Max. error from 0 to 60 °C (2)	0.50% FS	0.39% FS	0.50% FS	0.45% FS	0.56% FS	0.69% FS	0.86% FS	0.44% FS	0.27% FS	0.48% FS
Temp. probe ranges	Pt100 according to IEC			Pt1000 according to IEC			Ni1000 according to DIN			
Max. error at 25 °C (3)	1.2 °C			2.5 °C			1.1 °C			
Max. error from 0 to 60 °C (3)	2.4 °C			5.0 °C			2.0 °C			

- (1) The parameters for ranges 0.5 V and 0..20 mA or 1.5 V and 4..20 mA are set in the same way during configuration; the only difference lies in their installation (250 Ω shunt or not).
- (2) For electrical ranges, the data applies to the whole input range.
- (3) For temperature probe ranges, the data is given for the middle of the standard range, in 4-wire or 2-wire configuration, whilst conforming to connection restrictions (see section 4.5-3).

General characteristics (continued)

Thermocouple ranges (4)	B	E	J	K	L	N	R	S	T	U
Max. error IC at 25 °C (4) EC	3.5°C /	6.1°C 1.5°C	7.3°C 1.9°C	7.8°C 2.3°C	7.5°C 2.0°C	6.0°C 2.0°C	6.0°C 3.2°C	6.6°C 3.4°C	6.6°C 1.5°C	5.4°C 1.5°C
Max. error IC 0 to 60 °C EC	8.1°C /	8.1°C 3.2°C	9.5°C 4.0°C	10.5°C 4.7°C	9.8°C 4.2°C	8.7°C 4.3°C	11.0°C 7.7°C	12.0°C 8.5°C	8.8°C 3.3°C	7.3°C 3.1°C

(4) For thermocouple ranges, the data includes internal or external cold junction compensation after a stabilization of 30 min. and is given for the middle of the standard range.

"IC" signifies that **internal** compensation is used; in this case care must be taken with the installation (see section 4.5-4).

"EC" signifies that external compensation is used, across channel 0 for Pt100, with a class A probe.

4.4-2 Detailed input characteristics

The TSX AEY 414 module has 23 ranges on each of its inputs, which can be configured channel by channel.

Precision

The precision of each input is given by the following formula :

$$\text{Measurement} = C + K \times M$$

where **C** = constant for the range examined,

K = proportionality coefficient,

M = absolute value of the measurement.

The measurement error is therefore composed of a constant value (C) and a value proportional to the measurement (K), which can be different depending on the polarity of the measurement.

For thermocouple ranges, the measurement error also takes into account the cold junction compensation error and the linearization error, and for current ranges it takes into account the external resistance error (shunt).

Crosstalk

Crosstalk is expressed in dB and is given by the following formula :

$$\text{Crosstalk} = 20 \times \text{Log}_{10} (V_M / V_m)$$

where V_M = full scale voltage in the least sensitive range,

V_m = error voltage on the following channel, configured in the least sensitive range (due to the presence of V_M).

In this case, V_M equals +10 V and V_m is the error due to the presence of +10 V on the following channel configured for ± 20 mV.

Rejection in common mode

Rejection in common mode between channel and ground is expressed in dB and is given by the following formula :

$$\text{CM rejection} = 20 \times \text{Log}_{10} (V_{MC} / V_{em})$$

where V_{MC} = voltage in common mode, expressed in VDC or VAC (50 / 60 Hz),

V_{em} = error voltage on the measurement (reduced by the conversion resolution), expressed in VDC.

For a current range, rejection in common mode is naturally deduced from this formula. For temperature probe or thermocouple ranges, rejection in common mode has no significance.

Rejection in 50/60 Hz serial mode

Rejection in 50/60 Hz serial mode, superimposed on the measured value, is expressed in dB and is given by the following formula :

$$\text{SM rejection} = 20 \times \text{Log}_{10} (V_{MS} / V_{em})$$

where V_{MS} = serial mode voltage, expressed in peak to peak V,

V_{em} = voltage error on the measurement (reduced by the conversion resolution), expressed in VDC.

For a current range, rejection in common mode is naturally deduced from this formula. For temperature probe or thermocouple ranges, rejection in common mode has no significance.

Characteristics of the ± 10 V range

Range	± 10 V	
Full scale (FS)	10 V	
Conversion resolution	570 μ V	
Display resolution	1 mV	(0.01%)
Max. error at 25 °C	+2 mV + 0.0014 x M - 2 mV + 0.0025 x M	(0.27% FS)
Max error over 0 to 60 °C	0.50% FS	
Full scale range	± 10 V	(± 10000)
Range overshoot	± 10.5 V	(± 10500)
CM rejection channel / ground (VDC)	95 dB	
CM rejection channel / ground (VAC - 50 / 60 Hz)	105 dB	
SM rejection- 50 / 60 Hz	35 dB	

Errors at temperatures other than 25 °C and 60 °C can be deduced by linear extrapolation of the errors defined at 25 and 60 °C. The formula is :

Characteristics of the 0..10 V range

Range	0..10 V	
Full scale (FS)	10 V	
Conversion resolution	570 μ V	
Display resolution	1 mV	(0.01% FS)
Max. error at 25 °C	+2 mV + 0.0014 x M	(0.10% FS)
Max. error from 0 to 60 °C	0.39% FS	
Full scale range	0..10 V	(0..10000)
Range overshoot	-0.5..10.5 V	(-500..10500)
CM rejection channel / ground (VDC)	95 dB	
CM rejection channel / ground (VAC - 50 / 60 Hz)	105 dB	
SM rejection - 50 / 60 Hz	35 dB	

Characteristics of the \pm 5 V range

Range	\pm 5 V	
Full scale (FS)	5 V	
Conversion resolution	570 μ V	
Display resolution	0.5 mV	(0.01% FS)
Max. error at 25 °C	+1.5 mV + 0.0019 x M -1.5 mV + 0.0024 x M	(0.27% FS)
Max. error from 0 to 60 °C	0.50% FS	
Full scale range	\pm 5 V	(\pm 10000)
Range overshoot	\pm 5.25 V	(\pm 10500)
CM rejection channel / ground (VDC)	100 dB	
CM rejection channel / ground (VAC - 50 / 60 Hz)	110 dB	
SM rejection - 50 / 60 Hz	35 dB	

Errors at temperatures other than 25 °C and 60 °C can be deduced by linear extrapolation of the errors defined at 25 and 60 °C. The formula is :

$$E(T) = E(25^{\circ}\text{C}) + |T - 25^{\circ}\text{C}| \times [E(60^{\circ}\text{C}) - E(25^{\circ}\text{C})]/35$$

Characteristics of the 0..5 V range

Range	0..5 V	
Full scale (FS)	5 V	
Conversion resolution	570 μ V	
Display resolution	500 μ V	(0.01% FS)
Max. error at 25 °C	+1.5 mV + 0.0019 x M	(0.22% FS)
Max. error from 0 to 60 °C	0.45% FS	
Full scale range	0..5 V	(0..10000)
Range overshoot	-0.25..5.25 V	(-500..10500)
CM rejection channel / ground (VDC)	100 dB	
CM rejection channel / ground (VAC - 50 / 60 Hz)	110 dB	
SM rejection - 50 / 60 Hz	35 dB	

Characteristics of the 1..5 V range

Range	1..5 V	
Full scale (FS)	4 V	
Conversion resolution	570 μ V	
Display resolution	400 μ V	(0.01% FS)
Max. error at 25 °C	+3.2 mV + 0.0019 x M	(0.27% FS)
Max. error from 0 to 60 °C	0.56% FS	
Full scale range	1..5 V	(0..10000)
Range overshoot	0.8..5.2 V	(-500..10500)
CM rejection channel / ground (VDC)	100 dB	
CM rejection channel / ground (VAC - 50 / 60 Hz)	110 dB	
SM rejection - 50 / 60 Hz	35 dB	

Errors at temperatures other than 25 °C and 60 °C can be deduced by linear extrapolation of the errors defined at 25 and 60 °C. The formula is :

$$E(T) = E(25^{\circ}\text{C}) + (T - 25^{\circ}\text{C}) \times [E(60^{\circ}\text{C}) - E(25^{\circ}\text{C})]/35$$

Characteristics of the 0..20 mA range

Range	0..20 mA	
Full scale (FS)	20 mA	
Conversion resolution	2.28 μ A	
Display resolution	2 μ A	(0.01% FS)
Max. error at 25 °C	+6 μ A + 0.0033 x M	(0.36% FS)
Max. error from 0 to 60 °C	0.69% FS	
Full scale range	0..20 mA	(0..10000)
Range overshoot	-1..21 mA	(-500..10500)
CM rejection channel / ground (VDC)	100 dB	
CM rejection channel / ground (VAC - 50 / 60 Hz)	110 dB	
SM rejection - 50 / 60 Hz	35 dB	

Characteristics of the 4..20 mA range

Range	4..20 mA	
Full scale (FS)	16 mA	
Conversion resolution	2.28 μ A	
Display resolution	1.6 μ A	(0.01% FS)
Max. error at 25 °C	+19.2 μ A + 0.0033 x M	(0.45% FS)
Max. error from 0 to 60 °C	0.86% FS	
Full scale range	4..20 mA	(0..10000)
Range overshoot	3.2..20.8 mA	(-500..10500)
CM rejection channel / ground (VDC)	100 dB	
CM rejection channel / ground (VAC - 50 / 60 Hz)	110 dB	
SM rejection - 50 / 60 Hz	35 dB	

Errors at temperatures other than 25 °C and 60 °C can be deduced by linear extrapolation of the errors defined at 25 and 60 °C. The formula is :

$$E(T) = E(25^{\circ}\text{C}) + |T - 25^{\circ}\text{C}| \times [E(60^{\circ}\text{C}) - E(25^{\circ}\text{C})]/35$$

Precision includes the shunt (250 Ω - 0.1% - 25 ppm/°C). The influence of the shunt on the precision can be reduced by using a more precise resistance (0.01% - 10 ppm/°C).

Characteristics of the -13..63 mV range

Range	-13..63 mV	
Full scale (FS)	63 mV	
Conversion resolution	2.02 μ V	
Display resolution	6.3 μ V (1)	(0.01% FS)
Max. error at 25 °C	+18 μ V + 0.001581 x M -18 μ V + 0.004581 x M	(0.19% FS)
Max. error from 0 to 60 °C	0.44% FS	
Full scale range	-13..63 mV	(-2064..10000)
Range overshoot	-13..63 mV	(-2064..10000)
CM rejection channel / ground (VDC)	>140 dB	
CM rejection channel / ground (VAC - 50 / 60 Hz)	>150 dB	
SM rejection - 50 / 60 Hz	>35 dB	

Characteristics of the 0..400 Ω range

Range	0..400 Ω	
Full scale (FS)	400 Ω	
Conversion resolution	31 m Ω	
Display resolution	40 m Ω (1)	(0.01% FS)
Max. error at 25 °C	63 m Ω + 0.001180 x M	(0.13% FS)
Max. error from 0 to 60 °C	0.27% FS	
Full scale range	0..400 Ω	(0..10000)
Range overshoot	0..400 Ω	(0..10000)
CM rejection channel / ground (VDC)	>110 dB	
CM rejection channel / ground (VAC - 50 / 60 Hz)	>120 dB	
SM rejection - 50 / 60 Hz	>35 dB	

Errors at temperatures other than 25 °C and 60 °C can be deduced by linear extrapolation of the errors defined at 25 and 60 °C. The formula is :

$$E(T) = E(25^{\circ}\text{C}) + |T - 25^{\circ}\text{C}| \times [E(60^{\circ}\text{C}) - E(25^{\circ}\text{C})]/35$$

(1) Converter resolution can be achieved by redefining the limits in the User scale.

Characteristics of the 0..3850 Ω range

Range	0..3850 Ω	
Full scale (FS)	3850 Ω	
Conversion resolution	139 mΩ	
Display resolution	385 mΩ (1)	(0.01% FS)
Max. error at 25 °C	2.114 Ω + 0.001647 x M	(0.22% FS)
Max. error from 0 to 60 °C	0.48% FS	
Full scale range	0..3850 Ω	(0..10000)
Range overshoot	0..3850 Ω	(0..10000)
CM rejection channel / ground (VDC)	>110 dB	
CM rejection channel / ground (VAC - 50 / 60 Hz)	>120 dB	
SM rejection - 50 / 60 Hz	>35 dB	

Errors at temperatures other than 25 °C and 60 °C can be deduced by linear extrapolation of the errors defined at 25 and 60 °C. The formula is :

$$E(T) = E(25^{\circ}\text{C}) + |T - 25^{\circ}\text{C}| \times [E(60^{\circ}\text{C}) - E(25^{\circ}\text{C})]/35$$

(1) Converter resolution can be achieved by redefining the limits in the User scale.

Characteristics of the temperature probe ranges

Range	Pt100	Pt1000	Ni1000
Conversion resolution (1)	0.09 °C	0.04 °C	0.02 °C
Display resolution	0.1 °C	0.1 °C	0.1 °C
Max. error at 25 °C (2)			
Operating point			
-200 °C	0.3 °C	0.4 °C	
-100 °C	0.5 °C	0.8 °C	
0 °C	0.6 °C	1.2 °C	0.9 °C
100 °C	0.8 °C	1.6 °C	1.1 °C
200 °C	1.0 °C	2.1 °C	1.2 °C
300 °C	1.2 °C	2.5 °C	
400 °C	1.4 °C	3.0 °C	
500 °C	1.7 °C	3.4 °C	
600 °C	1.8 °C	4.0 °C	
700 °C	2.1 °C	4.5 °C	
800 °C	2.3 °C	5.1 °C	
Max. error from 0 to 60 °C			
Operating point			
-200 °C	0.5 °C	0.5 °C	
-100 °C	0.8 °C	1.4 °C	
0 °C	1.2 °C	2.2 °C	1.6 °C
100 °C	1.6 °C	3.1 °C	2.0 °C
200 °C	2.0 °C	4.0 °C	2.3 °C
300 °C	2.4 °C	4.9 °C	
400 °C	2.9 °C	5.9 °C	
500 °C	3.3 °C	7.0 °C	
600 °C	3.8 °C	8.0 °C	
700 °C	4.4 °C	9.1 °C	
800 °C	5.0 °C	10.3 °C	
Full scale range in °C in °F	-200..850 °C -328..1562 °F	-200..800 °C -328..1472 °F	-60..250 °C -76..482 °F

Errors at temperatures other than 25 °C and 60 °C can be deduced by linear extrapolation of the errors defined at 25 and 60 °C. The formula is :

$$E(T) = E(25^{\circ}\text{C}) + |T - 25^{\circ}\text{C}| \times [E(60^{\circ}\text{C}) - E(25^{\circ}\text{C})]/35$$

The data is given for 4-wire connections and include errors and drifts from the current source 2500 μA (Pt100) or 559.03 μA (Pt1000 or Ni1000).

The effect of self-heating does not cause a significant error on the measurement, whether the probe is in air or water.

- (1) these values are given for an operating point in the middle of the temperature probe range.
- (2) ambient temperature of TSX AEY 414.

Reference standard : NF C 42-330 June 1983 and IEC 751, 2nd edition 1986 for Pt100 / 1000, DIN 43760 September 1987 for Ni1000.

Characteristics of thermocouple ranges

Thermocouple range	B	E		J		K		
Conversion resolution (1)	0.24 °C	0.026 °C		0.037 °C		0.048 °C		
Display resolution	0.1 °C	0.1 °C		0.1 °C		0.1 °C		
Max. error at 25 °C (2)	IC / EC (°C) (3)	IC (°C)	EC (°C)	IC (°C)	EC (°C)	IC (°C)	EC (°C)	
Operating point	-200 °C	16.8	2.7			18.7	3.3	
	-100 °C	9.5	1.7			9.5	1.8	
	0 °C	7.5	1.5	7.4	1.5	7.5	1.6	
	100 °C	6.7	1.4	7.1	1.5	7.4	1.7	
	200 °C	6.2	1.5	7.1	1.7	7.8	1.9	
	300 °C	6.1	1.5	7.3	1.8	7.6	2.0	
	400 °C	6.1	1.7	7.4	2.0	7.6	2.1	
	500 °C	6.2	1.8	7.5	2.1	7.8	2.3	
	600 °C	4.7	6.4	2.0	7.3	2.2	7.9	2.4
	700 °C	4.0	6.6	2.1	7.0	2.2	8.2	2.6
	800 °C	4.0	6.8	2.3			8.6	2.8
	900 °C	3.8					8.9	3.1
	1000 °C	3.6					9.3	3.3
	1100 °C	3.5					9.8	3.6
	1200 °C	3.6					10.3	3.8
	1300 °C	3.6						
	1400 °C	3.5						
1500 °C	3.5							
1600 °C	3.7							
1700 °C	3.9							
Full scale range (4)	0..1802 °C	-270..812 °C		-210..1065 °C		-270..1372 °C		

Errors at temperatures other than 25 °C and 60 °C can be deduced by linear extrapolation of the errors defined at 25 and 60 °C. The formula is :

$$E(T) = E(25^{\circ}\text{C}) + I T - 25^{\circ}\text{C} \times [E(60^{\circ}\text{C}) - E(25^{\circ}\text{C})]/35$$

- (1) These values are given for an operating point in the middle of the thermocouple range.
- (2) "IC" signifies that **internal** compensation is used; in this case care must be taken with the installation (see section 4.5-4).
EC = ambient temperature of the TSX AEY 414 (4) and automatic **external** compensation, with Pt100 class A.
- (3) With thermocouple B, the type of cold junction compensation (internal or external) is not taken into account, since it has no effect on precision.
- (4) Internal compensation : ambient temperature = 20 °C,
External compensation : ambient temperature = 30 °C.

Reference standards : IEC 584-1, 1st edition 1977 and IEC 584-2, 2nd edition 1989.

Characteristics of thermocouple ranges (continued)

Thermocouple range	B	E		J		K	
Max. error at 25 °C (1)	CI / CE (°F) (2)	CI (°F)	CE (°F)	CI (°F)	CE (°F)	CI (°F)	CE (°F)
-300 °F		26.4	4.3			28.5	5.1
-100 °F		15.8	2.9			15.7	3.1
0 °F				13.6	2.7		
100 °F		12.8	2.6			13.2	2.9
200 °F				12.7	2.8		
300 °F		11.6	2.6			13.7	3.2
400 °F				12.8	3.0		
500 °F		11.0	2.7			13.8	3.5
600 °F				13.1	3.3		
700 °F		10.9	2.9			13.8	3.7
800 °F				13.4	3.6		
900 °F		11.1	3.2			13.9	4.0
1000 °F				13.4	3.9		
1100 °F	8.5	11.4	3.5			14.3	4.3
1200 °F				12.9	4.0		
1300 °F	7.3	11.8	3.9			14.7	4.7
1400 °F				12.5	4.0		
1500 °F	7.0	12.4	4.3			15.5	5.1
1700 °F	6.8					16.3	5.6
1900 °F	6.6					17.1	6.1
2100 °F	6.2					18.0	6.6
2300 °F	6.2					19.1	7.2
2500 °F	6.3						
2700 °F	6.4						
2900 °F	6.6						
3100 °F	7.0						
Full scale range (3)	32..3276 °F	-454..1493 °F		-346..1949 °F		-454..2502 °F	

- (1) "IC" signifies that **internal** compensation is used; in this case care must be taken with the installation (see section 4.5-4).
EC = ambient temperature of the TSX AEY 414 (3) and automatic **external** compensation, with Pt100 class A.
- (2) With thermocouple B, the type of cold junction compensation (internal or external) is not taken into account, since it has no effect on precision.
- (3) Internal compensation : ambient temperature = 20 °C,
External compensation : ambient temperature = 30 °C.

Characteristics of thermocouple ranges (continued)

Thermocouple range	L		N		R		S	
Conversion resolution (1)	0.036 °C		0.05 °C		0.16 °C		0.19 °C	
Display resolution	0.1 °C		0.1 °C		0.1 °C		0.1 °C	
Max. error at 25 °C (2)	IC (°C)	EC (°C)	IC (°C)	EC (°C)	IC (°C)	EC (°C)	IC (°C)	EC (°C)
	Operating point							
-200 °C			19.6	4.0				
-100 °C			9.5	2.1				
0 °C	7.5	1.5	7.8	1.8	11.4	4.8	11.2	4.7
100 °C	7.1	1.5	7.0	1.8	8.1	3.5	8.3	3.5
200 °C	7.2	1.7	6.5	1.7	7.1	3.2	7.4	3.3
300 °C	7.3	1.9	6.2	1.8	6.5	2.9	6.9	3.1
400 °C	7.5	2.0	6.0	1.9	6.3	3.0	6.8	3.2
500 °C	7.4	2.1	6.0	2.0	6.2	3.0	6.8	3.3
600 °C	7.4	2.2	6.1	2.1	6.1	3.1	6.8	3.4
700 °C	7.1	2.2	6.2	2.2	6.1	3.1	6.6	3.3
800 °C	6.8	2.3	6.3	2.4	6.0	3.2	6.6	3.4
900 °C	6.7	2.3	6.5	2.6	6.0	3.2	6.6	3.5
1000 °C			6.8	2.7	5.9	3.3	6.6	3.6
1100 °C			7.0	2.9	5.9	3.3	6.6	3.7
1200 °C			7.4	3.2	5.9	3.4	6.7	3.8
1300 °C					6.0	3.5	6.8	3.9
1400 °C					6.1	3.7	6.9	4.1
1500 °C					6.3	3.8	7.2	4.3
1600 °C					6.5	4.0	7.4	4.5
Full scale range (3)	-200..900 °C		-270..1300 °C		-50..1769 °C		-50..1769 °C	

Errors at temperatures other than 25 °C and 60 °C can be deduced by linear extrapolation of the errors defined at 25 and 60 °C. The formula is :

$$E(T) = E(25^{\circ}\text{C}) + |T - 25^{\circ}\text{C}| \times [E(60^{\circ}\text{C}) - E(25^{\circ}\text{C})]/35$$

- (1) These values are given for an operating point in the middle of the thermocouple range.
- (2) "IC" signifies that **internal** compensation is used; in this case care must be taken with the installation (see section 4.5-4).
EC = ambient temperature of the TSXAEY 414 (4) and automatic **external** compensation, with Pt100 class A.
- (3) Internal compensation : ambient temperature = 20 °C,
External compensation : ambient temperature = 30 °C.

Reference standards :

- thermocouple L : DIN 43710, edition December 1985,
- thermocouple N : IEC 584-1, 2nd edition 1989 and IEC 584-2, 2nd edition 1989,
- thermocouple R : IEC 584-1, 1st edition 1977 and IEC 584-2, 2nd edition 1989,
- thermocouple S : IEC 584-1, 1st edition 1977 and IEC 584-2, 2nd edition 1989.

Characteristics of thermocouple ranges (continued)

Thermocouple range	L		N		R		S	
Max. error at 25 °C (1)	CI (°F)	CE (°F)	CI (°F)	CE (°F)	CI (°F)	CE (°F)	CI (°F)	CE (°F)
-300 °F			29.4	6.0				
-100 °F			15.7	3.4				
0 °F	14.9	2.8			21.9	8.8	21.2	8.6
100 °F			13.5	3.3				
200 °F	13.1	2.7			14.8	6.4	15.1	6.5
300 °F			12.0	3.1				
400 °F	12.7	2.9			12.8	5.7	13.3	6.0
500 °F			11.2	3.2				
600 °F	13.0	3.2			11.9	5.6	12.3	5.5
700 °F			10.9	3.3				
800 °F	13.3	3.5			11.2	5.3	12.1	5.7
900 °F			10.9	3.5				
1000 °F	13.4	3.8			11.0	5.3	12.1	5.9
1100 °F			10.9	3.8				
1200 °F	13.3	4.0			10.8	5.4	12.1	6.0
1300 °F			11.1	4.0				
1400 °F	12.8	4.0			10.7	5.5	12.0	6.2
1500 °F	12.2	4.0	11.5	4.3				
1600 °F					10.5	5.6	11.9	6.3
1700 °F			11.9	4.7				
1800 °F					10.7	5.7	11.9	6.4
1900 °F			12.3	5.1				
2000 °F					10.6	6.0	3.9	2.3
2100 °F			13.0	5.5				
2200 °F					10.5	6.1	3.9	2.3
2300 °F			13.7	6.0				
2400 °F					10.5	6.2	4.0	2.4
2600 °F					10.4	6.3	4.1	2.5
2800 °F					10.4	6.4	4.2	2.6
3000 °F					10.7	6.7	4.4	2.8
Full scale range (2)	-328..1652 °F		-454..2372 °F		-58..3216 °F		-58..3216 °F	

(1) "IC" signifies that **internal** compensation is used; in this case care must be taken with the installation (see section 4.5-4).

EC = ambient temperature of the TSXAEY 414 (2) and automatic **external** compensation, with Pt100 class A.

(2) Internal compensation : ambient temperature = 20 °C,
External compensation : ambient temperature = 30 °C.

Characteristics of thermocouple ranges (continued)

Thermocouple range	T		U			
Conversion resolution (1)	0.046 °C		0.038 °C			
Display resolution	0.1 °C		0.1 °C			
Max. error at 25 °C (2)	Operating point	IC (°C)	EC (°C)	IC (°C)	EC (°C)	
		-200 °C	18,3	3,2		
		-150 °C	13,0	2,4		
		-100 °C	10,3	2,0		
		-50 °C	8,7	1,7		
		0 °C	7,7	1,6	7,7	1,6
		50 °C	7,1	1,5		
		100 °C	6,6	1,5	6,7	1,5
		150 °C	6,2	1,5		
		200 °C	5,9	1,5	5,8	1,5
		250 °C	5,7	1,5		
		300 °C	5,6	1,5	5,4	1,5
		350 °C	5,5	1,6		
400 °C			5,4	1,6		
500 °C			5,2	1,6		
600 °C			5,0	1,7		
Full scale range (3)	-270..400 °C		-200..600 °C			

Errors at temperatures other than 25 °C and 60 °C can be deduced by linear extrapolation of the errors defined at 25 and 60 °C. The formula is :

$$E(T) = E(25^{\circ}\text{C}) + I T - 25^{\circ}\text{C} \times [E(60^{\circ}\text{C}) - E(25^{\circ}\text{C})]/35$$

- (1) These values are given for an operating point in the middle of the thermocouple range.
- (2) "IC" signifies that **internal** compensation is used; in this case care must be taken with the installation (see section 4.5-4).
EC = ambient temperature of the TSX AEY 414 (4) and automatic **external** compensation, with Pt100 class A.
- (3) Internal compensation : ambient temperature = 20 °C,
External compensation : ambient temperature = 30 °C.

Reference standards :

- thermocouple T : IEC 584-1, 1st edition 1977 and IEC 584-2, 2nd edition 1989,
- thermocouple U : DIN 43710, edition December 1985.

Characteristics of thermocouple ranges (continued)

Thermocouple range	T		U	
	CI (°F)	CE (°F)	CI (°F)	CE (°F)
Max. error at 25 °C (1)				
Operating point	-300 °F	29,2	5,3	
	-200 °F	21,1	4,0	
	-100 °F	16,9	3,3	
	0 °F	14,4	3,0	14,3
	100 °F	13,0	2,8	
	200 °F	11,9	2,7	12,3
	300 °F	11,2	2,7	
	400 °F	10,6	2,7	10,5
	500 °F	10,3	2,7	
	600 °F	10,0	2,7	9,8
	700 °F	9,8	2,8	
800 °F			9,7	2,9
1000 °F			9,2	3,0
Full scale range (2)	-454..752 °F		-328..1112 °F	

- (1) "IC" signifies that **internal** compensation is used; in this case care must be taken with the installation (see section 4.5-4).
EC = ambient temperature of the TSX AEY 414 (2) and automatic **external** compensation, with Pt100 class A.
- (2) Internal compensation : ambient temperature = 20 °C,
External compensation : ambient temperature = 30 °C.

4.5 Connections

4.5-1 Terminal block pinout

The TSX AEY 414 module uses a TSX BLY 01 terminal block.

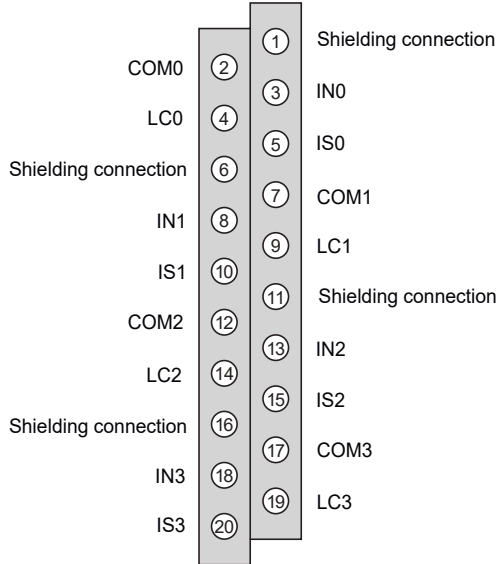

INx : +ve input channel x
COMx : -ve input channel x
ISx : +ve probe supply
LCx : Line compensation

Note

The terminal block is fitted with an internal shunt, which cannot be accessed at the terminals.

4.5-2 External shunts (0..20 mA and 4..20 mA range)

When the 0..20 mA or 4..20 mA range is used, an external shunt of $250 \Omega - 0.1\% - 1/2 W - 25\text{ppm}/^\circ\text{C}$ is required, connected in parallel on the input terminals. This shunt is supplied with the module in lots of 4, which can also be supplied separately, under reference TSX AAK2.

4.5-3 Sensor connection

It is advisable to use shielded cables and to link the shielding to the terminals designed for this purpose (Shielding connection).

For high level and thermocouple inputs, the "source + wiring" resistance should be less than 100Ω so as not to adversely affect the module performance.

For temperature probe inputs, the resistance of each of the wires in 4-wire configuration should be less than 50Ω , which corresponds to a copper wire with a cross-section of 0.6 mm^2 and maximum overall length of 3000 m.

For the 2-wire Pt100 temperature probes, the resistance of each of the wires should be less than $50 \text{ m}\Omega$ (so as not to introduce a measurement error caused by resistive losses in the cables).

Examples of wiring sensors on channel 0

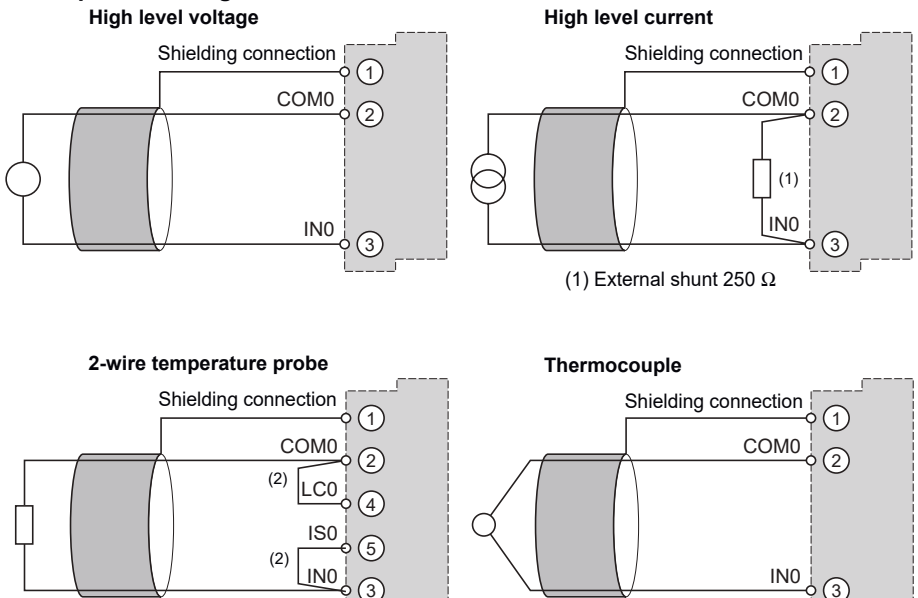

4.5-4 Recommendations for installing thermocouples

• Use of internal cold junction compensation

In the case of measurements by ET thermocouple with internal compensation (and only in this case) it is advisable to follow the rules below :

- the PLC must not be directly fan-cooled, convection must be natural,
- variations in ambient temperature must be less than 5 °C per hour,
- modules in close proximity must be able to dissipate between 2.2 W and 3.3 W, which corresponds to the most commonly used modules (TSX P5710, TSX P5720, TSX DEY 16D2, TSX DEY 32DK, TSX DEY 16FK, TSX DSY 16R5, TSX AEY 414, etc),
- the TSX AEY 414 module must be mounted in a PLC which has a minimum clearance height of 150 mm (D) and width (d) of 100 mm.

If these recommendations are followed, installation can be made in a wall or floor-mounted enclosure, or without an enclosure.

If the installation rules described above are not observed, module operation is not impaired. However, measurement precision on inputs set for thermocouple ranges will be affected. In stable ventilation conditions and for a fixed configuration, the measurement will simply be shifted by a stable value, which can be compensated by carrying out sensor alignment.

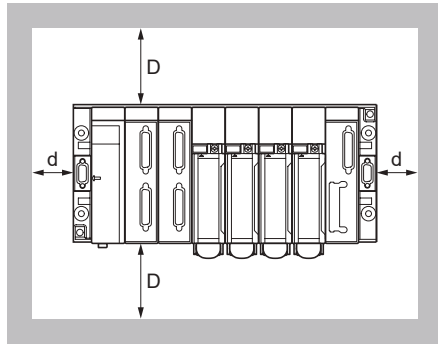

Since thermocouple B is not sensitive to cold junction compensation from 0 to 70 °C, these installation restrictions do not apply.

• Use of external cold junction compensation

If thermocouples with external compensation are used, the acquisition of the cold junction temperature must be made using a Pt100 class A probe on channel 0 (probe not supplied). Channels 1, 2 and 3 of the module can therefore be used for the thermocouple measurement.

In this case, there are no particular restrictions on TSX AEY 414 module installation. However, the Pt100 probe must be placed near to the cold junction terminal block, thus enabling the use of standard shielded copper cables instead of compensated cables.

5.1 Presentation

General

The TSX ASY 410 module has 4 analog outputs which are isolated from each other and have ranges of ± 10 V, 0..20 mA and 4..20 mA, without the need for an external supply.

It is possible to connect loads of 1 k Ω minimum on the voltage outputs and 600 Ω maximum on the current outputs (IEC 1131 standard values).

Note

The terminal block is supplied separately under reference TSX BLY 01.

Functions

This output module performs the following functions :

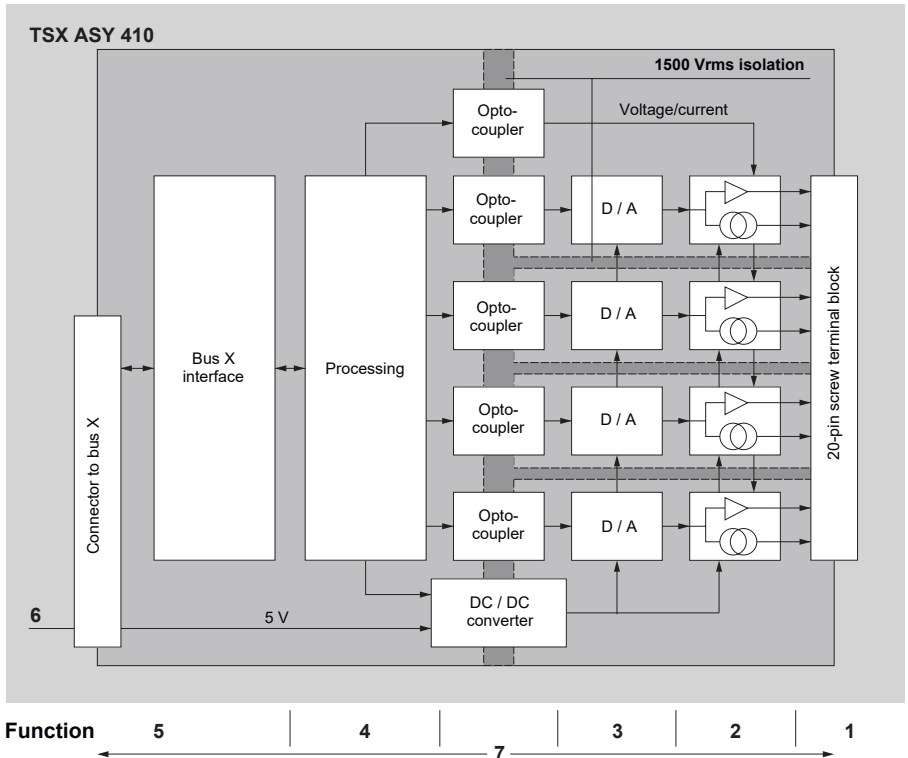
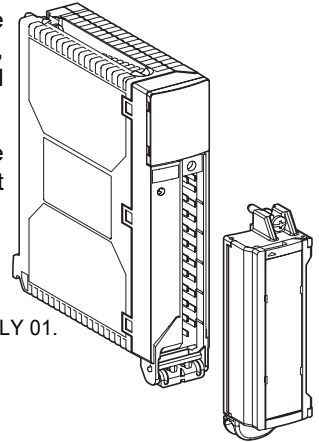

1 Connection to the process

- physical connection to the process, via a 20-pin screw terminal block,
- protection of the module against overvoltages.

2 Adaptation to different actuators (voltage or current output).

3 Conversion of digital data into analog signals

4 Converting application data into data which can be used by the digital/ analog converter.

5 Interface and communication with the application

- management of exchanges via bus X,
- geographical addressing,
- reception, from the application, of module and channel configuration parameters, as well as digital channel settings,
- transmission of module status to the application.

6 Module power supply

7 Monitoring the module and indicating possible faults to the application

- converter test,
- test for range overshoot on the channels,
- test for the presence of the terminal block,
- watchdog test.

5.2 Output processing

5.2-1 Writing to the outputs

The application must provide the outputs with standard format values -10000 to +10000.

C

5.2-2 Behavior of outputs when the program is in STOP or absent

When the task which controls the outputs is in STOP or when the program is absent, the outputs take the following position :

- programmable fallback, if the "Fallback" option was selected during module configuration,
- maintain last value transmitted, if the "Maintain" option was selected during module configuration.

The fallback value can be modified from the PL7 Junior debug screen or via the program.

5.2-3 Forcing outputs

From the PL7 Junior debug screen, each output can be forced to a value between -10000 and +10000, defined by the user. This function is mainly used for the wiring test.

Forcing cannot be accessed if the program task which controls the output is in RUN (the output is in Fallback or Maintain position when the program task is in STOP).

5.2-4 Overshoot monitoring

If the values supplied by the application are less than -10000 or greater than +10000, analog outputs will become saturated at the following value :

- -10 V or +10 V in the range ± 10 V,
- 4 mA or 20 mA in the range 4..20 mA,
- 0 mA or 20 mA in the range 0..20 mA.

An overshoot fault is signalled by a bit which can be used by the program (error bit **%Ix.y.i.ERR = 1** signals a fault on the channel and status word bit **%MWxy.i.2:X1 = 1** indicates a range overshoot on the channel).

5.2-5 Digital/analog conversion

Digital/analog conversion is executed on 11 bits + sign (-2048 to +2047). The data supplied by the program is converted automatically within the dynamic limits of the converter.

5.2-6 Updating the outputs

The maximum time between transmission of the output value to the PLC bus and its actual positioning on the terminal block is 2.5 ms.

Outputs can be individually assigned to the MAST task or to the FAST task of the application program.

5.3 Fault processing

5.3-1 External faults

Range overshoot

When the value transmitted by the program exceeds permissible limits (-10000 to +10000), the following bits are set to 1 :

- fault bit **%Ixy.i.ERR**, associated with the channel (for example, %I2.0.ERR for channel 0 of the module located in slot 2),
- bit 1 (range overshoot) of the status word associated with the channel (for example, %MW2.0.2:X1 channel 0 of the module located in slot 2).

The **I/O indicator lamp is permanently on** during the fault.

5.3-2 Internal faults

Each module carries out a series of self-tests (watchdog, memory, analog/digital conversion circuit). When an error occurs during these tests, an internal fault is signalled. The ERR indicator lamp is permanently on. If the module is able to do so, it signals a fault to the processor.

Self-test performed	Status of ERR indicator lamp during a fault	Feedback of fault to the processor
Watchdog test	Permanently on	no
Checksum of REPR0M memory	Permanently on	no
Test of bus X interface	Permanently on	no
Test of external RAM	Permanently on	no
Test of EEPROM memory	Permanently on	no

5.3-3 Fallback / Maintain outputs or set outputs to 0

When a fault occurs, according to the seriousness of the fault, outputs take the Fallback/Maintain value individually or together or are they forced to 0 (0 V or 0 mA).

Fault	Behavior of voltage outputs	Behavior of current outputs
Task in STOP or program absent	Fallback/Maintain (channel by channel)	Fallback/Maintain (channel by channel)
Communication fault	Fallback/Maintain (all channels)	Fallback/Maintain (all channels)
Configuration fault	0 V (channel by channel)	0 mA (channel by channel)
Internal module fault	0 V (all channels)	0 mA (all channels)
Value of outputs outside limits (range overshoot)	Value transmitted with saturation at +10 / -10 V (channel by channel)	Value transmitted with saturation to 4 / 20 mA or 0 / 20 mA (channel by channel)
Terminal block fault	Maintain value (all channels)	Maintain value (all channels)
Installation under power Processor stopped	Outputs to 0 (all channels)	0 mA (all channels)
Program reloading	0 V (all channels)	0 mA (all channels)

Fallback state or maintain current value is chosen during module configuration. The fallback value can be modified from the PL7 Junior debug screen or via the program.

5.3-4 Other faults

Communication fault

When a communication fault occurs, the channels go to fallback or maintained mode, according to the choice made during configuration. The **ERR indicator lamp flashes**.

Terminal block fault (user definable)

When a terminal block fault occurs, the following bits are set to 1 :

- fault bit %Ixy.i.ERR, associated with the channel (for example, %I2.0.ERR for channel 0 of the module located in slot 2),
- bit 2 (terminal block fault) of the status word associated with the channel (for example, %MW2.0.2:X2 for channel 0 of the module located in slot 2).

The **I/O indicator lamp flashes** during the fault.

5.3-5 Fault display

The module TSX ASY 410 is fitted with a display block comprising 3 indicator lamps which display the module operating modes and possible faults : RUN, ERR and I/O indicator lamps.

Module status	Status indicator lamps		
	RUN	ERR	I/O
Normal operation	●	○	○
External fault (range overshoot)	●	○	●
Internal fault (module failure)			
• communication with CPU possible	●	●	○
• communication with CPU not possible	○	●	○
Other fault (communication fault)	●	⊗	○
Other fault (terminal block fault)	●	○	⊗

○ indicator lamp off

⊗ indicator lamp flashing

● indicator lamp on

5.4 Characteristics

5.4-1 Output characteristics

Voltage or current outputs	
Number of channels	4
Conversion time	2.5 ms
Output power supply	by the PLC
Type of protection	short-circuits and overloads
Crosstalk between channels	≤ -80 dB
Monotonicity	yes
Non linearity	≤ 1 LSB
RC ground network	R = 50 MΩ, C = 4.7 nF
Isolation between channel and ground	500 VDC
Isolation between channels	1500 V rms
Isolation between bus and channels	1500 V rms
Voltage outputs	
Voltage output range	±10 V
Maximum voltage without damage for voltage output	±30 V
Load impedance	1 kΩ minimum
Capacitive load	< 0.1 μF
Maximum resolution	4.88 mV in ±10 V
Measurement error as a % of Full Scale : FS = 10 V	25 °C 0.45% 0 to 60 °C 0.75% (35 ppm / °C)
Current outputs	
Current output range	20 mA
Maximum voltage without damage for current output	±30 V
Load impedance	600 Ω maximum
Inductive load	< 300 μH
Maximum resolution	9.77 μA
Measurement error as a % of Full Scale : FS = 20 mA	25 °C 0.52% 0 to 60 °C 0.98% (70 ppm / °C)
Max. leakage current	50 μA

5.5 Connections

5.5-1 Terminal block pinout

The TSX ASY 410 module uses a TSX BLY 01 terminal block.

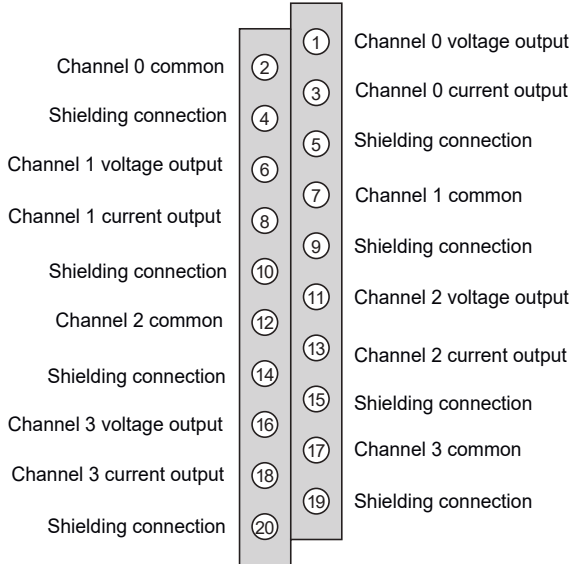

Note

It is advisable to use shielded cables and to link the shielding to the terminals designed for this purpose (Shielding connection).

TSX SCY 21600 module - PCMCIA cards

Part D

Section	Page
1 Presentation	1/1
1.1 Structure of network documentation	1/1
1.2 General communication architecture	1/1
1.3 Operating standards	1/2
2 Installation of the TSX SCY 21600 module	2/1
2.1 Presentation	2/1
2.2 Description	2/1
2.3 Characteristics of the integrated channel	2/2
2.4 Compatibility of the host channel	2/2
2.5 Installation	2/3
2.6 Operation	2/4
2.7 Module visual diagnostics	2/4
2.8 Connection of the integrated channel	2/6
2.8-1 Presentation	2/6
2.8-2 Connection to the UNI-TELWAY fieldbus	2/7
2.8-3 Principle of distributed adaptation for an RS485 line	2/8
2.8-4 Example of a UNI-TELWAY architecture	2/9
2.8-5 Connection to the Jbus/Modbus fieldbus	2/9
2.8-6 Principle of single line adaptation for an RS485 line	2/10
2.8-7 Example of a Modbus architecture	2/11

TSX SCY 21600 module - PCMCIA cards

Part D

Section	Page
2.8-8 Connection of the TSX SCA50 junction box	2/11
2.8-9 Connection in Character mode	2/12
2.8-10 TSX SCY 21600 module consumption	2/13

3 Installation of PCMCIA cards 3/1

3.1 Presentation	3/1
3.2 Description	3/3
3.3 Connection of the PCMCIA card host channel	3/4
3.3-1 Precautions relating to PCMCIA connections	3/4
3.3-2 Connecting PCMCIA cards	3/4
3.3-3 PCMCIA card references	3/4
3.3-4 Mounting cards and cables for TSX PREMIUM	3/5
3.3-5 Displaying the operating status of PCMCIA cards	3/6
3.3-6 PCMCIA card visual diagnostics	3/6
3.4 Connection of the TSX SCP 111 card	3/7
3.4-1 Point-to-point connection in character mode (DTE <==> DTE)	3/7
3.4-2 UNI-TELWAY, Modbus or Character mode connection via Modem	3/8
3.5 Connection of the TSX SCP 112 card	3/9
3.5-1 Point-to-point connection	3/9
3.5-2 Multidrop connection	3/10
3.5-3 Dynamic performance	3/11
3.5-4 Connection to April 5000/7000 PLCs	3/14
3.6 Connection of the TSX SCP 114 card	3/20
3.6-1 Connection to the UNI-TELWAY network	3/20
3.6-2 Connection to the Modbus/Jbus bus	3/22
3.6-3 Character mode asynchronous link connection	3/24

TSX SCY 21600 module - PCMCIA cards

Part D

Section	Page
3.7 Connection of TSX FPP 20 cards	3/25
3.8 Connection of TSX FPP 10 cards	3/26
3.9 Summary of connection cables	3/27
3.9-1 TSX SCP 111 card	3/27
3.9-2 TSX SCP 112 card	3/27
3.9-3 TSX SCP 114 card	3/27
3.9-4 TSX FPP 10 and TSX FPP 20 cards	3/27
3.10 Precautions for connecting PCMCIA cards	3/28
3.11 Current consumption of PCMCIA cards	3/28
3.11-1 Current consumption of TSX SCP 111 card	3/28
3.11-2 Current consumption of TSX SCP 112 card	3/28
3.11-3 Current consumption of TSX SCP 114 cards	3/28
3.11-4 Current consumption of TSX FPP 10 and TSX FPP20 cards	3/28

www.nicsanat.com
021-87700210



D

1.1 Structure of network documentation

This manual is aimed at users wishing to install a device with one or more communication networks.

Manuals :

TSX DM57 E : (this document) part D, provides general information regarding hardware aspects of network installation.

TSX DRNET E : reference manual provides an outline of the world of X-WAY communication, an overview of the various networks, and the X-WAY protocols.

Information on the individual networks is given in the following manuals :

TSX DG FPW E : FIPWAY network

TSX DG UTW E : UNI-TELWAY network

TSX DG MDB E : Modbus network

TSX DM COM PL7 13 E : PL7 communication manual, providing general information on software installation of the various networks.

D

1.2 General communication architecture

FIPWAY

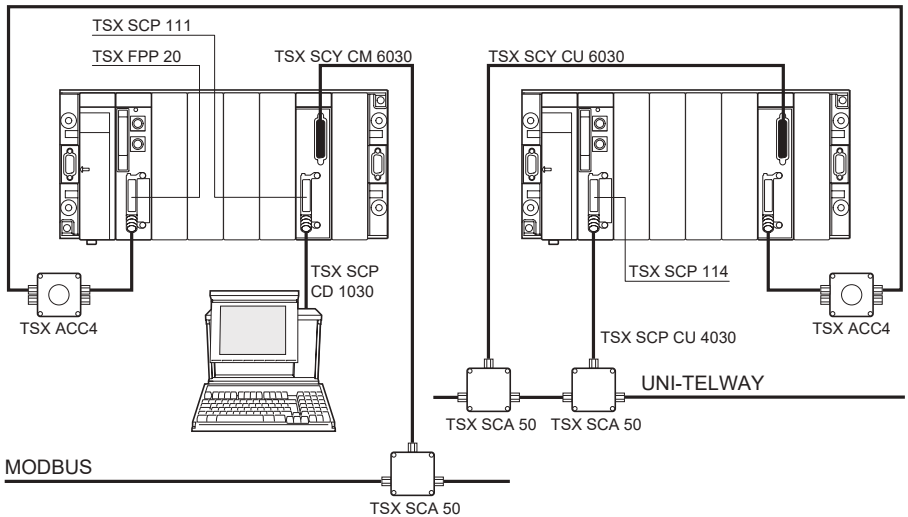

1.3 Operating standards

The **TSX SCY 21600** module and the **PCMCIA** communication cards comply with the following international standards :

- US standards : UL508, IEC 1131-2
- CANADA standards : CSA C22.2 / 142
- Conforming to regulations : FCC-B
- CE marking
- PCMCIA mechanical type III E standard
- PCMCIA 2.01.

The integrated link of the TSX SCY 21 600 module complies with the following communication standards :

- UNI-TELWAY,
- MODBUS,
- XWAY.

The TSX FPP 20 FIPWAY and TSX FPP10 FIPIO agent PCMCIA cards comply with the following communication standards :

- FIP protocol (link, network management),
- PCMCIA,
- XWAY.

The TSX SCP 111, 112, 114 PCMCIA cards comply with the following communication standards :

- UNI-TELWAY, Modbus protocols
- PCMCIA,
- XWAY.

2.1 Presentation

The TSX SCY 21600 communication module will take PCMCIA cards. It has two communication channels :

- One multiprotocol integrated channel (channel 0), isolated RS485 asynchronous serial link, for UNI-TELWAY, Jbus/Modbus, or Character Mode protocols,
- One PCMCIA host channel (channel 1) which supports the following protocols :
 - UNI-TELWAY, Jbus/Modbus, and Character Mode on an RS232-D, current loop or RS485 link corresponding to the TSX SCP 111, 112 and 114 cards.
 - FIPWAY cell network corresponding to the TSX FPP 20 card.

Important : the TSX SCY21600 module integrated channel is only compatible with a 2-wire RS485 link.

2.2 Description

The TSX SCY21600 module is a single format module for insertion in one of the TSX Premium PLC slots.

This module comprises the following components :

1 - Three indicator lamps on the front panel of the module :

- RUN and ERR indicate the module status,
- CH0 displays the communication status of the integrated serial link channel (channel 0),

2 - Integrated channel with a 25-pin female SUB-D connector, standard RS 485 link in half duplex mode (channel 0) :

- UNI-TELWAY
- Jbus/Modbus
- Character mode

3 - Host channel for PCMCIA type III cards (channel 1) :

- Serial link cards : TSX SCP 111, TSX SCP 112, or TSX SCP 114
- FIPWAY cell network :
TSX FPP 20

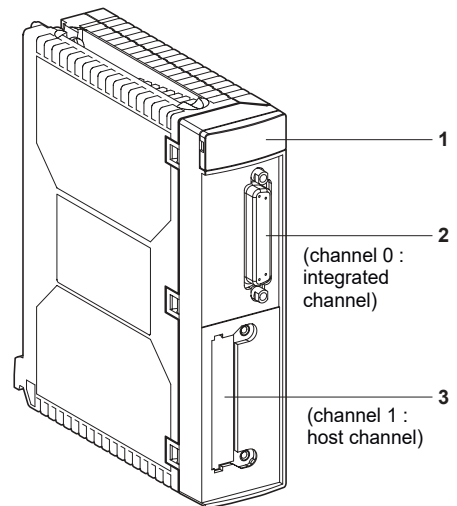

2.3 Characteristics of the integrated channel

The integrated channel of the TSX SCY 21 600 module comprises :

- an RS485 physical interface,
- a baseband asynchronous mode,
- a double twisted pair medium,
- UNITELWAY, Modbus and Character Mode protocols.

Protocol	UNITELWAY	Modbus	Character Mode
Type	Master-slave	Master-slave	Half duplex
Speed	9,600 bits/sec. Can be configured from 1,200 to 19,200 bits/sec	9,600 bits/sec. Can be configured from 1,200 to 19,200 bits/sec	9,600 bits/sec. Can be configured from 1,200 to 19,200 bits/sec
Number of devices	28	28	-
Number of slave addresses	98	98	-
Length of bus excluding tap-links	1000 m.	1000 m.	1000 m.
Size of messages	240 bytes	256 bytes	4 Kb
Function	Message handling Master-slave Slave-slave UNI-TE requests	Read Words/bits Write Words/bits Diagnostics	Transmission of character strings Reception of character strings

2.4 Compatibility of the host channel

The cards accepted by the host channel are :

- TSX SCP 111,112,114 PCMCIA cards which are used for communication with TSX 7 PLCs, series 1000, Modicon and other products compatible with UNITELWAY, Jbus/Modbus and Character mode. PCMCIA cards are also Jbus/Modbus compatible with series 1000 PLCs.
- The TSX FPP 20 card is compatible with FIPWAY devices :
 - model 40 PLCs (TSX 47-455, TSX 67-455 etc) later than version 5.0,
 - TSX 17 PLCs,
 - connected PC compatibles with TSX FPC10 and TSX FPC 20 cards.

Note : the host channel does not accept the TSX FPP 10 card.

2.5 Installation

The TSX SCY 21600 module can be installed in a TSX Premium rack equipped with a TSX 57-10 or TSX 57-20 processor, with a PLC application generated using PL7 Junior software.

The TSX SCY 21600 module is included in an X-WAY network architecture based on TSX series 7, TSX Micro and TSX Premium.

This communication module provides the standard TSX Premium application with :

- an isolated multiprotocol RS485 communication channel,
- a slot for a PCMCIA standard communication card.

The TSX SCY 21600 module can be connected to any rack on the TSX Premium PLC station. Depending on whether the power supply is single or double width, the processor is at slot 0 or 1. The TSX SCY 21600 module occupies one of the other available slots. The TSX SCY 21600 module can be located **remotely** in a Bus X remote rack of a TSX Premium PLC station.

Maximum number of TSX SCY 21600 modules

TSX P57-10 processor	Slot 1 to 710	2 modules maximum
TSX P57-20 processor	Slot 1 to 710	6 modules maximum

Insertion / removal :

The TSX SCY 21600 module can be **inserted or removed with the power on**. This device **does not have** memory **protection**. When the module is disconnected from the rack, its internal memory is erased. The module goes through an initialization phase when it is reinserted.

A TSX SCY 21600 module with a PCMCIA card can be removed with the power on.

⚠ PCMCIA cards **cannot be removed** with the power on.

2.6 Operation

The TSX SCY 21600 module is a two-channel communication module from the Premium range for use with TSX P57-10 and TSX P57-20 processors.

It is used for communication between the PLC and devices with an X-WAY architecture via UNI-TELWAY or Jbus/Modbus fieldbuses or the FIPWAY network.

The TSX SCY 21600 module manages two independent communication channels with their own functions :

- Channel 0 handles UNI-TELWAY, Jbus/Modbus, and Character mode protocols on a half duplex isolated standard RS485 physical link, with a speed restricted to 19200 bits per second,
- Channel 1 can take one of the following PCMCIA communication cards :
 - Fieldbus : TSX SCP111 (RS232), TSX SCP112 (current loop), TSX SCP114 (RS 422/RS485) cards, UNI-TELWAY, Jbus/Modbus and Character Mode,
 - Cell network : TSX FPP 20 FIPWAY card.

The PCMCIA card and protocol can be selected during configuration of the TSX SCY 21600 communication channels using PL7 Junior software.

2.7 Module visual diagnostics

There are three indicator lamps on the front panel of TSX SCY 21600 modules. These provide information on the **operating status of the module** and the **communication status** of the **integrated** serial link channel :

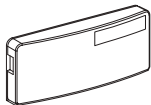

RUN (Green)
ERR (Red)
CH0 (Yellow)

The communication status of the **host channel** is indicated by the ERR and COM indicator lamps on the PCMCIA serial link or FIPWAY cards, see section 5.3.

The indicator lamps on the TSX SCY 21600 module indicate the operating mode of the integrated channel. These indicator lamps can be : on, off or flashing.

State of indicator lamps

RUN	ERR	CHO	Comments
○	(1)	(1)	Module powered down, or not operating
●	○	○	No communication on the integrated channel
●	○	●(2)	Communication on the integrated channel
●	●	(1)	Serious fault on the integrated channel
●	○	○	Fault on the integrated channel, configuration fault, no device OK on the channel
●	○	○	Faulty device on the integrated channel
○	○	○	Self-tests

Key :

- ● On
- ○ Off
- ○ Flashing
- (1) = Indeterminate state
- (2) = line activity display.

2.8 Connection of the integrated channel

2.8-1 Presentation

The wiring accessories for connecting the standard RS485 link of the TSX SCY 21600 module enable the following connections :

- connection to the UNI-TELWAY network via a TSX SCA 50 junction box with the TSX SCY CU 6030 cable, or via a TSX SCA62 junction box with the TSX SCY CU 6530 cable,
- connection to the Jbus/Modbus network via a TSX SCA 50 junction box with the TSX SCY 6030 cable,
- connection to RS485 standard devices using a connector suitable for the link with the TSX SCY CU 6030 or TSX SCY CM 6030 cable.

TSX SCY 21600

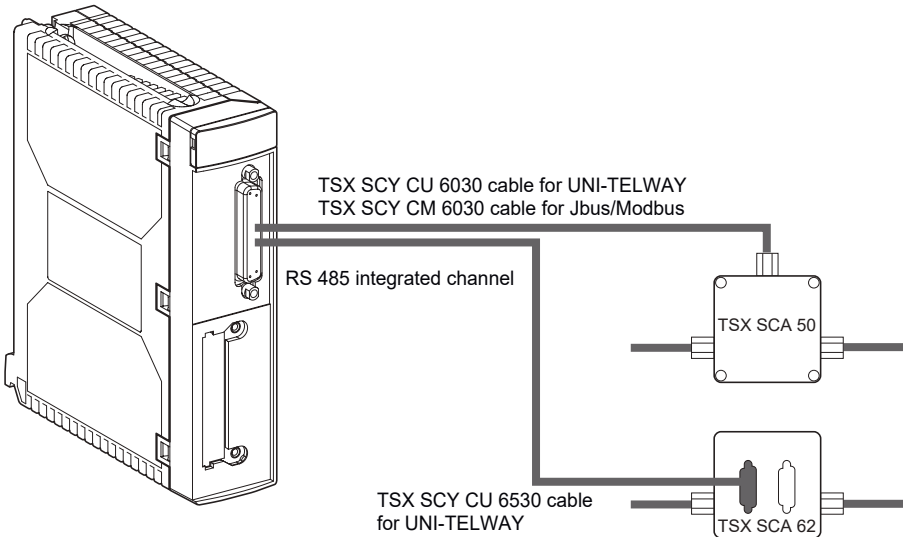

2.8-2 Connection to the UNI-TELWAY fieldbus

The communication channel integrated in the module is connected to the UNI-TELWAY fieldbus with the **TSX SCY CU 6030** connection cable, via the TSX SCA50 junction box.

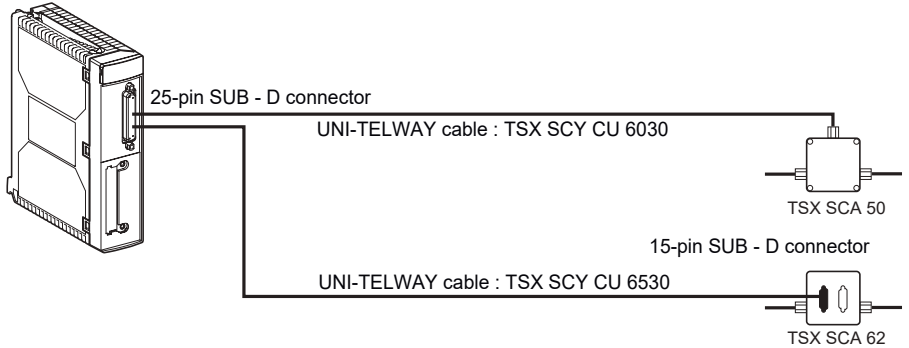

Description of the TSX SCY CU 6030 cable

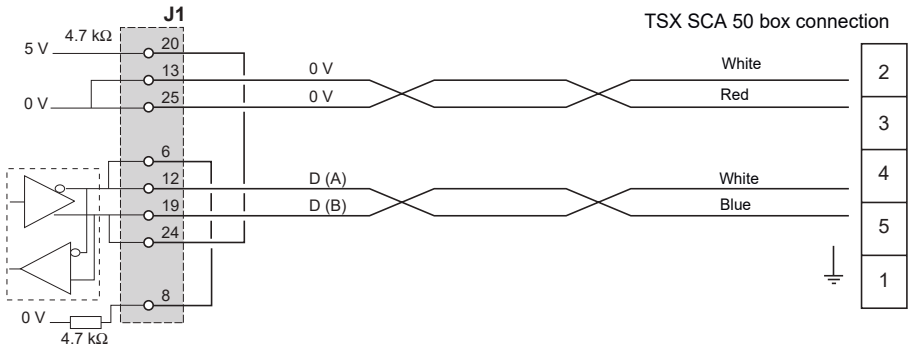

Description of the TSX SCY CU 6530 cable

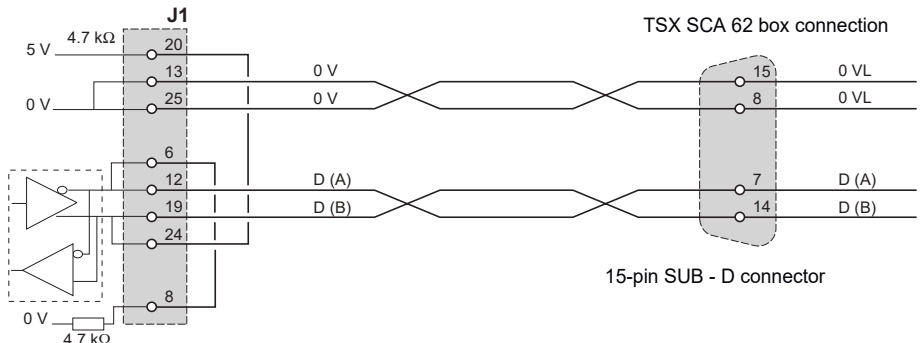

2.8-3 Principle of distributed adaptation for an RS485 line

This is the type of adaptation used for UNI-TELWAY networks

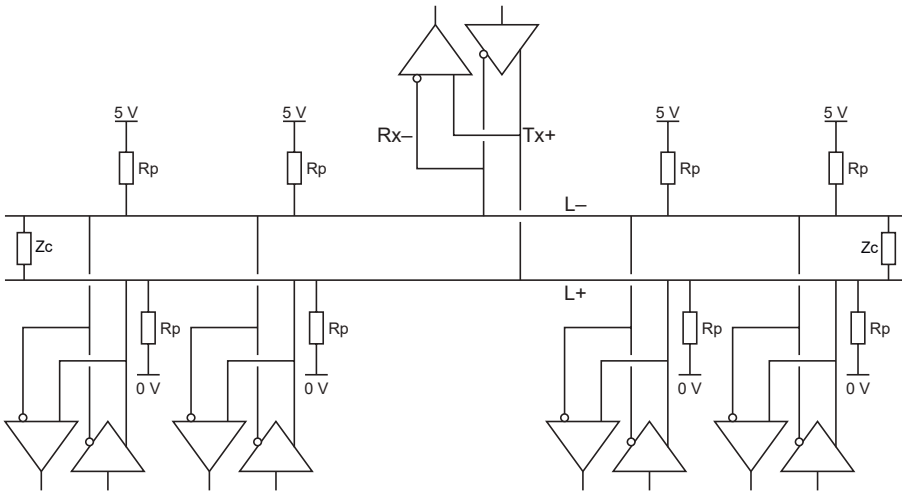

The above diagram shows the general architecture of a UNI-TELWAY network.

The network consists of a single shielded twisted pair. The various network stations are connected simply by linking :

- all the outputs marked + (Tx+, Rx+) on the + wire of the network marked (L+),
- all the outputs marked - (Tx-, Rx-) on the - wire of the network marked (L-).

The network impedance is matched by means of two line termination resistors (Zc) located on the stations at both ends of the network.

Distributed polarization of the network is achieved by connecting the L+ wire to the 0V and the L- wire to the 5V by means of two polarization resistors ($R = 4.7K\Omega$). This polarization keeps the network stable when it is de-energized. This adaptation must be performed for each network station.

The essential features are :

- up to 32 stations,
- maximum length : approximately 1,300 m,
- bus topology,
- tap link ≤ 15 m,
- half duplex on 2 wires,
- line termination on the end stations.
- distributed adaptation $R_p = 4.7K\Omega$

2.8-4 Example of a UNI-TELWAY architecture

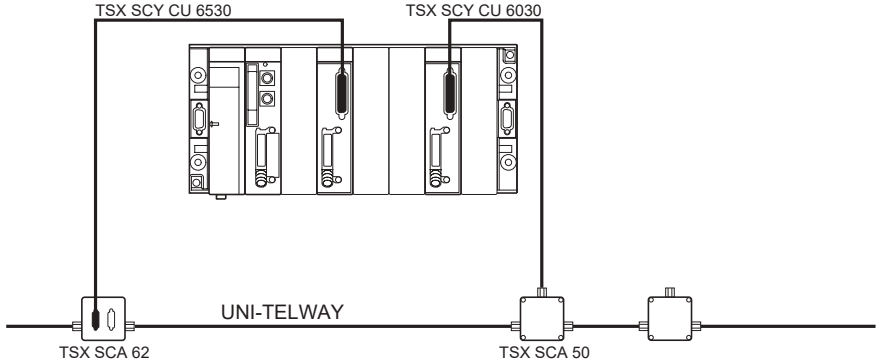

2.8-5 Connection to the Jbus/Modbus fieldbus

The integrated channel is connected to the bus via the TSC SCA 50 junction box with the TSX SCY 6030 connection cable.

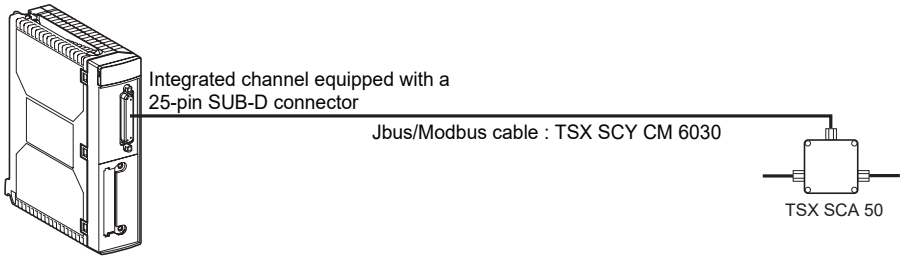

Description of the TSX SCY CM 6030 cable

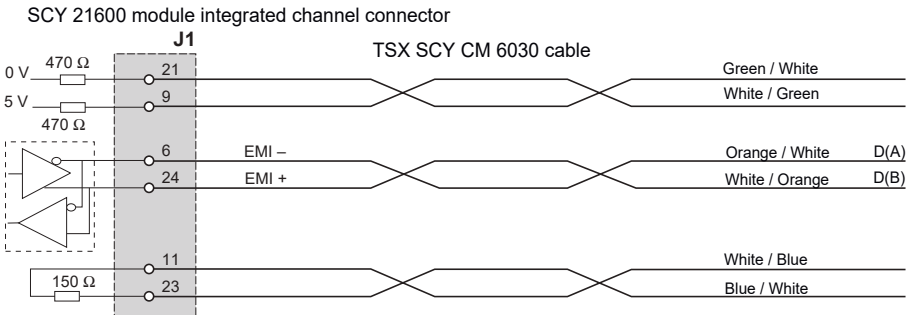

2.8-6 Principle of single adaptation for an RS485 line

This is the type of adaptation used for ModBus networks

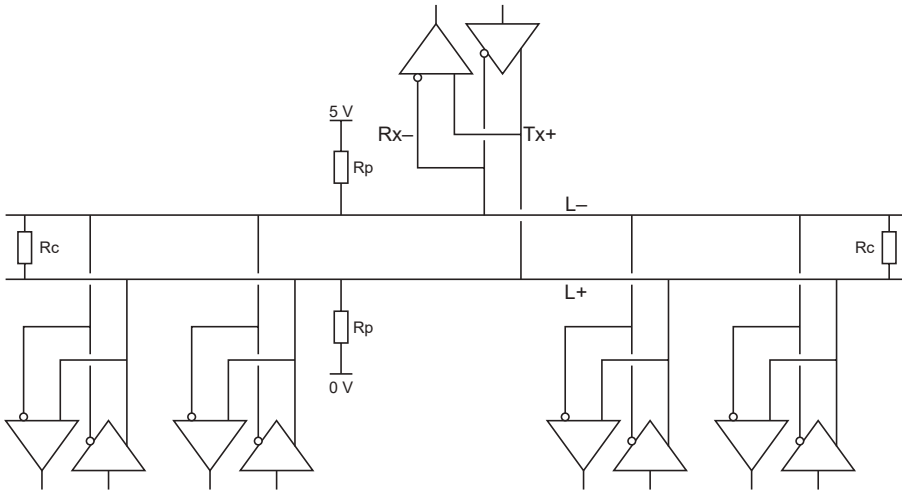

The above diagram shows the general architecture of an RS 485 network.

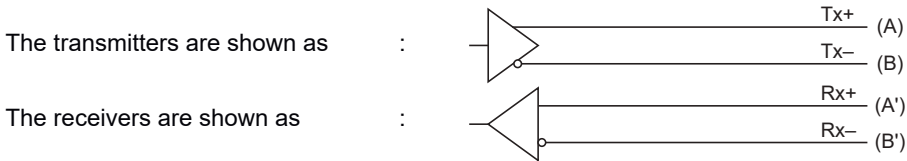

The network consists of a single shielded twisted pair. The various network stations are connected by linking :

- all the outputs marked + (Tx+, Rx+) on the + wire of the network marked (L+),
- all the outputs marked - (Tx-, Rx-) on the - wire of the network marked (L-).

The network impedance is matched by means of two line termination resistors (Rc) located on the stations at both ends of the network.

Polarization of the network is achieved by connecting the L+ wire to the 0 V and the L- wire to the 5V by means of two polarization resistors ($R = 4.7K\Omega$). This polarization ensures there is always a current flowing through the network, and can be located at any point along the network (in practice it is generally at the level of the master).

It must be the only one on the network, whatever the network length.

The essential characteristics are :

- up to 32 stations,
- maximum length : approximately 1,300 m,
- bus topology,
- tap link ≤ 15 m,
- half duplex on 2 wires,
- line termination on the end stations.
- single adaptation $R_p = 47K\Omega$

D

2.8-7 Example of a Modbus architecture

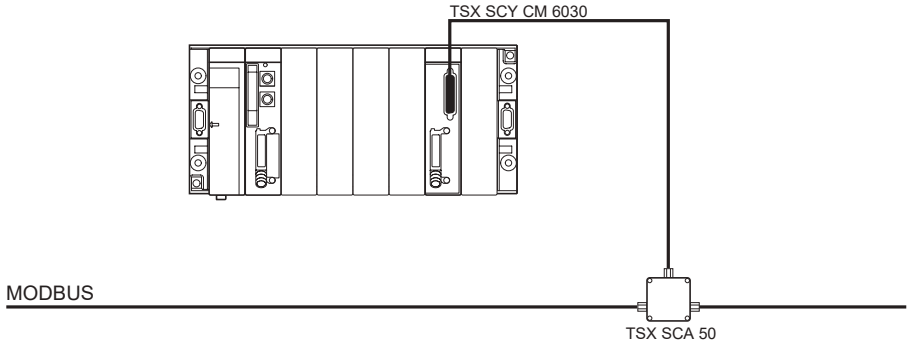

2.8-8 Connection of the TSX SCA50 junction box

- Modbus connection without line matching

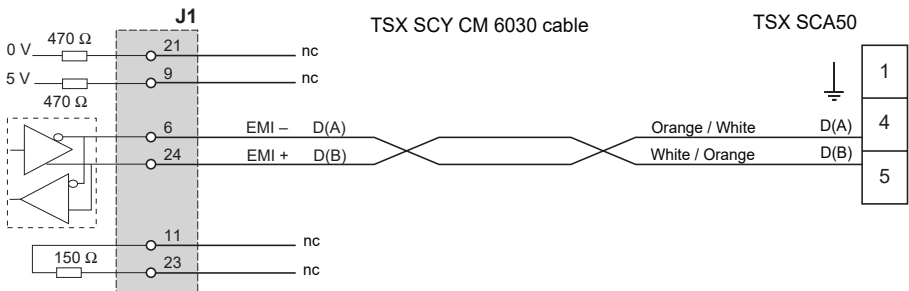

- Modbus connection with line matching

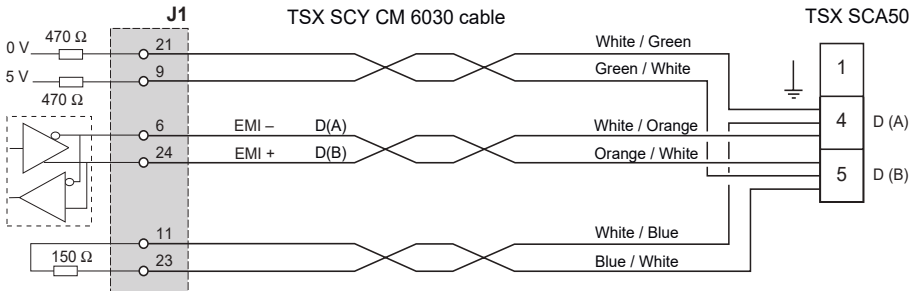

2.8-9 Connection in Character mode

The cable for connecting the TSX SCY 21600 module to an RS 485 standard device is the TSX SCY CM 6030 cable.

When connecting the TSX SCY 21600 integrated channel to a Half duplex standard RS 485 device in Character mode, the user makes the connection using the TSX SCY CM 6030 connection cable, adding a connector suitable for the device to be connected to the free end of the cable, and linking the required signals.

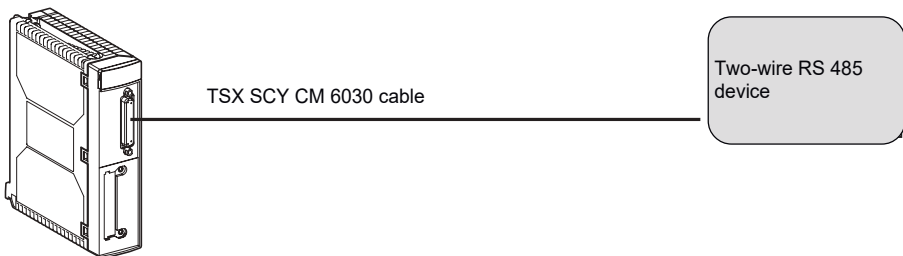

2.8-10 TSX SCY 21600 module consumption

This table shows the **consumption** of a TSX SCY 21600 communication module **without** a PCMCIA card **or** connection to the integrated channel :

Voltage	Typical current	Max current
5 Volts	350 mA	420 mA

3.1 Presentation

TSX Premium PLCs connect to networks, buses and communication links via PCMCIA communication cards.

The card comprises a metal case whose size conforms to the extended type III PCMCIA format.

These cards are inserted in the appropriate slot in the processor and/or TSX SCY 21600 module of TSX Premium PLCs.

Note:

⚠ PCMCIA cards must not be connected while the module is powered up.

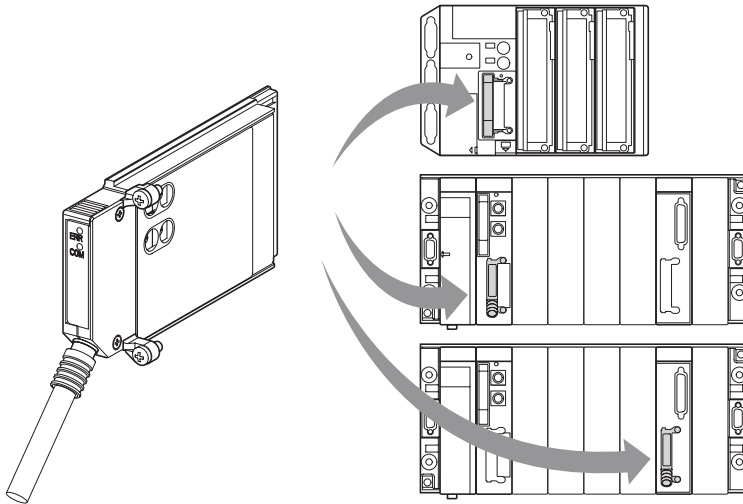

Each TSX SCP 11• PCMCIA card supports a different physical layer. This card family comprises three products.

- The RS 232-D link, reference TSX SCP 111,
- The current loop link (20 mA), reference TSX SCP 112,
- The RS 485 link (compatible with the RS 422), reference TSX SCP 114.

Each card in the TSX SCP 111, 112, 114 family offers all the communication protocols.

The protocols which can be used for each PCMCIA card are as follows :

- Modbus/Jbus protocol,
- UNI-TELWAY protocol,
- Character mode (asynchronous link).

The TSX FPP 20 PCMCIA card supports the FIP physical layer. The card is used to connect a TSX Premium PLC to a FIPWAY network, and is also suitable for devices made by manufacturers who wish to connect their products to the FIPWAY network.

The card has four selection switches **labelled "1"** used to set the code for the network and station number.

PCMCIA cards may also be used on devices with a type III slot, such as the CCX 17, FTX 417-40 terminals or third-party equipment, for example PC compatibles.

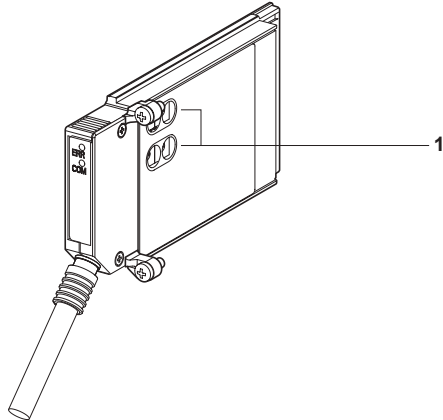

The PCMCIA TSX FPP 10 card is used to connect a TSX Premium PLC to a FIPIO bus by acting as a FIPIO agent and provides the link with TSX 47-107 and April 5000 PLCs.

Setup, use and maintenance of PCMCIA cards is performed using PL7 Junior programming and run-time software for TSX Premium PLCs.

3.2 Description

Type III E (extended) PCMCIA communication cards are incorporated in a metal case with the following dimensions :

- length 85.6 mm,
- width 51 mm,
- height 10 mm.

The front of the card displays the communication operating status and is the point of physical connection to the network.

The mechanical configuration of the card can be adapted according to the type of installation required. The PCMCIA card is fitted with either a removable cover with two lugs, or a plain removable cover.

The plain removable cover (1) is used for connecting PC compatible devices. The removable cover with lugs (2) has fixing screws for physically connecting the card in the host module (for example, PCMCIA card installed in the processor of the TSX Premium).

Note : Both covers are supplied with the card.

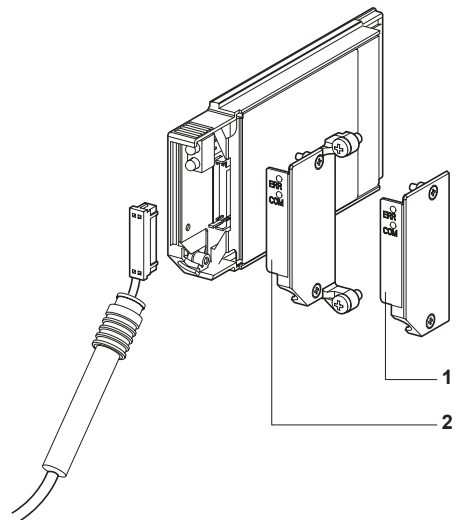

Connection to the network is obtained by connecting the cable to the front of the card. A module locating device prevents incorrect mounting. The product reference label informs the user of the type of physical layer supported by the card.

Note

The use of covers with lugs, mounted on the PCMCIA cards, prevents unintentional removal while the module is powered up and ensures correct card operation.

3.3 Connection of the PCMCIA card host channel

3.3-1 Precautions relating to PCMCIA connections

⚠ The PCMCIA card must only be handled **when the power is off**. When removing or inserting it, the unit may not operate. There are no warm restart procedures between the PCMCIA card and the TSX SCY 21600 host device.

If the operating environment makes it impossible to stop the application by switching the PLC off, it is advisable to remove both the TSX SCY 21600 module and the PCMCIA card.

The PCMCIA card must be fitted with its PLC version cover and must be screwed into the TSX SCY 21600 host module, before the unit is powered up (see section 4).

3.3-2 Connecting PCMCIA cards

The connection of PCMCIA cards on a UNI-TELWAY or Modbus/Jbus fieldbus or in Character mode to a standard device is described in section 4 of this document.

List of connection equipment required to use a specific protocol from a PCMCIA card :

PCMCIA cards	UNI-TELWAY	JBUS/MODBUS	Character mode
TSX SCP 111 (RS232)	(1)	(1)	TXS SCP CD 1030/1130
TSX SCP 112 (BC)	TSX SCP CX 2030	TSX SCP CX 2030	TSX SCP CX 2030
TSX SCP 114 (RS422/RS485)	TSX SCP CU 4030 and TSX SCA 50	TSX SCP CM 4030 and TSX SCA 50	TSX SCP CU 4030 TSX SCP CM 4030

(1) : with point-to-point : TSX SCP CD 1030/1130 cables, with multidrop via a modem : TSX SCP CC 1030 cable.

Connection of the TSX FPP 20 FIPWAY card via the host channel is performed using the TSX FPCG 10 or TSX FPCG 30 cable.

3.3-3 PCMCIA card references

PCMCIA card references are as follows :

- **TSX SCP 111** : multiprotocol card RS 232 D, 9 signals, not isolated,
- **TSX SCP 112** : multiprotocol card, 20 mA current loop,
- **TSX SCP 114** : multiprotocol RS 485 card, compatible with RS 422, isolated,
- **TSX FPP 20** : FIPWAY card
- **TSX FPP 10** : FIPIO Agent card

3.3-4 Mounting cards and cables for TSX PREMIUM

PCMCIA cards consist of the following components :

- 1 Assembled card.
- 2 Body, made of Zamak.
- 3 PCMCIA connector.
- 4 Upper cover.
- 5 Removable cover.
- 6 Connection cable with ferrule.

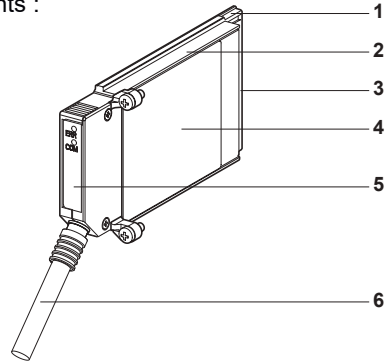

The removable cover (5) displays the operating status of the card in its environment. The function of the two indicator lamps is printed on the front of the removable cover.

The product reference label indicates the type of PCMCIA card. It is located on the upper cover (4).

The metal ferrule (6), located at the PCMCIA card end of the cable, prevents the cable being trapped by the removable cover. The ferrule eliminates the risk of the cable being subjected to a bending radius, which could have a detrimental effect on the quality of the connection.

PCMCIA cards are fitted by assembling the connection accessory (a cable which varies according to the type of transmission support chosen), and then screwing the removable cover with fixing lugs onto the base. This cover can be used to fix the PCMCIA card inside the processor or the TSX SCY 21600 module.

A 20-pin connector is used on the PCMCIA card end.

To fit the transmission support to the card, first unscrew the cover from the case, then assemble as described below :

- 1 Connect the cable.
- 2 Place the cover with lugs on the case.
- 3 Screw on the cover.
- 4 Next, insert the card in the appropriate slot in the host device.
- 5 Screw in the card to prevent it being removed while powered up and to ensure correct operation.

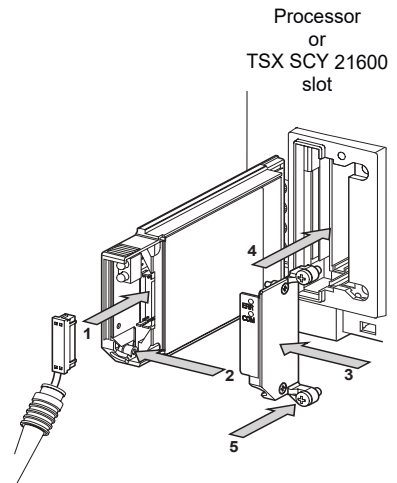

3.3-5 Displaying the operating status of PCMCIA cards

There are two diagnostic indicator lamps on the front of the card. They provide the user with information on the operating status of exchanges between the device supporting the PCMCIA card and the connected device.

"ERR" error indicator lamp (1) (normally off) displays faults.

The "ERR" indicator lamp is red.

"COM" communication indicator lamp (2) displays line activity.

The "COM" indicator lamp is yellow.

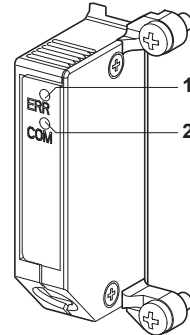

3.3-6 PCMCIA card visual diagnostics

The PCMCIA card indicator lamps show the communication operating mode and provide card diagnostics.

Indicator lamp state

ERR	COM	Meaning	Corrective action
○	○	Device not powered up No dialogue	Check power supply and connection to the card
○	○	Normal operation	
●	(1)	Serious fault	Change card
○	○	Operational fault	Check configuration and connection to communication bus
○	○	Operational fault	Check configuration

● Indicator on ○ Indicator off ● Indicator flashing.

(1) : state of the indicator lamp indeterminate.

When the "ERR" indicator lamp on the TSX FPP 20 card flashes, this indicates that an external fault has occurred. External faults include :

- line fault,
- station already present on the network,
- incorrect coding of the network-station address (selector switch coding).

3.4 Connection of the TSX SCP 111 card

3.4-1 Point-to-point connection in character mode (DTE <=> DTE)

The TSX SCP 111 card, with RS 232 D as the physical support, is inserted either in the processor or in the SCY 21600 module. It is connected via the TSX SCP CD 1030/1100 cable to the connected device.

DTE to DTE type devices such as terminals or printers can be connected (DTE means : Data Terminal Equipment).

The cable required for this connection is reference TSX SCP CD 1030/1100.

Type of connection

The TSX SCP 111 PCMCIA card is connected directly to the device via the TSX SCP CD 1030 cable.

The two connected devices are DTEs (Data Terminal Equipment).

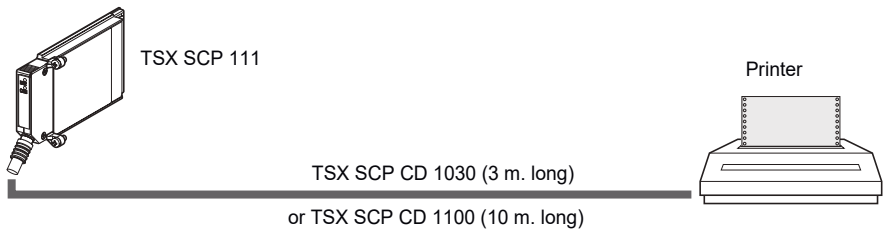

Description of the TSX SCP CD 1030 cable

The 20-pin miniature PCMCIA connector supports the following signals :

SUB-D 25 M connector

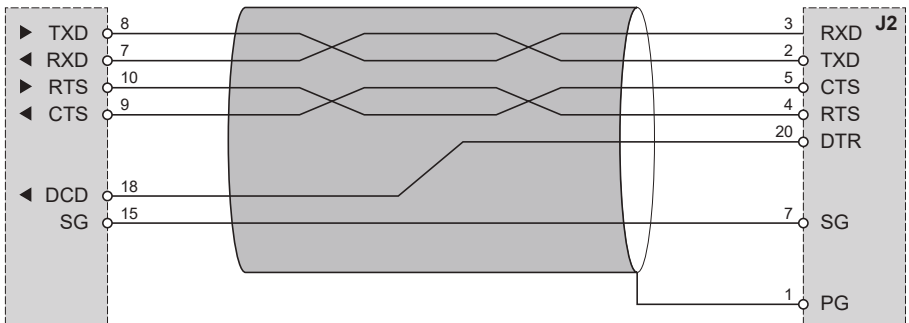

3.4-2 UNI-TELWAY, Modbus or Character mode connection via Modem

Connection of the PCMCIA card to the UNI-TELWAY, Modbus or Character mode bus via a Modem and a telephone link (DTE / DCE type) can be achieved using the TSX SCP CC 1030 cable. The card is either inserted into the processor or into the SCY 21600 module (DCE means : data communication device).

Type of connection

The TSX SCP 111 PCMCIA card is linked to the connected device via the TSX SCP CC 1030 cable.

The connected devices are DCE (Data Conversion Equipment) type; for example a MODEM or converters.

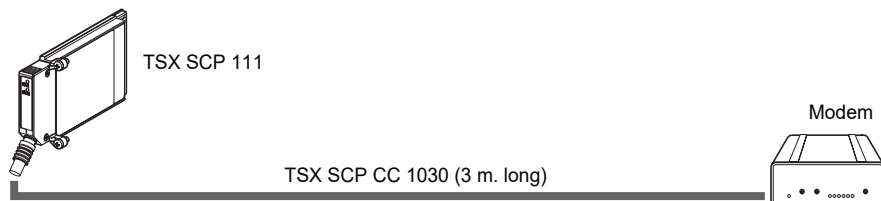

Description of the TSX SCP CC 1030 cable

The 20-pin miniature PCMCIA connector supports the following signals :

SUB-D 25 M connector

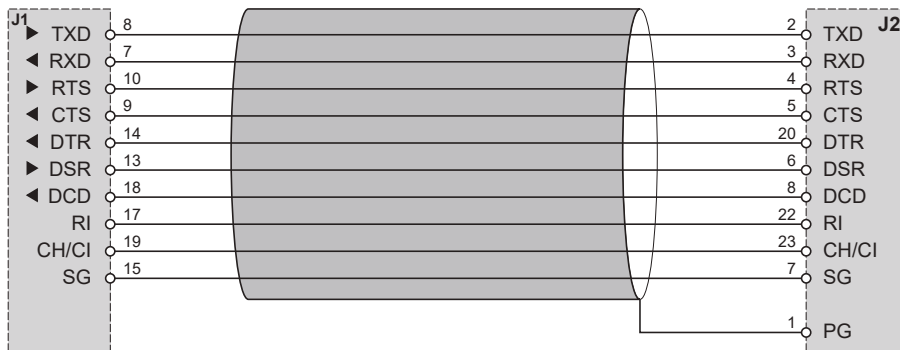

3.5 Connection of the TSX SCP 112 card

The TSX SCP 112 PCMCIA card is used to connect a TSX 57 PLC to a 20mA current loop link in point-to-point or multidrop connection.

An external power supply must always be used to provide the necessary current to power the current loop.

The TSX SCP CX 2030 cable is used to perform this type of connection (3m long).

Description of the TSX SCP CX 2030 cable

The 20-pin miniature PCMCIA connector supports the following signals:

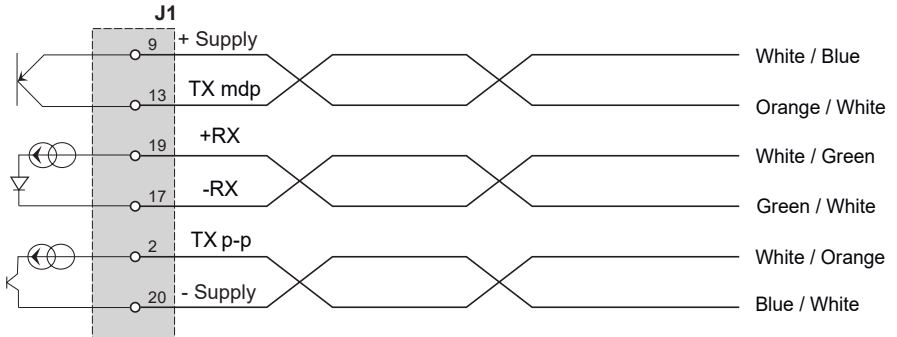

Notes

To connect the TSX SCP 112 card in multidrop mode, a screw terminal block must be used.

3.5-1 Point-to-point connection

Wiring principle for TSX SCP112 current loop PCMCIA cards in point-to-point. Point-to-point connection is only possible in 20mA inactive mode.

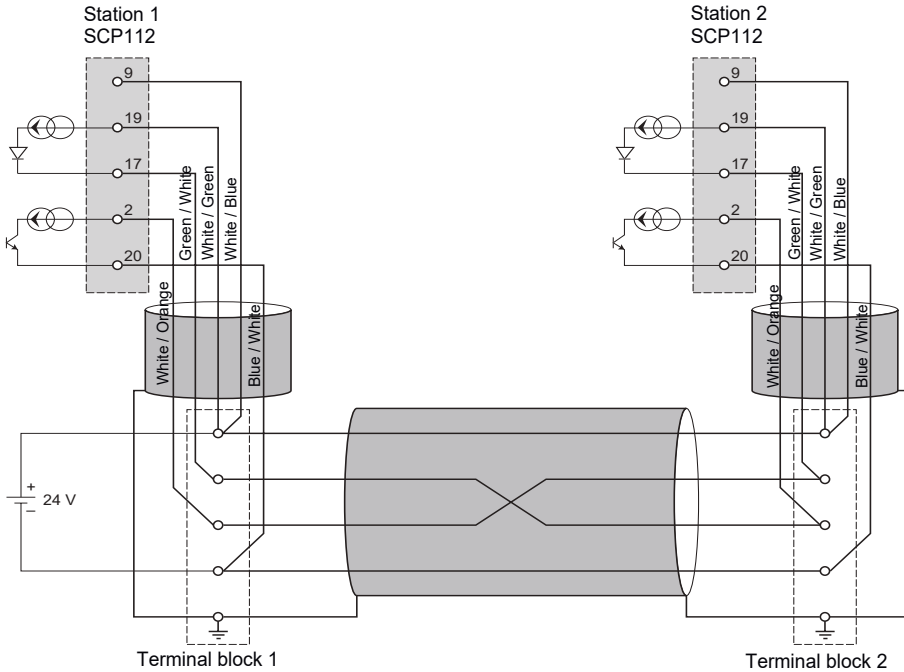

Important : the cable shielding must be connected as closely as possible to the terminal blocks.

3.5-2 Multidrop connection

Multidrop connection is only possible in 0mA inactive mode. Transmissions and receptions are wired in parallel. The Master is defined by the program.

Example of connection of n TSX SCP 112 cards :

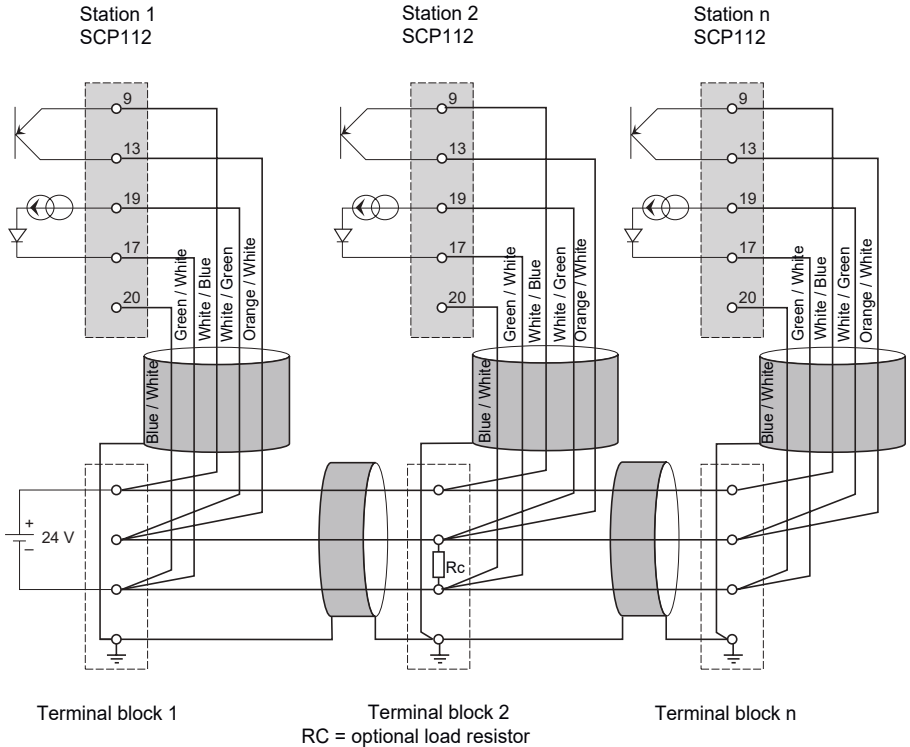

Important : the cable shielding must be connected as closely as possible to the terminal blocks.

3.5-3 Dynamic performance

The flow rate of a current loop link is limited by the cross-section and length of the cable used.

The user should refer to the two diagrams below to get an idea of the performance that can be achieved for his application.

Point-to-point

These curves are for a shielded two-pair cable (transmission in one pair, reception in the other). All precautions for use are adhered to.

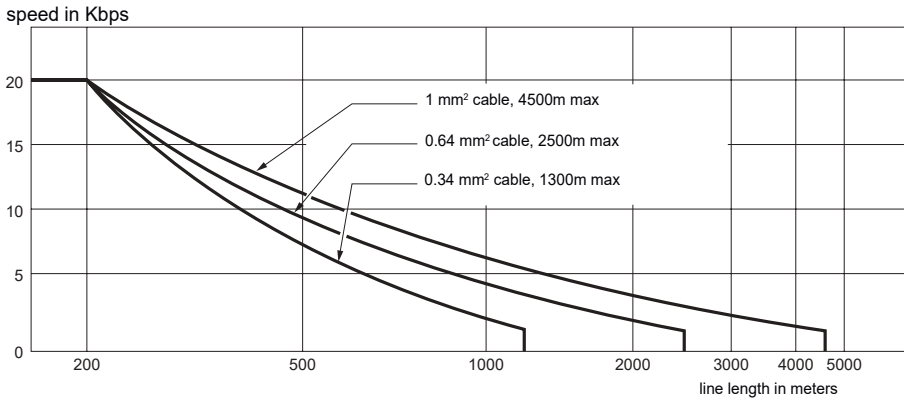

Multidrop

The graph below is for a shielded cable where the conductor cross-section is 0.34 mm², connected in accordance with the parallel multidrop diagram above. The use of conductors with a larger cross-section will improve the quality of the transmitted signals.

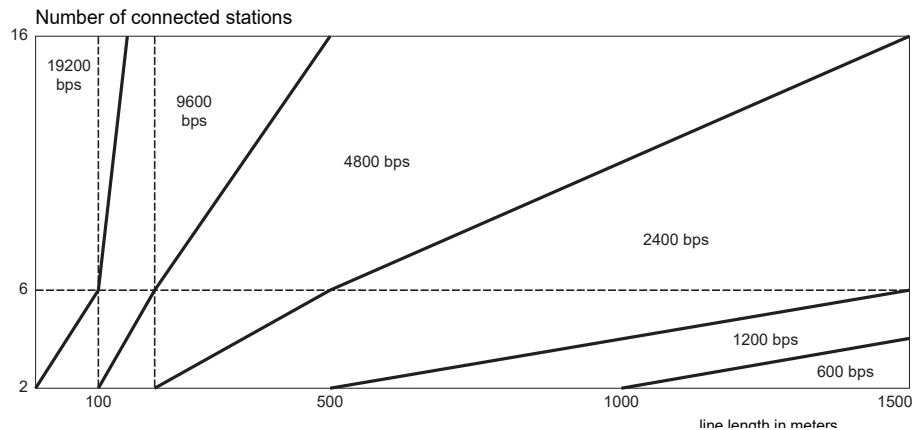

The performance of a multidrop link is much improved when a large number of stations are connected. The load on the line is greater, which improves the quality of the transmitted signal.

When connection is performed according to the preceding diagram, the number of stations can be artificially increased (up to a maximum of 16 stations) by loading the line at one end. This can be performed by incorporating a load resistor. This load resistor can be connected on any terminal block as long as it is between pins 17 and 19 of the SCP112 cards.

The value of resistor R, which simulates the load of "N" stations is determined by the formula :

$$R = \frac{U}{N \times 20}$$

R in KΩ
U = external power supply voltage
N = Number of stations to be simulated

Example :

An installation has 6 physically connected stations in multidrop in accordance with the preceding diagram, with a 24V external power supply.

The line performance will be the same as for 10 stations, with the load of 4 additional stations simulated by a resistor :

$$R = \frac{24}{4 \times 20} = 0.3K\Omega$$

Note : The load resistor should not produce any inductive effect, otherwise operation may be affected.

Use thick film type resistors.

3.5-4 TSX SCP 112 connection to April 5000/7000 PLCs

The 20 mA current loop TSX SCP 112 PCMCIA card is used to connect April communication modules, type JBU0220 and JBU0250. **Multidrop connection** of the TSX SCP 112 PCMCIA card to JBU0220 and JBU0250 modules is performed in **serial mode**. For connection of April modules refer to the TEM60000E reference manual.

Important : The TSX SCP 112 must be configured in **point-to-point** mode in the PL7 configuration screen, regardless of whether a point-to-point or a serial multidrop link is used.

Notes :

The current loop permits a current of 20 mA when the PLC is inactive in both point-to-point and multidrop mode.

If a slave is powered down, the transmitter of this slave becomes conducting, the line is available. If the loop power supply is located remotely, on one of the slaves, the powering down of this slave interrupts communication.

Point-to-point type link : JBU0220 or JBU0250 module active

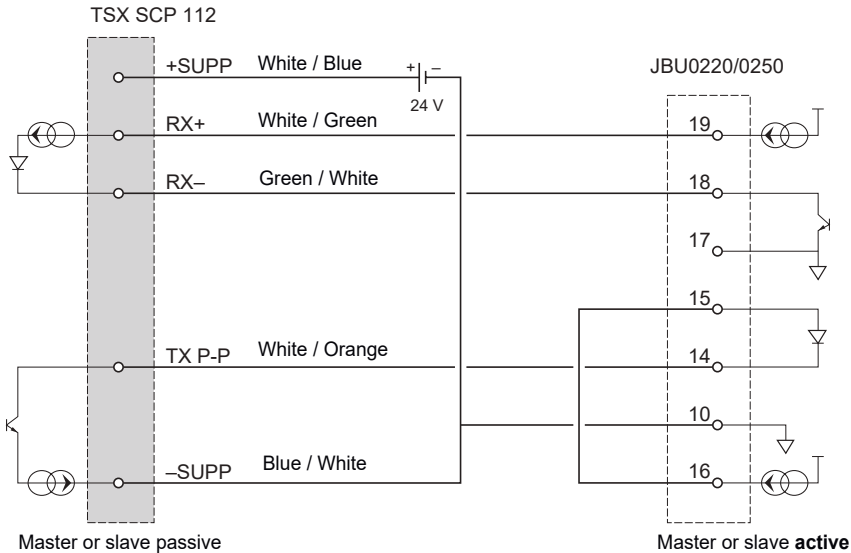

Point-to-point link : TSX SCP 112 card active

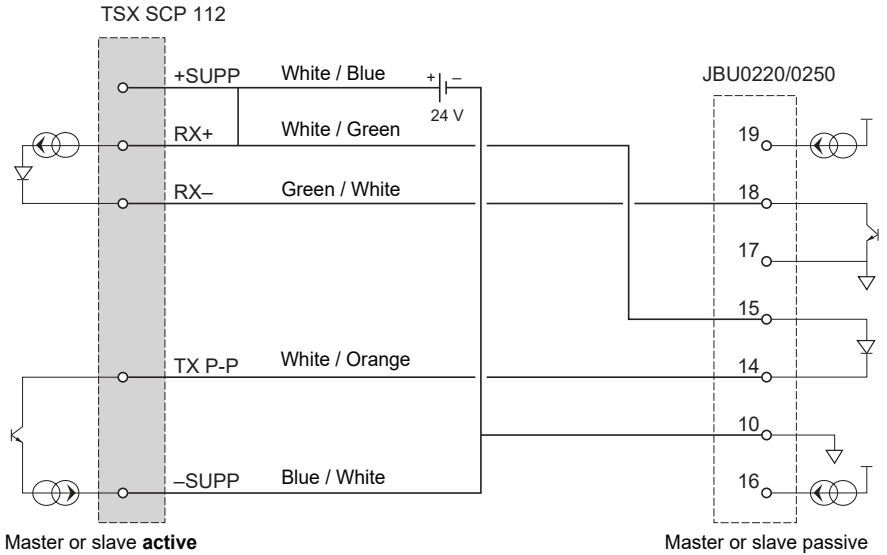

Mixed stations link

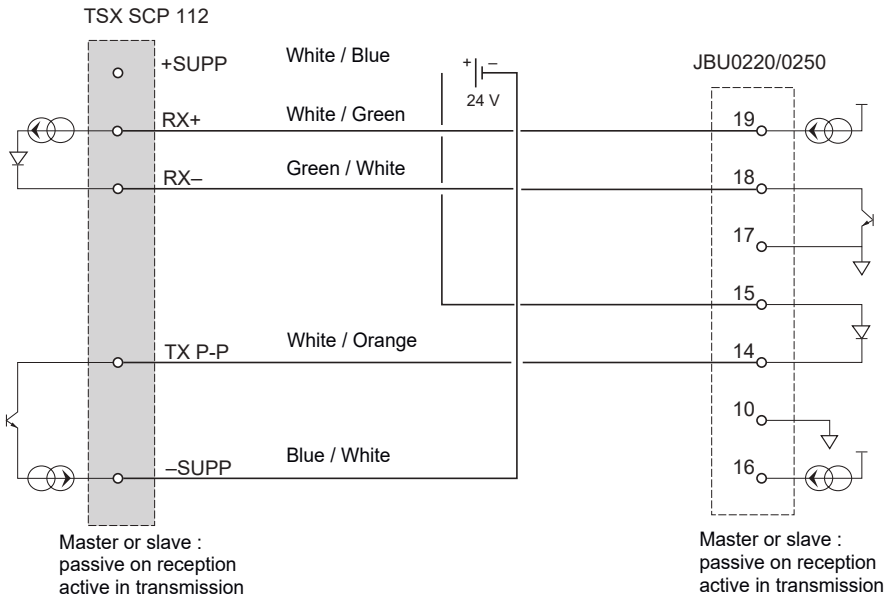

D

Multidrop type link

The following examples describe the various wiring possibilities for the TSX SCP 112 card with JBU0220/0250 modules.

Important : always connect the 24 V supply of each TSX SCP 112 in the loop, whether active or passive, otherwise the link may not operate.

These supplies must not have any common point (voltage).

Do not connect the -24 V of the supplies to ground.

Example 1 : Multidrop TSX SCP 112 master active

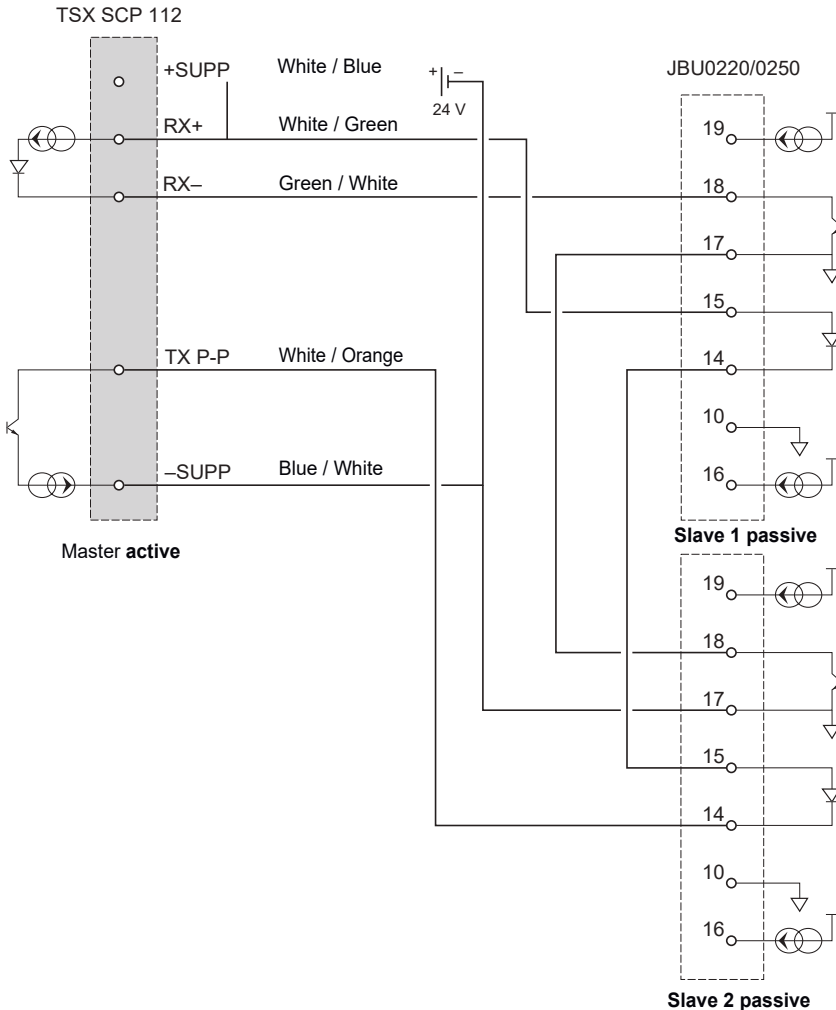

Example 2 : Multidrop master JBU0220/0250 active on transmission / reception

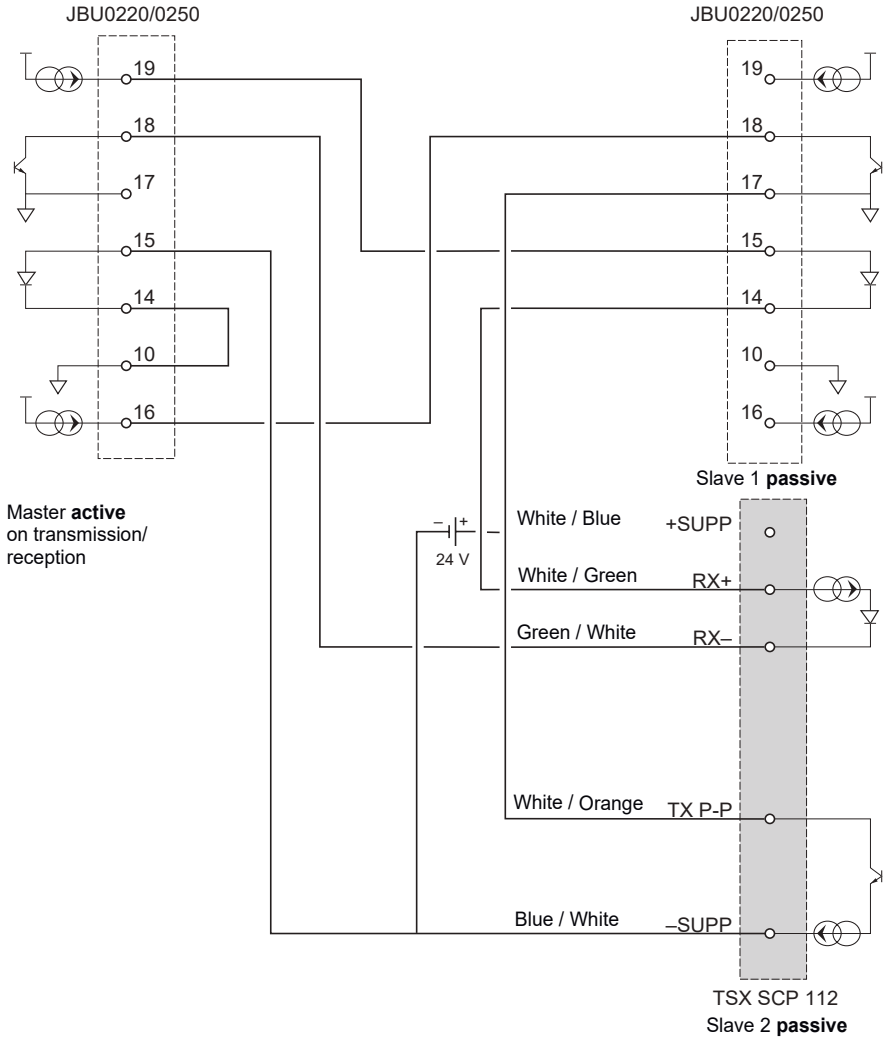

Example 3 : Multidrop master JBU0220/0250 active on transmission/reception - TSX SCP 112 slaves.

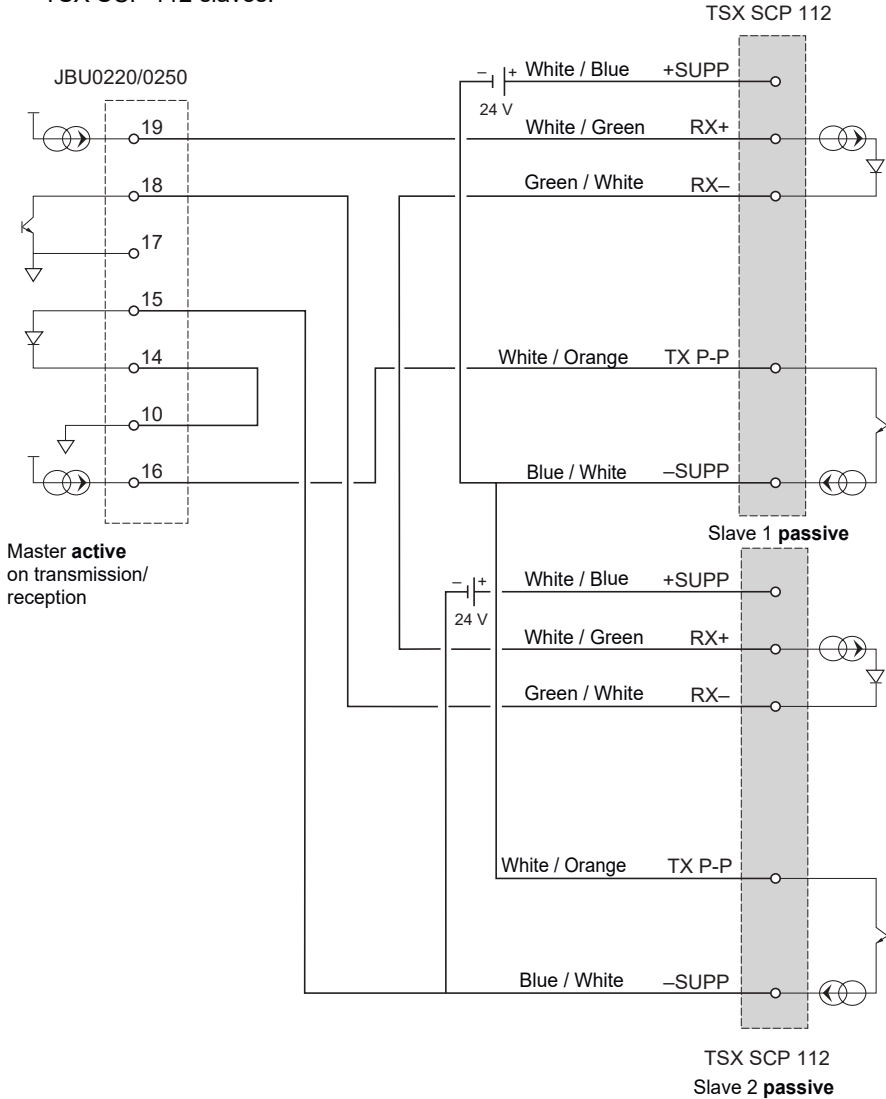

D

Example 4 : Multidrop master active TSX SCP 112.

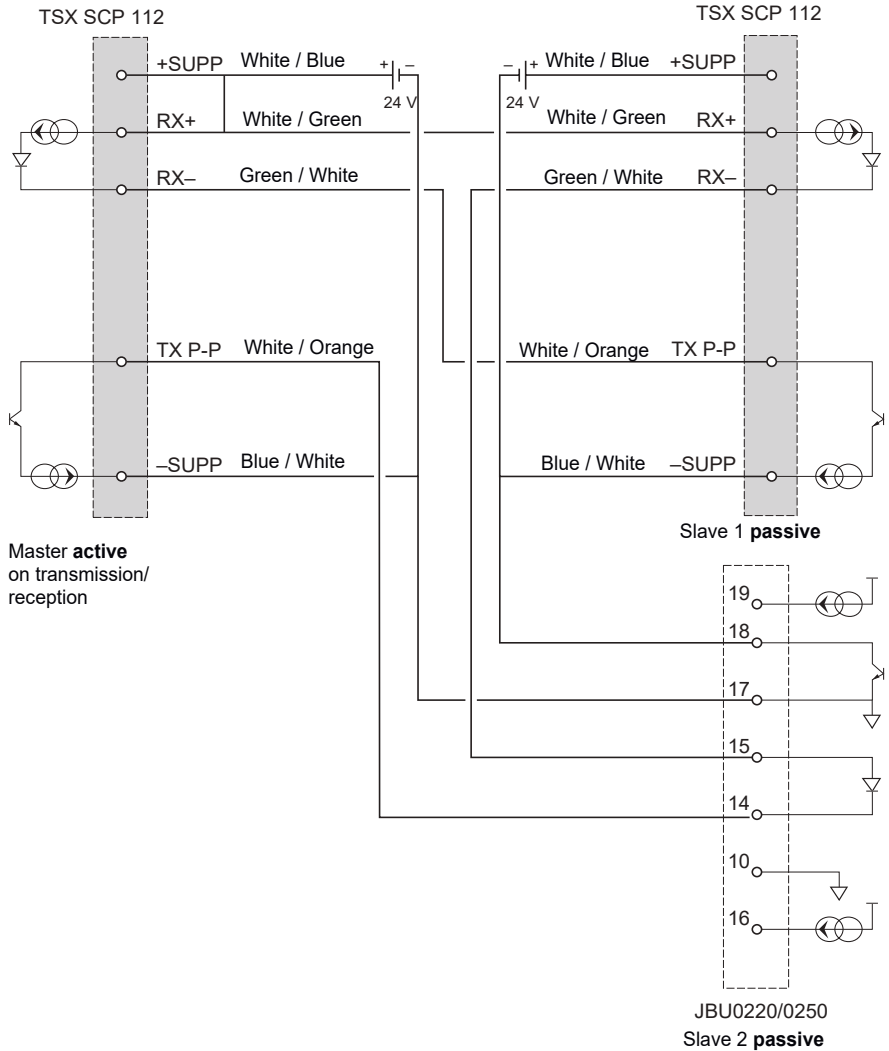

3.6 Connection of the TSX SCP 114 card

3.6-1 Connection to the UNI-TELWAY network

The TSX SCP 114 card, with RS 485 as the physical support, is connected to the UNI-TELWAY network using cable **TSX SCP CU 4030**, via the TSX SCA 50 junction box, or using cable **TSX SCP CU 4530** (fitted with a 15-pin SUB-D connector) via the TSX SCA62 junction box.

The card is inserted into the processor or into the SCY 21600 module.

The TSX SCA50 is passive, comprising a printed circuit with 3 sets of screw clamp terminals. It is used for connecting a station, via tap link, to the trunk cable segment of a UNI-TELWAY bus.

Electrical continuity of the signals, shielding and end of line termination are thus provided.

Type of connection

The cable of the PCMCIA card has flying leads for connection to the terminal block located inside the junction box.

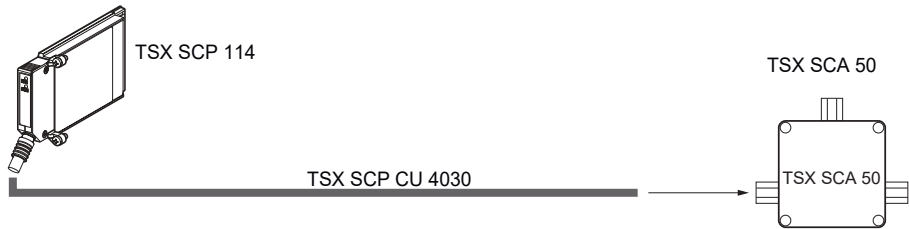

Note

Using the tap junction box configures the wiring system for the card as a tap-link type connection system.

Description of the TSX SCP CU 4030 cable

The 20-pin miniature PCMCIA connector supports the following signals :

TSX SCA 50 junction box

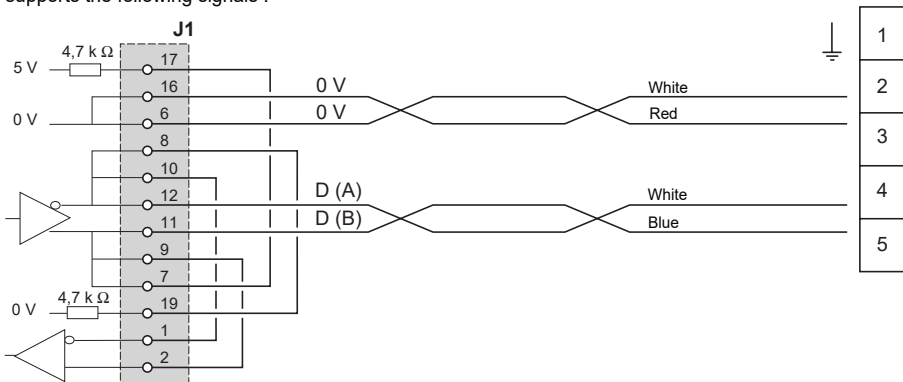

Connection via a TSX SCA 62 junction box

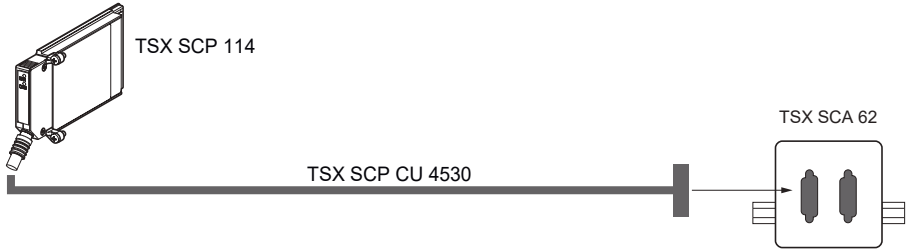

Description of the TSX SCP CU 4530 cable

The 20-pin miniature PCMCIA connector supports the following signals :

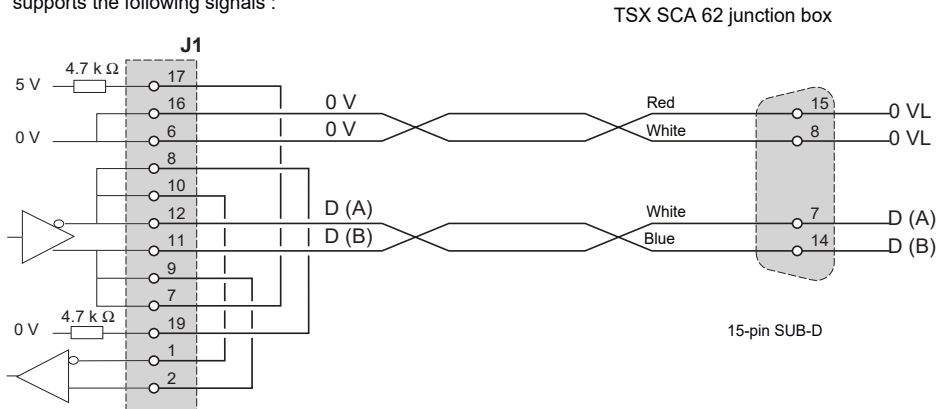

3.6-2 Connection to the Modbus/Jbus bus

The TSX SCP 114 PCMCIA card is connected to the Modbus bus via the TSX SCP CM 4030 serial link cable. This cable is connected to the TSX SCA 50 junction box.

Type of connection

The cable of the PCMCIA card has flying leads for connection to the terminal block located inside the connection box.

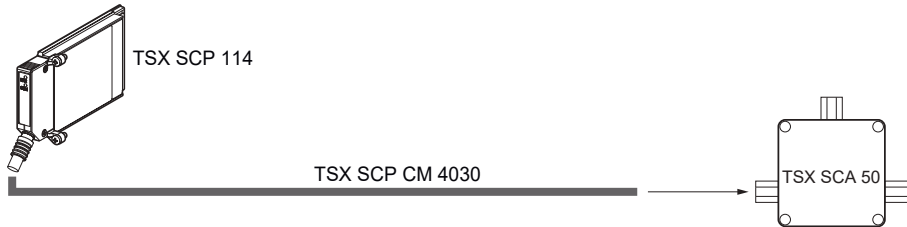

Comment :

The user cable (3 m) allows a device to be connected to a TSX SCA 50 junction box located at up to 3 meters from the card. This length ensures that connection is possible within a standard floor-standing enclosure.

Description of the TSX SCP CM 4030 cable

The 20-pin miniature PCMCIA connector supports the following signals :

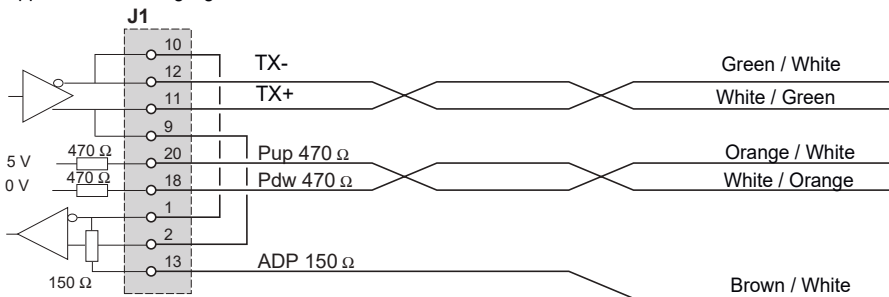

Important : on a Modbus / Jbus bus it is necessary to :

- Polarize the line, usually in one place only, (generally on the master device) using Pull-down and pull-up resistors of 470Ω available on the PCMCIA card. Connect pull-up R to TX+ (D(A)) and pull-down R to TX- (D(B)).
- Match the line on the two end devices by a 150Ω resistor between TX+ and TX- (connection on TX- is already internally performed by the card).

Important : to connect a TSX SCP114 card to a Series 1000 (S1000) PLC, it is essential to connect TX+ to L-.

Modbus connection to TSX SCA 50 box

Connection without line terminator

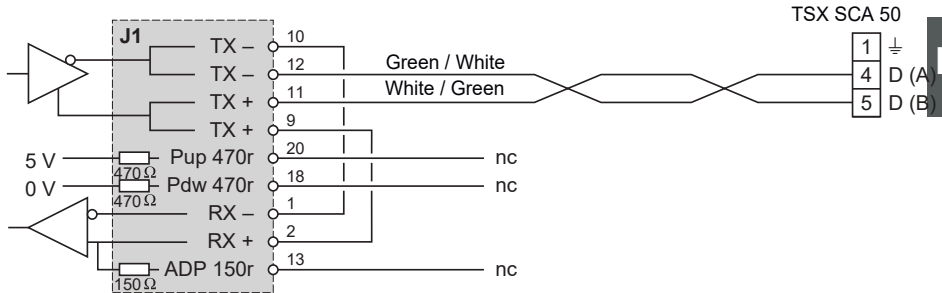

Connection of SCA 50 with line terminator

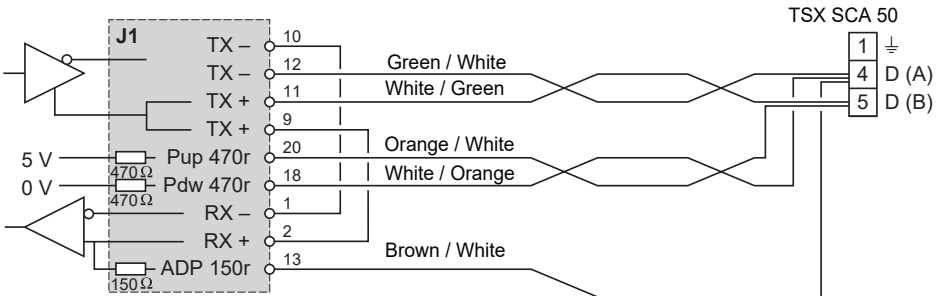

3.6-3 Multi-protocol asynchronous link connection, RS 422

No special accessories are required for connecting the TSX SCP 114 card in Character mode.

The reference number of the connection cable for the RS 485/RS 422 PCMCIA card is TSX SCP CX 4030. The cable is 3 meters long.

D

Type of connection

The TSX SCP 114 PCMCIA card is connected in point-to-point mode to a standard RS 422A VAX station type device.

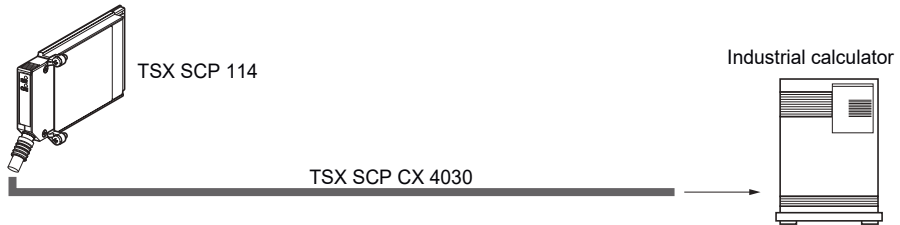

Description of the TSX SCP CX 4030 cable

The 20-pin miniature 20 PCMCIA connector supports the following signals :

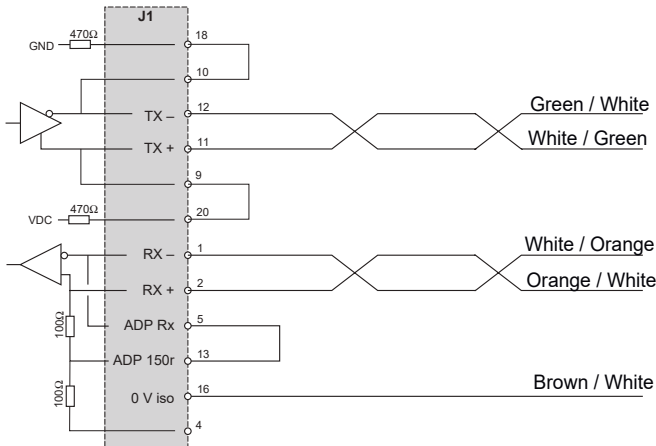

Also see section 2 for connection of the TSX SCY 21600 integrated link in character mode.

3.7 Connection of TSX FPP 20 cards

TSX FPP 20 PCMCIA cards are connected to the FIPWAY network using a TSX FP ACC4 or a TSX FP ACC12 type connector.

To connect the PCMCIA card to the ACC4/ACC12 connector, the user may select either :

- a 1 m cable, reference TSX FPCG 10,
- a 3 m cable, reference TSX FPCG 30.

The figure below shows the components needed to connect the TSX Premium PLC to the FIPWAY network :

- TSX 57 processor or SCY 21600 module,
- TSX FPP 20 PCMCIA card,
- TSX FPCG 10/30 cable,
- TSX FP ACC4 junction box.

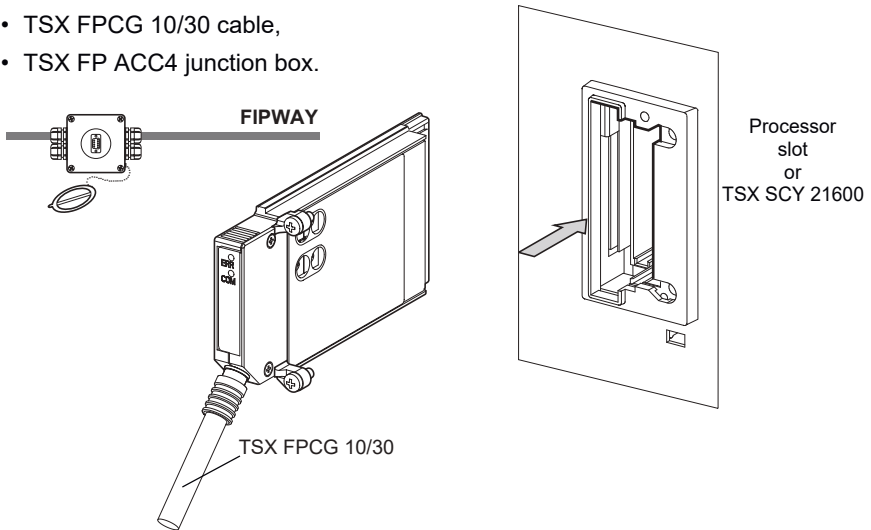

Important

The cables (TSX FPCG 10 and 30) may be connected to and disconnected from the PCMCIA card only when it is **powered down**.

3.8 Connection of TSX FPP 10 cards

TSX FPP 10 PCMCIA cards are connected to the FIPIO bus using a TSX FP ACC4 or TSX FP ACC12 type connector.

To connect the PCMCIA card to the ACC4/ACC12 connector, the user may select either :

- a 1m cable, reference TSX FPCG 10,
- a 3 m cable, reference TSX FPCG 30.

The figure below shows the components needed to connect the TSX Premium PLC to the FIPIO remote I/O bus :

- TSX P5710-20 processor,
- TSX FPP 10 PCMCIA card,
- TSX FPCG 10/30 cable,
- TSX FP ACC4 junction box.

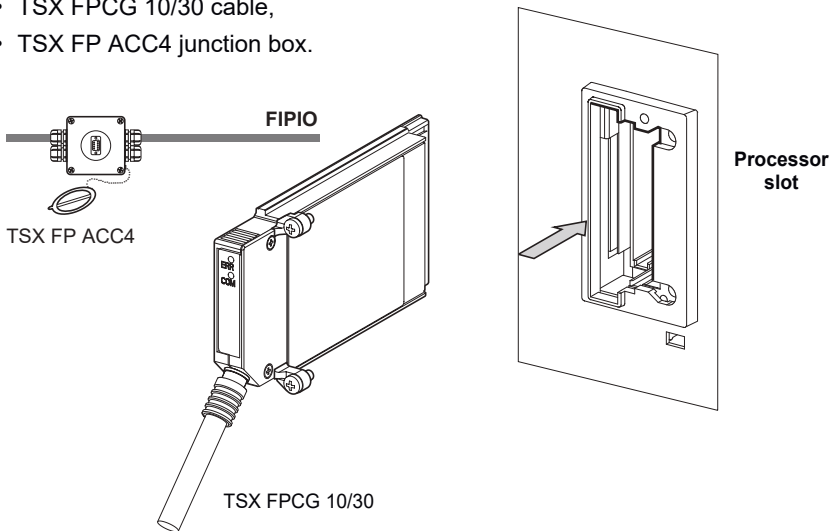

Important

The cables (TSX FPCG 10 and 30) may be connected to and disconnected from the PCMCIA card only when it is **powered down**.

3.9 Summary of connection cables

3.9-1 TSX SCP 111 card

Type of cable	Reference	Description
Modem cable	TSX SCP CC 1030	Cable for connection via Modem DTE/DCE, 9 signals, RS 232D, l = 3 m
Standard cable	TSX SCP CD 1030 TSX SCP CD 1100	Cable for DTE/DTE connection RS 232D, l = 3 m or 10 m

3.9-2 TSX SCP 112 card

Type of cable	Reference	Description
Current loop cable	TSX SCP CX 2030	20 mA CL cable l = 3m.

3.9-3 TSX SCP 114 card

Type of cable	Reference	Description
Universal cable	TSX SCP CX 4030	Universal cable, RS 485 type and RS 422A, l = 3 m
UNI-TELWAY cable	TSX SCP CU 4030	RS 485 2-wire cable, l = 3 m
Modbus cable	TSX SCP CM 4030	RS 485 2-wire cable, l = 3 m
Connection box	TSX SCA 50	Connection box (screw) to bus for RS 485 serial link
Connection box	TSX SCA 62	Connection box (connector) to bus for RS 485 serial link
Converter box	TSX SCA72	RS 232D / RS 485 converter box

3.9-4 TSX FPP 10 and TSX FPP 20 cards

Type of cable	Reference	Description
FIPWAY/FIPIO cable	TSX PPCG 10	Connection cable, l = 1 m
FIPWAY/FIPIO cable	TSX FPPCG 30	Connection cable, l = 3 m
Connection box	TSX FP ACC4	FIPWAY/FIPIO connection box
Connection box	TSX FP ACC12	Low-cost FIPWAY/FIPIO connection

3.10 Precautions for connecting PCMCIA cards

Important

PCMCIA cards must be connected to and disconnected from the host device (processor or TSX SCY 21600) with the device **powered down**.

The ferrule placed in direct contact with the PCMCIA card casing serves to discharge electrical interference carried by the connection cable braid.

3.11 Current consumption of PCMCIA cards

3.11-1 Current consumption of TSX SCP 111 card

Voltage	Typical current	Maximum current
5 volts	140 mA	300 mA

3.11-2 Current consumption of TSX SCP 112 card

Voltage	Typical current	Maximum current
5 volts	120 mA	300 mA

3.11-3 Current consumption of TSX SCP 114 cards

Voltage	Typical current	Maximum current
5 volts	150 mA	300 mA

3.11-4 Current consumption of TSX FPP 10 and TSX FPP20 cards

Voltage	Typical current	Maximum current
5 volts	280 mA	330 mA

Index

C

Cable	
TSX SCP CC 1030	D 3/8
TSX SCP CD 1030	D 3/7
TSX SCP CM 4030	D 3/22
TSX SCP CU 4030	D 3/20
TSX SCP CU 4530	D 3/21
TSX SCP CX 2030	D 3/9
TSX SCP CX 4030	D 3/24
TSX SCY CM 6030	D 2/9, D 2/11
TSX SCY CU 6030	D 2/7
TSX SCY CU 6530	D 2/7
Character mode connection	D 3/7
Characteristics	D 2/2
Integrated channel	D 2/2
Connection	D 3/7
TSX FPP 10	D 3/26
TSX FPP 20	D 3/25
TSX SCP 111	D 3/7
TSX SCP 112	D 3/9
TSX SCP 114	D 3/20
Connection in Character mode	D 2/12
Connection of the integrated channel	D 2/6
To the UNI-TELWAY fieldbus	D 2/7
Connection to the Jbus/Modbus fieldbus	D 2/9
Connection to the UNI-TELWAY network	D 3/20
Connection via Modem	D 3/8
Current consumption of PCMCIA cards	D 3/28

D

Distributed line matching	D 2/8
Dynamic performance	D 3/12

J

Junction box	
TSX SCA 62	D 3/21
TSX SCA 50	D 2/11

L

Link	
Multidrop	D 3/11
Point-to-point	D 3/10
SCP 112 / April 5000/7000 PLCs	D 3/14

M

Modbus architecture	D 2/11
Modbus/Jbus bus connection	D 3/22

N

Network architecture	D 1/1
Network documentation	D 1/1

O

Operation	D 2/4
-----------	-------

P

PCMCIA	
connection accessory	D 3/5
PCMCIA card	
protocols	D 3/1
PCMCIA card visual diagnostics	D 3/6
PCMCIA cards	D 3/1
Connection	D 3/4
Description	D 3/3
Display	D 3/6
Mounting	D 3/5
Precautions	D 3/4
Presentation	D 3/1
References	D 3/4
PCMCIA card consumption	D 3/28

R

RS 232 D physical support	D 3/7
RS 485 physical support	D 3/20

S

Single line matching	D 2/10
Standards	D 1/2
Summary of connection cables	D 3/27

T

TSX FPP 10	D 3/26
TSX FPP 20	D 3/25
"ERR" indicator lamp	D 3/6
TSX FPP 20 PCMCIA	D 3/2
TSX SCA 62	D 3/21
TSX SCA50	D 2/11
TSX SCP 111	D 3/7
TSX SCP 112	D 3/9
TSX SCP 114	D 3/20
TSX SCP CC 1030	D 3/8
TSX SCP CD 1030	D 3/7
TSX SCP CM 4030	D 3/22
TSX SCP CU 4030	D 3/20
TSX SCP CU 4530	D 3/21
TSX SCP CX 203	D 3/9
TSX SCP CX 4030	D 3/24
TSX SCP PCMCIA	
assembly	D 3/5
configuration	D 3/3
dimensions	D 3/3
indicator lamps	D 3/6
module locating device	D 3/3
slot	D 3/1
TSX SCY 21600	D 2/1
Description	D 2/1
Insertion / removal :	D 2/3
Installation	D 2/3
Presentation	D 2/1
TSX SCY 21600 module	
consumption	D 2/13
TSX SCY 21600 visual diagnostics	D 2/4

U

UNI-TELWAY architecture	D 2/9
-------------------------	-------

Section	Page
1 Presentation	1/1
1.1 Description	1/1
1.1-1 General	1/1
1.1-2 Physical description	1/2
2 Functions	2/1
2.1 Presentation of different counting functions	2/1
2.1-1 Downcounting function	2/1
2.1-2 Upcounting function	2/1
2.1-3 Up/down counting function	2/2
2.2 Upcounting or downcounting on TSX CTY 2A and TSX CTY 4A modules	2/3
2.3 Up/down counting on TSX CTY 2A and TSX CTY 4A modules	2/6
2.4 Connection principle of EPSR input "power supply return"	2/13
3 Setting up 40 kHz counting on TSX CTY 2A/4A modules	3/1
3.1 Number of counter modules controlled by a TSX 57 PLC	3/1
3.2 Positioning and inserting TSX CTY 2A/4A modules	3/2
3.3 Types of sensor which can be used on counter inputs	3/3
3.4 TSX CTY 2A/4A module electrical characteristics	3/4
3.4-1 General module characteristics	3/4
3.4-2 Counter input characteristics	3/5
3.4-3 Auxiliary input characteristics	3/7
3.4-4 Auxiliary output characteristics	3/9

Section	Page	
3.5	15-pin SUB-D and HE10 connector pinout	3/10
3.5-1	Standard 15-pin SUB-D connector	3/10
3.5-2	20-pin HE10 connector	3/11
3.6	Connection of encoder type counting sensors	3/12
3.6-1	Connection principle	3/12
3.6-2	Connection of the TSX CTY 2A/4A module to the encoder	3/14
3.6-3	Connection of the power supply and sensors to auxiliary inputs and outputs	3/18
3.7	Connections with proximity sensor type counting sensors	3/19
3.7-1	Connection principle	3/19
3.7-2	Connection of counting sensors and their power supply	3/20
3.7-3	Connection of sensors to auxiliary inputs and outputs and their power supply	3/21
3.7-4	Wiring precautions	3/22
3.8	General installation rules	3/23
3.8-1	Installation	3/23
3.8-2	General wiring instructions	3/23
3.8-3	Encoder and auxiliary sensor supplies	3/24
3.8-4	Software setup	3/24

Section	Page
4 Appendices	4/1
4.1 TELEFAST 2 connection sub-base : ABE-7CPA01	4/1
4.1-1 Presentation	4/1
4.1-2 Wiring diagram	4/2
4.1-3 Dimensions and mounting	4/2
4.1-4 Availability of counting signals on the TELEFAST screw terminal block	4/3
4.1-5 Correspondence betw. TELEFAST term. blocks and 15-pin SUB-D connectors	4/4
4.2 TELEFAST 2 connection sub-base : ABE-7H08R20	4/5
4.2-1 Presentation	4/5
4.2-2 Availability of signals on the TELEFAST screw terminal block	4/6
4.2-3 Correspondence betw. TELEFAST term. blocks and HE10 connectors	4/7
4.3 Wiring accessory for incremental encoder with RS 422/485 output : TAP S15 05 / TAP S15 24	4/8
4.3-1 Presentation	4/8
4.3-2 Installation of TSX TAP S15 ●●	4/9
4.3-3 Correspondence table between 15-pin SUB-D and 12-pin DIN connectors.	4/11
4.4 Connection to modules with HE10 connectors	4/12
4.4-1 20-wire preformed cable, 22 gauge (0.34 mm ²)	4/12
4.4-2 Preformed connection cable with flying leads and sheath, 28 gauge (0.08 mm ²)	4/13
4.4-3 Connection cable, 28 gauge (0.34 mm ²)	4/13
4.5 Module display	4/14

counter modules

Part E

E

1.1 Description

1.1-1 General

The TSX CTY 2A and 4A counter modules are standard format modules for counting pulses at a maximum frequency of 40 kHz. They can be installed in all TSX 57-10 or TSX 57-20 positions. These modules can be installed in the extension rack provided with the TSX 57-10 or in the 7 extension racks provided with the TSX 57-20.

The number of TSX CTY 2A/4A counter modules which can be used in a TSX 57-20 PLC is limited to 6 modules, and for a TSX 57-10 PLC to 2 modules.

These two modules differ only in the number of channels they have : 2 channels for the TSX CTY 2A module, 4 channels for the TSX CTY 4A module. Both perform upcounting, downcounting or up/down counting functions.

Sensors used on each channel can be :

- either 5 VDC or 10...30 VDC transistor outputs (RS 422 or Totem Pole standard line driver encoders), in this case the maximum counting frequency is up to 40 kHz,
- or volt-free contact outputs, in which case the input filtering for receiving the counting pulses is increased in order to prevent contact bounce being taken into account when the contact closes.

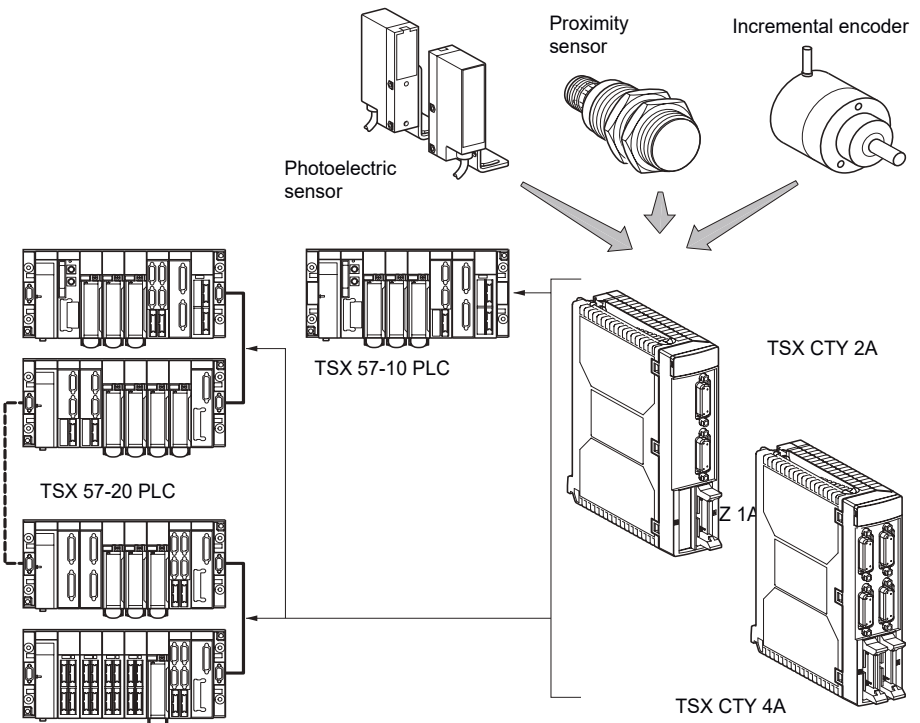

1.1-2 Physical description

- 1** Standard 15-pin SUB-D connector for connecting :
- the counting sensor(s) corresponding to channel 0 and 1 for module TSX CTY 2A and to channel 0, 1, 2 and 3 for module TSX CTY 4A.
 - the encoder power supply if this type of sensor is used,
 - the encoder power supply return which confirms that this is correctly supplied.
- 2** 20-pin HE10 connector for connecting (each channel) :
- auxiliary inputs :
 - resetting or setting preset value,
 - enable counter,
 - read,
 - auxiliary outputs,
 - external supply :
 - auxiliary input and output supply,
 - supply for other sensors.
- 3** Screw for fixing the module in its position.
- 4** Rigid casing providing :
- support for the electronic card,
 - guidance of module into its slot.

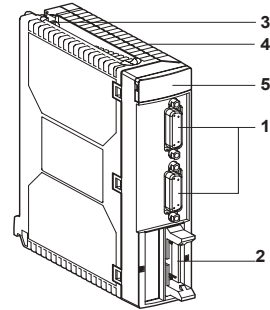

TSX CTY 2A

- 5** Module diagnostics indicator lamps :
- module level diagnostics :
 - RUN (green indicator lamp) : indicates module operating mode (module operative),
 - ERR (red indicator lamp) : indicates internal status of the module (internal fault, module failure),
 - I/O (red indicator lamp) : indicates external module fault.
 - channel level diagnostics :
 - CHx (green indicator lamp) : indicates channel diagnostics.

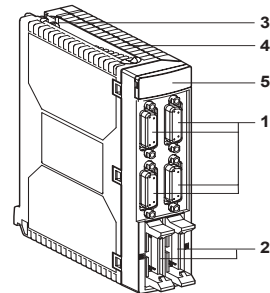

TSX CTY 4A

2.1 Presentation of different counting functions

2.1-1 Downcounting function

The downcounting function is used to downcount pulses (on 24 bits + sign) from a preset value of between 0 and + 16777215 and to signal when the current value is equal to or less than 0.

The downcounting range is from - 16777216 to + 16777215.

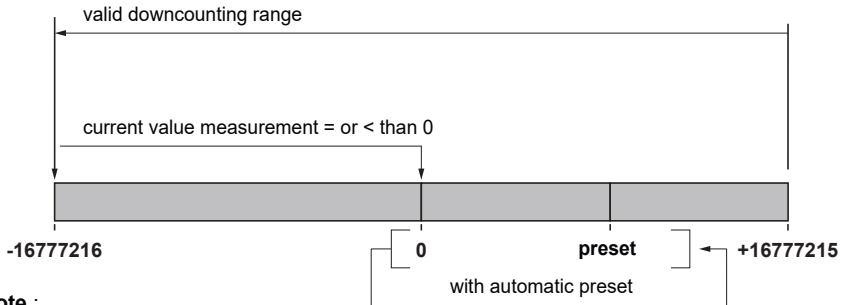

Note :

Operation of the downcounting function, associated language objects and software installation are explained in the programming manual - Part H (PL7 Junior)

2.1-2 Upcounting function

The upcounting function is used to upcount pulses (on 24 bits + sign) from the value 0 to a predefined value known as the setpoint value.

The upcounting range is from 0 to + 16777215.

The function indicates when the setpoint value is reached.

The current value of the counter is continuously compared with two adjustable thresholds (threshold 0 and threshold 1).

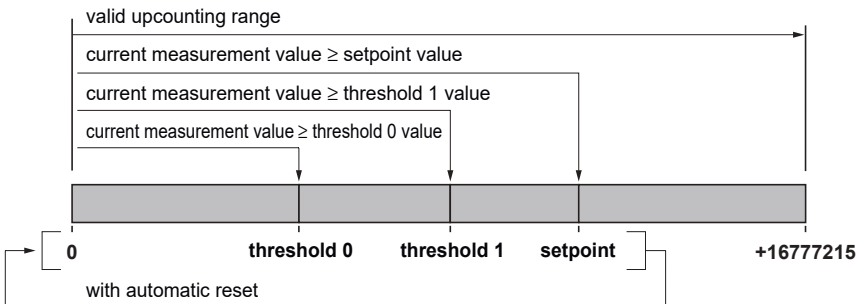

Note :

Operation of the upcounting function, associated language objects and software installation are

2.1-3 Up/down counting function

The up/down counting function performs on the same counter the upcounting of pulses and the downcounting of pulses (on 24 bits + sign) from a preset value which is within the up/down counting range. The up/down counting range is from - 16777216 to +16777215 and two setpoints (an upper and a lower setpoint) can be defined. The current value of the counter is continuously compared with two adjustable thresholds (threshold 0 and threshold 1).

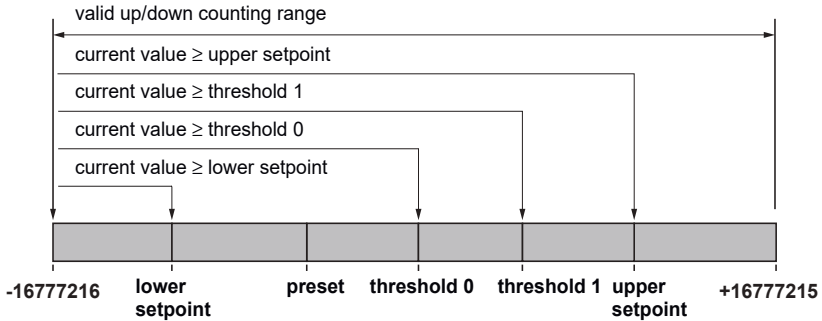

Note :

Operation of the up/down counting function, associated language objects and software installation are explained in the programming manual - Part H (PL7 Junior).

2.2 Upcounting or downcounting on TSX CTY 2A and TSX CTY 4A modules

The TSX CTY 2A/4A counter modules provide :

- 2 independent upcounter or downcounter channels for the TSX CTY 2A module.
- 4 independent upcounter or downcounter channels for the TSX CTY 4A module.

The maximum counting frequency on each channel is 40 kHz.

Upcounting or downcounting signals

Upcounting or downcounting signals relating to one channel, and the encoder supply which can generate these signals, are grouped together on a standard 15-pin SUB-D connector. Each upcounter or downcounter channel can receive 5 VDC or 24 VDC signals. Pulses are received on input **IA**

Auxiliary inputs

24 VDC auxiliary inputs (reset to 0 : upcounting, set to the preset value : downcounting and enable up/down counting) and the external supplies, are grouped together on an HE10 connector, common to channels 0/1 in the case of TSX CTY 2A/4A modules and to channels 2/3 in the case of the TSX CTY 4A module.

- **Reset** (upcounting) or **Preset** (downcounting)

The reset (upcounting) or set to the preset value (downcounting) can be performed in one of the ways described below :

- changing the state of the input **IPres** (rising or falling edge, selected during configuration),
- automatically as soon as the setpoint value is reached in upcounting or the value 0 is reached in downcounting (choice selected during configuration),
- directly by the program.

Note :

In upcounting, the input IPres is called IReset in PL7 Junior screens.

- **Enable counting**

Upcounting or downcounting is enabled in one of the ways described below :

- signal at state 1 (24 VDC) at input **IEna**,
- directly by the program.

Note :

The various functions of these auxiliary inputs are explained in the programming manual - Part H.

Line monitoring input : EPSR

This input, which is usually connected to the power supply return output of an encoder, checks that the power supply of the encoder is normal.

If there is a line break on the cable carrying the power supply voltage to the encoder, the fault which is generated is signalled and can be used by the application program.

The various connection principles of this input are explained in section 2.4.

Counter outputs

Upcounting and downcounting functions have counter outputs which can be associated by the program to reflex physical outputs Q0, Q1 on the counter module.

- downcounting function : one counter output with predefined activation and deactivation conditions :
 - activation when the current value is reset,
 - deactivation upon preset.
- upcounting function : two counter outputs
 - one counter output with predefined activation and deactivation conditions :
 - activation when the setpoint value is reached,
 - deactivation upon counter reset,
 - one counter output with activation and deactivation conditions defined by the user in a coding matrix, which can be accessed via the adjustment function.

Physical outputs

The physical output state can be controlled in 2 modes :

- automatic mode :
 - if the physical output is validated, the counter output state is copied to the physical output, otherwise the output state is 0.
- manual mode :
 - the physical output state is controlled.

Setting up these counter outputs and physical outputs is explained in the programming manual - Part H.

Simplified schematic

The simplified schematic below shows only one 15-pin SUB-D connector. In the case of TSX CTY 2A/4A modules, the 15-pin SUB-D connectors relating to the other channels perform exactly the same functions.

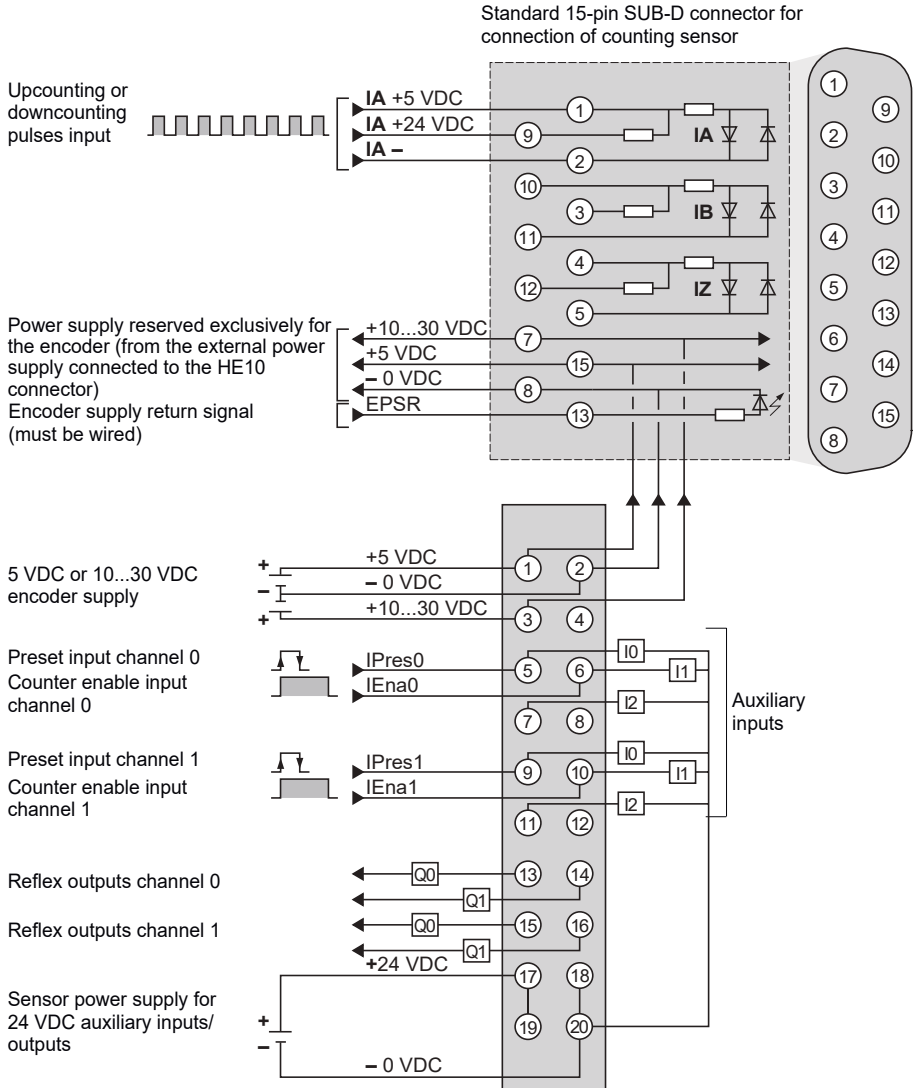

HE10 connector for connecting power supplies (encoders and sensors), auxiliary inputs (preset, enable, etc) and reflex outputs.

2.3 Up/down counting on TSX CTY 2A and CTY 4A modules

TSX CTY 2A/4A counter modules provide :

- 2 independent up/down counter channels for the TSX CTY 2A module,
- 4 independent up/down counter channels for the TSX CTY 4A module.

The maximum up/down counting frequency on each channel is 40 kHz.

Up/down counting signals

There are several possibilities for each channel :

- First possibility : (see simplified schematic 1, page 2/10)
Use a single physical up/down counter input, the direction (upcounting or downcounting) is defined by the application by setting a bit object to state 0 or 1.
Each up/down counter channel can receive 5 VDC or 24 VDC signals. The up/down counting pulses are received on input **IA**.
- Second possibility : (see simplified schematic 2, page 2/11)
Use a single physical up/down counter input, the direction (upcounting or downcounting) is defined by setting the second input to state 0 or 1.
The up/down counting pulses are received on input **IA**.
The direction (upcounting or downcounting) is defined by setting input **IB** to state 0 or 1 (state 1 : upcounting, state 0 : downcounting).

Note :

Pulses on input IA will be taken as upcounting if input IB is at 1 for more than 3 μ s.
Pulses on input IA will be taken as downcounting if input IB is at 0 for more than 3 μ s.

- Third possibility : (see simplified schematic 3, page 2/11)
Use two physical inputs, an upcounter input and a downcounter input :
Upcounting pulses are received on input **IA**.
Downcounting pulses are received on input **IB**.

Note :

All pulses on IA and IB are taken as upcounting whatever the synchronism of the signals.

- Fourth possibility : (see simplified schematic 4, page 2/12)
Use of two physical inputs with signals phase shifted by $\pi/2$ (incremental encoder signals).
In this case, it is possible to choose operation with multiplication by 1 or 4 during configuration :
Counting signals are received on input **IA** for A signals and on input **IB** for B signals.

Auxiliary inputs/outputs

24 VDC auxiliary inputs/outputs as well as external power supplies are grouped together on an HE10 connector. Each connector groups the 2 channels directly above.

The connector contains: set to preset value inputs (IPres0,1: channel 0,1 / IPres2,3: channel 2,3), upcounting or downcounting enable inputs (IEna0,1: channel 0,1 / IEna2,3: channel 2,3), current value read inputs (IRead0,2: channel 0,2 / IRead1,3: channel 1,3), outputs (Q0 and Q1 : channel 0,1/Q0 and Q1 channel 2,3).

• Preset

Preset can be executed in one of the following ways, (selected during configuration) :

- changing state of input **IPres●** (rising or falling edge) and enable by the program,
- on rising edge of input **IPres●**, if the direction is upcounting (positive) or on falling edge of input **IPres●**, if the direction is downcounting (negative) and enable by the program.

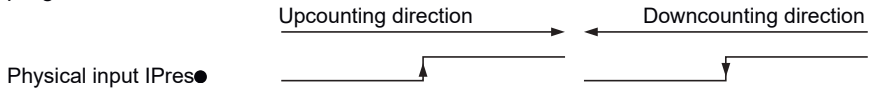

- on rising edge of input **IPres●**, if the direction is downcounting (negative) or on falling edge of input **IPres●**, if the direction is upcounting (positive) and enable by the program.



- on state 1 of input **IPres●** and enable by the program, the current value will not change as long as the input is at 1.

- on short cam reference point :
preset is executed :

- if the direction is upcounting (positive): input IPres● at 1 and rising edge of Zero marker input IZ, and enable by the program,
- if the direction is downcounting (negative): input IPres● at 1 and falling edge of Zero marker input IZ, and enable by the program,

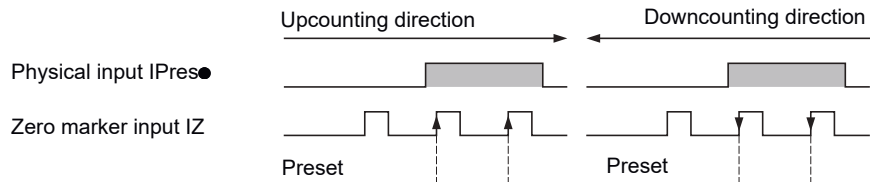

- on long cam reference point :

preset is taken into account on the first rising edge of the Zero marker input IZ after input IPres● has passed to state 0 in both upward and downward directions, and enable by program.

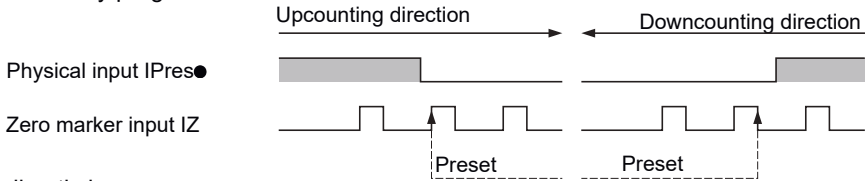

- directly by program.

Enable up/down counting

Upcounting or downcounting can be enabled in one of the ways described below :

- either on state 1 of the signal sent to input **IEna** and enable by the program,
- or directly by the program.

Capture

The capture instruction for the current value is executed in one of the ways described below :

- on change of state (rising or falling edge) of the input **IRead.** and enable by the program,
- or directly by the program.

Note :

The various functions of these auxiliary inputs are explained in the programming manual
- Part H.

Line monitoring input : EPSR

This input, which is usually connected to the power supply return output of an encoder, checks that the power supply of the encoder is normal.

If there is a line break on the cable carrying the power supply voltage to the encoder, the fault which is generated is signalled and can be used by the application program.

The various connection principles of this input are explained in section 2.4.

Counter outputs

The up/down counting function has two counter outputs which can be assigned to high-speed physical outputs located on the counter module.

These two counter outputs have activation and deactivation conditions defined by the user in a coding matrix which can be accessed via the adjustment function.

The physical output state can be controlled in manual or automatic mode.

The setting up of these counter outputs is explained in the programming manual - Part H.

Note :

The simplified schematics on the following pages are not shown in their entirety :

- in the case of TSX CTY 2A/4A modules, the standard 15-pin SUB-D connectors are used to connect the counting sensors relating to the various channels, their representations are exactly the same,
- on simplified schematics 2, 3 and 4 the HE10 connector is not depicted, see simplified schematic 1.

Simplified schematic 1

Use of a single physical up/down counter input, the direction (upcounting or downcounting) is defined by the application.

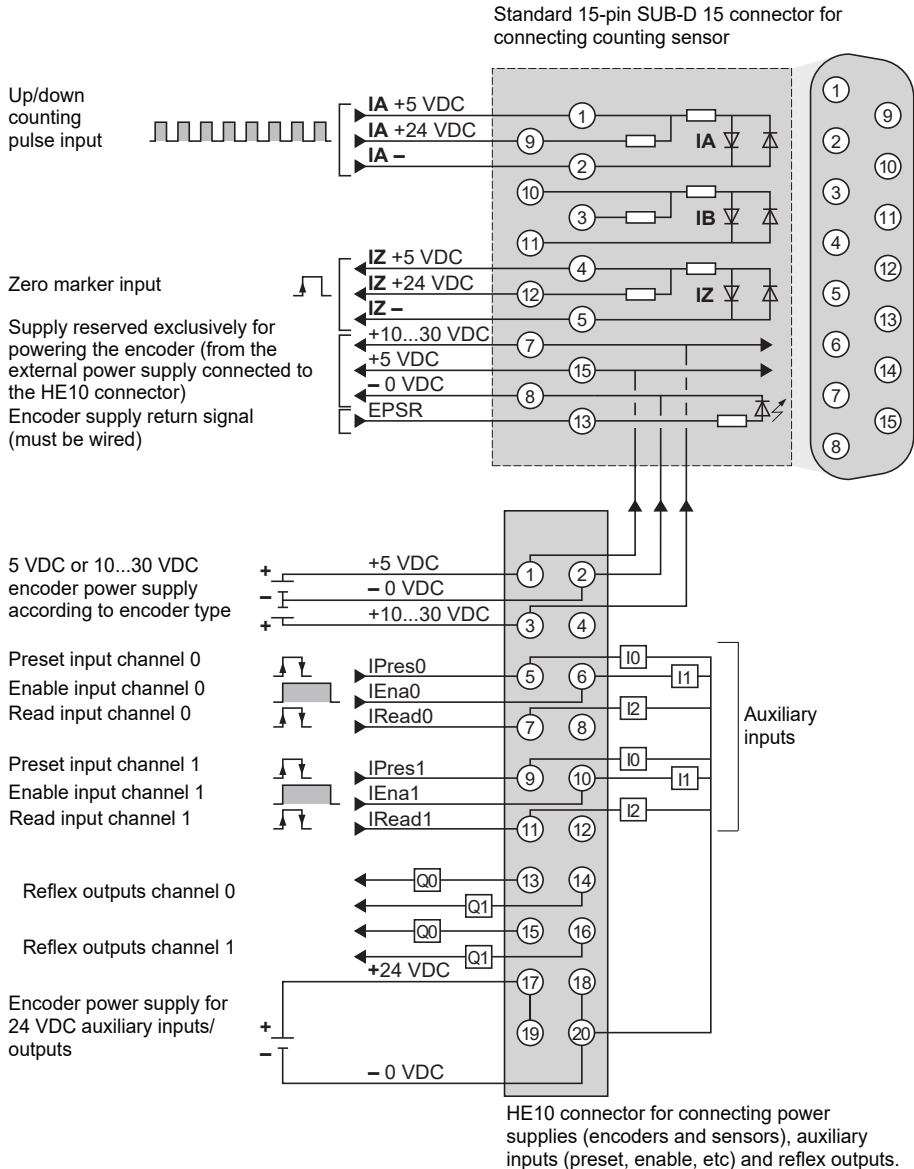

E

Simplified schematic 2

Use of a single physical up/down counter input, the direction (upcount or downcount) is defined by setting the second input to state 0 or 1.

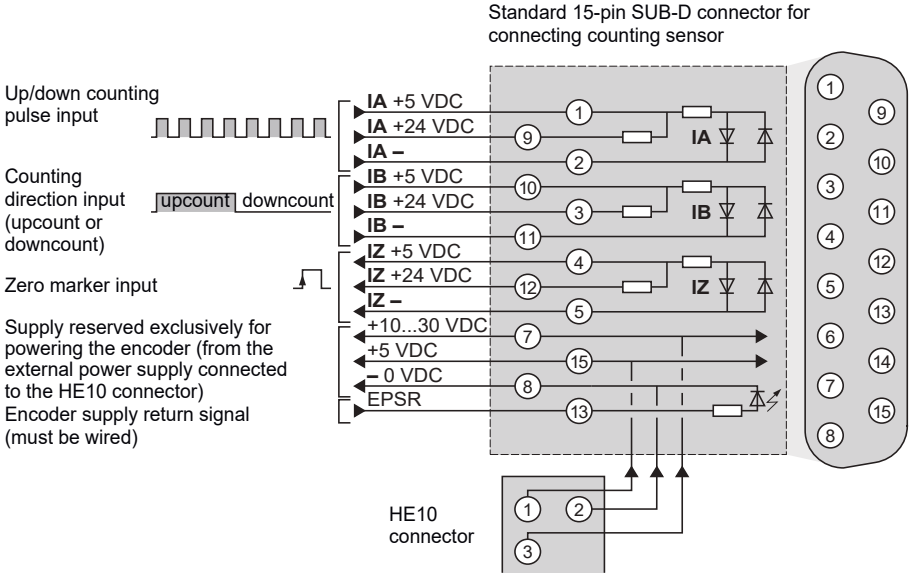

Simplified schematic 3

Use of two physical inputs, an upcounter and a downcounter input :

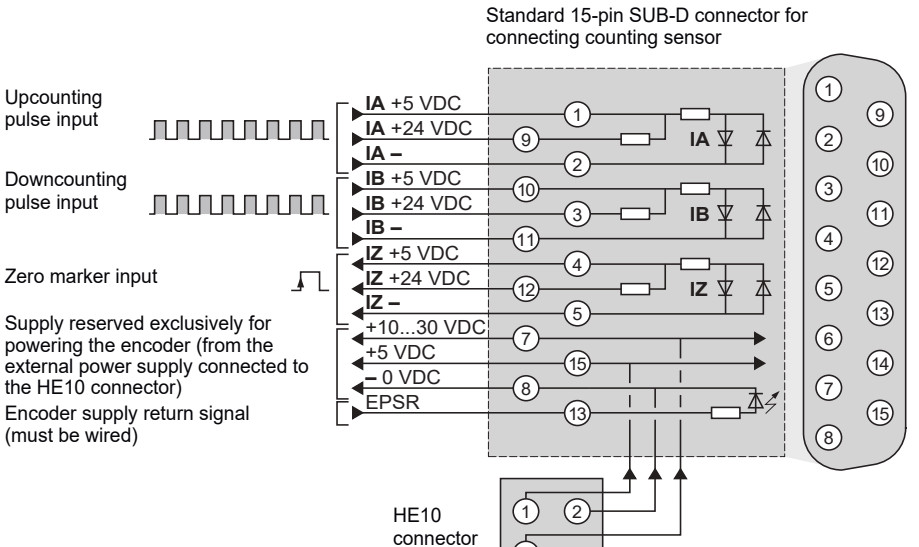

Simplified schematic 4

Use of two physical inputs with signals phase shifted by $\pi/2$ (incremental encoder signals) with the possibility of multiplication by 1 or 4 :

- with multiplication by 1 : up/down counting is performed on the rising edge of input IB,
- with multiplication by 4 : up/down counting is performed on all the rising and falling edges of inputs IA and IB.

E

Standard 15-pin SUB-D 15 connector for connecting counting sensor

Input signal A

Input signal B

Zero marker input

Supply reserved exclusively for powering the encoder (from the external power supply connected to the HE10 connector)

Encoder supply return signal (must be wired)

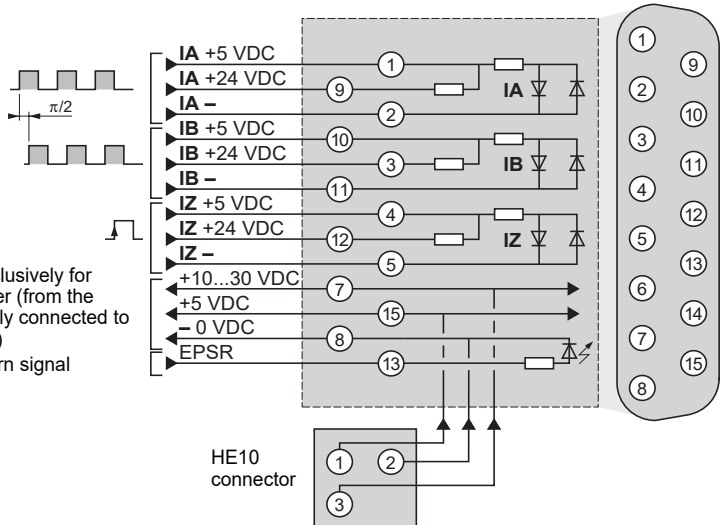

2.4 Connection principle of EPSR input "power supply return"

Several instances can occur :

- **counting with an encoder which has a power supply return output**
 - the EPSR input is connected to the encoder power supply return output

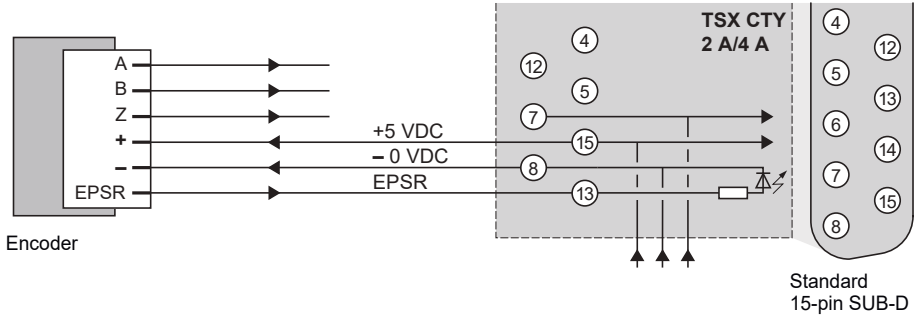

- **counting with an encoder which does not have a power supply return output**
 - the EPSR input is connected to the positive of the encoder power supply, encoder side.

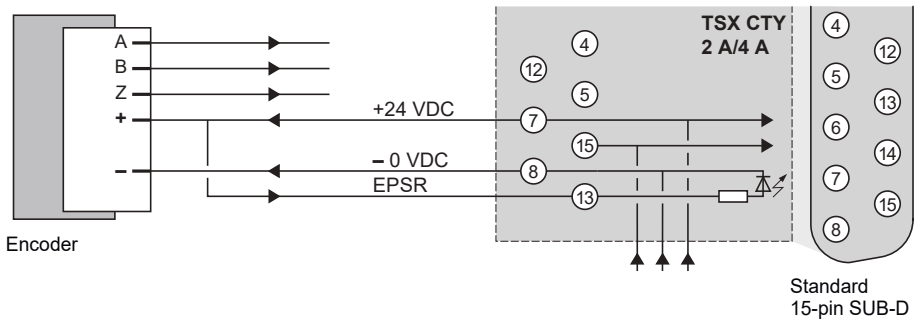

- **counting with inductive proximity sensors**

- the EPSR input is connected to the positive of the counting sensor power supply,
- the - 0 VDC output is connected to the negative of the power supply for the counting sensors.

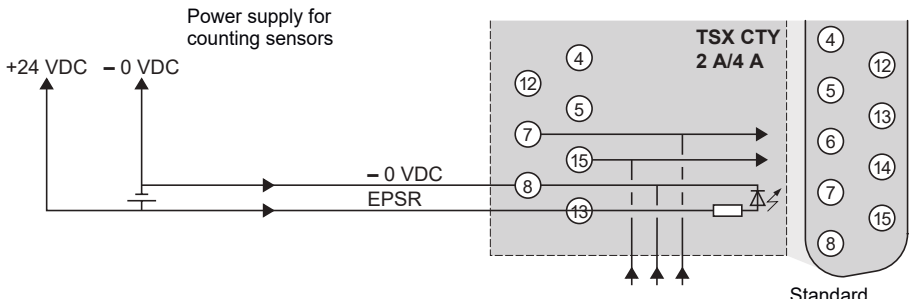

3.1 Number of counter modules controlled by a TSX 57 PLC

The maximum number of counter modules which can be installed on a TSX 57 PLC will depend on the reference :

- 2 modules for a TSX 57-10 PLC,
- 6 modules for a TSX 57-20 PLC.

3.2 Positioning and inserting TSX CTY 2A/4A modules

In a TSX 57-10 PLC

A TSX 57-10 PLC can accept a maximum of 2 TSX CTY 2A or TSX CTY 4A counter modules.

These modules can be installed in all the positions of the main rack and in all the positions of the extension rack (3 types of extension rack are available: 6, 8 and 12 positions).

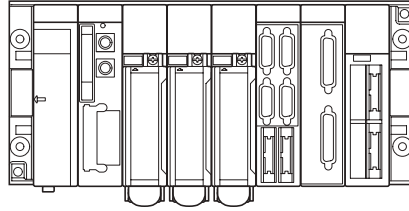

In a TSX 57-20 PLC

A TSX 57-20 PLC can accept a maximum of 6 counter modules.

These modules can be installed in all the positions of the main rack and in all the positions of the 7 extension racks (3 types of extension rack are available: 6, 8 and 12 positions).

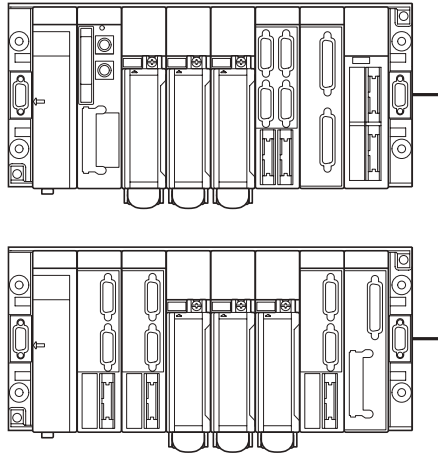

3.3 Types of sensor which can be used on counter inputs

Counter inputs on TSXCTY 2A/4A modules can receive pulses generated by :

- inductive, photoelectric or other types of sensor :
 - 24 VDC supply voltage,
 - 2-wire or 3-wire PNP or NPN type.
- incremental encoders, the main characteristics of which are defined below.

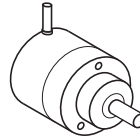
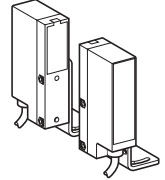
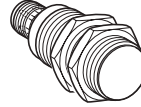

E

Types of incremental encoder most commonly used

Supply voltage	Output voltage	Type of output stage
5 V	5 V differential	RS 422/485 line driver
10...30 V	10...30 V	Totem Pole
10...30 V (1)	5 V differential	RS 422/485 line driver

(1) encoders not widely used.

3.4 TSX CTY 2A/4A module electrical characteristics

3.4-1 General module characteristics

Module	TSX CTY 2A	TSX CTY 4A
Maximum frequency of counter inputs	40 kHz	40 kHz
Current drawn by the module excluding preactuator / sensor current on internal 5 V	Typical: 280 mA Max: 330 mA	330 mA 470 mA
on 24 V sensor	Typical: 30 mA Max: 60 mA	36 mA 72 mA
Power dissipated in the module	Typical: 4.5 W Max: 6 W	8 W 11.5 W
Sensor supply monitor circuit	Yes	Yes
Operating temperature	0 to 60 °C	0 to 60 °C
Dielectric strength inputs/ground or inputs and internal logic	1000 V rms - 50/60 Hz - 1 min	
Insulation resistance	> 10 MΩ at 500 VDC	
Humidity	5% to 95% without condensation	
Storage temperature	- 25 ° to + 70 °C	
Operating altitude	0 to 2000 meters	

3.4-2 Counter input characteristics

Characteristics for use in RS 422 C

Example schematic for each counter input IA, IB, IZ.

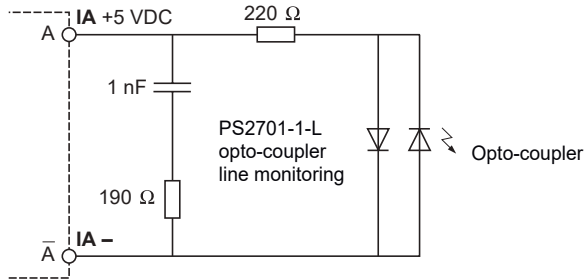

Inputs IA, IB and IZ used in RSS 422 are totally compatible with incremental encoder line drivers with RS 422 outputs and also with encoders with pushpull complementary outputs with a 5 V power supply. Line monitoring is performed on each output.

Characteristics for use at 5 VDC/24 VDC

Inputs		5 VDC counter (IA/IB/IZ)	24 VDC counter (IA/IB/IZ)	
Logic		Positive	Positive	
Nominal values	Voltage	5 V	24 V	
	Current	18 mA	18 mA	
	Sensor supply (ripple included)	–	19...30 V (possible up to 34 V, limited to 1hr per 24hrs)	
Limit values	Voltage	≤ 5.5 V	–	
	At state 1	Voltage	≥ 2.4 V	≥ 11 V
		Current	> 3.7 mA (1)	> 6 mA (2)
	At state 0	Voltage	≤ 1.2 V	≤ 5 V
		Current	< 1 mA (3)	< 2 mA (4)
Input impedance for U nominal		400 Ω	1.4 kΩ	
Input impedance for U = 2.4 V (RS 422 compatibility)		> 270 Ω	–	
Response time		Maximum permissible frequency 40 kHz		
Input type		Resistive	Resistive	
IEC 1131 conformity		–	Type 2	
2-wire prox. sensor compatibility (5)		–	Yes	
3-wire prox. sensor compatibility (5)		–	Yes	

(1) for U = 2.4 V, (2) for U = 11 V, (3) for U = 1.2 V, (4) for U = 5 V
(5) see part B - section 3.3 : compatibility of sensors with type 1 and type 2 inputs.

Characteristics of power supply control circuit for counting sensors (encoder or proximity sensor)

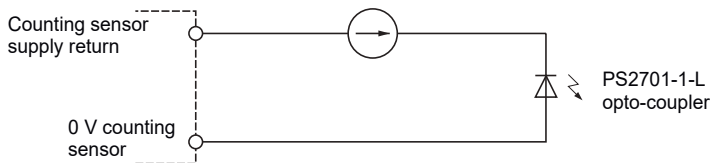

Voltage with no encoder or proximity sensor supply fault		2.5 V
Current with detection of a supply fault		0.5 mA
Limit values	Voltage	30 V (possible up to 34 V, limited to 1 hour per 24 hours)
	Current for 2.5 V < U < 30 V	3 mA

3.4-3 Auxiliary input characteristics

Inputs		24 VDC auxiliary (preset, enable, read)	
Logic		Positive	
Nominal values	Voltage	24 V	
	Current	7 mA	
Sensor supply (ripple included)		19...30 V (possible up to 34 V, limited to 1hr per 24hrs)	
Limit values	At state 1	Voltage	≥ 11 V
		Current	> 6 mA (1)
	At state 0	Voltage	≤ 5 V
		Current	< 2 mA
Voltage control thresholds	OK	> 18 V	
	Fault	< 14 V	
Response time for sensor voltage monitoring	Disappearance of 24 V supply	< 2.5 ms (4)	
	Appearance of 24 V supply	< 10 ms (4)	
Input impedance	3.4 k Ω		
Response time	State 0 to 1	< 250 μ s (3)	
	State 1 to 0	< 250 μ s (3)	
Input type	Current sink		
IEC 1131 conformity	Type 2		
2-wire proximity sensor compatibility (2)		Yes (all 24 VDC 2-wire proximity sensors)	
3-wire proximity sensor compatibility (2)		Yes (all 24 VDC 3-wire proximity sensors)	

(1) for $U = 11$ V

(2) see part B - section 3.3 "compatibility of sensors with type 1 and type 2 inputs".

(3) the auxiliary inputs are fast inputs (response time < 250 μ s) in accordance with the 40 KHz maximum permissible frequency of the counter inputs.

(4) when the sensor supply voltage disappears, the fast auxiliary inputs can be taken into account.

The **auxiliary inputs** receive a 24 V supply from a power supply on the connector.

Equivalent schematic :

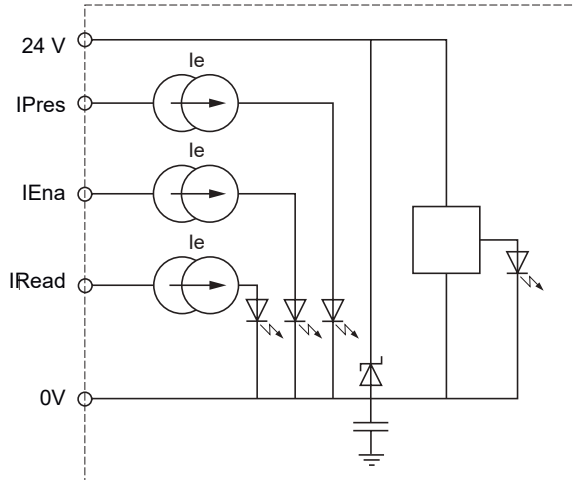

E

3.4-4 Auxiliary output characteristics

Equivalent schematic :

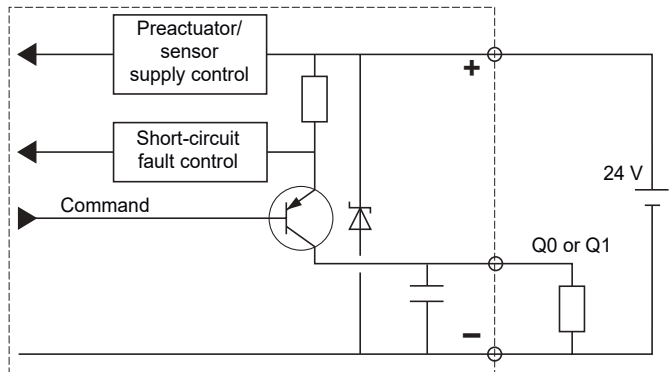

Outputs	24 VDC auxiliary
Nominal voltage	24 V
Voltage limits	19...30 V (possible up to 34 V, limited to 1hr per 24hrs)
Nominal current	500 mA
Max. voltage drop "On"	< 0.5 V
Leakage current	< 0.1 mA
Max. current at 30 V and at 34 V	375 mA
Switching time	< 250 μ s
Electronic discharge time	< L/R s
Switching frequency on inductive load	$F < 0.6 / (L I^2)$ Hz
Compatibility with DC inputs	All positive logic inputs whose input resistance is < 15 K Ω
IEC 1131-2 conformity	yes
Protections against overloads and short-circuits	By current limiter and thermal trip
Short-circuit monitoring on each channel	One signal bit per channel
Reset : * by application program * automatic	One bit per channel in program write mode
Protection against overvoltage on channels	zener diode between outputs and + 24 V
Protection against reverse polarity	by diode inverted on supply
Power of one filament lamp	8 W (max)

3.5 15-pin SUB-D and HE10 connector pinout

3.5-1 Standard 15-pin SUB-D connector

Connector for connecting counting sensors and encoder supply :

- TSX CTY 2A module : two 15-pin SUB-D connectors (channels 0 and 1),
- TSX CTY 4A module : four 15-pin SUB-D connectors (channels 0,1,2 and 3).

Note :

the pinouts of the various connectors are strictly identical.

Standard 15-pin SUB-D connector for connecting the counting sensor to channel 0 or 1

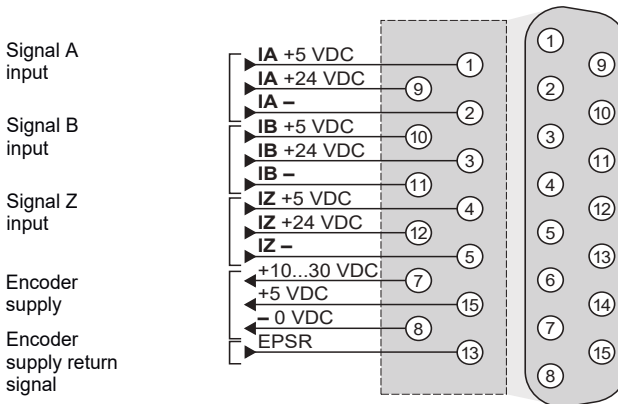

5 VDC signals	Pins
Input IA +	1
Input IA -	2
Input IB +	10
Input IB -	11
Input IZ +	4
Input IZ -	5
Encoder supply :	
+ 5 VDC	15
- 0 VDC	8
Encoder power supply return	13

10...30 VDC signals	Pins
Input IA +	9
Input IA -	2
Input IB +	3
Input IB -	11
Input IZ +	12
Input IZ -	5
Encoder supply :	
+ 10...30V	7
- 0 VDC	8
Encoder power supply return	13

3.5-2 20-pin HE10 connector

Connector designed for connecting auxiliary inputs, encoder supplies and other sensors.

The TSX CTY 2A module has a single HE10 connector for channels 0 and 1. The TSX CTY 4A module has two HE10 connectors for channels 0,1 and 2,3 respectively.

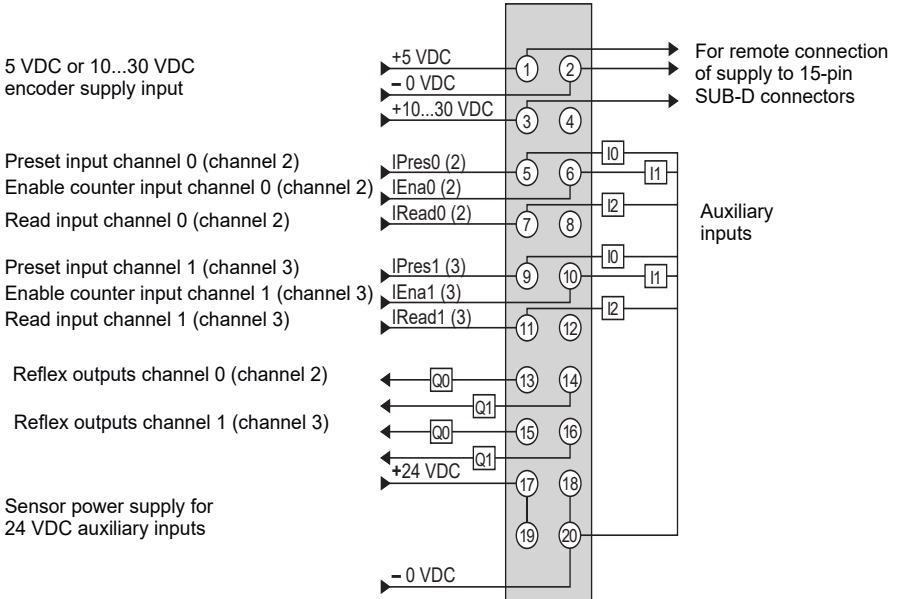

E

24 VDC signals	Pins	Supplies	Pins
Auxiliary inputs channel 0 (channel 2) :		Encoder supply :	
Preset IPres 0/2	5	+ 5 VDC	1
Enable IEna 0/2	6	- 0 VDC	2
Read IRead 0/2	7	- 10...30 VDC	3
Auxiliary inputs channel 1 (channel 3) :		Sensor supply :	
Preset IPres 1/3	9	+ 24 VDC	17 or 19
Enable IEna 1/3	10	- 0 VDC	18 or 20
Read IRead 1/3	11		
Reflex output channel 0 (channel 2) :			
Output Q0	13		
Output Q1	14		
Reflex output channel 1 (channel 3) :			
Output Q0	15		

3.6 Connection of encoder type counting sensors

3.6-1 Connection principle

In the case of a TSX CTY 2A module, only the elements relating to channels 0 and 1 should be connected.

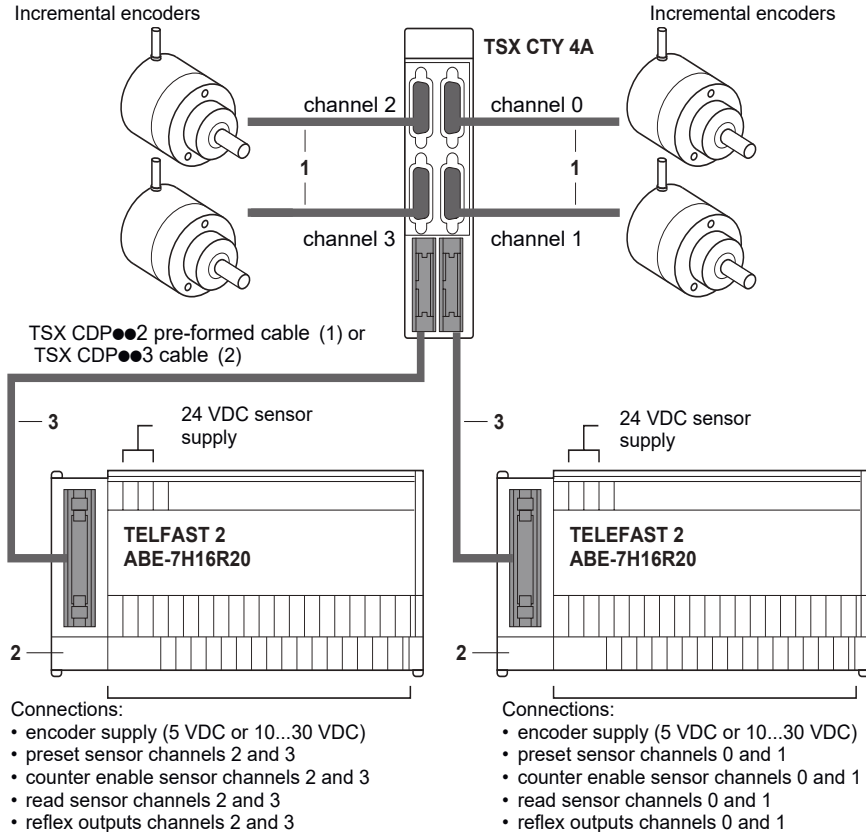

Notes :

- it is not obligatory but it is advisable to use a discrete TELEFAST connection sub-base in order to facilitate connection of power supplies and sensors to the auxiliary inputs and outputs,
- in the case of the TSX CTY 1A module, it is possible to use an ABE-7H08R10 sub-base,
- TELEFAST 2 connection sub-bases are described in part B1 - section 6 of this manual.

(1) TSX CDP 102 : 1 m long, TSX CDP 202 : 2 m long, TSX CDP 302 : 3 m long,

(2) TSX CDP 053 : 0.5 m long, TSX CDP 103 : 1 m long, TSX CDP 203 : 2 m long,

Description of the various connection elements

- 1 Equipment for connecting the encoder to the standard 15-pin SUB-D connector, located on the TSX CTY 2A/4A module. In view of the different types of encoder, the connection equipment is the user's responsibility and consists of :
 - a connector for the encoder (depends on the encoder used, generally a 12-pin female DIN connector),
 - a standard 15-pin male SUB-D connector for connection to the 15-pin female SUB-D connector on the TSX CTY ●A module. Element provided as a separate part under the reference TSX CAP S15,
 - a cable :
 - with twisted pairs (26 gauge) and shielding for an encoder with standard RS 422 line driver outputs,
 - multicore (24 gauge) with shielding for an encoder with Totem Pole outputs.The cable shielding is of the "braid + strip" type. Contact between the "braid + strip", and the ground for each connector, must be secured by clamping around the whole circumference of the cable.
The connection of this cable to the two connectors varies depending on the type of power supply used by the encoder (5 VDC or 10...30 VDC) and the type of outputs (RS 422, Totem Pole). Different types of connection are used as examples in this section.
- 2 TELEFAST 2 : connection sub-base ABE-7H16R20.
This enables rapid connection of :
 - the 24 VDC power supply for sensors other than the encoder,
 - the encoder power supply,
 - sensors to the auxiliary inputs (preset, enable, read).
 - outputsfor a TSX CTY 2A or TSX CTY 4A counter module.
- 3 Connection cable TSX CDP●●3 or pre-formed cable TSX CDP●● 2
(see part B for characteristics)

3.6-2 Connection of the TSX CTY 2A/4A module to the encoder

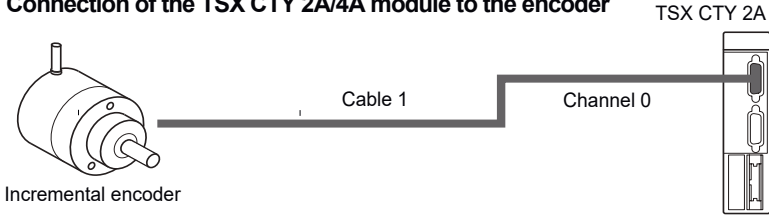

Example of module/encoder connection with RS 422 line driver outputs

Encoder characteristics

- supply voltage : 5 VDC,
- output voltage : 5 VDC differential,
- output stage : RS 422/485 standard line driver.

Simplified schematic

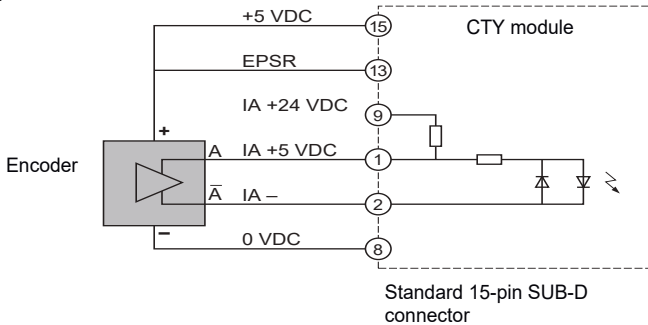

Simplified schematic for channel connection

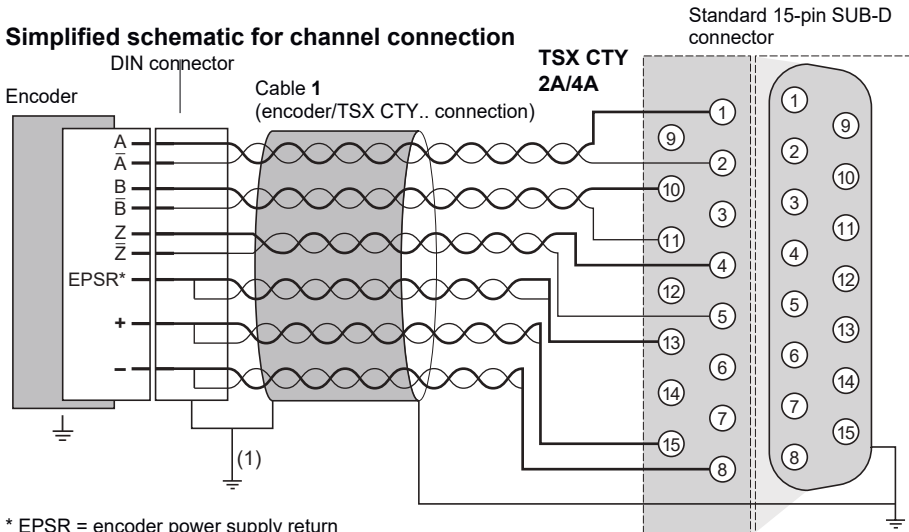

* EPSR = encoder power supply return

Example of PLC/encoder connection with Totem Pole outputs

Encoder characteristics

- supply voltage : 10...30 VDC,
- output voltage : 10...30 VDC,
- output stage : Totem Pole.

Simplified schematic

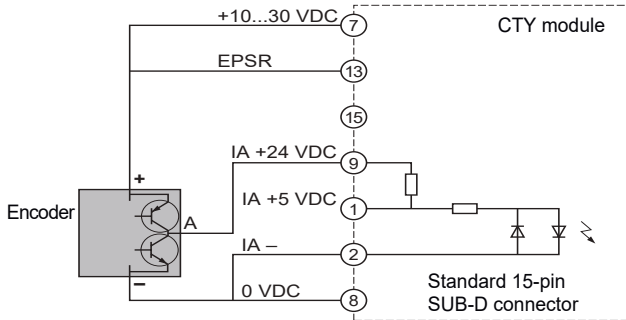

E

Schematic for channel connection

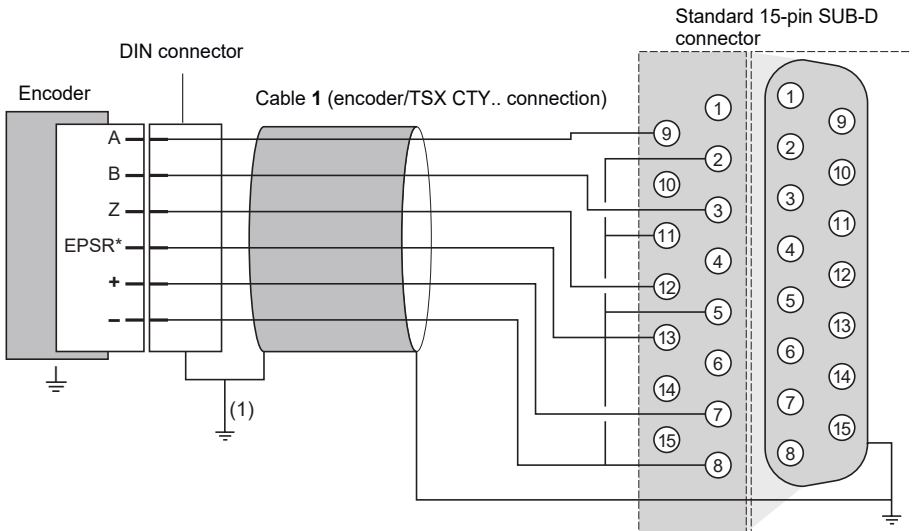

* EPSR = encoder power supply return

When the encoder does not have a supply return, the EPSR input should be linked on the encoder side to the positive of the power supply

(1) This link should be made directly if the encoder is isolated from ground

Example of PLC/encoder connections with NPN open collector outputs

Encoder characteristics

- supply voltage : 24 VDC
- output voltage : 24 VDC,
- output stage : NPN open collector.

Simplified schematic

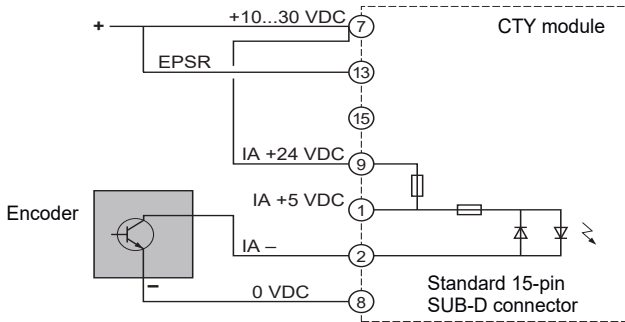

Schematic for channel connection

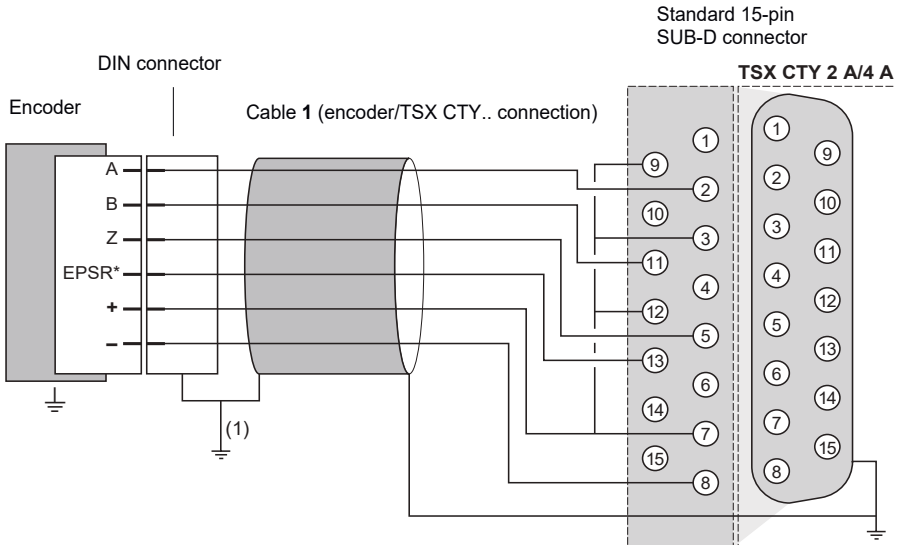

* EPSR : encoder power supply return.

When the encoder does not have a supply return, the EPSR input should be linked on the encoder side to the positive of the power supply.

(1) This link should be made directly if the encoder is isolated from ground

Example of PLC/encoder connections with PNP open collector outputs

Encoder characteristics

- supply voltage : 24 VDC
- output voltage : 24 VDC,
- output stage : PNP open collector.

Simplified schematic

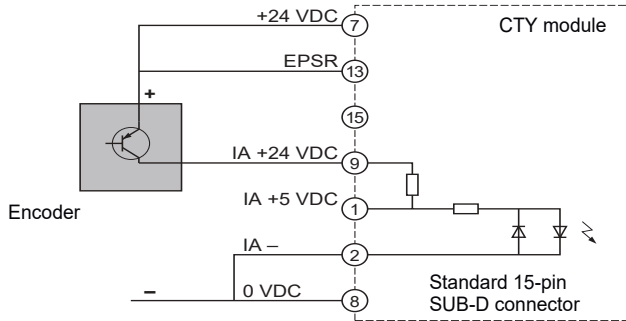

Schematic for channel connection

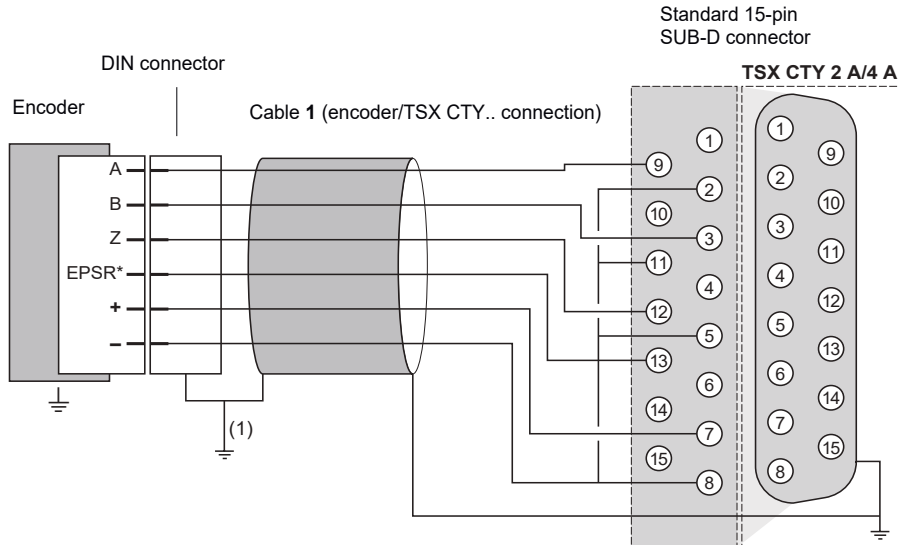

* EPSR : encoder power supply return.

When the encoder does not have a supply return, the EPSR input should be linked on the encoder side to the positive of the power supply.

(1) This link should be made directly if the encoder is isolated from ground

3.6-3 Connection of the power supply and sensors to auxiliary inputs and outputs

These are connected using a TELEFAST 2 prewired sub-base ABE-7H16R20 :

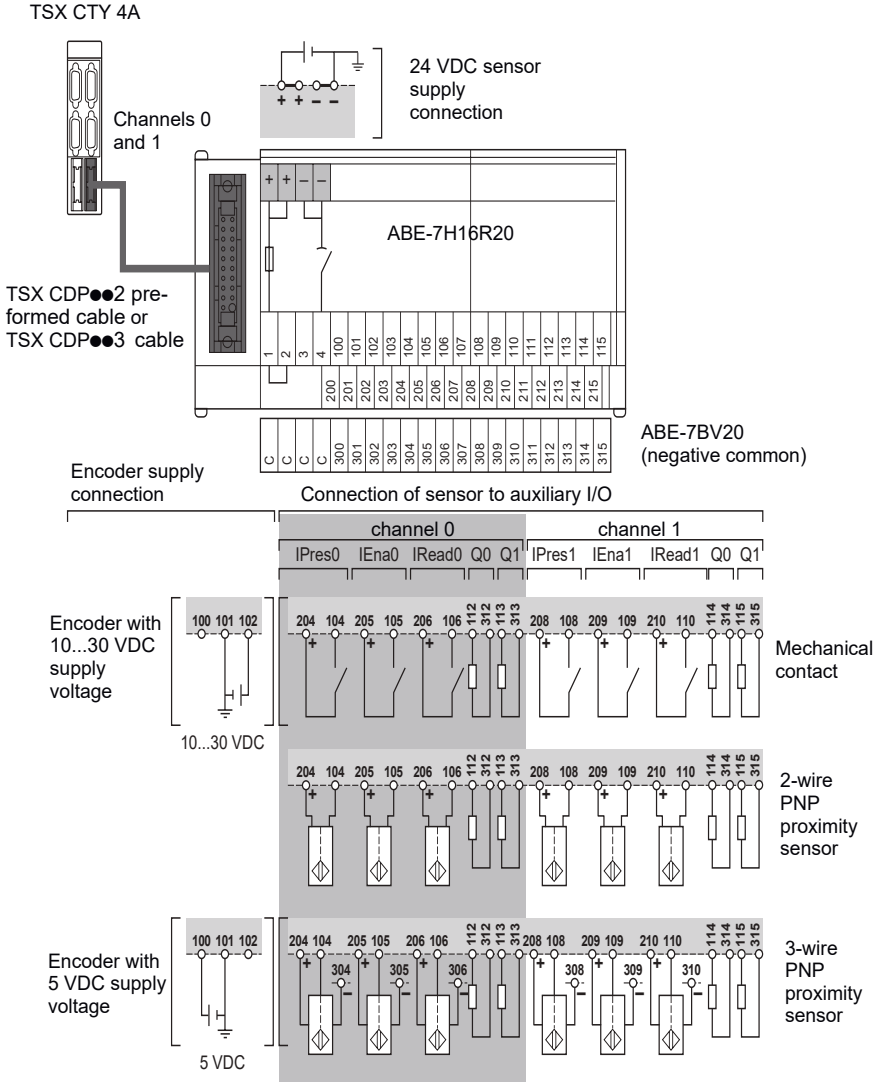

Note :

The connection of channels 2 and 3 of a TSX CTY 4A module is identical to that of channels 0 and 1.

3.7 Connections with proximity sensor type counting sensors

3.7-1 Connection principle

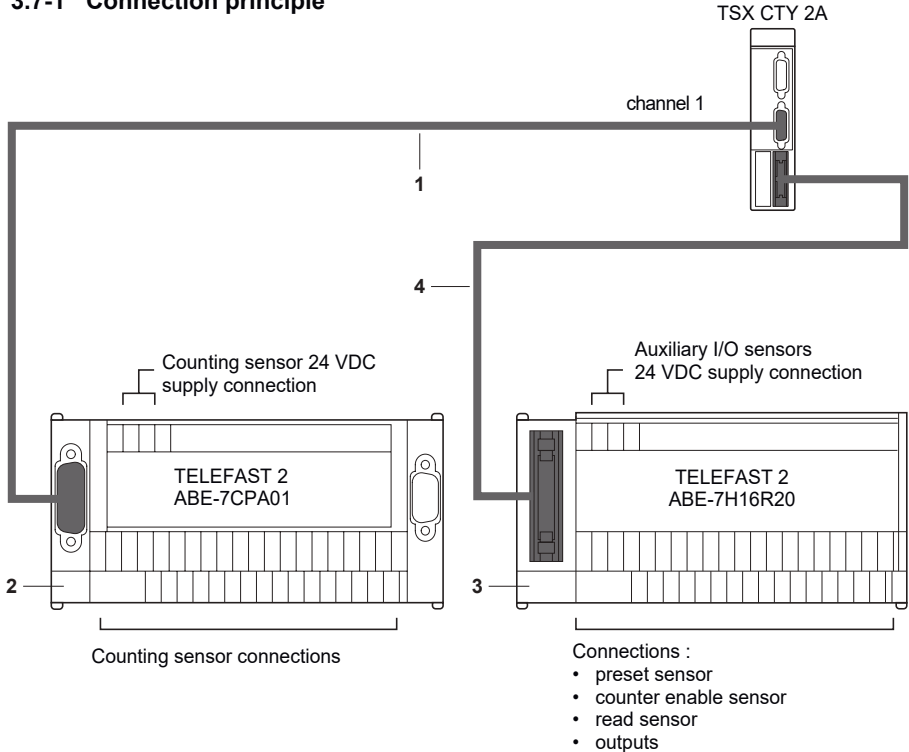

- 1 TSX CCP S15 cable, 2.5 m long with high density 15-pin SUB-D connectors + standard 15-pin SUB-D connector for connecting the counter channel to the TELEFAST 2 connection sub-base (ABE-7CPA01). This cable carries the various counter channel signals.
- 2 TELEFAST 2 connection sub-bases : ABE-7CPA01 : This is used to connect the counting sensors and their power supply to the relevant channel.
- 3 TELEFAST 2 connection sub-base : ABE-7H16R20. This is used to connect sensors relating to auxiliary inputs and their power supply.
- 4 TSX CDP ●●3 connection cable or TSX CDP●●2 cable (see part B1 - section 5.1-2 for characteristics). They connect the auxiliary inputs on the module to the TELEFAST 2 connection sub-base ABE-7H16R20.

Note :

The connection of channels 2 and 3 of a TSX CTD 4A module is identical to that of channels 0 and 1.

3.7-2 Connection of counting sensors and their power supply

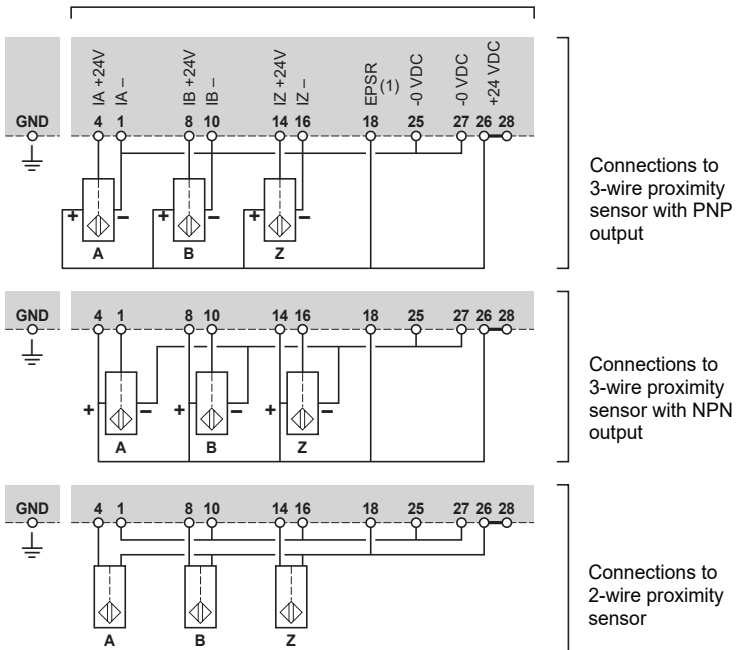
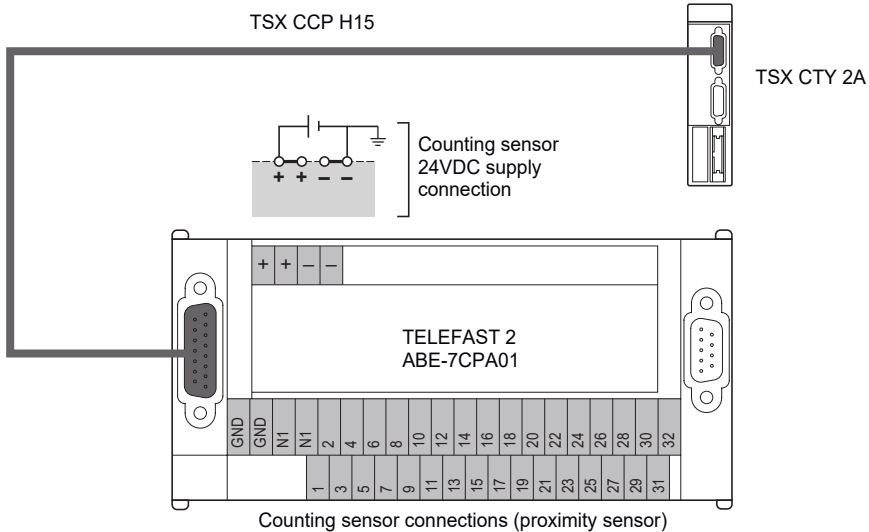

(1) When the counting sensors are proximity sensors, the EPSR input (encoder power supply return) must respect polarity :

- EPSR (terminal 18) to the 24VDC positive of the sensor supply (terminal 26 or 28),

3.7-3 Connection of sensors to auxiliary inputs and outputs and their power supply

These are connected via a TELEFAST 2 connection sub-base ABE-7H08R20 :

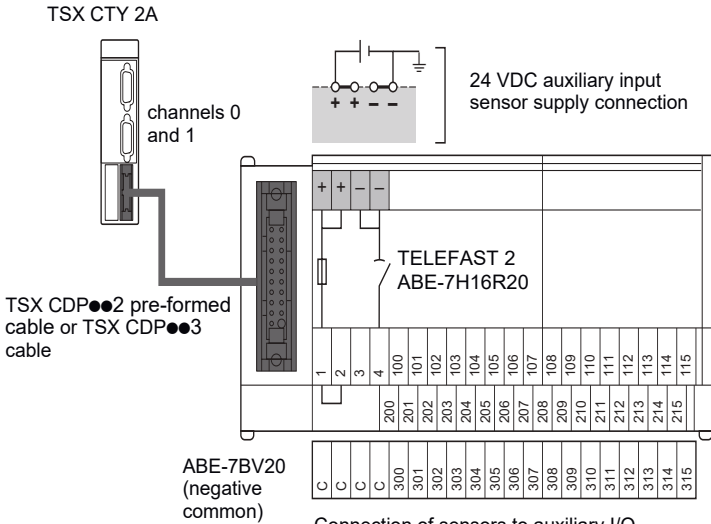

Connection of sensors to auxiliary I/O

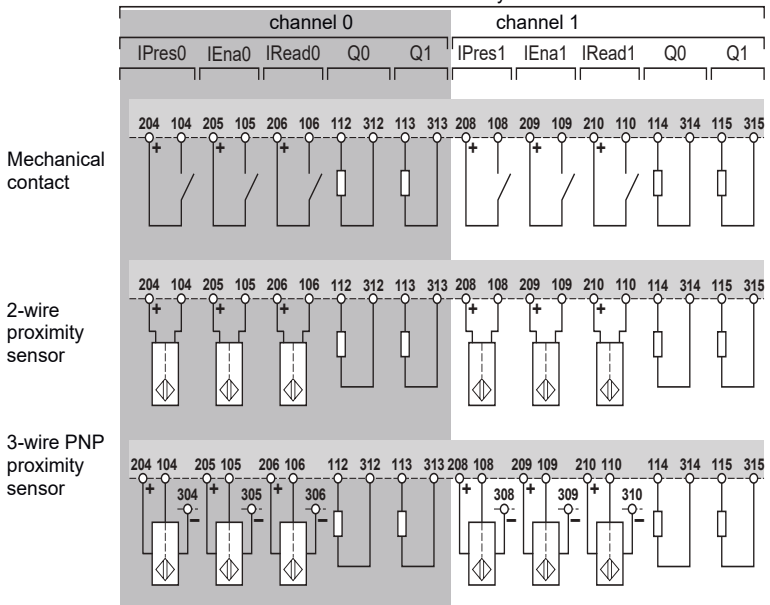

E

3.7-4 Wiring precautions

Inputs IPres, IEna, IRead are fast inputs which should be connected to the sensor by twisted pair if it is a volt-free contact, or by shielded cables if it is a 2 or 3-wire proximity sensor.

The module incorporates protections against short-circuits or voltage inversion. However, the module cannot withstand a fault for a long time. The fuses should therefore be in series with the power supply to ensure protection. These fuses should be fast-blow and rated no higher than 1A. The energy provided by the power supply should be sufficient to ensure correct fuse protection.

Important note : wiring solid state outputs Q0 or Q1

The actuator connected to outputs Q0 or Q1 has its common point at the 0V of the power supply. If for any reason (poor contact or accidental damage) there is a break in the 0V of the output amplifier power supply while the 0V of the actuators is still connected to the 0V of the power supply, there should be an output current of several mA from the amplifier sufficient to keep low power actuators energized.

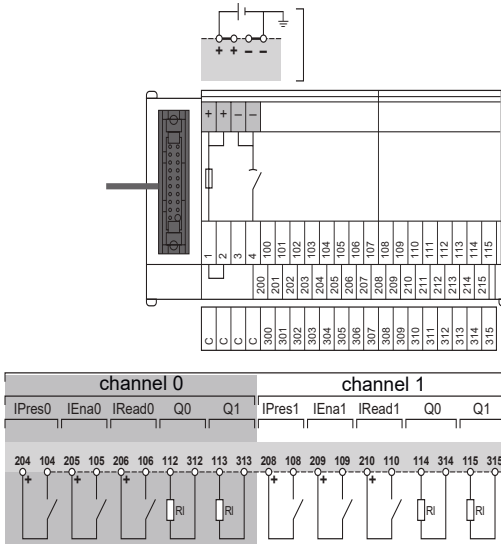

TELEFAST connection :

This type of connection is the most reliable provided that the actuator common is connected to the common points strip 2•• (jumper in position 1-2). In this case the module common cannot be disconnected without disconnecting the actuator common.

3.8 General installation rules

3.8-1 Installation

It is not advisable to connect or disconnect the standard 15-pin SUB-D connectors of TSX CTY 2A/4A modules with the encoder and sensor supplies present, as this could damage the encoder. Certain encoders cannot withstand a sudden power-up or simultaneous disconnection of the signals and power supplies.

3.8-2 General wiring instructions

Cross section of wires

Wires of a sufficient cross sectional area must be used in order to avoid voltage drops (mainly at 5 V) and temperature rises.

Example of voltage drops for encoders with a 5 V power supply and a 100 meter length of cable.

Wire cross section	Encoder consumption			
	50 mA	100 mA	150 mA	200 mA
0.08 mm ² (28 gauge)	1.1 V	2.2 V	3.3 V	4.4 V
0.12 mm ² (26 gauge)	-	1.4 V	-	-
0.22 mm ² (24 gauge)	-	0.8 V	-	-
0.34 mm ² (22 gauge)	0.25 V	0.5 V	0.75 V	1 V
0.5 mm ²	0.17 V	0.34 V	0.51 V	0.68 V
1 mm ²	0.09 V	0.17 V	0.24 V	0.34 V

Connection cables

All cables carrying power supplies to the sensors (encoders, proximity sensors, etc) and the counting signals must :

- be kept apart from power cables,
- be shielded with the shielding connected to the mechanical ground on both the PLC and the encoder,
- never carry signals other than counting signals and power supplies relating to the counting sensors.

The PLC/encoder connecting cable should be as short as possible in order to avoid loops causing coupling capacitances which can interfere with operation.

Note :

Ensure that the outward and return lines for a signal are in the same cable as the supply lines if necessary. In order to do this, it is preferable to use twisted pair cables.

3.8-3 Encoder and auxiliary sensor supplies

Encoder supply

This must be :

- reserved exclusively for supplying the encoder, so as to avoid interference pulses which could disrupt encoders with sensitive electronics,
- as near to the TELEFAST 2 sub-base as possible in order to reduce voltage drops and coupling with other cables,
- protected against short-circuits and overloads by fast blow fuses,
- have sufficient endurance to micro-cuts.

Auxiliary sensor supply

See part B1 - section 3-1 "choice of DC power supplies for sensors and preactuators".

Important :

The - 0VDC polarity of the encoder and auxiliary sensor power supplies must be connected to ground (\perp) as close as possible to the power supplies.
Cables carrying supply voltages should have their shielding connected to ground (\perp).

3.8-4 Software setup

The software setup and language objects associated with the various counter functions are explained in more detail in manual TLX DS PL7 J12E "Application-specific functions", part H.

4.1 TELEFAST 2 connections : ABE-7CPA01

4.1-1 Presentation

The TELEFAST 2 connection sub-base (ABE-7CPA01) transforms a 15-pin standard female SUB-D connector to a screw terminal block connector with :

- 32 terminals on two rows for connecting the various sensors and supplies,
- 4 terminals for onward connection (2 GND terminals + 2 terminals N1 for special connections),
- 4 terminals for connecting the sensor supply.

This enables rapid connection of the proximity detector type sensors to a counter channel on the TSX CTY 2A and TSX CTY 4A modules.

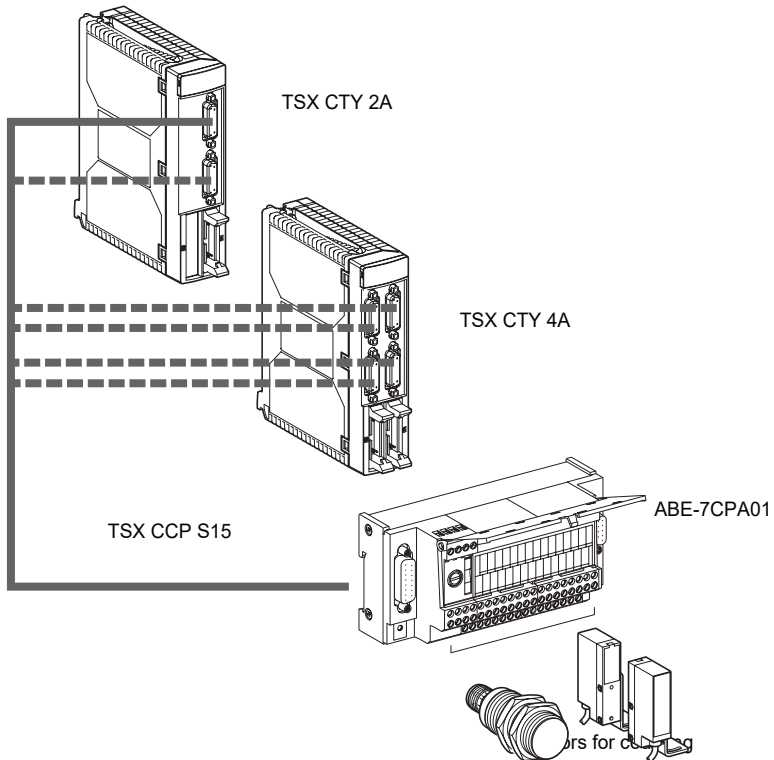

A 9-pin SUB-D connector is used to transfer information to an Altivar drive when using this sub-base with analog I/O.

4.1-2 Wiring diagram

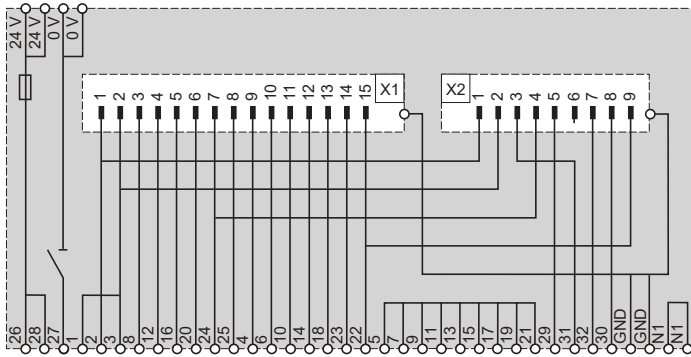

4.1-3 Dimensions and mounting

- Dimensions

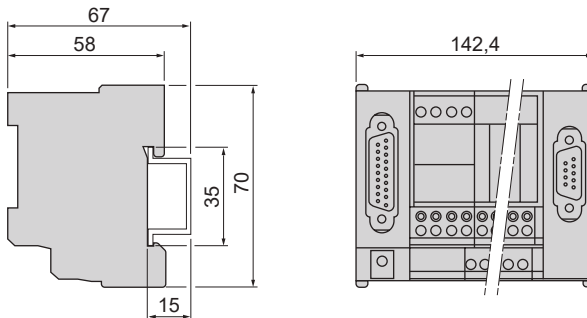

- Mounting

The ABE-7CPA01 connection sub-base is mounted on 35 mm DIN rails.

4.1-5 Correspondence betw. TELEFAST term. blocks and 15-pin SUB-D connectors

TELEFAST screw terminal block (term. N°)	Standard 15-pin SUB-D connector (pin N°)	Type of signal
1	2	IA -
2		
3	2	IA -
4	9	IA + 24 VDC
5		
6		
7		
8	3	IB + 24 VDC
9		
10	11	IB -
11		
12		
13		
14	12	IZ + 24 VDC
15		
16	5	IZ -
17		
18	13	Encoder power supply return (EPSR)
19		
20		
21		
22		
23		
24	7	+ 10...30 VDC encoder supply input
25	8	- 0 VDC encoder supply input
26		+ 24 V sensor supply output
27		- 0 V sensor supply output
28		+ 24 V sensor supply output
29		
30		
31		
32		

4.2 TELEFAST 2 connection sub-base : ABE-7H08R20

4.2-1 Presentation

The TELEFAST 2 connection sub-base (ABE-7H16R20) transforms a 20-pin HE10 connector to a screw terminal block connector for the rapid connection of the sensors and supplies to the auxiliary inputs of TSX CTY 2A/4A counter modules.

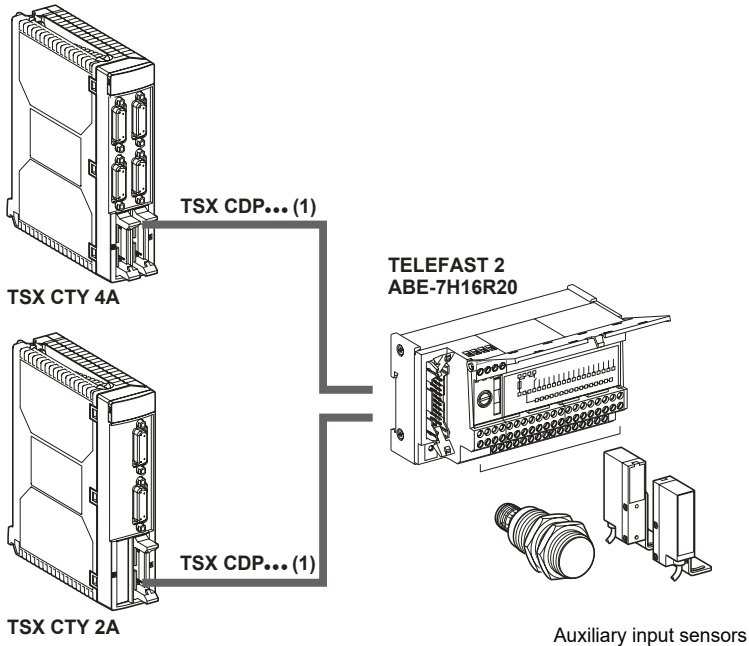

(1) TSX CDP ●●2 pre-formed cable or TSX CDP ●●3 cable (see part B - section 5.1-2 for characteristics).

Note :

The connection sub-bases for TELEFAST 2 discrete I/O are described in part B - section 6.

4.2-3 Correspondence betw. TELEFAST term. blocks and HE10 connectors

TELEFAST screw terminal block (term. N°)	20-pin HE10 connector (pin N°)	Type of signal	
100	1	+ 5 VDC	Encoder supply
101	2	- 0 VDC	
102	3	+ 10...30 VDC	
103	4		
104	5	IPres 0/2 (preset channel 0/2)	Auxiliary inputs channel 0/2
105	6	IEna 0/2 (counter enable channel 0/2)	
106	7	IRead 0/2 (read channel 0/2)	
107	8		
108	9	IPres 1/3 (preset channel 1/3)	Auxiliary inputs channel 1/3
109	10	IEna 1/3 (counter enable channel 1/3)	
110	11	IRead 1/3 (read channel 1/3)	
111	12		
112	13	Output Q0 channel 0/2	Aux. outputs channel 0/2
113	14	Output Q1 channel 0/2	
114	15	Output Q0 channel 1/3	Aux. outputs channel 1/3
115	16	Output Q1 channel 1/3	
+ 24 VDC	17	Auxiliary input sensor supply	
- 0 VDC	18		
+ 24 VDC	19		
- 0 VDC	20		
1	[All 2●● terminals at + 24 VDC	
2			
3	[All 2●● terminals at - 0 VDC	
4			
200...215		Connecting sensor commons to : + 24 VDC if terminals 1 & 2 are linked - 0 VDC if terminals 3 & 4 are linked	
300...315		On optional ABE-7BV20 strip, terminals may be used as sensor common.	

4.3 Wiring accessory for 24 V incremental encoder with Totem pole outputs : TSX TAP S15 24

4.3-1 Presentation

TSX TAP 15 is a connection module for 24 V incremental encoders (TSX TAP S15 24) with Totem pole (or push-pull) outputs.

TSX TAP 15 has 2 connectors :

- a 12-pin female round connector for screwing the encoder cable clockwise (the fixing ring is on the encoder cable),
- a standard 15-pin Sub-D connector for connecting to the SubD connector for the counter inputs on the module via a standard cable TSX CCP S15.

TSX TAP 15 can be mounted on a rail, using the bracket supplied with the product, or fitted through an enclosure, using the seal supplied.

Information regarding 12-pin round type FRB (a standard in the world of incremental encoders) connectors

The pins on these connectors are numbered in the following ways. Most encoders have a 12-pin integrated base and the pins are numbered anti-clockwise. The TSX TAP S15 has a female 12-pin sub-base which is numbered anti-clockwise. All user power leads should be fitted with connection sockets numbered clockwise, which will therefore ensure that the pin numbers correspond with the socket numbers on the wiring.

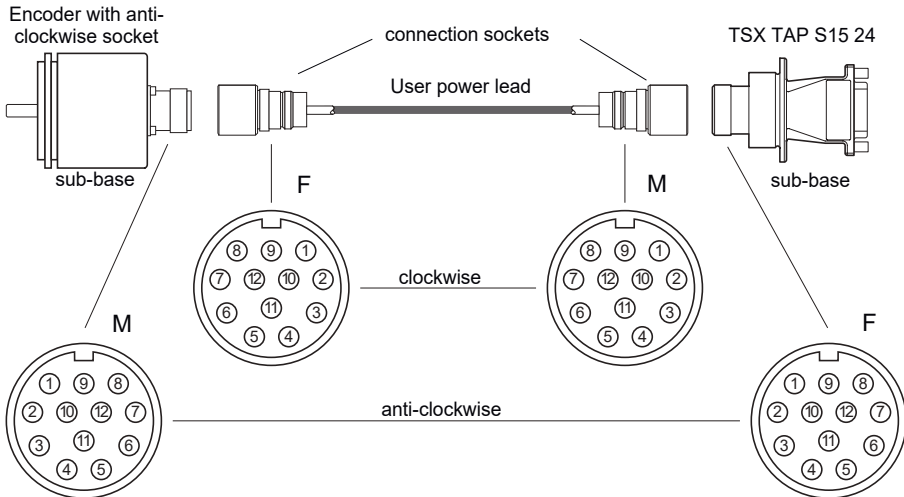

4.3-2 Mounting of TSX TAP S15 ●●

Mounting on a Telequick plate

The bracket supplied enables the TSX TAP S15 05/24 to be mounted on a pre-slotted plate type AM1-PA ... or on any other support.

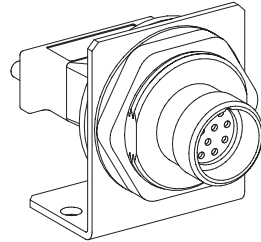
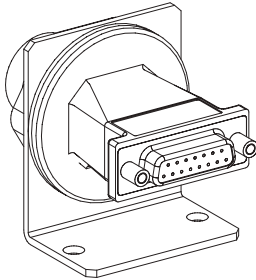

E

Mounting into an enclosure wall

By means of a fixing screw, the TSX TAP S15 05/24 can be mounted into an enclosure wall. A seal is provided to ensure dust and damp-proof protection between the inside and outside.

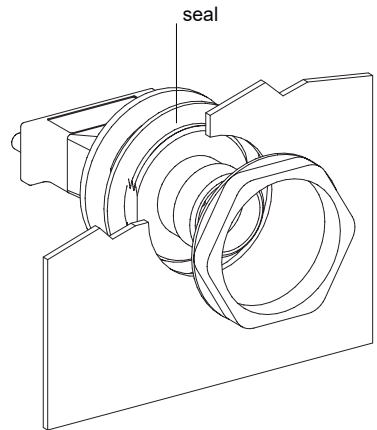
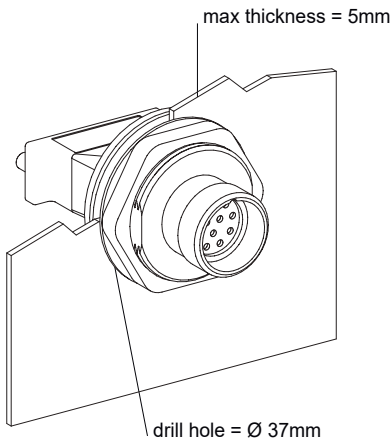

Dimensions :

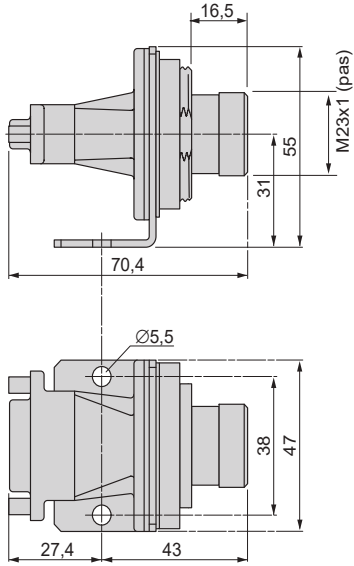

4.3-3 Connection of an encoder using the TSX TAP S15 24 accessory

The connection of an encoder via a TSX TAP S15 24 auxiliary requires the user to provide a specific cable between the accessory and the encoder. The TSX TAP S15 24 pinout is as follows :

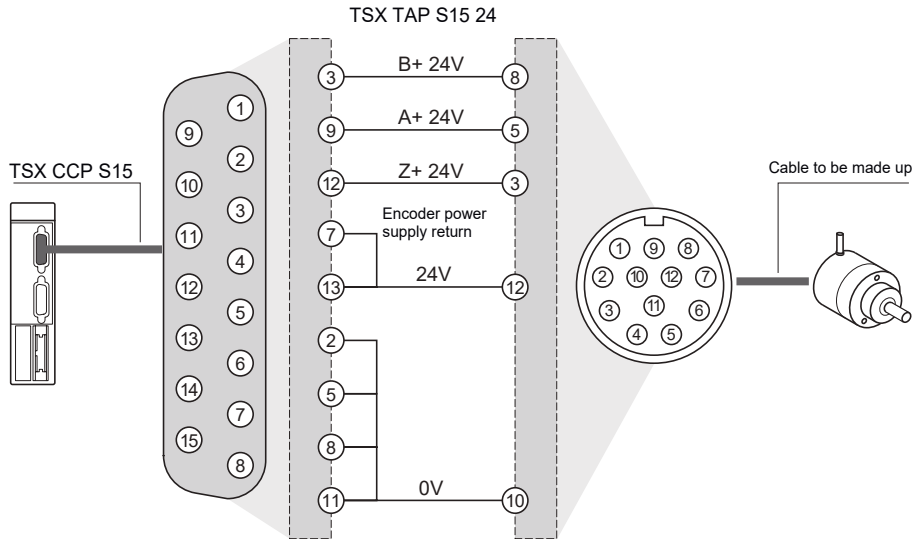

This type of connection is compatible with encoders with a 24V supply :

- Heidenheim
- Hengstler
- Codéchamp
- Ivo
- Ideacod, etc

4.4 Connection to modules with HE10 connectors

4.4-1 20-wire preformed cable, 22 gauge (0.34 mm²)

It is used for a simple and direct wire-to-wire connection of HE10 module I/O to sensors, pre-actuators or terminals.

This preformed cable consists of :

- an insulated HE10 connector at one end, with 20 0.34 mm² wires and sheath,
- flying leads at the other end, color-coded according to DIN 47100 standard.

Note : A nylon core in the cable enables the wire to be stripped easily.

Two kinds are available :
TSX CDP 301 : 3 m long,
TSX CDP 501 : 5 m long.

4.4-2 Preformed connection cable with flying leads and sheath, 28 gauge (0.08 mm²)

This is used to connect I/O of modules with HE10 connectors to connection and adaptation interfaces using TELEFAST 2 rapid wiring. This cable has 2 HE10 connectors and a ribbon cable with 0.08 mm² flying leads and sheath.

Given the small wire section, it is recommended to use it only on inputs or outputs with low current (<100 mA per input or output).

Three kinds are available :

- TSX CDP 102** : 1 m long,
- TSX CDP 202** : 2 m long,
- TSX CDP 302** : 3 m long.

E

4.4-3 Connection cable, 22 gauge (0.34 mm²)

This is used to connect I/O of modules with HE10 connectors to connection and adaptation interfaces using TELEFAST 2 rapid wiring. This cable has 2 insulated HE10 connectors and a cable with 0.34 mm² wires for higher currents (<500 mA).

Five kinds are available :

- TSX CDP 053** : 0.5 m long,
- TSX CDP 103** : 1 m long,
- TSX CDP 203** : 2 m long,
- TSX CDP 303** : 3 m long,
- TSX CDP 503** : 5 m long.

4.5 Module display :

TSX CTY 2A/4A modules have indicator lamps which display the status of the module and the channels.

- Module status indicator lamps (RUN, ERR, I/O)

The state of the three indicator lamps on the front panel signal the module operating mode (indicator lamp off, flashing or on) :

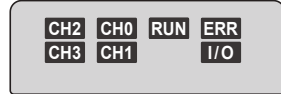

- RUN indicator lamp : signals the module operating status,
- ERR indicator lamp : signals an internal fault on the module,
- I/O indicator lamp : signals an external fault.

- Channel status indicator lamps (CH.)

TSX CTY 2A/4A modules have 2 or 4 indicator lamps which display and diagnose the status of each channel. These indicator lamps are green.

Indic. lamps \ State	On	Flashing	Off
	●	⊗	○
RUN	Module running	—	Module faulty or switched off
ERR	Internal fault module failure	Communication fault	No fault
I/O	External fault <ul style="list-style-type: none"> wiring fault encoder power supply fault measurement overrun Application fault	—	No fault
CH. TSX CTY 2A : CH0 and CH1 TSX CTY 4A : CH0, CH1, CH2, CH3	The channel is operating perfectly	The channel is not operating correctly due to : <ul style="list-style-type: none"> an internal fault, an external fault, a communication fault, an application fault. 	The channel is not operating, No configuration or incorrect configuration.

Setup

Part F

Section	Page
1 Presentation	1/1
1.1 Introduction	1/1
1.1-1 Axis control range	1/1
1.1-2 Set of two components	1/1
1.1-3 Setup software	1/2
1.2 Physical description	1/3
2 Functions	2/1
2.1 Functions	2/1
2.1-1 Configuring the axes	2/2
2.1-2 Adjusting the axes	2/3
2.1-3 Debugging	2/4
3 Setup	3/1
3.1 Setup	3/1
3.1-1 Basic configuration required	3/1
3.1-2 Installation procedure	3/1
3.1-3 General wiring instructions	3/1
3.2 Choice of encoder	3/2
3.2-1 Output interface	3/2
3.2-2 Encoder power supply	3/2
3.2-3 Shielding	3/2
3.3 Connecting the speed reference signals	3/3
3.3-1 Signal referencing	3/3
3.3-2 Connecting using a TSX CAP S9	3/3
3.3-3 Connecting using a TSX CDP 611 cable	3/4
3.3-4 Connecting to terminals with the Telefast pre-wired system	3/5
3.3-5 TAP MAS connection box	3/7
3.3-6 Connecting speed drives using the TAP MAS connection box	3/8

Setup

Part F

Section	Page
3.4	Connecting counter signals 3/9
3.4-1	Signal referencing 3/9
3.4-2	Connecting an incremental encoder 3/10
3.4-3	Connecting an SSI absolute encoder 3/11
3.4-4	Connecting encoder supplies 3/12
3.5	Wiring accessories 3/13
3.5-1	Encoder connection accessories 3/13
3.5-2	Mounting the TSX TAP S15 05 3/15
3.6	Connecting sensors, preactuators and supplies without a speed drive 3/18
3.6-1	Signal referencing 3/18
3.6-2	Telefast connection and wiring accessories 3/19
3.6-3	Signal availability on the TELEFAST screw terminal block 3/20
3.6-4	Connecting via TSX CDP 301 or 501 cable 3/23
3.6-5	Wiring precautions 3/24
3.7	Connecting speed drive command signals 3/26
3.7-1	Signal referencing 3/26
3.7-2	Connecting using the TELEFAST pre-wired system 3/27
3.7-3	Correspondence between TELEFAST terminal blocks and HE10 connector 3/28
3.8	Module electrical characteristics 3/29
3.8-1	General characteristics 3/29
3.8-2	Analog output characteristics 3/30
3.8-3	Counter input characteristics 3/30
3.8-4	Auxiliary input characteristics 3/33
3.8-5	Reflex output Q0 characteristics 3/34
3.8-6	Monitoring the sensor / preactuator voltage 3/35
3.8-7	Speed drive control input characteristics 3/36
3.8-8	Relay output characteristics 3/37
3.9	Module display : 3/38

Setup

Part F

Section	Page
4 Appendix	4/1
4.1 Appendix	4/1

Setup

Part F

F

1.1 Introduction

1.1-1 Axis control range

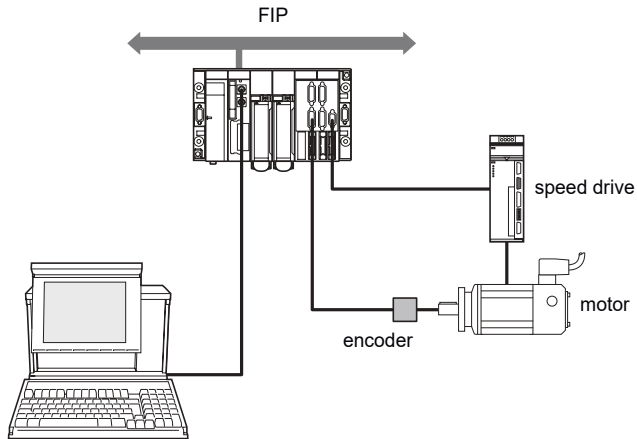

The servo-loop positioning axis control range for TSX model 57 PLCs is designed to meet the requirements of machine manufacturers. It is designed for machines which require high-performance motion control together with simultaneous sequential control via a PLC. The range is used to control movements on a restricted independent axis or on an infinite linear axis.

1.1-2 Set of two components

Multi-axis control module

There are two modules :

- a single format, 2-axis module with input for incremental encoder or SSI serial interface absolute encoder.

TSX CAY 21

- a double format, 4-axis module with input for incremental encoder or SSI serial interface absolute encoder.

TSX CAY 41

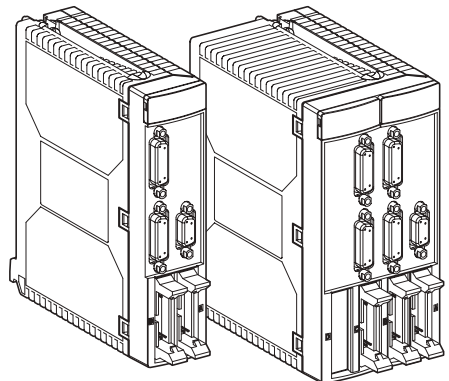

1.1-3 Setup software

The SMOVE function integrated in the PL7 Junior software is used to execute movements. A detailed screen can be called up in SMOVE. The function library provides user-friendly assistance for entering SMOVE function parameters.

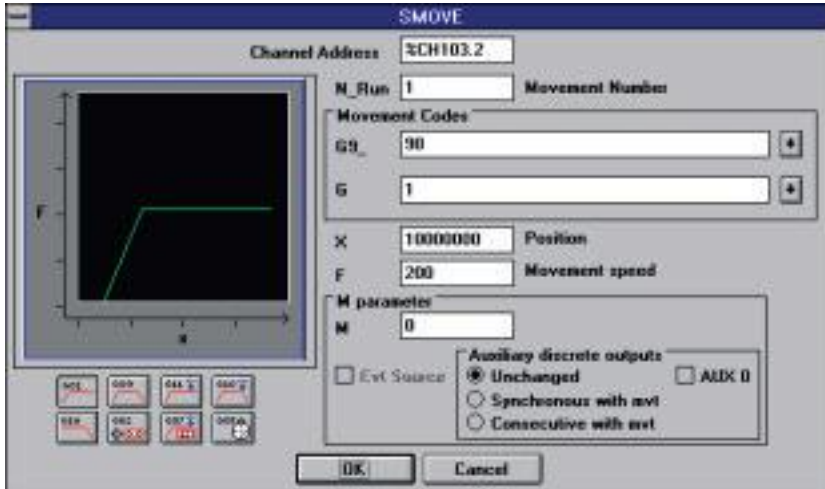

Screens for adjusting the axis parameters and setting up movements can be accessed via the PL7 Junior software.

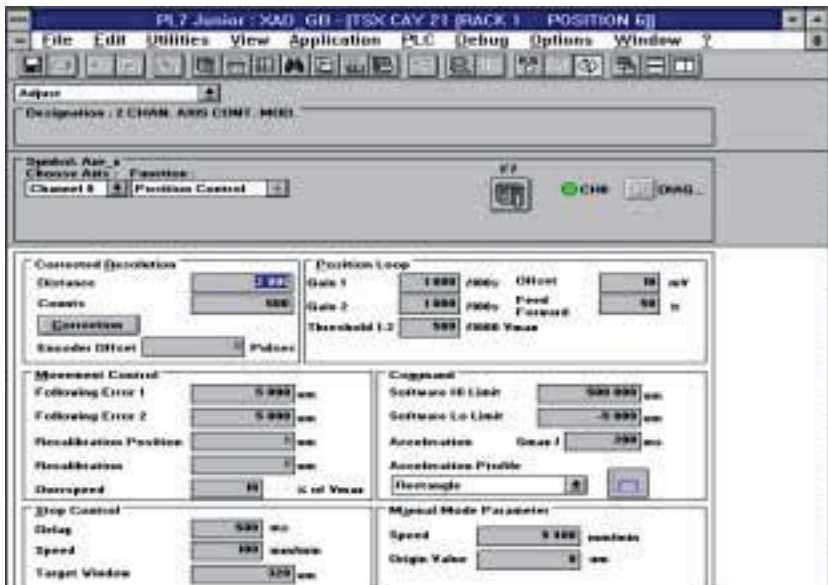

1.2 Physical description

TSX CAY 21 and TSX CAY 41 axis control modules comprise :

TSX CAY 21

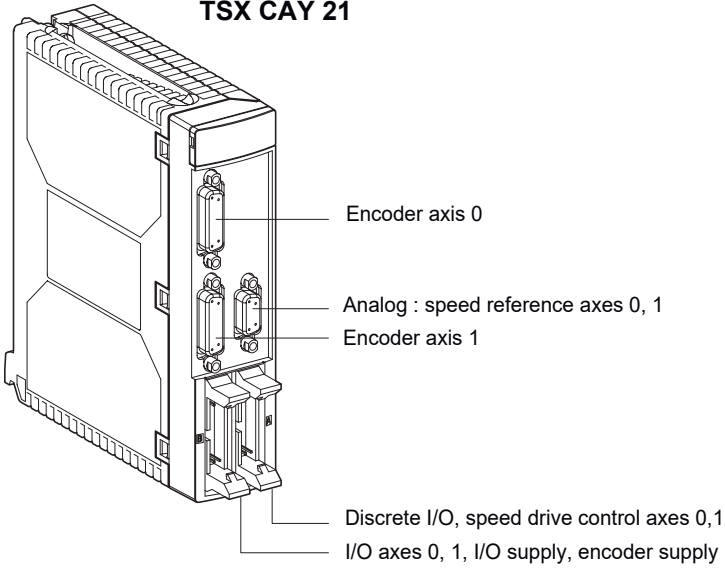

TSX CAY 41

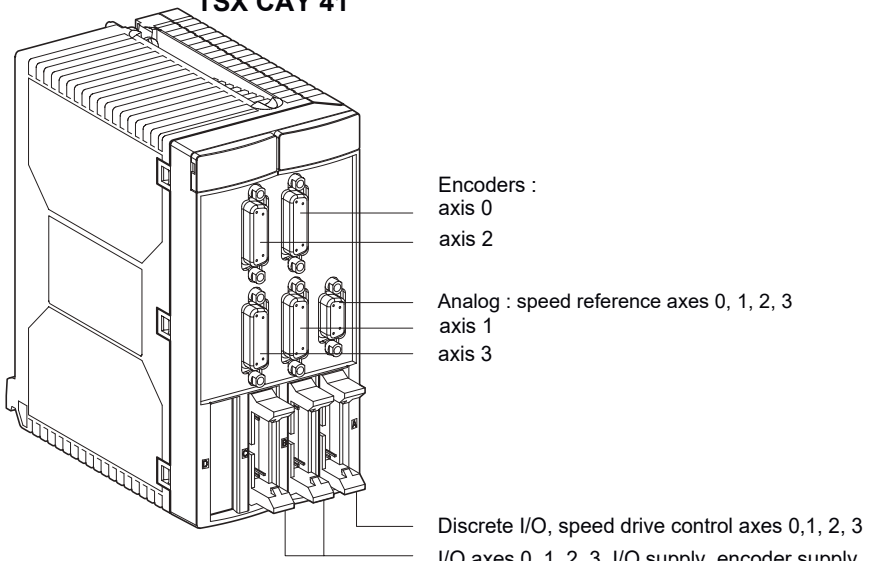

2.1 Functions

Block diagram of an axis control system

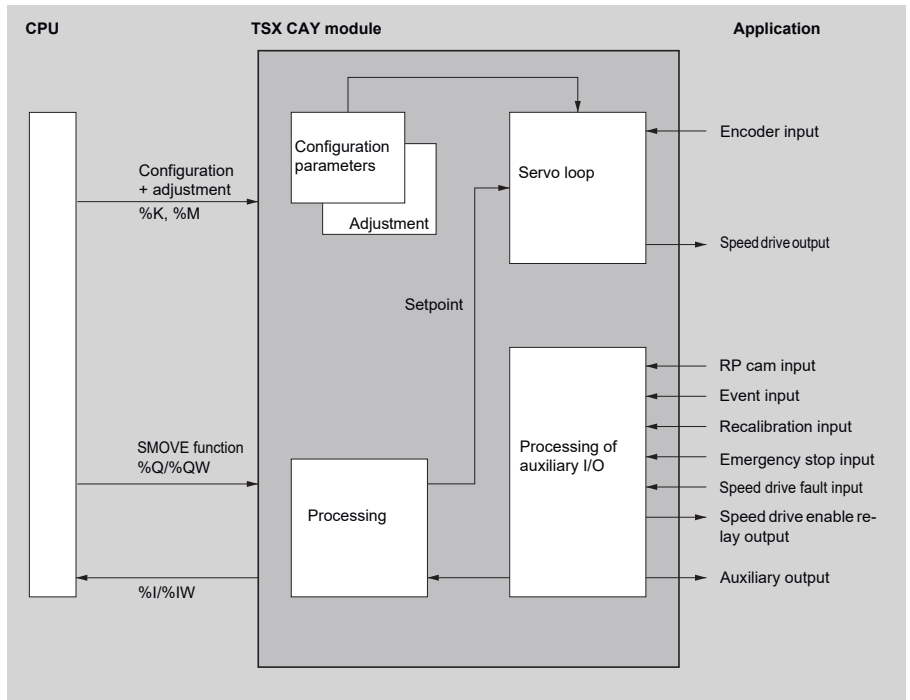

Axis control modules provide the following functions for each axis :

- Inputs

- input for reading position measurements :
 - incremental encoder, type RS 485 or 5V totem pole
 - absolute encoder, type SSI serial interface, 16 to 25 data bits
- machine reference point input
- event input
- speed drive fault input
- recalibration input
- emergency stop input

- Outputs

- isolated $\pm 10V$ analog output, resolution 13 bits + sign, to control the speed drives.
- speed drive enable relay output
- auxiliary solid state output

Processing commands :

Each movement, controlled by the PLC sequential program, is described by an SMOVE movement command function in PL7 language. The TSX CAY 21/41 module uses this SMOVE command to calculate a position / speed reference.

PL7 screens make it easy to configure, adjust and debug the axes.

2.1-1 Configuring the axes

This screen is used to enter the parameters required to adapt the module operation to the machine characteristics. These parameters are : type of encoder, position limits, maximum speed, etc. They cannot be modified by the program. There is no default configuration.

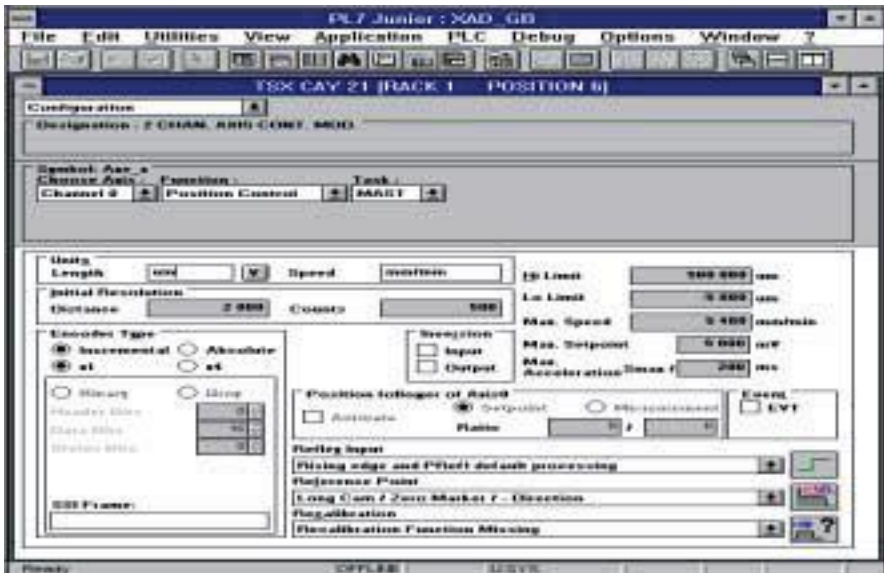

F

2.1-2 Adjusting the axes

These parameters are linked to operation of the axes. The parameters are adjusted online or offline.

The operating parameters are :

- corrected resolution
- movement control : deviation, recalibration, overspeed, etc.
- stop control : time, speed, target window
- position loop : position gain, feedforward coefficient, offset
- command : soft limits, acceleration, acceleration profile
- manual mode parameter : speed, reference point value, etc.

These parameters can be modified by the program.

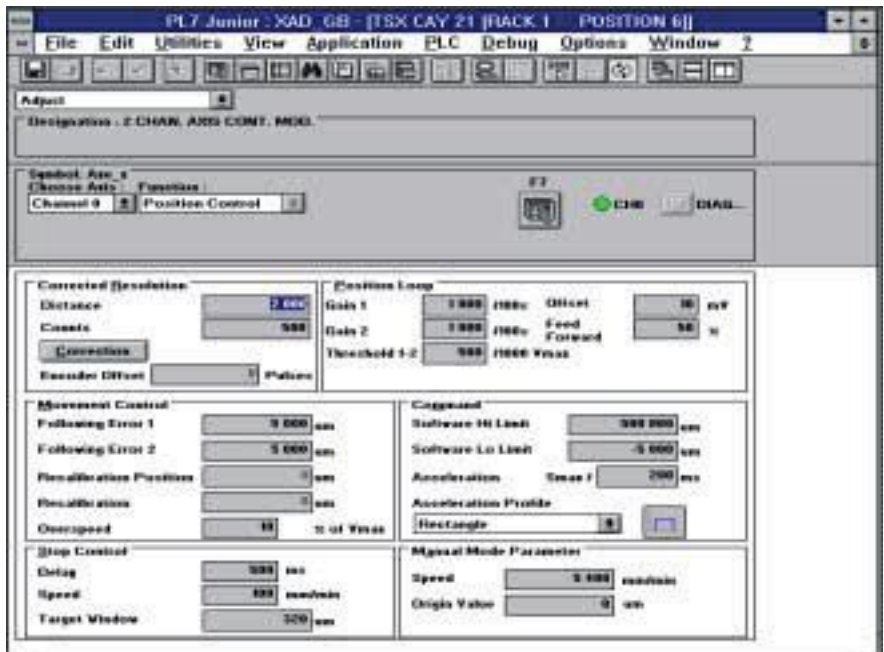

The screenshot shows the 'Adjust' window in the PL7 Junior software. The window title is 'PL7 Junior : XAD_GB - [TSX CAY 21 [RACK 1 POSITION 6]]'. The menu bar includes 'File', 'Edit', 'Utilities', 'View', 'Application', 'PLC', 'Debug', 'Options', and 'Window'. The toolbar contains various icons for navigation and control. Below the toolbar, there is a section for 'Designation : Z.CHAN, ADD CONT. MOD.' and a 'Send to Axis' section with 'Channel 0' selected and 'Position Control' as the mode. The main area is divided into several parameter groups:

- Corrected Resolution:** Distance (2.000), Counts (500), Resolution Offset (0).
- Position Loop:** Gain 1 (1.000), Offset (10), Gain 2 (1.000), Feed Forward (50), Threshold 1-2 (500).
- Movement Control:** Following Error 1 (5.000), Following Error 2 (5.000), Recalibration Position (0), Recalibration (0), Overspeed (10).
- Command:** Software Hi Limit (500.000), Software Lo Limit (-5.000), Acceleration (200), Acceleration Profile (Rectangle).
- Stop Control:** Delay (500), Speed (100), Target Window (500).
- Manual Mode Parameter:** Speed (5.000), Origin Value (0).

2.1-3 Debugging

Debug mode can be accessed online. It is used to control and observe axis behavior. The data and commands differ depending on the operating mode selected :

- automatic mode
- manual mode
- direct drive mode
- measurement mode (Off)

The upper area of the screen gives information about the module operating status and its diagnostics. The lower area of the screen gives access to the commands and information about the operation of movements, I/O, faults, etc.

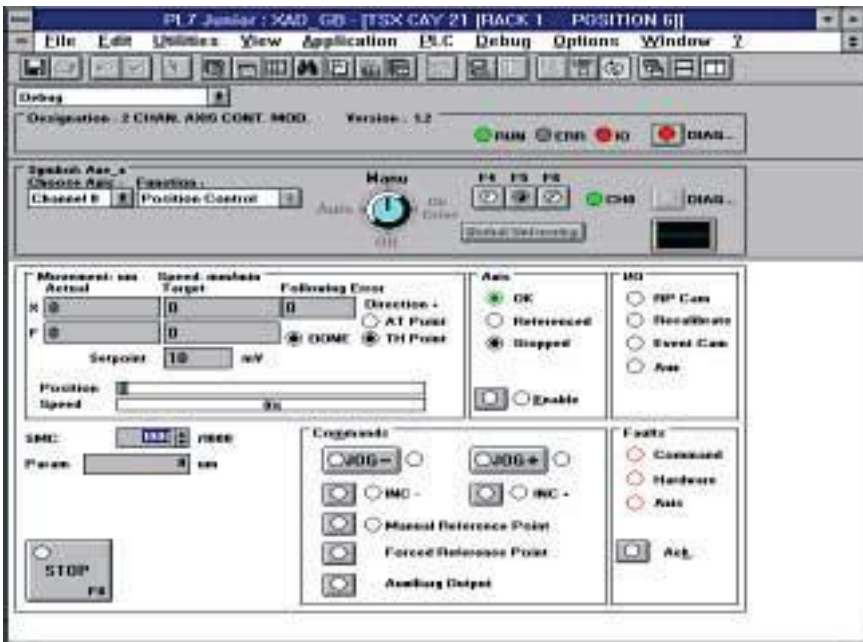

F

3.1 Setup

3.1-1 Basic configuration required

The servomotor axis control modules can be installed in any slot of a TSX 57 rack. The power supply to the rack must be chosen according to the number of modules installed. A TSX 57-10 processor can control a maximum of 2 intelligent modules (CTY, CAY, etc); a TSX 57-20 processor can control up to 6 intelligent modules.

3.1-2 Installation procedure

It is possible to install or remove a module without switching off the supply voltage to the rack. The module design enables this operation to be executed while powered up to ensure a device remains available for use.

Connection or disconnection of connectors with sensor supplies is however not recommended, as this is not possible with certain encoders. The auxiliary I/O connectors can be disconnected while powered up without damaging the module. Nevertheless, for the safety of personnel it is recommended that auxiliary supplies are switched off before any disconnection.

The module and connector fixing screws must be tightened correctly in order to obtain good electrical contacts, thus ensuring good protection against electrostatic and electromagnetic interference.

3.1-3 General wiring instructions

The sensor and actuator supplies must be protected against overloads or overvoltages by fast-blow fuses.

Use wires with an adequate cross-section to avoid line voltage drops or overheating. Keep sensor and actuator cables away from any source of radiation caused by high-power electrical circuit switching.

All cables connecting absolute or incremental encoders must be shielded. Shielding must be of high quality and connected to the machine ground at both the module and encoder ends. There must be continuity along the entire length of the connections. Only encoder signals should be carried on the cable.

For performance reasons, module auxiliary inputs have short response times and it is thus important that these inputs have an adequate independent supply to ensure that the module continues to operate correctly in the event of brief power outage. It is recommended that regulated supplies are used as they ensure the consistency of actuator and sensor response times. The supply 0V must be connected to the machine ground as near as possible to the supply output.

3.2 Choice of encoder

3.2-1 Output interface

The output interfaces of incremental encoders or pulse generators are :

- RS 422/485 standard output, two push-pull outputs complemented by signal
- 5V Totem Pole output, two complemented push-pull outputs.

The SSI-type serial absolute encoders have a standard RS485 interface for clock and data signals.

We recommend using an encoder with an opto type "CLOCK" signal input stage.

3.2-2 Encoder power supply

The module is designed to supply either 5V or 24V encoders. It is possible to mix supply voltages on all module channels.

Incremental encoders generally have a 5V supply.

SSI-type absolute encoders often have a 24V supply (10/30V).

5V encoder supply : maximum voltage drop

It is necessary in this case to take into account the line voltage drop, which depends on the cable length and the encoder consumption for a given wire gauge.

Example for a 100m cable :

Wire cross-section	Voltage drop for a 100m cable			
	50mA	100mA	150mA	200mA
Encoder consumption				
28-gauge = 0.08 mm ²	1.1V	2.2V	3.3V	4.4V
22-gauge = 0.34 mm ²	0.25V	0.5V	0.75V	1V
0.5 mm ²	0.17V	0.34V	0.51V	0.68V
1 mm ²	0.09V	0.17V	0.24V	0.34V

24V encoder supply

This type of encoder is recommended as there is no need for a precise supply (10V/30V). With a 24V power supply these encoders can use a very long cable, and the voltage drop along the cable is very small. This is the case with SSI-type serial link encoders.

If an SSI-type 24V serial absolute encoder is used it is not necessary to connect it to the 5V supply.

The 24V supply must be reserved for the encoders. The supplies must be able to operate independently for a sufficient length of time to power the encoder during microbreaks (≥ 10 ms).

3.2-3 Shielding

To ensure correct operation when the environment is subject to interference, it is necessary to choose an encoder with a metal coating referenced to machine ground of the connected equipment. The encoder must provide ground connection to the connection cable shielding.

3.3 Connecting the speed reference signals

3.3-1 Signal referencing

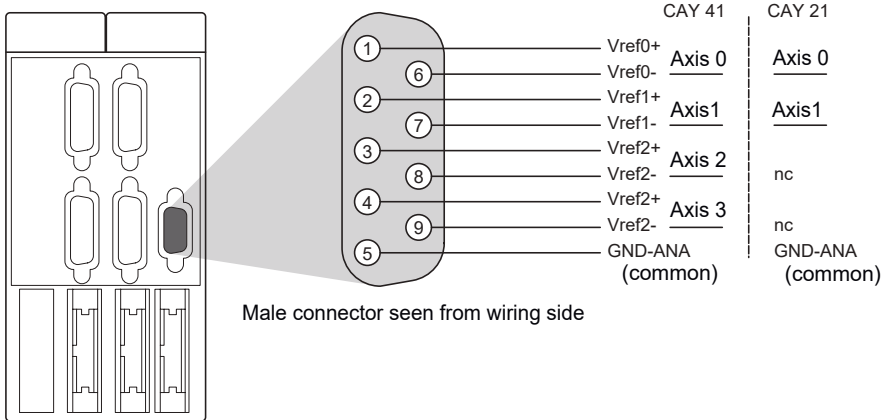

Connection of speed references :

There are four types of connection

- wiring with TSX CAP S9 connector and cover
- using a TSX CDP 611 cable
- wiring with output on terminal with Telefast ABE-7CPA01
- wiring with output to TAP MAS (distribution box)

3.3-2 Connecting using a TSX CAP S9

The user makes the connection by soldering directly onto the 9-pin Sub-D connector as shown in 3.3-1. Ensure that the cable shielding is correctly tightened onto the connector cap.

3.3-3 Connecting using a TSX CDP 611 cable

This pre-wired cable consists of a 9-pin Sub-D connector for connection to the TSX CAY 21/41 module end with flying leads at the other end. 6m long, it consists of 24-gauge wires which correspond to the pins on the Sub-D connector. It is used to connect devices directly to the module. The various signals are identified using a color code. The shielding must be connected to the machine ground of the connected device.

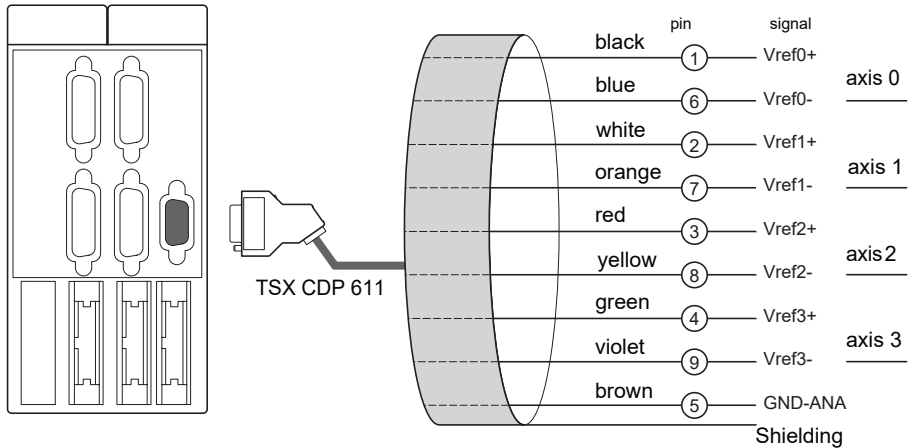

The TSX CDP 611 cable is 6m long.

F

3.3-4 Connecting to terminals with the Telefast pre-wired system

The Telefast 2 system is a range of products used for rapid connection of modules in the TSX Micro and TSX Premium ranges. This system replaces screw terminals and provides a single-wire remote connection.

It is necessary to connect speed references to terminals when the speed drives are not close to each other. The Telefast pre-wired system simplifies setup by giving access to signals via screw terminals. The module is connected to the Telefast (reference ABE-7CPA01) via a cable fitted with a 9-pin Sub-D connector at the module end and a 15-pin Sub-D connector at the Telefast end. This cable may either be a TSX CXP213 or a TSX CXP 613.

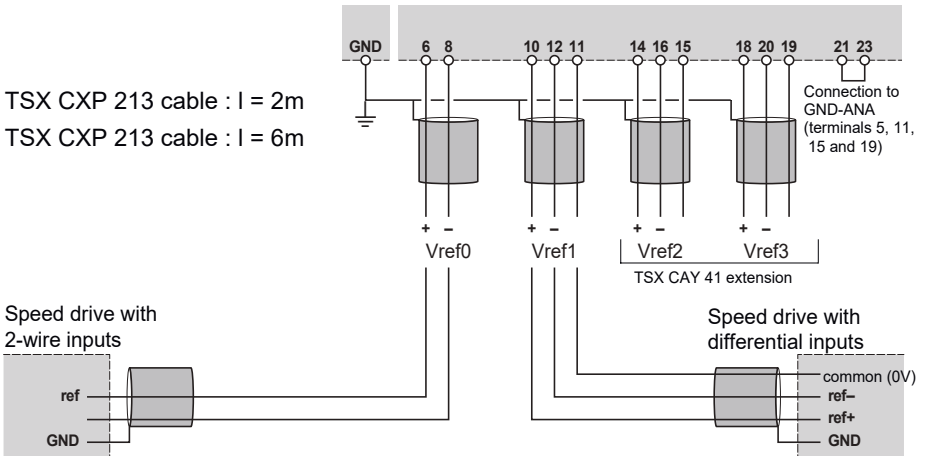
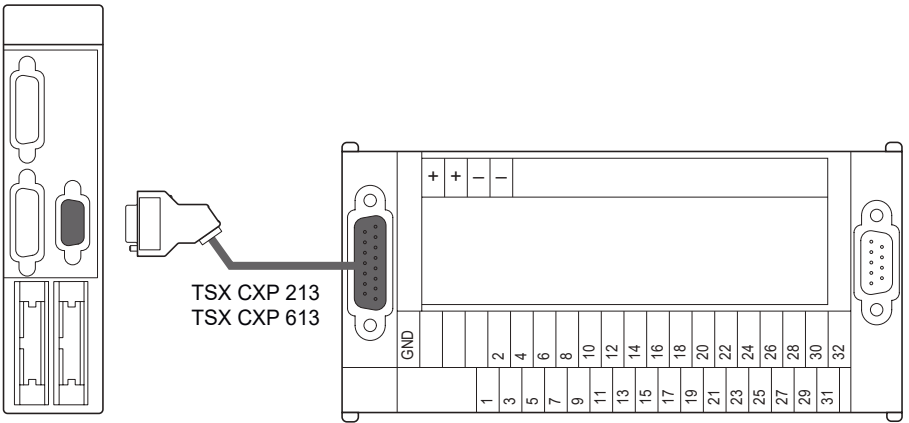

Correspondence between Sub-D connector pins and Telefast terminals

TELEFAST screw terminal (Terminal no.)	15-pin Sub-D connector (Pin no.)	9-pin Sub-D connector for the TSX CAY 21/41 module	Type of signal
2	1		
4	2		
5			
6	10	1	Vref0+
8	3	6	Vref0-
10	11	2	Vref1+
11			
12	4	7	Vref1-
14	12	3	Vref2+
15			
16	5	8	Vref2-
18	13	4	Vref3+
19			
20	6	9	Vref3-
21			connect to terminal 23
22	nc		
23	14	5	GND-ANA
24	nc		
26	nc		
28	nc		
30	nc		
32	nc		

note : nc = not connected

Terminal 23 of the lower Telefast terminal block (GND-ANA) must be connected to terminal 21 in order to distribute the GND-ANA to terminals 5, 11, 15 and 19.

F

3.3-5 TAP MAS connection box

The connection box is used to assign the speed references from each speed drive to a particular port, enabling simple connection of several speed drives while ensuring good ground continuity.

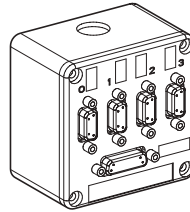

Dimensions and fixing :

The TSX TAP MAS box is installed on an AM1 PA-type perforated plate or on a DIN rail with an LA9 D09976 fixing plate using two M3× 8 or M3×10 screws.

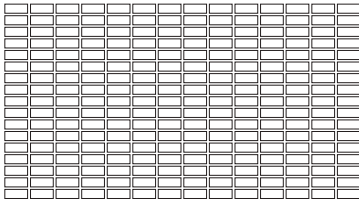

AM1-PA...



AM1-DE/EP

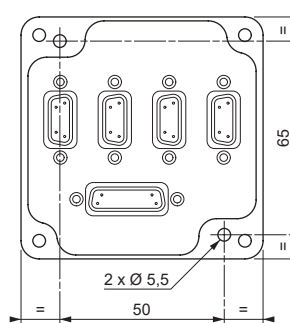

3.3-6 Connecting speed drives using the TAP MAS connection box

NUM MDLA modular speed drives can be connected to the TSX CAY21/41 module using a TSX TAP MAS connection box. Setup is simplified by the use of predefined cables and the connection box which directs the voltage references of the different axes in a simple manner.

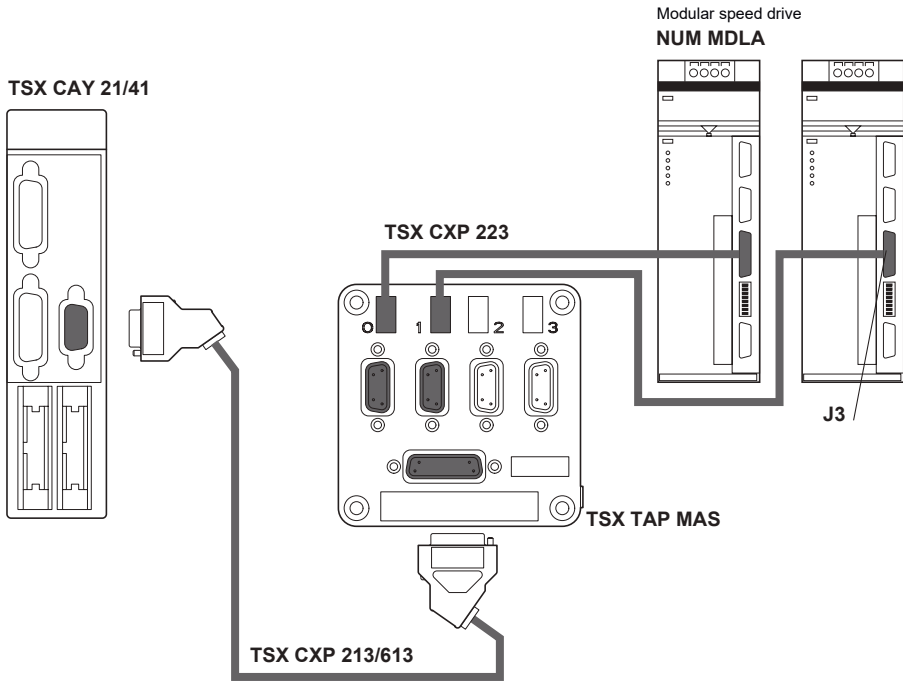

Cables :

TSX CXP 223 : length = 2.5m

TSX CXP 213 : length = 2.5m

TSX CXP 613 : length = 6m

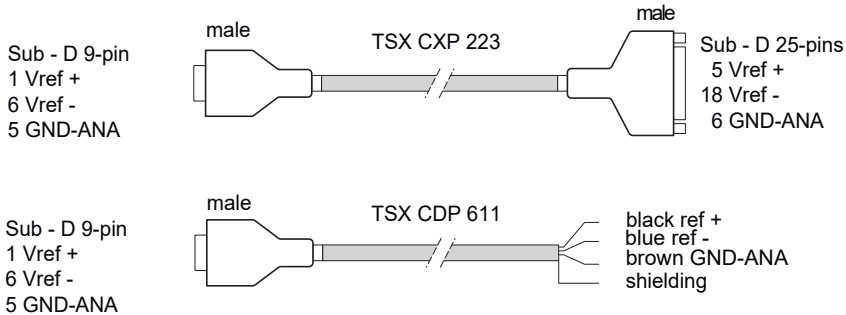

3.4 Connecting counter signals

To ensure position measurement on a TSX CAY 21/ 41 module, each channel has a connector which is compatible with either incremental encoders or absolute encoders with SSI-type serial link. Each channel may be fitted with an encoder of a different type.

3.4-1 Signal referencing

CAY 21/41 modules can be connected either to incremental encoders or to absolute encoders with SSI-type serial link. In configuration mode the following functions are available.

- Two types of interface are possible for incremental encoders :
 - RS 422/RS485 outputs with two outputs complemented by signal,
 - 5V Totem Pole outputs,
- SSI absolute encoder with RS 485 standard interface.

A 15-pin Sub-D connector is assigned to each channel. It is also used to supply power to the encoder. These supplies are generated via the HE10 connector discrete + supply. The encoder + supply feedback signal from the encoder enables accidental disconnection of the encoder to be detected.

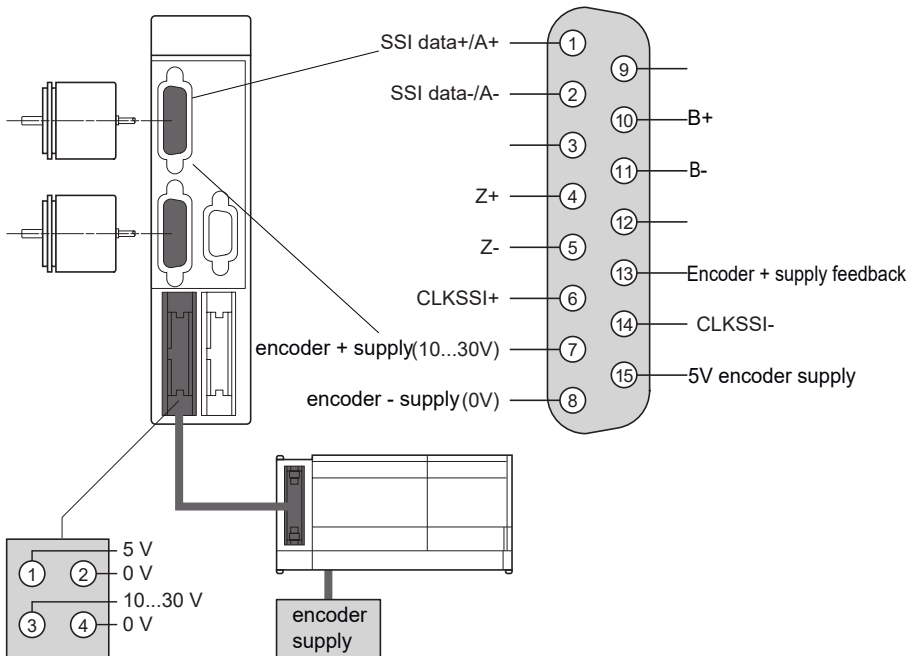

Connections :

Incremental encoder	input A+	1	input B+	10
	input A-	2	input B-	11
	input Z+	4	encoder supply	13
	input Z-	5	feedback	
	SSI absolute encoder	SSI data+	1	Clk data+
	SSI data-	2	Clk data-	14
5V encoder supply				
	+ supply (5V)	15	- supply (0V)	8
Encoder supply (10-30V)				
	+ supply (10-30V)	7	- supply (0V)	8

F

3.4-2 Connecting an incremental encoder

The interface is RS 422 / RS 485 or totem pole type

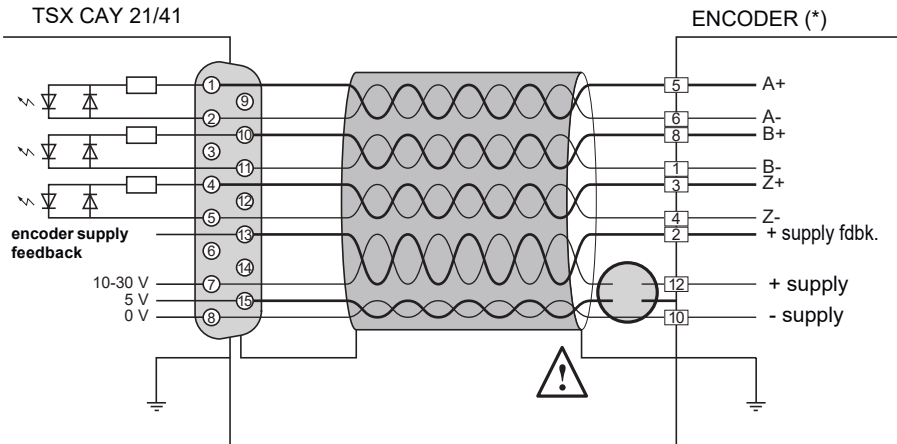

(*) standard pin-out of an encoder with a 12-pin DIN connector.

Each signal (A+,A- for example) must be connected by a twisted pair. To reduce line voltage drops, it is recommended that each supply point is connected through a pair. The cable shielding must be connected to the machine ground at each end.

 The DIN connector encoder + supply input must be connected to the 10-30V supply wire or to the 5V wire depending on the type of encoder used.

3.4-3 Connecting an SSI absolute encoder

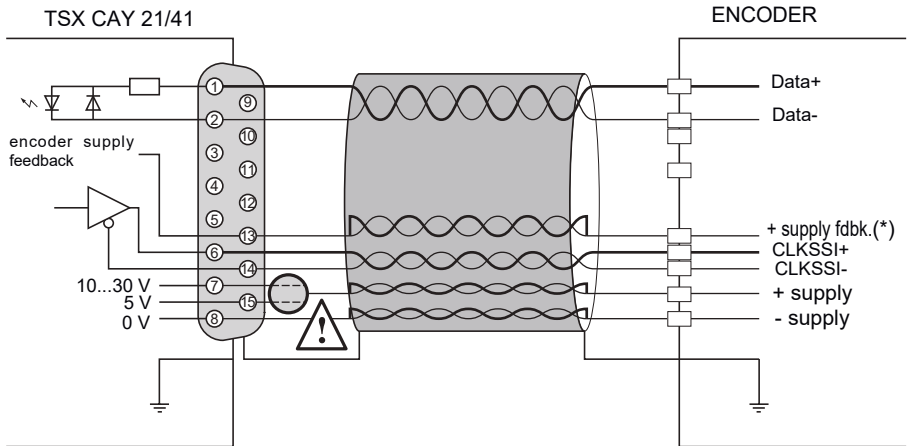

⚠ The encoder supply must be connected to pin number 15 or 7 of the Sub-D connector depending on the encoder supply voltage.

(*) + supply feedback : encoder output which sends the supply voltage to the module enabling the module to detect the presence of the encoder.

3.4-4 Connecting encoder supplies

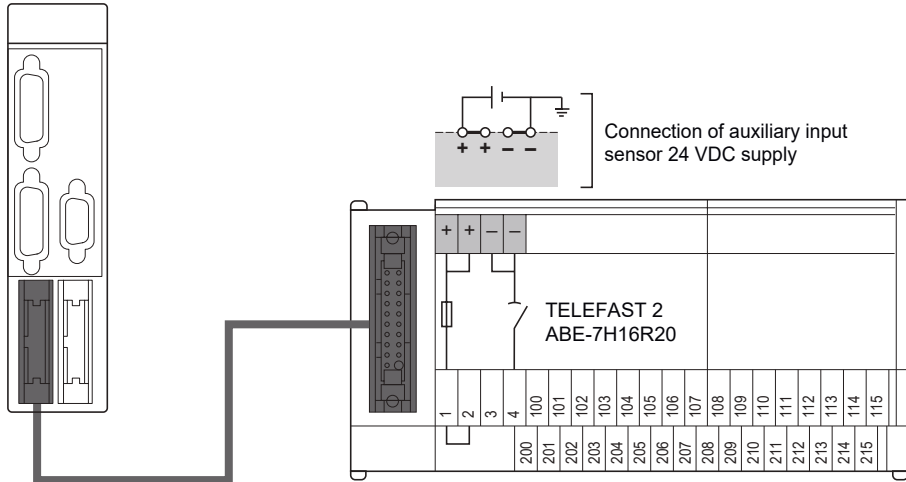

TSX CDP053 / 503 cable

Cable : length :

TSX CDP 053 : 0.5m

TSX CDP 103 : 1m

TSX CDP 203 : 2m

TSX CDP 303 : 3m

TSX CDP 503 : 5m

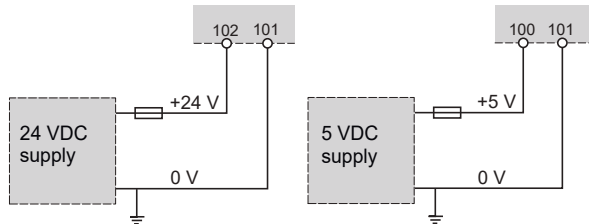

Important : the maximum length of the wires between the supply outputs and the Telefast connecting pins must be less than 0.5m.

Only one supply is necessary if the same type of encoder is used on both channels.

Fuses :

This module has as standard several systems to protect against wiring errors and accidental short-circuits on the cable, such as :

- inversion of supply polarity,
- inversion of 5V <- -> 10/30V supplies,
- 10/30V short-circuit on the CLOCK signal of the serial link.

As the module cannot withstand for any length of time, the fuses must blow very quickly. The fuses must therefore be "fast blow" type with 1A maximum rating. Supplies must have a limit current at such a level that the fuse can blow at the correct point.

3.5 Wiring accessories

3.5-1 Encoder connection accessories

A number of accessories are available to simplify setup and installation. These accessories are used for prewiring the installation.

TSX CAP S15 cover kits with a 15-pin Sub-D connector enable the user to make a direct link to the installation. To simplify installation, the TSX TAP S15 05 provides an interface between the Sub-D connector and the 12-pin DIN connector. This accessory can be fitted on a DIN rail using clips, or in the wall of a cabinet with a seal and locknut. A 2.5m TSX CCP S15 cable is used for connection to the module.

Examples :

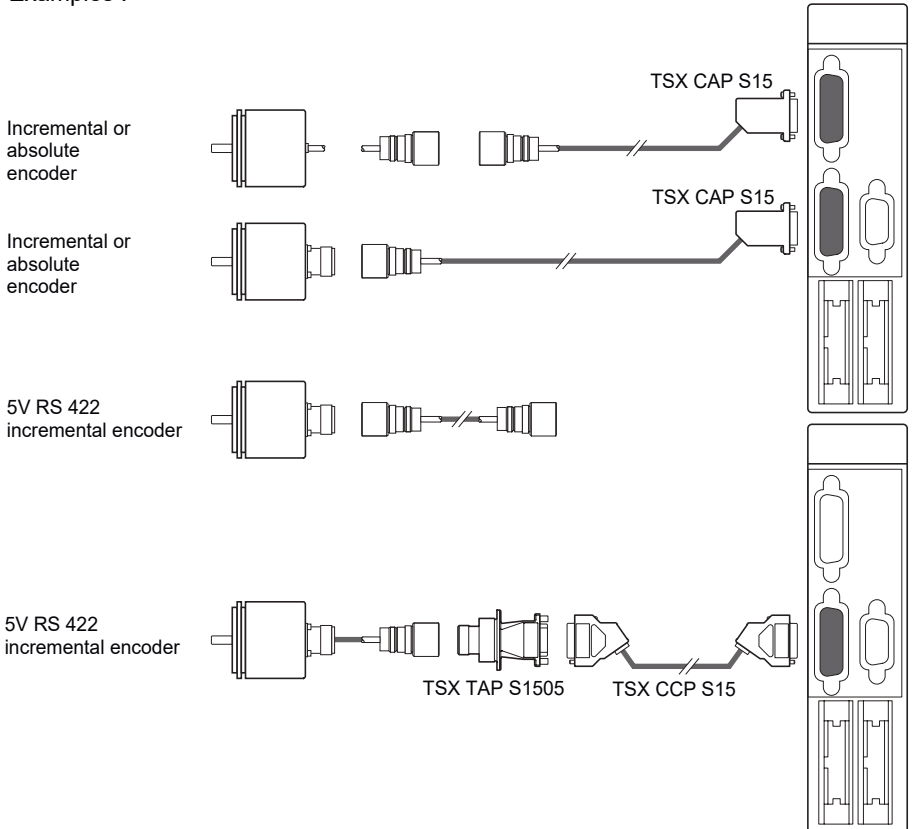

These accessories provide good signal and shielding continuity in adverse conditions. The encoder connection cables are generally offered by the encoder suppliers.

Precision with regard to 12-pin DIN connectors

The pins on these connectors are numbered in two different ways. Most encoders have an integrated 12-pin DIN base which is numbered in an anti-clockwise direction. The TSX TAP S15 has a 12-pin female DIN connector numbered in an anti-clockwise direction. All user leads must be fitted with plugs numbered in a clockwise direction, which means that the pin numbers correspond exactly during wiring.

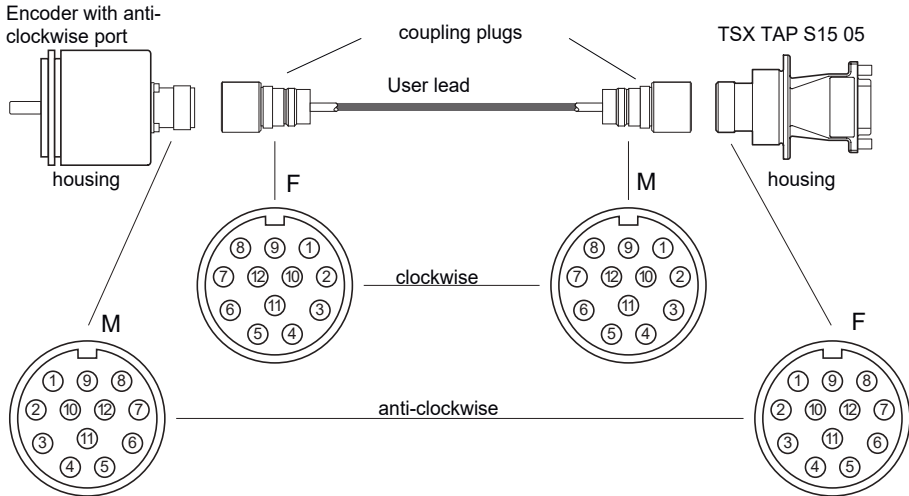

Pin references of the DIN and 15-pin Sub-D connectors on the TSX TAP S15 05

DIN		SUB-D
Pin	Signal	Pin
1	B-	11
2	Supply feedback	13
3	Z+	4
4	Z-	5
5	A+	1
6	A-	2
7	nc	
8	B+	10
9	nc	
10	0V	8
11	nc	
12	5V	15

Shielding must be continuous along the entire length of the connections, which must be connected to the machine ground at both ends.

3.5-2 Mounting the TSX TAP S15 05

Mounting on Telequick plate

The angle bracket supplied is used to fix the TSX TAP S15 05 to an AM1-PA... type perforated plate or to any other support.

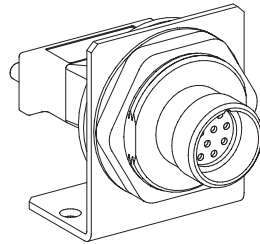
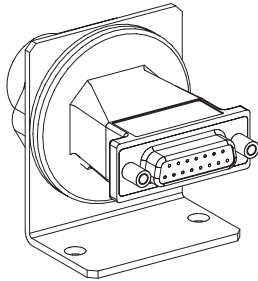

F

Mounting through the wall of a cabinet

The TSX TAP S15 05 can be fitted through the wall of a cabinet using its fixing nut. The seal ensures dust and damp protection between the inside and the outside.

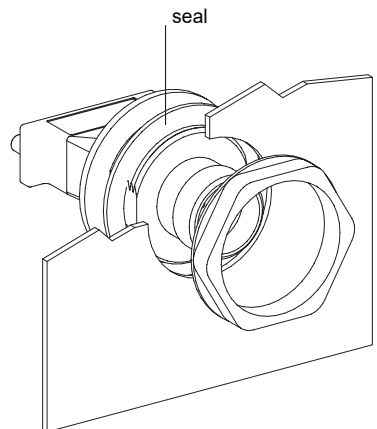
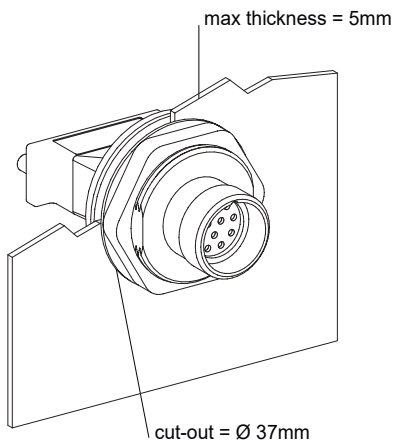

Dimensions :

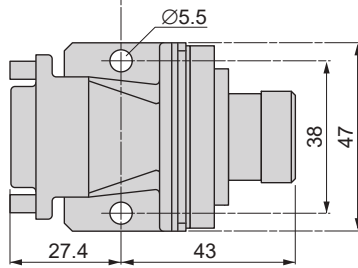
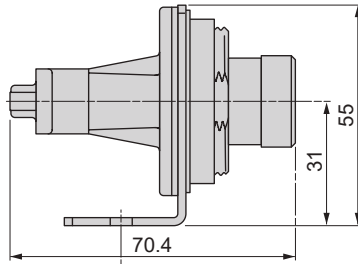

F

Connecting to a NUM MDLA speed drive

The NUM 400V speed drive integrates all of the elements necessary for its operation. To indicate position it has an output whose signals simulate the operation of an incremental encoder. The 2.5m or 6m TSX CXP 233 / 633 cable accessory is used for direct connection.

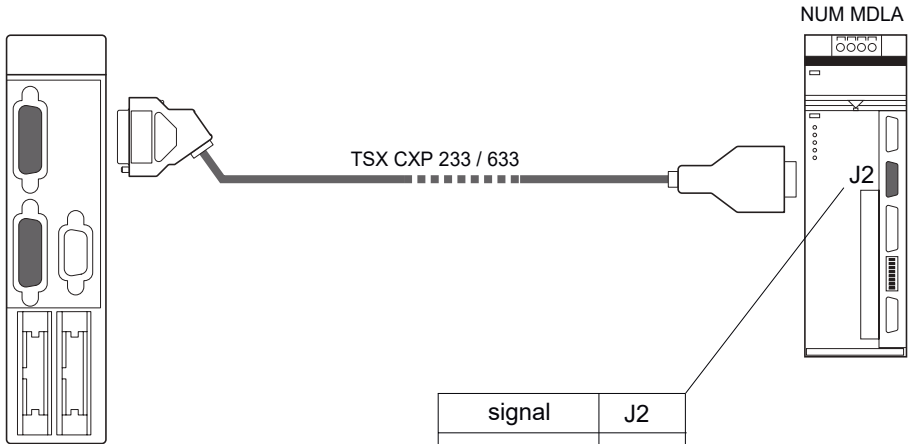

Cable : length :
TSX CXP 213 : 2.5m
TSX CXP 633 : 6m

signal	J2
A+	15
A -	5
B+	14
B -	4
Z+	13
Z -	3
encoder OK	12
OV encoder	8

Note : in this case no encoder supply is necessary.

3.6 Connecting sensors, preactuators and supplies without a speed drive

The TSX CAY 21 / 41 module is fitted as standard with dedicated I/O to ensure full operation of the motion control system, as well as providing the encoder supply.

3.6-1 Signal referencing

The connector is of the high density HE 10 type

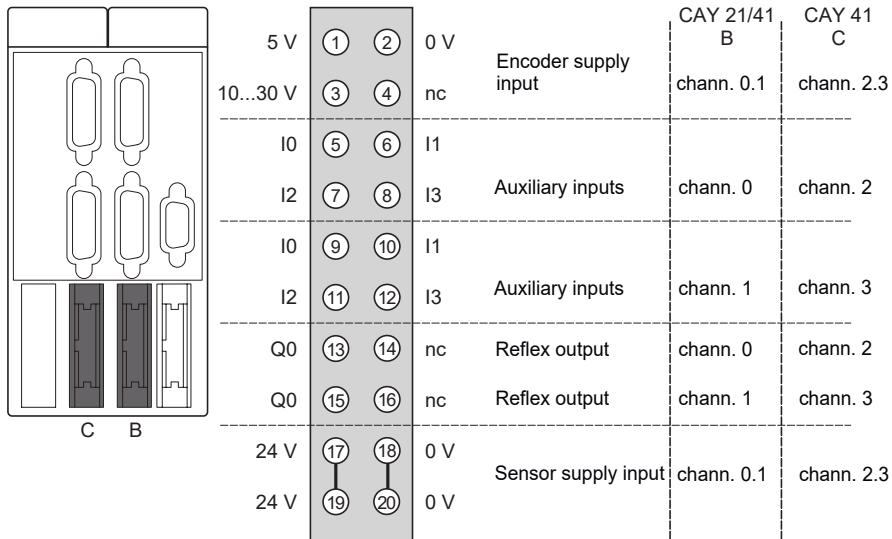

Channels 2 and 3 are assigned to the TSX CAY 41 module

The auxiliary I/Os are assigned to the following functions :

- I0 = reference point cam input,
- I1 = emergency stop input (stop if no current at input),
- I2 = event input,
- I3 = recalibration input,
- Q0 = reflex output (solid state output).
- 0 V = auxiliary inputs and reflex outputs common.

3.6-2 Telefast connection and wiring accessories

To connect this high-density connector, it is recommended to use the Telefast ABE 7H16R20 discrete prewiring accessory together with the TSX CDP 053 / 503 cable, or the 20-wire, 3m TSX CDP 301 or the 5m TSX CDP 501 cables, consisting of an HE10 connector at one end and flying leads at the other.

Wiring with discrete Telefast

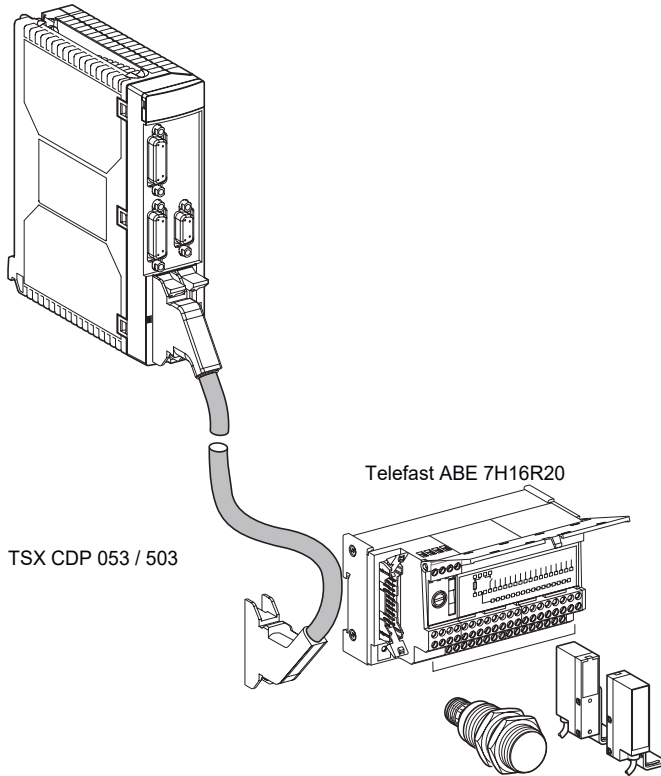

Cable :	length :
TSX CDP 053 :	0.5m
TSX CDP 103 :	1m
TSX CDP 203 :	2m
TSX CDP 303 :	3m
TSX CDP 503 :	5m

3.6-3 Signal availability on the TELEFAST screw terminal block

The terminal block below represents that of the ABE-7H16R20 sub-base. The signals are referenced using cable TSX CDP 053 / 503.

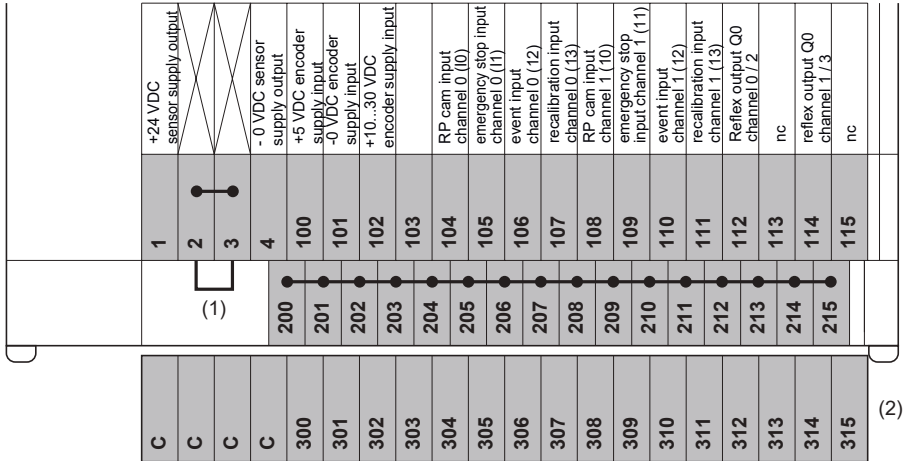

- (1) On the ABE-7H16R20 sub-base, the position of the jumper defines the polarity of all 2•• terminals :
- Jumper in position 1 and 2 : 2•• terminals have + polarity,
 - Jumper in position 3 and 4 : 2•• terminals have - polarity.
- (2) On the ABE-7H16R20 sub-base it is possible to add an optional ABE-7BV20 bar to create a second sensor common (+ or - selected by the user).

Example of connecting sensors on auxiliary inputs and their supplies

This connection is made using a TELEFAST 2 :
ABE-7H16R20 connection sub-base

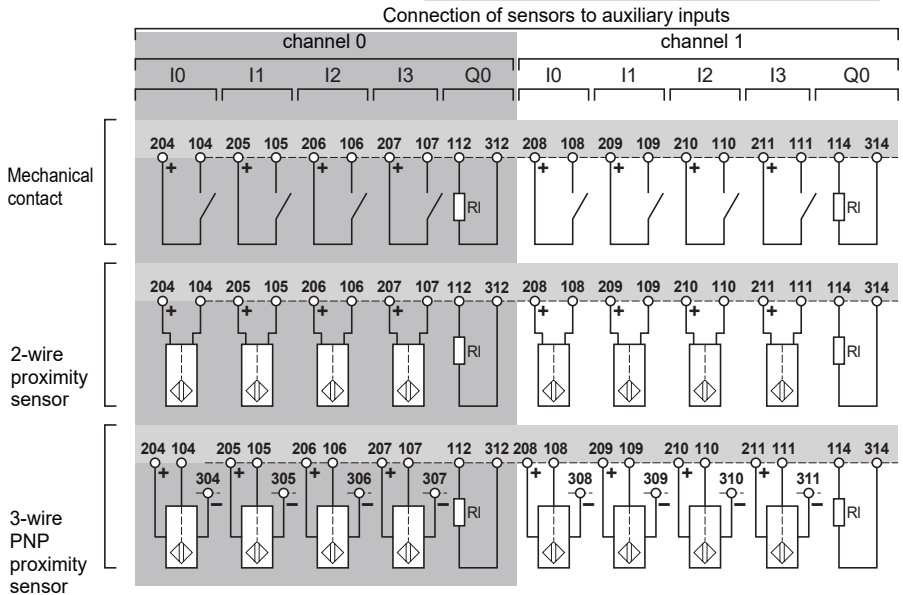
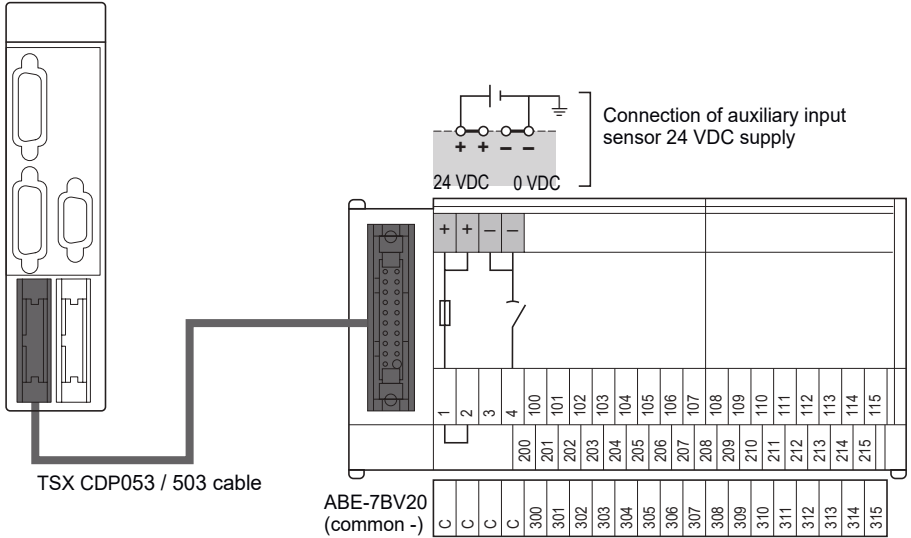

F

Correspondence between TELEFAST terminal blocks and HE10 connector

TELEFAST screw term. blk. (Terminal no.)	20-pin HE10 connector (Pin no.)	Type of signal	
100	1	+ 5 VDC	Encoder supply
101	2	- 0 VDC	
102	3	+ 10...30 VDC	
103	4		
104	5	reference point cam input I0 (channel 0)	Auxiliary inputs channel 0
105	6	emergency stop input I1 (channel 0)	
106	7	event input I2 (channel 0)	
107	8	recalibration input I3 (channel 0)	
108	9	reference point cam input I0 (channel 1)	Auxiliary inputs channel 1
109	10	emergency stop input I1 (channel 1)	
110	11	event input I2 (channel 1)	
111	12	recalibration input I3 (channel 1)	
112	13	reflex output Q0 (channel 0)	
113	14	nc	
114	15	reflex output Q0 (channel 1)	
115	16	nc (1)	
+ 24 VDC	17	Auxiliary input sensor supply	
- 0 VDC	18		
+ 24 VDC	19		
- 0 VDC	20		
1	[All 2● terminals at + 24 VDC	
2			
3	[All 2● terminals at - 0 VDC	
4			
200...215		Connection of sensor commons to : + 24 VDC if terminals 1 & 2 linked - 0 VDC if terminals 3 & 4 linked	
300...315		Terminals may be used as sensor common on optional ABE-7BV20 bar connected by wire to the common voltage.	

note (1) nc = not connected

The same wiring is used in the CAY 41 module for channels 2 and 3.

F

3.6-4 Connecting via TSX CDP 301 or 501 cable

Connecting via these cables gives a direct connection to the actuators, preactuators or terminals. The braid consists of twenty 22-gauge (0.34 mm²) wires, and has an HE10 connector at one end and flying leads at the other, referenced via a color code

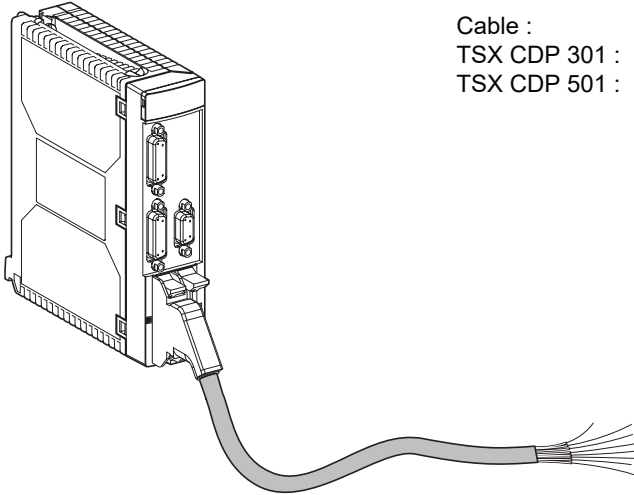

Cable : length :
 TSX CDP 301 : 3m
 TSX CDP 501 : 5m

F

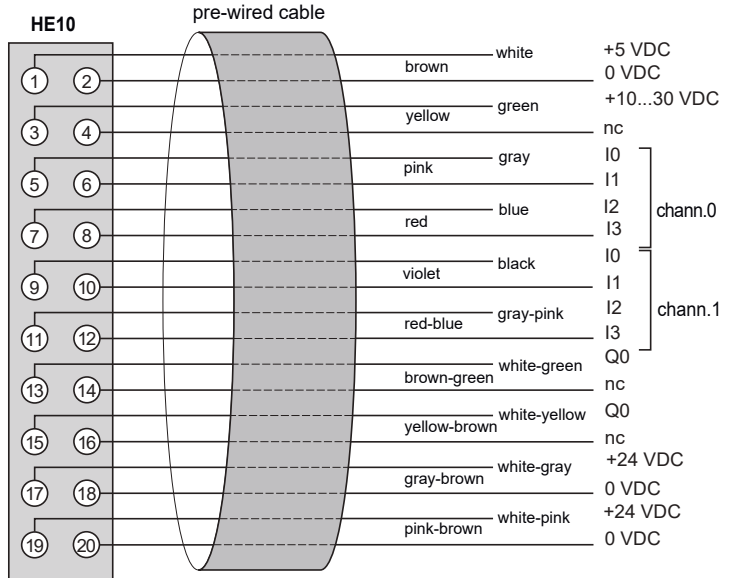

3.6-5 Wiring precautions

Inputs I0, I1, I2 and I3 are fast inputs and must be connected to the sensor by twisted wire if the sensor is volt-free contact type, or by shielded cables if it is a 2-wire or 3-wire proximity sensor.

This module is fitted as standard with devices to protect against short-circuits or voltage inversions. The module cannot however withstand a fault for any length of time and the fuses connected in series with the supplies give effective protection. The fuses must therefore be of the fast blow type with a maximum capacity of 1A. The supplies must provide sufficient power to blow the fuses.

Important note : wiring of solid state outputs Q0

The actuator is connected to output QO at its common point at supply 0V. If for any reason (poor contact or accidental disconnection) there is a break in the supply 0V of the output amplifier while the 0V of the actuators remains connected to the supply 0V, there may be an output current from the amplifier of a few mA which is sufficient to keep certain low-power actuators energized.

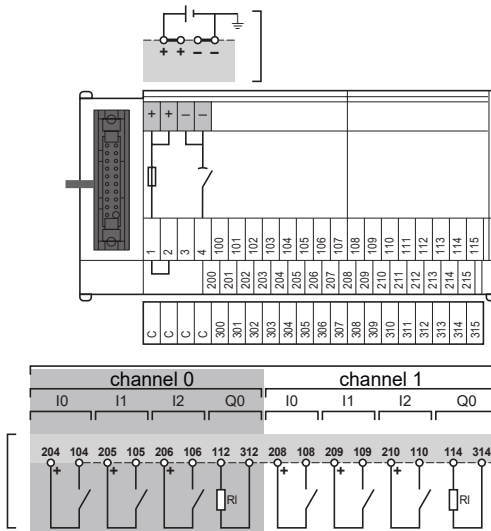

Connecting using Telefast :

This is the most reliable type of connection provided the actuator common is connected to the bar of the 2•• common points (jumper in position 1-2). In this case there can be no break in the module common without breaking the actuator common.

Connecting using TSX CDP 301/501 cable :

This type of connection requires very careful attention. Great care must be exercised during wiring, using for example cable ends at the screw terminals. If required it will be necessary to double up the connections to ensure permanent contacts. When the actuator supply is some distance from the modules and near to the actuator common, the connection between the common and 0V terminal of the module(s) may be accidentally broken.

TSX CAY 21/41

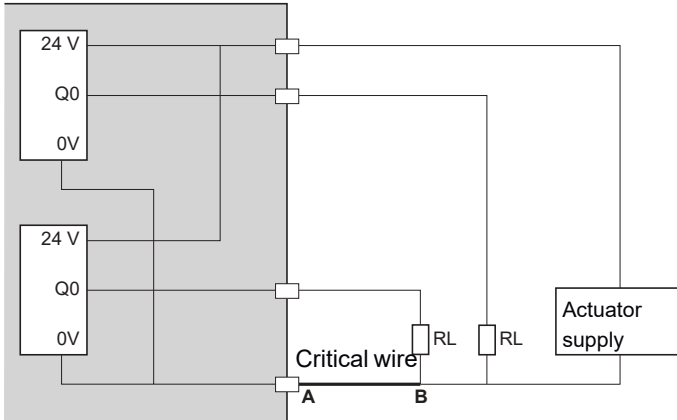

If there is a break in the supply cable segment between A and B, there is a risk of the RL actuators remaining energized. If possible, double the 0V supply connections for the module(s).

With the TSX CDP 301/501 cable :

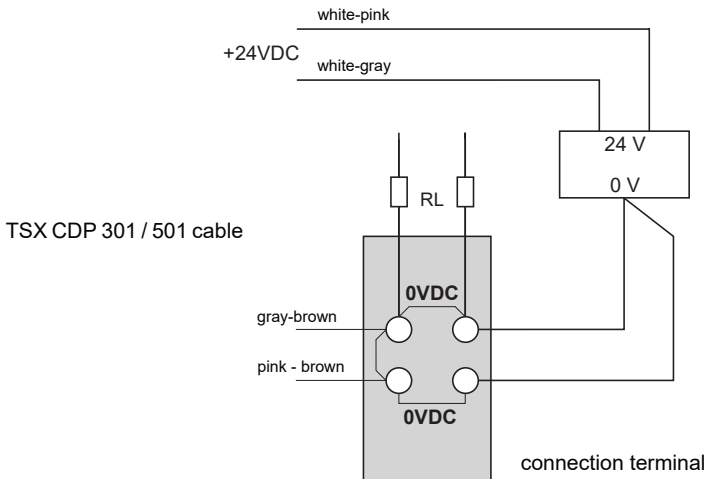

F

3.7 Connecting speed drive command signals

3.7-1 Signal referencing

The TSX CAY 21/41 module manages as standard the signals necessary for correct operation of the speed drives. This connector is used only for management of the 2 channels or 4 channels of the CAY 21/41 module.

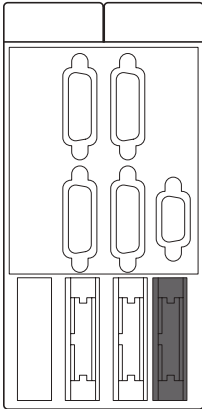

COM0	①	②	VALVAR0	
nc	③	④	COM1	
VALVAR1	⑤	⑥	nc	Relay outputs
COM2	⑦	⑧	VALVAR2	
nc	⑨	⑩	COM3	
VALVAR3	⑪	⑫	nc	
OK_VAR0	⑬	⑭	OK_VAR1	Speed drive command inputs
OK_VAR2	⑮	⑯	OK_VAR3	
nc	⑰	⑱	0 V	24 V common Auxiliary I/O supply
nc	⑲	⑳	0 V	

COM_x - VALVAR_x : volt-free contact for speed drive validation

OK_VAR_x : speed drive command input

24V - 0V sensor supply

Each channel has a volt-free N/O contact.

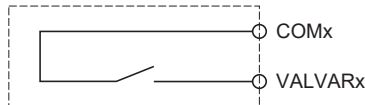

To connect the HE10 connector, use the following wiring accessories : Telefast discrete ABE-7H16R20 with TSX CDP 303 or TSX CDP 503 cable.

3.7-2 Connecting using the TELEFAST pre-wired system

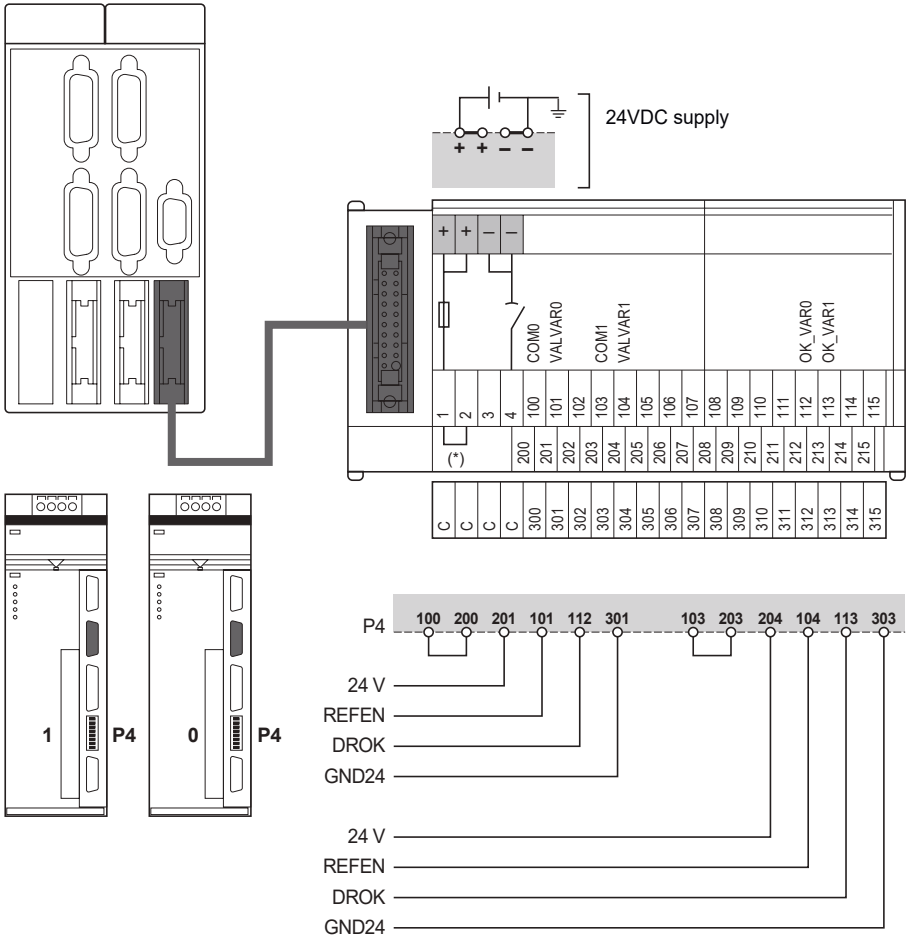

F

For direct connection use a TSX CDP 301 or 501 cable.
See section 3.6-3.

(*) Strap between 1 and 2 : all terminals 200 to 215 are at +24 VDC.

3.7-3 Correspondence between TELEFAST terminal blocks and HE10 connector

TELEFAST screw term. blk. (Terminal no.)	20-pin HE10 connector (Pin no.)	Type of signal	
100	1	COM0	contact closed = speed drive enabled
101	2	VALR0	
102	3	nc	
103	4	COM1	
104	5	VALR1	
105	6	nc	
106	7	COM2	
107	8	VALR2	
108	9	nc	
109	10	COM3	
110	11	VALR3	
111	12	nc	ENCoder OK = encoder supply voltage present
112	13	OK_VAR0	
113	14	OK_VAR1	
114	15	OK_VAR2	
115	16	OK_VAR3	
+ 24 VDC	17	Auxiliary input sensor supply	
- 0 VDC	18		
+ 24 VDC	19		
- 0 VDC	20		
1	[All 2● terminals at + 24 VDC	
2			
3	[All 2● terminals at - 0 VDC	
4			
200...215		Connection of sensor commons to : + 24 VDC if terminals 1 & 2 connected - 0 VDC if terminals 3 & 4 connected	
300...315		Terminals may be used as a sensor common on optional ABE-7BV20 bar	

note (1) nc = not connected

F

3.8 Module electrical characteristics

3.8-1 General characteristics

Maximum counting frequency :

SSI absolute encoder : CLK transmission frequency		200KHz
incremental encoder :	×1	500KHz
	×4	1MHz

Current drawn on internal 5V
(fan running)

	typical	max
CAY 21	1.1A	1.4A
CAY 41	1.5A	1.8A

Current drawn on sensor/
preactuator 24V, outputs OFF

	typical	max
CAY 21	15mA	18mA
CAY 41	30mA	36mA

Current drawn by module on
encoder 10/30V at 24V (2)

	typical	max
CAY 21	11mA	20mA
CAY 41	22mA	40mA

Power dissipated in module

	typical (3)	max (4)
CAY 21	7.2W	11.5W
CAY 41	10 W	17 W

Isolation resistance

> 10 MOhms at 500 VDC

Dielectric strength with ground
or PLC logic 0V

1000 V rms 50 / 60 Hz for 1 min

Operating temperature

0 to 60°C

Storage temperature

-25°C to 70°C

Relative humidity (without condensation)

5% to 95%

Operating altitude

< 2000 m

Note (1) : 250 kHz on input

Note (2) : Use of an absolute encoder and a single supply in 24V

Note (3) : normal conditions of use : one auxiliary input active per channel (at 24 V).

Note (4) : the "worst possibility" and extreme conditions : all auxiliary inputs active (at 30 V).

The module has a small internal fan to ensure correct operation across the whole temperature range. The fan is activated as necessary by a temperature sensor inside the module (triggered at 45 °C external temperature).

It is possible to use TSX FAN external ventilation units if the temperature conditions around the module exceed the parameters above, see section 8 of part A1 of this document.

3.8-2 Analog output characteristics

Parameters	Value	Unit
Range	± 10.24	V
Actual range	± 10.24	V
Resolution	13 bits + sign	
Value of LSB	1.25	mV
Max. current from one output	1.5	mA
Fallback value	max ± 1	LSB
Monotonicity	100	%
Differential linearity	± 2	LSB
Precision	0.5	% F.S.
Dielectric strength between channels and machine ground	1000VAC	

Each output is protected against short-circuits and overloads. If a fault occurs a signal is sent to the CPU via a status word. A short-circuit on these outputs will not damage the module.

The absence of the connector on the analog output is not monitored.

3.8-3 Counter input characteristics

Equivalent circuit diagram :
example of input A

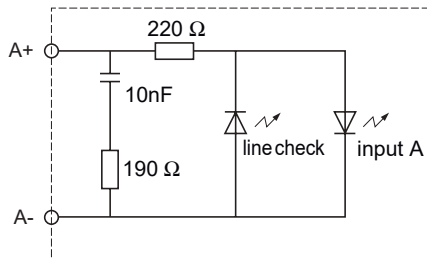

Characteristics for 5V use

Electrical characteristics	Symbol	Value	Unit
Nominal voltage	Un	± 5	V
Voltage limits	U1	± 5.5	V
Nominal current	In	± 18	mA
Input impedance (at 5 V)	Re	270	Ohms
Voltage in "On" state	Uon	$\geq +2.4$	V
Current in "On" state	Ion	$> +3.7$	mA
Voltage in "Off" state	Uoff	< 1.2	V
Current in "Off" state	Ioff	< 1	mA
Encoder / sensor voltage feedback check		Check presence	

F

Compatibility of inputs A, B and Z :

RS 422 / RS 485 line transmitter outputs with 7 mA current loop. Differential line check on each input.

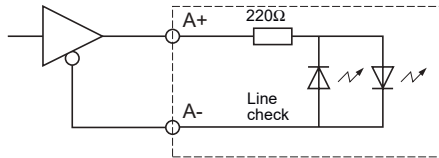

5V supply, totem pole outputs. Differential line check on each input.

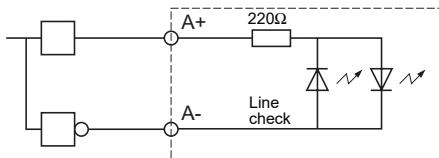

Encoder + supply feedback input characteristics :

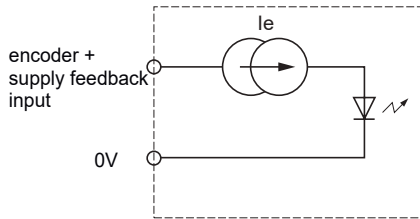

Electrical characteristics	Symbol	Value	Unit
Voltage in "On" state (OK)	U_{ok}	> 2.5	V
Voltage limits	U_{max}	30	V
Input current ($2.5 < U_{ok} < 30$)	I_{max}	3	mA

The presence of the encoder will be detected as long as the input is active.

3.8-4 Auxiliary input characteristics

The auxiliary inputs have a 24V supply from a supply to the connector.

Equivalent circuit diagram :

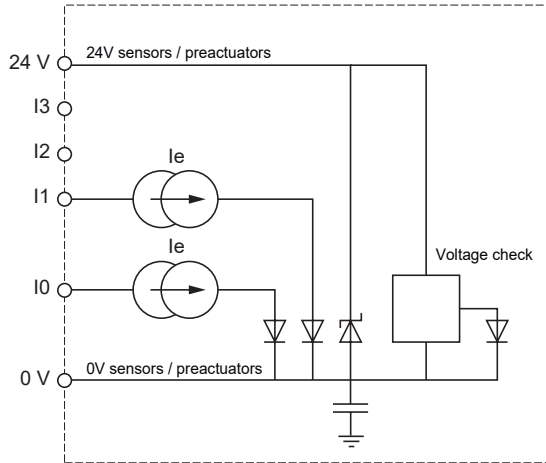

Electrical characteristics	Symbol	Value	Unit
Nominal voltage	U_n	24	V
Voltage limits (1) (including ripple)	U_1	19 to 30	V
	$U_{temp} (*)$	34	V
Nominal current	I_n	8	mA
Input impedance (at U_{nom})	R_e	3	KOHms
Voltage in "On" state	U_{on}	≥ 11	V
Current at U_{on} (11V)	I_{on}	> 6	mA
Voltage in "Off" state	U_{off}	< 5	V
Current at "Off" state	I_{off}	< 2	mA
Immunity Off --> On (for I0, I2 and I3) (for I1)	t_{on}	0.1 to 0.2 1 to 4	ms
Immunity On -->Off (for I0, I2 and I3) (for I1)	t_{on}	0.1 at 0.2 1 to 4	ms ms
Dielectric strength with ground		1500V rms 50 / 60 Hz for 1min	
IEC compatibility with sensors		type 2	
3-wire / 2-wire proximity sensor compatibility		all proximity sensors operating at 24VDC	
Input type		Current sink	
Logic type		Positive (sink)	

3.8-5 Reflex output Q0 characteristics

Each position control channel has an output controlled by the processor which is used for the integrated control of one function of the axis being controlled. For example, control of braking between two movements, safety, etc. This is a solid state output with the load common at the sensor / preactuator 0V voltage. It is protected against overloads and short-circuits, and fault information is provided to the processor if a fault occurs.

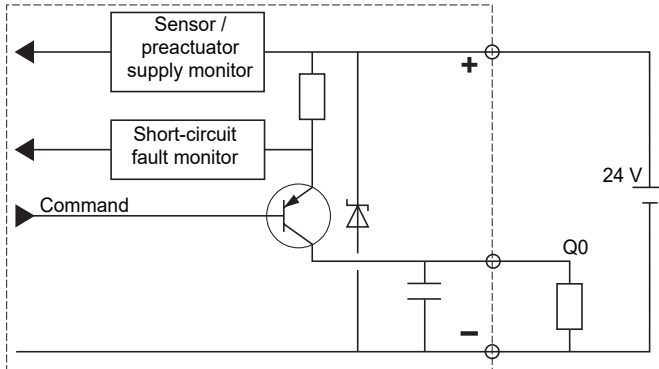

Electrical characteristics	Value	Unit
Nominal voltage	24	V
Voltage limits	19 to 30	V
Max for 1 hour / 24 hrs (Utemp)*	34	V
Nominal current	500	mA
Max voltage drop when "On"	< 1	V
Leakage current	< 0.3	mA
Max current at 30V and at 34V	0.625	mA
Switching time	<500	μs
Dielectric strength with the ground	1500 Vrms 50 / 60 Hz for 1 mn	
Compatible with DC inputs	All positive logic inputs where input resistance is less than 15KOhms	
IEC 1131 compatible	yes	
Short-circuit monitoring on each channel	One signalling bit per channel	

Electrical characteristics	Value	Unit
Reset : • by application program • automatic	one bit per channel written by program	
Protection against overvoltages and short-circuits	Per current limiter and thermal tripping ($0.7 < I_d < 2 A$)	
Protection against channel overvoltages	Zener diode between outputs and +24V	
Protection against polarity reversal	via inverted diode on the supply	
Power of filament lamp	10	W(max)

Note *

Utemp is the maximum voltage which can be applied to the module for 1 hour in one 24-hour operating period.

F

3.8-6 Monitoring the sensor / preactuator voltage

The module monitors the supply to the actuators / preactuators so that it can signal to the processor any malfunction which may cause incorrect operation.

Electrical characteristics	Symbol	Values	Unit
Voltage for OK state	Uok	>18	V
Voltage for fault state	Udef	<14	V
Immunity OK ---> Fault	Im.off	<1	ms
Immunity Fault---> OK	Im.on	<1	ms
Accept fault	Toff	<10	ms
Accept no fault	Ton	<10	ms

3.8-7 Speed drive control input characteristics

The speed drive control auxiliary inputs have the same supply as the speed drive I/O. The module does not monitor this supply, but any voltage drop below 5V on a CTRL_VAR input may signal a speed drive fault to the processor.

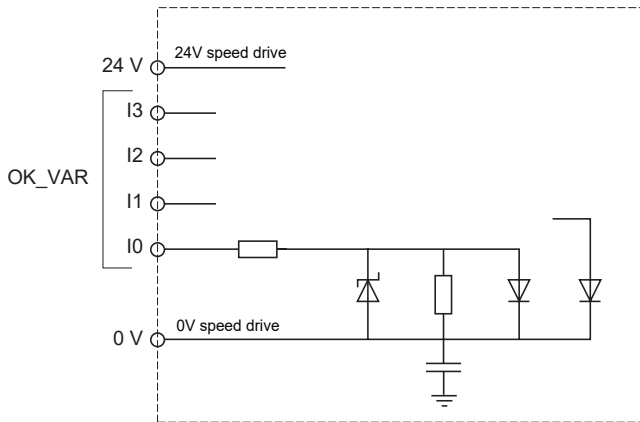

Electrical characteristics	Symbol	Values	Unit
Nominal voltage	Un	24	V
Voltage limits (1) (including ripple)	U1	19 to 30	V
	Utemp (*)	34	V
Nominal current	In	8	mA
Input impedance (at Un)	Re	3	KOhms
Voltage for OK state	Uon	>=11	V
Current at Uon (11V)	Ion	>3.5	mA
Voltage for "Fault" state	Uoff	<5	V
Current at "Fault" state	Ioff	<1.5	mA
Immunity OK --> Fault	toff	1 to 4	ms
Immunity Fault-->OK	ton	1 to 4	ms
Dielectric strength with ground		1500V rms 50 / 60 Hz for 1min	
IEC 1131 compatibility with sensors	type 1		
Logic type	Positive (sink)		

(*) Itemp : maximum voltage permitted for 1 hour in one 24-hour period

3.8-8 Relay output characteristics

Each channel has one relay output.

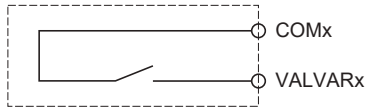

Electrical characteristics	Values	Unit
DC operating voltage	5 to 30	V
Permitted DC switching current 30V on resistive load	200	mA
Minimum permitted load	1V / 1mA	
Switching time	<5	ms
Dielectric strength :		
• between contacts and between channels	300VAC for 1min	
• between contacts and ground	1000VAC for 1 min	

3.9 Module display :

TSX CAY 21/41 modules have indicator lamps displaying the status of the module and the channels.

- Module status lamps (RUN, ERR, I/O)

The state of the three lamps on the front panel (off, flashing or on) indicates the module operating mode :

- RUN lamp : signals module operating state,
- ERR lamp : signals an internal module fault,
- I/O lamp : signals an external fault.

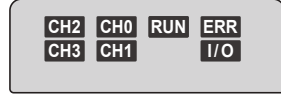

- Channel status lamps (CH.)

TSX CAY 21/41 modules have 2 or 4 indicator lamps to display and diagnose the status of each channel.

These lamps are green.

State Indicators	On ●	Flashing ⊗	Off ○
RUN	Normal operation	—	Module faulty or off
ERR	Internal fault module failure	Communication fault application absent, invalid or faulty execution	No fault
I/O	External fault • wiring fault • encoder supply and 10 / 30V supply fault • absolute encoder fault (*)	—	No fault
CH. TSX CAY 21 : CH0 and CH1 TSX CAY 41 : CH0, CH1, CH2, CH3	Channel is operational	Channel is not operating correctly because of : •an external fault, •a communication fault, •a process fault.	Channel not operating. No configuration or incorrect configuration.

(*) application fault :

4.1 Appendix

List of compatible SSI-type absolute encoders (tested) :

IVO brandname

- GM 400 0 10 11 01
24 Volts, Gray, 0 header bit, 25 data bits, 0 status bit, no parity.
- GM 401 1 30 R20 20 00
24 Volts, Gray, 0 header bit, 25 data bits, 1 status bit, even parity.

Hengstler brandname

- RA58-M/1212
24 Volts, Gray, 0 header bit, 24 data bits, 1 status bit, no parity.

Stegmann brandname

- AG 661 01
24 Volts, Gray, 0 header bit, 24 data bits, 0 status bit, no parity.

Section	Page
1 Presentation	1/1
1.1 Introduction	1/1
1.1-1 Stepper motor axis control range	1/1
1.1-2 Set of two components	1/1
1.1-3 Setup software	1/2
1.2 Physical description	1/3
2 Functions	2/1
2.1 Functions	2/1
2.1-1 Configuring the axes	2/2
2.1-2 Adjusting the axes	2/3
2.1-3 Debugging	2/4
3 Setup	3/1
3.1 Setup	3/1
3.1-1 Basic configuration required	3/1
3.1-2 Installation procedure	3/1
3.1-3 General wiring instructions	3/1
3.2 Choice of translator	3/2
3.2-1 I/O interfaces	3/2
3.2-2 Translator interface power supply	3/2
3.2-3 Shielding	3/2
3.3 Connecting translator signals	3/3
3.3-1 Signal referencing	3/3
3.3-2 Connecting a translator using an RS 422/485 interface	3/4
3.3-3 Connecting a translator using an NPN open collector interface	3/4

Section	Page
3.4 Connecting sensors / preactuators and power supplies	3/5
3.4-1 Signal referencing	3/5
3.4-2 Connections	3/5
3.4-3 Connecting auxiliary I/O to the process	3/6
3.4-4 Connecting using a TSX CDP 301/ 501 cable	3/7
3.4-5 Connecting using the TELEFAST pre-wired system	3/8
3.4-6 Signal availability on the TELEFAST terminal block	3/9
3.4-7 Correspondence between TELEFAST terminal blocks and HE10 connector	3/10
3.4-8 Wiring precautions	3/11
3.4-9 Connecting using a cable	3/12
3.5 Module electrical characteristics	3/13
3.5-1 General characteristics	3/13
3.5-2 Translator input characteristics (Sub-D connector)	3/14
3.5-3 Translator outputs characteristics (Sub-D connector)	3/14
3.5-4 Auxiliary input characteristics (HE10 connector)	3/15
3.5-5 Brake output Q0 characteristics	3/16
4 Appendices	4/1
4.1 Appendices	4/1
4.1-1 List of translators compatible with CFY 11 / 21	4/1

1.1 Introduction

1.1-1 Stepper motor axis control range

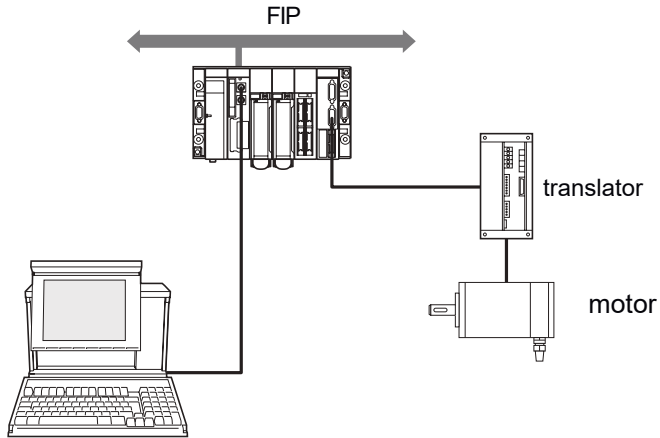

The CFY 11/21 stepper motor axis control range for TSX model 57 PLCs is designed to meet the requirements of machine manufacturers.

It is designed for machines which require motion control via stepper motor together with simultaneous sequential control via a PLC.

1.1-2 Set of two components

Stepper motor axis control

There are two modules :

- a single-axis module with one translator control output and sensor / preactuator I/O.

TSX CFY 11

- a 2-axis module with two translator control outputs and sensor / preactuator I/O.

TSX CFY 21

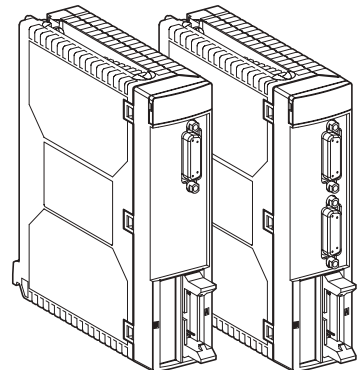

1.1-3 Setup software

PL7 Junior software can access screens to configure each axis and define elementary movements via a function library.

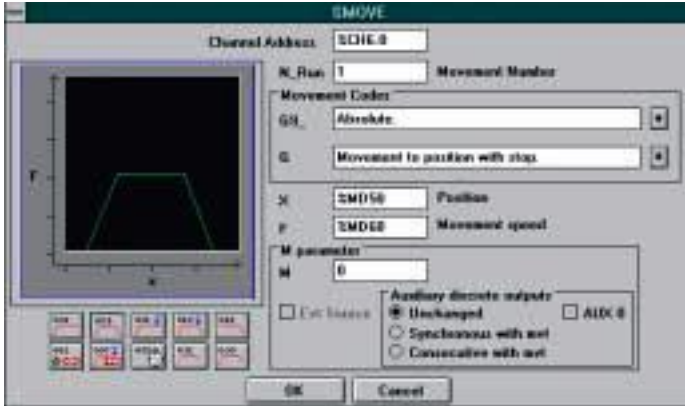

Screens for adjusting the axis parameters and setting up movements can also be accessed via PL7 Junior.



1.2 Physical description

Description of TSX CFY 11 and TSX CFY 21 stepper motor axis control modules

TSX CFY 11

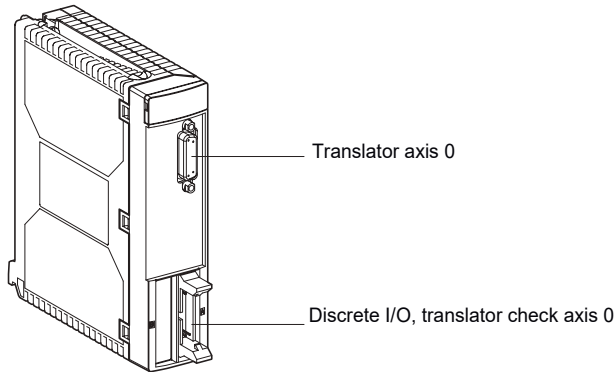

TSX CFY 21

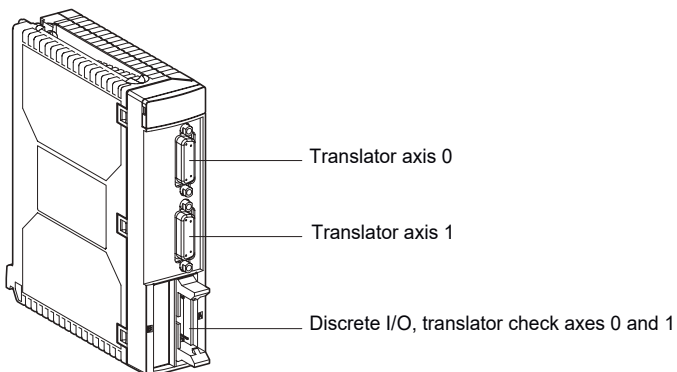

2.1 Functions

Block diagram of a stepper motor axis control system :

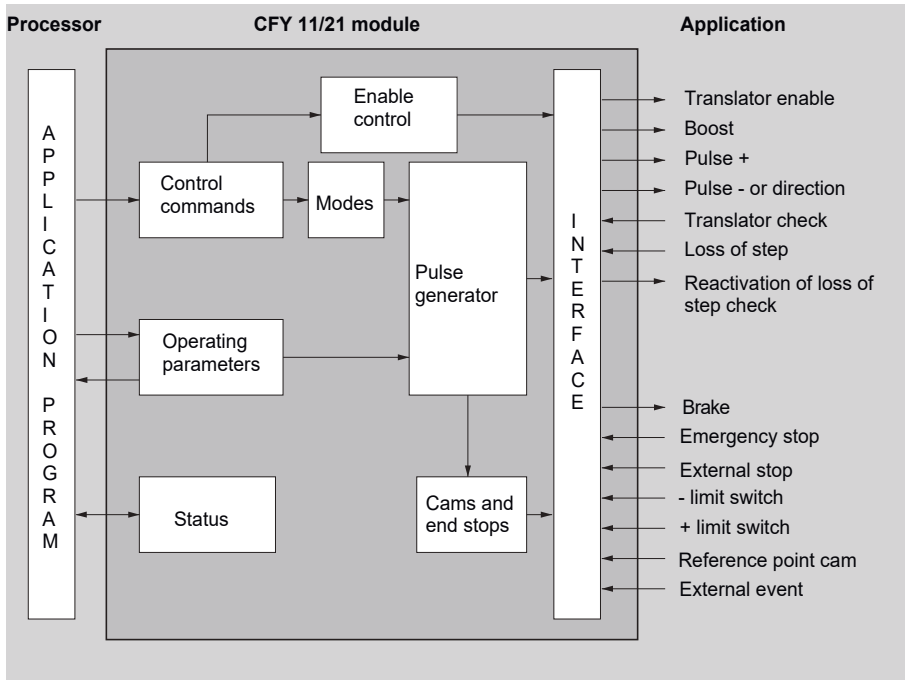

CFY 11/21 stepper motor axis control modules provide for each axis :

- inputs
 - translator check input
 - loss of step check input
 - + limit switch input
 - - limit switch input
 - reference point cam input
 - event input
 - emergency stop input
 - external stop input
- outputs
 - brake output
 - pulse + output
 - pulse - or direction output
 - reactivation of loss of step check output
 - boost output
 - translator enable output

Processing commands

Each movement, controlled by the PLC sequential program, is described by an SMOVE movement function in PL7 language. The CFY 11/12 module uses this SMOVE command to calculate a position setpoint / speed reference and generates movement pulses.

PL7 screens make it easy to adjust, debug and clearly display the status of the axes.

2.1-1 Configuring the axes

This screen is used to enter the parameters required to adapt the module operation to the machine axis characteristics and the technical characteristics of the power translators controlling the motor.

There is no default configuration in this screen. The configuration parameters cannot be modified by the program. Access is only possible via the programming terminal.

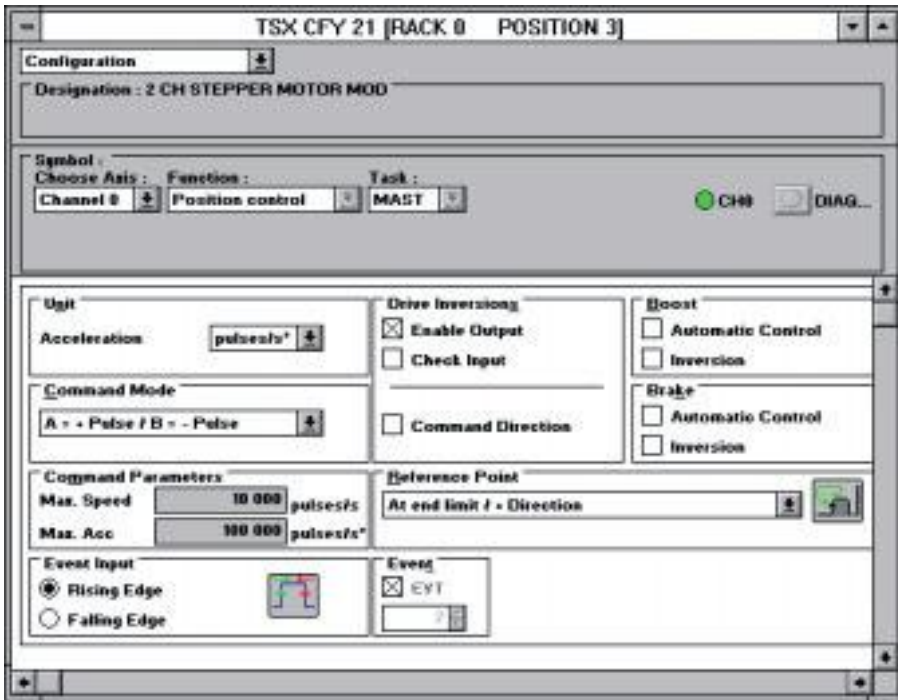

TSX CFY 21 (RACK 0 POSITION 3)

Configuration

Designation : 2 CH STEPPER MOTOR MOD

Symbol
Choose Axis : Channel 0 | Function : Position control | Task : MAST | CHN | DIAG...

Unit
Acceleration : pulses/s²

Command Mode
A = + Pulse / B = - Pulse

Command Parameters
Max. Speed : 10 000 pulses/s
Max. Acc : 100 000 pulses/s²

Event Input
 Rising Edge
 Falling Edge

Drive Inversion
 Enable Output
 Check Input
 Command Direction

Boost
 Automatic Control
 Inversion

Brake
 Automatic Control
 Inversion

Reference Point
At end limit / + Direction

Event
 EYT

2.1-2 Adjusting the axes

Adjustment parameters may be modified, either via the terminal (online or offline), or directly via the application program.

The operating parameters are :

- trajectory parameters : stop/start frequency, acceleration, soft stops, stop plateau duration,
- manual mode parameters : speed, reference point,
- brake output activation and deactivation delay times.

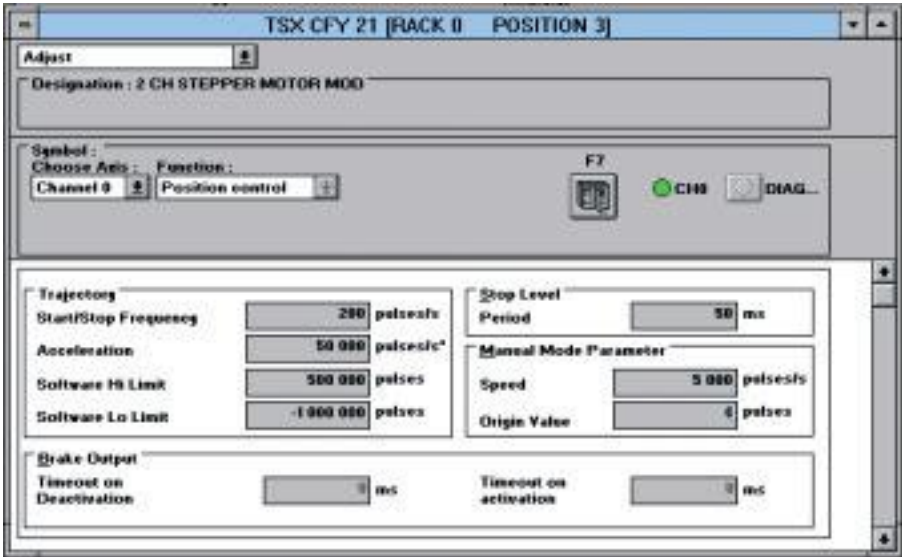

The screenshot shows a control interface for a TSX CFY 21 motor. The title bar indicates 'TSX CFY 21 [RACK 0 POSITION 3]'. The interface is divided into several sections:

- Designation:** 2 CH STEPPER MOTOR MOD
- Symbol:** Choose Axis: Channel 0, Function: Position control. Includes a 'F7' button, a green 'CHK' button, and a 'DIAG...' button.
- Trajectory Parameters:**

Start/Stop Frequency	200 pulses/s
Acceleration	50 000 pulse/s ²
Software Hi Limit	500 000 pulses
Software Lo Limit	-1 000 000 pulses
- Stop Level:** Period: 50 ms
- Manual Mode Parameter:**

Speed	5 000 pulses/s
Origin Value	0 pulses
- Brake Output:**

Timeout on Deactivation	ms	Timeout on activation	ms
-------------------------	----	-----------------------	----

2.1-3 Debugging

Debug mode can be accessed online and is used to control and observe axis behavior. The information shown differs depending on the operating mode selected :

- Off mode
- Dir Drive mode
- Manual mode
- Automatic mode

The upper part of the screen gives information about the module and axis operating status : the lower part of the screen gives information about the state of the module inputs and the position of the axis with respect to the programmed target position. Different manual movement modes are available, including a command for creating a machine reference point.

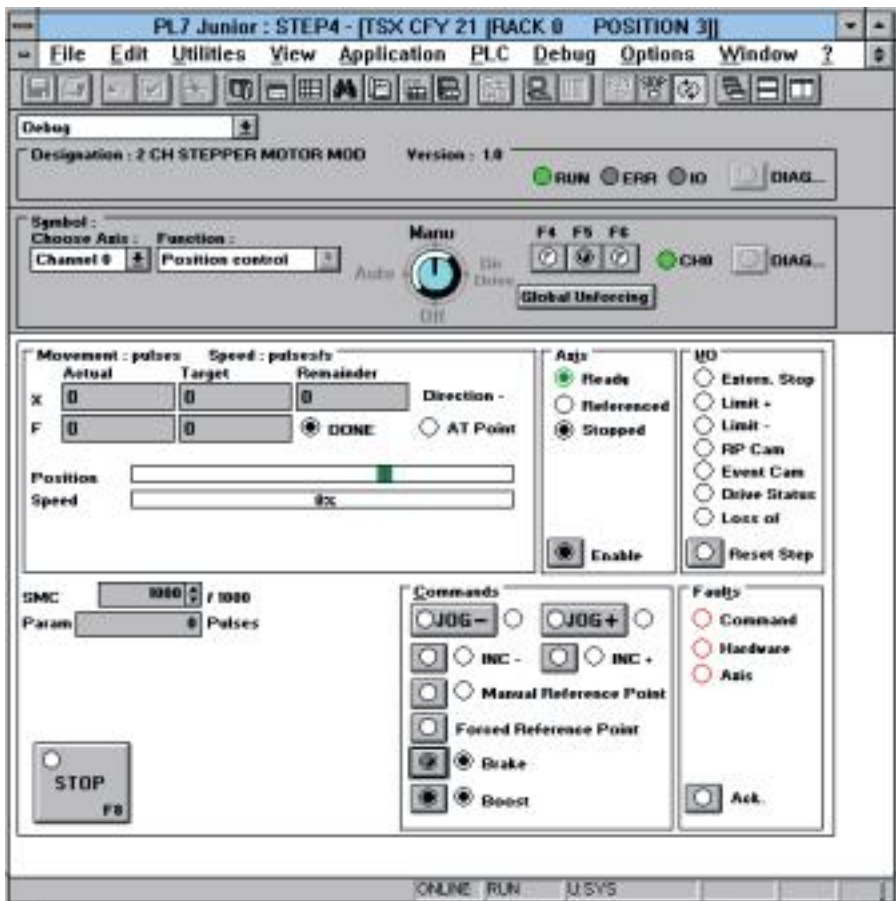

The screenshot displays the 'Debug' window for a '2 CH STEPPER MOTOR MOD'. The title bar indicates 'PL7 Junior : STEP4 - [TSX CFY 21 [RACK 0 POSITION 3]]'. The interface is divided into several functional areas:

- Top Panel:** Shows 'Designation : 2 CH STEPPER MOTOR MOD' and 'Version : 1.0'. It features status indicators for RUN (green), ERR (grey), ID (grey), and DIAG (grey).
- Control Panel:** Includes a 'Manual' knob with 'Auto', 'Dir Drive', and 'Off' positions. It also has 'F4', 'F5', 'F6' function buttons, a 'CH0' indicator, and a 'Global Unforcing' button.
- Movement Data:** A table showing 'Actual' and 'Target' values for 'X' and 'F' axes, along with 'Remainder' and 'Direction' (AT Point or DONE).
- Axis Status:** Radio buttons for 'Ready', 'Referenced', and 'Stopped'. An 'Enable' button is also present.
- IO Status:** A list of IO conditions such as 'Eterm. Stop', 'Limit -', 'Limit +', 'RP Cam', 'Event Cam', 'Drive Status', and 'Loss of', each with a corresponding indicator.
- Commands:** A set of buttons for 'JOG-', 'JOG+', 'INC-', 'INC+', 'Manual Reference Point', 'Forced Reference Point', 'Brake', and 'Boost'.
- Fastly:** A section for 'Command', 'Hardware', and 'Axis' status, with an 'Ack.' button.
- Bottom Panel:** A 'STOP' button (F8) and a status bar showing 'ONLINE RUN U.SYS'.

3.1 Setup

3.1-1 Basic configuration required

Stepper motor axis control modules can be installed in any slot of a TSX 57 rack. The power supply to the rack must be chosen according to the number of modules installed. A TSX 57-10 processor can control up to 2 intelligent modules (CTY, CAY, etc). A TSX 57-20 processor can control up to 6 intelligent modules, ie. 6 TSX CFY 11/21 modules, giving a maximum of 12 axes per PLC.

3.1-2 Installation procedure

It is possible to install or remove a module without switching off the rack supply voltage to ensure a device remains available for use.

However, connection or disconnection of connectors to the translator power supplies is not recommended, as certain translators cannot tolerate such handling. The auxiliary I/O connector can be disconnected while powered up without damaging the module. Nevertheless, for the safety of personnel it is recommended that auxiliary supplies are switched off before any disconnection.

The module and connector fixing screws must be tightened correctly in order to obtain good protection against electrostatic and electromagnetic interference.

3.1-3 General wiring instructions

The sensor and actuator power supplies must be protected against overloads or overvoltages by fast-blow fuses.

Use wires with an adequate cross-section to avoid line voltage drops or overheating. Keep sensor and actuator cables away from any source of radiation caused by high-power electrical circuit switching.

All cables connecting translators must be shielded. Shielding must be of high quality and connected to the machine ground at both the module and translator ends. There must be continuity along the entire length of the connections. Only translator signals should be carried on the cable.

For performance reasons, module auxiliary inputs have short response times and it is thus important that these inputs have an adequate independent supply to ensure that the module continues to operate correctly in the event of brief power outage. It is recommended that regulated supplies are used as they ensure the consistency of actuator and sensor response times. The supply 0V must be connected to the machine ground as near as possible to the supply output.

3.2 Choice of translator

3.2-1 I/O interfaces

The main interfaces for connecting translators are :

- open collector outputs supporting a maximum of 30V,
- RS422/RS485 differential outputs,
- current sinking inputs (TTL type),
- RS422/RS485 differential inputs.

We recommend using translators with RS422/485 interfaces as this type of interface enables high frequencies to be generated while ensuring the greatest immunity to electromagnetic disturbance.

3.2-2 Translator interface power supply

G The modules have an isolated 5V power supply which can power the translator interfaces if the translator does not provide power, as in the case of open collector output interfaces and TTL inputs. The 0V is common to both the inputs and the outputs, and must in all cases be wired between the module and the translator.

3.2-3 Shielding

To ensure correct operation of the module when the environment is subject to interference, shielding must be continuous along the entire length of the connector cables, and must be connected to machine ground at both ends of the cable.

3.3 Connecting translator signals

3.3-1 Signal referencing

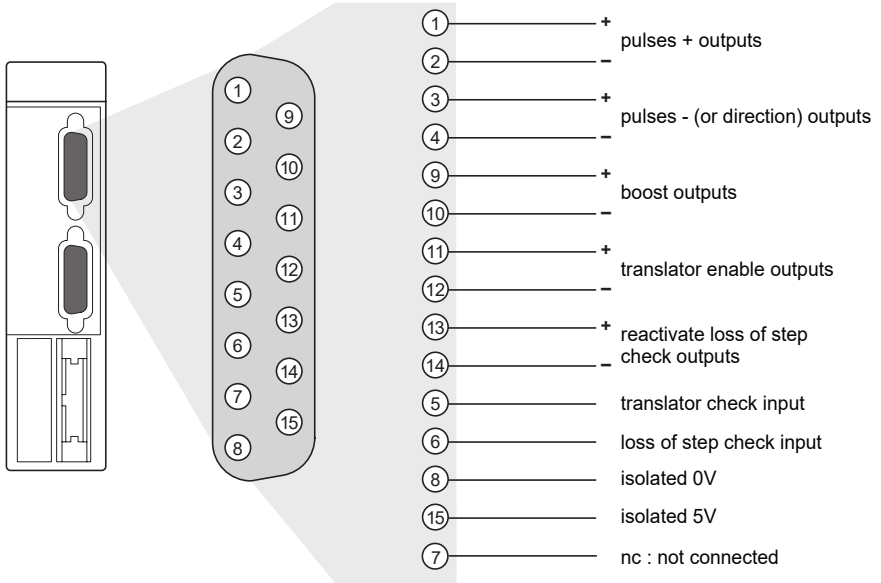

Each module output transmits an RS 485-type signal, and for each output there is thus a direct (+) signal and its complement (-). The inputs are TTL-compatible current sinking inputs. The 5V isolated supply is only available (if necessary) for the translator I/O interface. The 0V supply is common to both inputs and outputs. The 5V supply may only be used for translators with open collector outputs and TTL-type inputs (the 5V isolated supply is not supplied by the translator).

Physical interfaces of the module :

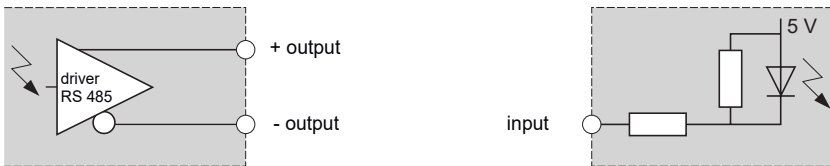

The suggested type of connection is to solder the wires directly onto the connector : kit TSX CAP S15 comprising a Sub-D connector and a protective cover.

3.3-2 Connecting a translator using an RS 422/485 interface

A shielded cable containing 7 twisted pairs is recommended for connection. The + and - wires for each module output signal must be connected to the same pair.

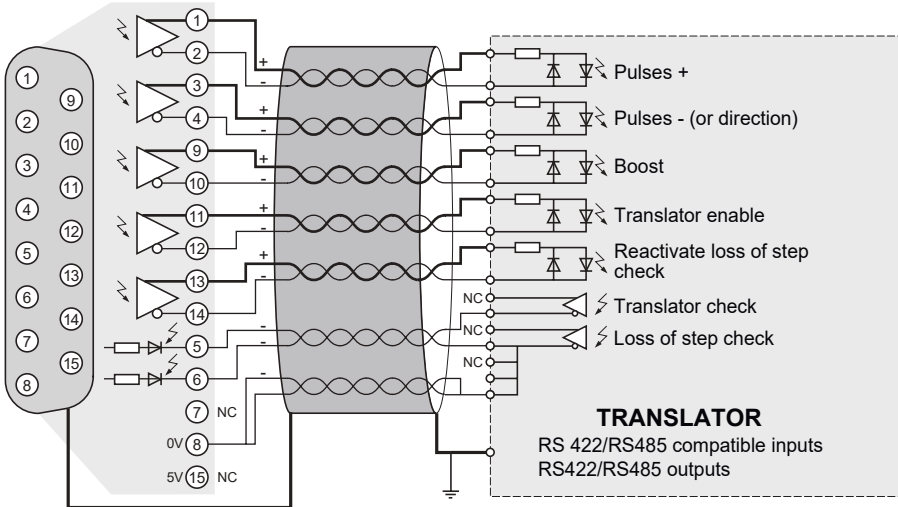

3.3-3 Connecting a translator using an NPN open collector interface

A single wire is used for each I/O signal. If the isolated 5V supply is not provided by the translator, the isolated 5V supply from the module must be used to supply the interface.

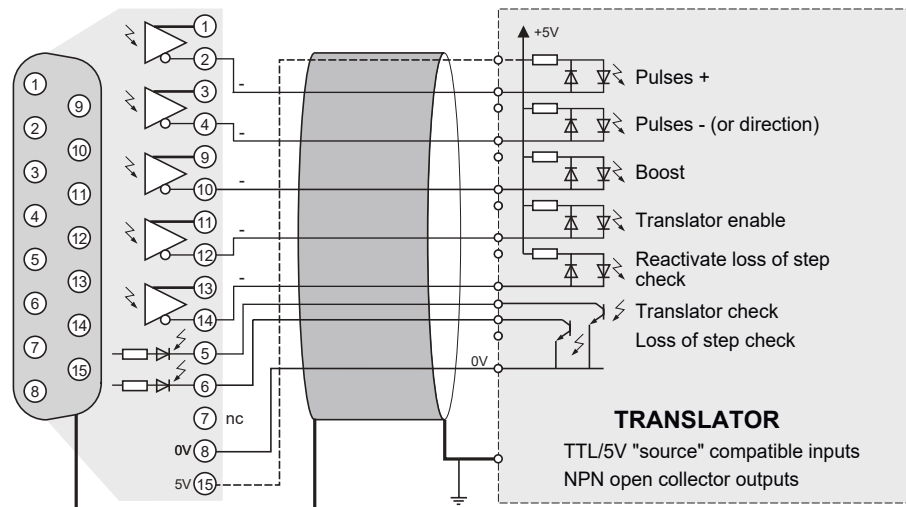

3.4 Connecting sensors / preactuators and power supplies

3.4-1 Signal referencing

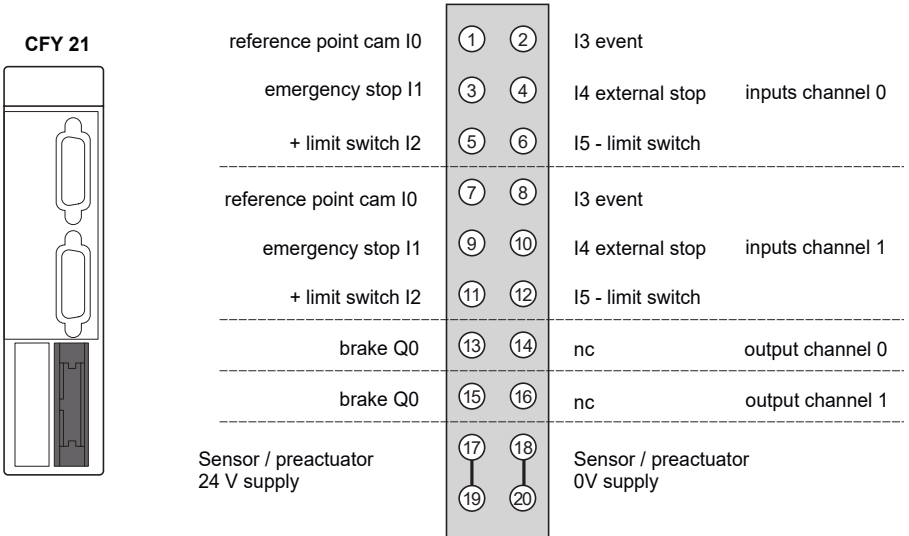

The 0V connection for the sensors / preactuators should be connected within the module to machine ground by an R/C circuit with value : $R = 10M\Omega$ / $C = 4.7nF$.

3.4-2 Connections

There are several possible solutions for connecting CFY 11 / 21 module sensors / preactuators. They may be connected directly via a TSX CDP 301 / 501 cable or via the discrete TELEFAST pre-wired system.

3.4-3 Connecting auxiliary I/O to the process

For optimum performance, the event and reference point inputs have low immunity. The use of bounce-free contacts (DDP for example) is recommended.

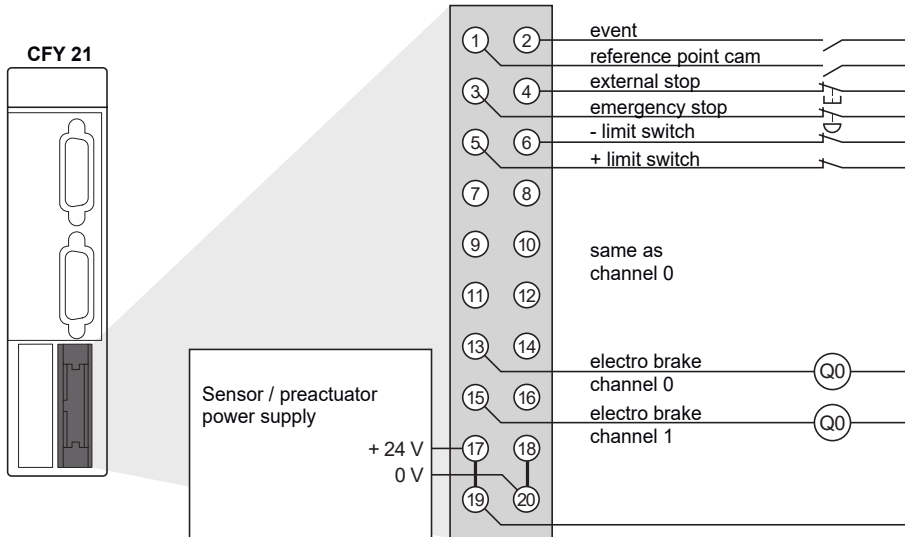

For reasons of personnel safety, emergency stop or limit switch contacts are normally closed.

3.4-4 Connecting using a TSX CDP 301/ 501 cable

This cable enables direct connection to actuators, preactuators or any system with terminals. The cable consists of twenty 22-gauge wires (0.34 mm²) with a connector at one end and color-coded flying leads at the other.

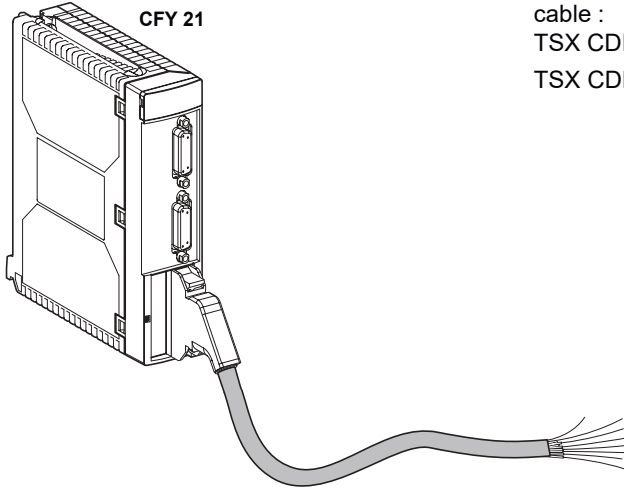

cable :	length :
TSX CDP 301	3m
TSX CDP 501	5m

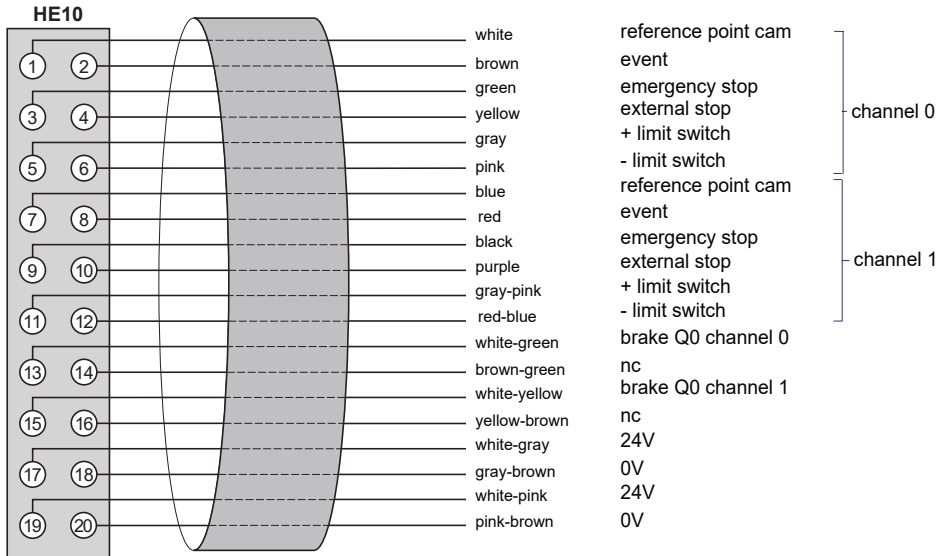

3.4-5 Connecting using the TELEFAST pre-wired system

Connection is by means of a ABE-7H16R20 TELEFAST 2 sub-base.

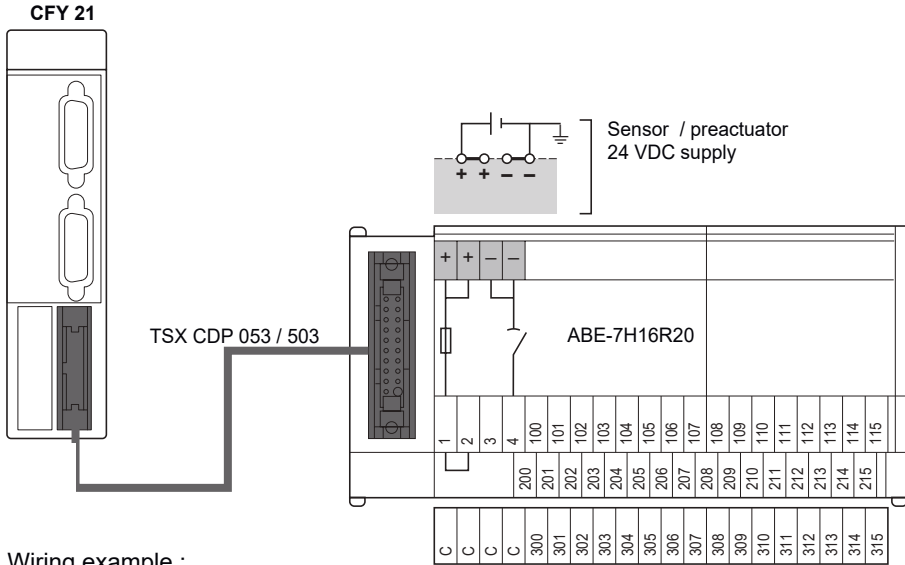

Wiring example :

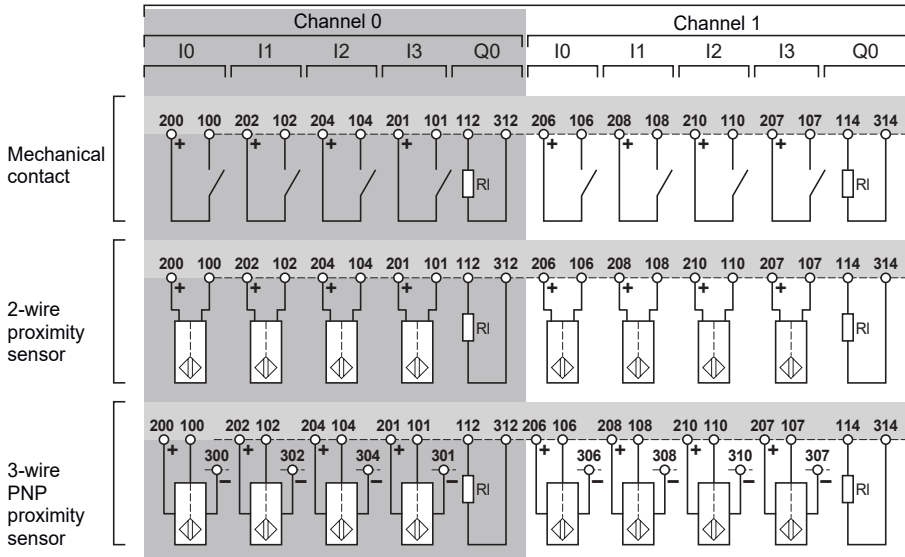

3.4-6 Signal availability on the TELEFAST terminal block

The terminal block below represents that of the ABE-7H16R20 sub-base. The signals are referenced using the TSX CDP 053 / 503 direct connection cable.

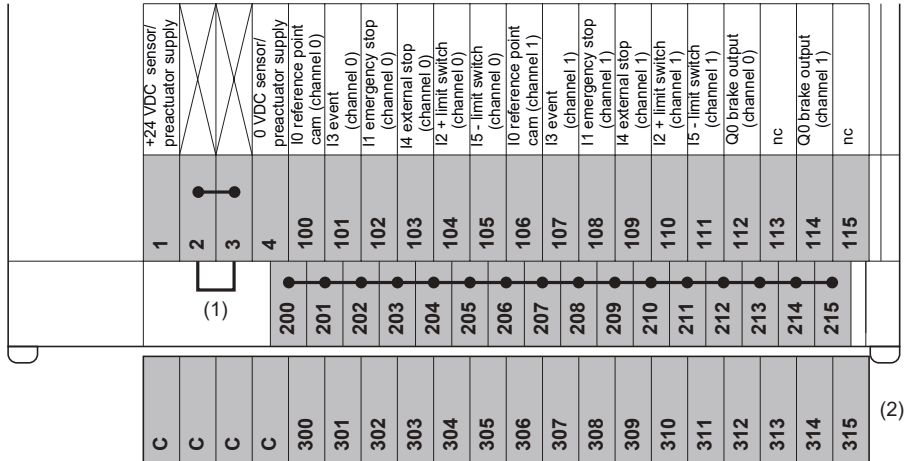

- (1) On the ABE-7H16R20 sub-base, the position of the jumper defines the polarity of all the 2•• terminals :
 - Jumper in position 1 and 2 : 2•• terminals have + polarity,
 - Jumper in position 3 and 4 : 2•• terminals have - polarity.
- (2) On the ABE-7H16R20 sub-base it is possible to add an optional ABE-7BV20 jumper bar to create a second sensor common (+ or - selected by the user).

3.4-7 Correspondence between TELEFAST terminal blocks and HE10 connector

TELEFAST screw term. blk. (Terminal no.)	20-pin HE10 connector (Pin no.)	Signal type	
100	1	I0 reference point cam	channel 0
101	2	I3 event	
102	3	I1 emergency stop	
103	4	I4 external stop	
104	5	I2 + limit switch	
105	6	I5 - limit switch	
106	7	I0 reference point cam	channel 1
107	8	I3 event	
108	9	I1 emergency stop	
109	10	I4 external stop	
110	11	I2 + limit switch	
111	12	I5 - limit switch	channel 0
112	13	Brake output Q 0	
113	14	nc	channel 1
114	15	Brake output Q0	
115	16	nc (1)	
+ 24 VDC	17	Sensor / actuator supply	
- 0 VDC	18		
+ 24 VDC	19		
- 0 VDC	20		
1	[All 2● terminals at + 24 VDC	
2			
3	[All 2● terminals at - 0 VDC	
4			
200...215		Connection of sensor commons to : + 24 VDC if terminals 1 & 2 linked - 0 VDC if terminals 3 & 4 linked	
300...315		On the optional ABE-7BV20 jumper bar, terminals may be used as sensor common, wired to the common voltage.	

note (1) nc = not connected

Signals corresponding to channel 1 are not connected for a CFY 11 module.

3.4-8 Wiring precautions

To ensure optimum performance, inputs I0 to I5 are fast inputs. If the actuator is a volt-free contact type, the inputs must be connected using a twisted pair, or a shielded cable if the sensor is a two or three-wire proximity sensor.

This module is fitted as standard with devices to protect against short-circuits or voltage inversions. However, the module cannot withstand a fault for any length of time and the fuses connected in series with the supplies give effective protection. The fuses must therefore be of the fast blow type with a maximum rating of 1A. The supplies must provide sufficient power to blow the fuses.

Important note : wiring of solid state outputs Q0

The actuator is connected to output QO at its common point at supply 0V. If for any reason (poor contact or accidental disconnection) there is a break in the supply 0V of the output amplifier while the 0V of the actuators remains connected to the supply 0V, there may be an output current from the amplifier of a few mA which is sufficient to keep certain low-power actuators energized.

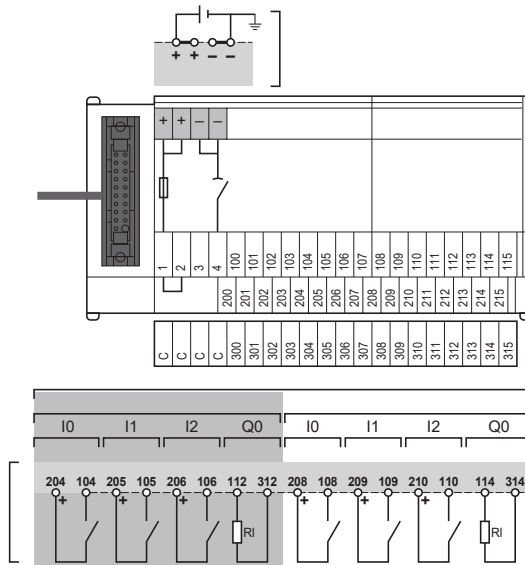

Connecting using TELEFAST :

This is the most reliable type of connection provided the actuator common is connected to the jumper bar of the 2•• common points (jumper in position 1-2). In this case there can be no break in the module common without breaking the actuator common.

3.4-9 Connecting using a cable

This type of connection requires very careful attention. Great care must be exercised during wiring, using for example cable ends at the screw terminals. In certain circumstances, it is necessary to double up the connections to ensure permanent contacts. When the actuator supply is some distance from the modules and near to the actuator common, the connection between the common and 0V terminal of the module(s) may be accidentally broken.

TSX CFY 11/21

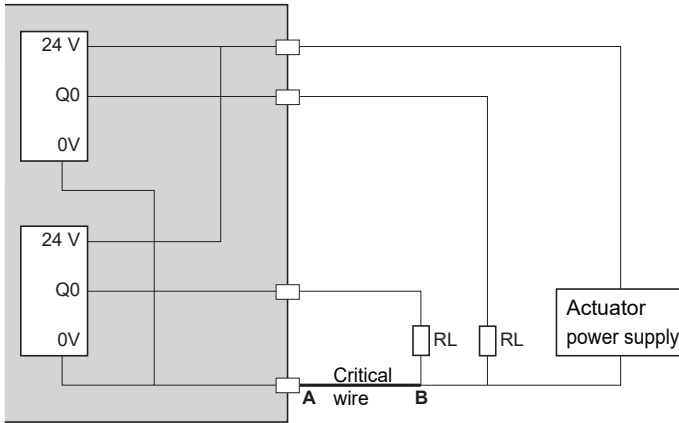

If there is a break in the supply cable segment between A and B, there is a risk of the RL actuators remaining energized. If possible, double the 0V supply connections for the module(s).

With the TSX CDP 301/501 cable :

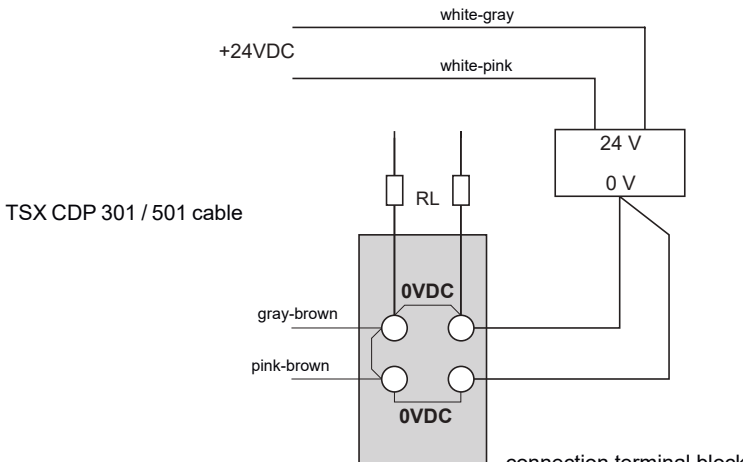

3.5 Module electrical characteristics

3.5-1 General characteristics

Electrical characteristics	Values	
Maximum pulse frequency	187.316	KHz
Current drawn on internal 5V	CFY 11 CFY 21	typical 510 mA 650 mA
Current drawn by module on sensor / preactuator 24V excluding sensor / preactuator current	CFY 11 CFY 21	typical 50 mA 100 mA
Power dissipated in module	CFY 11 CFY 21	typical 3.8 W 5.6 W
Isolation resistance	> 10 M Ω at 500 VDC	
Dielectric strength between "translator" I/O and machine ground or PLC logic	1000V rms 50 / 60 Hz for 1min	
Operating temperature	0 to 60°C	
Storage temperature	-25°C to 70°C	
Relative humidity (without condensation)	5% to 95%	
Operating altitude	< 2000 m	

3.5-2 Translator input characteristics (Sub-D connector)

These are current sinking inputs with negative logic.

diagram :

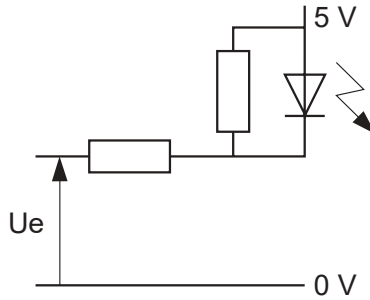

Characteristics	symbol	value	Unit
Nominal current ($U_e = 0V$)	I_e	4.5	mA
Voltage in ON state	U_{on}	2	V
Voltage in OFF state	U_{off}	3.6	V
Immunity of loss of step input		15 to 30	μs
Immunity of translator fault input		3 to 10	ms

3.5-3 Translator outputs characteristics (Sub-D connector)

These are isolated RS 422 / 485 type. There are two complementary outputs per signal.

Characteristics	value	units
Differential output voltage at R load $\leq 100\Omega$	± 2	V
Short-circuit current	< 150	mA
Permitted common mode voltage	≤ 7	V
Permitted differential voltage	≤ 12	V

3.5-4 Auxiliary input characteristics (HE10 connector)

Equivalent circuit diagram :

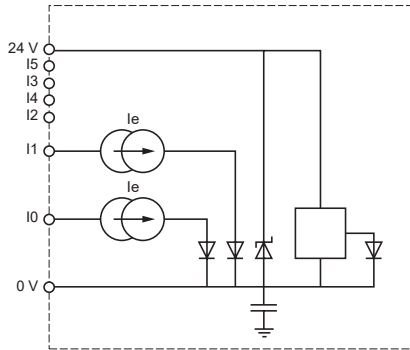

Characteristics	symbol	value	unit
Nominal voltage	Un	24	V
Nominal voltage limits (including ripple)	U1	19 to 30	V
	Utemp (1)	34	V
Nominal current	In	7	mA
Input impedance (at Un)	Re	3.4	KΩ
Voltage for ON state	Uon	>=11	V
Current at Uon (11V)	Ion	> 6	mA
Voltage for OFF state	Uoff	< 5	V
Current for OFF state	Ioff	< 2	mA
Input immunity :			
Reference point cam and event	ton/ toff (2)	< 250	μs
Other inputs	ton / toff	3 to 10	ms
IEC 1131 compatibility with sensors		type 2	
Compatibility with 2 and 3-wire sensors		all proximity sensors at 24 VDC	
Input type		current sink	
Logic type		positive (sink)	
Preactuator voltage check			
Supply threshold OK		> 18	V
Supply threshold fault		< 14	V
Supply detection time			
Supply OK		< 30	ms
Supply fault		> 1	ms

(1) Utemp : maximum permitted voltage for 1 hour in any 24-hour period.

(2) Inputs : reference point cam and event are fast inputs (response time < 250μs) in accordance with the maximum frequency of 187.316 KHz for translator control outputs.

3.5-5 Brake output Q0 characteristics

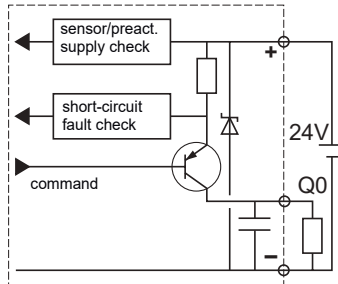

Electrical characteristics	value	unit
Nominal voltage	24	V
Voltage limits	19 to 30	V
Temporary voltage	34 (1)	V
Nominal current	500	mA
Maximum voltage drop when ON	< 1	V
Leakage current when OFF	< 0.3	mA
Load impedance	$80 < Z_{on} < 15000$	Ω
Maximum current at 30V and 34V	625	mA
Switching time	< 250	μs
Electro discharge time	< L/R	s
Maximum switching frequency on inductive load	$F < 0.6 / (LI^2)$	Hz
Inductive input compatibility	All inputs with R_e less than 15 K Ω and positive logic	
IEC 1131 conformity	yes	
Protection against overloads and short-circuits	via current limiter and tripping	
Short-circuit check on each channel	thermal with signaling : 1 bit per channel	
Reactivation : via program or automatic	1 bit per module	
Protection against channel overvoltages	Zener diode (55V) between outputs and +24V	
Protection against polarity inversions	via reverse-mounted diode on supply	
Permitted power of filament lamp	8	W
Preactuator voltage check	OK if supply > 18 (rising) not OK if supply < 14 (falling)	V V
Voltage check reaction time	NOK--> OK < 30 OK --> NOK > 1	ms ms

(1) : maximum permitted voltage for 1 hour in any 24-hour period.

4.1 Appendices

4.1-1 Translators compatible with CFY 11 / 21

Manufacturer	reference
Phytron	MSD mini 172-70 POWER PACK

Index

C

CFY 11/21	
Adjusting the axes	G2/3
Configuring the axes	G2/2
Debugging	G2/4
Functions	G2/1
Physical description	G1/3
Characteristics	
Auxiliary inputs	G3/15
Brake output Q0	G3/16
Modules, electrical	G3/13
Translator inputs	G3/14
Connecting	
Auxiliary I/O	G3/6
Sensors / preactuators	G3/5
Translator signals	G3/3
Using TSX CDP 301/501 cable	G3/12

I

Introduction	G1/1
--------------	------

S

Setup	G3/1
Basic configuration	G3/1
General wiring instructions	G3/1
I/O interfaces	G3/2
Installation procedure	G3/1
Shielding	G3/2
Translator interface power supply	G3/2
Stepper motor axis control	
TSX CFY 11	G1/1
TSX CFY 21	G1/1

T

TELEFAST	G3/8
Translator with NPN open collector interface	G3/4
Translator with RS 422/485 interface	G3/4
Translators compatible with CFY 11 / 21	G4/1

W

Wiring precautions	G3/11
--------------------	-------

Part H

Section	Page
1 Display	1/1
1.1 Introduction	1/1
1.2 Display of PLC status	1/1
1.3 Display of module status	1/2
1.3-1 Discrete I/O modules	1/2
1.3-2 Analog and application-specific modules	1/3
1.3-3 Power supply modules	1/6
2 Start-up	2/1
2.1 Checking discrete I/O connections	2/1
2.2 PLC and module states on initial power-up	2/2
3 Troubleshooting and fault analysis	3/1
3.1 Troubleshooting using the processor status indicator lamps	3/1
3.2 Reminder of system bits and system words	3/4
3.2-1 System bits	3/4
3.2-2 System words	3/9

Part H

1.1 Introduction

Every module has indicator lights which assist setup, operation, diagnostics and maintenance of the PLC :

- display the PLC status on the processor module,
- display the status of each module (discrete I/O, application-specific module, power supply)
- display the channels for each discrete I/O module and some of the application-specific modules
- I/O channel diagnostics.

1.2 Display of PLC status

The 4 indicator lamps RUN, TER, I/O, ERR situated on the processor provide information, depending on their state (off, flashing or on), on the PLC operating mode :

RUN : PLC Run/Stop

ERR : Processor or application fault

I/O : I/O fault (channel or module)

TER : Traffic on the terminal port



Indicator \ State	On ●	Flashing ⊗	Off ○
RUN (Green)	PLC running normally	PLC stopped	PLC faulty, application absent or not valid.
ERR (Red)	Blocking fault (1) : processor module failed, system or supply fault	Non-blocking fault (1) : • application absent, invalid or operating incorrectly • PCMCIA memory card failed or incompatible, battery fault.	No fault
I/O (Red)	• I/O fault from a station module or I/O configuration fault. • PCMCIA communication card failed or incompatible.	—	No fault
TER (Yellow)	Exchange in progress on terminal port (2)	—	No exchanges in progress

(1) For more information on blocking or non-blocking faults, refer to section 3.1

(2) Traffic on the terminal port may give the impression that this indicator is flashing.

Note : during the self-tests, the RUN, ERR, and I/O indicator lamps flash.

1.3 Display of module status

1.3-1 Discrete I/O modules

- Module status indicator lamps : (RUN, ERR, I/O)

Three or four indicator lamps situated on each module provide information, depending on their state (off, flashing or on), about the module operating mode :

- RUN indicator : signals the module operating status,
- ERR indicator : signals an internal module fault,
- I/O indicator : signals an external fault,
- indicator + 32 : signals the display of channels 32 to 63 on modules with 64 channels.

- Channel status indicator lamps : (0 to i)

Depending on the type of module, 8, 16 or 32 indicator lamps display and provide diagnostics on the status of each module channel.

Indicator \ State	On ●	Flashing ⊗	Off ○
RUN	Normal operation	—	Module faulty or powered off
ERR	Internal fault : module failure	Communication fault	No module fault
I/O	External fault : overload, short-circuit, sensor/preactuator voltage fault	Terminal block fault	No external fault
0...i	Channel at state 1	Channel faulty due to overload or short-circuit	Channel at state 0

Note : during the self-tests, the RUN, ERR, and I/O indicator lamps flash.

8-channel modules

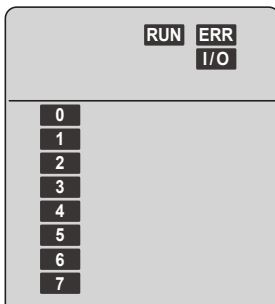

16-channel modules

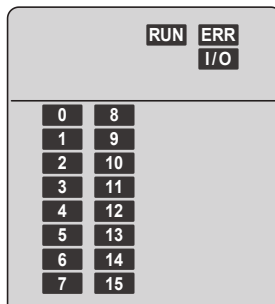

32 or 64-channel modules

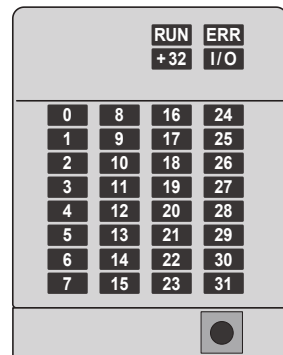

1.3-2 Analog and application-specific modules

Like discrete I/O modules, analog and application-specific modules (counter, axis control, etc) have indicator lamps which display the module status and channel status (on certain modules).

- Module status indicator lamps (RUN, ERR, I/O)

Three indicator lamps situated on each module give information, depending on their status (indicator off, flashing or on), about the module operating mode :

- RUN indicator : signals the module operating status,
- ERR indicator : signals an internal fault on the module,
- I/O indicator : signals an external fault,

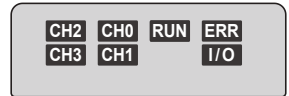

- Channel status indicator lamps (CH.)

Certain application-specific modules have 1, 2 or 4 indicator lamps which display and provide diagnostics for the status of each module channel.

TSX AEY / TSX ASY analog modules and TSX ISP Y100 weighing modules

State Indicator	On ●	Flashing ⊗	Off ○
RUN	Normal operation	—	Module faulty or powered off
ERR	Internal fault module failure	Communication fault on TSX ASY analog output module and TSX ISP Y100 weighing module	No module fault
I/O	External fault • range overshoot • sensor link fault (TSX AEY 414 module)	Terminal block fault	No external fault
CH.	No channel status indicator lamps		

TSX CTY 2A/4A counter modules

State Indicator	On ●	Flashing ⊗	Off ○
RUN	Normal operation	—	Module faulty or powered off
ERR	Internal fault module failure	Communication fault	No module fault
I/O	External fault • wiring fault • encoder supply fault • measurement overshoot Application fault (1).	—	No external fault
CH. TSX CTY 2A : CH0 and CH1 TSX CTY 4A : CH0, CH1, CH2, CH3	Channel is operational	Channel is not operating correctly due to : • an internal fault, (module absent or failed), • an external fault, (application fault), • communication fault.	Channel is not in service : No configuration or incorrect configuration.

TSX CAY 21/41 axis control modules

State Indicator	On ●	Flashing ⊗	Off ○
RUN	Normal operation	—	Module faulty or powered off
ERR	Internal fault module failure	Communication fault	No module fault
I/O	External fault • wiring fault, • encoder/24 V supply fault, • absolute encoder fault, • speed drive fault, Application fault (1).	—	No external fault
CH. TSX CAY 21 : CH0 and CH1 TSX CAY 41 : CH0, CH1, CH2, CH3	Channel is operational	Channel is not operating correctly due to : • an internal fault, (module absent or failed), • an external fault, (application fault), • communication fault.	Channel is not operational : No configuration or incorrect configuration.

TSX CTY 11/21 stepper control module

Indicator \ State	On ●	Flashing ⊗	Off ○
RUN	Normal operation	—	Module faulty or powered off
ERR	Internal fault module failure	Communication fault	No module fault
I/O	External fault <ul style="list-style-type: none"> wiring fault 24 V supply or encoder fault transporter fault, Application fault (1) 	—	No module fault
CH. TSX CFY 11 : CH0 TSX CFY 21 : CH0, CH1	Channel is operational	Channel is not operating correctly due to : <ul style="list-style-type: none"> an internal fault, (module absent or failed), an external fault, (application fault), communication fault. 	Channel is not operational, No configuration or incorrect configuration.

H

TSX SCY 21600 communication module

Indicator \ State	On ●	Flashing ⊗	Off ○
RUN	Normal operation	—	Module faulty or powered off
ERR	Internal fault module failure	Communication fault with the connected device, configuration fault	No module fault
CH0	Channel is operational	Channel is not operating correctly due to : <ul style="list-style-type: none"> an internal fault, (module absent or failed), an external fault, (application fault) communication fault, 	Channel is not operational,

1.3-3 Power supply modules

Each power supply module has a display block comprising :

- 3 indicator lamps (OK, BAT, 24V) on TSX PSY 2600/5500 power supply modules for an AC supply,
- 2 indicator lamps (OK, BAT) on TSX PSY 1610/3610/5520 power supply modules for a DC supply,



Indicator \ State	On ●	Flashing ⊗	Off ○
OK	Normal operation	—	Module powered off or output voltage outside monitoring range
BAT	Battery fault : battery absent, spent, incorrectly fitted, not compatible.	—	Normal operation
24V (only on modules for ~ supply)	Normal operation	—	24V sensor voltage outside monitoring range.

2.1 Checking discrete I/O connections

• Principle

This check consists of ensuring that :

- data originating from the sensor is taken into account by the corresponding inputs and the processor,
- commands from the processor are taken into account by the outputs and transmitted to the corresponding preactuators.



Activated outputs may cause machine movements. As a result, it is advisable to disconnect the power part before carrying out this check :

- **remove the motor control power fuses,**
- **disconnect the hydraulic and pneumatic power generators**
- **then power up the PLC equipped with its discrete I/O modules**

• Checking input connections without a terminal

This check is carried out by activating each sensor and checking that the corresponding input indicator lamp changes state. If it does not, check the wiring and that the sensor is operating normally.

• Checking I/O connections using a terminal

The use of a terminal enables I/O connections to be checked more thoroughly. To this end, an application (1) should first be loaded to the PLC from a programming terminal, even if it contains only the I/O configuration.

This check can be carried out with the PLC in RUN :

- either from an "ADJUST 117" adjustment terminal
- or from an FTX 417/507 terminal or PC equipped with PL7 Junior software which gives access to the debug functions (see the PL7 Junior software operating modes manual : TLX DM PL7J 12E).

Note :

This check can also be carried out with the complete application loaded in the memory. In this case, inhibit the MAST, FAST and event tasks to prevent the program from being processed, by setting system bits %S30, %S31, %S38 to 0.

- Checking inputs :

- 1 - activate each sensor and check that the corresponding input indicator changes state,
- 2 - check on the terminal screen that the corresponding input bit (%I .) also changes state.

- Checking outputs :

from the terminal, set each corresponding output bit (%Q .) to 1 then to 0 and check that the corresponding output indicator lamp switches on and off and that the associated preactuator is activated and deactivated.

(1) no module must be declared in FAST task if the application is empty.

2.2 PLC and module states on initial power-up

PLC status : on power-up, the processor executes its self-tests then waits for an application transfer. The various processor states are indicated on the display block by the RUN, ERR, I/O, indicator lamps. The following diagram shows the procedure to be followed on initial start-up, depending on the state of the indicator lamps.

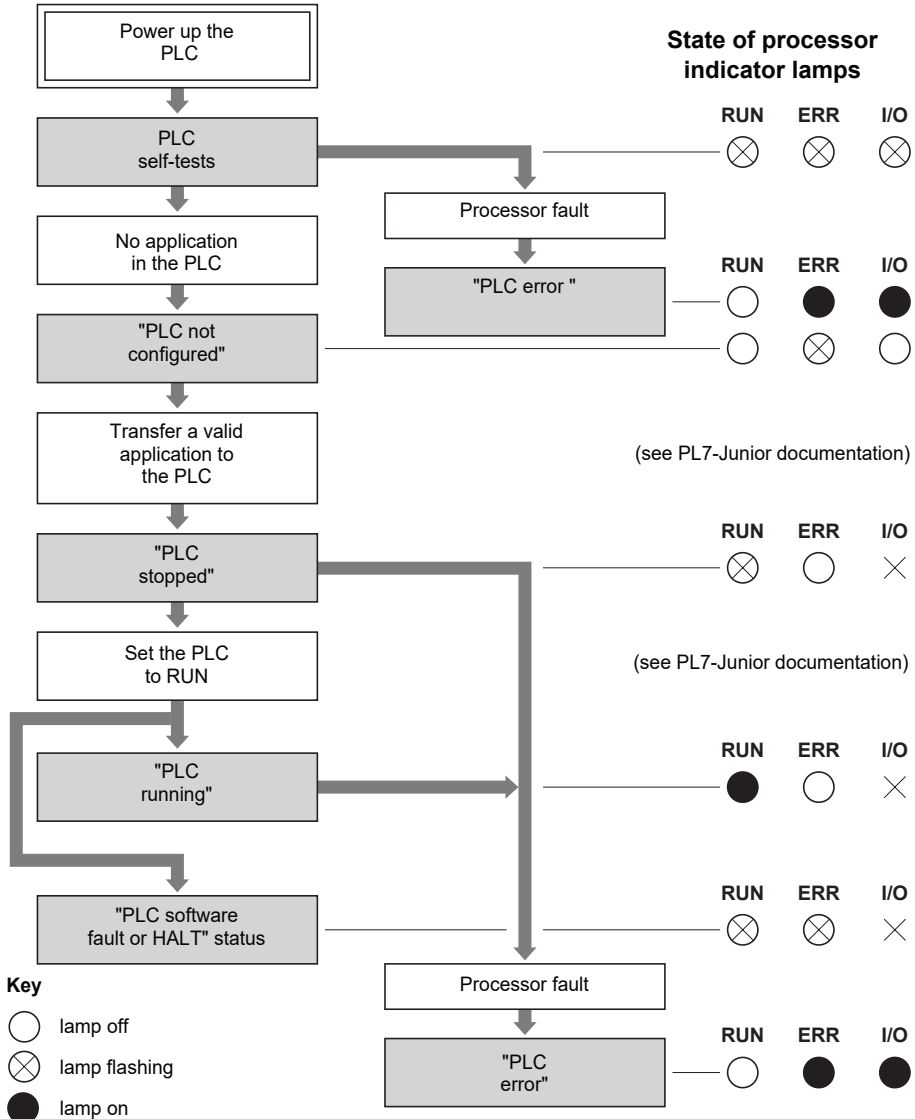

Description of the PLC states

PLC self-tests

The PLC processor executes its self-tests internally. The PLC does not control the process and cannot communicate via its terminal port (or networks). This state is signalled by all 3 indicator lamps RUN, ERR and I/O flashing.

"PLC error"

The processor is stopped after a hardware failure or system fault. The process is no longer controlled, communication is impossible and only a cold restart is possible (press the processor RESET button, move the memory card handle, etc). This state is signalled when the RUN indicator lamp is off and the ERR and I/O indicator lamps are on.

"PLC not configured"

The processor has started but does not contain any valid applications. It does not control the process but can communicate via its terminal port (or networks). This state is signalled when the RUN indicator lamp is off and the ERR indicator lamp is flashing.

"PLC software fault or HALT"

The application has changed to "watchdog timer overrun" or performed an unresolved JUMP, a HALT instruction or a blocking fault has appeared. This state is signalled by the RUN and ERR indicator lamps flashing.

"PLC stopped"

The PLC has a valid application which is stopped (the application is in an initial state when first powered up, tasks are stopped at the end of a cycle). The process commands are in fallback state. This state is signalled by the RUN indicator lamp flashing.

"PLC running"

The application operates normally in order to control the process. An application non-blocking fault (I/O fault or software fault) may also be present. This state is signalled when the RUN indicator lamp is on (and the I/O indicator lamp in the event of I/O faults).

Module states : During the module power-up phase, modules can be in one of the following five states :

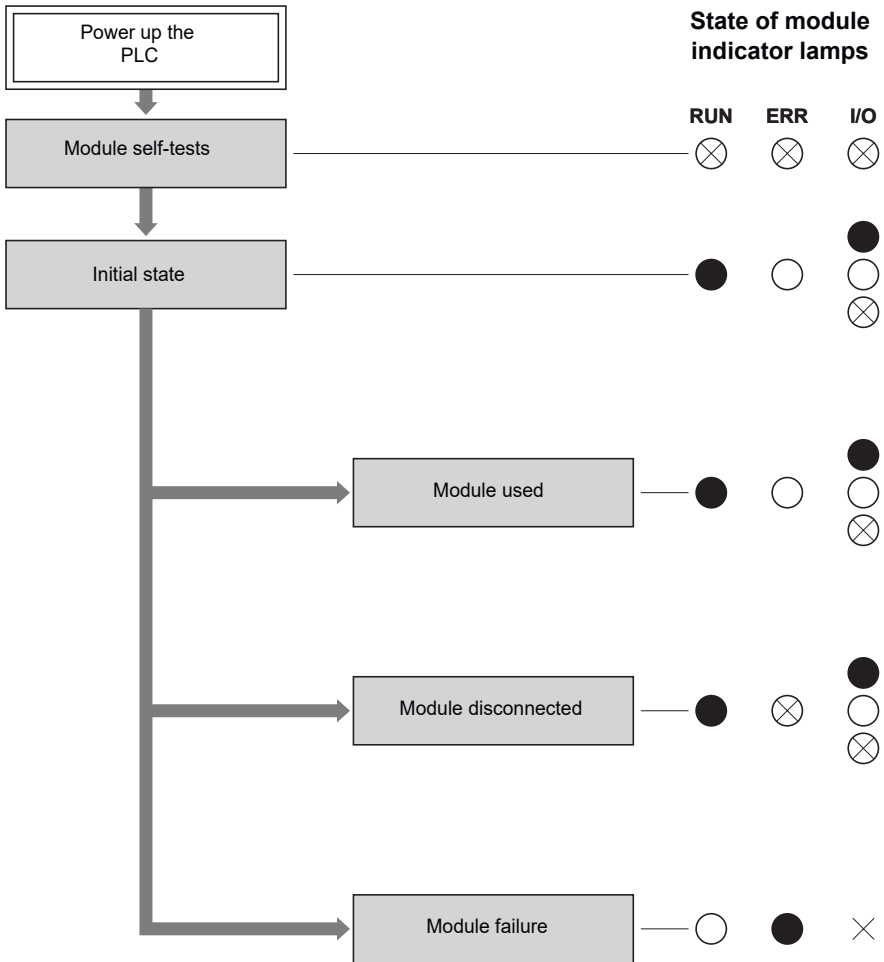

Key

- lamp off
- ⊗ lamp flashing
- lamp on
- × Indeterminate

H

Description of module states

Self-tests

On power-up, or reinitialization of the processor, the module runs its self-tests. This state is signalled by the RUN, ERR and I/O indicator lamps flashing.

Output state : safety value (state 0 for discrete I/O).

Initial state :

This is the normal module state, after the self-tests phase, when it is not being controlled by the application. This state is signalled when the RUN indicator lamp is on, the ERR indicator lamp is off and the I/O indicator lamp is on, flashing or off depending on the presence or not of an I/O fault.

Output state : safety value (state 0 for discrete outputs).

Module used

The module is used in the application, and its channels are controlled by control tasks (MAST, FAST, event). This state is signalled when the RUN indicator lamp is on, the ERR indicator lamp is off and the I/O indicator lamp is on, flashing or off, depending on the presence or not of an I/O fault.

The state of the outputs depends on the state of the task which controls them :

- state 0 if the controlling task has not been started,
- state 0 or 1 (value given by the application if the controlling task is in RUN),
- state at fallback value (configurable) if the controlling task is stopped in STOP, on a breakpoint (BKPT), on a HALT instruction or if system bit %S9=1.

Module disconnected

No more communication between the module and the processor (processor error or powered off, rack disconnected, etc). This state is signalled when the RUN indicator lamp is on, when the ERR indicator lamp is flashing and the I/O indicator lamp is on, flashing or off depending on the presence or not of an I/O fault.

This state is only controlled by the modules controlling the outputs. The other modules remain in the "module used" state in the event of a communication stop (discrete input modules for example).

Module failure

The module has an internal fault and has to be replaced. This state is signalled when the RUN indicator lamp is off, when the ERR indicator lamp is on and the I/O indicator lamp is in any state.

3.1 Troubleshooting using the processor status indicator lamps

The status indicator lamps situated on the processor inform the user about the PLC operating mode and also about any possible faults. Faults detected by the PLC concern :

- circuits in the PLC and/or its modules : internal faults,
- the process controlled by the PLC or the wiring to the process : external faults,
- the operation of the application executed by the PLC : internal or external faults.

Faults are detected during start-up (self-tests) or during operation (this is the case for the majority of hardware faults), during exchanges with the modules or upon the execution of a program instruction.

Certain "serious" faults require a PLC restart, with others, the user uses his discretion to decide on appropriate action, depending on the level of application required.

3 types of faults can be identified : non-blocking, blocking or processor faults.

• Non-blocking faults

This is an anomaly caused by an I/O fault or by the execution of an instruction. It may be processed by the user program and does not change the PLC status.

- Non-blocking faults linked to the I/O

A non-blocking fault linked to the I/O is signalled by :

- . the I/O status indicator lamp of the processor being on,
- . the I/O status indicator lamps of the faulty modules being on,
- . the fault bits and words associated with the channel:
 - %Ixy.i.ERR bit = 1 indicates channel in default (implicit exchanges),
 - %MWxy.i.2 words indicate the type of channel faults (explicit exchanges),
- . the fault bits and words associated with the module:
 - %Ixy.MOD.ERR bit = 1 indicates a module fault (implicit exchanges),
 - %MWxy.MOD.2 words indicate the type of module fault (explicit exchanges),
- . system bits %S10 : I/O fault, %S16: I/O fault in the task in progress %S40 to %S47: I/O fault in the rack, address 0 to 7 (see section 3.2).

Note: use of these bits and words with regard to the various applications: discrete I/O, counting, analog, etc ...is explained in PL7-Junior TLX DS PL7 12E documentation.

Status indicator lamps			System bits	Faults
RUN	ERR	I/O		
×	×	●	%S10 %S16 %S40 to %S47	I/O faults: channel supply fault, channel tripped, module not conforming to configuration, out of order, module supply fault I/O fault in a task Rack I/O fault (%S40: rack 0,.... %S47: rack 7)

Key ● Indicator lamp on × Indeterminate state

- Non-blocking faults linked to program execution

A non-blocking fault linked to the program execution is signalled by setting to 1 any of the system bits %S15, %S18 and %S20.

Testing and setting these system bits to 0 is the responsibility of the user.

Status indicator lamps			System bits	Faults
RUN	ERR	I/O		
●	×	×	%S15 = 1 %S18 = 1 %S20 = 1	Character string manipulation error. Capacity overflow, error on floating point or division by 0 Index overflow

Note : The program diagnostics function, which can be accessed via PL7 Junior software enables certain non-blocking faults linked to the execution of the program to be rendered blocking (see PL7 Junior manual TLX DM PL7J 12E part E - section 3.3). The type of fault is indicated in system word %SW 125.

• Blocking faults

These faults, caused by the application program, prevent the program from continuing to operate, but do not cause a system fault. When such a fault appears, the application stops immediately and changes to the HALT state (all tasks are stopped on the current instruction).

There are 2 ways of restarting the application :

- via the INIT command using PL7 Junior software,
- via the processor RESET pushbutton.

The application is then at its initial state : the data has its initial values, tasks are stopped at the end of the scan, the input image bits are updated and the outputs are set to fallback position ; the RUN command enables the application to be restarted.

A non-blocking fault is indicated by status indicator lamps (ERR and RUN) flashing and, depending on the type of fault, by the setting to 1 of one or both system bits %S11 and %S26. The type of fault is indicated in system word %SW 125.

Status indicator lamps			System bits	Faults
RUN	ERR	I/O		
⊗	⊗	×	%S11 = 1	Watchdog (overrun)
			%S26 = 1	Overrun of grafcet activity table Unresolved Grafcet step
				Execution of HALT instruction
				Execution of unresolved JUMP

Key : ● Indicator lamp on ⊗ Indicator lamp flashing × Indeterminate state

Diagnostic tools under PL7 Junior

The program diagnostics tool for PL7 Junior software shows "in plain language" the cause and origin of the change to a PLC blocking fault : watchdog overrun, character string fault, (see PL7 Junior manual TLX DM PL7 12E - part E - section 3.3). The type of fault is indicated in system word %SW 125.

Fault type	Meaning	System bits	System word %SW125
Blocking	Watchdog overrun	%S11 = 1	H'DEB0'
	Grafcet activity table overrun	%S26 = 1	H'DEF7'
	Unresolved Grafcet step	%S26 = 1	H'DEFE'
	Execution of HALT instruction		H'2258'
	Execution of unresolved JUMP		H'DEF8'
Non-blocking, rendered	Manipulation error on a character string	%S15 = 1	H'DEF1'
blocking	Division by 0	%S18 = 1	H'DEF0'
during program	Capacity overflow	%S18 = 1	H'DEF2'
diagnostics	Operation on floating point error	%S18 = 1	H'DE87'
	Index overflow	%S20 = 1	H'DEF3'

• Processor faults

These serious faults (hardware or software) mean that correct operation of the system is no longer assured. They cause a PLC to stop in ERROR which requires a cold restart. To prevent a PLC fault occurring again, the next cold start will be forced to STOP mode.

Status indicator lamps			System word %SW124	Faults
RUN	ERR	I/O		
⊗	●	●	H'80'	System watchdog fault or wiring fault on BusX
			H'81'	Wiring fault on BusX
				System code fault, interruption not expected, System task stack overflow PL7 Junior task stack overflow

Key : ● Indicator lamp on ⊗ Indeterminate state

Processor fault diagnostics :

When the PLC has stopped due to a fault, it can no longer communicate with a diagnostic device. Data relating to faults can only be accessed after a cold start (see system word %SW124). In general this data cannot be used by the operator. Only H'80' and H'81' data can be used to diagnose a wiring fault on BusX.

3.2 Reminder of system bits and system words

System bits %Si and system words %SWi provide information about the PLC status and can be used to control its operation. Some of these objects are managed entirely by the system, others are the user's responsibility. For more information on system bits and words refer to the PL7 Junior documentation (TLX DR PL7 12 E - section 3 of part B).

3.2-1 System bits

Bits	Function	Description
%S0	Cold start	Normally at state 0, this bit is set to 1 : <ul style="list-style-type: none"> • on power return with loss of data, • by the user program, • by the terminal, • on changing the PCMCIA memory card • by pressing the processor RESET button, • by manipulating the memory slot cover or the handle of the PCMCIA memory card. This bit is reset to 0 by the system after a normal program execution scan.
%S1	Warm restart	Normally at state 0, this bit is set to 1 : <ul style="list-style-type: none"> • on power return with data save, • by the user program, • by the terminal. This bit is reset to 0 by the system at the end of the first complete scan and before the outputs are updated.
%S4 to %S7	Time bases	%S4 changes state every 5 ms (Time base = 10 ms), %S5 changes state every 50 ms (TB = 100 ms), %S6 changes state every 500 ms (TB = 1 s), %S7 changes state every 30 s (TB = 1 min). These bits are not synchronized with the PLC scan.
%S9	Change of outputs to fallback state	Normally at state 0, this bit can be set to 1 via the program or via the terminal. %S9 = 1 : change to fallback state (0 or 1) depending on the choice made in configuration of all discrete and analog outputs, %S9 = 0 : normal output update.
%S10	I/O fault	Normally at state 1, this bit is set to 0 by the system at the time of an I/O fault on one of the station racks. This bit is reset to 1 by the system when the fault disappears.
%S11	Watchdog overflow	Normally at state 0, this bit is set to 1 by the system as soon as the program execution time becomes greater than the maximum execution time (watchdog) declared at configuration. Such a fault causes the PLC to change to HALT (software fault).

System bits (continued)

Bits	Function	Description
%S13	First scan	Normally at state 0, this bit is set to 1 by the system during the first scan after setting the PLC to RUN. In the case of a cold restart, %S13 can only change to 1 after the RESET button on the processor has been pressed or after manipulation of the PCMCIA memory card handle or slot cover.
%S15	Character string fault	Normally at state 0, this bit is set to 1 by the system when the size of the destination zone for the transfer of a character string is insufficient. This bit must be reset to 0 by the user.
%S16	I/O task fault	Normally at state 1, this bit is set to 0 by the system during a fault on an I/O module configured in the task. This bit must be reset to 1 by the user. Each task controls its own bit %S16.
%S17	Exit bit on a shift operation or arithmetic report	Normally at state 0, this bit is set to 1 by the system : <ul style="list-style-type: none"> • during a shift operation, contains the state of the last bit, • when an overrun occurs with unsigned arithmetic. This bit is reset to 0 by the user.
%S18	Arithmetic overflow or error	Normally at state 0, this bit is set to 1 by the system in the event of a capacity overflow during operation on a word : <ul style="list-style-type: none"> • result greater than +32767 or less than -32768 (single word), • result greater than +2147483647 or less than -2147483648 (double word), • overflow or error during operation on a floating point. The type of fault is given by the system word %SW17, • division by 0, • square root of a negative number, • forcing a DRUM to a non-existent step, • stacking a full register or unstacking an empty register. This bit must be reset to 0 by the user.
%S19	Task period overrun (periodical scan)	Normally at state 0, this bit is set to 1 by the system in the event of an overrun of the time defined for the task during configuration or programmed in %SW0 /%SW1. This bit is reset to 0 by the user. Each periodic task (MAST, FAST) controls its own bit %S19. Note : while the cause of the task time overrun persists, the task operates cyclically.
%S20	Index overrun	Normally at state 0, this bit is set to 1 by the system when the address of the indexed object becomes less than 0 or exceeds the number of objects declared during configuration. This bit is reset to 0 by the user.

System bits (continued)

Bits	Function	Description
%S21	Grafcet initialization	<p>Normally at state 0, this bit is set to state 1 by :</p> <ul style="list-style-type: none"> • a cold restart (%S0 = 1) • the user program exclusively in preprocessing, • the terminal <p>At state 1, it causes the Grafcet to be initialized. The active steps are deactivated and the initial steps are activated. It is reset to state 0 by the system at the end of preprocessing.</p>
%S21	Grafcet initialization	<p>Normally at state 0, this bit is set to state 1 by :</p> <ul style="list-style-type: none"> • a cold restart (%S0 = 1) • the user program exclusively in preprocessing, • the terminal <p>At state 1, it causes the Grafcet to be initialized. The active steps are deactivated and the initial steps are activated. It is reset to state 0 by the system at the end of preprocessing.</p>
%S22	Grafcet reset to zero	<p>Normally at state 0, this bit is managed by the user and can only be set to state 1 via the program during preprocessing. At state 1, all active steps are deactivated. It is reset to 0 by the system at the end of preprocessing.</p>
%S23	Grafcet freeze	<p>Normally at state 0, this bit is managed by the user and can only be set to state 1 via the program during preprocessing. Maintained at state 1 by the application program, it enables the Grafcet to remain in a given state (without changing). It must be reset to 0 only by program during preprocessing so that the Grafcet can change from the freeze situation.</p>
%S26	Table overflow (transition steps)	<p>Normally at state 0, this bit is set to state 1 when the number of possible steps or transitions has been exceeded. An overflow causes the PLC to change to STOP. Starting execution (RUN) via the terminal must be preceded by an initialization (setting %S21 to 1) by the same terminal. It is thus reset to 0 on initialization of the terminal. System words %SW20 and %SW21 contain the number of positions occupied in the Grafcet activity tables (%SW20 step positions, %SW21 transition positions). In the event of an overflow, the words %SW20 and %SW21 contain the number of positions corresponding to the scan before the overflow.</p>
%S30	Activation/deactivation of master task	<p>Normally at state 1, this bit is managed by the user :</p> <p>%S30 = 1, activation of master task, %S30 = 0, deactivation of master task.</p>
%S31	Activation/deactivation of fast task	<p>Normally at state 1, this bit is managed by the user :</p> <p>%S31 = 1, activation of the fast task, %S31 = 0, deactivation of the fast task. This bit is inactive if the fast task is not programmed</p>

System bits (continued)

Bits	Function	Description
%S38	Activation/ deactivation of events	Normally at state 1, this bit is managed by the user : %S38 = 1, activation of event-triggered processing, %S38 = 0, deactivation of event-triggered processing. This bit is inactive if no event is programmed as an event task.
%S39	Loss of events	This bit is set to 1 by the system to advise the application that one or more events have been lost following stack overflow. This bit should be reset to 0 by the application.
%S40 to %S47	I/O faults (racks)	Normally at state 1, each of these bits is set to state 0 on an I/O fault of the corresponding rack : %S40 for rack 0, %S41 for rack 1,, %S47 for rack 7. Setting one of these bits to 0 causes : <ul style="list-style-type: none"> • the %S10 general bit to be set to 0, • the I/O indicator lamp of the corresponding rack and processor to light up, • status module bit %Ixy.ERR to be set to 1. They are reset to 1 when the fault disappears. These various bits are used by the program to draw up the fault processing structure.
%S50	Updating of date and time by %SW50 to %SW53	Normally at state 0, this bit is managed by the user : %S50 = 0, access to date/time by reading words %SW50 to %SW53, %S50 = 1, updating of date/time by writing words %SW50 to %SW53.
%S51	Loss of time on the real-time clock	This bit managed by the system indicates at state 1 either the absence of real-time clock, or that the system words relating to the real-time clock have no significance; in this case the real-time clock must be reset. This automatically resets the bit to 0.
%S59	Updating date / time by %SW59	Normally at state 0, this bit is managed by the user : %S59 = 0, the system does not manage word %SW59, %S59 = 1, the system manages word %SW59,
%S67	PMCIA memory card battery status	This bit, managed by the system, is used to check the backup battery for the PMCIA memory card (RAM type) : %S67 = 0, battery present and operative, %S67 = 1, battery missing or inoperative.
%S68	Internal RAM backup battery status	This bit, managed by the system, is used to check the backup battery for the data and the program in the RAM memory : %S68 = 0, battery present and operative, %S68 = 1, battery missing or inoperative.
%S80	Reset message counters	Normally at state 0, this bit is set to 1 by the user to reset the message counters %SW80 to %SW86.

System bits (continued)

Bits	Function	Description
%S90	Updating the common words	Normally at state 0, this bit is set to 1 by the system on receipt of common words from another station. This bit is reset to 0 by the user.
%S100	Protocol on terminal port	This bit, managed by the system, takes the value 0 or 1 depending on the type of device connected to the terminal port : %S100 = 0, UNI-TELWAY master protocol, %S100 = 1, UNI-TELWAY slave or ASCII (character mode) protocol.

3.2-2 System words

Words	Function	Description
%SW0	Master task scan time	Used to modify the master task time, defined during configuration, via the program or the terminal. Time is expressed in ms (1 to 255 ms). During cyclic operation %SW0 = 0.
%SW1	Fast task scan time	Used to modify the fast task time, defined during configuration, via the program or the terminal. Time is expressed in ms (1 to 255 ms). This system word is not significant if the fast task is not programmed.
%SW8	Control of reading task inputs	Used to inhibit reading the inputs for each task : %SW8:X0 = 1 inhibit in the master task %SW8:X1 = 1 inhibit in fast task
%SW9	Control of updating task output	Used to inhibit updating the outputs of each task : %SW9:X0 = 1 inhibit in the master task %SW9:X1 = 1 inhibit in fast task
%SW10	Detection of a cold restart, at the end of the first scan of a task	This word indicates a change to RUN after a cold start Bit %SW10:X0 is associated with the MAST task, Bit %SW10:X1 is associated with the FAST task (if it is programmed). The value 0 of the current task bit means that it is executing its first scan after a cold start. Each bit is set to 1 after the associated task has been executed.
%SW11	Watchdog duration	Contains the duration of the watchdog defined during configuration It is expressed in ms (10 to 500 ms).
%SW12	Terminal port UNI-TELWAY address	UNI-TELWAY address of the terminal port defined during configuration and loaded in this word on a cold start. This word is updated by the system.
%SW13	Main station address	Indicates for the main network : • the station number (low order byte) : 0 to 127, • the network number (high order byte) : 0 to 63.
%SW17	Fault status of operations on floating points	Indicates the type of fault on a floating point operation: %SW17:X0 = 1 invalid operation %SW17:X1 = 1 non-standard operand %SW17:X2 = 1 division by 0 / the result is $\pm \infty$ %SW17:X3 = 1 overflow / the result is $\pm \infty$ %SW17:X4 = 1 underflow / the result is 0 %SW17:X5 to X15: unused, always at 0
%SD18 (%SW18 + %SW19)	Absolute time counter	This double word is used to calculate the duration. It is incremented by the system every 1/10th of a second (even when the PLC is in STOP). %SW18 represents the least significant bits and %SW19 represents the most significant bits of word %SD18

System words (continued)

Words	Function	Description
%SW20	Grafcet activity level	This word contains the number of active steps to be activated and deactivated for the current scan.
%SW21	Validity table for Grafcet transitions	This word contains the number of enabled transitions and transitions to be enabled and disabled for the current scan.
%SW30	Master task execution time	Shows, for the master task, the execution time of the last PLC scan (in ms)
%SW31	Max execution time for master task	Shows, for the master task, the longest execution time of the PLC scan since the last cold start (in ms).
%SW32	Min execution time for master task	Shows, for the master task, the shortest execution time of the PLC scan since the last cold start (in ms)
%SW33	Fast task execution time	Shows, for the fast task, the execution time of the last PLC scan (in ms)
%SW34	Max execution time of fast task	Shows, for the fast task, the longest execution time of the PLC scan since the last cold start (in ms).
%SW35	Min execution time of fast task	Shows, for the fast task, the shortest execution time of the PLC scan since the last cold start (in ms).
%SW48	Number of events	Indicates the number of events processed since the last cold start.
%SW49 to %SW53	Real-time clock function	Contains, in BCD, the current date / time value : %SW49 : day of the week, 1 to 7 (00DD) 1 = Monday, ..., 7 = Sunday %SW50 : Seconds, 0 to 59 (SS00), %SW51 : Hours, 0 to 23 / Minutes, 0 to 59 (HHMM), %SW52 : Month, 1 to 12 / day of month, 1 to 31 (MMDD), %SW53 : Century, 0 to 99 / Year, 0 to 99 (CCYY). These words are managed by the system when %S50 = 0. They can be accessed by the user in write mode when %S50 = 1.
%SW54 to %SW58	Real-time clock function	Contains, in BCD, the date / hour of the last power supply fault or PLC stop : %SW54 : Seconds, 0 to 59 (00SS) %SW55 : Hours, 0 to 23 / Minutes, 0 to 59 (HHMM), %SW56 : Month, 1 to 12 / day of month, 1 to 31 (MMDD), %SW57 : Century, 0 to 99 / Year, 0 to 99 (CCYY). %SW58 : day of the week on MSB, 1 to 7 (DD00) 1 = Monday, ..., 7 = Sunday

System words (continued)

Words	Function	Description																											
%SW58	Code of last stop	Contains the code of the cause of the last stop on the low order byte (00CC) : %SW58 = 1, change from RUN to STOP by the terminal, %SW58 = 2, stop on software fault (task overflow), %SW58 = 4, power fault or power supply RESET button pressed, %SW58 = 5, stop on hardware fault, %SW58 = 6, stop on HALT instruction.																											
%SW59	Adjustment of current date/time	Contains 2 series of 8 bits for adjusting the current date/time. The adjustment is made on the rising edge of a bit. The adjustment word is validated by %S59. <table border="1" style="width: 100%; border-collapse: collapse;"> <thead> <tr> <th>Incrementation</th> <th>Decrementation</th> <th>Parameter</th> </tr> </thead> <tbody> <tr> <td>bit %SW59:X0</td> <td>bit %SW59:X8</td> <td>day of the week</td> </tr> <tr> <td>bit %SW59:X1</td> <td>bit %SW59:X9</td> <td>seconds</td> </tr> <tr> <td>bit %SW59:X2</td> <td>bit %SW59:X10</td> <td>minutes</td> </tr> <tr> <td>bit %SW59:X3</td> <td>bit %SW59:X11</td> <td>hours</td> </tr> <tr> <td>bit %SW59:X4</td> <td>bit %SW59:X12</td> <td>day of month</td> </tr> <tr> <td>bit %SW59:X5</td> <td>bit %SW59:X13</td> <td>month</td> </tr> <tr> <td>bit %SW59:X6</td> <td>bit %SW59:X14</td> <td>year</td> </tr> <tr> <td>bit %SW59:X7</td> <td>bit %SW59:X15</td> <td>century</td> </tr> </tbody> </table>	Incrementation	Decrementation	Parameter	bit %SW59:X0	bit %SW59:X8	day of the week	bit %SW59:X1	bit %SW59:X9	seconds	bit %SW59:X2	bit %SW59:X10	minutes	bit %SW59:X3	bit %SW59:X11	hours	bit %SW59:X4	bit %SW59:X12	day of month	bit %SW59:X5	bit %SW59:X13	month	bit %SW59:X6	bit %SW59:X14	year	bit %SW59:X7	bit %SW59:X15	century
Incrementation	Decrementation	Parameter																											
bit %SW59:X0	bit %SW59:X8	day of the week																											
bit %SW59:X1	bit %SW59:X9	seconds																											
bit %SW59:X2	bit %SW59:X10	minutes																											
bit %SW59:X3	bit %SW59:X11	hours																											
bit %SW59:X4	bit %SW59:X12	day of month																											
bit %SW59:X5	bit %SW59:X13	month																											
bit %SW59:X6	bit %SW59:X14	year																											
bit %SW59:X7	bit %SW59:X15	century																											
%SW80 to %SW86	Message counters	%SW80 : number of messages transmitted by the system to the terminal port. %SW81 : number of messages received by the system from the terminal port. %SW82 : number of messages transmitted by the system to the PCMCIA communication card. %SW83 : number of messages received by the system from the PCMCIA communication card. %SW84 : number of telegrams transmitted by the system. %SW85 : number of telegrams received by the system. %SW86 : number of telegrams refused by the system.																											
%SW108	Number of forced bits	Indicates the number of forced bits in the application. Normally set to 0, it is updated by the system when forcing and unforcing bits in the application memory.																											
%SW109	Forced analog channel counter	Counts the number of analog channels forced to 0.																											

System words (continued)

Words	Function	Description
%SW124	Type of processor fault	Contains the last type of processor fault encountered. At values H'80' and H'81', it is used to diagnose a wiring fault on BusX. Read after PLC cold restart.
%SW125	Type of blocking fault	Contains the last type of blocking fault encountered (see section 3.1).
%SW126 and %SW127	Address of the blocking fault instruction	Contains the address of the instruction which generated the blocking fault (information for internal use). %SW126 contains the offset of this address %SW127 contains the base of this address



Service conditions

Part I

Section	Page
1 Standards / service conditions	1/1
1.1 Standards	1/1
1.2 Service conditions and requirements linked to the environment	1/1
1.2-1 Normal service conditions	1/1
1.2-2 Transport and storage requirements	1/2



Service conditions

Part I

1.1 Standards

TSX Premium PLCs have been developed to conform to the main national and international standards regarding electronic industrial control system products :

- Specific PLC requirements : operational characteristics, immunity, ruggedness, safety, etc.
EN61131-2 (IEC1131-2), CSA 22.2, UL 508
- Merchant navy requirements of principal European bodies :
BV, DNV, GL, LROS, RINA, etc.
- Compliance with European Directives (low voltage, Electromagnetic Compatibility), CE Marking.
- Electrical and self-extinguishing qualities of insulating materials :
UL 746C, UL 94, etc.

1.2 Service conditions and requirements linked to the environment

1.2-1 Normal service conditions

• Operating temperature/Humidity/Altitude

Ambient operating temperature	0°C to +60°C (IEC 1131-2 = +5°C to +55°C)
Relative humidity	30% to 95% (without condensation)
Altitude	0 to 2000 meters

• Supply voltages

Voltage	nominal	24VDC	48VDC	100...240VAC	100-120/200-240VAC
	limit	19..30VDC (1)	19..60VDC	90...264VAC	90..140/190..264VAC
Frequency	nominal	-	-	50/60 Hz	50/60 Hz
	limit	-	-	47/63 Hz	47/63 Hz
Micro-breaks	duration	≤ 1 ms	≤ 1 ms	≤ 1/2 period	≤ 1/2 period
	repetition	≥ 1s	≥ 1s	≥ 1s	≥ 1s
Total harmonic distortion	-	-	-	10%	10%
Residual ripple included	-	5%	5%	-	-

(1) Possible up to 34 VDC, limited to 1 hour per day.

With TSX PSY 1610 and TSX PSY 3610 power supplies, and if relay output modules are used, this range is reduced to 21.6V...26.4V

- **Mechanical withstand**

- Immunity to vibrations :
Complies with IEC 68-2-6, Fc test.
- Immunity to shocks:
Conforming to standard IEC 68-2-27, Ea test.

- **Electrostatic discharge withstand**

- Immunity to electrostatic discharges :
Conforming to standard IEC 1000-4-2, level 3 (1)

- **HF interference withstand**

- Immunity to electromagnetic radiation :
Conforming to standard IEC 1000-4-3, level 3 (1)
 - Immunity to bursts of rapid transients :
Conforming to standard IEC 1000-4-4, level 3 (1)
 - Immunity to shock waves :
Conforming to standard IEC 1000-4-5 (1)
 - Immunity to damped oscillatory waves :
Conforming to standard IEC 1000-4-12 (1)
- (1) minimum level in the test conditions laid down in the standards

- **LF interference withstand**

Conforming to standard IEC 1131-2.

- **TSX Premium PLC protective treatment**

TSX Premium PLCs meet the "TC" treatment (1) requirements.

For installing in an industrial production workshop or in an atmosphere corresponding to "TH" treatment (2), TSX Premium PLCs must be installed in at least IP54 protection enclosures as defined by the IEC 664 and NF C 20 040 standards.

TSX Premium PLCs offer their own protection index IP20 (3). They can therefore be installed without enclosures in reserved access premises which do not exceed pollution level 2 (control room with neither machines nor dust-producing activity).

- (1) "TC" treatment : all-atmosphere treatment.
- (2) "TH" treatment : treatment for warm or humid atmospheres.
- (3) When a position is not occupied by a module, a TSX RKA 02 protective cover must be placed over the position.

1.2-2 Transport and storage requirements

Conforming to the IEC 1131-2 requirements

Storage temperature	- 25°C to +70°C
----------------------------	-----------------

Section	Page
1 Presentation	1/1
1.1 General	1/1
1.2 Catalog	1/2
1.3 Physical description	1/4
1.3-1 TBX SUP 10 power supply block	1/4
1.3-2 TSX SUP 1101 power supply block	1/4
1.3-3 TSX SUP 1011/ 1021/ 1051 supply modules	1/5
1.4 Auxiliary functions	1/8
1.4-1 Parallel operation "with power optimization" mode	1/8
1.4-2 Redundancy / safety	1/9
2 Installation / Connections	2/1
2.1 TBX SUP 10 power supply block	2/1
2.2 TSX SUP 1101 power supply block	2/2
2.3 TSX SUP 1011 / 1021 / 1051 power supply modules	2/5
3 Characteristics	3/1
3.1 Electrical characteristics	3/1
3.2 Physical and environment characteristics	3/3

supply

Part J

1.1 General

The TBX SUP 10 and TSX SUP 1..1 process power supply blocks and modules supply ≈ 24 V to the peripherals of an application controlled by PLCs (TSX 37-..., TSX 57-..., etc). These peripherals include sensors, preactuators, encoders, operator terminals, loop controllers, indicator lamps, pushbuttons, pneumatic cylinders, etc.

The ≈ 24 V supply can be provided by a 100/240 V, 50/60 Hz AC supply or a DC supply for certain types of power supply.

A wide range of process power supplies are available providing the user with the best possible solution for his requirements :

- Power supply blocks : 24 VDC / 1A, 10A, can be integrated into the cabinet or enclosure with mounting on a Telequick pre-slotted plate AM1-PA or AM1-DE200/DP200 rail
- Power supply modules : 24 VDC / 1A, 2A, 5A, to TSX Premium PLC mechanical standard, can be integrated :
 - on TSX RKY .. racks,
 - into cabinet or enclosure, with mounting on Telequick pre-slotted plate AM1-PA or AM1-DE200/DP200 rail.

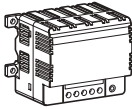
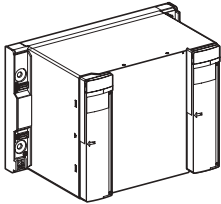
Power supply blocks	
Supply voltage 100...240VAC or 125VDC	Supply voltage 100...120/200...240VDC
	
24VDC / 1A	24VDC / 10A

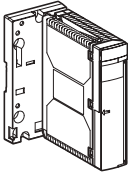
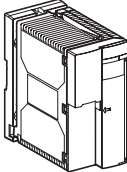
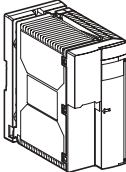
Power supply modules to TSX Premium PLC mechanical standard		
Supply voltage 100...240 VAC or 125 VDC	Supply voltage 100...120 or 200...240 VAC	
		
24VDC / 1A	24VDC / 1A	24VDC / 1A

1.2 Catalog

• Power supply blocks

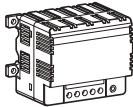
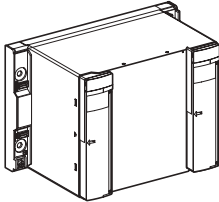
Type of supply	Blocks	
		
Input characteristics		
Nominal voltage	100...240 VAC or 125 VDC	100...120 VAC or 200...240 VAC
Limit values	90...264 VAC or 88...56 VDC	85...132 VAC or 170...264 VAC
Frequency limit	47...63 Hz	
Nominal input current	0.4A	3.5A
Output characteristics		
Useful power	24 W	240 W
--- output voltage	24 VDC	
Nominal current	1 A	10 A
Auxiliary functions		
VLSV (1)	No	Yes
Paralleling (2)	No	Yes with power optimization (3)
Redundancy	No	
References	TSX SUP 10	TSX SUP 1101

- (1) Construction characteristics conforming to standards IEC 950, IEC 1131-2, ensuring the safety of the user at the 24 V output, in terms of isolation between primary and secondary, maximum overvoltage on the output wiring and protection via the grounding circuit.
- (2) Option of paralleling 2 power supply outputs of the same type, to provide an output current greater than the maximum authorized by a single supply.
- (3) For 2 modules providing a total current of 100 %, each module supplies 50 % of the total. This improves the lifetime of the products.

• Power supply modules to TSX Premium PLC standard

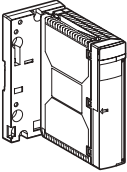
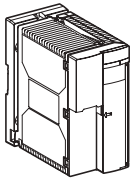
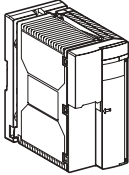
Type of supply	Modules		
			
Input characteristics			
Nominal voltage	100...240 VAC or 125 VDC	100...120 VAC or 200...240 VAC	
Value limits	85...264 VAC or 105...150 VDC	85...132 VAC or 170...264 VAC	
Frequency limit	47...63 Hz or 360...440 Hz		
Nominal input current	0.4 A	0.8 A	2 A
Output characteristics			
Useful power	26 W	53 W	120 W
⎓ output voltage	24 VDC		
Nominal current	1.1 A	2.2 A	5 A
Auxiliary functions			
VLSV (1)	Yes		
Paralleling (2)	Yes, with power optimization (3)		
Redundancy (4)	Yes		No
References	TSX SUP 1011	TSX SUP 1021	TSX SUP 1051

- (1) Construction characteristics conforming to standards IEC 950, IEC 1131-2, ensuring the safety of the user at the 24 V output, in terms of isolation between primary and secondary, maximum overvoltage on the output wiring and protection via the grounding circuit.
- (2) Option of paralleling 2 power supply outputs of the same type, to provide an output current greater than the maximum authorized by a single supply.
- (3) For 2 modules providing a total current of 100 %, each module supplies 50 % of the total. This improves the lifetime of the products.
- (4) Option of paralleling 2 power supply outputs of the same type, to provide an output current less than the maximum authorized by a single supply but ensuring availability of the output voltage even if one of the two modules becomes faulty.

1.3 Physical description

1.3-1 TBX SUP 10 power supply block

- 1 Lamp indicating module power-up.
- 2 Screw terminal block for wiring the power supply voltages.
- 3 Identification label for the wiring terminals.
- 4 Module mounting lugs.

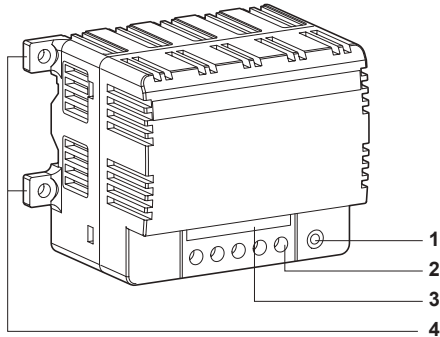

1.3-2 TSX SUP 1101 power supply block

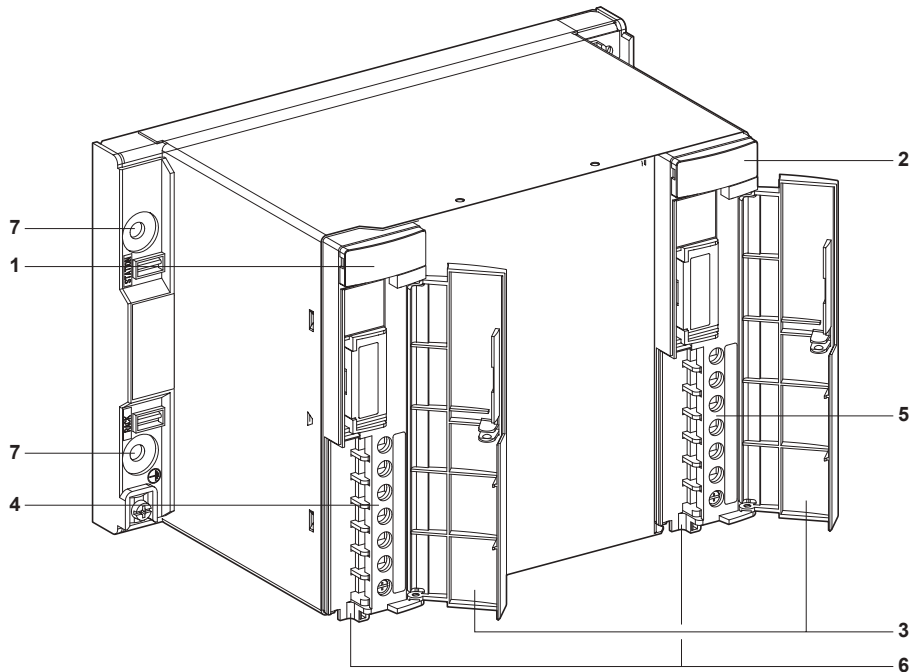

J

- 1 Display block comprising an ON indicator lamp (orange) : lit if the supply is powered up
- 2 Display block comprising a 24V indicator lamp (green) : lit if the 24 VDC output voltage is present and correct
- 3 Cover to protect the terminal blocks
- 4 Screw terminal block for connection to the AC supply
- 5 Screw terminal block for connection to the 24 VDC output
- 6 Slots for cable clamp
- 7 Four fixing holes for M6 screws.

1.3-3 TSX SUP 1011/ 1021/ 1051 supply modules

• TSX SUP 1011 module

- 1 Support plate for mounting the supply module directly on an AM1-DE200/ DP200 rail or an AM1-PA Telequick pre-slotted plate.
- 2 display block comprising:
 - A 24V indicator lamp (green) : lit if the internal and output voltages are established and correct.
 - An LSH indicator lamp (orange) "power optimization mode" : lit if the supply is operating in parallel mode with power optimization.
- 3 Cover to protect the terminal block
- 4 Screw terminal block for connection to the :
 - AC or DC supply,
 - 24VDC output.
- 5 Slots for cable clamp.
- 6 "NOR / LSH" switch on the rear of the module to control the power optimization device.
 - NOR position : normal operation without power optimization (default position),
 - LSH position : operation with power optimization.

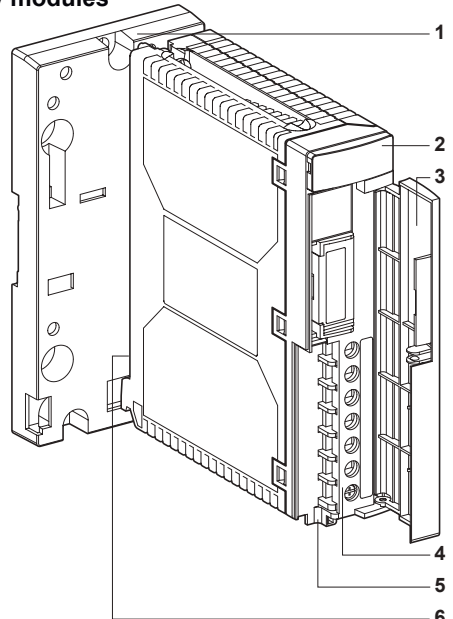

• TSX SUP 1021 /1051 modules

1 Support plate for mounting the supply module directly on an AM1-DE200/ DP200 rail or an AM1-PA Telequick pre-slotted plate.

2 Display block comprising :
- A 24V indicator lamp (green) : lit if the internal and output voltages are correct.
- An LSH indicator lamp (orange) "power optimization mode" : lit if the supply is operating in parallel mode with power optimization. Indicator lamp present only on the TSX SUP 1021 module.

3 Cover to protect the terminal block.

4 Screw terminal block for connection to the :
- AC or DC supply,
- 24VDC output.

5 Slots for cable clamp.

6 100/220 V voltage switch. When the module is supplied, the switch is set at 220.

7 "NOR / LSH" switch on the rear of the module to control the power optimization device. This switch is only present on the TSX SUP 1021 module

- NOR position : normal operation without power optimization (default position),
- LSH position : operation with power optimization.

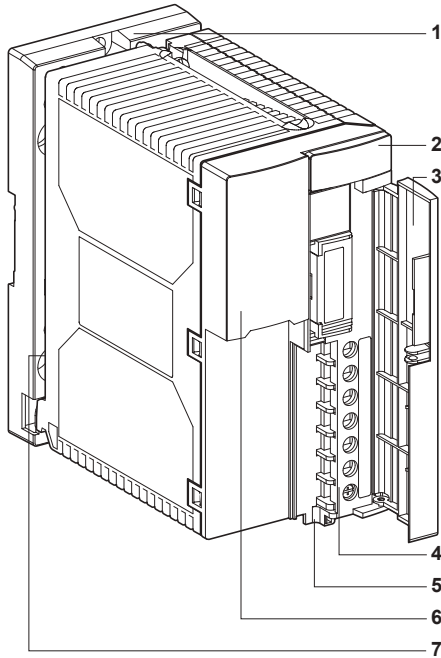

• Support plate

Each TSX SUP 10.1 power supply module comes with a support plate for fixing the power supply : either on an AM1-DE200 or AM1-DP200 rail, or an AM1-PA Telequick pre-slotted plate.

Each support plate can receive : either a TSX SUP 1021 or TSX SUP 1051 module, or one or two TSX SUP 1011 modules.

- 1 Three Ø 5.5 holes for mounting the support plate on a panel or AM1-PA pre-slotted plate at 140 mm centers.
- 2 Four Ø6.5 holes for mounting the support plate on a panel or AM1-PA pre-slotted plate at 88.9 mm centers.
- 3 Two M4 holes for fixing one or more TSX SUP 1011/1021/1051 power supply modules.
- 4 Slots for anchoring pins located at the bottom and rear of the module.

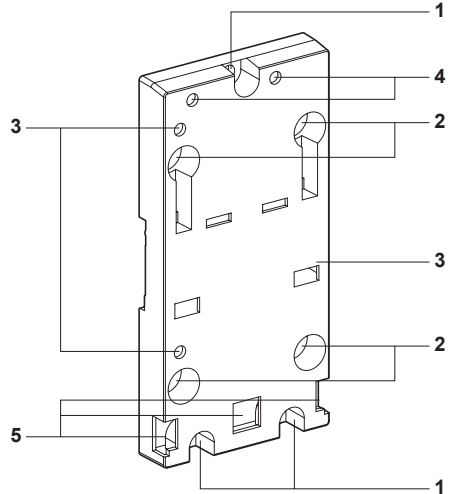

Notes :

- Each of these power supply modules can also be mounted on a TSX RKY .. rack replacing another module, with the exception of position PS, which must be used by a TSX PSY ... power supply module supplying rack modules.
- Plate support modules must be dismantled when performing the following operations :
 - setting the "NOR/LSH" switch to LSH,
 - mounting the plate on a panel or a pre-slotted AM1-PA plate,
 - mounting the module on a TSX RKY ... rack.

1.4 Auxiliary functions

1.4-1 Parallel operation "with power optimization" mode

• On TSX SUP 1011 / 1021 modules

In this mode, two or more modules with the same reference are placed in parallel. The resulting voltage depends on the current drawn by the power supplies and the initial precision of the no-load voltage of each power supply module. The precision of load sharing results from the dispersion of the no-load voltage of each power supply and the dispersion of the load control device. It is approximately 25%.

In this mode, the output voltage is in the range $24\text{ V} \pm 5\%$.

Example : Paralleling two power supplies to provide 1.6A.

V_{10} = no-load voltage supply 1
 V_{20} = no-load voltage supply 2
 V_{po} = voltage resulting from paralleling
supply 1 will provide 0.9A
supply 2 will provide 0.7A

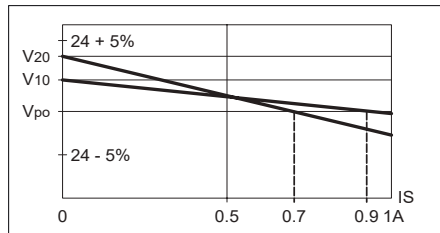

Parallel operation "with power optimization" is active when the **NOR/LSH** switch at the rear of the module is in the LSH position. The orange LED on the front of the module is lit when the mode is operational.

Current can be provided from 2 power supplies in parallel :

- 2.2 A with two TSX SUP 1011 power supplies,
- 4.4 A with two TSX SUP 1021 power supplies,

To use this mode, make the connections specified on sections 2.3

• On TSX SUP 1051 module and TSX SUP 1101 block

In this mode, two or more (modules or blocks) with the same reference can be placed in parallel. These power supply modules or blocks do not incorporate a diode in series with the output and therefore cannot be used in redundant configuration.

Unlike TSX SUP 1011/1021 modules, there is no mode switching. Connecting LSH terminals together from modules or blocks to be placed in parallel will cause automatic adjustment of the output current for each power supply as a function of the total current to be provided.

The connections specified in the sections below are required to operate this mode :

- 2.3, for the TSX SUP 1051 power supply module,
- 2.4, for the TSX SUP 1101 power supply block.

1.4-2 Redundancy / safety

The TSX SUP 1011 and TSX SUP 1021 power supplies incorporate a diode in series with the output (24V //) for paralleling. The point upstream from the diode (+24V), accessible at the terminal block, can be connected to a PLC input to provide an indication of the correct operation of the 2 power supplies.

Example : supply 1A with redundancy from the 2 TSX SUP 1011 power supplies.

Discrete inputs 1 and 2 of the PLC indicate the failure of one or other of the power supplies.

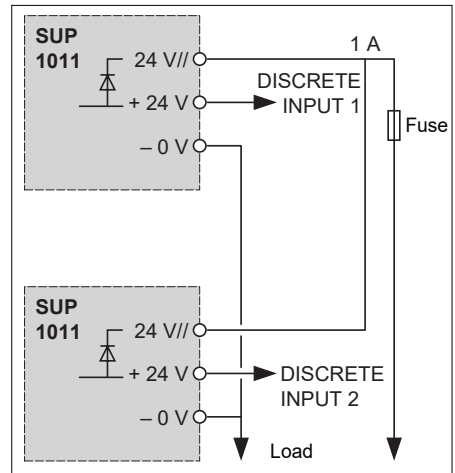

For power supplies operating in parallel, it is recommended to use the "power optimization mode" to ensure optimum lifetime of the 2 modules. Otherwise, the power supply with the higher output voltage will try to supply the maximum current with the other having practically no-load. The lifetime of the first supply will decrease more rapidly than that of the second supply.

2.1 TBX SUP 10 power supply block

• Dimensions / mounting

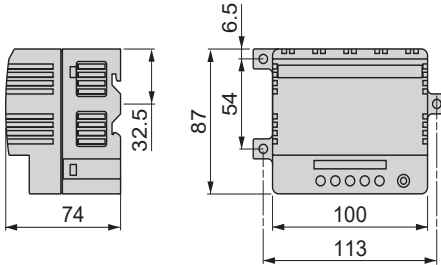

The TBX SUP 10 power supply block should be mounted vertically to ensure optimal air flow within the block.

It can be panel-mounted, on an AM1-PA Telequick pre-slotted plate or AM1-DE200 / DP200 rail.

• Connections

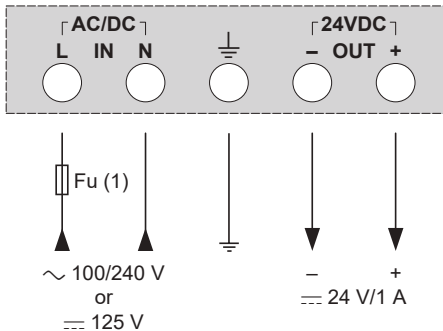

Note

Primary : if the module is supplied with 100/240 V \sim , the phase and the neutral must be respected when wiring. Conversely, if the module is supplied with 125 V \equiv , it is not necessary to respect the polarities.

Secondary : the - 24 V terminal (voltage of 0 V) must be connected to the ground at the output of the power supply module.

⚠ For safety of personnel, connect the ground terminal of the module to the protective ground with a green/yellow wire.

(1) External protection fuse on phase : 1A delayed 250 V for a single supply.

J

2.2 TSX SUP 1101 power supply block

- **Dimensions / mounting**

The TSX SUP 1101 supply block can be mounted on an AM1 - PA plate or on a panel

- **Mounting on a panel : drilling plan** (dimensions in millimeters)

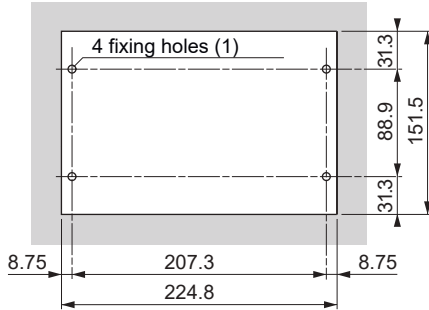

(1) The diameter of the fixing holes must be large enough to take M6 screws.

- **Mounting on an AM1-PA pre-slotted plate** (dimensions in millimeters)

Fix the power supply block using four M6x25 screws + washers and AF1-EA6 clip nuts

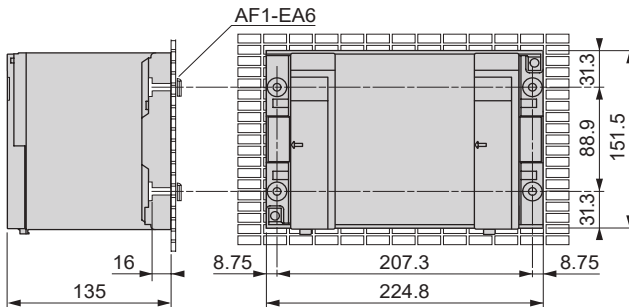

• Connections

Normal connection

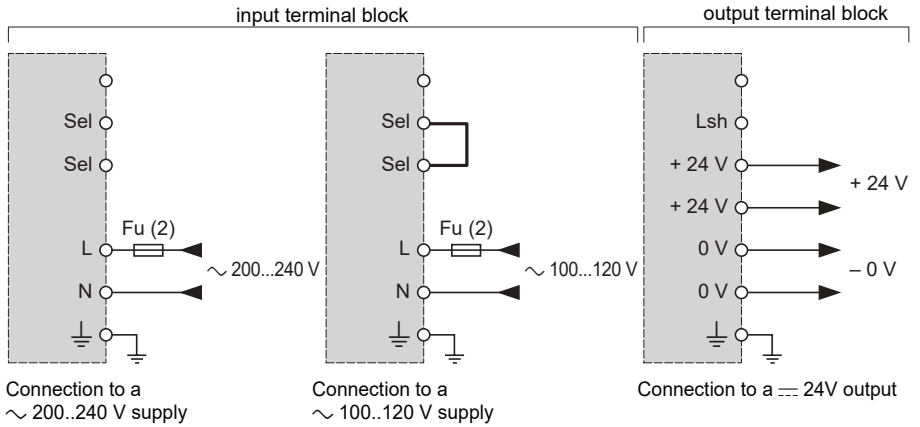

Paralleling

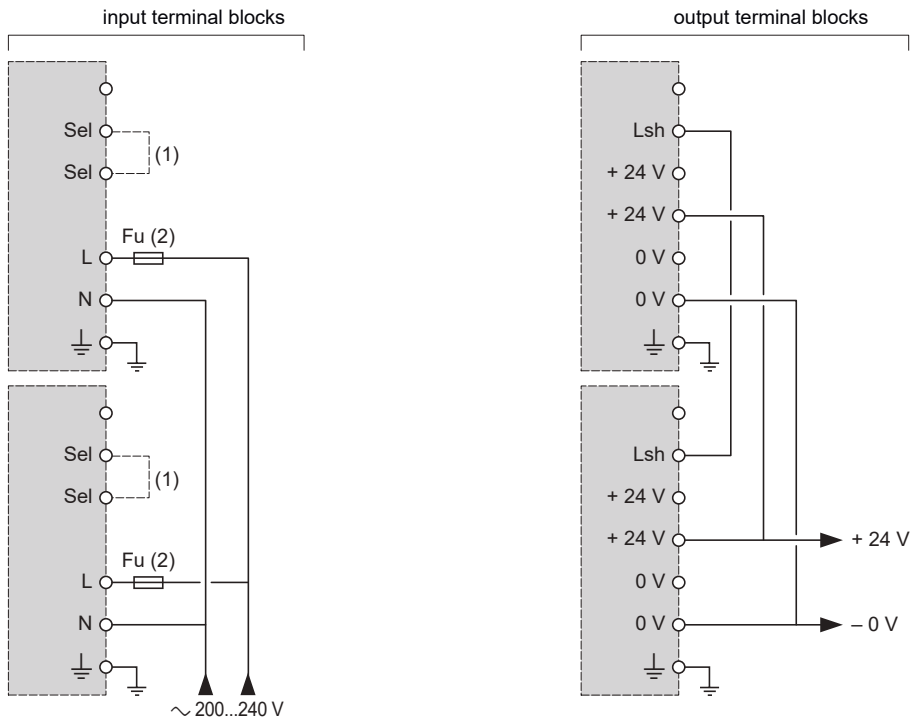

- (1) Connection to be performed if the power supply is $\sim 100...120\text{ V}$
- (2) External protection fuse on phase (Fu): 6.3A delayed action 250 V.

Connection rules

Primary : respect the phase and the neutral when wiring.

-  For safety of personnel, a green/yellow wire must be used to connect the ground terminal of the module to the protective ground.

The "~ power supply" and "24V output voltage" terminal blocks are protected by a cover which allows access to the wiring terminals. Wires exit vertically downwards. The wires can be held by a cable clamp.

In order to ensure 24 V VLSV isolation, use wires with :

- An operating voltage of ≥ 600 VAC and a cross section of 1.5 mm^2 for connecting to the AC supply,
- An operating voltage of ≥ 300 VAC and a cross section of 2.5 mm^2 for 24 V outputs and the ground.

2.3 TSX SUP 1011 / 1021 / 1051 power supply modules

• Dimensions / mounting

TSX SUP 1011/1021/1051 power supply modules

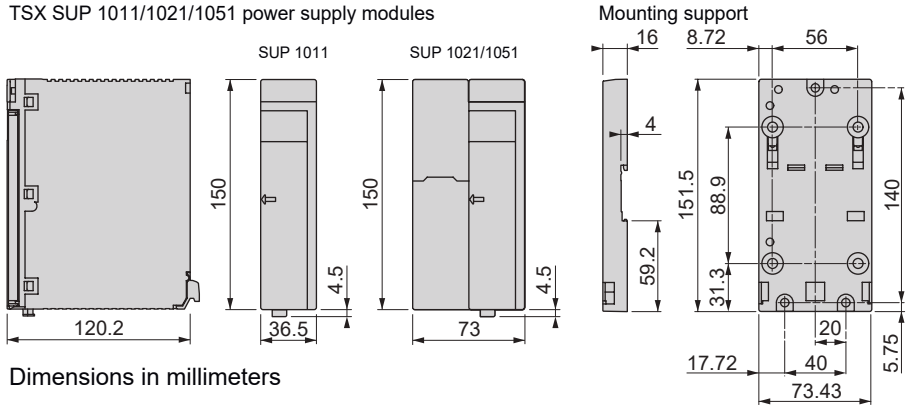

TSX SUP 1011/1021/1051 power supply modules can be mounted in the following ways :

Mounting on AM1-DE200 or AM1-DP200 rail or AM1-PA plate

Each power supply module comes mounted on a support for this type of mounting.

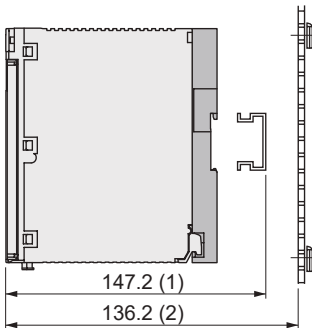

(1) module + support + AM1-DE200 rail. This dimension becomes 139.7 with AM1-DP200 rail
(2) module + support mounted directly on an AM1-PA plate

Mounting on an AM1-D.... rail

- 1 Check that the module is mounted on the support
- 2 Mount the combined module + support on the rail

Mounting on an AM1-PA rail

- 1 Dismantle the module from its support
- 2 Mount the support on the AM1-PA plate

Mounting the module on the support

Each power supply module has an integral support for mounting it directly on a DIN rail. The support can take 1 or 2 TSX SUP 1011 power supply modules or 1 TSX SUP 1021/1051 power supply module. The mounting procedure is identical to that for a module mounted on a TSX RKY .. rack (see Part A1 - section 5.4-1).

- 1 Fix the module pins in the slots on the lower part of the support.
- 2 Turn the module until it touches the support.
- 3 Tighten the screw on the upper part of the module to secure it to the support.

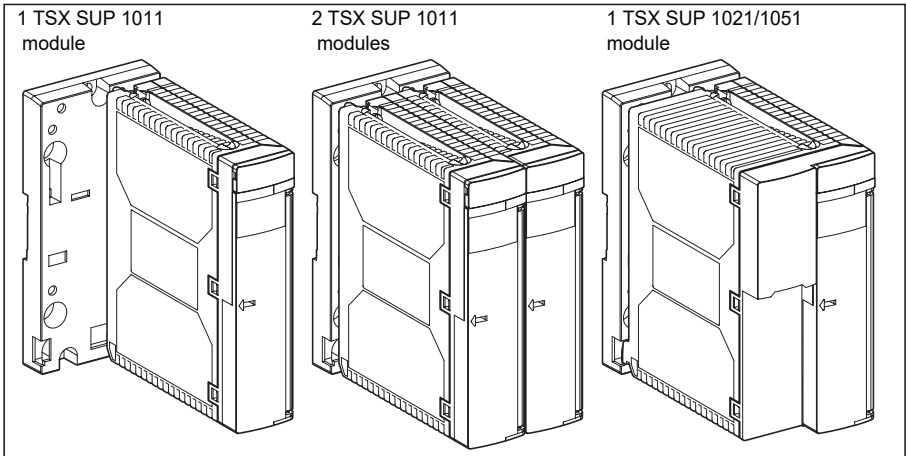

Mounting on a TSX RKY .. Rack

TSX SUP 1011/1021/1051 power supply modules can be mounted in any of the positions on a TSX RKY .. rack with the exception of position PS which is reserved for the rack power supply module. If this is the case, the support is not used and must be dismantled.

Note:

The TSX PSY... rack power supply module must be in position PS in order to supply the rack modules.

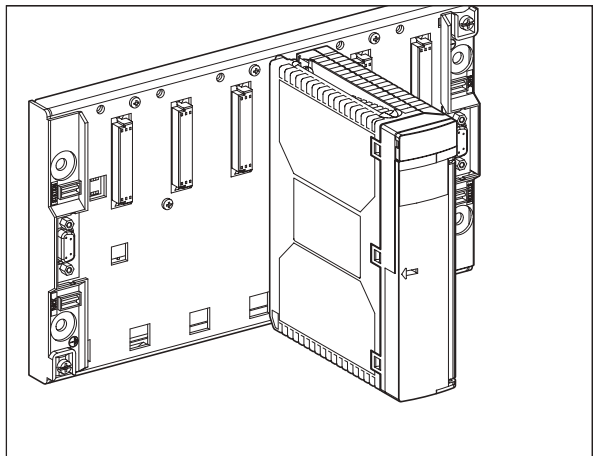

• Connecting TSX SUP 1011/1021 power supply modules

Normal connection

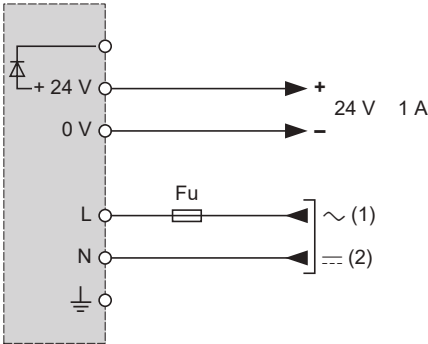

Paralleling

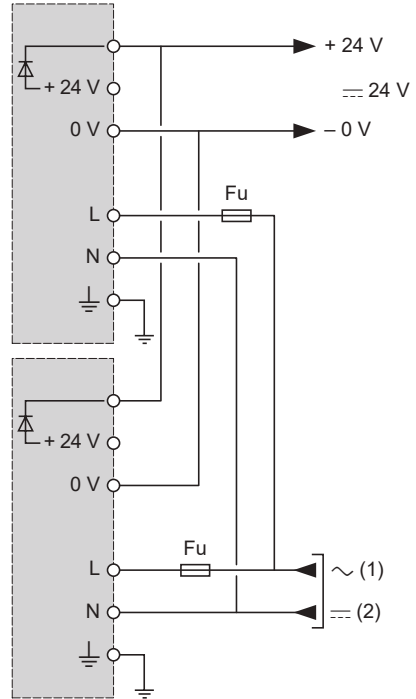

Fu = External protection fuse on phase
(Fu): 4A delayed action 250 V.

- (1) 100...240VAC on TSX SUP 1011
100...120 / 200...240VAC on TSX SUP 1021
- (2) 125 VDC, only on TSX SUP 1011

Connection rules

Primary : if the module is supplied with 100/240 V \sim , it is necessary to respect the phase and the neutral when wiring. Conversely, if the module is supplied with 125 V \equiv , it is not necessary to respect the polarities.

⚠ For safety of personnel, a green/yellow wire must be used to connect the module terminal to the protective ground.

The power supply terminal block is protected by a cover which allows access to the wiring terminals. Wires exit vertically downwards. The wires can be held by a cable clamp.

In order to ensure 24 V VLSV isolation, use wires with :

- An operating voltage of ≥ 600 VAC with a cross section of 1.5 mm² for connecting to the AC supply
- An operating voltage of ≥ 300 VAC with a cross section of 2.5 mm² for the 24 V outputs and the ground.

• Connecting TSX SUP 1051 power supply modules

Normal connection

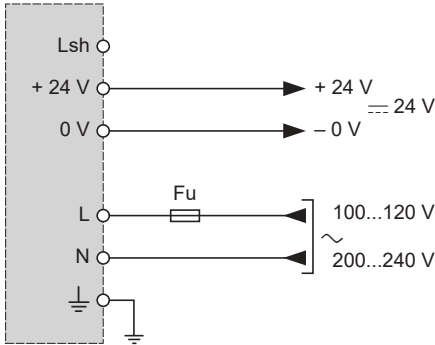

Paralleling

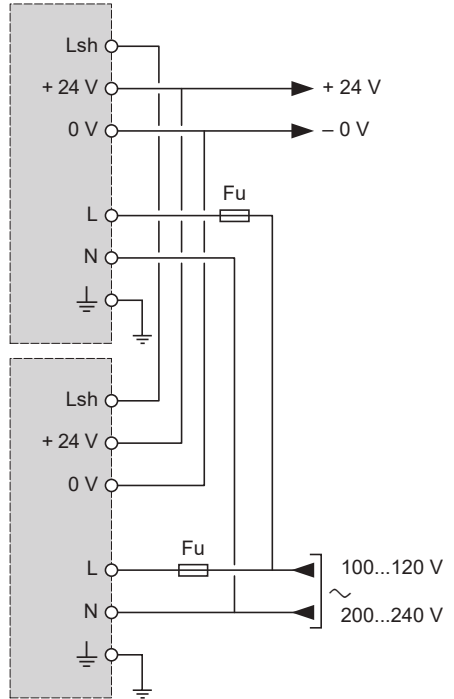

Fu = External protection fuse on phase
(Fu): 4A delayed action 250 V.

Connection rules

Primary : respect the phase and the neutral when wiring.



For safety of personnel, a green/yellow wire must be used to connect the module terminal to the protective ground.

The power supply terminal block is protected by a cover which allows access to the wiring terminals. Wires exit vertically downwards. The wires can be held by a cable clamp.

In order to ensure 24 V VLSV isolation, use wires with :

- An operating voltage of ≥ 600 VAC with a cross section of 1.5 mm^2 for connecting to the AC supply
- An operating voltage of ≥ 300 VAC with a cross section of 2.5 mm^2 for the 24 V output and the ground.

3.1 Electrical characteristics

Power supply blocks		TBX SUP 10 24 V / 1A	TSX SUP 1101 24V / 10A
Primary			
Nominal input voltage	V	~ 100 - 240 --- 125	~ 100...120/200...240
Input voltage limit	V	~ 90...264 --- 88...156	~ 85...132/170...264
Line frequency	Hz	47... 63	47...63/360...440
Nominal input current (U = 100V)	A	0.4	3.5
Max inrush current (1)	at 100 V	A	3
	at 240 V	A	30
It max on power up (1)	at 100 V	As	0.03
	at 240 V	As	0.07
I ² t max on power up (1)	at 100 V	A ² s	2
	at 240 V	A ² s	2
Power factor		0.6	0.6
Harmonic 3		10% ($\varphi = 0^\circ$ and 180°)	10% ($\varphi = 0^\circ$ and 180°)
Full load efficiency	%	> 75	> 80
Secondary			
Useful power	W	24	240
Nominal output current	A	1	10
Output voltage / specified at 25°C	V	24 ± 5 %	24 ± 1 %
Residual ripple (peak to peak) Max HF noise (peak to peak)	mV mV	240 240	200 240
Permitted AC supply microbreak period (2)	ms	≤ 10 in ~ ≤ 1 in ---	≤ 10 in ~
Protection against Short-circuits and overloads Overvoltages		continuous - automatic reactivation	current limiting
	V	peak limiting U > 36	peak limiting U > 32
Paralleling		no	yes with power optimization
Serial connection		no	yes

(1) Values on initial power up, at 25°C. These elements should be taken into account when starting up for sizing protection devices.

(2) Nominal voltage for a repetition frequency of 1 Hz.

Electrical characteristics (continued)

Power supply modules		TBX SUP 1011 24 V / 1A	TSX SUP 1021 24 V / 2A	TSX SUP 1051 24 V / 5A	
Primary					
Nominal input voltage	V	~ 100... 240 or --- 125	~ 100...120/200...240		
Input voltage limit	V	~ 85..264 or --- 105..150	~ 85...132/170...264		
Line frequency	Hz	47...63 / 360...440			
Nominal input current	A	0.4	0.8	2	
Max inrush current (1)	at 100 V	A	37	38	75
	at 240 V	A	75	38	75
It max on power up (1)	at 100 V	As	0.034	0.11	0.11
	at 240 V	As	0.067	0.11	0.11
I ² t max on power up (1)	at 100 V	A ² s	0.63	4	7.8
	at 240 V	A ² s	2.6	2	3.9
Power factor		0.6	0.6	0.6	
Harmonic 3		10% ($\varphi = 0^\circ$ and 180°)			
Full load efficiency	%	> 75		> 80	
Secondary					
Useful power (2)	W	26 (30)	53(60)	120	
Nominal output current (2)	A	1.1	2.2	5	
Output voltage (0°C - 60°C)	V	24 ± 3 %		24 ± 3 %	
Residual ripple (peak to peak)	mV	150		200	
Max HF noise (peak to peak) mV	mV	240			
Permitted AC supply microbreak period (3)	ms	≤ 10 in ~ and ≤ 1 in ---	≤ 10 in ~		
Start time on resistive load	s	< 1			
Protection against Shorts-circuits and overloads		fallback to 0 and automatic re- activation when error disappears		current limiting --- 105..150	
	Internal overvoltages	V	peak limiting U > 36	peak limiting U > 32	
Paralleling		yes with power optimization			
Serial connection		yes			

- (1) Values on initial power up, at 25°C. These elements should be taken into account when starting up for sizing protection devices.
- (2) Useful power and output current at a ambient temperature of 60°C. Value between () = useful power in a ventilated enclosure or a temperature range of 0...+40°C.
- (3) Nominal voltage for a repetition frequency of 1 Hz.

3.2 Physical and environment characteristics

Power supply modules / blocks		TBX SUP 10	TSX SUP 1011 / 1021 TSX SUP 1051 / 1101
Connection to screw terminals Max. capacity / terminal	mm ²	1 terminal per output 1 x 2.5	1011/1021/1051: 1 terminal/output 1101: 2 terminal/output 2x1.5 with cable end or 1 x 2.5
Temperatures : Storage Operation	° C ° C	-25 to +70 +5 to +55	-25 to +70 0 to +60
Relative humidity	%	5-95	
Cooling	%	By natural convection	
User safety		–	VLSV (EN 60950 and IEC1131-2)
Dielectric strength : Primary / secondary Primary / ground Secondary / Ground	rms V rms V rms V	50/60Hz- 1mn 1500 1500 500	3500 2200 500
Isolation resistance: Primary / secondary Primary / ground	MΩ MΩ	≥ 100 ≥ 100	
Leakage current		I ≤ 3.5 ms (EN 60950)	
Electrostatic discharge immunity		6 KV by contact / 8 KV in the air (conforms to IEC 1000-4-2)	
Electromagnetic field influence		10 V/m (80 MHz to 1 GHz)	
Electromagnetic interference rejection		(conforms to FCC 15-A and EN 55022 class A)	
Shock wave		Input : 4 kV MC, 2 KV MS Outputs: 2 kV MF, 0.5 kV MS (conforms to IEC 1000-4-5)	
Vibrations		1 mm 3 Hz to 13.2 Hz 1 g 57 Hz to 150 Hz (conforms to IEC 68-2-6, FC test)	
Degree of protection		IP 20.5	IP 20.5, IP 21.5 terminal block
MTBF	at 40°C	H	100 000
(Lifetime)	at 50°C	H	30 000



General presentation	A1
Terminal port communication	A2
Discrete I/O : TSX DEY ●●●● / DSY ●●●● modules	B
Analog : TSX AEY ●●● / ASY ●●● modules	C
Communication : TSX SCY 21600 module and PCMCIA cards	D
Counting : TSX CTY 2A / CTY 4A modules	E
Axis control : TSX CAY 21/ CAY 41 modules	F
Stepper control : TSX CFY 11/ CFY 21 modules	G
Startup / Diagnostics / Maintenance	H
Standards and installation conditions	I
Process supplies	J

A		TSX SCY CU 6030	D 2/7
		TSX SCY CU 6530	D 2/7
ABE 6 SD 2520	C 3/13	Cable ends	B 5/1
ABE 7 CP A 03	C 3/13	Cable routing	C 2/2
ABE 7 CP A02	C 3/13	Cable shielding	C 2/1
Acquisition cycle	C 3/11, C 4/11	Capacitive load	C 5/7
Adaptor sub-base	B 6/2	CFY 11/21	
Addressing discrete I/O channels	A1 7/1	Adjusting the axes	G2/3
Addressing racks in a PLC station	A1 2/5	Configuring the axes	G2/2
Aligned value	C 3/7, C 4/7	Debugging	G2/4
Alignment offset	C 3/7	Functions	G2/1
Altitude	I 1/1	Physical description	G1/3
Ambient temperature	I 1/1	Channel addressing	B 1/12
Analog input modules	C 3/1	Character mode connection	D 3/24
Analog/digital conversion	C 3/11, C 4/11	Characteristics	D 2/2
Application backup	A1 7/14	Auxiliary inputs	G3/15
Application memory	A1 7/12	Brake output Q0	G3/16
Application protection	A1 7/13	Integrated channel	D 2/2
AUX connector	A2 1/1	Module electrical	G3/13
AUX terminal port	A1 3/5, A2 1/1	Translator inputs	G3/14
Auxiliary inputs on TSX CTY .A modules		Characteristics of discrete I/O modules	B 4/1
Capture	E 2/8	TSX /16T3	B 4/7
Confirm	E 2/3	TSX DEY 08D2 / 16D2	B 4/1
Enable	E 2/8	TSX DEY 16A2	B 4/2
Line monitoring input - ERPS		TSX DEY 16A2/16A3/16A4/16A5	B 4/3
Preset	E 2/4, E 2/9	TSX DEY 16D3	B 4/1
Reset	E 2/3	TSX DEY 16FK	B 4/4
Axis control range	F 1/1	TSX DEY 32D2K/TSX DEY 64D2K	B 4/5
Physical description	F 1/3	TSX DSY 08R4D	B 4/9
TSX CAY 21	F 1/1	TSX DSY 08R5 / 16R5	B 4/8
TSX CAY41	F 1/1	TSX DSY 08R5A	B 4/10
		TSX DSY 08S5/TSX DSY 16S4	B 4/11
		TSX DSY 08T2/16T2/08T22	B 4/7
		TSX DSY 32T2K/TSX DSY 64T2K	B 4/12
B		Characteristics of the fan module	A1 8/7
Backup battery	A1 4/4	Characteristics of TSX PSY power supplies	A1 4/7
Blocking faults	H 3/2	Checking discrete I/O connections	H 2/1
Built-in protection for modules	B 2/8	Inputs	H 2/1
BusX extension cables	A1 2/4, A1 2/8	Outputs	H 2/1
C		Choice of encoder	F 3/2
Cable		Encoder power supply	F 3/2
TSX SCP CD 1030	D 3/7, D 3/8	Output interface	F 3/2
TSX SCP CM 4030	D 3/22	TSX CAP S9	F 3/3
TSX SCP CU 4030	D 3/20	Cold junction compensation	C 4/3, C 4/11
TSX SCP CU 4530	D 3/21	Cold start	A1 7/15
TSX SCP CX 2030	D 3/9	Common mode voltage	C 4/11
TSX SCP CX 4030	D 3/24		

Communication with an operator panel	A2 1/2	network	D 3/20
Compatibility of preactuators and discrete outputs	B 3/5	Connection via Modem	D 3/8
Compatibility of sensors and discrete inputs	B 3/5	Connections	F 3/10
Conductor type	C 2/1	Incremental encoder	F 3/10
Connecting	F 3/3	Connector pinout	C 3/12
Auxiliary I/O	G3/6	Control events	A1 7/10
Command signals	F 3/26	Conversion time	C 3/11, C 5/7
Connecting sensors and preactuators	F 3/18	Counter outputs	E 2/9
Counter signals	F 3/9	Up/down counting	E 2/9
NUM MDLA speed drive	F 3/17	Counter outputs - TSX CTY .A	
Speed reference signals	F 3/3	Upcounting or downcounting	E 2/4
SSI absolute encoder	F 3/11	Crosstalk	C 4/12
TAP MAS box	F 3/7	Crosstalk between channels	C 5/7
Telefast pre-wired system	F 3/5	Current consumed on 24 VR	C 1/2
Translator signals	G3/3	Current consumed on 5 V	C 1/2
Using a TSX CDP 310/501 cable	G3/12	Current consumption of PCMCIA cards	D 3/28
Using a TSX CDP 611 cable	F 3/4	Current consumption of TSX SCY 21600	D 2/13
Using TSX CDP 301 or 501 cable	F 3/23	Current outputs	C 5/7
Connecting the fan module	A1 8/6	Current shunt	C 3/8
Connection	D 3/7	Cyclic execution	A1 7/3
Encoder supplies	F 3/12		
TSX CAP S15	F 3/13	D	
TSX FPP 10	D 3/26	Devices which can be connected to	
TSX FPP 20	D 3/25	TSX P ACC01	A2 2/5
TSX SCP 111	D 3/7	Diagnostics	H 3/3
TSX SCP 112	D 3/9	Dielectric voltage	C 4/11
TSX SCP 114	D 3/20	Digital filter	C 4/11
TSX SUP 1011/1021/1051	J 2/7	Digital/analog conversion	C 5/4
Connection cables	B 6/8	Dimensions	A1 5/2
Connection in Character mode	D 2/12	Dimensions of the fan module	A1 8/3
Connection of TSX PSY ●●●● power supply modules	A1 6/6	Discrete I/O connection	B 5/1
Connection of the integrated channel	D 2/6	Discrete I/O display and diagnostics	B 3/10
To the UNI-TELWAY fieldbus	D 2/7	Discrete I/O module connections	B 5/4
Connection of TSX PSY iiiii power supplies	A1 6/2	TSX DEY 08D2	B 5/5
Connection of TSX PSY ●●●● power supply modules	A1 6/4	TSX DEY 16A2/16A3/16A4/16A5	B 5/8
Connection pinouts - TSX CTY .A		TSX DEY 16D2	B 5/6
15-pin SUB-D HD	E 3/10	TSX DEY 16D3	B 5/7
20-pin HE 10	E 3/11	TSX DEY 16FK	B 5/10
Connection to the Jbus/Modbus fieldbus	D 2/9	TSX DEY 32D2K	B 5/12
Connection to the Modbus/Jbus bus	D 3/22	TSX DEY 64D2K	B 5/13
		TSX DSY 08R5	B 5/18
		TSX DSY 08R5A / 08R4D	B 5/19
		TSX DSY 08S5 / 16S4	B 5/21
		TSX DSY 08T2/08T22	B 5/15
		TSX DSY 08T31	B 5/16

TSX DSY 16R5	B 5/18	External cold junction compensation	C 4/28
TSX DSY 16T2	B 5/15	External shunt	C 4/27
TSX DSY 16T3	B 5/16		
TSX DSY 32T2K / 64T2K	B 5/23		
Discrete inputs and outputs	B 1/1		
Display	A1 3/8		
Display block	C 3/10, C 4/10, C 5/6		
Display of module status	H 1/2		
Analog modules	H 1/3		
Application-specific modules	H 1/3		
Discrete I/O modules	H 1/2		
Power supply modules	H 1/6		
Display of PLC status	H 1/1		
ERR	H 1/1		
I/O	H 1/1		
RUN	H 1/1		
TER	H 1/1		
Distributed line adaptation	D 2/8		
Downcounting			
TSX CTY .A module	E 2/1		
Downcounting channels			
TSX CTY 1A/2A modules	E 2/3		
Downcounting inputs			
TSX CTY .A module	E 2/3		
Dynamic performance	D 3/11		

E			
Electrical characteristics	F 3/29	General wiring rules for discrete inputs	B 3/2
Monitoring the sensor voltage	F 3/35	Ground connections	A1 6/1
Of analog outputs	F 3/30	Grounding the modules	A1 6/1
Of auxiliary inputs	F 3/33	Grounding the racks	A1 6/1
Of relay outputs	F 3/37	Grouping of conductors	C 2/2
Of speed drive control inputs	F 3/36		
Electrical ranges	C 4/11		
-13..63 mV range	C 4/17		
±10 V range	C 4/13		
±5 V range	C 4/14		
0..10 V range	C 4/14		
0..20 mA range	C 4/16		
0..3850 Ohms range	C 4/18		
0..400 Ohms range	C 4/17		
0..5 V range	C 4/15		
1..5 V range	C 4/15		
4..20 mA range	C 4/16		
Encoding the terminal block	C 2/1		
Event management	B 2/5		
Event-triggered tasks	A1 7/10		
Extendable racks	A1 2/1 A1 2/2		
		F	
		Fallback value	C 5/3
		Fallback/Maintain outputs	C 5/5
		Fan modules	A1 8/1
		Fast cycle	C 3/3
		FAST task	A1 7/8
		Filter coefficient	C 3/4
		Filtering inhibited	C 3/3
		Fitting the RAM memory backup battery	A1 5/7
		Fixing racks	A1 5/3
		Forcing outputs	C 5/3
		Full scale	C 3/11, C 4/11
		Functions	F 2/1
		Adjusting the axes	F 2/3
		Block diagram of an axis control system	F 2/1
		Configuring the axes	F 2/2
		Debugging	F 2/4
		Fuse protection	B 2/8
		G	
		General wiring rules for discrete inputs	B 3/2
		Ground connections	A1 6/1
		Grounding the modules	A1 6/1
		Grounding the racks	A1 6/1
		Grouping of conductors	C 2/2
		I	
		Inductive load	C 5/7
		Initial power-up	
		Module states	H 2/2
		PLC status	H 2/2
		Input adaptor	B 6/2
		Inserting PCMCIA memory card	A1 5/8
		Inserting/removing I/O modules	B 1/9
		Inserting/removing modules	C 2/1
		Insertion of TSX PSY power supplies	A1 4/6
		Installation	
		Basic configuration	F 3/1
		Installation rules	A1 5/1
		Installation TSX PSY power supply	A1 4/6

Installing discrete I/O modules	B 1/9	Module self-tests	H 2/4
Installing the battery on a PCMCIA memory card	A1 5/9	Module used	H 2/4
Internal cold junction compensation	C 4/28	Module TSX DSZ 08T2	B 5/22
Internal conversion resistance	C 3/11	Modules	B 3/1
Internal faults	C 3/9, C 4/9, C 5/5	Monitoring preactuator voltage	B 2/7
Internal RAM memory	A1 3/6, A1 4/4	Monitoring presence of the terminal block	B 2/7
Isolation	C 3/11, C 5/7	Monitoring sensor voltage	B 2/7
J			
Junction box		Monitoring Short-circuit and Overload	B 2/7
TSX SCA 62	D 3/21	Monotonicity	C 5/7
TSX SCA50	D 2/11	Mounting fan modules	A1 8/4
L			
Labelling discrete I/O modules	B 1/10	Mounting modules	A1 5/5
Latching inputs	B 2/4	Mounting racks	A1 5/3
Leakage current	C 5/7	Mounting terminal blocks	A1 5/5
Line terminator	A1 2/4, A1 2/9	Mounting the TSX TAP S15 05	F 3/15
Linearization	C 4/11	Multidrop	D 3/10
Link		Multirange input module	C 4/1
SCP 112 / April 5000/7000 PLCs	D 3/14	Multitask application structure	A1 7/7
Multidrop	D 3/11	N	
Point to point	D 3/10	Network architecture	D 1/1
Loading an application "backup"	A1 7/14	Network documentation	D 1/1
M			
Maintain value	C 5/3	Non-blocking faults	H 3/1
Marking module positions	A1 2/11	Linked to program execution	H 3/2
Marking racks	A1 2/11	Normal cycle	C 3/3
MAST master task	A1 7/8	Number of analog modules	C 1/1
Master mode	A2 2/6	O	
Maximum error	C 3/11, C 4/11	Open lugs	B 5/1
Measurement filtering	C 3/4, C 4/5	Opening the cover	B 5/1
Measurement sampling	C 3/3, C 4/3	Operating modes	A1 7/15
Micro-cuts	I 1/1	Output fallback state	B 2/2
Modbus architecture	D 2/11	Output loads	C 5/1
Modem on terminal port	A2 1/7	Output power supply	C 5/7
Module addresses	A1 2/6	Output protection	C 5/7
Module diagnostics	B 2/6	Overcurrent permitted	C 4/11
Module display	F 3/38, E 4/14	Overshoot monitoring	C 3/4, C 4/3, C 5/3
Module functions	C 3/1, C 4/1, C 5/1	Overshoot values	C 4/4
Module identification	C 1/3	Overvoltage permitted	C 4/11
Module states		P	
Initial state	H 2/4	PCMCIA cards	D 3/1
Module disconnected	H 2/4	Connection	D 3/4
Module failure	H 2/4	Connection accessory	D 3/5
		Description	D 3/3
		Dislav	D 3/6

Mounting	D 3/5	TBX SUP 10	J 2/1
Precautions	D 3/4	TSX SUP 1011 / 1021 / 1051	J 2/5
Presentation	D 3/1	TSX SUP 1101	J 2/2
Protocols	D 3/1	Process power supply mounting	
References	D 3/4	TBX SUP 10	J 2/1
Visual diagnostics	D 3/6	TSX SUP 1011 / 1021 / 1051	J 2/5
PCMCIA memory cards	A1 3/6, A1 7/18	TSX SUP 1101	J 2/2
PCMCIA SCP 114 consumption	D 3/20	Processor characteristics	A1 3/11
Performance of the TSX Premium	A1 8/8	Processor faults	H 3/3
Periodic execution	A1 7/5	Processor installation	A1 3/4
Permissible overvoltage	C 3/11	Processor mounting	A1 3/4
PLC states	H 2/2	Processor RESET button	A1 7/18
PLC error	H 2/3	Processor RESET pushbutton	A1 3/7
PLC not configured	H 2/3	Processors	A1 3/1
PLC running	H 2/3	Programmable input filtering	B 2/3
PLC self-tests	H 2/3	Protecting the outputs	B 2/1
PLC software fault or HALT	H 2/3	Protection of relay output contacts	B 2/9
PLC stopped	H 2/3	Pt100 Class A probe	C 4/3
PLC station	A1 2/4		
Point-to-point connection	D 3/9	R	
Positioning the racks	A1 5/1	Range overshoot	C 3/9, C 3/11, C 4/8, C 5/4
Power consumption table	A1 4/11	Range selection	C 3/4, C 4/3
Power supply alarm relay	A1 4/4	RC network	C 5/7
Power supply failure and return	A1 7/16	Reactivating outputs	B 2/1
Power supply interlocking	A1 6/10	Realtime clock	A1 3/9
Power supply RESET button	A1 7/18	Recalibration	C 3/8, C 4/8
Power supply RESET pushbutton	A1 4/5	Recalibration range	C 4/8
Precision	C 4/12	Recommendations for use on discrete I/O	B 3/1
Process diagnostics	B 2/6	Rejection in common mode	C 4/13
Process power supply	J 1/1	Rejection in serial mode	C 4/13
Paralleling	J 1/9	Relative humidity	I 1/1
Power optimization	J 1/9	Relay output adaptor	B 6/3
Redundancy / safety	J 1/9	Resolution	C 3/11
Support plate	J 1/7	Response to cold start	A1 7/19
TBX SUP 10	J 1/4	Retrieving an application "backup"	A1 7/14
TSX SUP 1011/ 1021/ 1051	J 1/5	Return to factory parameters	C 3/8
TSX SUP 1031/1061/1121	J 1/4	RS 232 D physical support	D 3/7
TSX SUP 1101	J 1/8	RS 485 physical support	D 3/13
Process power supply characteristics		S	
TBX SUP 10	J 3/1	Scan time	C 4/3
TBX SUP 1011	J 3/2	Selecting a power supply module	A1 4/11
TSX SUP 1021	J 3/2	Self-tests	C 3/9, C 4/9
TSX SUP 1051	J 3/2	Sensor alignment	C 3/7, C 4/7
Process power supply connections		Sensor connection	C 4/27
TBX SUP 10	J 2/1	Sensor link fault	C 4/5, C 4/8
TSX SUP 1011/1021/1051	J 2/6		
TSX SUP 1101	J 2/3		
Process power supply dimensions			

Sensor link monitoring	C 4/5	Terminal port, communication	
Sensors not referenced to ground	C 2/2	Character string	A2 1/3
Sensors referenced to ground	C 2/2	Modem connection	A2 1/7
Sensors usable on TSX CTY .A		Operator panel	A2 1/2
Upcounting input	E 3/3	UNI-TELWAY master/slave	A2 1/3
Service conditions	I 1/1	Terminal port connections	A2 1/4
Set outputs to 0	C 5/5	Adjustment terminal and operator panel	A2 1/6
Setting the PLC to RUN/STOP	A1 7/2	Character string	A2 1/12
Setup	F 3/1, G 3/1	Operator panel	A2 1/6
Basic configuration	F 3/1, G 3/1	Programming / adjustment terminal	A2 1/5
Installation procedure	F 3/1, G 3/1	TSX model 40 master PLC type	A2 1/11
I/O interfaces	G 3/2	UNI-TELWAY inter-device	A2 1/10
Shielding	G 3/2	UNI-TELWAY inter-PLC	A2 1/9
Translator interface power supply	G 3/2	UNI-TELWAY master	A2 1/7
Wiring instructions	F 3/1, G 3/1	UNI-TELWAY slave	A2 1/8
Sharing the I/O	B 2/2	Terminal port pin connection	A2 1/17
Signal referencing	F 3/9	Thermocouple ranges	C 4/12, C 4/20
Single line adaptation	D 2/10	Translator with NPN open collector interface	G 3/4
Single task application structure	A1 7/3	Translator with RS 422/485 interface	G 3/4
Solid state adaptor	B 6/2	Troubleshooting	H 3/1
Standard display	C 3/6, C 4/6, C 4/7	TSX P ACC 01 isolation box	A2 1/1
Standard format	C 1/1	TSX AAK2	C 4/27
Standard racks	A1 2/1, A1 2/2	TSX BLY 01	C 1/1
Standards	C 3/11, C 4/11, D 1/2, I 1/1	TSX BLY 01 terminal block	C 4/26, C 5/8
Status indicator lamps	C 3/10, C 4/10, C 5/6	TSX CAP 030	C 3/13
Stepper motor axis control	G 1/1	TSX CAP S15	F 3/13
TSX CFY 11	G 1/1	TSX CAP S9	F 3/3
TSX CFY 21	G 1/1	TSX CDP 611	F 3/4
Summary of connection cables	D 3/27	TSX CTY .A characteristics	
System bits	H 3/4	Auxiliary inputs	E 3/7
System words	H 3/9	Auxiliary outputs	E 3/9
		Counting input	E 3/4
T		Modules	E 3/4
Task monitoring	A1 7/9	TSX CTY .A connections	
TELEFAST	C 3/13, G 3/8	ABE-7CPA01 sub-base	E 4/1
TELEFAST 2	B 6/1	ABE-7H08R10/16R20 sub-bases	E 4/5
Temperature display	C 4/7	Counting sensors	E 3/19
Temperature drift	C 3/11	Encoders	E 3/12
Temperature probe current	C 4/11	TSX CTY .A general rules	
Temperature probe ranges	C 4/11, C 4/19	Installation	E 3/23
TER connector	A2 1/1	Wiring	E 3/23
TER terminal port	A1 3/5, A2 1/1	TSX CTY 1A/2A counter modules	E 1/1
Terminal block fault	C 3/10, C 4/9, C 5/6	TSX CTY 1A/2A supply	
Terminal block label	C 1/3	Auxiliary sensors	E 3/24
Terminal block pinout	C 4/26, C 5/8	Encoder	E 3/24
Terminal port	A1 3/5, A2 1/1		
Terminal port characteristics	A2 1/16		

TSX CXP 213	F 3/8	TSX SCY 21600	D 2/1
TSX CXP 223	F 3/8	Description	D 2/1
TSX CXP 233	F 3/17	Insertion / removal :	D 2/3
TSX CXP 613	F 3/8	Installation	D 2/3
TSX CXP 633	F 3/17	Presentation	D 2/1
TSX FPP 10	D 3/26	TSX SCY 21600 module	
TSX FPP 20	D 3/25	consumption	D 2/13
"ERR" indicator lamp	D 3/6	TSX SCY 21600 visual diagnostics	D 2/4
TSX FPP 20 PCMCIA	D 3/2	TSX TAP S1505	F 3/13
TSX P ACC 01 box	A2 2/1		
TSX P ACC 01 connections	A2 2/3	U	
To the UNI-TELWAY bus	A2 2/3	UNI-TELWAY architecture	D 2/9
To TSX 57-●● PLCs	A2 2/3	Up/down counting	
TSX P ACC 01 box connectors	A2 2/9	TSX CTY .A module	E 2/2
TSX P ACC 01 configuration	A2 2/4	Up/down counting inputs	
TSX P ACC 01 connection between		TSX CTY .A module	E 2/6
two PLCs	A2 2/8	Upcounting	
TSX P ACC01 dimensions	A2 2/2	TSX CTY .A module	E 2/1
TSX P ACC01 fixing	A2 2/2	Upcounting channels	
TSX P ACC01 slave mode	A2 2/7	TSX CTY 1A/2A	E 2/3
TSX P57 10 processor	A1 3/1	Updating the outputs	C 5/4
TSX P57 20 processor	A1 3/1	User display	C 3/6, C 4/6
TSX PLY power supply catalog	A1 4/3	User memory structure	A1 7/12
TSX PSY ●●●● power supplies	A1 4/1	Using negative logic	B 3/8
TSX PSY ●●●● power supply			
modules	A1 4/1	V	
TSX PSY power supply display	A1 4/5	Voltage outputs	C 5/7
TSX RKA 02 protective cover	A1 2/10		
TSX RKY ●●● racks	A1 2/1	W	
TSX SCA 50	D 2/11	Warm restart	A1 7/16
TSX SCA 62	D 3/21	Wiring accessories	F 3/13
TSX SCP 111	D 3/7	TSX CAP S15	F 3/13
TSX SCP 112	D 3/9	TSX TAP S15 05	F 3/13
TSX SCP 114	D 3/20	Wiring precautions	E 3/22, F 3/24, G 3/11
TSX SCP CC 1030	D 3/8	Writing to the outputs	C 5/3
TSX SCP CD 1030	D 3/7		
TSX SCP CM 4030	D 3/22		
TSX SCP CU 4030	D 3/20		
TSX SCP CU 4530	D 3/21		
TSX SCP CX 203	D 3/9		
TSX SCP CX 4030	D 3/24		
TSX SCP PCMCIA			
Assembly	D 3/5		
Configuration	D 3/3		
Dimensions	D 3/3		
Indicator lamps	D 3/6		
Module locating device	D 3/3		
Slot	D 3/1		

05



W913293950302A 05



TSXDM57E

Schneider Electric Industries SAS

Headquarters

89, bd Franklin Roosevelt
F - 92506 Rueil Malmaison Cedex

<http://www.schneider-electric.com>

Owing to changes in standards and equipment,
the characteristics given in the text and images
in this document are not binding us
until they have been confirmed with us.