

Manual Edition 06/2003



# LOGO!

[www.nicsanat.com](http://www.nicsanat.com)  
021-87700210



# SIEMENS



[www.nicsanat.com](http://www.nicsanat.com)

021-87700210



1P

6ED1050-1AA00-0BE5

## Siemens AG

Bereich Automation and Drives  
Geschäftsgebiet Industrial Automation Systems  
Postfach 4848, D-90327 Nuernberg  
Copyright: © Siemens AG 2001 - 2003  
Subject to change without prior notice

# Preface

Dear customer

We thank you for purchasing LOGO! and congratulate you on your decision. With LOGO! you have acquired a logic module that meets the stringent quality requirements of ISO 9001.

LOGO! can be used in many fields of applications. Due to its high functionality and yet easy operation the LOGO! offers you highly efficient economies for almost any application.

## Purpose of this manual

This LOGO! manual provides you with information about the creation of circuit programs, about the installation and use of LOGO! 0BA4 devices and expansion modules, and about their compatibility to the previous 0BA0-0BA3 versions (0BAx are the last four characters of the order number and differentiate the device series).

## LOGO!'s place in information technology

The wiring information in your LOGO! manual is also found in the LOGO! Product Info included with all devices. For further information on programming the LOGO! on your PC, with the PC in the Online Help for LOGO!Soft Comfort.

LOGO!Soft Comfort is the programming software for PCs. It runs under Windows<sup>®</sup>, Linux<sup>®</sup>, Mac OS X<sup>®</sup> and helps you to get started with LOGO! and to write, test, print out and archive your programs, independent of the LOGO! .

## Guide

We have divided this manual into 9 chapters:

- Getting started with LOGO!
- LOGO! installation and wiring
- Programming LOGO!
- LOGO! functions
- Configuring LOGO!
- LOGO! program module (card)
- LOGO! software
- Applications
- Appendix

## Valid range of this manual

The manual applies to devices of the series 0BA4.

## Changes compared to previous releases of the manual

- LOGO! 24o was added.
- The digital module LOGO! DM 8 24R was added.
- The analog module LOGO! AM 2 PT100 was added.
- Description of changes and new features of the series 0BA4 devices.

## Main differences compared to previous devices (0BA0 to 0BA3)

- Higher performance: faster execution times
- New program module (card) with more memory and know-how protection, selectable at the parameters.
- Display with background lighting and 4 x 12 characters.

## New features of the current devices (0BA4)

- You have 130 blocks available for creating the circuit program.
- You can select retentivity also for time functions.
- You can use the LOGO! cursor keys as inputs.
- You can use the special functions “Shift register”, “Analog amplifier”, “Analog value monitoring” and “Analog differential trigger”.
- You can invert individual inputs.
- Six of the basic functions are expanded with four inputs.
- You can test your circuit program online using the PC.
- Parameters for certain functions can also be derived from analog values and counter values.
- Counter: You can also use fast inputs (I5, I6).

## Additional support

At our Internet address

<http://www.siemens.com/logo>

you can quickly and easily find answers to your queries about LOGO!.

You can reach Technical Support under:

Phone: +49 (0)180 5050-222

Fax: +49 (0)180 5050-223

E-Mail: [adsupport@siemens.com](mailto:adsupport@siemens.com)

## Safety guidelines

The notes in this user manual are for your own personal safety and for preventing damage to assets. You should read them carefully and follow the instructions they give you. These notes are highlighted with a warning triangle and are shown according to the degree of hazard as follows:

---



### Danger

Warns that death, serious harm to health or damage to assets **will** result if the respective precautionary measures are not taken.

---

---



### Warning

Warns that death, serious harm to health or damage to **can** result if the respective precautionary measures are not taken.

---

---



### Caution

Warns that harm to health or damage to assets can result if the respective precautionary measures are not taken.

---

---

### Caution

Means that material damage may occur if corresponding safety measures are not taken.

---

---

### Note

Draws your attention to particularly important information relating to the product and its handling, or to a part of the documentation requiring your special attention.

---

## Qualified personnel

Only **skilled personnel** should be allowed to start and operate this device. Qualified personnel in the sense of the information on safety technology in this manual are persons who are authorized to commission, to ground and to tag circuits, equipment and systems in accordance with safety regulations and standards.

### Use as intended

Please note:

---



#### Warning

This device must always be used as intended for the applications described in the catalog and in the technical specifications, and only in combination with third-party devices or components approved or recommended by Siemens.

Prerequisite for the safe and proper operation of the product is its proper transportation, storage, installation and mounting, and careful operator control and maintenance.

---

### Trademarks

LOGO! is a trademark of SIEMENS AG .

Other designations in this documentation may represent trademarks, whose use by third parties for their own purpose may infringe the right of the owner.

### Copyright © Siemens AG 1996 to 2003 All rights reserved

The reproduction, distribution or use of this document or its contents is not permitted without express written authority. Offenders will be liable for damages. All rights reserved, especially for the granting of patents or GM entries.

### Disclaimer of liability

We have examined the contents of this publication for agreement with the hardware and software described. Nevertheless, discrepancies can not be ruled out. Any liability and warranty for the accuracy of this information is excluded. The data in this manual are reviewed at regular intervals. Any corrections required are included in the subsequent editions. Suggestions for improvement are welcomed.

# Contents

<b>Preface</b> .....	<b>i</b>
<b>1 Getting started with LOGO!</b> .....	<b>1</b>
<b>2 LOGO! installation and wiring</b> .....	<b>11</b>
<b>2.1 Setup of the modular LOGO!</b> .....	<b>13</b>
2.1.1 Maximum setup .....	13
2.1.2 Setup with different voltage classes .....	14
<b>2.2 Installing/removing LOGO!</b> .....	<b>16</b>
2.2.1 DIN rail mounting .....	17
2.2.2 Wall-mounting .....	21
<b>2.3 Wiring the LOGO!</b> .....	<b>23</b>
2.3.1 Connecting the power supply .....	23
2.3.2 Connecting LOGO! inputs .....	25
2.3.3 Connecting outputs .....	31
<b>2.4 Switching on the LOGO!/Power On</b> .....	<b>33</b>
<b>3 Programming LOGO!</b> .....	<b>37</b>
<b>3.1 Connectors</b> .....	<b>39</b>
<b>3.2 Blocks and block numbers</b> .....	<b>42</b>
<b>3.3 The way to LOGO!, starting with the circuit diagram</b> .....	<b>45</b>
<b>3.4 The 4 Golden rules for the operation of LOGO!</b> ..	<b>48</b>
<b>3.5 Overview of the LOGO! menus</b> .....	<b>50</b>
<b>3.6 Writing and starting the circuit program</b> .....	<b>51</b>
3.6.1 Select programming mode .....	51
3.6.2 The first circuit program .....	53
3.6.3 Circuit program input .....	54
3.6.4 Assigning a circuit program name .....	60
3.6.5 Password .....	61
3.6.6 Switching LOGO! to RUN mode .....	66
3.6.7 Second circuit program .....	68
3.6.8 Deleting a block .....	74

3.6.9	Deleting block groups .....	75
3.6.10	Correcting typing errors .....	76
3.6.11	Deleting the circuit program .....	77
3.6.12	Summertime/wintertime conversion .....	78
3.6.13	Synchronization .....	83
<b>3.7</b>	<b>Memory space and circuit dimensions .....</b>	<b>84</b>
<b>4</b>	<b>LOGO! functions .....</b>	<b>89</b>
<b>4.1</b>	<b>Constants and connectors – Co .....</b>	<b>90</b>
<b>4.2</b>	<b>Basic functions list – GF .....</b>	<b>93</b>
4.2.1	AND (AND) .....	95
4.2.2	AND with edge evaluation .....	96
4.2.3	NAND (NOT AND) .....	97
4.2.4	NAND with edge evaluation .....	98
4.2.5	OR (OR) .....	99
4.2.6	NOR (NOT OR) .....	100
4.2.7	XOR (exclusive OR) .....	101
4.2.8	NOT (Negation, Inverter) .....	101
<b>4.3</b>	<b>Basics on special functions .....</b>	<b>102</b>
4.3.1	Designation of the inputs .....	103
4.3.2	Time response .....	104
4.3.3	Backup of the real-time clock .....	105
4.3.4	Retentivity .....	105
4.3.5	Parameter protection .....	106
4.3.6	Calculating the gain and offset of analog values ..	106
<b>4.4</b>	<b>Special functions list – SF .....</b>	<b>109</b>
4.4.1	On-delay .....	113
4.4.2	Off-delay .....	117
4.4.3	On-/Off-delay .....	119
4.4.4	Retentive on-delay .....	121
4.4.5	Wiping relay (pulse output) .....	123
4.4.6	Edge triggered wiping relay .....	125
4.4.7	Asynchronous pulse generator .....	128
4.4.8	Random generator .....	130
4.4.9	Stairway lighting switch .....	132
4.4.10	Multiple function switch .....	135
4.4.11	Weekly timer .....	138
4.4.12	Yearly timer .....	143
4.4.13	Up/down counter .....	146



4.4.14	Hours counter .....	150
4.4.15	Threshold trigger .....	155
4.4.16	Analog threshold trigger .....	158
4.4.17	Analog differential trigger .....	161
4.4.18	Analog comparator .....	165
4.4.19	Analog value monitoring .....	170
4.4.20	Analog amplifier .....	173
4.4.21	Latching relay .....	175
4.4.22	Pulse relay .....	176
4.4.23	Message texts .....	179
4.4.24	Softkey .....	186
4.4.25	Shift register .....	190
<b>5</b>	<b>Configuring LOGO! .....</b>	<b>193</b>
<b>5.1</b>	<b>Selecting parameter assignment mode .....</b>	<b>194</b>
5.1.1	Parameters .....	196
5.1.2	Selecting the parameters .....	197
5.1.3	Modifying parameters .....	198
<b>5.2</b>	<b>Setting the time-of-day and date (LOGO! ... C) .....</b>	<b>201</b>
<b>6</b>	<b>LOGO! program module (card) ....</b>	<b>203</b>
<b>6.1</b>	<b>Security function (CopyProtect) .....</b>	<b>205</b>
<b>6.2</b>	<b>Inserting and removing the program module (card) .....</b>	<b>208</b>
<b>6.3</b>	<b>Copying data from the LOGO! to the program module (card) .....</b>	<b>210</b>
<b>6.4</b>	<b>Copying data from the program module (card) to LOGO! .....</b>	<b>212</b>
<b>7</b>	<b>LOGO! Software .....</b>	<b>215</b>
<b>7.1</b>	<b>Connecting the LOGO! to a PC .....</b>	<b>218</b>

<b>8</b>	<b>Applications</b>	<b>221</b>
<b>8.1</b>	<b>Stairway or corridor lighting</b>	<b>223</b>
8.1.1	Requirements for a stairway lighting system	223
8.1.2	Previous solution	223
8.1.3	Lighting system with LOGO!	224
8.1.4	Special features and expansion options	226
<b>8.2</b>	<b>Automatic door</b>	<b>227</b>
8.2.1	Requirements of an automatic door	227
8.2.2	Conventional solution	228
8.2.3	Door control system with LOGO!	228
8.2.4	Special features and expansion options	231
8.2.5	Extended solution with LOGO! 230RC	231
<b>8.3</b>	<b>Air-conditioning System</b>	<b>234</b>
8.3.1	Requirements for an air-conditioning System	234
8.3.2	Advantages of using LOGO!	237
<b>8.4</b>	<b>Factory door</b>	<b>239</b>
8.4.1	Requirements for a gate control system	239
8.4.2	Previous solution	240
8.4.3	Extended LOGO! solution	242
<b>8.5</b>	<b>Centralized control and monitoring of several factory doors</b>	<b>243</b>
8.5.1	Requirements for a gate control system	244
<b>8.6</b>	<b>Luminous rows</b>	<b>247</b>
8.6.1	Requirements for a lighting system	247
8.6.2	Previous solution	248
8.6.3	Luminous row control system with LOGO! 230RC	249
<b>8.7</b>	<b>Service water pump</b>	<b>251</b>
8.7.1	Requirements for a control system of a service water pump	252
8.7.2	Previous solution	252
8.7.3	Service water pump system with LOGO! 230RC	253
8.7.4	Special features and expansions	254
<b>8.8</b>	<b>Further fields of application</b>	<b>255</b>

## Appendix

<b>A</b>	<b>Technical data</b> .....	<b>259</b>
A.1	General technical data .....	259
A.2	Technical data: LOGO! 230... and LOGO! DM8 230R .....	261
A.3	Technical data: LOGO! 24... and LOGO! DM8 24 .....	264
A.4	Technical data: LOGO! 24RC... and LOGO! DM8 24 R .....	267
A.5	Technical data: LOGO! 12/24... and LOGO! DM8 12/24R .....	270
A.6	Switching capacity and service life of the relay outputs .....	273
A.7	Technical data: LOGO! AM 2 .....	274
A.8	Technical data: LOGO! AM 2 PT100 .....	275
A.9	Technical data: LOGO!Power 12 V .....	277
A.10	Technical data: LOGO!Power 24 V .....	279
A.11	Technical data: LOGO! Contact 24/230 .....	281
<b>B</b>	<b>Determining the cycle time</b> .....	<b>283</b>
<b>C</b>	<b>LOGO! without display</b> .....	<b>285</b>
<b>D</b>	<b>LOGO! menu structure</b> .....	<b>289</b>
<b>E</b>	<b>Order numbers</b> .....	<b>291</b>
<b>F</b>	<b>Abbreviations</b> .....	<b>293</b>
	<b>Index</b> .....	<b>295</b>

[www.nicsanaf.com](http://www.nicsanaf.com)

021-87700210



# 1 Getting started with LOGO!

## Here's LOGO!

LOGO! is a universal logic module made by Siemens.

LOGO! integrates

- Controls
- Operator and display panel with background lighting
- Power supply
- Interface for expansion modules
- Interface for the program module (card) and a PC cable
- Pre-configured standard functions, e.g. on- and off-delays, pulse relay and softkey
- Timer
- Digital and analog flags
- Inputs and outputs, according to the device type.

## What LOGO! can do for you

LOGO! offers solutions for domestic and installation engineering (e.g. for stairway lighting, external lighting, sun blinds, shutters, shop window lighting etc.), switch cabinet engineering, as well as for mechanical and apparatus engineering (e.g. for gate control systems, air-conditioning systems, or rainwater pumps etc.).

LOGO! can also be implemented for special control systems in conservatories or greenhouses, for control signal processing and, by connecting a communication module (e.g. ASi) for distributed local controlling of machines and processes.

Special versions without operator panel and display unit are available for series production applications in small machine, apparatus, switching cabinet and installation engineering.

### Which devices are available?

LOGO! Basic is available in two voltage classes:

- Class 1  $\leq 24$  V, i.e. 12 V DC, 24 V DC, 24 V AC
- Class 2  $> 24$  V, i.e. 115...240 V AC/DC,

in the versions:

- With display: 8 inputs and 4 outputs.
- **Without display** ("LOGO! Pure"): 8 inputs and 4 outputs.

Each version is integrated into 4 subunits (SU), is equipped with an expansion interface and provides 33 pre-configured standard and special function blocks for the creation of your circuit program.

### Which expansion modules are available?

- LOGO! digital modules are available for operation with 12 V DC, 24 V AC/DC and 115...240 V AC/DC, and are equipped with four inputs and four outputs.
- LOGO! analog modules are available for operation with 12 V DC and 24 V DC, and are equipped with two analog inputs or two Pt100 inputs.
- LOGO! communications modules (CM), for example the communications module AS interface, that is described in a separate documentation.

The digital/analog modules are integrated in two subunits. Each one is equipped with two expansion interfaces for connecting additional modules.

### Devices no longer available

- All versions with **6** inputs.
- A long variant with 12 inputs and 8 outputs
- The bus version with 12 inputs and 8 outputs.

The modular features of LOGO! replace this type of equipment.

### It's your choice

The various LOGO! Basic versions and expansion modules offer you a highly flexible and adaptive system to suit your specific tasks.

The LOGO! system offers you many solutions such as for small domestic installations, simple automation tasks, and even complex engineering tasks involving its integration into a bus system (e.g. communications module AS interface).

---

### Note

LOGO! Basic may only be equipped with expansion modules of the same voltage class. Mechanical encoding pins in the housing prevent you from connecting devices of a different voltage class.

Exception: The left-hand interface of an analog module or communication module is galvanically isolated. This type of expansion module can therefore be connected to devices of a different voltage class. See also Chapter 2.1.

Each LOGO! Basic provides the following connections for the creation of the circuit program, regardless of the number of connected modules:

- Digital inputs I1 to I24
- Analog inputs AI1 to AI8
- Digital outputs Q1 to Q16
- Analog outputs AQ1 and AQ2
- Digital flag blocks M1 to M24, M8: Startup flag
- Analog flag blocks AM1 to AM6
- Shift register bits S1 to S8
- 4 cursor keys
- 16 blank outputs X1 to X16.

## The LOGO! structure

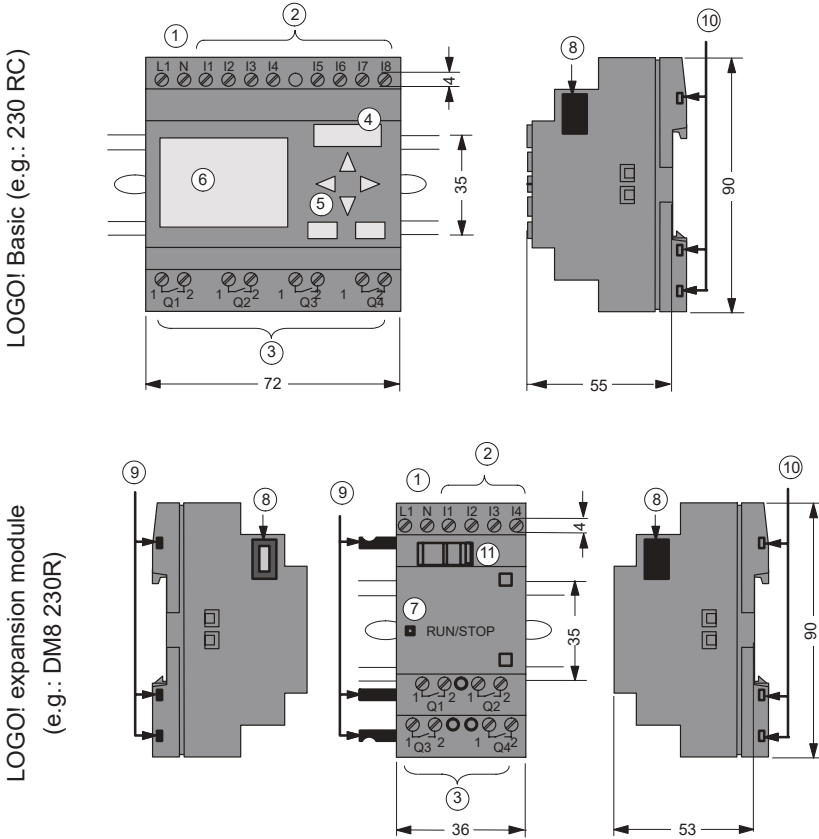

- |                        |                               |                             |
|------------------------|-------------------------------|-----------------------------|
| ① Power supply         | ⑤ Control panel (not for RCo) | ⑧ Expansion interface       |
| ② Inputs               | ⑥ LCD (not for RCo)           | ⑨ Mechanical coding pins    |
| ③ Outputs              | ⑦ RUN/STOP indicator          | ⑩ Mechanical coding sockets |
| ④ Module slot with cap |                               | ⑪ Slide                     |



LOGO! Basic (e.g.: 12/24 RC)

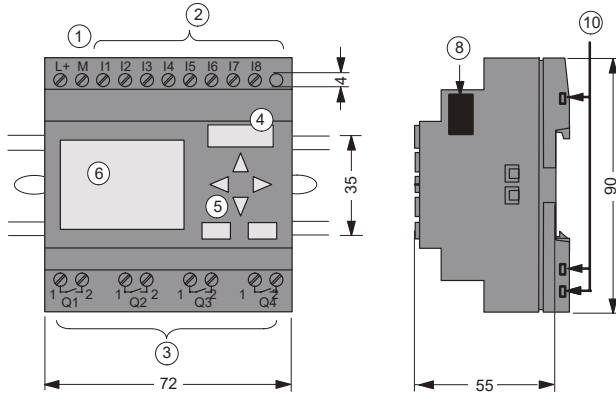

LOGO! expansion module  
(e.g.: DM8 12/24R)

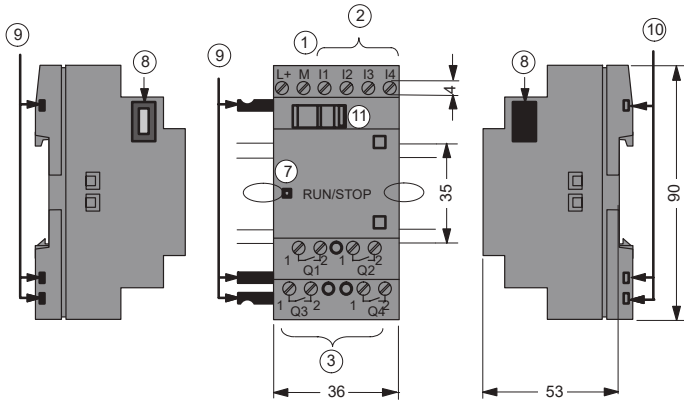

- |                        |                               |                             |
|------------------------|-------------------------------|-----------------------------|
| ① Power supply         | ⑤ Control panel (not for RCo) | ⑧ Expansion interface       |
| ② Inputs               | ⑥ LCD (not for RCo)           | ⑨ Mechanical coding pins    |
| ③ Outputs              | ⑦ RUN/STOP indicator          | ⑩ Mechanical coding sockets |
| ④ Module slot with cap |                               | ⑪ Slide                     |

## LOGO! AM 2

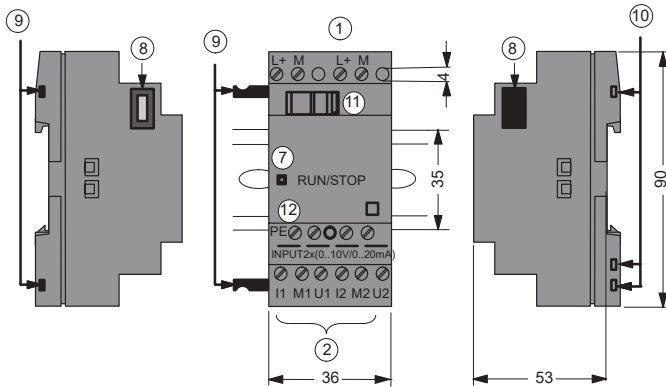

- ① Power supply
- ② Inputs
- ⑦ RUN/STOP indicator
- ⑧ Expansion interface
- ⑨ Mechanical coding pins
- ⑩ Mechanical coding sockets
- ⑪ Slide
- ⑫ PE terminal, for connecting earth and the shielding of analog measuring cables.

## LOGO! AM 2 PT100

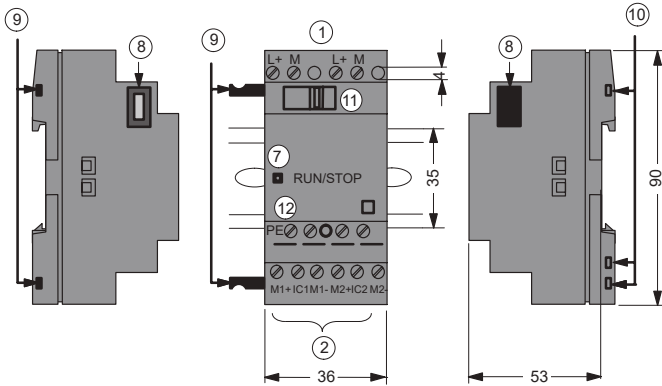

- ① Power supply
- ② Inputs
- ⑦ RUN/STOP indicator
- ⑧ Expansion interface
- ⑨ Mechanical coding pins
- ⑩ Mechanical coding sockets
- ⑪ Slide
- ⑫ PE terminal, for connecting earth and the shielding of analog measuring cables.

## How to identify the LOGO!

The LOGO! identifier informs you of various properties:

- 12: 12 V DC version
- 24: 24 V DC version
- 230: 115...240 V AC version
- R: Relay outputs (without R: solid-state outputs)
- C: Integrated Weekly timer
- o: Version without display (“LOGO! Pure”)
- DM: Digital module
- AM: Analog module
- CM: Communications module (e.g. AS interface)

## Symbols



Version with display unit is equipped with 8 inputs and 4 outputs



Version without display unit is equipped with 8 inputs and 4 outputs



The digital module is equipped with 4 digital inputs and 4 digital outputs





The analog module is equipped with 2 analog inputs



The communications module (CM) is equipped with 4 virtual inputs and 4 virtual outputs (e.g. AS interface)

## Versions

The following LOGO! versions are available:

Symbol	Designation	Supply voltage	Inputs	Outputs	Properties
	LOGO! 12/24 RC	12/24 V DC	8 digital (1)	4 relays (10 A)	
	LOGO! 24	24 V DC	8 digital (1)	4 solid state 24V / 0.3A	no clock
	LOGO! 24RC (3)	24 V AC/ 24 V DC	8 digital	4 relays (10A)	
	LOGO! 230RC (2)	115...240 V AC/DC	8 digital	4 relays (10A)	
	LOGO! 12/24RCo	12/24 V DC	8 digital (1)	4 relays (10A)	no display unit no keyboard
	LOGO! 24o	24 V DC	8 digital (1)	4 solid state 24 V / 0.3A	no display unit no keyboard no clock
	LOGO! 24RCo (3)	24 V AC / 24 V DC	8 digital	4 relays (10A)	no display unit no keyboard
	LOGO! 230RCo (2)	115...240 V AC/DC	8 digital	4 relays (10A)	no display unit no keyboard



(1): Of those can be used alternatively: 2 analog inputs (0 ... 10V) and 2 fast inputs.

(2): 230 V AC versions: Two groups consisting of 4 inputs each. Each group must be connected to the same phase. It is possible to interconnect groups with a different phase.

(3): The digital inputs can be operated with P or N action.

## Expansion modules

The following expansion modules can be connected to the LOGO!:

Symbol	Name	Power supply	Inputs	Outputs
	LOGO! DM 8 12/24R	12/24 V DC	4 digital	4 relays (5A)
	LOGO! DM 8 24	24 V DC	4 digital	4 solid state 24 V / 0.3 A
	LOGO! DM 8 24R <sup>(3)</sup>	24 V AC/DC	4 digital	4 relays (5A)
	LOGO! DM 8 230 R	115...240 V AC/DC	4 digital <sup>(1)</sup>	4 relays (5A)
	LOGO! AM 2	12/24 V DC	2 analog 0 ... 10 V or 0 ... 20 mA <sup>(2)</sup>	none
	LOGO! AM 2 PT100	12/24 V DC	2 Pt100 -50 °C to +200 °C	none

(1): Different phases are not allowed within the inputs.

(2): 0 ... 10 V, 0 ... 20 mA can be connected optionally.

(3): Digital inputs can be operated either with P or with N action.

## Certification and approvals

LOGO! is certified to cULus and FM.

- cULus Haz. Loc.  
Underwriters Laboratories Inc. (UL) to
  - UL 508 (Industrial Control Equipment)
  - CSA C22.2 No. 142 (Process Control Equipment)
  - UL 1604 (Hazardous Location)
  - CSA-213 (Hazardous Location)
 APPROVED for use in  
Class I, Division 2, Group A, B, C, D Tx  
Class I, Zone 2, Group IIC Tx
- FM Approval  
Factory Mutual Research (FM) to  
Approval Standard Class Number 3611, 3600, 3810  
APPROVED for use in  
Class I, Division 2, Group A, B, C, D Tx  
Class I, Zone 2, Group IIC Tx

---

### Note

You will find current approvals on the rating plate of the relevant module.

---



### Warning

Risk of personal injury and material damage.

In potentially explosive atmospheres, there is a risk of personal injury or damage to material if you disconnect connectors when the system is in RUN.

In potentially explosive atmospheres, always switch off the power supply to LOGO! and its components before you disconnect any connectors.

---

LOGO! is issued with the CE Certificate of Conformity. It is compliant with VDE 0631 and IEC 61131-2 and interference-proof to EN 55011, Limit Class B.

Marine certification has been requested.

- ABS (American Bureau of Shipping)
- BV (Bureau Veritas)
- DNV (Det Norske Veritas)
- GL (Germanischer Lloyd)
- LRS (Lloyds Register of Shipping)
- Class NK (Nippon Kaiji Kyokai)

LOGO! is therefore suitable for use both in industry and in the domestic area.

### ID for Australia



Our products carrying the label shown at the side are compliant with AS/NZS 2064:1997 (Class A) standard.

### Recycling and Disposal

LOGO! units can be fully recycled, due to their low-pollutant equipment. Contact a certified electronic waste disposal center for environmentally acceptable recycling and disposal of your old devices.

## 2 LOGO! installation and wiring

### General guidelines

Please note the following guidelines for the installation and wiring of your LOGO! :

- Always ensure that the wiring of your LOGO! is compliant with current rules and standards. Also, conform with all national and regional regulations when you install and operate the devices. For information on standards and regulations that apply to your specific case, contact your local authorities.
- Always use cables with an appropriate conductor cross-sections for the relevant current. You can wire the LOGO! with cable conductor cross-sections from 1.5 mm<sup>2</sup> to 2.5 mm<sup>2</sup>; see Chapter 2.3.
- Do not exceed the screw torque of the terminals. The maximum torque is: 0.5 N/m, see Chapter 2.3.
- Keep the cabling as short as possible. If longer cables are necessary, you should use shielded versions. You should always route your cables in pairs: i.e. one neutral conductor plus one phase conductor or signal line.
- Always keep separate:
  - The AC wiring
  - High-voltage DC circuits with high-frequency switching cycles
  - Low-voltage signal wiring.
- Ensure that the wires are installed with an appropriate strain relief.
- Provide a suitable lightning surge arrester for cables installed in relevant areas of hazard.

- Do not connect an external power supply in parallel to the output load of a DC output. This could develop a reverse current at the output if you have not installed a diode or similar barrier device.
- 

**Note**

LOGO! units may only be installed and wired by skilled personnel who know and follow the general engineering rules and the relevant regulations and standards.

---



## 2.1 Setup of the modular LOGO!

### 2.1.1 Maximum setup

#### Maximum setup of a LOGO! *with* analog inputs (LOGO! 12/24 RC/RCo and LOGO! 24/24o)

LOGO! Basic, 4 digital modules and 3 analog modules

I1.....I6, I7, I8 AI1, AI2	I9...I12	I13...I16	I17...I20	I21...I24	AI3, AI4	AI5, AI6	AI7, AI8
LOGO! Basic	LOGO! DM 8	LOGO! DM 8	LOGO! DM 8	LOGO! DM 8	LOGO! AM 2	LOGO! AM 2	LOGO! AM 2
Q1...Q4	Q5...Q8	Q9...Q12	Q13...Q16				

#### Maximum setup of a LOGO! *without* analog inputs (LOGO! 24 RC/RCo and LOGO! 230 RC/RCo)

LOGO! Basic, 4 digital modules and 4 analog modules

I1.....I8	I9...I12	I13...I16	I17...I20	I21...I24	AI1 , AI2	AI3, AI4	AI5, AI6	AI7, AI8
LOGO! Basic	LOGO! DM 8	LOGO! DM 8	LOGO! DM 8	LOGO! DM 8	LOGO! AM 2	LOGO! AM 2	LOGO! AM 2	LOGO! AM 2
Q1...Q4	Q5...Q8	Q9...Q12	Q13... Q16					

#### High-speed/optimal communication performance

For optimal and high-speed communication performance between LOGO! Basic and the various modules, we recommend you install the “digital modules first, then the analog modules” (example above).

## 2.1.2 Setup with different voltage classes

### Rules

Digital modules can only be connected to devices of the same voltage class.

You may connect analog and communications modules to devices of any voltage class.

### Overview:

#### Connecting an expansion module to LOGO! Basic

LOGO! Basic	Expansion modules					
	DM 8 12/24R	DM 8 24	DM 8 24R	DM 8 230R	AM2/ AM2 PT100	CM
LOGO! 12/24 RC	X	X	X	—	X	X
LOGO! 24	X	X	X	—	X	X
LOGO! 24 RC	X	X	X	—	X	X
LOGO! 230 RC	—	—	—	X	X	X
LOGO! 12/24RCo	X	X	X	—	X	X
LOGO! 24o	X	X	X	—	X	X
LOGO! 24 RCo	X	X	X	—	X	X
LOGO! 230 RCo	—	—	—	X	X	X

**Overview:**

**Connecting a further expansion module to an expansion module**

Expansion module	Further expansion modules					
	DM 8 12/24R	DM 8 24	DM 8 24R	DM 8 230R	AM2/ AM2 PT100	CM
DM 8 12/24 R	X	X	X	–	X	X
DM 8 24	X	X	X	–	X	X
DM 8 24 R	X	X	X	–	X	X
DM 8 230 R	–	–	–	X	X	X
AM2 / AM2 PT100	X	X	X	–	X	X
CM AS interface	X	X	X	–	X	X

## 2.2 Installing/removing LOGO!

### Dimensions

The LOGO! installation dimensions are compliant with DIN 43880.

LOGO! can be snap-mounted to 35 mm DIN rails to EN 50022 or on the wall.

LOGO! width:

- LOGO! Basic has a width of 72 mm, which corresponds with 4 subunits.
- LOGO! expansion modules have a width of 36 mm, which corresponds with 2 subunits.

---

### Note

The figure below shows you an example of the installation and removal of a LOGO! 230 RC and a digital module. The measures shown apply to all other LOGO! Basic versions and expansion modules.

---



---

### Warning

Always switch off power before you “remove” and “insert” an expansion module.

---

## 2.2.1 DIN rail mounting

### Mounting

How to **mount** a LOGO! Basic **and** a digital module onto a DIN rail:

*LOGO! Basic:*

1. Hook the LOGO! Basic module onto the rail and
2. then push down the lower end to snap it on. The mounting interlock at the rear must engage

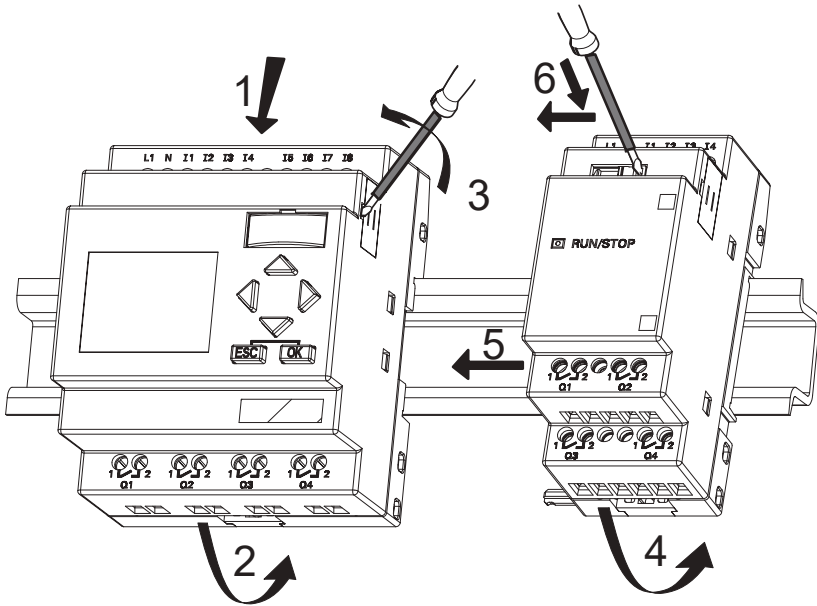

*LOGO! digital module:*

3. On the right side of the LOGO! Basic/LOGO! expansion module, remove the connector cap
4. Place the digital module onto the DIN rail on the right-hand side of the LOGO! Basic
5. Slide the digital module towards the left until it contacts the LOGO! Basic

- Using a screwdriver, push the interlock to the left. In its end position the slide interlock engages in the LOGO! Basic.

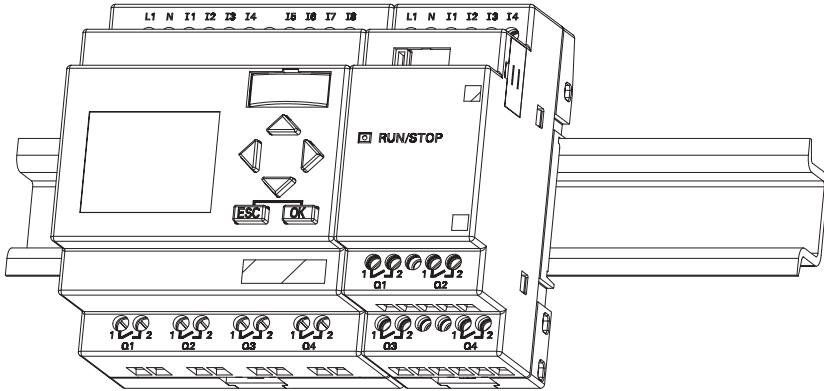

Repeat steps 3 through 6 to mount further expansion modules.

---

### Note

The expansion interface on the last expansion module must be covered.

---

## Removal

To **remove** the LOGO!:

..... if you have installed **only one LOGO! Basic**:

### Part **A**

1. Insert a screwdriver into the eyelet at the bottom of the slide interlock and move the latch downward
2. Swing the LOGO! Basic off the DIN rail.

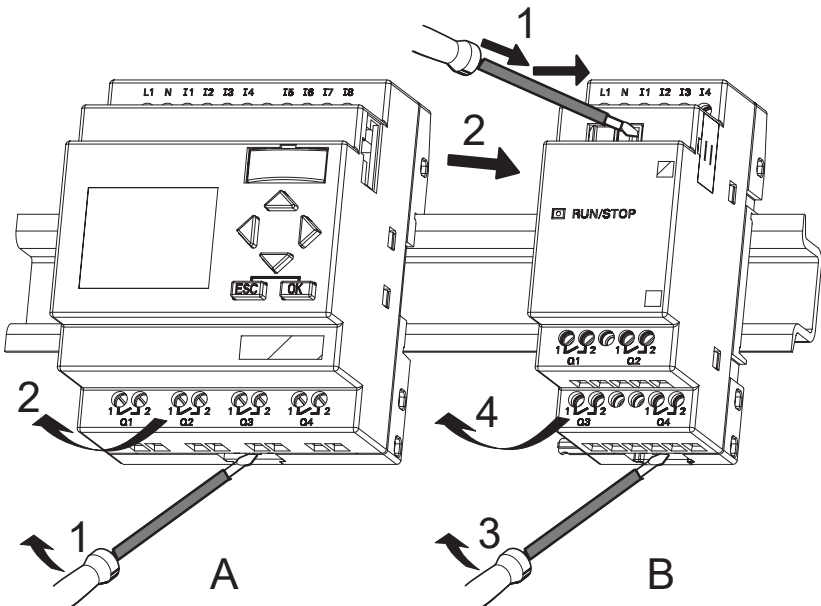

..... if you have connected **at least one expansion module** to the LOGO! Basic:

**Part B**

1. Using a screwdriver, push the integrate slide interlock to the right
2. Slide the expansion module off towards the right
3. Insert a screwdriver into the eyelet at the bottom of the slide interlock and lever it downward
4. Swing the expansion module off the profile rail.

Repeat steps 1 to 4 for all other expansion modules.

---

**Note**

If you have connected more than one expansion module, it is advisable to start removal with the last module at the right-hand side.

Make sure that the slide interlock of the module to be installed/removed is not engaged in the next module.

---



## 2.2.2 Wall-mounting

For wall-mounting, first slide the mounting slides on the rear side of the devices towards the **outside**. You can now wall-mount the LOGO! by means of two mounting slides and two  $\emptyset$  M4 screws (tightening torque 0.8 to 1.2 N/m).

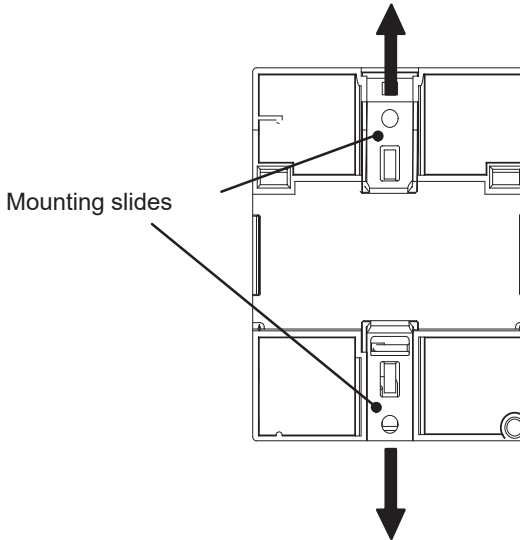

### Drilling template for wall-mounting

Before you can wall-mount the LOGO!, you need to drill holes using the template shown below.

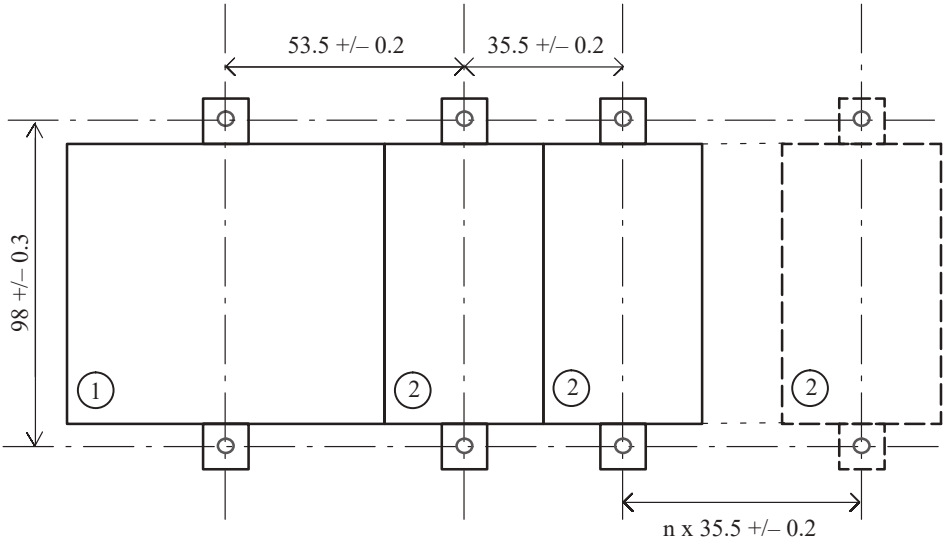

All dimensions in mm

- Bore hole for  $\emptyset$  M4 screw
- Tightening torque 0.8 to 1.2 N/m
- ① LOGO! Basic
- ② LOGO! expansion module

## 2.3 Wiring the LOGO!

Wire the LOGO! using a screwdriver with a 3-mm blade.

You do not need wire ferrules for the terminals. Permitted conductor cross-sections:

- 1 x 2.5 mm<sup>2</sup>
- 2 x 1.5 mm<sup>2</sup> for each second terminal chamber

Tightening torque: 0.4...0.5 N/m or 3...4 lbs/in

---

### Note

Always cover the terminals after you have completed the installation. To protect LOGO! adequately from impermissible contact to live parts, local standards must be complied with.

---

### 2.3.1 Connecting the power supply

The 230-V versions of LOGO! are suitable for operation with rated voltages of 115 V AC/DC and 240 V AC/DC. The LOGO! 24-V and 12-V versions can be operated with a 24 VDC, 24 V AC or 12 VDC power supply. For information on permissible voltage tolerances, line frequencies and power consumption, refer to the installation instructions in the Product Information supplied with your device and to the technical data in Appendix A.

---

### Note

A power failure may cause an additional edge triggering signal at the special functions, for example.

Data of the last uninterrupted cycle are stored in LOGO!.

---

## Connecting LOGO!

To connect LOGO! to the power supply:

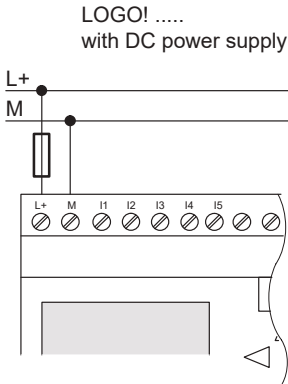

Protection with safety fuse  
if required (recommended) for:

12/24 RC...:	0.8 A
24:	2.0 A

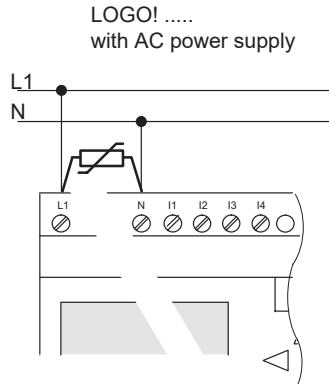

To suppress surge voltages,  
install varistors (MOV) with an  
operating voltage at least 20 %  
above the rated voltage.

---

### Note

LOGO! is a double-insulated switchgear. It is not required  
to connect an equipment grounding conductor.

---

## Circuit protection with AC voltage

To suppress voltage peaks on the power supply lines, you  
can install a metal oxide varistor (MOV) (MOV). Make sure  
that the operating voltage of the varistor (MOV) used lies at  
least 20 % above the rated voltage (for example S10K275).

## 2.3.2 Connecting LOGO! inputs

### Requirements

At the inputs you connect sensor elements such as: momentary switches, switches, light barriers, daylight control switches etc.

### Sensor characteristics for LOGO!

	LOGO! 12/24 RC/RCo LOGO! DM8 12/24 R		LOGO! 24/24o LOGO! DM8 24	
	I1 ... I6	I7, I8	I1 ... I6	I7, I8
<b>Signal status 0</b>	< 5 VDC	< 5 VDC	< 5 VDC	< 5 VDC
Input current	< 1.0 mA	< 0.05 mA	< 1.0 mA	< 0.05 mA
<b>Signal status 1</b>	> 8 V DC	> 8 V DC	> 8 V DC	> 8 V DC
Input current	> 1.5 mA	> 0.1 mA	> 1.5 mA	> 0.1 mA

	LOGO! 24 RC/RCo (AC) LOGO! DM8 24 R (AC)	LOGO! 24 RC/RCo (DC) LOGO! DM8 24 R (DC)	LOGO! 230 RC/RCo (AC) LOGO! DM8 230 R (AC)	LOGO! 230 RC/RCo (DC) LOGO! DM8 230 R (DC)
<b>Signal status 0</b>	< 5 V AC	< 5 V DC	< 40 V AC	< 30 V DC
Input current	< 1.0 mA	< 1.0 mA	< 003 mA	< 003 mA
<b>Signal status 1</b>	> 12 V AC	> 12 V DC	> 79 V AC	> 79 V DC
Input current	> 2.5 mA	> 2.5 mA	> 0.08 mA	> 0.08 mA

### Note

The digital inputs of LOGO! 230 RC/RCo are divided into two groups, each consisting of four inputs. **Within** the same group, all inputs must be operated on the **same** phase. **Different** phases are only possible **between** the groups.

Example: I1 to I4 on phase **L1**, I5 to I8 on phase **L2**.

Inputs within the LOGO! DM8 230R may **not** be connected to different phases.

## Sensor connections

### Connecting glow lamps and 2-wire proximity switches (Bero) to LOGO! 230 RC/230 RCo or LOGO! DM8 230 R (AC)

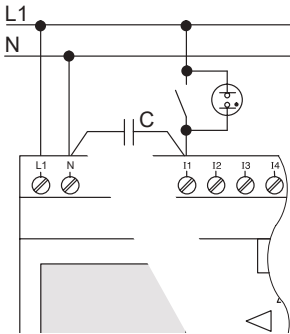

Order number for C:

Siemens  
Switchgear & Systems

—||— 3SB1420-3D

X-capacitor 2.5 kV, 100 nF

Take the quiescent current of any 2-wire proximity switches used into account. The level of the quiescent current of some 2-wire proximity switches is high enough to trigger a logical "1" signal at the LOGO! input. You should therefore compare the quiescent current of the proximity switches with the technical data of inputs Appendix A.

## Restrictions

- Signal status transitions  $0 \rightarrow 1 / 1 \rightarrow 0$

After a 0 to 1 or 1 to 0 transition, the signal must remain constant at the input at least for the duration of one program cycle, so that LOGO! can detect the new signal status.

The program execution time is determined by the size of the circuit program. Appendix B contains a benchmark test routine that you can use to determine the current scan cycle time.

## Special features of LOGO! 12/24 RC/RCo and LOGO! 24/24o

- *High-speed inputs: I5 and I6*

These versions are also equipped with high-speed counting inputs (Up/down counters, Threshold triggers). The restrictions mentioned earlier do not apply to these high-speed inputs.

---

## Note

The high-speed inputs I5 and I6 are the same as in the previous versions 0BA0 to 0BA3, i.e. a circuit program that is written in these versions can be transferred to the new 0BA4 units by means of the programming software LOGO! SoftComfort, without any changes to these features. In contrast to this, you need to modify circuit programs written for a LOGO!...L version (high-speed inputs I11/I12).

Expansion modules do not have high-speed inputs.

---

- *Analog inputs: I7 and I8*

The inputs I7 and I8 of LOGO! versions 12/24RC/RCo and 24/24o can be used both as standard digital inputs and as analog inputs. The input mode is defined in the LOGO! circuit program.

The inputs I7 / I8 provide digital functions, and the inputs AI1 and AI2 provide analog functions.

See also Chapter 4.1.

### Note

The LOGO! AM 2 expansion module provides further analog inputs. The LOGO! AM 2 PT100 expansion module provides Pt100 inputs.

Always use twisted and shielded cables for analog signals, and keep these as short as possible.

---

### Sensor connections

To connect sensors to the LOGO! :

#### LOGO! 12/24 ....

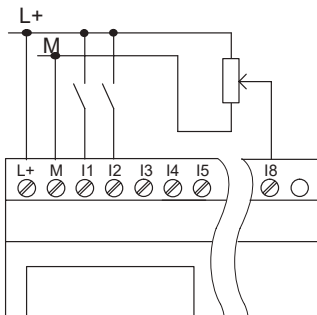

The inputs of these devices not isolated and therefore require a common reference potential (chassis ground ).

At the LOGO! 12/24RC/RCo and LOGO! 24/24o modules, you can tap analog signals between the supply voltage and chassis ground.

#### LOGO! 230 ....

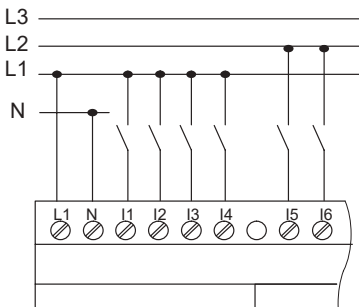

The inputs of these devices are arranged in 2 groups, each consisting of 4 inputs. Different phases are only possible between blocks, but not within the blocks.





**Warning**

Current safety regulations (VDE 0110, ... and IEC 61131-2, ... as well as cULus) do not permit the connection of different phases to an AC input group (I1 to I4 or I5 to I8) or to the inputs of a digital module.

**LOGO! AM 2**

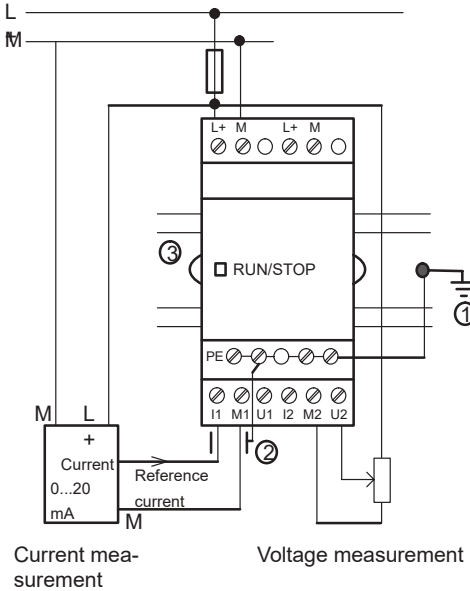

PE PE terminal for connecting earth and the shielding of the analog measuring cable

- ① Earth
- ② Cable shielding
- ③ DIN rail

## LOGO! AM 2 PT100

You can connect either a 2- or 3-wire Pt100 resistive thermocouple to the module.

For a **2-wire** connection, you need to short-circuit terminals M1+ and IC1 or M2+ and IC2. Errors caused by the ohmic resistance of the measuring line are not compensated with this type of connection. A line resistance of 1  $\Omega$  is proportional to a measuring error of +2.5  $^{\circ}\text{C}$ .

A **3-wire** technique suppresses the influence of the cable length (ohmic resistance) on the result of the measurement.

2-wire technique

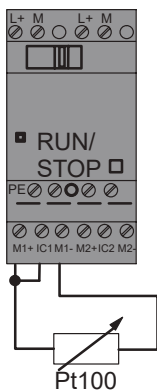

3-wire technique

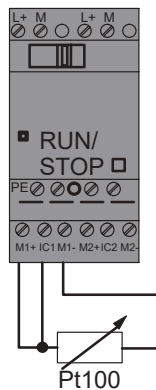

---

### Note

When you operate the LOGO! AM 2 PT100 expansion module on an ungrounded (floating potential) power supply, the indicated temperature value may be subject to heavy fluctuation.

In this case, connect the shielding of the thermocouple cable to the negative output / chassis ground output of the power supply module.

---

### 2.3.3 Connecting outputs

#### LOGO! ...R...

The LOGO! ...R... version is equipped with relay outputs. The potential of the relay contacts is isolated from the power supply and the inputs.

#### Requirements for relay outputs

You can connect various loads to the outputs, e.g. lamps, fluorescent lamps, motors, contactor relays etc. For information on the properties required for the loads connected to the LOGO! ...R..., refer to Appendix A.

#### Connecting

This is how you connect the load to LOGO! ...R...:

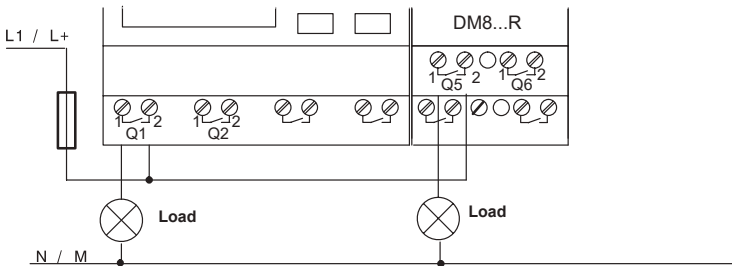

Protection with automatic circuit-breaker, max. 16 A, characteristics B16, e.g.: Power circuit-breaker 5SX2 116-6 (if required)

## LOGO! with solid-state outputs

LOGO! versions with solid-state outputs can be identified by the fact that the letter **R** is missing from their type name. The outputs are short circuit-proof and overload-proof. An auxiliary load voltage supply is not necessary, because LOGO! supplies the load voltage.

## Requirements for solid-state outputs

The load connected to LOGO! must have the following characteristics:

- The maximum switched current is 0.3 A per output.

## Connecting

This is how you connect the load to a LOGO! with solid-state outputs:

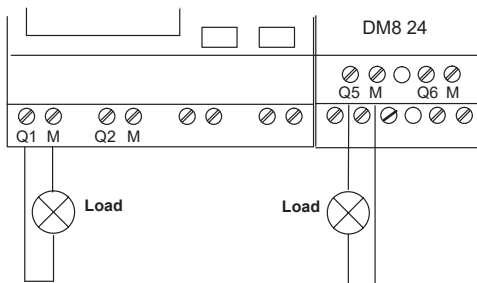

Load: 24 V DC, 0.3 A max.

## **2.4 Switching on the LOGO!/Power On**

LOGO! does not have a power switch. The reaction of LOGO! during startup depends on

- Whether a circuit program is stored in LOGO!
- Whether a program module (Card) is inserted
- Whether this is a LOGO! version without display unit (LOGO!...o)
- The status of LOGO! at the time of power failure.

All possible reaction of LOGO! are described on the following page.

# LOGO! installation and wiring

Before power off

After power on

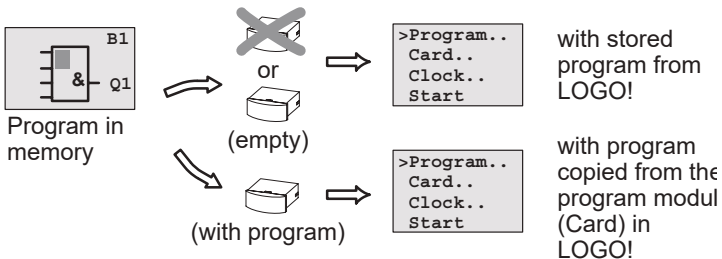
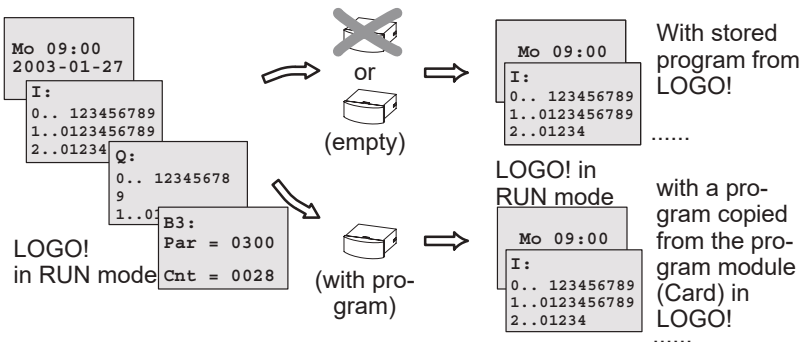
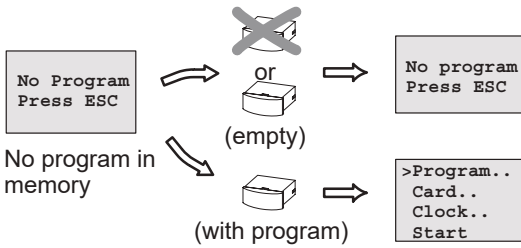

You can also memorize four simple rules for starting LOGO! :

1. If neither the LOGO! nor the inserted program module (Card) contains a circuit program, the LOGO! (with display unit ) reports: 'No Program / Press ESC'.
2. A circuit program on the program module (Card) is automatically copied to LOGO!. The circuit program in the LOGO! is overwritten.
3. If there is a circuit program in LOGO! or on the program module (Card), LOGO! adopts the operational state it had prior to POWER-OFF. Versions without display unit (LOGO!...o) automatically change from STOP to RUN (LED changes from red to green).
4. If you have enabled retentivity at least for one function, or a function is permanently retentive, the current values are retained at POWER-OFF.

---

### **Note**

When a power failure occurs while you are entering a circuit program, the program in LOGO! will be deleted after power is returned.

Before you modify the circuit program, you should therefore save a backup copy of your original to a program module (Card) or to a computer (LOGO!Soft Comfort).

---

## LOGO! Basic operating states

LOGO! Basic/Pure knows two operating states: STOP and RUN

STOP	RUN
<ul style="list-style-type: none"> <li>The display shows: 'No Program' (not LOGO!...o)</li> <li>Switching LOGO! to programming mode (not LOGO!...o)</li> <li>LED is red (only LOGO!...o)</li> </ul>	<ul style="list-style-type: none"> <li>Display: Screen mask for monitoring I/Os and messages (after START in the main menu) (not LOGO!...o)</li> <li>Switching LOGO! to parameter assignment mode (not LOGO!...o)</li> <li>LED is green (only LOGO!...o)</li> </ul>
<p>Action of LOGO!:</p> <ul style="list-style-type: none"> <li>The inputs data are not fetched.</li> <li>The circuit program is not executed</li> <li>The relay contacts are permanently open or the solid-state outputs are switched off</li> </ul>	<p>Action of LOGO!:</p> <ul style="list-style-type: none"> <li>LOGO! reads the status of the inputs</li> <li>LOGO! uses the circuit program to calculate the status of the outputs</li> <li>LOGO! switches the relay/ solid-state outputs on or off</li> </ul>

## LOGO! expansion modules, operating states

LOGO! expansion modules know three operating states: The LED is lit green, red or orange.

LED is lit		
Green (RUN)	Red (STOP)	Orange
The expansion module communicates with the device to its left	The expansion module does <b>not</b> communicate with the device to its left	Initialization phase of the expansion module



# 3 Programming LOGO!

## Getting started with LOGO!

Programming in our context refers to the creation of a circuit program. A LOGO! circuit program is actually no more than a circuit diagram presented in a slightly different form!

We have adapted this presentation to the LOGO! display field. In this chapter we are going to show you how to use LOGO! to create the LOGO! circuit programs for your application.

At this point, we once again refer to LOGO!Soft Comfort, which is the LOGO! programming software you can use to quickly and easily create, test, modify save and print the circuit programs. The topics in this manual relate only to the creation of circuit programs on the actual LOGO!, because the programming software LOGO!Soft Comfort already contains an extensive Online Help.

See also Chapter 7.

---

### Note

LOGO! versions without display unit, i.e. the LOGO! 24o, LOGO! 12/24RCo, LOGO! 24RCo and LOGO! 230RCo units, do not have an operator panel and display unit. They are primarily designed for use in small machine and process equipment engineering systems for series production.

LOGO!...o versions are not programmed directly at the unit. Instead, the circuit program is downloaded to this device by means of LOGO!Soft Comfort or program modules (Cards) of other LOGO! 0BA4 units.

LOGO! versions without display can not write data to program modules (Cards).

See Chapter 6, 7 and Appendix C.

---

A small example in the first part of this chapter introduces the operating principle of LOGO!.

- We shall first show you the meaning of two basic terms, namely the **connector** and the **block**.
- In the next step, we shall create a circuit program based on a simple conventional circuit, which you ...
- can enter directly in LOGO! in the third step.

It will take you only a few pages of this manual store your first executable circuit program in the LOGO! unit. With a suitable hardware (switches etc.), you will then be able to carry out first tests.

### 3.1 Connectors

The LOGO! is equipped with inputs and outputs

Example of a configuration with several modules:

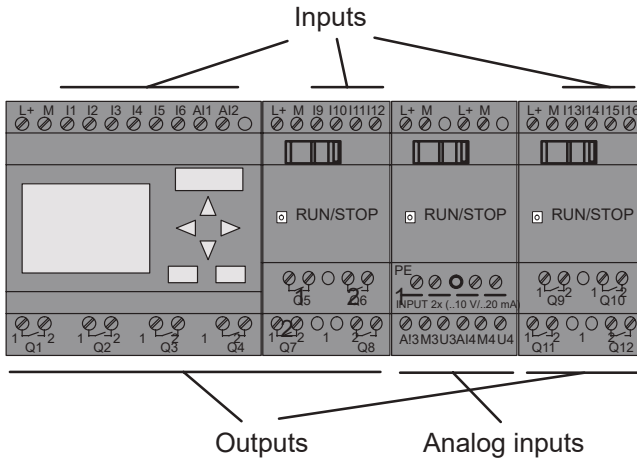

Each input is identified by the letter I plus a number. When you take a look at the LOGO! from the front, you can see the input terminals at the top. Only the analog modules LOGO! AM 2 and AM 2 PT100 have the inputs at the bottom.

Each output is identified by the letter Q plus a number. In the figure, you can see the output terminals at the bottom.

### Note

LOGO! can recognize, read and switch the I/O of all expansion modules, regardless of their type. The I/O are presented in the installation order of the modules.

The following I/Os and flag blocks are available for the creation of your circuit program: : I1 to I24, AI1 to AI8, Q1 to Q16, AQ1 and AQ2, M1 to M24 and AM1 to AM6. Also available are the shift register bits S1 to S8, 4 cursor keys C ▲, C ►, C ▼ and C ◀, as well as 16 blank outputs X1 to X16. More details are found in Chapter 4.1.

The following applies to the inputs I7 and I8 of LOGO! 12/24... and LOGO! 24/24o versions: If Ix is used in the circuit program, this input signal is digital; signals at AIx are analog. Input AIx can only represent the connector that is actually capable of handling analog signals.

---

### LOGO!'s connectors

The term connector refers to all connections and states in LOGO! .

The I/O status can be '0' or '1'. Status '0' means that the input does not carry a voltage. Status '1' means that the input carries voltage.

We have introduced 'hi', 'lo' and 'x' connectors to make it easier for you to create the circuit program:





'hi' (high) is assigned the status '1',

'lo' (low) is assigned the status '0'.

You do not have to use all the of connectors of a block. The circuit program automatically assigns the unused connectors a status that ensures proper functioning of the relevant block. If you prefer to do so, you can identify unused connectors with an 'x'.

For information on the meaning of the term "block", refer to Chapter 3.2.

**LOGO! knows the following connectors:**

Con-nectors	LOGO! Basic / Pure		DM	AM
				
Inputs	LOGO! 230RC/RCo, LOGO! 24 RC/RCo	Two groups: I1... I4 and I5 ... I8	I9 ... I24	AI1...AI8
	LOGO! 12/24RC/ RCo, LOGO! 24/24o	I1... I6, I7, I8 AI1, AI2	I9 ... I24	AI3...AI8
Outputs	Q1...Q4		Q5 ... Q16	none
lo	Logical '0' signals (off)			
hi	Logical '1' signals (on)			
x	An existing connection that is not used			

**DM:** Digital module.

**AM:** Analog module.

## 3.2 Blocks and block numbers

This chapter shows you how to use LOGO! elements to create complex circuits and how blocks and I/O are interconnected.

In Chapter 3.3 we are going to show you how to transform a conventional circuit to obtain a LOGO! circuit program.

### Blocks

A block in LOGO! represents a function that is used to convert input information into output information. Previously you had to wire the individual elements in a control cabinet or terminal box.

When you create the circuit program, you interconnect the blocks. To do so, simply select the connection you require from the **Co** menu. The menu name Co is an abbreviation of the term “Connector”.

### Logic operations

The most elementary blocks are the logic operations:

- AND
- OR
- ...

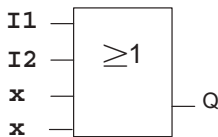

Inputs I1 and I2 are here connected to the OR block. The last two inputs of the block remain unused and are identified by the creator of the circuit program with an 'x'.

These special functions offer you a significantly higher performance:

- Pulse relay
- Up/down counter
- On-delay
- Softkey
- ....

In Chapter 4 you will find a full list of the LOGO! functions.

### View of blocks on the LOGO! display

The figure below shows a typical view of the LOGO! display. As you can see, it can show only one block at a time. We have therefore introduced block numbers to help you check the circuit structure.

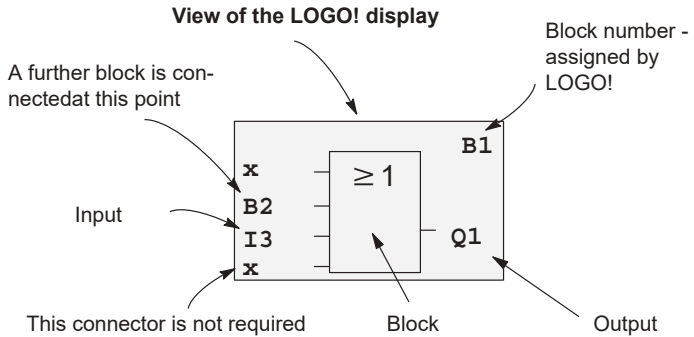

### Assigning a block number

LOGO! assigns each new block a circuit program a block number.

LOGO! uses these block numbers to indicate the block interconnections. Hence, these numbers primarily represent a help for your orientation in the circuit program.

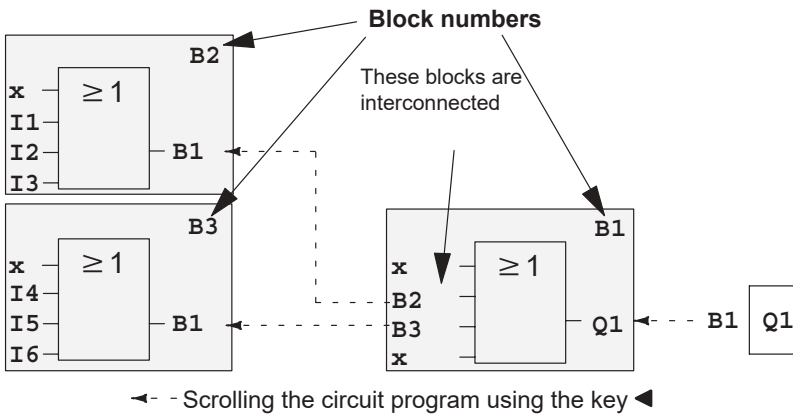

The figure above shows you three views of the LOGO! display, which represent the circuit program. As you can see, LOGO! interconnects the blocks using their numbers.

### **Advantages of the block numbers**

You can connect almost any block to an input of the current block by means of its block number. In this way, you can reuse the interim results of logical or other operations, reduce programming effort, save memory space and clean up your circuit layout. To do so, however, you need to know how LOGO! has named the blocks.

---

### **Note**

We advise you to create an organizational program chart. You will find this a valuable help when you create the circuit program, because you can enter all block numbers assigned by LOGO! in this chart.

By using the LOGO!Soft Comfort software to program the LOGO!, you can directly create a function chart of your circuit program. LOGO!Soft Comfort also allows you to assign 8-character names to up to 64 blocks, and to view these on the LOGO! display in parameter assignment and programming mode (see Chapter 3.4).

---



### 3.3 The way to LOGO!, starting with the circuit diagram

#### View of a circuit diagram

You know, of course, how a circuit logic is represented in a circuit diagram. Nevertheless, here is an example:

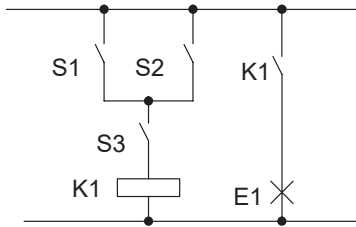

The load E1 is switched on and off by means of the switches (S1 **OR** S2) **AND** S3.

Relay K1 picks up when the condition (S1 **OR** S2) **AND** S3 is met.

#### Creating this circuit with LOGO!

In LOGO! you create a circuit logic by interconnecting blocks and connectors:

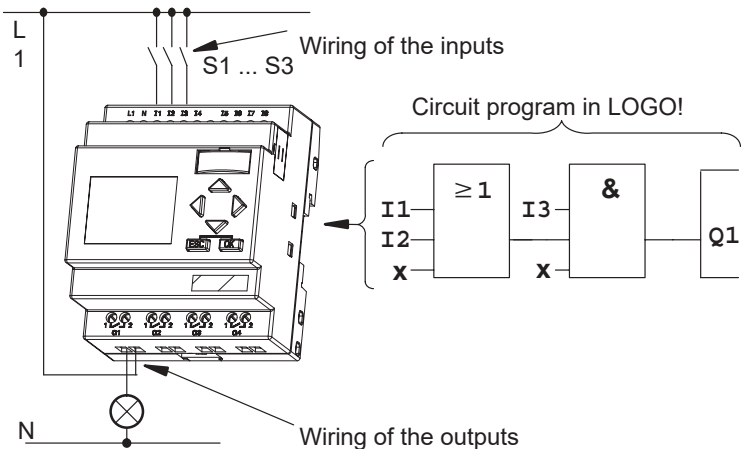

### Note

Although you have four inputs available for logic operations (Basic functions, see Chapter 4.2), most of the views will only show three inputs for reasons of clarity. You program this fourth input and assign parameters just like you do with the other three inputs.

---

To create a circuit logic in LOGO!, start at the output.

The output is the load or relay that is to be switched.

Convert the circuit logic into blocks by working through the circuit, starting at the output and ending at the input:

Step 1: The make contact S3 is interconnected in series to output Q1 and to a further circuit element. A series connection corresponds with the AND block:

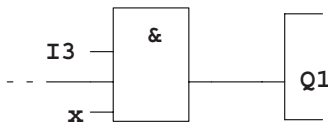

Step 2: S1 and S2 are connected in parallel. A parallel circuit corresponds with the OR block:

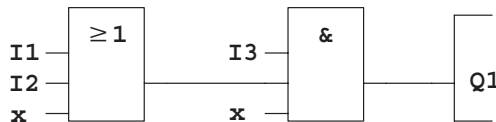

### Unused inputs

The circuit program automatically assigns the unused connectors a status that ensures proper functioning of the relevant block. If you like, you can label unused connectors with an 'x' identifier.

In our example we shall use only two inputs of the OR block and two inputs of the AND block; the relevant unused third and fourth inputs are identified at the connector with an 'x'.

Now connect the I/Os to the LOGO! .

## Wiring

Connect the switches S1 to S3 to the screw terminals of your LOGO! :

- S1 to connector I1 of LOGO!
- S2 to connector I2 of LOGO!
- S3 to connector I3 of LOGO!

The output of the AND block controls the relay at output Q1. The load E1 is connected to output Q1.

## Wiring example

The following figure shows you the wiring, based on a 230 V AC version of LOGO!.

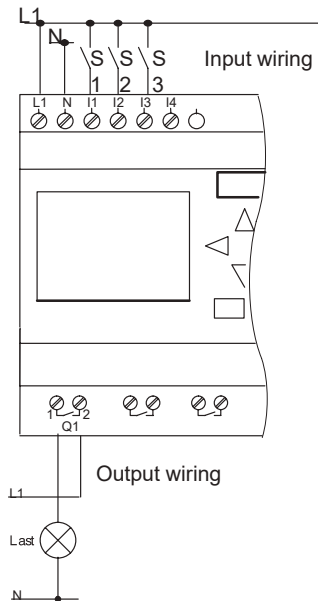

## 3.4 The 4 Golden rules for the operation of LOGO!

### Rule 1

#### Changing the operating mode

- You create the circuit program in **programming mode**. After power is on, and when the display shows “No Program / Press ESC”, press the **ESC** key to select programming mode.
- Timer and parameter values of an existing circuit program can be edited both in **parameter assignment mode** and in **programming mode**. During **parameter assignment** the LOGO! is in **RUN mode**, i.e. it continues execution of the circuit program (see Chapter 5). To work in **programming mode**, you need to terminate the circuit program by calling the “**Stop**” command.
- Select the 'Start' command on the main menu to set **RUN mode**.
- When the system is in **RUN**, you can return to **parameter assignment mode** by pressing the **ESC** key.
- When **parameter assignment mode** is open and you want to return to **programming mode**, select the “**Stop**” command from the parameter assignment menu, and confirm “**Stop Prg**” prompt with “**Yes**”. To do so, move the cursor to “**Yes**” and confirm with OK.

For more details on operating modes, refer to Appendix D.

---

### Note

The following applies to 0BA2 device versions and earlier:

- You can open programming mode by pressing ◀+▶+OK.
  - You set parameter assignment mode by pressing **ESC+OK**.
-

## Rule 2

### Outputs and inputs

- Always create your circuit program by working from the output to the input.
- You can connect an output to several inputs, but not the same input to several outputs.
- Within the same program path you may not connect an output to an upstream input. For such internal recursions you should interconnect flags or outputs.

## Rule 3

### Cursor and cursor movement

The following applies when you edit a circuit program:

- You can **move the cursor** when it appears in the form of an underscore:
  - Press ◀, ▶, ▼ or ▲ to move the cursor in the circuit program.
  - Press **OK** to change to "Select connector/block"
  - Press **ESC** to exit programming mode.
- You **select a connector/block**
- when the cursor appears as solid square
  - Press ▼ or ▲ to select a connector or a block.
  - Confirm with OK.
  - Press **ESC** to return to the previous step.

## Rule 4

### Planning

- Before you start to create a circuit program, you should either first create design on paper or program LOGO! directly using LOGO!Soft Comfort.
- LOGO! can only save complete and faultless circuit programs.

### 3.5 Overview of the LOGO! menus

#### Programming mode

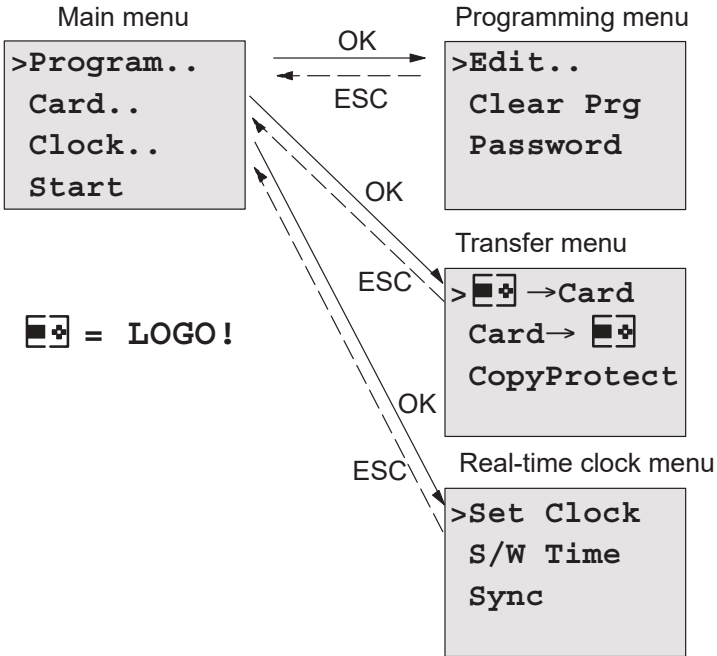

#### Parameter assignment mode

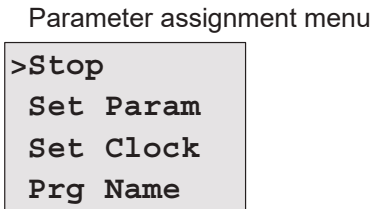

For more details on these menus, refer to Appendix D.

## 3.6 Writing and starting the circuit program

After you have designed a circuit, you want to write it to your LOGO! . The small example below shows how to do this.

### 3.6.1 Select programming mode

You have connected the LOGO! to the power supply and switched it on. The display now shows you the message:

```
No Program
Press ESC
```

Switch the LOGO! to programming mode by pressing the **ESC**. This will take you to the main menu of the LOGO!:

```
>Program..
  Card..
  Clock..
  Start
```

LOGO!'s main menu

The first character in the first line is the ">" cursor. Press ▲ and ▼ to move the ">" cursor up and down. Move it to "Program.." and confirm with **OK**. LOGO! opens the programming menu.

```
>Edit..
  Clear Prg
  Password
```

The LOGO!'s programming menu

Here you can also move the ">" cursor by pressing ▲ and ▼. Move the ">" cursor to "Edit.." (for editing, i.e. input) and confirm with **OK**.

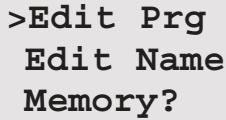

```
>Edit Prg
  Edit Name
  Memory?
```

The Edit menu of LOGO!

Move the ">" cursor to "Edit Prg" (for editing the circuit program) and confirm with **OK**. LOGO! now shows you the first output:

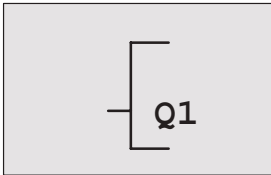

The first output of LOGO!

You are now in programming mode. Press ▲ and ▼ to select the other outputs. Now start to edit your circuit program.

---

### Note

Because we have not yet saved a **password** for the circuit program in LOGO!, you can directly enter editing mode. When you select "Edit Prg" after you have saved a password-protected circuit program, you are prompted to enter a password and to confirm it with **OK**. You can only edit the program after you have entered the correct password (see Chapter 3.6.5.).

---



### 3.6.2 The first circuit program

Let us now take a look at the following parallel circuit consisting of two switches.

#### Circuit diagram

The corresponding circuit diagram:

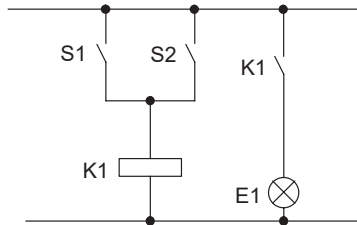

The load is switched on with S1 OR S2. LOGO! interprets this parallel circuit as an 'OR' logic, because S1 **OR** S2 switches on the output.

Translated into a LOGO! circuit program this means: Relay K1 is at output Q1 is controlled by means of an OR block.

#### Circuit program

S1 is connected to the I1 and S2 to the I2 input connector of the OR block.

The corresponding layout of the circuit program in LOGO!:

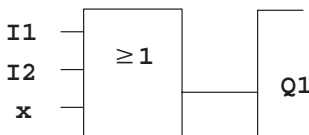

## Wiring

The corresponding wiring:

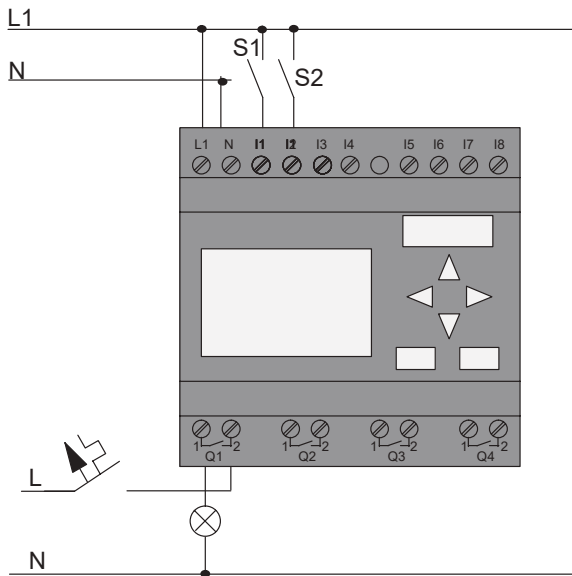

S1 switches input I1, while S2 switches input I2. The load is connected to the relay Q1.

### 3.6.3 Circuit program input

Let us now write the circuit program, starting at the output and working towards the input. LOGO! initially shows the output:

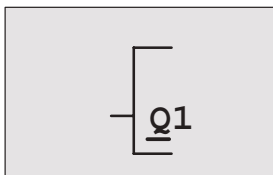

The first LOGO! output

You will see an underscore below the Q in Q1, which is the **cursor**. The cursor indicates your current position in the circuit program. You can move the cursor by pressing the ▲, ▼, ◀ and ▶ keys. Now press the ◀ key. The cursor moves to the left.

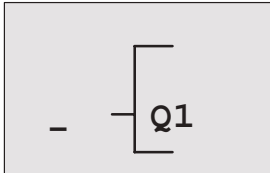

The cursor indicates your current position in the circuit program.

At this point you enter only the first (OR) block. Press **OK** to select editing mode.

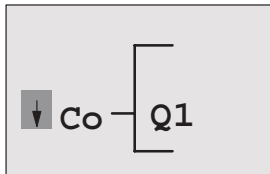

The cursor is displayed as a solid square: You can now select a connector or a block

The cursor no longer appears in the form of an underscore; but instead as a flashing solid square. LOGO! offers you here various options.

Select GF (basic functions) by pressing the ▼ key until GF appears, and confirm with **OK**. LOGO! now shows the first block from the list of basic functions:

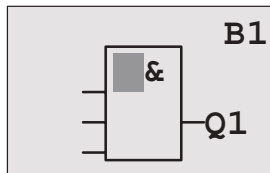

The AND is the first block of the basic functions list. The solid square cursor prompts you to select a block.

Now press ▼ or ▲ until the OR block appears on the display:

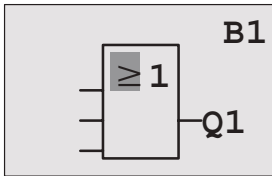

The solid square cursor is still positioned on the block.

Press **OK** to confirm your entries and exit the dialog.

The display now shows:

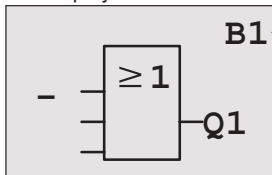

Block number

Your complete circuit program layout

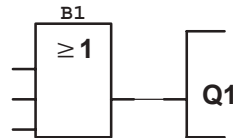

You have now entered the first block. Each new block is automatically assigned a block number. The only thing left to do is to interconnect the block inputs. This is how it is done:

Press **OK**.

The display now shows:

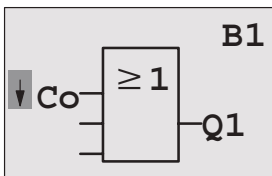

Select the **Co** list: Press **OK**

The display now shows:

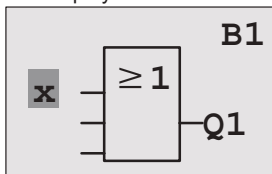

The first element of the **Co** list is the "Input not used" character, namely the 'x'. Press ▼ or ▲ to select input I1.

**Note**

Press ▼ to go the start of the Co list: I1, I2 .... to I0, then again 'x'. Press ▲ to go to the end of the Co list: I0, hi, Q ..... to I1, and once again 'x'.

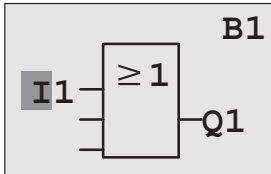

Press **OK**. I1 is now connected to the input of the OR block. The cursor jumps to the next input of the OR block.

The display now shows:

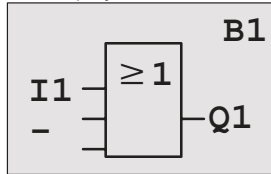

Your complete circuit program in LOGO! up to now:

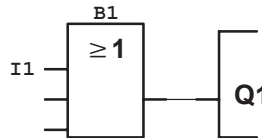

Now you connect input I2 to the input of the OR block. You already know how to do this:

- |                                  |                 |
|----------------------------------|-----------------|
| 1. Switch to editing mode:       | Press <b>OK</b> |
| 2. To select the <b>Co</b> list: | Press ▼ or ▲    |
| 3. To confirm the Co list with:  | Press <b>OK</b> |
| 4. To select <b>I2</b> :         | Press ▼ or ▲    |
| 5. To apply I2:                  | Press <b>OK</b> |

I2 is now connected to the input of the OR block:

The display now shows:

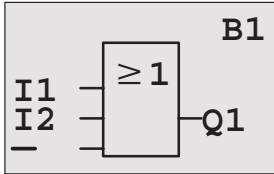

Your circuit program layout in LOGO! up to now

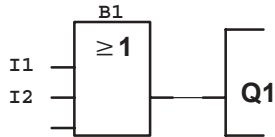

We do not need the last two inputs of the OR block for this circuit program. You can mark the unused inputs with an 'x'. Enter the 'x' character twice:

1. Switch to editing mode:
2. To select the **Co** list:
3. To accept the Co list:
4. To select 'x':
5. To apply x:

- Press **OK**  
Press **▼** or **▲**  
Press **OK**  
Press **▼** or **▲**  
Press **OK**

LOGO! returns to output Q1.

The display now shows:

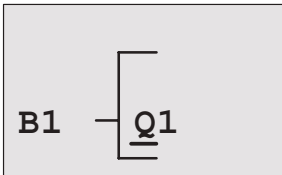

This is the layout of your circuit program

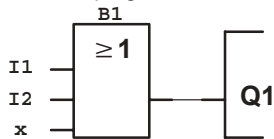

**Note**

You can invert individual inputs of the basic and special functions, i.e. if an input carries a logical “1” signal, the circuit program will output a logical “0”; vice versa, a logical “0” is inverted into a logical “1” signal.

To invert an input, move the cursor to the relevant position, e.g.:

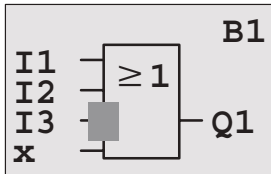

Confirm with **OK**.

Now press ▼ or ▲ to invert this input: ➔

Next, press **ESC**.

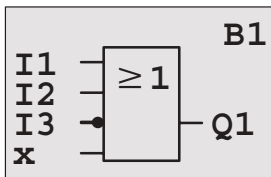

Your circuit program layout

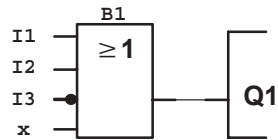

You can review your first circuit program by pressing ◀ or ▶ to move the cursor through the circuit program.

We shall now exit circuit programming mode. This is how it is done:

Return to the programming menu: Press **ESC**

**Note**

LOGO! has now saved your circuit program to nonvolatile memory. The circuit program remains in the LOGO! memory until you explicitly delete it.

---

**3.6.4 Assigning a circuit program name**

You can assign your circuit program a name that consists of up to 16 uppercase/lowercase letters, numbers and special characters.

In the programming menu:

1. To move the “>” cursor to 'Edit..': Press ▼ or ▲
2. To accept 'Edit': Press **OK**
3. Move the “>” cursor to 'Edit Name': Press ▼ or ▲
4. To accept 'Edit Name': Press **OK**

Press ▲ and ▼ to list the alphabet from A (a) to Z (z), numbers and special characters, either in ascending or descending order. You can select any letter, number or character.

To enter a space character, simply move the cursor with ► to the next position. This character is the first one in the list.

Examples:

Press ▼ once to select an “ A ”  
▲ four times to select “ { ”, etc.

The following character set is available:

	A	B	C	D	E	F	G	H	I	J	K	L	M	N	O
P	Q	R	S	T	U	V	W	X	Y	Z	a	b	c	d	e
f	g	h	i	j	k	l	m	n	o	p	q	r	s	t	u
v	w	x	y	z	0	1	2	3	4	5	6	7	8	9	!
”	#	\$	%	&	'	(	)	*	+	,	-	.	/	:	;
<	=	>	?	@	[	\	]	^	_	'	{		}	~	



Let us assume you want to name your circuit program “ABC”:

5. Select “A”: Press ▼
6. Move to the next letter: Press ►
7. Select “B”: Press ▼
8. Move to the next letter: Press ►
9. Select “C”: Press ▼
10. To confirm the complete name: Press **OK**

Your circuit program is now named “ABC”, and you are returned to the programming menu.

To **change** the name of your circuit program, proceed in the same way.

---

### Note

You can change the name of the circuit program only in programming mode. You can read the name both in programming **and** in parameter assignment mode

---

## 3.6.5 Password

You can protect a circuit program from unauthorized access by assigning it a password.

### To assign a password

A password may have a maximum length of 10 characters, and consists only of uppercase letters (A to Z). Directly at the LOGO!, the password can be assigned, edited or deactivated only in the “Password” menu.

In the programming menu:

1. Move the “>” cursor to ‘Password’: Press ▼ or ▲
2. To confirm the ‘Password’: Press **OK**

Press ▼ or ▲ to move up and down the alphabet to select your letters. Because LOGO! only provides uppercase letters for the password, you can quickly access to letters “at the end” of the alphabet by using the ▲ button:

Press ▲ once to select “Z”  
Press ▲ twice to select “Y”, etc.

Let us assign the password “AA” to our first circuit program. The display now shows:

**Old:**  
No Password  
**New:**  
■

This procedure is the same as for entering the name of the circuit program. Select “New” and enter:

3. Select “A”: Press ▼
4. To move to the next letter: Press ►
5. Select “A”: Press ▼

The display now shows:

**Old:**  
No Password  
**New:**  
■

6. To confirm the password: Press **OK**

Your circuit program is now protected with the password “AA”, and you are returned to the programming menu.

### Note

You can cancel the input of a new password with **ESC**. In this case, LOGO! returns to the programming menu without saving the password.

You can also set your password using LOGO!Soft Comfort. You can not edit a password-protected circuit program at the LOGO! or upload it to LOGO!Soft Comfort unless you enter the correct password.

To allow you to create and edit a circuit program for a protected module (Card), you first need to assign a password to this new program (see Chapter 6.1).

---

## Changing the Password

You need to know the current password in order to change it.

In the programming menu:

1. Move the '>' cursor to **'Password'**: Press ▼ or ▲
2. To confirm the 'Password': Press **OK**

Select "Old" and enter your old password (in our case: 'AA') by repeating steps 3 through 6 as described earlier.

The display now shows:

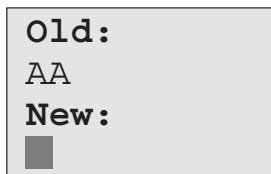

Old:  
AA  
New:  
■

Now you can select "New" to enter the new password, e.g. "ZZ":

3. Select "Z": Press ▲
4. To move to the next letter: Press ►
5. Select "Z": Press ▲

The display now shows:

<b>Old:</b> AA
<b>New:</b> ZZ

6. To confirm your new password: Press **OK**

Your new password “**ZZ**” is now set, and you are returned to the programming menu.

### Deactivating the Password

Let us assume you want to deactivate the password for whichever reason. For example, you want to allow another user to edit your circuit program. You must know your current password (in our example “**ZZ**”), same as if you were changing it.

In the programming menu:

1. Move the '>' cursor to '**Password**': Press ▼ or ▲
2. To confirm the 'Password': Press **OK**

Select “Old” and enter your current password under as described in steps 3 to 5. Confirm your entries with **OK**.

The display shows:

<b>Old:</b> ZZ
<b>New:</b> ■

**Clear** the password by leaving the input box **blank**:

3. To confirm the “blank” password: Press **OK**

The password is “cleared”, and you are returned to the programming menu.

### Note

This action disables the password prompt, and thus permits access without password.

Let the password prompt be **deactivated** for the time being, in order to accelerate progress in our further exercises and examples.

---

### Password: Wrong Password!

When the user inputs the **wrong** password and confirms the input with **OK**, LOGO! does not open editing mode, but returns to the programming menu. This repeats itself over and over again until you input the correct password.

### 3.6.6 Switching LOGO! to RUN mode

In the main menu, select RUN to start LOGO!.

1. To return to the main menu: Press **ESC**
2. Move the '>' cursor to **'Start'**: Press **▲** or **▼**
3. To confirm 'Start': Press **OK**

LOGO! runs the circuit program and shows the following display:

#### Display field of the LOGO! in RUN mode

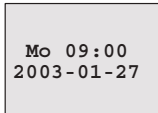

Date and current time-of-day (only for versions with real-time clock). This element flashes if the date and time are not set.

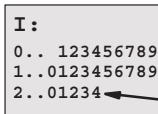

Inputs I1 to I9  
Inputs I10 to I19  
Inputs I20 to I24

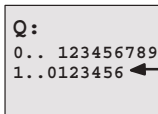

Outputs Q1 to Q9  
Outputs Q10 to Q16

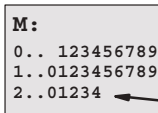

Flags M1 to M9  
Flags M10 to M19  
Flags M20 to M24

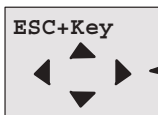

4 cursor keys for manual intervention in the circuit program (**ESC+key**)

## What is meant by: "LOGO! is in RUN"?

In RUN mode, LOGO! executes the circuit program. To do so, LOGO! first reads the status at the inputs, determines the status of the outputs by means of the user program, and switches these on or off according to your settings.

This is how LOGO! indicates the I/O status:

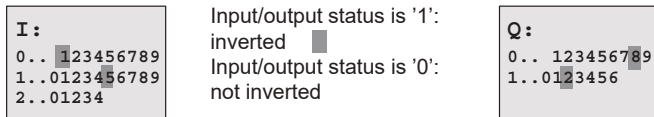

In this example, only the inputs I1, I15, Q8 and Q12 are set "high".

## Status indication on the display

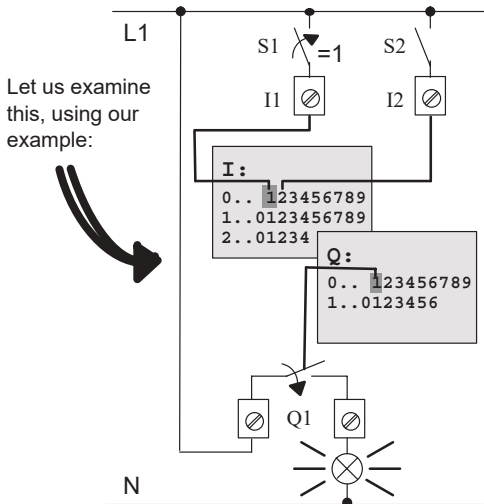

When switch S1 is closed, the status at input I1 is hi.

LOGO! computes the output states by means of the circuit program.

Output Q1 = '1', in this case.

When Q1 = '1', LOGO! sets relay Q1, and the load connected to Q1 is supplied with voltage.

### 3.6.7 Second circuit program

Up to this point, you have successfully created your first circuit, and assigned it a name and, if desired, a password. In this section we are going to show you how to modify existing circuit programs and how to use the special functions.

Using this second circuit program, we are going to show you how to:

- Add a block to an existing circuit program.
- Select a block for a special function.
- Assign parameters.

#### Modifying circuits

We shall use the first circuit program as a basis for the second, with some slight modifications.

Let us take a first look at the circuit diagram for the second circuit program:

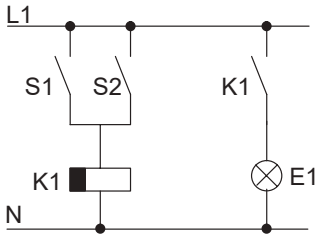

You already know the first part of the circuit. S1 and S2 switch a relay, which is to be used to switch on the load E1, and to switch off the load with a delay of 12 minutes.

In LOGO!, this is the circuit program layout:

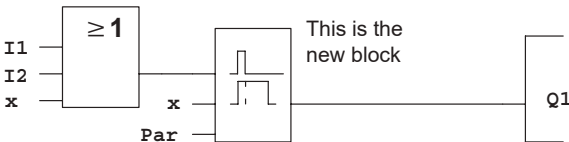

You can see the OR block and the output relay Q1 we have already used in the first circuit program. The only difference is the new off-delay block.



## Editing the circuit program

Switch the LOGO! to programming mode.

As a reminder:

1. Switch the LOGO! to programming mode (in RUN: Press **ESC** to enter the parameter assignment mode. Select the '**Stop**' command, confirm with **OK**, then move the '>' cursor to '**Yes**', and once again confirm with **OK**). See Page 48.
2. On the main menu, select "**Program**"
3. On the Programming menu, select "**Edit**", confirm with **OK**. Next, select "**Edit Prg**" and confirm with **OK**. If required, enter your password at the prompt and confirm with **OK**.

You can now modify the current circuit program.

## Adding a block to a circuit program

Move the cursor to the B in B1 (B1 is the number of the OR block):

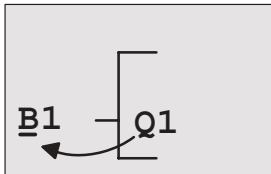

To move the cursor:  
Press ◀

We now insert the new block at this position.  
Confirm with **OK**.

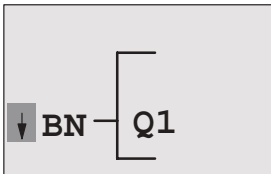

LOGO! shows you the BN list

Press ▼ to select the SF list:

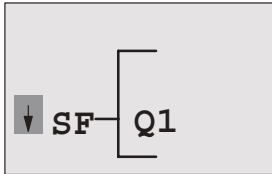

The SF list contains the special function blocks.

Press OK.

The block of the first special function is shown:

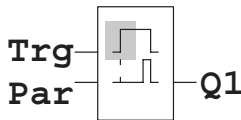

When you select a special or basic function block, LOGO! shows you the relevant function block. The solid square cursor is positioned on the block. Press ▼ or ▲ to select the required block.

Select your block (off-delay, see the next figure), and then press **OK**:

Before you press 'OK', this shows the entry **Trg**

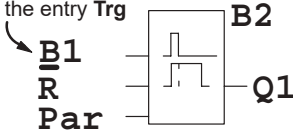

The added block is assigned the block number B2. The cursor is positioned at the top input of the added block.

The B1 block previously connected to Q1 is automatically connected to the uppermost input of the new block. Note that you can only interconnect digital inputs with digital outputs or analog inputs with analog outputs. The 'old' block will otherwise be lost.

The off-delay block has three inputs. At the top is the trigger input (Trg) you use to start the off-delay time. In our example, the OR block B1 triggers the off-delay. You reset the time and the output with a signal at the reset input. Set the off-delay time at parameter T of the input Par.

In our example we do not use the reset input of the off-delay function, and we identify it with an 'x' connector.

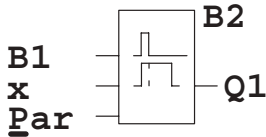

This is what the display should now show

### Assigning block parameters

Now you set the off-delay time T:

1. Move the cursor to **Par**, if it not already at this position:  
Press ▲ or ▼
2. Switch to editing mode: Press **OK**

LOGO! shows the parameters in the parameter assignment window:

T: The block parameter B2 is a time function

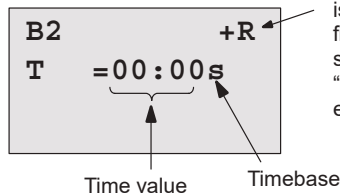

“+” means: The parameter is shown and can be modified in the parameter assignment mode.  
“R” means: Retentivity is enabled for this block.

To change the time value:

- Press ◀ and ▶ to position the cursor.
- Press ▲ and ▼ to modify the value at the relevant position.
- Confirm your entries with **OK**.

### Setting the time

Set the time T = 12:00 minutes:

1. Move the cursor to the first digit: Press ◀ or ▶
2. Select the digit '1': Press ▲ or ▼
3. Shift the cursor to the second digit: Press ◀ or ▶
4. Select digit '2': Press ▲ or ▼
5. Move the cursor to the unit: Press ◀ or ▶
6. Select the timebase 'm' (for minutes): Press ▲ or ▼

### Showing/hiding parameters – the parameter protection mode

If you want to show/hide the parameter and allow/prevent its modification in parameter assignment mode:

1. Move the cursor to the protection mode: Press ◀ or ▶
2. Select the protection mode: Press ▲ or ▼

The display should now show:

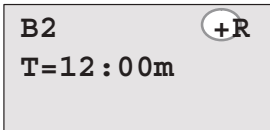

or

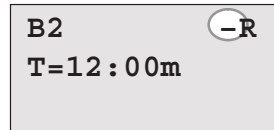

#### Protection mode +:

The value of the time T can be modified in parameter assignment mode

#### Protection mode -:

The value of the time T is hidden in parameter assignment mode

3. Confirm your entries with: **OK**

### Enabling/disabling retentivity

To decide whether you want to retain your current data after a power failure or not:

1. Move the cursor to the retentivity setting: Press ◀ or ▶
2. Select the retentivity setting: Press ▲ or ▼

The display now shows:

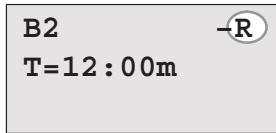

or

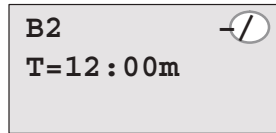

**Retentivity R:** Current data are retained

**Retentivity /:** Current data are not retained

3. Confirm your entries with **OK**

---

### Note

For further information on the protection mode, refer to Chapter 4.3.5.

For further information on retentivity, refer to Chapter 4.3.4.

You can modify the protection mode and retentivity setting only in programming mode, i.e. this is **not** possible in parameter assignment mode.

In this manual, the protection mode ("+" or "-") and retentivity ("R" or "/") settings are only shown in the displays where these can actually be changed.

---

### Verification of the circuit program

This program branch for Q1 is now completed. LOGO! shows you the output Q1. You can once again view the circuit program on the display. Use the keys to browse the circuit program, i.e. press ◀ or ▶ to move from block to block, ▲ and ▼ to move between the inputs at a block.

## Closing the programming mode

Although you were shown how to exit the programming mode when you created your first circuit program, here is a reminder:

1. To return to the programming menu: Press **ESC**
2. To return to the main menu: Press **ESC**
3. To move the '>' cursor to **'Start'**: Press **▲** or **▼**
4. To confirm 'Start': Press **OK**

LOGO! is back in RUN mode:

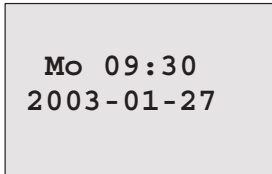

You can press ◀ or ▶ to scroll the pages and to monitor the I/O states.

### 3.6.8 Deleting a block

Let us assume you want to delete the block B2 from your circuit program and connect B1 directly to Q1.

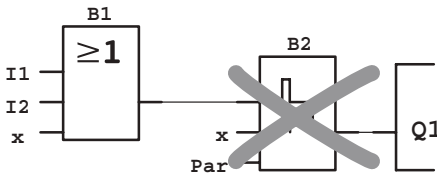

Proceed as follows:

1. Switch the LOGO! to programming mode (as a reminder, refer to Page 48).
2. Select **'Edit'**: Press **▲** or **▼**
3. Confirm 'Edit': Press **OK**
4. Select **'Edit Prg'**: Press **▲** or **▼**
5. Confirm 'Edit Prg': Press **OK**  
(If required, enter your password and confirm with **OK**).

- To move the cursor to the input of Q1, i.e. to B2, press **◀**:

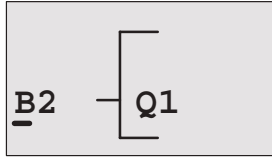

- Confirm with **OK**.
- Now replace block B2 with block B1 at output Q1. The procedure:

- Select the **BN** list: Press **▲** or **▼**
- Accept the BN list: Press **OK**
- Select '**B1**': Press **▲** or **▼**
- Apply 'B1': Press **OK**

**Result:** Block B2 is deleted, because it is no longer used in the circuit. Block B1 has replaced B2 directly at the output.

### 3.6.9 Deleting block groups

Let us assume you want to delete the blocks B1 and B2 from the following circuit program (corresponds with the circuit program in Chapter 3.6.7).

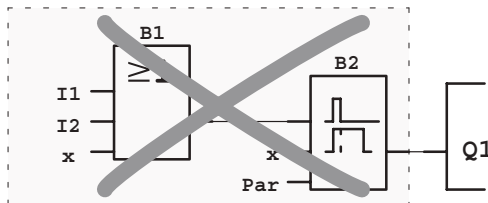

Proceed as follows:

- Switch the LOGO! to programming mode (as a reminder, refer to page 48).
- To select '**Edit**': Press **▲** or **▼**
- To confirm '**Edit**': Press **OK**
- To select '**Edit Prg**': Press **▲** or **▼**

5. To confirm 'Edit Prg': Press **OK**  
(if required, enter your password and confirm with **OK**).
6. To move the cursor to the input of Q1, i.e. to B2, press **◀**:

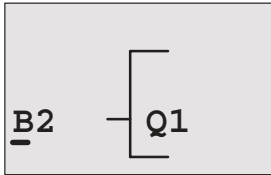

7. Confirm with **OK**.
8. Now set the connector 'x' at output Q1 instead of block B2. To do so:
  - Select the **Co** list: Press **▲** or **▼**
  - Accept the Co list: Press **OK**
  - Select '**x**': Press **▲** or **▼**
  - Apply '**x**': Press **OK**

**Result:** Block B2 is deleted, because it is no longer used in the circuit. This includes all blocks connected to B2. In this example, block B1 also.

### 3.6.10 Correcting typing errors

Programming errors can be corrected easily in LOGO! :

- Provided editing mode is not yet closed, you can revert by one step by pressing **ESC**.
- If you have already configured all inputs, simply reconfigure the faulty input:
  1. Move the cursor to the faulty position
  2. Change to editing mode. Press **OK**
  3. Enter the correct input circuit.

You can only replace a block with a block that has exactly the same number of inputs. However, you can delete the old block and then insert a new one. You can choose any new block.



### 3.6.11 Deleting the circuit program

To delete a circuit program:

1. Switch the LOGO! to programming mode

<pre>&gt;Program.. Card.. Clock.. Start</pre>	LOGO! opens the main menu
---	---------------------------

2. On the main menu, press ▲ or ▼ to move the '>' cursor to 'Program'. Press **OK**.

<pre>&gt;Edit.. Clear Prg Password</pre>	LOGO! changes to the programming menu
--	---------------------------------------

3. Move the '>' cursor to 'Clear Prg': Press ▲ or ▼
4. Confirm 'Clear Prg': Press **OK**

<pre>Clear Prg &gt;No Yes</pre>
---------------------------------

To cancel deletion of the circuit program, leave the '>' cursor at 'No' and press **OK**.

If you are sure that you want to delete the circuit program from memory:

5. Move the '>' cursor to **'Yes'**: Press ▲ or ▼
6. Press **OK**.

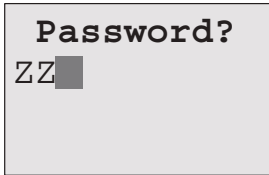

To prevent unintentional deletion of your circuit program, you are prompted to enter your password (provided you have assigned one).

7. Enter your password.
8. Press **OK**. The circuit program is deleted.

---

### Note

Although you may have forgotten your password, you can still delete the circuit program by entering the wrong password four times.

---

## 3.6.12 Summertime/wintertime conversion

You can enable or disable automatic Summertime/wintertime conversion in programming mode by calling the "Clock" menu command.

1. Switch the LOGO! to programming mode.
2. You are now in the main menu and want to select the **'Clock'** menu command: Press ▲ or ▼
3. Confirm **'Clock'**: Press **OK**
4. Move the '>' cursor to **'S/W Time'**: Press ▲ or ▼
5. Confirm **'S/W Time'**: Press **OK**

LOGO! shows the following display:

```
>On
  Off
S/W Time:
  Off
```

The current setting of automatic S/W Time conversion is shown in the bottom row. The default setting is 'Off': disabled.

### Enabling summertime/wintertime conversion

You now want to enable this conversion and define or set its parameters:

1. Move the '>' cursor to 'On': Press ▲ or ▼
2. Confirm 'On': Press **OK**

The display shows:

```
>EU
```

3. Select the desired conversion: Press ▲ or ▼

What is shown on the display ?:

- 'EU' represents the start and end of European summertime.
- 'UK' represents the start and end of summertime in the United Kingdom.
- 'US' represents the start and end of summertime in the United States.
- 'AUS' represents the start and end of Australian summertime.
- 'AUS-TAS' represents the start and end of Australian/Tasmanian summertime.
- 'NZ' represents the start and end of New Zealand summertime.

- . . . : Here you can enter any month, day and time zone difference.

The preset conversion data for EU, UK and US are found in the table below:

	Start of summertime	End of summertime	Time zone difference $\Delta$
<b>EU</b>	Last Sunday in March: 02:00—>03:00	Last Sunday in October: 03:00—>02:00	60 Min.
<b>UK</b>	Last Sunday in March: 01:00—>02:00	Last Sunday in October: 02:00—>01:00	60 Min.
<b>US</b>	First Sunday in April: 02:00—>03:00	Last Sunday in October: 02:00—>01:00	60 Min.
<b>AUS</b>	Last Sunday in October: 02:00—>03:00	Last Sunday in March: 03:00—>02:00	60 Min.
<b>AUS-TAS</b>	First Sunday in October: 02:00—>03:00	Last Sunday in March: 03:00—>02:00	60 Min.
<b>NZ</b>	First Sunday in October: 02:00—>03:00	Third Sunday in March: 03:00—>02:00	60 Min.
<b>..</b>	Customizing the month and the day: 02:00—>02:00 + Time zone difference	Customizing the month and the day: 03:00—>03:00 – Time zone difference	User-defined (resolution in minutes)

---

### Note

You can specify a time zone difference  $\Delta$  between 0 and 180 minutes.

---

Let us assume you want to enable European summertime/ wintertime conversion:

4. Move the '>' cursor to 'EU': Press ▲ or ▼
5. Confirm 'EU': Press **OK**

LOGO! shows the following display:

```
>On
  Off
S/W Time:
  On→EU
```

LOGO! indicates that European S/W Time conversion is enabled.

### User-defined parameters

If none of the parameters/conversions apply to your country, you can customize these under menu item '..'. To do so:

1. Confirm 'On' once again:            Press **OK**
2. Move the '>' cursor to '.'.':        Press **▲** or **▼**
3. Confirm the menu item '.'.':        Press **OK**

The display shows:

Cursor / solid square

<pre>MM-DD + : 01-01 - : 01-01 Δ =000min</pre>	<p>→ Month (MM) and Day (DD)</p> <p>→ Start of summertime</p> <p>→ End of summertime</p> <p>→ The desired time zone difference in [min]</p>
--	---

Let us assume you want to configure the following parameters: Start of summertime = 31st of March, end of summertime = 1st of November, time difference of 120 minutes.

This is how you can enter your data:

- Press **◀** or **▶** to move the solid square/cursor.
- Press **▲** and **▼** to change the value at the cursor position.

The display shows:

<b>MM-DD</b>	
<b>+ : 03-31</b>	→ 31. March
<b>- : 11-01</b>	→ 1. November
<b>Δ = 120 min</b>	→ Time difference of 120 min

- Confirm all your entries with **OK**.

You have now customized the summertime/wintertime conversion. The LOGO! display now shows:

```
>On
  Off
S/W Time:
  On→..
```

LOGO! indicates that summertime/wintertime conversion is enabled, and that user-defined parameters ( '..' ) have been set.

---

### Note

To disable summertime/wintertime conversion in this menu, you merely confirm 'Off' with **OK**.

---

### 3.6.13 Synchronization

Time synchronization between LOGO! and the connected expansion modules can be enabled/disabled in programming mode by means of the real-time clock menu ("Clock" menu item).

1. Switch the LOGO! to programming mode.
2. You are now in the main menu, and want to select '**Clock**': Press ▲ or ▼
3. Confirm '**Clock**': Press **OK**
4. Move the '>' cursor to '**Sync**': Press ▲ or ▼
5. Apply '**Sync**': Press **OK**

LOGO! shows the following display:

```
>On
  Off
Sync :
  Off
```

The current setting of the automatic synchronization function is displayed in the bottom row. The default setting is 'Off': disabled.

#### Enabling synchronization

You want to enable synchronization:

1. Move the '>' cursor to '**On**': Press ▲ or ▼
2. Confirm '**On**': Press **OK**

LOGO! shows the following display:

```
>On
  Off
Sync :
  On
```

When synchronization is enabled, LOGO! transmits the time-of-day to the expansion modules once daily, after each transition to RUN mode and when the TOD is changed after a 'Set Clock' is executed or after a summertime/winter-time conversion.

## 3.7 Memory space and circuit dimensions

The size of a circuit program in LOGO! is limited by the memory space (memory used by the blocks).

### Memory areas

- **Program memory:**  
LOGO! allows only a limited number of blocks in your circuit program.  
The second limitation is based on the maximum number of bytes a circuit program may contain. The total number of bytes used can be determined by adding up the number of bytes used for the relevant function blocks.
- **Retentive memory (Rem):**  
In this area, LOGO! stores process variables which need to be retentive, e.g. the hours counter value.  
Blocks with optional retentivity use this memory area only if this function is actually enabled.

### Resources available in LOGO!

A circuit program in LOGO! can occupy the following maximum resources:

Bytes	Blocks	REM
2000	130	60

LOGO! monitors memory utilization, and offers only those functions from the lists for which it can actually provide sufficient memory space.



## Memory requirements

The table below shows an overview of the memory requirements for the basic and special function blocks:

Function	Program memory	Rem memory*
<b>Basic functions</b>		
AND	12	–
AND with edge evaluation	12	–
NAND (NOT AND)	12	–
NAND with edge evaluation	12	–
OR	12	–
NOR (NOT OR)	12	–
XOR (exclusive OR)	8	–
NOT (Negation)	4	–
<b>Special functions</b>		
Times		
On-delay	8	3
Off-delay	12	3
On-/Off-delay	12	3
Retentive on-delay	12	3
Wiping relay (pulse output)	8	3
Edge triggered wiping relay	16	4
Asynchronous pulse generator	12	3
Random generator	12	–
Stairway lighting switch	12	3
Multiple function switch	16	3
Weekly timer	20	–
Yearly timer	8	–

Function	Program memory	Rem memory*
Counter		
Up/down counter	24	5
Hours counter	24	9
Threshold trigger	16	–
Analog		
Analog threshold trigger	16	–
Analog differential trigger	16	–
Analog comparator	24	–
Analog value monitoring	20	–
Analog amplifier	12	–
Others		
Latching relay	8	1
Pulse relay	12	1
Message texts	8	–
Softkey	8	2
Shift register	12	1

\*: Bytes in the Rem memory area, if retentivity is enabled.

### Utilization of memory areas

An indication of insufficient memory space is given, when the system does not allow you to add a further block to your circuit program. LOGO! offers you only the blocks for which it can provide sufficient memory space. If LOGO! memory space is insufficient to hold any further blocks you select from a block list, the system will deny access to this list.

If memory space is fully occupied, optimize your circuit program, or install a second LOGO!.

## Calculating memory requirements

When calculating the memory requirements of a circuit, you must always take all individual areas of memory into account.

### Example:

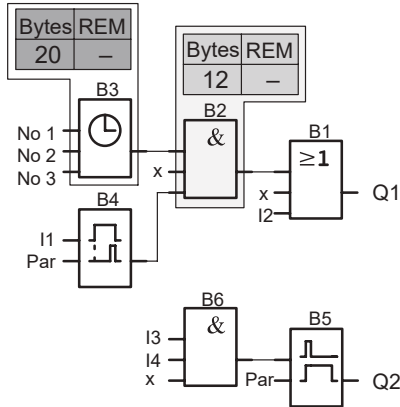

### The sample circuit program contains:

Block no.	Function	Memory area		
		Bytes	Blocks	REM
B1	OR	12	1	–
B2	AND	12	1	–
B3	Weekly timer	20	1	–
B4	On-delay*	8	1	3
B5	Stairway lighting switch	12	1	0
B6	AND	12	1	–
	Resources used by the circuit program	76	6	3
	Memory space limits in LOGO!	2000	130	60
	Still available in LOGO!	1924	124	57

\*: Configured with retentivity.

Hence, this circuit program fits into LOGO!.

## Indication of available memory space

LOGO! shows you the amount of free memory space.

Proceed as follows:

1. Switch the LOGO! to programming mode  
(as a reminder, refer to page 48).
2. Select '**Edit**': Press ▲ or ▼
3. Accept 'Edit': Press **OK**
4. Select '**Memory?**': Press ▲ or ▼
5. Accept 'Memory?': Press **OK**

The display now shows:

```
Free Memory:
Byte =1924
Block= 124
Rem  =  57
```

# 4 LOGO! functions

## Organization

LOGO! provides you with various elements in programming mode. In order to maintain the overview, we have organized the elements in 'Lists'. These lists are:

- ↓**Co**: Connector list (**C**onnecto**r**)  
(see Chapter 4.1)
- ↓**GF**: List of the basic functions AND, OR, ...  
(refer to Chapter 4.2)
- ↓**SF**: List of the special functions  
(refer to Chapter 4.4)
- ↓**BN**: List of reusable blocks configured in the circuit program

## List contents

All lists show the elements available in LOGO!. Usually, this includes all connectors, basic functions and special functions the LOGO! knows. This includes all the blocks you have created in LOGO! by the time you call the ↓**BN** list.

## If not all is shown

LOGO! does not show all elements if:

- No further blocks may be added.  
This is either an indication of insufficient memory space or that the maximum number of blocks has been reached.
- A specific block's memory space requirement would exceed the space available in LOGO!.

See Chapter 3.7.

## 4.1 Constants and connectors – Co

Constants and connectors (= Co) represent inputs, outputs, flags and constant voltage levels (constants).

### Inputs:

#### 1) Digital inputs

Digital inputs are identified with an **I**. The number of the digital inputs (I1, I2, ...) corresponds with the number of the input connectors of the LOGO! Basic and of the connected digital modules, in the order of their installation. See the following figure.

#### 2) Analog inputs

The LOGO! versions LOGO! 24, LOGO! 24o, LOGO! 12/24RC and LOGO! 12/24RCo are equipped with the inputs I7 and I8, which can also be programmed for use as **AI1** and **AI2** inputs. Signals at the I7 and I8 inputs are interpreted as digital values, and those at the AI1 and AI2 inputs are interpreted as analog values. The inputs of a connected analog module are numbered according to the already existing analog inputs. Special functions whose inputs should only be connected to analog inputs are offered in programming mode when you select the input signal, i.e. the analog inputs AI1...AI8, analog flags AM1...AM6, the block numbers of a function with analog output or the analog outputs AQ1 and AQ2.

### Outputs:

#### 1) Digital outputs

Digital outputs are identified by the character **Q**. The output numbers (Q1, Q2, ... Q16) correspond with the numbers of the output connectors at the LOGO! Basic and with those of the expansion modules, in their order of installation. See the following figure.

There are also 16 blank outputs available. These are identified with an **x** and can not be reused in a circuit program (in contrast to flags, for example). The list shows all programmed blank outputs, and one blank output which is not yet configured. A blank output, for example, is useful for the special function “Message texts” (see Chapter 4.4.23), if only the message text is of significance to a circuit program.

## 2) Analog outputs

Analog outputs are identified by the letters **AQ**. Two analog outputs are available, namely AQ1 and AQ2. You can only set an analog value at the analog output, i.e. a function with an analog output or analog flag AM.

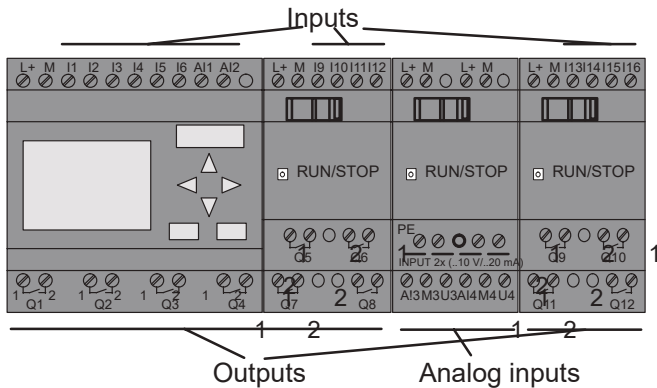

## Flag blocks

Flag blocks are identified by the letters **M** or **AM**. These are virtual outputs, which output the value of their inputs. LOGO! provides 24 digital flags M1 ... M24 and 6 analog flags AM1 ... AM6.

## Startup flag

Flag M8 is set in the first cycle of the user program and can thus be used in your circuit program as startup flag. This signal is automatically reset after the circuit program has completed its first cycle.

The M8 flag can be used in all further cycles for setting, deletion and evaluation procedures in the same way as other flags.

---

### Note

The output of the flag always carries the signal of the previous program cycle. This value does not change within the same program cycle.

---

## Shift register bits

LOGO! provides the shift register bits S1 to S8, which are assigned the read-only attribute in the circuit program. The content of shift register bits can only be modified by means of the "Shift register" special function (see Chapter 4.4.25).

## Cursor keys

Up to four cursor keys are available to you, namely C ▲, C ►, C ▼ and C ◀ ("C" = "Cursor"). Cursor keys are programmed for the circuit program in the same ways as other inputs. You can set the cursor keys in the corresponding display while the system is in RUN (see Chapter 3.6.6), and in an active message text (ESC + Key). Cursor keys can save switches and inputs, and allow operator control of the circuit program.

## Levels

Voltage levels are designated **hi** and **lo**. A constant "1" = hi or "0" = lo status at the block can be set by means of a permanent voltage level or constant value hi or lo.

## Open connectors

Unused block connectors can be identified with an **x**.







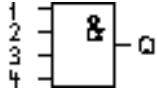
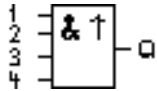
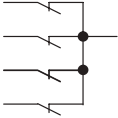
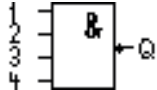

## 4.2 Basic functions list – GF

Basic functions represent simple logical elements of Boolean algebra.

You can invert the inputs of individual basic functions, i.e. the circuit program inverts a logical “1” at a relevant input to a logical “0”; if “0” is set at the input, the program sets a logical “1”. A programming example is found in Chapter 3.6.3.

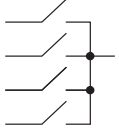
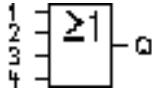
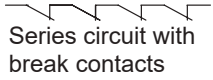
The GF list contains the basic function blocks you can use for your circuit program. The following basic functions are available:

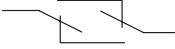
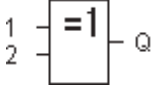
View in the circuit diagram	View in LOGO!	Name of the basic function
 <p>Series circuit make contact</p>		<p>AND (see page 95)</p>
		<p>AND with edge evaluation (see page 96)</p>
 <p>Parallel circuit with break contacts</p>		<p>NAND (NOT AND) (see page 97)</p>
		<p>NAND with edge evaluation (see page 98)</p>

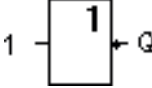
View in the circuit diagram	View in LOGO!	Name of the basic function
 <p>Parallel circuit with make contacts</p>		<p>OR (see page 99)</p>
 <p>Series circuit with break contacts</p>		<p>NOR (NOT OR) (see page 100)</p>
 <p>Double change-over contact</p>		<p>XOR (exclusive OR) (see page 101)</p>
 <p>Break contact</p>		<p>NOT (negation, inverter) (see page 101)</p>

## 4.2.1 AND

Circuit diagram of a series circuit with several make contacts:

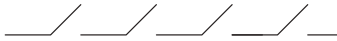

Symbol in LOGO!:

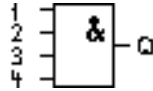

The output of the AND is only 1 if **all** inputs are 1, i.e. all contacts are closed.

At an unused block input (x):  $x = 1$ .

**Table of the AND logic**

1	2	3	4	Q
0	0	0	0	0
0	0	0	1	0
0	0	1	0	0
0	0	1	1	0
0	1	0	0	0
0	1	0	1	0
0	1	1	0	0
0	1	1	1	0
1	0	0	0	0
1	0	0	1	0
1	0	1	0	0
1	0	1	1	0
1	1	0	0	0
1	1	0	1	0
1	1	1	0	0
1	1	1	1	1

## 4.2.2 AND with edge evaluation

Symbol in LOGO!:

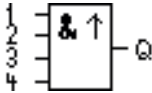

The output of an edge triggered AND is only 1 if **all** inputs are 1 and if **at least one** input was low in the previous cycle.

At an unused block input (x):  $x = 1$ .

### Timing diagram for the AND with edge evaluation

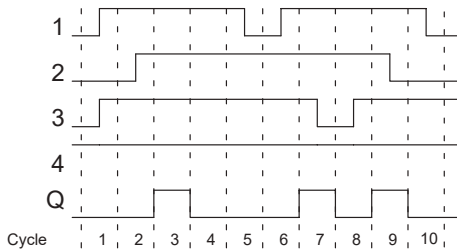

### 4.2.3 NAND (NOT AND)

Parallel circuit with multiple break contacts in the circuit diagram:

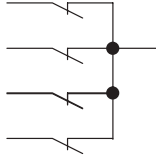

Symbol in LOGO!:

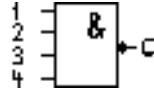

The output of the NAND is only 0 if the status at **all** inputs is 1, i.e. the contacts are closed.

At an unused block input (x):  $x = 1$ .

**Table of the NAND logic**

1	2	3	4	Q
0	0	0	0	1
0	0	0	1	1
0	0	1	0	1
0	0	1	1	1
0	1	0	0	1
0	1	0	1	1
0	1	1	0	1
0	1	1	1	1
1	0	0	0	1
1	0	0	1	1
1	0	1	0	1
1	0	1	1	1
1	1	0	0	1
1	1	0	1	1
1	1	1	0	1
1	1	1	1	0

## 4.2.4 NAND with edge evaluation

Symbol in LOGO!:

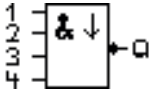

The output status of the NAND with edge evaluation is only 1 if **at least one** input is 0 and if **all** inputs were 1 in the previous cycle.

At an unused block input (x):  $x = 1$ .

### Timing diagram for the NAND with edge evaluation

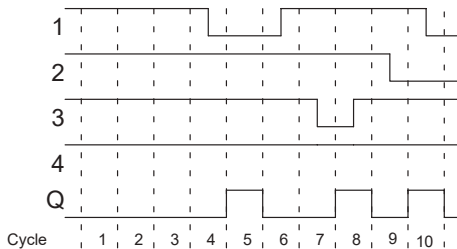

## 4.2.5 OR

Circuit diagram of a parallel circuit with several make contacts:

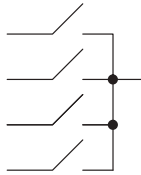

Symbol in LOGO!:

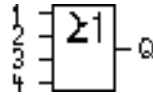

The output status of the OR element is only 1 if **at least one** input is 1, i.e. at least one of the contacts is closed.

At an unused block input (x):  $x = 0$ .

Table of the OR logic

1	2	3	4	Q
0	0	0	0	0
0	0	0	1	1
0	0	1	0	1
0	0	1	1	1
0	1	0	0	1
0	1	0	1	1
0	1	1	0	1
0	1	1	1	1
1	0	0	0	1
1	0	0	1	1
1	0	1	0	1
1	0	1	1	1
1	1	0	0	1
1	1	0	1	1
1	1	1	0	1
1	1	1	1	1

## 4.2.6 NOR (NOT OR)

Circuit diagram of a series circuit with several break contacts:

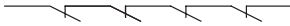

Symbol in LOGO!:

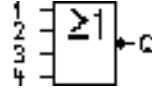

The output status of the NOR is only 1 if **all** inputs are 0, i.e. if switched off. The NOR output is set to 0 when one of the inputs is switched on (logical 1 status).

At an unused block input (x):  $x = 0$ .

**Table of the NOR logic**

1	2	3	4	Q
0	0	0	0	1
0	0	0	1	0
0	0	1	0	0
0	0	1	1	0
0	1	0	0	0
0	1	0	1	0
0	1	1	0	0
0	1	1	1	0
1	0	0	0	0
1	0	0	1	0
1	0	1	0	0
1	0	1	1	0
1	1	0	0	0
1	1	0	1	0
1	1	1	0	0
1	1	1	1	0



## 4.2.7 XOR (exclusive OR)

The XOR in a circuit diagram, shown as series circuit with 2 changeover contacts:

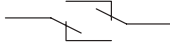

Symbol in LOGO!:

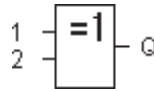

The output status of the XOR is 1 if the inputs are **not equivalent**.

At an unused block input (x):  $x = 0$ .

### Table of the XOR logic

1	2	Q
0	0	0
0	1	1
1	0	1
1	1	0

## 4.2.8 NOT (Negation, Inverter)

A break contact in the circuit diagram:

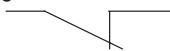

Symbol in LOGO!:

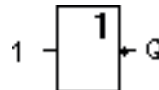

The output status is 1 if the input is 0. The NOT block inverts the input status.

Advantage of the NOT block, for example: The LOGO! does not require break contacts. You simply use a make contact and the NOT block to convert these into a break contact.

### Table of the NOT logic

1	Q
0	1
1	0

## 4.3 Basics on special functions

Because of their different input designation, you can see right away that there is a difference between the special functions and basic functions. SFs contain timer functions, retentive functions and various parameter assignment options, which allow you to adapt the circuit program to suit your own requirements.

This section provides you with a brief overview of input designations and with some particular background information on SFs. The SFs in particular are described in Chapter 4.4.

### 4.3.1 Designation of the inputs

#### Logical inputs

Here, you will find the description of the connectors you can use to create a logical link to other blocks or to the inputs of the LOGO! unit.

- **S (Set):**  
A signal at input S sets the output to logical "1".
- **R (Reset):**  
The reset input R takes priority over all other inputs and resets the outputs.
- **Trg (Trigger):**  
This input is used to trigger the start of a function.
- **Cnt (Count):**  
This input is used for counting pulses.
- **Fre (Frequency):**  
Frequency signals to be evaluated are applied to this input.
- **Dir (Direction):**  
This input determines the direction of count, for example.
- **En (Enable):**  
This input enables a block function. When this input is "0", other signal from the block will be ignored.
- **Inv (Invert):**  
A signal at this input inverts the output signal of the block.
- **Ral (Reset all):**  
All internal values are reset.

#### Connector X at SF inputs

SF inputs connected to connector x are set low. That is, the inputs carry a 'lo' signal.

## Parameter inputs

At some of the inputs you do not apply any signals. You configure the relevant block values instead. Examples:

- **Par (Parameter):**  
This input will not be connected. Here, you set the relevant block parameters (times, on/off thresholds etc.).
- **No (Cam):**  
This input will not be connected. Here, you configure the time patterns.
- **P (Priority):**  
This is an open input. Here, you define priorities and specify whether a message is to be acknowledged in RUN.

### 4.3.2 Time response

#### Parameter T

At some of the SFs it is possible to configure a time value T. When you preset this time, note that your input values are based on the timebase set:

Timebase	-- : --
s (seconds)	seconds : $\frac{1}{100}$ seconds
m (minutes)	minutes : seconds
h (hours)	hours : minutes

$  \begin{array}{r}  \mathbf{B1} \quad + \\  \mathbf{T} = \mathbf{04 : 10h}  \end{array}  $
---

Setting a time T of 250 minutes:

Unit in hours h:	
04:00 hours	240 minutes
00:10 hours	+10 minutes
=	250 minutes

---

#### Note

Always specify a time T in  $\geq 0.02$  s. The time T is not defined for T < 0.02 s.

---

## Accuracy of T

Because of slight tolerances in the characteristics of electronic components, the set time T may deviate. The LOGO! has a maximum tolerance of  $\pm 0.02\%$ .

When  $0.02\%$  of the time T is smaller than 0.02 seconds, the maximum deviation is 0.02 seconds.

### Example:

The maximum tolerance per hour (3600 seconds) is  $\pm 0.02\%$ , which is proportional to  $\pm 0.72$  seconds. The maximum tolerance per minute (60 seconds) is  $\pm 0.02$  seconds.

## Accuracy of the timer (weekly/yearly timer)

To prevent timing inaccuracy of the real-time clock in C versions caused by this deviation, the timer value is continuously compared with a high-precision timebase and corrected. The resultant maximum timing inaccuracy is  $\pm 5$  s/day.

### 4.3.3 Backup of the real-time clock

Because the internal real-time clock of a LOGO! is backed up, it continues operation after a power failure. The ambient temperature influences the backup time. At an ambient temperature of  $25^{\circ}\text{C}$ , the typical backup time is 80 hours.

### 4.3.4 Retentivity

The switching states and counter values of SFs can be set retentive. This means that current data are retained after a power failure, and that the block resumes operation at the break point. The timer is not reset, but resumes operation until the time-to-go has expired, for example.

To enable this response, however, the relevant functions must be set retentive. Two options are available:

R: The data are retained.

/: Current data are not retained (default). See the example on Page 72.

The hours counter forms an exception, because this function is always retentive.

### 4.3.5 Parameter protection

In the parameter protection settings, you can determine whether the parameters can be displayed and edited in LOGO! parameter assignment mode or not. Two options are available:

+: The parameter attribute permits read/write access in parameter assignment mode (default).

–: The parameter settings are read/write protected in parameter assignment mode, and can be edited only in the programming mode. See the example on Page 72.

### 4.3.6 Calculating the gain and offset of analog values

A sensor is connected to the analog input and converts a process variable into an electrical signal. This value of signal lies within the typical range of this sensor.

LOGO! always converts the electrical signals at the analog input into digital values from 0 to 1000.

A voltage of 0 to 10 V at input AI is transformed internally into range of values from 0 to 1000. An input voltage exceeding 10 V is shown as internal value 1000.

Because you can not always process the range of values from 0 to 1000 as predetermined by LOGO!, you can multiply the digital values by a gain factor and then shift the zero of the range of values (offset). This allows you to output an analog value to the LOGO! display, which is proportional to the actual process variable.

Parameter	Minimum	Maximum
Input voltage (in V)	0	$\geq 10$
Internal value	0	1000
Gain	00.00	10.00
Offset	-10000	+10000

## Mathematical rule

*Actual value Ax* =  
(internal value at input  $Ax \cdot \text{gain}$ ) + offset

## Gain and offset calculation

The gain and offset is calculated based on the relevant high and low values of the function.

### Example 1:

The available thermocouples have the following technical data:  $-30$  to  $+70^{\circ}\text{C}$ , 0 to 10 V DC (i.e. 0 to 1000 in LOGO!).

*Actual value* = (internal value  $\cdot$  gain) + offset, thus

$$-30 = (0 \cdot A) + B, \text{ i.e. offset } B = -30$$

$$+70 = (1000 \cdot A) - 30, \text{ i.e. gain } A = 0.1$$

### Example 2:

A pressure sensor converts a pressure of 1000 mbar into a voltage of 0 V, and a pressure of 5000 mbar into a voltage of 10 V.

*Actual value* = (internal value  $\cdot$  gain) + offset, thus

$$1000 = (0 \cdot A) + B, \text{ i.e. offset } B = 1000$$

$$5000 = (1000 \cdot A) + 1000, \text{ i.e. gain } A = 4$$

Example of analog values

Process variable	Voltage (V)	Internal value	Gain	Offset	Value shown (Ax)
-30° C	0	0	0.1	-30	-30
0° C	3	300	0.1	-30	0
+70° C	10	1000	0.1	-30	70
1000 mbar	0	0	4	1000	1000
3700 mbar	6.75	675	4	1000	3700
5000 mbar	10	1000	4	1000	5000
	0	0	0.01	0	0
	5	500	0.01	0	5
	10	1000	0.01	0	10
	0	0	1	0	0
	5	500	1	0	500
	10	1000	1	0	1000
	0	0	10	0	0
	5	500	10	0	5000
	10	1000	10	0	10000
	0	0	0.01	5	5
	5	500	0.01	5	10
	10	1000	0.01	5	15
	0	0	1	500	500
	5	500	1	500	1000
	10	1000	1	500	1500
	0	0	1	-200	-200
	5	500	1	-200	300
	10	1000	1	-200	800
	0	0	10	-10000	-10000
	10	1000	10	-10000	0
	0.02	2	0.01	0	0
	0.02	2	0.1	0	0
	0.02	2	1	0	2
	0.02	2	10	0	20

A sample application is found in the description of the “Analog comparator” SF on Page 165.

For further information on analog inputs, refer to Chapter 4.1.





## 4.4 Special functions list – SF

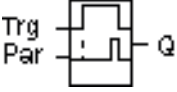
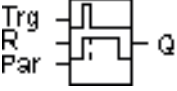
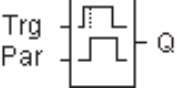
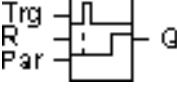
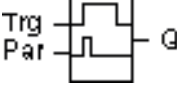

When you create your circuit program in LOGO!, you find the special function blocks in the SF list.

You can invert the inputs of SFs individually, i.e. the circuit program converts a logical “1” at the input into a logical “0”; a logical “0” it converts into a logical “1”. An example of the program code found in Chapter 3.6.3.

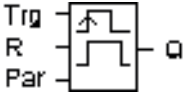
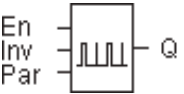
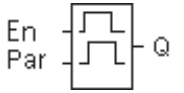
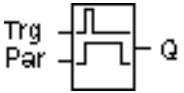
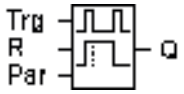
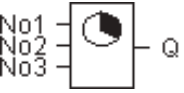
The table also specifies whether the relevant function can be set retentivity (Rem). The following SFs are available:

View inLOGO!	Name of the special function	Rem
<b>Times</b>		
	On-delay (see page 113)	REM
	Off-delay (see page 117)	REM
	On-/Off-delay (see Page 119)	REM
	Retentive on-delay (see page 121)	REM
	Wiping relay (pulse output) (see page 123)	REM

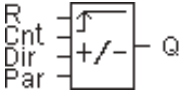
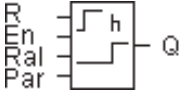
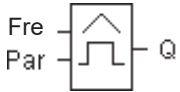
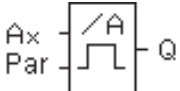
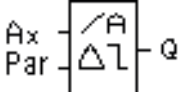
View inLOGO!	Name of the special function	Rem
	Edge triggered wiping relay (see page 125)	REM
	Asynchronous pulse gen- erator (see Page 128)	REM
	Random generator (see page 130)	
	Stairway lighting switch (see page 132)	REM
	Multiple function switch (see page 135)	REM
	Weekly timer (see Page 138)	
	Yearly timer (see Page 143)	

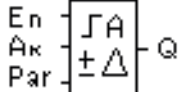
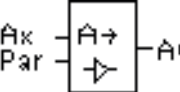
View inLOGO!	Name of the special function	Rem
<b>Counter</b>		
	Up/down counter (see Page 146)	REM
	Hours counter (see page 150)	REM
	Threshold trigger (see Page 155)	
<b>Analog</b>		
	Analog threshold trigger (see page 158)	
	Analog differential trigger (see page 161)	
	Analog comparator (see Page 165)	
	Analog value monitoring (see Page 170)	
	Analog amplifier (see Page 173)	

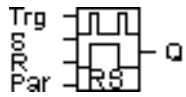
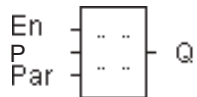
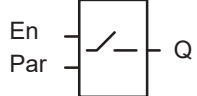
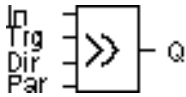
View inLOGO!	Name of the special function	Rem
<b>Miscellaneous</b>		
	Latching relay (see Page 175)	REM
	Pulse relay (see Page 176)	REM
	Message texts (see Page 179)	
	Softkey (see Page 186)	REM
	Shift register (see Page 190)	REM

## 4.4.1 On-delay

### Short description

The output is only set after a configurable on-delay time has expired.

Symbol in LOGO!	Wiring	Description
	Input Trg	You start the on-delay with a negative edge (1 to 0 transition) at input Trg (Trigger).
	Parameter	T represents the time after which the output is switched on (0 to 1 transition of the output signal). Retentivity: / = no retentivity R = the status is retentive.
	Output Q	Q is switched on when the set time T has expired, provided Trg is still set.

### Parameter T

Please note the defaults for parameter T in Chapter 4.3.2.

The time for parameter T can also be preset based on the actual value of another, already configured function. You can use the actual values of the following functions:

- Analog comparator (actual value  $A_x - A_y$ , see Chapter 4.4.18)
- Analog threshold trigger (actual value  $A_x$ , see Chapter 4.4.16)
- Analog amplifier (actual value  $A_x$ , see Chapter 4.4.20) and
- Counter (actual value  $Cnt$ , see Chapter 4.4.13).

Select the required function by means of the block number. The timebase is adjustable. Please note the following listing:

**Valid ranges of the timebase, if T = parameter**

Timebase	max. value	min. resolution	Accuracy
s (seconds)	99:99	10 ms	$\pm 10$ ms
m (minutes)	99:59	1s	$\pm 1$ s
h (hours)	99:59	1 min	$\pm 1$ min

The display in programming mode (example):

```

B12      +R
T   =04:10h
    
```

**Valid ranges of the timebase, if T = Actual value of an already programmed function**

Timebase	max. value	Meaning	Accuracy
ms	99990	Number of ms	$\pm 10$ ms
s	5999	Number of s	$\pm 1$ s
m	5999	Number of min	$\pm 1$ min

The display in programming mode (example):

```

B12      +R
T   →B006s
    
```

If the referenced block (B6, in the example) returns a value that lies out of the valid range, the value is rounded up or down to the next valid value.

### Parameter preset = Actual value of an already programmed function

How to include the actual value of an actual value of an already programmed function:

1. Press ► to move the cursor to the equal sign of parameter T.

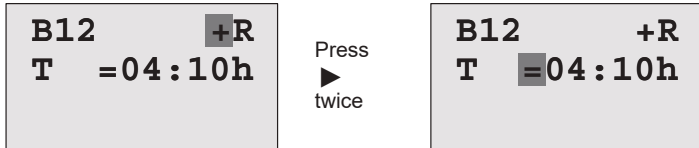

2. Press ▼ to change the equal sign into an arrow. If it exists, the last referenced block and its timebase is shown.

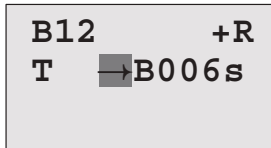

3. Press ► to move the cursor to the “B” of the shown block, and then press ▼ to select the required block number.
4. Press ► to move the cursor to the block’s timebase and press ▼ to select the required timebase.

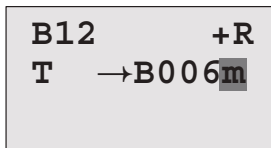

The view in parameter assignment mode (example):

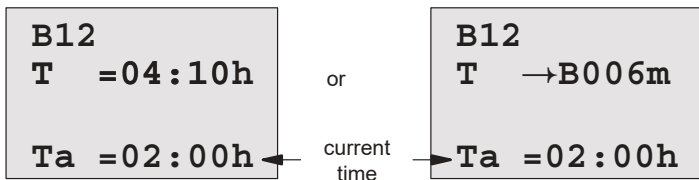

## Timing diagram

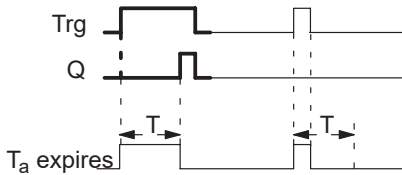

The bold section of the timing diagram is also shown in the on-delay icon.

## Functional description

The time  $T_a$  is triggered with a 0 to 1 transition at input Trg ( $T_a$  is the current LOGO! time).

If the status of input Trg is 1 at least for the duration of the configured time T, the output is set to 1 on expiration of this time (the output follows the input with on-delay).

The time is reset when the status at input Trg returns to 0 before the time T has expired.

The output is reset to 0 when the signal at input Trg is 0.

If retentivity is not set, output Q and the expired time are reset after a power failure.



## 4.4.2 Off-delay

### Short description

When an on-delay is set, the output is reset when the configured time has expired.

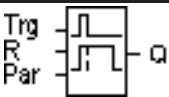
Symbol in LOGO!	Wiring	Description
	Input Trg	You start the off-delay time with a negative edge (1 to 0 transition) at input Trg (Trigger)
	Input R	A signal at input R resets the on-delay time and the output.
	Parameter	T is the time that expires after which the output is switched off (1 to 0 transition of the output signal). Retentivity: / = No retentivity R = The status is retentive.
	Output Q	Q is set with a signal at input Trg. It holds this state until T has expired.

### Parameter T

Please note the parameter T defaults specified in Chapter 4.3.2.

The time for parameter T can be based on the actual value of another, already configured function. You can use the process variables of the following functions:

- Analog comparator (actual value  $A_x - A_y$ , see Chapter 4.4.18)
- Analog threshold trigger (actual value  $A_x$ , see Chapter 4.4.16)

- Analog amplifier (actual value Ax, see Chapter 4.4.20) and
- Up/down counter (actual value Cnt, see Chapter 4.4.13).

Select the required function by means of the block number. The timebase is configurable. For information on valid timebase ranges and parameter preset, refer to Chapter 4.4.1.

### Timing diagram

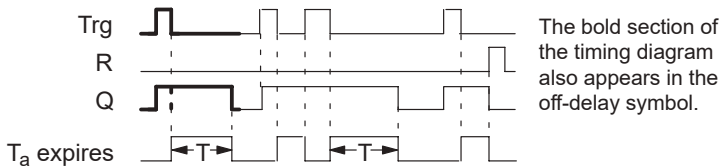

### Functional description

Output Q is set to hi immediately when the input Trg changes to hi.

The actual time  $T_a$  in LOGO! is retriggered at the 1 to 0 transition of Trg. The output remains set. Output Q is reset to 0 with off-delay when  $T_a$  reaches the value configured at T ( $T_a=T$ ).

The time  $T_a$  is retriggered with a one-shot at input Trg.

You can set input R (Reset) to reset the time  $T_a$  and the output before  $T_a$  has expired.

If retentivity is not set, output Q and the expired time are reset after a power failure.

### 4.4.3 On-/Off-delay

#### Short description

The on-/off-delay function sets the output after the set on-delay time has expired, and resets it upon expiration of the off-delay time.

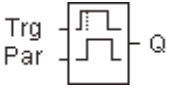
Symbol in LOGO!	Wiring	Description
	Input Trg	<p>A positive edge (0 to 1 transition) at input Trg (Trigger) triggers the on-delay time <math>T_H</math>.</p> <p>A negative edge (1 to 0 transition) at input Trg (Trigger) triggers the off-delay time <math>T_L</math>.</p>
	Parameter	<p><math>T_H</math> is the time after which the output is set hi (output signal transition 0 to 1).</p> <p><math>T_L</math> is the time after which the output is reset (output signal transition 1 to 0).</p> <p>Retentivity:            / = No retentivity            R = The status is retentive.</p>
	Output Q	<p>Q is set when the configured time <math>T_H</math> has expired and Trg is still set. It is reset on expiration of the time <math>T_L</math>, if the trigger Trg has not been set again.</p>

## Parameters $T_H$ and $T_L$

Note the preset values for the parameters  $T_H$  and  $T_L$  in Chapter 4.3.2.

## Timing diagram

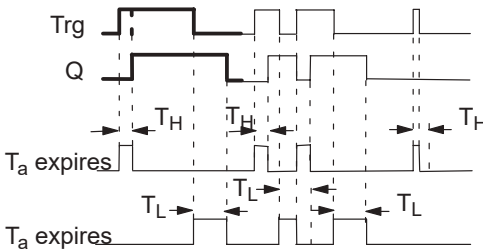

The bold section of the timing diagram is also shown in the on/off-delay symbol.

## Functional description

The time  $T_H$  is triggered with a 0 to 1 transition at input Trg. If the status at input Trg is 1 at least for the duration of the time  $T_H$ , the output is set to 1 on expiration of the time  $T_H$  (the output follows the input with on-delay).

The time is reset when the signal at input Trg is reset to 0 before the time  $T_H$  has expired..

A 1 to 0 transition at input Trg triggers the time  $T_L$ .

If the status at input Trg is 0 at least for the duration of the signal  $T_L$ , the output is set to 0 on expiration of the time  $T_L$  (the output follows the input with off-delay).

The time is reset when the signal at input Trg changes to 1 again before the time  $T_L$  has expired.

If retentivity is not set, output Q and the expired time are reset after a power failure.

## 4.4.4 Retentive on-delay

### Short description

A one-shot at the input triggers a configurable on-delay time. The output is set when this time has expired.

Symbol in LOGO!	Wiring	Description
	Input Trg	A signal at input Trg (Trigger) triggers the on-delay time.
	Input R	A signal at input R resets the on-delay time and the output.
	Parameter	T represents the on-delay time for the output (output status transition 0 to 1). Retentivity: / = no retentivity R = The status is retentive.
	Output Q	Q is set after the time T has expired.

### Parameter T

Note the defaults specified in Chapter 4.3.2.

The time for parameter T can be based on the process variable of another, already programmed function. You can use the process variables of the following functions:

- Analog comparator (actual value Ax - Ay, see Chapter 4.4.18)
- Analog threshold trigger (actual value Ax, see Chapter 4.4.16)
- Analog amplifier (actual value Ax, see Chapter 4.4.20) and
- Up/down counter (actual value Cnt, see Chapter 4.4.13).

Select the required function by means of the block number.  
The timebase is configurable. For information on valid ranges and parameter defaults, refer to Chapter 4.4.1.

### Timing diagram

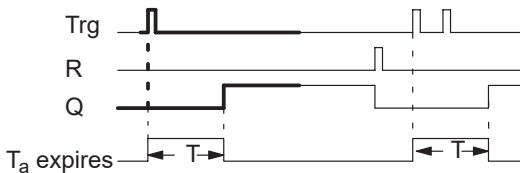

The bold section of the timing diagram is also shown in the symbol of the retentive on-delay.

### Functional description

The 0 to 1 signal transition at input Trg triggers the current time  $T_a$ . Output Q is set when  $T_a = T$ . A further signal at input Trg does not influence the time  $T_a$ .

The output and the time  $T_a$  are reset with the next 1 signal at input R.

If retentivity is not set, output Q and the expired time are reset after a power failure.

## 4.4.5 Wiping relay (pulse output)

### Short description

An input pulse generates a signal with a configurable period at the output.

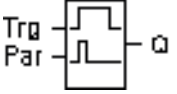
Symbol in LOGO!	Wiring	Description
	Input Trg	A signal at input Trg (Trigger) triggers the time for the wiping relay function.
	Parameter	The output is switched off after the time T has expired (output signal transition 1 to 0).  Retentivity: / = No retentivity R = The status is retentive.
	Output Q	A signal at input Trg sets Q. If the input signal = 1, output Q remains set for the time $T_a$ .

### Parameter T

Please note the information on parameter T in Chapter 4.3.2.

### Timing diagram

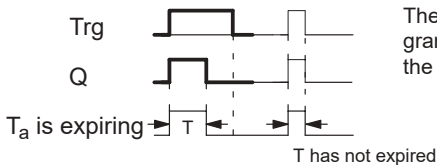

The bold section of the timing diagram also appears in the symbol of the wiping relay.

### **Functional description**

A 0 to 1 transition at input Trg sets the output, and triggers a time  $T_a$  during which the output remains set.

Output Q is reset to lo (pulse output) when  $T_a$  reaches the value preset at T ( $T_a = T$ ).

The output is immediately reset if there is a 1 to 0 transition at input Trg before the specified time has expired.

If retentivity is not set, output Q and the expired time are reset after a power failure.



## 4.4.6 Edge triggered wiping relay

### Short description

An input pulse generates a preset number of output pulses with a defined pulse/pause ratio (retriggerable), after a configured delay time has expired.

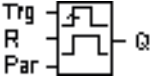
Symbol in LOGO!	Wiring	Description
	Input Trg	A signal at input Trg (Trigger) triggers the times for the edge triggered wiping relay.
	Input R	A signal at input R resets the current time ( $T_a$ ) and the output.
	Parameter	The interpulse width $T_L$ and the pulse width $T_H$ are configurable. N determines the number of pulse/pause cycles TL/TH: Range of values: 1...9 Retentivity: / = No retentivity R = The status is retentive.
	Output Q	Q is set after $T_L$ has expired, and reset after $T_H$ has expired.

### Parameter T

Please note the information on parameter T in Chapter 4.3.2.

### Timing diagram A

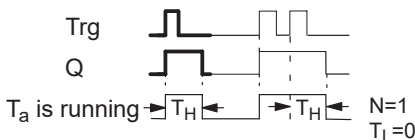

The bold section of the timing diagram also appears in the symbol of the edge triggered wiping relay.

## Timing diagram B



## Functional description

A 0 to 1 transition at input Trg triggers the time  $T_L$  (Time Low). After the time  $T_L$  has expired, output Q is set for the duration of  $T_H$  (Time High).

If there is a further 0 to 1 transition (retriggering pulse) at input Trg before the preset time ( $T_L + T_H$ ) has expired,  $T_a$  is reset and the pulse/pause cycle is restarted.

If retentivity is not set, output Q and the time are reset after a power failure.

## Preset of the Par parameter

View in programming mode (example):

<b>B25</b>	<b>1+R</b>	← Protection mode and retentivity
<b>TL</b>	<b>=02:00s</b>	← Interpulse width
<b>TH</b>	<b>=03:00s</b>	← Pulse width

Press ►

<b>B25</b>	<b>2</b>	
<b>N</b>	<b>=1</b>	← Number of pulse/pause cycles (example)

View in parameter assignment mode (example):

<b>B25</b>	
<b>TL =02:00s</b>	
<b>TH =03:00s</b>	
<b>Ta =01:15s</b>	← Current pulse width $T_L$ or $T_H$

## 4.4.7 Asynchronous pulse generator

### Short description

The output pulse shape can be modified by reconfiguring the pulse/pause ratio.

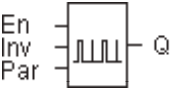
Symbol in LOGO!	Wiring	Description
	Input En	You can use input EN to set and reset the asynchronous pulse generator.
	Input INV	Input INV can be used to invert the output signal of the active asynchronous pulse generator.
	Parameter	You can configure the pulse width $T_H$ and the interpulse width $T_L$ . Retentivity: / = No retentivity R = The status is retentive.
	Output Q	Q is set and reset cyclically according to the pulse/pause ratio $T_H$ and $T_L$ .

### Timing diagram

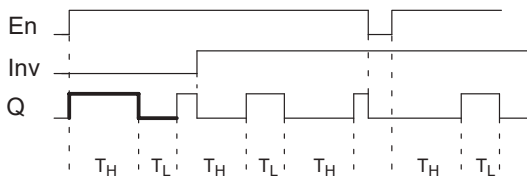

## Functional description

You can configure the pulse/interpulse width at the  $T_H$  (Time High) and  $T_L$  (Time Low) parameters .

Input Inv can be used to invert the output signal, provided the block is enabled with a signal at input EN.

If retentivity is not set, output Q and the expired time are reset after a power failure.

### 4.4.8 Random generator

#### Short description

The output of the random generator is set or reset within a configured time.

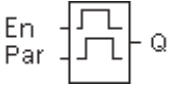
Symbol in LOGO!	Wiring	Description
	Input En	<p>A positive edge ( 0 to 1 transition) at input En (Enable) triggers the on-delay time of the random generator.</p> <p>A negative edge ( 1 to 0 transition) at input En (Enable) triggers the off-delay time of the random generator.</p>
	Parameter	<p>The on-delay is set at random to a value between 0 s and <math>T_H</math>.</p> <p>The off-delay is set at random to a value between 0 s and <math>T_L</math>.</p>
	Output Q	<p>Output Q is set when the on-delay has expired and if En is still set. It is reset when the off-delay has expired, provided En was not set again meanwhile.</p>

#### Parameter $T_H$ and $T_L$

Note the defaults of the  $T_H$  and  $T_L$  parameters listed in Chapter 4.3.2.

## Timing diagram

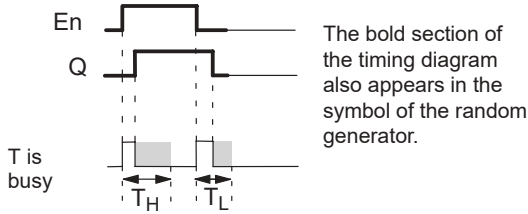

## Functional description

The 0 to 1 transition at input En triggers a random on-delay time between 0 s and  $T_H$ . The output is set when the on-delay time has expired and if the signal at input En remains hi at least for the duration of this time.

The time is reset if input En is reset before the on-delay time has expired.

A 1 to 0 transition at input EN triggers a random on-delay time between 0 s and  $T_L$ .

The output is reset after the off-delay time has expired, provided input En remains lo at least for the duration of this time.

The time is reset if the signal at input En changes to 1 again before the off-delay time has expired.

The time expired is reset after a power failure.

## 4.4.9 Stairway lighting switch

### Short description

An input edge triggers a configurable and retriggerable time. The output is reset after this time has expired. A warning signal can be output before this time has expired to warn of the impending shutdown.

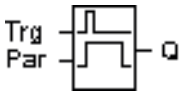
Symbol in LOGO!	Wiring	Description
	Input Trg	A signal at input Trg (Trigger) triggers the off-delay time for the stairway lighting switch.
	Parameter	<p>T represents the off-delay time of the output (output signal transition 1 to 0).</p> <p><math>T_1</math> determines the triggering time for the pre-warning.</p> <p><math>T_{IL}</math> determines the length of the pre-warning signal.</p> <p>Retentivity:                      / = No retentivity                      R = The status is retentive.</p>
	Output Q	Q is reset after the time T has expired. A warning signal can be output before this time has expired.

### Timing diagram

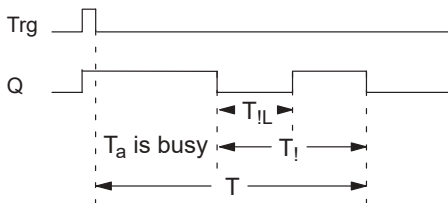



## Functional description

A 0 to 1 signal transition at input Trg sets output Q. The next 1 to 0 transition at Trg retriggers the current time  $T_a$ , and output Q remains set.

Output Q is reset when  $T_a = T$ . You can output a warning signal before the off-delay time  $(T - T_I)$  has expired to reset Q for the time of the pre-warning period  $T_{!L}$ .

A further one-shot at input Trg during  $T_a$  retriggers the time  $T_a$ .

If retentivity is not set, output Q and the expired time are reset after a power failure.

## Preset of the Par parameter

Note the defaults specified in Chapter 4.3.2.

### Note

All times must have the same timebase.

View in programming mode (example):

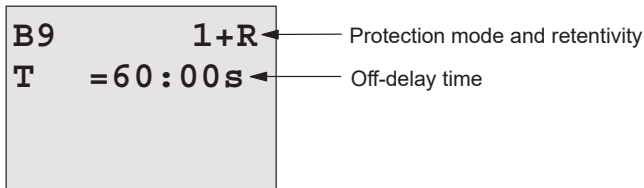

Press ►

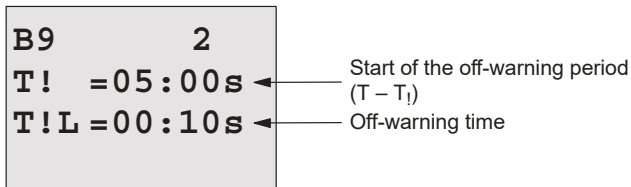

View in parameter assignment mode (example):

```
B9      1
T      =60:00s
Ta     =06:00s ← Current value of T
```

## 4.4.10 Multiple function switch

### Short description

Switch with two different functions:

- Pulse switch with off-delay
- Switch (permanent lighting)

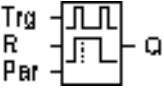
Symbol in LOGO!	Wiring	Description
 <p>The symbol shows a rectangular box with three input lines on the left labeled 'Trg', 'R', and 'Par', and one output line on the right labeled 'Q'. The 'Trg' input is connected to a pulse waveform, 'R' to a step function, and 'Par' to a pulse function.</p>	Input Trg	A signal at input Trg (Trigger) sets output Q (permanent light) or resets it with off-delay. When active, output Q can be reset with a signal at input Trg.
	Input R	A signal at input R resets the current time $T_a$ and the output.
	Parameter	<p><math>T</math> represents the time after which the output is reset (output signal transition 1 to 0).</p> <p><math>T_L</math> represents the time during which the output must be set to enable the permanent lighting function.</p> <p><math>T_I</math> represents the preset time for the start of the off-warning signal.</p> <p><math>T_{IL}</math> represents the length of the off-warning period.</p> <p>Retentivity:  / = No retentivity  R = The status is retentive.</p>
	Output Q	A signal at Trg switches on output Q. Depending on the length of the input at Trg, the output is switched off again or switched on permanently, or it is reset with a further signal at Trg.

### Timing diagram

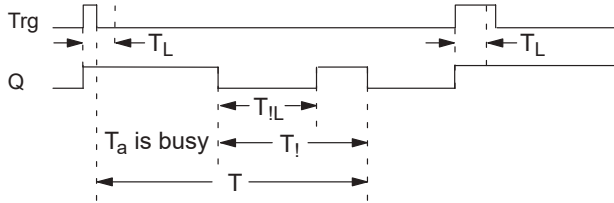

### Functional description

A 0 to 1 transition at input Trg sets output Q.

If output Q = 0, and input Trg is set hi at least for the duration of  $T_L$ , the permanent lighting function is enabled and output Q is set accordingly.

The off-delay T is triggered when input Trg returns to 0 before  $T_L$  has expired.

Output Q is reset when  $T_a = T$ .

You can output an off-warning signal prior to the expiration of the off-delay time ( $T - T_I$ ), to reset Q for the duration of the off-warning signal  $T_{IL}$ . A further signal at Trg always resets T and the output Q.

If retentivity is not set, output Q and the expired time are reset after a power failure.

### Preset of the Par parameter

Note the defaults specified in Chapter 4.3.2.

#### Note

T,  $T_I$  and  $T_{IL}$  must all have the same timebase.

View in programming mode (example):

<b>B5</b>	<b>1+R</b>	← Protection mode and retentivity
<b>T</b>	<b>=60:00s</b>	← Off-delay
<b>TL</b>	<b>=10:00s</b>	← Permanent light on-time

Press ►

<b>B5</b>	<b>2</b>	
<b>T!</b>	<b>=30:00s</b>	← Start of the off-warning period ( $T - T_I$ )
<b>T!L</b>	<b>=20:00s</b>	← Off-warning time

View in parameter assignment mode (example):

<b>B5</b>	<b>1</b>	
<b>T</b>	<b>=60:00s</b>	
<b>TL</b>	<b>=10:00s</b>	
<b>Ta</b>	<b>=06:00s</b>	← Current value of the time $T_L$ or $T$

## 4.4.11 Weekly timer

### Short description

The output is controlled by means of a configurable on/off date. The function supports any combination of weekdays. You select the active weekdays by hiding the inactive days.

### Note

Because the LOGO! 24/24o does not have a real-time clock, the weekly timer function is not available for this version.

Symbol in LOGO!	Wiring	Description
	Cam parameters No1, No2, No3	At the Cam parameters, you set the on- and off-times of the weekly timer for each <b>Cam</b> switch. Here you also configure the days and the time-of-day.
	Output Q	Q is set when the configured cam is actuated.

### Timing diagram (three examples)

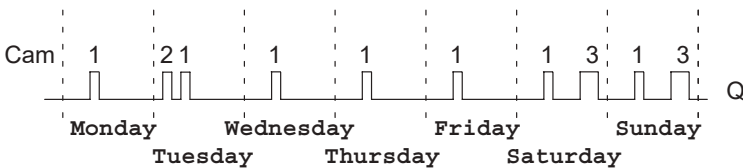

Cam No1:	Daily:	06:30 h to 08:00 h
Cam No2:	Tuesday:	03:10 h to 04:15 h
Cam No3:	Saturday and Sunday:	16:30 h to 23:10 h

## Functional description

Each weekly timer has three cams you can use to configure a time hysteresis. You specify the on- and off-times at the Cam parameters. The weekly timer sets the output at a certain on-time, if this is not already set.

The weekly timer resets the output at a certain off-time, if it is not switched off already. You will cause a conflict if the on- and off-times you set for the weekly timer are identical, though set on different cams. In this case, cam3 takes priority over cam2, whereas cam2 takes priority over cam1.

The switching state of the weekly timer is determined by the status of all three cams.

## Parameter assignment screen form

View of the parameter assignment screen form, for example for Cam1:

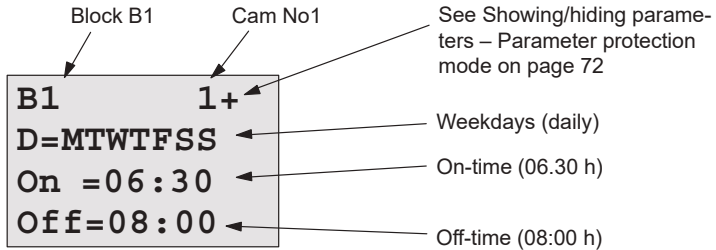

## Weekday

The suffix of “D=” (Day) has the following meaning:

- M : Monday
- T : Tuesday
- W : Wednesday
- T : Thursday
- F : Friday
- S : Saturday
- S : Sunday

The uppercase letter indicates: A weekday is selected. A “-” means: A weekday has not been selected.

### On-/Off-times

Possible is any time between 00:00 h and 23:59 h.

—:— means: No on-/off-times set.

### Setting the weekly timer

To set the on-/off-times:

1. Move the cursor to one of the Cam parameters of the timer (e.g. No1).
2. Press **OK**. LOGO! opens the Cam parameter assignment screen form. The cursor is positioned on the week-day.
3. Press **▲** and **▼** to select one or several weekdays.
4. Press **▶** to move the cursor to the first position of the on-time.
5. Set the on-time.  
Modify the value at the respective position, using the keys **▲** and **▼**. Move the cursor to the various positions, using the keys **◀** and **▶**. At the first position, you can only select the value —:—  
(—:— means: No on-/off-times set).
6. Press **▶** to move the cursor to the first position of the off-time.
7. Set the off-time (in same way as in step 5).
8. Confirm your entries with **OK**.  
The cursor is now positioned on the No2 parameter (Cam2) and you can configure a further cam.

---

### Note

For information on timer accuracy, refer to the technical data and to Chapter 4.3.2.

---



## Weekly timer: Example

The output of the weekly timer switch is to be set daily from 05:30 h to 07:40 h. The output should also be set every Tuesday from 03:10 h to 04:15 h, and at the weekends from 16:30 h to 23:10 h.

This requires three cams.

Here are the parameter assignment screen forms of the cams No 1, 2 and 3, based on the timing diagram shown earlier.

### Cam1

Cam No1 must set the output of the weekly timer daily from 05:30 h to 07:40 h.

<b>B1</b>	<b>1+</b>
<b>D=MTWTFSS</b>	
<b>On =05:30</b>	
<b>Off=07:40</b>	

### Cam2

Cam No2 must set the output of the weekly timer every Tuesday from 03:10 h to 04:15 h.

<b>B1</b>	<b>2</b>
<b>D=-T-----</b>	
<b>On =03:10</b>	
<b>Off=04:15</b>	

### Cam3

Cam No3 must set the output of the weekly timer switch every Saturday and Sunday from 16:30 h to 23:10 h.

<b>B1</b>	<b>3</b>
<b>D=-----SS</b>	
<b>On =16:30</b>	
<b>Off=23:10</b>	

### Result

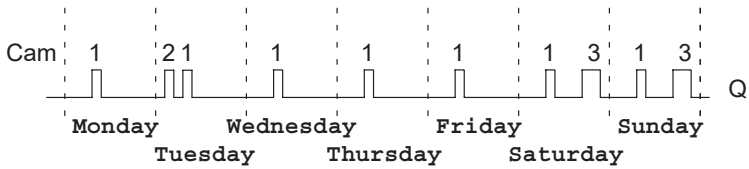

## 4.4.12 Yearly timer

### Short description

The output is controlled by means of a configurable on/off date.

### Note

Because LOGO! 24/24o does not have a real-time clock, the yearly timer is not available for this version.

Symbol in LOGO!	Wiring	Description
	Cam parameter	At the Cam parameter, you configure the on-/off-times for the cam of the yearly timer.
	Output Q	Q is set when the configured cam is actuated.

### Timing diagram

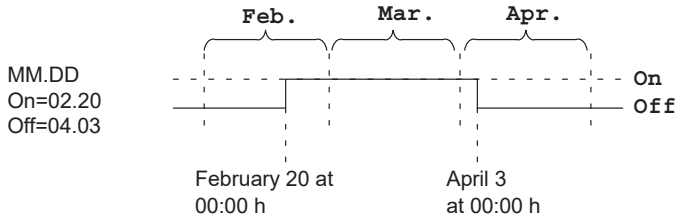

### Functional description

The yearly timer sets the output at a specific on-time, and resets it at a specific off-time. The off-date identifies the day on which the output is reset again. The first value identifies the month, the second the day. For "MM" you can select a placeholder (\*\*), so that the on- and off-time is set for a specific day each month.

### Sample configuration

The output of a LOGO! is to be set annually on March 1, reset on April 4, set again on July 7, and reset again on November 19. You need to configure two yearly timers with corresponding on-times. The outputs are then logically linked by means of an OR block

**B1**            +  
                  **MM-DD**  
**On** = **03-01**  
**Off** = **04-04**

On-time March 1  
Off-time April 4

**B2**            +  
                  **MM-DD**  
**On** = **07-07**  
**Off** = **11-19**

In addition:  
On-time July 7  
Off-time November 19

### Result

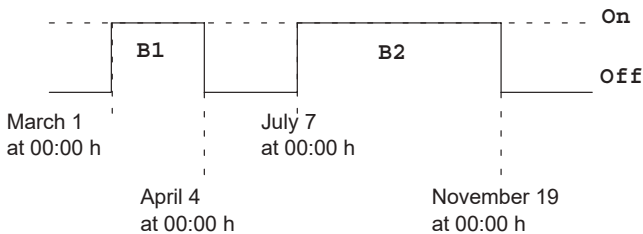

Further examples

```
B11      +
      ** -DD
On  =** -01
Off =** -02
```

On-time is the first,  
and off-time the second day each month.

```
B12      +
      ** -DD
On  =** -10
Off =** -20
```

Each month, from the 10th through  
to the 20th

```
B13      +
      ** -DD
On  =** -25
Off =** -05
```

In the next month,  
from the 25th through the 5th

### 4.4.13 Up/down counter

#### Short description

An input pulse increments or decrements an internal value, depending on the parameter setting. The output is set or reset when a configured threshold is reached. The direction of count can be changed with a signal at input Dir.

Symbol in LOGO!	Wiring	Description
	Input R	A signal at input R resets both the internal count value and the output to zero.
	Input Cnt	<p>The function counts the 0 to 1 transitions at input Cnt. 1 to 0 transitions are not counted.</p> <p>Use</p> <ul style="list-style-type: none"> <li>• inputs I5/I6 for high-speed counting (only LOGO! 12/24 RC/RCo and LOGO! 24/24o): max. 2 kHz.</li> <li>• any other input or circuit component for counting low frequency signals (5 Hz).</li> </ul>
	Input Dir	<p>You set the direction of count at input Dir:</p> <p>Dir = 0: Up count Dir = 1: Down count</p>

Symbol in LOGO!	Wiring	Description
	Parameter	On: On threshold Range of values: 0...999999  Off: Off threshold Range of values: 0...999999  Retentivity for internal counter value Cnt: / = No retentivity R = The status is retentive.
	Output Q	Q is set or reset, depending on the current value at Cnt and the set thresholds.

### Timing diagram

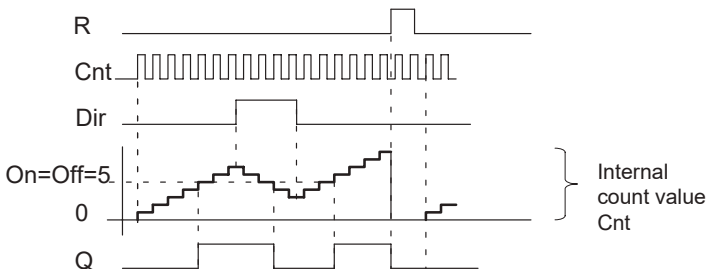

### Functional description

The internal counter increments (Dir = 0) or decrements (Dir = 1) by one count with every positive edge at input Cnt.

You can use input R to reset the output and the internal count value to '000000'. As long as R = 1, the output is also 0 and the pulses at input Cnt are not counted.

If retentivity is not set, output Q and the expired time are reset after a power failure.

Q is set or reset depending on the current value at Cnt and the set thresholds. See the calculation rule below.

### Calculation rule

- If the On threshold  $\geq$  Off threshold, then:  
Q = 1, if Cnt  $\geq$  On  
Q = 0, if Cnt < Off.
- If the On threshold < Off threshold, then Q = 1,  
if On  $\leq$  Cnt < Off.

### Default on/off parameters

The default limits for the on and/or off parameters can be derived from another, already programmed function. You can use the actual values of the following functions:

- Analog comparator (actual value Ax – Ay, see Chapter 4.4.18)
- Analog threshold trigger (actual value Ax, see Chapter 4.4.16)
- Analog amplifier (actual value Ax, see Chapter 4.4.20) and
- Up/down counter (actual value Cnt).

Select the required function by means of the block number. For information on parameter defaults, refer to Chapter 4.4.1.

---

### Note

The system scans the counter limit value cyclically.

Thus, if the pulse frequency at the fast inputs I5/I6 is faster than the cycle time, the special function might not switch until after the specified limit value is exceeded.

Example: Up to 100 pulses per cycle can be counted; 900 pulses have been counted so far. On = 950; Off = 10000. The output is set in the next cycle, after the value has reached 1000. (The output would not be set at all if the value Off = 980.)

---



View in programming mode (example):

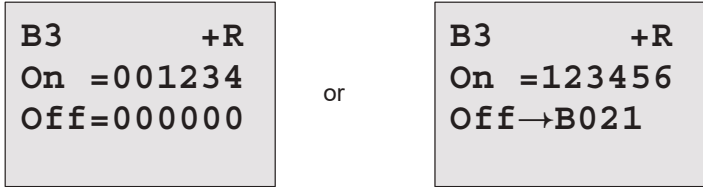

If the referenced block (B6, in the example) returns a value that lies out of the valid range, the value is rounded to the next valid value.

The view in parameter assignment mode (example):

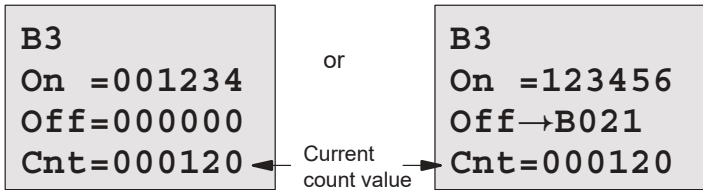

### 4.4.14 Hours counter

#### Short description

A configured time is triggered with a signal at the monitoring input. The output is set when this time has expired.

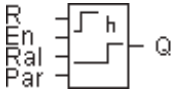
Symbol in LOGO!	Wiring	Description
	Input R	A positive edge (0 to 1 transition) at input R resets output Q and sets a configured value MI at the counter for the duration of the time-to-go (MN).
	Input En	En is the monitoring input. LOGO! scans the on-time of this input.
	Input Ral	A positive edge at input Ral (Reset all) resets both the hours counter (OT) and the output, and sets the configured value MI at the counter to for the duration of the time-to-go (MN). That is, <ul style="list-style-type: none"> <li>• output Q = 0,</li> <li>• measured operating time OT = 0 and</li> <li>• the time-to-go of the maintenance interval MN = MI.</li> </ul>

Symbol in LOGO!	Wiring	Description
	Parameter	<p>MI: Maintenance interval to be preset in hour units Range of values: 0000...9999 h</p> <p>OT: Total operating time Range of values: 00000...99999 h</p> <p>Q→0:</p> <ul style="list-style-type: none"> <li>When "R" is selected: Q = 1, if MN = 0; Q = 0, if R = 1 or Ral = 1</li> <li>When "R+En" is selected: Q = 1, if MN = 0; Q = 0, if R = 1 or Ral = 1 or En = 0.</li> </ul>
	Output Q	<p>The output is set when the time-to-go MN = 0.</p> <p>The output is reset:</p> <ul style="list-style-type: none"> <li>When "Q→0:R+En", if R = 1 or Ral = 1 or En = 0</li> <li>When "Q→0:R", if R = 1 or Ral = 1.</li> </ul>

MI = Configured time interval

MN= Time-to-go

OT= Total time expired since the last hi signal at input Ral

These values are always retentive!

## Timing diagram

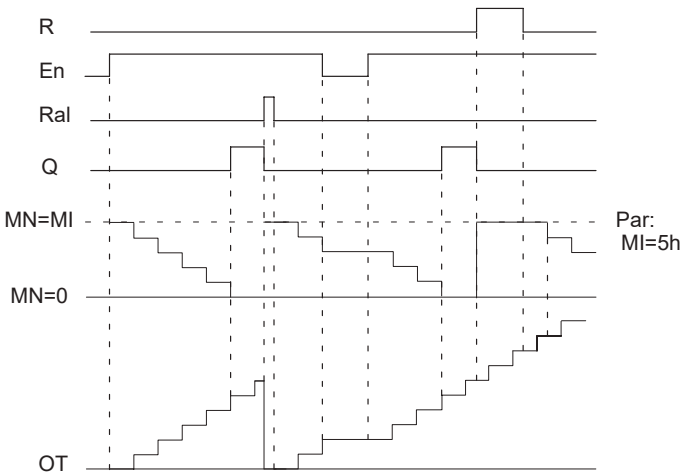

MI = Configured time interval

MN = Time-to-go

OT = Total time expired since the last hi signal at input Ral

## Functional description

The hours counter monitors input En. When En = 1, LOGO! computes the time expired and the time-to-go MN. LOGO! shows these times in parameter assignment mode. Output Q is set when the time-to-go MN = 0.

A signal at reset input R resets output Q and sets the pre-set value of MI at the counter for the duration of MN. The hours counter OT continues the count.

With a signal at the reset input Ral, you reset output Q and set the preset value of MI at the counter for the duration of MN. The hours counter OT is reset to zero.

Depending on your configuration of parameter Q, the output is either reset with a signal at input R or Ral ("Q→0:R"), or when a reset signal is set hi, or the En signal is set lo ("Q→0:R+En").

### Viewing the MI, MN and OT values

- LOGO! Basic with display unit: You can open the parameter assignment mode when the system is in RUN to view the actual values of MI, MN and OT.
- LOGO! Basic without display unit: In LOGO!Soft Comfort, you can use the Online Test to read these values (for further information, see Chapter 7).

### Limit value of OT

The value of the operating hours in OT are retained when you reset the hours counter with a signal at input R. The hours counter OT continues the count as long as  $En = 1$ , irrespective of the status at the reset input R.

The counter limit of OT is 99999 h.

The hours counter stops when it reaches this value.

In programming mode, you can set the initial value of OT.

The counter starts operation at any value other than zero.

MN is automatically calculated at the START, based on the MI and OT values

(Example: MI = 100, OT = 130, the result is MN = 70).

### Preset of the Par parameter

View in programming mode:

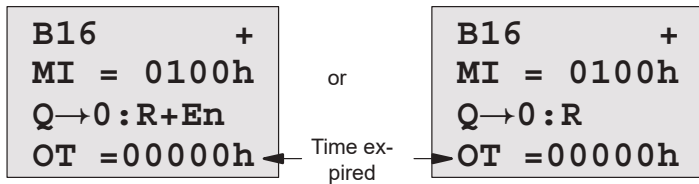

MI is the configurable time interval. Its permissible range of values lies between 0 and 9999 hours.

View in parameter assignment mode:

<b>B16</b>	
<b>MI = 0100h</b>	← Time interval
<b>MN = 0017h</b>	← Time-to-go
<b>OT = 00083h</b>	← Total operating hours

### 4.4.15 Threshold trigger

#### Short description

The output is set and reset with two configurable threshold triggers.

Symbol in LOGO!	Wiring	Description
	Input Fre	<p>The function counts the 0 to 1 transitions at input Fre. 1 to 0 transitions are not counted.</p> <p>Use</p> <ul style="list-style-type: none"> <li>inputs I5/I6 for high-speed counting (only LOGO! 12/24 RC/RCo and LOGO! 24/24o): max. 2 kHz.</li> <li>any other input or circuit component for counting low frequency signals (5 Hz).</li> </ul>
	Parameter	<p>On: On threshold Range of values: 0000...9999</p> <p>Off: Off threshold Range of values: 0000...9999</p> <p>G_T: Time interval or gate time during which the input pulses are measured. Range of values: 00:05 s...99:99 s</p>
	Output Q	Q is set and reset at the thresholds.

#### Timing diagram

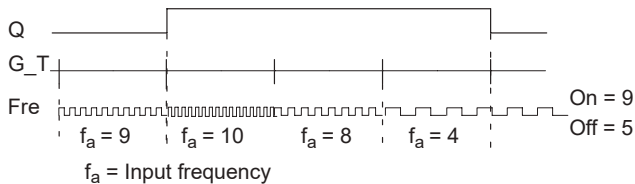

## Functional description

The threshold trigger measures the signals at input Fre.  
The pulses are recorded across a configurable time G\_T.  
Output Q is set and reset in accordance with the set thresholds. See the calculation rule below.

## Calculation rule

- If the On threshold  $\geq$  Off threshold, then:  
Q = 1, if  $f_a > \text{On}$   
Q = 0, if  $f_a \leq \text{Off}$ .
- If the On threshold  $<$  Off threshold, then Q = 1 if  
 $\text{On} \leq f_a < \text{Off}$ .

## Preset of the Par parameter

---

### Note

The system scans the counter limit value once per interval G\_T.

---

View in programming mode (example):

```
B15      1+  ← Parameter protection mode
On  =0009  ← On threshold
Off =0005  ← Off threshold
```

Press ►

```
B15      2
G_T=01:00s ← Time interval for pulses
              (example)
```



**Note**

The “seconds” timebase is here set as permanent default.

When you preset a time  $G\_T$  of 1 s, the LOGO! returns the current frequency in parameter  $f_a$  in Hz.

---

View in parameter assignment mode (example):

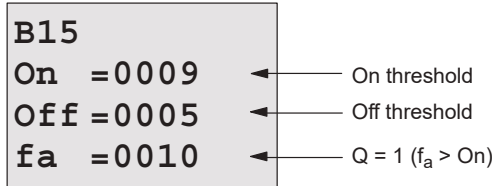

**Note**

$f_a$  always represents the total pulses measured per time unit  $G\_T$ .

---

## 4.4.16 Analog threshold trigger

### Short description

The output is set and reset at two configurable thresholds.

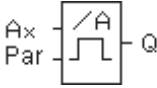
Symbol in LOGO!	Wiring	Description
	Input Ax	<p>You apply the analog signal to be analyzed at input Ax.</p> <p>Use the analog inputs AI1...AI8 (*), the analog flags AM1...AM6, the block number of a function with analog output, or the analog outputs AQ1 and AQ2.</p>
	Parameter	<p>A: Gain Range of values: 00.00...10.00</p> <p>B: Zero offset Range of values: ±10.000</p> <p>On: On threshold Range of values: ±20.000</p> <p>Off: Off threshold Range of values: ±20.000</p> <p>p: Number of decimals Range of values: 0, 1, 2, 3</p>
	Output Q	Q is set or reset by the threshold triggers.

\* AI1...AI8: 0...10 V corresponds with 0...1000 (internal value).

## Gain and offset parameters

Please note the information on gain and offset parameters in Chapter 4.3.6.

### Parameter p (number of decimals)

Does not apply to the display of On, Off and Ax values in a message text.

Does not apply to the comparison of On and Off values!  
(The compare function ignores the decimal point.)

### Timing diagram

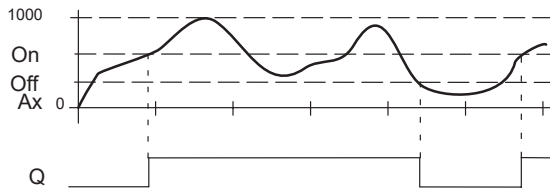

### Functional description

The function fetches the analog signal at input Ax.

Ax is multiplied by the value of the A (gain) parameter, and the value at parameter B (offset) is added to product, i.e.  
 $(Ax \cdot \text{gain}) + \text{offset} = \text{actual value of Ax}$ .

Output Q is set or reset, depending on the set thresholds.  
See the calculation rule below.

### Calculation rule

- If the On threshold  $\geq$  Off threshold, then:  
 $Q = 1$ , if the actual value  $Ax > \text{On}$   
 $Q = 0$ , if the actual value  $Ax \leq \text{Off}$ .
- If the On threshold  $<$  Off threshold, then  $Q = 1$  if  
 $\text{On} \leq \text{actual value } Ax < \text{Off}$ .

### Preset of the Par parameter

The gain and offset parameters are used to adapt the sensors to the relevant application.

View in programming mode (example):

```
B3      1+
On  =+04000
Off =+02000
```

← Parameter protection mode  
← On threshold  
← Off threshold

Press ►

```
B3      2
A   =01.00
B   =+00000
p   =2
```

← Gain  
← Offset  
← Decimals in the message text

View in parameter assignment mode (example):

```
B3
On  =+04000
Off =+02000
Ax  =+05000
```

← On threshold  
← Off threshold  
← Q = 1 (Ax > On)

View in the message text (example):

```
+050.00
```

← Ax, when p = 2  
Q = 1 (Ax > On)

## 4.4.17 Analog differential trigger

### Short description

The output is set and reset depending on a configurable threshold and a differential value.

Symbol in LOGO!	Wiring	Description
	Input Ax	<p>You apply the analog signal to be analyzed at input Ax.</p> <p>Use the analog inputs AI1...AI8 (*), the analog flags AM1...AM6, the block number of a function with analog output, or the analog outputs AQ1 and AQ2.</p>
	Parameter	<p>A: Gain Range of values: 00.00...10.00</p> <p>B: Zero offset Range of values: <math>\pm 10.000</math></p> <p>On: On/Off threshold Range of values: <math>\pm 20.000</math></p> <p><math>\Delta</math>: Differential value for calculating the off parameter Range of values: <math>\pm 20.000</math></p> <p>p: Number of decimals Range of values: 0, 1, 2, 3</p>
	Output Q	Q is set or reset, depending on the threshold and difference values.

\* AI1...AI8: 0...10 V corresponds with 0...1000 (internal value).

## Gain and offset parameters

Please note the information on gain and offset parameters in Chapter 4.3.6.

## Parameter p (number of decimals)

Does not apply to the display of On, Off and Ax values in a message text.

## Timing diagram A: Function with negative difference $\Delta$

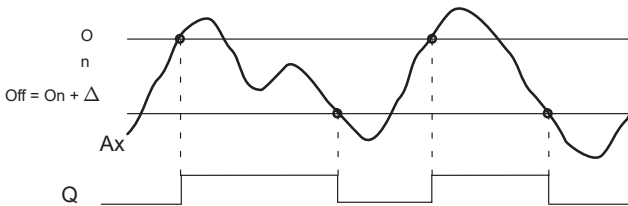

## Timing diagram B: Function with positive difference $\Delta$

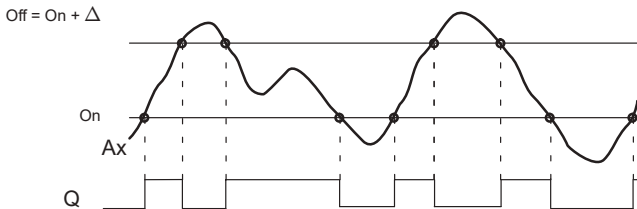

## Functional description

The function fetches the analog signal at input Ax.

Ax is multiplied by the value of the A (gain) parameter, and the value at parameter B (offset) is added to product, i.e.  $(Ax \cdot \text{gain}) + \text{offset} = \text{actual value of Ax}$ .

Output Q is set or reset, depending on the set (On) threshold and difference value ( $\Delta$ ). The function automatically calculates the Off parameter:  $\text{Off} = \text{On} + \Delta$ , whereby  $\Delta$  may be positive or negative. See the calculation rule below.

### Calculation rule

- When you set a negative differential value  $\Delta$ , the On threshold  $\geq$  Off threshold, and:  
 $Q = 1$ , if the actual value  $Ax > \text{On}$   
 $Q = 0$ , if the actual value  $Ax \leq \text{Off}$ .  
 See the timing diagram A.
- When you set a positive differential value  $\Delta$ , the On threshold  $<$  the Off threshold, and  $Q = 1$ , if:  
 $\text{On} \leq \text{actual value } Ax < \text{Off}$ .  
 See the timing diagram B.

### Preset of the Par parameter

The gain and offset parameters are used to adapt the sensors to the relevant application.

View in programming mode (example):

<b>B3</b>	<b>1+</b>	← Parameter protection mode
<b>On</b>	<b>=+04000</b>	← On/off threshold
<b><math>\Delta</math></b>	<b>=-02000</b>	← Differential value for the on/off threshold

Press ►

<b>B3</b>	<b>2</b>	
<b>A</b>	<b>=01.00</b>	← Gain
<b>B</b>	<b>=+00000</b>	← Offset
<b>p</b>	<b>=2</b>	← Decimals in the message text

View in parameter assignment mode (example):

<b>B3</b>		
<b>On</b>	<b>=+04000</b>	← On threshold
<b><math>\Delta</math></b>	<b>=-02000</b>	← Differential value for the off threshold
<b>Ax</b>	<b>=+05000</b>	← $Q = 1 (Ax > \text{On})$

Press ▼

**B3**  
**Off = +02000**

← Off threshold



## 4.4.18 Analog comparator

### Short description

The output is set and reset, depending on the difference  $A_x - A_y$  and on two configurable thresholds.

Symbol in LOGO!	Wiring	Description
	Inputs $A_x$ and $A_y$	<p>You apply the analog signals whose difference you want to analyze at the inputs <math>A_x</math> and <math>A_y</math>.</p> <p>Use the analog inputs <math>A1...A18</math> (*), the analog flags <math>AM1...AM6</math>, the block number of a function with analog output, or the analog outputs <math>AQ1</math> and <math>AQ2</math>.</p>
	Parameter	<p>A: Gain Range of values: 00.00...10.00</p> <p>B: Zero offset Range of values: <math>\pm 10.000</math></p> <p>On: On threshold Range of values: <math>\pm 20.000</math></p> <p>Off: Off threshold Range of values: <math>\pm 20.000</math></p> <p>p: Number of decimals Range of values: 0, 1, 2, 3</p>
	Output Q	Q is set or reset, depending on the difference $A_x - A_y$ and the set thresholds..

\*  $A1...A18$ : 0...10 V corresponds with 0...1000 (internal value).

## Gain and offset parameters

For more information on the gain and offset parameters, refer to Chapter 4.3.6.

## Parameter p (number of decimals)

Does not apply to Ax, Ay, On, Off and  $\Delta$  values displayed in a message text.

Does not apply to the comparison of on and off values!  
(The compare function ignores the decimal point.)

## Timing diagram

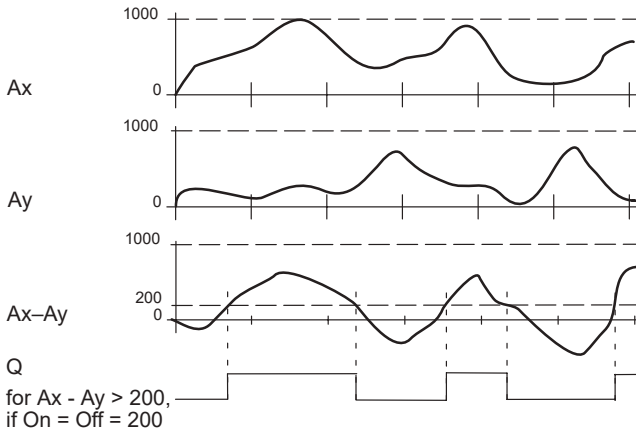

## Functional description

The function fetches the analog values from the inputs Ax and Ay.

Ax and Ay are each multiplied by the value of the A (gain) parameter, and the value at parameter B (offset) is then added to the relevant product, i.e.

$(Ax \cdot \text{gain}) + \text{offset} = \text{actual value Ax}$  or

$(Ay \cdot \text{gain}) + \text{offset} = \text{actual value Ay}$ .

The function forms the difference (" $\Delta$ ") between the actual values Ax - Ay.

Output Q is set or reset, depending on difference of the actual values Ax - Ay and the set thresholds. See the calculation rule below.

### Calculation rule

- If the On threshold  $\geq$  Off threshold, then:  
 $Q = 1$ , if:  
 $(\text{actual value } Ax - \text{actual value } Ay) > \text{On}$   
 $Q = 0$ , if:  
 $(\text{actual value } Ax - \text{actual value } Ay) \leq \text{Off}$ .
- If the On threshold  $<$  Off threshold, then  $Q = 1$ , if:  
 $\text{On} \leq (\text{actual value } Ax - \text{actual value } Ay) < \text{Off}$ .

### Preset of the Par parameter

The gain and offset parameters are used to adapt the sensors to the relevant application.

View in programming mode:

<b>B3</b>	<b>1+</b>	← Parameter protection mode
<b>On</b>	<b>=+00000</b>	← On threshold
<b>Off</b>	<b>=+00000</b>	← Off threshold

Press ►

<b>B3</b>	<b>2</b>	
<b>A</b>	<b>=00.00</b>	← Gain
<b>B</b>	<b>=+00000</b>	← Offset
<b>P</b>	<b>=0</b>	← Decimals in the message text

### Example

In a heating control system, the supply  $T_v$  and return line temperatures  $T_r$  are to be compared, for example with a sensor at AI2.

A control signal is to be triggered (for example "heater On"), when the difference between the supply and return line temperatures is greater than  $15^\circ$ . The control signal is reset when the difference is less than  $5^\circ\text{C}$ .

The process variable of the temperature is to be shown in parameter assignment mode.

The thermocouples available have the the following technical data:  $-30$  to  $+70$  °C, 0 to 10 VDC.

Application	Internal mapping
$-30$ to $+70$ °C = 0 to 10 V DC	0 to 1000
0 °C	300 → Offset = $-30$
Range of values: $-30$ to $+70$ °C = 100	1000 → Gain = $100/1000 = 0.1$
On threshold = 15 °C	Threshold = 15
Off threshold = 5 °C	Threshold = 5

See also Chapter 4.3.6.

Configuration (example):

<b>B3</b>	<b>1+</b>	← Protection mode
<b>On</b>	<b>=+00015</b>	← On threshold
<b>Off</b>	<b>=+00005</b>	← Off threshold

Press ►

<b>B3</b>	<b>2</b>	
<b>A</b>	<b>=00.10</b>	← Gain
<b>B</b>	<b>=-00030</b>	← Offset
<b>p</b>	<b>=0</b>	← Decimals in the message text (if used)

View in parameter assignment mode (example):

<b>B3</b>	<b>1</b>	
<b>On</b>	<b>=+00015</b>	← On threshold
<b>Off</b>	<b>=+00005</b>	← Off threshold

Press ▼

<b>B3</b>	<b>2</b>	
<b>Ax</b>	<b>=+00010</b>	Temperature values
<b>Ay</b>	<b>=-00020</b>	
<b>Δ</b>	<b>=+00030</b>	Q = 1 (differential value > On)

View in the message text (example):

<b>Ax</b>	<b>=+00010</b>
<b>Ay</b>	<b>=-00020</b>

### Reducing the input response of the analog comparator

You can selectively delay the output of an analog comparator by means of the “On-delay” and “Off-delay” special functions. With on-delay, output Q is only set if the pulse width of the triggering signal at input Trg (= analog comparator output) is longer than the on-delay time. With off-delay, output Q is only reset if the pulse width of the triggering signal at input Trg is longer than the off-delay time.

Using this method, you will obtain a virtual hysteresis and reduce the input response to short signals.

### Function block diagram

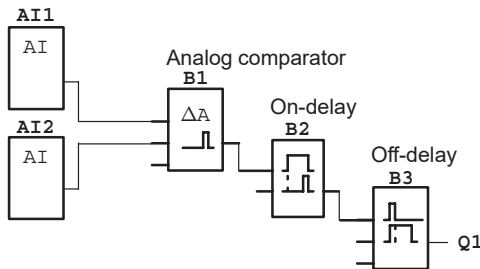

## 4.4.19 Analog value monitoring

### Short description

This special function saves the process variable of an analog input to memory, and sets the output when the output variable exceeds or drops below this stored value plus a configurable offset.

Symbol in LOGO!	Wiring	Description
	Input En	A positive edge (0 to 1 transition) at input En saves the analog value at input Ax ("Aen") to memory and starts monitoring of the analog range $Aen \pm \Delta$ .
	Input Ax	You apply the analog signal to be monitored at input Ax. Use the analog inputs AI1...AI8 (*), the analog flags AM1...AM6, the block number of a function with analog output, or the analog outputs AQ1 and AQ2.
	Parameter	A: Gain Range of values: 00.00...10.00 B: Zero offset Range of values: $\pm 10.000$ $\Delta$ : Difference value for the Aen on/off threshold Range of values: $\pm 20.000$ p: Number of decimals Range of values: 0, 1, 2, 3
	Output Q	Q is set/reset, depending on the stored analog value and the offset.

\* AI1...AI8: 0...10 V corresponds with 0...1000 (internal value).

## Gain and offset parameters

For more information on gain and offset parameters, refer to Chapter 4.3.6.

## Parameter p (number of decimals)

Applies only to the Aen, Ax and  $\Delta$  values displayed in a message text.

## Timing diagram

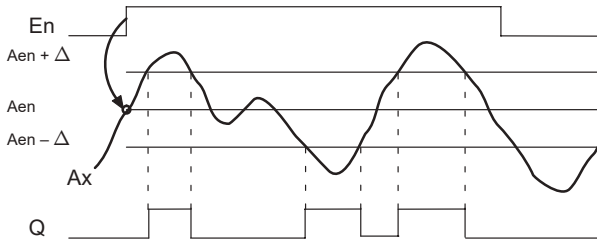

## Functional description

A 0 to 1 transition at input En saves the value of the signal at the analog input Ax. This saved process variable is referred to as "Aen".

Both the analog actual values Ax and Aen are multiplied by the value at parameter A (gain), and parameter B (offset) is then added to the product, i.e.

$(Ax \cdot \text{gain}) + \text{offset} = \text{Actual value Aen}$ , when input En changes from 0 to 1, or

$(Ax \cdot \text{gain}) + \text{offset} = \text{Actual value Ax}$ .

Output Q is set when the signal at input En = 1 and if the actual value at input Ax is out of range of  $Aen \pm \Delta$ .

Output Q is reset, when the actual value at input Ax lies within the range of  $Aen \pm \Delta$ , or when the signal at input En changes to 0.

### Preset of the Par parameter

The gain and offset parameters are used to adapt the used sensors to the respective application.

View in programming mode:

<b>B3</b>	<b>1+</b>	←	Parameter protection mode
<b>Δ</b>	<b>=±00000</b>	←	Differential value for the on/off threshold

Press ►

<b>B3</b>	<b>2</b>		
<b>A</b>	<b>=00.00</b>	←	Gain
<b>B</b>	<b>=+00000</b>	←	Offset
<b>P</b>	<b>=0</b>	←	Decimals in the message text

View in parameter assignment mode (example):

<b>B3</b>			
<b>Δ</b>	<b>=±00010</b>		
<b>Aen</b>	<b>=-00020</b>		
<b>Ax</b>	<b>=+00005</b>	←	Q = 1 (Ax is out of the range of Aen ± Δ)



## 4.4.20 Analog amplifier

### Short description

This special function amplifies the value of an analog input and outputs the result at an analog output.

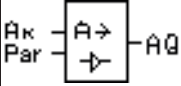
Symbol in LOGO!	Wiring	Description
	Input Ax	<p>You apply the analog signal to be amplified at input Ax.</p> <p>Use the analog inputs AI1...AI8 (*), the analog flags AM1...AM6, the block number of a function with analog output, or the analog outputs AQ1 and AQ2.</p>
	Parameter	<p>A: Gain Range of values: 00.00...10.00</p> <p>B: Zero offset Range of values: <math>\pm 10.000</math></p> <p>p: Number of decimals Range of values: 0, 1, 2, 3</p>
	Output AQ	<p>This special function has an analog output! This output can only be connected with the analog input of a function or with an analog flag.</p> <p>Range of values for AQ: -32768...+32767</p>

\* AI1...AI8: 0...10 V corresponds with 0...1000 (internal value).

### Gain and offset parameters

Please note the information on gain and offset parameters in Chapter 4.3.6.

### Parameter p (number of decimals)

Applies only to the AQ value in a message text.

### Functional description

The function fetches the analog signal of input Ax.

This value is multiplied by the value of the A (gain) parameter, and parameter B (offset) is then added to the product, i.e.  $(Ax \cdot \text{gain}) + \text{offset} = \text{actual value Ax}$ .

The actual value Ax is output at AQ.

### Preset of the Par parameter

The gain and offset parameters are used to adapt the sensors to the relevant application.

View in programming mode (example):

<b>B3</b>	<b>+</b>	
<b>A</b>	<b>=02.50</b>	← Gain
<b>B</b>	<b>==00300</b>	← Offset
<b>P</b>	<b>=0</b>	← Decimals in the message text

View in parameter assignment mode (example):

<b>B3</b>
<b>AQ ==00250</b>

## 4.4.21 Latching relay

### Short description

Input S sets output Q, input R resets output Q again.

Symbol in LOGO!	Wiring	Description
	Input S	You set output Q with a signal at input S.
	Input R	You reset output Q with a signal at input R. If S and R = 1, the output is reset.
	Parameter	Retentivity: / = No retentivity R = The status is retentive.
	Output Q	Q is set with a signal at input S, and reset with a signal at input R.

### Timing diagram

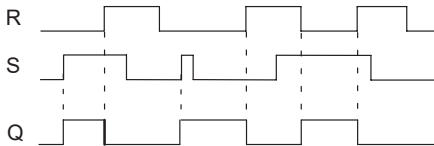

### Switching response

A latching relay represents a simple binary element. The output value depends on the status at the inputs and on the previous output status. The following table shows the logic once again:

$S_n$	$R_n$	Q	Comment
0	0	x	The status is retentive
0	1	0	Reset
1	0	1	Set
1	1	0	Reset (takes priority over Set)

When retentivity is enabled, the current status of the output signal is retained after a power failure.

## 4.4.22 Pulse relay

### Short description

A short pulse at the input sets and resets the output.

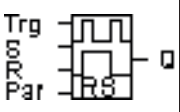
Symbol in LOGO!	Wiring	Description
	Input Trg	You set and reset output Q with a signal at input Trg (Trigger).
	Input S	You set output Q with a signal at input S.
	Input R	You reset output Q with a signal at input R.
	Parameter	Selection: RS (R input priority) or SR (S input priority)  Retentivity: / = No retentivity R = The status is retentive.
	Output Q	Q is set with a signal at Trg, and reset with the next signal at Trg, if S and R = 0.

### Timing diagram

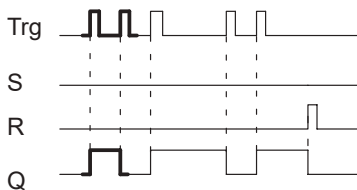

The bold printed section of the timing diagram is also shown in the symbol for the pulse relay.

## Functional description

Output Q changes its status, i.e. the output is set or reset, with each 0 to 1 transition at input Trg and if the inputs S and R = 0.

The signal at input Trg does not influence the special function when S or R = 1.

You set the pulse relay with a signal at input S, i.e. the output is set hi.

You reset the pulse relay with a signal at input R, i.e. the output is set lo.

## Status diagram

Par	$Q_{n-1}$	S	R	Trg	$Q_n$
*	0	0	0	0	0
*	0	0	0	0 → 1	1**
*	0	0	1	0	0
*	0	0	1	0 → 1	0
*	0	1	0	0	1
*	0	1	0	0 → 1	1
RS	0	1	1	0	0
RS	0	1	1	0 → 1	0
SR	0	1	1	0	1
SR	0	1	1	0 → 1	1
*	1	0	0	0	1
*	1	0	0	0 → 1	0**
*	1	0	1	0	0
*	1	0	1	0 → 1	0
*	1	1	0	0	1
*	1	1	0	0 → 1	1
RS	1	1	1	0	0
RS	1	1	1	0 → 1	0

Par	Q <sub>n-1</sub>	S	R	Trg	Q <sub>n</sub>
SR	1	1	1	0	1
SR	1	1	1	0 → 1	1

\*: RS or SR

\*\* : Triggering signal is effective, because S and R = 0.

Depending on your configuration, either input R takes priority over input S (i.e. input S is not effective when R = 1), or vice versa (i.e. input R is not effective when S = 1).

After a power failure, the pulse relay and output Q are reset if you have not enabled retentivity.

View in programming mode:

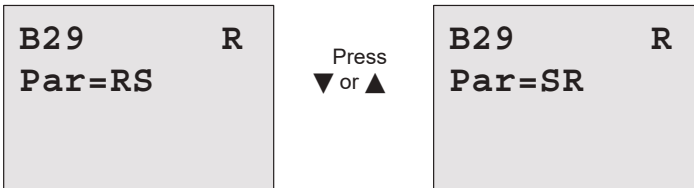

This special function is not available in parameter assignment mode.

---

### Note

If Trg = 0 and Par = RS, the special function “Pulse relay” corresponds with the special function “Latching relay” (see Chapter 4.4.21).

---

## 4.4.23 Message texts

### Short description

View of a configured message text in RUN mode.

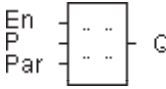
Symbol in LOGO!	Wiring	Description
 <p>The symbol is a rectangular box with three input terminals on the left labeled 'En', 'P', and 'Par', each with two dots representing connection points. On the right side, there is one output terminal labeled 'Q' with two dots representing connection points.</p>	Input En	A 0 to 1 transition at input En (Enable) starts the output of the message text.
	Input P	P: Priority of the message text Range of values: 0...30 Quit: Acknowledgment of the message text.
	Parameter	Text: Input of the message text Par: Parameter or actual value of another, already programmed function (see "Visible parameters or process variables") Time: Display of the continuously updated time-of-day Date: Display of the continuously updated date EnTime: Display of the time of the 0 to 1 transition of the signal at input En EnDate: Display of the date of the 0 to 1 transition of the signal at input En
	Output Q	Q remains set as long as the message text is set.

## Restriction

A maximum of 10 message text functions are available.

## Functional description

With the 0 to 1 transition of the signal at input En and when the system is in RUN, the message text you have configured (process variable, text, time-of-day, date) is output to the display.

Acknowledgment disabled (Quit = Off):

The message text is hidden when the status of the signal at input En changes from 1 to 0.

Acknowledgment enabled (Quit = On):

When the status of the signal at input En changes from 1 to 0, the message text is output until it is acknowledged with **OK**. When En = 1, you can not acknowledge the message text.

When multiple message text functions are triggered with En=1, the message text that has the highest priority is shown (0 = lowest, 30 = highest). This also means, that a newly activated message text is shown only if its priority is higher than that of previously activated message texts.

After a message text is disabled or acknowledged, the function automatically shows the previously active message text that takes the highest priority.

You can change the view and the message texts by pressing the keys ▲ and ▼ .



## Example

This is how tow message texts could be shown:

### Display field of the LOGO! in RUN mode

```
Motor 5
STOP AT
10:12
!!Action!!
```

← Example: Message text with priority 30

▼ Key ▲

```
Motor 2
3000
hours
MAINTENANCE!
```

← Example: Message text with priority 10

▼ Press ▲

```
Mo 09:00
2003-01-27
```

Date and current time-of-day (only for versions with real-time clock).

## Input P configuration

To configure the priority and the acknowledgment (programming mode):

```
B33 +
Priority
00
Quit=Off
```

“+” means: The parameters and actual values in an active message text can be edited

← Priority

← Status of the acknowledgment

1. Increase the priority to 1:                      Cursor on '0' + ▲
2. Change to 'Quit':                              Press ►
3. Enable 'Quit':                                  Press ▲ or ▼

LOGO! shows:

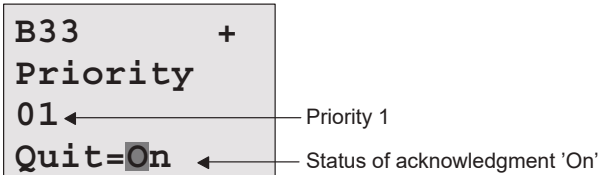

4. Confirm the entries with **OK**

### Visible parameters or process variables

The following parameter or process variables can be displayed in a message text:

Special function	Parameter or process variable visible in a message text
Times	
On-delay	T, T <sub>a</sub>
Off-delay	T, T <sub>a</sub>
On-/Off-delay	T <sub>a</sub> , T <sub>H</sub> , T <sub>L</sub>
Retentive on-delay	T, T <sub>a</sub>
Wiping relay (pulse output)	T, T <sub>a</sub>
Edge triggered wiping relay	T <sub>a</sub> , T <sub>H</sub> , T <sub>L</sub>
Asynchronous pulse generator	T <sub>a</sub> , T <sub>H</sub> , T <sub>L</sub>
Random generator	T <sub>H</sub> , T <sub>L</sub>
Stairway lighting switch	T <sub>a</sub> , T, T <sub>I</sub> , T <sub>IL</sub>
Multiple function switch	T <sub>a</sub> , T, T <sub>L</sub> , T <sub>I</sub> , T <sub>IL</sub>
Weekly timer	3*on/off/day
Yearly timer	On, Off
Counter	
Up/down counter	Cnt, On, Off
Hours counter	MI, Q, OT

Special function	Parameter or process variable visible in a message text
Threshold trigger	$f_a$ , On, Off, G_T
Analog	
Analog threshold trigger	On, Off, A, B, Ax
Analog differential trigger	On, $\Delta$ , A, B, Ax, Off
Analog comparator	On, Off, A, B, Ax, Ay, $\Delta A$
Analog value monitoring	$\Delta$ , A, B, Ax, Aen
Analog amplifier	A, B, Ax
Miscellaneous	
Latching relay	–
Pulse relay	–
Message texts	–
Softkey	On/Off
Shift register	–

### Changing parameters in the active message text

You can allow editing of parameter and process variables in an active message text by entering a “+” in the first line. To prevent changes, enter a “-” sign.

When the message text is active, press **ESC** to select the editing mode.

#### Note

You must keep the **ESC** key pressed at least for one second.

Press ◀ and ▶ to select the relevant line (you can only select lines that contain parameters). Press **OK** to change the parameter. Use the keys ◀, ▶, ▲ and ▼.

Confirm your changes with **OK**. You can now edit further parameters in the message text (if any exist). Press **ESC** to exit editing mode.

### Key input simulation in the active message text

You can enable the four cursor keys C ▲, C ►, C ▼ and C ◀ in an active message text by pressing **ESC** plus the relevant cursor key.

### Preset of the Par parameter

To configure the message text (programming mode):



Parameter assignment  
screen form for Par

Press ► to select a line for the message text.

Press ▲ and ▼ to select the relevant type of message text (Text, Par, Time...). Confirm with **OK**.

Further entries are required when “Text” or “Par” are selected:

Press ▲ and ▼ to select the letter to be displayed in the text. To move the cursor from one position to the other, press ◀ and ►.

The list of available characters is here the same as for the circuit program name. The character set is found in Chapter 3.6.4.

Press **OK** to confirm your changes, and press **ESC** to exit the editing mode.

To output a parameter (e.g. a process variable or function value) as message text, select the relevant line with ► and then press ▼:

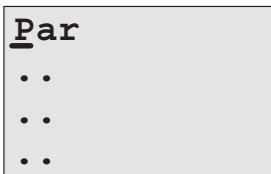

Press **OK** to open the editing mode:

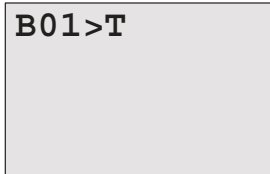

Press ◀ and ▶ to select the blocks to be displayed and the corresponding parameters.

Press ▲ and ▼ to select the block or parameter you want to view.

Select the parameter by pressing **OK**.

Press **ESC** to exit the parameter assignment mode and to apply your changes.

### 4.4.24 Softkey

#### Short description

This special function has the effect of a mechanical push-button or switch.

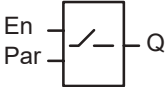
Symbol in LOGO!	Wiring	Description
	Input En	Output Q is set with a 0 to 1 transition of the signal at input En (Enable), and if 'Switch=On' was confirmed in parameter assignment mode.
	Parameter	<p><u>Programming mode:</u>                      Selecting the function for pushbutton action for the duration of one cycle, or for switching action.</p> <p>Start: On or off state, initialized at the first start of the program if retentivity is disabled.</p> <p>Retentivity:                      / = No retentivity                      R = The status is retentive.</p> <p><u>Parameter assignment mode (RUN mode):</u>                      Switch: Switches the momentary pushbutton or switch on or off.</p>
	Output Q	Switches on if En=1 and Switch=On was confirmed with <b>OK</b> .

#### Factory setting

The default setting at 'Par' is 'Momentary pushbutton' action.

## Timing diagram

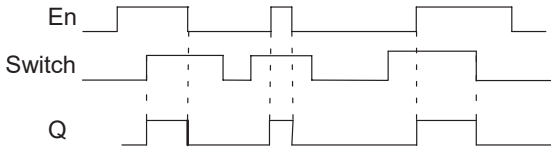

## Functional description

In parameter assignment mode, the output is set with a signal at input En, if the "Switch" parameter is set to 'On' and confirmed with **OK**. Whether the function was configured for pushbutton or switching action is here of no concern.

The output is reset to '0' in the following three cases:

- After a 0 to 1 transition at input En.
- When the function was configured for momentary pushbutton action, and one cycle has expired since it was switched on.
- When the position 'Off' was selected at the 'Switch' parameter and confirmed with **OK** in parameter assignment mode.

If retentivity is not set, output Q is initialized after a power failure according to your configuration at the "Start" parameter.

## Preset of the Par parameter

View in programming mode (example):

1. Select the 'Softkey' function.
2. Select input En and confirm with **OK**. The cursor is now positioned below 'Par'.
3. Change to the input mode of 'Par': Confirm with **OK** (the cursor is now positioned to 'On')

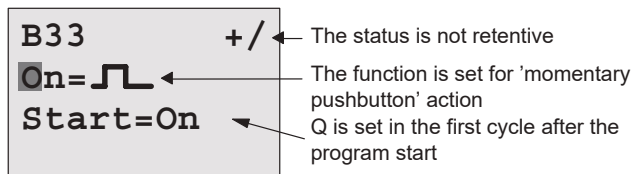

To change 'Par' to 'Switch' action and the initialization status after the program start:

- To select 'Momentary pushbutton' or 'Switch' action: Press ▲ or ▼

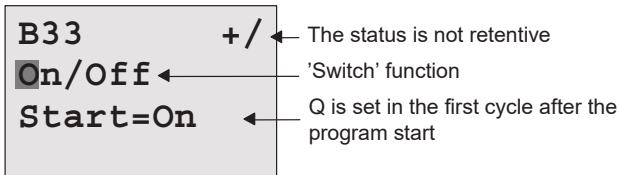

- To change to the start state: Press ◀ or ▶
- To change the start state: Press ▲ or ▼

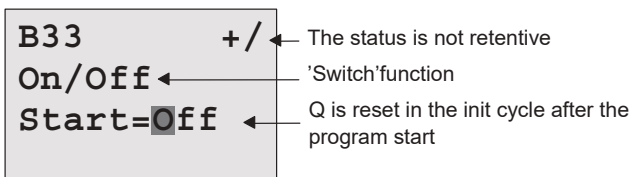

- Confirm your entries with **OK**

View in parameter assignment mode (example):

Here, you can set or reset the 'Switch' parameter (On/Off).  
When in RUN, the LOGO! shows the following display:



Let us assume you want to set 'Switch' (On).

- Change to the editing mode: Confirm with **OK**  
(the cursor is now positioned on 'Off')
- To change from 'Off' to 'On': Press ▲ or ▼
- Confirm your entries with Press **OK**



**B33**

**Switch=On**

The momentary pushbutton/switch  
is here switched on

## 4.4.25 Shift register

### Short description

You can use the shift register function to read the value of an input and to shift its bits left or right. The output value corresponds with the configured shift register bit. The shifting direction can be changed at a special input.

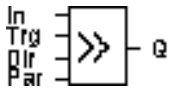
Symbol in LOGO!	Wiring	Description
	Input In	Input read at the start of the function.
	Input Trg	A positive edge (0 to 1 transition) at input Trg (Trigger) starts the special function. 1 to 0 transitions are irrelevant.
	Input Dir	The signal at input Dir determines the shifting direction for the shift register bits S1...S8 an: Dir = 0: Shift up (S1 >> S8) Dir = 1: Shift down (S8 >> S1)
	Parameter	Shift register bit that determines the value at output Q. Possible settings: S1 ... S8 Retentivity: / = No retentivity R = The status is retentive.
	Output Q	The output value corresponds with the configured shift register bit.

### Functional description

The function reads the value at input In with a positive edge (0 to 1 transition) at input Trg (Trigger).

This value is applied to shift register bit S1 or S8, depending on the shifting direction:

- Shift up: The value at input In is set at S1; the previous value at S1 is shifted to S2; the previous value at S2 is shifted to S3 etc.
- Shift down: The value at input In is set at S8; the previous value at S8 is shifted to S7; the previous value at S7 is shifted to S6 etc.

Output Q returns the value of the configured shift register bit.

If retentivity is disabled, the shift function restarts at S1 or S8 after a power failure. When enabled, retentivity always applies to all shift register bits.

### Note

The special function shift register can be used only once in the circuit program.

### Timing diagram

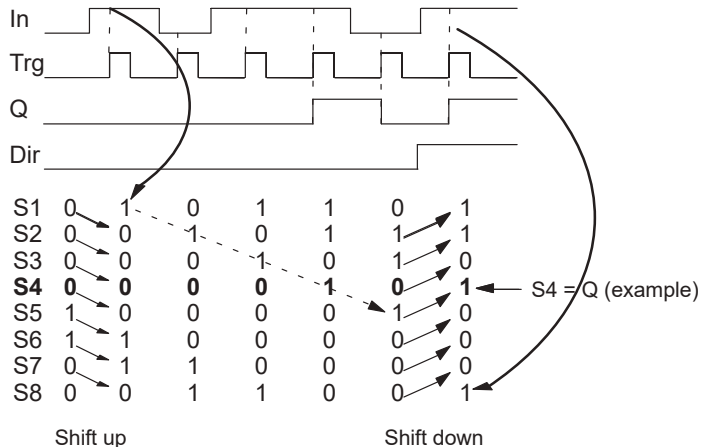

### Preset of the Par parameter

View in programming mode:

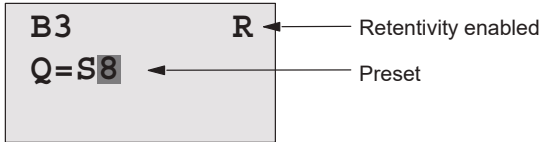

Press ▼

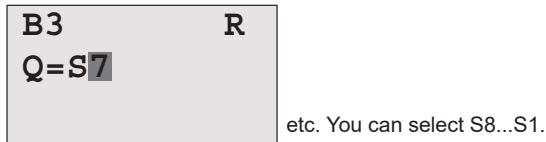

This special function is not available in parameter assignment mode.

## 5 Configuring LOGO!

When speaking of 'parameter assignment', we refer to the configuration of the block parameters. You can set delay times for time functions, the switching times of the timers, the counter threshold value, the monitoring interval of an hours counter and the on and off thresholds of the trigger.

You can configure the parameters

- In programming mode
- In parameter assignment mode

In programming mode, the author of the circuit program also sets the parameters.

We have added the parameter assignment mode to allow the editing of parameters without having to modify the circuit program. This feature is available for the user to edit parameters, without having to change to programming mode, for example. The advantage: The circuit program remains protected, but can be adapted by the user to meet specific requirements.

---

### Note

In parameter assignment mode, the LOGO! continues execution of the circuit program.

---

## 5.1 Selecting parameter assignment mode

Press **ESC** to change from RUN to parameter assignment mode:

```
Mo 09:00
2003-01-27
```

```
... Press
    ESC
```

---

### Note

The following applies to earlier device versions up to 0BA2:

- You open parameter assignment mode by pressing **ESC+OK**.

---

LOGO! changes to parameter assignment mode and opens the parameter assignment menu:

```
>Stop
  Set Param
  Set Clock
  Prg Name
```

## Description of the four menu items of the parameter assignment menu

- **Stop**

You select this command to stop your circuit program and thus change to the main menu of programming mode. To do so:

1. To move the '>' cursor to '**Stop**': Press ▲ or ▼
2. To confirm 'Stop': Press **OK**

```

Stop Prg
>No
Yes
    
```

3. To move the '>' cursor to '**Yes**': Press ▲ or ▼
4. To confirm 'Yes': Press **OK**

LOGO! shows the main menu of the programming mode:

```

>Program..
Card..
Clock..
Start
    
```

- **Set Param**

For information on the various parameters, refer to the Chapters 5.1.1 to 5.1.3.

- **Set clock**

The 'Set Clock' command is only executed if your LOGO! is equipped with a real-time clock (LOGO!..C). You set the real-time clock of LOGO! by means of the 'Set Clock' command. For details, refer to Chapter 5.2.

- **Prg Name**

This menu command only allows you to **read** the name of your circuit program. It is not possible to modify this name in parameter assignment mode. (see Chapter 3.6.4.)

## 5.1.1 Parameters

---

### Note

In the following discourse on parameters, we presume that the respective default parameter protection mode ("+") has been maintained. This is prerequisite for viewing and editing parameter in the parameter assignment mode!  
See Chapter 4.3.5 and the example on Page 72.

---

Parameters are, for example:

- The delay times of a timer relay.
- The switching times (cams) of a timer switch.
- Counter thresholds
- The monitoring time for hour counters
- The trigger thresholds.

Each one of the parameters is identified by its block number (Bx) and the shortname of the parameter. Examples:

- T: ...is a configurable time.
  - MI: ...is a configurable time interval.
- 

### Note

LOGO!Soft Comfort also allows you to assign names to blocks (for more information, refer to Chapter 7).

---



## 5.1.2 Selecting the parameters

To select a parameter:

1. On the parameter assignment menu, select 'Set Param': Press ▼ or ▲

```

Stop
>Set Param
Set Clock
Prg Name
    
```

2. Confirm with **OK**.  
LOGO! shows the first parameter. If no parameter can be set, you can press ESC to return to the parameter assignment menu.

```

B9      1
T =60:00s
Ta =06:00s
    
```

Block number  
 Display number for functions with several displays  
 The value set at parameter T (Time)  
 The current time in the LOGO!

```

No Param
Press ESC
    
```

No parameters for editing:  
 Press ESC to return to the parameter menu

3. Now, select the desired parameter:  
 Press ▲ or ▼.
4. Select the parameter you want to edit, and press **OK**.

### 5.1.3 Modifying parameters

You first select the parameter you want to edit (see Chapter 5.1.2).

You change the value of the parameter in the same way as you did in programming mode:

1. Move the cursor to the point at which you want to make the change: Press ◀ or ▶
2. To change this value: Press ▲ or ▼
3. To apply the value: **OK**

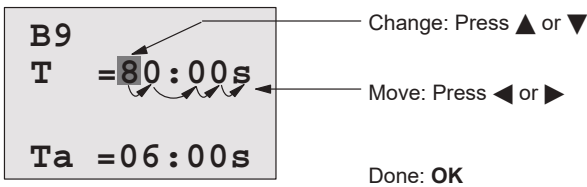

---

#### Note

Alongside with a change of the time parameters when the system is in RUN, you can also change the timebase (s = seconds, m = minutes, h = hours). This does not apply if the time parameter represents the result of another function (for an example, see Chapter 4.4.1). In this case you can neither change the value nor the timebase.

The current time is reset to zero when you change the timebase.

---

#### Current value of a time T

View of a time T in parameter assignment mode:

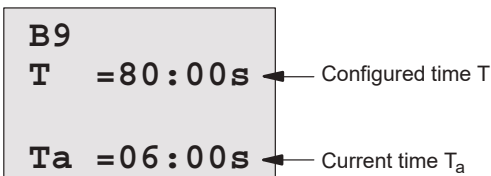

You can change the configured time T.

### Current timer value

View of a timer cam in parameter assignment mode:

```
B1      1
D=M-W-F--
On  = 09:00
Off=10:00
```

You can change the on/off times and the day.

### Current value of a counter

View of a counter parameter in parameter assignment mode:

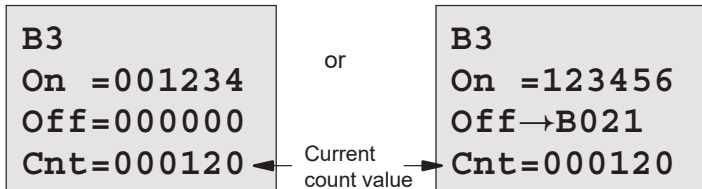

You can change the on/off threshold. This does not apply if the on or off threshold represents the result of another function (in the example, this is B21, see Chapter 4.4.13).

### Current value of an hour counter

View of an hour counter parameter in parameter assignment mode:

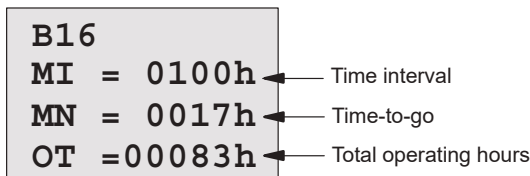

You can edit the configured time interval MI.

### Current value of a threshold trigger

View of the parameter of a threshold trigger in parameter assignment mode:

<b>B15</b>	
<b>On =0009</b>	← On threshold
<b>Off =0005</b>	← Off threshold
<b>fa =0010</b>	← Process variable

You can change the on/off threshold.

## 5.2 Setting the time-of-day and date (LOGO! ... C)

You can set the TOD and the date

- In parameter assignment mode
- In programming mode.

### To set the TOD and the date in parameter assignment mode:

1. Select parameter assignment mode. (see Chapter 5.1.)
2. On the parameter menu, select '**Set Clock**'  
(Press ▼ or ▲), and then press **OK**.

```
Set Clock
Mo 15:30
YYYY-MM-DD
2003-01-27
```

The cursor is positioned  
on the weekday.

3. Select the day of the week: Press ▲ or ▼
4. Move the cursor to the next position: Press ◀ or ▶
5. To change the value: Press ▲ or ▼
6. To set the correct TOD, repeat steps 4 and 5.
7. To set the correct date, repeat steps 4 and 5
8. To confirm your entries: Press **OK**

### To set the TOD and the date in programming mode:

1. Select programming mode (ESC / >Stop). (see Chapter 3.6.1.)
2. On the main menu, select '**Clock..**' (Press ▼ or ▲),  
and then press **OK**.
3. Go to the clock menu, and select '**Set Clock**'  
(Press ▼ or ▲), and the press **OK**.

You can now set the weekday and the time as described  
earlier (as of step 3.).

[www.nicsanaf.com](http://www.nicsanaf.com)

021-87700210



## 6 LOGO! program module (card)

LOGO! allows you to store only one circuit program in its memory. If you want to modify the circuit program or create a further one without deleting the first, you must archive it somewhere. One of the options is to use a program module/card.

The circuit program stored in LOGO! can be copied to a program module (card). You can then insert the program module/card in another LOGO! to copy the circuit program. using the program module (card), you can:

- Archiving circuit programs
- Reproducing circuit programs
- Send circuit programs by mail
- Write and test your circuit program at the office, and then transfer it to a LOGO! in the switching cabinet.

LOGO! is supplied with a hood. The program module (card) is supplied separately.

---

### Note

You do **not** need a module to backup the circuit program in your LOGO!.

The LOGO! circuit program is automatically stored in non-volatile memory when you exit the programming mode.

---

We shall now introduce the program module (Card) you can order for LOGO! The card can backup all data in the LOGO! circuit program memory.

The order number is found in the appendix.

## Compatibility

### **... to current versions (0BA4 devices):**

Data written to the program module (card) in a 0BA4 version can be read in all other 0BA4 versions.

### **... to earlier versions (0BA0 to 0BA3 devices):**

A program module (card) that contains data written in earlier versions (0BA0...0BA3 devices) can not be used in LOGO! devices of the 0BA4 generation. When the LOGO! system detects such an 'old' program module (card), the message "Unknown Card / Press ESC" is output to the display.

Vice versa, an 0BA4 program module (card) can not be used in LOGO! devices of the 0BA0...0BA3 family.

## Upward compatibility of circuit programs

Circuit programs written for the previous versions 0BA0...0BA3 can only be applied in 0BA4 units by means of LOGO!Soft Comfort.



## 6.1 Security function (CopyProtect)

We principally distinguish between program modules (card) with and without circuit program/copy protection.

### Unprotected program module (card)

You can edit circuit programs without restrictions, and exchange data between the program module (Card) and the device.

### Protected program module (card)

A circuit program is **protected** when it is transferred from a protected program module (card) to the LOGO!.

To execute this circuit program in LOGO!, the protected program module (card) must remain inserted during RUN, i.e. the circuit program stored on the program module (card) can not be copied to other LOGO! devices.

Over and above that, a protected circuit program is write-protected.

A circuit program with **password** protection is no longer protected after the correct password has been entered, i.e. you can then edit the program and remove the module.

---

### Note

You need to assign a password when you create the circuit program for a protected module (card) to be able to edit it at a later time (see Chapter 3.6.5).

---

### Correlation between the password and the protective function

Password	Protection	Editing	Copying	Deleting
–	–	Yes	Yes	Yes
Yes	–	Yes, with password	Yes	Yes, with password
–	Yes	No	No	Yes
Yes	Yes	Yes, with password	Yes, with password	Yes, with password

### Assigning a security function

To assign a circuit program and copy protection function to the program module (card), open the programming mode and select “Card”.

1. Switch the LOGO! to programming mode (ESC / >Stop).
2. The main menu opens. To select the '**Card**' command:  
Press ▲ or ▼
3. To apply you entry in 'Card':  
Press **OK**
4. Move the '>' cursor to '**CopyProtect**': Press ▲ or ▼
5. To apply 'CopyProtect':  
Press **OK**

LOGO! shows the following display:

```
>No
  Yes
CopyProtect:
  No
```

The current protection setting is shown in the bottom line. This function is disabled by default ("No": disabled).

## Enabling the security function

To set the security function:

1. Move the '>' cursor to '**Yes**': Press ▲ or ▼
2. Confirm 'Yes': Press **OK**

LOGO! shows the following display:

```
>No
  Yes
CopyProtect:
  Yes
```

---

### Note

This only generates a circuit program and copy protection for the program module (card); the circuit program itself must be copied separately from the LOGO! to the program module (card) (can also be done initially).

You can always change the “No” status (security function disabled) to “Yes” (security function enabled).

A status change from “Yes” (security function enabled) to “No” (security function disabled) is only possible if the program module (card) does not contain a circuit program.

---

## 6.2 Inserting and removing the program module (card)

When you remove a program module (card) with circuit program and copy protection attribute, note the following: The circuit program stored on the program module (card) can only be executed if the card remains inserted during system runtime.

After you have removed the program module (card), LOGO! outputs the message 'No Program'. A removal of the program module (card) during RUN will lead to impermissible operating states.

Always heed the following warning:



---

### Warning

Do not touch the open slot of the program module (card) neither with your fingers, nor with a metallic or conductive object.

The program module (card) socket may be under voltage if the polarity is reversed at L1 and N by accident.

The program module (card) may only be removed by qualified personnel.

---

## Removing the program module (card)

To remove the program module (card):

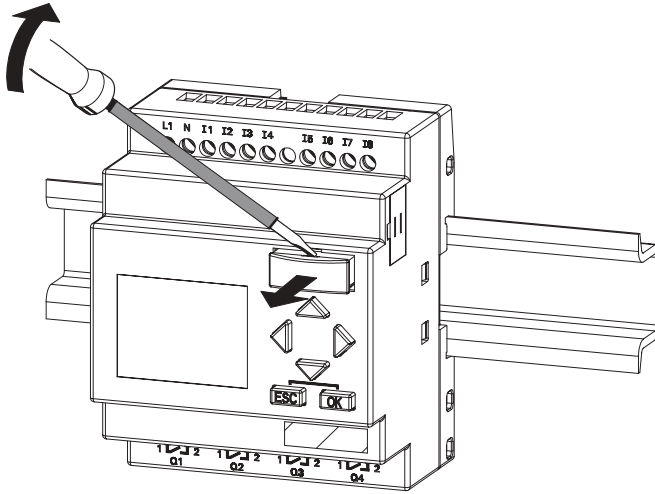

Carefully insert a screwdriver into the groove on the upper end of the program module (card) and lever the module partially out of the slot.

You can now remove the program module (card).

## Inserting a program module (card)

The entry of the program module (card) slot is chamfered on its bottom right. The edge of the program module (card) is chamfered accordingly. This encoding prevents you from inserting the program module (card) the wrong way round. Insert the program module (card) into the slot and push it in until it engages.

## 6.3 Copying data from the LOGO! to the program module (card)

To copy the circuit program to the program module (card):

1. Insert the program module (card) into the slot.
2. Switch the LOGO! to programming mode (ESC / >Stop).

```
>Program..
  Card..
  Clock..
  Start
```

LOGO! main menu

3. The main menu opens. To select the '**Card**' command:  
Press ▲ or ▼
4. Press **OK**. The transfer menu opens.

```
>[ESC]→Card
  Card→[ESC]
  CopyProtect
```

[ESC] = LOGO!

5. Move the '>' cursor to '**LOGO** → **Card**' (if required)  
Press ▲ or ▼
6. Press **OK**.

LOGO! now copies the circuit program to the program module (card).

When LOGO! has finished copying, it automatically returns you to the main menu:

```
>Program..
  Card..
  Clock..
  Start
```

The circuit program backup is now stored on your program module (card) and you can remove the card. **Do not forget** to replace the cap.

If power fails while LOGO! is copying the circuit program, repeat the process after Power On.

---

**Note**

The password X of a protected circuit program in LOGO! also applies to the copied program version on your program module (card).

---

## 6.4 Copying data from the program module (card) to LOGO!

You have a program module (card) that contains your circuit program. There are two ways to copy it to LOGO!:

- Automatically during the startup of LOGO! (POWER ON) or
- by means of the “Card” menu of LOGO!.

---

### Note

If the program on the module/card is protected with the password X, the copied program in the LOGO! is also protected with the same password.

---

### Automatic copying during the startup of LOGO!

Proceed as follows:

1. Switch off the power supply to the LOGO! (POWER OFF)
2. Remove the slot cover.
3. Insert the program module/card into the relevant slot.
4. Switch on the power supply to the LOGO!

LOGO! copies the program from the program module/card to LOGO!. When LOGO! has finished copying, it opens the main menu:

```
>Program..
  Card..
  Clock..
  Start
```



---

### Note

Before you switch the LOGO! to RUN, you must ensure that the system you are controlling with LOGO! does not represent a source of hazard.

---

1. Move the '>' cursor to 'Start': Press ▲ or ▼
2. Press **OK**.

### Copying by means of the “Card” menu

For information on the replacement of a program module (card), also note Chapter 6.2.

To copy a program from the program module (card) to LOGO!:

1. Insert the program module (card)
2. Switch the LOGO! to programming mode (ESC / >Stop).

```
>Program..
  Card..
  Clock..
  Start
```

3. Move the '>' cursor to 'Card': Press ▲ or ▼
4. Press **OK**. The transfer menu opens.
5. Move the '>' cursor to 'Card → LOGO!':  
Press ▲ or ▼

```
■+→Card
>Card→■+
  CopyProtect
```

■+ = LOGO!

6. Press **OK**.

LOGO! copies the circuit program from the program module (card) to LOGO!. When LOGO! has finished copying, it automatically returns to the main menu.

[www.nicsanaf.com](http://www.nicsanaf.com)

021-87700210



# 7 LOGO! Software

LOGO!Soft Comfort is available as a programming package for the PC. This software provides many features, for example:

- A graphic interface for offline creation of your circuit program by means of Ladder Diagram (contact chart / circuit diagram) or Function Block Diagram (function chart)
- Simulation of your circuit program on the PC
- Generating and printing of an overview chart for the circuit program
- Saving a backup of the circuit program on the hard drive or other media
- Comparing circuit programs
- Easy configuration of blocks
- Transferring the circuit program
  - from the LOGO! to the PC and
  - from the PC to LOGO!
- Reading the values of the hour counter
- Setting the TOD
- Summertime/wintertime conversion
- Online test: Display of status changes and process variables of LOGO! in RUN mode:
  - Status of a digital I/O, flags, shift register bits and cursor keys
  - The values of all analog I/Os and flags
  - The results of all blocks
  - The current values (including the times) of selected blocks
- Stopping circuit program execution via the PC (STOP).

## The LOGO! alternative

As you can see, LOGO!Soft Comfort represents an alternative to conventional engineering methods:

1. You start by developing the circuit program on your desktop.
2. You simulate the circuit program on your computer and verify its functions, before you actually implement it in your system.
3. You can add comments to the circuit program and create hardcopies.
4. You save a copy of your circuit program to the file system on your PC, to make it directly available for any modifications.
5. It takes only a few key actions to download the circuit program to LOGO!.

## LOGO!Soft Comfort

LOGO!Soft Comfort allows you the efficient, easy and concise creation of your circuit programs on the PC ("Wiring by means of Softkey"). After you have created the circuit program, you can either let the system decide which LOGO! version it requires for your program, or predetermine the relevant LOGO! version for the circuit program.

Particularly user-friendly functions are;

- Offline program simulation
- Simultaneous display of the status of several special functions
- Extensive options of circuit program documentation
- Display of the states and process variables of LOGO! in RUN mode
- a comprehensive Online Help.

LOGO!Soft Comfort runs under Windows 95/98, Windows NT 4.0, Windows Me<sup>®</sup>, Windows 2000<sup>®</sup>, Windows XP<sup>®</sup>, Linux<sup>®</sup> and Mac OS X<sup>®</sup>. LOGO!Soft Comfort is capable of client/server operation and offers you a high degree of freedom and comfort for creating your circuit program.

### **LOGO!Soft Comfort V4.0**

This is the current version of LOGO!Soft Comfort. You will find all the functions and the functionality of the devices described in this manual in the version 4.0 and later.

### **Updating LOGO!Soft Comfort versions V1.0 up to V3.0**

The update can only be installed for the full version of LOGO!Soft Comfort V1.0, V2.0 or V3.0.

order numbers are found in Appendix E.

### **Updates and info**

You can download demo versions of the software free of charge from the Internet address specified in the preface.

## 7.1 Connecting the LOGO! to a PC

### Connecting the PC cable

To connect the LOGO! to a PC, you need the LOGO! PC cable (order number is found in Appendix E).

Remove the cap or program module (card) from your LOGO! and connect the cable to this socket. Connect the other end of the cable to the serial port of your PC.

### Connecting the PC cable to the USB port

If your PC is only equipped with a USB interface (Universal Serial Bus), you will need a converter and a device driver to connect the LOGO! cable to this port. Follow the instructions on the screen when you install the driver for the converter. Make sure you specify the correct Windows OS version when you select the driver.

### Switching LOGO! to PC↔LOGO mode

1. Switch the LOGO! with/without display to STOP from your PC (refer to the LOGO!Soft Comfort Online Help), or select the ESC / >Stop command on a device with display and confirm the entry with 'Yes'.

When LOGO! is in STOP and online with the PC, the following PC commands are accepted:

- Switch LOGO! to RUN
  - Read/write the circuit program
  - Read/write the summertime/wintertime
2. When you start the upload/download in STOP, the following display appears automatically:

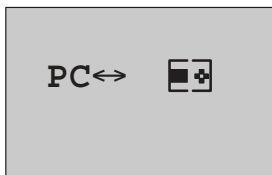

 = LOGO!

---

### Note

Earlier versions up to 0BA3 with/without display are automatically switched to PC $\leftrightarrow$ LOGO mode as follows:

1. Switch off the power supply to the LOGO!.
2. Remove the cover or the program module (card) and connect the cable to this socket.
3. Switch on power.

LOGO! switches automatically to PC  $\leftrightarrow$  LOGO mode.

The PC can now access the LOGO! For information on this function, refer to the LOGO!Soft Comfort Online Help.

For more information on LOGO! versions without display, refer to Appendix C.

---

### Closing the PC $\leftrightarrow$ LOGO mode

When the data transfer is completed, the connection to the PC is shut down automatically.

---

### Note

If the circuit program created with LOGO!Soft Comfort is password protected, both the circuit program and the password are downloaded to LOGO!. The password prompt is enabled at the end of the data transfer.

The upload of a password protected program created in LOGO! is only possible after the correct password is entered in LOGO!Soft Comfort.

---

[www.nicsanf.com](http://www.nicsanf.com)

021-87700210





## 8 Applications

We have provided a small collection of applications in this manual to give you an impression of the versatility of LOGO!. For these examples we have recorded once again the original solution of the circuit diagram, and compared it with the LOGO! solutions.

You can find solutions for the following tasks:	Page
Stairway or corridor lighting system	223
Automatic door	227
Ventilation system	234
Factory gate	239
Central controlling and monitoring of several factory gates	243
Luminous rows	247
Service water pump	251
Further applications	255

### Note

LOGO! applications are available to all our customers free of charge. The examples provided are noncommittal, serve as general information about the fields of application for LOGO!, and may be different to user-specific solutions.

The user operates the system at his own responsibility. We refer to the relevant national standards and system-related installation regulations.

Although you have four inputs available for logic operations (basic functions, see Chapter 4.2), the following figures will only show a maximum of three inputs for reasons of clarity. You program this fourth input and assign parameters just like the other three inputs.

Errors can not be ruled out, and the right to make changes is reserved.

---

These application and tips for further applications are also found on the Internet under the URL specified earlier in the preface.

## 8.1 Stairway or corridor lighting

### 8.1.1 Requirements for a stairway lighting system

The basic requirements for a stairway lighting system are as follows:

- When someone is using the stairway, the lighting should be switched on.
- If no-one is in the stairway, the lights should be switched off in order to save energy.

### 8.1.2 Previous solution

The two conventional options for switching the lights:

- With a pulse relay
- With an automatic stairway lighting switch

The wiring of both these lighting systems is identical.

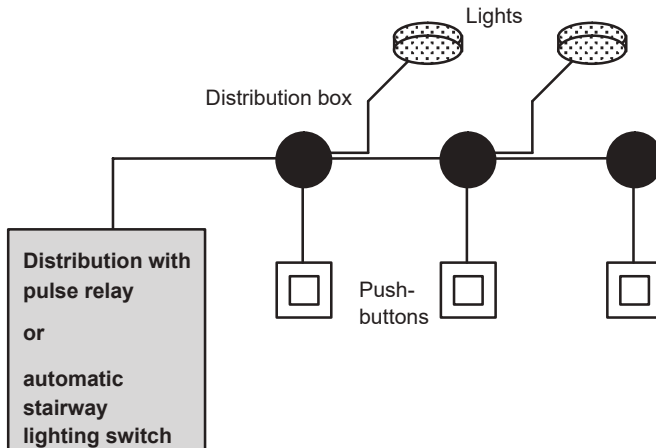

#### Components used

- Momentary switches
- Automatic stairway lighting switch or pulse relay

### Lighting system with pulse relay

Function of a lighting system with pulse relay:

- Press any pushbutton: The lighting is switched on
- Press any of the pushbuttons once again: The lighting is switched off.

**Disadvantage:** People often forget to switch off the lights.

### Lighting system with an automatic stairway lighting switch

Function of a lighting system with automatic stairway lighting switch:

- Press any pushbutton: The lighting is switched on
- The lights are switched off automatically when the pre-set time has expired.

**Disadvantage:** The lights can not be switched on for a longer period of time (e.g. when cleaning the stairway). The switch for permanent lighting is usually located on the automatic stairway lighting switch and may be difficult or impossible to access.

## 8.1.3 Lighting system with LOGO!

A LOGO! system allows you to replace the automatic stairway lighting switch or the pulse relay. You can also implement both functions (timed off-delay and pulse relay) in a single unit. What is more, you can incorporate extra functions without making any alterations to the wiring. Here are some examples:

- Pulse relay with LOGO!
- Automatic stairway lighting switch with LOGO!
- Multiple function switch with LOGO!
  - Switch light on
  - Switch on permanent lighting
  - Switch light off

## Wiring of a lighting system with LOGO! 230RC

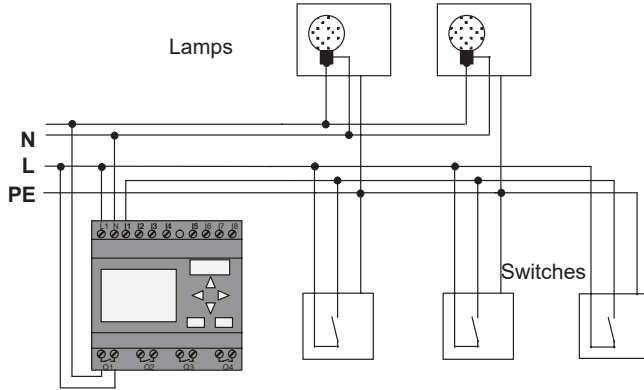

The external wiring of a lighting system with a LOGO! is no different than it is for a conventional stairway and corridor lighting system. Only the automatic stairway lighting switch/pulse relay is replaced. Supplementary functions are entered directly in LOGO!.

### Pulse relay with LOGO!

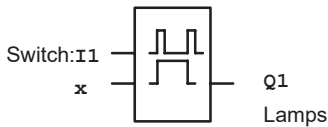

Output Q1 is toggled with a pulse signal at input I1.

### Automatic stairway lighting switch with LOGO!

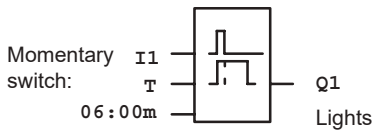

Output Q1 is set for the duration of 6 minutes with a pulse signal at input I1.

## Multiple function switch with LOGO!

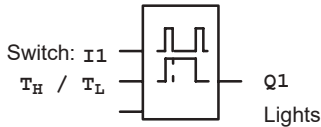

Output Q1 is set for the duration of a preset time  $T_H$  with a pulse signal at input I1.

The permanent lighting function is enabled by keeping the momentary switch pressed for a specified time  $T_L$ .

### 8.1.4 Special features and expansion options

Other options for increasing comfort or saving energy are, for example:

- A flashing function that indicates that the light is about to be switched off automatically.
- You can integrate various central functions:
  - Central off
  - Central on (panic button)
  - Control of all lamps or individual circuits by means of a daylight control switch
  - Controlling by means of an integrated timer (e.g. permanent lighting only until 24.00 h; disabled at specific times)
  - Automatically switching off the permanent lighting on expiration of a preset time (e.g. after 3 hours)

## 8.2 Automatic door

You often find automatic door control systems at the entrance to supermarkets, public buildings, banks, hospitals etc.

### 8.2.1 Requirements of an automatic door

- When a person approaches the door, it must open automatically.
- The door must remain open until the doorway is cleared.
- When the doorway is cleared, the door must close automatically with a short delay.

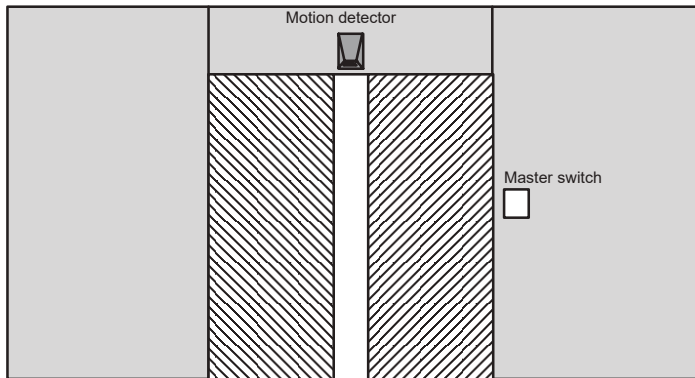
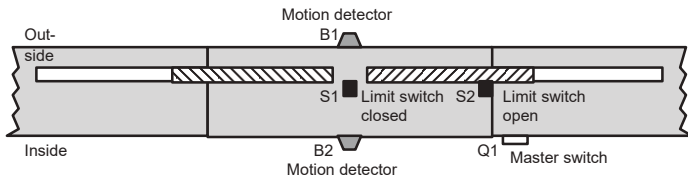

The door is usually driven by a motor that is equipped with a slip coupling. This prevents people from being squeezed in and injured. The control system is connected to the mains via a master switch.

## 8.2.2 Conventional solution

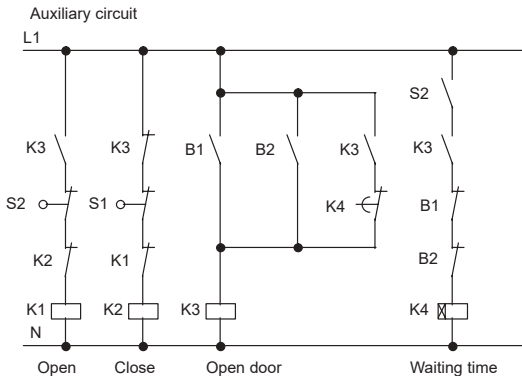

When someone enters the detection range of one of the motion sensors B1 or B2, the door opening motion is initiated by setting K3.

After the detection range of the two motion sensors has been cleared at least for a minimum time, K4 enables the closing motion.

## 8.2.3 Door control system with LOGO!

LOGO! can simplify this circuit considerably. You only need to connect the motion sensors, limit switches and the contactor relays to the LOGO! .



## Wiring of a door control system with LOGO! 230RC

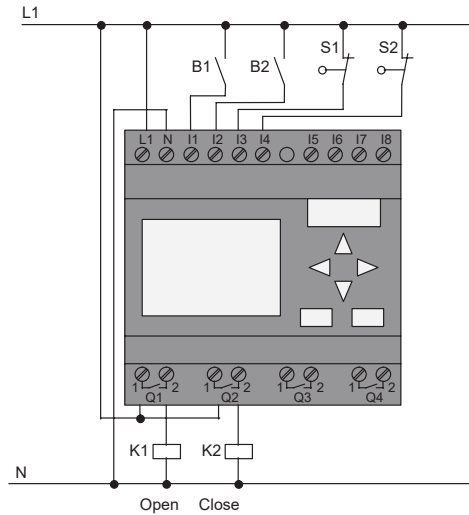

### Components used

- |                               |                                       |
|-------------------------------|---------------------------------------|
| • K1                          | contactor relay <i>open</i>           |
| • K2                          | contactor relay <i>Close</i>          |
| • S1 ( <i>break contact</i> ) | limit switch <i>Closed</i>            |
| • S2 ( <i>break contact</i> ) | limit switch <i>Open</i>              |
| • B1 ( <i>make contact</i> )  | infrared motion sensor <i>outside</i> |
| • B2 ( <i>make contact</i> )  | infrared motion sensor <i>inside</i>  |

### Door control system with LOGO!circuit diagram

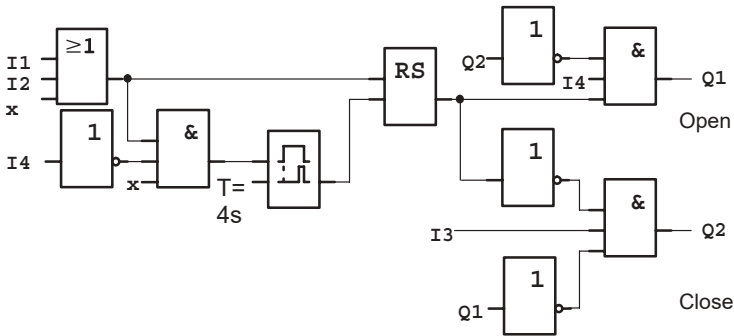

This is what the circuit diagram of the conventional solution looks like.

You can simplify this circuit if you make use of the LOGO! functions. You can use the off-delay function to replace the latching relay and the on-delay. The block diagram below illustrates this simplification:

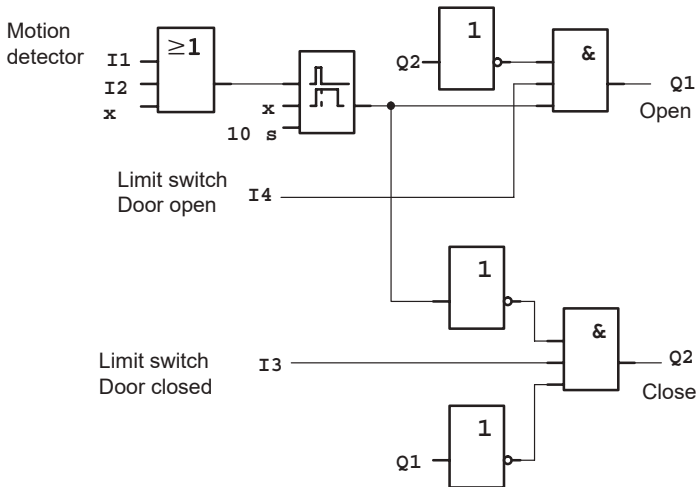

## 8.2.4 Special features and expansion options

Options for increasing comfort and user friendliness are, for example:

- You can connect an additional control switch with the positions: Open – Automatic – Closed (O-A-C)
- You can connect a buzzer to an output of the LOGO! to warn of the closing of the door.
- You can enable opening of the door time and direction-dependent, i.e. opening only during business hours, and opening only from the inside after closing time.

## 8.2.5 Extended solution with LOGO! 230RC

### Wiring the LOGO! extended solution

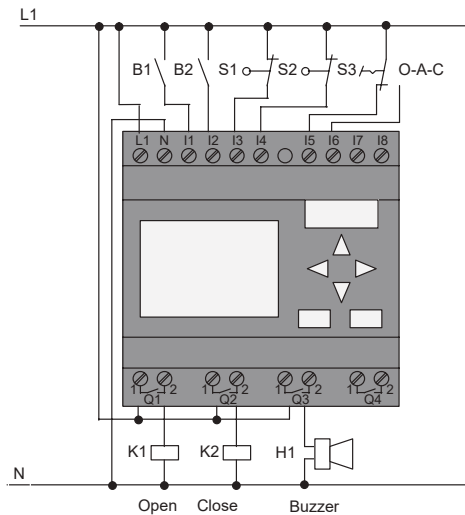

## Block diagram of the extended LOGO! solution

**Cam1:**

Day= Mo..Fr  
On = 09:00  
Off =18:00

**Cam2:**

Day= Sa  
On = 08:00  
Off =13:00

### Detecting motion

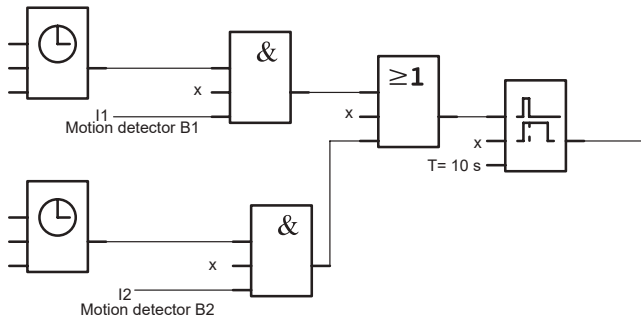

### Actuate motor for opening

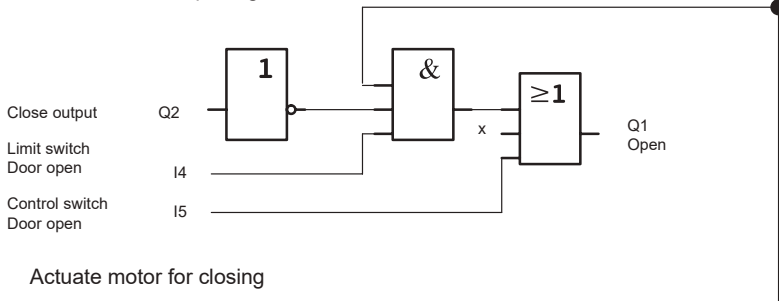

### Actuate motor for closing

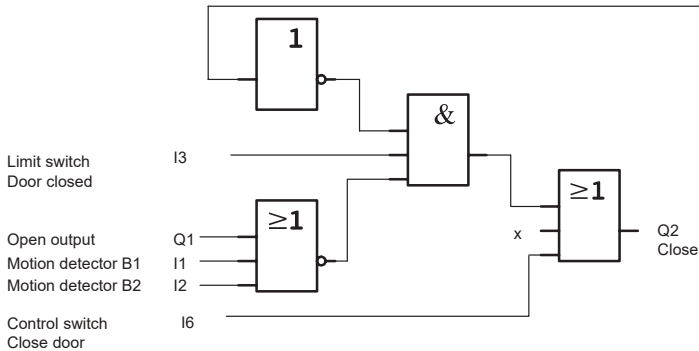

## Detecting motion

During business hours, the motion detector B1 initiates the opening of the door when somebody wants to enter the shop. Motion detector B2 initiates the opening of the door when somebody wants to leave the shop.

After closing time, the motion detector B2 continues to be used to open the door for 1 hour to allow the customers to leave the shop.

## Actuating the motor for opening

Output Q1 is set and opens the door when:

- The control switch at I5 is actuated (the door is permanently open), or
- The motion detectors indicate that somebody is approaching the door, and
- The door has not yet fully opened (limit switch at I4).

## Actuating the motor for closing

Output Q2 is set to close the door when:

- The control switch at I6 is actuated (the door is permanently closed) or
- The motion detectors indicate that there is nobody near the door, and
- The door has not yet fully closed (limit switch at I3).

## Buzzer

Connect the buzzer to output Q3. The buzzer gives a brief warning (in this case 1 second) when the door is closing. Enter the following circuit at Q3 in the circuit program:

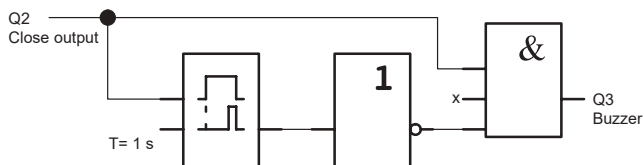

## 8.3 Air-conditioning System

### 8.3.1 Requirements for an air-conditioning System

The air-conditioning system supplies fresh air to a room or exhausts the contaminated air from a room. Let us examine following example:

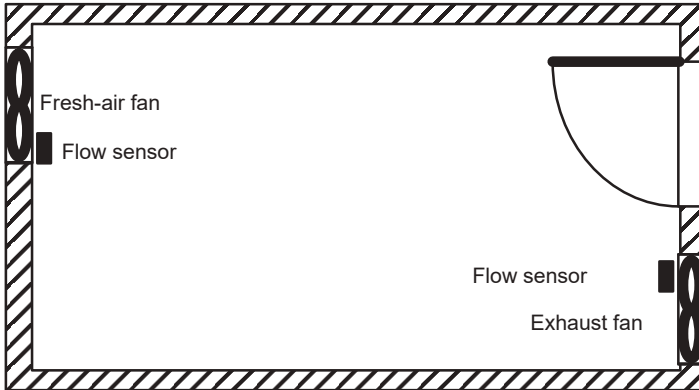

- The room is equipped with an exhaust fan and a fresh-air fan.
- Both fans are monitored by means of a flow sensor.
- An excess atmospheric pressure may never develop in the room.
- The fresh-air fan must only be switched on if safe functioning of the exhaust fan is signaled by the flow sensor.
- A warning lamp indicates failure of a fan.

The circuit diagram for conventional solutions is as follows:

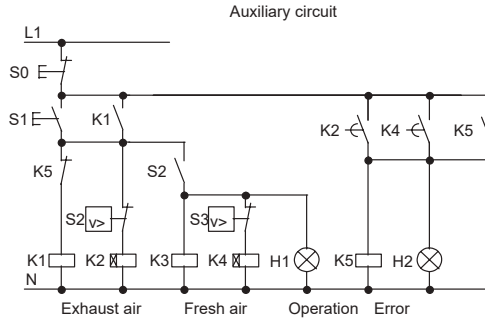

The fans are monitored by means of flow sensors. If no air flow is registered within a short waiting time, the system is switched off and an error message is output. This message can be acknowledged by pressing the OFF button.

In addition to the flow sensors, the fan monitoring system also requires an evaluating circuit with several switching devices. This evaluating circuit can be replaced by a single LOGO! unit.

### Wiring of an air-conditioning system with LOGO! 230RC

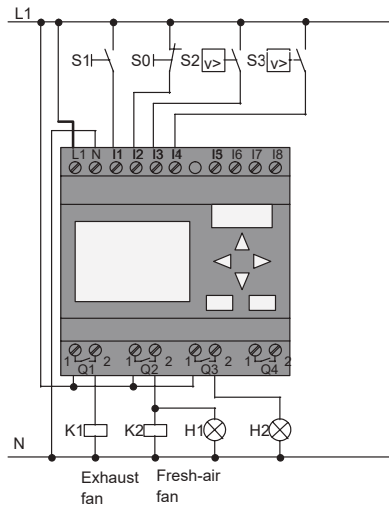

## Components used

- K1 contactor relay
- K2 contactor relay
- S0 (break contact) STOP pushbutton
- S1 (make contact) START pushbutton
- S2 (make contact) flow sensor
- S3 (make contact) flow sensor
- H1 signal lamp
- H2 signal lamp

## Block diagram of the LOGO! solution

The block diagram of the air-conditioning system with LOGO! :

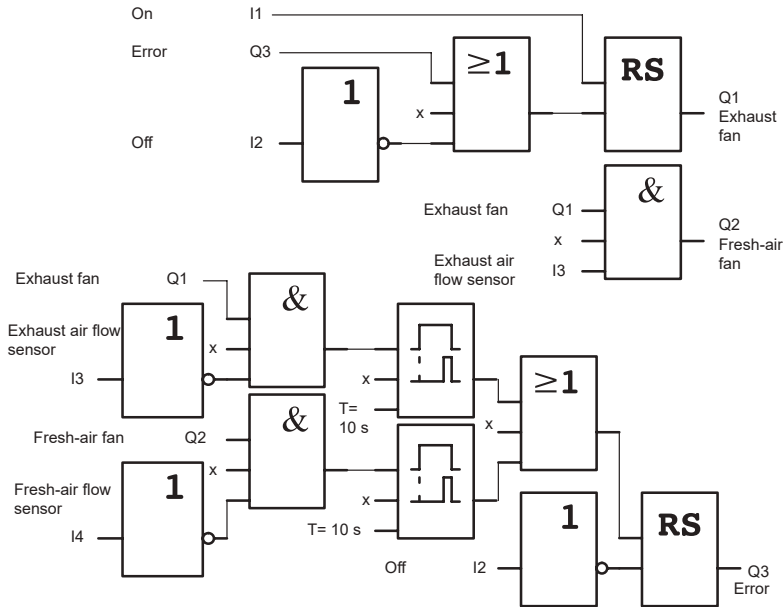



### 8.3.2 Advantages of using LOGO!

The LOGO! solution requires less switchgear. That saves you installation time and space in the control cabinet. You might even be able to use a smaller switching cabinet.

#### Additional LOGO! options

- The free output (Q4) can be used as isolated signal contact for reporting faults or power failure.
- It is possible to switch off of the fans by means of a sequential circuit.

These functions can be implemented without additional switchgear.

#### Block diagram of the extended LOGO! solution

The fans at Q1 and Q2 are switched on and off by means of the following circuit:

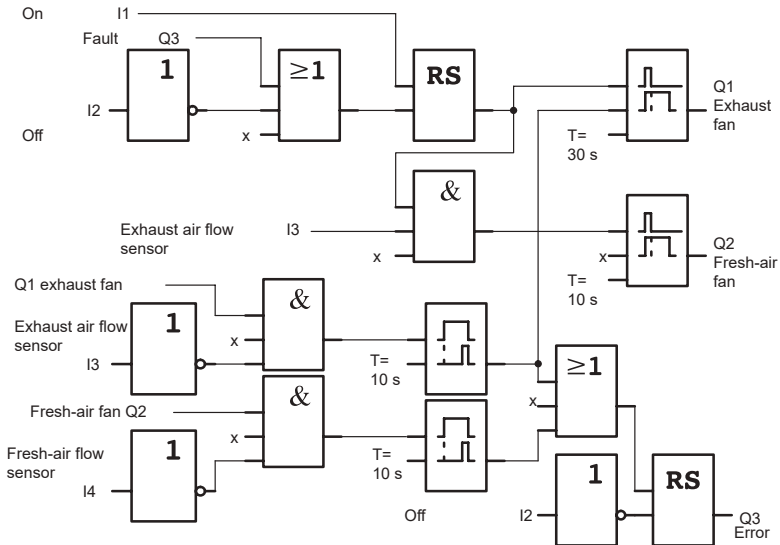

You can also generate a message at output Q4:

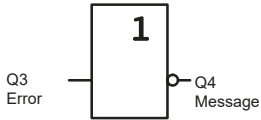

The relay contacts of output Q4 are always closed when the system is in operation. Relay Q4 does not drop off unless there is a power failure or a fault in the system. This contact can be used for remote monitoring, for example.

## 8.4 Factory door

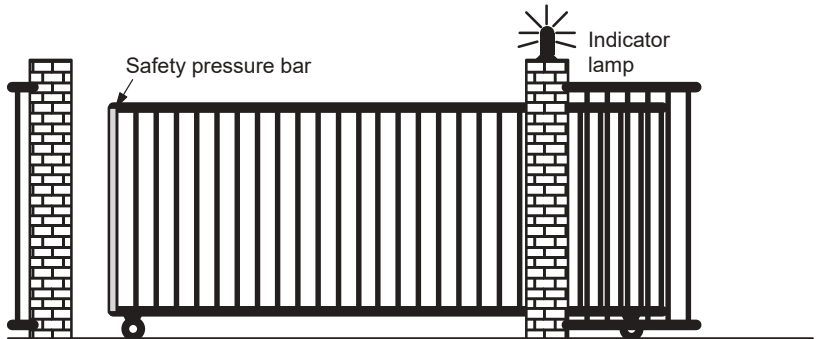

The entrance to a company's premises is often closed with a gate. The gate is only opened to let vehicles in and out. The gate is controlled by the porter.

### 8.4.1 Requirements for a gate control system

- The gate is opened and closed by means of pushbuttons in the gatehouse. The porter can monitor the operation of the gate at the same time.
- The gate is normally fully opened or fully closed. The gate motion can be interrupted at any time.
- An indicator lamp is switched on five seconds before the gate starts moving and when the gate is in motion.
- A safety pressure bar prevents harm to persons and objects from getting trapped or damaged when the gate is closing.

### 8.4.2 Previous solution

Various control systems are used to operate automatic gates. The circuit diagram below shows one of these options.

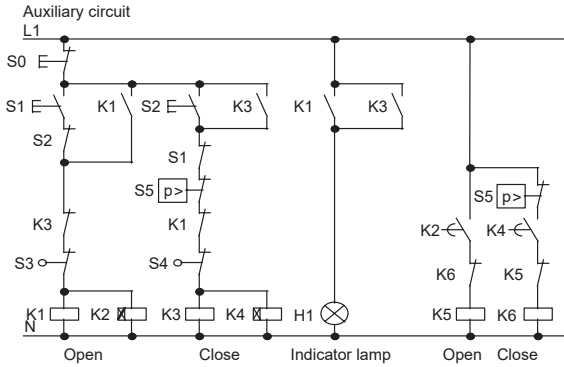

### Wiring of a gate control system with LOGO! 230RC

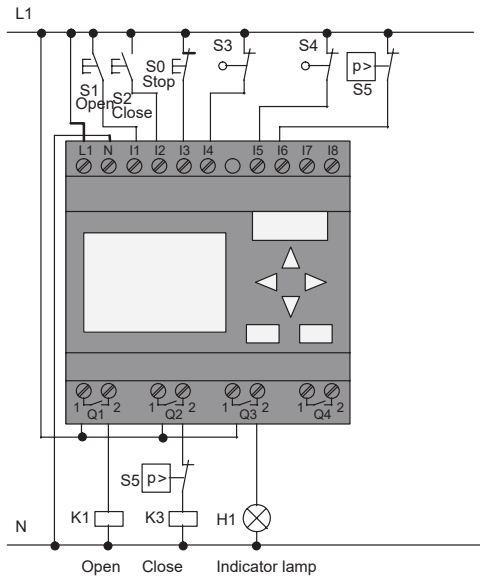

**Components used**

- K1 contactor relay
- K2 contactor relay
- S0 (break contact) STOP pushbutton
- S1 (make contact) OPEN pushbutton
- S2 (make contact) CLOSE pushbutton
- S3 (break contact) Position sensor OPEN
- S4 (break contact) Position sensor CLOSED
- S5 (break contact) Safety bar

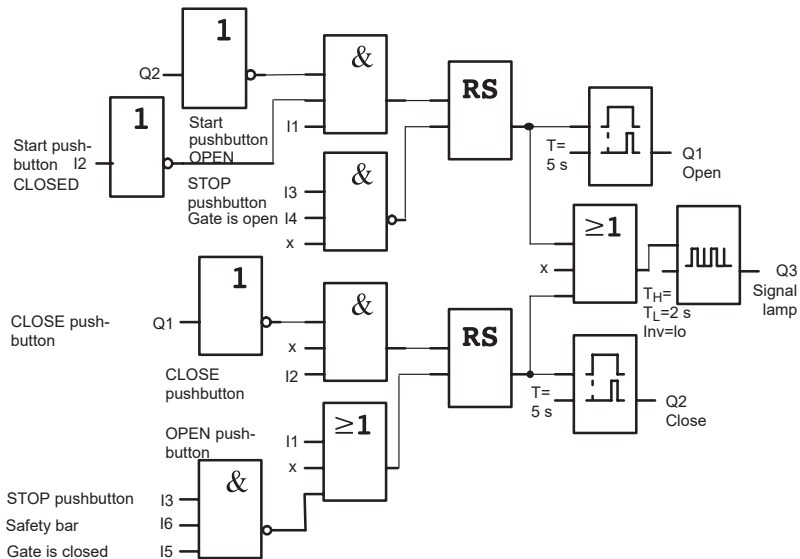
**Block diagram of the LOGO! solution**

The OPEN or CLOSE pushbuttons initiate the gate motion, provided it is not already moving in the other direction. The gate is stopped by means of the STOP pushbutton or the relevant limit switch. A safety bar furthermore interrupts the closing motion of the gate.

### 8.4.3 Extended LOGO! solution

Our extended control circuit is to open the gate automatically when the safety bar is actuated.

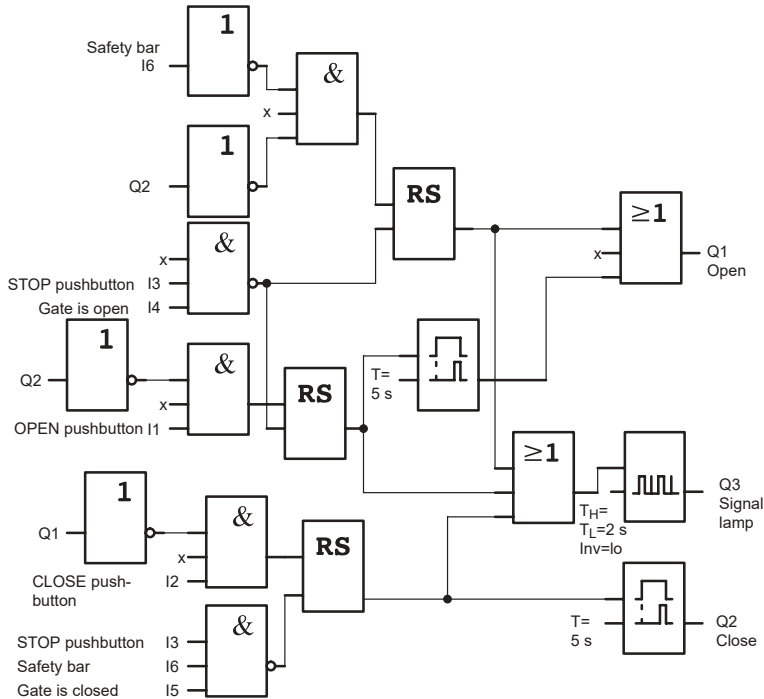

## 8.5 Centralized control and monitoring of several factory doors

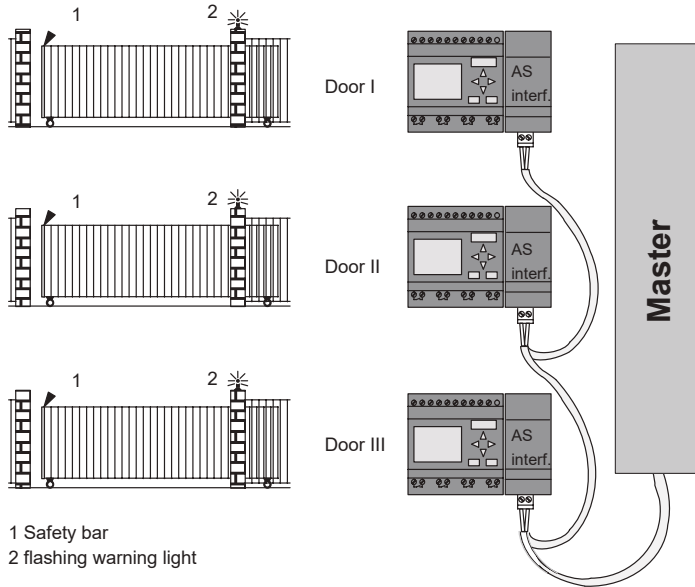

Often, a company's premises can be entered at several locations. Not all of the gates can always be monitored locally by personnel. They must therefore be able to be monitored and operated by the porter who sits in a central gate-house.

It must also be possible for a member of staff to open and close the gate locally.

For **each** gate we are going to use one LOGO! 230RC and one communication module AS interface. The modules and the master are interconnected by means of a bus system.

This chapter describes a gate control system. The structures of the other gate control systems are identical.

### 8.5.1 Requirements for a gate control system

- Every gate is opened and closed by means of a cord-operated switch. The gate is will be fully opened or fully closed.
- All gate can be opened and closed locally by means of pushbuttons.
- The gate can be opened and closed at the gatehouse by means of the bus system. The GATE OPEN or GATE CLOSED status is indicated.
- An indicator lamp is switched on five seconds before the gate starts moving and when the gate is in motion.
- A safety pressure bar prevents harm to persons and objects from getting trapped or damaged when the gate closes.

#### Wiring of the gate control system with LOGO! 230RC and CM AS interface

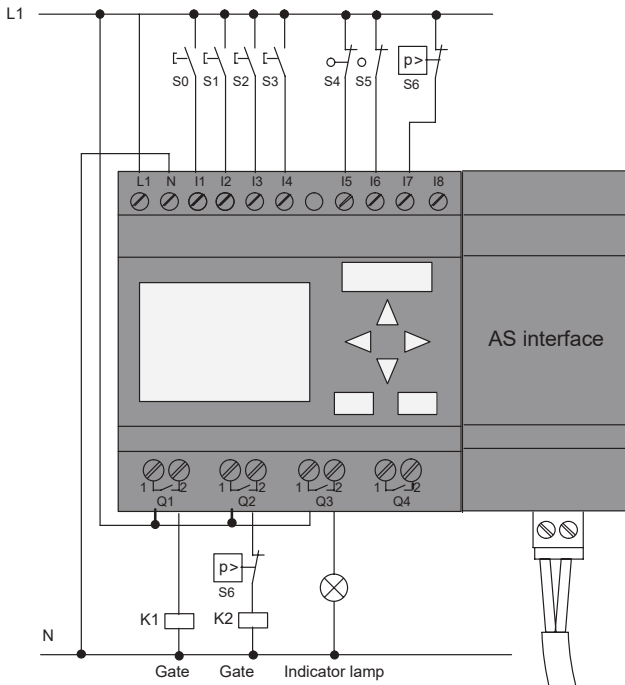



### Components used

- K1 contactor relay open
- K2 contactor relay Close
- S0 (*make contact*) cord operated switch OPEN
- S1 (*make contact*) cord operated switch CLOSE
- S2 (*make contact*) OPEN pushbutton
- S3 (*make contact*) CLOSE pushbutton
- S4 (*break contact*) position sensor GATE IS OPEN
- S5 (*break contact*) position sensor  
GATE IS CLOSED
- S6 (*break contact*) Safety bar

### Master control system

- Q5 position sensor GATE IS OPEN
- Q6 position sensor GATE IS CLOSED
- I9 external pushbutton OPEN GATE
- I10 external pushbutton CLOSE GATE

### Block diagram of the LOGO! solution

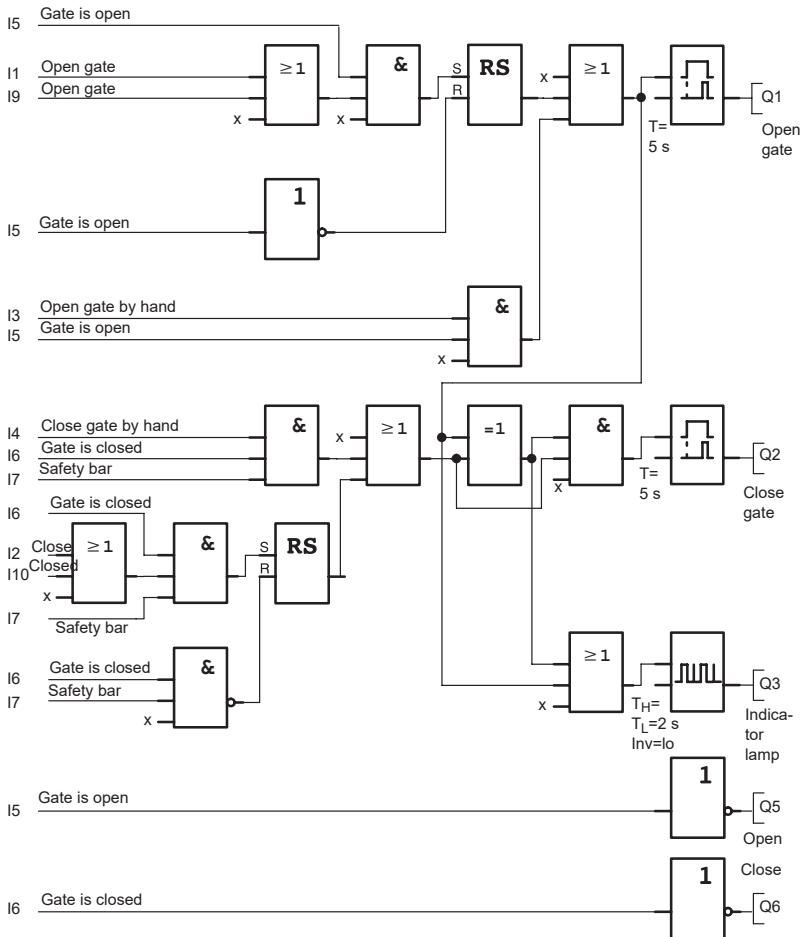

The OPEN GATE and CLOSE GATE pushbuttons initiate the gate motion, provided it is not already moving in the other direction. The gate motion ends at the respective limit switch. Closing of the gate is also interrupted by the safety bar.

## 8.6 Luminous rows

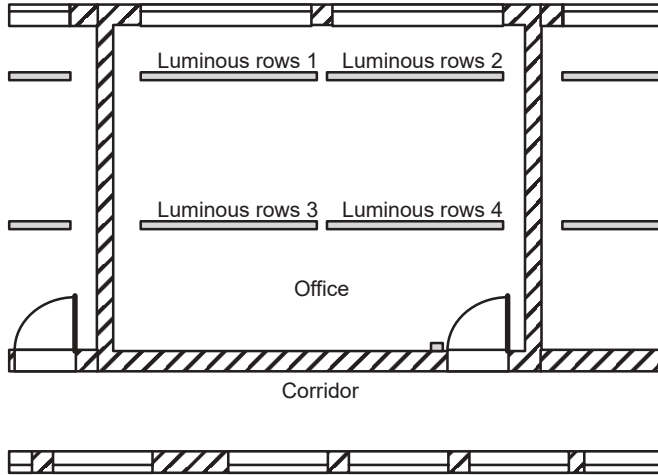

When planning lighting systems for commercial locations, the type and number of lamps used is determined by the luminance required. For reasons of cost efficiency, the installation often consists of fluorescent tubes arranged in luminous rows, and are divided into separate switching circuits, according to the way the room is used.

### 8.6.1 Requirements for a lighting system

- The various luminous rows are switched on and off locally.
- If there is sufficient daylight, the rows on the window side of the room are automatically switched off by means of a daylight control switch.
- The lights are switched off automatically at 20.00 h.
- Local manual operation of the lighting must be possible at all times.

## 8.6.2 Previous solution

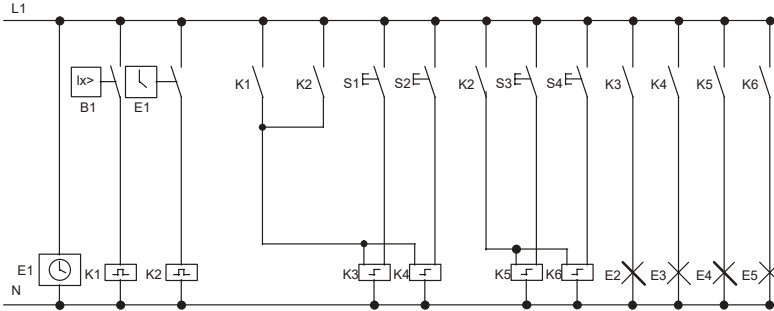

The lamps are switched on and off with pulse relays, by means of pushbutton control at the door. Regardless of this, they are reset with a timer or daylight control switch signal at the *central off* input. The pulse width of the off commands must be reduced by means of wiping relays to allow operation of the lights after they are switched off.

Components required:

- Pushbuttons S1 to S4
- Daylight control switch B1
- Timer E1
- Wiping relays K1 and K2
- Pulse switches K3 to K6 with central OFF function

### Disadvantages of the previous solution

- A substantial amount of switchgear needs to be installed to implement the necessary functions.
- Due to the large number of mechanical components, high wear and tear and maintenance expenditure is to be expected.
- The modification of functions involves considerable effort.

### 8.6.3 Luminous row control system with LOGO! 230RC

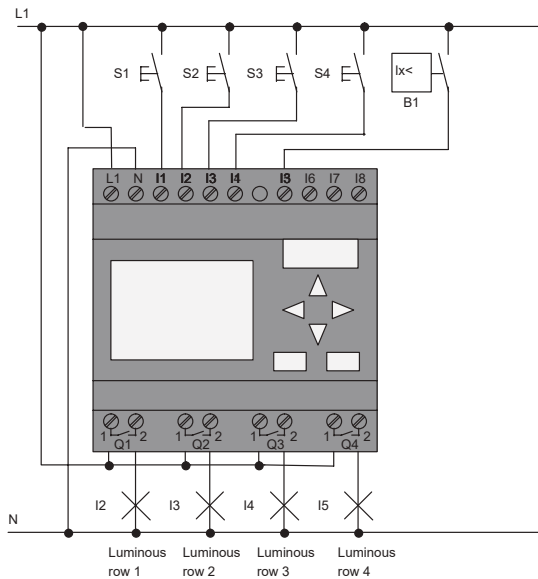

#### Components used

- S1 to S4 (*make contact*) momentary pushbutton
- B1 (*make contact*) daylight control switch

## Block diagram of the LOGO! solution

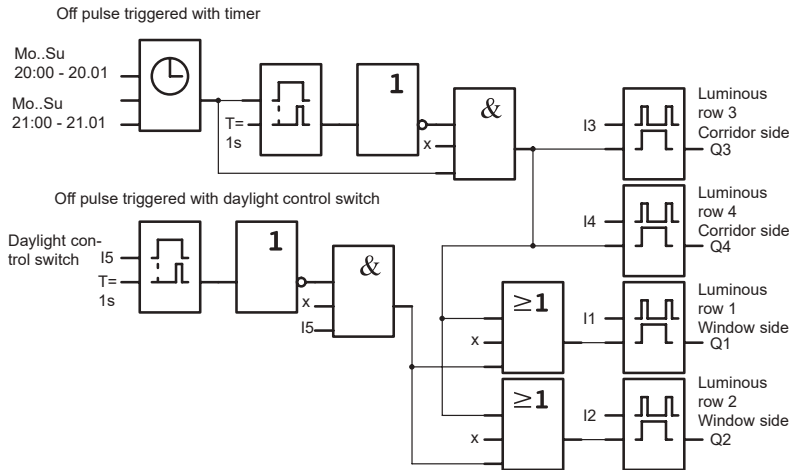

## Advantages of the LOGO! solution

- You can connect the lamps directly to the LOGO!, provided the power consumption does not exceed the switching capacity of the various outputs. Higher loads should be switched with a contactor relay.
- Connect the daylight control switch directly to an input of the LOGO! .
- You do not need an external timer, because this function is integrated in the LOGO! .
- Due to the reduced amount of switchgear, you can install a smaller and space-saving distribution cabinet.
- Fewer devices are required
- The lighting system can be easily modified.
- Additional switching times can be set as required (sequential circuit for the off pulses at the end of the day).
- The function of the daylight control switch can be easily applied to all lamps or to a modified group of lamps.

## 8.7 Service water pump

The use of rainwater as an addition to the drinking water supply is gaining importance in the domestic housing area. This saves money and helps to protect the environment. For example, rainwater can be used for:

- Washing clothes
- Irrigation system for gardens
- Watering indoor plants
- Car wash
- Toilet flushing installations

The sketch below illustrates how such a rainwater utilization system is operated:

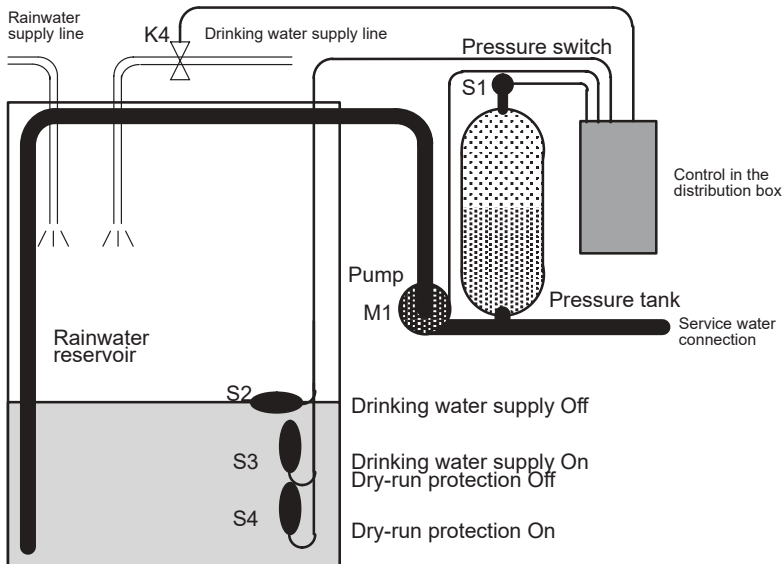

The rainwater is collected in a reservoir. From the reservoir, a pumping station supplies a respective line system. From there it can be tapped in the same way as normal drinking water. If the reservoir should run dry it can be topped up with drinking water.

## 8.7.1 Requirements for a control system of a service water pump

- Service water must be available at all times. In case of emergency, the control system must automatically switch over to drinking water supply.
- When switching over to the drinking water supply, the ingress of rainwater into the drinking water system must be prevented.
- The service water pump may not be switched on if the reservoir has run low of rainwater (dry-run protection).

## 8.7.2 Previous solution

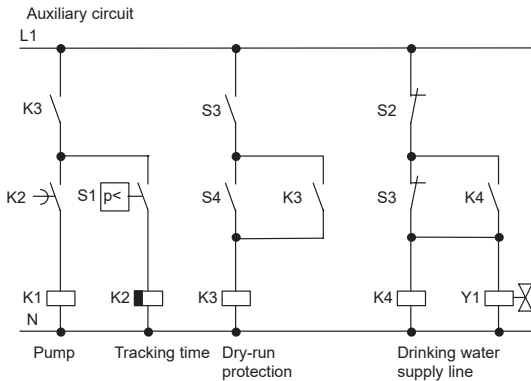

The pump and a solenoid valve are controlled by means of a pressure switch and 3 float switches, which are installed in the rainwater reservoir. The pump must be switched on when the pressure level in the boiler drops below minimum. After the operating pressure is reached, the pump is switched off again after a tracking time of a few seconds has expired. The tracking time prevents oscillation of the water pump if water is drawn off over a longer period of time.



### 8.7.3 Service water pump system with LOGO! 230RC

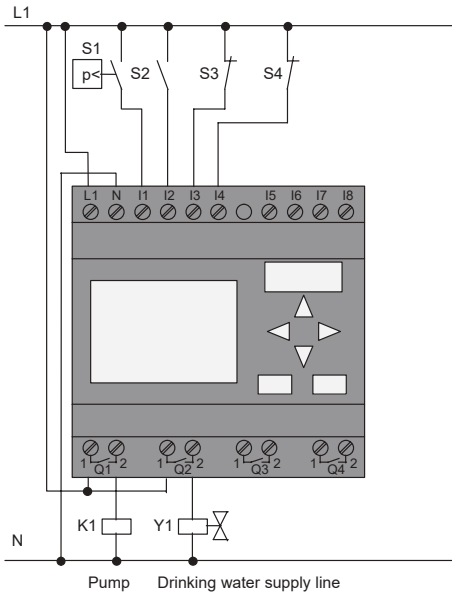

Apart from the LOGO!, all you need is a pressure switch and the float switches to control the pump. If you are using a 3-phase AC motor, you must use a contactor relay to switch the pump. For single-phase AC pump systems you must provide a contactor relay if the power consumption of the AC motor exceeds the capacity of the output relay Q1. The power consumption of a solenoid valve is usually low enough to allow direct controlling.

- K1 contactor relay
- Y1 solenoid valve
- S1 (*make contact*) pressure switch
- S2 (*make contact*) float switch
- S3 (*break contact*) float switch
- S4 (*break contact*) float switch

## Block diagram of the LOGO! solution

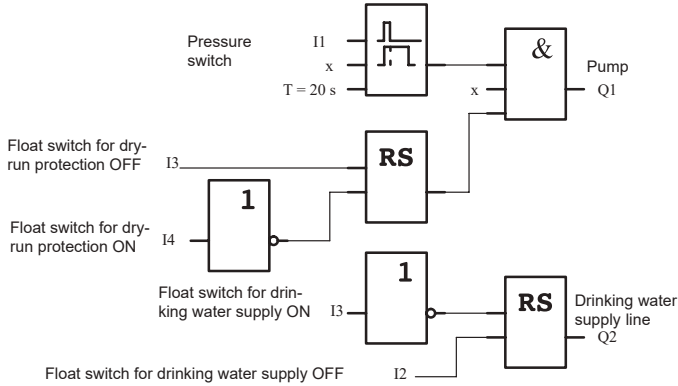

### 8.7.4 Special features and expansions

The block diagram shows how you can interconnect the pump controls and the solenoid valve. The layout corresponds with the circuit diagram. You also have the option to integrate further functions for specific applications, which can only be implemented in a conventional circuitry by adding further switchgear, e.g.:

- Enabling the pump at specific times
- Indication of imminent or existing water shortage
- Reporting of system faults

## 8.8 Further fields of application

In addition to the application samples shown above, we have placed further sample applications on the Internet (see the preface for the URL).

There you can find, for example:

- Irrigation system for greenhouse plants
- Conveyor control system
- Bending machine control system
- Shop window lighting
- Bell system (e.g. in a school)
- Parking lot surveillance
- Outdoor lighting
- Shutter control system
- Domestic outdoor and indoor lighting system
- Control system of a cream stirrer
- Sports hall lighting
- Constant load on 3 consumers
- Sequential control system for cable-welding machines for large cross-sections
- Step switch (e.g. for fans)
- Sequential control for boilers
- Control system for several pump sets with centralized operator control
- Cutting device (e.g. for detonating fuses)
- Monitoring periods of utilization, e.g. of a solar energy system
- Intelligent foot switches, e.g. for speed preselection)
- Elevating platform controls
- Impregnation of textiles, heating and conveyor belt controls
- Silo-filling system

and lots more.

On the Web you can also find descriptions and the corresponding circuit diagrams of the applications. You can read these \*.pdf files with the Adobe AcrobatReader. If you have installed LOGO!Soft Comfort on your computer, you can simply click the disk icon to download the relevant circuit programs, which you can then adapt to suit your application and download to the LOGO! directly via the PC cable.

### Benefits of LOGO!

LOGO! is a particularly useful feature

- For replacing auxiliary switchgear with the integrated LOGO! functions
- For saving wiring and installation work - because LOGO! keeps the wiring "in its head".
- For reducing space requirements for components in the control cabinet/distribution box. A smaller control cabinet/distribution box may provide sufficient space.
- For adding or changing functions, without having to install additional switchgear or change the wiring.
- For offering your customers new, additional functions for domestic and commercial housing installations. Examples:
  - Domestic security systems: LOGO! switches on a lamp at regular intervals or opens and closes the shutters while you are on holiday.
  - Central heating: LOGO! runs the circulation pump only when water or heating is actually required.
  - Refrigerating systems: LOGO! can defrost refrigerating systems at regular intervals to save energy costs.
  - You can illuminate aquaria and terraria on a time-dependent basis.

Last not least you can:

- Use commonly available switches and pushbuttons, which makes it easy to install a domestic system.
- Connect LOGO! directly to your domestic installation; the integrated power supply makes it possible.

### **Do you want more Info?**

For more information about LOGO!, see our web page (see the preface for the URL).

### **Do you have any suggestions?**

There are definitely many more useful applications for the LOGO! . If you know of one, why not write to us? We will collect all the suggestions made and distribute as many of them as we can. No matter whether your LOGO! circuit is particularly complex or simple, simply write to us. We shall be delighted to receive all your suggestions.

Write to:

Siemens AG  
A&D AS SM MA  
PO box 48 48  
D-90327 Nuremberg

[www.nicsanaf.com](http://www.nicsanaf.com)

021-87700210



# A Technical data

## A.1 General technical data

Criterion	Tested in accordance with	Values
<b>LOGO!Basic:</b> Dimensions (WxHxD) Weight Installation		72 x 90 x 55 mm Approx. 190 g on a 35 mm profile rail 4 module widths or wall mounting
<b>LOGO! expansion module:</b> Dimensions (WxHxD) Weight Installation		36 x 90 x 55 mm Approx. 90 g on a 35 mm profile rail 4 module widths or wall mounting
Climatic conditions		
Ambient temperature Horizontal installation Vertical installation	Low temperature to IEC 60068-2-1 High temperature to IEC 60068-2-2	0 ... 55 °C 0 ... 55 °C
Storage/shipping		— 40 °C ... +70 °C
Relative humidity	IEC 60068-2-30	From 10 to 95 % no condensation
Air pressure		795 ... 1080 hPa
Pollutants	IEC 60068-2-42 IEC 60068-2-43	SO <sub>2</sub> 10 cm <sup>3</sup> /m <sup>3</sup> , 4 days H <sub>2</sub> S 1 cm <sup>3</sup> /m <sup>3</sup> , 4 days

## Technical data

Criterion	Tested in accordance with	Values
Ambient mechanical conditions		
Protection mode		IP20
Vibrations:	IEC 60068-2-6	5 ... 9 Hz (constant amplitude 3.5 mm) 9 ... 150 Hz (constant acceleration 1 g)
Shock	IEC 60068-2-27	18 shocks (half-sine wave 15g/11 ms)
Drop	IEC 60068-2-31	Drop height 50 mm
Free fall (packaged)	IEC 60068-2-32	1 m
Electromagnetic compatibility (EMC)		
Noise emission	EN 55011/A EN 55022/B EN 50081-1 (domestic area)	Limit class B group 1
Electrostatic discharge	IEC 61000-4-2 Severity 3	8 kV air discharge 6 kV contact discharge
Electromagnetic fields	IEC 61000-4-3	Field strength 10 V/m
HF currents on cables and cable shielding	IEC 61000-4-6	10 V
Burst pulses	IEC 61000-4-4 Severity 3	2 kV (supply and signal lines)
High-energy surge pulse (applies only to LOGO! 230 ...)	IEC 61000-4-5 Severity 3	1 kV (power lines) symmetrical 2 kV (power lines) asymmetrical
Safety to IEC / VDE		
Clearance and creepage distance rating	IEC 60664, IEC 61131-2, EN 50178 cULus to UL 508, CSA C22.2 No. 142 With LOGO! 230 R/RC, also VDE 0631	Fulfilled
Insulation strength	IEC 61131-2	Fulfilled



## A.2 Technical data: LOGO! 230... and LOGO! DM8 230R

	LOGO! 230 RC LOGO! 230 RCo	LOGO! DM8 230R
<b>Power supply</b>		
Input voltage	115...240 V AC/DC	115...240 V AC/DC
Permissible range	85 ... 265 V AC 100 ... 253 V DC	85 ... 265 V AC 100 ... 253 V DC
Permissible mains frequency	47 ... 63 Hz	47 ... 63 Hz
Power consumption		
<ul style="list-style-type: none"> <li>• 115 V AC</li> <li>• 240 V AC</li> <li>• 115 V DC</li> <li>• 240 V DC</li> </ul>	10 ...40 mA 10 ... 25 mA 5 ... 25 mA 5 ... 15 mA	10 ... 30 mA 10 ... 20 mA 5 ... 15 mA 5 ... 10 mA
Voltage failure buffering		
<ul style="list-style-type: none"> <li>• 115 V AC/DC</li> <li>• 240 V AC/DC</li> </ul>	typ. 10 ms typ. 20 ms	typ. 10 ms typ. 20 ms
Power loss at		
<ul style="list-style-type: none"> <li>• 115 V AC</li> <li>• 240 V AC</li> <li>• 115 V DC</li> <li>• 240 V DC</li> </ul>	1.1 ... 4.6 W 2.4 ... 6.0 W 0.5 ... 2.9 W 1.2 ... 3.6 W	1.1 ... 3.5 W 2.4 ... 4.8 W 0.5 ... 1.8 W 1.2 ... 2.4 W
Backup of the real-time clock at 25 °C	typ. 80 h	
Accuracy of the real-time clock	typ. $\pm 2$ s / day	
<b>Digital inputs</b>		
Number	8	4
Electrical isolation	No	No

## Technical data

	LOGO! 230 RC LOGO! 230 RC <sub>0</sub>	LOGO! DM8 230R
Input voltage L1 <ul style="list-style-type: none"> <li>• Signal 0</li> <li>• Signal 1</li> <li>• Signal 0</li> <li>• Signal 1</li> </ul>	< 40 V AC > 79 V AC < 30 V DC > 79 V DC	< 40 V AC > 79 V AC < 30 V DC > 79 V DC
Input current at <ul style="list-style-type: none"> <li>• Signal 0</li> <li>• Signal 1</li> </ul>	< 0.03 mA > 0.08 mA	< 0.03 mA > 0.08 mA
Delay time at <ul style="list-style-type: none"> <li>• 0 to 1</li> <li>• 1 to 0</li> </ul>	typ. 50 ms typ. 50 ms	typ. 50 ms typ. 50 ms
Line length (unshielded)	100 m	100 m
<b>Digital outputs</b>		
Number	4	4
Output type	Relay outputs	Relay outputs
Electrical isolation	Yes	Yes
In groups of	1	1
Control of a digital input	Yes	Yes
Continuous current $I_{th}$	max. 10 A per relay	max. 5 A per relay
Incandescent lamp load (25000 switching cycles) at 230/240 V AC 115/120 V AC	1000 W 500 W	1000 W 500 W
Fluorescent tubes with ballast (25000 switching cycles)	10 x 58 W (at 230/240 V AC)	10 x 58 W (at 230/240 V AC)
Fluorescent tubes, conven- tionally compensated (25000 switching cycles)	1 x 58 W (at 230/240 V AC)	1 x 58 W (at 230/240 V AC)

	<b>LOGO! 230 RC</b> <b>LOGO! 230 RC<sub>o</sub></b>	<b>LOGO! DM8 230R</b>
Fluorescent tubes, uncompensated (25000 switching cycles)	10 x 58 W (at 230/240 V AC)	10 x 58 W (at 230/240 V AC)
Short circuit-proof cos 1	Power protection B16 600A	Power protection B16 600A
Short-circuit proof cos 0.5 to 0.7	Power protection B16 900A	Power protection B16 900A
Derating	none; across the entire temperature range	none; across the entire temperature range
Parallel output circuits for power increase	Not permitted	Not permitted
Protection of output relay (if desired)	max. 16 A, characteristic B16	max. 16 A, characteristic B16
<b>Switching rate</b>		
Mechanical	10 Hz	10 Hz
Ohmic load/lamp load	2 Hz	2 Hz
Inductive load	0.5 Hz	0.5 Hz

## A.3 Technical data: LOGO! 24... and LOGO! DM8 24

	LOGO! 24 LOGO! 24o	LOGO! DM8 24
<b>Power supply</b>		
Input voltage	24 V DC	24 V DC
Permissible range	20.4 ... 28.8 V DC	20.4 ... 28.8 V DC
Reverse polarity protection	Yes	Yes
Permissible mains frequency		
Power consumption from 24 V DC	30 ... 55 mA 0.3 A per output	30 ... 45 mA 0.3 A per output
Voltage failure buffering		
Power loss at 24 V	0.7 ... 1.3 W	0.8 ... 1.1 W
Backup of the real-time clock at 25 °C		
Accuracy of the real-time clock		
<b>Digital inputs</b>		
Number	8	4
Electrical isolation	No	No
Input voltage	L+	L+
<ul style="list-style-type: none"> <li>• Signal 0</li> <li>• Signal 1</li> </ul>	<ul style="list-style-type: none"> <li>&lt; 5 V DC</li> <li>&gt; 8 V DC</li> </ul>	<ul style="list-style-type: none"> <li>&lt; 5 V DC</li> <li>&gt; 8 V DC</li> </ul>

	LOGO! 24 LOGO! 24o	LOGO! DM8 24
Input current at <ul style="list-style-type: none"> <li>• Signal 0</li> <li>• Signal 1</li> </ul>	< 1.0 mA (I1...I6) < 0.05 mA (I7, I8) > 1.5 mA (I1... I6) > 0.1 mA (I7, I8)	< 1.0 mA > 1.5 mA
Delay time at <ul style="list-style-type: none"> <li>• 0 to 1</li> <li>• 1 to 0</li> </ul>	typ. 1.5 ms (I1...I4) <1.0 ms (I5, I6) typ. 300 ms (I7,I8) typ. 1.5 ms (I1...I4) <1.0 ms (I5, I6) typ. 300 ms (I7,I8)	typ. 1.5 ms typ. 1.5 ms
Line length (unshielded)	100 m	100 m
<b>Analog inputs</b>		
Number	2 (I7 and I8)	
Range	0 ... 10 V DC input impedance 76 kΩ	
max. input voltage	28.8 V DC	
Line length (shielded and twisted)	10 m	
<b>Digital outputs</b>		
Number	4	4
Output type	Transistor, current-sourcing	Transistor, current-sourcing
Electrical isolation	No	No
In groups of		
Control of a digital input	Yes	Yes
Output voltage	△ Supply voltage	△ Supply voltage
Output current	max. 0.3 A	max. 0.3 A

## Technical data

	LOGO! 24 LOGO! 24o	LOGO! DM8 24
Continuous current $I_{th}$		
Incandescent lamp load (25000 switching cycles) at		
Fluorescent tubes with ballast (25000 switching cycles)		
Fluorescent tubes, conven- tionally compensated (25000 switching cycles)		
Fluorescent tubes, uncom- pensated (25000 switching cycles)		
Short circuit-proof and over- load-proof	Yes	Yes
Short-circuit current limitation	Approx. 1 A	Approx. 1 A
Derating	none; across the entire temperature range	none; across the entire temperature range
Short circuit-proof cos 1		
Short-circuit proof cos 0.5 to 0.7		
Parallel output circuit for power increase	Not permitted	Not permitted
Protection of output relay (if desired)		
<b>Switching rate</b>		
Mechanical		
Electrical		10 Hz
Ohmic load/lamp load	10 Hz	10 Hz
Inductive load	0.5 Hz	0.5 Hz

## Produktinformation

## A.4 Technical data: LOGO! 24RC... and LOGO! DM8 24 R

	LOGO! 24RC LOGO! 24RC <sub>o</sub>	LOGO! DM8 24 R
<b>Power supply</b>		
Input voltage	24 V AC/DC	24 V AC/DC
Permissible range	20.4 ... 26.4 V AC 20.4 ... 28.8 V DC	20.4 ... 26.4 V AC 20.4 ... 28.8 V DC
Reverse polarity protection		
Permissible mains frequency	47 ... 63 Hz	47 ... 63 Hz
Power consumption		
• 24 V AC	40 ... 110 mA	40 ... 110 mA
• 24 V DC	20 ... 75 mA	20 ... 75 mA
Voltage failure buffering	typ. 5 ms	typ. 5 ms
Power loss		
• 24 V AC	0.9 ... 2.7 W	0.9 ... 2.7 W
• 24 V DC	0.4 ... 1.8 W	0.4 ... 1.8 W
Backup of the real-time clock at 25 °C	typ. 80 h	typ. 80 h
Accuracy of the real-time clock	typ. ± 2 s / day	
<b>Digital inputs</b>		
Number	8, optional P action or P action	4, optional P action or P action
<b>1.1 Welche Erweiterungsmodule gibt es?</b>		
Electrical isolation	No	No
Input voltage	<ul style="list-style-type: none"> <li>• LOGO! Digitalmodule DM8... gibt es für 12 V DC, 24 V AC/DC, 115...240 V AC/DC mit 4 Eingängen und 4 Ausgängen.</li> <li>• LOGO! Digitalmodule DM16... gibt es für 24 V DC und 115...240 V AC/DC mit 8 Eingängen und 8 Ausgängen.</li> </ul>	<ul style="list-style-type: none"> <li>• LOGO! Analogmodule gibt es für 12 V DC und 24 V DC mit bzw. mit 2 Pt100-Eingängen.</li> <li>• LOGO! Kommunikationsmodule (CM), wie z.B. Kommunikation...</li> </ul>

## Technical data

	LOGO! 24RC LOGO! 24RCo	LOGO! DM8 24 R
Input current at		
• Signal 0	< 1.0 mA	< 1.0 mA
• Signal 1	> 2.5 mA	> 2.5 mA
Delay time at		
• 0 to 1	typ. 1,5 ms	typ. 1.5 ms
• 1 to 0	typ. 15 ms	typ. 15 ms
Line length (unshielded)	100 m	100 m
<b>Analog inputs</b>		
Number		
Range		
max. Input voltage		
<b>Digital outputs</b>		
Number	4	4
Output type	Relay outputs	Relay outputs
Electrical isolation	Yes	Yes
In groups of	1	1
Control of a digital input	Yes	Yes
Output voltage		
Output current		
Continuous current $I_{th}$	max. 10 A per relay	max. 5 A per relay
Incandescent lamp load (25000 switching cycles) at	1000 W	1000 W
Fluorescent tubes with ballast (25000 switching cycles)	10 x 58 W	10 x 58 W



	LOGO! 24RC LOGO! 24RC <sub>o</sub>	LOGO! DM8 24 R
Fluorescent tubes, conventionally compensated (25000 switching cycles)	1 x 58 W	1 x 58 W
Fluorescent tubes, uncompensated (25000 switching cycles)	10 x 58 W	10 x 58 W
Short circuit-proof and overload-proof		
Short-circuit current limitation		
Derating	none; across the entire temperature range	none; across the entire temperature range
Short circuit-proof cos 1	Power protection B16, 600A	Power protection B16, 600A
Short-circuit proof cos 0.5 to 0.7	Power protection B16, 900A	Power protection B16, 900A
Parallel output circuits for power increase	Not permitted	Not permitted
Protection of output relay (if desired)	max. 16 A, characteristic B16	max. 16 A, characteristic B16
<b>Switching rate</b>		
Mechanical	10 Hz	10 Hz
Electrical		
Ohmic load/lamp load	2 Hz	2 Hz
Inductive load	0.5 Hz	0.5 Hz

## A.5 Technical data: LOGO! 12/24... and LOGO! DM8 12/24R

	LOGO! 12/24RC LOGO! 12/24RC <sub>0</sub>	LOGO! DM8 12/24R
<b>Power supply</b>		
Input voltage	12/24 V DC	12/24 V DC
Permissible range	10.8 ... 28.8 V DC	10.8 ... 28.8 V DC
Reverse polarity protection	Yes	Yes
Power consumption • 12 V DC • 24 V DC	30 ... 140 mA 20 ... 75 mA	30 ... 140 mA 20 ... 75 mA
Voltage failure buffering • 12 V DC • 24 V DC	typ. 2 ms typ. 5 ms	typ. 2 ms typ. 5 ms
Power loss • 12 V DC • 24 V DC	0.3 ... 1.7 W 0.4 ... 1.8 W	0.3 ... 1.7 W 0.4 ... 1.8 W
Backup of the real-time clock at 25 °C	typ. 80 h	
Accuracy of the real-time clock	typ. ± 2 s / day	
Electrical isolation	No	No
<b>Digital inputs</b>		
Number	8	4
Electrical isolation	No	No
Input voltage L+ • Signal 0 • Signal 1	< 5 V DC > 8 V DC	< 5 V DC > 8 V DC

	LOGO! 12/24RC LOGO! 12/24RCo	LOGO! DM8 12/24R
Input current at <ul style="list-style-type: none"> <li>• Signal 0</li> <li>• Signal 1</li> </ul>	< 1.0 mA (I1...I6) < 0.05 mA (I7, I8) > 1.5 mA (I1... I6) > 0.1 mA (I7, I8)	< 1.0 mA > 1.5 mA
Delay time at <ul style="list-style-type: none"> <li>• 0 to 1</li> <li>• 1 to 0</li> </ul>	typ. 1.5 ms <1.0 ms (I5, I6) typ. 300 ms (I7,I8) typ. 1.5 ms <1.0 ms (I5, I6) typ. 300 ms (I7,I8)	typ. 1.5 ms typ. 1.5 ms
Line length (unshielded)	100 m	100 m
<b>Analog inputs</b>		
Number	2 (I7, I8)	
Range	0 ... 10 V DC input impedance 76 kΩ	
max. Input voltage	28.8 V DC	
Line length (shielded and twisted)	10 m	
<b>Digital outputs</b>		
Number	4	4
Output type	Relay outputs	Relay outputs
Electrical isolation	Yes	Yes
In groups of	1	1
Control of a digital input	Yes	Yes
Output voltage		
Output current		

## Technical data

	<b>LOGO! 12/24RC</b> <b>LOGO! 12/24RCo</b>	<b>LOGO! DM8</b> <b>12/24R</b>
Continuous current $I_{th}$ (per terminal)	max. 10 A per relay	max. 5 A per relay
Incandescent lamp load (25000 switching cycles) at	1000 W	1000 W
Fluorescent tubes with ballast (25000 switching cycles)	10 x 58 W	10 x 58 W
Fluorescent tubes, conventionally compensated (25000 switching cycles)	1 x 58 W	1 x 58 W
Fluorescent tubes, uncompensated (25000 switching cycles)	10 x 58 W	10 x 58 W
Short circuit-proof and over-load-proof		
Short-circuit current limitation		
Derating	none; across the entire temperature range	none; across the entire temperature range
Short circuit-proof cos 1	Power protection B16 600A	Power protection B16 600A
Short-circuit proof cos 0.5 to 0.7	Power protection B16 900A	Power protection B16 900A
Parallel output circuits for power increase	Not permitted	Not permitted
Protection of output relay (if desired)	max. 16 A, characteristic B16	max. 16 A, characteristic B16
<b>Switching rate</b>		
Mechanical	10 Hz	10 Hz
Electrical		
Ohmic load/lamp load	2 Hz	2 Hz
Inductive load	0.5 Hz	0.5 Hz

## A.6 Switching capacity and service life of the relay outputs

### Ohmic load

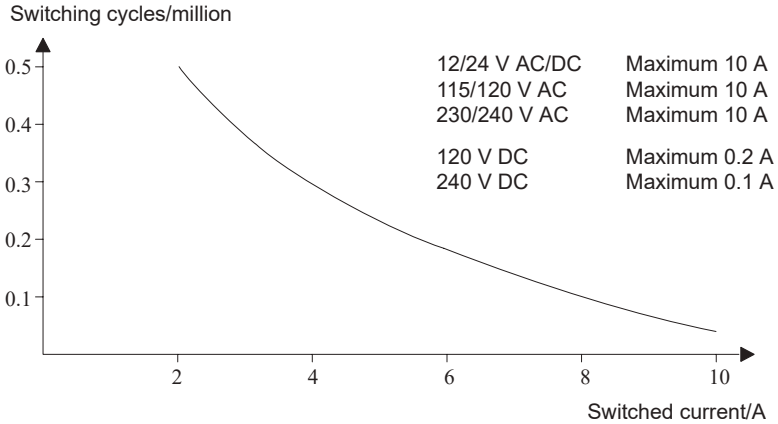

Figure A Switching capacity and service life of the contacts with ohmic load (heating)

### Inductive load

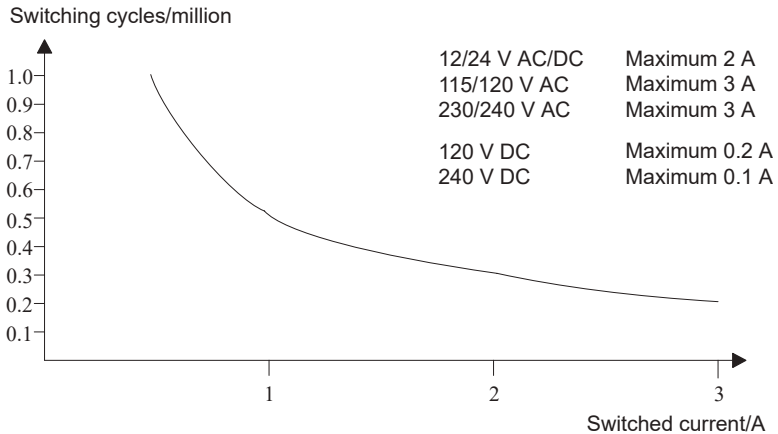

Figure B Switching capacity and service life of the contacts with high inductive load to IEC 947-5-1 DC 13/AC 15 (contactors, solenoid coils, motors)

## A.7 Technical data: LOGO! AM 2

LOGO! AM 2	
<b>Power supply</b>	
Input voltage	12/24 V DC
Permissible range	10.8 ... 28.8 V DC
Power consumption	25 ... 50 mA
Voltage failure buffering	typ. 5 ms
Power loss at	
• 12 V	0.3 ... 0.6 W
• 24 V	0.6 ... 1.2 W
Electrical isolation	No
Reverse polarity protection	Yes
Ground terminal	for connecting ground and shielding of the analog measuring line.
<b>Analog inputs</b>	
Number	2
Type	Unipolar
Input range	0 ... 10 V DC (input impedance 76 k $\Omega$ ) or 0 ... 20 mA (input impedance <250 $\Omega$ )
Resolution	10 bit, normalized to 0 ... 1000
Cycle time for analog value generation	50 ms
Electrical isolation	No
Line length (shielded and twisted)	10 m
Encoder supply voltage	none
Error limit	+/- 1.5 %
Interference frequency suppression	55 Hz

## A.8 Technical data: LOGO! AM 2 PT100

LOGO! AM 2 PT100	
<b>Power supply</b>	
Input voltage	12/24 V DC
Permissible range	10.8 ... 28.8 V DC
Power consumption	25 ... 50 mA
Voltage failure buffering	typ. 5 ms
Power loss at	
• 12 V	0.3 ... 0.6 W
• 24 V	0.6 ... 1.2 W
Electrical isolation	No
Reverse polarity protection	Yes
Ground terminal	for connecting ground and shielding of the measuring line
<b>Sensor inputs</b>	
Number	2
Type	Resistive thermocouple Pt100
Connection of sensors	
• 2-wire technique	Yes
• 3-wire technique	Yes
Measurement range	–50 °C ... +200 °C –58 °F ... +392 °F
Settings for the measurement display on the basic module:	
• 1 °C steps	Offset: –200, Gain: 25
• 0.25 °C steps (rounded to one decimal)	Offset: –200, Gain: 250
• 1 °C steps	Offset: –128, Gain: 45
• 0.25 °C steps (rounded to one decimal)	Offset: –128, Gain: 450

## Technical data

	<b>LOGO! AM 2 PT100</b>
Curve linearization	No
Measuring current I <sub>c</sub>	1.1 mA
Measurement rate	depends on the installation typical: 50 ms
Resolution	0.25 °C
Error limits	of the final measured value:
• 0 °C ... +200 °C	+/- 1.0 %
• -50 °C ... +200 °C	+/- 1.5 %
Electrical isolation	No
Cable length (shielded)	10 m
Interference frequency suppression	55 Hz



## A.9 Technical data: LOGO!Power 12 V

LOGO! Power 12 V is a primary-switched power supply unit for LOGO! devices. Two current ranges are available.

	LOGO! Power 12 V / 1.9 A	LOGO! Power 12 V / 4.5 A
<b>Input data</b>		
Input voltage	120 ... 230 V AC	
Permissible range	85 ... 264 V AC	
Permissible mains frequency	47 ... 63 Hz	
Voltage failure buffering	> 40 ms (at 187 V AC)	
Input current	0.3 ... 0.18 A	0.73 ... 0.43 A
Make current (25°C)	≤ 15 A	≤ 30 A
Device protection	Internal	
Recommended circuit breaker (IEC 898) in mains line	> 6 A characteristic D > 10 A characteristic C	
<b>Output data</b>		
Output voltage	12 V DC	
Overall tolerance	+/-3 %	
Adjustment range	11.1 ... 12.9 V DC	
Residual ripple	< 200 mV <sub>pp</sub>	
Output current	1.9 A	4.5 A
Overcurrent limiting	2.4 A	4.5 A
Efficiency	≥ 80 %	
Parallel circuit for power increase	Yes	
<b>Electromagnetic compatibility</b>		
Interference suppression	EN 50081-1, EN 55022 Class B	
Interference immunity	EN 50082-2	

## Technical data

	LOGO! Power 12 V / 1.9 A	LOGO! Power 12 V / 4.5 A
<b>Safety</b>		
Electrical isolation, primary/ secondary	Yes, SELV (to EN 60950/VDE 0805)	
Safety class	II (to IEC 536/VDE 0106 T1)	
Protection mode	IP 20 (to EN 60529/VDE 470 T1)	
CE marking	Yes	
UL/CSA certification	Yes; UL 508 / CSA 22.2	
FM approval	In preparation	
<b>General details</b>		
Ambient temperature range	-20 ... +55 °C, natural convection	
Storage and shipping temperature	-40 ... +70 °C	
Connections at input	One terminal (1 x 2.5 mm <sup>2</sup> or 2 x 1.5 mm <sup>2</sup> ) per L1 and N	
Connections at output	Two terminals (1x.2.5 mm <sup>2</sup> or 2 x 1.5 mm <sup>2</sup> ) per L+ and M	
Installation	On 35 mm DIN rail, snap-on	
Dimensions in mm (WxHxD)	72 x 80 x 55	126 x 90 x 55
Approx. weight	0.2 kg	0.4 kg

## A.10 Technical data: LOGO!Power 24 V

LOGO! Power 24 V is a primary-switched power supply module for LOGO! devices. Two current ranges are available.

	LOGO! Power 24 V / 1.3 A	LOGO! Power 24 V / 2.5 A
<b>Input data</b>		
Input voltage	120 ... 230 V AC	
Permissible range	85 ... 264 V AC	
Permissible mains frequency	47 ... 63 Hz	
Voltage failure buffering	40 ms (at 187 V AC)	
Input current	0.48 ... 0.3 A	0.85 ... 0.5 A
Inrush current (25 °C)	< 15 A	< 30 A
Device protection	Internal	
Recommended circuit breaker (IEC 898) in mains line	> 6 A characteristic D > 10 A characteristic C	
<b>Output data</b>		
Output voltage	24 V DC	
Overall tolerance	+/- 3 %	
Adjustment range	22.2 ... 25.8 V DC	
Residual ripple	< 250 mV <sub>pp</sub>	
Output current	1.3 A	2.5 A
Overcurrent limiting	1.6 A	2.8 A
Efficiency	> 80 %	
Parallel circuit for power increase	Yes	
<b>Electromagnetic compatibility</b>		
Interference suppression	EN 50081-1, EN 55022 Class B	
Interference immunity	EN 50082-2	

## Technical data

	LOGO! Power 24 V / 1.3 A	LOGO! Power 24 V / 2.5 A
<b>Safety</b>		
Electrical isolation, primary/ secondary	Yes, SELV (to EN 60950/VDE 0805)	
Safety class	II (to IEC 536/VDE 0106 T1)	
Protection mode	IP 20 (to EN 60529/VDE 470 T1)	
CE marking	Yes	
UL/CSA certification	Yes; UL 508 / CSA 22.2	
FM approval	Yes; Class I, Div. 2, T4	
<b>General details</b>		
Ambient temperature range	-20 ... +55°C, natural convection	
Storage and shipping temperature	-40 ... +70°C	
Connections at input	One terminal (1 x 2.5 mm <sup>2</sup> or 2 x 1.5 mm <sup>2</sup> ) per L1 and N	
Connections at output	Two terminals (1x.2.5 mm <sup>2</sup> or 2 x 1.5 mm <sup>2</sup> ) per L+ and M	
Installation	On 35 mm DIN rail, snap-on	
Dimensions in mm (WxHxD)	72 x 80 x 55	126 x 90 x 55
Approx. weight	0.2 kg	0.4 kg

## A.11 Technical data: LOGO! Contact 24/230

LOGO! Contact 24 and LOGO! Contact 230 are switching modules for direct switching of ohmic loads up to 20 Amps and motors up to 4 kW (without noise emission, hum-free).

	LOGO! Contact 24	LOGO! Contact 230
Operating voltage	24 V DC	230 V AC; 50/60 Hz
<b>Switching capacity</b>		
Utilization category AC-1: Switching of ohmic loads at 55 °C		
Operating current at 400 V	20 A	
Output with three-phase loads at 400 V	13 kW	
Utilization category AC-2, AC-3: Motor with slip ring induction/cage armature		
Operating current at 400 V	8.4 A	
Output with three-phase loads at 400 V	4 kW	
Short-circuit protection:		
Assignment type 1	25 A	
Assignment type 2	10 A	
Connecting leads	Fine-wire with wire end ferrules Solid wire 2 x (0.75 to 2.5) mm <sup>2</sup> 2 x (1 to 2.5) mm <sup>2</sup> 1 x 4 mm <sup>2</sup>	
Dimensions (WxHxD)	36 x 72 x 55	
Ambient temperature	-25 ... +55 °C	
Storage temperature	-50 ... +80 °C	

[www.nicsanaf.com](http://www.nicsanaf.com)

021-87700210



## B Determining the cycle time

The program cycle is the complete execution of the circuit program, that is, primarily the reading in of the inputs, the processing of the circuit program and the subsequent reading out of the outputs. The cycle time is the time required to execute a circuit program once in full.

The time required for a program cycle can be determined using a short test program. This test program is created in LOGO! and returns a value during its execution in parameter assignment mode from which the current cycle time is derived.

### Test program

1. Create the test program by linking an output to a threshold trigger and connecting the trigger input with an inverted flag.

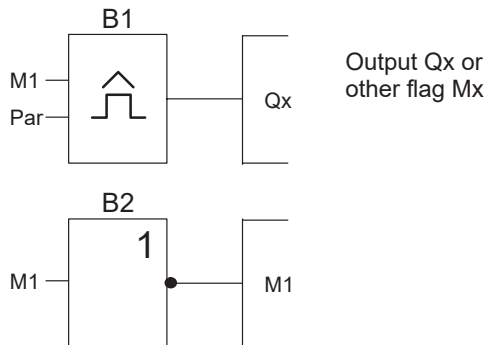

2. Configure the threshold trigger as shown below. A pulse is generated in each program cycle due to the inverted flag. The trigger interval is set to 2 seconds.

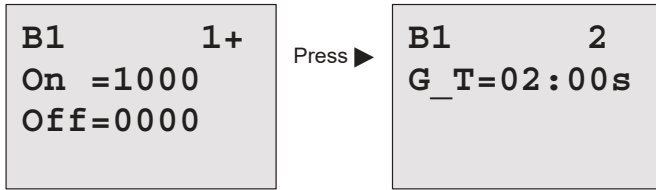

- Now start the circuit program and switch LOGO! to parameter assignment mode. In this mode, view the trigger parameters.

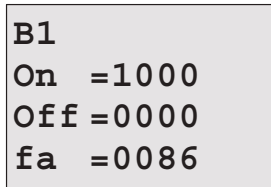

$f_a$  = total of measured pulses per timeb:

- The reciprocal value of  $f_a$  is equivalent to the LOGO! execution time of the current circuit program in its memory.

$$1/f_a = \text{cycle time in s}$$

### Explanation

The inverted flag block changes its output signal at each program execution. Thus, one logic level (high or low) width is exactly equivalent to the length of one cycle. Hence, a period lasts 2 cycles.

The threshold trigger indicates the ratio of periods per 2 seconds, which results in the ratio of cycles per second.

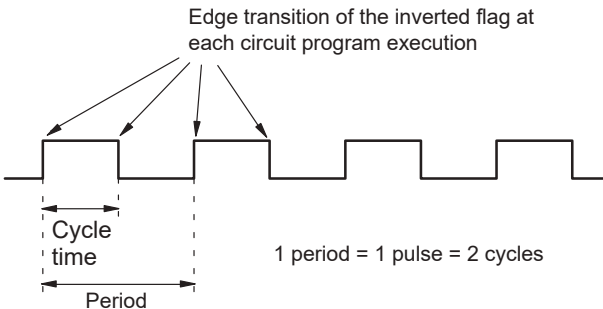



## C LOGO! without display



Because some specific applications do not require operator control and monitoring units such as buttons or a display, we provide the LOGO! 12/24RCo, LOGO! 24o, LOGO! 24RCo and LOGO! 230RCo versions without display.

View of a LOGO! 230RCo, for example:

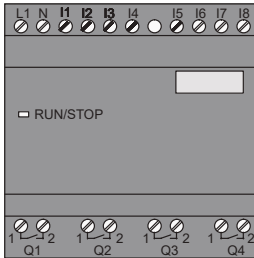

### Less is definitely more!

The versions without display offer you the following benefits:

- Even more cost-effective without the operating element.
- Requires less switch cabinet space than conventional hardware.
- Substantial benefits with regard to flexibility and prime costs compared to stand-alone electronic switchgear.
- Of advantage even for applications in which merely two or three conventional switching devices can be replaced.
- Very easy to use.
- Access protected.
- Compatible to LOGO! versions with display.
- Offers the option to read data by means of LOGO!Soft Comfort.

## Creating a circuit program without operator panel

There are two ways to create a circuit program for a LOGO! without display:

- You create the circuit program with LOGO!Soft Comfort on your PC and then download it to the LOGO! (see Chapter 7).
- You download the circuit program from a LOGO! program module (card) to your LOGO! without display (see Chapter 6).

## Operating characteristics

LOGO! is ready for operation when power is switched on. Switching off a LOGO! without display is equivalent to disconnecting the power supply, e.g. as if you were removing the plug.

The circuit program of LOGO!...o versions can not be started or stopped by means of buttons. This is why the LOGO!...o versions have other startup characteristics:

## Startup characteristics

If there is no circuit program in the LOGO! or on the inserted program module (card), LOGO! remains in STOP.

If there is a valid circuit program in LOGO! memory, the LOGO! automatically switches from STOP to RUN when power is switched on.

The circuit program on an inserted program module (card) is automatically copied to the LOGO!, immediately after power is switched on. The existing circuit program in LOGO! memory is overwritten. The system automatically changes from STOP to RUN.

Provided the PC cable is connected to the LOGO!, you can download the circuit program to LOGO! and start it by means of the LOGO!Soft Comfort PC software (see Chapter 7.1).

## Operating status indication

Operating states, e.g. Power On, RUN and STOP are indicated by an LED on the front hood.

- Red LED: Power On/STOP
- Green LED: Power On/RUN

The red LED is lit after Power On and in all LOGO! states other than RUN. The green LED is lit when LOGO! is in RUN mode.

## Reading current data

LOGO!Soft Comfort (see Chapter 7) provides an online test for reading the current data of all functions while the system is in RUN.

If your LOGO! without display holds a protected program module (card), you can not read the current data unless you enter the correct password for your the circuit program. The circuit program is otherwise deleted from LOGO! memory when you remove the program module (card) to connect the PC cable, for example (see Chapter 6.1).

[www.nicsanaf.com](http://www.nicsanaf.com)

021-87700210



# D LOGO! menu structure

## Menu overview

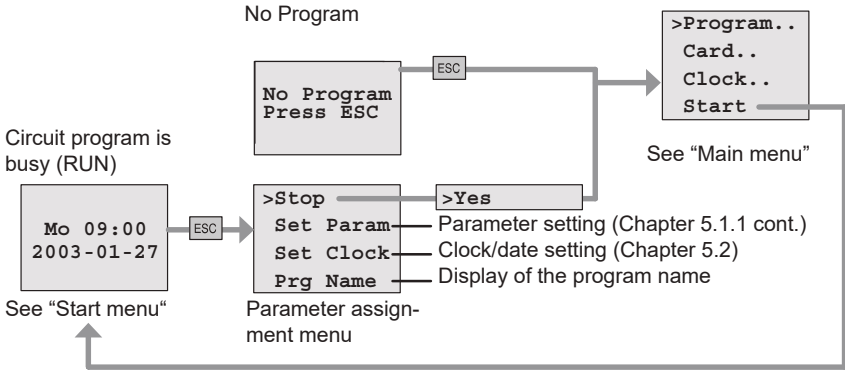

## Main menu (ESC / >Stop)

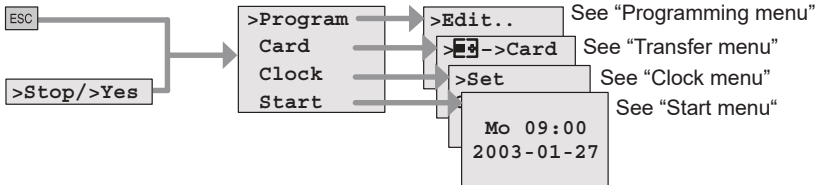

## Programming menu (ESC / >Stop → >Program)

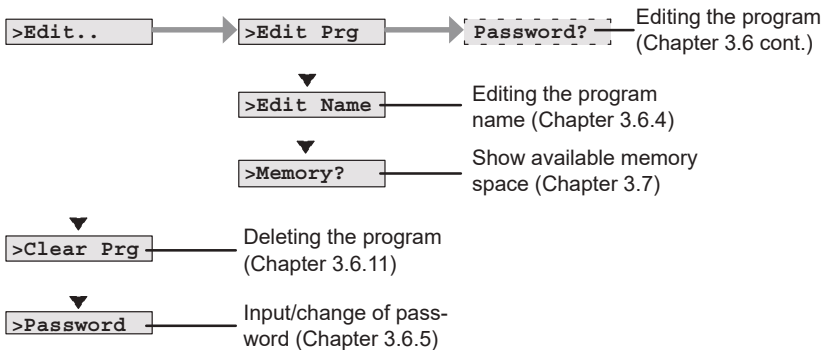

**Transfer menu (ESC / >Stop → >Card)**

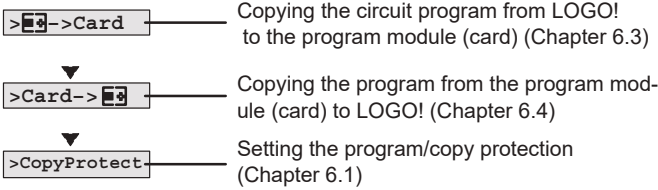

**Clock menu (ESC / >Stop → >Clock)**

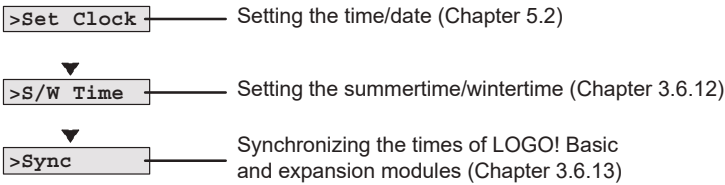

**Start menu (RUN)**

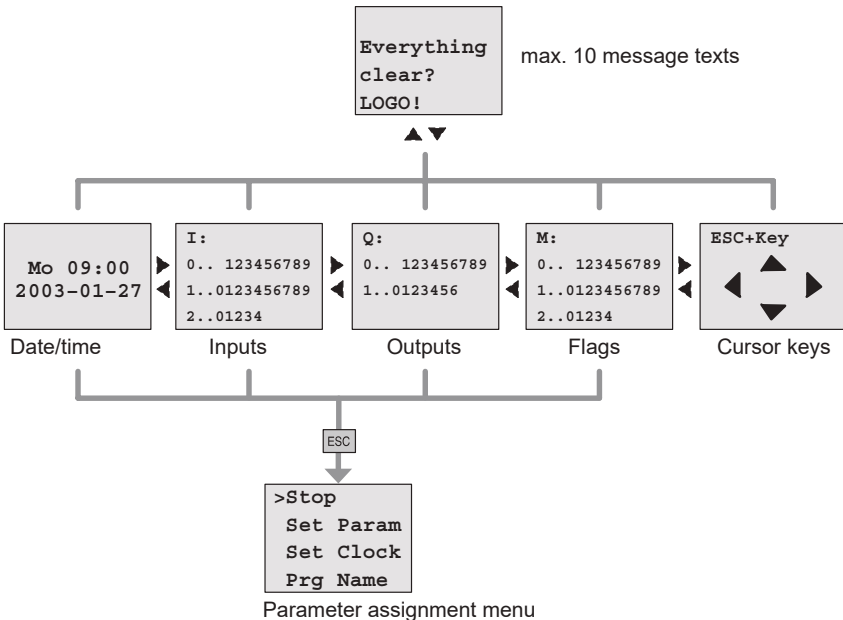

# E Order numbers

Table A

Variant	Designation	Order number
Basic	LOGO! 12/24 RC *	6ED1052-1MD00-0BA4
	LOGO! 24):	6ED1052-1CC00-0BA4
	LOGO! 24 RC (AC)	6ED1052-1HB00-0BA4
	LOGO! 230 RC	6ED1052-1FB00-0BA4
Basic without display (pure)	LOGO! 12/24 RC <sub>o</sub> *	6ED1052-2MD00-0BA4
	LOGO! 24 <sub>o</sub> *	6ED1052-2CC00-0BA4
	LOGO! 24 RC <sub>o</sub> (AC)	6ED1052-2HB00-0BA4
	LOGO! 230 RC <sub>o</sub>	6ED1052-2FB00-0BA4
Digital modules	LOGO! DM 8 12/24R	6ED1055-1MB00-0BA1
	LOGO! DM 8 24	6ED1055-1CB00-0BA0
	LOGO! DM 8 24R	6ED1055-1HB00-0BA0
	LOGO! DM 8 230R	6ED1055-1FB00-0BA1
Analog modules	LOGO! AM 2	6ED1055-1MA00-0BA0
	LOGO! AM 2 PT100	6ED1055-1MD00-0BA0

\*: Also with analog inputs

## Order numbers

---

Table B

Accessories	Designation	Order number
Software	LOGO!Soft Comfort V4.0	6ED1058-0BA00-0YA0
	Upgrade to LOGO!Soft Comfort V4.0	6ED1058-0CA00-0YE0
Program module (card)	LOGO! Card	6ED1056-5CA00-0BA0
Switching modules	LOGO!Contact 24 V	6ED1057-4CA00-0AA0
	LOGO!Contact 230 V	6ED1057-4EA00-0AA0
Power modules	LOGO!Power 12V/1.9A	6EP1321-1SH01
	LOGO!Power 12V/4.5A	6EP1322-1SH01
	LOGO!Power 24V/1.3A	6EP1331-1SH01
	LOGO!Power 24V/2.5A	6EP1332-1SH41
Others	PC cable	6ED1057-1AA00-0BA0
	Manual	6ED1050-1AA00-0BE5



# F Abbreviations

AM	Analog module
B1	Block number B1
BN	Block Number
C	LOGO! device designation: integrated clock
CM	Communication Module
Cnt	Count = Counter input
Co	Connector
Dir	Direction (of count, for example)
DM	Digital Module
En	Enable = switching on (clock generators, for example)
Fre	Input for frequency signals to be analyzed
GF	Basic Functions
Inv	Input for inverting the output signal
No	Cam (parameter of the timer)
o	in LOGO! designations: without display
Par	Parameter
R	Reset input
R	in LOGO! designations: Relay outputs
Ral	Reset all = Input for resetting all internal values
S	Set (latching relay, for example)
SF	Special functions
SU	Subunit
T	Time = parameter
Trg	Trigger (parameter)

0BA4 devices: the latest LOGO! Basic version, described in this Manual.

[www.nicsanaf.com](http://www.nicsanaf.com)

021-87700210



# Index

## A

- Abbreviations, 293
- AM. *See* Analog module
- Amplifier, analog, 173
- Analog
  - comparator, 165
  - values, 106
- Analog amplifier, 173
- Analog differential trigger, 161
- Analog module, 2, 7
- Analog threshold trigger, 158
- Analog value monitoring, 170
- AND, 95
- Applications, 221
- AS interface, 2, 243
- Asynchronous pulse generator, 128

## B

- Basic functions, 93
  - AND, 95
    - with edge, 96
  - NAND, 97
    - with edge, 98
  - NOR, 100
  - NOT, 101
  - OR, 99
  - XOR, 101
- Basics on special functions, 102

- BF, 89
- Blank outputs, 40
- blank outputs, 91
- Block, 42
  - deleting, 74
    - block groups, 75
  - inserting, 69
  - number, 42
    - assigning, 43
- BN, 89

## C

- Cap, 17
- Card. *See* Program module (card)
- CE label, 10
- Certification, 9
- Character set, 60
- Circuit diagram, 45
- Circuit program, input, 54
- circuit program, 84
  - deleting, 77
- Circuit program name, assigning, 60
- Circuit programs
  - archiving, 203
  - reproduce, 203
  - send by mail, 203
- Closing the programming mode, 74

CM. *See* Communications module  
Co, 89, 90  
Communication module, AS interface, 243  
Communications module, 2  
AS interface, 2, 7  
Compatibility, Versions, 204  
Connecting  
Inputs, 25  
outputs, 31  
Connector, 17  
Connectors, 39, 90  
blank, 40  
hi, 41  
inputs, 41  
lo, 41  
LOGO!'s, 40  
open, 92  
outputs, 41  
unused, 46  
x, 40, 41, 46, 103  
Constants, 90  
Control panel, 4, 5  
Conversion, Summertime and wintertime, 78  
Correcting typing errors, 76  
Counter  
Operating hours, 150  
Up/down, 146  
CSA, 9  
cULus , 9  
Cursor, 49  
Cursor keys, 40, 92, 184

Cursor movement, 49  
Cycle time, 283

## D

Demo versions, 217  
Device types, LOGO!, 2  
Digital module, 2, 7  
Dimensions, 16  
DIN rail, 16  
Display, 43  
Display view, 43  
Disposal, 10  
DM. *See* Digital module

## E

Earth connection, 24  
Edge evaluation, 96, 98  
Editing, 69  
Example  
Air-conditioning system, 234  
Automatic door, 227  
Factory door, 239  
factory door  
controlling, 243  
Monitoring, 243  
further options, 255  
lighting  
corridor, 223  
stairway, 223  
Luminous rows, 247  
Service water pump, 251

exclusive OR, 101

Expansion modules, 2  
 Analog module, 2, 41  
 Communications module, 2  
 Digital module, 41  
 digital module, 2  
 Operating state, 36  
 expansion modules, 39

## F

Flag blocks, 91  
 FM, 9  
 Four golden rules, 48  
 Function blocks, 42  
 Functions, 89

## G

Gain, 106  
 GF, 93  
 Golden rules, 48  
 Guidelines, 11

## H

Hiding, 72  
 high-speed counting, 27  
 Hours counter, 150  
 Reading the MN and OT values, 153  
 Hysteresis, 169

## I

Inputs, 90  
 Analog inputs, 27, 90  
 connection, 25  
 Cursor keys, 40, 92  
 Digital Inputs, 90  
 Groups, 25  
 inverting, 59, 93, 109  
 unused, 46  
 inputs, High-speed inputs, 27  
 Inserting, 69  
 Installation guidelines, 11  
 Interlock, 18, 20  
 Interpulse, width, 129  
 Inverter, 101

## L

Latching relay, 175  
 LCD, 4, 5  
 LED, 287  
 Levels, 92  
 List  
 BF, 89  
 BN, 89  
 Co, 89, 90  
 SF, 89, 109  
 List , GF, 93  
 Logic module, 1  
 Logical inputs, 103  
 LOGO!  
 connecting to PC, 218

Guidelines, 11  
identifying, 7  
Installing, 16  
Operating states, 36  
removing, 16  
Structure of, 4  
switching on, 33  
Versions, 8  
wiring, 23

LOGO! menus, 50

LOGO! software, 215

LOGO!Soft Comfort, 216

## M

Memory

areas, 84  
free, 88  
limitation, 84  
requirements, 85  
space, 84

Menu structure, 289

Menus

Main menu, 50  
Parameter assignment menu,  
50  
Programming menu, 50  
Real-time clock menu, 50  
Transfer menu, 50

Message texts, 179

Character set, 184

Mode

Parameter assignment, 194  
parameter assignment, 50  
PC-LOGO, 218  
programming, 50

Mounting

DIN rail mounting, 17  
Drilling template, 22  
Wall-mounting, 21

Multiple function switch, 135

## N

Name, 60

NAND, 97

Negation, 101

of a BF input, 93  
of an input, 59  
of an SF input, 109

NOR , 100

NOT , 101

NOT AND, 97

NOT OR, 100

## O

Off-delay, 117

Off-time, 140

Offset, 106

On-/Off-delay, 119

On-delay, 113  
retentive, 121

On-time, 140

Open connectors, 92

Operating

characteristics, 286

- Status indication, 287
  - Operating mode
    - Changing the operating mode, 48
    - Programming mode, 51
  - OR, 99
  - Order numbers, 291
  - Outputs, 90
    - Analog outputs, 91
      - blank, 40, 91
      - connecting, 31
    - Digital outputs, 90
- ## P
- Parameter, 196
    - 'Set Param', 195
    - Inputs, 104
    - selecting, 197
    - setting, 193
    - T, 104
  - Parameter assignment, 71
  - Parameter assignment menu, 194
  - Parameter assignment screen
    - form, 139, 181
  - Parameter protection, 106
  - Parameters, modifying, 198
  - parameters, showing/hiding, 72
  - Password
    - assigning, 61
    - changing, 63
    - deactivating, 64
    - wrong, 65
  - PC cable, 218
    - USB, 218
  - PC-LOGO, 218
  - Planning, 49
  - Power
    - off, 34
    - On, 33
    - on, 34
    - switch, 33
  - Power supply, connecting, 23
  - Program memory, 84
  - Program chart, 44
  - Program cycle, 283
  - Program module (card)
    - 'Card --> LOGO', 213
    - 'CopyProtect', 206
    - 'LOGO --> Card', 210
    - copying, 212
    - Enabling the security function, 207
    - inserting, 208, 209
    - removing, 208, 209
    - Security function, 205
  - Program name
    - change, 61
    - character set, 60
    - read, 195
  - Programs
    - 'Clear Prg', 77
    - 'Edit Name', 60
    - 'Edit Prg', 52
    - 'Password', 61
    - modifying, 68
  - Protection mode, 72
  - Pulse
    - Pause, 126
    - width, 126
    - width , 129

pulse generator, Asynchronous ,  
128

Pulse output, 123

Pulse relay, 176

## R

Random generator, 130

Recycling, 10

Relay outputs, 31, 273  
service life, 273  
switching capacity, 273

Removal, 19

Resources, 84

Retentive memory, 84

Retentive on—delay, 121

Retentivity, 105  
enabling/disabling, Retentivity  
setting, 72

Rules, Four golden, 48

RUN, 'Start', 66

## S

Sensor Characteristics, 25

Sensor connections, 28

Set clock, 'Set Clock', 201

Setting, time, 72

Setting the date, 201

Setting the time—of—day, 201  
'Set clock', 195

Setup, 13

Maximum setup, 13  
with different voltage classes,  
14

SF, 89, 109

SFs, Delay, On, 113

Shift register, 190

Shift register bits, 40, 92

Showing, 72

Signal status transitions, 27

Simulation, 215

Size of a circuit, 84

Softkey, 186

Software, 215

Solid—state outputs, 32

Special functions, 109  
Analog amplifier, 173  
Analog Comparator, 165  
Analog differential trigger, 161  
Analog threshold trigger, 158  
Analog value monitoring, 170  
Basics, 102  
Counter  
Hours counter, 150  
Up/down, 146  
Delay  
Off, 117  
On/Off, 119  
delay, ret. on, 121  
Message texts, 179  
Pulse generator, asynchronous,  
128  
Random generator, 130  
Relay, Latch, 175



relay, Pulse, 176  
 Shift register, 190  
 Softkey, 186  
 Switch  
   Comfort, 135  
   Stairway lighting, 132  
 Threshold trigger, Frequency, 155  
 Timer  
   Week, 138  
   Year, 143  
 Trigger, Analog threshold, 158  
 Wiping relay  
   edge triggered, 125  
   Pulse output, 123  
  
 Stairway lighting switch, 132  
 Start, 66  
 Startup characteristics, 286  
 Startup flag, 92  
 Stop, 195  
 Subunits, 16  
 Summertime, 78  
 Summertime/Wintertime Conversion, 'S/W Time', 78  
 Summertime/wintertime conversion, 78  
   disabling, 82  
   enabling, 79  
   user—define parameters, 81  
 Switch  
   Multiple function, 135  
   Stairway lighting, 132  
  
 Switched current, maximum, 32  
 Symbols, 7  
 Synchronization, 83  
   'Sync', 83

enabling, 83

## T

T, Parameter, 105  
 Technical data, 259  
   general, 259  
   LOGO! 12..., 270  
   LOGO! 230..., 261  
   LOGO! 24/24o, 264  
   LOGO! 24RC/24RCo, 267  
   LOGO! AM 2 PT100, 275  
   LOGO! AM2, 274  
   LOGO! DM8 12/24R, 270  
   LOGO! DM8 230R, 261  
   LOGO! DM8 24, 264  
   LOGO! DM8 24R, 267  
   LOGO!Contact, 281  
   LOGO!Power 12 V, 277  
  
 Threshold trigger, Frequencies, 155  
  
 Time, Accuracy of, 104  
 Time response, 104  
 Timebase, 71, 104, 113  
 Timer, 1  
   accuracy, 105  
 Timing inaccuracy, 105  
 Trigger, Analog threshold, 158  
 trigger, Analog, Differential, 161  
 type of equipment, LOGO!, 2

## U

Unused connectors, 46  
unused connectors, 40  
Unused inputs, 46  
Up/down counter, 146  
Update, 217  
Upward compatibility, 204  
USB, 218

## V

Verification, 73  
Voltage levels , 92  
Voltage supply, connecting, Circuit protection, 24

## W

Weekday, 139  
Weekly timer, 7, 140  
Examples, 141

setting, 140

Weekly timer , 138

Wintertime, 78

Wiping relay

edge triggered, 125

Pulse output, 123

Wire ferrules, 23

without display, 285

creating a circuit program, 37

PC-LOGO mode, 218

reading current data, 287

## X

XOR , 101

## Y

Yearly timer, 143

## Z

Zero offset, 106

## Vorbemerkung

Diese Produktinformation enthält wichtige Informationen zu LOGO.  
Sie ist als separater Bestandteil aufzufassen und in Zweifelsfällen  
Vorrang vor anderen Aussagen in Handbüchern und Katalogen über

Diese Produktinformation enthält die Ergänzungen für die LOGO-  
module DM16 24, DM16 24R und DM16 230R.

Copyright 2004 by Siemens AG  
A5E00324307-01

[www.nicsanat.com](http://www.nicsanat.com)  
021-87700210



clock		
<b>Digital inputs</b>		
Number	8, optional P action or	4, optional P action or
<b>1.1</b>	<b>Welche Erweiterungsmodule gibt es?</b>	
Electrical isolation	No	No
Input voltage	• LOGO! Digitalmodule DM8... gibt es für 12 V DC, 24 V AC/DC und 115...240 V AC/DC mit 4 Eingängen und 4 Ausgängen. • Signal 0 • Signal 1	• LOGO! Digitalmodule DM16... gibt es für 12 V DC, 24 V AC/DC und 115...240 V AC/DC mit 8 Eingängen und 8 Ausgängen.

In groups of
Control of a digital input
Output voltage
Output current
Continuous current I <sub>th</sub>
Incandescent lamp load (25000 switching cycles) a
Fluorescent tubes with ballast (25000 switching cycles)

- LOGO! Analogmodule gibt es für 12 V DC und 24 V DC mit 2 Analogeingängen bzw. mit 2 Pt100-Eingängen.
- LOGO! Kommunikationsmodule (CM) wie z.B. Kommunikationsmodul AS-Interface.

LOGO! Manual

www.nicsanaf.com  
021-87700210



kann.

## 1.2 So ist LOGO! aufgebaut

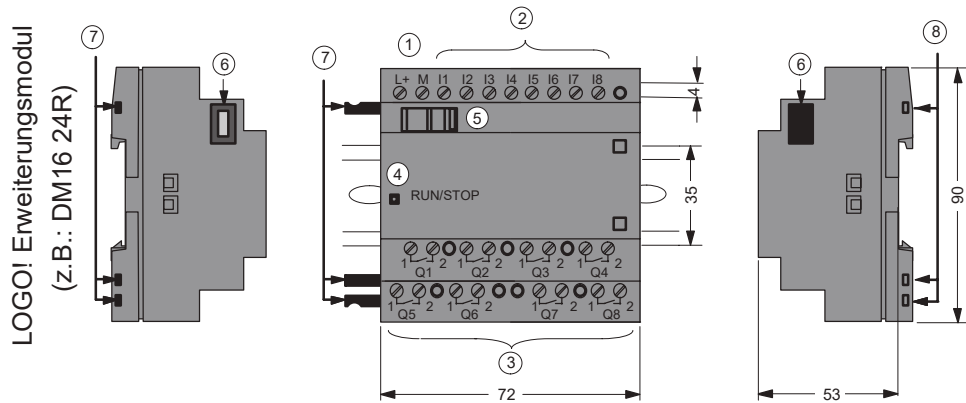

- ① Spannungsversorgung
- ② Eingänge
- ③ Ausgänge
- ④ Anzeige des Zustandes RUN/STOP
- ⑤ Schieber
- ⑥ Erweiterungsschnittstelle
- ⑦ Mechanische Codierung – Stifte
- ⑧ Mechanische Codierung – Buchsen

www.nicsanaf.com  
021-87700210





Digitalmodul verfügt über 4 Digitaleingänge und 4 Digitalausgänge



Digitalmodul verfügt über 8 Digitaleingänge und 8 Digitalausgänge

## 1.3 Erweiterungsmodule

An LOGO! können folgende Erweiterungsmodule angeschlossen werden:

Symbol	Bezeichnung	Versorgung	Eingänge	Ausgänge
	LOGO! DM 8 12/24R	12/24 V DC	4 Digital	4 Relais je 5A
	LOGO! DM 8 24	24 V DC	4 Digital	4 Transistor 24V / 0,3A
	LOGO! DM 8 24R <sup>(3)</sup>	24 V AC/DC	4 Digital	4 Relais je 5A
	LOGO! DM 8 230R	115...240 V AC/DC	4 Digital <sup>(1)</sup>	4 Relais je 5A
	LOGO! DM 16 24	24 V DC	8 Digital	8 Transistor 24V / 0,3A
	LOGO! DM 16 24R	24 V DC	8 Digital	8 Relais je 5A
	LOGO! DM 16 230R	115...240 V AC/DC	8 Digital <sup>(4)</sup>	8 Relais je 5A
	LOGO! AM 2	12/24 V DC	2 Analog 0 ... 10V oder 0 ... 20mA <sup>(2)</sup>	keine
	LOGO! AM 2 PT100	12/24 V DC	2 Pt100 -50 °C bis +200 °C	keine

(1): Keine unterschiedlichen Phasen innerhalb der Eingänge erlaubt.

(2): 0 ... 10V, 0 ... 20 mA sind wahlweise anschließbar.

(3): Digitaleingänge können wahlweise P-schaltend oder N-schaltend betrieben werden.

(4): Eingänge in zwei Gruppen von 4. Innerhalb der Gruppe nur eine gleiche Phase, zwischen den Gruppen verschiedene Phasen möglich.

## 1.4 Aufbau mit unterschiedlichen Spannungsklassen

### Regeln

Digitalmodule können Sie nur an Geräte der gleichen Spannungsklasse anschließen. Analogmodule und Kommunikationsmodule können Sie an Geräte mit beliebiger Spannungsklasse anschließen.

Sie können ohne eine Änderung des Schaltprogramms zwei gleiche DM8-Erweiterungsmodule durch ein gleichartiges DM16-Erweiterungsmodul ersetzen (und umgekehrt).

[www.nicsanat.com](http://www.nicsanat.com)  
021-87700210



1 24 V DC gegen

Zwei DM8 24R können nur in der Betriebsart DC, P-schaltend gegen ein DM16 24R getauscht werden.

**Übersicht:  
Erweiterungsmodul an LOGO! Basic anschließen**

LOGO! Basic	Erweiterungsmodul					
	DM8 12/24R, DM16 24R	DM8 24, DM16 24	DM8 24R	DM8 230R, DM16 230R	AM2, AM2 PT100	CM
LOGO! 12/24RC	X	X	X	–	X	X
LOGO! 24	X	X	X	–	X	X
LOGO! 24RC	X	X	X	–	X	X
LOGO! 230RC	–	–	–	X	X	X
LOGO! 12/24RCo	X	X	X	–	X	X
LOGO! 24o	X	X	X	–	X	X
LOGO! 24RCo	X	X	X	–	X	X
LOGO! 230RCo	–	–	–	X	X	X

**Übersicht:  
Erweiterungsmodul an Erweiterungsmodul anschließen**

Erweiterungs- modul	Weitere Erweiterungsmodul					
	DM8 12/24R, DM16 24R	DM8 24, DM16 24	DM 8 24R	DM8 230R, DM16 230R	AM2, AM2 PT100	CM
DM 8 12/24R, DM 16 24R	X	X	X	–	X	X
DM 8 24, DM 16 24	X	X	X	–	X	X
DM 8 24R	X	X	X	–	X	X
DM 8 230R, DM 16 230R	–	–	–	X	X	X
AM2 / AM2 PT100	X	X	X	–	X	X
CM	X	X	X	–	X	X



## 1.5 Abmessungen

LOGO! besitzt die Abmessungen für Installationsgeräte gemäß DIN 43880.

LOGO! kann auf eine 35 mm breite Hutschiene nach DIN EN 50022 aufgeschnappt oder an die Wand montiert werden.

Breite von LOGO!:

- LOGO! Basic ist 72 mm breit, das entspricht 4 Teilungseinheiten.
- LOGO! Erweiterungsmodule sind 36 mm bzw. 72 mm (DM16...) breit, das entspricht 2 bzw. 4 Teilungseinheiten.

## 1.6 Eingänge von LOGO! anschließen

### Sensoreigenschaften für LOGO!

	LOGO! DM16 24 R	LOGO! DM16 24	LOGO! DM16 230 R (AC)	LOGO! DM16 230 R (DC)
<b>Schaltzustand 0</b>	< 5 V DC	< 5 V DC	< 40 V AC	< 30 V DC
Eingangsstrom	< 1 mA	< 1 mA	< 0,05 mA	< 0,05 mA
<b>Schaltzustand 1</b>	> 12 V DC	> 12 V DC	> 79 V AC	> 79 V DC
Eingangsstrom	> 2 mA	> 2 mA	> 0,08 mA	> 0,08 mA

### Achtung

Die Digitaleingänge der LOGO! 230 RC/RCo und des Erweiterungsmoduls DM16 230R sind in zwei Gruppen aufgeteilt, die jeweils über 4 Eingänge verfügen.

**Innerhalb** einer Gruppe muss an allen Eingängen die **gleiche** Phase verwendet werden. **Verschiedene** Phasen sind nur **zwischen** den Gruppen möglich.

Beispiel: I1 bis I4 an Phase **L1**, I5 bis I8 an Phase **L2**.

Bei LOGO! DM8 230R dürfen innerhalb der Eingänge **keine** unterschiedlichen Phasen angeschlossen werden.

### Sensoranschlüsse

Anschließen von Glühlampen, 2-Draht-Näherungsschalter (Bero) an LOGO! 230RC/230RCo oder LOGO! DM8 230R (AC) und LOGO! DM16 230R (AC)

[www.nicsanat.com](http://www.nicsanat.com)

021-87700210

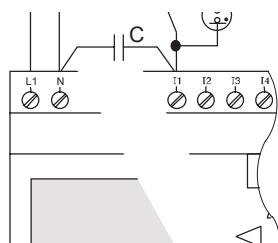

3SB1420-3D

X-Kondensator 2,5 kV, 100 nF

## 1.7 Technische Daten

### Allgemeine Technische Daten

Kriterium	Prüfung nach	Werte
<b>LOGO!Basic</b> Abmessungen BxHxT Gewicht Montage		72 x 90 x 55 mm ca. 190 g auf Hutschiene 35 mm 4 Teilungseinheiten breit oder Wandmontage
<b>LOGO! Erweiterungsmodule DM8..., AM...</b> Abmessungen BxHxT Gewicht Montage		36 x 90 x 53 mm ca. 90 g auf Hutschiene 35 mm 2 Teilungseinheiten breit oder Wandmontage
<b>LOGO! Erweiterungsmodule DM16...</b> Abmessungen BxHxT Gewicht Montage		72 x 90 x 53 mm ca. 190 g auf Hutschiene 35 mm 4 Teilungseinheiten breit oder Wandmontage
<b>Klimatische Umgebungsbedingungen</b>		
Umgebungstemperatur waagrechter Einbau senkrechter Einbau	Kälte nach IEC 60068-2-1 Wärme nach IEC 60068-2-2	0 ... 55 °C 0 ... 55 °C
Lagerung / Transport		-40 °C ... +70 °C
Relative Feuchte	IEC 60068-2-30	von 10 bis 95% keine Betauung
Luftdruck		795 ... 1080 hPa
Schadstoffe	IEC 60068-2-42 IEC 60068-2-43	SO <sub>2</sub> 10 cm <sup>3</sup> /m <sup>3</sup> , 4 Tage H <sub>2</sub> S 1 cm <sup>3</sup> /m <sup>3</sup> , 4 Tage
<div style="text-align: center;">  <p><a href="http://www.nicsanat.com">www.nicsanat.com</a> 021-87700210</p> </div>		
		9 ... 150 Hz (konstante Beschleunigung 1 g)
Schock	IEC 60068-2-27	18 Schocks (Halbsinus 15g/11ms)
Kippfallen	IEC 60068-2-31	Fallhöhe 50 mm
Freier Fall, verpackt	IEC 60068-2-32	1 m



Kriterium	Prüfung nach	Werte
<b>Elektromagnetische Verträglichkeit (EMV)</b>		
Störaussendung	EN 55011/A EN 55022/B EN 50081-1 (Wohnbereich)	Grenzwertklasse B Gruppe 1
Elektrostatische Entladung	IEC 61000-4-2 Schärfegrad 3	8 kV Luftentladung 6 kV Kontaktentladung
Elektromagnetische Felder	IEC 61000-4-3	Feldstärke 10 V/m
HF-Bestromung auf Leitungen und Leitungsschirmen	IEC 61000-4-6	10 V
Burst Impulse	IEC 61000-4-4 Schärfegrad 3	2 kV (Versorgungs- und Signalleitungen)
Energiereicher Einzelimpuls (Surge) (nur bei LOGO! 230....)	IEC 61000-4-5 Schärfegrad 3	1 kV (Versorgungsleitungen) symmetrisch 2 kV (Versorgungsleitungen) asymmetrisch
<b>Angaben über IEC- / VDE-Sicherheit</b>		
Bemessung der Luft- u. Kriechstrecken	IEC 60664, IEC 61131-2, EN 50178 cULus nach UL 508, CSA C22.2 No. 142 Bei LOGO! 230R/RC auch VDE 0631	erfüllt
Isolationsfestigkeit	IEC 61131-2	erfüllt

[www.nicsanaf.com](http://www.nicsanaf.com)  
021-87700210



## Technische Daten: LOGO! DM16 230R

LOGO! DM16 230R	
<b>Stromversorgung</b>	
Eingangsspannung	115 ... 240 V AC/DC
Zulässiger Bereich	85 ... 265 V AC 100 ... 253 V DC
Zulässige Netzfrequenz:	47 ... 63 Hz
Stromaufnahme	
• 115 V AC	10 ... 60 mA
• 240 V AC	10 ... 40 mA
• 115 V DC	5 ... 25 mA
• 240 V DC	5 ... 20 mA
Spannungsausfallüberbrückung	
• 115 V AC/DC	typ. 10 ms
• 240 V AC/DC	typ. 20 ms
Verlustleistung bei	
• 115 V AC	1,1 ... 4,5 W
• 240 V AC	2,4 ... 5,5 W
• 115 V DC	0,6 ... 2,9 W
• 240 V DC	1,2 ... 4,8 W
Pufferung der Uhr bei 25 °C	
Ganggenauigkeit der Echtzeituhr	
<b>Digitaleingänge</b>	
Anzahl	8
Potentialtrennung	nein
Eingangsspannung L1	
• Signal 0	< 40 V AC
• Signal 1	> 79 V AC
• Signal 0	< 30 V DC
• Signal 1	> 79 V DC
Eingangsstrom bei	
• Signal 0	< 0,05 mA
	
	<a href="http://www.nicsanat.com">www.nicsanat.com</a> 021-87700210
• 1 nach 0	typ. 50 ms
Leitungslänge (ungeschirmt)	100 m
<b>Digitalausgänge</b>	
Anzahl	8
Typ der Ausgänge	Relaisausgänge
Potentialtrennung	ja
in Gruppen zu	1
Ansteuerung eines Digitaleingangs	ja

	<b>LOGO! DM16 230R</b>
Dauerstrom $I_{th}$	max. 5 A je Relais
Glühlampenlast (25.000 Schaltspiele) bei 230/240 V AC 115/120 V AC	1000 W 500 W
Leuchtstoffröhren mit elektr. Vorschaltgerät (25.000 Schaltspiele)	10 x 58 W (bei 230/240 V AC)
Leuchtstoffröhren konventionell kompensiert (25.000 Schaltspiele)	1 x 58 W (bei 230/240 V AC)
Leuchtstoffröhren unkompensiert (25.000 Schaltspiele)	10 x 58 W (bei 230/240 V AC)
Kurzschlussfest cos 1	Leistungsschutz B16 600A
Kurzschlussfest cos 0.5 bis 0.7	Leistungsschutz B16 900A
Derating	kein; im gesamten Temperaturbereich
Parallelschaltung von Ausgängen zur Leistungserhöhung	nicht zulässig
Absicherung eines Ausgangsrelais (falls gewünscht)	max. 16 A, Charakteristik B16
<b>Schaltfrequenz</b>	
mechanisch	10 Hz
Ohmsche Last/Lampenlast	2 Hz
Induktive Last	0,5 Hz



## Technische Daten: LOGO! DM16 24

LOGO! DM16 24	
<b>Stromversorgung</b>	
Eingangsspannung	24 V DC
Zulässiger Bereich	20,4 ... 28,8 V DC
Verpolschutz	ja
Zulässige Netzfrequenz	
Stromaufnahme aus 24 V	30 ... 45 mA 0,3 A je Ausgang
Spannungsausfallüberbrückung	
Verlustleistung bei 24 V	0,8 ... 1,7 W
Pufferung der Uhr bei 25 °C	
Ganggenauigkeit der Echtzeituhr	
<b>Digitaleingänge</b>	
Anzahl	8
Potentialtrennung	nein
Eingangsspannung	L+
• Signal 0	< 5 V DC
• Signal 1	> 12 V DC
Eingangsstrom bei	
• Signal 0	< 1 mA
• Signal 1	> 2 mA
Verzögerungszeit bei	
• 0 nach 1	typ. 1,5 ms
• 1 nach 0	typ. 1,5 ms
Leitungslänge (ungeschirmt)	100 m
<b>Digitalausgänge</b>	
Anzahl	8
Typ der Ausgänge	Transistor, P-schaltend
Potentialtrennung	nein
	
Ausgangsspannung	= Versorgungsspannung
Ausgangsstrom	max. 0,3 A
Dauerstrom $I_{th}$	
Glühlampenlast (25.000 Schaltspiele) bei	
Leuchtstoffröhren mit elektr. Vorschaltgerät (25.000 Schaltspiele)	
Leuchtstoffröhren konventionell kompensiert (25.000 Schaltspiele)	
Leuchtstoffröhren unkompensiert (25.000 Schaltspiele)	

	<b>LOGO! DM16 24</b>
Kurzschlussfest und überlastsicher	ja
Kurzschlussstrombegrenzung	ca. 1 A
Derating	kein; im gesamten Temperaturbereich
Kurzschlussfest cos 1	
Kurzschlussfest cos 0.5 bis 0.7	
Parallelschaltung von Ausgängen zur Leistungserhöhung	nicht zulässig
Absicherung eines Ausgangsrelais (falls gewünscht)	
<b>Schaltfrequenz</b>	
mechanisch	
elektrisch	10 Hz
Ohmsche Last/Lampenlast	10 Hz
Induktive Last	0,5 Hz



## Technische Daten: LOGO! DM16 24R

LOGO! DM16 24R	
<b>Stromversorgung</b>	
Eingangsspannung	24 V DC
Zulässiger Bereich	20,4 ... 28,8 V DC
Verpolschutz	ja
Stromaufnahme • 24 V DC	30 ... 90 mA
Spannungsausfallüberbrückung • 24 V DC	typ. 5 ms
Verlustleistung • 24 V DC	0,7 ... 2,5 W
Pufferung der Uhr bei 25 °C	
Ganggenauigkeit der Echtzeituhr	
Potentialtrennung	nein
<b>Digitaleingänge</b>	
Anzahl	8
Potentialtrennung	nein
Eingangsspannung L+ • Signal 0 • Signal 1	< 5 V DC > 12 V DC
Eingangsstrom bei • Signal 0 • Signal 1	< 1 mA > 2 mA
Verzögerungszeit bei • 0 nach 1 • 1 nach 0	typ. 1,5 ms typ. 1,5 ms
Leitungslänge (ungeschirmt)	100 m
<b>Digitalausgänge</b>	
Anzahl	8
Typ der Ausgänge	Relaisausgänge
	
Installation eines Digitaleingangs	ja
Ausgangsspannung	
Ausgangsstrom	
Dauerstrom $I_{th}$ (je Klemme)	max. 5 A je Relais
Glühlampenlast (25.000 Schaltspiele)	1000 W
Leuchtstoffröhren mit elektr. Vorschaltgerät (25.000 Schaltspiele)	10 x 58 W
Leuchtstoffröhren konventionell kompensiert (25.000 Schaltspiele)	1 x 58 W

	<b>LOGO! DM16 24R</b>
Leuchtstoffröhren unkompensiert (25.000 Schaltspiele)	10 x 58 W
Kurzschlussfest und überlastsicher	
Kurzschlussstrombegrenzung	
Derating	kein; im gesamten Temperaturbereich
Kurzschlussfest cos 1	Leistungsschutz B16 600A
Kurzschlussfest cos 0.5 bis 0.7	Leistungsschutz B16 900A
Parallelschaltung von Ausgängen zur Leistungserhöhung	nicht zulässig
Absicherung eines Ausgangsrelais (falls gewünscht)	max. 16 A, Charakteristik B16
<b>Schaltfrequenz</b>	
mechanisch	10 Hz
elektrisch	
Ohmsche Last/Lampenlast	2 Hz
Induktive Last	0,5 Hz

## 1.8 Bestellnummern

Tabelle A

Variante	Bezeichnung	Bestellnummer
Basic	LOGO! 12/24RC * LOGO! 24 * LOGO! 24RC (AC) LOGO! 230RC	6ED1 052-1MD00-0BA4 6ED1 052-1CC00-0BA4 6ED1 052-1HB00-0BA4 6ED1 052-1FB00-0BA4
Basic ohne Display (Pure)	LOGO! 12/24RCo * LOGO! 24o * LOGO! 24RCo (AC) LOGO! 230RCo	6ED1 052-2MD00-0BA4 6ED1 052-2CC00-0BA4 6ED1 052-2HB00-0BA4 6ED1 052-2FB00-0BA4
	LOGO! DM 8 24R LOGO! DM 8 230R LOGO! DM 16 24 LOGO! DM 16 24R LOGO! DM 16 230R	6ED1 055-1HB00-0BA0 6ED1 055-1FB00-0BA1 6ED1055-1CB10-0BA0 6ED1055-1NB10-0BA0 6ED1055-1FB10-0BA0
Analogmodule	LOGO! AM 2 LOGO! AM 2 PT100	6ED1 055-1MA00-0BA0 6ED1 055-1MD00-0BA0

www.nicsanat.com  
021-87700210



\*: zusätzlich mit Analogeingängen

[www.nicsanat.com](http://www.nicsanat.com)

021-87700210





# SIEMENS

## Product information

07.2004

---

**Product Information on Manual LOGO!; from Edition 06/2003  
(A5E00228550-01)**

---

### Preliminary remarks

This Product Information contains additional information about LOGO!  
It is a separate component and should be considered more up-to-date than the  
information in the manuals and catalogs if uncertainties arise.

This Product Information provides information about LOGO! expansion modules  
DM16 24, DM16 24R and DM16 230R.

[www.nicsanat.com](http://www.nicsanat.com)  
021-87700210



## 2.1 Which expansion modules are available?

- LOGO! digital modules DM8... are available for operation with 12 V DC, 24 V AC/DC and 115...240 V AC/DC, and are equipped with four inputs and four outputs.
- LOGO! digital modules DM16... are available for operation with 24 V DC and 115...240 V AC/DC, and are equipped with eight inputs and eight outputs.
- LOGO! analog modules are available for operation with 12 V DC and 24 V DC, and are equipped with two analog inputs or two Pt100 inputs.
- LOGO! communications modules (CM), for example the communications module AS interface, that is described in a separate documentation.

The digital/analog modules are integrated in two or four subunits. Each one is equipped with two expansion interfaces for connecting additional modules.

## 2.2 The LOGO! structure

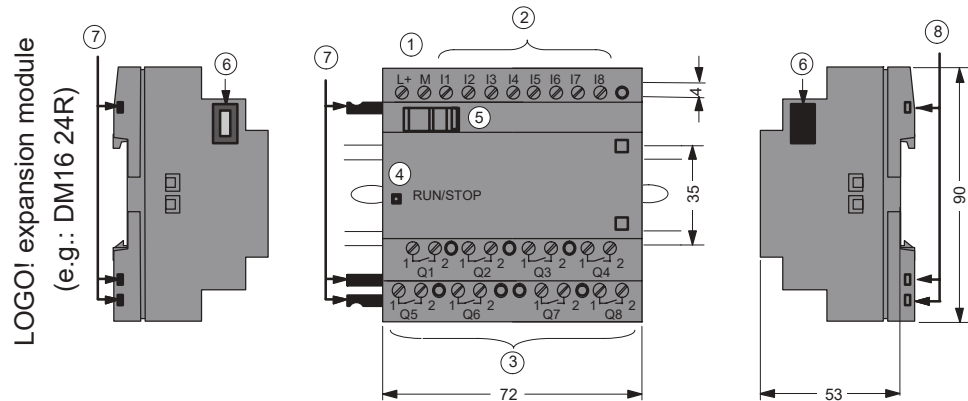

- |                |                       |                             |
|----------------|-----------------------|-----------------------------|
| ① Power supply | ④ RUN/STOP indicator  | ⑦ Mechanical coding pins    |
| ② Inputs       | ⑤ Slide               | ⑧ Mechanical coding sockets |
| ③ Outputs      | ⑥ Expansion interface |                             |

[www.nicsanaf.com](http://www.nicsanaf.com)  
021-87700210



### Symbols





The digital module is equipped with 4 digital inputs and 4 digital outputs



The digital module is equipped with 8 digital inputs and 8 digital outputs

## 2.3 Expansion modules

The following expansion modules can be connected to the LOGO!:

Symbol	Name	Power supply	Inputs	Outputs
	LOGO! DM 8 12/24R	12/24 V DC	4 digital	4 relays (5A)
	LOGO! DM 8 24	24 V DC	4 digital	4 solid state 24V / 0.3A
	LOGO! DM 8 24R <sup>(3)</sup>	24 V AC/DC	4 digital	4 relays (5A)
	LOGO! DM 8 230R	115...240 V AC/DC	4 digital <sup>(1)</sup>	4 relays (5A)
	LOGO! DM 16 24	24 V DC	8 digital	8 solid state 24V / 0.3A
	LOGO! DM 16 24R	24 V DC	8 digital	8 relays (5A)
	LOGO! DM 16 230R	115...240 V AC/DC	8 digital <sup>(4)</sup>	8 relays (5A)
	LOGO! AM 2	12/24 V DC	2 analog 0 ... 10V or 0 ... 20mA <sup>(2)</sup>	none
	LOGO! AM 2 PT100	12/24 V DC	2 Pt100 -50 °C to +200 °C	none

(1): Different phases are not allowed within the inputs.

(2): 0 ... 10 V, 0 ... 20 mA can be connected optionally.

(3): Digital inputs can be operated either with P or with N action.

(4): Two groups consisting of 4 inputs each. Each group must be connected to the same phase. It is possible to interconnect groups with a different phase.

## 2.4 Setup with different voltage classes

### Rules

Digital modules can only be connected to devices of the same voltage class.

You may connect analog and communications modules to devices of any voltage class.

You may replace two similar DM8 expansion modules by one appropriate DM16 expansion module (and vice versa) without having to change the circuit program.

[www.nicsanat.com](http://www.nicsanat.com)

021-87700210



ated with a power

supply of 24 V DC.

Two DM8 24R may be replaced by one DM16 24R only if operated with DC and P action.

**Overview:**  
**Connecting an expansion module to LOGO! Basic**

LOGO! Basic	Expansion modules					
	DM8 12/24R, DM16 24R	DM8 24, DM16 24	DM8 24R	DM8 230R, DM16 230R	AM2, AM2 PT100	CM
LOGO! 12/24RC	X	X	X	—	X	X
LOGO! 24	X	X	X	—	X	X
LOGO! 24RC	X	X	X	—	X	X
LOGO! 230RC	—	—	—	X	X	X
LOGO! 12/24RCo	X	X	X	—	X	X
LOGO! 24o	X	X	X	—	X	X
LOGO! 24RCo	X	X	X	—	X	X
LOGO! 230RCo	—	—	—	X	X	X

**Overview:**  
**Connecting a further expansion module to an expansion module**

Expansion module	Further Expansion modules					
	DM8 12/24R, DM16 24R	DM8 24, DM16 24	DM 8 24R	DM8 230R, DM16 230R	AM2, AM2 PT100	CM
DM 8 12/24R, DM 16 24R	X	X	X	—	X	X
DM 8 24, DM 16 24	X	X	X	—	X	X
DM 8 24R	X	X	X	—	X	X
DM 8 230R, DM 16 230R	—	—	—	X	X	X
AM2 / AM2 PT100	X	X	X	—	X	X
CM	X	X	X	—	X	X



## 2.5 Dimensions

The LOGO! installation dimensions are compliant with DIN 43880.

LOGO! can be snap-mounted to 35 mm DIN rails to EN 50022 or on the wall.

LOGO! width:

- LOGO! Basic has a width of 72 mm, which corresponds with 4 subunits.
- LOGO! expansion modules have a width of 36 mm or 72 mm (DM16...), which corresponds with 2 or 4 subunits.

## 2.6 Connecting LOGO! inputs

### Sensor characteristics for LOGO!

	LOGO! DM16 24 R	LOGO! DM16 24	LOGO! DM16 230 R (AC)	LOGO! DM16 230 R (DC)
<b>Signal status 0</b>	< 5 V DC	< 5 V DC	< 40 V AC	< 30 V DC
Input current	< 1 mA	< 1 mA	< 0.05 mA	< 0.05 mA
<b>Signal status 1</b>	> 12 V DC	> 12 V DC	> 79 V AC	> 79 V DC
Input current	> 2 mA	> 2 mA	> 0.08 mA	> 0.08 mA

### Note

The digital inputs of LOGO! 230 RC/RCo and of expansion module DM16 230R are divided into two groups, each consisting of four inputs. **Within** the same group, all inputs must be operated on the **same** phase. **Different** phases are only possible **between** the groups.

Example: I1 to I4 on phase **L1**, I5 to I8 on phase **L2**.

Inputs within the LOGO! DM8 230R may **not** be connected to different phases.

### Sensor connections

Connecting glow lamps and 2-wire proximity switches (Bero) to LOGO! 230 RC/230 RCo or LOGO! DM8 230 R (AC) and LOGO! DM16 230R (AC)

www.nicsanat.com  
021-87700210

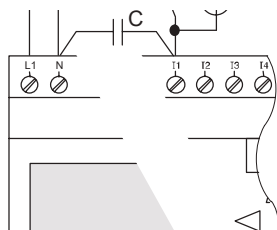

—||— 3SB1420-3D

X-capacitor 2.5 kV, 100 nF

## 2.7 Technical data

### General technical data

Criterion	Tested in accordance with	Values
<b>LOGO!Basic</b> Dimensions (WxHxD) Weight Installation		72 x 90 x 55 mm Approx. 190 g on a 35 mm profile rail 4 module widths or wall mounting
<b>LOGO! expansion modules DM8..., AM...</b> Dimensions (WxHxD) Weight Installation		36 x 90 x 53 mm Approx. 90 g on a 35 mm profile rail 2 module widths or wall mounting
<b>LOGO! expansion modules DM16...</b> Dimensions (WxHxD) Weight Installation		72 x 90 x 53 mm Approx. 190 g on a 35 mm profile rail 4 module widths or wall mounting
<b>Climatic conditions</b>		
Ambient temperature Horizontal installation Vertical installation	Low temperature to IEC 60068-2-1 High temperature to IEC 60068-2-2	0 ... 55 °C 0 ... 55 °C
Storage/shipping		-40 °C ... +70 °C
Relative humidity	IEC 60068-2-30	From 10 to 95 % no condensation
Air pressure		795 ... 1080 hPa
Pollutants	IEC 60068-2-42 IEC 60068-2-43	SO <sub>2</sub> 10 cm <sup>3</sup> /m <sup>3</sup> , 4 days H <sub>2</sub> S 1 cm <sup>3</sup> /m <sup>3</sup> , 4 days
<b>Ambient mechanical conditions</b>		
Protection mode		IP20
		: amplitude ant accel-
Shock	IEC 60068-2-27	18 shocks (half-sine wave 15g/11 ms)
Drop	IEC 60068-2-31	Drop height 50 mm
Free fall (packaged)	IEC 60068-2-32	1 m
<b>Electromagnetic compatibility (EMC)</b>		
Noise emission	EN 55011/A EN 55022/B EN 50081-1 (domestic area)	Limit class B group 1

Criterion	Tested in accordance with	Values
Electrostatic discharge	IEC 61000-4-2 Severity 3	8 kV air discharge 6 kV contact discharge
Electromagnetic fields	IEC 61000-4-3	Field strength 10 V/m
HF currents on cables and cable shielding	IEC 61000-4-6	10 V
Burst pulses	IEC 61000-4-4 Severity 3	2 kV (supply and signal lines)
High-energy surge pulse (applies only to LOGO! 230 ...)	IEC 61000-4-5 Severity 3	1 kV (power lines) symmetrical 2 kV (power lines) asymmetrical
<b>Safety to IEC / VDE</b>		
Clearance and creepage distance rating	IEC 60664, IEC 61131-2, EN 50178 cULus to UL 508, CSA C22.2 No. 142 With LOGO! 230 R/RC, also VDE 0631	Fulfilled
Insulation strength	IEC 61131-2	Fulfilled



## Technical data: LOGO! DM16 230R

LOGO! DM16 230R	
<b>Power supply</b>	
Input voltage	115 ... 240 V AC/DC
Permissible range	85 ... 265 V AC 100 ... 253 V DC
Permissible mains frequency	47 ... 63 Hz
Power consumption	<ul style="list-style-type: none"> <li>• 115 V AC 10 ... 60 mA</li> <li>• 240 V AC 10 ... 40 mA</li> <li>• 115 V DC 5 ... 25 mA</li> <li>• 240 V DC 5 ... 20 mA</li> </ul>
Voltage failure buffering	<ul style="list-style-type: none"> <li>• 115 V AC/DC typ. 10 ms</li> <li>• 240 V AC/DC typ. 20 ms</li> </ul>
Power loss at	<ul style="list-style-type: none"> <li>• 115 V AC 1.1 ... 4.5 W</li> <li>• 240 V AC 2.4 ... 5.5 W</li> <li>• 115 V DC 0.6 ... 2.9 W</li> <li>• 240 V DC 1.2 ... 4.8 W</li> </ul>
Backup of the real-time clock at 25 °C	
Accuracy of the real-time clock	
<b>Digital inputs</b>	
Number	8
Electrical isolation	No
Input voltage L1	<ul style="list-style-type: none"> <li>• Signal 0 &lt; 40 V AC</li> <li>• Signal 1 &gt; 79 V AC</li> <li>• Signal 0 &lt; 30 V DC</li> <li>• Signal 1 &gt; 79 V DC</li> </ul>
Input current at	<ul style="list-style-type: none"> <li>• Signal 0 &lt; 0.05 mA</li> </ul>
	 <p>www.nicsanat.com 021-87700210 NIC SANAT نیک صنعت</p>
<ul style="list-style-type: none"> <li>• 1 to 0</li> </ul>	typ. 50 ms
Line length (unshielded)	100 m
<b>Digital outputs</b>	
Number	8
Output type	Relay outputs
Electrical isolation	Yes
In groups of	1
Control of a digital input	Yes



	<b>LOGO! DM16 230R</b>
Continuous current $I_{th}$	max. 5 A per relay
Incandescent lamp load (25000 switching cycles) at 230/240 V AC 115/120 V AC	1000 W 500 W
Fluorescent tubes with ballast (25000 switching cycles)	10 x 58 W (at 230/240 V AC)
Fluorescent tubes, conventionally compensated (25000 switching cycles)	1 x 58 W (at 230/240 V AC)
Fluorescent tubes, uncompensated (25000 switching cycles)	10 x 58 W (at 230/240 V AC)
Short circuit-proof cos 1	Power protection B16 600A
Short-circuit proof cos 0.5 to 0.7	Power protection B16 900A
Derating	None; across the entire temperature range
Parallel output circuits for power increase	Not permitted
Protection of output relay (if desired)	max. 16 A, characteristic B16
<b>Switching rate</b>	
Mechanical	10 Hz
Ohmic load/lamp load	2 Hz
Inductive load	0.5 Hz



## Technical data: LOGO! DM16 24

LOGO! DM16 24	
<b>Power supply</b>	
Input voltage	24 V DC
Permissible range	20.4 ... 28.8 V DC
Reverse polarity protection	Yes
Permissible mains frequency	
Power consumption from 24 V DC	30 ... 45 mA 0.3 A per output
Voltage failure buffering	
Power loss at 24 V	0.8 ... 1.7 W
Backup of the real-time clock at 25 °C	
Accuracy of the real-time clock	
<b>Digital inputs</b>	
Number	8
Electrical isolation	No
Input voltage	L+
• Signal 0	< 5 V DC
• Signal 1	> 12 V DC
Input current at	
• Signal 0	< 1 mA
• Signal 1	> 2 mA
Delay time at	
• 0 to 1	typ. 1.5 ms
• 1 to 0	typ. 1.5 ms
Line length (unshielded)	100 m
<b>Digital outputs</b>	
Number	8
Output type	Transistor, current-sourcing
Electrical isolation	No
Output voltage	= Supply voltage
Output current	max. 0.3 A
Continuous current $I_{th}$	
Incandescent lamp load (25000 switching cycles) at	
Fluorescent tubes with ballast (25000 switching cycles)	
Fluorescent tubes, conventionally compensated (25000 switching cycles)	
Fluorescent tubes, uncompensated (25000 switching cycles)	

www.nicsanat.com

021-87700210



	<b>LOGO! DM16 24</b>
Short circuit-proof and overload-proof	Yes
Short-circuit current limitation	Approx. 1 A
Derating	None; across the entire temperature range
Short circuit-proof cos 1	
Short-circuit proof cos 0.5 to 0.7	
Parallel output circuit for power increase	Not permitted
Protection of output relay (if desired)	
<b>Switching rate</b>	
Mechanical	
Electrical	10 Hz
Ohmic load/lamp load	10 Hz
Inductive load	0.5 Hz



## Technical data: LOGO! DM16 24R

LOGO! DM16 24R	
<b>Power supply</b>	
Input voltage	24 V DC
Permissible range	20.4 ... 28.8 V DC
Reverse polarity protection	Yes
Power consumption from 24 V DC	30 ... 90 mA
Voltage failure buffering	
• 24 V DC	typ. 5 ms
Power loss at 24 V	
• 24 V DC	0.7 ... 2.5 W
Backup of the real-time clock at 25 °C	
Accuracy of the real-time clock	
Electrical isolation	No
<b>Digital inputs</b>	
Number	8
Electrical isolation	No
Input voltage	
• Signal 0	< 5 V DC
• Signal 1	> 12 V DC
Input current at	
• Signal 0	< 1 mA
• Signal 1	> 2 mA
Delay time at	
• 0 to 1	typ. 1.5 ms
• 1 to 0	typ. 1.5 ms
Line length (unshielded)	100 m
<b>Digital outputs</b>	
Number	8
Output type	Relay outputs
 <a href="http://www.nicsanat.com">www.nicsanat.com</a> 021-87700210 NICSANAT نیک صنعت	
Control of a digital input	100
Output voltage	
Output current	
Continuous current $I_{th}$	max. 5 A per relay
Incandescent lamp load (25000 switching cycles) at	1000 W
Fluorescent tubes with ballast (25000 switching cycles)	10 x 58 W
Fluorescent tubes, conventionally compensated (25000 switching cycles)	1 x 58 W

	LOGO! DM16 24R
Fluorescent tubes, uncompensated (25000 switching cycles)	10 x 58 W
Short circuit-proof and overload-proof	
Short-circuit current limitation	
Derating	None; across the entire temperature range
Short circuit-proof cos 1	Power protection B16 600A
Short-circuit proof cos 0.5 to 0.7	Power protection B16 900A
Parallel output circuit for power increase	Not permitted
Protection of output relay (if desired)	max. 16 A, characteristic B16
<b>Switching rate</b>	
Mechanical	10 Hz
Electrical	
Ohmic load/lamp load	2 Hz
Inductive load	0.5 Hz

## 2.8 Order numbers

Table A

Variant	Designation	Order number
Basic	LOGO! 12/24RC *	6ED1 052-1MD00-0BA4
	LOGO! 24 *	6ED1 052-1CC00-0BA4
	LOGO! 24RC (AC)	6ED1 052-1HB00-0BA4
	LOGO! 230RC	6ED1 052-1FB00-0BA4
Basic without display (pure)	LOGO! 12/24RCo *	6ED1 052-2MD00-0BA4
	LOGO! 24o *	6ED1 052-1CC00-0BA4
		6ED1 052-1CC00-0BA4 www.nicsanaf.com 021-87700210 NIC SANAT نیک صنعت
	LOGO! DM 8 24	6ED1 055-1CB00-0BA0
	LOGO! DM 8 24R	6ED1 055-1HB00-0BA0
	LOGO! DM 8 230R	6ED1 055-1FB00-0BA1
	LOGO! DM 16 24	6ED1055-1CB10-0BA0
	LOGO! DM 16 24R	6ED1055-1NB10-0BA0
	LOGO! DM 16 230R	6ED1055-1FB10-0BA0
Analog modules	LOGO! AM 2	6ED1 055-1MA00-0BA0
	LOGO! AM 2 PT100	6ED1 055-1MD00-0BA0

\*: Also with analog inputs

[www.nicsanat.com](http://www.nicsanat.com)

021-87700210

