

INOVANCE

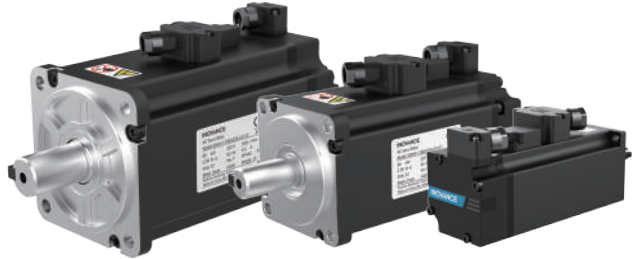

[www.nicsanat.com](http://www.nicsanat.com)

021-87700210



Selection Guide

MS1 Series Servo Motor



User Guide

A01  
Data code 19010786

## Preface

Thank you for purchasing the MS1 series servo motor.

This MS1 series servo motor selection guide provides the product information, installation guide, wiring guide, and other necessary information. Contact our technical personnel if you have any question about functions and performance of the motor.

Inovance commits itself to continuously improving the servo motor. Therefore, this document is subject to change without notice.

The guide is delivered to the end user together with the servo motor.

Precautions
<ul style="list-style-type: none"> <li>◆ The drawings in the guide are sometimes shown without covers or protective guards to help describe the product details clearly. Remember to install the covers or protective guards as specified first, and then perform operations in accordance with the guide.</li> <li>◆ The drawings in the guide are for reference only and may differ from the actual product.</li> <li>◆ The guide will be updated in time after product upgrades or specification changes, and for applicability and accuracy.</li> <li>◆ If your guide is damaged or missing, contact our agent in your region or our Customer Service Center for a new one.</li> <li>◆ In case of any question in use, contact our Customer Service Center.</li> <li>◆ Customer service hotline: 400-777-1260</li> </ul>

## Version History

Date	Version	Change Description
May 2018	A00	dFirst issue
January 2019	A01	Added a note for the flexible cable

# Contents

Preface .....	1
Version History .....	1
Safety Precautions .....	3
Safety Disclaimer .....	3
Details of Safety Precautions .....	3
1 Product Information .....	4
1.1 Nameplate and Model .....	4
1.2 Component Description .....	5
1.3 Specifications .....	6
1.3.1 Mechanical Characteristics .....	6
1.3.2 Ratings .....	7
1.3.3 Overload Characteristics .....	8
1.3.4 Radial/Axial Allowable Load .....	9
1.3.5 Electrical Specifications of Motor Brake .....	9
1.3.6 Torque/Speed Characteristics .....	10
1.3.7 Derating Characteristics .....	12
1.4 Cables .....	13
1.5 Connector Kit .....	15
2 Installation and Wiring .....	16
2.1 Installation .....	16
2.2 Wiring .....	17
2.2.1 Wiring of Power Cables .....	17
2.2.2 Wiring of Absolute Encoder .....	19
3 Mounting Dimension Diagrams .....	22
3.1 Flange Frame Size: 40 .....	22
3.2 Flange Frame Size: 60 .....	23
3.3 Flange Frame Size: 80 .....	24
4 Cable Information .....	25
4.1 Models with Front or Rear Cable Outlets .....	25
4.2 Appearance of Cables with Front Outlets .....	26
4.3 Appearance of Cables with Rear Outlets .....	27
4.4 Appearance of Connectors .....	28

# Safety Precautions

## Safety Disclaimer

- 1) Read and follow the safety precautions when installing, operating, and maintaining the product.
- 2) To ensure your safety and prevent damage to the device, follow the marks on the product and safety precautions in this guide when installing, operating, and maintaining the product.
- 3) The "CAUTION", "WARNING", and "DANGER" items in the guide do not include all safety precautions that need to be followed; instead, they just supplement the safety precautions.
- 4) Use this product in environments that meet the design and specification requirements; otherwise, a fault may occur. Faults and component damages caused by noncompliance are not covered by the product quality warranty.
- 5) Inovance assumes no legal responsibility for any personal safety accidents or property losses caused by improper operations of this product.

## Details of Safety Precautions

To use the product properly, read the Safety Precautions of High-Response Servo Motor (data code: 19010073) carefully.

You can visit [www.inovance.com](http://www.inovance.com) and choose Download > User Manual > Keywords "High-Response Servo Motor" to download the manual 19010073.

# 1 Product Information

## 1.1 Nameplate and Model

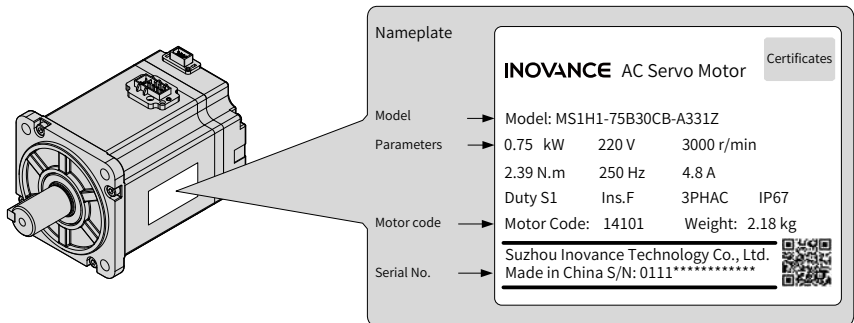
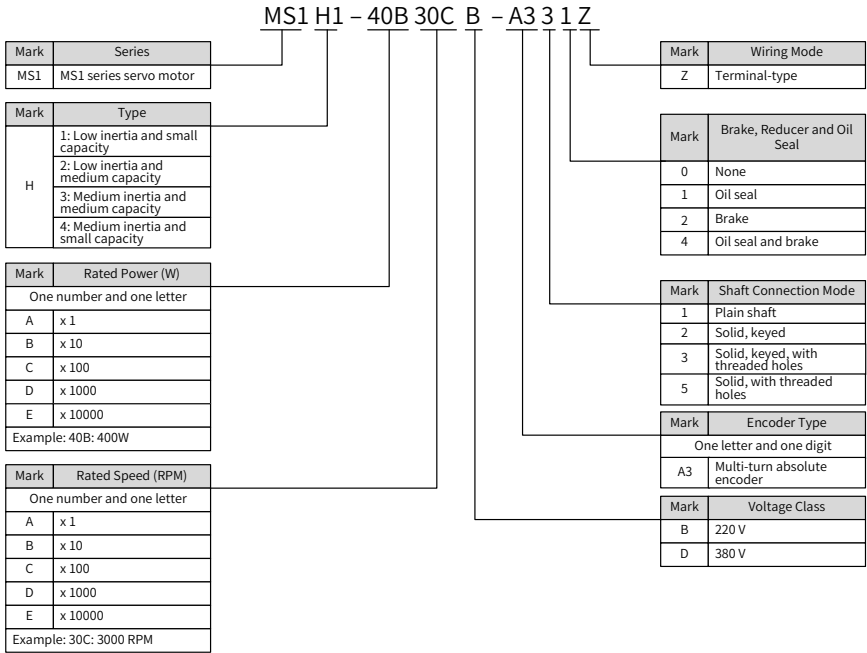

Figure 1-1 Model and nameplate



- ◆ The preceding product information is only for frame size 40, 60 and 80.
- ◆ You can set H00-00 (drive parameter) to 14000 to use the motor with an A3 multi-turn absolute encoder as one with an incremental encoder.

## 1.2 Component Description

Cable outlets of the MS1 series servo motor can be arranged in the front or rear.

For details, see Figures 1-2 and 1-3.

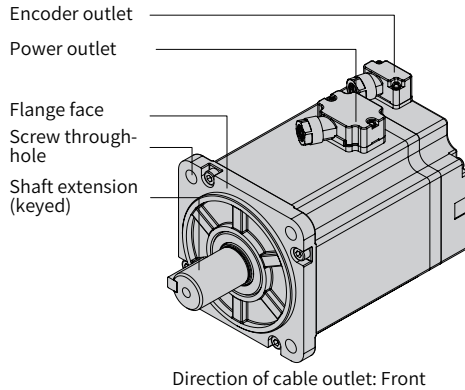

Figure 1-2 Diagram of components with front cable outlets

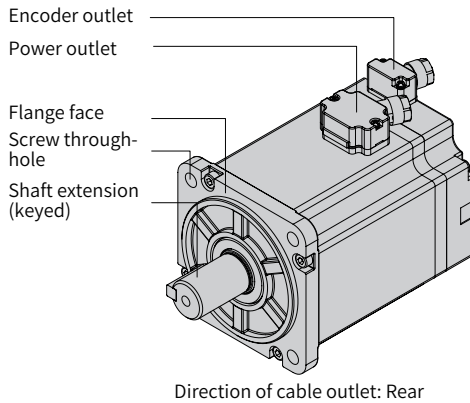

Figure 1-3 Diagram of components with rear cable outlets

## 1.3 Specifications

### 1.3.1 Mechanical Characteristics

Item	Description
Running mode	Continuous
Vibration level	V15
Insulation resistance	500 VDC, above 10 MΩ
Ambient temperature	0°C to 40°C
Excitation mode	Permanent magnetic
Installation method	Flanged
Heat-resisting level	Level F
Insulation voltage	1500 VAC 1 min (200 V) 1800 VAC 1 min (400 V)
Housing protection mode	H1: IP67 (excluding through shaft section) H4: IP67 (excluding through shaft section)
Ambient humidity	20% to 80% (no condensing)
Rotating direction	In forward RUN mode, the motor runs counterclockwise (CCW) when viewed from the load side.

### 1.3.2 Ratings

Model	Rated Output (kW) <sup>[1]</sup>	Rated Torque (N·m)	Maximum Torque (N·m)	Rated Current (Arms)	Maximum Current (Arms)
MS1H1-05B30CB	0.05	0.16	0.56	1.3	4.7
MS1H1-10B30CB	0.1	0.32	1.12	1.3	4.7
MS1H1-20B30CB	0.2	0.64	2.24	1.5	5.8
MS1H1-40B30CB	0.4	1.27	4.46	2.8	10.1
MS1H1-55B30CB	0.55	1.75	6.13	3.8	15.0
MS1H1-75B30CB	0.75	2.39	8.36	4.8	16.9
MS1H1-10C30CB	1.0	3.18	11.1	7.6	28.0
MS1H4-40B30CB	0.4	1.27	4.46	2.8	10.1
MS1H4-75B30CB	0.75	2.39	8.36	4.8	16.9
Model	Rated Speed (RPM)	Maximum Speed (RPM)	Torque Coefficient (N·m/Arms)	Rotor Inertia (10 <sup>-4</sup> kg·m <sup>2</sup> )	Voltage (V)
MS1H1-05B30CB	3000	6000	0.15	0.026 (0.028) <sup>[2]</sup>	220
MS1H1-10B30CB			0.26	0.041 (0.043) <sup>[2]</sup>	
MS1H1-20B30CB			0.46	0.207 (0.220) <sup>[2]</sup>	
MS1H1-40B30CB			0.53	0.376 (0.390) <sup>[2]</sup>	
MS1H1-55B30CB			0.49	1.06	
MS1H1-75B30CB			0.58	1.38 (1.43) <sup>[2]</sup>	
MS1H1-10C30CB			0.46	1.75	
MS1H4-40B30CB			0.53	0.657 (0.667) <sup>[2]</sup>	
MS1H4-75B30CB			0.58	2 (2.012) <sup>[2]</sup>	



- ◆ [1] The motor with oil sealing must be derated by 10% during use.
- ◆ [2] Parameters in ( ) are for the motor with brake.
- ◆ The parameters in the preceding table are the values when the motor works together with Inovance servo drive and the armature coil temperature is 20°C.
- ◆ The preceding features are based on the cooling conditions when the following heatsinks are installed.
- ◆ MS1H1/MS1H4: 250 x 250 x 6 mm (aluminum)

### 1.3.3 Overload Characteristics

Load Ratio (%)	Running Time (s)
120	230
130	80
140	40
150	30
160	20
170	17
180	15
190	12
200	10
210	8.5
220	7
230	6
240	5.5
250	5
300	3
350	2

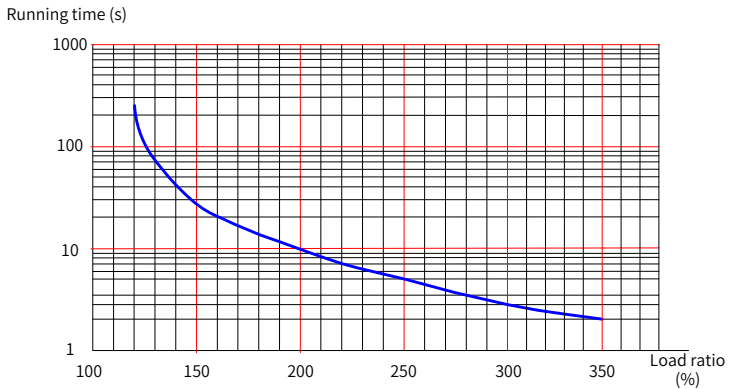

Figure 1-4 Overload curve



NOTE

◆ The maximum torque of an H1 or H4 motor is 3.5 times of the rated torque.

### 1.3.4 Radial/Axial Allowable Load

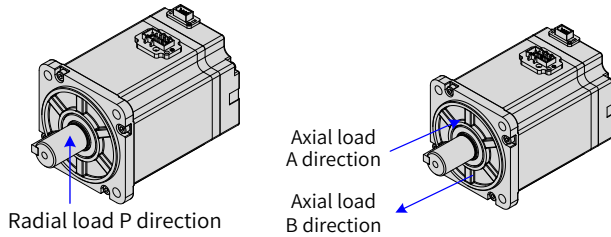

Figure 1-5 Diagram of radial and axial loads

Motor Model	Radial Allowable Load (N)	Axial Allowable Load (N)
MS1H1-05B30CB	78	54
MS1H1-10B30CB	78	54
MS1H1-20B30CB	245	74
MS1H1-40B30CB	245	74
MS1H1-55B30CB	392	147
MS1H1-75B30CB	392	147
MS1H1-10C30CB	392	147
MS1H4-40B30CB	245	74
MS1H4-75B30CB	392	147

### 1.3.5 Electrical Specifications of Motor Brake

Motor Model	Holding Torque (Nm)	Supply Voltage (V) $\pm 10\%$	Brake Release Time (ms)	Brake Apply Time (ms)	Rotary Clearance ( $^{\circ}$ )
MS1H1-05B/10B	0.3	DC 24	$\leq 20$	$\leq 35$	$< 1.7$
MS1H1-20B/40B	1.5	DC 24	$\leq 20$	$\leq 50$	$< 1.5$
MS1H4-40B	1.5	DC 24	$\leq 20$	$\leq 50$	$< 1.5$
MS1H*-75B	2.5	DC 24	$\leq 20$	$\leq 60$	$< 1.7$



NOTE

- ◆ The brake must not share power supply with other electrical devices. This is to prevent malfunction of the brake due to voltage or current drop when other electrical devices work.
- ◆ Cables thicker than 0.5 mm<sup>2</sup> are recommended.

### 1.3.6 Torque/Speed Characteristics

#### 1 MS1H1 (low inertia and small capacity)

- A █ Continuous operating area
- B █ Short-time operating area

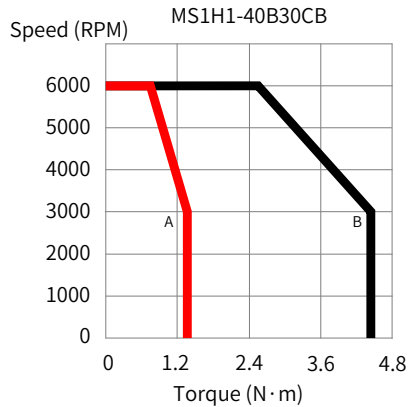
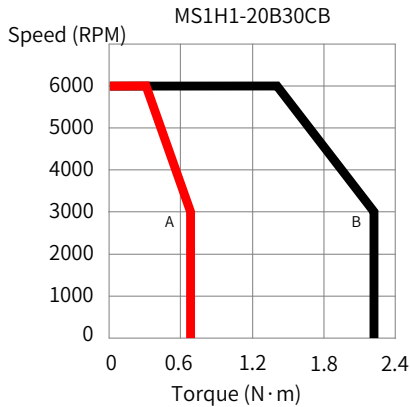
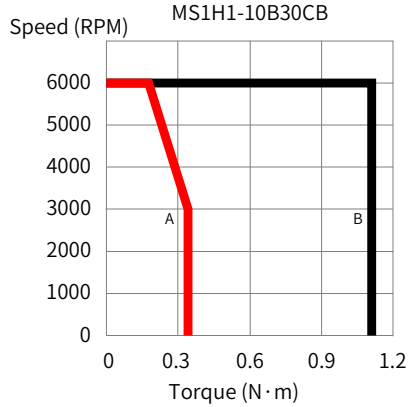
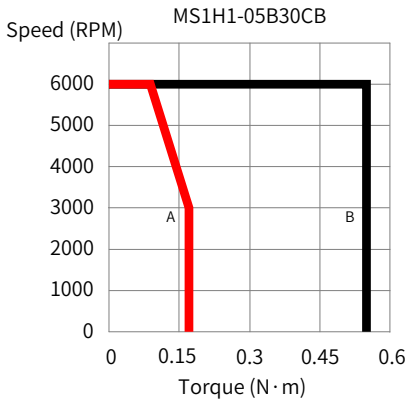

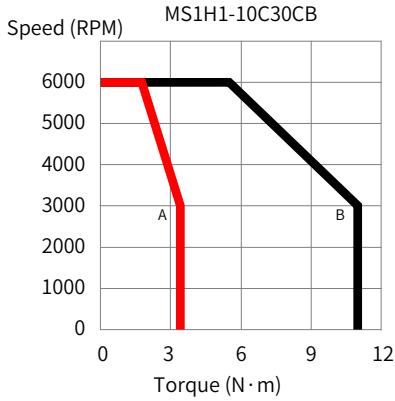
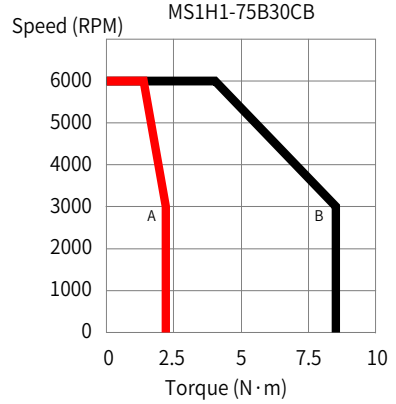
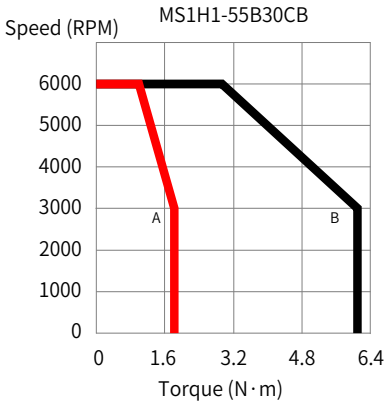

## 2 MS1H4 (medium inertia and small capacity)

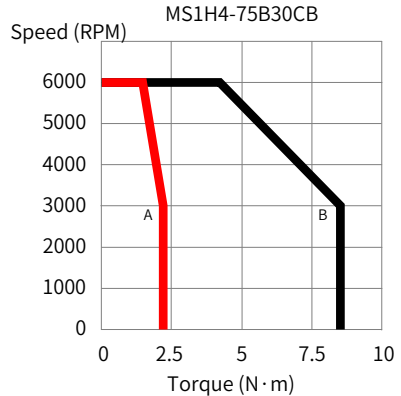
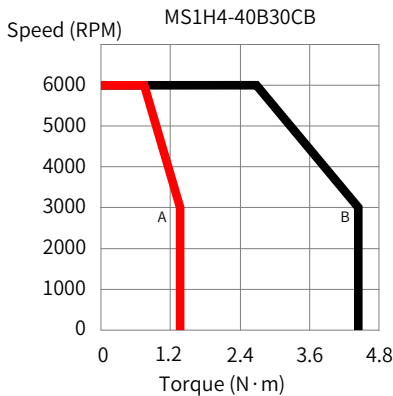

### 1.3.7 Derating Characteristics

- Derating curve (altitude)

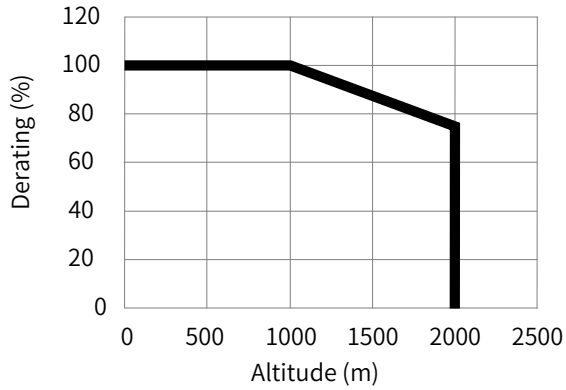

- Derating curve (high temperature)

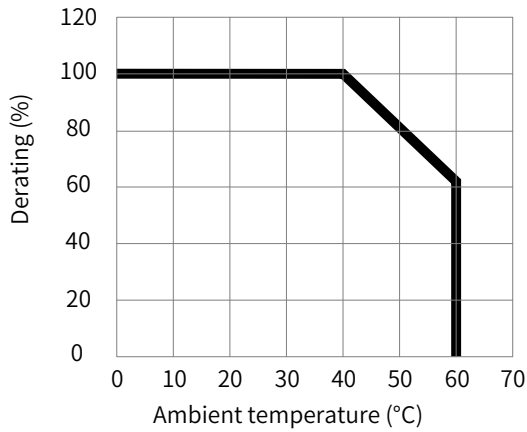

## 1.4 Cables

Table 1-1 Cables for terminal-type (Z series) motors with front cable outlets

Cable Type	Cable Length (m)			Drive Model
	3.0	5.0	10.0	
Power cable (without brake)	S6-L-M007-3.0	S6-L-M007-5.0	S6-L-M007-10.0	IS620P/N
Power cable (with brake)	S6-L-B007-3.0	S6-L-B007-5.0	S6-L-B007-10.0	
Absolute encoder cable	S6-L-P024-3.0	S6-L-P024-5.0	S6-L-P024-10.0	
Incremental encoder cable	S6-L-P014-3.0	S6-L-P014-5.0	S6-L-P014-10.0	
Power cable (without brake)	S6-L-M107-3.0	S6-L-M107-5.0	S6-L-M107-10.0	SV820N
Power cable (with brake)	S6-L-B107-3.0	S6-L-B107-5.0	S6-L-B107-10.0	
Absolute encoder cable	S6-L-P124-3.0	S6-L-P124-5.0	S6-L-P124-10.0	
Incremental encoder cable	S6-L-P114-3.0	S6-L-P114-5.0	S6-L-P114-10.0	
Power cable (without brake)	S6-L-M107-3.0	S6-L-M107-5.0	S6-L-M107-10.0	IS810N-INT
Power cable (with brake)	S6-L-B107-3.0	S6-L-B107-5.0	S6-L-B107-10.0	
Absolute encoder cable	S6-L-P024-3.0	S6-L-P024-5.0	S6-L-P024-10.0	
Incremental encoder cable	S6-L-P014-3.0	S6-L-P014-5.0	S6-L-P014-10.0	

Table 1-2 Cables for terminal-type (Z series) motors with rear cable outlets

Cable Type	Cable Length (m)			Drive Model
	3.0	5.0	10.0	
Power cable (without brake)	S6-L-M008-3.0	S6-L-M008-5.0	S6-L-M008-10.0	IS620P/N
Power cable (with brake)	S6-L-B008-3.0	S6-L-B008-5.0	S6-L-B008-10.0	
Absolute encoder cable	S6-L-P025-3.0	S6-L-P025-5.0	S6-L-P025-10.0	
Incremental encoder cable	S6-L-P015-3.0	S6-L-P015-5.0	S6-L-P015-10.0	
Power cable (without brake)	S6-L-M108-3.0	S6-L-M108-5.0	S6-L-M108-10.0	SV820N
Power cable (with brake)	S6-L-B108-3.0	S6-L-B108-5.0	S6-L-B108-10.0	
Absolute encoder cable	S6-L-P125-3.0	S6-L-P125-5.0	S6-L-P125-10.0	
Incremental encoder cable	S6-L-P115-3.0	S6-L-P115-5.0	S6-L-P115-10.0	
Power cable (without brake)	S6-L-M108-3.0	S6-L-M108-5.0	S6-L-M108-10.0	IS810N-INT
Power cable (with brake)	S6-L-B108-3.0	S6-L-B108-5.0	S6-L-B108-10.0	
Absolute encoder cable	S6-L-P025-3.0	S6-L-P025-5.0	S6-L-P025-10.0	
Incremental encoder cable	S6-L-P015-3.0	S6-L-P015-5.0	S6-L-P015-10.0	



◆ The servo motor encoder cable does not include a DB44 connector. Please purchase it separately. The model is S6-C8.

Table 1-3 Flexible cables for terminal-type (Z series) motors with front cable outlets

Cable Type	Cable Length (m)			Drive Model
	3.0	5.0	10.0	
Power cable (without brake)	S6-L-M007-3.0-T	S6-L-M007-5.0-T	S6-L-M007-10.0-T	IS620P/N
Power cable (with brake)	S6-L-B007-3.0-T	S6-L-B007-5.0-T	S6-L-B007-10.0-T	
Absolute encoder cable	S6-L-P024-3.0-T	S6-L-P024-5.0-T	S6-L-P024-10.0-T	
Incremental encoder cable	S6-L-P014-3.0-T	S6-L-P014-5.0-T	S6-L-P014-10.0-T	
Power cable (without brake)	S6-L-M107-3.0-T	S6-L-M107-5.0-T	S6-L-M107-10.0-T	SV820N
Power cable (with brake)	S6-L-B107-3.0-T	S6-L-B107-5.0-T	S6-L-B107-10.0-T	
Absolute encoder cable	S6-L-P124-3.0-T	S6-L-P124-5.0-T	S6-L-P124-10.0-T	
Incremental encoder cable	S6-L-P114-3.0-T	S6-L-P114-5.0-T	S6-L-P114-10.0-T	
Power cable (without brake)	S6-L-M107-3.0-T	S6-L-M107-5.0-T	S6-L-M107-10.0-T	IS810N-INT
Power cable (with brake)	S6-L-B107-3.0-T	S6-L-B107-5.0-T	S6-L-B107-10.0-T	
Absolute encoder cable	S6-L-P024-3.0-T	S6-L-P024-5.0-T	S6-L-P024-10.0-T	
Incremental encoder cable	S6-L-P014-3.0-T	S6-L-P014-5.0-T	S6-L-P014-10.0-T	

Table 1-4 Flexible cables for terminal-type (Z series) motors with rear cable outlets

Cable Type	Cable Length (m)			Drive Model
	3.0	5.0	10.0	
Power cable (without brake)	S6-L-M008-3.0-T	S6-L-M008-5.0-T	S6-L-M008-10.0-T	IS620P/N
Power cable (with brake)	S6-L-B008-3.0-T	S6-L-B008-5.0-T	S6-L-B008-10.0-T	
Absolute encoder cable	S6-L-P025-3.0-T	S6-L-P025-5.0-T	S6-L-P025-10.0-T	
Incremental encoder cable	S6-L-P015-3.0-T	S6-L-P015-5.0-T	S6-L-P015-10.0-T	
Power cable (without brake)	S6-L-M108-3.0-T	S6-L-M108-5.0-T	S6-L-M108-10.0-T	SV820N
Power cable (with brake)	S6-L-B108-3.0-T	S6-L-B108-5.0-T	S6-L-B108-10.0-T	
Absolute encoder cable	S6-L-P125-3.0-T	S6-L-P125-5.0-T	S6-L-P125-10.0-T	
Incremental encoder cable	S6-L-P115-3.0-T	S6-L-P115-5.0-T	S6-L-P115-10.0-T	
Power cable (without brake)	S6-L-M108-3.0-T	S6-L-M108-5.0-T	S6-L-M108-10.0-T	IS810N-INT
Power cable (with brake)	S6-L-B108-3.0-T	S6-L-B108-5.0-T	S6-L-B108-10.0-T	
Absolute encoder cable	S6-L-P025-3.0-T	S6-L-P025-5.0-T	S6-L-P025-10.0-T	
Incremental encoder cable	S6-L-P015-3.0-T	S6-L-P015-5.0-T	S6-L-P015-10.0-T	



- ◆ The servo motor encoder cable does not include a DB44 connector. Please purchase it separately. The model is S6-C8.
- ◆ Cables listed in Table 1-3 and Table 1-4 are flexible cables fit for drag chains.

## 1.5 Connector Kit

Motor Model	Connector	Drive Model
MS1H*-*****-****Z	S6-C8(see "4.4 Appearance of Connectors")	All Series

## 2 Installation and Wiring

### 2.1 Installation

#### 1 Installation location

Install the servo motor in an environment free from corrosive or inflammable gases or combustible goods, such as hydrogen sulfide, chlorine, ammonia, sulphur gas, chloridized gas, acid, soda and salt.

- Use the servo motor with oil sealing when the motor is to be used in a place with grinding fluid, oil spray, iron powder or cuttings.
- Install the servo motor away from heat sources such as heating stove.
- Do not use the servo motor in an enclosed environment. Working in the enclosed environment will lead to high temperature of the servo motor, which will shorten its service life.
- Prevent water and foreign matters from entering the terminals to avoid impacts on installation and use of the product.

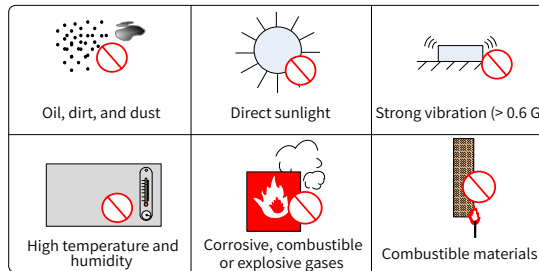

Figure 2-1 Installation environment requirements

#### 2 Installation environment

Table 2-1 Installation environment

Item	Description
Ambient temperature	0°C to 40°C (no freezing)
Ambient humidity	20% to 80%RH (no condensing)
Storage temperature	-20°C to 60°C (maximum temperature and duration: 80°C, 72h)
Storage humidity	20% to 90%RH (no condensing)
Vibration	Below 98 m/s <sup>2</sup>
Impact	Below 980 m/s <sup>2</sup>
Ingress protection	H1 and H4: IP67 (except for through-shaft section; connectors of power cables and encoder cables are in good connection)
Altitude	Below 1000 m (de-rated for altitude above 1000 m)

## 2.2 Wiring

### 2.2.1 Wiring of Power Cables

#### 1 Connection to power cables of IS620 series servo drive

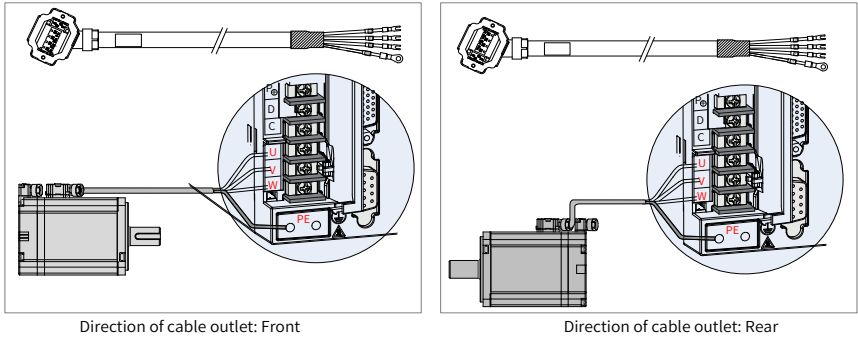

Direction of cable outlet: Front

Direction of cable outlet: Rear

Figure 2-2 Diagram of connection to power cables of IS620 series servo drive

Table 2-2 Connectors of power cables on the motor side

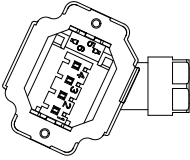
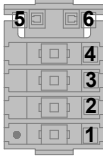
Connector Appearance	Pin Layout	Frame Size of Matching Motor <sup>[Note]</sup>																		
	Black 6-pin connector 	Terminal-type motor: Size 40 (Z series) Size 60 (Z series) Size 80 (Z series)																		
	<table border="1"> <thead> <tr> <th>Pin No.</th> <th>Signal</th> <th>Color</th> </tr> </thead> <tbody> <tr> <td>1</td> <td>PE</td> <td>Yellow/green</td> </tr> <tr> <td>2</td> <td>W</td> <td>Red</td> </tr> <tr> <td>3</td> <td>V</td> <td>Black</td> </tr> <tr> <td>4</td> <td>U</td> <td>White</td> </tr> <tr> <td>5</td> <td rowspan="2">Brake signal Positive or negative</td> <td>Brown</td> </tr> <tr> <td>6</td> <td>Blue</td> </tr> </tbody> </table>		Pin No.	Signal	Color	1	PE	Yellow/green	2	W	Red	3	V	Black	4	U	White	5	Brake signal Positive or negative	Brown
Pin No.	Signal	Color																		
1	PE	Yellow/green																		
2	W	Red																		
3	V	Black																		
4	U	White																		
5	Brake signal Positive or negative	Brown																		
6		Blue																		



- ◆ The frame size refers to flange width.
- ◆ The motor cable colors are subject to the actual. The cable colors mentioned in this guide are all Inovance cables.

## 2 Connect to power cables of SV820N or IS810N-INT series servo drive

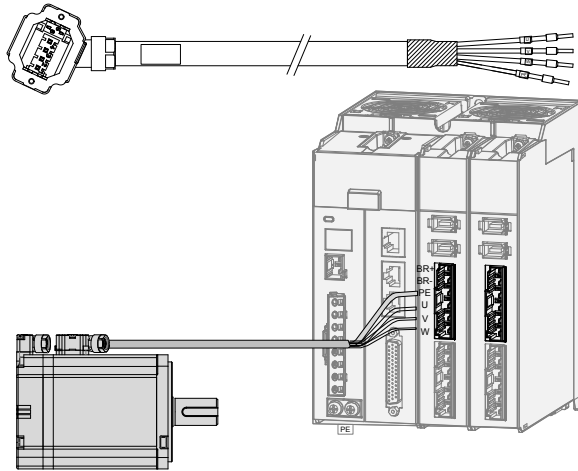
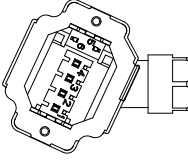
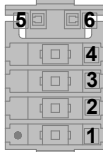

Figure 2-3 Diagram of connection to power cables of SV820N series servo drive

Table 2-3 Connectors of power cables on the motor side

Connector Appearance	Terminal Pin Arrangement	Frame Size of Matching Motor <sup>[Note]</sup>	
	Black 6-pin connector 		
	Pin No.	Signal	Color
	1	PE	Yellow/green
	2	W	Red
	3	V	Black
	4	U	White
	5	Brake signal	Positive or negative
6	Brake signal	negative	Blue
		Terminal-type motor: Size 40 (Z series) Size 60 (Z series) Size 80 (Z series)	



- ◆ The frame size refers to flange width.
- ◆ The motor cable colors are subject to the actual. The cable colors mentioned in this guide are all Inovance cables.



## 2.2.2 Wiring of Absolute Encoder

### 1 Connect to encoder cables of IS620 or IS810N-INT series servo drive

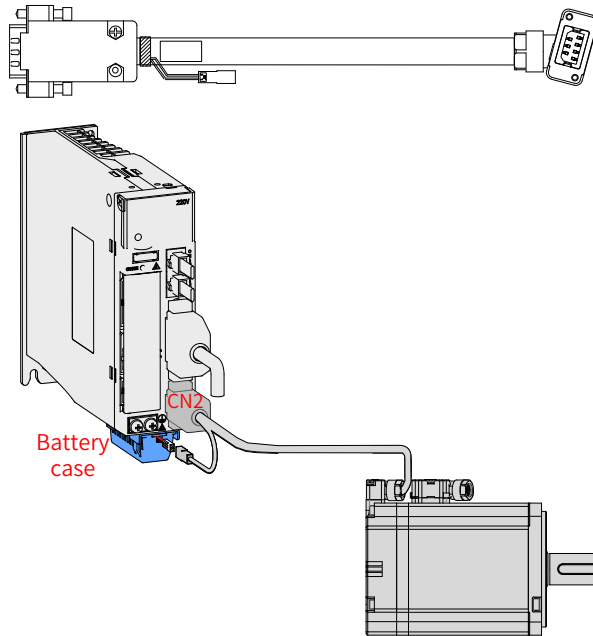

Figure 2-4 Diagram of connection to encoder cables of IS620 series servo drive

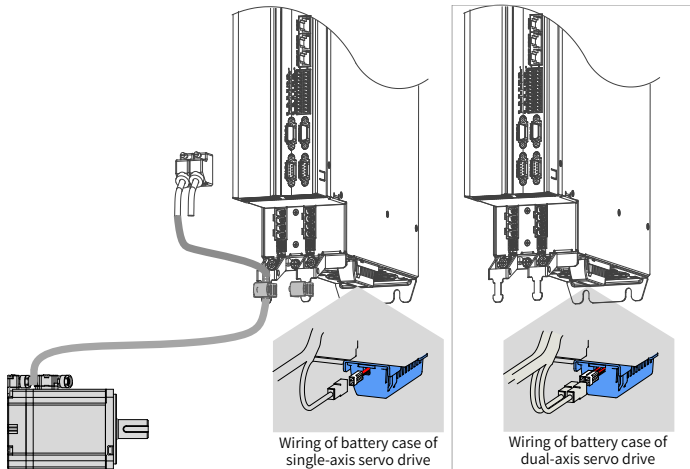
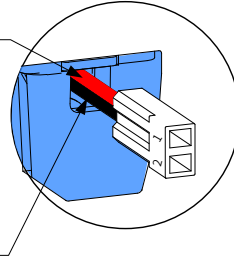

Figure 2-5 Diagram of connection to encoder cables of IS810N-INT series servo drive

Colors of external wires of the battery case:

Pin No.	Wire Color	Pin Definition
1	Red	Power supply+

Pin No.	Wire Color	Pin Definition
2	Black	Power supply-



◆ Model of battery case (including batteries):  
 Battery case of single-axis servo drive: S6-C4  
 Battery case of dual-axis servo drive: S81-C4

Table 2-4 Connectors of encoder cables

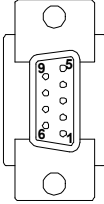
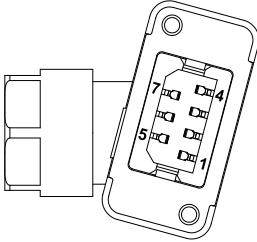
Connector Appearance and Pin Layout		Frame Size of Matching Motor <sup>[Note]</sup>																																																		
On drive side	On motor side																																																			
DB9 male connector 	7-pin connector 	Terminal-type motor: Size 40 (Z series) Size 60 (Z series) Size 80 (Z series)																																																		
<table border="1"> <thead> <tr> <th>Pin No.</th> <th>Signal</th> <th>Color</th> <th>Type</th> </tr> </thead> <tbody> <tr> <td>1</td> <td>PS+</td> <td>Blue</td> <td rowspan="2">Twisted-pair</td> </tr> <tr> <td>2</td> <td>PS-</td> <td>Purple</td> </tr> <tr> <td>7</td> <td>+5 V</td> <td>Red</td> <td rowspan="2">Twisted-pair</td> </tr> <tr> <td>8</td> <td>0 V</td> <td>Orange</td> </tr> <tr> <td>Housing</td> <td>PE</td> <td>-</td> <td>-</td> </tr> </tbody> </table>	Pin No.		Signal	Color	Type	1	PS+	Blue	Twisted-pair	2	PS-	Purple	7	+5 V	Red	Twisted-pair	8	0 V	Orange	Housing	PE	-	-	<table border="1"> <thead> <tr> <th>Pin No.</th> <th>Signal</th> <th>Color</th> <th>Type</th> </tr> </thead> <tbody> <tr> <td>1</td> <td>PS+</td> <td>Blue</td> <td rowspan="2">Twisted-pair</td> </tr> <tr> <td>2</td> <td>PS-</td> <td>Purple</td> </tr> <tr> <td>3</td> <td>DC+</td> <td>Brown</td> <td rowspan="2">Twisted-pair</td> </tr> <tr> <td>4</td> <td>DC-</td> <td>Black</td> </tr> <tr> <td>5</td> <td>+5 V</td> <td>Red</td> <td rowspan="2">Twisted-pair</td> </tr> <tr> <td>6</td> <td>0 V</td> <td>Orange</td> </tr> <tr> <td>7</td> <td>PE</td> <td>-</td> <td>-</td> </tr> </tbody> </table>	Pin No.	Signal	Color	Type	1	PS+	Blue	Twisted-pair	2	PS-	Purple	3	DC+	Brown	Twisted-pair	4	DC-	Black	5	+5 V	Red	Twisted-pair	6	0 V	Orange	7	PE	-
Pin No.	Signal	Color	Type																																																	
1	PS+	Blue	Twisted-pair																																																	
2	PS-	Purple																																																		
7	+5 V	Red	Twisted-pair																																																	
8	0 V	Orange																																																		
Housing	PE	-	-																																																	
Pin No.	Signal	Color	Type																																																	
1	PS+	Blue	Twisted-pair																																																	
2	PS-	Purple																																																		
3	DC+	Brown	Twisted-pair																																																	
4	DC-	Black																																																		
5	+5 V	Red	Twisted-pair																																																	
6	0 V	Orange																																																		
7	PE	-	-																																																	



◆ The frame size refers to flange width.



## 3 Mounting Dimension Diagrams

### 3.1 Flange Frame Size: 40

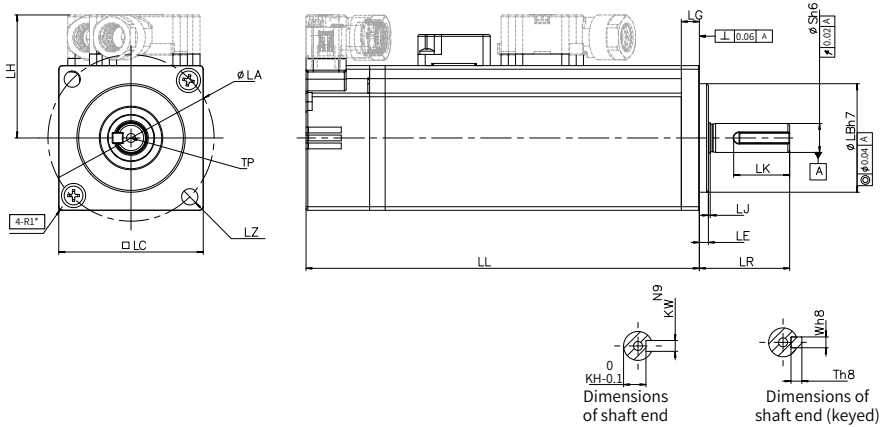

Motor Model	LL	LC	LR	LA	LZ	LH	LG	LE	LJ
MS1H1-05B30CB-A330Z	65	40	25 ± 0.5	46	2-φ4.5	34	5	2.5 ± 0.5	0.5 ± 0.35
MS1H1-05B30CB-A332Z	96	40	25 ± 0.5	46	2-φ4.5	34	5	2.5 ± 0.5	0.5 ± 0.35
MS1H1-10B30CB-A330Z	77.5	40	25 ± 0.5	46	2-φ4.5	34	5	2.5 ± 0.5	0.5 ± 0.35
MS1H1-10B30CB-A332Z	109	40	25 ± 0.5	46	2-φ4.5	34	5	2.5 ± 0.5	0.5 ± 0.35
Motor Model	S	LB	TP	LK	KH	KW	W	T	Weight (kg)
MS1H1-05B30CB-A330Z	8	30	M3 x 6	15.5	6.2	3	3	3	0.39
MS1H1-05B30CB-A332Z	8	30	M3 x 6	15.5	6.2	3	3	3	0.50
MS1H1-10B30CB-A330Z	8	30	M3 x 6	15.5	6.2	3	3	3	0.45
MS1H1-10B30CB-A332Z	8	30	M3 x 6	15.5	6.2	3	3	3	0.64



NOTE

- ◆ The dimensions are given in mm.
- ◆ Tighten the screws on the terminals with force 0.19 N·m to 0.21 N·m. Larger force may cause damage.

### 3.2 Flange Frame Size: 60

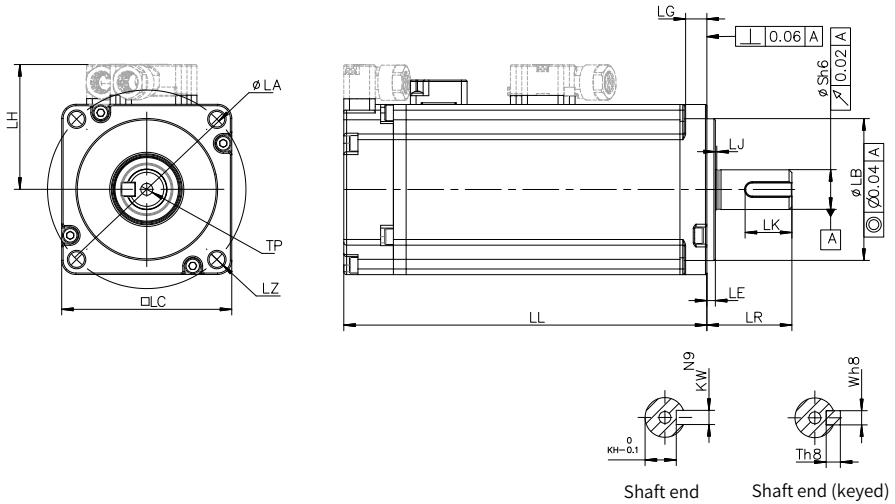

Motor Model	LL	LC	LR	LA	LZ	LH	LG	LE	LJ
MS1H1-20B30CB-A331Z	72.5	60	$30 \pm 0.5$	70	$4-\phi 5.5$	44	7.5	$3 \pm 0.5$	$0.5 \pm 0.35$
MS1H1-20B30CB-A334Z	100	60	$30 \pm 0.5$	70	$4-\phi 5.5$	44	7.5	$3 \pm 0.5$	$0.5 \pm 0.35$
MS1H1-40B30CB-A331Z	91	60	$30 \pm 0.5$	70	$4-\phi 5.5$	44	7.5	$3 \pm 0.5$	$0.5 \pm 0.35$
MS1H1-40B30CB-A334Z	119	60	$30 \pm 0.5$	70	$4-\phi 5.5$	44	7.5	$3 \pm 0.5$	$0.5 \pm 0.35$
MS1H4-40B30CB-A331Z	105	60	$30 \pm 0.5$	70	$4-\phi 5.5$	44	7.5	$3 \pm 0.5$	$0.5 \pm 0.35$
MS1H4-40B30CB-A334Z	128	60	$30 \pm 0.5$	70	$4-\phi 5.5$	44	7.5	$3 \pm 0.5$	$0.5 \pm 0.35$
Motor Model	S	LB	TP	LK	KH	KW	W	T	Weight (kg)
MS1H1-20B30CB-A331Z	14	50	M5 x 8	16.5	11	5	5	5	0.78
MS1H1-20B30CB-A334Z	14	50	M5 x 8	16.5	11	5	5	5	1.16
MS1H1-40B30CB-A331Z	14	50	M5 x 8	16.5	11	5	5	5	1.11
MS1H1-40B30CB-A334Z	14	50	M5 x 8	16.5	11	5	5	5	1.48
MS1H4-40B30CB-A331Z	14	50	M5 x 8	16.5	11	5	5	5	1.27
MS1H4-40B30CB-A334Z	14	50	M5 x 8	16.5	11	5	5	5	1.62



NOTE

- ◆ The dimensions are given in mm.
- ◆ Tighten the screws on the terminals with force  $0.19 \text{ N} \cdot \text{m}$  to  $0.21 \text{ N} \cdot \text{m}$ . Larger force may cause damage.

### 3.3 Flange Frame Size: 80

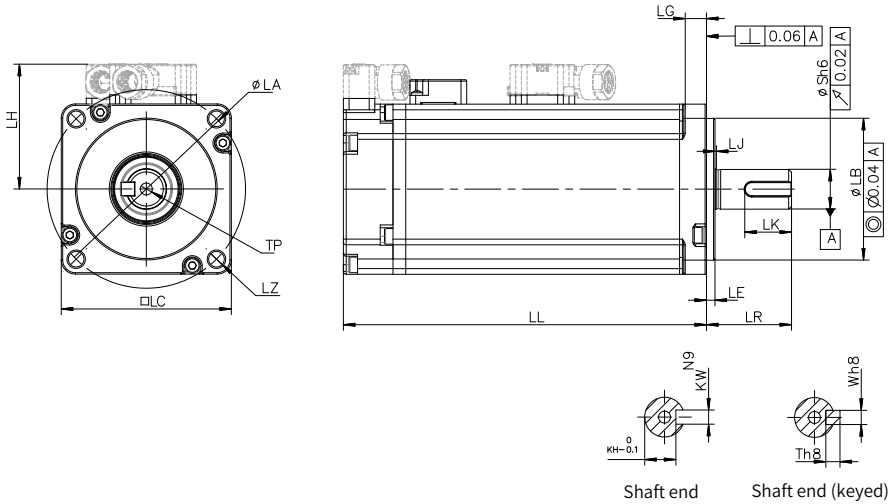

Motor Model	LL	LC	LR	LA	LZ	LH	LG	LE	LJ
MS1H1-55B30CB-A331Z	96.2	80	35 ± 0.5	90	4-φ7	54	7.7	3 ± 0.5	0.5 ± 0.35
MS1H1-75B30CB-A331Z	107	80	35 ± 0.5	90	4-φ7	54	7.7	3 ± 0.5	0.5 ± 0.35
MS1H1-75B30CB-A334Z	140	80	35 ± 0.5	90	4-φ7	54	7.7	3 ± 0.5	0.5 ± 0.35
MS1H1-10C30CB-A331Z	118.2	80	35 ± 0.5	90	4-φ7	54	7.7	3 ± 0.5	0.5 ± 0.35
MS1H4-75B30CB-A331Z	117.5	80	35 ± 0.5	90	4-φ7	54	7.7	3 ± 0.5	0.5 ± 0.35
MS1H4-75B30CB-A334Z	147.5	80	35 ± 0.5	90	4-φ7	54	7.7	3 ± 0.5	0.5 ± 0.35
Motor Model	S	LB	TP	LK	KH	KW	W	T	Weight (kg)
MS1H1-55B30CB-A331Z	19	70	M6 x 20	25	15.5	6	6	6	1.85
MS1H1-75B30CB-A331Z	19	70	M6 x 20	25	15.5	6	6	6	2.18
MS1H1-75B30CB-A334Z	19	70	M6 x 20	25	15.5	6	6	6	2.82
MS1H1-10C30CB-A331Z	19	70	M6 x 20	25	15.5	6	6	6	2.55
MS1H4-75B30CB-A331Z	19	70	M6 x 20	25	15.5	6	6	6	2.40
MS1H4-75B30CB-A334Z	19	70	M6 x 20	25	15.5	6	6	6	3.04



- ◆ The dimensions are given in mm.
- ◆ Tighten the screws on the terminals with force 0.19 N·m to 0.21 N·m. Larger force may cause damage.

## 4 Cable Information

### 4.1 Models with Front or Rear Cable Outlets

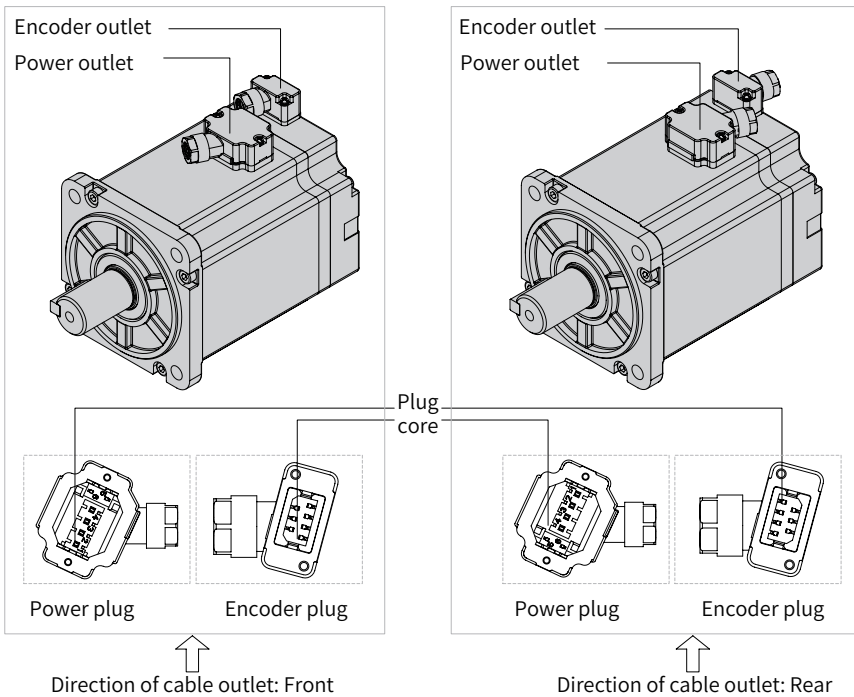

Figure 4-1 Models of Z series (terminal-type) motors with front or rear cable outlets



- ◆ You can adjust the direction of the plug core to switch between front cable outlet and rear cable outlet. Determine the cable specifications in advance because the stripped length is different for front and rear cable outlets during wiring.

## 4.2 Appearance of Cables with Front Outlets

Cable Type	Cable Model	Cable Length L (m)	Appearance	
Power cable (without brake)	S6-L-M007-3.0	3.0		
	S6-L-M007-5.0	5.0		
	S6-L-M007-10.0	10.0		
	Power cable (without brake)	S6-L-M107-3.0	3.0	
		S6-L-M107-5.0	5.0	
		S6-L-M107-10.0	10.0	
Power cable (with brake)	S6-L-B007-3.0	3.0		
	S6-L-B007-5.0	5.0		
	S6-L-B007-10.0	10.0		
	Power cable (with brake)	S6-L-B107-3.0	3.0	
		S6-L-B107-5.0	5.0	
		S6-L-B107-10.0	10.0	
Absolute encoder cable	S6-L-P024-3.0	3.0		
	S6-L-P024-5.0	5.0		
	S6-L-P024-10.0	10.0		
	Absolute encoder cable	S6-L-P124-3.0	3.0	
		S6-L-P124-5.0	5.0	
		S6-L-P124-10.0	10.0	
Incremental encoder cable	S6-L-P014-3.0	3.0		
	S6-L-P014-5.0	5.0		
	S6-L-P014-10.0	10.0		
	Incremental encoder cable	S6-L-P114-3.0	3.0	
		S6-L-P114-5.0	5.0	
		S6-L-P114-10.0	10.0	

### 4.3 Appearance of Cables with Rear Outlets

Cable Type	Cable Model	Cable Length L (m)	Appearance
Power cable (without brake)	S6-L-M008-3.0	3.0	
	S6-L-M008-5.0	5.0	
	S6-L-M008-10.0	10.0	
	S6-L-M108-3.0	3.0	
	S6-L-M108-5.0	5.0	
	S6-L-M108-10.0	10.0	
Power cable (with brake)	S6-L-B008-3.0	3.0	
	S6-L-B008-5.0	5.0	
	S6-L-B008-10.0	10.0	
	S6-L-B108-3.0	3.0	
	S6-L-B108-5.0	5.0	
	S6-L-B108-10.0	10.0	
Absolute encoder cable	S6-L-P025-3.0	3.0	
	S6-L-P025-5.0	5.0	
	S6-L-P025-10.0	10.0	
	S6-L-P125-3.0	3.0	
	S6-L-P125-5.0	5.0	
	S6-L-P125-10.0	10.0	
Incremental encoder cable	S6-L-P015-3.0	3.0	
	S6-L-P015-5.0	5.0	
	S6-L-P015-10.0	10.0	
	S6-L-P115-3.0	3.0	
	S6-L-P115-5.0	5.0	
	S6-L-P115-10.0	10.0	

### 4.4 Appearance of Connectors

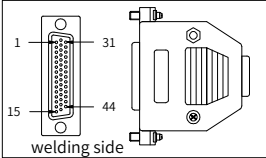
Model	Appearance
S6-C8	 <p data-bbox="632 406 796 427">DB 44 connector kit</p>

## Shenzhen Inovance Technology Co., Ltd.

Add.: Building E, Hongwei Industry Park, Liuxian Road, Baocheng No. 70 Zone, Bao'an District, Shenzhen

Tel: +86-755-2979 9595

Fax: +86-755-2961 9897

Service Hotline: 400-777-1260

<http://www.inovance.com>

## Suzhou Inovance Technology Co., Ltd.

Add.: No. 16 Youxiang Road, Yuexi Town, Wuzhong District, Suzhou 215104, P.R. China

Tel: +86-512-6637 6666

Fax: +86-512-6285 6720

Service Hotline: 400-777-1260

<http://www.inovance.com>

[www.nicsanal.com](http://www.nicsanal.com)

021-87700210



Copyright © Shenzhen Inovance Technology Co., Ltd.