



General-Purpose AC Servo

# MELSERVO-J3 Series

SSCNET III interface

MODEL

## MR-J3-□B

SERVO AMPLIFIER

INSTRUCTION MANUAL



[www.nicsanat.com](http://www.nicsanat.com)

021-87700210

G

## ● Safety Instructions ●

(Always read these instructions before using the equipment.)

Do not attempt to install, operate, maintain or inspect the converter unit, servo amplifier (drive unit) and servo motor until you have read through this Instruction Manual, Installation guide, Servo motor Instruction Manual (Vol.2) and appended documents carefully and can use the equipment correctly. Do not use the converter unit, servo amplifier (drive unit) and servo motor until you have a full knowledge of the equipment, safety information and instructions.

In this Instruction Manual, the safety instruction levels are classified into "WARNING" and "CAUTION".



**WARNING**

Indicates that incorrect handling may cause hazardous conditions, resulting in death or severe injury.



**CAUTION**

Indicates that incorrect handling may cause hazardous conditions, resulting in medium or slight injury to personnel or may cause physical damage.

Note that the CAUTION level may lead to a serious consequence according to conditions. Please follow the instructions of both levels because they are important to personnel safety.

What must not be done and what must be done are indicated by the following diagrammatic symbols.



: Indicates what must not be done. For example, "No Fire" is indicated by .



: Indicates what must be done. For example, grounding is indicated by .

In this Instruction Manual, instructions at a lower level than the above, instructions for other functions, and so on are classified into "POINT".

After reading this installation guide, always keep it accessible to the operator.

1. To prevent electric shock, note the following

 **WARNING**

- Before wiring or inspection, turn off the power and wait for 15 minutes or more (20 minutes or for drive unit 30kW or more) until the charge lamp turns off. Then, confirm that the voltage between P(+) and N(–) (L+ and L– for drive unit 30kW or more) is safe with a voltage tester and others. Otherwise, an electric shock may occur. In addition, always confirm from the front of the servo amplifier (converter unit), whether the charge lamp is off or not.
- Connect the converter unit, servo amplifier (drive unit) and servo motor to ground.
- Any person who is involved in wiring and inspection should be fully competent to do the work.
- Do not attempt to wire the converter unit, servo amplifier (drive unit) and servo motor until they have been installed. Otherwise, you may get an electric shock.
- Operate the switches with dry hand to prevent an electric shock.
- The cables should not be damaged, stressed loaded, or pinched. Otherwise, you may get an electric shock.
- During power-on or operation, do not open the front cover. You may get an electric shock.
- Do not operate the converter unit and servo amplifier (drive unit) with the front cover removed. High-voltage terminals and charging area are exposed and you may get an electric shock.
- Except for wiring or periodic inspection, do not remove the front cover even if the power is off. The servo amplifier (drive unit) is charged and you may get an electric shock.

2. To prevent fire, note the following

 **CAUTION**

- Install the converter unit, servo amplifier (drive unit), servo motor and regenerative resistor on incombustible material. Installing them directly or close to combustibles will lead to a fire.
- Always connect a magnetic contactor (MC) between the main circuit power supply and L<sub>1</sub>, L<sub>2</sub>, and L<sub>3</sub> of the converter unit, servo amplifier (drive unit), and configure the wiring to be able to shut down the power supply on the side of the converter unit, servo amplifier (drive unit) power supply. If a magnetic contactor (MC) is not connected, continuous flow of a large current may cause a fire when the converter unit, servo amplifier (drive unit) malfunctions.
- When a regenerative resistor is used, use an alarm signal to switch main power off. Otherwise, a regenerative transistor fault or the like may overheat the regenerative resistor, causing a fire.

3. To prevent injury, note the follow

 **CAUTION**

- Only the voltage specified in the instruction manual should be applied to each terminal, Otherwise, a burst, damage, etc. may occur.
- Connect the terminals correctly to prevent a burst, damage, etc.
- Ensure that polarity (+, –) is correct. Otherwise, a burst, damage, etc. may occur.
- Take safety measures, e.g. provide covers, to prevent accidental contact of hands and parts (cables, etc.) with the converter unit and servo amplifier (drive unit) heat sink, regenerative resistor, servo motor, etc. since they may be hot while power is on or for some time after power-off. Their temperatures may be high and you may get burnt or a parts may damaged.
- During operation, never touch the rotating parts of the servo motor. Doing so can cause injury.

#### 4. Additional instructions

The following instructions should also be fully noted. Incorrect handling may cause a fault, injury, electric shock, etc.

##### (1) Transportation and installation

## ⚠ CAUTION

- Transport the products correctly according to their weights.
- Stacking in excess of the specified number of products is not allowed.
- Do not carry the servo motor by the cables, shaft or encoder.
- Do not hold the front cover to transport the converter unit and servo amplifier (drive unit). The converter unit and servo amplifier (drive unit) may drop.
- Install the converter unit and servo amplifier (drive unit) in a load-bearing place in accordance with the Instruction Manual.
- Do not climb or stand on servo equipment. Do not put heavy objects on equipment.
- The converter unit, servo amplifier (drive unit), and servo motor must be installed in the specified direction.
- Leave specified clearances between the converter unit, servo amplifier (drive unit), and control enclosure walls or other equipment.
- Do not install or operate the converter unit, servo amplifier (drive unit), and servo motor which has been damaged or has any parts missing.
- When you keep or use it, please fulfill the following environmental conditions.

Environment		Conditions		
		Converter unit ▪ servo amplifier (drive unit)	Servo motor	
Ambient temperature	In operation	[°C]	0 to +55 (non-freezing)	0 to +40 (non-freezing)
		[°F]	32 to 131 (non-freezing)	32 to 104 (non-freezing)
	In storage	[°C]	-20 to +65 (non-freezing)	-15 to +70 (non-freezing)
		[°F]	-4 to 149 (non-freezing)	5 to 158 (non-freezing)
Ambient humidity	In operation	90%RH or less (non-condensing)		80%RH or less (non-condensing)
	In storage	90%RH or less (non-condensing)		
Ambience		Indoors (no direct sunlight) Free from corrosive gas, flammable gas, oil mist, dust and dirt		
Altitude		Max. 1000m (3280 ft) above sea level		
(Note) Vibration	[m/s <sup>2</sup> ]	5.9 or less	HF-MP series HF-KP series	X, Y: 49 m/s <sup>2</sup>
			HF-SP51 ▪ 81 HF-SP52 to 152 HF-SP524 to 1524 HC-RP Series HC-UP72 ▪ 152	X, Y: 24.5 m/s <sup>2</sup>
			HF-SP121 ▪ 201 HF-SP202 ▪ 352 HF-SP2024 ▪ 3524 HC-UP202 to 502	X: 24.5 m/s <sup>2</sup> Y: 49 m/s <sup>2</sup>
			HF-SP301 ▪ 421 HF-SP502 ▪ 702 HF-SP5024 ▪ 7024	X: 24.5 m/s <sup>2</sup> Y: 29.4 m/s <sup>2</sup>
			HC-LP52 to 152	X: 9.8 m/s <sup>2</sup> Y: 24.5 m/s <sup>2</sup>
			HC-LP202 to 302	X: 19.6 m/s <sup>2</sup> Y: 49 m/s <sup>2</sup>
			HA-LP601 to 12K1 HA-LP701M to 15K1M HA-LP502 to 22K2 HA-LP6014 ▪ 12K14 HA-LP701M4 ▪ 15K1M4 HA-LP11K24 to 22K24	X: 11.7 m/s <sup>2</sup> Y: 29.4 m/s <sup>2</sup>
			HA-LP15K1 to 37K1 HA-LP22K1M to 37K1M HA-LP30K2 ▪ 37K2 HA-LP15K14 to 37K14 HA-LP22K1M4 to 50K1M4 HA-LP30K24 to 55K24	X, Y: 9.8 m/s <sup>2</sup>

Note. Except the servo motor with reduction gear.

## ⚠ CAUTION

- Provide adequate protection to prevent screws and other conductive matter, oil and other combustible matter from entering the converter unit, servo amplifier (drive unit), and servo motor.
- Do not drop or strike converter unit, servo amplifier (drive unit), or servo motor. Isolate from all impact loads.
- Securely attach the servo motor to the machine. If attach insecurely, the servo motor may come off during operation.
- The servo motor with reduction gear must be installed in the specified direction to prevent oil leakage.
- Take safety measures, e.g. provide covers, to prevent accidental access to the rotating parts of the servo motor during operation.
- Never hit the servo motor or shaft, especially when coupling the servo motor to the machine. The encoder may become faulty.
- Do not subject the servo motor shaft to more than the permissible load. Otherwise, the shaft may break.
- When the equipment has been stored for an extended period of time, consult Mitsubishi.

### (2) Wiring

## ⚠ CAUTION

- Wire the equipment correctly and securely. Otherwise, the servo motor may operate unexpectedly.
- Do not install a power capacitor, surge absorber or radio noise filter (FR-BIF (-H) option) between the servo motor and servo amplifier (drive unit).
- Connect the wires to the correct phase terminals (U, V, W) of the servo amplifier (drive unit) and servo motor. Otherwise, the servo motor does not operate properly.
- Connect the servo motor power terminal (U, V, W) to the servo motor power input terminal (U, V, W) directly. Do not let a magnetic contactor, etc. intervene.

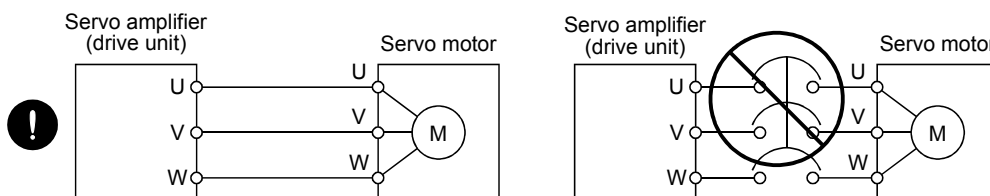

- Do not connect AC power directly to the servo motor. Otherwise, a fault may occur.
- The surge absorbing diode installed on the DC output signal relay of the servo amplifier (drive unit) must be wired in the specified direction. Otherwise, the forced stop (EM1) and other protective circuits may not operate.

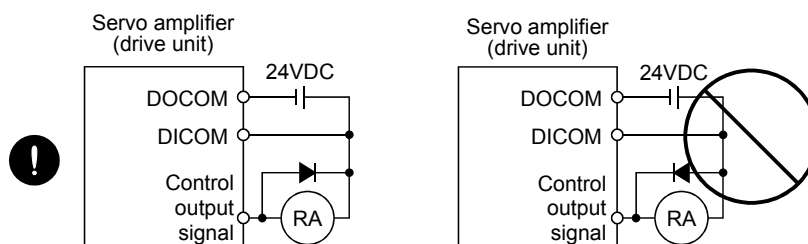

- When the cable is not tightened enough to the terminal block (connector), the cable or terminal block (connector) may generate heat because of the poor contact. Be sure to tighten the cable with specified torque.

### (3) Test run adjustment

## CAUTION

- Before operation, check the parameter settings. Improper settings may cause some machines to perform unexpected operation.
- The parameter settings must not be changed excessively. Operation will be insatiable.

### (4) Usage

## CAUTION

- Provide an external emergency stop circuit to ensure that operation can be stopped and power switched off immediately.
- Any person who is involved in disassembly and repair should be fully competent to do the work.
- Before resetting an alarm, make sure that the run signal of the servo amplifier (drive unit) is off to prevent an accident. A sudden restart is made if an alarm is reset with the run signal on.
- Do not modify the equipment.
- Use a noise filter, etc. to minimize the influence of electromagnetic interference, which may be caused by electronic equipment used near the converter unit and servo amplifier (drive unit).
- Burning or breaking a converter unit and servo amplifier (drive unit) may cause a toxic gas. Do not burn or break a converter unit and servo amplifier (drive unit).
- Use the converter unit and servo amplifier (drive unit) with the specified servo motor.
- The electromagnetic brake on the servo motor is designed to hold the motor shaft and should not be used for ordinary braking.
- For such reasons as service life and mechanical structure (e.g. where a ball screw and the servo motor are coupled via a timing belt), the electromagnetic brake may not hold the motor shaft. To ensure safety, install a stopper on the machine side.

### (5) Corrective actions

## ⚠ CAUTION

- When it is assumed that a hazardous condition may take place at the occur due to a power failure or a product fault, use a servo motor with an electromagnetic brake or an external brake mechanism for the purpose of prevention.
- Configure the electromagnetic brake circuit so that it is activated not only by the servo amplifier (drive unit) signals but also by an external forced stop (EM1).

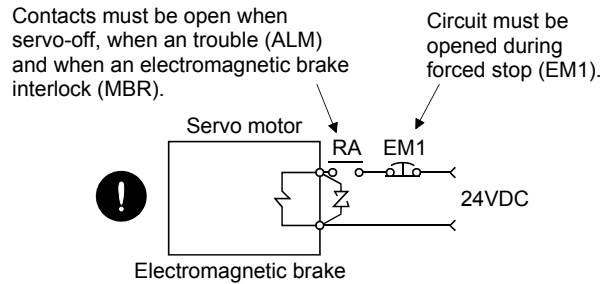

- When any alarm has occurred, eliminate its cause, ensure safety, and deactivate the alarm before restarting operation.
- When power is restored after an instantaneous power failure, keep away from the machine because the machine may be restarted suddenly (design the machine so that it is secured against hazard if restarted).

### (6) Maintenance, inspection and parts replacement

## ⚠ CAUTION

- With age, the electrolytic capacitor of the converter unit and servo amplifier (drive unit) will deteriorate. To prevent a secondary accident due to a fault, it is recommended to replace the electrolytic capacitor every 10 years when used in general environment.
- Please consult our sales representative.

### (7) General instruction

- To illustrate details, the equipment in the diagrams of this Specifications and Instruction Manual may have been drawn without covers and safety guards. When the equipment is operated, the covers and safety guards must be installed as specified. Operation must be performed in accordance with this Specifications and Instruction Manual.

## ● About processing of waste ●

When you discard converter unit and servo amplifier (drive unit), a battery (primary battery), and other option articles, please follow the law of each country (area).

### FOR MAXIMUM SAFETY

- These products have been manufactured as a general-purpose part for general industries, and have not been designed or manufactured to be incorporated in a device or system used in purposes related to human life.
- Before using the products for special purposes such as nuclear power, electric power, aerospace, medicine, passenger movement vehicles or under water relays, contact Mitsubishi.
- These products have been manufactured under strict quality control. However, when installing the product where major accidents or losses could occur if the product fails, install appropriate backup or failsafe functions in the system.

### EEP-ROM life

The number of write times to the EEP-ROM, which stores parameter settings, etc., is limited to 100,000. If the total number of the following operations exceeds 100,000, the converter unit, servo amplifier (drive unit) and/or converter unit may fail when the EEP-ROM reaches the end of its useful life.

- Write to the EEP-ROM due to parameter setting changes
- Write to the EEP-ROM due to device changes

## Precautions for Choosing the Products

Mitsubishi will not be held liable for damage caused by factors found not to be the cause of Mitsubishi; machine damage or lost profits caused by faults in the Mitsubishi products; damage, secondary damage, accident compensation caused by special factors unpredictable by Mitsubishi; damages to products other than Mitsubishi products; and to other duties.

# COMPLIANCE WITH EC DIRECTIVES

## 1. WHAT ARE EC DIRECTIVES?

The EC directives were issued to standardize the regulations of the EU countries and ensure smooth distribution of safety-guaranteed products. In the EU countries, the machinery directive (effective in January, 1995), EMC directive (effective in January, 1996) and low voltage directive (effective in January, 1997) of the EC directives require that products to be sold should meet their fundamental safety requirements and carry the CE marks (CE marking). CE marking applies to machines and equipment into which servo have been installed.

### (1) EMC directive

The EMC directive applies not to the servo units alone but to servo-incorporated machines and equipment. This requires the EMC filters to be used with the servo-incorporated machines and equipment to comply with the EMC directive. For specific EMC directive conforming methods, refer to the EMC Installation Guidelines (IB(NA)67310).

### (2) Low voltage directive

The low voltage directive applies also to servo units alone. Hence, they are designed to comply with the low voltage directive.

This servo is certified by TUV, third-party assessment organization, to comply with the low voltage directive.

### (3) Machine directive

Not being machines, the converter unit, servo amplifiers (drive unit) need not comply with this directive.

## 2. PRECAUTIONS FOR COMPLIANCE

### (1) Converter unit, servo amplifiers (drive unit), and servo motors used

Use the converter unit, servo amplifiers (drive unit), and servo motors which comply with the standard model.

Converter unit series	:MR-J3-CR55K MR-J3-CR55K4
Servo amplifier (drive unit) series	:MR-J3-10B to MR-J3-22KB MR-J3-10B1 to MR-J3-40B1 MR-J3-60B4 to MR-J3-22KB4 MR-J3-DU30KB to MR-J3-DU37KB MR-J3-DU30KB4 to MR-J3-DU55KB4
Servo motor series	:HF-MP□ HF-KP□ HF-SP□(Note) HF-SP□4(Note) HC-RP□ HC-UP□ HC-LP□ HA-LP□(Note) HA-LP□4 (Note)

Note. For the latest information of compliance, contact Mitsubishi.

## (2) Configuration

The control circuit provide safe separation to the main circuit in the converter unit and servo amplifier (drive unit).

(a) MR-J3-22KB(4) or less

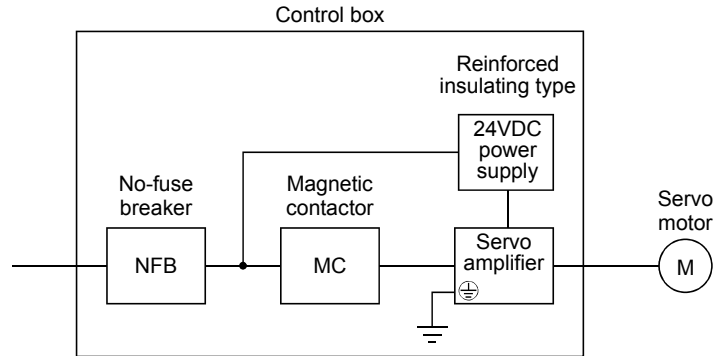

(b) MR-J3-DU30KB(4) or more

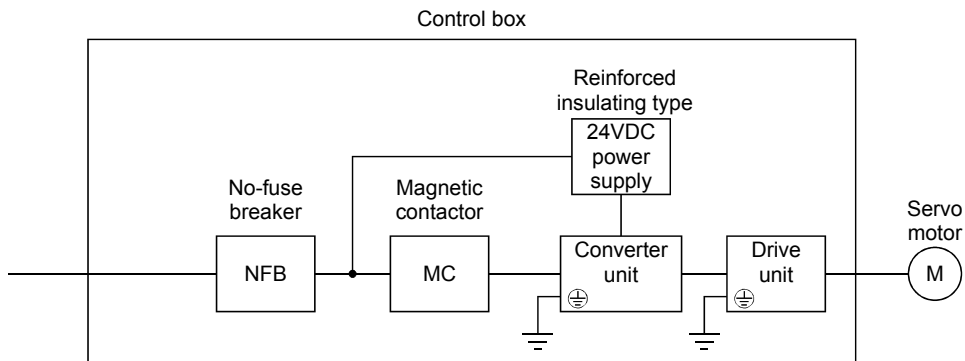

## (3) Environment

Operate the converter unit and servo amplifier (drive unit) at or above the contamination level 2 set forth in IEC60664-1. For this purpose, install the converter unit and servo amplifier (drive unit) in a control box which is protected against water, oil, carbon, dust, dirt, etc. (IP54).

## (4) Power supply

(a) This converter unit and servo amplifier (drive unit) can be supplied from star-connected supply with earthed neutral point of overvoltage category III set forth in IEC60664-1. However, when using the neutral point of 400V class for single-phase supply, a reinforced insulating transformer is required in the power input section.

(b) When supplying interface power from external, use a 24VDC power supply which has been insulation-reinforced in I/O.

## (5) Grounding

(a) To prevent an electric shock, always connect the protective earth (PE) terminals (marked ⊕) of the converter unit and servo amplifier (drive unit) to the protective earth (PE) of the control box.

- (b) Do not connect two ground cables to the same protective earth (PE) terminal. Always connect the cables to the terminals one-to-one.

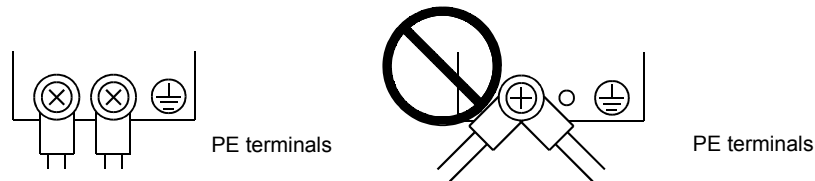

- (c) If a leakage current breaker is used to prevent an electric shock, the protective earth (PE) terminals of the converter unit and servo amplifier (drive unit) must be connected to the corresponding earth terminals.

#### (6) Wiring

- (a) The cables to be connected to the terminal block of the converter unit and servo amplifier (drive unit) must have crimping terminals provided with insulating tubes to prevent contact with adjacent terminals.

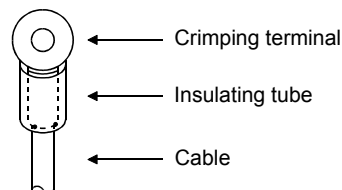

- (b) Use the servo motor side power connector which complies with the EN Standard. The EN Standard compliant power connector sets are available from us as options. (Refer to section 11.1)

#### (7) Auxiliary equipment and options

- (a) The no-fuse breaker and magnetic contactor used should be the EN or IEC standard-compliant products of the models described in section 11.12 (Section 13.9.5 for 30kW or more).

Use a type B (Note) breaker. When it is not used, provide insulation between the converter unit, servo amplifier (drive unit) and other device by double insulation or reinforced insulation, or install a transformer between the main power supply, converter unit and servo amplifier (drive unit).

Note. Type A: AC and pulse detectable

Type B: Both AC and DC detectable

- (b) The sizes of the cables described in section 11.8 meet the following requirements. To meet the other requirements, follow Table 5 and Appendix C in EN60204-1.

- Ambient temperature: 40 (104) [°C (°F)]
- Sheath: PVC (polyvinyl chloride)
- Installed on wall surface or open table tray

- (c) Use the EMC filter for noise reduction.

#### (8) Performing EMC tests

When EMC tests are run on a machine/device into which the converter unit and servo amplifier (drive unit) has been installed, it must conform to the electromagnetic compatibility (immunity/emission) standards after it has satisfied the operating environment/electrical equipment specifications.

For the other EMC directive guidelines on the converter unit and servo amplifier (drive unit), refer to the EMC Installation Guidelines (IB(NA)67310).

## CONFORMANCE WITH UL/C-UL STANDARD

### (1) Converter unit, servo amplifiers (drive unit) and servo motors used

Use the converter unit, servo amplifiers (drive unit) and servo motors which comply with the standard model.

Converter unit series	:MR-J3-CR55K MR-J3-CR55K4
Servo amplifier (drive unit) series	:MR-J3-10B to MR-J3-22KB MR-J3-10B1 to MR-J3-40B1 MR-J3-60B4 to MR-J3-22KB4 MR-J3-DU30KB to MR-J3-DU37KB MR-J3-DU30KB4 to MR-J3-DU55KB4
Servo motor series	:HF-MP □ HF-KP □ HF-SP □ (Note) HF-SP □ 4 (Note) HC-RP □ HC-UP □ HC-LP □ HA-LP □ (Note) HA-LP □ 4 (Note)

Note. For the latest information of compliance, contact Mitsubishi.

### (2) Installation

Install a fan of 100CFM (2.8m<sup>3</sup>/min) air flow 4[in] (10.16[cm]) above the servo amplifier (drive unit) or provide cooling of at least equivalent capability to ensure that the ambient temperature conforms to the environment conditions (55°C or less).

### (3) Short circuit rating: SCCR (Short Circuit Current Rating)

This servo amplifier (drive unit) conforms to the circuit whose peak current is limited to 100kA or less, 500Volts Maximum. Having been subjected to the short-circuit tests of the UL in the alternating-current circuit, the servo amplifier (drive unit) conforms to the above circuit.

(4) Capacitor discharge time

The capacitor discharge time is as listed below. To ensure safety, do not touch the charging section for 15 minutes (more than 20 minutes in case drive unit is 30kW or more) after power-off.

Servo amplifier	Discharge time [min]
MR-J3-10B · 20B	1
MR-J3-40B · 60B(4) · 10B1 · 20B1	2
MR-J3-70B	3
MR-J3-40B1	4
MR-J3-100B(4)	5
MR-J3-200B(4) · 350B	9
MR-J3-350B4 · 500B(4) · 700B(4)	10
MR-J3-11KB(4)	4
MR-J3-15KB(4)	6
MR-J3-22KB(4)	8

Converter unit	Drive unit	Discharge time [min]
MR-J3-CR55K	MR-J3-DU30KB	20
	MR-J3-DU37KB	
MR-J3-CR55K4	MR-J3-DU30KB4	
	MR-J3-DU37KB4	
	MR-J3-DU45KB4	
	MR-J3-DU55KB4	

(5) Options and auxiliary equipment

Use UL/C-UL standard-compliant products.

(6) Attachment of a servo motor

For the flange size of the machine side where the servo motor is installed, refer to “CONFORMANCE WITH UL/C-UL STANDARD” in the Servo Motor Instruction Manual (Vol.2).

(7) About wiring protection

For installation in United States, branch circuit protection must be provided, in accordance with the National Electrical Code and any applicable local codes.

For installation in Canada, branch circuit protection must be provided, in accordance with the Canada Electrical Code and any applicable provincial codes.

<<About the manuals>>

This Instruction Manual and the MELSERVO Servo Motor Instruction Manual (Vol.2) are required if you use the General-Purpose AC servo MR-J3-B for the first time. Always purchase them and use the MR-J3-B safely.

Relevant manuals

Manual name	Manual No.
MELSERVO-J3 Series Instructions and Cautions for Safe Use of AC Servos (Enclosed in converter unit and servo amplifier (drive unit).)	IB(NA)0300077
MELSERVO Servo Motor Instruction Manual Vol.2	SH(NA)030041
EMC Installation Guidelines	IB(NA)67310

Details of MR-J3-CR55K(4) and MR-J3-DU30KB(4) to MR-J3-DU55KB4 are described in chapter 13 of this INSTRUCTION MANUAL.

For the products of 30kW or more, refer to chapter 13.

<<About the wires used for wiring>>

Wiring wires mentioned in this instruction manual are selected based on the ambient temperature of 40°C (104°F).



## CONTENTS

<b>1. FUNCTIONS AND CONFIGURATION</b>	<b>1 - 1 to 1 -28</b>
1.1 Introduction.....	1 - 1
1.2 Function block diagram.....	1 - 2
1.3 Servo amplifier standard specifications.....	1 - 5
1.4 Function list.....	1 - 7
1.5 Model code definition.....	1 - 8
1.6 Combination with servo motor.....	1 -10
1.7 Structure.....	1 -11
1.7.1 Parts identification.....	1 -11
1.7.2 Removal and reinstallation of the front cover.....	1 -18
1.8 Configuration including auxiliary equipment.....	1 -21
<b>2. INSTALLATION</b>	<b>2 - 1 to 2 - 6</b>
2.1 Installation direction and clearances.....	2 - 1
2.2 Keep out foreign materials.....	2 - 3
2.3 Cable stress.....	2 - 3
2.4 SSCNETIII cable laying.....	2 - 4
2.5 Inspection items.....	2 - 6
2.6 Parts having service lives.....	2 - 6
<b>3. SIGNALS AND WIRING</b>	<b>3 - 1 to 3 -52</b>
3.1 Input power supply circuit.....	3 - 2
3.2 I/O signal connection example.....	3 -10
3.3 Explanation of power supply system.....	3 -12
3.3.1 Signal explanations.....	3 -12
3.3.2 Power-on sequence.....	3 -13
3.3.3 CNP1, CNP2, CNP3 wiring method.....	3 -14
3.4 Connectors and signal arrangements.....	3 -23
3.5 Signal (device) explanations.....	3 -24
3.6 Alarm occurrence timing chart.....	3 -27
3.7 Interfaces.....	3 -28
3.7.1 Internal connection diagram.....	3 -28
3.7.2 Detailed description of interfaces.....	3 -29
3.7.3 Source I/O interfaces.....	3 -31
3.8 Treatment of cable shield external conductor.....	3 -32
3.9 SSCNETIII cable connection.....	3 -33
3.10 Connection of servo amplifier and servo motor.....	3 -35
3.10.1 Connection instructions.....	3 -35
3.10.2 Power supply cable wiring diagrams.....	3 -36
3.11 Servo motor with an electromagnetic brake.....	3 -46
3.11.1 Safety precautions.....	3 -46
3.11.2 Timing charts.....	3 -47
3.11.3 Wiring diagrams (HF-MP series ▪ HF-KP series servo motor).....	3 -50
3.12 Grounding.....	3 -51

3.13 Control axis selection .....	3 -52
-----------------------------------	-------

<b>4. STARTUP</b>	<b>4 - 1 to 4 -10</b>
-------------------	-----------------------

4.1 Switching power on for the first time .....	4 - 1
4.1.1 Startup procedure.....	4 - 1
4.1.2 Wiring check .....	4 - 2
4.1.3 Surrounding environment.....	4 - 3
4.2 Start up .....	4 - 4
4.3 Servo amplifier display .....	4 - 5
4.4 Test operation .....	4 - 7
4.5 Test operation mode .....	4 - 8
4.5.1 Test operation mode in MR Configurator .....	4 - 8
4.5.2 Motorless operation in controller.....	4 -10

<b>5. PARAMETERS</b>	<b>5 - 1 to 5 -28</b>
----------------------	-----------------------

5.1 Basic setting parameters (No.PA□□) .....	5 - 1
5.1.1 Parameter list .....	5 - 2
5.1.2 Parameter write inhibit .....	5 - 3
5.1.3 Selection of regenerative option .....	5 - 4
5.1.4 Using absolute position detection system .....	5 - 5
5.1.5 Forced stop input selection .....	5 - 5
5.1.6 Auto tuning .....	5 - 6
5.1.7 In-position range.....	5 - 7
5.1.8 Selection of servo motor rotation direction .....	5 - 8
5.1.9 Encoder output pulse .....	5 - 8
5.2 Gain/filter parameters (No.PB□□).....	5 - 10
5.2.1 Parameter list .....	5 - 10
5.2.2 Detail list .....	5 -11
5.3 Extension setting parameters (No.PC□□).....	5 -18
5.3.1 Parameter list .....	5 -18
5.3.2 List of details.....	5 -19
5.3.3 Analog monitor .....	5 -22
5.3.4 Alarm history clear.....	5 -24
5.4 I/O setting parameters (No.PD□□) .....	5 -25
5.4.1 Parameter list .....	5 -25
5.4.2 List of details.....	5 -26

<b>6. GENERAL GAIN ADJUSTMENT</b>	<b>6 - 1 to 6 -12</b>
-----------------------------------	-----------------------

6.1 Different adjustment methods.....	6 - 1
6.1.1 Adjustment on a single servo amplifier.....	6 - 1
6.1.2 Adjustment using MR Configurator.....	6 - 2
6.2 Auto tuning .....	6 - 3
6.2.1 Auto tuning mode .....	6 - 3
6.2.2 Auto tuning mode operation.....	6 - 4
6.2.3 Adjustment procedure by auto tuning.....	6 - 5
6.2.4 Response level setting in auto tuning mode .....	6 - 6
6.3 Manual mode 1 (simple manual adjustment).....	6 - 7

6.4 Interpolation mode .....	6 -11
6.5 Differences between MELSERVO-J2-Super and MELSERVO-J3 in auto tuning .....	6 -12

<b>7. SPECIAL ADJUSTMENT FUNCTIONS</b>	<b>7 - 1 to 7 -16</b>
--	-----------------------

7.1 Function block diagram .....	7 - 1
7.2 Adaptive filter II .....	7 - 1
7.3 Machine resonance suppression filter .....	7 - 4
7.4 Advanced vibration suppression control .....	7 - 6
7.5 Low-pass filter .....	7 -10
7.6 Gain changing function .....	7 -10
7.6.1 Applications .....	7 -10
7.6.2 Function block diagram .....	7 -11
7.6.3 Parameters .....	7 -12
7.6.4 Gain changing operation .....	7 -14

<b>8. TROUBLESHOOTING</b>	<b>8 - 1 to 8 -10</b>
---------------------------	-----------------------

8.1 Alarms and warning list .....	8 - 1
8.2 Remedies for alarms .....	8 - 2
8.3 Remedies for warnings .....	8 - 8

<b>9. OUTLINE DRAWINGS</b>	<b>9 - 1 to 9 -12</b>
----------------------------	-----------------------

9.1 Servo amplifier .....	9 - 1
9.2 Connector .....	9 -10

<b>10. CHARACTERISTICS</b>	<b>10- 1 to 10-10</b>
----------------------------	-----------------------

10.1 Overload protection characteristics .....	10- 1
10.2 Power supply equipment capacity and generated loss .....	10- 3
10.3 Dynamic brake characteristics .....	10- 6
10.3.1 Dynamic brake operation .....	10- 6
10.3.2 The dynamic brake at the load inertia moment .....	10- 9
10.4 Cable flexing life .....	10-10
10.5 Inrush currents at power-on of main circuit and control circuit .....	10-10

<b>11. OPTIONS AND AUXILIARY EQUIPMENT</b>	<b>11- 1 to 11-90</b>
--	-----------------------

11.1 Cable/connector sets .....	11- 1
11.1.1 Combinations of cable/connector sets .....	11- 2
11.1.2 Encoder cable/connector sets .....	11- 8
11.1.3 Motor power supply cables .....	11-17
11.1.4 Motor brake cables .....	11-18
11.1.5 SSCNETIII cable .....	11-19
11.2 Regenerative options .....	11-21
11.3 FR-BU2-(H) Brake unit .....	11-34
11.3.1 Selection .....	11-35
11.3.2 Brake unit parameter setting .....	11-35
11.3.3 Connection example .....	11-36

11.3.4 Outline dimension drawings.....	11-43
11.4 Power regeneration converter .....	11-45
11.5 Power regeneration common converter.....	11-48
11.6 External dynamic brake .....	11-56
11.7 Junction terminal block PS7DW-20V14B-F (recommended).....	11-61
11.8 MR Configurator.....	11-62
11.9 Battery MR-J3BAT .....	11-64
11.10 Heat sink outside mounting attachment (MR-J3ACN).....	11-65
11.11 Selection example of wires.....	11-67
11.12 No-fuse breakers, fuses, magnetic contactors .....	11-72
11.13 Power factor improving DC reactor .....	11-72
11.14 Power factor improving AC reactors .....	11-74
11.15 Relays (recommended) .....	11-75
11.16 Surge absorbers (recommended) .....	11-76
11.17 Noise reduction techniques .....	11-76
11.18 Leakage current breaker.....	11-83
11.19 EMC filter (recommended) .....	11-85

## 12. ABSOLUTE POSITION DETECTION SYSTEM

12- 1 to 12- 6

12.1 Features .....	12- 1
12.2 Specifications .....	12- 2
12.3 Battery installation procedure .....	12- 3
12.4 Confirmation of absolute position detection data.....	12- 5

## 13. SERVO AMPLIFIERS WITH A LARGE CAPACITY (30k TO 55kW)

13- 1 to 13-102

13.1. Functions and menus .....	13- 1
13.1.1 Function block diagram.....	13- 2
13.1.2 Packing list .....	13- 4
13.1.3 Standard specifications.....	13- 5
13.1.4 Model definition .....	13- 8
13.1.5 Combinations of converter units, drive unit and servo motors .....	13- 9
13.1.6 Parts identification .....	13-10
13.1.7 Removal and reinstallation of the terminal block cover .....	13-13
13.1.8 Servo system with auxiliary equipment.....	13-19
13.2 Installation .....	13-20
13.2.1 Installation direction and clearances .....	13-21
13.2.2 Inspection .....	13-22
13.3 Signals and wiring .....	13-23
13.3.1 Magnetic contactor control connector (CNP1).....	13-24
13.3.2 Input power supply circuit .....	13-26
13.3.3 Terminal.....	13-31
13.3.4 How to use the connection bars .....	13-32
13.3.5 Connectors and signal arrangements .....	13-33
13.3.6 Converter unit signal (device) explanations .....	13-35
13.3.7 Timing chart.....	13-37
13.3.8 Servo motor side details .....	13-47
13.4 Display section and operation section of the converter unit.....	13-49

13.4.1 Display flowchart .....	13-49
13.4.2 Status display mode.....	13-50
13.4.3 Diagnostic mode .....	13-51
13.4.4 Alarm mode .....	13-53
13.4.5 Parameter mode .....	13-54
13.5. Parameters for converter unit .....	13-55
13.5.1 Parameter list .....	13-55
13.5.2 List of details.....	13-56
13.6 Troubleshooting .....	13-57
13.6.1 Converter unit.....	13-57
13.6.2 Drive unit.....	13-62
13.7 Outline drawings .....	13-64
13.7.1 Converter unit (MR-J3-CR55K(4)).....	13-64
13.7.2 Drive unit.....	13-65
13.8 Characteristics.....	13-67
13.8.1 Overload protection characteristics .....	13-67
13.8.2 Power supply equipment capacity and generated loss .....	13-68
13.8.3 Dynamic brake characteristics.....	13-69
13.8.4 Inrush currents at power-on of main circuit and control circuit .....	13-72
13.9 Options .....	13-72
13.9.1 Cables and connectors .....	13-72
13.9.2 Regenerative option .....	13-75
13.9.3 External dynamic brake .....	13-79
13.9.4 Selection example of wires .....	13-82
13.9.5 No-fuse breakers, fuses, magnetic contactors.....	13-84
13.9.6 Power factor improving DC reactor .....	13-84
13.9.7 Line noise filter (FR-BLF).....	13-85
13.9.8 Leakage current breaker.....	13-86
13.9.9 EMC filter (recommended).....	13-88
13.9.10 FR-BU2-(H) Brake Unit.....	13-90

APPENDIX	App.- 1 to App.- 9
----------	--------------------

App. 1 Parameter list.....	App.- 1
App. 2 Signal layout recording paper .....	App.- 3
App. 3 Twin type connector : Outline drawing for 721-2105/026-000 (WAGO).....	App.- 3
App. 4 Change of connector sets to the RoHS compatible products .....	App.- 4
App. 5 MR-J3-200B-RT servo amplifier .....	App.- 5
App. 6 Selection example of servo motor power cable .....	App.- 9



# 1. FUNCTIONS AND CONFIGURATION

---

## 1. FUNCTIONS AND CONFIGURATION

### 1.1 Introduction

The Mitsubishi MELSERVO-J3 series general-purpose AC servo has further higher performance and higher functions compared to the current MELSERVO-J2-Super series.

The MR-J3-B servo amplifier connects to servo system controller and others via high speed synchronous network and operates by directly reading position data. The rotation speed/direction control of servo motor and the high accuracy positioning are executed with the data from command module. SSCNETIII equipped by the MR-J3-B servo amplifier greatly improved its communication speed and noise tolerance by adopting optical communication system compared to the current SSCNET. For wiring distance, 50m of the maximum distance between electrodes is also offered.

The torque limit with clamping circuit is put on the servo amplifier in order to protect the power transistor of main circuit from the overcurrent caused by rapid acceleration/deceleration or overload. In addition, torque limit value can be changed to desired value in the controller.

As this new series has the USB communication function, a MR Configurator-installed personal computer or the like can be used to perform parameter setting, test operation, status display monitoring, gain adjustment, etc.

With real-time auto tuning, you can automatically adjust the servo gains according to the machine.

The MELSERVO-J3 series servo motor is with an absolute position encoder which has the resolution of 262144 pulses/rev to ensure more accurate control as compared to the MELSERVO-J2-Super series. Simply adding a battery to the servo amplifier makes up an absolute position detection system. This makes home position return unnecessary at power-on or alarm occurrence by setting a home position once.

# 1. FUNCTIONS AND CONFIGURATION

## 1.2 Function block diagram

The function block diagram of this servo is shown below.

(1) MR-J3-350B or less • MR-J3-200B4 or less

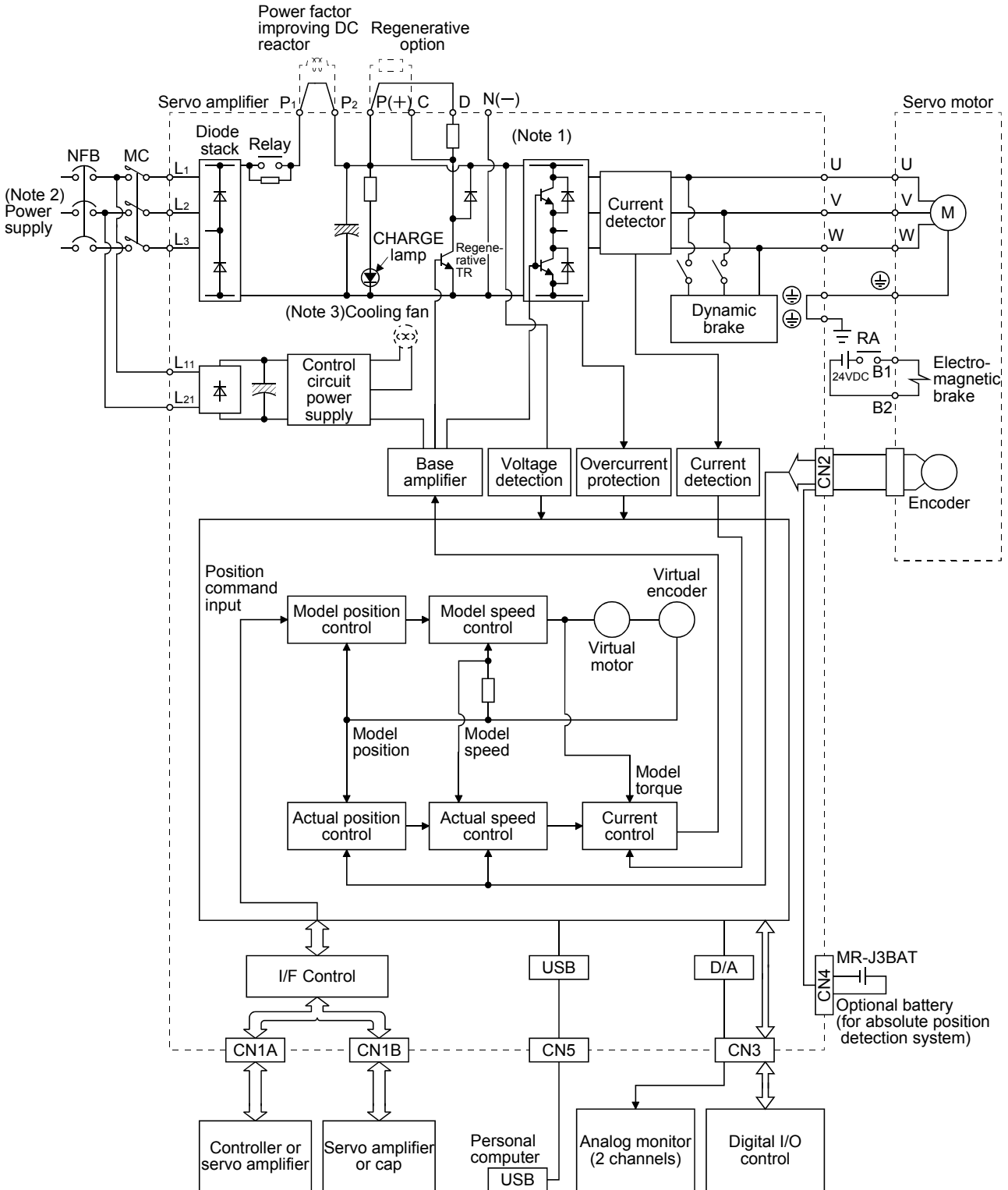

Note 1. The built-in regenerative resistor is not provided for the MR-J3-10B (1).

2. For 1-phase 200 to 230VAC, connect the power supply to L1, L2 and leave L3 open.

There is no L3 for 1-phase 100 to 120VAC power supply. Refer to section 1.3 for the power supply specification.

3. Servo amplifiers MR-J3-70B or greater have a cooling fan.

# 1. FUNCTIONS AND CONFIGURATION

(2) MR-J3-350B4 • MR-J3-500B(4) • MR-J3-700B(4)

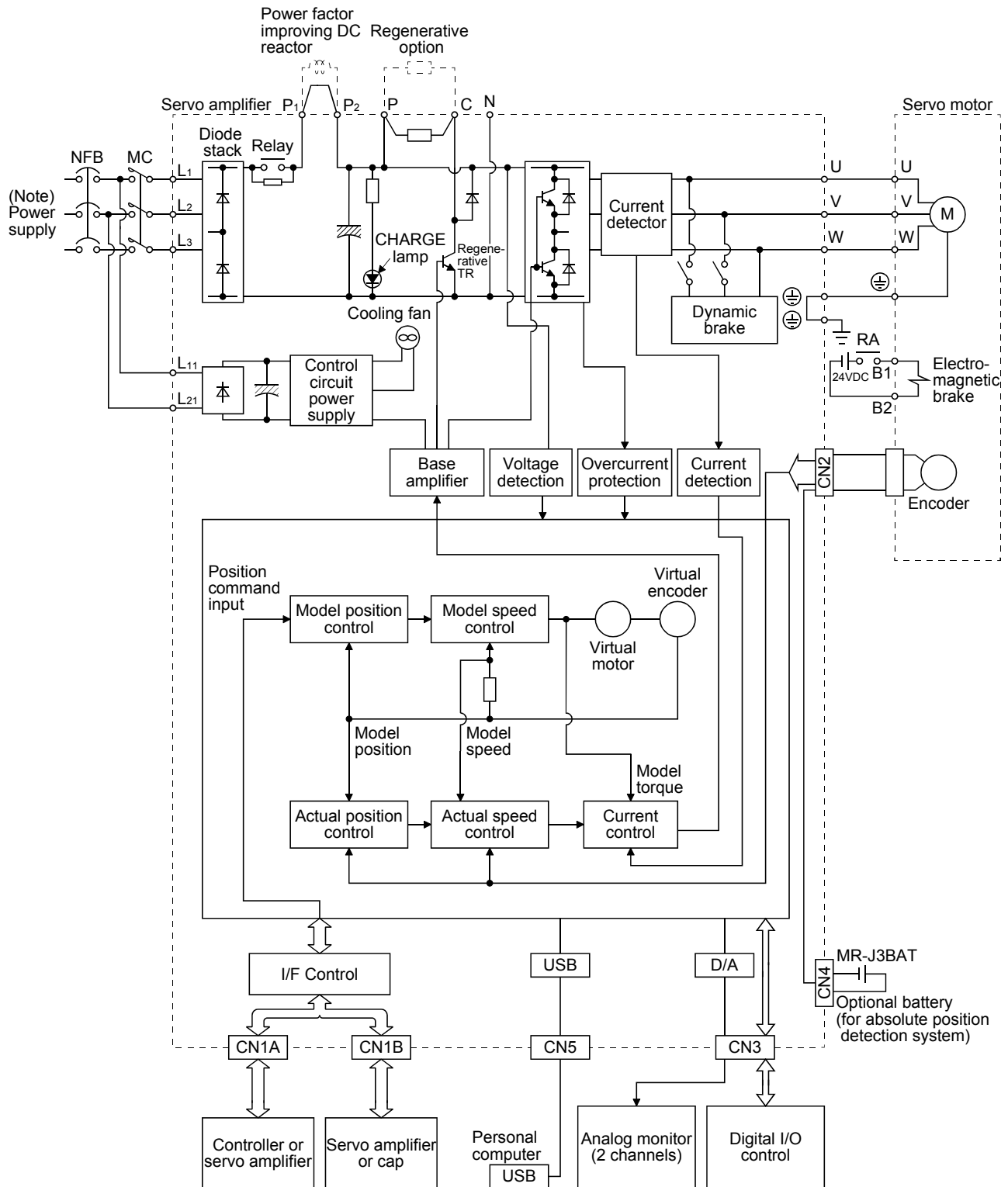

Note. Refer to section 1.3 for the power supply specification.

# 1. FUNCTIONS AND CONFIGURATION

(3) MR-J3-11KB(4) to 22KB(4)

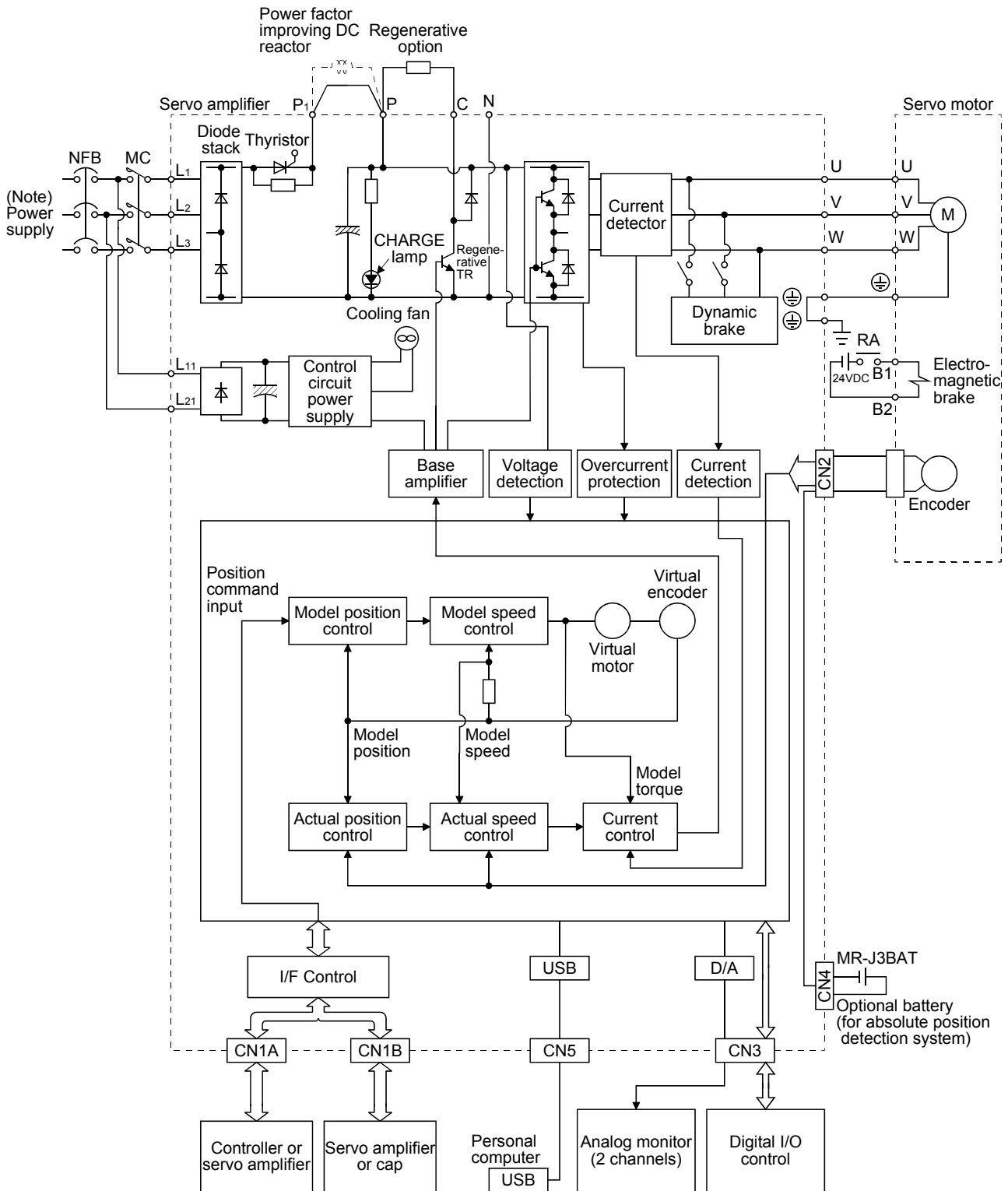

Note. Refer to section 1.3 for the power supply specification.

# 1. FUNCTIONS AND CONFIGURATION

## 1.3 Servo amplifier standard specifications

### (1) 200V class, 100V class

Item		Servo amplifier MR-J3-□																
		10B	20B	40B	60B	70B	100B	200B	350B	500B	700B	11KB	15KB	22KB	10B1	20B1	40B1	
Power supply	Voltage/frequency	3-phase or 1-phase 200 to 230VAC, 50/60Hz					3-phase 200 to 230VAC, 50/60Hz						1-phase 100V to 120VAC, 50/60Hz					
	Permissible voltage fluctuation	3-phase or 1-phase 200 to 230VAC: 170 to 253VAC					3-phase 170 to 253VAC						1-phase 85 to 132VAC					
	Permissible frequency fluctuation	Within ±5%																
	Power supply capacity	Refer to section 10.2																
	Inrush current	Refer to section 10.5																
Control circuit power supply	Voltage, frequency	1-phase 200 to 230VAC, 50/60Hz										1-phase 100 to 120VAC, 50/60Hz						
	Permissible voltage fluctuation	1-phase 170 to 253VAC										1-phase 85 to 132VAC						
	Permissible frequency fluctuation	Within ±5%																
	Input	30W					45W					30W						
	Inrush current	Refer to section 10.5																
Interface power supply	Voltage	24VDC ±10%																
	Power supply capacity	(Note 1) 150mA or more																
Control System	Sine-wave PWM control, current control system																	
Dynamic brake	Built-in					External option						Built-in						
Protective functions	Overcurrent shut-off, regenerative overvoltage shut-off, overload shut-off (electronic thermal relay), servo motor overheat protection, encoder error protection, regenerative error protection, undervoltage, instantaneous power failure protection, overspeed protection, excessive error protection.																	
Structure	Self-cooled, open (IP00)					Force-cooling, open (IP00)						Self-cooled, open (IP00)						
Environment	Ambient temperature	In operation	[°C]	(Note 2) 0 to +55 (non-freezing)														
			[°F]	32 to +131 (non-freezing)														
		In storage	[°C]	-20 to +65 (non-freezing)														
			[°F]	-4 to +149 (non-freezing)														
	Ambient humidity	In operation	90%RH or less (non-condensing)															
		In storage																
	Ambient	Indoors (no direct sunlight) Free from corrosive gas, flammable gas, oil mist, dust and dirt																
	Altitude	Max. 1000m above sea level																
Vibration	5.9 [m/s <sup>2</sup> ] or less																	
Mass	[kg]	0.8	0.8	1.0	1.0	1.4	1.4	2.1	2.3	4.6	6.2	18	18	19	0.8	0.8	1.0	
	[lb]	1.76	1.76	2.21	2.21	3.09	3.09	4.63	5.07	10.1	13.7	39.7	39.7	41.9	1.76	1.76	2.21	

Note 1. 150mA is the value applicable when all I/O signals are used. The current capacity can be decreased by reducing the number of I/O points.

2. When closely mounting the servo amplifier of 3.5kW or less, operate them at the ambient temperatures of 0 to 45°C or at 75% or smaller effective load ratio.

## 1. FUNCTIONS AND CONFIGURATION

### (2) 400V class

Item		Servo amplifier		60B4	100B4	200B4	350B4	500B4	700B4	11KB4	15KB4	22KB4	
		MR-J3-□											
Power supply	Voltage/frequency	3-phase 380 to 480VAC, 50/60Hz											
	Permissible voltage fluctuation	3-phase 323 to 528VAC											
	Permissible frequency fluctuation	Within ±5%											
	Power supply capacity	Refer to section 10.2											
	Inrush current	Refer to section 10.5											
Control circuit power supply	Voltage, frequency	1-phase 380 to 480VAC, 50/60Hz											
	Permissible voltage fluctuation	1-phase 323 to 528VAC											
	Permissible frequency fluctuation	Within ±5%											
	Input	30W					45W						
	Inrush current	Refer to section 10.5											
Interface power supply	Voltage	24VDC ±10%											
	Power supply capacity	(Note) 150mA											
Control System		Sine-wave PWM control, current control system											
Dynamic brake		Built-in								External option			
Protective functions		Overcurrent shut-off, regenerative overvoltage shut-off, overload shut-off (electronic thermal relay), servo motor overheat protection, encoder error protection, regenerative error protection, undervoltage, instantaneous power failure protection, overspeed protection, excessive error protection.											
Structure		Self-cooled, open (IP00)				Force-cooling, open (IP00)							
Environment	Ambient temperature	In operation	[°C]	0 to +55 (non-freezing)									
			[°F]	32 to +131 (non-freezing)									
		In storage	[°C]	-20 to +65 (non-freezing)									
			[°F]	-4 to +149 (non-freezing)									
	Ambient humidity	In operation	90%RH or less (non-condensing)										
		In storage											
	Ambient		Indoors (no direct sunlight) Free from corrosive gas, flammable gas, oil mist, dust and dirt										
	Altitude		Max. 1000m above sea level										
Vibration		5.9 [m/s <sup>2</sup> ] or less											
Mass	[kg]	1.7	1.7	2.1	4.6	4.6	6.2	18	18	19			
	[lb]	3.75	3.75	4.63	10.14	10.14	13.67	39.68	39.68	41.88			

Note. 150mA is the value applicable when all I/O signals are used. The current capacity can be decreased by reducing the number of I/O points.

## 1. FUNCTIONS AND CONFIGURATION

### 1.4 Function list

The following table lists the functions of this servo. For details of the functions, refer to the reference field.

Function	Description	Reference
High-resolution encoder	High-resolution encoder of 262144 pulses/rev is used as a servo motor encoder.	
Absolute position detection system	Merely setting a home position once makes home position return unnecessary at every power-on.	Chapter 12
Gain changing function	You can switch between gains during rotation and gains during stop or use an input device to change gains during operation.	Section 7.6
Advanced vibration suppression control	This function suppresses vibration at the arm end or residual vibration.	Section 7.4
Adaptive filter II	Servo amplifier detects mechanical resonance and sets filter characteristics automatically to suppress mechanical vibration.	Section 7.2
Low-pass filter	Suppresses high-frequency resonance which occurs as servo system response is increased.	Section 7.5
Machine analyzer function	Analyzes the frequency characteristic of the mechanical system by simply connecting a MR Configurator installed personal computer and servo amplifier. MR Configurator is necessary for this function.	
Machine simulation	Can simulate machine motions on a personal computer screen on the basis of the machine analyzer results. MR Configurator is necessary for this function.	
Gain search function	Personal computer changes gains automatically and searches for overshoot-free gains in a short time. MR Configurator is necessary for this function.	
Slight vibration suppression control	Suppresses vibration of $\pm 1$ pulse produced at a servo motor stop.	Parameters No.PB24
Auto tuning	Automatically adjusts the gain to optimum value if load applied to the servo motor shaft varies. Higher in performance than MR-J2-Super series servo amplifier.	Chapter 6
Brake unit	Used when the regenerative option cannot provide enough regenerative power. Can be used the 5kW or more servo amplifier.	Section 11.3
Return converter	Used when the regenerative option cannot provide enough regenerative power. Can be used the 5kW or more servo amplifier.	Section 11.4
Regenerative option	Used when the built-in regenerative resistor of the servo amplifier does not have sufficient regenerative capability for the regenerative power generated.	Section 11.2
Alarm history clear	Alarm history is cleared.	Parameter No.PC21
Output signal (DO) forced output	Output signal can be forced on/off independently of the servo status. Use this function for output signal wiring check, etc.	Section 4.5.1 (1) (d)
Test operation mode	JOG operation - positioning operation - DO forced output. However, MR Configurator is necessary for positioning operation.	Section 4.5
Analog monitor output	Servo status is output in terms of voltage in real time.	Parameter No.PC09
MR Configurator	Using a personal computer, parameter setting, test operation, status display, etc. can be performed.	Section 11.8

# 1. FUNCTIONS AND CONFIGURATION

## 1.5 Model code definition

### (1) Rating plate

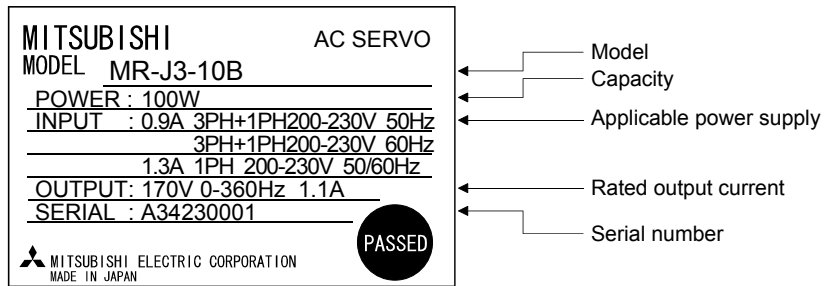

# 1. FUNCTIONS AND CONFIGURATION

## (2) Model

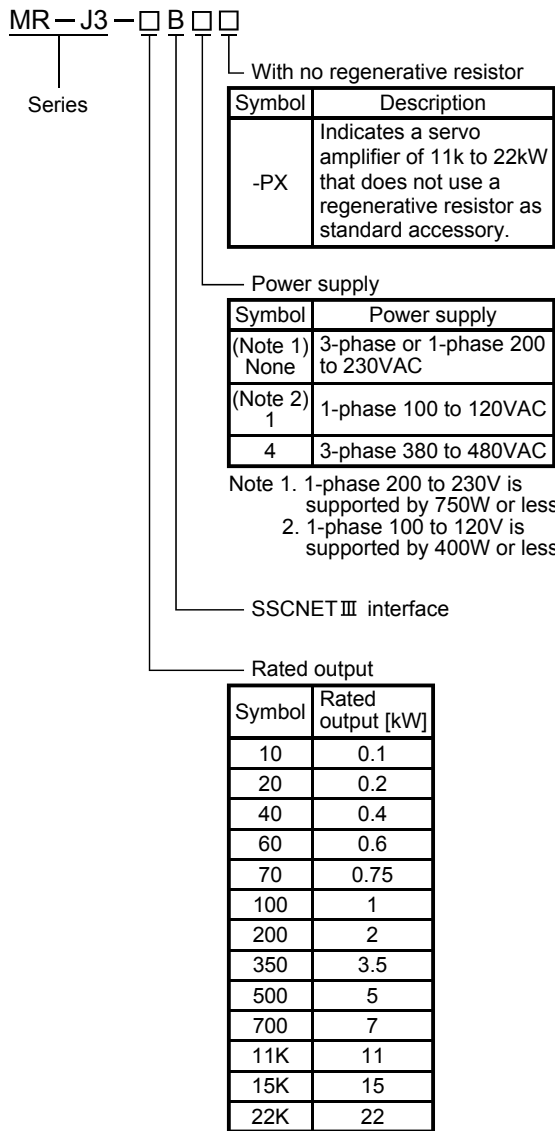

MR-J3-100B or less

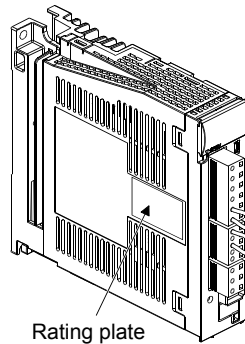

Rating plate

MR-J3-60B4 • 100B4

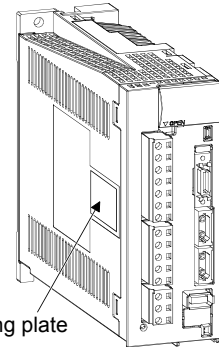

Rating plate

MR-J3-200B(4)

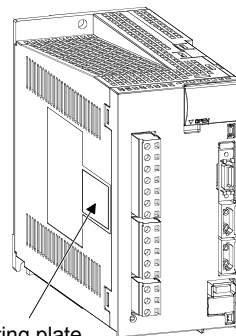

Rating plate

MR-J3-350B

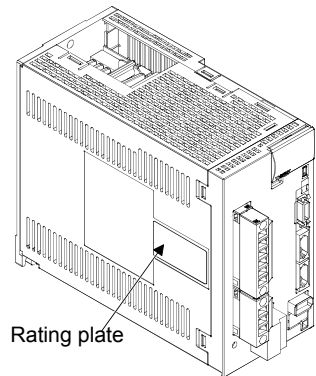

Rating plate

MR-J3-350B4 • 500B(4)

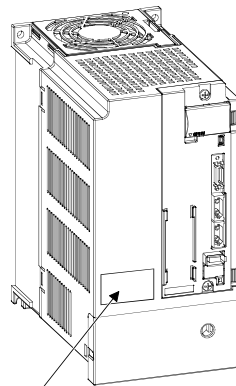

Rating plate

MR-J3-700B(4)

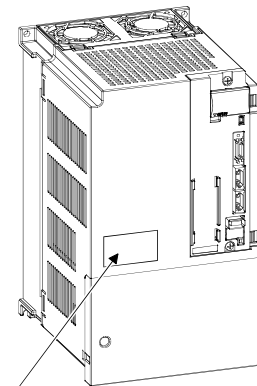

Rating plate

MR-J3-11KB(4) to 22KB(4)

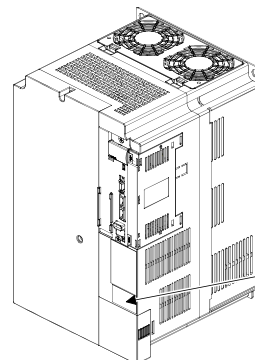

Rating plate

## 1. FUNCTIONS AND CONFIGURATION

### 1.6 Combination with servo motor

The following table lists combinations of servo amplifiers and servo motors. The same combinations apply to the models with an electromagnetic brake and the models with a reduction gear.

Servo amplifier	Servo motors						
	HF-MP□	HF-KP□	HF-SP□		HC-RP□	HC-UP□	HC-LP□
			1000r/min	2000r/min			
MR-J3-10B (1)	053 · 13	053 · 13					
MR-J3-20B (1)	23	23					
MR-J3-40B (1)	43	43					
MR-J3-60B			51	52			52
MR-J3-70B	73	73				72	
MR-J3-100B			81	102			102
MR-J3-200B			121 · 201	152 · 202	103 · 153	152	152
MR-J3-350B			301	352	203	202	202
MR-J3-500B			421	502	353 · 503	352 · 502	302
MR-J3-700B				702			
MR-J3-11KB							
MR-J3-15KB							
MR-J3-22KB							

Servo amplifier	Servo motors		
	HA-LP□		
	1000r/min	1500r/min	2000r/min
MR-J3-500B			502
MR-J3-700B	601	701M	702
MR-J3-11KB	801 · 12K1	11K1M	11K2
MR-J3-15KB	15K1	15K1M	15K2
MR-J3-22KB	20K1 · 25K1	22K1M	22K2

Servo amplifier	Servo motors			
	HF-SP	HA-LP□		
		1000r/min	1500r/min	2000r/min
MR-J3-60B4	524			
MR-J3-100B4	1024			
MR-J3-200B4	1524 · 2024			
MR-J3-350B4	3524			
MR-J3-500B4	5024			
MR-J3-700B4	7024	6014	701M4	
MR-J3-11KB4		8014 · 12K14	11K1M4	11K24
MR-J3-15KB4		15K14	15K1M4	15K24
MR-J3-22KB4		20K14	22K1M4	22K24

# 1. FUNCTIONS AND CONFIGURATION

## 1.7 Structure

### 1.7.1 Parts identification

#### (1) MR-J3-100B or less

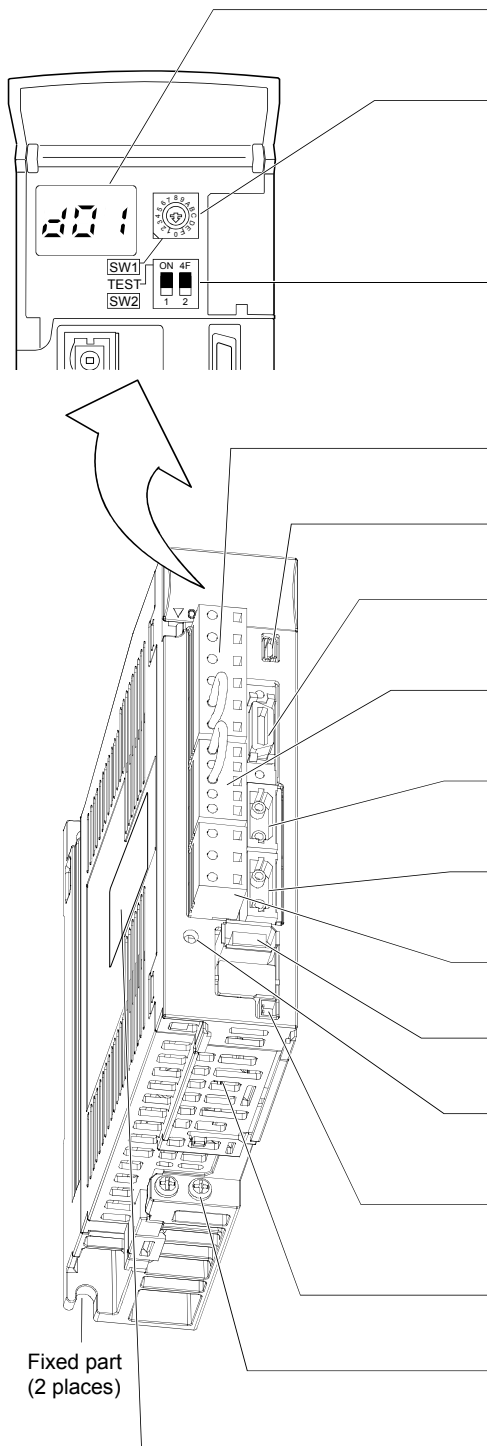

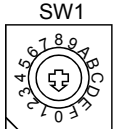
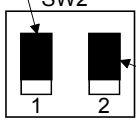
Name/Application	Detailed explanation
Display The 3-digit, seven-segment LED shows the servo status and alarm number.	Chapter 4
Rotary axis setting switch (SW1)  SW1 Used to set the axis No. of servo amplifier.	Section 3.13
Test operation select switch (SW2-1) Used to perform the test operation mode by using MR Configurator.  SW2 Spare (Be sure to set to the "Down" position).	Section 3.13
Main circuit power supply connector (CNP1) Connect the input power supply.	Section 3.1 Section 3.3
USB communication connector (CN5) Connect the personal computer.	Section 11.8
I/O signal connector (CN3) Used to connect digital I/O signals. More over an analog monitor is output.	Section 3.2 Section 3.4
Control circuit connector (CNP2) Connect the control circuit power supply/regenerative option.	Section 3.1 Section 3.3
SSCNET III cable connector (CN1A) Used to connect the servo system controller or the front axis servo amplifier.	Section 3.2 Section 3.4
SSCNET III cable connector (CN1B) Used to connect the rear axis servo amplifier. For the final axis, puts a cap.	Section 3.2 Section 3.4
Servo motor power connector (CNP3) Connect the servo motor.	Section 3.1 Section 3.3
Encoder connector (CN2) Used to connect the servo motor encoder.	Section 3.4 Section 11.1
Charge lamp Lit to indicate that the main circuit is charged. While this lamp is lit, do not reconnect the cables.	
Battery connector (CN4) Used to connect the battery for absolute position data backup.	Section 11.9 Chapter 12
Battery holder Contains the battery for absolute position data backup.	Section 12.3
Protective earth (PE) terminal (⊕) Ground terminal.	Section 3.1 Section 3.3
Rating plate	Section 1.5

# 1. FUNCTIONS AND CONFIGURATION

(2) MR-J3-60B4 • MR-J3-100B4

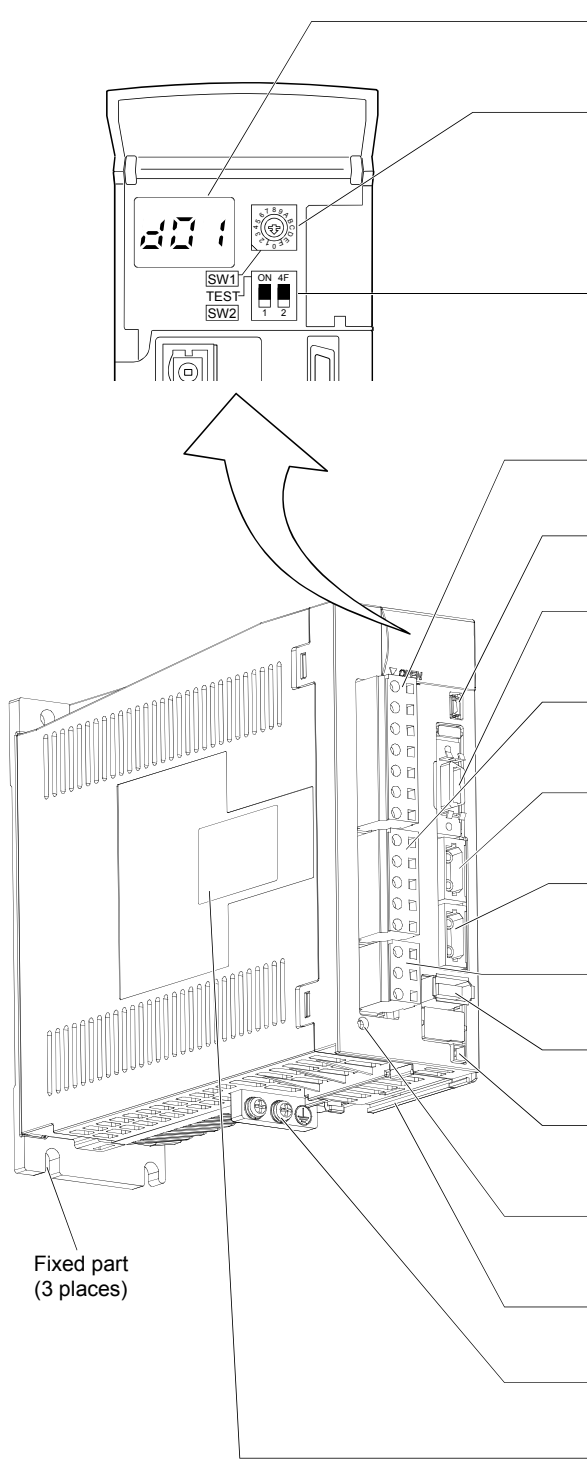

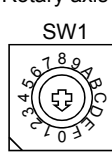
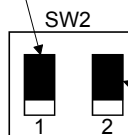
Name/Application	Detailed explanation
Display The 3-digit, seven-segment LED shows the servo status and alarm number.	Chapter 4
Rotary axis setting switch (SW1)  SW1 Used to set the axis No. of servo amplifier.	Section 3.13
Test operation select switch (SW2-1) Used to perform the test operation mode by using MR Configurator.  SW2 Spare (Be sure to set to the "Down" position).	Section 3.13
Main circuit power supply connector (CNP1) Connect the input power supply.	Section 3.1 Section 3.3
USB communication connector (CN5) Connect the personal computer.	Section 11.8
I/O signal connector (CN3) Used to connect digital I/O signals. More over an analog monitor is output.	Section 3.2 Section 3.4
Control circuit connector (CNP2) Connect the control circuit power supply/regenerative option.	Section 3.1 Section 3.3
SSCNET III cable connector (CN1A) Used to connect the servo system controller or the front axis servo amplifier.	Section 3.2 Section 3.4
SSCNET III cable connector (CN1B) Used to connect the rear axis servo amplifier. For the final axis, puts a cap.	Section 3.2 Section 3.4
Servo motor power connector (CNP3) Connect the servo motor.	Section 3.1 Section 3.3
Encoder connector (CN2) Used to connect the servo motor encoder.	Section 3.4 Section 11.1
Battery connector (CN4) Used to connect the battery for absolute position data backup.	Section 11.9 Chapter 12
Charge lamp Lit to indicate that the main circuit is charged. While this lamp is lit, do not reconnect the cables.	
Battery holder Contains the battery for absolute position data backup.	Section 12.3
Protective earth (PE) terminal (⊕) Ground terminal.	Section 3.1 Section 3.3
Rating plate	Section 1.5

Fixed part (3 places)

# 1. FUNCTIONS AND CONFIGURATION

## (3) MR-J3-200B(4)

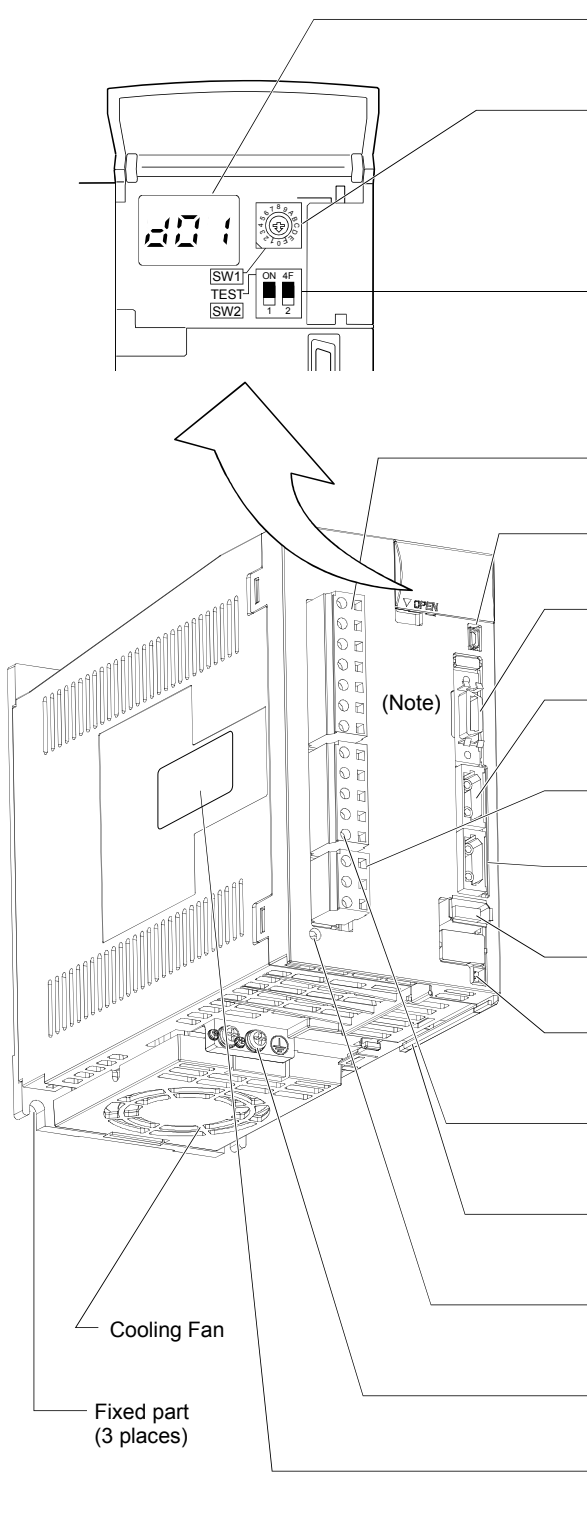

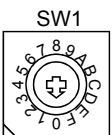
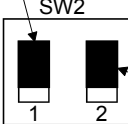
Name/Application	Detailed explanation
Display The 3-digit, seven-segment LED shows the servo status and alarm number.	Chapter 4
Rotary axis setting switch (SW1)  SW1 Used to set the axis No. of servo amplifier.	Section 3.13
Test operation select switch (SW2-1) Used to perform the test operation mode by using MR Configurator. Spare (Be sure to set to the "Down" position).  SW2	Section 3.13
Main circuit power supply connector (CNP1) Connect the input power supply.	Section 3.1 Section 3.3
USB communication connector (CN5) Connect the personal computer.	Section 11.8
I/O signal connector (CN3) Used to connect digital I/O signals. More over an analog monitor is output.	Section 3.2 Section 3.4
SSCNET III cable connector (CN1A) Used to connect the servo system controller or the front axis servo amplifier.	Section 3.2 Section 3.4
Servo motor power connector (CNP3) Connect the servo motor.	Section 3.1 Section 3.3
SSCNET III cable connector (CN1B) Used to connect the rear axis servo amplifier. For the final axis, puts a cap.	Section 3.2 Section 3.4
Encoder connector (CN2) Used to connect the servo motor encoder.	Section 3.4 Section 11.1
Battery connector (CN4) Used to connect the battery for absolute position data backup.	Section 11.9 Chapter 12
Control circuit connector (CNP2) Connect the control circuit power supply/regenerative option.	Section 3.1 Section 3.3
Battery holder Contains the battery for absolute position data backup.	Section 12.3
Charge lamp Lit to indicate that the main circuit is charged. While this lamp is lit, do not reconnect the cables.	
Protective earth (PE) terminal (⊕) Ground terminal.	Section 3.1 Section 3.3
Rating plate	Section 1.5

Labels in diagram: Cooling Fan, Fixed part (3 places), (Note), V OPEN

Note. Connectors (CNP1, CNP2, and CNP3) and appearance of MR-J3-200B servo amplifier have been changed from January 2008 production. Model name of the existing servo amplifier is changed to MR-J3-200B-RT. For MR-J3-200B-RT, refer to appendix 5.

# 1. FUNCTIONS AND CONFIGURATION

## (4) MR-J3-350B

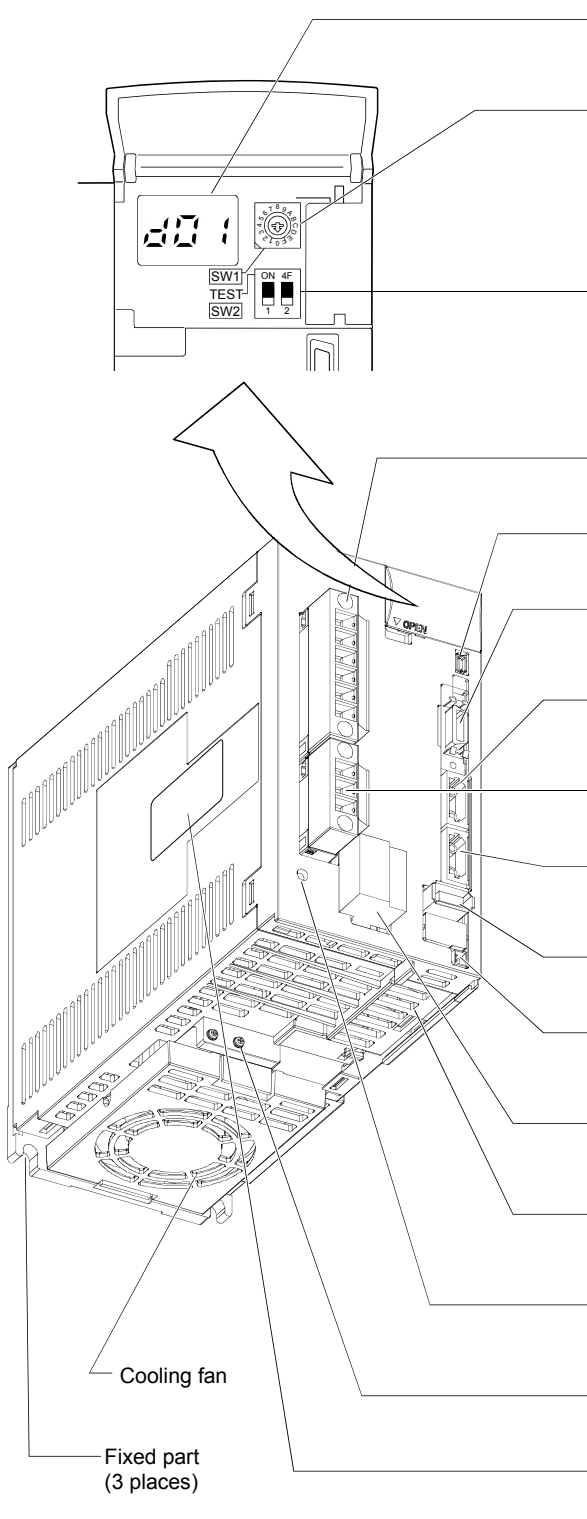

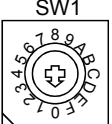
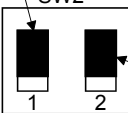
Name/Application	Detailed explanation
Display The 3-digit, seven-segment LED shows the servo status and alarm number.	Chapter 4
Rotary axis setting switch (SW1)  SW1  Used to set the axis No. of servo amplifier.	Section 3.13
Test operation select switch (SW2-1) Used to perform the test operation mode by using MR Configurator.  SW2  Spare (Be sure to set to the "Down" position).	Section 3.13
Main circuit power supply connector (CNP1) Connect the input power supply.	Section 3.1 Section 3.3
USB communication connector (CN5) Connect the personal computer.	Section 11.8
I/O signal connector (CN3) Used to connect digital I/O signals. More over an analog monitor is output.	Section 3.2 Section 3.4
SSCNET III cable connector (CN1A) Used to connect the servo system controller or the front axis servo amplifier.	Section 3.2 Section 3.4
Servo motor power connector (CNP3) Connect the servo motor.	Section 3.1 Section 3.3
SSCNET III cable connector (CN1B) Used to connect the rear axis servo amplifier. For the final axis, puts a cap.	Section 3.2 Section 3.4
Encoder connector (CN2) Used to connect the servo motor encoder.	Section 3.4 Section 11.1
Battery connector (CN4) Used to connect the battery for absolute position data backup.	Section 11.9 Chapter 12
Control circuit connector (CNP2) Connect the control circuit power supply/regenerative option.	Section 3.1 Section 3.3
Battery holder Contains the battery for absolute position data backup.	Section 12.3
Charge lamp Lit to indicate that the main circuit is charged. While this lamp is lit, do not reconnect the cables.	
Protective earth (PE) terminal (⊕) Ground terminal.	Section 3.1 Section 3.3
Rating plate	Section 1.5

Labels in diagram:  
Cooling fan  
Fixed part (3 places)

# 1. FUNCTIONS AND CONFIGURATION

(5) MR-J3-350B4 • MR-J3-500B(4)

**POINT**

- The servo amplifier is shown without the front cover. For removal of the front cover, refer to section 1.7.2.

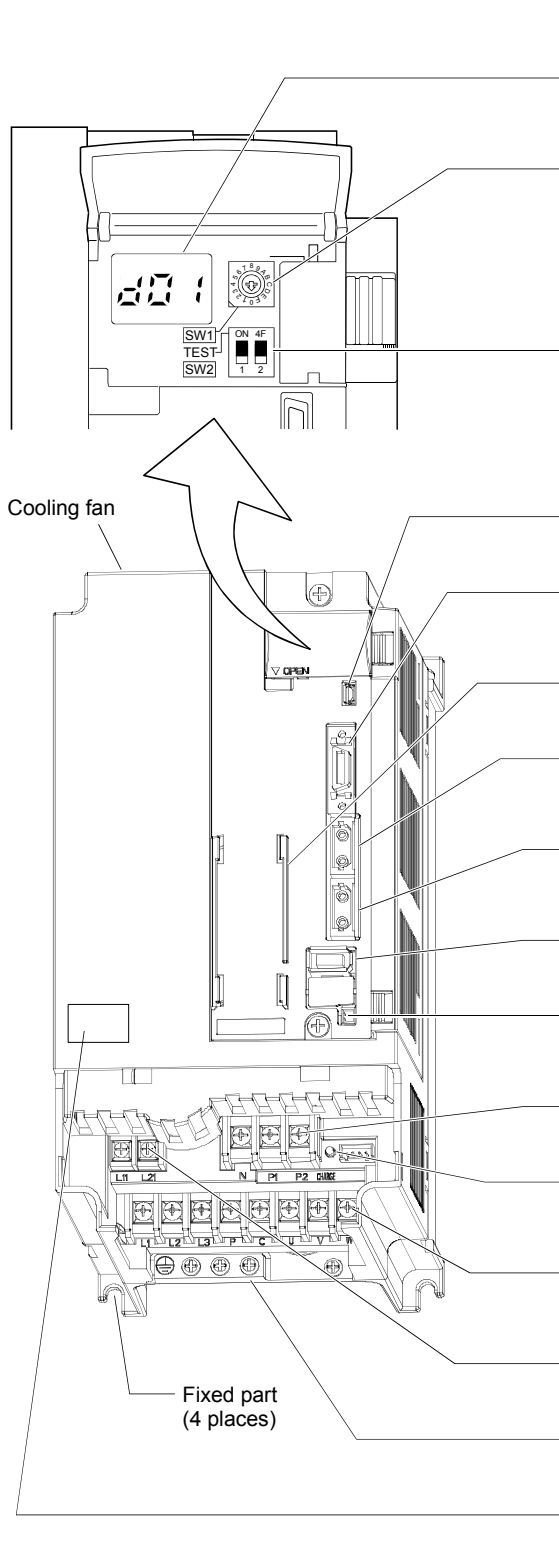

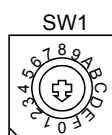
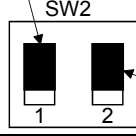
Name/Application	Detailed explanation
Display The 3-digit, seven-segment LED shows the servo status and alarm number.	Chapter 4
Rotary axis setting switch (SW1)  SW1 Used to set the axis No. of servo amplifier.	Section 3.13
SW2 Test operation select switch (SW2-1) Used to perform the test operation mode by using MR Configurator.  SW2 Spare (Be sure to set to the "Down" position).	Section 3.13
USB communication connector (CN5) Connect the personal computer.	Section 11.8
I/O signal connector (CN3) Used to connect digital I/O signals. More over an analog monitor is output.	Section 3.2 Section 3.4
Battery holder Contains the battery for absolute position data backup.	Section 12.3
SSCNET III cable connector (CN1A) Used to connect the servo system controller or the front axis servo amplifier.	Section 3.2 Section 3.4
SSCNET III cable connector (CN1B) Used to connect the rear axis servo amplifier. For the final axis, puts a cap.	Section 3.2 Section 3.4
Encoder connector (CN2) Used to connect the servo motor encoder.	Section 3.4 Section 11.1
Battery connector (CN4) Used to connect the battery for absolute position data backup.	Section 11.9 Chapter 12
DC reactor terminal block (TE3) Used to connect the DC reactor.	Section 3.4 Section 11.1
Charge lamp Lit to indicate that the main circuit is charged. While this lamp is lit, do not reconnect the cables.	
Main circuit terminal block (TE1) Used to connect the input power supply and servo motor.	Section 3.1 Section 3.3
Control circuit terminal block (TE2) Used to connect the control circuit power supply.	Section 3.1 Section 3.3
Protective earth (PE) terminal (⊕) Ground terminal.	Section 3.1 Section 3.3
Rating plate	Section 1.5

# 1. FUNCTIONS AND CONFIGURATION

## (6) MR-J3-700B(4)

**POINT**

- The servo amplifier is shown without the front cover. For removal of the front cover, refer to section 1.7.2.

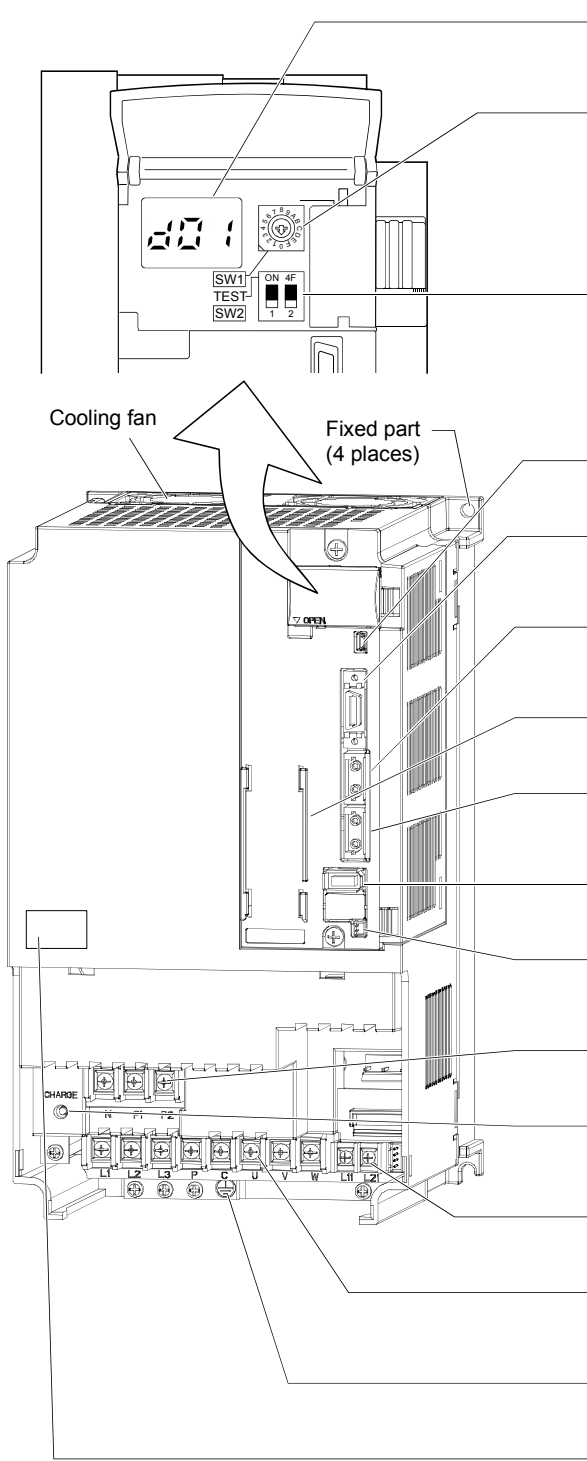

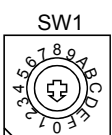
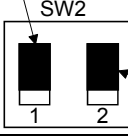
Name/Application	Detailed explanation
Display The 3-digit, seven-segment LED shows the servo status and alarm number.	Chapter 4
Rotary axis setting switch (SW1) 	Used to set the axis No. of servo amplifier. Section 3.13
SW2 	Test operation select switch (SW2-1) Used to perform the test operation mode by using MR Configurator. Spare (Be sure to set to the "Down" position). Section 3.13
USB communication connector (CN5) Connect the personal computer.	Section 11.8
I/O signal connector (CN3) Used to connect digital I/O signals. More over an analog monitor is output.	Section 3.2 Section 3.4
SSCNET III cable connector (CN1A) Used to connect the servo system controller or the front axis servo amplifier.	Section 3.2 Section 3.4
Battery holder Contains the battery for absolute position data backup.	Section 12.3
SSCNET III cable connector (CN1B) Used to connect the rear axis servo amplifier. For the final axis, puts a cap.	Section 3.2 Section 3.4
Encoder connector (CN2) Used to connect the servo motor encoder.	Section 3.4 Section 11.1
Battery connector (CN4) Used to connect the battery for absolute position data backup.	Section 11.9 Chapter 12
DC reactor terminal block (TE3) Used to connect the DC reactor.	Section 3.4 Section 11.1
Charge lamp Lit to indicate that the main circuit is charged. While this lamp is lit, do not reconnect the cables.	
Control circuit terminal block (TE2) Used to connect the control circuit power supply.	Section 3.1 Section 3.3
Main circuit terminal block (TE1) Used to connect the input power supply and servo motor.	Section 3.1 Section 3.3
Protective earth (PE) terminal (⊕) Ground terminal.	Section 3.1 Section 3.3
Rating plate	Section 1.5

# 1. FUNCTIONS AND CONFIGURATION

## (7) MR-J3-11KB(4) to MR-J3-22KB(4)

**POINT**

- The servo amplifier is shown without the front cover. For removal of the front cover, refer to section 1.7.2.

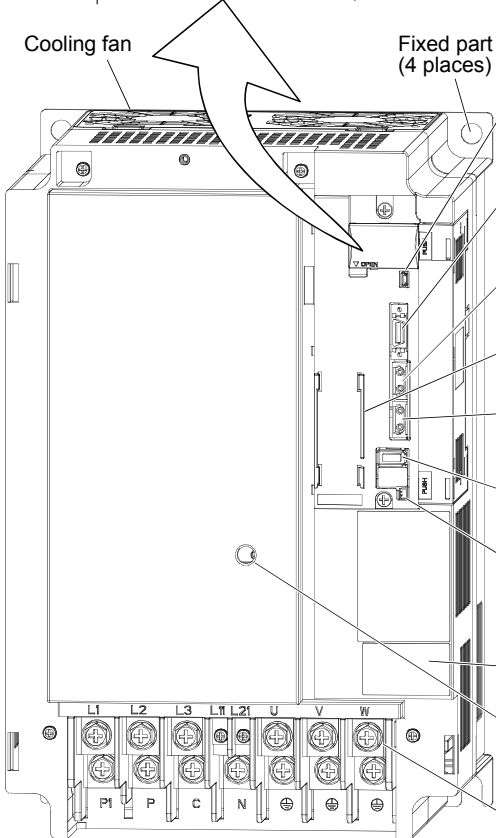
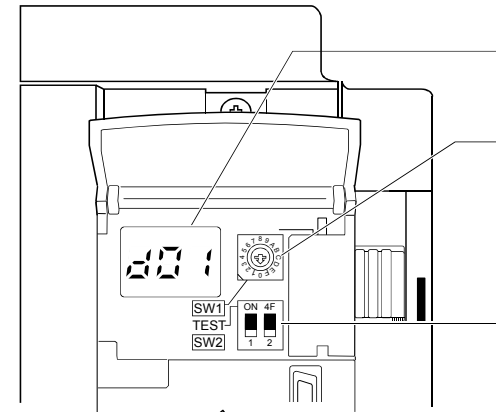

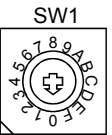
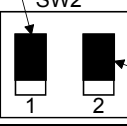
Name/Application	Detailed explanation
Display The 3-digit, seven-segment LED shows the servo status and alarm number.	Chapter 4
Rotary axis setting switch (SW1)  SW1 Used to set the axis No. of servo amplifier.	Section 3.13
Test operation select switch (SW2-1) Used to perform the test operation mode by using MR Configurator.  SW2 Spare (Be sure to set to the "Down" position).	Section 3.13
USB communication connector (CN5) Connect the personal computer.	Section 11.8
I/O signal connector (CN3) Used to connect digital I/O signals. More over an analog monitor is output.	Section 3.2 Section 3.4
SSCNET III cable connector (CN1A) Used to connect the servo system controller or the front axis servo amplifier.	Section 3.2 Section 3.4
Battery holder Contains the battery for absolute position data backup.	Section 12.3
SSCNET III cable connector (CN1B) Used to connect the rear axis servo amplifier. For the final axis, puts a cap.	Section 3.2 Section 3.4
Encoder connector (CN2) Used to connect the servo motor encoder.	Section 3.4 Section 11.1
Battery connector (CN4) Used to connect the battery for absolute position data backup.	Section 11.9 Chapter 12
Rating plate	Section 1.5
Charge lamp Lit to indicate that the main circuit is charged. While this lamp is lit, do not reconnect the cables.	
Main circuit terminal block • control circuit • protective earth (TE) Used to connect the input power supply, servo motor, regenerative option and ground.	Section 3.1 Section 3.3

## 1. FUNCTIONS AND CONFIGURATION

### 1.7.2 Removal and reinstallation of the front cover



• Before removing or installing the front cover, turn off the power and wait for 15 minutes or more until the charge lamp turns off. Then, confirm that the voltage between P(+) and N(–) is safe with a voltage tester and others. Otherwise, an electric shock may occur. In addition, always confirm from the front of the servo amplifier whether the charge lamp is off or not.

(1) For MR-J3-350B4 • MR-J3-500B(4) • MR-J3-700B(4)

Removal of the front cover

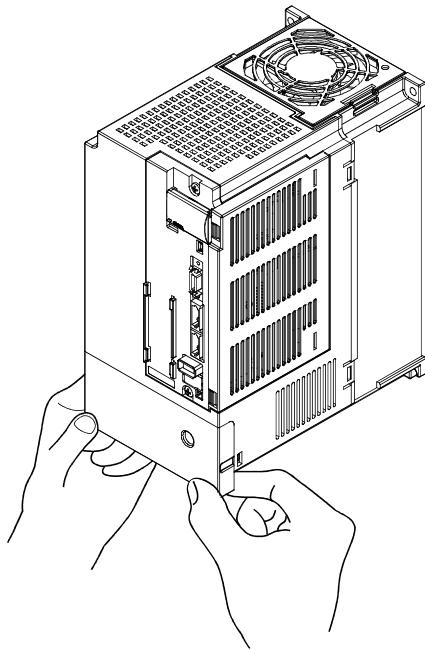

Hold the ends of lower side of the front cover with both hands.

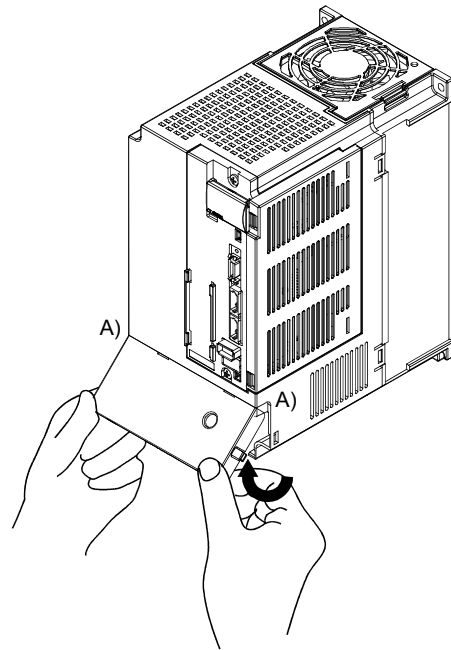

Pull up the cover, supporting at point A).

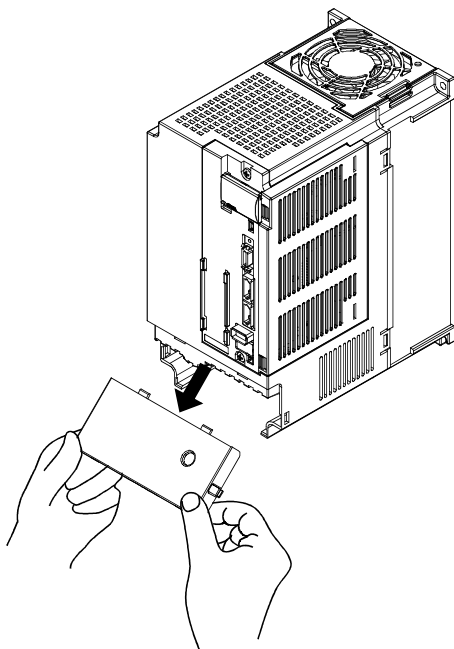

Pull out the front cover to remove.

# 1. FUNCTIONS AND CONFIGURATION

## Reinstallation of the front cover

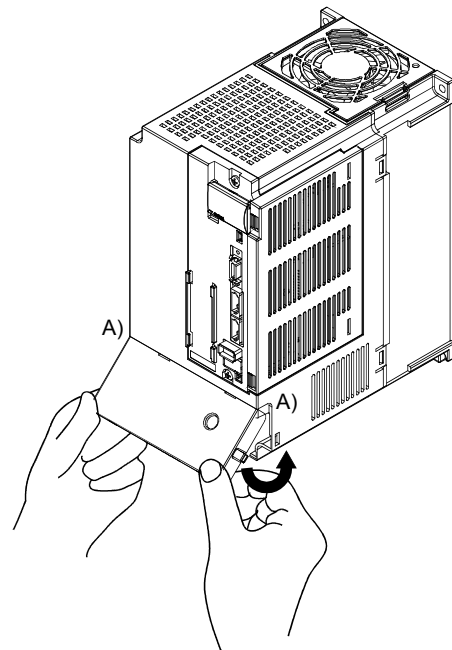
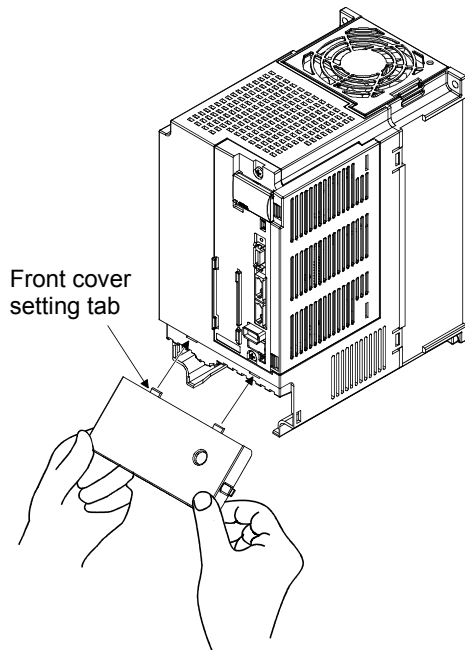

Insert the front cover setting tabs into the sockets of servo amplifier (2 places).

Pull up the cover, supporting at point A).

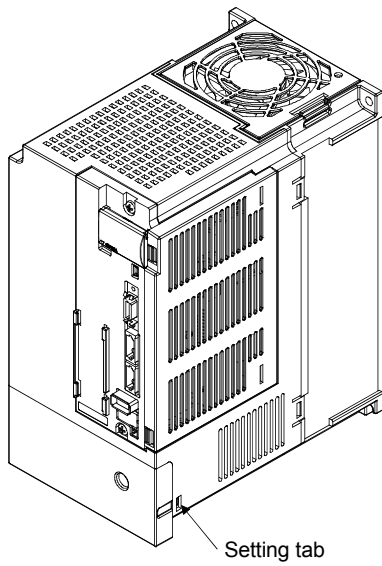

Push the setting tabs until they click.

# 1. FUNCTIONS AND CONFIGURATION

(2) For MR-J3-11KB(4) to MR-J3-22KB(4)

Removal of the front cover

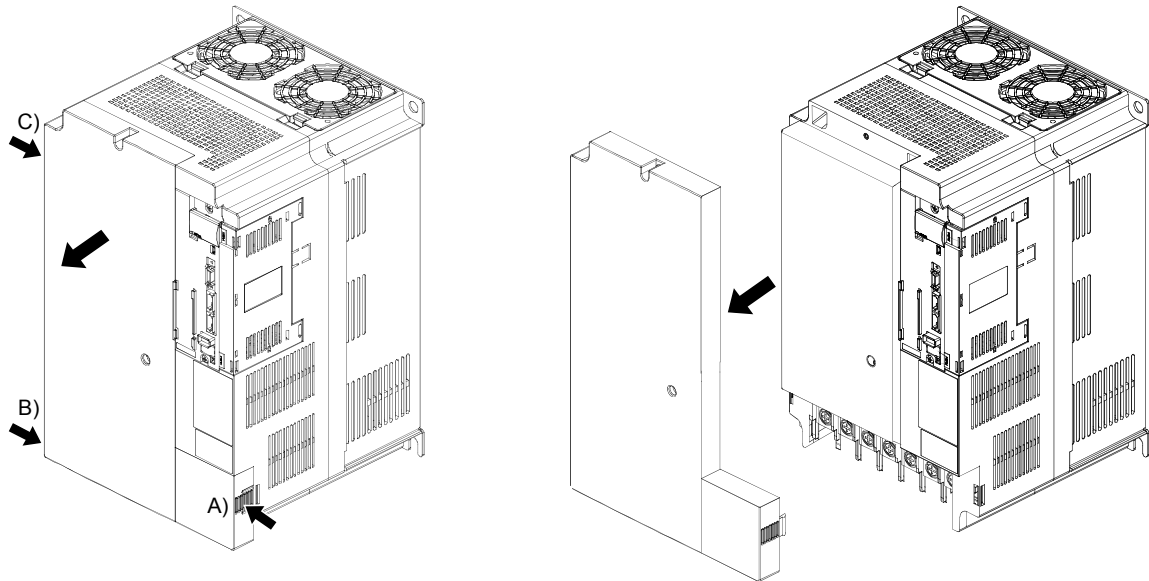

- 1) Press the removing knob on the lower side of the front cover ( A ) and B ) and release the installation hook.
- 2) Press the removing knob of C) and release the external hook.
- 3) Pull it to remove the front cover.

Reinstallation of the front cover

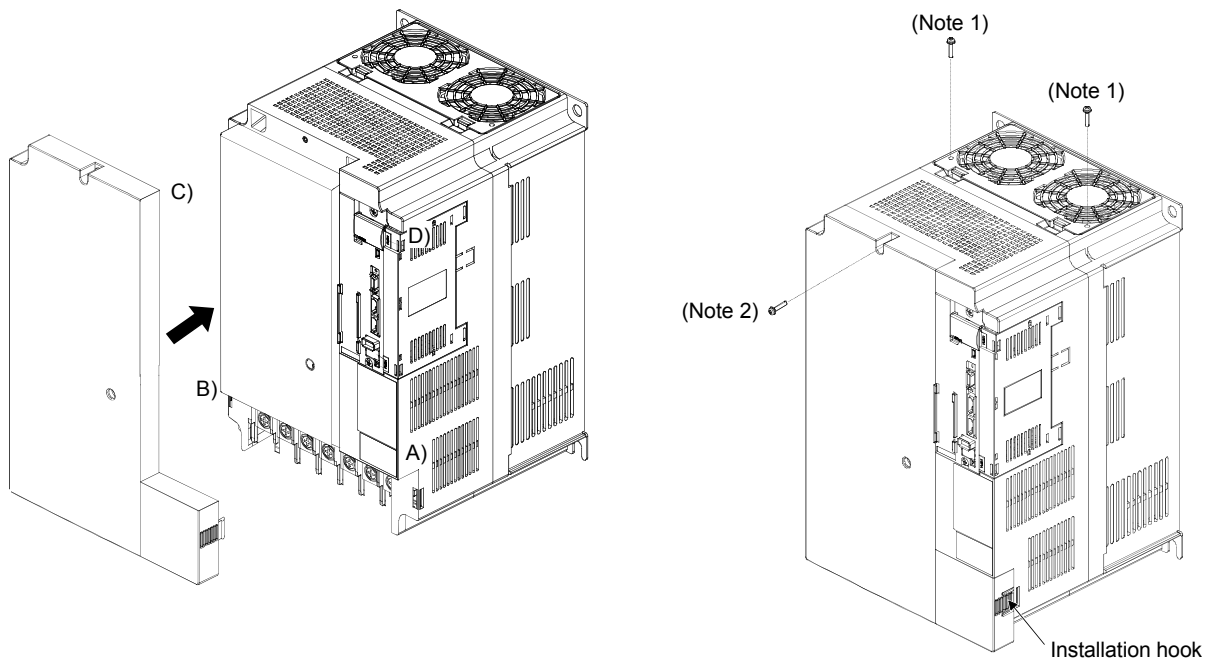

- 1) Fit the front cover installation hooks on the sockets of body cover ( A ) to D ) to reinstall it.
- 2) Push the front cover until you hear the clicking noise of the installation hook.

Note 1. The cooling fan cover can be locked with enclosed screws (M4 × 40).

2. By drilling approximately  $\phi 4$  of a hole on the front cover, the front cover can be locked on the body with an enclosed screw (M4 × 14).

# 1. FUNCTIONS AND CONFIGURATION

## 1.8 Configuration including auxiliary equipment

POINT
▪ Equipment other than the servo amplifier and servo motor are optional or recommended products.

### (1) MR-J3-100B or less

#### (a) For 3-phase or 1-phase 200V to 230VAC

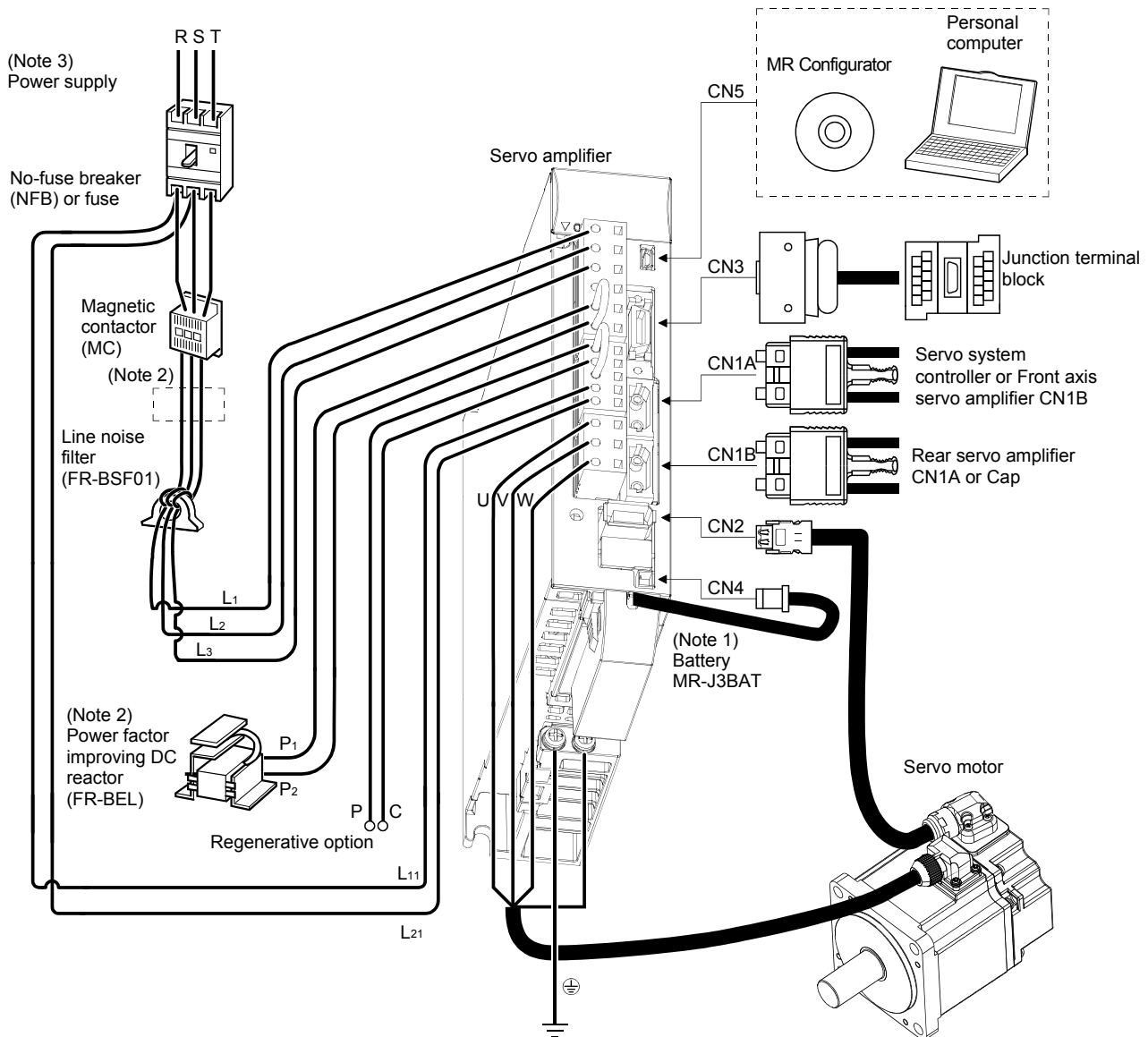

Note 1. The battery (option) is used for the absolute position detection system in the position control mode.

2. The AC reactor can also be used. In this case, the DC reactor cannot be used. When not using DC reactor, short P<sub>1</sub> and P<sub>2</sub>.

3. A 1-phase 200V to 230VAC power supply may be used with the servo amplifier of MR-J3-70B or less.

For 1-phase 200V to 230VAC, connect the power supply to L<sub>1</sub> • L<sub>2</sub> and leave L<sub>3</sub> open. Refer to section 1.3 for the power supply specification.

# 1. FUNCTIONS AND CONFIGURATION

(b) For 1-phase 100V to 120VAC

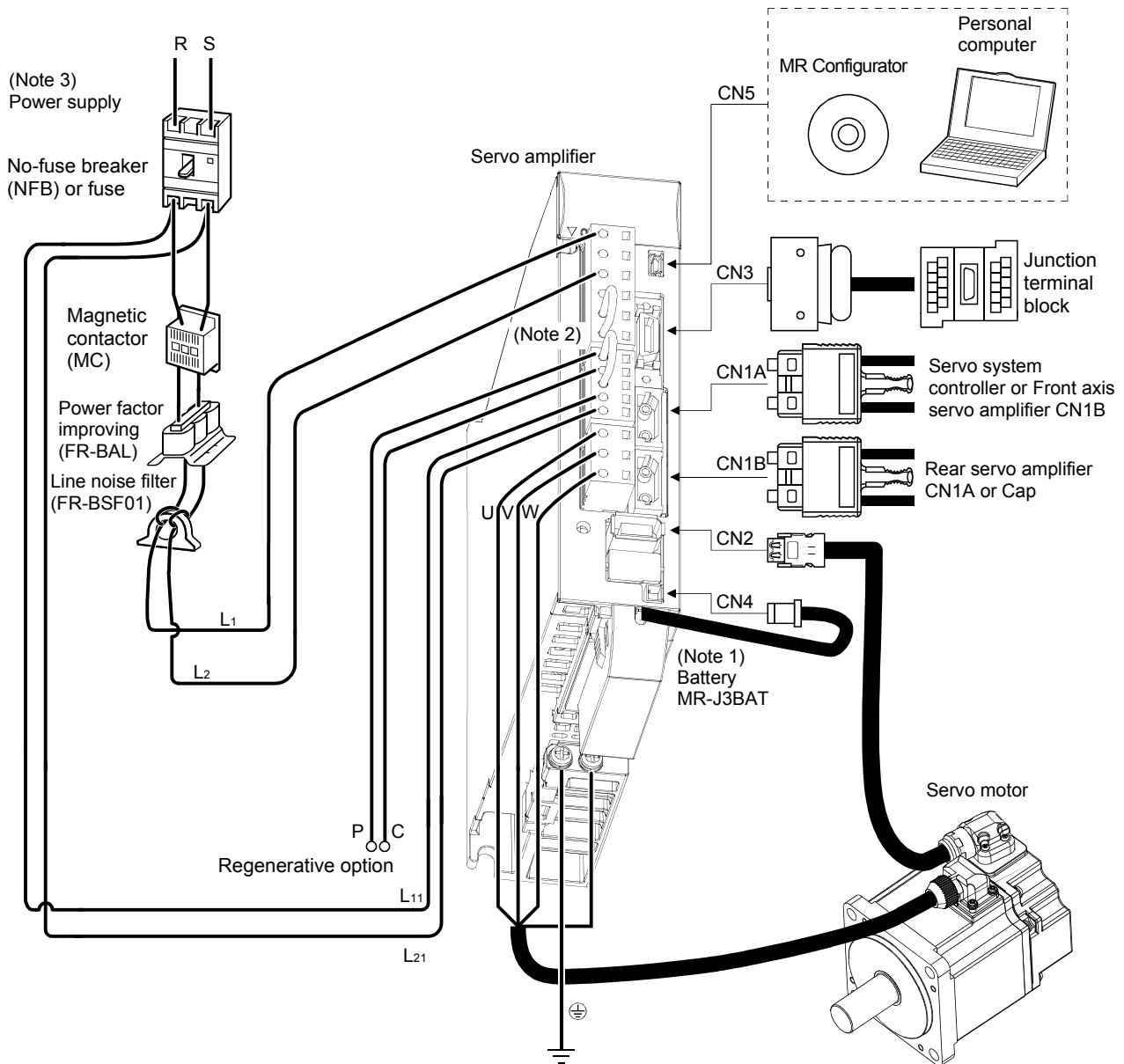

Note 1. The battery (option) is used for the absolute position detection system in the position control mode.

Note 2. The power factor improving DC reactor cannot be used.

Note 3. Refer to section 1.3 for the power supply specification.

# 1. FUNCTIONS AND CONFIGURATION

## (2) MR-J3-60B4 • MR-J3-100B4

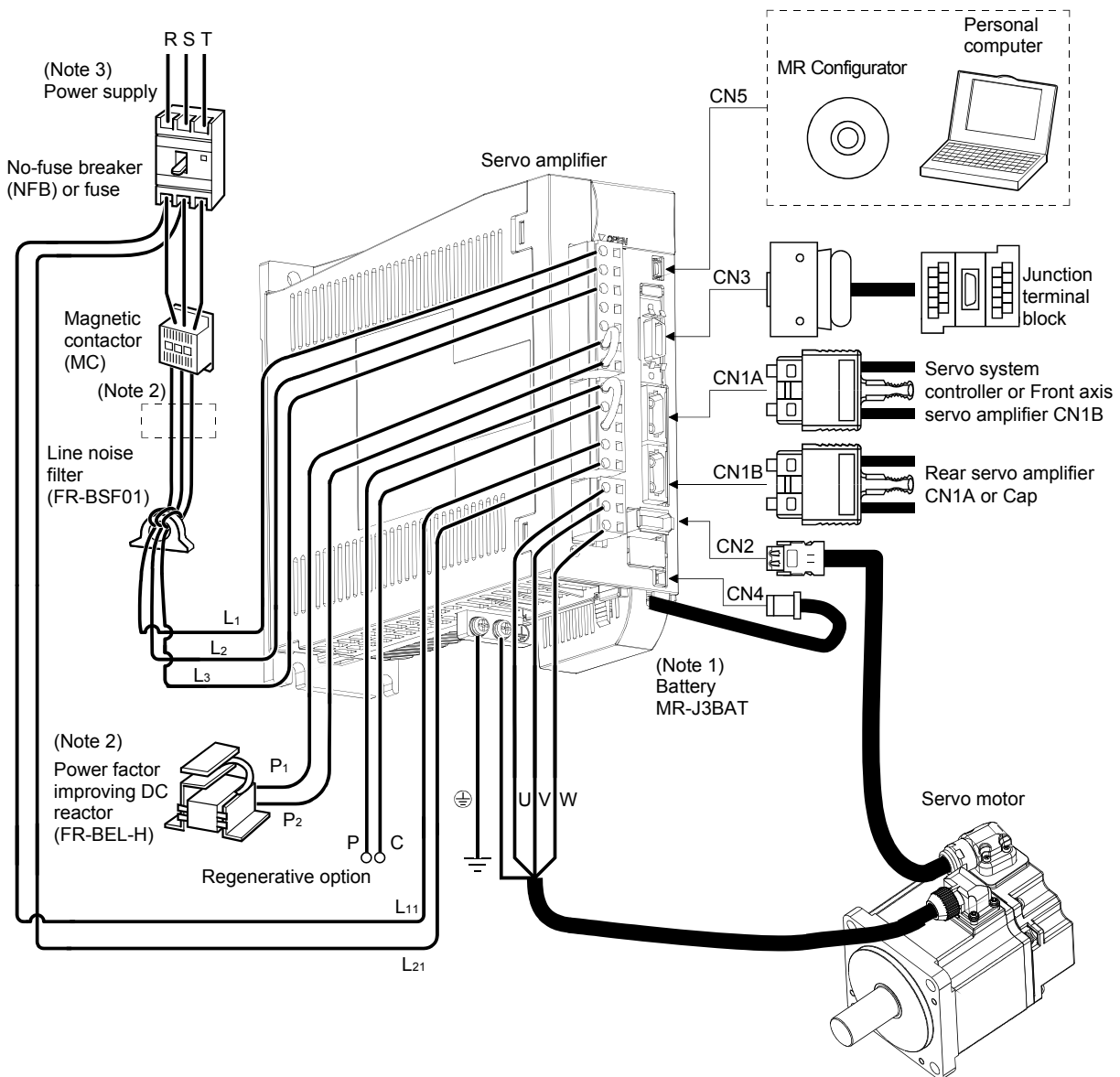

Note 1. The battery (option) is used for the absolute position detection system in the position control mode.

2. The AC reactor can also be used. In this case, the DC reactor cannot be used. When not using DC reactor, short P<sub>1</sub> and P<sub>2</sub>.

3. A 1-phase 200V to 230VAC power supply may be used with the servo amplifier of MR-J3-70B or less.

For 1-phase 200V to 230VAC, connect the power supply to L<sub>1</sub> • L<sub>2</sub> and leave L<sub>3</sub> open. Refer to section 1.3 for the power supply specification.

# 1. FUNCTIONS AND CONFIGURATION

## (3) MR-J3-200B(4)

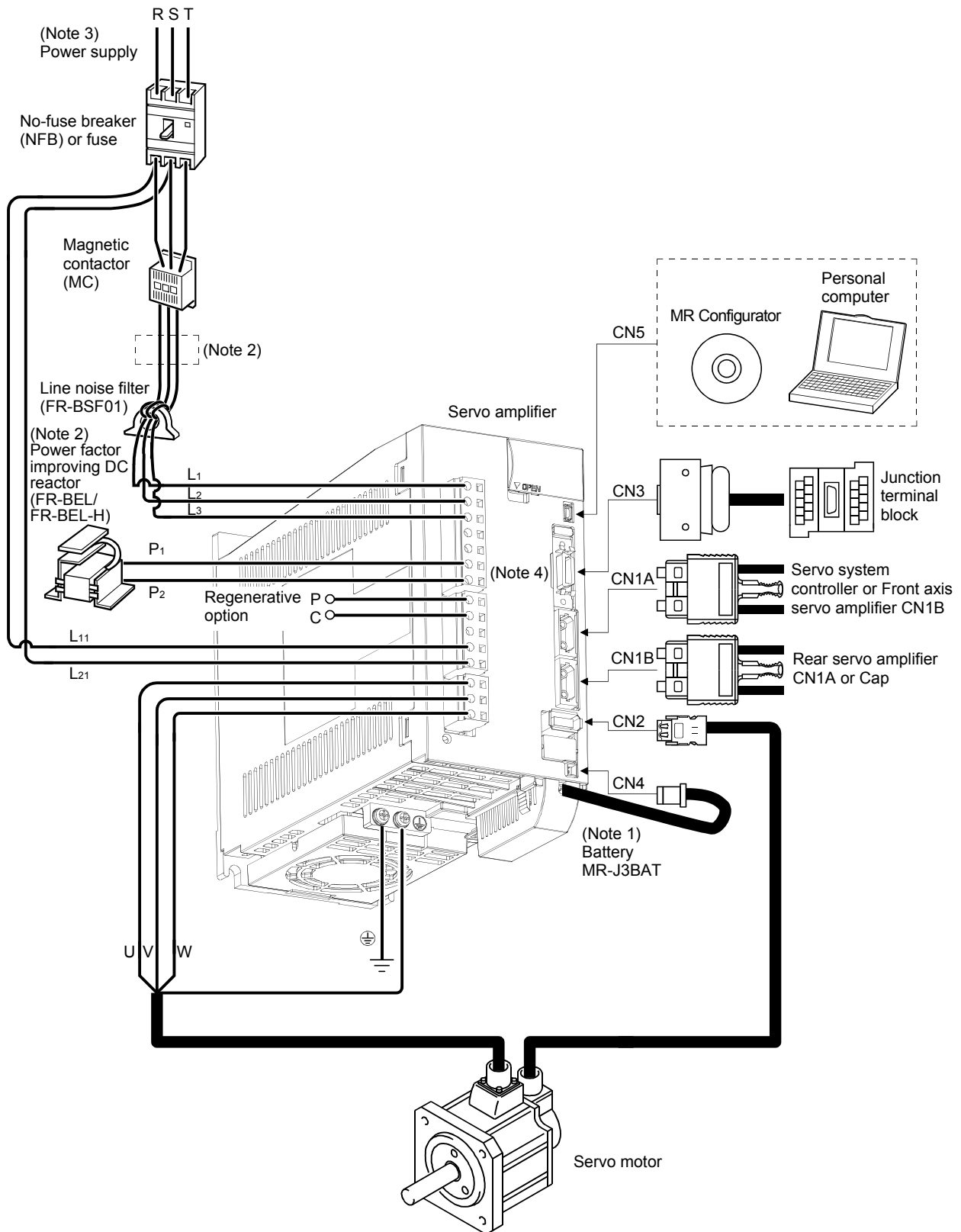

- Note 1. The battery (option) is used for the absolute position detection system in the position control mode.
2. The AC reactor can also be used. In this case, the DC reactor cannot be used. When not using DC reactor, short P<sub>1</sub> and P<sub>2</sub>.
3. Refer to section 1.3 for the power supply specification.
4. Connectors (CNP1, CNP2, and CNP3) and appearance of MR-J3-200B servo amplifier have been changed from January 2008 production. Model name of the existing servo amplifier is changed to MR-J3-200B-RT. For MR-J3-200B-RT, refer to appendix 5.

# 1. FUNCTIONS AND CONFIGURATION

## (4) MR-J3-350B

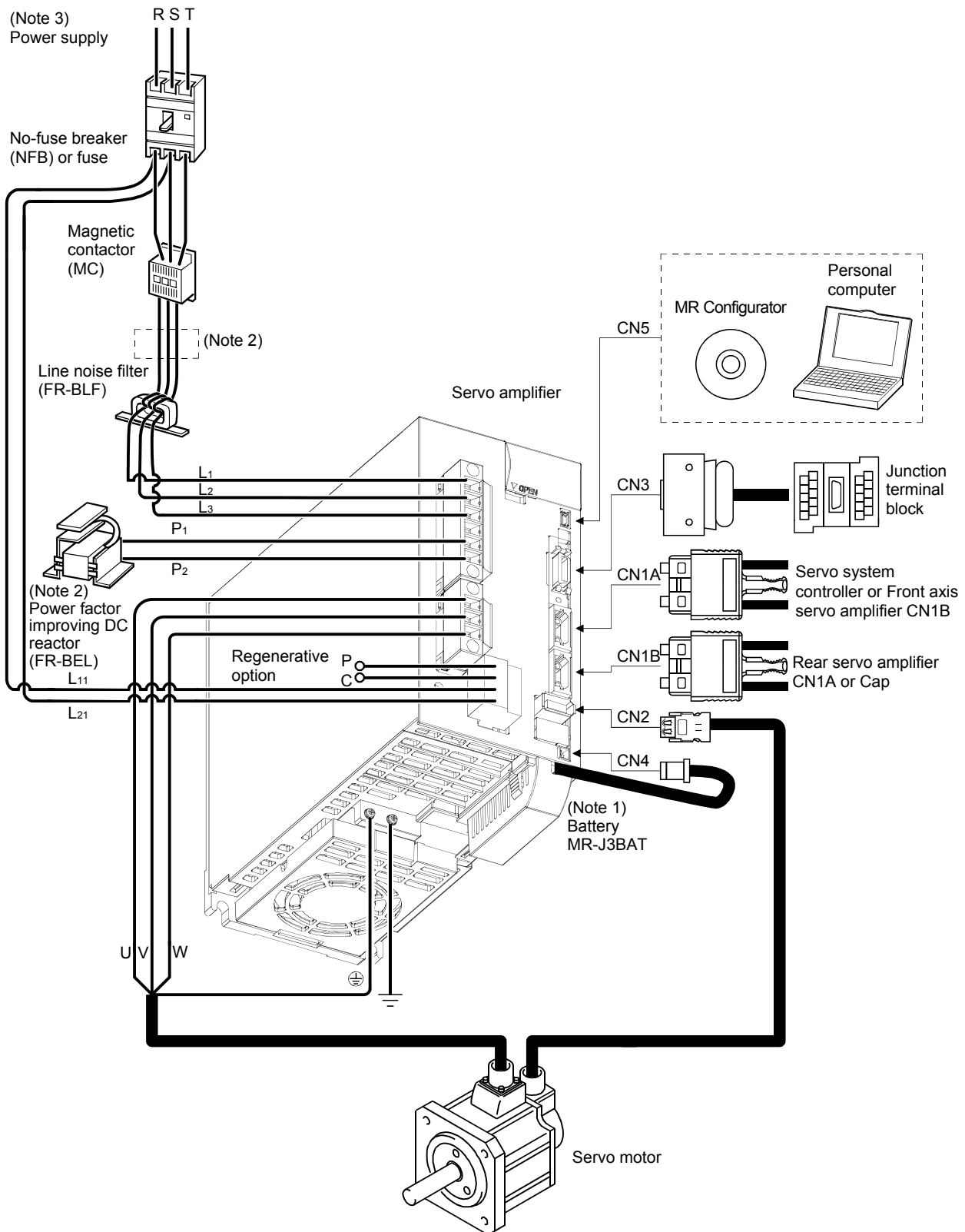

Note 1. The battery (option) is used for the absolute position detection system in the position control mode.

2. The AC reactor can also be used. In this case, the DC reactor cannot be used. When not using DC reactor, short P<sub>1</sub> and P<sub>2</sub>.

3. Refer to section 1.3 for the power supply specification.

# 1. FUNCTIONS AND CONFIGURATION

## (5) MR-J3-350B4 · MR-J3-500B(4)

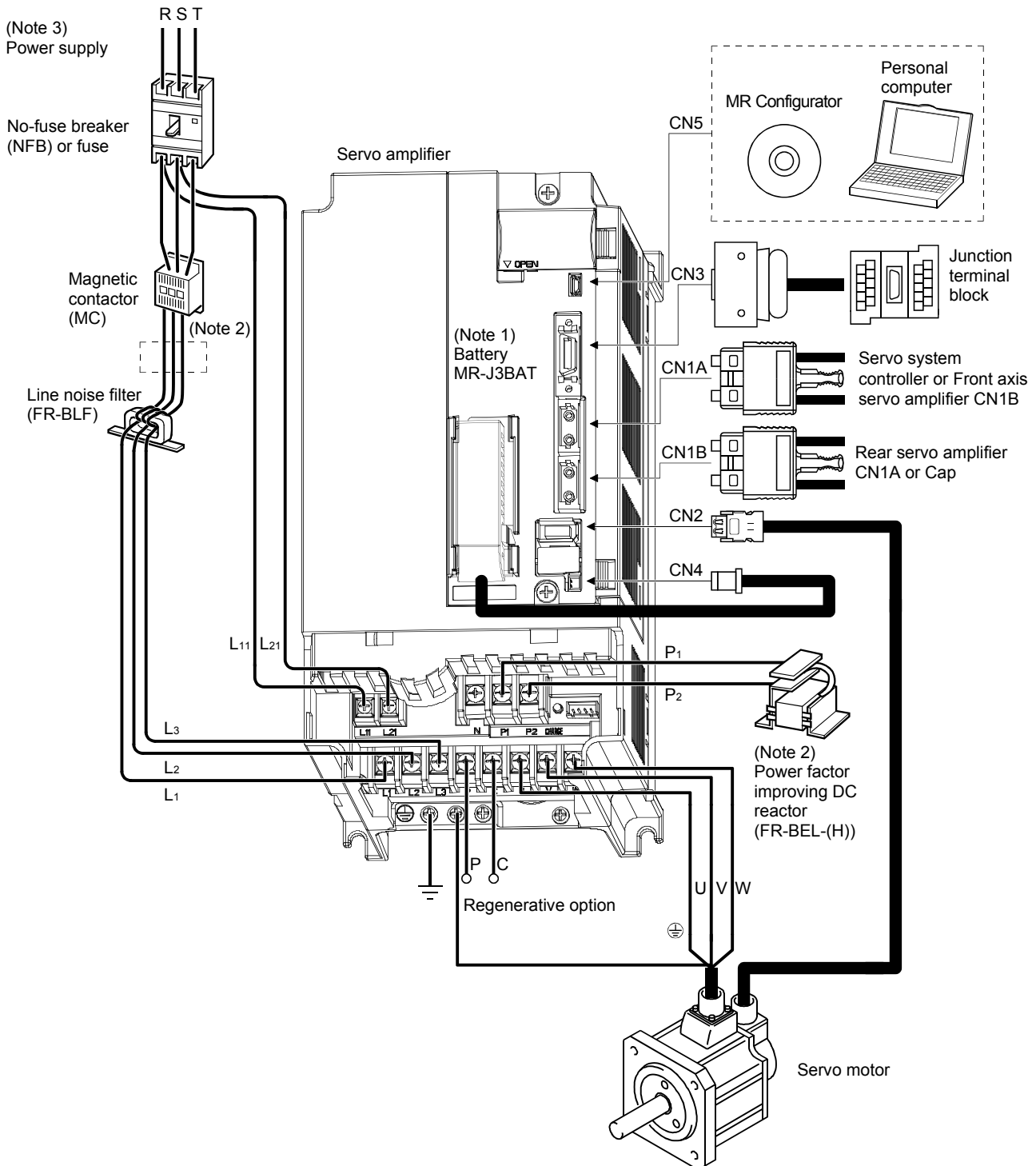

Note 1. The battery (option) is used for the absolute position detection system in the position control mode.

2. The AC reactor can also be used. In this case, the DC reactor cannot be used. When not using DC reactor, short P<sub>1</sub> and P<sub>2</sub>.

3. Refer to section 1.3 for the power supply specification.

# 1. FUNCTIONS AND CONFIGURATION

## (6) MR-J3-700B(4)

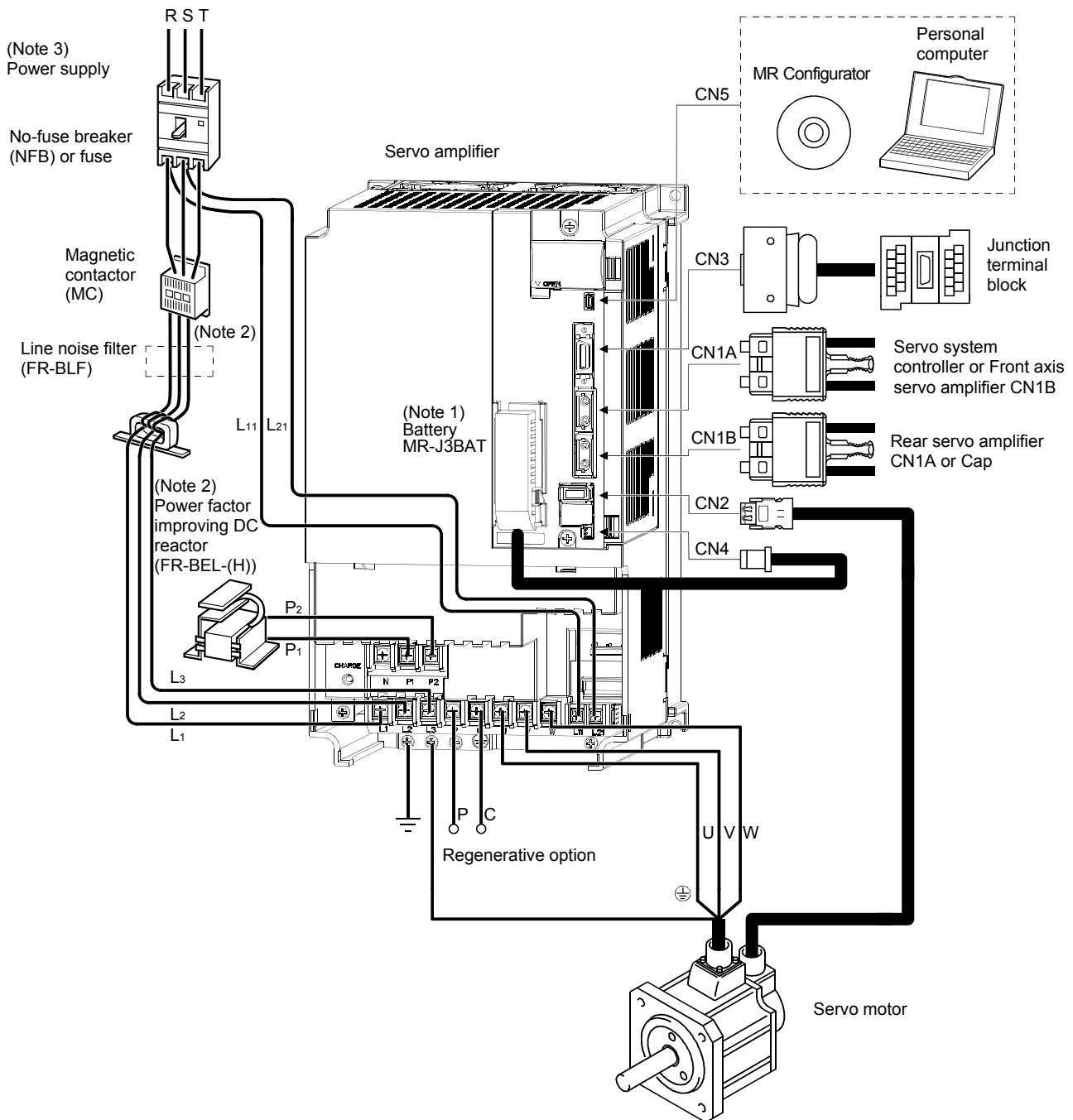

Note 1. The battery (option) is used for the absolute position detection system in the position control mode.

2. The AC reactor can also be used. In this case, the DC reactor cannot be used. When not using DC reactor, short P<sub>1</sub> and P<sub>2</sub>.

3. Refer to section 1.3 for the power supply specification.

# 1. FUNCTIONS AND CONFIGURATION

## (7) MR-J3-11KB(4) to MR-J3-22KB(4)

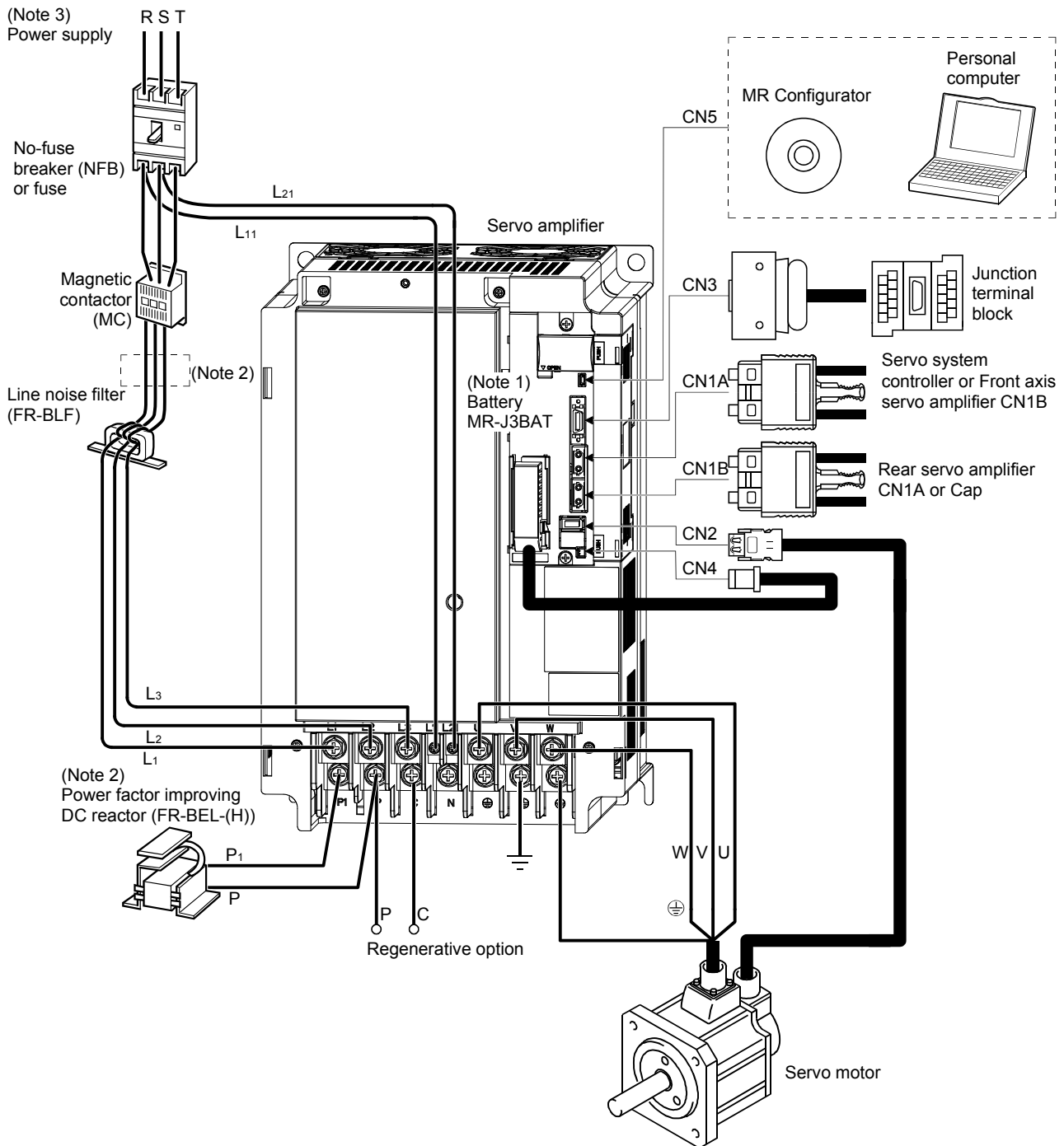

Note 1. The battery (option) is used for the absolute position detection system in the position control mode.

2. The AC reactor can also be used. In this case, the DC reactor cannot be used. When not using DC reactor, short P<sub>1</sub> and P.

3. Refer to section 1.3 for the power supply specification.

## 2. INSTALLATION

### 2. INSTALLATION

#### ⚠ CAUTION

- Stacking in excess of the limited number of products is not allowed.
- Install the equipment on incombustible material. Installing them directly or close to combustibles will lead to a fire.
- Install the equipment in a load-bearing place in accordance with this Instruction Manual.
- Do not get on or put heavy load on the equipment to prevent injury.
- Use the equipment within the specified environmental condition range. (For the environmental conditions, refer to section 1.3.)
- Provide an adequate protection to prevent screws, metallic detritus and other conductive matter or oil and other combustible matter from entering the servo amplifier.
- Do not block the intake/exhaust ports of the servo amplifier. Otherwise, a fault may occur.
- Do not subject the servo amplifier to drop impact or shock loads as they are precision equipment.
- Do not install or operate a faulty servo amplifier.
- When the product has been stored for an extended period of time, consult Mitsubishi.
- When treating the servo amplifier, be careful about the edged parts such as the corners of the servo amplifier.

#### 2.1 Installation direction and clearances

#### ⚠ CAUTION

- The equipment must be installed in the specified direction. Otherwise, a fault may occur.
- Leave specified clearances between the servo amplifier and control box inside walls or other equipment.

#### (1) 7kW or less

##### (a) Installation of one servo amplifier

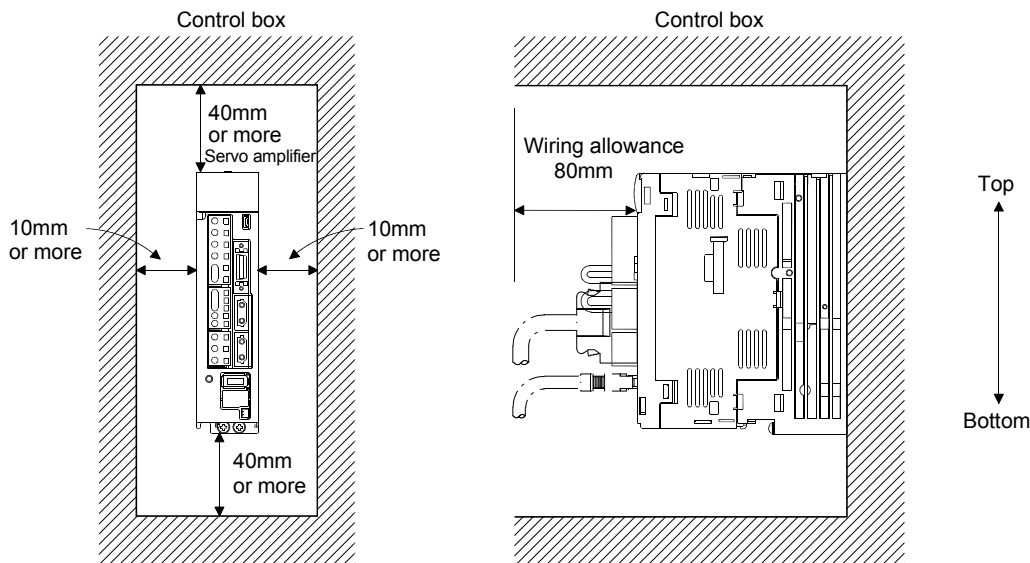

## 2. INSTALLATION

### (b) Installation of two or more servo amplifiers

POINT
<ul style="list-style-type: none"> <li>Close mounting is available for the servo amplifier of under 3.5kW for 200V class and 400W for 100V class.</li> </ul>

Leave a large clearance between the top of the servo amplifier and the internal surface of the control box, and install a cooling fan to prevent the internal temperature of the control box from exceeding the environmental conditions.

When installing the servo amplifiers closely, leave a clearance of 1mm between the adjacent servo amplifiers in consideration of mounting tolerances.

In this case, bring the ambient temperature within 0 to 45°C (32 to 113°F), or use it at 75% or smaller effective load ratio.

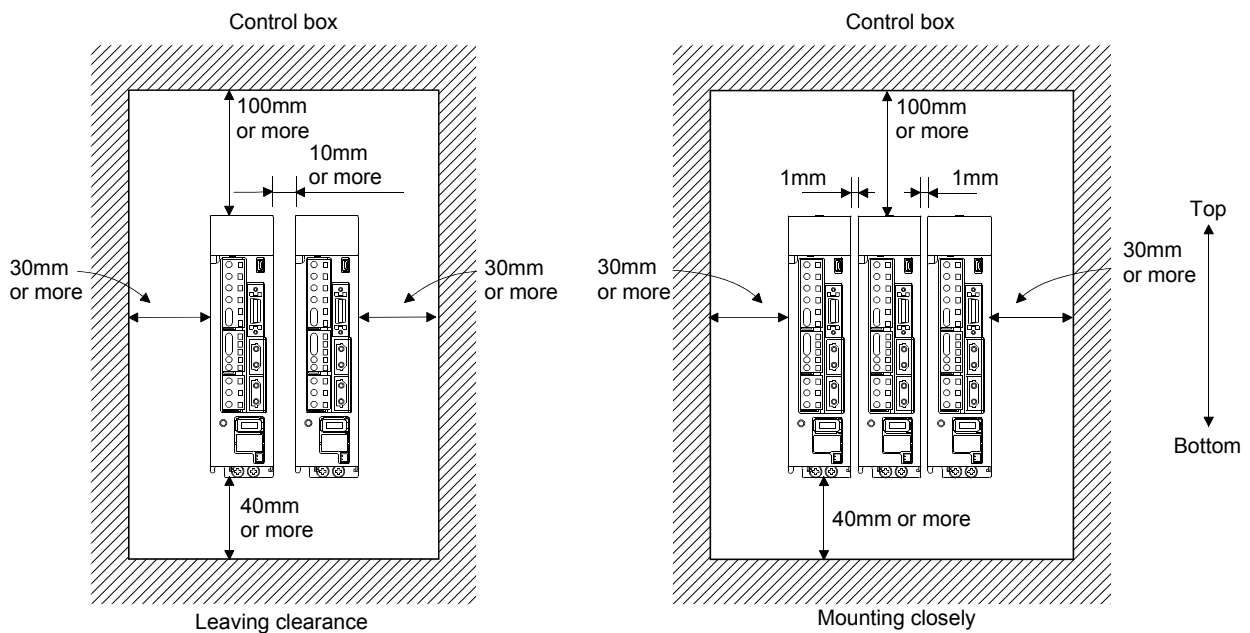

### (2) 11k to 22kW

#### (a) Installation of one servo amplifier

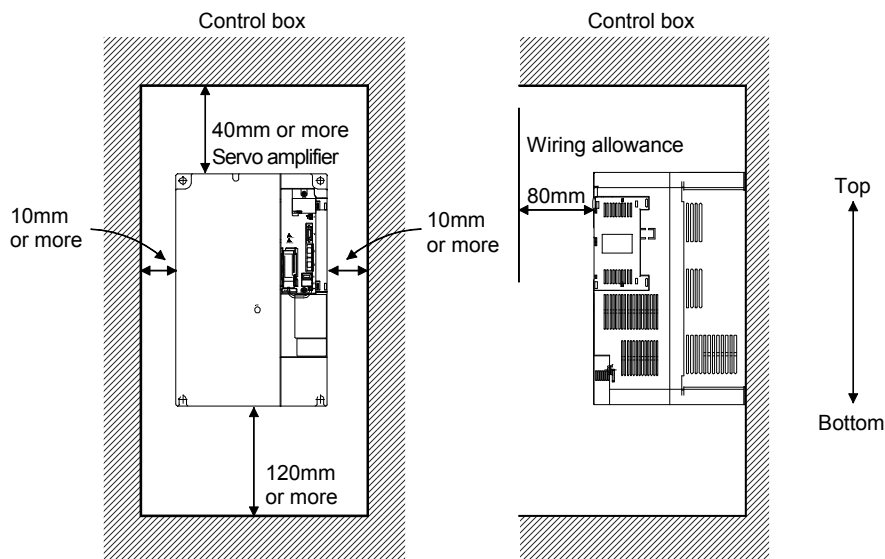

## 2. INSTALLATION

### (b) Installation of two or more servo amplifiers

Leave a large clearance between the top of the servo amplifier and the internal surface of the control box, and install a cooling fan to prevent the internal temperature of the control box from exceeding the environmental conditions.

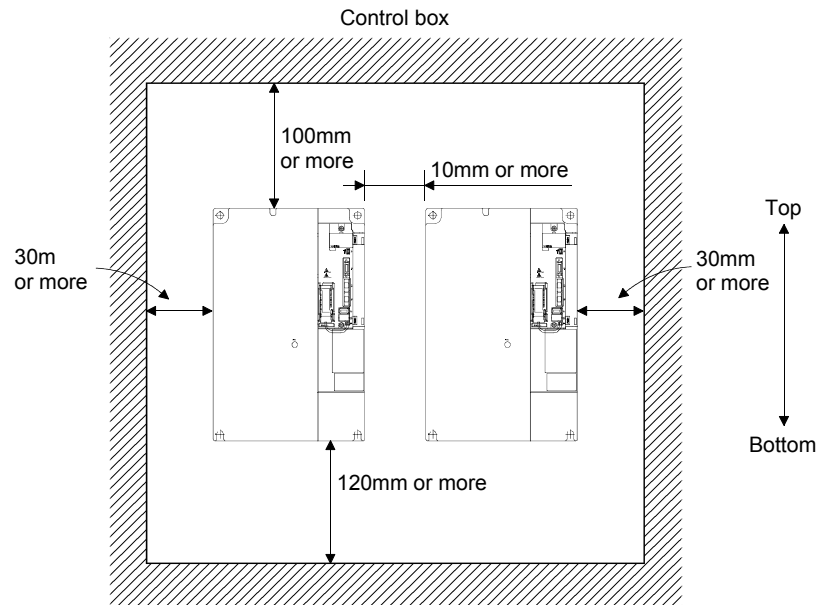

### (3) Others

When using heat generating equipment such as the regenerative option, install them with full consideration of heat generation so that the servo amplifier is not affected.

Install the servo amplifier on a perpendicular wall in the correct vertical direction.

### 2.2 Keep out foreign materials

- (1) When installing the unit in a control box, prevent drill chips and wire fragments from entering the servo amplifier.
- (2) Prevent oil, water, metallic dust, etc. from entering the servo amplifier through openings in the control box or a cooling fan installed on the ceiling.
- (3) When installing the control box in a place where there are much toxic gas, dirt and dust, conduct an air purge (force clean air into the control box from outside to make the internal pressure higher than the external pressure) to prevent such materials from entering the control box.

### 2.3 Cable stress

- (1) The way of clamping the cable must be fully examined so that flexing stress and cable's own weight stress are not applied to the cable connection.
- (2) For use in any application where the servo motor moves, fix the cables (encoder, power supply, brake) with having some slack from the connector connection part of the servo motor to avoid putting stress on the connector connection part. Use the optional encoder cable within the flexing life range. Use the power supply and brake wiring cables within the flexing life of the cables.

## 2. INSTALLATION

- (3) Avoid any probability that the cable sheath might be cut by sharp chips, rubbed by a machine corner or stamped by workers or vehicles.
- (4) For installation on a machine where the servo motor will move, the flexing radius should be made as large as possible. Refer to section 10.4 for the flexing life.

### 2.4 SSCNETIII cable laying

SSCNETIII cable is made from optical fiber. If optical fiber is added a power such as a major shock, lateral pressure, haul, sudden bending or twist, its inside distorts or breaks, and optical transmission will not be available. Especially, as optical fiber for MR-J3BUS □ M · MR-J3BUS □ M-A is made of synthetic resin, it melts down if being left near the fire or high temperature. Therefore, do not make it touched the part, which becomes high temperature, such as radiator or regenerative option of servo amplifier.

Read described item of this section carefully and handle it with caution.

#### (1) Minimum bend radius

Make sure to lay the cable with greater radius than the minimum bend radius. Do not press the cable to edges of equipment or others. For SSCNETIII cable, the appropriate length should be selected with due consideration for the dimensions and arrangement of servo amplifier. When closing the door of control box, pay careful attention for avoiding the case that SSCNETIII cable is hold down by the door and the cable bend becomes smaller than the minimum bend radius.

For the minimum bend radius, refer to section 11.1.5.

#### (2) Prohibition of vinyl tape use

Migrating plasticizer is used for vinyl tape. Keep the MR-J3BUS □ M, and MR-J3BUS □ M-A cables away from vinyl tape because the optical characteristic may be affected.

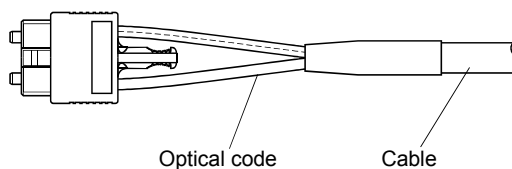

SSCNETIII cable	Code	Cable
MR-J3BUS □ M	△	
MR-J3BUS □ M-A	△	△
MR-J3BUS □ M-B	○	○

△: Phthalate ester plasticizer such as DBP and DOP may affect optical characteristic of cable.

○: Normally, cable is not affected by plasticizer.

#### (3) Precautions for migrating plasticizer added materials

Generally, soft polyvinyl chloride (PVC), polyethylene resin (PE) and fluorine resin contain non-migrating plasticizer and they do not affect the optical characteristic of SSCNETIII cable.

However, some wire sheaths and cable ties, which contain migrating plasticizer (phthalate ester), may affect MR-J3BUS □ M and MR-J3BUS □ M-A cables (made of plastic).

In addition, MR-J3BUS □ M-B cable (made of quartz glass) is not affected by plasticizer.

## 2. INSTALLATION

### (4) Bundle fixing

Fix the cable at the closest part to the connector with bundle material in order to prevent SSCNETIII cable from putting its own weight on CN1A · CN1B connector of servo amplifier. Optical cord should be given loose slack to avoid from becoming smaller than the minimum bend radius, and it should not be twisted.

When bundling the cable, fix and hold it in position by using cushioning such as sponge or rubber which does not contain migratable plasticizers.

If using adhesive tape for bundling the cable, fire resistant acetate cloth adhesive tape 570F (Teraoka Seisakusho Co., Ltd) is recommended.

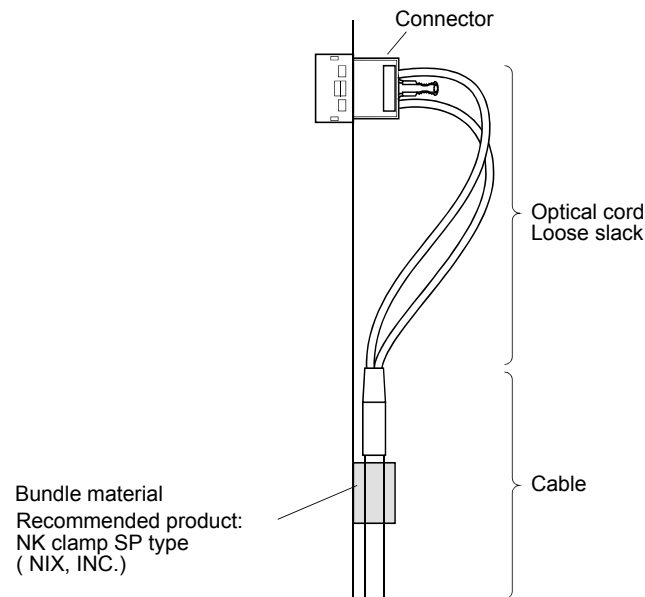

### (5) Tension

If tension is added on optical cable, the increase of transmission loss occurs because of external force which concentrates on the fixing part of optical fiber or the connecting part of optical connector. At worst, the breakage of optical fiber or damage of optical connector may occur. For cable laying, handle without putting forced tension. For the tension strength, refer to section 11.1.5.

### (6) Lateral pressure

If lateral pressure is added on optical cable, the optical cable itself distorts, internal optical fiber gets stressed, and then transmission loss will increase. At worst, the breakage of optical cable may occur. As the same condition also occurs at cable laying, do not tighten up optical cable with a thing such as nylon band (TY-RAP).

Do not trample it down or tuck it down with the door of control box or others.

### (7) Twisting

If optical fiber is twisted, it will become the same stress added condition as when local lateral pressure or bend is added. Consequently, transmission loss increases, and the breakage of optical fiber may occur at worst.

### (8) Disposal

When incinerating optical cable (cord) used for SSCNETIII, hydrogen fluoride gas or hydrogen chloride gas which is corrosive and harmful may be generated. For disposal of optical fiber, request for specialized industrial waste disposal services who has incineration facility for disposing hydrogen fluoride gas or hydrogen chloride gas.

## 2. INSTALLATION

### 2.5 Inspection items

#### WARNING

- Before starting maintenance and/or inspection, turn off the power and wait for 15 minutes or more until the charge lamp turns off. Then, confirm that the voltage between P(+) and N(–) is safe with a voltage tester and others. Otherwise, an electric shock may occur. In addition, always confirm from the front of the servo amplifier whether the charge lamp is off or not.
- Any person who is involved in inspection should be fully competent to do the work. Otherwise, you may get an electric shock. For repair and parts replacement, contact your sales representative.

#### POINT

- Do not test the servo amplifier with a megger (measure insulation resistance), or it may become faulty.
- Do not disassemble and/or repair the equipment on customer side.

It is recommended to make the following checks periodically.

- (1) Check for loose terminal block screws. Retighten any loose screws.
- (2) Check the cables and the like for scratches and cracks. Perform periodic inspection according to operating conditions.

### 2.6 Parts having service lives

The following parts must be changed periodically as listed below. If any part is found faulty, it must be changed immediately even when it has not yet reached the end of its life, which depends on the operating method and environmental conditions. For parts replacement, please contact your sales representative.

	Part name	Life guideline
Servo amplifier	Smoothing capacitor	10 years
	Relay	Number of power-on and number of emergency stop times : 100,000 times
	Cooling fan	10,000 to 30,000hours (2 to 3 years)
	Absolute position battery	Refer to section 12.2

#### (1) Smoothing capacitor

Affected by ripple currents, etc. and deteriorates in characteristic. The life of the capacitor greatly depends on ambient temperature and operating conditions. The capacitor will reach the end of its life in 10 years of continuous operation in normal air-conditioned environment.

#### (2) Relays

Their contacts will wear due to switching currents and contact faults occur. Relays reach the end of their life when the cumulative number of power-on and emergency stop times is 100,000, which depends on the power supply capacity.

#### (3) Servo amplifier cooling fan

The cooling fan bearings reach the end of their life in 10,000 to 30,000 hours. Normally, therefore, the cooling fan must be changed in a few years of continuous operation as a guideline.

It must also be changed if unusual noise or vibration is found during inspection.

### 3. SIGNALS AND WIRING

#### 3. SIGNALS AND WIRING

#### ⚠ WARNING

- Any person who is involved in wiring should be fully competent to do the work.
- Before wiring, turn off the power and wait for 15 minutes or more until the charge lamp turns off. Then, confirm that the voltage between P(+) and N(−) is safe with a voltage tester and others. Otherwise, an electric shock may occur. In addition, always confirm from the front of the servo amplifier whether the charge lamp is off or not.
- Ground the servo amplifier and the servo motor securely.
- Do not attempt to wire the servo amplifier and servo motor until they have been installed. Otherwise, you may get an electric shock.
- The cables should not be damaged, stressed excessively, loaded heavily, or pinched. Otherwise, you may get an electric shock.

#### ⚠ CAUTION

- Wire the equipment correctly and securely. Otherwise, the servo motor may operate unexpectedly, resulting in injury.
- Connect cables to correct terminals to prevent a burst, fault, etc.
- Ensure that polarity (+, −) is correct. Otherwise, a burst, damage, etc. may occur.
- The surge absorbing diode installed to the DC relay designed for control output should be fitted in the specified direction. Otherwise, the signal is not output due to a fault, disabling the forced stop (EM1) and other protective circuits.

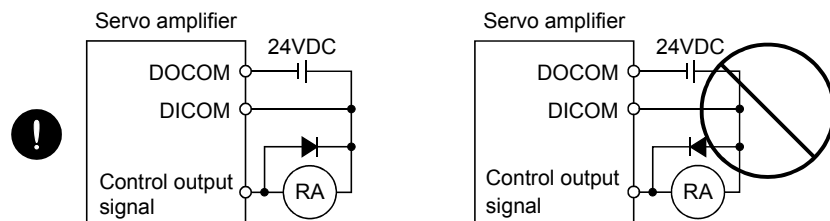

- Use a noise filter, etc. to minimize the influence of electromagnetic interference, which may be given to electronic equipment used near the servo amplifier.
- Do not install a power capacitor, surge suppressor or radio noise filter (FR-BIF (-H) option) with the power line of the servo motor.
- When using the regenerative resistor, switch power off with the alarm signal. Otherwise, a transistor fault or the like may overheat the regenerative resistor, causing a fire.
- Do not modify the equipment.
- During power-on, do not open or close the motor power line. Otherwise, a malfunction or faulty may occur.

### 3. SIGNALS AND WIRING

#### 3.1 Input power supply circuit

**CAUTION**

- Always connect a magnetic contactor (MC) between the main circuit power supply and L<sub>1</sub>, L<sub>2</sub>, and L<sub>3</sub> of the servo amplifier, and configure the wiring to be able to shut down the power supply on the side of the servo amplifier's power supply. If a magnetic contactor (MC) is not connected, continuous flow of a large current may cause a fire when the servo amplifier malfunctions.
- Use the trouble signal to switch main circuit power supply off. Otherwise, a regenerative transistor fault or the like may overheat the regenerative resistor, causing a fire.

**POINT**

- Even if alarm has occurred, do not switch off the control circuit power supply. When the control circuit power supply has been switched off, optical module does not operate, and optical transmission of SSCNETIII communication is interrupted. Therefore, the servo amplifier on the rear axis displays "AA" at the indicator and turns into base circuit shut-off. The servo amplifier stops with starting dynamic brake.

Wire the power supply/main circuit as shown below so that power is shut off and the servo-on command turned off as soon as an alarm occurs, a servo forced stop is made valid, or a controller forced stop is made valid. A no-fuse breaker (NFB) must be used with the input cables of the main circuit power supply.

(1) For 3-phase 200V to 230VAC power supply to MR-J3-10B to MR-J3-350B

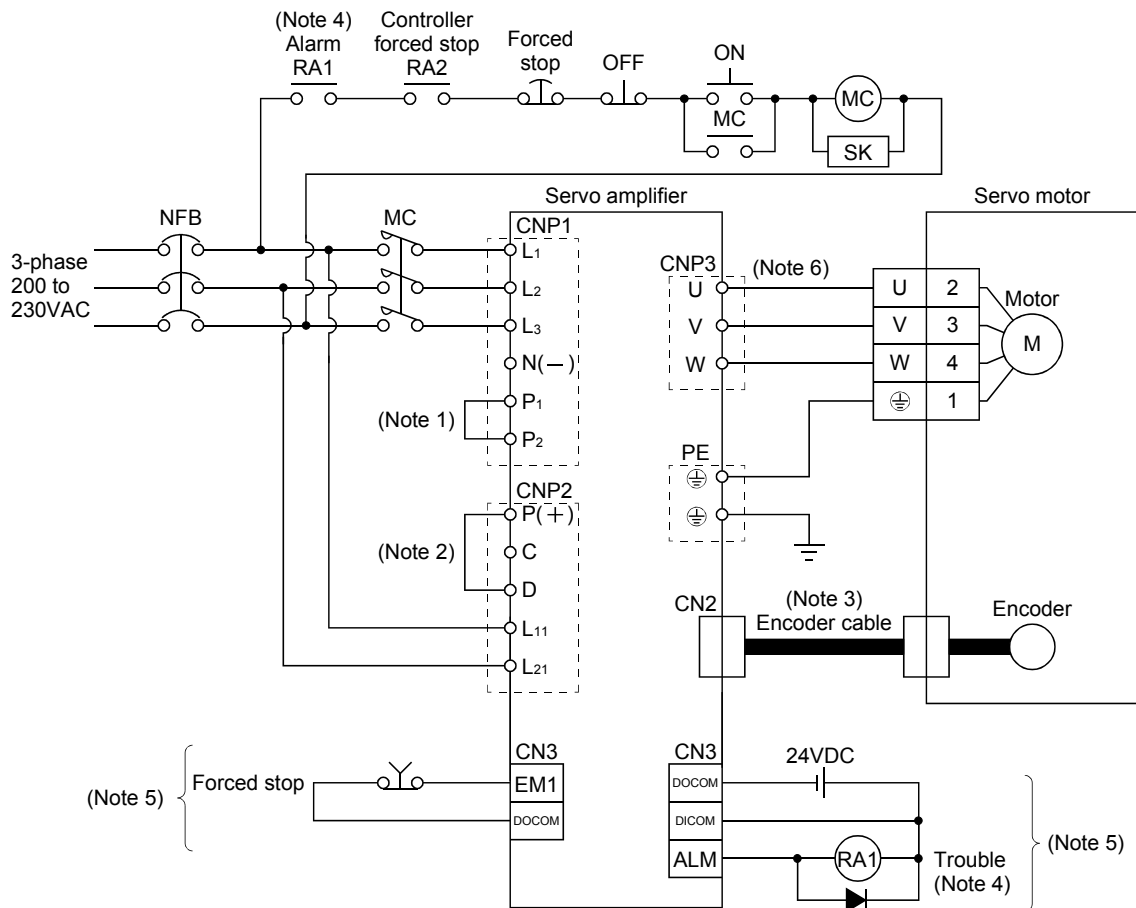

### 3. SIGNALS AND WIRING

- Note 1. Always connect P<sub>1</sub> and P<sub>2</sub>. (Factory-wired.) When using the power factor improving DC reactor, refer to section 11.13.  
 2. Always connect P(+) and D. (Factory-wired.) When using the regenerative option, refer to section 11.2.  
 3. For the encoder cable, use of the option cable is recommended. Refer to section 11.1 for selection of the cable.  
 4. If deactivating output of trouble (ALM) with parameter change, configure up the power supply circuit which switches off the magnetic contactor after detection of alarm occurrence on the controller side.  
 5. For the sink I/O interface. For the source I/O interface, refer to section 3.7.3.  
 6. Refer to section 3.10.

(2) For 1-phase 200V to 230VAC power supply to MR-J3-10B to MR-J3-70B

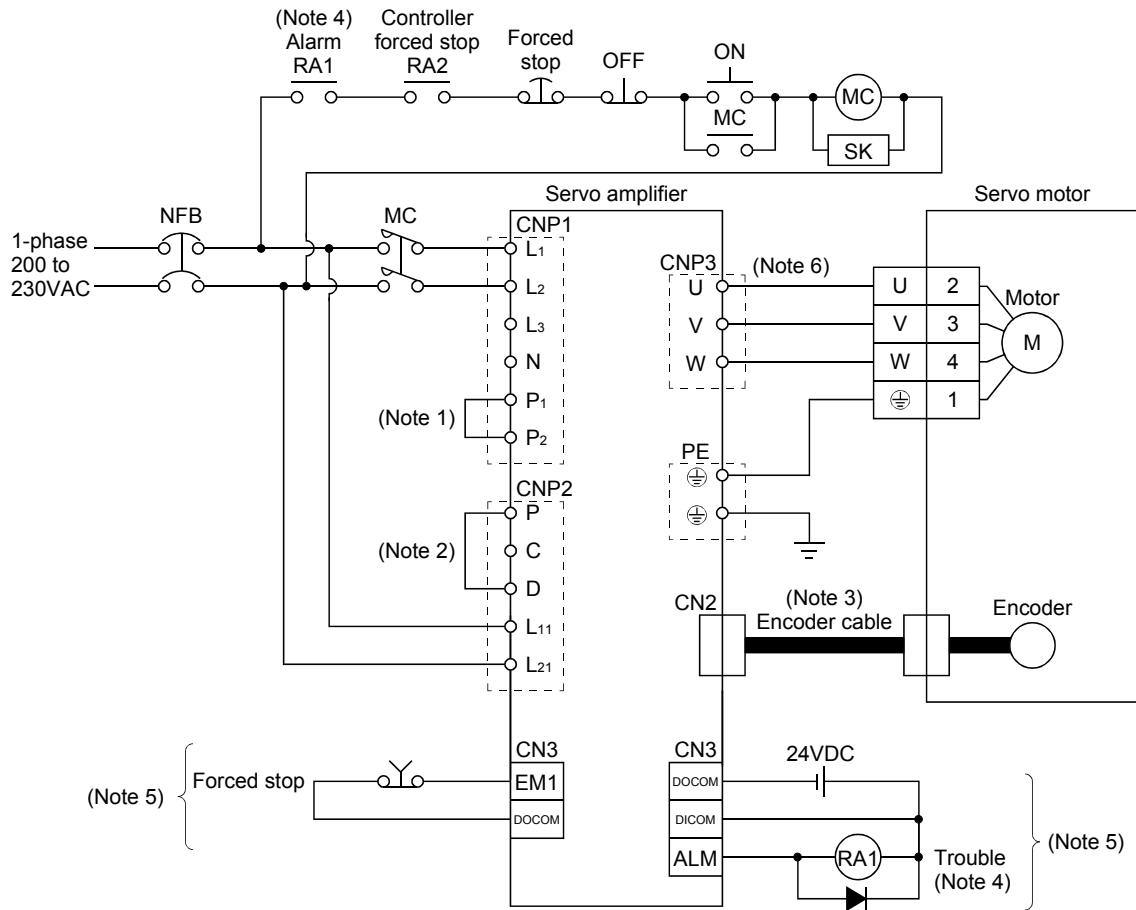

- Note 1. Always connect P<sub>1</sub> and P<sub>2</sub>. (Factory-wired.) When using the power factor improving DC reactor, refer to section 11.13.  
 2. Always connect P and D. (Factory-wired.) When using the regenerative option, refer to section 11.2.  
 3. For the encoder cable, use of the option cable is recommended. Refer to section 11.1 for selection of the cable.  
 4. If deactivating output of trouble (ALM) with parameter change, configure up the power supply circuit which switches off the magnetic contactor after detection of alarm occurrence on the controller side.  
 5. For the sink I/O interface. For the source I/O interface, refer to section 3.7.3.  
 6. Refer to section 3.10.

### 3. SIGNALS AND WIRING

(3) For MR-J3-10B1 to MR-J3-40B1

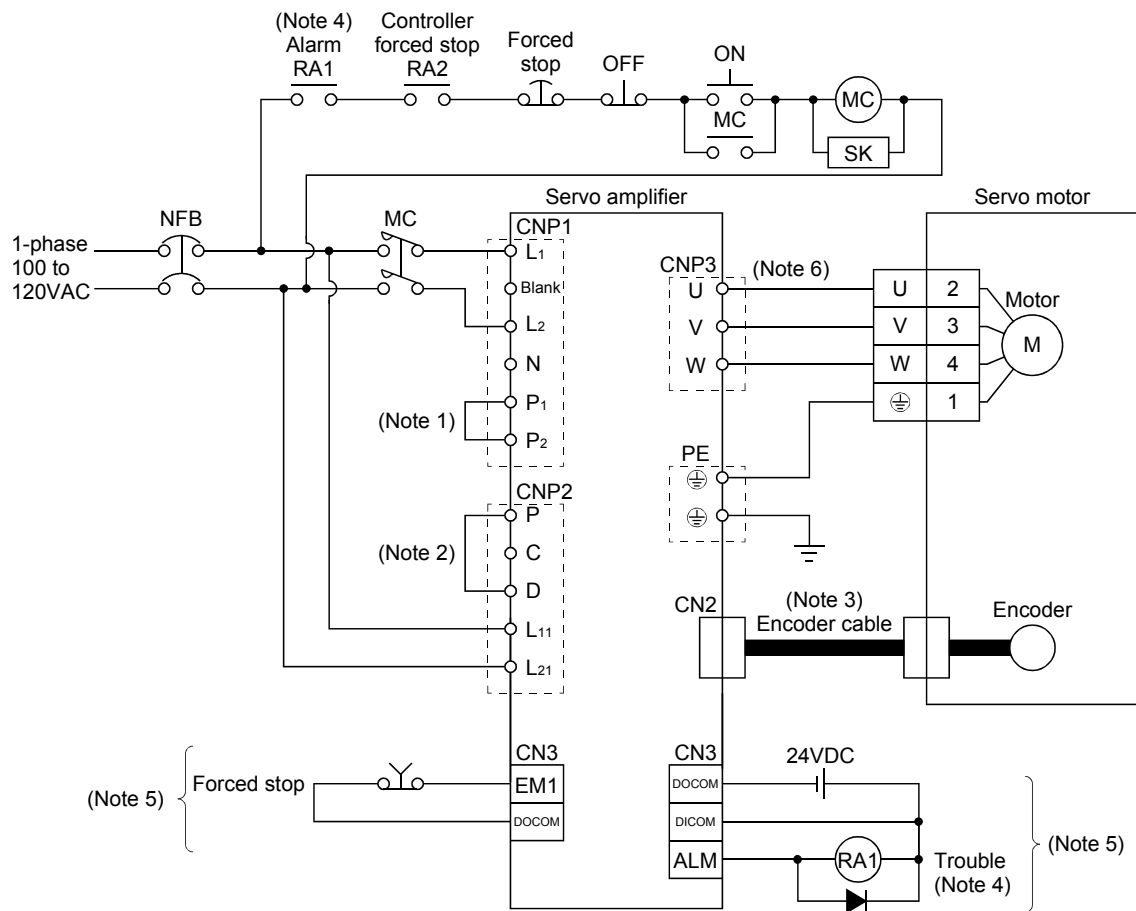

- Note 1. Always connect P<sub>1</sub> and P<sub>2</sub>. (Factory-wired.) The power factor improving DC reactor cannot be used.
2. Always connect P and D. (Factory-wired.) When using the regenerative option, refer to section 11.2.
3. For the encoder cable, use of the option cable is recommended. Refer to section 11.1 for selection of the cable.
4. If deactivating output of trouble (ALM) with parameter change, configure up the power supply circuit which switches off the magnetic contactor after detection of alarm occurrence on the controller side.
5. For the sink I/O interface. For the source I/O interface, refer to section 3.7.3.
6. Refer to section 3.10.

### 3. SIGNALS AND WIRING

#### (4) MR-J3-60B4 to MR-J3-200B4

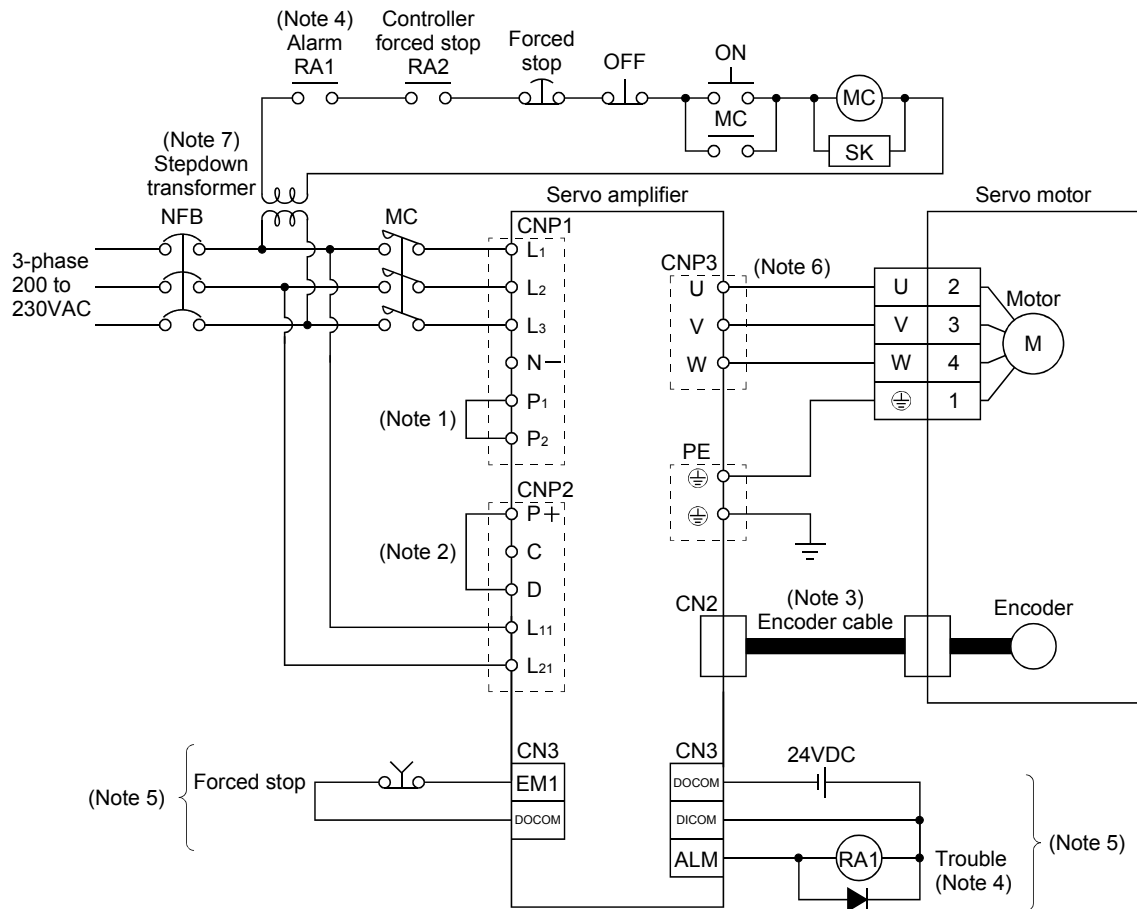

- Note 1. Always connect P<sub>1</sub> and P<sub>2</sub>. (Factory-wired.) When using the power factor improving DC reactor, refer to section 11.13.
- Note 2. Always connect P and D. (Factory-wired.) When using the regenerative option, refer to section 11.2.
- Note 3. For the encoder cable, use of the option cable is recommended. Refer to section 11.1 for selection of the cable.
- Note 4. If deactivating output of trouble (ALM) with parameter change, configure up the power supply circuit which switches off the magnetic contactor after detection of alarm occurrence on the controller side.
- Note 5. For the sink I/O interface. For the source I/O interface, refer to section 3.7.3.
- Note 6. Refer to section 3.10.
- Note 7. Stepdown transformer is required for coil voltage of magnetic contactor more than 200V class.

### 3. SIGNALS AND WIRING

#### (5) MR-J3-500B • MR-J3-700B

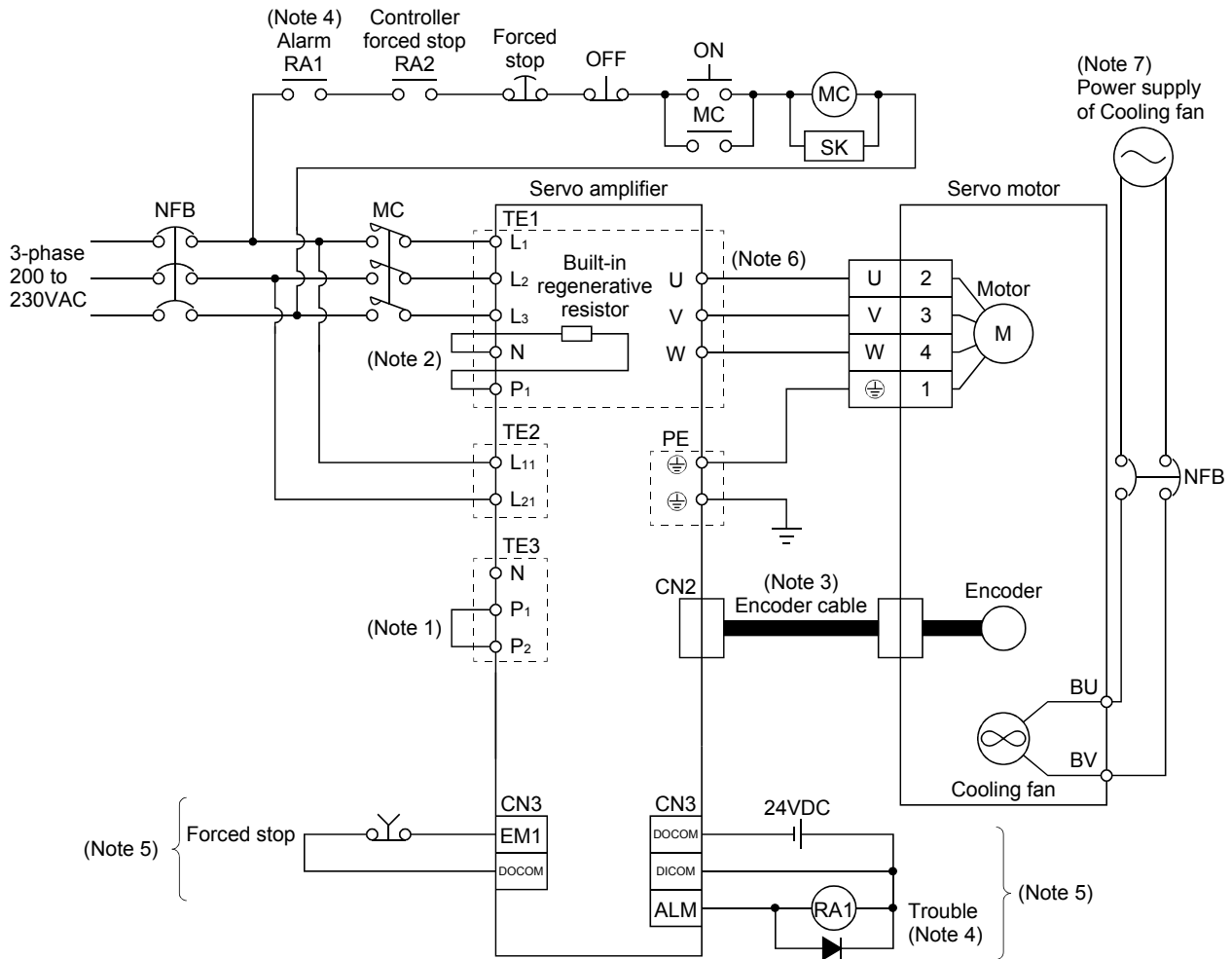

Note 1. Always connect P<sub>1</sub> and P<sub>2</sub>. (Factory-wired.) When using the power factor improving DC reactor, refer to section 11.13.

Note 2. When using the regenerative option, refer to section 11.2.

Note 3. For the encoder cable, use of the option cable is recommended. Refer to section 11.1 for selection of the cable.

Note 4. If deactivating output of trouble (ALM) with parameter change, configure up the power supply circuit which switches off the magnetic contactor after detection of alarm occurrence on the controller side.

Note 5. For the sink I/O interface. For the source I/O interface, refer to section 3.7.3.

Note 6. Refer to section 3.10.

Note 7. A cooling fan is attached to the HA-LP601 and the HA-LP701M servo motors. For power supply specification of the cooling fan, refer to section 3.10.2 (3) (b).

### 3. SIGNALS AND WIRING

#### (6) MR-J3-350B4 to MR-J3-700B4

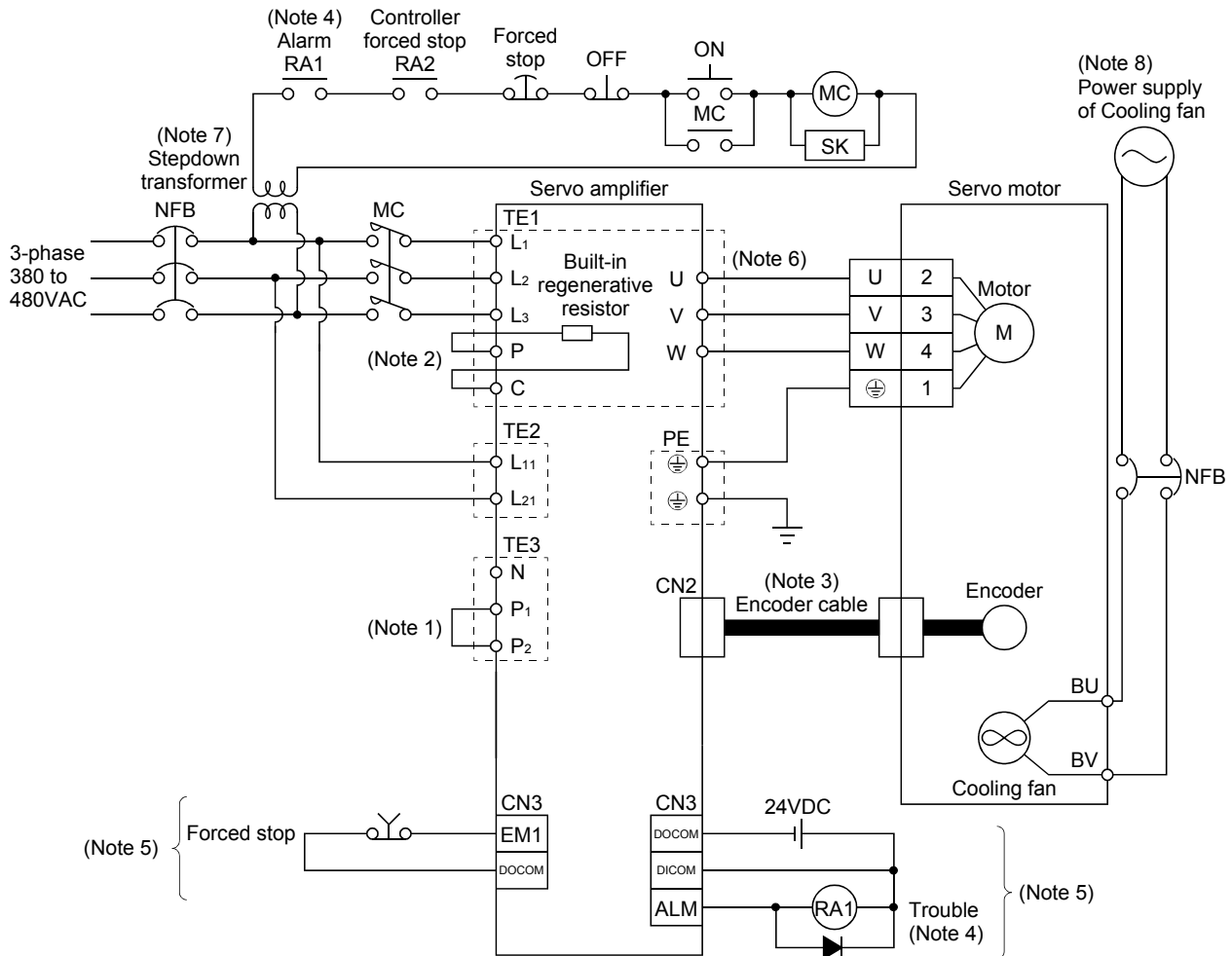

- Note 1. Always connect P<sub>1</sub> and P<sub>2</sub>. (Factory-wired.) When using the power factor improving DC reactor, refer to section 11.13.
2. When using the regenerative option, refer to section 11.2.
3. For the encoder cable, use of the option cable is recommended. Refer to section 11.1 for selection of the cable.
4. If deactivating output of trouble (ALM) with parameter change, configure up the power supply circuit which switches off the magnetic contactor after detection of alarm occurrence on the controller side.
5. For the sink I/O interface. For the source I/O interface, refer to section 3.7.3.
6. Refer to section 3.10.
7. Stepdown transformer is required for coil voltage of magnetic contactor more than 200V class.
8. A cooling fan is attached to the HA-LP6014 and the HA-LP701M4 servo motors. For power supply specification of the cooling fan, refer to section 3.10.2 (3) (b).



### 3. SIGNALS AND WIRING

#### (8) MR-J3-11KB4 to MR-J3-22KB4

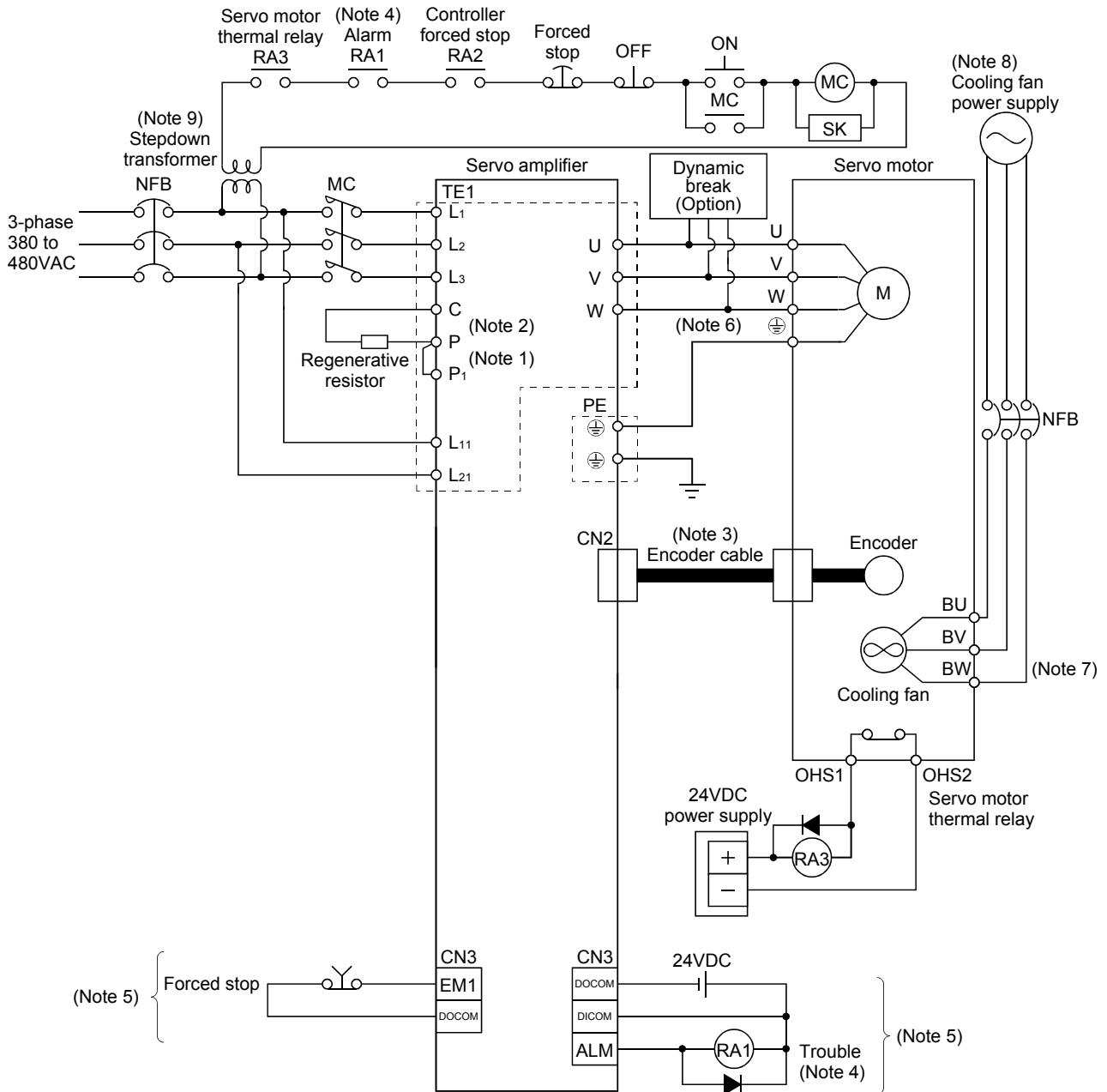

- Note 1. Always connect P<sub>1</sub> and P. (Factory-wired.) When using the power factor improving DC reactor, refer to section 11.13.
2. When using the regenerative option, refer to section 11.2.
3. For the encoder cable, use of the option cable is recommended. Refer to section 11.1 for selection of the cable.
4. If deactivating output of trouble (ALM) with parameter change, configure up the power supply circuit which switches off the magnetic contactor after detection of alarm occurrence on the controller side.
5. For the sink I/O interface. For the source I/O interface, refer to section 3.7.3.
6. Refer to section 3.10.
7. Servo amplifiers does not have BW when the cooling fan power supply is 1-phase.
8. For the cooling fan power supply, refer to section 3.10.2 (3) (b).
9. Stepdown transformer is required for coil voltage of magnetic contactor more than 200V class.

### 3. SIGNALS AND WIRING

#### 3.2 I/O signal connection example

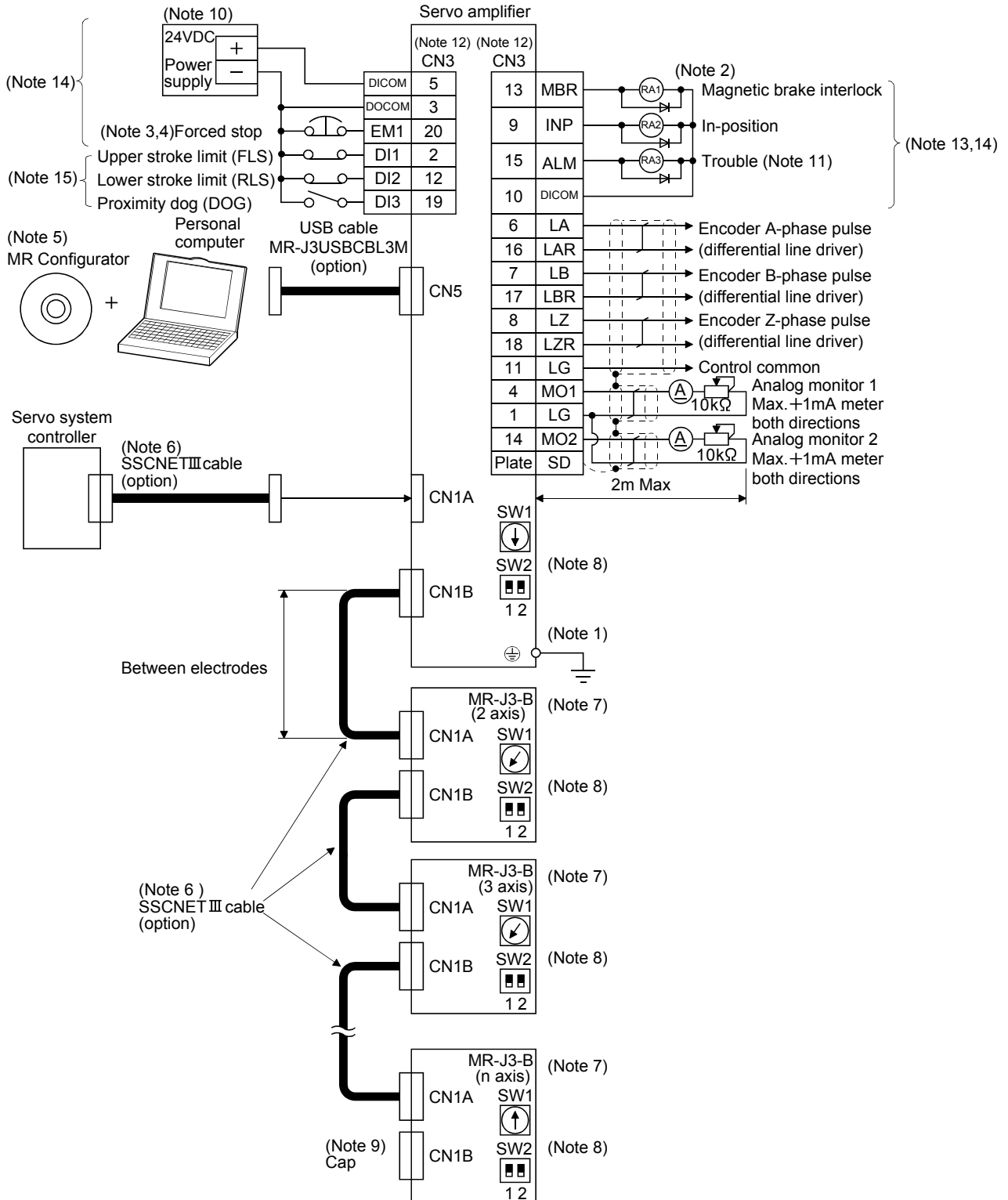

### 3. SIGNALS AND WIRING

- Note 1 To prevent an electric shock, always connect the protective earth (PE) terminal (terminal marked  $\oplus$ ) of the servo amplifier to the protective earth (PE) of the control box.
2. Connect the diode in the correct direction. If it is connected reversely, the servo amplifier will be faulty and will not output signals, disabling the forced stop (EM1) and other protective circuits.
  3. If the controller does not have an forced stop (EM1) function, always install a forced stop switch (Normally closed).
  4. When starting operation, always turn on the forced stop (EM1). (Normally closed contacts) By setting "□1□□" in DRU parameter No.PA04 of the drive unit, the forced stop (EM1) can be made invalid.
  5. Use MRZJW3-SETUP 221E.
  6. For the distance between electrodes of SSCNETIII cable, refer to the following table.

Cable	Cable model name	Cable length	Distance between electrodes
Standard code inside panel	MR-J3BUS □ M	0.15m to 3m	20m
Standard cable outside panel	MR-J3BUS □ M-A	5m to 20m	
Long-distance cable	MR-J3BUS □ M-B	30m to 50m	50m

7. The wiring of the second and subsequent axes is omitted.
8. Up to eight axes (n = 1 to 8) may be connected. Refer to section 3.13 for setting of axis selection.
9. Make sure to put a cap on the unused CN1A \* CN1B.
10. Supply 24VDC±10% 150mA current for interfaces from the outside. 150mA is the value applicable when all I/O signals are used. The current capacity can be decreased by reducing the number of I/O points. Refer to section 3.7.2 (1) that gives the current value necessary for the interface.
11. Trouble (ALM) turns on in normal alarm-free condition. When this signal is switched off (at occurrence of an alarm), the output of the programmable controller should be stopped by the sequence program.
12. The pins with the same signal name are connected in the servo amplifier.
13. The signal can be changed by parameter No.PD07, PD08, PD09.
14. For the sink I/O interface. For the source I/O interface, refer to section 3.7.3.
15. Devices can be assigned for DI1 \* DI2 \* DI3 with controller setting. For devices that can be assigned, refer to the controller instruction manual. The assigned devices are for the Q173DCPU \* Q172DCPU \* Q173HCPU \* Q172HCPU and QD75MH□.

### 3. SIGNALS AND WIRING

#### 3.3 Explanation of power supply system

##### 3.3.1 Signal explanations

<b>POINT</b>
<ul style="list-style-type: none"> <li>For the layout of connector and terminal block, refer to outline drawings in chapter 9.</li> </ul>

Abbreviation	Connection target (Application)	Description																										
L <sub>1</sub> L <sub>2</sub> L <sub>3</sub>	Main circuit power supply	<p>Supply the following power to L<sub>1</sub>, L<sub>2</sub>, L<sub>3</sub>. For the 1-phase 200V to 230VAC power supply, connect the power supply to L<sub>1</sub>, L<sub>2</sub>, and keep L<sub>3</sub> open.</p> <table border="1" style="width: 100%; border-collapse: collapse;"> <tr> <td style="text-align: center;">Servo amplifier</td> <td style="text-align: center;">MR-J3-10B to 70B</td> <td style="text-align: center;">MR-J3-100B to 22KB</td> <td style="text-align: center;">MR-J3-10B1 to 40B1</td> </tr> <tr> <td style="text-align: center;">Power supply</td> <td></td> <td></td> <td></td> </tr> <tr> <td>3-phase 200V to 230VAC, 50/60Hz</td> <td colspan="3" style="text-align: center;">L<sub>1</sub> • L<sub>2</sub> • L<sub>3</sub></td> </tr> <tr> <td>1-phase 200V to 230VAC, 50/60Hz</td> <td colspan="3" style="text-align: center;">L<sub>1</sub> • L<sub>2</sub></td> </tr> <tr> <td>1-phase 100V to 120VAC, 50/60Hz</td> <td></td> <td></td> <td style="text-align: center;">L<sub>1</sub> • L<sub>2</sub></td> </tr> </table> <table border="1" style="width: 100%; border-collapse: collapse;"> <tr> <td style="text-align: center;">Servo amplifier</td> <td style="text-align: center;">MR-J3-60B4 to 22KB4</td> </tr> <tr> <td style="text-align: center;">Power supply</td> <td></td> </tr> <tr> <td>3-phase 380V to 480VAC, 50/60Hz</td> <td style="text-align: center;">L<sub>1</sub> • L<sub>2</sub> • L<sub>3</sub></td> </tr> </table>	Servo amplifier	MR-J3-10B to 70B	MR-J3-100B to 22KB	MR-J3-10B1 to 40B1	Power supply				3-phase 200V to 230VAC, 50/60Hz	L <sub>1</sub> • L <sub>2</sub> • L <sub>3</sub>			1-phase 200V to 230VAC, 50/60Hz	L <sub>1</sub> • L <sub>2</sub>			1-phase 100V to 120VAC, 50/60Hz			L <sub>1</sub> • L <sub>2</sub>	Servo amplifier	MR-J3-60B4 to 22KB4	Power supply		3-phase 380V to 480VAC, 50/60Hz	L <sub>1</sub> • L <sub>2</sub> • L <sub>3</sub>
Servo amplifier	MR-J3-10B to 70B	MR-J3-100B to 22KB	MR-J3-10B1 to 40B1																									
Power supply																												
3-phase 200V to 230VAC, 50/60Hz	L <sub>1</sub> • L <sub>2</sub> • L <sub>3</sub>																											
1-phase 200V to 230VAC, 50/60Hz	L <sub>1</sub> • L <sub>2</sub>																											
1-phase 100V to 120VAC, 50/60Hz			L <sub>1</sub> • L <sub>2</sub>																									
Servo amplifier	MR-J3-60B4 to 22KB4																											
Power supply																												
3-phase 380V to 480VAC, 50/60Hz	L <sub>1</sub> • L <sub>2</sub> • L <sub>3</sub>																											
P <sub>1</sub> P <sub>2</sub>	Power factor improving DC reactor	<p>1) MR-J3-700B or less When not using the power factor improving DC reactor, connect P<sub>1</sub> and P<sub>2</sub>. (Factory-wired.) When using the power factor improving DC reactor, disconnect P<sub>1</sub> and P<sub>2</sub>, and connect the power factor improving DC reactor to P<sub>1</sub> and P<sub>2</sub>.</p> <p>2) MR-J3-11KB(4) to 22KB(4) MR-J3-11KB(4) to 22KB(4) do not have P<sub>2</sub>. When not using the power factor improving reactor, connect P<sub>1</sub> and P. (Factory-wired) When using the power factor improving reactor, connect it to P and P<sub>1</sub>. Refer to section 11.13.</p>																										
P C D	Regenerative option	<p>1) MR-J3-350B or less • MR-J3-200B4 or less When using servo amplifier built-in regenerative resistor, connect P(+) and D. (Factory-wired) When using regenerative option, disconnect P(+) and D, and connect regenerative option to P and C.</p> <p>2) MR-J3-350B4 • 500B(4) • 700B(4) MR-J3-350B4 • 500B(4) • 700B(4) do not have D. When using servo amplifier built-in regenerative resistor, connect P and C. (Factory-wired) When using regenerative option, disconnect P and C, and connect regenerative option to P and C.</p> <p>3) MR-J3-11KB(4) to 22KB(4) MR-J3-11KB(4) to 22KB(4) do not have D. When not using the power regenerative converter and the brake unit, make sure to connect the regenerative option to P and C. Refer to section 11.2 to 11.5.</p>																										
L <sub>11</sub> L <sub>21</sub>	Control circuit power supply	<p>Supply the following power to L<sub>11</sub> • L<sub>21</sub>.</p> <table border="1" style="width: 100%; border-collapse: collapse;"> <tr> <td style="text-align: center;">Servo amplifier</td> <td style="text-align: center;">MR-J3-10B to 22KB</td> <td style="text-align: center;">MR-J3-10B1 to 40B1</td> <td style="text-align: center;">MR-J3-60B4 to 22KB4</td> </tr> <tr> <td style="text-align: center;">Power supply</td> <td></td> <td></td> <td></td> </tr> <tr> <td>1-phase 200V to 230VAC, 50/60Hz</td> <td colspan="3" style="text-align: center;">L<sub>11</sub> • L<sub>21</sub></td> </tr> <tr> <td>1-phase 100V to 120VAC, 50/60Hz</td> <td></td> <td colspan="2" style="text-align: center;">L<sub>11</sub> • L<sub>21</sub></td> </tr> <tr> <td>1-phase 380V to 480VAC, 50/60Hz</td> <td></td> <td></td> <td style="text-align: center;">L<sub>11</sub> • L<sub>21</sub></td> </tr> </table>	Servo amplifier	MR-J3-10B to 22KB	MR-J3-10B1 to 40B1	MR-J3-60B4 to 22KB4	Power supply				1-phase 200V to 230VAC, 50/60Hz	L <sub>11</sub> • L <sub>21</sub>			1-phase 100V to 120VAC, 50/60Hz		L <sub>11</sub> • L <sub>21</sub>		1-phase 380V to 480VAC, 50/60Hz			L <sub>11</sub> • L <sub>21</sub>						
Servo amplifier	MR-J3-10B to 22KB	MR-J3-10B1 to 40B1	MR-J3-60B4 to 22KB4																									
Power supply																												
1-phase 200V to 230VAC, 50/60Hz	L <sub>11</sub> • L <sub>21</sub>																											
1-phase 100V to 120VAC, 50/60Hz		L <sub>11</sub> • L <sub>21</sub>																										
1-phase 380V to 480VAC, 50/60Hz			L <sub>11</sub> • L <sub>21</sub>																									
U V W	Servo motor power	Connect to the servo motor power supply terminals (U, V, W). During power-on, do not open or close the motor power line. Otherwise, a malfunction or faulty may occur.																										
N	Return converter Brake unit	When using the power regenerative converter/brake unit, connect it to P and N. Do not connect to servo amplifier MR-J3-350B(4) or less. For details, refer to section 11.3 to 11.5.																										
	Protective earth (PE)	Connect to the earth terminal of the servo motor and to the protective earth (PE) of the control box to perform grounding.																										

### 3. SIGNALS AND WIRING

#### 3.3.2 Power-on sequence

##### (1) Power-on procedure

- 1) Always wire the power supply as shown in above section 3.1 using the magnetic contactor with the main circuit power supply (three-phase: L1, L2, L3, single-phase: L1, L2). Configure up an external sequence to switch off the magnetic contactor as soon as an alarm occurs.
- 2) Switch on the control circuit power supply L11, L21 simultaneously with the main circuit power supply or before switching on the main circuit power supply. If the main circuit power supply is not on, the display shows the corresponding warning. However, by switching on the main circuit power supply, the warning disappears and the servo amplifier will operate properly.
- 3) The servo amplifier can accept the servo-on command within 3s the main circuit power supply is switched on. (Refer to paragraph (2) of this section.)

##### (2) Timing chart

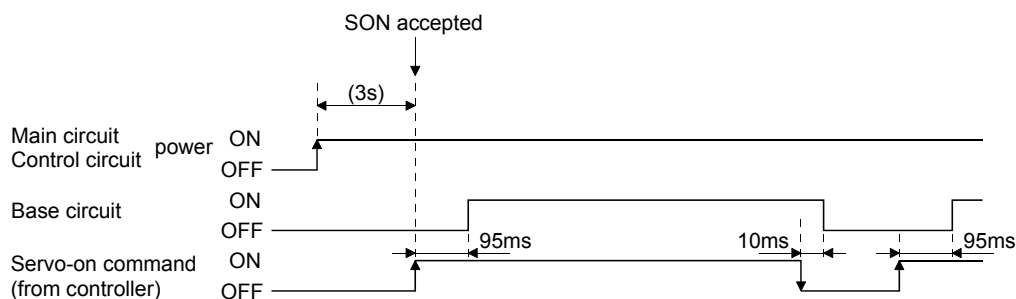

##### (3) Forced stop



#### CAUTION

Install an forced stop circuit externally to ensure that operation can be stopped and power shut off immediately.

If the controller does not have an forced stop function, make up a circuit that switches off main circuit power as soon as EM1 is turned off at a forced stop. When EM1 is turned off, the dynamic brake is operated to stop the servo motor. At this time, the display shows the servo forced stop warning (E6). During ordinary operation, do not use forced stop (EM1) to alternate stop and run. The service life of the servo amplifier may be shortened.

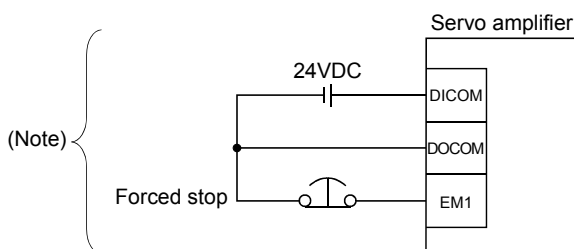

Note. For the sink I/O interface. For the source I/O interface, refer to section 3.7.3.

### 3. SIGNALS AND WIRING

#### 3.3.3 CNP1, CNP2, CNP3 wiring method

POINT
<ul style="list-style-type: none"> <li>Refer to table 11.1 in section 11.11 for the wire sizes used for wiring.</li> <li>MR-J3-500B or more • MR-J3-350B4 or more does not have these connectors.</li> </ul>

Use the supplied servo amplifier power supply connectors for wiring of CNP1, CNP2 and CNP3.

#### (1) MR-J3-10B to MR-J3-100B

##### (a) Servo amplifier power supply connectors

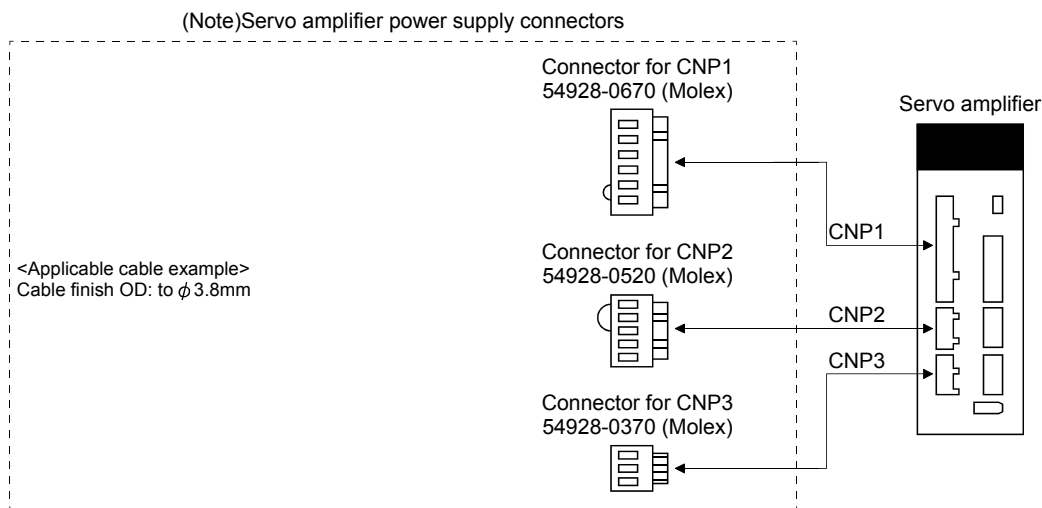

Note. These connectors are of insert type. As the crimping type, the following connectors (Molex) are recommended.

For CNP1: 51241-0600 (connector), 56125-0128 (terminal)

For CNP2: 51240-0500 (connector), 56125-0128 (terminal)

For CNP3: 51241-0300 (connector), 56125-0128 (terminal)

Crimping tool: CNP57349-5300

<Connector applicable cable example>

Cable finish OD: to  $\phi 3.8\text{mm}$

##### (b) Termination of the cables

Solid wire: After the sheath has been stripped, the cable can be used as it is.

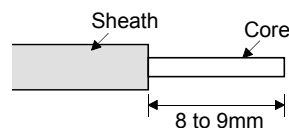

Twisted wire: Use the cable after stripping the sheath and twisting the core. At this time, take care to avoid a short caused by the loose wires of the core and the adjacent pole. Do not solder the core as it may cause a contact fault. Alternatively, a bar terminal may be used to put the wires together.

Cable size		Bar terminal type		Crimping tool (Note 2)
[mm <sup>2</sup> ]	AWG	For 1 cable (Note 1)	For 2 cable	
1.25/1.5	16	AI1.5-10BK	AI-TWIN2 × 1.5-10BK	Variocrimp 4 206-204
2/2.5	14	AI2.5-10BU		

Note 1. Manufacturer: Phoenix Contact

2. Manufacturer: WAGO

### 3. SIGNALS AND WIRING

- (c) The twin type connector for CNP2 (L<sub>11</sub> · L<sub>21</sub>): 721-2105/026-000 (WAGO)  
Using this connector enables passing a wire of control circuit power supply.  
Refer to appendix 3 for details of connector.

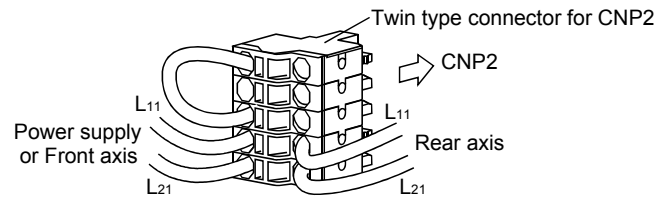

#### (2) MR-J3-200B · MR-J3-60B4 to MR-J3-200B4

- (a) Servo amplifier power supply connectors

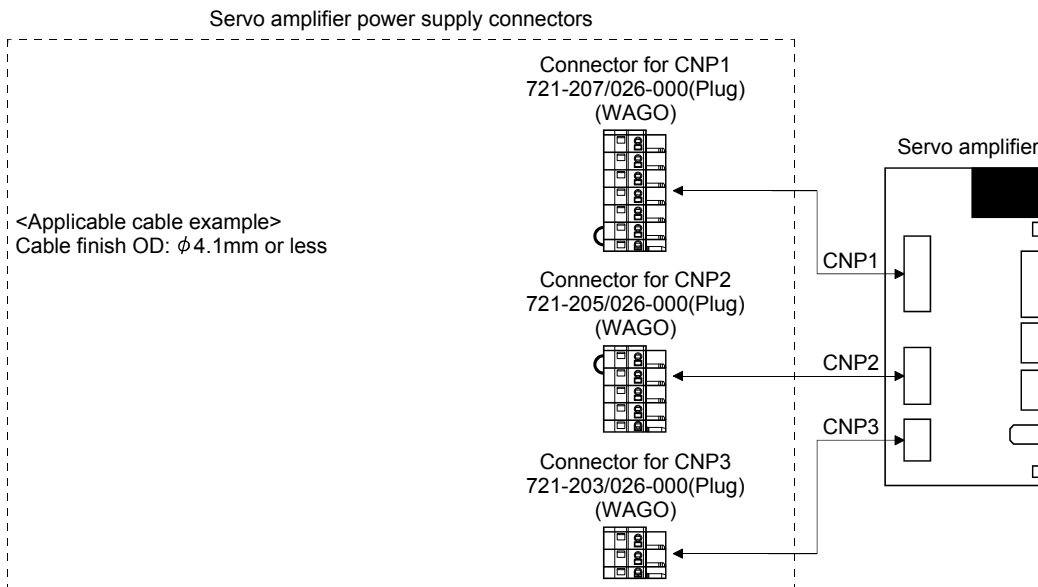

- (b) Termination of the cables

Solid wire: After the sheath has been stripped, the cable can be used as it is.

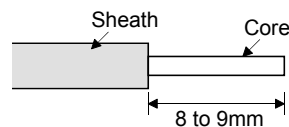

Twisted wire: Use the cable after stripping the sheath and twisting the core. At this time, take care to avoid a short caused by the loose wires of the core and the adjacent pole. Do not solder the core as it may cause a contact fault. Alternatively, a bar terminal may be used to put the wires together.

Cable size		Bar terminal type		Crimping tool (Note 2)
[mm <sup>2</sup> ]	AWG	For 1 cable (Note 1)	For 2 cable	
1.25/1.5	16	AI1.5-10BK	AI-TWIN2 × 1.5-10BK	Variocrimp 4 206-204
2/2.5	14	AI2.5-10BU		

Note 1. Manufacturer: Phoenix Contact

2. Manufacturer: WAGO

### 3. SIGNALS AND WIRING

- (c) The twin type connector for CNP2 (L<sub>11</sub> • L<sub>21</sub>): 721-2205/026-000 (WAGO)  
Using this connector enables passing a wire of control circuit power supply.  
Refer to appendix 3 for details of connector.

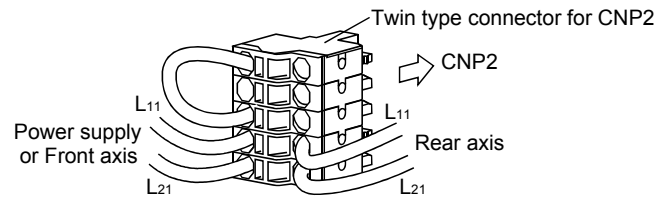

#### (3) MR-J3-350B

- (a) Servo amplifier power supply connectors

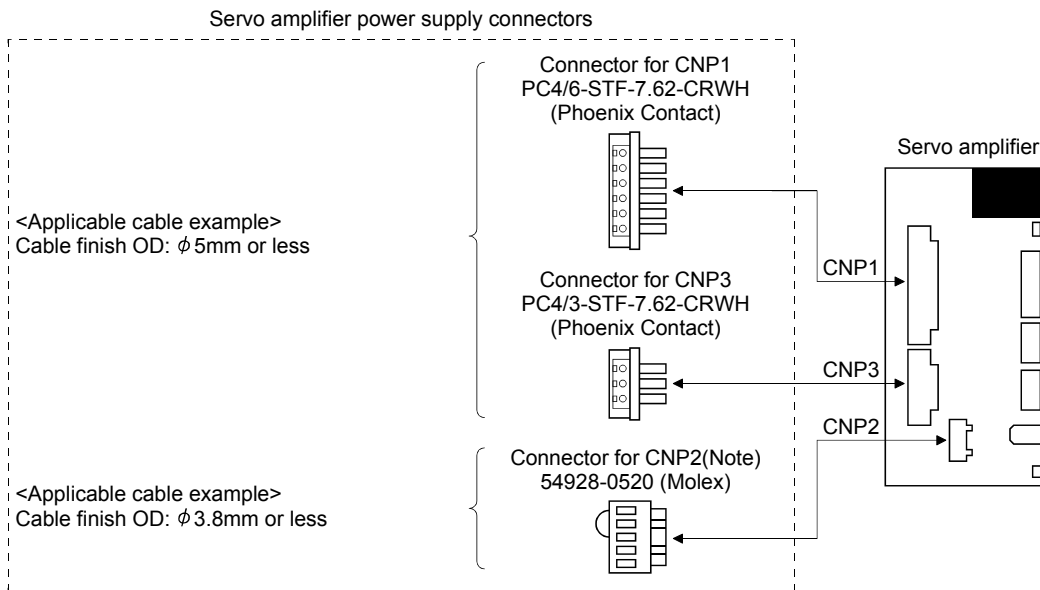

Note. As twin type connector for CNP2 (L<sub>11</sub>, L<sub>21</sub>) is the same as MR-J3-100B or smaller. Refer to (1) (c) of this section.

- (b) Termination of the cables

##### 1) CNP1 • CNP3

Solid wire: After the sheath has been stripped, the cable can be used as it is.

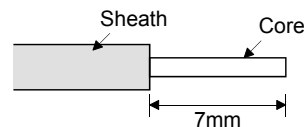

Twisted wire: Use the cable after stripping the sheath and twisting the core. At this time, take care to avoid a short caused by the loose wires of the core and the adjacent pole. Do not solder the core as it may cause a contact fault. Alternatively, a bar terminal may be used to put the wires together.

Cable size		Bar terminal type		Crimping tool	Manufacturer
[mm <sup>2</sup> ]	AWG	For 1 cable	For 2 cables		
1.25/1.5	16	AI1.5-8BK	AI-TWIN2 × 1.5-8BK	CRIMPFOX-ZA3	Phoenix Contact
2.0/2.5	14	AI2.5-8BU	AI-TWIN2 × 2.5-10BU		
3.5	12	AI4-10GY			

### 3. SIGNALS AND WIRING

#### 2) CNP2

CNP2 is the same as MR-J3-100B or smaller capacities. Refer to (1) (b) of this section.

#### (4) Insertion of cable into Molex and WAGO connectors

Insertion of cable into 54928-0610, 54928-0520, 54928 (Molex) connectors and 721-207/026-000, 721-205/026-000 and 721-203/026-000 (WAGO) connectors are as follows.

The following explains for Molex, however use the same procedures for inserting WAGO connectors as well.

POINT	
	<ul style="list-style-type: none"><li>▪ It may be difficult for a cable to be inserted to the connector depending on wire size or bar terminal configuration. In this case, change the wire type or correct it in order to prevent the end of bar terminal from widening, and then insert it.</li></ul>

How to connect a cable to the servo amplifier power supply connector is shown below.

### 3. SIGNALS AND WIRING

(a) When using the supplied cable connection lever

1) The servo amplifier is packed with the cable connection lever.

a) 54932-0000 (Molex)

[Unit: mm]

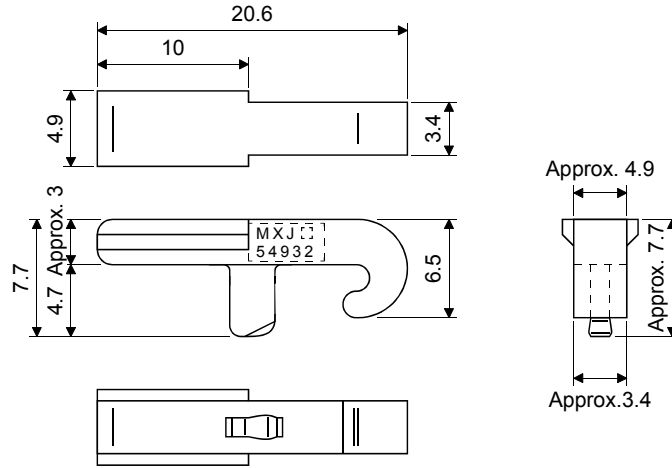

b) 231-131 (WAGO)

[Unit: mm]

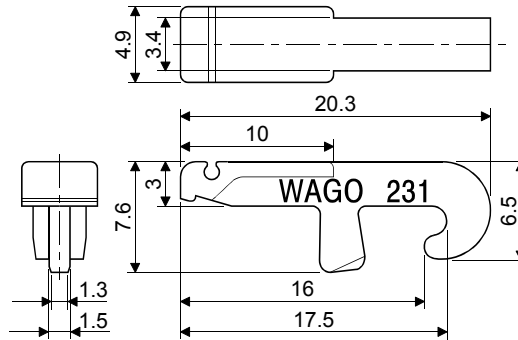

### 3. SIGNALS AND WIRING

#### 2) Cable connection procedure

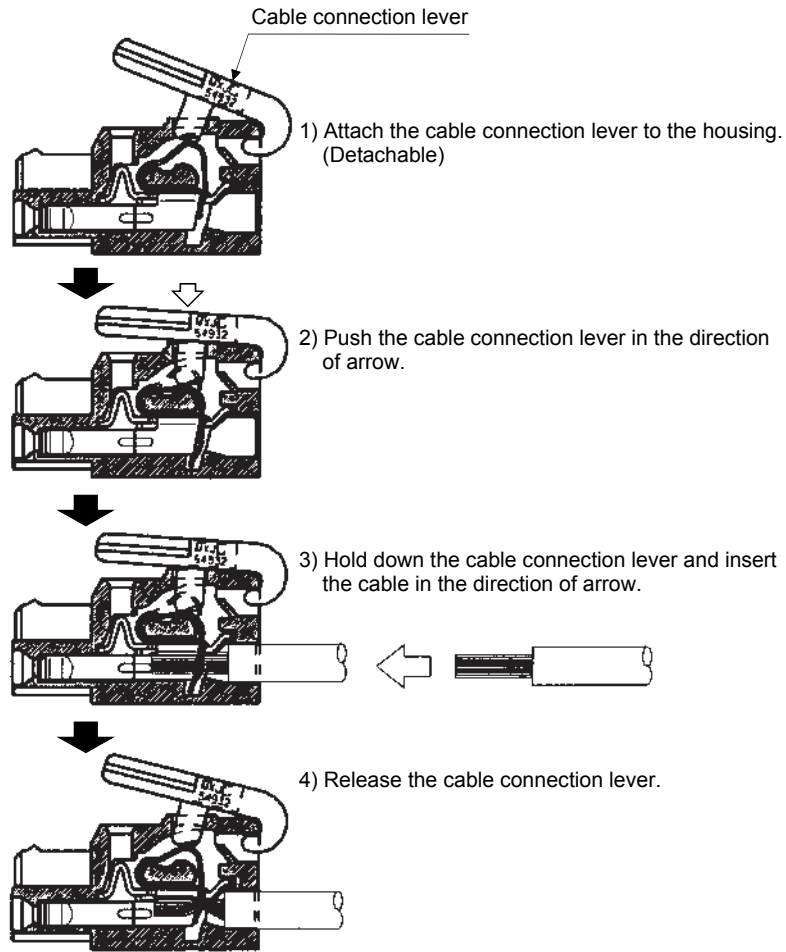

### 3. SIGNALS AND WIRING

#### (b) Inserting the cable into the connector

##### 1) Applicable flat-blade screwdriver dimensions

Always use the screwdriver shown here to do the work.

[Unit: mm]

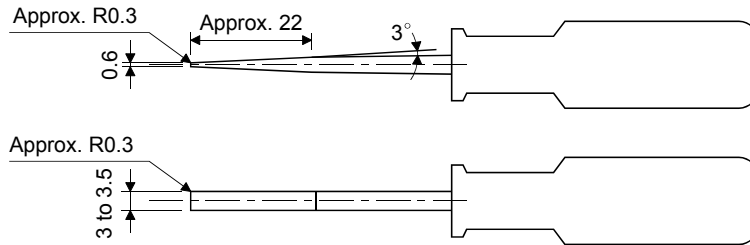

##### 2) When using the flat-blade screwdriver - part 1

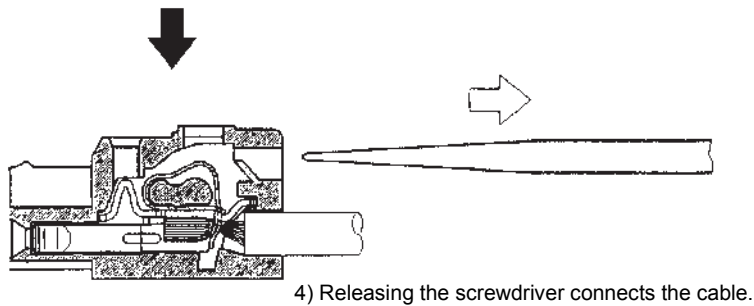
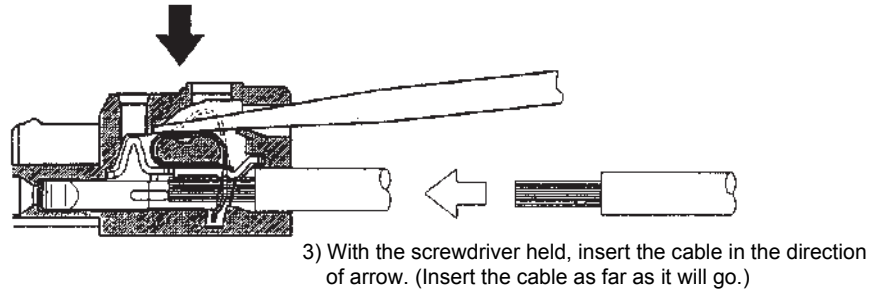
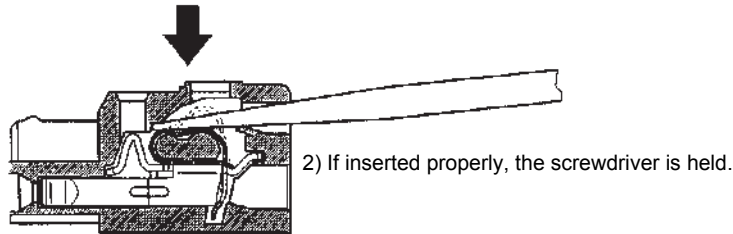
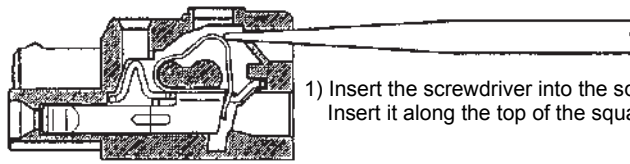

### 3. SIGNALS AND WIRING

#### 3) When using the flat-blade screwdriver - part 2

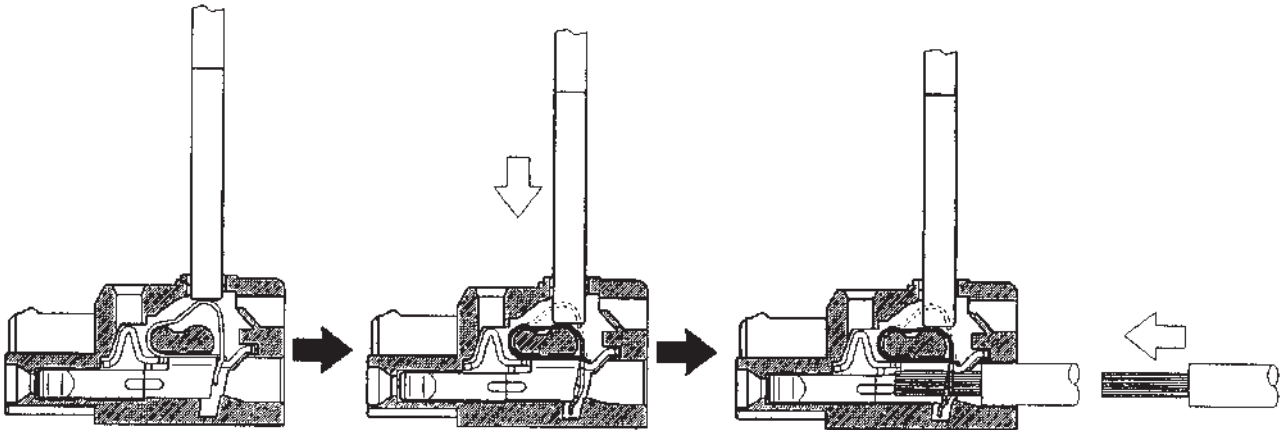

1) Insert the screwdriver into the square window at top of the connector.

2) Push the screwdriver in the direction of arrow.

3) With the screwdriver pushed, insert the cable in the direction of arrow. (Insert the cable as far as it will go.)

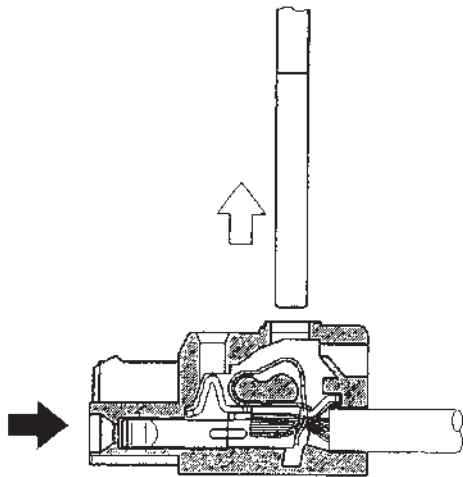

4) Releasing the screwdriver connects the cable.

### 3. SIGNALS AND WIRING

#### (4) How to insert the cable into Phoenix Contact connector

POINT
▪ Do not use a precision driver because the cable cannot be tightened with enough torque.

Insertion of cables into Phoenix Contact connector PC4/6-STF-7.62-CRWH or PC4/3-STF-7.62-CRWH is shown as follows.

Before inserting the cable into the opening, make sure that the screw of the terminal is fully loose. Insert the core of the cable into the opening and tighten the screw with a flat-blade screwdriver. When the cable is not tightened enough to the connector, the cable or connector may generate heat because of the poor contact.

(When using a cable of 1.5mm<sup>2</sup> or less, two cables may be inserted into one opening.)

Secure the connector to the servo amplifier by tightening the connector screw.

For securing the cable and the connector, use a flat-blade driver with 0.6mm blade edge thickness and 3.5mm diameter (Recommended flat-blade screwdriver: Phoenix Contact SZS 0.6×3.5). Apply 0.5 to 0.6 N · m torque to screw.

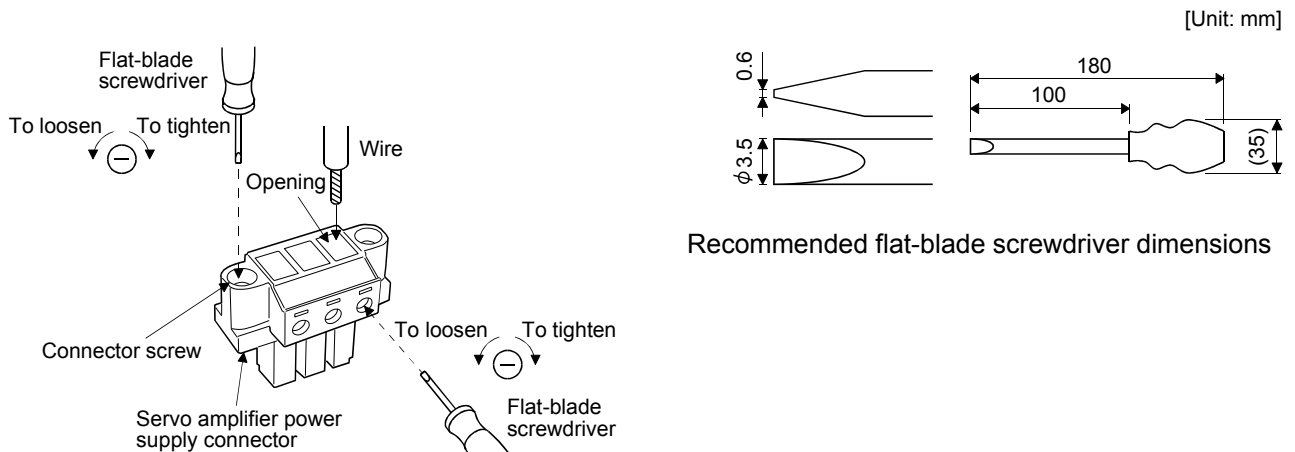

### 3. SIGNALS AND WIRING

#### 3.4 Connectors and signal arrangements

**POINT**

- The pin configurations of the connectors are as viewed from the cable connector wiring section.

##### (1) Signal arrangement

The servo amplifier front view shown is that of the MR-J3-20B or less. Refer to chapter 9 Outline Drawings for the appearances and connector layouts of the other servo amplifiers.

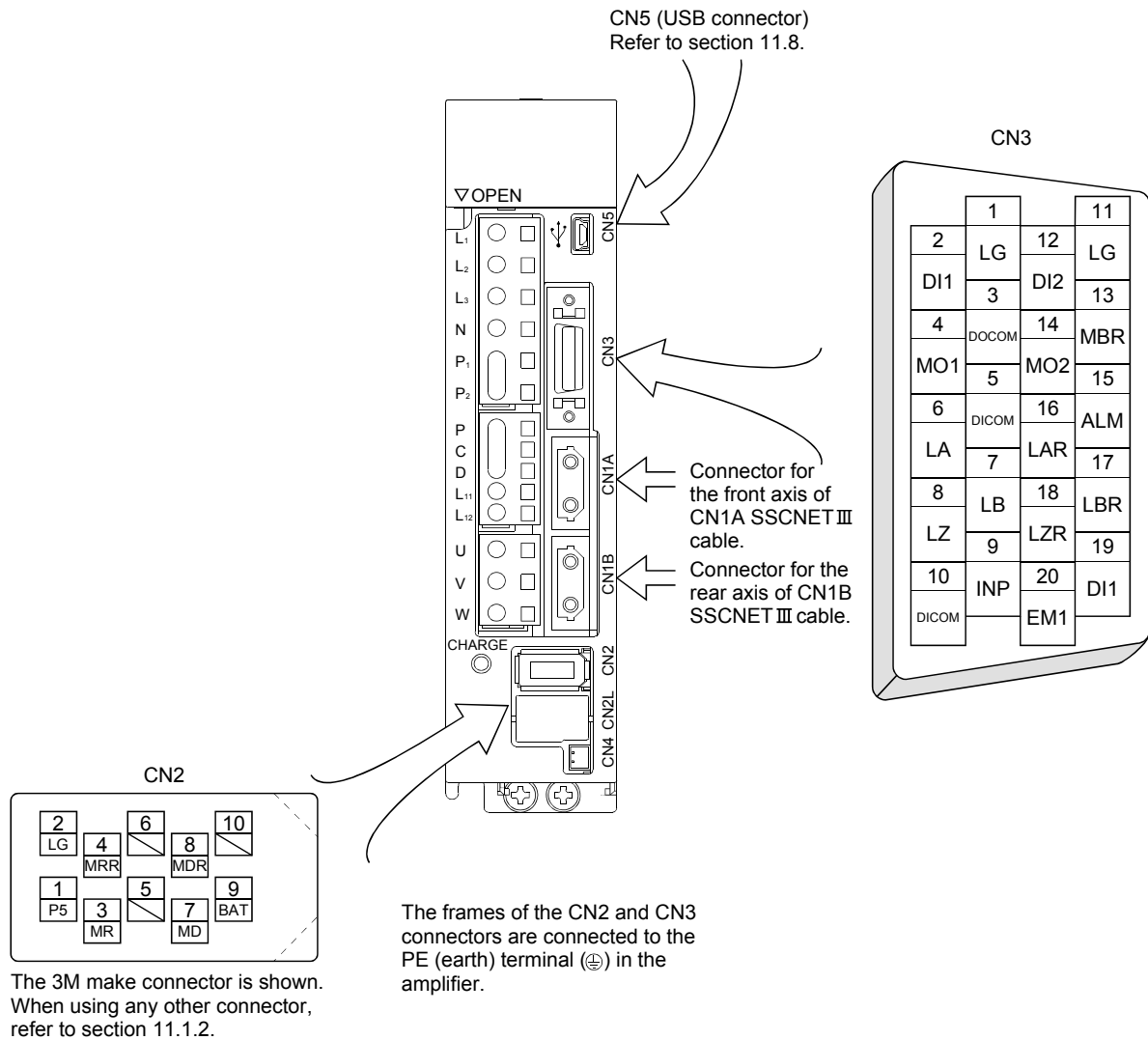

### 3. SIGNALS AND WIRING

#### 3.5 Signal (device) explanations

For the I/O interfaces (symbols in I/O division column in the table), refer to section 3.7.2.

In the control mode field of the table

The pin No.s in the connector pin No. column are those in the initial status.

##### (1) Connector applications

Connector	Name	Function/Application
CN1A	Connector for bus cable from preceding axis.	Used for connection with the controller or preceding-axis servo amplifier.
CN1B	Connector for bus cable to next axis	Used for connection with the next-axis servo amplifier or for connection of the cap.
CN2	Encoder connector	Used for connection with the servo motor encoder.
CN4	Battery connection connector	When using as absolute position detection system, connect to battery (MR-J3BAT). Before installing a battery, turn off the main circuit power while keeping the control circuit power on. Wait for 15 minutes or more (20 minutes or for drive unit 30kW or more) until the charge lamp turns off. Then, confirm that the voltage between P(+) and N(-) (L+ and L- for drive unit 30kW or more) is safe with a voltage tester and others. Otherwise, an electric shock may occur. In addition, always confirm from the front of the servo amplifier whether the charge lamp is off or not. Replace the battery with main circuit power OFF and with control circuit power ON. Replacing the battery with the control circuit power OFF results in losing absolute position data.
CN5	Communication connector	The personal computer is connected.

##### (2) I/O device

###### (a) Input device

Device	Symbol	Connector pin No.	Function/Application	I/O division
Forced stop	EM1	CN3-20	Turn EM1 off (open between commons) to bring the motor to an forced stop state, in which the base circuit is shut off and the dynamic brake is operated. Turn EM1 on (short between commons) in the forced stop state to reset that state. When parameter No.PA.04 is set to " □1□□ ", automatically ON (always ON) can be set inside.	DI-1
	DI1	CN3-2	Devices can be assigned for DI1 DI2 DI3 with controller setting.	DI-1
	DI2	CN3-12	For devices that can be assigned, refer to the controller instruction manual. The following devices can be assigned for Q172HCPU Q173HCPU QD75MH.	DI-1
	DI3	CN3-19	DI1: upper stroke limit (FLS) DI2: lower stroke limit (RLS) DI3: proximity dog (DOG)	DI-1

### 3. SIGNALS AND WIRING

#### (b) Output device

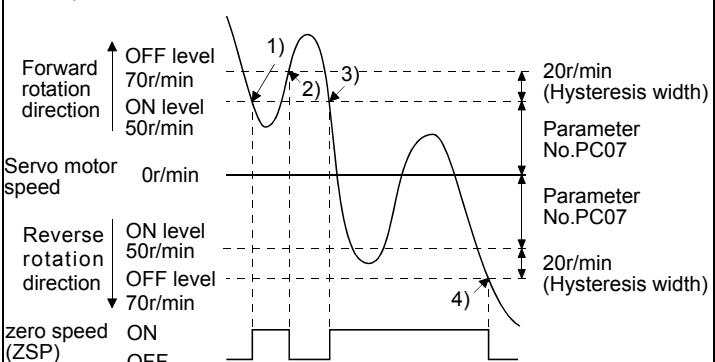
Device	Symbol	Connector pin No.	Function/Application	I/O division
Trouble	ALM	CN3-15	ALM turns off when power is switched off or the protective circuit is activated to shut off the base circuit. Without alarm occurring, ALM turns on within about 1s after power-on.	DO-1
Electromagnetic brake interlock	MBR	CN3-13	When using this signal, set operation delay time of the electromagnetic brake in parameter No.PC02. In the servo-off or alarm status, MBR turns off.	DO-1
In-position (Positioning completed)	INP	CN3-9	INP turns on when the number of droop pulses is in the preset in-position range. The in-position range can be changed using parameter No.PA10. When the in-position range is increased, INP may be on conductive status during low-speed rotation. INP turns on when servo on turns on. This signal cannot be used in the speed loop mode.	DO-1
Ready	RD		When using the signal, make it usable by the setting of parameter No.PD07 to PD09. RD turns on when the servo is switched on and the servo amplifier is ready to operate.	DO-1
Dynamic brake interlock	DB		When using the signal, make it usable by the setting of parameter No.PD07 to PD09. DB turns off simultaneously when the dynamic brake is operated. When using the external dynamic brake on the servo amplifier of 11 kW or more, this device is required. (Refer to section 11.6.) For the servo amplifier of 7kW or less, it is not necessary to use this device.	DO-1
Speed reached	SA		When using this signal, make it usable by the setting of parameter No.PD07 to PD09. When the servo is off, SA will be turned OFF. When servo motor rotation speed becomes approximately setting speed, SA will be turned ON. When the preset speed is 20r/min or less, SA always turns on. This signal cannot be used in position loop mode.	DO-1
Limiting torque	TLC		When using this signal, make it usable by the setting of parameter No.PD07 to PD09. When torque is produced level of torque set with controller, TLC will be turned ON. When the servo is off, TLC will be turned OFF.	DO-1
Zero speed	ZSP		<p>When using this signal, make it usable by the setting of parameter No.PD07 to PD09. When the servo is off, SA will be turned OFF. ZSP turns on when the servo motor speed is zero speed (50r/min) or less. Zero speed can be changed using parameter No.PC07. Example Zero speed is 50r/min</p>  <p>Forward rotation direction OFF level 70r/min ON level 50r/min</p> <p>Servo motor speed 0r/min</p> <p>Reverse rotation direction ON level 50r/min OFF level 70r/min</p> <p>zero speed (ZSP) ON OFF</p> <p>20r/min (Hysteresis width) Parameter No.PC07 20r/min (Hysteresis width)</p> <p>ZPS turns on 1) when the servo motor is decelerated to 50r/min, and ZPS turns off 2) when the servo motor is accelerated to 70r/min again. ZPS turns on 3) when the servo motor is decelerated again to 50r/min, and turns off 4) when the servo motor speed has reached -70r/min. The range from the point when the servo motor speed has reached ON level, and ZPS turns on, to the point when it is accelerated again and has reached OFF level is called hysteresis width. Hysteresis width is 20r/min for the MR-J3-B servo amplifier.</p>	DO-1

### 3. SIGNALS AND WIRING

Device	Symbol	Connector pin No.	Function/Application	I/O division
Warning	WNG	/	When using this signal, make it usable by the setting of parameter No.PD07 to PD09. When warning has occurred, WNG turns on. When there is no warning, WNG turns off within about 1.5s after power-on.	DO-1
Battery warning	BWNG		When using this signal, make it usable by the setting of parameter No.PD07 to PD09. BWNG turns on when battery cable disconnection warning (92) or battery warning (9F) has occurred. When there is no battery warning, BWNG turns off within about 1.5s after power-on.	DO-1
Variable gain selection	CDPS		When using this signal, make it usable by the setting of parameter No.PD07 to PD09. CDPS is on during variable gain.	DO-1
Absolute position erasing	ABSV		When using this signal, make it usable by the setting of parameter No.PD07 to PD09. ABSV turns on when the absolute position erased. This signal cannot be used in position loop mode.	DO-1

#### (c) Output signals

Signal name	Symbol	Connector pin No.	Function/Application
Encoder A-phase pulse (Differential line driver)	LA LAR	CN3-6 CN3-16	Outputs pulses per servo motor revolution set in parameter No.PA15 in the differential line driver system. In CCW rotation of the servo motor, the encoder B-phase pulse lags the encoder A-phase pulse by a phase angle of $\pi/2$ . The relationships between rotation direction and phase difference of the A- and B-phase pulses can be changed using parameter No.PC03. Output pulse specification and dividing ratio setting can be set. (Refer to section 5.1.9.)
Encoder B-phase pulse (Differential line driver)	LB LBR	CN3-7 CN3-17	
Encoder Z-phase pulse (Differential line driver)	LZ LZR	CN3-8 CN3-18	Outputs the zero-point signal in the differential line driver system of the encoder. One pulse is output per servo motor revolution. turns on when the zero-point position is reached. The minimum pulse width is about 400 $\mu$ s. For home position return using this pulse, set the creep speed to 100r/min. or less.
Analog monitor 1	MO1	CN3-4	Used to output the data set in parameter No.PC09 to across MO1-LG in terms of voltage. Resolution 10 bits
Analog monitor 2	MO2	CN3-14	Used to output the data set in parameter No.PC10 to across MO2-LG in terms of voltage. Resolution 10 bits

#### (d) Power supply

Signal name	Symbol	Connector pin No.	Function/Application
Digital I/F power supply input	DICOM	CN3-5 CN3-10	Used to input 24VDC (24VDC 10% 150mA) for I/O interface of the servo amplifier. The power supply capacity changes depending on the number of I/O interface points to be used. Connect the positive terminal of the 24VDC external power supply for the sink interface.
Digital I/F common	DOCOM	CN3-3	Common terminal for input device such as EM1 of the servo amplifier. Pins are connected internally. Separated from LG. Connect the positive terminal of the 24VDC external power supply for the source interface.
Monitor common	LG	CN3-1 CN3-11	Common terminal of M01 * M02 Pins are connected internally.
Shield	SD	Plate	Connect the external conductor of the shield cable.

### 3. SIGNALS AND WIRING

#### 3.6 Alarm occurrence timing chart



**CAUTION**

- When an alarm has occurred, remove its cause, make sure that the operation signal is not being input, ensure safety, and reset the alarm before restarting operation.
- As soon as an alarm occurs, make the Servo off status and interrupt the main circuit power.

When an alarm occurs in the servo amplifier, the base circuit is shut off and the servo motor is coated to a stop. Switch off the main circuit power supply in the external sequence. To deactivate the alarm, power the control circuit off, then on or give the error reset or CPU reset command from the servo system controller. However, the alarm cannot be deactivated unless its cause is removed.

(Note)

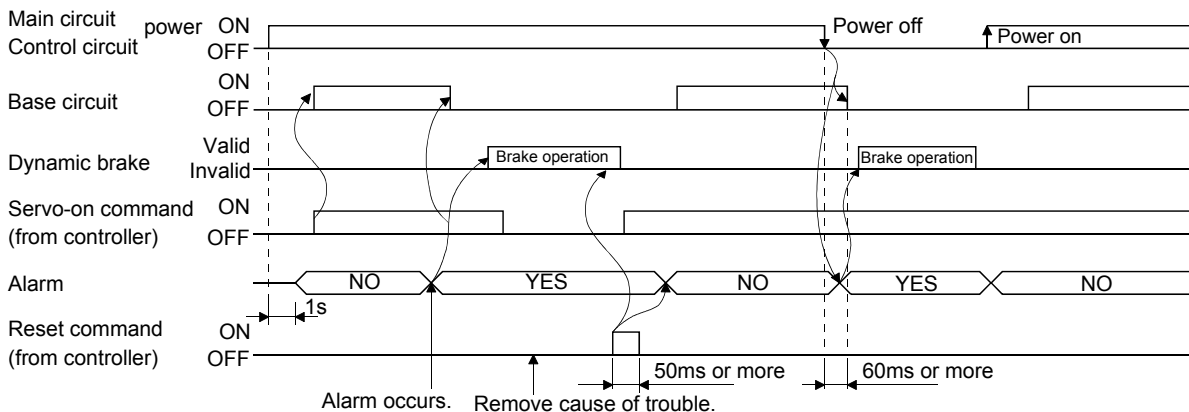

Note. Switch off the main circuit power as soon as an alarm occurs.

#### (1) Overcurrent, overload 1 or overload 2

If operation is repeated by switching control circuit power off, then on to reset the overcurrent (32), overload 1 (50) or overload 2 (51) alarm after its occurrence, without removing its cause, the servo amplifier and servo motor may become faulty due to temperature rise. Securely remove the cause of the alarm and also allow about 30 minutes for cooling before resuming operation.

#### (2) Regenerative alarm

If operation is repeated by switching control circuit power off, then on to reset the regenerative (30) alarm after its occurrence, the external regenerative resistor will generate heat, resulting in an accident.

#### (3) Instantaneous power failure

Undervoltage (10) occurs when the input power is in either of the following statuses.

- A power failure of the control circuit power supply continues for 60ms or longer and the control circuit is not completely off.
- The bus voltage dropped to 200VDC or less for the MR-J3-□B, to 158VDC or less for the MR-J3-□B1, or to 380VDC or less for the MR-J3-□B4.

### 3. SIGNALS AND WIRING

#### 3.7 Interfaces

##### 3.7.1 Internal connection diagram

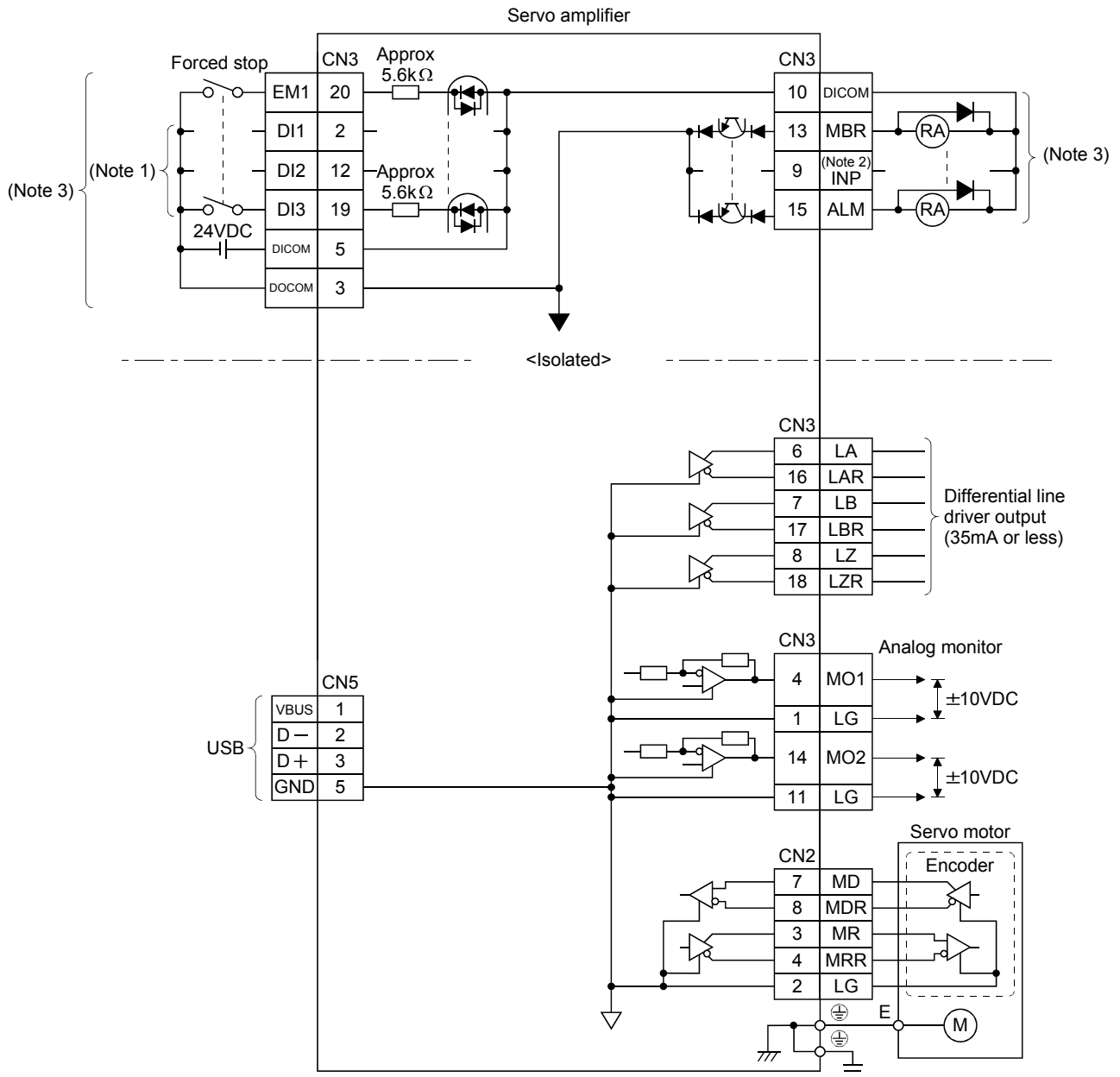

Note 1. Signal can be assigned for these pins with host controller setting.

For contents of signals, refer to the instruction manual of host controller.

2. This signal cannot be used with speed loop mode.

3. For the sink I/O interface. For the source I/O interface, refer to section 3.7.3.

### 3. SIGNALS AND WIRING

#### 3.7.2 Detailed description of interfaces

This section provides the details of the I/O signal interfaces (refer to the I/O division in the table) given in section 3.5. Refer to this section and make connection with the external equipment.

##### (1) Digital input interface DI-1

Give a signal with a relay or open collector transistor. Refer to section 3.7.3 for the source input.

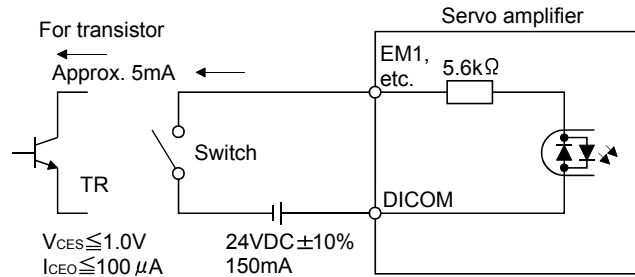

##### (2) Digital output interface DO-1

A lamp, relay or photocoupler can be driven. Install a diode (D) for an inductive load, or install an inrush current suppressing resistor (R) for a lamp load. (Rated current: 40mA or less, maximum current: 50mA or less, inrush current: 100mA or less) A maximum of 2.6V voltage drop occurs in the servo amplifier. Refer to section 3.7.3 for the source output.

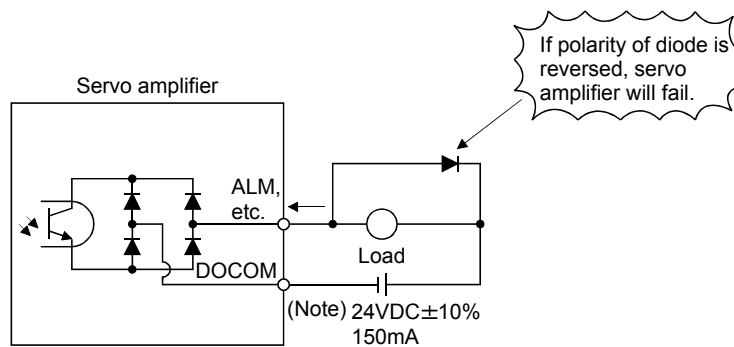

Note. If the voltage drop (maximum of 2.6V) interferes with the relay operation, apply high voltage (up to 26.4V) from external source.

### 3. SIGNALS AND WIRING

#### (3) Encoder output pulse DO-2 (Differential line driver system)

##### (a) Interface

Max. output current: 35mA

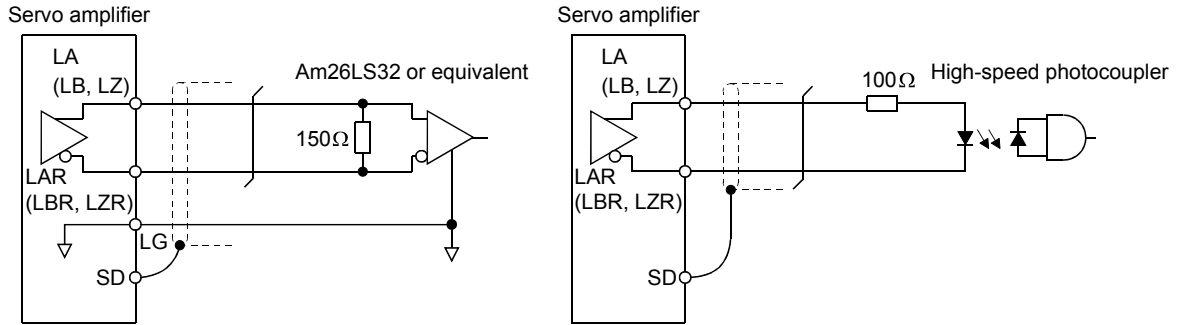

##### (b) Output pulse

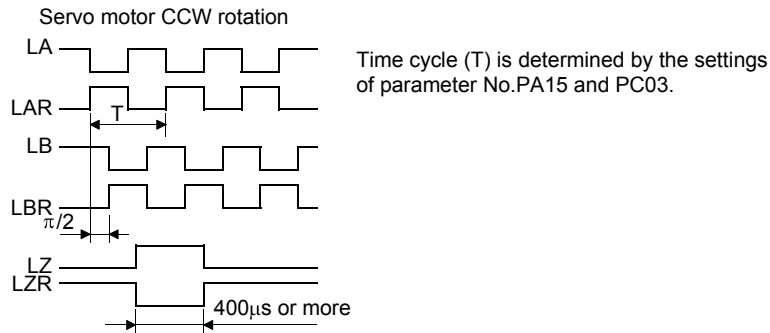

#### (4) Analog output

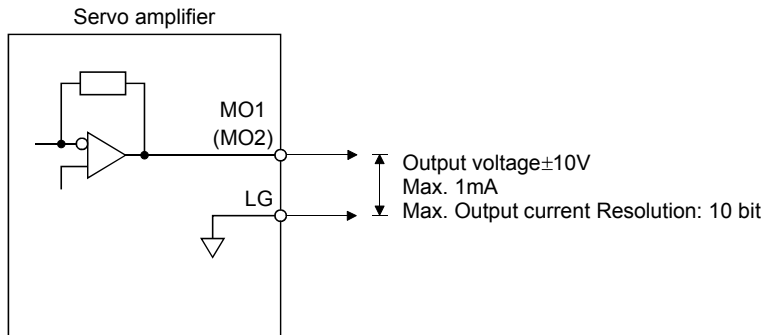

### 3. SIGNALS AND WIRING

#### 3.7.3 Source I/O interfaces

In this servo amplifier, source type I/O interfaces can be used. In this case, all DI-1 input signals and DO-1 output signals are of source type. Perform wiring according to the following interfaces.

##### (1) Digital input interface DI-1

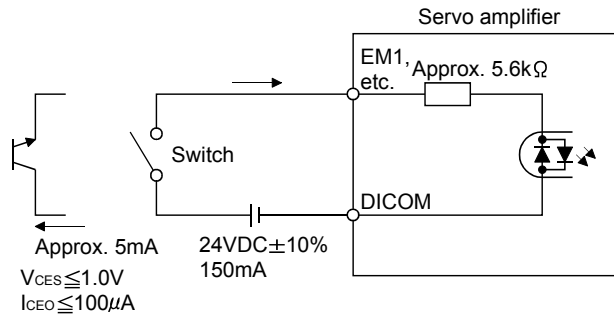

##### (2) Digital output interface DO-1

A maximum of 2.6V voltage drop occurs in the servo amplifier.

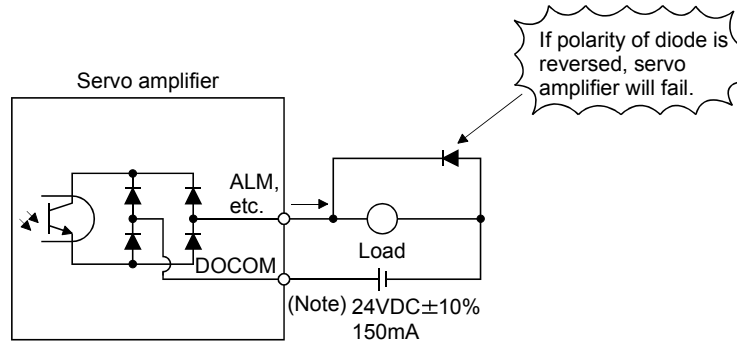

Note. If the voltage drop (maximum of 2.6V) interferes with the relay operation, apply high voltage (up to 26.4V) from external source.

### 3. SIGNALS AND WIRING

#### 3.8 Treatment of cable shield external conductor

In the case of the CN2 and CN3 connectors, securely connect the shielded external conductor of the cable to the ground plate as shown in this section and fix it to the connector shell.

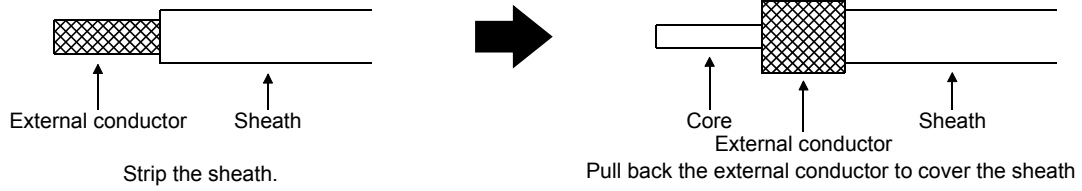

#### (1) For CN3 connector (3M connector)

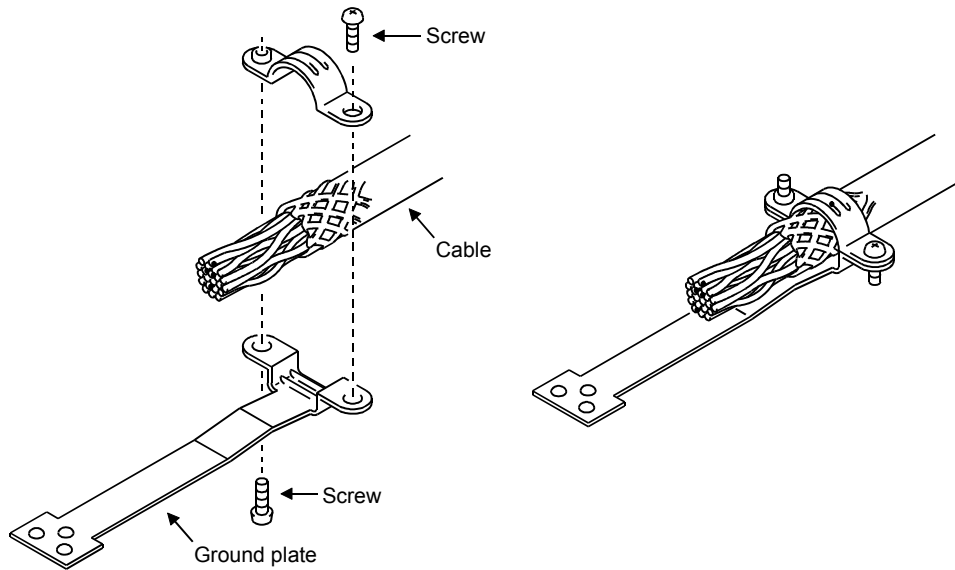

#### (2) For CN2 connector (3M or Molex connector)

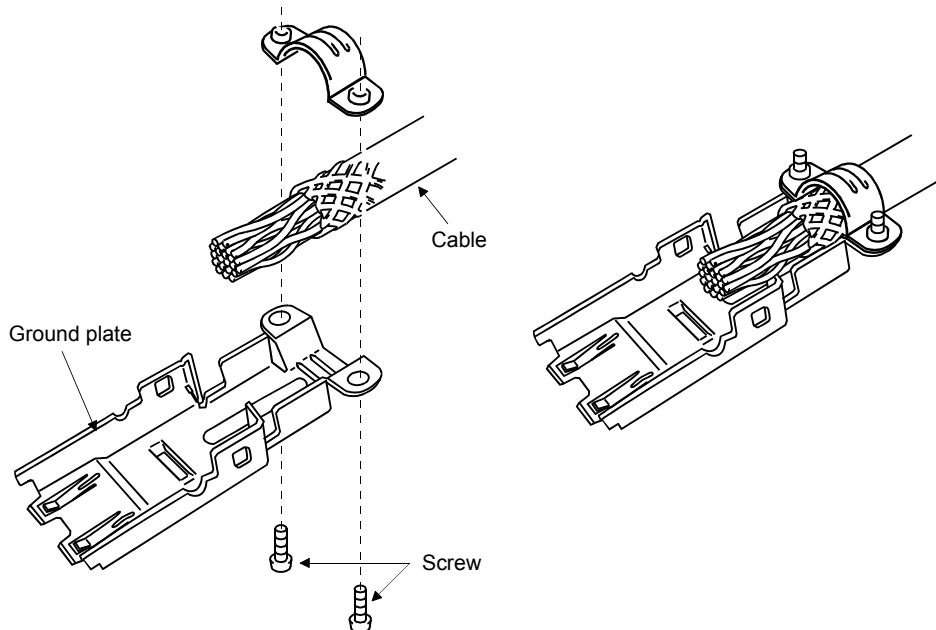

### 3. SIGNALS AND WIRING

#### 3.9 SSCNETIII cable connection

POINT
<ul style="list-style-type: none"> <li>Do not see directly the light generated from CN1A • CN1B connector of servo amplifier or the end of SSCNETIII cable.</li> <li>When the light gets into eye, may feel something is wrong for eye.</li> <li>(The light source of SSCNETIII complies with class1 defined in JIS C6802 or IEC60825-1.)</li> </ul>

#### (1) SSCNETIII cable connection

For CN1A connector, connect SSCNETIII cable connected to controller in host side or servo amplifier.

For CN1B connector, connect SSCNETIII cable connected to servo amplifier in lower side.

For CN1B connector of the final axis, put a cap came with servo amplifier.

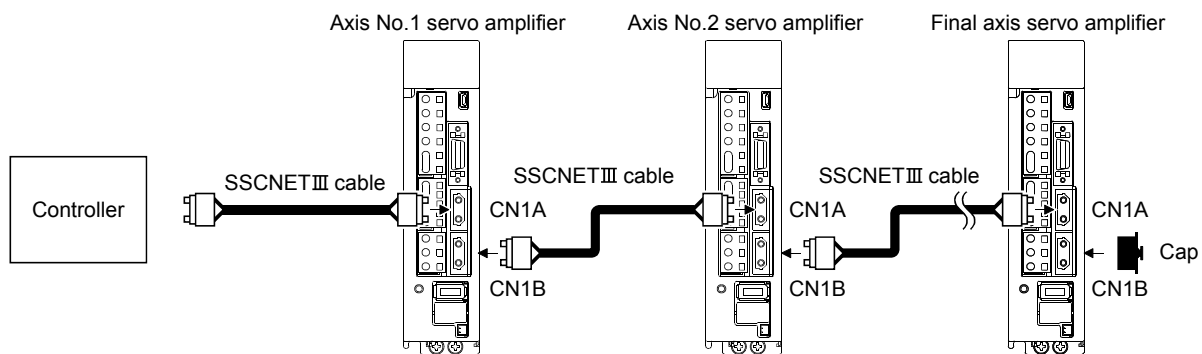

#### (2) How to connect/disconnect cable.

POINT
<ul style="list-style-type: none"> <li>CN1A • CN1B connector is put a cap to protect light device inside connector from dust.</li> <li>For this reason, do not remove a cap until just before mounting SSCNETIII cable.</li> <li>Then, when removing SSCNETIII cable, make sure to put a cap.</li> <li>Keep the cap for CN1A • CN1B connector and the tube for protecting light code end of SSCNETIII cable in a plastic bag with a zipper of SSCNETIII cable to prevent them from becoming dirty.</li> <li>When asking repair of servo amplifier for some troubles, make sure to put a cap on CN1A • CN1B connector.</li> <li>When the connector is not put a cap, the light device may be damaged at the transit.</li> <li>In this case, exchange and repair of light device is required.</li> </ul>

#### (a) Mounting

1) For SSCNETIII cable in the shipping status, the tube for protect light code end is put on the end of connector. Remove this tube.

2) Remove the CN1A • CN1B connector cap of servo amplifier.

### 3. SIGNALS AND WIRING

- 3) With holding a tab of SSCNETIII cable connector, make sure to insert it into CN1A - CN1B connector of servo amplifier until you hear the click.

If the end face of optical code tip is dirty, optical transmission is interrupted and it may cause malfunctions.

If it becomes dirty, wipe with a bonded textile, etc.

Do not use solvent such as alcohol.

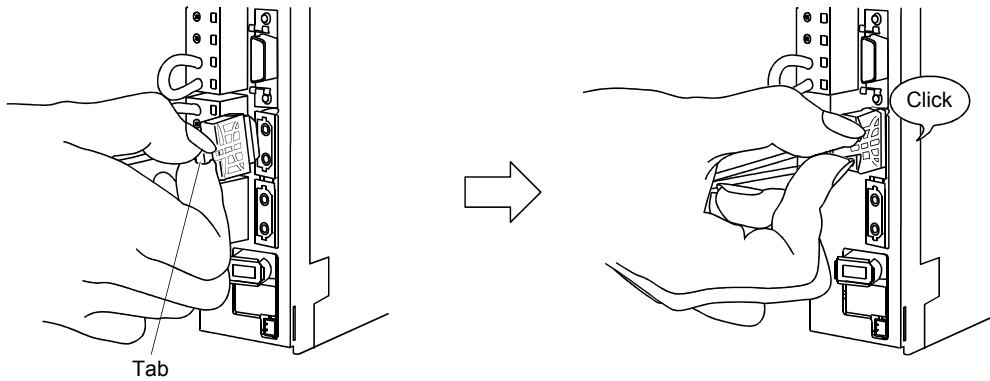

#### (b) Removal

With holding a tab of SSCNETIII cable connector, pull out the connector.

When pulling out the SSCNETIII cable from servo amplifier, be sure to put the cap on the connector parts of servo amplifier to prevent it from becoming dirty.

For SSCNETIII cable, attach the tube for protection optical code's end face on the end of connector.

### 3. SIGNALS AND WIRING

#### 3.10 Connection of servo amplifier and servo motor



#### CAUTION

- During power-on, do not open or close the motor power line. Otherwise, a malfunction or faulty may occur.

##### 3.10.1 Connection instructions



#### WARNING

- Insulate the connections of the power supply terminals to prevent an electric shock.



#### CAUTION

- Connect the wires to the correct phase terminals (U, V, W) of the servo amplifier and servo motor. Not doing so may cause unexpected operation.
- Do not connect AC power supply directly to the servo motor. Otherwise, a fault may occur.

#### POINT

- Refer to section 11.1 for the selection of the encoder cable.

This section indicates the connection of the servo motor power (U, V, W). Use of the optional cable and connector set is recommended for connection between the servo amplifier and servo motor. When the options are not available, use the recommended products. Refer to section 11.1 for details of the options.

- (1) For grounding, connect the earth cable of the servo motor to the protective earth (PE) terminal (⊕) of the servo amplifier and connect the ground cable of the servo amplifier to the earth via the protective earth of the control box. Do not connect them directly to the protective earth of the control panel.

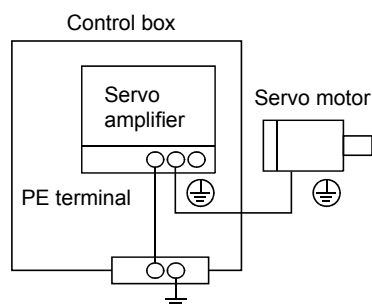

- (2) Do not share the 24VDC interface power supply between the interface and electromagnetic brake. Always use the power supply designed exclusively for the electromagnetic brake.

### 3. SIGNALS AND WIRING

#### 3.10.2 Power supply cable wiring diagrams

##### (1) HF-MP service • HF-KP series • HF-KP series servo motor

###### (a) When cable length is 10m or less

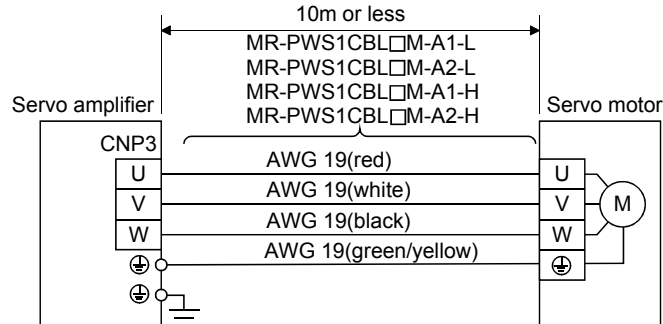

###### (b) When cable length exceeds 10m

When the cable length exceeds 10m, fabricate an extension cable as shown below. In this case, the motor power supply cable should be within 2m long.

Refer to section 11.11 for the wire used for the extension cable.

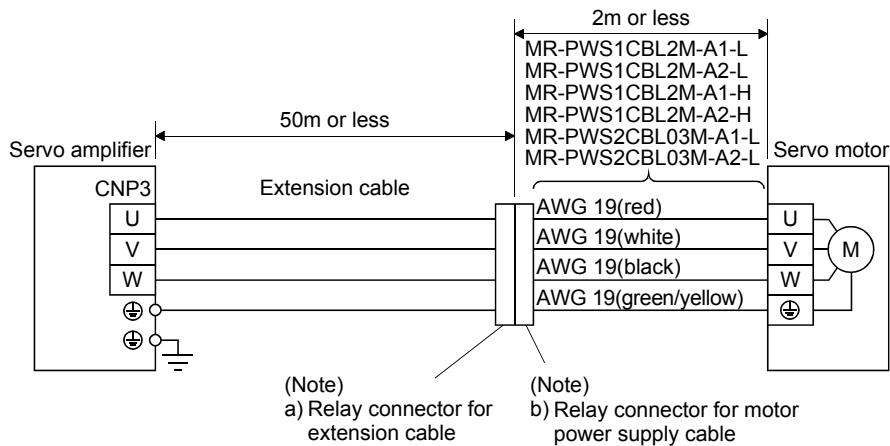

Note. Use of the following connectors is recommended when ingress protection (IP65) is necessary.

Relay connector	Description	Protective structure
a) Relay connector for extension cable	Connector: RM15WTPZ-4P(71) Cord clamp: RM15WTP-CP(5)(71) (Hirose Electric)      └ Numeral changes depending on the cable OD.	IP65
b) Relay connector for motor power supply cable	Connector: RM15WTJA-4S(71) Cord clamp: RM15WTP-CP(8)(71) (Hirose Electric)      └ Numeral changes depending on the cable OD.	IP65

### 3. SIGNALS AND WIRING

(2) HF-SP series • HC-RP series • HC-UP series • HC-LP series servo motor

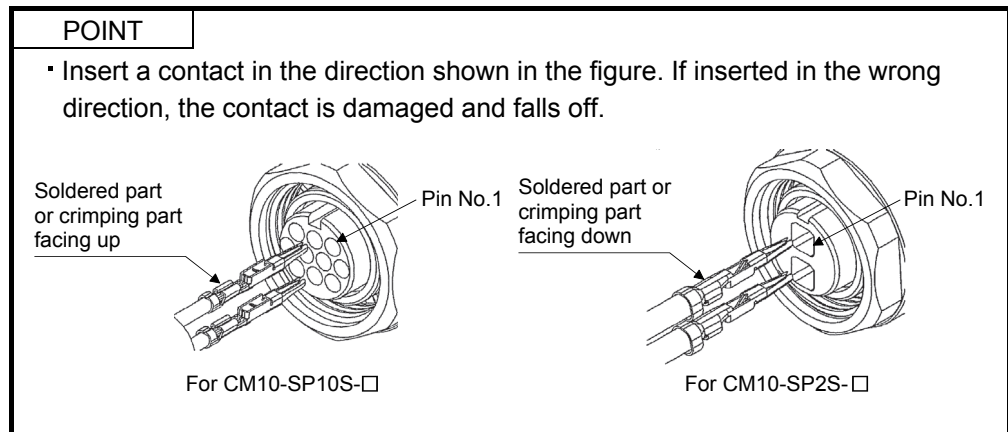

(a) Wiring diagrams

Refer to section 11.11 for the cables used for wiring.

1) When the power supply connector and the electromagnetic brake connector are separately supplied.

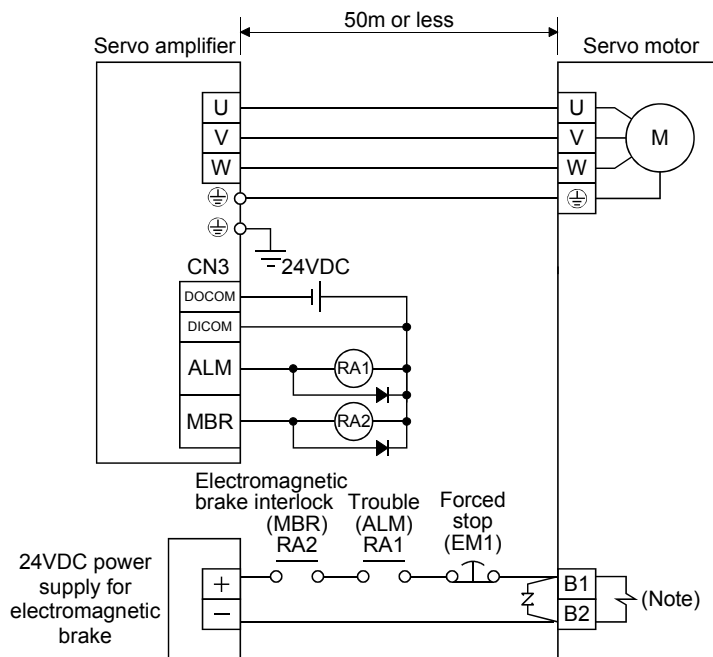

Note. There is no polarity in electromagnetic brake terminals B1 and B2.

### 3. SIGNALS AND WIRING

2) When the power supply connector and the electromagnetic brake connector are shared.

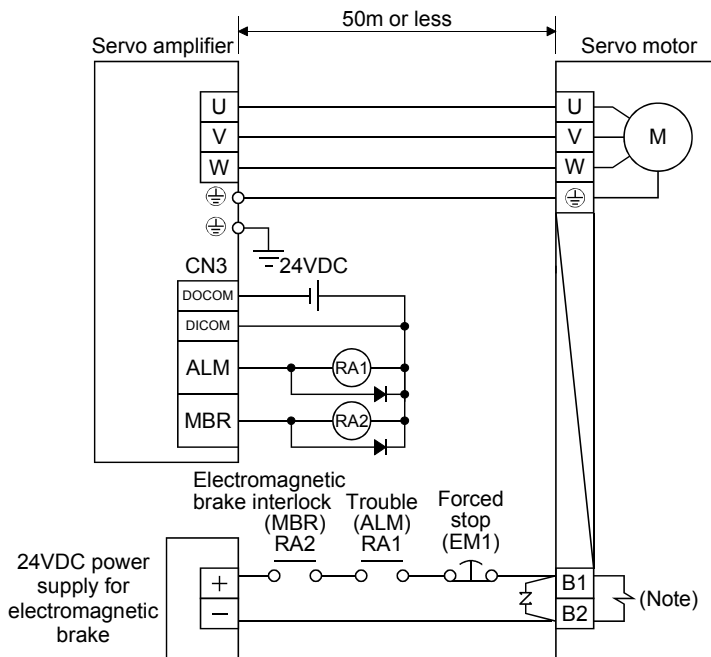

Note. There is no polarity in electromagnetic brake terminals B1 and B2.

(b) Connector and signal allotment

The connector fitting the servo motor is prepared as optional equipment. Refer to section 11.1. For types other than those prepared as optional equipment, refer to chapter 3 in Servo Motor Instruction Manual, Vol. 2 to select.

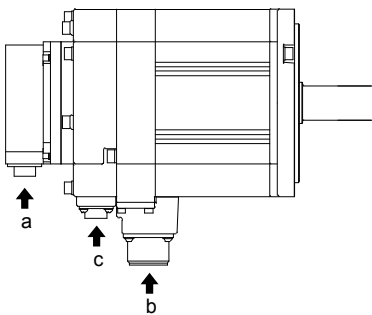

Servo motor	Servo motor side connectors		
	Encoder	Power supply	Electromagnetic brake
HF-SP52(4) to 152(4)	CM10-R10P (DDK)	MS3102A18-10P	CM10-R2P (DDK)
HF-SP51 * 81		MS3102A22-22P	
HF-SP202 * 352 * 502(4)			
HF-SP121 to 301		CE05-2A22-23PD-B	The connector for power is shared
HF-SP421 * 702(4)		CE05-2A24-10PD-B	
HC-RP103 to 203		CE05-2A22-23PD-B	
HC-RP353 * 503		CE05-2A24-10PD-B	MS3102A10SL-4P
HC-UP72 * 152		CE05-2A22-23PD-B	
HC-UP202 to 502		CE05-2A24-10PD-B	The connector for power is shared
HC-LP52 to 152		CE05-2A22-23PD-B	
HC-LP202 * 302	CE05-2A24-10PD-B	MS3102A10SL-4P	

### 3. SIGNALS AND WIRING

Encoder connector signal allotment  
CM10-R10P

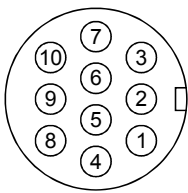

View a

Terminal No.	Signal
1	MR
2	MRR
3	
4	BAT
5	LG
6	
7	
8	P5
9	
10	SHD

Power supply connector signal allotment

MS3102A18-10P  
MS3102A22-22P  
CE05-2A32-17PD-B

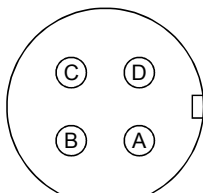

View b

Terminal No.	Signal
A	U
B	V
C	W
D	⊕ (earth)

Power supply connector signal allotment  
CE05-2A22-23PD-B

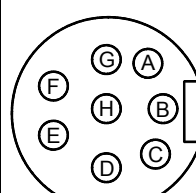

View b

Terminal No.	Signal
A	U
B	V
C	W
D	⊕ (earth)
E	
F	
G	B1 (Note)
H	B2 (Note)

Note. For the motor with an electromagnetic brake, supply electromagnetic brake power (24VDC). There is no polarity.

Power supply connector signal allotment  
CE05-2A24-10PD-B

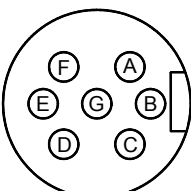

View b

Terminal No.	Signal
A	U
B	V
C	W
D	⊕ (earth)
E	B1 (Note)
F	B2 (Note)
G	

Note. For the motor with an electromagnetic brake, supply electromagnetic brake power (24VDC). There is no polarity.

Brake connector signal allotment

CM10-R2P

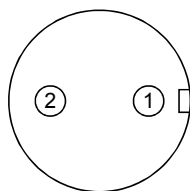

View c

Terminal No.	Signal
1	B1 (Note)
2	B2 (Note)

Note. For the motor with an electromagnetic brake, supply electromagnetic brake power (24VDC). There is no polarity.

Brake connector signal allotment

MS3102A10SL-4P

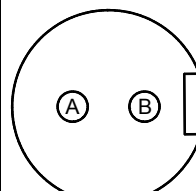

View c

Terminal No.	Signal
A	B1 (Note)
B	B2 (Note)

Note. For the motor with an electromagnetic brake, supply electromagnetic brake power (24VDC). There is no polarity.

### 3. SIGNALS AND WIRING

#### (3) HA-LP series servo motor

##### (a) Wiring diagrams

Refer to section 11.11 for the cables used for wiring.

##### 1) 200V class

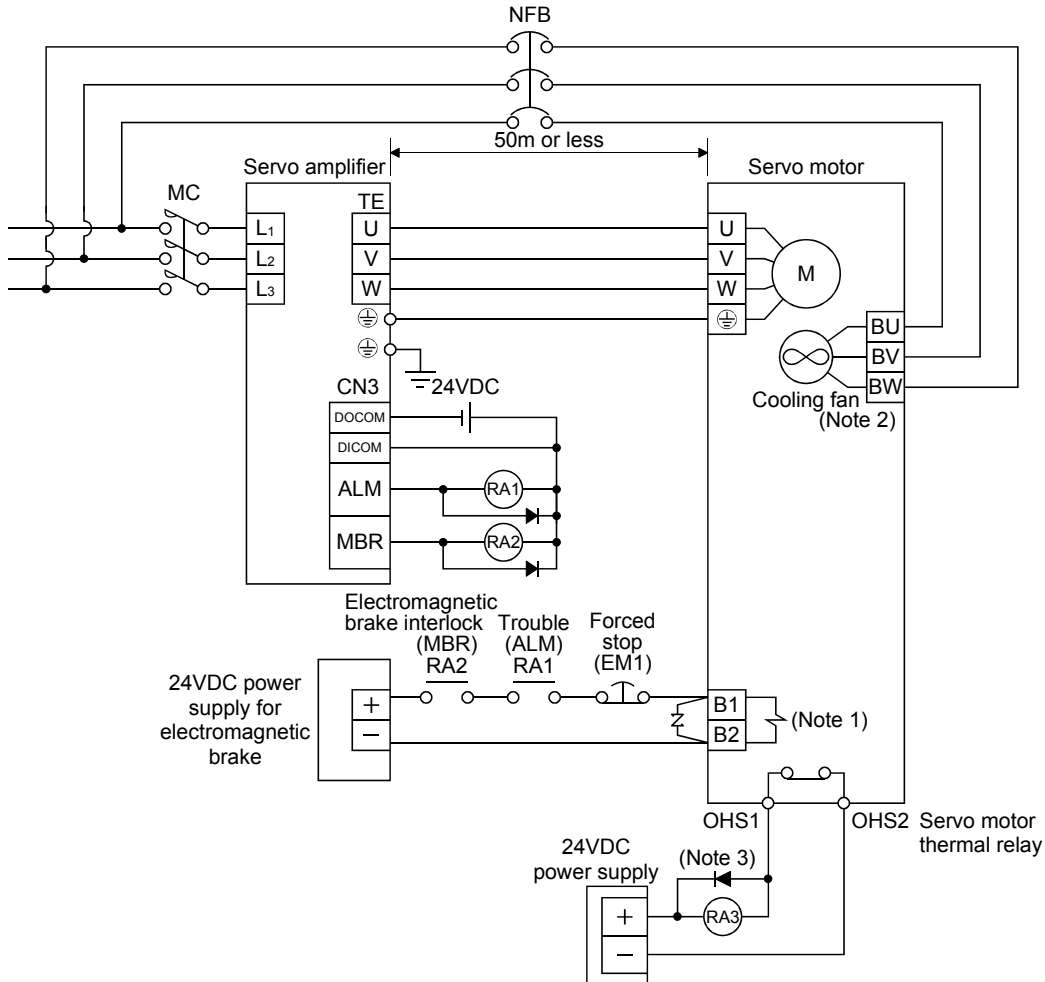

Note 1. There is no polarity in electromagnetic brake terminals B1 and B2.

2. Cooling fan power supply of the HA-LP601, the HA-LP701M and the HA-LP11K2 servo motor is 1-phase. Power supply specification of the cooling fan is different from that of the servo amplifier. Therefore, separate power supply is required.

3. Configure the power supply circuit which turns off the magnetic contactor after detection of servo motor thermal.

### 3. SIGNALS AND WIRING

#### 2) 400V class

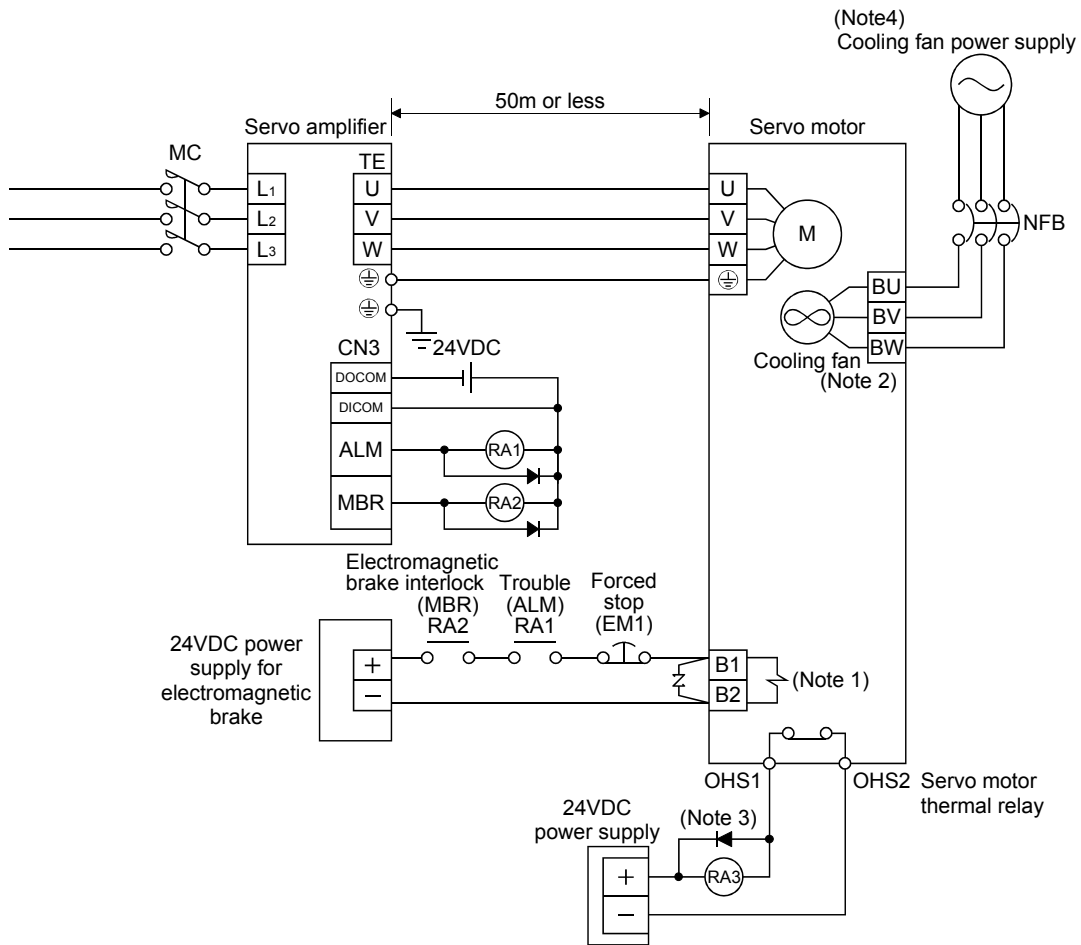

- Note 1. There is no polarity in electromagnetic brake terminals B1 and B2.
2. There is no BW when the power supply of the cooling fan is a 1-phase.
3. Configure the power supply circuit which turns off the magnetic contactor after detection of servo motor thermal.
4. For the cooling fan power supply, refer to (3) (b) of this section.

### 3. SIGNALS AND WIRING

#### (b) Servo motor terminals

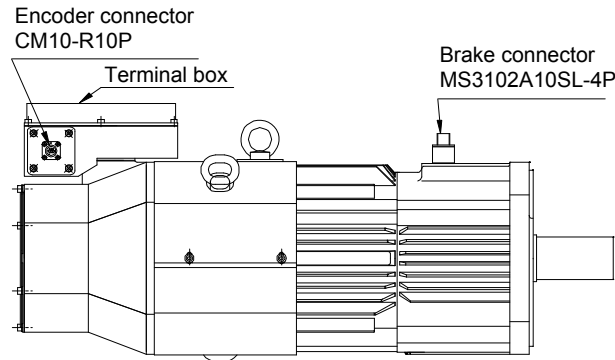

Encoder connector signal allotment  
CM10-R10P

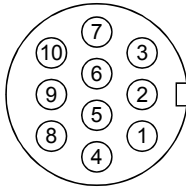

Terminal No.	Signal
1	MR
2	MRR
3	
4	BAT
5	LG
6	
7	
8	P5
9	
10	SHD

Brake connector signal allotment  
MS3102A10SL-4P

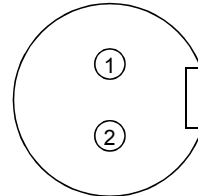

Terminal No.	Signal
1	B1 (Note)
2	B2 (Note)

Note. For the motor with an electromagnetic brake, supply electromagnetic brake power (24VDC). There is no polarity.

#### Terminal box inside (HA-LP601(4) · 701M(4) · 11K2(4) )

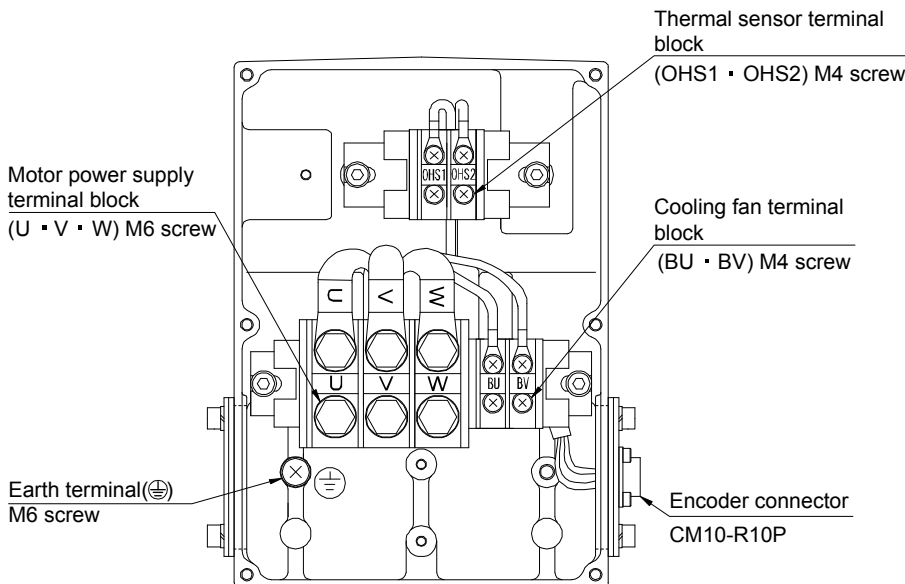

#### Terminal block signal arrangement

OHS1 OHS2

U V W BU BV

### 3. SIGNALS AND WIRING

Terminal box inside (HA-LP801(4) • 12K1(4) • 11K1M(4) • 15K1M(4) • 15K2(4) • 22K2(4))

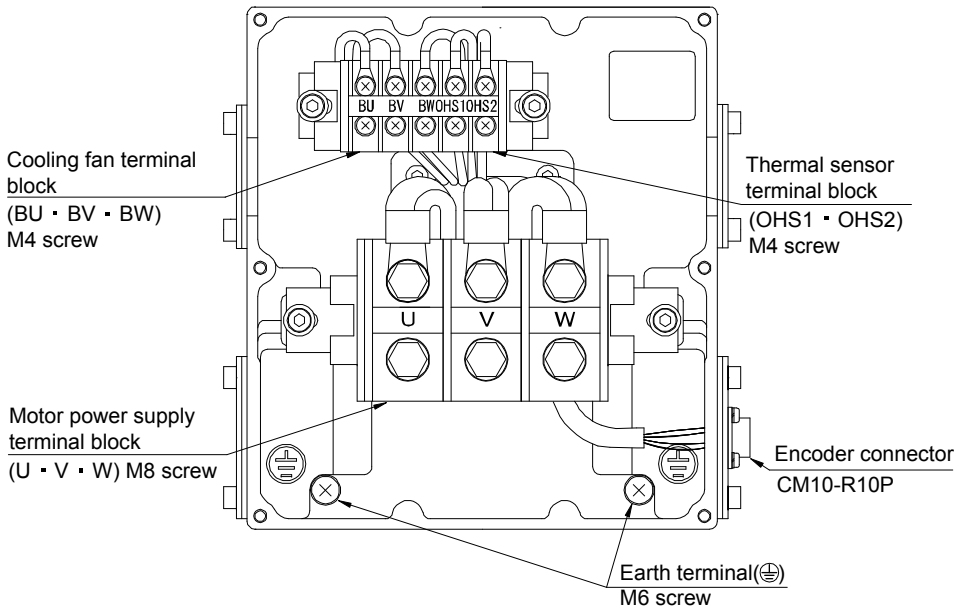

Terminal block signal arrangement

BU	BV	BW	OHS1	OHS2
----	----	----	------	------

U	V	W
---	---	---

Terminal box inside (HA-LP15K1(4) • 20K1(4) • 22K1M(4))

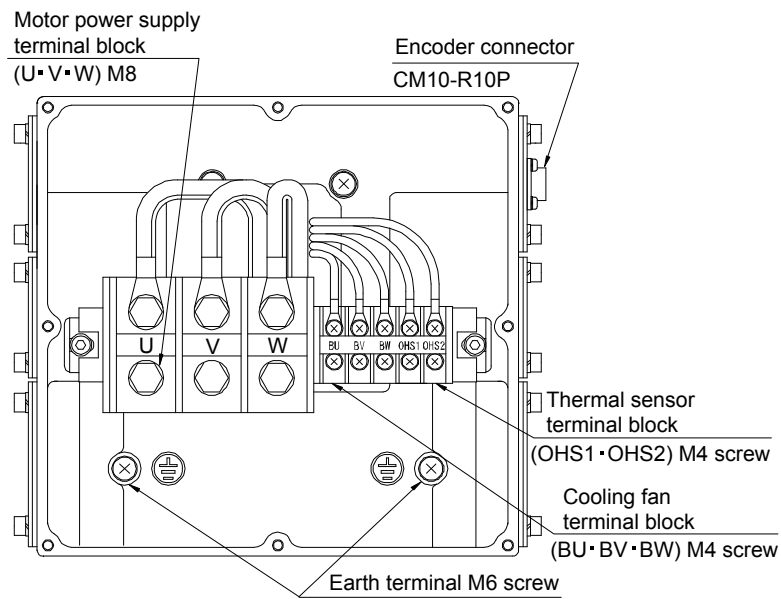

Terminal block signal arrangement

U	V	W	BU	BV	BW	OHS1	OHS2
---	---	---	----	----	----	------	------

### 3. SIGNALS AND WIRING

#### Terminal box inside (HA-LP25K1)

Motor power supply terminal block

(U · V · W) M10 screw

Encoder connector  
CM10-R10P

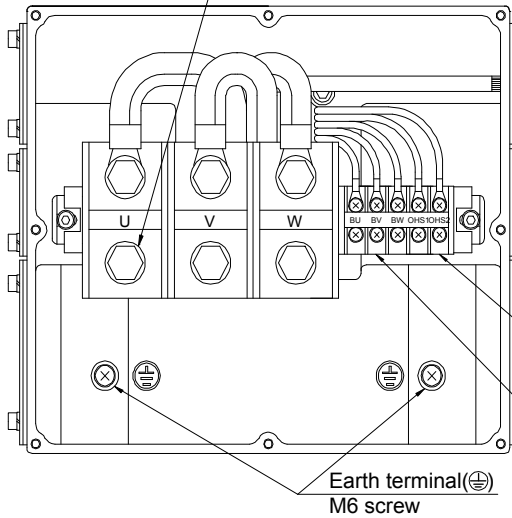

Thermal sensor terminal block  
(OHS1 · OHS2) M4 screw

Cooling fan terminal block  
(BU · BV · BW) M4 screw

Earth terminal(⊕)  
M6 screw

Terminal block signal arrangement

U	V	W	BU	BV	BW	OHS1	OHS2
---	---	---	----	----	----	------	------

### 3. SIGNALS AND WIRING

Signal name	Abbreviation	Description																																																												
Power supply	U · V · W	Connect to the motor output terminals (U, V, W) of the servo amplifier. During power-on, do not open or close the motor power line. Otherwise, a malfunction or faulty may occur.																																																												
Cooling fan	(Note) BU · BV · BW	<p>Supply power which satisfies the following specifications.</p> <table border="1"> <thead> <tr> <th>Servo motor</th> <th>Voltage division</th> <th>Voltage/ frequency</th> <th>Power consumption [W]</th> <th>Rated current [A]</th> </tr> </thead> <tbody> <tr> <td rowspan="2">HA-LP601, 701M, 11K2</td> <td rowspan="2">200V class</td> <td>3-phase 200 to 220VAC 50Hz</td> <td>42(50Hz) 54(60Hz)</td> <td>0.21(50Hz) 0.25(60Hz)</td> </tr> <tr> <td>3-phase 200 to 230VAC 60Hz</td> <td></td> <td></td> </tr> <tr> <td rowspan="3">HA-LP801, 12K1, 11K1M, 15K1M, 15K2, 22K2</td> <td rowspan="3">400V class</td> <td>3-phase 200 to 230VAC 50Hz/60Hz</td> <td>62(50Hz) 76(60Hz)</td> <td>0.18(50Hz) 0.17(60Hz)</td> </tr> <tr> <td></td> <td>65(50Hz) 85(60Hz)</td> <td>0.20(50Hz) 0.22(60Hz)</td> </tr> <tr> <td></td> <td>120(50Hz) 175(60Hz)</td> <td>0.65(50Hz) 0.80(60Hz)</td> </tr> <tr> <td rowspan="2">HA-LP15K1, 20K1, 22K1M</td> <td rowspan="2">400V class</td> <td>1-phase 200 to 220VAC 50Hz</td> <td>42(50Hz) 54(60Hz)</td> <td>0.21(50Hz) 0.25(60Hz)</td> </tr> <tr> <td>3-phase 200 to 230VAC 60Hz</td> <td></td> <td></td> </tr> <tr> <td>HA-LP25K1</td> <td></td> <td>3-phase 380 to 440VAC 50Hz</td> <td>62(50Hz) 76(60Hz)</td> <td>0.14(50Hz) 0.11(60Hz)</td> </tr> <tr> <td rowspan="2">HA-LP6014, 701M4, 11K24</td> <td rowspan="2">400V class</td> <td>3-phase 380 to 480VAC 60Hz</td> <td></td> <td></td> </tr> <tr> <td>3-phase 380 to 460VAC 50Hz</td> <td>65(50Hz) 85(60Hz)</td> <td>0.12(50Hz) 0.14(60Hz)</td> </tr> <tr> <td>HA-LP8014, 12K14, 11K1M4, 15K1M4, 15K24, 22K24</td> <td></td> <td>3-phase 380 to 480VAC 60Hz</td> <td>110(50Hz) 150(60Hz)</td> <td>0.20(50Hz) 0.22(60Hz)</td> </tr> <tr> <td>HA-LP15K14, 20K14, 22K1M4</td> <td></td> <td></td> <td></td> <td></td> </tr> <tr> <td>HA-LP25K14</td> <td></td> <td></td> <td></td> <td></td> </tr> </tbody> </table>	Servo motor	Voltage division	Voltage/ frequency	Power consumption [W]	Rated current [A]	HA-LP601, 701M, 11K2	200V class	3-phase 200 to 220VAC 50Hz	42(50Hz) 54(60Hz)	0.21(50Hz) 0.25(60Hz)	3-phase 200 to 230VAC 60Hz			HA-LP801, 12K1, 11K1M, 15K1M, 15K2, 22K2	400V class	3-phase 200 to 230VAC 50Hz/60Hz	62(50Hz) 76(60Hz)	0.18(50Hz) 0.17(60Hz)		65(50Hz) 85(60Hz)	0.20(50Hz) 0.22(60Hz)		120(50Hz) 175(60Hz)	0.65(50Hz) 0.80(60Hz)	HA-LP15K1, 20K1, 22K1M	400V class	1-phase 200 to 220VAC 50Hz	42(50Hz) 54(60Hz)	0.21(50Hz) 0.25(60Hz)	3-phase 200 to 230VAC 60Hz			HA-LP25K1		3-phase 380 to 440VAC 50Hz	62(50Hz) 76(60Hz)	0.14(50Hz) 0.11(60Hz)	HA-LP6014, 701M4, 11K24	400V class	3-phase 380 to 480VAC 60Hz			3-phase 380 to 460VAC 50Hz	65(50Hz) 85(60Hz)	0.12(50Hz) 0.14(60Hz)	HA-LP8014, 12K14, 11K1M4, 15K1M4, 15K24, 22K24		3-phase 380 to 480VAC 60Hz	110(50Hz) 150(60Hz)	0.20(50Hz) 0.22(60Hz)	HA-LP15K14, 20K14, 22K1M4					HA-LP25K14				
Servo motor	Voltage division	Voltage/ frequency	Power consumption [W]	Rated current [A]																																																										
HA-LP601, 701M, 11K2	200V class	3-phase 200 to 220VAC 50Hz	42(50Hz) 54(60Hz)	0.21(50Hz) 0.25(60Hz)																																																										
		3-phase 200 to 230VAC 60Hz																																																												
HA-LP801, 12K1, 11K1M, 15K1M, 15K2, 22K2	400V class	3-phase 200 to 230VAC 50Hz/60Hz	62(50Hz) 76(60Hz)	0.18(50Hz) 0.17(60Hz)																																																										
			65(50Hz) 85(60Hz)	0.20(50Hz) 0.22(60Hz)																																																										
			120(50Hz) 175(60Hz)	0.65(50Hz) 0.80(60Hz)																																																										
HA-LP15K1, 20K1, 22K1M	400V class	1-phase 200 to 220VAC 50Hz	42(50Hz) 54(60Hz)	0.21(50Hz) 0.25(60Hz)																																																										
		3-phase 200 to 230VAC 60Hz																																																												
HA-LP25K1		3-phase 380 to 440VAC 50Hz	62(50Hz) 76(60Hz)	0.14(50Hz) 0.11(60Hz)																																																										
HA-LP6014, 701M4, 11K24	400V class	3-phase 380 to 480VAC 60Hz																																																												
		3-phase 380 to 460VAC 50Hz	65(50Hz) 85(60Hz)	0.12(50Hz) 0.14(60Hz)																																																										
HA-LP8014, 12K14, 11K1M4, 15K1M4, 15K24, 22K24		3-phase 380 to 480VAC 60Hz	110(50Hz) 150(60Hz)	0.20(50Hz) 0.22(60Hz)																																																										
HA-LP15K14, 20K14, 22K1M4																																																														
HA-LP25K14																																																														
Motor thermal relay	OHS1 · OHS2	OHS1—OHS2 are opened when heat is generated to an abnormal temperature. Maximum rating: 125V AC/DC, 3A or 250V AC/DC, 2A Minimum rating: 6V AC/DC, 0.15A																																																												
Earth terminal	⊕	For grounding, connect to the earth of the control box via the earth terminal of the servo amplifier.																																																												

Note. There is no BW when the power supply of the cooling fan is a 1-phase.

### 3. SIGNALS AND WIRING

#### 3.11 Servo motor with an electromagnetic brake

##### 3.11.1 Safety precautions



**CAUTION**

- Configure the electromagnetic brake circuit so that it is activated not only by the interface unit signals but also by a forced stop (EM1).

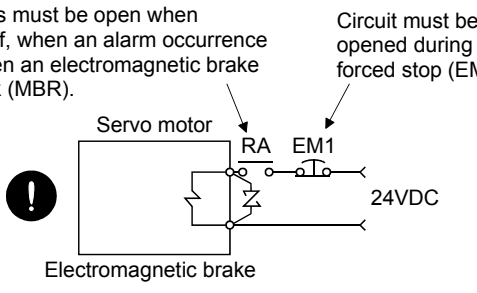

Contacts must be open when servo-off, when an alarm occurrence and when an electromagnetic brake interlock (MBR).

Circuit must be opened during forced stop (EM1).

- The electromagnetic brake is provided for holding purpose and must not be used for ordinary braking.
- Before performing the operation, be sure to confirm that the electromagnetic brake operates properly.

POINT
<ul style="list-style-type: none"> <li>Refer to the Servo Motor Instruction Manual (Vol.2) for specifications such as the power supply capacity and operation delay time of the electromagnetic brake.</li> </ul>

Note the following when the servo motor with an electromagnetic brake is used.

- 1) Do not share the 24VDC interface power supply between the interface and electromagnetic brake. Always use the power supply designed exclusively for the electromagnetic brake.
- 2) The brake will operate when the power (24VDC) switches off.
- 3) Switch off the servo-on command after the servo motor has stopped.

##### (1) Connection diagram

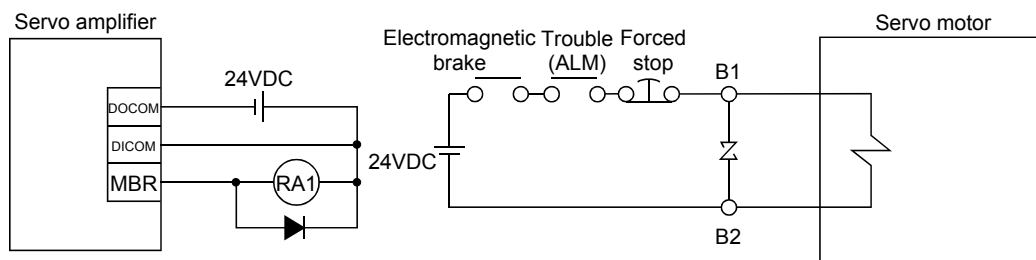

##### (2) Setting

In parameter No.PC02 (electromagnetic brake sequence output), set the time delay (Tb) from electromagnetic brake operation to base circuit shut-off at a servo off time as in the timing chart in section 3.11.2.

### 3. SIGNALS AND WIRING

#### 3.11.2 Timing charts

##### (1) Servo-on command (from controller) ON/OFF

T<sub>b</sub> [ms] after the servo-on is switched off, the servo lock is released and the servo motor coasts. If the electromagnetic brake is made valid in the servo lock status, the brake life may be shorter. Therefore, when using the electromagnetic brake in a vertical lift application or the like, set delay time (T<sub>b</sub>) to about the same as the electromagnetic brake operation delay time to prevent a drop.

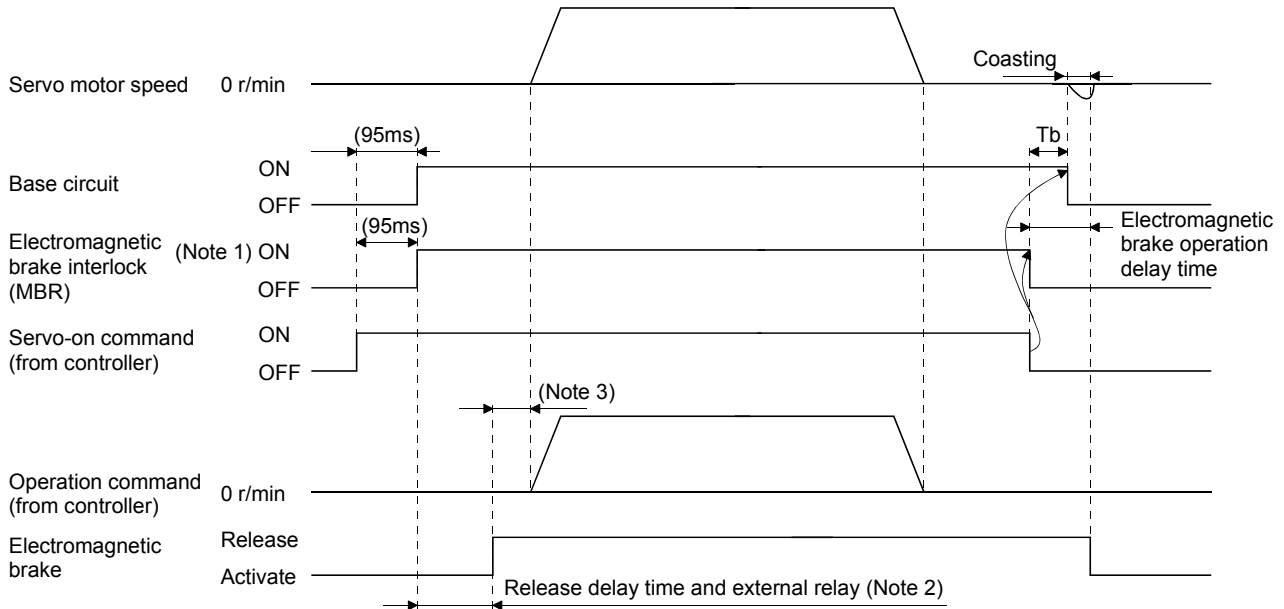

Note 1. ON: Electromagnetic brake is not activated.

OFF: Electromagnetic brake is activated.

2. Electromagnetic brake is released after delaying for the release delay time of electromagnetic brake and operation time of external circuit relay. For the release delay time of electromagnetic brake, refer to the Servo Motor Instruction Manual (Vol.2).

3. Give the operation command from the controller after the electromagnetic brake is released.

##### (2) Forced stop command (from controller) or forced stop (EM1) ON/OFF

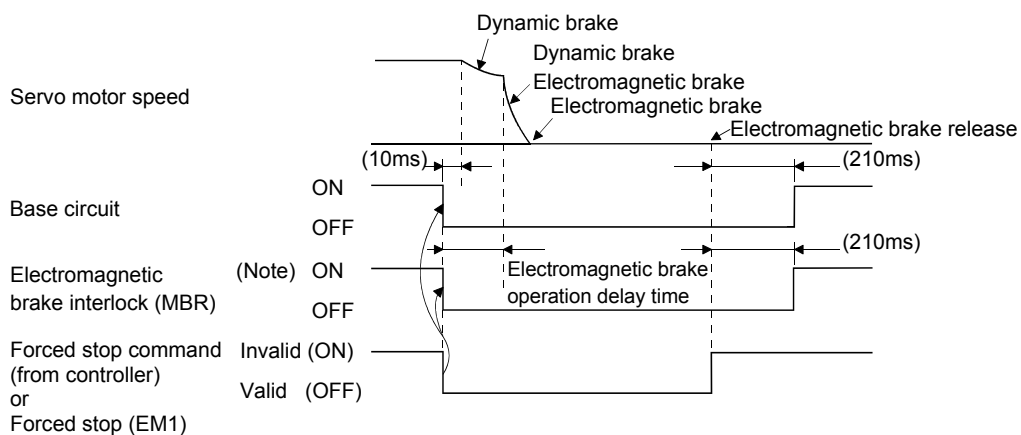

Note. ON: Electromagnetic brake is not activated.

OFF: Electromagnetic brake is activated.

### 3. SIGNALS AND WIRING

#### (3) Alarm occurrence

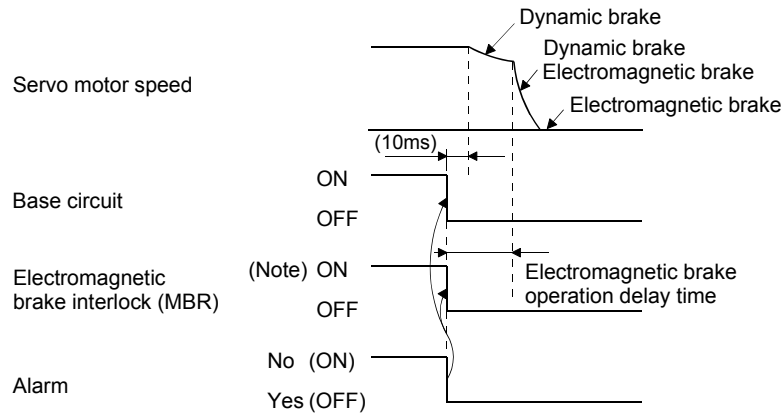

Note. ON: Electromagnetic brake is not activated.  
OFF: Electromagnetic brake is activated.

#### (4) Both main and control circuit power supplies off

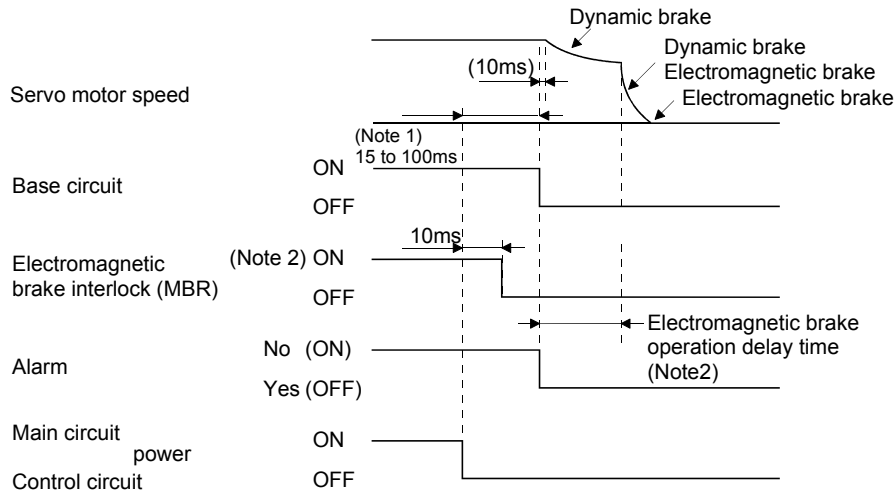

Note 1. Changes with the operating status.  
2. ON: Electromagnetic brake is not activated.  
OFF: Electromagnetic brake is activated.

### 3. SIGNALS AND WIRING

(5) Only main circuit power supply off (control circuit power supply remains on)

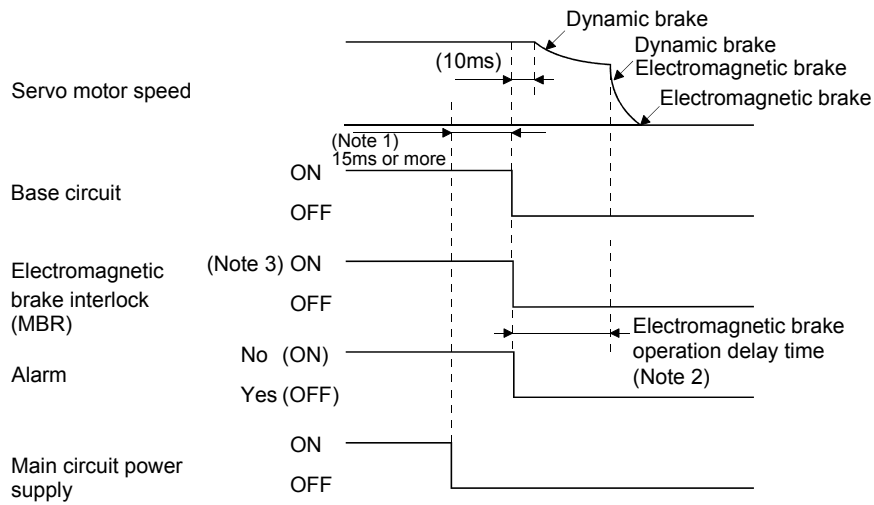

Note 1. Changes with the operating status.

2. When the main circuit power supply is off in a motor stop status, the main circuit off warning (E9) occurs and the alarm (ALM) does not turn off.

3. ON: Electromagnetic brake is not activated.

OFF: Electromagnetic brake is activated.

### 3. SIGNALS AND WIRING

#### 3.11.3 Wiring diagrams (HF-MP series • HF-KP series servo motor)

POINT
<ul style="list-style-type: none"> <li>For HF-SP series • HC-RP series • HC-UP series • HC-LP series servo motors, refer to section 3.10.2 (2).</li> </ul>

##### (1) When cable length is 10m or less

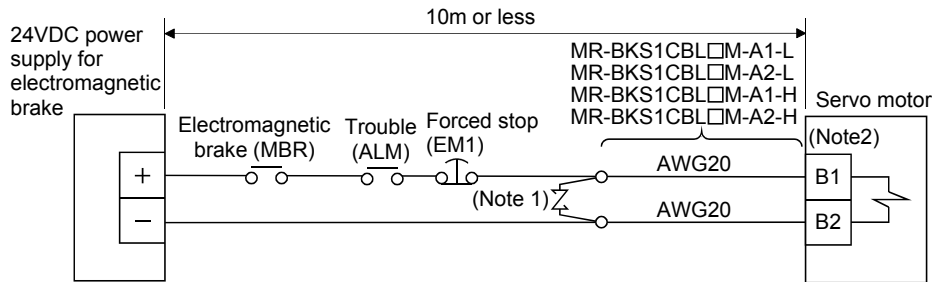

- Note 1. Connect a surge absorber as close to the servo motor as possible.  
2. There is no polarity in electromagnetic brake terminals (B1 and B2).

When fabricating the motor brake cable MR-BKS1CBL-□M-H, refer to section 11.1.4.

##### (2) When cable length exceeds 10m

When the cable length exceeds 10m, fabricate an extension cable as shown below on the customer side. In this case, the motor brake cable should be within 2m long.

Refer to section 11.8 for the wire used for the extension cable.

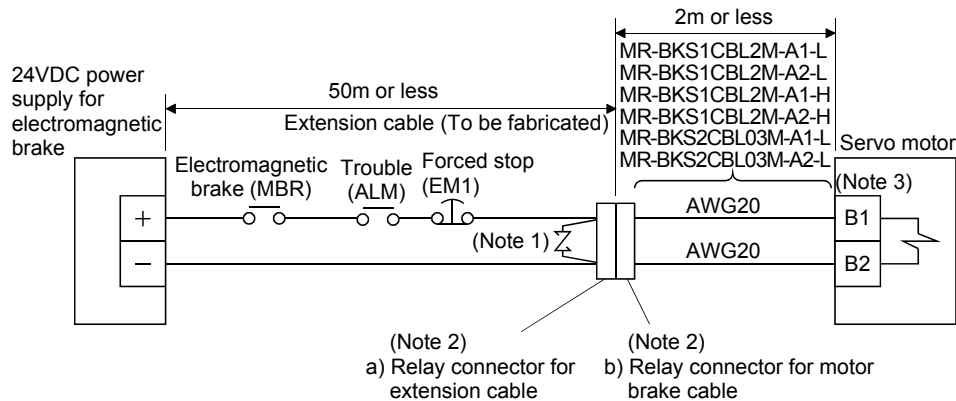

- Note 1. Connect a surge absorber as close to the servo motor as possible.  
2. Use of the following connectors is recommended when ingress protection (IP65) is necessary.

Relay connector	Description	Protective structure
a) Relay connector for extension cable	CM10-CR2P-* (DDK) Wire size: S, M, L	IP65
b) Relay connector for motor brake cable	CM10-SP2S-* (DDK) Wire size: S, M, L	IP65

3. There is no polarity in electromagnetic brake terminals (B1 and B2).

### 3. SIGNALS AND WIRING

#### 3.12 Grounding



#### WARNING

- Ground the servo amplifier and servo motor securely.
- To prevent an electric shock, always connect the protective earth (PE) terminal (terminal marked Ⓧ) of the servo amplifier with the protective earth (PE) of the control box.

The servo amplifier switches the power transistor on-off to supply power to the servo motor. Depending on the wiring and ground cable routing, the servo amplifier may be affected by the switching noise (due to di/dt and dv/dt) of the transistor. To prevent such a fault, refer to the following diagram and always ground. To conform to the EMC Directive, refer to the EMC Installation Guidelines (IB(NA)67310).

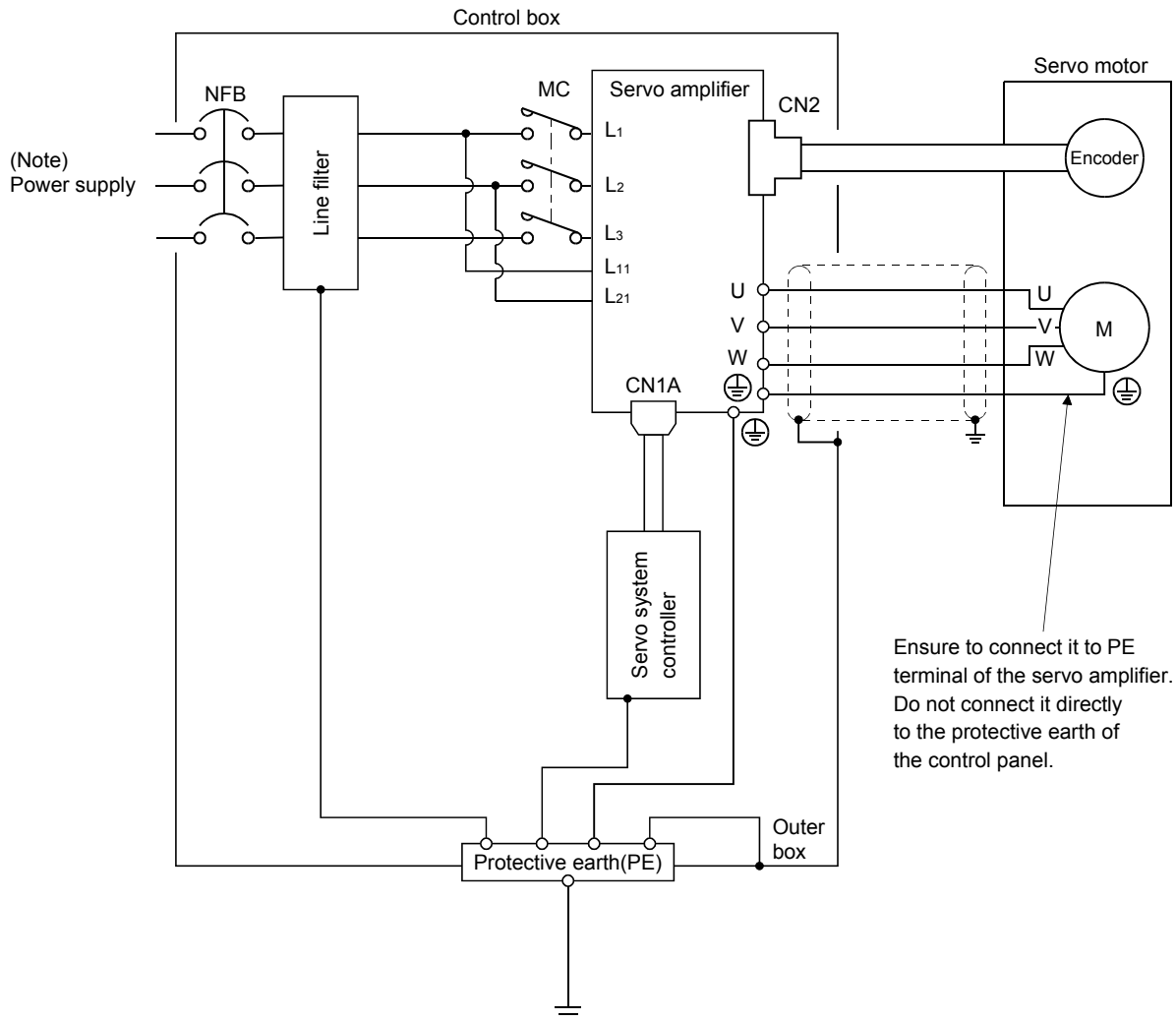

Note. For 1-phase 200V to 230VAC, connect the power supply to L<sub>1</sub> ▪ L<sub>2</sub> and leave L<sub>3</sub> open.

There is no L<sub>3</sub> for 1-phase 100 to 120VAC power supply. Refer to section 1.3 for the power supply specification.

### 3. SIGNALS AND WIRING

#### 3.13 Control axis selection

POINT
<ul style="list-style-type: none"> <li>The control axis number set to rotary axis setting switch (SW1) should be the same as the one set to the servo system controller.</li> </ul>

Use the rotary axis setting switch (SW1) to set the control axis number for the servo. If the same numbers are set to different control axes in a single communication system, the system will not operate properly. The control axes may be set independently of the SSCNET III cable connection sequence.

Rotary axis setting switch (SW1)

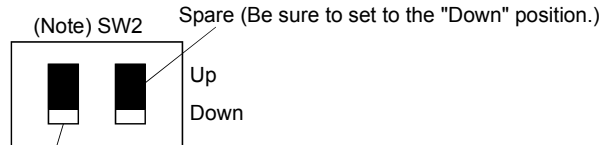
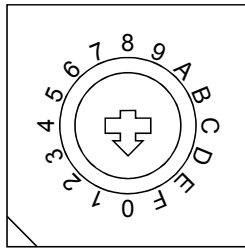

Test operation select switch (SW2-1)  
Set the test operation select switch to the "Up" position, when performing the test operation mode by using MR Configurator.

Note. This table indicates the status when the switch is set to "Down".  
(Default)

Spare	Rotary axis setting switch (SW1)	Description	Display
Down (Be sure to set to the "Down" position.)	0	Axis No.1	01
	1	Axis No.2	02
	2	Axis No.3	03
	3	Axis No.4	04
	4	Axis No.5	05
	5	Axis No.6	06
	6	Axis No.7	07
	7	Axis No.8	08
	8	Axis No.9	09
	9	Axis No.10	10
	A	Axis No.11	11
	B	Axis No.12	12
	C	Axis No.13	13
	D	Axis No.14	14
	E	Axis No.15	15
	F	Axis No.16	16

## 4. STARTUP

### 4. STARTUP



#### WARNING

Do not operate the switches with wet hands. You may get an electric shock.



#### CAUTION

- Before starting operation, check the parameters. Some machines may perform unexpected operation.
- Take safety measures, e.g. provide covers, to prevent accidental contact of hands and parts (cables, etc.) with the servo amplifier heat sink, regenerative resistor, servo motor, etc. since they may be hot while power is on or for some time after power-off. Their temperatures may be high and you may get burnt or a parts may damaged.
- During operation, never touch the rotating parts of the servo motor. Doing so can cause injury.

#### 4.1 Switching power on for the first time

When switching power on for the first time, follow this section to make a startup.

##### 4.1.1 Startup procedure

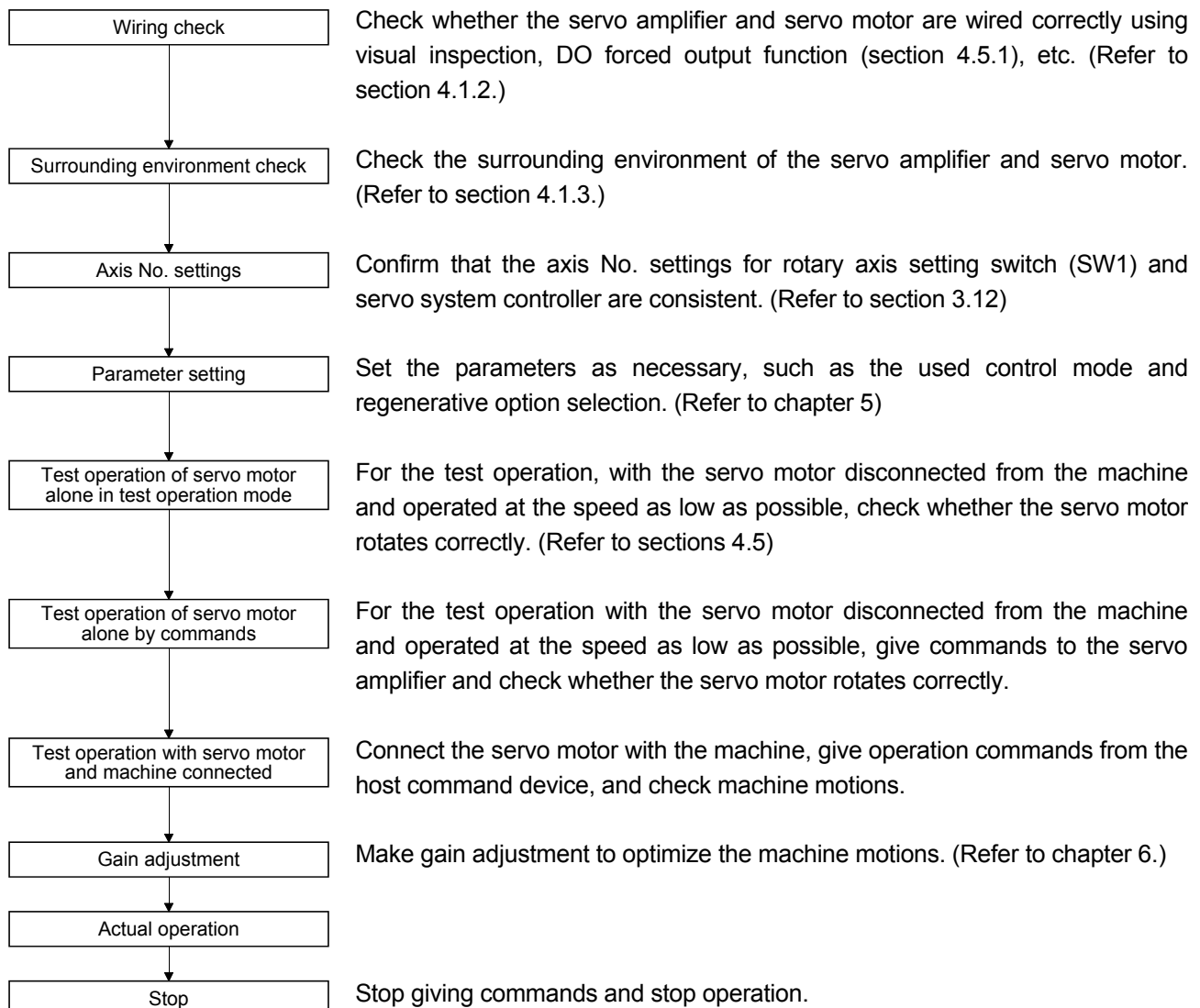

## 4. STARTUP

### 4.1.2 Wiring check

#### (1) Power supply system wiring

Before switching on the main circuit and control circuit power supplies, check the following items.

##### (a) Power supply system wiring

The power supplied to the power input terminals (L1, L2, L3, L11, L21) of the servo amplifier should satisfy the defined specifications. (Refer to section 1.3.)

##### (b) Connection of servo amplifier and servo motor

1) The servo motor power supply terminals (U, V, W) of the servo amplifier match in phase with the power input terminals (U, V, W) of the servo motor.

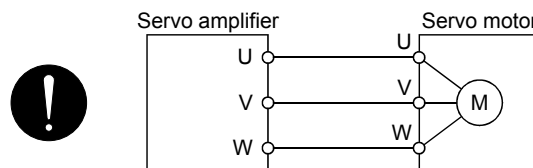

2) The power supplied to the servo amplifier should not be connected to the servo motor power supply terminals (U, V, W). To do so will fail the connected servo amplifier and servo motor.

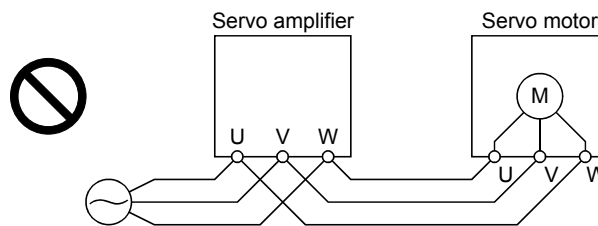

3) The earth terminal of the servo motor is connected to the PE terminal of the servo amplifier.

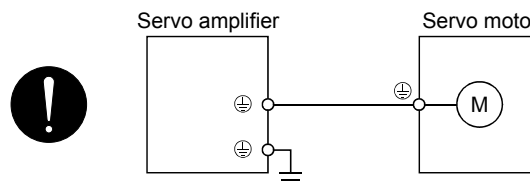

4) P<sub>1</sub>-P<sub>2</sub> (For 11kW or more, P<sub>1</sub>-P) should be connected.

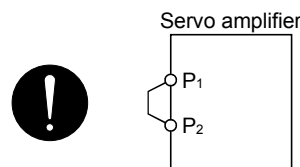

##### (c) When option and auxiliary equipment are used

- 1) When regenerative option is used under 3.5kW for 200V class and 2kW for 400V class
  - The lead between P terminal and D terminal of CNP2 connector should not be connected.
  - The generative brake option should be connected to P terminal and C terminal.
  - A twisted cable should be used. (Refer to section 11.2)

## 4. STARTUP

- 2) When regenerative option is used over 5kW for 200V class and 3.5kW for 400V class
  - The lead of built-in regenerative resistor connected to P terminal and C terminal of TE1 terminal block should not be connected.
  - The generative brake option should be connected to P terminal and C terminal.
  - A twisted cable should be used when wiring is over 5m and under 10m. (Refer to section 11.2)
- 3) When brake unit and power regenerative converter are used over 5kW
  - The lead of built-in regenerative resistor connected to P terminal and C terminal of TE1 terminal block should not be connected.
  - Brake unit, power regenerative converter or power regeneration converter should be connected to P terminal and N terminal. (Refer to section 11.3 to 11.5)
- 4) The power factor improving DC reactor should be connected P<sub>1</sub> and P<sub>2</sub> (For 11k to 22kW, P<sub>1</sub> and P). (Refer to section 11.13.)

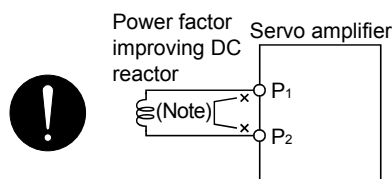

Note. Always disconnect P<sub>1</sub> and P<sub>2</sub>. (For 11k to 22kW P<sub>1</sub> and P)

### (2) I/O signal wiring

- (a) The I/O signals should be connected correctly.

Use DO forced output to forcibly turn on/off the pins of the CN3 connector. This function can be used to perform a wiring check. In this case, switch on the control circuit power supply only.

- (b) 24VDC or higher voltage is not applied to the pins of connectors CN3.

- (c) SD and DOCOM of connector CN3 is not shorted.

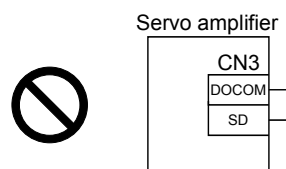

### 4.1.3 Surrounding environment

#### (1) Cable routing

- (a) The wiring cables are free from excessive force.
- (b) The encoder cable should not be used in excess of its flex life. (Refer to section 10.4.)
- (c) The connector part of the servo motor should not be strained.

#### (2) Environment

Signal cables and power cables are not shorted by wire offcuts, metallic dust or the like.

## 4. STARTUP

### 4.2 Start up

Connect the servo motor with a machine after confirming that the servo motor operates properly alone.

#### (1) Power on

When the main and control circuit power supplies are switched on, "b01" (for the first axis) appears on the servo amplifier display.

In the absolute position detection system, first power-on results in the absolute position lost (25) alarm and the servo system cannot be switched on.

The alarm can be deactivated by then switching power off once and on again.

Also in the absolute position detection system, if power is switched on at the servo motor speed of 500r/min or higher, position mismatch may occur due to external force or the like. Power must therefore be switched on when the servo motor is at a stop.

#### (2) Parameter setting

Set the parameters according to the structure and specifications of the machine. Refer to chapter 5 for the parameter definitions.

Parameter No.	Name	Setting	Description
PA14	Rotation direction setting	0	Increase in positioning address rotates the motor in the CCW direction.
PA08	Auto tuning mode	<input type="checkbox"/> <input type="checkbox"/> <input type="checkbox"/> 1	Used.
PA09	Auto tuning response	12	Slow response (initial value) is selected.

After setting the above parameters, switch power off once. Then switch power on again to make the set parameter values valid.

#### (3) Servo-on

Switch the servo-on in the following procedure.

- 1) Switch on main circuit/control circuit power supply.
- 2) The controller transmits the servo-on command.

When placed in the servo-on status, the servo amplifier is ready to operate and the servo motor is locked.

#### (4) Home position return

Always perform home position return before starting positioning operation.

#### (5) Stop

If any of the following situations occurs, the servo amplifier suspends the running of the servo motor and brings it to a stop.

When the servo motor is with an electromagnetic brake, refer to section 3.11.

	Operation/command	Stopping condition
Servo system controller	Servo off command	The base circuit is shut off and the servo motor coasts.
	Forced stop command	The base circuit is shut off and the dynamic brake operates to bring the servo motor to stop. The controller forced stop warning (E7) occurs.
Servo amplifier	Alarm occurrence	The base circuit is shut off and the dynamic brake operates to bring the servo motor to stop.
	Forced stop (EM1) OFF	The base circuit is shut off and the dynamic brake operates to bring the servo motor to stop. The servo forced stop warning (E6) occurs.

## 4. STARTUP

### 4.3 Servo amplifier display

On the servo amplifier display (three-digit, seven-segment display), check the status of communication with the servo system controller at power-on, check the axis number, and diagnose a fault at occurrence of an alarm.

#### (1) Display sequence

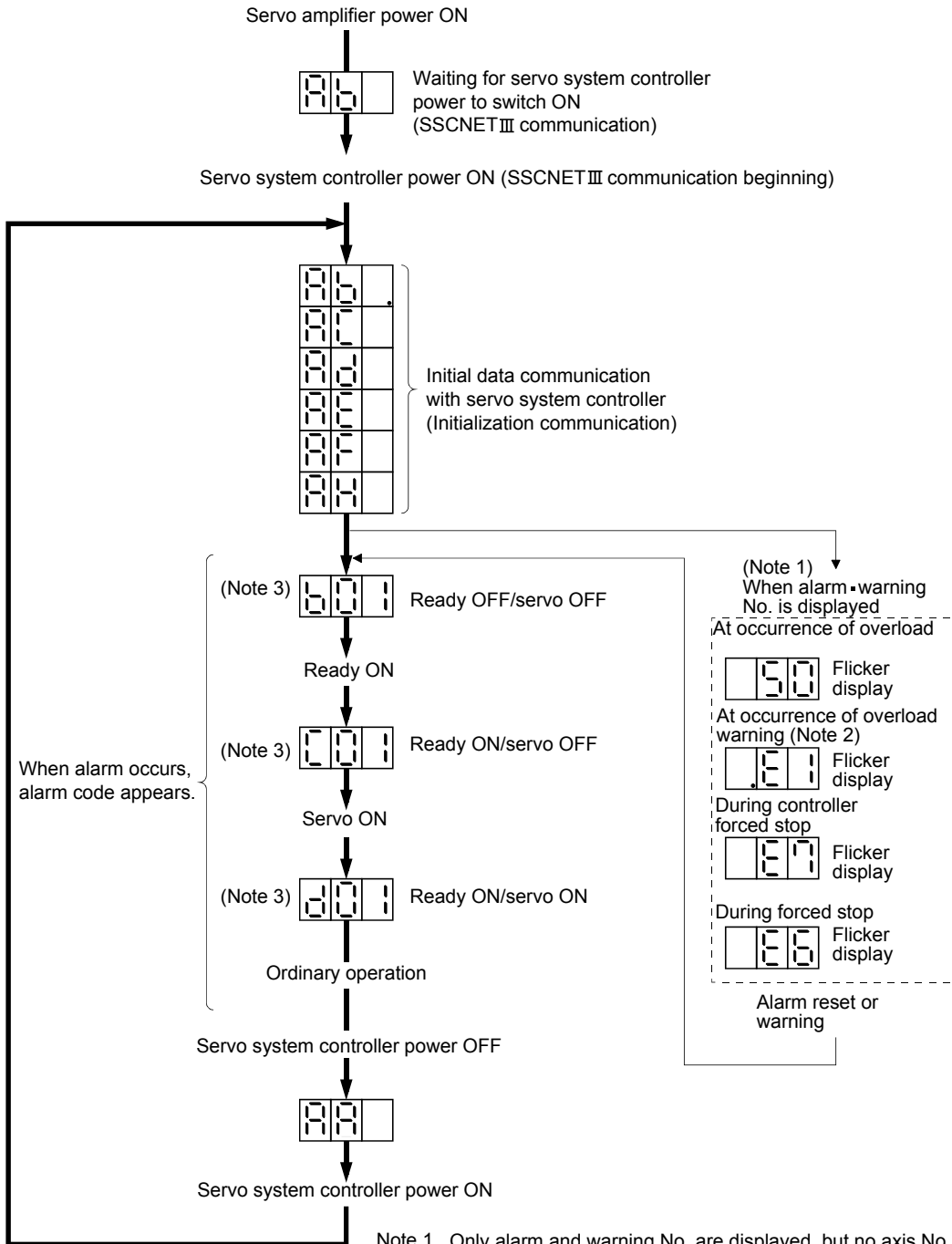

- Note 1. Only alarm and warning No. are displayed, but no axis No. is displayed  
 Note 2. If warning other than E6 or E7 occurs during the servo on, flickering the second place of decimal point indicates that it is during the servo on.  
 Note 3. The right-hand segments of b01, c02 and d16 indicate the axis number.  
 (Below example indicates Axis1)

b01 c02 ... d16  
 1 axis 2 axis 16 axis

## 4. STARTUP

### (2) Indication list

Indication	Status	Description
A b	Initializing	<ul style="list-style-type: none"> <li>Power of the servo amplifier was switched on at the condition that the power of servo system controller is OFF.</li> <li>The axis No. set to the servo system controller does not match the axis No. set with the rotary axis setting switch (SW1) of the servo amplifier.</li> <li>A servo amplifier fault occurred or an error took place in communication with the servo system controller. In this case, the indication changes. "Ab " → "AC " → "Ad " → "Ab "</li> <li>The servo system controller is faulty.</li> </ul>
A b .	Initializing	During initial setting for communication specifications
A C	Initializing	Initial setting for communication specifications completed, and then it synchronized with servo system controller.
A d	Initializing	During initial parameter setting communication with servo system controller
A E	Initializing	During motor · encoder information and telecommunication with servo system controller
A F	Initializing	During initial signal data communication with servo system controller
A H	Initializing completion	During the completion process for initial data communication with servo system controller
A A	Initializing standby	The power supply of servo system controller is turned off during the power supply of servo amplifier is on.
(Note 1) b # #	Ready OFF	The ready off signal from the servo system controller was received.
(Note 1) d # #	Servo ON	The ready off signal from the servo system controller was received.
(Note 1) C # #	Servo OFF	The ready off signal from the servo system controller was received.
(Note 2)  * *	Alarm · Warning	The alarm No./warning No. that occurred is displayed. (Refer to section 9.1.)
8 8 8	CPU Error	CPU watchdog error has occurred.
(Note 3) b 0 0.		JOG operation, positioning operation, programmed operation, DO forced output.
(Note 1) b # #.	(Note 3)	Motor-less operation
d # #.	Test operation mode	
C # #.		

Note 1. ## denotes any of numerals 00 to 16 and what it means is listed below.

#	Description
0	Set to the test operation mode.
1	First axis
2	Second axis
3	Third axis
4	Fourth axis
5	Fifth axis
6	Sixth axis
7	Seventh axis
8	Eighth axis
9	Ninth axis
10	Tenth axis
11	Eleventh axis
12	Twelfth axis
13	Thirteenth axis
14	Fourteenth axis
15	Fifteenth axis
16	Sixteenth axis

- \*\* indicates the warning/alarm No.
- Requires the MR Configurator.

## 4. STARTUP

### 4.4 Test operation

Before starting actual operation, perform test operation to make sure that the machine operates normally. Refer to section 4.2 for the power on and off methods of the servo amplifier.

POINT
-------

- |   |
|---|
| <ul style="list-style-type: none"><li>▪ If necessary, verify controller program by using motorless operation. Refer to section 4.5.2 for the motorless operation.</li></ul> |
|---|

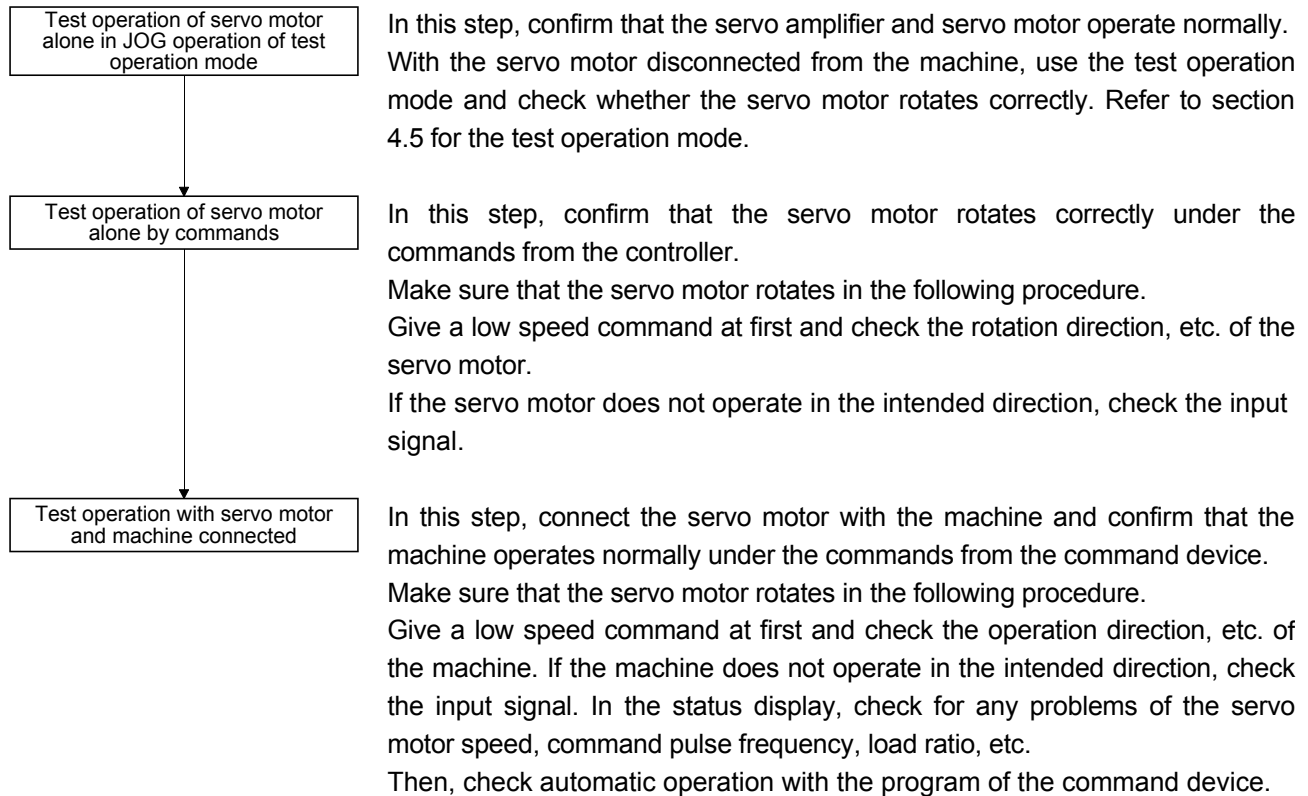

## 4. STARTUP

### 4.5 Test operation mode



#### CAUTION

- The test operation mode is designed for servo operation confirmation and not for machine operation confirmation. Do not use this mode with the machine. Always use the servo motor alone.
- If an operation fault occurred, use the forced stop (EM1) to make a stop.

#### POINT

- The content described in this section indicates the environment that servo amplifier and personal computer are directly connected.

By using a personal computer and the MR Configurator, you can execute jog operation, positioning operation, DO forced output program operation without connecting the servo system controller.

#### 4.5.1 Test operation mode in MR Configurator

##### (1) Test operation mode

###### (a) Jog operation

Jog operation can be performed without using the servo system controller. Use this operation with the forced stop reset. This operation may be used independently of whether the servo is on or off and whether the servo system controller is connected or not.

Exercise control on the jog operation screen of the MR Configurator.

###### 1) Operation pattern

Item	Initial value	Setting range
Speed [r/min]	200	0 to max. speed
Acceleration/deceleration time constant [ms]	1000	0 to 50000

###### 2) Operation method

Operation	Screen control
Forward rotation start	Click the "Forward" button.
Reverse rotation start	Click the "Reverse" button.
Stop	Click the "Stop" button.

###### (b) Positioning operation

Positioning operation can be performed without using the servo system controller. Use this operation with the forced stop reset. This operation may be used independently of whether the servo is on or off and whether the servo system controller is connected or not.

Exercise control on the positioning operation screen of the MR Configurator.

###### 1) Operation pattern

Item	Initial value	Setting range
Travel [pulse]	4000	0 to 99999999
Speed [r/min]	200	0 to max. speed
Acceleration/deceleration time constant [ms]	1000	0 to 50000

## 4. STARTUP

### 2) Operation method

Operation	Screen control
Forward rotation start	Click the "Forward" button.
Reverse rotation start	Click the "Reverse" button.
Pause	Click the "Pause" button.

### (c) Program operation

Positioning operation can be performed in two or more operation patterns combined, without using the servo system controller. Use this operation with the forced stop reset. This operation may be used independently of whether the servo is on or off and whether the servo system controller is connected or not.

Exercise control on the programmed operation screen of the MR Configurator. For full information, refer to the MR Configurator Installation Guide.

Operation	Screen control
Start	Click the "Start" button.
Stop	Click the "Reset" button.

### (d) Output signal (DO) forced output

Output signals can be switched on/off forcibly independently of the servo status. Use this function for output signal wiring check, etc.

Exercise control on the DO forced output screen of the MR Configurator.

### (2) Operation procedure

#### (a) Jog operation, positioning operation, program operation, DO forced output.

- 1) Switch power off.
- 2) Set SW2-1 to "UP".

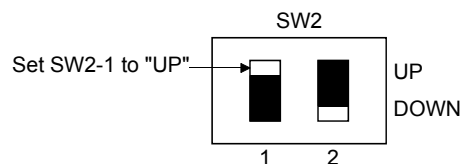

When SW1 and SW2-1 is set to the axis number and operation is performed by the servo system controller, the test operation mode screen is displayed on the personal computer, but no function is performed.

#### 3) Switch servo amplifier power on.

When initialization is over, the display shows the following screen.

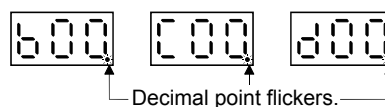

#### 4) Perform operation with the personal computer.

## 4. STARTUP

### 4.5.2 Motorless operation in controller

POINT
<ul style="list-style-type: none"> <li>Use motor-less operation which is available by making the servo system controller parameter setting.</li> <li>Motorless operation is done while connected with the servo system controller.</li> </ul>

#### (1) Motorless operation

Without connecting the servo motor, output signals or status displays can be provided in response to the servo system controller commands as if the servo motor is actually running. This operation may be used to check the servo system controller sequence. Use this operation with the forced stop reset. Use this operation with the servo amplifier connected to the servo system controller.

For stopping the motorless operation, set the selection of motorless operation to [Invalid] in servo parameter setting of servo system controller. Motorless operation will be invalid condition after switching on power supply next time.

#### (a) Load conditions

Load item	Condition
Load torque	0
Load inertia moment ratio	Same as servo motor inertia moment

#### (b) Alarms

The following alarms and warning do not occur. However, the other alarms and warnings occur as when the servo motor is connected.

- Encoder error 1 (16)
- Encoder error 2 (20)
- Absolute position erasure (25)
- Battery cable disconnection warning (92)
- Battery warning (9F)
- Converter error (1B) (Note 1)
- Converter warning (9C) (Note 1)
- Main circuit off warning (E9) (Note 2)

Note 1. Alarm and warning for the drive units of 30kW or more. For details, refer to section 13.6.2.

2. Main circuit off warning (E9) does not occur only when the forced stop of the converter unit is enabled as the cause of occurrence with the drive unit of 30kW or more. Main circuit of warning, otherwise, occurs when the cause of occurrence with the drive unit of 30kW or more is other than above, or with the servo amplifier of 22 kW or less.

#### (2) Operating procedure

1) Switch off servo amplifier

2) Set parameter No.PC05 to "1", change test operation mode switch (SW2-1) to normal condition side "Down", and then turn on the power supply.

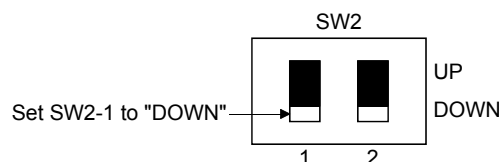

3) Perform motor-less operation with the personal computer.

The display shows the following screen.

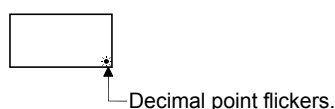

## 5. PARAMETERS

### 5. PARAMETERS



#### CAUTION

- Never adjust or change the parameter values extremely as it will make operation instable.

#### POINT

- When the servo amplifier is connected with the servo system controller, the parameters are set to the values of the servo system controller. Switching power off, then on makes the values set on the MR Configurator (servo configuration software) invalid and the servo system controller values valid.
- Setting may not be made to some parameters and ranges depending on the model or version of the servo system controller. For details, refer to the servo system controller user's manual.

In this servo amplifier, the parameters are classified into the following groups on a function basis.

Parameter group	Main description
Basic setting parameters (No.PA □□)	Make basic setting with these parameters. Generally, the operation is possible only with these parameter settings.
Gain/filter parameters (No.PB □□)	Use these parameters when making gain adjustment manually.
Extension setting parameters (No.PC □□)	When changing settings such as analog monitor output signal or encoder electromagnetic brake sequence output, use these parameters.
I/O setting parameters (No.PD □□)	Use these parameters when changing the I/O signals of the servo amplifier.

Mainly setting the basic setting parameters (No.PA □□) allows the setting of the basic parameters at the time of introduction.

#### 5.1 Basic setting parameters (No.PA□□)

#### POINT

- Parameter whose symbol is preceded by \* is made valid with the following conditions.
  - \* : Set the parameter value, switch power off once after setting, and then switch it on again, or perform the controller reset.
  - \*\* : Set the parameter value, switch power off once, and then switch it on again.
- Never change parameters for manufacturer setting.

## 5. PARAMETERS

### 5.1.1 Parameter list

No.	Symbol	Name	Initial value	Unit
PA01		For manufacturer setting	0000h	
PA02	**REG	Regenerative option	0000h	
PA03	*ABS	Absolute position detection system	0000h	
PA04	*AOP1	Function selection A-1	0000h	
PA05		For manufacturer setting	0	
PA06			1	
PA07			1	
PA08	ATU	Auto tuning mode	0001h	
PA09	RSP	Auto tuning response	12	
PA10	INP	In-position range	100	pulse
PA11		For manufacturer setting	1000.0	%
PA12			1000.0	%
PA13			0000h	
PA14	*POL	Rotation direction selection	0	
PA15	*ENR	Encoder output pulses	4000	pulse/rev
PA16		For manufacturer setting	0	
PA17			0000h	
PA18			0000h	
PA19	*BLK	Parameter write inhibit	000Bh	

## 5. PARAMETERS

### 5.1.2 Parameter write inhibit

Parameter			Initial value	Unit	Setting range
No.	Symbol	Name			
PA19	*BLK	Parameter write inhibit	000Bh		Refer to the text.

POINT
<ul style="list-style-type: none"> <li>▪ When setting the parameter values from the servo system controller, the parameter No.PA19 setting need not be changed.</li> <li>▪ This parameter is made valid when power is switched off, then on after setting, or when the controller reset has been performed.</li> </ul>

In the factory setting, this servo amplifier allows changes to the basic setting parameter, gain/filter parameter and extension setting parameter settings. With the setting of parameter No.PA19, write can be disabled to prevent accidental changes.

The following table indicates the parameters which are enabled for reference and write by the setting of parameter No.PA19. Operation can be performed for the parameters marked ○ .

Parameter No.PA19 setting	Setting operation	Basic setting parameters No.PA □□	Gain/filter parameters No.PB □□	Extension setting parameters No.PC □□	I/O setting parameters No.PD □□
0000h	Reference	○			
	Write	○			
000Bh (initial value)	Reference	○	○	○	
	Write	○	○	○	
000Ch	Reference	○	○	○	○
	Write	○	○	○	○
100Bh	Reference	○			
	Write	Parameter No.PA19 only			
100Ch	Reference	○	○	○	○
	Write	Parameter No.PA19 only			

## 5. PARAMETERS

### 5.1.3 Selection of regenerative option

Parameter			Initial value	Unit	Setting range
No.	Symbol	Name			
PA02	**REG	Regenerative option	0000h		Refer to the text.

POINT
<ul style="list-style-type: none"> <li>▪ This parameter value and switch power off once, then switch it on again to make that parameter setting valid.</li> <li>▪ Wrong setting may cause the regenerative option to burn.</li> <li>▪ If the regenerative option selected is not for use with the servo amplifier, parameter error (37) occurs.</li> <li>▪ For a drive unit of 30kW or more, always set the parameter to "□□00" since selecting regenerative option is carried out by the converter unit.</li> </ul>

Set this parameter when using the regenerative option, brake unit, power regeneration converter, or power regeneration common converter.

Parameter No.PA02

0	0		
---	---	--	--

Selection of regenerative option

00: Regenerative option is not used

- For servo amplifier of 100W, regenerative resistor is not used.
- For servo amplifier of 200 to 7kW, built-in regenerative resistor is used.
- Supplied regenerative resistors or regenerative option is used with the servo amplifier of 11k to 22kW.
- For a drive unit of 30kW or more, select regenerative option by the converter unit.

01: FR-BU2-(H)•FR-RC-(H)•FR-CV-(H)

02: MR-RB032

03: MR-RB12

04: MR-RB32

05: MR-RB30

06: MR-RB50(Cooling fan is required)

08: MR-RB31

09: MR-RB51(Cooling fan is required)

80: MR-RB1H-4

81: MR-RB3M-4(Cooling fan is required)

82: MR-RB3G-4(Cooling fan is required)

83: MR-RB5G-4(Cooling fanis required)

84: MR-RB34-4(Cooling fanis required)

85: MR-RB54-4(Cooling fanis required)

FA: When the supplied regenerative resistor is cooled by the cooling fan to increase the ability with the servo amplifier of 11k to 22kW.

## 5. PARAMETERS

### 5.1.4 Using absolute position detection system

Parameter			Initial value	Unit	Setting range
No.	Symbol	Name			
PA03	*ABS	Absolute position detection system	0000h		Refer to the text.

<b>POINT</b>
<ul style="list-style-type: none"> <li>▪ This parameter is made valid when power is switched off, then on after setting, or when the controller reset has been performed.</li> <li>▪ This parameter cannot be used in the speed control mode.</li> </ul>

Set this parameter when using the absolute position detection system in the position control mode.

Parameter No.PA03

0	0	0	
---	---	---	--

Selection of absolute position detection system (refer to chapter 12)  
 0: Used in incremental system  
 1: Used in absolute position detection system

### 5.1.5 Forced stop input selection

Parameter			Initial value	Unit	Setting range
No.	Symbol	Name			
PA04	*AOP1	Function selection A-1	0000h		Refer to the text.

<b>POINT</b>
<ul style="list-style-type: none"> <li>▪ This parameter is made valid when power is switched off, then on after setting, or when the controller reset has been performed.</li> </ul>

The servo forced stop function is avoidable.

Parameter No.PA04

0		0	0
---	--	---	---

Selection of servo forced stop  
 0: Valid (Forced stop (EM1) is used.)  
 1: Invalid (Forced stop (EM1) is not used.)

When not using the forced stop (EM1) of servo amplifier, set the selection of servo forced stop to Invalid (□1□□). At this time, the forced stop (EM1) automatically turns on inside the servo amplifier.

## 5. PARAMETERS

### 5.1.6 Auto tuning

Parameter			Initial value	Unit	Setting range
No.	Symbol	Name			
PA08	ATU	Auto tuning mode	0001h		Refer to the text.
PA09	RSP	Auto tuning response	12		1 to 32

Make gain adjustment using auto tuning. Refer to section 6.2 for details.

#### (1) Auto tuning mode (parameter No.PA08)

Select the gain adjustment mode.

Parameter No.PA08

0	0	0	
---	---	---	--

Gain adjustment mode setting

Setting	Gain adjustment mode	Automatically set parameter No. (Note)
0	Interpolation mode	PB06 · PB08 · PB09 · PB10
1	Auto tuning mode 1	PB06 · PB07 · PB08 · PB09 · PB10
2	Auto tuning mode 2	PB07 · PB08 · PB09 · PB10
3	Manual mode	

Note. The parameters have the following names.

Parameter No.	Name
PB06	Ratio of load inertia moment to servo motor inertia moment
PB07	Model loop gain
PB08	Position loop gain
PB09	Speed loop gain
PB10	Speed integral compensation

## 5. PARAMETERS

### (2) Auto tuning response (parameter No.PA09)

If the machine hunts or generates large gear sound, decrease the set value. To improve performance, e.g. shorten the settling time, increase the set value.

Setting	Response	Guideline for machine resonance frequency [Hz]	Setting	Response	Guideline for machine resonance frequency [Hz]
1	Low response ↑	10.0	17	Low response ↑	67.1
2		11.3	18		75.6
3		12.7	19		85.2
4		14.3	20		95.9
5		16.1	21		108.0
6		18.1	22		121.7
7		20.4	23		137.1
8		23.0	24		154.4
9		25.9	25		173.9
10		29.2	26		195.9
11		32.9	27		220.6
12		37.0	28		248.5
13		41.7	29		279.9
14		47.0	30		315.3
15	52.9	31	355.1		
16	Middle response	59.6	32	Middle response	400.0

### 5.1.7 In-position range

Parameter			Initial value	Unit	Setting range
No.	Symbol	Name			
PA10	INP	In-position range	100	pulse	0 to 65535

#### POINT

- This parameter cannot be used in the speed control mode.

Set the range, where in position (INP) is output, in the command pulse unit.

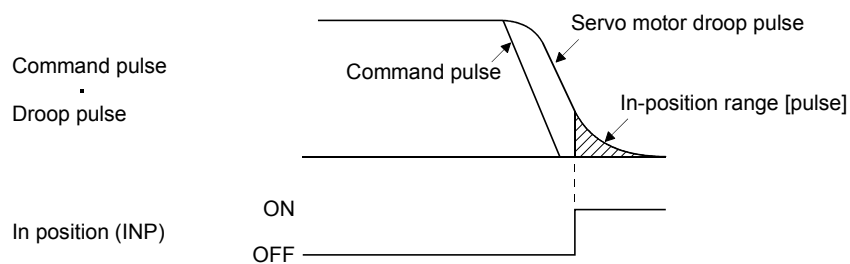

## 5. PARAMETERS

### 5.1.8 Selection of servo motor rotation direction

Parameter			Initial value	Unit	Setting range
No.	Symbol	Name			
PA14	*POL	Rotation direction selection	0		0 · 1

#### POINT

- This parameter is made valid when power is switched off, then on after setting, or when the controller reset has been performed.

Select servo motor rotation direction relative.

Parameter No.PA14 setting	Servo motor rotation direction	
	When positioning address increases	When positioning address decreases
0	CCW	CW
1	CW	CCW

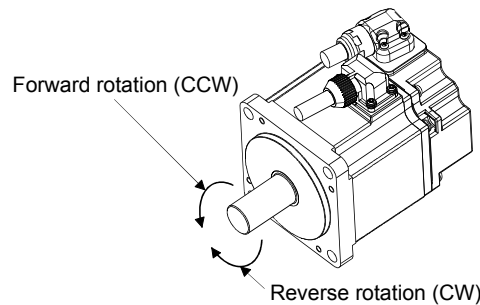

### 5.1.9 Encoder output pulse

Parameter			Initial value	Unit	Setting range
No.	Symbol	Name			
PA15	*ENR	Encoder output pulse	4000	pulse/rev	1 to 65535

#### POINT

- This parameter is made valid when power is switched off, then on after setting, or when the controller reset has been performed.

Used to set the encoder pulses (A-phase, B-phase) output by the servo amplifier.

Set the value 4 times greater than the A-phase or B-phase pulses.

You can use parameter No.PC03 to choose the output pulse setting or output division ratio setting.

The number of A/B-phase pulses actually output is 1/4 times greater than the preset number of pulses.

The maximum output frequency is 4.6Mpps (after multiplication by 4). Use this parameter within this range.

## 5. PARAMETERS

(1) For output pulse designation

Set "□□0□" (initial value) in parameter No.PC03.

Set the number of pulses per servo motor revolution.

Output pulse = set value [pulses/rev]

For instance, set "5600" to Parameter No.PA15, the actually output A/B-phase pulses are as indicated below.

$$A \cdot B\text{-phase output pulses} = \frac{5600}{4} = 1400[\text{pulse}]$$

(2) For output division ratio setting

Set "□□1□" in parameter No.PC03.

The number of pulses per servo motor revolution is divided by the set value.

$$\text{Output pulse} = \frac{\text{Resolution per servo motor revolution}}{\text{Set value}} [\text{pulses/rev}]$$

For instance, set "8" to Parameter No.PA15, the actually output A/B-phase pulses are as indicated below.

$$A \cdot B\text{-phase output pulses} = \frac{262144}{8} \cdot \frac{1}{4} = 8192[\text{pulse}]$$

## 5. PARAMETERS

### 5.2 Gain/filter parameters (No.PB□□)

<b>POINT</b>
<ul style="list-style-type: none"> <li>▪ Parameter whose symbol is preceded by * is made valid with the following conditions.</li> <li>* : Set the parameter value, switch power off once after setting, and then switch it on again, or perform the controller reset.</li> </ul>

#### 5.2.1 Parameter list

No.	Symbol	Name	Initial value	Unit
PB01	FILT	Adaptive tuning mode (Adaptive filter II)	0000h	
PB02	VRFT	Vibration suppression control tuning mode (advanced vibration suppression control)	0000h	
PB03		For manufacturer setting	0	
PB04	FFC	Feed forward gain	0	%
PB05		For manufacturer setting	500	
PB06	GD2	Ratio of load inertia moment to servo motor inertia moment	7.0	Multiplier (× 1)
PB07	PG1	Model loop gain	24	rad/s
PB08	PG2	Position loop gain	37	rad/s
PB09	VG2	Speed loop gain	823	rad/s
PB10	VIC	Speed integral compensation	33.7	ms
PB11	VDC	Speed differential compensation	980	
PB12		For manufacturer setting	0	
PB13	NH1	Machine resonance suppression filter 1	4500	Hz
PB14	NHQ1	Notch shape selection 1	0000h	
PB15	NH2	Machine resonance suppression filter 2	4500	Hz
PB16	NHQ2	Notch shape selection 2	0000h	
PB17		Automatic setting parameter		
PB18	LPF	Low-pass filter setting	3141	rad/s
PB19	VRF1	Vibration suppression control vibration frequency setting	100.0	Hz
PB20	VRF2	Vibration suppression control resonance frequency setting	100.0	Hz
PB21		For manufacturer setting	0.00	
PB22			0.00	
PB23	VFBF	Low-pass filter selection	0000h	
PB24	*MVS	Slight vibration suppression control selection	0000h	
PB25		For manufacturer setting	0000h	
PB26	*CDP	Gain changing selection	0000h	
PB27	CDL	Gain changing condition	10	
PB28	CDT	Gain changing time constant	1	ms
PB29	GD2B	Gain changing ratio of load inertia moment to servo motor inertia moment	7.0	Multiplier (× 1)
PB30	PG2B	Gain changing position loop gain	37	rad/s
PB31	VG2B	Gain changing speed loop gain	823	rad/s
PB32	VICB	Gain changing speed integral compensation	33.7	ms
PB33	VRF1B	Gain changing vibration suppression control vibration frequency setting	100.0	Hz
PB34	VRF2B	Gain changing vibration suppression control resonance frequency setting	100.0	Hz
PB35		For manufacturer setting	0.00	
PB36			0.00	
PB37			100	
PB38			0.0	
PB39			0.0	

## 5. PARAMETERS

No.	Symbol	Name	Initial value	Unit
PB40		For manufacturer setting	0.0	
PB41			1125	
PB42			1125	
PB43			0004h	
PB44			0.0	
PB45			0000h	

### 5.2.2 Detail list

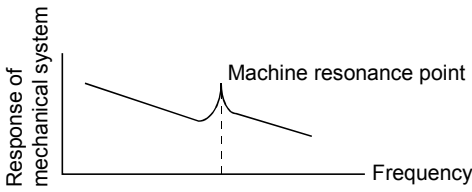
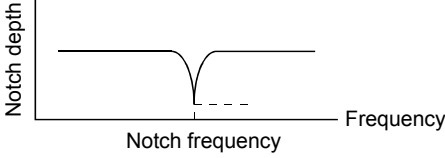
No.	Symbol	Name and function	Initial value	Unit	Setting range																
PB01	FILT	<p>Adaptive tuning mode (adaptive filter II)</p> <p>Select the setting method for filter tuning. Setting this parameter to "□□□1" (filter tuning mode 1) automatically changes the machine resonance suppression filter 1 (parameter No.PB13) and notch shape selection (parameter No.PB14).</p> <div style="text-align: center;">  <p>Response of mechanical system</p> <p>Frequency</p>  <p>Notch depth</p> <p>Notch frequency</p> <p>Frequency</p> </div> <div style="text-align: center;"> <table border="1" style="display: inline-table;"> <tr> <td style="width: 20px; height: 20px; text-align: center;">0</td> <td style="width: 20px; height: 20px; text-align: center;">0</td> <td style="width: 20px; height: 20px; text-align: center;">0</td> <td style="width: 20px; height: 20px; text-align: center;">□</td> </tr> </table> <p>Filter tuning mode selection</p> </div> <table border="1" style="margin-top: 10px; width: 100%;"> <thead> <tr> <th>Setting</th> <th>Filter adjustment mode</th> <th>Automatically set parameter</th> </tr> </thead> <tbody> <tr> <td style="text-align: center;">0</td> <td>Filter OFF</td> <td>(Note)</td> </tr> <tr> <td style="text-align: center;">1</td> <td>Filter tuning mode</td> <td>Parameter No.PB13 Parameter No.PB14</td> </tr> <tr> <td style="text-align: center;">2</td> <td>Manual mode</td> <td></td> </tr> </tbody> </table> <p>Note. Parameter No.PB13 and PB14 are fixed to the initial values.</p> <p>When this parameter is set to "□□□1", the tuning is completed after positioning is done the predetermined number or times for the predetermined period of time, and the setting changes to "□□□2". When the filter tuning is not necessary, the setting changes to "□□□0". When this parameter is set to "□□□0", the initial values are set to the machine resonance suppression filter 1 and notch shape selection. However, this does not occur when the servo off.</p>	0	0	0	□	Setting	Filter adjustment mode	Automatically set parameter	0	Filter OFF	(Note)	1	Filter tuning mode	Parameter No.PB13 Parameter No.PB14	2	Manual mode		0000h		
0	0	0	□																		
Setting	Filter adjustment mode	Automatically set parameter																			
0	Filter OFF	(Note)																			
1	Filter tuning mode	Parameter No.PB13 Parameter No.PB14																			
2	Manual mode																				

## 5. PARAMETERS

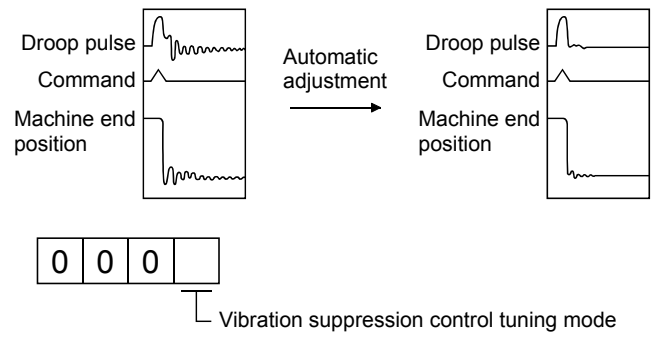
No.	Symbol	Name and function	Initial value	Unit	Setting range												
PB02	VRFT	<p>Vibration suppression control tuning mode (advanced vibration suppression control) This parameter cannot be used in the speed control mode. The vibration suppression is valid when the parameter No.PA08 (auto tuning) setting is "□□□2" or "□□□3". When PA08 is "□□□1", vibration suppression is always invalid.</p> <p>Select the setting method for vibration suppression control tuning. Setting this parameter to "□□□1" (vibration suppression control tuning mode) automatically changes the vibration suppression control vibration frequency (parameter No.PB19) and vibration suppression control resonance frequency (parameter No.PB20) after positioning is done the predetermined number of times.</p> <div style="text-align: center;">  <p style="text-align: center;">Vibration suppression control tuning mode</p> </div> <table border="1" style="margin-left: auto; margin-right: auto;"> <thead> <tr> <th>Setting</th> <th>Vibration suppression control tuning mode</th> <th>Automatically set parameter</th> </tr> </thead> <tbody> <tr> <td>0</td> <td>Vibration suppression control OFF</td> <td>(Note)</td> </tr> <tr> <td>1</td> <td>Vibration suppression control tuning mode (Advanced vibration suppression control)</td> <td>Parameter No.PB19 Parameter No.PB20</td> </tr> <tr> <td>2</td> <td>Manual mode</td> <td></td> </tr> </tbody> </table> <p>Note. Parameter No.PB19 and PB20 are fixed to the initial values.</p> <p>When this parameter is set to "□□□1", the tuning is completed after positioning is done the predetermined number or times for the predetermined period of time, and the setting changes to "□□□2". When the vibration suppression control tuning is not necessary, the setting changes to "□□□0". When this parameter is set to "□□□0", the initial values are set to the vibration suppression control vibration frequency and vibration suppression control resonance frequency. However, this does not occur when the servo off.</p>	Setting	Vibration suppression control tuning mode	Automatically set parameter	0	Vibration suppression control OFF	(Note)	1	Vibration suppression control tuning mode (Advanced vibration suppression control)	Parameter No.PB19 Parameter No.PB20	2	Manual mode		0000h		
Setting	Vibration suppression control tuning mode	Automatically set parameter															
0	Vibration suppression control OFF	(Note)															
1	Vibration suppression control tuning mode (Advanced vibration suppression control)	Parameter No.PB19 Parameter No.PB20															
2	Manual mode																
PB03		For manufacturer setting Do not change this value by any means.	0														
PB04	FFC	<p>Feed forward gain This parameter cannot be used in the speed control mode. Set the feed forward gain. When the setting is 100%, the droop pulses during operation at constant speed are nearly zero. However, sudden acceleration/deceleration will increase the overshoot. As a guideline, when the feed forward gain setting is 100%, set 1s or more as the acceleration/deceleration time constant up to the rated speed.</p>	0	%	0 to 100												
PB05		For manufacturer setting Do not change this value by any means.	500														

## 5. PARAMETERS

No.	Symbol	Name and function	Initial value	Unit	Setting range
PB06	GD2	Ratio of load inertia moment to servo motor inertia moment Used to set the ratio of the load inertia moment to the servo motor shaft inertia moment. When auto tuning mode 1 and interpolation mode is selected, the result of auto tuning is automatically used. (Refer to section 6.1.1) In this case, it varies between 0 and 100.0. When parameter No.PA08 is set to "□□□2" or "□□□3", this parameter can be set manually.	7.0	Multiplier (× 1)	0 to 300.0
PB07	PG1	Model loop gain Set the response gain up to the target position. Increase the gain to improve track ability in response to the command. When auto turning mode 1,2 is selected, the result of auto turning is automatically used. When parameter No.PA08 is set to "□□□1" or "□□□3", this parameter can be set manually.	24	rad/s	1 to 2000
PB08	PG2	Position loop gain This parameter cannot be used in the speed control mode. Used to set the gain of the position loop. Set this parameter to increase the position response to level load disturbance. Higher setting increases the response level but is liable to generate vibration and/or noise. When auto tuning mode 1,2 and interpolation mode is selected, the result of auto tuning is automatically used. When parameter No.PA08 is set to "□□□3", this parameter can be set manually.	37	rad/s	1 to 1000
PB09	VG2	Speed loop gain Set this parameter when vibration occurs on machines of low rigidity or large backlash. Higher setting increases the response level but is liable to generate vibration and/or noise. When auto tuning mode 1 * 2, manual mode and interpolation mode is selected, the result of auto tuning is automatically used. When parameter No.PA08 is set to "□□□3", this parameter can be set manually.	823	rad/s	20 to 50000
PB10	VIC	Speed integral compensation Used to set the integral time constant of the speed loop. Lower setting increases the response level but is liable to generate vibration and/or noise. When auto tuning mode 1 * 2 and interpolation mode is selected, the result of auto tuning is automatically used. When parameter No.PA08 is set to "□□□3", this parameter can be set manually.	33.7	ms	0.1 to 1000.0
PB11	VDC	Speed differential compensation Used to set the differential compensation. When parameter No.PB24 is set to "□□3□", this parameter is made valid. When parameter No.PA08 is set to "□□0□", this parameter is made valid by instructions of controller.	980		0 to 1000
PB12		For manufacturer setting Do not change this value by any means.	0		
PB13	NH1	Machine resonance suppression filter 1 Set the notch frequency of the machine resonance suppression filter 1. Setting parameter No.PB01 (filter tuning mode 1) to "□□□1" automatically changes this parameter. When the parameter No.PB01 setting is "□□□0", the setting of this parameter is ignored.	4500	Hz	100 to 4500

## 5. PARAMETERS

No.	Symbol	Name and function	Initial value	Unit	Setting range																												
PB14	NHQ1	<p>Notch shape selection 1 Used to selection the machine resonance suppression filter 1.</p> <p><input type="text" value="0"/> <input type="text"/> <input type="text"/> <input type="text" value="0"/></p> <p>Notch depth selection</p> <table border="1"> <thead> <tr> <th>Setting value</th> <th>Depth</th> <th>Gain</th> </tr> </thead> <tbody> <tr> <td>0</td> <td>Deep</td> <td>-40dB</td> </tr> <tr> <td>1</td> <td rowspan="2">to</td> <td>-14dB</td> </tr> <tr> <td>2</td> <td>-8dB</td> </tr> <tr> <td>3</td> <td>Shallow</td> <td>-4dB</td> </tr> </tbody> </table> <p>Notch width</p> <table border="1"> <thead> <tr> <th>Setting value</th> <th>Width</th> <th><math>\alpha</math></th> </tr> </thead> <tbody> <tr> <td>0</td> <td>Standard</td> <td>2</td> </tr> <tr> <td>1</td> <td rowspan="2">to</td> <td>3</td> </tr> <tr> <td>2</td> <td>4</td> </tr> <tr> <td>3</td> <td>Wide</td> <td>5</td> </tr> </tbody> </table> <p>Setting parameter No.PB01 (filter tuning mode 1) to "<input type="text"/> <input type="text"/> <input type="text"/> 1" automatically changes this parameter. When the parameter No.PB01 setting is "<input type="text"/> <input type="text"/> <input type="text"/> 0", the setting of this parameter is ignored.</p>	Setting value	Depth	Gain	0	Deep	-40dB	1	to	-14dB	2	-8dB	3	Shallow	-4dB	Setting value	Width	$\alpha$	0	Standard	2	1	to	3	2	4	3	Wide	5	0000h		Refer to Name and function column.
Setting value	Depth	Gain																															
0	Deep	-40dB																															
1	to	-14dB																															
2		-8dB																															
3	Shallow	-4dB																															
Setting value	Width	$\alpha$																															
0	Standard	2																															
1	to	3																															
2		4																															
3	Wide	5																															
PB15	NH2	<p>Machine resonance suppression filter 2 Set the notch frequency of the machine resonance suppression filter 2. Set parameter No.PB16 (notch shape selection 2) to "<input type="text"/> <input type="text"/> <input type="text"/> 1" to make this parameter valid.</p>	4500	Hz	100 to 4500																												
PB16	NHQ2	<p>Notch shape selection 2 Select the shape of the machine resonance suppression filter 2.</p> <p><input type="text" value="0"/> <input type="text"/> <input type="text"/> <input type="text"/></p> <p>Machine resonance suppression filter 2 selection 0: Invalid 1: Valid</p> <p>Notch depth selection</p> <table border="1"> <thead> <tr> <th>Setting value</th> <th>Depth</th> <th>Gain</th> </tr> </thead> <tbody> <tr> <td>0</td> <td>Deep</td> <td>-40dB</td> </tr> <tr> <td>1</td> <td rowspan="2">to</td> <td>-14dB</td> </tr> <tr> <td>2</td> <td>-8dB</td> </tr> <tr> <td>3</td> <td>Shallow</td> <td>-4dB</td> </tr> </tbody> </table> <p>Notch width</p> <table border="1"> <thead> <tr> <th>Setting value</th> <th>Width</th> <th><math>\alpha</math></th> </tr> </thead> <tbody> <tr> <td>0</td> <td>Standard</td> <td>2</td> </tr> <tr> <td>1</td> <td rowspan="2">to</td> <td>3</td> </tr> <tr> <td>2</td> <td>4</td> </tr> <tr> <td>3</td> <td>Wide</td> <td>5</td> </tr> </tbody> </table>	Setting value	Depth	Gain	0	Deep	-40dB	1	to	-14dB	2	-8dB	3	Shallow	-4dB	Setting value	Width	$\alpha$	0	Standard	2	1	to	3	2	4	3	Wide	5	0000h		Refer to Name and function column.
Setting value	Depth	Gain																															
0	Deep	-40dB																															
1	to	-14dB																															
2		-8dB																															
3	Shallow	-4dB																															
Setting value	Width	$\alpha$																															
0	Standard	2																															
1	to	3																															
2		4																															
3	Wide	5																															
PB17		<p>Automatic setting parameter The value of this parameter is set according to a set value of parameter No.PB06 (Ratio of load inertia moment to servo motor inertia moment).</p>																															

## 5. PARAMETERS

No.	Symbol	Name and function	Initial value	Unit	Setting range				
PB18	LPF	Low-pass filter setting Set the low-pass filter. Setting parameter No.PB23 (low-pass filter selection) to "□□0□" automatically changes this parameter. When parameter No.PB23 is set to "□□1□", this parameter can be set manually.	3141	rad/s	100 to 18000				
PB19	VRF1	Vibration suppression control vibration frequency setting This parameter cannot be used in the speed control mode. Set the vibration frequency for vibration suppression control to suppress low-frequency machine vibration, such as enclosure vibration. (Refer to section 7.4.(4)) Setting parameter No.PB02 (vibration suppression control tuning mode) to "□□□1" automatically changes this parameter. When parameter No.PB02 is set to "□□□2", this parameter can be set manually.	100.0	Hz	0.1 to 100.0				
PB20	VRF2	Vibration suppression control resonance frequency setting This parameter cannot be used in the speed control mode. Set the resonance frequency for vibration suppression control to suppress low-frequency machine vibration, such as enclosure vibration. (Refer to section 7.4.(4)) Setting parameter No.PB02 (vibration suppression control tuning mode) to "□□□1" automatically changes this parameter. When parameter No.PB02 is set to "□□□2", this parameter can be set manually.	100.0	Hz	0.1 to 100.0				
PB21		For manufacturer setting	0.00						
PB22		Do not change this value by any means.	0.00						
PB23	VFBF	Low-pass filter selection Select the low-pass filter. <table border="1" style="margin: 10px auto; text-align: center;"> <tr> <td style="width: 20px; height: 20px;">0</td> <td style="width: 20px; height: 20px;">0</td> <td style="width: 20px; height: 20px;">□</td> <td style="width: 20px; height: 20px;">0</td> </tr> </table> Low-pass filter selection 0: Automatic setting 1: Manual setting (parameter No.PB18 setting)  When automatic setting has been selected, select the filter that has the band width close to the one calculated with $\frac{VG2 \cdot 10}{1 + GD2}$ [rad/s]	0	0	□	0	0000h		Refer to Name and function column.
0	0	□	0						
PB24	*MVS	Slight vibration suppression control selection Select the slight vibration suppression control and PI-PID change. When parameter No.PA08 (auto tuning mode) is set to "□□□3", this parameter is made valid. (Slight vibration suppression control cannot be used in the speed control mode.) <table border="1" style="margin: 10px auto; text-align: center;"> <tr> <td style="width: 20px; height: 20px;">0</td> <td style="width: 20px; height: 20px;">0</td> <td style="width: 20px; height: 20px;">□</td> <td style="width: 20px; height: 20px;">□</td> </tr> </table> Slight vibration suppression control selection 0: Invalid 1: Valid PI-PID control switch over selection 0: PI control is valid. (Switching to PID control is possible with instructions of controller.) 3: PID control is always valid.	0	0	□	□	0000h		Refer to Name and function column.
0	0	□	□						
PB25		For manufacturer setting Do not change this value by any means.	0000h						

## 5. PARAMETERS

No.	Symbol	Name and function	Initial value	Unit	Setting range
PB26	*CDP	<p>Gain changing selection Select the gain changing condition. (Refer to section 7.6.)</p> <div style="display: flex; align-items: center;"> <div style="border: 1px solid black; padding: 2px; margin-right: 5px;">0</div> <div style="border: 1px solid black; padding: 2px; margin-right: 5px;">0</div> <div style="border: 1px solid black; padding: 2px; margin-right: 5px;"> </div> <div style="border: 1px solid black; padding: 2px;"> </div> </div> <p>Gain changing selection Under any of the following conditions, the gains change on the basis of the parameter No.PB29 to PB32 settings. 0: Invalid 1: Control instructions from a controller. 2: Command frequency (Parameter No.PB27 setting) 3: Droop pulse value (Parameter No.PB27 setting) 4: Servo motor speed (Parameter No.PB27 setting)</p> <p>Gain changing condition 0: Valid at more than condition (For control instructions from a controller, valid with ON) 1: Valid at less than condition (For control instructions from a controller, valid with OFF)</p>	0000h		Refer to Name and function column.
PB27	CDL	<p>Gain changing condition Used to set the value of gain changing condition (command frequency, droop pulses, servo motor speed) selected in parameter No.PB26.The set value unit changes with the changing condition item. (Refer to section 7.6.)</p>	10	kpps pulse r/min	0 to 9999
PB28	CDT	<p>Gain changing time constant Used to set the time constant at which the gains will change in response to the conditions set in parameters No.PB26 and PB27. (Refer to section 7.6.)</p>	1	ms	0 to 100
PB29	GD2B	<p>Gain changing ratio of load inertia moment to servo motor inertia moment Used to set the ratio of load inertia moment to servo motor inertia moment when gain changing is valid. This parameter is made valid when the auto tuning is invalid (parameter No.PA08: <input type="checkbox"/><input type="checkbox"/><input type="checkbox"/> 3).</p>	7.0	Multiplier (× 1)	0 to 300.0
PB30	PG2B	<p>Gain changing position loop gain This parameter cannot be used in the speed control mode. Set the position loop gain when the gain changing is valid. This parameter is made valid when the auto tuning is invalid (parameter No.PA08: <input type="checkbox"/><input type="checkbox"/><input type="checkbox"/> 3).</p>	37	rad/s	1 to 2000
PB31	VG2B	<p>Gain changing speed loop gain Set the speed loop gain when the gain changing is valid. This parameter is made valid when the auto tuning is invalid (parameter No.PA08: <input type="checkbox"/><input type="checkbox"/><input type="checkbox"/> 3).</p>	823	rad/s	20 to 20000
PB32	VICB	<p>Gain changing speed integral compensation Set the speed integral compensation when the gain changing is valid. This parameter is made valid when the auto tuning is invalid (parameter No.PA08: <input type="checkbox"/><input type="checkbox"/><input type="checkbox"/> 3).</p>	33.7	ms	0.1 to 5000.0
PB33	VRF1B	<p>Gain changing vibration suppression control vibration frequency setting This parameter cannot be used in the speed control mode. Set the vibration frequency for vibration suppression control when the gain changing is valid. This parameter is made valid when the parameter No.PB02 setting is "<input type="checkbox"/><input type="checkbox"/><input type="checkbox"/> 2" and the parameter No.PB26 setting is "<input type="checkbox"/><input type="checkbox"/><input type="checkbox"/> 1". When using the vibration suppression control gain changing, always execute the changing after the servo motor has stopped.</p>	100.0	Hz	0.1 to 100.0

## 5. PARAMETERS

No.	Symbol	Name and function	Initial value	Unit	Setting range
PB34	VRF2B	Gain changing vibration suppression control resonance frequency setting This parameter cannot be used in the speed control mode. Set the resonance frequency for vibration suppression control when the gain changing is valid. This parameter is made valid when the parameter No.PB02 setting is "□□□ 2" and the parameter No.PB26 setting is "□□□ 1". When using the vibration suppression control gain changing, always execute the changing after the servo motor has stopped.	100.0	Hz	0.1 to 100.0
PB35		For manufacturer setting	0.00		
PB36		Do not change this value by any means.	0.00		
PB37			100		
PB38			0.0		
PB39			0.0		
PB40			0.0		
PB41			1125		
PB42			1125		
PB43			0004h		
PB44			0.0		
PB45			0000h		

## 5. PARAMETERS

### 5.3 Extension setting parameters (No.PC□□)

























POINT
<ul style="list-style-type: none"> <li>▪ Parameter whose symbol is preceded by * is made valid with the following conditions.</li> <li>* : Set the parameter value, switch power off once after setting, and then switch it on again, or perform the controller reset.</li> <li>** : Set the parameter value, switch power off once, and then switch it on again.</li> </ul>

#### 5.3.1 Parameter list

No.	Symbol	Name	Initial value	Unit
PC01	ERZ	Error excessive alarm level	3	rev
PC02	MBR	Electromagnetic brake sequence output	0	ms
PC03	*ENRS	Encoder output pulses selection	0000h	
PC04	**COP1	Function selection C-1	0000h	
PC05	**COP2	Function selection C-2	0000h	
PC06	*COP3	Function selection C-3	0000h	
PC07	ZSP	Zero speed	50	r/min
PC08		For manufacturer setting	0	
PC09	MOD1	Analog monitor 1 output	0000h	
PC10	MOD2	Analog monitor 2 output	0001h	
PC11	MO1	Analog monitor 1 offset	0	mV
PC12	MO2	Analog monitor 2 offset	0	mV
PC13	MOSDL	Analog monitor feedback position output standard data Low	0	pulse
PC14	MOSDH	Analog monitor feedback position output standard data High	0	10000 pulse
PC15		For manufacturer setting	0	
PC16			0000h	
PC17	**COP4	Function selection C-4	0000h	
PC18		For manufacturer setting	0000h	
PC19			0000h	
PC20			0000h	
PC21	*BPS	Alarm history clear	0000h	
PC22		For manufacturer setting	0000h	
PC23			0000h	
PC24			0000h	
PC25			0000h	
PC26			0000h	
PC27			0000h	
PC28			0000h	
PC29			0000h	
PC30			0000h	
PC31			0000h	
PC32			0000h	

## 5. PARAMETERS

### 5.3.2 List of details

No.	Symbol	Name and function	Initial value	Unit	Setting range															
PC01	ERZ (Note 2)	Error excessive alarm level This parameter cannot be used in the speed control mode. Set error excessive alarm level with rotation amount of servo motor. Note 1. Setting can be changed in parameter No.PC06. 2. For a servo amplifier with software version of B2 or later, reactivating the power supply to enable the setting value is not necessary. For a servo amplifier with software version of earlier than B2, reactivating the power supply is required to enable the setting value.	3	rev (Note 1)	1 to 200															
PC02	MBR	Electromagnetic brake sequence output Used to set the delay time (Tb) between electronic brake interlock (MBR) and the base drive circuit is shut-off.	0	ms	0 to 1000															
PC03	*ENRS	Encoder output pulse selection Use to select the, encoder output pulse direction and encoder output pulse setting.  <div style="border: 1px solid black; padding: 5px; margin: 10px 0;"> <table border="1" style="width: 100%; text-align: center;"> <tr> <td style="width: 20px;">0</td> <td style="width: 20px;">0</td> <td style="width: 20px;"></td> <td style="width: 20px;"></td> </tr> </table> <p style="margin-left: 40px;">Encoder output pulse phase changing Changes the phases of A, B-phase encoder pulses output .</p> <table border="1" style="width: 100%; text-align: center;"> <thead> <tr> <th rowspan="2">Set value</th> <th colspan="2">Servo motor rotation direction</th> </tr> <tr> <th>CCW</th> <th>CW</th> </tr> </thead> <tbody> <tr> <td>0</td> <td>A-phase  B-phase </td> <td>A-phase  B-phase </td> </tr> <tr> <td>1</td> <td>A-phase  B-phase </td> <td>A-phase  B-phase </td> </tr> </tbody> </table> <p style="margin-left: 40px;">Encoder output pulse setting selection (refer to parameter No.PA15) 0: Output pulse designation 1: Division ratio setting</p> </div>	0	0			Set value	Servo motor rotation direction		CCW	CW	0	A-phase  B-phase 	A-phase  B-phase 	1	A-phase  B-phase 	A-phase  B-phase 	0000h		Refer to Name and function column.
0	0																			
Set value	Servo motor rotation direction																			
	CCW	CW																		
0	A-phase  B-phase 	A-phase  B-phase 																		
1	A-phase  B-phase 	A-phase  B-phase 																		
PC04	**COP1	Function selection C-1 Select the encoder cable communication system selection.  <div style="border: 1px solid black; padding: 5px; margin: 10px 0;"> <table border="1" style="width: 100%; text-align: center;"> <tr> <td style="width: 20px;"></td> <td style="width: 20px;">0</td> <td style="width: 20px;">0</td> <td style="width: 20px;">0</td> </tr> </table> <p style="margin-left: 40px;">Encoder cable communication system selection 0: Two-wire type 1: Four-wire type The following encoder cables are of 4-wire type. MR-EKCBL30M-L MR-EKCBL30M-H MR-EKCBL40M-H MR-EKCBL50M-H The other encoder cables are all of 2-wire type. Incorrect setting will result in an encoder alarm 1 (16) or encoder alarm 2 (20).</p> </div>		0	0	0	0000h		Refer to Name and function column.											
	0	0	0																	
PC05	**COP2	Function selection C-2 Motor-less operation select.  <div style="border: 1px solid black; padding: 5px; margin: 10px 0;"> <table border="1" style="width: 100%; text-align: center;"> <tr> <td style="width: 20px;">0</td> <td style="width: 20px;">0</td> <td style="width: 20px;">0</td> <td style="width: 20px;"></td> </tr> </table> <p style="margin-left: 40px;">Motor-less operation select. 0: Valid 1: Invalid</p> </div>	0	0	0		0000h		Refer to Name and function column.											
0	0	0																		

## 5. PARAMETERS

No.	Symbol	Name and function	Initial value	Unit	Setting range																														
PC06	*COP3	<p>Function selection C-3 Select the error excessive alarm level setting for parameter No.PC01.</p> <div style="border: 1px solid black; display: inline-block; padding: 2px;">0 0 0</div> <p>Error excessive alarm level setting selection 0: 1 [rev]unit 1: 0.1 [rev]unit 2: 0.01 [rev]unit 3: 0.001[rev]unit</p> <p>This parameter is available to software version B1 or later.</p>	0000h		Refer to Name and function column.																														
PC07	ZSP	<p>Zero speed Used to set the output range of the zero speed (ZSP). Zero speed signal detection has hysteresis width of 20r/min (Refer to section 3.5 (2) (b))</p>	50	r/min	0 to 10000																														
PC08		<p>For manufacturer setting Do not change this value by any means.</p>	0																																
PC09	MOD1	<p>Analog monitor 1 output Used to selection the signal provided to the analog monitor 1 (MO1) output. (Refer to section 5.3.3)</p> <div style="border: 1px solid black; display: inline-block; padding: 2px;">0 0 0</div> <p>Analog monitor 1 (MO1) output selection</p> <table border="1" style="width: 100%; border-collapse: collapse;"> <thead> <tr> <th>Setting</th> <th>Item</th> </tr> </thead> <tbody> <tr><td>0</td><td>Servo motor speed (<math>\pm 8V/\text{max. speed}</math>)</td></tr> <tr><td>1</td><td>Torque (<math>\pm 8V/\text{max. torque}</math>) (Note 2)</td></tr> <tr><td>2</td><td>Servo motor speed (<math>+8V/\text{max. speed}</math>)</td></tr> <tr><td>3</td><td>Torque (<math>+8V/\text{max. torque}</math>) (Note 2)</td></tr> <tr><td>4</td><td>Current command (<math>\pm 8V/\text{max. current command}</math>)</td></tr> <tr><td>5</td><td>Speed command (<math>\pm 8V/\text{max. current command}</math>)</td></tr> <tr><td>6</td><td>Droop pulses (<math>\pm 10V/100</math> pulses) (Note 1)</td></tr> <tr><td>7</td><td>Droop pulses (<math>\pm 10V/1000</math> pulses) (Note 1)</td></tr> <tr><td>8</td><td>Droop pulses (<math>\pm 10V/10000</math> pulses) (Note 1)</td></tr> <tr><td>9</td><td>Droop pulses (<math>\pm 10V/100000</math> pulses) (Note 1)</td></tr> <tr><td>A</td><td>Feedback position (<math>\pm 10V/1</math> Mpulses) (Note 1, 3)</td></tr> <tr><td>B</td><td>Feedback position (<math>\pm 10V/10</math> Mpulses) (Note 1, 3)</td></tr> <tr><td>C</td><td>Feedback position (<math>\pm 10V/100</math> Mpulses) (Note 1, 3)</td></tr> <tr><td>D</td><td>Bus voltage (<math>\pm 8V/400V</math>)(Note 4)</td></tr> </tbody> </table> <p>Note 1. Encoder pulse unit. 2. 8V is outputted at the maximum torque. 3. It can be used by the absolute position detection system. 4. For 400V class servo amplifier, the bus voltage becomes <math>+8V/800V</math>.</p>	Setting	Item	0	Servo motor speed ( $\pm 8V/\text{max. speed}$ )	1	Torque ( $\pm 8V/\text{max. torque}$ ) (Note 2)	2	Servo motor speed ( $+8V/\text{max. speed}$ )	3	Torque ( $+8V/\text{max. torque}$ ) (Note 2)	4	Current command ( $\pm 8V/\text{max. current command}$ )	5	Speed command ( $\pm 8V/\text{max. current command}$ )	6	Droop pulses ( $\pm 10V/100$ pulses) (Note 1)	7	Droop pulses ( $\pm 10V/1000$ pulses) (Note 1)	8	Droop pulses ( $\pm 10V/10000$ pulses) (Note 1)	9	Droop pulses ( $\pm 10V/100000$ pulses) (Note 1)	A	Feedback position ( $\pm 10V/1$ Mpulses) (Note 1, 3)	B	Feedback position ( $\pm 10V/10$ Mpulses) (Note 1, 3)	C	Feedback position ( $\pm 10V/100$ Mpulses) (Note 1, 3)	D	Bus voltage ( $\pm 8V/400V$ )(Note 4)	0000h		Refer to Name and function column.
Setting	Item																																		
0	Servo motor speed ( $\pm 8V/\text{max. speed}$ )																																		
1	Torque ( $\pm 8V/\text{max. torque}$ ) (Note 2)																																		
2	Servo motor speed ( $+8V/\text{max. speed}$ )																																		
3	Torque ( $+8V/\text{max. torque}$ ) (Note 2)																																		
4	Current command ( $\pm 8V/\text{max. current command}$ )																																		
5	Speed command ( $\pm 8V/\text{max. current command}$ )																																		
6	Droop pulses ( $\pm 10V/100$ pulses) (Note 1)																																		
7	Droop pulses ( $\pm 10V/1000$ pulses) (Note 1)																																		
8	Droop pulses ( $\pm 10V/10000$ pulses) (Note 1)																																		
9	Droop pulses ( $\pm 10V/100000$ pulses) (Note 1)																																		
A	Feedback position ( $\pm 10V/1$ Mpulses) (Note 1, 3)																																		
B	Feedback position ( $\pm 10V/10$ Mpulses) (Note 1, 3)																																		
C	Feedback position ( $\pm 10V/100$ Mpulses) (Note 1, 3)																																		
D	Bus voltage ( $\pm 8V/400V$ )(Note 4)																																		
PC10	MOD2	<p>Analog monitor 2 output Used to selection the signal provided to the analog monitor 2 (MO2) output. (Refer to section 5.3.3)</p> <div style="border: 1px solid black; display: inline-block; padding: 2px;">0 0 0</div> <p>Select the analog monitor 2 (MO2) output The settings are the same as those of parameter No.PC09.</p>	0001h		Refer to Name and function column.																														
PC11	MO1	<p>Analog monitor 1 offset Used to set the offset voltage of the analog monitor 1 (MO1) output.</p>	0	mV	-999 to 999																														

## 5. PARAMETERS

No.	Symbol	Name and function	Initial value	Unit	Setting range				
PC12	MO2	Analog monitor 2 offset Used to set the offset voltage of the analog monitor 2 (MO2) output.	0	mV	-999 to 999				
PC13	MOSDL	Analog monitor feedback position output standard data Low Used to set the standard position of feedback output with analog monitor 1 (M01) or 2 (M02). For this parameter, the lower-order four digits of standard position in decimal numbers are set.	0	pulse	-9999 to 9999				
PC14	MOSDH	Analog monitor feedback position output standard data High Used to set the standard position of feedback output with analog monitor 1 (M01) or 2 (M02). For this parameter, the higher-order four digits of standard position in decimal numbers are set.	0	10000 pulse	-9999 to 9999				
PC15		For manufacturer setting	0						
PC16		Do not change this value by any means.	0000h						
PC17	**COP4	Function Selection C-4 Home position setting condition in the absolute position detection system can be selected.  <table border="1" style="display: inline-table; vertical-align: middle;"> <tr> <td style="width: 20px; height: 20px; text-align: center;">0</td> <td style="width: 20px; height: 20px; text-align: center;">0</td> <td style="width: 20px; height: 20px; text-align: center;">0</td> <td style="width: 20px; height: 20px; text-align: center;"> </td> </tr> </table> Selection of home position setting condition 0: Need to pass motor Z-phase after the power supply is switched on. 1: Not need to pass motor Z-phase after the power supply is switched on.	0	0	0		0000h		Refer to Name and function column.
0	0	0							
PC18		For manufacturer setting	0000h						
PC19		Do not change this value by any means.	0000h						
PC20			0000h						
PC21	*BPS	Alarm history clear Used to clear the alarm history.  <table border="1" style="display: inline-table; vertical-align: middle;"> <tr> <td style="width: 20px; height: 20px; text-align: center;">0</td> <td style="width: 20px; height: 20px; text-align: center;">0</td> <td style="width: 20px; height: 20px; text-align: center;">0</td> <td style="width: 20px; height: 20px; text-align: center;"> </td> </tr> </table> Alarm history clear 0: Invalid 1: Valid When alarm history clear is made valid, the alarm history is cleared at next power-on. After the alarm history is cleared, the setting is automatically made invalid (reset to 0).	0	0	0		0000h		Refer to Name and function column.
0	0	0							
PC22		For manufacturer setting	0000h						
PC23		Do not change this value by any means.	0000h						
PC24			0000h						
PC25			0000h						
PC26			0000h						
PC27			0000h						
PC28			0000h						
PC29			0000h						
PC30			0000h						
PC31			0000h						
PC32			0000h						

## 5. PARAMETERS

### 5.3.3 Analog monitor

The servo status can be output to two channels in terms of voltage. The servo status can be monitored using an ammeter.

#### (1) Setting

Change the following digits of parameter No.PC09, PC10.

Parameter No.PC09

0	0	0	
---	---	---	--

Analog monitor (MO1) output selection  
(Signal output to across MO1-LG)

Parameter No.PC10

0	0	0	
---	---	---	--

Analog monitor (MO2) output selection  
(Signal output to across MO2-LG)

Parameters No.PC11 and PC12 can be used to set the offset voltages to the analog output voltages. The setting range is between  $-999$  and  $999$ mV.

Parameter No.	Description	Setting range [mV]
PC11	Used to set the offset voltage for the analog monitor 1 (MO1).	-999 to 999
PC12	Used to set the offset voltage for the analog monitor 2 (MO2).	

#### (2) Set content

The servo amplifier is factory-set to output the servo motor speed to analog monitor 1 (MO1) and the torque to analog monitor (MO2). The setting can be changed as listed below by changing the parameter No.PC14 and PC12 value.

Refer to (3) for the measurement point.

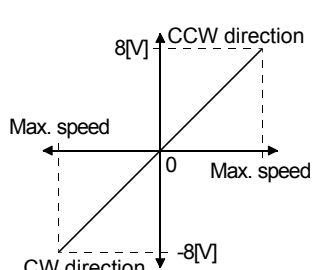
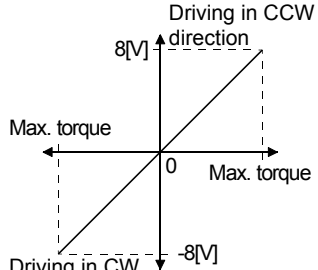
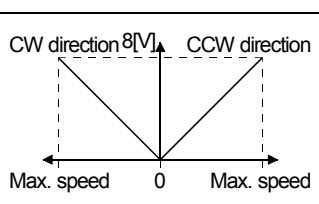
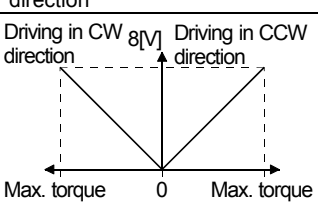
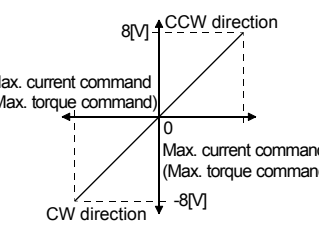
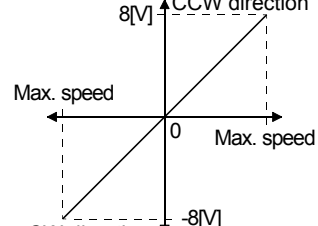
Setting	Output item	Description	Setting	Output item	Description
0	Servo motor speed		1	Torque (Note 3)	
2	Servo motor speed		3	Torque (Note 3)	
4	Current command		5	Speed command	

## 5. PARAMETERS

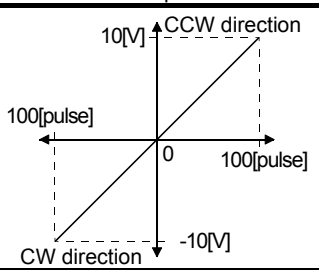
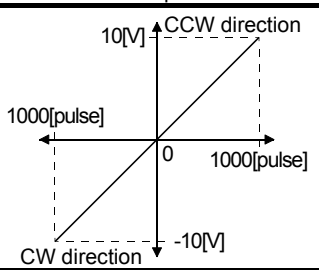
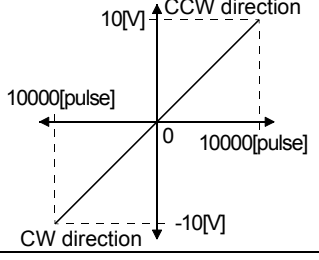
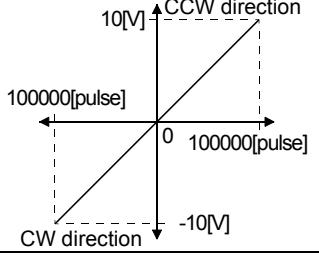
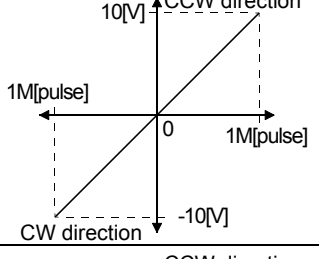
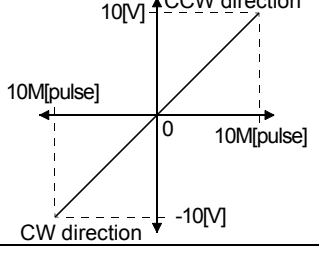
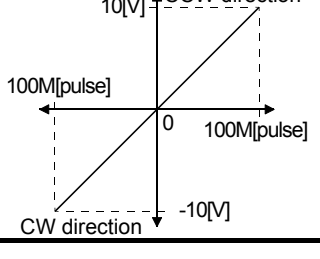
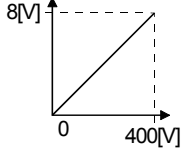
Setting	Output item	Description	Setting	Output item	Description
6	Droop pulses (Note 1) ( $\pm 10V/100$ pulses)		7	Droop pulses (Note 1) ( $\pm 10V/1000$ pulses)	
8	Droop pulses (Note 1) ( $\pm 10V/10000$ pulses)		9	Droop pulses (Note 1) ( $\pm 10V/100000$ pulses)	
A	Feedback position (Note 1,2) ( $\pm 10V/1$ Mpulses)		B	Feedback position (Note 1,2) ( $\pm 10V/10$ Mpulses)	
C	Feedback position (Note 1,2) ( $\pm 10V/100$ Mpulses)		D	Bus voltage (Note 4)	

Note 1. Encoder pulse unit.

2. Available in position control mode
3. Outputs 8V at the maximum torque.
4. For 400V class servo amplifier, the bus voltage becomes +8V/800V.

## 5. PARAMETERS

### (3) Analog monitor block diagram

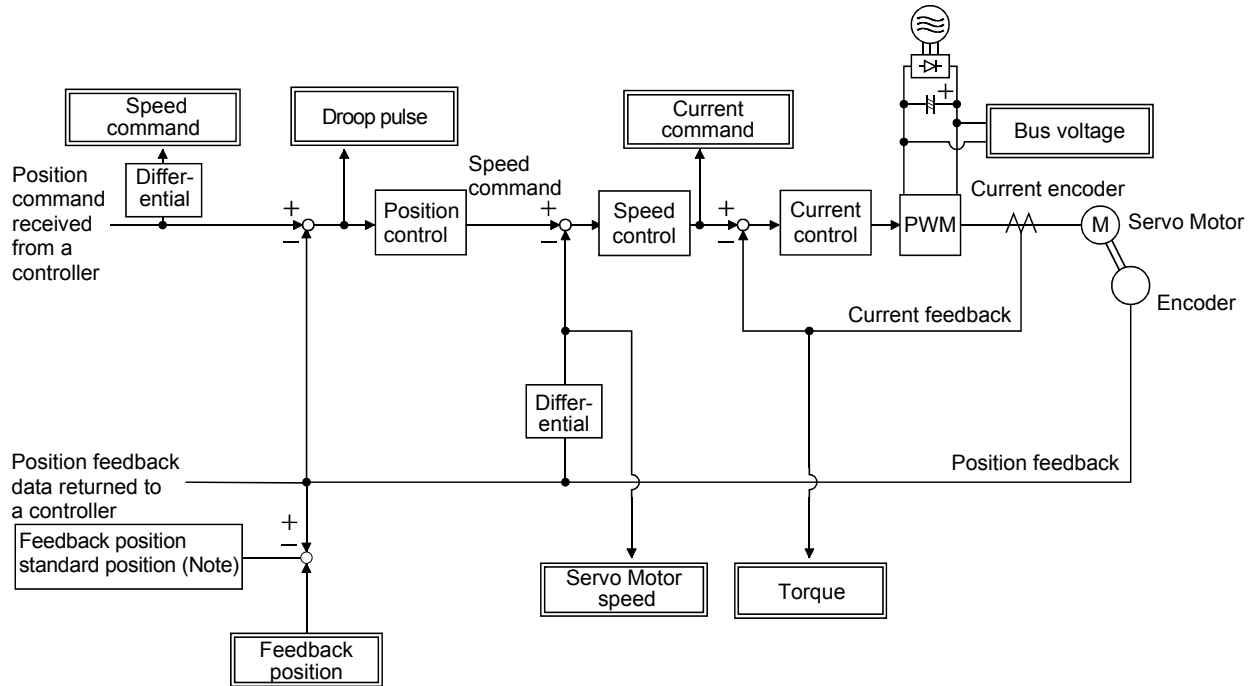

Note. The feedback position is output based on the position data passed between servo system controller and servo amplifier. The parameter number No.PC13/PC14 can set up the standard position of feedback position that is output to analog monitor in order to adjust the output range of feedback position. The setting range is between -99999999 and 99999999 pulses.

Standard position of feedback position = Parameter No.PC14 setting value × 10000 + Parameter No.PC13 setting value

Parameter No.	Description	Setting range
PC13	Sets the lower-order four digits of the standard position of feedback position	-9999 to 9999 [pulse]
PC14	Sets the higher-order four digits of the standard position of feedback position	-9999 to 9999 [10000pulses]

#### 5.3.4 Alarm history clear

The servo amplifier stores one current alarm and five past alarms from when its power is switched on first. To control alarms which will occur during operation, clear the alarm history using parameter No.PC21 before starting operation.

Clearing the alarm history automatically returns to "□□□0".

After setting, this parameter is made valid by switch power from OFF to ON.

Parameter No.PC21

0 0 0

Alarm history clear  
0: Invalid (not cleared)  
1: Valid (cleared)

## 5. PARAMETERS

### 5.4 I/O setting parameters (No.PD□□)

POINT
<ul style="list-style-type: none"> <li>Parameter whose symbol is preceded by * is made valid with the following conditions.</li> <li>* : Set the parameter value, switch power off once after setting, and then switch it on again, or perform the controller reset.</li> </ul>

#### 5.4.1 Parameter list







No.	Symbol	Name	Initial value	Unit
PD01		For manufacturer setting	0000h	
PD02			0000h	
PD03			0000h	
PD04			0000h	
PD05			0000h	
PD06			0000h	
PD07	*DO1	Output signal device selection 1 (CN3-13)	0005h	
PD08	*DO2	Output signal device selection 2 (CN3-9)	0004h	
PD09	*DO3	Output signal device selection 3 (CN3-15)	0003h	
PD10		For manufacturer setting	0000h	
PD11			0004h	
PD12			0000h	
PD13			0000h	
PD14	*DOP3	Function selection D-3	0000h	
PD15		For manufacturer setting	0000h	
PD16			0000h	
PD17			0000h	
PD18			0000h	
PD19			0000h	
PD20			0000h	
PD21			0000h	
PD22			0000h	
PD23			0000h	
PD24			0000h	
PD25			0000h	
PD26			0000h	
PD27			0000h	
PD28			0000h	
PD29			0000h	
PD30			0000h	
PD31			0000h	
PD32			0000h	

## 5. PARAMETERS

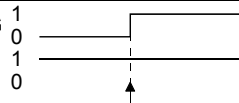
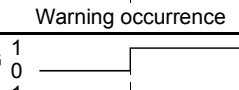
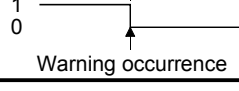
### 5.4.2 List of details

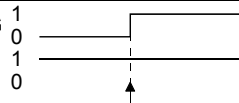
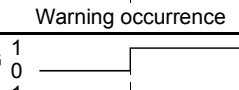
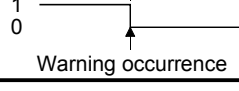
No.	Symbol	Name and function	Initial value	Unit	Setting range																																											
PD01		For manufacturer setting Do not change this value by any means.	0000h																																													
PD02			0000h																																													
PD03			0000h																																													
PD04			0000h																																													
PD05			0000h																																													
PD06			0000h																																													
PD07	*DO1	<p>Output signal device selection 1 (CN3-13) Any input signal can be assigned to the CN3-13 pin.</p> <div style="display: flex; align-items: center; margin-bottom: 10px;"> <div style="border: 1px solid black; padding: 2px 5px; margin-right: 5px;">0</div> <div style="border: 1px solid black; padding: 2px 5px; margin-right: 5px;">0</div> <div style="border: 1px solid black; padding: 2px 5px; margin-right: 5px;"></div> <div style="border: 1px solid black; padding: 2px 5px;"></div> </div> <p style="margin-left: 40px;">Select the output device of the CN3-13 pin.</p> <p>The devices that can be assigned in each control mode are those that have the symbols indicated in the following table.</p> <table border="1" style="width: 100%; border-collapse: collapse; text-align: center;"> <thead> <tr> <th>Setting</th> <th>Device</th> <th>Setting</th> <th>Device</th> </tr> </thead> <tbody> <tr> <td>00</td> <td>Always OFF</td> <td>0A</td> <td>Always OFF (Note 2)</td> </tr> <tr> <td>01</td> <td>For manufacturer setting (Note 3)</td> <td>0B</td> <td>For manufacturer setting (Note 3)</td> </tr> <tr> <td>02</td> <td>RD</td> <td>0C</td> <td>ZSP</td> </tr> <tr> <td>03</td> <td>ALM</td> <td>0D</td> <td>For manufacturer setting (Note 3)</td> </tr> <tr> <td>04</td> <td>INP (Note 1)</td> <td>0E</td> <td>For manufacturer setting (Note 3)</td> </tr> <tr> <td>05</td> <td>MBR</td> <td>0F</td> <td>CDPS</td> </tr> <tr> <td>06</td> <td>DB</td> <td>10</td> <td>For manufacturer setting (Note 3)</td> </tr> <tr> <td>07</td> <td>TLC</td> <td>11</td> <td>ABSV (Note 1)</td> </tr> <tr> <td>08</td> <td>WNG</td> <td>12 to 1F</td> <td>For manufacturer setting (Note 3)</td> </tr> <tr> <td>09</td> <td>BWNG</td> <td>20 to 3F</td> <td>For manufacturer setting (Note 3)</td> </tr> </tbody> </table> <p>Note 1. It becomes always OFF in speed control mode. 2. It becomes SA in speed control mode. 3. For manufacturer setting Never change this setting.</p>	Setting	Device	Setting	Device	00	Always OFF	0A	Always OFF (Note 2)	01	For manufacturer setting (Note 3)	0B	For manufacturer setting (Note 3)	02	RD	0C	ZSP	03	ALM	0D	For manufacturer setting (Note 3)	04	INP (Note 1)	0E	For manufacturer setting (Note 3)	05	MBR	0F	CDPS	06	DB	10	For manufacturer setting (Note 3)	07	TLC	11	ABSV (Note 1)	08	WNG	12 to 1F	For manufacturer setting (Note 3)	09	BWNG	20 to 3F	For manufacturer setting (Note 3)	0005h	Refer to Name and function column.
Setting	Device	Setting	Device																																													
00	Always OFF	0A	Always OFF (Note 2)																																													
01	For manufacturer setting (Note 3)	0B	For manufacturer setting (Note 3)																																													
02	RD	0C	ZSP																																													
03	ALM	0D	For manufacturer setting (Note 3)																																													
04	INP (Note 1)	0E	For manufacturer setting (Note 3)																																													
05	MBR	0F	CDPS																																													
06	DB	10	For manufacturer setting (Note 3)																																													
07	TLC	11	ABSV (Note 1)																																													
08	WNG	12 to 1F	For manufacturer setting (Note 3)																																													
09	BWNG	20 to 3F	For manufacturer setting (Note 3)																																													
PD08	*DO2	<p>Output signal device selection 2 (CN3-9) Any input signal can be assigned to the CN3-9 pin. The devices that can be assigned and the setting method are the same as in parameter No.PD07.</p> <div style="display: flex; align-items: center; margin-bottom: 10px;"> <div style="border: 1px solid black; padding: 2px 5px; margin-right: 5px;">0</div> <div style="border: 1px solid black; padding: 2px 5px; margin-right: 5px;">0</div> <div style="border: 1px solid black; padding: 2px 5px; margin-right: 5px;">0</div> <div style="border: 1px solid black; padding: 2px 5px;"></div> </div> <p style="margin-left: 40px;">Select the output device of the CN3-9 pin.</p>	0004h	Refer to Name and function column.																																												
PD09	*DO3	<p>Output signal device selection 3 (CN3-15) Any input signal can be assigned to the CN3-15 pin. The devices that can be assigned and the setting method are the same as in parameter No.PD07.</p> <div style="display: flex; align-items: center; margin-bottom: 10px;"> <div style="border: 1px solid black; padding: 2px 5px; margin-right: 5px;">0</div> <div style="border: 1px solid black; padding: 2px 5px; margin-right: 5px;">0</div> <div style="border: 1px solid black; padding: 2px 5px; margin-right: 5px;">0</div> <div style="border: 1px solid black; padding: 2px 5px;"></div> </div> <p style="margin-left: 40px;">Select the output device of the CN3-15 pin.</p>	0003h	Refer to Name and function column.																																												

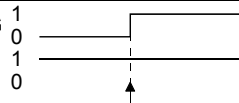
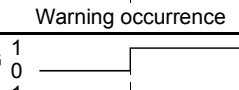
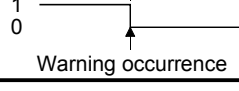
## 5. PARAMETERS

No.	Symbol	Name and function	Initial value	Unit	Setting range												
PD10		For manufacturer setting Do not change this value by any means.	0000h														
PD11			0004h														
PD12			0000h														
PD13			0000h														
PD14	*DOP3	Function selection D-3 Set the ALM output signal at warning occurrence. <div style="border: 1px solid black; display: inline-block; padding: 2px; margin: 5px 0;">0 0 0</div> Selection of output device at warning occurrence Select the warning (WNG) and trouble (ALM) output status at warning occurrence. Output of Servo amplifier <table border="1" style="margin: 10px auto;"> <thead> <tr> <th>Setting</th> <th>(Note) Device status</th> </tr> </thead> <tbody> <tr> <td rowspan="2">0</td> <td>WNG 1 0</td> <td></td> </tr> <tr> <td>ALM 1 0</td> <td></td> </tr> <tr> <td rowspan="2">1</td> <td>WNG 1 0</td> <td></td> </tr> <tr> <td>ALM 1 0</td> <td></td> </tr> </tbody> </table> Note. 0: off 1: on	Setting	(Note) Device status	0	WNG 1 0		ALM 1 0		1	WNG 1 0		ALM 1 0		0000h		Refer to Name and function column.
Setting	(Note) Device status																
0	WNG 1 0																
	ALM 1 0																
1	WNG 1 0																
	ALM 1 0																
PD15		For manufacturer setting Do not change this value by any means.	0000h														
PD16			0000h														
PD17			0000h														
PD18			0000h														
PD19			0000h														
PD20			0000h														
PD21			0000h														
PD22			0000h														
PD23			0000h														
PD24			0000h														
PD25			0000h														
PD26			0000h														
PD27			0000h														
PD28			0000h														
PD29			0000h														
PD30			0000h														
PD31			0000h														
PD32			0000h														



## 6. GENERAL GAIN ADJUSTMENT

### 6. GENERAL GAIN ADJUSTMENT

#### 6.1 Different adjustment methods

##### 6.1.1 Adjustment on a single servo amplifier

The gain adjustment in this section can be made on a single servo amplifier. For gain adjustment, first execute auto tuning mode 1. If you are not satisfied with the results, execute auto tuning mode 2 and manual mode in this order.

##### (1) Gain adjustment mode explanation

Gain adjustment mode	Parameter No.PA08 setting	Estimation of load inertia moment ratio	Automatically set parameters	Manually set parameters
Auto tuning mode 1 (initial value)	0001	Always estimated	GD2 (parameter No.PB06) PG2 (parameter No.PB08) PG1 (parameter No.PB07) VG2 (parameter No.PB09) VIC (parameter No.PB10)	Response level setting of parameter No.2
Auto tuning mode 2	0002	Fixed to parameter No. PB06 value	PG2 (parameter No.PB08) PG1 (parameter No.PB07) VG2 (parameter No.PB09) VIC (parameter No.PB10)	GD2 (parameter No.PB06) Response level setting of parameter No.PA09
Manual mode	0003			PG1 (parameter No.PB07) GD2 (parameter No.PB06) VG2 (parameter No.PB09) VIC (parameter No.PB10)
Interpolation mode	0000	Always estimated	GD2 (parameter No.PB06) PG2 (parameter No.PB08) VG2 (parameter No.PB09) VIC (parameter No.PB10)	PG1 (parameter No.PB07)

## 6. GENERAL GAIN ADJUSTMENT

### (2) Adjustment sequence and mode usage

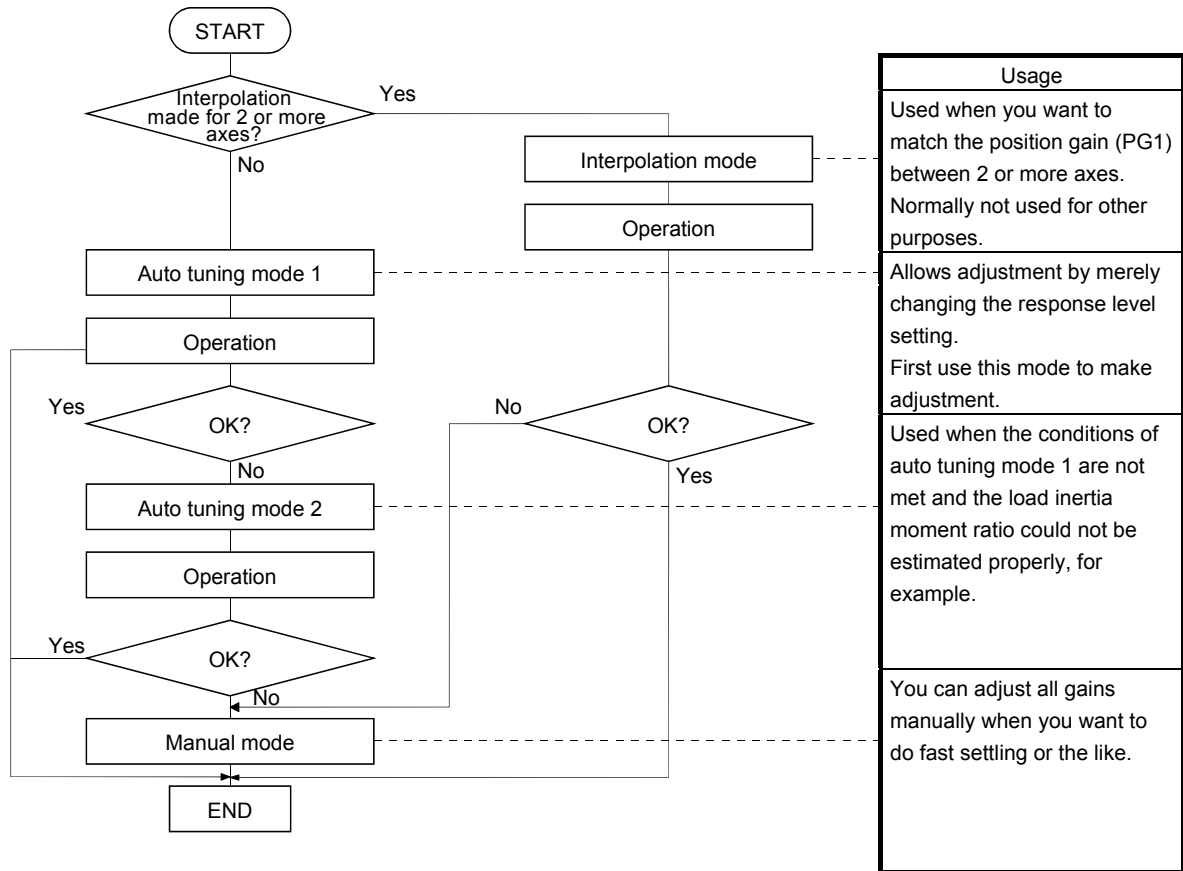

#### 6.1.2 Adjustment using MR Configurator

This section gives the functions and adjustment that may be performed by using the servo amplifier with the MR Configurator which operates on a personal computer.

Function	Description	Adjustment
Machine analyzer	With the machine and servo motor coupled, the characteristic of the mechanical system can be measured by giving a random vibration command from the personal computer to the servo and measuring the machine response.	<ul style="list-style-type: none"> <li>You can grasp the machine resonance frequency and determine the notch frequency of the machine resonance suppression filter.</li> <li>You can automatically set the optimum gains in response to the machine characteristic. This simple adjustment is suitable for a machine which has large machine resonance and does not require much settling time.</li> </ul>
Gain search	Executing gain search under to-and-fro positioning command measures settling characteristic while simultaneously changing gains, and automatically searches for gains which make settling time shortest.	<ul style="list-style-type: none"> <li>You can automatically set gains which make positioning settling time shortest.</li> </ul>
Machine simulation	Response at positioning settling of a machine can be simulated from machine analyzer results on personal computer.	<ul style="list-style-type: none"> <li>You can optimize gain adjustment and command pattern on personal computer.</li> </ul>

## 6. GENERAL GAIN ADJUSTMENT

### 6.2 Auto tuning

#### 6.2.1 Auto tuning mode

The servo amplifier has a real-time auto tuning function which estimates the machine characteristic (load inertia moment ratio) in real time and automatically sets the optimum gains according to that value. This function permits ease of gain adjustment of the servo amplifier.

##### (1) Auto tuning mode 1

The servo amplifier is factory-set to the auto tuning mode 1.

In this mode, the load inertia moment ratio of a machine is always estimated to set the optimum gains automatically.

The following parameters are automatically adjusted in the auto tuning mode 1.

Parameter No.	Abbreviation	Name
PB06	GD2	Ratio of load inertia moment to servo motor inertia moment
PB07	PG1	Model loop gain
PB08	PG2	Position loop gain
PB09	VG2	Speed loop gain
PB10	VIC	Speed integral compensation

POINT
<ul style="list-style-type: none"> <li>▪ The auto tuning mode 1 may not be performed properly if the following conditions are not satisfied.</li> <li>▪ Time to reach 2000r/min is the acceleration/deceleration time constant of 5s or less.</li> <li>▪ Speed is 150r/min or higher.</li> <li>▪ The ratio of load inertia moment to servo motor inertia moment is 100 times or less.</li> <li>▪ The acceleration/deceleration torque is 10% or more of the rated torque.</li> <li>▪ Under operating conditions which will impose sudden disturbance torque during acceleration/deceleration or on a machine which is extremely loose, auto tuning may not function properly, either. In such cases, use the auto tuning mode 2 or manual mode to make gain adjustment.</li> </ul>

##### (2) Auto tuning mode 2

Use the auto tuning mode 2 when proper gain adjustment cannot be made by auto tuning mode 1. Since the load inertia moment ratio is not estimated in this mode, set the value of a correct load inertia moment ratio (parameter No.PB06).

The following parameters are automatically adjusted in the auto tuning mode 2.

Parameter No.	Abbreviation	Name
PB07	PG1	Model loop gain
PB08	PG2	Position loop gain
PB09	VG2	Speed loop gain
PB10	VIC	Speed integral compensation

## 6. GENERAL GAIN ADJUSTMENT

### 6.2.2 Auto tuning mode operation

The block diagram of real-time auto tuning is shown below.

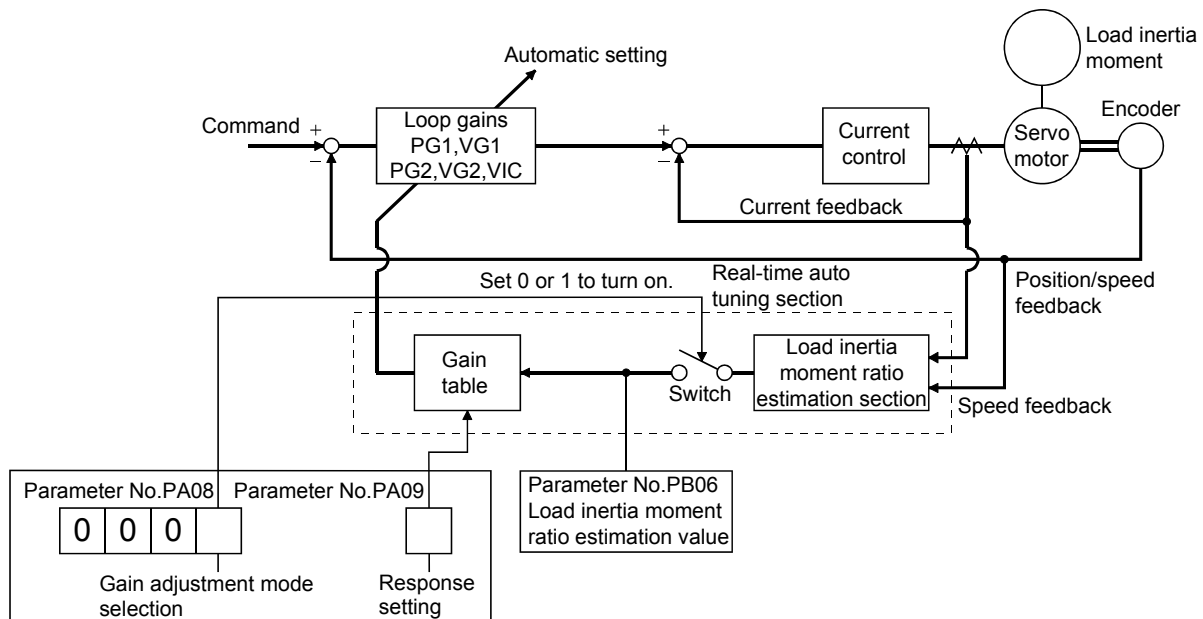

When a servo motor is accelerated/decelerated, the load inertia moment ratio estimation section always estimates the load inertia moment ratio from the current and speed of the servo motor. The results of estimation are written to parameter No.PB06 (the ratio of load inertia moment to servo motor). These results can be confirmed on the status display screen of the MR Configurator.

If the value of the load inertia moment ratio is already known or if estimation cannot be made properly, chose the "auto tuning mode 2" (parameter No.PA08: 0002) to stop the estimation of the load inertia moment ratio (Switch in above diagram turned off), and set the load inertia moment ratio (parameter No.34) manually.

From the preset load inertia moment ratio (parameter No.PB06) value and response level (parameter No.PA09), the optimum loop gains are automatically set on the basis of the internal gain tale.

The auto tuning results are saved in the EEP-ROM of the servo amplifier every 60 minutes since power-on. At power-on, auto tuning is performed with the value of each loop gain saved in the EEP-ROM being used as an initial value.

POINT
<ul style="list-style-type: none"> <li>▪ If sudden disturbance torque is imposed during operation, the estimation of the inertia moment ratio may malfunction temporarily. In such a case, choose the "auto tuning mode 2" (parameter No.PA08: 0002) and set the correct load inertia moment ratio in parameter No.PB06.</li> <li>▪ When any of the auto tuning mode 1 and auto tuning mode settings is changed to the manual mode 2 setting, the current loop gains and load inertia moment ratio estimation value are saved in the EEP-ROM.</li> </ul>

## 6. GENERAL GAIN ADJUSTMENT

### 6.2.3 Adjustment procedure by auto tuning

Since auto tuning is made valid before shipment from the factory, simply running the servo motor automatically sets the optimum gains that match the machine. Merely changing the response level setting value as required completes the adjustment. The adjustment procedure is as follows.

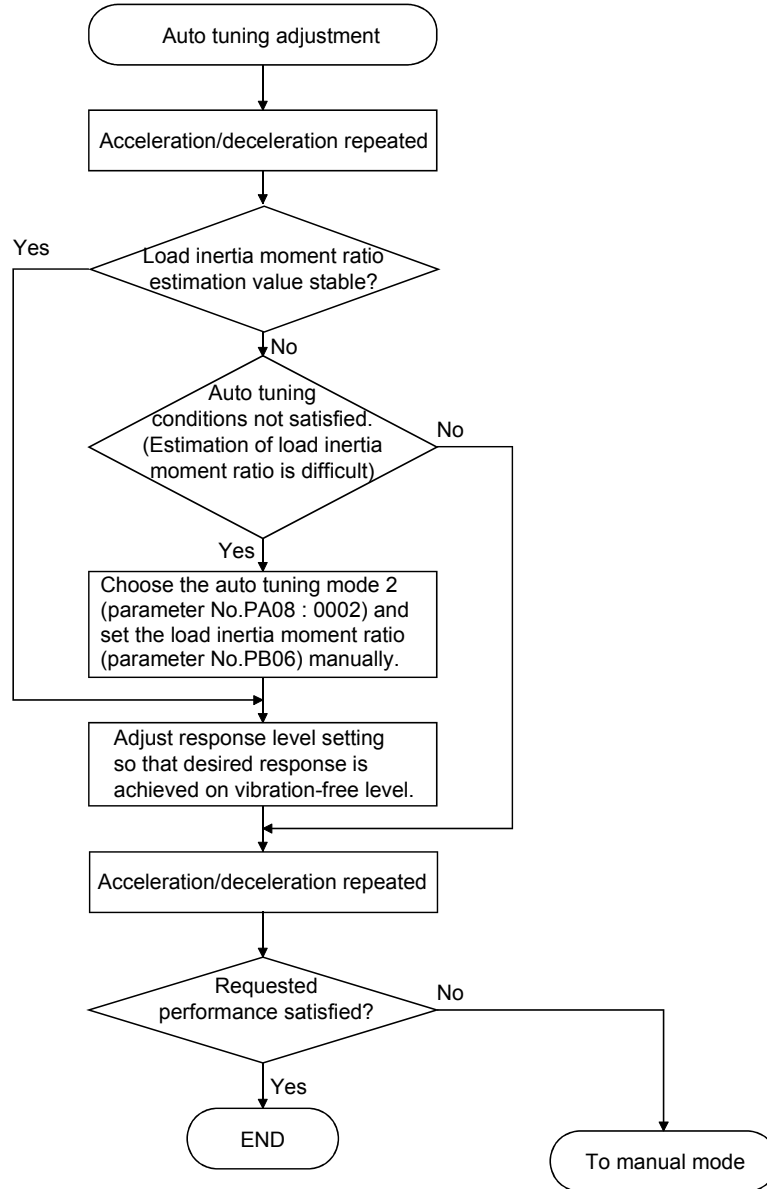

## 6. GENERAL GAIN ADJUSTMENT

### 6.2.4 Response level setting in auto tuning mode

Set the response (The first digit of parameter No.PA09) of the whole servo system. As the response level setting is increased, the track ability and settling time for a command decreases, but a too high response level will generate vibration. Hence, make setting until desired response is obtained within the vibration-free range. If the response level setting cannot be increased up to the desired response because of machine resonance beyond 100Hz, filter tuning mode (parameter No.PB01) or machine resonance suppression filter (parameter No.PB13 to PB16) may be used to suppress machine resonance. Suppressing machine resonance may allow the response level setting to increase. Refer to section 7.3 for filter tuning mode and machine resonance suppression filter.

#### Setting of parameter No.PA09

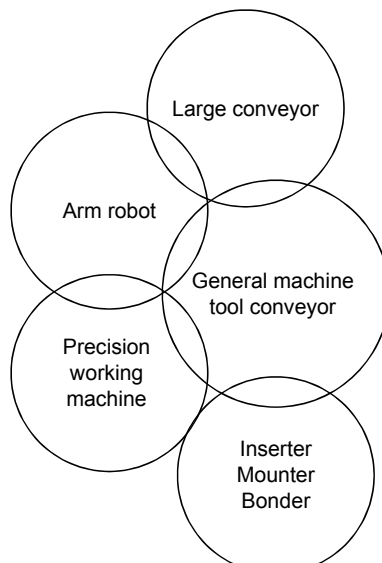
Response level setting	Machine characteristic		
	Machine rigidity	Machine resonance frequency guideline	Guideline of corresponding machine
1	Low ↑	10.0	
2		11.3	
3		12.7	
4		14.3	
5		16.1	
6		18.1	
7		20.4	
8		23.0	
9		25.9	
10		29.2	
11		32.9	
12		37.0	
13	41.7		
14	47.0		
15	52.9		
16	Middle	59.6	
17	↓ ↑	67.1	
18		75.6	
19		85.2	
20		95.9	
21		108.0	
22		121.7	
23		137.1	
24		154.4	
25		173.9	
26		195.9	
27		220.6	
28		248.5	
29		279.9	
30		315.3	
31		355.1	
32		High	

## 6. GENERAL GAIN ADJUSTMENT

### 6.3 Manual mode 1 (simple manual adjustment)

If you are not satisfied with the adjustment of auto tuning, you can make simple manual adjustment with three parameters.

POINT
<ul style="list-style-type: none"> <li>If machine resonance occurs, filter tuning mode (parameter No.PB01) or machine resonance suppression filter (parameter No.PB13 to PB16) may be used to suppress machine resonance. (Refer to section 7.3.)</li> </ul>

#### (1) For speed control

##### (a) Parameters

The following parameters are used for gain adjustment.

Parameter No.	Abbreviation	Name
PB06	GD2	Ratio of load inertia moment to servo motor inertia moment
PB07	PG1	Model loop gain
PB09	VG2	Speed loop gain
PB10	VIC	Speed integral compensation

##### (b) Adjustment procedure

Step	Operation	Description
1	Brief-adjust with auto tuning. Refer to section 6.2.3.	
2	Change the setting of auto tuning to the manual mode (Parameter No.PA08: 0003).	
3	Set an estimated value to the ratio of load inertia moment to servo motor inertia moment. (If the estimate value with auto tuning is correct, setting change is not required.)	
4	Set a slightly smaller value to the model loop gain Set a slightly larger value to the speed integral compensation.	
5	Increase the speed loop gain within the vibration- and unusual noise-free range, and return slightly if vibration takes place.	Increase the speed loop gain.
6	Decrease the speed integral compensation within the vibration-free range, and return slightly if vibration takes place.	Decrease the time constant of the speed integral compensation.
7	Increase the model loop gain, and return slightly if overshooting takes place.	Increase the model loop gain.
8	If the gains cannot be increased due to mechanical system resonance or the like and the desired response cannot be achieved, response may be increased by suppressing resonance with filter tuning mode or machine resonance suppression filter and then executing steps 2 and 3.	Suppression of machine resonance. Refer to section 7.2, 7.3.
9	While checking the settling characteristic and rotational status, fine-adjust each gain.	Fine adjustment

## 6. GENERAL GAIN ADJUSTMENT

### (c) Adjustment description

#### 1) Speed loop gain (parameter No.PB09)

This parameter determines the response level of the speed control loop. Increasing this value enhances response but a too high value will make the mechanical system liable to vibrate. The actual response frequency of the speed loop is as indicated in the following expression.

$$\text{Speed loop response frequency(Hz)} = \frac{\text{Speed loop gain setting}}{(1 + \text{ratio of load inertia moment to servo motor inertia moment}) \times 2\pi}$$

#### 2) Speed integral compensation (VIC: parameter No.PB10)

To eliminate stationary deviation against a command, the speed control loop is under proportional integral control. For the speed integral compensation, set the time constant of this integral control. Increasing the setting lowers the response level. However, if the load inertia moment ratio is large or the mechanical system has any vibratory element, the mechanical system is liable to vibrate unless the setting is increased to some degree. The guideline is as indicated in the following expression.

$$\text{Speed integral compensation setting(ms)} \geq \frac{2000 \text{ to } 3000}{\text{Speed loop gain setting} / (1 + \text{ratio of load inertia moment to servo motor inertia moment setting})}$$

#### 3) Model loop gain (PG1: Parameter No.PB07)

This parameter determines the response level to a position command. Increasing the model loop gain improves track ability to a position command, but a too high value will make overshooting liable to occur at the time of setting.

$$\text{Model loop gain guideline} \leq \frac{\text{Speed loop gain setting}}{(1 + \text{ratio of load inertia moment to servo motor inertia moment})} \times \left( \frac{1}{4} \text{ to } \frac{1}{8} \right)$$

## 6. GENERAL GAIN ADJUSTMENT

(2) For position control

(a) Parameters

The following parameters are used for gain adjustment.

Parameter No.	Abbreviation	Name
PB06	GD2	Ratio of load inertia moment to servo motor inertia moment
PB07	PG1	Model loop gain
PB08	PG2	Position loop gain
PB09	VG2	Speed loop gain
PB10	VIC	Speed integral compensation

(b) Adjustment procedure

Step	Operation	Description
1	Brief-adjust with auto tuning. Refer to section 6.2.3.	
2	Change the setting of auto tuning to the manual mode (Parameter No.PA08: 0003).	
3	Set an estimated value to the ratio of load inertia moment to servo motor inertia moment. (If the estimate value with auto tuning is correct, setting change is not required.)	
4	Set a slightly smaller value to the model loop gain and the position loop gain. Set a slightly larger value to the speed integral compensation.	
5	Increase the speed loop gain within the vibration- and unusual noise-free range, and return slightly if vibration takes place.	Increase the speed loop gain.
6	Decrease the speed integral compensation within the vibration-free range, and return slightly if vibration takes place.	Decrease the time constant of the speed integral compensation.
7	Increase the position loop gain, and return slightly if vibration takes place.	Increase the position loop gain.
8	Increase the model loop gain, and return slightly if overshooting takes place.	Increase the position loop gain.
9	If the gains cannot be increased due to mechanical system resonance or the like and the desired response cannot be achieved, response may be increased by suppressing resonance with filter tuning mode or machine resonance suppression filter and then executing steps 3 to 5.	Suppression of machine resonance. Refer to section 7.2 • 7.3.
10	While checking the settling characteristic and rotational status, fine-adjust each gain.	Fine adjustment

## 6. GENERAL GAIN ADJUSTMENT

### (c) Adjustment description

#### 1) Speed loop gain (VG2: parameter No.PB09)

This parameter determines the response level of the speed control loop. Increasing this value enhances response but a too high value will make the mechanical system liable to vibrate. The actual response frequency of the speed loop is as indicated in the following expression.

$$\text{Speed loop response frequency(Hz)} = \frac{\text{Speed loop gain 2 setting}}{(1 + \text{ratio of load inertia moment to servo motor inertia moment}) \times 2\pi}$$

#### 2) Speed integral compensation (VIC: parameter No.PB10)

To eliminate stationary deviation against a command, the speed control loop is under proportional integral control. For the speed integral compensation, set the time constant of this integral control. Increasing the setting lowers the response level. However, if the load inertia moment ratio is large or the mechanical system has any vibratory element, the mechanical system is liable to vibrate unless the setting is increased to some degree. The guideline is as indicated in the following expression.

$$\text{Speed integral compensation setting(ms)} \geq \frac{2000 \text{ to } 3000}{\text{Speed loop gain 2 setting} / (1 + \text{ratio of load inertia moment to servo motor inertia moment 2 setting})}$$

#### 3) Model loop gain (PG1: Parameter No.PB07)

This parameter determines the response level to a position command. Increasing the model loop gain improves track ability to a position command, but a too high value will make overshooting liable to occur at the time of setting.

$$\text{Model loop gain guideline} \leq \frac{\text{Speed loop gain setting}}{(1 + \text{ratio of load inertia moment to servo motor inertia moment})} \times \left(\frac{1}{4} \text{ to } \frac{1}{8}\right)$$

#### 4) Model loop gain (PG1: parameter No.PB07)

This parameter determines the response level to a position command. Increasing position loop gain 1 improves track ability to a position command but a too high value will make overshooting liable to occur at the time of settling.

$$\text{Model loop gain guideline} \leq \frac{\text{Speed loop gain 2 setting}}{(1 + \text{ratio of load inertia moment to servo motor inertia moment})} \times \left(\frac{1}{4} \text{ to } \frac{1}{8}\right)$$

## 6. GENERAL GAIN ADJUSTMENT

### 6.4 Interpolation mode

The interpolation mode is used to match the position loop gains of the axes when performing the interpolation operation of servo motors of two or more axes for an X-Y table or the like. In this mode, manually set the model loop gain that determines command track ability. Other parameters for gain adjustment are set automatically.

#### (1) Parameter

##### (a) Automatically adjusted parameters

The following parameters are automatically adjusted by auto tuning.

Parameter No.	Abbreviation	Name
PB06	GD2	Ratio of load inertia moment to servo motor inertia moment
PB08	PG2	Position loop gain
PB09	VG2	Speed loop gain
PB10	VIC	Speed integral compensation

##### (b) Manually adjusted parameters

The following parameters are adjustable manually.

Parameter No.	Abbreviation	Name
PB07	PG1	Model loop gain

#### (2) Adjustment procedure

Step	Operation	Description
1	Set to the auto tuning mode.	Select the auto tuning mode 1.
2	During operation, increase the response level setting (parameter No.PA09), and return the setting if vibration occurs.	Adjustment in auto tuning mode 1.
3	Check the values of model loop gain.	Check the upper setting limits.
4	Set the interpolation mode (parameter No.PA08: 0000).	Select the interpolation mode.
5	Set the model loop gain of all the axes to be interpolated to the same value. At that time, adjust to the setting value of the axis, which has the smallest model loop gain.	Set position loop gain.
6	Looking at the interpolation characteristic and rotation status, fine-adjust the gains and response level setting.	Fine adjustment.

#### (3) Adjustment description

##### (a) Model loop gain (parameter No.PB07)

This parameter determines the response level of the position control loop. Increasing model loop gain improves track ability to a position command but a too high value will make overshooting liable to occur at the time of settling. The droop pulse value is determined by the following expression.

$$\text{Droop pulse value (pulse)} = \frac{\frac{\text{Rotation speed (r/min)}}{60} \times 262144(\text{pulse})}{\text{Model loop gain setting}}$$

## 6. GENERAL GAIN ADJUSTMENT

### 6.5 Differences between MELSERVO-J2-Super and MELSERVO-J3 in auto tuning

To meet higher response demands, the MELSERVO-J3 series has been changed in response level setting range from the MELSERVO-J2S-Super series. The following table lists comparison of the response level setting.

MELSERVO-J2-Super		MELSERVO-J3	
Parameter No.9 setting	Guideline for machine resonance frequency [Hz]	Parameter No.PA09 setting	Guideline for machine resonance frequency [Hz]
		1	10.0
		2	11.3
		3	12.7
1	15	4	14.3
		5	16.1
		6	18.1
		7	20.4
2	20	8	23.0
		9	25.9
		10	29.2
		11	32.9
3	25	12	37.0
		13	41.7
		14	47.0
		15	52.9
4	30	16	59.6
		17	67.1
		18	75.6
		19	85.2
5	35	20	95.9
		21	108.0
		22	121.7
		23	137.1
6	45	24	154.4
		25	173.9
		26	195.9
		27	220.6
7	55	28	248.5
		29	279.9
		30	315.3
		31	355.1
8	70	32	400.0
9	85		
A	105		
B	130		
C	160		
D	200		
E	240		
F	300		

Note that because of a slight difference in gain adjustment pattern, response may not be the same if the resonance frequency is set to the same value.

## 7. SPECIAL ADJUSTMENT FUNCTIONS

### 7. SPECIAL ADJUSTMENT FUNCTIONS

**POINT**

- The functions given in this chapter need not be used generally. Use them if you are not satisfied with the machine status after making adjustment in the methods in chapter 7.

If a mechanical system has a natural resonance point, increasing the servo system response level may cause the mechanical system to produce resonance (vibration or unusual noise) at that resonance frequency. Using the machine resonance suppression filter and adaptive tuning can suppress the resonance of the mechanical system.

#### 7.1 Function block diagram

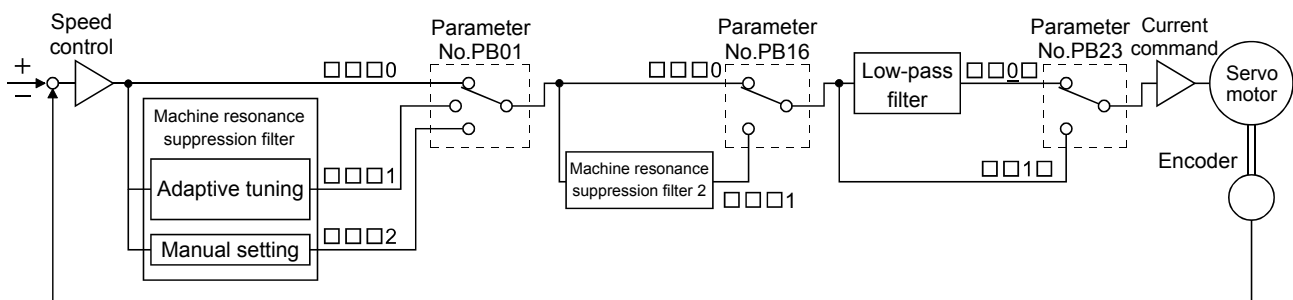

#### 7.2 Adaptive filter II

##### (1) Function

Adaptive filter II (adaptive tuning) is a function in which the servo amplifier detects machine vibration for a predetermined period of time and sets the filter characteristics automatically to suppress mechanical system vibration. Since the filter characteristics (frequency, depth) are set automatically, you need not be conscious of the resonance frequency of a mechanical system.

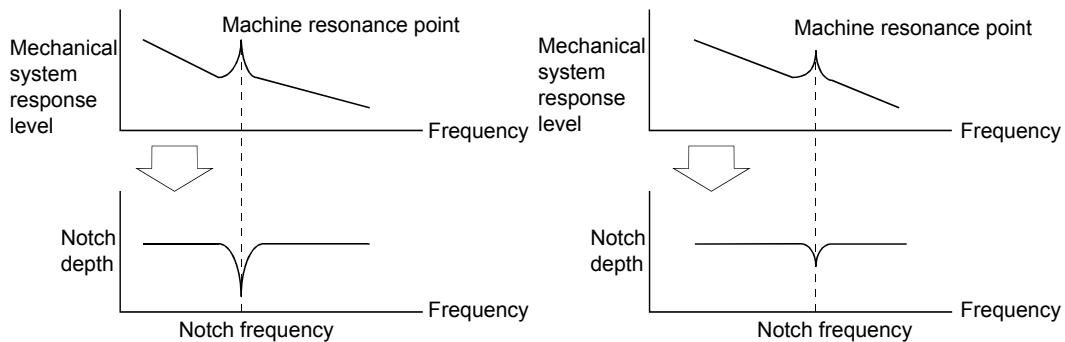

When machine resonance is large and frequency is low    When machine resonance is small and frequency is high

**POINT**

- The machine resonance frequency which adaptive tuning mode can respond to is about 100 to 2.25kHz. Adaptive vibration suppression control has no effect on the resonance frequency outside this range.
- Adaptive vibration suppression control may provide no effect on a mechanical system which has complex resonance characteristics.

## 7. SPECIAL ADJUSTMENT FUNCTIONS

### (2) Parameters

The operation of adaptive tuning mode (parameter No.PB01).

Parameter No.PB01

0	0	0	
---	---	---	--

Filter tuning mode selection

Setting	Filter adjustment mode	Automatically set parameter
0	Filter OFF	(Note)
1	Filter tuning mode	Parameter No.PB13 Parameter No.PB14
2	Manual mode	

Note. Parameter No.PB19 and PB20 are fixed to the initial values.

## 7. SPECIAL ADJUSTMENT FUNCTIONS

### (3) Adaptive tuning mode procedure

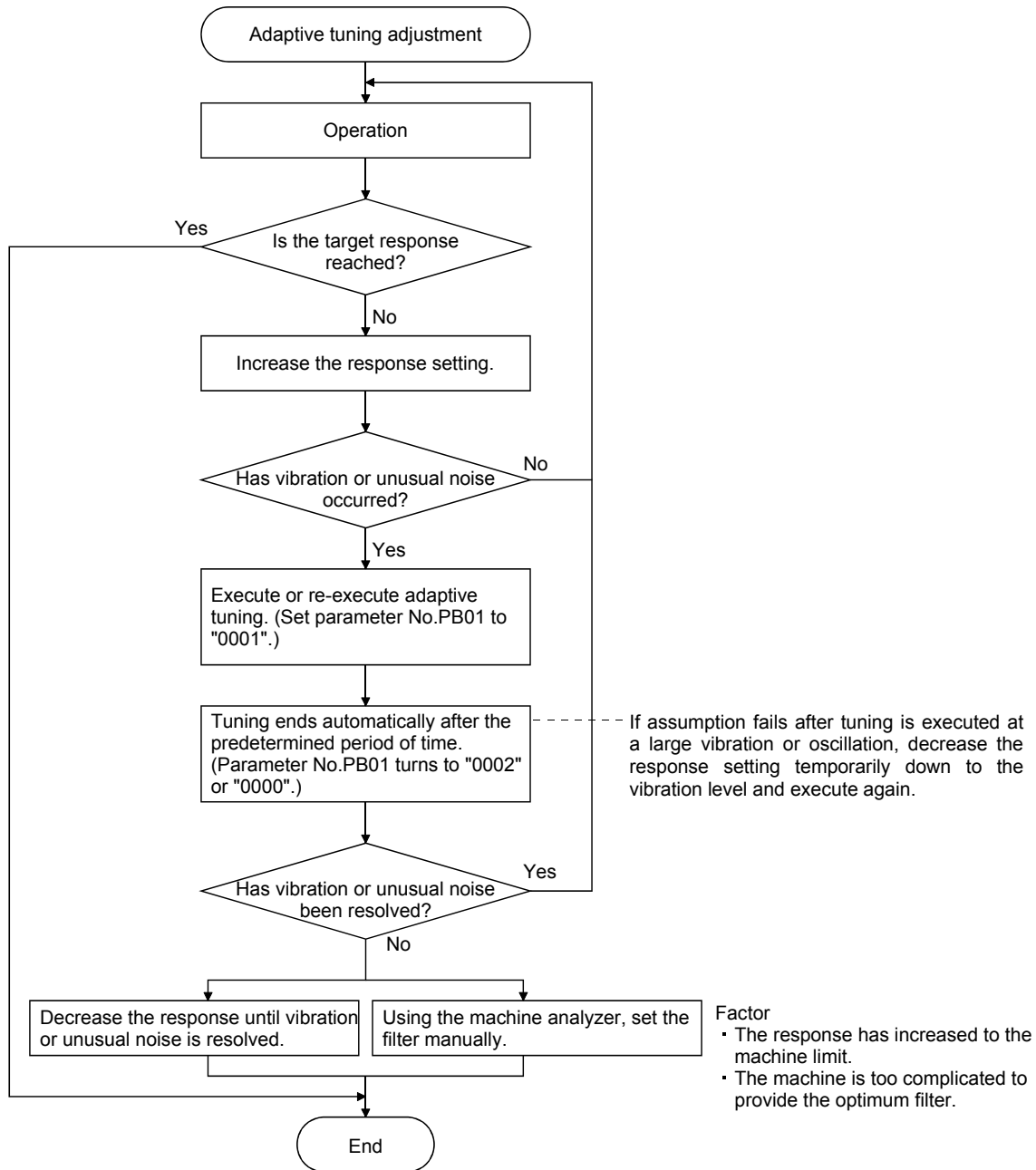

## 7. SPECIAL ADJUSTMENT FUNCTIONS

POINT
<ul style="list-style-type: none"> <li>▪ "Filter OFF" enables a return to the factory-set initial value.</li> <li>▪ When adaptive tuning is executed, vibration sound increases as an excitation signal is forcibly applied for several seconds.</li> <li>▪ When adaptive tuning is executed, machine resonance is detected for a maximum of 10 seconds and a filter is generated. After filter generation, the adaptive tuning mode automatically shifts to the manual mode.</li> <li>▪ Adaptive tuning generates the optimum filter with the currently set control gains. If vibration occurs when the response setting is increased, execute adaptive tuning again.</li> <li>▪ During adaptive tuning, a filter having the best notch depth at the set control gain is generated. To allow a filter margin against machine resonance, increase the notch depth in the manual mode.</li> </ul>

### 7.3 Machine resonance suppression filter

#### (1) Function

The machine resonance suppression filter is a filter function (notch filter) which decreases the gain of the specific frequency to suppress the resonance of the mechanical system. You can set the gain decreasing frequency (notch frequency), gain decreasing depth and width.

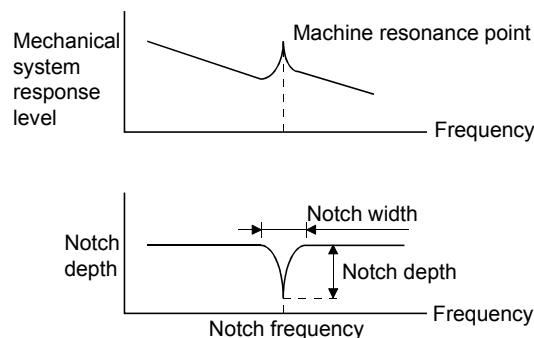

You can use the machine resonance suppression filter 1 (parameter No.PB13, PB14) and machine resonance suppression filter 2 (parameter No.PB15, PB16) to suppress the vibration of two resonance frequencies. Execution of adaptive tuning in the filter tuning mode automatically adjusts the machine resonance suppression filter. When adaptive tuning is ON, the adaptive tuning mode shifts to the manual mode after the predetermined period of time. The manual mode enables manual setting using the machine resonance suppression filter 1.

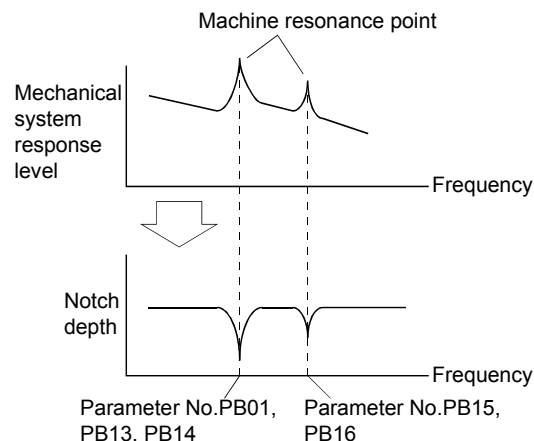

## 7. SPECIAL ADJUSTMENT FUNCTIONS

### (2) Parameters

#### (a) Machine resonance suppression filter 1 (parameter No.PB13, PB14)

Set the notch frequency, notch depth and notch width of the machine resonance suppression filter 1 (parameter No.PB13, PB14)

When you have made adaptive filter tuning mode (parameter No.PB01) "manual mode", set up the machine resonance suppression filter 1 becomes effective.

POINT
<ul style="list-style-type: none"><li>▪ The machine resonance suppression filter is a delay factor for the servo system. Hence, vibration may increase if you set a wrong resonance frequency or a too deep notch.</li><li>▪ If the frequency of machine resonance is unknown, decrease the notch frequency from higher to lower ones in order. The optimum notch frequency is set at the point where vibration is minimal.</li><li>▪ A deeper notch has a higher effect on machine resonance suppression but increases a phase delay and may increase vibration.</li><li>▪ A deeper notch has a higher effect on machine resonance suppression but increases a phase delay and may increase vibration.</li><li>▪ The machine characteristic can be grasped beforehand by the machine analyzer on the MR Configurator. This allows the required notch frequency and depth to be determined.</li></ul>

## 7. SPECIAL ADJUSTMENT FUNCTIONS

### 7.4 Advanced vibration suppression control

#### (1) Operation

Vibration suppression control is used to further suppress machine end vibration, such as workpiece end vibration and base shake. The motor side operation is adjusted for positioning so that the machine does not shake.

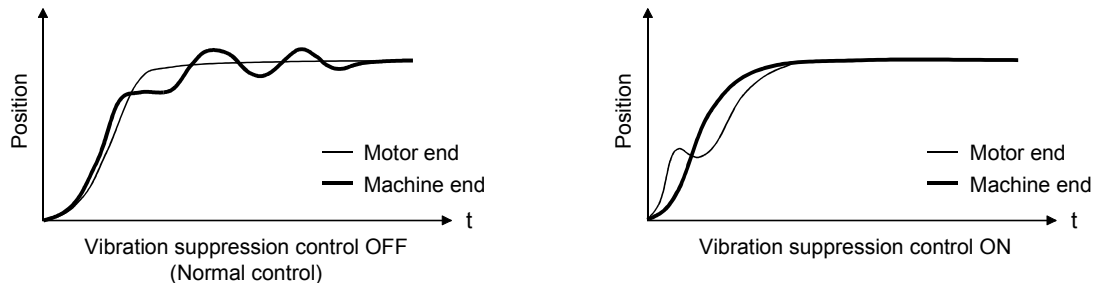

When the advanced vibration suppression control (vibration suppression control tuning mode parameter No.PB02) is executed, the vibration frequency at machine end can automatically be estimated to suppress machine end vibration.

In the vibration suppression control tuning mode, this mode shifts to the manual mode after operation is performed the predetermined number of times. The manual mode enables manual setting using the vibration suppression control vibration frequency setting (parameter No.PB19) and vibration suppression control resonance frequency setting (parameter No.PB20).

#### (2) Parameter

Select the operation of the vibration suppression control tuning mode (parameter No.PB02).

Parameter No.PB02

0	0	0	
---	---	---	--

Vibration suppression control tuning mode

Setting	Vibration suppression control tuning mode	Automatically set parameter
0	Vibration suppression control OFF	(Note)
1	Vibration suppression control tuning mode (Advanced vibration suppression control)	Parameter No.PB19 Parameter No.PB20
2	Manual mode	

Note. Parameter No.PB19 and PB20 are fixed to the initial values.

POINT
<ul style="list-style-type: none"> <li>The function is made valid when the auto tuning mode (parameter No.PA08) is the auto tuning mode 2 ("0002") or manual mode ("0003").</li> <li>The machine resonance frequency supported in the vibration suppression control tuning mode is 1.0Hz to 100.0Hz. The function is not effective for vibration outside this range.</li> <li>Stop the motor before changing the vibration suppression control-related parameters (parameter No.PB02, PB19, PB20, PB33, PB34). A failure to do so will cause a shock.</li> <li>For positioning operation during execution of vibration suppression control tuning, provide a stop time to ensure a stop after full vibration damping.</li> <li>Vibration suppression control tuning may not make normal estimation if the residual vibration at the motor end is small.</li> <li>Vibration suppression control tuning sets the optimum parameter with the currently set control gains. When the response setting is increased, set vibration suppression control tuning again.</li> </ul>

## 7. SPECIAL ADJUSTMENT FUNCTIONS

### (3) Vibration suppression control tuning mode procedure

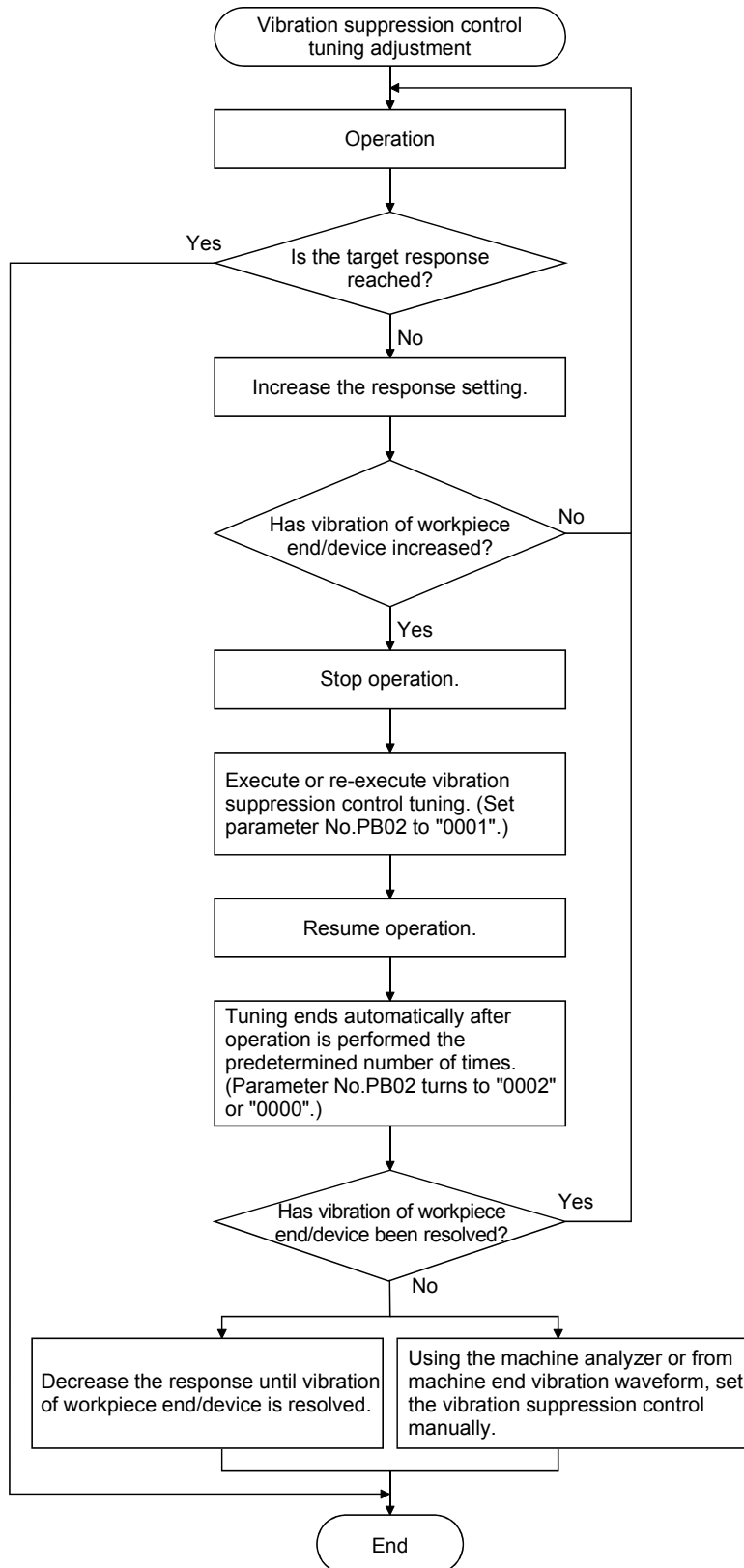

**Factor**

- Estimation cannot be made as machine end vibration has not been transmitted to the motor end.
- The response of the model loop gain has increased to the machine end vibration frequency (vibration suppression control limit).

## 7. SPECIAL ADJUSTMENT FUNCTIONS

### (4) Vibration suppression control manual mode

Measure work end vibration and device shake with the machine analyzer or external measuring instrument, and set the vibration suppression control vibration frequency (parameter No.PB19) and vibration suppression control resonance frequency (parameter No.PB20) to set vibration suppression control manually.

(a) When a vibration peak can be confirmed using MR Configurator, machine analyzer or external FFT equipment

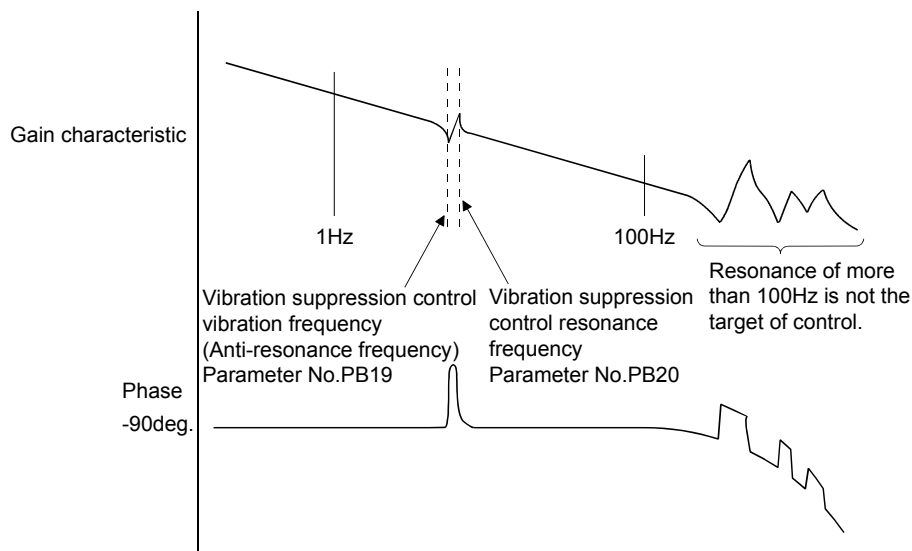

(b) When vibration can be confirmed using monitor signal or external sensor

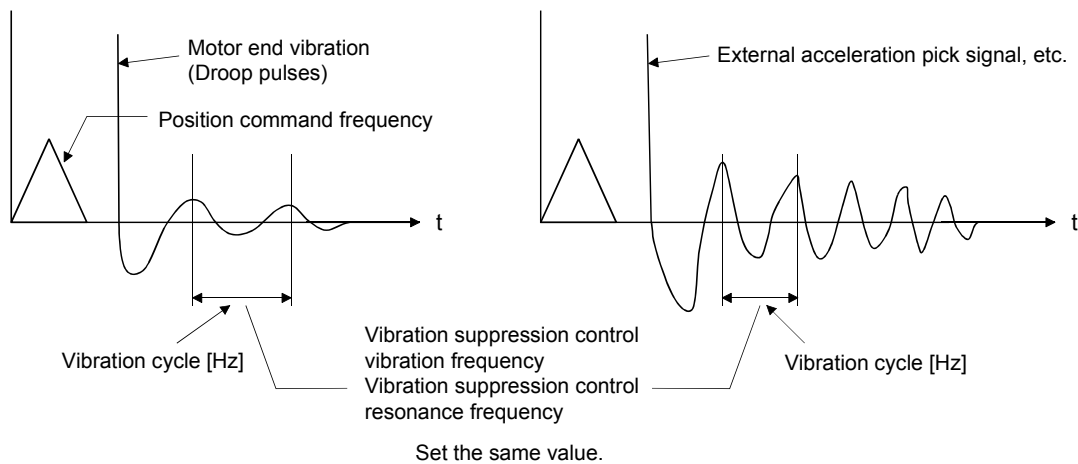

## 7. SPECIAL ADJUSTMENT FUNCTIONS

POINT
<ul style="list-style-type: none"><li>▪ When machine end vibration does not show up in motor end vibration, the setting of the motor end vibration frequency does not produce an effect.</li><li>▪ When the anti-resonance frequency and resonance frequency can be confirmed using the machine analyzer or external FFT device, do not set the same value but set different values to improve the vibration suppression performance.</li><li>▪ A vibration suppression control effect is not produced if the relationship between the model loop gain (parameter No.PB07) value and vibration frequency is as indicated below. Make setting after decreasing PG1, e.g. reduce the response setting.</li></ul> $\frac{1}{2\pi} (1.5 \times PG1) > \text{vibration frequency}$

## 7. SPECIAL ADJUSTMENT FUNCTIONS

### 7.5 Low-pass filter

#### (1) Function

When a ball screw or the like is used, resonance of high frequency may occur as the response level of the servo system is increased. To prevent this, the low-pass filter is factory-set to be valid for a torque command. The filter frequency of this low-pass filter is automatically adjusted to the value in the following expression.

$$\text{Filter frequency(rad/s)} = \frac{VG2}{1 + GD2} \times 10$$

When parameter No.PB23 is set to " □ □ 1 □ ", manual setting can be made with parameter No.PB18.

#### (2) Parameter

Set the operation of the low-pass filter selection (parameter No.PB23.)

Parameter No.PB23



Low-pass filter selection

0: Automatic setting (initial value)

1: Manual setting (parameter No.PB18 setting)

### 7.6 Gain changing function

This function can change the gains. You can change between gains during rotation and gains during stop or can use an input device to change gains during operation.

#### 7.6.1 Applications

This function is used when.

- (1) You want to increase the gains during servo lock but decrease the gains to reduce noise during rotation.
- (2) You want to increase the gains during settling to shorten the stop settling time.
- (3) You want to change the gains using an input device to ensure stability of the servo system since the load inertia moment ratio varies greatly during a stop (e.g. a large load is mounted on a carrier).

## 7. SPECIAL ADJUSTMENT FUNCTIONS

### 7.6.2 Function block diagram

The valid loop gains PG2, VG2, VIC and GD2 of the actual loop are changed according to the conditions selected by gain changing selection CDP (parameter No.PB26) and gain changing condition CDS (parameter No.PB27).

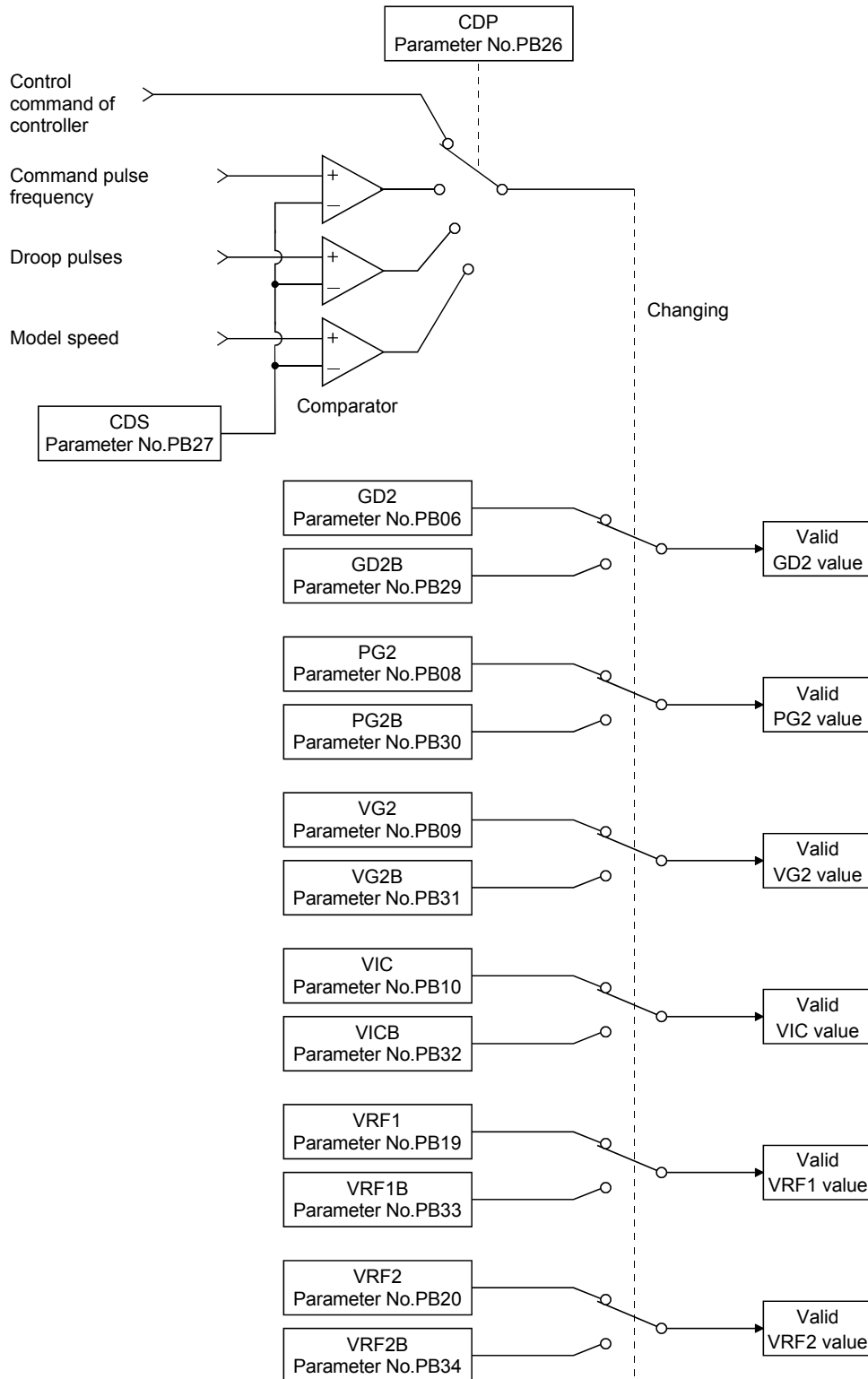

## 7. SPECIAL ADJUSTMENT FUNCTIONS

### 7.6.3 Parameters

When using the gain changing function, always set "□□□3" in parameter No.PA08 (auto tuning) to choose the manual mode of the gain adjustment modes. The gain changing function cannot be used in the auto tuning mode.

Parameter No.	Abbreviation	Name	Unit	Description
PB06	GD2	Ratio of load inertia moment to servo motor inertia moment	Multiplier (× 1)	Control parameters before changing
PB07	PG1	Model loop gain	rad/s	Position and speed gains of a model used to set the response level to a command. Always valid.
PB08	PG2	Position loop gain	rad/s	
PB09	VG2	Speed loop gain	rad/s	
PB10	VIC	Speed integral compensation	ms	
PB29	GD2B	Gain changing ratio of load inertia moment to servo motor inertia moment	Multiplier (× 1)	Used to set the ratio of load inertia moment to servo motor inertia moment after changing.
PB30	PG2B	Gain changing position loop gain 2	rad/s	Used to set the value of the after-changing position loop gain 2.
PB31	VG2B	Gain changing speed loop gain 2	rad/s	Used to set the value of the after-changing speed loop gain.
PB32	VICB	Gain changing speed integral compensation	ms	Used to set the value of the after-changing speed integral compensation.
PB26	CDP	Gain changing selection		Used to select the changing condition.
PB27	CDS	Gain changing condition	kpps pulse r/min	Used to set the changing condition values.
PB28	CDT	Gain changing time constant	ms	You can set the filter time constant for a gain change at changing.
PB33	VRF1B	Gain changing vibration suppression control vibration frequency setting	Hz	Used to set the value of the after-changing vibration suppression control vibration frequency setting.
PB34	VRF2B	Gain changing vibration suppression control resonance frequency setting	Hz	Used to set the value of the after-changing vibration suppression control resonance frequency setting.

## 7. SPECIAL ADJUSTMENT FUNCTIONS

### (1) Parameters No.PB06 to PB10

These parameters are the same as in ordinary manual adjustment. Gain changing allows the values of ratio of load inertia moment to servo motor inertia moment, position loop gain, speed loop gain and speed integral compensation to be changed.

### (2) Gain changing ratio of load inertia moment to servo motor inertia moment (GD2B: parameter No.PB29)

Set the ratio of load inertia moment to servo motor inertia moment after changing. If the load inertia moment ratio does not change, set it to the same value as ratio of load inertia moment to servo motor inertia moment (parameter No.PB06).

### (3) Gain changing position loop gain (parameter No.PB30), Gain changing speed loop gain (parameter No.PB31), Gain changing speed integral compensation (parameter No.PB32)

Set the values of after-changing position loop gain, speed loop gain and speed integral compensation.

### (4) Gain changing selection (parameter No.PB26)

Used to set the gain changing condition. Choose the changing condition in the first digit and second digit. If you set "1" in the first digit here, you can use the control command from controller is valid for gain changing.

0	0		
---	---	--	--

Gain changing selection

Under any of the following conditions, the gains change on the basis of the parameter No.PB29 to PB32 settings.

0: Invalid

1: Control command from controller is valid

2: Command frequency (Parameter No.PB27 setting)

3: Droop pulse value (Parameter No.PB27 setting)

4: Servo motor speed (Parameter No.PB27 setting)

Gain changing condition

0: Valid at more than condition (Valid with ON for control command from controller.)

1: Valid at less than condition (Valid with OFF for control command from controller.)

### (5) Gain changing condition (parameter No.PB27)

When you selected "command frequency", "droop pulses" or "servo motor speed" in gain changing selection (parameter No.PB26), set the gain changing level.

The setting unit is as follows.

Gain changing condition	Unit
Command frequency	kpps
Droop pulses	pulse
Servo motor speed	r/min

### (6) Gain changing time constant (parameter No.PB28)

You can set the primary delay filter to each gain at gain changing. This parameter is used to suppress shock given to the machine if the gain difference is large at gain changing, for example.

## 7. SPECIAL ADJUSTMENT FUNCTIONS

### 7.6.4 Gain changing operation

This operation will be described by way of setting examples.

(1) When you choose changing by input device

(a) Setting

Parameter No.	Abbreviation	Name	Setting	Unit
PB07	PG1	Model loop gain	100	rad/s
PB06	GD2	Ratio of load inertia moment to servo motor inertia moment	4.0	Multiplier (× 1)
PB08	PG2	Position loop gain	120	rad/s
PB09	VG2	Speed loop gain	3000	rad/s
PB10	VIC	Speed integral compensation	20	Ms
PB29	GD2B	Gain changing ratio of load inertia moment to servo motor inertia moment	10.0	Multiplier (× 1)
PB30	PG2B	Gain changing position loop gain	84	rad/s
PB31	VG2B	Gain changing speed loop gain	4000	rad/s
PB32	VICB	Gain changing speed integral compensation	50	ms
PB26	CDP	Gain changing selection	0001 (Changed by ON/OFF of input device)	
PB28	CDT	Gain changing time constant	100	ms
PB33	VRF1B	Gain changing vibration suppression control vibration frequency setting	Used to set the value of the after-changing vibration suppression control vibration frequency setting.	Hz
PB34	VRF2B	Gain changing vibration suppression control resonance frequency setting	Used to set the value of the after-changing vibration suppression control resonance frequency setting.	Hz

(b) Changing operation

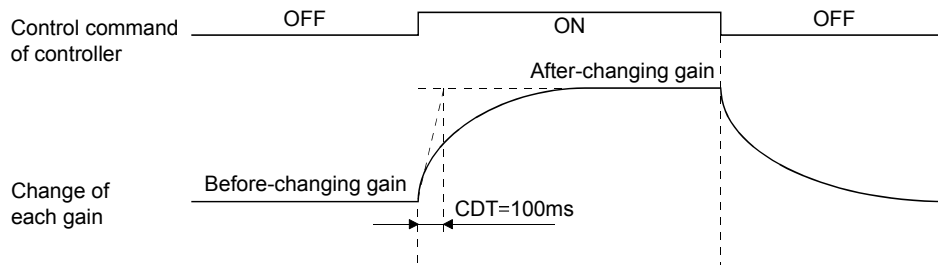

Model loop gain 1			100		
Ratio of load inertia moment to servo motor inertia moment	4.0	→	10.0	→	4.0
Position loop gain	120	→	84	→	120
Speed loop gain	3000	→	4000	→	3000
Speed integral compensation	20	→	50	→	20

## 7. SPECIAL ADJUSTMENT FUNCTIONS

(2) When you choose changing by droop pulses

(a) Setting

Parameter No.	Abbreviation	Name	Setting	Unit
PB07	PG1	Model loop gain	100	rad/s
PB06	GD2	Ratio of load inertia moment to servo motor inertia moment	4.0	Multiplier (× 1)
PB08	PG2	Position loop gain	120	rad/s
PB09	VG2	Speed loop gain	3000	rad/s
PB10	VIC	Speed integral compensation	20	ms
PB29	GD2B	Gain changing ratio of load inertia moment to servo motor inertia moment	10.0	Multiplier (× 1)
PB30	PG2B	Gain changing position loop gain	84	rad/s
PB31	VG2B	Gain changing speed loop gain	4000	rad/s
PB32	VICB	Gain changing speed integral compensation	50	ms
PB26	CDP	Gain changing selection	0003 (Changed by droop pulses)	
PB27	CDS	Gain changing condition	50	pulse
PB28	CDT	Gain changing time constant	100	ms

(b) Changing operation

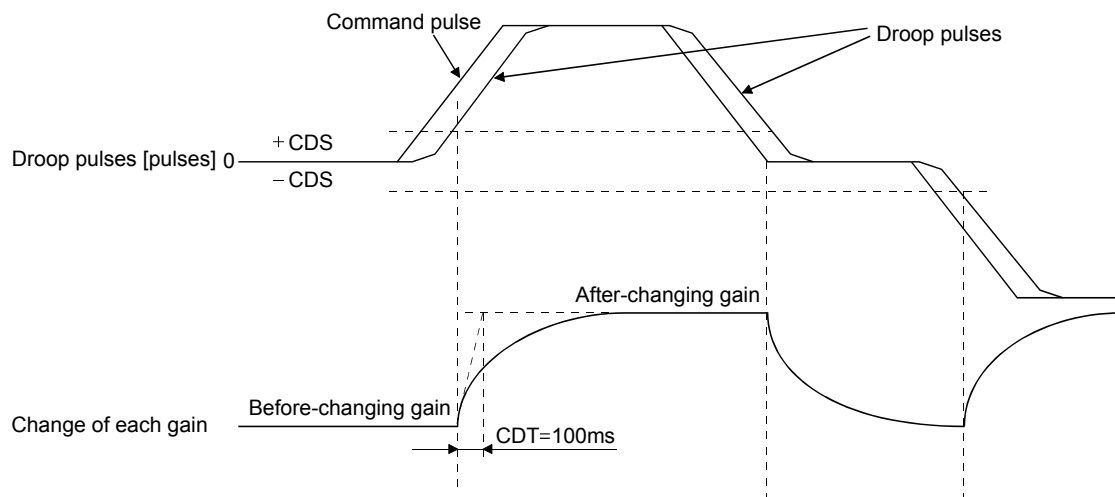

Model loop gain	100						
Ratio of load inertia moment to servo motor inertia moment	4.0	→	10.0	→	4.0	→	10.0
Position loop gain	120	→	84	→	120	→	84
Speed loop gain	3000	→	4000	→	3000	→	4000
Speed integral compensation	20	→	50	→	20	→	50



## 8. TROUBLESHOOTING

### 8. TROUBLESHOOTING

POINT
<ul style="list-style-type: none"> <li>As soon as an alarm occurs, make the Servo off status and interrupt the main circuit power.</li> </ul>

If an alarm/warning has occurred, refer to this chapter and remove its cause.

#### 8.1 Alarms and warning list

When a fault occurs during operation, the corresponding alarm or warning is displayed. If any alarm or warning has occurred, refer to section 8.2 or 8.3 and take the appropriate action. When an alarm occurs, the ALM turns OFF.

After its cause has been removed, the alarm can be deactivated in any of the methods marked ○ in the alarm deactivation column. The alarm is automatically canceled after removing the cause of occurrence.

	Display	Name	Alarm deactivation		
			Power OFF→ON	Error reset	CPU reset
Alarms	10	Undervoltage	○	○	○
	12	Memory error 1 (RAM)	○		
	13	Clock error	○		
	15	Memory error 2 (EEP-ROM)	○		
	16	Encoder error 1 (At power on)	○		
	17	Board error	○		
	19	Memory error 3 (Flash-ROM)	○		
	1A	Motor combination error	○		
	20	Encoder error 2	○		
	24	Main circuit error	○	○	○
	25	Absolute position erase	○		
	30	Regenerative error	(Note 1) ○	(Note 1) ○	(Note 1) ○
	31	Overspeed	○	○	○
	32	Overcurrent	○		
	33	Overvoltage	○	○	○
	34	Receive error 1	○	(Note 2) ○	○
	35	Command frequency error	○	○	○
	36	Receive error 2	○	○	○
	37	Parameter error	○		
	45	Main circuit device overheat	(Note 1) ○	(Note 1) ○	(Note 1) ○
	46	Servo motor overheat	(Note 1) ○	(Note 1) ○	(Note 1) ○
	47	Cooling fan error	○		
	50	Overload 1	(Note 1) ○	(Note 1) ○	(Note 1) ○
	51	Overload 2	(Note 1) ○	(Note 1) ○	(Note 1) ○
	52	Error excessive	○	○	○
	8A	USB communication time-out error	○	○	○
	8E	USB communication error	○	○	○
	888	Watchdog	○		

	Display	Name
Warnings	92	Battery cable disconnection warning
	96	Home position setting warning
	9F	Battery warning
	E0	Excessive regeneration warning
	E1	Overload warning 1
	E3	Absolute position counter warning
	E4	Parameter warning
	E6	Servo forced stop warning
	E7	Controller forced stop warning
	E8	Cooling fan speed reduction warning
	E9	Main circuit off warning
	EC	Overload warning 2
ED	Output watt excess warning	

Note 1. Deactivate the alarm about 30 minutes of cooling time after removing the cause of occurrence.

2. In some controller communication status, the alarm factor may not be removed.

## 8. TROUBLESHOOTING

### 8.2 Remedies for alarms



- When any alarm has occurred, eliminate its cause, ensure safety, then reset the alarm, and restart operation. Otherwise, injury may occur.
- If an absolute position erase (25) occurred, always make home position setting again. Not doing so may cause unexpected operation.
- As soon as an alarm occurs, mark Servo-off and power off the main circuit and control circuit.

#### POINT

- When any of the following alarms has occurred, do not deactivate the alarm and resume operation repeatedly. To do so will cause the servo amplifier/servo motor to fail. Remove the cause of occurrence, and leave a cooling time of more than 30 minutes before resuming operation. To protect the main circuit elements, any of these servo alarms cannot be deactivated from the servo system controller until the specified time elapses after its occurrence. Judging the load changing condition until the alarm occurs, the servo amplifier calculates this specified time automatically.
- Regenerative error (30)
- Overload 1 (50)
- Overload 2 (51)
- The alarm can be deactivated by switching power off, then on or by the error reset command • CPU reset from the servo system controller. For details, refer to section 8.1.

When an alarm occurs, the trouble (ALM) switches off and the dynamic brake is operated to stop the servo motor. At this time, the display indicates the alarm No.

The servo motor comes to a stop. Remove the cause of the alarm in accordance with this section. Use the MR Configurator to refer to a factor of alarm occurrence.

Display	Name	Definition	Cause	Action
10	Undervoltage	Power supply voltage dropped. MR-J3-□B: 160VAC or less MR-J3-□B1: 83VAC or less MR-J3-□B4: 280VAC or less	1. Power supply voltage is low.	Check the power supply.
			2. There was an instantaneous control power failure of 60ms or longer.	
			3. Shortage of power supply capacity caused the power supply voltage to drop at start, etc.	
			4. The bus voltage dropped to the following value or less. MR-J3-□B: 200VDC MR-J3-□B1: 158VDC MR-J3-□B4: 380VDC	
			5. Faulty parts in the servo amplifier	Change the servo amplifier.
			Checking method Alarm (10) occurs if power is switched on after disconnection of all cables but the control circuit power supply cables.	

## 8. TROUBLESHOOTING

Display	Name	Definition	Cause	Action
12	Memory error 1 (RAM)	RAM, memory fault	Faulty parts in the servo amplifier	Change the servo amplifier.
13	Clock error	Printed board fault	<p>Checking method</p> <p>Alarm (any of 12 and 13) occurs if power is switched on after disconnection of all cables but the control circuit power supply cables.</p>	
		Clock error transmitted from the controller	<p>Faulty controller</p> <p>Checking method</p> <p>Alarm (13) occurs, if servo controller is used in multiple CPU system.</p>	Change the servo system controller.
15	Memory error 2 (EEP-ROM)	EEP-ROM fault	<p>1. Faulty parts in the servo amplifier</p> <p>Checking method</p> <p>Alarm (15) occurs if power is switched on after disconnection of all cables but the control circuit power supply cables.</p> <p>2. The number of write times to EEPROM exceeded 100,000.</p>	Change the servo amplifier.
16	Encoder error 1 (At power on)	Communication error occurred between encoder and servo amplifier.	<p>1. Encoder connector (CN2) disconnected.</p> <p>2. Encoder fault</p> <p>3. Encoder cable faulty (Wire breakage or shorted)</p> <p>4. Encoder cable type (2-wire, 4-wire) selection was wrong in parameter setting.</p>	<p>Connect correctly.</p> <p>Change the servo motor.</p> <p>Repair or change the cable.</p> <p>Correct the setting in the fourth digit of parameter No.PC04.</p>
17	Board error 2	CPU/parts fault	Faulty parts in the servo amplifier	Change the servo amplifier.
19	Memory error 3 (Flash ROM)	ROM memory fault	<p>Checking method</p> <p>Alarm (17 or 19) occurs if power is switched on after disconnection of all cables but the control circuit power supply cable.</p>	
1A	Motor combination error	Wrong combination of servo amplifier and servo motor.	Wrong combination of servo amplifier and servo motor connected.	Use correct combination.
20	Encoder error 2	Communication error occurred between encoder and servo amplifier.	<p>1. Encoder connector (CN2) disconnected.</p> <p>2. Encoder cable faulty (Wire breakage or shorted)</p> <p>3. Encoder fault</p>	<p>Connect correctly.</p> <p>Repair or change the cable.</p> <p>Change the servo motor.</p>
24	Main circuit error	Ground fault occurred at the servo motor power (U,V and W phases) of the servo amplifier.	<p>1. Power input wires and servo motor power wires are in contact.</p> <p>2. Sheathes of servo motor power cables deteriorated, resulting in ground fault.</p> <p>3. Main circuit of servo amplifier failed.</p> <p>Checking method</p> <p>Alarm (24) occurs if the servo is switched on after disconnecting the U, V, W power cables from the servo amplifier.</p>	<p>Connect correctly.</p> <p>Change the cable.</p> <p>Change the servo amplifier.</p>
25	Absolute position erase	Absolute position data in error	<p>1. Voltage drop in encoder (Battery disconnected.)</p> <p>2. Battery voltage low</p> <p>3. Battery cable or battery is faulty.</p> <p>4. Home position not set.</p>	<p>After leaving the alarm occurring for a few minutes, switch power off, then on again. Always make home position setting again.</p> <p>Change the battery.</p> <p>Always make home position setting again.</p> <p>After leaving the alarm occurring for a few minutes, switch power off, then on again. Always make home position setting again.</p>
		Power was switched on for the first time in the absolute position detection system.		After leaving the alarm occurring for a few minutes, switch power off, then on again. Always make home position setting again.

## 8. TROUBLESHOOTING

Display	Name	Definition	Cause	Action
30	Regenerative error	Permissible regenerative power of the built-in regenerative resistor or regenerative option is exceeded.	1. Wrong setting of parameter No. PA02	Set correctly.
			2. Built-in regenerative resistor or regenerative option is not connected.	Connect correctly.
			3. High-duty operation or continuous regenerative operation caused the permissible regenerative power of the regenerative option to be exceeded.	1. Reduce the frequency of positioning. 2. Use the regenerative option of larger capacity. 3. Reduce the load.
			Checking method Call the status display and check the regenerative load ratio.	
			4. Power supply voltage is abnormal. MR-J3-□B:260VAC or more MR-J3-□B1:More than 135VAC MR-J3-□B4: 535VAC or more	Check the power supply.
		5. Built-in regenerative resistor or regenerative option faulty.	Change the servo amplifier or regenerative option.	
		Regenerative transistor fault	6. Regenerative transistor faulty.	Change the servo amplifier.
Checking method 1) The regenerative option has overheated abnormally. 2) The alarm occurs even after removal of the built-in regenerative resistor or regenerative option.				
31	Overspeed	Speed has exceeded the instantaneous permissible speed.	1. Small acceleration/deceleration time constant caused overshoot to be large.	Increase acceleration/deceleration time constant.
			2. Servo system is instable to cause overshoot.	1. Re-set servo gain to proper value. 2. If servo gain cannot be set to proper value. 1) Reduce load inertia moment ratio; or 2) Reexamine acceleration/ deceleration time constant.
			3. Encoder faulty.	Change the servo motor.
32	Overcurrent	Current that flew is higher than the permissible current of the servo amplifier. (If the alarm (32) occurs again when turning ON the servo after resetting the alarm by turning OFF/ON the power when the alarm (32) first occurred, the transistor (IPM · IGBT) of the servo amplifier may be at fault. In the case, do not repeat to turn OFF/ON the power. Check the transistor with the checking method of "Cause 2".)	1. Short occurred in servo motor power (U, V, W).	Correct the wiring.
			2. Transistor (IPM · IGBT) of the servo amplifier faulty.	Change the servo amplifier.
			Checking method Alarm (32) occurs if power is switched on after U,V and W are disconnected.	
			3. Ground fault occurred in servo motor power (U, V, W).	Correct the wiring.
			4. External noise caused the overcurrent detection circuit to misoperate.	Take noise suppression measures.

## 8. TROUBLESHOOTING

Display	Name	Definition	Cause	Action
33	Overvoltage	The following shows the input value of converter bus voltage. MR-J3-□B(1): 400VDC or more MR-J3-□B4: 800VDC or more	1. Regenerative option is not used.	Use the regenerative option.
			2. Though the regenerative option is used, the parameter No.PA02 setting is "□□00 (not used)".	Set correctly.
			3. Lead of built-in regenerative resistor or regenerative option is open or disconnected.	1. Change the lead. 2. Connect correctly.
			4. Regenerative transistor faulty.	Change the servo amplifier.
			5. Wire breakage of built-in regenerative resistor or regenerative option	1. For wire breakage of built-in regenerative resistor, change the servo amplifier. 2. For wire breakage of regenerative option, change the regenerative option.
			6. Capacity of built-in regenerative resistor or regenerative option is insufficient.	Add regenerative option or increase capacity.
			7. Power supply voltage high.	Check the power supply.
			8. Ground fault occurred in servo motor power (U, V, W).	Correct the wiring.
			9. The jumper across BUE-SD of the FR-BU2 brake unit is removed.	Fit the jumper across BUE-SD.
34	Receive error 1	SSCNETIII communication error (Continuously communication error with about 3.5ms interval.)	1. The SSCNETIII cable is disconnected.	Connect it after turning off the control circuit power supply for servo amplifier.
			2. The surface at the end of SSCNETIII cable got dirty.	Wipe dirt at the surface away. (Refer to section 3.9)
			3. The SSCNETIII cable is broken or severed.	Change the cable.
			4. Noise entered the servo amplifier.	Take noise suppression measures.
			5. Optical characteristic of SSCNETIII cable deteriorated because vinyl tape and/or wire sheath, which contains migrating plasticizer, adhered to the cable.	Remove the vinyl tape and/or wire sheath, which contains migrating plasticizer, and exchange the cable.
35	Command frequency error	Input pulse frequency of command pulse is too high.	1. Command given is greater than the maximum speed of the servo motor.	Check operation program.
			2. Servo system controller failure.	Change the servo system controller.
			3. Noise entered the servo amplifier.	Take noise of I/O signal suppression measures.
			4. Noise entered the controller.	Take noise from the controller suppression measures.
36	Receive error 2	SSCNETIII communication error (Intermittently communication error with about 70ms interval.)	1. The SSCNETIII cable is disconnected.	Connect it after turning off the control circuit power supply for servo amplifier.
			2. The surface at the end of SSCNETIII cable got dirty.	Wipe dirt away from the surface. (Refer to section 3.9)
			3. The SSCNETIII cable is broken or severed.	Change the cable.
			4. Noise entered the servo amplifier.	Take noise suppression measures.
			5. Optical characteristic of SSCNETIII cable deteriorated because vinyl tape and/or wire sheath, which contains migrating plasticizer, adhered to the cable.	Remove the vinyl tape and/or wire sheath, which contains migrating plasticizer, and exchange the cable.

## 8. TROUBLESHOOTING

Display	Name	Definition	Cause	Action
37	Parameter error	Parameter setting is wrong.	1. Servo amplifier fault caused the parameter setting to be rewritten.	Change the servo amplifier.
			2. There is a parameter whose value was set to outside the setting range by the controller.	Change the parameter value to within the setting range.
			3. The number of write times to EEPROM exceeded 100,000 due to parameter write, etc.	Change the servo amplifier.
45	Main circuit device overheat	Main circuit device overheat	1. Servo amplifier faulty.	Change the servo amplifier.
			2. The power supply was turned on and off continuously by overloaded status.	The drive method is reviewed.
			3. Ambient temperature of servo motor is over 55°C.	Check environment so that ambient temperature is 0 to 55°C.
			4. Used beyond the specifications of close mounting.	Use within the range of specifications.
46	Servo motor overheat	Servo motor temperature rise actuated the thermal sensor.	1. Ambient temperature of servo motor is over 40°C.	Check environment so that ambient temperature is 0 to 40°C.
			2. Servo motor is overloaded.	1. Reduce load. 2. Check operation pattern. 3. Use servo motor that provides larger output.
			3. Thermal sensor in encoder is faulty.	Change the servo motor.
47	Cooling fan error	The cooling fan of the servo amplifier stopped, or its speed decreased to or below the alarm level.	1. Cooling fan life expiration (Refer to section 2.5.)	Change the cooling fan of the servo amplifier.
			2. Foreign matter caught in the cooling fan stopped rotation.	Remove the foreign matter.
			3. The power supply of the cooling fan failed.	Change the servo amplifier.
50	Overload 1	Load exceeded overload protection characteristic of servo amplifier.	1. Servo amplifier is used in excess of its continuous output current.	1. Reduce load. 2. Check operation pattern. 3. Use servo motor that provides larger output.
			2. Servo system is instable and hunting.	1. Repeat acceleration/ deceleration to execute auto tuning. 2. Change the auto tuning response setting. 3. Set auto tuning to OFF and make gain adjustment manually.
			3. Machine struck something.	1. Check operation pattern. 2. Install limit switches.
			4. Wrong connection of servo motor. Servo amplifier's output terminals U, V, W do not match servo motor's input terminals U, V, W.	Connect correctly.
			5. Encoder faulty.	Change the servo motor.
			<div style="border: 1px solid black; padding: 5px; width: fit-content;"> <p>Checking method</p> <p>When the servo motor shaft is rotated with the servo off, the cumulative feedback pulses do not vary in proportion to the rotary angle of the shaft but the indication skips or returns midway.</p> </div>	
6. After Overload 2 (51) occurred, turn OFF/ON the power supply to clear the alarm. Then the overload operation is repeated.	1. Reduce load. 2. Check operation pattern. 3. Use servo motor that provides larger output.			

## 8. TROUBLESHOOTING

Display	Name	Definition	Cause	Action
51	Overload 2	Machine collision or the like caused max. For the time of the alarm occurrence, refer to the section 10.1.	1. Machine struck something.	1. Check operation pattern. 2. Install limit switches.
			2. Wrong connection of servo motor. Servo amplifier's output terminals U, V, W do not match servo motor's input terminals U, V, W.	Connect correctly.
			3. Servo system is instable and hunting.	1. Repeat acceleration/deceleration to execute auto tuning. 2. Change the auto tuning response setting. 3. Set auto tuning to OFF and make gain adjustment manually.
			4. Encoder faulty.  <div style="border: 1px solid black; padding: 5px; width: fit-content;">           Checking method            When the servo motor shaft is rotated with the servo off, the cumulative feedback pulses do not vary in proportion to the rotary angle of the shaft but the indication skips or returns midway.         </div>	Change the servo motor.
52	Error excessive	The deviation between the model position and the actual servo motor position exceeds the parameter No.PC01 setting value (initial value: 3 revolutions).	1. Acceleration/deceleration time constant is too small.	Increase the acceleration/deceleration time constant.
			2. Torque limit value set with controller is too small.	Increase the torque limit value.
			3. Motor cannot be started due to torque shortage caused by power supply voltage drop.	1. Check the power supply capacity. 2. Use servo motor which provides larger output.
			4. Position loop gain 1 (parameter No.PB08) value is small.	Increase set value and adjust to ensure proper operation.
			5. Servo motor shaft was rotated by external force.	1. When torque is limited, increase the limit value. 2. Reduce load. 3. Use servo motor that provides larger output.
			6. Machine struck something.	1. Check operation pattern. 2. Install limit switches.
			7. Encoder faulty	Change the servo motor.
			8. Wrong connection of servo motor. Servo amplifier's output terminals U, V, W do not match servo motor's input terminals U, V, W.	Connect correctly.
			9. SSCNETIII cable fault	Change the SSCNETIII cable.
			10. Optical characteristic of SSCNETIII cable deteriorated because vinyl tape and/or wire sheath, which contains migrating plasticizer, adhered to the cable.	Remove the vinyl tape and/or wire sheath, which contains migrating plasticizer, and exchange the cable.
8A	USB communication time-out error	Communication with MR Configurator in test operation mode stopped for longer than the specified time.	1. USB cable breakage.	Change the USB cable.
8E	USB communication error	Serial communication error occurred between servo amplifier and communication device (e.g. personal computer).	1. USB cable fault (Open cable or short circuit)	Change the USB cable.
			2. Communication device (e.g. personal computer) faulty	Change the communication device (e.g. personal computer).

## 8. TROUBLESHOOTING

Display	Name	Definition	Cause	Action
(Note) 888	Watchdog	CPU, parts faulty	Fault of parts in servo amplifier  Checking method Alarm (888) occurs if power is switched on after disconnection of all cables but the control circuit power supply cable.	Change the servo amplifier.

Note. At power-on, "888" appears instantaneously, but it is not an error.

### 8.3 Remedies for warnings



▪ If an absolute position counter warning (E3) occurred, always make home position setting again. Not doing so may cause unexpected operation.

#### POINT

- When any of the following alarms has occurred, do not resume operation by switching power of the servo amplifier OFF/ON repeatedly. The servo amplifier and servo motor may become faulty. If the power of the servo amplifier is switched OFF/ON during the alarms, allow more than 30 minutes for cooling before resuming operation.
  - Excessive regenerative warning (E0)
  - Overload warning 1 (E1)

If E6, E7 or E9 occurs, the servo off status is established. If any other warning occurs, operation can be continued but an alarm may take place or proper operation may not be performed.

Remove the cause of warning according to this section. Use the MR Configurator to refer to a factor of warning occurrence.

Display	Name	Definition	Cause	Action
92	Battery cable disconnection warning	Absolute position detection system battery voltage is low.	1. Battery cable is open.	Repair cable or changed.
			2. Battery voltage supplied from the servo amplifier to the encoder fell to about 3V or less. (Detected with the encoder)	Change the battery.
96	Home position setting warning	Home position setting could not be made.	1. Droop pulses remaining are greater than the in-position range setting.	Remove the cause of droop pulse occurrence
			2. Command pulse entered after clearing of droop pulses.	Do not enter command pulse after clearing of droop pulses.
			3. Creep speed high.	Reduce creep speed.
9F	Battery warning	Voltage of battery for absolute position detection system reduced.	Battery voltage fell to 3.2V or less. (Detected with the servo amplifier)	Change the battery.
E0	Excessive regeneration warning	There is a possibility that regenerative power may exceed permissible regenerative power of built-in regenerative resistor or regenerative option.	Regenerative power increased to 85% or more of permissible regenerative power of built-in regenerative resistor or regenerative option.  Checking method Call the status display and check regenerative load ratio.	1. Reduce frequency of positioning. 2. Change the regenerative option for the one with larger capacity. 3. Reduce load.

## 8. TROUBLESHOOTING

Display	Name	Definition	Cause	Action
E1	Overload warning 1	There is a possibility that overload alarm 1 or 2 may occur.	Load increased to 85% or more of overload alarm 1 or 2 occurrence level. Cause, checking method Refer to 50,51.	Refer to 50, 51.
E3	Absolute position counter warning	Absolute position encoder pulses faulty.	1. Noise entered the encoder.	Take noise suppression measures.
			2. Encoder faulty.	Change the servo motor.
		The multi-revolution counter value of the absolute position encoder exceeded the maximum revolution range.	3. The movement amount from the home position exceeded a 32767 rotation or 37268 rotation in succession.	Make home position setting again.
E4	Parameter warning	Parameter outside setting range	Parameter value set from servo system controller is outside setting range	Set it correctly.
E6	Servo forced stop warning	EM1 is off.	External forced stop was made valid. (EM1 was turned off.)	Ensure safety and deactivate forced stop.
E7	Controller forced stop warning		Forced stop signal was entered into the servo system controller.	Ensure safety and deactivate forced stop.
E8	Cooling fan speed reduction warning	The speed of the servo amplifier decreased to or below the warning level. This warning is not displayed with MR-J3-70B/100B among servo amplifiers equipped with a cooling fan.	Cooling fan life expiration (Refer to section 2.5.)	Change the cooling fan of the servo amplifier.
			The power supply of the cooling fan is broken.	Change the servo amplifier.
E9	Main circuit off warning	Servo-on command was issued with main circuit power off.		Switch on main circuit power.
EC	Overload warning 2	Operation, in which a current exceeding the rating flew intensively in any of the U, V and W phases of the servo motor, was repeated.	During a stop, the status in which a current flew intensively in any of the U, V and W phases of the servo motor occurred repeatedly, exceeding the warning level.	1. Reduce the positioning frequency at the specific positioning address. 2. Reduce the load. 3. Replace the servo amplifier/ servo motor with the one of larger capacity.
ED	Output watt excess warning	The status, in which the output wattage (speed × torque) of the servo motor exceeded the rated output, continued steadily.	Continuous operation was performed with the output wattage (speed × torque) of the servo motor exceeding 150% of the rated output.	1. Reduce the servo motor speed. 2. Reduce the load.





## 9. OUTLINE DRAWINGS

### (2) MR-J3-40B • MR-J3-60B MR-J3-40B1

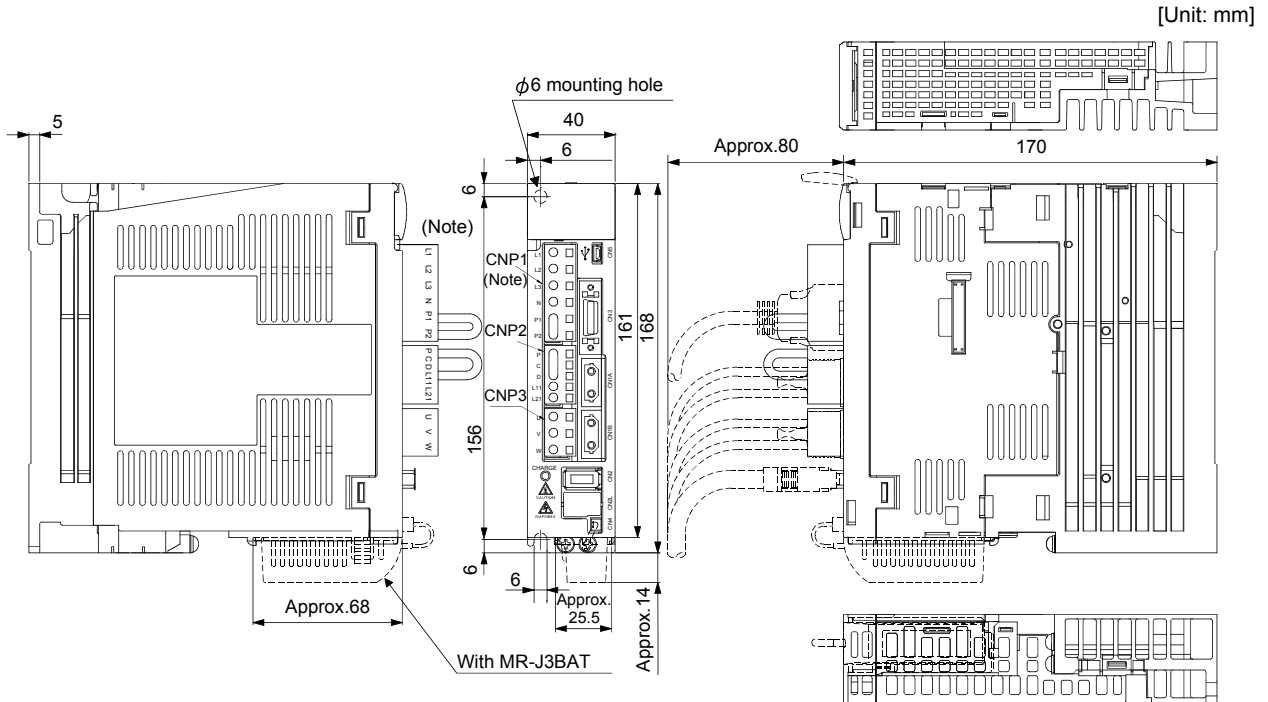

Note. This data applies to the 3-phase or 1-phase 200 to 230VAC power supply models.  
For a single-phase, 100 to 120VAC power supply, refer to the terminal signal layout.

Mass: 1.0 [kg] (2.21 [lb])

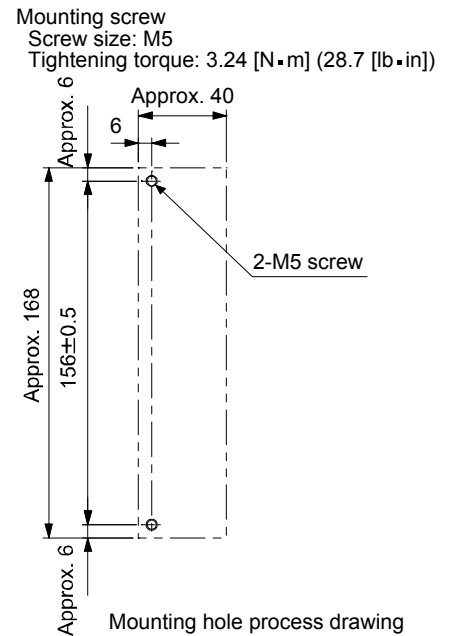
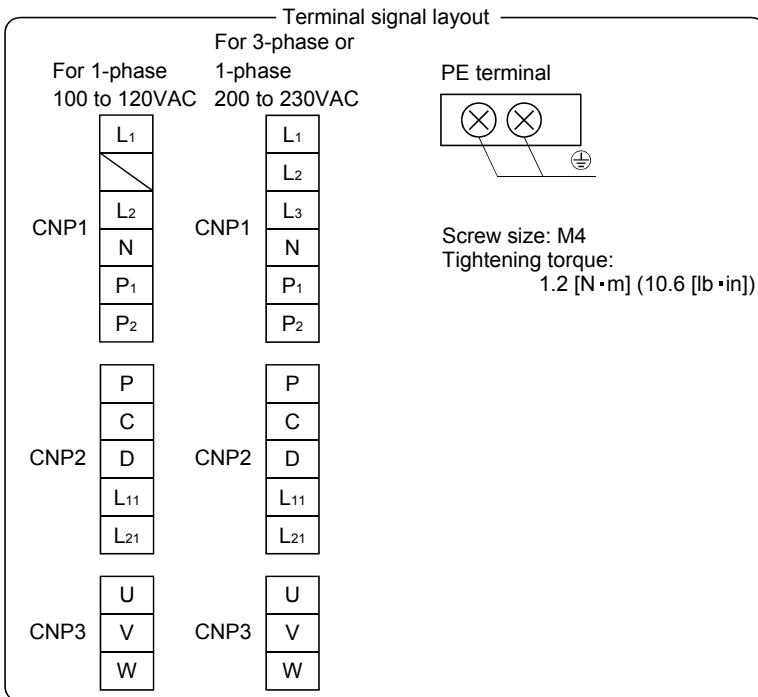

## 9. OUTLINE DRAWINGS

### (3) MR-J3-70B • MR-J3-100B

[Unit: mm]

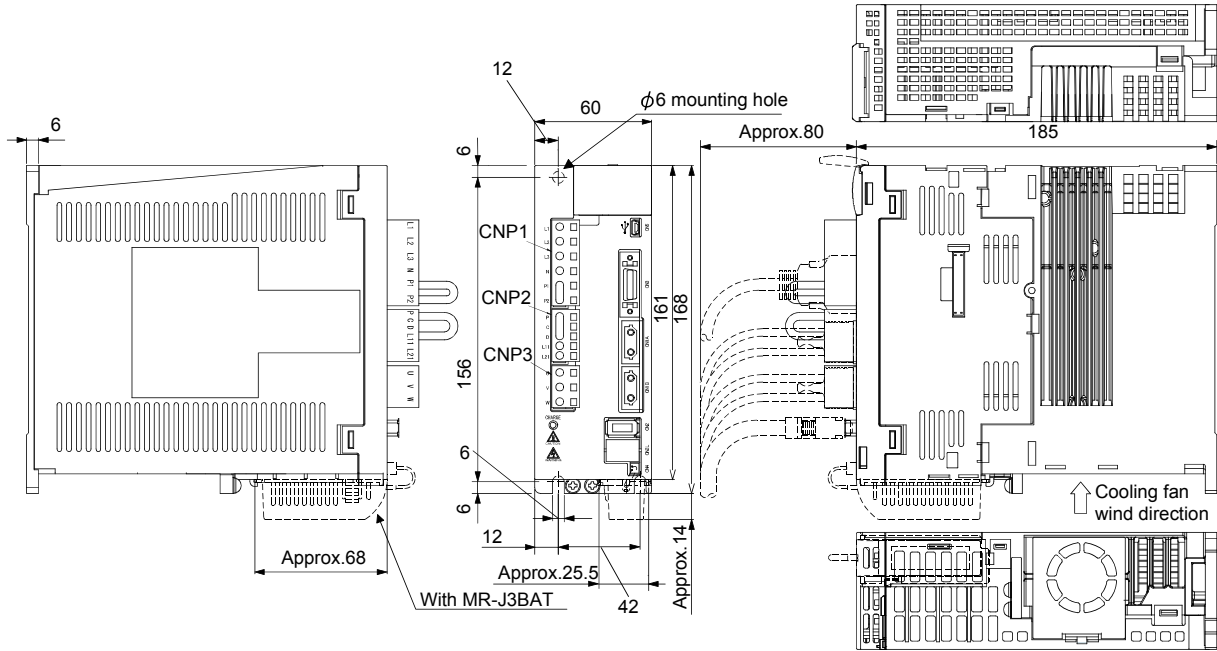

Mass: 1.4 [kg] (3.09 [lb])

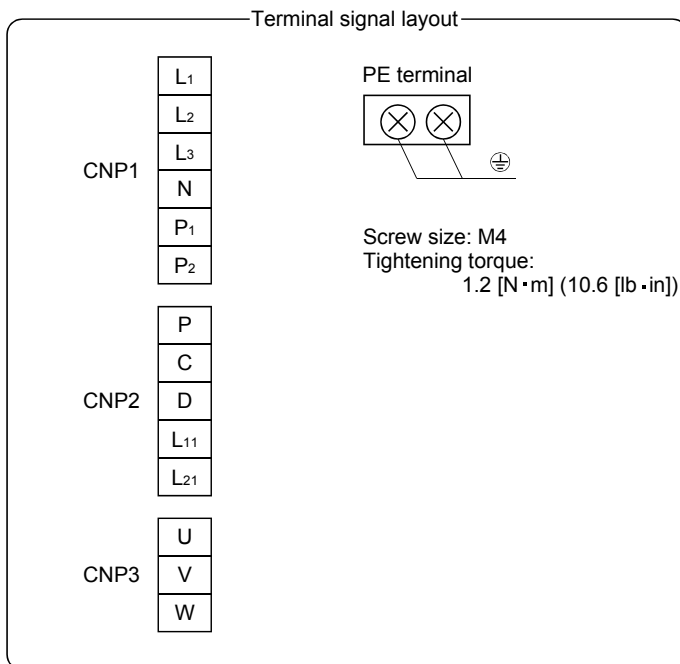

Mounting screw  
Screw size: M5  
Tightening torque: 3.24 [N·m] (28.7 [lb·in])

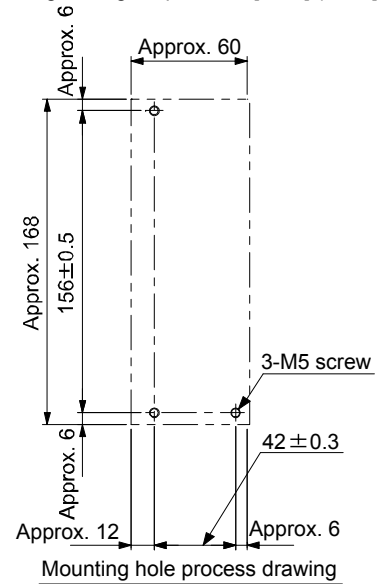

## 9. OUTLINE DRAWINGS

### (4) MR-J3-60B4 • MR-J3-100B4

[Unit: mm]

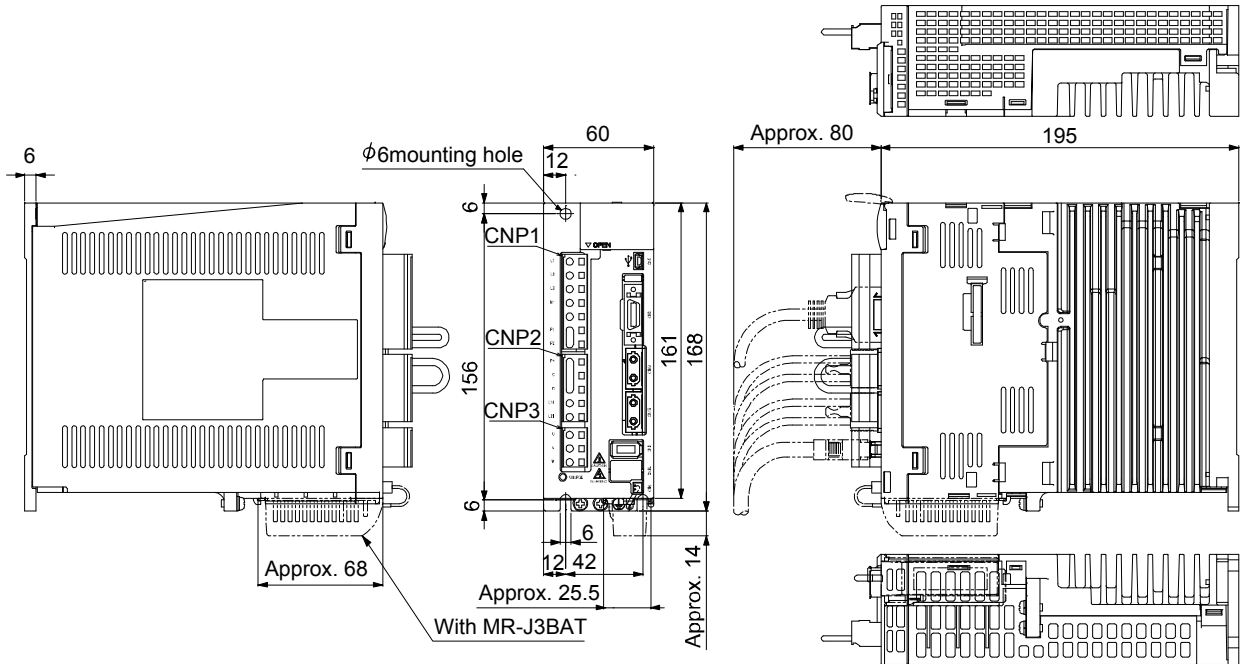

Mass: 1.7 [kg] (3.75 [lb])

Terminal signal layout

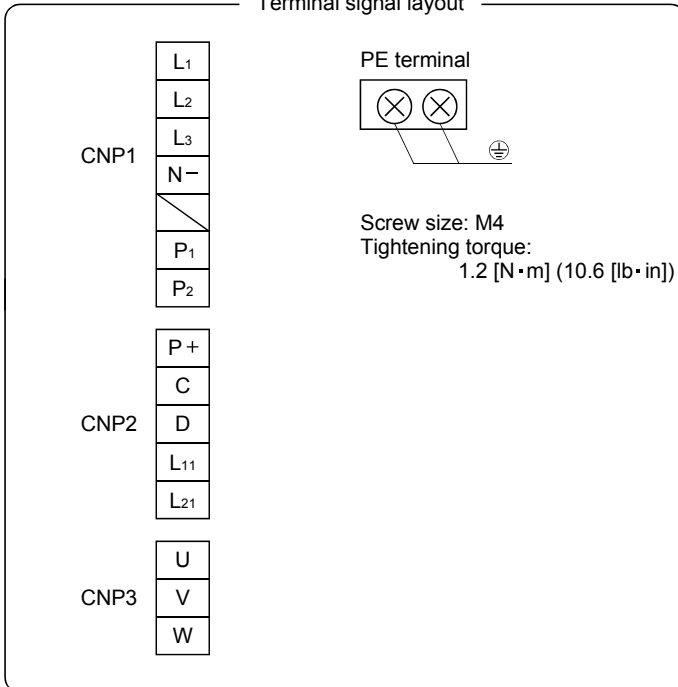

Mounting screw

Screw size: M5

Tightening torque: 3.24 [N·m] (28.7 [lb·in])

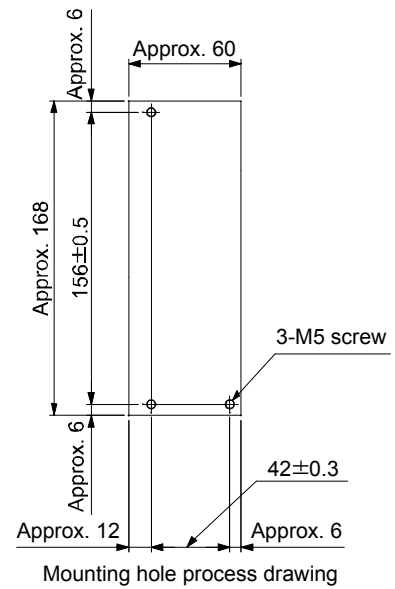

## 9. OUTLINE DRAWINGS

### (5) MR-J3-200B(4)

POINT
<ul style="list-style-type: none"> <li>Connectors (CNP1, CNP2, and CNP3) and appearance of MR-J3-200B servo amplifier have been changed from January 2008 production. Model name of the existing servo amplifier is changed to MR-J3-200B-RT. For MR-J3-200B-RT, refer to appendix 5.</li> </ul>

[Unit: mm]

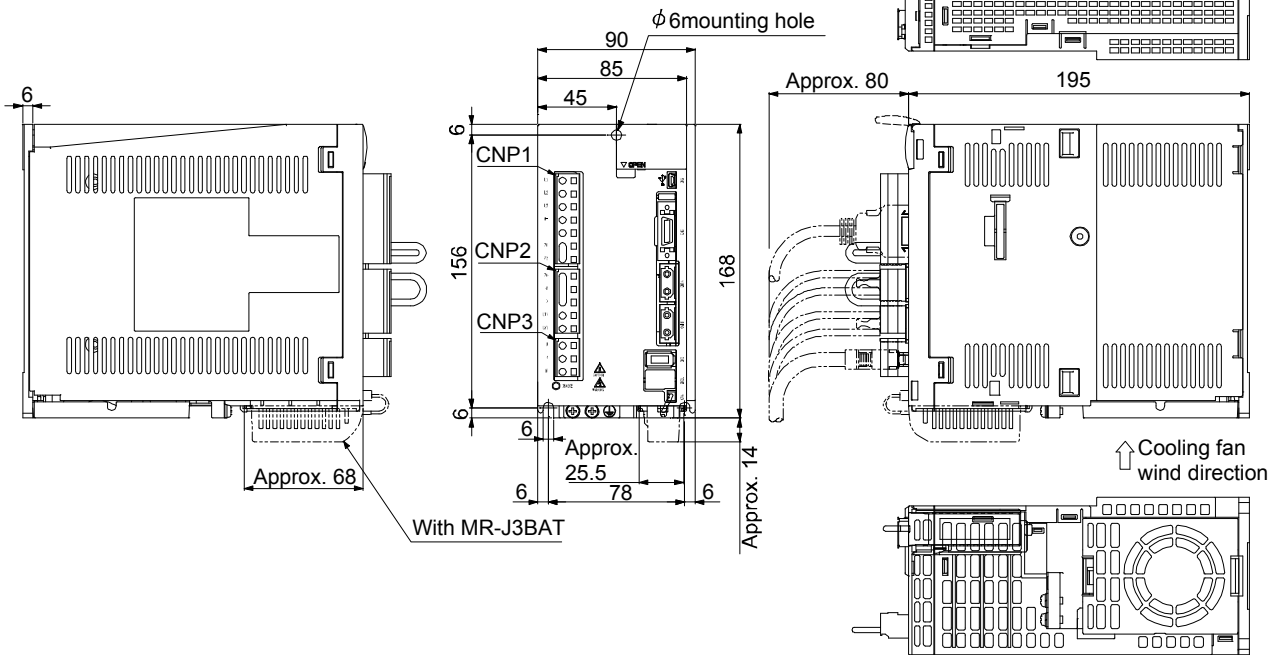

Mass: 2.1 [kg] (4.63 [lb])

Mounting screw

Screw size: M5

Tightening torque: 3.24 [N · m] (28.7 [lb · in])

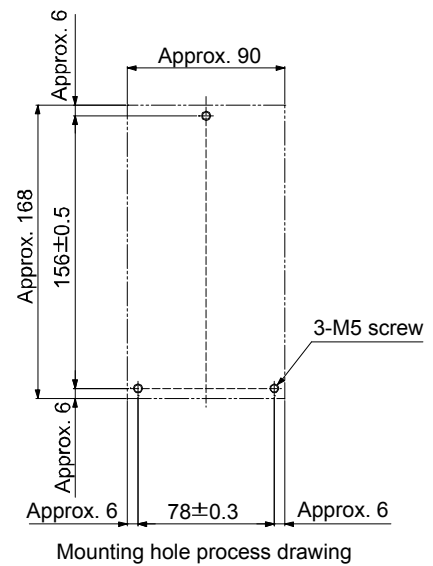
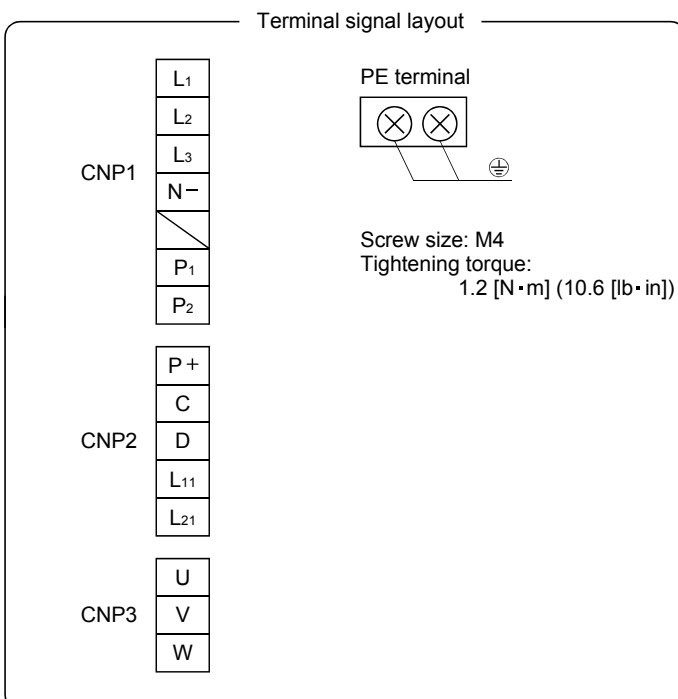

### 9. OUTLINE DRAWINGS

#### (6) MR-J3-350B

[Unit: mm]

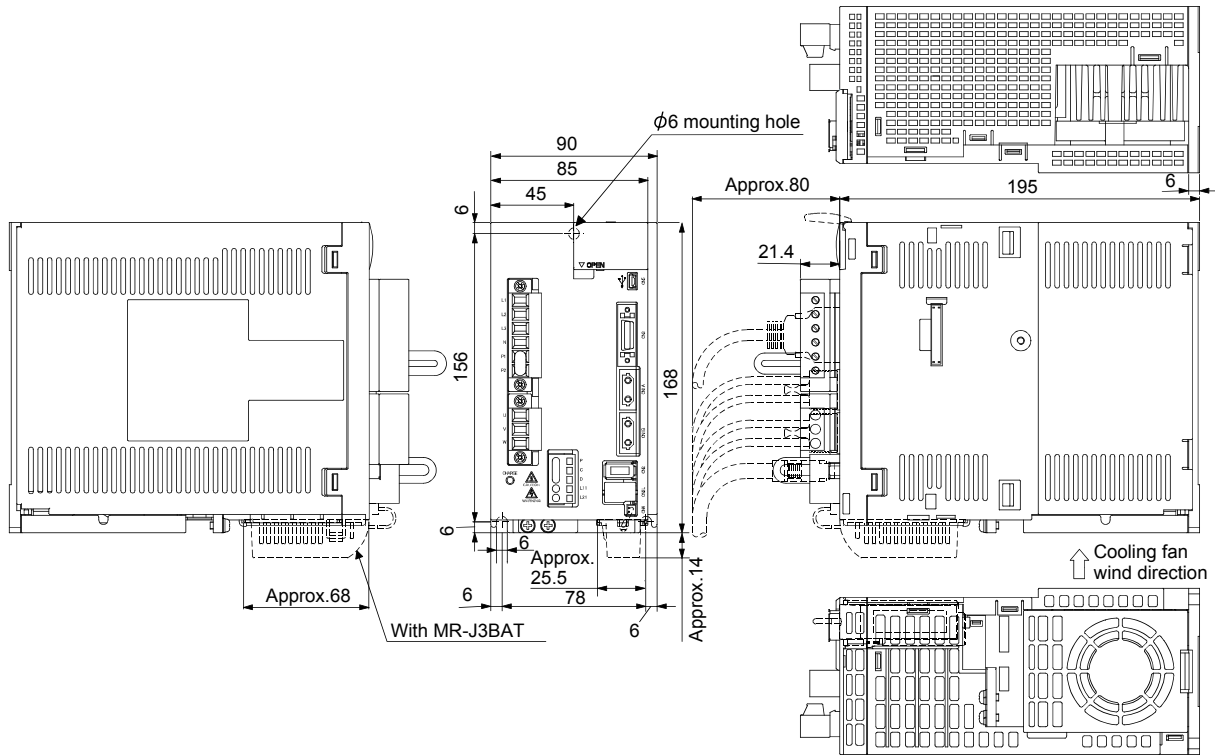

Mass: 2.3 [kg] (5.07 [lb])

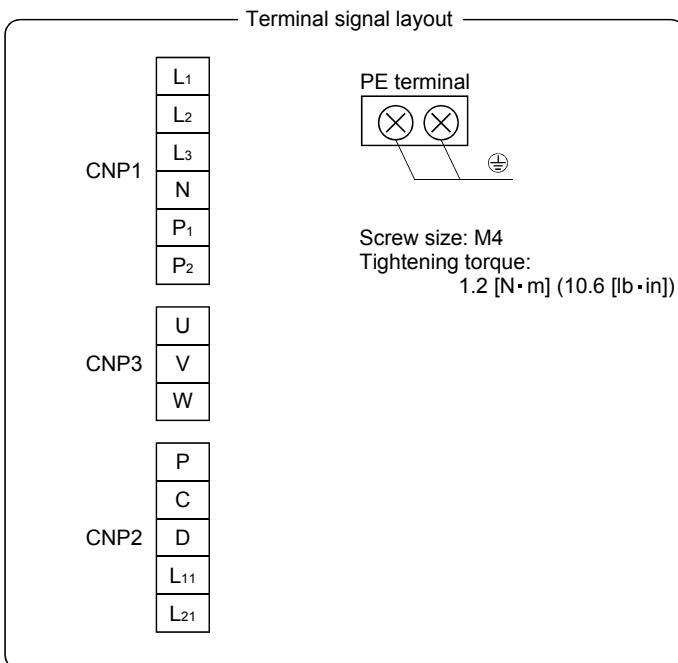

Mounting screw  
Screw size: M5  
Tightening torque: 3.24 [N·m] (28.7 [lb·in])

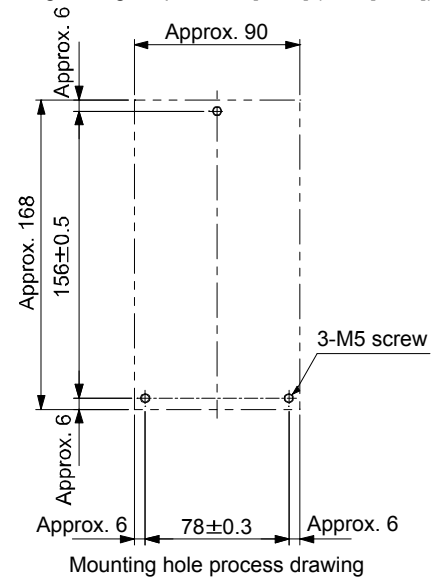

## 9. OUTLINE DRAWINGS

### (7) MR-J3-350B4 • MR-J3-500B(4)

[Unit: mm]

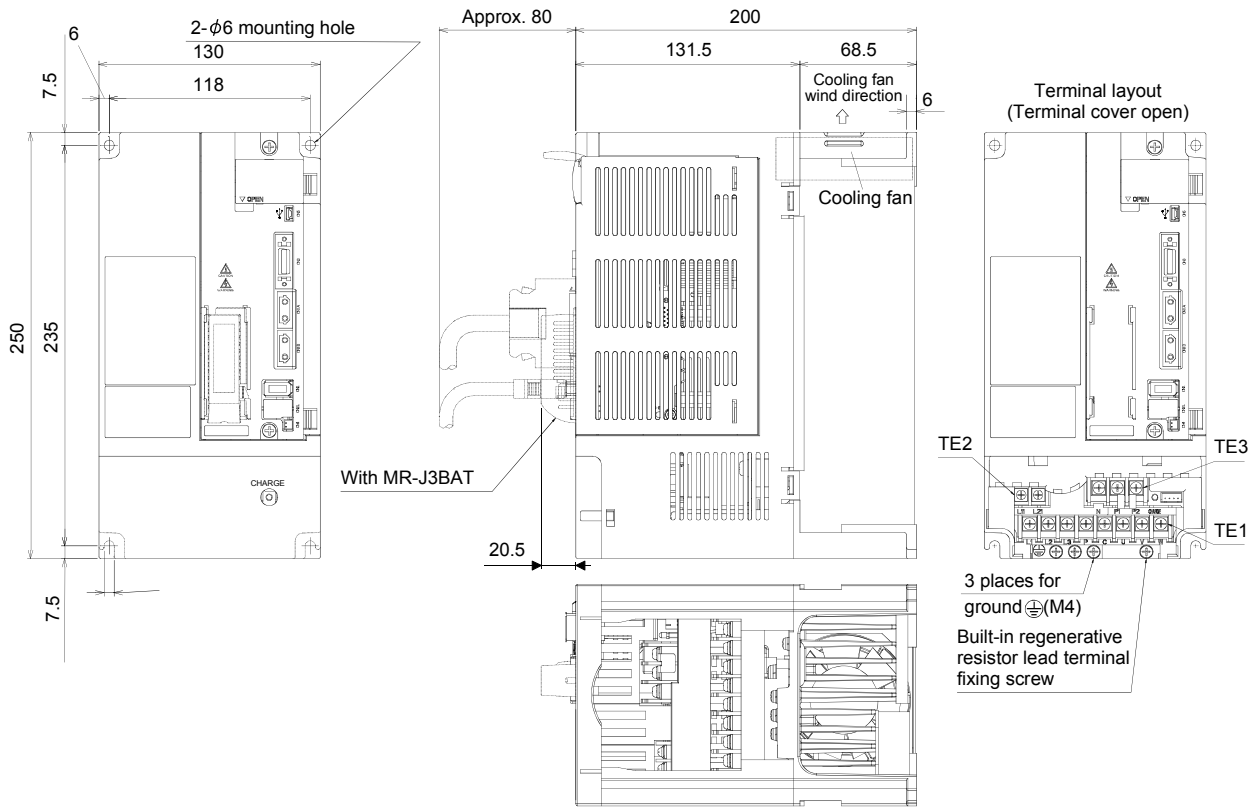

Mass: 4.6 [kg] (10.1 [lb])

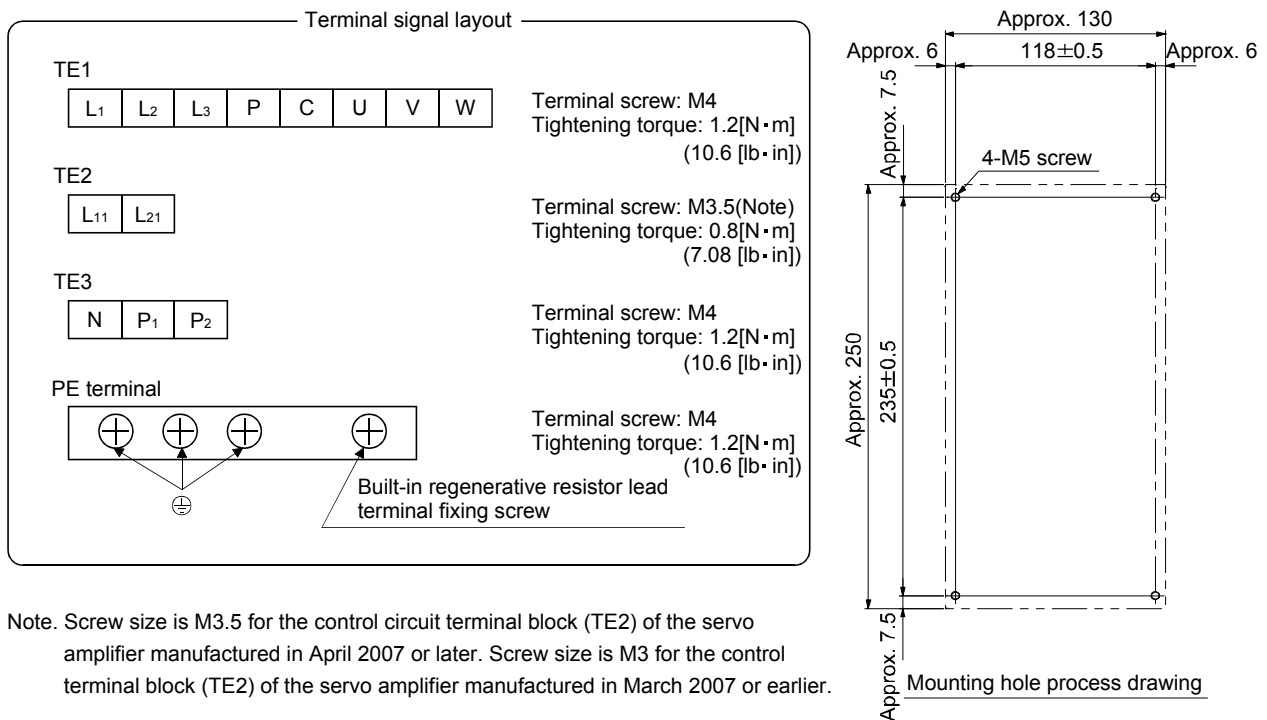

Note. Screw size is M3.5 for the control circuit terminal block (TE2) of the servo amplifier manufactured in April 2007 or later. Screw size is M3 for the control terminal block (TE2) of the servo amplifier manufactured in March 2007 or earlier.

## 9. OUTLINE DRAWINGS

### (8) MR-J3-700B(4)

[Unit: mm]

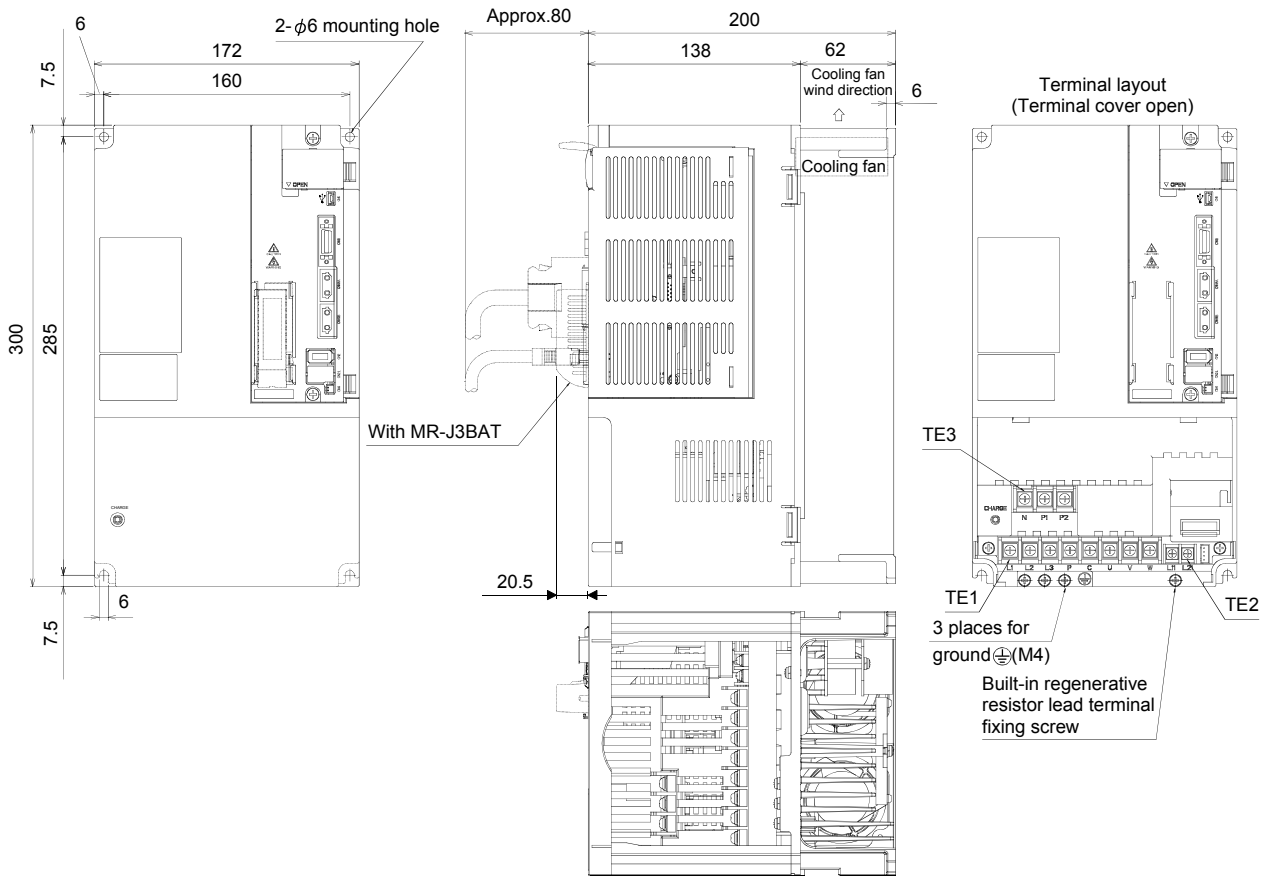

Mass: 6.2 [kg] (13.7[lb])

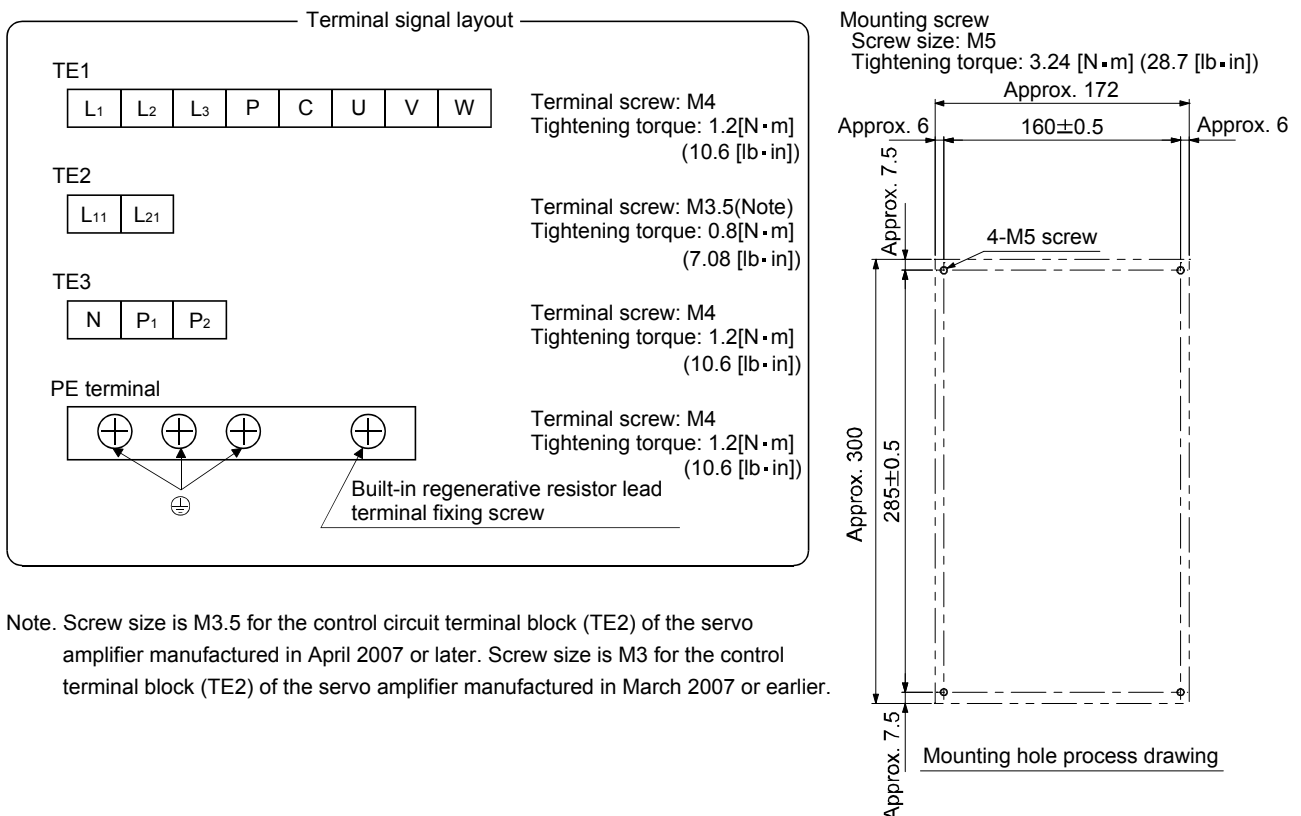

Note. Screw size is M3.5 for the control circuit terminal block (TE2) of the servo amplifier manufactured in April 2007 or later. Screw size is M3 for the control terminal block (TE2) of the servo amplifier manufactured in March 2007 or earlier.

## 9. OUTLINE DRAWINGS

### (9) MR-J3-11KB(4) to 22KB(4)

[Unit: mm]

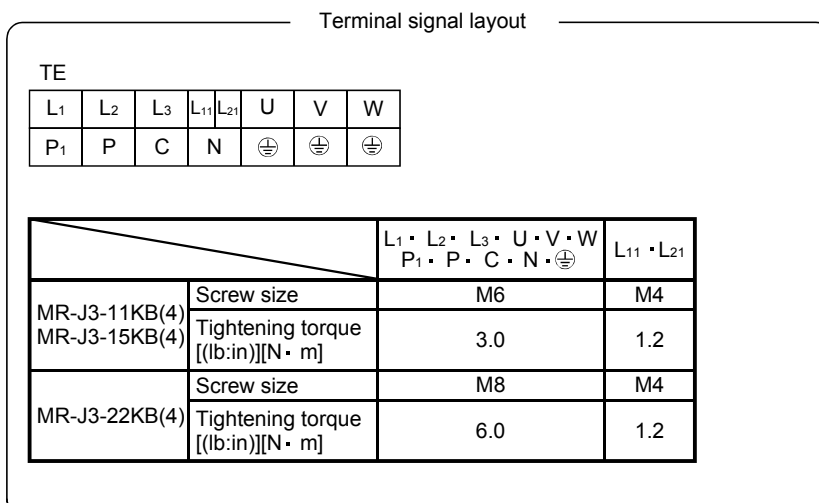
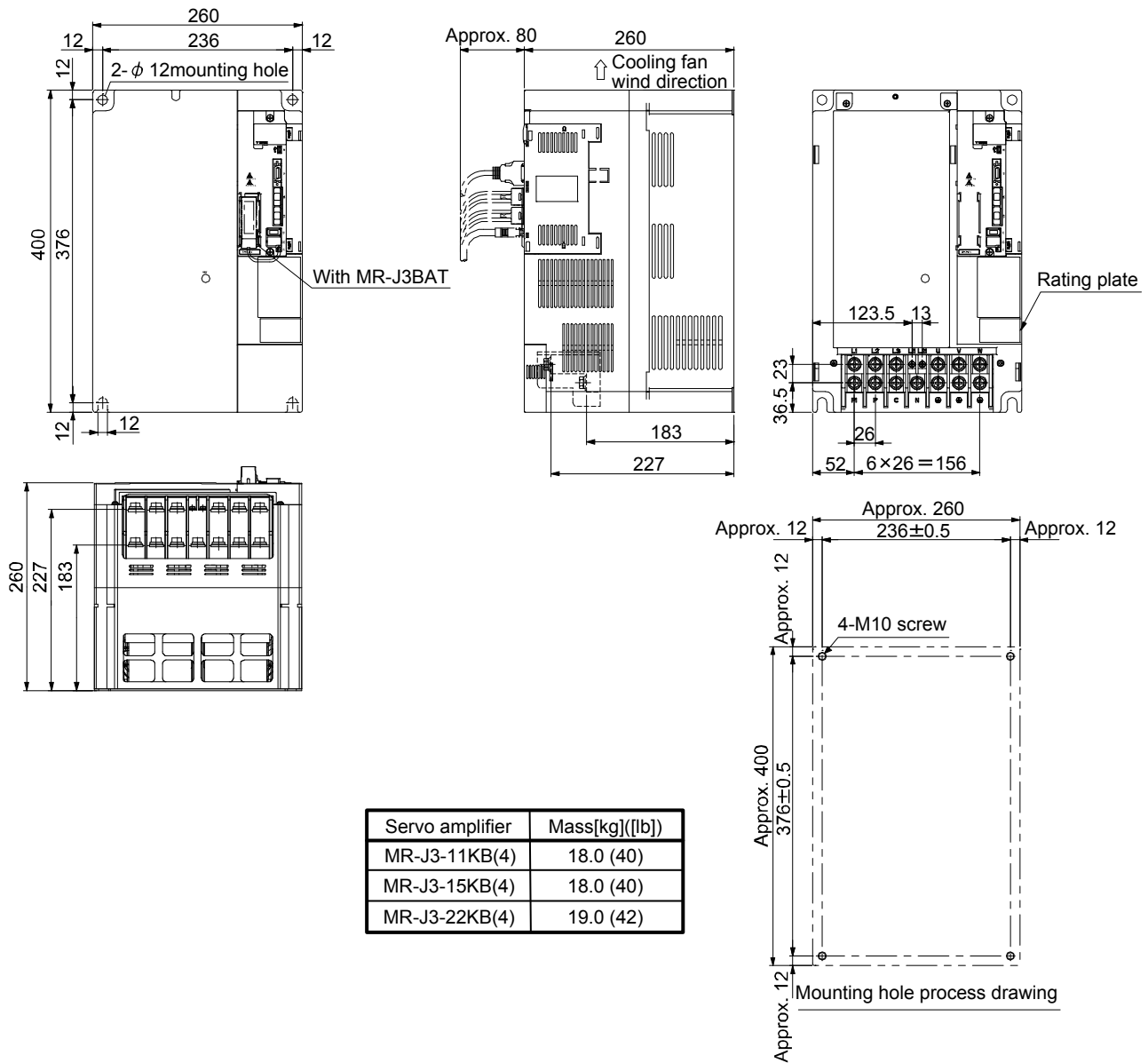

#### Mounting screw

Servo amplifier	Screw size	Tightening torque [N·m][(lb.in)]
MR-J3-11KB(4)	M10	26.5 (234.5)
MR-J3-15KB(4)		
MR-J3-22KB(4)		

## 9. OUTLINE DRAWINGS

### 9.2 Connector

#### (1) CN1A • CN1B connector

[Unit: mm]

F0-PF2D103

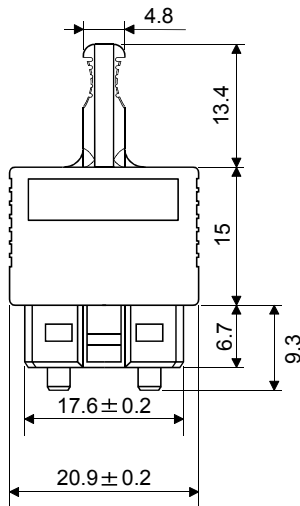

F0-PF2D103-S

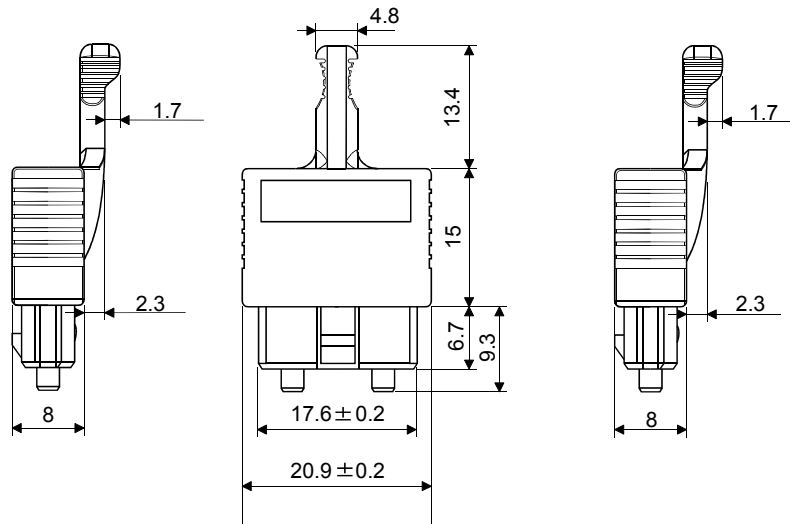

#### (2) Miniature delta ribbon (MDR) system (3M)

##### (a) One-touch lock type

[Unit: mm]

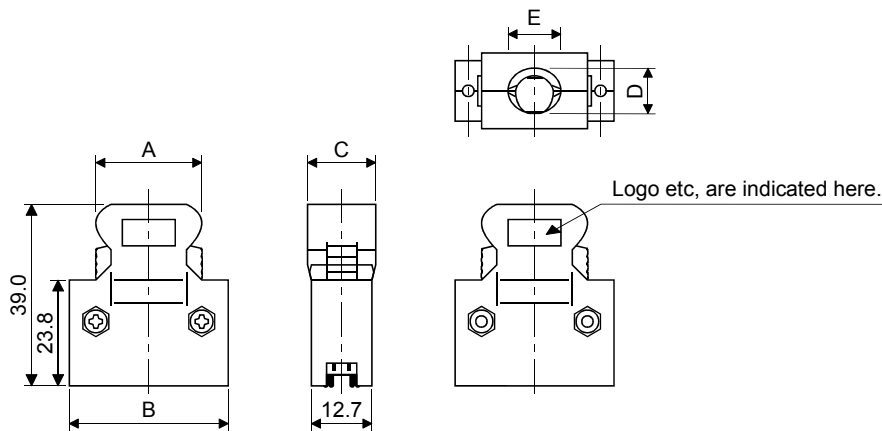

Connector	Shell kit	Each type of dimension				
		A	B	C	D	E
10120-3000PE	10320-52F0-008	22.0	33.3	14.0	10.0	12.0

## 9. OUTLINE DRAWINGS

(b) Jack screw M2.6 type

This is not available as option.

[Unit: mm]

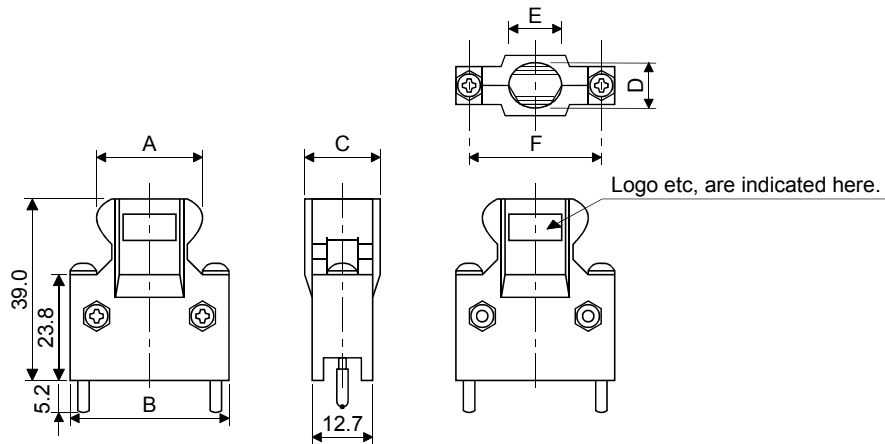

Connector	Shell kit	Each type of dimension					
		A	B	C	D	E	F
10120-3000PE	10320-52F0-008	22.0	33.3	14.0	10.0	12.0	27.4

(3) SCR connector system (3M)

Receptacle: 36210-0100PL

Shell kit : 36310-3200-008

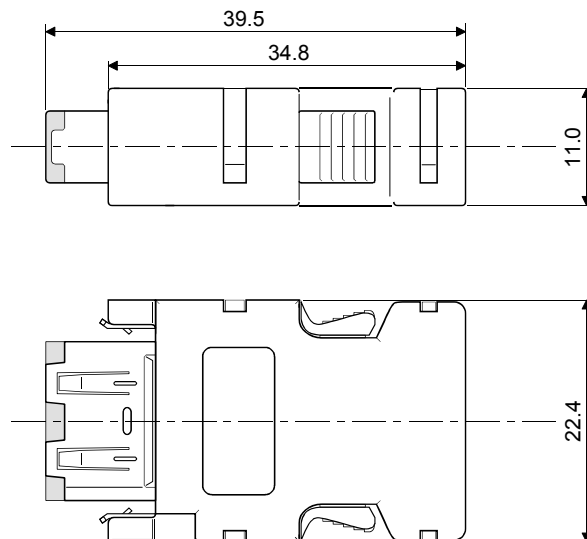



# 10. CHARACTERISTICS

## 10. CHARACTERISTICS

### 10.1 Overload protection characteristics

An electronic thermal relay is built in the servo amplifier to protect the servo motor and servo amplifier from overloads. Overload 1 alarm (50) occurs if overload operation performed is above the electronic thermal relay protection curve shown in any of Figs 10.1. Overload 2 alarm (51) occurs if the maximum current flow continuously for several seconds due to machine collision, etc. Use the equipment on the left-hand side area of the continuous or broken line in the graph.

In a machine like the one for vertical lift application where unbalanced torque will be produced, it is recommended to use the machine so that the unbalanced torque is 70% or less of the rated torque.

When you carry out adhesion mounting of the servo amplifier, make circumference temperature into 0 to 45°C, or use it at 75% or smaller effective load ratio.

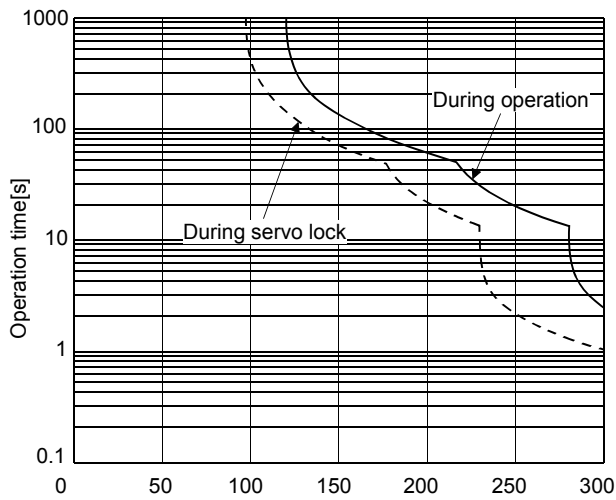

(Note) Load ratio [%]

MR-J3-10B(1)

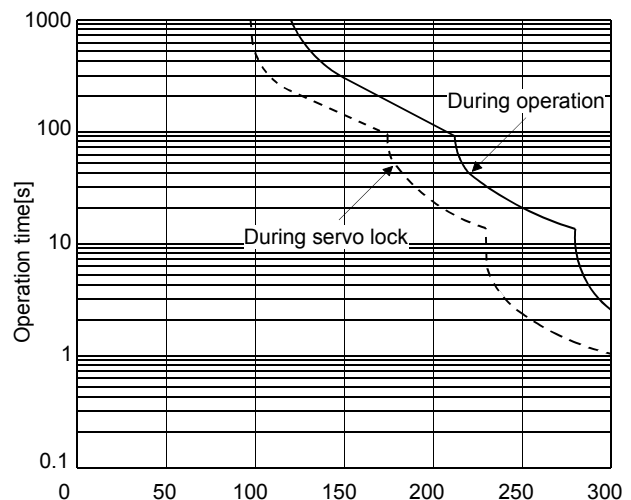

(Note) Load ratio [%]

MR-J3-20B(1) • MR-J3-40B(1)  
MR-J3-60B(4) to MR-J3-100B(4)

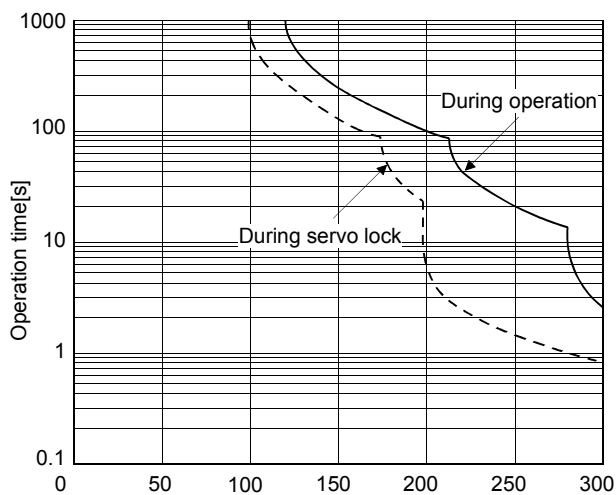

(Note) Load ratio [%]

MR-J3-200B(4) to MR-J3-350B(4)

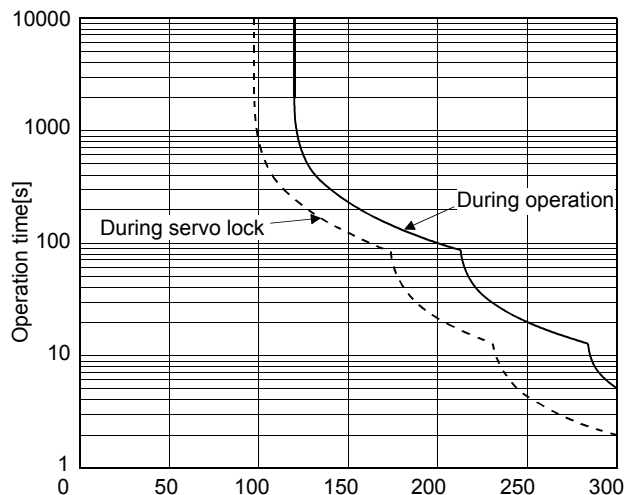

(Note) Load ratio [%]

MR-J3-500B(4) • MR-J3-700B(4)

## 10. CHARACTERISTICS

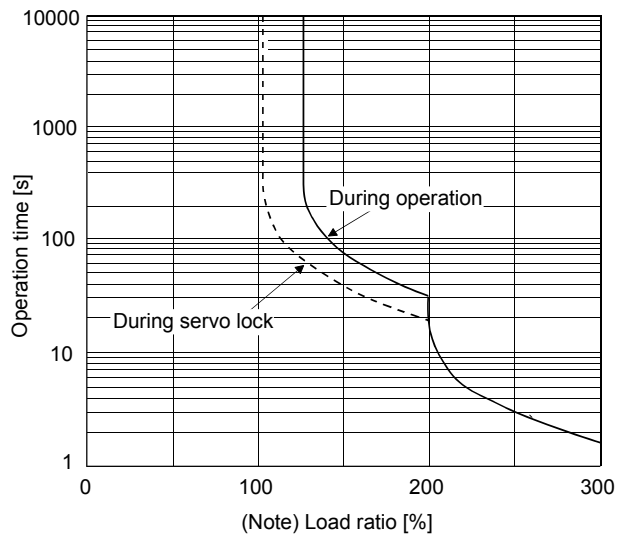

MR-J3-11KB(4) to MR-J3-22KB(4)

Note. If operation that generates torque more than 100% of the rating is performed with an abnormally high frequency in a servo motor stop status (servo lock status) or in a 30r/min or less low-speed operation status, the servo amplifier may fail even when the electronic thermal relay protection is not activated.

Fig 10.1 Electronic thermal relay protection characteristics

## 10. CHARACTERISTICS

### 10.2 Power supply equipment capacity and generated loss

#### (1) Amount of heat generated by the servo amplifier

Table 10.1 indicates servo amplifiers' power supply capacities and losses generated under rated load. For thermal design of an enclosure, use the values in Table 10.1 in consideration for the worst operating conditions. The actual amount of generated heat will be intermediate between values at rated torque and servo off according to the duty used during operation. When the servo motor is run at less than the maximum speed, the power supply capacity will be smaller than the value in the table, but the servo amplifier's generated heat will not change.

Table 10.1 Power supply capacity and generated heat per servo amplifier at rated output

Servo amplifier	Servo motor	(Note 1) Power supply capacity[kVA]	(Note 2) Servo amplifier-generated heat[W]		Area required for heat dissipation [m <sup>2</sup> ]
			At rated torque	With servo off	
MR-J3-10B (1)	HF-MP053	0.3	25	15	0.5
	HF-MP13	0.3	25	15	0.5
	HF-KP053 * 13	0.3	25	15	0.5
MR-J3-20B (1)	HF-MP23	0.5	25	15	0.5
	HF-KP23	0.5	25	15	0.5
MR-J3-40B (1)	HF-MP43	0.9	35	15	0.7
	HF-KP43	0.9	35	15	0.7
MR-J3-60B (4)	HF-SP52 (4)	1.0	40	15	0.8
	HF-SP51	1.0	40	15	0.8
	HC-LP52	1.0	40	15	0.8
MR-J3-70B	HF-MP73	1.3	50	15	1.0
	HF-KP73	1.3	50	15	1.0
	HC-UP72	1.3	50	15	1.0
MR-J3-100B (4)	HF-SP102 (4)	1.7	50	15	1.0
	HF-SP81	1.5	50	15	1.0
	HC-LP102	1.7	50	15	1.0
MR-J3-200B (4)	HF-SP152 (4)	2.5	90	20	1.8
	HF-SP202 (4)	3.5	90	20	1.8
	HF-SP121	2.1	90	20	1.8
	HF-SP201	3.5	90	20	1.8
	HC-RP103	1.8	50	15	1.0
	HC-RP153	2.5	90	20	1.8
	HC-UP152	2.5	90	20	1.8
HC-LP152	2.5	90	20	1.8	
MR-J3-350B (4)	HF-SP352 (4)	5.5	130	20 (25) (Note 3)	2.7
	HC-RP203	3.5	90	20	1.8
	HC-UP202	3.5	90	20	1.8
	HC-LP202	3.5	90	20	1.8
	HF-SP301	4.8	120	20	2.4
MR-J3-500B (4)	HF-SP502 (4)	7.5	195	25	3.9
	HC-RP353	5.5	135	25	2.7
	HC-RP503	7.5	195	25	3.9
	HC-UP352	5.5	195	25	3.9
	HC-UP502	7.5	195	25	3.9
	HC-LP302	4.5	120	25	2.4
	HA-LP502	7.5	195	25	3.9
HF-SP421	6.7	160	25	3.2	

## 10. CHARACTERISTICS

Servo amplifier	Servo motor	(Note 1) Power supply capacity[kVA]	(Note 2) Servo amplifier-generated heat[W]		Area required for heat dissipation [m <sup>2</sup> ]
			At rated torque	With servo off	
MR-J3-700B (4)	HF-SP702 (4)	10.0	300	25	6.0
	HA-LP702	10.6	300	25	6.0
	HA-LP601 (4)	10.0	260	25	5.2
	HA-LP701M (4)	11.0	300	25	6.0
MR-J3-11KB	HC-LP11K2 (4)	16.0	530	45	11.0
	HC-LP801 (4)	12.0	390	45	7.8
	HC-LP12K1 (4)	18.0	580	45	11.6
	HC-LP11K1M (4)	16.0	530	45	11.0
MR-J3-15KB	HC-LP15K2 (4)	22.0	640	45	13.0
	HC-LP15K1 (4)	22.0	640	45	13.0
	HC-LP15K1M (4)	22.0	640	45	13.0
MR-J3-22KB	HC-LP22K2 (4)	33.0	850	55	17.0
	HC-LP20K1 (4)	30.1	775	55	15.5
	HC-LP25K1	37.6	970	55	19.4
	HC-LP22K1M (4)	33.0	850	55	17.0

Note 1. Note that the power supply capacity will vary according to the power supply impedance. This value is applicable when the power factor improving reactor is not used.

- Heat generated during regeneration is not included in the servo amplifier-generated heat. To calculate heat generated by the regenerative option, refer to section 11.2.
- For 400V class, the value is within the ( ).

## 10. CHARACTERISTICS

### (2) Heat dissipation area for enclosed servo amplifier

The enclosed control box (hereafter called the control box) which will contain the servo amplifier should be designed to ensure that its temperature rise is within +10°C at the ambient temperature of 40°C. (With a 5°C (41°F) safety margin, the system should operate within a maximum 55°C (131°F) limit.) The necessary enclosure heat dissipation area can be calculated by Equation 10.1.

$$A = \frac{P}{K \cdot \Delta T} \dots\dots\dots (10.1)$$

- where, A : Heat dissipation area [m<sup>2</sup>]
- P : Loss generated in the control box [W]
- ΔT : Difference between internal and ambient temperatures [°C]
- K : Heat dissipation coefficient [5 to 6]

When calculating the heat dissipation area with Equation 10.1, assume that P is the sum of all losses generated in the enclosure. Refer to Table 10.1 for heat generated by the servo amplifier. "A" indicates the effective area for heat dissipation, but if the enclosure is directly installed on an insulated wall, that extra amount must be added to the enclosure's surface area.

The required heat dissipation area will vary with the conditions in the enclosure. If convection in the enclosure is poor and heat builds up, effective heat dissipation will not be possible. Therefore, arrangement of the equipment in the enclosure and the use of a cooling fan should be considered.

Table 10.1 lists the enclosure dissipation area for each servo amplifier when the servo amplifier is operated at the ambient temperature of 40°C (104°F) under rated load.

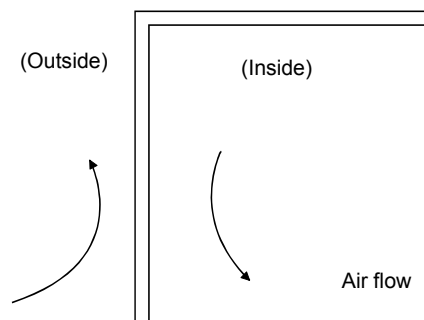

Fig. 10.2 Temperature distribution in enclosure

When air flows along the outer wall of the enclosure, effective heat exchange will be possible, because the temperature slope inside and outside the enclosure will be steeper.

## 10. CHARACTERISTICS

### 10.3 Dynamic brake characteristics

#### 10.3.1 Dynamic brake operation

##### (1) Calculation of coasting distance

Fig. 10.3 shows the pattern in which the servo motor comes to a stop when the dynamic brake is operated. Use Equation 10.2 to calculate an approximate coasting distance to a stop. The dynamic brake time constant  $\tau$  varies with the servo motor and machine operation speeds. (Refer to (2)(a), (b) of this section.)

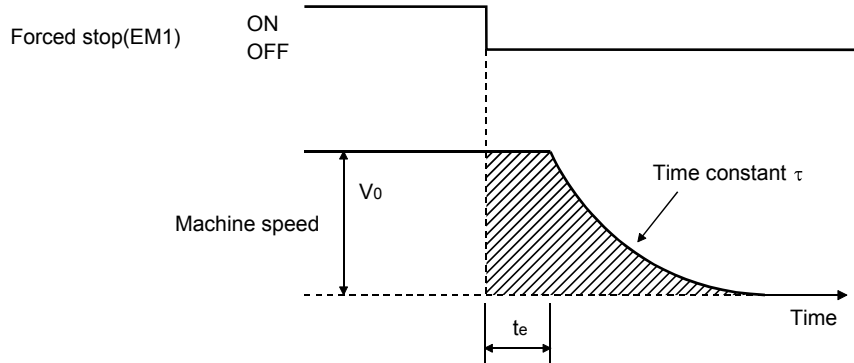

Fig. 10.3 Dynamic brake operation diagram

$$L_{\max} = \frac{V_0}{60} \cdot \left\{ t_e + \tau \left[ 1 + \frac{J_L}{J_M} \right] \right\} \dots \dots \dots (10.2)$$

- $L_{\max}$  : Maximum coasting distance ..... [mm][in]
- $V_0$  : Machine rapid feed rate ..... [mm/min][in/min]
- $J_M$  : Servo motor inertial moment..... [kg · cm<sup>2</sup>][oz · in<sup>2</sup>]
- $J_L$  : Load inertia moment converted into equivalent value on servo motor shaft ..... [kg · cm<sup>2</sup>][oz · in<sup>2</sup>]
- $\tau$  : Brake time constant ..... [s]
- $t_e$  : Delay time of control section..... [s]

For 7kW or less servo, there is internal relay delay time of about 30ms. For 11k to 22kW servo, there is delay time of about 100ms caused by a delay of the external relay and a delay of the magnetic contactor built in the external dynamic brake.

##### (2) Dynamic brake time constant

The following shows necessary dynamic brake time constant  $\tau$  for the equations (10.2).

##### (a) 200V class servo motor

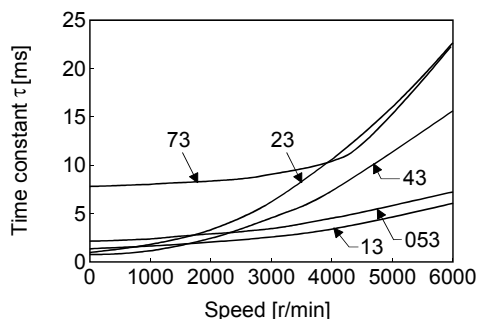

HF-MP series

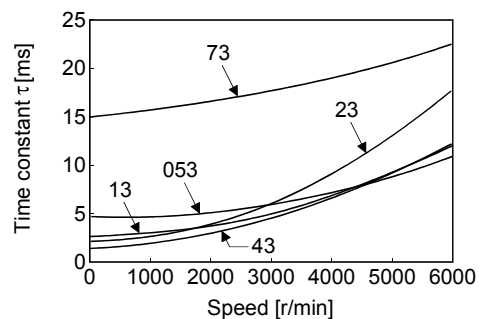

HF-KP series

## 10. CHARACTERISTICS

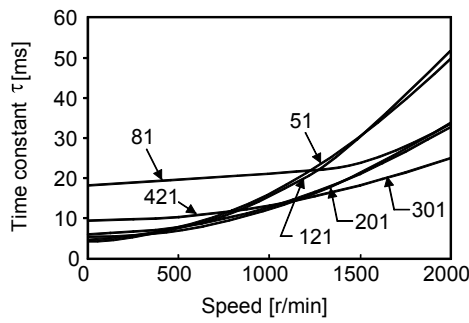

HF-SP1000r/min series

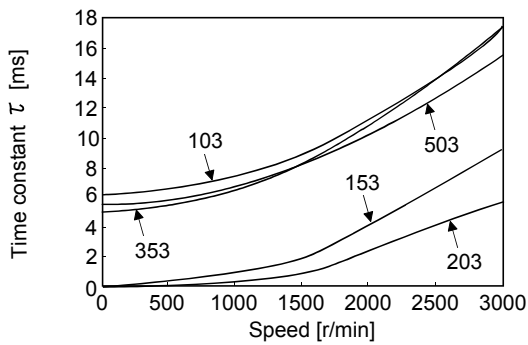

HF-SP2000r/min series

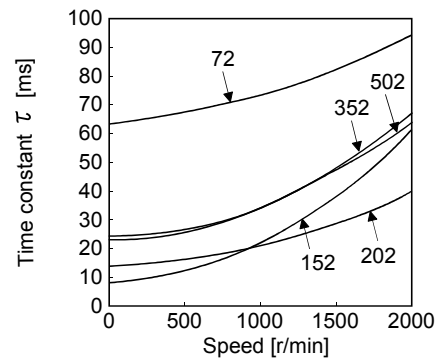
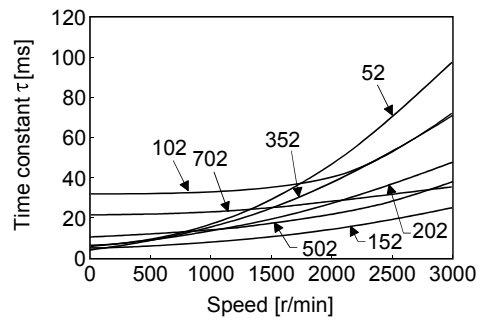

HC-UP2000r/min series

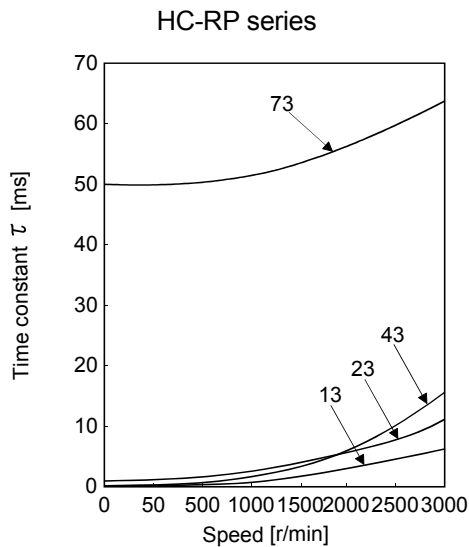

HC-UP3000r/min

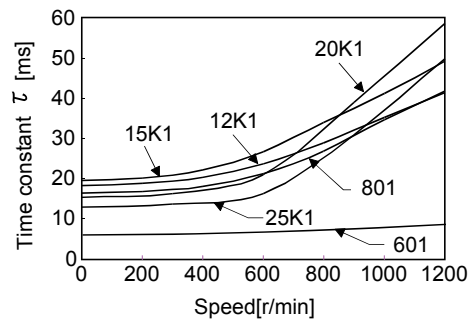

HA-LP1000r/min series

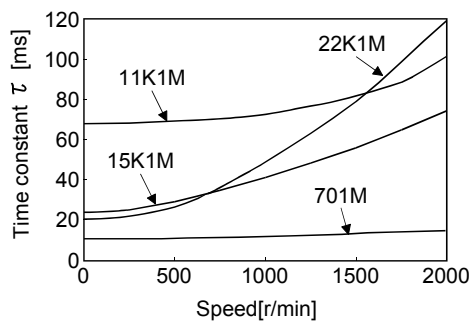

HA-LP1500r/min series

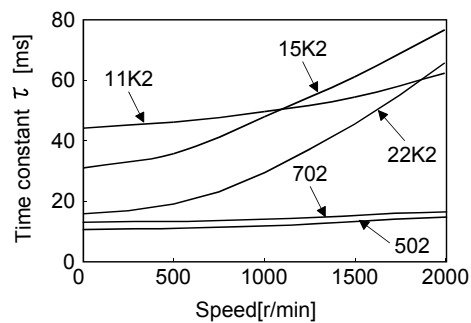

HA-LP2000r/min series

## 10. CHARACTERISTICS

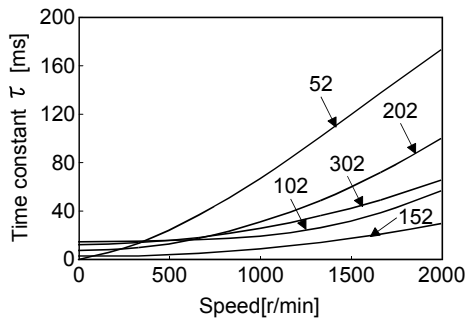

HC-LP series

(b) 400V class servo motor

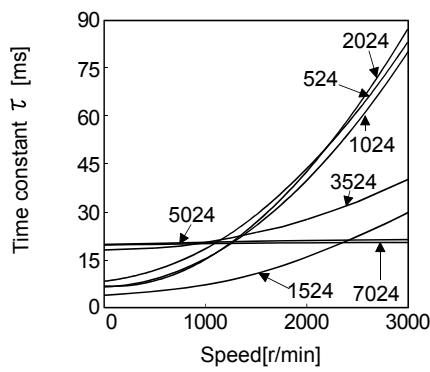

HA-SP2000r/min series

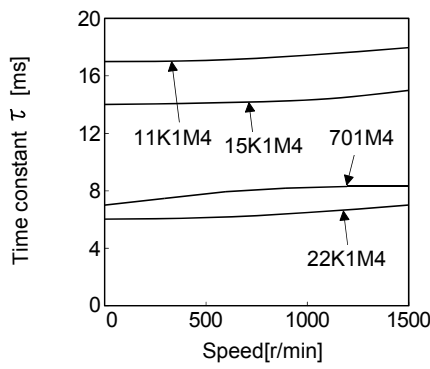

HA-LP1500r/min series

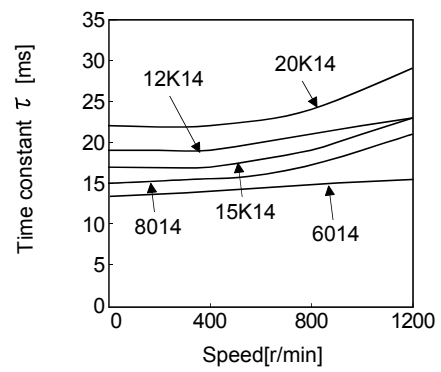

HA-LP1000r/min series

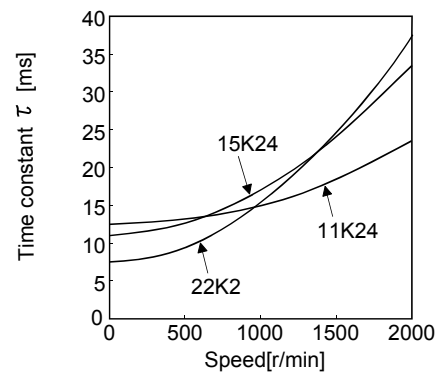

HA-LP2000r/min series

## 10. CHARACTERISTICS

### 10.3.2 The dynamic brake at the load inertia moment

Use the dynamic brake under the load inertia moment ratio indicated in the following table. If the load inertia moment is higher than this value, the built-in dynamic brake may burn. If there is a possibility that the load inertia moment may exceed the value, contact Mitsubishi.

The values of the load inertia moment ratio in the table are the values at the maximum rotation speed of the servo motor.

Servo amplifier	Servo motor									
	HF-KP□	HF-MP□	HF-SP□1	HF-SP□2	HC-RP□	HC-UP□	HC-LP□	HA-LP□1	HA-LP□1M	HA-LP□2
MR-J3-10B(1)	30	30	/	/	/	/	/	/	/	/
MR-J3-20B(1)	30	30								
MR-J3-40B(1)	30	30								
MR-J3-60B	/	/	30	30	/	/	30	/	/	/
MR-J3-70B			30	30			30			
MR-J3-100B			30	30			30			
MR-J3-200B	/	/	30	30	30	30	30	/	/	/
MR-J3-350B			16	16	16	16				
MR-J3-500B			15	15	15	15				
MR-J3-700B	/	/	/	5 (Note 1)	/	/	/	5 (Note 1)	5 (Note 1)	5 (Note 1)
MR-J3-11KB (Note 2)				30				30	30	
MR-J3-15KB (Note 2)				30				30	30	
MR-J3-22KB (Note 2)				30				30	30	

Servo amplifier	Servo motor			
	HF-SP□4	HA-LP□14	HA-LP□1M4	HA-LP□24
MR-J3-60B4	5 (Note 1)	/	/	/
MR-J3-100B4	5 (Note 1)			
MR-J3-200B4	5 (Note 1)			
MR-J3-350B4	5 (Note 1)			
MR-J3-500B4	5 (Note 1)			
MR-J3-700B4	5 (Note 1)	10	10	/
MR-J3-11KB4 (Note 2)	30	30	30	
MR-J3-15KB4 (Note 2)	30	30	30	
MR-J3-22KB4 (Note 2)	30	30	30	

Note 1. The load inertia moment ratio is 15 at the rated rotation speed.

2. When the external dynamic brake is used.

## 10. CHARACTERISTICS

### 10.4 Cable flexing life

The flexing life of the cables is shown below. This graph calculated values. Since they are not guaranteed values, provide a little allowance for these values.

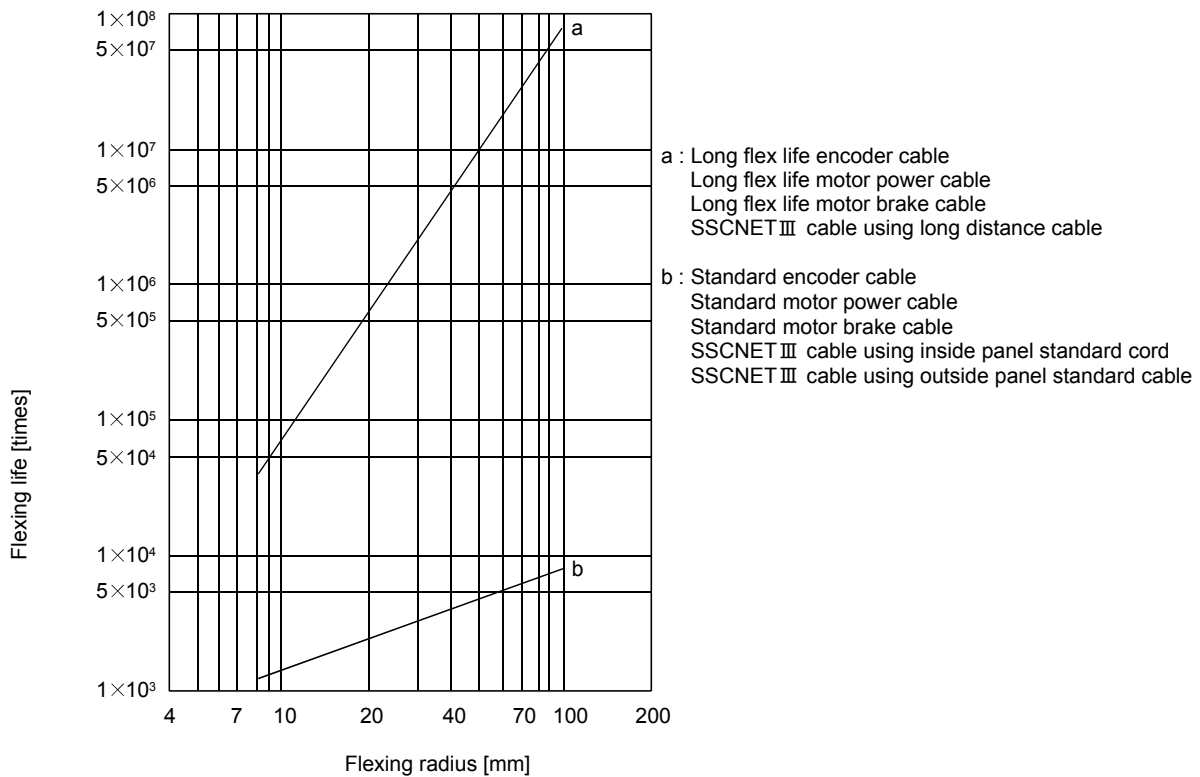

### 10.5 Inrush currents at power-on of main circuit and control circuit

The following table indicates the inrush currents (reference data) that will flow when the maximum permissible voltage (200V class: 253VAC, 400V class: 528VAC) is applied at the power supply capacity of 2500kVA and the wiring length of 1m (3.28ft).

Servo amplifier	Inrush currents ( $A_{0-p}$ )	
	Main circuit power supply ( $L_1, L_2, L_3$ )	Control circuit power supply ( $L_{11}, L_{21}$ )
MR-J3-10B1 to 40B1	38A (Attenuated to approx. 14A in 10ms)	20 to 30A (Attenuated to approx. 0A in 1 to 2ms)
MR-J3-10B to 60B	30A (Attenuated to approx. 5A in 10ms)	
MR-J3-70B · 100B	54A (Attenuated to approx. 12A in 10ms)	
MR-J3-200B · 350B	120A (Attenuated to approx. 12A in 20ms)	
MR-J3-500B	44A (Attenuated to approx. 20A in 20ms)	30A (Attenuated to approx. 0A in 3ms)
MR-J3-700B	88A (Attenuated to approx. 20A in 20ms)	
MR-J3-11KB	235A (Attenuated to approx. 20A in 20ms)	
MR-J3-15KB		
MR-J3-22KB		
MR-J3-60B4 · 100B4	100A (Attenuated to approx. 5A in 10ms)	40 to 50A (Attenuated to approx. 0A in 2ms)
MR-J3-200B4	120A (Attenuated to approx. 12A in 20ms)	
MR-J3-350B4 · 500B4	66A (Attenuated to approx. 10A in 20ms)	41A (Attenuated to approx. 0A in 3ms)
MR-J3-700B4	67A (Attenuated to approx. 34A in 20ms)	
MR-J3-11KB4	325A (Attenuated to approx. 20A in 20ms)	45A (Attenuated to approx. 0A in 3ms)
MR-J3-15KB4		
MR-J3-22KB4		

Since large inrush currents flow in the power supplies, always use no-fuse breakers and magnetic contactors. (Refer to section 11.12.)

When circuit protectors are used, it is recommended to use the inertia delay type that will not be tripped by an inrush current.

## 11. OPTIONS AND AUXILIARY EQUIPMENT

### 11. OPTIONS AND AUXILIARY EQUIPMENT

#### WARNING

- Before connecting any option or peripheral equipment, turn off the power and wait for 15 minutes or more until the charge lamp turns off. Then, confirm that the voltage between P(+) and N(–) is safe with a voltage tester and others. Otherwise, an electric shock may occur. In addition, always confirm from the front of the servo amplifier whether the charge lamp is off or not.

#### CAUTION

- Use the specified auxiliary equipment and options. Unspecified ones may lead to a fault or fire.

#### 11.1 Cable/connector sets

##### POINT

- Protective structure indicated for cables and connectors is for a cable or connector alone. When the cables and connectors are used to connect the servo amplifier and servo motor, and if protective structures of the servo amplifier and servo motor are lower than that of the cable and connector, specifications of the servo amplifier and servo motor apply.

As the cables and connectors used with this servo, purchase the options indicated in this section.

# 11. OPTIONS AND AUXILIARY EQUIPMENT

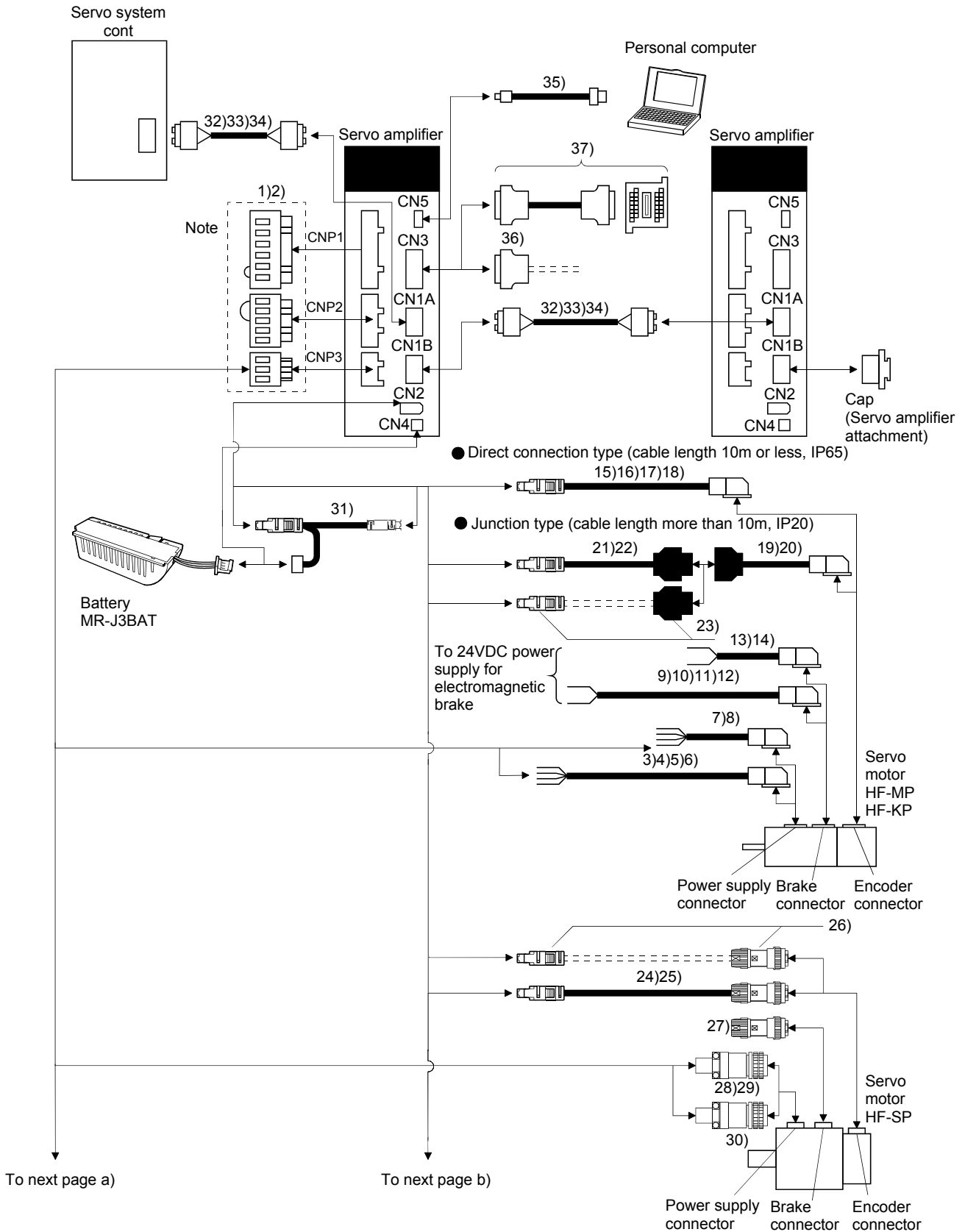

## 11.1.1 Combinations of cable/connector sets





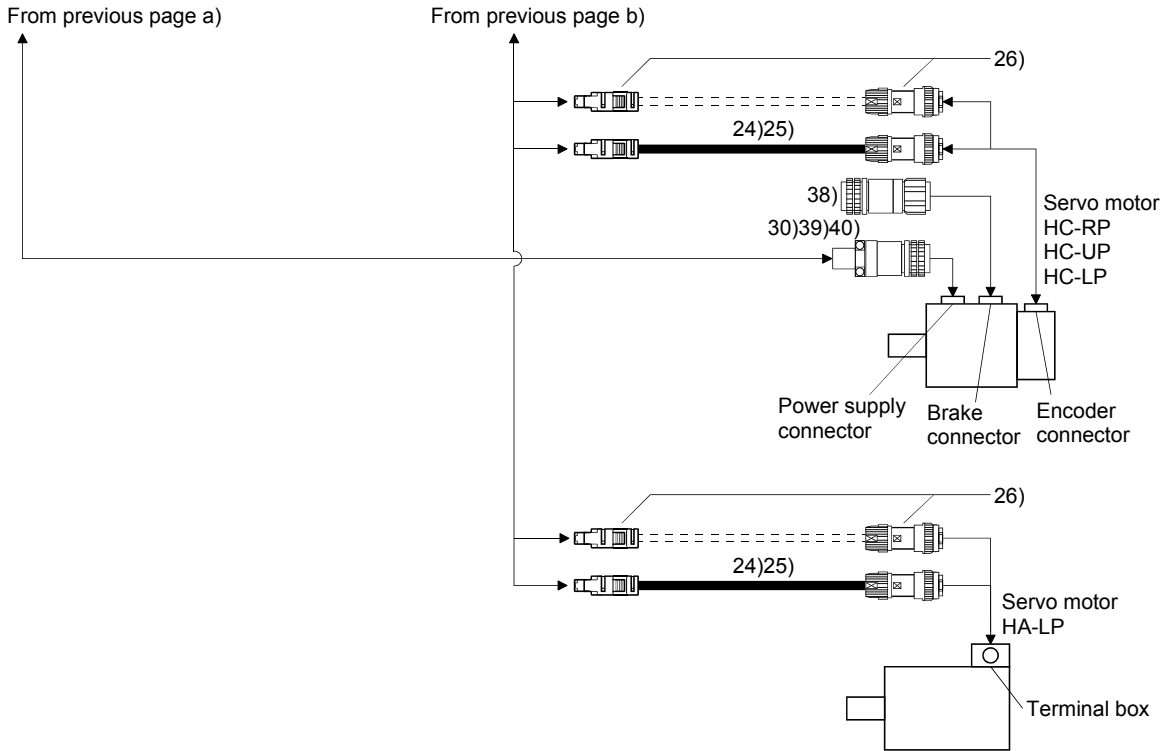

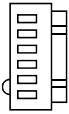

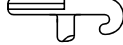
Note. Connectors for 3.5kW or less. For 5kW or more, terminal blocks.

## 11. OPTIONS AND AUXILIARY EQUIPMENT



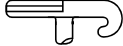
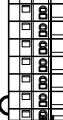



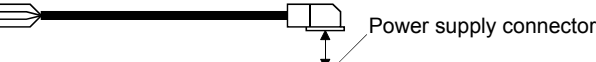
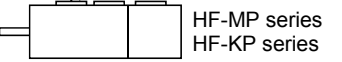
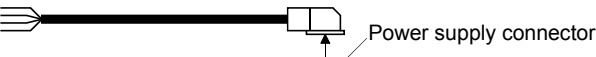
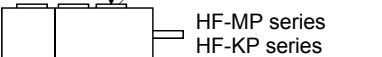
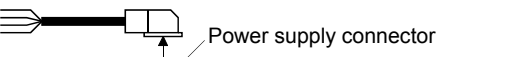
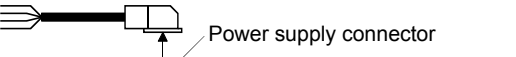



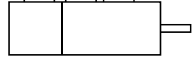

No.	Product	Model	Description	Application
1)	Servo amplifier power supply connector		   CNP1 connector: 54928-0610 (Molex) CNP2 connector: 54928-0520 (Molex) CNP3 connector: 54928-0310 (Molex) <Applicable cable example> Wire size: 0.14mm <sup>2</sup> (AWG26) to 2.5mm <sup>2</sup> (AWG14) Cable finish OD: to $\phi$ 3.8mm  REC. Lever: 54932-0000 (Molex)	Supplied with servo amplifiers of 1kW or less in 100V class and 200V class



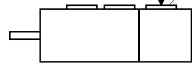

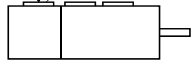

## 11. OPTIONS AND AUXILIARY EQUIPMENT

No.	Product	Model	Description	Application		
2)	Servo amplifier power supply connector		 <p>CNP1 connector: PC4/6-STF-7.62-CRWH (Phoenix Contact) &lt;Applicable cable example&gt; Wire size: 0.2mm<sup>2</sup> (AWG24) to 5.5mm<sup>2</sup> (AWG10) Cable finish OD: to <math>\phi</math> 5mm</p>	 <p>CNP2 connector: 54928-0520 (Molex)</p>	 <p>CNP3 connector: PC4/3-STF-7.62-CRWH (Phoenix Contact)</p>  <p>REC. Level: 54932-0000 (Molex)</p>	Supplied with servo amplifiers of 3.5kW in 200V class
			 <p>CNP1 connector: 721-207/026-000 (Plug) (WAGO)</p>	 <p>CNP2 connector: 721-205/026-000 (Plug) (WAGO)</p>	 <p>CNP3 connector: 721-203/026-000 (Plug) (WAGO)</p>  <p>REC. Level: 231-131 (WAGO)</p>	Supplied with servo amplifiers of 2kW in 200V class and 2kW in 400V class
3)	Motor power supply cable	MR-PWS1CBL □ M-A1-L Cable length: 2 · 5 · 10m	 <p>Power supply connector</p>	IP65 Load side lead		
4)	Motor power supply cable	MR-PWS1CBL □ M-A1-H Cable length: 2 · 5 · 10m	 <p>HF-MP series HF-KP series</p> <p>Refer to section 11.1.3 for details.</p>	IP65 Load side lead Long flex life		
5)	Motor power supply cable	MR-PWS1CBL □ M-A2-L Cable length: 2 · 5 · 10m	 <p>Power supply connector</p>	IP65 Opposite-to-load side lead		
6)	Motor power supply cable	MR-PWS1CBL □ M-A2-H Cable length: 2 · 5 · 10m	 <p>HF-MP series HF-KP series</p> <p>Refer to section 11.1.3 for details.</p>	IP65 Opposite-to-load side lead Long flex life		
7)	Motor power supply cable	MR-PWS2CBL03M-A1-L Cable length: 0.3m	 <p>Power supply connector</p> <p>HF-MP series HF-KP series</p> <p>Refer to section 11.1.3 for details.</p>	IP55 Load side lead		
8)	Motor power supply cable	MR-PWS2CBL03M-A2-L Cable length: 0.3m	 <p>Power supply connector</p> <p>HF-MP series HF-KP series</p> <p>Refer to section 11.1.3 for details.</p>	IP55 Opposite-to-load side lead		



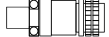
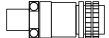
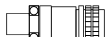

## 11. OPTIONS AND AUXILIARY EQUIPMENT

No.	Product	Model	Description	Application
9)	Motor brake cable	MR-BKS1CBL □ M-A1-L Cable length: 2 · 5 · 10m	 Brake connector	IP65 Load side lead
10)	Motor brake cable	MR-BKS1CBL □ M-A1-H Cable length: 2 · 5 · 10m	 HF-MP series HF-KP series	IP65 Load side lead Long flex life
			Refer to section 11.1.4 for details.	
11)	Motor brake cable	MR-BKS1CBL □ M-A2-L Cable length: 2 · 5 · 10m	 Brake connector	IP65 Opposite-to-load side lead
12)	Motor brake cable	MR-BKS1CBL □ M-A2-H Cable length: 2 · 5 · 10m	 HF-MP series HF-KP series	IP65 Opposite-to-load side lead Long flex life
			Refer to section 11.1.4 for details.	
13)	Motor brake cable	MR-BKS2CBL03M-A1-L Cable length: 0.3m	 Brake connector	IP55 Load side lead
			Refer to section 11.1.4 for details.	
14)	Motor brake cable	MR-BKS2CBL03M-A2-L Cable length: 0.3m	 Brake connector	IP55 Opposite-to-load side lead
			Refer to section 11.1.4 for details.	
15)	Encoder cable	MR-J3ENCBL □ M-A1-L Cable length: 2 · 5 · 10m	 Encoder connector	IP65 Load side lead
16)	Encoder cable	MR-J3ENCBL □ M-A1-H Cable length: 2 · 5 · 10m	 HF-MP series HF-KP series	IP65 Opposite-to-load side lead Long flex life
			Refer to section 11.1.2 (1) for details.	
17)	Encoder cable	MR-J3ENCBL □ M-A2-L Cable length: 2 · 5 · 10m	 Encoder connector	IP65 Opposite-to-load side lead
18)	Encoder cable	MR-J3ENCBL □ M-A2-H Cable length: 2 · 5 · 10m	 HF-MP series HF-KP series	IP65 Opposite-to-load side lead Long flex life
			Refer to section 11.1.2 (1) for details.	
19)	Encoder cable	MR-J3JCBL03M-A1-L Cable length: 0.3m	 Encoder connector	IP20 Load side lead
			Refer to section 11.1.2 (3) for details.	
20)	Encoder cable	MR-J3JCBL03M-A2-L Cable length: 0.3m	 Encoder connector	IP20 Opposite-to-load side lead
			Refer to section 11.1.2 (3) for details.	

## 11. OPTIONS AND AUXILIARY EQUIPMENT

No	Product	Model	Description	Application
21)	Encoder cable	MR-EKCBL □ M-L Cable length: 20 • 30m		IP20
22)	Encoder cable	MR-EKCBL □ M-H Cable length: 20 • 30 • 40 • 50m	For HF-MP • HF-KP series Refer to section 11.1.2 (2) for details.	IP20 Long flex life
23)	Encoder connector set	MR-ECNM	 For HF-MP • HF-KP series Refer to section 11.1.2 (2) for details.	IP20
24)	Encoder cable	MR-J3ENSCBL □ M-L Cable length: 2 • 5 • 10 • 20 • 30m		IP67 Standard flex life
25)	Encoder cable	MR-J3ENSCBL □ M-H Cable length: 2 • 5 • 10 • 20 • 30 • 40 • 50m	For HF-SP • HC-UP • HC-LP • HC-RP • HA-LP series Refer to section 11.1.2 (4) for details.	IP67 Long flex life
26)	Encoder connector set	MR-J3SCNS	 For HF-SP • HC-UP • HC-LP • HC-RP • HA-LP series Refer to section 11.1.2 (4) for details.	IP67
27)	Brake connector set	MR-BKCNS1	Straight plug: CM10-SP2S-L Socket contact: CM10-#22SC(S2)-100 (DDK)  For HF-SP series	IP67
28)	Power supply connector set	MR-PWCNS4	Plug: CE05-6A18-10SD-D-BSS Cable clamp: CE3057-10A-1-D (DDK) Example of applicable cable Applicable wire size: 2mm <sup>2</sup> (AWG14) to 3.5mm <sup>2</sup> (AWG12) Cable finish $\phi$ D: $\phi$ 10.5 to 14.1mm  For HF-SP51 • 81 For HF-SP52 • 152	IP67
29)	Power supply connector set	MR-PWCNS5	Plug: CE05-6A22-22SD-D-BSS Cable clamp: CE3057-12A-1-D (DDK) Example of applicable cable Applicable wire size: 5.5mm <sup>2</sup> (AWG10) to 8mm <sup>2</sup> (AWG8) Cable finish $\phi$ D: $\phi$ 12.5 to 16mm  For HF-SP121 to 301 For HF-SP202 to 502	IP67
30)	Power supply connector set	MR-PWCNS3	Plug: CE05-6A32-17SD-D-BSS Cable clamp: CE3057-20A-1-D (DDK) Example of applicable cable Applicable wire size: 14mm <sup>2</sup> (AWG6) to 22mm <sup>2</sup> (AWG4) Cable finish $\phi$ D: $\phi$ 22 to 23.8mm  For HF-SP421 For HF-SP702 For HA-LP702	IP67 Be sure to use this when corresponding to EN Standard.
31)	Cable for connecting battery	MR-J3BTCBL03M	 Refer to section 11.1.2 (5) for details.	For connection of battery

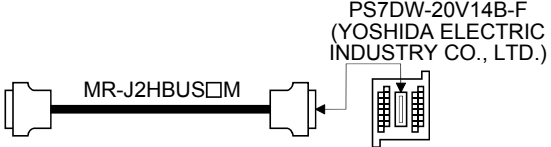
## 11. OPTIONS AND AUXILIARY EQUIPMENT

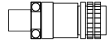
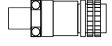
No.	Product	Model	Description	Application	
32)	SSCNETⅢ cable	MR-J3BUS□M Cable length: 0.15 to 3m (Refer to section 11.1.5.)	Connector: PF-2D103 (Japan Aviation Electronics Industry, Ltd.)	Connector: PF-2D103 (Japan Aviation Electronics Industry, Ltd.)	Inside panel standard cord
33)	SSCNETⅢ cable	MR-J3BUS□M-A Cable length: 5 to 20m (Refer to section 11.1.5.)			Outside panel standard cable
34)	SSCNETⅢ cable	MR-J3BUS□M-B Cable length: 30 to 50m (Refer to section 11.1.5.)	Connector: PF-2D103 (Japan Aviation Electronics Industry, Ltd.)	Connector: PF-2D103 (Japan Aviation Electronics Industry, Ltd.)	Long distance cable
35)	USB cable	MR-J3USBCBL3M Cable length: 3m	For CN5 connector minB connector (5 pins)	For personal computer connector A connector	For connection with PC-AT compatible personal computer
36)	Connector set	MR-CCN1			Connector: 10120-3000PE Shell kit: 10320-52F0-008 (3M or similar product)
37)	Junction terminal block (Recommended)		 <p>PS7DW-20V14B-F (YOSHIDA ELECTRIC INDUSTRY CO., LTD.)</p> <p>MR-J2HBUS□M</p>		
			Junction terminal block PS7DW-20V14B-F is not available from us as option. For using the junction terminal block, our option MR-J2HBUS□M is necessary. Refer to section 11.7 for details.		
38)	Break connector set	MR-BKCN	Plug: D/MS3106A10SL-4S(D190) (DDK) For cable connector : YS010-5-8(Daiwa Dengyo) Example of applicable cable Applicable wire size: 0.3mm <sup>2</sup> (AWG22) to 1.25mm <sup>2</sup> (AWG16) Cable finish: φ5 to 8.3mm	 For HA-LP For HC-UP For HC-LP	EN standard compliant IP65
39)	Power supply connector set	MR-PWCNS1	Plug: CE05-6A22-23SD-D-BSS Cable clamp: CE3057-12A-2-D (DDK) Example of applicable cable Applicable wire size: 2mm <sup>2</sup> (AWG14) to 3.5mm <sup>2</sup> (AWG12) Cable finish: φ9.5 to 13mm	 For HC-UP For HC-LP For HC-RP	Be sure to use this when corresponding to EN standard IP65
40)	Power supply connector set	MR-PWCNS2	Plug: CE05-6A24-10SD-D-BSS Cable clamp: CE3057-16A-2-D (DDK) Example of applicable cable Applicable wire size: 5.5mm <sup>2</sup> (AWG10) to 8mm <sup>2</sup> (AWG8) Cable finish: φ13 to 15.5mm	 For HA-LP For HC-UP For HC-LP For HC-RP	

## 11. OPTIONS AND AUXILIARY EQUIPMENT

### 11.1.2 Encoder cable/connector sets



#### (1) MR-J3ENCBL □ M-A1-L/H • MR-J3ENCBL □ M-A2-L/H

These cables are encoder cables for the HF-MP • HF-KP series servo motors. The numerals in the Cable Length field of the table are the symbols entered in the □ part of the cable model. The cables of the lengths with the symbols are available.

Cable model	Cable length							Protective structure	Flex life	Application
	2m	5m	10m	20m	30m	40m	50m			
MR-J3ENCBL □ M-A1-L	2	5	10	/	/	/	/	IP65	Standard	For HF-MP • HF-KP servo motor
MR-J3ENCBL □ M-A1-H	2	5	10	/	/	/	/	IP65	Long flex life	Load side lead
MR-J3ENCBL □ M-A2-L	2	5	10	/	/	/	/	IP65	Standard	For HF-MP • HF-KP servo motor
MR-J3ENCBL □ M-A2-H	2	5	10	/	/	/	/	IP65	Long flex life	Opposite-to-load side lead

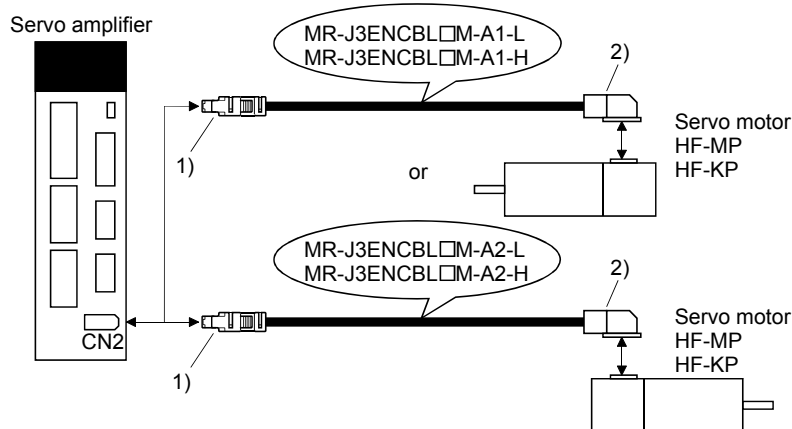
#### (a) Connection of servo amplifier and servo motor

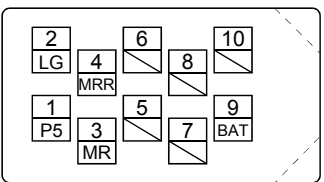
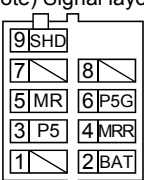
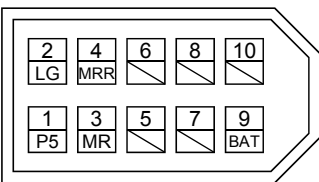
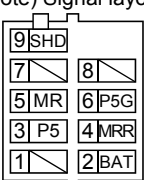

Cable model	1) For CN2 connector	2) For encoder connector
MR-J3ENCBL □ M-A1-L	Receptacle: 36210-0100PL Shell kit: 36310-3200-008 (3M)	Connector: 1674320-1 Crimping tool for ground clip: 1596970-1 Crimping tool for receptacle contact: 1596847-1 (Tyco Electronics)
MR-J3ENCBL □ M-A1-H	(Note) Signal layout  View seen from wiring side.	(Note) Signal layout  View seen from wiring side.
MR-J3ENCBL □ M-A2-L	(Note) Signal layout  View seen from wiring side.	(Note) Signal layout  View seen from wiring side.
MR-J3ENCBL □ M-A2-H	Note. Keep open the pins shown with  . Especially, pin 10 is provided for manufacturer adjustment. If it is connected with any other pin, the servo amplifier cannot operate normally.	Note. Keep open the pin shown with an  .

## 11. OPTIONS AND AUXILIARY EQUIPMENT

(b) Cable internal wiring diagram

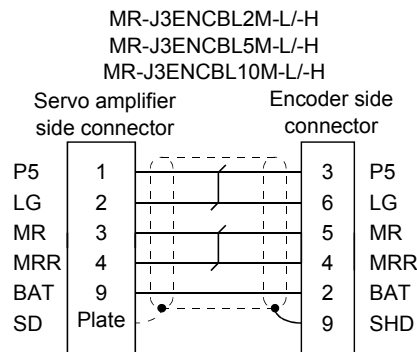

(2) MR-EKCBL □ M-L/H

POINT
<ul style="list-style-type: none"> <li>The following encoder cables are of four-wire type. When using any of these encoder cables, set parameter No.PC04 to "1 □ □ □" to select the four-wire type.</li> </ul> <p>MR-EKCBL30M-L MR-EKCBL30M-H MR-EKCBL40M-H MR-EKCBL50M-H</p>

The servo amplifier and servo motor cannot be connected with these cables only. The servo motor side encoder cable (MR-J3JCBL03M-A1-L or MR-J3JCBL03M-A2-L) is required.

The numerals in the Cable Length field of the table are the symbols entered in the □ part of the cable model. The cables of the lengths with the symbols are available.





Cable model	Cable length							Protective structure	Flex life	Application
	2m	5m	10m	20m	30m	40m	50m			
MR-EKCBL □ M-L				20	(Note) 30			IP20	Standard	For HF-MP • HF-KP servo motor
MR-EKCBL □ M-H				20	(Note) 30	(Note) 40	(Note) 50	IP20	Long flex life	Use in combination with MR-J3JCBL03M-A1-L or MR-J3JCBL03M-A2-L.

Note. Four-wire type cable.

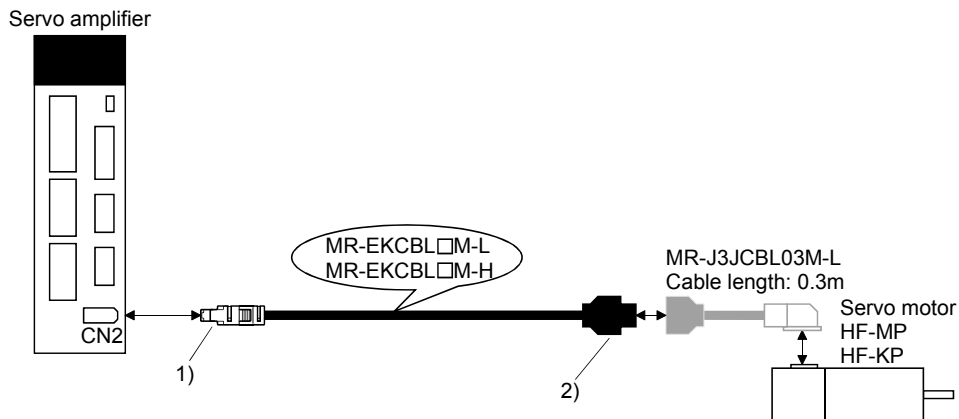
## 11. OPTIONS AND AUXILIARY EQUIPMENT

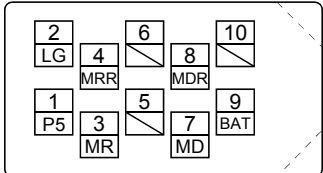
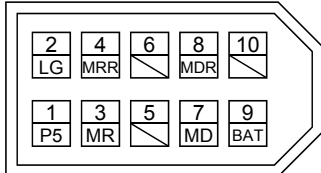
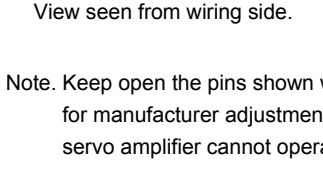
### (a) Connection of servo amplifier and servo motor

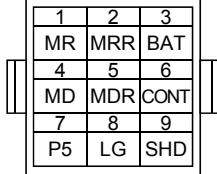

Cable model	1) For CN2 connector	2) For encoder connector
MR-EKCBL □ M-L	<p>Receptacle: 36210-0100PL Shell kit: 36310-3200-008 (3M)</p> <p>(Note) Signal layout</p>  <p>View seen from wiring side.</p>	<p>Housing: 1-172161-9 Crimping pin: 170359-1 (Tyco Electronics or equivalent) Cable clamp: MTI-0002 (Toa Electric Industries)</p> <p>Signal layout</p>  <p>View seen from wiring side.</p>
MR-EKCBL □ M-H	<p>(Note) Signal layout</p>  <p>View seen from wiring side.</p> <p>Note. Keep open the pins shown with . Especially, pin 10 is provided for manufacturer adjustment. If it is connected with any other pin, the servo amplifier cannot operate normally.</p>	<p>Signal layout</p>  <p>View seen from wiring side.</p> <p>Note. Keep open the pin shown with an .</p>

## 11. OPTIONS AND AUXILIARY EQUIPMENT

### (b) Internal wiring diagram

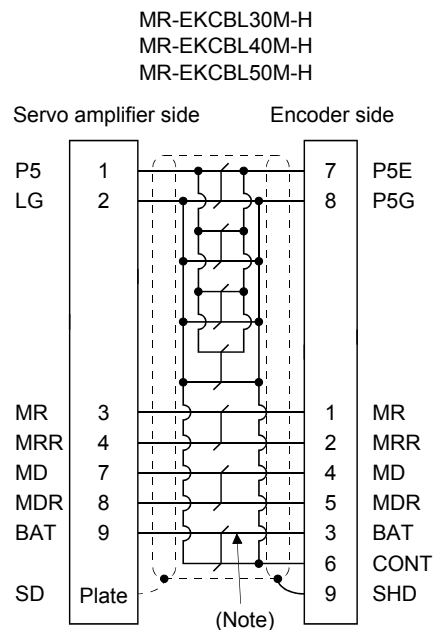
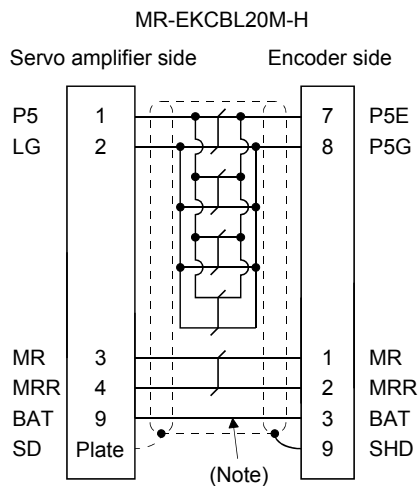
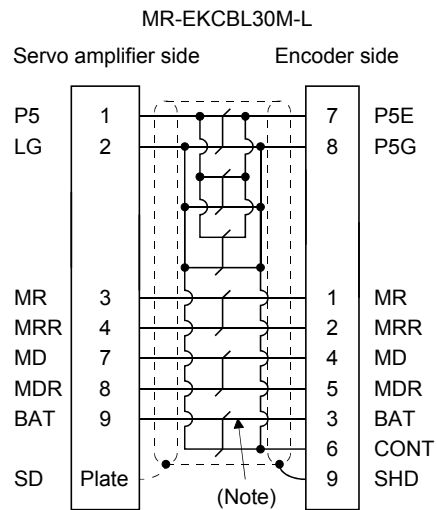
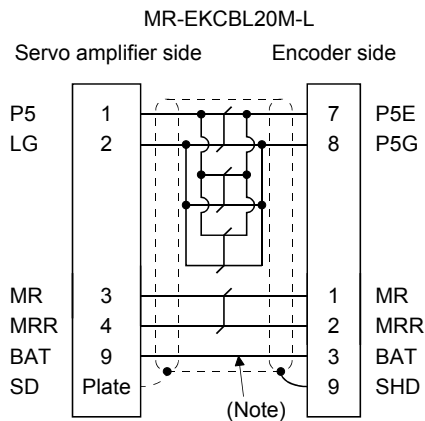

Note. Always make connection for use in an absolute position detection system. Wiring is not necessary for use in an incremental system.



When fabricating the cable, use the wiring diagram corresponding to the length indicated below.

Cable flex life	Applicable wiring diagram	
	Less than 10m	30m to 50m
Standard	MR-EKCBL20M-L	
Long flex life	MR-EKCBL20M-H	MR-EKCBL30M-H MR-EKCBL40M-H MR-EKCBL50M-H

## 11. OPTIONS AND AUXILIARY EQUIPMENT

### (c) When fabricating the encoder cable

When fabricating the cable, prepare the following parts and tool, and fabricate it according to the wiring diagram in (b). Refer to section 11.8 for the specifications of the used cable.

Parts/tool	Description	
Connector set	MR-ECNM	
		
	Servo amplifier side connector Receptacle: 36210-0100PL Shell kit: 536310-3200-008 (3M) Or Connector set: 54599-1019(Molex)	Encoder side connector Housing: 1-172161-9 Connector pin: 170359-1 (Tyco Electronics or equivalent) Cable clamp: MTI-0002 (Toa Electric Industries)

### (3) MR-J3JCBL03M-A1-L • MR-J3JCBL03M-A2-L

The servo amplifier and servo motor cannot be connected with these cables only. The servo motor side encoder cable (MR-EKCBL □ M-L/H) is required.

Cable model	Cable length	Protective structure	Flex life	Application
MR-J3JCBL03M-A1-L	0.3m	IP20	Standard	For HF-MP • HF-KP servo motor Load side lead Use in combination with MR-EKCBL □ M-L/H.
MR-J3JCBL03M-A2-L				For HF-MP • HF-KP servo motor Opposite-to-load side lead Use in combination with MR-EKCBL □ M-L/H.

# 11. OPTIONS AND AUXILIARY EQUIPMENT

(a) Connection of servo amplifier and servo motor

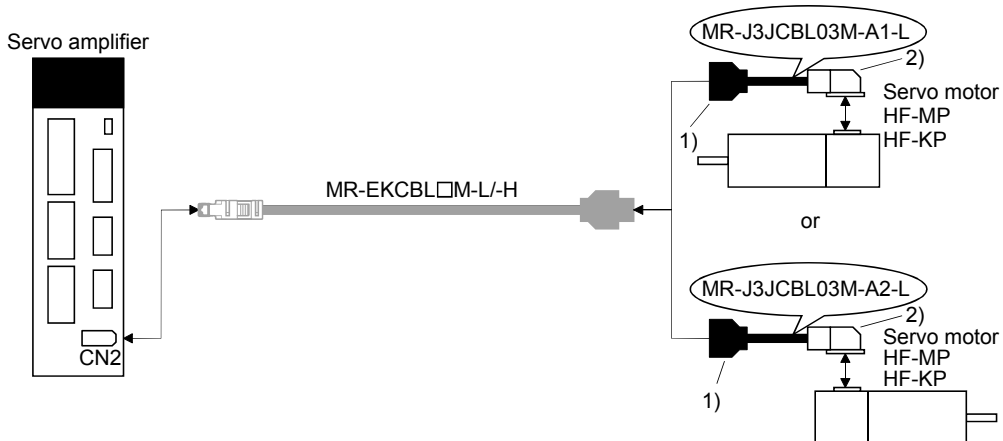

Cable model	1) Junction connector	2) For encoder connector																																				
MR-J3JCBL03M-A1-L	Housing: 1-172169-9 Contact: 1473226-1 Cable clamp: 316454-1 Crimping tool: 91529-1 (Tyco Electronics)	Connector: 1674320-1 Crimping tool for ground clip: 1596970-1 Crimping tool for receptacle contact: 1596847-1 (Tyco Electronics)																																				
MR-J3JCBL03M-A2-L	<p style="text-align: center;">Signal layout</p> <table border="1" style="margin: auto;"> <tr><td>3</td><td>2</td><td>1</td></tr> <tr><td>BAT</td><td>MRR</td><td>MR</td></tr> <tr><td>6</td><td>5</td><td>4</td></tr> <tr><td>CONT</td><td>MDR</td><td>MD</td></tr> <tr><td>9</td><td>8</td><td>7</td></tr> <tr><td>SHD</td><td>LG</td><td>P5</td></tr> </table> <p style="text-align: center;">View seen from wiring side.</p>	3	2	1	BAT	MRR	MR	6	5	4	CONT	MDR	MD	9	8	7	SHD	LG	P5	<p style="text-align: center;">Signal layout</p> <table border="1" style="margin: auto;"> <tr><td>9</td><td>SHD</td></tr> <tr><td>7</td><td>MDR</td><td>8</td><td>MD</td></tr> <tr><td>5</td><td>MR</td><td>6</td><td>P5G</td></tr> <tr><td>3</td><td>P5</td><td>4</td><td>MRR</td></tr> <tr><td>1</td><td>CONT</td><td>2</td><td>BAT</td></tr> </table> <p style="text-align: center;">View seen from wiring</p>	9	SHD	7	MDR	8	MD	5	MR	6	P5G	3	P5	4	MRR	1	CONT	2	BAT
3	2	1																																				
BAT	MRR	MR																																				
6	5	4																																				
CONT	MDR	MD																																				
9	8	7																																				
SHD	LG	P5																																				
9	SHD																																					
7	MDR	8	MD																																			
5	MR	6	P5G																																			
3	P5	4	MRR																																			
1	CONT	2	BAT																																			

(b) Internal wiring diagram

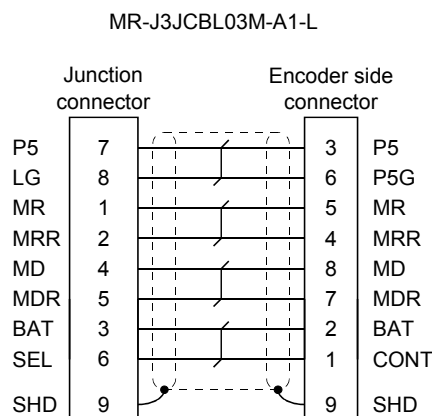

## 11. OPTIONS AND AUXILIARY EQUIPMENT





### (4) MR-J3ENSCBL □ M-L • MR-J3ENSCBL □ M-H

These cables are detector cables for HF-SP • HA-LP • HC-RP • HC-UP • HC-LP Series servo motors. The number in the cable length column of the table indicates the symbol filling the square □ in the cable model. Cable lengths corresponding to the specified symbols are prepared.

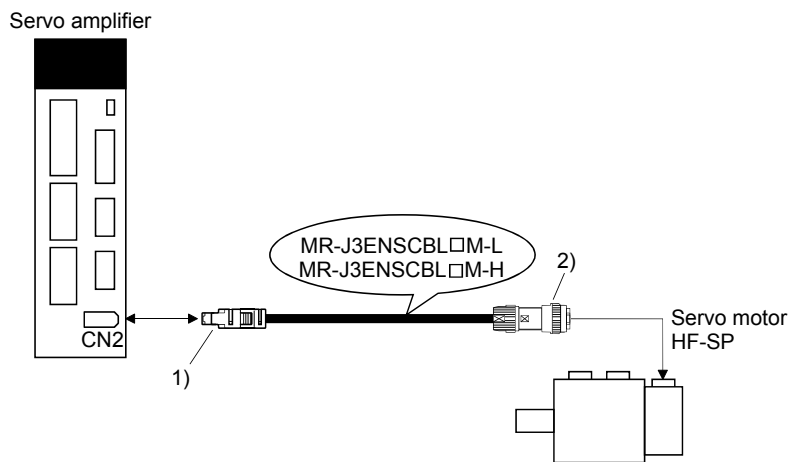
Cable model	Cable length							Protective structure	Flex life	Application
	2m	5m	10m	20m	30m	40m	50m			
MR-J3ENSCBL □ M-L	2	5	10	20	30	/	/	IP67	Standard	For HF-SP • HA-LP • HC-RP • HC-UP • HC-LP servo motor
MR- J3ENSCBL □ M-H	2	5	10	20	30	40	50	IP67	Long flex life	

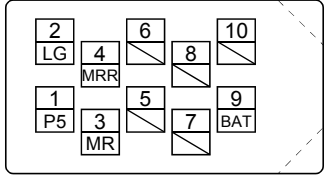
#### (a) Connection of servo amplifier and servo motor

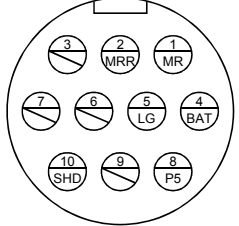

Cable model	1) For CN2 connector	2) For encoder connector
MR-J3ENSCBL □ M-L	<p>Receptacle: 36210-0100PL Shell kit: 36310-3200-008 (3M)</p> <p>(Note) Signal layout</p>  <p>View seen from wiring side.</p>	<p>Connector set: 54599-1019(Molex)</p> <p>In case of 10m or shorter cables Straight plug: CM10-SP10S-M Socket contact: CM10- #22SC(C1)-100 Crimping tool: 357J-50446 (DDK) Applicable cable AWG20 to 22</p> <p>In case of 20m or longer cables Straight plug: CM10-SP10S-M Socket contact: CM10- #22SC(C2)-100 Crimping tool: 357J-50447 (DDK) Applicable cable AWG23 to 28</p>
MR-J3ENSCBL □ M-H	<p>Note. Keep open the pins shown with . Especially, pin 10 is provided for manufacturer adjustment. If it is connected with any other pin, the servo amplifier cannot operate normally.</p>	<p>(Note) Signal layout</p>  <p>View seen from wiring side</p> <p>Note. Keep open the pin shown with an .</p>

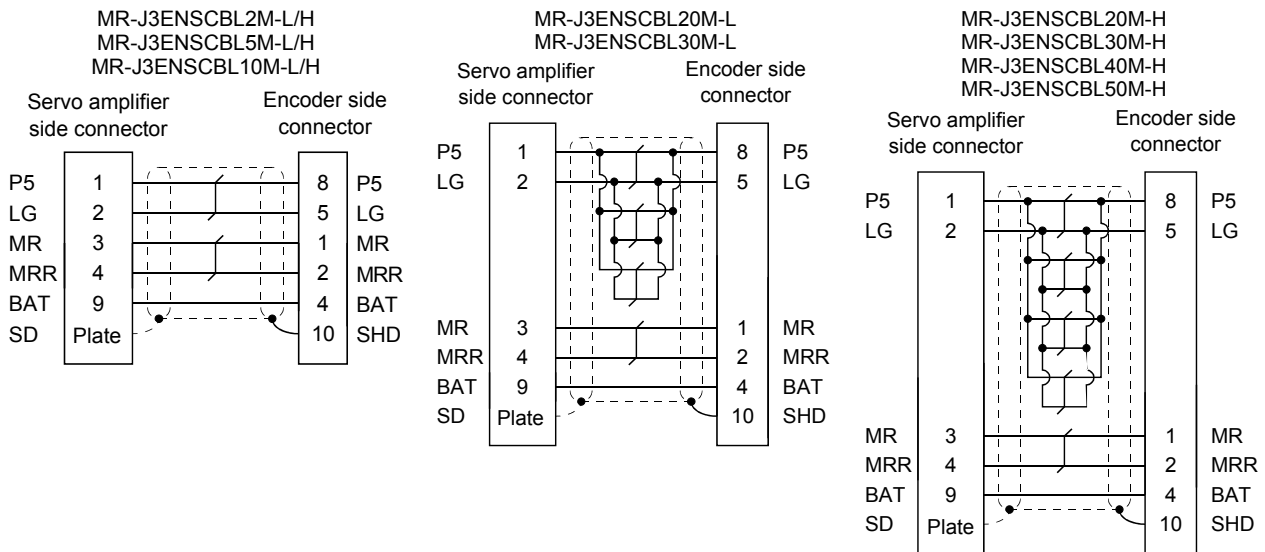

## 11. OPTIONS AND AUXILIARY EQUIPMENT

### (b) Internal wiring diagram



### (c) When fabricating the encoder cable

When fabricating the cable, prepare the following parts and tool, and fabricate it according to the wiring diagram in (b). Refer to section 11.8 for the specifications of the used cable.

Parts/Tool	Description
Connector set	MR- J3SCNS (Option)
	 
	Servo amplifier side connector Receptacle: 36210-0100PL Shell kit: 536310-3200-008 (3M) Or Connector set: 54599-1019 (Molex)
	Encoder side connector Straight plug: CM10-SP10S-M Socket contact: CM10-#22SC(S1)-100 Applicable wire size: AWG20 or less Recommended tightening jig: 357J-51456T (DDK)

## 11. OPTIONS AND AUXILIARY EQUIPMENT

### (5) MR-J3BTCBL03M

This cable is a battery connection cable. Use this cable to retain the current position even if the detector cable is disconnected from the servo amplifier.

Cable model	Cable length	Application
MR-J3BTCBL03M	0.3m	For HF-MP ▪ HF-KP ▪ HF-SP ▪ HA-LP ▪ HC-RP ▪ HC-UP ▪ HC-LP servo motor

#### (a) Connection of servo amplifier and servo motor

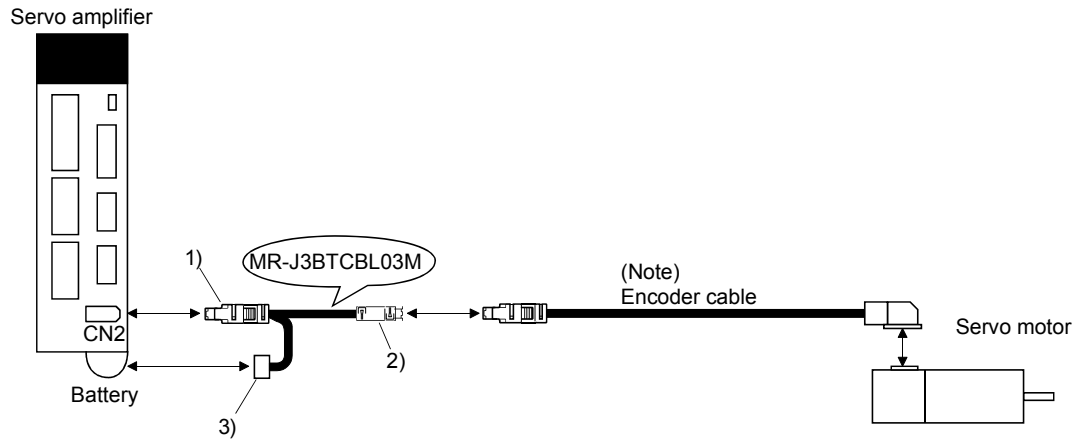

Note. For the detector cable, refer to (1), (2), (3) and (4) of this section.

Cable model	1) For CN2 connector	2) Junction connector	3) For battery connector
MR-J3BTCBL03M	Receptacle: 36210-0100PL Shell kit: 536310-3200-008 (3M) Or Connector set: 54599-1019 (Molex)	Plug: 36110-3000FD Shell kit: 36310-F200-008 (3M)	Connector: DF3-2EP-2C Contact: DF3-EP2428PCA (Hirose Denki)

## 11. OPTIONS AND AUXILIARY EQUIPMENT

### 11.1.3 Motor power supply cables

These cables are motor power supply cables for the HF-MP • HF-KP series servo motors. The numerals in the Cable length field of the table are the symbols entered in the □ part of the cable model. The cables of the lengths with the symbols are available.

Refer to section 3.10 when wiring.

Cable model	Cable length				Protective structure	Flex life	Application
	0.3m	2m	5m	10m			
MR-PWS1CBL □ M-A1-L		2	5	10	IP65	Standard	For HF-MP • HF-KP servo motor Load side lead
MR-PWS1CBL □ M-A2-L		2	5	10	IP65	Standard	For HF-MP • HF-KP servo motor Opposite-to-load side lead
MR-PWS1CBL □ M-A1-H		2	5	10	IP65	Long flex life	For HF-MP • HF-KP servo motor Load side lead
MR-PWS1CBL □ M-A2-H		2	5	10	IP65	Long flex life	For HF-MP • HF-KP servo motor Opposite-to-load side lead
MR-PWS2CBL □ M-A1-L	03				IP55	Standard	For HF-MP • HF-KP servo motor Load side lead
MR-PWS2CBL □ M-A2-L	03				IP55	Standard	For HF-MP • HF-KP servo motor Opposite-to-load side lead

#### (1) Connection of servo amplifier and servo motor

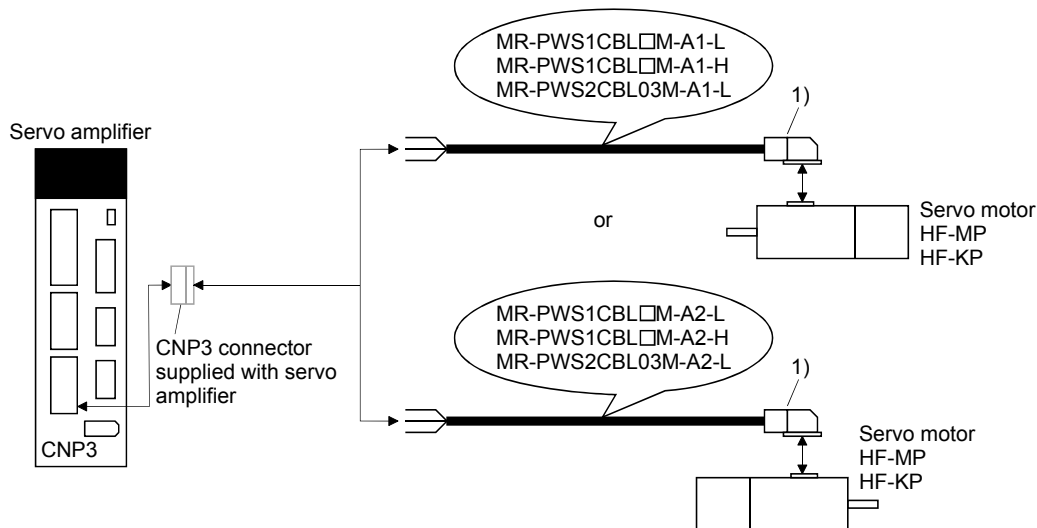

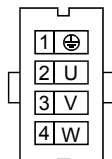
Cable model	1) For motor power supply connector	
MR-PWS1CBL □ M-A1-L	Connector: JN4FT04SJ1-R Hood, socket insulator Bushing, ground nut Contact: ST-TMH-S-C1B-100-(A534G) Crimping tool: CT160-3-TMH5B (Japan Aviation Electronics Industry)	Signal layout  View seen from wiring side.
MR-PWS1CBL □ M-A2-L		
MR-PWS1CBL □ M-A1-H		
MR-PWS1CBL □ M-A2-H		
MR-PWS2CBL03M-A1-L	Connector: JN4FT04SJ2-R Hood, socket insulator Bushing, ground nut Contact: ST-TMH-S-C1B-100-(A534G) Crimping tool: CT160-3-TMH5B (Japan Aviation Electronics Industry)	
MR-PWS2CBL03M-A2-L		

#### (2) Internal wiring diagram

MR-PWS1CBL□M-A1-H    MR-PWS1CBL□M-A2-H  
MR-PWS2CBL03M-A1-L    MR-PWS2CBL03M-A2-L

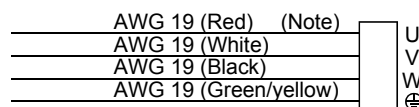

Note. These are not shielded cables.

## 11. OPTIONS AND AUXILIARY EQUIPMENT

### 11.1.4 Motor brake cables

These cables are motor brake cables for the HF-MP • HF-KP series servo motors. The numerals in the Cable length field of the table are the symbols entered in the □ part of the cable model. The cables of the lengths with the symbols are available.

Refer to section 3.11 when wiring.

Cable model	Cable length				Protective structure	Flex life	Application
	0.3m	2m	5m	10m			
MR-PWS1CBL □ M-A1-L		2	5	10	IP65	Standard	For HF-MP • HF-KP servo motor Load side lead
MR-PWS1CBL □ M-A2-L		2	5	10	IP65	Standard	For HF-MP • HF-KP servo motor Opposite-to-load side lead
MR-PWS1CBL □ M-A1-H		2	5	10	IP65	Long flex life	For HF-MP • HF-KP servo motor Load side lead
MR-PWS1CBL □ M-A2-H		2	5	10	IP65	Long flex life	For HF-MP • HF-KP servo motor Opposite-to-load side lead
MR-PWS2CBL □ M-A1-L	03				IP55	Standard	For HF-MP • HF-KP servo motor Load side lead
MR-PWS2CBL □ M-A2-L	03				IP55	Standard	For HF-MP • HF-KP servo motor Opposite-to-load side lead

#### (1) Connection of servo amplifier and servo motor

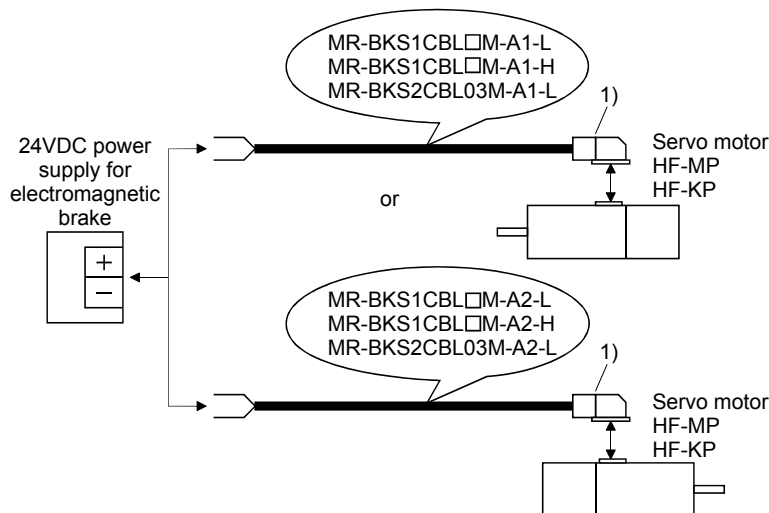

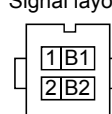
Cable model	1) For motor brake connector	
MR-BKS1CBL □ M-A1-L	Connector: JN4FT02SJ1-R Hood, socket insulator Bushing, ground nut Contact: ST-TMH-S-C1B-100-(A534G) Crimping tool: CT160-3-TMH5B (Japan Aviation Electronics Industry)	Signal layout  View seen from wiring side.
MR-BKS1CBL □ M-A2-L		
MR-BKS1CBL □ M-A1-H		
MR-BKS1CBL □ M-A2-H		
MR-BKS2CBL03M-A1-L	Connector: JN4FT02SJ2-R Hood, socket insulator Bushing, ground nut Contact: ST-TMH-S-C1B-100-(A534G) Crimping tool: CT160-3-TMH5B (Japan Aviation Electronics Industry)	
MR-BKS2CBL03M-A2-L		

#### (2) Internal wiring diagram

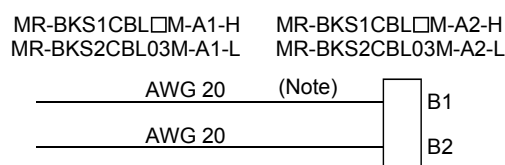

Note. These are not shielded cables.

## 11. OPTIONS AND AUXILIARY EQUIPMENT

### 11.1.5 SSCNETIII cable

POINT
<ul style="list-style-type: none"> <li>Do not see directly the light generated from CN1A · CN1B connector of servo amplifier or the end of SSCNETIII cable. When the light gets into eye, you may feel something is wrong for eye. (The light source of SSCNETIII complies with class1 defined in JIS C6802 or IEC60825-1.)</li> </ul>

#### (1) Model explanations

Numeral in the column of cable length on the table is a symbol put in the □ part of cable model. Cables of which symbol exists are available.

Cable model	Cable length											Flex life	Application · remark
	0.15m	0.3m	0.5m	1m	3m	5m	10m	20m	30m	40m	50m		
MR-J3BUS□M	015	03	05	1	3							Standard	Using inside panel standard cord
MR-J3BUS□M-A						5	10	20				Standard	Using outside panel standard cable
(Note) MR-J3BUS□M-B									30	40	50	Long flex life	Using long distance cable

Note. For cable of 30m or less, contact our company.

#### (2) Specifications

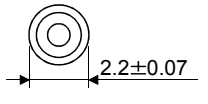
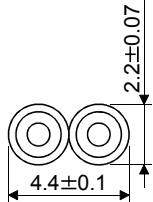
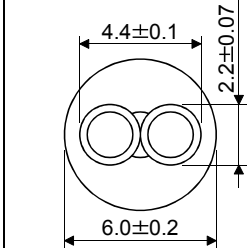
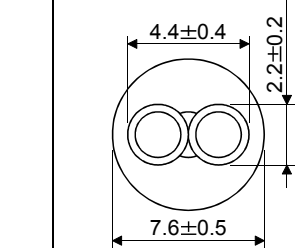
		Description				
SSCNETIII cable model		MR-J3BUS□M		MR-J3BUS□M-A	MR-J3BUS□M-B	
SSCNETIII cable length		0.15m	0.3 to 3m	5 to 20m	30 to 50m	
Optical cable (cord)	Minimum bend radius	25mm			Enforced covering cord: 50mm Cord: 25mm	Enforced covering cord: 50mm Cord: 30mm
	Tension strength	70N	140N	420N (Enforced covering cord)	980N (Enforced covering cord)	
	Temperature range for use (Note)	-40 to 85°C				-20 to 70°C
	Ambient	Indoors (no direct sunlight) No solvent or oil				
External appearance [mm]						

Note. This temperature range for use is the value for optical cable (cord) only. Temperature condition for the connector is the same as that for servo amplifier.

## 11. OPTIONS AND AUXILIARY EQUIPMENT

### (3) Outline drawings

#### (a) MR-J3BUS015M

[Unit: mm]

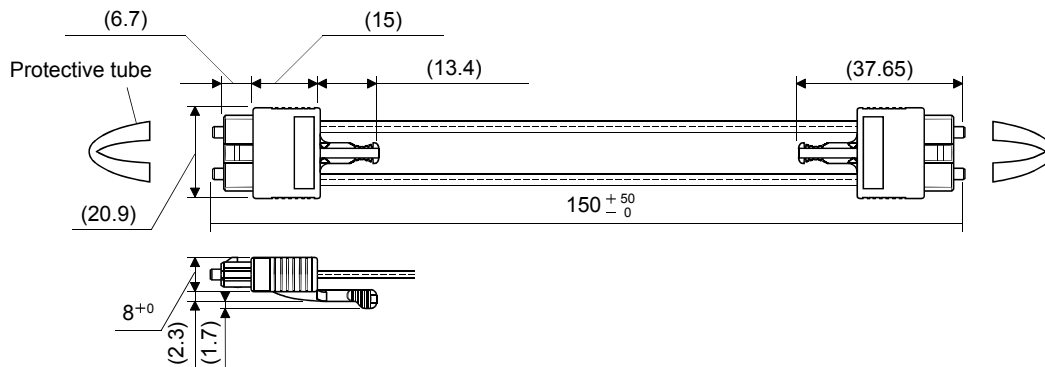

#### (b) MR-J3BUS03M to MR-J3BUS3M

Refer to the table shown in (1) of this section for cable length (L).

[Unit: mm]

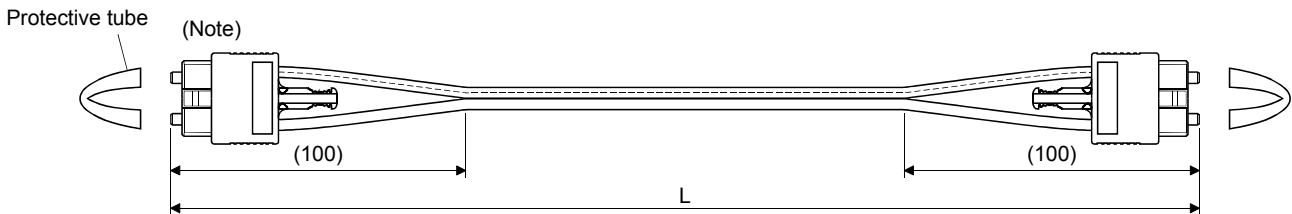

Note. Dimension of connector part is the same as that of MR-J3BUS015M.

#### (c) MR-J3BUS5M-A to MR-J3BUS20M-A • MR-J3BUS30M-B to MR-J3BUS50M-B

Refer to the table shown in (1) of this section for cable length (L).

SSCNETIII cable	Distortion dimension [mm]	
	A	B
MR-J3BUS5M-A to MR-J3BUS20M-A	100	30
MR-J3BUS30M-B to MR-J3BUS50M-B	150	50

[Unit: mm]

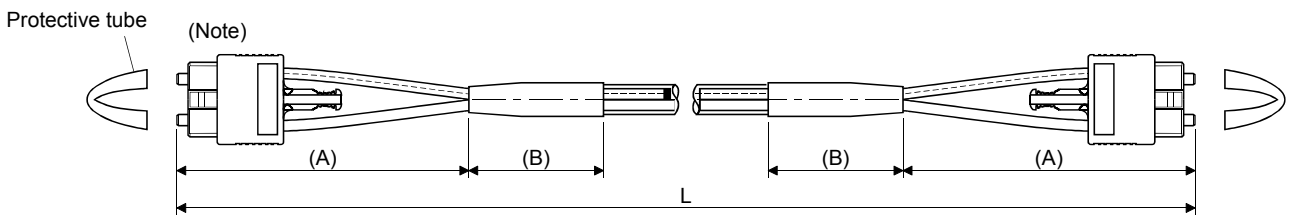

Note. Dimension of connector part is the same as that of MR-J3BUS015M.

## 11. OPTIONS AND AUXILIARY EQUIPMENT

### 11.2 Regenerative options



• The specified combinations of regenerative options and servo amplifiers may only be used. Otherwise, a fire may occur.

#### (1) Combination and regenerative power

The power values in the table are resistor-generated powers and not rated powers.

Servo amplifier	Regenerative power[W]							
	Built-in regenerative resistor	MR-RB032 [40Ω]	MR-RB12 [40Ω]	MR-RB30 [13Ω]	MR-RB31 [6.7Ω]	MR-RB32 [40Ω]	(Note 1) MR-RB50 [13Ω]	(Note 1) MR-MB51 [6.7Ω]
MR-J3-10B (1)		30						
MR-J3-20B (1)	10	30	100					
MR-J3-40B (1)	10	30	100					
MR-J3-60B	10	30	100					
MR-J3-70B	20	30	100			300		
MR-J3-100B	20	30	100			300		
MR-J3-200B	100			300			500	
MR-J3-350B	100			300			500	
MR-J3-500B	130				300			500
MR-J3-700B	170				300			500

Servo amplifier	Regenerative power[W]						
	Built-in regenerative resistor	MR-RB1H-4 [82Ω]	(Note 1) MR-RB3M-4 [120Ω]	(Note 1) MR-RB3G-4 [47Ω]	(Note 1) MR-RB5G-4 [47Ω]	(Note 1) MR-RB34-4 [26Ω]	(Note 1) MR-RB54-4 [26Ω]
MR-J3-60B4	15	100	300				
MR-J3-100B4	15	100	300				
MR-J3-200B4	100			300	500		
MR-J3-350B4	100			300	500		
MR-J3-500B4	130					300	500
MR-J3-700B4	170					300	500

Servo amplifier	(Note 2) Regenerative power[W]						
	External regenerative resistor (Accessory)	MR-RB5E [6Ω]	MR-RB9P [4.5Ω]	MR-RB9F [3Ω]	MR-RB6B-4 [20Ω]	MR-RB60-4 [12.5Ω]	MR-RB6K-4 [10Ω]
MR-J3-11KB	500 (800)	500 (800)					
MR-J3-15KB	850 (1300)		850 (1300)				
MR-J3-22KB	850 (1300)			850 (1300)			
MR-J3-11KB4	500 (800)				500 (800)		
MR-J3-15KB4	850 (1300)					850 (1300)	
MR-J3-22KB4	850 (1300)						850 (1300)

Note 1. Always install a cooling fan.

2. Values in parentheses assume the installation of a cooling fan.

## 11. OPTIONS AND AUXILIARY EQUIPMENT

### (2) Selection of the regenerative option

Use the following method when regeneration occurs continuously in vertical motion applications or when it is desired to make an in-depth selection of the regenerative option.

#### (a) Regenerative energy calculation

Use the following table to calculate the regenerative energy.

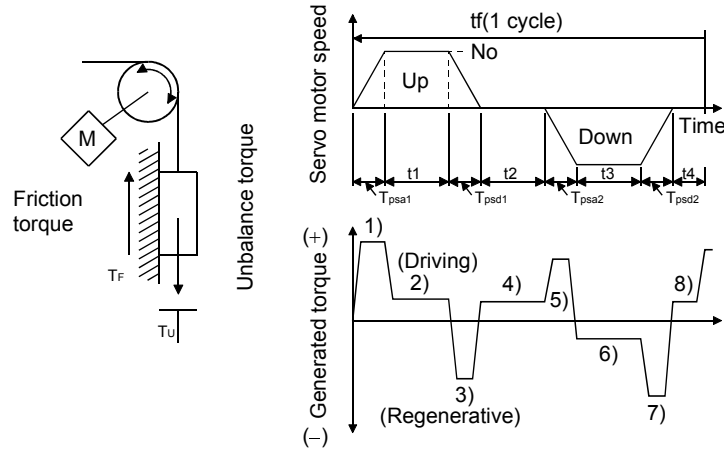

Formulas for calculating torque and energy in operation

Regenerative power	Torque applied to servo motor [N · m]	Energy [J]
1)	$T_1 = \frac{(J_L + J_M) \cdot N_0}{9.55 \times 10^4} \cdot \frac{1}{T_{psa1}} + T_U + T_F$	$E_1 = \frac{0.1047}{2} \cdot N_0 \cdot T_1 \cdot T_{psa1}$
2)	$T_2 = T_U + T_F$	$E_2 = 0.1047 \cdot N_0 \cdot T_2 \cdot t_1$
3)	$T_3 = \frac{-(J_L + J_M) \cdot N_0}{9.55 \times 10^4} \cdot \frac{1}{T_{psd1}} + T_U + T_F$	$E_3 = \frac{0.1047}{2} \cdot N_0 \cdot T_3 \cdot T_{psd1}$
4), 8)	$T_4 = T_U$	$E_4 \geq 0$ (No regeneration)
5)	$T_5 = \frac{(J_L + J_M) \cdot N_0}{9.55 \times 10^4} \cdot \frac{1}{T_{psa2}} - T_U + T_F$	$E_5 = \frac{0.1047}{2} \cdot N_0 \cdot T_5 \cdot T_{psa2}$
6)	$T_6 = -T_U + T_F$	$E_6 = 0.1047 \cdot N_0 \cdot T_6 \cdot t_3$
7)	$T_7 = \frac{-(J_L + J_M) \cdot N_0}{9.55 \times 10^4} \cdot \frac{1}{T_{psd2}} - T_U + T_F$	$E_7 = \frac{0.1047}{2} \cdot N_0 \cdot T_7 \cdot T_{psd2}$

From the calculation results in 1) to 8), find the absolute value ( $E_s$ ) of the sum total of negative energies.

## 11. OPTIONS AND AUXILIARY EQUIPMENT

### (b) Losses of servo motor and servo amplifier in regenerative mode

The following table lists the efficiencies and other data of the servo motor and servo amplifier in the regenerative mode.

Servo amplifier	Inverse efficiency[%]	Capacitor charging[J]	Servo amplifier	Inverse efficiency[%]	Capacitor charging[J]
MR-J3-10B	55	9	MR-J3-200B	85	40
MR-J3-10B1	55	4	MR-J3-200B4	85	25
MR-J3-20B	70	9	MR-J3-350B	85	40
MR-J3-20B1	70	4	MR-J3-350B4	85	36
MR-J3-40B	85	11	MR-J3-500B(4)	90	45
MR-J3-40B1	85	10	MR-J3-700B(4)	90	70
MR-J3-60B(4)	85	11	MR-J3-11KB(4)	90	120
MR-J3-70B	80	18	MR-J3-15KB(4)	90	170
MR-J3-100B	80	18	MR-J3-22KB(4)	90	250
MR-J3-100B4	80	12			

Inverse efficiency ( $\eta$ ) : Efficiency including some efficiencies of the servo motor and servo amplifier when rated (regenerative) torque is generated at rated speed. Since the efficiency varies with the speed and generated torque, allow for about 10%.

Capacitor charging ( $E_c$ ) : Energy charged into the electrolytic capacitor in the servo amplifier.

Subtract the capacitor charging from the result of multiplying the sum total of regenerative energies by the inverse efficiency to calculate the energy consumed by the regenerative option.

$$ER [J] = \eta \cdot E_s - E_c$$

Calculate the power consumption of the regenerative option on the basis of single-cycle operation period  $t_f$  [s] to select the necessary regenerative option.

$$PR [W] = ER/t_f$$

### (3) Parameter setting

Set parameter No.PA02 according to the option to be used.

Parameter No.PA02

0	0		
---	---	--	--

Selection of regenerative option

00: Regenerative option is not used

- For servo amplifier of 100W, regenerative resistor is not used.
- For servo amplifier of 200 to 7kW, built-in regenerative resistor is used.
- Supplied regenerative resistors or regenerative option is used with the servo amplifier of 11k to 22kW.
- For a drive unit of 30kW or more, select regenerative option by the converter unit.

01: FR-BU2-(H)•FR-RC-(H)•FR-CV-(H)

02: MR-RB032

03: MR-RB12

04: MR-RB32

05: MR-RB30

06: MR-RB50(Cooling fan is required)

08: MR-RB31

09: MR-RB51(Cooling fan is required)

80: MR-RB1H-4

81: MR-RB3M-4(Cooling fan is required)

82: MR-RB3G-4(Cooling fan is required)

83: MR-RB5G-4(Cooling fanis required)

84: MR-RB34-4(Cooling fanis required)

85: MR-RB54-4(Cooling fanis required)

FA: Whenhe supplied regenerative resistor is cooled by the cooling fan to increase the ability with the servo amplifier of 11k to 22kW.

## 11. OPTIONS AND AUXILIARY EQUIPMENT

The following are setting values for regenerative resistor and regenerative option which are used with a servo amplifier of 11k to 22kW.

Regenerative resistor, regenerative option	Setting value
Standard supplied regenerative resistor	00
Standard supplied regenerative resistor (with a cooling fan to cool it)	FA
MR-RB5E	00
MR-RB5E (with a cooling fan to cool it)	FA
MR-RB9P	00
MR-RB9P (with a cooling fan to cool it)	FA
MR-RB9F	00
MR-RB9F (with a cooling fan to cool it)	FA
MR-RB6B-4	00
MR-RB6B-4 (with a cooling fan to cool it)	00
MR-RB60-4	FA
MR-RB60-4 (with a cooling fan to cool it)	00
MR-RB6K-4	FA
MR-RB6K-4 (with a cooling fan to cool it)	00

### (4) Connection of the regenerative option

POINT
<ul style="list-style-type: none"> <li>▪ When the MR-RB50 ▪ MR-RB51 ▪ MR-RB3M-4 ▪ MR-RB3G-4 ▪ MR-RB5G-4 ▪ MR-RB34-4 ▪ MR-RB54-4 is used, a cooling fan is required to cool it. The cooling fan should be prepared by the customer.</li> <li>▪ For the sizes of wires used for wiring, refer to section 11.11.</li> </ul>

The regenerative option will cause a temperature rise of +100°C relative to the ambient temperature. Fully examine heat dissipation, installation position, used cables, etc. before installing the option. For wiring, use flame-resistant wires and keep them clear of the regenerative option body. Always use twisted cables of max. 5m length for connection with the servo amplifier.

## 11. OPTIONS AND AUXILIARY EQUIPMENT

(a) MR-J3-350B or less • MR-J3-200B4 or less

Always remove the wiring from across P-D and fit the regenerative option across P-C.

The G3 and G4 terminals act as a thermal sensor. G3-G4 is disconnected when the regenerative option overheats abnormally.

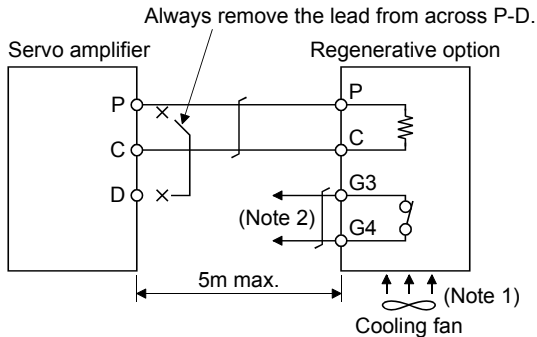

Note 1. When using the MR-RB50 • MR-RB3M-4 • MR-RB3G-4 • MR-RB5G-4, forcibly cool it with a cooling fan (92×92, minimum air flow : 1.0m<sup>3</sup>).

2. Make up a sequence which will switch off the magnetic contactor (MC) when abnormal heating occurs.

G3-G4 contact specifications

Maximum voltage: 120V AC/DC

Maximum current: 0.5A/4.8VDC

Maximum capacity: 2.4VA

For the MR-RB50 • MR-RB3M-4 • MR-RB3G-4 • MR-RB5G-4 install the cooling fan as shown.

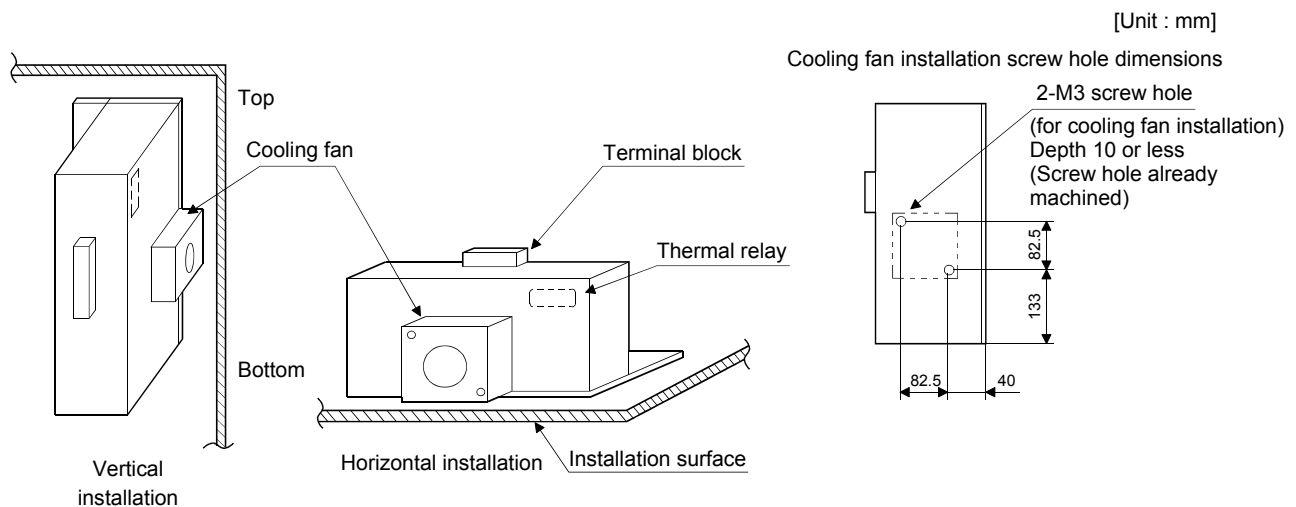

## 11. OPTIONS AND AUXILIARY EQUIPMENT

(b) MR-J3-350B4 • MR-J3-500B(4) • MR-J3-700B(4)

Always remove the wiring (across P-C) of the servo amplifier built-in regenerative resistor and fit the regenerative option across P-C.

The G3 and G4 terminals act as a thermal sensor. G3-G4 is opened when the regenerative option overheats abnormally.

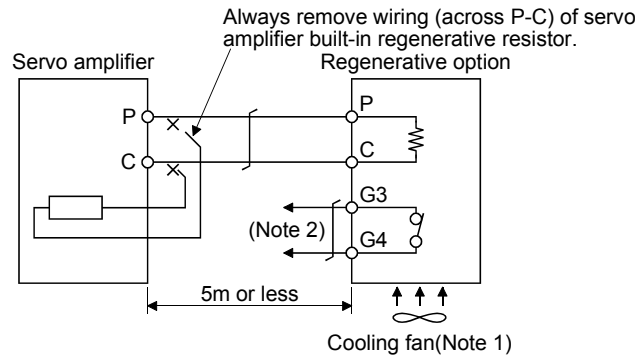

Note 1. When using the MR-RB51 • MR-RB3G-4 • MR-RB5G-4 • MR-RB34-4 • MR-RB54-4, forcibly cool it with a cooling fan (92×92, minimum air flow : 1.0m<sup>3</sup>).

2. Make up a sequence which will switch off the magnetic contactor (MC) when abnormal heating occurs.

G3-G4 contact specifications

Maximum voltage: 120V AC/DC

Maximum current: 0.5A/4.8VDC

Maximum capacity: 2.4VA

When using the regenerative resistor option, remove the servo amplifier's built-in regenerative resistor terminals (across P-C), fit them back to back, and secure them to the frame with the accessory screw as shown below.

### Mounting method

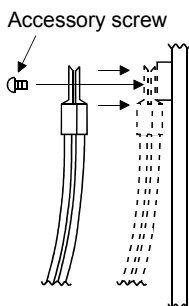

## 11. OPTIONS AND AUXILIARY EQUIPMENT

The drawing below shows the MR-J3-350B4 • MR-J3-500B(4). Refer to section 9.1 (6) outline drawings for the position of the fixing screw for MR-J3-700B(4).

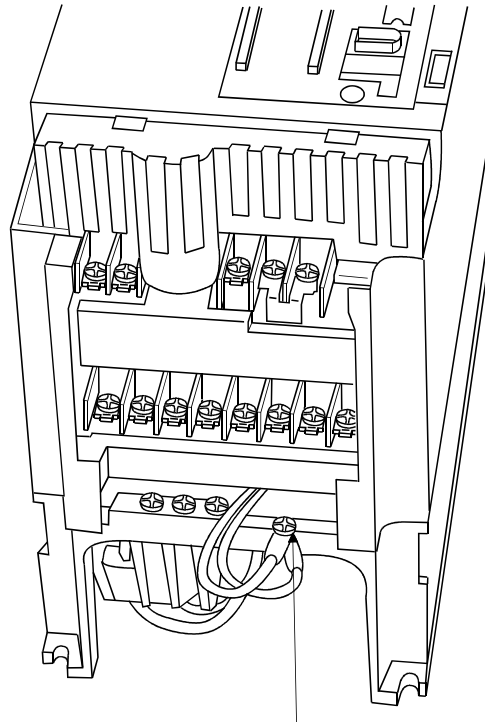

Built-in regenerative resistor  
lead terminal fixing screw

For the MR-RB51, MR-RB3G-4, MR-RB5G-4, MR-RB34-4 or MR-RB54-4 install the cooling fan as shown.

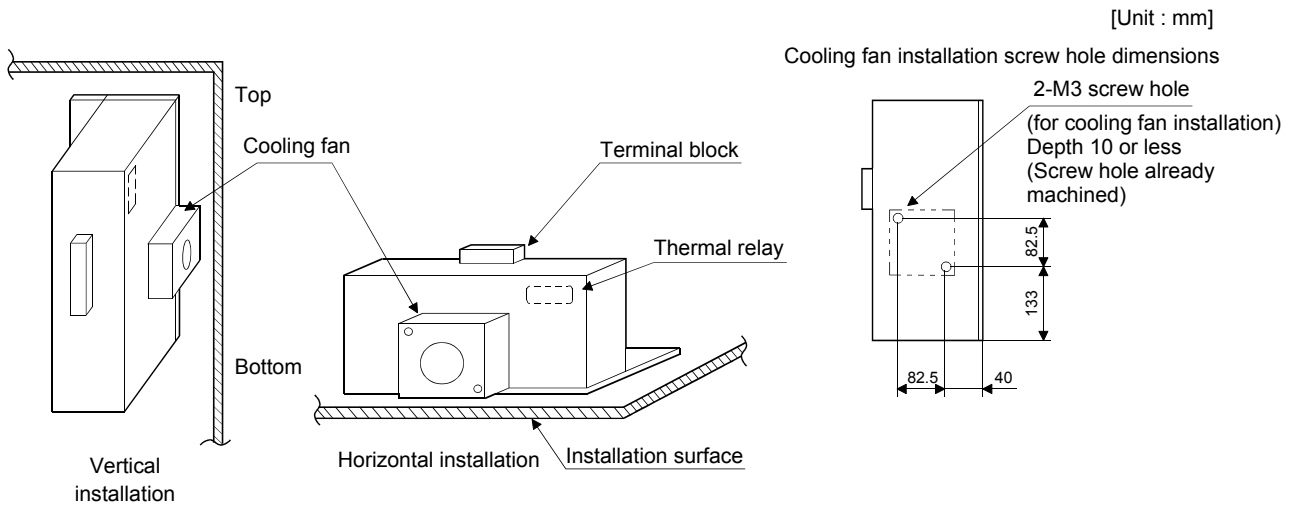

## 11. OPTIONS AND AUXILIARY EQUIPMENT

(c) MR-J3-11KB(4) to MR-J3-22KB(4) (when using the supplied regenerative resistor)

### ! CAUTION

- The regenerative resistor supplied with 11 kW to 22 kW servo amplifiers does not have a protect cover. Touching the resistor (including wiring/screw hole area) may cause a burn injury and electric shock. Even if the power was shut-off, be careful until the bus voltage discharged and the temperature decreased because of the following reasons.
  - It may cause a burn injury due to very high temperature without cooling.
  - It may cause an electric shock due to charged capacitor of the servo amplifier.

When using the regenerative resistors supplied to the servo amplifier, the specified number of resistors (4 or 5 resistors) must be connected in series. If they are connected in parallel or in less than the specified number, the servo amplifier may become faulty and/or the regenerative resistors burn. Install the resistors at intervals of about 70mm. Cooling the resistors with two cooling fans (92×92, minimum air flow : 1.0m<sup>3</sup>) improves the regeneration capability. In this case, set "□□FA" in parameter No.PA02.

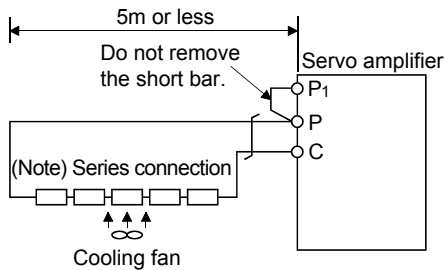

Note. The number of resistors connected in series depends on the resistor type. The thermal sensor is not mounted on the attached regenerative resistor. An abnormal heating of resistor may be generated at a regenerative circuit failure. Install a thermal sensor near the resistor and establish a protective circuit to shut off the main circuit power supply when abnormal heating occurs. The detection level of the thermal sensor varies according to the settings of the resistor. Set the thermal sensor in the most appropriate position on your design basis or use the thermal sensor built-in regenerative option (MR-RB5E, 9P, 9F, 6B-4, 60-4 and 6K-4) provided by Mitsubishi Electric Corporation.

Servo amplifier	Regenerative resistor	Regenerative power [W]		Resistance [Ω]	Number of resistors
		Normal	Cooling		
MR-J3-11KB	GRZG400-1.5Ω	500	800	6	4
MR-J3-15KB	GRZG400-0.9Ω	850	1300	4.5	5
MR-J3-22KB	GRZG400-0.6Ω	850	1300	3	5
MR-J3-11KB4	GRZG400-5.0Ω	500	800	20	4
MR-J3-15KB4	GRZG400-2.5Ω	850	1300	12.5	5
MR-J3-22KB4	GRZG400-2.0Ω	850	1300	10	5

## 11. OPTIONS AND AUXILIARY EQUIPMENT

### (d) MR-J3-11KB(4)-PX to MR-J3-22KB(4)-PX (when using the regenerative option)

The MR-J3-11KB(4)-PX to MR-J3-22KB(4)-PX servo amplifiers are not supplied with regenerative resistors. When using any of these servo amplifiers, always use the MR-RB5E, 9P, 9F, 6B-4, 60-4 and 6K-4 regenerative option.

The MR-RB5E, 9P, 9F, 6B-4, 60-4 and 6K-4 are regenerative options that have encased the GRZG400-1.5Ω, GRZG400-0.9Ω, GRZG400-0.6Ω, GRZG400-5.0Ω, GRZG400-2.5Ω, GRZG400-2.0Ω respectively. When using any of these regenerative options, make the same parameter setting as when using the GRZG400-1.5Ω, GRZG400-0.9Ω, GRZG400-0.6Ω, GRZG400-5.0Ω, GRZG400-2.5Ω, GRZG400-2.0Ω (supplied regenerative resistors or regenerative option is used with 11kW or more servo amplifier).

Cooling the regenerative option with cooling fans improves regenerative capability.

The G3 and G4 terminals are for the thermal protector. G3-G4 is opened when the regenerative option overheats abnormally.

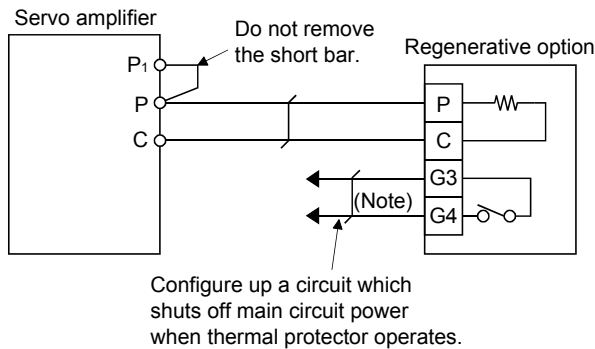

Note. Specifications of contact across G3-G4

Maximum voltage : 120V AC/DC

Maximum current : 0.5A/4.8VDC

Maximum capacity : 2.4VA

Servo amplifier	Regenerative option model	Resistance [ $\Omega$ ]	Regenerative power [W]	
			Without cooling fans	With cooling fans
MR-J3-11KB-PX	MR-RB5E	6	500	800
MR-J3-15KB-PX	MR-RB9P	4.5	850	1300
MR-J3-22KB-PX	MR-RB9F	3	850	1300
MR-J3-11KB4-PX	MR-RB6B-4	20	500	800
MR-J3-15KB4-PX	MR-RB60-4	12.5	850	1300
MR-J3-22KB4-PX	MR-RB6K-4	10	850	1300

When using cooling fans, install them using the mounting holes provided in the bottom of the regenerative option. In this case, set "□□FA" in parameter No.PA02.

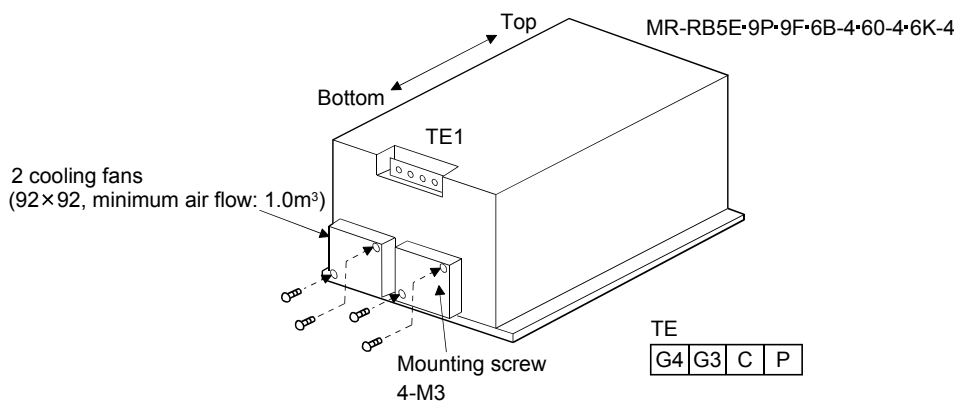

## 11. OPTIONS AND AUXILIARY EQUIPMENT

### (5) Outline drawing

#### (a) MR-RB032 · MR-RB12

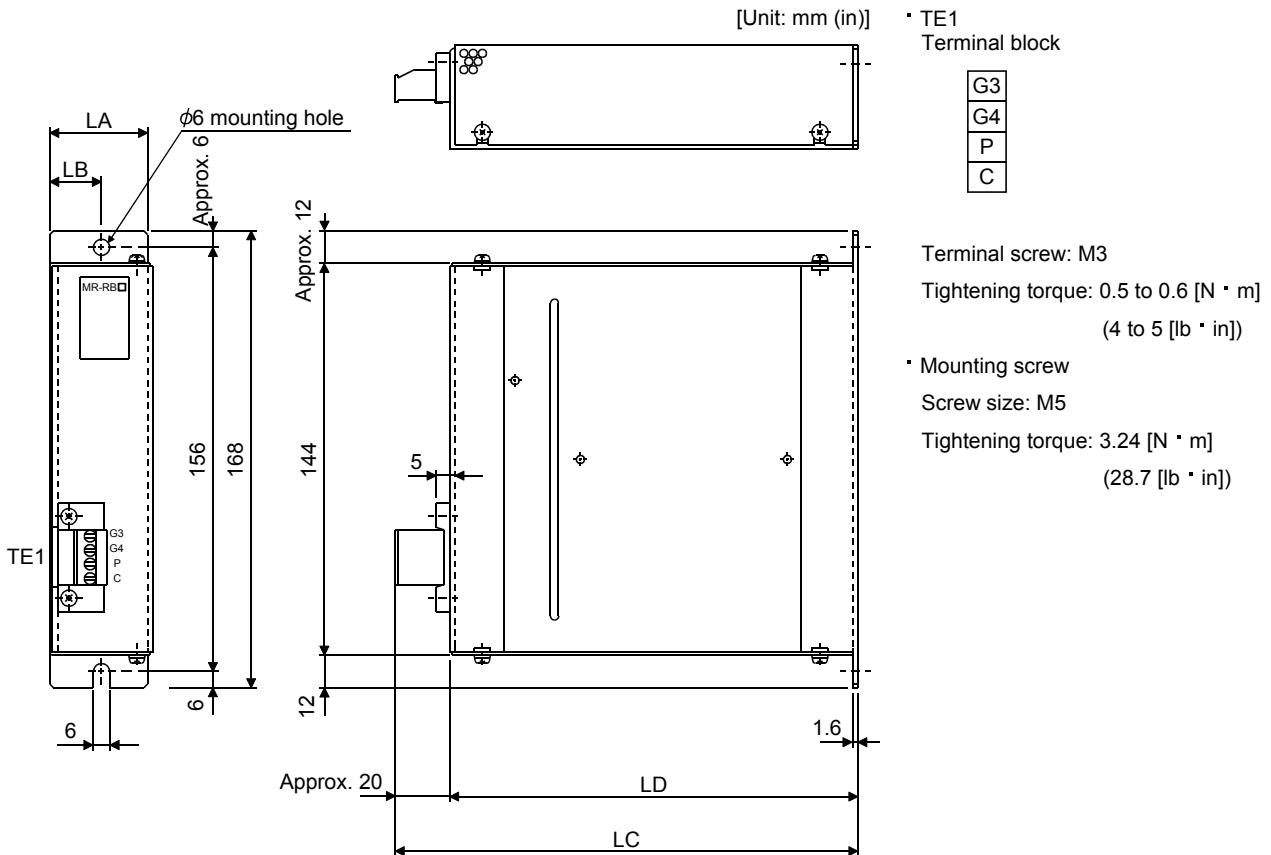

Regenerative option	Variable dimensions				Mass	
	LA	LB	LC	LD	[kg]	[lb]
MR-RB032	30	15	119	99	0.5	1.1
MR-RB12	40	15	169	149	1.1	2.4

## 11. OPTIONS AND AUXILIARY EQUIPMENT

### (b) MR-RB30 · MR-RB31 · MR-RB32 · MR-RB34-4 · MR-RB3M-4 · MR-RB3G-4

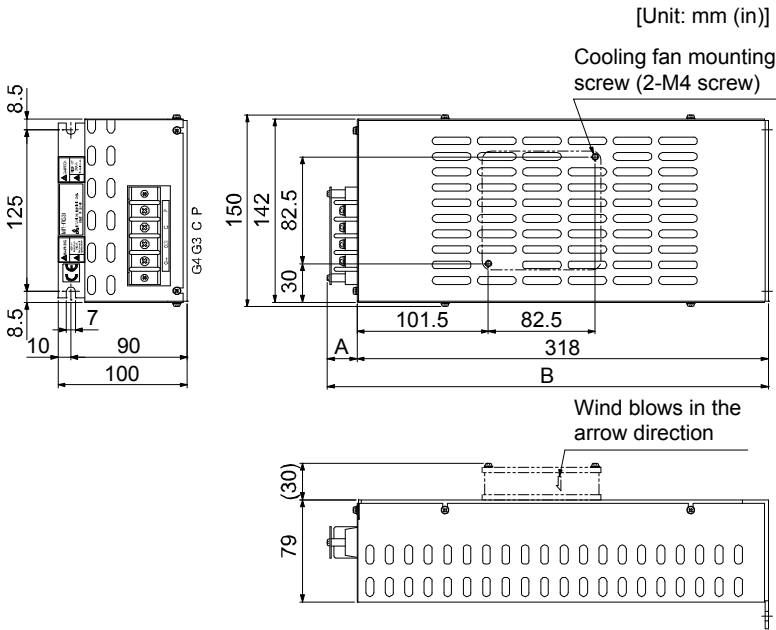

TE1 Terminal block

P
C
G3
G4

Terminal screw: M4  
Tightening torque: 1.2 [N · m] (10.62 [lb · in])  
Mounting screw  
Screw size: M6  
Tightening torque: 5.4 [N · m] (47.79 [lb · in])

Regenerative option	Variable dimensions		Mass [kg] (lb)
	A	B	
MR-RB30	17	335	2.9 (6.4)
MR-RB31			
MR-RB32			
MR-RB34-4	23	341	
MR-RB3M-4			
MR-RB3G-4			

### (c) MR-RB50 · MR-RB51 · MR-RB54-4 · MR-RB5G-4

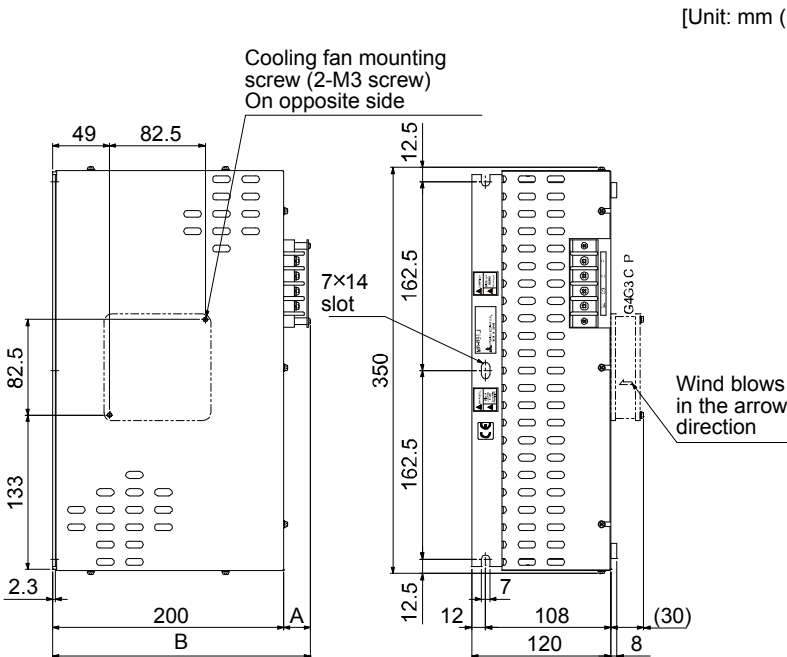

TE1 Terminal block

P
C
G3
G4

Terminal screw: M4  
Tightening torque: 1.2 [N · m] (10.62 [lb · in])  
Mounting screw  
Screw size: M6  
Tightening torque: 5.4 [N · m] (47.79 [lb · in])

Regenerative option	Variable dimensions		Mass [kg] (lb)
	A	B	
MR-RB50	17	217	5.6 (12.3)
MR-RB51			
MR-RB54-4	23	233	
MR-RB5G-4			

## 11. OPTIONS AND AUXILIARY EQUIPMENT

### (d) MR-RB5E • MR-RB9P • MR-RB9F • MR-RB6B-4 • MR-RB60-4 • MR-RB6K-4

[Unit: mm (in)]

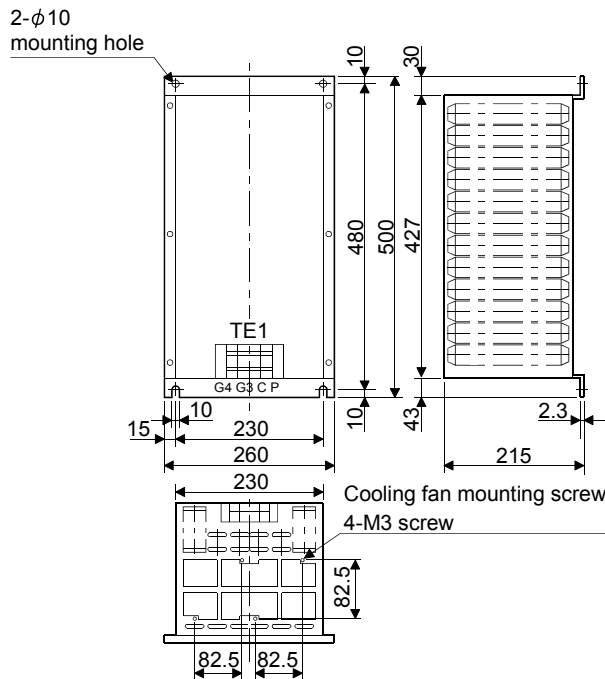

• Terminal block

G4	G3	C	P
----	----	---	---

Terminal screw: M5

Tightening torque: 2.0 [N · m] (17.70 [lb · in])

• Mounting screw

Screw size: M8

Tightening torque: 13.2 [N · m] (116.83 [lb · in])

Regenerative option	Mass	
	[kg]	[lb]
MR-RB5E	10	22.0
MR-RB9P	11	24.3
MR-RB9F	11	24.3
MR-RB6B-4	10	22.0
MR-RB60-4	11	24.3
MR-RB6K-4	11	24.3

### (e) GRZG400-1.5 $\Omega$ • GRZG400-0.9 $\Omega$ • GRZG400-0.6 $\Omega$ • GRZG400-5.0 $\Omega$ • GRZG400-2.5 $\Omega$ • GRZG400-2.0 $\Omega$ (standard accessories)

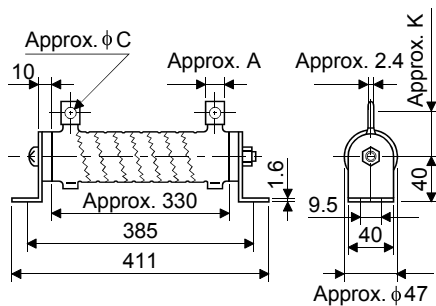

Regenerative brake	Variable dimensions			Mounting screw size	Tightening torque [N · m] (lb · in)	Mass [kg] (lb)
	A	C	K			
GRZG400-1.5 $\Omega$	10	5.5	39	M8	13.2 (116.83)	0.8 (1.76)
GRZG400-0.9 $\Omega$						
GRZG400-0.6 $\Omega$	16	8.2	46			
GRZG400-5.0 $\Omega$						
GRZG400-2.5 $\Omega$	10	5.5	39			
GRZG400-2.0 $\Omega$						

## 11. OPTIONS AND AUXILIARY EQUIPMENT

(f) MR-RB1H-4

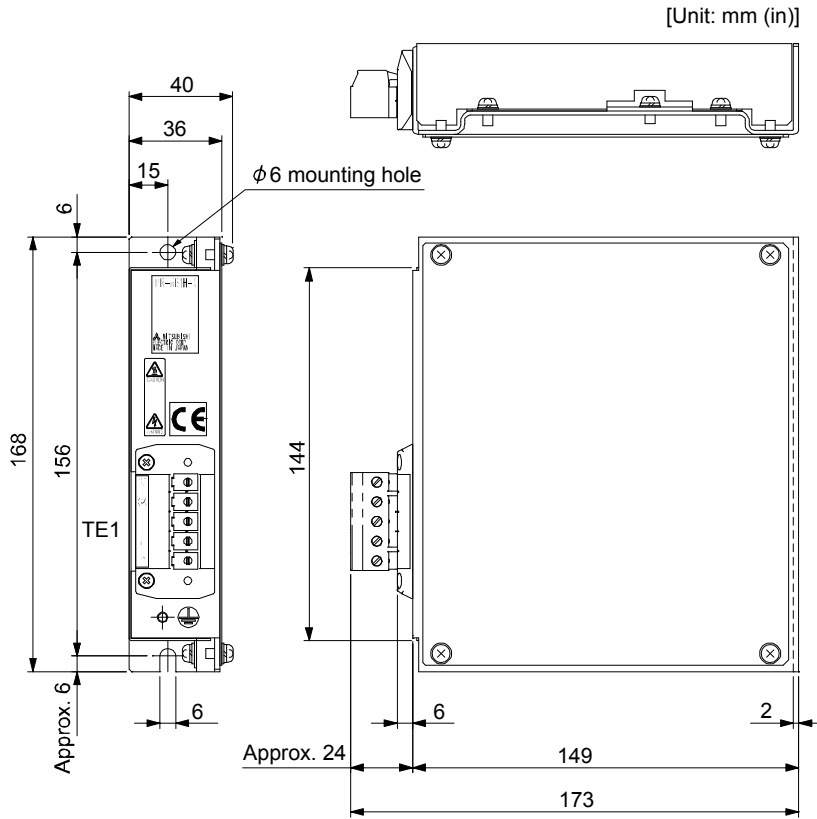

Terminal screw: M3  
Tightening torque: 0.5 to 0.6 [N · m]  
(4.43 to 5.31 [lb · in])

G3
G4
P
⊘
C

• Mounting screw  
Screw size: M5  
Tightening torque: 3.24 [N · m]  
(28.32 [lb · in])

Regenerative option	Mass [kg] ([lb])
MR-RB1H-4	1.1 (2.4)

## 11. OPTIONS AND AUXILIARY EQUIPMENT

### 11.3 FR-BU2-(H) Brake unit

POINT
<ul style="list-style-type: none"><li>▪ Use a 200V class brake unit and a resistor unit with a 200V class servo amplifier, and a 400V class brake unit and a resistor unit with a 400V class servo amplifier. Combination of different voltage class units and servo amplifier cannot be used.</li><li>▪ Install a brake unit and a resistor unit on a flat surface vertically. When the unit is installed horizontally or diagonally, the heat dissipation effect diminishes.</li><li>▪ Temperature of the resistor unit case rises to higher than 100°C. Keep cables and flammable materials away from the case.</li><li>▪ Ambient temperature condition of the brake unit is between <math>-10^{\circ}\text{C}</math> (<math>14^{\circ}\text{F}</math>) and <math>+50^{\circ}\text{C}</math> (<math>122^{\circ}\text{F}</math>). Note that the condition is different from the ambient temperature condition of the servo amplifier (between <math>0^{\circ}\text{C}</math> (<math>32^{\circ}\text{F}</math>) and <math>+55^{\circ}\text{C}</math> (<math>131^{\circ}\text{F}</math>)).</li><li>▪ Configure the circuit to shut down the power-supply with the alarm output of the brake unit and resistor unit under abnormal condition.</li><li>▪ Use the brake unit with a combination indicated in section 11.3.1.</li><li>▪ For executing a continuous regenerative operation, use FR-RC-(H) power regeneration converter or FR-CV-(H) power regeneration common converter.</li><li>▪ Brake unit and regenerative options (Regenerative resistor) cannot be used simultaneously.</li></ul>

Connect the brake unit to the bus of the servo amplifier. As compared to the MR-RB regenerative option, the brake unit can return larger power. Use the brake unit when the regenerative option cannot provide sufficient regenerative capability.

When using the brake unit, set the parameter No.PA02 of the servo amplifier to "□□01".

When using the brake unit, always refer to the FR-BU2-(H) Brake Unit Instruction Manual.

## 11. OPTIONS AND AUXILIARY EQUIPMENT

### 11.3.1 Selection

Use a combination of servo amplifier, brake unit and resistor unit listed below.

Brake unit		Resistor unit	Number of connected units	Permissible continuous power [kW]	Total resistance [ $\Omega$ ]	Applicable servo amplifier
200V class	FR-BU2-15K	FR-BR-15K	1	0.99	8	MR-J3-500B (Note)
			2 (parallel)	1.98	4	MR-J3-500B MR-J3-700B MR-J3-11KB MR-J3-15KB
	FR-BU2-30K	FR-BR-30K	1	1.99	4	MR-J3-500B MR-J3-700B MR-J3-11KB MR-J3-15KB
	FR-BU2-55K	FR-BR-55K	1	3.91	2	MR-J3-11KB MR-J3-15KB MR-J3-22KB
		MT-BR5-55K	1	5.5	2	MR-J3-22KB
	400V class	FR-BU2-H30K	FR-BR-H30K	1	1.99	16
FR-BU2-H55K		FR-BR-H55K	1	3.91	8	MR-J3-11KB4 MR-J3-15KB4 MR-J3-22KB4
FR-BU2-H75K		MT-BR5-H75K	1	7.5	6.5	MR-J3-22KB4

### 11.3.2 Brake unit parameter setting

Normally, when using the FR-BU2-(H), changing parameters is not necessary. Whether a parameter can be changed or not is listed below.

Parameter		Change possible/ impossible	Remarks
No.	Name		
0	Brake mode switchover	Impossible	Do not change the parameter.
1	Monitor display data selection	Possible	Refer to the FR-BU2-(H) Brake Unit Instruction Manual.
2	Input terminal function selection 1	Impossible	Do not change the parameter.
3	Input terminal function selection 2		
77	Parameter write selection		
78	Cumulative energization time carrying-over times		
CLr	Parameter clear		
ECL	Alarm history clear		
C1	For manufacturer setting		

## 11. OPTIONS AND AUXILIARY EQUIPMENT

### 11.3.3 Connection example

POINT
<ul style="list-style-type: none"> <li>Connecting PR terminal of the brake unit to P terminal of the servo amplifier results in brake unit malfunction. Always connect the PR terminal of the brake unit to the PR terminal of the resistor unit.</li> </ul>

#### (1) Combination with FR-BR-(H) resistor unit

##### (a) When connecting a brake unit to a servo amplifier

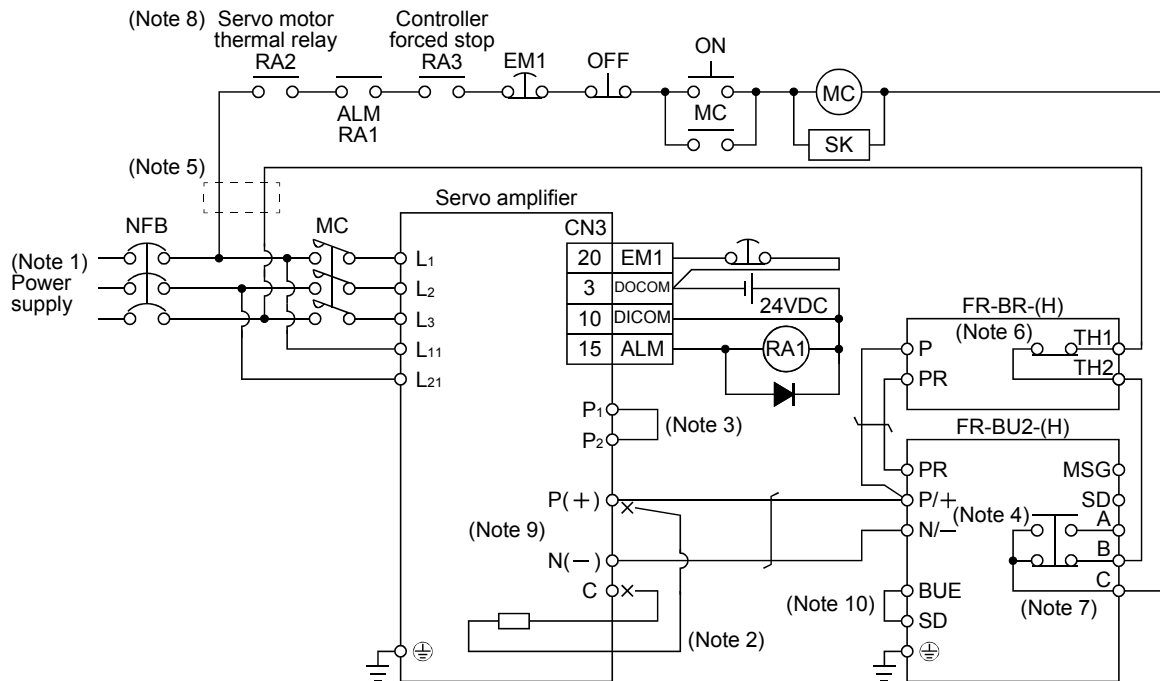

Note 1. For power supply specifications, refer to section 1.3.

2. For the servo amplifier of 5kW and 7kW, always disconnect the lead of built-in regenerative resistor, which is connected to the P and C terminals. For the servo amplifier of 11kW to 22kW, do not connect a supplied regenerative resistor to the P and C terminals.

3. Always connect P<sub>1</sub> and P<sub>2</sub> terminals (P<sub>1</sub> and P for the servo amplifier of 11kW to 22kW) (Factory-wired). When using the power factor improving DC reactor, refer to section 11.13.

4. Connect the P/+ and N/- terminals of the brake unit to a correct destination. Wrong connection results in servo amplifier and brake unit malfunction.

5. For 400VAC class, a step-down transformer is required.

6. Contact rating: 1b contact, 110VAC\_5A/220VAC\_3A

Normal condition: TH1-TH2 is conducting. Abnormal condition: TH1-TH2 is not conducting.

7. Contact rating: 230VAC\_0.3A/30VDC\_0.3A

Normal condition: B-C is conducting/A-C is not conducting. Abnormal condition: B-C is not conducting/A-C is conducting.

8. For the servo amplifier of 11kW or more, connect the thermal relay sensor of the servo amplifier.

9. Do not connect more than one cable to each P(+) to N(-) terminals of the servo amplifier.

10. Always connect BUE and SD terminals (Factory-wired).

## 11. OPTIONS AND AUXILIARY EQUIPMENT

(b) When connecting two brake units to a servo amplifier

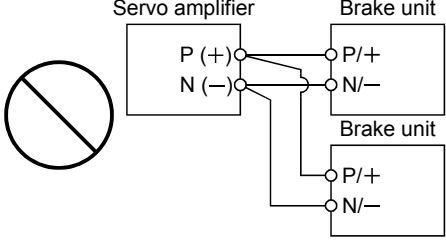
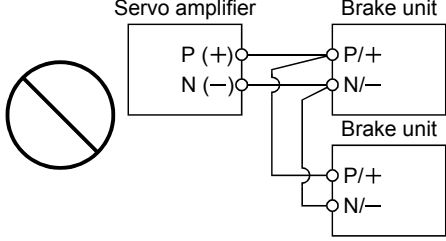
POINT
<ul style="list-style-type: none"><li>▪ To use brake units with a parallel connection, use two sets of FR-BU2 brake unit. Combination with other brake unit results in alarm occurrence or malfunction.</li><li>▪ Always connect the master and slave terminals (MSG and SD) of the two brake units.</li><li>▪ Do not connect the servo amplifier and brake units as below. Connect the cables with a terminal block to distribute as indicated in this section.</li></ul>
<div style="display: flex; justify-content: space-around;"><div style="text-align: center;"><p>Connecting two cables to P and N terminals</p></div><div style="text-align: center;"><p>Passing wiring</p></div></div>

## 11. OPTIONS AND AUXILIARY EQUIPMENT

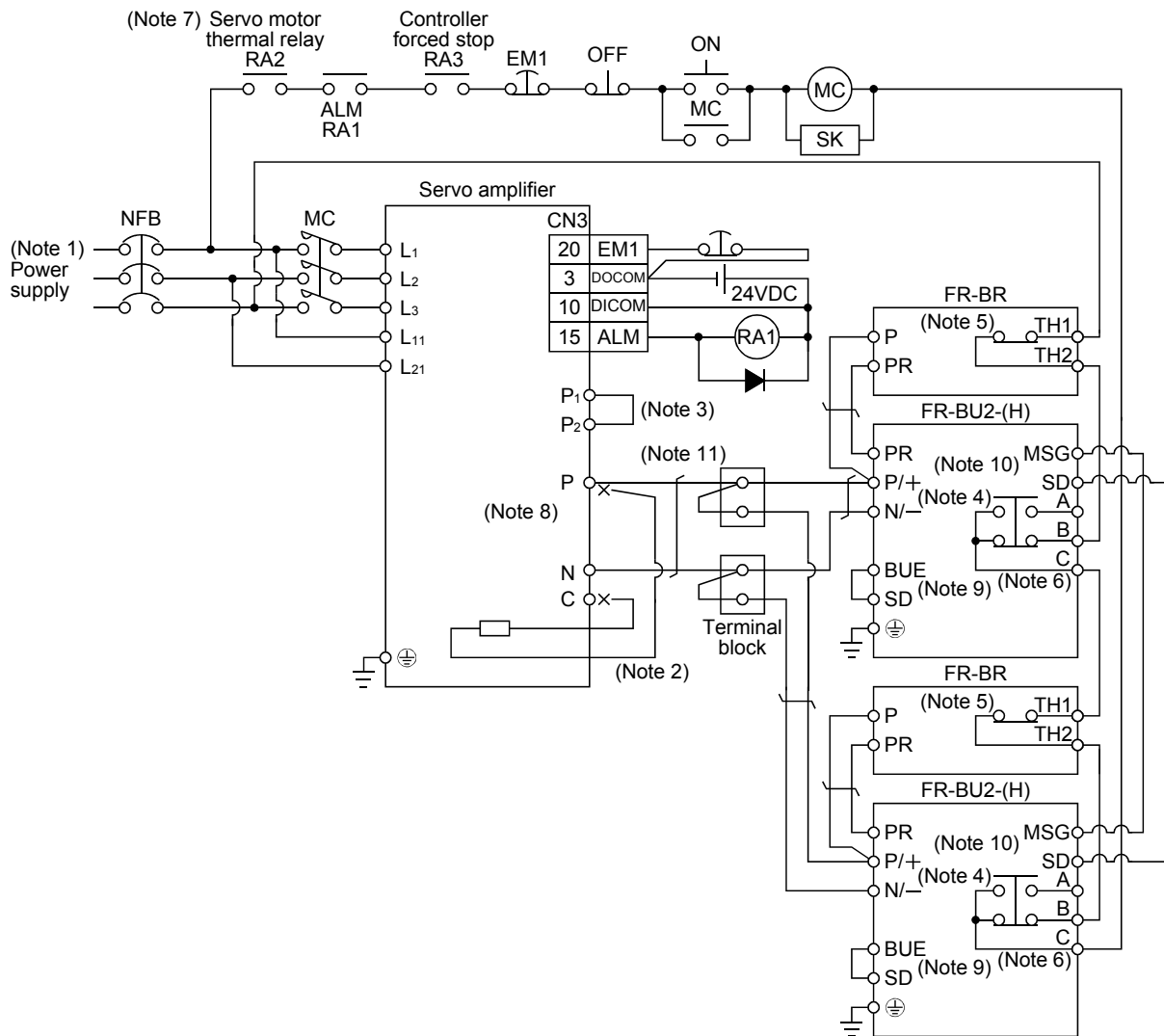

Note 1. For power supply specifications, refer to section 1.3.

2. For the servo amplifier of 5k and 7kW, always disconnect the lead of built-in regenerative resistor, which is connected to the P and C terminals. For the servo amplifier of 11k and 15kW, do not connect a supplied regenerative resistor to the P and C terminals.
3. Always connect P<sub>1</sub> and P<sub>2</sub> terminals (P<sub>1</sub> and P for the servo amplifier of 11k and 15kW) (Factory-wired). When using the power factor improving DC reactor, refer to section 11.13.
4. Connect the P/+ and N/− terminals of the brake unit to a correct destination. Wrong connection results in servo amplifier and brake unit malfunction.
5. Contact rating: 1b contact, 110VAC\_5A/220VAC\_3A  
Normal condition: TH1-TH2 is conducting. Abnormal condition: TH1-TH2 is not conducting.
6. Contact rating: 230VAC\_0.3A/30VDC\_0.3A  
Normal condition: B-C is conducting/A-C is not conducting. Abnormal condition: B-C is not conducting/A-C is conducting.
7. For the servo amplifier of 11kW or more, connect the thermal relay sensor of the servo amplifier.
8. Do not connect more than one cable to each P and N terminals of the servo amplifier.
9. Always connect BUE and SD terminals (Factory-wired).
10. Connect the MSG and SD terminals of the brake unit to a correct destination. Wrong connection results in servo amplifier and brake unit malfunction.
11. For the cable to connect the terminal block and the P and N terminals of the servo amplifier, use the cable indicated in (4) (b) of this section.

## 11. OPTIONS AND AUXILIARY EQUIPMENT

### (2) Combination with MT-BR5-(H) resistor unit

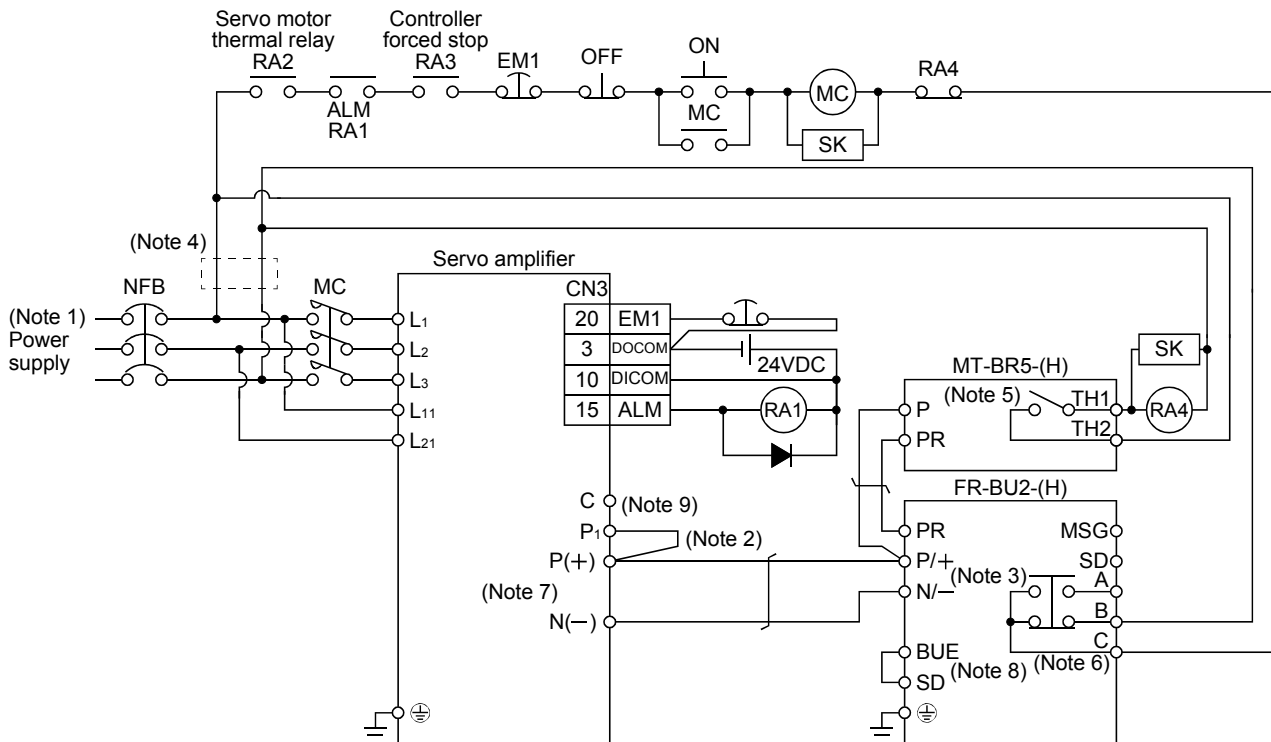

Note 1. For power supply specifications, refer to section 1.3.

2. Always connect P<sub>1</sub> - P(+) terminals (Factory-wired). When using the power factor improving DC reactor, refer to section 11.13.
3. Connect the P/+ and N/- terminals of the brake unit to a correct destination. Wrong connection results in servo amplifier and brake unit malfunction.
4. For the servo amplifier of 400V class, a step-down transformer is required.
5. Contact rating: 1a contact, 110VAC\_5A/220VAC\_3A  
Normal condition: TH1-TH2 is not conducting. Abnormal condition: TH1-TH2 is conducting.
6. Contact rating: 230VAC\_0.3A/30VDC\_0.3A  
Normal condition: B-C is conducting/A-C is not conducting. Abnormal condition: B-C is not conducting/A-C is conducting.
7. Do not connect more than one cable to each P and N terminals of the servo amplifier.
8. Always connect BUE and SD terminals (Factory-wired).
9. For the servo amplifier of 22kW, do not connect a supplied regenerative resistor to the P and C terminals.

## 11. OPTIONS AND AUXILIARY EQUIPMENT

### (3) Precautions for wiring

The cables between the servo amplifier and the brake unit, and between the resistor unit and the brake unit should be as short as possible. Always twist the cable longer than 5m (twist five times or more per one meter). Even when the cable is twisted, the cable should be less than 10m. Using cables longer than 5m without twisting or twisted cables longer than 10m, may result in the brake unit malfunction.

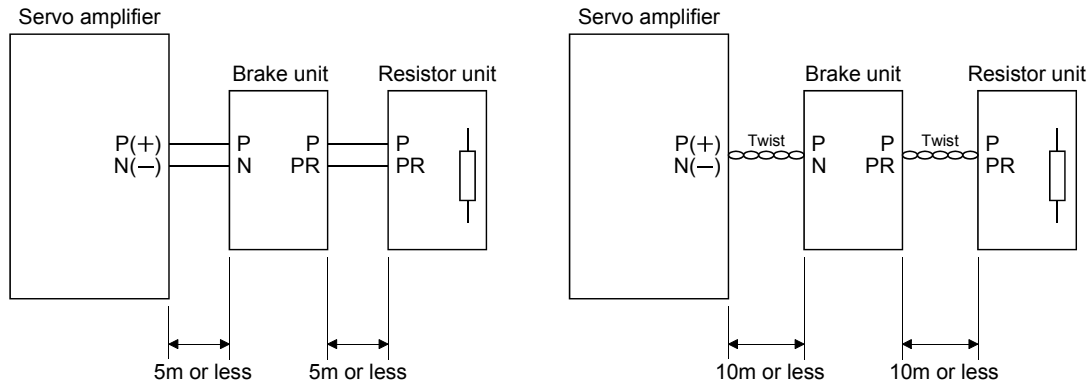

### (4) Cables

#### (a) Cables for the brake unit

For the brake unit, HIV wire (600V Grade heat-resistant polyvinyl chloride insulated wire) is recommended.

#### 1) Main circuit terminal

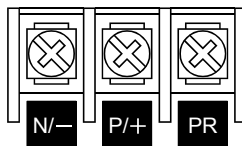

Terminal block

Brake unit		Main circuit terminal screw size	Crimping terminal N/-, P/+, PR, ⊕	Tightening torque	Wire size	
					N/-, P/+, PR, ⊕	
				HIV wire [mm <sup>2</sup> ]		AWG
200V class	FR-BU2-15K	M4	5.5-4	1.5	3.5	12
	FR-BU2-30K	M5	5.5-5	2.5	5.5	10
	FR-BU2-55K	M6	14-6	4.4	14	6
400V class	FR-BU2-H30K	M4	5.5-4	1.5	3.5	12
	FR-BU2-H55K	M5	5.5-5	2.5	5.5	10
	FR-BU2-H75K	M6	14-6	4.4	14	6

## 11. OPTIONS AND AUXILIARY EQUIPMENT

### 2) Control circuit terminal

POINT
<ul style="list-style-type: none"> <li>Undertightening can cause a cable disconnection or malfunction.</li> <li>Overtightening can cause a short circuit or malfunction due to damage to the screw or the brake unit.</li> </ul>



Terminal block

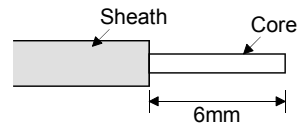

Wire the stripped cable after twisting to prevent the cable from becoming loose. In addition, do not solder it.

Screw size: M3

Tightening torque: 0.5N · m to 0.6N · m

Wire size: 0.3mm<sup>2</sup> to 0.75 mm<sup>2</sup>

Screw driver: Small flat-blade screwdriver

(Tip thickness: 0.4mm/Tip width 2.5mm)

(b) Cables for connecting the servo amplifier and a distribution terminal block when connecting two sets of the brake unit

Brake unit	Wire size	
	HIV wire [mm <sup>2</sup> ]	AWG
FR-BU2-15K	8	8

## 11. OPTIONS AND AUXILIARY EQUIPMENT

### (5) Crimping terminals for P and N terminals of servo amplifier

#### (a) Recommended crimping terminals

POINT
<ul style="list-style-type: none"> <li>Always use recommended crimping terminals or equivalent since some crimping terminals cannot be installed depending on the size.</li> </ul>

	Servo amplifier	Brake unit	Number of connected units	Crimping terminal (Manufacturer)	(Note 1) Applicable tool
200V class	MR-J3-500B	FR-BU2-15K	1	FVD5.5-S4(Japan Solderless Terminal)	c
			2	8-4NS(Japan Solderless Terminal) (Note 2)	d
	MR-J3-700B	FR-BU2-30K	1	FVD5.5-S4(Japan Solderless Terminal)	c
			2	8-4NS(Japan Solderless Terminal) (Note 2)	d
	MR-J3-11KB	FR-BU2-15K	2	FVD8-6(Japan Solderless Terminal)	a
			1	FVD5.5-6(Japan Solderless Terminal)	c
			1	FVD14-6(Japan Solderless Terminal)	b
	MR-J3-15KB	FR-BU2-30K	2	FVD8-6(Japan Solderless Terminal)	a
			1	FVD5.5-6(Japan Solderless Terminal)	c
			1	FVD14-6(Japan Solderless Terminal)	b
MR-J3-22KB	FR-BU2-55K	1	FVD14-8(Japan Solderless Terminal)	b	
400V class	MR-J3-500B4	FR-BU2-H30K	1	FVD5.5-S4(Japan Solderless Terminal)	c
	MR-J3-700B4	FR-BU2-H30K	1	FVD5.5-S4(Japan Solderless Terminal)	c
	MR-J3-11KB4	FR-BU2-H30K	1	FVD5.5-6(Japan Solderless Terminal)	c
			1	FVD5.5-6(Japan Solderless Terminal)	c
	MR-J3-15KB4	FR-BU2-H55K	1	FVD5.5-6(Japan Solderless Terminal)	c
	MR-J3-22KB4	FR-BU2-H55K	1	FVD5.5-8(Japan Solderless Terminal)	c
1			FVD14-8(Japan Solderless Terminal)	b	

Note 1. Symbols in the applicable tool field indicate applicable tools in (5)(b) of this section.

2. Coat the crimping part with an insulation tube.

#### (b) Applicable tool

Symbol	Servo amplifier side crimping terminals				Manufacturer
	Crimping terminal	Applicable tool			
		Body	Head	Dice	
a	FVD8-6	YF-1 · E-4	YNE-38	DH-111 · DH121	Japan Solderless Terminal
b	FVD14-6 FVD14-8	YF-1 · E-4	YNE-38	DH-112 · DH122	
c	FDV5.5-S4 FDV5.5-6	YNT-1210S			
d	8-4NS	YHT-8S			

# 11. OPTIONS AND AUXILIARY EQUIPMENT

## 11.3.4 Outline dimension drawings

### (1) FR-BU2- (H) brake unit

[Unit: mm]

FR-BU2-15K

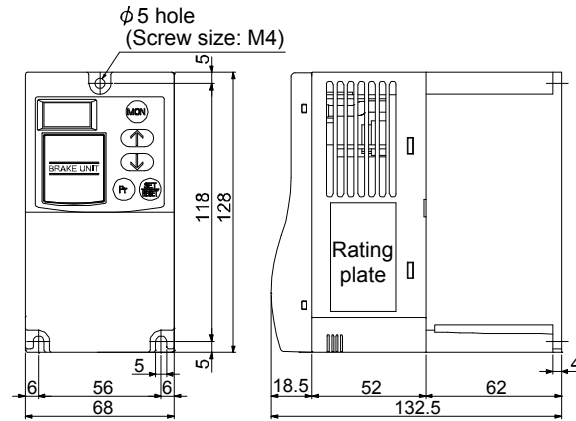

FR-BU2-30K  
FR-BU2-H30K

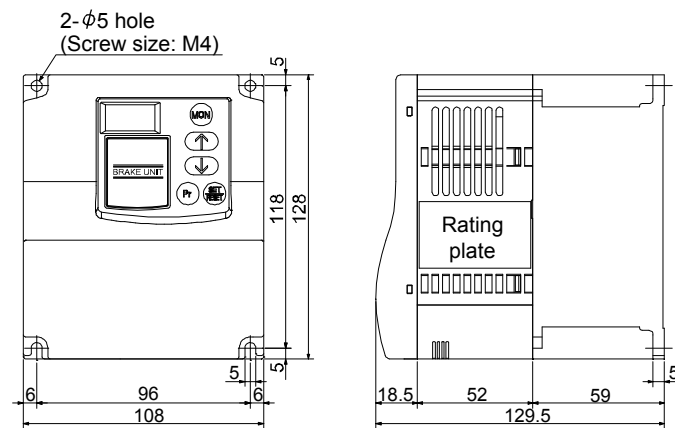

FR-BU2-55K  
FR-BU2-H55K, H75K

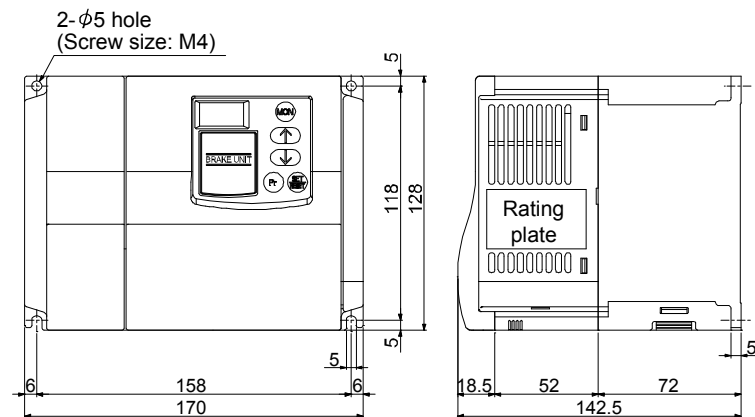

## 11. OPTIONS AND AUXILIARY EQUIPMENT

### (2) FR-BR- (H) resistor unit

[Unit: mm]

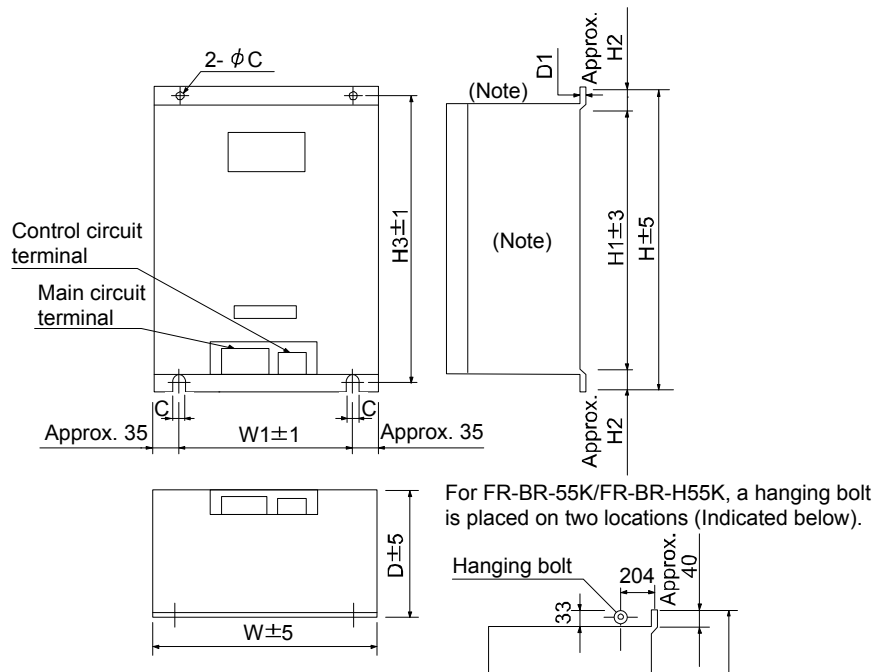

Note. Ventilation ports are provided on both sides and the top. The bottom is open.

Resistor unit		W	W1	H	H1	H2	H3	D	D1	C	Approximate mass [kg]
200V class	FR-BR-15K	170	100	450	410	20	432	220	3.2	6	15
	FR-BR-30K	340	270	600	560	20	582	220	4	10	30
	FR-BR-55K	480	410	700	620	40	670	450	3.2	12	70
400V class	FR-BR-H30K	340	270	600	560	20	582	220	4	10	30
	FR-BR-H55K	480	410	700	620	40	670	450	3.2	12	70

### (3) MT-BR5- (H) resistor unit

[Unit: mm]

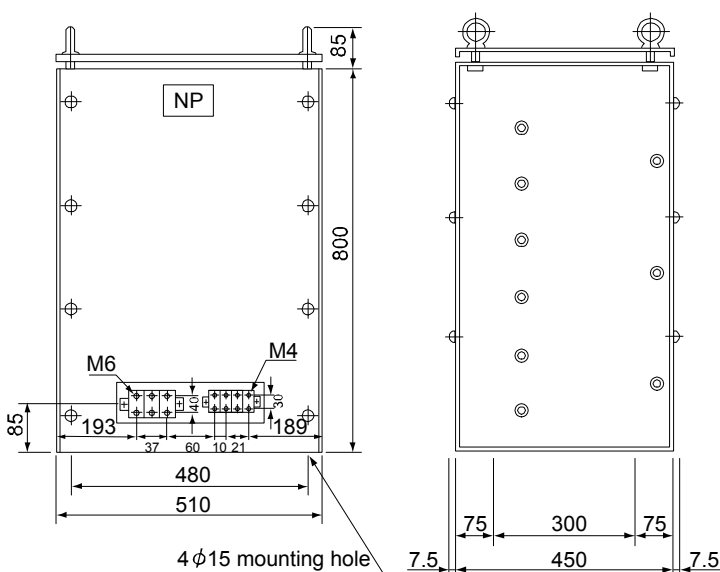

Resistor unit		Resistance value	Approximate mass [kg]
200V class	MT-BR5-55K	$2.0 \Omega$	50
400V class	MT-BR5-H75K	$6.5 \Omega$	70

## 11. OPTIONS AND AUXILIARY EQUIPMENT

### 11.4 Power regeneration converter

POINT
<ul style="list-style-type: none"> <li>When using the FR-RC-(H) power regenerative converter, refer to "Power Regeneration Converter FR-RC Instruction Manual (IB(NA)66330)".</li> </ul>

When using the power regeneration converter, set "□□ 01" in parameter No.PA02.

#### (1) Selection

The converters can continuously return 75% of the nominal regenerative power. They are applied to the servo amplifiers of the 5k to 22kW.

Power regeneration converter	Nominal regenerative power (kW)	Servo amplifier
FR-RC-15K	15	MR-J3-500B MR-J3-700B
FR-RC-30K	30	MR-J3-11KB MR-J3-15KB
FR-RC-55K	55	MR-J3-22KB
FR-RC-H15K	15	MR-J3-500B4 MR-J3-700B4
FR-RC-H30K	30	MR-J3-11KB4 MR-J3-15KB4
FR-RC-H55K	55	MR-J3-22KB4

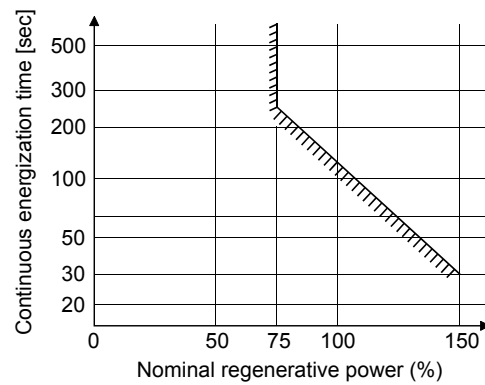

## 11. OPTIONS AND AUXILIARY EQUIPMENT

### (2) Connection example

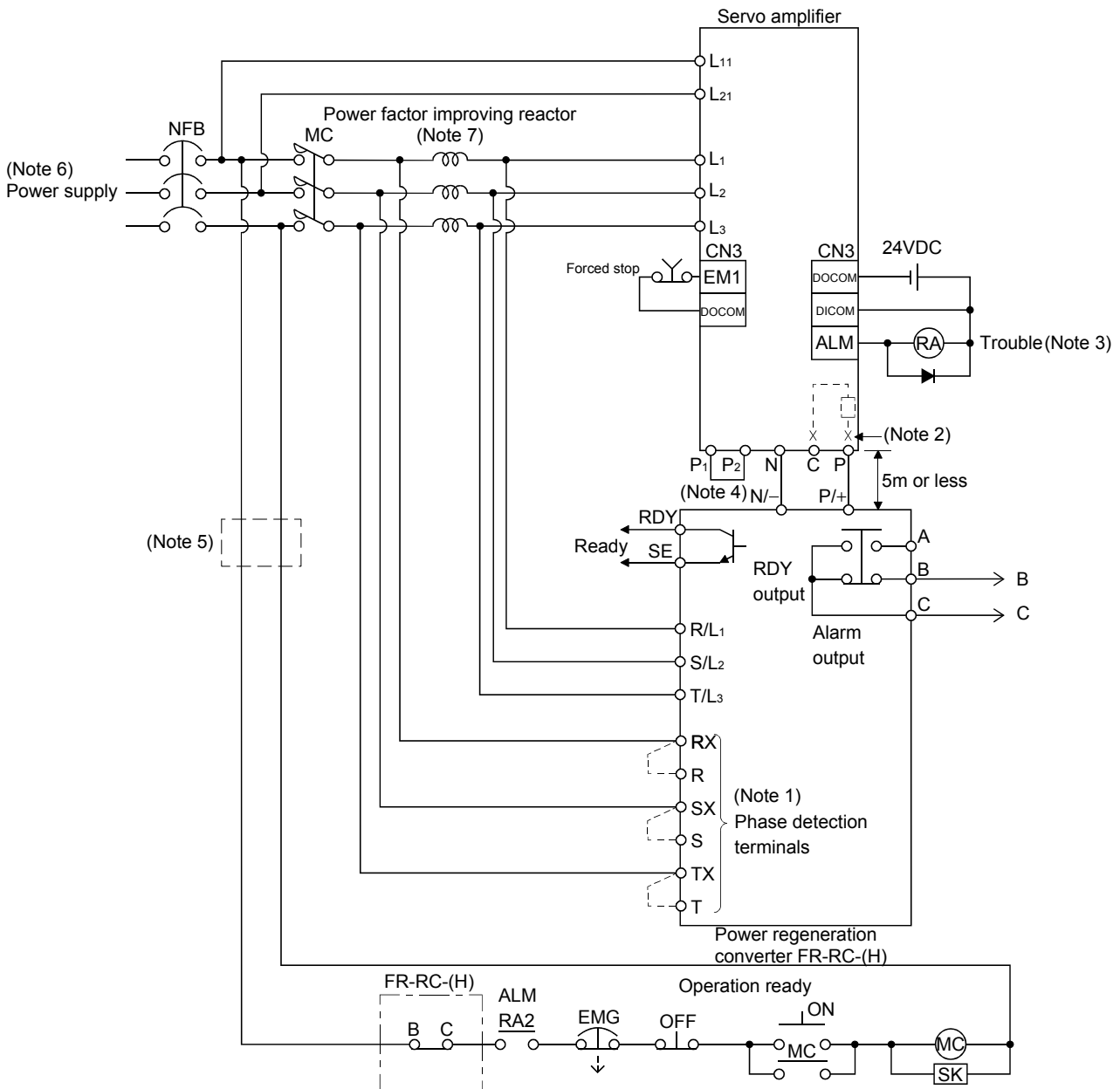

Note 1. When not using the phase detection terminals, fit the jumpers across RX-R, SX-S and TX-T. If the jumpers remain removed, the FR-RC-(H) will not operate.

2. When using servo amplifiers of 5kW and 7kW, always remove the lead of built-in regenerative resistor connected to P terminal and C terminal.

3. When setting not to output Trouble (ALM) with parameter change, configure power supply circuit for turning magnetic contactor off after detecting an occurrence of alarm on the controller side.

4. Between P<sub>1</sub> and P<sub>2</sub> (P<sub>1</sub> and P for 11kW to 22kW) is connected by default.

5. Stepdown transformer is required for coil voltage of magnetic contactor more than 200V class in 400V class servo amplifiers.

6. Refer to section 1.3 for the power supply specification.

7. For selection of power factor improving AC reactors, refer to "Power Regeneration Converter FR-RC Instruction Manual (IB(NA)66330)".

## 11. OPTIONS AND AUXILIARY EQUIPMENT

### (3) Outside dimensions of the power regeneration converters

[Unit : mm]

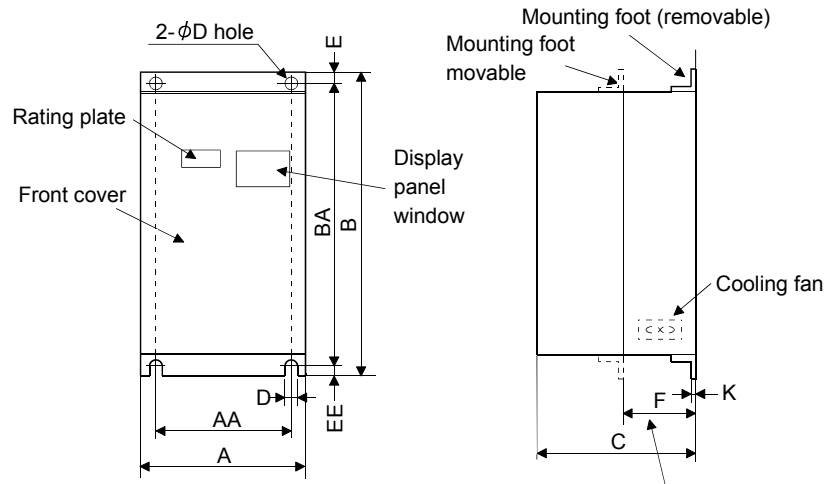

Heat generation area outside mounting dimension

Power regeneration converter	A	AA	B	BA	C	D	E	EE	K	F	Approx. mass [kg(lb)]
FR-RC-15K	270	200	450	432	195	10	10	8	3.2	87	19 (41.888)
FR-RC-H15K	340	270	600	582	195	10	10	8	3.2	90	31 (68.343)
FR-RC-30K											
FR-RC-H30K											
FR-RC-55K	480	410	700	670	250	12	15	15	3.2	135	55 (121.3)
FR-RC-H55K											

### (4) Mounting hole machining dimensions

When the power regeneration converter is fitted to a totally enclosed type box, mount the heat generating area of the converter outside the box to provide heat generation measures. At this time, the mounting hole having the following dimensions is machined in the box.

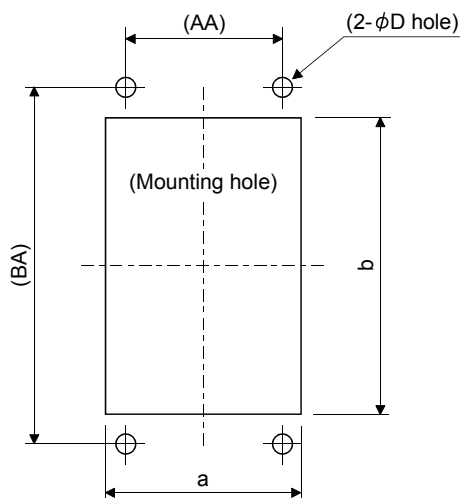

[Unit : mm]

Power regeneration converter	a	b	D	AA	BA
FR-RC-15K	260	412	10	200	432
FR-RC-H15K	330	562	10	270	582
FR-RC-30K					
FR-RC-H30K					
FR-RC-55K	470	642	12	410	670
FR-RC-H55K					

## 11. OPTIONS AND AUXILIARY EQUIPMENT

### 11.5 Power regeneration common converter

POINT
<ul style="list-style-type: none"> <li>Use the FR-CV for the servo amplifier of 200V class and the FR-CV-H for that of 400V class.</li> <li>For details of the power regeneration common converter FR-CV-(H), refer to the FR-CV-(H) Installation Guide (IB(NA)0600075).</li> <li>Do not supply power to the main circuit power supply terminals (L<sub>1</sub>, L<sub>2</sub>, L<sub>3</sub>) of the servo amplifier. Doing so will fail the servo amplifier and FR-CV-(H).</li> <li>Connect the DC power supply between the FR-CV-(H) and servo amplifier with correct polarity. Connection with incorrect polarity will fail the FR-CV-(H) and servo amplifier.</li> <li>Two or more FR-CV-(H)'s cannot be installed to improve regeneration capability. Two or more FR-CV-(H)'s cannot be connected to the same DC power supply line.</li> </ul>

When using the power regeneration common converter, set parameter No.PA02 to "□□01".

#### (1) Model

FR-CV-□□

Capacity

Symbol	Capacity [kW]
7.5K	7.5
11K	11
15K	15
22K	22
30K	30
37K	37
55K	55

Symbol	Voltage class
None	200V class
H	400V class

#### (2) Selection

The power regenerative common converter FR-CV can be used for the servo amplifier of 200V class with 750 to 22kW and that of 400V class with 11k to 22kW. The following shows the restrictions on using the FR-CV-(H).

- Up to six servo amplifiers can be connected to one FR-CV-(H).
- FR-CV-(H) capacity [W] Total of rated capacities [W] of servo amplifiers connected to FR-CV-(H) 2
- The total of used servo motor rated currents should be equal to or less than the applicable current [A] of the FR-CV-(H).
- Among the servo amplifiers connected to the FR-CV-(H), the servo amplifier of the maximum capacity should be equal to or less than the maximum connectable capacity [W].

## 11. OPTIONS AND AUXILIARY EQUIPMENT

The following table lists the restrictions.

Item	FR-CV-□						
	7.5K	11K	15K	22K	30K	37K	55K
Maximum number of connected servo amplifiers	6						
Total of connectable servo amplifier capacities [kW]	3.75	5.5	7.5	11	15	18.5	27.5
Total of connectable servo motor rated currents [A]	33	46	61	90	115	145	215
Maximum servo amplifier capacity [kW]	3.5	5	7	11	15	15	22

Item	FR-CV-H□			
	22K	30K	37K	55K
Maximum number of connected servo amplifiers	6			
Total of connectable servo amplifier capacities [kW]	11	15	18.5	27.5
Total of connectable servo motor rated currents [A]	90	115	145	215
Maximum servo amplifier capacity [kW]	11	15	15	22

When using the FR-CV-(H), always install the dedicated stand-alone reactor (FR-CVL-(H)).

Power regeneration common converter	Dedicated stand-alone reactor
FR-CV-7.5K(-AT)	FR-CVL-7.5K
FR-CV-11 K(-AT)	FR-CVL-11 K
FR-CV-15K(-AT)	FR-CVL-15K
FR-CV-22K(-AT)	FR-CVL-22K
FR-CV-30K(-AT)	FR-CVL-30K
FR-CV-37K	FR-CVL-37K
FR-CV-55K	FR-CVL-55K
FR-CV-H22K(-AT)	FR-CVL-H22K
FR-CV-H30K(-AT)	FR-CVL-H30K
FR-CV-H37K	FR-CVL-H37K
FR-CV-H55K	FR-CVL-H55K

## 11. OPTIONS AND AUXILIARY EQUIPMENT

### (3) Connection diagram (a) 200V class

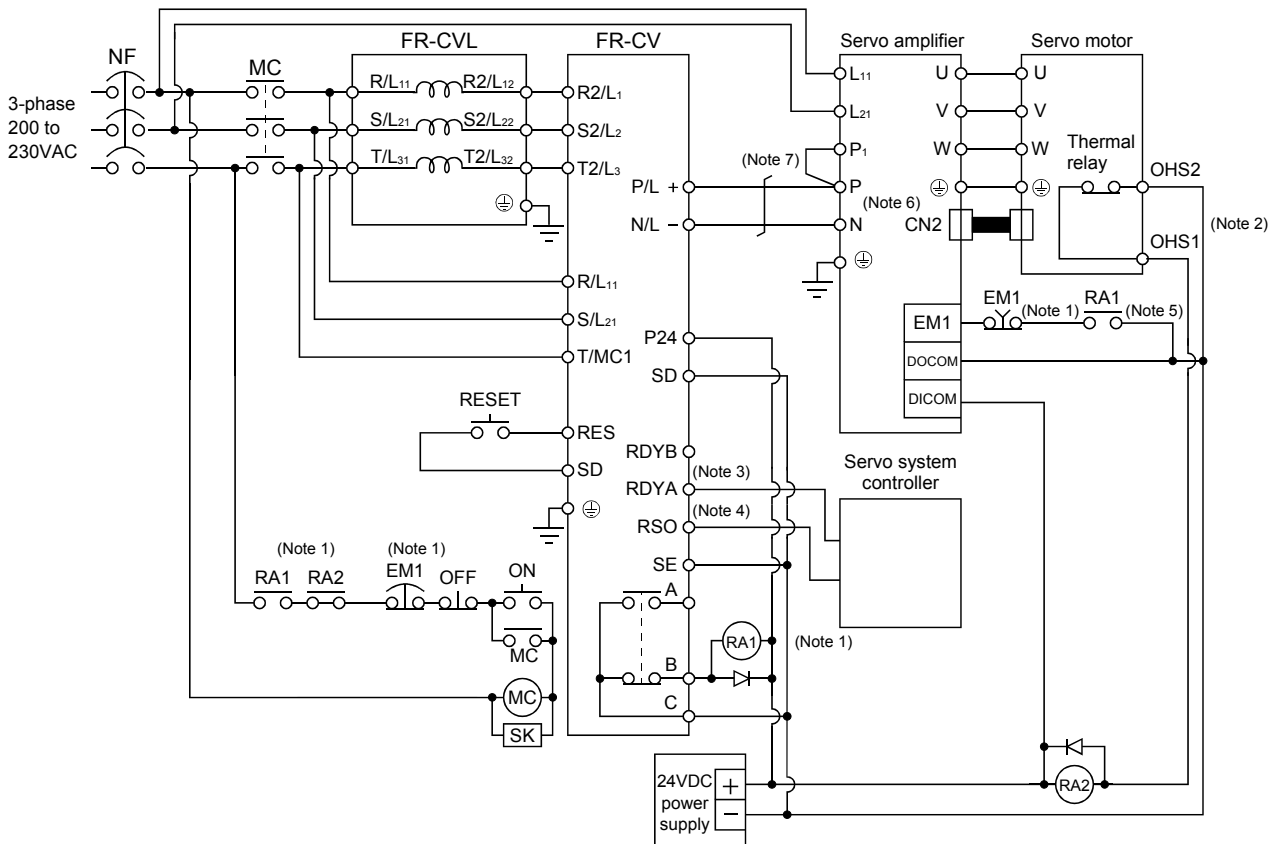

Note 1. Configure a sequence that will shut off main circuit power at an emergency stop or at FR-CV or servo amplifier alarm occurrence.

2. For the servo motor with thermal relay, configure a sequence that will shut off main circuit power when the thermal relay operates.

3. For the servo amplifier, configure a sequence that will switch the servo on after the FR-CV is ready.

4. For the FR-CV, the RSO turns off when it is put in a ready-to-operate status where the reset signal is input. Configure a sequence that will make the servo inoperative when the RSO signal is on.

5. Configure a sequence that will make a stop with the emergency stop input of the servo system controller if an alarm occurs in the FR-CV. When the servo system controller does not have an emergency stop input, use the forced stop input of the servo amplifier to make a stop as shown in the diagram.

6. When using the servo amplifier of 7kW or less, make sure to disconnect the wiring of built-in regenerative resistor (3.5kW or less: P and D, 5k/7kW: P and C).

7. When using the servo amplifier of 11k to 22kW, make sure to connect P<sub>1</sub> and P. (Factory-wired.)

## 11. OPTIONS AND AUXILIARY EQUIPMENT

(b) 400V class

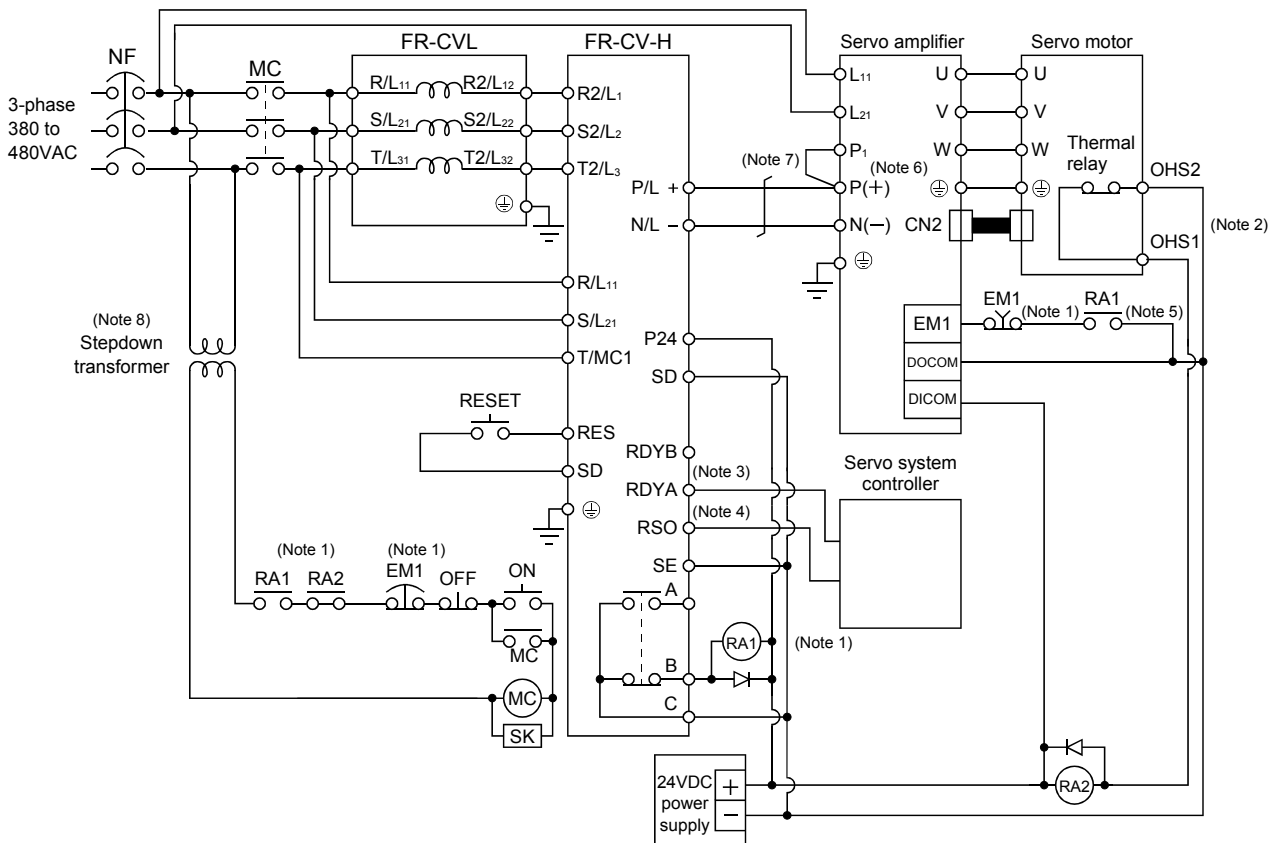

- Note 1. Configure a sequence that will shut off main circuit power at an emergency stop or at FR-CV-H or servo amplifier alarm occurrence.
- For the servo motor with thermal relay, configure a sequence that will shut off main circuit power when the thermal relay operates.
  - For the servo amplifier, configure a sequence that will switch the servo on after the FR-CV-H is ready.
  - For the FR-CV-H, the RSO signal turns off when it is put in a ready-to-operate status where the reset signal is input. Configure a sequence that will make the servo inoperative when the RSO signal is on.
  - Configure a sequence that will make a stop with the emergency stop input of the servo system controller if an alarm occurs in the FR-CV-H. When the servo system controller does not have an emergency stop input, use the forced stop input of the servo amplifier to make a stop as shown in the diagram.
  - When using the servo amplifier of 7kW or less, make sure to disconnect the wiring of built-in regenerative resistor (2kW or less: P+ and D, 3.5k to 7kW: P+ and C).
  - When using the servo amplifier of 11k to 22kW, make sure to connect P<sub>1</sub> and P(+). (Factory-wired.)
  - Stepdown transformer is required for coil voltage of magnetic contactor more than 200V class servo amplifiers.

## 11. OPTIONS AND AUXILIARY EQUIPMENT

### (4) Selection example of wires used for wiring

POINT
<ul style="list-style-type: none"> <li>Selection condition of wire size is as follows.</li> </ul> <p>Wire type: 600V Polyvinyl chloride insulated wire (IV wire)</p> <p>Construction condition: One wire is constructed in the air</p>

### (a) Wire sizes

#### 1) Across P-P(+), N-N(-)

The following table indicates the connection wire sizes of the DC power supply (P, N terminals) between the FR-CV and servo amplifier.

Total of servo amplifier capacities [kW]	Wires[mm <sup>2</sup> ]
1 or less	2
2	3.5
5	5.5
7	8
11	14
15	22
22	50

The following table indicates the connection wire sizes of the DC power supply (P(+), N(-) terminals) between the FR-CV-H and servo amplifier.

Total of servo amplifier capacities [kW]	Wires[mm <sup>2</sup> ]
1 or less	2
2	3.5
5	5.5
7	8
11	8
15	22
22	22

#### 2) Grounding

For grounding, use the wire of the size equal to or greater than that indicated in the following table, and make it as short as possible.

Power regeneration common converter	Grounding wire size [mm <sup>2</sup> ]
FR-CV-7.5K to FR-CV-15K	14
FR-CV-22K * FR-CV-30K	22
FR-CV-37K * FR-CV-55K	38
FR-CV-H22K * FR-CV-H30K	8
FR-CV-H37K * FR-CV-H55K	22

## 11. OPTIONS AND AUXILIARY EQUIPMENT

### (b) Example of selecting the wire sizes

When connecting multiple servo amplifiers, always use junction terminals for wiring the servo amplifier terminals P, N. Also, connect the servo amplifiers in the order of larger to smaller capacities.

#### 1) 200V class

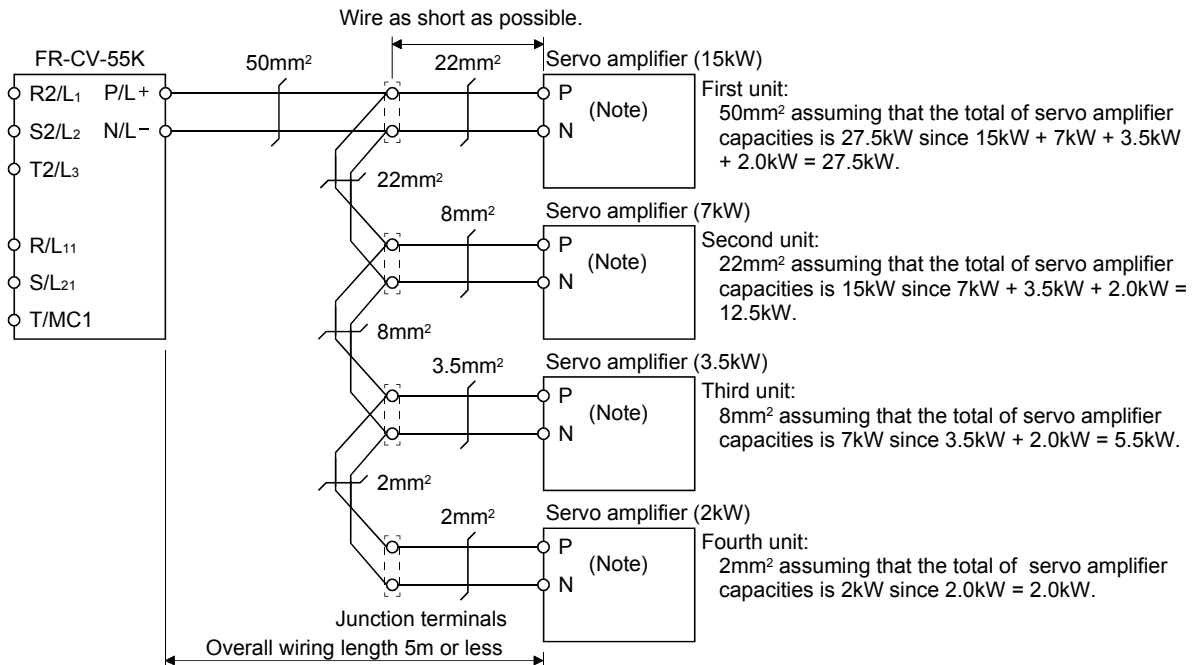

Note. When using the servo amplifier of 7kW or less, make sure to disconnect the wiring of built-in regenerative resistor (3.5kW or less: P-D, 5k/7kW: P-C).

#### 2) 400V class

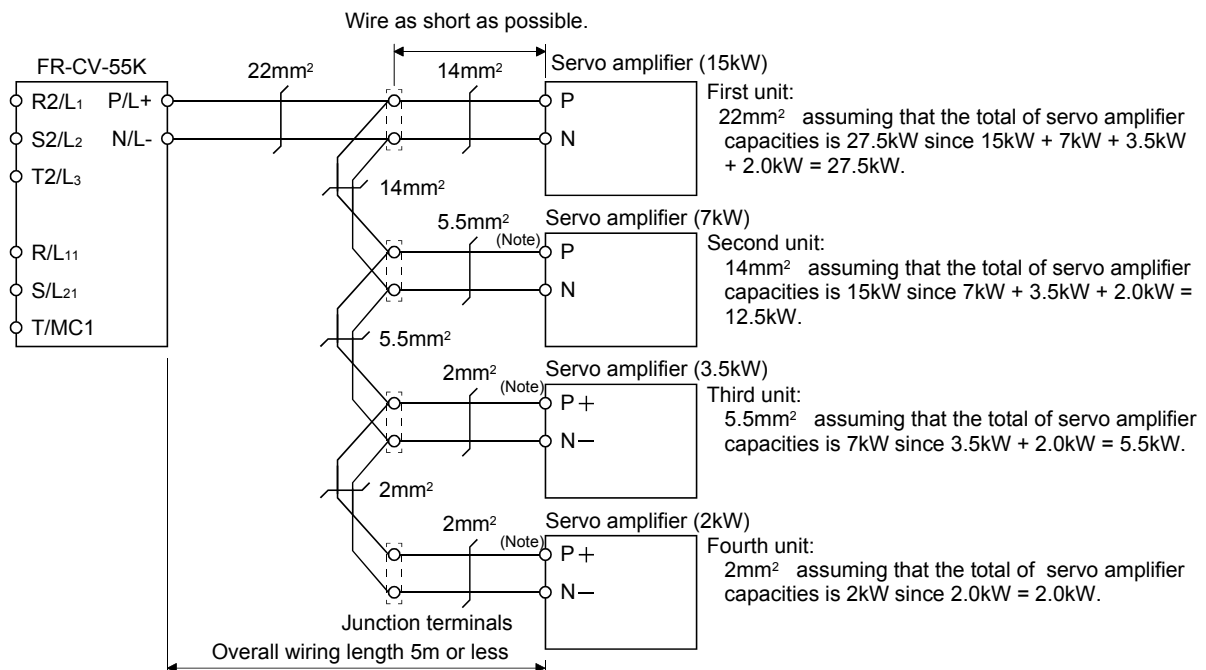

Note. These servo amplifiers are development forecasted.

## 11. OPTIONS AND AUXILIARY EQUIPMENT

---

### (5) Other precautions

- (a) Always use the FR-CVL-(H) as the power factor improving reactor. Do not use the FR-BAL or FR-BEL.
- (b) The inputs/outputs (main circuits) of the FR-CV-(H) and servo amplifiers include high-frequency components and may provide electromagnetic wave interference to communication equipment (such as AM radios) used near them. In this case, interference can be reduced by installing the radio noise filter (FR-BIF-(H)) or line noise filter (FR-BSF01, FR-BLF).
- (c) The overall wiring length for connection of the DC power supply between the FR-CV-(H) and servo amplifiers should be 5m or less, and the wiring must be twisted.

## 11. OPTIONS AND AUXILIARY EQUIPMENT

### (6) Specifications

Power regeneration common converter FR-CV-□		Item						
		7.5K	11K	15K	22K	30K	37K	55K
Total of connectable servo amplifier capacities [kW]		3.75	5.5	7.5	11	15	18.5	27.5
Maximum servo amplifier capacity [kW]		3.5	5	7	11	15	15	22
Output	Total of connectable servo motor rated currents [A]	33	46	61	90	115	145	215
	Regenerative braking torque	Short-time rating	Total capacity of applicable servo motors, 300% torque, 60s (Note 1)					
		Continuous rating	100% torque					
Power supply	Rated input AC voltage/frequency	Three-phase 200 to 220V 50Hz, 200 to 230V 60Hz						
	Permissible AC voltage fluctuation	Three-phase 170 to 242V 50Hz, 170 to 253V 60Hz						
	Permissible frequency fluctuation	±5%						
	Power supply capacity (Note 2) [kVA]	17	20	28	41	52	66	100
Protective structure (JEM 1030), cooling system		Open type (IP00), forced cooling						
Environment	Ambient temperature	-10°C to +50°C (non-freezing)						
	Ambient humidity	90%RH or less (non-condensing)						
	Ambience	Indoors (without corrosive gas, flammable gas, oil mist, dust and dirt)						
Altitude, vibration		1000m or less above sea level, 5.9m/s <sup>2</sup> 2 or less						
No-fuse breaker or leakage current breaker		30AF	50AF	100AF	100AF	225AF	225AF	225AF
		30A	50A	75A	100A	125A	125A	175A
Magnetic contactor		S-N20	S-N35	S-N50	S-N65	S-N95	S-N95	S-N125

Power regeneration common converter FR-CV-H□		Item			
		22K	30K	37K	55K
Total of connectable servo amplifier capacities [kW]		11	15	18.5	27.5
Maximum servo amplifier capacity [kW]		11	15	15	22
Output	Total of connectable servo motor rated currents [A]	43	57	71	110
	Regenerative braking torque	Short-time rating	Total capacity of applicable servo motors, 300% torque, 60s (Note 1)		
		Continuous rating	100% torque		
Power supply	Rated input AC voltage/frequency	Three-phase 380 to 480V, 50Hz/60Hz			
	Permissible AC voltage fluctuation	Three-phase 323 to 528V, 50Hz/60Hz			
	Permissible frequency fluctuation	±5%			
	Power supply capacity [kVA]	41	52	66	100
Protective structure (JEM 1030), cooling system		Open type (IP00), forced cooling			
Environment	Ambient temperature	-10°C to +50°C (non-freezing)			
	Ambient humidity	90%RH or less (non-condensing)			
	Ambience	Indoors (without corrosive gas, flammable gas, oil mist, dust and dirt)			
Altitude, vibration		1000m or less above sea level, 5.9m/s <sup>2</sup> 2 or less			
No-fuse breaker or leakage current breaker		60AF	100AF	100AF	225AF
		60A	175A	175A	125A
Magnetic contactor		S-N25	S-N35	S-N35	S-N65

Note 1. This is the time when the protective function of the FR-CV-(H) is activated. The protective function of the servo amplifier is activated in the time indicated in section 10.1.

2. When connecting the capacity of connectable servo amplifier, specify the value of servo amplifier.

## 11. OPTIONS AND AUXILIARY EQUIPMENT

### 11.6 External dynamic brake

POINT
<ul style="list-style-type: none"> <li>▪ Configure up a sequence which switches off the contact of the brake unit after (or as soon as) it has turned off the servo on signal at a power failure or failure.</li> <li>▪ For the braking time taken when the dynamic brake is operated, refer to section 10.3.</li> <li>▪ The brake unit is rated for a short duration. Do not use it for high duty.</li> <li>▪ When using the 400V class dynamic brake, the power supply voltage is restricted to 1-phase 380VAC to 463VAC (50Hz/60Hz).</li> </ul>

#### (1) Selection of dynamic brake

The dynamic brake is designed to bring the servo motor to a sudden stop when a power failure occurs or the protective circuit is activated, and is built in the 7kW or less servo amplifier. Since it is not built in the 11kW or more servo amplifier, purchase it separately if required. Assign the dynamic brake interlock (DB) to any of CN3-9, CN3-13, and CN3-15 pins in parameter No.PD07 to PD09.

Servo amplifier	Dynamic brake
MR-J3-11KB	DBU-11K
MR-J3-15KB	DBU-15K
MR-J3-22KB	DBU-22K
MR-J3-11KB4	DBU-11K-4
MR-J3-15KB4	DBU-22K-4
MR-J3-22KB4	

## 11. OPTIONS AND AUXILIARY EQUIPMENT

### (2) Connection example

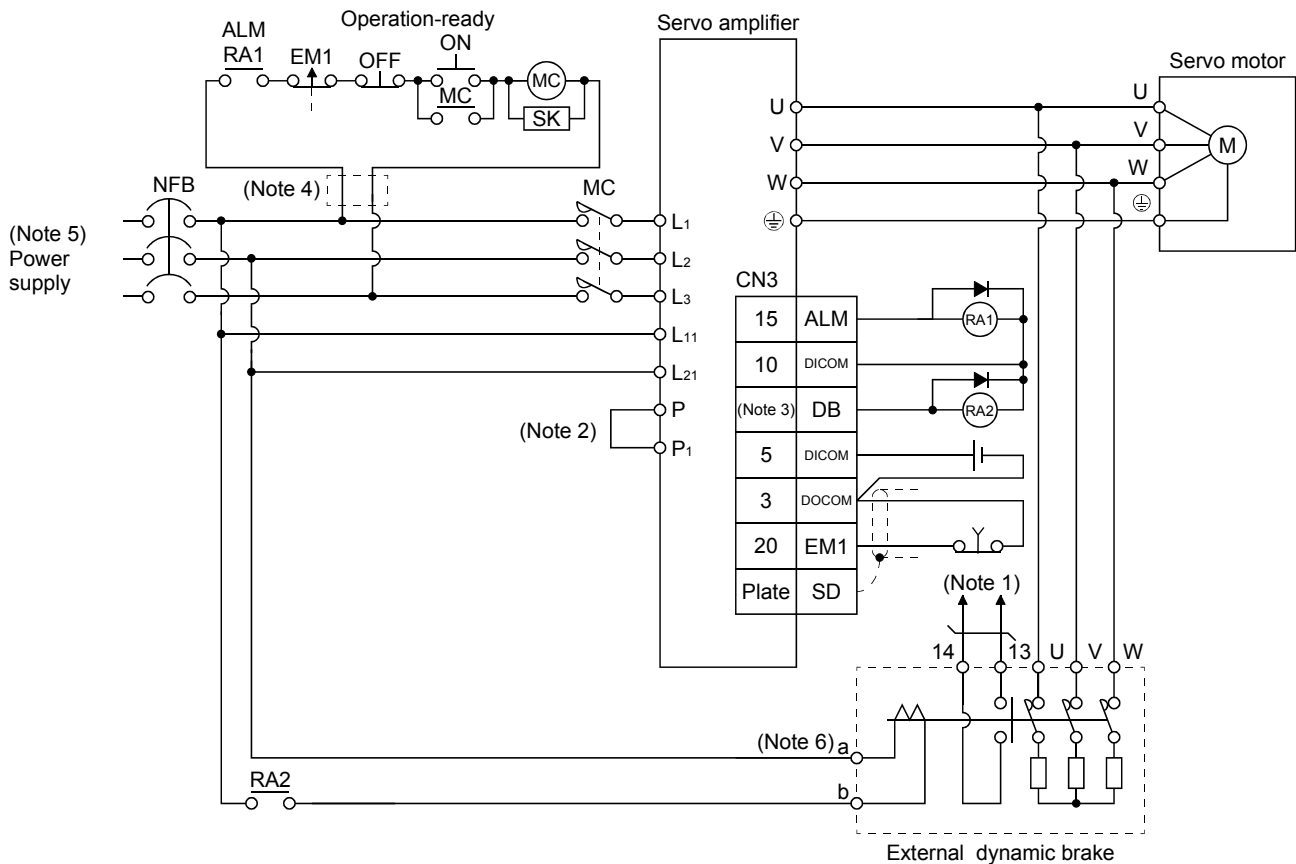

Note 1. Terminals 13, 14 are normally open contact outputs. If the dynamic brake is seized, terminals 13, 14 will open.

Therefore, configure up an external sequence to prevent servo-on.

2. For the servo amplifiers from 11kW to 22kW, be sure to connect P<sub>1</sub> and P. (Factory-wired)

When using the power factor DC reactor, refer to section 11.13.

3. Assign the dynamic brake interlock (DB) in the parameters No.PD07 to PD09.

4. Stepdown transformer is required for coil voltage of magnetic contactor more than 200V class in 400V class servo amplifiers.

5. Refer to section 1.3 for the power supply specification.

6. The power supply voltage of the inside magnet contactor for 400V class dynamic brake DBU-11K-4 and DBU-22K-4 is restricted as follows. When using these dynamic brakes, use them within the range of the power supply.

Dynamic brake	Power supply voltage
DBU-11K-4	1-phase 380 to 463VAC 50Hz/60Hz
DBU-22K-4	

## 11. OPTIONS AND AUXILIARY EQUIPMENT

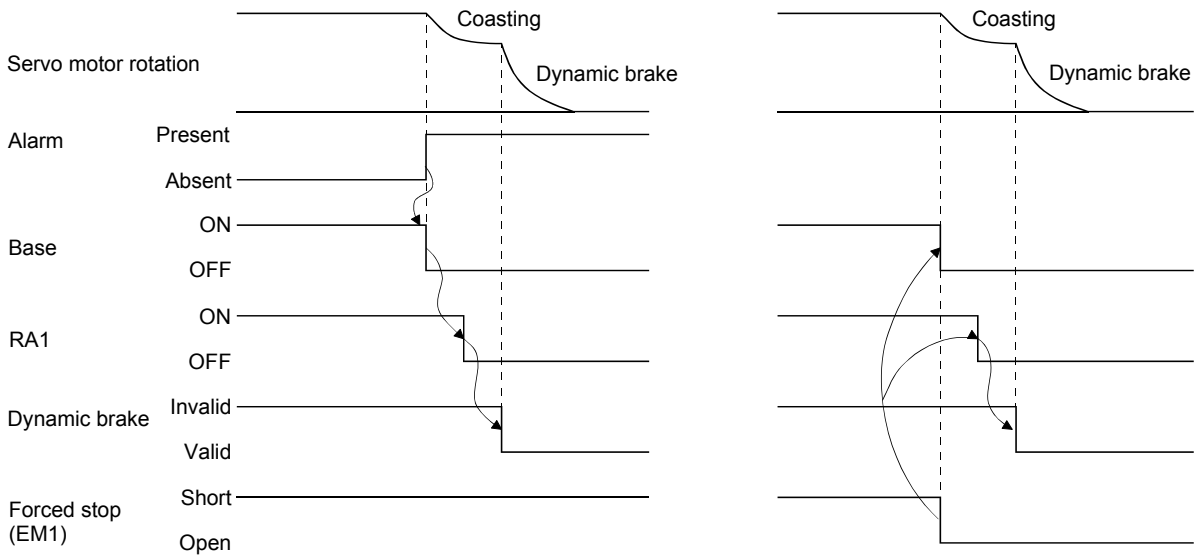

a. Timing chart at alarm occurrence

b. Timing chart at forced stop (EM1) validity

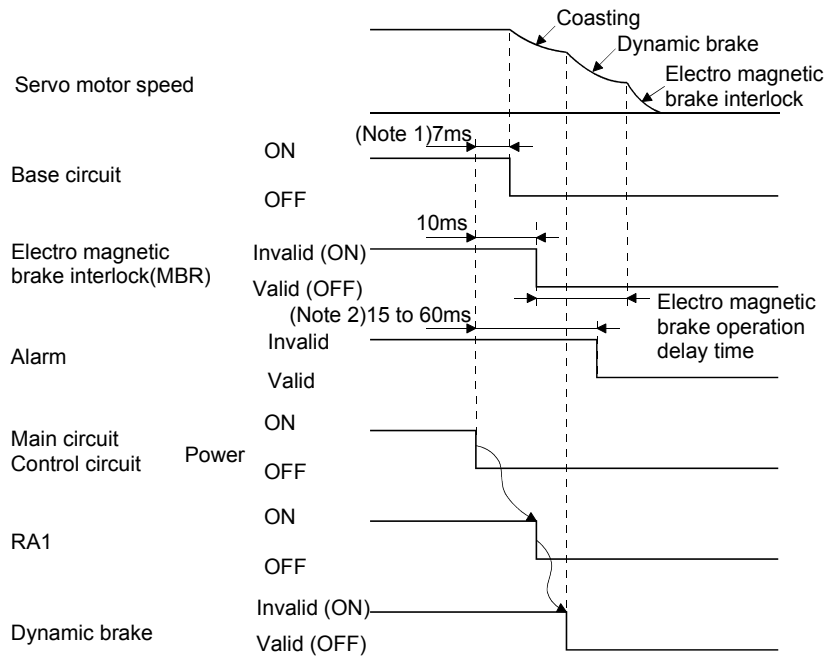

Note 1. When powering OFF, the RA1 of external dynamic brake circuit will be turned OFF, and the base circuit is turned OFF earlier than usual before an output shortage occurs.

(Only when assigning the DB as the output signal in the parameter No.PD07, PD08 or PD09)

2. Variable according to the operation status.

c. Timing chart when both of the main and control circuit power are OFF

## 11. OPTIONS AND AUXILIARY EQUIPMENT

### (3) Outline dimension drawing

#### (a) DBU-11K • DBU-15K • DBU-22K

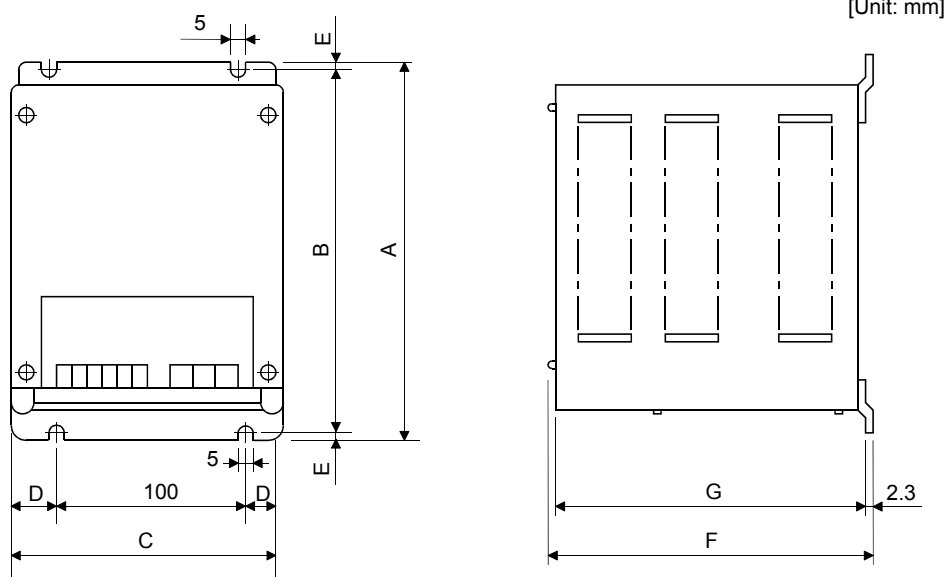

Terminal block

E		a	b	13	14
(GND)					

Screw : M3.5

Tightening torque: 0.8 [N·m](7 [lb·in])

U	V	W
---	---	---

Screw : M4

Tightening torque: 1.2 [N·m](10.6 [lb·in])

Dynamic brake	A	B	C	D	E	F	G	Mass [kg]([lb])	Connection wire [mm <sup>2</sup> ] (Note)
DBU-11K	200	190	140	20	5	170	163.5	2 (4.41)	5.5
DBU-15K, 22K	250	238	150	25	6	235	228	6 (13.23)	5.5

Note. Selection condition of wire size is as follows.

Wire type: 600V Polyvinyl chloride insulated wire (IV wire)

Construction condition: One wire is constructed in the air

# 11. OPTIONS AND AUXILIARY EQUIPMENT

(b) DBU-11K-4 • DBU-22K-4

[Unit: mm]

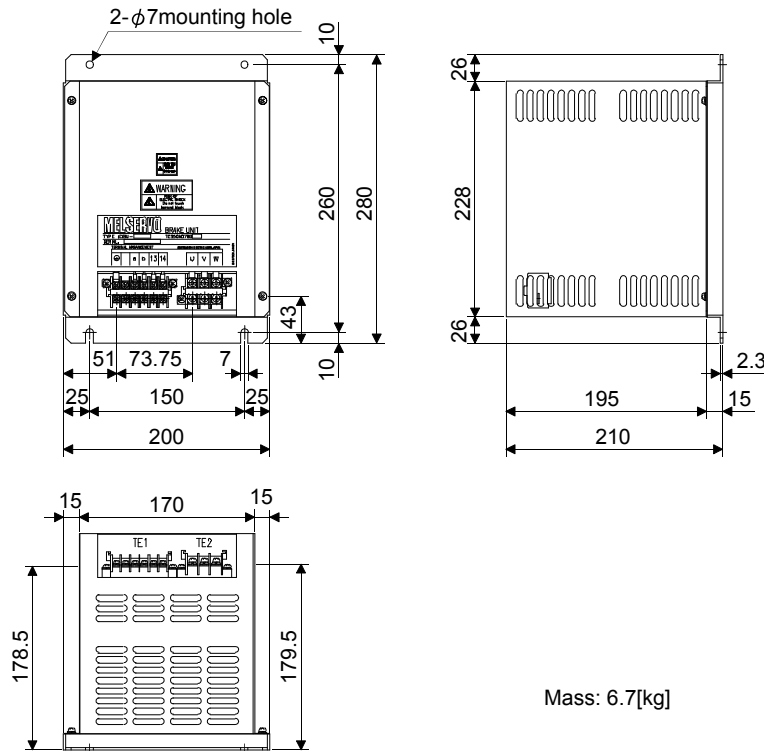

Mass: 6.7[kg]

Terminal block

TE1

⊕	a	b	13	14
---	---	---	----	----

Screw: M3.5

Tightening torque: 0.8[N·m](7[lb·in])

TE2

U	V	W
---	---	---

Screw: M4

Tightening torque: 1.2[N·m](10.6[lb·in])

Dynamic brake	Wire [mm <sup>2</sup> ] (Note)	
	a · b	U · V · W
DBU-11K	2	5.5
DBU-15K, 22K	2	5.5

Note. Selection condition of wire size is as follows.

Wire type: 600V Polyvinyl chloride insulated wire (IV wire)

Construction condition: One wire is constructed in the air

## 11. OPTIONS AND AUXILIARY EQUIPMENT

### 11.7 Junction terminal block PS7DW-20V14B-F (recommended)

#### (1) How to use the junction terminal block

Always use the junction terminal block (PS7W-20V14B-F(YOSHIDA ELECTRIC INDUSTRY)) with the option cable (MR-J2HBUS□M) as a set. A connection example is shown below.

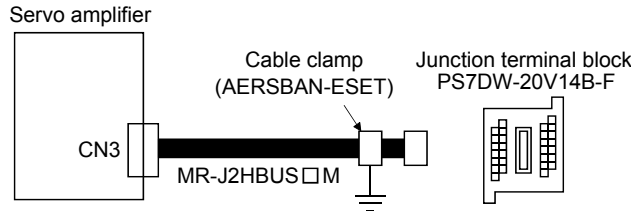

Ground the option cable on the junction terminal block side with the cable clamp fitting (AERSBAN-ESET). For the use of the cable clamp fitting, refer to section 11.14, (2)(c).

#### (2) Connection of MR-J2HBUS□M cable and junction terminal block

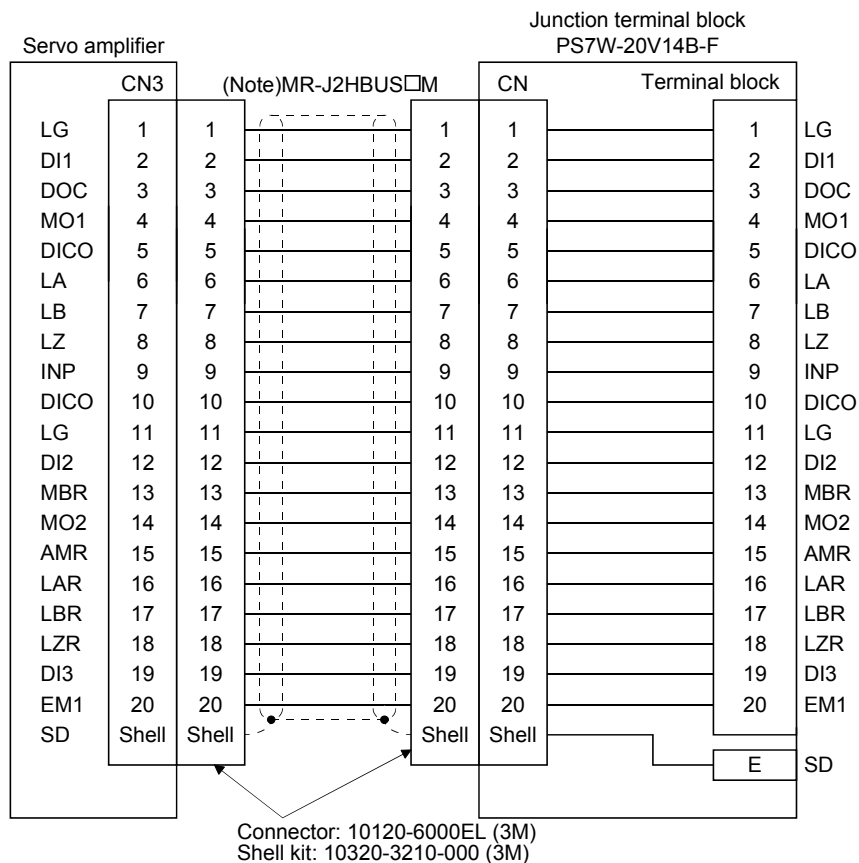

Note. Symbol indicating cable length is put in □.

05: 0.5m

1: 1m

5: 5m

## 11. OPTIONS AND AUXILIARY EQUIPMENT

### (3) Outline drawings of junction terminal block

[Unit : mm]

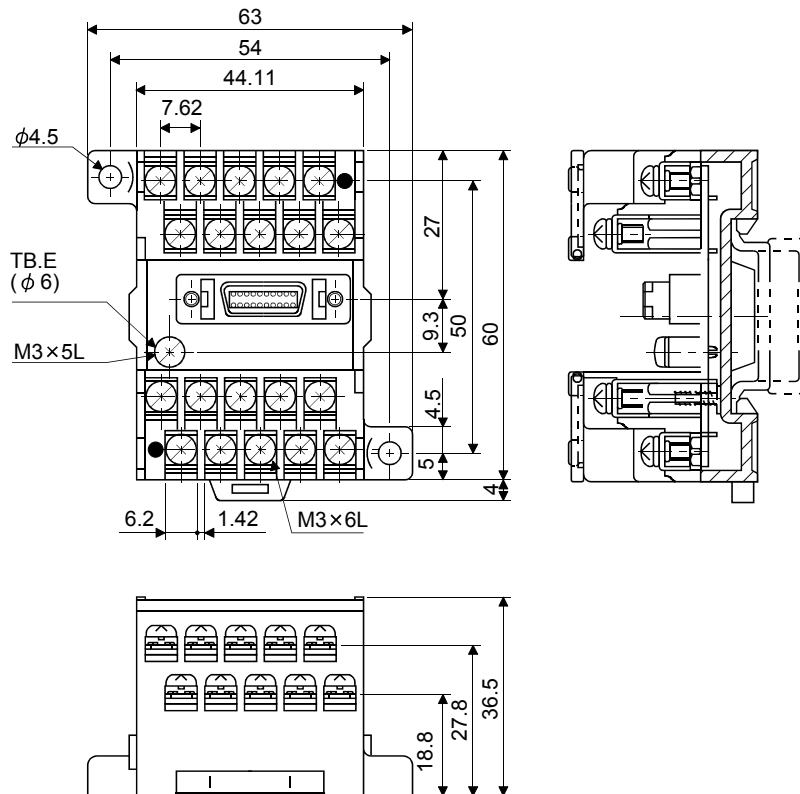

### 11.8 MR Configurator

The MR Configurator (MRZJW3-SETUP221E) uses the communication function of the servo amplifier to perform parameter setting changes, graph display, test operation, etc. on a personal computer.

#### (1) Specifications

Item	Description																																	
Compatibility with a servo amplifier	The following table shows MR Configurator software version for each servo amplifier.																																	
	<table border="1"> <thead> <tr> <th rowspan="3">Version</th> <th colspan="6">Compatible servo amplifier (Drive unit)</th> </tr> <tr> <th colspan="3">100V class - 200V class</th> <th colspan="3">400V class</th> </tr> <tr> <th>7kW or less</th> <th>11k to 22kW</th> <th>30k to 37kW</th> <th>7kW or less</th> <th>11k to 22kW</th> <th>30k to 55kW</th> </tr> </thead> <tbody> <tr> <td>B1</td> <td>○</td> <td>○</td> <td>△</td> <td>△</td> <td>○</td> <td>△</td> </tr> <tr> <td>C0 or later</td> <td>○</td> <td>○</td> <td>○</td> <td>○</td> <td>○</td> <td>○</td> </tr> </tbody> </table>	Version	Compatible servo amplifier (Drive unit)						100V class - 200V class			400V class			7kW or less	11k to 22kW	30k to 37kW	7kW or less	11k to 22kW	30k to 55kW	B1	○	○	△	△	○	△	C0 or later	○	○	○	○	○	○
	Version		Compatible servo amplifier (Drive unit)																															
100V class - 200V class			400V class																															
7kW or less		11k to 22kW	30k to 37kW	7kW or less	11k to 22kW	30k to 55kW																												
B1	○	○	△	△	○	△																												
C0 or later	○	○	○	○	○	○																												
Monitor	Display, high speed monitor, trend graph Minimum resolution changes with the processing speed of the personal computer.																																	
Alarm	Display, history, amplifier data																																	
Diagnostic	Digital I/O, no motor rotation, total power-on time, amplifier version info, motor information, tuning data, absolute encoder data, Axis name setting.																																	
Parameters	Parameter list, turning, change list, detailed information																																	
Test operation	Jog operation, positioning operation, Do forced output, program operation.																																	
Advanced function	Machine analyzer, gain search, machine simulation.																																	
File operation	Data read, save, delete, print																																	
Others	Automatic demo, help display																																	

## 11. OPTIONS AND AUXILIARY EQUIPMENT

### (2) System configuration

#### (a) Components

To use this software, the following components are required in addition to the servo amplifier and servo motor.

Equipment	(Note 1) Description	
(Note 2, 3) Personal computer	OS	IBM PC/AT compatible where the English version of Windows® 98, Windows® Me, Windows® 2000 Professional, Windows® XP Professional, Windows® XP Home Edition, Windows Vista® Home Basic, Windows Vista® Home Premium, Windows Vista® Business, Windows Vista® Ultimate, Windows Vista® Enterprise operates
	Processor	Pentium® 133MHz or more (Windows® 98, Windows® 2000 Professional) Pentium® 150MHz or more (Windows® Me) Pentium® 300MHz or more (Windows® XP Professional, Windows® XP Home Edition) 32-bit (x86) processor of 1GHz or higher (Windows Vista® Home Basic, Windows Vista® Home Premium, Windows Vista® Business, Windows Vista® Ultimate, Windows Vista® Enterprise)
	Memory	24MB or more (Windows® 98) 32MB or more (Windows® Me, Windows® 2000 Professional) 128MB or more (Windows® XP Professional, Windows® XP Home Edition) 512MB or more (Windows Vista® Home Basic) 1GB or more (Windows Vista® Home Premium, Windows Vista® Business, Windows Vista® Ultimate, Windows Vista® Enterprise)
	Hard Disk	130MB or more of free space
Browser	Internet Explorer 4.0 or more	
Display	One whose resolution is 800 × 600 or more and that can provide a high color (16 bit) display. Connectable with the above personal computer.	
Keyboard	Connectable with the above personal computer.	
Mouse	Connectable with the above personal computer.	
Printer	Connectable with the above personal computer.	
USB cable	MR-J3USBCBL3M	

Note 1. Windows and Windows Vista is the registered trademarks of Microsoft Corporation in the United States and other countries.

Pentium is the registered trademarks of Intel Corporation.

2. On some personal computers, MR Configurator may not run properly.

3. 64-bit Windows XP and 64-bit Windows Vista are not supported.

#### (b) Connection with servo amplifier

##### 1) For use of USB

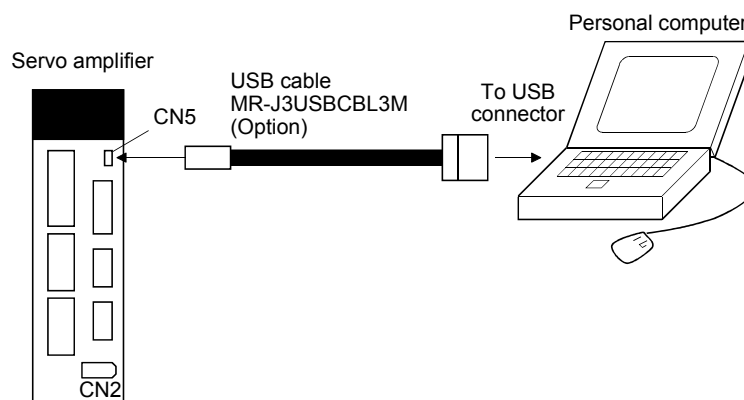

## 11. OPTIONS AND AUXILIARY EQUIPMENT

### 11.9 Battery MR-J3BAT

POINT
<ul style="list-style-type: none"> <li>The revision (Edition 44) of the Dangerous Goods Rule of the International Air Transport Association (IATA) went into effect on January 1, 2003 and was enforced immediately. In this rule, "provisions of the lithium and lithium ion batteries" were revised to tighten the restrictions on the air transportation of batteries. However, since this battery is non-dangerous goods (non-Class 9), air transportation of 24 or less batteries is outside the range of the restrictions. Air transportation of more than 24 batteries requires packing compliant with the Packing Standard 903. When a self-certificate is necessary for battery safety tests, contact our branch or representative. For more information, consult our branch or representative. (As of Jun, 2008).</li> </ul>

#### (1) Purpose of use for MR-J3BAT

This battery is used to construct an absolute position detection system. Refer to section 12.3 for the fitting method, etc.

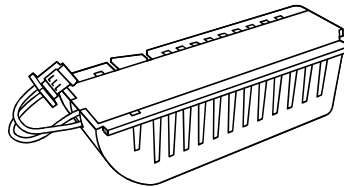

#### (2) Year and month when MR-J3BAT is manufactured

The year and month when MR-J3BAT is manufactured are written down in Serial No. on the rating plate of the battery back face.

The year and month of manufacture are indicated by the last one digit of the year and 1 to 9, X(10), Y(11), Z(12).

For October 2004, the Serial No. is like, "SERIAL □4X□□□□□□".

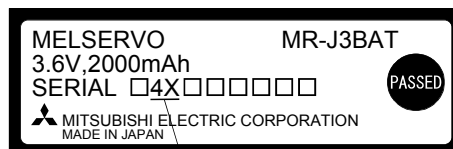

The year and month of manufacture

## 11. OPTIONS AND AUXILIARY EQUIPMENT

### 11.10 Heat sink outside mounting attachment (MR-J3ACN)

Use the heat sink outside mounting attachment to mount the heat generation area of the servo amplifier in the outside of the control box to dissipate servo amplifier-generated heat to the outside of the box and reduce the amount of heat generated in the box, thereby allowing a compact control box to be designed.

In the control box, machine a hole having the panel cut dimensions, fit the heat sink outside mounting attachment to the servo amplifier with the fitting screws (4 screws supplied), and install the servo amplifier to the control box.

The environment outside the control box when using the heat sink outside mounting attachment should be within the range of the servo amplifier operating environment conditions.

The heat sink outside mounting attachment of MR-J3ACN can be used for MR-J3-11KB(4) to MR-J3-22KB(4).

#### (1) Panel cut dimensions

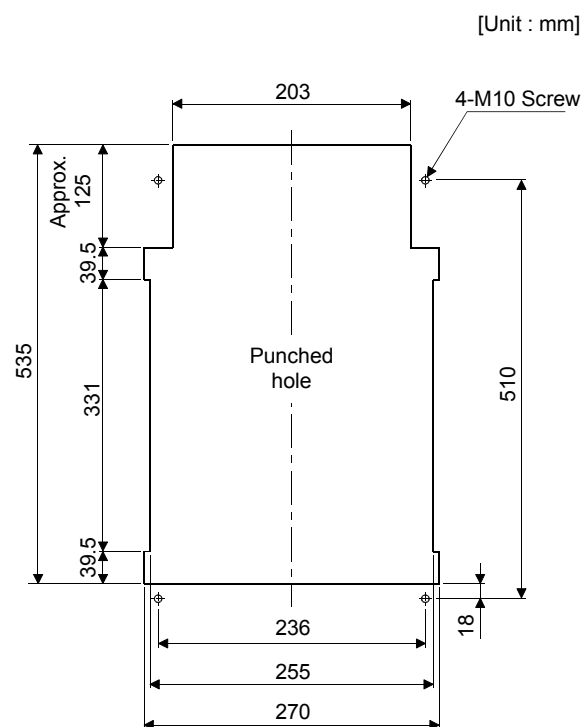

#### (2) How to assemble the attachment for a heat sink outside mounting attachment

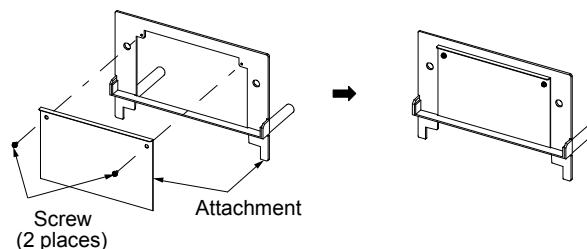

## 11. OPTIONS AND AUXILIARY EQUIPMENT

### (3) Fitting method

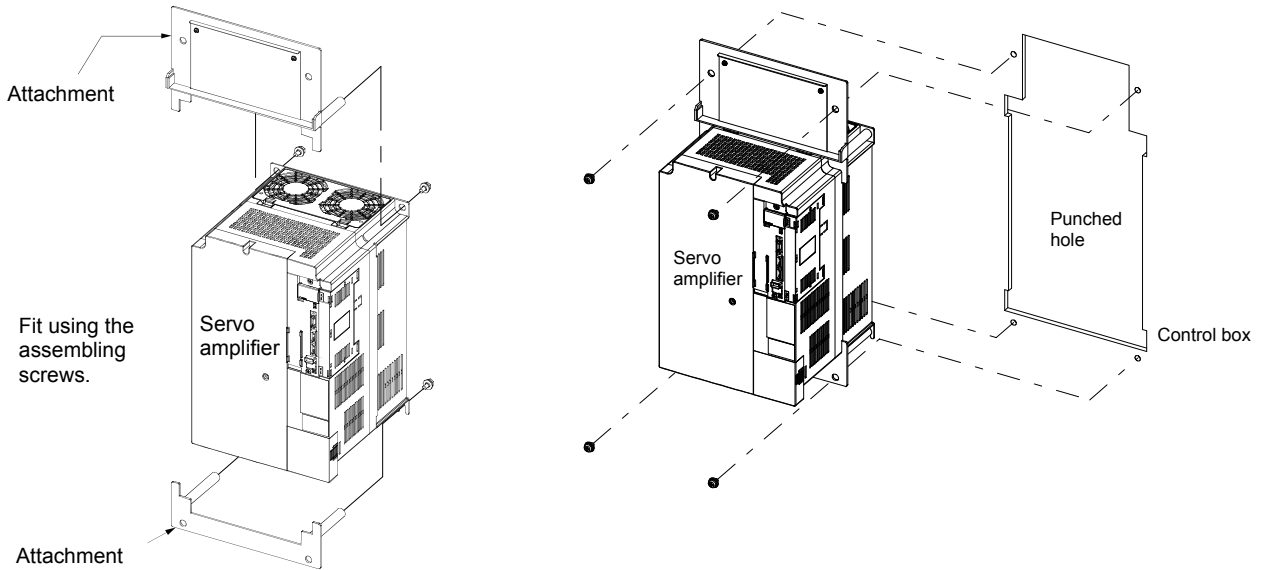

a. Assembling the heat sink outside mounting attachment

b. Installation to the control box

### (4) Outline dimension drawing

[Unit: mm]

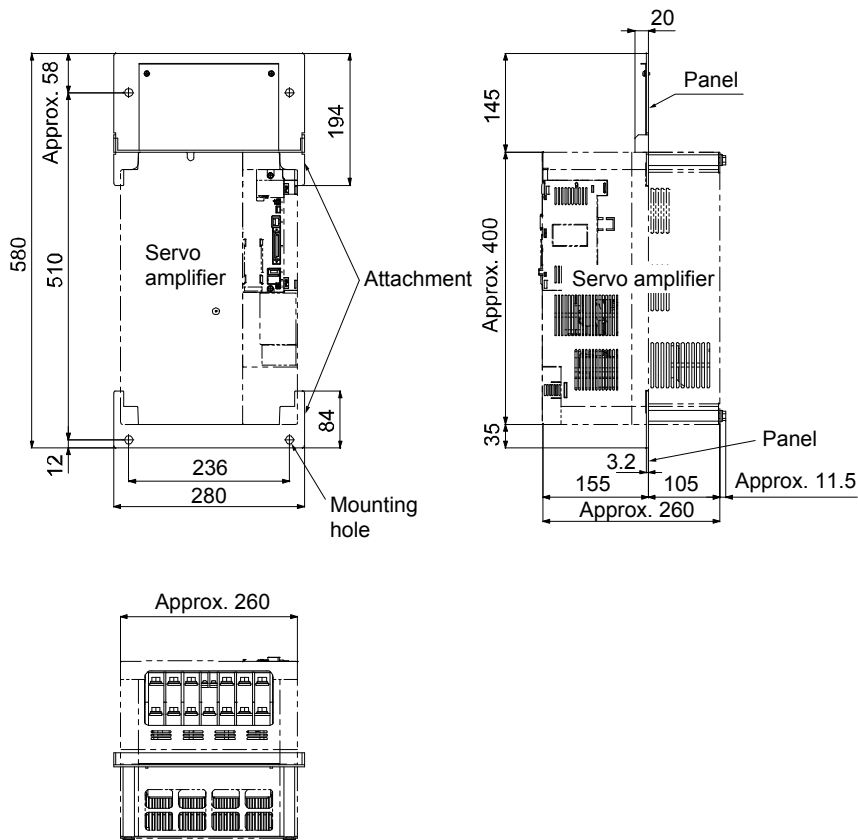

## 11. OPTIONS AND AUXILIARY EQUIPMENT

### 11.11 Selection example of wires

POINT
<ul style="list-style-type: none"> <li>Refer to section 11.1.5 for SSCNETIII cable.</li> <li>Wires indicated in this section are separated wires. When using a cable for power line (U, V, and W) between the servo amplifier and servo motor, use a 600V grade EP rubber insulated chloroprene sheath cab-tire cable (2PNCT). For selection of cables, refer to appendix 6.</li> <li>To comply with the UL/C-UL (CSA) Standard, use UL-recognized copper wires rated at 60°C (140°F) or more for wiring. To comply with other standards, use a wire that is complied with each standard</li> <li>Selection condition of wire size is as follows. Construction condition: One wire is constructed in the air Wire length: 30m or less</li> </ul>

#### (1) Wires for power supply wiring

The following diagram shows the wires used for wiring. Use the wires given in this section or equivalent.

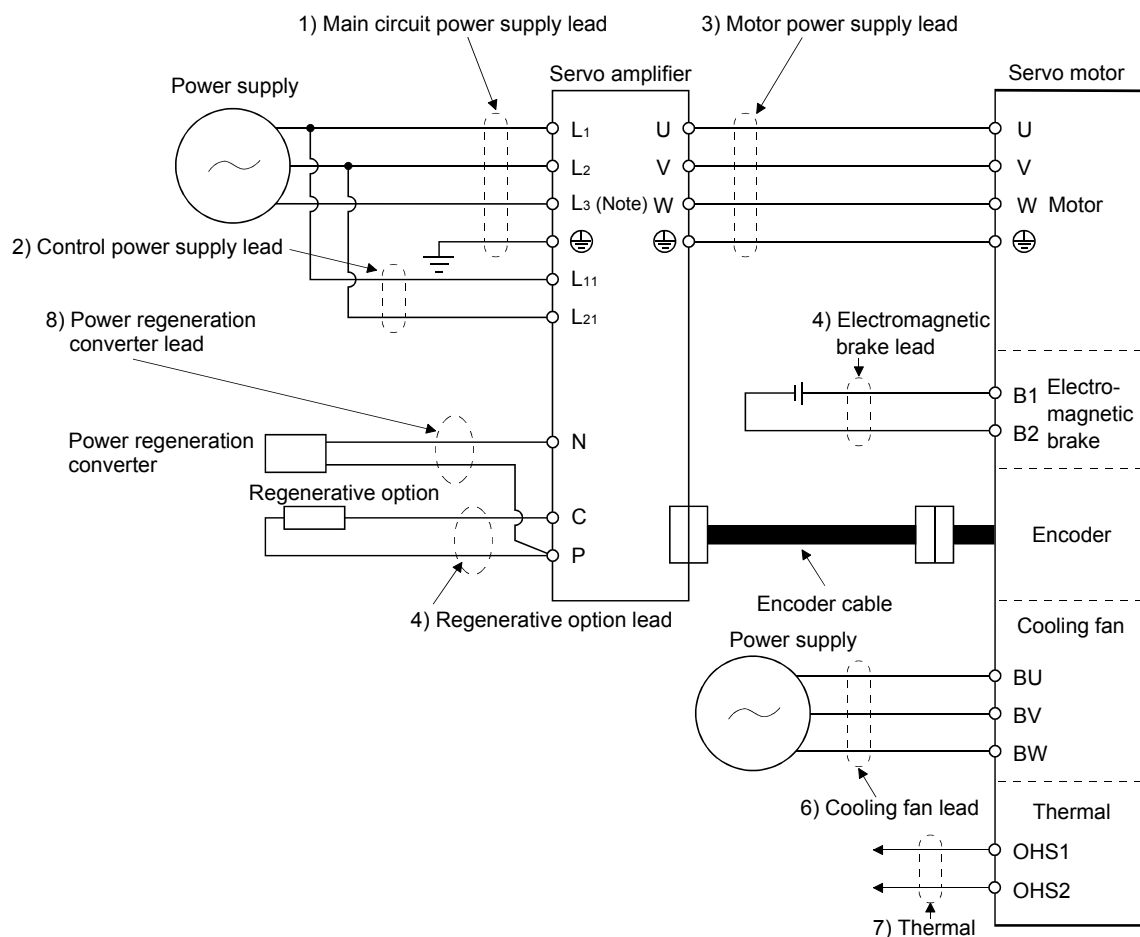

Note. There is no L<sub>3</sub> for 1-phase 100 to 120VAC power supply.

## 11. OPTIONS AND AUXILIARY EQUIPMENT

- (a) When using the 600V Polyvinyl chloride insulated wire (IV wire)  
Selection example of wire size when using IV wires is indicated below.

Table 11.1 Wire size selection example 1 (IV wire)

Servo amplifier	Wires [mm <sup>2</sup> ] (Note 1, 4)								
	1) L <sub>1</sub> · L <sub>2</sub> · L <sub>3</sub> · ⊕	2) L <sub>11</sub> · L <sub>21</sub>	3) U · V · W · ⊕	4) P · C	5) B1 · B2	6) BU · BV · BW	7) OHS1 · OHS2		
MR-J3-10B(1)	2(AWG14)	1.25(AWG16)	1.25(AWG16)	2(AWG14)	1.25(AWG16)				
MR-J3-20B(1)									
MR-J3-40B(1)									
MR-J3-60B			3.5(AWG12)					3.5(AWG12)	
MR-J3-70B									
MR-J3-100B									
MR-J3-200B									
MR-J3-350B	5.5(AWG10): a	5.5(AWG10): a	2(AWG14): g						
MR-J3-500B (Note 2)									
MR-J3-700B (Note 2)	8(AWG8): b	h	8(AWG8): b	3.5(AWG12): a		2(AWG14) (Note 3)	1.25(AWG16) (Note 3)		
MR-J3-11KB (Note 2)	14(AWG6): c	1.25(AWG16): g	22(AWG4): d	5.5(AWG10): j		2(AWG14)	1.25(AWG16)		
MR-J3-15KB (Note 2)	22(AWG4): d		30(AWG2): e						
MR-J3-22KB (Note 2)	50(AWG1/0): f		60(AWG2/0): f					5.5(AWG10): k	
MR-J3-60B4	2(AWG14)	1.25(AWG16)	1.25(AWG16)	2(AWG14)					
MR-J3-100B4			2(AWG14)						
MR-J3-200B4			2(AWG14): g					1.25(AWG16): h	2(AWG14): g
MR-J3-350B4									
MR-J3-500B4 (Note 2)	5.5(AWG10): a	h	5.5(AWG10): a	2(AWG14): g				2(AWG14) (Note 3)	1.25(AWG16) (Note 3)
MR-J3-700B4 (Note 2)									
MR-J3-11KB4 (Note 2)	8(AWG8): l	1.25(AWG16): g	8(AWG8): l	3.5(AWG12): j				2(AWG14)	1.25(AWG16)
MR-J3-15KB4 (Note 2)	14(AWG6): c		22(AWG4): d	5.5(AWG10): j					
MR-J3-22KB4 (Note 2)	14(AWG6): m		22(AWG4): n	5.5(AWG10): k					

Note 1. Alphabets in the table indicate crimping tools. For crimping terminals and applicable tools, refer to (1) (c) in this section.

- When connecting to the terminal block, be sure to use the screws which are provided with the terminal block.
- For the servo motor with a cooling fan.
- Wires are selected based on the highest rated current among combining servo motors.

Use wires 8) of the following sizes with the power regeneration converter (FR-RC-(H)).

Model	Wires[mm <sup>2</sup> ]
FR-RC-15K	14(AWG6)
FR-RC-30K	14(AWG6)
FR-RC-55K	22(AWG4)
FR-RC-H15K	14(AWG6)
FR-RC-H30K	14(AWG6)
FR-RC-H55K	14(AWG6)

## 11. OPTIONS AND AUXILIARY EQUIPMENT

(b) When using the 600V Grade heat-resistant polyvinyl chloride insulated wire (HIV wire)

Selection example of wire size when using HIV wires is indicated below. For the wire (8)) for power regeneration converter (FR-RC-(H)), use the IV wire indicated in (1) (a) in this section.

Table 11.2 Wire size selection example 2 (HIV wire)

Servo amplifier	Wires [mm <sup>2</sup> ] (Note 1, 4)						
	1) L <sub>1</sub> · L <sub>2</sub> · L <sub>3</sub> · ⊕	2) L <sub>11</sub> · L <sub>21</sub>	3) U · V · W · ⊕	4) P · C	5) B1 · B2	6) BU · BV · BW	7) OHS1 · OHS2
MR-J3-10B(1)	2(AWG14)	1.25(AWG16)	1.25(AWG16)	2(AWG14)	1.25(AWG16)	/	/
MR-J3-20B(1)							
MR-J3-40B(1)							
MR-J3-60B							
MR-J3-70B							
MR-J3-100B							
MR-J3-200B							
MR-J3-350B	3.5(AWG12)		3.5(AWG12)				
MR-J3-500B (Note 2)	5.5(AWG10): a	1.25(AWG16): h	5.5(AWG10): a	2(AWG14): g			
MR-J3-700B (Note 2)	8(AWG8): b		8(AWG8): b	2(AWG14): g	1.25(AWG16) (Note 3)	1.25(AWG16) (Note 3)	
MR-J3-11KB (Note 2)	14(AWG6): c	1.25(AWG16): g	14(AWG6): c	3.5(AWG12): j	1.25(AWG16)	1.25(AWG16)	1.25(AWG16)
MR-J3-15KB (Note 2)	22(AWG4): d		22(AWG4): d				
MR-J3-22KB (Note 2)	38(AWG1): p		38(AWG1): p	5.5(AWG10): k			
MR-J3-60B4	2(AWG14)	1.25(AWG16)	1.25(AWG16)	2(AWG14)	1.25(AWG16)	/	/
MR-J3-100B4							
MR-J3-200B4							
MR-J3-350B4	2(AWG14): g	1.25(AWG16): h	2(AWG14): g	2(AWG14): g	1.25(AWG16)	1.25(AWG16) (Note 3)	1.25(AWG16) (Note 3)
MR-J3-500B4 (Note 2)	3.5(AWG12): a		3.5(AWG12): a				
MR-J3-700B4 (Note 2)			5.5(AWG10): a				
MR-J3-11KB4 (Note 2)	5.5(AWG10): j	1.25(AWG16): g	8(AWG8): l	2(AWG14): q	1.25(AWG16)	1.25(AWG16)	1.25(AWG16)
MR-J3-15KB4 (Note 2)	8(AWG8): l		14(AWG6): c	3.5(AWG12): j			
MR-J3-22KB4 (Note 2)	14(AWG6): m		14(AWG6): m	3.5(AWG12): k			

Note 1. Alphabets in the table indicate crimping tools. For crimping terminals and applicable tools, refer to (1) (c) in this section.

2. When connecting to the terminal block, be sure to use the screws which are provided with the terminal block.
3. For the servo motor with a cooling fan.
4. Wires are selected based on the highest rated current among combining servo motors.

## 11. OPTIONS AND AUXILIARY EQUIPMENT

### (c) Selection example of crimping terminals

Selection example of crimping terminals for the servo amplifier terminal box when using the wires mentioned in (1) (a) and (b) in this section is indicated below.

Symbol	Servo amplifier side crimping terminals				Manufacturer
	(Note 2) Crimping terminal	Applicable tool			
		Body	Head	Dice	
a	FVD5.5-4	YNT-1210S			Japan Solderless Terminal
(Note 1)b	8-4NS	YHT-8S			
c	FVD14-6	YF-1 · E-4	YNE-38	DH-112 · DH122	
d	FVD22-6			DH-113 · DH123	
(Note 1)e	38-6	YPT-60-21		TD-112 · TD-124	
		YF-1 · E-4			
(Note 1)f	R60-8	YPT-60-21		TD-113 · TD-125	
		YF-1 · E-4			
g	FVD2-4	YNT-1614			
h	FVD2-M3				
j	FVD5.5-6				
k	FVD5.5-8				
l	FVD8-6	YF-1 · E-4	YNE-38	DH-111 · DH121	
m	FVD14-8			DH-112 · DH122	
n	FVD22-8			DH-113 · DH123	
(Note 1)p	R38-8	YPT-60-21		TD-112 · TD-124	
		YF-1 · E-4			
q	FVD2-6	YNT-1614			

Note 1. Coat the part of crimping with the insulation tube.

2. Some crimping terminals may not be mounted depending on the size. Make sure to use the recommended ones or equivalent ones.

## 11. OPTIONS AND AUXILIARY EQUIPMENT

### (2) Wires for cables

When fabricating a cable, use the wire models given in the following table or equivalent.

Table 11.3 Wires for option cables

Type	Model	Length [m]	Core size [mm <sup>2</sup> ]	Number of Cores	Characteristics of one core			(Note 3) Finishing OD [mm]	Wire model
					Structure [Wires/mm]	Conductor resistance [Ω/mm]	Insulation coating OD d [mm] (Note 1)		
Encoder cable	MR-J3ENCBL □ M-A1-L	2 to 10	AWG22	6 (3 pairs)	7/0.26	53 or less	1.2	7.1±0.3	(Note 3) VSVP 7/0.26 (AWG#22 or equivalent)-3P Ban-gi-shi-16823
	MR-J3ENCBL □ M-A2-L								
	MR-J3ENCBL □ M-A1-H	2 to 10	AWG22	6 (3 pairs)	70/0.08	56 or less	1.2	7.1±0.3	(Note 3) ETFE • SVP 70/0.08 (AWG#22 or equivalent)-3P Ban-gi-shi-16824
	MR-J3ENCBL □ M-A2-H								
	MR-J3CBL03M-A1-L	0.3	AWG26	8 (4 pairs)	30/0.08	233 or less	1.2	7.1±0.3	(Note 5) T/2464-1061/II A-SB 4P × 26AWG
	MR-J3CBL03M-A2-L								
	MR-EKCBL □ M-L	2 to 10	0.3mm <sup>2</sup>	4 (2 pairs)	12/0.18	65.7 or less	1.3	7.3	(Note 3) 20276 composite 4-pair shielded cable (A-TYPE)
			0.08mm <sup>2</sup>	4 (2 pairs)	7/0.127	234 or less	0.67		
		20 • 30	0.3mm <sup>2</sup>	12 (6 pairs)	12/0.18	63.6 or less	1.2	8.2	UL20276 AWG#23 6pair(BLACK)
	MR-EKCBL □ M-H	20	0.2mm <sup>2</sup>	12 (6 pairs)	40/0.08	105 or less	0.88	7.2	(Note 3) A14B2343 6P
		30 to 50	0.2mm <sup>2</sup>	14 (7 pairs)	40/0.08	105 or less	0.88	8.0	(Note 3) J14B0238(0.2*7P)
	MR-J3ENSCBL □ M-L	2 to 10	AWG22	6 (3 pairs)	7/0.26	53 or less	1.2	7.1±0.3	(Note 3) VSVP 7/0.26 (Equivalent to AWG#22)-3P Ban-gi-shi-16823
		20 • 30	AWG23	12 (6 pairs)	12/0.18	63.3 or less	1.2	8.2±0.3	(Note 3) 20276 VSVCAWG#23 × 6P Ban-gi-shi-15038
	MR-J3ENSCBL □ M-H	2 to 10	AWG22	6 (3 pairs)	70/0.08	56 or less	1.2	7.1±0.3	(Note 3) ETEF SVP 70/0.08 (Equivalent to AWG#22)-3P Ban-gi-shi-16824
20 to 50		AWG24	12 (6 pairs)	40/0.08	105 or less	0.88	7.2	(Note 3) ETFE • SVP 40/0.08mm × 6P Ban-gi-shi-15266	
Motor power supply cable	MR-PWS1CBL □ M-A1-L	2 to 10	(Note 6) AWG19	4	50/0.08	25.40 or less	1.8	5.7±0.3	(Note 4) UL Style 2103 AWG19 4 cores
	MR-PWS1CBL □ M-A2-L	2 to 10							
	MR-PWS1CBL □ M-A1-H	2 to 10							
	MR-PWS1CBL □ M-A2-H	2 to 10							
	MR-PWS2CBL03M-A1-L	0.3							
	MR-PWS2CBL03M-A2-L	0.3							
Motor brake cable	MR-BKS1CBL □ M-A1-L	2 to 10	(Note 6) AWG20	2	100/0.08	38.14 or less	1.3	4.0±0.3	(Note 4) UL Style 2103 AWG20 2 cores
	MR-BKS1CBL □ M-A2-L	2 to 10							
	MR-BKS1CBL □ M-A1-H	2 to 10							
	MR-BKS1CBL □ M-A2-H	2 to 10							
	MR-BKS2CBL03M-A1-L	0.3							
	MR-BKS2CBL03M-A2-L	0.3							

Note 1. d is as shown below.

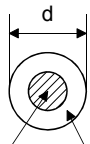

Conductor Insulation sheath

2. Purchased from Toa Electric Industry
3. Standard OD. Max. OD is about 10% greater.
4. Kurabe
5. Taiyo Electric Wire and Cable
6. These wire sizes assume that the UL-compliant wires are used at the wiring length of 10m.

## 11. OPTIONS AND AUXILIARY EQUIPMENT

### 11.12 No-fuse breakers, fuses, magnetic contactors

Always use one no-fuse breaker and one magnetic contactor with one servo amplifier. When using a fuse instead of the no-fuse breaker, use the one having the specifications given in this section.

Servo amplifier	No-fuse breaker		(Note) Class	Fuse		Magnetic contactor		
	Not using power factor improving reactor	Using power factor improving reactor		Current [A]	Voltage AC [V]			
MR-J3-10B (1)	30A frame 5A	30A frame 5A	T	10	250	S-N10		
MR-J3-20B	30A frame 5A	30A frame 5A		10				
MR-J3-20B1	30A frame 10A	30A frame 10A		15				
MR-J3-40B	30A frame 10A	30A frame 5A		15				
MR-J3-60B MR-J3-70B MR-J3-100B MR-J3-40B1	30A frame 15A	30A frame 10A		20				
MR-J3-200B	30A frame 20A	30A frame 15A		40				
MR-J3-350B	30A frame 30A	30A frame 30A		70				
MR-J3-500B	50A frame 50A	50A frame 40A		125				
MR-J3-700B	100A frame 75A	50A frame 50A		150				
MR-J3-11KB	100A frame 100A	100A frame 75A		200				
MR-J3-15KB	225A frame 125A	100A frame 100A		250				
MR-J3-22KB	225A frame 175A	225A frame 150A		350				
MR-J3-60B4	30A frame 5A	30A frame 5A		10			600	S-N10
MR-J3-100B4	30A frame 10A	30A frame 10A		15				
MR-J3-200B4	30A frame 15A	30A frame 15A		25				
MR-J3-350B4	30A frame 20A	30A frame 20A		35				
MR-J3-500B4	30A frame 30A	30A frame 30A		50				
MR-J3-700B4	50A frame 40A	50A frame 30A		65				
MR-J3-11KB4	60A frame 60A	50A frame 50A		100				
MR-J3-15KB4	100A frame 75A	60A frame 60A		150				
MR-J3-22KB4	225A frame 125A	100A frame 100A	175					

Note. When not using the servo amplifier as a UL/C-UL Standard compliant product, K5 class fuse can be used.

### 11.13 Power factor improving DC reactor

POINT
<ul style="list-style-type: none"> <li>For the 100V power supply type (MR-J3-□B1), the power factor improving DC reactor cannot be used.</li> </ul>

The power factor improving DC reactor increases the form factor of the servo amplifier's input current to improve the power factor. It can decrease the power supply capacity. As compared to the power factor improving AC reactor (FR-BAL), it can decrease the loss. The input power factor is improved to about 95%. It is also effective to reduce the input side harmonics.

When connecting the power factor improving DC reactor to the servo amplifier, always disconnect  $P_1$  and  $P_2$  (For 11kW or more, disconnect  $P_1$  and P). If it remains connected, the effect of the power factor improving DC reactor is not produced.

When used, the power factor improving DC reactor generates heat. To release heat, therefore, leave a 10cm or more clearance at each of the top and bottom, and a 5cm or more clearance on each side.

## 11. OPTIONS AND AUXILIARY EQUIPMENT

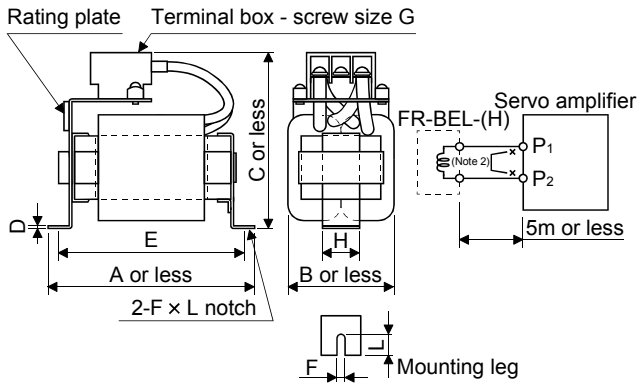

Fig. 11.1

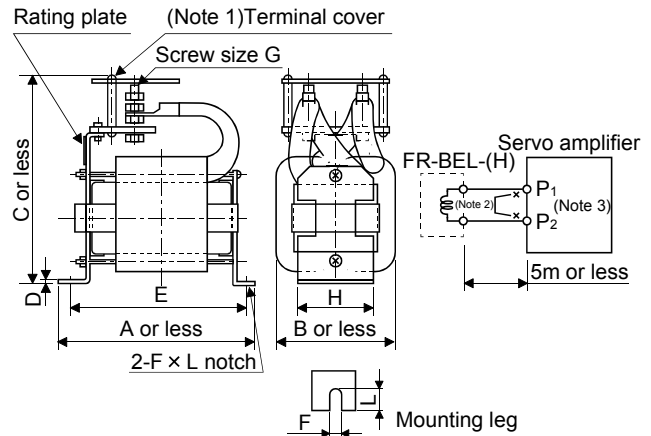

Fig. 11.2

Note 1. Since the terminal cover is supplied, attach it after connecting a wire.

2. When using DC reactor, disconnect P<sub>1</sub> and P<sub>2</sub>.
3. When over 11kW, "P<sub>2</sub>" becomes "P", respectively.

Servo amplifier	Power factor improving DC reactor	Outline drawing	Dimensions [mm]									Mounting screw size	Mass [kg(lb)]	Wire [mm <sup>2</sup> ] (Note)
			A	B	C	D	E	F	L	G	H			
MR-J3-10B • 20B	FR-BEL-0.4K	Fig. 11.1	110	50	94	1.6	95	6	12	M3.5	25	M5	0.5(1.10)	2(AWG14)
MR-J3-40B	FR-BEL-0.75K		120	53	102	1.6	105	6	12	M4	25	M5	0.7(1.54)	
MR-J3-60B • 70B	FR-BEL-1.5K		130	65	110	1.6	115	6	12	M4	30	M5	1.1(2.43)	
MR-J3-100B	FR-BEL-2.2K		130	65	110	1.6	115	6	12	M4	30	M5	1.2(2.65)	
MR-J3-200B	FR-BEL-3.7K		150	75	102	2.0	135	6	12	M4	40	M5	1.7(3.75)	3.5(AWG12)
MR-J3-350B	FR-BEL-7.5K		150	75	126	2.0	135	6	12	M5	40	M5	2.3(5.07)	
MR-J3-500B	FR-BEL-11K		170	93	132	2.3	155	6	14	M5	50	M5	3.1(6.83)	
MR-J3-700B	FR-BEL-15K	Fig. 11.2	170	93	170	2.3	155	6	14	M8	56	M5	3.8(8.38)	8(AWG8)
MR-J3-11KB			185	119	182	2.6	165	7	15	M8	70	M6	5.4(11.91)	22(AWG4)
MR-J3-15KB	FR-BEL-22K	Fig. 11.2	185	119	201	2.6	165	7	15	M8	70	M6	6.7(14.77)	60(AWG2/0)
MR-J3-22KB	FR-BEL-30K		185	119	201	2.6	165	7	15	M8	70	M6	6.7(14.77)	
MR-J3-60B4	FR-BEL-H1.5K	Fig. 11.1	130	63	89	1.6	115	6	12	M3.5	32	M5	0.9(1.98)	2(AWG14)
MR-J3-100B4	FR-BEL-H2.2K		130	63	101	1.6	115	6	12	M3.5	32	M5	1.1(2.43)	
MR-J3-200B4	FR-BEL-H3.7K		150	75	102	2	135	6	12	M4	40	M5	1.7(3.75)	
MR-J3-350B4	FR-BEL-H7.5K		150	75	124	2	135	6	12	M4	40	M5	2.3(5.07)	
MR-J3-500B4	FR-BEL-H11K		170	93	132	2.3	155	6	14	M5	50	M5	3.1(6.83)	5.5(AWG10)
MR-J3-700B4	FR-BEL-H15K	Fig. 11.2	170	93	160	2.3	155	6	14	M6	56	M5	3.7(8.16)	8(AWG8)
MR-J3-11KB4			185	119	171	2.6	165	7	15	M6	70	M6	5.0(11.02)	22(AWG4)
MR-J3-15KB4	FR-BEL-H22K	185	119	189	2.6	165	7	15	M6	70	M6	6.7(14.77)		
MR-J3-22KB4	FR-BEL-H30K	185	119	189	2.6	165	7	15	M6	70	M6	6.7(14.77)		

Note. Selection condition of wire size is as follows.

Wire type: 600V Polyvinyl chloride insulated wire (IV wire)

Construction condition: One wire is constructed in the air

## 11. OPTIONS AND AUXILIARY EQUIPMENT

### 11.14 Power factor improving AC reactors

The power factor improving AC reactors improve the phase factor by increasing the form factor of servo amplifier's input current.

It can reduce the power capacity.

The input power factor is improved to be about 90%. For use with a 1-phase power supply, it may be slightly lower than 90%.

In addition, it reduces the higher harmonic of input side.

When using power factor improving reactors for two servo amplifiers or more, be sure to connect a power factor improving reactor to each servo amplifier.

If using only one power factor improving reactor, enough improvement effect of phase factor cannot be obtained unless all servo amplifiers are operated.

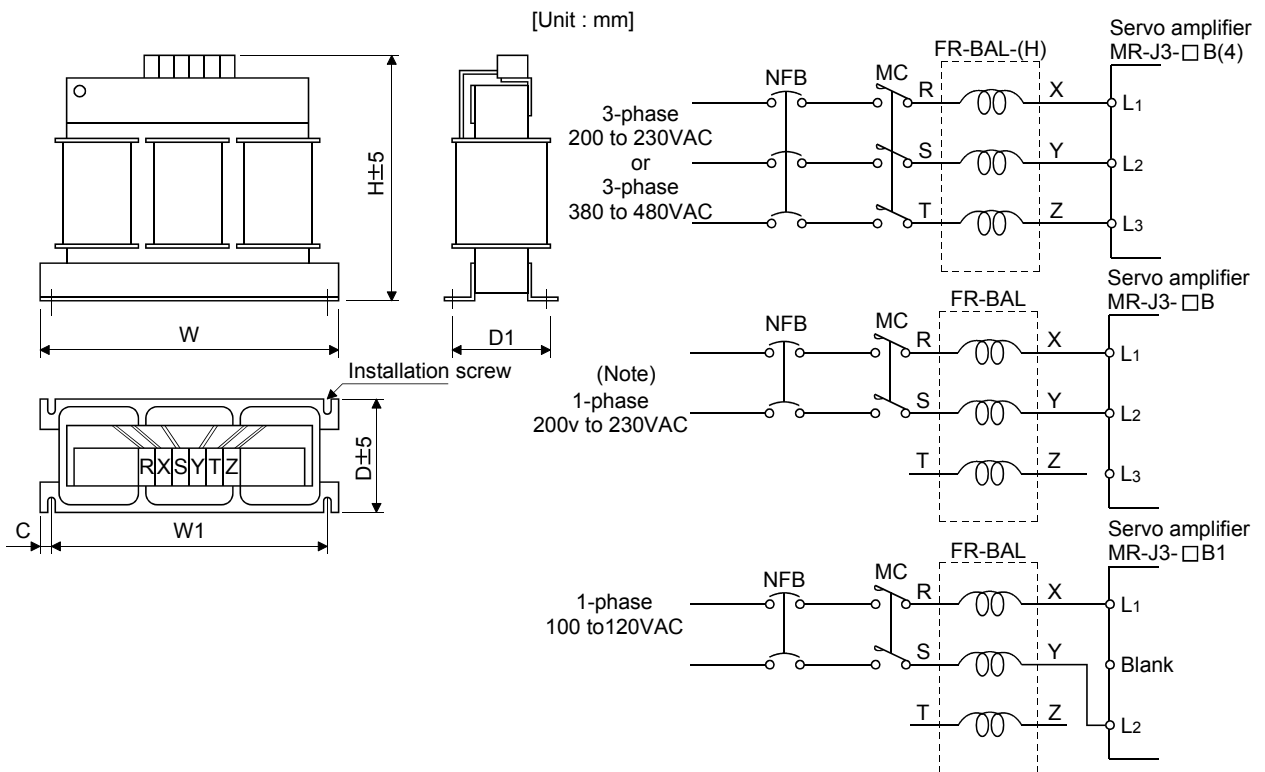

Note. For the 1-phase 200V to 230V power supply, Connect the power supply to L<sub>1</sub>, L<sub>2</sub> and leave L<sub>3</sub> open.

## 11. OPTIONS AND AUXILIARY EQUIPMENT

Servo amplifier	Model	Dimensions [mm]						Mounting screw size	Terminal screw size	Mass [kg (lb)]
		W	W1	H	D	D1	C			
MR-J3-10B • 20B • 10B1	FR-BAL-0.4K	135	120	115	59	45 <sup>0</sup> <sub>-2.5</sub>	7.5	M4	M3.5	2.0 (4.41)
MR-J3-40B • 20B1	FR-BAL-0.75K	135	120	115	69	57 <sup>0</sup> <sub>-2.5</sub>	7.5	M4	M3.5	2.8 (6.17)
MR-J3-60B • 70B • 40B1	FR-BAL-1.5K	160	145	140	71	55 <sup>0</sup> <sub>-2.5</sub>	7.5	M4	M3.5	3.7 (8.16)
MR-J3-100B	FR-BAL-2.2K	160	145	140	91	75 <sup>0</sup> <sub>-2.5</sub>	7.5	M4	M3.5	5.6 (12.35)
MR-J3-200B	FR-BAL-3.7K	220	200	192	90	70 <sup>0</sup> <sub>-2.5</sub>	10	M5	M4	8.5 (18.74)
MR-J3-350B	FR-BAL-7.5K	220	200	194	120	100 <sup>0</sup> <sub>-2.5</sub>	10	M5	M5	14.5 (31.97)
MR-J3-500B	FR-BAL-11K	280	255	220	135	100 <sup>0</sup> <sub>-2.5</sub>	12.5	M6	M6	19 (41.89)
MR-J3-700B	FR-BAL-15K	295	270	275	133	110 <sup>0</sup> <sub>-2.5</sub>	12.5	M6	M6	27 (59.53)
MR-J3-11KB										
MR-J3-15KB	FR-BAL-22K	290	240	301	199	170±5	25	M8	M8	35 (77.16)
MR-J3-22KB	FR-BAL-30K	290	240	301	219	190±5	25	M8	M8	43 (94.80)
MR-J3-60B4	FR-BAL-H1.5K	160	145	140	87	70 <sup>0</sup> <sub>-2.5</sub>	7.5	M4	M3.5	5.3 (11.68)
MR-J3-100B4	FR-BAL-H2.2K	160	145	140	91	75 <sup>0</sup> <sub>-2.5</sub>	7.5	M4	M3.5	5.9 (13.01)
MR-J3-200B4	FR-BAL-H3.7K	220	200	190	90	70 <sup>0</sup> <sub>-2.5</sub>	10	M5	M3.5	8.5 (18.74)
MR-J3-350B4	FR-BAL-H7.5K	220	200	192	120	100±5	10	M5	M4	14 (30.87)
MR-J3-500B4	FR-BAL-H11K	280	255	226	130	100±5	12.5	M6	M5	18.5 (40.79)
MR-J3-700B4	FR-BAL-H15K	295	270	244	130	110±5	12.5	M6	M5	27 (59.53)
MR-J3-11KB4										
MR-J3-15KB4	FR-BAL-H22K	290	240	269	199	170±5	25	M8	M8	Approx.35 (Approx.77.16)
MR-J3-22KB4	FR-BAL-H30K	290	240	290	219	190±5	25	M8	M8	Approx.43 (Approx.94.80)

### 11.15 Relays (recommended)

The following relays should be used with the interfaces.

Interface	Selection example
Relay used for digital input command signals (interface DI-1)	To prevent defective contacts , use a relay for small signal (twin contacts). (Ex.) Omron : type G2A , MY
Relay used for digital output signals (interface DO-1)	Small relay with 12VDC or 24VDC of rated current 40mA or less (Ex.) Omron : type MY

## 11. OPTIONS AND AUXILIARY EQUIPMENT

### 11.16 Surge absorbers (recommended)

A surge absorber is required for the electromagnetic brake. Use the following surge absorber or equivalent. When using the surge absorber, perform insulation beforehand to prevent short-circuit.

Maximum rating					Maximum limit voltage		Static capacity (reference value)	Varistor voltage rating (range) V1mA
Permissible circuit voltage		Surge immunity	Energy immunity	Rated power				
AC[Vma]	DC[V]	[A]	[J]	[W]	[A]	[V]	[pF]	[V]
140	180	(Note) 500/time	5	0.4	25	360	300	220 (198 to 242)

Note. 1 time =  $8 \times 20\mu\text{s}$

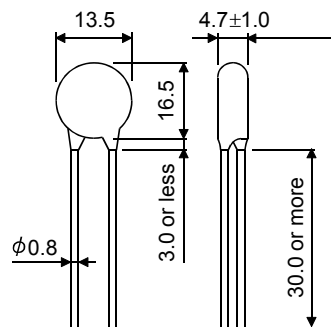

[Unit: mm]

(Example) ERZV10D221 (Matsushita Electric Industry)  
TNR-10V221K (Nippon chemi-con)  
Outline drawing [mm] (ERZ-C10DK221)

### 11.17 Noise reduction techniques

Noises are classified into external noises which enter the servo amplifier to cause it to malfunction and those radiated by the servo amplifier to cause peripheral devices to malfunction. Since the servo amplifier is an electronic device which handles small signals, the following general noise reduction techniques are required. Also, the servo amplifier can be a source of noise as its outputs are chopped by high carrier frequencies. If peripheral devices malfunction due to noises produced by the servo amplifier, noise suppression measures must be taken. The measures will vary slightly with the routes of noise transmission.

#### (1) Noise reduction techniques

##### (a) General reduction techniques

- Avoid laying power lines (input and output cables) and signal cables side by side or do not bundle them together. Separate power lines from signal cables.
- Use shielded, twisted pair cables for connection with the encoder and for control signal transmission, and connect the shield to the SD terminal.
- Ground the servo amplifier, servo motor, etc. together at one point (refer to section 3.12).

##### (b) Reduction techniques for external noises that cause the servo amplifier to malfunction

If there are noise sources (such as a magnetic contactor, an electromagnetic brake, and many relays which make a large amount of noise) near the servo amplifier and the servo amplifier may malfunction, the following countermeasures are required.

- Provide surge absorbers on the noise sources to suppress noises.
- Attach data line filters to the signal cables.
- Ground the shields of the encoder connecting cable and the control signal cables with cable clamp fittings.
- Although a surge absorber is built into the servo amplifier, to protect the servo amplifier and other equipment against large exogenous noise and lightning surge, attaching a varistor to the power input section of the equipment is recommended.

## 11. OPTIONS AND AUXILIARY EQUIPMENT

(c) Techniques for noises radiated by the servo amplifier that cause peripheral devices to malfunction

Noises produced by the servo amplifier are classified into those radiated from the cables connected to the servo amplifier and its main circuits (input and output circuits), those induced electromagnetically or statically by the signal cables of the peripheral devices located near the main circuit cables, and those transmitted through the power supply cables.

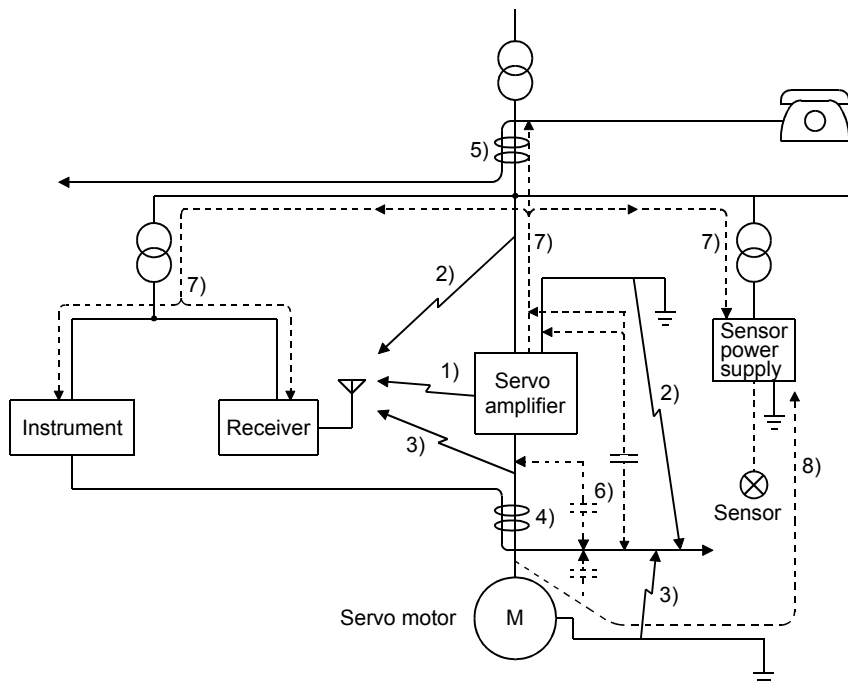
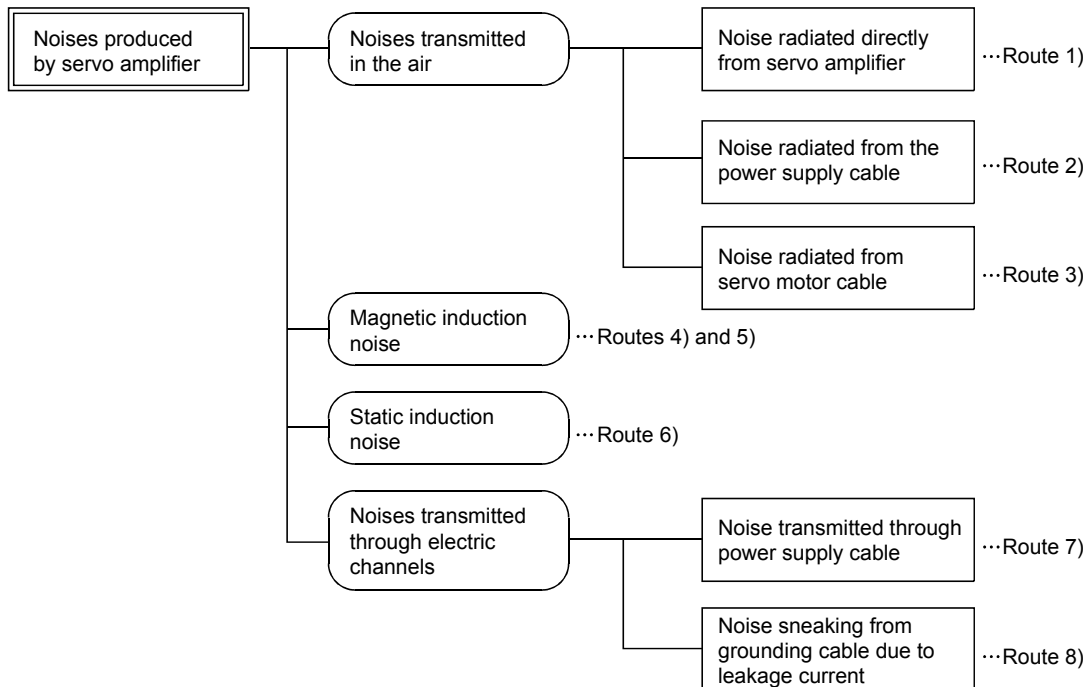

## 11. OPTIONS AND AUXILIARY EQUIPMENT

Noise transmission route	Suppression techniques
1) 2) 3)	<p>When measuring instruments, receivers, sensors, etc. which handle weak signals and may malfunction due to noise and/or their signal cables are contained in a control box together with the servo amplifier or run near the servo amplifier, such devices may malfunction due to noises transmitted through the air. The following techniques are required.</p> <ol style="list-style-type: none"> <li>1. Provide maximum clearance between easily affected devices and the servo amplifier.</li> <li>2. Provide maximum clearance between easily affected signal cables and the I/O cables of the servo amplifier.</li> <li>3. Avoid laying the power lines (Input cables of the servo amplifier) and signal cables side by side or bundling them together.</li> <li>4. Insert a line noise filter to the I/O cables or a radio noise filter on the input line.</li> <li>5. Use shielded wires for signal and power cables or put cables in separate metal conduits.</li> </ol>
4) 5) 6)	<p>When the power lines and the signal cables are laid side by side or bundled together, magnetic induction noise and static induction noise will be transmitted through the signal cables and malfunction may occur. The following techniques are required.</p> <ol style="list-style-type: none"> <li>1. Provide maximum clearance between easily affected devices and the servo amplifier.</li> <li>2. Provide maximum clearance between easily affected signal cables and the I/O cables of the servo amplifier.</li> <li>3. Avoid laying the power lines (I/O cables of the servo amplifier) and signal cables side by side or bundling them together.</li> <li>4. Use shielded wires for signal and power cables or put the cables in separate metal conduits.</li> </ol>
7)	<p>When the power supply of peripheral devices is connected to the power supply of the servo amplifier system, noises produced by the servo amplifier may be transmitted back through the power supply cable and the devices may malfunction. The following techniques are required.</p> <ol style="list-style-type: none"> <li>1. Insert the radio noise filter (FR-BIF-(H)) on the power cables (Input cables) of the servo amplifier.</li> <li>2. Insert the line noise filter (FR-BSF01 · FR-BLF) on the power cables of the servo amplifier.</li> </ol>
8)	<p>When the cables of peripheral devices are connected to the servo amplifier to make a closed loop circuit, leakage current may flow to malfunction the peripheral devices. If so, malfunction may be prevented by disconnecting the grounding cable of the peripheral device.</p>

### (2) Noise reduction products

#### (a) Data line filter (Recommended)

Noise can be prevented by installing a data line filter onto the encoder cable, etc. For example, the ZCAT3035-1330 of TDK and the ESD-SR-25 of NEC TOKIN make are available as data line filters. As a reference example, the impedance specifications of the ZCAT3035-1330 (TDK) are indicated below. This impedances are reference values and not guaranteed values.

Impedance[Ω]	
10 to 100MHz	100 to 500MHz
80	150

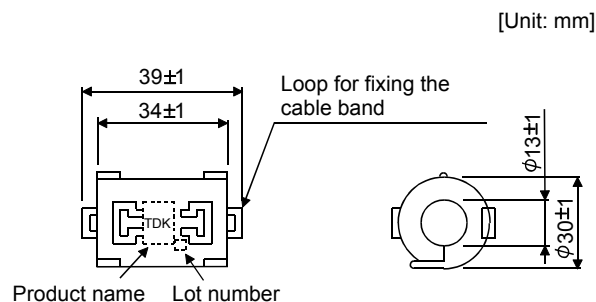

Outline drawing (ZCAT3035-1330)

## 11. OPTIONS AND AUXILIARY EQUIPMENT

### (b) Surge suppressor

The recommended surge suppressor for installation to an AC relay, AC valve or the like near the servo amplifier is shown below. Use this product or equivalent.

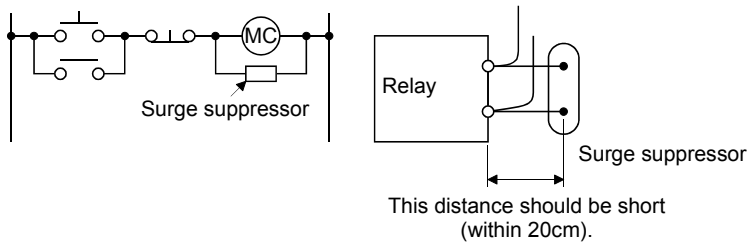

(Ex.) 972A.2003 50411  
(Matsuo Electric Co.,Ltd.—200VAC rating)

Rated voltage AC[V]	C [ $\mu$ F]	R [ $\Omega$ ]	Test voltage AC[V]
200	0.5	50 (1W)	Across T-C 1000(1 to 5s)

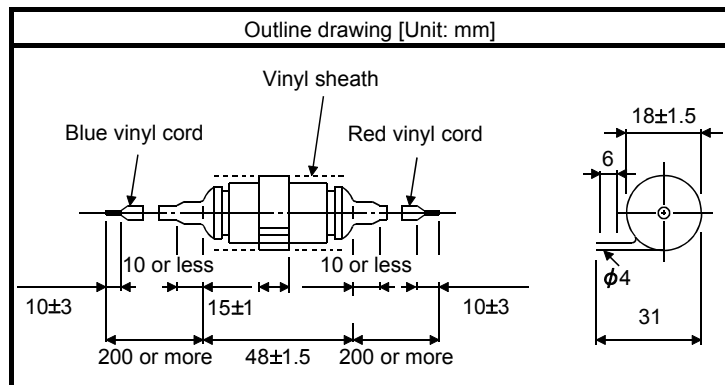

Note that a diode should be installed to a DC relay, DC valve or the like.

Maximum voltage: Not less than 4 times the drive voltage of the relay or the like

Maximum current: Not less than twice the drive current of the relay or the like

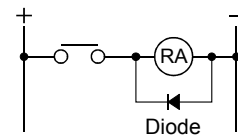

### (c) Cable clamp fitting AERSBAN-□SET

Generally, the earth of the shielded cable may only be connected to the connector's SD terminal. However, the effect can be increased by directly connecting the cable to an earth plate as shown below. Install the earth plate near the servo amplifier for the encoder cable. Peel part of the cable sheath to expose the external conductor, and press that part against the earth plate with the cable clamp. If the cable is thin, clamp several cables in a bunch.

The clamp comes as a set with the earth plate.

[Unit: mm]

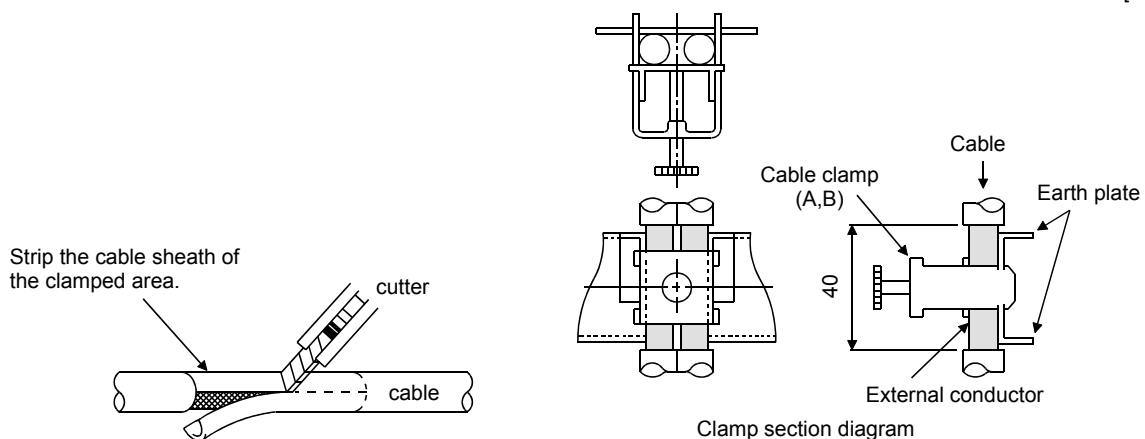

# 11. OPTIONS AND AUXILIARY EQUIPMENT

• Outline drawing

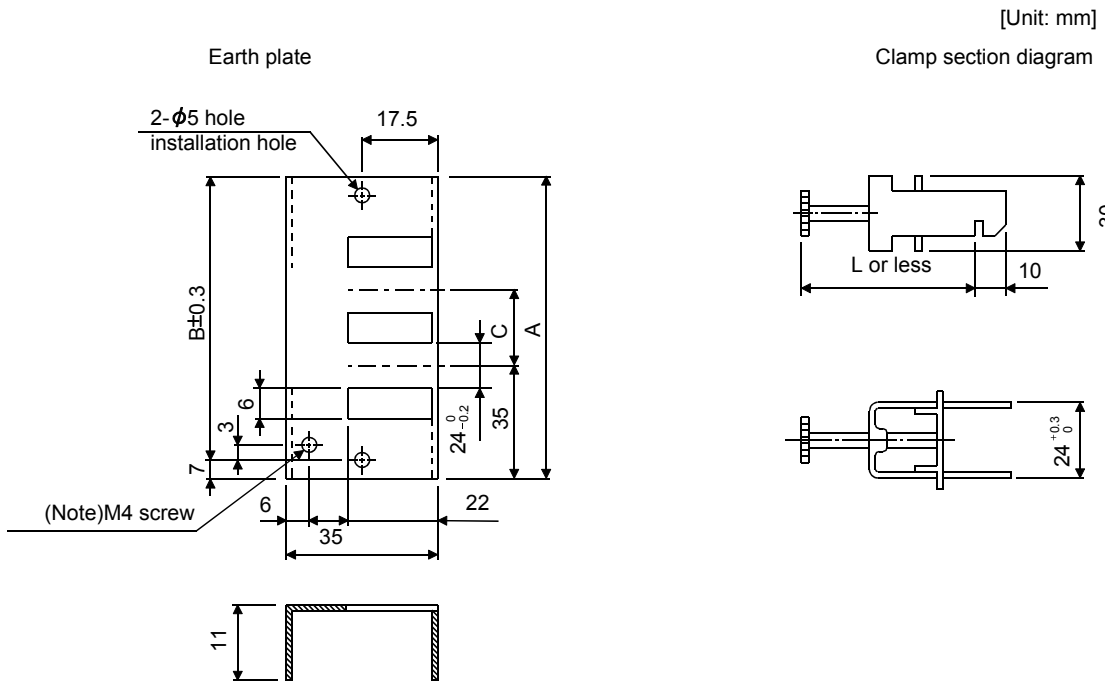

Note. Screw hole for grounding. Connect it to the earth plate of the control box.

Type	A	B	C	Accessory fittings
AERSBAN-DSET	100	86	30	clamp A: 2pcs.
AERSBAN-ESET	70	56		clamp B: 1pc.

Clamp fitting	L
A	70
B	45

## 11. OPTIONS AND AUXILIARY EQUIPMENT

### (d) Line noise filter (FR-BSF01, FR-BLF)

This filter is effective in suppressing noises radiated from the power supply side and output side of the servo amplifier and also in suppressing high-frequency leakage current (zero-phase current) especially within 0.5MHz to 5MHz band.

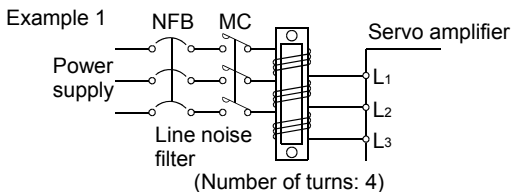
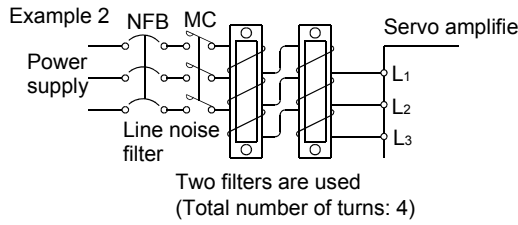
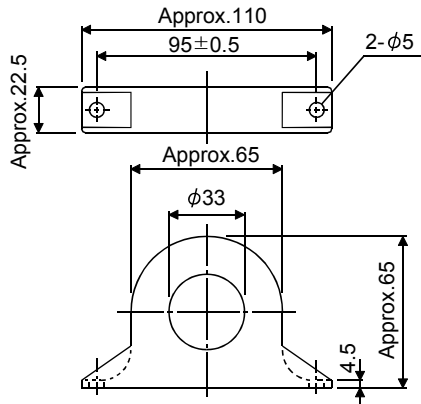
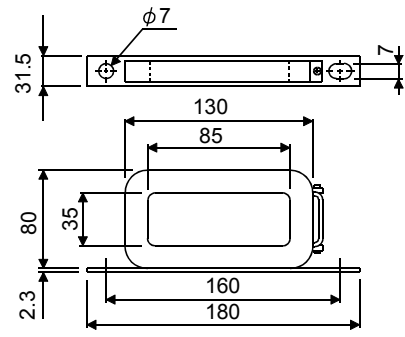
Connection diagram	Outline drawing [Unit: mm]
<p>Use the line noise filters for wires of the main power supply (L<sub>1</sub> · L<sub>2</sub> · L<sub>3</sub>) and of the motor power supply (U · V · W). Pass each of the 3-phase wires through the line noise filter an equal number of times in the same direction. For the main power supply, the effect of the filter rises as the number of passes increases, but generally four passes would be appropriate. For the motor power supply, passes must be four times or less. Do not pass the grounding (earth) wire through the filter, or the effect of the filter will drop. Wind the wires by passing through the filter to satisfy the required number of passes as shown in Example 1. If the wires are too thick to wind, use two or more filters to have the required number of passes as shown in Example 2. Place the line noise filters as close to the servo amplifier as possible for their best performance.</p> <p><b>Example 1</b></p>  <p>(Number of turns: 4)</p> <p><b>Example 2</b></p>  <p>Two filters are used (Total number of turns: 4)</p>	<p>FR-BSF01 (for wire size 3.5mm<sup>2</sup> (AWG12) or less)</p> 
	<p>FR-BLF (for wire size 5.5mm<sup>2</sup> (AWG10) or more)</p> 

### (e) Radio noise filter (FR-BIF-(H))

This filter is effective in suppressing noises radiated from the power supply side of the servo amplifier especially in 10MHz and lower radio frequency bands. The FR-BIF (-H) is designed for the input only.

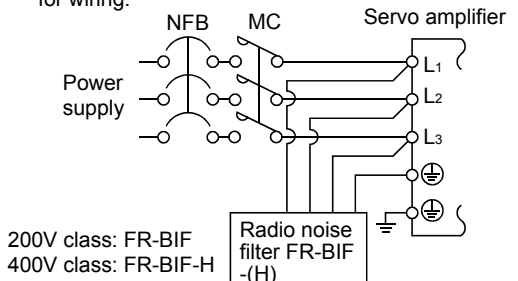
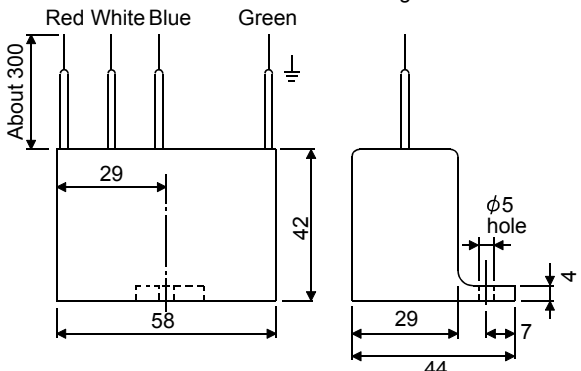
Connection diagram	Outline drawing (Unit: mm)
<p>Make the connection cables as short as possible. Grounding is always required. When using the FR-BIF with a single-phase power supply, always insulate the wires that are not used for wiring.</p>  <p>200V class: FR-BIF 400V class: FR-BIF-H</p>	<p>Leakage current: 4mA</p> 

## 11. OPTIONS AND AUXILIARY EQUIPMENT

### (f) Varistors for input power supply (Recommended)

Varistors are effective to prevent exogenous noise and lightning surge from entering the servo amplifier. When using a varistor, connect it between each phase of the input power supply of the equipment. For varistors, the TND20V-431K, TND20V-471K and TND20V-102K, manufactured by NIPPON CHEMI-CON, are recommended. For detailed specification and usage of the varistors, refer to the manufacturer catalog.

Power supply voltage	Varistor	Maximum rating				Maximum limit voltage		Static capacity (reference value) [pF]	Varistor voltage rating (range) V1mA [V]	
		Permissible circuit voltage		Surge current immunity	Energy immunity	Rated pulse power [W]	[A]			[V]
		AC[V <sub>rms</sub> ]	DC[V]	8/20μs[A]	2ms[J]					
100V class	TND20V-431K	275	350	10000/1 time	195	1.0	100	710	1300	430(387 to 473)
200V class	TND20V-471K	300	385	7000/2 time	215			775	1200	470(423 to 517)
400V class	TND20V-102K	625	825	7500/1 time 6500/2 time	400			1650	500	1000(900 to 1100)

[Unit: mm]

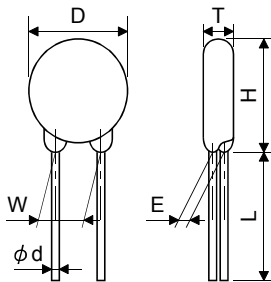

Model	D Max.	H Max.	T Max.	E ±1.0	(Note)L min.	φd ±0.05	W ±1.0
TND20V-431K	21.5	24.5	6.4	3.3	20	0.8	10.0
TND20V-471K			6.6	3.5			
TND20V-102K	22.5	25.5	9.5	6.4			

Note. For special purpose items for lead length (L), contact the manufacturer.

## 11. OPTIONS AND AUXILIARY EQUIPMENT

### 11.18 Leakage current breaker

#### (1) Selection method

High-frequency chopper currents controlled by pulse width modulation flow in the AC servo circuits. Leakage currents containing harmonic contents are larger than those of the motor which is run with a commercial power supply.

Select a leakage current breaker according to the following formula, and ground the servo amplifier, servo motor, etc. securely.

Make the input and output cables as short as possible, and also make the grounding cable as long as possible (about 30cm) to minimize leakage currents.

$$\text{Rated sensitivity current} \geq 10 \cdot \{I_{g1} + I_{gn} + I_{ga} + K \cdot (I_{g2} + I_{gm})\} \text{ [mA]} \quad (11.1)$$

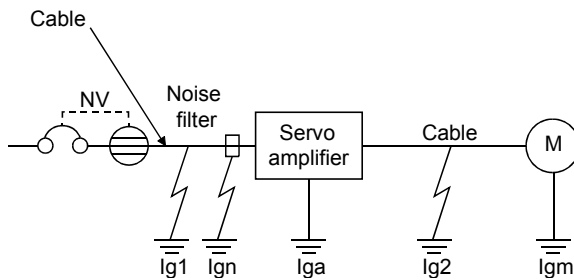

K: Constant considering the harmonic contents

Leakage current breaker		
Type	Mitsubishi products	K
Models provided with harmonic and surge reduction techniques	NV-SP	1
	NV-SW	
	NV-CP	
	NV-CW	
	NV-L	
General models	BV-C1	3
	NFB	
	NV-L	

I<sub>g1</sub>: Leakage current on the electric channel from the leakage current breaker to the input terminals of the servo amplifier (Found from Fig. 11.3.)

I<sub>g2</sub>: Leakage current on the electric channel from the output terminals of the servo amplifier to the servo motor (Found from Fig. 11.3.)

I<sub>gn</sub>: Leakage current when a filter is connected to the input side (4.4mA per one FR-BIF(-H))

I<sub>ga</sub>: Leakage current of the servo amplifier (Found from Table 11.5.)

I<sub>gm</sub>: Leakage current of the servo motor (Found from Table 11.4.)

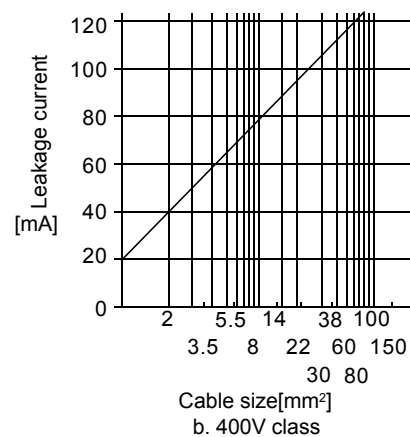
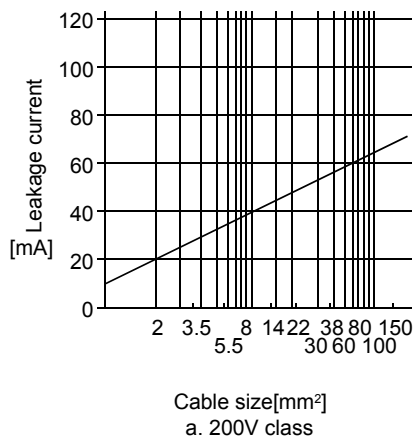

Fig. 11.3 Leakage current example (I<sub>g1</sub>, I<sub>g2</sub>) for CV cable run in metal conduit

## 11. OPTIONS AND AUXILIARY EQUIPMENT

Table 11.4 Servo motor's leakage current example (Igm)

Servo motor power [kW]	Leakage current [mA]
0.05 to 1	0.1
2	0.2
3.5	0.3
5	0.5
7	0.7
11	1.0
15	1.3
22	2.3

Table 11.5 Servo amplifier's leakage current example (Iga)

Servo amplifier capacity [kW]	Leakage current [mA]
0.1 to 0.6	0.1
0.75 to 3.5 (Note)	0.15
5 • 7	2
11 • 15	5.5
22	7

Note. For the 3.5kW of 400V class, leakage current is 2mA, which is the same as for 5kW and 7kW.

Table 11.6 Leakage circuit breaker selection example

Servo amplifier	Rated sensitivity current of leakage circuit breaker [mA]
MR-J3-10B to MR-J3-350B MR-J3-10B1 to MR-J3-40B1 MR-J3-60B4 to MR-J3-350B4	15
MR-J3-500B(4)	30
MR-J3-700B(4)	50
MR-J3-11KB(4) to MR-J3-22KB(4)	100

### (2) Selection example

Indicated below is an example of selecting a leakage current breaker under the following conditions.

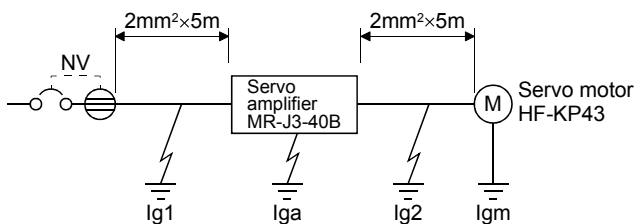

Use a leakage current breaker generally available.

Find the terms of Equation (11.1) from the diagram.

$$I_{g1} = 20 \cdot \frac{5}{1000} = 0.1 \text{ [mA]}$$

$$I_{g2} = 20 \cdot \frac{5}{1000} = 0.1 \text{ [mA]}$$

$$I_{gn} = 0 \text{ (not used)}$$

$$I_{ga} = 0.1 \text{ [mA]}$$

$$I_{gm} = 0.1 \text{ [mA]}$$

Insert these values in Equation (11.1).

$$I_g \geq 10 \cdot \{0.1+0+0.1+1 \cdot (0.1+0.1)\}$$

$$\geq 4.0 \text{ [mA]}$$

According to the result of calculation, use a leakage current breaker having the rated sensitivity current (I<sub>g</sub>) of 4.0[mA] or more. A leakage current breaker having I<sub>g</sub> of 15[mA] is used with the NV-SP/SW/CP/CW/HW series.

## 11. OPTIONS AND AUXILIARY EQUIPMENT

### 11.19 EMC filter (recommended)

For compliance with the EMC directive of the EN Standard, it is recommended to use the following filter. Some EMC filters are large in leakage current.

#### (1) Combination with the servo amplifier

Servo amplifier	Recommended filter (Soshin Electric)		Mass [kg](lb)
	Model	Leakage current [mA]	
MR-J3-10B to MR-J3-100B MR-J3-10B1 to MR-J3-40B1	(Note) HF3010A-UN	5	3 (6.61)
MR-J3-250B * MR-J3-350B	(Note) HF3030A-UN		5.5 (12.13)
MR-J3-500B * MR-J3-700B	(Note) HF3040A-UN	1.5	6.0 (13.23)
MR-J3-11KB to MR-J3-22KB	(Note) HF3100A-UN	6.5	15 (33.07)
MR-J3-60B4 * MR-J3-100B4	TF3005C-TX	5.5	6(13.23)
MR-J3-200B4 to MR-J3-700B4	TF3020C-TX		
MR-J3-11KB4	TF3030C-TX		7.5(16.54)
MR-J3-15KB4	TF3040C-TX		12.5(27.56)
MR-J3-22KB4	TF3060C-TX		

Note. A surge protector is separately required to use any of these EMC filters.

#### (2) Connection example

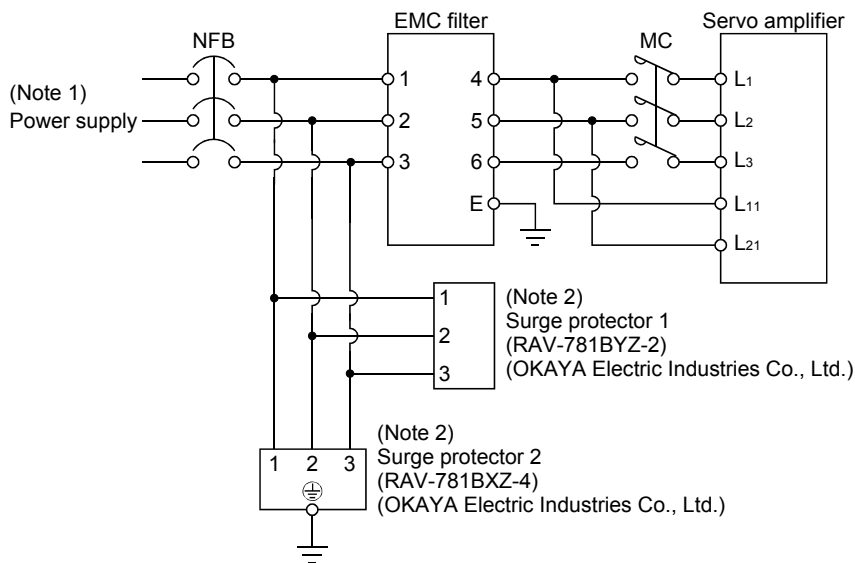

Note 1. For 1-phase 200V to 230VAC power supply, connect the power supply to L<sub>1</sub>, L<sub>2</sub> and leave L<sub>3</sub> open.

There is no L<sub>3</sub> for 1-phase 100 to 120VAC power supply. Refer to section 1.3 for the power supply specification.

2. The example is when a surge protector is connected.

## 11. OPTIONS AND AUXILIARY EQUIPMENT

### (3) Outline drawing

#### (a) EMC filter

HF3010A-UN

[Unit: mm]

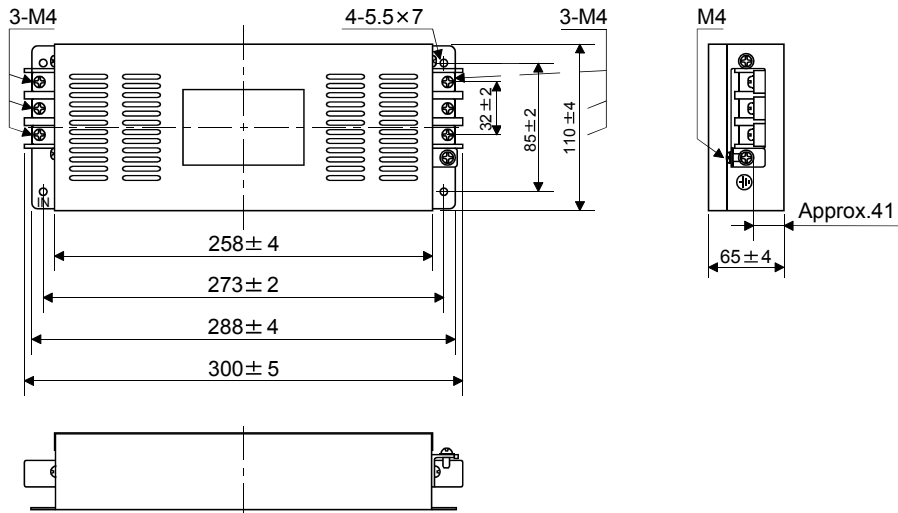

HF3030A-UN • HF-3040A-UN

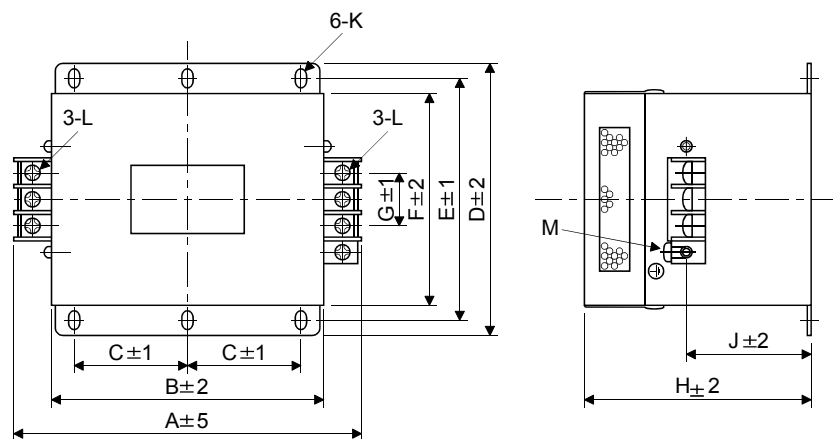

Model	Dimensions [mm]											
	A	B	C	D	E	F	G	H	J	K	L	M
HF3030A-UN	260	210	85	155	140	125	44	140	70	R3.25, length 8	M5	M4
HF3040A-UN	260	210	85	155	140	125	44	140	70		M5	M4

# 11. OPTIONS AND AUXILIARY EQUIPMENT

HF3100A-UN

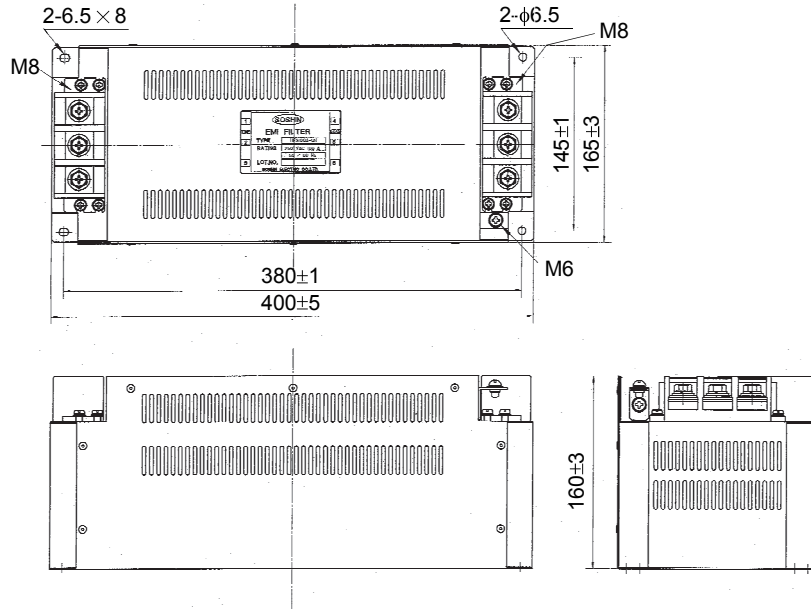

TF3005C-TX • TX3020C-TX • TF3030C-TX

[Unit: mm]

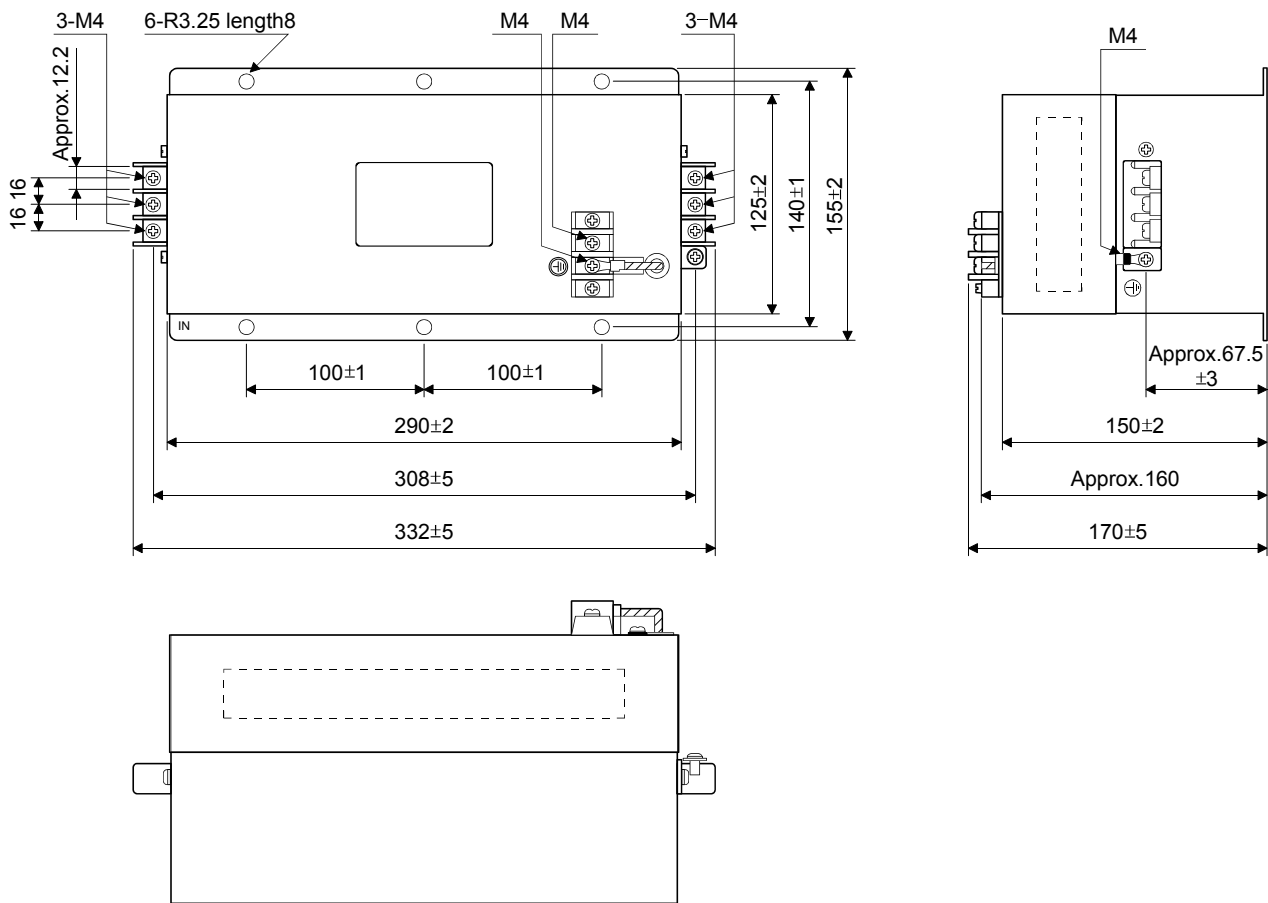

# 11. OPTIONS AND AUXILIARY EQUIPMENT

TF3040C-TX • TF3060C-TX

[Unit: mm]

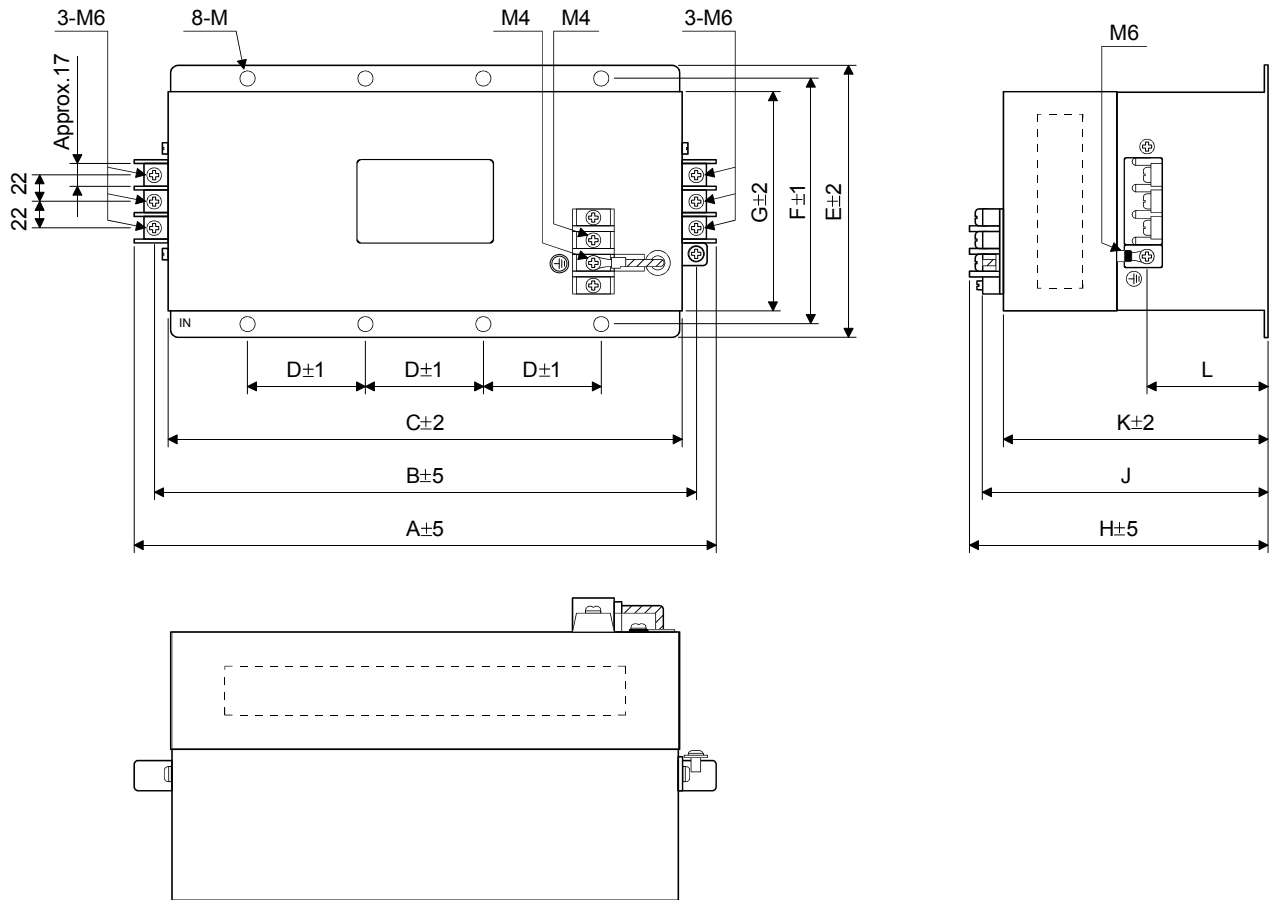

Model	Dimensions [mm]											
	A	B	C	D	E	F	G	H	J	K	L	M
TF3040C-TX	438	412	390	100	175	160	145	200	Approx.190	180	Approx.91.5	R3.25 length 8 (M6)
TF3060C-TX												

# 11. OPTIONS AND AUXILIARY EQUIPMENT

(b) Surge protector

RAV-781BYZ-2

[Unit: mm]

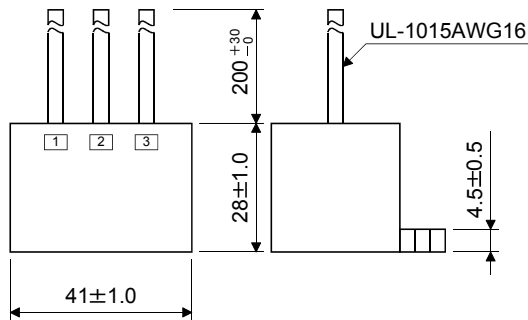
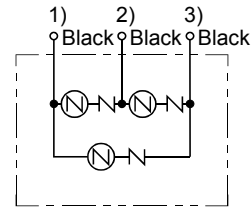
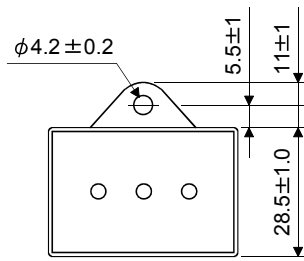

RAV-781BXZ-4

[Unit: mm]

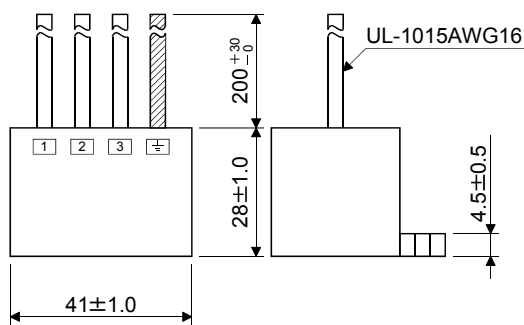
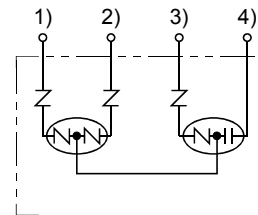
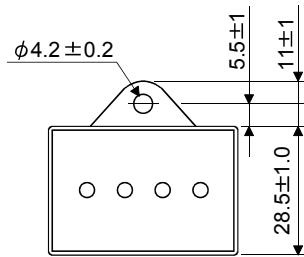



## 12. ABSOLUTE POSITION DETECTION SYSTEM

### 12. ABSOLUTE POSITION DETECTION SYSTEM



- If an absolute position erase alarm (25) or absolute position counter warning (E3) has occurred, always perform home position setting again. Not doing so can cause runaway. Not doing so may cause unexpected operation.

#### POINT

- If the encoder cable is disconnected, absolute position data will be lost in the following servo motor series. HF-MP, HF-KP, HC-SP, HC-RP, HC-UP, HC-LP, and HA-LP. After disconnecting the encoder cable, always execute home position setting and then positioning operation.

#### 12.1 Features

For normal operation, as shown below, the encoder consists of a detector designed to detect a position within one revolution and a cumulative revolution counter designed to detect the number of revolutions.

The absolute position detection system always detects the absolute position of the machine and keeps it battery-backed, independently of whether the servo system controller power is on or off.

Therefore, once home position return is made at the time of machine installation, home position return is not needed when power is switched on thereafter.

If a power failure or a fault occurs, restoration is easy.

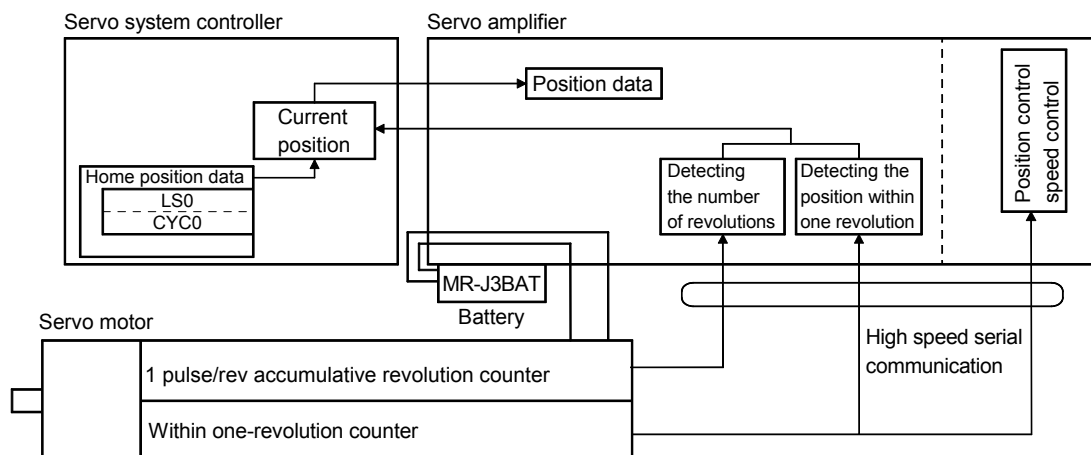

## 12. ABSOLUTE POSITION DETECTION SYSTEM

### 12.2 Specifications

POINT	<ul style="list-style-type: none"> <li>Replace the battery with only the control circuit power ON. Removal of the battery with the control circuit power OFF will erase the absolute position data.</li> </ul>
-------	--

#### (1) Specification list

Item	Description
System	Electronic battery backup system
Battery	1 piece of lithium battery ( primary battery, nominal + 3.6V) Type: MR-J3BAT
Maximum revolution range	Home position $\pm$ 32767 rev.
(Note 1) Maximum speed at power failure	3000r/min
(Note 2) Battery backup time	Approx. 10,000 hours (battery life with power off)
Battery storage period	5 years from date of manufacture

Note 1. Maximum speed available when the shaft is rotated by external force at the time of power failure or the like.

2. Time to hold data by a battery with power off. It is recommended to replace the battery in three years independently of whether power is kept on or off.

#### (2) Configuration

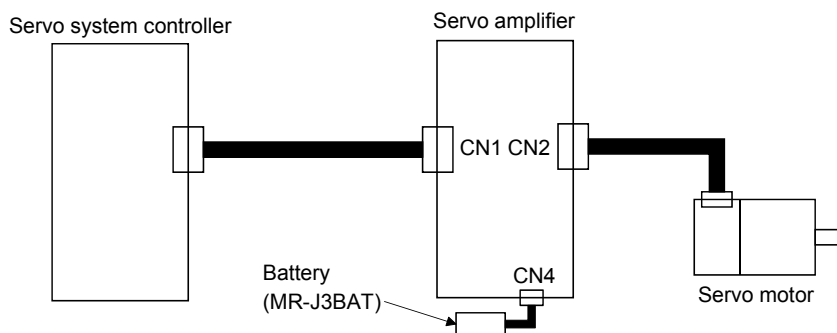

#### (3) Parameter setting

Set "□□□1" in parameter No.PA03 to make the absolute position detection system valid.

Parameter No.PA03

--	--	--	--

Absolute position detection system selection  
0: Used in incremental system  
1: Used in absolute position detection system

## 12. ABSOLUTE POSITION DETECTION SYSTEM

### 12.3 Battery installation procedure

#### WARNING

- Before installing a battery, turn off the main circuit power while keeping the control circuit power on. Wait for 15 minutes or more (20 minutes or for drive unit 30kW or more) until the charge lamp turns off. Then, confirm that the voltage between P(+) and N(–) (L+ and L– for drive unit 30kW or more) is safe with a voltage tester and others. Otherwise, an electric shock may occur. In addition, always confirm from the front of the servo amplifier whether the charge lamp is off or not.

#### POINT

The internal circuits of the servo amplifier may be damaged by static electricity. Always take the following precautions.

- Ground human body and work bench.
- Do not touch the conductive areas, such as connector pins and electrical parts, directly by hand.
- Before starting battery changing procedure, make sure that the main circuit power is switched OFF with the control circuit power ON. When battery is changed with the control power OFF, the absolute position data is lost.

(1) For MR-J3-350B or less ▪ MR-J3-200B4 or less

#### POINT

- For the servo amplifier with a battery holder on the bottom, it is not possible to wire for the earth with the battery installed. Insert the battery after executing the earth wiring of the servo amplifier.

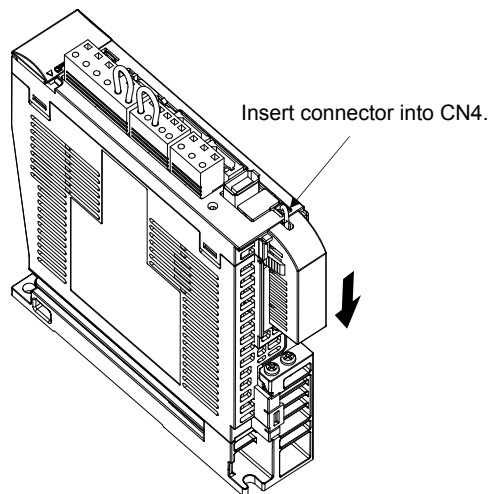

## 12. ABSOLUTE POSITION DETECTION SYSTEM

(2) For MR-J3-500B or more • MR-J3-350B4 or more

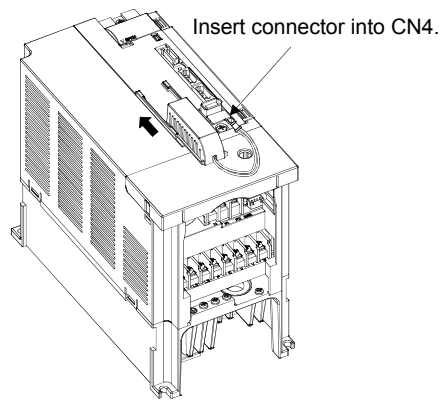

## 12. ABSOLUTE POSITION DETECTION SYSTEM

### 12.4 Confirmation of absolute position detection data

You can confirm the absolute position data with MR Configurator.

Choose "Diagnostics" and "Absolute Encoder Data" to open the absolute position data display screen.

(1) Choosing "Diagnostics" in the menu opens the sub-menu as shown below:

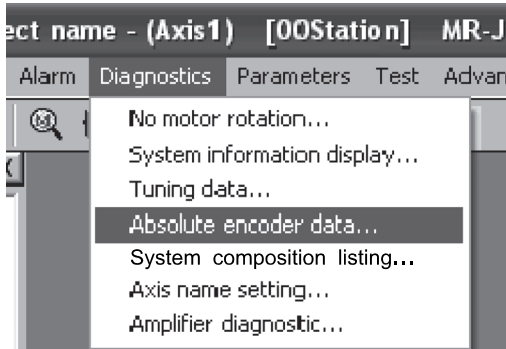

(2) By choosing "Absolute Encoder Data" in the sub-menu, the absolute encoder data display window appears.

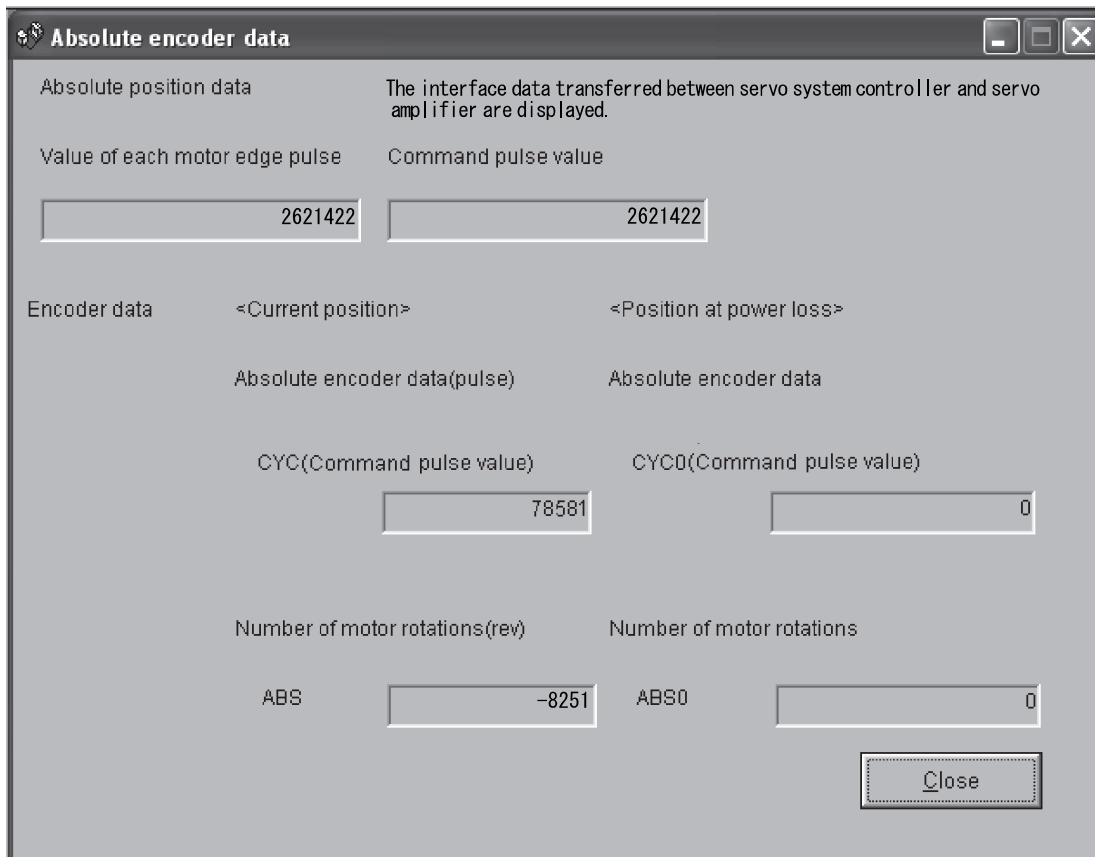

(3) Press the "Close" button to close the absolute encoder data display window.



## 13. SERVO AMPLIFIERS WITH A LARGE CAPACITY (30k TO 55kW)

### 13. SERVO AMPLIFIERS WITH A LARGE CAPACITY (30k TO 55kW)

This chapter explains the MELSERVO-J3-B series AC servo featuring a large capacity of 200V (30k to 37kW)/400V (30k to 55kW).

Explanation made in this chapter is exclusively for the MR-J3-CR□(4) converter units and the MR-J3-DU□B(4) drive units. Explanations on the following items are the same as those for servo amplifiers with 22kW or less. For such explanations, refer to the section indicated in the table.

Item	Reference
Startup	Chapter 4
General gain adjustment	Chapter 6
Special adjustment functions	Chapter 7
Absolute position detection system	Chapter 12

#### 13.1. Functions and menus

POINT
<ul style="list-style-type: none"><li>▪ Explanations on the following item are the same as those for servo amplifiers with 22kW or less. Refer to the section below for details.</li><li>▪ Function list section 1.4</li></ul>

### 13. SERVO AMPLIFIERS WITH A LARGE CAPACITY (30k TO 55kW)

#### 13.1.1 Function block diagram

The function block diagram of this servo is shown below.

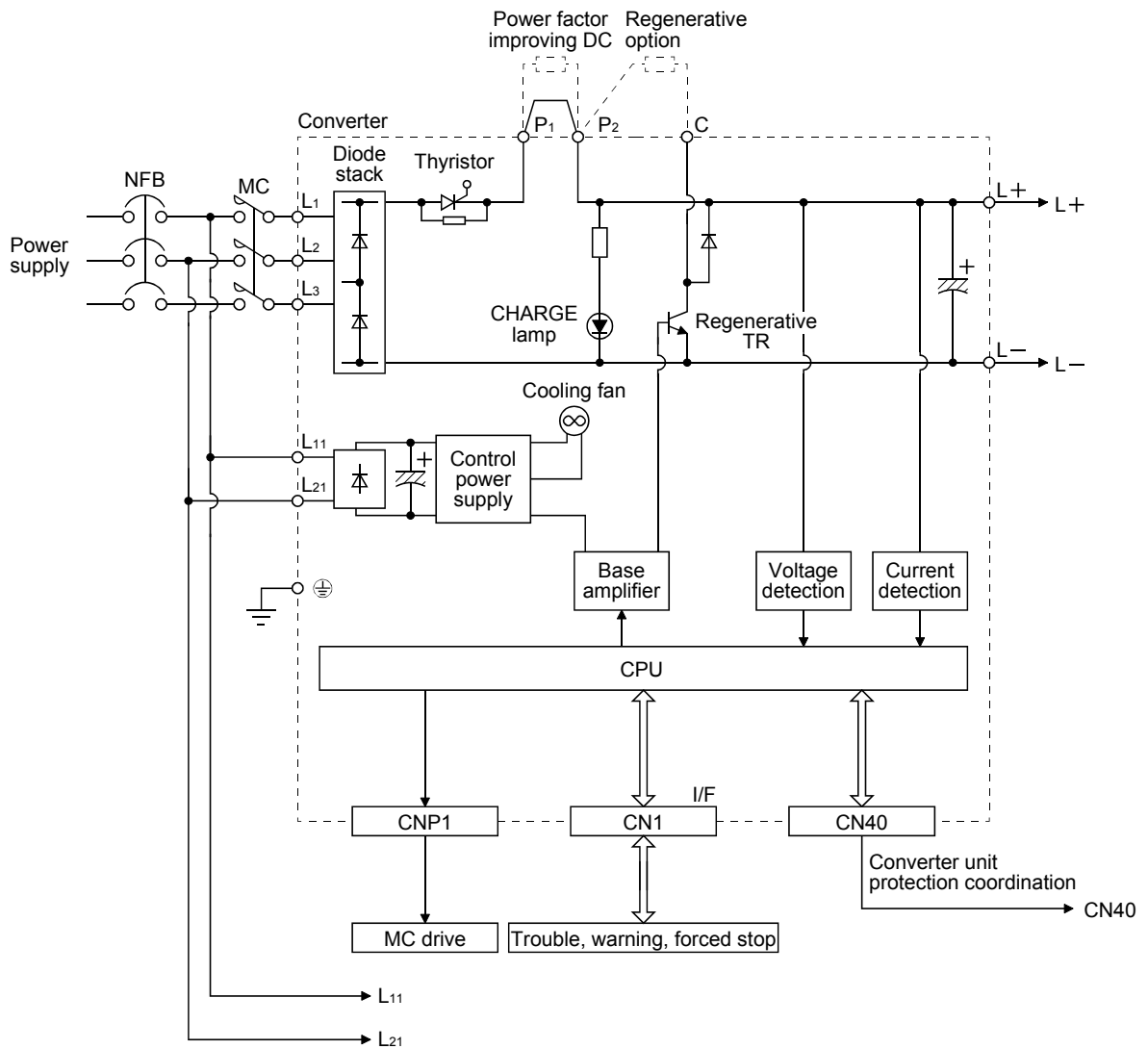

### 13. SERVO AMPLIFIERS WITH A LARGE CAPACITY (30kW TO 55kW)

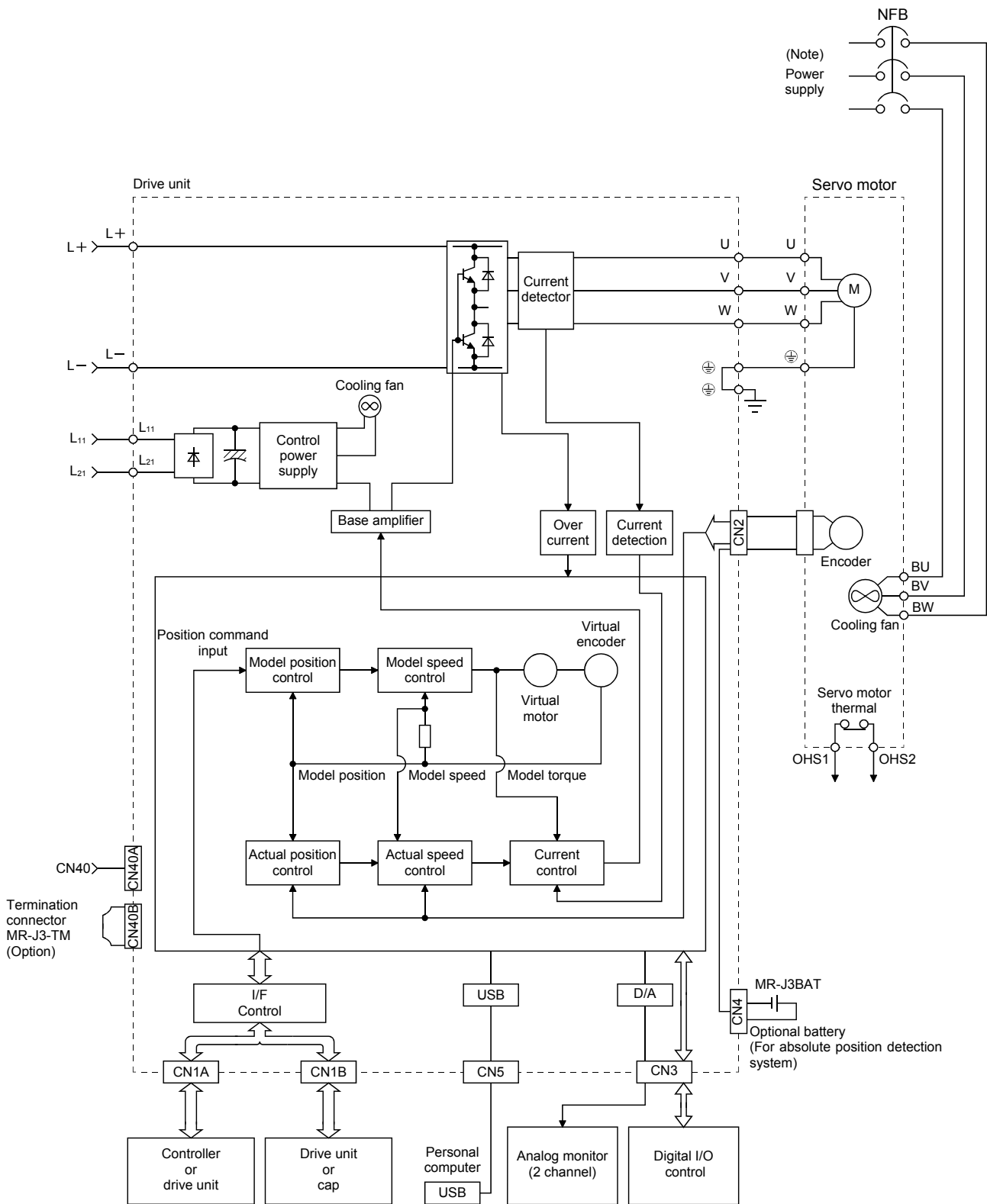

Note. Refer to section 13.3.6 for the power supply specification of the servo motor cooling fan.

## 13. SERVO AMPLIFIERS WITH A LARGE CAPACITY (30k TO 55kW)

### 13.1.2 Packing list

Unpack the product and check the rating plate to see if the converter unit, drive unit and servo motor are as you ordered.

#### (1) Converter unit

POINT
<ul style="list-style-type: none"> <li>Regenerative resistor and power factor improving DC reactors are option.</li> </ul> <p>Purchase them separately if required. (Section 13.9.2, 13.9.6)</p>

Model	Converter unit [units]	Eyebolt [pcs.]	Magnetic contactor wiring connector [pcs.] (Note)	Digital I/O connector [pcs.]	To use the AC servo safely [manuals]
MR-J3-CR55K	1	2	1	1	1
MR-J3-CR55K4					

Note. Magnetic contactor control connector is mounted to CNP1 of the converter unit before shipping.

#### (2) Drive unit

Model	Drive unit [units]	Connection conductor [pcs.]	Eyebolt [pcs.]	To use the AC servo safely [manuals]
MR-J3-DU30KB • MR-J3-DU37KB	1	2	2	1
MR-J3-DU30KB4 to MR-J3-DU55KB4				

#### (3) Servo motor

Model	Servo motor [units]	To use the AC servo safely [manuals]
HA-LP30K1 • HA-LP37K1 HA-LP30K1M • HA-LP37K1M HA-LP30K2 • HA-LP37K2	1	1
HA-LP25K14 to HA-LP37K14 HA-LP30K1M4 to HA-LP50K1M4 HA-LP30K24 to HA-LP55K24		

## 13. SERVO AMPLIFIERS WITH A LARGE CAPACITY (30k TO 55kW)

### 13.1.3 Standard specifications

#### (1) Converter unit

Item		Model	MR-J3-CR55K	MR-J3-CR55K4	
Main circuit power supply	Voltage/frequency		3-phase 200 to 230VAC, 50/60Hz	3-phase 380 to 480VAC, 50/60Hz	
	Permissible voltage fluctuation		3-phase 170 to 253VAC	3-phase 323 to 528VAC	
	Permissible frequency fluctuation		Within $\pm 5\%$		
Control power supply	Voltage/frequency		1-phase 200 to 230VAC, 50/60Hz	1-phase 380 to 480VAC, 50/60Hz	
	Permissible voltage fluctuation		1-phase 170 to 253VAC	1-phase 323 to 528VAC	
	Permissible frequency fluctuation		Within $\pm 5\%$		
	Power consumption		45W		
Interface power supply	Voltage		24VDC $\pm 10\%$		
	Power supply capacity		(Note) 130mA		
Rated output			55kW		
Regenerative power (Using regenerative option)			One MR-RB139: 1300W Three MR-RB137: 3900W	One MR-RB136-4: 1300W Three MR-RB138-4: 3900W	
Protective function			Regenerative overvoltage shutoff, overload shutoff (electronic thermal protector) Regenerative alarm protection, undervoltage, instantaneous power failure protection		
Structure			Force-cooling, open (IP00)		
Environment	Ambient temperature	In operation	[°C]	0 to +55 (non-freezing)	
			[°F]	32 to +131 (non-freezing)	
		In storage	[°C]	-20 to +65 (non-freezing)	
			[°F]	-4 to +149 (non-freezing)	
	Ambient humidity	In operation	90%RH or less (non-condensing)		
		In storage			
	Ambient		Indoors (no direct sunlight) Free from corrosive gas, flammable gas, oil mist, dust and dirt		
	Altitude		Max. 1000m above sea level		
Vibration		5.9 [m/s <sup>2</sup> ] or less			
		19.4 [ft/s <sup>2</sup> ] or less			
Mass	[kg]		25		
	[lb]		55.1		

Note. 130mA is the value applicable when all I/O signals are used. The current capacity can be decreased by reducing the number of I/O points.

### 13. SERVO AMPLIFIERS WITH A LARGE CAPACITY (30k TO 55kW)

#### (2) Drive unit

##### (a) 200V class

Item		Model	MR-J3-DU30KB	MR-J3-DU37KB
Control power supply	Voltage/frequency		1-phase 200 to 230VAC, 50/60Hz	
	Permissible voltage fluctuation		1-phase 170 to 253VAC	
	Permissible frequency fluctuation		Within $\pm 5\%$	
	Power consumption		45W	
Main circuit power supply			The main circuit power of the drive unit is supplied by the converter unit.	
Interface power supply	Voltage		24VDC $\pm 10\%$	
	Power supply capacity		(Note) 150mA	
Control system			Sine-wave PWM control, current control system	
Dynamic brake			External option	
Protective function			Overcurrent shut-off, overload shutoff (electronic thermal protector) Servo motor overheat protection, encoder error protection, undervoltage Instantaneous power failure protection, overspeed protection Excessive error protection	
Structure			Force-cooling, open (IP00)	
Environment	Ambient temperature	In operation	[°C]	0 to +55 (non-freezing)
			[°F]	32 to +131 (non-freezing)
		In storage	[°C]	-20 to +65 (non-freezing)
			[°F]	-4 to +149 (non-freezing)
	Ambient humidity	In operation		90%RH or less (non-condensing)
		In storage		
	Ambient			Indoors (no direct sunlight) Free from corrosive gas, flammable gas, oil mist, dust and dirt
	Altitude			Max. 1000m above sea level
Vibration			5.9 [m/s <sup>2</sup> ] or less	
			19.4 [ft/s <sup>2</sup> ] or less	
Mass		[kg]	26	
		[lb]	57.3	

Note. 150mA is the value applicable when all I/O signals are used. The current capacity can be decreased by reducing the number of I/O points.

### 13. SERVO AMPLIFIERS WITH A LARGE CAPACITY (30k TO 55kW)

(b) 400V class

Item		Model		MR-J3-DU30KB4	MR-J3-DU37KB4	MR-J3-DU45KB4	MR-J3-DU55KB4
Control power supply	Voltage/frequency		1-phase 380 to 480VAC, 50/60Hz				
	Permissible voltage fluctuation		1-phase 323 to 528VAC				
	Permissible frequency fluctuation		Within $\pm 5\%$				
	Power consumption		45W				
Main circuit power supply			The main circuit power of the drive unit is supplied by the converter unit.				
Interface power supply	Voltage		24VDC $\pm 10\%$				
	Power supply capacity		(Note)150mA				
Control system			Sine-wave PWM control, current control system				
Dynamic brake			External option				
Protective function			Overcurrent shut-off, overload shutoff (electronic thermal protector) Servo motor overheat protection, encoder error protection, undervoltage Instantaneous power failure protection, overspeed protection Excessive error protection				
Structure			Force-cooling, open(IP00)				
Environment	Ambient temperature	In operation	[°C]	0 to +55 (non-freezing)			
			[°F]	32 to +131 (non-freezing)			
		In storage	[°C]	-20 to +65 (non-freezing)			
			[°F]	-4 to +149 (non-freezing)			
	Ambient humidity	In operation		90%RH or less (non-condensing)			
		In storage					
	Ambient		Indoors (no direct sunlight) Free from corrosive gas, flammable gas, oil mist, dust and dirt				
	Altitude		Max. 1000m above sea level				
Vibration		5.9 [m/s <sup>2</sup> ] or less					
		19.4 [ft/s <sup>2</sup> ] or less					
Mass		[kg]	18		26		
		[lb]	39.7		57.3		

Note. 150mA is the value applicable when all I/O signals are used. The current capacity can be decreased by reducing the number of I/O points.

## 13. SERVO AMPLIFIERS WITH A LARGE CAPACITY (30k TO 55kW)

### 13.1.4 Model definition

#### (1) Rating plate

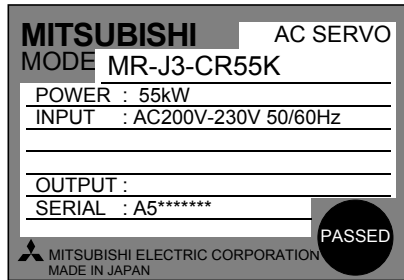

Model  
Capacity  
Applicable power supply  
Rated output current  
Serial number

**MITSUBISHI** AC SERVO  
MODE **MR-J3-CR55K**  
POWER : 55kW  
INPUT : AC200V-230V 50/60Hz  
OUTPUT :  
SERIAL : A5\*\*\*\*\*  
PASSED  
MITSUBISHI ELECTRIC CORPORATION  
MADE IN JAPAN

#### (2) Model

##### (a) Converter unit

MR - J 3 - CR 5 5 K □

Series

Indicates converter unit.

Power supply

Symbol	Power supply
None	3-phase 200 to 230VAC
4	3-phase 380 to 480VAC

Rated output: 55kW

##### (b) Drive unit

MR - J 3 - DU □ B □

Series

Indicates drive unit.

Power supply

Symbol	Power supply
None	3-phase 200 to 230VAC
4	3-phase 380 to 480VAC

SSCNET III interface

Rated output

Symbol	Rated output [kW]	
	200V class	400V class
30K	30	30
37K	37	37
45K		45
55K		55

## 13. SERVO AMPLIFIERS WITH A LARGE CAPACITY (30k TO 55kW)

### 13.1.5 Combinations of converter units, drive unit and servo motors

The following tables indicate the combinations of the converter units, drive unit and servo motors.

#### (1) 200V class

Converter unit	Drive unit	Servo motor		
		HA-LP□		
		1000r/min	1500r/min	2000r/min
MR-J3-CR55K	MR-J3-DU30KB	30K1	30K1M	30K2
	MR-J3-DU37KB	37K1	37K1M	37K2

#### (2) 400V class

Converter unit	Drive unit	Servo motor		
		HA-LP□		
		1000r/min	1500r/min	2000r/min
MR-J3-CR55K4	MR-J3-DU30KB4	25K14 30K14	30K1M4	30K24
	MR-J3-DU37KB4	37K14	37K1M4	37K24
	MR-J3-DU45KB4		45K1M4	45K24
	MR-J3-DU55KB4		50K1M4	55K24

## 13. SERVO AMPLIFIERS WITH A LARGE CAPACITY (30k TO 55kW)

### 13.1.6 Parts identification

#### (1) Converter unit (MR-J3-CR55K(4))

POINT
<ul style="list-style-type: none"> <li>The servo amplifier is shown without the front cover. For removal of the front cover, refer to section 13.1.7.</li> </ul>

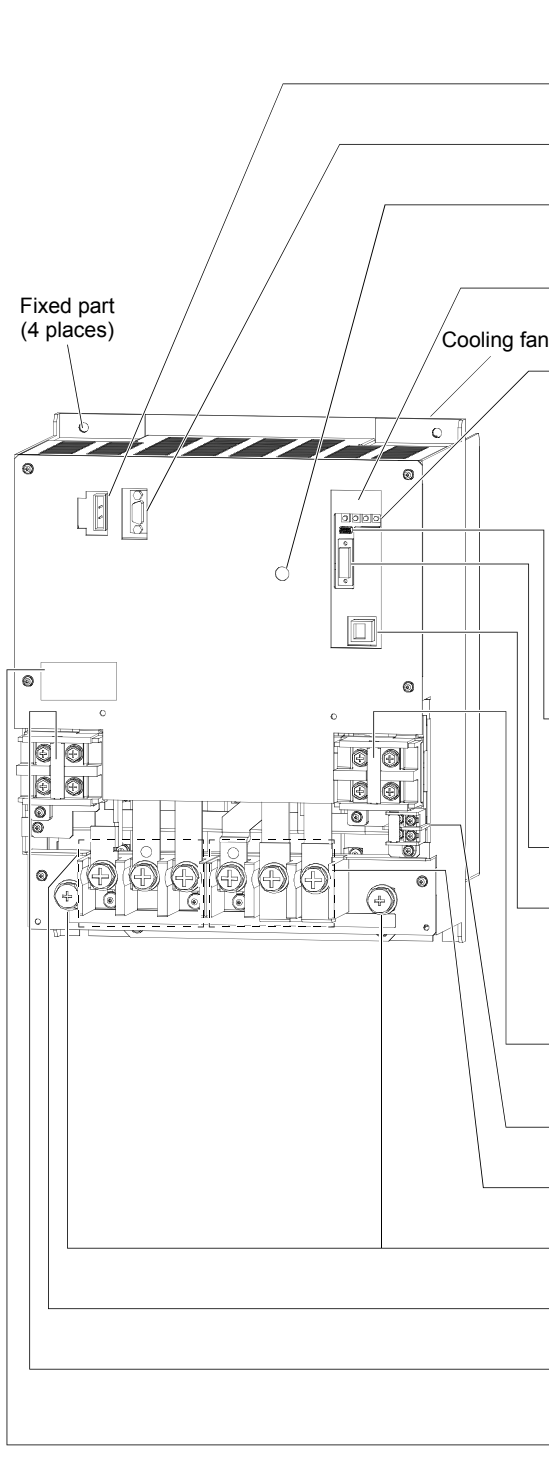

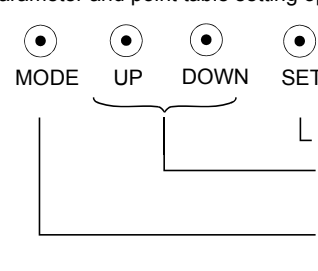
Name/Application	Detailed explanation
Magnetic contactor control connector (CNP1) Connect to the operation coil of the magnetic contactor.	Section 13.3.4
I/O signal connector (CN1) Used to connect digital I/O signals.	
Charge lamp Lit to indicate that the main circuit is charged. While this lamp is lit, do not reconnect the cables.	Section 13.4
Display The 3-digit, seven-segment LED shows the servo status and alarm number.	
Operation section Used to perform status display, diagnostic, alarm, parameter and point table setting operations.	Section 13.4
 <p>MODE    UP    DOWN    SET</p> <p>Used to set data.</p> <p>Used to change the display or data in each mode.</p> <p>Used to change the mode.</p>	
For manufacturer setting connector (CN6) The connector is for manufacturer setting. Although the shape is similar to analog monitor connector (CN6) of the drive unit, do not connect anything including an analog monitor.	Section 13.3.3
Protection coordination connector (CN40) Connect to CN40A of the drive unit.	
For manufacturer setting connector (CN3) For manufacturer adjustment. Though the shape is similar to RS-422 communication connector (CN3), do not connect anything, including a personal computer and MR-PRU03 parameter unit.	Section 13.3.3
L+L—terminal (TE2-2) Used to connect to a drive unit using a connection conductor supplied with drive unit.	
Control circuit terminal L <sub>11</sub> , L <sub>21</sub> (TE3) Supply control circuit power.	Section 13.3.3
Regenerative option Power factor improving DC reactor (TE1-2)	
Protective earth (PE) terminal (⊕) Ground terminal.	Section 13.3.3
Main circuit terminal block (TE1-1) Supply main circuit power.	
L+L—terminal (TE2-1) When using brake unit, connect it to this terminal. Do not connect anything other than the brake unit.	Section 13.9.10
Rating plate	Section 13.1.4



### 13. SERVO AMPLIFIERS WITH A LARGE CAPACITY (30k TO 55kW)

#### (2) Drive unit (MR-J3-DU30KB4 • MR-J3-DU37KB4)

**POINT**

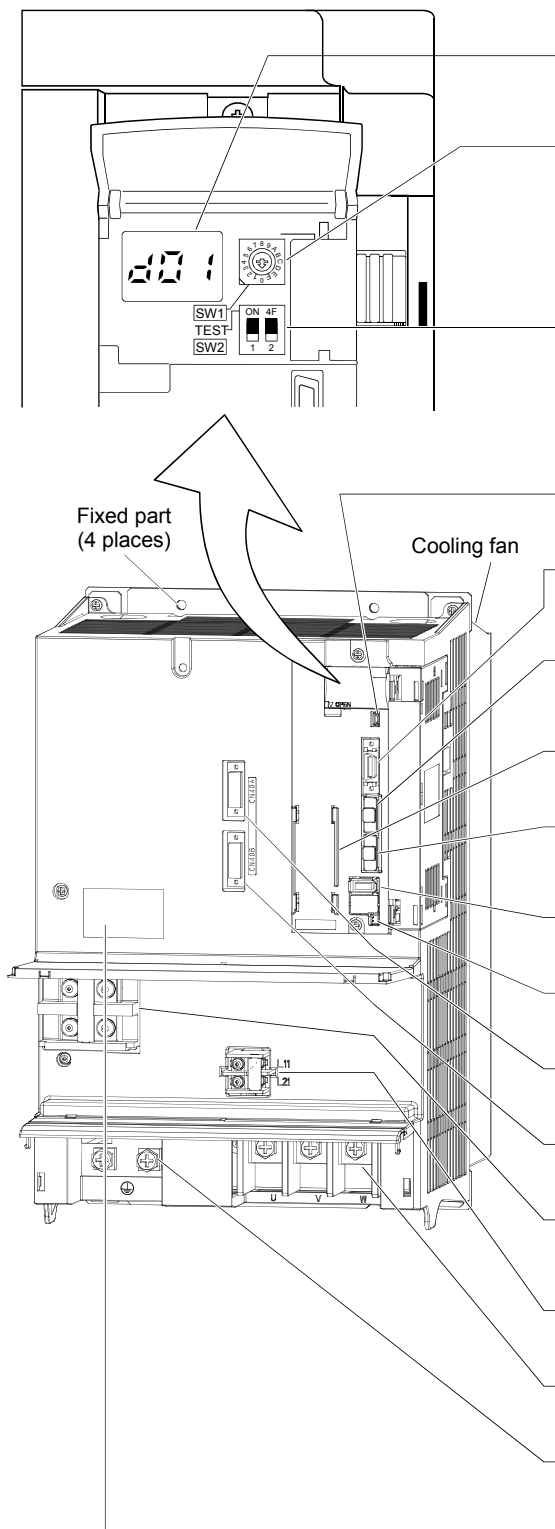
• The servo amplifier is shown with the front cover opened. For removal of the front cover, refer to section 13.1.7.

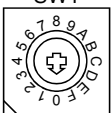



Name/Application	Detailed explanation
Display The 3-digit, seven-segment LED shows the servo status and alarm number.	Chapter 4
Rotary axis setting switch (SW1) SW1 	Used to set the axis No. of drive unit. Section 3.13
Test operation select switch (SW2-1) SW2  Spare (Be sure to set to the "Down" position).	Used to perform the test operation mode by using MR Configurator. Section 3.13
USB communication connector (CN5) Connect with the personal computer.	Section 11.8
I/O signal connector (CN3) Used to connect digital I/O signals. More over an analog monitor is output	Section 3.2 Section 3.4
SSCNET III cable connector (CN1A) Used to connect the servo system controller or the front axis drive unit.	Section 3.2 Section 3.4
Battery holder Contains the battery for absolute position data backup.	Section 12.3
SSCNET III cable connector (CN1B) Used to connect the rear axis drive unit. For the final axis, puts a cap.	Section 3.2 Section 3.4
Encoder connector (CN2) Used to connect the servo motor encoder.	Section 3.4 Section 11.1
Battery connector (CN4) Used to connect the battery for absolute position data	Section 11.9 Chapter 12
Converter unit connectors (CN40A) Connect to CN40 of the converter unit.	Section 13.3.2
Converter unit connectors (CN40B) Connect the termination connector (MR-J3-TM).	
L + L- terminals (TE2) Connect to the L + L- terminals of the converter unit using the connection conductors supplied.	Section 13.3.3
Control circuit terminal L <sub>11</sub> • L <sub>21</sub> (TE3) Supply control circuit power.	
Motor power supply terminals (TE1) Connect to U, V, W of the servo motor.	
Protective earth (PE) terminal (⊕) Ground terminal.	
Rating plate	Section 13.1.4

### 13. SERVO AMPLIFIERS WITH A LARGE CAPACITY (30k TO 55kW)

(3) Drive unit (MR-J3-DU30KB • MR-J3-DU37KB • MR-J3-DU45KB4 • MR-J3-DU55KB4)

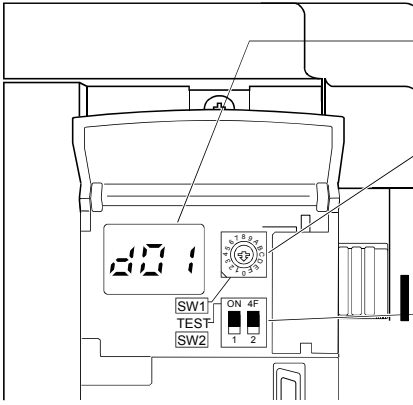
POINT
<ul style="list-style-type: none"> <li>This servo amplifier is shown without the front cover. For removal of the front cover, refer to section 13.1.7.</li> </ul>

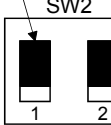
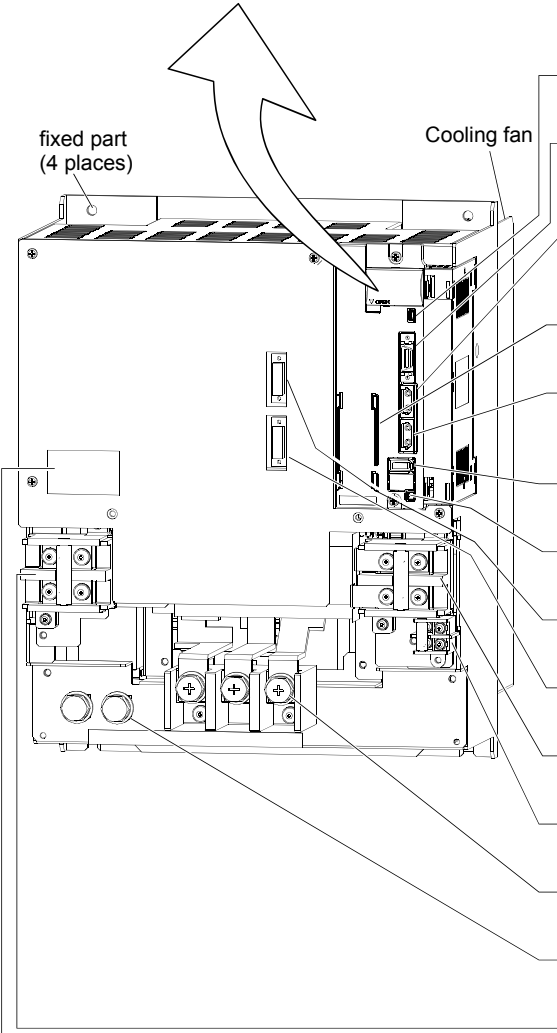
Name/Application	Detailed explanation
 <p>Display The 3-digit, seven-segment LED shows the servo status and alarm number.</p> <p>Rotary axis setting switch (SW1) SW1  Used to set the axis No. of drive unit.</p> <p>Test operation select switch (SW2-1) SW2  Used to perform the test operation mode by using MR Configurator. Spare (Be sure to set to the "Down" position).</p>	<p>Chapter 4</p> <p>Section 3.13</p>
 <p>fixed part (4 places)</p> <p>Cooling fan</p> <p>USB communication connector (CN5) Connect with the personal computer.</p> <p>I/O signal connector (CN3) Used to connect digital I/O signals. More over an analog monitor is output</p> <p>SSCNET III cable connector (CN1A) Used to connect the servo system controller or the front axis drive unit.</p> <p>Battery holder Contains the battery for absolute position data backup.</p> <p>SSCNET III cable connector (CN1B) Used to connect the rear axis drive unit. For the final axis, puts a cap.</p> <p>Encoder connector (CN2) Used to connect the servo motor encoder.</p> <p>Battery connector (CN4) Used to connect the battery for absolute position data</p> <p>Converter unit connectors (CN40A) Connect to CN40 of the converter unit.</p> <p>Converter unit connectors (CN40B) Connect the termination connector (MR-J3-TM).</p> <p>TE2-2 For manufacturer adjustment. Leave this open.</p> <p>Control circuit terminal L<sub>11</sub> • L<sub>21</sub> (TE3) Supply control circuit power.</p> <p>Motor power supply terminals (TE1) Connect to U, V, W of the servo motor.</p> <p>Protective earth (PE) terminal (⊕) Ground terminal.</p> <p>L + L- terminals (TE2) Connect to the L + L- terminals of the converter unit using the connection conductors supplied.</p>	<p>Section 11.8</p> <p>Section 3.2 Section 3.4</p> <p>Section 12.3</p> <p>Section 3.2 Section 3.4</p> <p>Section 3.4 Section 11.1</p> <p>Section 11.9 Chapter 12</p> <p>Section 13.3.2</p> <p>Section 13.3.3</p> <p>Section 13.1.4</p>
Rating plate	Section 13.1.4

## 13. SERVO AMPLIFIERS WITH A LARGE CAPACITY (30k TO 55kW)

### 13.1.7 Removal and reinstallation of the terminal block cover



• Before removing or installing the front cover, turn off the power and wait for 20 minutes or more until the charge lamp turns off. Then, confirm that the voltage between L+ and L- is safe with a voltage tester and others. Otherwise, an electric shock may occur. In addition, always confirm from the front of the servo amplifier whether the charge lamp is off or not.

(1) MR-J3-CR55K(4), MR-J3-DU30KB, MR-J3-DU37KB, MR-J3-DU45KB4 or MR-J3-DU55KB4

Here, the method for removing and reinstalling the terminal block cover using the figure of converter unit as an example. For a drive unit, the shape of the main unit is different. However, the removal and reinstallation of the terminal block can be performed in the same procedure.

(a) How to remove the terminal block cover

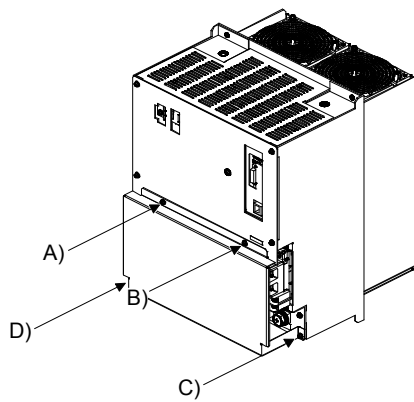

Remove the installation screws (A), B), C), D)) on the four corners of the terminal block cover.

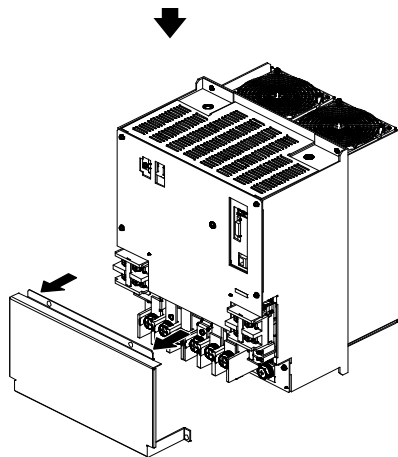

Pull the terminal block cover toward you and remove it.

### 13. SERVO AMPLIFIERS WITH A LARGE CAPACITY (30k TO 55kW)

(b) How to reinstall the terminal block cover

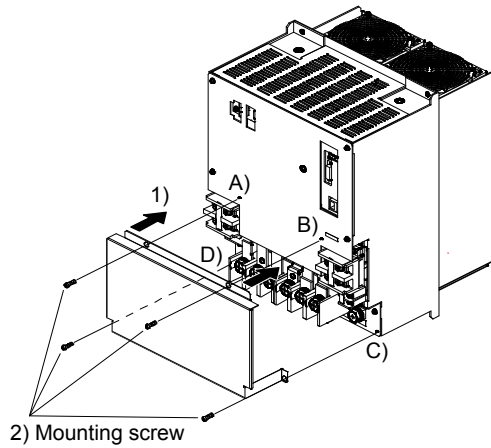

- 1) Put the terminal block cover on and match the screw holes of the cover fit with those of the main unit.
- 2) Install the installing screws into the screw holes (A, B, C, D)).

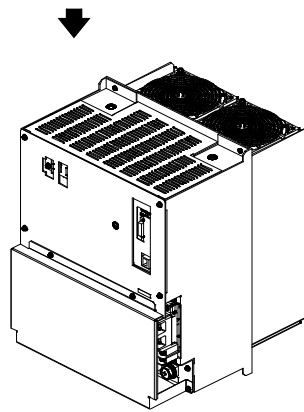

### 13. SERVO AMPLIFIERS WITH A LARGE CAPACITY (30k TO 55kW)

- (2) MR-J3-DU30KB4 or MR-J3-DU37KB4
  - (a) Upper terminal block cover
    - 1) How to open

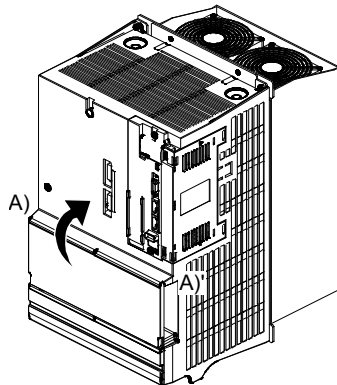

Pull up the cover using the axis A), A)' as a support.

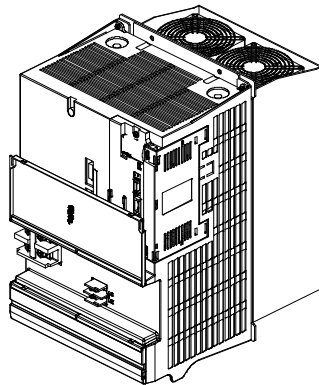

When pulled up to the top, the cover is fixed.

### 13. SERVO AMPLIFIERS WITH A LARGE CAPACITY (30k TO 55kW)

#### 2) How to close

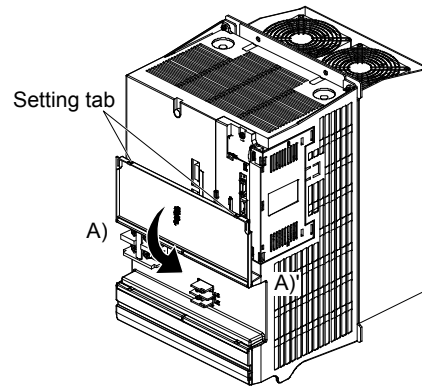

Close the cover using the axis A), A)' as a support.

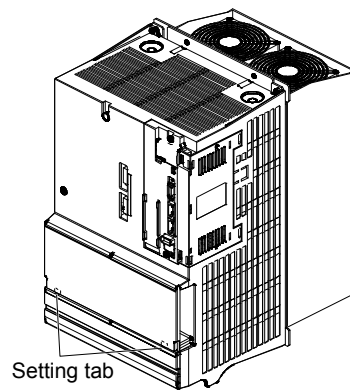

Press the cover against the terminal box until the installing knobs click.

### 13. SERVO AMPLIFIERS WITH A LARGE CAPACITY (30k TO 55kW)

(b) Lower terminal block cover

1) How to open

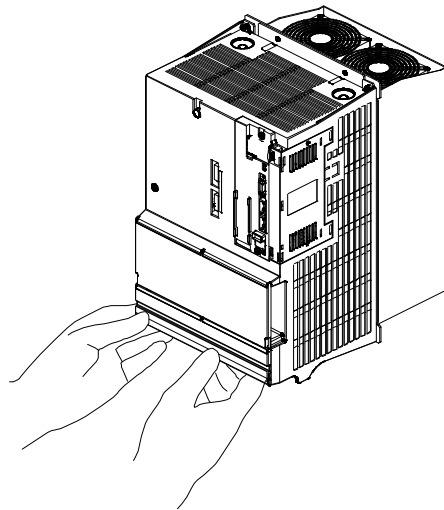

Hold the bottom of the terminal block cover with both hands.

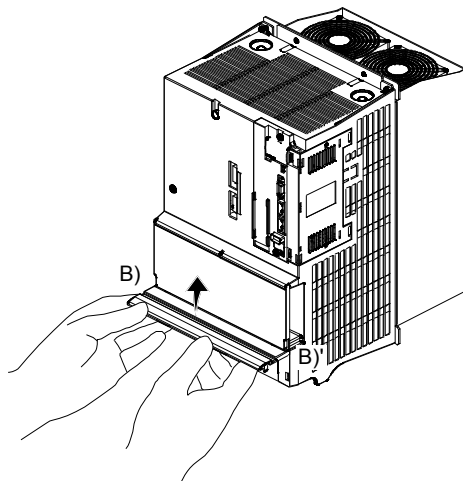

Pull up the cover using the axis B), B)' as a support.

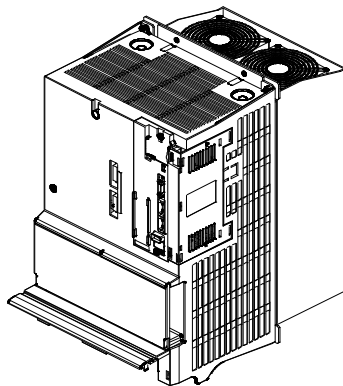

When pulled up to the top, the cover is fixed.

### 13. SERVO AMPLIFIERS WITH A LARGE CAPACITY (30k TO 55kW)

#### 2) How to close

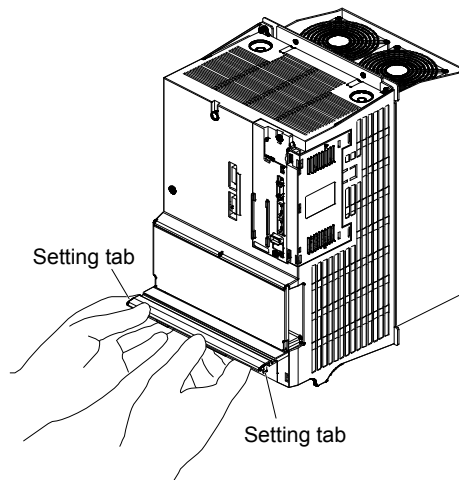

Hold the bottom of the terminal block cover with both hands.

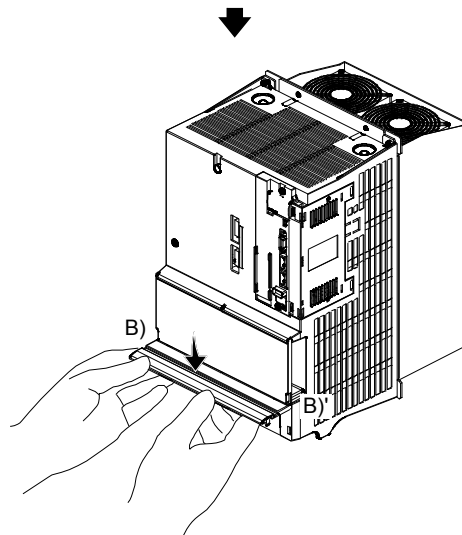

Close the cover using the axis B), B)' as a support.

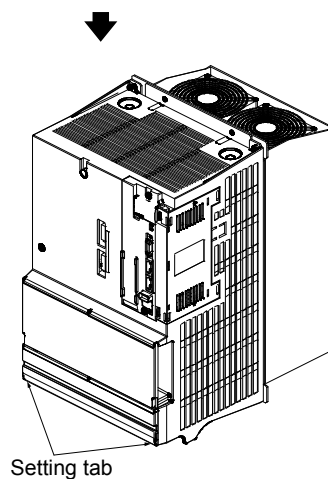

Press the cover against the terminal box until the installing knobs click.

## 13. SERVO AMPLIFIERS WITH A LARGE CAPACITY (30k TO 55kW)

### 13.1.8 Servo system with auxiliary equipment

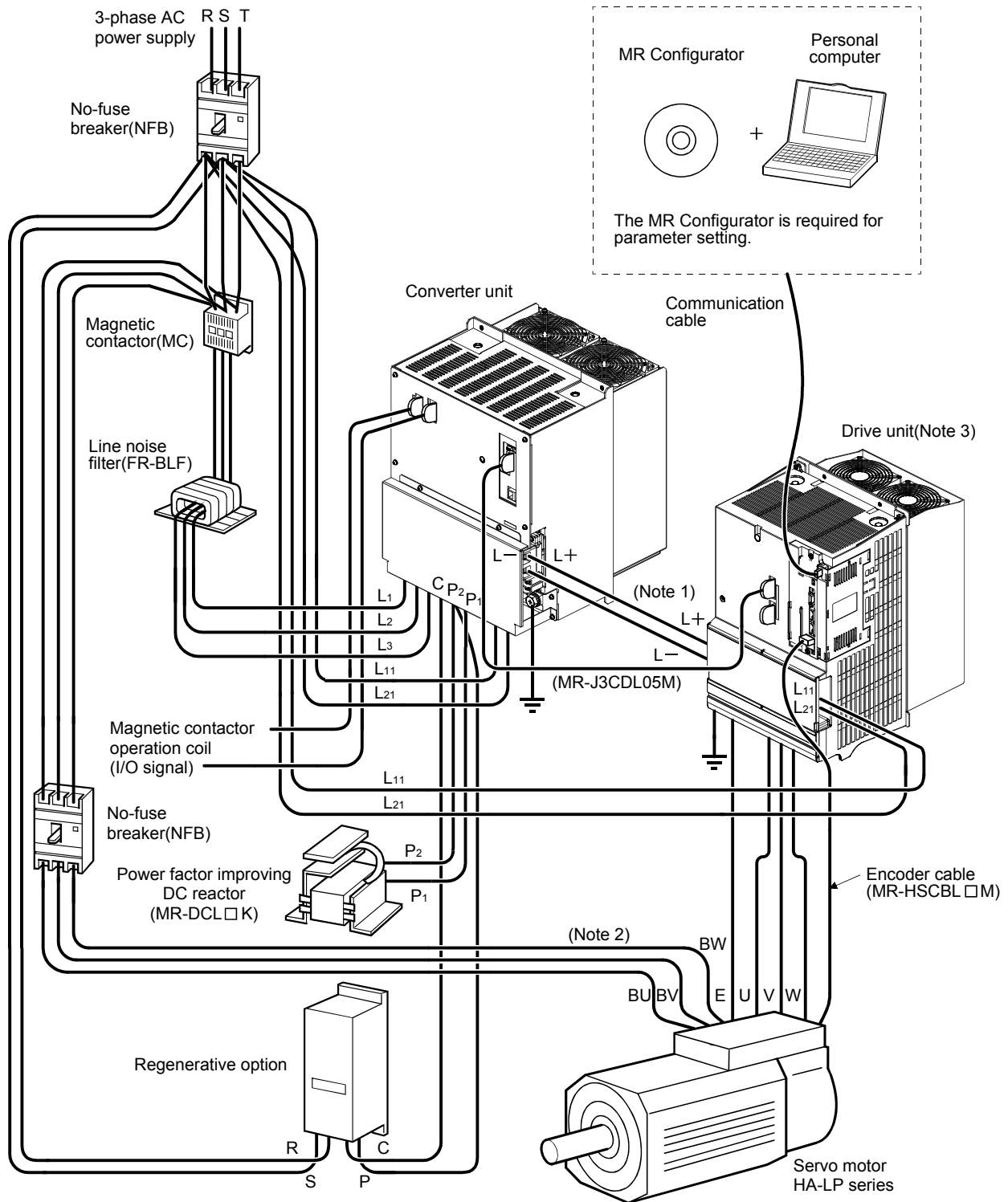

Note 1. The L+ and L- connection conductors used to connect a converter unit to a drive unit are standard accessories. The converter unit is attached to the drive unit actually. (Refer to section 13.2.1.)

2. The power supply of the servo motor cooling fan differs depending on the capacity of a servo motor. Refer to section 13.3.6.

3. For MR-J3-DU30KB4 or MR-J3-DU37KB4.

## 13. SERVO AMPLIFIERS WITH A LARGE CAPACITY (30k TO 55kW)

### 13.2 Installation



- Stacking in excess of the limited number of products is not allowed.
- Install the equipment to incombustibles. Installing them directly or close to combustibles will led to a fire.
- Install the equipment in a load-bearing place in accordance with this Instruction Manual.
- Do not get on or put heavy load on the equipment to prevent injury.
- Use the equipment within the specified environmental condition range. (For the environmental conditions, refer to section 13.1.3.)
- Provide an adequate protection to prevent screws, metallic detritus and other conductive matter or oil and other combustible matter from entering the converter unit ▪ drive unit.
- Do not block the intake/exhaust ports of the converter unit ▪ drive unit. Otherwise, a fault may occur.
- Do not subject the converter unit ▪ drive unit to drop impact or shock loads as they are precision equipment.
- Do not install or operate a faulty converter unit ▪ drive unit.
- When the product has been stored for an extended period of time, consult Mitsubishi.
- When treating the converter unit ▪ drive unit, be careful about the edged parts such as the corners of the converter unit ▪ drive unit.

#### POINT

- Explanations on the following item are the same as those for servo amplifiers with 22kW or less. Refer to the section below for details.
  - Keep out foreign materials Refer to section 2.2.
  - Cable stress Refer to section 2.3.
  - SSCNETIII cable laying Refer to section 2.4.
  - Parts Having Service Lives Refer to section 2.6.

### 13. SERVO AMPLIFIERS WITH A LARGE CAPACITY (30k TO 55kW)

#### 13.2.1 Installation direction and clearances

 <b>CAUTION</b>	<ul style="list-style-type: none"> <li>Install the equipment in the specified direction. Not doing so can cause a failure.</li> <li>Leave the specified clearances between the converter unit/drive unit and the control box inside walls or other equipment. Not doing so can cause a failure.</li> </ul>
--	--

#### (1) Installation

<b>POINT</b>
<ul style="list-style-type: none"> <li>Make sure to connect a drive unit to the right side of a converter unit as shown in the diagram.</li> </ul>

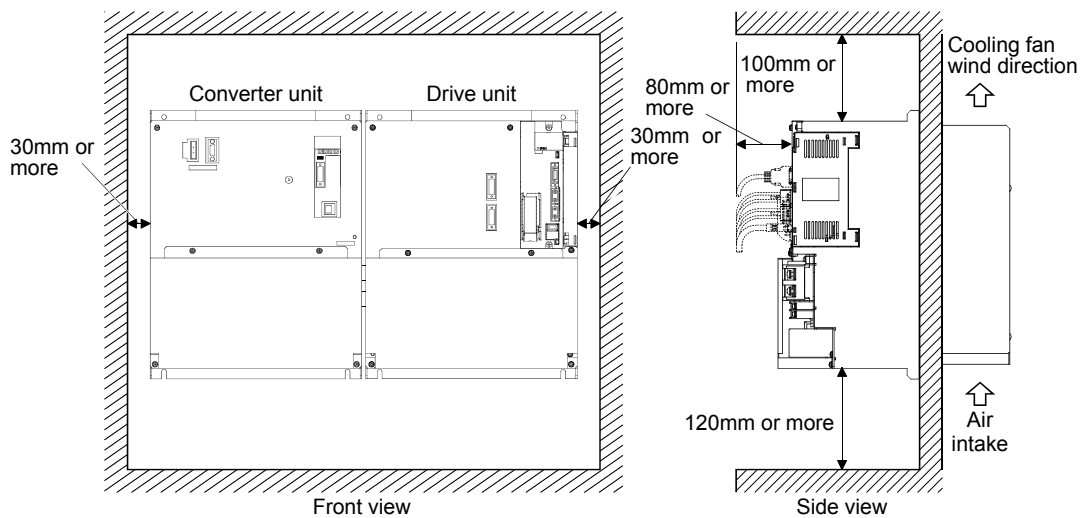

#### (2) Mounting dimensional diagram

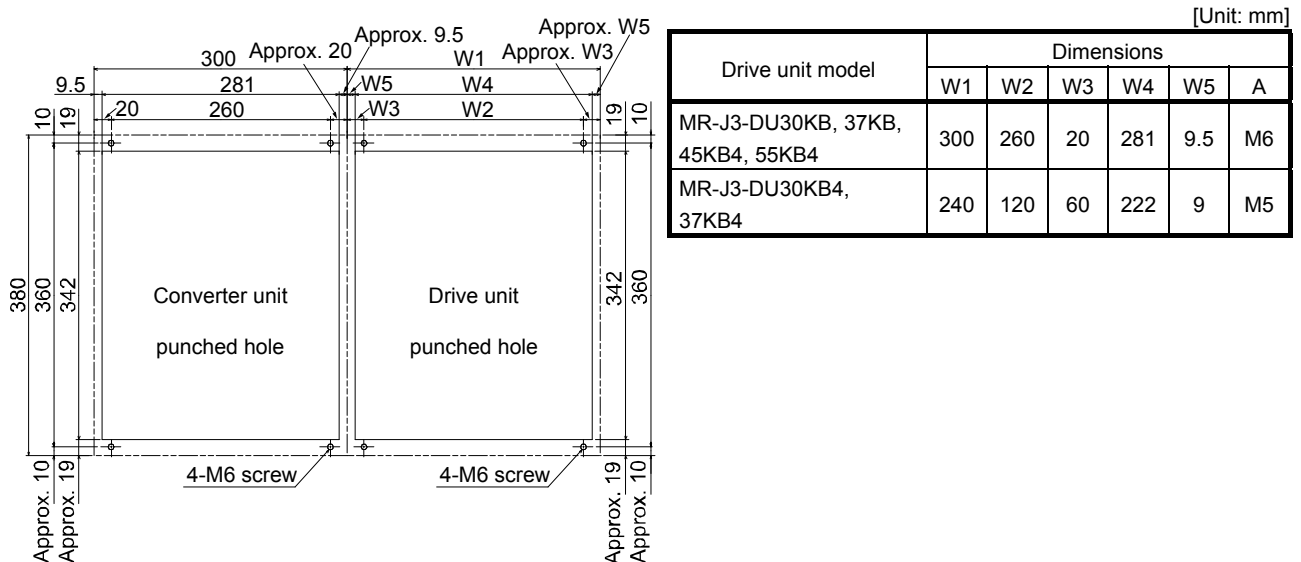

#### (3) Others

When using heat generating equipment such as the regenerative option, install them with full consideration of heat generation so that the converter unit and drive unit is not affected.

Install the converter unit and drive unit on a perpendicular wall in the correct vertical direction.

## 13. SERVO AMPLIFIERS WITH A LARGE CAPACITY (30k TO 55kW)

### 13.2.2 Inspection

#### WARNING

- Before starting maintenance and/or inspection, turn off the power and wait for 20 minutes or more until the charge lamp turns off. Then, confirm that the voltage between L+ and L— is safe with a voltage tester and others. Otherwise, an electric shock may occur. In addition, always confirm from the front of the converter unit whether the charge lamp is off or not.

#### CAUTION

- Any person who is involved in inspection should be fully competent to do the work. Otherwise, you may get an electric shock. For repair and parts replacement, contact your safes representative.

#### POINT

- Do not test the converter unit ▪ drive unit with a megger (measure insulation resistance), or it may become faulty.

It is recommended to make the following checks periodically.

- 1) Check for loose terminal block screws. Retighten any loose screws.
- 2) Check the servo motor bearings, brake section, etc. for unusual noise.
- 3) Check the cables and the like for scratches and cracks. Perform periodic inspection according to operating conditions.
- 4) Check the servo motor shaft and coupling for misalignment.

## 13. SERVO AMPLIFIERS WITH A LARGE CAPACITY (30k TO 55kW)

### 13.3 Signals and wiring

#### ⚠ WARNING

- Any person who is involved in wiring should be fully competent to do the work.
- Before wiring, turn off the power and wait for 20 minutes or more until the charge lamp turns off. Then, confirm that the voltage between L+ and L- is safe with a voltage tester and others. Otherwise, an electric shock may occur. In addition, always confirm from the front of the converter unit whether the charge lamp is off or not.
- Ground the converter unit • drive unit and the servo motor securely.
- Do not attempt to wire the converter unit • drive unit and servo motor until they have been installed. Otherwise, you may get an electric shock.
- The cables should not be damaged, stressed excessively, loaded heavily, or pinched. Otherwise, you may get an electric shock.

#### ⚠ CAUTION

- Wire the equipment correctly and securely. Otherwise, the servo motor may operate unexpectedly, resulting in injury.
- Connect cables to correct terminals to prevent a burst, fault, etc.
- Ensure that polarity (+, -) is correct. Otherwise, a burst, damage, etc. may occur.
- The surge absorbing diode installed to the DC relay designed for control output should be fitted in the specified direction. Otherwise, the signal is not output due to a fault, disabling the forced stop (EM1) and other protective circuits.

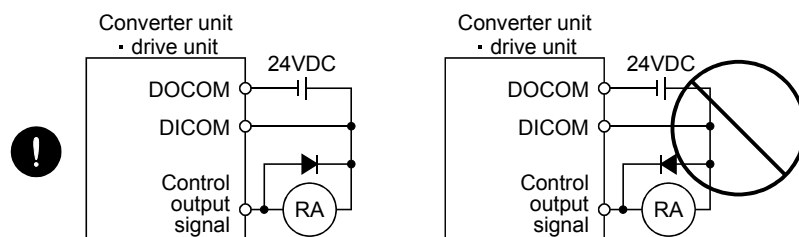

- Use a noise filter, etc. to minimize the influence of electromagnetic interference, which may be given to electronic equipment used near the converter unit • drive unit.
- Do not install a power capacitor, surge suppressor or radio noise filter (FR-BIF-(H) option) with the power line of the servo motor.
- When using the regenerative resistor, switch power off with the alarm signal. Otherwise, a transistor fault or the like may overheat the regenerative resistor, causing a fire.
- Do not modify the equipment.
- During power-on, do not open or close the motor power line. Otherwise, a malfunction or faulty may occur.

## 13. SERVO AMPLIFIERS WITH A LARGE CAPACITY (30k TO 55kW)

POINT
<ul style="list-style-type: none"><li>▪ Explanations on the following item are the same as those for servo amplifiers with 22kW or less. Refer to the section below for details.<ul style="list-style-type: none"><li>▪ I/O signal connection example Refer to section 3.2.</li><li>▪ Signal (device) explanations Refer to section 3.5.</li><li>▪ Interfaces Refer to section 3.7.</li><li>▪ Treatment of cable shield external conductor Refer to section 3.8.</li><li>▪ SSCNETIII cable connection Refer to section 3.9.</li><li>▪ Grounding Refer to section 3.12.</li><li>▪ Control axis selection Refer to section 3.13.</li></ul></li><li>▪ The pins with the same signal name are connected in the drive unit.</li></ul>

### 13.3.1 Magnetic contactor control connector (CNP1)



#### WARNING

- Always connect the magnetic contactor wiring connector to the converter unit. If the connector is not connected, an electric shock may occur since CNP1-1 and L11 are always conducting.

By enabling the control function of the magnetic contactor (parameter No.PA02=1 (initial value)), main circuit power supply can be shut off automatically when an alarm occurs on the converter unit or the drive unit.

Parameter No.PA02

<input type="checkbox"/>	<input type="checkbox"/>	<input type="checkbox"/>	1
--------------------------	--------------------------	--------------------------	---

- Used to select the output of the external magnet contactor drive signal.
- 0: No used
- 1: Used (initial value)

### 13. SERVO AMPLIFIERS WITH A LARGE CAPACITY (30k TO 55kW)

(1) Enabling control function of magnetic contactor (parameter No.PA02=□□□1 (initial value))

Connecting the magnetic contactor control connector (CNP1) to the operating coil of the magnetic contactor enables to control the magnetic contactor.

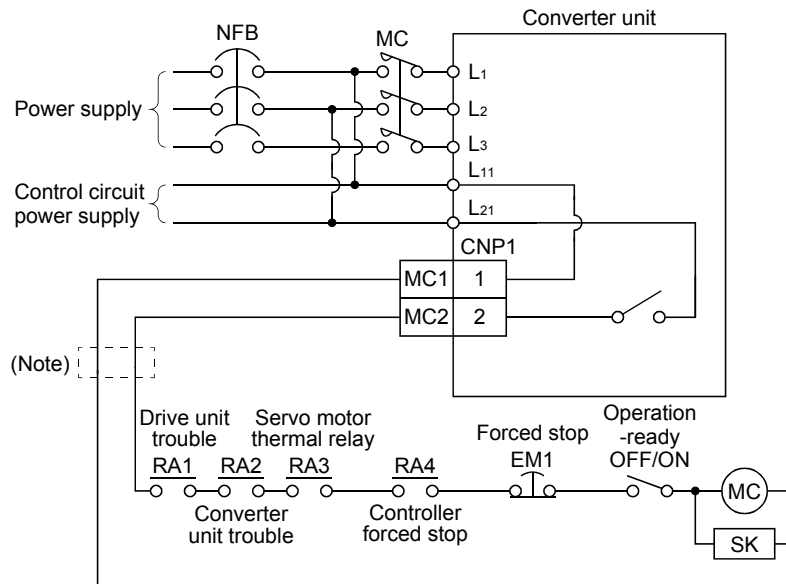

Note. Stepdown transformer is required when coil voltage of the magnetic contactor is 200V class, and the converter unit and the drive unit are 400V class.

When the converter unit receives a start command from the drive unit while the magnetic contactor control connector (CNP1) is connected to the magnetic contactor (refer to section 13.3.2 (1)), CNP1-2 and L21 conduct in the converter unit. Then the control circuit power is supplied to turn ON the magnetic contactor and the main circuit power is supplied to the converter unit.

Either when an alarm occurs on the converter unit or the drive unit while the control function of the magnetic contactor is enabled, or when the forced stop (EM1) of the converter unit or the drive unit is turned OFF, the switch between CNP1-2 and L21 in the converter unit is disconnected and the main circuit power supply is automatically shut off.

To automatically shut off the main circuit power supply by alarm, enable the control function of the magnetic contactor.

(2) Disabling control function of magnetic contactor (parameter No.PA02=□□□0)

When not connecting the magnetic contactor control connector (CNP1) to the operating coil of the magnetic contactor, configure the circuit to shut off the main circuit power supply when detecting an alarm since the main circuit power supply is not automatically shut off even when an alarm occurs on the converter unit or the drive unit.

## 13. SERVO AMPLIFIERS WITH A LARGE CAPACITY (30k TO 55kW)

### 13.3.2 Input power supply circuit



#### WARNING

- Insulate the connections of the power supply terminals. Not doing so can cause an electric shock.
- Magnetic contactor wiring connector on the converter unit CNP1. Unattached state may cause an electric shock.



#### CAUTION

- Always, connect the magnetic contactor (MC) between the main circuit power supply and L<sub>1</sub>, L<sub>2</sub>, and L<sub>3</sub> of the converter unit, and configure to shut off the power supply on the side of the converter unit power supply. If the magnetic contactor (MC) is not connected, a large current keeps flowing and may cause a fire when the converter unit or the drive unit malfunctions.
- Use the trouble signal to switch power off. Otherwise, a regenerative transistor fault or the like may overheat the regenerative resistor, causing a fire.
- Connect the power supply phases (U, V, W) of the servo amplifier and servo motor correctly. Not doing so can cause the servo motor to run abnormally.
- Do not connect a 3-phase 200V power supply or a 3-phase 400V power supply directly to the servo motor. Doing so can cause a failure.

#### POINT

- Magnetic contactor control connector (CNP1) of the converter unit can be made valid or invalid with parameter No.PA02 of the converter unit. Refer to section 13.3.1 and 13.3.6 for details of CNP1 and section 13.5 for the parameter settings.
- When using the external dynamic brake, refer to section 11.6 and 13.9.3.

### 13. SERVO AMPLIFIERS WITH A LARGE CAPACITY (30kW TO 55kW)

(1) When magnetic contactor control connector (CNP1) is made valid (factory-set)

POINT
<ul style="list-style-type: none"> <li>The converter unit controls the main circuit magnetic contactor.</li> <li>Refer to section 13.3.7 (1) for the power circuit timing chart, section 13.3.7 (2) for the alarm occurrence timing chart, section 13.3.7 (3) for the forced stop (EM1) timing chart.</li> <li>Always connect a protection coordination cable (MR-J3CDL05M) and a termination connector (MR-J3-TM). When they are not connected properly, the servo-on may not be turned ON.</li> <li>For the control power supplies of the converter unit and the drive unit, always turn ON or OFF at the same time.</li> </ul>

(a) 200V class (MR-J3-DU30KB • MR-J3-DU37KB)

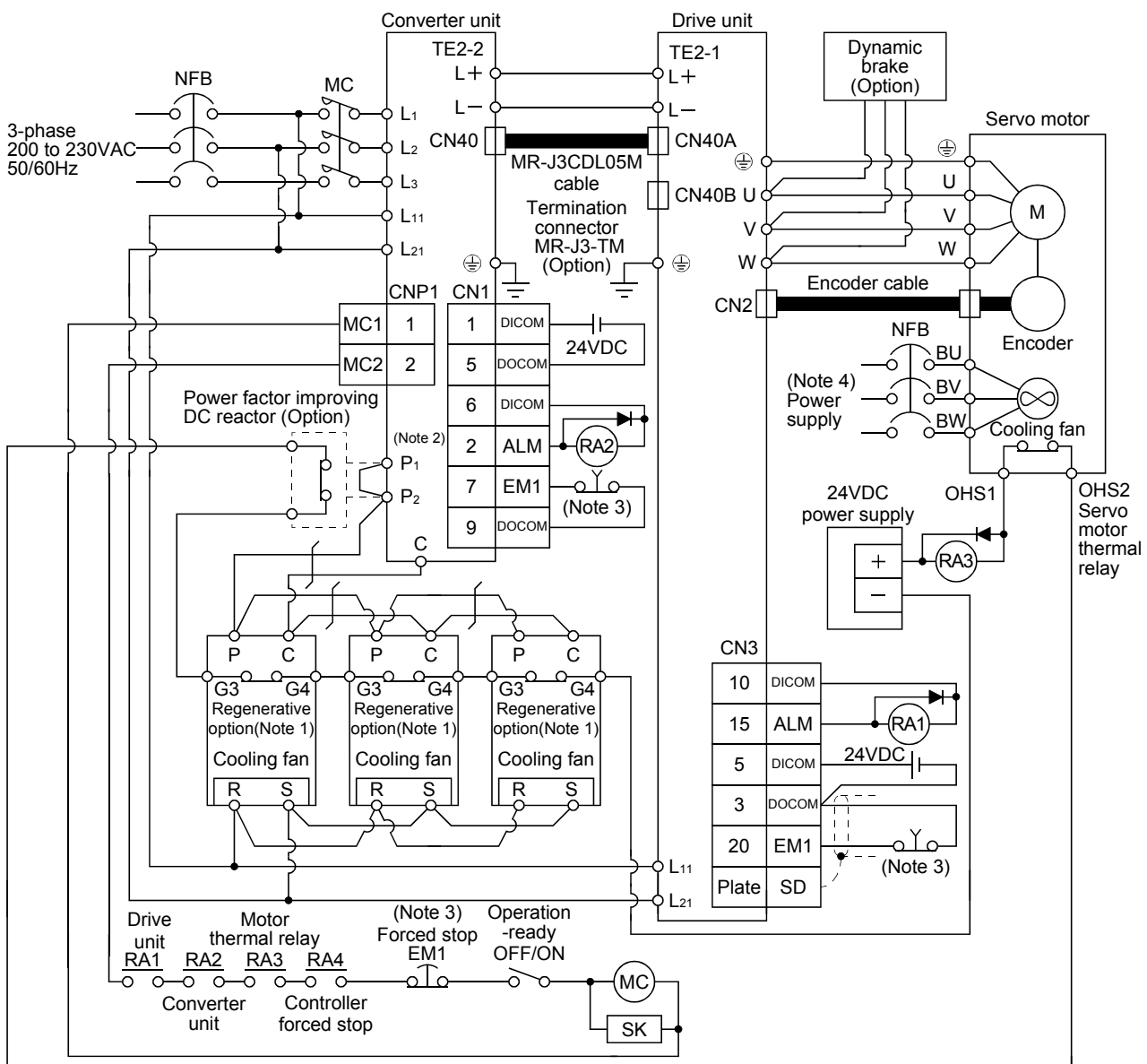

Note 1. For the MR-RB137. For the MR-RB137, three units are used as one set (permissible wattage: 3900W).

2. When using the Power factor improving DC reactor, disconnect the short bar across P<sub>1</sub>-P<sub>2</sub>.

3. Make up a sequence that turns off the drive unit forced stop (EM1) and the converter unit forced stop (EM1) at the same time.

4. For specifications of cooling fan power supply, refer to section 13.3.8.

### 13. SERVO AMPLIFIERS WITH A LARGE CAPACITY (30k TO 55kW)

(b) 400V class (MR-J3-DU30KB4 to MR-J3-DU55KB4)

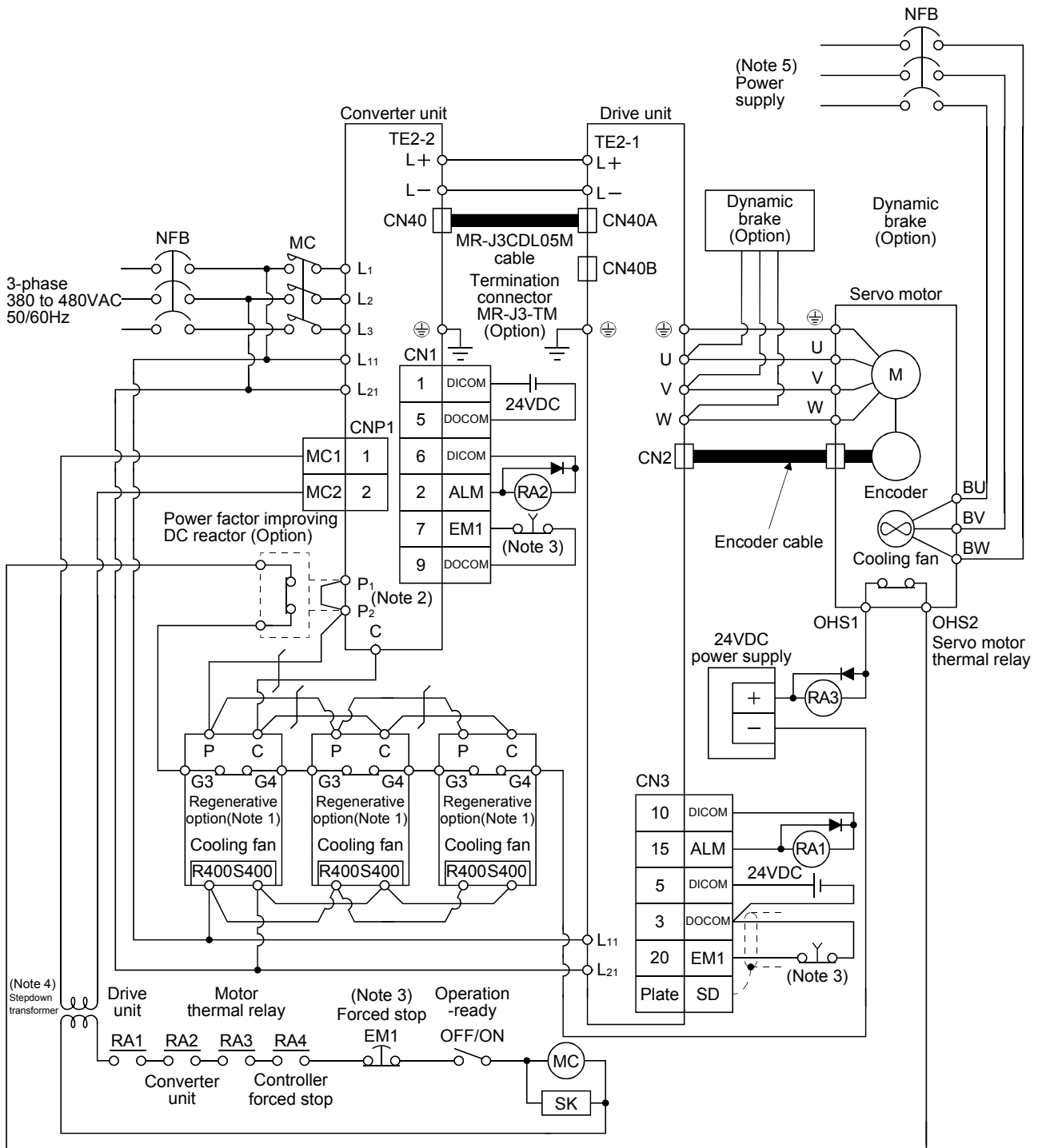

Note 1. For the MR-RB138-4, three units are used as one set (permissible wattage: 3900W).

2. When using the Power factor improving DC reactor, disconnect the short bar across P<sub>1</sub>-P<sub>2</sub>.

3. Make up a sequence that turns off the drive unit forced stop (EM1) and the converter unit forced stop (EM1) at the same time.

4. Stepdown transformer is required for coil voltage of magnetic contactor more than 200V class.

5. For specifications of cooling fan power supply, refer to section 13.3.8.

### 13. SERVO AMPLIFIERS WITH A LARGE CAPACITY (30kW TO 55kW)

(2) When magnetic contactor control connector (CNP1) is made invalid

POINT
<ul style="list-style-type: none"> <li>▪ The converter unit controls the main circuit magnetic contactor.</li> <li>▪ When making CNP1 invalid, set "0000" in parameter No.PA02. (Refer to section 13.5.)</li> <li>▪ Always connect a protection coordination cable (MR-J3CDL05M) and a termination connector (MR-J3-TM). When they are not connected properly, the servo-on may not be turned ON.</li> <li>▪ For the control power supplies of the converter unit and the drive unit, always turn ON or OFF at the same time. ▪</li> </ul>

(a) 200V class (MR-J3-DU30KB • MR-J3-DU37KB)

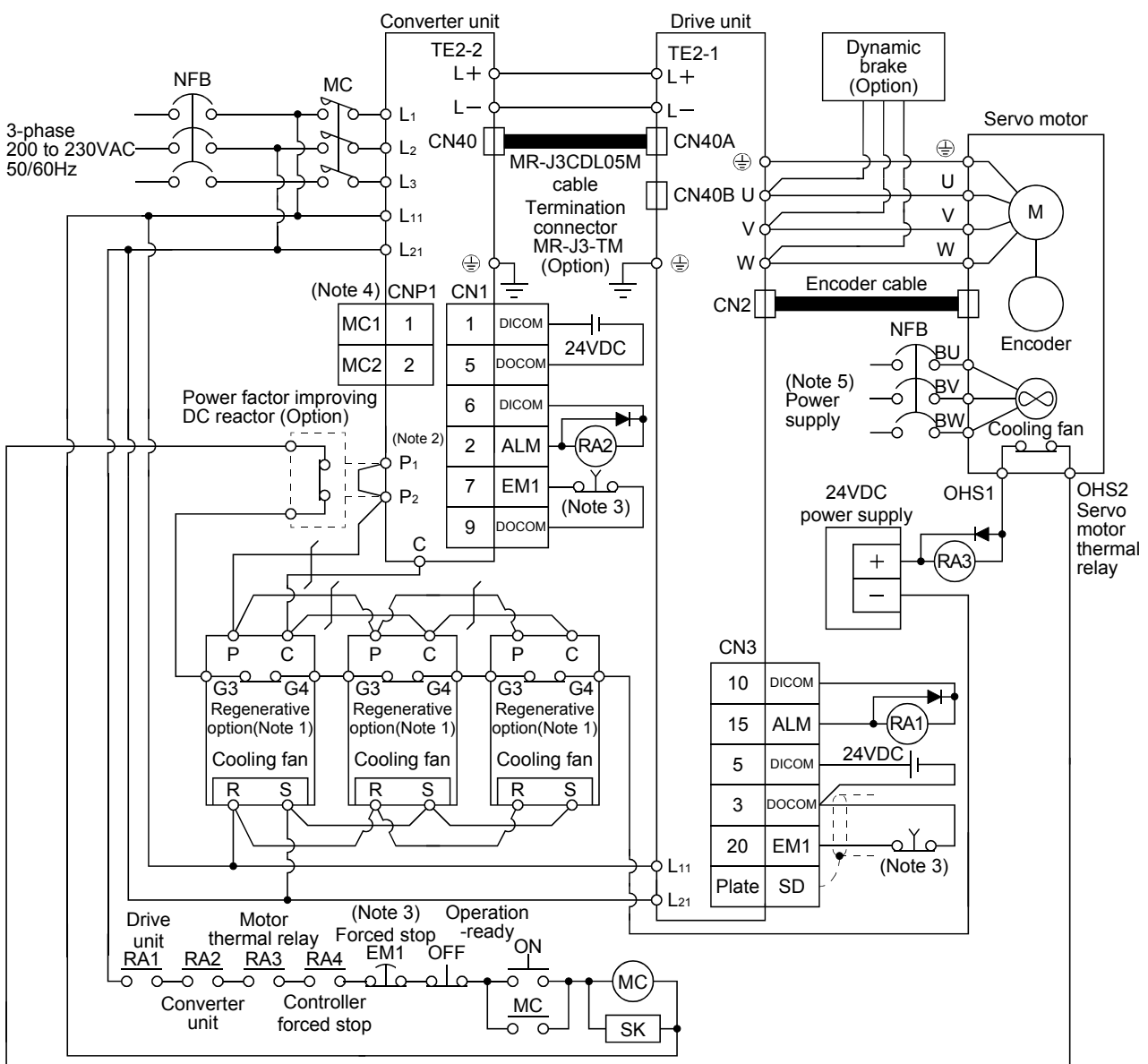

Note 1. For the MR-RB137. For the MR-RB137, three units are used as one set (permissible wattage: 3900W).

2. When using the Power factor improving DC reactor, disconnect the short bar across P<sub>1</sub>-P<sub>2</sub>.

3. Make up a sequence that turns off the drive unit forced stop (EM1) and the converter unit forced stop (EM1) at the same time.

4. Attach connector for magnetic contactor control (CNP1) on the converter unit. Unattached state may cause an electric shock.

5. For specifications of cooling fan power supply, refer to section 13.3.8.

### 13. SERVO AMPLIFIERS WITH A LARGE CAPACITY (30kW TO 55kW)

(b) 400V class (MR-J3-DU30KB4 to MR-J3-DU55KB4)

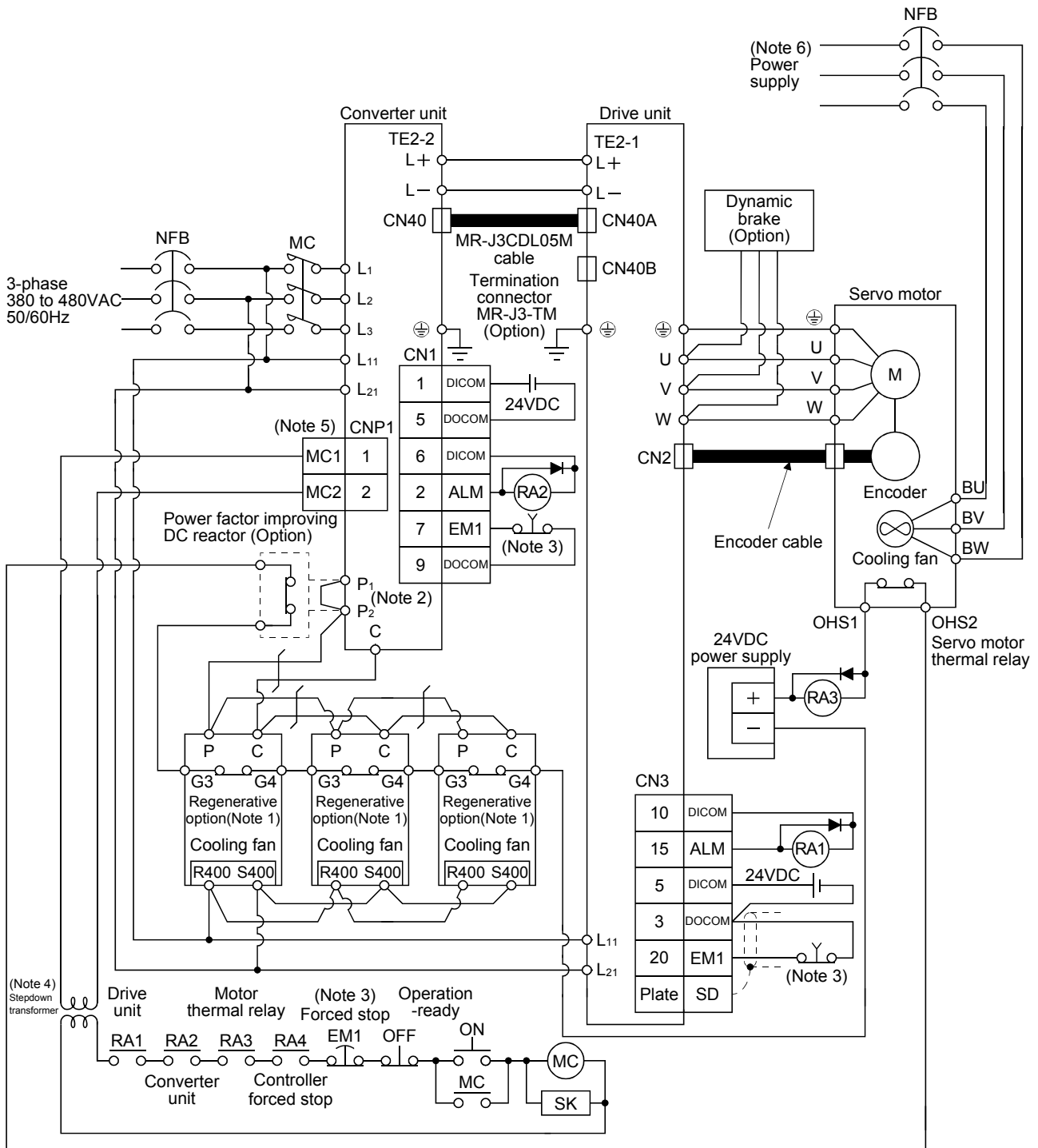

Note 1. For the MR-RB138-4. For the MR-RB138-4, three units are used as one set (permissible wattage: 3900W).

2. When using the Power factor improving DC reactor, disconnect the short bar across P<sub>1</sub>-P<sub>2</sub>.

3. Make up a sequence that turns off the drive unit forced stop (EM1) and the converter unit forced stop (EM1) at the same time.

4. Stepdown transformer is required for coil voltage of magnetic contactor more than 200V class.

5. Attach connector for magnetic contactor wiring on the converter unit. Unattached state may cause an electric shock.

6. For specifications of cooling fan power supply, refer to section 13.3.8.

## 13. SERVO AMPLIFIERS WITH A LARGE CAPACITY (30k TO 55kW)

### 13.3.3 Terminal

Refer to section 13.7 for the terminal block arrangement and signal layout.

#### (1) Converter unit

Connection target (Application)	Abbreviation	(Note) Terminal block	Description	
			MR-J3-CR55K	MR-J3-CR55K4
Main circuit power supply	L <sub>1</sub> • L <sub>2</sub> • L <sub>3</sub>	TE1-1	Connect 3-phase 200 to 230VAC, 50/60Hz to L <sub>1</sub> , L <sub>2</sub> , L <sub>3</sub> .	Connect 3-phase 380 to 480VAC, 50/60Hz to L <sub>1</sub> , L <sub>2</sub> , L <sub>3</sub> .
Control circuit power supply	L <sub>11</sub> • L <sub>21</sub>	TE3	Connect 1-phase 200 to 230VAC, 50/60Hz.	Connect 1-phase 380 to 480VAC, 50/60Hz.
Power factor improving DC reactor	P <sub>1</sub> • P <sub>2</sub>	TE1-2	When using the power factor improving DC reactor, connect it after removing the connection plate across P <sub>1</sub> -P <sub>2</sub> .	
Regenerative brake	P <sub>2</sub> • C	TE1-2	Connect to the P <sub>2</sub> and C terminals of the regenerative option.	
DC link	L+ • L-	TE2-2	Connect to the L+, L- terminals of the drive unit. Use the connection bar, which is supplied with the drive unit, to connect.	
Grounding	⊕	PE	Connect this terminal to the protective earth (PE) terminals of the servo motor and control box for grounding.	

Note. The permissible tension applied to any of the terminal blocks TE1-1, TE1-2, TE2-2 is 350[N].

#### (2) Drive unit

Connection target (Application)	Abbreviation	(Note) Terminal block	Description	
			MR-J3-DU30KB • MR-J3-DU37KB	MR-J3-DU30KB4 to MR-J3-DU55KB4
Control circuit power supply	L <sub>11</sub> • L <sub>21</sub>	TE3	Connect 1-phase 200 to 230VAC, 50/60Hz.	Connect 1-phase 380 to 480VAC, 50/60Hz.
L+L- power supply input	L+ • L-	TE2-1	Connect to the L+ and L- terminals of the converter unit. Use the connection bar, which is supplied with the drive unit, to connect.	
Servo motor power	U • V • W	TE1A	Connect to the servo motor power terminals (U, V, W).	
Grounding	⊕	PE	Connect this terminal to the protective earth (PE) terminals of the servo motor and control box for grounding.	

Note. The permissible tension applied to any of the terminal blocks TE1, TE2-1 is 350[N].

## 13. SERVO AMPLIFIERS WITH A LARGE CAPACITY (30k TO 55kW)

### 13.3.4 How to use the connection bars

Make sure to use the supplied connection conductors and connect the L+ and L- of the drive unit to those of the converter unit as shown below. Never use connection conductors other than the ones supplied with the drive unit. Both units are shown without the front covers.

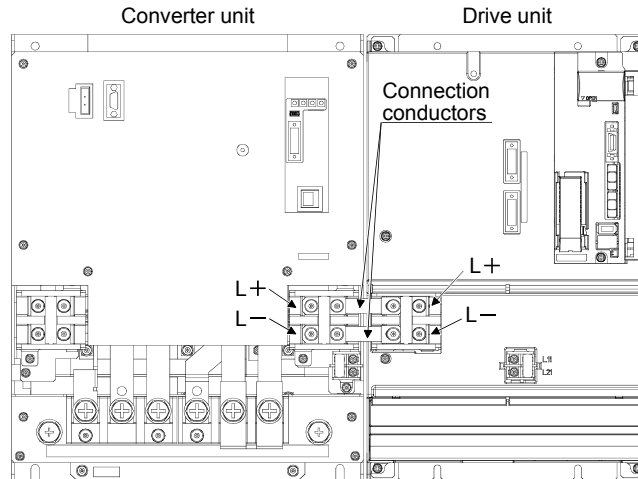

## 13. SERVO AMPLIFIERS WITH A LARGE CAPACITY (30k TO 55kW)

### 13.3.5 Connectors and signal arrangements

**POINT**

- The pin configurations of the connectors are as viewed from the cable connector wiring section.

#### (1) Converter unit

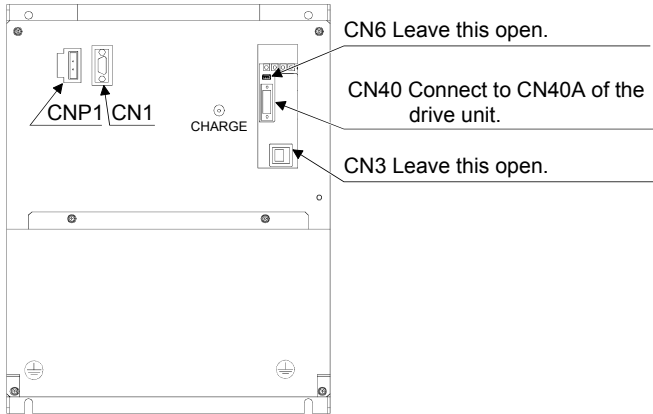

CN1 (Digital I/O connector)

Model: 17JE-23090-02 (D8A) K11-CG (D-sub 9 pin or equivalent)

(DDK)

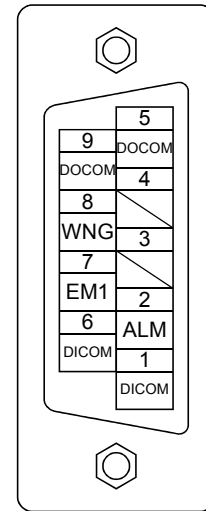

CNP1 (Magnetic contactor wiring connector)

Model: GFKC 2.5/2-STF-7.62

(Phoenix Contact)

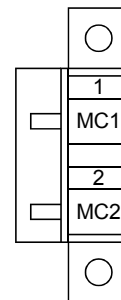

### 13. SERVO AMPLIFIERS WITH A LARGE CAPACITY (30k TO 55kW)

#### (2) Drive unit

The drive unit front view shown is that of the MR-J3-DU30KB4, MR-J3-DU37KB4 or less. Refer to section 13.7 Outline Drawings for the appearances and connector layouts of the MR-J3-DU30KB, MR-J3-DU37KB, MR-J3-DU45KB4, MR-J3-DU55KB4.

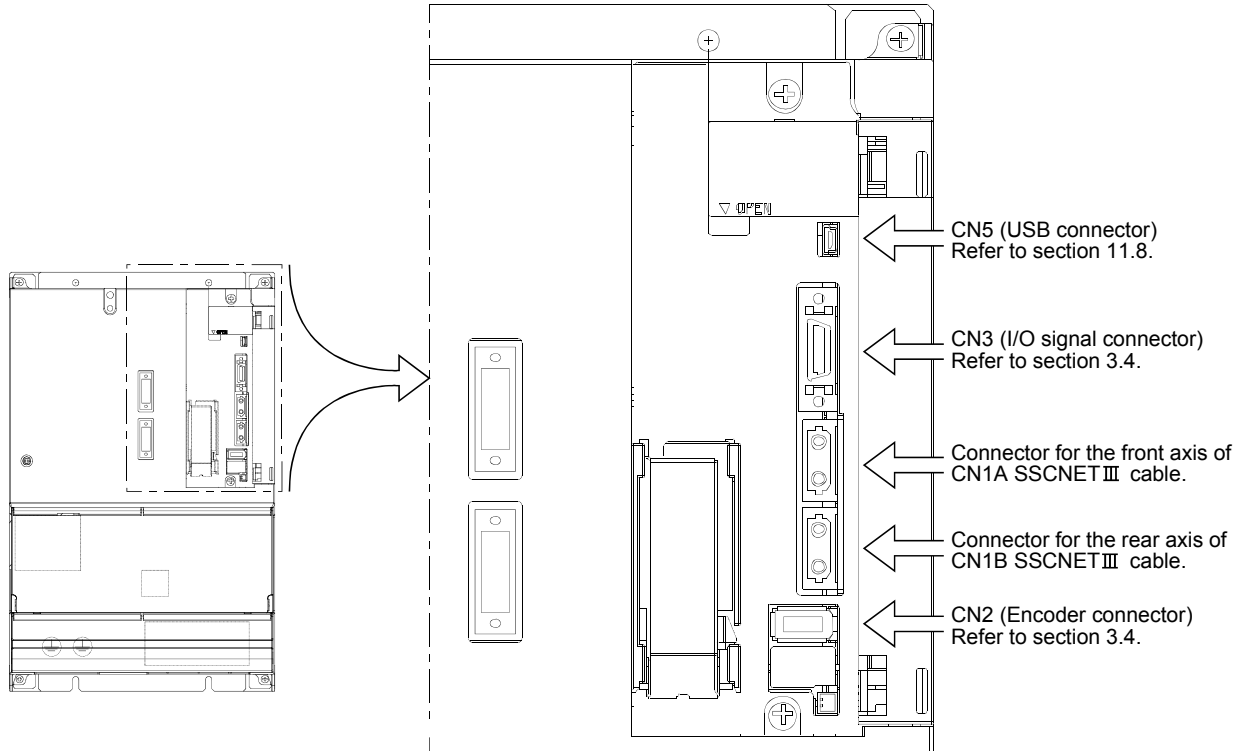

The frames of the CN2 and CN3 connectors are connected to the PE (earth) terminal in the amplifier.

## 13. SERVO AMPLIFIERS WITH A LARGE CAPACITY (30kW TO 55kW)

### 13.3.6 Converter unit signal (device) explanations

POINT
<ul style="list-style-type: none"> <li>Explanations on the drive unit signals are the same as those for servo amplifiers with 22kW or less. Refer to section 3.5.</li> </ul>

#### (1) Signals

For the I/O interfaces (symbols in I/O column in the table), refer to (b) of this section.

Signal name	Pin code	Pin No.	Function/Application	I/O division
Digital I/F power supply input	DICOM	CN1-1 CN1-6	Used to input 24VDC (24VDC±10% 150mA) for I/O interface. The power supply capacity changes depending on the number of I/O interface points to be used. For the source interface, connect ⊖ of 24VDC external power supply.	
Forced stop	EM1	CN1-7	Turn EM1 off to bring the motor to a forced stop state, in which the magnetic connector is turned off and the servo-off signal is output to the drive unit. Turn EM1 on in the forced stop state to reset that state.	DI
Trouble	ALM	CN1-2	ALM turns off when power is switched off or the protective circuit is activated. Without alarm occurring, ALM turns on within about 1.5s after power-on.	DO
Warning	WNG	CN1-8	When warning has occurred, WNG turns on.	DO
Digital I/F common	DOCOM	CN1-5 CN1-9	Common terminal for the ALM and WNG output signals of the converter unit. Separated from LG. Pins are connected internally. For the source interface, connect ⊕ of 24VDC external power supply.	
Magnetic contactor drive output	MC1	CNP1-1	Connect to the operation coil of the magnetic contactor. Always supplies the control circuit power since it is conducted with L <sub>11</sub> in the converter unit. <div style="border: 1px solid black; padding: 5px; margin: 10px 0;">  <b>WARNING</b> <ul style="list-style-type: none"> <li>Magnetic contactor wiring connector on the converter unit. Connected state may cause an electric shock.</li> </ul> </div>	
	MC2	CNP1-2 (Note)	Connect to the operation coil of the magnetic contactor. When the converter unit receives a start command from the drive unit, it is conducted with L <sub>21</sub> inside, the control circuit power is supplied, and then the magnetic contactor is turned ON. Change parameter No.PA02 setting to "□□□0" when controlling without magnetic contactor control connector (CNP1). (Refer to section 13.3.1.)	

### 13. SERVO AMPLIFIERS WITH A LARGE CAPACITY (30k TO 55kW)

#### (2) I/O interfaces

##### (a) Digital input interface (DI)

Give a signal with a relay or open collector transistor. Refer to section 3.7.3 for the source input.

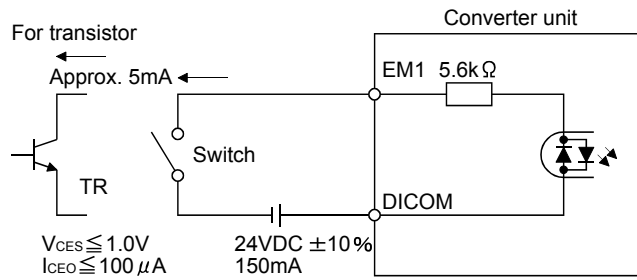

##### (b) Digital output interface (DO)

A lamp, relay or photocoupler can be driven. Install a diode for an inductive load, or install an inrush current suppressing resistor for a lamp load. (Permissible current: 40mA or less, inrush current: 100mA or less) A maximum of 2.6V voltage drop occurs in the servo amplifier.

Refer to section 3.7.3 for the source output.

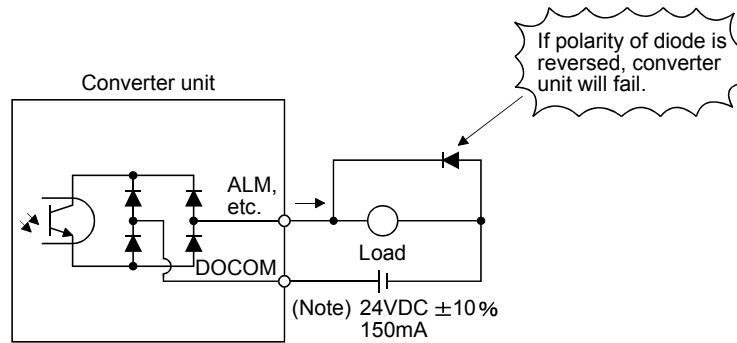

Note. If the voltage drop (maximum of 2.6V) interferes with the relay operation, apply high voltage (up to 26.4V) from external source.

## 13. SERVO AMPLIFIERS WITH A LARGE CAPACITY (30k TO 55kW)

### 13.3.7 Timing chart

#### (1) Power circuit timing chart

##### Power-on procedure

- Always wire the power supply as shown in above section 13.3.2 using the magnetic contactor with the main circuit power supply (3-phase: L1, L2, L3). Configure up an external sequence to switch off the magnetic contactor as soon as an alarm occurs.
- Switch on the control circuit power supply L11, L21 simultaneously with the main circuit power supply or before switching on the main circuit power supply. If the main circuit power supply is not on, the display shows the corresponding warning. However, by switching on the main circuit power supply, the warning disappears and the drive unit will operate properly.

- When control function of magnetic contactor is enabled and the status remains at ready on  
The main circuit power is not shut off with servo off.

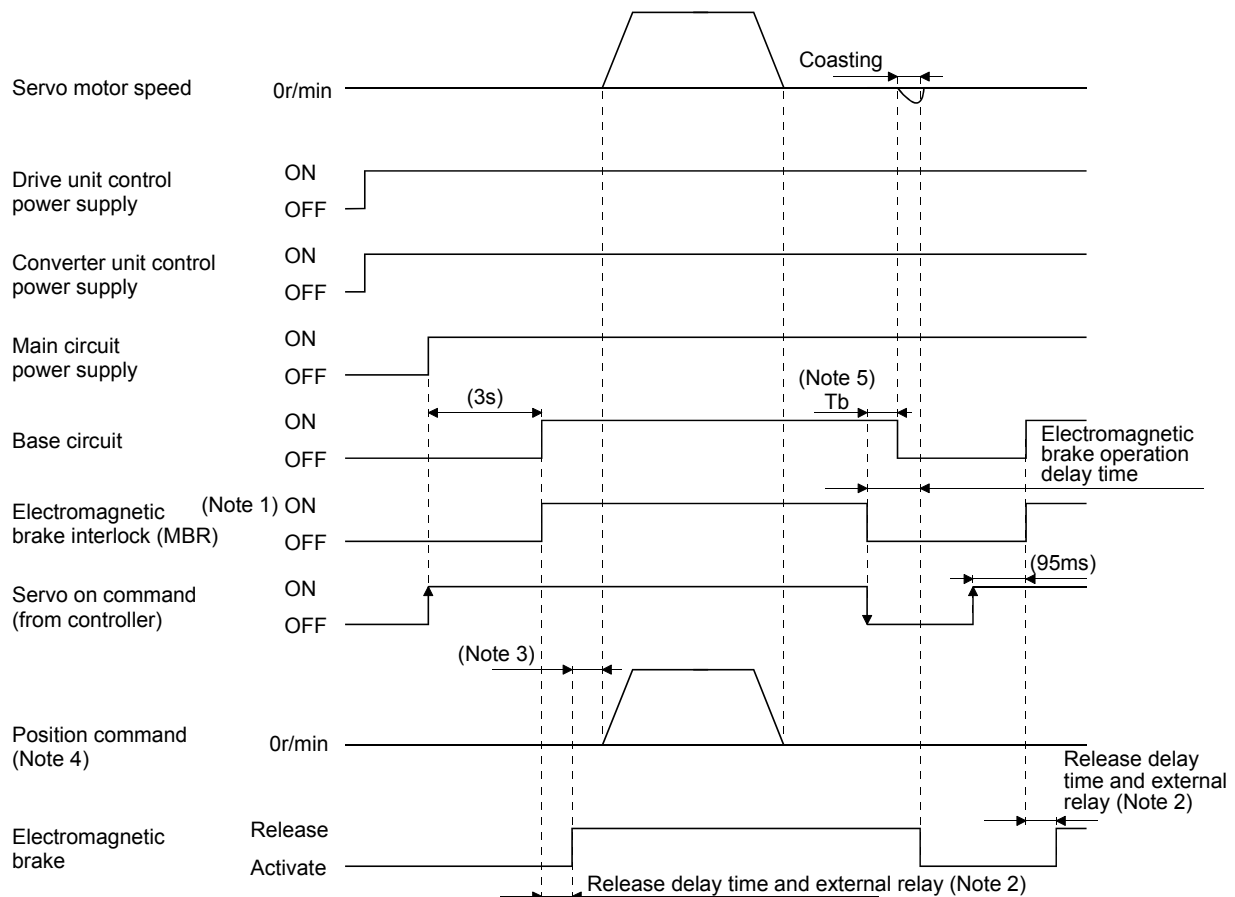

Note 1. ON: Electromagnetic brake is not activated.

OFF: Electromagnetic brake is activated

2. Electromagnetic brake is released after delaying for the release time of electromagnetic brake and operation time of external circuit relay. For the release delay time of electromagnetic brake, refer to the Servo Motor Instruction Manual (Vol.2).

3. Make the controller execute the position command after the electromagnetic brake is released.

4. In position control mode

5. "T<sub>b</sub>" refers to a delay time when the electromagnetic brake interlock (MBR) is turned off until when the base circuit is shut off at servo-off. Set T<sub>b</sub> using parameter No.PC02.

### 13. SERVO AMPLIFIERS WITH A LARGE CAPACITY (30k TO 55kW)

- 2) When control function of magnetic contactor is enabled and the status returns to ready off  
The magnetic contactor of the converter unit is turned off with servo off, and the main circuit magnetic contactor is shut off.

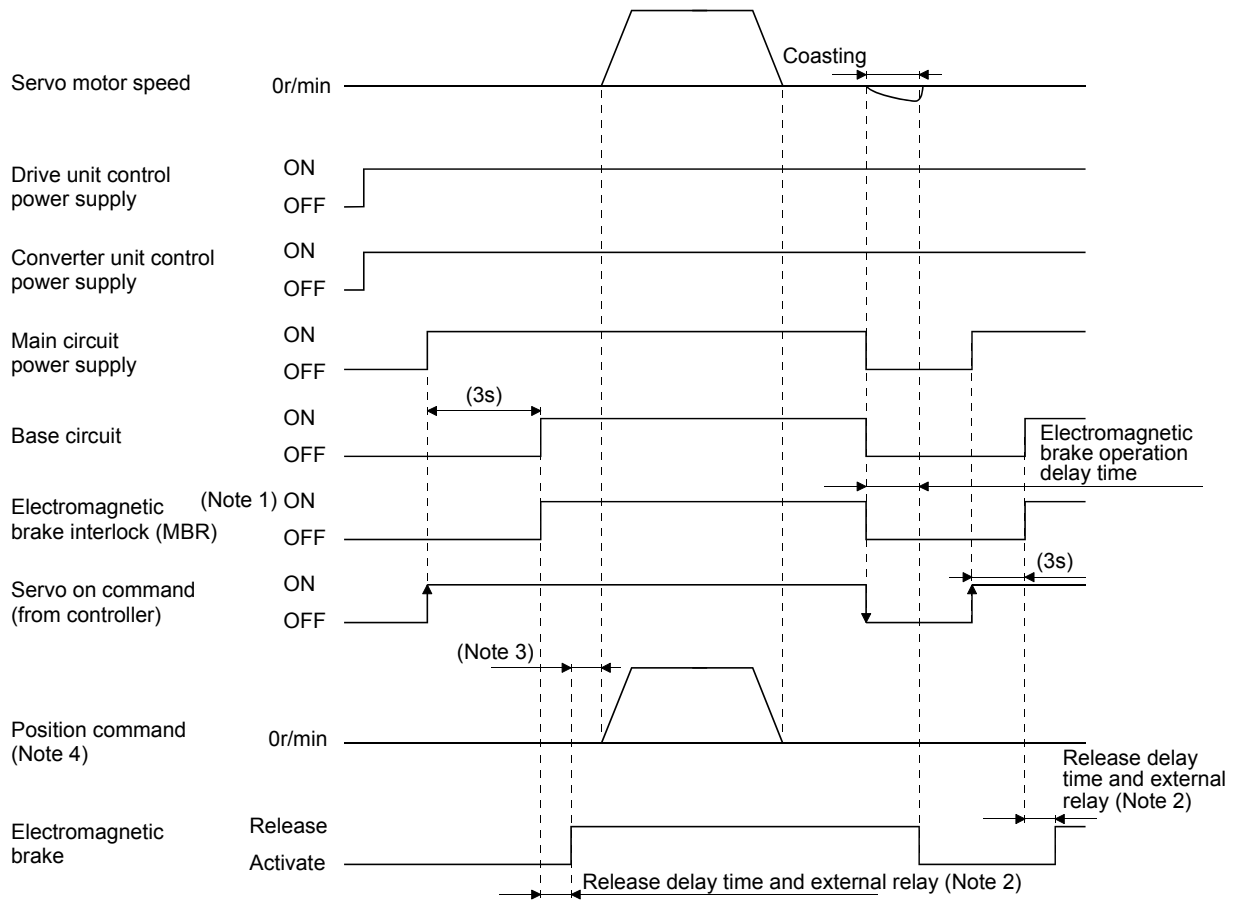

Note 1. ON: Electromagnetic brake is not activated.

OFF: Electromagnetic brake is activated

2. Electromagnetic brake is released after delaying for the release time of electromagnetic brake and operation time of external circuit relay. For the release delay time of electromagnetic brake, refer to the Servo Motor Instruction Manual (Vol.2).

3. Make the controller execute the position command after the electromagnetic brake is released.

4. In position control mode

### 13. SERVO AMPLIFIERS WITH A LARGE CAPACITY (30k TO 55kW)

#### 3) When controlling magnetic contactor by external sequence

When an alarm occurs, turn OFF the magnetic contactor by the external sequence and shut off the main circuit power supply.

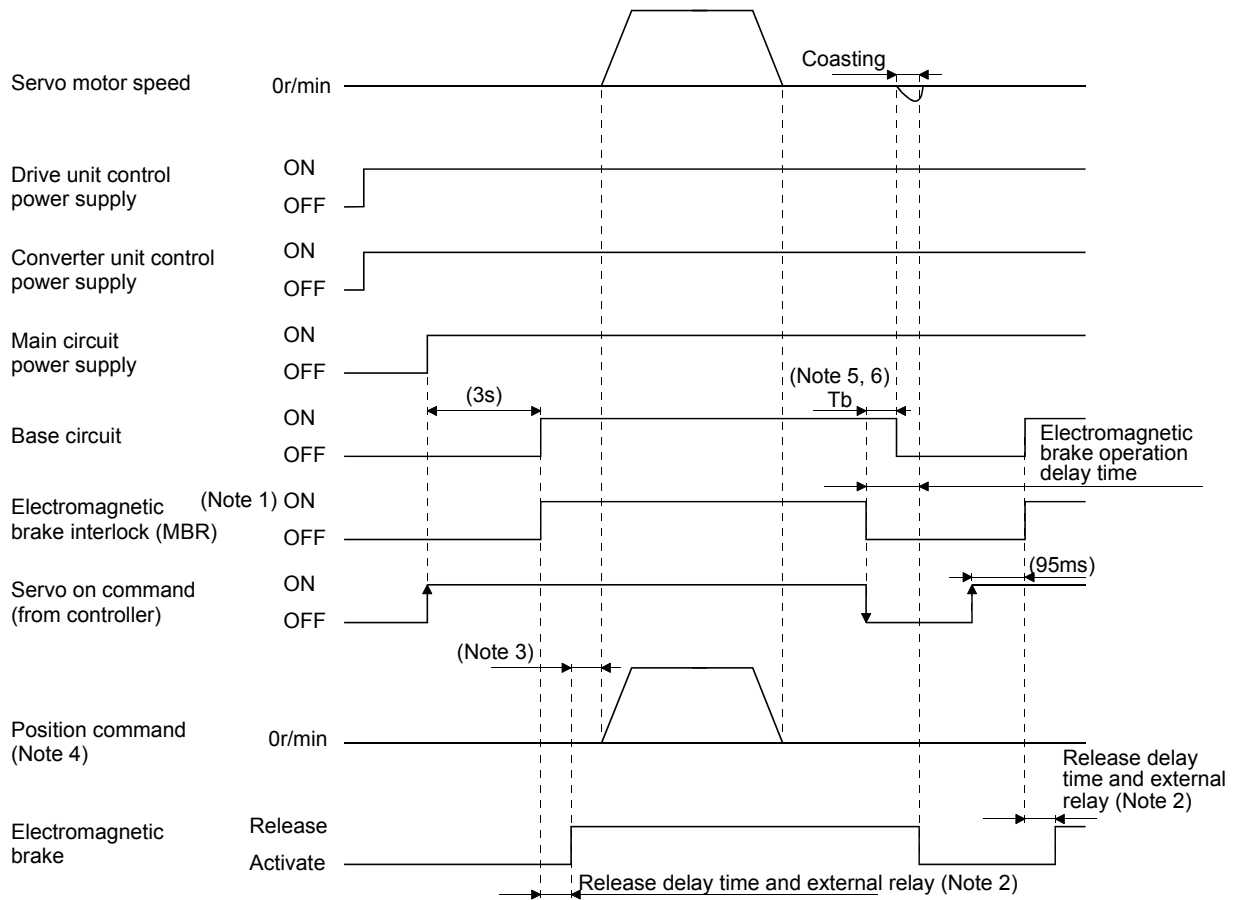

Note 1. ON: Electromagnetic brake is not activated.

OFF: Electromagnetic brake is activated

- Electromagnetic brake is released after delaying for the release time of electromagnetic brake and operation time of external circuit relay. For the release delay time of electromagnetic brake, refer to the Servo Motor Instruction Manual (Vol.2).
- Make the controller execute the position command after the electromagnetic brake is released.
- In position control mode
- " $T_b$ " refers to a delay time when the electromagnetic brake interlock (MBR) is turned off until when the base circuit is shut off at servo-off. Set  $T_b$  using parameter No.PC02.
- When turning OFF servo amplifiers, the base circuit remains ready on state. When the status is ready off, the base circuit and the servo-on command turns OFF at the same time. ( $T_b=0$ )

### 13. SERVO AMPLIFIERS WITH A LARGE CAPACITY (30k TO 55kW)

#### (2) Alarm occurrence timing chart



- When an alarm has occurred, remove its cause, make sure that the operation signal is not being input, ensure safety, and reset the alarm before restarting operation.
- As soon as an alarm occurs, make the Servo off status and interrupt the main circuit power.

#### (a) When control function of magnetic contactor is enabled

##### 1) Converter unit

When an alarm occurs in the converter unit, the magnetic contactor is turned off and the main circuit magnetic contactor is shut off. The drive unit in operation stops. To deactivate the alarm, turn the control circuit power off, then on or request the operation from the driver unit. However, the alarm cannot be deactivated unless its cause is removed.

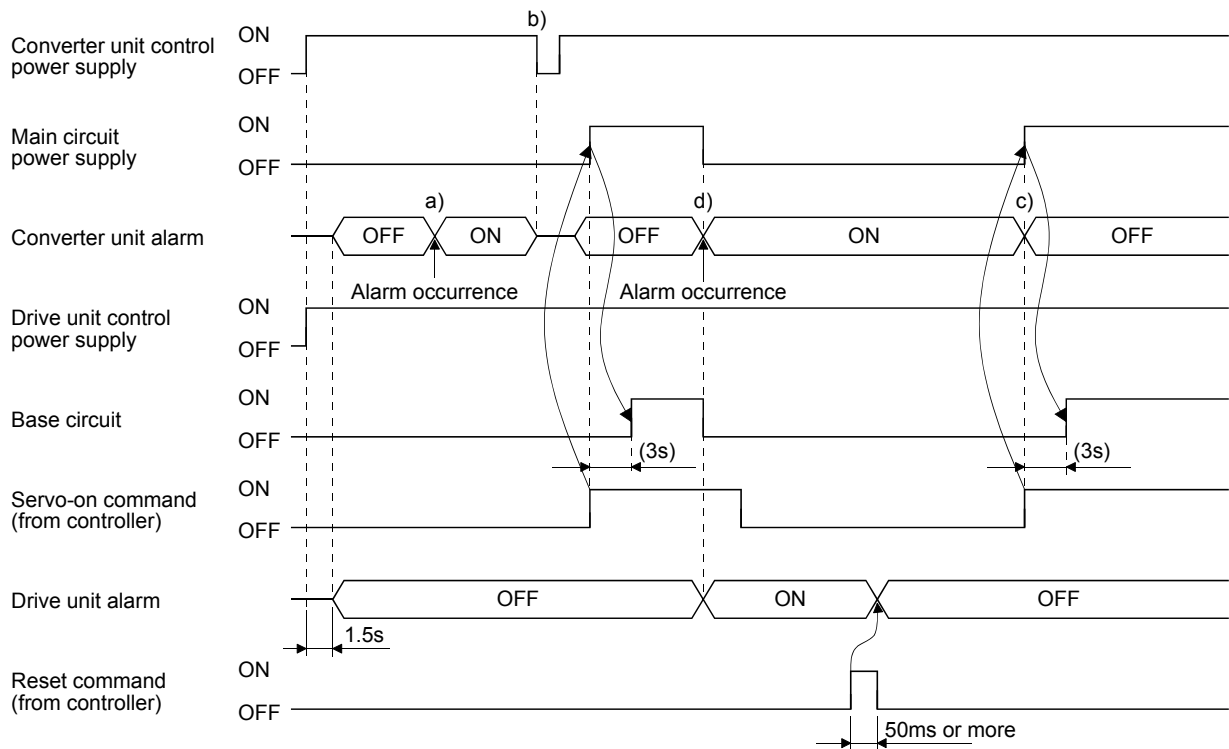

- a) in Figure Even if an alarm occurs in the converter when the drive unit is at servo off, the drive unit does not detect the alarm.
- b) c) in Figure To deactivate the alarm of the converter unit, turn the power of the converter unit off, and then on (b)) or make the drive unit servo on (c)). (Refer to section 13.6.1.)
- d) in Figure If an alarm occurs in the converter when the drive unit is at servo on, the alarm also occurs in the drive unit and the drive unit becomes servo off.

### 13. SERVO AMPLIFIERS WITH A LARGE CAPACITY (30k TO 55kW)

#### 2) Drive unit

When an alarm occurs on the drive unit, the base circuit is shut off and the servo motor coasts. When using a dynamic brake (option), the dynamic brake is activated to stop the servo motor. To deactivate the alarm, power the control circuit off, then on, turn the reset (RES) on or CPU reset command.

However, the alarm cannot be deactivated unless its cause is removed.

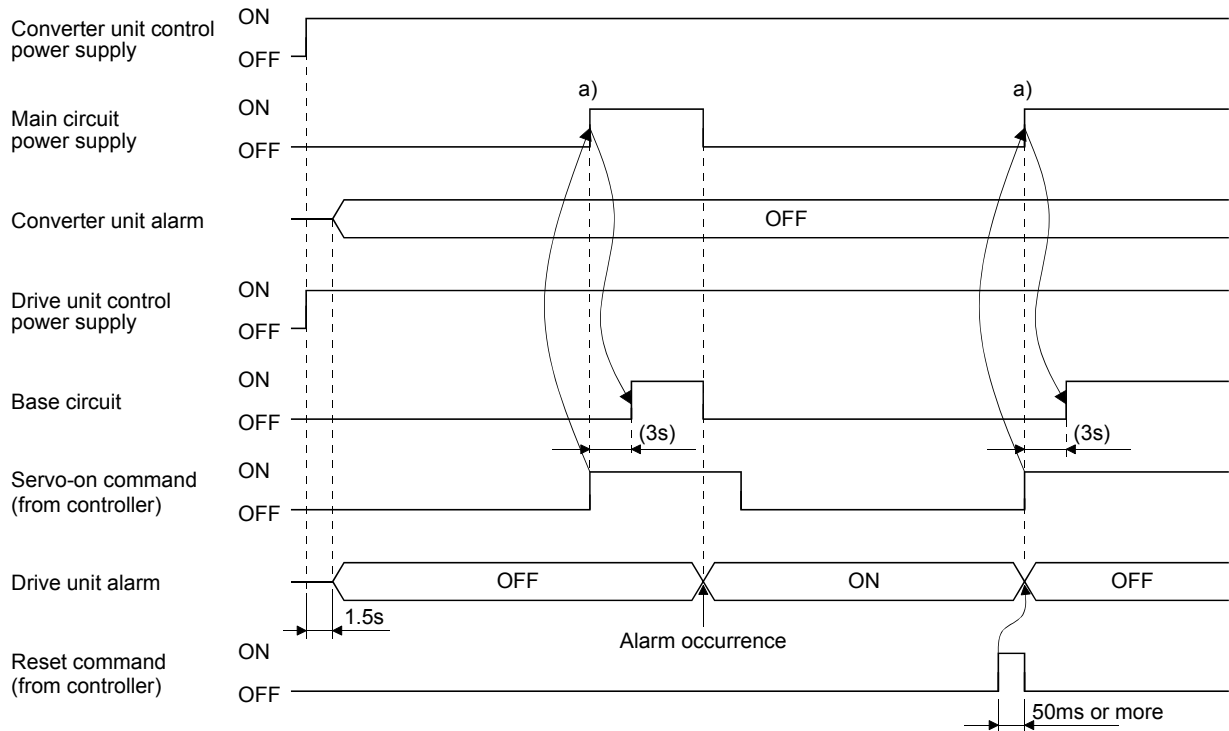

a) in Figure After completing to start the drive unit, the main circuit power is supplied while the drive unit and the converter unit have no alarms.

### 13. SERVO AMPLIFIERS WITH A LARGE CAPACITY (30k TO 55kW)

(b) When controlling magnetic contactor by external sequence

1) Converter unit

When an alarm occurs on the converter unit, the servo-on turns OFF; however, the main circuit power supply is not shut off. Therefore, shut off the main circuit power supply by the external sequence.

After cancelling the alarm on the converter unit (when an alarm is also occurring on the drive unit after cancelling the alarm on the drive unit as well), turning ON the reset command enables to operate again.

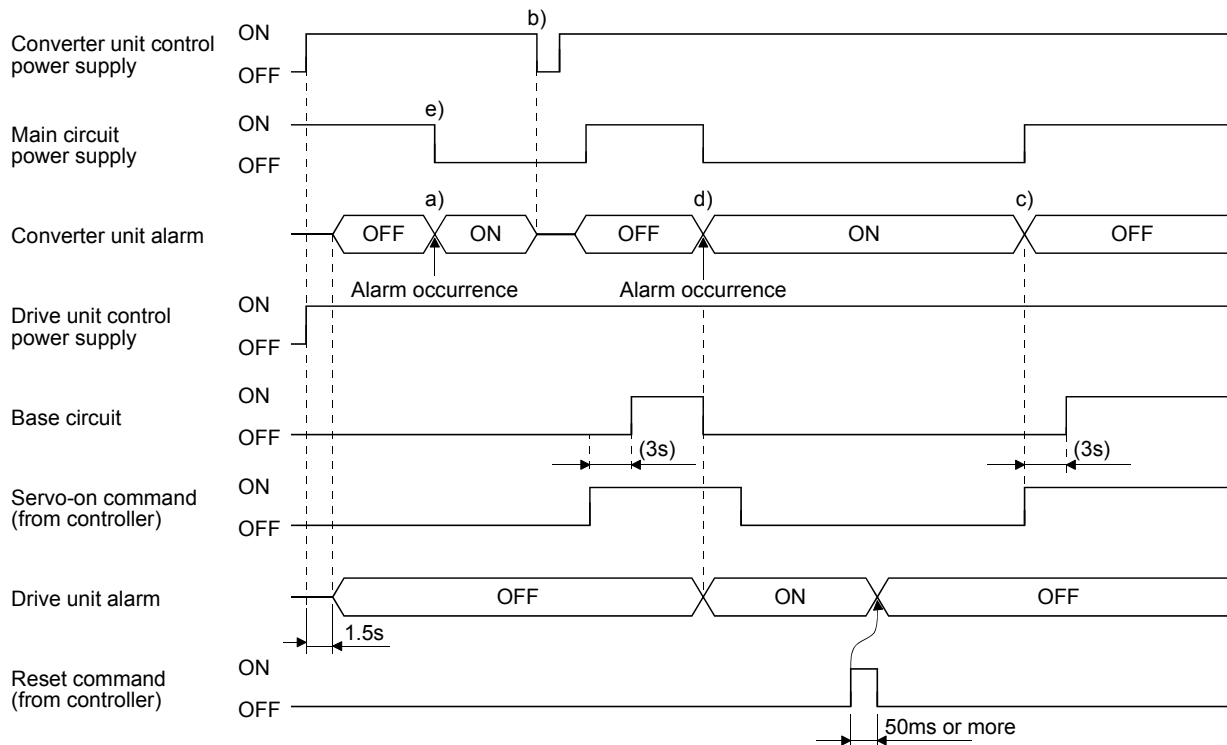

- a) in Figure Even if an alarm occurs in the converter when the drive unit is at servo off, the drive unit does not detect the alarm.
- b) c) in Figure To deactivate the alarm of the converter unit, turn the power of the converter unit off, and then on (b)) or make the drive unit servo on (c)). (Refer to section 13.6.1.)
- d) in Figure If an alarm occurs in the converter unit when the drive unit is at servo on, the alarm also occurs in the drive unit and the drive unit becomes servo off.
- e) in Figure Shut off the main circuit power supply by the external sequence as soon as an alarm occurs.

### 13. SERVO AMPLIFIERS WITH A LARGE CAPACITY (30k TO 55kW)

#### 2) Drive unit

When an alarm occurs in the drive unit, the drive unit turns into the servo off but the main circuit power supply is not shut off. Therefore, shut off the main circuit power supply using the external sequence. Operation can be resumed by turning the reset (RES) ON after the alarm is deactivated in the drive unit.

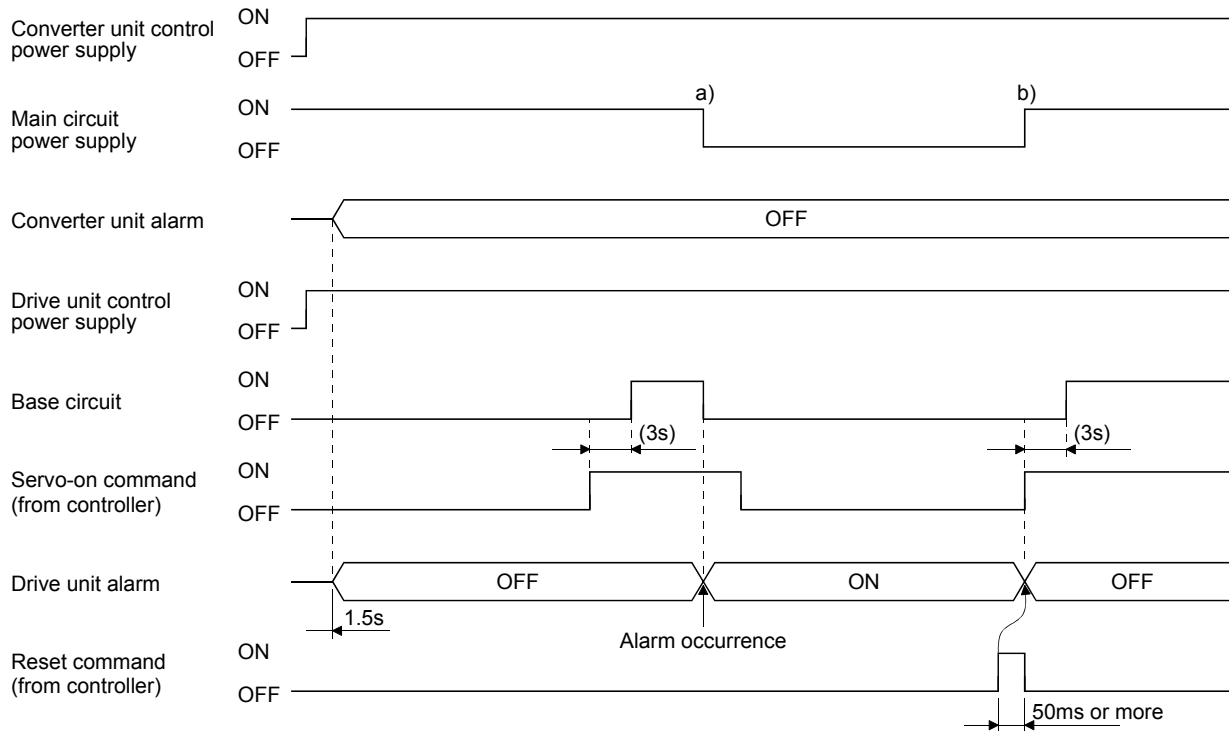

- a) in Figure When an alarm occurs on the drive unit, shut off the main circuit power supply by the external sequence.
- b) in Figure Turn ON the main circuit power supply while an alarm of the drive unit is cancelled.

### 13. SERVO AMPLIFIERS WITH A LARGE CAPACITY (30k TO 55kW)

#### (3) Forced stop (EM1) ON/OFF timing chart

##### (a) When control function of magnetic controller is enabled

##### 1) Converter unit

When the forced stop (EM1) is made valid in the converter unit, the magnetic contactor is turned off and the main circuit power supply is shut off. The drive unit in operation stops, and Main circuit off warning (E9) appears. When the forced stop (EM1) is deactivated in the converter unit, the magnetic contactor is turned on, the main circuit power is supplied, and then the drive unit automatically resumes the operation.

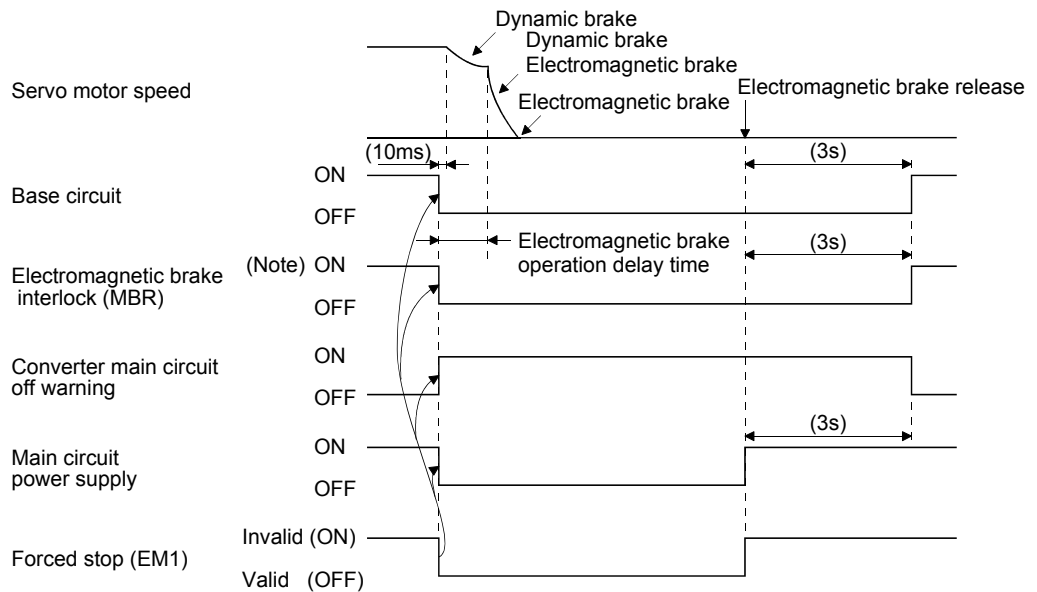

Note. ON: Electromagnetic brake is not activated.

OFF: Electromagnetic brake is activated

### 13. SERVO AMPLIFIERS WITH A LARGE CAPACITY (30k TO 55kW)

#### 2) When CNP1 is invalid

When the forced stop (EM1) is input in the converter unit, the drive unit in operation stops and Main circuit off warning (E9) appears. When the forced stop (EM1) is deactivated in the converter unit, the drive unit automatically resumes the operation.

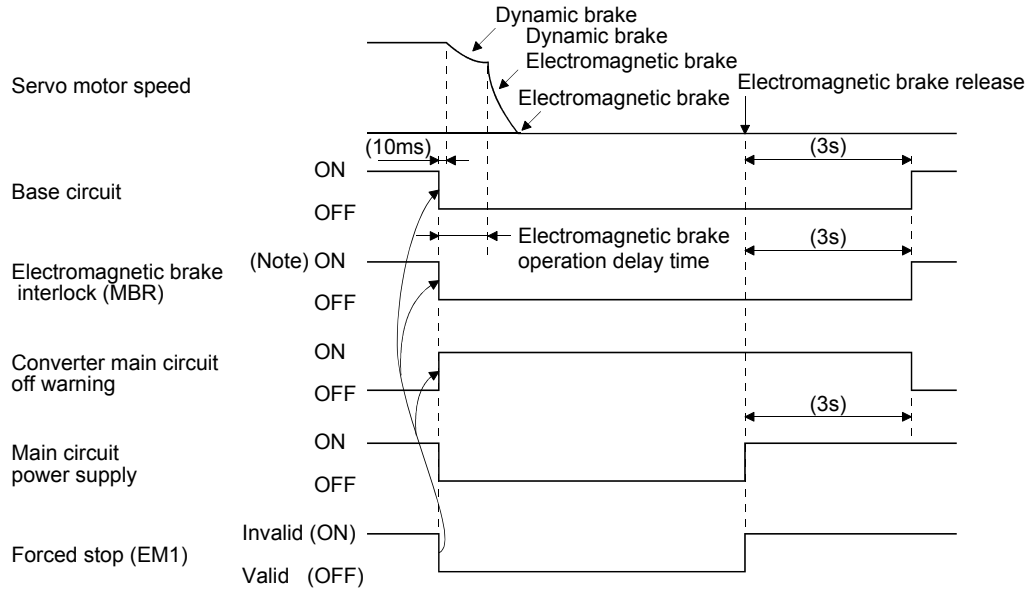

Note. ON: Electromagnetic brake is not activated.  
OFF: Electromagnetic brake is activated

### 13. SERVO AMPLIFIERS WITH A LARGE CAPACITY (30k TO 55kW)

(b) Forced stop in the drive unit

When the forced stop (EM1) is made valid in the drive unit, the drive unit in operation stops, Main circuit off warning (E9) appears, and then the drive unit is forcedly stopped. Configure to activate the forced stop (EM1) of the drive unit as the forced stop (EM1) of the converter unit is activated, and to activate the forced stop (EM1) of the converter unit as the forced stop (EM1) of the drive unit is activated. Shut off the power supply by the external sequence as soon as the forced stop (EM1) is activated.

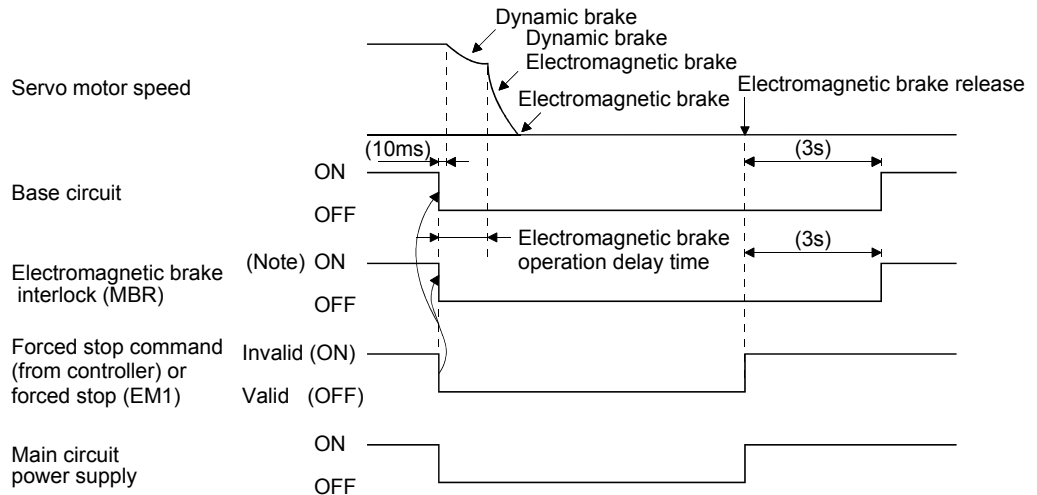

Note. ON: Electromagnetic brake is not activated.  
OFF: Electromagnetic brake is activated

### 13. SERVO AMPLIFIERS WITH A LARGE CAPACITY (30k TO 55kW)

#### 13.3.8 Servo motor side details

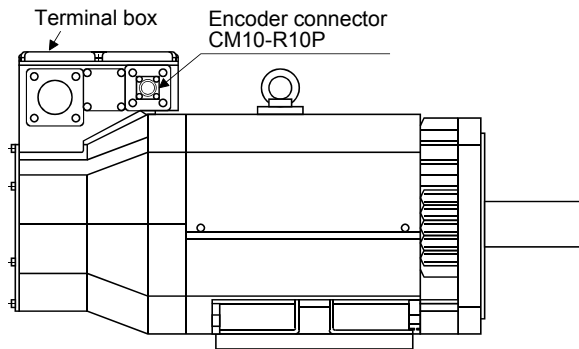

Encoder connector signal arrangement  
CM10-R10P

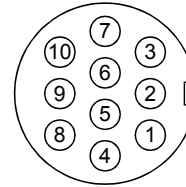

Terminal No.	Signal
1	MR
2	MRR
3	
4	BAT
5	LG
6	
7	
8	P5
9	
10	SHD

	HA-LP30K1M4 HA-LP30K24 HA-LP37K24	HA-LP30K1 HA-LP37K1 HA-LP30K1M HA-LP37K1M HA-LP30K2	HA-LP37K2 HA-LP25K14 HA-LP30K14 HA-LP37K14 HA-LP37K1M4	HA-LP45K1M4 HA-LP50K1M4 HA-LP45K24 HA-LP55K24
Motor power supply terminal block screw size	M8	M10		
Earth screw size	M6	M6		

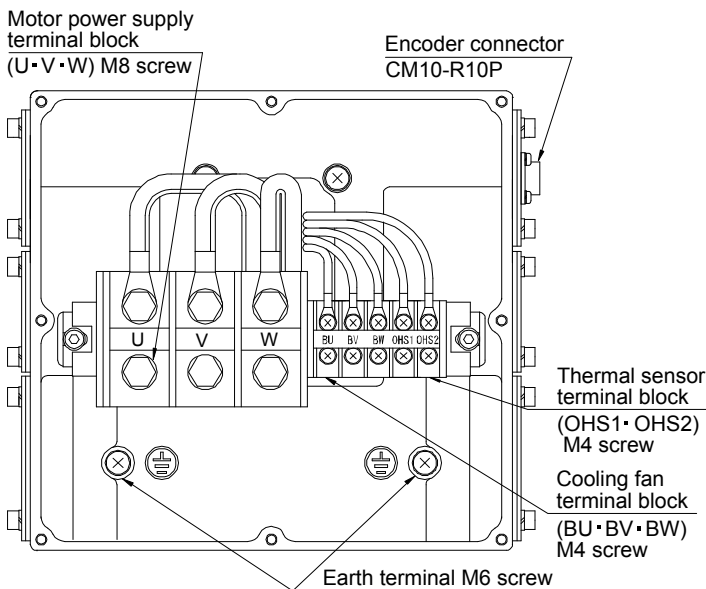

Terminal block signal arrangement

U	V	W	BU	BV	BW	OHS1	OHS2
---	---	---	----	----	----	------	------

### 13. SERVO AMPLIFIERS WITH A LARGE CAPACITY (30k TO 55kW)

Signal name	Abbreviation	Description																																						
Servo motor power supply	U · V · W	Connect to the motor power terminals (U, V, W) of the drive unit. During power-on, do not open or close the motor power line. Otherwise, a malfunction or faulty may occur.																																						
Cooling fan	BU · BV · BW	Supply power which satisfies the following specifications.																																						
		<table border="1"> <thead> <tr> <th>Servo motor</th> <th>Voltage division</th> <th>Voltage/ frequency</th> <th>Power consumption [W]</th> <th>Rated current [A]</th> </tr> </thead> <tbody> <tr> <td rowspan="2">HA-LP30K1M, 30K2, 37K2</td> <td rowspan="2">200V class</td> <td rowspan="2">3-phase 200 to 230VAC 50Hz/60Hz</td> <td>65(50Hz)</td> <td>0.20(50Hz)</td> </tr> <tr> <td>85(60Hz)</td> <td>0.22(60Hz)</td> </tr> <tr> <td>HA-LP30K1, 37K1, 37K1M</td> <td rowspan="3">400V class</td> <td rowspan="3">3-phase 380 to 460VAC 50Hz</td> <td>120(50Hz)</td> <td>0.65(50Hz)</td> </tr> <tr> <td rowspan="2">HA-LP30K1M4, 30K24, 37K24</td> <td rowspan="2">3-phase 380 to 480VAC 60Hz</td> <td>175(60Hz)</td> <td>0.80(60Hz)</td> </tr> <tr> <td>65(50Hz)</td> <td>0.12(50Hz)</td> </tr> <tr> <td>HA-LP30K14, 37K14, 37K1M4, 45K1M4, 50K1M4, 45K24, 55K24</td> <td></td> <td></td> <td>85(60Hz)</td> <td>0.14(60Hz)</td> </tr> <tr> <td></td> <td></td> <td></td> <td>110(50Hz)</td> <td>0.20(50Hz)</td> </tr> <tr> <td></td> <td></td> <td></td> <td>150(60Hz)</td> <td>0.22(60Hz)</td> </tr> </tbody> </table>	Servo motor	Voltage division	Voltage/ frequency	Power consumption [W]	Rated current [A]	HA-LP30K1M, 30K2, 37K2	200V class	3-phase 200 to 230VAC 50Hz/60Hz	65(50Hz)	0.20(50Hz)	85(60Hz)	0.22(60Hz)	HA-LP30K1, 37K1, 37K1M	400V class	3-phase 380 to 460VAC 50Hz	120(50Hz)	0.65(50Hz)	HA-LP30K1M4, 30K24, 37K24	3-phase 380 to 480VAC 60Hz	175(60Hz)	0.80(60Hz)	65(50Hz)	0.12(50Hz)	HA-LP30K14, 37K14, 37K1M4, 45K1M4, 50K1M4, 45K24, 55K24			85(60Hz)	0.14(60Hz)				110(50Hz)	0.20(50Hz)				150(60Hz)	0.22(60Hz)
		Servo motor	Voltage division	Voltage/ frequency	Power consumption [W]	Rated current [A]																																		
		HA-LP30K1M, 30K2, 37K2	200V class	3-phase 200 to 230VAC 50Hz/60Hz	65(50Hz)	0.20(50Hz)																																		
					85(60Hz)	0.22(60Hz)																																		
HA-LP30K1, 37K1, 37K1M	400V class	3-phase 380 to 460VAC 50Hz	120(50Hz)	0.65(50Hz)																																				
HA-LP30K1M4, 30K24, 37K24			3-phase 380 to 480VAC 60Hz	175(60Hz)	0.80(60Hz)																																			
				65(50Hz)	0.12(50Hz)																																			
HA-LP30K14, 37K14, 37K1M4, 45K1M4, 50K1M4, 45K24, 55K24			85(60Hz)	0.14(60Hz)																																				
			110(50Hz)	0.20(50Hz)																																				
			150(60Hz)	0.22(60Hz)																																				
Motor thermal relay	OHS1 · OHS2	OHS1-OHS2 are opened when heat is generated to an abnormal temperature. Maximum rating: 125V AC/DC, 3A or 250V AC/DC, 2A Minimum rating: 6V AC/DC, 0.15A																																						
Earth terminal	⊕	For grounding, connect to the earth of the control box via the earth terminal of the drive unit.																																						

## 13. SERVO AMPLIFIERS WITH A LARGE CAPACITY (30k TO 55kW)

### 13.4 Display section and operation section of the converter unit

#### 13.4.1 Display flowchart

Use the display (3-digit, 7-segment LED) on the front panel of the converter unit for status display, parameter setting, etc. Set the parameters before operation, diagnose an alarm, confirm external sequences, and/or confirm the operation status.

Press the MODE, UP or DOWN button once to move the next screen.

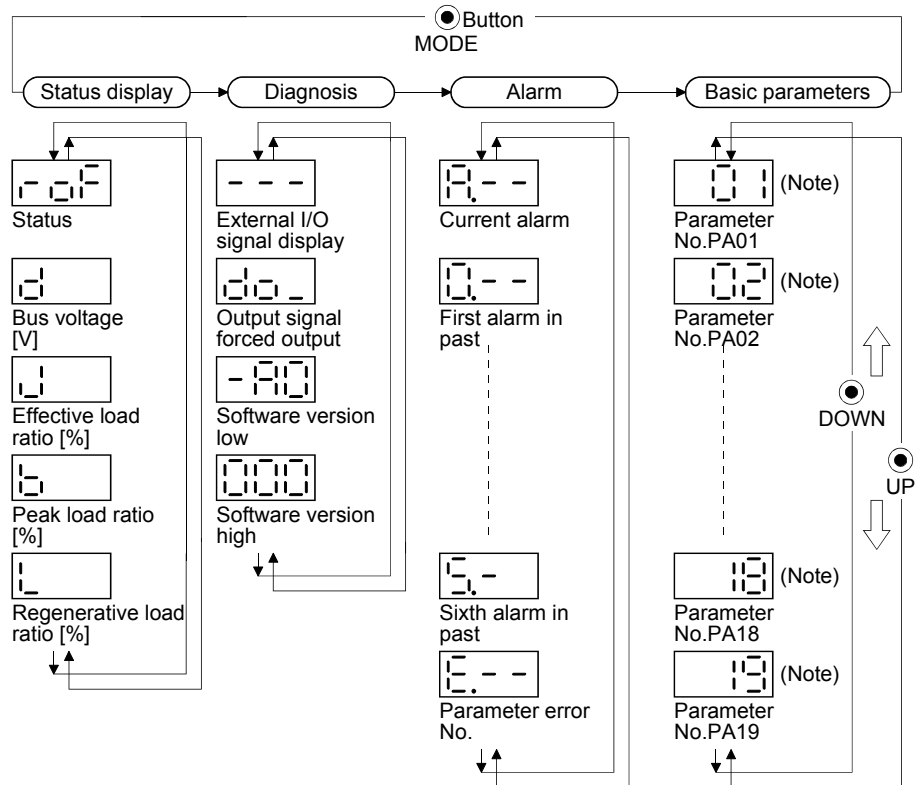

Note. When parameter is selected, parameter group and parameter No. are displayed alternately. Refer to section 13.4.5 for details.

### 13. SERVO AMPLIFIERS WITH A LARGE CAPACITY (30k TO 55kW)

#### 13.4.2 Status display mode

The servo status during operation is shown on the 3-digit, 7-segment LED display. Press the "UP" or "DOWN" button to change display data as desired.

When the required data is selected, the corresponding symbol is displayed. Press the "SET" button to display that data.

The converter unit display section can show four items of data such as the effective load factor.

#### (1) Display examples

The following table shows the display examples.

Item	Status	Display
Status	Ready off	roF
	Ready on	ron
Bus voltage	300[V]	300
Effective load ratio	67[%]	67
Peak load ratio	95[%]	95
Regenerative load ratio	90[%]	90

#### (2) Status display list

The following table lists the converter unit statuses that may be displayed.







Status display	Symbol	Unit	Description	Indication range
Status	Ready off		The ready off is displayed during initialization or alarm occurrence, in the forced stop status, or when the bus voltage is not established.	roF
	Ready on		The ready on is displayed when the servo was switched on after completion of initialization and the servo amplifier is ready to operate.	ron
Bus voltage	d	V	The converter unit voltage is displayed.	0 to 999
Effective load ratio	J	%	Continuous effective load torque is displayed. (Note) The effective value in the past 15 seconds is displayed relative to the rated current of 100%.	0 to 300
Peak load ratio	b	%	The peak output is displayed. (Note) The peak value in the past 15 seconds is displayed relative to the rated torque of 100%.	0 to 400
Regenerative load ratio	L	%	The percentage of regenerative power to the permissible regenerative value is displayed.	0 to 300

Note. Output = converter unit bus voltage × output current

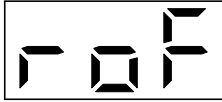
## 13. SERVO AMPLIFIERS WITH A LARGE CAPACITY (30k TO 55kW)

### 13.4.3 Diagnostic mode

#### (1) Diagnostic list

Name	Display	Unit
Sequence		Not ready. ▪ Initializing. ▪ An alarm occurred. ▪ External forced stop status. ▪ Bus voltage is not established.
		Ready Indicates that the servo was switched on after completion of initialization and the drive unit is ready to operate.
External I/O signal display		Indicates the ON/OFF status of external I/O signal. Lit : ON Extinguished: OFF For details, refer to (2) of this section.
Output signal forced output		Allows external I/O signal to be switched on/off forcibly. For details, refer to (3) of this section.
Software version low		Indicates the version of the software.
Software version high		Indicates the system number of the software.

#### (2) External I/O signal display

The ON/OFF states of the digital I/O signals connected to the converter unit can be confirmed.

##### (a) Operation

Call the display screen shown after power-on. Using the "MODE" button, show the diagnostic screen.

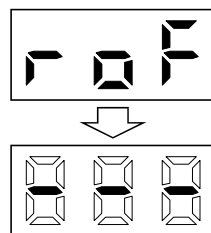

 Press MODE once.

..... External I/O signal display screen

### 13. SERVO AMPLIFIERS WITH A LARGE CAPACITY (30k TO 55kW)

(b) Display definition

The 7-segment LED segments and CN1 connector pins correspond as shown below.

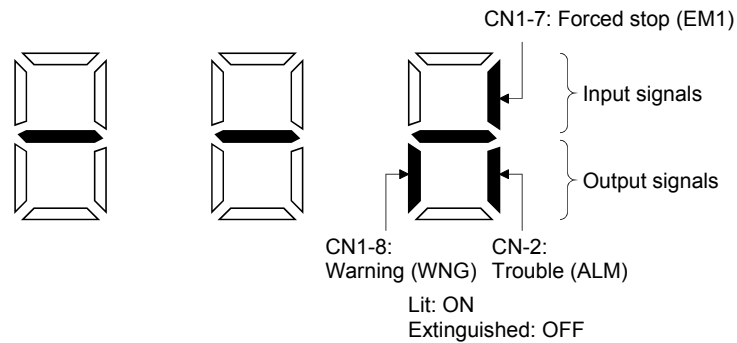

The LED segment corresponding to the pin is lit to indicate ON, and is extinguished to indicate OFF.

(3) Output signal forced output

You can force the output signal to be switched on/off, independently of the converter status.

This function is used for wiring check of output signal.

When turning CN1-8 on and off

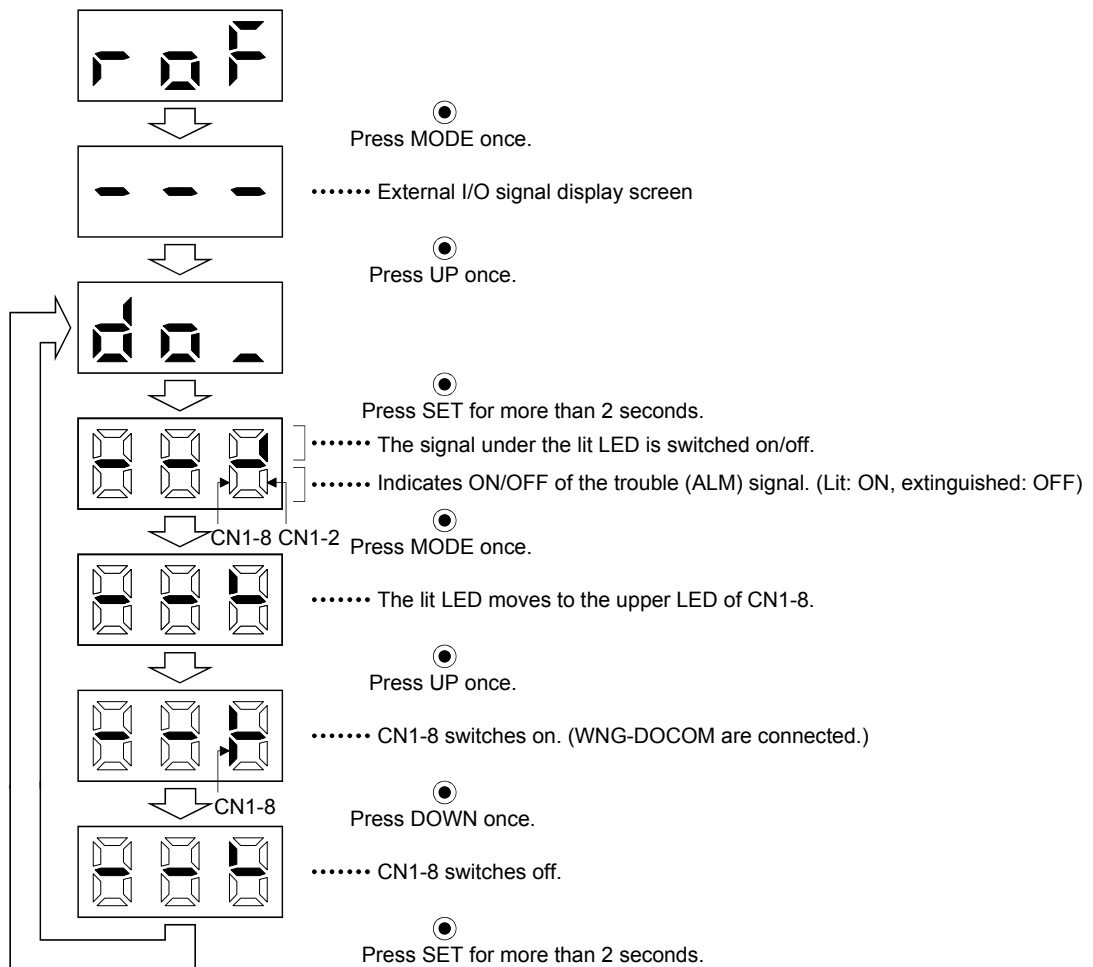

Call the display screen shown after power-on.









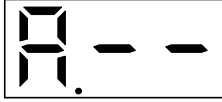

### 13. SERVO AMPLIFIERS WITH A LARGE CAPACITY (30k TO 55kW)

#### 13.4.4 Alarm mode

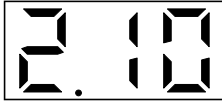
The current alarm, parameter error and point table error are displayed.

The lower 2 digits on the display indicate the alarm number that has occurred or the parameter number in error.

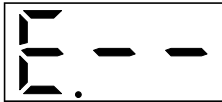
Display example are shown below.

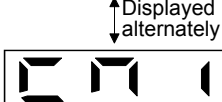
Name	Display	Description
Current alarm		Indicates on occurrence of an alarm.
		Indicates that overvoltage (A.33) occurred. Flickers at alarm occurrence.
Alarm history		Indicates that the last alarm is overload (A.50).
		Indicates that the second alarm in the past is overvoltage (A.33).
		Indicates that the third alarm in the past is undervoltage (A.10).
		Indicates that the fourth alarm in the past is undervoltage (A.10).
		Indicates that the fifth alarm in the past is undervoltage (A.10).
		Indicates that the sixth alarm in the past is overload (A.50).
Parameter error No.		Indicates no occurrence of parameter error (A.37).
		Indicates that the data of parameter No.PA01 is faulty.
		

### 13. SERVO AMPLIFIERS WITH A LARGE CAPACITY (30k TO 55kW)

Functions at occurrence of an alarm

- (1) Any mode screen displays the current alarm.
- (2) The other screen is visible during occurrence of an alarm. At this time, the decimal point in the third digit flickers.
- (3) To clear any alarm, switch power off, then on or press the "SET" button on the current alarm screen. Note that this should be done after removing the cause of the alarm.

#### 13.4.5 Parameter mode

POINT
<ul style="list-style-type: none"> <li>▪ The display section of the converter unit has three digits. When a parameter No. is displayed, parameter group and parameter No. are displayed alternately.</li> </ul> <p>When, for example, "PA01" is displayed, <span style="border: 1px solid black; padding: 2px;">PA</span> and <span style="border: 1px solid black; padding: 2px;">01</span> are displayed alternately.</p>

The following example gives the operation procedure after power-on for use of the regenerative options (MR-RB137).

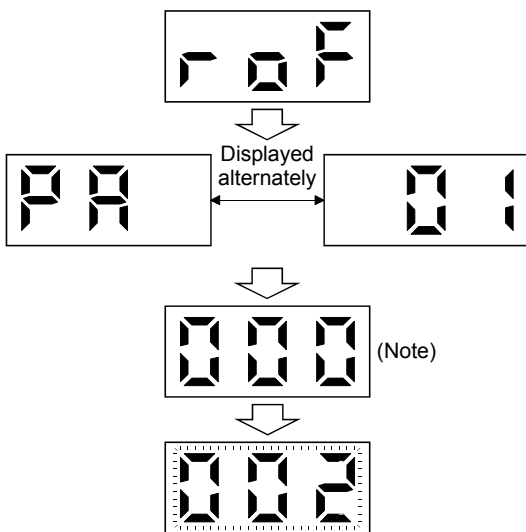

- Press MODE three time  
..... The parameter number is displayed.  
For parameter No.PA01, "PA" and "01" are displayed alternately.
- Press UP or DOWN to change the number.
- Press MODE twice  
..... The set value of the specified parameter number flickers.  
In this case, the lower three digits "0000" of the set value "0000" are displayed.
- Press MODE once  
..... During flickering, the set value can be change.
- Use UP or DOWN .  
(□□□2: MR-RB137 (3 pcs.) are used.)
- Press SET to enter.

Note. If the "MODE" button is pressed when the lower three digits of the four digits "0000" are displayed, the fourth digit "0000" is displayed as □□. However, do not change the setting of the fourth digit. Press the "MODE" button again to reset the display to the lower three digits □□□.

To shift to the next parameter, press the "UP"/"DOWN" button.

When changing the parameter No.PA01 setting, change its set value, then switch power off once and switch it on again to make the new value valid.

## 13. SERVO AMPLIFIERS WITH A LARGE CAPACITY (30k TO 55kW)

### 13.5. Parameters for converter unit



#### CAUTION

- Never adjust or change the parameter values extremely as it will make operation instable.

#### POINT

- Refer to chapter 5 for parameters for drive unit.
- Parameter whose symbol is preceded by \* is made valid with the following conditions.
  - \* : Set the parameter value, switch power off once after setting, and then switch it on again, or perform the controller reset.
- Never change parameters for manufacturer setting.

#### 13.5.1 Parameter list

No.	Symbol	Name	Initial value	Unit
PA01	*REG	Regenerative option	0000h	
PA02	*MCC	Magnetic contactor drive output selection	0001h	
PA03		For manufacturer setting	0001h	
PA04			0	
PA05			100	
PA06			0	
PA07			100	
PA08	*DMD	Status display selection	0000h	
PA09	*BPS	Alarm history clear	0000h	
PA10		For manufacturer setting	0	
PA11			0000h	
PA12	*DIF	Input filter setting	0002h	
PA13		For manufacturer setting	0000h	
PA14			0000h	
PA15			0000h	
PA16			0000h	
PA17			0000h	
PA18			0000h	
PA19			0000h	

### 13. SERVO AMPLIFIERS WITH A LARGE CAPACITY (30k TO 55kW)

#### 13.5.2 List of details

No.	Symbol	Name and function	Initial value	Unit	Setting range				
PA01	*REG	<p>Regenerative option Used to select the regenerative option.</p> <table border="1" style="margin-left: 20px;"> <tr> <td style="width: 20px; height: 20px; text-align: center;">0</td> <td style="width: 20px; height: 20px; text-align: center;">0</td> <td style="width: 20px; height: 20px;"></td> <td style="width: 20px; height: 20px;"></td> </tr> </table> <p style="margin-left: 40px;">Select the regenerative option. 00: No used 01: MR-RB139 02: MR-RB137(3 pcs.) } Only for MR-J3-CR55K 11: MR-RB136-4 12: MR-RB138-4(3 pcs.) } Only for MR-J3-CR55K4 "01" and "02" are the set values for the MR-J3-CR55K only, and "11" and "12" are those for the MR-J3-CR55K4 only. Wrong setting will result in parameter alarm (A.37).</p>	0	0			0000h		Refer to Name and function column.
0	0								
PA02	*MCC	<p>Magnetic contactor drive output selection Used to select the output of the magnetic contactor drive power supply.</p> <table border="1" style="margin-left: 20px;"> <tr> <td style="width: 20px; height: 20px; text-align: center;">0</td> <td style="width: 20px; height: 20px; text-align: center;">0</td> <td style="width: 20px; height: 20px; text-align: center;">0</td> <td style="width: 20px; height: 20px;"></td> </tr> </table> <p style="margin-left: 40px;">Used to select the output of the magnetic contactor drive power supply. 0: No used 1: Used</p>	0	0	0		0001h		Refer to Name and function column.
0	0	0							
PA03		For manufacturer setting	0001h						
PA04		Do not change this value by any means.	0						
PA05			100						
PA06			0						
PA07			100						
PA08	*DMD	<p>Status display selection Used to select the status display shown at power-on.</p> <table border="1" style="margin-left: 20px;"> <tr> <td style="width: 20px; height: 20px; text-align: center;">0</td> <td style="width: 20px; height: 20px; text-align: center;">0</td> <td style="width: 20px; height: 20px; text-align: center;">0</td> <td style="width: 20px; height: 20px;"></td> </tr> </table> <p style="margin-left: 40px;">Status display of converter unit display section at power-on. 0: Status 1: Bus voltage 2: Effective load ratio 3: Peak load ratio 4: Regenerative load ratio</p>	0	0	0		0000h		Refer to Name and function column.
0	0	0							
PA09	*BPS	<p>Alarm history clear Used to clear the alarm history.</p> <table border="1" style="margin-left: 20px;"> <tr> <td style="width: 20px; height: 20px; text-align: center;">0</td> <td style="width: 20px; height: 20px; text-align: center;">0</td> <td style="width: 20px; height: 20px; text-align: center;">0</td> <td style="width: 20px; height: 20px;"></td> </tr> </table> <p style="margin-left: 40px;">Alarm history clear 0: Invalid 1: Valid When alarm history clear is made valid, the alarm history is cleared at next power-on. After the alarm history is cleared, the setting is automatically made invalid (reset to 0).</p>	0	0	0		0000h		Refer to Name and function column.
0	0	0							
PA10		For manufacturer setting	0						
PA11		Do not change this value by any means.	0000h						

### 13. SERVO AMPLIFIERS WITH A LARGE CAPACITY (30k TO 55kW)

No.	Symbol	Name and function	Initial value	Unit	Setting range
PA12	*DIF	Input filter setting Select the input filter. <div style="border: 1px solid black; display: inline-block; padding: 2px;"> <span style="border: 1px solid black; padding: 0 5px;">0</span> <span style="border: 1px solid black; padding: 0 5px;">0</span> <span style="border: 1px solid black; padding: 0 5px;">0</span> <span style="border: 1px solid black; padding: 0 5px;"> </span> </div> Input signal filter If external input signal causes chattering due to noise, etc., input filter is used to suppress it. 0: None 1: 1.777[ms] 2: 3.555[ms] 3: 5.333[ms]	0002h		Refer to Name and function column.
PA13		For manufacturer setting	0000h		
PA14		Do not change this value by any means.	0000h		
PA15			0000h		
PA16			0000h		
PA17			0000h		
PA18			0000h		
PA19			0000h		

#### 13.6 Troubleshooting

##### 13.6.1 Converter unit

###### (1) Alarms and warning list

When a fault occurs during operation, the corresponding alarm or warning is displayed. If any alarm or warning has occurred, refer to (2) or (3) of this section and take the appropriate action.

Switch power off, then on to deactivate the alarm. The alarms marked "○" in the alarm deactivation column of the table can be deactivated by pressing the "RES" key of the converter unit side parameter unit or switching on the reset signal (RES).

	Display	Name	Alarm deactivation	
			Power OFF→ON	Error reset
Alarm	A.10	Undervoltage	○	○
	A.12	Memory error1 (RAM)	○	⚡
	A.15	Memory error2 (EEP-ROM)	○	⚡
	A.17	Board error	○	⚡
	A.19	Memory error3 (Flash-ROM)	○	⚡
	A.30	Regenerative error	(Note) ○	(Note) ○
	A.33	Over voltage	○	○
	A.37	Parameter error	○	⚡
	A.38	MC drive circuit error	○	⚡
	A.39	Open phase	○	⚡
	A.3A	Inrush current suppressor circuit error	○	⚡
	A.45	Main circuit device overheat	(Note) ○	(Note) ○
	A.47	Cooling fan error	○	⚡
	A.50	Over load 1	(Note) ○	(Note) ○
	A.51	Over load 2	(Note) ○	(Note) ○
888	Watchdog	○	⚡	

	Display	Name
Warning	A.91	Overheat warning
	A.E0	Excessive regenerative load warning
	A.E1	Over load warning
	A.E6	Converter forced stop warning
	A.E8	Cooling fan speed reduction warning

Note. Deactivate the alarm about 30 minutes of cooling time after removing the cause of occurrence.

### 13. SERVO AMPLIFIERS WITH A LARGE CAPACITY (30k TO 55kW)

#### (2) Remedies for alarms



• When any alarm has occurred, eliminate its cause, ensure safety, then reset the alarm, and restart operation. Otherwise, injury may occur.

#### POINT

- When any of the following alarms has occurred, always remove its cause and allow about 30 minutes for cooling before resuming operation. If operation is resumed by switching control circuit power off, then on to reset the alarm, the converter unit and regenerative option may become faulty.
  - Regenerative error (A.30)
  - Over load 1 (A.50)
  - Over load 2 (A.51)
  - Main circuit device overheat (A.45)
- The alarm can be deactivated by switching the power off, then on or by the error reset command from the host controller. Refer to (1) in this section for details.

When an alarm occurs, the trouble (ALM) signal switches off and the display section shows the alarm number. Remove the cause of the alarm in accordance with this section.

Display	Name	Definition	Cause	Action
A.10	Undervoltage	Power supply voltage dropped.	1. Instantaneous control power failure occurred for more than 60ms.	Review the power supply.
			2. Shortage of power supply capacity caused the power supply voltage to drop at start, etc.	
			3. Failure of the part in the converter unit.  <div style="border: 1px solid black; padding: 5px; width: fit-content;">                     — Checking method —                      Alarm (A.10) occurs if power is switched on after connectors disconnected.                 </div>	Change the Converter unit.
A.12	Memory error 1 (RAM)	RAM memory fault	Failure of the part in the converter unit.  <div style="border: 1px solid black; padding: 5px; width: fit-content;">                     — Checking method —                      Alarm (A.12) occurs if power is switched on after connectors disconnected.                 </div>	Change the converter unit.
A.15	Memory error 2 (EEP-ROM)	EEP-ROM fault	1. Failure of the part in the converter unit.  <div style="border: 1px solid black; padding: 5px; width: fit-content;">                     — Checking method —                      Alarm (A.15) occurs if power is switched on after connectors disconnected.                 </div>	Change the converter unit.
			2. The number of write times to EEPROM exceeded 100,000.	
A.17	Board error	CPU/parts fault	Failure of the part in the converter unit.	Change the converter unit.
A.19	Memory error 3 (Flash-ROM)	ROM memory fault	<div style="border: 1px solid black; padding: 5px; width: fit-content;">                     — Checking method —                      Alarm (A.17/A.19) occurs if power is switched on after connectors disconnected.                 </div>	

### 13. SERVO AMPLIFIERS WITH A LARGE CAPACITY (30k TO 55kW)

Display	Name	Definition	Cause	Action
A.30	Regenerative error	Permissible regenerative power of regenerative option is exceeded.	1. Wrong setting of parameter No.PA01	Set correctly.
			2. Regenerative option is not connected.	Connect correctly.
			3. High-duty operation or continuous regenerative operation caused the permissible regenerative power of the regenerative option to be exceeded.  <div style="border: 1px solid black; padding: 5px; width: fit-content;">                     — Checking method —                      Call the status display and check the regenerative load ratio.                 </div>	1. Reduce the frequency of positioning. 2. Use the regenerative option of larger capacity. 3. Reduce the load.
			4. Power supply voltage is abnormal. MR-J3-CR55K: 260VAC or more MR-J3-CR55K4: 520VAC or more	Review power supply
			5. Regenerative option faulty.	Change converter unit or regenerative option.
			6. Ground fault occurred in servo motor power (U, V, W).	Correct the wiring.
		Regenerative transistor fault	7. Regenerative transistor faulty. <div style="border: 1px solid black; padding: 5px; width: fit-content;">                     — Checking method —                      1) The regenerative option has overheated abnormally.                      2) The alarm occurs even after removal of the built-in regenerative resistor or regenerative option.                 </div>	Change the converter unit.
A.33	Over voltage	Converter bus voltage exceeded to following voltage. MR-J3-CR55K: 400VDC MR-J3-CR55K4: 800VDC	1. Regenerative option is not used.	Use the regenerative option.
			2. Though the regenerative option is used, the parameter No.PA01 setting is "□□00 (not used)".	Set correctly.
			3. Lead of regenerative option is open or disconnected.	1. Change lead. 2. Connect correctly.
			4. Regenerative transistor faulty.	Change the converter unit.
			5. Wire breakage of regenerative option.	Change the regenerative option.
			6. Capacity of regenerative option is insufficient.	Add regenerative option or increase capacity.
			7. Power supply voltage high.	Review the power supply.
			8. Ground fault occurred in servo motor power (U, V, W).	Correct the wiring.
A.37	Parameter error	Parameter setting is wrong.	1. Converter unit fault caused the parameter setting to be rewritten.	Change the converter unit.
			2. Regenerative option not used with converter unit was selected in parameter No.PA02.	Set parameter No.PA01 correctly.
			3. The number of write times to EEP-ROM exceeded 100,000 due to parameter write, etc.	Change the converter unit.

### 13. SERVO AMPLIFIERS WITH A LARGE CAPACITY (30k TO 55kW)

Display	Name	Definition	Cause	Action
A.38	MC drive circuit error	Magnetic contactor drive circuit error (When the magnetic contactor is turned on: the main circuit power supply is not turned on within two seconds after the servo-on of the drive unit. When the magnetic contactor is opened: the main circuit power supply is turned on although the magnetic contactor is opened.)	1. Wrong connection of the magnetic contactor.	Review the wiring.
			2. Parameters specifying whether to use/not use the magnetic contactor do not match the configuration.	Set parameter No.PA02 correctly.
			3. Magnetic contactor failed.	Change the magnetic contactor.
			4. Magnetic contactor drive circuit faulty.  <div style="border: 1px solid black; padding: 5px; width: fit-content;"> <p>————— Checking method —————</p> <p>Check the output of magnetic contactor control connector (CNP1) . Power supply voltage is applied to this connector. Take care to avoid an electric shock at connecting.</p> </div>	Change the converter unit.
			5. Mismatch of an external sequence.	Review the power-on sequence. (Refer to section 3.3.2.)
A.39	Open phase	Power supply error	1. Any of L <sub>1</sub> , L <sub>2</sub> and L <sub>3</sub> is disconnected. Or, open.	Review the wiring.
			2. Failure of the part in the converter unit.	Change the converter unit.
A.3A	Inrush current suppressor circuit error	Inrush current suppressor circuit error	1. Power-on/off was repeated with high frequency.	Review operation pattern.
			2. Inrush current suppressor resistance overheated.	Change the converter unit.
			3. Inrush current suppressor circuit faulty.	
A.45	Main circuit device overheat	Main circuit device overheat.	1. The power supply was turned on and off continuously by overloaded status.	Review operation pattern.
			2. Ambient temperature of converter unit is over 55°C.	Review environment so that ambient temperature is 0 to 55°C.
			3. Converter unit faulty.	Change the converter unit.
A.47	Cooling fan alarm	The cooling fan of the converter unit stopped, or its speed decreased to or below the alarm level.	1. Cooling fan life expiration. (Refer to section 2.6.)	Change the cooling fan of the converter unit.
			2. Foreign matter caught in the cooling fan stopped rotation.	Remove the foreign matter.
			3. The power supply of the cooling fan failed.	Change the converter unit.
A.50	Overload 1	Load exceeded overload protection characteristic of converter unit.	Converter unit is used in excess of its continuous output current.	1. Reduce load. 2. Review operation pattern.
A.51	Overload 2	Load exceeded overload protection characteristic of converter unit.	Converter unit is used in excess of its output current for a short time.	Review operation pattern of a drive unit.
(Note) 888	Watchdog	CPU/parts fault	Failure of the part in the converter unit.  <div style="border: 1px solid black; padding: 5px; width: fit-content;"> <p>————— Checking method —————</p> <p>Alarm (888) occurs if power is switched on after connectors disconnected.</p> </div>	Change the converter unit.

Note. At power-on, "888" appears instantaneously, but it is not an error.

### 13. SERVO AMPLIFIERS WITH A LARGE CAPACITY (30k TO 55kW)

#### (3) Remedies for warnings

Continuing operation in an alarm occurrence status may result in an alarm or disable proper operation.

Eliminate the cause of the warning according to this section. The warning displayed will disappear when the cause of its occurrence is resolved.

Display	Name	Definition	Cause	Action
A.91	Overheat warning	The temperature of the fin exceeded the warning level.	1. Operated in the overloaded status.	Review operation pattern.
			2. Ambient temperature of converter unit is over 55°C.	Review environment so that ambient temperature is 0 to 55°C.
			3. Used beyond the specifications of close mounting.	Use within the range of specifications.
			4. Converter unit faulty.	Change the converter unit.
A.E0	Excessive regenerative load warning	There is a possibility that regenerative power may exceed permissible regenerative power of regenerative option.	Regenerative power increased to 85% or more of permissible regenerative power of regenerative option. <div style="border: 1px solid black; padding: 2px; width: fit-content;">                     — Checking method —                      Call the status display and check the regenerative load ratio.                 </div>	1. Reduce frequency of positioning. 2. Change regenerative option for the one with larger capacity. 3. Reduce load.
A.E1	Overload warning	There is a possibility that overload alarm 1 or 2 may occur.	Load increased to 85% or more of overload alarm 1 or 2 occurrence level. <div style="border: 1px solid black; padding: 2px; width: fit-content;">                     — Cause, checking method —                      Refer to A.50, 51.                 </div>	Refer to A.50, A.51.
A.E6	Converter forced stop warning	EM1 is off.	External forced stop was made valid. (EM1 was turned off.)	Ensure safety and deactivate forced stop.
A.E8	Cooling fan speed reduction warning	The speed of the converter unit cooling fan decreased to or below the warning level.	1. Cooling fan life expiration. (Refer to section 2.6.)	Change the cooling fan of the converter unit.
			2. The power supply of the cooling fan failed.	Change the converter unit.

#### (4) Clearing the alarm history

You can clear the alarm numbers stored in the alarm history of the alarm mode. To ensure that you can control the alarms that will occur after regular operation, make this setting before starting regular operation to clear the alarm history.

After setting "0001" in parameter No.PA09, switch power off once. Switching it on again clears the alarm history. At this time, the parameter No.PA09 setting returns to "0000".

### 13. SERVO AMPLIFIERS WITH A LARGE CAPACITY (30kW TO 55kW)

#### 13.6.2 Drive unit

<b>POINT</b>
<ul style="list-style-type: none"> <li>Explanation made in this section is exclusively for the driver unit. Other troubleshooting is the same as that for servo amplifiers with 22kW or less. Refer to chapter 8.</li> <li>As soon as an alarm occurs, make the Servo off status and interrupt the main circuit power.</li> </ul>

#### (1) Alarms and warning list

When a fault occurs during operation, the corresponding alarm or warning is displayed. If any alarm or warning has occurred, refer to (2) or (3) of this section and take the appropriate action. When an alarm occurs, the ALM turns OFF.

After its cause has been removed, the alarm can be deactivated in any of the methods marked in the alarm deactivation column. The alarm is automatically canceled after removing the cause of occurrence.

	Display	Name	Alarm deactivation		
			Power OFF → ON	Error reset	CPU reset
Alarms	1B	Converter alarm	○	○	○

	Display	Name
Alarms	9C	Converter warning
	E9	Main circuit off warning

#### (2) Remedies for alarms

 <b>CAUTION</b>	<ul style="list-style-type: none"> <li>When any alarm has occurred, eliminate its cause, ensure safety, then reset the alarm, and restart operation. Otherwise, injury may occur.</li> <li>As soon as an alarm occurs, mark servo-off and power off the main circuit and control circuit.</li> </ul>
--	--

<b>POINT</b>
<ul style="list-style-type: none"> <li>The alarm can be deactivated by switching power off, then on or by the error reset command CPU reset from the servo system controller. For details, refer to (1) of this section.</li> </ul>

When an alarm occurs, the trouble (ALM) switches off and the dynamic brake is operated to stop the servo motor. At this time, the display indicates the alarm No.

The servo motor comes to a stop. Remove the cause of the alarm in accordance with this section. MR Configurator may be used to refer to the cause.

Display	Name	Definition	Cause	Action
1B	Converter alarm	An alarm occurred in the converter unit during servo on.	1. An alarm occurred in the converter unit during servo on.	Check the alarm of the converter unit, and take the action following the remedies for alarms of the converter unit. (Refer to section 13.6.1 (2).)
			2. The protection coordination cable or terminal connector is not correctly connected.	Connect correctly.

### 13. SERVO AMPLIFIERS WITH A LARGE CAPACITY (30k TO 55kW)

#### (3) Remedies for warnings

Continuing operation in an alarm occurrence status may result in an alarm or disable proper operation.

Eliminate the cause of the warning according to this section. The warning displayed will disappear when the cause of its occurrence is resolved.

Indication	Name	Definition	Cause	Action
9C	Converter warning	A warning occurred in the converter unit during the servo-on command.		Check the warning of the converter unit, and take the action following the remedies for warnings of the converter unit. (Refer to section 13.6.1 (3).)
E9	Main circuit off warning	The forced stop of the converter unit is made valid during the servo-on command.	1. The forced stop of the converter unit is made valid.	Deactivate the forced stop of the converter unit.
			2. The protection coordination cable or terminal connector is not correctly connected.	Connect correctly.

### 13. SERVO AMPLIFIERS WITH A LARGE CAPACITY (30k TO 55kW)

#### 13.7 Outline drawings

**POINT**  
• Refer to section 13.2.1 for outline dimension drawing.

#### 13.7.1 Converter unit (MR-J3-CR55K(4))

[Unit: mm]

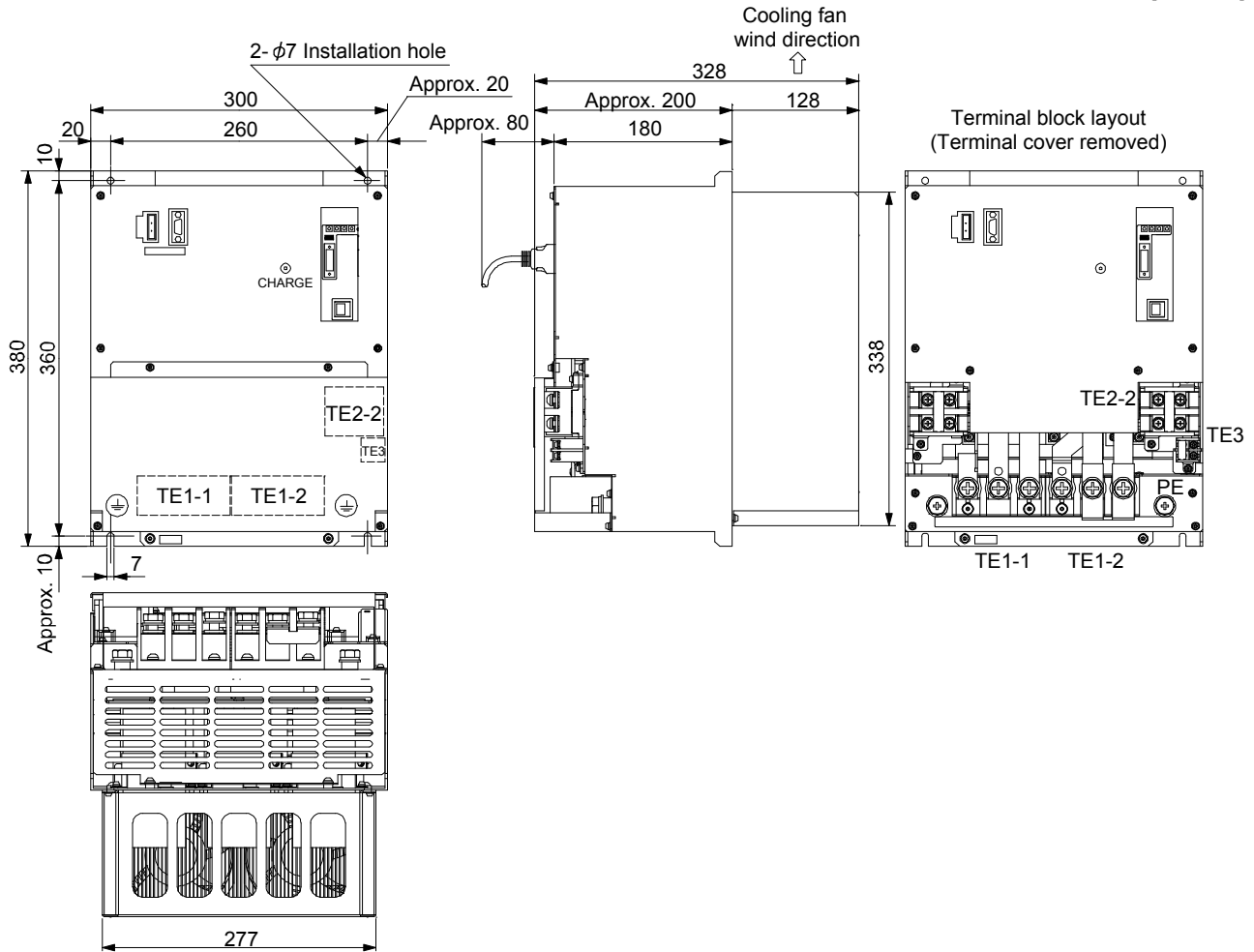

Mass: 25[kg] (55.2[lb])

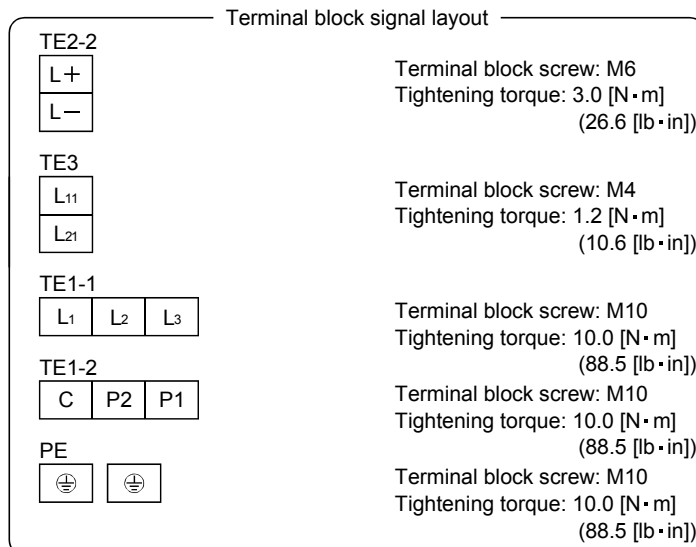

Mounting screw  
Screw size: M6  
Tightening torque: 5.4 [N·m]  
(47.8 [lb·in])

### 13. SERVO AMPLIFIERS WITH A LARGE CAPACITY (30k TO 55kW)

#### 13.7.2 Drive unit

- (1) MR-J3-DU30KB • MR-J3-DU37KB  
MR-J3-DU45KB4 • MR-J3-DU55KB4

[Unit: mm]

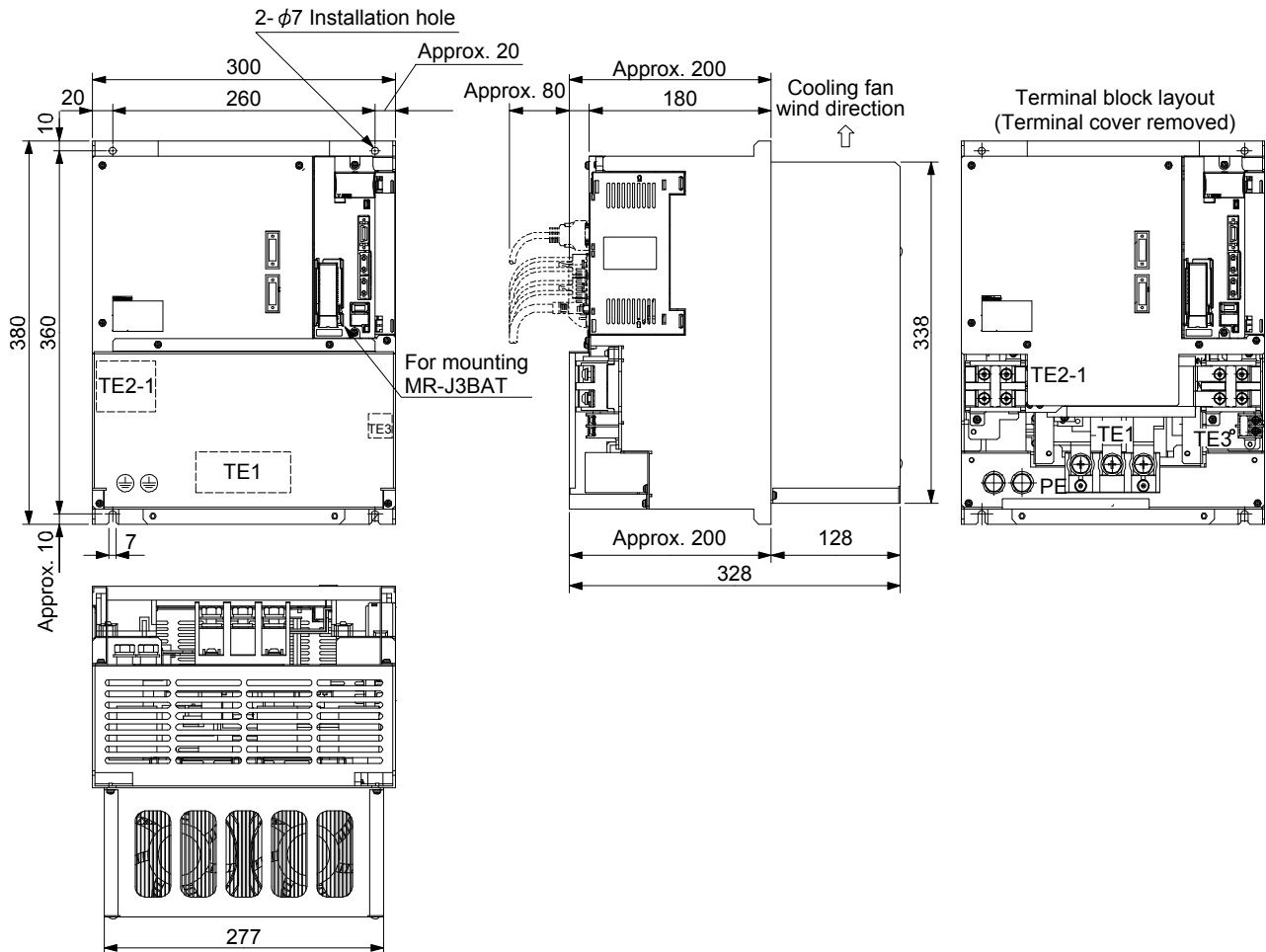

Mass: 26[kg] (57.3[lb])

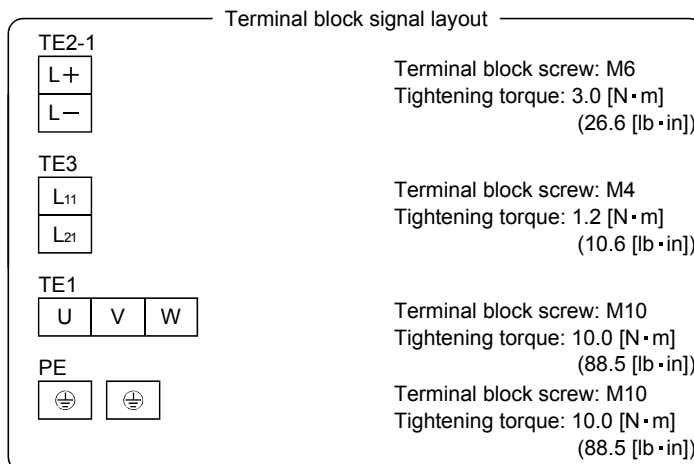

Mounting screw  
Screw size: M6  
Tightening torque: 5.4 [N·m]  
(47.8 [lb·in])

### 13. SERVO AMPLIFIERS WITH A LARGE CAPACITY (30k TO 55kW)

(2) MR-J3-DU30KB4 • MR-J3-DU37KB4

[Unit: mm]

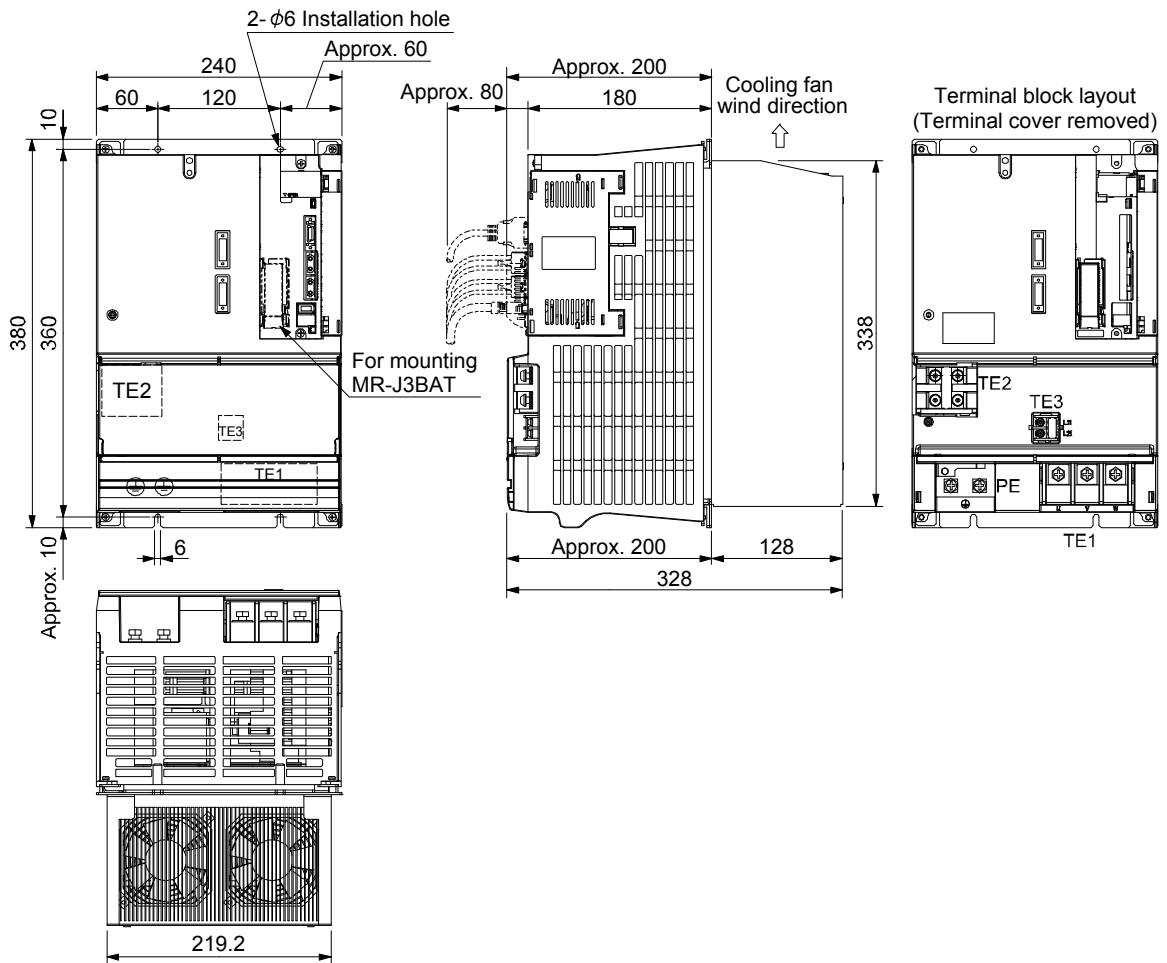

Mass: 18[kg] (39.7[lb])

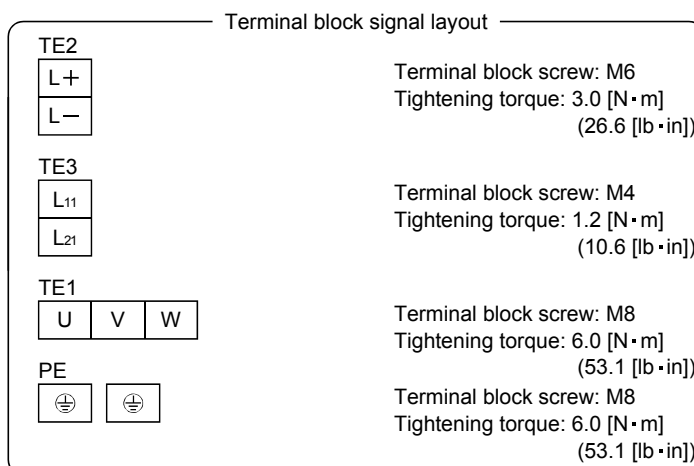

Mounting screw  
Screw size: M5  
Tightening torque: 3.2 [N·m]  
(28.3 [lb·in])

## 13. SERVO AMPLIFIERS WITH A LARGE CAPACITY (30k TO 55kW)

### 13.8 Characteristics

#### 13.8.1 Overload protection characteristics

An electronic thermal relay is built in the converter unit and drive unit to protect the servo motor, converter unit and drive unit from overloads.

Overload 1 alarm (50) occurs if overload operation performed is above the electronic thermal relay protection curve shown below. Overload 2 alarm (51) occurs if the maximum current flow continuously for several seconds due to machine collision, etc. Use the equipment on the left-hand side area of the continuous or broken line in the graph.

It is recommended to use the machine which generates unbalanced torque, e.g. a vertical lift application, so that the unbalanced torque is not more than 70% of the rated torque.

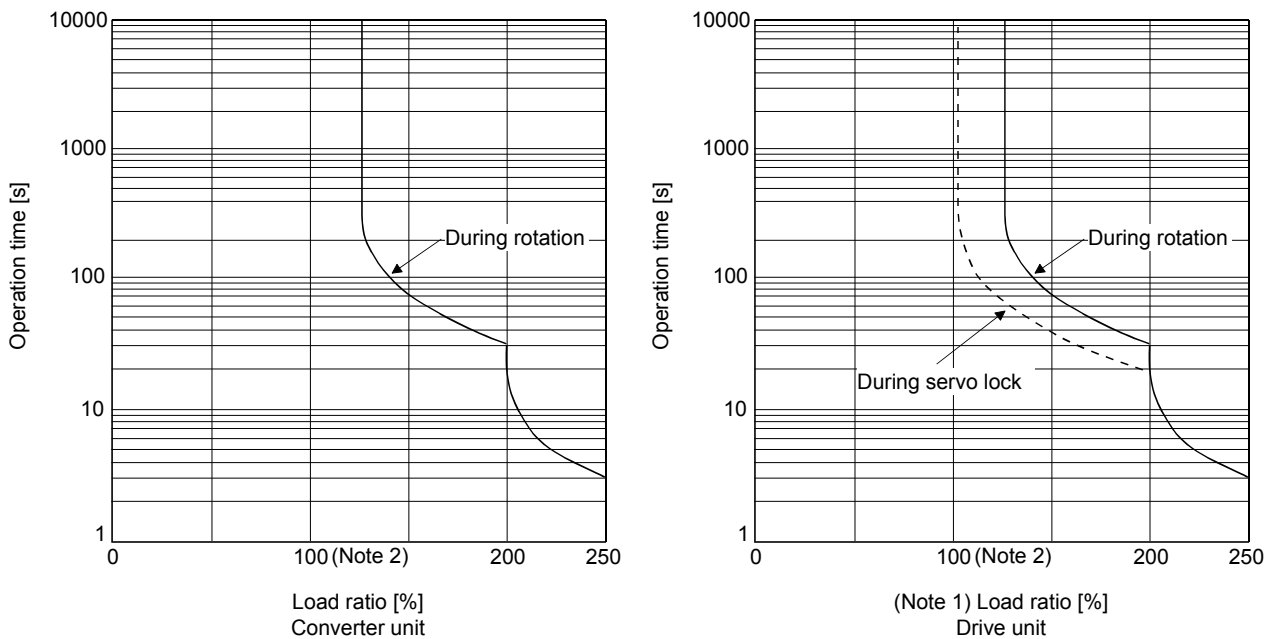

Note 1. If operation that generates torque more than 100% of the rating is performed with an abnormally high frequency in a servo motor stop status (servo lock status) or in a 30r/min or less low-speed operation status, the drive unit may fail even when the electronic thermal relay protection is not activated.

2. Load ratio 100% indicates the rated output of each converter unit and drive unit. Refer to section 13.1.4 for rated output.

Fig. 13.1 Overload protection characteristics

### 13. SERVO AMPLIFIERS WITH A LARGE CAPACITY (30kW TO 55kW)

#### 13.8.2 Power supply equipment capacity and generated loss

POINT
<ul style="list-style-type: none"> <li>The calculation method of heat dissipation area for enclosed control panel is the same as that for servo amplifiers with 22kW or less. Refer to section 10.2 (2).</li> </ul>

Table 13.1 indicates the generated loss and power supply capacity under rated load per combination of the converter unit and drive unit. When the servo motors is run at less than the maximum speed, the power supply equipment capacity is lower than the value in the table but the heat generated does not change.

Since the servo motor requires 2 to 2.5 times greater instantaneous power for acceleration, use the power supply which ensures that the voltage lies within the permissible voltage fluctuation at the main circuit power supply terminals (L<sub>1</sub>, L<sub>2</sub>, L<sub>3</sub>) of the converter unit. The power supply equipment capacity changes with the power supply impedance.

The actually generated heat falls within the ranges at rated torque and at zero torque according to the frequencies of use during operation. When designing an enclosed control box, use the values in the table, considering the worst operating conditions. The generated heat in Table 13.1 does not include heat produced during regeneration.

Table 13.1 Power supply capacity and generated heat per servo amplifier at rated output

Converter unit	Drive unit	Servo motor	Power supply capacity [kVA]		(Note) Drive unit-generated heat[W]		Area required for heat dissipation [m <sup>2</sup> ]
			Power factor improving DC reactor is not used	Power factor improving DC reactor is used	At rated torque	At zero torque	
MR-J3-CR55K	MR-J3-DU30KB	HA-LP30K1 HA-LP30K1M HA-LP30K2	48	40	1550(1100+450)	60(30+30)	31.0
	MR-J3-DU37KB	HA-LP37K1 HA-LP37K1M HA-LP37K2	59	49	1830(1280+550)		36.6
MR-J3-CR55K4	MR-J3-DU30KB4	HA-LP25K14	40	35	1080(850+230)		21.6
		HA-LP30K14 HA-LP30K1M4 HA-LP30K24	48	40	1290(1010+280)		25.8
	MR-J3-DU37KB4	HA-LP37K14 HA-LP37K1M4 HA-LP37K24	59	49	1542(1200+342)		30.8
	MR-J3-DU45KB4	HA-LP45K1M4 HA-LP45K24	71	59	1810(1370+440)		36.2
	MR-J3-DU55KB4	HA-LP50K1M4	80	67	2120(1650+470)		42.4
		HA-LP55K24	87	72	2150(1650+500)		43.0

Note. The heat generated by the drive unit is indicated in the left term within the parentheses, and the heat generated by the converter unit in the right term.

### 13. SERVO AMPLIFIERS WITH A LARGE CAPACITY (30k TO 55kW)

#### 13.8.3 Dynamic brake characteristics

##### (1) Dynamic brake operation

###### (a) Calculation of coasting distance

Fig. 13.2 shows the pattern in which the servo motor comes to a stop when the dynamic brake is operated. Use Equation 13.1 to calculate an approximate coasting distance to a stop. The dynamic brake time constant  $\tau$  varies with the servo motor and machine operation speeds. (Refer to (b)). Please contact us for the servo motor not indicated.)

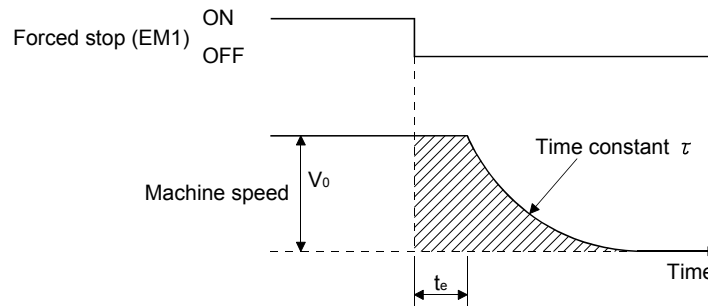

Fig 13.2 Dynamic Brake Operation Diagram

$$L_{\max} = \frac{V_0}{60} \cdot \left\{ t_e + \tau \left( 1 + \frac{J_L}{J_M} \right) \right\} \quad (13.1)$$

- $L_{\max}$  : Maximum coasting distance ..... [mm]
- $V_0$  : Machine rapid feed rate ..... [mm/min][in/min]
- $J_M$  : Servo motor inertial moment ..... [kg · cm<sup>2</sup>][oz · in<sup>2</sup>]
- $J_L$  : Load inertia moment converted into equivalent value on servo motor shaft ..... [kg · cm<sup>2</sup>][oz · in<sup>2</sup>]
- $\tau$  : Brake time constant ..... [s]
- $t_e$  : Delay time of control section ..... [s]

For 7kW or less servo, there is internal relay delay time of about 30ms. For 11k to 22kW servo, there is delay time of about 100ms caused by a delay of the external relay and a delay of the magnetic contactor built in the external dynamic brake.

### 13. SERVO AMPLIFIERS WITH A LARGE CAPACITY (30k TO 55kW)

(b) Dynamic brake time constant

The following shows necessary dynamic brake time constant  $\tau$  for the equations (13.1).

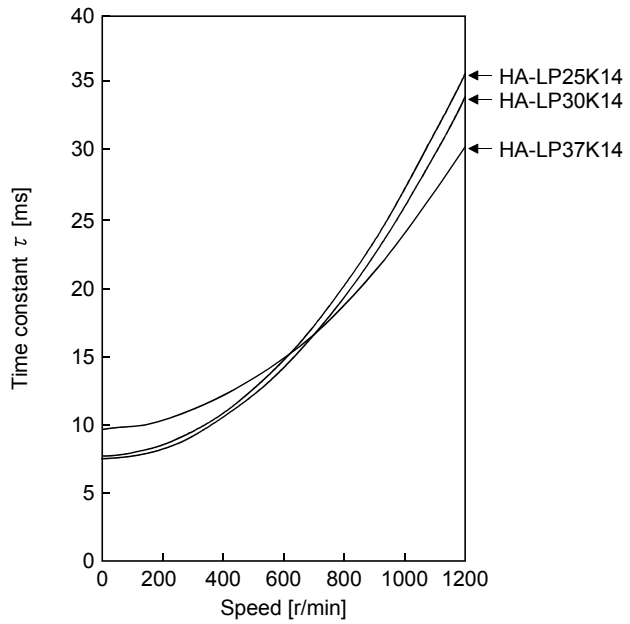
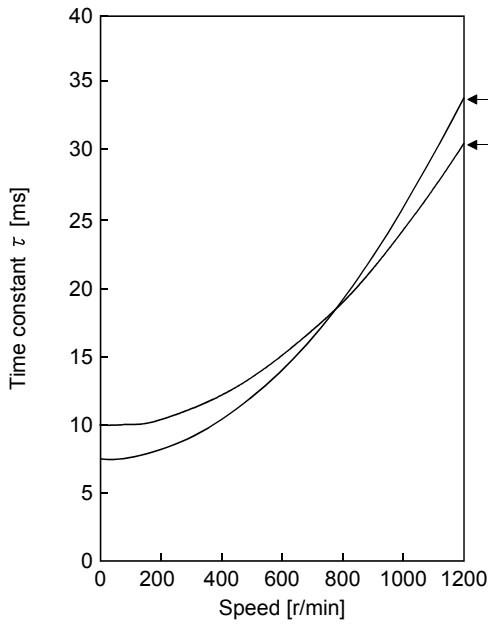

HA-LP1000r/min series

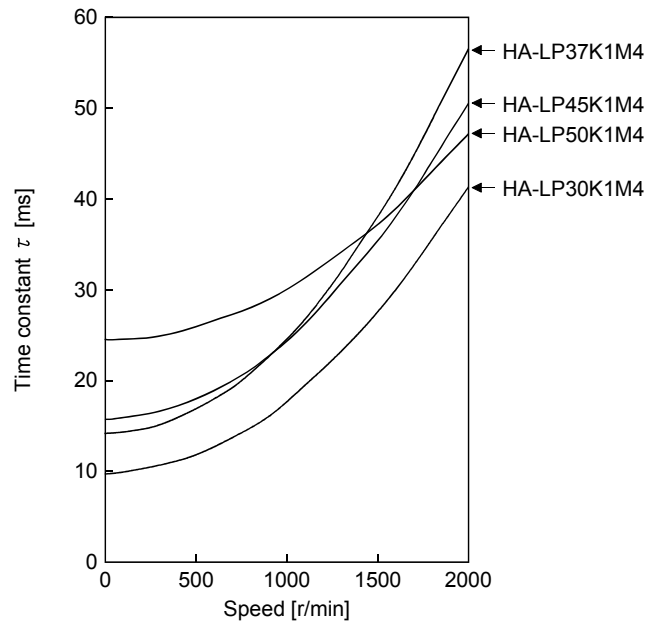
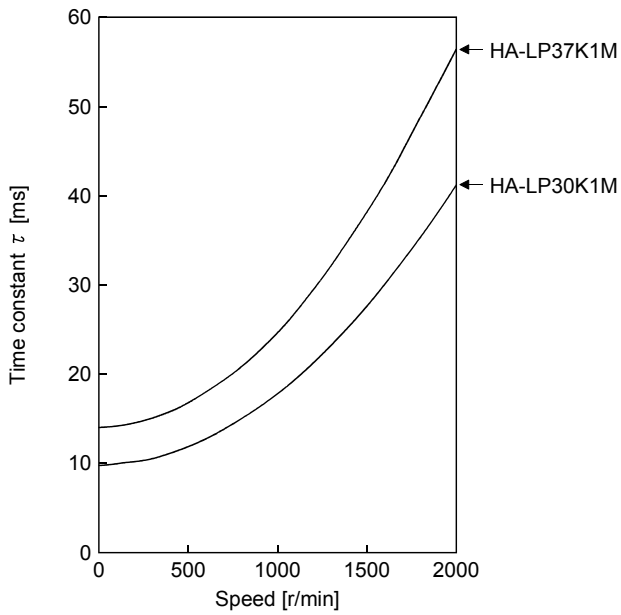

HA-LP1500r/min series

### 13. SERVO AMPLIFIERS WITH A LARGE CAPACITY (30k TO 55kW)

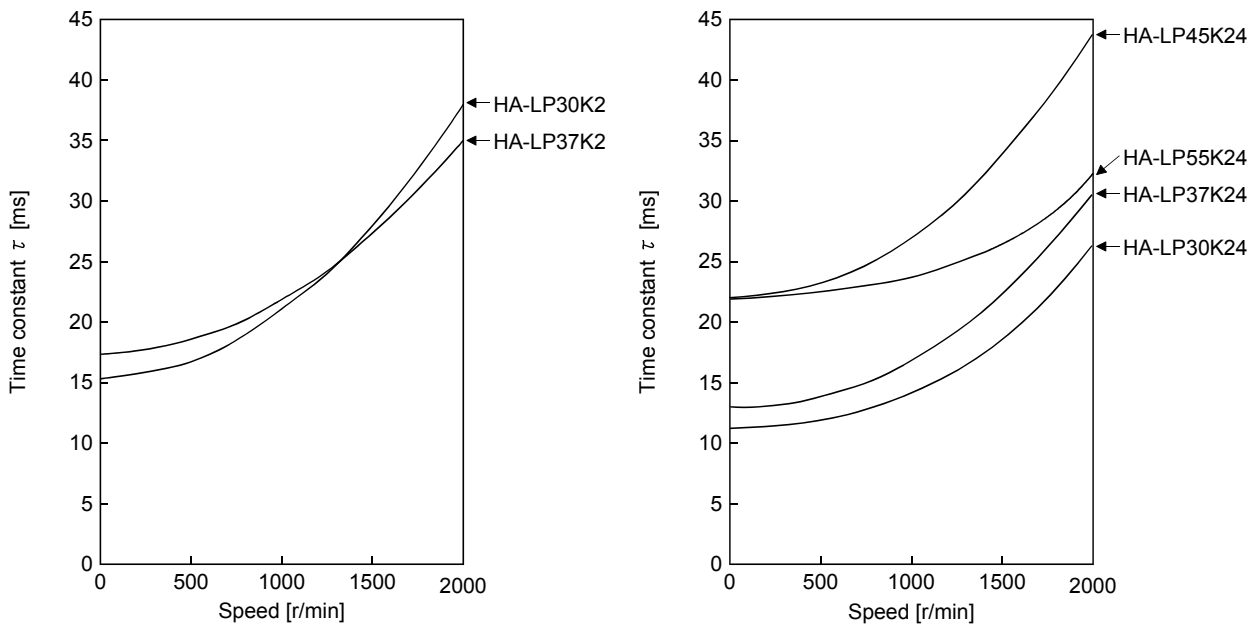

HA-LP2000r/min series

(2) The dynamic brake at the load inertia moment

Use the dynamic brake under the load inertia moment ratio indicated in the following table. If the load inertia moment is higher than this value, the external dynamic brake may burn. If there is a possibility that the load inertia moment may exceed the value, contact Mitsubishi.

The values of the load inertia moment ratio in the table are the values at the maximum rotation speed of the servo motor.

Drive unit	Load inertia moment ratio [Multiplier (× 1)]
MR-J3-DU30KB(4)	10
MR-J3-DU37KB(4)	
MR-J3-DU45KB4	
MR-J3-DU55KB4	

## 13. SERVO AMPLIFIERS WITH A LARGE CAPACITY (30k TO 55kW)

### 13.8.4 Inrush currents at power-on of main circuit and control circuit

The following table indicates the inrush currents (reference data) that will flow when the maximum permissible voltage (200V class: 253VAC, 400V class: 528VAC) is applied at the power supply capacity of 2500kVA and the wiring length of 1m.

Converter unit	Drive unit	Inrush currents (A <sub>0-p</sub> )	
		Main circuit power supply (L <sub>1</sub> , L <sub>2</sub> , L <sub>3</sub> )	Control circuit power supply (L <sub>11</sub> , L <sub>21</sub> )
MR-J3-CR55K	MR-J3-DU30KB	163A	18A
	MR-J3-DU37KB	(Attenuated to approx. 20A in 180ms)	(Attenuated to approx. 0A in 100ms)
MR-J3-CR55K4	MR-J3-DU30KB4	339A	19A
	MR-J3-DU37KB4		
	MR-J3-DU45KB4		
	MR-J3-DU55KB4		

Since large inrush currents flow in the power supplies, always use no-fuse breakers and magnetic contactors. (Refer to section 13.9.5.)

When circuit protectors are used, it is recommended to use the inertia delay type that will not be tripped by an inrush current.

### 13.9 Options

#### WARNING

- Before connecting any option or peripheral equipment, turn off the power and wait for 20 minutes or more until the charge lamp turns off. Then, confirm that the voltage between L+ and L- is safe with a voltage tester and others. Otherwise, an electric shock may occur. In addition, always confirm from the front of the converter unit whether the charge lamp is off or not.

#### CAUTION

- Use the specified auxiliary equipment and options. Unspecified ones may lead to a fault or fire.

#### POINT

- Explanations on the following item are the same as those for servo amplifiers with 22kW or less. Refer to the section below for details.
  - Cable/connector sets Refer to section 11.1.
  - Junction terminal block Refer to section 11.7.
  - MR Configurator Refer to section 11.8.
  - Battery Refer to section 11.9.
  - Relays Refer to section 11.15.
  - Surge absorbers Refer to section 11.16.
  - Radio noise filter (FR-BIF(-H)) Refer to section 11.17 (2) (e).

### 13.9.1 Cables and connectors

#### POINT

- Other connectors are the same as those for servo amplifiers with 22kW or less. Refer to section 11.1.

### 13. SERVO AMPLIFIERS WITH A LARGE CAPACITY (30k TO 55kW)

(1) Makeup of cables and like

The following shows the cable makeup for connection with the servo motor and other model.

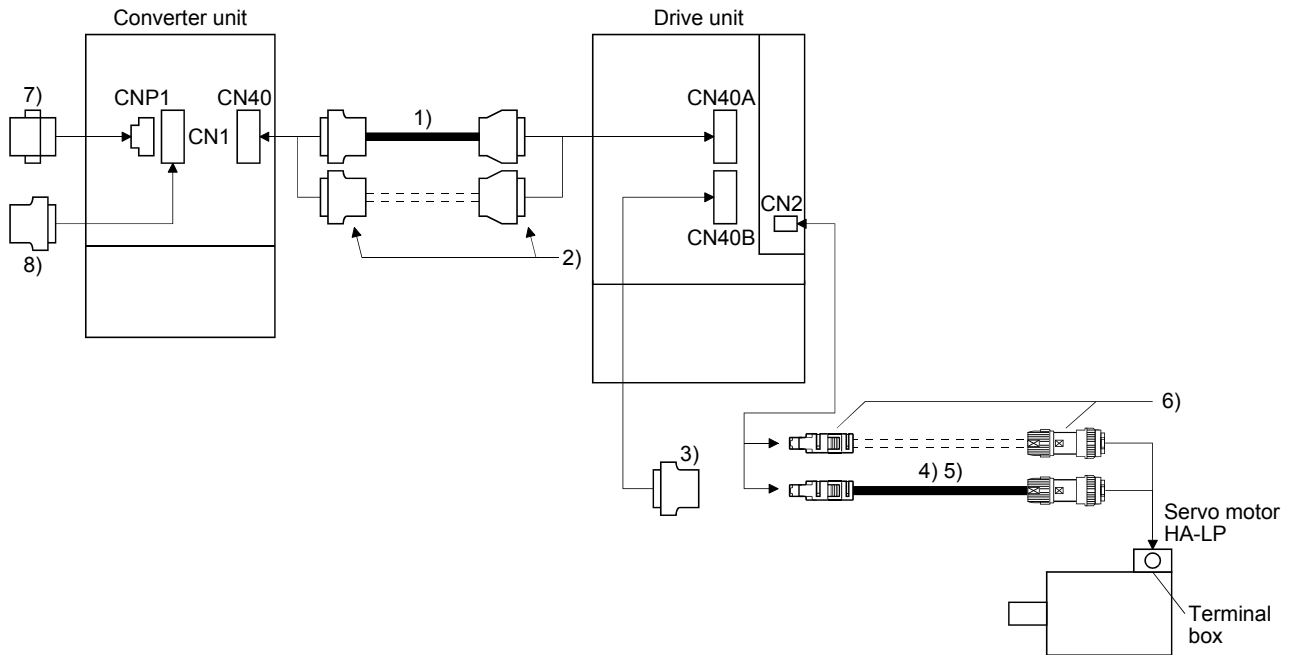

No.	Product	Model	Description		Application
1)	Protection coordination cable	MR-J3CDL□M Refer to (2) of this section.	Connector: 10120-3000PE Shell kit: 10320-52F0-008 (3M or equivalent)	Connector: PCR-S20FS+ Case: PCR-LS20LA1 (Honda Tsushin Kogyo)	
2)	Connector set	MR-J2CN1-A Refer to (2) of this section.	Connector: 10120-3000PE Shell kit: 10320-52F0-008 (3M or equivalent)	Connector: PCR-S20FS+ Shell kit: PCR-LS20LA1 (Honda Tsushin Kogyo)	
3)	Termination connector	MR-J3-TM			
4)	Encoder cable	MR-J3ENSCL□M-L Cable length: 2 • 5 • 10 • 20 • 30m	For HA-LP series Refer to section 11.1.2 (4) for details.		IP67 Standard life
5)	Encoder cable	MR-J3ENSCL□M-H Cable length: 2 • 5 • 10 • 20 • 30 • 40 • 50m			IP67 Long flex life
6)	Encoder connector set	MR-J3SCNS			IP67
7)	Magnetic contactor wiring connector		Converter unit side connector (Phoenix Contact) Socket: GFKC 2.5/2-STF-7.62		Supplied with converter unit
8)	Digital I/O connector		Converter unit side connector (DDK) Connector: 17JE23090-02(D8A)K11-CG		

### 13. SERVO AMPLIFIERS WITH A LARGE CAPACITY (30k TO 55kW)

(2) MR-J3CDL05M(0.5m) Protection coordination cable



▪ Connect protection coordination cables correctly if they are fabricated.  
Otherwise, the system may perform unexpected operation.

When fabricating a protection coordination cable, use the recommended wires given in section 13.9.4, and fabricate a protection coordination cable as shown in the wiring diagram in this section.

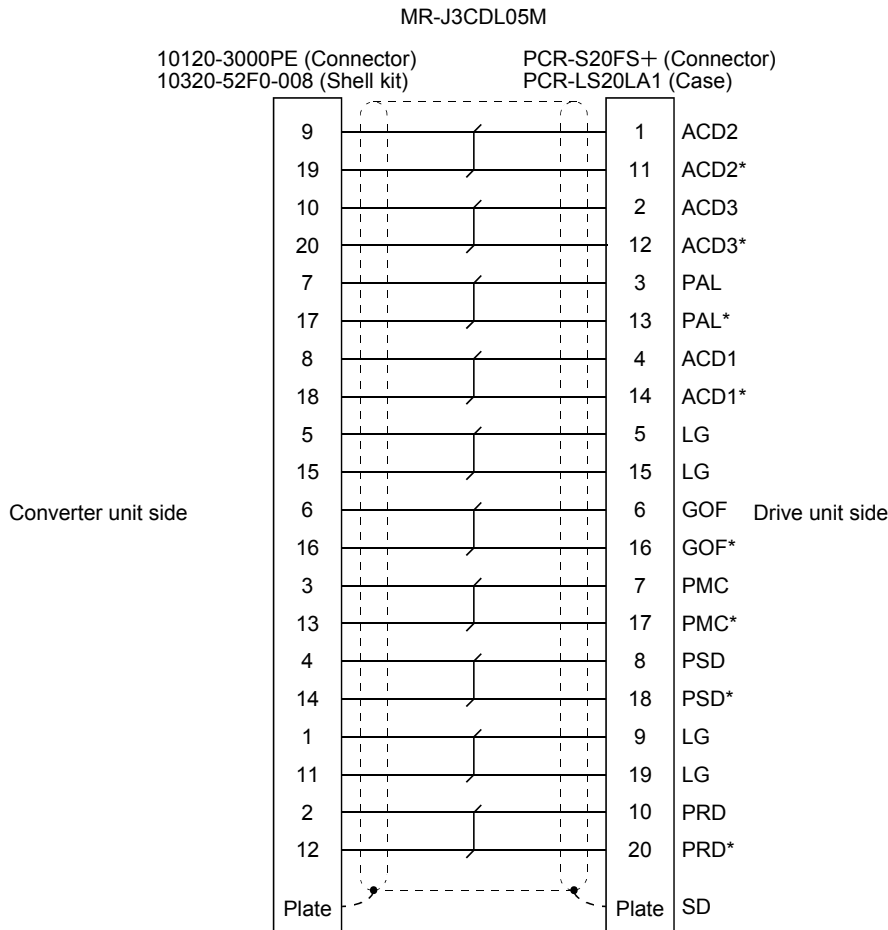
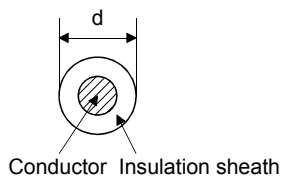

Table 13.2 Recommended wire

Model	Length [m(ft)]	Core size [mm <sup>2</sup> ]	Number of cores	Characteristics of one core			(Note 2) Finishing OD [mm]	Wire model
				Structure [Wires/mm]	Conductor resistance [ $\Omega$ /mm]	Insulation coating OD d[mm] (Note 1)		
MR-J3CDL05M	0.5 to 5 (1.64 to 16.4)	0.08	20 (10 pairs)	7/0.127	222	0.38	6.1	UL20276 AWG#28 10pair (CREAM)

Note 1. d is as shown below.



2. Standard OD. Max. OD is about 10% greater.

### 13. SERVO AMPLIFIERS WITH A LARGE CAPACITY (30kW TO 55kW)

#### 13.9.2 Regenerative option

**CAUTION** ▪ The specified combinations of regenerative options, converter unit and drive unit may only be used. Otherwise, a fire may occur.

**POINT** ▪ The calculation method of regenerative energy is the same as that for servo amplifiers with 22kW or less. Refer to section 11.2 (2).

#### (1) Combination and regenerative power

The regenerative power values in the table are the regenerative power of the resistor and are not the rated power.

Converter unit	Drive unit	Regenerative Power [W]			
		MR-RB139 (1.3 Ω)	(Note 1) Three MR-RB137 (1.3Ω) in parallel	MR-RB136-4 (5Ω)	(Note 2) Three MR-RB138-4 (5Ω) in parallel
MR-J3-CR55K	MR-J3-DU30KB	1300	3900	/	/
	MR-J3-DU37KB				
MR-J3-CR55K4	MR-J3-DU30KB4	/	/	1300	3900
	MR-J3-DU37KB4				
	MR-J3-DU45KB4				
	MR-J3-DU55KB4				

Note. 1. The composite resistor value of three options is 1.3Ω. The resistor value of one option is 4Ω.

2. The composite resistor value of three options is 5Ω. The resistor value of one option is 15Ω.

#### (2) Parameter setting

**POINT** ▪ Always set parameter No.PA02 of the drive unit to “□□00”(Not used) since the regenerative option cannot be connected to the drive unit.

When using the regenerative option, set the parameter of the converter unit. Match parameter No.PA01 to the regenerative option used.

Parameter No.PA01

0	0		
---	---	--	--

Regenerative option selection

- 00: Not used
- 01: MR-RB139
- 02: MR-RB137 (3 pcs.)
- 11: MR-RB136-4
- 12: MR-RB138-4 (3 pcs.)

#### (3) Regenerative loss of drive unit and servo motor

Drive unit	Inverse efficiency [%]	C charge [J]
MR-J3-DU30KB	90	450
MR-J3-DU37KB		
MR-J3-DU30KB4		
MR-J3-DU37KB4		
MR-J3-DU45KB4		
MR-J3-DU55KB4		

### 13. SERVO AMPLIFIERS WITH A LARGE CAPACITY (30k TO 55kW)

#### (4) Connection of the regenerative option

Always supply 1-phase 200V and 400V respectively to the cooling fan. The cooling fan specifications are as follows.

Table 13.3 Cooling fan

Item	200V class	400V class
Model	MR-RB137 • MR-RB139	MR-RB136-4 • MR-RB138-4
Voltage • Frequency	1-phase 198 to 242VAC, 50/60Hz	1-phase 380 to 480VAC, 50/60Hz
Power consumption [W]	20 (50Hz)/18 (60Hz)	20 (50Hz)/18 (60Hz)

The regenerative option generates heat of +100°C higher than the ambient temperature. Fully consider heat dissipation, installation position, used wires, etc. to place the option. For wiring, use flame-resistant wires or make the wires flame-resistant and keep them away from the regenerative option. The G3 and G4 terminals act as a thermal sensor. G3-G4 are opened when the regenerative option overheats abnormally.

Always twist the wires for connection with the converter unit and connect the wires within the overall distance of 5m.

#### (a) MR-RB139 • MR-RB136-4

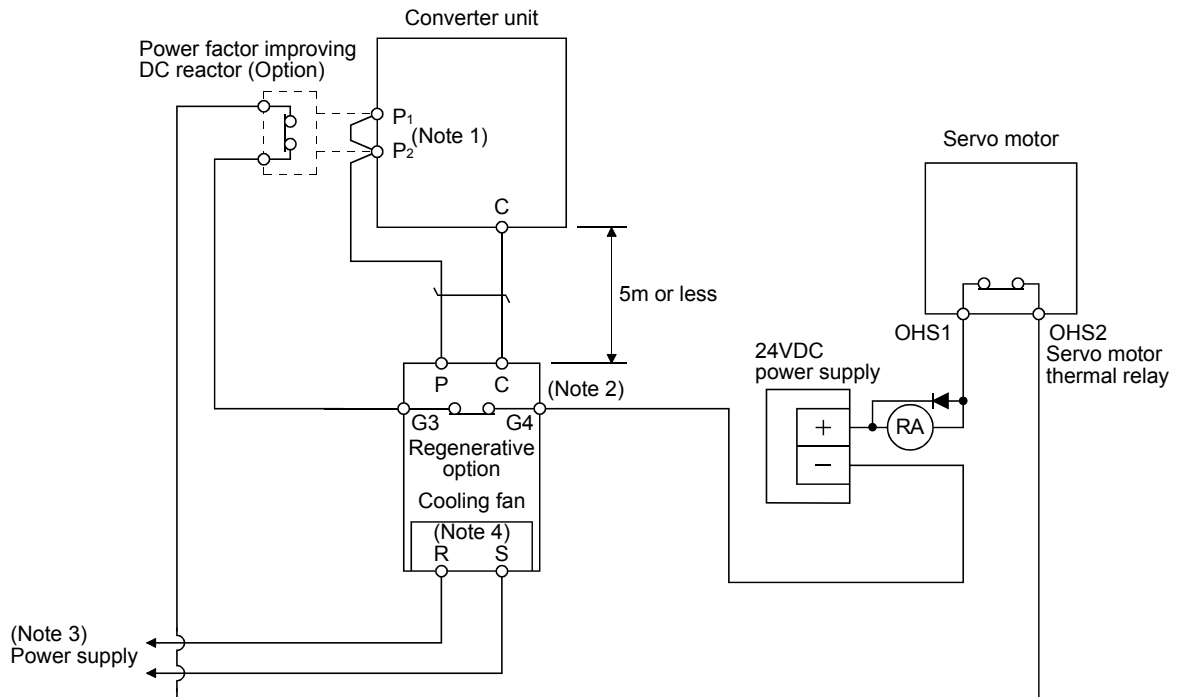

Note 1. When using the Power factor improving DC reactor, remove the short bar across P<sub>1</sub>-P<sub>2</sub>.

2. G3-G4 contact specifications

Maximum voltage: 120V AC/DC

Maximum current: 0.5V/4.8VDC

Maximum capacity: 2.4VA

3. For specifications of cooling fan power supply, refer to Table 13.3.

4. For MR-RB136-4, "R" is "R400" and "S" is "S400".

### 13. SERVO AMPLIFIERS WITH A LARGE CAPACITY (30kW TO 55kW)

(b) MR-RB137 • MR-RB138-4

POINT
<ul style="list-style-type: none"> <li>Three of MR-RB137 or MR-RB138-4 are required per converter unit. Please purchase three of MR-RB137 or MR-RB138-4.</li> </ul>

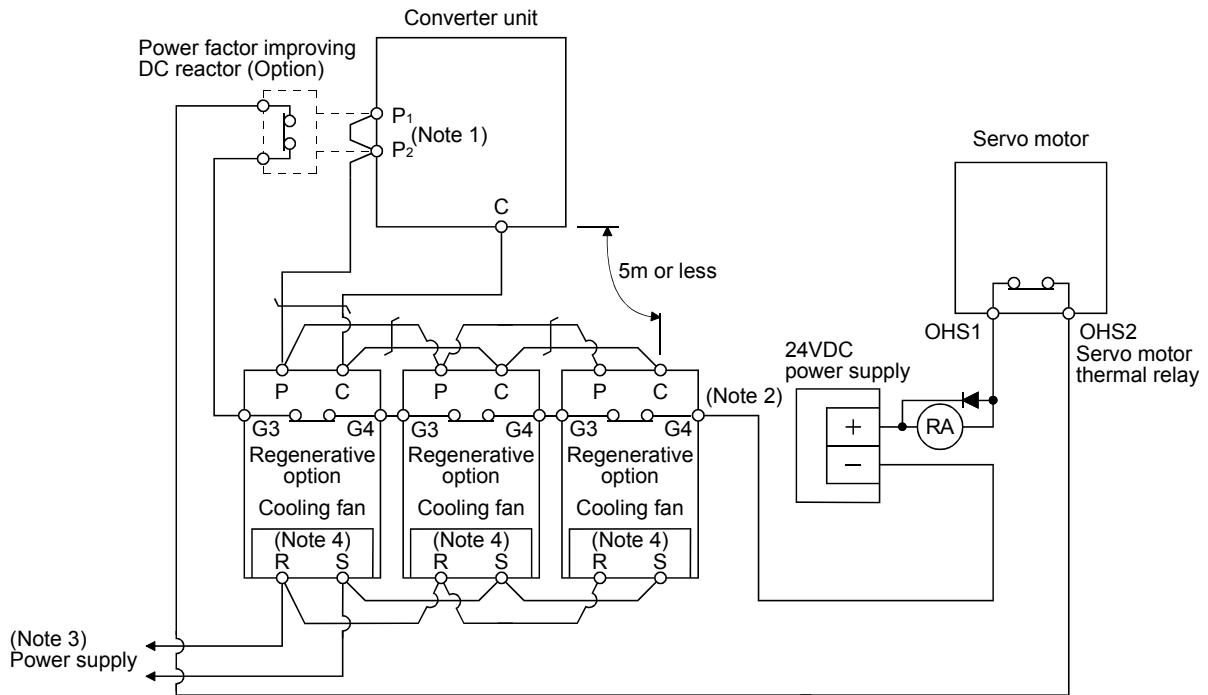

Note 1. When using the Power factor improving DC reactor, remove the short bar across P<sub>1</sub>-P<sub>2</sub>.

2. G3-G4 contact specifications

Maximum voltage: 120V AC/DC

Maximum current: 0.5V/4.8VDC

Maximum capacity: 2.4VA

3. For specifications of cooling fan power supply, refer to Table 13.3.

4. For MR-RB138-4, "R" is "R400" and "S" is "S400".

### 13. SERVO AMPLIFIERS WITH A LARGE CAPACITY (30k TO 55kW)

#### (5) Outline dimension drawings

[Unit:mm]

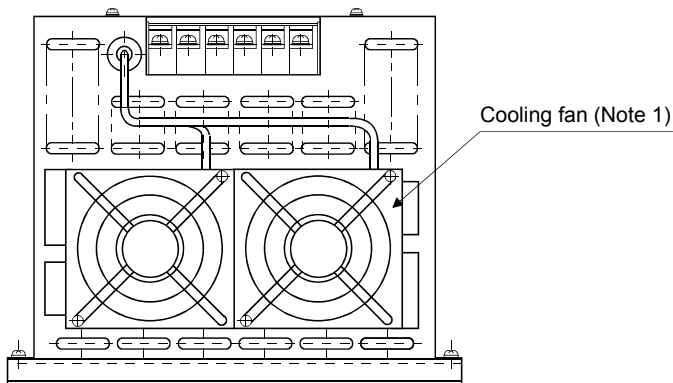
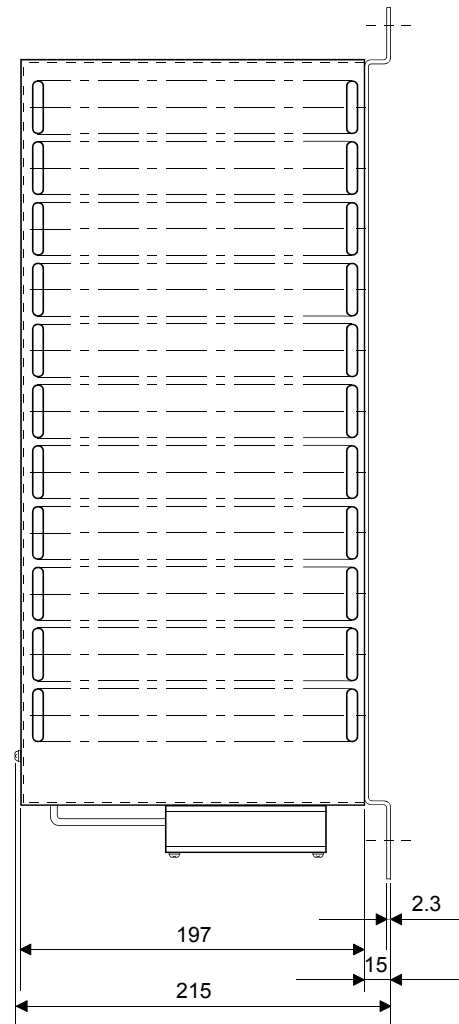
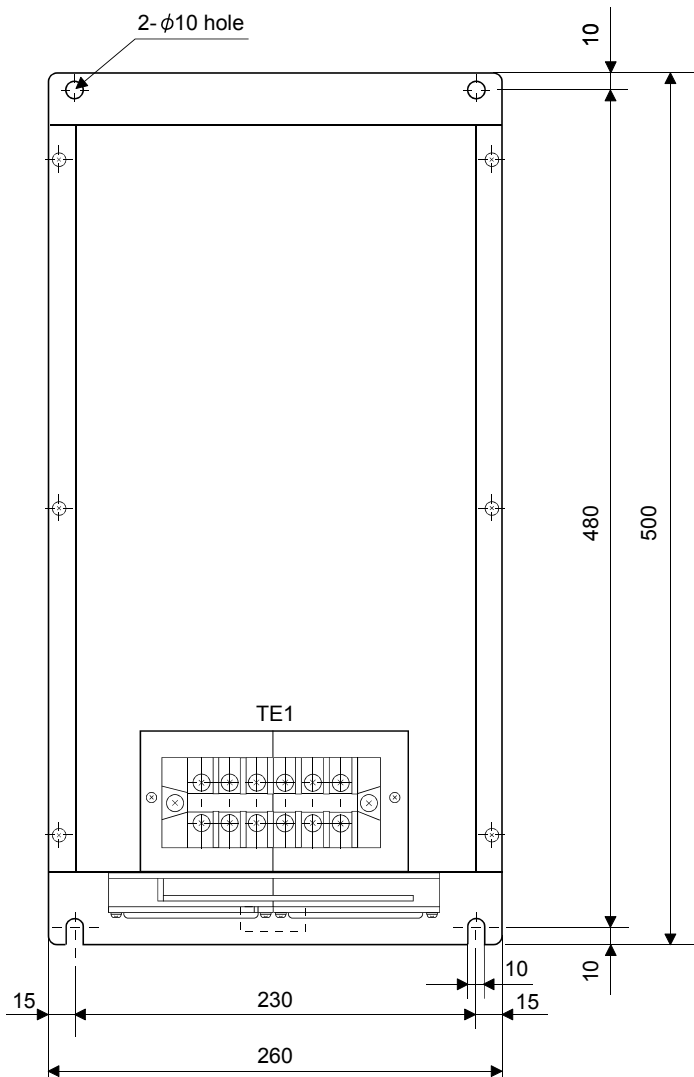

Regenerative option	Mass [kg(lb)]
MR-RB139 • MR-RB136-4	10(22.05)
MR-RB137 • MR-RB138-4	11(24.25)

- Terminal block signal layout  
TE1

R <small>(Note 2)</small>	S <small>(Note 2)</small>	G4	G3	C	P
------------------------------	------------------------------	----	----	---	---

Terminal screw: M5  
Tightening torque: 2.0 [N·m] (17.7 [lb·in])

- Mounting screw  
Screw size: M8  
Tightening torque: 13.2 [N·m] (117 [lb·in])

Note 1. One cooling fan for MR-RB136-4, MR-RB138-4.  
2. For MR-RB138-4, "R" is "R400" and "S" is "S400".

## 13. SERVO AMPLIFIERS WITH A LARGE CAPACITY (30k TO 55kW)

### 13.9.3 External dynamic brake

POINT
<ul style="list-style-type: none"> <li>▪ Configure up a sequence which switches off the contact of the brake unit after (or as soon as) it has turned off the servo on (signal) at a power failure or failure.</li> <li>▪ For the braking time taken when the dynamic brake is operated, refer to section 13.8.3.</li> <li>▪ The brake unit is rated for a short duration. Do not use it for high duty.</li> <li>▪ The specifications of the input power supply for external dynamic brake are the same as those of the converter unit control circuit power supply.</li> <li>▪ Operation timing is the same as that for servo amplifiers with 22kW or less. Refer to section 11.6.</li> </ul>

#### (1) Selection of dynamic brake

The dynamic brake is designed to bring the servo motor to a sudden stop when a power failure occurs or the protective circuit is activated. When using the external dynamic brake, assign the dynamic brake interlock (DB) to any of CN3-9, CN3-13, and CN3-15 pins in parameter No.PD07 to PD09.

Converter unit	Drive unit	Dynamic brake
MR-J3-CR55K	MR-J3-DU30KB	DBU-37K
	MR-J3-DU37KB	
MR-J3-CR55K4	MR-J3-DU30KB4	DBU-55K-4
	MR-J3-DU37KB4	
	MR-J3-DU45KB4	
	MR-J3-DU55KB4	

#### (2) Connection example

Use the following wires to connect the dynamic brake.

Dynamic brake	Wire[mm <sup>2</sup> ] (Note)	
	a * b	U * V * W
DBU-37K	2	14
DBU-55K-4		

Note. Selection condition of wire size is as follows.

Wire type: 600V Polyvinyl chloride insulated wire (IV wire)

Construction condition: One wire is constructed in the air

### 13. SERVO AMPLIFIERS WITH A LARGE CAPACITY (30k TO 55kW)

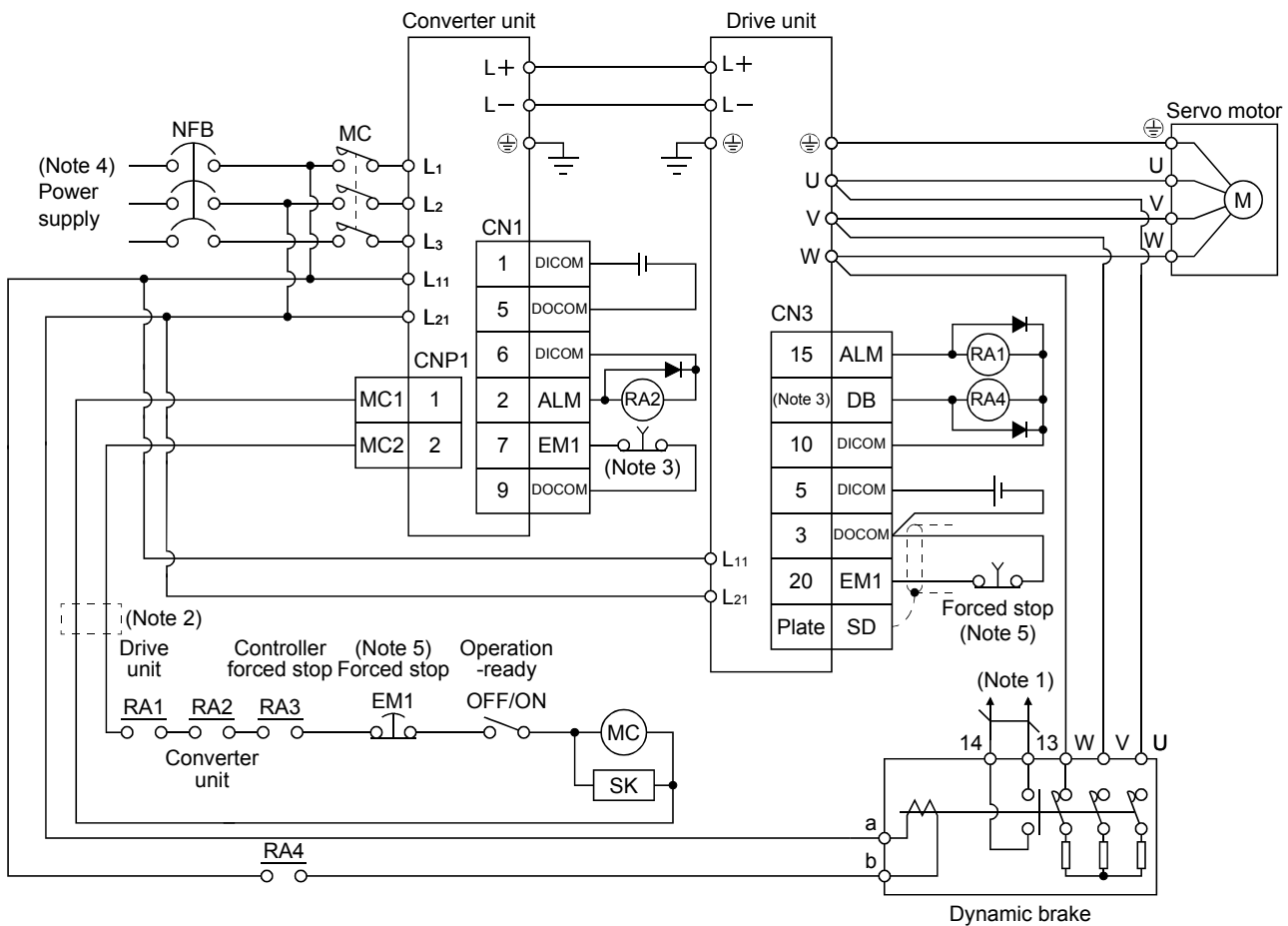

Note 1 Terminals 13, 14 are N/O contact outputs. When the dynamic brake has stuck, terminals 13, 14 are opened. Therefore, configure up the circuit to prevent servo-on in the external sequence.

2. For converter unit and servo amplifier 400 V class, stepdown transformer is required for coil voltage of magnetic contactor more than 200 V class.
3. Assign the dynamic brake interlock (DB) in parameter No.PD07 to PD09.
4. Refer to section 13.1.3 for the power supply specifications.
5. Make up a sequence that turns off the drive unit forced stop (EM1) and the converter unit forced stop (EM1) at the same time.

### 13. SERVO AMPLIFIERS WITH A LARGE CAPACITY (30k TO 55kW)

#### (3) Outline dimension drawing

[Unit:mm]

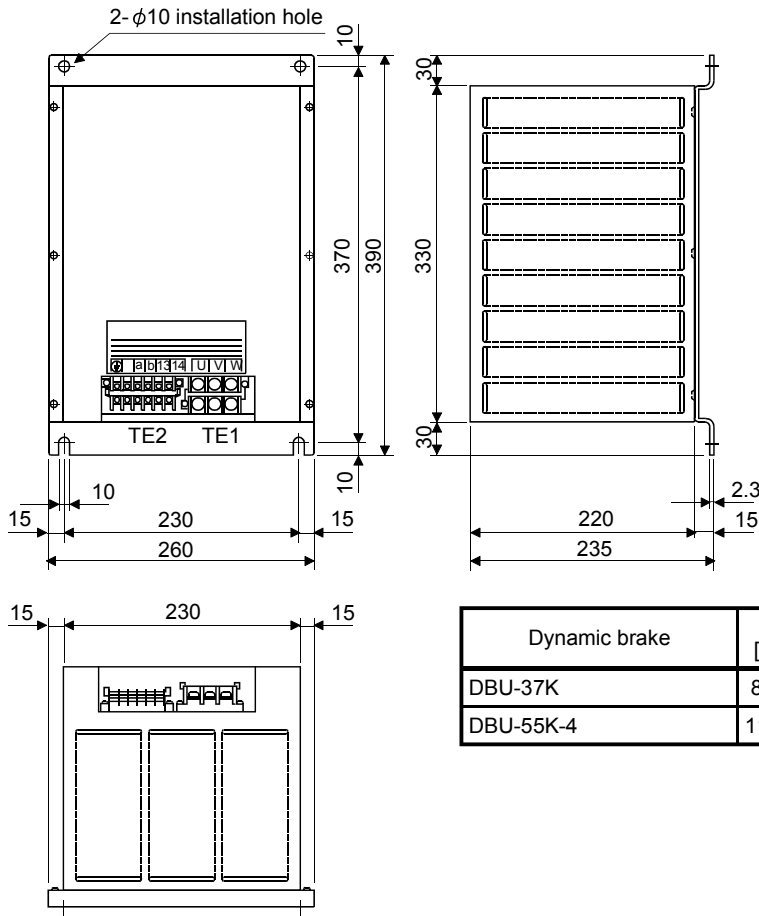

## 13. SERVO AMPLIFIERS WITH A LARGE CAPACITY (30k TO 55kW)

### 13.9.4 Selection example of wires

POINT
<ul style="list-style-type: none"> <li>Wires indicated in this section are separated wires. When using a cable for power line (U, V, and W) between the servo amplifier and servo motor, use a 600V grade EP rubber insulated chloroprene sheath cab-tire cable (2PNCT). For selection of cables, refer to appendix 6.</li> <li>To comply with the UL/C-UL (CSA) Standard, use UL-recognized copper wires rated at 60°C (140°F) or more for wiring. To comply with other standards, use a wire that is complied with each standard</li> <li>Selection condition of wire size is as follows. Construction condition: One wire is constructed in the air Wire length: 30m or less</li> </ul>

The following diagram shows the wires used for wiring. Use the wires given in this paragraph or equivalent.

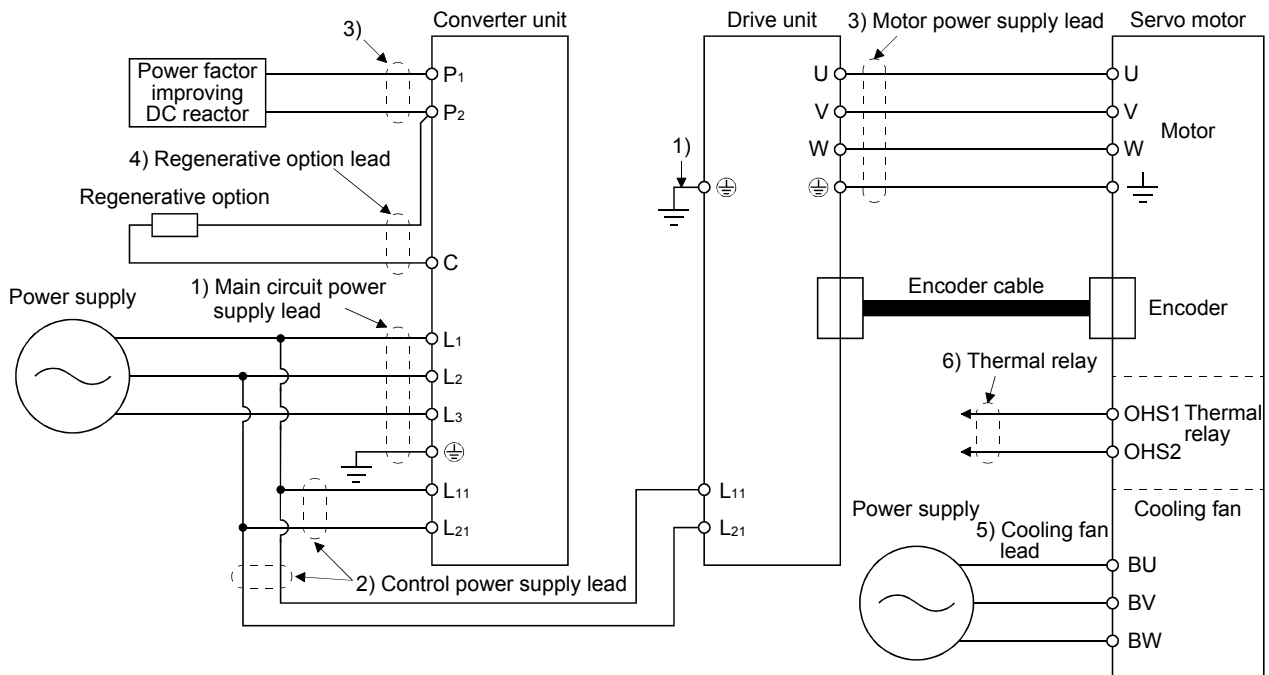

### 13. SERVO AMPLIFIERS WITH A LARGE CAPACITY (30k TO 55kW)

- (1) When using the 600V Polyvinyl chloride insulated wire (IV wire)  
Selection example of wire size when using IV wires is indicated below.

Table 13.4 Wire size selection example 1 (IV wire)

Converter unit	(Note 2) Drive unit	Wires[mm <sup>2</sup> ] (Note 1, 3)					
		1) L <sub>1</sub> · L <sub>2</sub> · L <sub>3</sub> · ⊕	2) L <sub>11</sub> · L <sub>21</sub>	3) U · V · W P <sub>1</sub> · P <sub>2</sub> · ⊕	4) P <sub>2</sub> · C	5) BU · BV · BW	6) OHS1 · OHS2
MR-J3-CR55K	MR-J3-DU30KB	50(AWG1/0): d	2(AWG14)	60(AWG2/0): d	5.5(AWG10): a	2(AWG14)	1.25(AWG16)
	MR-J3-DU37KB	60(AWG2/0): d		(Note 4)			
MR-J3-CR55K4	MR-J3-DU30KB4	22(AWG4): b		30(AWG2): c			
	MR-J3-DU37KB4	30(AWG2): c		38(AWG2): c			
	MR-J3-DU45KB4	38(AWG2): c		50(AWG1/0): d			
	MR-J3-DU55KB4	50(AWG1/0): d		60(AWG2/0): d			

- Note 1. Alphabets in the table indicate crimping tools. For crimping terminals and applicable tools, refer to (3) in this section.  
2. When connecting to the terminal block, be sure to use the screws which are provided with the terminal block.  
3. For the servo motor with a cooling fan.  
4. Wires are selected based on the highest rated current among combining servo motors.

- (2) When using the 600V Grade heat-resistant polyvinyl chloride insulated wire (HIV wire)  
Selection example of wire size when using HIV wires is indicated below.

Table 13.5 Wire size selection example 2 (HIV wire)

Converter unit	(Note 2) Drive unit	Wires[mm <sup>2</sup> ] (Note 1, 3)					
		1) L <sub>1</sub> · L <sub>2</sub> · L <sub>3</sub> · ⊕	2) L <sub>11</sub> · L <sub>21</sub>	3) U · V · W P <sub>1</sub> · P <sub>2</sub> · ⊕	4) P <sub>2</sub> · C	5) BU · BV · BW	6) OHS1 · OHS2
MR-J3-CR55K	MR-J3-DU30KB	38(AWG2): c	2(AWG14)	60(AWG2/0): d	5.5(AWG10): a	2(AWG14)	1.25(AWG16)
	MR-J3-DU37KB	60(AWG2/0): d		60(AWG2/0): d			
MR-J3-CR55K4	MR-J3-DU30KB4	22(AWG4): b		22(AWG4): e			
	MR-J3-DU37KB4	22(AWG4): b		22(AWG4): e			
	MR-J3-DU45KB4	38(AWG2): c		38(AWG2): c			
	MR-J3-DU55KB4	38(AWG2): c		38(AWG2): c			

- Note 1. Alphabets in the table indicate crimping tools. For crimping terminals and applicable tools, refer to (3) in this section.  
2. When connecting to the terminal block, be sure to use the screws which are provided with the terminal block.  
3. For the servo motor with a cooling fan.

- (3) Selection example of crimping terminals

The table below shows a selection example of crimping terminals for the servo amplifier terminal block when using the wires mentioned in (1) and (2) in this section.

Symbol	Servo amplifier side crimping terminals				Manufacturer
	(Note 2) Crimping terminal	Applicable tool			
		Body	Head	Dice	
a	FVD5.5-10	YNT-1210S			Japan Solderless Terminal
b	FVD22-10	YF-1 · E-4	YNE-38	DH-123 · DH113	
(Note 1) c	R38-8	YPT-60-21		TD-124 · TD112	
	R38-10	YF-1 · E-4	YET-60-1		
(Note 1) d	R60-10	YPT-60-21		TD-125 · TD113	
		YF-1 · E-4	YET-60-1		
e	FVD22-8	YF-1 · E-4	YNE-38	DH-123 · DH-113	

- Note 1. Coat the part of crimping with the insulation tube.  
2. Make sure to use recommended crimping terminals or equivalent since some crimping terminals cannot be installed depending on the size.

### 13. SERVO AMPLIFIERS WITH A LARGE CAPACITY (30k TO 55kW)

#### 13.9.5 No-fuse breakers, fuses, magnetic contactors.

Always use one no-fuse breakers and one magnetic contactor with one drive unit.

Converter unit	Drive unit	No-fuse breaker		Fuse			Magnetic contactor
		Power factor improving DC reactor is not used	Power factor improving DC reactor is used	Class	Current [A]	Voltage AC [V]	
MR-J3-CR55K	MR-J3-DU30KB	400A frame 250A	225A frame 225A	T	450	250	S-N150
	MR-J3-DU37KB	400A frame 300A	400A frame 300A		500		S-N180
MR-J3-CR55K4	MR-J3-DU30KB4	225A frame 150A	225A frame 125A		225	600	S-N95
	MR-J3-DU37KB4	225A frame 175A	225A frame 150A		250		S-N125
	MR-J3-DU45KB4	225A frame 225A	225A frame 175A		350		S-N150
	MR-J3-DU55KB4	400A frame 250A	225A frame 225A		400		S-N180

#### 13.9.6 Power factor improving DC reactor

The input power factor is improved to about 95%.

[Unit: mm]

Converter unit	Drive unit	Power factor improving DC reactor	W	D	H	W1	X	Terminal screw	Mass [kg (lb)]			
MR-J3-CR55K	MR-J3-DU30KB	MR-DCL30K	135	255	215	80	232	M12	9.5 (20.94)			
	MR-J3-DU37KB	MR-DCL37K		205	200	80	175	M8	6.5 (14.33)			
MR-J3-CR55K4	MR-J3-DU30KB4	MR-DCL30K-4							225	197	7	
	MR-J3-DU37KB4	MR-DCL37K-4							240	212	7.5 (16.54)	
	MR-J3-DU45KB4	MR-DCL45K-4							260	215	232	9.5 (20.94)
	MR-J3-DU55KB4	MR-DCL55K-4										

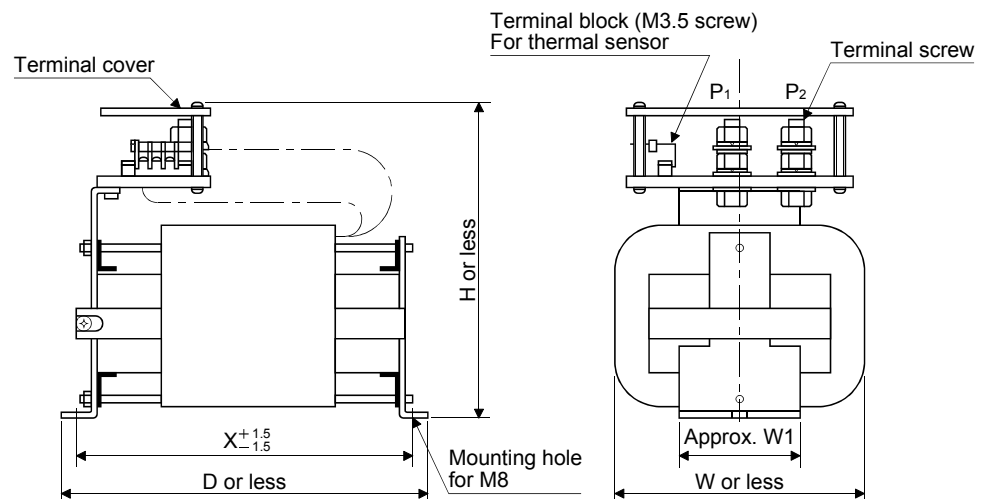

## 13. SERVO AMPLIFIERS WITH A LARGE CAPACITY (30k TO 55kW)

### 13.9.7 Line noise filter (FR-BLF)

POINT
<ul style="list-style-type: none"> <li>This section explains how to use the line noise filter unique to servo amplifiers with a large capacity. Other noise reduction products are the same as those for servo amplifiers with 22kW or less. Refer to section 11.17.</li> </ul>

This filter is effective in suppressing noises radiated from the power supply side and output side of the converter unit, drive unit and also in suppressing high-frequency leakage current (zero-phase current) especially within 0.5MHz to 5MHz band. The filters are used with the converter power supply wires ( $L_1 \cdot L_2 \cdot L_3$ ) and drive unit power wires ( $U \cdot V \cdot W$ ).

#### (1) Usage

Pass the 3-phase wires through four line noise filters. When using the line noise filters with the power wires, passing the power wires together with the ground wire will reduce the filter effect. Run the ground wire separately from the power wires.

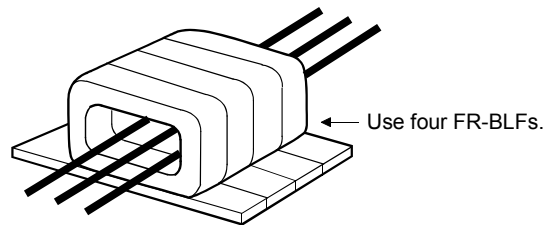

#### (2) Outline drawing

[Unit: mm]

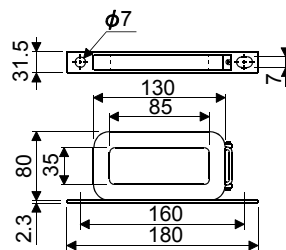

### 13. SERVO AMPLIFIERS WITH A LARGE CAPACITY (30k TO 55kW)

#### 13.9.8 Leakage current breaker

##### (1) Selection method

High-frequency chopper currents controlled by pulse width modulation flow in the AC servo circuits. Leakage currents containing harmonic contents are larger than those of the motor which is run with a commercial power supply.

Select a leakage current breaker according to the following formula, and ground the drive unit, servo motor, etc. securely.

Make the input and output cables as short as possible, and also make the grounding cable as long as possible (about 30cm) to minimize leakage currents.

$$\text{Rated sensitivity current} \geq 10 \cdot \{I_{g1} + I_{gn} + I_{ga} + K \cdot (I_{g2} + I_{gm})\} + [\text{mA}] \quad (13.2)$$

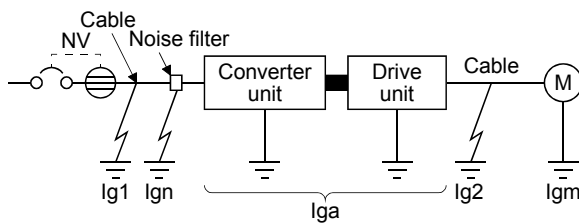

K: Constant considering the harmonic contents

Leakage current breaker		K
Type	Mitsubishi products	
Models provided with harmonic and surge reduction techniques	NV-SP	1
	NV-SW	
	NV-CP	
	NV-CW	
	NV-HW	
General models	BV-C1	3
	NFB	
	NV-L	

I<sub>g1</sub>: Leakage current on the electric channel from the leakage current breaker to the input terminals of the drive unit (Found from Fig. 13.3.)

I<sub>g2</sub>: Leakage current on the electric channel from the output terminals of the servo amplifier to the servo motor (Found from Fig. 13.3.)

I<sub>gn</sub>: Leakage current when a filter is connected to the input side (4.4mA per one FR-BIF or FR-BIF-H)

I<sub>ga</sub>: Leakage current of the drive unit (Found from Table 13.7.)

I<sub>gm</sub>: Leakage current of the servo motor (Found from Table 13.6.)

Table 13.6 Servo motor's leakage current example (I<sub>gm</sub>)

Servo motor power [kW]	Leakage current [mA]
30 to 55	2.5

Table 13.7 Converter unit · drive unit's leakage current Example (I<sub>ga</sub>)

Converter unit Drive unit	Leakage current [mA]
All series	5

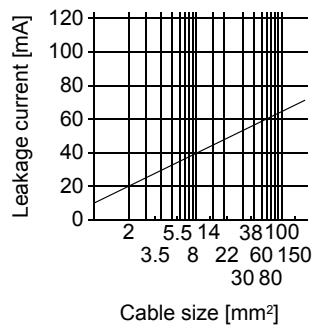

a) 200V class

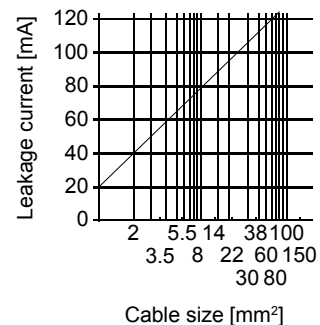

b) 400V class

Fig.13.3 Leakage current example (I<sub>g1</sub>, I<sub>g2</sub>) for CV cable run in metal conduit

### 13. SERVO AMPLIFIERS WITH A LARGE CAPACITY (30k TO 55kW)

#### (2) Selection example

Indicated below is an example of selecting a leakage current breaker under the following conditions.

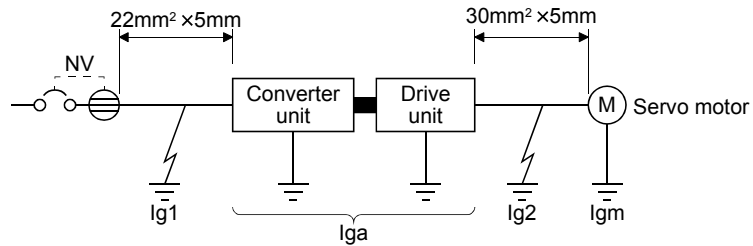

Use a leakage current breaker designed for suppressing harmonics/surges.

Find the terms of Equation (13.2) from the diagram.

$$I_{g1} = 95 \times \frac{5}{1000} = 0.475 \text{ [mA]}$$

$$I_{g2} = 105 \times \frac{5}{1000} = 0.525 \text{ [mA]}$$

$$I_{gn} = 0 \text{ (not used)}$$

$$I_{ga} = 5 \text{ [mA]}$$

$$I_{gm} = 2.5 \text{ [mA]}$$

Insert these values in Equation (13.2).

$$I_g \geq 10 \cdot \{0.475 + 0 + 5 + 1 \cdot (0.525 + 2.5)\} \\ \geq 85 \text{ [mA]}$$

According to the result of calculation, use a leakage current breaker having the rated sensitivity current ( $I_g$ ) of 85[mA] or more. A leakage current breaker having  $I_g$  of 200[mA] is used with the NV-SP/SW/CP/CW/HW series.

## 13. SERVO AMPLIFIERS WITH A LARGE CAPACITY (30k TO 55kW)

### 13.9.9 EMC filter (recommended)

For compliance with the EMC directive of the EN Standard, it is recommended to use the following filter. Some EMC filters are large in leakage current.

#### (1) Converter unit • Drive unit

Converter unit	Drive unit	Recommended filter (Soshin Electric)		Mass [kg]
		Model	Leakage current [mA]	
MR-J3-CR55K	MR-J3-DU30KB • MR-J3-DU37KB	HF3200A-UN	9	18
MR-J3-CR55K4	MR-J3-DU30KB4 to MR-J3-DU55KB4	TF3150C-TX	5.5	31

#### (2) Connection example

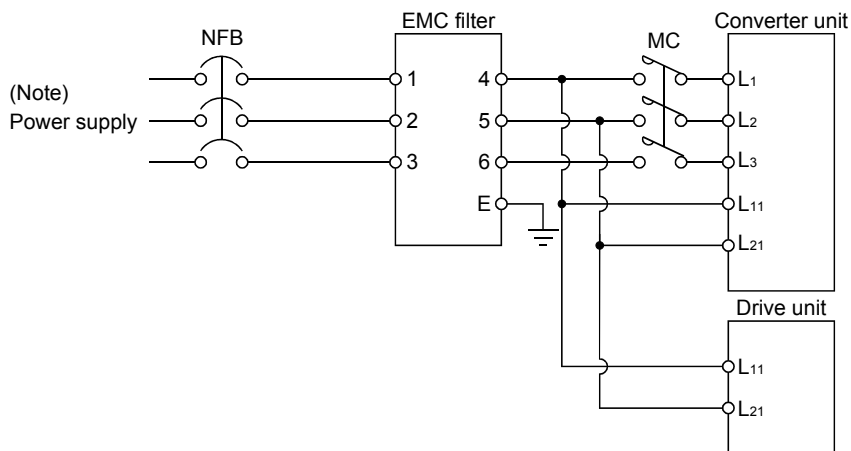

Note. For power supply specifications, refer to section 13.1.3.

### 13. SERVO AMPLIFIERS WITH A LARGE CAPACITY (30k TO 55kW)

(3) Outline drawing

HF3200A-UN

[Unit: mm]

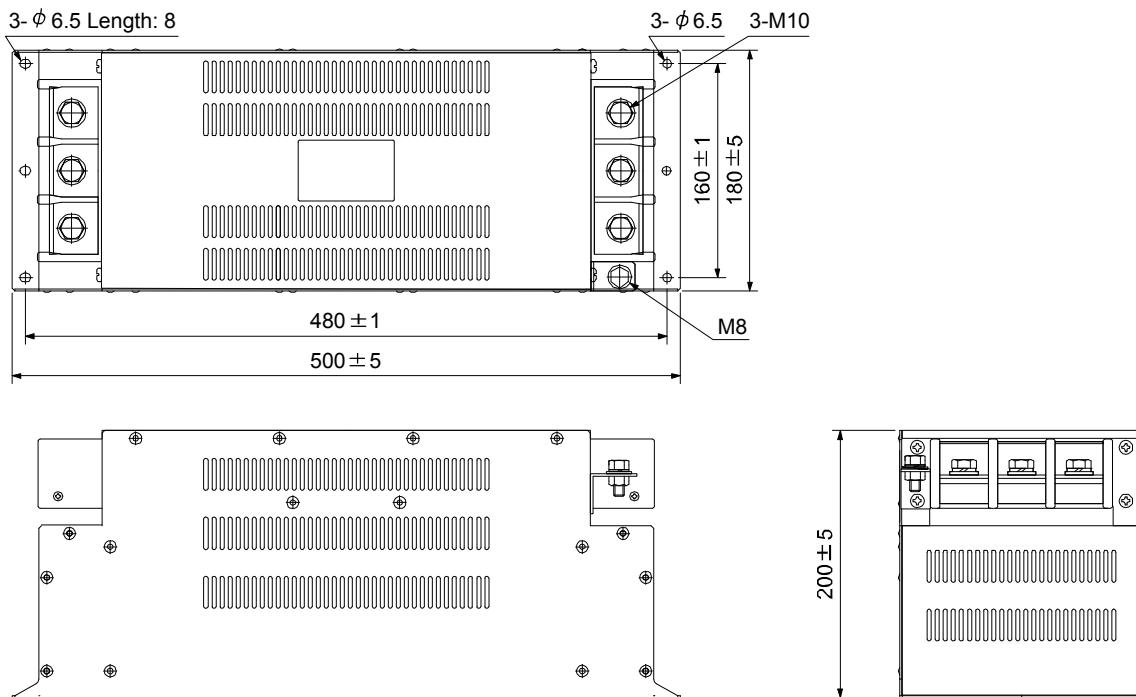

TF3150C-TX

[Unit: mm]

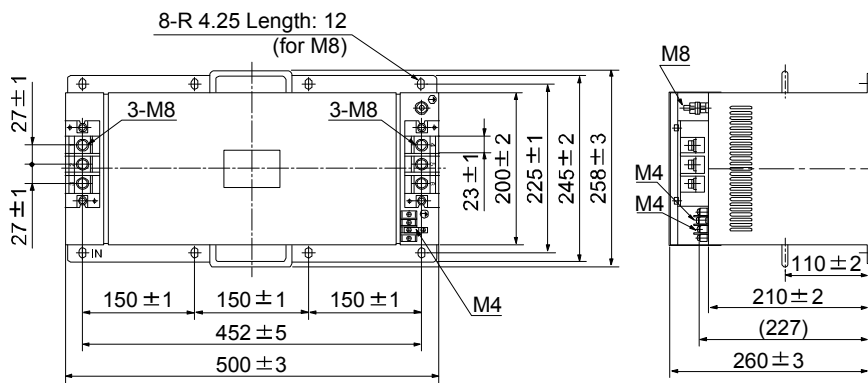

## 13. SERVO AMPLIFIERS WITH A LARGE CAPACITY (30k TO 55kW)

### 13.9.10 FR-BU2-(H) Brake Unit

POINT							
	<ul style="list-style-type: none"> <li>Use a 200V class brake unit and a resistor unit with a 200V class converter unit, and a 400V class brake unit and a resistor unit with a 400V class converter unit. Combination of different voltage class units cannot be used.</li> <li>Install a brake unit and a resistor unit on a flat surface vertically. When the unit is installed horizontally or diagonally, the heat dissipation effect diminishes.</li> <li>Temperature of the resistor unit case rises to higher than 100°C. Keep cables and flammable materials away from the case.</li> <li>Ambient temperature condition of the brake unit is between –10°C to +50°C. Note that the condition is different from the ambient temperature condition of the converter unit (between 0°C to +55°C).</li> <li>Configure the circuit to shut down the power-supply with the alarm output of the brake unit and the resistor unit under abnormal condition.</li> <li>Use the brake unit with a combination indicated in (1) of this section.</li> <li>For executing a continuous regenerative operation, use FR-RC-(H) power regeneration converter or FR-CV-(H) power regeneration common converter.</li> <li>When using the brake unit, set the parameters as shown below.</li> </ul>						
	<table border="1"> <thead> <tr> <th></th> <th>Setting value</th> </tr> </thead> <tbody> <tr> <td>Parameter No.PA01 of the MR-J3-CR55K(4) converter unit</td> <td><input type="checkbox"/><input type="checkbox"/>00 (Initial value)</td> </tr> <tr> <td>Parameter No.PA02 of the drive unit</td> <td><input type="checkbox"/><input type="checkbox"/>00 (Initial value)</td> </tr> </tbody> </table>		Setting value	Parameter No.PA01 of the MR-J3-CR55K(4) converter unit	<input type="checkbox"/> <input type="checkbox"/> 00 (Initial value)	Parameter No.PA02 of the drive unit	<input type="checkbox"/> <input type="checkbox"/> 00 (Initial value)
	Setting value						
Parameter No.PA01 of the MR-J3-CR55K(4) converter unit	<input type="checkbox"/> <input type="checkbox"/> 00 (Initial value)						
Parameter No.PA02 of the drive unit	<input type="checkbox"/> <input type="checkbox"/> 00 (Initial value)						

Connect the brake unit to the bus of the converter unit (L+ and L– of TE2-1) for use. As compared to the MR-RB regenerative brake option, the brake unit can return larger power. Use the brake unit when the regenerative brake option cannot provide sufficient regenerative brake capability.

When using the brake unit, always refer to the FR-BU2-(H) Brake Unit Instruction Manual.

#### (1) Selection

Use a combination of converter unit, brake unit and resistor unit listed below.

	Brake unit	Resistor unit	Number of connected units	Permissible continuous power [kW]	Total resistance [ $\Omega$ ]	Applicable converter unit
200V class	FR-BU2-55K	FR-BR-55K	2 (parallel)	7.82	1	MR-J3-CR55K
		MT-BR5-55K	2 (parallel)	11.0	1	MR-J3-CR55K
400V class	FR-BU2-H55K	FR-BR-H55K	2 (parallel)	7.82	4	MR-J3-CR55K4
	FR-BU2-H75K	MT-BR5-H75K	2 (parallel)	15.0	3.25	MR-J3-CR55K4

### 13. SERVO AMPLIFIERS WITH A LARGE CAPACITY (30k TO 55kW)

#### (2) Brake unit parameter setting

Normally, changing parameters of the FR-BU2-(H) is not necessary. Whether a parameter can be changed or not is listed below.

Parameter		Change possible/ impossible	Remarks
No.	Name		
0	Brake mode switchover	Impossible	Do not change the parameter.
1	Monitor display data selection	Possible	Refer to FR-BU2-(H) Brake Unit Instruction Manual.
2	Input terminal function selection 1	Impossible	Do not change the parameter
3	Input terminal function selection 2		
77	Parameter write selection		
78	Cumulative energization time carrying-over times		
CLr	Parameter clear		
ECL	Alarm history clear		
C1	For manufacturer setting		

#### (3) Connection example

POINT
<ul style="list-style-type: none"> <li>Connecting PR terminal of the brake unit to L+ terminal of the converter unit results in a brake unit malfunction. Always connect the PR terminal of the brake unit to the PR terminal of the resistor unit.</li> </ul>

#### (a) Combination with FR-BR-(H) resistor unit

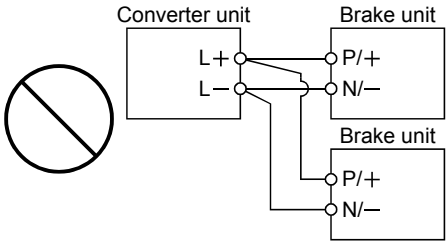
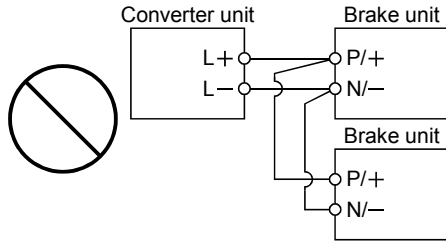
POINT	
<ul style="list-style-type: none"> <li>To use brake units with a parallel connection, use two sets of FR-BU2-(H) brake unit. Combination with other brake unit results in alarm occurrence or malfunction.</li> <li>Always connect the master and slave terminals (MSG and SD) of the two brake units.</li> <li>Do not connect as shown below.</li> </ul>	
 <p>Connecting two cables to P and N terminals</p>	 <p>Passing wiring</p>

### 13. SERVO AMPLIFIERS WITH A LARGE CAPACITY (30k TO 55kW)

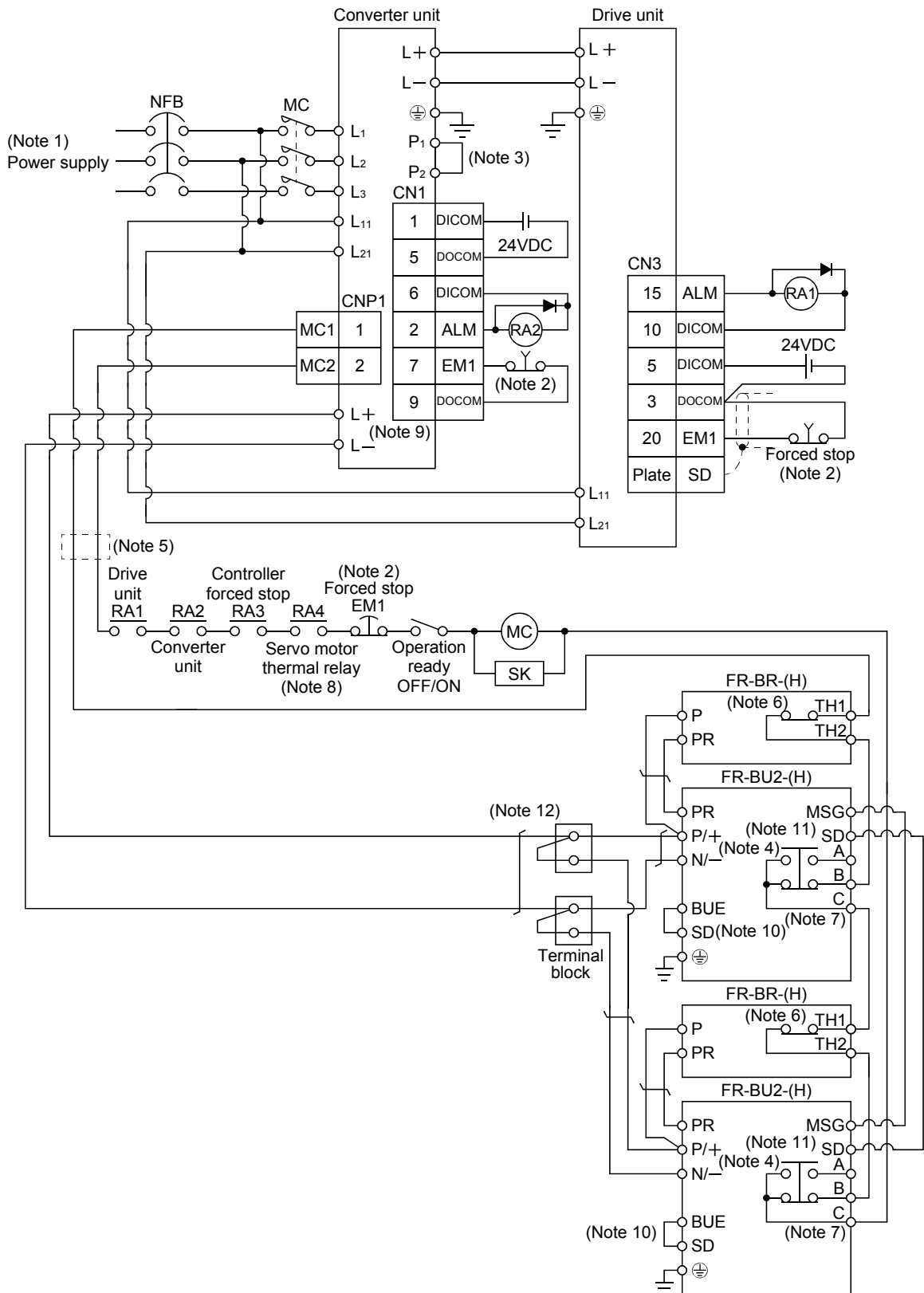

## 13. SERVO AMPLIFIERS WITH A LARGE CAPACITY (30k TO 55kW)

Note 1. For power supply specifications, refer to section 13.1.3.

2. Configure the circuit to turn OFF the forced stop (EM1) of the drive unit and the converter unit at the same time.
3. Always connect P<sub>1</sub> and P<sub>2</sub> terminals (Factory-wired). When using the power factor improving DC reactor, refer to section 13.9.6.
4. Connect P/+ and N/- terminals of the brake unit to a correct destination. Wrong connection results in the converter unit and brake unit malfunction.
5. For the converter unit and the drive unit of 400V class, a stepdown transformer is required.
6. Contact rating: 1b contact, 110VAC\_5A/220VAC\_3A  
Normal condition: TH1-TH2 is conducting. Abnormal condition: TH1-TH2 is not conducting.
7. Contact rating: 230VAC\_0.3A/30VDC\_0.3A  
Normal condition: B-C is conducting/A-C is not conducting. Abnormal condition: B-C is not conducting/A-C is conducting.
8. Connect the thermal relay sensor of the servo motor.
9. Do not connect more than one cable to each L+ and L- terminals of TE2-1 of the converter unit.
10. Always connect BUE and SD terminals (Factory-wired).
11. Connect MSG and SD terminals of the brake unit to a correct destination. Wrong connection results in the converter unit and brake unit malfunction.
12. For connecting L+ and L- terminals of TE2-1 of the converter unit to the terminal block, use the cable indicated in (3) (d) of this section.

### 13. SERVO AMPLIFIERS WITH A LARGE CAPACITY (30kW TO 55kW)

(b) Combination with MT-BR5-(H) resistor unit

1) When connecting a brake unit to a converter unit

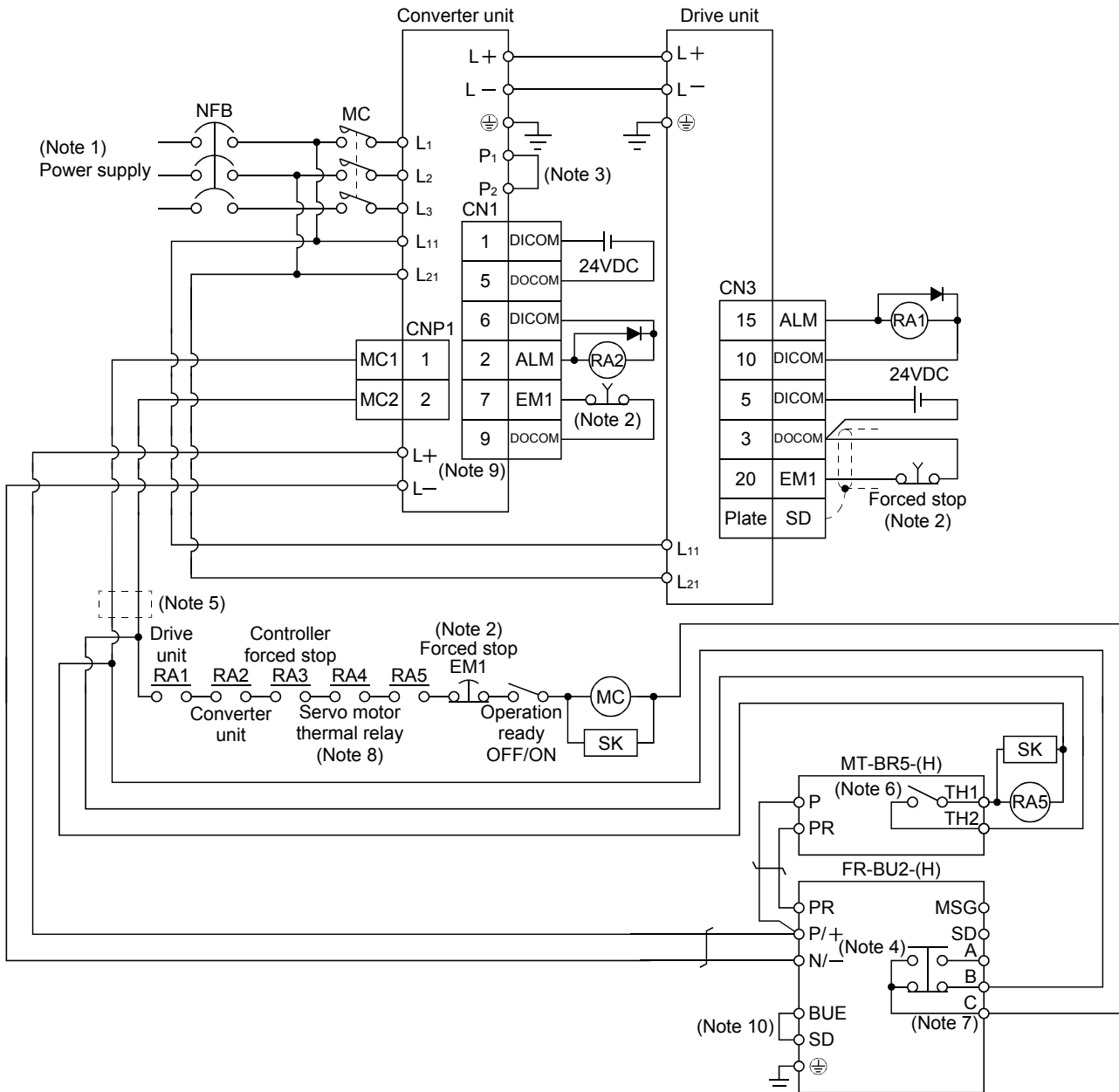

Note 1. For power supply specifications, refer to section 13.1.3.

2. Configure the circuit to turn OFF the forced stop (EM1) of the drive unit and the converter unit at the same time.

3. Always connect P<sub>1</sub> and P<sub>2</sub> terminals (Factory-wired). When using the power factor improving DC reactor, refer to section 13.9.6.

4. Connect P/+ and N/- terminals of the brake unit to a correct destination. Wrong connection results in the converter unit and brake unit malfunction.

5. For the converter unit and the drive unit of 400V class, a stepdown transformer is required.

6. Contact rating: 1a contact, 110VAC\_5A/220VAC\_3A

Normal condition: TH1-TH2 is not conducting. Abnormal condition: TH1-TH2 is conducting.

7. Contact rating: 230VAC\_0.3A/30VDC\_0.3A

Normal condition: B-C is conducting/A-C is not conducting. Abnormal condition: B-C is not conducting/A-C is conducting.

8. Connect the thermal relay censor of the servo motor.

9. Do not connect more than one cable to each L+ and L- terminals of TE2-1 of the converter unit.

10. Always connect BUE and SD terminals (Factory-wired).

### 13. SERVO AMPLIFIERS WITH A LARGE CAPACITY (30k TO 55kW)

2) When connecting two brake units to a converter unit

POINT
<ul style="list-style-type: none"><li>▪ To use brake units with a parallel connection, use two sets of FR-BU2-(H) brake unit. Combination with other brake unit results in alarm occurrence or malfunction.</li><li>▪ Always connect the master and slave terminals (MSG and SD) of the two brake units.</li><li>▪ Do not connect the converter unit and brake units as below. Connect the cables with a terminal block to distribute as indicated in this section.</li></ul>
<p>Connecting two cables to P and N terminals</p> <p>Passing wiring</p>

### 13. SERVO AMPLIFIERS WITH A LARGE CAPACITY (30k TO 55kW)

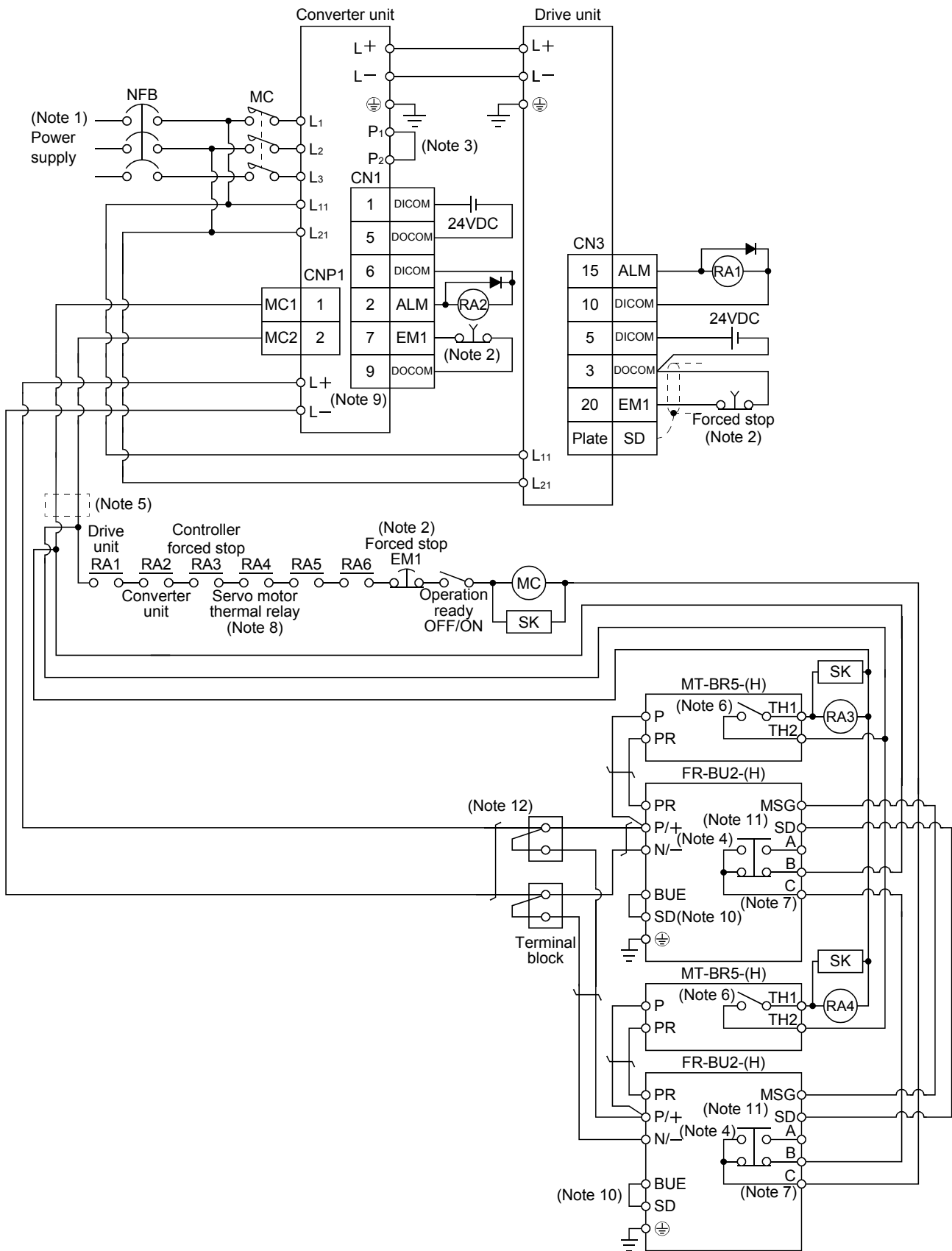

### 13. SERVO AMPLIFIERS WITH A LARGE CAPACITY (30k TO 55kW)

Note 1. For power supply specifications, refer to section 13.1.3.

2. Configure the circuit to turn OFF the forced stop (EM1) of the drive unit and the converter unit at the same time.
3. Always connect P<sub>1</sub> and P<sub>2</sub> terminals (Factory-wired). When using the power factor improving DC reactor, refer to section 13.9.6.
4. Connect P/+ and N/- terminals of the brake unit to a correct destination. Wrong connection results in the converter unit and brake unit malfunction.
5. For the converter unit and the drive unit of 400V class, a stepdown transformer is required.
6. Contact rating: 1a contact, 110VAC\_5A/220VAC\_3A  
Normal condition: TH1-TH2 is conducting. Abnormal condition: TH1-TH2 is not conducting.
7. Contact rating: 230VAC\_0.3A/30VDC\_0.3A  
Normal condition: B-C is conducting/A-C is not conducting. Abnormal condition: B-C is not conducting/A-C is conducting.
8. Connect the thermal relay sensor of the servo motor.
9. Do not connect more than one cable to each L+ and L- terminals of TE2-1 of the converter unit.
10. Always connect BUE and SD terminals (Factory-wired).
11. Connect MSG and SD terminals of the brake unit to a correct destination. Wrong connection results in the converter unit and brake unit malfunction.
12. For connecting L+ and L- terminals of TE2-1 of the converter unit to the terminal block, use the cable indicated in (3) (d) of this section.

#### (c) Precautions for wiring

The cables between the converter unit and the brake unit, and between the resistor unit and the brake unit should be as short as possible. Always twist the cable longer than 5m (twist five times or more per one meter). Even when the cable is twisted, the cable should be less than 10m. Using cables longer than 5m without twisting or twisted cables longer than 10m, may result in the brake unit malfunction.

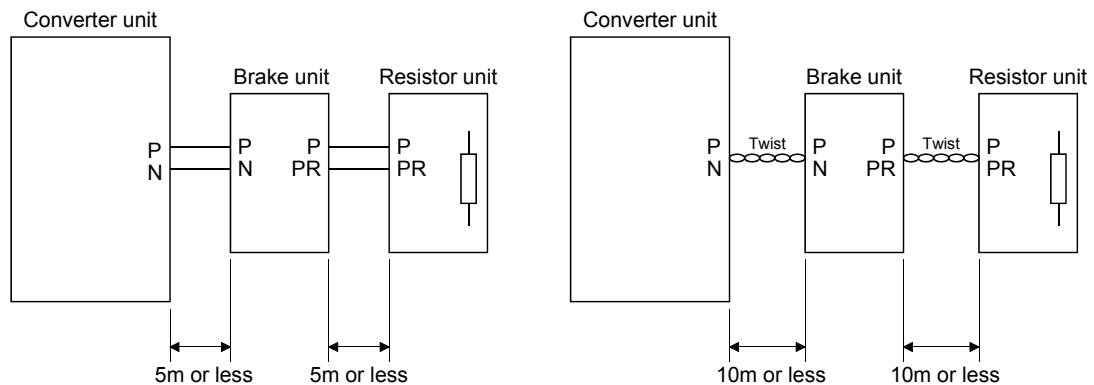

#### (d) Cables

##### 1) Cables for the brake unit

For the brake unit, HIV cable (600V grade heat-resistant PVC insulated wire) is recommended.

##### a) Main circuit terminal

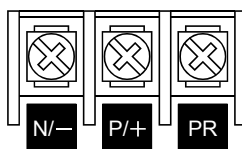

Terminal block

	Brake unit	Main circuit terminal screw size	Crimping terminal N/-, P/+, PR, ⊕	Tightening torque [N · m]	Wire size	
					N/-, P/+, PR, ⊕	
					HIV wire [mm <sup>2</sup> ]	AWG
200V class	FR-BU2-55K	M6	14-6	4.4	14	6
400V class	FR-BU2-H55K	M5	5.5-5	2.5	5.5	10
	FR-BU2-H75K	M6	14-6	4.4	14	6

### 13. SERVO AMPLIFIERS WITH A LARGE CAPACITY (30k TO 55kW)

b) Control circuit terminal

**POINT**

- Under tightening can cause a cable disconnection or malfunction. Over tightening can cause a short circuit or malfunction due to damage to the screw or the brake unit.



Terminal block

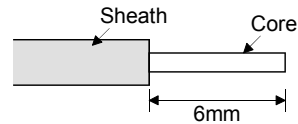

Wire the stripped cable after twisting to prevent the cable from becoming loose. In addition, do not solder it.

Screw size: M3

Tightening torque: 0.5N · m to 0.6N · m

Wire size: 0.3mm<sup>2</sup> to 0.75 mm<sup>2</sup>

Screw driver: Small flat-blade screwdriver

(Tip thickness: 0.4mm/Tip width 2.5mm)

2) Cables for connecting the servo amplifier and a distribution terminal block when connecting two sets of the brake unit

Brake unit		Wire size	
		HIV wire [mm <sup>2</sup> ]	AWG
200V class	FR-BU2-55K	38	2
400V class	FR-BU2-H55K	14	6
	FR-BU2-H75K	38	2

### 13. SERVO AMPLIFIERS WITH A LARGE CAPACITY (30k TO 55kW)

(e) Crimping terminals for L+ and L– terminals of TE2-1 of servo amplifier

1) Recommended crimping terminals

POINT
<ul style="list-style-type: none"> <li>Always use recommended crimping terminals or equivalent since some crimping terminals cannot be installed depending on the size.</li> </ul>

	Converter unit	Brake unit	Number of connected units	Crimping terminal (Manufacturer)	(Note 1) Applicable tool
200V class	MR-J3-CR55K	FR-BU2-55K	2	38-S6(Japan Solderless Terminal) (Note 2) R38-6S (NICHIFU) (Note 2)	a
400V class	MR-J3-CR55K4	FR-BU2-H55K	2	FVD14-6(Japan Solderless Terminal)	b
		FR-BU2-H75K	2	38-S6(Japan Solderless Terminal) (Note 2) R38-6S (NICHIFU) (Note 2)	a

Note 1. Symbols in the applicable tool field indicate the following applicable tools.

Symbol	Servo amplifier side crimping terminals				Manufacturer
	Crimping terminal	Crimping terminal			
		Body	Head	Dice	
a	38-S6	YPT-60-21	YET-60-1	TD-124 · TD-112	Japan Solderless Terminal
		YF-1 · E-4			
	R38-6S	NOP60 NOM60			NICHIFU
b	FDV14-6	YF-1 · E-4	YNE-38	DH-112 · DH-122	Japan Solderless Terminal

2. Coat the crimping part with an insulation tube.

### 13. SERVO AMPLIFIERS WITH A LARGE CAPACITY (30k TO 55kW)

- (4) Outline dimension drawings  
(a) FR-BU2- (H) brake unit

[Unit: mm]

FR-BU2-55K  
FR-BU2-H55K, H75K

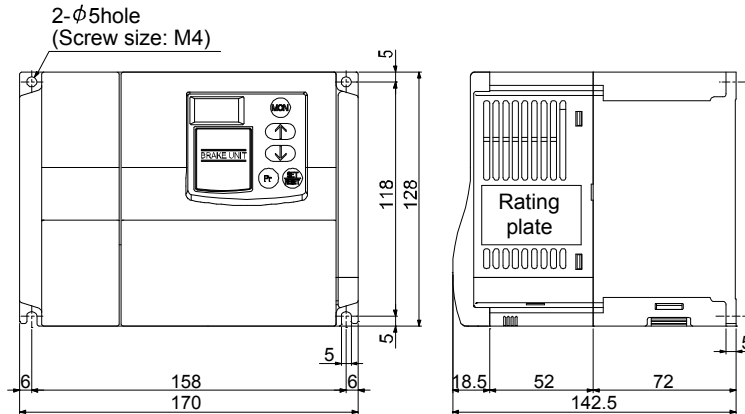

- (b) FR-BR- (H) resistor unit

[Unit: mm]

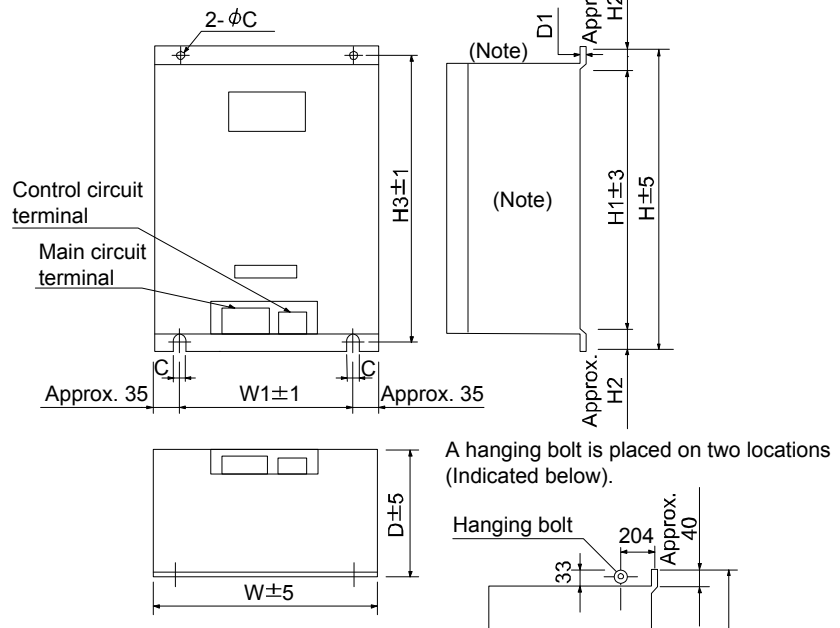

Note. Ventilation ports are provided on both sides and the top. The bottom is open.

Resistor unit		W	W1	H	H1	H2	H3	D	D1	C	Approximate mass [kg]
200V class	FR-BR-55K	480	410	700	620	40	670	450	3.2	12	70
400V class	FR-BR-H55K	480	410	700	620	20	670	450	3.2	12	70

### 13. SERVO AMPLIFIERS WITH A LARGE CAPACITY (30k TO 55kW)

(c) MT-BR5- (H) resistor unit

[Unit: mm]

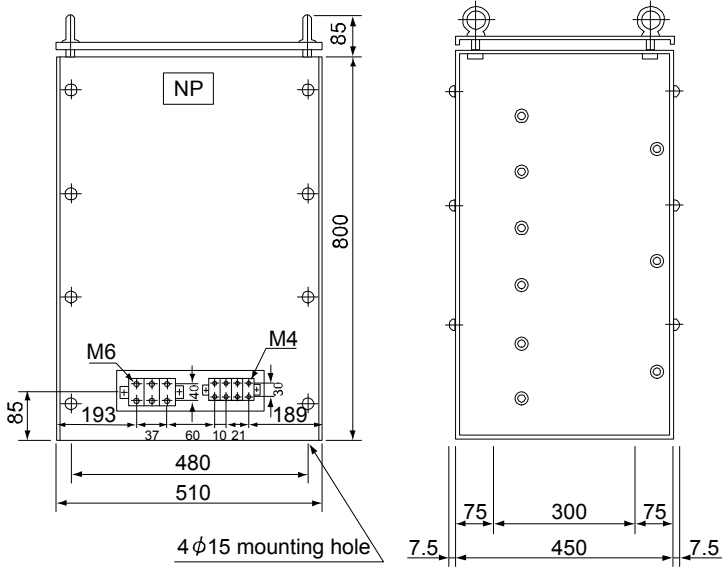

Resistor unit	Resistance value	Approximate mass [kg]
200V class MT-BR5-55K	2.0 Ω	50
400V class MT-BR5-H75K	6.5 Ω	70



## APPENDIX

### App. 1 Parameter list

POINT
<ul style="list-style-type: none"> <li>Parameter whose symbol is preceded by * is made valid with the following conditions.</li> <li>* : Set the parameter value, switch power off once after setting, and then switch it on again, or perform the controller reset.</li> <li>** : Set the parameter value, switch power off once, and then switch it on again.</li> </ul>

#### App. 1.1 Servo amplifier (drive unit)

Basic setting parameters (PA □□)		
No.	Symbol	Name
PA01		For manufacturer setting
PA02	**REG	Regenerative option
PA03	*ABS	Absolute position detection system
PA04	*AOP1	Function selection A-1
PA05 to PA07		For manufacturer setting
PA08	ATU	Auto tuning mode
PA09	RSP	Auto tuning response
PA10	INP	In-position range
PA11 to PA13		For manufacturer setting
PA14	*POL	Rotation direction selection
PA15	*ENR	Encoder output pulses
PA16 to PA18		For manufacturer setting
PA19	*BLK	Parameter write inhibit

Gain/filter parameters (PB □□)		
No.	Symbol	Name
PB01	FILT	Adaptive tuning mode (Adaptive filter II)
PB02	VRFT	Vibration suppression control filter tuning mode (advanced vibration suppression control)
PB03		For manufacturer setting
PB04	FFC	Feed forward gain
PB05		For manufacturer setting
PB06	GD2	For manufacturer setting Ratio of load inertia moment to servo motor inertia moment
PB07	PG1	Model loop gain
PB08	PG2	Position loop gain
PB09	VG2	Speed loop gain
PB10	VIC	Speed integral compensation
PB11	VDC	Speed differential compensation
PB12		For manufacturer setting
PB13	NH1	Machine resonance suppression filter 1
PB14	NHQ1	Notch form selection 1
PB15	NH2	Machine resonance suppression filter 2
PB16	NHQ2	Notch form selection 2
PB17		Automatic setting parameter
PB18	LPF	Low-pass filter
PB19	VRF1	Vibration suppression control vibration frequency setting
PB20	VRF2	Vibration suppression control resonance frequency setting
PB21 to PB22		For manufacturer setting
PB23	VFBF	Low-pass filter selection
PB24	*MVS	Slight vibration suppression control selection
PB25		For manufacturer setting
PB26	*CDP	Gain changing selection
PB27	CDL	Gain changing condition
PB28	CDT	Gain changing time constant
PB29	GD2B	Gain changing ratio of load inertia moment to servo motor inertia moment
PB30	PG2B	Gain changing position loop gain
PB31	VG2B	Gain changing speed loop gain
PB32	VICB	Gain changing speed integral compensation
PB33	VRF1B	Gain changing vibration suppression control vibration frequency setting
PB34	VRF2B	Gain changing vibration suppression control resonance frequency setting
PB35 to PB45		For manufacturer setting

## APPENDIX

Extension setting parameters (PC □□)		
No.	Symbol	Name
PC01	*ERZ	Error excessive alarm level
PC02	MBR	Electromagnetic brake sequence output
PC03	*ENRS	Encoder output pulses selection
PC04	**COP1	Function selection C-1
PC05	**COP2	Function selection C-2
PC06	*COP3	Function selection C-3
PC07	ZSP	Zero speed
PC08		For manufacturer setting
PC09	MOD1	Analog monitor 1 output
PC10	MOD2	Analog monitor 2 output
PC11	MO1	Analog monitor 1 offset
PC12	MO2	Analog monitor 2 offset
PC13	MOSDL	Analog monitor feedback position output standard data Low
PC14	MOSDH	Analog monitor feedback position output standard data High
PC15 to PC16		For manufacturer setting
PC17	**COP4	Function selection C-4
PC18 to PC20		For manufacturer setting
PC21	*BPS	Alarm history clear
PC22 to PC32		For manufacturer setting

I/O setting parameters (PD □□)		
No.	Symbol	Name
PD01 to PD06		For manufacturer setting
PD07	*DO1	Output signal device selection 1 (CN3-13)
PD08	*DO2	Output signal device selection 2 (CN3-9)
PD09	*DO3	Output signal device selection 3 (CN3-15)
PD10 to PD13		For manufacturer setting
PD14	*DOP3	Function selection D-3
PD15 to PD32		For manufacturer setting

### App. 1.2 Converter unit

No.	Symbol	Name
PA01	*REG	Regenerative selection
PA02	*MCC	Magnetic contactor drive output selection
PA03 to PA07		For manufacturer setting
PA08	*DMD	Status display selection
PA09	*BPS	Alarm history clear
PA10 to PA11		For manufacturer setting
PA12	*DIF	Input filter setting
PA13 to PA19		For manufacture setting

# APPENDIX

## App. 2 Signal layout recording paper

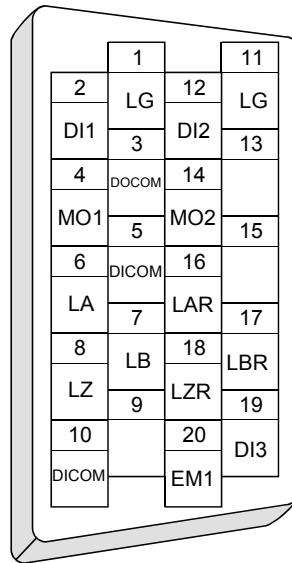

## App. 3 Twin type connector : Outline drawing for 721-2105/026-000 (WAGO)

Model	Size [mm]			
	A	B	C	D
721-2105/026-000	5	20	5	5.25
721-2205/026-000	7.5	30	7.5	7.75

[Unit: mm]

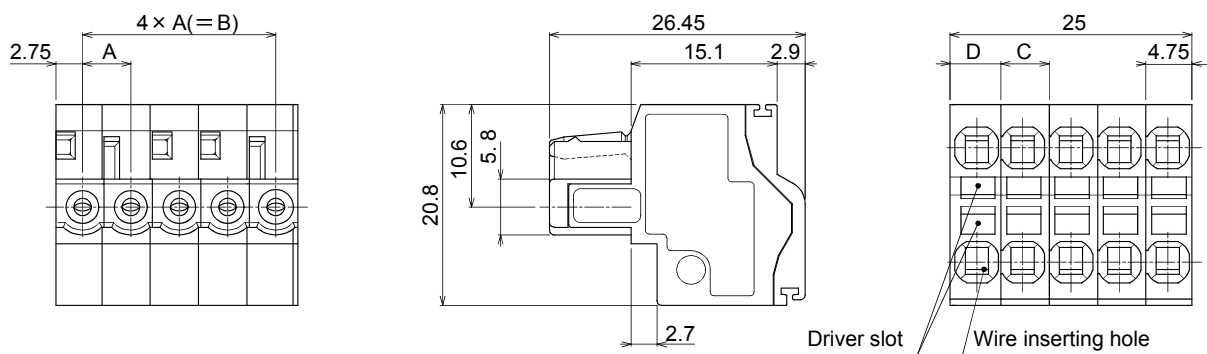

## APPENDIX

### App. 4 Change of connector sets to the RoHS compatible products

The following connector sets have been changed to RoHS compliant since June 2014.

RoHS compliant and non-RoHS compliant connector sets may be mixed based on availability.

Only the components of the connector set that have changed are listed below.

Model	Current Product	RoHS Compatible Product
MR-J3SCNS MR-ECNM	Amplifier connector (3M or equivalent of 3M) 36210-0100JL (Receptacle) (Note)	Amplifier connector (3M or equivalent of 3M) 36210-0100PL (Receptacle)
MR-PWCNS4	Power supply connector (DDK) CE05-6A18-10SD-B-BSS (Connector and Back shell) CE3057-10A-1 (D265) (Cable clump)	Power supply connector (DDK) CE05-6A18-10SD-D-BSS (Connector and Back shell) CE3057-10A-1-D (Cable clump)
MR-PWCNS5	Power supply connector (DDK) CE05-6A22-22SD-B-BSS (Connector and Back shell) CE3057-12A-1 (D265) (Cable clump)	Power supply connector (DDK) CE05-6A22-22SD-D-BSS (Connector and Back shell) CE3057-12A-1-D (Cable clump)
MR-PWCNS3	Power supply connector (DDK) CE05-6A32-17SD-B-BSS (Connector and Back shell) CE3057-20A-1 (D265) (Cable clump)	Power supply connector (DDK) CE05-6A32-17SD-D-BSS (Connector and Back shell) CE3057-20A-1-D (Cable clump)
MR-PWCNS1	Power supply connector (DDK) CE05-6A22-23SD-B-BSS (Connector and Back shell) CE3057-12A-2 (D265) (Cable clump)	Power supply connector (DDK) CE05-6A22-23SD-D-BSS (Connector and Back shell) CE3057-12A-2-D (Cable clump)
MR-PWCNS2	Power supply connector (DDK) CE05-6A24-10SD-B-BSS (Connector and Back shell) CE3057-16A-2 (D265) (Cable clump)	Power supply connector (DDK) CE05-6A24-10SD-D-BSS (Connector and Back shell) CE3057-16A-2-D (Cable clump)
MR-BKCN	Electromagnetic brake connector MS3106A10SL-4S(D190) (Plug, DDK)	Electromagnetic brake connector D/MS3106A10SL-4S(D190) (Plug, DDK)
MR-CCN1	Amplifier connector (3M or equivalent of 3M) 10120-3000VE (connector)	Amplifier connector (3M or equivalent of 3M) 10120-3000PE (connector)

Note. RoHS compatible 36210-0100FD may be packed with current connector sets.

## APPENDIX

### App. 5 MR-J3-200B-RT servo amplifier

Connectors (CNP1, CNP2, and CNP3) and appearance of MR-J3-200B servo amplifier have been changed from January 2008 production. Model name of the existing servo amplifier is changed to MR-J3-200B-RT. The difference between new MR-J3-200B servo amplifier and existing MR-J3-200B-RT servo amplifier is described in this appendix. Sections within parentheses in the following sections indicate corresponding sections of the instruction manual.

#### App. 5.1 Parts identification (1.7.1 Parts identification)

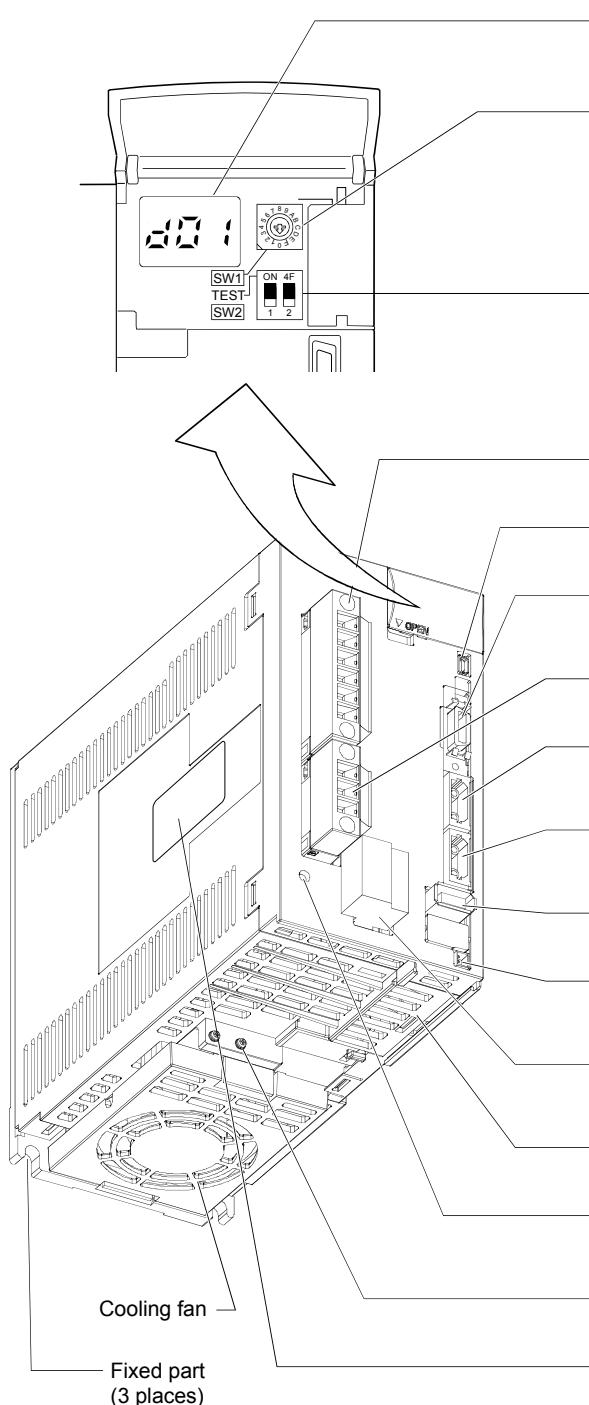

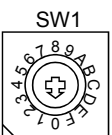
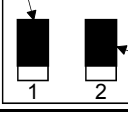
Name/Application	Detailed explanation
Display The 3-digit, seven-segment LED shows the servo status and alarm number.	Chapter 4
Rotary axis setting switch (SW1)  SW1 Used to set the axis No. of servo amplifier.	Section 3.13
Test operation select switch (SW2-1) Used to perform the test operation mode by using MR Configurator.  SW2 Spare (Be sure to set to the "Down" position).	Section 3.13
Main circuit power supply connector (CNP1) Connect the input power supply.	Section 3.1 Section 3.3
USB communication connector (CN5) Connect the personal computer.	Section 11.8
I/O signal connector (CN3) Used to connect digital I/O signals. More over an analog monitor is output.	Section 3.2 Section 3.4
Servo motor power connector (CNP3) Connect the servo motor.	Section 3.1 Section 3.3
SSCNET III cable connector (CN1A) Used to connect the servo system controller or the front axis servo amplifier.	Section 3.2 Section 3.4
SSCNET III cable connector (CN1B) Used to connect the rear axis servo amplifier. For the final axis, puts a cap.	Section 3.2 Section 3.4
Encoder connector (CN2) Used to connect the servo motor encoder.	Section 3.4 Section 11.1
Battery connector (CN4) Used to connect the battery for absolute position data backup.	Section 11.9 Chapter 12
Control circuit connector (CNP2) Connect the control circuit power supply/regenerative option.	Section 3.1 Section 3.3
Battery holder Contains the battery for absolute position data backup.	Section 12.3
Charge lamp Lit to indicate that the main circuit is charged. While this lamp is lit, do not reconnect the cables.	
Protective earth (PE) terminal (⊕) Ground terminal.	Section 3.1 Section 3.3
Rating plate	Section 1.5

## APPENDIX

### App. 5.2 Configuration including auxiliary equipment (1.8 Configuration including auxiliary equipment)

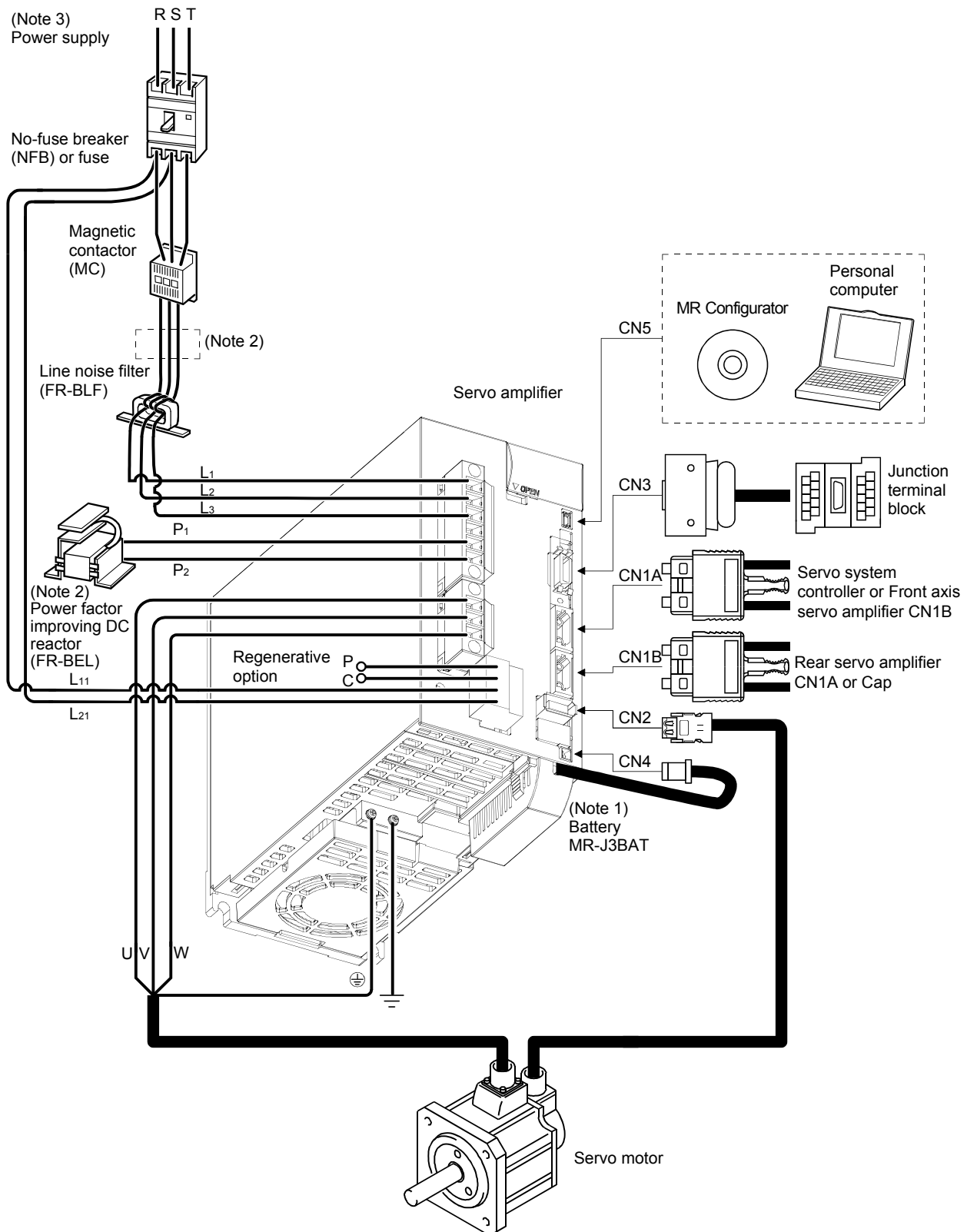

Note 1. The battery (option) is used for the absolute position detection system in the position control mode.

2. The AC reactor can also be used. In this case, the DC reactor cannot be used. When not using DC reactor, short P<sub>1</sub>-P<sub>2</sub>.

3. Refer to section 1.3 for the power supply specification.

## APPENDIX

### App. 5.3 CNP1, CNP2, CNP3 wiring method (3.3.3 CNP1, CNP2, CNP3 wiring method)

#### (a) Servo amplifier power supply connectors

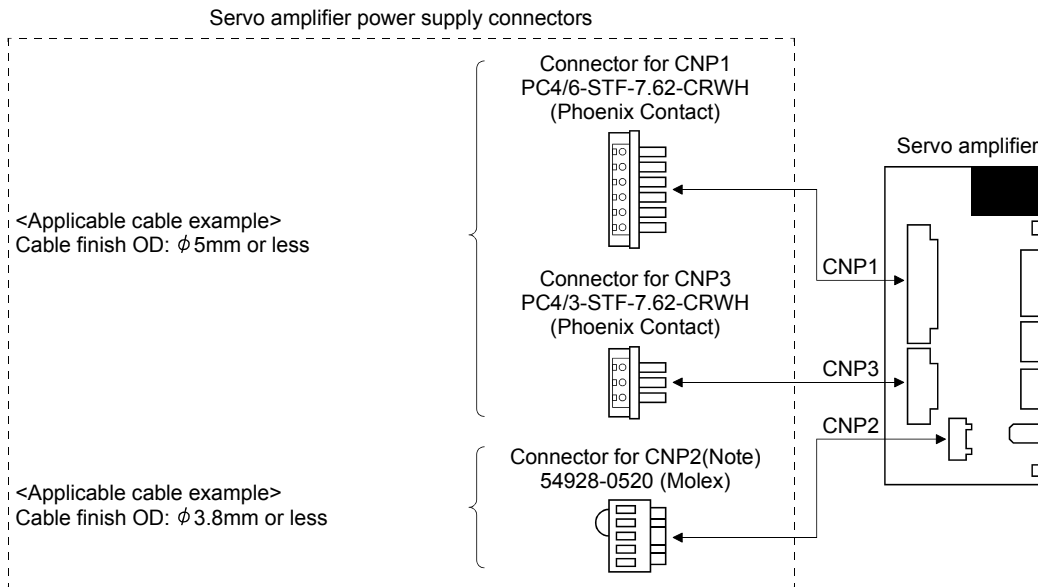

Note. As twin type connector for CNP2 (L<sub>11</sub>, L<sub>21</sub>) is the same as MR-J3-100B or smaller. Refer to section (1) (c).

#### (b) Termination of the cables

##### 1) CNP1 · CNP3

Solid wire: After the sheath has been stripped, the cable can be used as it is.

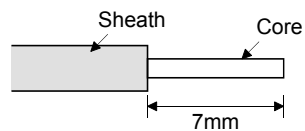

Twisted wire: Use the cable after stripping the sheath and twisting the core. At this time, take care to avoid a short caused by the loose wires of the core and the adjacent pole. Do not solder the core as it may cause a contact fault. Alternatively, a bar terminal may be used to put the wires together.

Cable size		Bar terminal type		Crimping tool	Manufacturer
[mm <sup>2</sup> ]	AWG	For 1 cable	For 2 cables		
1.25/1.5	16	AI1.5-8BK	AI-TWIN2×1.5-8BK	CRIMPFOX-ZA3	Phoenix Contact
2.0/2.5	14	AI2.5-8BU	AI-TWIN2×2.5-10BU		
3.5	12	AI4-10Y			

##### 2) CNP2

CNP2 is the same as MR-J3-100B or smaller capacities. Refer to section 3.3.3 (1) (b).

# APPENDIX

## App. 5.4 OUTLINE DRAWINGS (Chapter 9 OUTLINE DRAWINGS)

[Unit: mm]

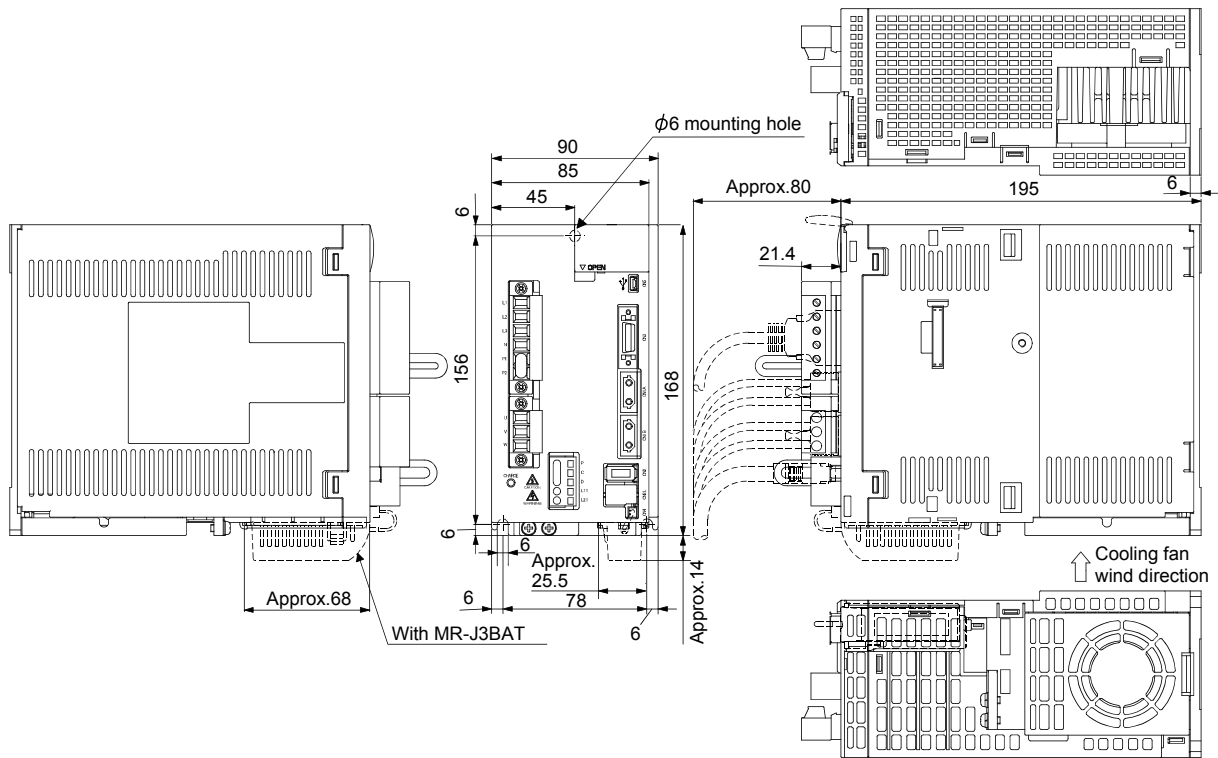

Mass: 2.3 [kg] (5.07 [lb])

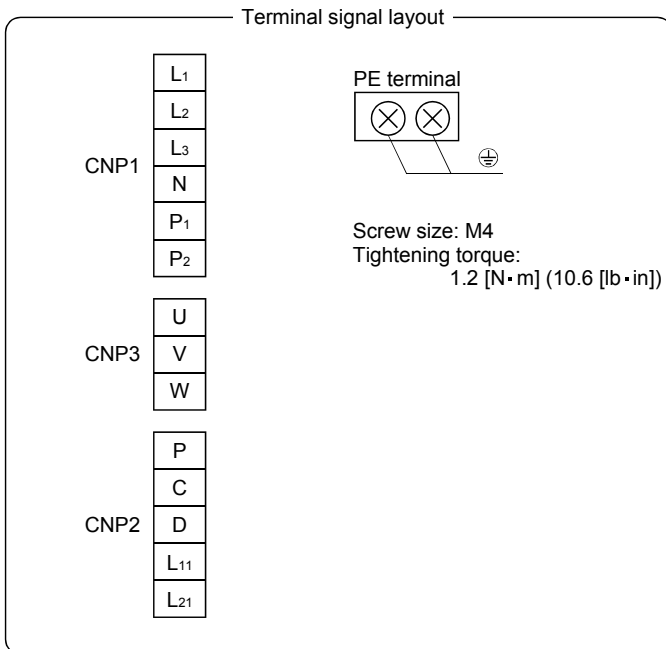

Mounting screw  
Screw size: M5  
Tightening torque: 3.24 [N·m] (28.7 [lb·in])

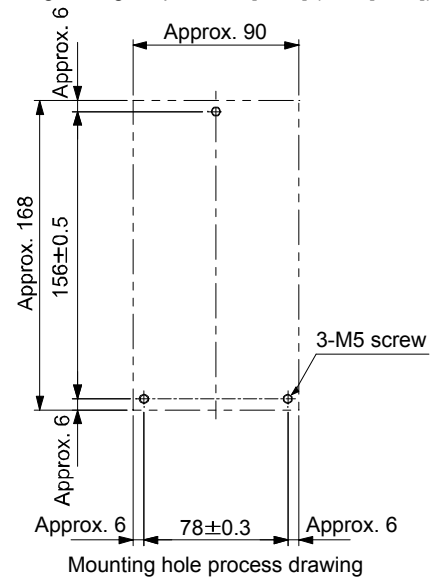

## APPENDIX

### App. 6 Selection example of servo motor power cable

POINT
<ul style="list-style-type: none"> <li>Selection condition of wire size is as follows. Wire length: 30m or less</li> <li>Depending on the cable selected, there may be cases that the cable does not fit into the Mitsubishi optional or recommended cable clamp. Select a cable clamp according to the cable diameter.</li> </ul>

Selection example when using the 600V grade EP rubber insulated chloroprene sheath cab-tire cable (2PNCT) for servo motor power (U, V, and W) is indicated below.

Servo motor	Wire size [mm <sup>2</sup> ]
HF-SP52	1.25
HF-SP102	1.25
HF-SP152	2
HF-SP202	2
HF-SP352	3.5
HF-SP502	5.5
HF-SP702	8
HF-SP51	1.25
HF-SP81	1.25
HF-SP121	2
HF-SP201	2
HF-SP301	3.5
HF-SP421	5.5
HF-SP524	1.25
HF-SP1024	1.25
HF-SP1524	2
HF-SP2024	2
HF-SP3524	2
HF-SP5024	3.5
HF-SP7024	5.5
HC-RP103	2
HC-RP153	2
HC-RP203 (Note)	3.5
HC-RP353 (Note)	5.5
HC-RP503 (Note)	5.5
HC-LP52	1.25
HC-LP102	1.25

Servo motor	Wire size [mm <sup>2</sup> ]
HC-LP152	2
HC-LP202	3.5
HC-LP302	5.5
HC-UP72	1.25
HC-UP152	2
HC-UP202	3.5
HC-UP352	5.5
HC-UP502	5.5
HA-LP601	8
HA-LP801	14
HA-LP12K1	14
HA-LP15K1	22
HA-LP20K1	38
HA-LP25K1	38
HA-LP30K1	38
HA-LP37K1	60
HA-LP701M	8
HA-LP11K1M	14
HA-LP15K1M	22
HA-LP22K1M	38
HA-LP30K1M	60
HA-LP37K1M	60
HA-LP502	5.5
HA-LP702	8
HA-LP11K2	14
HA-LP15K2	22
HA-LP22K2	22

Servo motor	Wire size [mm <sup>2</sup> ]
HA-LP30K2	60
HA-LP37K2	60
HA-LP6014	5.5
HA-LP8014	5.5
HA-LP12K14	8
HA-LP15K14	14
HA-LP20K14	14
HA-LP25K14	22
HA-LP30K14	22
HA-LP37K14	22
HA-LP701M4	5.5
HA-LP11K1M4	8
HA-LP15K1M4	14
HA-LP22K1M4	14
HA-LP30K1M4	22
HA-LP37K1M4	22
HA-LP45K1M4	38
HA-LP50K1M4	38
HA-LP11K24	8
HA-LP15K24	14
HA-LP22K24	14
HA-LP30K24	22
HA-LP37K24	22
HA-LP45K24	38
HA-LP55K24	38

Note. Use a composite cable and others when combining with wiring of the electromagnetic brake power in the same cable.

## REVISIONS

\*The manual number is given on the bottom left of the back cover.

Print Data	*Manual Number	Revision
May. 2005	SH(NA)030051-A	First edition
Jan. 2006	SH(NA)030051-B	Addition of servo amplifier MR-J3-11KB(4), 15KB(4) and 22KB(4) Addition of servo motor HC-RP, HC-UP, HC-LP and HA-LP4 series Section 1.5 (2) : Addition of regeneration brake resistor-less specification Section 1.7.2 : Addition of removal and reinstallation of front cover for 11KB(4) or more Section 2.1 : (1) Addition of 7kW or less (2) Addition of 11kW or more Section 3.7.1 : Error correction of differential line driver output as 35mA Section 3.8 (2) : Addition of "For CN2 connector" Section 3.11.2 (4) : Addition of time from invalid to valid of electromagnetic brake interlock Section 5.1.3 : Addition of sentence when using with 11KB or more for parameter No.PA02 00 * Addition of FA Section 5.3.1 : PC13 * PC14 description change Section 5.3.2 : PC13 * PC14 description change Section 5.3.3 (2) : Addition of Note3 Section 5.3.3 (3) : Partial figure change of analog monitor block Section 5.4.2 : Partial sentence addition of parameter No.PD07 Section 8.2 : Addition of "IGBT" to Cause 2. of alarm No. 32 indicated as Display in the remedies list for alarms Section 8.3 : Addition of POINT Section 11.1.1 : Partial figure addition Section 11.2 (3) : Addition of sentence when using with 11KB or more for parameter No.PA02 00 * Addition of FA Section 11.2 (5) (d) : Addition Section 11.5 : Addition Section 11.6 : Addition Section 11.7 : Error correction Section 11.10 : Addition Section 11.11 : Addition of cooling fan * thermal Addition of Table 11.2, Note. 2 Section 11.19 : Addition of EMC filter HF3100A-UN
Jul. 2007	SH(NA)030051-C	Addition of servo amplifier MR-J3-60B4 to 350B4 Addition of servo amplifier MR-J3-500B4 and 700B4 Addition of servo motor HF-SP524 / 1024 / 1524 / 2024 / 3524 Addition of drive units MR-J3-DU30KB(4), 37KB(4), 45KB4 and 55KB4 Addition of converter unit MR-J3-CR55K(4) Deletion of setup software notation Compliance with RoHS Safety instructions 1.: To prevent electric shock: Addition of Note for 30kW or more Safety instructions 4.: Additional instructions (2): Correction of the connection diagram Conformance with UL/C-UL standard (4): Addition of the capacitor discharge time for 30kW or more Conformance with UL/C-UL standard (5): Addition of the fuse for 30kW or more About the manuals : Addition of description about MR-J3-DU□B(4) Section 1.2 : Power supply description change

Print Data	*Manual Number	Revision
Jul. 2007	SH(NA)030051-C	<p>Section 1.2(1) : Unification of Note 3 to Note 2, addition of new Note 3</p> <p>Section 1.3 : Addition of MR-J3-500B4 and 700B4</p> <p>Section 1.3(2) : Addition of MR-J3-60B4 to 350B4</p> <p>Section 1.5(2) : Addition of MR-J3-60B4 to 350B4</p> <p>Section 1.6 : Addition of MR-J3-500B4 and 700B4 Addition of combination: MR-J3-60B4 to 350B4 and servo motor</p> <p>Section 1.7 : Addition of MR-J3-60B4 to 350B4 as (2) and (4)</p> <p>Section 1.7.1(1) (3) : Change of description for "servo motor power supply connector" to "servo motor power connector"</p> <p>Section 1.7.2 : Change CAUTION to WARNING</p> <p>Section 1.8 : Power supply description change</p> <p>Section 1.8(1) (a) : Unification of Note 4 to Note 3, addition of explanation to Note 2</p> <p>Section 1.8(2) to (7) : Addition of explanation to Note 2</p> <p>Section 2.1(b) : Change of description to "Mounting closely is available for a combination of servo amplifiers of 200V, 3.5kW or less"</p> <p>Chapter 3 : Addition of CAUTION</p> <p>Section 3.1 : Addition of MR-J3-500B4 and 700B4</p> <p>Section 3.1(4) : Addition of MR-J3-60B4 to 350B4</p> <p>Section 3.1(6) : Addition of Note 7</p> <p>Section 3.1(7) : Change of description for Note 7</p> <p>Section 3.1(8) : Change of description for Note 7, addition of Note 9</p> <p>Section 3.3.1 : Addition of sentence to UVW Description Addition of MR-J3-60B4 to 350B4 notation to L1, L2, L3, L11 and L21</p> <p>Section 3.3.3(1) (b) : Table content change</p> <p>Section 3.3.3(2) (b) : Table content change</p> <p>Section 3.3.3(3) : Addition of POINT Addition of cable handling procedures for MR-J3-200B4 and 350B4</p> <p>Section 3.3.3(4) : Addition and change of description</p> <p>Section 3.3.3(5) : Change of description</p> <p>Section 3.4 : Change of CN2 connection diagram to RoHS compliant parts</p> <p>Section 3.5(2) : Addition of sentence to the dynamic brake interlock description Change of the zero speed diagram</p> <p>Section 3.5(2) (d) : Change of description for Function/Application of Digital I/F common from "DOG • EMG" to "EM1"</p> <p>Section 3.7.2(3) (b) : Addition of supplementary explanation to the output pulse</p> <p>Section 3.10 : Addition of CAUTION</p> <p>Section 3.10.1 : Change of description for "motor power supply" to "servo motor power"</p> <p>Section 3.10.2(2) : Addition of POINT for contactor connection, Change of Note1, Change of "servo alarm" switch to "trouble (ALM)" in (a) Wiring diagrams</p>

Print Data	*Manual Number	Revision
Jul. 2007	SH(NA)030051-C	<p>Section 3.10.2(3) : Change of Note1 and 3 in (a) 1) and 2), Addition and change of (b) Terminal box inside diagrams, Addition and change of corresponding motor models in the cooling fan power supply list</p> <p>Section 3.10.2(3) (b) : Change of servo motor diagram</p> <p>Section 3.11.3(1) : Change of Note1</p> <p>Section 3.12 : Deletion of power specification notation, addition of Note</p> <p>Section 4.3(2) : Correction of indication "Ab." To "Ab .", Change of description for "AC"</p> <p>Chapter 5 : Change of Basic setting parameters description</p> <p>Section 5.1.3 : Addition of setting available options Addition of parameter setting due to addition of regenerative option</p> <p>Section 5.1.8 : Deletion of POINT "This parameter cannot be used in the speed control mode"</p> <p>Section 5.2.1 : Change of parameter No.PB17 from "for manufacturer setting" to "Automatic setting parameter"</p> <p>Section 5.3.1 : Change of parameter No.PC06 from "for manufacturer setting" to "function selection C-3"</p> <p>Section 5.3.2 : Addition of Note for parameter No.PC01, Change of parameter No.PC06 from "for manufacturer setting" to "function selection C-3", Addition of Note4 for parameter No.PC09, Change of setting description for parameter No.PC10</p> <p>Section 5.3.3(2) : Addition of Note4</p> <p>Section 6.3(1) (a) : Addition of parameter No.PB07</p> <p>Section 6.4(2) : Change of description for Adjustment procedure Step5</p> <p>Section 8.2 : Addition of Note to the Definition for alarm (32), Correction of the Cause4 for alarm (52)</p> <p>Section 9.1 : Addition of MR-J3-60B4 to 350B4</p> <p>Section 9.1(1) to (7) : Addition of mounting hole dimension diagram</p> <p>Section 9.2(3) : Description method change</p> <p>Section 10.1 : Change of graph from servo motor standards to servo amplifier standards Addition of MR-J3-60B4 to 350B4</p> <p>Section 10.2 : Addition of MR-J3-60B4 to 350B4 and corresponding servo motor</p> <p>Section 10.2(1) : Addition of MR-J3-500B4 and 700B4</p> <p>Section 10.3 : Addition of MR-J3-500B4 and 700B4 Paragraphing of section 10.3.1 and section 10.3.2 Addition of dynamic brake time constant for servo motor HF-SP524 / 1024 / 1524 / 2024 / 3524 Addition of section 10.3.2: Permissible inertia load moment for MR-J3-60B4 to 350B4</p> <p>Section 10.5 : Addition of MR-J3-500B4 and 700B4 Addition of inrush current for MR-J3-60B4 to 350B4</p>

Print Data	*Manual Number	Revision
Jul. 2007	SH(NA)030051-C	<p>Section 11.1.1 : Change of Application description for No.34 from “outside panel long distance cable” to “long distance cable” Change of connector model Addition of 2) Connector for 2kW and 3.5kW (400V)</p> <p>Section 11.1.2(1) : Deletion of 0.3m from table</p> <p>Section 11.1.2(1) (a) : Change of CN2 connection diagram to RoHS compliant parts</p> <p>Section 11.1.2(1) (a) (c) : Addition and change of connector description</p> <p>Section 11.1.2(2) : Deletion of 0.3m from table</p> <p>Section 11.1.2(2) (a) : Addition and change of connector description Change of CN2 connection diagram to RoHS compliant parts</p> <p>Section 11.1.2(3) (a) (c) : Addition and change of connector description</p> <p>Section 11.1.2(4) (a) : Change of CN2 connection diagram to RoHS compliant parts</p> <p>Section 11.1.2(5) (a) : Addition of connector set</p> <p>Section 11.1.4 : Deletion of 20 to 30m from table</p> <p>Section 11.2 : Addition of regenerative brake options for MR-J3-500B4 and 700B4</p> <p>Section 11.2(1) : Addition of regenerative option capable for MR-J3-60B4 to 350B4</p> <p>Section 11.2(2) (b) : Addition of inverse efficiency and capacitor charging for MR-J3-350B4</p> <p>Section 11.2(3) : Addition of parameter setting due to addition of regenerative option</p> <p>Section 11.2(4) : Addition of regenerative option MR-RB5G-4</p> <p>Section 11.2(5) (b) : Addition of regenerative option MR-RB3M-4, MR-RB3G-4</p> <p>Section 11.2(5) (c) : Addition of regenerative option MR-RB5G-4</p> <p>Section 11.2(5) (f) : Addition of regenerative option MR-RB1H-4</p> <p>Section 11.3 : Addition of brake unit for MR-J3-500B4 and 700B4</p> <p>Section 11.3(3) (b) : Change of description</p> <p>Section 11.4 : Addition of power regeneration converter for MR-J3-500B4 and 700B4</p> <p>Section 11.4(2) : Deletion of notation for power supply specification, change of description in Note 5, addition of Note 6</p> <p>Section 11.4(3) (b) : Addition of Note 6 to disconnect the wiring of regenerative brake register in servo amplifier of 7kW or less</p> <p>Section 11.5(3) (b) : Addition of Note 8</p> <p>Section 11.5(4) (b) 2) : Revision of cable diameter for 400V, deletion of Note</p> <p>Section 11.5(6) : For item: Altitude, vibration, deletion of description “compliant with JIS”</p> <p>Section 11.6(1) : Addition of Note 5</p> <p>Section 11.6(2) : Change of CN3 description Deletion of Note 1</p> <p>Section 11.8(1) : Addition of MR Configurator compatible version</p> <p>Section 11.11 : Addition of recommended wires for MR-J3-500B4 and 700B4</p>

Print Data	*Manual Number	Revision
Jul. 2007	SH(NA)030051-C	Section 11.11(1) : Addition of cable diameter for MR-J3-60B4 to 350B4, addition of Note 3: Cable 5) to 7) of MR-J3-700B(4)
		Section 11.12 : Addition of MR-J3-60B4 to 350B4 compliant products Addition of no-fuse breakers, fuses and magnetic contactors for MR-J3-500B4 and 700B4
		Section 11.13 : Addition of MR-J3-60B4 to 350B4 compliant products, unification of (1) and (2) Addition of power factor improving DC reactors for MR-J3-500B4 and 700B4 Change of (2) Note2 Addition of Note3
		Section 11.14 : Addition of MR-J3-60B4 to 350B4 compliant products Addition of power factor improving AC reactors for MR-J3-500B4 and 700B4
		Section 11.18 : Addition of MR-J3-60B4 to 350B4 as earth leakage circuit breaker selection example
		Section 11.19 : Addition of EMC filter for MR-J3-500B4 and 700B4
		Section 11.19(1) : Addition of MR-J3-60B4 to 350B4 compliant products, deletion of Note from TX series
		Section 11.19(3) : Addition of TF3005C-TX
		Section 12.3(1) : Addition of description for 30kW or more in "WARNING", Addition of POINT
		Chapter 13 : New addition of the details for 30kW or more Change of notation "magnet contactor" to "magnetic contactor"
		Section 13.1.6(1) : Change of description "I/O signal connector" to "Digital I/O connector", addition of rating plate Change in description of CN3 and CN6
		Section 13.1.6(2) (3) : Change of rating plate designated position
		Section 13.1.7 : Enlargement of diagram for removing and reinstalling terminal block cover
		Section 13.3 : Addition of POINT: reference "Signal (device) explanations, section 3.5"
		Section 13.3.1(1) (a) : Revision of magnetic contactor sequence, addition of Note 3
		Section 13.3.1(1) (b) : Revision of magnetic contactor sequence, addition of Note 3 and 4
		Section 13.3.1(2) (a) : Revision of magnetic contactor sequence, addition of Note 3 and 4, addition of magnetic contactor control (CNP1)
		13.3.1(2) (b) : Revision of magnetic contactor sequence, addition of Note 3 to 5, addition of magnetic contactor control (CNP1)
		13.3.2(1), (2) : Change of description in Note for "servo motor output" and "servo motor power supply" to "servo motor power"
		Section 13.3.4(2) : Correction of reference for CN2 and CN3
		Section 13.3.6 : Raise of section 13.3.5 (3) to section 13.3.6
		Section 13.3.7 : Raise from section 13.3.6, Change of description in chart: "servo motor power" to "servo motor power supply"
		Section 13.4.3(2) (b) : Change of display
		Section 13.4.3(3) : Deletion

Print Data	*Manual Number	Revision	
Jul. 2007	SH(NA)030051-C	Section 13.5.2	: Deletion of parameter No.PA08 name and initial value
		Section 13.6.1(3)	: Deletion of "built-in regenerative register" from excessive regenerative load warning (A.E0) definition and cause
		Section 13.8.1	: Division of Load ratio graph for MR-J3-□B(4) and MR-J3-CR55K(4)
		Section 13.9.1	: Addition of notation "supplied with converter unit" for 7) and 8)
		Section 13.9.2(5)	: Addition of Note
		Section 13.9.3(2)	: Revision of connection diagram, change of Note 2, addition of Note 5
		Section 13.9.3(3)	: Addition of mass table
		Section 13.9.4	: Deletion of notation for UL/C-UL from body paragraph
		Section 13.9.5	: Deletion of Note
		Section 13.9.7	: Change of body paragraph
		Section 13.9.8(1) (2)	: Change of Iga display range in the diagram
		Appendix 1	: Change of parameter No.PB17 from "for manufacturer setting" to "Automatic setting parameter" Change of parameter No.PC06 from "for manufacturer setting" to "function selection C-3"
		Appendix 5	: Update of the "combination of servo amplifier and servo motor" table
Jun. 2008	SH(NA)030051-D	(2)Wiring	: Change of description for "the servo motor will operate improperly" to "the servo motor will not operate properly" for the item of connection between the servo amplifier and the servo motor
		Conformance with UL/C-UL standard (3):	Change of description
		Conformance with UL/C-UL standard (5):	Deletion of list of combination with fuse
		About the wires used for wiring:	Addition of the selected standard temperature
		Section 1.2 (1) to (3)	: Change of switch numbers
		Section 1.3 (1)	: Change of description for the mass "2.3" to "2.1" of MR-J3-200B, Change of pound notation for mass to three significant digits
		Section 1.5 (2)	: Change of appearance of MR-J3-200B to the same as MR-J3-200B4
		Section 1.6	: Addition of models with reduction gear to body paragraph
		Section 1.7.1 (3) (4)	: Switch between (3) and (4), Change of the description for MR-J3-200B to the same as MR-J3-200B4, Addition of Note 4 to (3).
		Section 1.8 (3) (4)	: Switch between (3) and (4), Change of the description for MR-J3-200B to the same as MR-J3-200B4, Addition of Note 4 to (3). Deletion of Note 3 from (4) Addition of description for FR-BEL to (3)
		Section 2.1 (1) (b)	: Change of description for "Mounting closely is available for a combination of servo amplifiers of 3.5kW or less in 200V or 100V class." to "Mounting closely is available for a combination of servo amplifiers of 3.5kW or less in 200V or 400W or less in 100V class."
		Section 2.3 (2)	: Change of description
		Section 3.1 (5) to (8)	: Addition of NFB for the fan power cables of the servo motor's cooling fan

Print Data	*Manual Number	Revision
Jun. 2008	SH(NA)030051-D	<p>Section 3.2 : Change of Note 15</p> <p>Section 3.3.3 (1) (a) : Change of CNP2 connector model from "54927-0520" to "54928-0520"</p> <p>Section 3.3.3 (2) (3) : Switch between (2) and (3), Change of the description for MR-J3-200B to the same as MR-J3-200B4</p> <p>Section 3.7.2 (2) : Addition of description for the condition "Maximum current: 50mA or less" to body paragraph</p> <p>Section 3.10.2 (3) (a) 1) to 2) : Addition of NFB for fan power cable of servo motor's cooling fan, Change of description for Note 1</p> <p>Section 3.10.2 (3) (b) : Change of servo motor's terminal diagram</p> <p>Section 3.11.2 : Change of timing chart</p> <p>Section 4.1.2 (1) (c) 2) to 3) : Change of description for "D terminal" to "C terminal"</p> <p>Section 5.2.1 : Change of PB06 and PB29 unit for "times" to "Multiplier(×1)"</p> <p>Section 7.4 : Change of description</p> <p>Section 7.6.3 : Change of PB06 and PB29 unit for "times" to "Multiplier(×1)"</p> <p>Section 7.6.4 (1) (a) : Change of PB06 and PB29 unit for "times" to "Multiplier(×1)"</p> <p>Section 7.6.4 (2) (a) : Change of PB06 and PB29 unit for "times" to "Multiplier(×1)"</p> <p>Section 10.1 (5) (6) : Switch between (5) and (6), Change of the description for MR-J3-200B to the same as MR-J3-200B4, Addition of POINT to (5)</p> <p>Section 10.3.1 (2) : Addition of dynamic brake characteristics of HA-SP, HA-LP, HC-RP, HC-UP, and HC-LP</p> <p>Section 11.1 : Addition of POINT for protective structure</p> <p>Section 11.1.1 : Deletion of 2kW from Application, upper stand of 2) in Table, Change of description for "2kW or less in 400V class" to "2kW in 200V and 400V class", Change of corresponding model from "HF-SP121·201" to "HF-SP121 to 301" for 29) in Table, Change of corresponding model for 30) in Table, Deletion of IP65 from Application, Change of corresponding model for 38) and 40) in Table, Deletion of IP67 from Application, Deletion of IP67 from Application for 39) in Table</p> <p>Section 11.1.2 (2) (b) : Correction of Note position for connecting diagrams such as MR-EKCBL30M-H</p> <p>Section 11.1.2 (3) (a) : Addition of description "Crimping tool: 91529-1" in the list of Junction Connector</p> <p>Section 11.1.2 (4) : Change of corresponding model of "HF-SP" to "HF-SP·HA-LP·HC-RP·HC-UP·HC-LP"</p> <p>Section 11.1.2 (5) : Addition of corresponding model of "HA-LP·HC-RP·HC-UP·HC-LP"</p> <p>Section 11.1.2 (5) (a) : Change of junction connector of "36110-3000PL" to "36110-3000FD", Battery connector from "DF3-EP2428PCFA" to "DF3-EP2428PCA"</p> <p>Section 11.1.3 (2) : Addition of Note</p> <p>Section 11.1.4 (2) : Addition of Note</p> <p>Section 11.2 (1) : Change of built-in regenerative register value of MR-J3-60B4·100B4 from "15" to "20", Addition of Note 1</p>

Print Data	*Manual Number	Revision	
Jun. 2008	SH(NA)030051-D	Section 11.2 (4)	: Change of description
		Section 11.2 (5) (a)	: Change of tightening torque size from "3.2" to "3.24"
		Section 11.3.3 (4) (a)	: Change of description
		Section 11.3.4 (2)	: Correction of C dimension
		Section 11.5 (4) (a) 1)	: Addition of POINT for selection condition of wire sizes, Deletion of "The used wires are based on the 600V vinyl wires." from the sentence
		Section 11.5 (4) (b) 1)	: Change of wiring length of servo amplifier (3.5kW) in connection diagram from "5.5mm <sup>2</sup> " to "3.5mm <sup>2</sup> "
		Section 11.5 (4) (b) 2)	: Change of wiring length between the servo amplifier (2kW) and the one (15kW) in connecting diagram
		Section 11.6 (3) (a)	: Addition of Note to Table
		Section 11.6 (3) (b)	: Addition of Note to Table
		Section 11.8 (2) (a)	: Table content change, Change of ® position for Windows Vista, Deletion of RS-422/232C conversion cable
		Section 11.11	: Change of description for "Recommended wires" to "Wires selection example", Addition of three POINTs
		Section 11.11 (1)	: Deletion of body paragraph, Change of description for IV wires selection example, Addition of HIV wires selection example, Change of crimping terminal selection example
		Section 11.12	: Change of Table
		Section 11.13	: Addition of table for dynamic brake wire size
		Section 11.17 (2) (b)	: Deletion of AC electromagnetic brake from body paragraph
		Chapter 12	: Change of description for Note, Addition of POINT
		Section 13.1.5	: Partial deletion of body paragraph
		Section 13.3	: Change of description for Note
		Section 13.3.7 (1) (b)	: Change of timing chart
		Section 13.3.7 (3) (a) 1) to 3)	: Addition of Note
		Section 13.7.1	: Change of pound notation for mass to three significant digits
		Section 13.7.2	: Change of pound notation for mass to three significant digits
		Section 13.8.3	: Change of description form, Change of dynamic brake of HA-LP2000r/min series characteristics, Change of body paragraph
		Section 13.9.1 (2)	: Change of Note
		Section 13.9.3 (2)	: Addition of Note to Table
		Section 13.9.4	: Change of description for "Recommended wires" to "Wires selection examples", Addition of three POINTs
		Section 13.9.4 (1)	: Deletion of body paragraph, Change of description for IV wires selection example, Addition of HIV wires selection example, Change of crimping terminal selection example
		Section 13.9.5	: Deletion of Note
		Section 13.9.9 (2)	: Deletion of surge protectors from wiring diagram
		Section 13.9.10 (4) (b)	: Correction of C dimension
		Appendix 4	: Change of body paragraph
		Appendix 5	: New addition for explanation of servo amplifier MR-J3-200B-RT

Print Data	*Manual Number	Revision	
Jun. 2008	SH(NA)030051-D	Appendix 6	: New addition of servo motor power cables selection example
Dec. 2011	SH(NA)030051-E	Section 1.5(2) Section 2.4(2)(3) Section 13.1.4(2)(b)	The description is changed. The description is changed. The description is changed.
Aug. 2013	SH(NA)030051-F	Section 11.4 Section 11.4(2) Section 13.9.10	POINT is added. Note is added. POINT is added.
Jun. 2014	SH(NA)030051-G	Section 11.2 (4) (c)	CAUTION is added.

This manual confers no industrial property rights or any rights of any other kind, nor does it confer any patent licenses. Mitsubishi Electric Corporation cannot be held responsible for any problems involving industrial property rights which may occur as a result of using the contents noted in this manual.

Country/Region	Sales office	Tel/Fax
USA	MITSUBISHI ELECTRIC AUTOMATION, INC. 500 Corporate Woods Parkway, Vernon Hills, IL 60061, U.S.A.	Tel : +1-847-478-2100 Fax : +1-847-478-2253
Mexico	MITSUBISHI ELECTRIC AUTOMATION, INC. Mexico Branch Mariano Escobedo #69, Col.Zona Industrial, Tlalnepantla Edo, C.P.54030, México	Tel : +52-55-9171-7600 Fax : +52-55-9171-7649
Brazil	MITSUBISHI ELECTRIC DO BRASIL COMÉRCIO E SERVIÇOS LTDA. Rua Jussara, 1750- Bloco B Anexo, Jardim Santa Cecilia, CÉP 06465-070, Barueri - SP, Brasil	Tel : +55-11-4689-3000 Fax : +55-11-4689-3016
Germany	MITSUBISHI ELECTRIC EUROPE B.V. German Branch Gothaer Strasse 8, D-40880 Ratingen, Germany	Tel : +49-2102-486-0 Fax : +49-2102-486-1120
UK	MITSUBISHI ELECTRIC EUROPE B.V. UK Branch Travellers Lane, Hatfield, Hertfordshire, AL10 8XB, U.K.	Tel : +44-1707-28-8780 Fax : +44-1707-27-8695
Italy	MITSUBISHI ELECTRIC EUROPE B.V. Italian Branch Centro Direzionale Colleoni - Palazzo Sirio Viale Colleoni 7, 20864 Agrate Brianza(Milano) Italy	Tel : +39-039-60531 Fax : +39-039-6053-312
Spain	MITSUBISHI ELECTRIC EUROPE, B.V. Spanish Branch Carretera de Rubí, 76-80-Apdo. 420, 08173 Sant Cugat del Vallés (Barcelona), Spain	Tel : +34-935-65-3131 Fax : +34-935-89-1579
France	MITSUBISHI ELECTRIC EUROPE B.V. French Branch 25, Boulevard des Bouvets, F-92741 Nanterre Cedex, France	Tel : +33-1-55-68-55-68 Fax : +33-1-55-68-57-57
Czech Republic	MITSUBISHI ELECTRIC EUROPE B.V. Czech Branch Avenir Business Park, Radlicka 751/113e, 158 00 Praha5, Czech Republic	Tel : +420-251-551-470 Fax : +420-251-551-471
Poland	MITSUBISHI ELECTRIC EUROPE B.V. Polish Branch ul. Krakowska 50, 32-083 Balice, Poland	Tel : +48-12-630-47-00 Fax : +48-12-630-47-01
Russia	MITSUBISHI ELECTRIC EUROPE B.V. Russian Branch St. Petersburg office Piskarevsky pr. 2, bld 2, lit "Sch", BC "Benua", office 720; RU-195027 St. Petersburg, Russia	Tel : +7-812-633-3497 Fax : +7-812-633-3499
Turkey	MITSUBISHI ELECTRIC TURKEY A.S Ümraniye Branch Şerifali Mahallesi Nutuk Sokak No:5 TR-34775 Ümraniye, İstanbul, Turkey	Tel : +90-216-526-3990 Fax : +90-216-526-3995
South Africa	ADROIT TECHNOLOGIES 20 Waterford Office Park, 189 Witkoppen Road, ZA-Fourways, South Africa	Tel : +27-11-658-8100 Fax : +27-11-658-8101
China	MITSUBISHI ELECTRIC AUTOMATION (CHINA) LTD. No.1386 Hongqiao Road, Mitsubishi Electric Automation Center, Changning District, Shanghai, China	Tel : +86-21-2322-3030 Fax : +86-21-2322-3000
Taiwan	SETSUYO ENTERPRISE CO., LTD. 6F, No.105, Wugong 3rd Road, Wugu District, New Taipei City 24889, Taiwan, R.O.C.	Tel : +886-2-2299-2499 Fax : +886-2-2299-2509
Korea	MITSUBISHI ELECTRIC AUTOMATION KOREA CO., LTD. 1480-6, Gayang-Dong, Gangseo-Gu, Seoul, 157-200, Korea	Tel : +82-2-3660-9510 Fax : +82-2-3664-8372/8335
Singapore	MITSUBISHI ELECTRIC ASIA PTE. LTD. 307, Alexandra Road, Mitsubishi Electric Building, Singapore 159943	Tel : +65-6473-2308 Fax : +65-6476-7439
Thailand	MITSUBISHI ELECTRIC FACTORY AUTOMATION (THAILAND) CO., LTD. 12th Floor, SV.City Building, Office Tower 1, No. 896/19 and 20 Rama 3 Road, Kwaeng Bangpompang, Khet Yannawa, Bangkok 10120,Thailand	Tel : +66-2682-6522 to 6531 Fax : +66-2682-6020
Indonesia	PT. MITSUBISHI ELECTRIC INDONESIA Gedung Jaya 11th Floor, JL. MH. Thamrin No.12, Jakarta Pusat 10340, Indonesia	Tel : +62-21-3192-6461 Fax : +62-21-3192-3942
Vietnam	MITSUBISHI ELECTRIC VIETNAM COMPANY LIMITED Unit 01 - 04, 10th Floor, Vincom Center, 72 Le Thanh Ton Street, District 1, Ho Chi Minh City, Vietnam	Tel : +84-8-3910-5945 Fax : +84-8-3910-5947
India	MITSUBISHI ELECTRIC INDIA PVT. LTD. Pune Branch Emerald House, EL-3, J Block, M.I.D.C., Bhosari, Pune, 411026, Maharashtra State, India	Tel : +91-20-2710-2000 Fax : +91-20-2710-2100
Australia	MITSUBISHI ELECTRIC AUSTRALIA PTY. LTD. 348 Victoria Road, P.O. Box 11, Rydalmere, N.S.W 2116, Australia	Tel : +61-2-9684-7777 Fax : +61-2-9684-7245

MELSERVO is a trademark or registered trademark of Mitsubishi Electric Corporation in Japan and/or other countries.  
 Microsoft, Windows, Internet Explorer, and Windows Vista are registered trademarks or trademarks of Microsoft Corporation in the United States, Japan, and/or other countries.  
 Intel, Pentium, and Celeron are trademarks of Intel Corporation in the United States and/or other countries.  
 All other product names and company names are trademarks or registered trademarks of their respective companies.

## Warranty

### 1. Warranty period and coverage

We will repair any failure or defect hereinafter referred to as "failure" in our FA equipment hereinafter referred to as the "Product" arisen during warranty period at no charge due to causes for which we are responsible through the distributor from which you purchased the Product or our service provider. However, we will charge the actual cost of dispatching our engineer for an on-site repair work on request by customer in Japan or overseas countries. We are not responsible for any on-site readjustment and/or trial run that may be required after a defective unit are repaired or replaced.

### [Term]

The term of warranty for Product is twelve (12) months after your purchase or delivery of the Product to a place designated by you or eighteen (18) months from the date of manufacture whichever comes first ("Warranty Period"). Warranty period for repaired Product cannot exceed beyond the original warranty period before any repair work.

### [Limitations]

- (1) You are requested to conduct an initial failure diagnosis by yourself, as a general rule.  
It can also be carried out by us or our service company upon your request and the actual cost will be charged. However, it will not be charged if we are responsible for the cause of the failure.
- (2) This limited warranty applies only when the condition, method, environment, etc. of use are in compliance with the terms and conditions and instructions that are set forth in the instruction manual and user manual for the Product and the caution label affixed to the Product.
- (3) Even during the term of warranty, the repair cost will be charged on you in the following cases:
  - (i) a failure caused by your improper storing or handling, carelessness or negligence, etc., and a failure caused by your hardware or software problem
  - (ii) a failure caused by any alteration, etc. to the Product made on your side without our approval
  - (iii) a failure which may be regarded as avoidable, if your equipment in which the Product is incorporated is equipped with a safety device required by applicable laws and has any function or structure considered to be indispensable according to a common sense in the industry
  - (iv) a failure which may be regarded as avoidable if consumable parts designated in the instruction manual, etc. are duly maintained and replaced
  - (v) any replacement of consumable parts (battery, fan, smoothing capacitor, etc.)
  - (vi) a failure caused by external factors such as inevitable accidents, including without limitation fire and abnormal fluctuation of voltage, and acts of God, including without limitation earthquake, lightning and natural disasters
  - (vii) a failure generated by an unforeseeable cause with a scientific technology that was not available at the time of the shipment of the Product from our company
  - (viii) any other failures which we are not responsible for or which you acknowledge we are not responsible for

### 2. Term of warranty after the stop of production

- (1) We may accept the repair at charge for another seven (7) years after the production of the product is discontinued. The announcement of the stop of production for each model can be seen in our Sales and Service, etc.
- (2) Please note that the Product (including its spare parts) cannot be ordered after its stop of production.

### 3. Service in overseas countries

Our regional FA Center in overseas countries will accept the repair work of the Product. However, the terms and conditions of the repair work may differ depending on each FA Center. Please ask your local FA center for details.

### 4. Exclusion of responsibility for compensation against loss of opportunity, secondary loss, etc.

Whether under or after the term of warranty, we assume no responsibility for any damages arisen from causes for which we are not responsible, any losses of opportunity and/or profit incurred by you due to a failure of the Product, any damages, secondary damages or compensation for accidents arisen under a specific circumstance that are foreseen or unforeseen by our company, any damages to products other than the Product, and also compensation for any replacement work, readjustment, start-up test run of local machines and the Product and any other operations conducted by you.

### 5. Change of Product specifications

Specifications listed in our catalogs, manuals or technical documents may be changed without notice.

### 6. Application and use of the Product

- (1) For the use of our General-Purpose AC Servo, its applications should be those that may not result in a serious damage even if any failure or malfunction occurs in General-Purpose AC Servo, and a backup or fail-safe function should operate on an external system to General-Purpose AC Servo when any failure or malfunction occurs.
- (2) Our General-Purpose AC Servo is designed and manufactured as a general purpose product for use at general industries. Therefore, applications substantially influential on the public interest for such as atomic power plants and other power plants of electric power companies, and also which require a special quality assurance system, including applications for railway companies and government or public offices are not recommended, and we assume no responsibility for any failure caused by these applications when used  
In addition, applications which may be substantially influential to human lives or properties for such as airlines, medical treatments, railway service, incineration and fuel systems, man-operated material handling equipment, entertainment machines, safety machines, etc. are not recommended, and we assume no responsibility for any failure caused by these applications when used.  
We will review the acceptability of the abovementioned applications, if you agree not to require a specific quality for a specific application. Please contact us for consultation.

MELSERVO-J3 Series

MR-J3-□B Servo Amplifier Instruction Manual



General-Purpose AC Servo

# MELSERVO-J3 Series

SSCNET III interface

MODEL

## MR-J3-□B

SERVO AMPLIFIER

INSTRUCTION MANUAL

MODEL	MR-J3-B INSTRUCTIONMANUAL
MODEL CODE	1CW202

**MITSUBISHI ELECTRIC CORPORATION**

HEAD OFFICE : TOKYO BLDG MARUNOUCHI TOKYO 100-8310

