

CNC

**MELDAS AC SERVO
MR-J2-CT Series**

SPECIFICATIONS AND INSTRUCTION MANUAL



www.nicsanat.com

021-87700210

BNP-B3944E(ENG)

Introduction

Thank you for purchasing the Mitsubishi NC.

This instruction manual describes the handling and caution points for using this NC.

Incorrect handling may lead to unforeseen accidents, so always read this instruction manual thoroughly to ensure correct usage.

Make sure that this instruction manual is delivered to the end user.

Precautions for safety

Please read this instruction manual and auxiliary documents before starting installation, operation, maintenance or inspection to ensure correct usage. Thoroughly understand the device, safety information and precautions before starting operation.

The safety precautions in this instruction manual are ranked as **"DANGER"** and **"CAUTION"**.



When a dangerous situation may occur if handling is mistaken leading to fatal or major injuries.



When a dangerous situation may occur if handling is mistaken leading to medium or minor injuries, or physical damage.

Note that some items described as  **CAUTION** may lead to major results depending on the situation. In any case, important information that must be observed is described.

The signs indicating prohibited and mandatory items are described below.



This sign indicates that the item is prohibited (must not be carried out). For example,  is used to indicate "Fire Prohibited".



This sign indicates that the item is mandatory (must be carried out). For example,  is used to indicate grounding.

After reading this instruction manual, keep it in a safe place for future reference.



POINT

In this manual, this mark indicates important matters the operator should be aware of when using the NC.



CAUTION

The MR-J2-CT Series saves the parameters in the amplifier. Thus, always observe the following points.

1. The amplifiers cannot be exchanged between two axes, even if the capacities are the same.
2. The amplifier for another axis cannot be used instead of a faulty amplifier.
3. Always write in the parameters, and the reference point data if using the absolute position system, when amplifier has been replaced.

For Safe Use

1. Electric shock prevention

DANGER



Wait at least 10 minutes after turning the power OFF, confirm that the CHARGE lamp has gone out, and check the voltage between P and N terminals with a tester, etc., before starting wiring or inspections.

Failure to observe this could lead to electric shocks.



Ground the servo amplifier and servomotor with Class 3 grounding or higher.



Wiring and inspection work must be done by a qualified technician.



Wire the servo amplifier and servomotor after installation. Failure to observe this could lead to electric shocks.



Do not touch the switches with wet hands. Failure to observe this could lead to electric shocks.



Do not damage, apply forcible stress, place heavy items or engage the cable. Failure to observe this could lead to electric shocks.

2. Fire prevention

CAUTION



Install the servo amplifier, servomotor and regenerative resistor on noncombustible material. Direct installation on combustible material or near combustible materials could lead to fires.







Following the instructions in this manual, always install no-fuse breakers and contactors on the servo amplifier power input. Select the correct no-fuse breakers and contactors using this manual as a reference. Incorrect selection could lead to fires.



Shut off the main circuit power at the contactors to emergency stop when an alarm occurs.

3. Injury prevention

CAUTION











-  Do not apply a voltage other than that specified in Instruction Manual on each terminal. Failure to observe this item could lead to ruptures or damage, etc.
-  Do not mistake the terminal connections. Failure to observe this item could lead to ruptures or damage, etc.
-  Do not mistake the polarity(\oplus , \ominus) . Failure to observe this item could lead to ruptures or damage, etc.
-  Do not touch the servo amplifier fins, regenerative resistor or servomotor, etc., while the power is turned ON or immediately after turning the power OFF. Some parts are heated to high temperatures, and touching these could lead to burns.

4. Various precautions

Observe the following precautions. Incorrect handling of the unit could lead to faults, injuries and electric shocks, etc.

(1) Transportation and installation

CAUTION

-  Correctly transport the product according to its weight.
-  Do not stack the products above the tolerable number.
-  Do not hold the cables, axis or detector when transporting the servomotor.
-  Do not hold the front cover when transporting the servo amplifier. The unit could drop.
-  Follow this Instruction Manual and install the unit in a place where the weight can be borne.
-  Do not get on top of or place heavy objects on the unit.
-  Always observe the installation directions.
-  Secure the specified distance between the servo amplifier and control panel, or between the servo amplifier and other devices.
-  Do not install or run a servo amplifier or servomotor that is damaged or missing parts.
-  Do not let conductive objects such as screws or metal chips, etc., or combustible materials such as oil enter the servo amplifier or servomotor.
-  The servo amplifier and servomotor are precision devices, so do not drop them or apply strong impacts to them.

CAUTION



Store and use the units under the following environment conditions.

| Environment | Conditions | | |
|---------------------|--|---|---|
| | Servo amplifier | Servomotor | |
| Ambient temperature | 0°C to +55°C (with no freezing) | 0°C to +40°C (with no freezing) | |
| Ambient humidity | 90% RH or less (with no dew condensation) | 80%RH or less (with no dew condensation) | |
| Storage temperature | -20°C to +65°C (with no freezing) | -15°C to +70°C (with no freezing) | |
| Storage humidity | 90% RH or less (with no dew condensation) | | |
| Atmosphere | Indoors (Where unit is not subject to direct sunlight) With no corrosive gas or combustible gas. With no oil mist or dust | | |
| Altitude | 1000m or less above sea level | | |
| Vibration | 5.9m/sec ² (0.6G) or less | HC-SF (1.5kW or less) HC-RF | X: 9.8m/sec ² (1G) Y: 24.5m/sec ² (2.5G) or less |
| | | HC-SF (2.0kW or more) | X: 19.6m/sec ² (2G) Y: 49m/sec ² (5G) or less |
| | | HA-FF, HC-MF | X: 19.6m/sec ² (2G) Y: 19.6m/sec ² (2G) or less |



Securely fix the servomotor to the machine. Insufficient fixing could lead to the servomotor deviating during operation.



Never touch the rotary sections of the servomotor during operations. Install a cover, etc., on the shaft.



When coupling to a servomotor shaft end, do not apply an impact by hammering, etc. The detector could be damaged.







Do not apply a load exceeding the tolerable load onto the servomotor shaft. The shaft could break.



When storing for a long time, please contact your dealer.

(2) Wiring

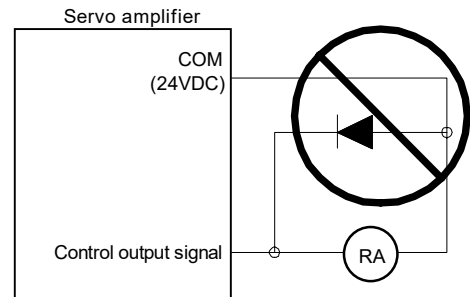

CAUTION

-  Correctly and securely perform the wiring. Failure to do so could lead to runaway of the servomotor.
-  Do not install a phase advancing capacity, surge absorber or radio noise filter on the output side of the servo amplifier.
-  Correctly connect the output side (terminals U, V, W). Failure to do so could lead to abnormal operation of the servomotor.
-  Do not directly connect a commercial power supply to the servomotor. Doing so could lead to faults.
-  When connecting a DC relay for the control output signals such as the brake signal or contactor, do not mistake the polarity of the diode. Failure to observe this could cause the signals not to be output due to a fault or the protective circuit to fail.



(3) Trial operation and adjustment

CAUTION

-  Check and adjust each parameter before starting operation. Failure to do so could lead to unforeseen operation of the machine.
-  Do not make remarkable adjustments and changes as the operation could become unstable.

(4) Usage methods

⚠ CAUTION

- ⚠ Install an external emergency stop circuit so that the operation can be stopped and power shut off immediately.
- ⚠ Unqualified persons must not disassemble or repair the unit.
- ⚠ The machine will start suddenly if an alarm reset (RST) is carried out while an operation start signal (ST) is being input. Therefore, always confirm that the operation signal is OFF before carrying out an alarm reset. Failure to do so could lead to accidents or injuries.
- ⚠ Never make modifications.
- ⚠ Reduce magnetic interference by installing a noise filter. The electronic devices used near the servo amplifier could be affected by magnetic noise. Install a line noise filter, etc., when there is an influence from magnetic interference.
- ⚠ Always use the servomotor and servo amplifier with the designated combination.
- ⚠ The servomotor's magnetic brakes are for holding purposes. Do not use them for normal braking.
- ⚠ There may be cases when holding is not possible due to the magnetic brake's life or the machine construction (when ball screw and servomotor are coupled via a timing belt, etc.). Install a stop device to ensure safety on the machine side.

(5) Troubleshooting

⚠ CAUTION

- ⚠ If a hazardous situation is predicted during stop or product trouble, use a servomotor with magnetic brakes or install an external brake mechanism.
- ⚠ Use a double circuit configuration that allows the operation circuit for the magnetic brakes to be operated even by the external emergency stop signal.
- ⚠ If an alarm occurs, remove the cause and secure the safety before resetting the alarm.
- ⚠ Never go near the machine after restoring the power after a failure, as the machine could start suddenly.
(Design the machine so that personal safety can be ensured even if the machine starts suddenly.)

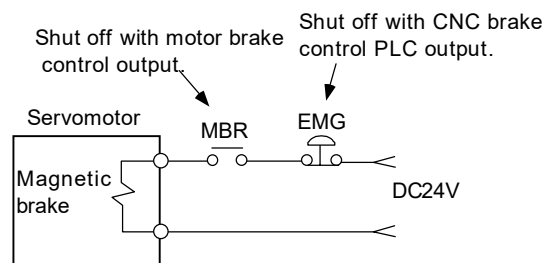

(6) Maintenance, inspection and part replacement

CAUTION



The capacity of the electrolytic capacitor will drop due to deterioration. To prevent secondary damage due to failures, replacing this part every ten years when used under a normal environment is recommended. Contact the nearest dealer for repair and replacement of parts.

(7) Disposal

CAUTION



Treat this unit as general industrial waste.

(8) General precautions

CAUTION



The drawings given in this Specifications and Maintenance Instruction Manual show the covers and safety partitions, etc., removed to provide a clearer explanation. Always return the covers or partitions to their respective places before starting operation, and always follow the instructions given in this manual.

Compliance to European EC Directives

1. European EC Directives

The European EC Directives were issued to unify Standards within the EU Community and to smooth the distribution of products of which the safety is guaranteed. In the EU Community, the attachment of a CE mark (CE marking) to the product being sold is mandatory to indicate that the basic safety conditions of the Machine Directives (issued Jan. 1995), EMC Directives (issued Jan. 1996) and the Low-voltage Directives (issued Jan. 1997) are satisfied. The machines and devices in which the servo is assembled are a target for CE marking.

The servo is a component designed not to function as a single unit but to be used with a combination of machines and devices. Thus, it is not subject to the EMC Directives, and instead the machines and devices in which the servo is assembled are targeted.

This servo complies with the Standards related to the Low-voltage Directives in order to make CE marking of the assembled machines and devices easier. The EMC INSTALLATION GUIDELINES (IB (NA) 67303) which explain the servo amplifier installation method and control panel manufacturing method, etc., has been prepared to make compliance to the EMC Directives easier. Contact Mitsubishi or your dealer for more information.

2. Cautions of compliance

Use the standard servo amplifier and EN Standards compliance part (some standard models are compliant) for the servomotor. In addition to the items described in this instruction manual, observe the items described below.

(1) Environment

The servo amplifier must be used within an environment having a Pollution Class of 2 or more (Pollution Class 1 or 2) as stipulated in the IEC664. For this, install the servo amplifier in a control panel having a structure (IP54) into which water, oil, carbon and dust cannot enter.

(2) Power supply

- The servo amplifier must be used with the overvoltage category II conditions stipulated in IEC664. For this, prepare a reinforced insulated transformer that is IEC or EN Standards complying at the power input section.
- When supplying the control signal input/output power supply from an external source, use a 24 VDC power supply of which the input and output have been reinforced insulated.

(3) Installation

- To prevent electric shocks, always connect the servo amplifier protective earth (PE) terminal (terminal with \oplus mark) to the protective earth (PE) on the control panel.
- When connecting the earthing wire to the protective earth (PE) terminal, do not tighten the wire terminals together. Always connect one wire to one terminal.



(4) Wiring

- Always use crimp terminals with insulation tubes so that the wires connected to the servo amplifier terminal block do not contact the neighboring terminals.

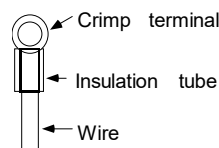

- Connect the HC-MF Series servomotor power lead to the servo amplifier using a fixed terminal block. Do not connect the wires directly. (EN standards compliance parts of the HA-FF motor have cannon plug specifications.)

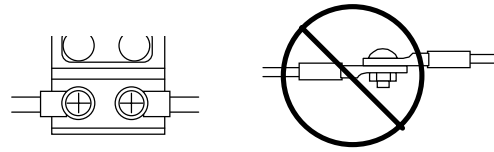

(5) Peripheral devices

- Use a no-fuse breaker and magnetic contactor that comply with the EN/IEC Standards described in "Chapter 4 Options and Peripheral Devices".
- The wires sizes must follow the conditions below. When using other conditions, follow Table 5 of EN60204 and the Appendix C.
 - Ambient temperature: 40°C
 - Sheath: PVC (polyvinyl chloride)
 - Install on wall or open table tray

(6) Servomotor

A servomotor that complies with the EN Standards as a standard, and an EN Standards compatible servomotor are available.

| Motor series name | EN Standards compatible servomotor |
|-------------------|------------------------------------|
| HC-SF series | Complies as a standard |
| HC-RF series | |
| HA-FF series | HA-FF**C-UE |
| HC-MF series | HC-MF**-UE HC-MF**-S15 |

Refer to "Chapter 6 Setup and Operation" for the connectors and detector cables, and use the EN Standards compatible parts.

(7) Miscellaneous

The EMC test for a machine or device incorporating a servo amplifier must match the magnetism compatibility (immunity and emission) standards in the state that the working environment and electric device specifications are satisfied.

Refer to the EMC INSTALLATION GUIDELINES (IB (NA) 67303) for other EMC Directive measures related to the servo amplifier.

Compliance to UL/c-UL Standards

The handling, performance and specifications, etc., of the UL/c-UL Standards compliant parts are the same as the standard parts unless noted otherwise. When using options or peripheral devices, use UL/c-UL Standards compliant parts.

Cautions for compliance to UL/c-UL Standards

The following matters must be observed for UL/c-UL Standards compliance.

(1) General precautions

The capacitor discharge time is as shown below. For safety purposes, wait at least 15 minutes before touching the charged sections after turning the power OFF.

| Amplifier type | Discharge time (min.) |
|---------------------|-----------------------|
| MR-J2-10CT, -20CT | 1 |
| MR-J2-40CT, -60CT | 2 |
| MR-J2-70CT, -100CT | 3 |
| MR-J2-200CT, -350CT | |

(2) Installation

The MR-J2-CT Series servo amplifier is designed for installation in a panel. The capacity of the panel must be 150% or more of the total unit volume in the panel. Design the panel so that the unit's ambient temperature does not exceed 55°C (131°F).

(Refer to "Chapter 3 Installation".)

If necessary, install a fan in the power distribution panel to agitate the heat over the amplifier. When carrying out the temperature test with the following installation conditions, the standards are satisfied by ventilating the inside of the panel with a fan.

| Amplifier type | Power distribution panel size | Ventilation conditions |
|----------------|-------------------------------|---|
| MR-J2-350CT | 150% of amplifier volume | Install a fan with 100CFM air flow 10cm (4 inches) above the amplifier. |

(3) Short-circuit ratings

A UL short-circuit test has been carried out with the servo amplifier using an AC circuit having a peak current limited at 5000[A] or less. The servo amplifier complies with this circuit.

(4) Installing the servomotor

Install the servomotor on the following flange sizes, or on material having the equivalent or higher heat dissipation effect.

| Flange size (mm) | Motor type and capacity | | | |
|------------------|-------------------------|-----------|--------------|-------------|
| | HC-SF | HC-RF | HA-FF | HC-MF |
| 150 × 150 × 6 | | | 50 to 100 W | 50 to 100 W |
| 250 × 250 × 6 | | | 200 to 300 W | 200 W |
| 250 × 250 × 12 | 0.5 to 1.5 kW | 1 to 2 kW | 400 to 600 W | 400 W |
| 300 × 300 × 12 | | | | 700 W |
| 300 × 300 × 20 | 2 to 3.5 kW | | | |

(5) External wiring

The UL-recommended round crimp terminals are used for wiring the input/output terminals. Use the crimp tool designated by the terminal maker.

| Amplifier type | Wire size (Note 1) | | | | | Crimp terminal (Note 2) | |
|----------------|--------------------------|---------------------|---------------------|------------------|---------------------|-------------------------|-------|
| | L1, L2, L3 ⊕ (Note 3) | L11, L21 | U, V, W (Note 4) | P, C (Note 5) | Magnetic brakes | Type | Tool |
| MR-J2-10CT | IV1.25SQ (AWG16) | IV1.25SQ (AWG16) | IV1.25SQ (AWG16) | IV2SQ (AWG14) | IV1.25SQ (AWG16) | 32959 | 47387 |
| MR-J2-20CT | | | | | | | |
| MR-J2-40CT | | | | | | | |
| MR-J2-60CT | IV2SQ (AWG14) | IV1.25SQ (AWG16) | IV2SQ (AWG14) | IV2SQ (AWG14) | IV1.25SQ (AWG16) | 32968 | 59239 |
| MR-J2-70CT | | | | | | | |
| MR-J2-100CT | | | | | | | |
| MR-J2-200CT | 3.5 (AWG12) | IV1.25SQ (AWG16) | 3.5 (AWG12) | IV2SQ (AWG14) | IV1.25SQ (AWG16) | 32968 | 59239 |
| MR-J2-350CT | 5.5 (AWG10) | | 5.5 (AWG10) | | | | |

(Note 1) As a standard, the wire is a 600V vinyl wire (the conductor must be copper).

(Note 2) This indicates the UL/c-UL Standards compliant wire. (AMP). Refer to section 2-2-3 for the L11, L21, P and C below 100CT.

(Note 3) This value is for the single part. Refer to Chapter 4 when wiring across several amplifiers.

(Note 4) The wires (U, V, W) in the table indicate the case when the distance between the servomotor and servo amplifier is 30m or less.

(Note 5) Twist the wire for the regenerative option (P, C).

(6) Terminal block tightening torque

Wire to the terminal block with the appropriate tightening torque.

| Amplifier type | L1,L2,L3,U,V,W | | L11,L21,P,C | | PE | |
|----------------|-------------------|----------------------|------------------------------------|----------------------|-------------------|----------------------|
| | Terminal screw | Tightening torque | Terminal screw | Tightening torque | Terminal screw | Tightening torque |
| MR-J2-10CT | M4 × 0.7 | 1.24 N·m | Built-in insertion plug type | 0.5 to 0.6 N·m | M4 × 0.7 | 1.24 N·m |
| MR-J2-20CT | | | | | | |
| MR-J2-40CT | | | | | | |
| MR-J2-60CT | | | | | | |
| MR-J2-70CT | | | | | | |
| MR-J2-100CT | | | | | | |
| MR-J2-200CT | | | M4 × 0.7 | 1.24 N·m | | |
| MR-J2-350CT | | | | | | |

(7) Peripheral devices

Select peripheral devices that match the UL/c-UL Standards. The following table shows the devices for one axis capacities. When using multiple axes, or when sharing the power supply with other units, refer to "Chapter 4 Options and Peripheral Devices".

| Amplifier type | No-fuse breaker | Fuse (Class K5) | Contactor |
|----------------|-----------------|-----------------|---------------|
| MR-J2-10CT | NF30 type 5A | 250 VAC 10A | S-N10 200 VAC |
| MR-J2-20CT | | 250 VAC 15A | |
| MR-J2-40CT | NF30 type 15A | 250 VAC 20A | |
| MR-J2-60CT | | 250 VAC 25A | |
| MR-J2-70CT | | | |
| MR-J2-100CT | NF30 type 20A | 250 VAC 40A | S-N18 200 VAC |
| MR-J2-200CT | NF30 type 30A | 250 VAC 70A | S-N20 200 VAC |



1. When installing in the United States, provide protection for each branch circuit according to the National Electrical Code and any applicable local codes.
2. When installing in Canada, provide protection for each branch circuit according to the Canada Electrical Code and any applicable local codes.

Contents

Chapter 1 Preface

| | | |
|------------|--|------------|
| 1-1 | Inspection at purchase..... | 1-2 |
| 1-1-1 | Package contents | 1-2 |
| 1-1-2 | Explanation of types..... | 1-2 |
| 1-2 | Explanation of each part..... | 1-5 |
| 1-2-1 | Explanation of each servo amplifier part | 1-5 |
| 1-2-2 | Explanation of each servomotor part | 1-5 |
| 1-3 | Basic configuration | 1-6 |
| 1-3-1 | Examples of MR-J2-10CT to MR-J2-100CT basic configurations | 1-6 |
| 1-3-2 | Examples of MR-J2-200CT and MR-J2-350CT basic configurations | 1-7 |
| 1-4 | Combinations of servo amplifier and servomotor capacities | 1-8 |
| 1-5 | Outline of built-in function..... | 1-9 |
| 1-5-1 | Axis control function..... | 1-9 |
| 1-5-2 | Servo control function | 1-9 |
| 1-5-3 | Feed function | 1-9 |
| 1-5-4 | Coordinate system setting function | 1-9 |
| 1-5-5 | Command method | 1-10 |
| 1-5-6 | Operation function | 1-10 |
| 1-5-7 | Absolute position detection function..... | 1-11 |
| 1-5-8 | Machine compensation function..... | 1-11 |
| 1-5-9 | Protective functions | 1-11 |
| 1-5-10 | Operation auxiliary function..... | 1-11 |
| 1-5-11 | Diagnosis function | 1-11 |

Chapter 2 Wiring and Connection

| | | |
|------------|--|-------------|
| 2-1 | System connection diagram..... | 2-3 |
| 2-2 | Servo amplifier main circuit terminal block, control circuit terminal block.... | 2-4 |
| 2-2-1 | Main circuit terminal block, control circuit terminal block signal layout | 2-4 |
| 2-2-2 | Names and application of main circuit terminal block and control circuit terminal block signals | 2-5 |
| 2-2-3 | How to use the control circuit terminal block (MR-J2-10CT to 100CT)..... | 2-6 |
| 2-3 | NC and servo amplifier connection..... | 2-7 |
| 2-4 | Motor and detector connection | 2-8 |
| 2-4-1 | Connection of HC-SF52, HC-SF53, HC-SF102, HC-SF103..... | 2-8 |
| 2-4-2 | Connection of HC-SF152, HC-SF153 | 2-8 |
| 2-4-3 | Connection of HC-SF202, HC-SF203, HC-SF352, HC-SF353..... | 2-9 |
| 2-4-4 | Connection of HC-RF103, HC-RF153, HC-RF203 | 2-9 |
| 2-4-5 | Connection of HA-FF Series | 2-10 |
| 2-4-6 | Connection of HA-FF• C-UE Series | 2-10 |
| 2-4-7 | Connection of HC-MF(-UE) Series..... | 2-11 |
| 2-4-8 | Connection of HC-MF• S15 Series | 2-11 |
| 2-5 | Connection of power supply..... | 2-12 |
| 2-5-1 | Example of connection when controlling the contactor with the MR-J2-CT | 2-12 |
| 2-5-2 | Example of connection when using converter unit | 2-13 |

| | | |
|------------|---|-------------|
| 2-6 | Connection of regenerative resistor | 2-15 |
| 2-6-1 | Standard built-in regenerative resistor | 2-15 |
| 2-6-2 | External option regenerative resistor..... | 2-15 |
| 2-7 | Connection of digital input/output (DIO) signals | 2-16 |
| 2-7-1 | Types and functions of digital input/output (DIO) signals | 2-16 |
| 2-7-2 | Wiring of digital input/output (DIO) signals..... | 2-17 |
| 2-8 | Connection with personal computer..... | 2-20 |

Chapter 3 Installation

| | | |
|------------|--|------------|
| 3-1 | Installation of the servo amplifier | 3-2 |
| 3-1-1 | Environmental conditions | 3-2 |
| 3-1-2 | Installation direction and clearance | 3-3 |
| 3-1-3 | Prevention of entering of foreign matter..... | 3-3 |
| 3-2 | Installation of servomotor..... | 3-4 |
| 3-2-1 | Environmental conditions | 3-4 |
| 3-2-2 | Cautions for mounting load (prevention of impact on shaft) | 3-5 |
| 3-2-3 | Installation direction | 3-5 |
| 3-2-4 | Tolerable load of axis..... | 3-5 |
| 3-2-5 | Oil and waterproofing measures | 3-6 |
| 3-2-6 | Cable stress..... | 3-8 |
| 3-3 | Noise measures | 3-9 |

Chapter 4 Options and Peripheral Devices

| | | |
|------------|---|-------------|
| 4-1 | Regenerative option | 4-2 |
| 4-1-1 | Combinations with servo amplifiers..... | 4-2 |
| 4-1-2 | Outline dimension drawing of option regenerative resistor | 4-3 |
| 4-2 | Battery option for absolute position system | 4-5 |
| 4-2-1 | Battery (MR-BAT) | 4-5 |
| 4-2-2 | Battery unit (MDS-A-BT-2/-4/-6/-8) | 4-6 |
| 4-3 | Relay terminal block..... | 4-7 |
| 4-4 | Cables and connectors | 4-8 |
| 4-4-1 | Cable option list | 4-9 |
| 4-4-2 | Connector outline dimension drawings | 4-12 |
| 4-4-3 | Flexible conduits | 4-17 |
| 4-4-4 | Cable wire and assembly | 4-19 |
| 4-4-5 | Option cable connection diagram..... | 4-20 |
| 4-5 | Setup software..... | 4-24 |
| 4-5-1 | Setup software specifications | 4-24 |
| 4-5-2 | System configuration | 4-24 |
| 4-6 | Selection of wire..... | 4-25 |
| 4-7 | Selection of no-fuse breakers | 4-26 |
| 4-8 | Selection of contactor..... | 4-27 |
| 4-8-1 | Selection from rush current..... | 4-27 |
| 4-8-2 | Selection from input current..... | 4-28 |
| 4-9 | Control circuit related | 4-29 |
| 4-9-1 | Circuit protector | 4-29 |

| | | |
|-------|---------------------|------|
| 4-9-2 | Relays..... | 4-29 |
| 4-9-3 | Surge absorber..... | 4-29 |

Chapter 5 Operation Control Signal

| | | |
|------------|---|-------------|
| 5-1 | System configuration | 5-2 |
| 5-1-1 | Built-in indexing function | 5-2 |
| 5-1-2 | Parameters | 5-3 |
| 5-2 | R register..... | 5-4 |
| 5-3 | Explanation of operation commands (NC • •servo amplifier)..... | 5-5 |
| 5-4 | Explanation of operation status signals (servo amplifier • •NC)..... | 5-11 |

Chapter 6 Setup and Operation

| | | |
|------------|--|-------------|
| 6-1 | Setup of servo amplifier..... | 6-2 |
| 6-1-1 | Parameter initialization..... | 6-2 |
| 6-1-2 | Transition of LED display after power is turned ON | 6-2 |
| 6-1-3 | Servo parameter default settings | 6-3 |
| 6-1-4 | Operation parameter group default settings..... | 6-4 |
| 6-1-5 | Setting during emergency stops | 6-7 |
| 6-2 | Test operation..... | 6-9 |
| 6-2-1 | Test operation..... | 6-9 |
| 6-2-2 | JOG operation | 6-10 |
| 6-2-3 | Incremental feed operation | 6-11 |
| 6-2-4 | Handle feed operation..... | 6-11 |
| 6-3 | Setting the coordinate zero point..... | 6-12 |
| 6-3-1 | Dog-type reference point return | 6-12 |
| 6-3-2 | Adjusting the dog-type reference point return | 6-14 |
| 6-3-3 | Memory-type reference point return..... | 6-16 |
| 6-3-4 | Mode with no reference point..... | 6-16 |
| 6-4 | Positioning operations by the station method..... | 6-17 |
| 6-4-1 | Setting the station..... | 6-17 |
| 6-4-2 | Setting linear axis stations | 6-19 |
| 6-4-3 | Automatic operation..... | 6-21 |
| 6-4-4 | Manual operation | 6-23 |
| 6-5 | Stopper positioning operation..... | 6-24 |
| 6-5-1 | Operation sequence | 6-24 |
| 6-5-2 | Setting the parameters | 6-26 |
| 6-6 | Machine compensation and protection functions | 6-27 |
| 6-6-1 | Backlash compensation | 6-27 |
| 6-6-2 | Interlock function | 6-27 |
| 6-6-3 | Soft limit..... | 6-28 |
| 6-6-4 | Servo OFF | 6-29 |
| 6-6-5 | READY OFF | 6-30 |
| 6-6-6 | Data protect..... | 6-30 |
| 6-7 | Miscellaneous functions..... | 6-31 |
| 6-7-1 | Feedrate override | 6-31 |
| 6-7-2 | Position switches | 6-31 |

Chapter 7 Absolute Position Detection System

| | |
|--|------------|
| 7-1 Setting of absolute position detection system..... | 7-2 |
| 7-1-1 Starting the system | 7-2 |
| 7-1-2 Initialization methods | 7-2 |
| 7-2 Setting up the absolute position detection system | 7-3 |
| 7-2-1 Reference point return method | 7-3 |
| 7-2-2 Machine stopper method | 7-3 |
| 7-2-3 Reference point setting method | 7-4 |

Chapter 8 Servo Adjustment

| | |
|--|------------|
| 8-1 Measuring the adjustment data | 8-2 |
| 8-1-1 D/A output..... | 8-2 |
| 8-1-2 Graph display..... | 8-2 |
| 8-2 Automatic tuning | 8-3 |
| 8-2-1 Model adaptive control..... | 8-3 |
| 8-2-2 Automatic tuning specifications..... | 8-3 |
| 8-2-3 Adjusting the automatic tuning..... | 8-4 |
| 8-3 Manual adjustment | 8-5 |
| 8-3-1 Setting the model inertia | 8-5 |
| 8-3-2 Adjusting the gain | 8-6 |
| 8-4 Characteristics improvements | 8-7 |
| 8-4-1 Vibration suppression measures..... | 8-7 |
| 8-4-2 Overshooting measures..... | 8-7 |
| 8-5 Adjusting the acceleration/deceleration operation | 8-8 |
| 8-5-1 Setting the operation speed | 8-8 |
| 8-5-2 Setting the acceleration/deceleration time constant..... | 8-8 |

Chapter 9 Inspections

| | |
|------------------------------|------------|
| 9-1 Inspections | 9-2 |
| 9-2 Life parts | 9-2 |

Chapter 10 Troubleshooting

| | |
|--|-------------|
| 10-1 Troubleshooting at start up | 10-2 |
| 10-2 Displays and countermeasures for various alarms | 10-2 |
| 10-2-1 Amplifier unit LED display during alarm | 10-2 |
| 10-2-2 Alarm/warning list | 10-3 |
| 10-3 Detailed explanations and countermeasures of alarms | 10-4 |
| 10-3-1 Detailed explanations and countermeasures for servo alarms..... | 10-4 |
| 10-3-2 Detailed explanations and countermeasures for system alarms | 10-9 |
| 10-3-3 Detailed explanations and countermeasures for operation alarms..... | 10-10 |

Chapter 11 Characteristics

| | |
|--|-------------|
| 11-1 Overload protection characteristics | 11-2 |
| 11-2 Servo amplifier generation loss | 11-3 |
| 11-2-1 Servo amplifier calorific value | 11-3 |
| 11-2-2 Heat radiation area of fully closed type control panel..... | 11-4 |

| | |
|--|--------------|
| 11-3 Magnetic brake characteristics | 11-5 |
| 11-3-1 Motor with magnetic brakes | 11-5 |
| 11-3-2 Magnetic brake characteristics..... | 11-6 |
| 11-3-3 Magnetic brake power supply | 11-8 |
| 11-4 Dynamic brake characteristics | 11-9 |
| 11-4-1 Deceleration torque | 11-9 |
| 11-4-2 Coasting amount..... | 11-10 |
| 11-5 Vibration class | 11-11 |

Chapter 12 Specifications

| | |
|---|-------------|
| 12-1 Servo amplifiers..... | 12-2 |
| 12-1-1 List of specifications..... | 12-2 |
| 12-1-2 Outline dimension drawings | 12-3 |
| 12-2 Servomotor | 12-5 |
| 12-2-1 List of specifications..... | 12-5 |
| 12-2-2 Torque characteristic drawings | 12-8 |
| 12-2-3 Outline dimension drawings | 12-11 |
| 12-2-4 Special axis servomotor..... | 12-25 |

Chapter 13 Selection

| | |
|---|--------------|
| 13-1 Outline..... | 13-2 |
| 13-1-1 Servomotor | 13-2 |
| 13-1-2 Regeneration methods..... | 13-3 |
| 13-2 Selection of servomotor series | 13-4 |
| 13-2-1 Motor series characteristics | 13-4 |
| 13-2-2 Servomotor precision | 13-4 |
| 13-3 Selection of servomotor capacity | 13-5 |
| 13-3-1 Load inertia ratio | 13-5 |
| 13-3-2 Short time characteristics..... | 13-5 |
| 13-3-3 Continuous characteristics | 13-6 |
| 13-4 Selection of regenerative resistor | 13-9 |
| 13-4-1 Calculation of regenerative energy | 13-9 |
| 13-4-2 Calculation of positioning frequency | 13-11 |
| 13-5 Example of servo selection | 13-12 |
| 13-5-1 Motor selection calculation..... | 13-12 |
| 13-5-2 Regenerative resistor selection calculation | 13-15 |
| 13-5-3 Servo selection results..... | 13-15 |
| 13-6 Motor shaft conversion load torque..... | 13-16 |
| 13-7 Expressions for load inertia calculation..... | 13-17 |

Appendix Parameter Lists

Chapter 1 Preface

| | | |
|------------|--|------------|
| 1-1 | Inspection at purchase | 1-2 |
| 1-1-1 | Package contents | 1-2 |
| 1-1-2 | Explanation of types | 1-2 |
| 1-2 | Explanation of each part | 1-5 |
| 1-2-1 | Explanation of each servo amplifier part | 1-5 |
| 1-2-2 | Explanation of each servomotor part | 1-5 |
| 1-3 | Basic configuration | 1-6 |
| 1-3-1 | Examples of MR-J2-10CT to MR-J2-100CT basic configurations | 1-6 |
| 1-3-2 | Examples of MR-J2-200CT and MR-J2-350CT basic configurations | 1-7 |
| 1-4 | Combinations of servo amplifier and servomotor capacities | 1-8 |
| 1-5 | Outline of built-in function | 1-9 |
| 1-5-1 | Axis control function..... | 1-9 |
| 1-5-2 | Servo control function | 1-9 |
| 1-5-3 | Feed function..... | 1-9 |
| 1-5-4 | Coordinate system setting function | 1-9 |
| 1-5-5 | Command method | 1-10 |
| 1-5-6 | Operation function | 1-10 |
| 1-5-7 | Absolute position detection function..... | 1-11 |
| 1-5-8 | Machine compensation function..... | 1-11 |
| 1-5-9 | Protective functions | 1-11 |
| 1-5-10 | Operation auxiliary function | 1-11 |
| 1-5-11 | Diagnosis function | 1-11 |

Chapter 1 Preface

1-1 Inspection at purchase

Open the package, and read the rating nameplate to confirm that the servo amplifier and servomotor are as ordered.

1-1-1 Package contents





- Servo amplifier

| Packaged parts | Qty. |
|---|------|
| Servo amplifier | 1 |
| Control power connector [Excluding MR-J2-200CT and MR-J2-350CT] | 1 |

- Servomotor

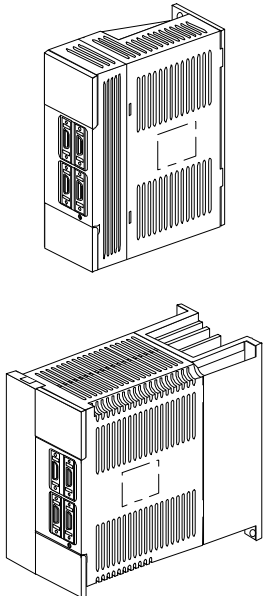
| Packaged parts | Qty. |
|----------------|------|
| Servomotor | 1 |

1-1-2 Explanation of types

| Appearance | Rating nameplate and type configuration | | | | | | | | | | | | | | | | | | | | | | | | | | | | | | | | | | | | | | | | | | | | | | | | | | | | | | | | | | | | | | | | | | | | | | | | | | | | | |
|--|--|----------------------|----------------------|----------------------|----------------------|-------|--|-------|--|-------|--|----------------------------|--|--------------------|------------|---------------------------------------|--|--|--|--------|---------------------|--|--|--|--|----------------------|----------------------|----------------------|----------------------|----------------------|----|---|---|---|---------|---------|----|---|---|---|----|----|----|---|---|---|--------|----|----|----|----|---|----|---|----|---|---|---|---|----|-----|-----|-----|---|---|---|-----|----------|----------|----------|---|---|-----|-----|-----|-----|---|---|
| <div style="writing-mode: vertical-rl; transform: rotate(180deg);">Servo amplifier</div>  | <div style="display: flex; justify-content: space-between;"> <div style="width: 45%;"> <p>Type →</p> <p>Rated input →</p> <p>Rated output →</p> <p>Current status →</p> <p>Serial No. →</p> </div> <div style="width: 50%; border: 1px solid black; padding: 5px;"> <table style="width: 100%; border-collapse: collapse;"> <tr> <td style="width: 50%;">MITSUBISHI</td> <td style="width: 50%;">SERVO DRIVE UNIT</td> </tr> <tr> <td>TYPE</td> <td>MR-J2-20CT</td> </tr> <tr> <td colspan="2">.....</td> </tr> <tr> <td colspan="2">.....</td> </tr> <tr> <td colspan="2">.....</td> </tr> <tr> <td colspan="2">S/W BND517W00C5 H/W VER. M</td> </tr> <tr> <td>SERIAL# XXXXXXXXXX</td> <td>DATE 00/01</td> </tr> <tr> <td colspan="2">MITSUBISHI ELECTRIC CORPORATION JAPAN</td> </tr> <tr> <td colspan="2" style="text-align: center;">  </td> </tr> </table> </div> </div> <p style="text-align: center;">MR - J2 - • • CT</p> <p>Mitsubishi AC servo MR-J2 series</p> <p style="text-align: center;">Capacity class symbol</p> <table border="1" style="width: 100%; border-collapse: collapse; text-align: center;"> <thead> <tr> <th rowspan="2">Symbol</th> <th colspan="5">Corresponding motor</th> </tr> <tr> <th>HC-SF (2000r/min)</th> <th>HC-SF (3000r/min)</th> <th>HC-RF (3000r/min)</th> <th>HA-FF (3000r/min)</th> <th>HC-MF (3000r/min)</th> </tr> </thead> <tbody> <tr> <td>10</td> <td>–</td> <td>–</td> <td>–</td> <td>053, 13</td> <td>053, 13</td> </tr> <tr> <td>20</td> <td>–</td> <td>–</td> <td>–</td> <td>23</td> <td>23</td> </tr> <tr> <td>40</td> <td>–</td> <td>–</td> <td>–</td> <td>33, 43</td> <td>43</td> </tr> <tr> <td>60</td> <td>52</td> <td>53</td> <td>–</td> <td>63</td> <td>–</td> </tr> <tr> <td>70</td> <td>–</td> <td>–</td> <td>–</td> <td>–</td> <td>73</td> </tr> <tr> <td>100</td> <td>102</td> <td>103</td> <td>–</td> <td>–</td> <td>–</td> </tr> <tr> <td>200</td> <td>152, 202</td> <td>153, 203</td> <td>103, 153</td> <td>–</td> <td>–</td> </tr> <tr> <td>300</td> <td>352</td> <td>353</td> <td>203</td> <td>–</td> <td>–</td> </tr> </tbody> </table> <p>(Note) As a standard, the MR-J2-CT servo amplifier complies with the EN Standards and UL Standards.</p> | MITSUBISHI | SERVO DRIVE UNIT | TYPE | MR-J2-20CT | | | | | | | S/W BND517W00C5 H/W VER. M | | SERIAL# XXXXXXXXXX | DATE 00/01 | MITSUBISHI ELECTRIC CORPORATION JAPAN | |  | | Symbol | Corresponding motor | | | | | HC-SF (2000r/min) | HC-SF (3000r/min) | HC-RF (3000r/min) | HA-FF (3000r/min) | HC-MF (3000r/min) | 10 | – | – | – | 053, 13 | 053, 13 | 20 | – | – | – | 23 | 23 | 40 | – | – | – | 33, 43 | 43 | 60 | 52 | 53 | – | 63 | – | 70 | – | – | – | – | 73 | 100 | 102 | 103 | – | – | – | 200 | 152, 202 | 153, 203 | 103, 153 | – | – | 300 | 352 | 353 | 203 | – | – |
| MITSUBISHI | SERVO DRIVE UNIT | | | | | | | | | | | | | | | | | | | | | | | | | | | | | | | | | | | | | | | | | | | | | | | | | | | | | | | | | | | | | | | | | | | | | | | | | | | | | |
| TYPE | MR-J2-20CT | | | | | | | | | | | | | | | | | | | | | | | | | | | | | | | | | | | | | | | | | | | | | | | | | | | | | | | | | | | | | | | | | | | | | | | | | | | | | |
| | | | | | | | | | | | | | | | | | | | | | | | | | | | | | | | | | | | | | | | | | | | | | | | | | | | | | | | | | | | | | | | | | | | | | | | | | | | | | | |
| | | | | | | | | | | | | | | | | | | | | | | | | | | | | | | | | | | | | | | | | | | | | | | | | | | | | | | | | | | | | | | | | | | | | | | | | | | | | | | |
| | | | | | | | | | | | | | | | | | | | | | | | | | | | | | | | | | | | | | | | | | | | | | | | | | | | | | | | | | | | | | | | | | | | | | | | | | | | | | | |
| S/W BND517W00C5 H/W VER. M | | | | | | | | | | | | | | | | | | | | | | | | | | | | | | | | | | | | | | | | | | | | | | | | | | | | | | | | | | | | | | | | | | | | | | | | | | | | | | |
| SERIAL# XXXXXXXXXX | DATE 00/01 | | | | | | | | | | | | | | | | | | | | | | | | | | | | | | | | | | | | | | | | | | | | | | | | | | | | | | | | | | | | | | | | | | | | | | | | | | | | | |
| MITSUBISHI ELECTRIC CORPORATION JAPAN | | | | | | | | | | | | | | | | | | | | | | | | | | | | | | | | | | | | | | | | | | | | | | | | | | | | | | | | | | | | | | | | | | | | | | | | | | | | | | |
|  | | | | | | | | | | | | | | | | | | | | | | | | | | | | | | | | | | | | | | | | | | | | | | | | | | | | | | | | | | | | | | | | | | | | | | | | | | | | | | |
| Symbol | Corresponding motor | | | | | | | | | | | | | | | | | | | | | | | | | | | | | | | | | | | | | | | | | | | | | | | | | | | | | | | | | | | | | | | | | | | | | | | | | | | | | |
| | HC-SF (2000r/min) | HC-SF (3000r/min) | HC-RF (3000r/min) | HA-FF (3000r/min) | HC-MF (3000r/min) | | | | | | | | | | | | | | | | | | | | | | | | | | | | | | | | | | | | | | | | | | | | | | | | | | | | | | | | | | | | | | | | | | | | | | | | | |
| 10 | – | – | – | 053, 13 | 053, 13 | | | | | | | | | | | | | | | | | | | | | | | | | | | | | | | | | | | | | | | | | | | | | | | | | | | | | | | | | | | | | | | | | | | | | | | | | |
| 20 | – | – | – | 23 | 23 | | | | | | | | | | | | | | | | | | | | | | | | | | | | | | | | | | | | | | | | | | | | | | | | | | | | | | | | | | | | | | | | | | | | | | | | | |
| 40 | – | – | – | 33, 43 | 43 | | | | | | | | | | | | | | | | | | | | | | | | | | | | | | | | | | | | | | | | | | | | | | | | | | | | | | | | | | | | | | | | | | | | | | | | | |
| 60 | 52 | 53 | – | 63 | – | | | | | | | | | | | | | | | | | | | | | | | | | | | | | | | | | | | | | | | | | | | | | | | | | | | | | | | | | | | | | | | | | | | | | | | | | |
| 70 | – | – | – | – | 73 | | | | | | | | | | | | | | | | | | | | | | | | | | | | | | | | | | | | | | | | | | | | | | | | | | | | | | | | | | | | | | | | | | | | | | | | | |
| 100 | 102 | 103 | – | – | – | | | | | | | | | | | | | | | | | | | | | | | | | | | | | | | | | | | | | | | | | | | | | | | | | | | | | | | | | | | | | | | | | | | | | | | | | |
| 200 | 152, 202 | 153, 203 | 103, 153 | – | – | | | | | | | | | | | | | | | | | | | | | | | | | | | | | | | | | | | | | | | | | | | | | | | | | | | | | | | | | | | | | | | | | | | | | | | | | |
| 300 | 352 | 353 | 203 | – | – | | | | | | | | | | | | | | | | | | | | | | | | | | | | | | | | | | | | | | | | | | | | | | | | | | | | | | | | | | | | | | | | | | | | | | | | | |

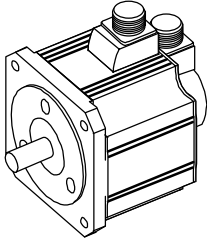
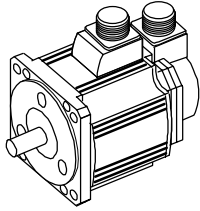
| | Appearance | Rating nameplate and type configuration | | | | | | | | | | | | | | | | | | | | | | | | | | | | | | | | | | | | | | | | | | | | | | | | | | | | | | | | | | | | | | | | | | | |
|------------------|--|--|---------------|------------------|---------------|----------|---|-------|---|--------|--------|----------------|------|------|---|---------------------|--------------|--|--|--|--------------|--|------------------|--|------------------|--|------------------|--|--------|---------------|--------|---------------|--------|---------------|----|-------|----|-------|-----|-------|-----|-------|-----|-------|-----|-------|-----|-------|-----|-------|-----|-------|-----|-------|-----|-------|--|--|-----|-------|-----|-------|--|--|--------|--------------|-------|---------------------------------|-------|
| Servomotor | <p>HC-SF Series</p> <ul style="list-style-type: none"> • Medium inertia • Peripheral axis, for general industrial machines  | <div style="display: flex; align-items: center;"> <div style="margin-right: 20px;"> <p>Type →</p> <p>Rated output →</p> <p>Rated speed →</p> <p>Serial No., →</p> </div> <div style="border: 1px solid black; padding: 5px; width: fit-content;"> <p style="text-align: center;">MITSUBISHI AC SERVO MOTOR HC-SF52</p> <p style="text-align: center;">.....8AO•120V 3.2A</p> <p style="text-align: center;">.....0.5kW IEC34-1 1884</p> <p style="text-align: center;">.....IP65•G.F 5.0kg</p> <p style="text-align: center;">.....</p> <p style="text-align: center;">MITSUBISHI ELECTRIC MADE IN JAPAN</p> </div> </div> | | | | | | | | | | | | | | | | | | | | | | | | | | | | | | | | | | | | | | | | | | | | | | | | | | | | | | | | | | | | | | | | | | | |
| | <p>HC-RF Series</p> <ul style="list-style-type: none"> • Low inertia • Peripheral axis, for general industrial machines  | <p style="text-align: center;">HC-SF </p> <div style="margin-left: 40px;"> <p>• Shaft end shape</p> <table border="1" style="border-collapse: collapse;"> <thead> <tr> <th>Symbol</th> <th>Shaft end shape</th> </tr> </thead> <tbody> <tr> <td>None</td> <td>Straight</td> </tr> <tr> <td>T</td> <td>Taper</td> </tr> <tr> <td>K</td> <td>Keyway</td> </tr> </tbody> </table> <p style="font-size: small; margin-left: 20px;">The taper axis specifications are compatible only with the SF52 to 152, 53 to 153 and RF103 to 203. The key is not provided with the keyway axis specifications.</p> </div> <div style="margin-left: 40px;"> <p>• Magnetic brake</p> <table border="1" style="border-collapse: collapse;"> <thead> <tr> <th>Symbol</th> <th>Magnetic brake</th> </tr> </thead> <tbody> <tr> <td>None</td> <td>None</td> </tr> <tr> <td>B</td> <td>With magnetic brake</td> </tr> </tbody> </table> </div> <div style="margin-left: 40px;"> <p>• Rated output and rated speed</p> <table border="1" style="border-collapse: collapse; width: 100%;"> <thead> <tr> <th colspan="4">HC-SF Series</th> <th colspan="2">HC-RF Series</th> </tr> <tr> <th colspan="2">Rating 2000r/min</th> <th colspan="2">Rating 3000r/min</th> <th colspan="2">Rating 3000r/min</th> </tr> <tr> <th>Symbol</th> <th>Rating output</th> <th>Symbol</th> <th>Rating output</th> <th>Symbol</th> <th>Rating output</th> </tr> </thead> <tbody> <tr> <td>52</td> <td>0.5kW</td> <td>53</td> <td>0.5kW</td> <td>103</td> <td>1.0kW</td> </tr> <tr> <td>102</td> <td>1.0kW</td> <td>103</td> <td>1.0kW</td> <td>153</td> <td>0.5kW</td> </tr> <tr> <td>152</td> <td>1.5kW</td> <td>153</td> <td>1.5kW</td> <td>203</td> <td>2.0kW</td> </tr> <tr> <td>202</td> <td>2.0kW</td> <td>203</td> <td>2.0kW</td> <td></td> <td></td> </tr> <tr> <td>352</td> <td>3.5kW</td> <td>353</td> <td>3.5kW</td> <td></td> <td></td> </tr> </tbody> </table> </div> <div style="margin-left: 40px;"> <p>• Motor series</p> <table border="1" style="border-collapse: collapse;"> <thead> <tr> <th>Symbol</th> <th>Motor series</th> </tr> </thead> <tbody> <tr> <td>HC-SF</td> <td>Medium inertia, medium capacity</td> </tr> <tr> <td>HC-RF</td> <td>Low inertia, medium capacity</td> </tr> </tbody> </table> </div> | Symbol | Shaft end shape | None | Straight | T | Taper | K | Keyway | Symbol | Magnetic brake | None | None | B | With magnetic brake | HC-SF Series | | | | HC-RF Series | | Rating 2000r/min | | Rating 3000r/min | | Rating 3000r/min | | Symbol | Rating output | Symbol | Rating output | Symbol | Rating output | 52 | 0.5kW | 53 | 0.5kW | 103 | 1.0kW | 102 | 1.0kW | 103 | 1.0kW | 153 | 0.5kW | 152 | 1.5kW | 153 | 1.5kW | 203 | 2.0kW | 202 | 2.0kW | 203 | 2.0kW | | | 352 | 3.5kW | 353 | 3.5kW | | | Symbol | Motor series | HC-SF | Medium inertia, medium capacity | HC-RF |
| Symbol | Shaft end shape | | | | | | | | | | | | | | | | | | | | | | | | | | | | | | | | | | | | | | | | | | | | | | | | | | | | | | | | | | | | | | | | | | | | |
| None | Straight | | | | | | | | | | | | | | | | | | | | | | | | | | | | | | | | | | | | | | | | | | | | | | | | | | | | | | | | | | | | | | | | | | | | |
| T | Taper | | | | | | | | | | | | | | | | | | | | | | | | | | | | | | | | | | | | | | | | | | | | | | | | | | | | | | | | | | | | | | | | | | | | |
| K | Keyway | | | | | | | | | | | | | | | | | | | | | | | | | | | | | | | | | | | | | | | | | | | | | | | | | | | | | | | | | | | | | | | | | | | | |
| Symbol | Magnetic brake | | | | | | | | | | | | | | | | | | | | | | | | | | | | | | | | | | | | | | | | | | | | | | | | | | | | | | | | | | | | | | | | | | | | |
| None | None | | | | | | | | | | | | | | | | | | | | | | | | | | | | | | | | | | | | | | | | | | | | | | | | | | | | | | | | | | | | | | | | | | | | |
| B | With magnetic brake | | | | | | | | | | | | | | | | | | | | | | | | | | | | | | | | | | | | | | | | | | | | | | | | | | | | | | | | | | | | | | | | | | | | |
| HC-SF Series | | | | HC-RF Series | | | | | | | | | | | | | | | | | | | | | | | | | | | | | | | | | | | | | | | | | | | | | | | | | | | | | | | | | | | | | | | | | |
| Rating 2000r/min | | Rating 3000r/min | | Rating 3000r/min | | | | | | | | | | | | | | | | | | | | | | | | | | | | | | | | | | | | | | | | | | | | | | | | | | | | | | | | | | | | | | | | | |
| Symbol | Rating output | Symbol | Rating output | Symbol | Rating output | | | | | | | | | | | | | | | | | | | | | | | | | | | | | | | | | | | | | | | | | | | | | | | | | | | | | | | | | | | | | | | | |
| 52 | 0.5kW | 53 | 0.5kW | 103 | 1.0kW | | | | | | | | | | | | | | | | | | | | | | | | | | | | | | | | | | | | | | | | | | | | | | | | | | | | | | | | | | | | | | | | |
| 102 | 1.0kW | 103 | 1.0kW | 153 | 0.5kW | | | | | | | | | | | | | | | | | | | | | | | | | | | | | | | | | | | | | | | | | | | | | | | | | | | | | | | | | | | | | | | | |
| 152 | 1.5kW | 153 | 1.5kW | 203 | 2.0kW | | | | | | | | | | | | | | | | | | | | | | | | | | | | | | | | | | | | | | | | | | | | | | | | | | | | | | | | | | | | | | | | |
| 202 | 2.0kW | 203 | 2.0kW | | | | | | | | | | | | | | | | | | | | | | | | | | | | | | | | | | | | | | | | | | | | | | | | | | | | | | | | | | | | | | | | | | |
| 352 | 3.5kW | 353 | 3.5kW | | | | | | | | | | | | | | | | | | | | | | | | | | | | | | | | | | | | | | | | | | | | | | | | | | | | | | | | | | | | | | | | | | |
| Symbol | Motor series | | | | | | | | | | | | | | | | | | | | | | | | | | | | | | | | | | | | | | | | | | | | | | | | | | | | | | | | | | | | | | | | | | | | |
| HC-SF | Medium inertia, medium capacity | | | | | | | | | | | | | | | | | | | | | | | | | | | | | | | | | | | | | | | | | | | | | | | | | | | | | | | | | | | | | | | | | | | | |
| HC-RF | Low inertia, medium capacity | | | | | | | | | | | | | | | | | | | | | | | | | | | | | | | | | | | | | | | | | | | | | | | | | | | | | | | | | | | | | | | | | | | | |
| | | <p>(Note) As a standard, the HC-SF, HC-RF motor complies with the EN Standards and UL Standards.</p> | | | | | | | | | | | | | | | | | | | | | | | | | | | | | | | | | | | | | | | | | | | | | | | | | | | | | | | | | | | | | | | | | | | |

Chapter 1 Preface

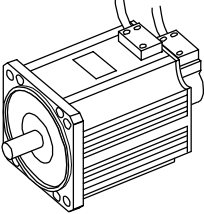
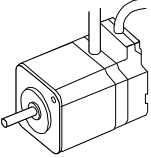
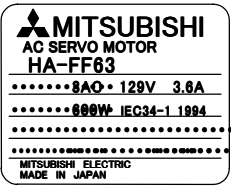
| Appearance | Rating nameplate and type configuration | | | | | | | | | | | | | | | | | | | | | | | | | | | | | | | | | | | | | | | | | | | | | | | | | | | | | | | | | | | | | | | | | | | | | | | | | | | | | | | | | | | | | | |
|--|--|-------------------|--------------------------------------|-------------------|---------------------------|-----|---|------|---|--------|-------|--|-------|--|--------|-------|--------|-------|------|----------|-------------------|----------|----------|---|---|---|---|-------------------|---|-------|----|-------|----|--------|----------------|------|------|---|---------------------|--------|-------------|------|------|---|------------------|--------------|--|--------------|--|------------------|--|------------------|--|--------|---------------|--------|---------------|-----|--------|-----|--------|----|-------|----|-------|----|-------|----|-------|----|-------|----|-------|----|-------|----|--------|----|-------|--|--|--------|--------------|-------|-----------------------------|-------|-----------------------------------|
| <p>HA-FF Series</p> <ul style="list-style-type: none"> • Compact low inertia • Peripheral axis, for general industrial machines  <p>HC-MF Series</p> <ul style="list-style-type: none"> • Ultra-compact low inertia • Peripheral axis, for general industrial machines  | <div style="display: flex; justify-content: space-between;"> <div style="width: 30%;"> <p>Type →</p> <p>Rated output →</p> <p>Detector →</p> <p>Serial No. →</p> </div> <div style="width: 65%;">  </div> </div> <p>HA-FF [] [] [] [] [] []</p> <ul style="list-style-type: none"> • Standards and environment compliance <table border="1" data-bbox="946 741 1437 891"> <thead> <tr> <th>Symbol</th> <th>Standards and environment compliance</th> </tr> </thead> <tbody> <tr> <td>None</td> <td>None (IP44 specification)</td> </tr> <tr> <td>-UE</td> <td>EN Standards + UL Standards (only the HA-FF follows IP54 specification)</td> </tr> <tr> <td>-S15</td> <td>EN Standards + UL Standards + IP65 specification (Set for HC-MF13,23,43 and 73)</td> </tr> </tbody> </table> <ul style="list-style-type: none"> • Shaft end shape <table border="1" data-bbox="935 931 1433 1111"> <thead> <tr> <th rowspan="2">Symbol</th> <th colspan="2">HA-FF</th> <th colspan="2">HC-MF</th> </tr> <tr> <th>053•13</th> <th>23~63</th> <th>053•13</th> <th>23~73</th> </tr> </thead> <tbody> <tr> <td>None</td> <td>Straight</td> <td>Keyway (with key)</td> <td>Straight</td> <td>Straight</td> </tr> <tr> <td>K</td> <td>.</td> <td>.</td> <td>.</td> <td>Keyway (with key)</td> </tr> <tr> <td>D</td> <td>D cut</td> <td>••</td> <td>D cut</td> <td>••</td> </tr> </tbody> </table> <ul style="list-style-type: none"> • Magnetic brake <table border="1" data-bbox="935 1151 1294 1234"> <thead> <tr> <th>Symbol</th> <th>Magnetic brake</th> </tr> </thead> <tbody> <tr> <td>None</td> <td>None</td> </tr> <tr> <td>B</td> <td>With magnetic brake</td> </tr> </tbody> </table> <ul style="list-style-type: none"> • Power input <table border="1" data-bbox="935 1283 1190 1384"> <thead> <tr> <th>Symbol</th> <th>Power input</th> </tr> </thead> <tbody> <tr> <td>None</td> <td>Lead</td> </tr> <tr> <td>C</td> <td>Cannon connector</td> </tr> </tbody> </table> <p>Always attach "C" to the HA-FF-UE. There is no "C" for other series servomotors.</p> <ul style="list-style-type: none"> • Rated output and rated speed <table border="1" data-bbox="935 1440 1422 1675"> <thead> <tr> <th colspan="2">HA-FF Series</th> <th colspan="2">HC-MF Series</th> </tr> <tr> <th colspan="2">Rating 3000r/min</th> <th colspan="2">Rating 3000r/min</th> </tr> <tr> <th>Symbol</th> <th>Rating output</th> <th>Symbol</th> <th>Rating output</th> </tr> </thead> <tbody> <tr> <td>053</td> <td>0.05kW</td> <td>053</td> <td>0.05kW</td> </tr> <tr> <td>13</td> <td>0.1kW</td> <td>13</td> <td>0.1kW</td> </tr> <tr> <td>23</td> <td>0.2kW</td> <td>23</td> <td>0.2kW</td> </tr> <tr> <td>33</td> <td>0.3kW</td> <td>43</td> <td>0.4kW</td> </tr> <tr> <td>43</td> <td>0.4kW</td> <td>73</td> <td>0.75kW</td> </tr> <tr> <td>63</td> <td>0.6kW</td> <td></td> <td></td> </tr> </tbody> </table> <ul style="list-style-type: none"> • Motor series <table border="1" data-bbox="935 1731 1417 1809"> <thead> <tr> <th>Symbol</th> <th>Motor series</th> </tr> </thead> <tbody> <tr> <td>HA-FF</td> <td>Low inertia, small capacity</td> </tr> <tr> <td>HC-MF</td> <td>Ultra-low inertia, small capacity</td> </tr> </tbody> </table> | Symbol | Standards and environment compliance | None | None (IP44 specification) | -UE | EN Standards + UL Standards (only the HA-FF follows IP54 specification) | -S15 | EN Standards + UL Standards + IP65 specification (Set for HC-MF13,23,43 and 73) | Symbol | HA-FF | | HC-MF | | 053•13 | 23~63 | 053•13 | 23~73 | None | Straight | Keyway (with key) | Straight | Straight | K | . | . | . | Keyway (with key) | D | D cut | •• | D cut | •• | Symbol | Magnetic brake | None | None | B | With magnetic brake | Symbol | Power input | None | Lead | C | Cannon connector | HA-FF Series | | HC-MF Series | | Rating 3000r/min | | Rating 3000r/min | | Symbol | Rating output | Symbol | Rating output | 053 | 0.05kW | 053 | 0.05kW | 13 | 0.1kW | 13 | 0.1kW | 23 | 0.2kW | 23 | 0.2kW | 33 | 0.3kW | 43 | 0.4kW | 43 | 0.4kW | 73 | 0.75kW | 63 | 0.6kW | | | Symbol | Motor series | HA-FF | Low inertia, small capacity | HC-MF | Ultra-low inertia, small capacity |
| Symbol | Standards and environment compliance | | | | | | | | | | | | | | | | | | | | | | | | | | | | | | | | | | | | | | | | | | | | | | | | | | | | | | | | | | | | | | | | | | | | | | | | | | | | | | | | | | | | | | |
| None | None (IP44 specification) | | | | | | | | | | | | | | | | | | | | | | | | | | | | | | | | | | | | | | | | | | | | | | | | | | | | | | | | | | | | | | | | | | | | | | | | | | | | | | | | | | | | | | |
| -UE | EN Standards + UL Standards (only the HA-FF follows IP54 specification) | | | | | | | | | | | | | | | | | | | | | | | | | | | | | | | | | | | | | | | | | | | | | | | | | | | | | | | | | | | | | | | | | | | | | | | | | | | | | | | | | | | | | | |
| -S15 | EN Standards + UL Standards + IP65 specification (Set for HC-MF13,23,43 and 73) | | | | | | | | | | | | | | | | | | | | | | | | | | | | | | | | | | | | | | | | | | | | | | | | | | | | | | | | | | | | | | | | | | | | | | | | | | | | | | | | | | | | | | |
| Symbol | HA-FF | | HC-MF | | | | | | | | | | | | | | | | | | | | | | | | | | | | | | | | | | | | | | | | | | | | | | | | | | | | | | | | | | | | | | | | | | | | | | | | | | | | | | | | | | | | |
| | 053•13 | 23~63 | 053•13 | 23~73 | | | | | | | | | | | | | | | | | | | | | | | | | | | | | | | | | | | | | | | | | | | | | | | | | | | | | | | | | | | | | | | | | | | | | | | | | | | | | | | | | | | |
| None | Straight | Keyway (with key) | Straight | Straight | | | | | | | | | | | | | | | | | | | | | | | | | | | | | | | | | | | | | | | | | | | | | | | | | | | | | | | | | | | | | | | | | | | | | | | | | | | | | | | | | | | |
| K | . | . | . | Keyway (with key) | | | | | | | | | | | | | | | | | | | | | | | | | | | | | | | | | | | | | | | | | | | | | | | | | | | | | | | | | | | | | | | | | | | | | | | | | | | | | | | | | | | |
| D | D cut | •• | D cut | •• | | | | | | | | | | | | | | | | | | | | | | | | | | | | | | | | | | | | | | | | | | | | | | | | | | | | | | | | | | | | | | | | | | | | | | | | | | | | | | | | | | | |
| Symbol | Magnetic brake | | | | | | | | | | | | | | | | | | | | | | | | | | | | | | | | | | | | | | | | | | | | | | | | | | | | | | | | | | | | | | | | | | | | | | | | | | | | | | | | | | | | | | |
| None | None | | | | | | | | | | | | | | | | | | | | | | | | | | | | | | | | | | | | | | | | | | | | | | | | | | | | | | | | | | | | | | | | | | | | | | | | | | | | | | | | | | | | | | |
| B | With magnetic brake | | | | | | | | | | | | | | | | | | | | | | | | | | | | | | | | | | | | | | | | | | | | | | | | | | | | | | | | | | | | | | | | | | | | | | | | | | | | | | | | | | | | | | |
| Symbol | Power input | | | | | | | | | | | | | | | | | | | | | | | | | | | | | | | | | | | | | | | | | | | | | | | | | | | | | | | | | | | | | | | | | | | | | | | | | | | | | | | | | | | | | | |
| None | Lead | | | | | | | | | | | | | | | | | | | | | | | | | | | | | | | | | | | | | | | | | | | | | | | | | | | | | | | | | | | | | | | | | | | | | | | | | | | | | | | | | | | | | | |
| C | Cannon connector | | | | | | | | | | | | | | | | | | | | | | | | | | | | | | | | | | | | | | | | | | | | | | | | | | | | | | | | | | | | | | | | | | | | | | | | | | | | | | | | | | | | | | |
| HA-FF Series | | HC-MF Series | | | | | | | | | | | | | | | | | | | | | | | | | | | | | | | | | | | | | | | | | | | | | | | | | | | | | | | | | | | | | | | | | | | | | | | | | | | | | | | | | | | | | |
| Rating 3000r/min | | Rating 3000r/min | | | | | | | | | | | | | | | | | | | | | | | | | | | | | | | | | | | | | | | | | | | | | | | | | | | | | | | | | | | | | | | | | | | | | | | | | | | | | | | | | | | | | |
| Symbol | Rating output | Symbol | Rating output | | | | | | | | | | | | | | | | | | | | | | | | | | | | | | | | | | | | | | | | | | | | | | | | | | | | | | | | | | | | | | | | | | | | | | | | | | | | | | | | | | | | |
| 053 | 0.05kW | 053 | 0.05kW | | | | | | | | | | | | | | | | | | | | | | | | | | | | | | | | | | | | | | | | | | | | | | | | | | | | | | | | | | | | | | | | | | | | | | | | | | | | | | | | | | | | |
| 13 | 0.1kW | 13 | 0.1kW | | | | | | | | | | | | | | | | | | | | | | | | | | | | | | | | | | | | | | | | | | | | | | | | | | | | | | | | | | | | | | | | | | | | | | | | | | | | | | | | | | | | |
| 23 | 0.2kW | 23 | 0.2kW | | | | | | | | | | | | | | | | | | | | | | | | | | | | | | | | | | | | | | | | | | | | | | | | | | | | | | | | | | | | | | | | | | | | | | | | | | | | | | | | | | | | |
| 33 | 0.3kW | 43 | 0.4kW | | | | | | | | | | | | | | | | | | | | | | | | | | | | | | | | | | | | | | | | | | | | | | | | | | | | | | | | | | | | | | | | | | | | | | | | | | | | | | | | | | | | |
| 43 | 0.4kW | 73 | 0.75kW | | | | | | | | | | | | | | | | | | | | | | | | | | | | | | | | | | | | | | | | | | | | | | | | | | | | | | | | | | | | | | | | | | | | | | | | | | | | | | | | | | | | |
| 63 | 0.6kW | | | | | | | | | | | | | | | | | | | | | | | | | | | | | | | | | | | | | | | | | | | | | | | | | | | | | | | | | | | | | | | | | | | | | | | | | | | | | | | | | | | | | | |
| Symbol | Motor series | | | | | | | | | | | | | | | | | | | | | | | | | | | | | | | | | | | | | | | | | | | | | | | | | | | | | | | | | | | | | | | | | | | | | | | | | | | | | | | | | | | | | | |
| HA-FF | Low inertia, small capacity | | | | | | | | | | | | | | | | | | | | | | | | | | | | | | | | | | | | | | | | | | | | | | | | | | | | | | | | | | | | | | | | | | | | | | | | | | | | | | | | | | | | | | |
| HC-MF | Ultra-low inertia, small capacity | | | | | | | | | | | | | | | | | | | | | | | | | | | | | | | | | | | | | | | | | | | | | | | | | | | | | | | | | | | | | | | | | | | | | | | | | | | | | | | | | | | | | | |

Servomotor

Chapter 1 Preface

1-2 Explanation of each part

1-2-1 Explanation of each servo amplifier part

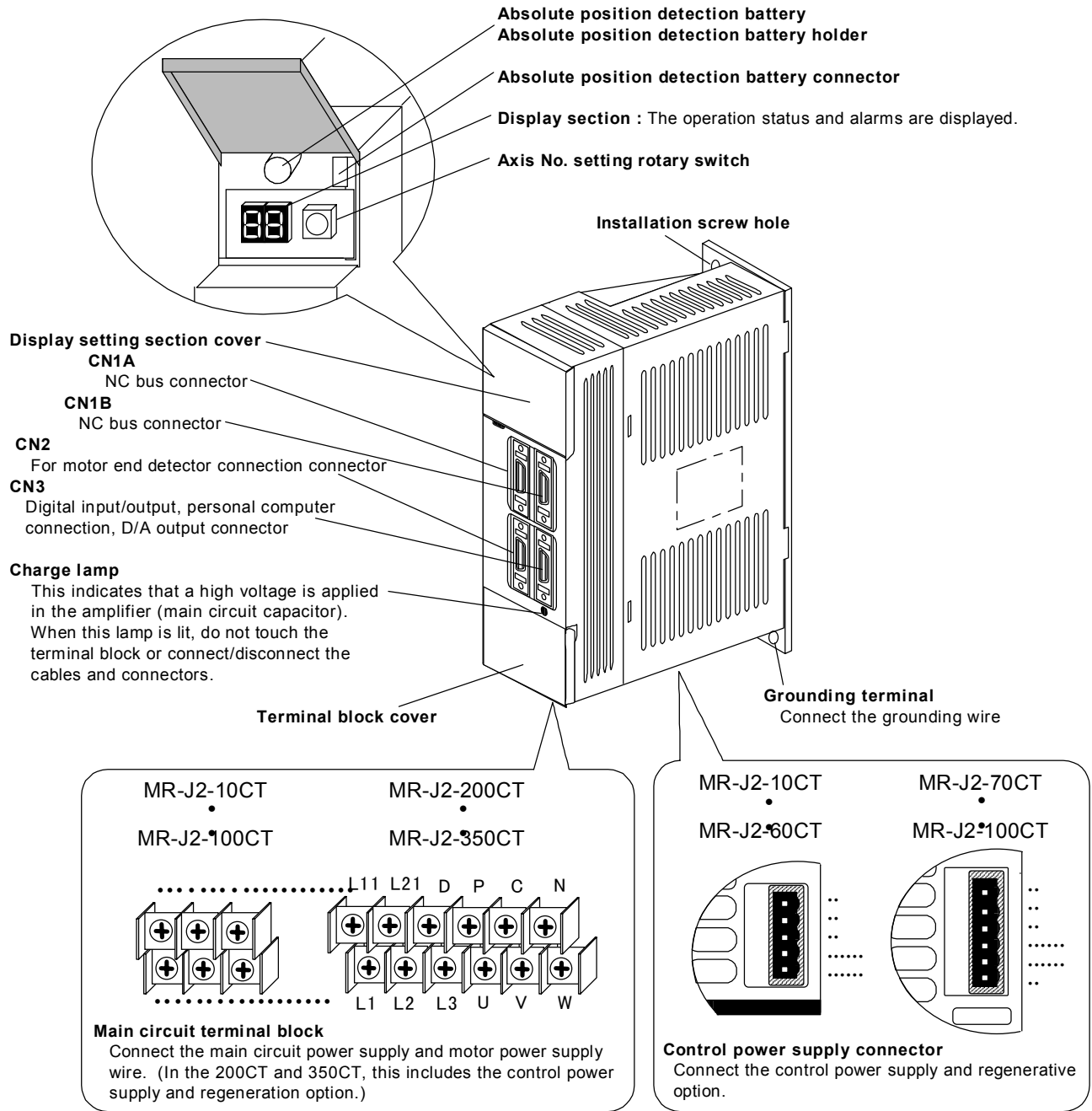

1-2-2 Explanation of each servomotor part

HC-SF, HC-RF Series

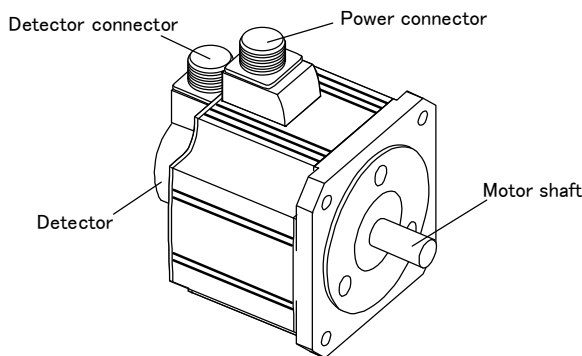

HA-FF, HC-MF Series

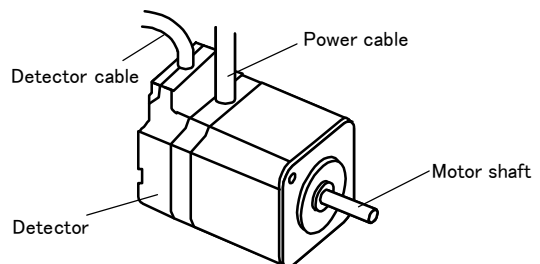

1-3 Basic configuration

The MR-J2-CT is a Mitsubishi NC auxiliary axis servo amplifier with an indexing function for the rotation axis built in.

The MR-J2-CT is used with a high-speed serial bus connection to the Mitsubishi NC. The run command to the MR-J2-CT is issued from the PLC built into the NC.

1-3-1 Examples of MR-J2-10CT to MR-J2-100CT basic configurations

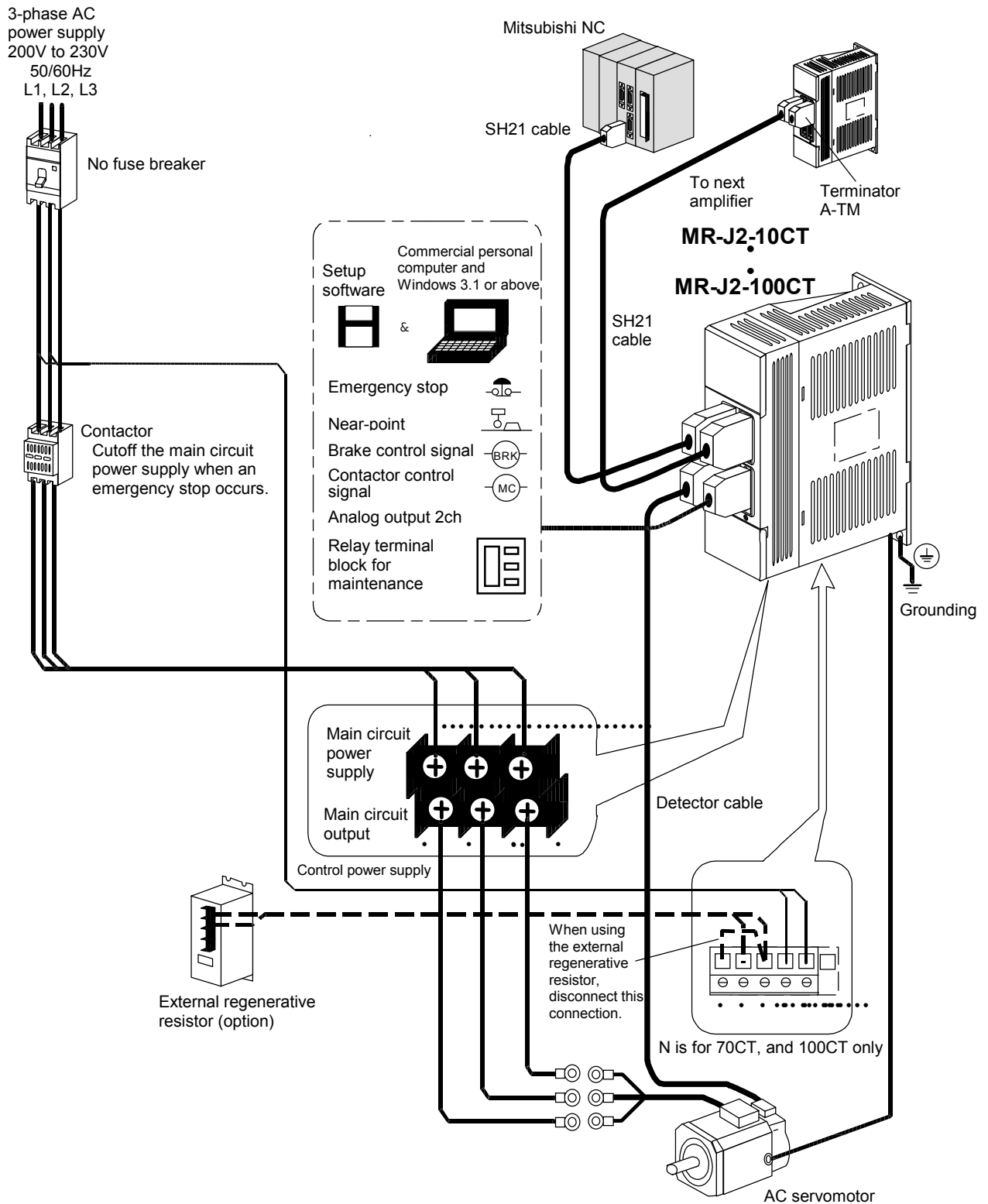

Chapter 1 Preface

1-3-2 Examples of MR-J2-200CT and MR-J2-350CT basic configurations

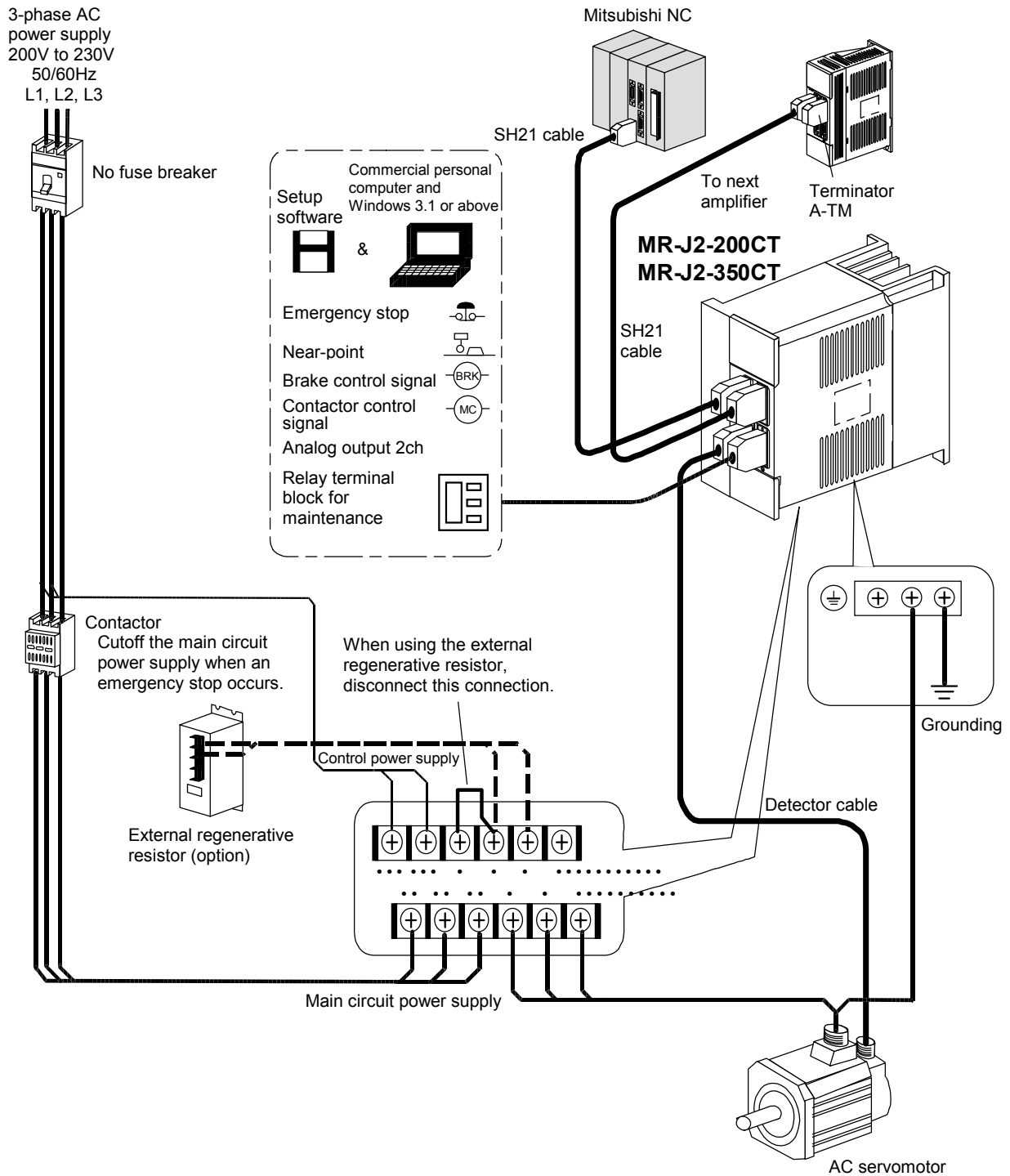

Chapter 1 Preface

1-4 Combinations of servo amplifier and servomotor capacities

Top line : Rated output, Middle line : Rated speed, Bottom line : Max. torque

| | | MR-J2-10CT | MR-J2-20CT | MR-J2-40CT | MR-J2-60CT | MR-J2-70CT | MR-J2-100CT | MR-J2-200CT | MR-J2-350CT |
|--|----------|----------------------------|---------------------------|---------------------------|----------------------------|---------------------------|-----------------------------|-----------------------------|-----------------------------|
| Medium capacity Medium inertia (IP65) | HC-SF52 | | | | 500W 2000rpm 7.16N·m | | | | |
| | HC-SF102 | | | | | | 1000W 2000rpm 14.4N·m | | |
| | HC-SF152 | | | | | | | 1500W 2000rpm 21.6N·m | |
| | HC-SF202 | | | | | | | 2000W 2000rpm 28.5N·m | |
| | HC-SF352 | | | | | | | | 3500W 2000rpm 50.1N·m |
| | HC-SF53 | | | | 500W 3000rpm 4.77N·m | | | | |
| | HC-SF103 | | | | | | 1000W 3000rpm 9.55N·m | | |
| | HC-SF153 | | | | | | | 1500W 3000rpm 14.3N·m | |
| | HC-SF203 | | | | | | | 2000W 3000rpm 19.1N·m | |
| | HC-SF353 | | | | | | | | 3500W 3000rpm 33.4N·m |
| Medium capacity Low inertia (IP65) | HC-RF103 | | | | | | | 1000W 3000rpm 7.95N·m | |
| | HC-RF153 | | | | | | | 1500W 3000rpm 11.9N·m | |
| | HC-RF203 | | | | | | | | 2000W 3000rpm 15.9N·m |
| (Note 2) Small capacity Low inertia (IP54) (IP44) | HA-FF053 | 50W 3000rpm 0.48N·m | | | | | | | |
| | HA-FF13 | 100W 3000rpm 0.95N·m | | | | | | | |
| | HA-FF23 | | 200W 3000rpm 1.9N·m | | | | | | |
| | HA-FF33 | | | 300W 3000rpm 2.9N·m | | | | | |
| | HA-FF43 | | | 400W 3000rpm 3.8N·m | | | | | |
| | HA-FF63 | | | | 600W 3000rpm 5.7N·m | | | | |
| Small capacity Ultra-low inertia (IP44) | HA-MF053 | 50W 3000rpm 0.48N·m | | | | | | | |
| | HA-MF13 | 100W 3000rpm 0.95N·m | | | | | | | |
| | HC-MF23 | | 200W 3000rpm 1.9N·m | | | | | | |
| | HC-MF43 | | | 400W 3000rpm 3.8N·m | | | | | |
| | HC-MF73 | | | | | 750W 3000rpm 7.2N·m | | | |

(Note 1) Blank boxes in the table indicate that a combination is not possible.

(Note 2) Take care to the HC-RF motor and amplifier capacity combination.

Chapter 1 Preface

1-5 Outline of built-in function

1-5-1 Axis control function

- No. of control axes : 1 axis
- Command and setting unit : 0.001deg.
- Positioning resolution : Follows No. of detector pulses and gear ratio.

<Example>

When using an HC-SF motor (No. of detector pulses: 16384 pulses/rev) motor and a gear ratio of 1:10, the positioning resolution will be: (Refer to Chapter 13)

Positioning resolution =

$$\text{Detector resolution} \times 2 = \frac{360^\circ \times 2}{16384 \times 10} = 0.0044^\circ$$

- Servo OFF function : The power to the motor can be randomly cut off (motor free run) using commands.
- Follow up function : The axis movement is monitored even during servo OFF or emergency stop, and the machine position counter is updated.
- Torque limit function : The motor's output torque can be limited. Four random limit values can be set, and one selected with a command.

1-5-2 Servo control function

- Control method : The real-time automatic tuning function with model adaptive control is incorporated. The servo's characteristic gain does not need to be adjusted.
- Vibration suppressing function : The vibration caused by machine resonance can be suppressed with a notch filter and jitter compensation.

1-5-3 Feed function

- Feedrate designation : Four per-minute feeds can be set with a deg/min unit (rotation axis) or mm/min (linear axis), and one selected with a command. The feedrate command range is 1 to 100000.
- Acceleration/deceleration method : The inclined constant acceleration/deceleration is automatically controlled. The linear acceleration/deceleration or soft acceleration/deceleration can be selected.
- Acceleration/deceleration pattern designation : Four acceleration/deceleration patterns can be set, and method one selected with a command.
- Short-cut control : When using the rotation axis, the rotation direction with least movement distance is automatically judged and the axis is rotated. The rotation direction can be designated with a command.

1-5-4 Coordinate system setting function

- Coordinate system : Corresponds to the rotation axis coordinates (0° to 360°) and the linear coordinates.
- Coordinate system shift function : The machine coordinates can be shifted.

Chapter 1 Preface

1-5-5 Command method

Station method (for rotation axis) : A point (station) obtained by equally dividing the rotation axis can be selected with a command, and positioned to. The max. No. of divisions is 360.

<When eight stations are set (8 divisions)>

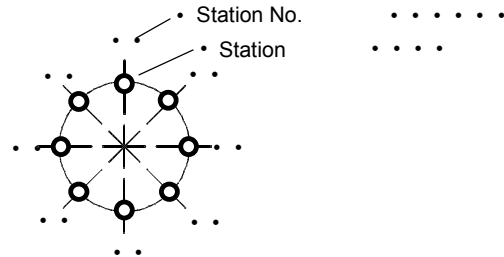

Station method (for linear axis) : The equal division points (stations) are determined by the valid stroke length and No. of stations. The Max. No. of stations is 360.

<When five stations are set>

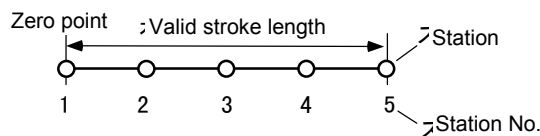

- The zero point is station 1, and the final end of the valid stroke is station 5.
- When using a linear axis, the No. of equal divisions is "No. of stations -1".

Uneven station method : When the positioning positions (stations) are not at an equal pitch, up to eight coordinate points can be randomly set to determine the station coordinates. This can be used for either the rotation axis or linear axis.

Random coordinate designation method : Random coordinates (absolute coordinates using zero point as reference) can be transferred from the PLC and used for positioning.

1-5-6 Operation function

The following seven operation modes can be used. The operation mode is changed with commands from the PLC.

- Automatic mode : This mode carries out positioning to the designated station No. with the start signal. If the start signal turns OFF before the positioning is finished, the axis will be positioned to the nearest station position. Positioning to random coordinates is also possible.
- Manual mode : This mode rotates at a set speed in the designated direction while the start signal is ON. If the start signal turns OFF, the axis will be positioned to the nearest station position.
- JOG mode : This mode rotates at a set speed in the designated direction while the start signal is ON.
- Incremental feed mode : This feed mode moves only the designated movement amount at each start.
- Manual handle mode : This mode moves the axis with the pulse command (manual handle signal) transferred from the NC.

Chapter 1 Preface

- Reference point return mode : This mode positions to the reference point. The dog switch method, or the method to position to the reference point registered in the memory can be used.
- Stopper positioning mode : This mode positions by pressing against the machine end, etc. The approach amount, pressing amount, pressing speed, and pressing torque limit amount can be set.

1-5-7 Absolute position detection function

The detector monitors the machine movement even when the power is turned OFF. After turning the power ON, automatic operation can be started immediately without returning to the reference point (zero point).

1-5-8 Machine compensation function

- Electronic gears : By setting the gear ratio and ball screw pitch (for linear axis), the commanded position and speed will be automatically converted to the motor's rotation angle and speed. All settings can be made with the machine end movement amount and speed without considering the weight of one detector pulse.
- Backlash compensation : The positioning error caused by backlash of the gear or ball screw, etc., can be compensated.

1-5-9 Protective functions

- Emergency stop function : A hot line can be established with the NC allowing the external emergency stop signal to be directly input. During an emergency stop, the axis can be stopped with the dynamic brakes built in the amplifier, or by decelerating to a stop.
- Excessive error monitor function : The max. tolerable amount of the axis tracking delay (droop) can be monitored during feed. If a droop exceeding the tolerable value occurs, the servomotor will emergency stop.
- Interlock : Movement of the axis in a specific direction can be prohibited.
- Edit lock : Rewriting of the parameters can be prohibited.

1-5-10 Operation auxiliary function

- PSW : Eight sets of position switches using software processing are mounted. Using these, the axis movement state can be monitored even without mechanical switches.

1-5-11 Diagnosis function

- Self diagnosis : The various alarms are displayed on the main unit's 7-segment LED display, and output to the NC and personal computer.
- Servo monitor : The operation state (speed, current, etc.) is output to the NC and personal computer. The personal computer requires dedicated setup software.
- Signal monitor : The commands sent to the personal computer from the PLC and the status output signal to the PLC can be monitored. The personal computer requires dedicated setup software.
- Test operation : Commands from the personal computer can be fed and operated. The personal computer requires dedicated setup software.
- Analog monitor : The operation state (speed, current, etc.) to the amplifier CN3 connector are analog output. Two channels can be used simultaneously.
- Alarm history : The past six alarms can be recorded and output to the NC or personal computer.

Chapter 2 Wiring and Connection

| | | |
|------------|--|-------------|
| 2-1 | System connection diagram | 2-3 |
| 2-2 | Servo amplifier main circuit terminal block, control circuit terminal block | 2-4 |
| 2-2-1 | Main circuit terminal block, control circuit terminal block signal layout | 2-4 |
| 2-2-2 | Names and application of main circuit terminal block and control circuit terminal block signals..... | 2-5 |
| 2-2-3 | How to use the control circuit terminal block (MR-J2-10CT to 100CT)..... | 2-6 |
| 2-3 | NC and servo amplifier connection | 2-7 |
| 2-4 | Motor and detector connection | 2-8 |
| 2-4-1 | Connection of HC-SF52, HC-SF53, HC-SF102, HC-SF103..... | 2-8 |
| 2-4-2 | Connection of HC-SF152, HC-SF153 | 2-8 |
| 2-4-3 | Connection of HC-SF202, HC-SF203, HC-SF352, HC-SF353..... | 2-9 |
| 2-4-4 | Connection of HC-RF103, HC-RF153, HC-RF203..... | 2-9 |
| 2-4-5 | Connection of HA-FF Series | 2-10 |
| 2-4-6 | Connection of HA-FF• C-UE Series..... | 2-10 |
| 2-4-7 | Connection of HC-MF(-UE) Series..... | 2-11 |
| 2-4-8 | Connection of HC-MF• S15 Series | 2-11 |
| 2-5 | Connection of power supply | 2-12 |
| 2-5-1 | Example of connection when controlling the contactor with the MR-J2-CT | 2-12 |
| 2-5-2 | Example of connection when using converter unit | 2-13 |
| 2-6 | Connection of regenerative resistor..... | 2-15 |
| 2-6-1 | Standard built-in regenerative resistor | 2-15 |
| 2-6-2 | External option regenerative resistor | 2-15 |
| 2-7 | Connection of digital input/output (DIO) signals..... | 2-16 |
| 2-7-1 | Types and functions of digital input/output (DIO) signals | 2-16 |
| 2-7-2 | Wiring of digital input/output (DIO) signals..... | 2-17 |
| 2-8 | Connection with personal computer..... | 2-20 |

Chapter 2 Wiring and Connection

DANGER

1. Wiring work must be done by a qualified technician.
2. Wait at least 10 minutes after turning the power OFF and check the voltage with a tester, etc., before starting wiring. Failure to observe this could lead to electric shocks.
3. Securely ground the servo amplifier and servomotor with Class 3 grounding or higher.
4. Wire the servo amplifier and servomotor after installation. Failure to observe this could lead to electric shocks.
5. Do not damage, apply forcible stress, place heavy items or engage the cable. Failure to observe this could lead to electric shocks.
6. Always insulate the connection of the power terminal. Failure to observe this could lead to electric shocks.

CAUTION

1. Correctly and securely perform the wiring. Failure to do so could lead to runaway of the servomotor.
2. Do not mistake the terminal connections. Failure to observe this item could lead to ruptures or damage, etc.
3. Do not mistake the polarity (+ , -). Failure to observe this item could lead to ruptures or damage, etc.
4. Do not mistake the direction of the diodes for the surge absorption installed on the DC relay for the motor brake and contactor (magnetic contact) control. The signal might not be output when a failure occurs.

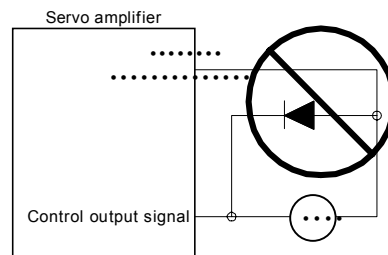

5. Electronic devices used near the servo amplifier may receive magnetic obstruction. Reduce the effect of magnetic obstacles by installing a noise filter, etc.
6. Do not install a phase advancing capacitor, surge absorber or radio noise filter on the power supply wire (U, V, W) of the servomotor.
7. Do not modify this unit.
8. The CN1A, CN1B, CN2 and CN3 connectors on the front of the amplifier have the same shape. If the connectors are connected incorrectly, faults could occur. Make sure that the connection is correct.
9. When grounding the motor, connect to the protective grounding terminal on the servo amplifier, and ground from the other protective grounding terminal. (Use one-point grounding)
Do not separately ground the connected motor and servo amplifier as noise could be generated.

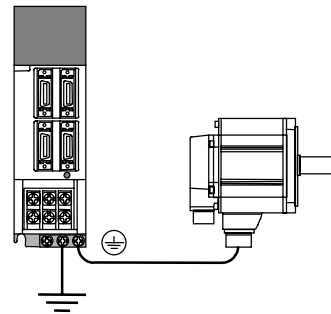

Chapter 2 Wiring and Connection

2-1 System connection diagram

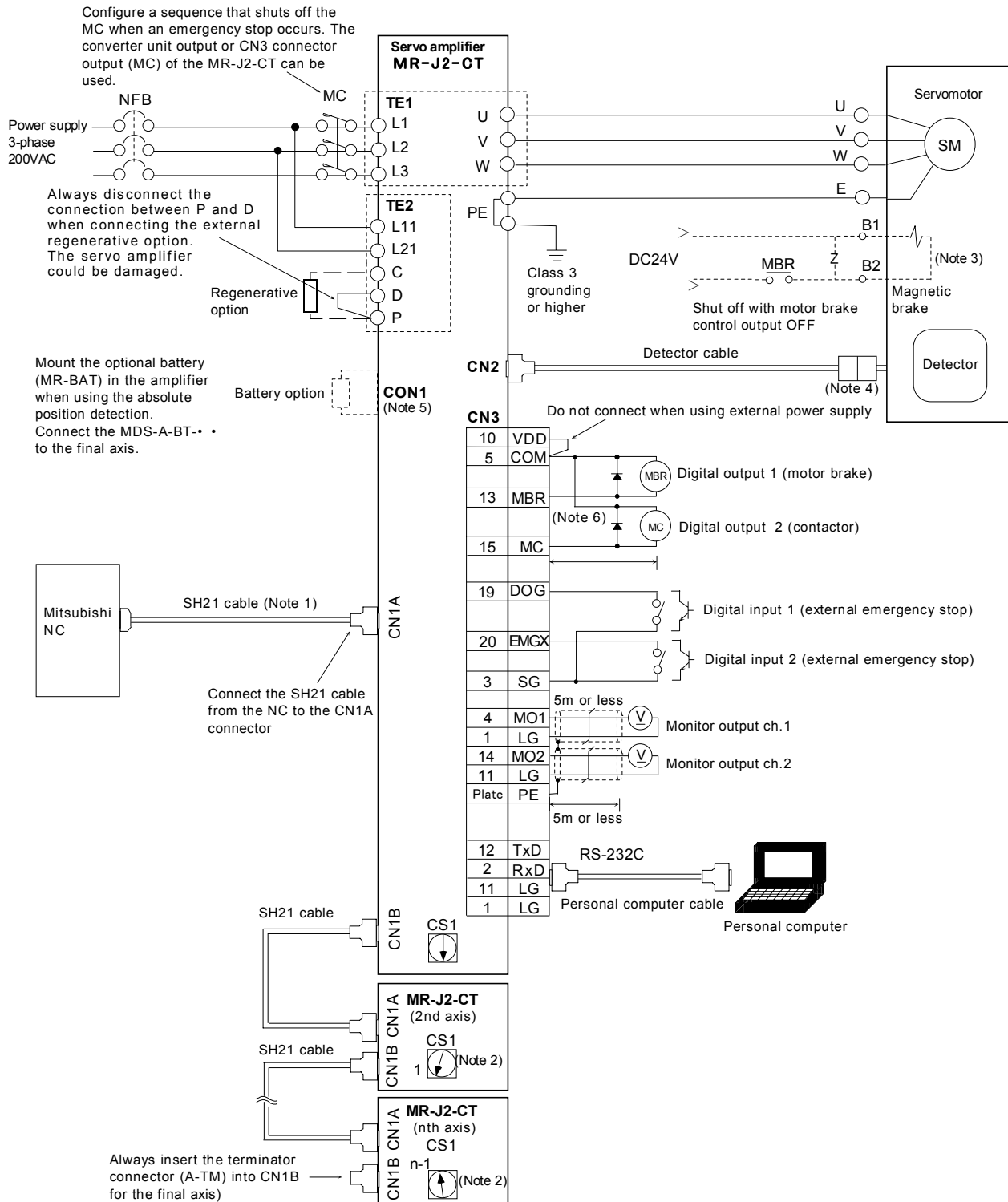

Notes

1. The total length of the SH21 cable must be within 30 m.
2. The motor side connections following the 2nd axis have been omitted.
3. This is a motor with magnetic brakes. The power connected to the magnetic brake does not have a polarity.
4. The connection method will differ according to the motor.
5. When using as an absolute position detector, connect MR-BAT or MDS-A-BT-• • instead of the terminator connector.
6. Do not mistake the diode direction. If connected in reverse, the amplifier will fail and the signal will not be output.

Chapter 2 Wiring and Connection

2-2 Servo amplifier main circuit terminal block, control circuit terminal block









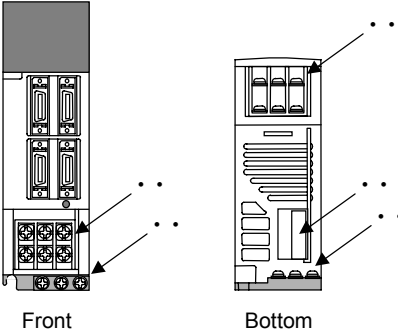
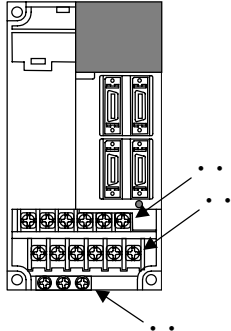
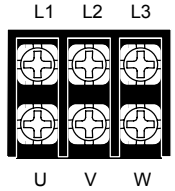

CAUTION

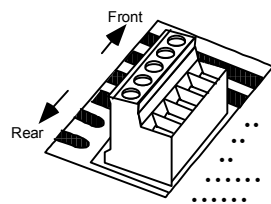
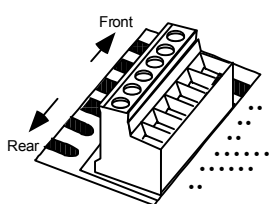
Do not apply a voltage other than that specified in Instruction Manual on each terminal. Failure to observe this item could lead to ruptures or damage, etc.

2-2-1 Main circuit terminal block, control circuit terminal block signal layout

The signal layout of each terminal block is as shown below.

| Servo amplifier | | MR-J2-10CT MR-J2-20CT MR-J2-40CT MR-J2-60CT | MR-J2-70CT MR-J2-100CT | MR-J2-200CT MR-J2-350CT |
|-------------------|--|--|---|--|
| Terminal | | | | |
| Terminal position | |  <p>Front Bottom</p> | |  |
| Terminal signal | Main circuit terminal block (TE1) |  <p>L1 L2 L3 U V W Terminal screw : M4 × 0.7 Tightening torque: 1.24 N·m</p> | |  <p>L1 L2 L3 U V W Terminal screw : M4 × 0.7 Tightening torque: 1.24 N·m</p> |
| | Control circuit terminal block (TE2) |  |  |  <p>L11 L21 D P C N Terminal screw : M4 × 0.7 Tightening torque: 1.24 N·m</p> |
| | Protective grounding terminal block (PE) |  <p>MR-J2-10CT to 20CT</p>  <p>MR-J2-40CT to 60CT</p> <p>Terminal screw : M4 × 0.7 Tightening torque: 1.24 N·m</p> |  <p>Terminal screw : M4 × 0.7 Tightening torque: 1.24 N·m</p> |  <p>Terminal screw : M4 × 0.7 Tightening torque: 1.24 N·m</p> |

Chapter 2 Wiring and Connection

2-2-2 Names and application of main circuit terminal block and control circuit terminal block signals

The following table shows the details for each terminal block signal.

| Name | Signal name | Description |
|---|----------------------------------|--|
| L1·L2·L3 | Main circuit power supply | Main circuit power supply input terminal Connect a 3-phase 200 to 230VAC, 50/60Hz power supply. |
| L11·L12 | Control circuit power supply | Control circuit power supply input terminal Connect a single-phase 200 to 230VAC, 50/60Hz power supply. Connect the same power supply phase for L11 and L1, and L21 and L2. |
| P·C·D | Regenerative option | Regenerative option connection terminal. P to D is wired at shipment. When using the regenerative option, disconnect the wire between P and D and wire the regenerative option between P and C. |
| (N) | Main circuit reference potential | This is not used normally. (This is the reference potential for the main circuit DC voltage.) |
| U·V·W | Servomotor output | Servomotor power supply output terminal The servomotor power supply terminal (U, V, W) is connected. |
|  | Protective grounding (PE) | Grounding terminal The servomotor grounding terminal is connected and grounded. |



DANGER

Never connect anything to the main circuit reference voltage (N). Failure to observe this could lead to electric shock or servo amplifier damage.



CAUTION

When using a standard built-in regenerative resistor, connect it between the P and D terminals. (Shipment state.)
When using an external option regenerative resistor, disconnect the wiring between the P and D terminals, and connect between P and C. Standard built-in regenerative resistors cannot be used in combination with an external option regenerative resistor.

Chapter 2 Wiring and Connection

2-2-3 How to use the control circuit terminal block (MR-J2-10CT to 100CT)

- • **Treatment of wire end**

Single strand: Peel the wire sheath, and use the wire.
(Wire size: 0.25 to 2.5 mm²)

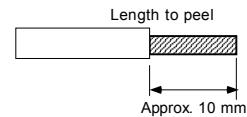

Stranded wire: Peel the wire sheath, and then twist the core wires. Take care to prevent short circuits with the neighboring poles due to the fine strands of the core wires. Solder plating onto the core wire section could cause a contact defect and must be avoided. (Wire size: 0.25 to 2.5 mm²)
Use a bar terminal and bundle the strands. (Phoenix contact)



Bar terminal for one wire
(Bar terminal phenol with insulation sleeve)



Bar terminal for two wires
(TWIN phenol with insulation sleeve)

| Wire size | | Bar terminal type | | Crimping tool |
|--------------------|-----|-----------------------------|---|---------------|
| [mm ²] | AWG | For one wire | For two wires | |
| 0.25 | 24 | AI0.25-6YE AI0.25-8YE | – | CRIMPFOX-UD6 |
| 0.5 | 20 | AI0.5-6WH AI0.5-8WH | – | |
| 0.75 | 18 | AI0.75-6GY AI0.75-8GY | AI-TWIN2×0.75-8GY AI-TWIN2×0.75-10GY | |
| 1 | 18 | AI1-6RD AI1-8RD | AI-TWIN2×1-8RD AI-TWIN2×1-10RD | |
| 1.5 | 16 | AI1.5-6BK AI1.5-8BK | AI-TWIN2×1.5-8BK AI-TWIN2×1.5-12BK | |
| 2.5 | 14 | AI2.5-8BU AI2.5-8BU-1000 | AI-TWIN2×2.5-10BU AI-TWIN2×2.5-13BU | |

- • **Connection method**

Insert the core wire section of the wire into the opening, and tighten with a screwdriver so that the wire does not come out. (Tightening torque: 0.5 to 0.6 N•m) When inserting the wire into the opening, make sure that the terminal screw is sufficiently loose. When using a wire that is 1.5 mm² or less, two wires can be inserted into one opening.

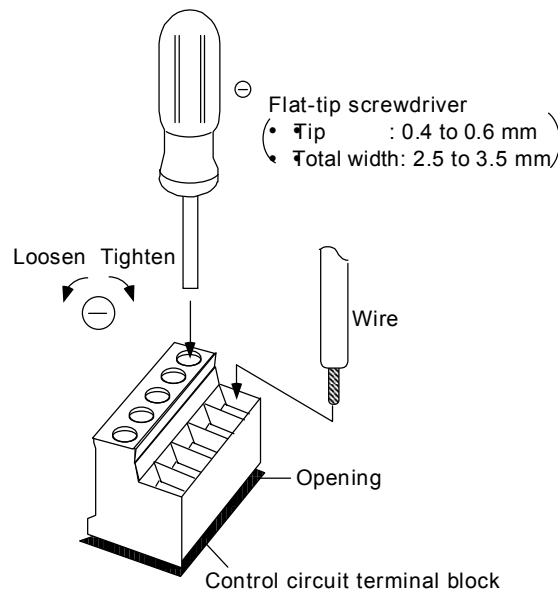

2-3 NC and servo amplifier connection

The NC bus cables are connected from the NC to each servo amplifier so that they run in a straight line from the NC to the terminator connector (battery unit). The NC bus is dedicated for the MR-J2-CT Series, so other servo amplifiers, etc., cannot be connected to the same NC bus. Up to seven axes can be connected per system. (Note that the number of connected axes is limited by the NC. The following drawing shows an example with three axes connected.)

< Connection >

CN1A : CN1B connector of NC side amplifier or NC output

CN1B : CN1A connector of terminator connector side amplifier or terminator connector (battery unit)

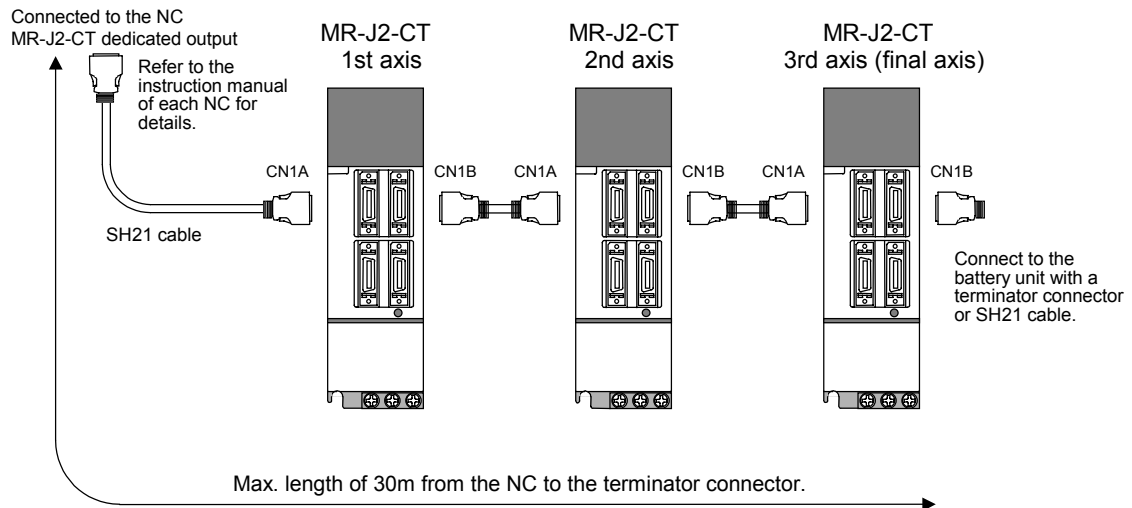

CAUTION

Arrange the NC and servo amplifiers so that the NC bus cable length from the NC to the terminator connector (battery unit) is 30m or less.



POINT

Axis Nos. are determined by the rotary switch for setting the axis No. (Refer to section "6-1-1 Setting the rotary switches".) The axis No. has no relation to the order for connecting to the NC.

Chapter 2 Wiring and Connection

2-4 Motor and detector connection

2-4-1 Connection of HC-SF52, HC-SF53, HC-SF102, HC-SF103

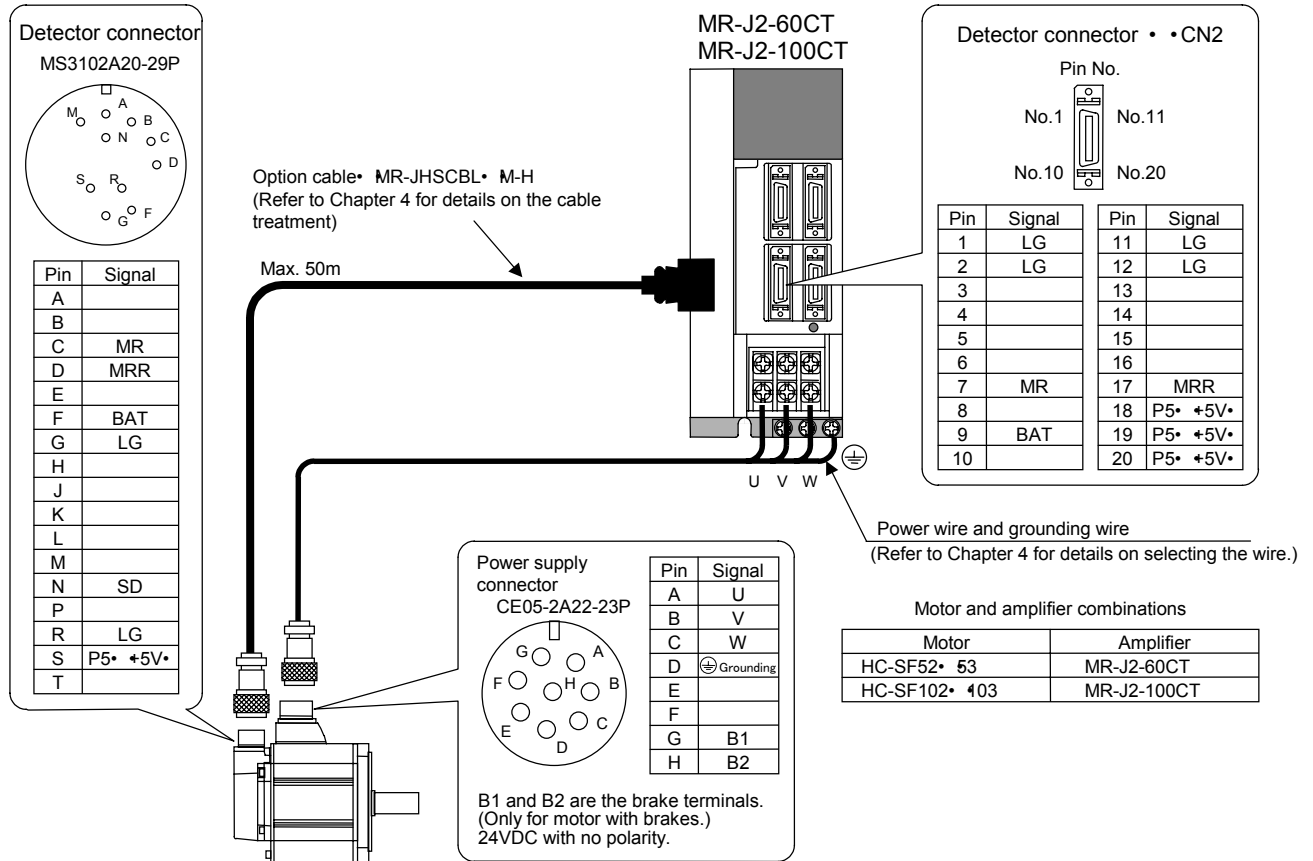

2-4-2 Connection of HC-SF152, HC-SF153

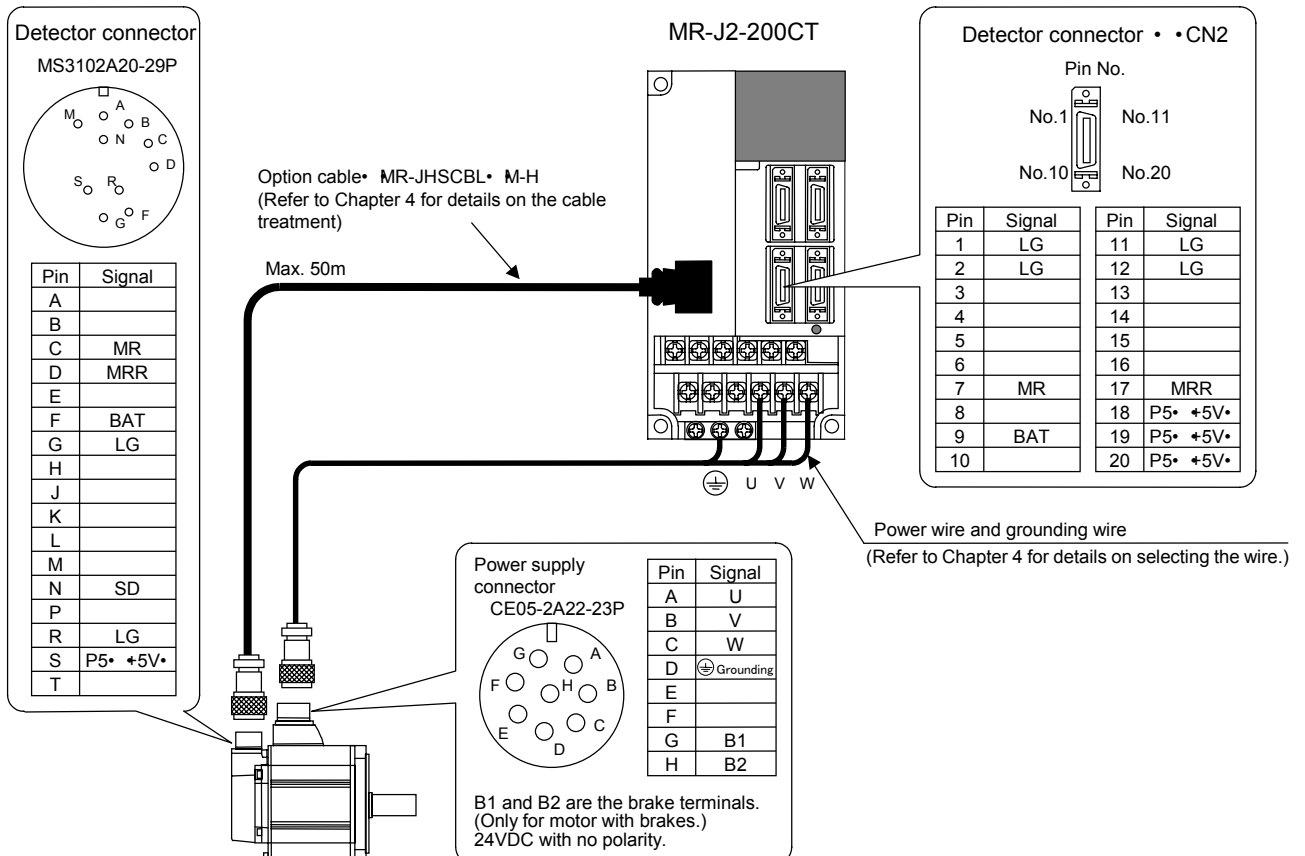

Chapter 2 Wiring and Connection

2-4-3 Connection of HC-SF202, HC-SF203, HC-SF352, HC-SF353

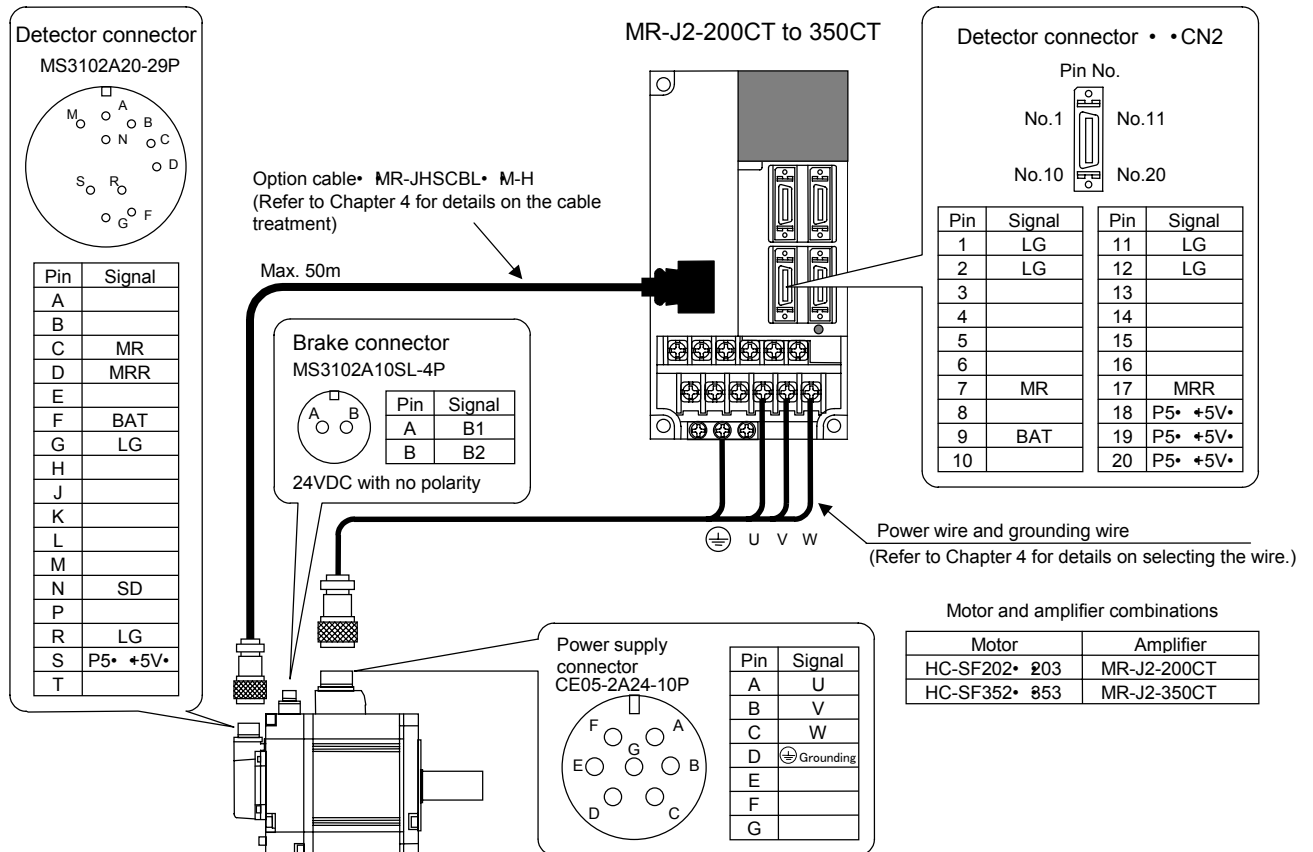

2-4-4 Connection of HC-RF103, HC-RF153, HC-RF203

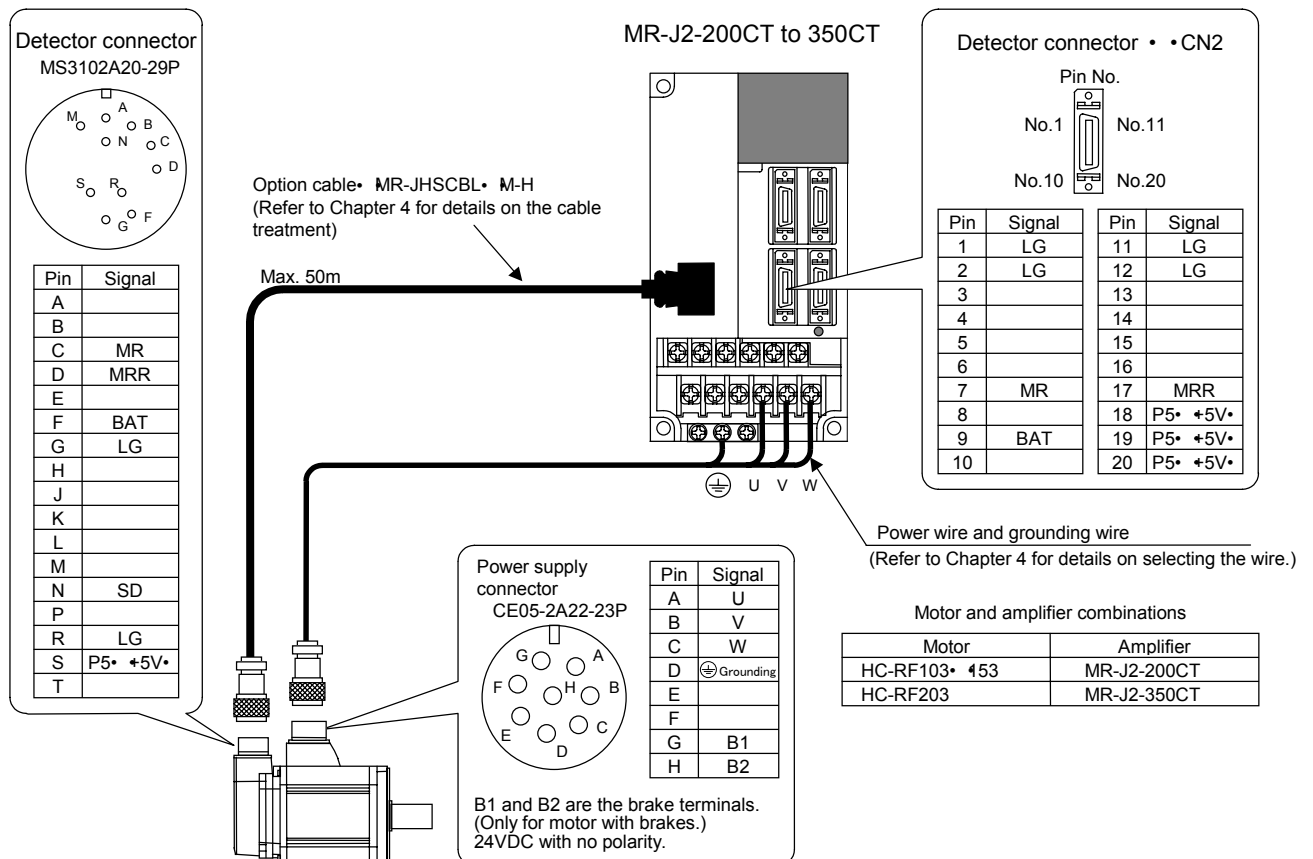

Chapter 2 Wiring and Connection

2-4-5 Connection of HA-FF Series

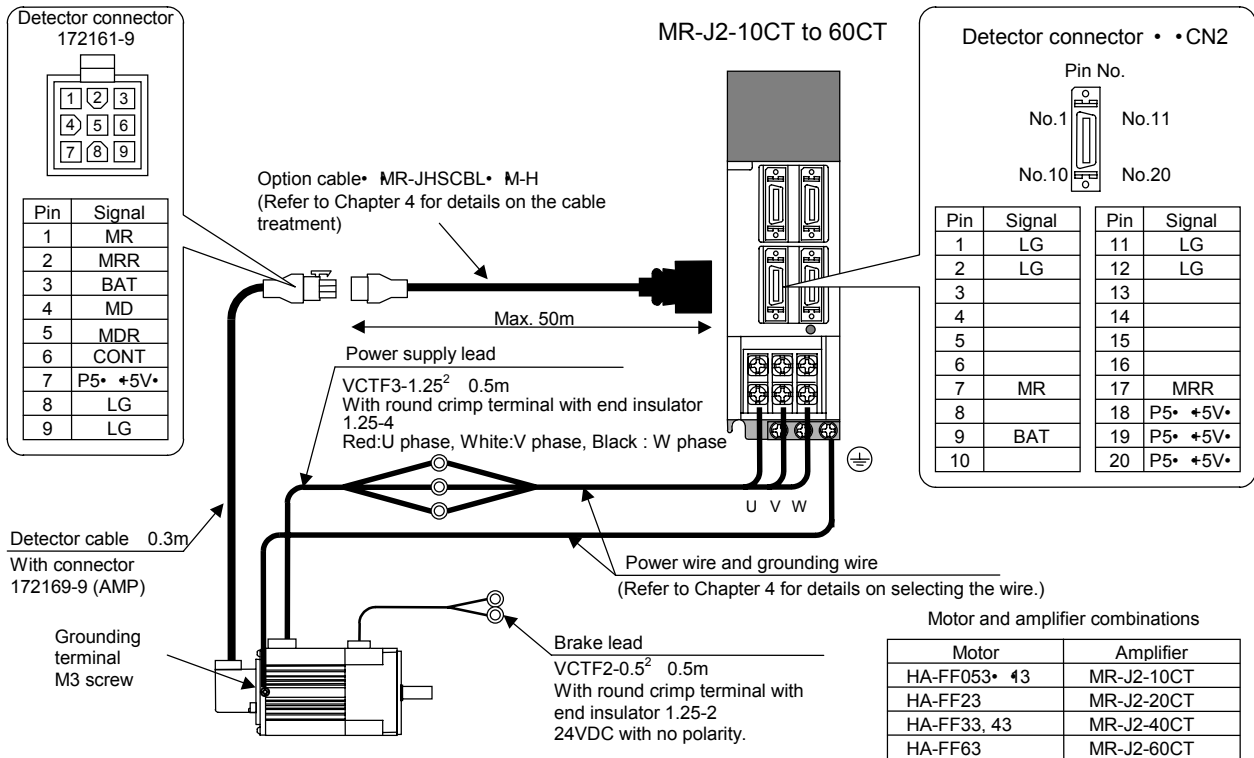

2-4-6 Connection of HA-FF• C-UE Series

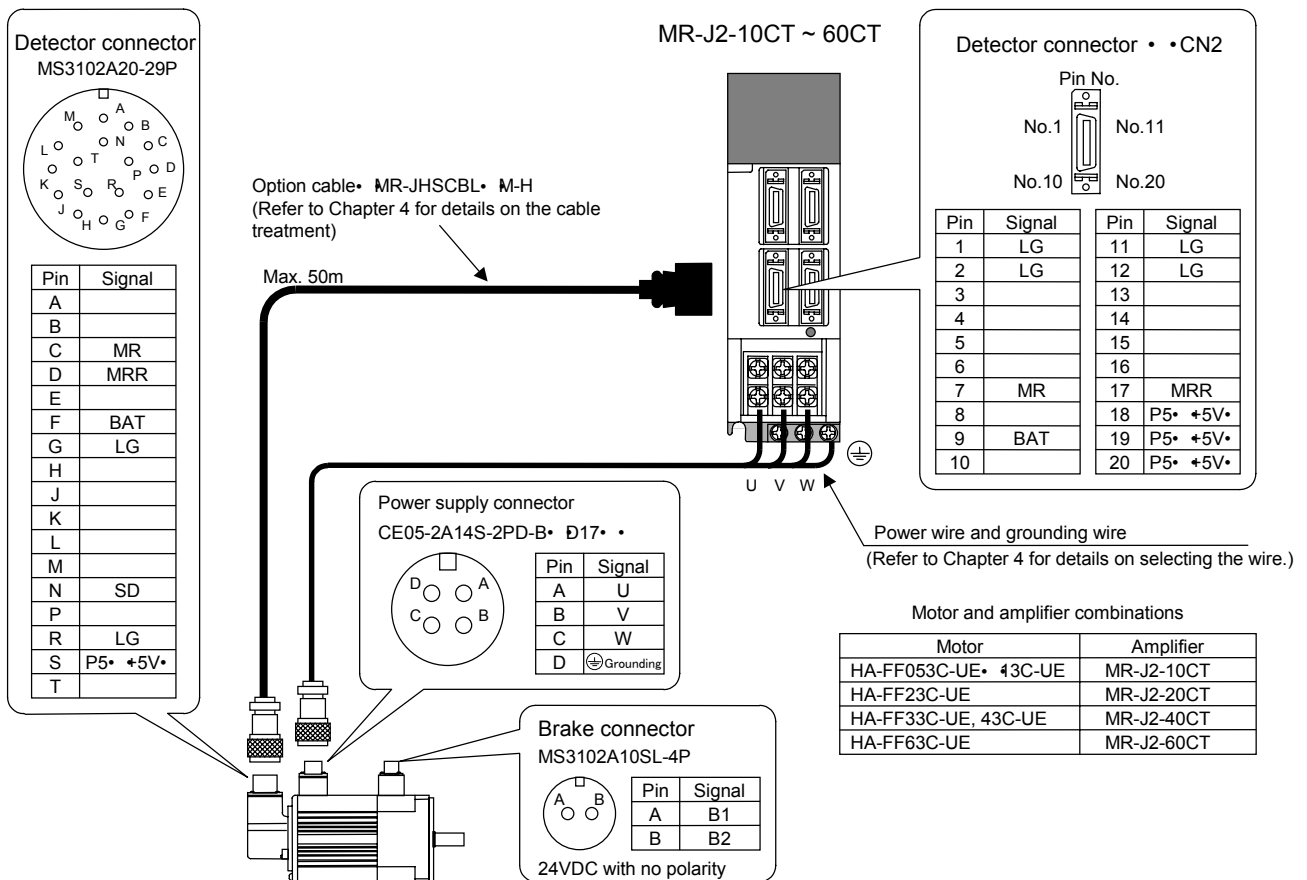

Chapter 2 Wiring and Connection

2-4-7 Connection of HC-MF(-UE) Series

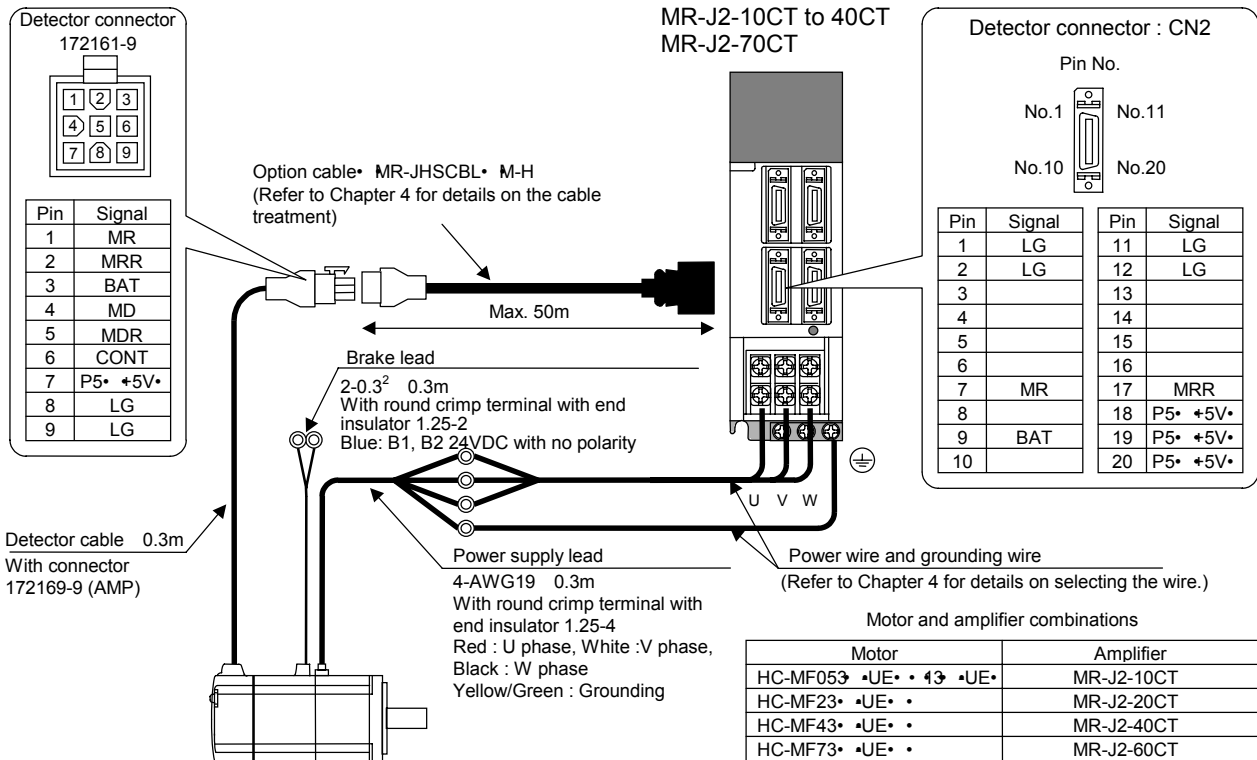

2-4-8 Connection of HC-MF• S15 Series

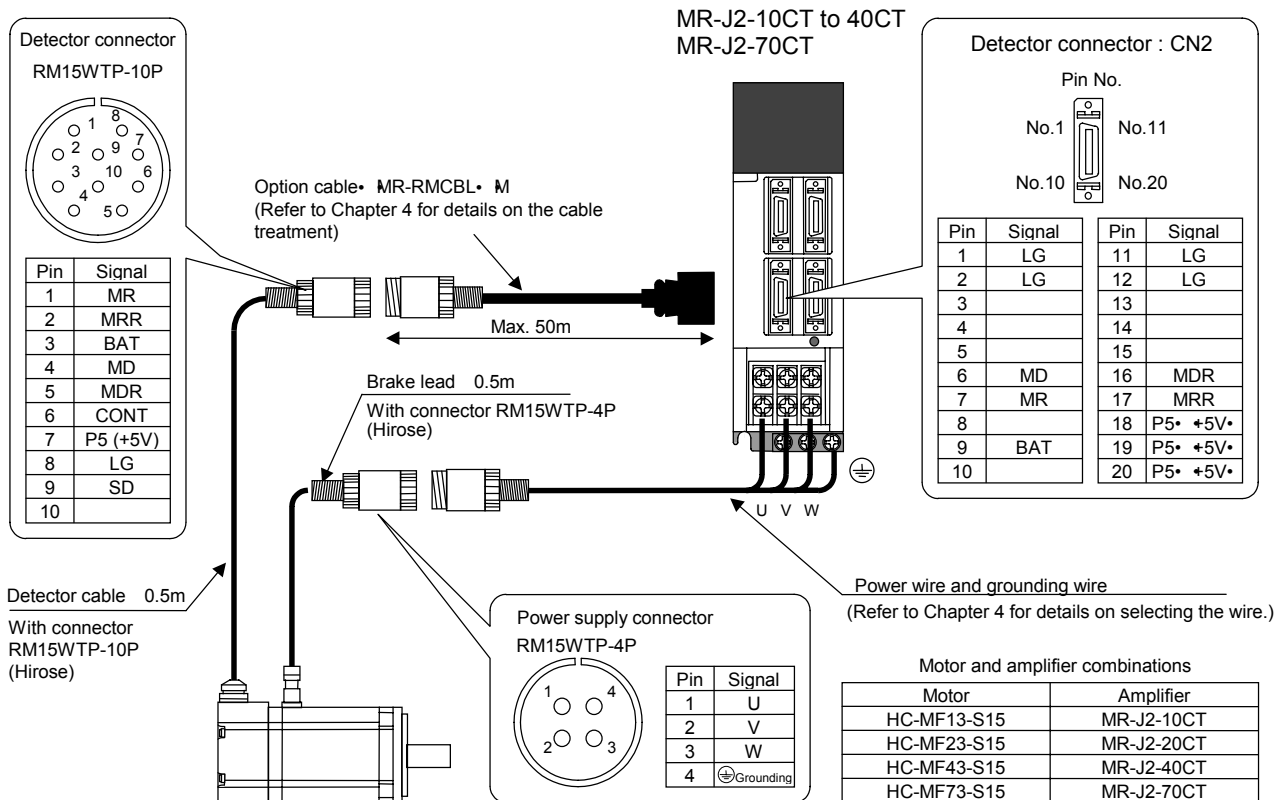

Chapter 2 Wiring and Connection

2-5 Connection of power supply

⚠ CAUTION

1. Make sure that the power supply voltage is within the specified range of the servo amplifier. Failure to observe this could lead to damage or faults.
2. For safety purposes, always install a no-fuse breaker (NFB), and make sure that the circuit is cut off when an error occurs or during inspections. Refer to Chapter 4 and select the no-fuse breaker.
3. The wire size will differ according to the amplifier capacity. Refer to Chapter 4 and select the size.
4. For safety purposes, always install a contactor (magnetic contactor) on the main circuit power supply input. Large rush currents will flow when the power is turned ON. Refer to Chapter 4 and select the correct contactor.
5. When the MR-J2-CT emergency stop sequence is separated from other amplifiers using a parameter setting, always install a contactor dedicated for that axis.

2-5-1 Example of connection when controlling the contactor with the MR-J2-CT

Drive the contactor via the relay from the contactor control output of the (MC) CN3 connector. There are also some types of contactors that can be directly driven with 24VDC.

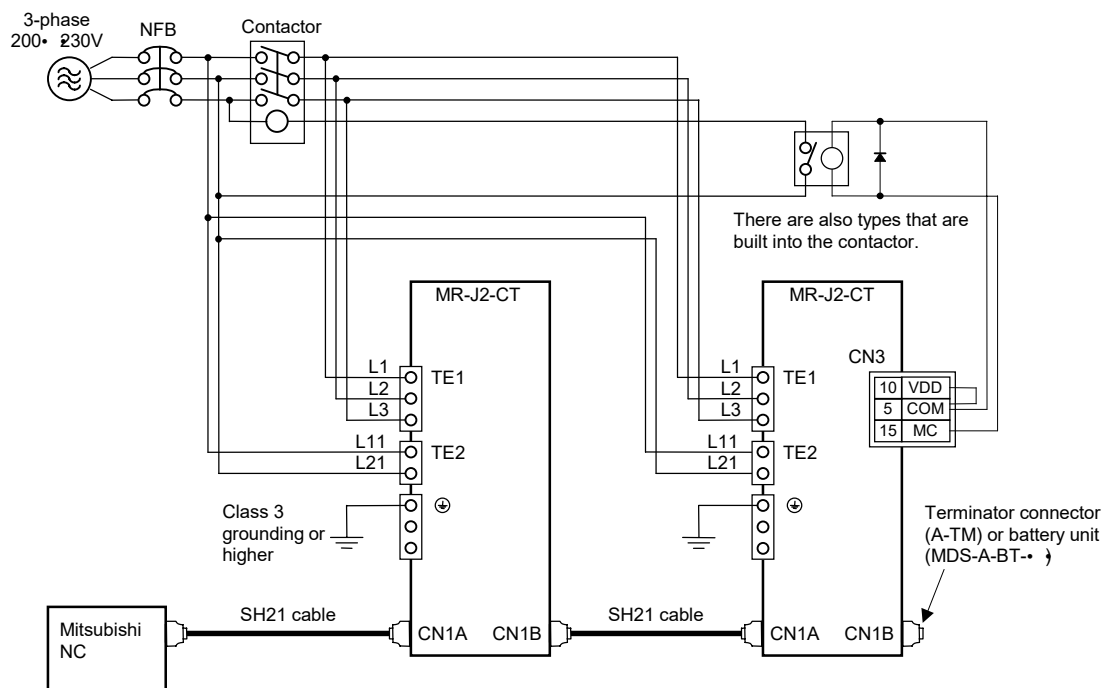

(2) When not sharing a converter and power supply

If the rated current exceeds 60A by the selection of the no-fuse breaker when the converter and power supply are shared, install the no-fuse breakers and contactors separate from the converter unit .

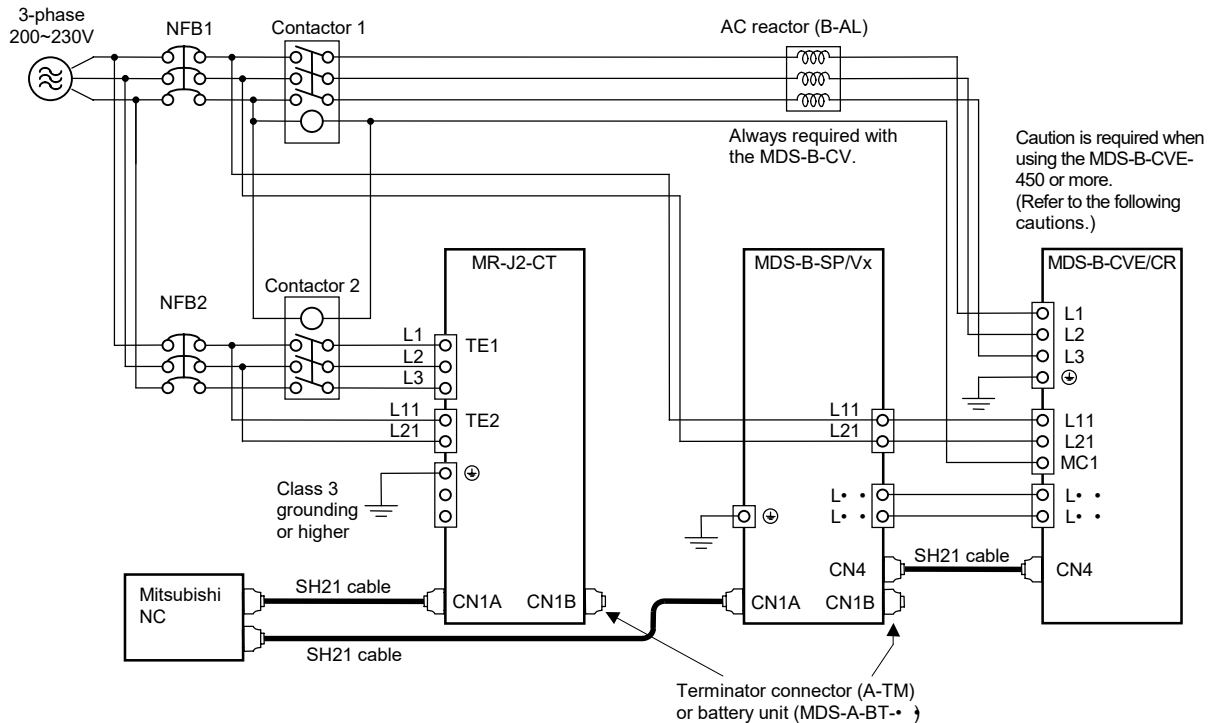

DANGER Install independent no-fuse breakers and contactors as the MR-J2-CT main circuit power supply if the total current capacity exceeds 60A when the converter and power supply are shared. No-fuse breakers may not operate for short-circuits in small capacity amplifiers if they are shared with a large capacity unit, and this could cause fires. For the MR-J2-CT, use an NF60 type or lower capacity breaker. (Refer to section "4-7 Selection of no-fuse breakers".)



CAUTION If the converter capacity is more than MDS-B-CVE-450, the MR-J2-CT contactor drive cannot be shared with the converter. Refer to "2-5-1 Example of connection when controlling the contactor with the MR-J2-CT", and control contactor 2 from the MR-J2-CT.

2-6 Connection of regenerative resistor

2-6-1 Standard built-in regenerative resistor

The built-in regenerative resistor is connected by short-circuiting between the P and D terminals of the control circuit terminal block (TE2). (Shipment state). Confirm that a short bar has been connected between the P and D terminals.

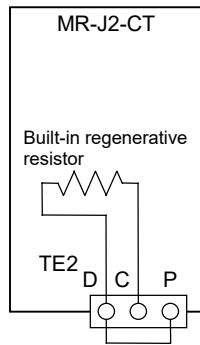

(Note) The terminal block TE2 is on the top front of the amplifier in the MR-J2-200CT and -350CT.

Confirm that a short bar has been connected between the P and D terminals

2-6-2 External option regenerative resistor

Disconnect the short bar connected between the P and D terminals, and connect the option regeneration resistor between the P and C terminals. The servo amplifier has an internal regenerative resistor electronic thermal (software process), and when overheating of the regenerative resistor is detected, an over-regeneration (alarm 30) is detected. The thermal protector terminals (G3, G4) are used when double-protecting against overheating of the regenerative resistor. When double-protecting, construct a sequence in which an emergency stop occurs if a current stops flowing between G3 and G4.

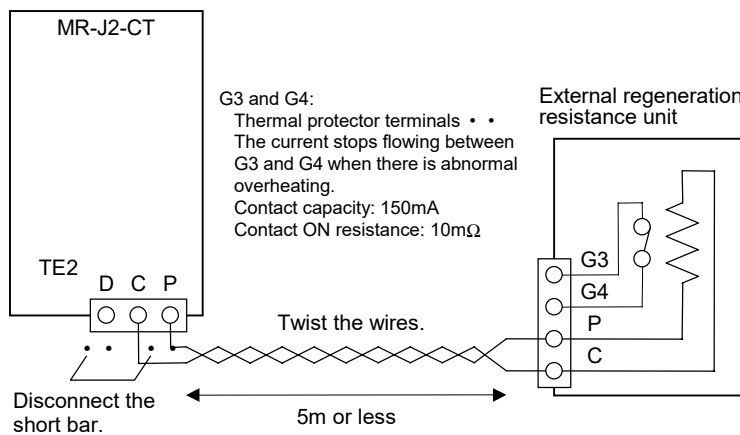

DANGER

1. Be careful when selecting the installation location. Choose a location where foreign matter (cutting chips, cutting oil, etc.) does not adhere to the external regenerative resistor terminal. A short-circuit between the P and C terminals could lead to servo amplifier damage.
2. The regenerative resistor generates heat of approximately 100 degrees (or higher, depending on the installation conditions). Give sufficient consideration to heat dissipation and installation position.
 - Use flame resisting wire.
 - Make sure the wires do not contact the regenerative resistor unit.

CAUTION

Always use twisted pair cable to connect to the servo amplifier, and keep the length of the wiring to 5m or less.

2-7 Connection of digital input/output (DIO) signals

2-7-1 Types and functions of digital input/output (DIO) signals

The digital input/output (DIO) signals are assigned to the connector CN3, and have the following functions.

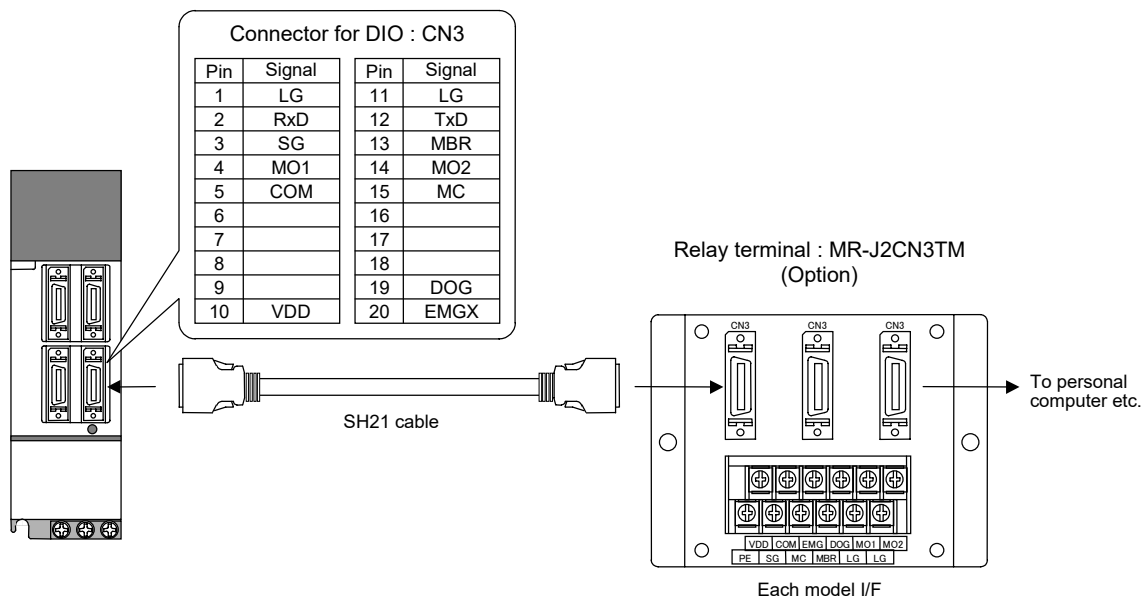

| Signal name | Abbrev. | Connector pin No. | Function and application | I/O class |
|------------------------|---------|-------------------|--|-----------|
| Magnetic brake control | MBR | CN3-13 | This is the motor magnetic brake control output signal. The brakes are released by the SERVO ON signal (motor power ON), and operated by the SERVO OFF (motor power OFF) signal. | DO |
| Contactor control | MC | CN3-15 | Contactor control output signal. The contactor is turned ON by the READY ON signal, and turned OFF by the READY OFF signal. | DO |
| Near-point dog | DOG | CN3-19 | This inputs a near-point signal when executing dog-type zero point return. | DI |
| Emergency stop | EMGX | CN3-20 | This is the external emergency stop signal input. | DI |



POINT

- The MBR and MC pin Nos. are set to the default parameter settings. The output pin No. can be changed with the MBR and MC signals by parameter setting. (Refer to the table below.)
- The external emergency stop input (EMGX) is invalid when the parameters are set to their default values. Set parameter #103.bit0 to "0" to use this function.

| No. | Abbrev. | Parameter name | Description | | | | | | | | | | | | | | | | | | | | | | | | | | | | | | | | | | | | | | | | | | | | | | | | | | | | | | | | | | | |
|---------------|----------------------------------|----------------------------------|--|-----|---|---|---|---|---|---|---|---|---|---|---|---|---|---|---|---|---------------|---|---|---|---|---|---|---|---|---|---|---|---|---|---|---|---|---|-----|--------------------------|--------------------------|---|----------------------------------|------------------------------|---|-------------|---------------|---|---------------------------------|----------------------------------|---|------------------|----------------------|---|--------------------------------|-------------------------------|---|-------------------------------|-------------------------------|---|-----------------------|-----------------------------|
| #102 | *Cont2 | Control parameter 2 | <p>HEX setting parameter. Set bits without a description to their default values.</p> <table border="1" style="width: 100%; text-align: center;"> <thead> <tr> <th>bit</th> <th>F</th> <th>E</th> <th>D</th> <th>C</th> <th>B</th> <th>A</th> <th>9</th> <th>8</th> <th>7</th> <th>6</th> <th>5</th> <th>4</th> <th>3</th> <th>2</th> <th>1</th> <th>0</th> </tr> </thead> <tbody> <tr> <td>Default value</td> <td>0</td> <td>0</td> <td>0</td> <td>0</td> <td>0</td> <td>0</td> <td>0</td> <td>0</td> <td>1</td> <td>0</td> <td>0</td> <td>0</td> <td>0</td> <td>0</td> <td>1</td> <td>1</td> <td>0</td> </tr> </tbody> </table> <table border="1" style="width: 100%; text-align: center;"> <thead> <tr> <th>bit</th> <th>Meaning when "0" is set.</th> <th>Meaning when "1" is set.</th> </tr> </thead> <tbody> <tr> <td>1</td> <td>Error not corrected at servo OFF</td> <td>Error corrected at servo OFF</td> </tr> <tr> <td>2</td> <td>Linear axis</td> <td>Rotation axis</td> </tr> <tr> <td>3</td> <td>Station assignment direction CW</td> <td>Station assignment direction CCW</td> </tr> <tr> <td>4</td> <td>Uniform indexing</td> <td>Non-uniform indexing</td> </tr> <tr> <td>5</td> <td>DO channel standard assignment</td> <td>DO channel reverse assignment</td> </tr> <tr> <td>6</td> <td>2-wire detector communication</td> <td>4-wire detector communication</td> </tr> <tr> <td>7</td> <td>Incremental detection</td> <td>Absolute position detection</td> </tr> </tbody> </table> | bit | F | E | D | C | B | A | 9 | 8 | 7 | 6 | 5 | 4 | 3 | 2 | 1 | 0 | Default value | 0 | 0 | 0 | 0 | 0 | 0 | 0 | 0 | 1 | 0 | 0 | 0 | 0 | 0 | 1 | 1 | 0 | bit | Meaning when "0" is set. | Meaning when "1" is set. | 1 | Error not corrected at servo OFF | Error corrected at servo OFF | 2 | Linear axis | Rotation axis | 3 | Station assignment direction CW | Station assignment direction CCW | 4 | Uniform indexing | Non-uniform indexing | 5 | DO channel standard assignment | DO channel reverse assignment | 6 | 2-wire detector communication | 4-wire detector communication | 7 | Incremental detection | Absolute position detection |
| bit | F | E | D | C | B | A | 9 | 8 | 7 | 6 | 5 | 4 | 3 | 2 | 1 | 0 | | | | | | | | | | | | | | | | | | | | | | | | | | | | | | | | | | | | | | | | | | | | | | |
| Default value | 0 | 0 | 0 | 0 | 0 | 0 | 0 | 0 | 1 | 0 | 0 | 0 | 0 | 0 | 1 | 1 | 0 | | | | | | | | | | | | | | | | | | | | | | | | | | | | | | | | | | | | | | | | | | | | | |
| bit | Meaning when "0" is set. | Meaning when "1" is set. | | | | | | | | | | | | | | | | | | | | | | | | | | | | | | | | | | | | | | | | | | | | | | | | | | | | | | | | | | | | |
| 1 | Error not corrected at servo OFF | Error corrected at servo OFF | | | | | | | | | | | | | | | | | | | | | | | | | | | | | | | | | | | | | | | | | | | | | | | | | | | | | | | | | | | | |
| 2 | Linear axis | Rotation axis | | | | | | | | | | | | | | | | | | | | | | | | | | | | | | | | | | | | | | | | | | | | | | | | | | | | | | | | | | | | |
| 3 | Station assignment direction CW | Station assignment direction CCW | | | | | | | | | | | | | | | | | | | | | | | | | | | | | | | | | | | | | | | | | | | | | | | | | | | | | | | | | | | | |
| 4 | Uniform indexing | Non-uniform indexing | | | | | | | | | | | | | | | | | | | | | | | | | | | | | | | | | | | | | | | | | | | | | | | | | | | | | | | | | | | | |
| 5 | DO channel standard assignment | DO channel reverse assignment | | | | | | | | | | | | | | | | | | | | | | | | | | | | | | | | | | | | | | | | | | | | | | | | | | | | | | | | | | | | |
| 6 | 2-wire detector communication | 4-wire detector communication | | | | | | | | | | | | | | | | | | | | | | | | | | | | | | | | | | | | | | | | | | | | | | | | | | | | | | | | | | | | |
| 7 | Incremental detection | Absolute position detection | | | | | | | | | | | | | | | | | | | | | | | | | | | | | | | | | | | | | | | | | | | | | | | | | | | | | | | | | | | | |

2-7-2 Wiring of digital input/output (DIO) signals

Either an internal or external power supply can be used, but they cannot be used together in the same amplifier.

(1) Motor brake control signal (MBR) output circuit

The motor brake power supply is controlled via a relay. When using an inductive load, install a diode. (Tolerable current: 40mA or less, rush current: 100mA or less)

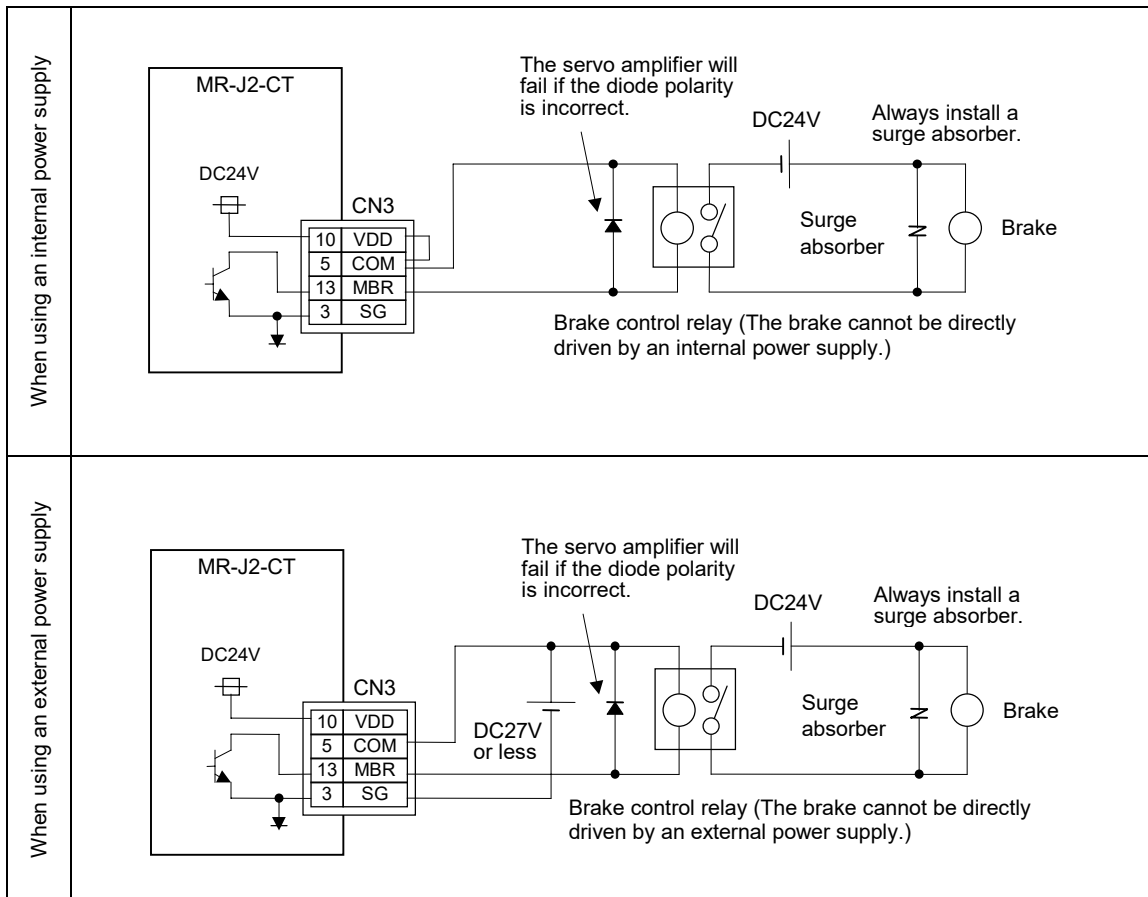

POINT

When using an internal power supply, the power supply can be directly connected to VDD if only the digital output (MC, MBR) is being used. When using the digital input (DOG, EMGX), always connect between VDD and COM.



CAUTION

1. Always install a surge absorber near the motor's brake terminal to eliminate noise and protect the contacts.
2. The magnetic brakes cannot be directly driven with the output signal from the servo amplifier. Always install a relay.
3. The magnetic brakes cannot be driven by the servo amplifier's VDD (24VDC). Always install a separate power supply.

Chapter 2 Wiring and Connection

(2) Contactor control signal (MC) output circuit

A relay or photocoupler can be driven with this circuit. When using an inductive load, install a diode. (Tolerable current: 40mA or less, rush current: 100mA or less)

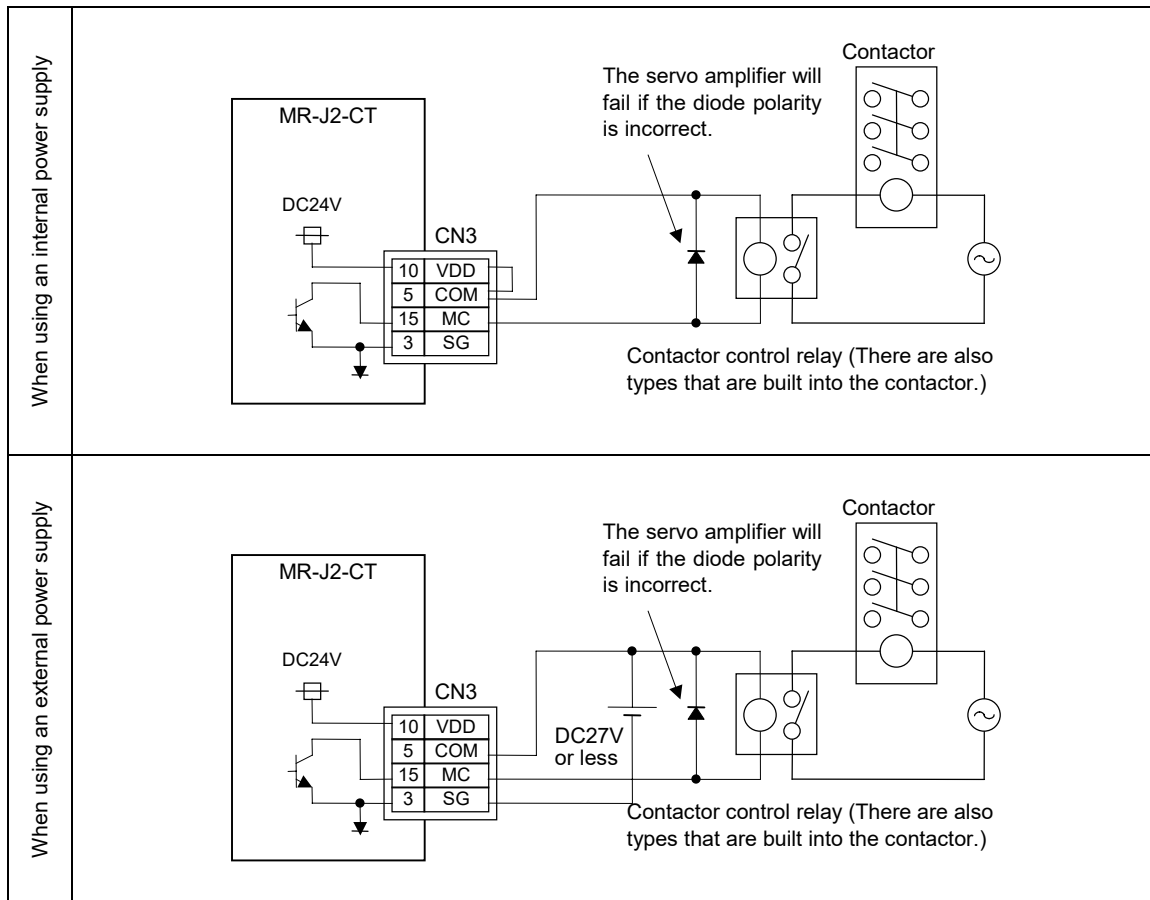

POINT

When using an internal power supply, the power supply can be directly connected to VDD if only the digital output (MC, MBR) is being used. When using the digital input (DOG, EMGX), always connect between VDD and COM.

Chapter 2 Wiring and Connection

(3) Near point dog signal (DOG) input circuit

Issue a signal using a relay or open-collector transistor.

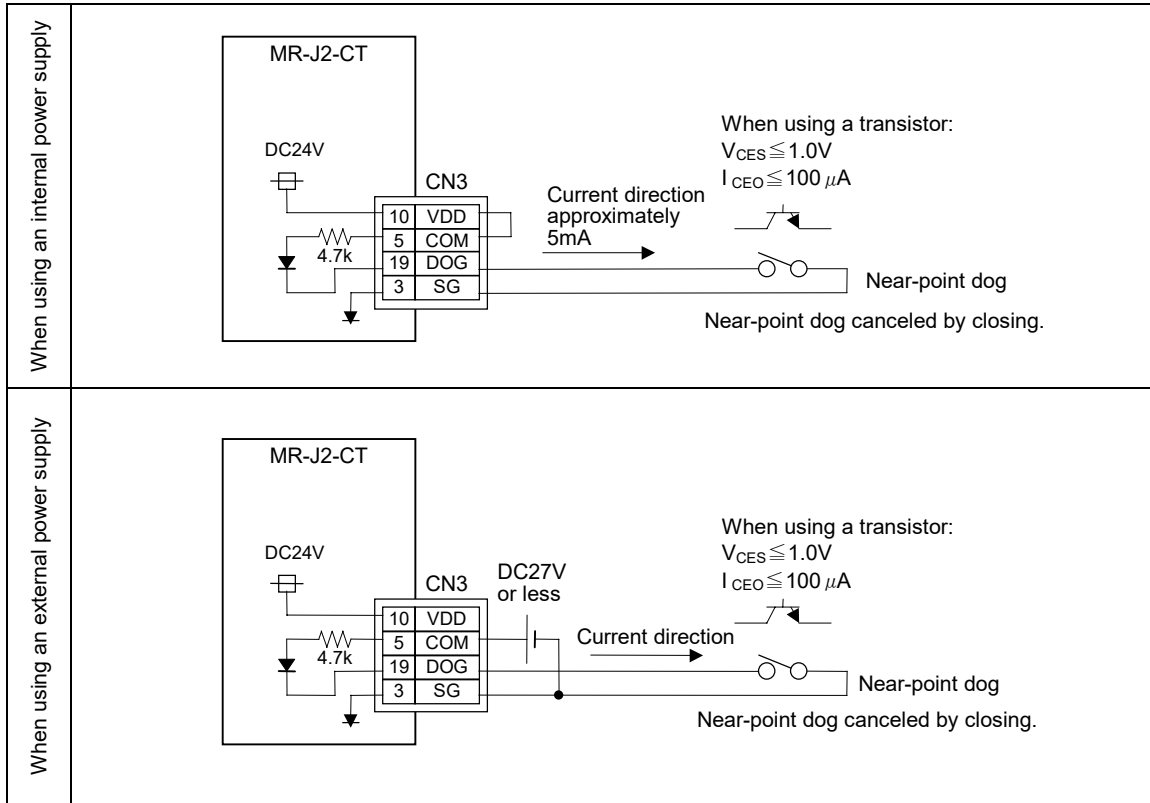

(4) External emergency stop signal (EMGX) input circuit

Issue a signal using a relay or open-collector transistor.

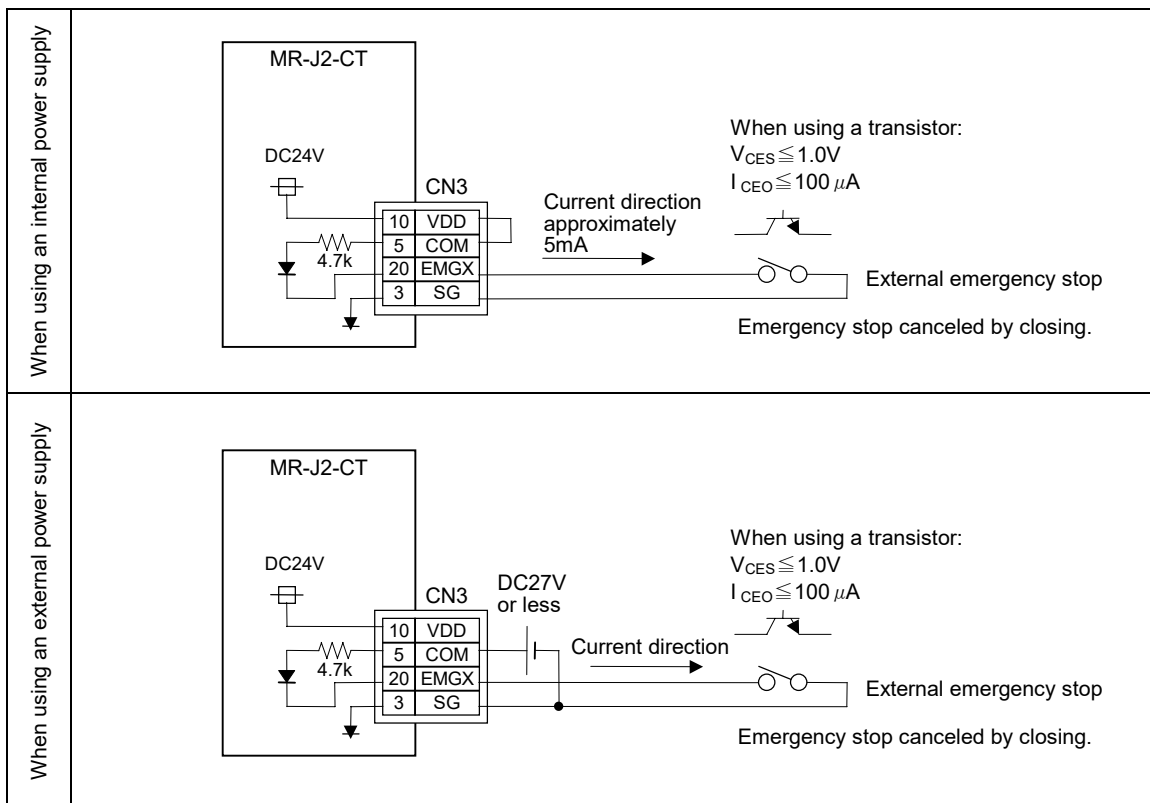

Chapter 2 Wiring and Connection

2-8 Connection with personal computer

RS-232-C is used for connection with the commercial personal computer. The connector is CN3.

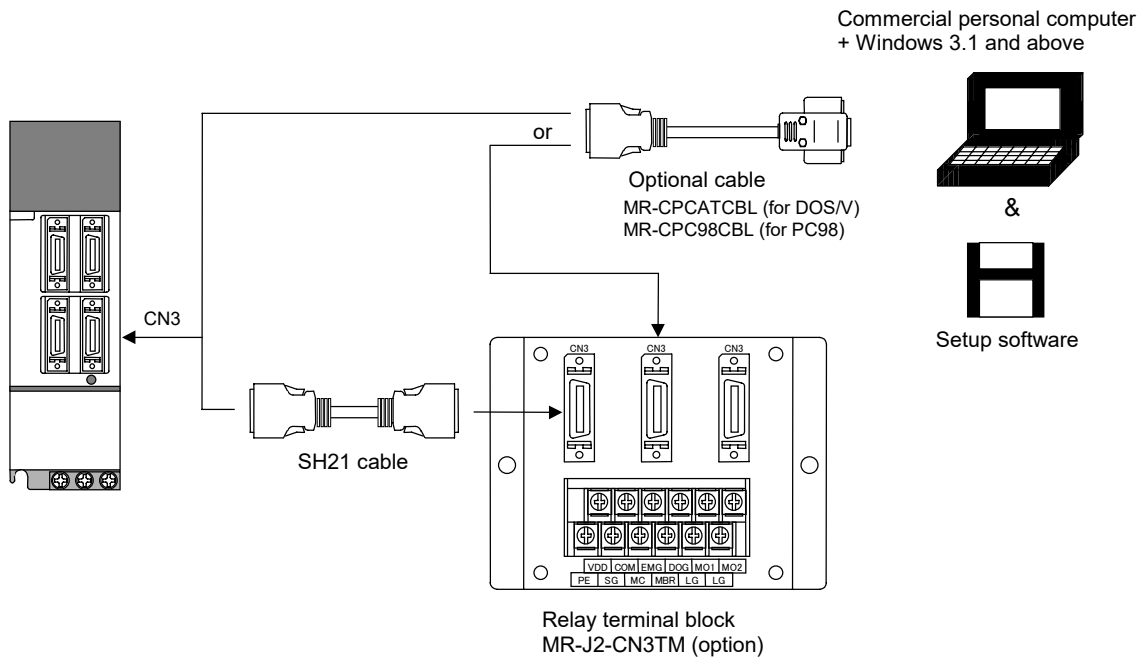

Chapter 3 Installation

| | | |
|------------|---|------------|
| 3-1 | Installation of the servo amplifier | 3-2 |
| 3-1-1 | Environmental conditions..... | 3-2 |
| 3-1-2 | Installation direction and clearance..... | 3-3 |
| 3-1-3 | Prevention of entering of foreign matter | 3-3 |
| 3-2 | Installation of servomotor | 3-4 |
| 3-2-1 | Environmental conditions..... | 3-4 |
| 3-2-2 | Cautions for mounting load (prevention of impact on shaft)..... | 3-5 |
| 3-2-3 | Installation direction..... | 3-5 |
| 3-2-4 | Tolerable load of axis | 3-5 |
| 3-2-5 | Oil and waterproofing measures..... | 3-6 |
| 3-2-6 | Cable stress | 3-8 |
| 3-3 | Noise measures | 3-9 |

Chapter 3 Installation



CAUTION

1. Install the unit on noncombustible material. Direct installation on combustible material or near combustible materials could lead to fires.
2. Follow this Instruction Manual and install the unit in a place where the weight can be borne.
3. Do not get on top of or place heavy objects on the unit.
Failure to observe this could lead to injuries.
4. Always use the unit within the designated environment conditions.
5. Do not let conductive objects such as screws or metal chips, etc., or combustible materials such as oil enter the servo amplifier or servomotor.
6. Do not block the servo amplifier intake and outtake ports. Doing so could lead to failure.
7. The servo amplifier and servomotor are precision devices, so do not drop them or apply strong impacts to them.
8. Do not install or run a servo amplifier or servomotor that is damaged or missing parts.
9. When storing for a long time, please contact your dealer.

3-1 Installation of the servo amplifier



CAUTION

1. Always observe the installation directions. Failure to observe this could lead to faults.
2. Secure the specified distance between the servo amplifier and control panel, or between the servo amplifier and other devices. Failure to observe this could lead to faults.

3-1-1 Environmental conditions

| Environment | Conditions |
|---------------------|--|
| Ambient temperature | 0°C to +55°C (with no freezing) |
| Ambient humidity | 90% RH or less (with no dew condensation) |
| Storage temperature | -20°C to +65°C (with no freezing) |
| Storage humidity | 90% RH or less (with no dew condensation) |
| Atmosphere | Indoors (Where unit is not subject to direct sunlight) With no corrosive gas, combustible gas, oil mist or dust |
| Altitude | 1000m or less above sea level |
| Vibration | 5.9m/sec ² (0.6G) or less |

Chapter 3 Installation

3-1-2 Installation direction and clearance

Install the servo amplifier so that the front side is visible. Refer to the following drawings for the heat dissipation and wiring of each unit, and secure sufficient space for ventilation.

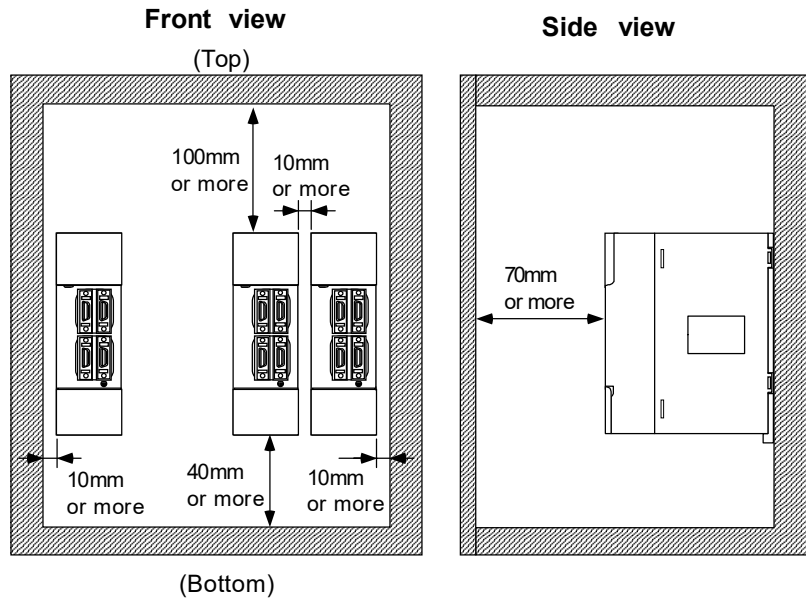

⚠ CAUTION

The ambient temperature condition for the servo amplifier is 55°C or less. Because heat can easily accumulate in the upper portion of the amplifier, give sufficient consideration to heat dissipation when designing the power distribution panel. If required, install a fan in the power distribution panel to agitate the heat in the upper portion of the amplifier.

3-1-3 Prevention of entering of foreign matter

Treat the cabinet with the following items.

- Make sure that the cable inlet is dust and oil proof by using packing, etc.
- Make sure that the external air does not enter inside by using head radiating holes, etc.
- Close all clearances.
- Securely install door packing.
- If there is a rear cover, always apply packing.
- Oil will tend to accumulate on the top. Take special measures such as oil-proofing the top so that oil does not enter the cabinet from the screw holds.
- After installing each unit, avoid machining in the periphery. If cutting chips, etc., stick onto the electronic parts, trouble may occur.

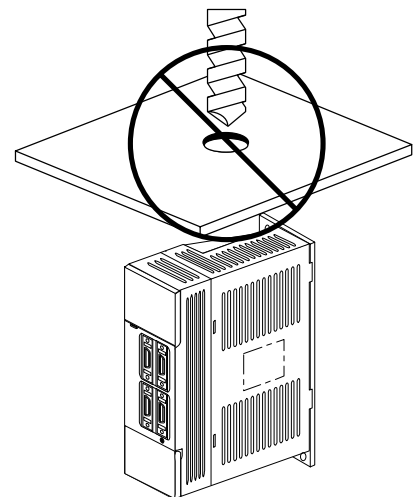

Chapter 3 Installation

3-2 Installation of servomotor

⚠ CAUTION

1. Do not hold the cables, axis or detector when transporting the servomotor. Failure to observe this could lead to faults or injuries.
2. Securely fix the servomotor to the machine. Insufficient fixing could lead to the servomotor deviating during operation. Failure to observe this could lead to injuries.
3. When coupling to a servomotor shaft end, do not apply an impact by hammering, etc. The detector could be damaged.
4. Never touch the rotary sections of the servomotor during operations. Install a cover, etc., on the shaft.
5. Do not apply a load exceeding the tolerable load onto the servomotor shaft. The shaft could break.
6. Do not connect or disconnect any of the connectors while the power is ON.

3-2-1 Environmental conditions

| Environment | Conditions | |
|---------------------|--|--|
| Ambient temperature | 0°C to +40°C (with no freezing) | |
| Ambient humidity | 80% RH or less (with no dew condensation) | |
| Storage temperature | -15°C to +70°C (with no freezing) | |
| Storage humidity | 90% RH or less (with no dew condensation) | |
| Atmosphere | <ul style="list-style-type: none"> • Indoors (Where unit is not subject to direct sunlight) • With no corrosive gas or combustible gas, mist or dust | |
| Altitude | 1000m or less above sea level | |
| Vibration | HC-SF (1.5kW) or less HC-RF | X: 9.8 m/sec ² (1G) Y: 24.5m/sec ² (2.5G) or less |
| | HC-SF (2.0kW) or less | X: 19.6 m/sec ² (2G) Y: 49 m/sec ² (5G) or less |
| | HA-FF, HC-MF | X: 19.6 m/sec ² (2G) Y: 19.6 m/sec ² (2G) or less |

The vibration conditions are as shown below.

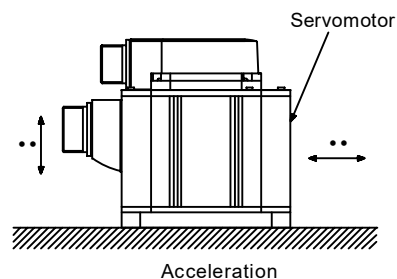
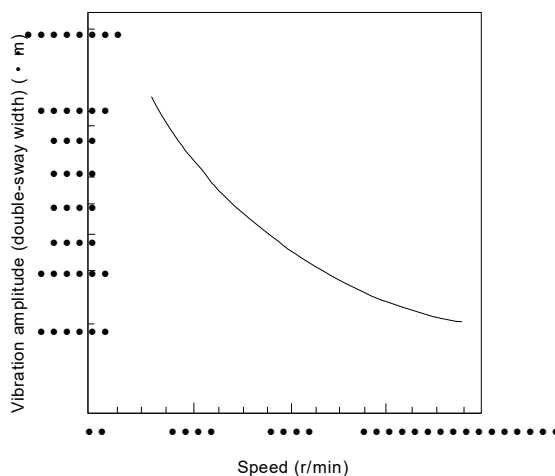

Chapter 3 Installation

3-2-2 Cautions for mounting load (prevention of impact on shaft)

- When using the servomotor with key way, use the screw hole at the end of the shaft to mount the pulley onto the shaft. To install, first place the double-end stud into the shaft screw holes, contact the coupling end surface against the washer, and press in as if tightening with a nut. When the shaft does not have a key way, use a frictional coupling, etc.
- When removing the pulley, use a pulley remover, and make sure not to apply an impact on the shaft.
- Install a protective cover on the rotary sections such as the pulley installed on the shaft to ensure safety.
- The direction of the detector installation on the servomotor cannot be changed.

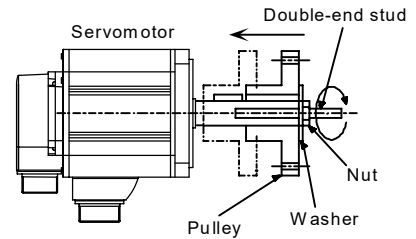

CAUTION

Never hammer the end of the shaft during assembly.

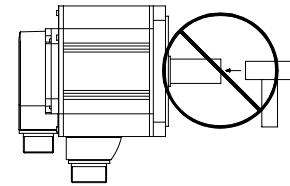

3-2-3 Installation direction

There are no restrictions on the installation direction. Installation in any direction is possible, but as a standard the servomotor is installed so that the motor power supply wire and detector cable cannot plugs (lead-in wires) face downward. Installation in the standard direction is effective against dripping. Measure against oil and water must be taken when not installing in the standard direction. Refer to section "3-2-5 Oil and waterproofing measures" and take appropriate measures.

The brake plates may make a sliding sound when a servomotor with magnetic brake is installed with the shaft facing upward, but this is not a fault.

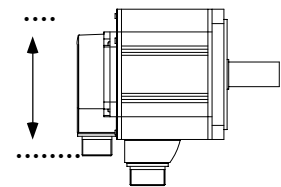

Standard installation direction

3-2-4 Tolerable load of axis

There are limits to the load that can be applied to the motor shaft. When mounting the motor on a machine, make sure the loads applied in the radial direction and thrust direction are less than the tolerable values shown in the table below. These loads can cause motor output torque, so this point should be carefully considered when designing the machine.

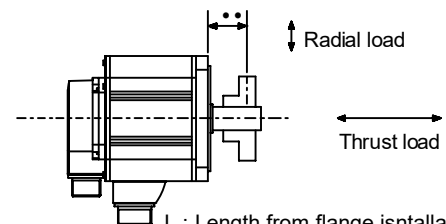

L : Length from flange installation surface to center of load weight [mm]

| Servomotor | Tolerable radial load | Tolerable thrust load |
|---|-----------------------|-----------------------|
| HC-SF52T, 53T, 102T, 103T, 152T, 153T (taper shaft) | 392N (L=58) | 490N |
| HC-SF52, 53, 102, 103, 152, 153 (straight shaft) | 980N (L=55) | 490N |
| HC-SF202, 203, 352, 353 | 2058N (L=79) | 980N |
| HC-RF103T, 153T, 203T (taper shaft) | 392N (L=58) | 196N |
| HC-RF103, 153, 203 (straight shaft) | 686N (L=45) | 196N |
| HA-FF053 | 108N (L=30) | 98N |
| HA-FF13 | 118N (L=30) | 98N |
| HA-FF23, 33 | 176N (L=30) | 147N |
| HA-FF43, 63 | 323N (L=40) | 284N |
| HC-MF053, 13, 23 | 88N (L=25) | 59N |
| HC-MF43 | 245N (L=30) | 98N |
| HC-MF73 | 392N (L=40) | 147N |

Chapter 3 Installation

⚠ CAUTION

1. Use a flexible coupling when connecting with a ball screw, etc., and keep the shaft center deviation to below the tolerable radial load of the shaft.
2. When directly installing the gears on the motor shaft, the radial load increases as the diameter of the gear decreases. This should be carefully considered when designing the machine.
3. When directly installing the pulley on the motor shaft, carefully consider so that the radial load (double the tension) generated from the timing belt tension is less than the values shown in the table above.
4. In machines where thrust loads such as a worm gear are applied, carefully consider providing separate bearings, etc., on the machine side so that loads exceeding the tolerable thrust loads are not applied to the motor.
5. Do not use a rigid coupling as an excessive bending load will be applied on the shaft and could cause the shaft to break.

3-2-5 Oil and waterproofing measures

- A form based on IEC standards (IP types) is displayed as the servomotor protective form (Refer to "12-2-1 List of Specifications."). However, these standards are short-term performance specifications. They do not guarantee continuous environmental protection characteristics. Measures such as covers, etc., must be provided if there is any possibility that oil or water will fall on the motor, or the motor will be constantly wet and permeated by water. Note that IP-type motors are not indicated as corrosion-resistant.
- When a gear box is installed on the servomotor, make sure that the oil level height from the center of the shaft is higher than the values given below. Open a breathing hole on the gear box so that the inner pressure does not rise. An oil seal is provided only on the HA-FF**C-UE and HC-MF**-S15 of the HA-FF and HC-MF Series.

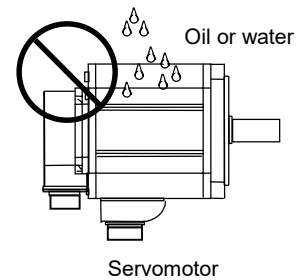

| Servomotor | Oil level (mm) |
|--|----------------|
| HC-SF52, 102, 152 HC-SF53, 103, 153 | 20 |
| HC-SF202, 203, 352, 353 | 25 |
| HC-RF103, 153, 203 | 20 |
| HA-FF053C-UE, 13C-UE | 8 |
| HA-FF23C-UE, 33C-UE | 12 |
| HA-FF43C-UE, 63C-UE | 14 |
| HC-MF13-S15 | 10 |
| HC-MF23-S15, 43-S15 | 15 |
| HC-MF73-S15 | 20 |

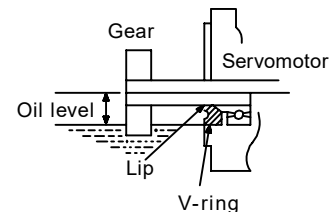

⚠ CAUTION

1. The servomotors, including those having IP65 specifications, do not have a completely waterproof (oil-proof) structure. Do not allow oil or water to constantly contact the motor, enter the motor, or accumulate on the motor. Oil can also enter the motor through cutting chip accumulation, so be careful of this also.
2. When the motor is installed facing upwards, take measures on the machine side so that gear oil, etc., does not flow onto the motor shaft.
3. The HC-MF Series and standard HA-FF Series servomotors do not have an oil seal. Provide a seal on the gear box side so that lubricating oil, etc., does not enter the servomotor.
4. Do not remove the detector from the motor. (The detector installation screw is treated for sealing.)

Chapter 3 Installation

- When installing the servomotor horizontally, set the power cable and detector cable to face downward. When installing vertically or on an inclination, provide a cable trap.

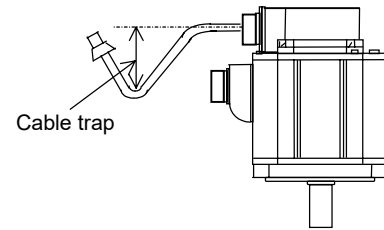

- Do not use the unit with the cable submerged in oil or water. (Refer to right drawing.)

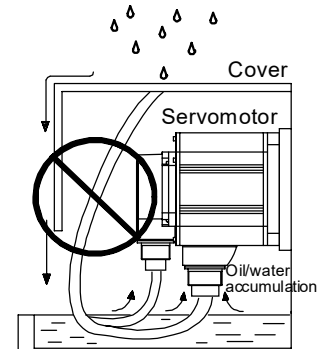

<Fault> Capillary tube phenomenon

- Make sure that oil and water do not flow along the cable into the motor or detector. (Refer to right drawing.)

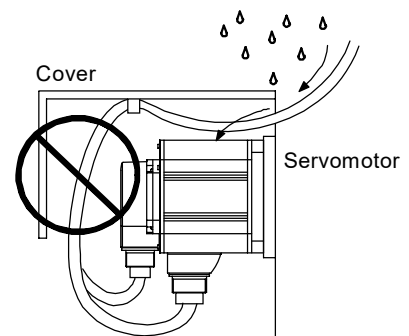

<Fault> Breathing action

- When installing on the top of the shaft end, make sure that oil from the gear box, etc., does not enter the servomotor. The servomotor does not have a waterproof structure.

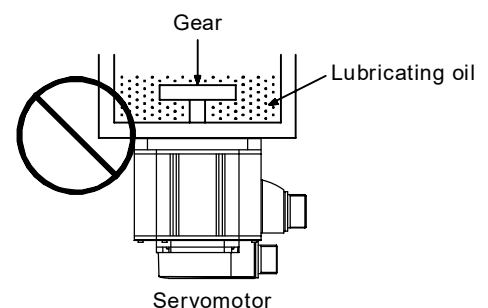

3-2-6 Cable stress

- Sufficiently consider the cable clamping method so that bending stress and the stress from the cable's own weight is not applied on the cable connection.
- In applications where the servomotor moves, make sure that excessive stress is not applied on the cable.
If the detector cable and servomotor wiring are stored in a cable bear and the servomotor moves, make sure that the cable bending section is within the range of the optional detector cable. Fix the detector cable and power cable enclosed with the servomotor.
- Make sure that the cable sheathes will not be cut by sharp cutting chips, worn by contacting the machine corners, or stepped on by workers or vehicles.
- The bending life of the detector cable is as shown below. Regard this with a slight allowance. If the servomotor is installed on a machine that moves, make the bending radius as large as possible.

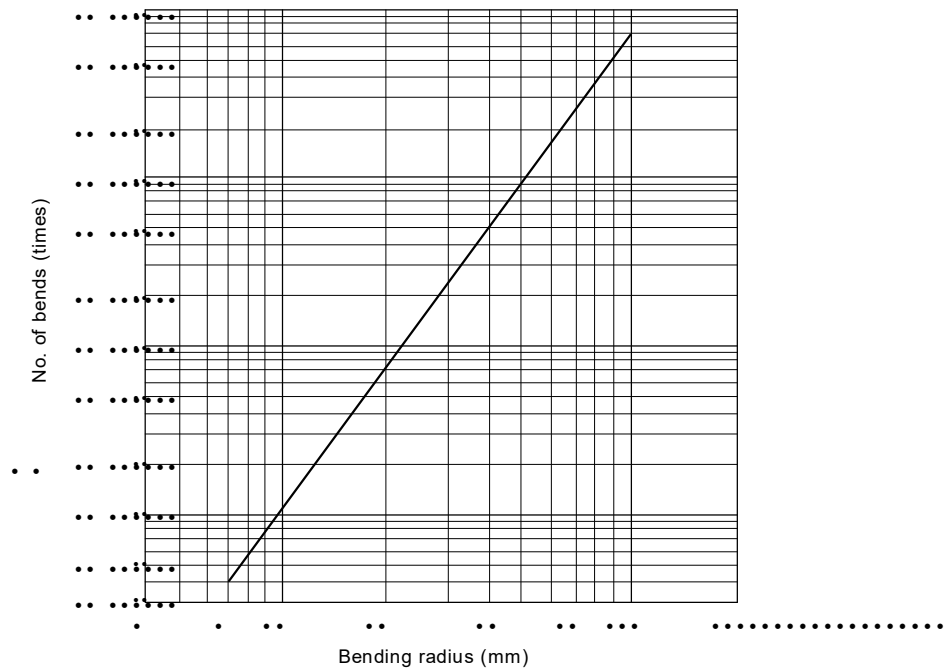

Detector cable bending life

(The optional detector cable and wire of our company: A14B2343)

Note: The values in this graph are calculated values and are not guaranteed.

Chapter 3 Installation

3-3 Noise measures

Noise includes that which enters the servo amplifier from an external source and causes the servo amplifier to malfunction, and that which is radiated from the servo amplifier or motor and causes the peripheral devices or amplifier itself to malfunction. The servo amplifier output is a source of noise as the DC voltage is switched at a high frequency. If the peripheral devices or amplifier malfunction because of the noise, measures must be taken to suppress this noise. These measures differ according to the propagation path of the noise.

(1) General measures for noise

- Avoid wiring the servo amplifier's power supply wire and signal wires in parallel or in a bundled state. Always use separate wiring. Use a twisted pair shield wire for the detector cable, the control signal wires for the bus cable, etc., and for the control power supply wire. Securely ground the shield.
- Use one-point grounding for the servo amplifier and motor.

(2) Measures against noise entering from external source and causing servo amplifier to malfunction

If a device generating noise is installed near the servo amplifier, and the servo amplifier could malfunction, take the following measures.

- Install a surge killer on devices (magnetic contactor, relay, etc.) that generate high levels of noise.
- Install a data line filter on the control signal wire.
- Ground the detector cable shield with a cable clamp.

(3) Measures against noise radiated from the servo amplifier and causing peripheral devices to malfunction

The types of propagation paths of the noise generated from the servo amplifier and the noise measures for each propagation path are shown below.

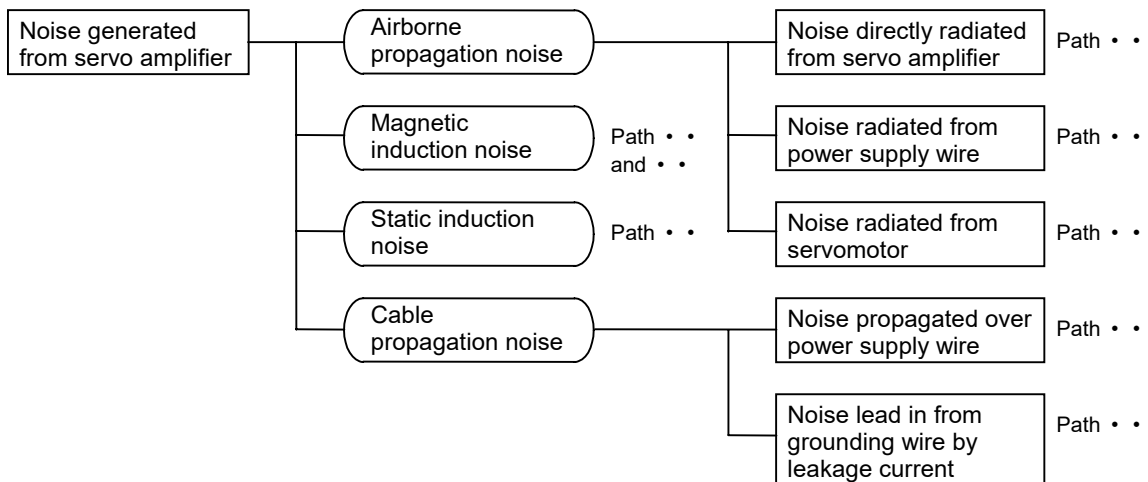

Chapter 3 Installation

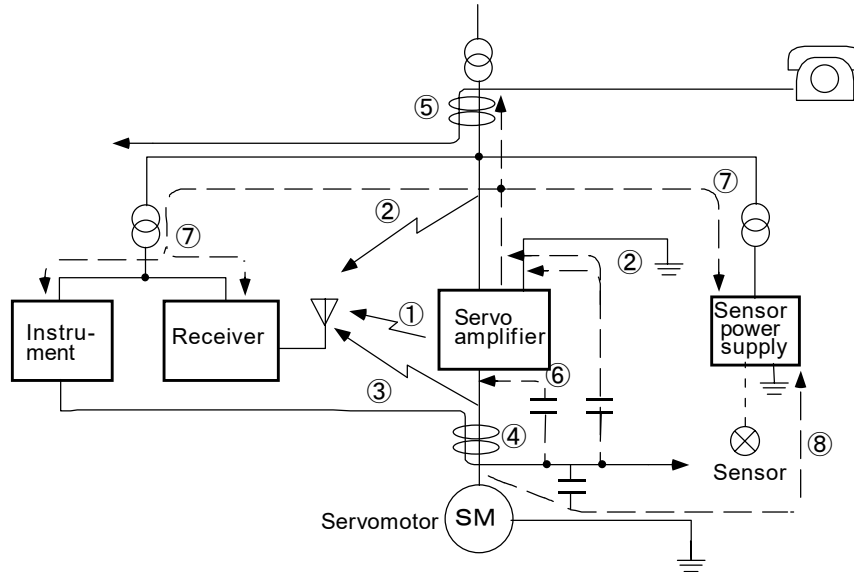

| Noise propaga- tion path | Measures |
|-----------------------------|--|
| • • • • | <p>When devices such as instruments, receivers or sensors, which handle minute signals and are easily affected by noise, or the signal wire of these devices, are stored in the same panel as the servo amplifier and the wiring is close, the device could malfunction due to airborne propagation of the noise. In this case, take the following measures.</p> <p>(1) Install devices easily affected as far away from the servo amplifier as possible.</p> <p>(2) Lay the signals wires easily affected as far away from the input wire with the servo amplifier.</p> <p>(3) Avoid parallel wiring or bundled wiring of the signal wire and power wire.</p> <p>(4) Insert a line noise filter on the input/output wire or a radio noise filter on the input to suppress noise radiated from the wires.</p> <p>(5) Use a shield wire for the signal wire and power wire, or place in separate metal ducts.</p> |
| • • • • | <p>If the signal wire is laid in parallel to the power wire, or if it is bundled with the power wire, the noise could be propagated to the signal wire and cause malfunction because of the magnetic induction noise or static induction noise. In this case, take the following measures.</p> <p>(1) Install devices easily affected as far away from the servo amplifier as possible.</p> <p>(2) Lay the signals wires easily affected as far away from the input wire with the servo amplifier.</p> <p>(3) Avoid parallel wiring or bundled wiring of the signal wire and power wire.</p> <p>(4) Use a shield wire for the signal wire and power wire, or place in separate metal ducts.</p> |
| • • | <p>If the power supply for the peripheral devices is connected to the power supply in the same system as the servo amplifier, the noise generated from the servo amplifier could back flow over the power supply wire and cause the devices to malfunction. In this case, take the following measures.</p> <p>(1) Install a radio noise filter on the servo amplifier's power wire.</p> <p>(2) Install a line noise filter on the servo amplifier's power wire.</p> |
| • • | <p>If a closed loop is structured by the peripheral device and servo amplifier's grounding wires, the leakage current could penetrate and cause the devices to malfunction. In this case, change the device grounding methods and the grounding place.</p> |

Chapter 4 Options and Peripheral Devices

| | |
|--|-------------|
| 4-1 Regenerative option | 4-2 |
| 4-1-1 Combinations with servo amplifiers | 4-2 |
| 4-1-2 Outline dimension drawing of option regenerative resistor..... | 4-3 |
| 4-2 Battery option for absolute position system | 4-5 |
| 4-2-1 Battery (MR-BAT) | 4-5 |
| 4-2-2 Battery unit (MDS-A-BT-2/-4/-6/-8) | 4-6 |
| 4-3 Relay terminal block | 4-7 |
| 4-4 Cables and connectors | 4-8 |
| 4-4-1 Cable option list | 4-9 |
| 4-4-2 Connector outline dimension drawings | 4-12 |
| 4-4-3 Flexible conduits | 4-17 |
| 4-4-4 Cable wire and assembly | 4-19 |
| 4-4-5 Option cable connection diagram | 4-20 |
| 4-5 Setup software | 4-24 |
| 4-5-1 Setup software specifications | 4-24 |
| 4-5-2 System configuration | 4-24 |
| 4-6 Selection of wire | 4-25 |
| 4-7 Selection of no-fuse breakers | 4-26 |
| 4-8 Selection of contactor | 4-27 |
| 4-8-1 Selection from rush current | 4-27 |
| 4-8-2 Selection from input current..... | 4-28 |
| 4-9 Control circuit related | 4-29 |
| 4-9-1 Circuit protector | 4-29 |
| 4-9-2 Relays | 4-29 |
| 4-9-3 Surge absorber..... | 4-29 |

Chapter 4 Options and Peripheral Devices



Wait at least 10 minutes after turning the power OFF, confirm that the CHARGE lamp has gone out, and check the voltage with a tester, etc., before connecting the options or peripheral devices. Failure to observe this could lead to electric shocks.



1. Always use the designated option.
Failure to do so could lead to faults or fires.
2. Take care to the installation environment of the option regenerative resistor so that cutting chips and oil do not come in contact.
There is a risk of short-circuit accidents at the resistor terminal block and of the oil adhered on the resistor burning. These can cause fires.

4-1 Regenerative option

4-1-1 Combinations with servo amplifiers

Confirm the regenerative resistor capacity and possibility of connecting with the servo amplifier. Refer to section "13-4 Selection of regenerative resistor" for details on selecting an option regenerative resistor.

| Corresponding servo amplifier | Standard built-in regenerative resistor | | External option regenerative resistor | | | | |
|-------------------------------|---|------|---------------------------------------|---------|---------|---------|---------|
| | Regenerative capacity | | MR-RB032 | MR-RB12 | MR-RB32 | MR-RB30 | MR-RB50 |
| | Resistance value | | 30W | 100W | 300W | 300W | 500W |
| | | | 40Ω | 40Ω | 40Ω | 13Ω | 13Ω |
| MR-J2-10CT | No built-in resistor | | • • | | | | |
| MR-J2-20CT | 10W | 100Ω | • | • | • | • | |
| MR-J2-40CT | 10W | 100Ω | • | • | • | • | |
| MR-J2-60CT | 10W | 40Ω | • | • | • | • | |
| MR-J2-70CT | 20W | 40Ω | | • | • | • | • |
| MR-J2-100CT | 20W | 40Ω | | • | • | • | • |
| MR-J2-200CT | 100W | 13Ω | | | | • | • |
| MR-J2-350CT | 100W | 13Ω | | | | • | • |

| No. | Abbrev. | Parameter name | Explanation | | | | | | | | | | | | | | | | | | |
|---------------|---|--------------------------|--|---------------|--------------|---|---|---|--------------------|---|----------------|---|----------------|---|----------------|---|----------------|---|----------------|-------|--------------------|
| #002 | *RTY | Regenerative option type | <p>Set the regenerative resistor type.</p> <p>0 0 0 0 (Initialized setting value)</p> <table border="1"> <thead> <tr> <th>Setting value</th> <th>Descriptions</th> </tr> </thead> <tbody> <tr> <td>0</td> <td>Amplifier standard built-in resistor (10CT has no built-in resistor.)</td> </tr> <tr> <td>1</td> <td>Setting prohibited</td> </tr> <tr> <td>2</td> <td>MR-RB032 (30W)</td> </tr> <tr> <td>3</td> <td>MR-RB12 (100W)</td> </tr> <tr> <td>4</td> <td>MR-RB32 (300W)</td> </tr> <tr> <td>5</td> <td>MR-RB30 (300W)</td> </tr> <tr> <td>6</td> <td>MR-RB50 (500W)</td> </tr> <tr> <td>7 ~ F</td> <td>Setting prohibited</td> </tr> </tbody> </table> | Setting value | Descriptions | 0 | Amplifier standard built-in resistor (10CT has no built-in resistor.) | 1 | Setting prohibited | 2 | MR-RB032 (30W) | 3 | MR-RB12 (100W) | 4 | MR-RB32 (300W) | 5 | MR-RB30 (300W) | 6 | MR-RB50 (500W) | 7 ~ F | Setting prohibited |
| Setting value | Descriptions | | | | | | | | | | | | | | | | | | | | |
| 0 | Amplifier standard built-in resistor (10CT has no built-in resistor.) | | | | | | | | | | | | | | | | | | | | |
| 1 | Setting prohibited | | | | | | | | | | | | | | | | | | | | |
| 2 | MR-RB032 (30W) | | | | | | | | | | | | | | | | | | | | |
| 3 | MR-RB12 (100W) | | | | | | | | | | | | | | | | | | | | |
| 4 | MR-RB32 (300W) | | | | | | | | | | | | | | | | | | | | |
| 5 | MR-RB30 (300W) | | | | | | | | | | | | | | | | | | | | |
| 6 | MR-RB50 (500W) | | | | | | | | | | | | | | | | | | | | |
| 7 ~ F | Setting prohibited | | | | | | | | | | | | | | | | | | | | |



The regenerative option and servo amplifier cannot be set to a combination other than that designated. Failure to use the correct combination could lead to fires.

Chapter 4 Options and Peripheral Devices

4-1-2 Outline dimension drawing of option regenerative resistor

<MR-RB032>

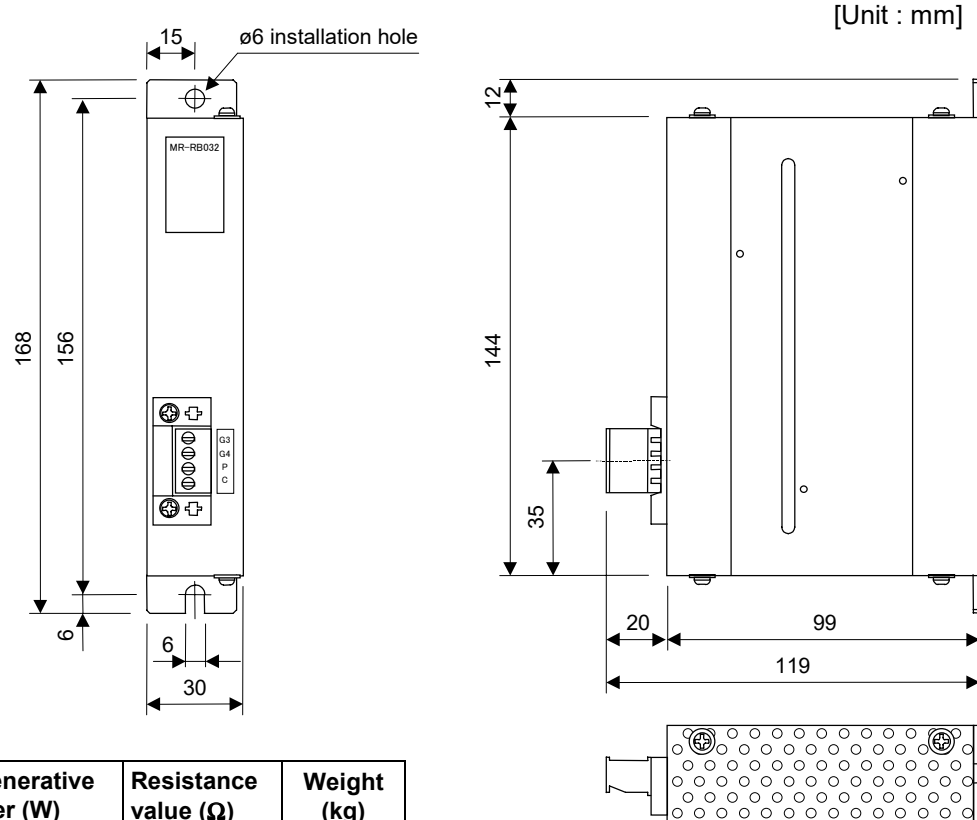

| Regenerative option | Regenerative power (W) | Resistance value (Ω) | Weight (kg) |
|---------------------|------------------------|-------------------------------|-------------|
| MR-RB032 | 30 | 40 | 0.5 |

<MR-RB12>

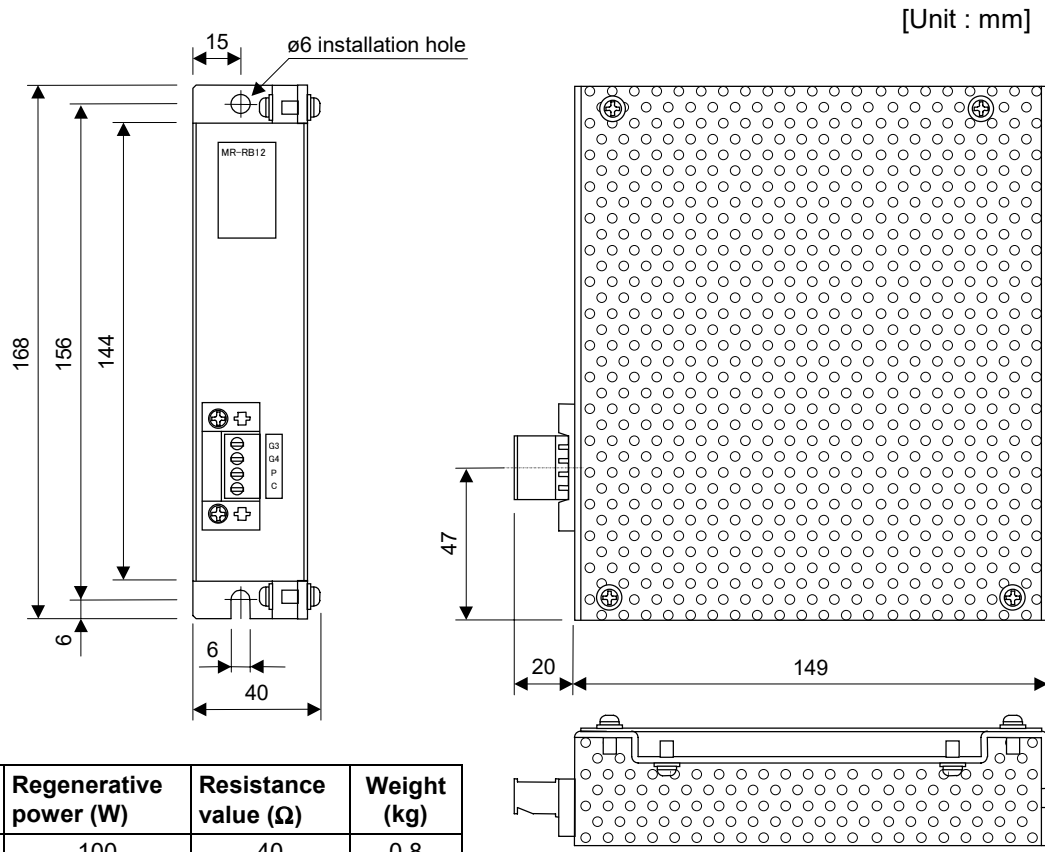

| Regenerative option | Regenerative power (W) | Resistance value (Ω) | Weight (kg) |
|---------------------|------------------------|-------------------------------|-------------|
| MR-RB12 | 100 | 40 | 0.8 |

Chapter 4 Options and Peripheral Devices

<MR-RB32, MR-RB30>

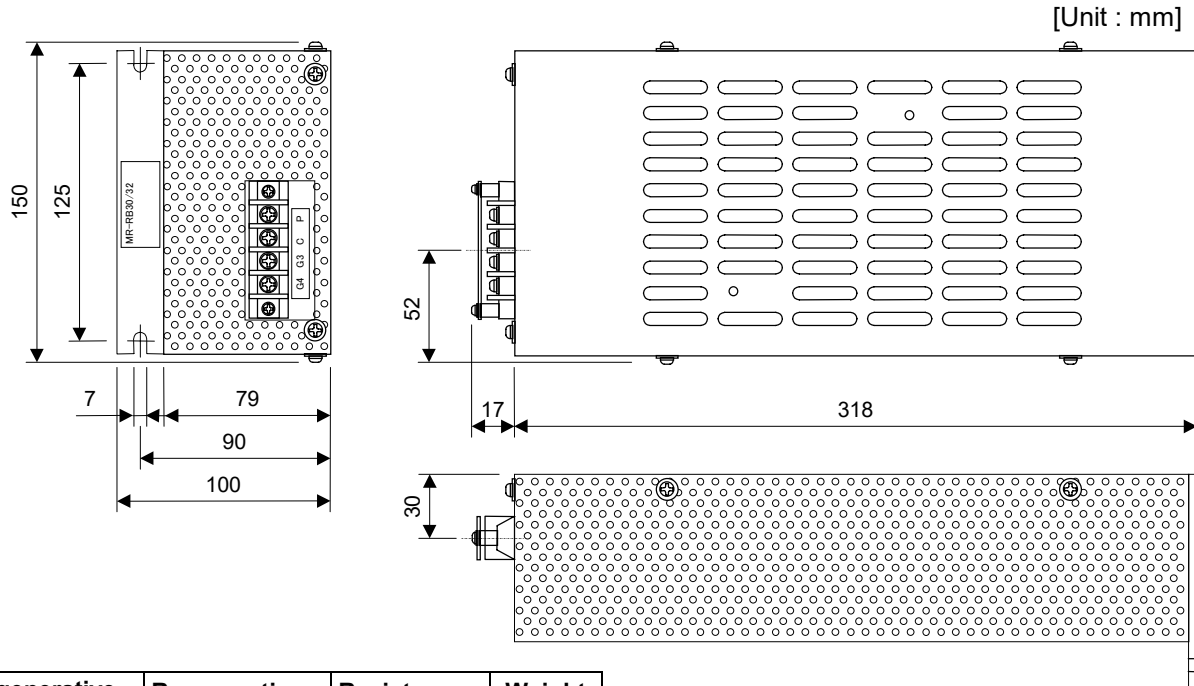

| Regenerative option | Regenerative power (W) | Resistance value (Ω) | Weight (kg) |
|---------------------|------------------------|-------------------------------|-------------|
| MR-RB32 | 300 | 40 | 2.9 |
| MR-RB30 | 300 | 13 | 2.9 |

<MR-RB50>

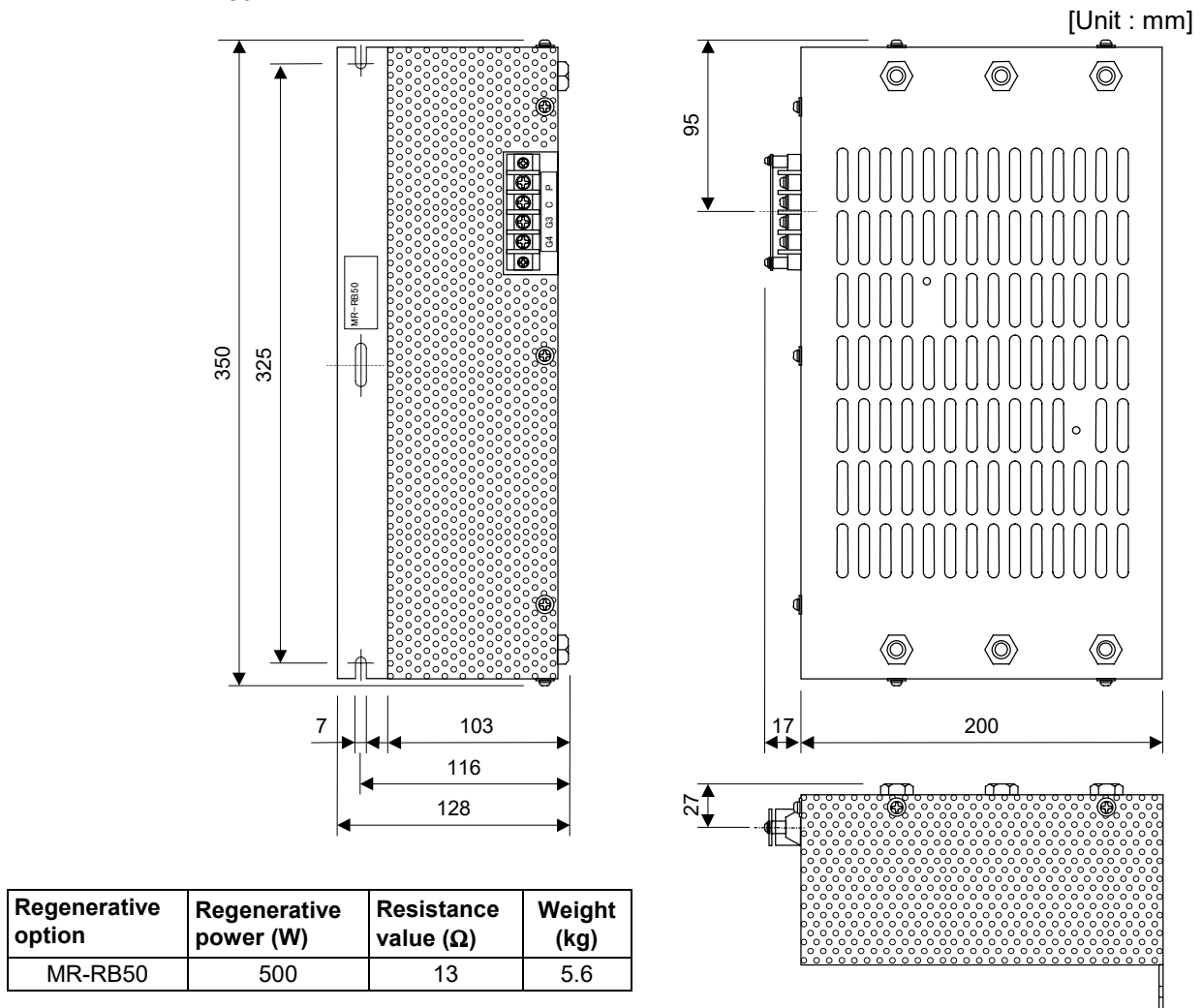

| Regenerative option | Regenerative power (W) | Resistance value (Ω) | Weight (kg) |
|---------------------|------------------------|-------------------------------|-------------|
| MR-RB50 | 500 | 13 | 5.6 |

Chapter 4 Options and Peripheral Devices

4-2 Battery option for absolute position system

A battery or battery unit is required for the absolute position system.

Battery option specifications

| Item | Battery | Battery unit | | | |
|---|---|--|---------|----------|----------|
| Type | MR-BAT | MDS-A-BT-2, -BT-4, -BT-6, -BT-8 | | | |
| Nominal voltage | 3.6V | 3.6V | | | |
| Nominal capacity | 1700mAh | BT-2 | BT-4 | BT-6 | BT-8 |
| | | 4000mAh | 8000mAh | 12000mAh | 16000mAh |
| No. of backup axes | Only one axis by mounted amplifier | Max. 7 axes in one system (in same NC bus) | | | |
| Battery continuous back up time | Approx. 10,000 hours | Approx. 12,000 hours | | | |
| Battery useful life | 5 years from date of battery manufacture | 7 years from date of unit manufacture | | | |
| Data save time during battery replacement | HC-SF, HC-RF : 20 hours at time of delivery, 10 hours after 5 years | | | | |
| | HA-FF, HC-MF : 2 hours at time of delivery, 1 hour after 5 years | | | | |
| Back up time from battery warning to alarm occurrence | Approx. 100 hours | | | | |

⚠ CAUTION

1. To protect the absolute position, do not shut off the servo amplifier control power supply if the battery voltage becomes drop (S52 0092).
2. The battery life will be greatly affected by the ambient temperature. The above data shows the theoretic values for when the ambient temperature of the battery is 25°C. If the ambient temperature rises, generally the back up time and useful life will be shorter.

4-2-1 Battery (MR-BAT)

This is a battery that is built in the servo amplifier. It must be stored in the servo amplifier of the absolute position control axis.

⚠ CAUTION

The internal circuit of the servo amplifier can be damaged by static electricity. Always observe the following points.

- Always ground the body and work table.
- Never touch the conductive parts such as the connector pins or electrical parts by hand.

Mount the battery into the servo amplifier with the following procedure.

- Open the operation section window. (For the MR-J2-200CT/-350CT, also remove the front cover.)
- Mount the battery into the battery holder.
- Insert the battery connector into CON1 until a click is heard.

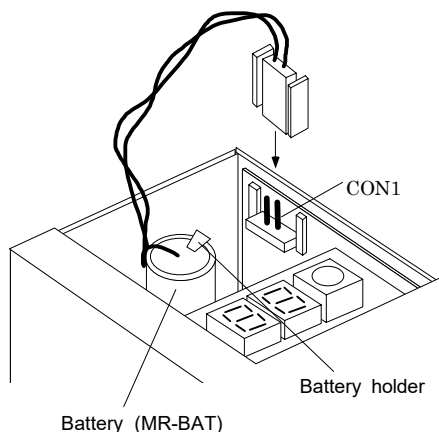

For MR-J2-10CT to MR-J2-100CT

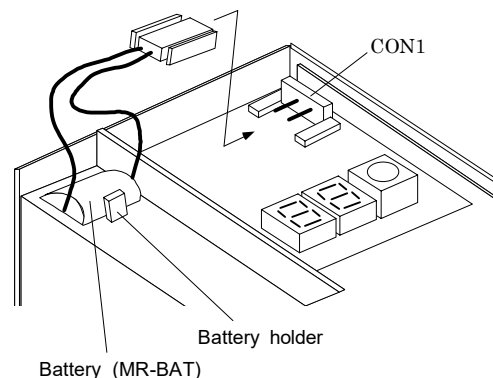

For MR-J2-200CT and MR-J2-350CT

Chapter 4 Options and Peripheral Devices

4-2-2 Battery unit (MDS-A-BT-2/-4/-6/-8)

This is a battery that is installed outside of the servo amplifier.
One battery unit can back up the absolute position data for the servo amplifiers of several axes. The number of servo amplifiers that can be backed up with one battery unit is as follows.

| Battery unit type | No. of units that can be backed up |
|-------------------|------------------------------------|
| MDS-A-BT-2 | 2 units |
| MDS-A-BT-4 | 4 units |
| MDS-A-BT-6 | 6 units |
| MDS-A-BT-8 | 7 units |

<Outline dimension drawing>

MDS-A-BT-2/-4/-6/-8

[Unit : mm]

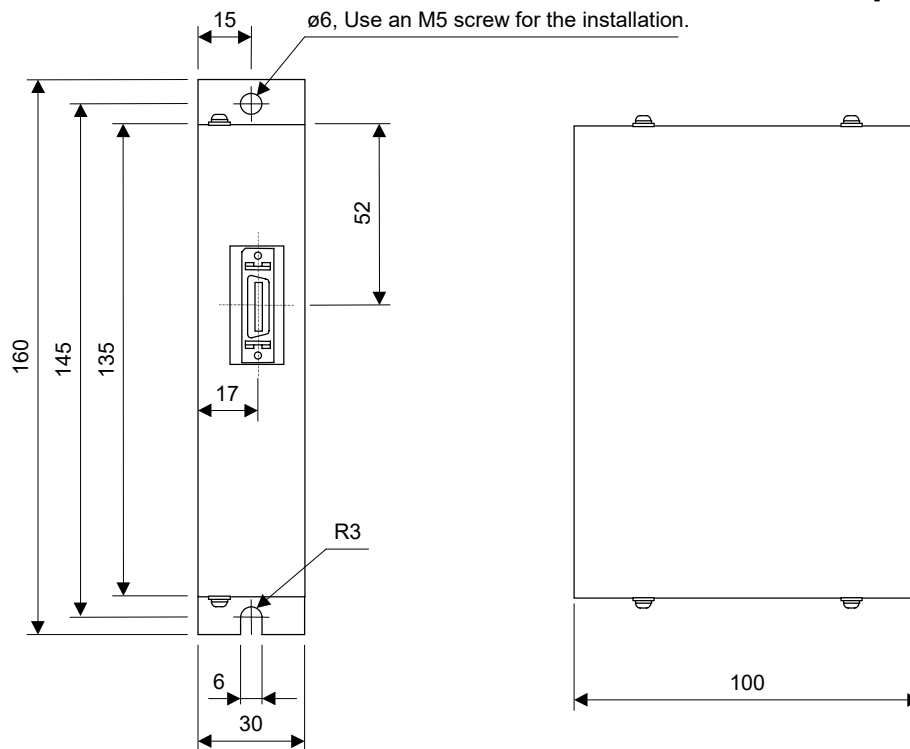

<Connection>

The battery unit is connected with a bus cable (SH21) between the amplifiers instead of the terminator.

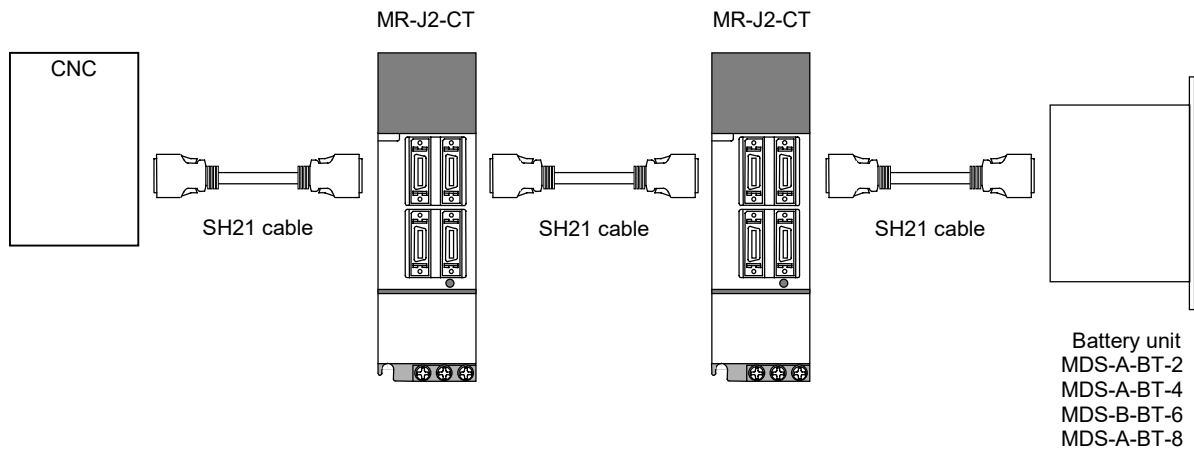

Chapter 4 Options and Peripheral Devices

4-3 Relay terminal block

Signals input/output from the CN3 connector on the front of the servo amplifier can be sent to the terminal block. Connect the terminal block to the CN3 connector with an SH21 cable. This can also be used with the servo amplifier MDS-B-SVJ2 Series.

| Abbrev. | Name | Descriptions |
|---------|-------------------------------|---|
| CN3A | Connector 3 input/output A | Connect from the CN3 connector with an SH21 cable. Common for any connector, so each signal will pass through. Generally when the CN3 control signal is being used, each signal can be output from the relay terminal block by relaying through these connectors. |
| CN3B | Connector 3 input/output B | |
| CN3C | Connector 3 input/output C | |
| VDD | Internal power supply output | This is the 24V power supply output in the amplifier. When using an internal power supply, use relayed once through the COM terminal. |
| COM | Common power supply | Connect VDD when using the amplifier internal power supply. Connect the + side of the external power supply when using an external power supply. |
| EMG | External emergency stop input | This is the input terminal for external emergency stops. |
| DOG | Dog | Input the near-point dog signal when carrying out a dog-type zero point return. |
| MO1 | Monitor output 1 | This is the D/A output ch.1. Measure the voltage across MO1-LG. |
| MO2 | Monitor output 2 | This is the D/A output ch.2. Measure the voltage across MO2-LG. |
| PE | Plate ground | This has the same potential as the amplifier FG or cable shield. |
| SG | 24V power supply ground | This is the ground when using digital input/output. |
| MC | Contact control output | This is the output terminal for contactor control. |
| MBR | Motor brake control output | This is the output terminal for motor brake control. |
| LG | 5V power supply ground | This is the ground when using D/A output. |

< Outline dimension drawing >

MR-J2CN3TM

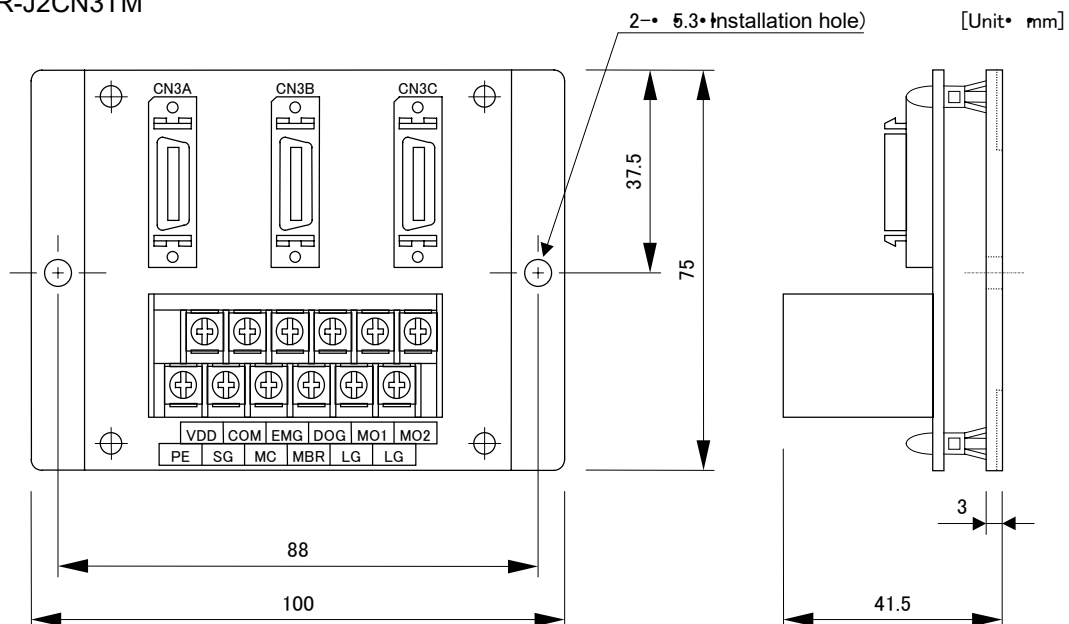

Chapter 4 Options and Peripheral Devices

4-4 Cables and connectors

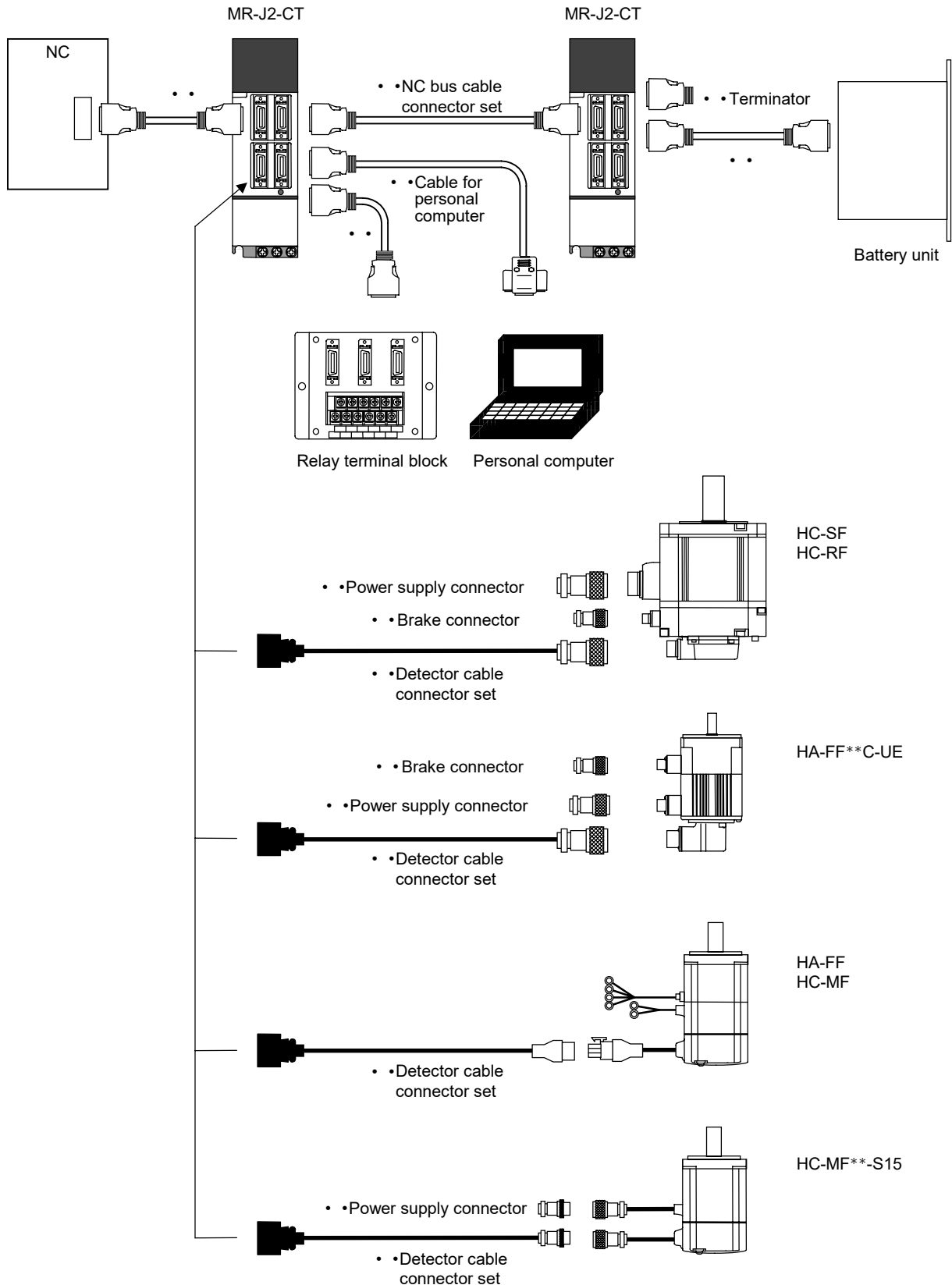

The cables and connectors that can be ordered from Mitsubishi Electric Corp. as option parts are shown below. Cables can only be ordered in the designated lengths shown on the following pages. Purchase a connector set, etc., to create special length cables when required.



Chapter 4 Options and Peripheral Devices

4-4-1 Cable option list

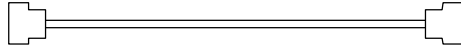
(1) Cables

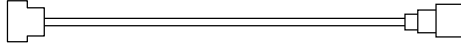
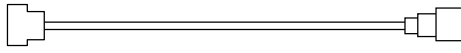
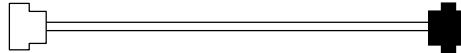
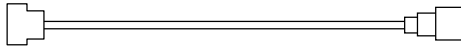
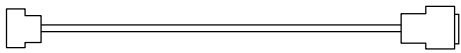
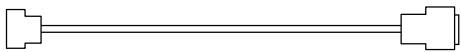
| Part name | | | Type | Descriptions | | |
|----------------------|---|---|---|--|---|--|
| For CN1A, CN1B | Communication cable for NC unit - Amplifier Amplifier - Amplifier | | SH21 Length: 0.35, 0.5, 0.7, 1, 1.5, 2, 2.5, 3, 3.5, 4, 4.5, 5, 6, 7, 8, 9, 10, 15, 20, 30m { FCUA-R000 and MR- J2HBUS• M can also be used. } | Servo amplifier side connector (Sumitomo 3M) Connector: 10120-6000EL Shell kit: 10320-3210-000  | Servo amplifier side connector (Sumitomo 3M) Connector: 10120-6000EL Shell kit: 10320-3210-000 | |
| | Terminator connector | | A-TM | Terminator connector  | | |
| For CN2 | Detector cable for HC-SF, HC-RF, HA-FF**C-UE | IP65 and EN Standard compati- ble | Straight | MR-ENCBL• M-H The value in • • indicates the length. 2, 5, 10, 20, 30m | Servo amplifier side connector (Sumitomo 3M) Connector: 10120-3000VE Shell kit: 10320-52F0-008  | Servomotor detector side connector (DDK) Connector: MS3106A20-29S(D190) Straight back shell: CE02-20BS-S Clamp: CE3057-12A-3 |
| | | For general environ- ment | Straight | MR-JHSCBL• M-H The value in • • indicates the length. 2, 5, 10, 20, 30m | Servo amplifier side connector (Sumitomo 3M) Connector: 10120-3000VE Shell kit: 10320-52F0-008  | Servomotor detector side connector (DDK) Plug: MS3106B20-29S Clamp: MS3057-12A |
| | Detector cable for HA-FF, HC-MF | For general environ- ment | Straight | MR-JCCBL• M-H The value in • • indicates the length. 2, 5, 10, 20, 30m | Servo amplifier side connector (Sumitomo 3M) Connector: 10120-3000VE Shell kit: 10320-52F0-008  | Servomotor detector side connector (Japan AMP) Connector: 172161-9 Connector pin: 170359-1 Clamp: MT1-0002 |
| | • • Detector cable for HC-MF** S15 | IP65 compati- ble | Straight | MR-RMCBL• M The value in • • indicates the length. 2, 5, 10, 20, 30m | Servo amplifier side connector (Sumitomo 3M) Connector: 10120-3000VE Shell kit: 10320-52F0-008  | Servomotor detector side connector (Hirose Electric) Plug: RM15WTJA-10S Clamp: RM15WTP-CP(7) |
| For CN3 | • • Communication cable for PC98 | | MR-CPC98CBL3M Length : 3m | Servo amplifier side connector (3M or equivalent part) Connector: 10120-6000EL Shell kit: 10320-3210-000  | PC98 series Personal computer side connector GM-25LM (Honda Tsushin) | |
| | • • Communication cable for DOS/V | | MR-CPCATCBL3M Length : 3m | Servo amplifier side connector (3M or equivalent part) Connector: 10120-6000EL Shell kit: 10320-3210-000  | DOS/V series Personal computer side connector GM-9LM (Honda Tsushin) | |















(Note) The connector maker may change without notice.



The PC98 notebook also has half-pitch, 14-pin type connectors. Check the shape of the RS-232-C connector on the personal computer being used, and prepare a commercially available conversion connector if required.









Chapter 4 Options and Peripheral Devices

(2) Connector sets

| Part name | | | Type | Descriptions | | |
|------------------------|---|---------------------------------|------------|---|---|--|
| For CN1A, CN1B | • • Communication connector set for NC - Amplifier Amplifier - Amplifier | | FCUA-CS000 | Servo amplifier side connector (Sumitomo 3M) Connector: 10120-3000VE Shell kit: 10320-52F0-008  | Servo amplifier side connector (Sumitomo 3M) Connector: 10120-3000VE Shell kit: 10320-52F0-008  | |
| For CN2 | • • Detector connector set for HC-SF, HC-RF, HA-FF**C-UE | IP65 and EN Standard compatible | Straight | MR-ENCNS Compliant cable range $\phi 6.8 \sim \phi 10$ | Servo amplifier side connector (Sumitomo 3M) Connector: 10120-3000VE Shell kit: 10320-52F0-008  | Servomotor detector side connector (DDK) Connector: MS3106A20-29S(D190) Back shell: CE02-20BS-S Clamp: CE3057-12A-3  |
| | | For general environment | Straight | MR-J2CNS | Servo amplifier side connector (Sumitomo 3M) Connector: 10120-3000VE Shell kit: 10320-52F0-008  | Servomotor detector side connector (DDK) Connector: MS3106B20-29S Cable clamp: CE3057-12A  |
| | • • Detector connector set for HA-FF, HC-MF | For general environment | Straight | MR-J2CNM | Servo amplifier side connector (Sumitomo 3M) Connector: 10120-3000VE Shell kit: 10320-52F0-008  | Servomotor detector side connector (DDK) Connector: 172161-9 Connector pin: 170359-1 Clamp: MTI-0002  |
| | • • Detector connector set for HC-MF**-S15 | IP65 compatible | Straight | MR-RMCS Compliant cable range $\phi 6.5 \sim \phi 7.5$ | Servo amplifier side connector (Sumitomo 3M) Connector: 10120-3000VE Shell kit: 10320-52F0-008  | Servomotor detector side connector (Hirose Electric) Plug: RM15WTJA-10S Clamp: RM15WTP-CP(7)  |
| For motor power supply | • • Power supply connector for HC-SF52 ~ 152, HC-SF53 ~ 153, HC-RF103 ~ 203 | IP67 and EN Standard compatible | Straight | PWCE22-23S Compliant cable range $\phi 9.5 \sim \phi 13$ { MR-PWCNS1 } can also be used. | | Servomotor side power supply connector (DDK) Connector: CE05-6A22-23SD-B-BSS Clamp: CE3057-12A-2 (D265)  |
| | | | Angle | PWCE22-23L Compliant cable range $\phi 9.5 \sim \phi 13$ | | Servomotor side power supply connector (DDK) Connector: CE05-8A22-23SD-B-BAS Clamp: CE3057-12A-2 (D265)  |
| | For general environment | For general environment | Straight | FCUA-CN802 | | Servomotor side power supply connector (DDK) Connector: MS3106B22-23S Clamp: MS3057-12A  |
| | | | Angle | FCUA-CN806 | | Servomotor side power supply connector (DDK) Connector: MS3108B22-23S Clamp: MS3057-12A  |

(Note) The connector maker may change without notice.

Chapter 4 Options and Peripheral Devices

| Part name | | Type | Descriptions | | |
|------------------------|--|---|-------------------------|---|--|
| For motor power supply | • •Power supply connector for HC-SF202~352, HC-SF203~353 | IP67 and EN standard compatible | Straight | PWCE24-10S Compliant cable range ø13 ~ ø15.5 [MR-WCNS2 can also be used.] | Servomotor side power supply connector (DDK) Connector : CE05-6A24-10SD-B-BSS Clamp : CE3057-16A-2 (D265)  |
| | | For general environment | Angle | PWCE24-10L Compliant cable range ø13 ~ ø15.5 | Servomotor side power supply connector (DDK) Connector : CE05-8A24-10SD-B-BAS Clamp : CE3057-16A-2 (D265)  |
| | | | Straight | FCUA-CN803 | Servomotor side power supply connector (DDK) Connector : MS3106B24-10S Clamp : MS3057-16A  |
| | | • •Power supply connector for HA-FF**C-UE | For general environment | Angle | FCUA-CN807 |
| | Straight | | | MR-PWCNF | Servomotor side power supply connector Connector : CE05-6A14S-2SD-B (DDK) Clamp : YSO14-9-11 (Daiwa)  |
| | • •Power supply connector for HC-MF**S15 | IP65 compatible | Straight | MR-RM4S (• •) The value in • • indicates the cable clamp diameter. 8, 9, 10 mm Compliant cable range Clamp diameter ±0.5mm | Servomotor side power supply connector (Hirose Electric) Plug : RM15WTJA-4S Clamp : RM15WTP-CP(8/9/10)  |
| | | | For motor brakes | IP67 and EN standard compatible | Straight |
| | Angle | BRKP10SL-4L Compliant cable range ø5 ~ ø8.3 | | | Servomotor side brake connector Connector : MS3106A10SL-4S (D190) (DDK) Clamp : YLO10-5-8 (Daiwa)  |
| | For general environment | Straight | | FCUA-CN804 | Servomotor side brake connector (Japan Aviation Electronics) Connector : MS3106B10SL-4S Clamp : MS3057-4A  |
| | | Angle | | FCUA-CN808 | Servomotor side brake connector (Japan Aviation Electronics) Connector : MS3108B10SL-4S Clamp : MS3057-4A  |

(Note) The connector maker may change without notice.

Chapter 4 Options and Peripheral Devices

4-4-2 Connector outline dimension drawings

Servo amplifier CN2 connector

Maker: Sumitomo 3M

[Unit: mm]

<Type>

Connector: 10120-3000VE
Shell kit: 10320-52F0-008

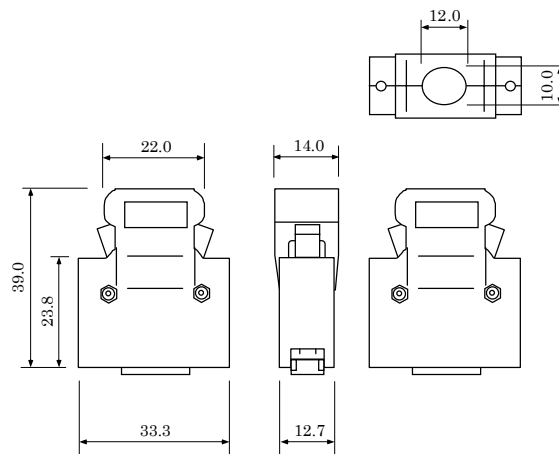

Maker: Sumitomo 3M

[Unit: mm]

<Type>

Connector: 10120-6000EL
Shell kit: 10320-3210-000

Because this connector is an integrated molding part of the cable, it is not an option setting in the connector set. The terminator connector (A-TM) also has the same outline.

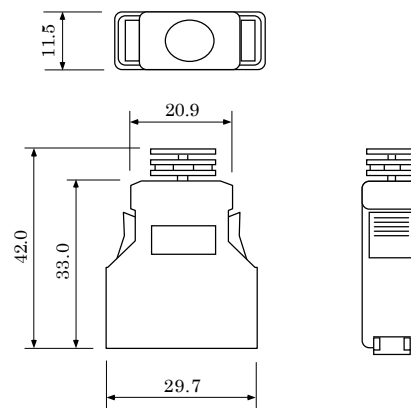

D-SUB connector for personal computer

Maker: Honda Tsushin

[Unit: mm]

<Type>

For PC98: GM-25L (25 pins)
For DOS/V: GM-9L (9 pins)

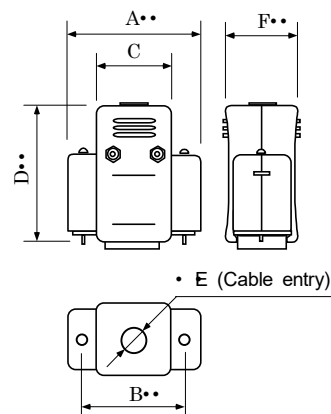

| Type | A | B | C | D | E | F |
|--------|----|-------|------|----|----|------|
| GM-9L | 33 | 24.99 | 18.5 | 33 | 6 | 17.9 |
| GM-25L | 55 | 47.04 | 40 | 46 | 10 | 20.6 |

Chapter 4 Options and Peripheral Devices

Connectors for detector and motor power supply (IP67 and EN Standard compatible)

Straight plug
Maker : DDK

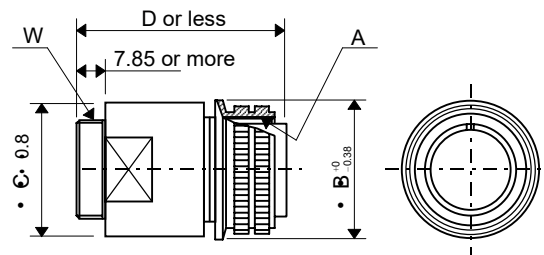

[Unit: mm]

| Type | A | B ^{+0/-0.38} | C±0.8 | D or less | W |
|----------------------|--|-----------------------|-------|-----------|---|
| CE05-6A22-23SD-B-BSS | 1 ³ / ₈ -18UNEF-2B | 40.48 | 38.3 | 61 | 1 ³ / ₁₆ -18UNEF-2A |
| CE05-6A24-10SD-B-BSS | 1 ¹ / ₂ -18UNEF-2B | 43.63 | 42.0 | 68 | 1 ¹ / ₁₆ -18UNEF-2A |

Angle plug
Maker : DDK

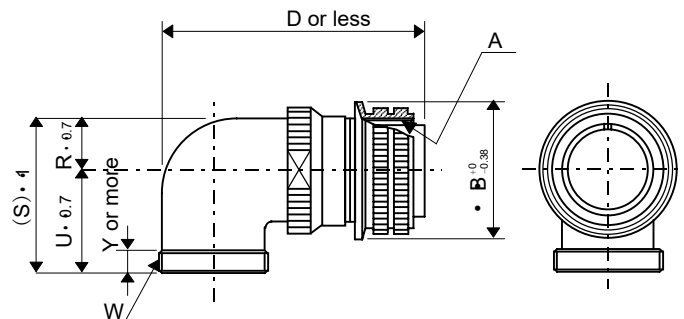

[Unit: mm]

| Type | A | B ^{+0/-0.38} | D or less | W | R±0.7 | U±0.7 | (S)±1 | Y or more |
|----------------------|--|-----------------------|-----------|---|-------|-------|-------|-----------|
| CE05-8A22-23SD-B-BAS | 1 ³ / ₈ -18UNEF-2B | 40.48 | 75.5 | 1 ³ / ₁₆ -18UNEF-2A | 16.3 | 33.3 | 49.6 | 7.5 |
| CE05-8A24-10SD-B-BAS | 1 ¹ / ₂ -18UNEF-2B | 43.63 | 86.3 | 1 ¹ / ₁₆ -18UNEF-2A | 18.2 | 36.5 | 54.7 | 7.5 |

Cable clamp
Maker : DDK

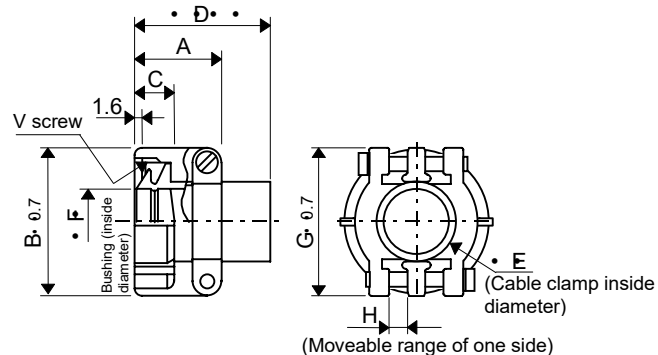

[Unit: mm]

| Type | Shell size | Total length | Outside dia. | | Effective screw length | D | E | F | G | H | Installation screws (V) | Bushing | Compliant cable |
|---------------------|------------|--------------|--------------|------|------------------------|------|------|------|-----|---|-------------------------|-----------|-----------------|
| | | | A | B | | | | | | | | | |
| CE3057-12A-2 (D265) | 20 | 23.8 | 35 | 10.3 | 41.3 | 19 | 13 | 37.3 | 4 | 1 ³ / ₁₆ -18UNEF-2B | CE3420-12-2 | ø9.5~ø13 | |
| CE3057-12A-3 (D265) | 22 | | | | | | 10 | | | | | | |
| CE3057-16A-2 (D265) | 24 | 26.2 | 42.1 | 10.3 | 41.3 | 23.8 | 15.5 | 42.9 | 4.8 | 1 ¹ / ₁₆ -18UNEF-2B | CE3420-16-2 | ø13~ø15.5 | |

Chapter 4 Options and Peripheral Devices

Connectors for detectors, motor power supply and brakes (IP67 and EN Standard compatible)

Straight plug
Maker : DDK

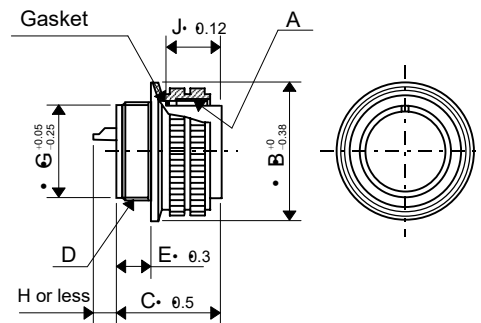

[Unit: mm]

| Type | A | B ⁺⁰ / _{-0.38} | C±0.5 | D | E±0.3 | G ^{+0.05} / _{-0.25} | J±0.12 |
|-----------------------|-----------------|------------------------------------|-------|-----------------|-------|---------------------------------------|--------|
| MS3106A10SL-4S (D190) | 5/8-24UNEF-2B | 22.22 | 23.3 | 9/16-24UNEF-2A | 7.5 | 12.5 | 13.49 |
| MS3106A20-29S (D190) | 1 1/4-18UNEF-2B | 37.28 | 34.11 | 1 1/8-18UNEF-2A | 12.16 | 26.8 | 18.26 |

Straight plug

Maker : DDK
Type : CE05-6A14S-2SD-B

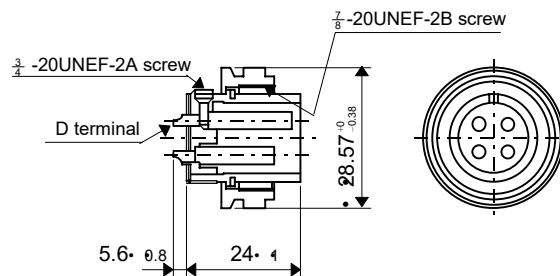

[Unit: mm]

Straight back shell

Maker : DDK
Type : CE02-20BS-S

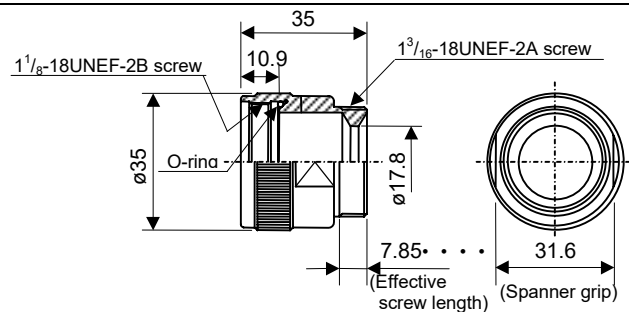

[Unit: mm]

Connectors for motor power supply and brakes (IP67 and EN Standard compatible)

Cable clamp
Maker : Daiwa

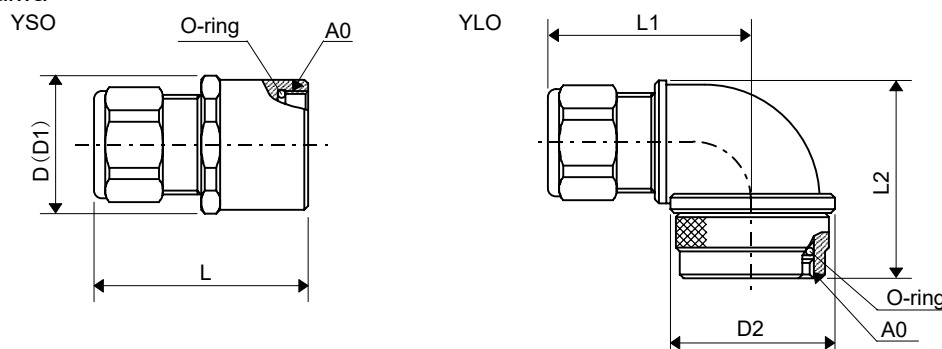

[Unit: mm]

| Type | Accommodating outside diameter | American standard screw thread A0 | Length before tightening | | Side to side D | Corner to corner D1 | D2 |
|-----------------------------|--------------------------------|-----------------------------------|--------------------------|------|----------------|---------------------|----|
| | | | L | L1 | | | |
| YSO10-5 ~ 8, YLO10-5 ~ 8 | ø5 ~ 8.3 | 9/16-24UNEF-2B | 43 | 39 | 42.5 | 24 | 26 |
| YSO14-9 ~ 11 | ø8.3 ~ 11.3 | 3/4-20UNEF-2B | 44 | 43.5 | 44.5 | 26 | 28 |

Chapter 4 Options and Peripheral Devices

Connectors for detectors, motor power supply and brakes (for general environment)

Straight plug
Maker : DDK

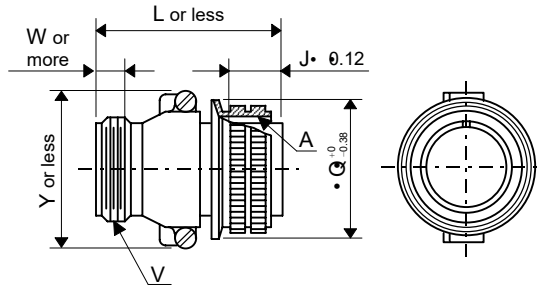

[Unit: mm]

| Type | Coupling screw A | Length of coupling section J ± 0.12 | Total length L or less | Connection nut outside diameter øQ ⁺⁰ _{-0.38} | Cable clamp installation screw V | Effective screw length W or more | Max. width Y or less |
|---------------|---------------------------------------|--|---------------------------|--|--|-------------------------------------|-------------------------|
| MS3106B20-29S | 1 ¹ / ₄ -18UNEF | 18.26 | 55.57 | 37.28 | 1 ³ / ₁₆ -18UNEF | 9.53 | 47 |
| MS3106B22-23S | 1 ³ / ₈ -18UNEF | 18.26 | 55.57 | 40.48 | 1 ³ / ₁₆ -18UNEF | 9.53 | 50 |
| MS3106B24-10S | 1 ¹ / ₂ -18UNEF | 18.26 | 58.72 | 43.63 | 1 ¹ / ₁₆ -18UNEF | 9.53 | 53 |

Angle plug
Maker : DDK

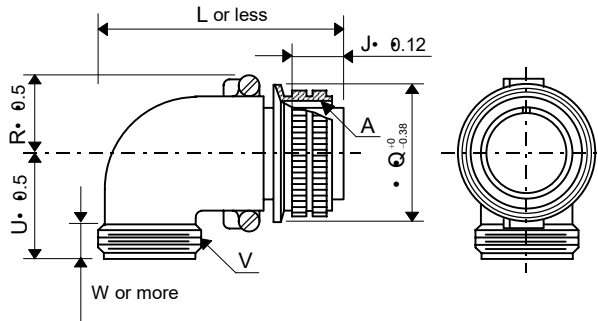

[Unit: mm]

| Type | Coupling screw A | Length of coupling section J ± 0.12 | Total length L or less | Connection nut outside diameter øQ ⁺⁰ _{-0.38} | R±0.5 | U±0.5 | Cable clamp installation screw V | Effective screw length W or more |
|---------------|---------------------------------------|--|---------------------------|--|-------|-------|--|-------------------------------------|
| MS3108B22-23S | 1 ³ / ₈ -18UNEF | 18.26 | 76.98 | 40.48 | 24.1 | 33.3 | 1 ³ / ₁₆ -18UNEF | 9.53 |
| MS3108B24-10S | 1 ¹ / ₂ -18UNEF | 18.26 | 86.51 | 43.63 | 25.6 | 36.5 | 1 ¹ / ₁₆ -18UNEF | 9.53 |

Straight plug

Maker : Japan Aviation Electronics
Type: MS3106B10SL-4S

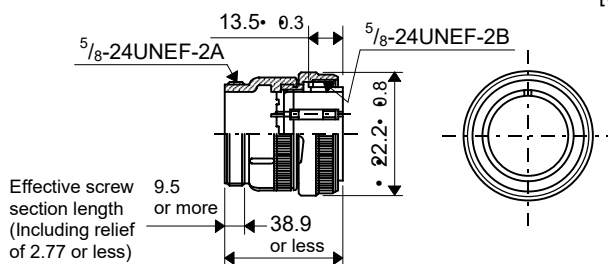

[Unit:mm]

Angle plug

Maker : Japan Aviation Electronics
Type: MS3106B10SL-4S

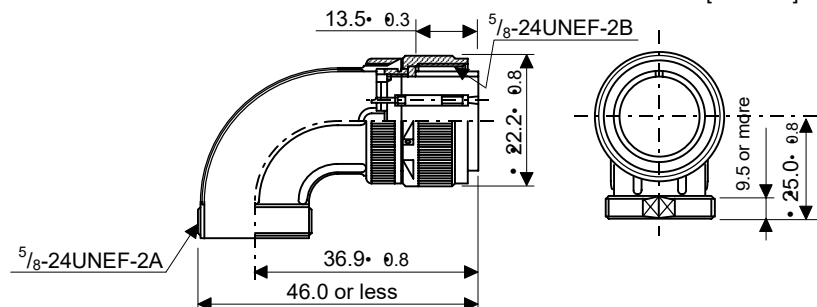

[Unit:mm]

Chapter 4 Options and Peripheral Devices

Connectors for detectors, motor power supply and brakes (for general environment)

Cable clamp
Maker : DDK

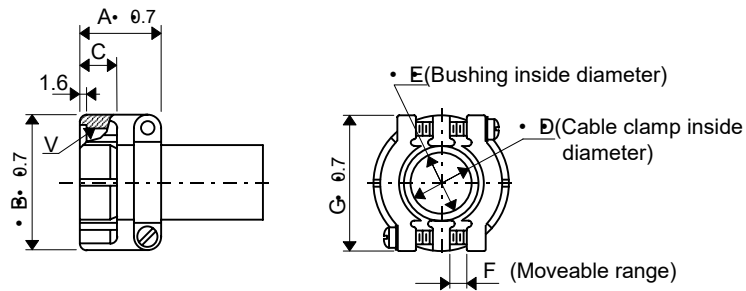

[Unit: mm]

| Type | Shell size | Total length A±0.7 | Outside diameter øB±0.7 | Effective screw length C | øD | øE | F | G±0.7 | Installation screw V | Bushing |
|------------|------------|-----------------------|----------------------------|-----------------------------|------|------|-----|-------|-------------------------|-----------|
| MS3057-4A | 10SL, 12S | 20.6 | 20.6 | 10.3 | 7.9 | 5.6 | 1.6 | 22.2 | 5/16-24UNEF | AN3420-4 |
| MS3057-12A | 20, 22 | 23.8 | 35.0 | 10.3 | 19.0 | 15.9 | 4.0 | 37.3 | 1 3/16-18UNEF | AN3420-12 |
| MS3057-16A | 24, 28 | 26.2 | 42.1 | 10.3 | 23.8 | 19.1 | 4.8 | 42.9 | 1 7/16-18UNEF | AN3420-16 |

HA-FF, HC-MF motor detector connector (for general environment)

Maker: Japan AMP

[Unit: mm]

<Type>

Connector: 1-172161-9
Connector pin: 170359-1
Crimp tool: 755330-1

A crimp tool is required for wiring to the connector.
Contact Japan AMP (Ltd.) for the crimping tool.

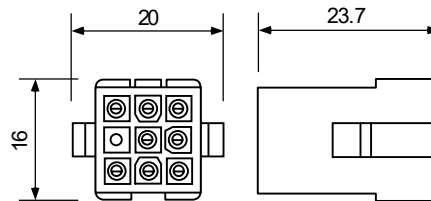

Connectors for HC-MF**-S15 motor detector and power supply (IP65 compatible)

Straight plug

[Unit: mm]

Maker : Hirose Electric
Type : RM15WTJA-4S
RM15WTJA-10S

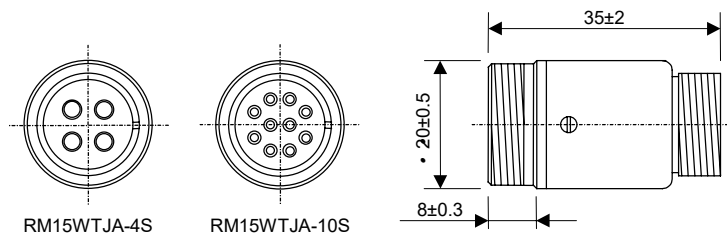

Cable clamp

[Unit: mm]

Maker : Hirose Electric
Type : RM15WTP-CP ()

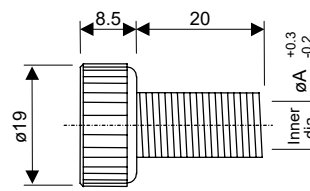

| Cable clamp type | Cable clamp dia. | Spring inner dia. øA |
|------------------|------------------|----------------------|
| RM15WTP-CP (7) | ø7 | 8.0 |
| RM15WTP-CP (8) | ø8 | 10.5 |
| RM15WTP-CP (9) | ø9 | 10.5 |
| RM15WTP-CP (10) | ø10 | 10.5 |

Chapter 4 Options and Peripheral Devices

4-4-3 Flexible conduits

Basically, splash proofing can be ensured if cab-tire cable and connectors with IP65 or higher specifications are used. However, to further improve the oil resistance (chemical resistance to oil), weather resistance (resistance to the environment when used outdoors, etc.), durability, tensile strength, flattening strength, etc., run the cable through a flexible conduit when wiring.

The following shows an example of a flexible conduit. Contact the connector maker for more information.

(1) Method for connecting to a connector with back shell

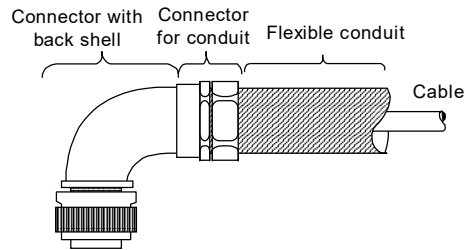

| Application | Applicable motors | Type | | | |
|---------------------|-------------------|----------------------|----------------------|---|--------------------------------|
| | | DDK | | Japan Flex | |
| | | Connector (straight) | Connector (angle) | Connector for conduit | Flexible conduit |
| For power supply | HC-SF52~152 | CE05-6A22-23SD-B-BSS | CE05-8A22-23SD-B-BAS | RCC-104CA2022 | VF-04 (Min. inside dia.: 14) |
| | HC-SF53~153 | | | RCC-106CA2022 | VF-06 (Min. inside dia.: 19) |
| | HC-RF103~203 | CE05-6A24-10SD-B-BSS | CE05-8A24-10SD-B-BAS | RCC-106CA2428 | VF-06 (Min. inside dia.: 19) |
| | HC-SF202 ~ 352 | | | RCC-108CA2428 | VF-08 (Min. inside dia.: 24.4) |
| | HC-SF203 ~ 353 | | | Select according to section "(2) Method for connecting to the connector main body". | |
| HA-FF053C-UE~63C-UE | | | | | |

(Note) None of the parts in this table can be ordered from Mitsubishi Electric Corp.

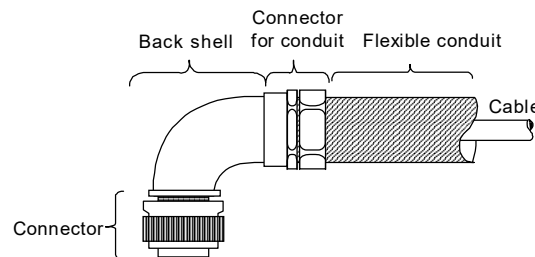

| Application | Applicable motors | Type | | | |
|---------------|--|---|--------------------------------|-----------------------|------------------------------|
| | | DDK | | Japan Flex | |
| | | Connector/ back shell (straight) | Connector/ back shell (angle) | Connector for conduit | Flexible conduit |
| For brakes | HC-SF202B ~ 352B HC-SF203B ~ 353B HA-FF**CB-UE | Select according to section "(2) Method for connecting to the connector main body". | | | |
| For detectors | HC-SF HC-RF HA-FF**C-UE | Connector MS3106A20-29S (D190) | Connector MS3106A20-29S (D190) | RCC-104CA2022 | VF-04 (Min. inside dia.: 14) |
| | | Back shell CE02-20BS-S | Back shell CE-20BA-S | RCC-106CA2022 | VF-06 (Min. inside dia.: 19) |

(Note) None of the parts in this table can be ordered from Mitsubishi Electric Corp.

Chapter 4 Options and Peripheral Devices

(2) Method for connecting to the connector main body

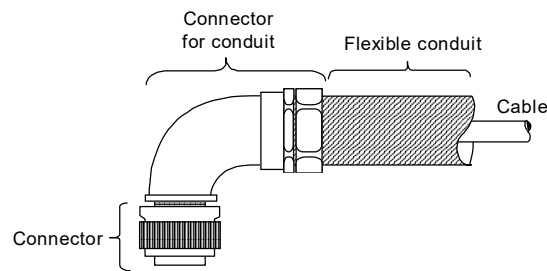

| Application | Applicable motors | Type | | |
|------------------|--|-----------------------|---|-----------------------------------|
| | | DDK | DAIWA DENGYO Co., Ltd. | |
| | | Connector (straight) | Connector for conduit | Flexible conduit |
| For power supply | HC-SF52 ~ 152, HC-SF53 ~ 153 HC-RF103 ~ 203 | CE05-6A22-23SD-B | MSA-16-22 (Straight) MAA-16-22 (Angle) | FCV16 (Min. inside dia.: 15.8) |
| | MSA-22-22 (Straight) MAA-22-22 (Angle) | | FCV22 (Min. inside dia.: 20.8) | |
| | HC-SF202~352, HC-SF203~353 | CE05-6A24-10SD-B | MSA-22-24 (Straight) MAA-22-24 (Angle) | FCV22 (Min. inside dia.: 20.8) |
| For power supply | HA-FF053C-UE~63C-UE | CE05-6A14S-2SD-B | MSA-28-24 (Straight) MAA-28-24 (Angle) | FCV28 (Min. inside dia.: 26.4) |
| | | | MSA-12-14 (Straight) MAA-12-14 (Angle) | FCV12 (Min. inside dia.: 12.3) |
| For brakes | HC-SF202B ~ 352B, HC-SF203B ~ 353B, HA-FF**CB-UE | MS3106A10SL-4S (D190) | MSA-10-10 (Straight) MAA-10-10 (Angle) | FCV10 (Min. inside dia.: 10.0) |
| For detectors | HC-SF HC-RF HA-FF**CB-UE | MS3106A20-29S (D190) | MSA-16-20 (Straight) MAA-16-20 (Angle) | FCV16 (Min. inside dia.: 15.8) |
| | | | MSA-22-20 (Straight) MAA-22-20 (Angle) | FCV22 (Min. inside dia.: 20.8) |

(Note) None of the parts in this table can be ordered from Mitsubishi Electric Corp.

Chapter 4 Options and Peripheral Devices

4-4-4 Cable wire and assembly

(1) Cable wire

The following shows the specifications and processing of the wire used in each cable. Manufacture the cable using the recommended wire or equivalent parts.

| Recommended wire type (Cannot be directly ordered from Mitsubishi Electric Corp.) | Finished outside diameter | Sheath material | No. of pairs | Wire characteristics | | | | Application |
|--|---------------------------|-----------------|--------------|-----------------------|----------------------|-------------------|-----------------------|---------------------------------------|
| | | | | Configuration | Conductor resistance | Withstand voltage | Insulation resistance | |
| UL20276 AWG28 7pair | 5.6mm | PVC | 7 | 7 strands/ 0.13mm | 222Ω/km or less | AC350/ 1min | 1MΩ/km or more | Personal computer communication cable |
| UL20276 AWG28 10pair | 6.1mm | PVC | 10 | 7 strands/ 0.13mm | 222Ω/km or less | AC350/ 1min | 1MΩ/km or more | NC unit bus cable |
| A14B2343 (Note) | 7.2mm | PVC | 6 | 14 strands/ 0.08mm | 105Ω/km or less | AC500/ 1min | 1500MΩ/km or more | Detector cable |

(Note) Junko Co. (Dealer: Toa Denki)

(2) Cable assembly

Assemble the cable as shown in the following drawing, with the cable shield wire securely connected to the ground plate of the connector.

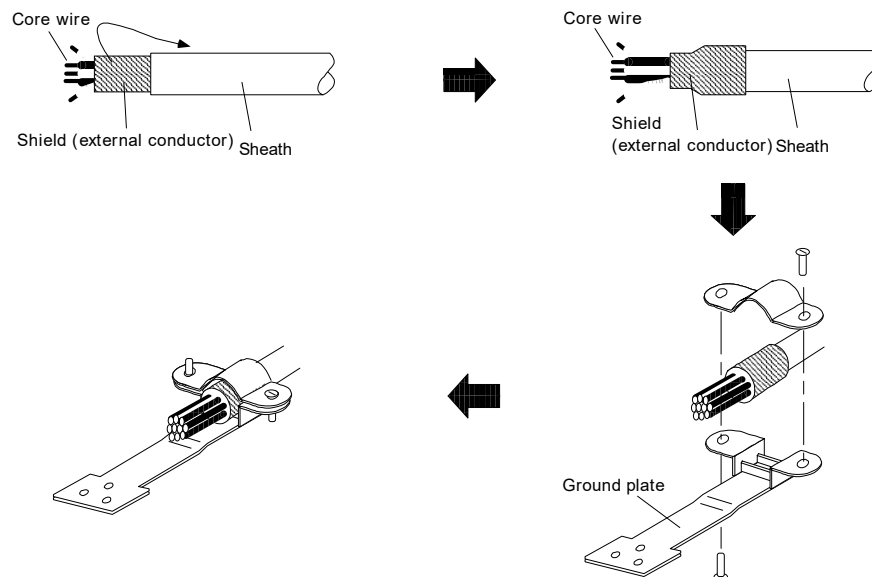

(3) Cable protection tube (noise countermeasure)

If influence from noise is unavoidable, or further noise resistance is required, selecting a flexible tube and running the signal cable through this tube is effective. This is also an effective countermeasure for preventing the cable sheath from being cut or becoming worn.

A cable clamp (MS3057) is not installed on the detector side, so be particularly careful of broken wires in applications involving bending and vibration.

| Supplier | Tube | Connector | | |
|--------------|-----------------------------------|--|---|---------------------|
| | | Amplifier side | Installation screws | Motor detector side |
| Japan Flex | FBA-4 (FePb wire braid sheath) | RBC-104 (straight) RBC-204 (45°) RBC-304 (90°) | G16 G16 G16 | RCC-104-CA2022 |
| Daiwa | Hi-flex PT #17 (FePb sheath) | PSG-104 (straight) PLG-17 (90°) PS-17 (straight) | Screw diameter ø26.4 Screw diameter ø26.4 PF1/2 | PDC20-17 |
| Sankei Works | Purika Tube PA-2 (FePb sheath) | BC-17 (straight) | Wire conduit tube screws : 15 | PDC20-17 |

(Note) None of the parts in this table can be ordered from Mitsubishi Electric Corp.

Chapter 4 Options and Peripheral Devices

4-4-5 Option cable connection diagram



CAUTION

Do not mistake the connection when manufacturing the detector cable. Failure to observe this could lead to faults, runaway or fires.

(1) NC unit bus cable

< SH21 cable connection diagram >

This is an actual connection diagram for the SH21 cable supplied by Mitsubishi.
Manufacture the cable as shown below. The cable can be up to 30m long.
Refer to section "4-4-4 Cable wire and assembly" for details on wire.

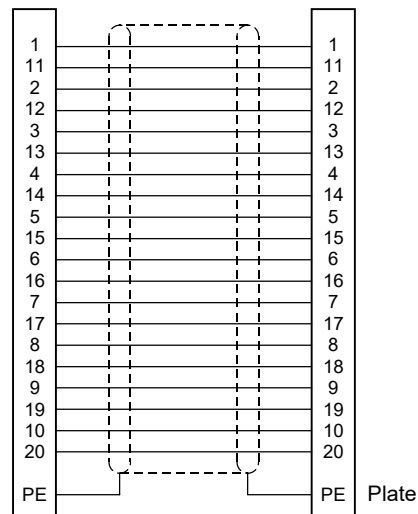

Chapter 4 Options and Peripheral Devices

(2) Detector cable for HC-SF, HC-RF and HA-FF C-UE motors

< MR-JHSCBL• M-H cable connection diagram >

This is an actual connection diagram for the MR-JHSCBL• M-H cable supplied by Mitsubishi. The connection differs according to the cable length.

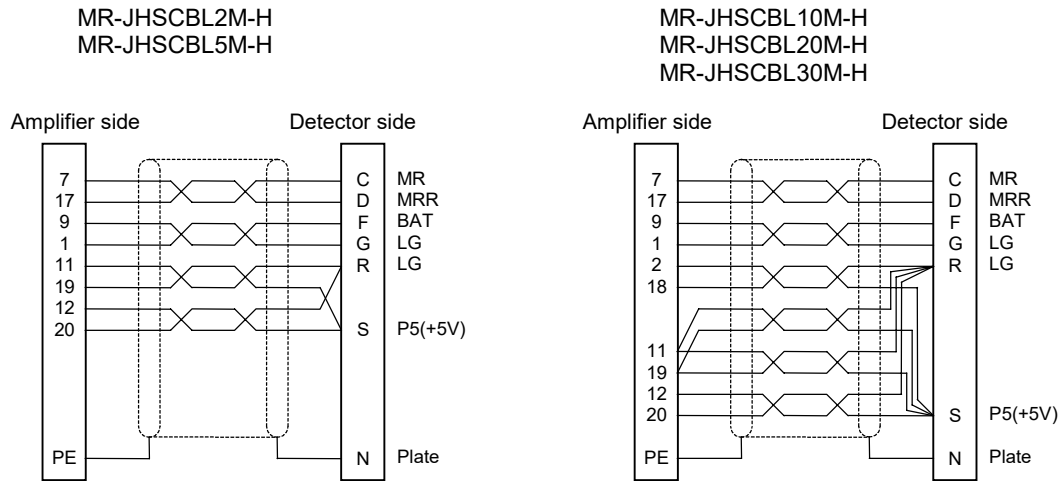

< Connection diagram for cable manufacturing >

Manufacture the cable as shown below. The cable can be up to 50m long.

Refer to section "4-4-4 Cable wire and assembly" for details on wire.

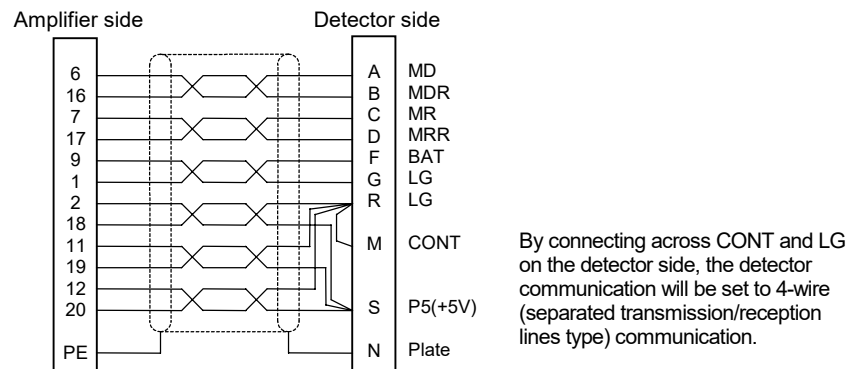

| No. | Abbreviation | Parameter name | Explanation | | | | | | | | | | | | | | | | | | | | | | | | | | | | | | | | | | | | | | | | | |
|---------------|-------------------------------|-------------------------------|---|-----|---|---|---|---|---|---|---|---|---|---|---|---|---|---|---|---|---------------|---|---|---|---|---|---|---|---|---|---|---|---|---|---|---|---|---|-----|-------------------------|-------------------------|---|-------------------------------|-------------------------------|
| #102 | *Cont2 | Control parameter 2 | <p>Set the following parameters for the 4-wire detector communication.</p> <table border="1" style="width: 100%; text-align: center;"> <tr> <th>Bit</th> <th>F</th> <th>E</th> <th>D</th> <th>C</th> <th>B</th> <th>A</th> <th>9</th> <th>8</th> <th>7</th> <th>6</th> <th>5</th> <th>4</th> <th>3</th> <th>2</th> <th>1</th> <th>0</th> </tr> <tr> <th>Default value</th> <td>0</td> <td>0</td> <td>0</td> <td>0</td> <td>0</td> <td>0</td> <td>0</td> <td>0</td> <td>0</td> <td>1</td> <td>0</td> <td>0</td> <td>0</td> <td>0</td> <td>1</td> <td>1</td> <td>0</td> </tr> </table> <table border="1" style="width: 100%; text-align: center;"> <tr> <th>bit</th> <th>Meaning when set to "0"</th> <th>Meaning when set to "1"</th> </tr> <tr> <td>6</td> <td>2-wire detector communication</td> <td>4-wire detector communication</td> </tr> </table> | Bit | F | E | D | C | B | A | 9 | 8 | 7 | 6 | 5 | 4 | 3 | 2 | 1 | 0 | Default value | 0 | 0 | 0 | 0 | 0 | 0 | 0 | 0 | 0 | 1 | 0 | 0 | 0 | 0 | 1 | 1 | 0 | bit | Meaning when set to "0" | Meaning when set to "1" | 6 | 2-wire detector communication | 4-wire detector communication |
| Bit | F | E | D | C | B | A | 9 | 8 | 7 | 6 | 5 | 4 | 3 | 2 | 1 | 0 | | | | | | | | | | | | | | | | | | | | | | | | | | | | |
| Default value | 0 | 0 | 0 | 0 | 0 | 0 | 0 | 0 | 0 | 1 | 0 | 0 | 0 | 0 | 1 | 1 | 0 | | | | | | | | | | | | | | | | | | | | | | | | | | | |
| bit | Meaning when set to "0" | Meaning when set to "1" | | | | | | | | | | | | | | | | | | | | | | | | | | | | | | | | | | | | | | | | | | |
| 6 | 2-wire detector communication | 4-wire detector communication | | | | | | | | | | | | | | | | | | | | | | | | | | | | | | | | | | | | | | | | | | |

⚠ CAUTION

- The cable manufacturing connection diagram shows the connection for a 4-wire detector communication (separated transmission/reception lines type). This motor's detector communication is normally 2-wire communication (common transmission/reception lines type). However, 4-wire type communication is more effective against noise than the 2-wire type.
- To use 4-wire communication, the parameters must be set in addition to the settings made with the cable.
Set #102 *Cont2.bit6 to 1.
- Do not connect the pins that have no particular description. (Leave these OPEN.)
- Consult with Mitsubishi when manufacturing a cable longer than 50m.

Chapter 4 Options and Peripheral Devices

(3) Detector cable for HC-MF, HA-FF motors

< MR-JCCBL• M-H cable connection diagram >

This is an actual connection diagram for the MR-JCCBL• M-H cable supplied by Mitsubishi. The connection differs according to the cable length.

MR-JCCBL2M-H
MR-JCCBL5M-H

MR-JCCBL10M-H
MR-JCCBL20M-H
MR-JCCBL30M-H

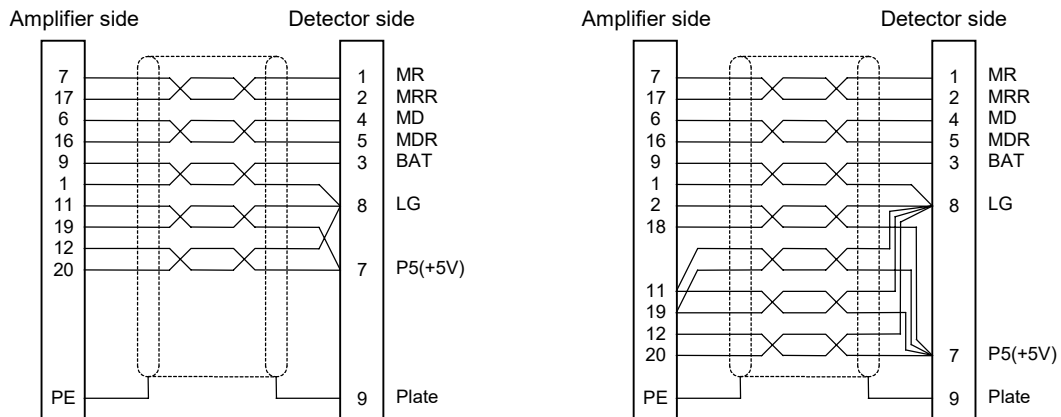

< Connection diagram for cable manufacturing >

Manufacture the detector cable as shown below. The cable can be up to 50m long. Refer to section "4-4-4 Cable wire and assembly" for details on wire.

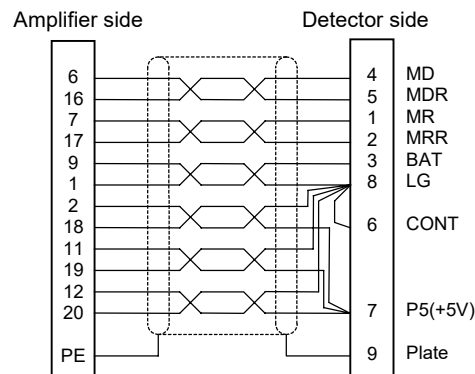

By connecting across CONT and LG on the detector side, the detector communication will be set to 4-wire (separated transmission/reception lines type) communication.



POINT

The MR-JCCBL• M-H cable is a general-purpose cable that can be used with other detectors. If the MR-JCCBL• M-H cable is used with the HA-FF or HC-MF types, the communication will be 2-wire detector communication (common transmission/reception lines type), and the MD and MDR signals will not be used.



CAUTION

1. The cable manufacturing connection diagram shows the connection for a 4-wire detector communication (separated transmission/reception lines type). This motor's detector communication is normally 2-wire communication (common transmission/reception lines type). However, 4-wire type communication is more effective against noise than the 2-wire type.
2. To use 4-wire communication, the parameters must be set in addition to the settings made with the cable.
Set #102 *Cont2.bit6 to 1.
3. Do not connect the pins that have no particular description. (Leave these OPEN.)
4. Consult with Mitsubishi when manufacturing a cable longer than 50m.

Chapter 4 Options and Peripheral Devices

< Personal computer communication cable connection diagram >

This is the actual connection diagram for the personal computer communication cables supplied by Mitsubishi.

MR-CPC98CBL3M
(For PC98)

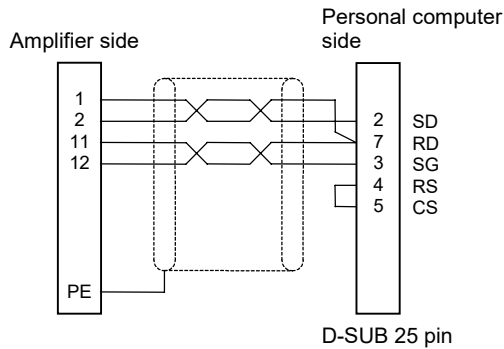

MR-CPCATCBL3M
(For DOS/V)

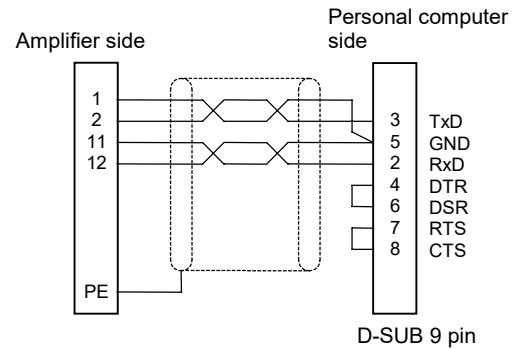

< Connection diagram for cable manufacturing >

Follow the connection diagrams above when manufacturing cables. Refer to section "4-4-4 Cable wire and assembly" for details on wire types.

CAUTION

1. The PC98 notebook also has half-pitch, 14-pin type connectors. Check the shape of the RS-232-C connector on the personal computer being used.
2. The wiring distances will differ according to the working environment, but can be up to 15m in an office, etc., where there is little noise present.

Chapter 4 Options and Peripheral Devices

4-5 Setup software

The setup software is used to set and change the parameters, check the operation state and carry out test operation from the personal computer using the servo amplifier's communication function.

4-5-1 Setup software specifications

| Item | Details (Note 1) |
|----------------------|---|
| Type | Japanese: FWS-B02B012 English : FWS-B05B013 |
| Communication signal | RS-232-C compliance |
| Transmission speed | 9600bps |
| Monitor | Batch display, high-speed display, graphic display |
| Alarm | Alarm display, alarm history |
| Diagnosis | Input/output signal display, power ON cumulative display, automatic tuning status display, absolute position monitor |
| Parameter | Data setting list display, change list display, detailed information display |
| Test operation | Automatic operation, manual operation, jog operation, reference point return, absolute position reference point setting |
| File operation | Data write, save, print |

(Note 1) This software may not run correctly depending on the personal computer being used.

4-5-2 System configuration

The following items are required to use this software.

| Model | Details |
|---------------------|--|
| Personal computer | Provided with 80386 or more CPU, Windows 3.1 compatible (80486 or more is recommended) (Note 1) RAM: 8MB or more, Hard disk: 1MB or more, Serial port used |
| OS | Windows 3.1 (Note 2) |
| Display | 640 × 400 or more color, or 16 tone monochrome, Windows 3.1 compatible |
| Keyboard | Compatible with personal computer |
| Mouse | Windows 3.1 compatible. Note that a serial mouse cannot be used. |
| Printer | Windows 3.1 compatible |
| Communication cable | MR-CPC98CBL3M, MR-CPCATCBL3M When not using these cables, refer to section 4-4-5 (4), and manufacture a cable. |

(Note 1) Windows is a registered trademark of Microsoft Corporation.

(Note 2) Windows 95 can be run. Note that this is a 16-bit application, so there may be some Windows 95 functions that do not work.

Chapter 4 Options and Peripheral Devices

4-6 Selection of wire

Select the wire size for each servo amplifier capacity as shown below.

| Amplifier type | Wire size (Note 1) | | | | | Crimp terminal (Note 2) | |
|----------------|--------------------------|---------------------|---------------------|------------------|---------------------|-------------------------|-------|
| | L1, L2, L3 ⊕ (Note 3) | L11, L21 | U, V, W (Note 4) | P, C (Note 5) | Magnetic brakes | Type | Tool |
| MR-J2-10CT | IV1.25SQ (AWG16) | IV1.25SQ (AWG16) | IV1.25SQ (AWG16) | IV2SQ (AWG14) | IV1.25SQ (AWG16) | 32959 | 47387 |
| MR-J2-20CT | | | IV1.25SQ (AWG16) | | | | |
| MR-J2-40CT | | | IV1.25SQ (AWG16) | | | | |
| MR-J2-60CT | IV2SQ (AWG14) | | IV2SQ (AWG14) | | | | |
| MR-J2-70CT | | | IV2SQ (AWG14) | | | | |
| MR-J2-100CT | | | IV2SQ (AWG14) | | | | |
| MR-J2-200CT | 3.5 (AWG12) | | 3.5 (AWG12) | | | | |
| MR-J2-350CT | 5.5 (AWG10) | 5.5 (AWG10) | 32968 | 59239 | | | |

(Note 1) As a standard, the wire is a 600V vinyl wire (the conductor must be copper).

(Note 2) This indicates the UL/c-UL Standard compliant wire. (AMP). Refer to section 2-2-3 for the L11, L21, P and C below 100CT.

(Note 3) This value is for the single amplifier. Refer to the following table when wiring across several amplifiers.

(Note 4) The wires (U, V, W) in the table are for when the distance between the servomotor and servo amplifier is 30m or less.

(Note 5) Twist and wire the connecting wire for the regenerative option (P, C).

When wiring L1, L2, L3 and the ground wire across several servo amplifiers, use the following table and select the wire size from the total capacity of the motors connected downward.

| Total motor capacity | 1kW or less | 2.5kW or less | 6kW or less | 9kW or less | 12kW or less |
|------------------------------|---------------------|------------------|--------------------|--------------------|-----------------|
| Wire size (mm ²) | IV1.25SQ (AWG16) | IV2SQ (AWG14) | IV3.5SQ (AWG12) | IV5.5SQ (AWG10) | IV8SQ (AWG8) |

(Note) Select IV3.5SQ if the SVJ2-20 is included, even when the total amplifier capacity is 2.5kW or less.

Chapter 4 Options and Peripheral Devices

4-7 Selection of no-fuse breakers

Use the following table to obtain the NFB (no-fuse breaker) rated current from the total rated capacity (J2-CT total output capacity) of the motor driving the MR-J2-CT to be connected to the NFB to be selected, and select the no-fuse breaker.

When the MDS-B-SVJ2 Series servo amplifier is being used, select the no-fuse breaker in the same manner from the total rated output (J2-CT+SVJ2 total output capacity) of the motor including the J2-CT and SVJ2.

When the MDS-B-SPJ2 spindle amplifier or converter unit will share no-fuse breakers, select from the total NFB rated current of each SVJ2 total output capacity and SPJ2 spindle amplifier or converter unit. However, separate the MR-J2-CT servo amplifier no-fuse breaker from the others, and select the NF60 type (60A) or smaller capacity dedicated for MR-J2-CT servo amplifiers if the total NFB rated current exceeds 60A.

NFB rated current table

| J2-CT (+SVJ2) total rated capacity | 1.5kW or less | 3.5kW or less | 7kW or less | 10kW or less | 13kW or less | 16kW or less |
|------------------------------------|---------------|---------------|-------------|--------------|--------------|--------------|
| NFB rated current | 10A | 20A | 30A | 40A | 50A | 60A |

| | | | | | |
|-------------------|---|---|------------------------------|------------------------------|-------------------------------|
| MDS-B-SPJ2 | MDS-B-SPJ2-02 MDS-B-SPJ2-04 MDS-B-SPJ2-075 MDS-B-SPJ2-15 | MDS-B-SPJ2-22 MDS-B-SPJ2-37 | MDS-B-SPJ2-55 | MDS-B-SPJ2-75 | MDS-B-SPJ2-110 |
| Converter unit | MDS-A-CR-10 MDS-A-CR-15 | MDS-A/B-CV-37 MDS-A-CR-22 MDS-A-CR-37 | MDS-A/B-CV-55 MDS-A-CR-55 | MDS-A/B-CV-75 MDS-A-CR-75 | MDS-A-CR-90 MDS-A/B-CV-110 |
| NFB rated current | 10A | 20A | 30A | 40A | 50A |



No-fuse breaker selection table

| NFB rated current | 10A | 20A | 30A | 40A | 50A | 60A |
|--|--------------|--------------|--------------|--------------|--------------|--------------|
| Recommended NFB (Mitsubishi Electric Corp.: Option part) | NF30-CS3P10A | NF30-CS3P20A | NF30-CS3P30A | NF50-CP3P40A | NF50-CP3P50A | NF60-CP3P60A |

Separately ordered parts: These parts are not handled by either the NC Dept. or dealers.

(Example 1)

The NFB is selected when one MR-J2-60CT (HC-SF52) axis and three MDS-B-SVJ2-10 (HC102) axes are connected.

The total motor output of all J2-CT and SVJ2 axes is calculated as shown below.

$$0.5\text{kW} + 1.0\text{kW} \times 3 = 3.5\text{kW}$$

Thus, the total NFB rated current is 20A, and from that the NF30-CP3P20A NFB is selected.

(Example 2)

The NFB is selected when one MR-J2-60CT (HC-FF63) axis, one MR-J2-200CT (HC-SF202) axis, and an MDS-B-CR-90 (HC102) are connected.

The MR-J2-CT side capacity is calculated as shown below.

$$0.6\text{kW} + 2.0\text{kW} = 2.6\text{kW}$$

From that, the NFB rated current of 20A is obtained from the table.

The MDS-B-CV-90 NFB rated current of 50A is obtained from the table.

Thus, the total NFB rated current is 70A, and from that the NFB is separated from the converter unit, and the NF30-CS3P20A NFB is selected for the MR-J2-CT. (Refer to the section "MDS-A/B Series Specification Manual" to select the converter NFB.)



DANGER

Install independent no-fuse breakers and contactors as the MR-J2-CT main circuit power supply if the total current capacity exceeds 60A when the power supply is shared between the converter and a large capacity SPJ2 spindle amplifier.

No-fuse breakers may not operate for short-circuits in small capacity amplifiers if they are shared with a large capacity unit, and this could cause fires. For the MR-J2-CT, use an NF60 type or lower capacity breaker.

Chapter 4 Options and Peripheral Devices

4-8 Selection of contactor

Select the contactor based on section "4-8-1 Selection from rush current" when the system connected to the contactor to be selected is an MR-J2-CT or MDS-B-SVJ2 and 3.7kW or less MDS-B-SPJ2 spindle amplifier.

When a converter unit or 5.5kW or more MDS-B-SPJ2 spindle amplifier is included, calculate both the capacities in sections "4-8-1 Selection from rush current" and "4-8-2 Selection from input current", and select the larger of the two capacities.



POINT

The contactors can be directly driven from the SVJ2 contactor control output (24VDC) if a DC/AC interface unit is added.

4-8-1 Selection from rush current

Use the following table to select the contactors so the total rush current for each unit does not exceed the closed circuit current amount.

Rush current table

| | | | | |
|-----------------------|--|--------------------------|---|--|
| MR-J2-CT | MR-J2-10CT MR-J2-20CT | MR-J2-40CT MR-J2-60CT | MR-J2-70CT MR-J2-100CT | MR-J2-200CT MR-J2-350CT |
| Rush current | 45A | 50A | 70A | 100A |
| MDS-B-SVJ2 | MDS-B-SVJ2-01 MDS-B-SVJ2-03 MDS-B-SVJ2-04 | MDS-B-SPJ2-06 | MDS-B-SVJ2-07 | MDS-B-SVJ2-10 MDS-B-SVJ2-20 |
| Rush current | 45A | 50A | 70A | 100A |
| MDS-B-SPJ2 | MDS-B-SPJ2-02 MDS-B-SPJ2-04 | MDS-B-SPJ2-075 | MDS-B-SPJ2-15 MDS-B-SPJ2-22 MDS-B-SPJ2-37 | MDS-B-SPJ2-55 MDS-B-SPJ2-75 MDS-B-SPJ2-110 |
| Rush current | 45A | 50A | 100A | 15A |
| Converter unit | MDS-A-CR-10 ~ MDS-A-CR-90 MDS-A/B-CV-37 ~ MDS-A/B-CV-75 | | MDS-A/B-CV-110 | |
| Rush current | 15A | | 40A | |



Contactor selection table 1

| | | | | | | | | |
|---|-----------------|-----------------|-----------------|-----------------|-----------------|-----------------|-----------------|-----------------|
| Contactor closed current capacity (Total rush current) | 110A | 200A | 220A | 300A | 400A | 550A | 650A | 850A |
| Recommended contactor (Mitsubishi Electric Corp.: Option part) | S-N10 AC200V | S-N18 AC200V | S-N20 AC200V | S-N25 AC200V | S-N35 AC200V | S-K50 AC200V | S-K65 AC200V | S-K80 AC200V |

Separately ordered parts: These parts are not handled by either the NC Dept. or dealers.



POINT

The rush current of the MDS-B-SPJ2 spindle amplifier decreases at capacities of 5.5kW or more.

(Example 1)

The contactor is selected for the MDS-B-SVJ2-10 (HC102) with 3 axes and one MR-J2-350CT (HC-SF352) axis connected.

< Selection only from rush current >

$$(350CT \times 1 \text{ axis rush current}) + (SVJ2-10 \times 3 \text{ axes rush current})$$

$$= 1 \times 100A + 3 \times 100A = 400A$$

Therefore, S-N35 200VAC is selected.

Chapter 4 Options and Peripheral Devices

4-8-2 Selection from input current

Use the following table to select the contactors so the total input current for each unit does not exceed the rated continuity current.

Input current table

| J2-CT (+SVJ2) total output capacity | 1.5kW or less | 3.5kW or less | 7kW or less | 10kW or less | 13kW or less | 16kW or less |
|--|---------------|---------------|-------------|--------------|--------------|--------------|
| Input current | 10A | 20A | 30A | 40A | 50A | 60A |

| MDS-B-SPJ2 | MDS-B-SPJ2-02 MDS-B-SPJ2-04 MDS-B-SPJ2-075 MDS-B-SPJ2-15 | MDS-B-SPJ2-22 MDS-B-SPJ2-37 | MDS-B-SPJ2-55 | MDS-B-SPJ2-75 | MDS-B-SPJ2-110 |
|---------------|---|--------------------------------|---------------|---------------|----------------|
| Input current | 10A | 20A | 30A | 40A | 50A |

| Converter unit | MDS-A-CR-10 MDS-A-CR-15 | MDS-A/B-CV-37 MDS-A-CR-22 MDS-A-CR-37 | MDS-A/B-CV-55 MDS-A-CR-55 | MDS-A/B-CV-75 MDS-A-CR-75 | MDS-A-CR-90 MDS-A/B-CV-110 |
|----------------|----------------------------|---|------------------------------|------------------------------|-------------------------------|
| Input current | 10A | 20A | 30A | 40A | 50A |



Contactor selection table 2

| Contactor rated continuity current (Total input current) | 20A | 32A | 50A | 60A |
|--|-----------------|-----------------|-----------------|-----------------|
| Recommended contactor (Mitsubishi Electric Corp.: Option part) | S-N10 AC200V | S-N20 AC200V | S-N25 AC200V | S-N35 AC200V |

Separately ordered parts: These parts are not handled by either the NC Dept. or dealers.

(Example 2)

The contactor is selected for the MR-J2-70CT (HC-MF73) with 4 axes and an MDS-B-CV-75 connected.

< Selection from rush current >

$$(70CT \times 3 \text{ axes rush current}) + (\text{MDS-B-CV-75 rush current}) = 3 \times 75A + 15A = 225A$$

Therefore, S-N25 200VAC.

< Selection from input current >

$$(70CT \times 3 \text{ axes input current}) + (\text{MDS-B-CV-75 input current}) = 20A + 40A = 60A$$

Therefore, S-N35 200VAC.

From these, the S-N35 200VAC is selected as having the larger of the two capacities.

Chapter 4 Options and Peripheral Devices

4-9 Control circuit related

4-9-1 Circuit protector

When installing a circuit protector dedicated for the control power input, use a circuit protector with inertial delay to prevent malfunctioning in respect to the rush current generated when the power is turned ON. The size and conductivity time of the rush current fluctuate according to the power supply impedance and potential.

| Servo amplifier | Rush current | Conductivity time | Recommended circuit protector (Mitsubishi Electric Corp.: Option part) | CP30-BA type with medium-speed inertial delay |
|---------------------|--------------|-------------------|--|---|
| MR-J2-10CT ~ 100CT | 70 ~ 100A | 0.5 ~ 1msec | Rated current of circuit protector | 1.0A per axis |
| MR-J2-200CT ~ 350CT | 100 ~ 130A | 0.5 ~ 1msec | | |

Separately ordered parts: These parts are not handled by either the NC Dept. or dealers.

4-9-2 Relays

Use the following relays for the input/output interface (motor brake output: MBR, contactor output: MC, near point dog : DOG external emergency stop : EMGX.)

| Interface name | Selection example |
|--------------------------------------|---|
| For digital input signal (DOG, EMGX) | Use a minute signal relay (twin contact) to prevent a contact defect. <Example> OMRON: G2A type, MY type |
| For digital output signal (MBR, MC) | Use a compact relay with 24VDC, 40mA or less. <Example> OMRON: MY type |

4-9-3 Surge absorber

A surge absorber is required when using magnetic brakes. Use a surge absorber with the following specifications or an equivalent part.

When using the surge absorber, carry out insulation treatment with a vinyl tube, etc., as shown in the outline dimension drawing.

| Max. rating | | | | | Max. limit voltage | | Static electricity capacity (reference value) | Varistor voltage rating (range) |
|---------------------------|-------|------------------------|-------------------------|-------------|--------------------|-----|---|---------------------------------|
| Tolerable circuit voltage | | Surge with-stand level | Energy with-stand level | Rated power | | | | |
| AC(V) | DC(V) | (A) | (J) | (W) | (A) | (V) | (pF) | (V) |
| 140 | 180 | 500/time | 5 | 0.4 | 25 | 360 | 300 | 220 (198 ~ 242) |

<Example> (These parts cannot be directly ordered from Mitsubishi Electric Corp.)

- ERZV10DK221 (Matsushita Denki)
- TNR-12G221K (Malcon Denshi)

<Outline dimension drawing>

ERZ-C10DK221

[Unit: mm]

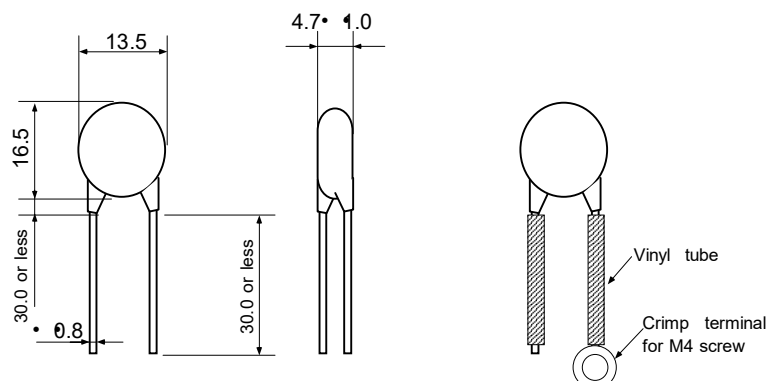

Chapter 5 Operation Control Signal

| | |
|---|-------------|
| 5-1 System configuration | 5-2 |
| 5-1-1 Built-in indexing function..... | 5-2 |
| 5-1-2 Parameters..... | 5-3 |
| 5-2 R register | 5-4 |
| 5-3 Explanation of operation commands (NC • •servo amplifier)..... | 5-5 |
| 5-4 Explanation of operation status signals (servo amplifier • •NC)..... | 5-11 |

Chapter 5 Operation control signal

5-1 System configuration

5-1-1 Built-in indexing function

Conventional NC servo amplifiers received acceleration/deceleration commands to the target position from the NC and controlled the motor. With the MR-J2-CT, the acceleration/deceleration commands that were until now received from the NC are created in the amplifier, and the motor is controlled. The operation commands for the MR-J2-CT are all carried out from the user PLC via the R-register. The response signals from the MR-J2-CT indicating the operation status are also returned to the user PLC R-register. These signals are automatically communicated with the MR-J2-CT by the NC via high-speed serial communication.

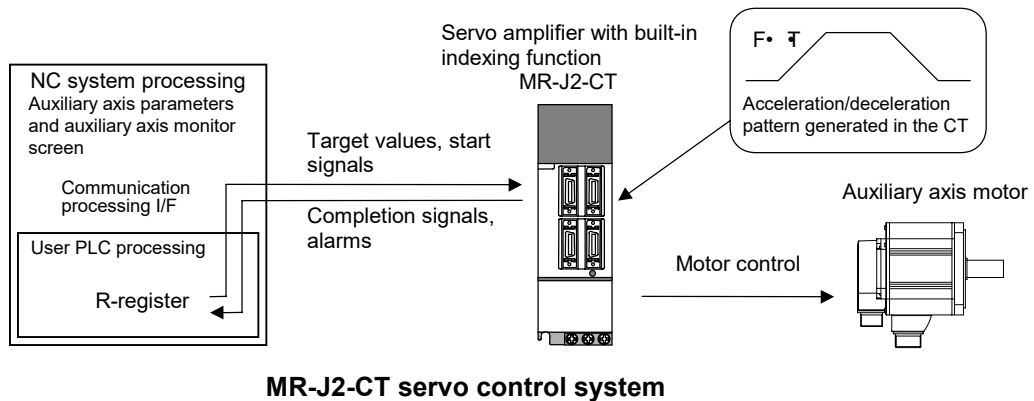
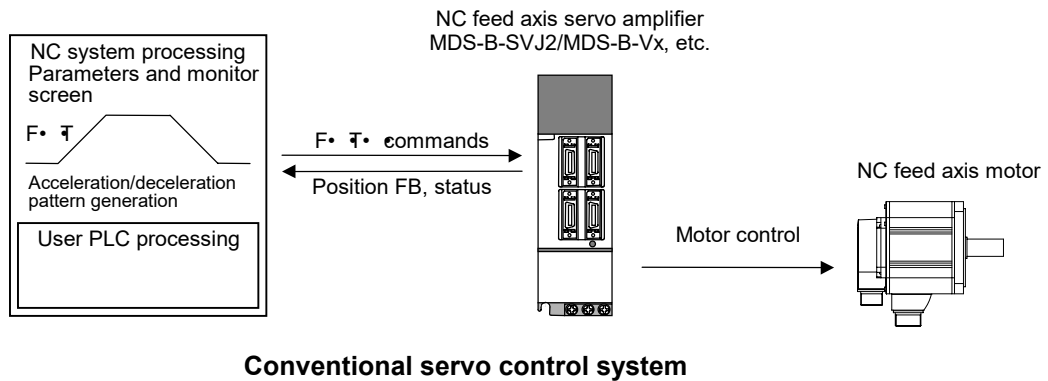

POINT

1. The MR-J2-CT carries out position control as a single amplifier unit; it is a positioning-dedicated servo amplifier. Use a conventional servo amplifier (MDS-B-SVJ2, MDS-B-Vx Series) when interpolation control is required.
2. The connections between the NC and MR-J2-CT, monitor screens, parameter input methods, etc., differ according to the NC, so refer to the appropriate instruction manual for the NC being used.

Chapter 5 Operation control signal

5-1-2 Parameters

All parameters, including absolute position data, are saved in the MR-J2-CT. Using separately sold setup software, it is possible to rewrite the parameters and set the reference point from the personal computer using RS-232-C serial communication, and adjustment, test operation, etc., of individual auxiliary axes is supported. Note that because the parameters and absolute position data are saved in the amplifier, this data must be written to the new amplifier when the amplifier is replaced.

When replacing the amplifier, first upload the parameters from the old amplifier and store them in the memory of the NC, then download them into the new amplifier. The absolute position data is constantly backed up in the NC, so download that data into the new amplifier. This function is mounted on all NC's supporting MR-J2-CT amplifiers. Refer to the appropriate instruction manual of the NC being used for information on the operation method.

If the parameters cannot be uploaded from the old amplifier, download the NC backup parameters. Note that because the parameters are reset by the auto-tuning function, the control immediately after amplifier replacement may be unstable. However, if the amplifier continues to be used in that condition the auto-tuning will cause the parameters to reach a convergent value, and the characteristics will improve.

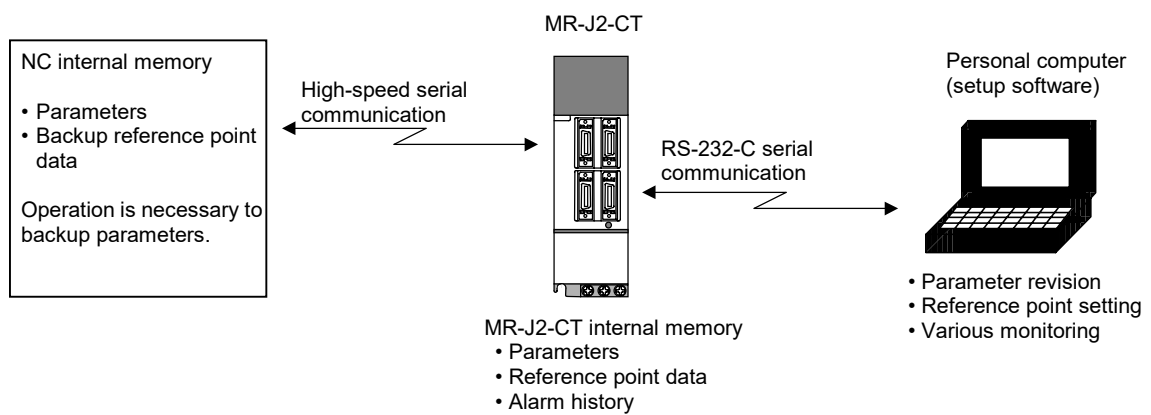

Chapter 5 Operation control signal

5-2 R register

The MR-J2-CT is controlled by the input/output from the PLC program to the R-registers in the table below. The R-register addresses differ according to the NC type and MR-J2-CT axis No. settings. (The order in the table below is an example.)

(1) List of operation commands (NC → servo amplifier)

| | bit7 | bit6 | bit5 | bit4 | bit3 | bit2 | bit1 | bit0 |
|------------|---|---------------------------------|--|---|---------------------------------------|----------------------------------|---------------------------------|------------------------------------|
| | bitF | bitE | bitD | bitC | bitB | bitA | bit9 | bit8 |
| R (aaaa+0) | H | RDF | *IT- | *IT+ | MRST | *PRT1 | QEMG | *SVF |
| | Handle feed operation mode selection | READY OFF | Interlock (-) | Interlock (+) | Master reset | Data protect | PLC emergency stop | Servo OFF |
| | S | ZST | AZS | | ZRN | J | MAN | AUT |
| | Incremental feed operation mode selection | Reference point setting | Reference point default setting mode selection | | Reference point return mode selection | JOG operation mode selection | Manual operation mode selection | Automatic operation mode selection |
| R (aaaa+1) | PR2 | PR1 | MP2 | MP1 | PUS | STS | DIR | ST |
| | Operation parameter selection 2 | Operation parameter selection 1 | Incremental feed magnification factor 2 | Incremental feed magnification factor 1 | Stopper positioning commands valid | Random point feed commands valid | Rotation direction | Operation start |
| | | | | | | | | |
| R (aaaa+2) | ST128 | ST64 | ST32 | ST16 | ST8 | ST4 | ST2 | ST1 |
| | Station selection 128 | Station selection 64 | Station selection 32 | Station selection 16 | Station selection 8 | Station selection 4 | Station selection 2 | Station selection 1 |
| | | | | | | | | ST256 Station selection 256 |
| R (aaaa+3) | OVR | OV64 | OV32 | OV16 | OV8 | OV4 | OV2 | OV1 |
| | Speed override valid | Speed override 64 | Speed override 32 | Speed override 16 | Speed override 8 | Speed override 4 | Speed override 2 | Speed override 1 |
| | | | | | | | | |
| R (aaaa+4) | Command position when random point feed commands are valid. (32bit) | | | | | | | |
| R (aaaa+5) | | | | | | | | |

(2)List of operation status signals (servo amplifier → NC)

| | bit7 | bit6 | bit5 | bit4 | bit3 | bit2 | bit1 | bit0 |
|------------|------------------------------------|---|--------------------------------|---|------------------------------|-------------------------------|--------------------------|--------------------------------|
| | bitF | bitE | bitD | bitC | bitB | bitA | bit9 | bit8 |
| R (bbbb+0) | ADJ | TLQ | MVN | MVP | AX1 | SMZ | INP | RDY |
| | Machine being adjusted | Torque limited | Axis moving (-) | Axis moving (+) | Axis selection output | Smoothing zero | In-position | Servo READY |
| | NEAR | JST | JSTA | SA | MA | HO | RST | ZP |
| | Near set position | Set position reached | Automatic set position reached | Servo READY | Controller ready | In handle feed operation mode | Resetting | Reference point reached |
| R (bbbb+1) | SO | AZSO | DOG | ZRNO | ARNN | JO | MANO | AUTO |
| | In incremental feed operation mode | In reference point default setting mode | Near-point dog | In reference point return mode | Returning to reference point | In JOG operation mode | In manual operation mode | In automatic operation mode |
| | ZSE | ZSF | ZSN | ABS | BAT | AL4 | AL2 | AL1 |
| | Default setting error finished | Default setting completed | Absolute position data loss | Absolute position power off movement exceeded | Battery voltage low | Alarm 4 | Alarm 2 | Alarm 1 |
| R (bbbb+2) | STO128 | STO64 | STO32 | STO16 | STO8 | STO4 | STO2 | STO1 |
| | Station position 128 | Station position 64 | Station position 32 | Station position 16 | Station position 8 | Station position 4 | Station position 2 | Station position 1 |
| | | | | | | | | STO256 Station position 256 |
| R (bbbb+3) | PSW8 | PSW7 | PSW6 | PSW5 | PSW4 | PSW3 | PSW2 | PSW1 |
| | Position switch 8 | Position switch 7 | Position switch 6 | Position switch 5 | Position switch 4 | Position switch 3 | Position switch 2 | Position switch 1 |
| | | | | | | PSI | PFN | PMV |
| | | | | | In stopper | Positioning completed | In positioning operation | |



1. The array of R-register addresses in the table is an example. The R-register assignments differ for each NC, so refer to the appropriate instruction manual for the NC being used.
2. Signals indicated with an asterisk (*) are handled as B contacts (Valid at OFF "0").

Chapter 5 Operation control signal

5-3 Explanation of operation commands (NC • •servo amplifier)

| Abbreviation | *SVF | Signal name | Servo OFF | R (aaaa+0).bit0 |
|--|------|-------------|-----------|-----------------|
| <p>When the servo OFF signal is set to "0" (B contact), the control axis enters the servo OFF status. No matter which operation mode the servo is in and turned OFF, the axis movement will stop, and the servo will turn OFF. The axis movement restarts when the servo is turned ON again.</p> <p>If the axis moves for any reason while the servo is OFF, it can be selected whether to compensate that movement amount when the servo turns ON the next time. Select with parameter "#102 cont2 Control parameter 2 bit1".</p> <p>(1) When carrying out movement amount compensation (# 102 bit1= 1) When the servo is OFF, the coordinates are always updated by the amount the axis has moved. When the servo is OFF, the coordinates show the machine position.</p> <p>(2) When not carrying out movement amount compensation (# 102 bit1=0) When the servo is OFF, the coordinates are not updated even when the axis moves. When the servo is OFF, the coordinates show the machine position when the servo is OFF. When the servo is turned ON, the axis is moved to the position where the servo was turned OFF. When the servo is OFF and the axis movement exceeds the excessive error width (whichever was selected among parameter #155, #163, #171, and #179), a servo alarm occurs.</p> <p>(Caution) The actual servo OFF operation is validated after the In-position (INP) is completed. When using a mechanical clamp, carry out the clamp operation after confirming the In-position status.</p> <p>< Memo > When the power is turned ON, the servo OFF signal turns OFF ("0") and the servo OFF function becomes valid. It is necessary to turn the servo OFF to ON ("1"), and release the servo OFF before operation using the NC user PLC.</p> | | | | |

| Abbreviation | QEMG | Signal name | PLC emergency stop | R (aaaa+0).bit1 |
|---|------|-------------|--------------------|-----------------|
| <p>This signal from the NC (host controller) built-in PLC causes the direct emergency stop function to work. When this signal is ON, this servo amplifier enters the emergency stop state. It is released when the signal is turned OFF.</p> <p>When the emergency stop signal output is validated, an emergency stop signal for other amplifiers is also output by this signal in an emergency stop state.</p> | | | | |

| Abbreviation | *PRT1 | Signal name | Data protect 1 | R (aaaa+0).bit2 |
|--|-------|-------------|----------------|-----------------|
| <p>This is a signal to protect the parameters stored in the MR-J2-CT.</p> <p>When this signal is OFF, parameters cannot be downloaded using the setup software. Note that this signal is invalid for the write functions from the NC, not from the setup software.</p> | | | | |

| Abbreviation | MRST | Signal name | Master reset | R (aaaa+0).bit3 |
|---|------|-------------|--------------|-----------------|
| <p>This signal resets the MR-J2-CT.</p> <p>When the master reset (MRST) signal is ON, the following reset operations are carried out.</p> <ol style="list-style-type: none"> (1) The axis movement decelerates to a stop. (2) Alarms that can be released by the reset are released. (3) A signal is output while resetting (RST). | | | | |

| Abbreviation | *IT+ | Signal name | Interlock + | R (aaaa+0).bit4 |
|--|------|-------------|-------------|-----------------|
| <p>When the control axis is moving in the + direction, this signal decelerates and stops the axis movement immediately.</p> <p>When this signal is OFF from before movement, the motion is stopped in the same manner as without starting. In any case the movement is started or restarted by turning this signal ON.</p> | | | | |

| Abbreviation | *IT- | Signal name | Interlock - | R (aaaa+0).bit5 |
|---|------|-------------|-------------|-----------------|
| <p>This is the same as above, the only difference being that the direction differs from the interlock + (IT+) signal.</p> | | | | |





Chapter 5 Operation control signal

| Abbreviation | RDF | Signal name | READY OFF | R (aaaa+0).bit6 |
|---|-----|-------------|---------------------------------------|-----------------|
| <p>This is a signal to turn OFF the READY status. When put into a READY OFF status, the power supply to the servomotor is shut off, and the contactor control output is simultaneously turned OFF. If the motor is in operation, it will stop by a dynamic brake stop or a deceleration control stop. Servo READY (SA) and servo READY (RDY) are also turned OFF, but an alarm does not occur. When this signal is turned OFF, the machine immediately returns to the original state.</p> | | | | |
| Abbreviation | H | Signal name | Handle mode selection | R (aaaa+0).bit7 |
| <p>This signal selects the handle feed mode. The axis will move for the amount determined by input pulse multiplied by feed magnification after this signal is turned ON, each signal [operation parameter selection (PR1, PR2), and incremental feed magnification (MP1, MP2)] is determined, and the handle pulse is input.</p> <p>(Caution 1) Turning this signal ON when other operation modes are ON will result in a "M01 0101 No operation mode" type operation alarm.</p> <p>(Caution 2) The handle mode acceleration/deceleration time is the acceleration/deceleration time constant 2 linear acceleration/deceleration of the selected operation parameter group.</p> | | | | |
| Abbreviation | AUT | Signal name | Automatic operation mode selection | R (aaaa+0).bit8 |
| <p>This signal selects the automatic operation mode. When the station No. is designated and the operation start (ST) is ON, the movement toward the designated station begins.</p> <p>(Caution) Turning the manual operation mode selection signal ON when other operation mode selection signals are ON will result in a "M01 0101 No operation mode" type operation alarm.</p> | | | | |
| Abbreviation | MAN | Signal name | Manual operation mode selection | R (aaaa+0).bit9 |
| <p>This signal selects the manual operation mode. When the rotation direction is designated and the operation start signal (ST) is turned ON, the axis will begin moving, and the rotation will continue in the designated direction until the operation start signal (ST) is turned OFF. When the operation start signal (ST) turns OFF, the axis will be positioned to the nearest station.</p> <p>(Caution) Turning the JOG mode selection signal ON when other operation mode selection signals are ON will result in a "No operation mode" type operation alarm.</p> | | | | |
| Abbreviation | J | Signal name | JOG mode selection | R (aaaa+0).bitA |
| <p>This signal selects the JOG mode. When the rotation direction is designated and the operation start signal (ST) is turned ON, the axis will begin moving, and the rotation will continue in the designated direction until the operation start signal (ST) is turned OFF. Unlike the manual operation mode, when the operation start signal (ST) is turned OFF, the axis immediately decelerate to a stop.</p> <p>(Caution) Turning the JOG mode selection signal ON when other operation mode selection signals are ON will result in a "No operation mode" type operation alarm.</p> | | | | |
| Abbreviation | ZRN | Signal name | Reference point return mode selection | R (aaaa+0).bitB |
| <p>This signal selects the reference point return mode. When the reference point return mode signal (ZRN) is ON, the mode is designated for reference point return. After the reference point return mode signal is turned ON, and the operation parameter group is selected, the reference point return is begun by turning the operation start signal (ST) ON. In the incremental specifications, the first reference point return after turning the power ON will be dog-type. However, after the first time, the dog-type or memory-type reference point return will be set by the parameter "#101 cont1 Control parameter bit1". When the absolute position coordinate system is established in the absolute position specifications, the reference point return will be memory-type every time.</p> | | | | |

Chapter 5 Operation control signal

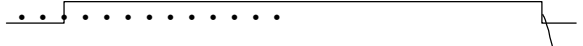
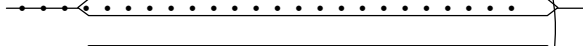
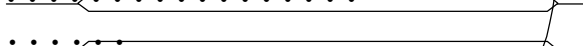
| Abbreviation | AZS | Signal name | Reference point initialization mode selection | R (aaaa+0).bitD |
|---|-----|-------------|---|-----------------|
| <p>This signal selects the mode that initializes the reference point for the absolute position detection system. When this signal is turned ON, the reference point initialization mode is held until the NC power is turned OFF. (Cannot be canceled)</p> <p>When the stopper method is selected, the operation parameter group 4 torque limit value and the excessive error detection width are automatically selected.</p> | | | | |

| Abbreviation | ZST | Signal name | Reference point set | R (aaaa+0).bitE |
|--|-----|-------------|---------------------|-----------------|
| <p>This signal turns ON when designating the reference point position with the reference point initialization for the absolute position detection system. When this signal is turned ON by the initialization mode of the reference point system, that position is set as the absolute position reference point.</p> | | | | |

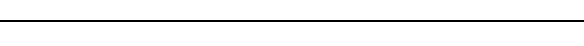
| Abbreviation | S | Signal name | Incremental feed mode selection | R (aaaa+0).bitF |
|--|---|--|---------------------------------|-----------------|
| <p>This signal selects the incremental feed mode. The axis movement will begin after this signal is turned ON, each signal [operation parameter selection (PR1, PR2), incremental feed magnification (MP1, MP2), and rotation direction (DIR)] is determined, and the operation start signal (ST) is turned ON.</p> <p>(Caution 1) Turning this signal ON when other operation modes are ON will result in a "No operation mode" type operation alarm.</p> <p>(Caution 2) In the incremental mode, the axis will inch, even if the start signal ST is OFF.</p> | | | | |
| Incremental mode selection (s) | |  | | |
| Incremental feed magnification selection (MP1, MP2) | |  | | |
| Operation parameter selection (PR1, PR2) | |  | | |
| Rotation direction selection (DIR) | |  | | |
| Reset (RST) | |  | | |
| Start signal (ST) | |  | | |
| Axis movement | |  | | |

Chapter 5 Operation control signal

| Abbreviation | ST | Signal name | Operation start | R (aaaa+1).bit0 |
|--------------|----|-------------|-----------------|-----------------|
|--------------|----|-------------|-----------------|-----------------|

This signal starts the operation in each operation mode. When this signal is turned ON, the operation will start. The operation start signal (hereafter "start signal") is handled as a status, so the ON status must be maintained until the operation is finished.

[Operation movement in each operation mode]

(1) Automatic operation mode

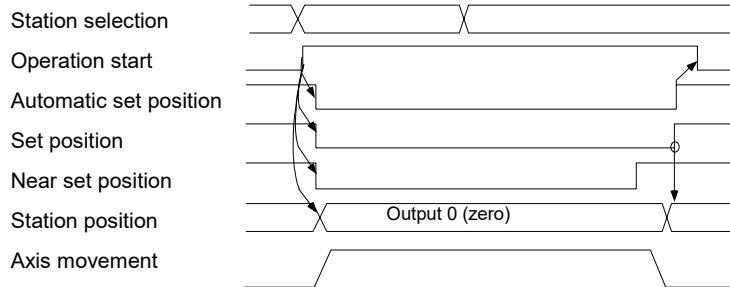

The station selection signal (ST1 to ST256) and operation parameter selection (PR1, PR2) are established before inputting the operation start signal. These signals are read in by the startup of the start signal, so they are held even if they are changed after the startup.

When the start signal is input, the output signals related to the set position all turn OFF. The station position output will be output as 0. Because the automatic set position (JSTA) and set position (JST) is output when the positioning is completed, the operation start signal turns OFF. Even when the start signal turns OFF, the output signal related to the set position is held as it is.

When the start signal ST is turned OFF during axis movement, the axis will stop at the nearest station. Note that for a linear axis, if there is not a nearest point in the movement direction, the commanded station becomes the nearest point.

< Memo > When the shortcut function is OFF for the rotating axis, the positioning direction can be designated with the rotation direction (DIR).

(2) Manual operation mode

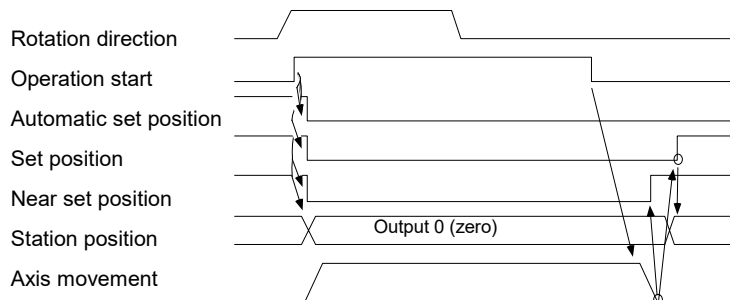

The rotation direction (DIR) and operation parameter selection (PR1, PR2) are established before inputting the operation start signal. These signals are read in by the startup of the start signal, so they are held even if they are changed after the startup.

When the start signal is input, the output signals related to the set position all turn OFF. The station position output will be output as 0.

While the start signal is ON, the rotation direction continues in the designated direction. When the start signal is turned OFF, positioning is carried out to the nearest station that can be stopped at in the rotation direction. Note that for a linear axis, if there is no nearest point in the movement direction, the axis will immediately decelerate to a stop.

When positioning is completed, a set position (JST) is output.

< Memo > The automatic set position (JSTA) will not be output.

Chapter 5 Operation control signal

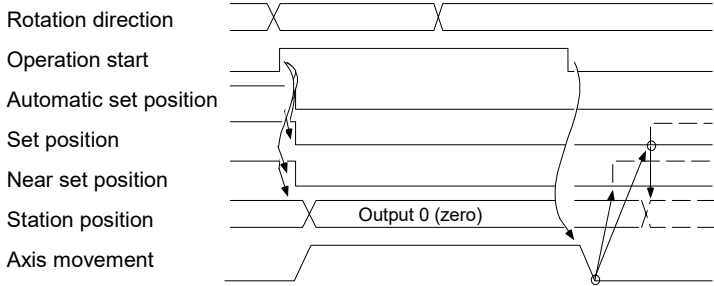
| Abbreviation | ST | Signal name | Operation start | R (aaaa+1).bit0 |
|---|----|-------------|-----------------|-----------------|
| (3) JOG operation mode | | | | |
|  | | | | |
| <p>The rotation direction (DIR) and operation parameter selection (PR1, PR2) are established before inputting the operation start signal. These signals are read in by the startup of the start signal, so they are held even if they are changed after the startup.</p> <p>When the start signal is input, the output signals related to the set position all turn OFF. The station position output will be output as 0.</p> <p>While the start signal is ON, the rotation direction continues in the designated direction. When the start signal is turned OFF, the axis decelerates to a stop.</p> <p>The set position (JST) and near set position (NEAR) are output if the axis is stopped within each tolerable width from the station position.</p> | | | | |

| Abbreviation | DIR | Signal name | Rotation direction designation | R (aaaa+1).bit1 | | | | | | | | | |
|--|-------------------------|-------------------------------------|--------------------------------|-----------------|------------|-------------------------|----------------------------|---|-------------|-------------------------------------|---|-------------|-------------------------------------|
| <p>This signal designates the rotation direction of the operation in each operation mode. It is input before the operation start (ST), to designate the rotation direction.</p> <p>This signal is invalid in the automatic operation mode when the shortcut control is set and selected by the parameter.</p> <p>When the shortcut control is not selected, positioning is carried out according to the direction designated by this signal.</p> <p>This signal is read in at the operation start (ST). Consequently, it is ignored after starting, even if the signal changes.</p> <p>The actual motor rotation direction is reversed by changing the setting of parameter #102.bit3.</p> | | | | | | | | | | | | | |
| <table border="1" style="width: 100%; border-collapse: collapse;"> <thead> <tr> <th style="width: 15%;">DIR signal</th> <th style="width: 25%;">Axis rotation direction</th> <th style="width: 60%;">Station movement direction</th> </tr> </thead> <tbody> <tr> <td style="text-align: center;">0</td> <td style="text-align: center;">Forward run</td> <td style="text-align: center;">Direction of increasing station No.</td> </tr> <tr> <td style="text-align: center;">1</td> <td style="text-align: center;">Reverse run</td> <td style="text-align: center;">Direction of decreasing station No.</td> </tr> </tbody> </table> | | | | | DIR signal | Axis rotation direction | Station movement direction | 0 | Forward run | Direction of increasing station No. | 1 | Reverse run | Direction of decreasing station No. |
| DIR signal | Axis rotation direction | Station movement direction | | | | | | | | | | | |
| 0 | Forward run | Direction of increasing station No. | | | | | | | | | | | |
| 1 | Reverse run | Direction of decreasing station No. | | | | | | | | | | | |

| Abbreviation | STS | Signal name | Random point feed command valid | R (aaaa+1).bit2 |
|--|-----|-------------|---------------------------------|-----------------|
| <p>This signal selects the mode that executes the positioning in 0.001° units toward the random position (coordinate) transferred from the NC. When the random point feed command valid is executed, it is necessary to turn ON the automatic operation mode selection (AUT) simultaneously.</p> | | | | |

| Abbreviation | PUS | Signal name | Pressing positioning command valid | R (aaaa+1).bit3 |
|---|-----|-------------|------------------------------------|-----------------|
| <p>This signal selects the mode that executes random point feed including pressing operation. The positioning coordinates are the random position (coordinates) transferred from the NC as with the random point feed command.</p> <p>When the random coordinate command is executed, it is necessary to simultaneously turn ON the automatic operation mode select (AUT). It is not necessary to simultaneously turn ON the random point feed command valid (STS). (An operation error will occur)</p> | | | | |

Chapter 5 Operation control signal

| Abbreviation | MP1, MP2 | Signal name | Incremental feed magnification 1 and 2 | R (aaaa+1).bit4 to 5 | | | | | | | | | | | | | | | |
|---|------------|--------------------|--|----------------------|------------|------------|-------------|---|---|--------|---|---|-------|---|---|------|---|---|----|
| <p>This signal selects the incremental feed amount, and the handle feed magnification. In the handle feed, the selection is the movement amount per handle notch.</p> <table border="1" style="width: 100%; border-collapse: collapse; margin: 10px auto;"> <thead> <tr> <th style="width: 25%;">MR2 signal</th> <th style="width: 25%;">MR1 signal</th> <th style="width: 50%;">Feed amount</th> </tr> </thead> <tbody> <tr> <td style="text-align: center;">0</td> <td style="text-align: center;">0</td> <td style="text-align: center;">0.001°</td> </tr> <tr> <td style="text-align: center;">0</td> <td style="text-align: center;">1</td> <td style="text-align: center;">0.01°</td> </tr> <tr> <td style="text-align: center;">1</td> <td style="text-align: center;">0</td> <td style="text-align: center;">0.1°</td> </tr> <tr> <td style="text-align: center;">1</td> <td style="text-align: center;">1</td> <td style="text-align: center;">1°</td> </tr> </tbody> </table> | | | | | MR2 signal | MR1 signal | Feed amount | 0 | 0 | 0.001° | 0 | 1 | 0.01° | 1 | 0 | 0.1° | 1 | 1 | 1° |
| MR2 signal | MR1 signal | Feed amount | | | | | | | | | | | | | | | | | |
| 0 | 0 | 0.001° | | | | | | | | | | | | | | | | | |
| 0 | 1 | 0.01° | | | | | | | | | | | | | | | | | |
| 1 | 0 | 0.1° | | | | | | | | | | | | | | | | | |
| 1 | 1 | 1° | | | | | | | | | | | | | | | | | |

| Abbreviation | PR1, PR2 | Signal name | Operation parameter selection 1, 2 | R (aaaa+1).bit6 to 7 | | | | | | | | | | | | | | | |
|---|------------|------------------------------------|------------------------------------|----------------------|------------|------------|------------------------------------|---|---|---|---|---|---|---|---|---|---|---|---|
| <p>This signal selects one set of parameter group to actually be used from the four sets of parameter group 4 that designate the axis feed operation. The operation group cannot be changed while the operation start (ST) signal is input (The group is held in the amplifier.)</p> <p style="text-align: center;">Operation parameters (four sets)</p> <div style="display: flex; justify-content: space-around; align-items: center;"> <div style="border: 1px solid black; padding: 5px; width: 45%;"> <p style="text-align: center; margin: 0;">Operation parameter group 1</p> <ul style="list-style-type: none"> • Automatic feedrate • Manual feedrate • Acceleration/deceleration time constant 1 • Acceleration/deceleration time constant 2 • Torque limit • Excessive error detection width • Set position detection width • Near set position detection width </div> <div style="text-align: center; width: 10%;"> <p>Selection →</p> </div> <div style="border: 1px solid black; padding: 5px; width: 45%;"> <p style="text-align: center; margin: 0;">Operation parameter</p> <ul style="list-style-type: none"> • Automatic feedrate • Manual feedrate • Acceleration/deceleration time constant 1 • Acceleration/deceleration time constant 2 • Torque limit • Excessive error detection width • Set position detection width • Near set position detection width </div> </div> <table border="1" style="width: 100%; border-collapse: collapse; margin: 10px auto;"> <thead> <tr> <th style="width: 25%;">PR2 signal</th> <th style="width: 25%;">PR1 signal</th> <th style="width: 50%;">Selected operation parameter group</th> </tr> </thead> <tbody> <tr> <td style="text-align: center;">0</td> <td style="text-align: center;">0</td> <td style="text-align: center;">1</td> </tr> <tr> <td style="text-align: center;">0</td> <td style="text-align: center;">1</td> <td style="text-align: center;">2</td> </tr> <tr> <td style="text-align: center;">1</td> <td style="text-align: center;">0</td> <td style="text-align: center;">3</td> </tr> <tr> <td style="text-align: center;">1</td> <td style="text-align: center;">1</td> <td style="text-align: center;">4</td> </tr> </tbody> </table> | | | | | PR2 signal | PR1 signal | Selected operation parameter group | 0 | 0 | 1 | 0 | 1 | 2 | 1 | 0 | 3 | 1 | 1 | 4 |
| PR2 signal | PR1 signal | Selected operation parameter group | | | | | | | | | | | | | | | | | |
| 0 | 0 | 1 | | | | | | | | | | | | | | | | | |
| 0 | 1 | 2 | | | | | | | | | | | | | | | | | |
| 1 | 0 | 3 | | | | | | | | | | | | | | | | | |
| 1 | 1 | 4 | | | | | | | | | | | | | | | | | |

| | | | | |
|---|--------------|--------------------|-------------------------|----------------------|
| Abbreviation | ST1 to ST256 | Signal name | Station selection 1~256 | R (aaaa+2).bit0 to 8 |
| <p>This signal designates the index station No. in the automatic operation mode. The index station No. is input before operation start (ST) is input in the automatic operation mode. This signal is input with as a 9-digit binary. Input 000000001 corresponds to station No. 1. This signal is read in at the startup of the operation Start (ST). Consequently, it is ignored after starting, even if the signal changes. When this signal is set to 000000000, and the automatic operation is started, a one station rotation special command will result. (Note that this cannot be used when the station positions are determined in non-uniform assignments.)</p> | | | | |

| | | | | |
|---|-------------|--------------------|------------------------|----------------------|
| Abbreviation | OV1 to OV64 | Signal name | Speed override 1 to 64 | R (aaaa+3).bit0 to 6 |
| <p>This signal designates the override value added to the selected feedrate. The override value is designated by a binary.</p> $\text{Effective feedrate} = \frac{\text{Selected speed} \times \text{speed override}}{100}$ | | | | |

| | | | | |
|--|-----|--------------------|----------------------|-----------------|
| Abbreviation | OVR | Signal name | Speed override valid | R (aaaa+3).bit7 |
| <p>This is a signal to validate the speed override. When this signal is turned OFF, the set feedrate becomes the operation speed without calculating the override.</p> | | | | |

Chapter 5 Operation control signal

5-4 Explanation of operation status signals (servo amplifier • •NC)

| Abbreviation | RDY | Signal name | Servo READY | R (bbbb+0).bit0 |
|---|-----|-------------|-------------|-----------------|
| <p>This signal indicates that the servo system is in an operable status. This signal turns ON in the following situations:</p> <ol style="list-style-type: none"> (1) When the servo system diagnosis is normally completed after turning the power ON. (2) After a servo alarm occurrence, when that alarm has been released by the reset (MRST). (3) When the emergency stop has been released. (4) When the READY OFF (RDF) and servo OFF (*SVF) has been released. <p>This signal turns OFF in the following situations:</p> <ol style="list-style-type: none"> (1) When the servo READY (SA) signal is turned OFF. (2) When the servo OFF signal is input, and the amplifier is in a servo OFF state. | | | | |

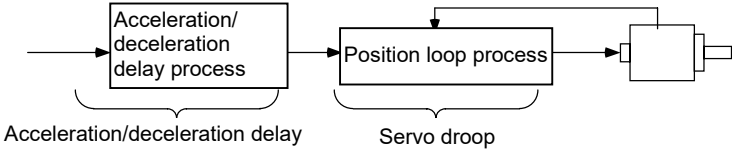
| Abbreviation | INP | Signal name | In-position | R (bbbb+0).bit1 |
|---|-----|-------------|-------------|-----------------|
| <p>This signal notifies that the control axis is in-position. This signal turns ON in the following situation:</p> <ol style="list-style-type: none"> (1) When the smoothing zero (SMZ) signal is turned ON, and the droop is within the range set in the parameters. <p>This signal turns OFF in the following situations:</p> <ol style="list-style-type: none"> (1) When the smoothing zero (SMZ) signal is turned OFF. (When there is a movement command.) (2) When the droop exceeds the range set in the parameters. <p>(Caution 1) The "in-position (INP)" signal may turn ON, even during movement, when the axis is moving at extremely low speeds.</p> <p>(Caution 2) The in-position detection range is set in the parameter "#006 INP In-position detection width".</p> <div style="text-align: center;">  </div> | | | | |

| Abbreviation | SMZ | Signal name | Smoothing zero | R (bbbb+0).bit2 |
|---|-----|-------------|----------------|-----------------|
| <p>This signal indicates that the acceleration/deceleration process in the built-in controller is finished, and that no command to the control section remains.</p> | | | | |

Chapter 5 Operation control signal

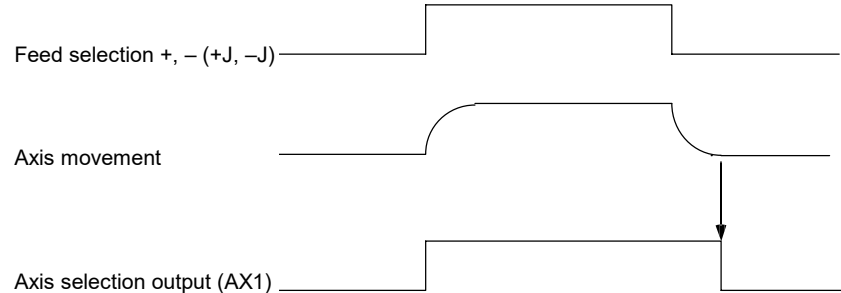
| Abbreviation | AX1 | Signal name | Axis selection output | R (bbbb+0).bit3 |
|---|-----|-------------|-----------------------|-----------------|
| <p>This signal indicates that the control axis has received the movement command. This signal turns ON in the following cases, and turns OFF after smoothing zero (SMZ) is detected.</p> <p>[In automatic operation mode] The operation start (ST) turns ON, and is ON while the axis is moving.</p> <p>[In manual operation mode] The operation start (ST) turns ON, and is ON while the axis is moving.</p> <p>[In JOG mode] The operation start (ST) turns ON, and is ON while the axis is moving.</p> <p>[In reference point return mode] This signal turns ON while the operation start (ST) signal is ON, and the axis is moving. Note that after the near-point dog is detected and the axis slows to creep speed, the axis selection output signal remains ON until the reference point is reached, even if the feed selection signal is turned OFF. When the interlock is applied, this signal remains ON even when the servo is OFF. This signal will turn OFF during emergency stop.</p> | | | | |
|  | | | | |

| Abbreviation | MVP | Signal name | In Axis movement + | R (bbbb+0).bit4 |
|--|-----|-------------|--------------------|-----------------|
| <p>This signal turns ON when the axis starts moving in the + direction, and turns OFF after smoothing zero (SMZ) is detected or the axis starts moving in the – direction.</p> | | | | |

| Abbreviation | MVN | Signal name | In Axis movement – | R (bbbb+0).bit5 |
|--|-----|-------------|--------------------|-----------------|
| <p>This signal turns ON when the axis starts moving in the – direction, and turns OFF after smoothing zero (SMZ) is detected or the axis starts moving in the + direction.</p> | | | | |

| Abbreviation | TLQ | Signal name | Torque limited | R (bbbb+0).bit6 |
|--|-----|-------------|----------------|-----------------|
| <p>This signal turns ON when the motor output torque (motor current) is limited at the torque limit value of the selected operation parameter group.</p> | | | | |

| Abbreviation | ADJ | Signal name | Adjusting machine | R (bbbb+0).bit7 |
|--|-----|-------------|-------------------|-----------------|
| <p>This signal indicates that the machine is being adjusted by the setup software adjusting function. When this signal turns ON, the signal from the setup software is validated and the control signal from the NC side cannot be received.</p> | | | | |

| Abbreviation | ZP | Signal name | Reference point reached | R (bbbb+0).bit8 |
|---|----|-------------|-------------------------|-----------------|
| <p>This signal indicates that the control axis is on the reference point. This signal turns ON in the following situation:</p> <ol style="list-style-type: none"> (1) When the reference point is reached in the reference point return mode. The signal will not turn ON when the reference point is reached by another mode or command. <p>This signal turns OFF in the following situations:</p> <ol style="list-style-type: none"> (1) When moved from the reference point by a movement command, etc. (2) When the machine is in an emergency stop status due to an emergency stop or servo alarm occurrence, etc. (3) When the axis moved by the servo OFF. | | | | |

Chapter 5 Operation control signal

| Abbreviation | RST | Signal name | Resetting | R (bbbb+0).bit9 |
|---|-----|-------------|-----------|-----------------|
| <p>This signal indicates that the built-in controller is being reset. This signal turns ON in the following situations:</p> <ol style="list-style-type: none"> (1) When the MRST signal turns ON. (2) When the MRST signal is turned ON, and the built-in controller is being reset. (3) When in an emergency stop status. | | | | |

| Abbreviation | HO | Signal name | In handle mode | R (bbbb+0).bitA |
|--|----|-------------|----------------|-----------------|
| <p>This signal indicates that the handle mode has been selected.</p> | | | | |

| Abbreviation | MA | Signal name | Controller preparation complete | R (bbbb+0).bitB |
|--|----|-------------|---------------------------------|-----------------|
| <p>This signal notifies that the positioning controller built in the amplifier is in a status to carry out normal operation. This signal turns ON in the following situation:</p> <ol style="list-style-type: none"> (1) When normal operation has begun after turning the power ON. <p>The signal turns OFF in the following situations:</p> <ol style="list-style-type: none"> (1) When the power is turned OFF. (2) When an MR-J2-CT error such as a CPU error, or memory error, etc. is detected. (3) When a servo error that cannot be released unless the MR-J2-CT is first turned OFF occurs. | | | | |

| Abbreviation | SA | Signal name | Servo preparation complete | R (bbbb+0).bitC |
|---|----|-------------|----------------------------|-----------------|
| <p>This signal indicates that the servo system is in a status to carry out normal operation. Conversely, when this signal is not ON, it shows that the servo (position control) is not operating. This signal turns ON in the following situations:</p> <ol style="list-style-type: none"> (1) When the servo system diagnosis is normally completed after turning the power ON. (2) After a servo alarm occurrence, when that alarm has been released by the master reset (MRST). (3) When the emergency stop has been released. (4) When the READY OFF (RDF) signal is turned OFF. <p>This signal turns OFF in the following situations:</p> <ol style="list-style-type: none"> (1) When the controller READY (MA) signal is turned OFF. (2) When a servo alarm occurs. (3) When the machine is in an emergency stop status. (4) When the READY OFF (RDF) signal is turned ON. <p>When an MR-J2-,CT error such as a CPU error, or memory error, etc. is detected.</p> <p>(Caution 1) With the servo OFF (*SVF), the servo preparation complete (SA) will not turn OFF as long as there are no separate conditions for turning the SA OFF.</p> <p>(Caution 2) In OFF condition (3), all I/O output points will turn OFF.</p> | | | | |

Chapter 5 Operation control signal

| Abbreviation | JSTA | Signal name | Automatic set position reached | | R (bbbb+0).bitD |
|--|------|-------------|--------------------------------|--|-----------------|
| <p>In the automatic operation, this signal notifies that the positioning to the commanded station No. is complete. The same tolerable ON width is as set position reached is used.</p> <p>This signal turns ON in the following situation:</p> <p>(1) In the automatic operation mode, when the positioning to the designated station No. is complete. The signal actually turns ON before the positioning is complete, when the tolerable width is entered.</p> <p>The signal turns OFF in the following situations:</p> <p>(1) When the start signal is input in any of the operation modes.</p> <p>(2) When the axis deviates outside the tolerable width.</p> <p>(Caution 1) In automatic operation, this signal will not turn ON when positioning to the nearest station is carried out by the start signal OFF.</p> <p>(Caution 2) When this signal is ON, it will not turn OFF if the same station No. index is started.</p> <p>(Caution 3) When the positioning to the station is completed by the manual mode, if the same station No. index is started, this signal will turn ON. However, there will be no movement.</p> <p>(Caution 4) Once turned OFF, this signal will not turn ON again even if the tolerable width is returned to.</p> | | | | | |

| Abbreviation | JST | Signal name | Set position reached | | R (bbbb+0).bitE |
|---|-----|-------------|----------------------|--|-----------------|
| <p>This signal notifies that the positioning to the station position is complete.</p> <p>It is ON when the machine position is at any of the station positions. The tolerable ON width is set beforehand as a parameter.</p> <p>This signal turns ON in the following situations:</p> <p>(1) When the positioning to the station is complete in automatic or manual operation. The signal actually turns ON before the positioning is complete, when the tolerable width is entered.</p> <p>(2) When the stop position after JOG operation is the station position or within the tolerable width.</p> <p>(3) When the reference point return position corresponds to those of the stop position in (2).</p> <p>Other than the above conditions, this signal normally monitors the machine position, and carries out comparisons between stations. Therefore, this signal is output even when the machine moves to a station position outside the operation.</p> <p>This signal turns OFF in the following situations:</p> <p>(1) When the start signal is input in any of the operation modes. When the operation is started by a start signal, this signal will not turn ON, even when a station position is passed during operation.</p> <p>(2) When the axis deviates outside the tolerable width.</p> | | | | | |

| Abbreviation | NEAR | Signal name | Near set position | | R (bbbb+0).bitF |
|--|------|-------------|-------------------|--|-----------------|
| <p>This signal notifies that the machine position is near the station.</p> <p>It operates in the same manner as the set position (JST), but the tolerable width setting is treated separately. Generally, the tolerable width setting values are set larger than those for the set position, and a mechanical clamp operation is begun just before completion of the positioning, etc.</p> | | | | | |

| Abbreviation | AUTO | Signal name | In automatic operation mode | | R (bbbb+1).bit0 |
|--|------|-------------|-----------------------------|--|-----------------|
| This signal indicates that the automatic operation mode has been selected. | | | | | |

| Abbreviation | MANO | Signal name | In manual operation mode | | R (bbbb+1).bit1 |
|---|------|-------------|--------------------------|--|-----------------|
| This signal indicates that the manual operation mode has been selected. | | | | | |

| Abbreviation | JO | Signal name | In JOG operation mode | | R (bbbb+1).bit2 |
|--|----|-------------|-----------------------|--|-----------------|
| This signal indicates that the JOG operation mode has been selected. | | | | | |

| Abbreviation | ARNN | Signal name | In reference point return | | R (bbbb+1).bit3 |
|---|------|-------------|---------------------------|--|-----------------|
| This signal indicates that the machine is in dog-type reference point return. | | | | | |

Chapter 5 Operation control signal

| | | | | |
|--|------|--------------------|---|-----------------|
| Abbreviation | ZRNO | Signal name | In reference point return mode | R (bbbb+1).bit4 |
| This signal indicates that the reference point return mode has been selected. | | | | |
| Abbreviation | DOG | Signal name | Near-point dog | R (bbbb+1).bit5 |
| The input status of the near-point dog for the reference point return is output as is. This is used to confirm the near-point dog signal. (The near-point dog signal is input from connector CN3.) | | | | |
| Abbreviation | AZSO | Signal name | Reference point initialization mode | R (bbbb+1).bit6 |
| This signal indicates that the reference point initialization mode has been selected. Before switching from another mode to the absolute position reference point initialization mode, smoothing zero (command acceleration/deceleration delay is zero) is confirmed. | | | | |
| Abbreviation | SO | Signal name | In incremental feed operation mode | R (bbbb+1).bit7 |
| This signal indicates that the incremental mode has been selected. | | | | |
| Abbreviation | AL1 | Signal name | Alarm 1 | R (bbbb+1).bit8 |
| This signal indicates that an alarm has occurred requiring the power to be turned ON again after the cause is removed. | | | | |
| Abbreviation | AL2 | Signal name | Alarm 2 | R (bbbb+1).bit9 |
| This signal indicates that an alarm has occurred which can be released by the master reset signal after the cause is removed. | | | | |
| Abbreviation | AL4 | Signal name | Alarm 4 | R (bbbb+1).bitA |
| This signal indicates that an operation alarm or absolute position alarm has occurred. | | | | |
| Abbreviation | BAT | Signal name | Battery voltage low | R (bbbb+1).bitB |
| This signal indicates that the voltage of the absolute position system battery is low. | | | | |
| Abbreviation | ABS | Signal name | Absolute position power OFF movement exceeded | R (bbbb+1).bitC |
| This signal indicates that the axis moved beyond the tolerable amount while the control power was OFF in the absolute position system. | | | | |
| Abbreviation | ZSN | Signal name | Absolute position loss | R (bbbb+1).bitD |
| This signal indicates that the absolute position data has been lost in the absolute position system. | | | | |
| Abbreviation | ZSF | Signal name | Initialization error completed | R (bbbb+1).bitE |
| This signal indicates that in the absolute position system the reference point initialization has completed normally, and that the absolute position coordinates have been established. | | | | |
| Abbreviation | ZSE | Signal name | Initialization set error finished | R (bbbb+1).bitF |
| This signal indicates that the reference point initialization has not finished normally in the absolute position system. | | | | |

Chapter 5 Operation control signal

| | | | | |
|--|----------------|--------------------|---------------------------|----------------------|
| Abbreviation | STO1 to STO256 | Signal name | Station position 1 to 256 | R (bbbb+2).bit0 to 8 |
| <p>This signal shows the present station No. in as a 9-digit binary. This signal outputs the station position when the set position reached (JST) signal is ON, and outputs a "0" when the set position reached signal is OFF.</p> | | | | |

| | | | | |
|--|-----------|--------------------|------------------------|----------------------|
| Abbreviation | PSW1 to 8 | Signal name | Position switch 1 to 8 | R (bbbb+3).bit0 to 7 |
| <p>This signal turns ON when the axis is within the setting range of the respective position switches.</p> | | | | |

| | | | | |
|---|-----|--------------------|--------------------------|-----------------|
| Abbreviation | PMV | Signal name | In positioning operation | R (bbbb+3).bit8 |
| <p>This signal indicates that the positioning is being carried out in the pressing positioning mode operation. The positioning finishes, smoothing zero is confirmed, and the signal turns OFF.</p> | | | | |

| | | | | |
|--|-----|--------------------|----------------------|-----------------|
| Abbreviation | PFN | Signal name | Positioning complete | R (bbbb+3).bit9 |
| <p>This signal indicates that the positioning is finished in the pressing positioning mode operation. This signal turns ON when the "In positioning operation" (PMV) turns OFF. It is held until the next start.</p> | | | | |

| | | | | |
|--|-----|--------------------|-------------|-----------------|
| Abbreviation | PSI | Signal name | Pressing in | R (bbbb+3).bitA |
| <p>This signal is ON while moving the set pressing amount in operation in the pressing positioning mode.</p> | | | | |

Chapter 6 Setup and Operation

| | | |
|------------|--|-------------|
| 6-1 | Setup of servo amplifier | 6-2 |
| 6-1-1 | Parameter initialization..... | 6-2 |
| 6-1-2 | Transition of LED display after power is turned ON | 6-2 |
| 6-1-3 | Servo parameter default settings | 6-3 |
| 6-1-4 | Operation parameter group default settings..... | 6-4 |
| 6-1-5 | Setting during emergency stops | 6-7 |
| 6-2 | Test operation | 6-9 |
| 6-2-1 | Test operation..... | 6-9 |
| 6-2-2 | JOG operation | 6-10 |
| 6-2-3 | Incremental feed operation | 6-11 |
| 6-2-4 | Handle feed operation | 6-11 |
| 6-3 | Setting the coordinate zero point | 6-12 |
| 6-3-1 | Dog-type reference point return | 6-12 |
| 6-3-2 | Adjusting the dog-type reference point return | 6-14 |
| 6-3-3 | Memory-type reference point return..... | 6-16 |
| 6-3-4 | Mode with no reference point..... | 6-16 |
| 6-4 | Positioning operations by the station method | 6-17 |
| 6-4-1 | Setting the station | 6-17 |
| 6-4-2 | Setting linear axis stations | 6-19 |
| 6-4-3 | Automatic operation..... | 6-21 |
| 6-4-4 | Manual operation | 6-23 |
| 6-5 | Stopper positioning operation | 6-24 |
| 6-5-1 | Operation sequence | 6-24 |
| 6-5-2 | Setting the parameters | 6-26 |
| 6-6 | Machine compensation and protection functions | 6-27 |
| 6-6-1 | Backlash compensation..... | 6-27 |
| 6-6-2 | Interlock function | 6-27 |
| 6-6-3 | Soft limit..... | 6-28 |
| 6-6-4 | Servo OFF..... | 6-29 |
| 6-6-5 | READY OFF | 6-30 |
| 6-6-6 | Data protect | 6-30 |
| 6-7 | Miscellaneous functions | 6-31 |
| 6-7-1 | Feedrate override | 6-31 |
| 6-7-2 | Position switches | 6-31 |

6-1 Setup of servo amplifier

6-1-1 Parameter initialization

When starting up MR-J2-CT with a machine for the first time, initialize the parameters first. Then, set and adjust the machine specifications. To initialize the parameters, open the window on the top of the amplifier, and set the axis No. setting rotary switch to "7". Then turn the amplifier control power ON. When the amplifier LEDs change from a "dot display (..)" to an "end display (En)", the parameter initialization has been completed. (With software version C4 and below, the initialization is completed when the display changes to the "alarm display".) Set the axis No. setting rotary switch to the specified axis No., turn the amplifier control power ON again and connect with the NC. When the parameters are initialized, the absolute position data will also be initialized, so "Zero Point Initialization Incomplete (Z70 0001)" will always occur when the power is turned ON next.

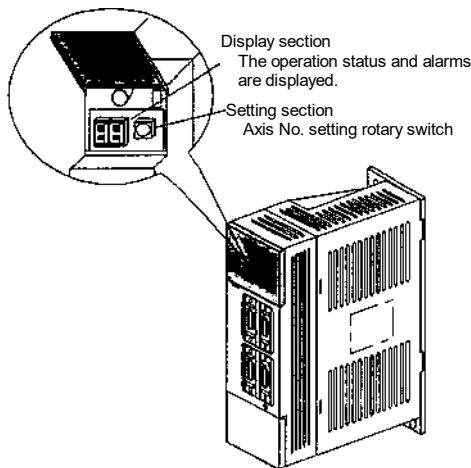

| Rotary switch setting | Set axis No. |
|-----------------------|--------------------------|
| 0 | 1st axis |
| 1 | 2nd axis |
| 2 | 3rd axis |
| 3 | 4th axis |
| 4 | 5th axis |
| 5 | 6th axis |
| 6 | 7th axis |
| 7 | Parameter initialization |
| 8 | Setting prohibited |
| 9 | |
| A | |
| B | |
| C | |
| D | Test operation mode |
| E | |
| F | |



CAUTION

1. Be aware that if the power is turned ON during parameter initialization (rotary switch = 7), absolute position data and all parameters will be lost.
2. The test operation mode is a mode commanded from the personal computer setup software. Commands and emergency stop signals from the NC are ignored.

6-1-2 Transition of LED display after power is turned ON

When the axis No. is set, and the servo amplifier power and NC power are turned ON, the servo amplifier will carry out a self-diagnosis, and the initial signal with the NC will start.

The LEDs on the front of the servo amplifier will change as shown below according to the progression of these processes.

If an alarm occurs, the alarm No. will appear on the LEDs. Refer to "Chapter 10 Troubleshooting" for details on the alarm displays.

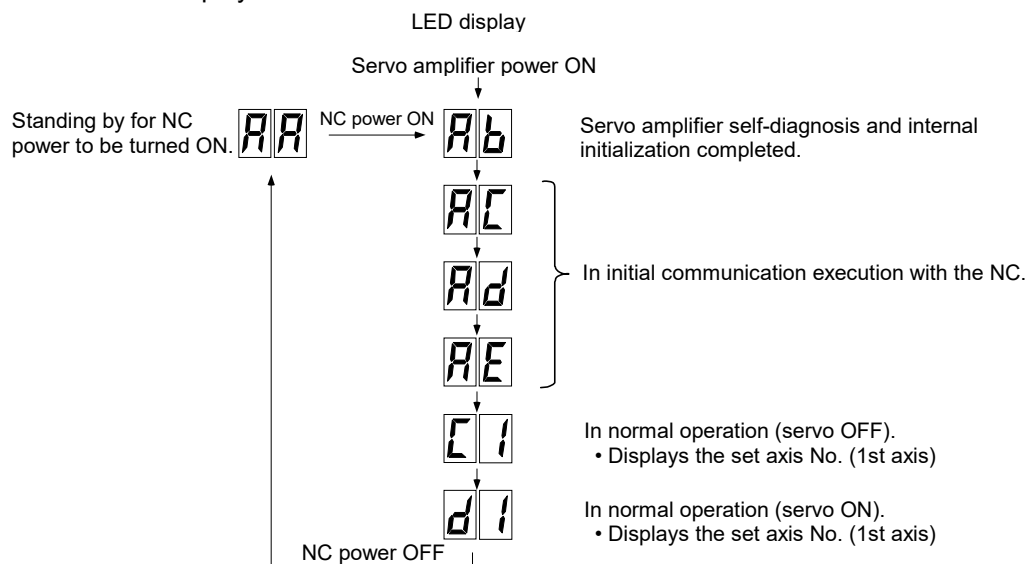

Chapter 6 Setup and Operation

6-1-3 Servo parameter default settings

"Servo parameters" mainly mean the parameters (#001 to #099) related to servo control. Because the motor type and detector resolution are automatically set in the MR-J2-CT, set the parameters related to the following specifications first when setting up. The servo gain is automatically adjusted by the auto-tuning. The operation when starting may be unstable. However, the gain will gradually be tuned to the optimum value by the acceleration/deceleration operation of the servomotor. The adjusted parameters will be saved even when the power is turned OFF.

| No. | Abbrev. | Parameter name | Default value | Unit | Explanation | Setting range |
|-------|---------|--|---------------|----------|--|---------------|
| #0002 | *RTY | Regenerative option type | 0000 | | Set the regenerative resistor type when an external option regenerative resistor is used. Do not set values that have no description. Built-in standard regenerative resistor : 0000 (Default value) MR-RB032 : 0200 MR-RB12 : 0300 MR-RB32 : 0400 MR-RB30 : 0500 MR-RB50 : 0600 | |
| #0003 | *PC1 | Motor side gear ratio (machine rotation ratio) | 1 | | Set as an integer expressing the reduced fraction of the No. of gear teeth on the motor side and the No. of gear teeth on the machine side. If there are multiple gear levels, set the total gear ratio. For rotation axes, set the No. of motor rotations per one machine rotation. | 1 ~ 32767 |
| #0004 | *PC2 | Machine side gear ratio (motor rotation ratio) | 1 | | | 1 ~ 32767 |
| #0005 | *PIT | Feed pitch | 360 | deg (mm) | Set 360 for rotation axes. (Default value). Set the feed lead for linear axes. | 1 ~ 32767 |

(1) Setting the gear ratio

Set the No. of gear teeth on the motor side in PC1, and the No. of gear teeth on the machine side in PC2. If there are multiple gear levels, set the total gear ratio in a form reduced to its lowest terms. PC2/ PC1 becomes the motor speed when the axis is moved the amount set in the feed pitch parameter (PIT).

The final axis rotation becomes 360 deg. for rotation axes. For example, with the magazine shown in the drawing at the right, one magazine cycle is 360 deg., and the gear ratio is the No. of motor rotations required to rotate the magazine one cycle. For the drawing at the right, the parameter default values are as follows.

- * PC1 = 1
- * PC2 = 50
- * PIT = 360

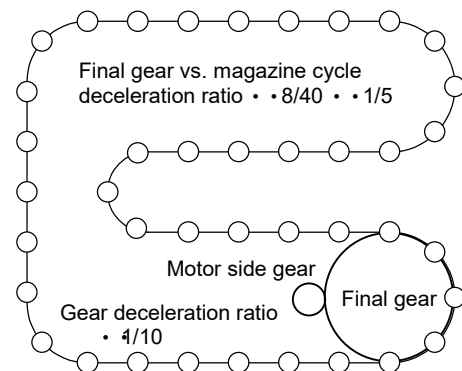

40-magazine gear ratio setting • $\frac{1}{50}$



POINT

For rotation axes, set the motor speed required to rotate the axis end one rotation (position the axis 360 deg) in the gear ratio.

(2) Setting the feed pitch

Set the feed pitch to 360 for rotation axes. Set the ball screw lead for linear axes that use a ball screw.

For rack and pinion, etc., structures, set the movement amount per final gear (final step of the rotation system) rotation. In this case, set the deceleration ratio to the final gear for the gear ratio.

6-1-4 Operation parameter group default settings

(1) Operation parameter group

There are eight types of parameters related to feed control such as feedrate and acceleration/deceleration time constants of the axes in each operation mode. When these are put together in a set, they are called an operation parameter group. A total of four operation parameter groups can be set. By selecting any set of operation parameter selections 1 and 2 (PR1, PR2) from the PLC and operating, the operating conditions can be changed to match the machine status each time. There are also operation modes such as stopper positioning control, in which the amplifier automatically selects the operation parameter group and controls the machine.

Parameters determining the operation pattern

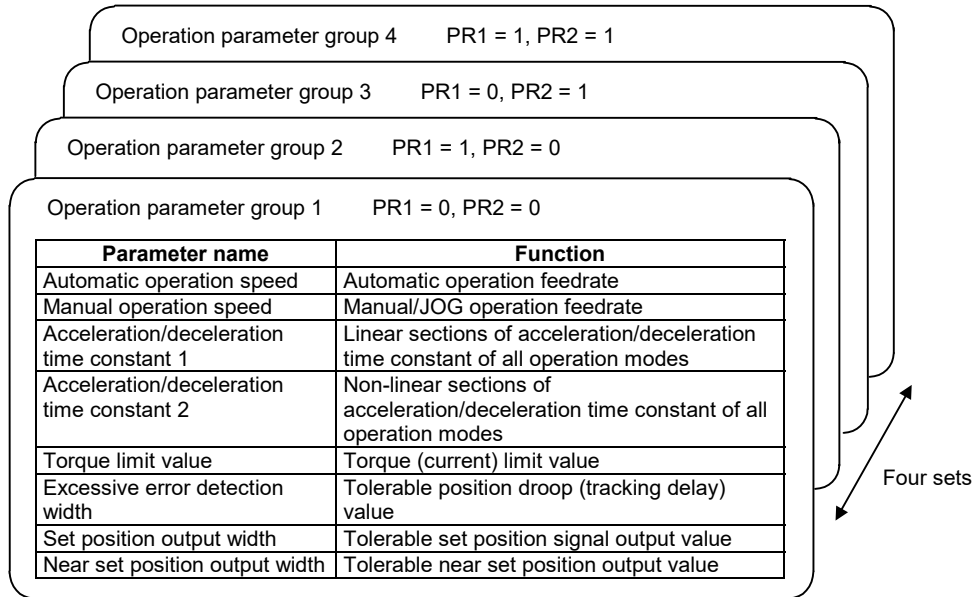

(2) Setting the feedrate

The machine end speed is set as a feedrate in a parameter separately for automatic operation and manual operation. Because the electronic gear automatically calculates the motor speed, etc., setting can be done without being concerned with gear ratio, pitch, detector resolution, etc. Moreover, the parameter #150 automatic operation speed operation parameter group 1 (Aspeed1) as a clamp speed (feedrate upper limit value). The axis feedrate will be limited at the value set in Aspeed1, even if a higher speed than this is set in another parameter.

| No. | Abbrev. | Parameter name | Default value | Unit | Explanation | Setting range |
|------|---------|---|---------------|---------------------|--|---------------|
| #150 | Aspeed1 | Operation parameter 1 Automatic operation speed | 5000 | deg/min (mm/min) | Set the feedrate during automatic operation when each operation parameter group is selected. #150 Aspeed1 functions as the clamp value for the automatic operation speeds and manual operation speeds of all operation groups. A speed exceeding Aspeed1 cannot be commanded, even if set in the parameters. | 1~100000 |
| #158 | Aspeed2 | Operation parameter 2 Automatic operation speed | | | | |
| #166 | Aspeed3 | Operation parameter 3 Automatic operation speed | | | | |
| #174 | Aspeed4 | Operation parameter 4 Automatic operation speed | | | | |
| #151 | Mspeed1 | Operation parameter group 1 Manual operation speed | 2000 | deg/min (mm/min) | Set the feedrate during manual operation and JOG operation when each operation parameter group is selected. | 1~100000 |
| #159 | Mspeed2 | Operation parameter group 2 Manual operation speed | | | | |
| #167 | Mspeed3 | Operation parameter group 3 Manual operation speed | | | | |
| #175 | Mspeed4 | Operation parameter group 4 Manual operation speed | | | | |



POINT

The operation parameter group 1 automatic operation speed (Aspeed1) works as the clamp speed for all operation speeds. A feedrate exceeding Aspeed1 cannot be commanded.

Chapter 6 Setup and Operation

(3) Setting the acceleration/deceleration pattern and acceleration/deceleration time constant

A constant inclination acceleration/deceleration operation is carried out for all axis movement (In the handle feed operation mode, a constant time linear acceleration/deceleration operation is carried out). As for the acceleration/deceleration time constants, set all linear acceleration/deceleration times for clamp speed (Aspeed1) in acceleration/deceleration time constant 1 (timeN.1). When operating at speeds less than the clamp speed, the axis will accelerate/decelerate at the same inclination. At this time, set 1 (default value) in the acceleration/deceleration time constant 2 (timeN.2).

S-character (soft) acceleration/deceleration operation is carried out if any value other than 1 is set in the acceleration/deceleration time constant 2 (timeN.2). In this case, set the time of the linear part for acceleration/deceleration time constant 1, and the total time of the non-linear parts (same as the non-linear time at acceleration start and finish) for acceleration/deceleration time constant 2. Thus, the total acceleration/deceleration time becomes the sum of the acceleration/deceleration time constant 1 and acceleration/deceleration time constant 2.

In the handle feed operation mode, only acceleration/deceleration time constant 2 (timeN.2) is used, and a linear acceleration/deceleration operation is carried out.

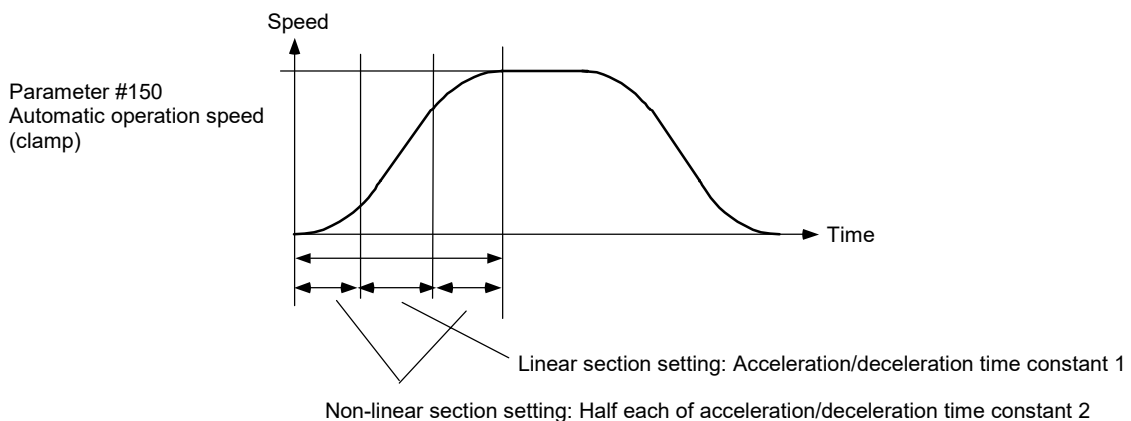

All acceleration/deceleration time is the sum of acceleration/deceleration time 1 + acceleration/deceleration time 2

| No. | Abbrev. | Parameter name | Default value | Unit | Explanation | Setting range |
|------|---------|--|---------------|------|---|---------------|
| #152 | time1.1 | Operation parameter group 1 Acceleration/deceleration time constant 1 | 100 | msec | Set the linear acceleration/deceleration time for the operation parameter group 1 automatic operation speed (clamp speed) when each operation parameter group is selected. When operating at speeds less than the clamp speed, the axis will linearly accelerate/decelerate at the inclination determined above. When this is set together with acceleration/deceleration time constant 2, S-character acceleration/deceleration is carried out. In this case, set the acceleration/deceleration time of the linear part in this parameter. | 1 ~ 9999 |
| #160 | time2.1 | Operation parameter group 2 Acceleration/deceleration time constant 1 | | | | |
| #168 | time3.1 | Operation parameter group 3 Acceleration/deceleration time constant 1 | | | | |
| #176 | time4.1 | Operation parameter group 4 Acceleration/deceleration time constant 1 | | | | |
| #153 | time1.2 | Operation parameter group 1 Acceleration/deceleration time constant 2 | 1 | msec | Set the linear acceleration/deceleration time constant in the handle feed operation mode when each operation parameter group is selected. When S-character acceleration/deceleration is carried out, set the total time of the non-linear parts. When 1 is set in this parameter, linear acceleration/deceleration is carried out. | 1 ~ 9999 |
| #161 | time2.2 | Operation parameter group 2 Acceleration/deceleration time constant 2 | | | | |
| #169 | time3.2 | Operation parameter group 3 Acceleration/deceleration time constant 2 | | | | |
| #177 | time4.2 | Operation parameter group 4 Acceleration/deceleration time constant 2 | | | | |



POINT

Set the acceleration/deceleration time constant as the acceleration/deceleration time for the clamp speed (Aspeed1).
When operating at speeds less than the clamp speed, the acceleration/deceleration operation is carried out at the same inclination as when operating at clamp speed.

Chapter 6 Setup and Operation

(4) Setting the torque limit value

Each operation parameter group has an individual torque limit value (current limit value). When set to the default value 500, the torque is automatically limited at the maximum torque determined in the motor specifications. Operate with the default value when not especially limiting the torque.

| No. | Abbrev. | Parameter name | Default value | Unit | Explanation | Setting range |
|------|---------|--|---------------|------|---|---------------|
| #154 | TL1 | Operation parameter group 1 Torque limit value | 500 | % | Set the motor output torque limit value when each operation parameter group is selected. At the default value of 500, the torque is limited at the maximum torque of the motor specifications. Set the default value when torque limiting is not especially required. | 1 ~ 500 |
| #162 | TL2 | Operation parameter group 2 Torque limit value | | | | |
| #172 | TL3 | Operation parameter group 3 Torque limit value | | | | |
| #178 | TL4 | Operation parameter group 4 Torque limit value | | | | |

(5) Setting the excessive error detection width

Each operation parameter group has an individual excessive error alarm (S03 0052). An alarm is detected when the position droop (position command - position FB) exceeds the setting value. The standard setting value is calculated from the feedrate using the following equation. Excessive error alarms can occur easily when the load inertia is large or the auto-tuning response is lowered, so raise the excessive error detection width in these cases.

$$OD (N) = \frac{A\text{speed} (N)}{1000} \text{ (deg or mm)}$$

| No. | Abbrev. | Parameter name | Default value | Unit | Explanation | Setting range |
|------|---------|---|---------------|----------|--|---------------|
| #155 | OD1 | Operation parameter group 1 Excessive error detection width | 100 | deg (mm) | Set the excessive error detection width when each operation parameter group is selected. An excessive error alarm (S03 0052) is detected when the position droop becomes larger than this setting value. | 0 ~ 32767 |
| #163 | OD2 | Operation parameter group 2 Excessive error detection width | | | | |
| #171 | OD3 | Operation parameter group 3 Excessive error detection width | | | | |
| #179 | OD4 | Operation parameter group 4 Excessive error detection width | | | | |

(6) Setting the output width of signals related to the set position

Set the respective detection widths of the set position reached (JST) and automatic set position reached (JSTA) signals that indicate that the machine positioning is completed. Also set the detection width for the near set position (NEAR) signal that indicates that the machine position is near each station.

| No. | Abbrev. | Parameter name | Default value | Unit | Explanation | Setting range |
|------|---------|--|---------------|----------|--|-------------------|
| #152 | just1 | Operation parameter group 1 Set position output width | 0.500 | deg (mm) | The signal indicating that the machine position is at any one of the stations is the set position reached (JST) signal. During automatic operation, the automatic set position reached (JSTA) signal is detected under the same conditions. Set the tolerable values at which these signals are output when each operation parameter group is selected. These signals turn OFF when the machine position is separated from the station by more than this value. | 0.000 ~ 99999.999 |
| #160 | just2 | Operation parameter group 2 Set position output width | | | | |
| #168 | just3 | Operation parameter group 3 Set position output width | | | | |
| #176 | just4 | Operation parameter group 4 Set position output width | | | | |
| #153 | near1 | Operation parameter group 1 Near set position output width | 1.000 | deg (mm) | The signal indicating that the machine position is near any one of the station positions is the near set position (NEAR) signal. Set the tolerable values at which these signals are output when each operation parameter group is selected. These values are generally set wider than the set position output width. In terms of operations, this is related to special commands when the station selection is 0. Refer to section "6-4-3 Automatic operation." | 0.000 ~ 99999.999 |
| #161 | near2 | Operation parameter group 2 Near set position output width | | | | |
| #169 | near3 | Operation parameter group 3 Near set position output width | | | | |
| #177 | near4 | Operation parameter group 4 Near set position output width | | | | |

Chapter 6 Setup and Operation

6-1-5 Setting during emergency stops

(1) Setting the emergency stop

Emergency stop circuits are wired in the NC bus in the same manner as a normal feed axis servo, but in addition they are also input in the CN3 connector on the front of the amplifier. These emergency stops can be set to valid/invalid in the parameters. The parameters can be set to select whether the emergency stop for trouble occurring in an auxiliary axis extends to other auxiliary axes and feed axis servos, or whether an axis itself emergency stops for alarms occurring in other auxiliary axes or feed axis servos.

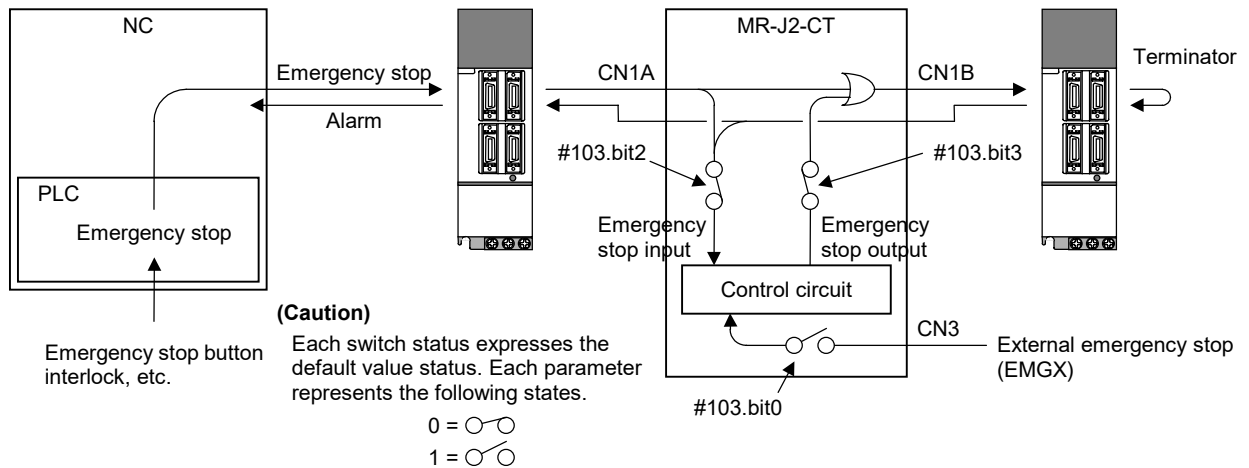

| No. | Abbrev. | Parameter name | Explanation | | | | | | | | | | | | | | | | | | | | | | | | | | | | | | | | | | | | | | | | | | | | | | | | | |
|---------------|--------------------------------------|---|---|-----|---|---|---|---|---|---|---|---|---|---|---|---|---|---|---|---|---------------|---|---|---|---|---|---|---|---|---|---|---|---|---|---|---|---|-----|--------------------------|--------------------------|---|-------------------------------|---|---|--------------------------------------|---|---|-----------------------------------|-------------------------------------|---|------------------------------------|--------------------------------------|
| #103 | *Emgcont | Emergency stop control | This is a HEX setting parameter. Set bits without a description to their default values. <table border="1" style="width: 100%; text-align: center;"> <thead> <tr> <th>bit</th> <th>F</th> <th>E</th> <th>D</th> <th>C</th> <th>B</th> <th>A</th> <th>9</th> <th>8</th> <th>7</th> <th>6</th> <th>5</th> <th>4</th> <th>3</th> <th>2</th> <th>1</th> <th>0</th> </tr> </thead> <tbody> <tr> <td>Default value</td> <td>0</td> <td>0</td> <td>0</td> <td>0</td> <td>0</td> <td>0</td> <td>0</td> <td>0</td> <td>0</td> <td>0</td> <td>0</td> <td>0</td> <td>0</td> <td>0</td> <td>0</td> <td>1</td> </tr> </tbody> </table> <table border="1" style="width: 100%; text-align: center;"> <thead> <tr> <th>bit</th> <th>Meaning when "0" is set.</th> <th>Meaning when "1" is set.</th> </tr> </thead> <tbody> <tr> <td>0</td> <td>External emergency stop valid</td> <td>External emergency stop invalid (default value)</td> </tr> <tr> <td>1</td> <td>Dynamic brake stop at emergency stop</td> <td>Deceleration control stop at emergency stop</td> </tr> <tr> <td>2</td> <td>NC bus emergency stop input valid</td> <td>NC bus emergency stop input invalid</td> </tr> <tr> <td>3</td> <td>NC bus emergency stop output valid</td> <td>NC bus emergency stop output invalid</td> </tr> </tbody> </table> | bit | F | E | D | C | B | A | 9 | 8 | 7 | 6 | 5 | 4 | 3 | 2 | 1 | 0 | Default value | 0 | 0 | 0 | 0 | 0 | 0 | 0 | 0 | 0 | 0 | 0 | 0 | 0 | 0 | 0 | 1 | bit | Meaning when "0" is set. | Meaning when "1" is set. | 0 | External emergency stop valid | External emergency stop invalid (default value) | 1 | Dynamic brake stop at emergency stop | Deceleration control stop at emergency stop | 2 | NC bus emergency stop input valid | NC bus emergency stop input invalid | 3 | NC bus emergency stop output valid | NC bus emergency stop output invalid |
| bit | F | E | D | C | B | A | 9 | 8 | 7 | 6 | 5 | 4 | 3 | 2 | 1 | 0 | | | | | | | | | | | | | | | | | | | | | | | | | | | | | | | | | | | | |
| Default value | 0 | 0 | 0 | 0 | 0 | 0 | 0 | 0 | 0 | 0 | 0 | 0 | 0 | 0 | 0 | 1 | | | | | | | | | | | | | | | | | | | | | | | | | | | | | | | | | | | | |
| bit | Meaning when "0" is set. | Meaning when "1" is set. | | | | | | | | | | | | | | | | | | | | | | | | | | | | | | | | | | | | | | | | | | | | | | | | | | |
| 0 | External emergency stop valid | External emergency stop invalid (default value) | | | | | | | | | | | | | | | | | | | | | | | | | | | | | | | | | | | | | | | | | | | | | | | | | | |
| 1 | Dynamic brake stop at emergency stop | Deceleration control stop at emergency stop | | | | | | | | | | | | | | | | | | | | | | | | | | | | | | | | | | | | | | | | | | | | | | | | | | |
| 2 | NC bus emergency stop input valid | NC bus emergency stop input invalid | | | | | | | | | | | | | | | | | | | | | | | | | | | | | | | | | | | | | | | | | | | | | | | | | | |
| 3 | NC bus emergency stop output valid | NC bus emergency stop output invalid | | | | | | | | | | | | | | | | | | | | | | | | | | | | | | | | | | | | | | | | | | | | | | | | | | |



CAUTION

When setting so that an emergency stop is ignored, give safety in the system consideration. PLC emergency stops (QEMG) are always valid, regardless of the parameter settings.

Chapter 6 Setup and Operation

(2) Deceleration control during emergency stops

The method by which the motor stops during emergency stops can be set in the parameters. Either a dynamic brake method or a deceleration control method can be selected. Consider the characteristics in the following table, and select the method appropriate for the machine being used.

| Deceleration stop method during emergency stop | Deceleration control | Dynamic brake |
|--|---|---|
| Stopping distance | A shorter stopping distance is possible than with a dynamic brake. | The stopping distance is longer than with deceleration control. |
| Deceleration torque | Because the stop is carried out using software control, the deceleration torque (deceleration time constant) can be freely set. | The deceleration torque cannot be limited. The deceleration torque also becomes smaller as the speed drops. |
| During alarm occurrence | When an alarm occurs in which motor control itself becomes impossible, the machine stops by a dynamic brake. | The machine can stop by a dynamic brake for all alarm occurrences. |
| SW | The software is interposed in the motor stop control after an emergency stop occurs (software stop). | The software is not interposed in the motor stop control after an emergency stop occurs (hardware stop). |

| No. | Abbrev. | Parameter name | Default value | Unit | Explanation | Setting range |
|------|---------|------------------------------------|---------------|------|--|---------------|
| #010 | EMGt | Deceleration control time constant | 500 | msec | Set the deceleration time from the clamp speed (Aspeed1). Set the same value as the acceleration/deceleration time constant for normal rapid traverse. | 0 ~ 32768 |



POINT

When a dynamic brake stop is selected, the software does not play any part in the motor stop control after the emergency stop occurs.

6-2 Test operation

Operation using the following mode is also possible before the coordinate zero point (reference point) is confirmed (zero point initial setting incomplete: Z70 0001 occurring.).

6-2-1 Test operation

Operation of only the servo amplifier unit can be carried out without communicating with the NC. The connected personal computer setup software substitutes for the NC commands.

In the test operation mode, operation is possible in all operation modes except the handle mode.

(Note that automatic operation and manual operation are not possible before the reference point is set.)

Absolute position initialization can also be carried out.

(1) Starting the test operation

When the rotary switch that sets the axis No. is set to F, and the power is turned ON, the machine changes to test operation mode.

When the test operation menu from the setup software is selected, and the communication is begun, a servo ON signal is automatically output, and the test operation is prepared for.

(2) Operating the test operation

Operation is conducted in the following manner: In the setup software, select the operation mode, operation parameters, and other selections (in incremental feed, the feed magnification, etc.). Click on the forward run or reverse run button. A start signal will be input, and the operation will begin.

(3) Test operation during normal operation

It is possible to conduct test operation with the setup software, even when normally connected to the NC.

It is possible to change from the setup software to the test operation mode.

In this case, when the test operation mode is switched to, the various signals from the NC are temporarily intercepted, and the commands from the setup software take priority. However, the following signals from the NC are valid.

| Abbreviation | Signal name |
|--------------|--------------------|
| QEMG | PLC emergency stop |
| MRST | Master reset |
| *IT+, *IT- | Interlock |



POINT

Refer to the "Setup Software Instruction Manual (BNP-B2208)" for information on how to use the setup software.

Chapter 6 Setup and Operation

6-2-2 JOG operation

When the rotation direction is designated and the start signal is input, rotation begins in the designated direction, and continues until the start signal turns OFF. The machine immediately decelerates to a stop when the start signal turns OFF.

(1) Setting the JOG operation mode

Set the following signals before inputting an operation start (ST) signal. The settings are validated when the operation start signal is input.

| Abbrev. | Signal name | Explanation |
|----------|---------------------------------------|--|
| JOG | JOG operation mode selection | Select the JOG operation mode. "M01 0101 No operation mode" will occur if the selected mode duplicates another operation mode. Always leave this signal ON during JOG operation. |
| DIR | Rotation direction | The rotation direction can also be reversed using the parameter #102.bit3 setting. |
| PR1, PR2 | Operation parameter selection 1 and 2 | The machine is operated at the manual operation speed (Mspeed) of the selected operation group. |

(2) Starting the JOG operation

Turn ON the "Operation start (ST)" signal. Because this signal is treated as a status, the rotation will continue until the signal turns OFF. When the start signal turns OFF, the machine will immediately decelerate to a stop.

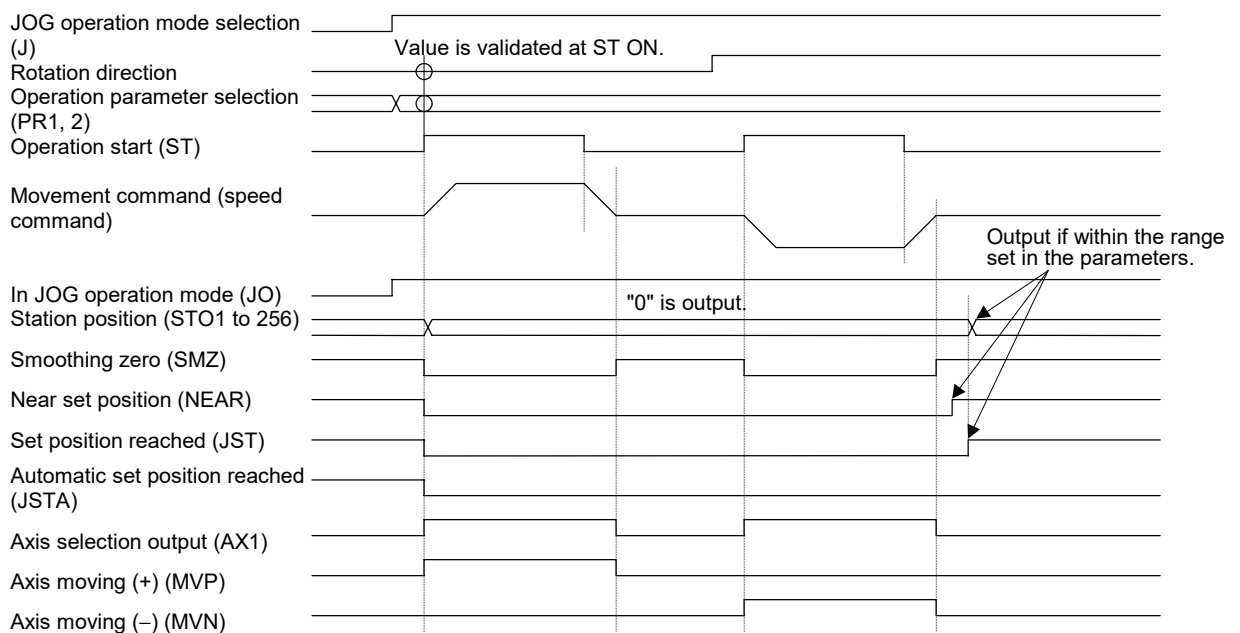

POINT

1. If the position where the motor stops is coincidentally within the set position output width of a particular station, a set position reached (JST) signal and that station position (STO1 to 256) will be output.
2. In the JOG operation mode, the automatic set position reached (JSTA) signal does not turn ON even if the machine is positioned on the station.

Chapter 6 Setup and Operation

6-2-3 Incremental feed operation

In this mode a constant amount of feed is executed each time a start signal is input.

(1) Setting the incremental feed operation mode

Set the following signals before inputting an operation start (ST) signal. The settings are validated when the operation start signal is input.

| Abbrev. | Signal name | Explanation |
|----------|---|---|
| S | Incremental feed operation mode selection | Select the incremental feed operation mode. "M01 0101 No operation mode" will occur if the selected mode duplicates another operation mode. |
| DIR | Rotation direction | The rotation direction can also be reversed using the parameter #102.bit3 setting. |
| PR1, PR2 | Operation parameter selection 1 and 2 | The acceleration/deceleration is carried out with the acceleration/deceleration time constant of the selected operation group. |
| MP1, MP2 | Incremental feed magnification factor 1 and 2 | Select the feed amount for each time the operation is started. |

(2) Starting the incremental feed operation mode

Turn ON the operation start (ST) signal. The axis will move the designated feed amount and stop, even if this signal is turned OFF during movement.

6-2-4 Handle feed operation

In this mode the axis feed is carried out in response to the amount of handle pulses transferred from the NC via a high-speed serial bus. The axis feed can be carried out using the pulse generator attached to new model NCs.

(1) Setting the handle feed operation mode

Set the following signals.

| Abbrev. | Signal name | Explanation |
|----------|---|--|
| H | Handle feed operation mode selection | Select the handle feed operation mode. "M01 0101 No operation mode" will occur if the selected mode duplicates another operation mode. The handle input is prioritized for the auxiliary axis (MR-J2-CT) by turning this signal ON. |
| DIR | Rotation direction | The rotation direction can also be reversed using the parameter #102.bit3 setting. |
| PR1, PR2 | Operation parameter selection 1 and 2 | The acceleration/deceleration is carried out with the acceleration/deceleration time constant 2 of the selected operation group. In this case, constant time acceleration/deceleration is carried out. |
| MP1, MP2 | Incremental feed magnification factor 1 and 2 | Select the movement amount per handle 1 pulse (1 notch). |

(2) Starting the handle feed operation mode

The handle pulse input is prioritized for the auxiliary axis (MR-J2-CT) by inputting the handle feed operation mode selection (H). Confirm the in handle feed operation mode (HO) signal before inputting the handle pulses.

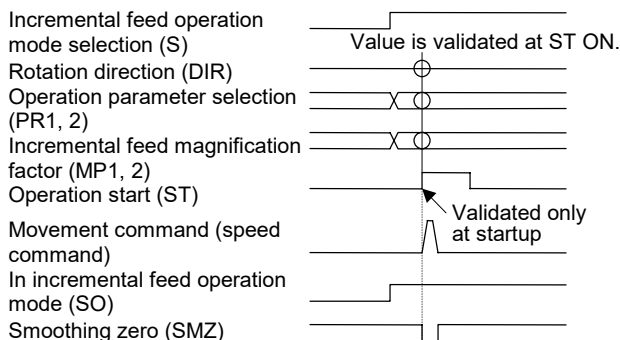

Incremental feed operation

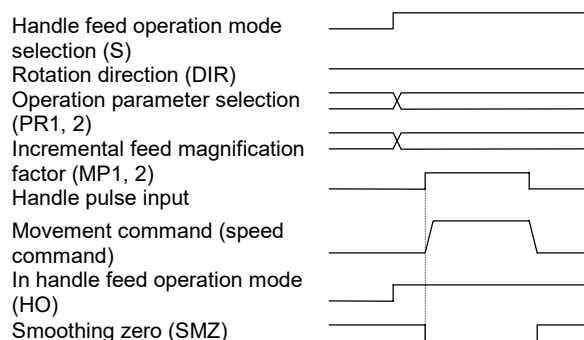

Handle feed operation

6-3 Setting the coordinate zero point

It is necessary to determine the coordinate zero point before positioning operation. The index function built into the MR-J2-CT carries out positioning with the coordinate zero point as a reference.



POINT

Refer to Chapter 7 "Absolute position detection system" for the setting method of the absolute position system coordinate zero point.

6-3-1 Dog-type reference point return

The dog-type reference point return is a method for establishing the coordinate zero point in an incremental system. The coordinate zero point is determined with the electrically determined reference point (machine specific point) used as a reference. This reference point is determined by the signals (near-point dog signals) turned ON/OFF by the near-point dog and limit switch.

In the motor end position detector there is a Z phase signal that is output once per rotation. Looking from the movable section of the machine driven by the motor, a Z phase signal is output for every set movement amount. The position at which this Z phase is output is called the grid. One specific point of these grid points is recognized as the electrical zero point by the servo amplifier. The dog signal is used as a means to designate/recognize which grid point is the electrical zero point in the servo amplifier.

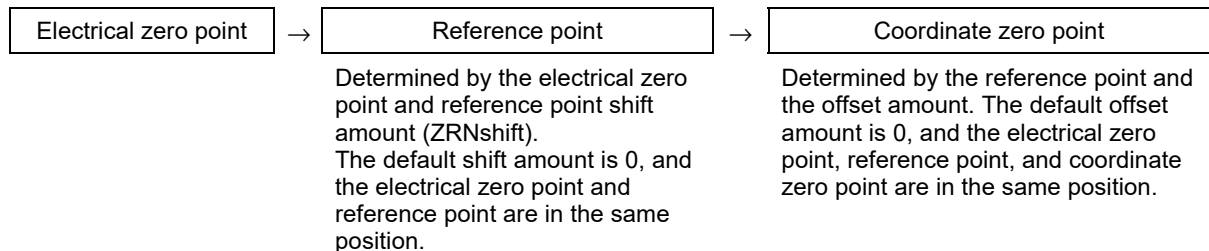

(1) Operation principle

The operation to determine the electrical zero point is explained below.

The dog signal is OFF when the limit switch is on the near-point dog. The dog signal is a B contact that is ON, when the limit switch is not on the near-point dog.

- (1) When the machine movable parts are moved, the dog signal limit switch is ON from the near-point dog, and the dog signal is OFF.

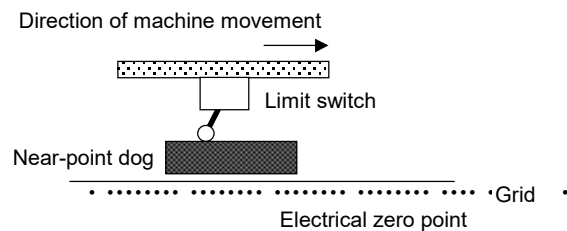

- (2) When the machine movable parts are moved further in the same direction, the limit switch leaves the dog, and the dog signal turns ON.

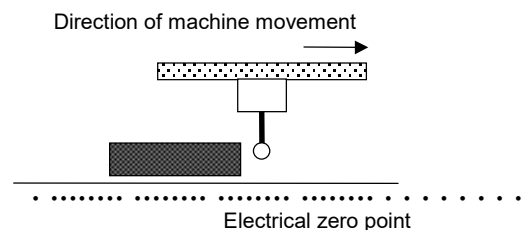

- (3) The servo amplifier recognizes the first grid point after the dog signal turns ON as the electrical zero point.

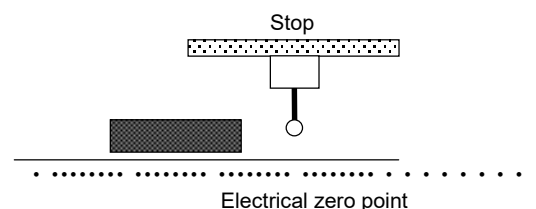

Chapter 6 Setup and Operation

(2) Execution procedure

The execution procedure for dog-type reference point return is shown below.

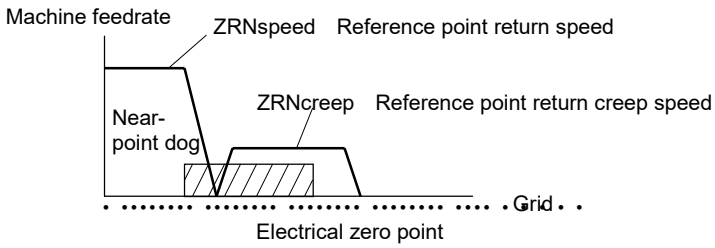
| (1) Initial setting | <p>Confirm that the parameter "#101 cont1.bit D No zero point" setting is to 0 (zero). < Memo > When "#101 cont1 bit-D No zero point"= 1, the specification will be that there is no reference point. The machine position when the power is turned ON becomes the reference point.</p> | | | | | | |
|---|--|---|--------------------|---|---------------------------------|---|----------------------------------|
| (2) Set the speed | <p>Set the parameters that designate the axis feedrate during reference point return "#110 ZRNspeed Reference point return speed" and "#111 ZRNcreep Reference point return creep speed". < Memo > If the reference point return speed is too fast, it may not be able to decelerate fully when the limit switch is ON, and a "dog length insufficient alarm" may occur. If this alarm occurs, decrease the reference point return speed.</p>  | | | | | | |
| (3) Designate the reference point return direction | <p>Determine the motor rotation direction for reference point return execution with parameter "#101 cont1.bit8 Reference point return direction".</p> <table border="1" data-bbox="550 891 1401 1016"> <thead> <tr> <th># 101 cont1. bit8 Reference point return direction</th> <th>Approach direction</th> </tr> </thead> <tbody> <tr> <td>0</td> <td>Motor rotates CW and approaches</td> </tr> <tr> <td>1</td> <td>Motor rotates CCW and approaches</td> </tr> </tbody> </table> | # 101 cont1. bit8 Reference point return direction | Approach direction | 0 | Motor rotates CW and approaches | 1 | Motor rotates CCW and approaches |
| # 101 cont1. bit8 Reference point return direction | Approach direction | | | | | | |
| 0 | Motor rotates CW and approaches | | | | | | |
| 1 | Motor rotates CCW and approaches | | | | | | |
| (4) Select the reference point mode | <p>When the "reference point return mode (ZRN)" signal is turned ON, and the start signal is turned ON, reference point return will be executed. The axis automatically stops at the electrical zero point. < Memo > The default settings are electrical zero point = reference point = coordinate zero point. Refer to the next section when setting the reference point and coordinate zero point to a different position than the electrical zero point.</p> | | | | | | |

| No. | Abbrev. | Parameter name | Default value | Unit | Explanation | Setting range | | | | | | | | | | | | | | | | | | | | | | | | | | | | | | | | | | | | | | | | | | | | | | | | | | | | | | | | | | | |
|---------------|---|---|--|------------------|---|---------------|-----|---|---|---|---|---|---|---|---|---|---|---|---|---|---|---|---|---------------|---|---|---|---|---|---|---|---|---|---|---|---|---|---|---|---|-----|--------------------------|--------------------------|---|---|--|---|--------------------------------------|--------------------------------------|---|--------------------------------------|--|---|--|--|---|--------------------------------------|--|---|--|--|---|--|---|--|
| #101 | *Cont1 | Control parameter 1 | This is a HEX setting parameter. Set bits without a description to their default values. <table border="1" data-bbox="715 1339 1423 1400"> <thead> <tr> <th>bit</th> <th>F</th> <th>E</th> <th>D</th> <th>C</th> <th>B</th> <th>A</th> <th>9</th> <th>8</th> <th>7</th> <th>6</th> <th>5</th> <th>4</th> <th>3</th> <th>2</th> <th>1</th> <th>0</th> </tr> </thead> <tbody> <tr> <td>Default value</td> <td>0</td> <td>0</td> <td>0</td> <td>0</td> <td>0</td> <td>0</td> <td>1</td> <td>0</td> <td>0</td> <td>0</td> <td>0</td> <td>0</td> <td>0</td> <td>0</td> <td>0</td> <td>0</td> </tr> </tbody> </table> <table border="1" data-bbox="715 1422 1423 1836"> <thead> <tr> <th>bit</th> <th>Meaning when "0" is set.</th> <th>Meaning when "1" is set.</th> </tr> </thead> <tbody> <tr> <td>1</td> <td>High-speed zero point return after zero point establishment</td> <td>Dog-type method for each zero point return operation</td> </tr> <tr> <td>8</td> <td>Reference point return direction (+)</td> <td>Reference point return direction (-)</td> </tr> <tr> <td>9</td> <td>Rotation direction determined by DIR</td> <td>Rotation direction in the shortcut direction</td> </tr> <tr> <td>A</td> <td>Machine reference position becomes the reference point</td> <td>Electrical zero point becomes the reference position</td> </tr> <tr> <td>D</td> <td>Coordinate zero point creation valid</td> <td>Zero point established at power supply ON position</td> </tr> <tr> <td>E</td> <td>Rotation direction in DIR or in the shortcut direction</td> <td>Rotation direction in the random position command sign direction</td> </tr> <tr> <td>F</td> <td>Stopper direction is positioning direction</td> <td>Stopper direction is for the stopper amount in the sign direction</td> </tr> </tbody> </table> | | | | bit | F | E | D | C | B | A | 9 | 8 | 7 | 6 | 5 | 4 | 3 | 2 | 1 | 0 | Default value | 0 | 0 | 0 | 0 | 0 | 0 | 1 | 0 | 0 | 0 | 0 | 0 | 0 | 0 | 0 | 0 | bit | Meaning when "0" is set. | Meaning when "1" is set. | 1 | High-speed zero point return after zero point establishment | Dog-type method for each zero point return operation | 8 | Reference point return direction (+) | Reference point return direction (-) | 9 | Rotation direction determined by DIR | Rotation direction in the shortcut direction | A | Machine reference position becomes the reference point | Electrical zero point becomes the reference position | D | Coordinate zero point creation valid | Zero point established at power supply ON position | E | Rotation direction in DIR or in the shortcut direction | Rotation direction in the random position command sign direction | F | Stopper direction is positioning direction | Stopper direction is for the stopper amount in the sign direction | |
| bit | F | E | D | C | B | A | 9 | 8 | 7 | 6 | 5 | 4 | 3 | 2 | 1 | 0 | | | | | | | | | | | | | | | | | | | | | | | | | | | | | | | | | | | | | | | | | | | | | | | | | |
| Default value | 0 | 0 | 0 | 0 | 0 | 0 | 1 | 0 | 0 | 0 | 0 | 0 | 0 | 0 | 0 | 0 | | | | | | | | | | | | | | | | | | | | | | | | | | | | | | | | | | | | | | | | | | | | | | | | | |
| bit | Meaning when "0" is set. | Meaning when "1" is set. | | | | | | | | | | | | | | | | | | | | | | | | | | | | | | | | | | | | | | | | | | | | | | | | | | | | | | | | | | | | | | | |
| 1 | High-speed zero point return after zero point establishment | Dog-type method for each zero point return operation | | | | | | | | | | | | | | | | | | | | | | | | | | | | | | | | | | | | | | | | | | | | | | | | | | | | | | | | | | | | | | | |
| 8 | Reference point return direction (+) | Reference point return direction (-) | | | | | | | | | | | | | | | | | | | | | | | | | | | | | | | | | | | | | | | | | | | | | | | | | | | | | | | | | | | | | | | |
| 9 | Rotation direction determined by DIR | Rotation direction in the shortcut direction | | | | | | | | | | | | | | | | | | | | | | | | | | | | | | | | | | | | | | | | | | | | | | | | | | | | | | | | | | | | | | | |
| A | Machine reference position becomes the reference point | Electrical zero point becomes the reference position | | | | | | | | | | | | | | | | | | | | | | | | | | | | | | | | | | | | | | | | | | | | | | | | | | | | | | | | | | | | | | | |
| D | Coordinate zero point creation valid | Zero point established at power supply ON position | | | | | | | | | | | | | | | | | | | | | | | | | | | | | | | | | | | | | | | | | | | | | | | | | | | | | | | | | | | | | | | |
| E | Rotation direction in DIR or in the shortcut direction | Rotation direction in the random position command sign direction | | | | | | | | | | | | | | | | | | | | | | | | | | | | | | | | | | | | | | | | | | | | | | | | | | | | | | | | | | | | | | | |
| F | Stopper direction is positioning direction | Stopper direction is for the stopper amount in the sign direction | | | | | | | | | | | | | | | | | | | | | | | | | | | | | | | | | | | | | | | | | | | | | | | | | | | | | | | | | | | | | | | |
| #110 | ZRNspeed | Reference point return speed | 1000 | deg/min (mm/min) | Set the clamp value for the feedrate when a reference point return is carried out. The feedrate becomes the manual operation speed of the parameter group selected at that time, but it is clamped by this parameter setting value. | 1~100000 | | | | | | | | | | | | | | | | | | | | | | | | | | | | | | | | | | | | | | | | | | | | | | | | | | | | | | | | | | | |
| #111 | ZRNcreep | Reference point return creep speed | 200 | deg/min (mm/min) | Set the approach speed to the reference point after dog detection during a reference point return. | 1~65535 | | | | | | | | | | | | | | | | | | | | | | | | | | | | | | | | | | | | | | | | | | | | | | | | | | | | | | | | | | | |

Chapter 6 Setup and Operation

6-3-2 Adjusting the dog-type reference point return

The procedure to adjust the reference point return should always be executed in the following order.

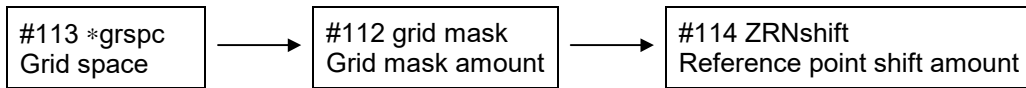

(1) Setting the grid spacing

The normal grid spacing is a space per rotation of the detector. When incremental system detection is used, the grid spacing per detector rotation can be pseudo-divided. Using this, the distance from leaving the dog to reaching the electrical zero point becomes shorter, and the time necessary for reference point return can be shortened.

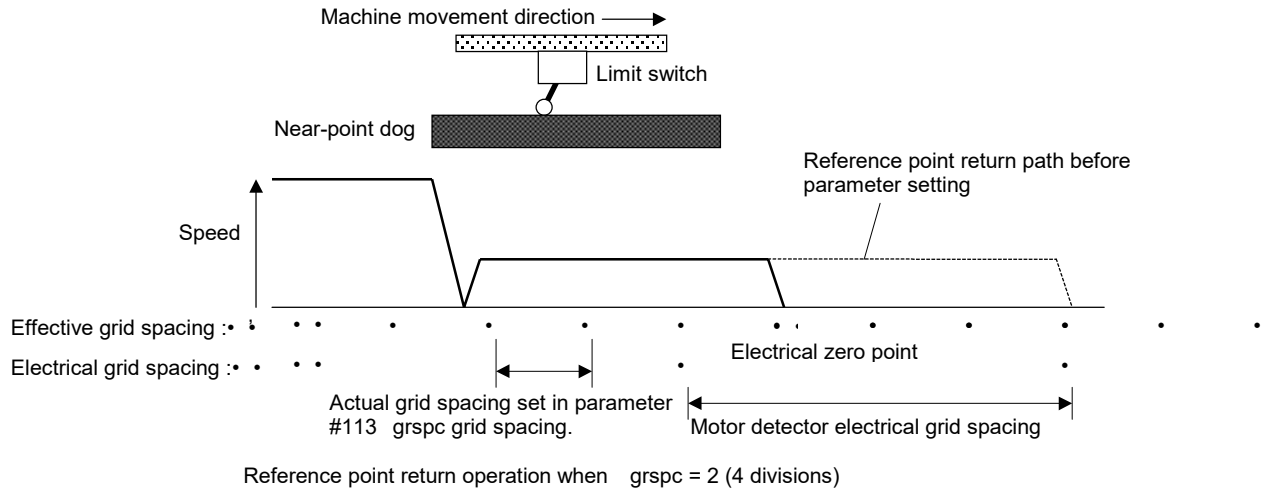

The divided grid spacing is obtained with the following expression.

Electrical grid spacing : τ

$$= \frac{\text{No. of gear teeth on the motor side}}{\text{No. of gear teeth on the machine side}} \times \text{Pitch} = \text{Movement amount per motor rotation}$$

$$\text{Effective grid spacing } \tau' = \frac{\text{Electrical grid spacing } \tau}{2^n} \quad (n: \#113 \text{ grspc grid spacing})$$

| No. | Abbrev. | Parameter name | Default value | Unit | Explanation | Setting range |
|------|---------|----------------|---------------|-------------------|--|---------------|
| #113 | *grspc | Grid spacing | 0 | $1/2^n$ divisions | Divide the grid spacing that is the conventional motor rotation movement amount into 2, 4, 8, or 16 divisions. | 0 ~ 4 |

Chapter 6 Setup and Operation

(2) Setting the grid mask

After leaving the dog, the first grid point becomes the reference point. However, if the position where the dog is left and the grid point are close, the second grid encountered may accidentally become the reference point. This is due to variation in the time the limit switch contact takes to turn OFF. Ideally, the position where the dog is left should be in the center of the grid spacing.

The dog installation can be changed and this can be adjusted. However, by pseudo-extending the dog length with the parameter "#112 grid mask Grid mask amount", the dog OFF point can be simply and ideally adjusted.

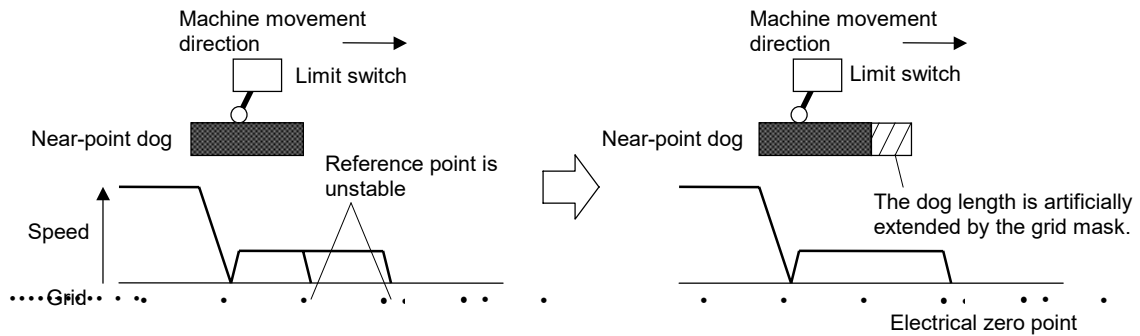

| No. | Abbrev. | Parameter name | Default value | Unit | Explanation | Setting range |
|------|-----------|------------------|---------------|----------------|---|---------------|
| #112 | grid mask | Grid mask amount | 0 | 1/1000deg (μm) | Set the amount that the dog is artificially extended. Set 1/2 the grid spacing as a standard. | 0 ~ 65536 |

(3) Setting the reference point shift amount

To set the reference point (machine zero point) to a random position, outside the equally spaced grid points, set the shift amount in the parameter "#114 ZRNshift Reference point shift amount".

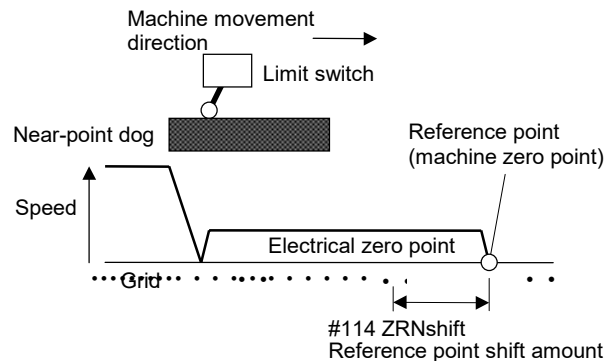

| No. | Abbrev. | Parameter name | Default value | Unit | Explanation | Setting range |
|------|----------|------------------------------|---------------|----------------|---|---------------|
| #114 | ZRNshift | Reference point shift amount | 0 | 1/1000deg (μm) | Set the shift amount in a dog-type reference point return from the electric zero point determined on the grid to the reference point. | 0 ~ 65536 |

(4) Adjusting the reference point return speed

When the near-point dog signal is turned OFF in dog-type reference point returns, the machine stops temporarily, the distance to the electric zero point is obtained, and the movement at creep speed begins. If the near-point dog is short at this time, the machine is not able to stop within the dog, and the changeover to the creep speed occurs away from the dog. Because of this, the initial grid may not be read. In this case, lower the reference point return speed, and adjust so the changeover to creep speed occurs within the dog.

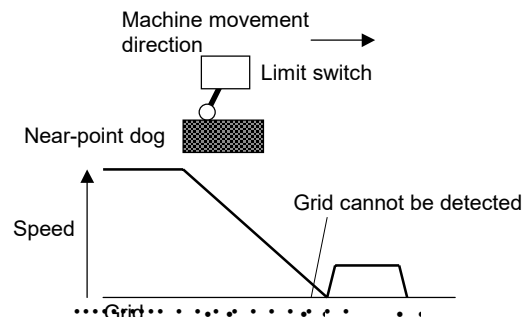

| No. | Abbrev. | Parameter name | Default value | Unit | Explanation | Setting range |
|------|----------|------------------------------|---------------|------------------|--|---------------|
| #110 | ZRNspped | Reference point return speed | 1000 | deg/min (mm/min) | Set the clamp value of the feedrate during a reference point return. | 1~100000 |

Chapter 6 Setup and Operation

6-3-3 Memory-type reference point return

This function registers the reference point in the controller of the incremental system, and executes rapid reference point return.

Only the first reference point return after the power is turned ON is with the dog-type method. All subsequent returns after the first time are carried out with the memory method. Set parameter "#101 Cont1.bit1" to "1" to have the machine carry out dog-type reference point returns subsequent to the first return also.

| # 101 Cont1.bit1 | Explanation |
|------------------|---|
| 0 | A dog-type reference point index operation is carried out before the reference point is determined (first time), but after the reference point is determined positioning to the reference point is carried out at high speed (without being clamped at the ZRNspeed). |
| 1 | For reference point return operations, reference point index operations are carried out each time with the dog-type method regardless of the reference point determination. |

6-3-4 Mode with no reference point

In this mode the position when the machine is turned ON in the incremental system becomes the reference point.

It can be changed by the parameter "#101 Cont1.bit D.

| # 101 Cont1.bit D | Explanation |
|-------------------|--|
| 0 | A dog-type reference point return operation is required to determine the reference point. |
| 1 | The position where the power was turned ON becomes the reference point. A dog-type reference point return operation is not required. |

| No. | Abbrev. | Parameter name | Default value | Unit | Explanation | Setting range | | | | | | | | | | | | | | | | | | | | | | | | | | | | | | | | | | |
|---------------|---|---|---|------|--|---------------|-----|--------------------------|--------------------------|---|---|--|---|--------------------------------------|--------------------------------------|---|--------------------------------------|--|---|--|--|---|--------------------------------------|--|---|--|--|---|--|---|---|---|---|---|---|---|---|---|---|---|
| #101 | *Cont1 | Control parameter 1 | | | This is a HEX setting parameter. Set bits without a description to their default values. | | | | | | | | | | | | | | | | | | | | | | | | | | | | | | | | | | | |
| | | | <table border="1"> <thead> <tr> <th>bit</th> <th>F</th> <th>E</th> <th>D</th> <th>C</th> <th>B</th> <th>A</th> <th>9</th> <th>8</th> <th>7</th> <th>6</th> <th>5</th> <th>4</th> <th>3</th> <th>2</th> <th>1</th> <th>0</th> </tr> </thead> <tbody> <tr> <td>Default value</td> <td>0</td> <td>0</td> <td>0</td> <td>0</td> <td>0</td> <td>0</td> <td>1</td> <td>0</td> <td>0</td> <td>0</td> <td>0</td> <td>0</td> <td>0</td> <td>0</td> <td>0</td> <td>0</td> </tr> </tbody> </table> | | | | bit | F | E | D | C | B | A | 9 | 8 | 7 | 6 | 5 | 4 | 3 | 2 | 1 | 0 | Default value | 0 | 0 | 0 | 0 | 0 | 0 | 1 | 0 | 0 | 0 | 0 | 0 | 0 | 0 | 0 | 0 |
| bit | F | E | D | C | B | A | 9 | 8 | 7 | 6 | 5 | 4 | 3 | 2 | 1 | 0 | | | | | | | | | | | | | | | | | | | | | | | | |
| Default value | 0 | 0 | 0 | 0 | 0 | 0 | 1 | 0 | 0 | 0 | 0 | 0 | 0 | 0 | 0 | 0 | | | | | | | | | | | | | | | | | | | | | | | | |
| | | | <table border="1"> <thead> <tr> <th>bit</th> <th>Meaning when "0" is set.</th> <th>Meaning when "1" is set.</th> </tr> </thead> <tbody> <tr> <td>1</td> <td>High-speed zero point return after zero point establishment</td> <td>Dog-type method for each zero point return operation</td> </tr> <tr> <td>8</td> <td>Reference point return direction (+)</td> <td>Reference point return direction (-)</td> </tr> <tr> <td>9</td> <td>Rotation direction determined by DIR</td> <td>Rotation direction in the shortcut direction</td> </tr> <tr> <td>A</td> <td>Machine reference position becomes the reference point</td> <td>Electrical zero point becomes the reference position</td> </tr> <tr> <td>D</td> <td>Coordinate zero point creation valid</td> <td>Zero point established at power supply ON position</td> </tr> <tr> <td>E</td> <td>Rotation direction in DIR or in the shortcut direction</td> <td>Rotation direction in the random position command sign direction</td> </tr> <tr> <td>F</td> <td>Stopper direction is positioning direction</td> <td>Stopper direction is for the stopper amount in the sign direction</td> </tr> </tbody> </table> | | | | bit | Meaning when "0" is set. | Meaning when "1" is set. | 1 | High-speed zero point return after zero point establishment | Dog-type method for each zero point return operation | 8 | Reference point return direction (+) | Reference point return direction (-) | 9 | Rotation direction determined by DIR | Rotation direction in the shortcut direction | A | Machine reference position becomes the reference point | Electrical zero point becomes the reference position | D | Coordinate zero point creation valid | Zero point established at power supply ON position | E | Rotation direction in DIR or in the shortcut direction | Rotation direction in the random position command sign direction | F | Stopper direction is positioning direction | Stopper direction is for the stopper amount in the sign direction | | | | | | | | | | |
| bit | Meaning when "0" is set. | Meaning when "1" is set. | | | | | | | | | | | | | | | | | | | | | | | | | | | | | | | | | | | | | | |
| 1 | High-speed zero point return after zero point establishment | Dog-type method for each zero point return operation | | | | | | | | | | | | | | | | | | | | | | | | | | | | | | | | | | | | | | |
| 8 | Reference point return direction (+) | Reference point return direction (-) | | | | | | | | | | | | | | | | | | | | | | | | | | | | | | | | | | | | | | |
| 9 | Rotation direction determined by DIR | Rotation direction in the shortcut direction | | | | | | | | | | | | | | | | | | | | | | | | | | | | | | | | | | | | | | |
| A | Machine reference position becomes the reference point | Electrical zero point becomes the reference position | | | | | | | | | | | | | | | | | | | | | | | | | | | | | | | | | | | | | | |
| D | Coordinate zero point creation valid | Zero point established at power supply ON position | | | | | | | | | | | | | | | | | | | | | | | | | | | | | | | | | | | | | | |
| E | Rotation direction in DIR or in the shortcut direction | Rotation direction in the random position command sign direction | | | | | | | | | | | | | | | | | | | | | | | | | | | | | | | | | | | | | | |
| F | Stopper direction is positioning direction | Stopper direction is for the stopper amount in the sign direction | | | | | | | | | | | | | | | | | | | | | | | | | | | | | | | | | | | | | | |

6-4 Positioning operations by the station method

This method equally divides one rotation of the rotation axis (360 degrees) and uses the respective division points as positioning targets.

These equally divided respective points are called stations, and are automatically assigned station Nos. in order from the one nearest to the reference point (zero point).

6-4-1 Setting the station

(1) Setting the No. of stations

Set the No. of equal divisions of one rotation (360 degrees) of the rotation axis (the No. of stations) in the parameter "#100 station No. of Indexing stations". The No. of stations is an integer from 2~360. Set station 1 in the reference point, and assign the station Nos. from station 2 onwards in order in the motor CW (forward run) direction.

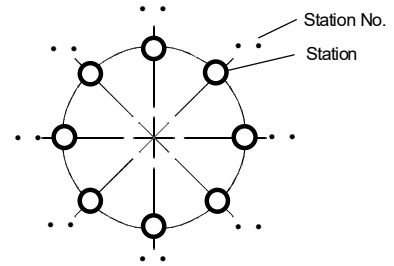

Example of stations determined with 8 equal divisions

(2) Setting the station offset

By setting the distance between the reference point and the station No. "1" position (station offset amount), the position of all stations can be shifted.

When the offset amount is 0 (zero), the reference point becomes the station No. "1" position.

Set the station offset amount in parameter "#115 ST. offset Station offset".

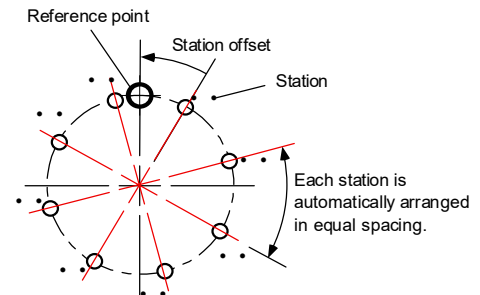

POINT

In the dogless method absolute position detection system, the coordinate zero point is determined first, then the reference point is determined by the parameter (the opposite for dog-type). Consequently, even if the station offset is set, the coordinate zero point (station 1 position) will not shift, and the reference point side will shift. In this case, shift the coordinate zero point in the "#116 ABS Base Absolute position zero point" setting.

Chapter 6 Setup and Operation

(3) Setting the station No. automatic assignment direction

The station No. assignment direction can be selected with parameters.

| # 102 Cont1.bit3 | Explanation |
|------------------|--|
| 0 | Assign the station Nos. in the motor rotation CW direction. When forward run is selected in rotation direction (DIR), the motor rotates in the CW direction (in the direction of increasing station Nos.). |
| 1 | Assign the station Nos. in the motor rotation CCW direction. When forward run is selected in rotation direction (DIR), the motor rotates in the CCW direction (in the direction of increasing station Nos.). |

| No. | Abbrev. | Parameter name | Default value | Unit | Explanation | Setting range | | | | | | | | | | | | | | | | | | | | | | | | | | | | | | | | | | |
|---------------|----------------------------------|----------------------------------|---|----------|--|--------------------------|-----|--------------------------|--------------------------|---|----------------------------------|------------------------------|---|-------------|---------------|---|---------------------------------|----------------------------------|---|---------------|-------------------|---|--------------------------------|-------------------------------|---|-------------------------------|-------------------------------|---|-----------------------|-----------------------------|---|---|---|---|---|---|---|---|---|---|
| #100 | *station | Index No. of stations | 2 | | Set the No. of stations. In linear axes, the No. of divisions = No. of stations – 1. | 2 ~ 360 | | | | | | | | | | | | | | | | | | | | | | | | | | | | | | | | | | |
| #102 | *Cont2 | Control parameter 2 | This is a HEX setting parameter. Set bits without a description to their default values. | | | | | | | | | | | | | | | | | | | | | | | | | | | | | | | | | | | | | |
| | | | <table border="1"> <thead> <tr> <th>bit</th> <th>F</th> <th>E</th> <th>D</th> <th>C</th> <th>B</th> <th>A</th> <th>9</th> <th>8</th> <th>7</th> <th>6</th> <th>5</th> <th>4</th> <th>3</th> <th>2</th> <th>1</th> <th>0</th> </tr> </thead> <tbody> <tr> <td>Default value</td> <td>0</td> <td>0</td> <td>0</td> <td>0</td> <td>0</td> <td>0</td> <td>0</td> <td>0</td> <td>1</td> <td>0</td> <td>0</td> <td>0</td> <td>0</td> <td>1</td> <td>1</td> <td>0</td> </tr> </tbody> </table> | | | | bit | F | E | D | C | B | A | 9 | 8 | 7 | 6 | 5 | 4 | 3 | 2 | 1 | 0 | Default value | 0 | 0 | 0 | 0 | 0 | 0 | 0 | 0 | 1 | 0 | 0 | 0 | 0 | 1 | 1 | 0 |
| bit | F | E | D | C | B | A | 9 | 8 | 7 | 6 | 5 | 4 | 3 | 2 | 1 | 0 | | | | | | | | | | | | | | | | | | | | | | | | |
| Default value | 0 | 0 | 0 | 0 | 0 | 0 | 0 | 0 | 1 | 0 | 0 | 0 | 0 | 1 | 1 | 0 | | | | | | | | | | | | | | | | | | | | | | | | |
| | | | <table border="1"> <thead> <tr> <th>bit</th> <th>Meaning when "0" is set.</th> <th>Meaning when "1" is set.</th> </tr> </thead> <tbody> <tr> <td>1</td> <td>Error not corrected at servo OFF</td> <td>Error corrected at servo OFF</td> </tr> <tr> <td>2</td> <td>Linear axis</td> <td>Rotation axis</td> </tr> <tr> <td>3</td> <td>Station assignment direction CW</td> <td>Station assignment direction CCW</td> </tr> <tr> <td>4</td> <td>Uniform index</td> <td>Non-uniform index</td> </tr> <tr> <td>5</td> <td>DO channel standard assignment</td> <td>DO channel reverse assignment</td> </tr> <tr> <td>6</td> <td>2-wire detector communication</td> <td>4-wire detector communication</td> </tr> <tr> <td>7</td> <td>Incremental detection</td> <td>Absolute position detection</td> </tr> </tbody> </table> | | | | bit | Meaning when "0" is set. | Meaning when "1" is set. | 1 | Error not corrected at servo OFF | Error corrected at servo OFF | 2 | Linear axis | Rotation axis | 3 | Station assignment direction CW | Station assignment direction CCW | 4 | Uniform index | Non-uniform index | 5 | DO channel standard assignment | DO channel reverse assignment | 6 | 2-wire detector communication | 4-wire detector communication | 7 | Incremental detection | Absolute position detection | | | | | | | | | | |
| bit | Meaning when "0" is set. | Meaning when "1" is set. | | | | | | | | | | | | | | | | | | | | | | | | | | | | | | | | | | | | | | |
| 1 | Error not corrected at servo OFF | Error corrected at servo OFF | | | | | | | | | | | | | | | | | | | | | | | | | | | | | | | | | | | | | | |
| 2 | Linear axis | Rotation axis | | | | | | | | | | | | | | | | | | | | | | | | | | | | | | | | | | | | | | |
| 3 | Station assignment direction CW | Station assignment direction CCW | | | | | | | | | | | | | | | | | | | | | | | | | | | | | | | | | | | | | | |
| 4 | Uniform index | Non-uniform index | | | | | | | | | | | | | | | | | | | | | | | | | | | | | | | | | | | | | | |
| 5 | DO channel standard assignment | DO channel reverse assignment | | | | | | | | | | | | | | | | | | | | | | | | | | | | | | | | | | | | | | |
| 6 | 2-wire detector communication | 4-wire detector communication | | | | | | | | | | | | | | | | | | | | | | | | | | | | | | | | | | | | | | |
| 7 | Incremental detection | Absolute position detection | | | | | | | | | | | | | | | | | | | | | | | | | | | | | | | | | | | | | | |
| #115 | ST.offset | Station offset | 0.000 | deg (mm) | Set the distance (offset) from the reference point to station 1. | -99999.999 ~ 9999.999 | | | | | | | | | | | | | | | | | | | | | | | | | | | | | | | | | | |

Chapter 6 Setup and Operation

6-4-2 Setting linear axis stations

(1) For uniform assignment

In linear axes, determine the spacing between stations from the stroke length and No. of stations, and assign stations at uniform spacing. Station 1 is assigned to the coordinate zero point (coordinate position = 0). Set the station Nos. in order following the assignment direction parameter (#102.bit3). Thus, the final station is set at the coordinates separated from station 1 by only the linear axis stroke length (#104 tleng).

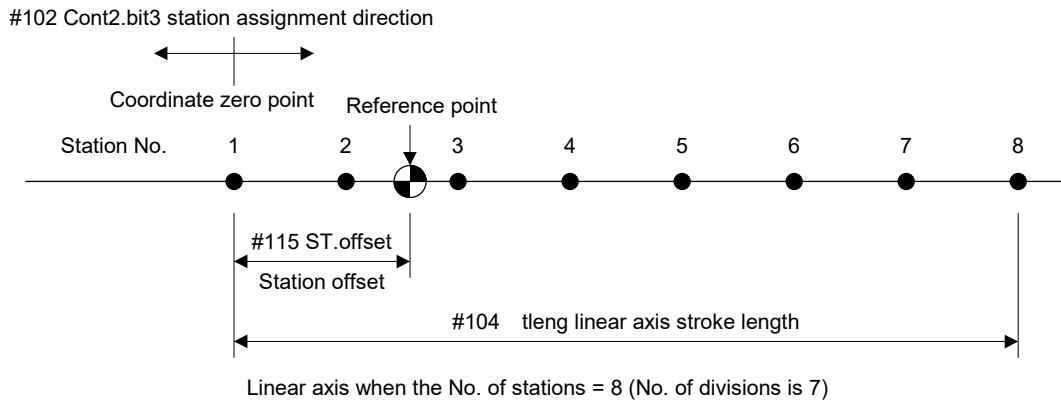

| No. | Abbrev. | Parameter name | Default value | Unit | Explanation | Setting range | | | | | | | | | | | | | | | | | | | | | | | | | | | | | | | | | | | |
|---|----------------------------------|----------------------------------|--|----------|---|------------------------|-----|--------------------------|--------------------------|---|----------------------------------|------------------------------|---|-------------|---------------|---|---------------------------------|----------------------------------|---|---------------|-------------------|---|--------------------------------|-------------------------------|---|-------------------------------|-------------------------------|---|-----------------------|-----------------------------|---|---|---|---|---|---|---|---|---|---|---|
| #100 | *station | Index No. of stations | 2 | | Set the No. of stations. In linear axes, the No. of divisions = No. of stations – 1. | 2 ~ 360 | | | | | | | | | | | | | | | | | | | | | | | | | | | | | | | | | | | |
| #102 | *Cont2 | Control parameter 2 | This is a HEX setting parameter. Set bits without a description to their default values. | | | | | | | | | | | | | | | | | | | | | | | | | | | | | | | | | | | | | | |
| <table border="1"> <thead> <tr> <th>bit</th> <th>F</th> <th>E</th> <th>D</th> <th>C</th> <th>B</th> <th>A</th> <th>9</th> <th>8</th> <th>7</th> <th>6</th> <th>5</th> <th>4</th> <th>3</th> <th>2</th> <th>1</th> <th>0</th> </tr> </thead> <tbody> <tr> <td>Default value</td> <td>0</td> <td>0</td> <td>0</td> <td>0</td> <td>0</td> <td>0</td> <td>0</td> <td>0</td> <td>1</td> <td>0</td> <td>0</td> <td>0</td> <td>0</td> <td>0</td> <td>1</td> <td>1</td> <td>0</td> </tr> </tbody> </table> | | | | | | | bit | F | E | D | C | B | A | 9 | 8 | 7 | 6 | 5 | 4 | 3 | 2 | 1 | 0 | Default value | 0 | 0 | 0 | 0 | 0 | 0 | 0 | 0 | 1 | 0 | 0 | 0 | 0 | 0 | 1 | 1 | 0 |
| bit | F | E | D | C | B | A | 9 | 8 | 7 | 6 | 5 | 4 | 3 | 2 | 1 | 0 | | | | | | | | | | | | | | | | | | | | | | | | | |
| Default value | 0 | 0 | 0 | 0 | 0 | 0 | 0 | 0 | 1 | 0 | 0 | 0 | 0 | 0 | 1 | 1 | 0 | | | | | | | | | | | | | | | | | | | | | | | | |
| <table border="1"> <thead> <tr> <th>bit</th> <th>Meaning when "0" is set.</th> <th>Meaning when "1" is set.</th> </tr> </thead> <tbody> <tr> <td>1</td> <td>Error not corrected at servo OFF</td> <td>Error corrected at servo OFF</td> </tr> <tr> <td>2</td> <td>Linear axis</td> <td>Rotation axis</td> </tr> <tr> <td>3</td> <td>Station assignment direction CW</td> <td>Station assignment direction CCW</td> </tr> <tr> <td>4</td> <td>Uniform index</td> <td>Non-uniform index</td> </tr> <tr> <td>5</td> <td>DO channel standard assignment</td> <td>DO channel reverse assignment</td> </tr> <tr> <td>6</td> <td>2-wire detector communication</td> <td>4-wire detector communication</td> </tr> <tr> <td>7</td> <td>Incremental detection</td> <td>Absolute position detection</td> </tr> </tbody> </table> | | | | | | | bit | Meaning when "0" is set. | Meaning when "1" is set. | 1 | Error not corrected at servo OFF | Error corrected at servo OFF | 2 | Linear axis | Rotation axis | 3 | Station assignment direction CW | Station assignment direction CCW | 4 | Uniform index | Non-uniform index | 5 | DO channel standard assignment | DO channel reverse assignment | 6 | 2-wire detector communication | 4-wire detector communication | 7 | Incremental detection | Absolute position detection | | | | | | | | | | | |
| bit | Meaning when "0" is set. | Meaning when "1" is set. | | | | | | | | | | | | | | | | | | | | | | | | | | | | | | | | | | | | | | | |
| 1 | Error not corrected at servo OFF | Error corrected at servo OFF | | | | | | | | | | | | | | | | | | | | | | | | | | | | | | | | | | | | | | | |
| 2 | Linear axis | Rotation axis | | | | | | | | | | | | | | | | | | | | | | | | | | | | | | | | | | | | | | | |
| 3 | Station assignment direction CW | Station assignment direction CCW | | | | | | | | | | | | | | | | | | | | | | | | | | | | | | | | | | | | | | | |
| 4 | Uniform index | Non-uniform index | | | | | | | | | | | | | | | | | | | | | | | | | | | | | | | | | | | | | | | |
| 5 | DO channel standard assignment | DO channel reverse assignment | | | | | | | | | | | | | | | | | | | | | | | | | | | | | | | | | | | | | | | |
| 6 | 2-wire detector communication | 4-wire detector communication | | | | | | | | | | | | | | | | | | | | | | | | | | | | | | | | | | | | | | | |
| 7 | Incremental detection | Absolute position detection | | | | | | | | | | | | | | | | | | | | | | | | | | | | | | | | | | | | | | | |
| #104 | *tleng | Linear axis stroke length | 100.00 | mm | Set the movement stroke length for linear axes. This is meaningless when setting non-uniform assignments or commanding random positions. | 0.001 ~ 9999.999 | | | | | | | | | | | | | | | | | | | | | | | | | | | | | | | | | | | |
| #115 | ST.offset | Station offset | 0.000 | deg (mm) | Set the distance (offset) from the reference point to station 1. | -99999.999 ~ 99999.999 | | | | | | | | | | | | | | | | | | | | | | | | | | | | | | | | | | | |



POINT

Set the distance from the reference point (#116 ABS base absolute position zero point) after determining the reference point in the absolute position system, and determine the linear coordinate zero point (station 1).

The reference point is not especially used in the coordinate zero point creation process. However, by setting "0" (default value) in the #115 ST.offset station offset, it is generally used as "reference point = coordinate zero point." In this case, the reference point return operation becomes a positioning operation to the coordinate zero point.



CAUTION

When the station offset (#115 ST.offset) is set, the coordinates of all stations move only the setting value.

Chapter 6 Setup and Operation

(2) For non-uniform assignment

When the required positioning coordinates are not uniformly spaced, set the station positions at the respective coordinate positions. Station 1 is assigned to the coordinate zero point (coordinate position = 0). Up to 9 stations including station 1 can be assigned to random coordinates. This can also be used for rotation axes.

Set parameter "#102 cont2 control parameter 2 bit.4" to "1", select non-uniform assignment, and set the coordinate values of stations 2 to 9 in "#190 stops 2 to #197 stops9".

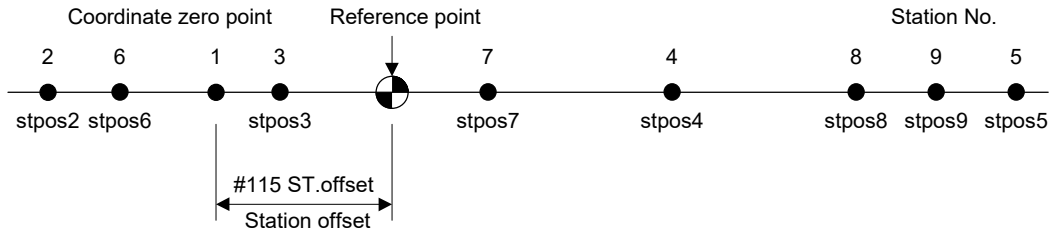

Up to 9 stations can be set (station 1 is fixed at the coordinate zero point)

| No. | Abbrev. | Parameter name | Default value | Unit | Explanation | Setting range |
|------|---------|----------------------------|---------------|----------|---|--------------------------|
| #190 | stpos2 | Station 2 coordinate value | 0.000 | deg (mm) | Set the coordinate value of each station when non-uniform assignment is selected. The station 1 coordinate value is fixed at 0.000 (machine coordinate zero point). | -99999.999 ~99999.999 |
| #191 | stpos3 | Station 3 coordinate value | | | | |
| #192 | stpos4 | Station 4 coordinate value | | | | |
| #193 | stpos5 | Station 5 coordinate value | | | | |
| #194 | stpos6 | Station 6 coordinate value | | | | |
| #195 | stpos7 | Station 7 coordinate value | | | | |
| #196 | stpos8 | Station 8 coordinate value | | | | |
| #197 | stpos9 | Station 9 coordinate value | | | | |



POINT

1. Setting is also possible for rotation axes.
2. The station Nos. do not have to be arrayed in increasing order.
3. Commands are designated with the station Nos. (1 to 9), in the same manner as normal indexing.
4. Station No. 0 designated special feed commands cannot be used.
5. If the required positioning coordinates exceed 9 locations, carry out positioning with a random point feed command.



CAUTION

The coordinates of all stations move only the setting value when the station offset (#115 ST.offset) is set, even if setting non-uniform assignments.

6-4-3 Automatic operation

In this operation mode the automatic positioning is carried out to the designated station No. When the station No. is designated and the operation start is input, positioning is carried out to the station of the designated No. When the positioning is completed, each of the following signals are output: Automatic set position reached (JSTA), Set position reached (JST), Near set position (NEAR), and the station No. (STO1 to STO256). Shortcut rotation direction or direction rotation can be selected using the parameters.

(1) Setting the automatic operation mode

Set the following signals before inputting an operation start signal. The settings are validated when the operation start signal (ST) is input.

| Abbrev. | Signal name | Explanation |
|-------------|---------------------------------------|--|
| AUT | Automatic operation mode selection | Select the automatic operation mode. "M01 0101 No operation mode" will occur if the selected mode duplicates another operation mode. Always leave this signal ON during automatic operation. |
| DIR | Rotation direction | Set the station No. assignment direction to "standard". This is meaningless for shortcut rotation setting. |
| PR1, PR2 | Operation parameter selection 1 and 2 | The operation is carried out with the automatic operation speed (Aspeed) and acceleration/deceleration time constant (timeN.1, timeN.2) of the selected operation group. |
| ST1 ~ ST256 | Station selection 1 to 256 | Set the station No. to which the positioning is carried out. Setting to "0" will result in a special command. |

(2) Starting the automatic operation mode

Start the operation by turning ON the operation start (ST) signal. The operation start is held until positioning is completed.

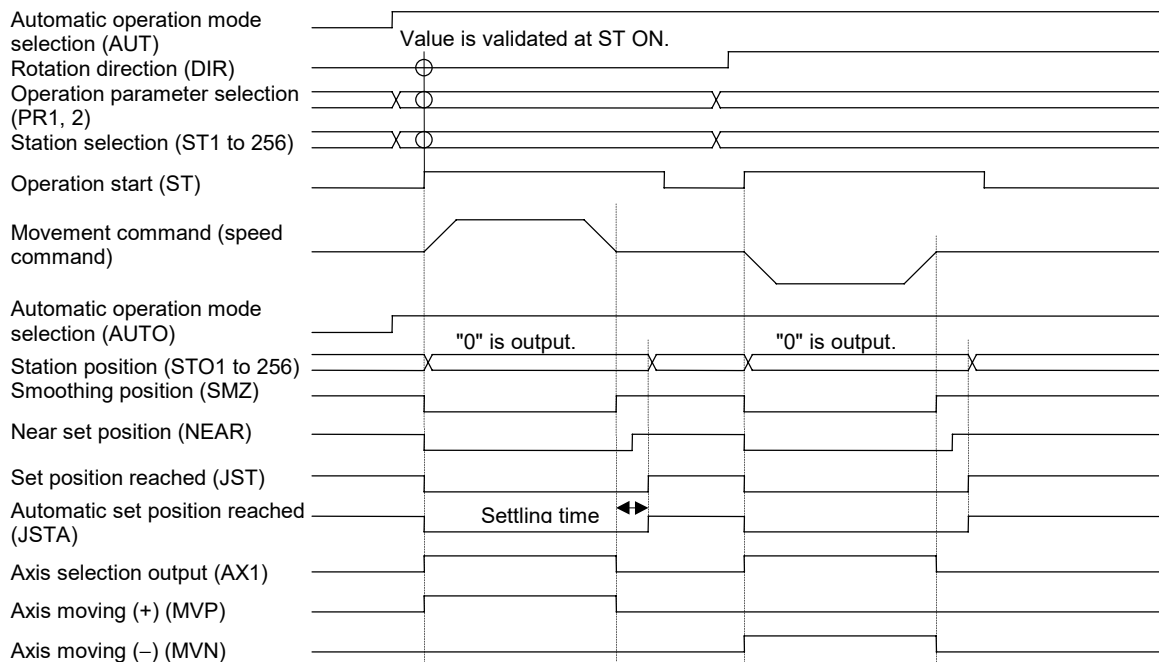

POINT

1. A settling time is required from when the movement commands become zero (SMZ=1) until the positioning is completed. The settling time will lengthen if a set position output width narrower than required is set, so set the required positioning accuracy in the set position output width.
2. If the start signal is turned OFF during positioning, the positioning will be carried out to the nearest station. In this case, an automatic set position reached (JSTA) signal will not be output.



CAUTION

The control axis rotation direction is determined by a combination of the following: Operation mode, input control signal "rotation direction (DIR)", parameter "#101 cont1 control parameter 1.bit9 rotation direction shortcut", and "#102 cont2 control parameter 2. bit3 station assignment direction CCW". At operation start, pay careful attention to the motor rotation direction. When operating the servomotor for the first time, the motor should be operated as a single unit to confirm the operation, etc.

Chapter 6 Setup and Operation

(3) Designating the shortcut rotation control

This function automatically judges the direction with the least rotation when positioning to a station in automatic operation.

When the shortcut rotation control function is valid, the axis rotates in the direction with the fewest No. of motor rotations, and positioning is carried out. Thus, the axis does not rotate over 180 degrees.

(4) Special station No.

A special operation for one station feed is carried out when station No. 0 is designated and a start signal is input. At this time, the operation will differ depending upon whether the machine position is inside or outside the "near" range.

| Station No. | Machine position at start | # 101 Cont1.bit9 | Positioning operation | Explanation drawing |
|-------------|---------------------------|------------------|---|---------------------|
| 0 | Inside the "near" range | - | Positioning is carried out to the next station in the designated rotation direction. | Fig. 1 |
| | Outside the "near" range | 1 | Positioning is carried out to the nearest station in the shortcut rotation direction. | Fig. 2 |
| | | 0 | Positioning is carried out to the nearest station in the designated rotation direction. | Fig. 3 |

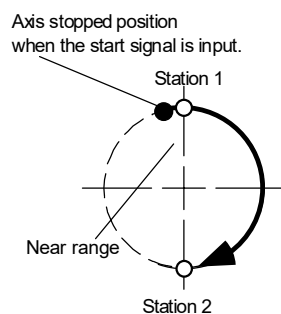

Fig. 1

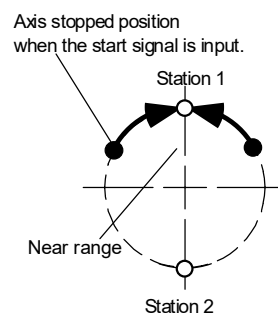

Fig. 2

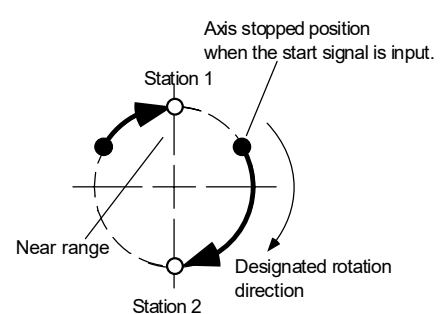

Fig. 3

(5) Random position command operation

In this mode the positioning coordinates are directly commanded from the PLC in 0.001 deg. (mm) units, and positioning is carried out to a random position other than a station. In addition to the settings during normal automatic operation, set the following signals before inputting an operation start signal.

For rotation axes, when #101 Cont1.bitE = 1 is set to "1", the axis rotates in the sign direction of the random position command, and positioning is carried out to coordinates having a plus value separate from the rotation sign. If a command exceeding 360 degrees is issued, the integer expressing "command value/360" becomes the No. of rotations, and the fraction becomes the positioning coordinates.

| Abbrev. | Signal name | Explanation |
|---------|---------------------------------|--|
| STS | Random point feed command valid | The positioning position input from the PLC is validated. Always turn ON during the random position command operation. |

| No. | Abbrev. | Parameter name | Default value | Unit | Explanation | Setting range | | | | | | | | | | | | | | | | | | | | | | | | | | | | | | | | | | |
|---------------|---|---|--|------|--|---------------|-----|--------------------------|--------------------------|---|---|--|---|--------------------------------------|--------------------------------------|---|--------------------------------------|--|---|--|--|---|--------------------------------------|--|---|--|--|---|--|---|---|---|---|---|---|---|---|---|---|---|
| #101 | *Cont1 | Control parameter 1 | | | This is a HEX setting parameter. Set bits without a description to their default values. | | | | | | | | | | | | | | | | | | | | | | | | | | | | | | | | | | | |
| | | | <table border="1" style="width: 100%; text-align: center;"> <tr> <th>bit</th> <td>F</td><td>E</td><td>D</td><td>C</td><td>B</td><td>A</td><td>9</td><td>8</td><td>7</td><td>6</td><td>5</td><td>4</td><td>3</td><td>2</td><td>1</td><td>0</td> </tr> <tr> <th>Default value</th> <td>0</td><td>0</td><td>0</td><td>0</td><td>0</td><td>0</td><td>1</td><td>0</td><td>0</td><td>0</td><td>0</td><td>0</td><td>0</td><td>0</td><td>0</td><td>0</td> </tr> </table> | | | | bit | F | E | D | C | B | A | 9 | 8 | 7 | 6 | 5 | 4 | 3 | 2 | 1 | 0 | Default value | 0 | 0 | 0 | 0 | 0 | 0 | 1 | 0 | 0 | 0 | 0 | 0 | 0 | 0 | 0 | 0 |
| bit | F | E | D | C | B | A | 9 | 8 | 7 | 6 | 5 | 4 | 3 | 2 | 1 | 0 | | | | | | | | | | | | | | | | | | | | | | | | |
| Default value | 0 | 0 | 0 | 0 | 0 | 0 | 1 | 0 | 0 | 0 | 0 | 0 | 0 | 0 | 0 | 0 | | | | | | | | | | | | | | | | | | | | | | | | |
| | | | <table border="1" style="width: 100%; text-align: center;"> <tr> <th>bit</th> <th>Meaning when "0" is set.</th> <th>Meaning when "1" is set.</th> </tr> <tr> <td>1</td> <td>High-speed zero point return after zero point establishment</td> <td>Dog-type method for each zero point return operation</td> </tr> <tr> <td>8</td> <td>Reference point return direction (+)</td> <td>Reference point return direction (-)</td> </tr> <tr> <td>9</td> <td>Rotation direction determined by DIR</td> <td>Rotation direction in the shortcut direction</td> </tr> <tr> <td>A</td> <td>Machine reference position becomes the reference point</td> <td>Electrical zero point becomes the reference position</td> </tr> <tr> <td>D</td> <td>Coordinate zero point creation valid</td> <td>Zero point established at power supply ON position</td> </tr> <tr> <td>E</td> <td>Rotation direction in DIR or in the shortcut direction</td> <td>Rotation direction in the random position command sign direction</td> </tr> <tr> <td>F</td> <td>Stopper direction is positioning direction</td> <td>Stopper direction is for the stopper amount in the sign direction</td> </tr> </table> | | | | bit | Meaning when "0" is set. | Meaning when "1" is set. | 1 | High-speed zero point return after zero point establishment | Dog-type method for each zero point return operation | 8 | Reference point return direction (+) | Reference point return direction (-) | 9 | Rotation direction determined by DIR | Rotation direction in the shortcut direction | A | Machine reference position becomes the reference point | Electrical zero point becomes the reference position | D | Coordinate zero point creation valid | Zero point established at power supply ON position | E | Rotation direction in DIR or in the shortcut direction | Rotation direction in the random position command sign direction | F | Stopper direction is positioning direction | Stopper direction is for the stopper amount in the sign direction | | | | | | | | | | |
| bit | Meaning when "0" is set. | Meaning when "1" is set. | | | | | | | | | | | | | | | | | | | | | | | | | | | | | | | | | | | | | | |
| 1 | High-speed zero point return after zero point establishment | Dog-type method for each zero point return operation | | | | | | | | | | | | | | | | | | | | | | | | | | | | | | | | | | | | | | |
| 8 | Reference point return direction (+) | Reference point return direction (-) | | | | | | | | | | | | | | | | | | | | | | | | | | | | | | | | | | | | | | |
| 9 | Rotation direction determined by DIR | Rotation direction in the shortcut direction | | | | | | | | | | | | | | | | | | | | | | | | | | | | | | | | | | | | | | |
| A | Machine reference position becomes the reference point | Electrical zero point becomes the reference position | | | | | | | | | | | | | | | | | | | | | | | | | | | | | | | | | | | | | | |
| D | Coordinate zero point creation valid | Zero point established at power supply ON position | | | | | | | | | | | | | | | | | | | | | | | | | | | | | | | | | | | | | | |
| E | Rotation direction in DIR or in the shortcut direction | Rotation direction in the random position command sign direction | | | | | | | | | | | | | | | | | | | | | | | | | | | | | | | | | | | | | | |
| F | Stopper direction is positioning direction | Stopper direction is for the stopper amount in the sign direction | | | | | | | | | | | | | | | | | | | | | | | | | | | | | | | | | | | | | | |

6-4-4 Manual operation

In this operation mode, the axis is moved only while the operation start signal is being input. Positioning is carried out to the nearest station after the operation start signal turns OFF. When the positioning is completed, the following signals are output: Set position reached (JST), Near set position (NEAR), and the station No. (STO1 to STO256).

(1) Setting the manual operation mode

Set the following signals before inputting an operation start signal. The settings are validated when the operation start signal (ST) is input.

| Abbrev. | Signal name | Explanation |
|----------|---------------------------------------|--|
| MAN | Manual operation mode selection | Select the manual operation mode. "M01 0101 No operation mode" will occur if the selected mode duplicates another operation mode. Always leave this signal ON during manual operation. |
| DIR | Rotation direction | Set the station No. assignment direction to "standard". |
| PR1, PR2 | Operation parameter selection 1 and 2 | The operation is carried out with the manual operation speed (Mspeed) and acceleration/deceleration time constant (timeN.1, timeN.2) of the selected operation group. |

(2) Starting the manual operation mode

Start the operation by turning ON the operation start (ST) signal. The operation start is held until positioning is completed.

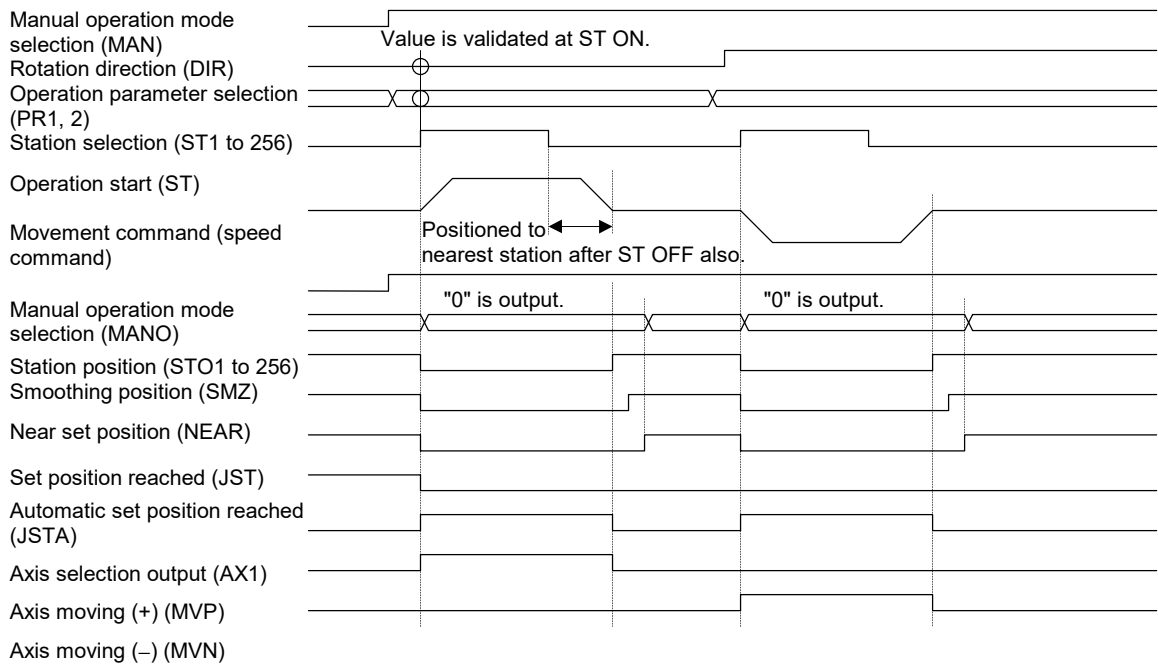

POINT

In the manual operation mode, the automatic set position reached (JSTA) signal does not turn ON, even when positioning is carried out to a station.

Chapter 6 Setup and Operation

6-5 Stopper positioning operation

In this operation mode, positioning is carried out with the axis presses against a stopper, etc.

This operation mode is an expansion function of random position designation automatic operation. Besides normal random point positioning, stopper operation and torque control are automatically carried out.



POINT

The station method is not used in stopper positioning operations. Commands are carried out with random position command operations.

6-5-1 Operation sequence

(1) Setting the stopper positioning operation mode

Set the following signals before the operation start signal. When the stopper positioning command valid (PUS) signal is turned ON, and random position positioning is carried out to the stopper starting coordinates, stopper positioning is carried out after positioning is completed, following the value set in the parameters.

| Abbrev. | Signal name | Explanation |
|---------|------------------------------------|--|
| AUT | Automatic operation mode selection | Select the automatic operation mode. "M01 0101 No operation mode" will occur if the selected mode duplicates another operation mode. |
| PUS | Stopper positioning command valid | Select the stopper positioning mode. When this signal is turned ON and the positioning is started, execute the stopper positioning sequence. |



POINT

1. The rotation direction (DIR) signal setting is meaningless.
2. The operation parameter group to be used is automatically selected in each operation.

Chapter 6 Setup and Operation

(2) Explanation of operation in the stopper positioning operation mode

The stopper positioning operation is as follows.

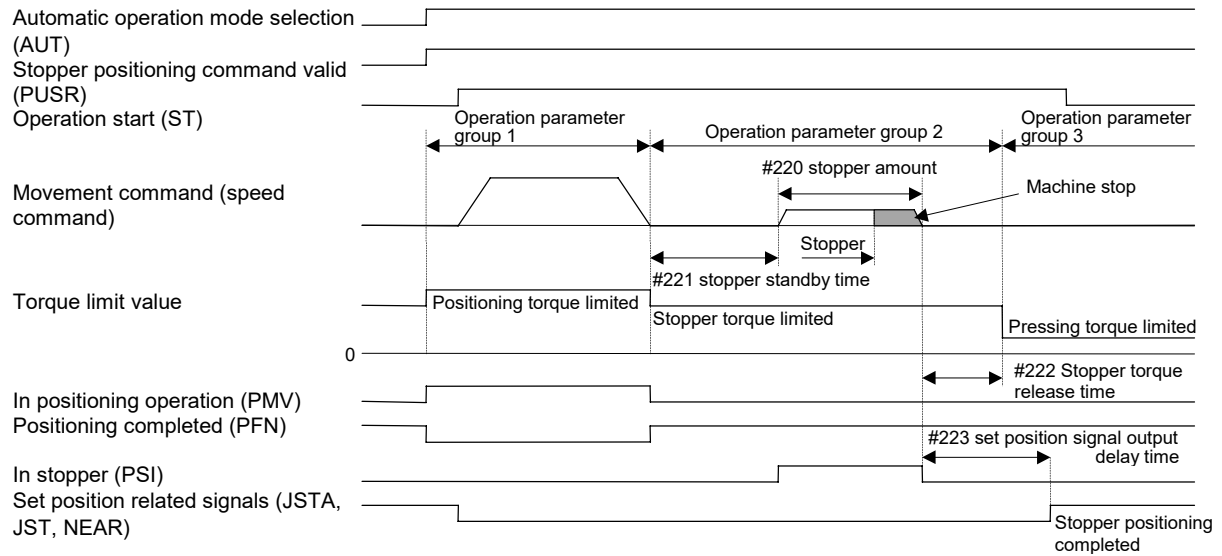

| Operation | Explanation | Related parameter |
|---|--|--------------------------------------|
| • Stopper starting coordinate positioning | When the operation start (ST) signal is input in the stopper positioning mode, positioning is carried out to the command coordinates (stopper starting coordinates). This operation is carried out with operation parameter group 1. A positioning operation using shortcut control can be carried out by parameter setting. During positioning, the In positioning operation (PMV) signal is output. The positioning completed (PFN) signal turns ON when the positioning is completed. | < Operation group 1 > |
| • Stopper standby | After the positioning operation deceleration stops, the operation will stop for the time set in the parameter (#221 stopper standby time). If the parameter value is 0, the operation will immediately move to the next stopper operation after deceleration stopping. | < Operation group 2 > #221 pusht1 |
| • Stopper | After stopper standby, the stopper operation is executed. The stopper amount is set in the parameters (#220 stopper amount). At this time, the positioning operation is carried out using the speed, time constant, and torque limit value of operation parameter 2. During stopper operation, an in stopper (PSI) signal is output. | < Operation group 2 > #220 push |
| • Pressing torque changeover | After the stopper operation finishes and the parameter (#222 stopper torque release time) time has lapsed, the torque changes over to the pressing torque. The pressing torque is the torque limit value of operation parameter group 3. | < Operation group 3 > #222 pusht2 |
| • Set position related signal output | The automatic set position reached (JSTA), set position reached (JST), and near set position (NEAR) signals are turned ON after the stopper operation is completed and the time set in the parameter (#222 stopper torque release time) has lapsed. This status is held until the rising edge of the next operation start signal. | < Operation group 3 > #223 pusht3 |



POINT

1. Set point related signals (automatic set position, set position, and near set position) are output for pressing positions. At that time, operation parameter group 3 becomes valid.
2. After the pressing is completed, and the pressing torque limit has been switched, this torque limit value (TL3) will be held until the next operation start (ST) startup, or until the pressing positioning command valid (PUSR) is turned OFF.
3. The station position (STO1 to 256) normally outputs as 0.
4. The manual mode cannot be selected in the pressing positioning command mode. When the operation start is turned ON with the manual mode, an operation error "M01 0164" will result. It is possible to select other operation modes.
5. If the start signal is turned OFF before a series of operations finishes, a deceleration stop will occur at that position. At that time, the automatic set position signal will not turn ON. If this happens during positioning, the positioning complete signal also will not turn ON.

Chapter 6 Setup and Operation

6-5-2 Setting the parameters

The stopper positioning operation method can be selected using the parameter settings.

(1) Method for positioning to the stopper starting coordinates

The method for positioning for rotation axes can be selected from the following three methods by parameter setting.

| Positioning method | # 101 Cont1.bit9 | # 101 Cont1.bitE | Explanation |
|--------------------------------|------------------|------------------|---|
| Shortcut invalid | 0 | 0 | The command coordinates are absolute position coordinates, handled within 360 deg. The positioning direction is that which does not cross 0 deg. |
| Shortcut valid | 1 | 0 | The command coordinates are absolute position coordinates, short cut rotation is executed and positioning is carried out to those coordinates. Even commands of 360 deg. or more will result in positioning within 180 deg. If the movement amount is 180 deg., positioning is in the (+) direction. |
| Rotation direction designation | Meaningless | 1 | The command sign expresses the rotation direction, and positioning is carried out as an absolute position to a value having a plus value separate from the rotation sign. If the commanded coordinates exceed 360.000, the axis will move one rotation or more. For the movement amount in this case, the integer expressing "command value/360" becomes the No. of rotations, and the fraction becomes the positioning coordinates. For example, a command of -400.000 will result in positioning of one rotation in the (-) direction from the current position, to a position of 40.000. Note that only when the command value is ± 360.000 is the command handled as ± 0.000 . |

(2) Setting the stopper direction

The stopper operation is automatically started after the positioning to the stopper starting coordinates is completed. The operation direction can be selected from one of the two following methods by parameter setting.

| Stopper direction | # 101 cont1.bitF | Explanation |
|-----------------------|------------------|--|
| Positioning direction | 0 | The stopper is carried out in the same direction as the positioning to the stopper starting coordinates. |
| Parameter direction | 1 | The stopper direction is fixed at the same direction as the stopper amount parameter sign. |

| No. | Abbrev. | Parameter name | Default value | Unit | Explanation | Setting range | | | | | | | | | | | | | | | | | | | | | | | | | | | | | | | | | | | |
|---------------|---|---|---|----------|---|-----------------|-----|--------------------------|--------------------------|---|---|--|---|--------------------------------------|--------------------------------------|---|--------------------------------------|--|---|--|--|---|--------------------------------------|--|---|--|--|---|--|---|---|---|---|---|---|---|---|---|---|---|--|
| #101 | *Cont1 | Control parameter 1 | This is a HEX setting parameter. Set bits without a description to their default values. | | | | | | | | | | | | | | | | | | | | | | | | | | | | | | | | | | | | | | |
| | | | <table border="1"> <thead> <tr> <th>bit</th> <th>F</th> <th>E</th> <th>D</th> <th>C</th> <th>B</th> <th>A</th> <th>9</th> <th>8</th> <th>7</th> <th>6</th> <th>5</th> <th>4</th> <th>3</th> <th>2</th> <th>1</th> <th>0</th> </tr> </thead> <tbody> <tr> <td>Default value</td> <td>0</td> <td>0</td> <td>0</td> <td>0</td> <td>0</td> <td>0</td> <td>1</td> <td>0</td> <td>0</td> <td>0</td> <td>0</td> <td>0</td> <td>0</td> <td>0</td> <td>0</td> <td>0</td> </tr> </tbody> </table> | | | | bit | F | E | D | C | B | A | 9 | 8 | 7 | 6 | 5 | 4 | 3 | 2 | 1 | 0 | Default value | 0 | 0 | 0 | 0 | 0 | 0 | 1 | 0 | 0 | 0 | 0 | 0 | 0 | 0 | 0 | 0 | |
| bit | F | E | D | C | B | A | 9 | 8 | 7 | 6 | 5 | 4 | 3 | 2 | 1 | 0 | | | | | | | | | | | | | | | | | | | | | | | | | |
| Default value | 0 | 0 | 0 | 0 | 0 | 0 | 1 | 0 | 0 | 0 | 0 | 0 | 0 | 0 | 0 | 0 | | | | | | | | | | | | | | | | | | | | | | | | | |
| | | | <table border="1"> <thead> <tr> <th>bit</th> <th>Meaning when "0" is set.</th> <th>Meaning when "1" is set.</th> </tr> </thead> <tbody> <tr> <td>1</td> <td>High-speed zero point return after zero point establishment</td> <td>Dog-type method for each zero point return operation</td> </tr> <tr> <td>8</td> <td>Reference point return direction (+)</td> <td>Reference point return direction (-)</td> </tr> <tr> <td>9</td> <td>Rotation direction determined by DIR</td> <td>Rotation direction in the shortcut direction</td> </tr> <tr> <td>A</td> <td>Machine reference position becomes the reference point</td> <td>Electrical zero point becomes the reference position</td> </tr> <tr> <td>D</td> <td>Coordinate zero point creation valid</td> <td>Zero point established at power supply ON position</td> </tr> <tr> <td>E</td> <td>Rotation direction in DIR or in the shortcut direction</td> <td>Rotation direction in the random position command sign direction</td> </tr> <tr> <td>F</td> <td>Stopper direction is positioning direction</td> <td>Stopper direction is for the stopper amount in the sign direction</td> </tr> </tbody> </table> | | | | bit | Meaning when "0" is set. | Meaning when "1" is set. | 1 | High-speed zero point return after zero point establishment | Dog-type method for each zero point return operation | 8 | Reference point return direction (+) | Reference point return direction (-) | 9 | Rotation direction determined by DIR | Rotation direction in the shortcut direction | A | Machine reference position becomes the reference point | Electrical zero point becomes the reference position | D | Coordinate zero point creation valid | Zero point established at power supply ON position | E | Rotation direction in DIR or in the shortcut direction | Rotation direction in the random position command sign direction | F | Stopper direction is positioning direction | Stopper direction is for the stopper amount in the sign direction | | | | | | | | | | | |
| bit | Meaning when "0" is set. | Meaning when "1" is set. | | | | | | | | | | | | | | | | | | | | | | | | | | | | | | | | | | | | | | | |
| 1 | High-speed zero point return after zero point establishment | Dog-type method for each zero point return operation | | | | | | | | | | | | | | | | | | | | | | | | | | | | | | | | | | | | | | | |
| 8 | Reference point return direction (+) | Reference point return direction (-) | | | | | | | | | | | | | | | | | | | | | | | | | | | | | | | | | | | | | | | |
| 9 | Rotation direction determined by DIR | Rotation direction in the shortcut direction | | | | | | | | | | | | | | | | | | | | | | | | | | | | | | | | | | | | | | | |
| A | Machine reference position becomes the reference point | Electrical zero point becomes the reference position | | | | | | | | | | | | | | | | | | | | | | | | | | | | | | | | | | | | | | | |
| D | Coordinate zero point creation valid | Zero point established at power supply ON position | | | | | | | | | | | | | | | | | | | | | | | | | | | | | | | | | | | | | | | |
| E | Rotation direction in DIR or in the shortcut direction | Rotation direction in the random position command sign direction | | | | | | | | | | | | | | | | | | | | | | | | | | | | | | | | | | | | | | | |
| F | Stopper direction is positioning direction | Stopper direction is for the stopper amount in the sign direction | | | | | | | | | | | | | | | | | | | | | | | | | | | | | | | | | | | | | | | |
| #220 | push | Stopper amount | 0.000 | deg (mm) | Set the command stroke during the stopper. | 0.000 ~ 359.999 | | | | | | | | | | | | | | | | | | | | | | | | | | | | | | | | | | | |
| #221 | pusht1 | Stopper standby time | 0 | msec | Set the standby time from the stopper starting coordinate positioning to the operation start. | 0~9999 | | | | | | | | | | | | | | | | | | | | | | | | | | | | | | | | | | | |
| #222 | pusht2 | Stopper torque release time | 0 | msec | Set the time from the completion of the stopper operation to the changeover of the pressing torque. | 0~9999 | | | | | | | | | | | | | | | | | | | | | | | | | | | | | | | | | | | |
| #223 | pusht3 | Set position signal output delay time | 0 | msec | Set the time from the completion of the stopper operation to the output of the automatic set position reached (JSTA), set position reached (JST), and near set position (NEAR) signals. | 0~9999 | | | | | | | | | | | | | | | | | | | | | | | | | | | | | | | | | | | |

6-6 Machine compensation and protection functions

6-6-1 Backlash compensation

This function compensates the error (backlash) in the machine system when the movement direction is reversed. When the axis movement direction is reversed, the compensation amount set in the parameter is automatically added. The compensation amount is not added to the machine position coordinates. This function compensates the actual machine position.

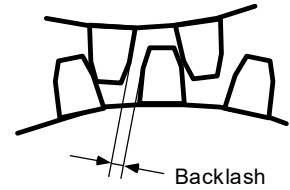

| No. | Abbrev. | Parameter name | Default value | Unit | Explanation | Setting range |
|------|----------|------------------------------|---------------|----------------|---------------------------------------|---------------|
| #130 | backlash | Backlash compensation amount | 0 | 1/1000deg (μm) | Set the backlash compensation amount. | 0 ~ 9999 |

6-6-2 Interlock function

This function interrupts the axis movement with a signal input, and immediately causes the servomotor to deceleration stop. For feed in the plus direction, the axis movement is interrupted and the motor is deceleration stopped when the interlock (+) (IT+) is turned ON. For feed in the plus direction, the same occurs when the interlock (-) (IT-) is turned ON (B contact). The movement will start again when the interlock is turned OFF. The speed and acceleration/deceleration time constant at this time follows the setting of the selected operation parameter group.

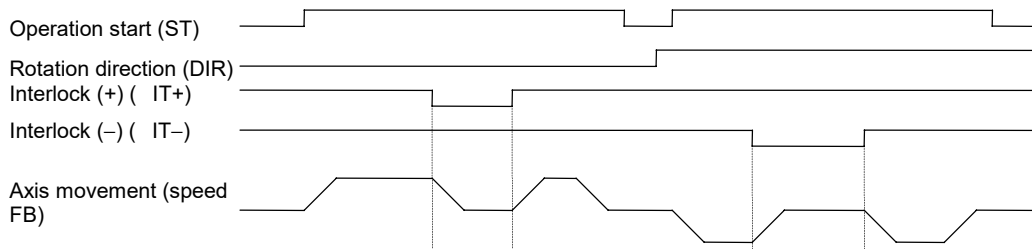

Chapter 6 Setup and Operation

6-6-3 Soft limit

For linear axes, this function prevents the machine collision to the machine end by setting the moveable range. Commands exceeding the soft limit points cannot be issued in any operation mode. An operation error (M01 0007) will occur when the machine is stopped by the soft limit function. If the machine position is outside the moveable range, only movement commands in the direction to return to the moveable range will be allowed.

To operate this function, set the plus direction limit position and minus direction limit position in the respective parameters.

The soft limit will not function if the plus and minus direction parameters are set to the same value.

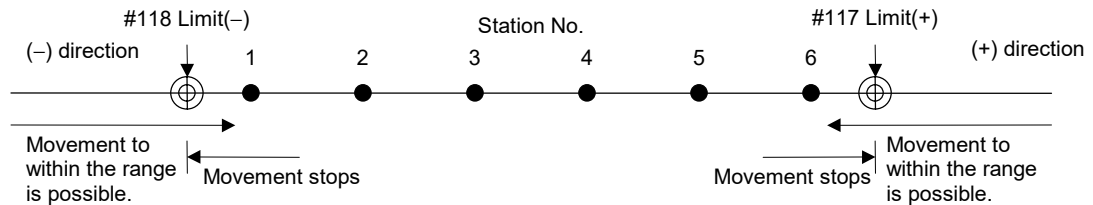

| No. | Abbrev. | Parameter name | Default value | Unit | Explanation | Setting range |
|------|-----------|----------------|---------------|------|---|--------------------------|
| #117 | Limit (+) | Soft limit (+) | 1.000 | mm | Commands in the plus direction that exceed this value are not possible. If the machine is in a position exceeding the setting value, commands in the minus direction are possible. The soft limit function will not operate if Limit (+) and Limit (-) are set to the same value. | -99999.999 ~99999.999 |
| #118 | Limit (-) | Soft limit (-) | 1.000 | mm | Commands in the minus direction that exceed this value are not possible. If the machine is in a position exceeding the setting value, commands in the plus direction are possible. | -99999.999 ~99999.999 |



POINT

The soft limit function is only valid for linear axis settings. In actual operation, the axis stops slightly before the setting position.

Chapter 6 Setup and Operation

6-6-4 Servo OFF

This function releases the servo lock. When locking the machine with an external force, such as a mechanical clamp, the servo control is turned OFF, and torque is not output for the deflection that occurs due to the external force. When the servo OFF state is entered, servo READY (RDY) turns OFF. The motor brake braking control (MBR) also turns OFF, and the motor brakes are activated.

By using the vertical axis drop prevention function, READY OFF can be delayed from the servo OFF command input by the time set with the parameters. With this, dropping of the axis is prevented by a delay in the brake operation. Set the time to delay READY OFF in "#013 MBR Vertical axis drop prevention time". Input the servo OFF while confirming the position, and set the minimum delay time at which the axis does not drop.

If the servo is turned OFF during machine movement, the speed command will decelerate to a stop. When the in-position is detected, the servo OFF state will be entered. If the operation is still starting, operation will resume after servo OFF is canceled.

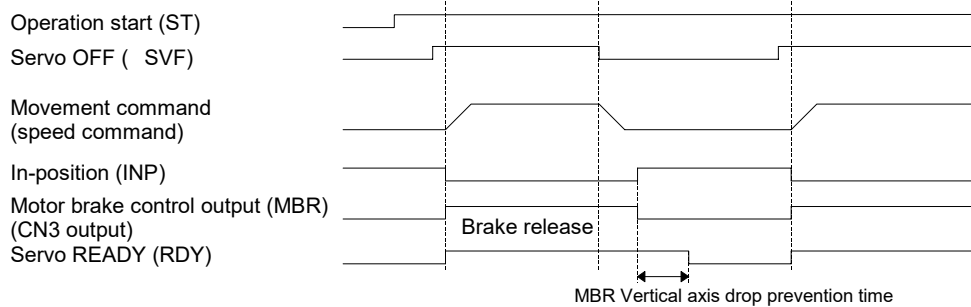

The amount of movement during servo OFF is constantly monitored, so there is no coordinate deviation. The handling for this movement amount can be selected from the following two methods by parameter setting.

| During servo OFF | #102 Cont2.bit1 | Explanation |
|---------------------|-----------------|---|
| Error not corrected | 0 | The movement amount during servo OFF becomes the droop. When the servo is turned ON again, the machine will return to the position where the servo was turned OFF. An alarm will occur if the droop that occurs during servo OFF exceeds the excessive error detection width. |
| Error corrected | 1 | Even if the machine moves during servo OFF, the machine position (command position) is updated without this amount becoming the droop. Thus, at the next servo ON the machine will stop at the position to which it moved. |

| No. | Abbrev. | Parameter name | Default value | Unit | Explanation | Setting range | | | | | | | | | | | | | | | | | | | | | | | | | | | | | | | | | | | |
|--|----------------------------------|------------------------------------|--|----------------|--|---------------|-----|--------------------------|--------------------------|---|----------------------------------|------------------------------|---|-------------|---------------|---|---------------------------------|----------------------------------|---|---------------|-------------------|---|--------------------------------|-------------------------------|---|-------------------------------|-------------------------------|---|-----------------------|-----------------------------|---|---|---|---|---|---|---|---|---|---|---|
| #006 | INP | In-position detection width | 50 | 1/1000deg (μm) | The in-position is detected when the position droop becomes equal to or less than this setting value. | 1 ~ 32767 | | | | | | | | | | | | | | | | | | | | | | | | | | | | | | | | | | | |
| #013 | MBR | Vertical axis drop prevention time | 100 | msec | Input the time to delay servo OFF when the servo OFF command is input. Increment in 100msec units, and set the min. value at which the axis does not drop. | 0 ~ 1000 | | | | | | | | | | | | | | | | | | | | | | | | | | | | | | | | | | | |
| #102 | *Cont2 | Control parameter 2 | This is a HEX setting parameter. Set bits without a description to their default values. | | | | | | | | | | | | | | | | | | | | | | | | | | | | | | | | | | | | | | |
| <table border="1" style="width: 100%; text-align: center;"> <thead> <tr> <th>bit</th> <th>F</th> <th>E</th> <th>D</th> <th>C</th> <th>B</th> <th>A</th> <th>9</th> <th>8</th> <th>7</th> <th>6</th> <th>5</th> <th>4</th> <th>3</th> <th>2</th> <th>1</th> <th>0</th> </tr> </thead> <tbody> <tr> <td>Default value</td> <td>0</td> <td>0</td> <td>0</td> <td>0</td> <td>0</td> <td>0</td> <td>0</td> <td>0</td> <td>1</td> <td>0</td> <td>0</td> <td>0</td> <td>0</td> <td>0</td> <td>1</td> <td>1</td> <td>0</td> </tr> </tbody> </table> | | | | | | | bit | F | E | D | C | B | A | 9 | 8 | 7 | 6 | 5 | 4 | 3 | 2 | 1 | 0 | Default value | 0 | 0 | 0 | 0 | 0 | 0 | 0 | 0 | 1 | 0 | 0 | 0 | 0 | 0 | 1 | 1 | 0 |
| bit | F | E | D | C | B | A | 9 | 8 | 7 | 6 | 5 | 4 | 3 | 2 | 1 | 0 | | | | | | | | | | | | | | | | | | | | | | | | | |
| Default value | 0 | 0 | 0 | 0 | 0 | 0 | 0 | 0 | 1 | 0 | 0 | 0 | 0 | 0 | 1 | 1 | 0 | | | | | | | | | | | | | | | | | | | | | | | | |
| <table border="1" style="width: 100%; text-align: center;"> <thead> <tr> <th>bit</th> <th>Meaning when "0" is set.</th> <th>Meaning when "1" is set.</th> </tr> </thead> <tbody> <tr> <td>1</td> <td>Error not corrected at servo OFF</td> <td>Error corrected at servo OFF</td> </tr> <tr> <td>2</td> <td>Linear axis</td> <td>Rotation axis</td> </tr> <tr> <td>3</td> <td>Station assignment direction CW</td> <td>Station assignment direction CCW</td> </tr> <tr> <td>4</td> <td>Uniform index</td> <td>Non-uniform index</td> </tr> <tr> <td>5</td> <td>DO channel standard assignment</td> <td>DO channel reverse assignment</td> </tr> <tr> <td>6</td> <td>2-wire detector communication</td> <td>4-wire detector communication</td> </tr> <tr> <td>7</td> <td>Incremental detection</td> <td>Absolute position detection</td> </tr> </tbody> </table> | | | | | | | bit | Meaning when "0" is set. | Meaning when "1" is set. | 1 | Error not corrected at servo OFF | Error corrected at servo OFF | 2 | Linear axis | Rotation axis | 3 | Station assignment direction CW | Station assignment direction CCW | 4 | Uniform index | Non-uniform index | 5 | DO channel standard assignment | DO channel reverse assignment | 6 | 2-wire detector communication | 4-wire detector communication | 7 | Incremental detection | Absolute position detection | | | | | | | | | | | |
| bit | Meaning when "0" is set. | Meaning when "1" is set. | | | | | | | | | | | | | | | | | | | | | | | | | | | | | | | | | | | | | | | |
| 1 | Error not corrected at servo OFF | Error corrected at servo OFF | | | | | | | | | | | | | | | | | | | | | | | | | | | | | | | | | | | | | | | |
| 2 | Linear axis | Rotation axis | | | | | | | | | | | | | | | | | | | | | | | | | | | | | | | | | | | | | | | |
| 3 | Station assignment direction CW | Station assignment direction CCW | | | | | | | | | | | | | | | | | | | | | | | | | | | | | | | | | | | | | | | |
| 4 | Uniform index | Non-uniform index | | | | | | | | | | | | | | | | | | | | | | | | | | | | | | | | | | | | | | | |
| 5 | DO channel standard assignment | DO channel reverse assignment | | | | | | | | | | | | | | | | | | | | | | | | | | | | | | | | | | | | | | | |
| 6 | 2-wire detector communication | 4-wire detector communication | | | | | | | | | | | | | | | | | | | | | | | | | | | | | | | | | | | | | | | |
| 7 | Incremental detection | Absolute position detection | | | | | | | | | | | | | | | | | | | | | | | | | | | | | | | | | | | | | | | |



Do not set a vertical axis drop prevention time longer than required. Doing so could cause the servo control and brakes to collide, the overload alarm to occur and the amplifier to be damaged. There will be no problem if the overlapping time is within 100msec.

Chapter 6 Setup and Operation

6-6-5 READY OFF

This is a function to turn OFF the main circuit power to each amplifier. When the amplifier enters a READY OFF state, the servo READY (RDY) and servo READY (SA) signals turn OFF, and the CN3 connector motor brake control output (MBR) and contactor control output (MC) signals turn OFF. When starting the operation again after the READY OFF is canceled, carry out an operation start.

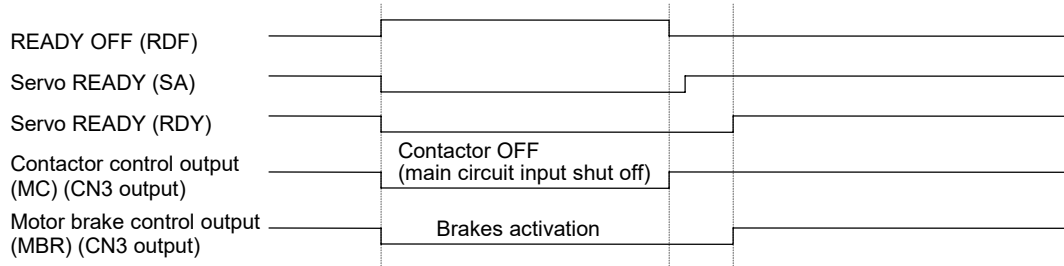

CAUTION

1. Always install an independent contactor in the servo amplifier in which the READY OFF is commanded, and carry out control with that amplifier's contactor control output.
2. For safety, issue the READY OFF command after confirming that the motor has stopped.

6-6-6 Data protect

This function protects the parameters stored in the amplifier main unit. When the data protect (PRT1) signal is ON (B contact), the downloading of parameters from the personal computer setup software is prohibited. Parameter downloading from the NC screen is not prohibited.

Chapter 6 Setup and Operation

6-7 Miscellaneous functions

6-7-1 Feedrate override

The effective feedrate is the speed set in the parameters multiplied by the override (%). The override range is from 0 to 100%, which can be commanded in 1% units. This override is valid for all movement except that in the handle mode. The override is invalidated when the override valid (OVR) signal is turned OFF, and the set speed will become the effective feedrate as is.

The override command is designated by a 7-bit binary (OV1 to OV64). The override is handled as 100% if the command exceeds 100%. If a 0% override is commanded, the axis will deceleration stop, and an operation error "M01 0103 feedrate zero" will occur.

6-7-2 Position switches

There are eight types of position switches (PSW1 to PSW8) that indicate that the machine is in the designated region. The region where each position switch outputs ON is set in the parameters. The machine position to be judged can be selected from the machine position of the command system without consideration of the droop, or from the machine FB position (actual machine position) which includes the droop.

| No. | Abbrev. | Parameter name | Default value | Unit | Explanation | Setting range | | | | | | | | | | | | | | | | | | | | | | | | | | | | | | | | | | | |
|---------------|---|--|--|----------|--|--------------------------|-----|--------------------------|--------------------------|---|---|--|---|---|---|---|---|---|---|---|---|---|---|---------------|---|---|---|---|---|---|---|---|---|---|---|---|---|---|---|---|--|
| #200 | PSWcheck | PSW detection method | This is a HEX setting parameter. Set bits without a description to their default values. | | | | | | | | | | | | | | | | | | | | | | | | | | | | | | | | | | | | | | |
| | | | <table border="1"> <thead> <tr> <th>bit</th> <th>F</th> <th>E</th> <th>D</th> <th>C</th> <th>B</th> <th>A</th> <th>9</th> <th>8</th> <th>7</th> <th>6</th> <th>5</th> <th>4</th> <th>3</th> <th>2</th> <th>1</th> <th>0</th> </tr> </thead> <tbody> <tr> <td>Default value</td> <td>0</td> <td>0</td> <td>0</td> <td>0</td> <td>0</td> <td>0</td> <td>0</td> <td>0</td> <td>0</td> <td>0</td> <td>0</td> <td>0</td> <td>0</td> <td>0</td> <td>0</td> <td>0</td> </tr> </tbody> </table> | | | | bit | F | E | D | C | B | A | 9 | 8 | 7 | 6 | 5 | 4 | 3 | 2 | 1 | 0 | Default value | 0 | 0 | 0 | 0 | 0 | 0 | 0 | 0 | 0 | 0 | 0 | 0 | 0 | 0 | 0 | 0 | |
| bit | F | E | D | C | B | A | 9 | 8 | 7 | 6 | 5 | 4 | 3 | 2 | 1 | 0 | | | | | | | | | | | | | | | | | | | | | | | | | |
| Default value | 0 | 0 | 0 | 0 | 0 | 0 | 0 | 0 | 0 | 0 | 0 | 0 | 0 | 0 | 0 | 0 | | | | | | | | | | | | | | | | | | | | | | | | | |
| | | | <table border="1"> <thead> <tr> <th>bit</th> <th>Meaning when "0" is set.</th> <th>Meaning when "1" is set.</th> </tr> </thead> <tbody> <tr> <td>0</td> <td rowspan="2">The position switch output is judged by the machine position of the command system.</td> <td rowspan="2">The position switch output is judged by the machine FB position (actual position).</td> </tr> <tr> <td>1</td> </tr> <tr> <td>2</td> <td></td> <td></td> </tr> <tr> <td>3</td> <td></td> <td></td> </tr> <tr> <td>4</td> <td></td> <td></td> </tr> <tr> <td>5</td> <td></td> <td></td> </tr> <tr> <td>6</td> <td></td> <td></td> </tr> <tr> <td>7</td> <td></td> <td></td> </tr> </tbody> </table> | | | | bit | Meaning when "0" is set. | Meaning when "1" is set. | 0 | The position switch output is judged by the machine position of the command system. | The position switch output is judged by the machine FB position (actual position). | 1 | 2 | | | 3 | | | 4 | | | 5 | | | 6 | | | 7 | | | | | | | | | | | | |
| bit | Meaning when "0" is set. | Meaning when "1" is set. | | | | | | | | | | | | | | | | | | | | | | | | | | | | | | | | | | | | | | | |
| 0 | The position switch output is judged by the machine position of the command system. | The position switch output is judged by the machine FB position (actual position). | | | | | | | | | | | | | | | | | | | | | | | | | | | | | | | | | | | | | | | |
| 1 | | | | | | | | | | | | | | | | | | | | | | | | | | | | | | | | | | | | | | | | | |
| 2 | | | | | | | | | | | | | | | | | | | | | | | | | | | | | | | | | | | | | | | | | |
| 3 | | | | | | | | | | | | | | | | | | | | | | | | | | | | | | | | | | | | | | | | | |
| 4 | | | | | | | | | | | | | | | | | | | | | | | | | | | | | | | | | | | | | | | | | |
| 5 | | | | | | | | | | | | | | | | | | | | | | | | | | | | | | | | | | | | | | | | | |
| 6 | | | | | | | | | | | | | | | | | | | | | | | | | | | | | | | | | | | | | | | | | |
| 7 | | | | | | | | | | | | | | | | | | | | | | | | | | | | | | | | | | | | | | | | | |
| #201 | PSW1dog1 | PSW1 region setting 1 | 0.000 | deg (mm) | When the machine is in the region between region settings 1 and 2, the position switch of each No. will turn ON. The size of the setting value for region setting 1 and 2 does not affect the position switch operation. For rotation axes, the output turns ON at the region not including 0.000. | -99999.999 ~99999.999 | | | | | | | | | | | | | | | | | | | | | | | | | | | | | | | | | | | |
| #202 | PSW1dog2 | PSW1 region setting 2 | | | | | | | | | | | | | | | | | | | | | | | | | | | | | | | | | | | | | | | |
| #203 | PSW2dog1 | PSW2 region setting 1 | | | | | | | | | | | | | | | | | | | | | | | | | | | | | | | | | | | | | | | |
| #204 | PSW2dog2 | PSW2 region setting 2 | | | | | | | | | | | | | | | | | | | | | | | | | | | | | | | | | | | | | | | |
| #205 | PSW3dog1 | PSW3 region setting 1 | | | | | | | | | | | | | | | | | | | | | | | | | | | | | | | | | | | | | | | |
| #206 | PSW3dog2 | PSW3 region setting 2 | | | | | | | | | | | | | | | | | | | | | | | | | | | | | | | | | | | | | | | |
| #207 | PSW4dog1 | PSW4 region setting 1 | | | | | | | | | | | | | | | | | | | | | | | | | | | | | | | | | | | | | | | |
| #208 | PSW4dog2 | PSW4 region setting 2 | | | | | | | | | | | | | | | | | | | | | | | | | | | | | | | | | | | | | | | |
| #209 | PSW5dog1 | PSW5 region setting 1 | | | | | | | | | | | | | | | | | | | | | | | | | | | | | | | | | | | | | | | |
| #210 | PSW5dog2 | PSW5 region setting 2 | | | | | | | | | | | | | | | | | | | | | | | | | | | | | | | | | | | | | | | |
| #211 | PSW6dog1 | PSW6 region setting 1 | | | | | | | | | | | | | | | | | | | | | | | | | | | | | | | | | | | | | | | |
| #212 | PSW6dog2 | PSW6 region setting 2 | | | | | | | | | | | | | | | | | | | | | | | | | | | | | | | | | | | | | | | |
| #213 | PSW7dog1 | PSW7 region setting 1 | | | | | | | | | | | | | | | | | | | | | | | | | | | | | | | | | | | | | | | |
| #214 | PSW7dog2 | PSW7 region setting 2 | | | | | | | | | | | | | | | | | | | | | | | | | | | | | | | | | | | | | | | |
| #215 | PSW8dog1 | PSW8 region setting 1 | | | | | | | | | | | | | | | | | | | | | | | | | | | | | | | | | | | | | | | |
| #216 | PSW8dog2 | PSW8 region setting 2 | | | | | | | | | | | | | | | | | | | | | | | | | | | | | | | | | | | | | | | |

Chapter 7 Absolute Position Detection System

| | | |
|------------|--|------------|
| 7-1 | Setting of absolute position detection system | 7-2 |
| 7-1-1 | Starting the system | 7-2 |
| 7-1-2 | Initialization methods | 7-2 |
| 7-2 | Setting up the absolute position detection system | 7-3 |
| 7-2-1 | Reference point return method | 7-3 |
| 7-2-2 | Machine stopper method | 7-3 |
| 7-2-3 | Reference point setting method | 7-4 |

Chapter 7 Absolute Position Detection System

7-1 Setting of absolute position detection system

The control unit registers the initially set reference point, and the detector monitors the movement direction and distance that the machine moves even when the power is turned OFF. Thus, when the power is turned ON again, automatic operation can be started automatically without returning to the reference point.

7-1-1 Starting the system

Turn the power ON, and set parameter #102 Cont2.bit7 to "1" to validate the absolute position detection. The absolute position detection is selected even after the parameters are initialized (refer to section 6-1-1 Initializing the parameters). When the power is turned ON again after making the setting, the absolute position detection system will be validated.

If the absolute position detection is set for the first time after connecting the motor and amplifier, the ABSOLUTE POSITION LOST (S01 0025) alarm will occur, so turn the amplifier power ON again.

If only the alarm ZERO POINT NOT INITIALIZED (Z70 0001) occurs, the absolute position detection system has started up correctly. This alarm will be reset when the absolute position is established with the following procedures.

7-1-2 Initialization methods

The following three types of initialization methods can be selected with the parameter settings.

| Initialization method | # 120 ABS Type.bit1 | # 120 ABS Type.bit2 | Explanation |
|--------------------------------|---------------------|---------------------|---|
| Reference point return method | 0 | Meaningless | The reference point is determined using the near-point dog. The operation method is the same as the dog-type reference point return using the incremental system. |
| Machine stopper method | 1 | 0 | The reference point is determined by pushing against a machine end, etc., with the torque (current) limit set. |
| Reference point setting method | 1 | 1 | The reference point is determined by setting the axis to the machine's reference point. |

| No. | Abbrev. | Parameter name | Default value | Unit | Explanation | Setting range | | | | | | | | | | | | | | | | | | | | | | | | | | | | | | | | | | | | |
|---------------|-----------------------------------|--|---|------|-------------|---------------|-----|--------------------------|--------------------------|---|----------------------------------|------------------------------|---|--------------------------------|--|---|-----------------------------------|-----------------------------------|---|---------------|-------------------|---|--------------------------------|-------------------------------|---|-------------------------------|-------------------------------|---|-----------------------|-----------------------------|---|---|---|---|---|---|---|---|---|---|---|--|
| #102 | *Cont2 | Control parameter 2 | This is a HEX setting parameter. Set bits without a description to their default values. | | | | | | | | | | | | | | | | | | | | | | | | | | | | | | | | | | | | | | | |
| | | | <table border="1"> <thead> <tr> <th>bit</th> <th>F</th> <th>E</th> <th>D</th> <th>C</th> <th>B</th> <th>A</th> <th>9</th> <th>8</th> <th>7</th> <th>6</th> <th>5</th> <th>4</th> <th>3</th> <th>2</th> <th>1</th> <th>0</th> </tr> </thead> <tbody> <tr> <td>Default value</td> <td>0</td> <td>0</td> <td>0</td> <td>0</td> <td>0</td> <td>0</td> <td>0</td> <td>0</td> <td>1</td> <td>0</td> <td>0</td> <td>0</td> <td>0</td> <td>0</td> <td>1</td> <td>1</td> <td>0</td> </tr> </tbody> </table> | | | | bit | F | E | D | C | B | A | 9 | 8 | 7 | 6 | 5 | 4 | 3 | 2 | 1 | 0 | Default value | 0 | 0 | 0 | 0 | 0 | 0 | 0 | 0 | 1 | 0 | 0 | 0 | 0 | 0 | 1 | 1 | 0 | |
| bit | F | E | D | C | B | A | 9 | 8 | 7 | 6 | 5 | 4 | 3 | 2 | 1 | 0 | | | | | | | | | | | | | | | | | | | | | | | | | | |
| Default value | 0 | 0 | 0 | 0 | 0 | 0 | 0 | 0 | 1 | 0 | 0 | 0 | 0 | 0 | 1 | 1 | 0 | | | | | | | | | | | | | | | | | | | | | | | | | |
| | | | <table border="1"> <thead> <tr> <th>bit</th> <th>Meaning when "0" is set.</th> <th>Meaning when "1" is set.</th> </tr> </thead> <tbody> <tr> <td>1</td> <td>Error not corrected at servo OFF</td> <td>Error corrected at servo OFF</td> </tr> <tr> <td>2</td> <td>Linear axis</td> <td>Rotation axis</td> </tr> <tr> <td>3</td> <td>Station assignment direction CW</td> <td>Station assignment direction CCW</td> </tr> <tr> <td>4</td> <td>Uniform index</td> <td>Non-uniform index</td> </tr> <tr> <td>5</td> <td>DO channel standard assignment</td> <td>DO channel reverse assignment</td> </tr> <tr> <td>6</td> <td>2-wire detector communication</td> <td>4-wire detector communication</td> </tr> <tr> <td>7</td> <td>Incremental detection</td> <td>Absolute position detection</td> </tr> </tbody> </table> | | | | bit | Meaning when "0" is set. | Meaning when "1" is set. | 1 | Error not corrected at servo OFF | Error corrected at servo OFF | 2 | Linear axis | Rotation axis | 3 | Station assignment direction CW | Station assignment direction CCW | 4 | Uniform index | Non-uniform index | 5 | DO channel standard assignment | DO channel reverse assignment | 6 | 2-wire detector communication | 4-wire detector communication | 7 | Incremental detection | Absolute position detection | | | | | | | | | | | | |
| bit | Meaning when "0" is set. | Meaning when "1" is set. | | | | | | | | | | | | | | | | | | | | | | | | | | | | | | | | | | | | | | | | |
| 1 | Error not corrected at servo OFF | Error corrected at servo OFF | | | | | | | | | | | | | | | | | | | | | | | | | | | | | | | | | | | | | | | | |
| 2 | Linear axis | Rotation axis | | | | | | | | | | | | | | | | | | | | | | | | | | | | | | | | | | | | | | | | |
| 3 | Station assignment direction CW | Station assignment direction CCW | | | | | | | | | | | | | | | | | | | | | | | | | | | | | | | | | | | | | | | | |
| 4 | Uniform index | Non-uniform index | | | | | | | | | | | | | | | | | | | | | | | | | | | | | | | | | | | | | | | | |
| 5 | DO channel standard assignment | DO channel reverse assignment | | | | | | | | | | | | | | | | | | | | | | | | | | | | | | | | | | | | | | | | |
| 6 | 2-wire detector communication | 4-wire detector communication | | | | | | | | | | | | | | | | | | | | | | | | | | | | | | | | | | | | | | | | |
| 7 | Incremental detection | Absolute position detection | | | | | | | | | | | | | | | | | | | | | | | | | | | | | | | | | | | | | | | | |
| #120 | ABS Type | Absolute position detector parameter | This is a HEX setting parameter. Set bits without a description to their default values. | | | | | | | | | | | | | | | | | | | | | | | | | | | | | | | | | | | | | | | |
| | | | <table border="1"> <thead> <tr> <th>bit</th> <th>F</th> <th>E</th> <th>D</th> <th>C</th> <th>B</th> <th>A</th> <th>9</th> <th>8</th> <th>7</th> <th>6</th> <th>5</th> <th>4</th> <th>3</th> <th>2</th> <th>1</th> <th>0</th> </tr> </thead> <tbody> <tr> <td>Default value</td> <td>0</td> <td>0</td> <td>0</td> <td>0</td> <td>0</td> <td>0</td> <td>0</td> <td>0</td> <td>0</td> <td>0</td> <td>0</td> <td>0</td> <td>0</td> <td>1</td> <td>0</td> <td>0</td> </tr> </tbody> </table> | | | | bit | F | E | D | C | B | A | 9 | 8 | 7 | 6 | 5 | 4 | 3 | 2 | 1 | 0 | Default value | 0 | 0 | 0 | 0 | 0 | 0 | 0 | 0 | 0 | 0 | 0 | 0 | 0 | 1 | 0 | 0 | | |
| bit | F | E | D | C | B | A | 9 | 8 | 7 | 6 | 5 | 4 | 3 | 2 | 1 | 0 | | | | | | | | | | | | | | | | | | | | | | | | | | |
| Default value | 0 | 0 | 0 | 0 | 0 | 0 | 0 | 0 | 0 | 0 | 0 | 0 | 0 | 1 | 0 | 0 | | | | | | | | | | | | | | | | | | | | | | | | | | |
| | | | <table border="1"> <thead> <tr> <th>bit</th> <th>Meaning when "0" is set.</th> <th>Meaning when "1" is set.</th> </tr> </thead> <tbody> <tr> <td>1</td> <td>Dog-less type initialization</td> <td>Dog-type initialization</td> </tr> <tr> <td>2</td> <td>Machine stopper initialization</td> <td>Reference point setting initialization</td> </tr> <tr> <td>3</td> <td>Electrical zero point direction +</td> <td>Electrical zero point direction -</td> </tr> </tbody> </table> | | | | bit | Meaning when "0" is set. | Meaning when "1" is set. | 1 | Dog-less type initialization | Dog-type initialization | 2 | Machine stopper initialization | Reference point setting initialization | 3 | Electrical zero point direction + | Electrical zero point direction - | | | | | | | | | | | | | | | | | | | | | | | | |
| bit | Meaning when "0" is set. | Meaning when "1" is set. | | | | | | | | | | | | | | | | | | | | | | | | | | | | | | | | | | | | | | | | |
| 1 | Dog-less type initialization | Dog-type initialization | | | | | | | | | | | | | | | | | | | | | | | | | | | | | | | | | | | | | | | | |
| 2 | Machine stopper initialization | Reference point setting initialization | | | | | | | | | | | | | | | | | | | | | | | | | | | | | | | | | | | | | | | | |
| 3 | Electrical zero point direction + | Electrical zero point direction - | | | | | | | | | | | | | | | | | | | | | | | | | | | | | | | | | | | | | | | | |



POINT

1. The battery option is required to use the absolute position system. Refer to the section "4-2 Battery option for absolute position system" for details.
2. After establishing the coordinate zero point with the absolute position detection system, if the parameters are set to the incremental detection, the coordinate data will be set. If the parameter is returned to the absolute position detection, the coordinate zero point will need to be established again.

Chapter 7 Absolute Position Detection System

7-2 Setting up the absolute position detection system

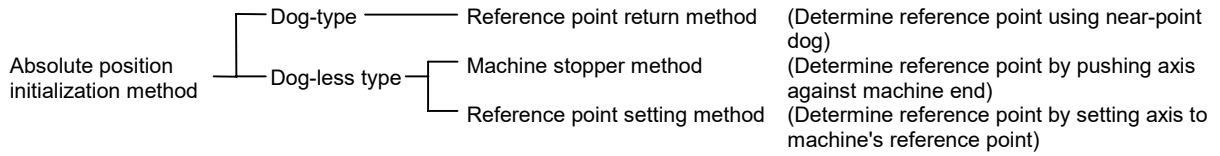

7-2-1 Reference point return method

The coordinate zero point is established with the dog-type reference point return operation. The operation method is the same as the dog-type reference point return using the incremental system. Refer to the section "6-3 Setting the coordinate zero point".

7-2-2 Machine stopper method

Jog feed is carried out with the torque (current) limit set, and the axis is pushed against the machine end, etc., to determine the absolute position reference point.

(1) Initialization

Turn the following signal ON, and change to the absolute position reference point initialization mode. The operation parameter group 4 will be automatically selected during the reference point initialization mode. Set the torque limit value (TL4) and excessive error detection width (OD4) to values appropriate for the pushing operation. (Refer to following table.)

| Abbrev. | Signal name | Explanation |
|---------|---|---|
| AZS | Reference point initialization mode selection | The absolute position reference point initialization mode is entered. Set the parameter to the machine stopper method, and then initialize the reference zero point. This mode is held until the NC power is turned OFF. |

(2) Explanation of operations

- The axis is pushed against the machine end stopper with jog or handle feed. When the torque (current) reaches the limit value due to this pushing, the limiting torque (TLQ) is output, and the position is saved as the "absolute position reference point".
- The axis is moved in the direction opposite the pushing direction. When the axis moves and reaches the first grid point, the axis automatically stops, and the absolute position coordinates are established.

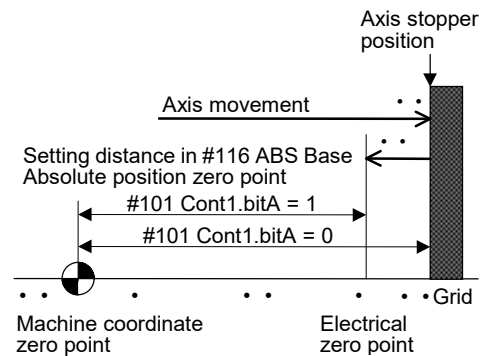

- If parameter "101 Cont1.bitA" is set to "1", the electrical zero point (grid) will be set as the "absolute position reference point" instead of the pushed position.
- In this state, the absolute position reference point will become the coordinate zero point. To set a point other than the push position or electrical zero point as the absolute position coordinate zero point, move the machine coordinate zero point with parameter #116 ABS Base Absolute position zero point.

Chapter 7 Absolute Position Detection System

| No. | Abbrev. | Parameter name | Default value | Unit | Explanation | Setting range | | | | | | | | | | | | | | | | | | | | | | | | | | | | | | | | | | | |
|---------------|---|---|---|----------|--|---------------|-----|--------------------------|--------------------------|---|---|--|---|--------------------------------------|--------------------------------------|---|--------------------------------------|--|---|--|--|---|--------------------------------------|--|---|--|--|---|--|---|---|---|---|---|---|---|---|---|---|---|--|
| #101 | *Cont1 | Control parameter 1 | This is a HEX setting parameter. Set bits without a description to their default values. | | | | | | | | | | | | | | | | | | | | | | | | | | | | | | | | | | | | | | |
| | | | <table border="1"> <thead> <tr> <th>bit</th> <th>F</th> <th>E</th> <th>D</th> <th>C</th> <th>B</th> <th>A</th> <th>9</th> <th>8</th> <th>7</th> <th>6</th> <th>5</th> <th>4</th> <th>3</th> <th>2</th> <th>1</th> <th>0</th> </tr> </thead> <tbody> <tr> <td>Default value</td> <td>0</td> <td>0</td> <td>0</td> <td>0</td> <td>0</td> <td>0</td> <td>1</td> <td>0</td> <td>0</td> <td>0</td> <td>0</td> <td>0</td> <td>0</td> <td>0</td> <td>0</td> <td>0</td> </tr> </tbody> </table> | | | | bit | F | E | D | C | B | A | 9 | 8 | 7 | 6 | 5 | 4 | 3 | 2 | 1 | 0 | Default value | 0 | 0 | 0 | 0 | 0 | 0 | 1 | 0 | 0 | 0 | 0 | 0 | 0 | 0 | 0 | 0 | |
| bit | F | E | D | C | B | A | 9 | 8 | 7 | 6 | 5 | 4 | 3 | 2 | 1 | 0 | | | | | | | | | | | | | | | | | | | | | | | | | |
| Default value | 0 | 0 | 0 | 0 | 0 | 0 | 1 | 0 | 0 | 0 | 0 | 0 | 0 | 0 | 0 | 0 | | | | | | | | | | | | | | | | | | | | | | | | | |
| | | | <table border="1"> <thead> <tr> <th>bit</th> <th>Meaning when "0" is set.</th> <th>Meaning when "1" is set.</th> </tr> </thead> <tbody> <tr> <td>1</td> <td>High-speed zero point return after zero point establishment</td> <td>Dog-type method for each zero point return operation</td> </tr> <tr> <td>8</td> <td>Reference point return direction (+)</td> <td>Reference point return direction (-)</td> </tr> <tr> <td>9</td> <td>Rotation direction determined by DIR</td> <td>Rotation direction in the shortcut direction</td> </tr> <tr> <td>A</td> <td>Machine reference position becomes the reference point</td> <td>Electrical zero point becomes the reference position</td> </tr> <tr> <td>D</td> <td>Coordinate zero point creation valid</td> <td>Zero point established at power supply ON position</td> </tr> <tr> <td>E</td> <td>Rotation direction in DIR or in the shortcut direction</td> <td>Rotation direction in the random position command sign direction</td> </tr> <tr> <td>F</td> <td>Stopper direction is positioning direction</td> <td>Stopper direction is for the stopper amount in the sign direction</td> </tr> </tbody> </table> | | | | bit | Meaning when "0" is set. | Meaning when "1" is set. | 1 | High-speed zero point return after zero point establishment | Dog-type method for each zero point return operation | 8 | Reference point return direction (+) | Reference point return direction (-) | 9 | Rotation direction determined by DIR | Rotation direction in the shortcut direction | A | Machine reference position becomes the reference point | Electrical zero point becomes the reference position | D | Coordinate zero point creation valid | Zero point established at power supply ON position | E | Rotation direction in DIR or in the shortcut direction | Rotation direction in the random position command sign direction | F | Stopper direction is positioning direction | Stopper direction is for the stopper amount in the sign direction | | | | | | | | | | | |
| bit | Meaning when "0" is set. | Meaning when "1" is set. | | | | | | | | | | | | | | | | | | | | | | | | | | | | | | | | | | | | | | | |
| 1 | High-speed zero point return after zero point establishment | Dog-type method for each zero point return operation | | | | | | | | | | | | | | | | | | | | | | | | | | | | | | | | | | | | | | | |
| 8 | Reference point return direction (+) | Reference point return direction (-) | | | | | | | | | | | | | | | | | | | | | | | | | | | | | | | | | | | | | | | |
| 9 | Rotation direction determined by DIR | Rotation direction in the shortcut direction | | | | | | | | | | | | | | | | | | | | | | | | | | | | | | | | | | | | | | | |
| A | Machine reference position becomes the reference point | Electrical zero point becomes the reference position | | | | | | | | | | | | | | | | | | | | | | | | | | | | | | | | | | | | | | | |
| D | Coordinate zero point creation valid | Zero point established at power supply ON position | | | | | | | | | | | | | | | | | | | | | | | | | | | | | | | | | | | | | | | |
| E | Rotation direction in DIR or in the shortcut direction | Rotation direction in the random position command sign direction | | | | | | | | | | | | | | | | | | | | | | | | | | | | | | | | | | | | | | | |
| F | Stopper direction is positioning direction | Stopper direction is for the stopper amount in the sign direction | | | | | | | | | | | | | | | | | | | | | | | | | | | | | | | | | | | | | | | |
| #178 | TL4 | Operation parameter group 4 Torque limit value | 500 | % | Set so that the torque limit is not reached with the acceleration to the pushing speed, and so that the value is less than 100%. | 1 ~ 500 | | | | | | | | | | | | | | | | | | | | | | | | | | | | | | | | | | | |
| #179 | OD4 | Operation parameter group 4 Excessive error detection width | 100 | deg (mm) | Set a value that will not cause an excessive error alarm when pushing. | 0 ~ 32767 | | | | | | | | | | | | | | | | | | | | | | | | | | | | | | | | | | | |

7-2-3 Reference point setting method

The absolute position reference point is determined by setting the axis to the machine's reference point.

(1) Initialization

Turn the following signal ON, and change to the absolute position reference point initialization mode.

Set the direction from the position to carry out reference point setting to the grid to be used as the electrical zero point in parameter #120 ABS Type Absolute position detection parameter bit3.

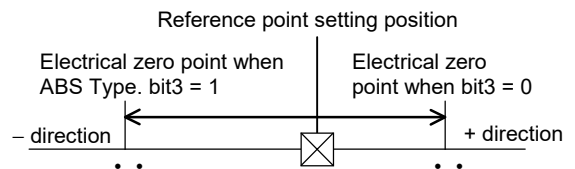

| Abbrev. | Signal name | Explanation |
|---------|---|---|
| AZS | Reference point initialization mode selection | The absolute position reference point initialization mode is entered. Set the parameter to the reference point setting method, and then initialize the reference zero point. This mode is held until the NC power is turned OFF. |

Chapter 7 Absolute Position Detection System

(2) Explanation of operation

- Using jog, handle or incremental feed, set the axis position to the position to become the "absolute position reference point".
- Turn the reference point setting (ZST) signal ON.
- Using jog, handle or incremental feed, move the axis in the direction of the grid to be the electrical zero point. When the axis reaches the grid to be the electrical zero point, it will automatically stop, and the absolute position coordinates will be established.

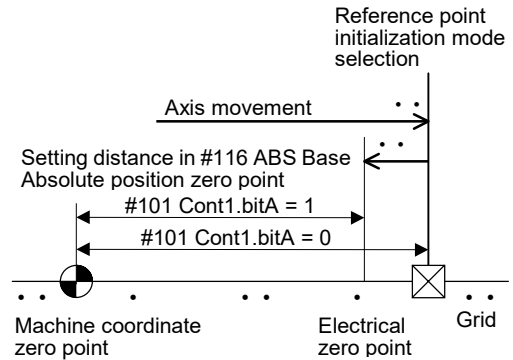

If parameter #101 Cont1.bitA is set to "1", the electrical zero point (grid) will be set as the "absolute position reference point" instead of the position where reference point setting was turned ON.

- In this state, the absolute position reference point will become the coordinate zero point. To set a point other than the position where reference point setting (ZST) was turned ON or the electrical zero point as the absolute position coordinate zero point, move the machine coordinate zero point with parameter #116 ABS Base Absolute position zero point.

| No. | Abbrev. | Parameter name | Default value | Unit | Explanation | Setting range | | | | | | | | | | | | | | | | | | | | | | | | | | | | | | | | | | |
|---|---|---|--|----------|---|--------------------------|-----|--------------------------|--------------------------|---|---|--|---|--------------------------------------|--|---|--------------------------------------|--|---|--|--|---|--------------------------------------|--|---|--|--|---|--|---|---|---|---|---|---|---|---|---|---|---|
| #101 | *Cont1 | Control parameter 1 | This is a HEX setting parameter. Set bits without a description to their default values. | | | | | | | | | | | | | | | | | | | | | | | | | | | | | | | | | | | | | |
| <table border="1"> <thead> <tr> <th>bit</th> <th>F</th> <th>E</th> <th>D</th> <th>C</th> <th>B</th> <th>A</th> <th>9</th> <th>8</th> <th>7</th> <th>6</th> <th>5</th> <th>4</th> <th>3</th> <th>2</th> <th>1</th> <th>0</th> </tr> </thead> <tbody> <tr> <td>Default value</td> <td>0</td> <td>0</td> <td>0</td> <td>0</td> <td>0</td> <td>0</td> <td>1</td> <td>0</td> <td>0</td> <td>0</td> <td>0</td> <td>0</td> <td>0</td> <td>0</td> <td>0</td> <td>0</td> </tr> </tbody> </table> | | | | | | | bit | F | E | D | C | B | A | 9 | 8 | 7 | 6 | 5 | 4 | 3 | 2 | 1 | 0 | Default value | 0 | 0 | 0 | 0 | 0 | 0 | 1 | 0 | 0 | 0 | 0 | 0 | 0 | 0 | 0 | 0 |
| bit | F | E | D | C | B | A | 9 | 8 | 7 | 6 | 5 | 4 | 3 | 2 | 1 | 0 | | | | | | | | | | | | | | | | | | | | | | | | |
| Default value | 0 | 0 | 0 | 0 | 0 | 0 | 1 | 0 | 0 | 0 | 0 | 0 | 0 | 0 | 0 | 0 | | | | | | | | | | | | | | | | | | | | | | | | |
| <table border="1"> <thead> <tr> <th>bit</th> <th>Meaning when "0" is set.</th> <th>Meaning when "1" is set.</th> </tr> </thead> <tbody> <tr> <td>1</td> <td>High-speed zero point return after zero point establishment</td> <td>Dog-type method for each zero point return operation</td> </tr> <tr> <td>8</td> <td>Reference point return direction (+)</td> <td>Reference point return direction (-)</td> </tr> <tr> <td>9</td> <td>Rotation direction determined by DIR</td> <td>Rotation direction in the shortcut direction</td> </tr> <tr> <td>A</td> <td>Machine reference position becomes the reference point</td> <td>Electrical zero point becomes the reference position</td> </tr> <tr> <td>D</td> <td>Coordinate zero point creation valid</td> <td>Zero point established at power supply ON position</td> </tr> <tr> <td>E</td> <td>Rotation direction in DIR or in the shortcut direction</td> <td>Rotation direction in the random position command sign direction</td> </tr> <tr> <td>F</td> <td>Stopper direction is positioning direction</td> <td>Stopper direction is for the stopper amount in the sign direction</td> </tr> </tbody> </table> | | | | | | | bit | Meaning when "0" is set. | Meaning when "1" is set. | 1 | High-speed zero point return after zero point establishment | Dog-type method for each zero point return operation | 8 | Reference point return direction (+) | Reference point return direction (-) | 9 | Rotation direction determined by DIR | Rotation direction in the shortcut direction | A | Machine reference position becomes the reference point | Electrical zero point becomes the reference position | D | Coordinate zero point creation valid | Zero point established at power supply ON position | E | Rotation direction in DIR or in the shortcut direction | Rotation direction in the random position command sign direction | F | Stopper direction is positioning direction | Stopper direction is for the stopper amount in the sign direction | | | | | | | | | | |
| bit | Meaning when "0" is set. | Meaning when "1" is set. | | | | | | | | | | | | | | | | | | | | | | | | | | | | | | | | | | | | | | |
| 1 | High-speed zero point return after zero point establishment | Dog-type method for each zero point return operation | | | | | | | | | | | | | | | | | | | | | | | | | | | | | | | | | | | | | | |
| 8 | Reference point return direction (+) | Reference point return direction (-) | | | | | | | | | | | | | | | | | | | | | | | | | | | | | | | | | | | | | | |
| 9 | Rotation direction determined by DIR | Rotation direction in the shortcut direction | | | | | | | | | | | | | | | | | | | | | | | | | | | | | | | | | | | | | | |
| A | Machine reference position becomes the reference point | Electrical zero point becomes the reference position | | | | | | | | | | | | | | | | | | | | | | | | | | | | | | | | | | | | | | |
| D | Coordinate zero point creation valid | Zero point established at power supply ON position | | | | | | | | | | | | | | | | | | | | | | | | | | | | | | | | | | | | | | |
| E | Rotation direction in DIR or in the shortcut direction | Rotation direction in the random position command sign direction | | | | | | | | | | | | | | | | | | | | | | | | | | | | | | | | | | | | | | |
| F | Stopper direction is positioning direction | Stopper direction is for the stopper amount in the sign direction | | | | | | | | | | | | | | | | | | | | | | | | | | | | | | | | | | | | | | |
| #116 | ABS base | Absolute position zero point | 0.000 | deg (mm) | Set the movement amount when the machine coordinate zero point is to be moved from the reference point during absolute position initialization. | -99999.999 ~99999.999 | | | | | | | | | | | | | | | | | | | | | | | | | | | | | | | | | | |
| #120 | ABS Type | Absolute position detector parameter | This is a HEX setting parameter. Set bits without a description to their default values. | | | | | | | | | | | | | | | | | | | | | | | | | | | | | | | | | | | | | |
| <table border="1"> <thead> <tr> <th>bit</th> <th>F</th> <th>E</th> <th>D</th> <th>C</th> <th>B</th> <th>A</th> <th>9</th> <th>8</th> <th>7</th> <th>6</th> <th>5</th> <th>4</th> <th>3</th> <th>2</th> <th>1</th> <th>0</th> </tr> </thead> <tbody> <tr> <td>Default value</td> <td>0</td> <td>0</td> <td>0</td> <td>0</td> <td>0</td> <td>0</td> <td>0</td> <td>0</td> <td>0</td> <td>0</td> <td>0</td> <td>0</td> <td>0</td> <td>1</td> <td>0</td> <td>0</td> </tr> </tbody> </table> | | | | | | | bit | F | E | D | C | B | A | 9 | 8 | 7 | 6 | 5 | 4 | 3 | 2 | 1 | 0 | Default value | 0 | 0 | 0 | 0 | 0 | 0 | 0 | 0 | 0 | 0 | 0 | 0 | 0 | 1 | 0 | 0 |
| bit | F | E | D | C | B | A | 9 | 8 | 7 | 6 | 5 | 4 | 3 | 2 | 1 | 0 | | | | | | | | | | | | | | | | | | | | | | | | |
| Default value | 0 | 0 | 0 | 0 | 0 | 0 | 0 | 0 | 0 | 0 | 0 | 0 | 0 | 1 | 0 | 0 | | | | | | | | | | | | | | | | | | | | | | | | |
| <table border="1"> <thead> <tr> <th>bit</th> <th>Meaning when "0" is set.</th> <th>Meaning when "1" is set.</th> </tr> </thead> <tbody> <tr> <td>1</td> <td>Dog-less type initialization</td> <td>Dog-type initialization</td> </tr> <tr> <td>2</td> <td>Machine stopper initialization</td> <td>Reference point setting initialization</td> </tr> <tr> <td>3</td> <td>Electrical zero point direction +</td> <td>Electrical zero point direction -</td> </tr> </tbody> </table> | | | | | | | bit | Meaning when "0" is set. | Meaning when "1" is set. | 1 | Dog-less type initialization | Dog-type initialization | 2 | Machine stopper initialization | Reference point setting initialization | 3 | Electrical zero point direction + | Electrical zero point direction - | | | | | | | | | | | | | | | | | | | | | | |
| bit | Meaning when "0" is set. | Meaning when "1" is set. | | | | | | | | | | | | | | | | | | | | | | | | | | | | | | | | | | | | | | |
| 1 | Dog-less type initialization | Dog-type initialization | | | | | | | | | | | | | | | | | | | | | | | | | | | | | | | | | | | | | | |
| 2 | Machine stopper initialization | Reference point setting initialization | | | | | | | | | | | | | | | | | | | | | | | | | | | | | | | | | | | | | | |
| 3 | Electrical zero point direction + | Electrical zero point direction - | | | | | | | | | | | | | | | | | | | | | | | | | | | | | | | | | | | | | | |

Chapter 8 Servo Adjustment

| | | |
|------------|--|------------|
| 8-1 | Measuring the adjustment data | 8-2 |
| 8-1-1 | D/A output..... | 8-2 |
| 8-1-2 | Graph display | 8-2 |
| 8-2 | Automatic tuning | 8-3 |
| 8-2-1 | Model adaptive control..... | 8-3 |
| 8-2-2 | Automatic tuning specifications..... | 8-3 |
| 8-2-3 | Adjusting the automatic tuning..... | 8-4 |
| 8-3 | Manual adjustment | 8-5 |
| 8-3-1 | Setting the model inertia | 8-5 |
| 8-3-2 | Adjusting the gain | 8-6 |
| 8-4 | Characteristics improvements | 8-7 |
| 8-4-1 | Vibration suppression measures..... | 8-7 |
| 8-4-2 | Overshooting measures..... | 8-7 |
| 8-5 | Adjusting the acceleration/deceleration operation | 8-8 |
| 8-5-1 | Setting the operation speed..... | 8-8 |
| 8-5-2 | Setting the acceleration/deceleration time constant..... | 8-8 |

Chapter 8 Servo Adjustment

8-1 Measuring the adjustment data

8-1-1 D/A output

The MR-J2-CT has a function to D/A output the various control data. To adjust the servo and set the servo parameters matching the machine, the status in the servo must be observed using D/A output. Measure using a hi-corder or synchroscope on hand.

(1) Specifications

| Item | Explanation |
|----------------------|--|
| No. of changes | 2ch |
| Output frequency | 888 μ sec (Minimum value) |
| Output accuracy | 8bit |
| Output voltage range | -10V ~ 0 ~ +10V |
| Output scale setting | Fixed |
| Output pins | CN3 connector MO1 = pin 4 MO2 = pin 14 GND = pin 1, 11 |
| Function | Offset amount adjustment function |
| Option | Relay terminal block: MR-J2CN3TM Lead out the SH21 cable from the CN3 connector, and connect. |

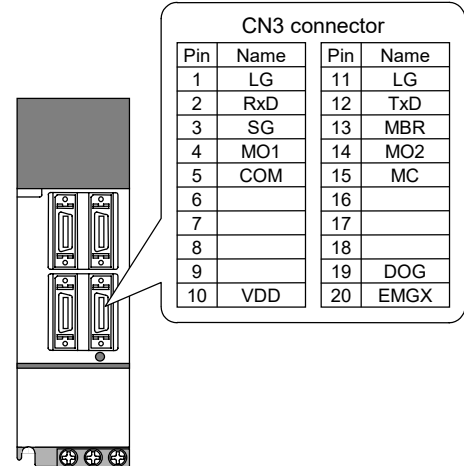

(2) Setting the output data

| No. | Abbrev. | Parameter name | Explanation | | | | | | | | | | | | | | | | | | | | | | | | | | | | | | | | | | | | |
|------|-----------------------------|-------------------------------|--|-----|---------|-------|---|-------------------------|-----------------|---|---------------------------|----------------------------|---|---------------------------|-----------------|---|-----------------------------|----------------------------|---|-----------------|----------------------------|---|--------------------------|-----------------------|---|---------------|--------------------|---|---------------|--------------------|---|----------------|---------------------|---|----------------|---------------------|---|----------------|----------------------|
| #050 | MD1 | D/A output channel 1 data No. | Set the No. of the data to be output to each D/A output channel. <div style="border: 1px solid black; padding: 2px; display: inline-block;"> 0 0 0 0 </div> (Default value) | | | | | | | | | | | | | | | | | | | | | | | | | | | | | | | | | | | | |
| #053 | MD2 | D/A output channel 2 data No. | | | | | | | | | | | | | | | | | | | | | | | | | | | | | | | | | | | | | |
| | | | <table border="1"> <thead> <tr> <th>No.</th> <th>Details</th> <th>Scale</th> </tr> </thead> <tbody> <tr><td>0</td><td>Speed feedback (signed)</td><td>Max. speed = 8V</td></tr> <tr><td>1</td><td>Current feedback (signed)</td><td>Max. current (torque) = 8V</td></tr> <tr><td>2</td><td>Speed feedback (unsigned)</td><td>Max. speed = 8V</td></tr> <tr><td>3</td><td>Current feedback (unsigned)</td><td>Max. current (torque) = 8V</td></tr> <tr><td>4</td><td>Current command</td><td>Max. current (torque) = 8V</td></tr> <tr><td>5</td><td>Command F\cdot τ</td><td>10000 [deg/min] = 10V</td></tr> <tr><td>6</td><td>Droop 1 (1/1)</td><td>2048 [pulse] = 10V</td></tr> <tr><td>7</td><td>Droop 2 (1/4)</td><td>8192 [pulse] = 10V</td></tr> <tr><td>8</td><td>Droop 3 (1/16)</td><td>32768 [pulse] = 10V</td></tr> <tr><td>9</td><td>Droop 4 (1/32)</td><td>65536 [pulse] = 10V</td></tr> <tr><td>A</td><td>Droop 5 (1/64)</td><td>131072 [pulse] = 10V</td></tr> </tbody> </table> | No. | Details | Scale | 0 | Speed feedback (signed) | Max. speed = 8V | 1 | Current feedback (signed) | Max. current (torque) = 8V | 2 | Speed feedback (unsigned) | Max. speed = 8V | 3 | Current feedback (unsigned) | Max. current (torque) = 8V | 4 | Current command | Max. current (torque) = 8V | 5 | Command F \cdot τ | 10000 [deg/min] = 10V | 6 | Droop 1 (1/1) | 2048 [pulse] = 10V | 7 | Droop 2 (1/4) | 8192 [pulse] = 10V | 8 | Droop 3 (1/16) | 32768 [pulse] = 10V | 9 | Droop 4 (1/32) | 65536 [pulse] = 10V | A | Droop 5 (1/64) | 131072 [pulse] = 10V |
| No. | Details | Scale | | | | | | | | | | | | | | | | | | | | | | | | | | | | | | | | | | | | | |
| 0 | Speed feedback (signed) | Max. speed = 8V | | | | | | | | | | | | | | | | | | | | | | | | | | | | | | | | | | | | | |
| 1 | Current feedback (signed) | Max. current (torque) = 8V | | | | | | | | | | | | | | | | | | | | | | | | | | | | | | | | | | | | | |
| 2 | Speed feedback (unsigned) | Max. speed = 8V | | | | | | | | | | | | | | | | | | | | | | | | | | | | | | | | | | | | | |
| 3 | Current feedback (unsigned) | Max. current (torque) = 8V | | | | | | | | | | | | | | | | | | | | | | | | | | | | | | | | | | | | | |
| 4 | Current command | Max. current (torque) = 8V | | | | | | | | | | | | | | | | | | | | | | | | | | | | | | | | | | | | | |
| 5 | Command F \cdot τ | 10000 [deg/min] = 10V | | | | | | | | | | | | | | | | | | | | | | | | | | | | | | | | | | | | | |
| 6 | Droop 1 (1/1) | 2048 [pulse] = 10V | | | | | | | | | | | | | | | | | | | | | | | | | | | | | | | | | | | | | |
| 7 | Droop 2 (1/4) | 8192 [pulse] = 10V | | | | | | | | | | | | | | | | | | | | | | | | | | | | | | | | | | | | | |
| 8 | Droop 3 (1/16) | 32768 [pulse] = 10V | | | | | | | | | | | | | | | | | | | | | | | | | | | | | | | | | | | | | |
| 9 | Droop 4 (1/32) | 65536 [pulse] = 10V | | | | | | | | | | | | | | | | | | | | | | | | | | | | | | | | | | | | | |
| A | Droop 5 (1/64) | 131072 [pulse] = 10V | | | | | | | | | | | | | | | | | | | | | | | | | | | | | | | | | | | | | |

(3) Setting the offset amount

If the D/A output's zero level does not match (is not set to 0V), adjust the output offset with the following parameters.

| No. | Abbrev. | Parameter name | Default value | Unit | Explanation | Setting range |
|------|---------|------------------------------------|---------------|------|--|---------------|
| #051 | MO1 | D/A output channel 1 output offset | 0 | mV | Set if the zero level of each D/A output channel does not match. | -999~999 |
| #052 | MO2 | D/A output channel 2 output offset | | | | |

8-1-2 Graph display

When the setup software is used, the adjustment data can be displayed on the personal computer screen as a graph. Refer to the "Setup Software Instruction Manual (BNP-B2208)" for details on the handling methods, etc.

Chapter 8 Servo Adjustment

8-2 Automatic tuning

8-2-1 Model adaptive control

The MR-J2-CT servo control has the following type of model scale type control system. It is two free structures having position loop gain and speed loop gain on both the model loop side and actual loop side. If the model load inertia (GD2) is equivalent to the actual load inertia, the actual load can be correctly driven with the torque command (current command) created on the model loop side. If an error is generated between the actual load response and model response, due to disturbance, etc., the actual loop will function to compensate for the error amount.

In this manner, by setting the responsiveness for the command and the responsiveness for disturbance independently, the model adaptive control can realize control capable of relatively high-speed control even with a low actual loop gain.

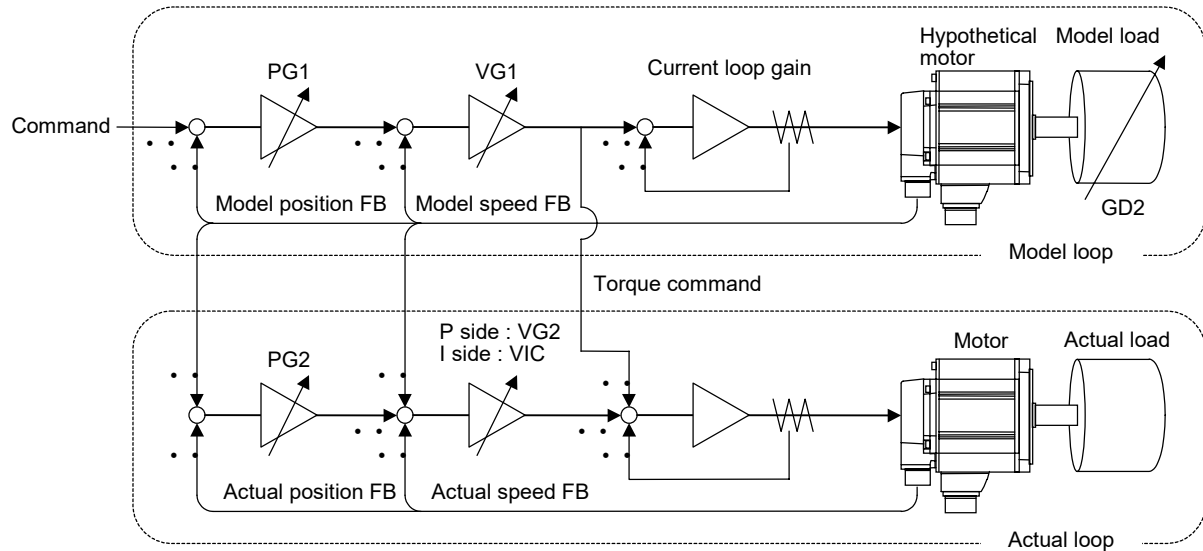

Model adaptive control

8-2-2 Automatic tuning specifications

The MR-J2-CT has a built-in automatic tuning function, so bothersome servo gain adjustments are carried out by the servo amplifier. With automatic tuning, the size of the motor load inertia is automatically detected, and the optimum servo gain for that inertia is set. The load inertia is detected and the servo gain adjusted while the motor is accelerating and decelerating, so acceleration/deceleration operation is always required for automatic tuning. If the load inertia changes because the No. of tools in the magazine has been changed or the arm is grasping the workpiece, a new gain will be set accordingly.

The adjusted gain is saved in the amplifier's memory, so control will be carried out with the adjusted gain even after the amplifier's power is turned ON again.

Automatically tuned parameters

| No. | Abbrev. | Parameter name | Details |
|------|---------|-----------------------------|--|
| #008 | PG1 | Position loop gain 1 | This determines the tracking in respect to the position command. |
| #019 | PG2 | Position loop gain 2 | This determines the position responsiveness in respect to the load disturbance. |
| #020 | VG1 | Speed loop gain 1 | This determines the tracking in respect to the speed command. |
| #021 | VG2 | Speed loop gain 2 | This determines the speed responsiveness in respect to the load disturbance. |
| #022 | VIC | Speed integral compensation | This determines the responsiveness of the low-frequency region of speed control. |
| #024 | GD2 | Load inertia ratio | This determines the load inertia ratio in respect to the motor inertia. |



POINT

1. Automatic tuning detects the load inertia and adjusts the gain while the motor is accelerating or decelerating. Thus, acceleration/deceleration operation is required for tuning. Even if there is a load torque, tuning (gain adjustment) will not be carried out while the motor is stopped or during constant speed feed.
2. If the detected load inertia does not change, the gain setting value will also not change.

Chapter 8 Servo Adjustment

8-2-3 Adjusting the automatic tuning

Automatic tuning detects the load inertia and automatically sets the servo gain. However, whether to set a generally higher gain (high response) or a lower gain (low response) is adjusted with the parameters. Set a low responsiveness if the load vibrates easily, and set a high responsiveness to shorten the settling time and thereby reduce the positioning time. If no problems occur with the standard setting, there is no need to change the parameters.

| Machine operation | Ideal machine operation | Setting method |
|--|---|---|
| Machine resonance occurs The machine gears can be heard | Suppress the machine resonance. Reduce the gear noise. | Decrease the responsiveness setting value. |
| The machine overshoots when stopping | Reduce the overshooting. | Increase the friction characteristic selection. Decrease the responsiveness setting value. |
| The stop settling time is long (Note) | Reduce the stop settling time. | Increase the responsiveness setting value. |

(Note) Stop settling time: Time for servomotor to stop after command changes to zero.



POINT

- Automatic tuning sets the various gain to match the load inertia or with the optimum balance. Note that the machine rigidity must be determined and set by the operator.
- The automatic tuning responsiveness can be increased by using the vibration suppressing function.

| No. | Abbrev. | Parameter name | Explanation | | | | | | | | | | | | | | | | | | | | | | | | | | |
|---------------|--|------------------|--|---------------|---------|---|--|---|------------------------|---|------------------------|---|------------------------|---|--|---------------|---------|---|----------|---|---|---------------|---------|---|---|---|---|---|----------------------------|
| #007 | ATU | Automatic tuning | <p>Set the adjustment parameters for automatic tuning. Do not set the values having no explanation.</p> <p>0 1 0 2 (Default value)</p> <table border="1"> <thead> <tr> <th>Setting value</th> <th>Details</th> </tr> </thead> <tbody> <tr> <td>1</td> <td>Low response (Load with low rigidity, load that easily vibrates)</td> </tr> <tr> <td>2</td> <td>Standard setting value</td> </tr> <tr> <td>3</td> <td>Standard setting value</td> </tr> <tr> <td>4</td> <td>Standard setting value</td> </tr> <tr> <td>5</td> <td>High response (Load with high rigidity, load that does not easily vibrate)</td> </tr> </tbody> </table> <table border="1"> <thead> <tr> <th>Setting value</th> <th>Details</th> </tr> </thead> <tbody> <tr> <td>0</td> <td>Standard</td> </tr> <tr> <td>1</td> <td>Large friction (Set the position loop gain to a low value.)</td> </tr> </tbody> </table> <table border="1"> <thead> <tr> <th>Setting value</th> <th>Details</th> </tr> </thead> <tbody> <tr> <td>0</td> <td>Automatically tune only PG2, VG2, VIC, and GD2.</td> </tr> <tr> <td>1</td> <td>Automatically tune PG1, PG2, VG1, VG2, VIC and GD2 (all gains).</td> </tr> <tr> <td>2</td> <td>Do not automatically tune.</td> </tr> </tbody> </table> | Setting value | Details | 1 | Low response (Load with low rigidity, load that easily vibrates) | 2 | Standard setting value | 3 | Standard setting value | 4 | Standard setting value | 5 | High response (Load with high rigidity, load that does not easily vibrate) | Setting value | Details | 0 | Standard | 1 | Large friction (Set the position loop gain to a low value.) | Setting value | Details | 0 | Automatically tune only PG2, VG2, VIC, and GD2. | 1 | Automatically tune PG1, PG2, VG1, VG2, VIC and GD2 (all gains). | 2 | Do not automatically tune. |
| Setting value | Details | | | | | | | | | | | | | | | | | | | | | | | | | | | | |
| 1 | Low response (Load with low rigidity, load that easily vibrates) | | | | | | | | | | | | | | | | | | | | | | | | | | | | |
| 2 | Standard setting value | | | | | | | | | | | | | | | | | | | | | | | | | | | | |
| 3 | Standard setting value | | | | | | | | | | | | | | | | | | | | | | | | | | | | |
| 4 | Standard setting value | | | | | | | | | | | | | | | | | | | | | | | | | | | | |
| 5 | High response (Load with high rigidity, load that does not easily vibrate) | | | | | | | | | | | | | | | | | | | | | | | | | | | | |
| Setting value | Details | | | | | | | | | | | | | | | | | | | | | | | | | | | | |
| 0 | Standard | | | | | | | | | | | | | | | | | | | | | | | | | | | | |
| 1 | Large friction (Set the position loop gain to a low value.) | | | | | | | | | | | | | | | | | | | | | | | | | | | | |
| Setting value | Details | | | | | | | | | | | | | | | | | | | | | | | | | | | | |
| 0 | Automatically tune only PG2, VG2, VIC, and GD2. | | | | | | | | | | | | | | | | | | | | | | | | | | | | |
| 1 | Automatically tune PG1, PG2, VG1, VG2, VIC and GD2 (all gains). | | | | | | | | | | | | | | | | | | | | | | | | | | | | |
| 2 | Do not automatically tune. | | | | | | | | | | | | | | | | | | | | | | | | | | | | |

Chapter 8 Servo Adjustment

8-3 Manual adjustment

With automatic tuning, the model loop load inertia (GD2) is set to the actual load inertia, and the optimum gain is automatically set according to the size of that inertia. The method of manually setting (inputting the parameters) each gain is explained in this section.

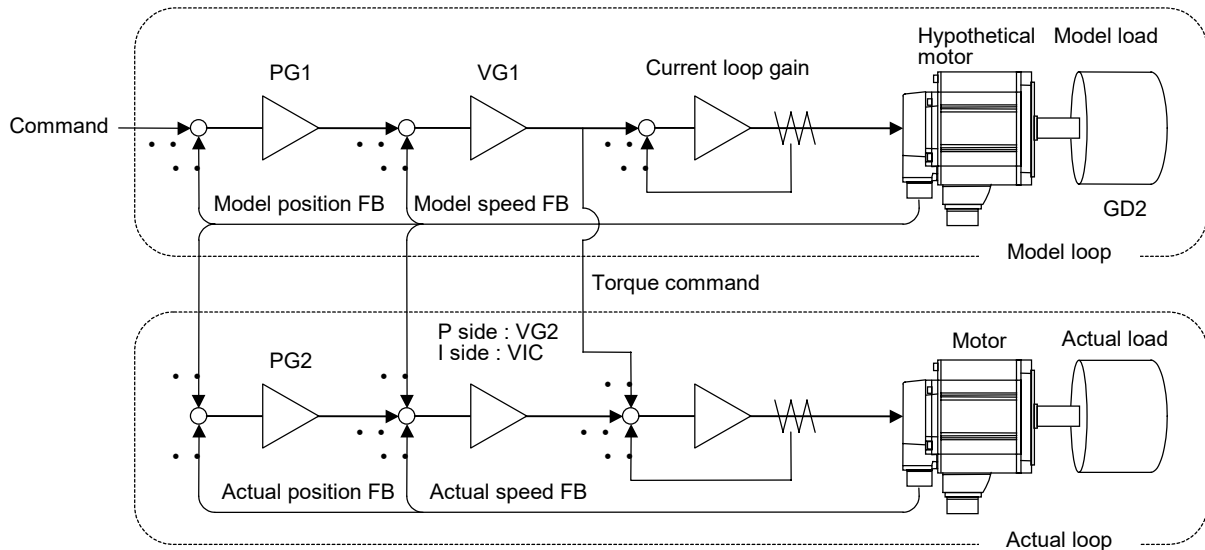

8-3-1 Setting the model inertia

Manual adjustment is carried out when sufficient characteristics cannot be obtained with automatic tuning. This often occurs when the load inertia is not correctly detected. If the load inertia ratio on the MONITOR screen greatly differs from the calculated value, or if it is unstable, manually set only the load inertia ratio. Then, set the gain for that load inertia ratio to the optimum value with automatic tuning.

| Machine characteristics | Monitor' s load inertia ratio (GD2) phenomenon | Explanation |
|--|--|--|
| The machine friction is large | The difference between the value after acceleration and the value after deceleration is large. | The load inertia is detected while the motor is accelerating or decelerating, so if the friction is large, a large inertia will be detected during acceleration, and a small inertia will be detected during deceleration. The average value obtained from the values after acceleration and deceleration is the true load inertia ratio. |
| Cam drive (The load inertia changes during constant speed operation) | The value is extremely small compared to the calculated value. | The detected load inertia is the load inertia during acceleration/deceleration. Normally, the inertia during the lightest load is detected, so this can be improved by setting the inertia to math the load during actual drive. In this case, the load inertia itself will not change, so improvements can also be made by increasing the automatic tuning responsiveness. (Set a higher gain for the same load inertia.) |

| Step | Operation | Explanation |
|------|--|---|
| 1 | Set parameter "#007 ATU" to 0101. | Start the automatic tuning with a low response. |
| 2 | Set the load inertia ratio in parameter "#024 GD2". | When the load inertia is set, the following parameter will be set to the set load inertia. Do not drive the motor at this time. #008 PG1 : Position loop gain 1 #019 PG2 : Position loop gain 2 #020 VG1 : Speed loop gain 1 #021 VG2 : Speed loop gain 2 #022 VIC : Speed integral compensation |
| 3 | Set parameter "#007 ATU" to 0201. | Stop the automatic tuning, and fix the set gain. |
| 4 | Confirm the operation, and if vibration, etc., is not occurring, raise the automatic tuning responsiveness, and repeat (Step 1) to (Step 3). | The optimum value is just before the vibration increases. |

Chapter 8 Servo Adjustment

8-3-2 Adjusting the gain

If the balance of the various gains set with automatic tuning does not match the machine, the gains must be adjusted individually. Adjust with the following procedure.

(1) GD2: Load inertia ratio

Set the model load inertia to be used in the model loop. If the model load inertia and actual load inertia match, the model section operation will approach the actual operation. Thus, there is no need to raise the actual loop gain PG2 or VG2 more than necessary.

Even when adjusting manually, adjust the following gain using the gain determined in section "8-2-1 Setting the model inertia" as the default value.

$$GD2 = \frac{J_L}{J_M} \quad (J_L: \text{Load inertia, } J_M: \text{Motor inertia})$$

(2) VG2: Speed loop gain 2

The speed loop gain dominates the response damping. If this gain is extremely low, vibration will occur at the PG2 frequency, and if too high, machine resonance will be induced. To adjust, gradually raise VG2, and set at 70% of the max. value where the machine resonance does not occur.

The VG2 unit is the response frequency, but in actual use, it is the response setting including the load inertia. Thus, the actual response frequency (rad/sec) will be the value divided by the load inertia rate $(1+J_L/J_M)$.

(3) VG2: Position loop gain 2

PG2 determines the position response in respect to disturbance. Normally it is set with the following equation. Adjust PG1 to shorten the settling time.

$$PG2 = \frac{6 \times VG2}{1 + (J_L/J_M)} \quad (\text{rad/sec})$$

(4) VIC: Speed integral compensation

If the load torque fluctuation is large or the machine friction is large, uneven rotation or overshooting during position settling will increase. In this case, the position and speed fluctuation can be reduced by reducing VIC. However, if it is too low, vibration will occur. Adjust with the load inertia ratio while referring to the following table.

| Load inertia ratio | 1 | 3 | 5 | 10 | 20 | 30 or more |
|------------------------------------|----|----|----|----|-----|------------|
| Speed integral compensation (msec) | 20 | 30 | 40 | 60 | 100 | 200 |

(5) VG1: Speed loop gain 1

(6) PG1: Position loop gain 1

These are the model loop side gains that determine the responsiveness in respect to the command. The model side makes an ideal response, so no matter how high these gains are set, the model system will not resonate. However, the impact to the machine during acceleration/deceleration will increase, so the vibration during acceleration/deceleration and the overshooting when stopping will increase. Adjust to the optimum value while actually driving the machine and maintaining the relation given in the following equation.

PG1 is directly related to the target response characteristics, so if this gain is increased, the settling time will be shortened.

$$PG1 = \frac{VG1}{4} \quad (\text{rad/sec})$$

| No. | Abbrev. | Parameter name | Default value | Unit | Explanation | Setting range |
|------|---------|-----------------------------|---------------|---------|--|---------------|
| #008 | PG1 | Position loop gain 1 | 70 | rad/sec | Set the position loop gain for the model loop. This determines the tracking in respect to the position command. | 4 ~ 1000 |
| #019 | PG2 | Position loop gain 2 | 25 | rad/sec | Set the position loop gain for the actual loop. This determines the position responsiveness in respect to disturbance. | 1 ~ 500 |
| #020 | VG1 | Speed loop gain 1 | 1200 | rad/sec | Set the speed loop gain for the model loop. This determines the tracking in respect to the speed command. | 20 ~ 5000 |
| #021 | VG2 | Speed loop gain 2 | 600 | rad/sec | Set the speed loop gain for the actual loop. This determines the speed responsiveness in respect to disturbance. | 20 ~ 8000 |
| #022 | VIC | Speed integral compensation | 20 | msec | This determines the responsiveness of the low-frequency region of speed control. | 1 ~ 1000 |
| #024 | GD2 | Load inertia ratio | 2.0 | fold | This determines the load inertia ratio in respect to the motor inertia. | 0.0 ~ 50.0 |

8-4 Characteristics improvements

8-4-1 Vibration suppression measures

(1) Notch filter

The resonance elimination filter operates at the set frequency. Observe the FB torque (current FB) waveform using the monitor output function or setup software graph display function, etc., and measure the resonance frequency. Note that the resonance frequency that can be observed is approx. 0 to 500Hz. Directly observe the phase current using a current probe, etc., for resonance exceeding 500Hz. Note that when the filter is set, other frequency resonance could occur.

| No. | Abbrev. | Parameter name | Explanation | | | | | | | | | | | | | | | | | | |
|----------------|--------------|------------------|---|---------------|-----|-----|-----|-----|---|---|---|---|----------------|--------------|------|-----|-----|-----|-----|-----|-----|
| #014 | NCH | Notch filter No. | Set the frequency of the machine resonance suppressing filter. Do not set the values having no explanation. <table border="1" style="margin-left: 20px;"> <thead> <tr> <th>Setting value</th> <th>0</th> <th>1</th> <th>2</th> <th>3</th> <th>4</th> <th>5</th> <th>6</th> <th>7</th> </tr> </thead> <tbody> <tr> <td>Frequency (Hz)</td> <td>Non-starting</td> <td>1125</td> <td>563</td> <td>375</td> <td>282</td> <td>225</td> <td>188</td> <td>161</td> </tr> </tbody> </table> | Setting value | 0 | 1 | 2 | 3 | 4 | 5 | 6 | 7 | Frequency (Hz) | Non-starting | 1125 | 563 | 375 | 282 | 225 | 188 | 161 |
| Setting value | 0 | 1 | 2 | 3 | 4 | 5 | 6 | 7 | | | | | | | | | | | | | |
| Frequency (Hz) | Non-starting | 1125 | 563 | 375 | 282 | 225 | 188 | 161 | | | | | | | | | | | | | |

(2) Jitter compensation

If the motor position enters the machine's backlash when stopping, the load inertia will be very small. This is because a very large speed loop gain is set in respect to the load inertia, so vibration occurs.

Jitter compensation allows the vibration that occurs while the motor is stopping to be suppressed by ignoring the speed feedback pulses of the backlash amount when the speed feedback polarity changes. Set the value to suppress the vibration by increasing the No. of ignored pulses one pulse at a time. (The position feedback is controlled as normal, so there is no worry of positional deviation.)

Note that if an axis with which vibration does not occur is set, vibration could be induced.

| No. | Abbrev. | Parameter name | Explanation | | | | | | | | | | |
|-----------------------|--------------|---------------------|---|---------------|---|---|---|---|-----------------------|--------------|---|---|---|
| #016 | JIT | Jitter compensation | Set the No. of pulses ignored for jitter compensation. Do not set the values having no explanation. <table border="1" style="margin-left: 20px;"> <thead> <tr> <th>Setting value</th> <th>0</th> <th>1</th> <th>2</th> <th>3</th> </tr> </thead> <tbody> <tr> <td>No. of ignored pulses</td> <td>Non-starting</td> <td>1</td> <td>2</td> <td>3</td> </tr> </tbody> </table> | Setting value | 0 | 1 | 2 | 3 | No. of ignored pulses | Non-starting | 1 | 2 | 3 |
| Setting value | 0 | 1 | 2 | 3 | | | | | | | | | |
| No. of ignored pulses | Non-starting | 1 | 2 | 3 | | | | | | | | | |



POINT

Jitter compensation is effective in suppressing vibration only while the motor is stopped.

8-4-2 Overshooting measures

(1) Speed differential compensation

With normal PI control, the torque when the position droop reaches zero is held while the motor is stopped. However, with a machine having a large frictional torque, the holding torque will increase, and thus overshooting may occur. By lowering the speed differential compensation from the standard value, overshooting can be compensated.

| No. | Abbrev. | Parameter name | Default value | Unit | Explanation | Setting range |
|------|---------|---------------------------------|---------------|------|--|---------------|
| #024 | VDC | Speed differential compensation | 1000 | | When the default value 1000 is set, the normal PI control will be applied. Adjust the overshooting amount by reducing this value in units of 20. | 0 ~ 1000 |

8-5 Adjusting the acceleration/deceleration operation

8-5-1 Setting the operation speed

The operation speed is set to match the motor speed to the machine specifications within a range less than the max. speed. The operation speed is set for each operation group, but the operation group used with each operation mode is determined with the PLC group structure. The operation speed can be set freely for each operation group, but operation at a speed exceeding the operation parameter group 1 automatic operation speed (#150: Aspeed1) is not possible.



POINT

The parameter #150 (Aspeed1) operation parameter group 1 automatic operation speed will be the clamp value (max. limit speed) for the automatic operation speed and manual operation speed in all operation groups.

8-5-2 Setting the acceleration/deceleration time constant

For the acceleration/deceleration time constant, the linear acceleration/deceleration time in respect to the operation parameter group 1 automatic operation speed is set with an msec unit. Even if the operation group is not 1, the acceleration/deceleration inclination will be set with the time to accelerate to #150:Aspeed1.

The acceleration/deceleration time constant for rapid traverse (speed used for positioning at the highest speed) is set so that the max. current during rapid traverse acceleration/deceleration is within the range given below (this applies to only when the operation speed is less than the rated speed).

The max. current can be confirmed with the MAX CURRENT 2 display on the NC auxiliary axis monitor or the peak load rate display in the setup software. With the setup software, the command torque can be displayed in a graph and confirmed. Set the acceleration/deceleration time constants for the operation modes to a value higher than the acceleration/deceleration time constant for rapid traverse. When using deceleration control to control the stopping of the motor during an emergency stop, set the same value as the rapid traverse acceleration/deceleration time constant in the deceleration control time constant (#010: EMGt).

If the operation speed exceeds the motor's rated speed, adjust the acceleration/deceleration time constant so that the output torque at the high speed region is within the motor's specification range. The output torque is especially limited if the servomotor is at a speed higher than the rated speed. An insufficient torque will occur easily if the amplifier input voltage is low (170 to 190V), and can cause an excessive error to occur during acceleration or deceleration. The S-character acceleration/deceleration function is effective for reducing the acceleration/deceleration torque in high speed regions.

Max. current for acceleration/deceleration

| HC-SF series | | HC-RF series | | HA-FF series | |
|--------------|--------------|--------------|--------------|--------------|--------------|
| Motor type | Max. current | Motor type | Max. current | Motor type | Max. current |
| HC-SF52 | 240 ~ 270% | HC-RF103 | 200 ~ 225% | HA-FF053 | 240 ~ 270% |
| HC-SF102 | 240 ~ 270% | HC-RF153 | 200 ~ 225% | HA-FF13 | 240 ~ 270% |
| HC-SF152 | 240 ~ 270% | HC-RF203 | 200 ~ 225% | HA-FF23 | 240 ~ 270% |
| HC-SF202 | 240 ~ 270% | HC-MF series | | HA-FF33 | 240 ~ 270% |
| HC-SF352 | 240 ~ 270% | | | Motor type | Max. current |
| HC-SF53 | 240 ~ 270% | HC-MF053 | 260 ~ 290% | HA-FF63 | 240 ~ 270% |
| HC-SF103 | 240 ~ 270% | HC-MF13 | 260 ~ 290% | | |
| HC-SF153 | 240 ~ 270% | HC-MF23 | 280 ~ 290% | | |
| HC-SF203 | 240 ~ 270% | HC-MF43 | 275 ~ 290% | | |
| HC-SF353 | 240 ~ 270% | HC-MF73 | 280 ~ 290% | | |



POINT

The acceleration deceleration time constants of all operation groups will be set to the acceleration/deceleration time constant in respect to the speed set in parameter #150 (Aspeed1).





CAUTION

When using at a region higher than the rated speed, take special care to the acceleration/deceleration torque. If the amplifier's input voltage is low (170 to 190V), an excessive error could occur easily during acceleration/deceleration. When adjusting, determine the acceleration/deceleration time constant from the motor's speed - torque characteristics so that the acceleration/deceleration torque is within the specifications. The output torque at high speed regions can be reduced by using the S-character acceleration/deceleration function.

Chapter 9 Inspections

| | | |
|-----|-------------------|-----|
| 9-1 | Inspections | 9-2 |
| 9-2 | Life parts | 9-2 |

Chapter 9 Inspections

| | |
|--|---|
|  DANGER | <ol style="list-style-type: none"> 1. Wait at least 10 minutes after turning the power OFF and check that the input/output and voltage are zero with a tester, etc., before starting wiring or inspections. Failure to observe this could lead to electric shocks. 2. Only qualified persons must carry out the inspections. Failure to observe this could lead to electric shocks. Contact your dealer for repairs or part replacements. |
|  CAUTION | <ol style="list-style-type: none"> 3. Do not perform a megger test (insulation resistance measurement) on the servo amplifier. Failure to observe this could lead to faults. 4. Never disassemble or modify the unit. |

9-1 Inspections

Periodically inspecting the following points is recommended.

- Are any screws on the terminal block loose? Tighten if loose.
- Is there any abnormal noise from the servomotor bearings or the brakes?
- Are any of the cables damaged or cracked? If the cable moves with the machine, carry out a periodic inspection according to the usage conditions.
- Is the axis at the load coupling section misaligned?

9-2 Life parts

The guidelines for the part replacement interval are as shown below. These will differ according to the usage methods and environmental conditions, of if an abnormality is found, the part must be replaced. Contact your dealer for repairs and part replacements.

| Part name | | Standard replacement time | Remarks |
|-----------------|--------------------|--|---|
| Servo amplifier | Smoothing capacity | 10 years | The standard replacement time is a reference time. If an abnormality is found before the standard replacement time is reached, the part must be replaced. |
| | Relay | – | |
| | Cooling fan | 10,000 to 30,000 hours (2 to 3 years) | |
| | Battery | 10,000 hours | |
| Servomotor | Bearings | 20,000 to 30,000 hours | |
| | Detector | 20,000 to 30,000 hours | |
| | Oil seal, V-ring | 5,000 hours | |

- Smoothing capacitor : The smoothing capacitor characteristics will deteriorate due to the effect of the ripple current, etc. The capacitor life will be greatly affected by the ambient temperature and usage conditions, but when run continuously in a normal air-conditioned environment, the life will be reached in 10 years.
- Relays : Contact defects will occur due to contact wear caused by the switching current. This will differ according to the power capacity, but the life will be reached at a No. of cumulative switches (switching life) of 100,000 times.
- Servomotor bearings : When used at the rated speed and rated load, replace the bearings after about 20,000 to 30,000 hours. This will differ according to the operation state, but if abnormal noise or vibration is found during the inspection, the bearings must be replaced.
- Servomotor oil seal, V-ring: These parts must be replaced after about 5,000 hours of operation at the rated speed. This will differ according to the operation state, but these parts must be replaced if oil leaks, etc., are found during the inspection.

Chapter 10 Troubleshooting

| | | |
|-------------|--|-------------|
| 10-1 | Troubleshooting at start up | 10-2 |
| 10-2 | Displays and countermeasures for various alarms | 10-2 |
| 10-2-1 | Amplifier unit LED display during alarm..... | 10-2 |
| 10-2-2 | Alarm/warning list..... | 10-3 |
| 10-3 | Detailed explanations and countermeasures of alarms | 10-4 |
| 10-3-1 | Detailed explanations and countermeasures for servo alarms | 10-4 |
| 10-3-2 | Detailed explanations and countermeasures for system alarms..... | 10-9 |
| 10-3-3 | Detailed explanations and countermeasures for operation alarms | 10-10 |

10-1 Troubleshooting at start up



CAUTION

Excessive adjustment and changes of the parameters will cause unstable operation, so do not carry out.
The fault items that might occur when starting up, and countermeasures for these faults are shown below. Remedy according to each item.

| No. | Start up flow | Fault item | Investigation item | Assumed cause |
|-----|------------------|---|---|--|
| 1 | Power ON | The LED does not light. | Does not improve even when connectors CN1A, CN1B, CN2 and CN3 are disconnected. | <ul style="list-style-type: none"> • Power voltage defect • Servo amplifier fault |
| | | | Improved when connectors CN1A, CN1B and CN3 are disconnected. | The power supply of the CN1A, CN1B or CN3 cable wiring is short circuited. |
| | | | Improved when connector CN2 is disconnected. | <ul style="list-style-type: none"> • The power supply of the detector cable is short circuited. • Detector fault |
| | | An alarm occurs. | Refer to section 10-3 and remove the cause. | |
| 2 | Servo ON | An alarm occurs. | Refer to section 10-3 and remove the cause. | |
| | | The servo does not lock. (The motor shaft is free.) | <ul style="list-style-type: none"> • Confirm whether the NC is outputting a servo ON signal. • Confirm whether the servo amplifier is receiving the servo ON signal. (A personal computer and setup software are required.) | NC side sequence program defect. |
| 3 | Servo adjustment | The speed is inconsistent at low speeds. | Adjust the gain with the following procedure. <ul style="list-style-type: none"> • Increase the automatic tuning responsiveness. • Carry out acceleration/ deceleration to complete automatic tuning. | Incorrect gain adjustment. |

10-2 Displays and countermeasures for various alarms

10-2-1 Amplifier unit LED display during alarm

The MR-J2-• CT has various self diagnosis functions built in. If these self diagnosis functions detect an error, the alarm classification code and alarm No. will be displayed on the 7-segment LED on the upper front of the amplifier unit. The 7-segment LED displays in the following order.

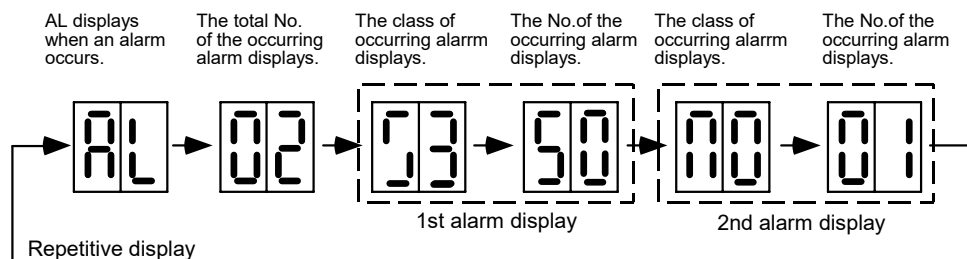

Chapter 10 Troubleshooting

10-2-2 Alarm/warning list

| Class | Alarm No. (displayed on personal computer) | Main unit LED display | Details |
|-----------------|--|--|--|
| Servo alarm | S01 0011 | S1 11 | PCB error (control circuit error) |
| | S01 0013 | S1 13 | Software processing timeout |
| | S01 0016 | S1 16 | Motor type error, detector initial communication error, detector CPU error |
| | S01 0017 | S1 17 | PCB error (A/D conversion initial error) |
| | S01 0025 | S1 25 | Absolute position lost |
| | S01 0034 | S1 34 | CRC error |
| | S01 0036 | S1 36 | Timeout, NC power down |
| | S01 0037 | S1 37 | Parameter error (regenerative resistor type error) |
| | S01 0038 | S1 38 | Communication frame error |
| | S01 0039 | S1 39 | Communication INFO error |
| | S02 0011 | S2 11 | PCB error (drive circuit error) |
| | S02 0013 | S2 13 | Software processing timeout, clock error |
| | S02 0015 | S2 15 | EEROM error |
| | S02 0017 | S2 17 | PCB error (A/D conversion error) |
| | S02 0018 | S2 18 | PCB error (LSI error) |
| | S02 0020 | S2 20 | Detector error (detector data alarm, detector communication error) |
| | S02 0024 | S2 24 | Ground fault detection at power ON |
| | S03 0010 | S3 10 | Undervoltage |
| | S03 0030 | S3 30 | Regeneration error (regeneration transistor error, over-regeneration) |
| | S03 0031 | S3 31 | Overspeed |
| S03 0032 | S3 32 | Overcurrent (hardware overcurrent, software overcurrent) | |
| S03 0033 | S3 33 | Overvoltage | |
| S03 0046 | S3 46 | Motor overheating, detector heating | |
| S03 0050 | S3 50 | Overload 1 (amplifier overload, motor overload) | |
| S03 0051 | S3 51 | Overload 2 (collision detection) | |
| S03 0052 | S3 52 | Excessive error | |
| Servo warning | S52 0092 | S- 92 | Battery voltage drop |
| | S52 00E0 | S- E0 | Over-regeneration warning |
| | S52 00E1 | S- E1 | Amplifier overload warning, motor overload warning |
| | S52 00E3 | S- E3 | Absolute position counter warning |
| | S52 00E9 | S- E9 | Main circuit OFF warning |
| System alarms | Z70 0001 | Z0 01 | Zero point initialization incomplete |
| | Z70 0002 | Z0 02 | Absolute position reference data lost |
| | Z70 0003 | Z0 03 | Absolute position parameter changed or lost |
| | Z71 0001 | Z1 01 | Absolute position detector data lost |
| | Z73 0001 | Z3 01 | Battery voltage drop warning |
| | Z73 0003 | Z3 03 | Absolute position counter warning |
| | | 88 display | Watch dog |
| | Q01 ##### | q1 ## | Emergency stop |
| Operation alarm | M01 0001 | M0 01 | Near-point dog length insufficient |
| | M01 0003 | M0 03 | Zero point return direction illegal |
| | M01 0004 | M0 04 | External interlock |
| | M01 0005 | M0 05 | Internal interlock |
| | M01 0007 | M0 07 | Soft limit |
| | M01 0024 | M0 24 | In absolute position alarm. Zero point return not possible. |
| | M01 0025 | M0 25 | In initializing absolute position. Zero point return not possible. |
| | M01 0101 | M1 01 | No operation mode |
| | M01 0103 | M1 03 | Feedrate 0 |
| | M01 0160 | M1 60 | Station No. designation illegal. Starting not possible. |
| | M01 0161 | M1 61 | Zero point return incomplete. Starting not possible. |
| | M01 0162 | M1 62 | In initializing zero point. Starting not possible. |
| | M01 0163 | M1 63 | In absolute position alarm. Starting not possible. |
| | M01 0164 | M1 64 | In random positioning mode. Manual operation not possible. |
| | M01 0165 | M1 65 | Uneven indexing station No. illegal. Starting not possible. |

Chapter 10 Troubleshooting

10-3 Detailed explanations and countermeasures of alarms

10-3-1 Detailed explanations and countermeasures for servo alarms

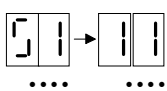
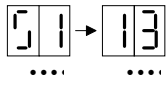
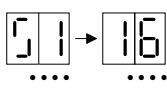
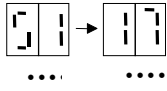
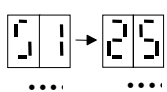
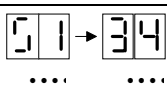
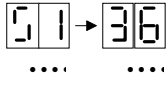
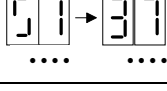
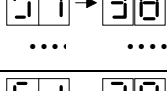
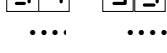
| These alarms indicate that an error has occurred in the servo control circuit. | | | | | |
|--|---|--|--|---|--|
| Personal computer display | Main unit LED display | Name | Details | Cause | Remedy |
| S01 0011 |  | PCB error 1 | An error occurred in the amplifier's internal PCB. | Servo amplifier internal part fault <Investigation method> • Alarm (AL11) occurs even when all connectors are disconnected and power is turned ON. | Replace servo amplifier. |
| S01 0013 |  | Software processing timeout, clock error | An error occurred in the amplifier's internal reference clock. | | Replace servo amplifier. |
| S01 0016 |  | Motor type, detector type error | Motor type error | A type or capacity motor that cannot be driven is connected. | Use a correct amplifier and motor combination. |
| | | | Detector initial communication error. | The detector cable connector is disconnected. | Connect correctly. |
| | | | | Detector fault. | Replace the motor. |
| | | | | Detector cable defect (broken wire or short circuit) | Replace or repair cable. |
| | | Detector CPU error | Detector fault. | Replace the motor (detector). | |
| S01 0017 |  | PCB error (A/D conversion initial error) | An error occurred in the amplifier's internal A/D converter. | Servo amplifier internal part fault <Investigation method> • Alarm (AL10) occurs even when all connectors are disconnected and power is turned ON. | Replace servo amplifier. |
| S01 0025 |  | Absolute position lost | An error occurred in the detector's internal absolute position data. | The voltage of the super capacitor in the detector has dropped. (During setup or when unit was left with detector cable disconnected for one hour or more.) | Turn the power ON for 2 to 3 minutes while the alarm is occurring, and then turn the power ON again. |
| | | | | Battery voltage drop | Replace the battery, and initialize the absolute position again. |
| S01 0034 |  | CRC error | An error occurred in the communication with the NC. | An error occurred in the communication data due to disturbance such as noise. | Take countermeasures against noise. |
| S01 0036 |  | Communication timeout, NC down | Communication with the NC was cut off. | The bus cable (SH21) connection was disconnected. | Connect correctly. |
| | | | | The NC power was turned OFF. | Turn the NC power ON. |
| | | | | The amplifier or NC is faulty. | Replace the amplifier or NC. |
| S01 0037 |  | Parameter error | The parameter setting value is incorrect. | An external regenerative resistor that is not combined was designated with parameter #002. | Set the parameter correctly. |
| S01 0038 |  | Frame error | An error occurred in the communication with the NC. | An error occurred in the communication data due to disturbance such as noise. | Take countermeasures against noise. |
| S01 0039 |  | INFO error | Undefined data was transferred from the NC. | An incompatible NC is connected to. | Change the NC software version to a compatible version. |

Chapter 10 Troubleshooting

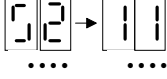
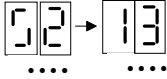
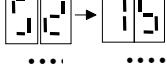
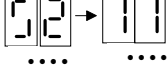
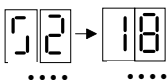
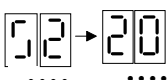
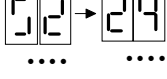
| These alarms indicate that an error has occurred in the servo control circuit. | | | | | |
|--|---|--|--|--|--|
| Personal computer display | Main unit LED display | Name | Details | Cause | Remedy |
| S02 0011 |  | PCB error 1 (drive circuit error) | An error occurred in the amplifier's internal PCB. | Servo amplifier internal part fault <Investigation method> • Alarm (AL11) occurs even when all connectors are disconnected and power is turned ON. | Replace servo amplifier. |
| S02 0013 |  | Software processing timeout, clock error | An error occurred in the amplifier's internal reference clock. | | Replace servo amplifier. |
| S02 0015 |  | EEROM error | A write error occurred to the EEROM in the amplifier. | EEROM defect | Replace servo amplifier. |
| S02 0017 |  | PCB error (A/D conversion error) | An error occurred in the amplifier's internal A/D converter. | Servo amplifier internal part fault <Investigation method> • Alarm (AL17) occurs even when all connectors are disconnected and power is turned ON. | Replace servo amplifier. |
| S02 0018 |  | PCB error (LSI error) | An error occurred in the amplifier's internal LSI. | Servo amplifier internal part fault <Investigation method> • Alarm (AL18) occurs even when all connectors are disconnected and power is turned ON. | Replace servo amplifier. |
| S02 0020 |  | Detector error | An error occurred in the communication between the servo amplifier and detector. | • The detector cable connection is disconnected. | Connect correctly. |
| | | | | • Detector cable defect (broken wire or short circuit) | Replace or repair cable. |
| S02 0024 |  | Ground fault detection | A ground fault of the output was detected when the power was turned ON. | • There is a ground fault in the output wire or the in the motor. | Repair the ground fault section. Replace the cable or motor. |

Chapter 10 Troubleshooting

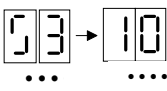
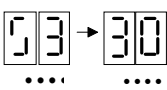
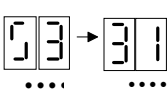
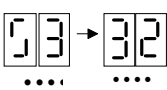
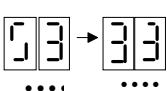
| These alarms indicate that an error has occurred in the servo control circuit. | | | | | |
|--|---|-------------------------------|---|--|--|
| Personal computer display | Main unit LED display | Name | Details | Cause | Remedy |
| S03 0010 |  | Undervoltage | The power voltage is 160V or less. | The power voltage is low. | Review the power supply. |
| | | | | A momentary power failure lasting 15ms or longer occurred. | |
| | | | | The power capacity is insufficient causing a power voltage drop when starting. | |
| | | | | The power was turned ON immediately after turning the power OFF. | Replace the servo amplifier. |
| S03 0030 |  | Regeneration error | The tolerable regeneration power of the internal regenerative resistor or external regenerative option was exceeded. | Parameter #002 setting is incorrect. | Set correctly. |
| | | | | The external regenerative option is not connected, or the TE2 short cable is not connected. | Connect correctly. |
| | | | | The tolerable regeneration power was exceeded due to high frequency operation or continuous regeneration operation. | Lower the positioning frequency. Change the regenerative option to a larger capacity. Lower the load. |
| | | Regenerative transistor error | The regenerative transistor in the servo amplifier is faulty. <Investigation method> The alarm occurs even when the external regenerative option and TE2 short cable is disconnected. | Replace the servo amplifier. | |
| S03 0031 |  | Overspeed | The motor's speed exceeded the tolerable momentary speed. | The acceleration/deceleration time constant is small causing a large overshoot. | Increase the acceleration/deceleration time constant. |
| | | | | The electronic gear ratio is large. | Review the gear ratio. |
| | | | | Detector fault. | Replace the detector. |
| S03 0032 |  | Overcurrent | A current exceeding the servo amplifier's tolerable current flowed. | The servo amplifier's output U, V and W phases are short circuited. | Repair the wiring. |
| | | | | The servo amplifier's output U, V and W phases ground faulted during operation. | Replace the servo amplifier. Correct the wiring. |
| | | | | The overcurrent detection circuit malfunctioned due to external noise. The servo amplifier's power module is faulty. <Investigation method> Alarm 32 occurs even when the servo amplifier output (terminal block TE1's U, V, W) is disconnected. | Take countermeasures against noise. |
| S03 0033 |  | Overvoltage | The voltage of the converter in the servo amplifier was 400V or more. | The TE2 short cable or external regenerative resistor lead wire is broken or disconnected. | Wire correctly. |
| | | | | The regenerative resistance transistor is faulty. | Replace the servo amplifier. |
| | | | | The internal regenerative resistor or external regenerative option has a broken wire. | For the internal regenerative resistor, replace the amplifier. For the external regenerative option, replace the regenerative option. |



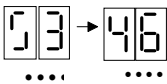
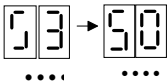
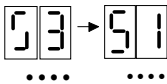
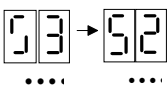

Chapter 10 Troubleshooting

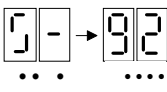
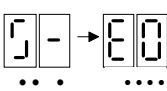
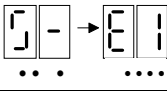
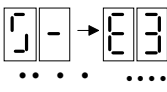
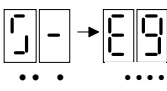
| These alarms indicate that an error has occurred in the servo control circuit. | | | | | |
|--|---|-------------------|--|--|--|
| Personal computer display | Main unit LED display | Name | Details | Cause | Remedy |
| S03 0046 |  | Motor overheating | An operation state causing the motor to overheat continued. | The servomotor is in the overload state. | Reduce the motor load. Review the operation pattern. |
| | | | | The thermal protector in the detector is faulty. | Replace the detector. |
| S03 0050 |  | Overload 1 | The servo amplifier or servo overload protection function activated. (Refer to the graph in 11-1 Overload protection characteristics.) | The servomotor's continuous output exceeded the rated output. | Reduce the motor load. Review the operation pattern. Change to a motor or amplifier with large output. |
| | | | | The servo amplifier output exceeded the tolerable instantaneous output. | Change the setting of the automatic tuning response characteristics. |
| | | | | The servo system is unstable, and hunting is occurring. | Change the setting of the automatic tuning response characteristics. |
| | | | | The motor connection is incorrect. | Correct the connection. |
| | | | | The detector is faulty. | Replace the servomotor. |
| S03 0051 |  | Overload 2 | The max. output current flowed for several seconds due to a machine collision or overload. | The machine axis was collided against. | Review the operation pattern. |
| | | | | The motor connection is incorrect. | Correct the connection. |
| | | | | The servo system is unstable, and hunting is occurring. | Change the setting of the automatic tuning response characteristics. |
| | | | | The detector is faulty. | Replace the servomotor. |
| S03 0052 |  | Excessive error | A position deflection exceeding the excessive error detection setting value occurred. | The acceleration/deceleration time constant is too low. | Increase the acceleration/deceleration time constant. |
| | | | | The torque limit value is too low. | Increase the torque limit value. |
| | | | | Starting is not possible due to low torque caused by power voltage drop. | Review the power facility capacity. Use a motor with a large output. |
| | | | | The machine end was collided with. | Review the operation pattern. |
| | | | | The detector is faulty. | Replace the servomotor. |
| | | | | The motor connection is incorrect. | Connect correctly. |
| | | | | Communication cable defect (broken wire or short circuit) | Repair or replace the cable. |

Chapter 10 Troubleshooting

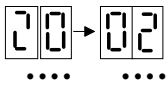
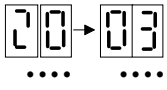
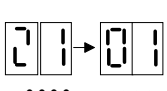
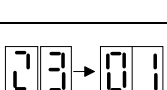
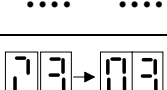
| These alarms indicate that an error has occurred in the servo control circuit. | | | | | |
|--|--|-----------------------------------|---|---|---|
| Personal computer display | Main unit LED display | Name | Details | Cause | Remedy |
| S52 0092 |  | Battery voltage drop | The absolute position detection battery voltage dropped. | The battery is not mounted. | Mount a battery. |
| | | | | Battery life | Replace the battery and initialize the absolute position. |
| S52 00E0 |  | Over-regeneration warning | The regeneration power may have exceeded the tolerable range of the built-in regenerative resistor or external regenerative option. | A level 85% or more of the built-in regenerative resistor or external regenerative option's tolerable regeneration power was reached. | <ol style="list-style-type: none"> 1. Lower the positioning frequency. 2. Change the regenerative option to a larger one. 3. Lower the load. |
| S52 00E1 |  | Overload warning | The overload 1 alarm could occur. | 85% or more of the overload 1 alarm occurrence level was reached. | Refer to the items for S03 0050. |
| S52 00E3 |  | Absolute position counter warning | There is an error in the absolute position detector internal data. | 1. Noise entered the detector. | Take countermeasures against noise. |
| | | | | 2. Detector fault. | Replace the servomotor. |
| S52 00E9 |  | Main circuit OFF warning | | The servo ON signal was input while the main circuit power was OFF. The contactor operation is faulty. | Turn ON the main circuit power. |

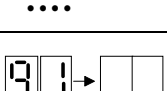
10-3-2 Detailed explanations and countermeasures for system alarms

| Personal computer display | Main unit LED display | Name | Cause | Remedy |
|---------------------------|---|--|--|--|
| Z70 0001 | | Zero point initialization incomplete | The zero point (reference point) has not been initialized in the absolute position system. | Initialize the zero point (reference point). |
| Z70 0002 |  | Absolute position reference data lost | The absolute position reference coordinate data in the amplifier has been lost. | Initialize the zero point (reference point). |
| Z70 0003 |  | Absolute position system related parameter error | The absolute position system related parameters have been changed or lost. | Correctly set the parameters and then initialize the zero point (reference point). |
| Z71 0001 |  | Absolute position detector data lost | The data in the detector has been lost due to a battery voltage drop. Battery voltage drop Detector cable wire breakage or looseness | Check the battery and detector cable and then initialize the zero point (reference point). |
| Z73 0001 |  | Absolute position memory battery voltage warning | Battery voltage drop Detector cable wire breakage or looseness | Check the battery and detector cable. The zero point does not need to be initialized. |
| Z73 0003 |  | Absolute position counter warning | An error occurred in the detector's absolute position counter. | Replace the detector. |
| |  | Watch dog | An error occurred in the amplifier's control circuit. | Replace the amplifier. |
| Q01 ##### |  | Emergency stop | An emergency stop occurred due to a cause other than bus emergency stop input or external emergency stop input. | The emergency stop cause is displayed with bit correspondence in ##, so check the cause. |
| |  | Emergency stop | A bus emergency stop or external emergency stop was input. | Check the NC emergency stop and external emergency stop. |

<Details of emergency stop causes>

Each bit data is displayed as a hexadecimal.

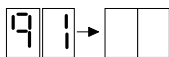







| | |
|-------|-------------------------------------|
| bit 0 | Servo alarm |
| bit 1 | Absolute position lost |
| bit 2 | Bus emergency stop high-order input |
| bit 3 | Bus emergency stop low-order input |

| | |
|-------|-------------------------|
| bit 4 | External emergency stop |
| bit 5 | |
| bit 6 | PLC emergency stop |
| bit 7 | Other cause |

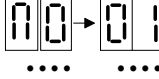
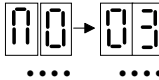
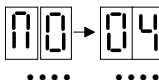
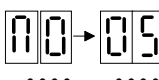
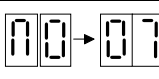
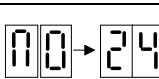
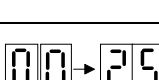
.....

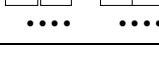
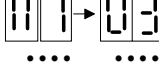
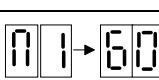
Chapter 10 Troubleshooting

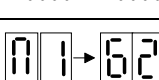
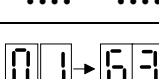
10-3-3 Detailed explanations and countermeasures for operation alarms

| These alarms indicate that there is a mistake in the operation or in the operation command. | | | | |
|---|---|---|--|--|
| Personal computer display | Main unit LED display | Name | Cause | Remedy |
| M01 0001 |  | Near-point dog length insufficient | When executing dog-type reference point, the zero point return speed is too fast or the dog length is too short. | Lower the zero point return speed or increase the dog length. |
| M01 0003 |  | Reference point return direction illegal | When executing reference point return, the axis was moved in the opposite of the designated direction. | Move the axis in the correct direction. |
| M01 0004 |  | External interlock | The axis interlock function is valid. | Cancel the interlock signal |
| M01 0005 |  | Internal interlock | An interlock was established by the servo OFF function. | Cancel the servo OFF. |
| M01 0007 |  | Soft limit | The soft limit was reached. | Check the soft limit setting and machine position |
| M01 0024 |  | In absolute position alarm. Reference point return not possible. | Reference point return was executed during an absolute position alarm. | Initialize the absolute position reference point and then fix the absolute position coordinates. |
| M01 0025 |  | In initializing absolute position. Reference point return not possible. | Reference point return was executing while initializing the absolute position. | Initialize the absolute position reference point and then fix the absolute position coordinates. |
| M01 0101 |  | No operation mode | The operation mode is not designated, or the operation mode was changed during axis movement. | Correctly designate the operation mode. |
| M01 0103 |  | Feedrate 0 | The operation parameter's feedrate setting is zero. The operation parameter feedrate setting is zero. Or, the override is valid, and the override value is zero. | Set a value other than zero in the feedrate setting or override value. |
| M01 0160 |  | Station No. designation illegal. Starting not possible. | A station No. exceeding the No. of indexed divisions was designated. | Correctly designate the station No. |
| M01 0161 |  | Reference point return incomplete. Starting not possible. | Automatic/manual operation was started before reference point return was executed with the incremental system. | Execute the reference point return. |
| M01 0162 |  | In initializing reference point. Starting not possible. | The start signal was input while initializing the absolute position reference point. | Complete the absolute position reference point initialization. |
| M01 0163 |  | In absolute position alarm. Starting not possible. | The start signal was input during an absolute position alarm. | Initialize the absolute position reference point and then fix the absolute position coordinates. |
| M01 0164 |  | In random positioning mode. Manual operation not possible. | The manual operation mode was started during the random positioning mode. | Turn the random positioning mode OFF before switching to the manual operation mode. |
| M01 0165 |  | Uneven indexing station No. illegal. Starting not possible. | During uneven indexing, the commanded station No. exceeded the number of indexing stations or 9. | Check the commanded station No. and #100 No. of indexing stations. |

Chapter 11 Characteristics

| | | |
|-------------|---|--------------|
| 11-1 | Overload protection characteristics..... | 11-2 |
| 11-2 | Servo amplifier generation loss..... | 11-3 |
| 11-2-1 | Servo amplifier calorific value | 11-3 |
| 11-2-2 | Heat radiation area of fully closed type control panel..... | 11-4 |
| 11-3 | Magnetic brake characteristics..... | 11-5 |
| 11-3-1 | Motor with magnetic brakes | 11-5 |
| 11-3-2 | Magnetic brake characteristics | 11-6 |
| 11-3-3 | Magnetic brake power supply | 11-8 |
| 11-4 | Dynamic brake characteristics | 11-9 |
| 11-4-1 | Deceleration torque | 11-9 |
| 11-4-2 | Coasting amount | 11-10 |
| 11-5 | Vibration class | 11-11 |

11-1 Overload protection characteristics

The servo amplifier has an electronic thermal relay to protect the servomotor and servo amplifier from overloads. The operation characteristics of the electronic thermal relay are shown below.

If overload operation over the electronic thermal relay protection curve shown below is carried out, overload 1 alarm will occur. If the maximum current flows continuously for several seconds due to a machine collision, etc., overload 2 alarm will occur. Use within the region to the left of the solid or dotted line in the graph.

When applying a load while stopped (during servo lock), make sure that 70% or the rated torque is not exceeded.

- a : HC-MF Series
- HA-FF Series
- (300W or more)
- HC-SF Series
- HC-RF Series

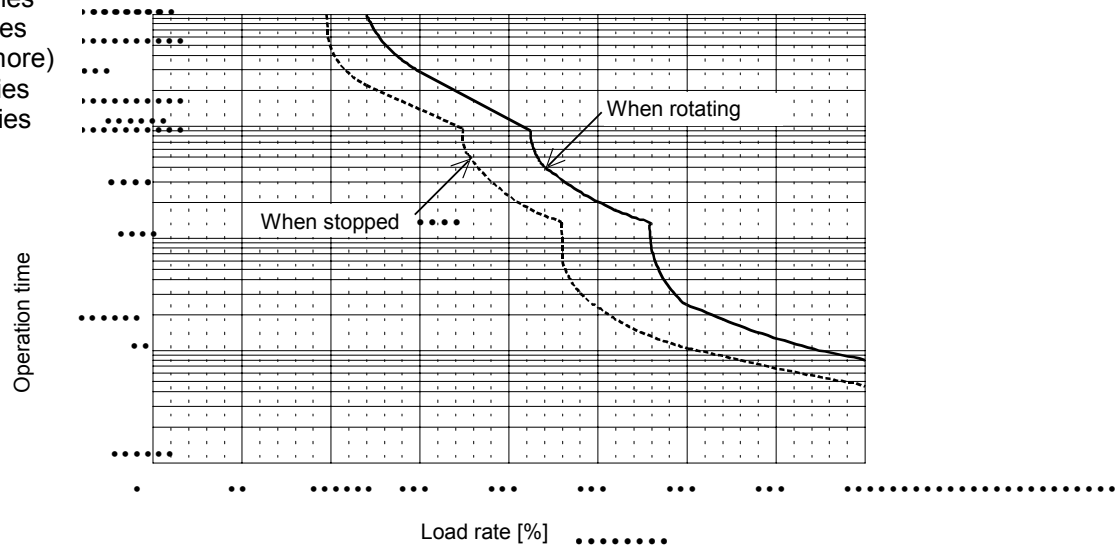

- b : HA-FF Series
- (200W or less)

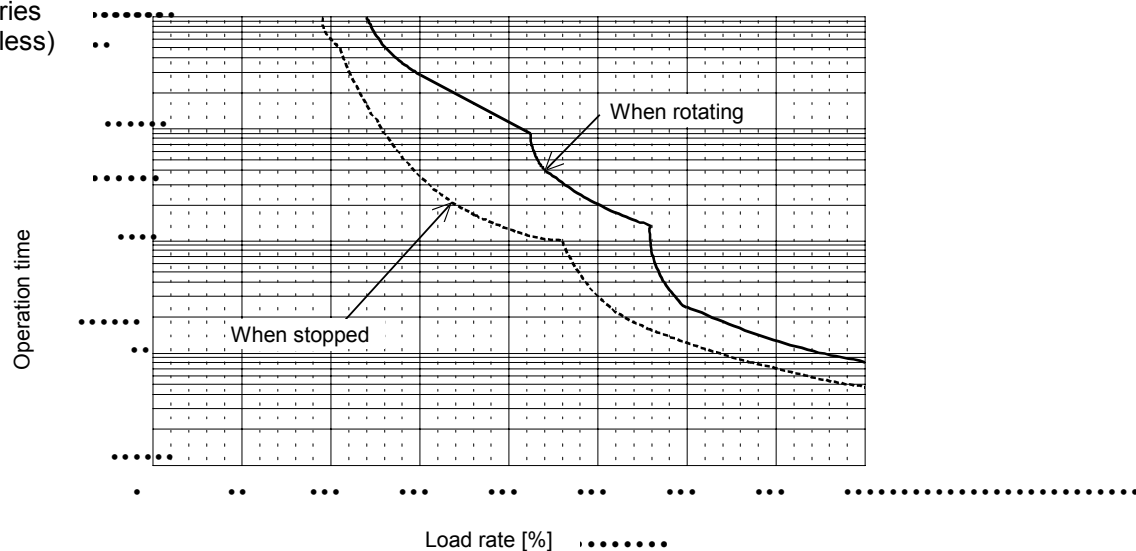

Fig. 11-1 Overload protection characteristics of MR-J2-CT

11-2 Servo amplifier generation loss

11-2-1 Servo amplifier calorific value

The servo amplifier calorific value is determined from the following table by the motor with which the servo amplifier is combined. The calorific value for the actual machine will be a value between the calorific values at the stall torque (at the rated torque) and the zero torque according to the frequency during operation. Consider the worst usage conditions for the thermal design of the fully closed type control panel, and use the values given below. Even when the servomotor is run below the maximum speed, the servo amplifier calorific value will not change if the generated torque is the same.

Table 11-1 Servo amplifier calorific values

| Motor type | Calorific value (W) | | Area required for heat radiation (m ²) | Motor type | Calorific value (W) | | Area required for heat radiation (m ²) |
|------------|---------------------|----------------|--|------------|---------------------|----------------|--|
| | At rated torque | At zero torque | | | At rated torque | At zero torque | |
| HC-SF52 | 40 | 15 | 0.8 | HC-FF053 | 25 | 15 | 0.5 |
| HC-SF102 | 50 | 15 | 1.0 | HC-FF13 | 25 | 15 | 0.5 |
| HC-SF152 | 60 | 20 | 1.2 | HC-FF23 | 25 | 15 | 0.5 |
| HC-SF202 | 85 | 20 | 1.7 | HC-FF33 | 30 | 15 | 0.6 |
| HC-SF352 | 140 | 20 | 2.8 | HC-FF43 | 35 | 15 | 0.7 |
| HC-SF53 | 40 | 15 | 0.8 | HC-FF63 | 40 | 15 | 0.8 |
| HC-SF103 | 50 | 15 | 1.0 | | | | |
| HC-SF153 | 60 | 20 | 1.2 | HC-MF053 | 25 | 15 | 0.5 |
| HC-SF203 | 85 | 20 | 1.7 | HC-MF13 | 25 | 15 | 0.5 |
| HC-SF353 | 140 | 20 | 2.8 | HC-MF23 | 25 | 15 | 0.5 |
| | | | | HC-MF43 | 35 | 15 | 0.7 |
| HC-RF103 | 45 | 15 | 0.9 | HC-MF73 | 50 | 15 | 1.0 |
| HC-RF153 | 60 | 20 | 1.2 | | | | |
| HC-RF203 | 120 | 20 | 2.4 | | | | |



POINT

1. The heat generated by the regeneration resistor is not included in the servo amplifier calorific value. Refer to section "13-4 Selection of regenerative resistor" and calculate the calorific value of the regenerative resistor using the regeneration load and positioning frequency.
2. The area required for heat radiation is the heat radiation area (guideline) of the fully closed type control panel storing the servo amplifier when using the unit at an ambient temperature of 40°C and stall (rated) load.

11-2-2 Heat radiation area of fully closed type control panel

Set the temperature in the fully closed type control panel (hereafter control panel) in which the servo amplifier is stored so that the ambient temperature is 40°C +10°C or less. (Provide a 5°C allowance in respect to the maximum working environmental conditions temperature of 55°C.) The control panel heat radiation area is usually calculated with the following expression.

$$A = \frac{P}{K \cdot \Delta T} \dots\dots\dots (11-1)$$

- A : Heat radiation area [m²]
- P : Loss generated in control panel
- ΔT : Temperature difference between control panel and outside air [°C]
- K : Heat radiation coefficient (5 ~ 6)

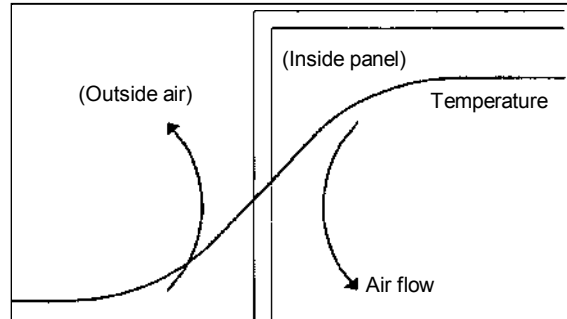

Fig. 11-2 Fully closed type control panel temperature gradient

When air flows along the outside of the panel, the temperature slope will become sudden, and an effective heat exchange will be possible both inside and outside of the fully closed control type panel.

When calculating the heat radiation area with the above expression (11-1), use P as the total loss generated in the control panel. Refer to the table in section "11-2-1 Servo amplifier calorific value" for the servo amplifier calorific values. A indicates the area effective for heat radiation, so if the control panel is directly installed on a heat insulating wall, etc., provide the control panel's surface area as an allowance.

The required heat radiation area will also differ according to the conditions in the control panel. If the convection in the control panel is poor, effective heat radiation will not be possible. In this case, when designing the control panel, consider the placement of devices in the control panel, and mixing the air with a fan, etc.

11-3 Magnetic brake characteristics

 **CAUTION**

1. The axis will not be mechanically held even when the dynamic brakes are used. If the machine could drop when the power fails, use a servomotor with magnetic brakes or provide an external brake mechanism as holding means to prevent dropping.
2. The magnetic brakes are used for holding, and must not be used for normal braking. There may be cases when holding is not possible due to the life or machine structure (when ball screw and servomotor are coupled with a timing belt, etc.). Provide a stop device on the machine side to ensure safety. When releasing the brakes, always confirm that the servo is ON first. Sequence control considering this condition is possible if the amplifier motor brake control signal (MBR) is used.
3. When operating the brakes, always turn the servo OFF (or ready OFF). When releasing the brakes, always confirm that the servo is ON first. Sequence control considering this condition is possible if the amplifier motor brake control signal (MBR) is used.
4. When the vertical axis drop prevention function is used, the drop of the vertical axis at the servo OFF command input can be suppressed to a minimum.

11-3-1 Motor with magnetic brakes

(1) Types

The motor with magnetic brakes is set for each motor. The "B" following the standard motor type indicates the motor with brakes.

(2) Applications

When this type of motor is used for the vertical feed axis in a machining center, etc., slipping and dropping of the spindle head can be prevented even when the hydraulic balancer's hydraulic pressure reaches zero when the power turns OFF. When used with a robot, deviation of the posture when the power is turned OFF can be prevented.

When used for the feed axis of a grinding machine, a double safety measures is formed with the deceleration stop (dynamic brake stop), and the risks of colliding with the grinding stone and scattering can be prevented.

This motor cannot be used for purposes other than holding and braking during a power failure (emergency stop). (This cannot be used for normal deceleration, etc.)

(3) Features

- The magnetic brakes use a DC excitation method, thus:
 - The brake mechanism is simple and the reliability is high.
 - There is no need to change the brake tap between 50 Hz and 60 Hz.
 - There is no rush current when the excitation occurs, and shock does not occur.
 - The brake section is not larger than the motor section.
- The magnetic brakes are built into the motor, and the installation dimensions (flange size) are the same as the motor without brakes.

Chapter 11 Characteristics

11-3-2 Magnetic brake characteristics

Table 11-2 (1) Magnetic brake characteristics 1

| Item | Motor type | HC-SF Series | | HC-RF Series |
|--------------------------------------|-----------------------------------|------------------------------------|--------------------------|------------------|
| | | 52B, 102B, 152B 53B, 103B, 153B | 202B, 352B 203B, 353B | 103B, 153B, 203B |
| Type (Note 1) | | Spring braking type safety brakes | | |
| Rated voltage | | 24 VDC | | |
| Rated current at 20°C | (A) | 0.8 | 1.4 | 0.8 |
| Excitation coil resistance at 20°C | (Ω) | 29 | 16.8 | 30 |
| Capacity | (W) | 19 | 34 | 19 |
| Attraction current | (A) | 0.2 | 0.4 | 0.25 |
| Dropping current | (A) | 0.08 | 0.2 | 0.085 |
| Static friction torque | (N·m) | 8.3 | 43.1 | 6.8 |
| Inertia (Note 2) | (kg·cm ²) | 2.0 | 10 | 0.35 |
| Release delay time (sec) (Note 3) | | 0.04 | 0.1 | 0.03 |
| Braking delay time (sec) (Note 3) | AC OFF (sec) | 0.12 | 0.12 | 0.12 |
| | DC OFF (sec) | 0.03 | 0.03 | 0.03 |
| Tolerable braking work amount | Per braking (J) | 400 | 4,500 | 400 |
| | Per hour (J) | 4,000 | 45,000 | 4,000 |
| Brake play at motor axis (deg.) | | 0.2 ~ 0.6 | 0.2 ~ 0.6 | 0.2 ~ 0.6 |
| Brake life (Note 4) | No. of braking operations (times) | 20,000 | 20,000 | 20,000 |
| | Braking amount per braking (J) | 200 | 1,000 | 200 |

Chapter 11 Characteristics

Table 11-2 (2) Magnetic brake characteristics 2

| Item | Motor type | HA-FF Series | | | HC-MF Series | | |
|--|-----------------------------------|-----------------------------------|-----------|-----------|--------------|------------|-----------|
| | | 053B, 13B | 23B, 33B | 43B, 63B | 053B, 13B | 23B, 43B | 73B |
| Type (Note 1) | | Spring braking type safety brakes | | | | | |
| Rated voltage | | 24 VDC | | | | | |
| Rated current at 20°C (A) | | 0.22 | 0.31 | 0.46 | 0.26 | 0.33 | 0.42 |
| Excitation coil resistance at 20°C (Ω) | | 111 | 78 | 52 | 91 | 73 | 57 |
| Capacity (W) | | 7 | 7.4 | 11 | 6.3 | 7.9 | 10 |
| Attraction current (A) | | 0.15 | 0.2 | 0.3 | 0.18 | 0.18 | 0.2 |
| Dropping current (A) | | 0.06 | 0.06 | 0.1 | 0.06 | 0.11 | 0.12 |
| Static friction torque (N·m) | | 0.39 | 1.18 | 2.3 | 0.32 | 1.3 | 2.4 |
| Inertia (Note 2) (kg·cm ²) | | 0.02 | 0.13 | 0.34 | 0.0031 | 0.04 | 0.13 |
| Release delay time (Note 3) (sec) | | 0.03 | 0.03 | 0.03 | 0.03 | 0.03 | 0.03 |
| Braking delay time (sec) (Note 3) | AC OFF (sec) | 0.08 | 0.1 | 0.12 | 0.08 | 0.1 | 0.12 |
| | DC OFF (sec) | 0.01 | 0.03 | 0.03 | 0.01 | 0.02 | 0.03 |
| Tolerable braking work amount | Per braking (J) | 3.9 | 18.0 | 46.0 | 5.6 | 22.0 | 64.0 |
| | Per hour (J) | 39 | 180 | 460 | 56 | 220 | 640 |
| Brake play at motor axis (deg.) | | 0.3 ~ 3.5 | 0.2 ~ 2.0 | 0.2 ~ 1.3 | 0.19 ~ 2.5 | 0.12 ~ 1.2 | 0.1 ~ 0.9 |
| Brake life (Note 4) | No. of braking operations (times) | 30,000 | 30,000 | 30,000 | 20,000 | 20,000 | 20,000 |
| | Braking amount per braking (J) | 4 | 18 | 47 | 4 | 15 | 32 |

Notes:

1. There is no manual release mechanism. If handling is required such as during the machine core alignment work, prepare a separate 24 VDC power supply, and electrically release the brakes.
2. These are the values added to the servomotor without brakes.
3. This is the value for 20°C at the initial attraction gap.
4. The brake gap will widen through brake lining wear caused by braking. However, the gap cannot be adjusted. Thus, the brake life is reached when adjustments are required.
5. The internal power output (VDD) 24 VDC for digital output cannot be used. Always prepare a separate power supply.
6. A leakage flux will be generated at the shaft end of the servomotor with magnetic brakes.
7. When operating in low speed regions, the sound of loose brake lining may be heard. However, this is not a problem in terms of function.

11-3-3 Magnetic brake power supply



CAUTION

1. The internal power supply output (VDD) 24 VDC as digital output cannot be used for the magnetic brake release power supply. Always prepare an external release power supply dedicated for the magnetic brakes.
2. Always install a surge absorber on the brake terminal when using DC OFF.
3. Do not connector or disconnect the cannon plug while the brake power is ON. The cannon plug pins could be damaged by sparks.

(1) Brake excitation power supply

- Prepare a brake excitation power supply that can accurately ensure the attraction current in consideration of the voltage fluctuation and excitation coil temperature.
- The brake terminal polarity is random. Make sure not to mistake the terminals with other circuits.

(2) Brake excitation circuit

(a) AC OFF and (b) DC OFF can be used to turn OFF the brake excitation power supply (to apply the brakes).

(a) AC OFF

The braking delay time will be longer, but the excitation circuit will be simple, and the relay cut off capacity will be smaller.

(b) DC OFF

The braking delay time can be shortened, but a surge absorber will be required and the relay cut off capacity will increase.

<Cautions>

- Provide sufficient DC cut off capacity at the contact.
- Always use a surge absorber.
- When using the cannon plug type, the surge absorber will be further away, so use shielded wires between the motor and surge absorber.

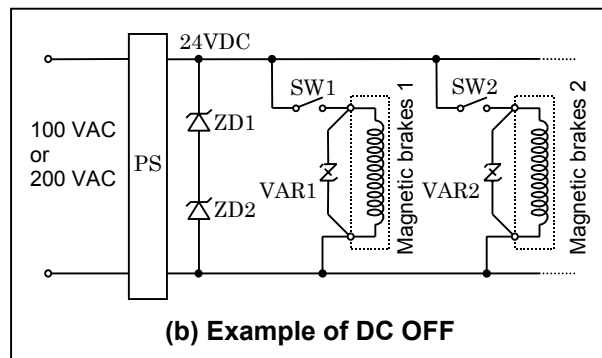
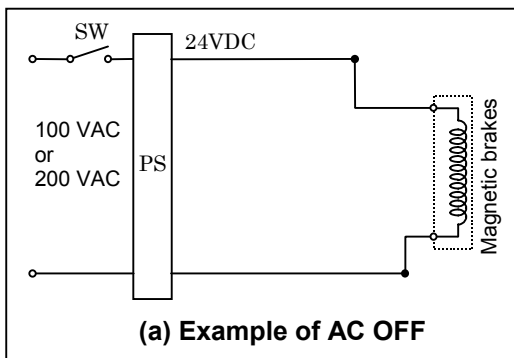

- PS : 25 VDC stabilized power supply
 ZD1, ZD2 : Zener diode for power supply protection (1W, 24V)
 VAR1, VAR2: Surge absorber (220V)

Fig. 11-3 Magnetic brake circuits

11-4 Dynamic brake characteristics

When an emergency stop occurs due to an alarm occurrence, the dynamic brakes will activate and the motor will stop. (A deceleration control stop can also be selected with the parameter setting.)

11-4-1 Deceleration torque

The dynamic brakes use the motor as a generator, and obtains the deceleration torque by consuming that energy with the dynamic brake resistance. The characteristics of this deceleration torque have a maximum deceleration torque (T_{dp}) regarding the motor speed as shown in the following drawing. The torque for each motor is shown in the following table.

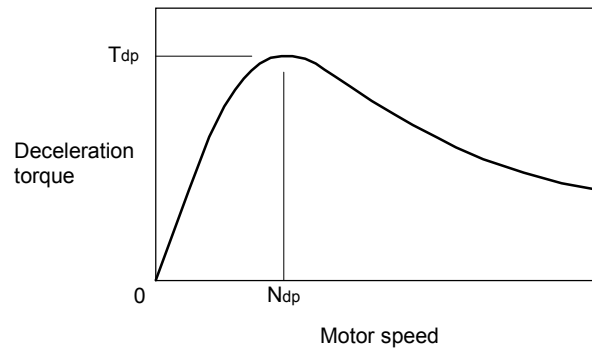

Fig. 11-4 Deceleration torque characteristics of a dynamic brake stop

Table 11-3 Max. deceleration torque of a dynamic brake stop

| Motor type | Rated torque (N·m) | T_{dp} (N·m) | N_{dp} (r/min) | Motor type | Rated torque (N·m) | T_{dp} (N·m) | N_{dp} (r/min) |
|------------|--------------------|----------------|------------------|------------|--------------------|----------------|------------------|
| HA-SF52 | 2.39 | 2.40 | 496 | HA-FF053 | 0.16 | 0.12 | 3509 |
| HA-SF102 | 4.78 | 5.59 | 473 | HA-FF13 | 0.32 | 0.17 | 2646 |
| HA-SF152 | 7.16 | 18.49 | 1062 | HA-FF23 | 0.64 | 0.38 | 1163 |
| HA-SF202 | 9.55 | 10.56 | 457 | HA-FF33 | 0.95 | 0.56 | 1064 |
| HA-SF352 | 16.70 | 32.57 | 945 | HA-FF43 | 1.30 | 0.75 | 668 |
| HA-SF53 | 1.59 | 2.54 | 472 | HA-FF63 | 1.90 | 0.96 | 624 |
| HA-SF103 | 3.18 | 5.36 | 417 | | | | |
| HA-SF153 | 4.78 | 18.88 | 1676 | HC-MF053 | 0.16 | 0.11 | 1445 |
| HA-SF203 | 6.37 | 10.63 | 771 | HC-MF13 | 0.32 | 0.34 | 1642 |
| HA-SF353 | 11.1 | 22.94 | 1338 | HC-MF23 | 0.64 | 0.40 | 465 |
| | | | | HC-MF43 | 1.30 | 0.76 | 426 |
| HC-RF103 | 3.18 | 3.67 | 582 | HC-MF73 | 2.40 | 1.59 | 260 |
| HC-RF153 | 4.78 | 5.44 | 668 | | | | |
| HC-RF203 | 6.37 | 7.16 | 973 | | | | |

Chapter 11 Characteristics

11-4-2 Coasting amount

The motor coasting amount when stopped by a dynamic brake can be approximated using the following expression.

$$C_{MAX} = \frac{N_o}{60} \cdot t_e + \left(1 + \frac{J_L}{J_M} \right) \cdot (A \cdot N_o^3 + B \cdot N_o)$$

- C_{MAX} : Maximum motor coasting amount (turn)
 N_o : Initial motor speed (r/min)
 J_M : Motor inertia ($kg \cdot cm^2$)
 J_L : Motor shaft conversion load inertia ($kg \cdot cm^2$)
 t_e : Brake drive relay delay time (sec) (Normally, 0.03sec)
 A : Coefficient A (Refer to the table below)
 B : Coefficient B (Refer to the table below)

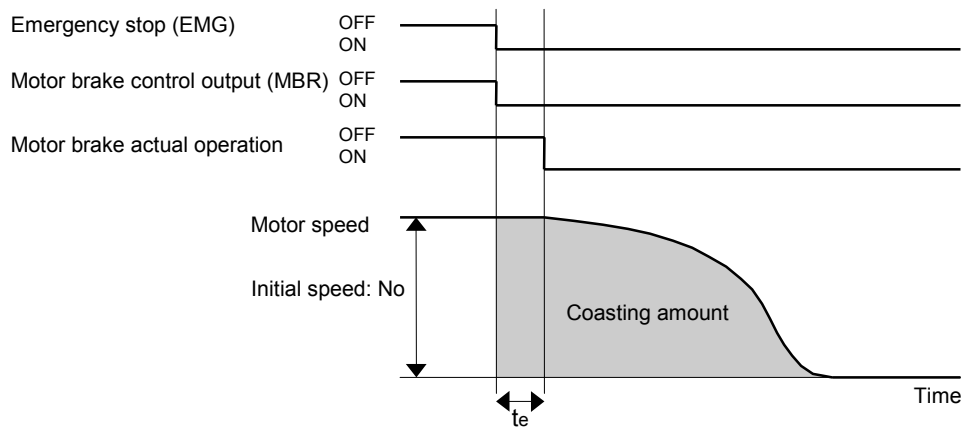

Fig. 11-5 Dynamic brake braking diagram

Table 11-4 Coasting amount calculation coefficients

| Motor type | J_M ($kg \cdot cm^2$) | A | B | Motor type | J_M ($kg \cdot cm^2$) | A | B |
|------------|------------------------------|-------------------------|------------------------|------------|------------------------------|------------------------|------------------------|
| HA-SF52 | 6.5 | 16.13×10^{-11} | 11.93×10^{-5} | HA-FF053 | 0.063 | 0.11×10^{-11} | 16.21×10^{-5} |
| HA-SF102 | 13.6 | 14.97×10^{-11} | 10.03×10^{-5} | HA-FF13 | 0.095 | 0.15×10^{-11} | 12.72×10^{-5} |
| HA-SF152 | 20.0 | 2.96×10^{-11} | 10.03×10^{-5} | HA-FF23 | 0.35 | 0.58×10^{-11} | 9.35×10^{-5} |
| HA-SF202 | 42.5 | 25.60×10^{-11} | 16.07×10^{-5} | HA-FF33 | 0.5 | 0.61×10^{-11} | 8.23×10^{-5} |
| HA-SF352 | 82.0 | 7.75×10^{-11} | 20.76×10^{-5} | HA-FF43 | 0.98 | 1.42×10^{-11} | 7.60×10^{-5} |
| HA-SF53 | 6.6 | 15.99×10^{-11} | 10.71×10^{-5} | HA-FF63 | 1.2 | 1.46×10^{-11} | 6.83×10^{-5} |
| HA-SF103 | 13.6 | 17.70×10^{-11} | 9.24×10^{-5} | | | | |
| HA-SF153 | 20.0 | 1.84×10^{-11} | 15.49×10^{-5} | HC-MF053 | 0.019 | 0.35×10^{-11} | 2.17×10^{-5} |
| HA-SF203 | 42.5 | 15.08×10^{-11} | 26.92×10^{-5} | HC-MF13 | 0.03 | 0.16×10^{-11} | 1.27×10^{-5} |
| HA-SF353 | 82.0 | 7.77×10^{-11} | 41.74×10^{-5} | HC-MF23 | 0.088 | 1.38×10^{-11} | 0.90×10^{-5} |
| | | | | HC-MF43 | 0.143 | 1.29×10^{-11} | 0.70×10^{-5} |
| HC-RF103 | 1.5 | 2.04×10^{-11} | 2.07×10^{-5} | HC-MF73 | 0.6 | 4.29×10^{-11} | 0.87×10^{-5} |
| HC-RF153 | 1.9 | 1.52×10^{-11} | 2.04×10^{-5} | | | | |
| HC-RF203 | 2.3 | 0.96×10^{-11} | 2.73×10^{-5} | | | | |

11-5 Vibration class

The vibration class of the servomotor is V-10 at the rated speed. The servomotor installation posture and measurement position to be used when measuring the vibration are shown below.

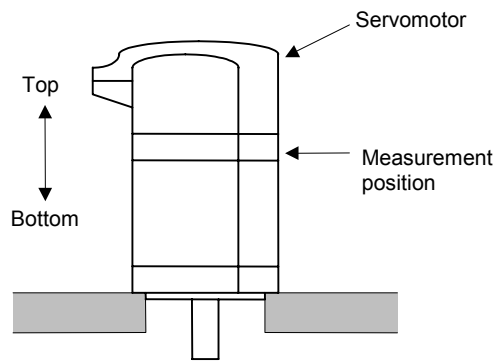

Fig. 11-6 Servomotor vibration measurement conditions

Chapter 12 Specifications

| | |
|---|-------------|
| 12-1 Servo amplifiers | 12-2 |
| 12-1-1 List of specifications | 12-2 |
| 12-1-2 Outline dimension drawings | 12-3 |
| 12-2 Servomotor | 12-5 |
| 12-2-1 List of specifications | 12-5 |
| 12-2-2 Torque characteristic drawings | 12-8 |
| 12-2-3 Outline dimension drawings | 12-11 |
| 12-2-4 Special axis servomotor | 12-25 |

12-1 Servo amplifiers

12-1-1 List of specifications

| Servo amplifier type (MR-J2-) | | 10CT | 20CT | 40CT | 60CT | 70CT | 100CT | 200CT | 350CT |
|-------------------------------|---------------------------------|---|-----------------------------|------|------|------|-------|-------|-------|
| Power supply | Voltage, frequency | 3-phase 200 to 230 VAC/ 50, 60 Hz | | | | | | | |
| | Tolerable voltage fluctuation | 3-phase 170 to 253 VAC/ 50, 60 Hz | | | | | | | |
| | Tolerable frequency fluctuation | Within $\pm 5\%$ | | | | | | | |
| Method | | Sine wave PWM control, current control method | | | | | | | |
| Dynamic brakes | | Built-in | | | | | | | |
| Regenerative resistor | | External only | Built-in or external option | | | | | | |
| External digital input | | External emergency stop input | | | | | | | |
| External digital output | | Contactor control output, motor brake control output | | | | | | | |
| External analog output | | $\pm 10V$, 2ch | | | | | | | |
| Protective functions | | Overcurrent cut off, over voltage cut off, overload cut off (electronic thermal relay), servomotor overheating protection, detector error protection, regeneration error protection, undervoltage, instantaneous power failure protection, overspeed protection, excessive error protection | | | | | | | |
| Structure | | Protection type (protection method: IP20) | | | | | | | |
| Environment conditions | | To follow section 3-1-1 Environmental conditions | | | | | | | |
| Weight [kg] | | 0.7 | 0.7 | 0.7 | 1.1 | 1.5 | 1.5 | 2.0 | 2.0 |

Chapter 12 Specifications

12-1-2 Outline dimension drawings

• MR-J2-10CT, -20CT

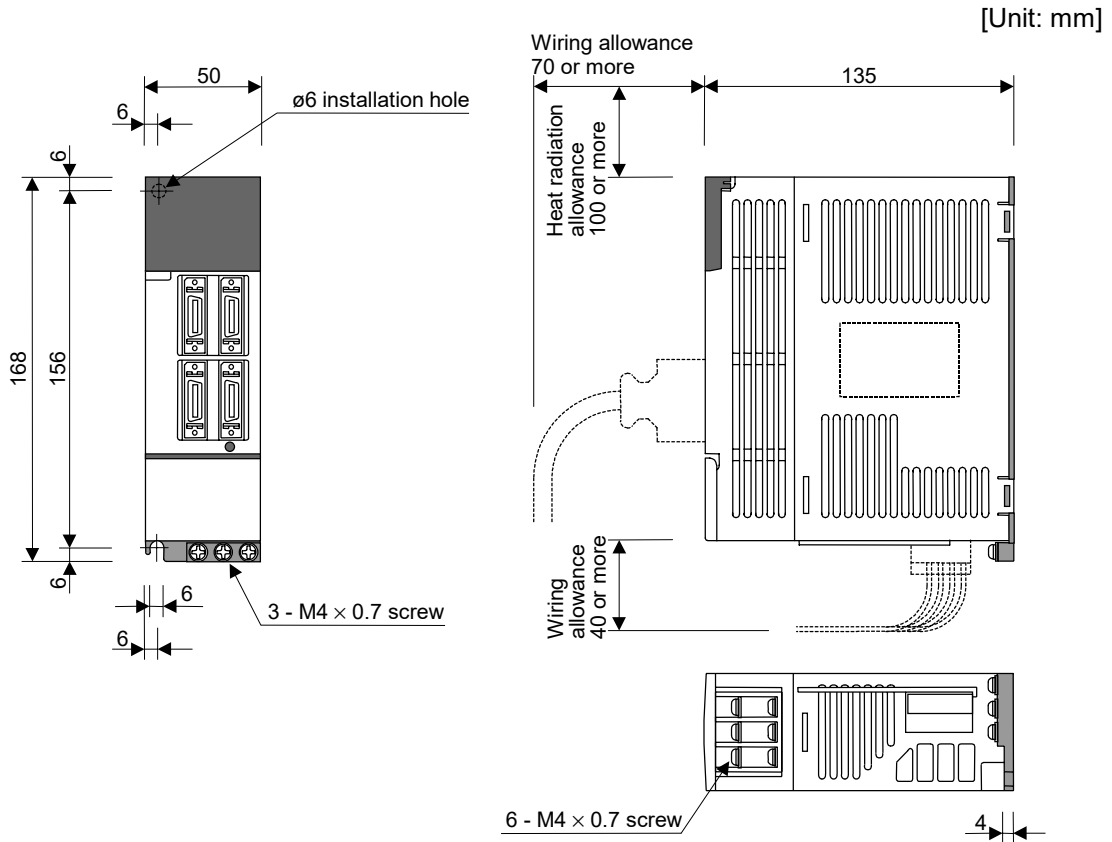

• MR-J2-40CT, -60CT

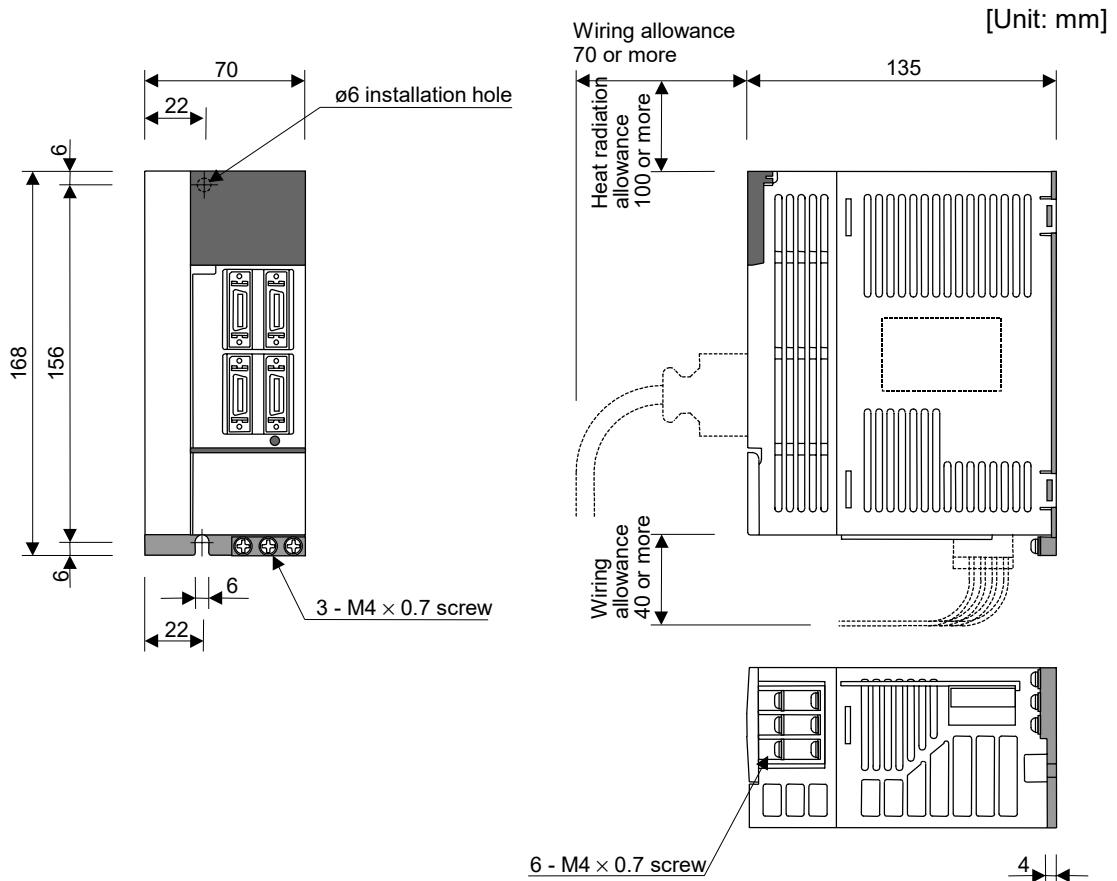

Chapter 12 Specifications

12-2 Servomotor

12-2-1 List of specifications

| Servomotor type | | HC-SF Series (2000r/min rating) | | | | |
|--|--------------------|--|-----------|----------|----------|----------|
| | | Absolute position standard | | | | |
| | | HC-SF52 | HC-SF102 | HC-SF152 | HC-SF202 | HC-SF352 |
| Corresponding servo amplifier type | | SVJ2-06 | SVJ2-07 | SVJ2-10 | | SVJ2-20 |
| Continuous characteristics | Rated output [kW] | 0.5 | 1.0 | 1.5 | 2.0 | 3.5 |
| | Rated current [A] | 3.2 | 6.0 | 9.0 | 10.7 | 16.6 |
| | Rated torque [N.m] | 2.39 | 4.78 | 7.16 | 9.55 | 16.7 |
| Rated speed [r/min] | | 2000 | | | | |
| Max. speed [r/min] | | 3000 | | | 2500 | |
| Max. current [A] | | 9.6 | 18 | 27 | 33 | 51 |
| Max. torque [N.m] | | 7.16 | 14.4 | 21.6 | 28.5 | 50.1 |
| Power rate at continuous rated torque [kW/sec] | | 8.7 | 16.7 | 25.6 | 21.5 | 34.1 |
| Motor inertia [kg.cm ²] | | 6.6 | 13.7 | 20.0 | 42.5 | 82.0 |
| Motor inertia with brakes [kg.cm ²] | | 8.6 | 15.7 | 22.0 | 52.5 | 92.0 |
| Recommended motor shaft conversion load inertia rate | | 10-times or less of motor inertia | | | | |
| Power facility capacity [kVA] | | 1.0 | 1.7 | 2.5 | 3.5 | 5.5 |
| Speed/position detector | | Resolution per motor rotation 16384 (pulse/rev) | | | | |
| Structure | | Fully closed, self-cooling (protection method: IP65) | | | | |
| Environment conditions | | To follow section 3-2-1 Environment conditions | | | | |
| Weight With/without brakes [kg] | | 5.0 / 7.5 | 7.0 / 9.0 | 9.0 / 11 | 12 / 18 | 19 / 25 |
| Armature insulation class | | Class F | | | | |

(Note) The above characteristic values are the central values. The maximum current and maximum torque are the values when combined with the amplifier.

| Servomotor type | | HC-SF Series (3000r/min rating) | | | | |
|--|--------------------|--|-----------|----------|----------|----------|
| | | Absolute position standard | | | | |
| | | HC-SF53 | HC-SF103 | HC-SF153 | HC-SF203 | HC-SF353 |
| Corresponding servo amplifier type | | SVJ2-06 | SVJ2-07 | SVJ2-10 | | SVJ2-20 |
| Continuous characteristics | Rated output [kW] | 0.5 | 1.0 | 1.5 | 2.0 | 3.5 |
| | Rated current [A] | 3.2 | 5.4 | 8.6 | 10.2 | 16.8 |
| | Rated torque [N.m] | 1.59 | 3.18 | 4.78 | 6.37 | 11.1 |
| Rated speed [r/min] | | 3000 | | | | |
| Max. speed [r/min] | | 3000 | | | | |
| Max. current [A] | | 9.6 | 16 | 26 | 31 | 49 |
| Max. torque [N.m] | | 4.77 | 9.55 | 14.3 | 19.1 | 33.4 |
| Power rate at continuous rated torque [kW/sec] | | 3.8 | 7.4 | 11.4 | 9.5 | 15.1 |
| Motor inertia [kg.cm ²] | | 6.6 | 13.7 | 20.0 | 42.5 | 82.0 |
| Motor inertia with brakes [kg.cm ²] | | 8.6 | 15.7 | 22.0 | 52.5 | 92.0 |
| Recommended motor shaft conversion load inertia rate | | 10-times or less of motor inertia | | | | |
| Power facility capacity [kVA] | | 1.0 | 1.7 | 2.5 | 3.5 | 5.5 |
| Speed/position detector | | Resolution per motor rotation 16384 (pulse/rev) | | | | |
| Structure | | Fully closed, self-cooling (protection method: IP65) | | | | |
| Environment conditions | | To follow section 3-2-1 Environment conditions | | | | |
| Weight With/without brakes [kg] | | 5.0 / 7.5 | 7.0 / 9.0 | 9.0 / 11 | 12 / 18 | 19 / 25 |
| Armature insulation class | | Class F | | | | |

(Note) The above characteristic values are the central values. The maximum current and maximum torque are the values when combined with the amplifier.

Chapter 12 Specifications

| Servomotor type | | HC-RF Series | | |
|--|--------------------|--|-----------|-----------|
| | | Absolute position standard | | |
| | | HC-RF103 | HC-RF153 | HC-RF203 |
| Corresponding servo amplifier type | | SVJ2-10 | | SVJ2-20 |
| Continuous characteristics | Rated output [kW] | 1.0 | 1.5 | 2.0 |
| | Rated current [A] | 6.1 | 8.8 | 14 |
| | Rated torque [N.m] | 3.18 | 4.77 | 6.37 |
| Rated speed [r/min] | | 3000 | | |
| Max. speed [r/min] | | 4500 | | |
| Max. current [A] | | 18.4 | 23.4 | 37 |
| Max. torque [N.m] | | 7.95 | 11.9 | 15.9 |
| Power rate at continuous rated torque [kW/sec] | | 67.4 | 120 | 176 |
| Motor inertia [kg.cm ²] | | 1.5 | 1.9 | 2.3 |
| Motor inertia with brakes [kg.cm ²] | | 1.9 | 2.3 | 2.7 |
| Recommended motor shaft conversion load inertia rate | | 5-times or less of motor inertia | | |
| Power facility capacity [kVA] | | 1.7 | 2.5 | 3.5 |
| Speed/position detector | | Resolution per motor rotation 16384 (pulse/rev) | | |
| Structure | | Fully closed, self-cooling (protection method: IP65) | | |
| Environment conditions | | To follow section 3-2-1 Environment conditions | | |
| Weight With/without brakes [kg] | | 3.9 / 6.0 | 5.0 / 7.0 | 6.2 / 8.3 |
| Armature insulation class | | Class F | | |

(Note) The above characteristic values are the central values. The maximum current and maximum torque are the values when combined with the amplifier.

| Servomotor type | | HA-FF Series | | | | | |
|--|--------------------|--|-----------|-----------|-----------|-----------|-----------|
| | | Absolute position standard | | | | | |
| | | HA-FF053 | HA-FF13 | HA-FF23 | HA-FF33 | HA-FF43 | HA-FF63 |
| Corresponding servo amplifier type | | SVJ2-01 | | SVJ2-03 | | SVJ2-04 | SVJ2-06 |
| Continuous characteristics | Rated output [kW] | 0.05 | 0.1 | 0.2 | 0.3 | 0.4 | 0.6 |
| | Rated current [A] | 0.6 | 1.1 | 1.3 | 1.9 | 2.5 | 3.6 |
| | Rated torque [N.m] | 0.16 | 0.32 | 0.64 | 0.95 | 1.3 | 1.9 |
| Rated speed [r/min] | | 3000 | | | | | |
| Max. speed [r/min] | | 4000 | | | | | |
| Max. current [A] | | 1.8 | 3.3 | 3.9 | 5.7 | 7.5 | 10.8 |
| Max. torque [N.m] | | 0.48 | 0.95 | 1.9 | 2.9 | 3.8 | 5.7 |
| Power rate at continuous rated torque [kW/sec] | | 4.0 | 10.2 | 11.7 | 18.1 | 17.2 | 30.1 |
| Motor inertia [kg.cm ²] | | 0.063 | 0.095 | 0.35 | 0.5 | 0.98 | 1.2 |
| Motor inertia with brakes [kg.cm ²] | | 0.08 | 0.113 | 0.483 | 0.633 | 1.325 | 1.55 |
| Recommended motor shaft conversion load inertia rate | | 10-times or less of motor inertia | | | | | |
| Power facility capacity [kVA] | | 0.3 | 0.3 | 0.5 | 0.7 | 0.9 | 1.1 |
| Speed/position detector | | Resolution per motor rotation 8192 (pulse/rev) | | | | | |
| Structure | | Fully closed, self-cooling (protection method: IP44, excluding connector section. IP54 for HA-FF**C-UE Series.) | | | | | |
| Environment conditions | | To follow section 3-2-1 Environment conditions | | | | | |
| Weight With/without brakes [kg] | | 1.3 / 1.6 | 1.5 / 1.8 | 2.3 / 2.9 | 2.6 / 3.2 | 4.2 / 5.0 | 4.8 / 5.6 |
| Armature insulation class | | Class B | | | | | |

(Note) The above characteristic values are the central values. The maximum current and maximum torque are the values when combined with the amplifier.

| Servomotor type | | HC-MF Series | | | | |
|--|--------------------|--|-------------|------------|------------|-----------|
| | | Absolute position standard | | | | |
| | | HC-MF053 | HC-MF13 | HC-MF23 | HC-MF43 | HC-MF73 |
| Corresponding servo amplifier type | | SVJ2-01 | | SVJ2-03 | SVJ2-04 | SVJ2-06 |
| Continuous characteristics | Rated output [kW] | 0.05 | 0.1 | 0.2 | 0.4 | 0.75 |
| | Rated current [A] | 0.85 | 0.85 | 1.5 | 2.8 | 5.2 |
| | Rated torque [N.m] | 0.16 | 0.32 | 0.64 | 1.3 | 2.4 |
| Rated speed [r/min] | | 3000 | | | | |
| Max. speed [r/min] | | 4500 | | | | |
| Max. current [A] | | 2.6 | 2.6 | 5.0 | 9.0 | 18 |
| Max. torque [N.m] | | 0.48 | 0.95 | 1.9 | 3.8 | 7.2 |
| Power rate at continuous rated torque [kW/sec] | | 13.47 | 34.13 | 41.8 | 116.55 | 94.43 |
| Motor inertia [kg.cm ²] | | 0.019 | 0.03 | 0.088 | 0.143 | 0.6 |
| Motor inertia with brakes [kg.cm ²] | | 0.022 | 0.033 | 0.13 | 0.19 | 0.8 |
| Recommended motor shaft conversion load inertia rate | | 30-times or less of motor inertia | | | | |
| Power facility capacity [kVA] | | 0.3 | 0.3 | 0.5 | 0.9 | 1.3 |
| Speed/position detector | | Resolution per motor rotation 8192 (pulse/rev) | | | | |
| Structure | | Fully closed, self-cooling (protection method: IP44 excluding the shaft penetration section and connectors) | | | | |
| Environment conditions | | To follow section 3-2-1 Environment conditions | | | | |
| Weight With/without brakes [kg] | | 0.40 / 0.75 | 0.53 / 0.89 | 0.99 / 1.6 | 1.45 / 2.1 | 3.0 / 4.0 |
| Armature insulation class | | Class B | | | | |

(Note) The above characteristic values are the central values. The maximum current and maximum torque are the values when combined with the amplifier.

Chapter 12 Specifications

12-2-2 Torque characteristic drawings

(1) HC-SF Series

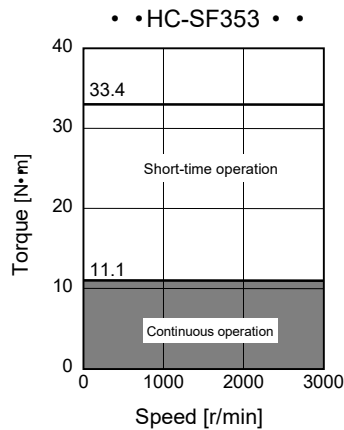
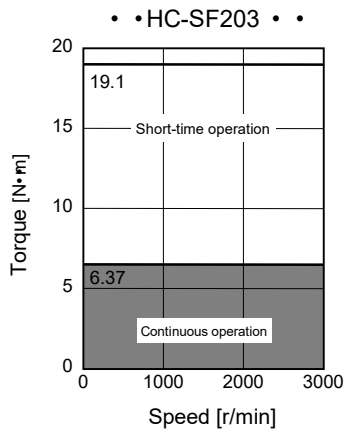
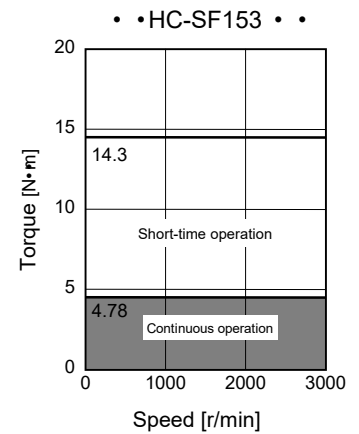
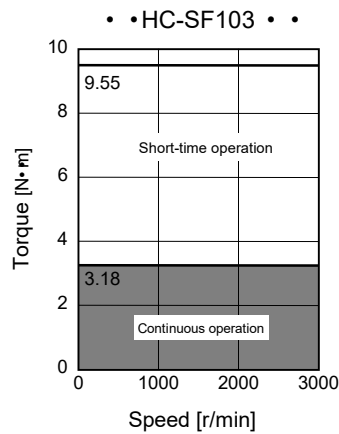
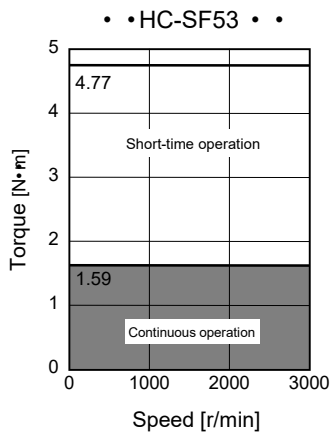
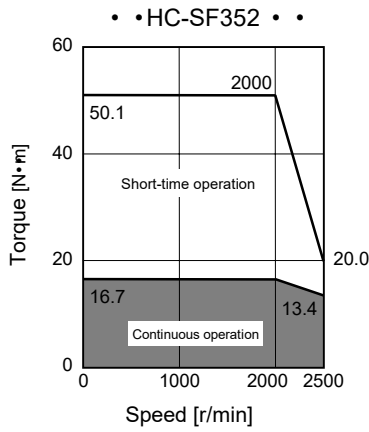
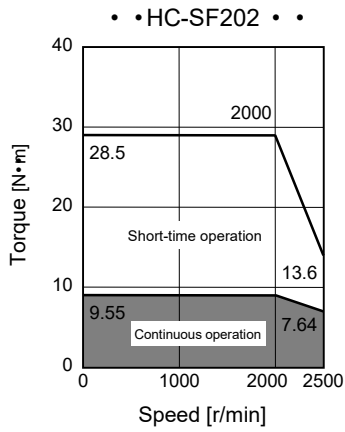
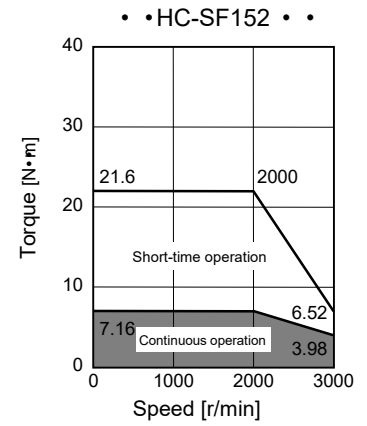
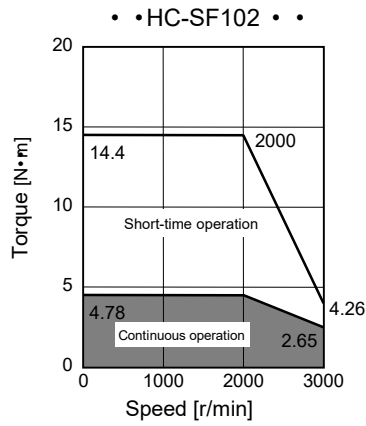
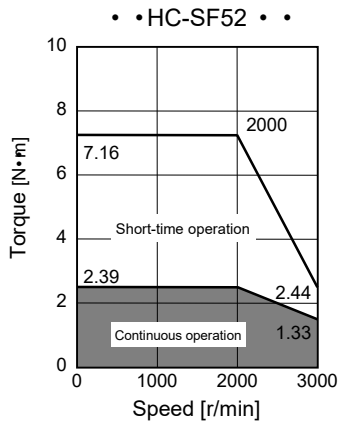

(Caution) The data in these characteristics is for an input voltage of 200VAC.

(2) HC-RF Series

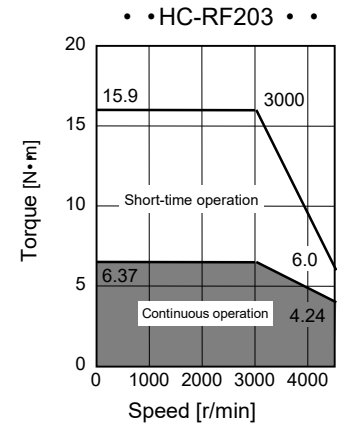
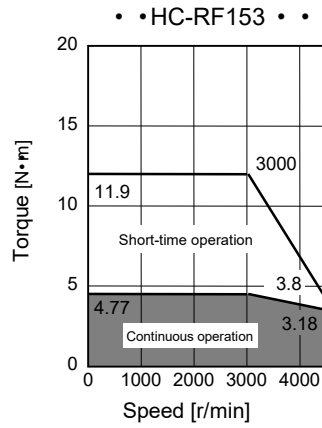
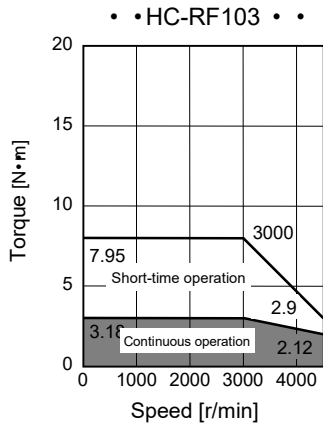

(Caution) The data in these characteristics is for an input voltage of 200VAC.

(3) HA-FF Series

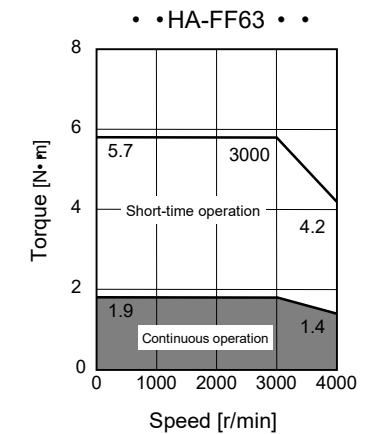
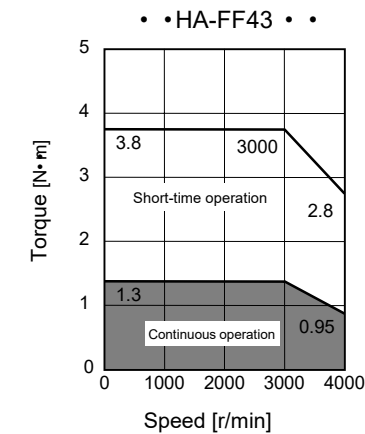
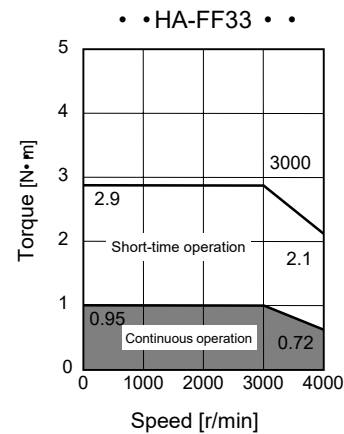
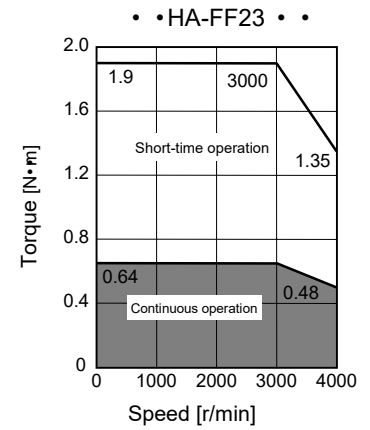
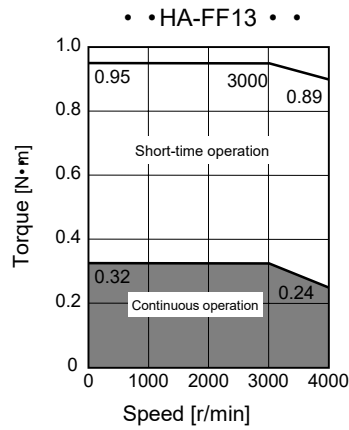
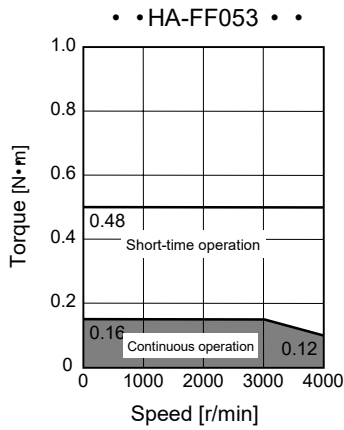

(Caution) The data in these characteristics is for an input voltage of 200VAC.

Chapter 12 Specifications

(4) HC-MF Series

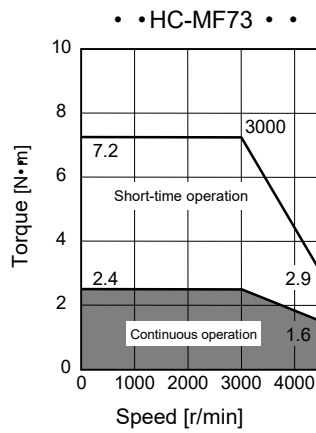
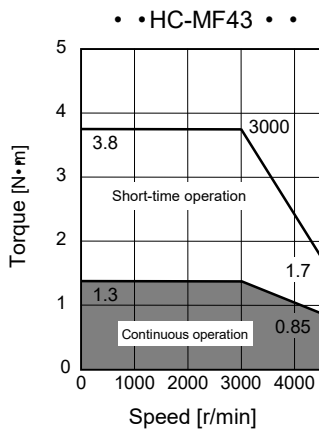
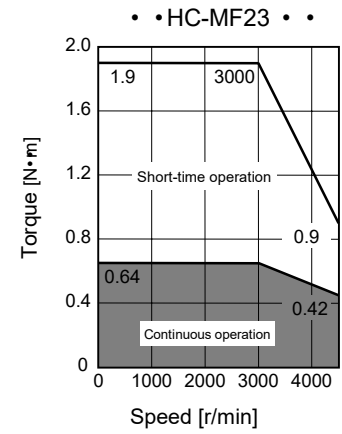
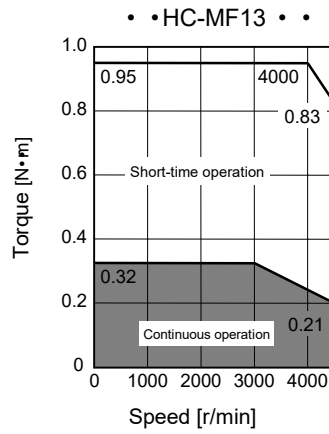
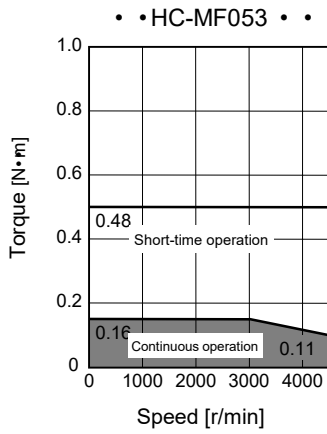

(Caution) The data in these characteristics is for an input voltage of 200VAC.

Chapter 12 Specifications

12-2-3 Outline dimension drawings

- HC-SF52(B)(K) • HC-SF53(B)(K)
- HC-SF102(B)(K) • HC-SF103(B)(K)
- HC-SF152(B)(K) • HC-SF153(B)(K)

- HC-SF53(B)T • HC-SF53(B)T
- HC-SF103(B)T • HC-SF103(B)T
- HC-SF153(B)T • HC-SF153(B)T

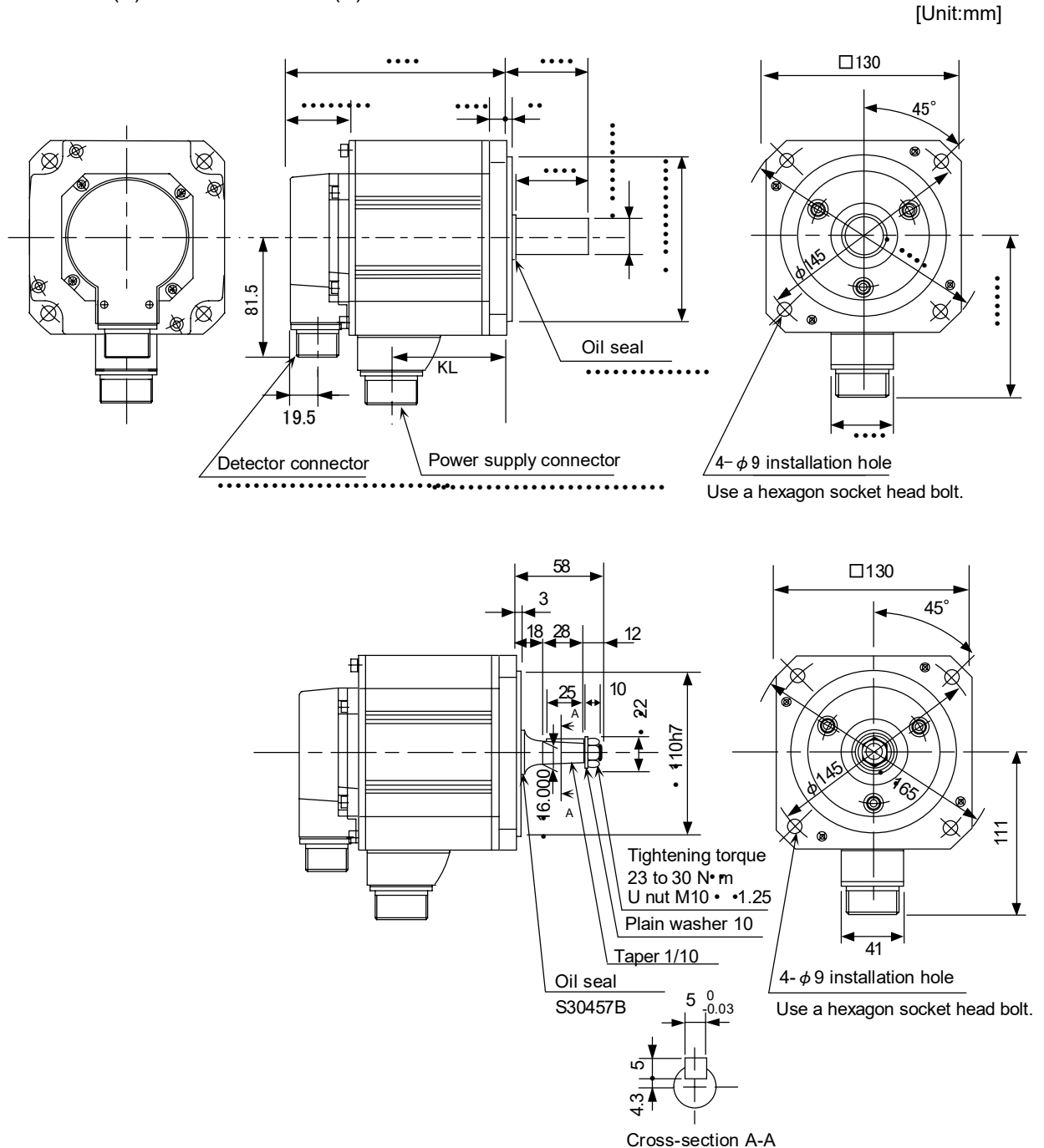

| Servomotor type | | L (Note 1) | KL |
|-----------------|-------------|------------|-------|
| 2000r/min | 3000r/min | | |
| HC-SF52(B) | HC-SF53(B) | 120(153) | 51.5 |
| HC-SF102(B) | HC-SF103(B) | 145(178) | 76.5 |
| HC-SF152(B) | HC-SF153(B) | 170(203) | 101.5 |

Note 1. The dimensions given in parentheses are for when magnetic brakes are provided.

Note 2. Refer to section 12-2-4 for the dimensions of K (keyway).

Chapter 12 Specifications

- HC-SF202(K)
- HC-SF203(K)
- HC-SF352(K)
- HC-SF353(K)

[Unit:mm]

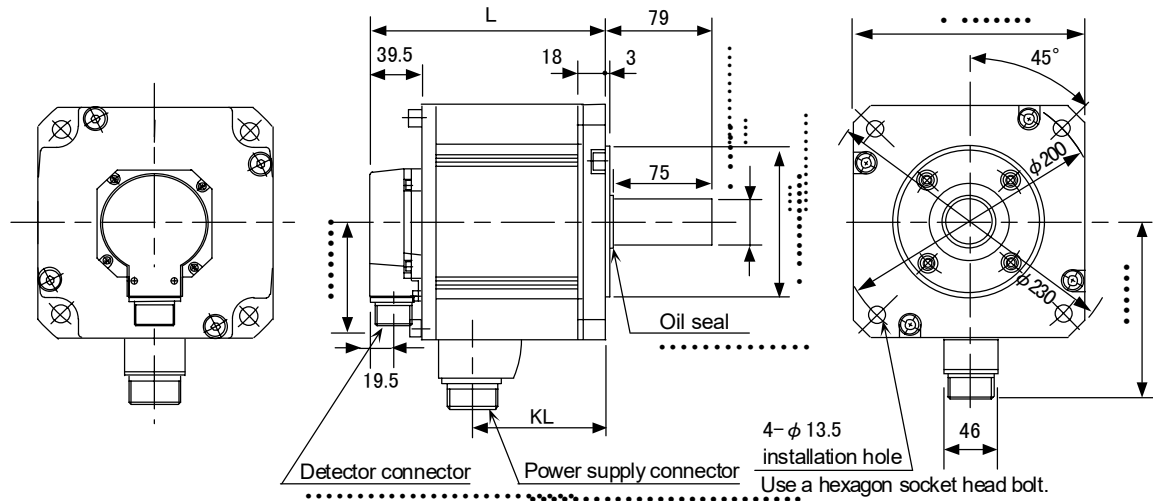

| Servomotor type | | L | KL |
|-----------------|-----------|-----|-------|
| 2000r/min | 3000r/min | | |
| HC-SF202 | HC-SF203 | 145 | 68.5 |
| HC-SF352 | HC-SF353 | 187 | 110.5 |

Note 1. Refer to section 12-2-4 for the dimensions of K (keyway).

- HC-SF202B(K)
- HC-SF203B(K)
- HC-SF352B(K)
- HC-SF353B(K)

[Unit:mm]

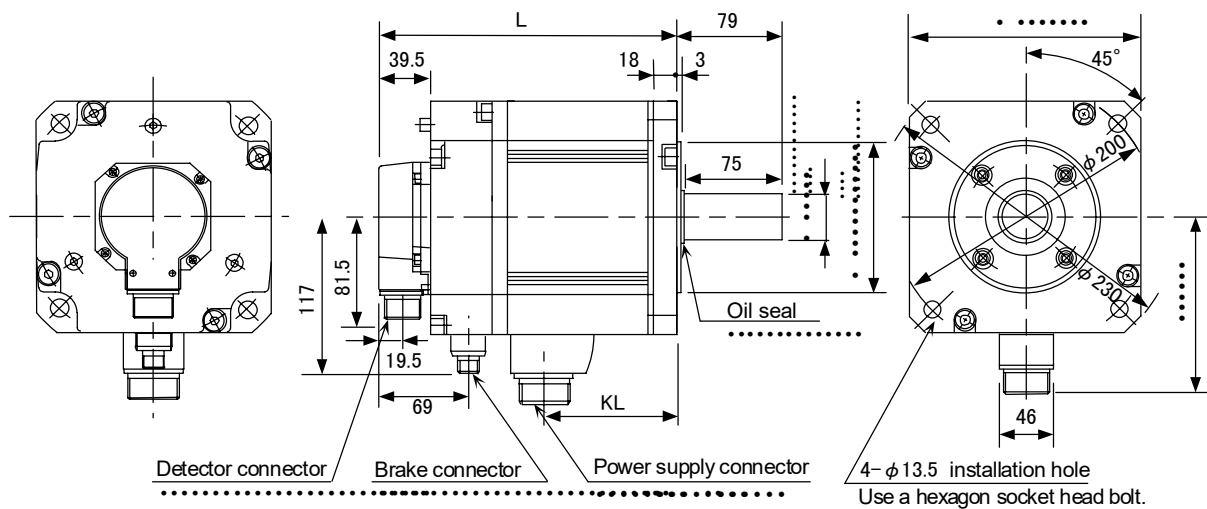

| Servomotor type | | L | KL |
|-----------------|-----------|-----|-------|
| 2000r/min | 3000r/min | | |
| HC-SF202B | HC-SF203B | 193 | 68.5 |
| HC-SF352B | HC-SF353B | 235 | 110.5 |

Note 1. Refer to section 12-2-4 for the dimensions of K (keyway).

Chapter 12 Specifications

- HC-RF103(B)(K)
- HC-RF153(B)(K)
- HC-RF203(B)(K)
- HC-RF103(B)T
- HC-RF153(B)T
- HC-RF203(B)T

[Unit:mm]

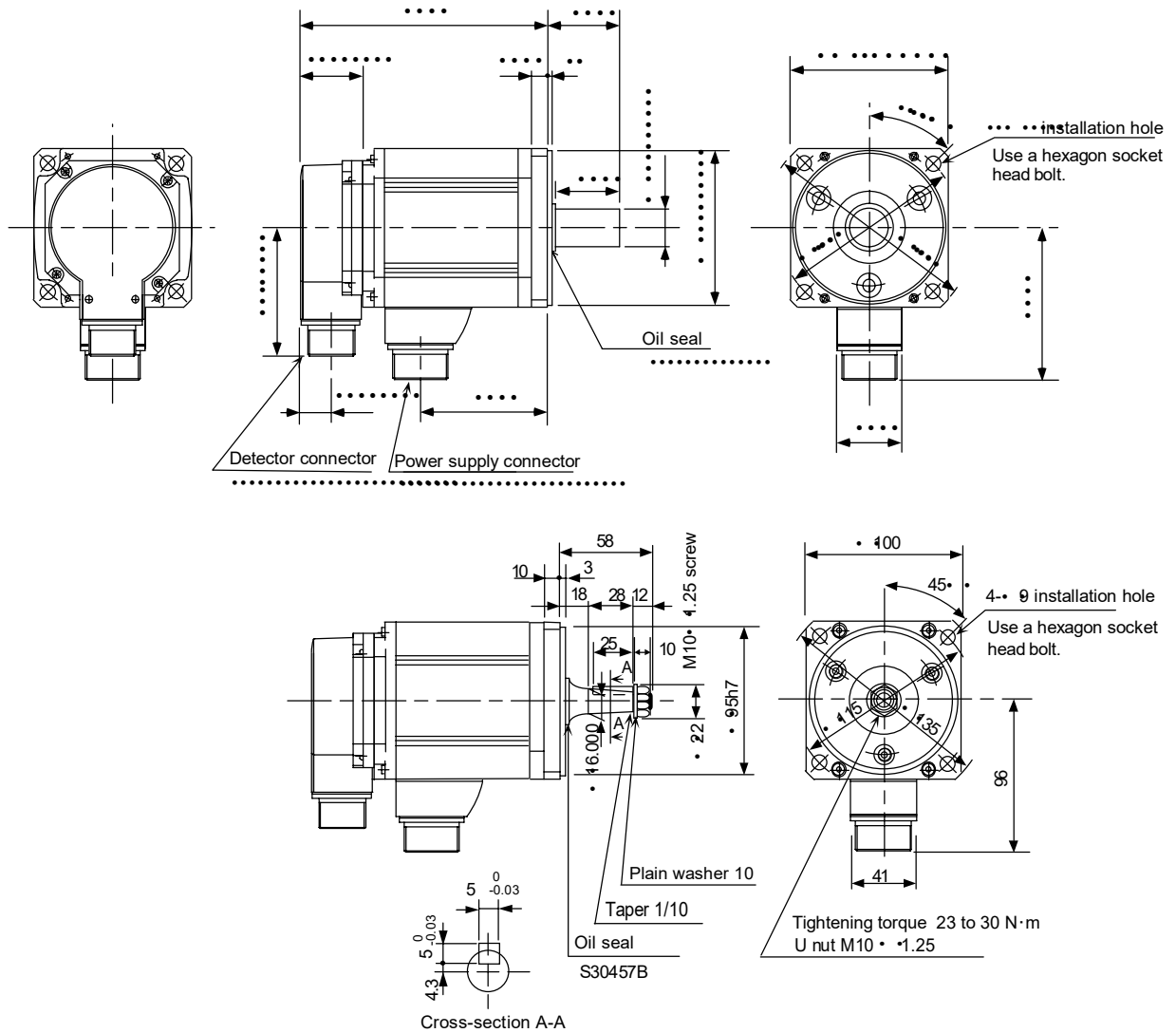

| Servomotor type | L (Note 1) | KL |
|-----------------|------------|-----|
| HC-RF103(B) | 147(185) | 71 |
| HC-RF153(B) | 172(210) | 96 |
| HC-RF203(B) | 197(235) | 121 |

Note 1. The dimensions given in parentheses are for when magnetic brakes are provided.

Note 2. Refer to section 12-2-4 for the dimensions of K (keyway).

Chapter 12 Specifications

- HA-FF053(D)
- HA-FF13(D)

[Unit:mm]

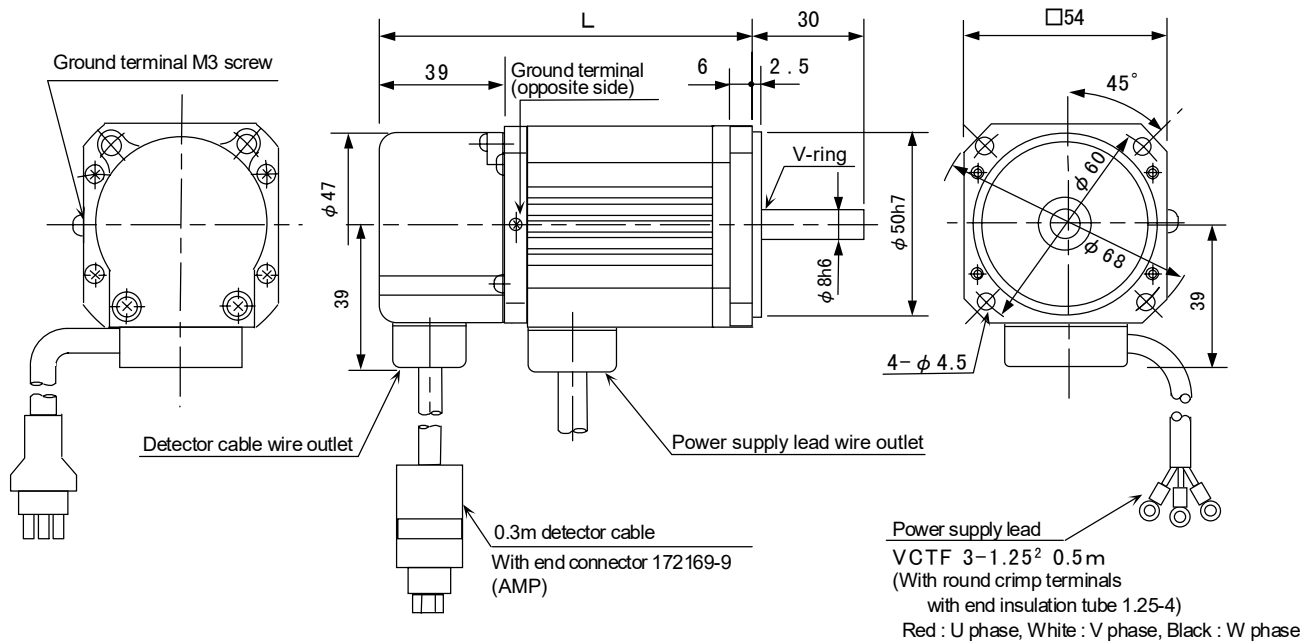

| Servomotor type | L |
|-----------------|-----|
| HA-FF053 | 106 |
| HA-FF13 | 123 |

Note 1. Use a friction coupling (Spun ring, etc.) to connect with the load.

Note 2. Refer to section 12-2-4 for the dimensions of D (D cut).

- HA-FF053B(D)
- HA-FF13B(D)

[Unit:mm]

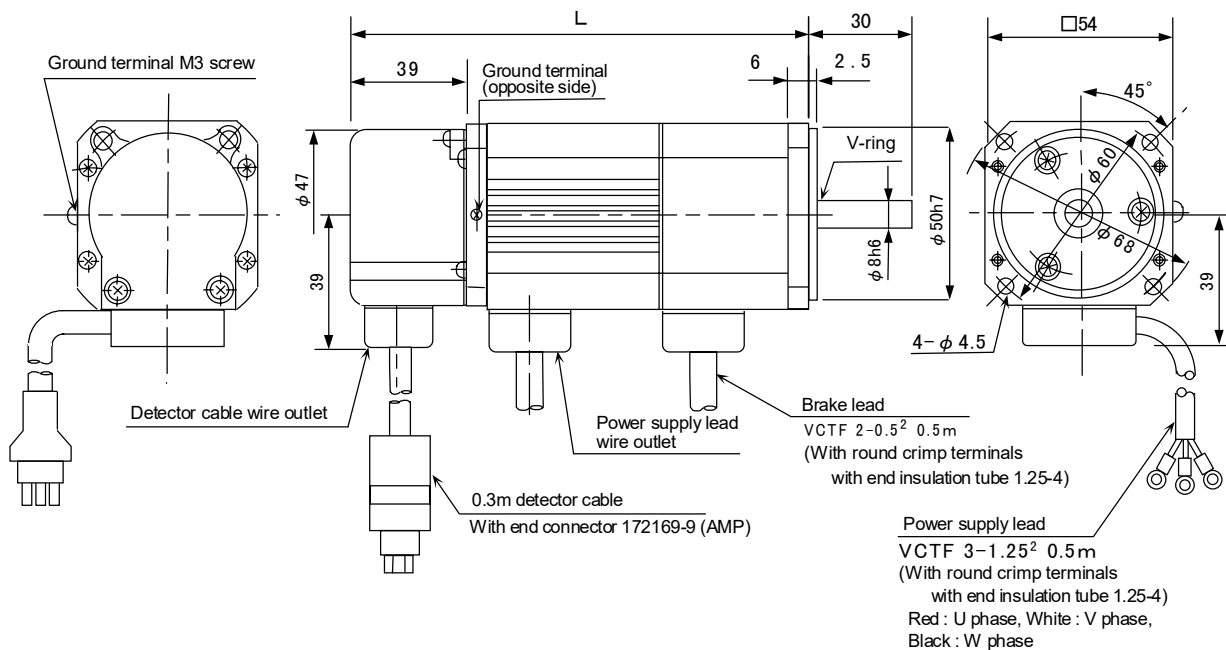

| Servomotor type | L |
|-----------------|-----|
| HA-FF053B | 141 |
| HA-FF13B | 158 |

Note 1. Use a friction coupling (Spun ring, etc.) to connect with the load.

Note 2. Refer to section 12-2-4 for the dimensions of D (D cut).

Chapter 12 Specifications

- HA-FF23
- HA-FF33

[Unit:mm]

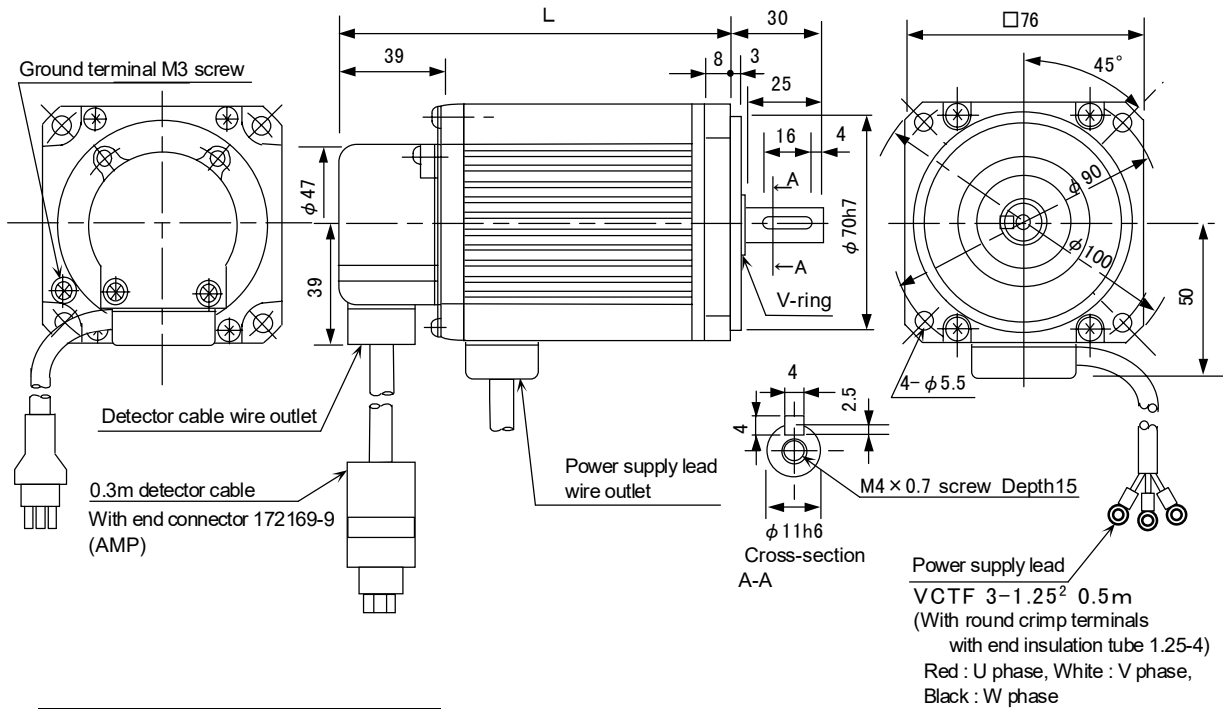

| Servomotor type | L |
|-----------------|-------|
| HA-FF23 | 130.5 |
| HA-FF33 | 148 |

- HA-FF23B
- HA-FF33B

[Unit:mm]

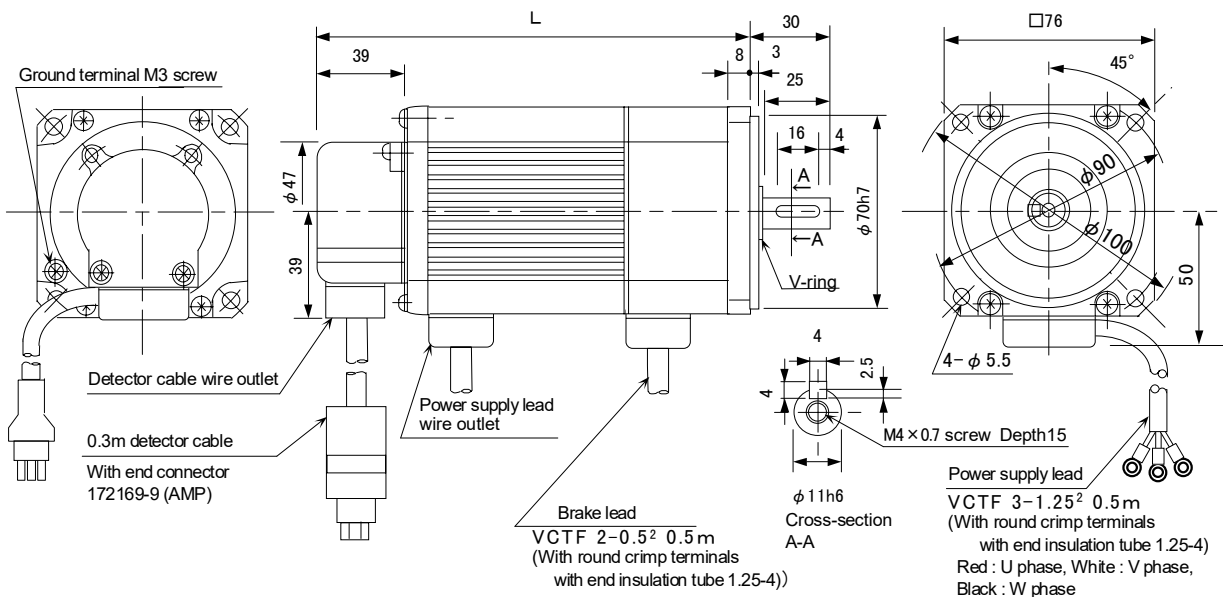

| Servomotor type | L |
|-----------------|-------|
| HA-FF23B | 168 |
| HA-FF33B | 185.5 |

Chapter 12 Specifications

- HA-FF43
- HA-FF63

[Unit:mm]

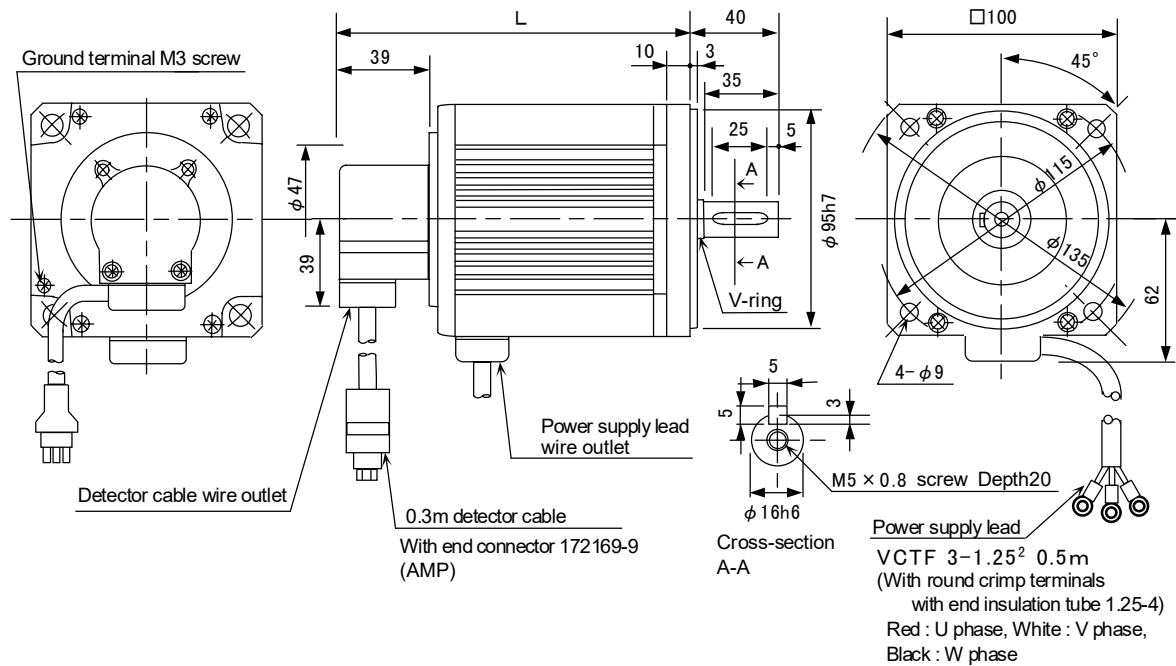

| Servomotor type | L |
|-----------------|-------|
| HA-FF43 | 154.5 |
| HA-FF63 | 169.5 |

- HA-FF43B
- HA-FF63B

[Unit:mm]

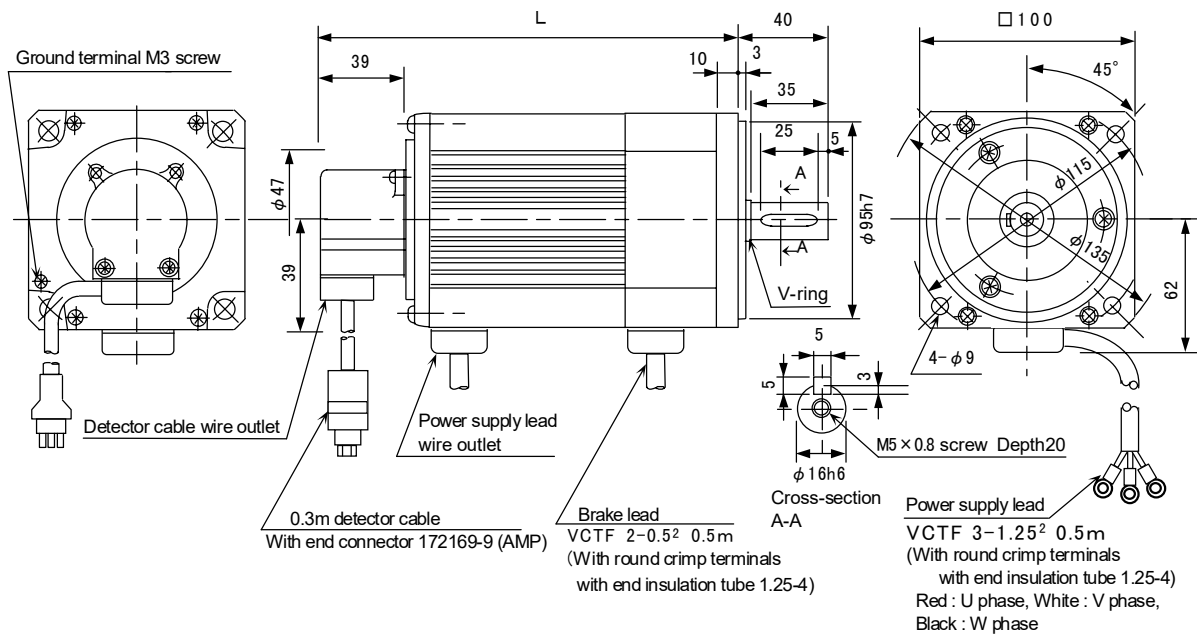

| Servomotor type | L |
|-----------------|-------|
| HA-FF43B | 191.5 |
| HA-FF63B | 206.5 |

Chapter 12 Specifications

- HA-FF053C(D)-UE
- HA-FF13C(D)-UE

[Unit:mm]

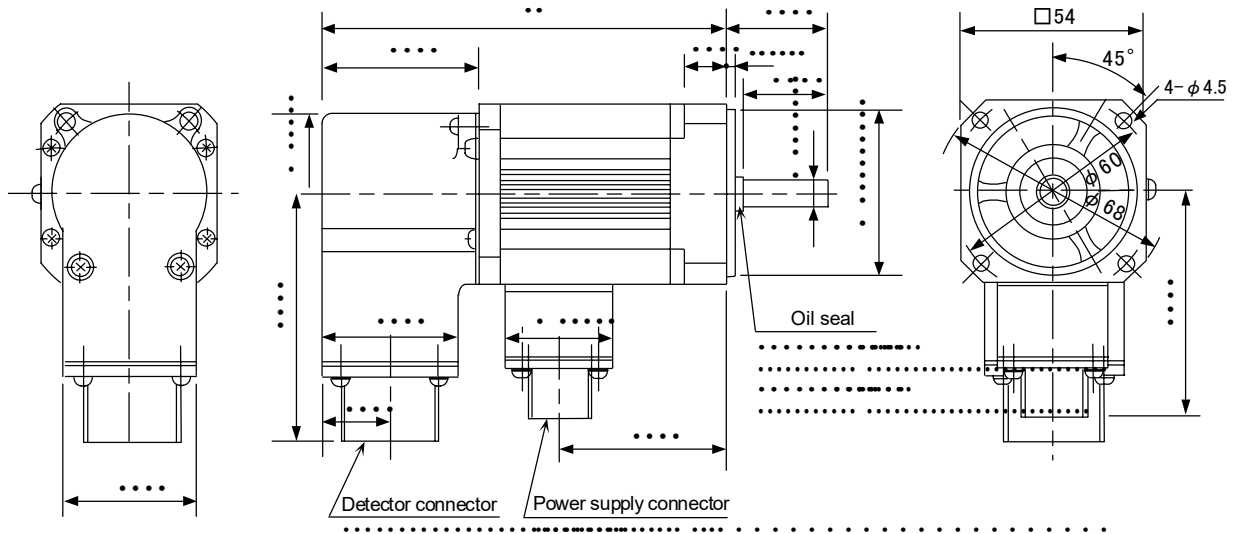

| Servomotor type | L | KL |
|-----------------|-----|------|
| HA-FF053C-UE | 120 | 49.5 |
| HA-FF13C-UE | 137 | 66.5 |

Note 1. Use a friction coupling (Spun ring, etc.) to connect with the load.

Note 2. Refer to section 12-2-4 for the dimensions of D (D cut).

- HA-FF053CB(D)-UE
- HA-FF13CB(D)-UE

[Unit:mm]

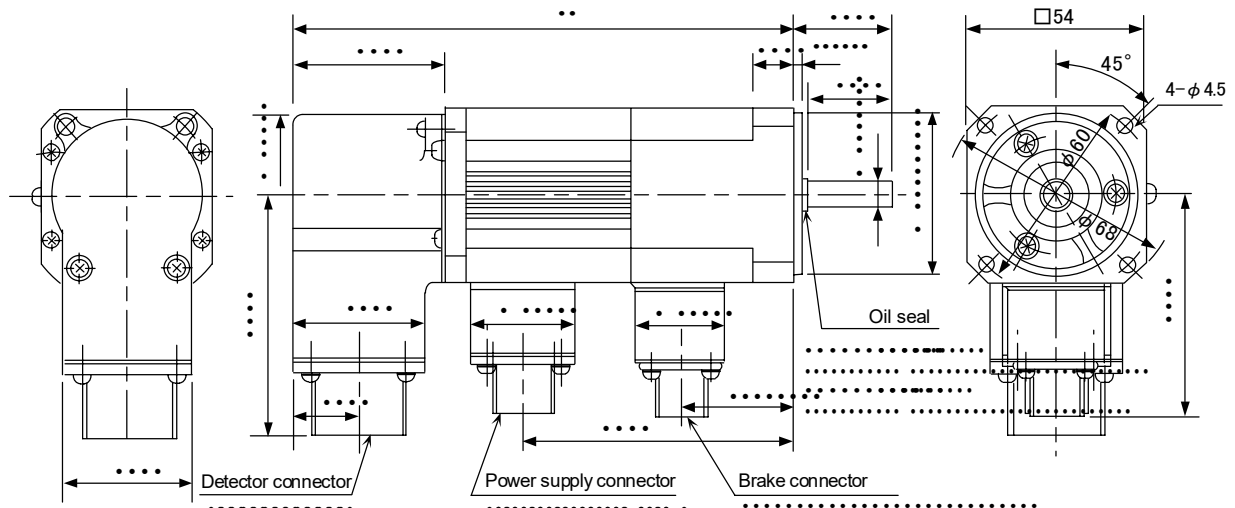

| Servomotor type | L | KL |
|-----------------|-----|-----|
| HA-FF053CB-UE | 155 | 84 |
| HA-FF13CB-UE | 172 | 101 |

Note 1. Use a friction coupling (Spun ring, etc.) to connect with the load.

Note 2. Refer to section 12-2-4 for the dimensions of D (D cut).

Chapter 12 Specifications

- HA-FF23C-UE
- HA-FF33C-UE

[Unit:mm]

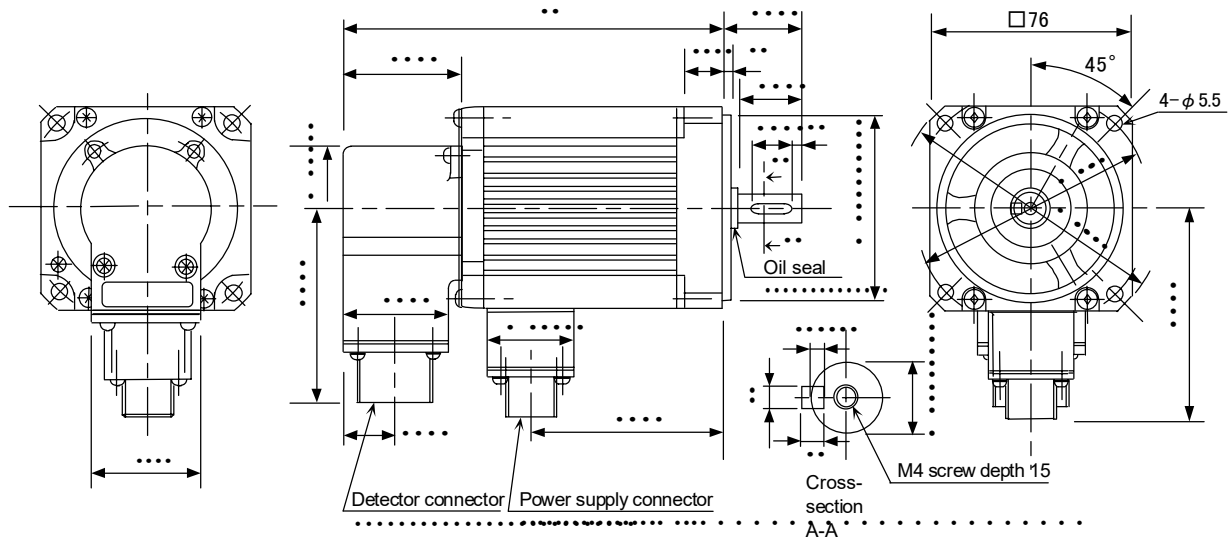

| Servomotor type | L | KL |
|-----------------|-----|------|
| HA-FF23C -UE | 145 | 71.5 |
| HA-FF33C -UE | 162 | 89 |

- HA-FF23CB-UE
- HA-FF33CB-UE

[Unit:mm]

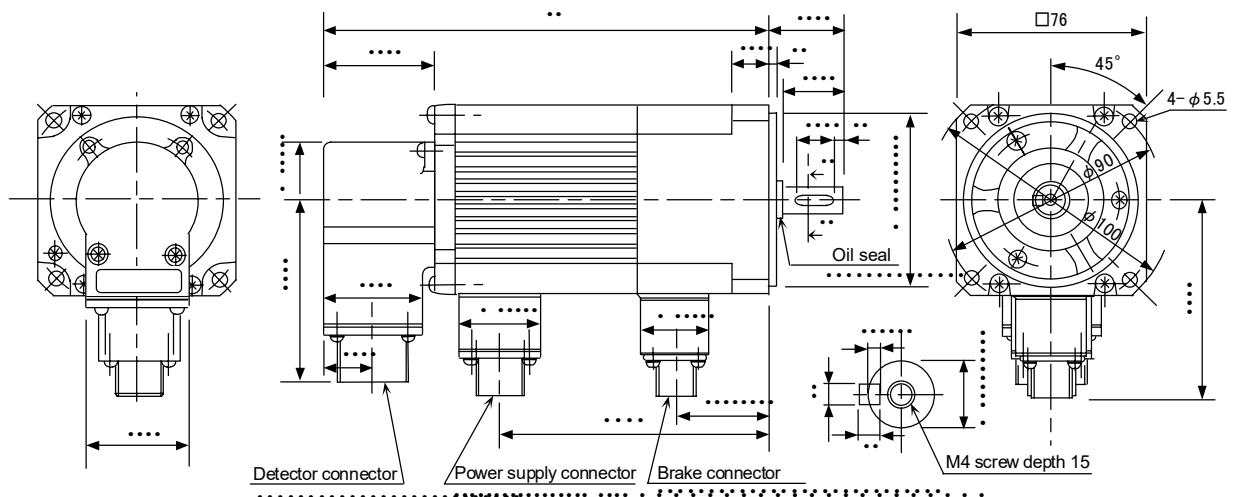

| Servomotor type | L | KL |
|-----------------|-----|-----|
| HA-FF23CB-UE | 182 | 109 |
| HA-FF33CB-UE | 200 | 127 |

Chapter 12 Specifications

- HA-FF43C-UE
- HA-FF63C-UE

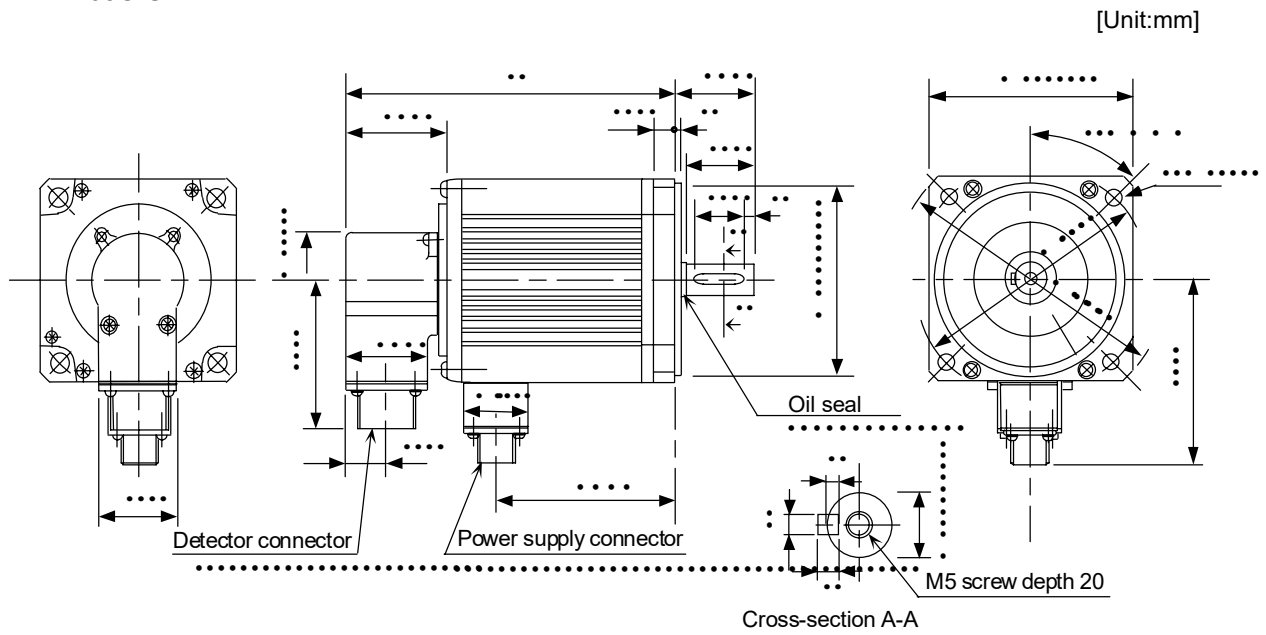

| Servomotor type | L | KL |
|-----------------|-----|-----|
| HA-FF43C-UE | 169 | 93 |
| HA-FF63C-UE | 184 | 108 |

- HA-FF43CB-UE
- HA-FF63CB-UE

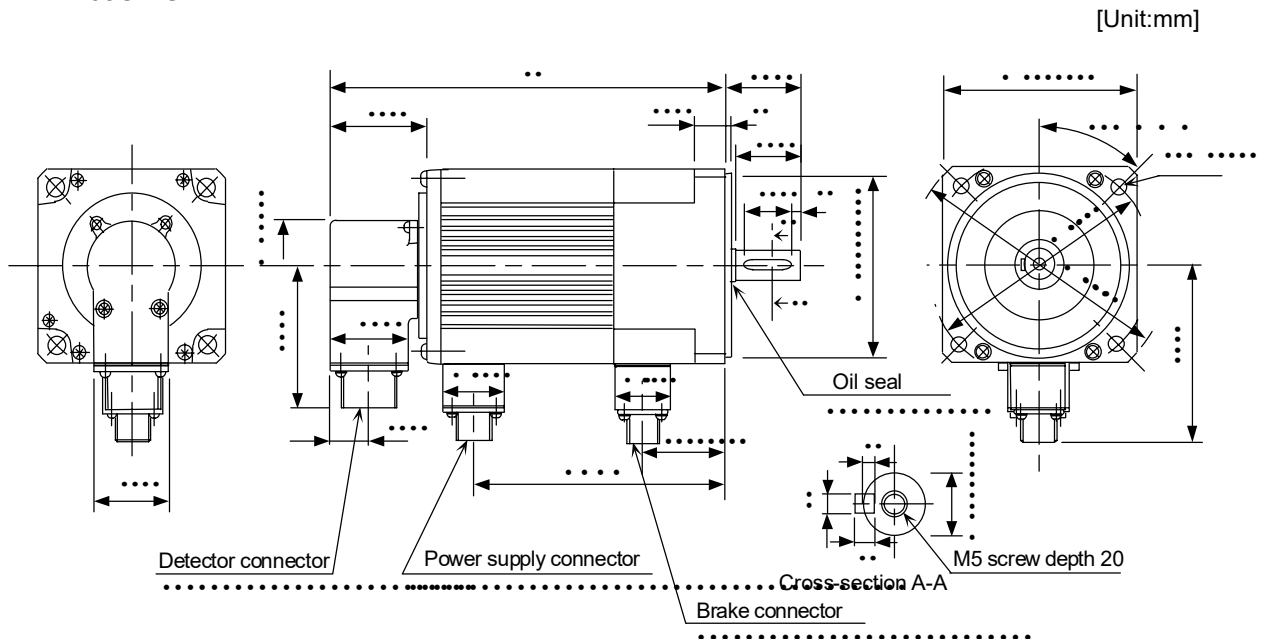

| Servomotor type | L | KL |
|-----------------|-----|-----|
| HA-FF43CB-UE | 206 | 130 |
| HA-FF63CB-UE | 221 | 145 |

Chapter 12 Specifications

- HC-MF053 (D) (-UE)
- HC-MF13 (D) (-UE)

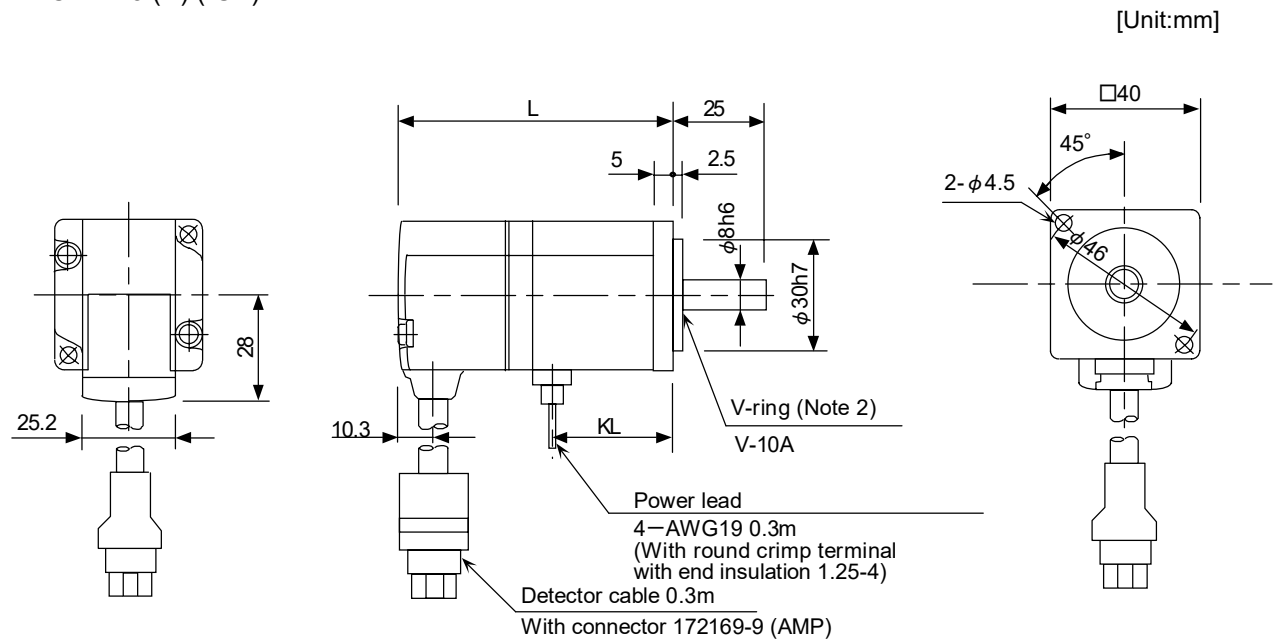

| Servomotor type | L | KL |
|-----------------|-------------|------------|
| HC-MF053(-UE) | 81.5(89.5) | 30.5(38.5) |
| HC-MF13(-UE) | 96.5(104.5) | 45.5(53.5) |

Note 1. Use a frictional coupler (Shupan ring, etc.) when connecting to the load.

Note 2. The EN Standards compliant part (HC-MF053-UE, HC-MF13-UE) has a V-ring.

Note 3. Refer to section 12-2-4 for the dimensions of D (D cut).

- HC-MF053B (D) (-UE)
- HC-MF13B (D) (-UE)

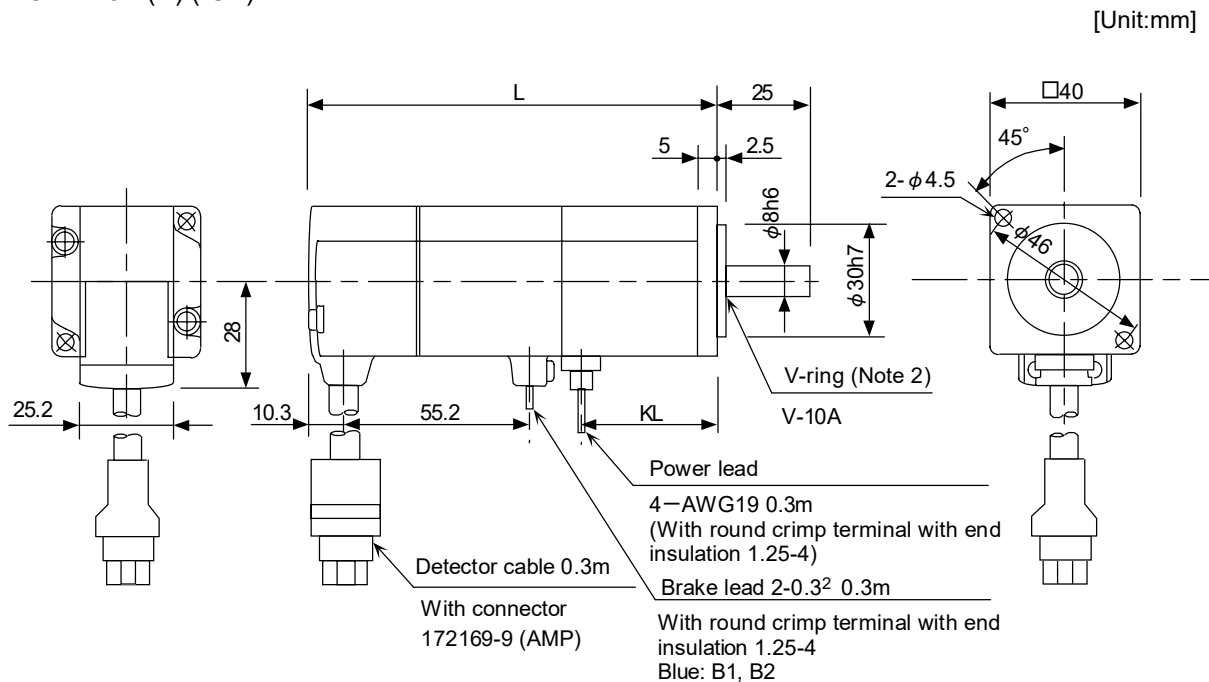

| Servomotor type | L | KL |
|-----------------|--------------|------------|
| HC-MF053B(-UE) | 109.5(117.5) | 30.5(38.5) |
| HC-MF13B(-UE) | 124.5(132.5) | 45.5(53.5) |

Note 1. Use a frictional coupler (Shupan ring, etc.) when connecting to the load.

Note 2. The EN Standards compliant part (HC-MF053B-UE, HC-MF13B-UE) has a V-ring.

Note 3. Refer to section 12-2-4 for the dimensions of D (D cut).

Chapter 12 Specifications

- HC-MF23 (K) (-UE)
- HC-MF43 (K) (-UE)

[Unit:mm]

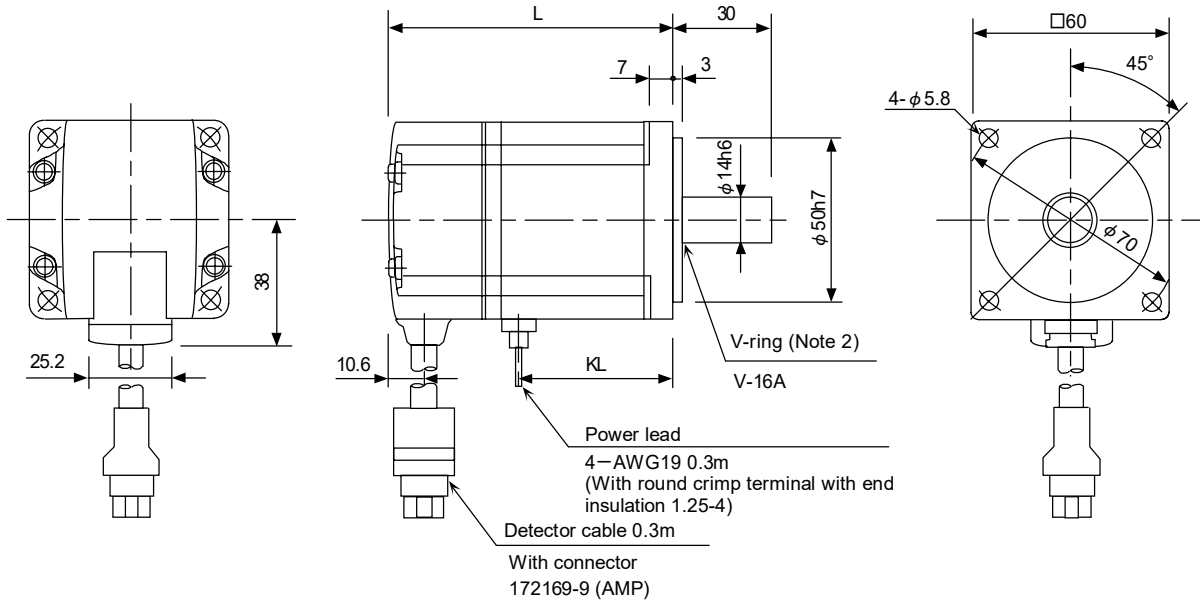

| Servomotor type | L | KL |
|-----------------|--------------|--------|
| HC-MF23(-UE) | 99.5(108.5) | 50(59) |
| HC-MF43(-UE) | 124.5(133.5) | 75(84) |

- Note 1. Use a frictional coupler (Shupan ring, etc.) when connecting to the load.
 Note 2. The EN Standards compliant part (HC-MF23-UE, HC-MF43-UE) has a V-ring.
 Note 3. Refer to section 12-2-4 for the dimensions of K (keyway).

- HC-MF23B (K) (-UE)
- HC-MF43B (K) (-UE)

[Unit:mm]

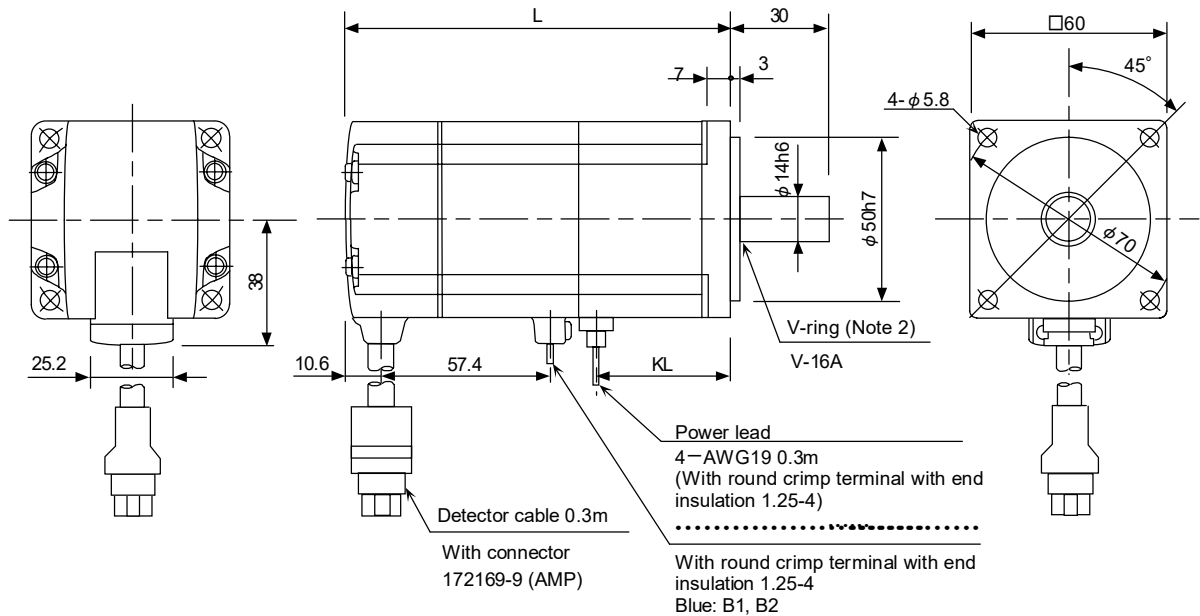

| Servomotor type | L | KL |
|-----------------|--------------|--------|
| HC-MF23B(-UE) | 131.5(140.5) | 50(59) |
| HC-MF43B(-UE) | 156.5(165.5) | 75(84) |

- Note 1. Use a frictional coupler (Shupan ring, etc.) when connecting to the load.
 Note 2. The EN Standards compliant part (HC-MF23B-UE, HC-MF43B-UE) has a V-ring.
 Note 3. Refer to section 12-2-4 for the dimensions of K (keyway).

Chapter 12 Specifications

• HC-MF73 (K) (-UE)

[Unit:mm]

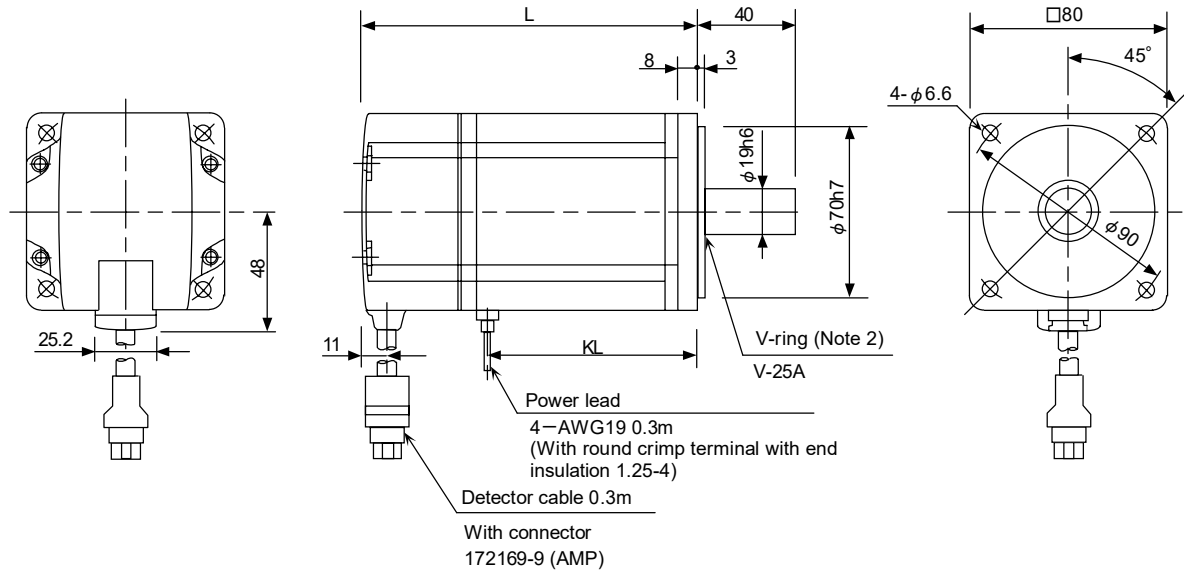

| Servomotor type | L | KL |
|-----------------|----------|--------|
| HC-MF73(-UE) | 142(150) | 90(98) |

Note 1. Use a frictional coupler (Shupan ring, etc.) when connecting to the load.

Note 2. The EN Standards compliant part (HC-MF73-UE) has a V-ring.

Note 3. Refer to section 12-2-4 for the dimensions of K (keyway).

• HC-MF73B (K) (-UE)

[Unit:mm]

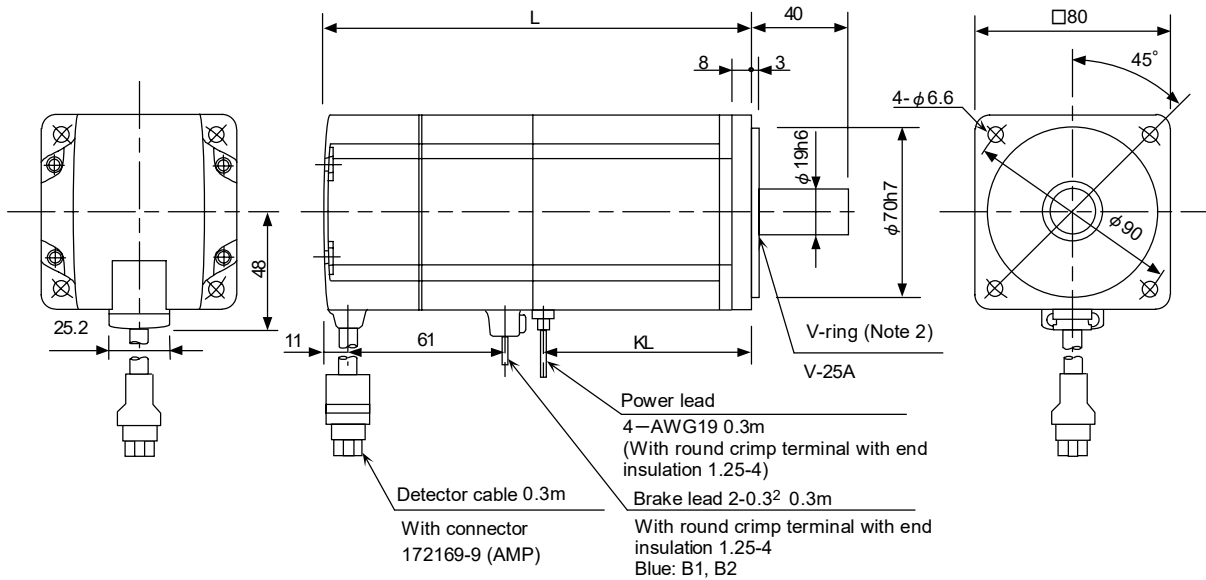

| Servomotor type | L | KL |
|-----------------|--------------|--------|
| HC-MF73B(-UE) | 177.5(185.5) | 90(98) |

Note 1. Use a frictional coupler (Shupan ring, etc.) when connecting to the load.

Note 2. The EN Standards compliant part (HC-MF73B-UE) has a V-ring.

Note 3. Refer to section 12-2-4 for the dimensions of K (keyway).

Chapter 12 Specifications

• HC-MF13 (D)-S15

[Unit:mm]

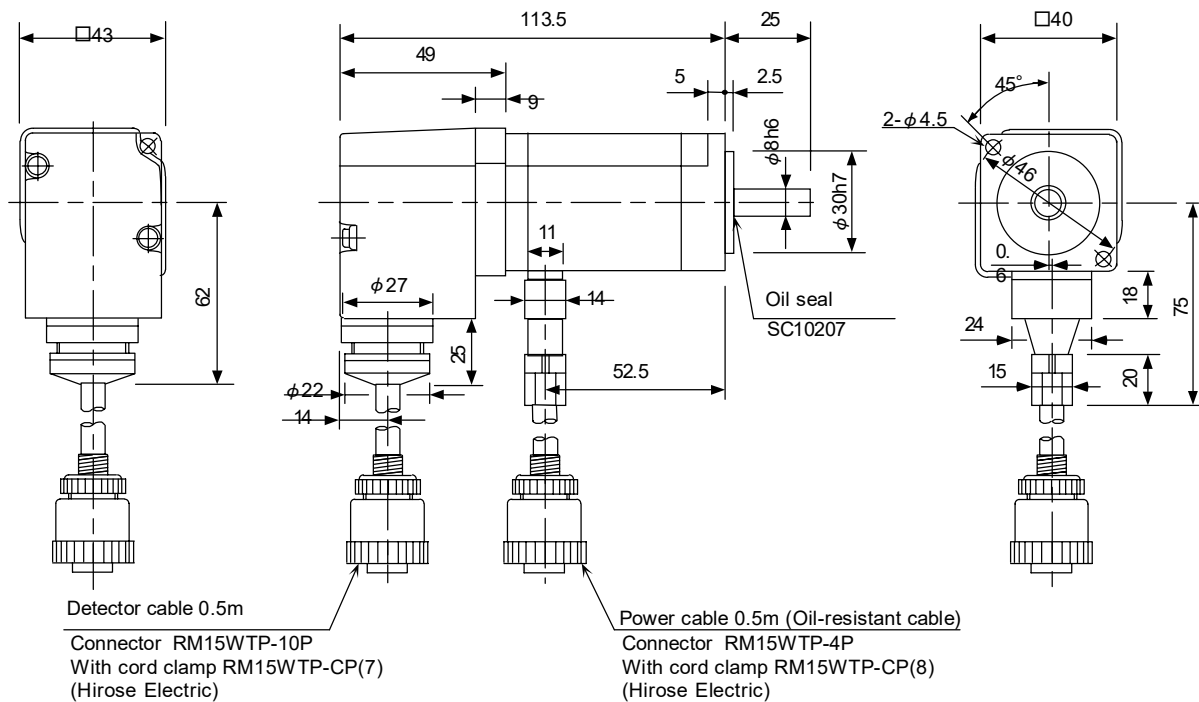

Note 1. Use a frictional coupler (Shupan ring, etc.) when connecting to the load.

Note 2. Refer to section 12-2-4 for the dimensions of D (D cut).

Note 3. The magnetic brakes are special specifications. Contact Mitsubishi or your dealer for details on the specifications.

• HC-MF23 (K)-S15

• HC-MF43 (K)-S15

[Unit:mm]

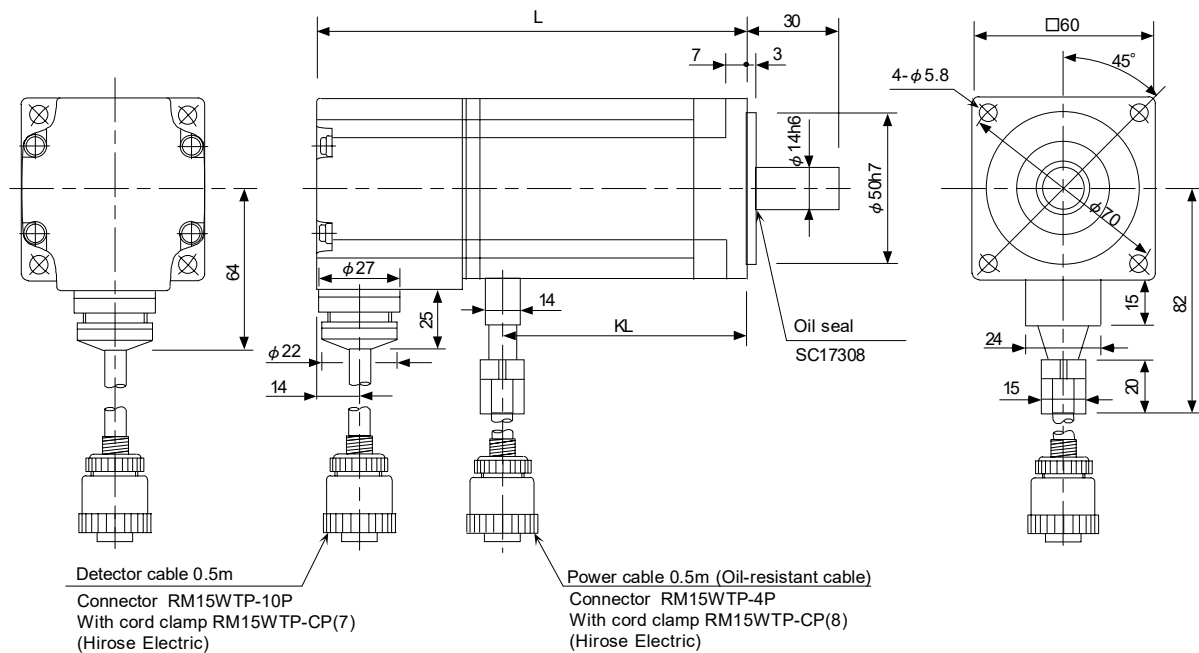

| Servomotor type | L | KL |
|-----------------|-----|----|
| HC-MF23-S15 | 117 | 56 |
| HC-MF43-S15 | 142 | 81 |

Note 1. Use a frictional coupler (Shupan ring, etc.) when connecting to the load.

Note 2. Refer to section 12-2-4 for the dimensions of K (keyway).

Note 3. The magnetic brakes are special specifications. Contact Mitsubishi or your dealer for details on the specifications.

Chapter 12 Specifications

• HC-MF73 (K)-S15

[Unit:mm]

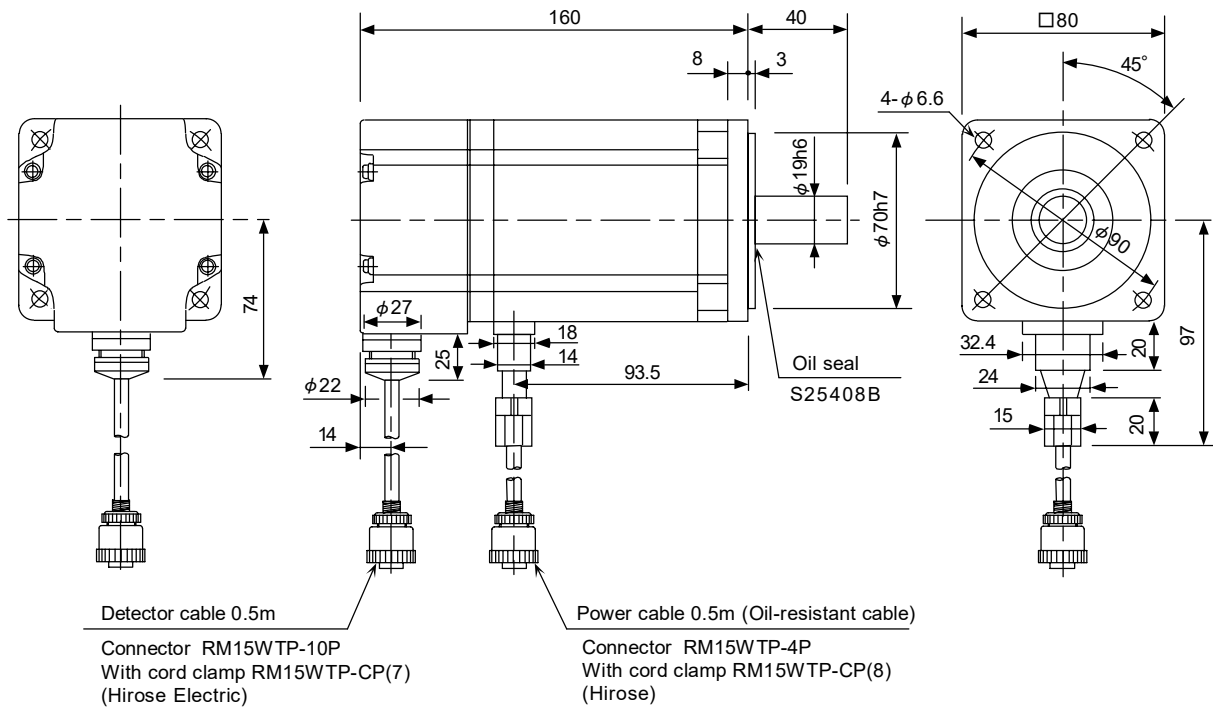

Note 1. Use a frictional coupler (Shupan ring, etc.) when connecting to the load.

Note 2. Refer to section 12-2-4 for the dimensions of K (keyway).

Note 3. The magnetic brakes are special specifications. Contact Mitsubishi or your dealer for details on the specifications.

Chapter 12 Specifications

12-2-4 Special axis servomotor

The servomotors have a no keyway, straight axis as a standard. However, a keyway axis and D-cut axis have been prepared as special shaft shapes. Note that models HA-FF23 to 63 have keyway axes as a standard. Also, some motors may not be compatible.

| Servomotor type | Shaft shape | |
|-----------------|-------------|-------|
| | Key way | D cut |
| HC-MF053, 13 | • | • |
| HC-MF23 ~ 73 | (Note 1) • | • |
| HA-FF053, 13 | • | • |
| HA-FF23 ~ 63 | (Note 2) • | • |

| Servomotor type | Shaft shape | |
|-----------------|-------------|-------|
| | Key way | D cut |
| HC-SF52 ~ 352 | • | • |
| HC-SF53 ~ 353 | • | • |
| HC-RF103 ~ 203 | • | • |

(Note 1) With key.

(Note 2) With key as a standard. Refer to section "12-2-3 Outline dimensions drawings" for the shapes.

With key

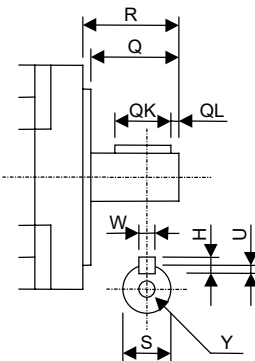

Changed dimensions table (Unit: mm)

| Servomotor type | Changed dimensions | | | | | | | | |
|----------------------|--------------------|----|----|---|----|----|-----|---|----------------------|
| | S | R | Q | W | QK | QL | U | H | Y |
| HC-MF23K HC-MF43K | 14h6 | 30 | 27 | 5 | 20 | 3 | 3 | 5 | M4 × 0.7 Depth 15 |
| HC-MF73K | 19h6 | 40 | 37 | 6 | 25 | 5 | 3.5 | 6 | M5 × 0.8 Depth 20 |

With key

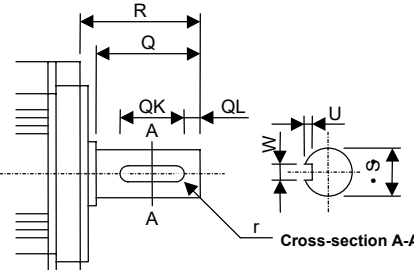

Changed dimensions table (Unit : mm)

| Servomotor type | Changed dimensions | | | | | | | |
|--------------------------------------|--------------------|----|----|-------------------|----|----|----------------|---|
| | S | R | Q | W | QK | QL | U | r |
| HC-SF52K ~ 152K HC-SF53K ~ 153K | 24h6 | 55 | 50 | $8^{0}_{-0.036}$ | 36 | 5 | $4^{+0.2}_{0}$ | 4 |
| HC-SF202K ~ 352K HC-SF203K ~ 353K | $35^{+0.01}_{0}$ | 79 | - | $10^{0}_{-0.036}$ | 55 | 5 | $5^{+0.2}_{0}$ | 5 |
| HC-RF103K ~ 203K | 24h6 | 45 | 40 | $8^{0}_{-0.036}$ | 25 | 5 | $4^{+0.2}_{0}$ | 4 |

D cut

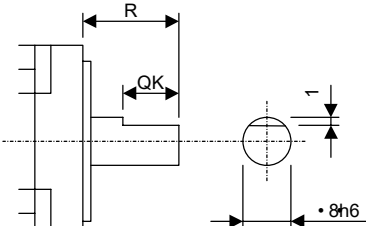

Changed dimensions table (Unit : mm)

| Servomotor type | Changed dimensions | |
|-----------------|--------------------|------|
| | R | QK |
| HC-MF053D, 13D | 25 | 20.5 |
| HA-FF053D, 13D | 30 | 25.5 |

Chapter 13 Selection

| | |
|--|--------------|
| 13-1 Outline | 13-2 |
| 13-1-1 Servomotor | 13-2 |
| 13-1-2 Regeneration methods | 13-3 |
| 13-2 Selection of servomotor series | 13-4 |
| 13-2-1 Motor series characteristics | 13-4 |
| 13-2-2 Servomotor precision | 13-4 |
| 13-3 Selection of servomotor capacity | 13-5 |
| 13-3-1 Load inertia ratio | 13-5 |
| 13-3-2 Short time characteristics..... | 13-5 |
| 13-3-3 Continuous characteristics..... | 13-6 |
| 13-4 Selection of regenerative resistor | 13-9 |
| 13-4-1 Calculation of regenerative energy | 13-9 |
| 13-4-2 Calculation of positioning frequency | 13-11 |
| 13-5 Example of servo selection | 13-12 |
| 13-5-1 Motor selection calculation..... | 13-12 |
| 13-5-2 Regenerative resistor selection calculation | 13-15 |
| 13-5-3 Servo selection results..... | 13-15 |
| 13-6 Motor shaft conversion load torque | 13-16 |
| 13-7 Expressions for load inertia calculation | 13-17 |

13-1 Outline

13-1-1 Servomotor

It important to select a servomotor matched to the purpose of the machine that will be installed. If the servomotor and machine to be installed do not match, the motor performance cannot be fully realized, and it will also be difficult to adjust the parameters. Be sure to understand the servomotor characteristics in this chapter to select the correct motor.

(1) Motor inertia

The servomotor series is mainly categorized according to the motor inertia size. The features in Table 13-1 are provided according to the motor inertia size.

Table 13-1 Motor inertia

| Motor model | Medium inertia motor | Low inertia motor |
|-----------------------------|--|--|
| Motor type | HC-SF | HC-RF, HA-FF, HC-MF |
| Inertia | The flange size is large. The inertia is comparatively large. | The flange size is small. The inertia is small. |
| Acceleration/deceleration | The acceleration/deceleration time constant does not change much even for a low inertia load. The effect of the motor inertia is large. | Acceleration/deceleration is possible with a short time constant in respect to low inertia loads. The effect of the motor inertia is small. |
| Installation | The motor size in respect to the output capacity is large, and the installation space is large. | The motor size in respect to the output capacity is small, and the installation space is smaller. |
| Disturbance characteristics | The effect of disturbance is small. | The effect of disturbance is large. |
| Speed fluctuation | The effect of the torque ripple and cogging torque is small, and speed fluctuation does not occur easily. | The effect of the torque ripple and cogging torque is large, and speed fluctuation occurs easily. |
| Suitability | Suitable for high precision interpolation control | Suitable for high speed high frequency positioning |

The servomotor has an optimum load inertia scale. If the load inertia exceeds the optimum range, the control becomes unstable and the servo parameters become difficult to adjust. When the load inertia is too large, decelerate with the gears (The motor axis conversion load inertia is proportional to the square of the deceleration ratio.), or change to a motor with a large inertia.



POINT

The HC-MF motor has the lowest inertia. This series pursues low inertia motor performance. To realize the proper acceleration/deceleration performance of the low inertia motor, set the load inertia to within five times of the motor inertia. If the load inertia ratio increases, the control stability will deteriorate, and in the end the positioning will take longer.

(2) Rated speed

Even with motors having the same capacity, the rated speed will differ according to the motor. The motor's rated output is designed to be generated at the rated speed, and the output P (W) is expressed with expression (13-1). Thus, even when the motors have the same capacity, the rated torque will differ according to the rated speed.

$$P = 2\pi NT (W)$$

$$\dots\dots\dots (13-1)$$

N : Motor speed (1/sec)

T : Output torque (N·m)

In other words, even with motors having the same capacities, the one with the lower rated speed will generate a larger torque. When actually mounted on the machine, if the positioning distance is short and the motor cannot reach the maximum speed, the motor with the lower rated speed will have a shorter positioning time. When selecting the motor, consider the axis stroke and usage methods, and select the motor with the optimum rated speed.

Due to the relation with the above expression, the continuous characteristic torque will be less than the rated torque in the range from the rated speed to the maximum speed.

13-1-2 Regeneration methods

When the servomotor decelerates, rotating load inertia or the operation energy of the moving object is returned to the servo amplifier through the servomotor as electrical power. This is called "regeneration". The three general methods of processing regeneration energy are shown below.

Table 13-2 Servo amplifier regeneration methods

| Regeneration method | Explanation |
|-------------------------------------|---|
| 1. Condenser regeneration method | This is a regeneration method for small-capacity amplifiers. The regeneration energy is charged to the condenser in the amplifier, and this energy is used during the next acceleration. The regeneration capacity decreases as the power supply voltage becomes higher. |
| 2. Resistance regeneration method | If the condenser voltage rises too high when regenerating with the condenser only, the regenerative electrical power is consumed using the resistance. If the regeneration energy is small, it will only be charged to the condenser. Because regeneration energy becomes heat due to resistance, heat radiation must be considered. In large capacity servo amplifiers the regenerative resistance becomes large and this is not practical. |
| 3. Power supply regeneration method | This is a method to return the regeneration energy to the power supply. The regeneration energy does not become heat as in regenerative resistance. (Heat is generated due to regeneration efficiency problems.) The circuit becomes complicated, but in large capacity servo amplifiers having large regeneration capacity this method is more advantageous than resistance regeneration. |

The condenser regeneration method and resistance regeneration method are used in the MR-J2-CT. For amplifiers (20CT and higher) of 200W or more, the regenerative resistor is mounted in the amplifier as a standard. If the regenerative capacity becomes large, an option regenerative resistor is connected externally to the amplifier. (Combined use with the built-in resistor is not possible.)



POINT

The MR-J2-10CT (100W) uses condenser regeneration as a standard. A built-in regenerative resistor is not mounted.

13-2 Selection of servomotor series

13-2-1 Motor series characteristics

The servomotor series is categorized according to purpose, motor inertia size, and detector resolution. Select the motor series that matches the purpose of the machine to be installed.

Table 13-3 Motor series characteristics

| Motor series | Capacity (rated speed) | Detector resolution | Characteristics |
|--------------|--|---------------------|--|
| HC-SF | 0.5 to 3.5kW (2000r/min) 0.5 to 3.5kW (3000r/min) | 16384p/rev | This is a motor for medium inertia and medium capacity. It is suitable for comparatively heavy load positioning such as for pallet changers, etc. It is drip-proofed against cutting oil entering the unit, and it clears IP65 specifications for environmental resistance performance. |
| HC-RF | 1.0 to 2.0kW (3000r/min) | 16384p/rev | This is a motor for medium inertia and medium capacity. It has a high output, compact design, and is suitable for high speed driving of light loads such as loaders. It is drip-proofed against cutting oil entering the unit, and it clears IP65 specifications for environmental resistance performance. |
| HA-FF | 50 to 600W (3000r/min) | 8192p/rev | This is a motor for low inertia and small capacity. It is suitable for high speed positioning of light loads such as for tool changers and turrets. The HA-FF**C-UE Series with canon plug specifications wiring is also available. |
| HC-MF | 50 to 750W (3000r/min) | 8192p/rev | This is a motor for ultra-low inertia and small capacity. It is suitable for ultra-high speed positioning of light loads such as high speed arms and machine end sections. A molded structure using high heat conducting resin is utilized to realize a high output motor with a compact design. The motor characteristics can be realized even further and the positioning time shortened by making the load inertia ratio smaller. |

13-2-2 Servomotor precision

The control precision of the servomotor is determined by the detector resolution, motor characteristics and parameter adjustment. This section examines the following three types of servomotor control precision when the servo parameters are adjusted. When selecting a servo, confirm that these types of precision satisfy the machine specifications before determining the servomotor series.

(1) Theoretic precision: $\Delta\epsilon$

This value is determined from the motor detector precision, and is the control resolution per machine end rotation.

(2) Positioning precision : $\Delta\epsilon_p$

This value expresses the machine positioning precision. When the motor is a single unit, this matches with the theoretic precision $\Delta\epsilon$. However, when the motor is actually installed on a machine, the positioning precision $\Delta\epsilon$ becomes 1 to 2 times the theoretic precision $\Delta\epsilon$. This is due to the effect on the motor control by the machine rigidity, etc. Furthermore, the value to which the error from the motor shaft to the machine end is added becomes the actual machine end positioning precision $\Delta\epsilon_p$.

(3) Absolute position repeatability : $\Delta\epsilon_a$

This is the precision outline that affects the absolute position system machine, and expresses the repeatability of the position before the power was shut off and the position when the power is turned on again.

With the single motor unit, the precision is 1 to 2 times the theoretic precision $\Delta\epsilon$. Note that the absolute position repeatability $\Delta\epsilon_a$ is the difference from when the power was turned off last and returned on. This error is not cumulated.

Table 13-4 Precision by motor series

| Motor series | Control resolution RNG (pulse/rev) | Theoretic precision $\Delta\epsilon$ | Positioning precision $\Delta\epsilon_p$ | Absolute position repeatability $\Delta\epsilon_a$ |
|--------------|------------------------------------|---|--|--|
| HC-SF | 16384 | $\frac{360 \times *PC1}{RNG \times *PC2}$ | $\Delta\epsilon \sim 2\Delta\epsilon$ | $\Delta\epsilon \sim 2\Delta\epsilon$ |
| HC-RF | 16384 | | | |
| HA-FF | 8192 | | | |
| HC-MF | 8192 | | | |

(Note 1) □PC1: Motor side gear ratio, □PC2: Machine side gear ratio

(Note 2) The calculation expression in the table expresses the approximate precision at the motor end. The actual precision at the machine end is obtained by adding the machine precision to this value.

13-3 Selection of servomotor capacity

The following three elements are used to determine the servomotor capacity.

1. Load inertia ratio
2. Short time characteristics (acceleration/deceleration torque)
3. Continuous characteristics (continuous effective load torque)

Carry out appropriate measures, such as increasing the motor capacity, if any of the above conditions is not fulfilled.

13-3-1 Load inertia ratio

Each servomotor has an appropriate load inertia ratio (load inertia/motor inertia). The control becomes unstable when the load inertia ratio is too large, and the positioning time cannot be shortened due to the lengthening of the settling time.

If the load inertia ratio exceeds the recommended value in the servomotor list of specifications, increase the motor capacity or change to a motor series with a large inertia. Note that the recommended value for the load inertia ratio is strictly one guideline. This does not mean that controlling a load with inertia exceeding the recommended value is impossible.

13-3-2 Short time characteristics

In addition to the rated output, the servomotor has an output range that can only be used for short times such as acceleration/deceleration. This range is expressed at the maximum torque. The maximum torque differs for each motor even at the same capacity, so confirm the torque in section "12-2 Servomotor".

The maximum torque affects the acceleration/deceleration time constant that can be driven. The linear acceleration/deceleration time constant t_a can be approximated from the machine specifications using expression (13-2). Determine the maximum motor torque required from this expression, and select the motor capacity. The same selection can also be made by using the "Simple motor capacity selection diagrams" on the page 13-8.

$$t_a = \frac{(J_L + J_M) \times N}{95.5 \times (0.8 \times T_{MAX} - T_L)} \quad (\text{msec}) \quad \dots\dots\dots (13-2)$$

- N : Motor reach speed (r/min)
- J_L : Motor shaft conversion load inertia (kg·cm²)
- J_M : Motor inertia (kg·cm²)
- T_{MAX} : Maximum motor torque (N·m)
- T_L : Motor shaft conversion load (friction, unbalance) torque (N·m)

13-3-3 Continuous characteristics

A typical operation pattern is assumed, and the motor's continuous effective load torque (T_{rms}) is calculated from the motor shaft conversion and load torque. If numbers 1 to 8 in the following drawing were considered a one cycle operation pattern, the continuous effective load torque is obtained from the root mean square of the torque during each operation, as shown in the expression (13-3).

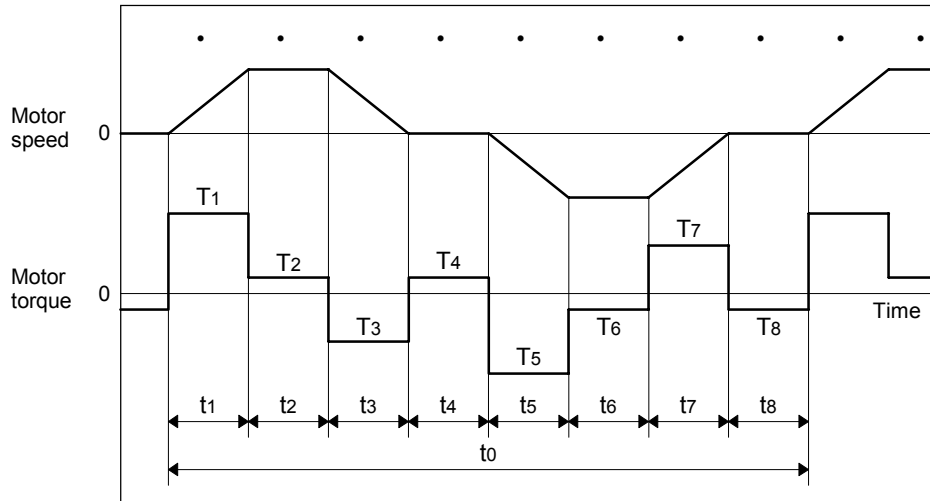

Fig. 13-1 Continuous operation pattern

$$T_{rms} = \sqrt{\frac{T_1^2 \cdot t_1 + T_2^2 \cdot t_2 + T_3^2 \cdot t_3 + T_4^2 \cdot t_4 + T_5^2 \cdot t_5 + T_6^2 \cdot t_6 + T_7^2 \cdot t_7 + T_8^2 \cdot t_8}{t_0}} \quad (13-3)$$

Select a motor so that the continuous effective load torque (T_{rms}) is 80% or less of the motor rated torque (T_{ra}).

$$T_{rms} \leq 0.8 \cdot T_{ra} \quad (13-4)$$

The amount of acceleration torque (T_a) shown in tables 13-5 and 13-6 is the torque to accelerate the load inertia in a frictionless state. It can be calculated by the expression (13-5). (For linear acceleration/deceleration)

$$T_a = \frac{(J_L + J_M) \times N}{95.5 \times t_a} \quad (N \cdot m) \quad (13-5)$$

- N : Motor reach speed (r/min)
- J_L : Motor shaft conversion load inertia ($kg \cdot cm^2$)
- J_M : Motor inertia ($kg \cdot cm^2$)
- t_a : Linear acceleration/deceleration time constant (msec)

Chapter 13 Selection

(1) Horizontal axis load torque

When operations • •to • •are for a horizontal axis, calculate so that the following torques are required in each period.

Table 13-5 Load torques of horizontal axes

| Period | Load torque calculation method | Explanation |
|--------|---|---|
| • • | (Amount of acceleration torque) + (Kinetic friction torque) | Normally the acceleration/deceleration time constant is calculated so this torque is 80% of the maximum torque of the motor. |
| • • | (Kinetic friction torque) | |
| • • | (Amount of deceleration torque) + (Kinetic friction torque) | The signs for the amount of acceleration torque and amount of deceleration torque are reversed when the absolute value is the same value. |
| • • | (Static friction torque) | Calculate so that the static friction torque is always required during a stop. |
| • • | – (Amount of acceleration torque) – (Kinetic friction torque) | The signs are reversed with period • •when the kinetic friction does not change according to movement direction. |
| • • | – (Kinetic friction torque) | The signs are reversed with period • •when the kinetic friction does not change according to movement direction. |
| • • | – (Amount of deceleration torque) – (Kinetic friction torque) | The signs are reversed with period • •when the kinetic friction does not change according to movement direction. |
| • • | – (Static friction torque) | Calculate so that the static friction torque is always required during a stop. |

(2) Unbalance axis load torque

When operations • •to • •are for an unbalance axis, calculate so that the following torques are required in each period. Note that the forward speed shall be an upward movement.

Table 13-6 Load torques of unbalance axes

| Period | Load torque calculation method | Explanation |
|--------|--|---|
| • • | (Amount of acceleration torque) + (Kinetic friction torque) + (Unbalance torque) | Normally the acceleration/deceleration time constant is calculated so this torque is 80% of the maximum torque of the motor. |
| • • | (Kinetic friction torque) + (Unbalance torque) | |
| • • | (Amount of deceleration torque) + (Kinetic friction torque) + (Unbalance torque) | The signs for the amount of acceleration torque and amount of deceleration torque are reversed when the absolute value is the same value. |
| • • | (Static friction torque) + (Unbalance torque) | The holding torque during a stop becomes fairly large. (Upward stop) |
| • • | – (Amount of acceleration torque) – (Kinetic friction torque) + (Unbalance torque) | |
| • • | – (Kinetic friction torque) + (Unbalance torque) | The generated torque may be in the reverse of the movement direction, depending on the size of the unbalance torque. |
| • • | – (Amount of deceleration torque) – (Kinetic friction torque) + (Unbalance torque) | |
| • • | – (Static friction torque) + (Unbalance torque) | The holding torque becomes smaller than the upward stop. (Downward stop) |



POINT

During a stop, the static friction torque may constantly be applied. The static friction torque and unbalance torque may particularly become larger during an unbalance upward stop, and the torque during a stop may become extremely large. Therefore, caution is advised.

Chapter 13 Selection

< Acceleration/deceleration time constant 2 for servomotors >
When No. = Rated speed.

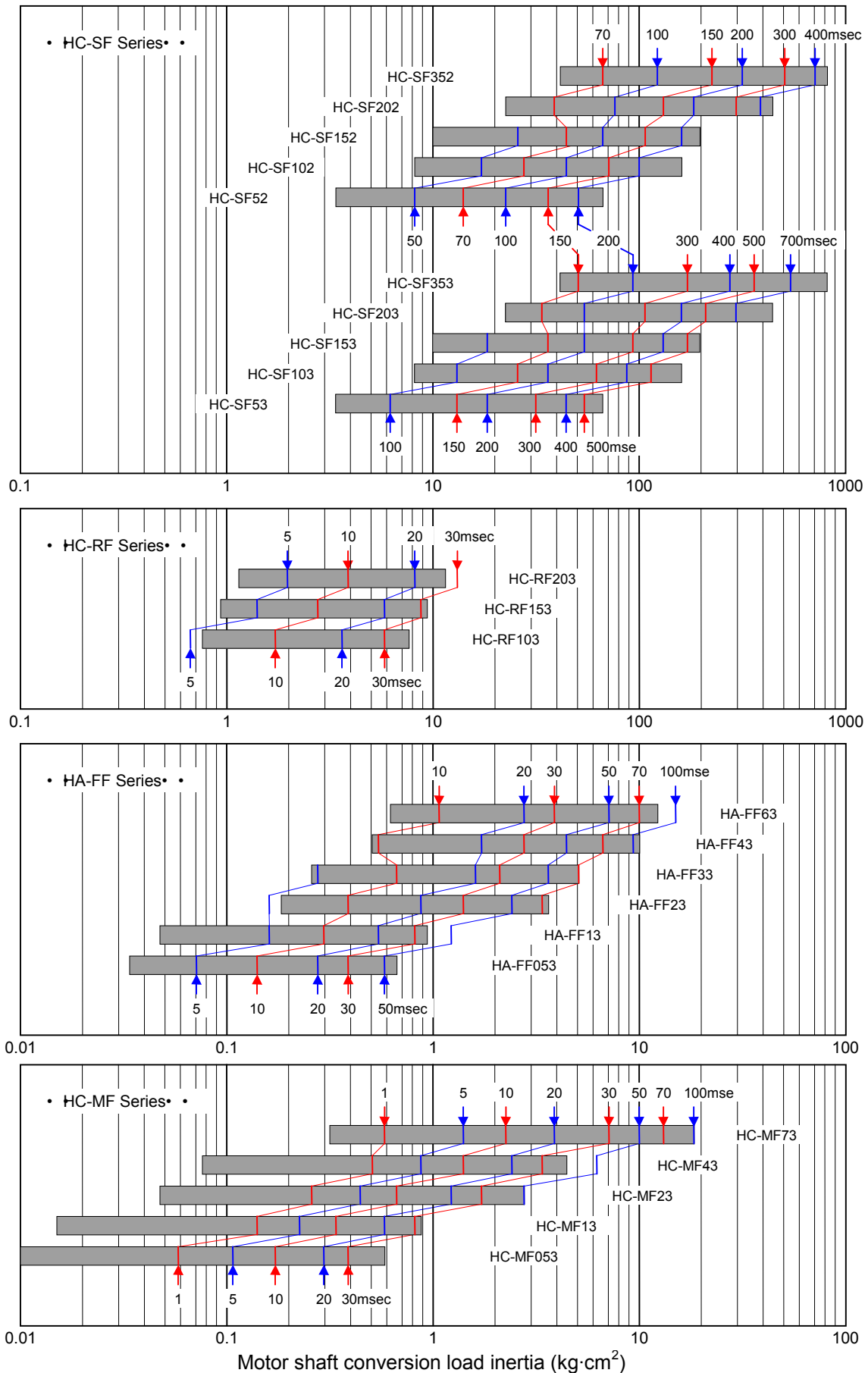

Fig. 13-2 (2) Simple motor capacity selection diagram
(Friction and unbalance torque are not considered in this diagram.)

13-4 Selection of regenerative resistor

To select the regenerative resistor, first the regenerative energy from when each axis stops (is positioned) is calculated. A regenerative resistor having a capacity to satisfy the positioning frequency, determined from the machine specifications, is selected.

13-4-1 Calculation of regenerative energy

(1) For horizontal axis

For the horizontal axis, the regenerative energy E_R consumed by the regenerative resistor can be calculated with the expression (13-6). If the E_R value is negative, all of the regenerative energy is absorbed (condenser regeneration) by the capacitor on the amplifier, and the energy consumption by the regenerative resistor is zero ($E_R = 0$).

$$E_R = 5.48 \times 10^{-7} \cdot \eta \cdot (J_L + J_M) \cdot N^2 - E_c \text{ (J)} \quad \dots\dots\dots (13-6)$$

- η : Motor reverse effect
- J_L : Motor inertia (kg·cm²)
- J_M : Load inertia (kg·cm²)
- N : Motor speed (r/min)
- E_c : Amplifier charging energy (J)

Example

The regeneration energy is obtained for when the axis stops from the rated speed while a load with the same inertia as the motor is connected to the HC-SF52 motor. Regeneration energy E_R is calculated using expression (13-6) below.

$$E_R = 5.48 \times 10^{-7} \times 0.85 \times (6.6 + 6.6) \times 2000^2 - 11 = 13.6 \text{ (J)}$$

Table 13-7 Servomotor reverse effect and amplifier charging energy

| Servomotor | Motor reverse effect η | Charging energy E_c (J) | Servomotor | Motor reverse effect η | Charging energy E_c (J) |
|------------|-----------------------------|---------------------------|------------|-----------------------------|---------------------------|
| HA-SF52 | 0.85 | 11 | HA-FF053 | 0.35 | 9 |
| HA-SF102 | 0.85 | 20 | HA-FF13 | 0.55 | 9 |
| HA-SF152 | 0.85 | 40 | HA-FF23 | 0.70 | 9 |
| HA-SF202 | 0.85 | 40 | HA-FF33 | 0.75 | 9 |
| HA-SF352 | 0.85 | 40 | HA-FF43 | 0.85 | 9 |
| HA-SF53 | 0.85 | 11 | HA-FF63 | 0.85 | 11 |
| HA-SF103 | 0.85 | 20 | | | |
| HA-SF153 | 0.85 | 40 | HC-MF053 | 0.35 | 9 |
| HA-SF203 | 0.85 | 40 | HC-MF13 | 0.55 | 9 |
| HA-SF353 | 0.85 | 40 | HC-MF23 | 0.70 | 9 |
| | | | HC-MF43 | 0.85 | 9 |
| HC-RF103 | 0.85 | 40 | HC-MF73 | 0.85 | 20 |
| HC-RF153 | 0.85 | 40 | | | |
| HC-RF203 | 0.85 | 40 | | | |



POINT

The regenerative energy is the value for when the amplifier input power voltage is 220 V. If the input voltage is higher than this, the charging energy will decrease and the regeneration energy will increase.

(2) For an unbalance axis (for linear axes)

The regenerative energy differs in the upward stop and downward stop for an unbalance axis. A constant regeneration state results during downward movement if the unbalance torque is the same as or larger than the friction torque.

| Regeneration energy | |
|--|---|
| Upward stop | <p>A regeneration state only occurs when deceleration torque (downward torque) is generated.</p> $E_{RU} = 5.24 \times 10^{-5} \cdot \eta \cdot T_{du} \cdot N \cdot td - E_c \text{ (J)} \dots\dots\dots (13-7)$ <p style="text-align: right;"> η : Motor reverse efficiency T_{du} : Upward stop deceleration torque (N·m) N : Motor speed (r/min) td : Deceleration time (time constant) (msec) E_c : Amplifier charging energy (J) </p> |
| Downward stop | <p>A regeneration state occurs even during constant rate feed when the upward torque T_s during dropping is generated. Calculated so that $T_s = 0$ when T_s is downward.</p> $E_{RD} = \frac{2\pi \cdot \eta \cdot T_s \cdot L}{\Delta S} + 5.24 \times 10^{-5} \cdot \eta \cdot T_{dd} \cdot N \cdot td - E_c \text{ (J)} \dots\dots\dots (13-8)$ <p style="text-align: right;"> η : Motor reverse efficiency T_s : Upward torque during dropping (N·m) L : Constant rate travel (mm) ΔS : Travel per motor rotation (mm) T_{dd} : Downward stop deceleration torque (N·m) N : Motor speed (r/min) td : Deceleration time (time constant) (msec) E_c : Amplifier charging energy (J) </p> |
| <p>One return is assumed to be one cycle, and the regeneration energy per cycle (E_R) is obtained using expression (13-9).</p> $E_R = E_{RU} + E_{RD} \text{ (J)} \dots\dots\dots (11-9)$ | |

(Example)

In a vertical axis driven by an HC-SF52 motor, a return operation is executed at an acceleration/deceleration time constant of 50msec. The operation is executed with a feed of 20000mm/min for a distance of 200mm. The regenerative energy per return operation is obtained at this time.

Note the following :

- Travel per upward motor rotation : 10mm
- Upward stop deceleration torque : 5N·m
- Downward stop deceleration torque : 8N·m
- Upward torque during downward movement : 0.5N·m

Using expression (13-7), the upward stop regeneration energy E_{RU} is as follows :

$$E_{RU} = 5.24 \times 10^{-5} \times 0.85 \times 5 \times 2000 \times 50 - 11 = 11.3 \text{ (J)}$$

The acceleration/deceleration distance required to accelerate at the 50msec acceleration/ deceleration time constant to 20000mm/min. is as follows:

$$\frac{20000 \times 50}{2 \times 60 \times 1000} = 8.3 \text{ (mm)}$$

Therefore, the constant speed travel is 183.4mm.

The downward stop regeneration energy E_{RD} is obtained using the following expression (13-8).

$$E_{RD} = \frac{2\pi \times 0.85 \times 0.5 \times 183.4}{10} + 5.24 \times 10^{-5} \times 0.85 \times 8 \times 2000 \times 50 - 11 = 73.6 \text{ (J)}$$

Thus, the regeneration energy per return operation E_R is as follows :

$$E_R = 11.3 + 73.6 = 84.9 \text{ (J)}$$

13-4-2 Calculation of positioning frequency

Select the regenerative resistor so that the positioning frequency DP (times/minute) calculated by the regenerative resistor capacity P_R (W) and the regenerative energy E_R (J) consumed by the regenerative resistor is within the range shown in expression (13-10). With the unbalance axis, the number of times for one cycle to raise and lower the axis is judged as DP.

$$DP < 48 \cdot \frac{P_R}{E_R} \quad (\text{times/minute}) \quad \dots\dots\dots (13-10)$$

Table 13-8 Regenerative resistor correspondence table

| Corresponding servo amplifier | Standard built-in regenerative resistor | | External option regenerative resistor | | | | |
|-------------------------------|---|------------------|---------------------------------------|---------|---------|---------|---------|
| | PR = Regeneration amount | Resistance value | MR-RB032 | MR-RB12 | MR-RB32 | MR-RB30 | MR-RB50 |
| | | | 30W | 100W | 300W | 300W | 500W |
| MR-J2-10CT | No built-in resistor | | • • | | | | |
| MR-J2-20CT | 10W | 100Ω | • | • | • | • | |
| MR-J2-40CT | 10W | 100Ω | • | • | • | • | |
| MR-J2-60CT | 10W | 100Ω | • | • | • | • | |
| MR-J2-70CT | 20W | 40Ω | | • | • | • | • |
| MR-J2-100CT | 20W | 40Ω | | • | • | • | • |
| MR-J2-200CT | 100W | 13Ω | | | | • | • |
| MR-J2-350CT | 100W | 13Ω | | | | • | • |

13-5 Example of servo selection

A servomotor is selected using a magazine with the following specifications as an example.

| Specification item | Unit | Magazine axis |
|---|--------------------|---------------|
| Axis type | | Rotation |
| No. of mounting tools | tools | 40 |
| Tool spacing | mm | 100 |
| Magazine circumferential speed | mm/min | 40000 |
| Maximum tool weight | kg | 10 |
| Chain drive frictional force | kgf | 80 |
| Motor deceleration ratio | | 1/200 |
| Motor shaft conversion load inertia (with no tools) | kg·cm ² | 20.0 |
| Positioning time | msec | Within 4000 |
| Positioning frequency | time/min | 3 |
| Motor brakes | | Available |

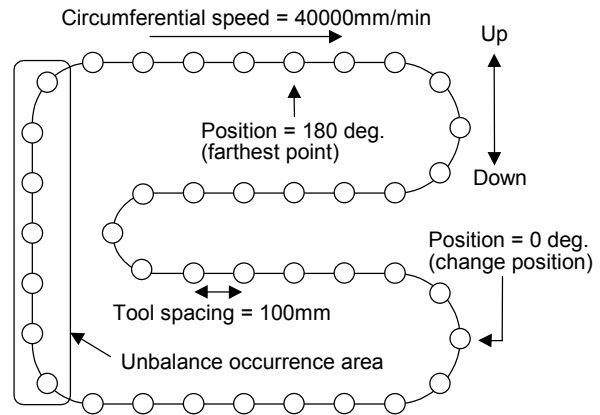

Fig. 13-3 40-magazine configuration

13-5-1 Motor selection calculation

(1) Obtaining load inertia

The load inertia in the selection is always judged as the maximum value. Because the load inertia without tools is provided by the specifications, the load inertia at maximum load when all tools are attached is obtained. The tool inertia for a chain-driven magazine can be calculated as the object of linear movement. Due to this, the motor shaft conversion load inertia of one tool weighing the maximum 10kg is obtained.

- **Motor shaft conversion load inertia per tool: J_T**

Obtain the tool movement amount per motor rotation ΔS before calculating the inertia.

$$\Delta S = \text{Chain circumference} \times \text{deceleration ratio} = (40 \times 100) \cdot \frac{1}{200} = 20 \text{ (mm)}$$

Conversion to the motor shaft by the deceleration ratio is included in the movement amount per motor rotation. Refer to "13-7 Calculation of load inertia".

$$J_T = W \cdot \left(\frac{\Delta S}{20\pi} \right)^2 = 10 \cdot \left(\frac{20}{20\pi} \right)^2 = 1.013 \text{ (kg·cm}^2\text{)}$$

- **Motor shaft conversion total load inertia: J_L**

This is the sum of the load inertia with no tools and the tool inertia.

$$J_L = 20.0 + 40 \times 1.013 = 60.5 \text{ (kg·cm}^2\text{)}$$

(2) Obtaining unbalance torque

The unbalance torque is the largest when all the tools are in the unbalance occurrence area on the left side of Fig. 13-3, and no tools are on the vertical movement area on the right side. For simplification purposes here, if it is assumed all seven tools in the unbalance occurrence area are in a part where they move vertically, then an unbalance weight of 70kg would act upon the magazine chain. If the magazine and motor are likened to 4000mm and 20mm circumference pulleys, as in Fig. 13-4, 70kg of unbalance weight acts upon the motor side pulley. Thus, the unbalance torque is obtained as follows:

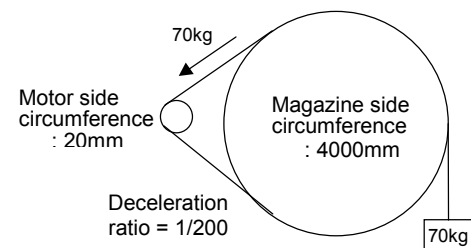

Fig. 13-4 Unbalance torque

$$T_U = \frac{70 \times g \times ((\text{motor side pulley radius}))}{1000\text{mm}} = \frac{70 \times 9.8 \times 20}{1000 \times 2\pi} = 2.2 \text{ (N·m)}$$

(3) Obtaining friction torque

The friction torque is obtained from the chain drive frictional force, in the same manner as the unbalance torque.

$$T_F = \frac{80 \times 9.8 \times 20}{1000 \times 2\pi} = 2.5 \text{ (N}\cdot\text{m)}$$

(4) Selecting the appropriate motor from the load inertia ratio

The motor series is limited to the HC-SF Series, because of the load inertia and recommended load inertia of the motor. The motor speed is 2000r/min, because of the magazine circumferential speed and deceleration ratio. Furthermore, because a motor with brakes is required, a 2000r/min-rated HC-SF series motor with brakes is selected.

Determine the motor series at this time, also giving careful consideration to the details in sections "13-1 Outline" and "13-2 Selection of servomotor series".

| Motor type | Motor inertia (kg·cm ²) | Load inertia (kg·cm ²) | Load inertia magnification | Judgment |
|------------|-------------------------------------|------------------------------------|----------------------------|----------|
| HC-SF52B | 8.6 | 60.5 | 7.03 | •• |
| HC-SF102B | 15.7 | 60.5 | 3.85 | •• |
| HC-SF152B | 22.0 | 60.5 | 2.75 | •• |
| HC-SF202B | 52.5 | 60.5 | 1.15 | •• |
| HC-SF352B | 92.0 | 60.5 | 0.66 | •• |

(5) Selecting the appropriate motor from the short time characteristics

If the acceleration/deceleration time constant is included in the specifications, the appropriate motor is selected by calculating the acceleration/deceleration time constant for each motor from expression (13-2). Judgment here is by the positioning time rather than the acceleration/deceleration time constant. The positioning that takes the most time is that from the farthest point (180 degree position), and that positioning time will be calculated here using the HC-SF52B motor.

- **Acceleration/deceleration time constant: ta**

This is obtained from expression (13-2).

$$t_a = \frac{(J_L + J_M) \times N}{95.5 \times (0.8 \times T_{MAX} - T_U - T_F)} = \frac{(60.5 + 8.6) \times 2000}{95.5 \times (0.8 \times 7.16 - 2.2 - 2.5)} = 1408 \text{ (msec)}$$

- **Acceleration/deceleration distance: La**

This value is obtained with a linear acceleration/deceleration carried out at the angle that the axis moves from the start until the acceleration finishes and the maximum speed (3600 deg./min) is reached. The circumferential speed 4000mm/min becomes 3600 deg./min at the MR-J2-CT parameter settings (angular speed setting).

$$L_a = \frac{1}{2} \times \frac{3600 \times 1408}{60 \times 1000} = 42.2 \text{ (deg)}$$

- **Constant rate travel: Lc**

This is the angle at which the axis moves at maximum speed.

$$L_c = 180 - 2 \times 42.2 = 95.6 \text{ (deg)}$$

- **Longest positioning time: P**

The positioning time at a movement angle of 180 deg. is calculated. When actually controlled with a motor, a settling time is required from when the commands become zero to when the motor starts positioning. That time is considered to be 100msec here.

$$P = 1408 \times 2 + \frac{95.6 \times 60 \times 1000}{3600} + 100 = 2816 + 1593 + 100 = 4509 \text{ (msec)}$$

Chapter 13 Selection

The following table shows the results when these values are calculated for other motors in the same manner. The acceleration/deceleration time constants of the HC-SF152B and HC-SF202B motors do not change much. This is because the inertia of the motor itself greatly increases due to the larger flange sizes on HC-SF202 or higher rated motors. An HC-SF102B or higher rated motor satisfies the specifications (4000msec).

| Motor type | Acceleration/ deceleration time constant (msec) | Constant rate travel distance (deg) | Constant rate travel time (msec) | Longest positioning time (msec) | Judgment |
|------------|---|---|--|---------------------------------------|----------|
| HC-SF52B | 1408 | 95.6 | 1593 | 4509 | • • |
| HC-SF102B | 234 | 166.0 | 2767 | 3335 | • • |
| HC-SF152B | 137 | 171.8 | 2863 | 3237 | • • |
| HC-SF202B | 131 | 172.2 | 2870 | 3232 | • • |
| HC-SF352B | 90 | 174.6 | 2910 | 3190 | • • |

(6) Selecting the appropriate motor from the continuous characteristics

The torque generated in each state is obtained using the HC-SF102B motor as an example. In rotation axes, because the direction of the unbalance torque differs from that of linear axes and cannot be defined, the torque is always obtained as if it acts in the direction of the load. Because there is always a possibility that friction torque and unbalance torque act also when the motor is stopped, these are also considered in the calculation.

- **Acceleration torque: T_a**

$$T_a = 0.8 \cdot T_{MAX} = 0.8 \times 14.4 = 11.5 \text{ (N}\cdot\text{m)}$$

- **Torque during constant rate travel**

$$T_c = T_u + T_f = 2.2 + 2.5 = 4.7 \text{ (N}\cdot\text{m)}$$

- **Deceleration torque**

$$T_d = T_a - 2 \times T_f = 11.5 - 2 \times 2.5 = 6.5 \text{ (N}\cdot\text{m)}$$

- **Torque during stop**

$$T_s = T_u + T_f = 2.2 + 2.5 = 4.7 \text{ (N}\cdot\text{m)}$$

Following the specifications, the continuous effective load torque is obtained when positioning is carried out three times per minute.

$$T_{rms} = \sqrt{\frac{11.5^2 \times 702 + 4.7^2 \times 8301 + 6.5^2 \times 702 + 4.7^2 \times 50295}{60 \times 1000}} = 4.86 \text{ (N}\cdot\text{m)}$$

The following table shows the results when the continuous effective load torque is obtained for other motors in the same manner. An HC-SF152B or higher rated motor satisfies the expression (13-4).

| Motor type | Rated torque (N·m) | During acceleration | | During constant rate travel | | During deceleration | | During stop | | Effective load torque | Judgment |
|------------|--------------------|---------------------|-------------|-----------------------------|-------------|---------------------|-------------|--------------|-------------|-----------------------|----------|
| | | Torque (N·m) | Time (msec) | Torque (N·m) | Time (msec) | Torque (N·m) | Time (msec) | Torque (N·m) | Time (msec) | | |
| HC-SF102B | 4.78 | 11.5 | 702 | 4.7 | 8301 | 6.5 | 702 | 4.7 | 50295 | 4.86 | • • |
| HC-SF152B | 7.16 | 17.3 | 411 | 4.7 | 8589 | 12.3 | 411 | 4.7 | 50589 | 4.98 | • • |
| HC-SF202B | 9.55 | 22.8 | 393 | 4.7 | 8610 | 17.8 | 393 | 4.7 | 50604 | 5.22 | • • |
| HC-SF352B | 16.7 | 40.1 | 270 | 4.7 | 8730 | 35.1 | 270 | 4.7 | 50730 | 5.89 | • • |

As a result of the selection calculations above, the motors that satisfy conditions (4) to (6) are the HC-SF152B to HC-SF352B models. Thus, the appropriate motor for this magazine axis is the HC-SF152B (MR-J2-200CT).



POINT

Because there is always a possibility that friction torque and unbalance torque act also when the motor is stopped, the sum of these is calculated as the torque during stop.

13-5-2 Regenerative resistor selection calculation

Because unbalance torque occurs in this magazine axis, the regenerative load should be calculated as an unbalance axis. However, because the direction of the unbalance torque generation cannot be defined, the regenerative load is calculated from the load inertia only (as a horizontal axis).

(1) Obtaining the regeneration energy

The regeneration energy per braking is obtained from expression (13-6) for MR-J2-200CT + HC-SF152B.

$$E_R = 5.48 \times 10^{-7} \times 0.85 \times (60.5 + 22.0) \times 2000^2 - 40 = 113.7 \text{ (J)}$$

(2) Obtaining the tolerable No. of positionings

The tolerable cycle operation frequency per minute DP is calculated for a standard built-in regenerative resistor. Refer to expression (13-10).

$$DP = 48 \cdot \frac{P_R}{E_R} = 48 \times \frac{100}{113.7} = 42.2 \text{ (times)}$$

Because the No. of positionings shown in the specifications is 3 times/min., the standard built-in regenerative resistor can be judged to be sufficient.



POINT

Try to choose a resistor with some allowance, because the regeneration load can easily become large compared to a horizontal axis.

13-5-3 Servo selection results

As a result of calculating the servo selection, the servo specifications for this magazine axis have been determined.

| Item | Type |
|-----------------------|-------------|
| Servo amplifier | MR-J2-200CT |
| Servomotor | HC-SF152B |
| Regenerative resistor | Built-in |

The shape of the motor shaft (with/without key) will be determined based on separate machine specifications.

13-6 Motor shaft conversion load torque

The main load torque calculation expressions are shown below.

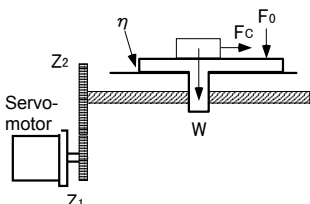
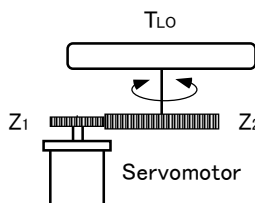
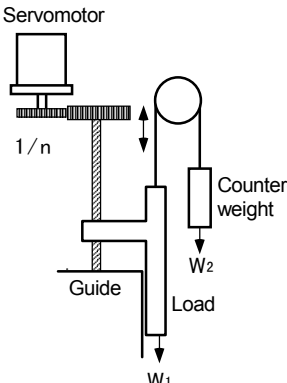
| Type | Mechanism | Calculation expression |
|-------------------|---|---|
| Linear movement |  | $T_L = \frac{F}{2 \times 10^3 \pi \eta} \cdot \left(\frac{V}{N} \right) = \frac{F \cdot \delta}{2 \times 10^3 \pi \eta}$ <p> T_L : Load torque (N·m) F : Force in axial direction of linear motion machine (N) η : Drive system efficiency (%) V : Speed of linear operation object (mm/min) N : Motor speed (r/min) δ: Object movement amount per motor rotation (mm) Z_1, Z_2: Deceleration ratio </p> <p>F in the above expression is obtained from the lower expression when the table is moved as shown on the left.</p> $F = F_c + \mu (W \cdot g + F_0)$ <p> F_c : Force applied on axial direction of moving section (N) F_0 : Tightening force on inner surface of table guide (N) W : Total weight of moving section (kg) g : Gravitational acceleration (m/sec²) μ : Friction coefficient </p> |
| Rotary movement |  | $T_L = \frac{Z_1}{Z_2} \cdot \frac{1}{\eta} \cdot T_{LO} + T_F = \frac{1}{n} \cdot \frac{1}{\eta} \cdot T_{LO} + T_F$ <p> T_L : Load torque (N·m) T_{LO} : Load torque on load shaft (N) T_F : Motor shaft conversion load friction torque (N·m) η : Drive system efficiency Z_1, Z_2 : Deceleration ratio n : Deceleration rate </p> |
| Vertical movement |  | <p>When rising $T_L = T_U + T_F$</p> <p>When lowering $T_L = -T_U \cdot \eta^2 + T_F$</p> <p> T_L : Load torque (N·m) T_U : Unbalanced torque (N·m) T_F : Friction torque on moving section (N·m) </p> $T_U = \frac{(W_1 - W_2) \cdot g}{2 \times 10^3 \pi \eta} \cdot \left(\frac{V}{N} \right) = \frac{(W_1 - W_2) \cdot g \cdot \delta}{2 \times 10^3 \pi \eta}$ $T_F = \frac{\mu \cdot (W_1 + W_2) \cdot g \cdot \delta}{2 \times 10^3 \pi \eta}$ <p> W_1 : Load weight (kg) W_2 : Counterweight weight (kg) η : Drive system efficiency g : Gravitational acceleration = 9.8 (m/sec²) V : Speed of linear operation object (mm/min) N : Motor speed (r/min) δ: Object movement speed per motor rotation (mm) μ : Friction coefficient </p> |

Chapter 13 Selection

13-7 Expressions for load inertia calculation

The calculation method for a representative load inertia is shown.

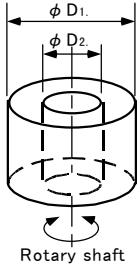
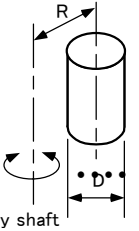
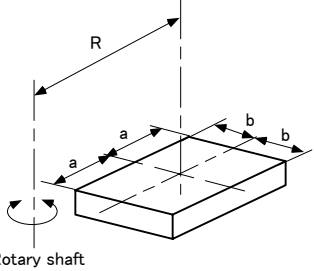
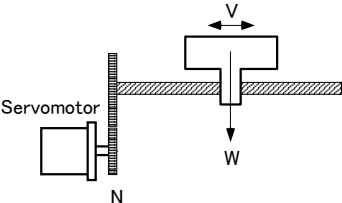
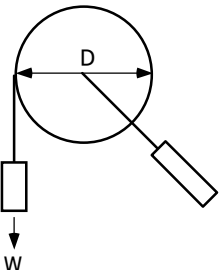
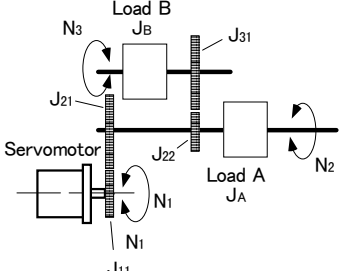
| Type | Mechanism | Calculation expression |
|----------------------------|--|--|
| Cylinder | <p>Rotary shaft is cylinder center</p>  <p>Rotary shaft</p> | $J_L = \frac{\pi \cdot \rho \cdot L}{32} (D_1^4 - D_2^4) = \frac{W}{8} (D_1^2 - D_2^2)$ <p> J_L : Load inertia [kg·cm²] ρ : Density of cylinder material [kg·cm⁻³] L : Length of cylinder [cm] D_1 : Outer diameter of cylinder [cm] D_2 : Inner diameter of cylinder [cm] W : Weight of cylinder [kg] </p> <p>Reference data Material densities Iron 7.80×10⁻³ [kg/cm³] Aluminum 2.70×10⁻³ [kg/cm³] Copper 8.96×10⁻³ [kg/cm³]</p> |
| | <p>When rotary shaft and cylinder shaft are deviated</p>  <p>Rotary shaft</p> | $J_L = \frac{W}{8} (D^2 + 8R^2)$ <p> J_L : Load inertia [kg·cm²] W : Weight of cylinder [kg] D : Outer diameter of cylinder [cm] R : Distance between rotary axis and cylinder axis [cm] </p> |
| Column |  <p>Rotary shaft</p> | $J_L = W \left(\frac{a^2 + b^2}{8} + R^2 \right)$ <p> J_L : Load inertia [kg·cm²] W : Weight of cylinder [kg] a, b, R : Left diagram [cm] </p> |
| Object that moves linearly |  <p>Servomotor</p> <p>N</p> <p>W</p> <p>V</p> | $J_L = W \left(\frac{1}{2\pi N} \cdot \frac{V}{10} \right)^2 = W \left(\frac{\cdot \mathcal{S}}{20\pi} \right)^2$ <p> J_L : Load inertia [kg·cm²] W : Weight of object that moves linearly [kg] N : Motor speed [r/min] V : Speed of object that moves linearly [mm/min] $\cdot \mathcal{S}$: Stroke of object that moves linearly per motor rotation [mm] </p> |
| Suspended object |  <p>W</p> <p>D</p> | $J_L = W \left(\frac{D}{2} \right)^2 + J_P$ <p> J_L : Load inertia [kg·cm²] W : Weight of object [kg] D : Diameter of pulley [cm] J_P : Inertia of pulley [kg·cm²] </p> |
| Converted load |  <p>Servomotor</p> <p>Load B</p> <p>Load A</p> <p>N₃</p> <p>N₂</p> <p>N₁</p> <p>J_B</p> <p>J_A</p> <p>J₃₁</p> <p>J₂₂</p> <p>J₂₁</p> <p>J₁₁</p> | $J_L = J_{11} + (J_{21} + J_{22} + J_A) \cdot \left(\frac{N_2}{N_1} \right)^2 + (J_{31} + J_B) \cdot \left(\frac{N_3}{N_1} \right)^2$ <p> J_L : Load inertia [kg·cm²] J_A, J_B : Inertia of load A, B [kg·cm²] $J_{11} \sim J_{31}$: Inertia [kg·cm²] $N_1 \sim N_3$: Each shaft's speed [r/min] </p> |

Appendix Parameter Lists

Appendix Parameter Lists

| No. | Abbrev. | Parameter name | Default value | Unit | Explanation | Setting range | | | | | | | | | | | | | | | | | | |
|---------------|--|--|--|-----------------|--|---------------|---------------|-------------|---|--|---|---|---|------------------------|---|------------------------|---|--|---|----------------|---|----------------|-----|--------------------|
| #001 | *MSR | Motor series | 0000 | | Set the motor series. This is automatically judged by the system when the default value (0000) is set. | | | | | | | | | | | | | | | | | | | |
| #002 | *RTY | Regeneration option type | Set the regenerative resistor type. Do not set values without a description. | | | | | | | | | | | | | | | | | | | | | |
| | | | <div style="border: 1px solid black; display: inline-block; padding: 2px;">0 0 0 0</div> (Default setting value) | | | | | | | | | | | | | | | | | | | | | |
| | | | <table border="1" style="width: 100%; border-collapse: collapse;"> <thead> <tr> <th style="width: 10%;">Setting value</th> <th style="width: 90%;">Description</th> </tr> </thead> <tbody> <tr> <td>0</td> <td>Amplifier standard built-in resistor (10CT has no built-in resistor)</td> </tr> <tr> <td>1</td> <td>Setting prohibited</td> </tr> <tr> <td>2</td> <td>MR-RB032 (30W)</td> </tr> <tr> <td>3</td> <td>MR-RB12 (100W)</td> </tr> <tr> <td>4</td> <td>MR-RB32 (300W)</td> </tr> <tr> <td>5</td> <td>MR-RB30 (300W)</td> </tr> <tr> <td>6</td> <td>MR-RB50 (500W)</td> </tr> <tr> <td>7~F</td> <td>Setting prohibited</td> </tr> </tbody> </table> | | | | Setting value | Description | 0 | Amplifier standard built-in resistor (10CT has no built-in resistor) | 1 | Setting prohibited | 2 | MR-RB032 (30W) | 3 | MR-RB12 (100W) | 4 | MR-RB32 (300W) | 5 | MR-RB30 (300W) | 6 | MR-RB50 (500W) | 7~F | Setting prohibited |
| Setting value | Description | | | | | | | | | | | | | | | | | | | | | | | |
| 0 | Amplifier standard built-in resistor (10CT has no built-in resistor) | | | | | | | | | | | | | | | | | | | | | | | |
| 1 | Setting prohibited | | | | | | | | | | | | | | | | | | | | | | | |
| 2 | MR-RB032 (30W) | | | | | | | | | | | | | | | | | | | | | | | |
| 3 | MR-RB12 (100W) | | | | | | | | | | | | | | | | | | | | | | | |
| 4 | MR-RB32 (300W) | | | | | | | | | | | | | | | | | | | | | | | |
| 5 | MR-RB30 (300W) | | | | | | | | | | | | | | | | | | | | | | | |
| 6 | MR-RB50 (500W) | | | | | | | | | | | | | | | | | | | | | | | |
| 7~F | Setting prohibited | | | | | | | | | | | | | | | | | | | | | | | |
| #003 | *PC1 | Motor side gear ratio (machine rotation ratio) | 1 | | Set the No. of gear teeth on the motor side and the No. of gear teeth on the machine side as an integer reduced to its lowest terms. Set the total gear ratio if there are multiple gear levels. For rotation axes, set the No. of motor rotations per machine rotation. | 1 ~ 32767 | | | | | | | | | | | | | | | | | | |
| #004 | *PC2 | Machine side gear ratio (motor rotation ratio) | 1 | | | 1 ~ 32767 | | | | | | | | | | | | | | | | | | |
| #005 | *PIT | Feed pitch | 360 | deg (mm) | Set 360 (default value) for rotation axes. Set the feed lead for linear axes. | 1 ~ 32767 | | | | | | | | | | | | | | | | | | |
| #006 | INP | In-position detection width | 50 | 1/1000 deg (μm) | In-position is detected when the position droop becomes this setting value or less. | 1 ~ 32767 | | | | | | | | | | | | | | | | | | |
| #007 | ATU | Auto-tuning | Set the adjustment of the auto-tuning. Do not set values without a description. | | | | | | | | | | | | | | | | | | | | | |
| | | | <div style="border: 1px solid black; display: inline-block; padding: 2px;">0 1 0 2</div> (Default setting value) | | | | | | | | | | | | | | | | | | | | | |
| | | | <table border="1" style="width: 100%; border-collapse: collapse;"> <thead> <tr> <th style="width: 10%;">Setting value</th> <th style="width: 90%;">Description</th> </tr> </thead> <tbody> <tr> <td>1</td> <td>Low response (low-rigidity loads, loads which easily vibrate)</td> </tr> <tr> <td>2</td> <td>Standard setting value</td> </tr> <tr> <td>3</td> <td>Standard setting value</td> </tr> <tr> <td>4</td> <td>Standard setting value</td> </tr> <tr> <td>5</td> <td>High response (high-rigidity loads, loads which do not easily vibrate)</td> </tr> </tbody> </table> | | | | Setting value | Description | 1 | Low response (low-rigidity loads, loads which easily vibrate) | 2 | Standard setting value | 3 | Standard setting value | 4 | Standard setting value | 5 | High response (high-rigidity loads, loads which do not easily vibrate) | | | | | | |
| Setting value | Description | | | | | | | | | | | | | | | | | | | | | | | |
| 1 | Low response (low-rigidity loads, loads which easily vibrate) | | | | | | | | | | | | | | | | | | | | | | | |
| 2 | Standard setting value | | | | | | | | | | | | | | | | | | | | | | | |
| 3 | Standard setting value | | | | | | | | | | | | | | | | | | | | | | | |
| 4 | Standard setting value | | | | | | | | | | | | | | | | | | | | | | | |
| 5 | High response (high-rigidity loads, loads which do not easily vibrate) | | | | | | | | | | | | | | | | | | | | | | | |
| | | | <table border="1" style="width: 100%; border-collapse: collapse;"> <thead> <tr> <th style="width: 10%;">Setting value</th> <th style="width: 90%;">Description</th> </tr> </thead> <tbody> <tr> <td>0</td> <td>Standard</td> </tr> <tr> <td>1</td> <td>Large friction amount (set the position loop gain slightly lower)</td> </tr> </tbody> </table> | | | | Setting value | Description | 0 | Standard | 1 | Large friction amount (set the position loop gain slightly lower) | | | | | | | | | | | | |
| Setting value | Description | | | | | | | | | | | | | | | | | | | | | | | |
| 0 | Standard | | | | | | | | | | | | | | | | | | | | | | | |
| 1 | Large friction amount (set the position loop gain slightly lower) | | | | | | | | | | | | | | | | | | | | | | | |
| | | | <table border="1" style="width: 100%; border-collapse: collapse;"> <thead> <tr> <th style="width: 10%;">Setting value</th> <th style="width: 90%;">Description</th> </tr> </thead> <tbody> <tr> <td>0</td> <td>Only auto-tune PG2, VG2, VIC, and GD2.</td> </tr> <tr> <td>1</td> <td>Only auto-tune PG1, PG2, VG1, VG2, VIC, and GD2 (total gain).</td> </tr> <tr> <td>2</td> <td>No auto-tuning.</td> </tr> </tbody> </table> | | | | Setting value | Description | 0 | Only auto-tune PG2, VG2, VIC, and GD2. | 1 | Only auto-tune PG1, PG2, VG1, VG2, VIC, and GD2 (total gain). | 2 | No auto-tuning. | | | | | | | | | | |
| Setting value | Description | | | | | | | | | | | | | | | | | | | | | | | |
| 0 | Only auto-tune PG2, VG2, VIC, and GD2. | | | | | | | | | | | | | | | | | | | | | | | |
| 1 | Only auto-tune PG1, PG2, VG1, VG2, VIC, and GD2 (total gain). | | | | | | | | | | | | | | | | | | | | | | | |
| 2 | No auto-tuning. | | | | | | | | | | | | | | | | | | | | | | | |
| #008 | PG1 | Position loop gain 1 | 70 | rad/sec | Set the position loop gain of the model loop. Determine the tracking ability regarding the position commands. | 4 ~ 1000 | | | | | | | | | | | | | | | | | | |
| #009 | | | 0 | | Not used. | | | | | | | | | | | | | | | | | | | |
| #010 | EMGt | Deceleration control time constant | 500 | msec | Set the deceleration time from the clamp speed (Aspeed1). For normal rapid traverse, set the same value as the acceleration/deceleration time constant. | 0 ~ 32768 | | | | | | | | | | | | | | | | | | |

Appendix Parameter Lists

| No. | Abbrev. | Parameter name | Default value | Unit | Explanation | Setting range | | | | | | | | | | | | | | | | | | | | | | | | | | | | | | | | | | | | |
|------------------------|---------------------------------|------------------------------------|---|---------|--|---------------|---------------|-------------|---------------|---|----------------------------|-------------------------|----------|------------------------------|-------------------------------|----------------|-------------------------------|--------------------|-----|---------------------------------|-------------------------------|-----|-----------------|-------------------------------|---|--------------|------------------------|---|------------------------|--------------------|---|------------------------|----------------|---|-------------------------|-----------------|---|-------------------------|---------------------|---|-------------------------|----------------------|
| #011 | | | 0 | | Not used. | | | | | | | | | | | | | | | | | | | | | | | | | | | | | | | | | | | | | |
| #012 | | | 0 | | Not used. | | | | | | | | | | | | | | | | | | | | | | | | | | | | | | | | | | | | | |
| #013 | MBR | Vertical axis drop prevention time | 100 | msec | Input the time to delay servo OFF when the servo OFF command is input. Increase the setting by 100msec at a time and set the minimum value where the axis does not drop. | 0 ~ 1000 | | | | | | | | | | | | | | | | | | | | | | | | | | | | | | | | | | | | |
| #014 | NCH | Notch filter No. | Set the frequency of the mechanical resonance control filter. Do not set values without a description. | | | | | | | | | | | | | | | | | | | | | | | | | | | | | | | | | | | | | | | |
| | | | <table border="1" style="width: 100%; border-collapse: collapse;"> <tr> <th style="width: 15%;">Setting value</th> <td style="width: 5%;">0</td> <td style="width: 5%;">1</td> <td style="width: 5%;">2</td> <td style="width: 5%;">3</td> <td style="width: 5%;">4</td> <td style="width: 5%;">5</td> <td style="width: 5%;">6</td> <td style="width: 5%;">7</td> </tr> <tr> <th>Frequency (Hz)</th> <td>No start</td> <td>1125</td> <td>563</td> <td>375</td> <td>282</td> <td>225</td> <td>188</td> <td>161</td> </tr> </table> | | | | Setting value | 0 | 1 | 2 | 3 | 4 | 5 | 6 | 7 | Frequency (Hz) | No start | 1125 | 563 | 375 | 282 | 225 | 188 | 161 | | | | | | | | | | | | | | | | | | |
| Setting value | 0 | 1 | 2 | 3 | 4 | 5 | 6 | 7 | | | | | | | | | | | | | | | | | | | | | | | | | | | | | | | | | | |
| Frequency (Hz) | No start | 1125 | 563 | 375 | 282 | 225 | 188 | 161 | | | | | | | | | | | | | | | | | | | | | | | | | | | | | | | | | | |
| #015 | | | 0 | | Not used | | | | | | | | | | | | | | | | | | | | | | | | | | | | | | | | | | | | | |
| #016 | JIT | Jitter compensation | Set the No. of ignored jitter compensation pulses. Do not set values without a description. | | | | | | | | | | | | | | | | | | | | | | | | | | | | | | | | | | | | | | | |
| | | | <table border="1" style="width: 100%; border-collapse: collapse;"> <tr> <th style="width: 20%;">Setting value</th> <td style="width: 10%;">0</td> <td style="width: 10%;">1</td> <td style="width: 10%;">2</td> <td style="width: 10%;">3</td> </tr> <tr> <th>No. of ignored pulses.</th> <td>No start</td> <td>1</td> <td>2</td> <td>3</td> </tr> </table> | | | | Setting value | 0 | 1 | 2 | 3 | No. of ignored pulses. | No start | 1 | 2 | 3 | | | | | | | | | | | | | | | | | | | | | | | | | | |
| Setting value | 0 | 1 | 2 | 3 | | | | | | | | | | | | | | | | | | | | | | | | | | | | | | | | | | | | | | |
| No. of ignored pulses. | No start | 1 | 2 | 3 | | | | | | | | | | | | | | | | | | | | | | | | | | | | | | | | | | | | | | |
| #017 | | | 0 | | Not used. | | | | | | | | | | | | | | | | | | | | | | | | | | | | | | | | | | | | | |
| #018 | | | 0 | | Not used. | | | | | | | | | | | | | | | | | | | | | | | | | | | | | | | | | | | | | |
| #019 | PG2 | Position loop gain 2 | 25 | rad/sec | Set the position loop gain of the actual loop. Determine the position responsiveness for external disturbance. | 1 ~ 500 | | | | | | | | | | | | | | | | | | | | | | | | | | | | | | | | | | | | |
| #020 | VG1 | Speed loop gain 1 | 1200 | rad/sec | Set the speed loop gain of the model loop. Determine the tracking ability regarding the speed commands. | 20 ~ 5000 | | | | | | | | | | | | | | | | | | | | | | | | | | | | | | | | | | | | |
| #021 | VG2 | Speed loop gain 2 | 600 | rad/sec | Set the speed loop gain of the actual loop. Determine the speed responsiveness for external disturbance. | 20 ~ 8000 | | | | | | | | | | | | | | | | | | | | | | | | | | | | | | | | | | | | |
| #022 | VIC | Speed integral compensation | 20 | msec | Determine the characteristics of the speed low-frequency region. | 1 ~ 1000 | | | | | | | | | | | | | | | | | | | | | | | | | | | | | | | | | | | | |
| #023 | VDC | Speed differential compensation | 1000 | | PI control normally results from a default value of 1000. Adjust the override amount by lowering in increments of 20. | 0 ~ 1000 | | | | | | | | | | | | | | | | | | | | | | | | | | | | | | | | | | | | |
| #024 | GD2 | Load inertia ratio | | -fold | Set the load inertia ratio for the motor inertia. | 0.0 ~ 50.0 | | | | | | | | | | | | | | | | | | | | | | | | | | | | | | | | | | | | |
| #025 | | | | | Not used | | | | | | | | | | | | | | | | | | | | | | | | | | | | | | | | | | | | | |
| #030 | *MTY | Motor type | Set the motor type. This is automatically judged by the system when the default value (0000) is set. | | | | | | | | | | | | | | | | | | | | | | | | | | | | | | | | | | | | | | | |
| #050 | MD1 | D/A output channel 1 data Nos. | Set the Nos. of the data to be output on D/A output channel 1. | | | | | | | | | | | | | | | | | | | | | | | | | | | | | | | | | | | | | | | |
| | | | <table border="1" style="width: 100%; border-collapse: collapse;"> <tr> <td style="width: 20px; text-align: center;">0</td> <td style="width: 20px; text-align: center;">0</td> <td style="width: 20px; text-align: center;">0</td> <td style="width: 20px; text-align: center;">0</td> <td style="width: 20px; text-align: center;">0</td> <td>(Default setting value)</td> </tr> </table> | | | | 0 | 0 | 0 | 0 | 0 | (Default setting value) | | | | | | | | | | | | | | | | | | | | | | | | | | | | | | |
| 0 | 0 | 0 | 0 | 0 | (Default setting value) | | | | | | | | | | | | | | | | | | | | | | | | | | | | | | | | | | | | | |
| | | | <table border="1" style="width: 100%; border-collapse: collapse;"> <thead> <tr> <th style="width: 5%;">No.</th> <th style="width: 60%;">Description</th> <th style="width: 35%;">Magnification</th> </tr> </thead> <tbody> <tr> <td style="text-align: center;">0</td> <td>Speed feedback (with sign)</td> <td>Maximum speed = 8V</td> </tr> <tr> <td style="text-align: center;">1</td> <td>Current feedback (with sign)</td> <td>Maximum current (torque) = 8V</td> </tr> <tr> <td style="text-align: center;">2</td> <td>Speed feedback (without sign)</td> <td>Maximum speed = 8V</td> </tr> <tr> <td style="text-align: center;">3</td> <td>Current feedback (without sign)</td> <td>Maximum current (torque) = 8V</td> </tr> <tr> <td style="text-align: center;">4</td> <td>Current command</td> <td>Maximum current (torque) = 8V</td> </tr> <tr> <td style="text-align: center;">5</td> <td>Command F• ħ</td> <td>100000 [deg/min] = 10V</td> </tr> <tr> <td style="text-align: center;">6</td> <td>Position droop 1 (1/1)</td> <td>2048 [pulse] = 10V</td> </tr> <tr> <td style="text-align: center;">7</td> <td>Position droop 2 (1/4)</td> <td>8192lse] = 10V</td> </tr> <tr> <td style="text-align: center;">8</td> <td>Position droop 3 (1/16)</td> <td>32768lse] = 10V</td> </tr> <tr> <td style="text-align: center;">9</td> <td>Position droop 4 (1/32)</td> <td>65536 [pulse] = 10V</td> </tr> <tr> <td style="text-align: center;">A</td> <td>Position droop 5 (1/64)</td> <td>131072 [pulse] = 10V</td> </tr> </tbody> </table> | | | | No. | Description | Magnification | 0 | Speed feedback (with sign) | Maximum speed = 8V | 1 | Current feedback (with sign) | Maximum current (torque) = 8V | 2 | Speed feedback (without sign) | Maximum speed = 8V | 3 | Current feedback (without sign) | Maximum current (torque) = 8V | 4 | Current command | Maximum current (torque) = 8V | 5 | Command F• ħ | 100000 [deg/min] = 10V | 6 | Position droop 1 (1/1) | 2048 [pulse] = 10V | 7 | Position droop 2 (1/4) | 8192lse] = 10V | 8 | Position droop 3 (1/16) | 32768lse] = 10V | 9 | Position droop 4 (1/32) | 65536 [pulse] = 10V | A | Position droop 5 (1/64) | 131072 [pulse] = 10V |
| No. | Description | Magnification | | | | | | | | | | | | | | | | | | | | | | | | | | | | | | | | | | | | | | | | |
| 0 | Speed feedback (with sign) | Maximum speed = 8V | | | | | | | | | | | | | | | | | | | | | | | | | | | | | | | | | | | | | | | | |
| 1 | Current feedback (with sign) | Maximum current (torque) = 8V | | | | | | | | | | | | | | | | | | | | | | | | | | | | | | | | | | | | | | | | |
| 2 | Speed feedback (without sign) | Maximum speed = 8V | | | | | | | | | | | | | | | | | | | | | | | | | | | | | | | | | | | | | | | | |
| 3 | Current feedback (without sign) | Maximum current (torque) = 8V | | | | | | | | | | | | | | | | | | | | | | | | | | | | | | | | | | | | | | | | |
| 4 | Current command | Maximum current (torque) = 8V | | | | | | | | | | | | | | | | | | | | | | | | | | | | | | | | | | | | | | | | |
| 5 | Command F• ħ | 100000 [deg/min] = 10V | | | | | | | | | | | | | | | | | | | | | | | | | | | | | | | | | | | | | | | | |
| 6 | Position droop 1 (1/1) | 2048 [pulse] = 10V | | | | | | | | | | | | | | | | | | | | | | | | | | | | | | | | | | | | | | | | |
| 7 | Position droop 2 (1/4) | 8192lse] = 10V | | | | | | | | | | | | | | | | | | | | | | | | | | | | | | | | | | | | | | | | |
| 8 | Position droop 3 (1/16) | 32768lse] = 10V | | | | | | | | | | | | | | | | | | | | | | | | | | | | | | | | | | | | | | | | |
| 9 | Position droop 4 (1/32) | 65536 [pulse] = 10V | | | | | | | | | | | | | | | | | | | | | | | | | | | | | | | | | | | | | | | | |
| A | Position droop 5 (1/64) | 131072 [pulse] = 10V | | | | | | | | | | | | | | | | | | | | | | | | | | | | | | | | | | | | | | | | |

Appendix Parameter Lists

| No. | Abbrev. | Parameter name | Default value | Unit | Explanation | Setting range | | | | | | | | | | | | | | | | | | | | | | | | | | | | | | | | | | | | | | | | | | | | | | | | | | | | | | | | | | | |
|----------------------|---|--|--|------|---|---------------|-----|---|---|---|---|---|---|---|---|---|---|---|---|---|---|---|---|----------------------|---|---|---|---|---|---|---|---|---|---|---|---|---|---|---|---|-----|--------------------------|--------------------------|--------------------------|---|---|------------------------------|--------------------------------------|---|---------------|--------------------------------------|--|----------------------------------|--|--|-------------------|--------------------------------------|--|-------------------------------|--|--|-------------------------------|--|--|-----------------------------|
| #051 | MO1 | D/A output channel 1 output offset | 0 | mV | Set this value when the zero level of D/A output channel 1 is not suitable. | -999 ~ 999 | | | | | | | | | | | | | | | | | | | | | | | | | | | | | | | | | | | | | | | | | | | | | | | | | | | | | | | | | | | |
| #052 | | | 0 | | Not used | | | | | | | | | | | | | | | | | | | | | | | | | | | | | | | | | | | | | | | | | | | | | | | | | | | | | | | | | | | | |
| #053 | MD2 | D/A output channel 2 data No. | | | Set the Nos. of the data to be output on D/A output channel 2. The descriptions are the same as those of #050 MD1D/A output channel data No. 1. | | | | | | | | | | | | | | | | | | | | | | | | | | | | | | | | | | | | | | | | | | | | | | | | | | | | | | | | | | | | |
| #054 | MO2 | D/A output channel 2 output offset | 0 | mV | Set this value when the zero level of D/A output channel 2 is not suitable. | -999 ~ 999 | | | | | | | | | | | | | | | | | | | | | | | | | | | | | | | | | | | | | | | | | | | | | | | | | | | | | | | | | | | |
| #055 | | | 0 | | Not used | | | | | | | | | | | | | | | | | | | | | | | | | | | | | | | | | | | | | | | | | | | | | | | | | | | | | | | | | | | | |
| #100 | *station | No. of indexing stations | 2 | | Set the No. of stations. For linear axes, this value is expressed by: No. of divisions = No. of stations - 1. | 2 ~ 360 | | | | | | | | | | | | | | | | | | | | | | | | | | | | | | | | | | | | | | | | | | | | | | | | | | | | | | | | | | | |
| #101 | *Cont1 | Control parameter 1 | <p>This is a HEX setting parameter. Set bits without a description to their default values.</p> <table border="1" style="width: 100%; text-align: center; border-collapse: collapse;"> <thead> <tr> <th>bit</th> <th>F</th> <th>E</th> <th>D</th> <th>C</th> <th>B</th> <th>A</th> <th>9</th> <th>8</th> <th>7</th> <th>6</th> <th>5</th> <th>4</th> <th>3</th> <th>2</th> <th>1</th> <th>0</th> </tr> </thead> <tbody> <tr> <td>Default value</td> <td>0</td> <td>0</td> <td>0</td> <td>0</td> <td>0</td> <td>0</td> <td>1</td> <td>0</td> <td>0</td> <td>0</td> <td>0</td> <td>0</td> <td>0</td> <td>0</td> <td>0</td> <td>0</td> </tr> </tbody> </table> <table border="1" style="width: 100%; border-collapse: collapse;"> <thead> <tr> <th>bit</th> <th>Meaning when "0" is set.</th> <th>Meaning when "1" is set.</th> </tr> </thead> <tbody> <tr> <td>1</td> <td>High-speed zero point return after establishment of zero point.</td> <td>Dog-type return for each zero point return operation.</td> </tr> <tr> <td>8</td> <td>Reference point return direction (+)</td> <td>Reference point return direction (-)</td> </tr> <tr> <td>9</td> <td>Rotation direction determined by DIR</td> <td>Rotation direction in the shortcut direction</td> </tr> <tr> <td>A</td> <td>Machine reference position becomes the reference point</td> <td>Electrical zero point becomes the reference position</td> </tr> <tr> <td>D</td> <td>Coordinate zero point creation valid</td> <td>Zero point established at power supply ON position</td> </tr> <tr> <td>E</td> <td>Rotation direction in DIR or in the shortcut direction</td> <td>Rotation direction in the random position command sign direction</td> </tr> <tr> <td>F</td> <td>Stopper direction is positioning direction</td> <td>Stopper direction is in the sign direction of the stopper amount</td> </tr> </tbody> </table> | | | | bit | F | E | D | C | B | A | 9 | 8 | 7 | 6 | 5 | 4 | 3 | 2 | 1 | 0 | Default value | 0 | 0 | 0 | 0 | 0 | 0 | 1 | 0 | 0 | 0 | 0 | 0 | 0 | 0 | 0 | 0 | bit | Meaning when "0" is set. | Meaning when "1" is set. | 1 | High-speed zero point return after establishment of zero point. | Dog-type return for each zero point return operation. | 8 | Reference point return direction (+) | Reference point return direction (-) | 9 | Rotation direction determined by DIR | Rotation direction in the shortcut direction | A | Machine reference position becomes the reference point | Electrical zero point becomes the reference position | D | Coordinate zero point creation valid | Zero point established at power supply ON position | E | Rotation direction in DIR or in the shortcut direction | Rotation direction in the random position command sign direction | F | Stopper direction is positioning direction | Stopper direction is in the sign direction of the stopper amount | |
| bit | F | E | D | C | B | A | 9 | 8 | 7 | 6 | 5 | 4 | 3 | 2 | 1 | 0 | | | | | | | | | | | | | | | | | | | | | | | | | | | | | | | | | | | | | | | | | | | | | | | | | |
| Default value | 0 | 0 | 0 | 0 | 0 | 0 | 1 | 0 | 0 | 0 | 0 | 0 | 0 | 0 | 0 | 0 | | | | | | | | | | | | | | | | | | | | | | | | | | | | | | | | | | | | | | | | | | | | | | | | | |
| bit | Meaning when "0" is set. | Meaning when "1" is set. | | | | | | | | | | | | | | | | | | | | | | | | | | | | | | | | | | | | | | | | | | | | | | | | | | | | | | | | | | | | | | | |
| 1 | High-speed zero point return after establishment of zero point. | Dog-type return for each zero point return operation. | | | | | | | | | | | | | | | | | | | | | | | | | | | | | | | | | | | | | | | | | | | | | | | | | | | | | | | | | | | | | | | |
| 8 | Reference point return direction (+) | Reference point return direction (-) | | | | | | | | | | | | | | | | | | | | | | | | | | | | | | | | | | | | | | | | | | | | | | | | | | | | | | | | | | | | | | | |
| 9 | Rotation direction determined by DIR | Rotation direction in the shortcut direction | | | | | | | | | | | | | | | | | | | | | | | | | | | | | | | | | | | | | | | | | | | | | | | | | | | | | | | | | | | | | | | |
| A | Machine reference position becomes the reference point | Electrical zero point becomes the reference position | | | | | | | | | | | | | | | | | | | | | | | | | | | | | | | | | | | | | | | | | | | | | | | | | | | | | | | | | | | | | | | |
| D | Coordinate zero point creation valid | Zero point established at power supply ON position | | | | | | | | | | | | | | | | | | | | | | | | | | | | | | | | | | | | | | | | | | | | | | | | | | | | | | | | | | | | | | | |
| E | Rotation direction in DIR or in the shortcut direction | Rotation direction in the random position command sign direction | | | | | | | | | | | | | | | | | | | | | | | | | | | | | | | | | | | | | | | | | | | | | | | | | | | | | | | | | | | | | | | |
| F | Stopper direction is positioning direction | Stopper direction is in the sign direction of the stopper amount | | | | | | | | | | | | | | | | | | | | | | | | | | | | | | | | | | | | | | | | | | | | | | | | | | | | | | | | | | | | | | | |
| #102 | *Cont2 | Control parameter 2 | <p>This is a HEX setting parameter. Set bits without a description to their default values.</p> <table border="1" style="width: 100%; text-align: center; border-collapse: collapse;"> <thead> <tr> <th>bit</th> <th>F</th> <th>E</th> <th>D</th> <th>C</th> <th>B</th> <th>A</th> <th>9</th> <th>8</th> <th>7</th> <th>6</th> <th>5</th> <th>4</th> <th>3</th> <th>2</th> <th>1</th> <th>0</th> </tr> </thead> <tbody> <tr> <td>Default value</td> <td>0</td> <td>0</td> <td>0</td> <td>0</td> <td>0</td> <td>0</td> <td>0</td> <td>0</td> <td>1</td> <td>0</td> <td>0</td> <td>0</td> <td>0</td> <td>0</td> <td>1</td> <td>1</td> <td>0</td> </tr> </tbody> </table> <table border="1" style="width: 100%; border-collapse: collapse;"> <thead> <tr> <th>bit</th> <th>Meaning when "0" is set.</th> <th>Meaning when "1" is set.</th> </tr> </thead> <tbody> <tr> <td>1</td> <td>Error not corrected at servo OFF</td> <td>Error corrected at servo OFF</td> </tr> <tr> <td>2</td> <td>Linear axis</td> <td>Rotation axis</td> </tr> <tr> <td>3</td> <td>Station assignment direction CW</td> <td>Station assignment direction CCW</td> </tr> <tr> <td>4</td> <td>Uniform index</td> <td>Non-uniform index</td> </tr> <tr> <td>5</td> <td>DO channel standard assignment</td> <td>DO channel reverse assignment</td> </tr> <tr> <td>6</td> <td>2-wire detector communication</td> <td>4-wire detector communication</td> </tr> <tr> <td>7</td> <td>Incremental detection</td> <td>Absolute position detection</td> </tr> </tbody> </table> | | | | bit | F | E | D | C | B | A | 9 | 8 | 7 | 6 | 5 | 4 | 3 | 2 | 1 | 0 | Default value | 0 | 0 | 0 | 0 | 0 | 0 | 0 | 0 | 1 | 0 | 0 | 0 | 0 | 0 | 1 | 1 | 0 | bit | Meaning when "0" is set. | Meaning when "1" is set. | 1 | Error not corrected at servo OFF | Error corrected at servo OFF | 2 | Linear axis | Rotation axis | 3 | Station assignment direction CW | Station assignment direction CCW | 4 | Uniform index | Non-uniform index | 5 | DO channel standard assignment | DO channel reverse assignment | 6 | 2-wire detector communication | 4-wire detector communication | 7 | Incremental detection | Absolute position detection |
| bit | F | E | D | C | B | A | 9 | 8 | 7 | 6 | 5 | 4 | 3 | 2 | 1 | 0 | | | | | | | | | | | | | | | | | | | | | | | | | | | | | | | | | | | | | | | | | | | | | | | | | |
| Default value | 0 | 0 | 0 | 0 | 0 | 0 | 0 | 0 | 1 | 0 | 0 | 0 | 0 | 0 | 1 | 1 | 0 | | | | | | | | | | | | | | | | | | | | | | | | | | | | | | | | | | | | | | | | | | | | | | | | |
| bit | Meaning when "0" is set. | Meaning when "1" is set. | | | | | | | | | | | | | | | | | | | | | | | | | | | | | | | | | | | | | | | | | | | | | | | | | | | | | | | | | | | | | | | |
| 1 | Error not corrected at servo OFF | Error corrected at servo OFF | | | | | | | | | | | | | | | | | | | | | | | | | | | | | | | | | | | | | | | | | | | | | | | | | | | | | | | | | | | | | | | |
| 2 | Linear axis | Rotation axis | | | | | | | | | | | | | | | | | | | | | | | | | | | | | | | | | | | | | | | | | | | | | | | | | | | | | | | | | | | | | | | |
| 3 | Station assignment direction CW | Station assignment direction CCW | | | | | | | | | | | | | | | | | | | | | | | | | | | | | | | | | | | | | | | | | | | | | | | | | | | | | | | | | | | | | | | |
| 4 | Uniform index | Non-uniform index | | | | | | | | | | | | | | | | | | | | | | | | | | | | | | | | | | | | | | | | | | | | | | | | | | | | | | | | | | | | | | | |
| 5 | DO channel standard assignment | DO channel reverse assignment | | | | | | | | | | | | | | | | | | | | | | | | | | | | | | | | | | | | | | | | | | | | | | | | | | | | | | | | | | | | | | | |
| 6 | 2-wire detector communication | 4-wire detector communication | | | | | | | | | | | | | | | | | | | | | | | | | | | | | | | | | | | | | | | | | | | | | | | | | | | | | | | | | | | | | | | |
| 7 | Incremental detection | Absolute position detection | | | | | | | | | | | | | | | | | | | | | | | | | | | | | | | | | | | | | | | | | | | | | | | | | | | | | | | | | | | | | | | |
| #103 | *Emgcont | Emergency stop control | <table border="1" style="width: 100%; text-align: center; border-collapse: collapse;"> <thead> <tr> <th>bit</th> <th>F</th> <th>E</th> <th>D</th> <th>C</th> <th>B</th> <th>A</th> <th>9</th> <th>8</th> <th>7</th> <th>6</th> <th>5</th> <th>4</th> <th>3</th> <th>2</th> <th>1</th> <th>0</th> </tr> </thead> <tbody> <tr> <td>Default value</td> <td>0</td> <td>0</td> <td>0</td> <td>0</td> <td>0</td> <td>0</td> <td>0</td> <td>0</td> <td>0</td> <td>0</td> <td>0</td> <td>0</td> <td>0</td> <td>0</td> <td>0</td> <td>1</td> </tr> </tbody> </table> <table border="1" style="width: 100%; border-collapse: collapse;"> <thead> <tr> <th>bit</th> <th>Meaning when "0" is set.</th> <th>Meaning when "1" is set.</th> </tr> </thead> <tbody> <tr> <td>0</td> <td>External emergency stop valid</td> <td>External emergency stop invalid (default value)</td> </tr> <tr> <td>1</td> <td>Dynamic brake stop at emergency stop</td> <td>Deceleration control stop at emergency stop</td> </tr> <tr> <td>2</td> <td>CNC bus emergency stop input valid</td> <td>CNC bus emergency stop input invalid</td> </tr> <tr> <td>3</td> <td>CNC bus emergency stop output valid</td> <td>CNC bus emergency stop output invalid</td> </tr> </tbody> </table> | | | | bit | F | E | D | C | B | A | 9 | 8 | 7 | 6 | 5 | 4 | 3 | 2 | 1 | 0 | Default value | 0 | 0 | 0 | 0 | 0 | 0 | 0 | 0 | 0 | 0 | 0 | 0 | 0 | 0 | 0 | 1 | bit | Meaning when "0" is set. | Meaning when "1" is set. | 0 | External emergency stop valid | External emergency stop invalid (default value) | 1 | Dynamic brake stop at emergency stop | Deceleration control stop at emergency stop | 2 | CNC bus emergency stop input valid | CNC bus emergency stop input invalid | 3 | CNC bus emergency stop output valid | CNC bus emergency stop output invalid | | | | | | | | | | |
| bit | F | E | D | C | B | A | 9 | 8 | 7 | 6 | 5 | 4 | 3 | 2 | 1 | 0 | | | | | | | | | | | | | | | | | | | | | | | | | | | | | | | | | | | | | | | | | | | | | | | | | |
| Default value | 0 | 0 | 0 | 0 | 0 | 0 | 0 | 0 | 0 | 0 | 0 | 0 | 0 | 0 | 0 | 1 | | | | | | | | | | | | | | | | | | | | | | | | | | | | | | | | | | | | | | | | | | | | | | | | | |
| bit | Meaning when "0" is set. | Meaning when "1" is set. | | | | | | | | | | | | | | | | | | | | | | | | | | | | | | | | | | | | | | | | | | | | | | | | | | | | | | | | | | | | | | | |
| 0 | External emergency stop valid | External emergency stop invalid (default value) | | | | | | | | | | | | | | | | | | | | | | | | | | | | | | | | | | | | | | | | | | | | | | | | | | | | | | | | | | | | | | | |
| 1 | Dynamic brake stop at emergency stop | Deceleration control stop at emergency stop | | | | | | | | | | | | | | | | | | | | | | | | | | | | | | | | | | | | | | | | | | | | | | | | | | | | | | | | | | | | | | | |
| 2 | CNC bus emergency stop input valid | CNC bus emergency stop input invalid | | | | | | | | | | | | | | | | | | | | | | | | | | | | | | | | | | | | | | | | | | | | | | | | | | | | | | | | | | | | | | | |
| 3 | CNC bus emergency stop output valid | CNC bus emergency stop output invalid | | | | | | | | | | | | | | | | | | | | | | | | | | | | | | | | | | | | | | | | | | | | | | | | | | | | | | | | | | | | | | | |

Appendix Parameter Lists

| No. | Abbrev. | Parameter name | Default value | Unit | Explanation | Setting range | | | | | | | | | | | | | | | | | | | | | | | | | | | | | | | | | | |
|--|---|--|--|----------------------------|---|------------------------|-----|--------------------------|--------------------------|---|-------------------------------------|---------------------------------|---|---|---|---|-------------------------------------|-------------------------------------|---|---|---|---|---|---------------|---|---|---|---|---|---|---|---|---|---|---|---|---|---|---|---|
| #104 | *tleng | Linear axis stroke length | 100.000 | mm | Set the movement stroke length for linear axes. This is meaningless when setting non-uniform assignments or commanding random positions. | 0.001 ~ 99999.999 | | | | | | | | | | | | | | | | | | | | | | | | | | | | | | | | | | |
| #110 | ZRNspeed | Reference point return speed | 1000 | deg/min (mm/min) | Set the clamp value of the feedrate when a reference point return is carried out. The feedrate becomes the manual operation speed of the parameter group selected at that time, but it is clamped by this parameter setting value. | 1 ~ 100000 | | | | | | | | | | | | | | | | | | | | | | | | | | | | | | | | | | |
| #111 | ZRNcreep | Reference point return creep speed | 200 | deg/min (mm/min) | Set the approach speed to the reference point after dog detection during a reference point return. | 1 ~ 65535 | | | | | | | | | | | | | | | | | | | | | | | | | | | | | | | | | | |
| #112 | grid mask | Grid mask | 0 | 1/1000 deg (μm) | Set the amount that the dog is artificially extended. Set 1/2 the grid spacing as a standard. | 0 ~ 65536 | | | | | | | | | | | | | | | | | | | | | | | | | | | | | | | | | | |
| #113 | * grspc | Grid spacing | 0 | 1/2 ⁿ divisions | Divide the grid spacing that is the conventional motor rotation movement amount into 2, 4, 8, or 16 divisions. | 0 ~ 4 | | | | | | | | | | | | | | | | | | | | | | | | | | | | | | | | | | |
| #114 | ZRNshift | Reference point shift amount | 0 | 1/1000 deg (μm) | Set the shift amount in a dog-type reference point return from the electric zero point determined on the grid to the reference point. | 0 ~ 65536 | | | | | | | | | | | | | | | | | | | | | | | | | | | | | | | | | | |
| #115 | ST.offset | Station offset | 0.000 | deg (mm) | Set the distance (offset) from the reference point to station 1. | -99999.999 ~ 99999.999 | | | | | | | | | | | | | | | | | | | | | | | | | | | | | | | | | | |
| #116 | *ABS base | Absolute position zero point | 0.000 | deg (mm) | When movement of the machine coordinate zero point from the reference point is required during absolute position default setting, set that movement amount. | -99999.999 ~ 99999.999 | | | | | | | | | | | | | | | | | | | | | | | | | | | | | | | | | | |
| #117 | Limit (+) | Soft limit (+) | 1.000 | mm | Commands in the plus direction that exceed this setting value are not possible. If the machine is in a position exceeding the setting value, commands in the minus direction are possible. The soft limit function will not operate if Limit (+) and Limit (-) are set to the same value. | -99999.999 ~ 99999.999 | | | | | | | | | | | | | | | | | | | | | | | | | | | | | | | | | | |
| #118 | Limit (-) | Soft limit (-) | 1.000 | mm | Commands in the minus direction that exceed this value are not possible. If the machine is in a position exceeding the setting value, commands in the plus direction are possible. | -99999.999 ~ 99999.999 | | | | | | | | | | | | | | | | | | | | | | | | | | | | | | | | | | |
| #120 | ABS Type | Absolute position detection parameter | This is a HEX setting parameter. Set bits without a description to their default values. | | | | | | | | | | | | | | | | | | | | | | | | | | | | | | | | | | | | | |
| <table border="1" style="width: 100%; text-align: center;"> <thead> <tr> <th>bit</th> <th>F</th> <th>E</th> <th>D</th> <th>C</th> <th>B</th> <th>A</th> <th>9</th> <th>8</th> <th>7</th> <th>6</th> <th>5</th> <th>4</th> <th>3</th> <th>2</th> <th>1</th> <th>0</th> </tr> </thead> <tbody> <tr> <td>Default value</td> <td>0</td> <td>0</td> <td>0</td> <td>0</td> <td>0</td> <td>0</td> <td>0</td> <td>0</td> <td>0</td> <td>0</td> <td>0</td> <td>0</td> <td>0</td> <td>1</td> <td>0</td> <td>0</td> </tr> </tbody> </table> | | | | | | | bit | F | E | D | C | B | A | 9 | 8 | 7 | 6 | 5 | 4 | 3 | 2 | 1 | 0 | Default value | 0 | 0 | 0 | 0 | 0 | 0 | 0 | 0 | 0 | 0 | 0 | 0 | 0 | 1 | 0 | 0 |
| bit | F | E | D | C | B | A | 9 | 8 | 7 | 6 | 5 | 4 | 3 | 2 | 1 | 0 | | | | | | | | | | | | | | | | | | | | | | | | |
| Default value | 0 | 0 | 0 | 0 | 0 | 0 | 0 | 0 | 0 | 0 | 0 | 0 | 0 | 1 | 0 | 0 | | | | | | | | | | | | | | | | | | | | | | | | |
| <table border="1" style="width: 100%; text-align: center;"> <thead> <tr> <th>bit</th> <th>Meaning when "0" is set.</th> <th>Meaning when "1" is set.</th> </tr> </thead> <tbody> <tr> <td>1</td> <td>Dogless-type method default setting</td> <td>Dog-type method default setting</td> </tr> <tr> <td>2</td> <td>Mechanical stopper method default setting</td> <td>Reference point matching method default setting</td> </tr> <tr> <td>3</td> <td>Electrical zero point direction (+)</td> <td>Electrical zero point direction (-)</td> </tr> </tbody> </table> | | | | | | | bit | Meaning when "0" is set. | Meaning when "1" is set. | 1 | Dogless-type method default setting | Dog-type method default setting | 2 | Mechanical stopper method default setting | Reference point matching method default setting | 3 | Electrical zero point direction (+) | Electrical zero point direction (-) | | | | | | | | | | | | | | | | | | | | | | |
| bit | Meaning when "0" is set. | Meaning when "1" is set. | | | | | | | | | | | | | | | | | | | | | | | | | | | | | | | | | | | | | | |
| 1 | Dogless-type method default setting | Dog-type method default setting | | | | | | | | | | | | | | | | | | | | | | | | | | | | | | | | | | | | | | |
| 2 | Mechanical stopper method default setting | Reference point matching method default setting | | | | | | | | | | | | | | | | | | | | | | | | | | | | | | | | | | | | | | |
| 3 | Electrical zero point direction (+) | Electrical zero point direction (-) | | | | | | | | | | | | | | | | | | | | | | | | | | | | | | | | | | | | | | |
| #123 | ABScheck | Absolute position power OFF tolerable movement value | 0.000 | deg (mm) | Set the value for the tolerable amount of movement for a machine that moved during power OFF in an absolute position detection system. The "Absolute position power OFF movement exceeded (ABS)" signal will turn ON if the machine moves more than this setting value during while the power is OFF. The movement amount is not checked when this parameter is set to 0.000. | 0.000 ~ 99999.999 | | | | | | | | | | | | | | | | | | | | | | | | | | | | | | | | | | |
| #130 | backlash | Backlash compensation amount | 0 | 1/1000 deg (μm) | Set the backlash compensation amount. | 0 ~ 9999 | | | | | | | | | | | | | | | | | | | | | | | | | | | | | | | | | | |
| #132 | | | 0 | | Not used | | | | | | | | | | | | | | | | | | | | | | | | | | | | | | | | | | | |
| #133 | | | 0 | | Not used | | | | | | | | | | | | | | | | | | | | | | | | | | | | | | | | | | | |
| #134 | | | 0 | | Not used | | | | | | | | | | | | | | | | | | | | | | | | | | | | | | | | | | | |
| #135 | | | 0 | | Not used | | | | | | | | | | | | | | | | | | | | | | | | | | | | | | | | | | | |

Appendix Parameter Lists

< Operation parameter group 1 >

| No. | Abbrev. | Parameter name | Default value | Unit | Explanation | Setting range |
|------|---------|--|---------------|---------------------|--|-------------------|
| #150 | Aspeed1 | Operation parameter group 1 Automatic operation speed | 5000 | deg/min (mm/min) | Set the feedrate during automatic operation when operation parameter group 1 is selected. This parameter functions as the clamp value for the automatic operation speeds and manual operation speeds of all operation groups. A speed exceeding Aspeed1 cannot be commanded, even if set in the parameters. | 1 ~ 100000 |
| #151 | Mspeed1 | Operation parameter group 1 Manual operation speed | 2000 | deg/min (mm/min) | Set the feedrate during manual operation and JOG operation when operation parameter group 1 is selected. | 1 ~ 100000 |
| #152 | time1.1 | Operation parameter group 1 Acceleration/deceleration time constant 1 | 100 | msec | Set the linear acceleration/deceleration time for the operation parameter group 1 automatic operation speed (clamp speed) when operation parameter group 1 is selected. When operating at speeds less than the clamp speed, the axis will linearly accelerate/decelerate at the inclination determined above. When this is set together with acceleration/deceleration time constant 2, S-character acceleration/deceleration is carried out. In this case, set the acceleration/deceleration time of the linear part in this parameter. | 1 ~ 9999 |
| #153 | time1.2 | Operation parameter group 1 Acceleration/deceleration time constant 2 | 1 | msec | Set this parameter when carrying out S-character acceleration/deceleration. When S-character acceleration/deceleration is carried out, set the total time of the non-linear parts. When 1 is set in this parameter, linear acceleration/deceleration is carried out. For the handle feed operation mode, this becomes the linear acceleration/deceleration that is the acceleration/deceleration time constant. | 1 ~ 9999 |
| #154 | TL1 | Operation parameter group 1 Torque limit value | 500 | % | Set the motor output torque limit value when operation parameter group 1 is selected. At the default value, the torque is limited at the maximum torque of the motor specifications. Set the default value when torque limiting is not especially required. In the stopper positioning operation mode, this becomes the torque limit value when positioning to the stopper starting coordinates. | 1 ~ 500 |
| #155 | OD1 | Operation parameter group 1 Excessive error detection width | 100 | deg (mm) | Set the excessive error detection width when operation parameter group 1 is selected. An excessive error alarm (S03 0052) is detected when the position droop becomes larger than this setting value. | 0 ~ 32767 |
| #156 | just1 | Operation parameter group 1 Set position output width | 0.500 | deg (mm) | The signal indicating that the machine position is at any one of the stations is the set position reached (JST) signal. During automatic operation, the automatic set position reached (JSTA) signal is also output under the same conditions. Set the tolerable values at which these signals are output when operation parameter group 1 is selected. These signals turn OFF when the machine position is separated from the station by more than this value. | 0.000 ~ 99999.999 |
| #157 | near1 | Operation parameter group 1 Near set position output width | 1.000 | deg (mm) | The signal indicating that the machine position is near any one of the station positions is the near set position (NEAR) signal. Set the tolerable values at which these signals are output when operation parameter group 1 is selected. These values are generally set wider than the set position output width. During operations, this is related to special commands when the station selection is 0. Refer to section "6-4-3 Automatic operation." | 0.000 ~ 99999.999 |

Appendix Parameter Lists

< Operation parameter group 2 >

| No. | Abbrev. | Parameter name | Default value | Unit | Explanation | Setting range |
|------|---------|---|---------------|---------------------|--|-------------------|
| #158 | Aspeed2 | Operation parameter group 2 Automatic operation speed | 5000 | deg/min (mm/min) | Set the feedrate during automatic operation when operation parameter group 2 is selected. | 1 ~ 100000 |
| #159 | Mspeed2 | Operation parameter group 2 Manual operation speed | 2000 | deg/min (mm/min) | Set the feedrate during manual operation and JOG operation when operation parameter group 2 is selected. | 1 ~ 100000 |
| #160 | time2.1 | Operation parameter group 2 Acceleration/deceleration time constant 1 | 100 | msec | Set the linear acceleration/deceleration time for the operation parameter group 1 automatic operation speed (clamp speed) when operation parameter group 2 is selected. When operating at speeds less than the clamp speed, the axis will linearly accelerate/decelerate at the inclination determined above. When this is set together with acceleration/deceleration time constant 2, S-character acceleration/deceleration is carried out. In this case, set the acceleration/deceleration time of the linear part in this parameter. | 1 ~ 9999 |
| #161 | time2.2 | Operation parameter group 2 Acceleration/deceleration time constant 2 | 1 | msec | Set this parameter when carrying out S-character acceleration/deceleration. When S-character acceleration/deceleration is carried out, set the total time of the non-linear parts. When 1 is set in this parameter, linear acceleration/deceleration is carried out. For the handle feed operation mode, this becomes the linear acceleration/deceleration that is the acceleration/deceleration time constant. | 1 ~ 9999 |
| #162 | TL2 | Operation parameter group 2 Torque limit value | 500 | % | Set the motor output torque limit value when operation parameter group 2 is selected. At the default value, the torque is limited at the maximum torque of the motor specifications. In the stopper positioning operation mode, this becomes the torque limit value during stopper operation. | 1 ~ 500 |
| #163 | OD2 | Operation parameter group 2 Excessive error detection width | 100 | deg (mm) | Set the excessive error detection width when operation parameter group 2 is selected. An excessive error alarm (S03 0052) is detected when the position droop becomes larger than this setting value. In the stopper positioning operation mode, this becomes the torque limit value excessive error detection width during stopper operation. | 0 ~ 32767 |
| #164 | just2 | Operation parameter group 2 Set position output width | 0.500 | deg (mm) | The signal indicating that the machine position is at any one of the stations is the set position reached (JST) signal. During automatic operation, the automatic set position reached (JSTA) signal is also output under the same conditions. Set the tolerable values at which these signals are output when operation parameter group 2 is selected. These signals turn OFF when the machine position is separated from the station by more than this value. | 0.000 ~ 99999.999 |
| #165 | near2 | Operation parameter group 2 Near set position output width | 1.000 | deg (mm) | The signal indicating that the machine position is near any one of the station positions is the near set position (NEAR) signal. Set the tolerable values at which these signals are output when operation parameter group 2 is selected. These values are generally set wider than the set position output width. During operations, this is related to special commands when the station selection is 0. Refer to section "6-4-3 Automatic operation." | 0.000 ~ 99999.999 |

Appendix Parameter Lists

< Operation parameter group 3 >

| No. | Abbrev. | Parameter name | Default value | Unit | Explanation | Setting range |
|------|---------|---|---------------|---------------------|--|-------------------|
| #166 | Aspeed3 | Operation parameter group 3 Automatic operation speed | 5000 | deg/min (mm/min) | Set the feedrate during automatic operation when operation parameter group 3 is selected. | 1 ~ 100000 |
| #167 | Mspeed3 | Operation parameter group 3 Manual operation speed | 2000 | deg/min (mm/min) | Set the feedrate during manual operation and JOG operation when operation parameter group 3 is selected. | 1 ~ 100000 |
| #168 | time3.1 | Operation parameter group 3 Acceleration/deceleration time constant 1 | 100 | msec | Set the linear acceleration/deceleration time for the operation parameter group 1 automatic operation speed (clamp speed) when operation parameter group 3 is selected. When operating at speeds less than the clamp speed, the axis will linearly accelerate/decelerate at the inclination determined above. When this is set together with acceleration/deceleration time constant 2, S-character acceleration/deceleration is carried out. In this case, set the acceleration/deceleration time of the linear part in this parameter. | 1 ~ 9999 |
| #169 | time3.2 | Operation parameter group 3 Acceleration/deceleration time constant 2 | 1 | msec | Set this parameter when carrying out S-character acceleration/deceleration. When S-character acceleration/deceleration is carried out, set the total time of the non-linear parts. When 1 is set in this parameter, linear acceleration/deceleration is carried out. For the handle feed operation mode, this becomes the linear acceleration/deceleration that is the acceleration/deceleration time constant. | 1 ~ 9999 |
| #170 | TL3 | Operation parameter group 3 Torque limit value | 500 | % | Set the motor output torque limit value when operation parameter group 3 is selected. At the default value, the torque is limited at the maximum torque of the motor specifications. In the stopper positioning operation mode, this becomes the pressing torque limit value after completion of the positioning. | 1 ~ 500 |
| #171 | OD3 | Operation parameter group 3 Excessive error detection width | 100 | deg (mm) | Set the excessive error detection width when operation parameter group 3 is selected. An excessive error alarm (S03 0052) is detected when the position droop becomes larger than this setting value. In the stopper positioning operation mode, this becomes the excessive error detection width during pressing after completion of the positioning. | 0 ~ 32767 |
| #172 | just3 | Operation parameter group 3 Set position output width | 0.500 | deg (mm) | The signal indicating that the machine position is at any one of the stations is the set position reached (JST) signal. During automatic operation, the automatic set position reached (JSTA) signal is also output under the same conditions. Set the tolerable values at which these signals are output when operation parameter group 3 is selected. These signals turn OFF when the machine position is separated from the station by more than this value. | 0.000 ~ 99999.999 |
| #173 | near3 | Operation parameter group 3 Near set position output width | 1.000 | deg (mm) | The signal indicating that the machine position is near any one of the station positions is the near set position (NEAR) signal. Set the tolerable values at which these signals are output when operation parameter group 3 is selected. These values are generally set wider than the set position output width. During operations, this is related to special commands when the station selection is 0. Refer to section "6-4-3 Automatic operation." | 0.000 ~ 99999.999 |

Appendix Parameter Lists

< Operation parameter group 4 >

| No. | Abbrev. | Parameter name | Default value | Unit | Explanation | Setting range |
|------|---------|---|---------------|---------------------|--|-------------------|
| #174 | Aspeed4 | Operation parameter group 4 Automatic operation speed | 5000 | deg/min (mm/min) | Set the feedrate during automatic operation when operation parameter group 4 is selected. | 1 ~ 100000 |
| #175 | Mspeed4 | Operation parameter group 4 Manual operation speed | 2000 | deg/min (mm/min) | Set the feedrate during manual operation and JOG operation when operation parameter group 4 is selected. | 1 ~ 100000 |
| #176 | time4.1 | Operation parameter group 4 Acceleration/deceleration time constant 1 | 100 | msec | Set the linear acceleration/deceleration time for the operation parameter group 1 automatic operation speed (clamp speed) when operation parameter group 4 is selected. When operating at speeds less than the clamp speed, the axis will linearly accelerate/decelerate at the inclination determined above. When this is set together with acceleration/deceleration time constant 2, S-character acceleration/deceleration is carried out. In this case, set the acceleration/deceleration time of the linear part in this parameter. | 1 ~ 9999 |
| #177 | time4.2 | Operation parameter group 4 Acceleration/deceleration time constant 2 | 1 | msec | Set this parameter when carrying out S-character acceleration/deceleration. When S-character acceleration/deceleration is carried out, set the total time of the non-linear parts. When 1 is set in this parameter, linear acceleration/deceleration is carried out. For the handle feed operation mode, this becomes the linear acceleration/deceleration that is the acceleration/deceleration time constant. | 1 ~ 9999 |
| #178 | TL4 | Operation parameter group 4 Torque limit value | 500 | % | Set the motor output torque limit value when operation parameter group 4 is selected. At the default value, the torque is limited at the maximum torque of the motor specifications. In the stopper default setting mode in absolute position detection systems, this becomes the torque limit value during stopper operation. | 1 ~ 500 |
| #179 | OD4 | Operation parameter group 4 Excessive error detection width | 100 | deg (mm) | Set the excessive error detection width when operation parameter group 4 is selected. An excessive error alarm (S03 0052) is detected when the position droop becomes larger than this setting value. In the stopper default setting mode in absolute position detection systems, this becomes the excessive error detection width during stopper operation. | 0 ~ 32767 |
| #180 | just4 | Operation parameter group 4 Set position output width | 0.500 | deg (mm) | The signal indicating that the machine position is at any one of the stations is the set position reached (JST) signal. During automatic operation, the automatic set position reached (JSTA) signal is also output under the same conditions. Set the tolerable values at which these signals are output when operation parameter group 4 is selected. These signals turn OFF when the machine position is separated from the station by more than this value. | 0.000 ~ 99999.999 |
| #181 | near4 | Operation parameter group 4 Near set position output width | 1.000 | deg (mm) | The signal indicating that the machine position is near any one of the station positions is the near set position (NEAR) signal. Set the tolerable values at which these signals are output when operation parameter group 4 is selected. These values are generally set wider than the set position output width. During operations, this is related to special commands when the station selection is 0. Refer to section "6-4-3 Automatic operation." | 0.000 ~ 99999.999 |

Appendix Parameter Lists

| No. | Abbrev. | Parameter name | Default value | Unit | Explanation | Setting range | | | | | | | | | | | | | | | | | | | | | | | | | | | | | | | | | | | | | | | | | | | | | | | |
|---|---|--|--|----------|---|--------------------------|-----|---|---|---|---|---|---|---|---|---|---|---|---|---|---|---|---|---------------|---|---|---|---|---|---|---|---|---|---|---|---|---|---|---|---|-----|--------------------------|--------------------------|---|---|--|---|---|---|---|---|---|---|
| #190 | stops2 | Station 2 coordinate value | 0.000 | deg (mm) | Set the coordinate value of each station when non-uniform assignment is selected. The station 1 coordinate value is fixed at 0.000 (machine coordinate zero point). | -99999.999 ~99999.999 | | | | | | | | | | | | | | | | | | | | | | | | | | | | | | | | | | | | | | | | | | | | | | | |
| #191 | stops3 | Station 3 coordinate value | | | | | | | | | | | | | | | | | | | | | | | | | | | | | | | | | | | | | | | | | | | | | | | | | | | |
| #192 | stops4 | Station 4 coordinate value | | | | | | | | | | | | | | | | | | | | | | | | | | | | | | | | | | | | | | | | | | | | | | | | | | | |
| #193 | stops5 | Station 5 coordinate value | | | | | | | | | | | | | | | | | | | | | | | | | | | | | | | | | | | | | | | | | | | | | | | | | | | |
| #194 | stops6 | Station 6 coordinate value | | | | | | | | | | | | | | | | | | | | | | | | | | | | | | | | | | | | | | | | | | | | | | | | | | | |
| #195 | stops7 | Station 7 coordinate value | | | | | | | | | | | | | | | | | | | | | | | | | | | | | | | | | | | | | | | | | | | | | | | | | | | |
| #196 | stops8 | Station 8 coordinate value | | | | | | | | | | | | | | | | | | | | | | | | | | | | | | | | | | | | | | | | | | | | | | | | | | | |
| #197 | stops9 | Station 9 coordinate value | | | | | | | | | | | | | | | | | | | | | | | | | | | | | | | | | | | | | | | | | | | | | | | | | | | |
| #200 | PSWcheck | PSW detection method | This is a HEX setting parameter. Set bits without a description to their default values. | | | | | | | | | | | | | | | | | | | | | | | | | | | | | | | | | | | | | | | | | | | | | | | | | | |
| <table border="1" style="width: 100%; border-collapse: collapse; text-align: center;"> <thead> <tr> <th>bit</th> <th>F</th> <th>E</th> <th>D</th> <th>C</th> <th>B</th> <th>A</th> <th>9</th> <th>8</th> <th>7</th> <th>6</th> <th>5</th> <th>4</th> <th>3</th> <th>2</th> <th>1</th> <th>0</th> </tr> </thead> <tbody> <tr> <td>Default value</td> <td>0</td> <td>0</td> <td>0</td> <td>0</td> <td>0</td> <td>0</td> <td>0</td> <td>0</td> <td>0</td> <td>0</td> <td>0</td> <td>0</td> <td>0</td> <td>0</td> <td>0</td> <td>0</td> </tr> </tbody> </table> <table border="1" style="width: 100%; border-collapse: collapse;"> <thead> <tr> <th>bit</th> <th>Meaning when "0" is set.</th> <th>Meaning when "1" is set.</th> </tr> </thead> <tbody> <tr> <td>0</td> <td rowspan="7">The position switch output is judged by the machine position of the command system.</td> <td rowspan="7">The position switch output is judged by the machine FB position (actual position).</td> </tr> <tr> <td>1</td> </tr> <tr> <td>2</td> </tr> <tr> <td>3</td> </tr> <tr> <td>4</td> </tr> <tr> <td>5</td> </tr> <tr> <td>6</td> </tr> <tr> <td>7</td> </tr> </tbody> </table> | | | | | | | bit | F | E | D | C | B | A | 9 | 8 | 7 | 6 | 5 | 4 | 3 | 2 | 1 | 0 | Default value | 0 | 0 | 0 | 0 | 0 | 0 | 0 | 0 | 0 | 0 | 0 | 0 | 0 | 0 | 0 | 0 | bit | Meaning when "0" is set. | Meaning when "1" is set. | 0 | The position switch output is judged by the machine position of the command system. | The position switch output is judged by the machine FB position (actual position). | 1 | 2 | 3 | 4 | 5 | 6 | 7 |
| bit | F | E | D | C | B | A | 9 | 8 | 7 | 6 | 5 | 4 | 3 | 2 | 1 | 0 | | | | | | | | | | | | | | | | | | | | | | | | | | | | | | | | | | | | | |
| Default value | 0 | 0 | 0 | 0 | 0 | 0 | 0 | 0 | 0 | 0 | 0 | 0 | 0 | 0 | 0 | 0 | | | | | | | | | | | | | | | | | | | | | | | | | | | | | | | | | | | | | |
| bit | Meaning when "0" is set. | Meaning when "1" is set. | | | | | | | | | | | | | | | | | | | | | | | | | | | | | | | | | | | | | | | | | | | | | | | | | | | |
| 0 | The position switch output is judged by the machine position of the command system. | The position switch output is judged by the machine FB position (actual position). | | | | | | | | | | | | | | | | | | | | | | | | | | | | | | | | | | | | | | | | | | | | | | | | | | | |
| 1 | | | | | | | | | | | | | | | | | | | | | | | | | | | | | | | | | | | | | | | | | | | | | | | | | | | | | |
| 2 | | | | | | | | | | | | | | | | | | | | | | | | | | | | | | | | | | | | | | | | | | | | | | | | | | | | | |
| 3 | | | | | | | | | | | | | | | | | | | | | | | | | | | | | | | | | | | | | | | | | | | | | | | | | | | | | |
| 4 | | | | | | | | | | | | | | | | | | | | | | | | | | | | | | | | | | | | | | | | | | | | | | | | | | | | | |
| 5 | | | | | | | | | | | | | | | | | | | | | | | | | | | | | | | | | | | | | | | | | | | | | | | | | | | | | |
| 6 | | | | | | | | | | | | | | | | | | | | | | | | | | | | | | | | | | | | | | | | | | | | | | | | | | | | | |
| 7 | | | | | | | | | | | | | | | | | | | | | | | | | | | | | | | | | | | | | | | | | | | | | | | | | | | | | |
| #201 | PSW1dog1 | PSW1 region setting 1 | 0.000 | deg (mm) | When the machine position is in the region between region settings 1 and 2, the position switch of each No. will turn ON. The size of the setting value for region setting 1 and 2 does not affect the position switch operation. For rotation axes, the output turns ON at the region not including 0.000. | -99999.999 ~99999.999 | | | | | | | | | | | | | | | | | | | | | | | | | | | | | | | | | | | | | | | | | | | | | | | |
| #202 | PSW1dog2 | PSW1 region setting 2 | | | | | | | | | | | | | | | | | | | | | | | | | | | | | | | | | | | | | | | | | | | | | | | | | | | |
| #203 | PSW2dog1 | PSW2 region setting 1 | | | | | | | | | | | | | | | | | | | | | | | | | | | | | | | | | | | | | | | | | | | | | | | | | | | |
| #204 | PSW2dog2 | PSW2 region setting 2 | | | | | | | | | | | | | | | | | | | | | | | | | | | | | | | | | | | | | | | | | | | | | | | | | | | |
| #205 | PSW3dog1 | PSW3 region setting 1 | | | | | | | | | | | | | | | | | | | | | | | | | | | | | | | | | | | | | | | | | | | | | | | | | | | |
| #206 | PSW3dog2 | PSW3 region setting 2 | | | | | | | | | | | | | | | | | | | | | | | | | | | | | | | | | | | | | | | | | | | | | | | | | | | |
| #207 | PSW4dog1 | PSW4 region setting 1 | | | | | | | | | | | | | | | | | | | | | | | | | | | | | | | | | | | | | | | | | | | | | | | | | | | |
| #208 | PSW4dog2 | PSW4 region setting 2 | | | | | | | | | | | | | | | | | | | | | | | | | | | | | | | | | | | | | | | | | | | | | | | | | | | |
| #209 | PSW5dog1 | PSW5 region setting 1 | | | | | | | | | | | | | | | | | | | | | | | | | | | | | | | | | | | | | | | | | | | | | | | | | | | |
| #210 | PSW5dog2 | PSW5 region setting 2 | | | | | | | | | | | | | | | | | | | | | | | | | | | | | | | | | | | | | | | | | | | | | | | | | | | |
| #211 | PSW6dog1 | PSW6 region setting 1 | | | | | | | | | | | | | | | | | | | | | | | | | | | | | | | | | | | | | | | | | | | | | | | | | | | |
| #212 | PSW6dog2 | PSW6 region setting 2 | | | | | | | | | | | | | | | | | | | | | | | | | | | | | | | | | | | | | | | | | | | | | | | | | | | |
| #213 | PSW7dog1 | PSW7 region setting 1 | | | | | | | | | | | | | | | | | | | | | | | | | | | | | | | | | | | | | | | | | | | | | | | | | | | |
| #214 | PSW7dog2 | PSW7 region setting 2 | | | | | | | | | | | | | | | | | | | | | | | | | | | | | | | | | | | | | | | | | | | | | | | | | | | |
| #215 | PSW8dog1 | PSW8 region setting 1 | | | | | | | | | | | | | | | | | | | | | | | | | | | | | | | | | | | | | | | | | | | | | | | | | | | |
| #216 | PSW8dog2 | PSW8 region setting 2 | | | | | | | | | | | | | | | | | | | | | | | | | | | | | | | | | | | | | | | | | | | | | | | | | | | |
| #220 | push | Stopper amount | 0.000 | deg (mm) | Set the command stroke of the stopper operation during stopper positioning operations. | 0.000 ~ 359.999 | | | | | | | | | | | | | | | | | | | | | | | | | | | | | | | | | | | | | | | | | | | | | | | |
| #221 | pusht1 | Stopper standby time | 0 | msec | Set the standby time from the stopper starting coordinate positioning to the stopper operation start during stopper positioning operations. | 0 ~ 9999 | | | | | | | | | | | | | | | | | | | | | | | | | | | | | | | | | | | | | | | | | | | | | | | |
| #222 | pusht2 | Stopper torque release time | 0 | msec | Set the time from the completion of the stopper operation to the changeover of the pressing torque during stopper positioning operations. | 0 ~ 9999 | | | | | | | | | | | | | | | | | | | | | | | | | | | | | | | | | | | | | | | | | | | | | | | |
| #223 | pusht3 | Set position signal output delay time | 0 | msec | Set the time from the completion of the stopper operation to the output of the automatic set position reached (JSTA), set position reached (JST), and near set position (NEAR) signals during stopper positioning operations. | 0 ~ 9999 | | | | | | | | | | | | | | | | | | | | | | | | | | | | | | | | | | | | | | | | | | | | | | | |

Revision History

| Date of print | Specifications and Instruction Manual No. | Revision details |
|---------------|---|--|
| Aug., 1996 | BCN-32105-004A | Provisional temporary version, simple print (unofficial version) |
| Mar., 1997 | BNP-B3944B | Revision temporary version, simple print (unofficial version) |
| June, 1997 | BNP-B3944C | First official version print |
| Jan., 1999 | BNP-B3944D | <p>Added HC-SF (3000rpm rating) Series (HC-SF53, HC-SF103, HC-SF153, HC-SF203, HC-SF353).</p> <p>Preface Added explanations. Revised errors.</p> <p>Section 1-1-1 Revised servomotor packing details.</p> <p>Section 1-1-2 Revised type display errors. Added new motor type descriptions</p> <p>Section 1-2-1 Revised control power supply connector terminal name errors.</p> <p>Section 1-2-2 Revised motor drawings.</p> <p>Section 1-3 Changed CN3 alarm signals to contactor control signals. Revised motor ground wire connection errors.</p> <p>Section 1-4 Added new motor.</p> <p>Section 1-5-3 Revised omissions.</p> <p>Section 1-5-6 Revised incremental feed mode additions.</p> <p>Section 1-5-11 Revised analog monitor description.</p> <p>Ch. 2 Preface Changed caution additions.</p> <p>Section 2-1 Revised system connection diagram errors.</p> <p>Section 2-2-1 Revised amplifier and terminal block drawings.</p> <p>Section 2-2-3 Added crimp tool maker name.</p> <p>Section 2-3 Revised drawing moved from section 2-6.</p> <p>Section 2-4 Revised connection diagrams. Added new motor. Changed P5E → P5. Revised errors.</p> <p>Section 2-5 Reviewed power supply connection method.</p> <p>Section 2-6 Newly added.</p> <p>Section 2-7-1 Revised drawings. Changed DO name alarm (ALM) to contactor control (MC).</p> <p>Section 2-7-2 Reviewed details and revised drawings.</p> <p>Section 3-1-2 Revised wiring allowance dimensions. Added cautions.</p> <p>Section 3-2-3 Moved from section 3-2-5.</p> <p>Section 3-2-4 Added new motor. Revised description details. Added cautions.</p> <p>Section 3-2-5 Revised description details. Added new motor.</p> <p>Section 3-2-6 Revised drawings.</p> <p>Section 4-1 Overall revision. Revised option regenerative resistor outline drawing.</p> <p>Section 4-2 Added item on battery option specifications.</p> <p>Section 4-2-2 Revised outline drawing. Revised connection diagram.</p> <p>Section 4-3 Newly added.</p> <p>Section 4-4 Revised system drawing.</p> <p>Section 4-4-1 Added new option part.</p> <p>Section 4-4-2 Added outline drawing of new option part.</p> <p>Section 4-4-3 Combined with old section 4-4 Changed name of Daiwa Conjet type.</p> <p>Section 4-4-4 Added descriptions of wire and cable protection tubes.</p> <p>Section 4-4-5 Added NC bus cable connection diagram. Reviewed detector cable connection diagram.</p> <p>Section 4-6 Reviewed wire selection method.</p> <p>Section 4-7 Reviewed no-fuse breaker selection method.</p> <p>Section 4-8 Reviewed contactor selection method.</p> <p>Section 5-1 Overall revision.</p> <p>Section 5-2 Newly added.</p> <p>Section 5-3 Eliminated automatic default setting mode selection. Added READY OFF. Revised errors.</p> <p>Section 5-4 Eliminated "In automatic default setting mode". Added near-point dog. Revised errors.</p> |

| Date of print | Specifications and Instruction Manual No. | Revision details | |
|---------------|---|---|---|
| Jan., 1999 | BNP-B3944D | <p>Section 6-1</p> <p>Section 6-2</p> <p>Section 6-3</p> <p>Section 6-4</p> <p>Section 6-6</p> <p>Section 6-7</p> <p>Section 7-1</p> <p>Section 7-2</p> <p>Section 8-1</p> <p>Section 8-2</p> <p>Section 8-3</p> <p>Section 8-4</p> <p>Chapter 10</p> <p>Section 11-2-1</p> <p>Section 11-3-2</p> <p>Section 11-4</p> <p>Section 12-1-1</p> <p>Section 12-1-2</p> <p>Section 12-2-1</p> <p>Section 12-2-2</p> <p>Section 12-2-3</p> <p>Section 12-2-4</p> <p>Section 13-1-2</p> <p>Section 13-2-1</p> <p>Section 13-3-1</p> <p>Section 13-3-2</p> <p>Section 13-3-3</p> <p>Section 13-4-1</p> <p>Section 13-4-2</p> <p>Section 13-5</p> <p>Section 13-6</p> <p>Section 13-7</p> <p>Appendix</p> | <p>Added details of parameter default setting. Revised errors. Added details.</p> <p>Added signal sequence. Revised errors. Added details.</p> <p>Added details.</p> <p>Included random position command operation in automatic operation. Added signal sequence. Revised errors. Added details.</p> <p>Added soft limit function and READY OFF function.</p> <p>Newly added.</p> <p>Moved battery specification to Chapter 4.</p> <p>Eliminated automatic stopper method.</p> <p>Added explanation related to model adaptive control.</p> <p>Overall detail revision.</p> <p>Newly added.</p> <p>Newly added.</p> <p>Revised errors.</p> <p>Added new motor.</p> <p>Added new motor. Revised errors.</p> <p>Changed overall explanation of dynamic brake characteristics.</p> <p>Added item on servo amplifier specifications. Revised protective form.</p> <p>Moved from section 12-2-21 Revised servo amplifier outline drawing.</p> <p>Added new motor. Revised errors in HA-FF33 specification data. Added description of HA-FF structure.</p> <p>Added new motor. Separated from list of motor specifications.</p> <p>Added new motor. Separated from those with brakes. Added HA-FF C-UE Series. Revised HC-SF, HC-MF(B)-UE motor dimensions.</p> <p>Newly added.</p> <p>Newly added.</p> <p>Newly added.</p> <p>Newly added.</p> <p>Added simplified of acceleration/deceleration time constant drawing. (End of section.)</p> <p>Added description of load torque.</p> <p>Added new motor. Changed regeneration energy calculation method table. Added example.</p> <p>Change unbalance axis regeneration capacity calculation method. Added example.</p> <p>Added new servo selection example.</p> <p>Revised errors in linear operation calculation method.</p> <p>Revised errors in prism calculation method.</p> <p>Changed setting ranges of #152, #153, #160, #161, #168, #169, #176, and #177. Changed default setting value of #120.</p> |
| June, 2000 | BNP-B3944E | <p>Unified units to SI units due to the new measuring laws. Changed font size and line pitch.</p> <p>Acquired UL/c-UL Standards compliance.</p> <p>Preface</p> <p>Section 1-1-2</p> | <p>Added explanation regarding UL Standards. Changed cautions on page 1.</p> <p>Changed servo amplifier rating nameplate to comply with UL Standards.</p> <p>Added HC-SF and HC-RF motor taper shaft specifications. Added HC-MF -S15 (IP65 specification).</p> <p>Added description regarding UL Standards compliance.</p> |

| Date of print | Specifications and Instruction Manual No. | Revision details | |
|---------------|---|--|---|
| June, 2000 | BNP-B3944E | <p>Section 2-2-1</p> <p>Section 2-4</p> <p>Section 2-4-5</p> <p>Section 2-4-7</p> <p>Section 2-4-8</p> <p>Section 2-5-2</p> <p>Section 3-2-2</p> <p>Section 3-2-4</p> <p>Section 3-2-5</p> <p>Section 4-4</p> <p>Section 4-4-5</p> <p>Section 4-6</p> <p>Section 4-7</p> <p>Section 4-8</p> <p>Section 4-9-1</p> <p>Section 4-9-3</p> <p>Chapter 6</p> <p>Section 6-4-4</p> <p>Chapter 7</p> <p>Section 10-2-2</p> <p>Section 10-3</p> <p>Section 10-3-3</p> <p>Section 11-4-2</p> <p>Section 12-1-2</p> <p>Section 12-2-3</p> <p>Section 13-5-1</p> <p>Appendix</p> | <p>Added terminal screw size and tightening torque for each terminal block.</p> <p>Added MD, MDR and CONT to the amplifier connector pin displays and detector connector pin displays.</p> <p>Corrected detector cable connector type. Added detector connector type.</p> <p>Corrected detector connector pin 9 name (LG → SD).</p> <p>Corrected detector cable connector type. Added detector connector type.</p> <p>Corrected detector connector pin 9 name (LG → SD).</p> <p>Added HC-MF -S15 (IP65 specification) connection drawing.</p> <p>Changed converter type description to MDS-B-CVE. (1) Added cautions. (2) Added cautions for MDS-B-CVE-450 and above.</p> <p>Changed explanatory drawing.</p> <p>Added HC-SF and HC-RF motor taper shaft specifications. Corrected HC-MF23 tolerable shaft load.</p> <p>Added items, and changed explanatory drawing. Added cautions. Added HC-MF motor IP65 specification.</p> <p>Added detector cable, connector set and power supply connector for MC-MF -S15 (IP65 specification).</p> <p>Changed (2) and (3) detector cable manufacturing connection drawing to 4-wire communication.</p> <p>Added UL Standards compliance notations to the wire sizes. Added crimp terminal and tool type.</p> <p>Changed converter series to MDS-B-CVE.</p> <p>Changed converter series to MDS-B-CVE.</p> <p>Corrected circuit protector rated current.</p> <p>Revised surge absorber (Matsushita Denki) to the new series type.</p> <p>Added explanation of bit6 to parameter explanation #102 *Cont2. (3 places)</p> <p>(2) Made correction. (MAN → MANO)</p> <p>Added explanation of bit6 to parameter explanation #102 *Cont2. (1 place)</p> <p>Revised "Display on personal computer" in table to "Display on NC screen".</p> <p>Revised "Personal computer display" in table to "NC screen display".</p> <p>Revised causes of M01 0165 occurrence.</p> <p>Revised Fig. 11-5.</p> <p>Added notation on terminal block screw sizes.</p> <p>Added outline dimension drawing for the HC-SF and HC-RF motor taper shaft specifications. Added cautions.</p> <p>Divided HC-MF motor outline drawing into three capacities. Added HC-MF -S15 (IP65 specification). Changed tightening torque unit (kgf·cm → N·m).</p> <p>Revised Fig. 13-4.</p> <p>Added explanation of #102 *Cont2.bit6.</p> |

Notice

Every effort has been made to keep up with software and hardware revisions in the contents described in this manual. However, please understand that in some unavoidable cases simultaneous revision is not possible.

Please contact your Mitsubishi Electric dealer with any questions or comments regarding the use of this product.

Duplication Prohibited

This instruction manual may not be reproduced in any form, in part or in whole, without written permission from Mitsubishi Electric Corporation.

© 1999 MITSUBISHI ELECTRIC CORPORATION
ALL RIGHTS RESERVED



mitsubishi MITSUBISHI ELECTRIC CORPORATION

HEAD OFFICE: MITSUBISHI DENKI BLD. MARUNOUCHI. TOKYO 100-0005 TEL:03-218-3426

These products or technologies are subject to Japanese and/or
COCOM strategic restriction contrary thereto is prohibit.