



General-Purpose AC Servo

MITSUBISHI SERVO AMPLIFIERS & MOTORS
MELSERVO-J4

SSCNET III/H Interface AC Servo
MODEL

MR-J4- _B

SERVO AMPLIFIER
INSTRUCTION MANUAL



www.nicsanat.com

021-87700210

● Safety Instructions ●

Please read the instructions carefully before using the equipment.

To use the equipment correctly, do not attempt to install, operate, maintain, or inspect the equipment until you have read through this Instruction Manual, Installation guide, and appended documents carefully. Do not use the equipment until you have a full knowledge of the equipment, safety information and instructions. In this Instruction Manual, the safety instruction levels are classified into "WARNING" and "CAUTION".



Indicates that incorrect handling may cause hazardous conditions, resulting in death or severe injury.



Indicates that incorrect handling may cause hazardous conditions, resulting in medium or slight injury to personnel or may cause physical damage.

Note that the CAUTION level may lead to a serious consequence according to conditions. Please follow the instructions of both levels because they are important to personnel safety. What must not be done and what must be done are indicated by the following diagrammatic symbols.



Indicates what must not be done. For example, "No Fire" is indicated by .



Indicates what must be done. For example, grounding is indicated by .

In this Instruction Manual, instructions at a lower level than the above, instructions for other functions, and so on are classified into "POINT".

After reading this Instruction Manual, keep it accessible to the operator.

1. To prevent electric shock, note the following

WARNING

- Before wiring and inspections, turn off the power and wait for 15 minutes or more until the charge lamp turns off. Then, confirm that the voltage between P+ and N- is safe with a voltage tester and others. Otherwise, an electric shock may occur. In addition, when confirming whether the charge lamp is off or not, always confirm it from the front of the servo amplifier.
- Ground the servo amplifier and servo motor securely.
- Any person who is involved in wiring and inspection should be fully competent to do the work.
- Do not attempt to wire the servo amplifier and servo motor until they have been installed. Otherwise, it may cause an electric shock.
- Do not operate switches with wet hands. Otherwise, it may cause an electric shock.
- The cables should not be damaged, stressed, loaded, or pinched. Otherwise, it may cause an electric shock.
- During power-on or operation, do not open the front cover of the servo amplifier. Otherwise, it may cause an electric shock.
- Do not operate the servo amplifier with the front cover removed. High-voltage terminals and charging area are exposed and you may get an electric shock.
- Except for wiring and periodic inspection, do not remove the front cover of the servo amplifier even if the power is off. The servo amplifier is charged and you may get an electric shock.
- To prevent an electric shock, always connect the protective earth (PE) terminal (marked \oplus) of the servo amplifier to the protective earth (PE) of the cabinet.
- When using a residual current device (RCD), select the type B.
- To avoid an electric shock, insulate the connections of the power supply terminals.

2. To prevent fire, note the following

CAUTION

- Install the servo amplifier, servo motor, and regenerative resistor on incombustible material. Installing it directly or close to combustibles will lead to a fire.
- Always connect a magnetic contactor between the power supply and the main circuit power supply (L1, L2, and L3) of the servo amplifier, in order to configure a circuit that shuts down the power supply on the side of the servo amplifier's power supply. If a magnetic contactor is not connected, continuous flow of a large current may cause a fire when the servo amplifier malfunctions.
- When using the regenerative resistor, switch power off with the alarm signal. Not doing so may cause a fire when a regenerative transistor malfunctions or the like may overheat the regenerative resistor.
- Provide adequate protection to prevent screws and other conductive matter, oil and other combustible matter from entering the servo amplifier and servo motor.
- Always connect a molded case circuit breaker to the power supply of the servo amplifier.

3. To prevent injury, note the following

CAUTION

- Only the voltage specified in the Instruction Manual should be applied to each terminal. Otherwise, a burst, damage, etc. may occur.
- Connect cables to the correct terminals. Otherwise, a burst, damage, etc. may occur.
- Ensure that polarity (+/-) is correct. Otherwise, a burst, damage, etc. may occur.
- The servo amplifier heat sink, regenerative resistor, servo motor, etc. may be hot while power is on or for some time after power-off. Take safety measures, e.g. provide covers, to prevent accidental contact of hands and parts (cables, etc.) with them.

4. Additional instructions

The following instructions should also be fully noted. Incorrect handling may cause a fault, injury, electric shock, etc.

(1) Transportation and installation

CAUTION

- Transport the products correctly according to their mass.
- Stacking in excess of the specified number of product packages is not allowed.
- Do not hold the front cover when transporting the servo amplifier. Otherwise, it may drop.
- Install the servo amplifier and the servo motor in a load-bearing place in accordance with the Instruction Manual.
- Do not get on or put heavy load on the equipment.
- The equipment must be installed in the specified direction.
- Leave specified clearances between the servo amplifier and the cabinet walls or other equipment.
- Do not install or operate the servo amplifier and servo motor which have been damaged or have any parts missing.
- Do not block the intake and exhaust areas of the servo amplifier. Otherwise, it may cause a malfunction.
- Do not drop or strike the servo amplifier and servo motor. Isolate them from all impact loads.
- When you keep or use the equipment, please fulfill the following environment.

Items		Environment
Ambient temperature	Operation	0 °C to 55 °C (non-freezing)
	Storage	-20 °C to 65 °C (non-freezing)
Ambient humidity	Operation	90% RH or less (non-condensing)
	Storage	
Ambience		Indoors (no direct sunlight), free from corrosive gas, flammable gas, oil mist, dust, and dirt
Altitude		Max. 1000 m above sea level
Vibration		5.9 m/s ² or less at 10 Hz to 55 Hz (directions of X, Y, and Z axes)

- When the equipment has been stored for an extended period of time, consult your local sales office.
- When handling the servo amplifier, be careful about the edged parts such as corners of the servo amplifier.
- The servo amplifier must be installed in the metal cabinet.

(2) Wiring

⚠ CAUTION

- Wire the equipment correctly and securely. Otherwise, the servo motor may operate unexpectedly.
- Do not install a power capacitor, surge killer, or radio noise filter (FR-BIF option) on the servo amplifier output side.
- To avoid a malfunction, connect the wires to the correct phase terminals (U, V, and W) of the servo amplifier and servo motor.
- Connect the servo amplifier power output (U, V, and W) to the servo motor power input (U, V, and W) directly. Do not let a magnetic contactor, etc. intervene. Otherwise, it may cause a malfunction.

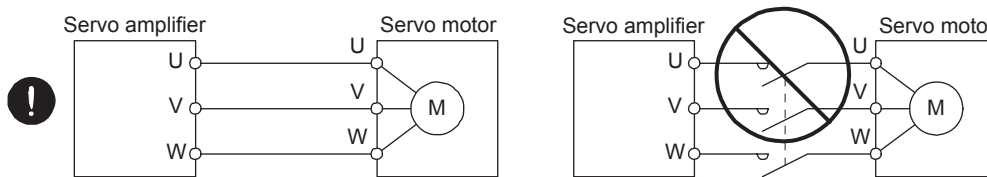

- The surge absorbing diode installed to the DC relay for control output should be fitted in the specified direction. Otherwise, the emergency stop and other protective circuits may not operate.

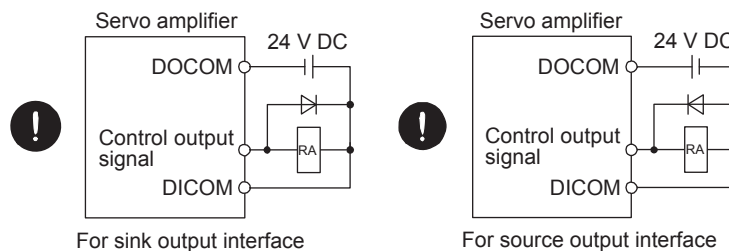

- When the cable is not tightened enough to the terminal block, the cable or terminal block may generate heat because of the poor contact. Be sure to tighten the cable with specified torque.

(3) Test run and adjustment

⚠ CAUTION

- Before operation, check the parameter settings. Improper settings may cause some machines to perform unexpected operation.
- Never adjust or change the parameter values extremely as it will make operation unstable.

(4) Usage

⚠ CAUTION

- Provide an external emergency stop circuit to ensure that operation can be stopped and power switched off immediately.
- Do not disassemble, repair, or modify the equipment.
- Before resetting an alarm, make sure that the run signal of the servo amplifier is off in order to prevent a sudden restart. Otherwise, it may cause an accident.
- Use a noise filter, etc. to minimize the influence of electromagnetic interference. Electromagnetic interference may be given to the electronic equipment used near the servo amplifier.

! CAUTION

- Burning or breaking a servo amplifier may cause a toxic gas. Do not burn or break it.
- Use the servo amplifier with the specified servo motor.
- The electromagnetic brake on the servo motor is designed to hold the motor shaft and should not be used for ordinary braking.
- For such reasons as service life and mechanical structure (e.g. where a ball screw and the servo motor are coupled via a timing belt), the electromagnetic brake may not hold the motor shaft. To ensure safety, install a stopper on the machine side.

(5) Corrective actions

! CAUTION

- When it is assumed that a hazardous condition may occur due to a power failure or product malfunction, use a servo motor with an electromagnetic brake or external brake to prevent the condition.
- Configure an electromagnetic brake circuit so that it is activated also by an external EMG stop switch.

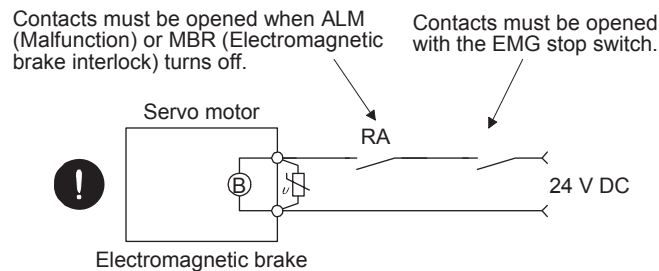

- When any alarm has occurred, eliminate its cause, ensure safety, and deactivate the alarm before restarting operation.
- Provide an adequate protection to prevent unexpected restart after an instantaneous power failure.

(6) Maintenance, inspection and parts replacement

! CAUTION

- With age, the electrolytic capacitor of the servo amplifier will deteriorate. To prevent a secondary accident due to a malfunction, it is recommended that the electrolytic capacitor be replaced every 10 years when it is used in general environment. Please contact your local sales office.

(7) General instruction

- To illustrate details, the equipment in the diagrams of this Instruction Manual may have been drawn without covers and safety guards. When the equipment is operated, the covers and safety guards must be installed as specified. Operation must be performed in accordance with this Specifications and Instruction Manual.

● DISPOSAL OF WASTE ●

Please dispose a servo amplifier, battery (primary battery) and other options according to your local laws and regulations.

EEPROM life

The number of write times to the EEPROM, which stores parameter settings, etc., is limited to 100,000. If the total number of the following operations exceeds 100,000, the servo amplifier may malfunction when the EEPROM reaches the end of its useful life.

- Write to the EEPROM due to parameter setting changes
- Write to the EEPROM due to device changes

STO function of the servo amplifier

When using the STO function of the servo amplifier, refer to chapter 13.
For the MR-J3-D05 safety logic unit, refer to appendix 7.

COMPLIANCE WITH CE MARKING

Refer to Appendix 4 for the compliance with CE marking.

COMPLIANCE WITH UL/CSA STANDARD

Refer to Appendix 5 for the compliance with UL/CSA standard.

<<About the manuals>>

You must have this Instruction Manual and the following manuals to use this servo. Ensure to prepare them to use the servo safely.

Relevant manuals

Manual name	Manual No.
MELSERVO-J4 Series Instructions and Cautions for Safe Use of AC Servos (Packed with the servo amplifier)	IB(NA)0300175
MELSERVO-J4 SERVO AMPLIFIER INSTRUCTION MANUAL (TROUBLESHOOTING)	SH(NA)030109
MELSERVO Servo Motor Instruction Manual (Vol. 3) (Note 1)	SH(NA)030113
MELSERVO Linear Servo Motor Instruction Manual (Note 2)	SH(NA)030110
MELSERVO Direct Drive Motor Instruction Manual (Note 3)	SH(NA)030112
MELSERVO Linear Encoder Instruction Manual (Note 2, 4)	SH(NA)030111
EMC Installation Guidelines	IB(NA)67310

- Note 1. It is necessary for using a rotary servo motor.
 2. It is necessary for using a linear servo motor.
 3. It is necessary for using a direct drive motor.
 4. It is necessary for using a fully closed loop system.

<<Wiring>>

Wires mentioned in this Instruction Manual are selected based on the ambient temperature of 40 °C.

<<U.S. customary units>>

U.S. customary units are not shown in this manual. Convert the values if necessary according to the following table.

Quantity	SI (metric) unit	U.S. customary unit
Mass	1 [kg]	2.2046 [lb]
Length	1 [mm]	0.03937 [in]
Torque	1 [N·m]	141.6 [oz·in]
Moment of inertia	1 [($\times 10^{-4}$ kg·m ²)]	5.4675 [oz·in ²]
Load (thrust load/axial load)	1 [N]	0.2248 [lbf]
Temperature	N [°C] $\times 9/5 + 32$	N [°F]

CONTENTS

1. FUNCTIONS AND CONFIGURATION	1- 1 to 1-18
1.1 Summary	1- 1
1.2 Function block diagram	1- 2
1.3 Servo amplifier standard specifications	1- 4
1.4 Combinations of servo amplifiers and servo motors	1- 6
1.5 Function list	1- 7
1.6 Model designation	1- 8
1.7 Structure	1- 9
1.7.1 Parts identification	1- 9
1.7.2 Removal and reinstallation of the front cover	1-13
1.8 Configuration including auxiliary equipment	1-15
2. INSTALLATION	2- 1 to 2- 8
2.1 Installation direction and clearances	2- 2
2.2 Keep out foreign materials	2- 3
2.3 Encoder cable stress	2- 4
2.4 SSCNET III cable laying	2- 4
2.5 Inspection items	2- 6
2.6 Parts having service lives	2- 7
3. SIGNALS AND WIRING	3- 1 to 3-38
3.1 Input power supply circuit	3- 2
3.2 I/O signal connection example	3- 8
3.2.1 For sink I/O interface	3- 8
3.2.2 For source I/O interface	3-10
3.3 Explanation of power supply system	3-11
3.3.1 Signal explanations	3-11
3.3.2 Power-on sequence	3-13
3.3.3 Wiring CNP1, CNP2, and CNP3	3-12
3.4 Connectors and pin assignment	3-15
3.5 Signal (device) explanations	3-17
3.5.1 Input device	3-17
3.5.2 Output device	3-18
3.5.3 Output signal	3-19
3.5.4 Power supply	3-19
3.6 Forced stop deceleration function	3-20
3.6.1 Forced stop deceleration function (SS1)	3-20
3.6.2 Base circuit shut-off delay time function	3-21
3.6.3 Vertical axis freefall prevention function	3-22
3.6.4 Residual risks of the forced stop function (EM2)	3-23
3.7 Alarm occurrence timing chart	3-24
3.7.1 When you use the forced stop deceleration function	3-24
3.7.2 When you do not use the forced stop deceleration function	3-25
3.8 Interfaces	3-26
3.8.1 Internal connection diagram	3-26
3.8.2 Detailed description of interfaces	3-27

3.8.3 Source I/O interface	3-29
3.9 SSCNET III cable connection	3-30
3.10 Servo motor with an electromagnetic brake	3-32
3.10.1 Safety precautions	3-32
3.10.2 Timing chart	3-33
3.11 Grounding	3-37

4. STARTUP	4- 1 to 4-18
-------------------	---------------------

4.1 Switching power on for the first time	4- 1
4.1.1 Startup procedure	4- 2
4.1.2 Wiring check	4- 3
4.1.3 Surrounding environment	4- 4
4.2 Startup	4- 5
4.3 Switch setting and display of the servo amplifier	4- 6
4.3.1 Switches	4- 6
4.3.2 Scrolling display	4-10
4.3.3 Status display of an axis	4-11
4.4 Test operation	4-13
4.5 Test operation mode	4-13
4.5.1 Test operation mode in MR Configurator2	4-14
4.5.2 Motor-less operation in controller	4-17

5. PARAMETERS	5- 1 to 5-48
----------------------	---------------------

5.1 Parameter list	5- 1
5.1.1 Basic setting parameters ([Pr. PA_ _])	5- 2
5.1.2 Gain/filter setting parameters ([Pr. PB_ _])	5- 3
5.1.3 Extension setting parameters ([Pr. PC_ _])	5- 4
5.1.4 I/O setting parameters ([Pr. PD_ _])	5- 6
5.1.5 Extension setting 2 parameters ([Pr. PE_ _])	5- 7
5.1.6 Extension setting 3 parameters ([Pr. PF_ _])	5- 8
5.1.7 Linear servo motor/DD motor setting parameters ([Pr. PL_ _])	5- 9
5.2 Detailed list of parameters	5- 11
5.2.1 Basic setting parameters ([Pr. PA_ _])	5- 11
5.2.2 Gain/filter setting parameters ([Pr. PB_ _])	5- 20
5.2.3 Extension setting parameters ([Pr. PC_ _])	5- 33
5.2.4 I/O setting parameters ([Pr. PD_ _])	5- 39
5.2.5 Extension setting 2 parameters ([Pr. PE_ _])	5- 42
5.2.6 Extension setting 3 parameters ([Pr. PF_ _])	5- 44
5.2.7 Linear servo motor/DD motor setting parameters ([Pr. PL_ _])	5- 45

6. NORMAL GAIN ADJUSTMENT	6- 1 to 6-18
----------------------------------	---------------------

6.1 Different adjustment methods	6- 1
6.1.1 Adjustment on a single servo amplifier	6- 1
6.1.2 Adjustment using MR Configurator2	6- 2
6.2 One-touch tuning	6- 3
6.2.1 One-touch tuning flowchart	6- 3
6.2.2 Display transition and operation procedure of one-touch tuning	6- 4
6.2.3 Caution for one-touch tuning	6- 8

6.3 Auto tuning	6- 9
6.3.1 Auto tuning mode	6- 9
6.3.2 Auto tuning mode basis	6-10
6.3.3 Adjustment procedure by auto tuning	6-11
6.3.4 Response level setting in auto tuning mode	6-12
6.4 Manual mode	6-13
6.5 2 gain adjustment mode	6-17

7. SPECIAL ADJUSTMENT FUNCTIONS

7- 1 to 7-28

7.1 Filter setting	7- 1
7.1.1 Machine resonance suppression filter	7- 1
7.1.2 Adaptive filter II	7- 4
7.1.3 Shaft resonance suppression filter	7- 6
7.1.4 Low-pass filter	7- 7
7.1.5 Advanced vibration suppression control II	7- 7
7.1.6 Command notch filter	7-12
7.2 Gain switching function	7-13
7.2.1 Applications	7-14
7.2.2 Function block diagram	7-15
7.2.3 Parameter	7-16
7.2.4 Gain switching procedure	7-19
7.3 Tough drive function	7-22
7.3.1 Vibration tough drive function	7-22
7.3.2 Instantaneous power failure tough drive function	7-24

8. TROUBLESHOOTING

8- 1 to 8- 8

8.1 Alarm and warning list	8- 1
8.2 Troubleshooting at power on	8- 7

9. OUTLINE DRAWINGS

9- 1 to 9-10

9.1 Servo amplifier	9- 1
9.2 Connector	9- 8

10. CHARACTERISTICS

10- 1 to 10-8

10.1 Overload protection characteristics	10- 1
10.2 Power supply capacity and generated loss	10- 3
10.3 Dynamic brake characteristics	10- 5
10.3.1 Dynamic brake operation	10- 5
10.3.2 Permissible load to motor inertia when the dynamic brake is used	10- 6
10.4 Cable bending life	10- 7
10.5 Inrush currents at power-on of main circuit and control circuit	10- 7

11. OPTIONS AND AUXILIARY EQUIPMENT

11- 1 to 11-52

11.1 Cable/connector sets	11- 1
11.1.1 Combinations of cable/connector sets	11- 2
11.1.2 MR-D05UDL3M-B STO cable	11- 4

11.1.3 SSCNET III cable	11- 5
11.2 Regenerative options	11- 7
11.2.1 Combination and regenerative power	11- 7
11.2.2 Selection of the regenerative option.....	11- 8
11.2.3 parameter setting	11-11
11.2.4 Connection of regenerative option	11-11
11.2.5 Dimensions.....	11-14
11.3 FR-BU2 Brake unit.....	11-16
11.3.1 Selection.....	11-16
11.3.2 Brake unit parameter setting	11-16
11.3.3 Connection example.....	11-17
11.3.4 Dimensions.....	11-22
11.4 FR-RC Power regenerative converter	11-23
11.5 Power regenerative common converter.....	11-26
11.6 Junction terminal block PS7DW-20V14B-F (recommended)	11-30
11.7 MR Configurator2	11-31
11.8 Battery	11-33
11.9 Selection example of wires	11-34
11.10 Molded case circuit breakers, fuses, magnetic contactors.....	11-36
11.11 Power factor improving DC reactors.....	11-36
11.12 Power factor improving AC reactors	11-38
11.13 Relays (recommended)	11-39
11.14 Noise reduction techniques	11-39
11.15 Leakage current breaker.....	11-47
11.16 EMC filter (recommended).....	11-50

12. ABSOLUTE POSITION DETECTION SYSTEM

12- 1 to 12- 6

12.1 Features	12- 1
12.2 Specifications	12- 2
12.3 Battery replacement procedure	12- 3
12.4 Battery installation and removal procedure	12- 4
12.5 Confirmation of absolute position detection data.....	12- 6

13. USING STO FUNCTION

13- 1 to 13-12

13.1 Introduction	13- 1
13.1.1 Summary	13- 1
13.1.2 Terms related to safety.....	13- 1
13.1.3 Cautions	13- 1
13.1.4 Residual risks of the STO function.....	13- 2
13.1.5 Specifications	13- 3
13.1.6 Maintenance	13- 4
13.2 STO I/O signal connector (CN8) and signal layouts.....	13- 4
13.2.1 Pin assignment.....	13- 4
13.2.2 Signal (device) explanations	13- 5
13.2.3 How to pull out the STO cable	13- 5
13.3 Connection example	13- 6
13.3.1 Connection example for CN8 connector.....	13- 6
13.3.2 External I/O signal connection example using a MR-J3-D05 safety logic unit	13- 7
13.3.3 External I/O signal connection example using an external safety relay unit.....	13- 8

13.3.4 External I/O signal connection example using a motion controller	13- 9
13.4 Detailed description of interfaces.....	13-10
13.4.1 Sink I/O interface.....	13-10
13.4.2 Source I/O interface	13-11

14. USING A LINEAR SERVO MOTOR	14- 1 to 14-30
---------------------------------------	-----------------------

14.1 Functions and configuration.....	14- 1
14.1.1 Summary	14- 1
14.1.2 Servo system with auxiliary equipment	14- 2
14.2 Signals and wiring	14- 3
14.3 Operation and functions.....	14- 5
14.3.1 Startup	14- 5
14.3.2 Magnetic pole detection	14- 8
14.3.3 Home position return	14-16
14.3.4 Test operation mode in MR Configurator2.....	14-20
14.3.5 Operation from controller.....	14-22
14.3.6 Function.....	14-23
14.3.7 Absolute position detection system.....	14-25
14.4 Characteristics	14-26
14.4.1 Overload protection characteristics.....	14-26
14.4.2 Power supply capacity and generated loss.....	14-27
14.4.3 Dynamic brake characteristics	14-28
14.4.4 Permissible load to motor mass ratio when the dynamic brake is used	14-29

15. USING A DIRECT DRIVE MOTOR	15- 1 to 15-20
---------------------------------------	-----------------------

15.1 Functions and configuration.....	15- 1
15.1.1 Summary	15- 1
15.1.2 Servo system with auxiliary equipment	15- 2
15.2 Signals and wiring	15- 3
15.3 Operation and functions.....	15- 4
15.3.1 Startup procedure.....	15- 5
15.3.2 Magnetic pole detection	15- 6
15.3.3 Operation from controller.....	15-13
15.3.4 Function.....	15-15
15.4 Characteristics	15-16
15.4.1 Overload protection characteristics.....	15-16
15.4.2 Power supply capacity and generated loss.....	15-18
15.4.3 Dynamic brake characteristics	15-18

16. FULLY CLOSED LOOP SYSTEM (available in the future)	16- 1 to 16-24
---	-----------------------

16.1 Functions and configuration.....	16- 1
16.1.1 Function block diagram	16- 1
16.1.2 Selecting procedure of control mode	16- 3
16.1.3 System configuration.....	16- 4
16.2 Load-side encoder	16- 5
16.2.1 LINEAR ENCODER	16- 5
16.2.2 Rotary encoder.....	16- 5
16.2.3 Configuration diagram of encoder cable	16- 5

16.2.4 MR-J4FCCBL03M branch cable	16- 7
16.3 Operation and functions	16- 8
16.3.1 Startup	16- 8
16.3.2 Home position return	16-14
16.3.3 Operation from controller.....	16-17
16.3.4 Fully closed loop control error detection functions.....	16-19
16.3.5 Absolute position detection system under fully closed loop system	16-21
16.3.6 About MR Configurator 2.....	16-22

APPENDIX	App.- 1 to App.-40
----------	--------------------

App. 1 Auxiliary equipment manufacturer (for reference).....	App.- 1
App. 2 Handling of AC servo amplifier batteries for the United Nations Recommendations on the Transport of Dangerous Goods.....	App.- 1
App. 3 Symbol for the new EU Battery Directive	App.- 4
App. 4 Compliance with the CE marking	App.- 4
App. 5 Compliance with UL/CSA standard	App.- 6
App. 6 Compliance with KC mark	App.- 9
App. 7 MR-J3-D05 Safety logic unit.....	App.-10
App. 8 EC declaration of conformity	App.-29
App. 9 How to replace servo amplifier without magnetic pole detection	App.-30
App. 10 Two-wire type encoder cable for HG-MR/HG-KR	App.-31
App. 11 SSCNET III cable (SC-J3BUS_M-C) manufactured by Mitsubishi Electric System & Service.....	App.-33
App.12 Analog monitor	App.-33

1. FUNCTIONS AND CONFIGURATION

1. FUNCTIONS AND CONFIGURATION

1.1 Summary

The Mitsubishi MELSERVO-J4 series general-purpose AC servo has further higher performance and higher functions compared to the previous MELSERVO-J3 series.

MR-J4-B servo amplifier is connected to controllers, including a servo system controller, on the high-speed synchronous network SSCNET III/H. The servo amplifier directly receives a command from a controller to drive a servo motor.

MELSERVO-J4 series compatible rotary servo motor is equipped with 22-bit (4194304 pulses/rev) high-resolution absolute encoder. In addition, speed frequency response is increased to 2.5 kHz. Thus, faster and more accurate control is enabled as compared to MELSERVO-J3 series.

MR-J4-B servo amplifier operates MELSERVO-J4 series compatible rotary servo motors, linear servo motors, and direct drive motors as standard.

With one-touch tuning and real-time auto tuning, you can automatically adjust the servo gains according to the machine.

The tough drive function and the drive recorder function, which are well-received in the MELSERVO-JN series, have been improved. The MR-J4 servo amplifier supports the improved functions. Additionally, the preventive maintenance support function detects an error in the machine parts. This function provides strong support for the machine maintenance and inspection.

SSCNET III/H achieves high-speed communication of 150 Mbps full duplex with high noise immunity due to the SSCNET III optical cables. Large amounts of data are exchanged in real-time between the controller and the servo amplifier. Servo monitor information is stored in the upper information system and is used for control.

On the SSCNET III/H network, the stations are connected with a maximum distance of 100 m between them. This allows you to create a large system.

MR-J4-B servo amplifier supports the Safe Torque Off (STO) function for safety. When the MR-J4W_-B servo amplifier is connected to a SSCNET III/H-compatible motion controller, in addition to the STO function, the servo amplifier also supports the Safe Stop 1 (SS1), Safe Stop 2 (SS2), Safe Operating Stop (SOS), Safely-Limited Speed (SLS), Safe Brake Control (SBC), and Safe Speed Monitor (SSM) functions.

The MR-J4W_-B servo amplifier has a USB communication interface. Therefore, you can connect the servo amplifier to the personal computer with MR Configurator2 installed to perform the parameter setting, test operation, gain adjustment, and others.

1. FUNCTIONS AND CONFIGURATION

1.2 Function block diagram

The function block diagram of this servo is shown below.

(1) MR-J4-500B or less

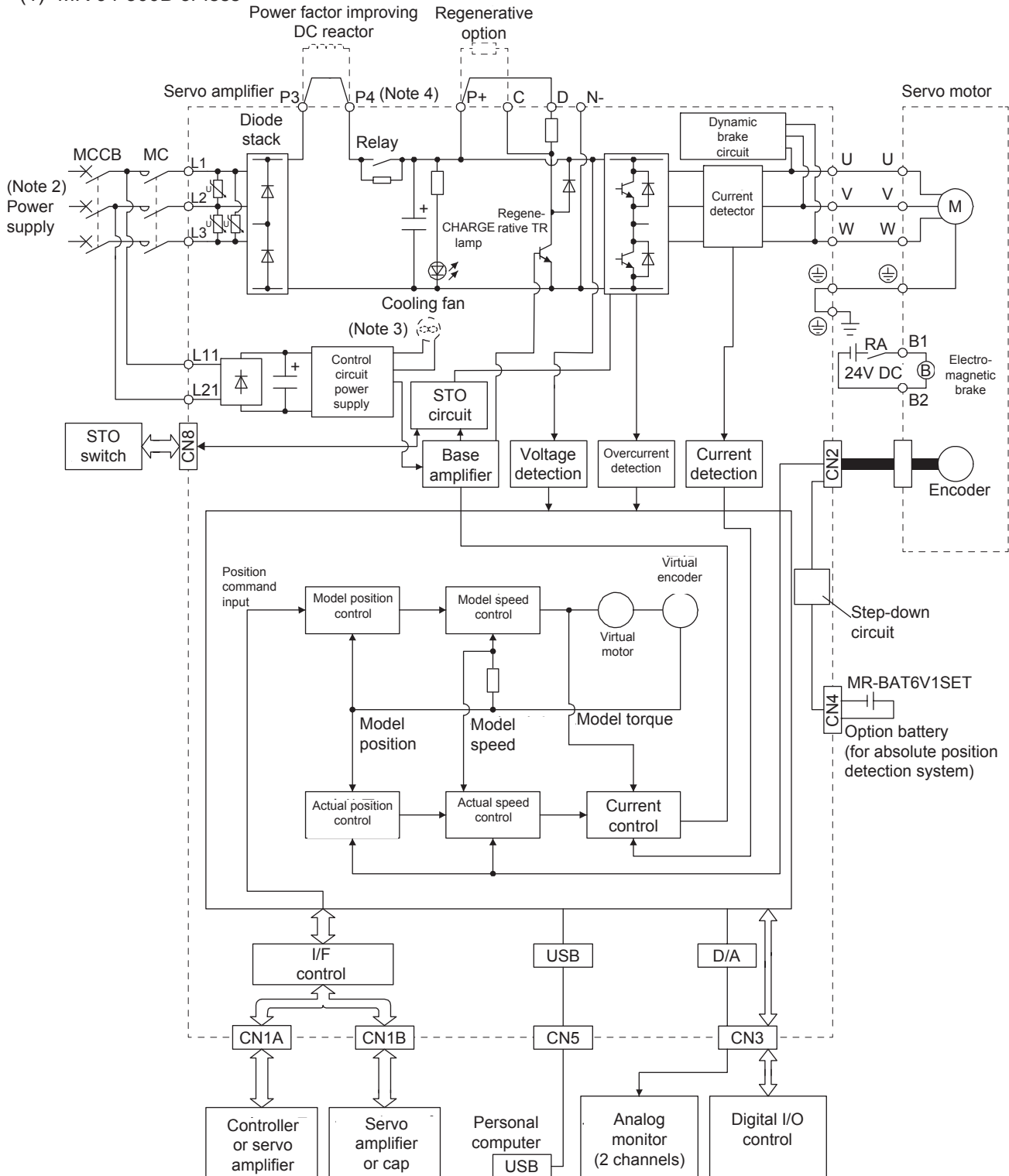

- Note
1. The built-in regenerative resistor is not provided for the MR-J4-10B.
 2. For 1-phase 200 V AC to 240 V AC, connect the power supply to L1 and L3. Leave L2 open.
For the power supply specifications, refer to section 1.3.
 3. Servo amplifiers MR-J4-70B or greater have a cooling fan.
 4. MR-J4 servo amplifier has P3 and P4 in the upstream of the inrush current suppression circuit. They are different from P1 and P2 of MR-J3 servo amplifiers.

1. FUNCTIONS AND CONFIGURATION

(2) MR-J4-700B

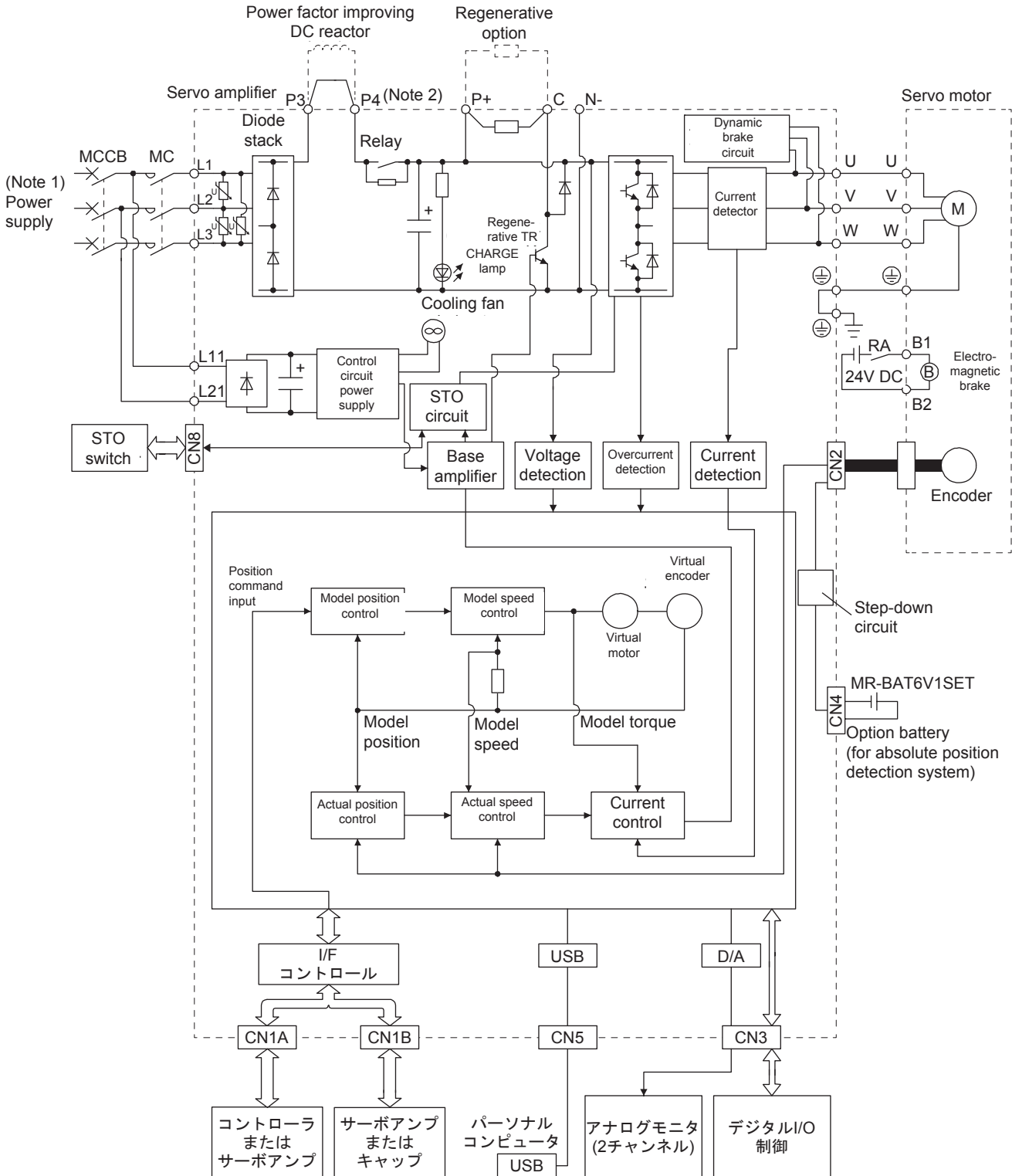

Note 1. Refer to section 1.3 for the power supply specification.

Note 2. MR-J4 servo amplifier has P3 and P4 in the upstream of the inrush current suppression circuit. They are different from P1 and P2 of MR-J3 servo amplifiers.

1. FUNCTIONS AND CONFIGURATION

1.3 Servo amplifier standard specifications

Model MR-J4-		10B	20B	40B	60B	70B	100B	200B	350B	500B	700B
Output	Rated voltage	3-phase 170 V AC									
	Rated current [A]	1.1	1.5	2.8	3.2	5.8	6.0	11.0	17.0	28.0	37.0
Main circuit power supply input	Power supply/Frequency	3-phase or 1-phase 200 V AC to 240 V AC, 50 Hz /60 Hz					3-phase 200 V AC to 240 V AC, 50 Hz/60 Hz				
	Rated current [A]	0.9	1.5	2.6	3.2 (Note 6)	3.8	5.0	10.5	16.0	21.7	28.9
	Permissible voltage fluctuation	3-phase or 1-phase 170 V AC to 264V AC					3-phase 170 V AC to 264 V AC				
	Permissible frequency fluctuation	Within ±5%									
	Power supply capacity [kVA]	Refer to section 10.2.									
	Inrush current [A]	Refer to section 10.5.									
Control circuit power supply	Power supply/Frequency	1-phase 200 V AC to 240 V AC, 50 Hz/60 Hz									
	Rated current [A]	0.2								0.3	
	Permissible voltage fluctuation	1-phase 170 V AC to 264V AC									
	Permissible frequency fluctuation	Within ±5%									
	Power consumption [W]	30								45	
	Inrush current [A]	20 to 30								30	
Interface power supply	Voltage/Frequency	24 V DC ± 10%									
	Power supply capacity [A]	(Note 1) 0.3 (including CN8 connector signals)									
Load-side encoder interface (Note 5)		Mitsubishi high-speed serial communication									
Control method		Sine-wave PWM control, current control method									
Dynamic brake		Built-in									
Fully closed loop control		Available in the future.									
Communication function	USB	Connection to a personal computer or others (MR Configurator2-compatible)									
Protective functions		Overcurrent shut-off, regenerative overvoltage shut-off, overload shut-off (electronic thermal), servo motor overheat protection, encoder error protection, regenerative error protection, undervoltage protection, instantaneous power failure protection, overspeed protection, error excessive protection, magnetic pole detection protection, linear servo control error protection									
Safety function		STO (IEC/EN 61800-5-2)									
Safety performance	Standards certified by CB (Note 7)	EN ISO 13849-1 category 3 PL d, EN 61508 SIL 2, EN 62061 SIL CL 2, and EN 61800-5-2 SIL 2									
	Response performance (Note 3)	8 ms or less (STO input off → energy shut off)									
	Test pulse input (STO)	Test pulse interval: 1 Hz to 25 Hz Test pulse off time: Up to 1 ms									
Compliance to standards	CE marking	LVD: EN 61800-5-1 EMC: EN 61800-3 MD: EN ISO 13849-1, EN 61800-5-2, EN 62061									
	UL standard	UL 508C									
Structure (IP rating)		Natural cooling, open (IP20)				Force cooling, open (IP20)				Force cooling, open (IP20) (Note 4)	
Close mounting (Note 2)		Possible								Impossible	

1. FUNCTIONS AND CONFIGURATION

Model MR-J4-			10B	20B	40B	60B	70B	100B	200B	350B	500B	700B
Environment	Ambient temperature	Operation	0 °C to 55 °C (non-freezing)									
		Storage	-20 °C to 65 °C (non-freezing)									
	Ambient humidity	Operation	90% RH or less (non-condensing)									
		Storage	90% RH or less (non-condensing)									
	Ambience		Indoors (no direct sunlight), free from corrosive gas, flammable gas, oil mist, dust, and dirt									
	Altitude		Max. 1000 m above sea level									
Vibration		5.9 m/s ² or less at 10 Hz to 55 Hz (directions of X, Y and Z axes)										
Mass [kg]			0.8	0.8	1.0	1.0	1.4	1.4	2.1	2.3	4.0	6.2

- Note
- 0.3A is the value applicable when all I/O signals are used. The current capacity can be decreased by reducing the number of I/O points.
 - When closely mounting the servo amplifier of 3.5 kW or less, operate them at the ambient temperatures of 0 °C to 45 °C or at 75% or smaller effective load ratio.
 - This function diagnoses malfunction of contacts including an external circuit by shortly turning off signals from a controller to the servo amplifier at a constant period while input signals of the servo amplifier are on.
 - Except for the terminal block.
 - It is not compatible with pulse train interface (ABZ-phase output type).
 - The rated current is 2.9 A when the servo amplifier is used with UL or CSA compliant servo motor.
 - Available in the future.

1. FUNCTIONS AND CONFIGURATION

1.4 Combinations of servo amplifiers and servo motors

Servo amplifier	Rotary servo motor	Linear servo motor (primary side)	Direct drive motor
MR-J4-10B	HG-KR053, HG-KR13 HG-MR053, HG-MR13		
MR-J4-20B	HG-KR23 HG-MR23	LM-U2PAB-05M-0SS0 LM-U2PBB-07M-1SS0	TM-RFM002C20
MR-J4-40B	HG-KR43 HG-MR43	LM-H3P2A-07P-BSS0 LM-H3P3A-12P-CSS0 LM-K2P1A-01M-2SS1 LM-U2PAD-10M-0SS0 LM-U2PAF-15M-0SS0	TM-RFM004C20
MR-J4-60B	HG-SR51, HG-SR52	LM-U2PBD-15M-1SS0	TM-RFM006C20 TM-RFM006E20
MR-J4-70B	HG-KR73 HG-MR73	LM-H3P3B-24P-CSS0 LM-H3P3C-36P-CSS0 LM-H3P7A-24P-ASS0 LM-K2P2A-02M-1SS1 LM-U2PBF-22M-1SS0	TM-RFM012E20 TM-RFM012G20 TM-RFM040J10
MR-J4-100B	HG-SR81, HG-SR102		TM-RFM018E20
MR-J4-200B	HG-SR121, HG-SR201, HG-SR152, HG-SR202	LM-H3P3D-48P-CSS0 LM-H3P7B-48P-ASS0 LM-H3P7C-72P-ASS0 LM-FP2B-06M-1SS0 LM-K2P1C-03M-2SS1 LM-U2P2B-40M-2SS0	
MR-J4-350B	HG-SR301, HG-SR352	LM-H3P7D-96P-ASS0 LM-K2P2C-07M-1SS1 LM-K2P3C-14M-1SS1 LM-U2P2C-60M-2SS0	TM-RFM048G20 TM-RFM072G20 TM-RFM120J10
MR-J4-500B	HG-SR421, HG-SR502	LM-FP2D-12M-1SS0 LM-FP4B-12M-1SS0 LM-K2P2E-12M-1SS1 LM-K2P3E-24M-1SS1 LM-U2P2D-80M-2SS0	TM-RFM240J10
MR-J4-700B	HG-SR702	LM-FP2F-18M-1SS0 LM-FP4D-24M-1SS0	

1. FUNCTIONS AND CONFIGURATION

1.5 Function list

The following table lists the functions of this servo. For details of the functions, refer to the reference field.

Function	Description	Detailed explanation
Position control mode	This servo is used as a position control servo.	
Speed control mode	This servo is used as a speed control servo.	
Torque control mode	This servo is used as a torque control servo.	
High-resolution encoder	High-resolution encoder of 4194304 pulses/rev is used as the encoder of the rotary servo motor compatible with the MELSERVO-J4 series.	
Absolute position detection system	Merely setting a home position once makes home position return unnecessary at every power-on.	Chapter 12
Gain switching function	You can switch between gains during rotation and gains during stop or can use an input device to switch gains during operation.	Section 7.2
Advanced vibration suppression control II	This function suppresses vibration at the arm end or residual vibration.	Section 7.1.5
Adaptive filter II	Servo amplifier detects mechanical resonance and sets filter characteristics automatically to suppress mechanical vibration.	Section 7.1.2
Low-pass filter	Suppresses high-frequency resonance which occurs as servo system response is increased.	Section 7.1.4
Machine analyzer function	Analyzes the frequency characteristic of the mechanical system by simply connecting a MR Configurator2 installed personal computer and servo amplifier. MR Configurator2 is necessary for this function.	
Robust filter	This function provides better disturbance response in case low response level that load to motor inertia ratio is high for such as roll send axes.	[Pr. PE41]
Slight vibration suppression control	Suppresses vibration of ± 1 pulse produced at a servo motor stop.	[Pr. PB24]
Auto tuning	Automatically adjusts the gain to optimum value if load applied to the servo motor shaft varies. Higher in performance than MR-J3 series servo amplifier.	Section 6.3
Brake unit	Used when the regenerative option cannot provide enough regenerative power. Can be used for the 5 kW or more servo amplifier.	Section 11.3
Power regenerative converter	Used when the regenerative option cannot provide enough regenerative power. Can be used for the 5 kW or more servo amplifier.	Section 11.4
Regenerative option	Used when the built-in regenerative resistor of the servo amplifier does not have sufficient regenerative capability for the regenerative power generated.	Section 11.2
Alarm history clear	Alarm history is cleared.	[Pr. PC21]
Output signal selection (device settings)	The pins that output the output devices, including ALM (Malfunction) and DB (Dynamic brake interlock), can be assigned to certain pins of the CN3 connectors.	[Pr. PD07] to [Pr. PD09]
Output signal (DO) forced output	Output signal can be forced on/off independently of the servo status. Use this function for output signal wiring check and others.	Section 4.5.1 (1) (d)
Test operation mode	Jog operation, positioning operation, motor-less operation, DO forced output, and program operation MR Configurator2 is necessary for this function.	Section 4.5
Analog monitor output	Servo status is output in terms of voltage in real time.	[Pr. PC09], [Pr. PC10]
MR Configurator2	Using a personal computer, you can perform the parameter setting, test operation, monitoring, and others.	Section 11.7
Fully closed loop system (Available in the future.)	Fully closed system can be configured using the load-side encoder.	Chapter 16
One-touch tuning	Gain adjustment is performed just by one click on a certain button on MR Configurator2. MR Configurator2 is necessary for this function.	Section 6.2
Tough drive function	This function makes the equipment continue operating even under the condition that an alarm occurs. The tough drive function includes two types: the vibration tough drive and the instantaneous power failure tough drive.	Section 7.3

1. FUNCTIONS AND CONFIGURATION

Function	Description	Detailed explanation
Drive recorder function	This function continuously monitors the servo status and records the status transition before and after an alarm for a fixed period of time. You can check the recorded data on the drive recorder window on MR Configurator2 by clicking the "Graph" button. However, the drive recorder will not operate on the following conditions. 1. You are using the graph function of MR Configurator2. 2. You are using the machine analyzer function. 3. [Pr. PF21] is set to "-1".	[Pr. PA23]
STO function	This function is a safety function that complies with IEC/EN 61800-5-2. You can create a safety system for the equipment easily.	
Servo amplifier life diagnostic function	You can check the cumulative energization time and the number of on/off times of the inrush relay. This function gives an indication of the replacement time for parts of the servo amplifier including a capacitor and a relay before they malfunction. MR Configurator2 is necessary for this function.	
Power monitoring function	This function calculates the power running energy and the regenerative power from the data in the servo amplifier such as speed and current. For the SSCNET III/H system, MR Configurator2 can display the data, including the power consumption. Since the servo amplifier can send the data to a motion controller, you can analyze the data and display the data on a display.	
Machine diagnostic function	From the data in the servo amplifier, this function estimates the friction and vibrational component of the drive system in the equipment and recognizes an error in the machine parts, including a ball screw and bearing. MR Configurator2 is necessary for this function.	

1.6 Model designation

(1) Rating plate

 MITSUBISHI	AC SERVO SER.S21001001	Serial number
MODEL <u>MR-J4-10B</u>		Model
POWER: 100W		Capacity
INPUT : 3AC/AC200-240V 0.9A/1.5A 50/60Hz		Applicable power supply
OUTPUT: 3PH170V 0-360Hz 1.1A		Rated output current
STD.: IEC/EN61800-5-1 MAN.: IB(NA)0300175		Standard, Manual number
Max. Surrounding Air Temp.: 55°C		Ambient temperature
IP20		IP rating
KCC-REI-MEK- TC300A624G51 DATE:2012-01		The year and month of manufacture
MITSUBISHI ELECTRIC CORPORATION TOKYO 100-8310, JAPAN	PASSED	

(2) Model

The following describes what each block of a model name indicates.



Symbol	Rated output [kW]
10	0.1
20	0.2
40	0.4
60	0.6
70	0.75
100	1
200	2
350	3.5
500	5
700	7

1. FUNCTIONS AND CONFIGURATION

1.7 Structure

1.7.1 Parts identification

(1) MR-J4-200B or less

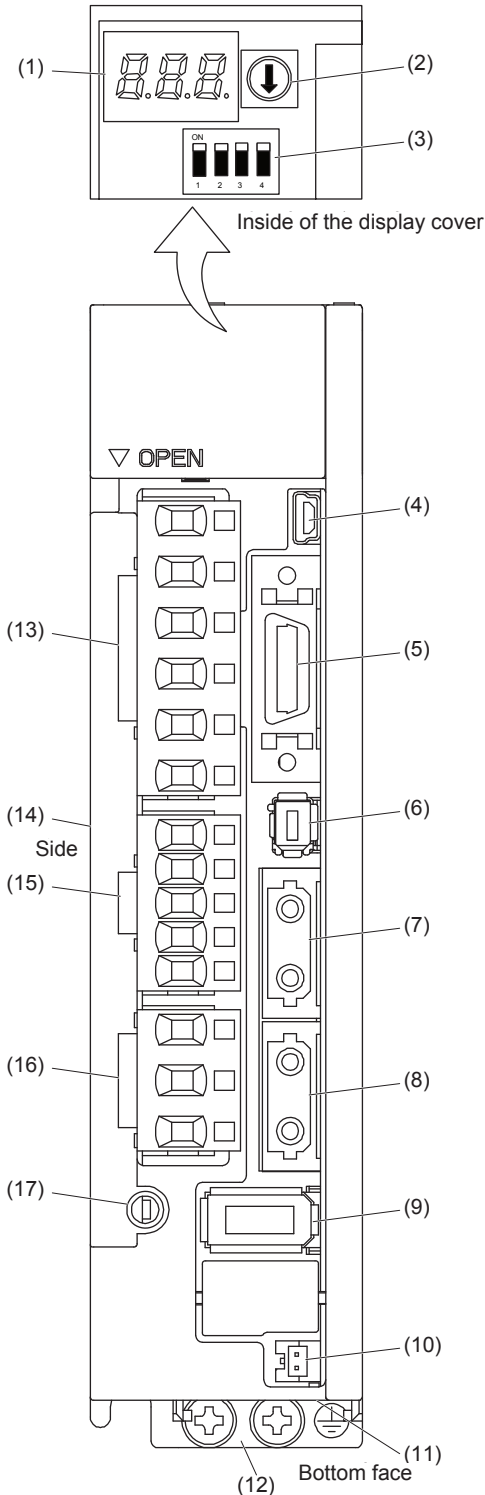

No.	Name/Application	Detailed explanation
(1)	Display The 3-digit, seven-segment LED shows the servo status and the alarm number.	Chapter 4
(2)	Axis selection rotary switch (SW1) Used to set the axis No. of servo amplifier.	Section 4.3
(3)	Control axis setting switch (SW2) The test operation switch, the control axis deactivation setting switch, and the auxiliary axis number setting switch are available.	
(4)	USB communication connector (CN5) Connect with the personal computer.	
(5)	I/O signal connector (CN3) Used to connect digital I/O signals.	Section 3.2 Section 3.4
(6)	STO input signal connector (CN8) Used to connect MR-J3-D05 safety logic unit and external safety relay.	Chapter 13 App. 1
(7)	SSCNET III cable connector (CN1A) Used to connect the servo system controller or the previous axis servo amplifier.	Section 3.2
(8)	SSCNET III cable connector (CN1B) Used to connect the next axis servo amplifier. For the final axis, put a cap.	Section 3.4
(9)	Encoder connector (CN2) Used to connect the servo motor encoder.	Section 3.4
(10)	Battery connector (CN4) Used to connect the battery or the battery unit for absolute position data backup.	Chapter 12
(11)	Battery holder Install the the battery for absolute position data backup.	Section 12.4
(12)	Protective earth (PE) terminal Grounding terminal	Section 3.1
(13)	Main circuit power supply connector (CNP1) Connect the input power supply.	Section 3.3
(14)	Rating plate	Section 1.6
(15)	Control circuit power supply connector (CNP2) Connect the control circuit power supply or regenerative option.	Section 3.1
(16)	Servo motor power supply connector (CNP3) Connect the servo motor.	Section 3.3
(17)	Charge lamp Lit to indicate that the main circuit is charged. While this lamp is lit, do not reconnect the cables.	

Note. The illustration above is of MR-J4-10B.

1. FUNCTIONS AND CONFIGURATION

(2) MR-J4-350B

The broken line area is the same as MR-J4-200B or less.

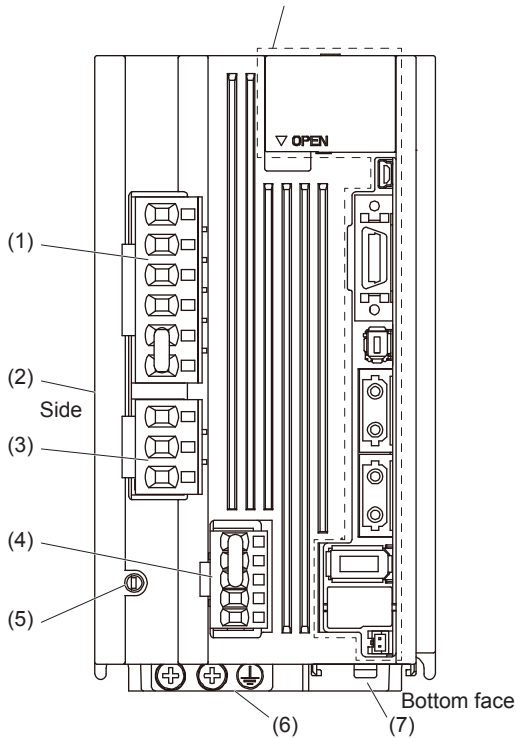

No.	Name/Application	Detailed explanation
(1)	Main circuit power supply connector (CNP1) Connect the input power supply.	Section 3.1 Section 3.3
(2)	Rating plate	Section 1.6
(3)	Servo motor power supply connector (CNP3) Connect the servo motor.	Section 3.1
(4)	Control circuit power supply connector (CNP2) Connect the control circuit power supply or regenerative option.	Section 3.3
(5)	Charge lamp Lit to indicate that the main circuit is charged. While this lamp is lit, do not reconnect the cables.	
(6)	Protective earth (PE) terminal Grounding terminal	Section 3.1 Section 3.3
(7)	Battery holder Install the the battery for absolute position data backup.	Section 12.4

1. FUNCTIONS AND CONFIGURATION

(3) MR-J4-500B

POINT

- The servo amplifier is shown with the front cover open. The front cover cannot be removed.

The broken line area is the same as MR-J4-200B or less.

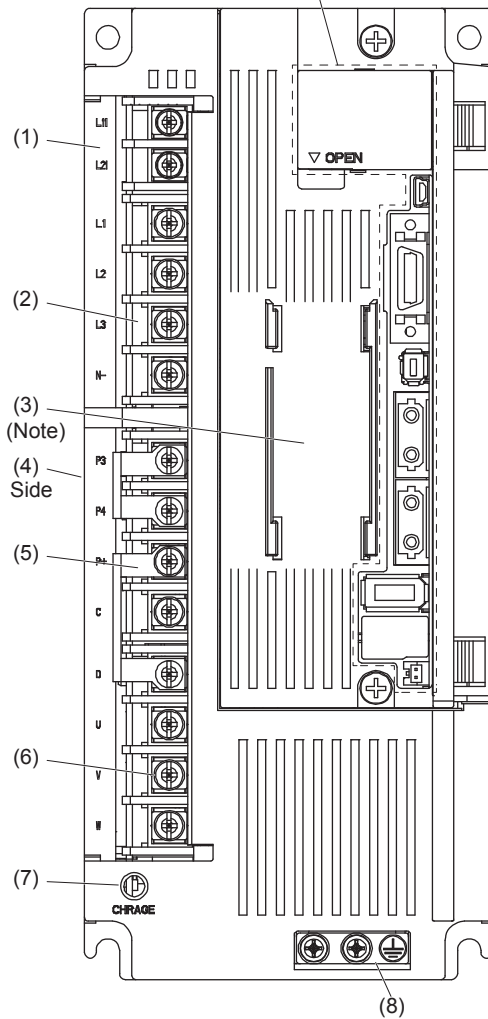

No.	Name/Application	Detailed explanation
(1)	Control circuit terminal block (TE2) Used to connect the control circuit power supply.	Section 3.1
(2)	Main circuit terminal block (TE1) Connect the input power supply.	Section 3.3
(3)	Battery holder Install the the battery for absolute position data backup.	Section 12.4
(4)	Rating plate	Section 1.6
(5)	Regenerative option/power factor improving reactor terminal block (TE3) Used to connect regenerative options and a power factor improving DC reactor.	Section 3.1 Section 3.3
(6)	Servo motor power supply terminal block (TE4) Connect the servo motor.	Section 3.3
(7)	Charge lamp Lit to indicate that the main circuit is charged. While this lamp is lit, do not reconnect the cables.	
(8)	Protective earth (PE) terminal Grounding terminal	Section 3.1 Section 3.3

Note. Lines around the battery holder are omitted from the illustration.

1. FUNCTIONS AND CONFIGURATION

(4) MR-J4-700B

POINT
<p>● The servo amplifier is shown without the front cover. For removal of the front cover, refer to section 1.7.2.</p>

The broken line area is the same as MR-J4-200B or less.

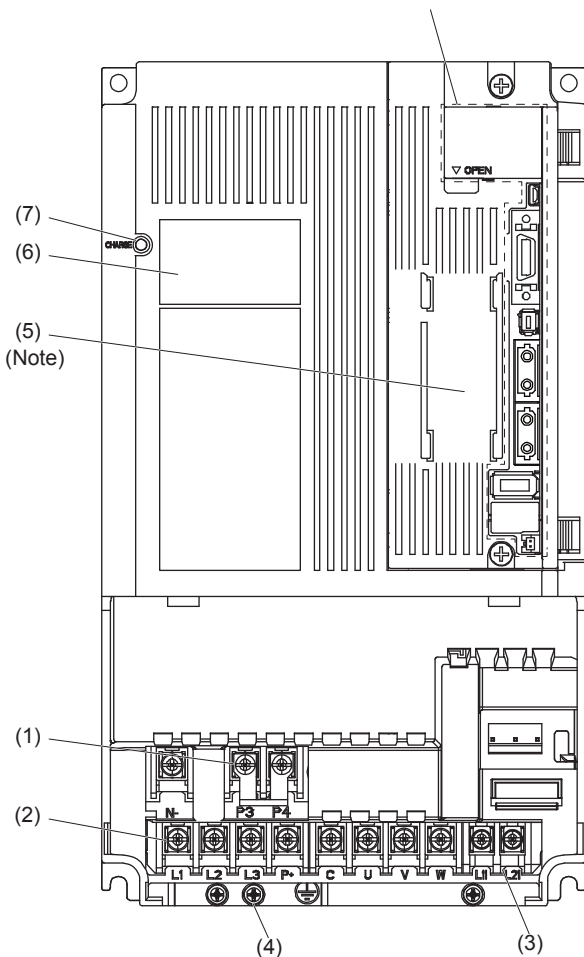

No.	Name/Application	Detailed explanation
(1)	Power factor improving reactor terminal block (TE3) Used to connect the DC reactor.	Section 3.1 Section 3.3
(2)	Main circuit terminal block (TE1) Used to connect the input power supply, regenerative option, and servo motor.	
(3)	Control circuit terminal block (TE2) Used to connect the control circuit power supply.	
(4)	Protective earth (PE) terminal Grounding terminal	
(5)	Battery holder Install the the battery for absolute position data backup.	Section 12.4
(6)	Rating plate	Section 1.6
(7)	Charge lamp Lit to indicate that the main circuit is charged. While this lamp is lit, do not reconnect the cables.	

Note. Lines around the battery holder are omitted from the illustration.

1. FUNCTIONS AND CONFIGURATION

1.7.2 Removal and reinstallation of the front cover



CAUTION

● Before removing or installing the front cover, turn off the power and wait for 15 minutes or more until the charge lamp turns off. Then, confirm that the voltage between P+ and N- is safe with a voltage tester and others. Otherwise, an electric shock may occur. In addition, when confirming whether the charge lamp is off or not, always confirm it from the front of the servo amplifier.

(1) For MR-J4-700B

Removal of the front cover

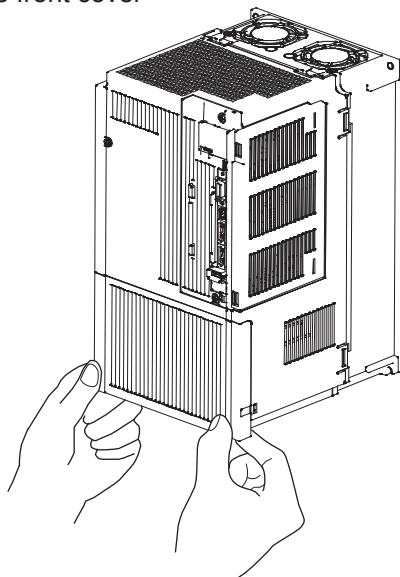

1) Hold the ends of lower side of the front cover with both hands.

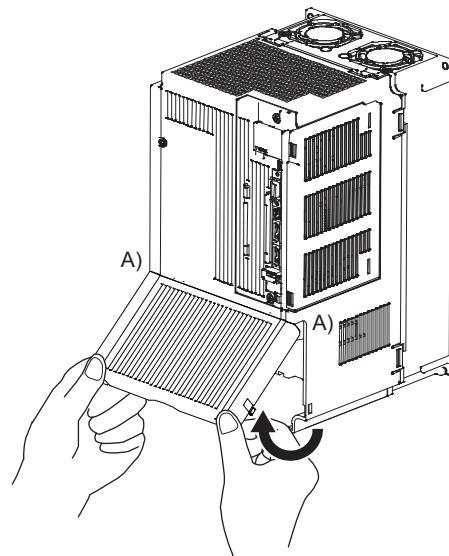

2) Pull up the cover, supporting at point A).

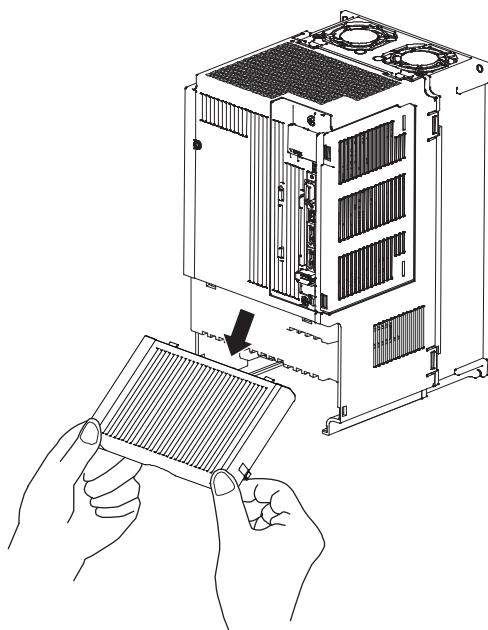

3) Pull out the front cover to remove. Hold the ends of lower side of the front cover with both hands.

1. FUNCTIONS AND CONFIGURATION

Reinstallation of the front cover

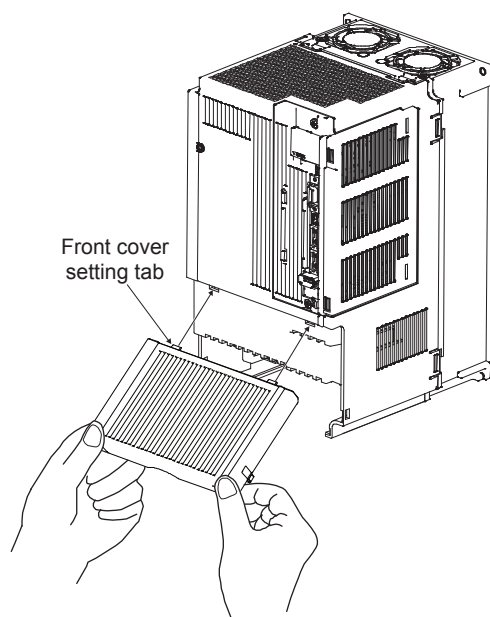

- 1) Insert the front cover setting tabs into the sockets of servo amplifier (2 places).

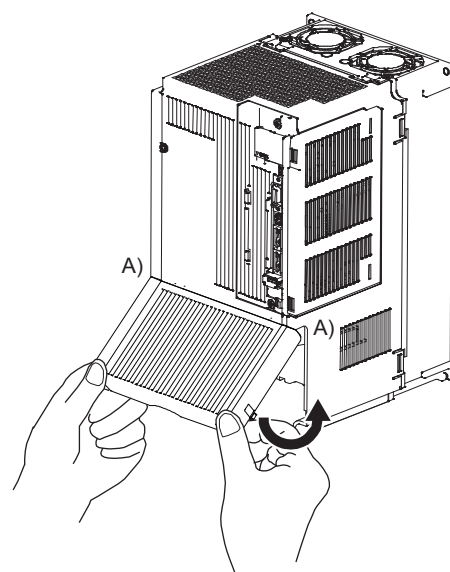

- 2) Push down the cover, supporting at point A).

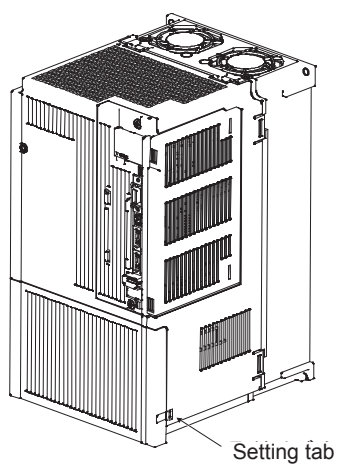

- 3) Press the cover against the terminal box until the installing knobs click.

1. FUNCTIONS AND CONFIGURATION

1.8 Configuration including auxiliary equipment

POINT

● Equipment other than the servo amplifier and servo motor are optional or recommended products.

(1) MR-J4-200B or less

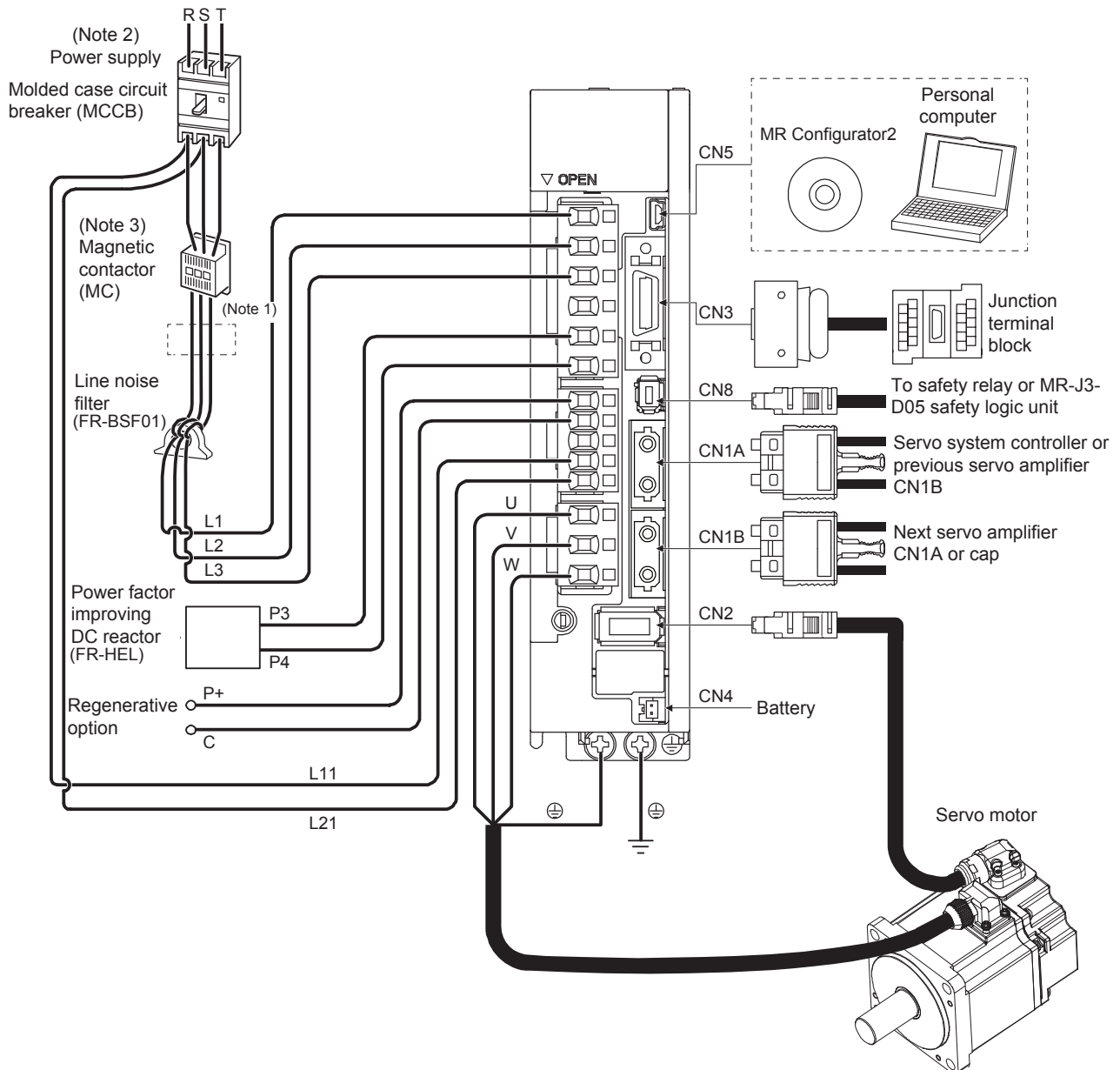

- Note 1. The power factor improving AC reactor can also be used. In this case, the power factor improving DC reactor cannot be used. When not using the power factor improving DC reactor, short P3 and P4.
- Note 2. A 1-phase 200 V AC to 240 V AC power supply may be used with the servo amplifier of MR-J4-70B or less. For 1-phase 200 V AC to 240 V AC, connect the power supply to L1 and L3. Leave L2 open. For the power supply specifications, refer to section 1.3.
- Note 3. Depending on the main circuit voltage and operation pattern, bus voltage decreases, and that may cause the forced stop deceleration to shift to the dynamic brake deceleration. When dynamic brake deceleration is not required, slow the time to turn off the magnetic contactor.

1. FUNCTIONS AND CONFIGURATION

(2) MR-J4-350B

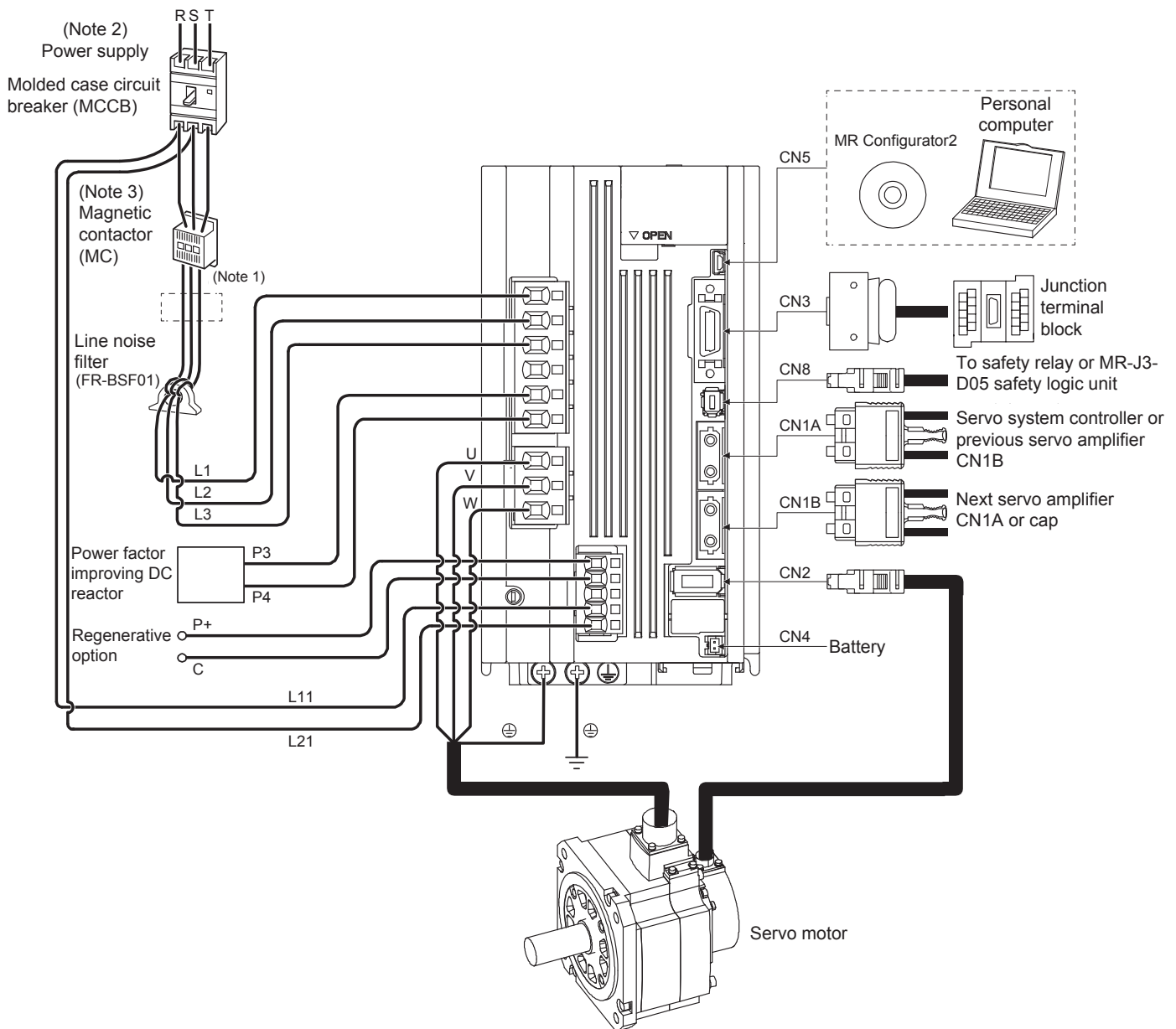

- Note 1. The power factor improving AC reactor can also be used. In this case, the power factor improving DC reactor cannot be used. When not using the power factor improving DC reactor, short P3 and P4.
- Note 2. Refer to section 1.3 for the power supply specification.
- Note 3. Depending on the main circuit voltage and operation pattern, bus voltage decreases, and that may cause the forced stop deceleration to shift to the dynamic brake deceleration. When dynamic brake deceleration is not required, slow the time to turn off the magnetic contactor.

1. FUNCTIONS AND CONFIGURATION

(3) MR-J4-500B

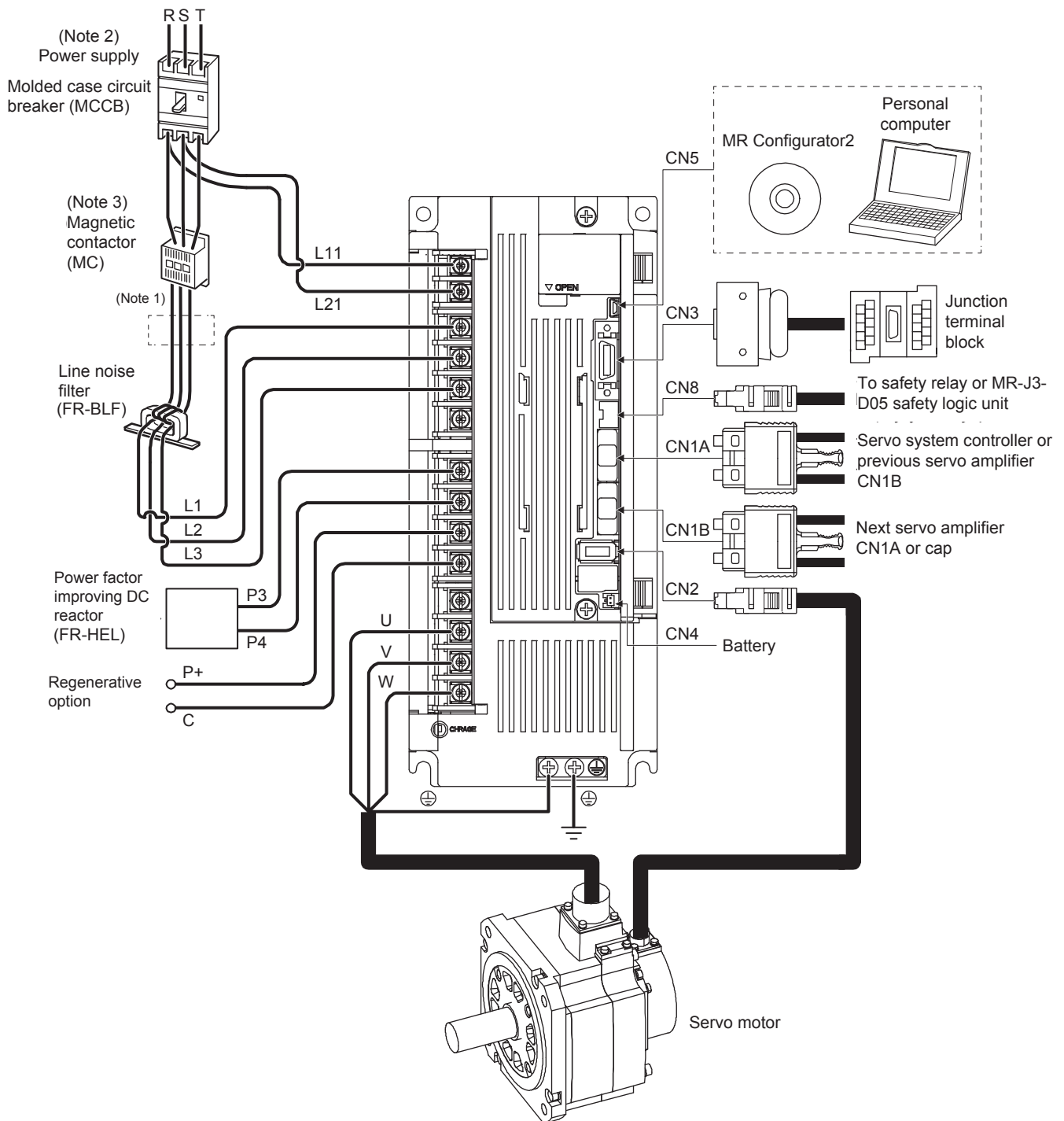

- Note 1. The power factor improving AC reactor can also be used. In this case, the power factor improving DC reactor cannot be used. When not using the power factor improving DC reactor, short P3 and P4.
- Note 2. Refer to section 1.3 for the power supply specification.
- Note 3. Depending on the main circuit voltage and operation pattern, bus voltage decreases, and that may cause the forced stop deceleration to shift to the dynamic brake deceleration. When dynamic brake deceleration is not required, slow the time to turn off the magnetic contactor.

1. FUNCTIONS AND CONFIGURATION

(4) MR-J4-700B



- Note 1. The power factor improving AC reactor can also be used. In this case, the power factor improving DC reactor cannot be used. When not using the power factor improving DC reactor, short P3 and P4.
- Note 2. Refer to section 1.3 for the power supply specification.
- Note 3. Depending on the main circuit voltage and operation pattern, bus voltage decreases, and that may cause the forced stop deceleration to shift to the dynamic brake deceleration. When dynamic brake deceleration is not required, slow the time to turn off the magnetic contactor.

2. INSTALLATION

2. INSTALLATION



WARNING ● To prevent electric shock, ground each equipment securely.



CAUTION

- Stacking in excess of the specified number of product packages is not allowed.
- Install the equipment on incombustible material. Installing it directly or close to combustibles will lead to a fire.
- Install the servo amplifier and the servo motor in a load-bearing place in accordance with the Instruction Manual.
- Do not get on or put heavy load on the equipment. Otherwise, it may cause injury.
- Use the equipment within the specified environment. For the environment, refer to section 1.3.
- Provide an adequate protection to prevent screws and other conductive matter, oil and other combustible matter from entering the servo amplifier.
- Do not block the intake and exhaust areas of the servo amplifier. Otherwise, it may cause a malfunction.
- Do not drop or strike the servo amplifier. Isolate it from all impact loads.
- Do not install or operate the servo amplifier which have been damaged or have any parts missing.
- When the equipment has been stored for an extended period of time, contact your local sales office.
- When handling the servo amplifier, be careful about the edged parts such as corners of the servo amplifier.
- The servo amplifier must be installed in the metal cabinet.

POINT

- When pulling out CNP1, CNP2, and CNP3 connectors of MR-J4-40B or less servo amplifiers, pull out CN3 and CN8 connectors beforehand.

2. INSTALLATION

2.1 Installation direction and clearances



CAUTION

- The equipment must be installed in the specified direction. Otherwise, it may cause a malfunction.
- Leave specified clearances between the servo amplifier and the cabinet walls or other equipment. Otherwise, it may cause a malfunction.

(1) 7 kW or less

(a) Installation of one servo amplifier

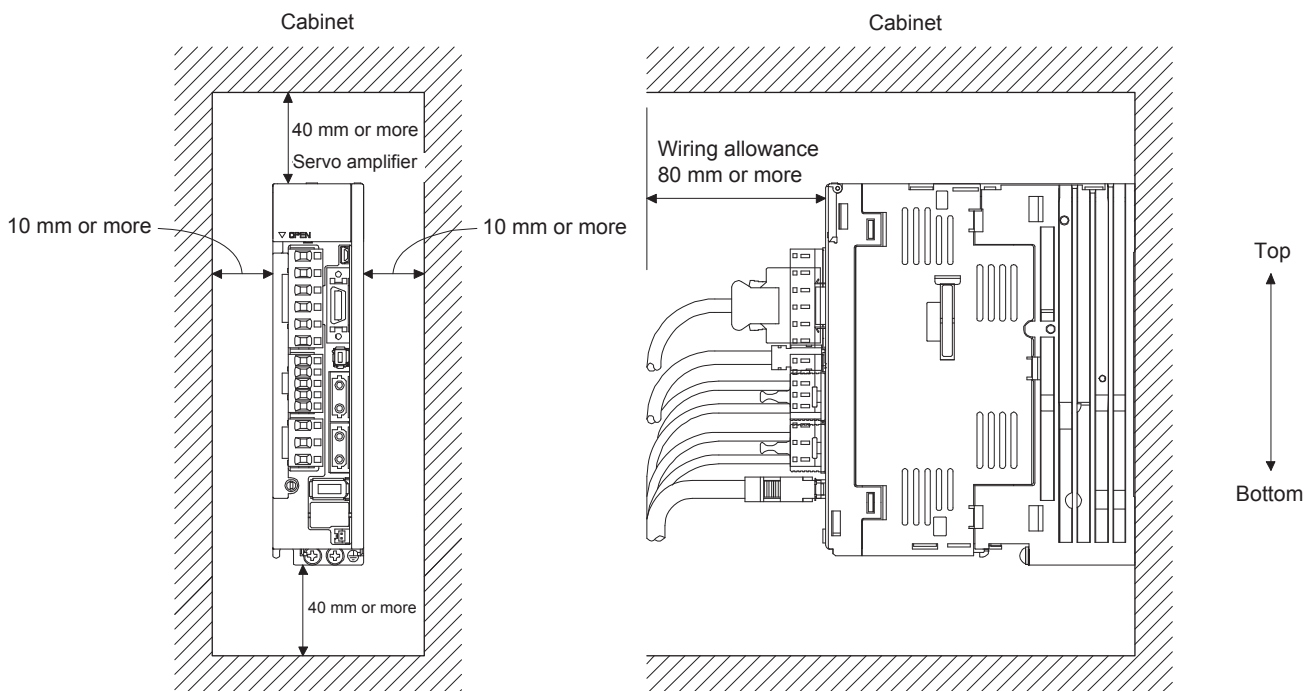

2. INSTALLATION

(b) Installation of two or more servo amplifiers

POINT
<ul style="list-style-type: none"> ● Close mounting is possible depending on the capacity of the servo amplifier. Refer to section 1.3 for availability of close mounting. ● When mounting the servo amplifiers closely, do not install the servo amplifier whose depth is larger than that of the left side servo amplifier since CNP1, CNP2, and CNP3 connectors cannot be disconnected.

Leave a large clearance between the top of the servo amplifier and the cabinet walls, and install a cooling fan to prevent the internal temperature of the cabinet from exceeding the environment. When mounting the servo amplifiers closely, leave a clearance of 1 mm between the adjacent servo amplifiers in consideration of mounting tolerances. In this case, keep the ambient temperature within 0 °C to 45 °C or use the servo amplifier with 75% or less of the effective load ratio.

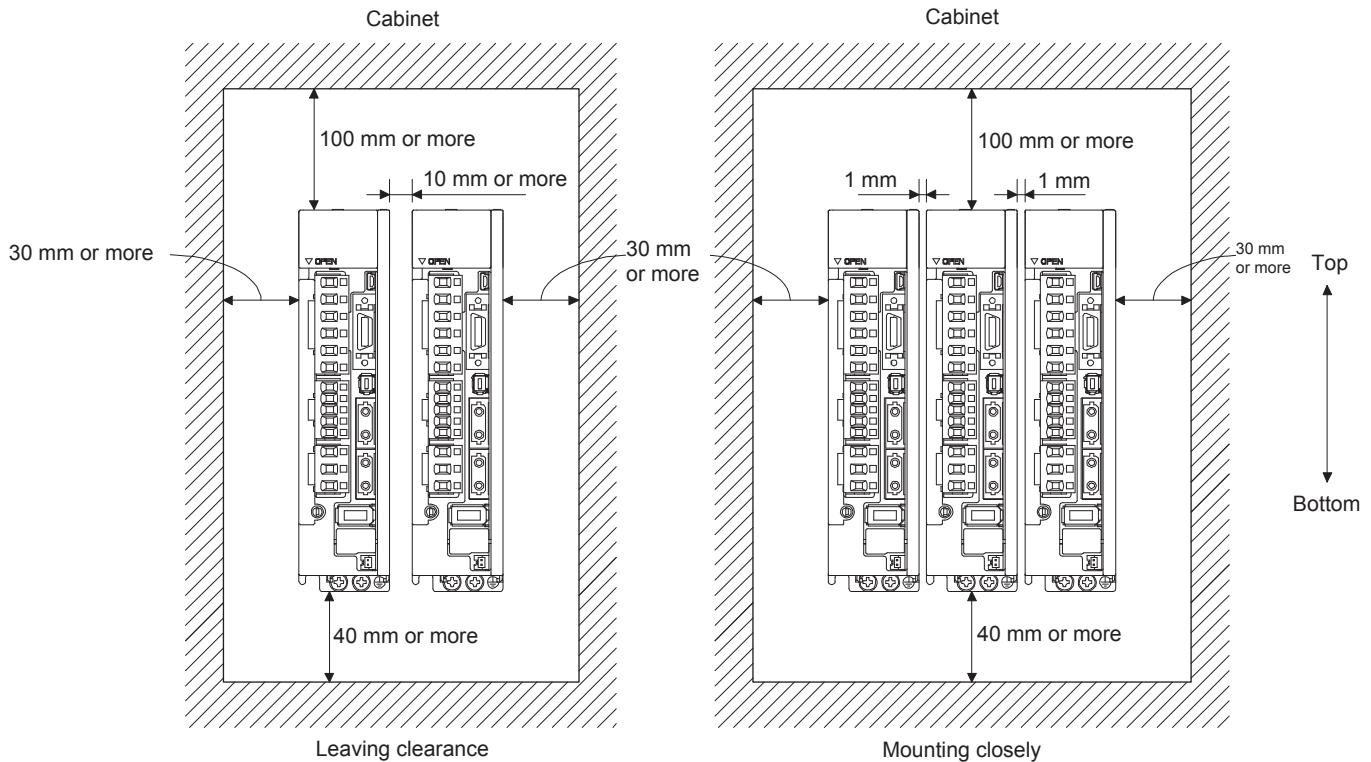

(2) Others

When using heat generating equipment such as the regenerative option, install them with full consideration of heat generation so that the servo amplifier is not affected.

Install the servo amplifier on a perpendicular wall in the correct vertical direction.

2.2 Keep out foreign materials

(1) When drilling in the cabinet, prevent drill chips and wire fragments from entering the servo amplifier.

(2) Prevent oil, water, metallic dust, etc. from entering the servo amplifier through openings in the cabinet or a cooling fan installed on the ceiling.

2. INSTALLATION

- (3) When installing the cabinet in a place where toxic gas, dirt and dust exist, conduct an air purge (force clean air into the cabinet from outside to make the internal pressure higher than the external pressure) to prevent such materials from entering the cabinet.

2.3 Encoder cable stress

- (1) The way of clamping the cable must be fully examined so that flexing stress and cable's own weight stress are not applied to the cable connection.
- (2) For use in any application where the servo motor moves, fix the cables (encoder, power supply, and brake) with having some slack from the connector connection part of the servo motor to avoid putting stress on the connector connection part. Use the optional encoder cable within the bending life range. Use the power supply and brake wiring cables within the bending life of the cables.
- (3) Avoid any probability that the cable sheath might be cut by sharp chips, rubbed by a machine corner or stamped by workers or vehicles.
- (4) For installation on a machine where the servo motor moves, the flexing radius should be made as large as possible. Refer to section 10.4 for the bending life.

2.4 SSCNET III cable laying

SSCNET III cable is made from optical fiber. If optical fiber is added a power such as a major shock, lateral pressure, haul, sudden bending or twist, its inside distorts or breaks, and optical transmission will not be available. Especially, as optical fiber for MR-J3BUS_M/MR-J3BUS_M-A is made of synthetic resin, it melts down if being left near the fire or high temperature. Therefore, do not make it touched the part, which can become hot, such as radiator or regenerative option of servo amplifier.

Read described item of this section carefully and handle it with caution.

(1) Minimum bend radius

Make sure to lay the cable with greater radius than the minimum bend radius. Do not press the cable to edges of equipment or others. For SSCNET III cable, the appropriate length should be selected with due consideration for the dimensions and arrangement of servo amplifier. When closing the door of cabinet, pay careful attention for avoiding the case that SSCNET III cable is hold down by the door and the cable bend becomes smaller than the minimum bend radius. For the minimum bend radius, refer to section 11.1.3.

(2) Prohibition of vinyl tape use

Migrating plasticizer is used for vinyl tape. Keep the MR-J3BUS_M, and MR-J3BUS_M-A cables away from vinyl tape because the optical characteristic may be affected.

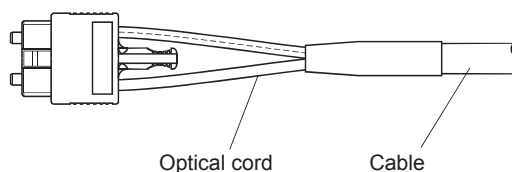

SSCNET III cable	Cord	Cable
MR-J3BUS_M	△	
MR-J3BUS_M-A	△	△
MR-J3BUS_M-B	○	○

△ : Phthalate ester plasticizer such as DBP and DOP may affect optical characteristic of cable.

○ : Cord and cable are not basically affected by plasticizer.

2. INSTALLATION

(3) Precautions for migrating plasticizer added materials

Generally, soft polyvinyl chloride (PVC), polyethylene resin (PE) and fluorine resin contain non-migrating plasticizer and they do not affect the optical characteristic of SSCNET III cable. However, some wire sheaths and cable ties, which contain migrating plasticizer (phthalate ester), may affect MR-J3BUS_M and MR-J3BUS_M-A cables (plastic).

In addition, MR-J3BUS_M-B cable (silica glass) is not affected by plasticizer.

A chemical substance may affect its optical characteristic. Therefore, previously check that the cable is not affected by the environment.

(4) Bundle fixing

Fix the cable at the closest part to the connector with bundle material in order to prevent SSCNET III cable from putting its own weight on CN1A/CN1B connector of servo amplifier. Optical cord should be given loose slack to avoid from becoming smaller than the minimum bend radius, and it should not be twisted.

When bundling the cable, fix and hold it in position by using cushioning such as sponge or rubber which does not contain migratable plasticizers.

If adhesive tape for bundling the cable is used, fire resistant acetate cloth adhesive tape 570F (Teraoka Seisakusho Co., Ltd) is recommended.

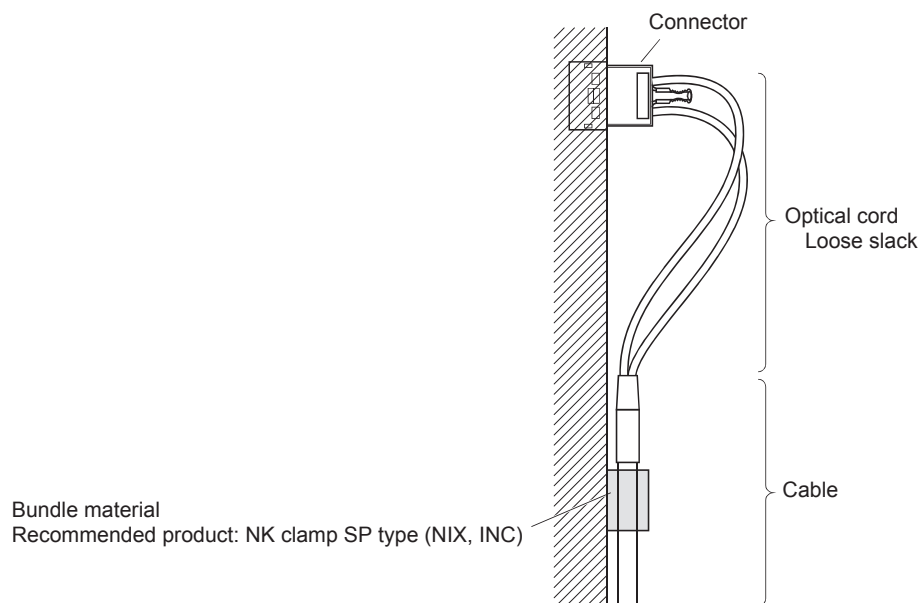

(5) Tension

If tension is added on optical cable, the increase of transmission loss occurs because of external force which concentrates on the fixing part of optical fiber or the connecting part of optical connector. Doing so may cause the breakage of the optical fiber or damage of the optical connector. For cable laying, handle without putting forced tension. For the tension strength, refer to section 11.1.3.

(6) Lateral pressure

If lateral pressure is added on optical cable, the optical cable itself distorts, internal optical fiber gets stressed, and then transmission loss will increase. Doing so may cause the breakage of the optical cable. As the same condition also occurs at cable laying, do not tighten up optical cable with a thing such as nylon band (TY-RAP).

Do not trample it down or tuck it down with the door of cabinet or others.

2. INSTALLATION

(7) Twisting

If optical fiber is twisted, it will become the same stress added condition as when local lateral pressure or bend is added. Consequently, transmission loss increases, and the breakage of optical fiber may occur.

(8) Disposal

When incinerating optical cable (cord) used for SSCNET III, hydrogen fluoride gas or hydrogen chloride gas which is corrosive and harmful may be generated. For disposal of optical fiber, request for specialized industrial waste disposal services who has incineration facility for disposing hydrogen fluoride gas or hydrogen chloride gas.

2.5 Inspection items



WARNING

- Before starting maintenance and/or inspection, turn off the power and wait for 15 minutes or more until the charge lamp turns off. Then, confirm that the voltage between P+ and N- is safe with a voltage tester and others. Otherwise, an electric shock may occur. In addition, when confirming whether the charge lamp is off or not, always confirm it from the front of the servo amplifier.
- To avoid an electric shock, only qualified personnel should attempt inspections. For repair and parts replacement, contact your local sales office.

POINT

- Do not perform insulation resistance test on the servo amplifier. Otherwise, it may cause a malfunction.
- Do not disassemble and/or repair the equipment on customer side.

It is recommended that the following points periodically be checked.

- (1) Check for loose terminal block screws. Retighten any loose screws.
- (2) Check the cables and the like for scratches or cracks. Inspect them periodically according to operating conditions especially when the servo motor is movable.
- (3) Check that the connector is securely connected to the servo amplifier.
- (4) Check that the wires are not coming out from the connector.
- (5) Check for dust accumulation on the servo amplifier.
- (6) Check for unusual noise generated from the servo amplifier.

2. INSTALLATION

2.6 Parts having service lives

Service lives of the following parts are listed below. However, the service lives vary depending on operation and environment. If any fault is found in the parts, they must be replaced immediately regardless of their service lives. For parts replacement, please contact your local sales office.

Part name	Life guideline
Smoothing capacitor	10 years
Relay	Number of power-on times: 100,000 times Number of on and off for STO: 1,000,000 times
Cooling fan	10,000 hours to 30,000 hours (2 years to 3 years)
Absolute position battery	Refer to section 12.2.

(1) Smoothing capacitor

The characteristic of smoothing capacitor is deteriorated due to ripple currents, etc. The life of the capacitor greatly depends on ambient temperature and operating conditions. The capacitor will reach the end of its life in 10 years of continuous operation in normal air-conditioned environment (40 °C surrounding air temperature or less).

(2) Relays

Contact faults will occur due to contact wear arisen from switching currents. Relays reach the end of their lives when the power has been turned on 100,000 times, or when the STO has been turned on and off 1,000,000 times while the servo motor is stopped under servo-off state. However, the lives of relays may depend on the power supply capacity.

(3) Servo amplifier cooling fan

The cooling fan bearings reach the end of their life in 10,000 hours to 30,000 hours. Normally, therefore, the cooling fan must be replaced in a few years of continuous operation as a guideline. It must also be changed if unusual noise or vibration is found during inspection.

The life indicates under the yearly average ambient temperature of 40 °C, free from corrosive gas, flammable gas, oil mist, dust and dirt.

3. SIGNALS AND WIRING

3. SIGNALS AND WIRING



WARNING

- Any person who is involved in wiring should be fully competent to do the work.
- Before wiring, turn off the power and wait for 15 minutes or more until the charge lamp turns off. Then, confirm that the voltage between P+ and N- is safe with a voltage tester and others. Otherwise, an electric shock may occur. In addition, when confirming whether the charge lamp is off or not, always confirm it from the front of the servo amplifier.
- Ground the servo amplifier and servo motor securely.
- Do not attempt to wire the servo amplifier and servo motor until they have been installed. Otherwise, it may cause an electric shock.
- The cables should not be damaged, stressed, loaded, or pinched. Otherwise, it may cause an electric shock.
- To avoid an electric shock, insulate the connections of the power supply terminals.



CAUTION

- Wire the equipment correctly and securely. Otherwise, the servo motor may operate unexpectedly, resulting in injury.
- Connect cables to the correct terminals. Otherwise, a burst, damage, etc. may occur.
- Ensure that polarity (+/-) is correct. Otherwise, a burst, damage, etc. may occur.
- The surge absorbing diode installed to the DC relay for control output should be fitted in the specified direction. Otherwise, the emergency stop and other protective circuits may not operate.

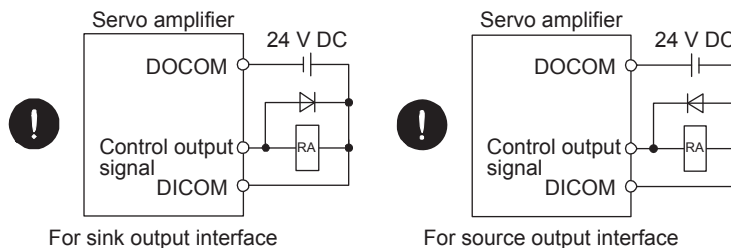

- Use a noise filter, etc. to minimize the influence of electromagnetic interference. Electromagnetic interference may be given to the electronic equipment used near the servo amplifier.
- Do not install a power capacitor, surge killer or radio noise filter (FR-BIF option) with the power line of the servo motor.
- When using the regenerative resistor, switch power off with the alarm signal. Otherwise, a transistor fault or the like may overheat the regenerative resistor, causing a fire.
- Do not modify the equipment.

3. SIGNALS AND WIRING

- Connect the servo amplifier power output (U, V, and W) to the servo motor power input (U, V, and W) directly. Do not let a magnetic contactor, etc. intervene. Otherwise, it may cause a malfunction.

! CAUTION

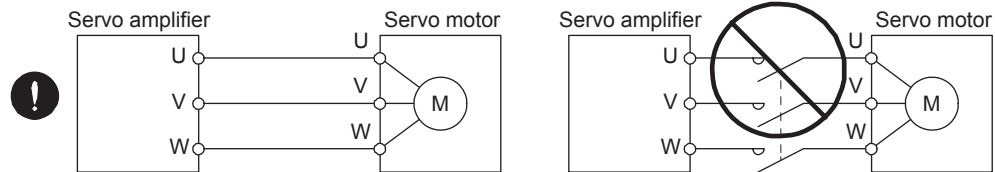

POINT

- When you use a linear servo motor, replace the following left words to the right words.
 Load to motor inertia ratio → Load to motor mass ratio
 Torque [N·m] → Thrust [N]
 (Servo motor) Speed [r/min] → (Linear servo motor) Speed [mm/s]

3.1 Input power supply circuit

- Always connect a magnetic contactor between the power supply and the main circuit power supply (L1, L2, and L3) of the servo amplifier, in order to configure a circuit that shuts down the power supply on the side of the servo amplifier's power supply. If a magnetic contactor is not connected, continuous flow of a large current may cause a fire when the servo amplifier malfunctions.
- Use ALM (Malfunction) to switch main circuit power supply off. Not doing so may cause a fire when a regenerative transistor malfunctions or the like may overheat the regenerative resistor.
- Check the servo amplifier model, and then input proper voltage to the servo amplifier power supply. If input voltage exceeds the upper limit, the servo amplifier will break down.
- The servo amplifier has a built-in surge absorber (varistor) to reduce noise and to suppress lightning surge. The varistor can break down due to its aged deterioration. To prevent a fire, use a molded case circuit breaker or fuse for input power supply.

! CAUTION

POINT

- Even if alarm has occurred, do not switch off the control circuit power supply. When the control circuit power supply has been switched off, optical module does not operate, and optical transmission of SSCNET III/H communication is interrupted. Therefore, the next axis servo amplifier displays "AA" at the indicator and turns into base circuit shut-off. The servo amplifier stops with starting dynamic brake.
- EM2 has the same function as EM1 in the torque control mode.
- Connect the 1-phase 200 V AC to 240 V AC power supply to L1 and L3. One of the connecting destinations is different from MR-J3 Series Servo Amplifier. When using MR-J4 as a replacement for MR-J3, be careful not to connect the power to L2.

3. SIGNALS AND WIRING

Configure the wiring so that the main circuit power supply is shut off and the servo-on command turned off after deceleration to a stop due to an alarm occurring, an enabled servo forced stop, or an enabled controller forced stop. A molded case circuit breaker (MCCB) must be used with the input cables of the main circuit power supply.

3. SIGNALS AND WIRING

(1) For 3-phase 200 V AC to 240 V AC power supply of MR-J4-10B to MR-J4-350B

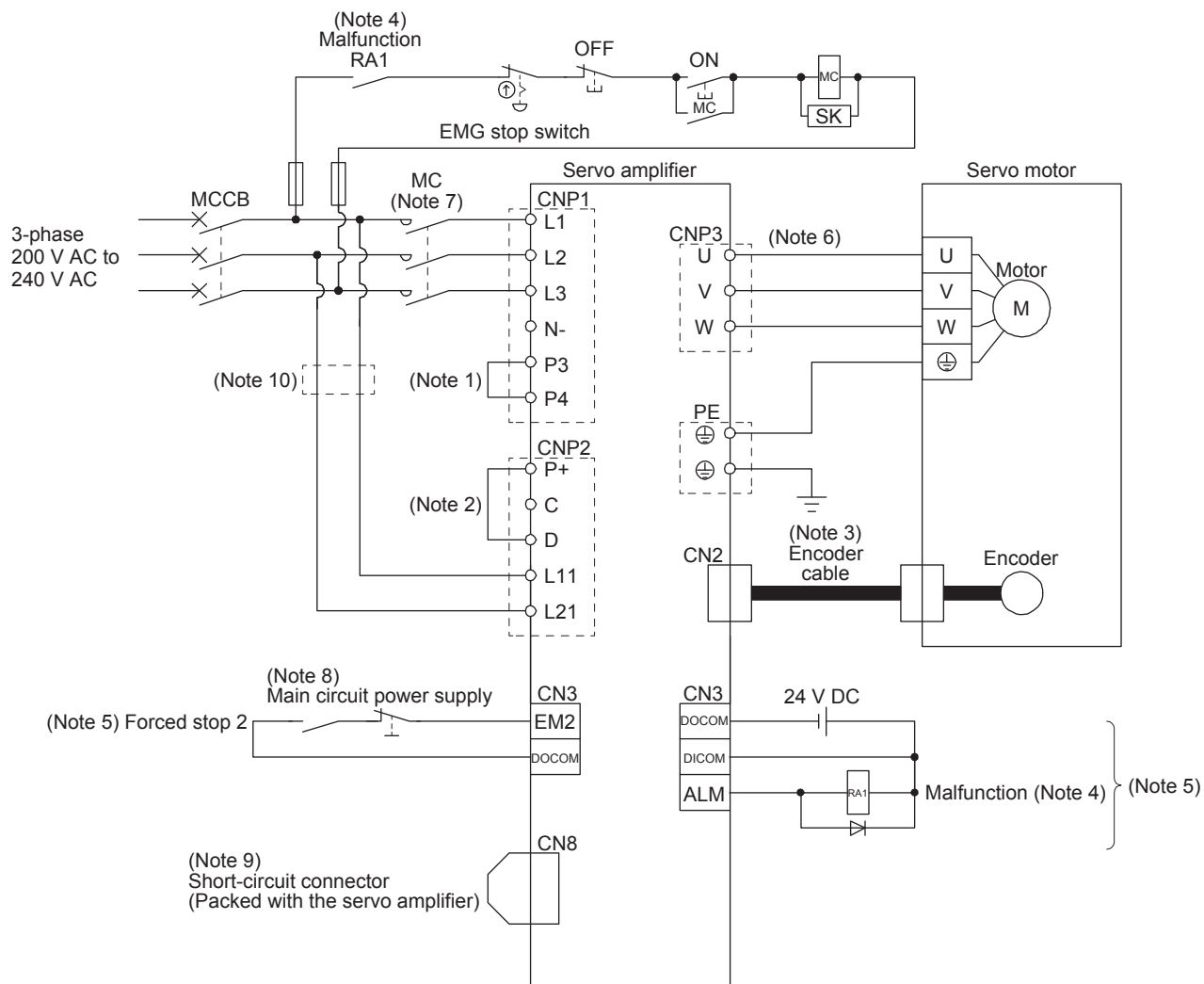

- Note 1. Always connect P3 and P4 terminals. (factory-wired) When using the power factor improving DC reactor, refer to section 11.11. Use either the power factor improving DC reactor or the power factor improving AC reactor.
2. Always connect P+ and D. (factory-wired) When using the regenerative option, refer to section 11.2.
3. For the encoder cable, use of the option cable is recommended. For connecting servo motor power wires, refer to Servo Motor Instruction Manual (Vol. 3).
4. If disabling ALM (Malfunction) output with the parameter, configure up the power supply circuit which switches off the magnetic contactor after detection of alarm occurrence on the controller side.
5. This diagram is for sink I/O interface. For source I/O interface, refer to section 3.8.3.
6. For connecting servo motor power wires, refer to each Servo Motor Instruction Manual (Vol. 3).
7. Use a magnetic contactor with an operation delay time (interval between current being applied to the coil until closure of contacts) of 80 ms or less. Depending on the main circuit voltage and operation pattern, bus voltage decreases, and that may cause the forced stop deceleration to shift to the dynamic brake deceleration. When dynamic brake deceleration is not required, slow the time to turn off the magnetic contactor.
8. Configure up a circuit to turn off EM2 when the main circuit power is turned off to prevent an unexpected restart of the servo amplifier.
9. When not using the STO function, attach a short-circuit connector supplied with a servo amplifier.
10. When wires used for L11 and L21 are thinner than wires used for L1, L2, and L3, use a molded case circuit breaker. (Refer to section 11.10.)

3. SIGNALS AND WIRING

(2) For 1-phase 200 V AC to 240 V AC power supply of MR-J4-10B to MR-J4-70B

POINT
<p>● Connect the 1-phase 200 V AC to 240 V AC power supply to L1 and L3. One of the connecting destination is different from MR-J3 Series Servo Amplifier. When using MR-J4 as a replacement for MR-J3, be careful not to connect the power to L2.</p>

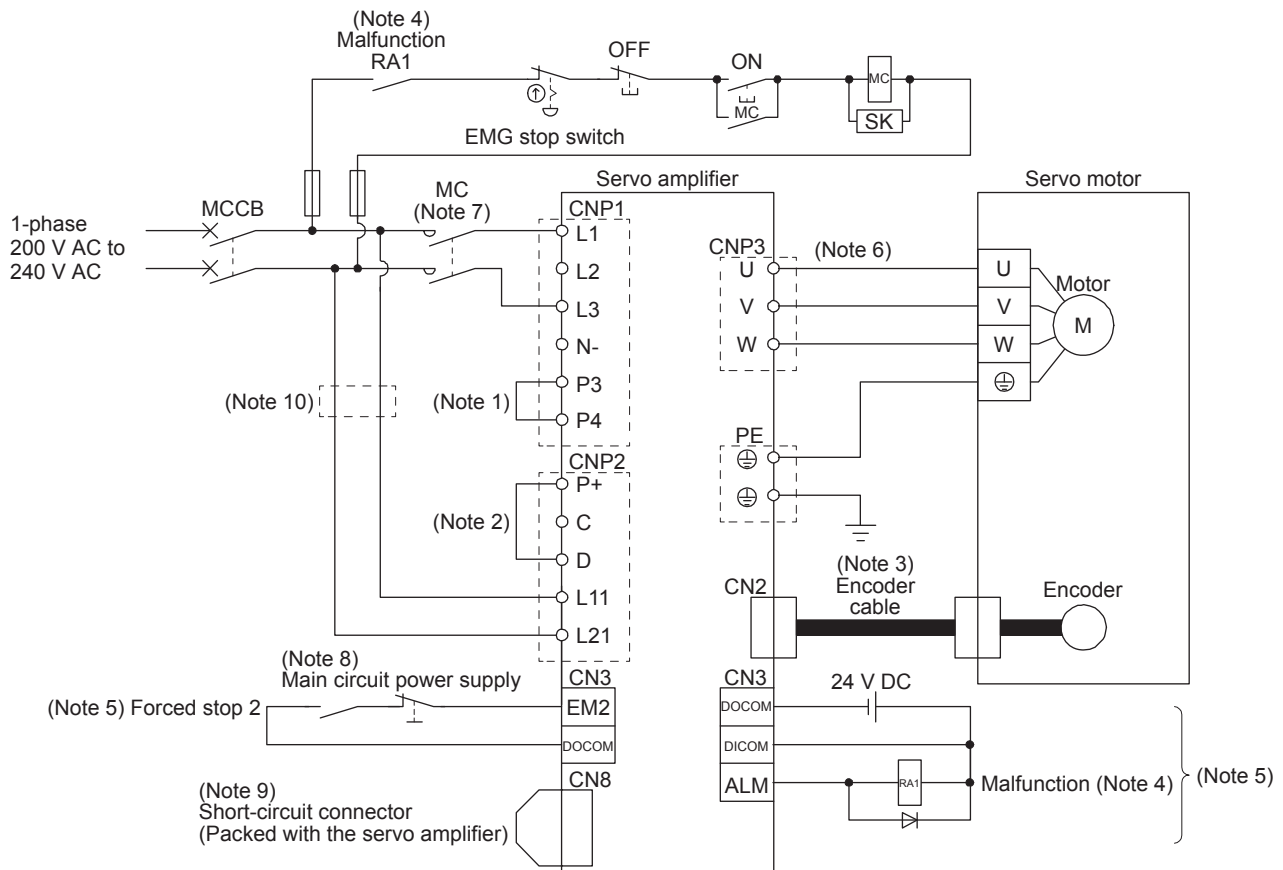

- Note 1. Always connect P3 and P4 terminals. (factory-wired) When using the power factor improving DC reactor, refer to section 11.11. Use either the power factor improving DC reactor or the power factor improving AC reactor.
2. Always connect P+ and D. (factory-wired) When using the regenerative option, refer to section 11.2.
3. For the encoder cable, use of the option cable is recommended. For connecting servo motor power wires, refer to Servo Motor Instruction Manual (Vol. 3).
4. If disabling ALM (Malfunction) output with the parameter, configure up the power supply circuit which switches off the magnetic contactor after detection of alarm occurrence on the controller side.
5. This diagram is for sink I/O interface. For source I/O interface, refer to section 3.8.3.
6. For connecting servo motor power wires, refer to each Servo Motor Instruction Manual (Vol. 3).
7. Use a magnetic contactor with an operation delay time (interval between current being applied to the coil until closure of contacts) of 80 ms or less. Depending on the main circuit voltage and operation pattern, bus voltage decreases, and that may cause the forced stop deceleration to shift to the dynamic brake deceleration. When dynamic brake deceleration is not required, slow the time to turn off the magnetic contactor.
8. Configure up a circuit to turn off EM2 when the main circuit power is turned off to prevent an unexpected restart of the servo amplifier.
9. When not using the STO function, attach a short-circuit connector supplied with a servo amplifier.
10. When wires used for L11 and L21 are thinner than wires used for L1 and L2, use a molded case circuit breaker. (Refer to section 11.10.)

3. SIGNALS AND WIRING

(3) MR-J4-500B

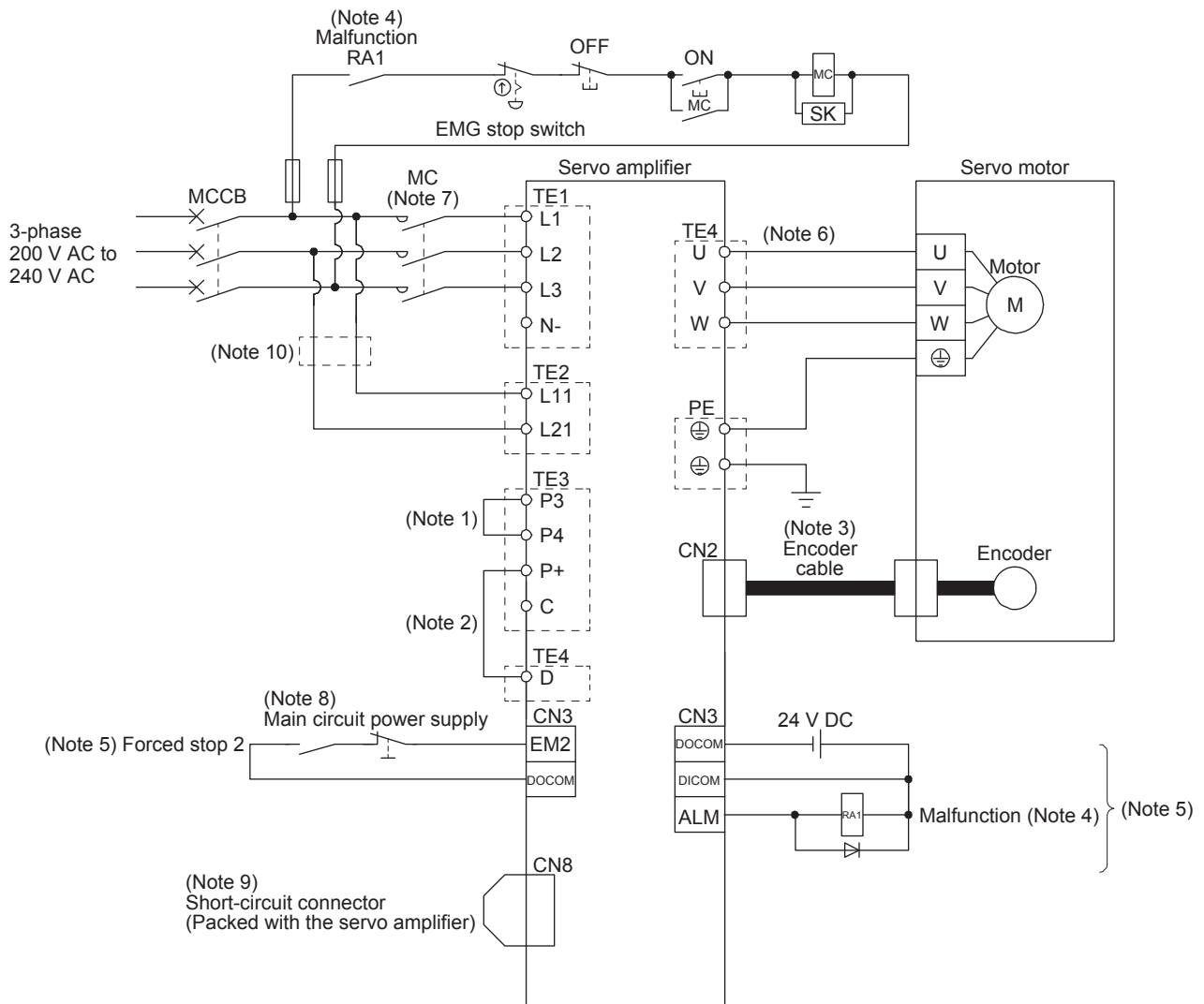

- Note 1. Always connect P3 and P4 terminals. (factory-wired) When using the power factor improving DC reactor, refer to section 11.11. Use either the power factor improving DC reactor or the power factor improving AC reactor.
2. Always connect P+ and D. (factory-wired) When using the regenerative option, refer to section 11.2.
3. For the encoder cable, use of the option cable is recommended. For connecting servo motor power wires, refer to Servo Motor Instruction Manual (Vol. 3).
4. If disabling ALM (Malfunction) output with the parameter, configure up the power supply circuit which switches off the magnetic contactor after detection of alarm occurrence on the controller side.
5. This diagram is for sink I/O interface. For source I/O interface, refer to section 3.8.3.
6. For connecting servo motor power wires, refer to each Servo Motor Instruction Manual (Vol. 3).
7. Use a magnetic contactor with an operation delay time (interval between current being applied to the coil until closure of contacts) of 80 ms or less. Depending on the main circuit voltage and operation pattern, bus voltage decreases, and that may cause the forced stop deceleration to shift to the dynamic brake deceleration. When dynamic brake deceleration is not required, slow the time to turn off the magnetic contactor.
8. Configure up a circuit to turn off EM2 when the main circuit power is turned off to prevent an unexpected restart of the servo amplifier.
9. When not using the STO function, attach a short-circuit connector supplied with a servo amplifier.
10. When wires used for L11 and L21 are thinner than wires used for L1, L2, and L3, use a molded case circuit breaker. (Refer to section 11.10.)

3. SIGNALS AND WIRING

(4) MR-J4-700B

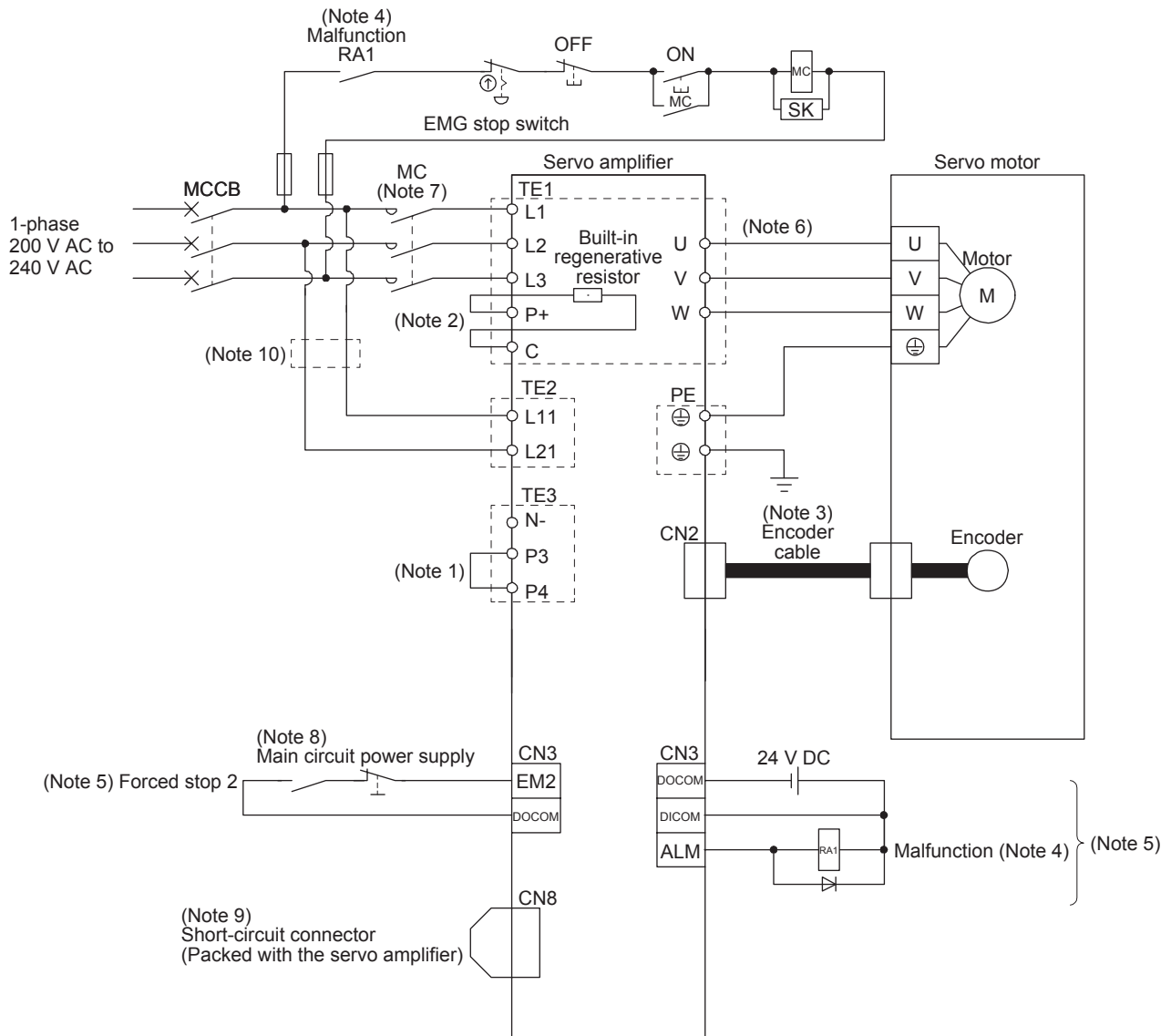

- Note 1. Always connect P3 and P4 terminals. (factory-wired) When using the power factor improving DC reactor, refer to section 11.11. Use either the power factor improving DC reactor or the power factor improving AC reactor.
2. When using the regenerative option, refer to section 11.2.
3. For the encoder cable, use of the option cable is recommended. For connecting servo motor power wires, refer to Servo Motor Instruction Manual (Vol. 3).
4. If disabling ALM (Malfunction) output with the parameter, configure up the power supply circuit which switches off the magnetic contactor after detection of alarm occurrence on the controller side.
5. This diagram is for sink I/O interface. For source I/O interface, refer to section 3.8.3.
6. For connecting servo motor power wires, refer to each Servo Motor Instruction Manual (Vol. 3).
7. Use a magnetic contactor with an operation delay time (interval between current being applied to the coil until closure of contacts) of 80 ms or less. Depending on the main circuit voltage and operation pattern, bus voltage decreases, and that may cause the forced stop deceleration to shift to the dynamic brake deceleration. When dynamic brake deceleration is not required, slow the time to turn off the magnetic contactor.
8. Configure up a circuit to turn off EM2 when the main circuit power is turned off to prevent an unexpected restart of the servo amplifier.
9. When not using the STO function, attach a short-circuit connector supplied with a servo amplifier.
10. When wires used for L11 and L21 are thinner than wires used for L1, L2, and L3, use a molded case circuit breaker. (Refer to section 11.10.)

3. SIGNALS AND WIRING

3.2 I/O signal connection example

POINT
● EM2 has the same function as EM1 in the torque control mode.

3.2.1 For sink I/O interface

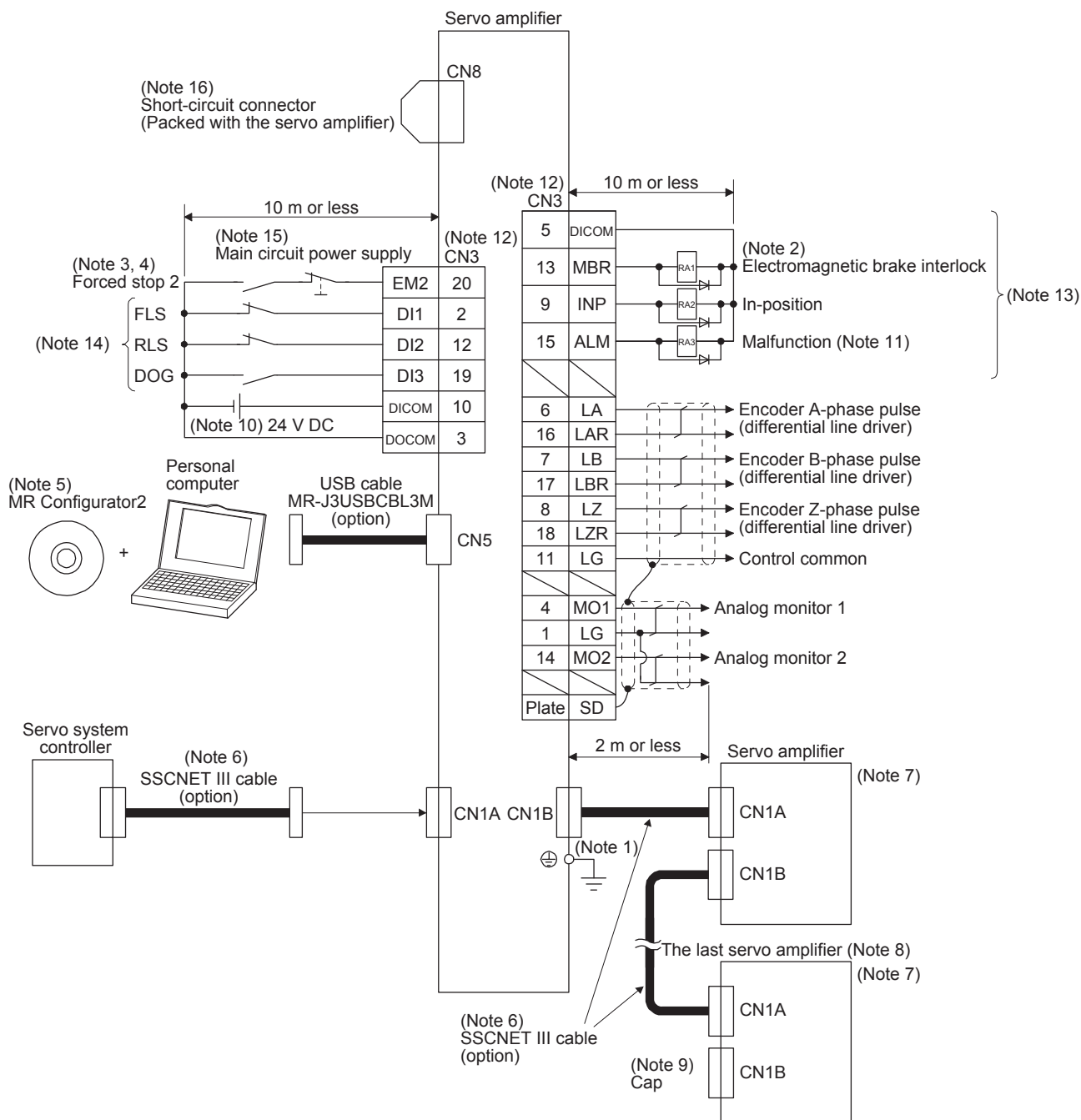

3. SIGNALS AND WIRING

- Note 1. To prevent an electric shock, always connect the protective earth (PE) terminal (marked \oplus) of the servo amplifier to the protective earth (PE) of the cabinet.
2. Connect the diode in the correct direction. If it is connected reversely, the servo amplifier will malfunction and will not output signals, disabling EM2 (Forced stop 2) and other protective circuits.
 3. If the controller does not have forced stop function, always install the forced stop 2 switch (Normally closed contact).
 4. When starting operation, always turn on EM2 (Forced stop 2). (Normally closed contact)
 5. Use SW1DNC-MRC2-E. (Refer to section 11.8.)
 6. Use SSCNET III cables listed in the following table.

Cable	Cable model	Cable length
Standard cord inside panel	MR-J3BUS_M	0.15 m to 3 m
Standard cable outside panel	MR-J3BUS_M-A	5 m to 20 m
Long-distance cable	MR-J3BUS_M-B	30 m to 50 m

7. The wiring after the second servo amplifier is omitted.
8. Up to 64 axes of servo amplifiers can be connected. The number of connectable axes depends on the controller you use. Refer to section 4.6 for setting of axis selection.
9. Make sure to cap the unused CN1B connector.
10. Supply 24 V DC \pm 10% 200 mA current for interfaces from the outside. 200 mA is the value applicable when all I/O signals are used. The current capacity can be decreased by reducing the number of I/O points. Refer to section 3.8.2 (1) that gives the current value necessary for the interface.
11. ALM (Malfunction) turns on in normal alarm-free condition.
12. The pins with the same signal name are connected in the servo amplifier.
13. You can change devices of these pins with [Pr. PD07], [Pr. PD08], and [Pr. PD09].
14. Devices can be assigned for these signals with controller setting. For devices that can be assigned, refer to the controller instruction manual. The following devices can be assigned for Q172DSCPU, Q173DSCPU, and QD77MS_.
 FLS: Upper stroke limit
 RLS: Lower stroke limit
 DOG: Proximity dog
15. Configure up a circuit to turn off EM2 when the main circuit power is turned off to prevent an unexpected restart of the servo amplifier.
16. When not using the STO function, attach a short-circuit connector supplied with a servo amplifier.

3. SIGNALS AND WIRING

3.2.2 For source I/O interface

POINT
● For notes, refer to section 3.2.1.

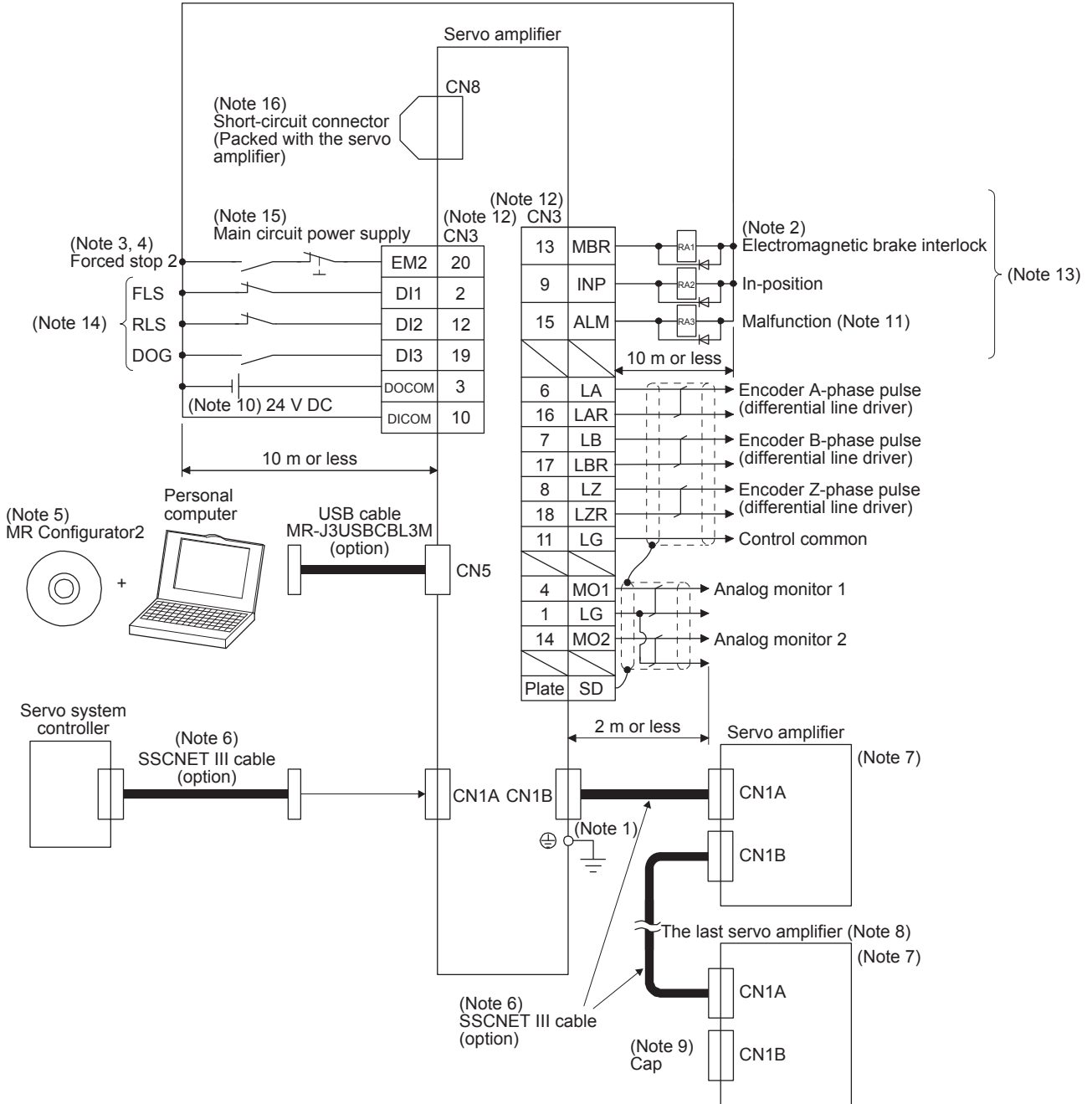

3. SIGNALS AND WIRING

3.3 Explanation of power supply system

3.3.1 Signal explanations

POINT
● For the layout of connector and terminal block, refer to chapter 9 DIMENSIONS.

Abbreviation	Connection target (Application)	Description												
L1/L2/L3	Main circuit power supply	<p>Supply the following power to L1, L2, and L3. For 1-phase 200 V AC to 240 V AC, connect the power supply to L1 and L3. Leave L2 open.</p> <table border="1" style="width: 100%; border-collapse: collapse;"> <tr> <td style="text-align: center;">Servo amplifier</td> <td style="text-align: center;">MR-J4-10B to MR-J4-70B</td> <td style="text-align: center;">MR-J4-100B to MR-J4-700B</td> </tr> <tr> <td style="text-align: center;">Power supply</td> <td colspan="2"></td> </tr> <tr> <td>3-phase 200 V AC to 240 V AC, 50/60 Hz</td> <td colspan="2" style="text-align: center;">L1/L2/L3</td> </tr> <tr> <td>1-phase 200 V AC to 240 V AC, 50/60 Hz</td> <td style="text-align: center;">L1/L3</td> <td></td> </tr> </table>	Servo amplifier	MR-J4-10B to MR-J4-70B	MR-J4-100B to MR-J4-700B	Power supply			3-phase 200 V AC to 240 V AC, 50/60 Hz	L1/L2/L3		1-phase 200 V AC to 240 V AC, 50/60 Hz	L1/L3	
Servo amplifier	MR-J4-10B to MR-J4-70B	MR-J4-100B to MR-J4-700B												
Power supply														
3-phase 200 V AC to 240 V AC, 50/60 Hz	L1/L2/L3													
1-phase 200 V AC to 240 V AC, 50/60 Hz	L1/L3													
P3/P4	Power factor improving DC reactor	<p>When not using the power factor improving DC reactor, connect P3 and P4. (factory-wired)</p> <p>When using the power factor improving DC reactor, disconnect P3 and P4, and connect the power factor improving DC reactor to P3 and P4.</p> <p>Refer to section 11.11 for details.</p>												
P+/C/D	Regenerative option	<p>1) MR-J4-350B or less</p> <p>When using servo amplifier built-in regenerative resistor, connect P+ and D. (factory-wired)</p> <p>When using a regenerative option, disconnect P+ and D, and connect the regenerative option to P+ and C.</p> <p>2) MR-J4-350B to MR-J4-700B</p> <p>MR-J4-350B to MR-J4-700B do not have D.</p> <p>When using a servo amplifier built-in regenerative resistor, connect P+ and C. (factory-wired)</p> <p>When using a regenerative option, disconnect wires of P+ and C for the built-in regenerative resistor. And then connect wires of the regenerative option to P+ and C.</p> <p>Refer to section 11.2 to 11.5 for details.</p>												
L11/L21	Control circuit power supply	<p>Supply the following power to L11 and L21.</p> <table border="1" style="width: 100%; border-collapse: collapse;"> <tr> <td style="text-align: center;">Servo amplifier</td> <td style="text-align: center;">MR-J4-10B to MR-J4-700B</td> </tr> <tr> <td style="text-align: center;">Power supply</td> <td></td> </tr> <tr> <td>1-phase 200 V AC to 240 V AC</td> <td style="text-align: center;">L11/L21</td> </tr> </table>	Servo amplifier	MR-J4-10B to MR-J4-700B	Power supply		1-phase 200 V AC to 240 V AC	L11/L21						
Servo amplifier	MR-J4-10B to MR-J4-700B													
Power supply														
1-phase 200 V AC to 240 V AC	L11/L21													
U/V/W	Servo motor power supply	<p>Connect to the servo motor power supply terminals (U, V, and W). During power-on, do not open or close the servo motor power supply. Otherwise, it may cause a malfunction.</p>												
N-	Return converter Brake unit	<p>When using a power regenerative converter or brake unit, connect it to P+ and N-.</p> <p>Refer to section 11.3 to 11.5 for details.</p>												
⊕	Protective earth (PE)	<p>Connect it to the grounding terminal of the servo motor and to the protective earth (PE) of the cabinet for grounding.</p>												

3. SIGNALS AND WIRING

3.3.2 Power-on sequence

(1) Power-on procedure

- 1) Always wire the power supply as shown in above section 3.1 using the magnetic contactor with the main circuit power supply (3-phase: L1, L2, and L3, 1-phase: L1 and L3). Configure up an external sequence to switch off the magnetic contactor as soon as an alarm occurs.
- 2) Switch on the control circuit power supply (L11 and L21) simultaneously with the main circuit power supply or before switching on the main circuit power supply. If the control circuit power supply is turned on with the main circuit power supply off, and then the servo-on command is transmitted, [AL. E9 Main circuit off warning] will occur. Turning on the main circuit power supply stops the warning and starts the normal operation.
- 3) The servo amplifier receives the servo-on command within 3 s to 4 s after the main circuit power supply is switched on.
(Refer to paragraph (2) of this section.)

(2) Timing chart

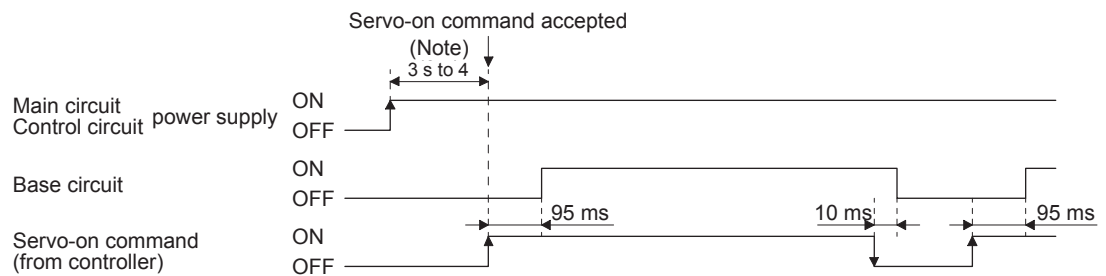

Note. The time will be longer during the magnetic pole detection of a linear servo motor and direct drive motor.

3. SIGNALS AND WIRING

3.3.3 Wiring CNP1, CNP2, and CNP3

POINT
● For the sizes of wires used for wiring, refer to section 11.11.
● MR-J3-500B or more do not have these connectors.

Use the servo amplifier power supply connector for wiring CNP1, CNP2 and CNP3.

(1) Connectors

(a) MR-J4-10B to MR-J4-100B

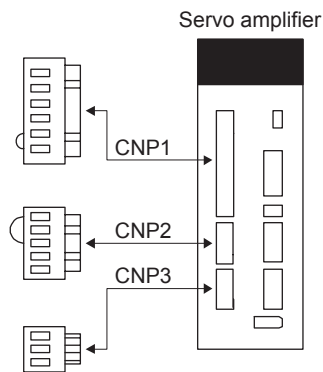

Table 3.1 Connector and applicable cable

Connector	Receptacle assembly	Applicable cable		Stripped length [mm]	Open tool	Manufacturer
		Size	Insulator OD			
CNP1	06JFAT-SAXGDK-H7.5	AWG 18 to 14	3.9 mm or less	9 mm	J-FAT-OT	JST
CNP2	05JFAT-SAXGDK-H5.0					
CNP3	03JFAT-SAXGDK-H7.5					

(b) MR-J4-200B/MR-J4-350B

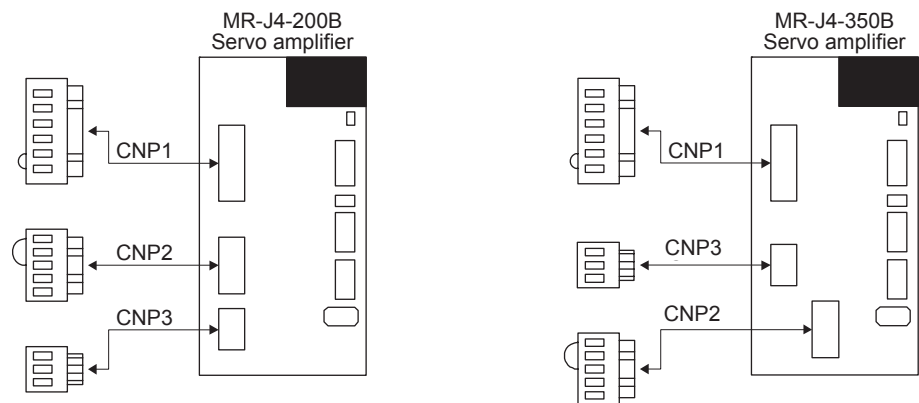

Table 3.2 Connector and applicable cable

Connector	Receptacle assembly	Applicable cable		Stripped length [mm]	Open tool	Manufacturer
		Size	Insulator OD			
CNP1	06JFAT-SAXGFK-XL	AWG 16 to 10	4.7 mm or less	11.5 mm	J-FAT-OT-EXL	JST
CNP3	03JFAT-SAXGFK-XL					
CNP2	05JFAT-SAXGDK-H5.0	AWG 18 to 14	3.9 mm or less	9 mm		

3. SIGNALS AND WIRING

(2) Cable connection procedure

(a) Cable making

Refer to table 3.1 and 3.2 for stripped length of cable insulator. The appropriate stripped length of cables depends on their type, etc. Set the length considering their status.

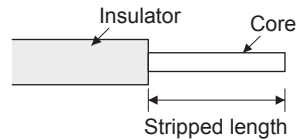

Twist strands slightly and straighten them as follows.

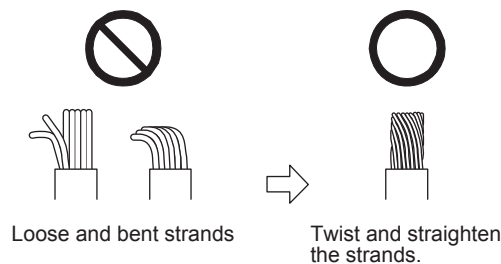

(b) Inserting wire

Insert the open tool as follows and push down it to open the spring. While the open tool is pushed down, insert the stripped wire into the wire insertion hole. Check the insertion depth so that the cable insulator does not get caught by the spring.

Release the open tool to fix the wire. Pull the wire lightly to confirm that the wire is surely connected. The following shows a connection example of the CNP3 connector for 2 kW and 3.5 kW.

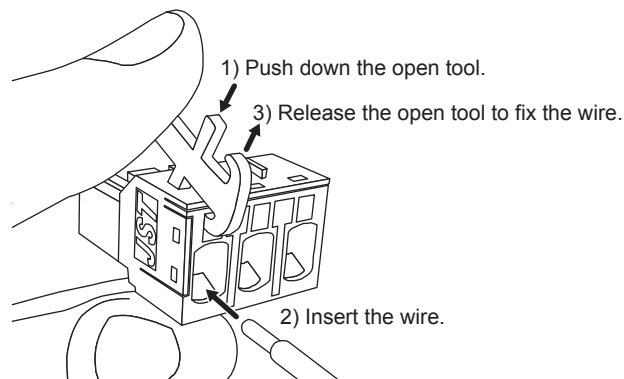

3. SIGNALS AND WIRING

3.4 Connectors and pin assignment

POINT
<ul style="list-style-type: none">● The pin assignment of the connectors are as viewed from the cable connector wiring section.● For the STO I/O signal connector (CN8), refer to chapter 13.● In the case of the CN3 connector, securely connect the shielded external conductor of the cable to the ground plate and fix it to the connector shell.

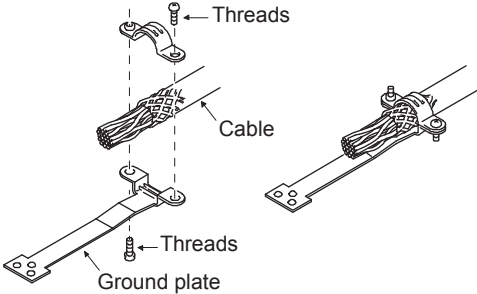

3. SIGNALS AND WIRING

The servo amplifier front view shown is that of the MR-J4-20B or less. Refer to chapter 9 DIMENSIONS for the appearances and connector layouts of the other servo amplifiers.

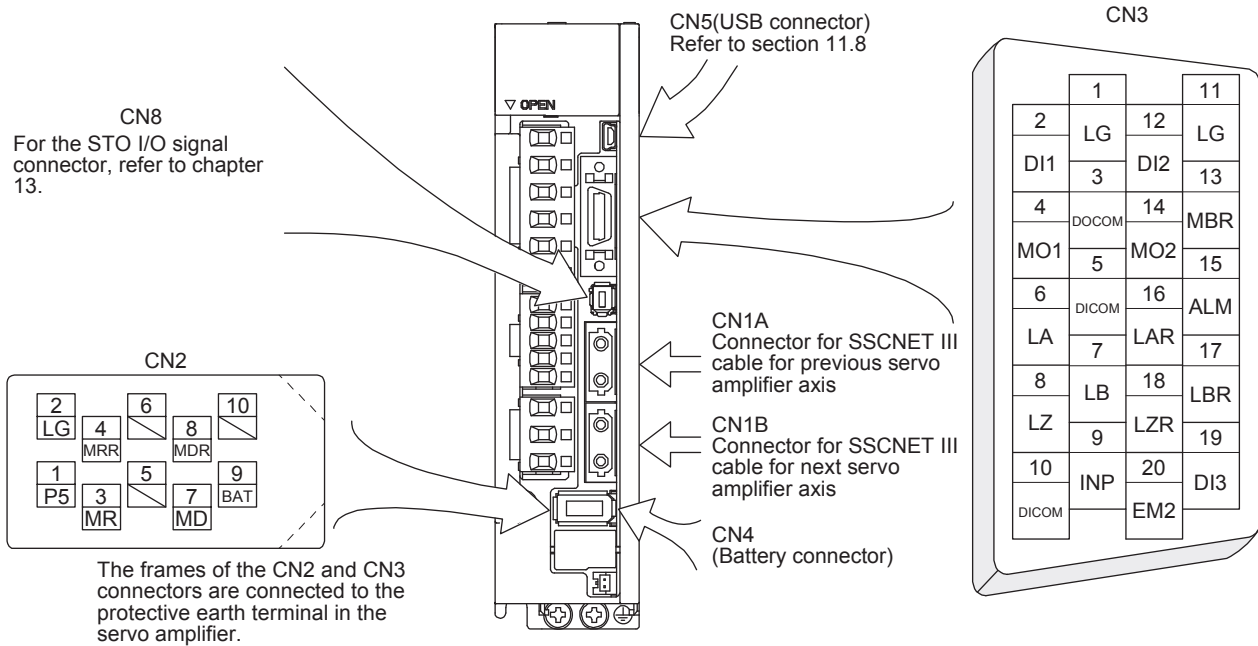

Connector	Name	Description
CN1A	Connector for SSCNET III cable for previous servo amplifier axis	Used for connection with the controller or previous axis servo amplifier.
CN1B	Connector for SSCNET III cable for next servo amplifier axis	Used for connection with the next axis servo amplifier or for connection of the cap.
CN2	Connector for encoder	Used to connect the servo motor encoder.
CN4	Connector for encoder battery	When using it as absolute position detection system, connect to battery (MR-BAT6V1SET). Before mounting a battery, turn off the main circuit power and wait for 15 minutes or longer until the charge lamp turns off. Then, check the voltage between P+ and N- with a voltage tester or others. Otherwise, an electric shock may occur. In addition, when confirming whether the charge lamp is off or not, always confirm it from the front of the servo amplifier. Replace the battery with main circuit power-off and with control circuit power-on. Replacing the battery with the control circuit power-off results in losing absolute position data.
CN5	USB connector	The personal computer is connected.
CN8	STO I/O signal connector	For the STO I/O signal connector (CN8), refer to chapter 13.

3. SIGNALS AND WIRING

3.5 Signal (device) explanations

For the I/O interfaces (symbols in I/O division column in the table), refer to section 3.8.2. In the control mode field of the table

The pin No.s in the connector pin No. column are those in the initial status.

3.5.1 Input device

Device	Abbreviation	Connector pin No.	Function and application	I/O division																					
Forced stop 2	EM2	CN3-20	Turn off EM2 (open between commons) to decelerate the servo motor to a stop with commands. Turn EM2 on (short between commons) in the forced stop state to reset that state. Set [Pr. PA04] to "2 1 __" to disable EM2. The following shows the setting of [Pr. PA04].	DI-1																					
			<table border="1"> <thead> <tr> <th rowspan="2">[Pr. PA04] setting</th> <th rowspan="2">EM2/EM1</th> <th colspan="2">Deceleration</th> </tr> <tr> <th>EM2 or EM1 is off</th> <th>Alarm occurred</th> </tr> </thead> <tbody> <tr> <td>0 0 __</td> <td>EM1</td> <td>MBR (Electromagnetic brake interlock) turns off without the forced stop deceleration.</td> <td>MBR (Electromagnetic brake interlock) turns off without the forced stop deceleration.</td> </tr> <tr> <td>2 0 __</td> <td>EM2</td> <td>MBR (Electromagnetic brake interlock) turns off after the forced stop deceleration.</td> <td>MBR (Electromagnetic brake interlock) turns off after the forced stop deceleration.</td> </tr> <tr> <td>0 1 __</td> <td>Not using EM2 or EM1</td> <td rowspan="2" style="text-align: center;">/</td> <td>MBR (Electromagnetic brake interlock) turns off without the forced stop deceleration.</td> </tr> <tr> <td>2 1 __</td> <td>Not using EM2 or EM1</td> <td>MBR (Electromagnetic brake interlock) turns off after the forced stop deceleration.</td> </tr> </tbody> </table>		[Pr. PA04] setting	EM2/EM1	Deceleration		EM2 or EM1 is off	Alarm occurred	0 0 __	EM1	MBR (Electromagnetic brake interlock) turns off without the forced stop deceleration.	MBR (Electromagnetic brake interlock) turns off without the forced stop deceleration.	2 0 __	EM2	MBR (Electromagnetic brake interlock) turns off after the forced stop deceleration.	MBR (Electromagnetic brake interlock) turns off after the forced stop deceleration.	0 1 __	Not using EM2 or EM1	/	MBR (Electromagnetic brake interlock) turns off without the forced stop deceleration.	2 1 __	Not using EM2 or EM1	MBR (Electromagnetic brake interlock) turns off after the forced stop deceleration.
			[Pr. PA04] setting				EM2/EM1	Deceleration																	
					EM2 or EM1 is off	Alarm occurred																			
			0 0 __		EM1	MBR (Electromagnetic brake interlock) turns off without the forced stop deceleration.	MBR (Electromagnetic brake interlock) turns off without the forced stop deceleration.																		
2 0 __	EM2	MBR (Electromagnetic brake interlock) turns off after the forced stop deceleration.	MBR (Electromagnetic brake interlock) turns off after the forced stop deceleration.																						
0 1 __	Not using EM2 or EM1	/	MBR (Electromagnetic brake interlock) turns off without the forced stop deceleration.																						
2 1 __	Not using EM2 or EM1		MBR (Electromagnetic brake interlock) turns off after the forced stop deceleration.																						
			EM2 and EM1 are mutually exclusive. However, EM2 has the same function as EM1 in the torque control mode.																						
Forced stop 1	EM1	(CN3-20)	When using EM1, set [Pr. PA04] to "0 0 __" to enable EM1. Turn EM1 off (open between commons) to bring the motor to an forced stop state. The base circuit is shut off, the dynamic brake is operated and decelerate the servo motor to a stop. Turn EM1 on (short between commons) in the forced stop state to reset that state. Set [Pr. PA04] to "0 1 __" to disable EM1.	DI-1																					
	DI1	CN3-2	Devices can be assigned for these signals with controller setting. For devices that can be assigned, refer to the controller instruction manual. The following devices can be assigned for MR-J4 compatible controller (Q172DSCPU, Q173DSCPU, and QD77MS_).	DI-1																					
	DI2	CN3-12		DI-1																					
	DI3	CN3-19		DI-1																					

3. SIGNALS AND WIRING

3.5.2 Output device

(1) Output device pin

The following shows the output device pins and parameters for assigning devices.

Connector pin No.	Parameter	Initial device	I/O division
CN3-13	[Pr. PD07]	MBR	DO-1
CN3-15	[Pr. PD09]	ALM	
CN3-9	[Pr. PD08]	INP	

(2) Output device explanations

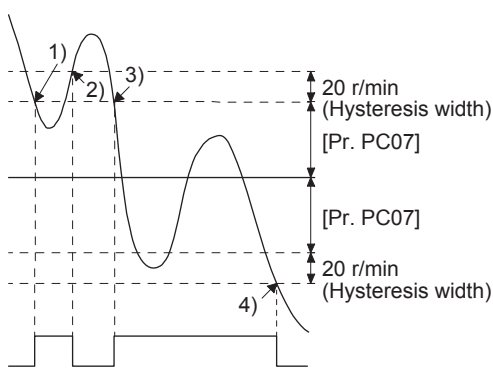
Device	Abbreviation	Function and application
Electromagnetic brake interlock	MBR	When using the device, set operation delay time of the electromagnetic brake in [Pr. PC02]. When the servo-off status or alarm occurs, MBR will turn off.
Malfunction	ALM	When the protective circuit is activated to shut off the base circuit, ALM will turn off. Without alarm occurring, ALM turns on about 2.5 s to 3.5 s after power-on.
In-position	INP	When the number of droop pulses is in the in-position range, INP will turn on. The in-position range can be changed using [Pr. PA10]. When the in-position range is increased, INP may be on during low-speed rotation. INP turns on when servo-on turns on. The device cannot be used in the speed control mode and torque control mode.
Ready	RD	RD turns on when the servo is switched on and the servo amplifier is ready to operate.
Speed reached	SA	SA will turn off during servo-off. When servo motor rotation speed reaches approximately target speed, SA will turn on. When the preset speed is 20 r/min or less, SA always turns on. The signal cannot be used in the position control mode and torque control mode.
limiting torque	VLC	When the speed reaches the speed limit value in the torque control mode, VLC will turn on. When the servo is off, TLC will be turned off. The device cannot be used in the position control mode and speed control mode.
Limiting torque	TLC	When the torque reaches the torque limit value during torque generation, TLC will turn on. When the servo is off, TLC will be turned off. This device cannot be used in the torque control mode.
Zero speed detection	ZSP	ZSP turns on when the servo motor speed is zero speed (50 r/min) or less. Zero speed can be changed using [Pr. PC07]. <div style="display: flex; align-items: center;"> <div style="margin-right: 20px;"> <p>Forward rotation direction ↑</p> <p>OFF level 70 r/min</p> <p>ON level 50 r/min</p> </div> <div style="margin-right: 20px;"> <p>Servo motor speed</p> <p>0 r/min</p> </div> <div style="margin-right: 20px;"> <p>Reverse rotation direction ↓</p> <p>ON level -50 r/min</p> <p>OFF level -70 r/min</p> </div> <div style="margin-right: 20px;"> <p>ZSP (Zero speed detection)</p> <p>ON</p> <p>OFF</p> </div>  </div> <p>ZSP will turn on when the servo motor is decelerated to 50 r/min (at 1)), and will turn off when the servo motor is accelerated to 70 r/min again (at 2)). ZSP will turn on when the servo motor is decelerated again to 50 r/min (at 3)), and will turn off when the servo motor speed has reached -70 r/min (at 4)). The range from the point when the servo motor speed has reached on level, and ZSP turns on, to the point when it is accelerated again and has reached off level is called hysteresis width. Hysteresis width is 20 r/min for this servo amplifier. When you use a linear servo motor, [r/min] explained above will be [mm/s].</p>

3. SIGNALS AND WIRING

Device	Abbreviation	Function and application
Warning	WNG	When warning has occurred, WNG turns on. Without warning occurring, WNG turns off about 2.5 s to 3.5 s after power-on.
Battery warning	BWNG	BWNG turns on when [AL. 92 Battery cable disconnection warning] or [AL. 9F Battery warning] has occurred. When the battery warning is not occurring, BWNG will turn off about 2.5 s to 3.5 s after power-on.
Variable gain selection	CDPS	CDPS will turn on during variable gain.
Absolute position undetermined	ABSV	ABSV turns on when the absolute position erased. The device cannot be used in the speed control mode and torque control mode.
During tough drive	MTTR	When a tough drive is enabled in [Pr. PA20], activating the instantaneous power failure tough drive will turn on MTTR.

3.5.3 Output signal

Signal name	Abbreviation	Connector pin No.	Function and application
Encoder A-phase pulse (differential line driver)	LA LAR	CN3-6 CN3-16	These devices output pulses of encoder output set in [Pr. PA15] and [Pr. PA16] in the differential line driver type. In CCW rotation of the servo motor, the encoder B-phase pulse lags the encoder A-phase pulse by a phase angle of $\pi/2$.
Encoder B-phase pulse (differential line driver)	LB LBR	CN3-7 CN3-17	The relationships between rotation direction and phase difference of the A-phase and B-phase pulses can be changed using [Pr. PC03]. Output pulse specification, dividing ratio setting, and electronic gear setting can be selected.
Encoder Z-phase pulse (differential line driver)	LZ LZR	CN3-8 CN3-18	Outputs the zero-point signal in the differential line driver type of the encoder. One pulse is output per servo motor revolution. Turns on when the zero-point position is reached. (negative logic) The minimum pulse width is about 400 μ s. For home position return using this pulse, set the creep speed to 100 r/min. or less.
Analog monitor 1	MO1	CN3-4	Used to output the data set in [Pr. PC09] to across MO1-LG in terms of voltage. Resolution: 10 bits or equivalent
Analog monitor 2	MO2	CN3-14	This signal output the data set in [Pr. PC09] to between MO2 and LG in terms of voltage. Resolution: 10 bits or equivalent

3.5.4 Power supply

Signal name	Abbreviation	Connector pin No.	Function and application
Digital I/F power supply input	DICOM	CN3-5 CN3-10	Input 24 V DC (24 V DC \pm 10% 200 mA) for I/O interface. The power supply capacity changes depending on the number of I/O interface points to be used. For sink interface, connect + of 24 V DC external power supply. For source interface, connect - of 24 V DC external power supply.
Digital I/F common	DOCOM	CN3-3	Common terminal for input device such as EM2 of the servo amplifier. DOCOM is separated from LG. For sink interface, connect - of 24 V DC external power supply. For source interface, connect + of 24 V DC external power supply.
Monitor common	LG	CN3-1 CN3-11	Common terminal of MO1 and MO2. Pins are connected internally.
Shield	SD	Plate	Connect the external conductor of the shielded wire.

3. SIGNALS AND WIRING

3.6 Forced stop deceleration function

POINT
<ul style="list-style-type: none"> ● When alarms not related to the forced stop function occur, control of motor deceleration can not be guaranteed. (Refer to section 8.1.) ● In the torque control mode, the forced stop deceleration function is not available.

3.6.1 Forced stop deceleration function (SS1)

When EM2 is turned off, dynamic brake will start to stop the servo motor after forced stop deceleration. During this sequence, the display shows [AL. E6 Servo forced stop warning].

During normal operation, do not use EM2 (Forced stop 2) to alternate stop and run. The the servo amplifier life may be shortened.

(1) Connection diagram

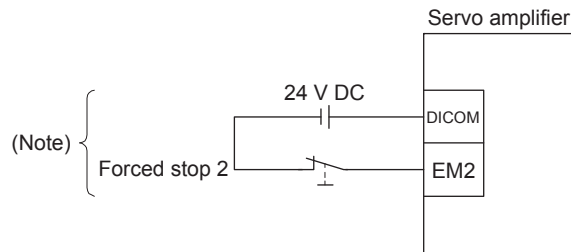

Note. This diagram is for sink I/O interface. For source I/O interface, refer to section 3.8.3.

(2) Timing chart

When EM2 (Forced stop 2) turns off, the motor will decelerate according to [Pr. PC24 Forced stop deceleration time constant]. Once the motor speed is below [Pr. PC07 Zero speed], base power is cut and the dynamic brake activates.

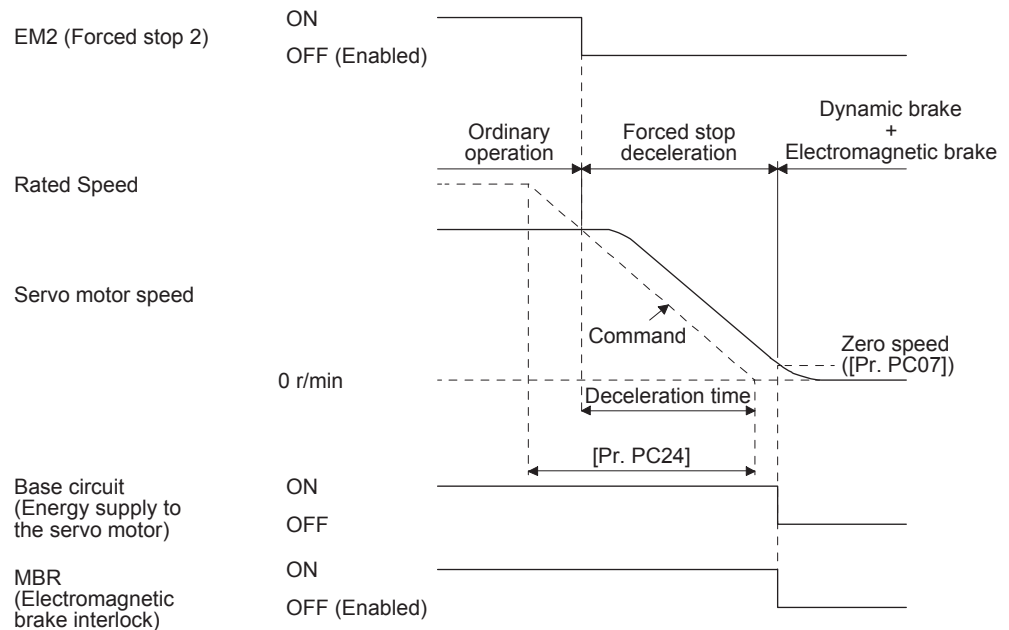

3. SIGNALS AND WIRING

3.6.2 Base circuit shut-off delay time function

The base circuit shut-off delay time function is used to maintain power at the motor for a specified time delay after a forced stop activation (EM2 goes off). The time between completion of EM2 (Forced stop 2) or activation of MBR (Electromagnetic brake interlock) due to an alarm occurrence, and the time at which the base is cut, is the base cut delay time and is set by [Pr. PC02].

(1) Timing chart

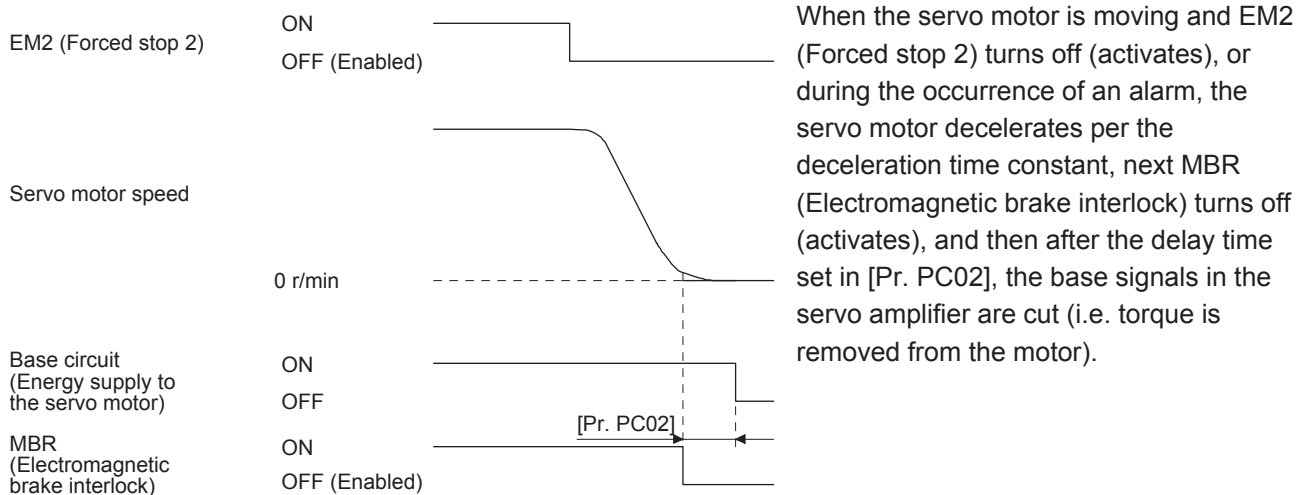

(2) Adjustment

While the servo motor is stopped, activate (turn off) EM2 (Forced stop 2), adjust the base cut delay time in [Pr. PC02], setting the value to approximately 1.5 times the smallest delay time in which the servo motor does not freefall.

3. SIGNALS AND WIRING

3.6.3 Vertical axis freefall prevention function

The vertical axis freefall prevention function avoids machine damage by pulling up the shaft slightly the following case.

When the servo motor is used for operating vertical axis, the servo motor electromagnetic brake and the base circuit shut-off delay time function avoid dropping axis at forced stop. However, the functions may not avoid dropping axis a few μm due to the backlash of the servo motor electromagnetic brake.

The vertical axis freefall prevention function is enabled with the following conditions.

- Other than "0" is set in [Pr. PC31 Vertical axis freefall prevention compensation amount].
- The servo motor speed decelerates lower than the value of zero speed by turning off EM2 (Forced stop 2) or by an alarm occurrence.
- The base circuit shut-off delay time function is enabled.

When [Pr. PC31 Vertical axis freefall prevention compensation amount] is set to a value other than "0", and when the servo motor speed decelerates lower than the value of zero speed by turning off EM2 (Forced stop 2) or by an alarm occurrence, the freefall prevention function begins to work.

(1) Timing chart

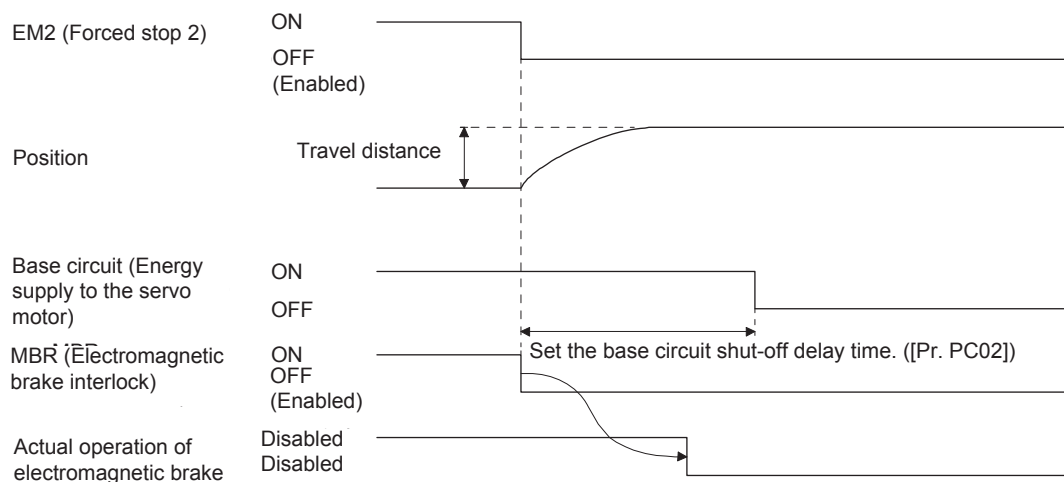

(2) Adjustment

- Set the freefall prevention compensation amount in [Pr. PC31].
- While the servo motor is stopped, turn off the EM2 (Forced stop 2). Adjust the base circuit shut-off delay time in [Pr. PC02] in accordance with the travel distance ([Pr. PC31]). Adjust it considering the freefall prevention compensation amount by checking the servo motor speed, torque ripple, etc.

3. SIGNALS AND WIRING

3.6.4 Residual risks of the forced stop function (EM2)

- (1) The forced stop function is not available for alarms that activate the dynamic brake when the alarms occur.
- (2) When an alarm that activates the dynamic brake during forced stop deceleration occurs, the braking distance until the servo motor stops will be longer than that of normal forced stop deceleration without the dynamic brake.
- (3) If STO is turned off during forced stop deceleration, [AL.63 STO timing error] will occur.

3. SIGNALS AND WIRING

3.7 Alarm occurrence timing chart

 CAUTION	<ul style="list-style-type: none"> When an alarm has occurred, remove its cause, make sure that the operation signal is not being input, ensure safety, and reset the alarm before restarting operation.
--	---

POINT	<ul style="list-style-type: none"> In the torque control mode, the forced stop deceleration function is not available.
-------	---

To deactivate the alarm, cycle the control circuit power or give the error reset or CPU reset command from the servo system controller. However, the alarm cannot be deactivated unless its cause is removed.

3.7.1 When you use the forced stop deceleration function

POINT	<ul style="list-style-type: none"> To enable the function, set "2 ____(initial value)" in [Pr. PA04].
-------	--

(1) When the forced stop deceleration function is valid

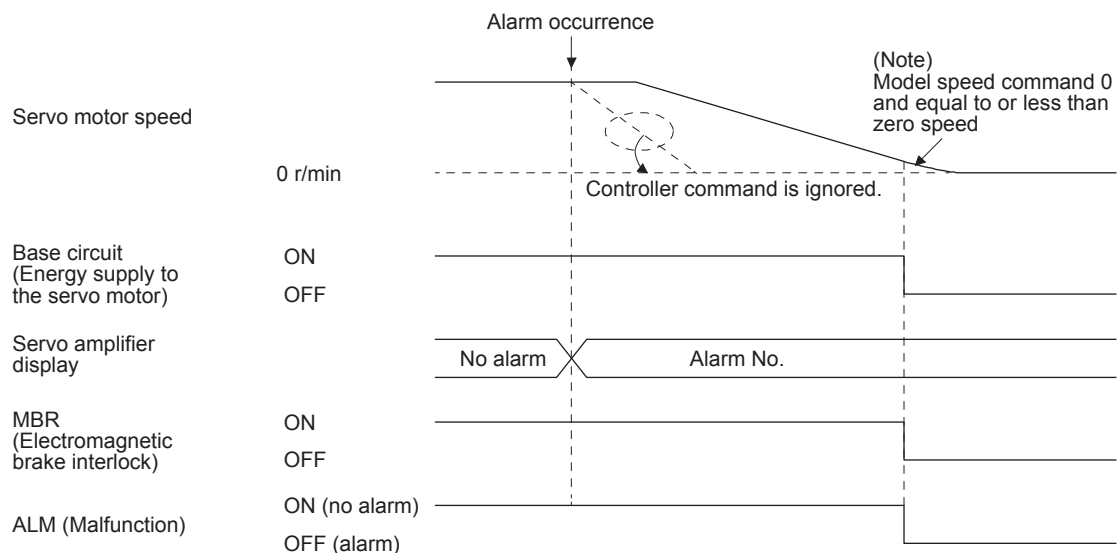

Note. The model speed command is a speed command made in the servo amplifier for forced stop deceleration of the servo motor.

3. SIGNALS AND WIRING

(2) When the forced stop deceleration function is invalid

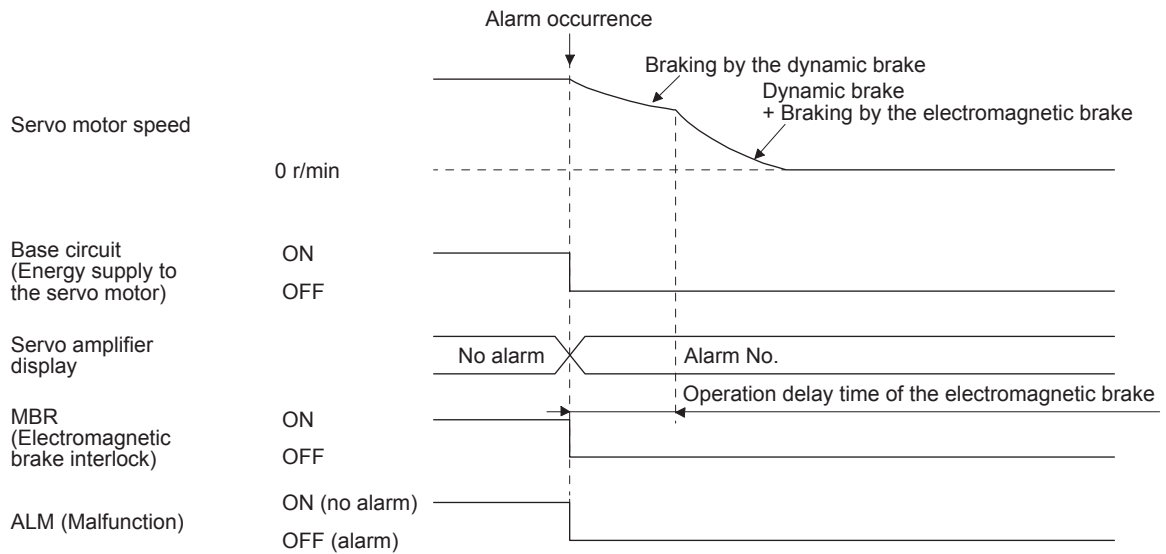

(3) When SSCNET III/H communication brake occurs

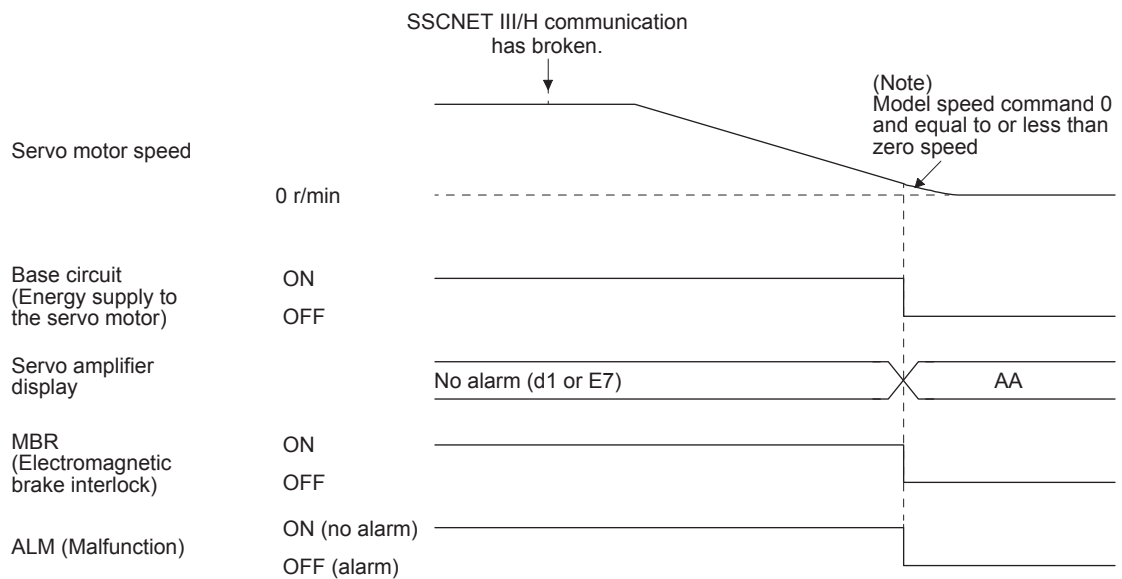

Note. The model speed command is a speed command made in the servo amplifier for forced stop deceleration of the servo motor.

3.7.2 When you do not use the forced stop deceleration function

POINT
● To disable the function, set "0 _ _ _" in [Pr. PA04].

The timing chart that shows the servo motor condition when an alarm or SSCNETIII/H communication brake occurs is the same as section 3.7.1 (2).

3. SIGNALS AND WIRING

3.8 Interfaces

3.8.1 Internal connection diagram

POINT
● Refer to section 13.3.1 for the CN8 connector.

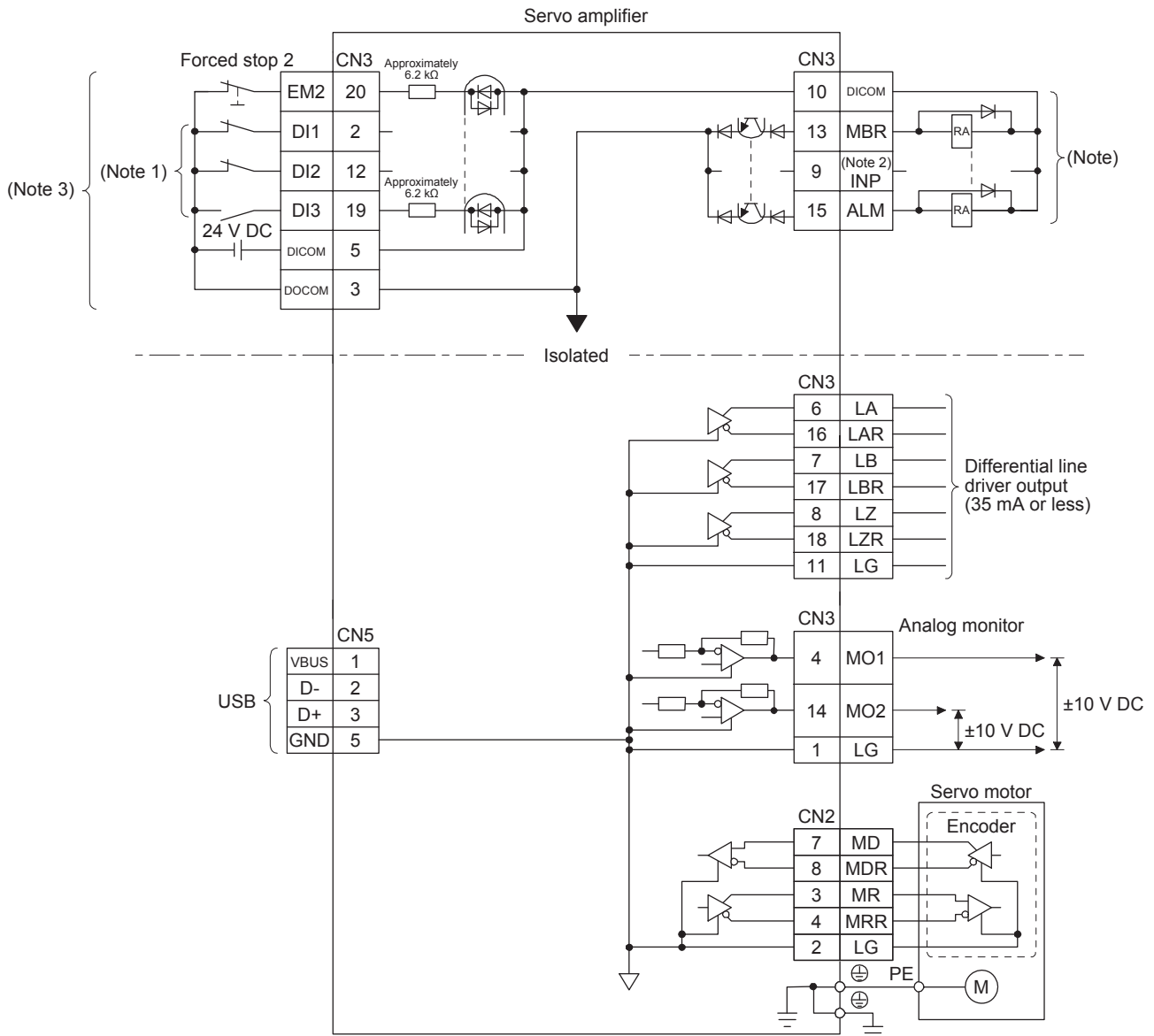

- Note 1. Signal can be assigned for these pins with host controller setting.
For contents of signals, refer to the instruction manual of host controller.
2. The signal cannot be used in the speed control mode and torque control mode.
3. This diagram is for sink I/O interface. For source I/O interface, refer to section 3.8.3.

3. SIGNALS AND WIRING

3.8.2 Detailed description of interfaces

This section provides the details of the I/O signal interfaces (refer to the I/O division in the table) given in section 3.5. Refer to this section and make connection with the external device.

(1) Digital input interface DI-1

Turn on/off the input signal with a relay or open collector transistor. The following is a connection diagram for sink input. Refer to section 3.8.3 for source input.

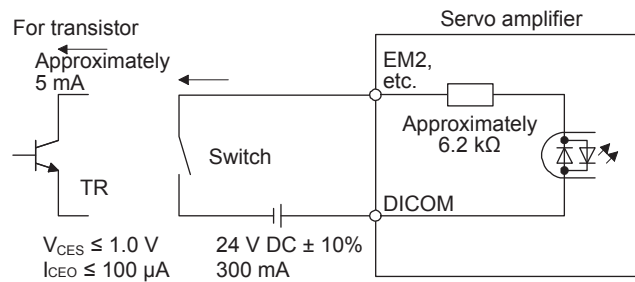

(2) Digital output interface DO-1

A lamp, relay or photocoupler can be driven. Install a diode (D) for an inductive load, or install an inrush current suppressing resistor (R) for a lamp load.

(Rated current: 40 mA or less, maximum current: 50 mA or less, inrush current: 100 mA or less) A maximum of 2.6 V voltage drop occurs in the servo amplifier.

The following is a connection diagram for sink output. Refer to section 3.8.3 for source output.

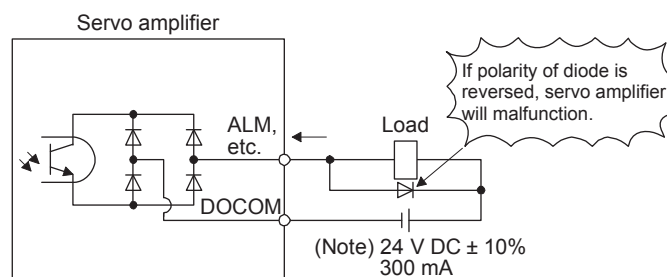

Note. If the voltage drop (maximum of 2.6 V) interferes with the relay operation, apply high voltage (maximum of 26.4 V) from external source.

3. SIGNALS AND WIRING

(3) Encoder output pulses DO-2 (differential line driver type)

(a) Interface

Max. output current: 35 mA

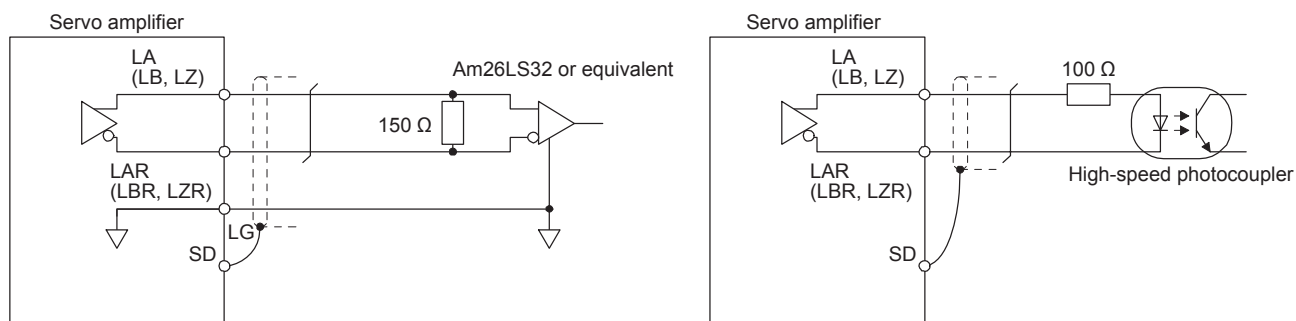

(b) Output pulse

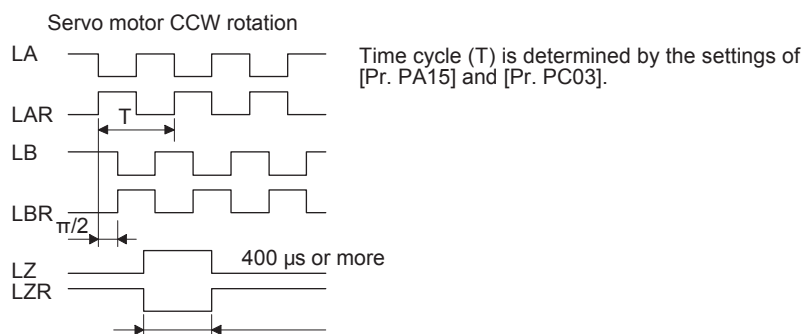

(4) Analog output

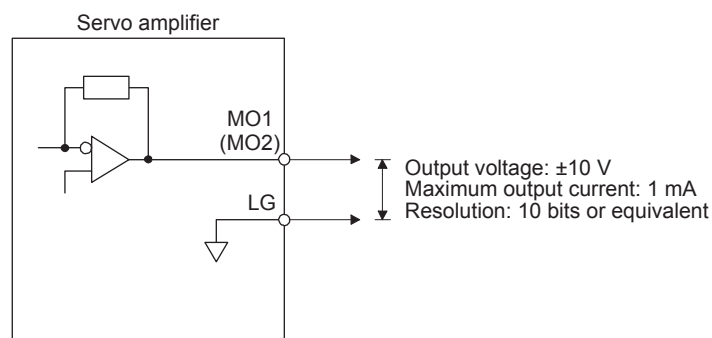

Note. Output voltage range varies depending on the output contents. (Refer to section 5.3.3.)

3. SIGNALS AND WIRING

3.8.3 Source I/O interface

In this servo amplifier, source type I/O interfaces can be used. In this case, all DI-1 input signals and DO-1 output signals are of source type. Perform wiring according to the following interfaces.

(1) Digital input interface DI-1

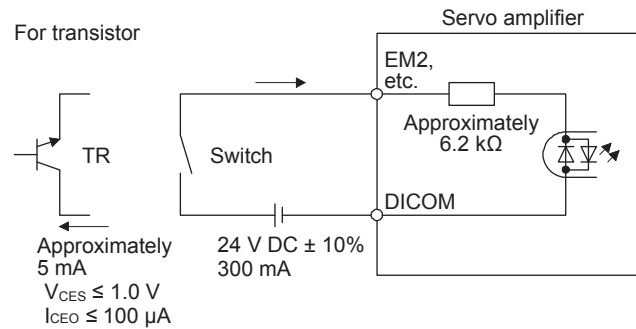

(2) Digital output interface DO-1

A maximum of 2.6 V voltage drop occurs in the servo amplifier.

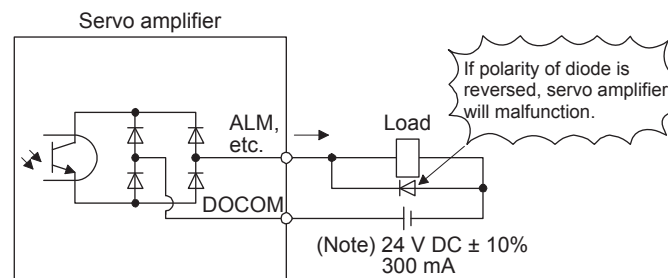

Note. If the voltage drop (maximum of 2.6 V) interferes with the relay operation, apply high voltage (maximum of 26.4 V) from external source.

3. SIGNALS AND WIRING

3.9 SSCNET III cable connection

POINT
<ul style="list-style-type: none"> ● Do not look directly at the light generated from CN1A/CN1B connector of the servo amplifier or the end of SSCNET III cable. The light can be a discomfort when it enters the eye. (The light source of SSCNET III/H complies with class1 defined in JIS C6802 or IEC 60825-1.)

(1) SSCNET III cable connection

For the CN1A connector, connect the SSCNET III cable connected to a controller in host side or a servo amplifier of the previous axis. For CN1B connector, connect SSCNET III cable connected to servo amplifier of the next axis. For CN1B connector of the final axis, put a cap came with servo amplifier.

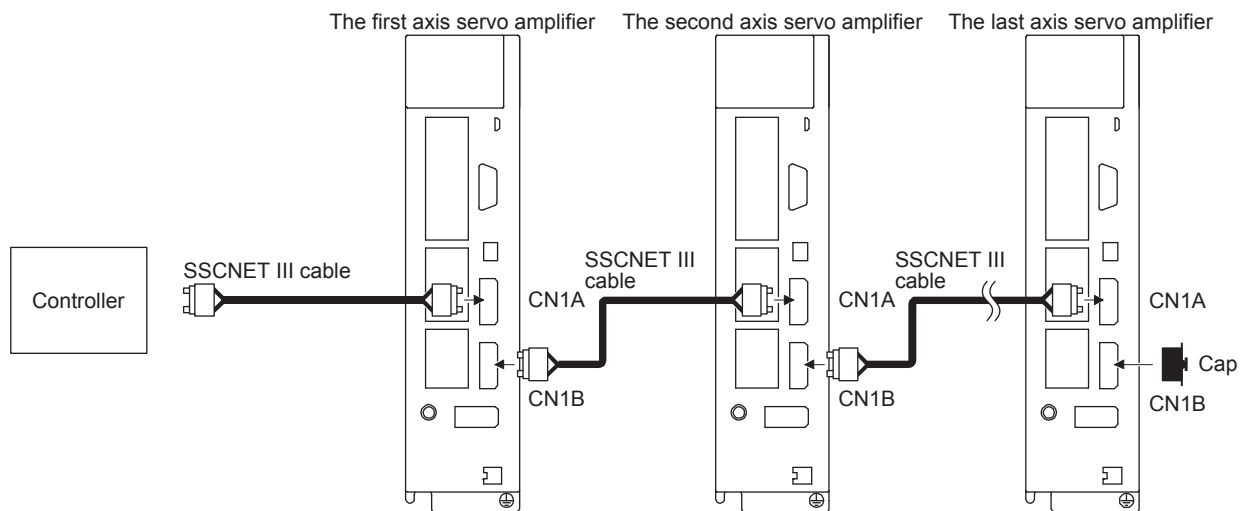

(2) How to connect/disconnect cable

POINT
<ul style="list-style-type: none"> ● CN1A and CN1B connector are capped to protect light device inside connector from dust. For this reason, do not remove a cap until just before mounting SSCNET III cable. Then, when removing SSCNET III cable, make sure to put a cap. ● Keep the cap for CN1A/CN1B connector and the tube for protecting optical cord end of SSCNET III cable in a plastic bag with a zipper of SSCNET III cable to prevent them from becoming dirty. ● When asking repair of servo amplifier for some malfunctions, make sure to cap CN1A and CN1B connector. When the connector is not put a cap, the light device may be damaged at the transit. In this case, replacing and repairing the light device is required.

(a) Connection

- 1) For SSCNET III cable in the shipping status, the tube for protect optical cord end is put on the end of connector. Remove this tube.
- 2) Remove the CN1A and CN1B connector caps of the servo amplifier.

3. SIGNALS AND WIRING

- 3) With holding a tab of SSCNET III cable connector, make sure to insert it into the CN1A and CN1B connector of the servo amplifier until you hear the click. If the end face of optical cord tip is dirty, optical transmission is interrupted and it may cause malfunctions. If it becomes dirty, wipe with a bonded textile, etc. Do not use solvent such as alcohol.

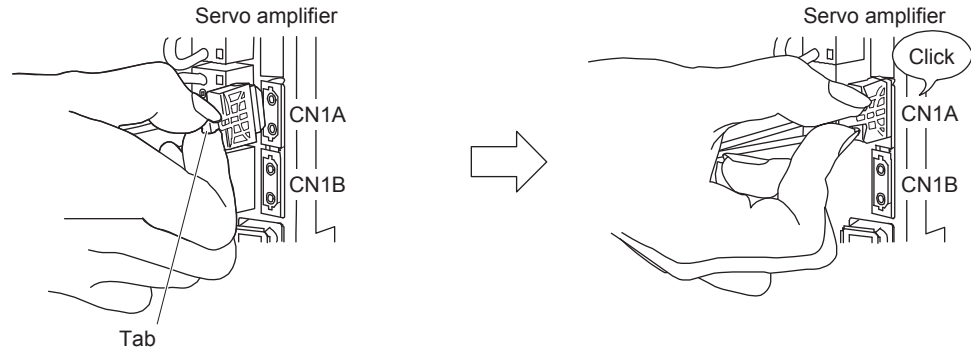

(b) Disconnection

With holding a tab of SSCNET III cable connector, pull out the connector.

When pulling out the SSCNET III cable from servo amplifier, be sure to put the cap on the connector parts of servo amplifier to prevent it from becoming dirty. For SSCNET III cable, attach the tube for protection optical cord's end face on the end of connector.

3. SIGNALS AND WIRING

3.10 Servo motor with an electromagnetic brake

3.10.1 Safety precautions

- Configure an electromagnetic brake circuit so that it is activated also by an external EMG stop switch.

Contacts must be opened when ALM (Malfunction) or MBR (Electromagnetic brake interlock) turns off.

Contacts must be opened with the EMG stop switch.

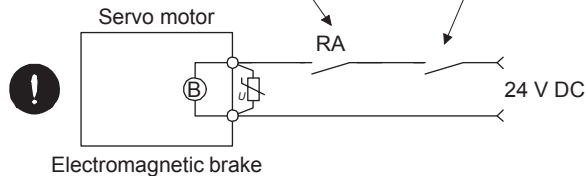

CAUTION

- The electromagnetic brake is provided for holding purpose and must not be used for ordinary braking.
- Before performing the operation, be sure to confirm that the electromagnetic brake operates properly.
- Do not use the 24 V DC interface power supply for the electromagnetic brake. Always use the power supply designed exclusively for the electromagnetic brake. Otherwise, it may cause a malfunction.

POINT

- Refer to the Servo Motor Instruction Manual (Vol. 3) for specifications such as the power supply capacity and operation delay time of the electromagnetic brake.
- Refer to the Servo Motor Instruction Manual (Vol. 3) or section 11.19 for the selection of a surge absorber for the electromagnetic brake.

Note the following when the servo motor with an electromagnetic brake is used.

- 1) The brake will operate when the power (24 V DC) turns off.
- 2) Turn off the servo-on command after the servo motor stopped.

(1) Connection diagram

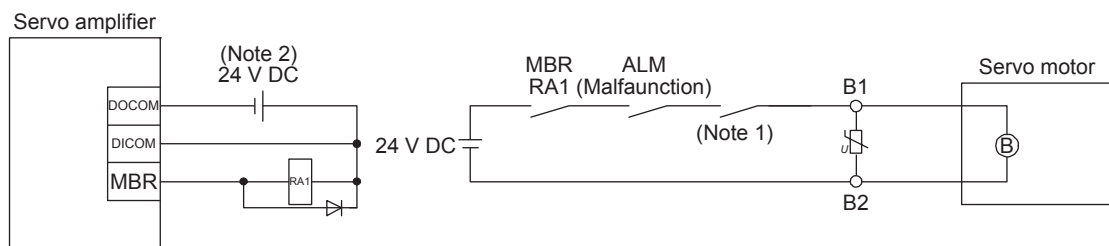

- Note 1. Create the circuit in order to shut off by interlocking with the emergency stop switch.
 2. Do not use the 24 V DC interface power supply for the electromagnetic brake.

(2) Setting

In [Pr. PC02 Electromagnetic brake sequence output], set the time delay (Tb) from electromagnetic brake operation to base circuit shut-off at a servo off time as in the timing chart in section 3.10.2.

3. SIGNALS AND WIRING

3.10.2 Timing chart

(1) When you use the forced stop deceleration function

POINT
● To enable the function, set "2 __ __ (initial value)" in [Pr. PA04].

(a) Servo-on command (from controller) on/off

T_b [ms] after the servo-on is switched off, the servo lock is released and the servo motor coasts. If the electromagnetic brake is enabled during servo-lock, the brake life may be longer. Therefore, when using the electromagnetic brake in a vertical lift application or the like, set delay time (T_b) to about the same as the electromagnetic brake operation delay time to prevent a drop.

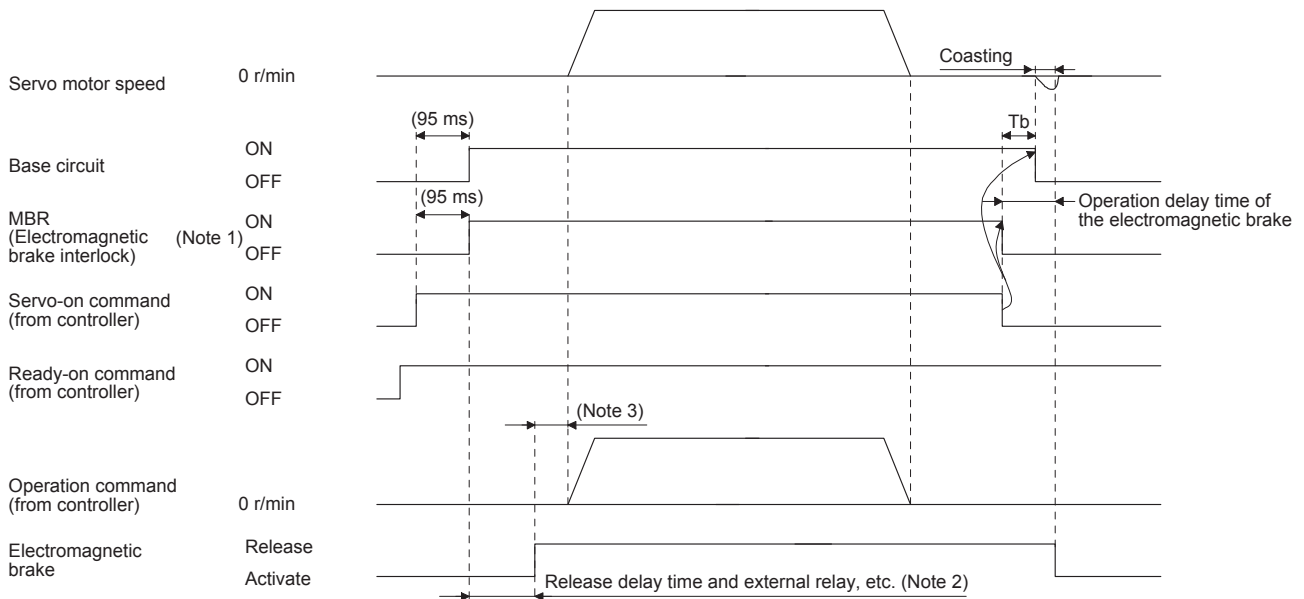

Note 1. ON: Electromagnetic brake is not activated.

OFF: Electromagnetic brake is activated.

- Electromagnetic brake is released after delaying for the release delay time of electromagnetic brake and operation time of external circuit relay. For the release delay time of electromagnetic brake, refer to the Servo Motor Instruction Manual (Vol. 3).
- Give the operation command from the controller after the electromagnetic brake is released.

3. SIGNALS AND WIRING

(b) EMG stop 2 switch on/off

POINT	● In the torque control mode, the forced stop deceleration function is not available.
-------	---

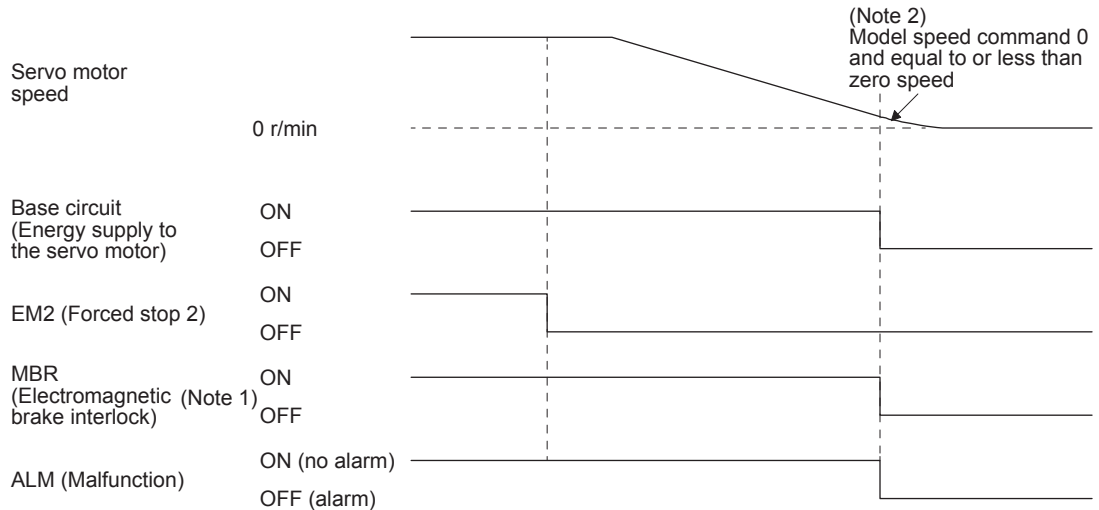

Note 1. ON: Electromagnetic brake is not activated.

OFF: Electromagnetic brake is activated.

2. The model speed command is a speed command made in the servo amplifier for forced stop deceleration of the servo motor.

(c) Alarm occurrence

The operation status during an alarm is the same as section 3.7.

(d) Both main and control circuit power supplies off

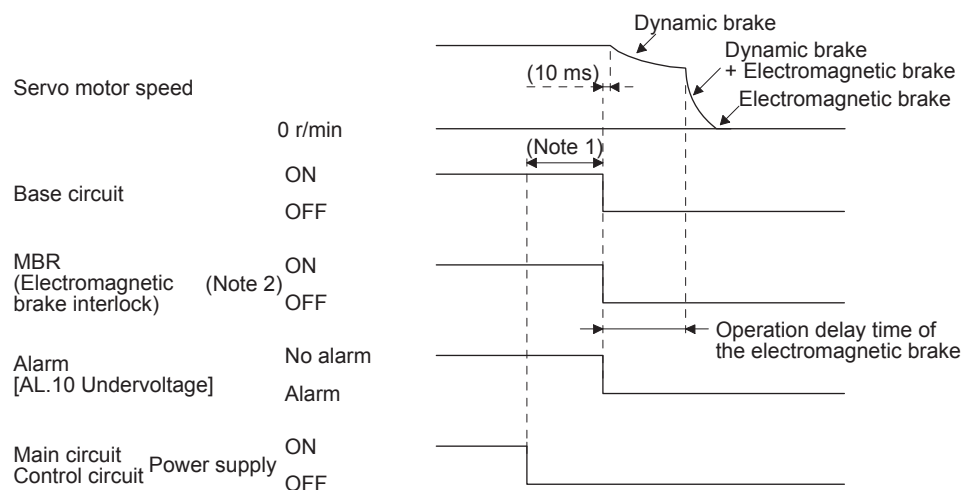

Note 1. Variable according to the operation status.

2. ON: Electromagnetic brake is not activated.

OFF: Electromagnetic brake is activated.

3. SIGNALS AND WIRING

(e) Main circuit power supply off during control circuit power supply on

POINT
● In the torque control mode, the forced stop deceleration function is not available.

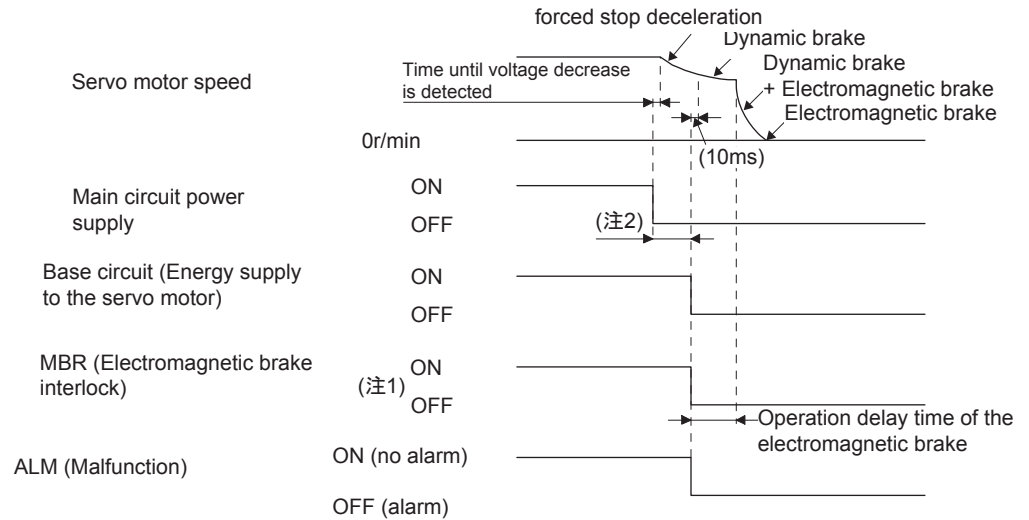

- Note 1. ON: Electromagnetic brake is not activated.
OFF: Electromagnetic brake is activated.
2. Variable according to the operation status.

(f) Ready-off command from controller

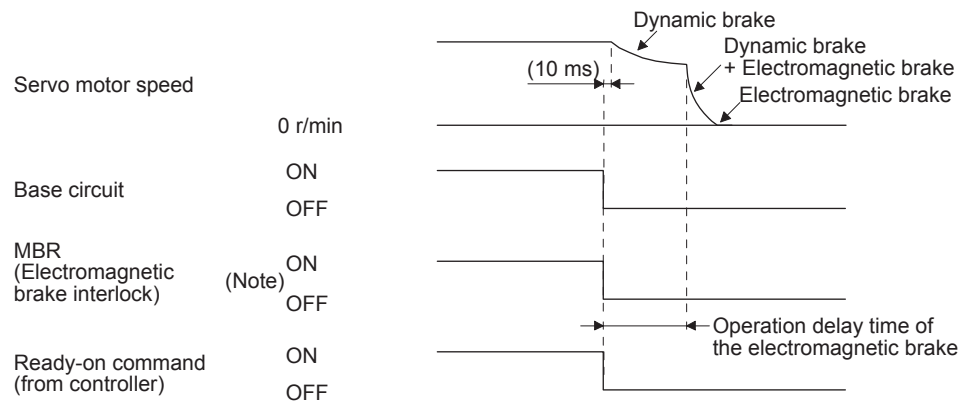

- Note. ON: Electromagnetic brake is not activated.
OFF: Electromagnetic brake is activated.

3. SIGNALS AND WIRING

(2) When you do not use the forced stop deceleration function

POINT
● To disable the function, set "0 _ _ _" in [Pr. PA04].

(a) Servo-on command (from controller) on/off

It is the same as (1) (a) in this section.

(b) Off/on of the forced stop command (from controller) or EM1 (Forced stop 1)

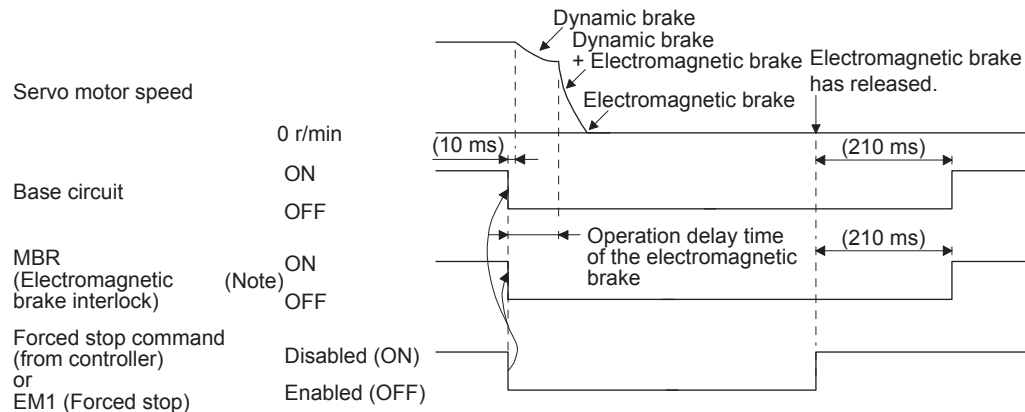

(c) Alarm occurrence

The operation status during an alarm is the same as section 3.7.

(d) Both main and control circuit power supplies off

It is the same as (1) (d) in this section.

(e) Main circuit power supply off during control circuit power supply on

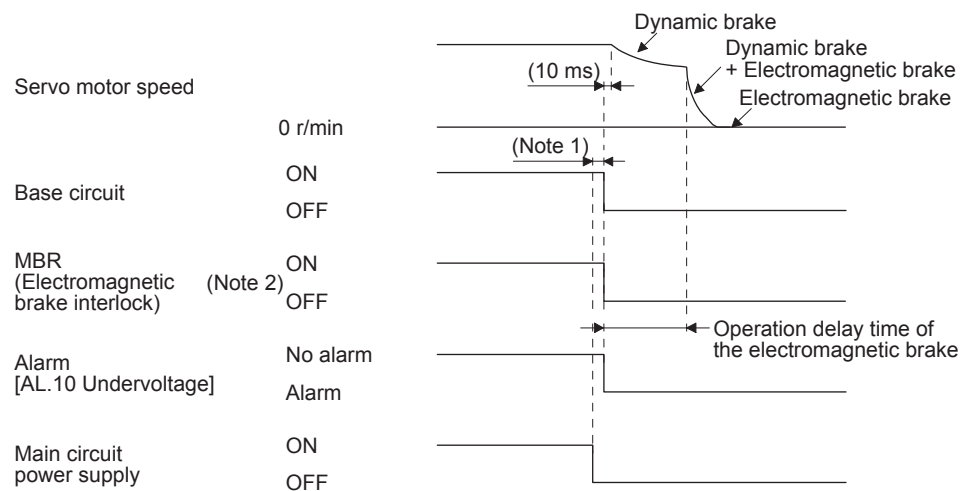

4. STARTUP

4. STARTUP



WARNING ● Do not operate the switches with wet hands. Otherwise, it may cause an electric shock.



CAUTION

- Before starting operation, check the parameters. Improper settings may cause some machines to operate unexpectedly.
- The servo amplifier heat sink, regenerative resistor, servo motor, etc. may be hot while power is on or for some time after power-off. Take safety measures, e.g. provide covers, to prevent accidental contact of hands and parts (cables, etc.) with them.
- During operation, never touch the rotor of the servo motor. Otherwise, it may cause injury.

POINT

- When you use a linear servo motor, replace the following left words to the right words.

Load to motor inertia ratio → Load to motor mass ratio

Torque [N•m] → Thrust [N]

(Servo motor) Speed [r/min] → (Linear servo motor) Speed [mm/s]

4.1 Switching power on for the first time

When switching power on for the first time, follow this section to make a startup.

4. STARTUP

4.1.1 Startup procedure

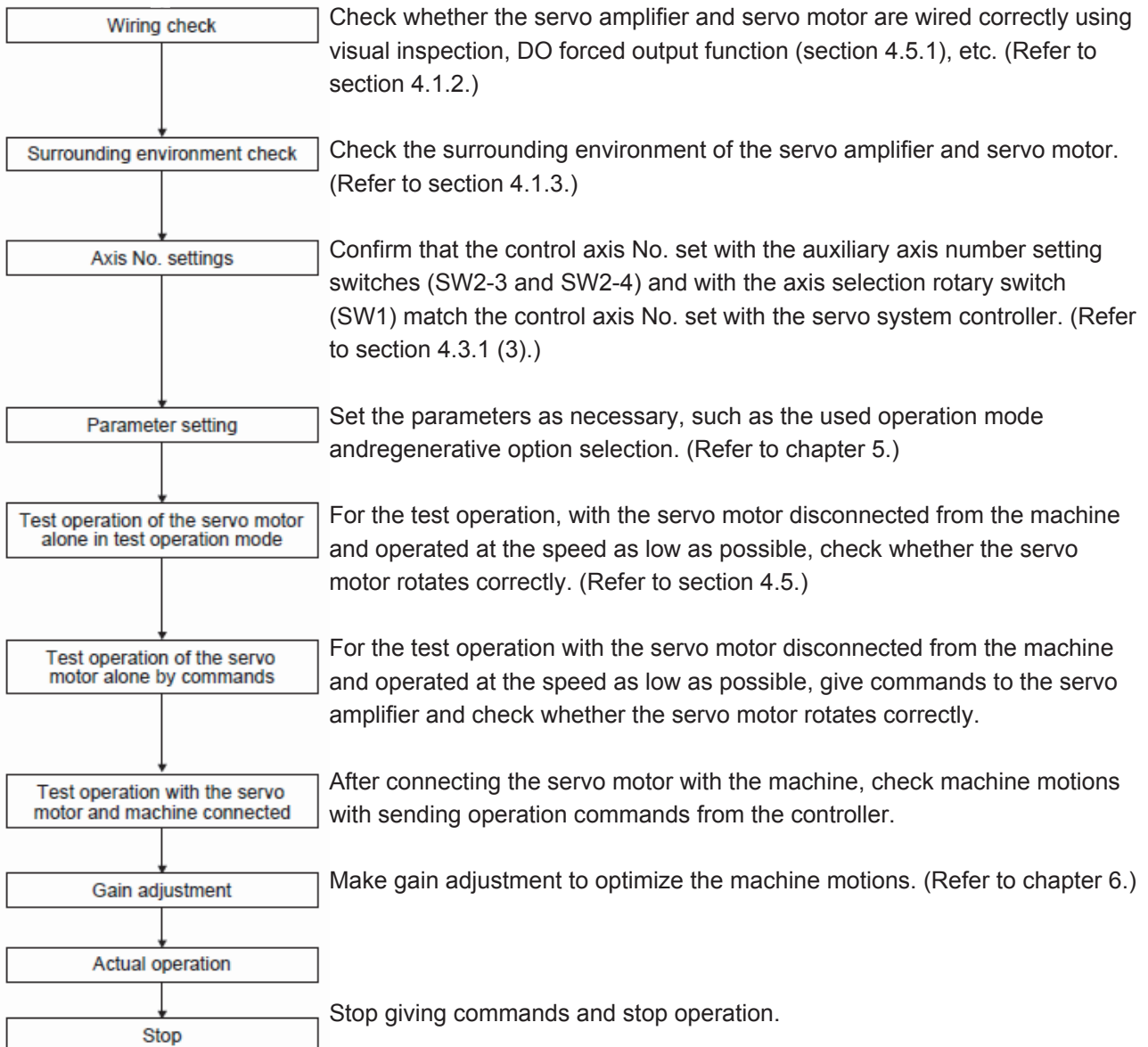

4. STARTUP

4.1.2 Wiring check

(1) Power supply system wiring

Before switching on the main circuit and control circuit power supplies, check the following items.

(a) Power supply system wiring

The power supplied to the power input terminals (L1, L2, L3, L11, and L21) of the servo amplifier should satisfy the defined specifications. (Refer to section 1.3.)

(b) Connection of servo amplifier and servo motor

- 1) The servo amplifier power output (U, V, and W) should match in phase with the servo motor power input terminals (U, V, and W).

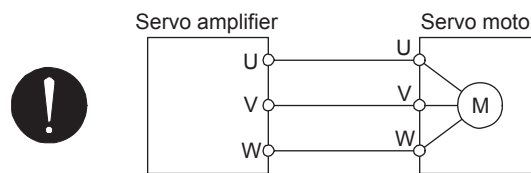

- 2) The power supplied to the servo amplifier should not be connected to the servo motor power terminals (U, V, and W). To do so will fail the connected servo amplifier and servo motor.

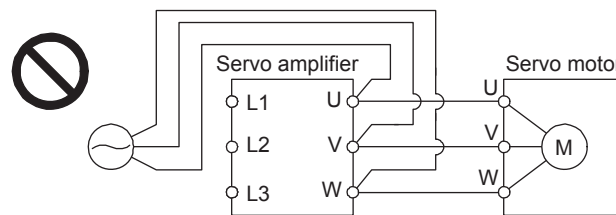

The grounding terminal of the servo motor is connected to the PE terminal of the servo amplifier.

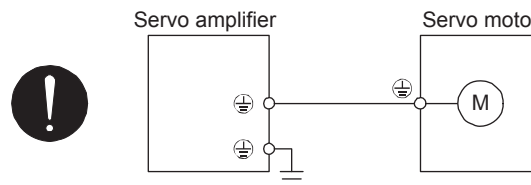

(c) When you use an option and auxiliary equipment

- 1) When you use a regenerative option for amplifiers under 5 kW for 200 V class

- The lead wire between P+ and D terminal of CNP2 connector (3.5 kW or under) or TE3 terminal block (5kW) should not be connected.
- The regenerative option wire should be connected between P+ and C terminal.
- A twisted cable should be used. (Refer to section 11.2.4.)

- 2) When you use a regenerative option for amplifiers under 7 kW for 200 V class

- The lead wire of built-in regenerative resistor connected to P+ terminal and C terminal should not be connected.
- The regenerative option wire should be connected between P+ and C terminal.
- A twisted cable should be used when wiring is over 5 m and under 10 m. (Refer to section 11.2.4.)

4. STARTUP

- 3) When you use a brake unit and power regenerative converter for over 7 kW
 - The lead wire of built-in regenerative resistor connected to P+ terminal and C terminal should not be connected.
 - Brake unit, power regenerative converter or power regenerative common converter should be connected to P+ terminal and N- terminal. (Refer to section 11.3 to 11.5.)
- 4) The power factor improving DC reactor should be connected between P3 and P4. (Refer to section 11.13.)

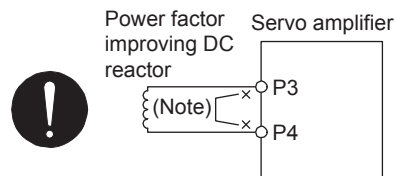

Note. Always disconnect between P3 and P4 terminals.

(2) I/O signal wiring

- (a) The I/O signals should be connected correctly.
 - Use DO forced output to forcibly turn on/off the pins of the CN3 connector. This function can be used to perform a wiring check. In this case, switch on the control circuit power supply only. Refer to section 3.2 for details of I/O signal connection.
- (b) 24 V DC or higher voltage is not applied to the pins of the CN3 connector.
- (c) SD and DOCOM of the CN3 connector is not shorted.

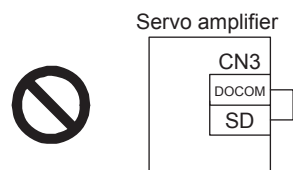

4.1.3 Surrounding environment

(1) Cable routing

- (a) The wiring cables should not be stressed.
- (b) The encoder cable should not be used in excess of its bending life. (Refer to section 10.4.)
- (c) The connector of the servo motor should not be stressed.

(2) Environment

Signal cables and power cables are not shorted by wire offcuts, metallic dust or the like.

4. STARTUP

4.2 Startup

Connect the servo motor with a machine after confirming that the servo motor operates properly alone.

(1) Power on

When the main and control circuit power supplies are turned on, "b01" (for the first axis) appears on the servo amplifier display.

When the absolute position detection system is used in a rotary servo motor, first power-on results in [AL. 25 Absolute position erased] and the servo-on cannot be ready. The alarm can be deactivated by then switching power off once and on again.

Also, if power is switched on at the servo motor speed of 3000 r/min or higher, position mismatch may occur due to external force or the like. Power must therefore be switched on when the servo motor is at a stop.

(2) Parameter setting

POINT
<ul style="list-style-type: none"> ● The following encoder cables are of four-wire type. When using any of these encoder cables, set [Pr. PC04] to "1 _ _ _" to select the four-wire type. Incorrect setting will result in [AL. 16 Encoder initial communication error 1].
MR-EKCBL30M-L
MR-EKCBL30M-H
MR-EKCBL40M-H
MR-EKCBL50M-H

Set the parameters according to the structure and specifications of the machine. Refer to chapter 5 for details.

After setting the above parameters, turn power off as necessary. Then switch power on again to enable the parameter values.

(3) Servo-on

Enable the servo-on with the following procedure.

(a) Switch on main circuit power supply and control circuit power supply.

(b) Transmit the servo-on command with the controller.

When the servo-on status is enabled, the servo amplifier is ready to operate and the servo motor is locked.

(4) Home position return

Always perform home position return before starting positioning operation.

4. STARTUP

(5) Stop

If any of the following situations occurs, the servo amplifier suspends the running of the servo motor and brings it to a stop.

Refer to section 3.10. for the servo motor with an electromagnetic brake.

	Operation/command	Stopping condition
Servo system controller	Servo-off command	The base circuit is shut off and the servo motor coasts.
	Ready-off command	The base circuit is shut off and the dynamic brake operates to bring the servo motor to a stop.
	Forced stop command	The servo motor decelerates to a stop with the command. [AL. E7 Controller forced stop warning] occurs.
Servo amplifier	Alarm occurrence	The servo motor decelerates to a stop with the command. With some alarms, however, the dynamic brake operates to bring the servo motor to a stop. (Refer to section 8. (Note))
	EM2 (Forced stop 2) off	The servo motor decelerates to a stop with the command. [AL. E6 Servo forced stop warning] occurs. EM2 is the same signal as EM1 in the torque control mode. EM2 has the same function as EM1 in the torque control mode. Refer to section 3.5 for EM1.
	STO (STO1, STO2) off	The base circuit is shut off and the dynamic brake operates to bring the servo motor to a stop.

Note. Only a list of alarms and warnings is listed in chapter 8. Refer to "MELSERVO-J4 Servo Amplifier Instruction Manual (Troubleshooting)" for details of alarms and warnings.

4.3 Switch setting and display of the servo amplifier

Switching to the test operation mode, deactivating control axes, and setting control axis No. are enabled with switches on the servo amplifier.

On the servo amplifier display (three-digit, seven-segment LED), check the status of communication with the servo system controller at power-on, and the axis number, and diagnose a malfunction at occurrence of an alarm.

4.3.1 Switches



WARNING

- When switching the axis selection rotary switch (SW1) and auxiliary axis number setting switch (SW2), use an insulation screw driver. Do not use a metal screw driver. Touching patterns on electronic boards, lead of electronic parts, etc. may cause an electric shock.

POINT

- Turning "ON (up)" all the control axis setting switches (SW2) enables an operation mode for manufacturer setting and displays "off". The mode is not available. Set the control axis setting switches (SW2) correctly according to this section.
- Cycling the main circuit power supply and control circuit power supply enables the setting of each switch.

4. STARTUP

The following explains the test operation select switch, the disabling control axis switch, auxiliary axis number setting switches, and the axis selection rotary switch.

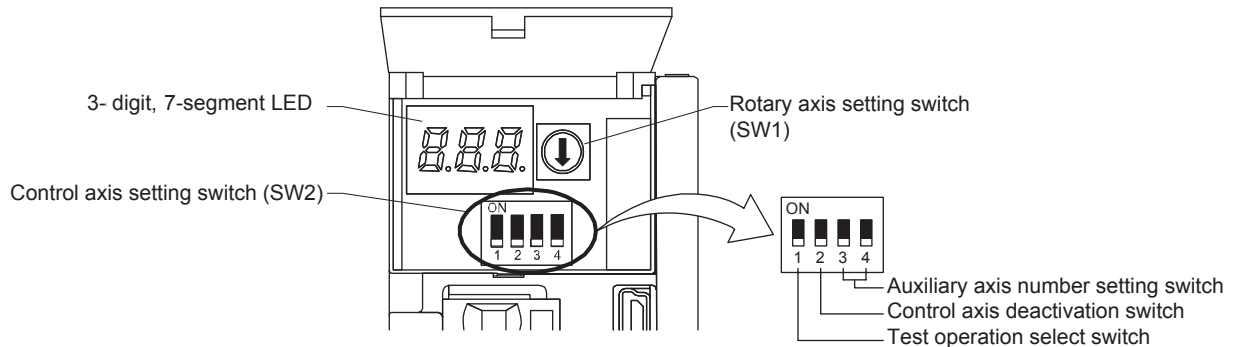

(1) Test operation select switch (SW2-1)

To use the test operation mode, turn "ON (up)" the switch. Turning "ON (up)" the switch enables the test operation mode. In the test operation mode, the functions such as JOG operation, positioning operation, and machine analyzer are available with MR Configurator2. Before turning "ON (up)" the test operation select switch, turn "OFF (down)" the disabling control axis switch.

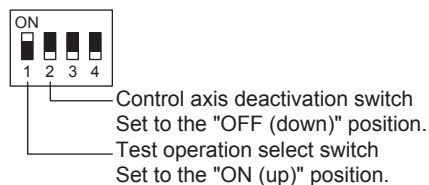

(2) Disabling control axis switch (SW2-2)

Turning "ON (up)" the disabling control axis switch disables the corresponding servo motor. The servo motor will be disabled-axis status and will not be recognized by the controller.

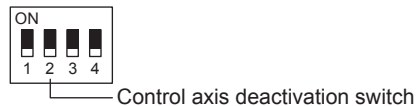

4. STARTUP

(3) Switches for setting control axis No.

POINT
<ul style="list-style-type: none"> ● The control axis No. set to the auxiliary axis number setting switches (SW2-3 and SW2-4) and the axis selection rotary switch (SW1) should be the same as the one set to the servo system controller. The number of the axes you can set depends on the controller. ● For setting the axis selection rotary switch, use a flat-blade screwdriver with the blade edge width of 2.1 mm to 2.3 mm and the blade edge thickness of 0.6 mm to 0.7 mm. ● When the test operation mode is selected with the test operation select switch (SW2-1), the SSCNET III/H communication for the servo amplifier in the test operation mode and the following servo amplifiers is blocked.

You can set the control axis No. between 1 and 64 by using auxiliary axis number setting switches with the axis selection rotary switch. (Refer to (3) (c) of this section.)

If the same numbers are set to different control axes in a single communication system, the system will not operate properly. The control axes may be set independently of the SSCNET III cable connection sequence. The following shows the description of each switch.

(a) Auxiliary axis number setting switches (SW2-3 and SW2-4)

Turning these switches "ON (up)" enables you to set the axis No. 17 or more.

(b) Axis selection rotary switch (SW1)

You can set the control axis No. between 1 and 64 by using auxiliary axis number setting switches with the axis selection rotary switch. (Refer to (3) (c) of this section.)



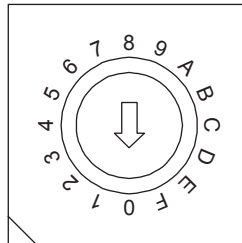

Rotary axis setting switch (SW1)



4. STARTUP

(c) Switch combination list for the control axis No. setting

The following lists show the setting combinations of the auxiliary axis number setting switches and the axis selection rotary switch.

Auxiliary axis number setting switch	Axis selection rotary switch	Control axis No.	Auxiliary axis number setting switch	Axis selection rotary switch	Control axis No.
	0	1		0	17
	1	2		1	18
	2	3		2	19
	3	4		3	20
	4	5		4	21
	5	6		5	22
	6	7		6	23
	7	8		7	24
	8	9		8	25
	9	10		9	26
	A	11		A	27
	B	12		B	28
	C	13		C	29
	D	14		D	30
	E	15		E	31
	F	16		F	32
	0	33		0	49
	1	34		1	50
	2	35		2	51
	3	36		3	52
	4	37		4	53
	5	38		5	54
	6	39		6	55
	7	40		7	56
	8	41		8	57
	9	42		9	58
	A	43		A	59
	B	44		B	60
	C	45		C	61
	D	46		D	62
	E	47		E	63
	F	48		F	64

4. STARTUP

4.3.2 Scrolling display

(1) Normal display

When there is no alarm, the axis No. and blank are displayed in rotation.

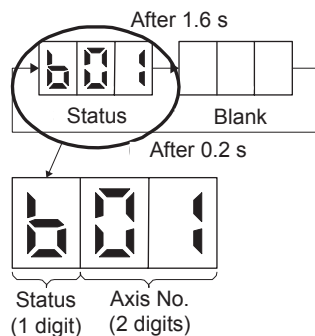

"b": Indicates ready-off and servo-off status.

"C": Indicates ready-on and servo-off status.

"d": Indicates ready-on and servo-on status.

(2) Alarm display

When an alarm occurs, the alarm number (two digits) and the alarm detail (one digit) are displayed following the status display. For example, the following shows when [AL. 32 Overcurrent] is occurring.

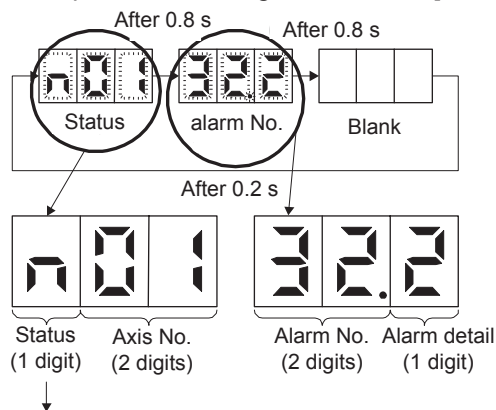



"n": Indicates that an alarm is occurring.

4. STARTUP

4.3.3 Status display of an axis

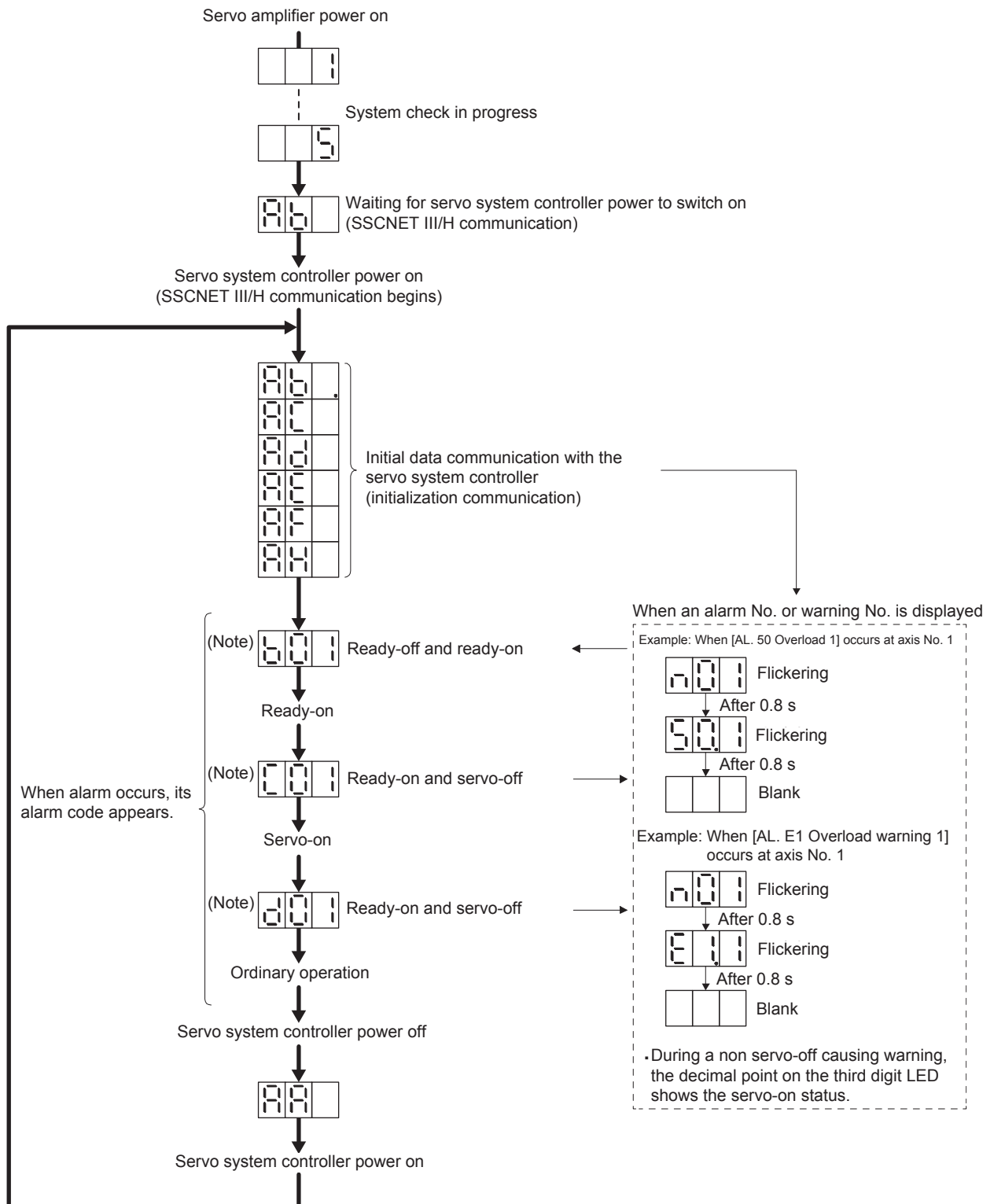









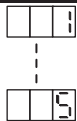





(1) Display sequence



Note.  The segment of the last 2 digits shows the axis number.
 Axis No. 1 Axis No. 2 Axis No. 64

4. STARTUP

(2) Indication list

Indication	Status	Description
	Initializing	System check in progress
	Initializing	<ul style="list-style-type: none"> Power of the servo amplifier was switched on at the condition that the power of the servo system controller is off. The control axis No. set to the auxiliary axis number setting switches (SW2-3 and SW2-4) and the axis selection rotary switch (SW1) do not match the one set to the servo system controller. A servo amplifier malfunctioned, or communication error occurred with the servo system controller or the previous axis servo amplifier. In this case, the indication changes as follows: "Ab", "AC", "Ad", and "Ab" The servo system controller is malfunctioning.
	Initializing	During initial setting for communication specifications
	Initializing	Initial setting for communication specifications completed, and then it synchronized with servo system controller.
	Initializing	During initial parameter setting communication with servo system controller
	Initializing	During the servo motor/encoder information and telecommunication with servo system controller
	Initializing	During initial signal data communication with servo system controller
	Initializing completion	The process for initial data communication with the servo system controller is completed.
	Initializing standby	The power supply of servo system controller is turned off during the power supply of servo amplifier is on.
(Note 1) 	Ready-off	The ready-off signal from the servo system controller was received.
(Note 1) 	Servo-on	The ready-off signal from the servo system controller was received.
(Note 1) 	Servo-off	The ready-off signal from the servo system controller was received.
(Note 2) 	Alarm and warning	The alarm No. and the warning No. that occurred is displayed. (Refer to section 8. (Note 4))
	CPU error	CPU watchdog error has occurred.
(Note 1)   	(Note 3) Test operation mode	Motor-less operation

Note 1. The meanings of ## are listed below.

##	Description
01	Axis No. 1
to	to
64	Axis No. 64

- *** indicates the alarm No. and the warning No.
- Requires the MR Configurator2.
- Only a list of alarms and warnings is listed in chapter 8. Refer to "MELSERVO-J4 Servo Amplifier Instruction Manual (Troubleshooting)" for details of alarms and warnings.

4. STARTUP

4.4 Test operation

Before starting actual operation, perform test operation to make sure that the machine operates normally. Refer to section 4.2 for the power on and off methods of the servo amplifier.

POINT

- If necessary, verify controller program by using motor-less operation. Refer to section 4.5.2 for the motor-less operation.

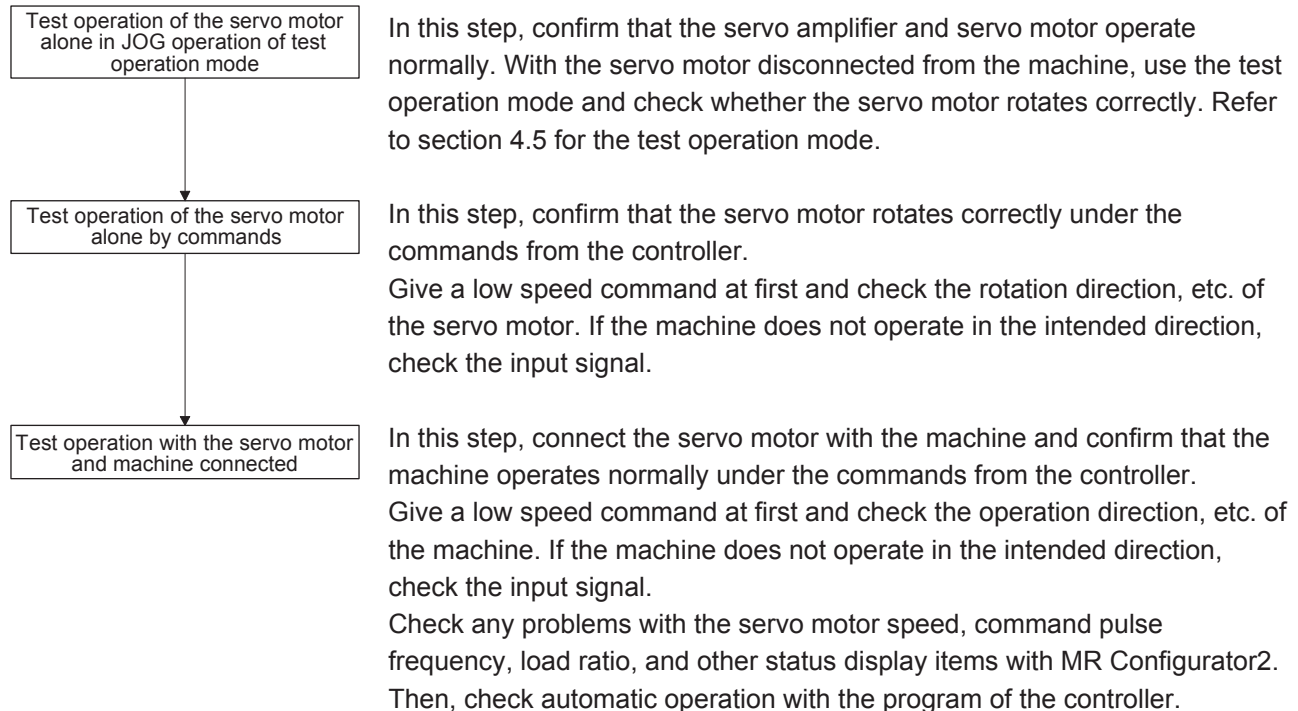

4.5 Test operation mode

CAUTION

- The test operation mode is designed for checking servo operation. It is not for checking machine operation. Do not use this mode with the machine. Always use the servo motor alone.
- If the servo motor operates abnormally, use EM2 (Forced stop 2) to stop it.

POINT

- The content described in this section indicates that the servo amplifier and a personal computer are directly connected.

By using a personal computer and MR Configurator2, you can execute jog operation, positioning operation, DO forced output program operation without connecting the servo system controller.

4. STARTUP

4.5.1 Test operation mode in MR Configurator2

POINT
<ul style="list-style-type: none"> ● When the test operation mode is selected with the test operation select switch (SW2-1), the SSCNET III/H communication for the servo amplifier in the test operation mode and the following servo amplifiers is blocked.

(1) Test operation mode

(a) Jog operation

Jog operation can be performed without using the servo system controller. Use this operation with the forced stop reset. This operation may be used independently of whether the servo is on or off and whether the servo system controller is connected or not.

Exercise control on the jog operation screen of MR Configurator2.

1) Operation pattern

Item	initial value	Setting range
Speed [r/min]	200	0 to max. speed
Acceleration/deceleration time constant [ms]	1000	0 to 50000

2) Operation method

- When the check box of "Rotation only while the button is being pushed" is checked.

Operation	Screen control
Forward rotation start	Keep pressing the "Forward" button.
Reverse rotation start	Keep pressing the "Reverse" button.
Stop	Release the "Forward" or "Reverse" button.
Forced stop	Click the "Forced stop"

- When the check box of "Rotation only while the button is being pushed" is not checked.

Operation	Screen control
Forward rotation start	Click the "Forward" button.
Reverse rotation start	Click the "Reverse" button.
Stop	Click the "Stop" button.
Forced stop	Click the "Forced stop" button.

(b) Positioning operation

Positioning operation can be performed without using the servo system controller. Use this operation with the forced stop reset. This operation may be used independently of whether the servo is on or off and whether the servo system controller is connected or not.

Exercise control on the positioning operation screen of MR Configurator2.

1) Operation pattern

Item	initial value	Setting range
Travel distance [pulse]	4000	0 to 99999999
Speed [r/min]	200	0 to max. speed
Acceleration/deceleration time constant [ms]	1000	0 to 50000
Repeat pattern	Fwd. rot. (CCW) to rev. rot. (CW)	Fwd. rot. (CCW) to rev. rot. (CW) Fwd. rot. (CCW) to fwd. rot. (CCW) Rev. rot. (CW) to fwd. rot. (CCW) Rev. rot. (CW) to rev. rot. (CW)
Dwell time [s]	2.0	0.1 to 50.0
Number of repeats [time]	1	1 to 9999

4. STARTUP

2) Operation method

Operation	Screen control
Forward rotation start	Click the "Forward" button.
Reverse rotation start	Click the "Reverse" button.
Pause	Click the "Pause" button.
Stop	Click the "Stop" button.
Forced stop	Click the "Forced stop" button.

(c) Program operation

Positioning operation can be performed in two or more operation patterns combined, without using the servo system controller. Use this operation with the forced stop reset. This operation may be used independently of whether the servo is on or off and whether the servo system controller is connected or not.

Exercise control on the program operation screen of MR Configurator2. For full information, refer to the MR Configurator2 Installation Guide.

Operation	Screen control
Start	Click the "Start" button.
Stop	Click the "Stop" button.
Forced stop	Click the "Forced stop" button.

(d) Output signal (DO) forced output

Output signals can be switched on/off forcibly independently of the servo status. Use this function for output signal wiring check, etc. Exercise control on the DO forced output screen of MR Configurator2.

4. STARTUP

(2) Operation procedure

- 1) Turn off the power.
- 2) Turn "ON (up)" SW2-1.

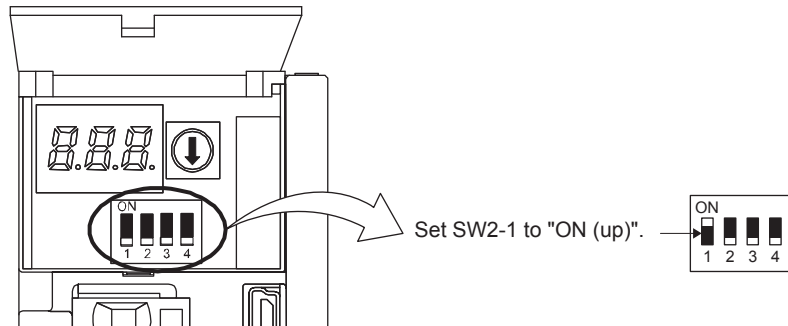

Turning "ON (up)" SW2-1 during power-on will not start the test operation mode.

3) Turn on the servo amplifier.

When initialization is completed, the decimal point on the first digit will flicker.

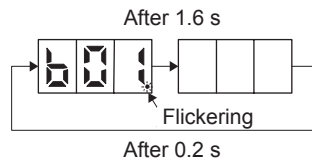

When an alarm or warning also occurs during the test operation, the decimal point on the first digit will flicker as follows.

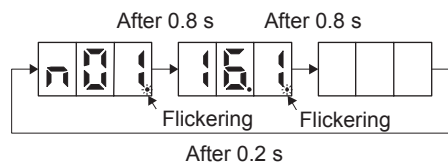

4) Start operation with the personal computer.

4. STARTUP

4.5.2 Motor-less operation in controller

POINT
<ul style="list-style-type: none"> ● Use motor-less operation which is available by making the servo system controller parameter setting. ● Motor-less operation is done while connected with the servo system controller. ● The motor-less operation using a controller is available with rotary servo motors only. It will be available with linear servo motors and direct drive motors in the future.

(1) Motor-less operation

Without connecting the servo motor, output signals or status displays can be provided in response to the servo system controller commands as if the servo motor is actually running. This operation may be used to check the servo system controller sequence. Use this operation with the forced stop reset. Use this operation with the servo amplifier connected to the servo system controller.

To stop the motor-less operation, set the motor-less operation selection to "Disable" in the servo parameter setting of the servo system controller. When the power supply is turned on next time, motor-less operation will be disabled.

(a) Load conditions

Load item	Condition
Load torque	0
Load to motor inertia ratio	Same as the moment of inertia of the servo motor

(b) Alarms

The following alarms and warning do not occur. However, the other alarms and warnings occur as when the servo motor is connected.

Alarm and warning	Rotary servo motor	Linear servo motor	Direct drive motor	Rotary servo motor in fully closed loop system (available in the future)
[AL.16 Encoder initial communication error 1]	○	○	○	○
[AL.1E Encoder initial communication error 2]	○	○	○	○
[AL.1F Encoder initial communication error 3]	○	○	○	○
[AL.20 Encoder normal communication error 1 (serial communication input)]	○	○	○	○
[AL.20 Encoder normal communication error 1 (ABZ input)]	○	○	○	○
[AL.21 Encoder normal communication error 2]	○	○	○	○
[AL. 25 Absolute position erased]	○	○	○	○
[AL. 28 Linear encoder error 2]	○	○	○	○
[AL. 2A Linear encoder error 1]	○	○	○	○
[AL. 2B Encoder counter error]	○	○	○	○
[AL. 92 Battery cable disconnection warning]	○	○	○	○
[AL. 9F Battery warning]	○	○	○	○
[AL. E9 Main circuit off warning]	○	○	○	○
[AL. 70 Load-side encoder error 1]	○	○	○	○
[AL. 71 Load-side encoder error 2]	○	○	○	○

4. STARTUP

(2) Operation procedure

- 1) Set the servo amplifier to the servo-off status.
- 2) Set [Pr. PC05] to "___ 1", turn "OFF (down: normal condition side)" the test operation mode switch (SW2-1), and then turn on the power supply.

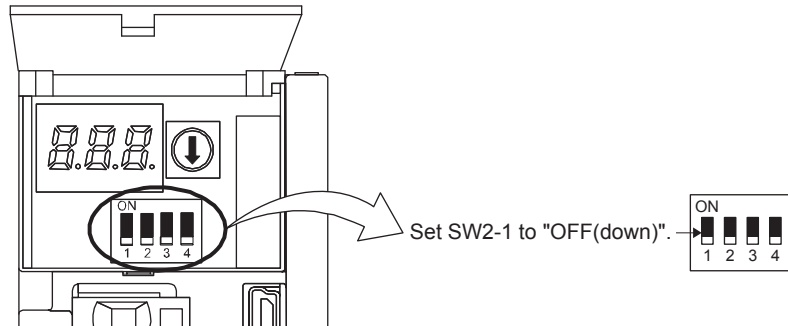

- 3) Start the motor-less operation with the servo system controller.
The display shows the following screen.

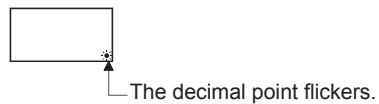

5. PARAMETERS

5. PARAMETERS



CAUTION

- Never adjust or change the parameter values extremely as it will make operation unstable.
- If fixed values are written in the digits of a parameter, do not change these values.
- Do not change parameters for manufacturer setting.

POINT

- When you connect the amplifier to a servo system controller, servo parameter values of the servo system controller will be written to each parameters.
- Setting may not be made to some parameters and their ranges depending on the servo system controller model, servo amplifier software version, and MR Configurator2 software version. For details, refer to the servo system controller user's manual.

5.1 Parameter list

POINT

- The parameter whose symbol is preceded by * is enabled with the following conditions:
 - *: After setting the parameter, cycle the power or reset the controller.
 - ** : After setting the parameter, cycle the power.
- Abbreviations of operation modes indicate the followings.
 - Norm.: Normal (semi closed loop system) use of the rotary servo motor
 - Full.: Fully closed loop system use of the rotary servo motor (Available in the future.)
 - Lin.: Linear servo motor use.
 - D.D.: Direct drive (D.D.) motor use.

5. PARAMETERS

5.1.1 Basic setting parameters ([Pr. PA_ _])

No.	Symbol	Name	Initial value	Unit	Operation mode			
					Standard	(Note) Full.	Lin.	D.D.
PA01	**STY	Operation mode	1000h		<input type="radio"/>	<input type="radio"/>	<input type="radio"/>	<input type="radio"/>
PA02	**REG	Regenerative option	0000h		<input type="radio"/>	<input type="radio"/>	<input type="radio"/>	<input type="radio"/>
PA03	*ABS	Absolute position detection system	0000h		<input type="radio"/>	<input type="radio"/>	<input type="radio"/>	<input type="radio"/>
PA04	*AOP1	Function selection A-1	2000h		<input type="radio"/>	<input type="radio"/>	<input type="radio"/>	<input type="radio"/>
PA05		For manufacturer setting	10000		<input type="radio"/>	<input type="radio"/>	<input type="radio"/>	<input type="radio"/>
PA06			1					
PA07			1					
PA08	ATU	Auto tuning mode	0001h		<input type="radio"/>	<input type="radio"/>	<input type="radio"/>	<input type="radio"/>
PA09	RSP	Auto tuning response	16		<input type="radio"/>	<input type="radio"/>	<input type="radio"/>	<input type="radio"/>
PA10	INP	In-position range	1600	[pulse]	<input type="radio"/>	<input type="radio"/>	<input type="radio"/>	<input type="radio"/>
PA11		For manufacturer setting	1000.0		<input type="radio"/>	<input type="radio"/>	<input type="radio"/>	<input type="radio"/>
PA12			1000.0					
PA13			0000h					
PA14	*POL	Rotation direction selection/travel direction selection	0		<input type="radio"/>	<input type="radio"/>	<input type="radio"/>	<input type="radio"/>
PA15	*ENR	Encoder output pulses	4000	[pulse/rev]	<input type="radio"/>	<input type="radio"/>	<input type="radio"/>	<input type="radio"/>
PA16	*ENR2	Encoder output pulses 2	1		<input type="radio"/>	<input type="radio"/>	<input type="radio"/>	<input type="radio"/>
PA17	**MSR	Servo motor series setting	0000h		<input type="radio"/>	<input type="radio"/>	<input type="radio"/>	<input type="radio"/>
PA18	**MTY	Servo motor type setting	0000h		<input type="radio"/>	<input type="radio"/>	<input type="radio"/>	<input type="radio"/>
PA19	*BLK	Parameter writing inhibit	00ABh		<input type="radio"/>	<input type="radio"/>	<input type="radio"/>	<input type="radio"/>
PA20	*TDS	Tough drive setting	0000h		<input type="radio"/>	<input type="radio"/>	<input type="radio"/>	<input type="radio"/>
PA21	*AOP3	Function selection A-3	0001h		<input type="radio"/>	<input type="radio"/>	<input type="radio"/>	<input type="radio"/>
PA22		For manufacturer setting	0000h		<input type="radio"/>	<input type="radio"/>	<input type="radio"/>	<input type="radio"/>
PA23	DRAT	Drive recorder arbitrary alarm trigger setting	0000h		<input type="radio"/>	<input type="radio"/>	<input type="radio"/>	<input type="radio"/>
PA24	AOP4	Function selection A-4	0000h		<input type="radio"/>	<input type="radio"/>	<input type="radio"/>	<input type="radio"/>
PA25		For manufacturer setting	0		<input type="radio"/>	<input type="radio"/>	<input type="radio"/>	<input type="radio"/>
PA26			0000h					
PA27			0000h					
PA28			0000h					
PA29			0000h					
PA30			0000h					
PA31			0000h					
PA32			0000h					

Note. Available in the future.

5. PARAMETERS

5.1.2 Gain/filter setting parameters ([Pr. PB_ _])

No.	Symbol	Name	Initial value	Unit	Operation mode			
					Standard	(Note) Full.	Lin.	D.D.
PB01	FILT	Adaptive tuning mode (adaptive filter II)	0000h		<input type="radio"/>	<input type="radio"/>	<input type="radio"/>	<input type="radio"/>
PB02	VRFT	Vibration suppression control tuning mode (advanced vibration suppression control II)	0000h		<input type="radio"/>	<input type="radio"/>	<input type="radio"/>	<input type="radio"/>
PB03	TFBGN	Torque feedback loop gain	18000	[rad/s]	<input type="radio"/>	<input type="radio"/>	<input type="radio"/>	<input type="radio"/>
PB04	FFC	Feed forward gain	0	[%]	<input type="radio"/>	<input type="radio"/>	<input type="radio"/>	<input type="radio"/>
PB05		For manufacturer setting	500		<input type="radio"/>	<input type="radio"/>	<input type="radio"/>	<input type="radio"/>
PB06	GD2	Load to motor inertia ratio/load to motor mass ratio	7.00	[Multiplier]	<input type="radio"/>	<input type="radio"/>	<input type="radio"/>	<input type="radio"/>
PB07	PG1	Model loop gain	15.0	[rad/s]	<input type="radio"/>	<input type="radio"/>	<input type="radio"/>	<input type="radio"/>
PB08	PG2	Position loop gain	37.0	[rad/s]	<input type="radio"/>	<input type="radio"/>	<input type="radio"/>	<input type="radio"/>
PB09	VG2	Speed loop gain	823	[rad/s]	<input type="radio"/>	<input type="radio"/>	<input type="radio"/>	<input type="radio"/>
PB10	VIC	Speed integral compensation	33.7	[ms]	<input type="radio"/>	<input type="radio"/>	<input type="radio"/>	<input type="radio"/>
PB11	VDC	Speed differential compensation	980		<input type="radio"/>	<input type="radio"/>	<input type="radio"/>	<input type="radio"/>
PB12	OVA	Overshoot amount compensation	0	[%]	<input type="radio"/>	<input type="radio"/>	<input type="radio"/>	<input type="radio"/>
PB13	NH1	Machine resonance suppression filter 1	4500	[Hz]	<input type="radio"/>	<input type="radio"/>	<input type="radio"/>	<input type="radio"/>
PB14	NHQ1	Notch shape selection 1	0000h		<input type="radio"/>	<input type="radio"/>	<input type="radio"/>	<input type="radio"/>
PB15	NH2	Machine resonance suppression filter 2	4500	[Hz]	<input type="radio"/>	<input type="radio"/>	<input type="radio"/>	<input type="radio"/>
PB16	NHQ2	Notch shape selection 2	0000h		<input type="radio"/>	<input type="radio"/>	<input type="radio"/>	<input type="radio"/>
PB17	NHF	Shaft resonance suppression filter	0000h		<input type="radio"/>	<input type="radio"/>	<input type="radio"/>	<input type="radio"/>
PB18	LPF	Low-pass filter setting	3141	[rad/s]	<input type="radio"/>	<input type="radio"/>	<input type="radio"/>	<input type="radio"/>
PB19	VRF11	Vibration suppression control 1 - Vibration frequency	100.0	[Hz]	<input type="radio"/>	<input type="radio"/>	<input type="radio"/>	<input type="radio"/>
PB20	VRF12	Vibration suppression control 1 - Resonance frequency	100.0	[Hz]	<input type="radio"/>	<input type="radio"/>	<input type="radio"/>	<input type="radio"/>
PB21	VRF13	Vibration suppression control 1 - Vibration frequency damping	0.00		<input type="radio"/>	<input type="radio"/>	<input type="radio"/>	<input type="radio"/>
PB22	VRF14	Vibration suppression control 1 - Resonance frequency damping	0.00		<input type="radio"/>	<input type="radio"/>	<input type="radio"/>	<input type="radio"/>
PB23	VFBF	Low-pass filter selection	0000h		<input type="radio"/>	<input type="radio"/>	<input type="radio"/>	<input type="radio"/>
PB24	*MVS	Slight vibration suppression control	0000h		<input type="radio"/>	<input type="radio"/>	<input type="radio"/>	<input type="radio"/>
PB25		For manufacturer setting	0000h		<input type="radio"/>	<input type="radio"/>	<input type="radio"/>	<input type="radio"/>
PB26	*CDP	Gain switching function	0000h		<input type="radio"/>	<input type="radio"/>	<input type="radio"/>	<input type="radio"/>
PB27	CDL	Gain switching condition	10	[kpps]/ [pulse]/ [r/min]	<input type="radio"/>	<input type="radio"/>	<input type="radio"/>	<input type="radio"/>
PB28	CDT	Gain switching time constant	1	[ms]	<input type="radio"/>	<input type="radio"/>	<input type="radio"/>	<input type="radio"/>
PB29	GD2B	Load to motor inertia ratio/load to motor mass ratio after gain switching	7.00	[Multiplier]	<input type="radio"/>	<input type="radio"/>	<input type="radio"/>	<input type="radio"/>
PB30	PG2B	Position loop gain after gain switching	0.0	[rad/s]	<input type="radio"/>	<input type="radio"/>	<input type="radio"/>	<input type="radio"/>
PB31	VG2B	Speed loop gain after gain switching	0	[rad/s]	<input type="radio"/>	<input type="radio"/>	<input type="radio"/>	<input type="radio"/>
PB32	VICB	Speed integral compensation after gain switching	0.0	[ms]	<input type="radio"/>	<input type="radio"/>	<input type="radio"/>	<input type="radio"/>
PB33	VRF11B	Vibration suppression control 1 - Vibration frequency after gain switching	0.0	[Hz]	<input type="radio"/>	<input type="radio"/>	<input type="radio"/>	<input type="radio"/>
PB34	VRF12B	Vibration suppression control 1 - Resonance frequency after gain switching	0.0	[Hz]	<input type="radio"/>	<input type="radio"/>	<input type="radio"/>	<input type="radio"/>
PB35	VRF13B	Vibration suppression control 1 - Vibration frequency damping after gain switching	0.00		<input type="radio"/>	<input type="radio"/>	<input type="radio"/>	<input type="radio"/>
PB36	VRF14B	Vibration suppression control 1 - Resonance frequency damping after gain switching	0.00		<input type="radio"/>	<input type="radio"/>	<input type="radio"/>	<input type="radio"/>
PB37		For manufacturer setting	1600		<input type="radio"/>	<input type="radio"/>	<input type="radio"/>	<input type="radio"/>
PB38		For manufacturer setting	0.00		<input type="radio"/>	<input type="radio"/>	<input type="radio"/>	<input type="radio"/>
PB39			0.00		<input type="radio"/>	<input type="radio"/>	<input type="radio"/>	<input type="radio"/>
PB40			0.00		<input type="radio"/>	<input type="radio"/>	<input type="radio"/>	<input type="radio"/>
PB41			0		<input type="radio"/>	<input type="radio"/>	<input type="radio"/>	<input type="radio"/>
PB42			0		<input type="radio"/>	<input type="radio"/>	<input type="radio"/>	<input type="radio"/>
PB43			0000h		<input type="radio"/>	<input type="radio"/>	<input type="radio"/>	<input type="radio"/>
PB44			0.00		<input type="radio"/>	<input type="radio"/>	<input type="radio"/>	<input type="radio"/>
PB45	CNHF		Command notch filter	0000h		<input type="radio"/>	<input type="radio"/>	<input type="radio"/>

5. PARAMETERS

No.	Symbol	Name	Initial value	Unit	Operation mode			
					Standard	(Note) Full.	Lin.	D.D.
PB46	NH3	Machine resonance suppression filter 3	4500	[Hz]	<input type="radio"/>	<input type="radio"/>	<input type="radio"/>	<input type="radio"/>
PB47	NHQ3	Notch shape selection 3	0000h		<input type="radio"/>	<input type="radio"/>	<input type="radio"/>	<input type="radio"/>
PB48	NH4	Machine resonance suppression filter 4	4500	[Hz]	<input type="radio"/>	<input type="radio"/>	<input type="radio"/>	<input type="radio"/>
PB49	NHQ4	Notch shape selection 4	0000h		<input type="radio"/>	<input type="radio"/>	<input type="radio"/>	<input type="radio"/>
PB50	NH5	Machine resonance suppression filter 5	4500	[Hz]	<input type="radio"/>	<input type="radio"/>	<input type="radio"/>	<input type="radio"/>
PB51	NHQ5	Notch shape selection 5	0000h		<input type="radio"/>	<input type="radio"/>	<input type="radio"/>	<input type="radio"/>
PB52	VRF21	Vibration suppression control 2 - Vibration frequency	100.0	[Hz]	<input type="radio"/>	<input type="radio"/>	<input type="radio"/>	<input type="radio"/>
PB53	VRF22	Vibration suppression control 2 - Resonance frequency	100.0	[Hz]	<input type="radio"/>	<input type="radio"/>	<input type="radio"/>	<input type="radio"/>
PB54	VRF23	Vibration suppression control 2 - Vibration frequency damping	0.00		<input type="radio"/>	<input type="radio"/>	<input type="radio"/>	<input type="radio"/>
PB55	VRF24	Vibration suppression control 2 - Resonance frequency damping	0.00		<input type="radio"/>	<input type="radio"/>	<input type="radio"/>	<input type="radio"/>
PB56	VRF21B	Vibration suppression control 2 - Vibration frequency after gain switching	0.0	[Hz]	<input type="radio"/>	<input type="radio"/>	<input type="radio"/>	<input type="radio"/>
PB57	VRF22B	Vibration suppression control 2 - Resonance frequency after gain switching	0.0	[Hz]	<input type="radio"/>	<input type="radio"/>	<input type="radio"/>	<input type="radio"/>
PB58	VRF23B	Vibration suppression control 2 - Vibration frequency damping after gain switching	0.00		<input type="radio"/>	<input type="radio"/>	<input type="radio"/>	<input type="radio"/>
PB59	VRF24B	Vibration suppression control 2 - Resonance frequency damping after gain switching	0.00		<input type="radio"/>	<input type="radio"/>	<input type="radio"/>	<input type="radio"/>
PB60	PG1B	Model loop gain after gain switching	0.0	[rad/s]	<input type="radio"/>	<input type="radio"/>	<input type="radio"/>	<input type="radio"/>
PB61		For manufacturer setting	0.0		<input type="radio"/>	<input type="radio"/>	<input type="radio"/>	<input type="radio"/>
PB62			0000h		<input type="radio"/>	<input type="radio"/>	<input type="radio"/>	<input type="radio"/>
PB63			0000h		<input type="radio"/>	<input type="radio"/>	<input type="radio"/>	<input type="radio"/>
PB64			0000h		<input type="radio"/>	<input type="radio"/>	<input type="radio"/>	<input type="radio"/>

Note. Available in the future.

5.1.3 Extension setting parameters ([Pr. PC__])

No.	Symbol	Name	Initial value	Unit	Operation mode			
					Standard	(Note) Full.	Lin.	D.D.
PC01	ERZ	Error excessive alarm level	0	[rev]/ [mm]	<input type="radio"/>	<input type="radio"/>	<input type="radio"/>	<input type="radio"/>
PC02	MBR	Electromagnetic brake sequence output	0	[ms]	<input type="radio"/>	<input type="radio"/>	<input type="radio"/>	<input type="radio"/>
PC03	*ENRS	Encoder output pulse selection	0000h		<input type="radio"/>	<input type="radio"/>	<input type="radio"/>	<input type="radio"/>
PC04	**COP1	Function selection C-1	0000h		<input type="radio"/>	<input type="radio"/>	<input type="radio"/>	<input type="radio"/>
PC05	**COP2	Function selection C-2	0000h		<input type="radio"/>	<input type="radio"/>	<input type="radio"/>	<input type="radio"/>
PC06	*COP3	Function selection C-3	0000h		<input type="radio"/>	<input type="radio"/>	<input type="radio"/>	<input type="radio"/>
PC07	ZSP	Zero speed	50	[r/min]/ [mm/s]	<input type="radio"/>	<input type="radio"/>	<input type="radio"/>	<input type="radio"/>
PC08	OSL	Overspeed alarm detection level	0	[r/min]/ [mm/s]	<input type="radio"/>	<input type="radio"/>	<input type="radio"/>	<input type="radio"/>
PC09	MOD1	Analog monitor 1 output	0000h		<input type="radio"/>	<input type="radio"/>	<input type="radio"/>	<input type="radio"/>
PC10	MOD2	Analog monitor 2 output	0001h		<input type="radio"/>	<input type="radio"/>	<input type="radio"/>	<input type="radio"/>
PC11	MO1	Analog monitor 1 offset	0	[mV]	<input type="radio"/>	<input type="radio"/>	<input type="radio"/>	<input type="radio"/>
PC12	MO2	Analog monitor 2 offset	0	[mV]	<input type="radio"/>	<input type="radio"/>	<input type="radio"/>	<input type="radio"/>
PC13	MOSDL	Analog monitor - Feedback position output standard data - Low	0	[pulse]	<input type="radio"/>	<input type="radio"/>	<input type="radio"/>	<input type="radio"/>
PC14	MOSDH	Analog monitor - Feedback position output standard data - High	0	[10000pulses]	<input type="radio"/>	<input type="radio"/>	<input type="radio"/>	<input type="radio"/>
PC15		For manufacturer setting	0		<input type="radio"/>	<input type="radio"/>	<input type="radio"/>	<input type="radio"/>
PC16			0000h		<input type="radio"/>	<input type="radio"/>	<input type="radio"/>	<input type="radio"/>

5. PARAMETERS

No.	Symbol	Name	Initial value	Unit	Operation mode			
					Standard	(Note) Full.	Lin.	D.D.
PC17	**COP4	Function selection C-4	0000h		<input type="checkbox"/>	<input type="checkbox"/>	<input type="checkbox"/>	<input type="checkbox"/>
PC18	*COP5	Function selection C-5	0000h		<input type="checkbox"/>	<input type="checkbox"/>	<input type="checkbox"/>	<input type="checkbox"/>
PC19		For manufacturer setting	0000h		<input type="checkbox"/>	<input type="checkbox"/>	<input type="checkbox"/>	<input type="checkbox"/>
PC20	*COP7	Function selection C-7	0000h		<input type="checkbox"/>	<input type="checkbox"/>	<input type="checkbox"/>	<input type="checkbox"/>
PC21	*BPS	Alarm history clear	0000h		<input type="checkbox"/>	<input type="checkbox"/>	<input type="checkbox"/>	<input type="checkbox"/>
PC22		For manufacturer setting	0		<input type="checkbox"/>	<input type="checkbox"/>	<input type="checkbox"/>	<input type="checkbox"/>
PC23			0000h		<input type="checkbox"/>	<input type="checkbox"/>	<input type="checkbox"/>	<input type="checkbox"/>
PC24	RSBR	Forced stop deceleration time constant	100	[ms]	<input type="checkbox"/>	<input type="checkbox"/>	<input type="checkbox"/>	<input type="checkbox"/>
PC25		For manufacturer setting	0		<input type="checkbox"/>	<input type="checkbox"/>	<input type="checkbox"/>	<input type="checkbox"/>
PC26			0000h		<input type="checkbox"/>	<input type="checkbox"/>	<input type="checkbox"/>	<input type="checkbox"/>
PC27	**COP9	Function selection C-9	0000h		<input type="checkbox"/>	<input type="checkbox"/>	<input type="checkbox"/>	<input type="checkbox"/>
PC28		For manufacturer setting	0000h		<input type="checkbox"/>	<input type="checkbox"/>	<input type="checkbox"/>	<input type="checkbox"/>
PC29	*COPB	Function Selection C-B	0000h		<input type="checkbox"/>	<input type="checkbox"/>	<input type="checkbox"/>	<input type="checkbox"/>
PC30		For manufacturer setting	0		<input type="checkbox"/>	<input type="checkbox"/>	<input type="checkbox"/>	<input type="checkbox"/>
PC31	RSUP1	Vertical axis freefall prevention compensation amount	0	[0.0001rev]/ [0.01mm]	<input type="checkbox"/>	<input type="checkbox"/>	<input type="checkbox"/>	<input type="checkbox"/>
PC32		For manufacturer setting	0000h		<input type="checkbox"/>	<input type="checkbox"/>	<input type="checkbox"/>	<input type="checkbox"/>
PC33			0		<input type="checkbox"/>	<input type="checkbox"/>	<input type="checkbox"/>	<input type="checkbox"/>
PC34			100		<input type="checkbox"/>	<input type="checkbox"/>	<input type="checkbox"/>	<input type="checkbox"/>
PC35			0000h		<input type="checkbox"/>	<input type="checkbox"/>	<input type="checkbox"/>	<input type="checkbox"/>
PC36			0000h		<input type="checkbox"/>	<input type="checkbox"/>	<input type="checkbox"/>	<input type="checkbox"/>
PC37			0000h		<input type="checkbox"/>	<input type="checkbox"/>	<input type="checkbox"/>	<input type="checkbox"/>
PC38			0000h		<input type="checkbox"/>	<input type="checkbox"/>	<input type="checkbox"/>	<input type="checkbox"/>
PC39			0000h		<input type="checkbox"/>	<input type="checkbox"/>	<input type="checkbox"/>	<input type="checkbox"/>
PC40			0000h		<input type="checkbox"/>	<input type="checkbox"/>	<input type="checkbox"/>	<input type="checkbox"/>
PC41			0000h		<input type="checkbox"/>	<input type="checkbox"/>	<input type="checkbox"/>	<input type="checkbox"/>
PC42			0000h		<input type="checkbox"/>	<input type="checkbox"/>	<input type="checkbox"/>	<input type="checkbox"/>
PC43			0000h		<input type="checkbox"/>	<input type="checkbox"/>	<input type="checkbox"/>	<input type="checkbox"/>
PC44			0000h		<input type="checkbox"/>	<input type="checkbox"/>	<input type="checkbox"/>	<input type="checkbox"/>
PC45			0000h		<input type="checkbox"/>	<input type="checkbox"/>	<input type="checkbox"/>	<input type="checkbox"/>
PC46			0000h		<input type="checkbox"/>	<input type="checkbox"/>	<input type="checkbox"/>	<input type="checkbox"/>
PC47			0000h		<input type="checkbox"/>	<input type="checkbox"/>	<input type="checkbox"/>	<input type="checkbox"/>
PC48			0000h		<input type="checkbox"/>	<input type="checkbox"/>	<input type="checkbox"/>	<input type="checkbox"/>
PC49			0000h		<input type="checkbox"/>	<input type="checkbox"/>	<input type="checkbox"/>	<input type="checkbox"/>
PC50			0000h		<input type="checkbox"/>	<input type="checkbox"/>	<input type="checkbox"/>	<input type="checkbox"/>
PC51			0000h		<input type="checkbox"/>	<input type="checkbox"/>	<input type="checkbox"/>	<input type="checkbox"/>
PC52			0000h		<input type="checkbox"/>	<input type="checkbox"/>	<input type="checkbox"/>	<input type="checkbox"/>
PC53			0000h		<input type="checkbox"/>	<input type="checkbox"/>	<input type="checkbox"/>	<input type="checkbox"/>
PC54			0000h		<input type="checkbox"/>	<input type="checkbox"/>	<input type="checkbox"/>	<input type="checkbox"/>
PC55			0000h		<input type="checkbox"/>	<input type="checkbox"/>	<input type="checkbox"/>	<input type="checkbox"/>
PC56			0000h		<input type="checkbox"/>	<input type="checkbox"/>	<input type="checkbox"/>	<input type="checkbox"/>
PC57			0000h		<input type="checkbox"/>	<input type="checkbox"/>	<input type="checkbox"/>	<input type="checkbox"/>
PC58			0000h		<input type="checkbox"/>	<input type="checkbox"/>	<input type="checkbox"/>	<input type="checkbox"/>
PC59			0000h		<input type="checkbox"/>	<input type="checkbox"/>	<input type="checkbox"/>	<input type="checkbox"/>
PC60			0000h		<input type="checkbox"/>	<input type="checkbox"/>	<input type="checkbox"/>	<input type="checkbox"/>
PC61			0000h		<input type="checkbox"/>	<input type="checkbox"/>	<input type="checkbox"/>	<input type="checkbox"/>
PC62			0000h		<input type="checkbox"/>	<input type="checkbox"/>	<input type="checkbox"/>	<input type="checkbox"/>
PC63			0000h		<input type="checkbox"/>	<input type="checkbox"/>	<input type="checkbox"/>	<input type="checkbox"/>
PC64			0000h		<input type="checkbox"/>	<input type="checkbox"/>	<input type="checkbox"/>	<input type="checkbox"/>

Note. Available in the future.

5. PARAMETERS

5.1.4 I/O setting parameters ([Pr. PD_ _])

No.	Symbol	Name	Initial value	Unit	Operation mode			
					Standard	(Note) Full.	Lin.	D.D.
PD01		For manufacturer setting	0000h					
PD02	*DIA2	Input signal automatic on selection 2	0000h		<input type="radio"/>	<input type="radio"/>	<input type="radio"/>	<input type="radio"/>
PD03		For manufacturer setting	0020h					
PD04			0021h					
PD05			0022h					
PD06			0000h					
PD07	*DO1		Output device selection 1	0005h		<input type="radio"/>	<input type="radio"/>	<input type="radio"/>
PD08	*DO2	Output device selection 2	0004h		<input type="radio"/>	<input type="radio"/>	<input type="radio"/>	<input type="radio"/>
PD09	*DO3	Output device selection 3	0003h		<input type="radio"/>	<input type="radio"/>	<input type="radio"/>	<input type="radio"/>
PD10		For manufacturer setting	0000h					
PD11			0004h					
PD12	*DOP1	Function selection D-1	0000h				<input type="radio"/>	<input type="radio"/>
PD13		For manufacturer setting	0000h					
PD14	*DOP3	Function selection D-3	0000h		<input type="radio"/>	<input type="radio"/>	<input type="radio"/>	<input type="radio"/>
PD15		For manufacturer setting	0000h					
PD16			0000h					
PD17			0000h					
PD18			0000h					
PD19			0000h					
PD20			0					
PD21			0					
PD22			0					
PD23			0					
PD24			0000h					
PD25			0000h					
PD26			0000h					
PD27			0000h					
PD28			0000h					
PD29			0000h					
PD30			0					
PD31			0					
PD32			0					
PD33			0000h					
PD34			0000h					
PD35			0000h					
PD36			0000h					
PD37			0000h					
PD38			0000h					
PD39			0000h					
PD40			0000h					
PD41			0000h					
PD42			0000h					
PD43			0000h					
PD44			0000h					
PD45			0000h					
PD46			0000h					
PD47			0000h					
PD48			0000h					

Note. Available in the future.

5. PARAMETERS

5.1.5 Extension setting 2 parameters ([Pr. PE_ _])

No.	Symbol	Name	Initial value	Unit	Operation mode			
					Standard	(Note) Full.	Lin.	D.D.
PE01	**FCT1	Fully closed loop function selection 1	0000h			<input type="radio"/>		
PE02		For manufacturer setting	0000h					
PE03	*FCT2	Fully closed loop function selection 2	0003h			<input type="radio"/>		
PE04	**FBN	Fully closed loop control - Feedback pulse electronic gear 1 - Numerator	1			<input type="radio"/>		
PE05	**FBD	Fully closed loop control - Feedback pulse electronic gear 1 - Denominator	1			<input type="radio"/>		
PE06	BC1	Fully closed loop control - Speed deviation error detection level	400	[r/min]		<input type="radio"/>		
PE07	BC2	Fully closed loop control - Position deviation error detection level	100	[kpulse]		<input type="radio"/>		
PE08	DUF	Fully closed loop dual feedback filter	10	[rad/s]		<input type="radio"/>		
PE09		For manufacturer setting	0000h					
PE10	FCT3	Fully closed loop function selection 3	0000h			<input type="radio"/>		
PE11		For manufacturer setting	0000h					
PE12			0000h					
PE13			0000h					
PE14			0111h					
PE15			20					
PE16			0000h					
PE17			0000h					
PE18			0000h					
PE19			0000h					
PE20			0000h					
PE21			0000h					
PE22			0000h					
PE23			0000h					
PE24			0000h					
PE25			0000h					
PE26			0000h					
PE27			0000h					
PE28			0000h					
PE29			0000h					
PE30			0000h					
PE31			0000h					
PE32			0000h					
PE33			0000h					
PE34	**FBN2	Fully closed loop control - Feedback pulse electronic gear 2 - Numerator	1			<input type="radio"/>		
PE35	**FBD2	Fully closed loop control - Feedback pulse electronic gear 2 - Denominator	1			<input type="radio"/>		
PE36		For manufacturer setting	0.0					
PE37			0.00					
PE38			0.00					
PE39			20					
PE40			0000h					
PE41	EOP3	Function selection E-3	0000h			<input type="radio"/>	<input type="radio"/>	<input type="radio"/>
PE42		For manufacturer setting	0					
PE43			0.0					
PE44			0000h					
PE45			0000h					
PE46			0000h					
PE47			0000h					
PE48			0000h					

5. PARAMETERS

No.	Symbol	Name	Initial value	Unit	Operation mode			
					Standard	(Note) Full.	Lin.	D.D.
PE49		For manufacturer setting	0000h					
PE50			0000h					
PE51			0000h					
PE52			0000h					
PE53			0000h					
PE54			0000h					
PE55			0000h					
PE56			0000h					
PE57			0000h					
PE58			0000h					
PE59			0000h					
PE60			0000h					
PE61			0.00					
PE62			0.00					
PE63			0.00					
PE64			0.00					

Note. Available in the future.

5.1.6 Extension setting 3 parameters ([Pr. PF_ _])

No.	Symbol	Name	Initial value	Unit	Operation mode			
					Standard	(Note) Full.	Lin.	D.D.
PF01		For manufacturer setting	0000h					
PF02			0000h					
PF03			0000h					
PF04			0					
PF05			0000h					
PF06			0000h					
PF07			0000h					
PF08			0000h					
PF09			0					
PF10			0					
PF11			0					
PF12			2000					
PF13			0000h					
PF14			10					
PF15			0000h					
PF16			0000h					
PF17			0000h					
PF18			0000h					
PF19			0000h					
PF20			0000h					
PF21	DRT	Drive recorder switching time setting	0	[S]	<input type="radio"/>	<input type="radio"/>	<input type="radio"/>	<input type="radio"/>
PF22		For manufacturer setting	200		<input type="radio"/>	<input type="radio"/>	<input type="radio"/>	<input type="radio"/>
PF23	OSCL1	Vibration tough drive - Oscillation detection level	50	[%]	<input type="radio"/>	<input type="radio"/>	<input type="radio"/>	<input type="radio"/>
PF24	*OSCL2	Vibration tough drive function selection	0000h		<input type="radio"/>	<input type="radio"/>	<input type="radio"/>	<input type="radio"/>

5. PARAMETERS

No.	Symbol	Name	Initial value	Unit	Operation mode			
					Standard	(Note) Full.	Lin.	D.D.
PF25	CVAT	Instantaneous power failure tough drive - Detection time	200	[ms]	<input type="radio"/>	<input type="radio"/>	<input type="radio"/>	<input type="radio"/>
PF26		For manufacturer setting	0					
PF27			0					
PF28			0					
PF29			0000h					
PF30			0					
PF31	FRIC	Machine diagnosis function - Friction judgement speed	0	[r/min]/ [mm/s]	<input type="radio"/>	<input type="radio"/>	<input type="radio"/>	<input type="radio"/>
PF32		For manufacturer setting	50					
PF33			0000h					
PF34			0000h					
PF35			0000h					
PF36			0000h					
PF37			0000h					
PF38			0000h					
PF39			0000h					
PF40			0000h					
PF41			0000h					
PF42			0000h					
PF43			0000h					
PF44			0000h					
PF45			0000h					
PF46			0000h					
PF47			0000h					
PF48			0000h					

Note. Available in the future.

5.1.7 Linear servo motor/DD motor setting parameters ([Pr. PL_ _])

No.	Symbol	Name	Initial value	Unit	Operation mode			
					Standard	(Note) Full.	Lin.	D.D.
PL01	**LIT1	Linear servo motor/DD motor function selection 1	0301h				<input type="radio"/>	<input type="radio"/>
PL02	**LIM	Linear encoder resolution - Numerator	1000	[μ m]			<input type="radio"/>	<input type="radio"/>
PL03	**LID	Linear encoder resolution - Denominator	1000	[μ m]			<input type="radio"/>	<input type="radio"/>
PL04	*LIT2	Linear servo motor/DD motor function selection 2	0003h				<input type="radio"/>	<input type="radio"/>
PL05	LB1	Position deviation error detection level	0	[mm]/ [0.01rev]			<input type="radio"/>	<input type="radio"/>
PL06	LB2	Speed deviation error detection level	0	[r/min]/ [mm/s]			<input type="radio"/>	<input type="radio"/>
PL07	LB3	Torque/thrust deviation error detection level	100	[%]			<input type="radio"/>	<input type="radio"/>
PL08	*LIT3	Linear servo motor/DD motor function selection 3	0010h				<input type="radio"/>	<input type="radio"/>
PL09	LPWM	Magnetic pole detection voltage level	30	[%]			<input type="radio"/>	<input type="radio"/>
PL10		For manufacturer setting	5					
PL11			100					
PL12			500					
PL13			0000h					
PL14			0					

5. PARAMETERS

No.	Symbol	Name	Initial value	Unit	Operation mode			
					Standard	(Note) Full.	Lin.	D.D.
PL15		For manufacturer setting	20					
PL16			0					
PL17	LTSTS	Magnetic pole detection - Minute position detection method - Function selection	0000h				<input type="radio"/>	<input type="radio"/>
PL18	IDLV	Magnetic pole detection - Minute position detection method - Identification signal amplitude	0	[%]			<input type="radio"/>	<input type="radio"/>
PL19		For manufacturer setting	0					
PL20			0					
PL21			0					
PL22			0					
PL23			0000h					
PL24			0					
PL25			0000h					
PL26			0000h					
PL27			0000h					
PL28			0000h					
PL29			0000h					
PL30			0000h					
PL31			0000h					
PL32			0000h					
PL33			0000h					
PL34			0000h					
PL35			0000h					
PL36			0000h					
PL37			0000h					
PL38			0000h					
PL39			0000h					
PL40			0000h					
PL41			0000h					
PL42			0000h					
PL43			0000h					
PL44			0000h					
PL45			0000h					
PL46			0000h					
PL47			0000h					
PL48			0000h					

Note. Available in the future.

5. PARAMETERS

5.2 Detailed list of parameters

POINT
<ul style="list-style-type: none"> ● "x" in the "Setting digit" columns means which digit to set a value. ● The fully closed loop system will be available in the future.

5.2.1 Basic setting parameters ([Pr. PA_ _])

No.	Symbol	Name and function	Initial value (unit)	Setting range															
PA01	**STY	Operation mode Select a operation mode. <table border="1" style="width: 100%; margin-top: 10px;"> <thead> <tr> <th>Setting digit</th> <th>Explanation</th> <th>Initial value</th> </tr> </thead> <tbody> <tr> <td>__ _ x</td> <td>For manufacturer setting</td> <td>0h</td> </tr> <tr> <td>__ x _</td> <td> Operation mode selection 0: Standard control mode 1: Fully closed loop control mode 4: Linear servo motor control mode 6: DD motor control mode Setting other than above will result in [AL. 37 Parameter error]. </td> <td>0h</td> </tr> <tr> <td>_ x _ _</td> <td>For manufacturer setting</td> <td>0h</td> </tr> <tr> <td>x _ _ _</td> <td> Operation mode selection To change this digit, use an application software "MR-J4(W)-B mode selection". When you change it without the application, [AL. 3E Operation mode error] will occur. 0: J3 compatibility mode 1: J4 mode </td> <td>1h</td> </tr> </tbody> </table>	Setting digit	Explanation	Initial value	__ _ x	For manufacturer setting	0h	__ x _	Operation mode selection 0: Standard control mode 1: Fully closed loop control mode 4: Linear servo motor control mode 6: DD motor control mode Setting other than above will result in [AL. 37 Parameter error].	0h	_ x _ _	For manufacturer setting	0h	x _ _ _	Operation mode selection To change this digit, use an application software "MR-J4(W)-B mode selection". When you change it without the application, [AL. 3E Operation mode error] will occur. 0: J3 compatibility mode 1: J4 mode	1h	Refer to Name and function column.	
Setting digit	Explanation	Initial value																	
__ _ x	For manufacturer setting	0h																	
__ x _	Operation mode selection 0: Standard control mode 1: Fully closed loop control mode 4: Linear servo motor control mode 6: DD motor control mode Setting other than above will result in [AL. 37 Parameter error].	0h																	
_ x _ _	For manufacturer setting	0h																	
x _ _ _	Operation mode selection To change this digit, use an application software "MR-J4(W)-B mode selection". When you change it without the application, [AL. 3E Operation mode error] will occur. 0: J3 compatibility mode 1: J4 mode	1h																	

5. PARAMETERS

No.	Symbol	Name and function	Initial value (unit)	Setting range															
PA02	**REG	<p>Regenerative option Used to select the regenerative option. Incorrect setting may cause the regenerative option to burn. If a selected regenerative option is not for use with the servo amplifier, [AL. 37 Parameter error] occurs.</p> <table border="1"> <thead> <tr> <th>Setting digit</th> <th>Explanation</th> <th>Initial value</th> </tr> </thead> <tbody> <tr> <td>__ x x</td> <td> Regenerative option selection 00: Regenerative option is not used <ul style="list-style-type: none"> For servo amplifier of 100 W, regenerative resistor is not used. For servo amplifier of 0.2 kW to 7 kW, built-in regenerative resistor is used. 01: FR-RC/FR-CV/FR-BU2 When you use FR-RC, FR-CV, or FR-BU2, select "Mode 2 (_ _ 1)" of "Undervoltage alarm detection mode selection" in [Pr. PC20]. 02: MR-RB032 03: MR-RB12 04: MR-RB32 05: MR-RB30 06: MR-RB50 (Cooling fan is required.) 08: MR-RB31 09: MR-RB51 (Cooling fan is required.) 0B: MR-RB3N 0C: MR-RB5N (Cooling fan is required.) </td> <td>00h</td> </tr> <tr> <td>_ x _ _</td> <td>For manufacturer setting</td> <td>0h</td> </tr> <tr> <td>x _ _ _</td> <td></td> <td>0h</td> </tr> </tbody> </table>	Setting digit	Explanation	Initial value	__ x x	Regenerative option selection 00: Regenerative option is not used <ul style="list-style-type: none"> For servo amplifier of 100 W, regenerative resistor is not used. For servo amplifier of 0.2 kW to 7 kW, built-in regenerative resistor is used. 01: FR-RC/FR-CV/FR-BU2 When you use FR-RC, FR-CV, or FR-BU2, select "Mode 2 (_ _ 1)" of "Undervoltage alarm detection mode selection" in [Pr. PC20]. 02: MR-RB032 03: MR-RB12 04: MR-RB32 05: MR-RB30 06: MR-RB50 (Cooling fan is required.) 08: MR-RB31 09: MR-RB51 (Cooling fan is required.) 0B: MR-RB3N 0C: MR-RB5N (Cooling fan is required.)	00h	_ x _ _	For manufacturer setting	0h	x _ _ _		0h	Refer to Name and function column.				
Setting digit	Explanation	Initial value																	
__ x x	Regenerative option selection 00: Regenerative option is not used <ul style="list-style-type: none"> For servo amplifier of 100 W, regenerative resistor is not used. For servo amplifier of 0.2 kW to 7 kW, built-in regenerative resistor is used. 01: FR-RC/FR-CV/FR-BU2 When you use FR-RC, FR-CV, or FR-BU2, select "Mode 2 (_ _ 1)" of "Undervoltage alarm detection mode selection" in [Pr. PC20]. 02: MR-RB032 03: MR-RB12 04: MR-RB32 05: MR-RB30 06: MR-RB50 (Cooling fan is required.) 08: MR-RB31 09: MR-RB51 (Cooling fan is required.) 0B: MR-RB3N 0C: MR-RB5N (Cooling fan is required.)	00h																	
_ x _ _	For manufacturer setting	0h																	
x _ _ _		0h																	
PA03	*ABS	<p>Absolute position detection system Set this parameter when using the absolute position detection system. The parameter is not available in the speed control mode and torque control mode.</p> <table border="1"> <thead> <tr> <th>Setting digit</th> <th>Explanation</th> <th>Initial value</th> </tr> </thead> <tbody> <tr> <td>___ x</td> <td> Absolute position detection system selection 0: Disabled (used in incremental system) 1: Enabled (used in absolute position detection system) </td> <td>0h</td> </tr> <tr> <td>_ _ x _</td> <td>For manufacturer setting</td> <td>0h</td> </tr> <tr> <td>_ x _ _</td> <td></td> <td>0h</td> </tr> <tr> <td>x _ _ _</td> <td></td> <td>0h</td> </tr> </tbody> </table>	Setting digit	Explanation	Initial value	___ x	Absolute position detection system selection 0: Disabled (used in incremental system) 1: Enabled (used in absolute position detection system)	0h	_ _ x _	For manufacturer setting	0h	_ x _ _		0h	x _ _ _		0h	Refer to Name and function column.	
Setting digit	Explanation	Initial value																	
___ x	Absolute position detection system selection 0: Disabled (used in incremental system) 1: Enabled (used in absolute position detection system)	0h																	
_ _ x _	For manufacturer setting	0h																	
_ x _ _		0h																	
x _ _ _		0h																	
PA04	*AOP1	<p>Function selection A-1 This is used to select the forced stop input and forced stop deceleration function.</p> <table border="1"> <thead> <tr> <th>Setting digit</th> <th>Explanation</th> <th>Initial value</th> </tr> </thead> <tbody> <tr> <td>___ x</td> <td>For manufacturer setting</td> <td>0h</td> </tr> <tr> <td>_ _ x _</td> <td></td> <td>0h</td> </tr> <tr> <td>_ x _ _</td> <td> Servo forced stop selection 0: Enabled (The forced stop input EM2 or EM1 is used.) 1: Disabled (The forced stop input EM2 and EM1 are not used.) Refer to table 5.1 for details. </td> <td>0h</td> </tr> <tr> <td>x _ _ _</td> <td> Forced stop deceleration function selection 0: Forced stop deceleration function disabled (EM1) 2: Forced stop deceleration function enabled (EM2) Refer to table 5.1 for details. </td> <td>2h</td> </tr> </tbody> </table>	Setting digit	Explanation	Initial value	___ x	For manufacturer setting	0h	_ _ x _		0h	_ x _ _	Servo forced stop selection 0: Enabled (The forced stop input EM2 or EM1 is used.) 1: Disabled (The forced stop input EM2 and EM1 are not used.) Refer to table 5.1 for details.	0h	x _ _ _	Forced stop deceleration function selection 0: Forced stop deceleration function disabled (EM1) 2: Forced stop deceleration function enabled (EM2) Refer to table 5.1 for details.	2h	Refer to Name and function column.	
Setting digit	Explanation	Initial value																	
___ x	For manufacturer setting	0h																	
_ _ x _		0h																	
_ x _ _	Servo forced stop selection 0: Enabled (The forced stop input EM2 or EM1 is used.) 1: Disabled (The forced stop input EM2 and EM1 are not used.) Refer to table 5.1 for details.	0h																	
x _ _ _	Forced stop deceleration function selection 0: Forced stop deceleration function disabled (EM1) 2: Forced stop deceleration function enabled (EM2) Refer to table 5.1 for details.	2h																	

5. PARAMETERS

No.	Symbol	Name and function	Initial value (unit)	Setting range																															
PA04	*AOP1	<p style="text-align: center;">Table 5.1 Deceleration method</p> <table border="1"> <thead> <tr> <th rowspan="2">Setting value</th> <th rowspan="2">EM2/EM1</th> <th colspan="2">Deceleration method</th> </tr> <tr> <th>EM2 or EM1 is off</th> <th>Alarm occurred</th> </tr> </thead> <tbody> <tr> <td>0 0 __</td> <td>EM1</td> <td>MBR (Electromagnetic brake interlock) turns off without the forced stop deceleration.</td> <td>MBR (Electromagnetic brake interlock) turns off without the forced stop deceleration.</td> </tr> <tr> <td>2 0 __</td> <td>EM2</td> <td>MBR (Electromagnetic brake interlock) turns off after the forced stop deceleration.</td> <td>MBR (Electromagnetic brake interlock) turns off after the forced stop deceleration.</td> </tr> <tr> <td>0 1 __</td> <td>Not using EM2 or EM1</td> <td style="text-align: center;">/</td> <td>MBR (Electromagnetic brake interlock) turns off without the forced stop deceleration.</td> </tr> <tr> <td>2 1 __</td> <td>Not using EM2 or EM1</td> <td style="text-align: center;">/</td> <td>MBR (Electromagnetic brake interlock) turns off after the forced stop deceleration.</td> </tr> </tbody> </table>	Setting value	EM2/EM1	Deceleration method		EM2 or EM1 is off	Alarm occurred	0 0 __	EM1	MBR (Electromagnetic brake interlock) turns off without the forced stop deceleration.	MBR (Electromagnetic brake interlock) turns off without the forced stop deceleration.	2 0 __	EM2	MBR (Electromagnetic brake interlock) turns off after the forced stop deceleration.	MBR (Electromagnetic brake interlock) turns off after the forced stop deceleration.	0 1 __	Not using EM2 or EM1	/	MBR (Electromagnetic brake interlock) turns off without the forced stop deceleration.	2 1 __	Not using EM2 or EM1	/	MBR (Electromagnetic brake interlock) turns off after the forced stop deceleration.	Refer to Name and function column.										
Setting value	EM2/EM1	Deceleration method																																	
		EM2 or EM1 is off	Alarm occurred																																
0 0 __	EM1	MBR (Electromagnetic brake interlock) turns off without the forced stop deceleration.	MBR (Electromagnetic brake interlock) turns off without the forced stop deceleration.																																
2 0 __	EM2	MBR (Electromagnetic brake interlock) turns off after the forced stop deceleration.	MBR (Electromagnetic brake interlock) turns off after the forced stop deceleration.																																
0 1 __	Not using EM2 or EM1	/	MBR (Electromagnetic brake interlock) turns off without the forced stop deceleration.																																
2 1 __	Not using EM2 or EM1	/	MBR (Electromagnetic brake interlock) turns off after the forced stop deceleration.																																
PA08	ATU	<p>Auto tuning mode Select the gain adjustment mode.</p> <table border="1"> <thead> <tr> <th>Setting digit</th> <th>Explanation</th> <th>Initial value</th> </tr> </thead> <tbody> <tr> <td>___ x</td> <td>Gain adjustment mode selection 0: 2 gain adjustment mode 1 (interpolation mode) 1: Auto tuning mode 1 2: Auto tuning mode 2 3: Manual mode 4: 2 gain adjustment mode 2 Refer to table 5.2 for details.</td> <td>1h</td> </tr> <tr> <td>__ x _</td> <td rowspan="3">For manufacturer setting</td> <td>0h</td> </tr> <tr> <td>_ x _ _</td> <td>0h</td> </tr> <tr> <td>x _ _ _</td> <td>0h</td> </tr> </tbody> </table> <p style="text-align: center;">Table 5.2 Gain adjustment mode selection</p> <table border="1"> <thead> <tr> <th>Setting value</th> <th>Gain adjustment mode</th> <th>Automatically adjusted parameter</th> </tr> </thead> <tbody> <tr> <td>___ 0</td> <td>2 gain adjustment mode 1 (interpolation mode)</td> <td>[Pr. PB06 Load to motor inertia ratio/load to motor mass ratio] [Pr. PB08 Position loop gain] [Pr. PB09 Speed loop gain] [Pr. PB10 Speed integral compensation]</td> </tr> <tr> <td>___ 1</td> <td>Auto tuning mode 1</td> <td>[Pr. PB06 Load to motor inertia ratio/load to motor mass ratio] [Pr. PB07 Model loop gain] [Pr. PB08 Position loop gain] [Pr. PB09 Speed loop gain] [Pr. PB10 Speed integral compensation]</td> </tr> <tr> <td>___ 2</td> <td>Auto tuning mode 2</td> <td>[Pr. PB07 Model loop gain] [Pr. PB08 Position loop gain] [Pr. PB09 Speed loop gain] [Pr. PB10 Speed integral compensation]</td> </tr> <tr> <td>___ 3</td> <td>Manual mode</td> <td style="text-align: center;">/</td> </tr> <tr> <td>___ 4</td> <td>2 gain adjustment mode 2</td> <td>[Pr. PB08 Position loop gain] [Pr. PB09 Speed loop gain] [Pr. PB10 Speed integral compensation]</td> </tr> </tbody> </table>	Setting digit	Explanation	Initial value	___ x	Gain adjustment mode selection 0: 2 gain adjustment mode 1 (interpolation mode) 1: Auto tuning mode 1 2: Auto tuning mode 2 3: Manual mode 4: 2 gain adjustment mode 2 Refer to table 5.2 for details.	1h	__ x _	For manufacturer setting	0h	_ x _ _	0h	x _ _ _	0h	Setting value	Gain adjustment mode	Automatically adjusted parameter	___ 0	2 gain adjustment mode 1 (interpolation mode)	[Pr. PB06 Load to motor inertia ratio/load to motor mass ratio] [Pr. PB08 Position loop gain] [Pr. PB09 Speed loop gain] [Pr. PB10 Speed integral compensation]	___ 1	Auto tuning mode 1	[Pr. PB06 Load to motor inertia ratio/load to motor mass ratio] [Pr. PB07 Model loop gain] [Pr. PB08 Position loop gain] [Pr. PB09 Speed loop gain] [Pr. PB10 Speed integral compensation]	___ 2	Auto tuning mode 2	[Pr. PB07 Model loop gain] [Pr. PB08 Position loop gain] [Pr. PB09 Speed loop gain] [Pr. PB10 Speed integral compensation]	___ 3	Manual mode	/	___ 4	2 gain adjustment mode 2	[Pr. PB08 Position loop gain] [Pr. PB09 Speed loop gain] [Pr. PB10 Speed integral compensation]	Refer to Name and function column.	
Setting digit	Explanation	Initial value																																	
___ x	Gain adjustment mode selection 0: 2 gain adjustment mode 1 (interpolation mode) 1: Auto tuning mode 1 2: Auto tuning mode 2 3: Manual mode 4: 2 gain adjustment mode 2 Refer to table 5.2 for details.	1h																																	
__ x _	For manufacturer setting	0h																																	
_ x _ _		0h																																	
x _ _ _		0h																																	
Setting value	Gain adjustment mode	Automatically adjusted parameter																																	
___ 0	2 gain adjustment mode 1 (interpolation mode)	[Pr. PB06 Load to motor inertia ratio/load to motor mass ratio] [Pr. PB08 Position loop gain] [Pr. PB09 Speed loop gain] [Pr. PB10 Speed integral compensation]																																	
___ 1	Auto tuning mode 1	[Pr. PB06 Load to motor inertia ratio/load to motor mass ratio] [Pr. PB07 Model loop gain] [Pr. PB08 Position loop gain] [Pr. PB09 Speed loop gain] [Pr. PB10 Speed integral compensation]																																	
___ 2	Auto tuning mode 2	[Pr. PB07 Model loop gain] [Pr. PB08 Position loop gain] [Pr. PB09 Speed loop gain] [Pr. PB10 Speed integral compensation]																																	
___ 3	Manual mode	/																																	
___ 4	2 gain adjustment mode 2	[Pr. PB08 Position loop gain] [Pr. PB09 Speed loop gain] [Pr. PB10 Speed integral compensation]																																	

5. PARAMETERS

No.	Symbol	Name and function	Initial value (unit)	Setting range																																																																																								
PA09	RSP	Auto tuning response Set a response of the auto tuning. <table border="1" style="margin-top: 10px;"> <thead> <tr> <th rowspan="2">Setting value</th> <th colspan="2">Machine characteristic</th> </tr> <tr> <th>Response</th> <th>Guideline for machine resonance frequency [Hz]</th> </tr> </thead> <tbody> <tr><td>1</td><td rowspan="10">Low response</td><td>2.7</td></tr> <tr><td>2</td><td>3.6</td></tr> <tr><td>3</td><td>4.9</td></tr> <tr><td>4</td><td>6.6</td></tr> <tr><td>5</td><td>10.0</td></tr> <tr><td>6</td><td>11.3</td></tr> <tr><td>7</td><td>12.7</td></tr> <tr><td>8</td><td>14.3</td></tr> <tr><td>9</td><td>16.1</td></tr> <tr><td>10</td><td>18.1</td></tr> <tr><td>11</td><td>20.4</td></tr> <tr><td>12</td><td>23.0</td></tr> <tr><td>13</td><td>25.9</td></tr> <tr><td>14</td><td>29.2</td></tr> <tr><td>15</td><td>32.9</td></tr> <tr><td>16</td><td>37.0</td></tr> <tr><td>17</td><td>41.7</td></tr> <tr><td>18</td><td>47.0</td></tr> <tr><td>19</td><td rowspan="10">Middle response</td><td>52.9</td></tr> <tr><td>20</td><td>59.6</td></tr> <tr><td>21</td><td>67.1</td></tr> <tr><td>22</td><td>75.6</td></tr> <tr><td>23</td><td>85.2</td></tr> <tr><td>24</td><td>95.9</td></tr> <tr><td>25</td><td>108.0</td></tr> <tr><td>26</td><td>121.7</td></tr> <tr><td>27</td><td>137.1</td></tr> <tr><td>28</td><td>154.4</td></tr> <tr><td>29</td><td>173.9</td></tr> <tr><td>30</td><td>195.9</td></tr> <tr><td>31</td><td>220.6</td></tr> <tr><td>32</td><td>248.5</td></tr> <tr><td>33</td><td>279.9</td></tr> <tr><td>34</td><td>315.3</td></tr> <tr><td>35</td><td>355.1</td></tr> <tr><td>36</td><td>400.0</td></tr> <tr><td>37</td><td rowspan="4">High response</td><td>446.6</td></tr> <tr><td>38</td><td>501.2</td></tr> <tr><td>39</td><td>571.5</td></tr> <tr><td>40</td><td>642.7</td></tr> </tbody> </table>	Setting value	Machine characteristic		Response	Guideline for machine resonance frequency [Hz]	1	Low response	2.7	2	3.6	3	4.9	4	6.6	5	10.0	6	11.3	7	12.7	8	14.3	9	16.1	10	18.1	11	20.4	12	23.0	13	25.9	14	29.2	15	32.9	16	37.0	17	41.7	18	47.0	19	Middle response	52.9	20	59.6	21	67.1	22	75.6	23	85.2	24	95.9	25	108.0	26	121.7	27	137.1	28	154.4	29	173.9	30	195.9	31	220.6	32	248.5	33	279.9	34	315.3	35	355.1	36	400.0	37	High response	446.6	38	501.2	39	571.5	40	642.7	16	1 to 40
Setting value	Machine characteristic																																																																																											
	Response	Guideline for machine resonance frequency [Hz]																																																																																										
1	Low response	2.7																																																																																										
2		3.6																																																																																										
3		4.9																																																																																										
4		6.6																																																																																										
5		10.0																																																																																										
6		11.3																																																																																										
7		12.7																																																																																										
8		14.3																																																																																										
9		16.1																																																																																										
10		18.1																																																																																										
11	20.4																																																																																											
12	23.0																																																																																											
13	25.9																																																																																											
14	29.2																																																																																											
15	32.9																																																																																											
16	37.0																																																																																											
17	41.7																																																																																											
18	47.0																																																																																											
19	Middle response	52.9																																																																																										
20		59.6																																																																																										
21		67.1																																																																																										
22		75.6																																																																																										
23		85.2																																																																																										
24		95.9																																																																																										
25		108.0																																																																																										
26		121.7																																																																																										
27		137.1																																																																																										
28		154.4																																																																																										
29	173.9																																																																																											
30	195.9																																																																																											
31	220.6																																																																																											
32	248.5																																																																																											
33	279.9																																																																																											
34	315.3																																																																																											
35	355.1																																																																																											
36	400.0																																																																																											
37	High response	446.6																																																																																										
38		501.2																																																																																										
39		571.5																																																																																										
40		642.7																																																																																										
PA10	INP	In-position range Set an in-position range per command pulse.	1600 [pulse]	0 to 65535																																																																																								

5. PARAMETERS

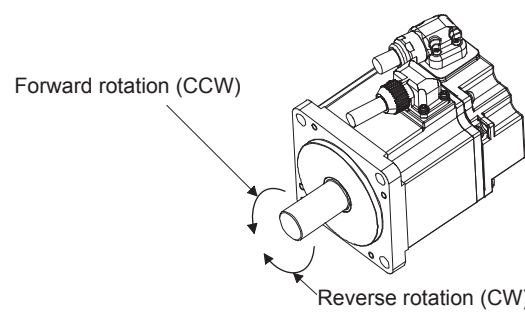
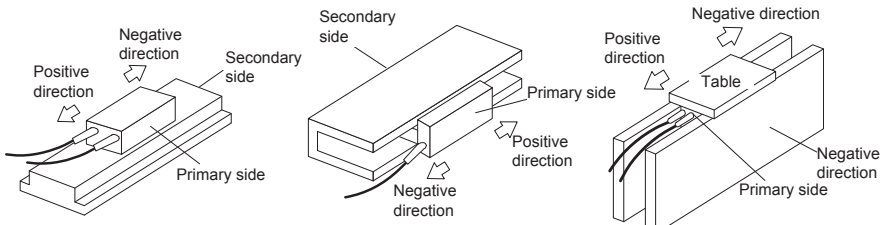
No.	Symbol	Name and function	Initial value (unit)	Setting range											
PA14	*POL	<p>Rotation direction selection/travel direction selection This is used to select a rotation direction or travel direction.</p> <table border="1" style="margin-left: 20px;"> <thead> <tr> <th rowspan="2">Setting value</th> <th colspan="2">Servo motor rotation direction/linear servo motor travel direction</th> </tr> <tr> <th>Positioning address increase</th> <th>Positioning address decrease</th> </tr> </thead> <tbody> <tr> <td>0</td> <td>CCW or positive direction</td> <td>CW or negative direction</td> </tr> <tr> <td>1</td> <td>CW or negative direction</td> <td>CCW or positive direction</td> </tr> </tbody> </table> <p>The following shows the servo motor rotation directions.</p>  <p>The positive/negative directions of the linear servo motor are as follows.</p>  <p style="text-align: center;"> LM-H3/LM-F series LM-U2 series LM-K2 series </p>	Setting value	Servo motor rotation direction/linear servo motor travel direction		Positioning address increase	Positioning address decrease	0	CCW or positive direction	CW or negative direction	1	CW or negative direction	CCW or positive direction	0	0 to 1
Setting value	Servo motor rotation direction/linear servo motor travel direction														
	Positioning address increase	Positioning address decrease													
0	CCW or positive direction	CW or negative direction													
1	CW or negative direction	CCW or positive direction													
PA15	*ENR	<p>Encoder output pulses Set the encoder output pulses from the servo amplifier by using the number of output pulses per revolution, dividing ratio, or electronic gear ratio. (after multiplication by 4) To set a numerator of the electronic gear, select "A-phase/B-phase pulse electronic gear setting (_ _ 3 _)" of "Encoder output pulse setting selection" in [Pr. PC03]. The maximum output frequency is 4.6 Mpps. Set the parameter within this range.</p>	4000 [pulse/rev]	1 to 65535											
PA16	*ENR2	<p>Encoder output pulses 2 Set a denominator of the electronic gear for the A/B-phase pulse output. To set a denominator of the electronic gear, select " A-phase/B-phase pulse electronic gear setting (_ _ 3 _)" of "Encoder output pulse setting selection" in [Pr. PC03].</p>	1	1 to 65535											

5. PARAMETERS

No.	Symbol	Name and function	Initial value (unit)	Setting range																																																																																
PA17	**MSR	<p>Servo motor series setting</p> <p>When you use a linear servo motor, select its model from [Pr. PA17] and [Pr. PA18]. Set this and [Pr. PA18] at a time.</p> <p>Refer to the following table for settings.</p> <table border="1" data-bbox="347 459 1230 1570"> <thead> <tr> <th rowspan="2">Linear servo motor series</th> <th rowspan="2">Servo motor model (primary side)</th> <th colspan="2">Parameter</th> </tr> <tr> <th>[Pr. PA17] setting</th> <th>[Pr. PA18] setting</th> </tr> </thead> <tbody> <tr> <td rowspan="9">LM-H3</td> <td>LM-H3P2A-07P-BSS0</td> <td rowspan="9">00BBh</td> <td>2101h</td> </tr> <tr> <td>LM-H3P3A-12P-CSS0</td> <td>3101h</td> </tr> <tr> <td>LM-H3P3B-24P-CSS0</td> <td>3201h</td> </tr> <tr> <td>LM-H3P3C-36P-CSS0</td> <td>3301h</td> </tr> <tr> <td>LM-H3P3D-48P-CSS0</td> <td>3401h</td> </tr> <tr> <td>LM-H3P7A-24P-ASS0</td> <td>7101h</td> </tr> <tr> <td>LM-H3P7B-48P-ASS0</td> <td>7201h</td> </tr> <tr> <td>LM-H3P7C-72P-ASS0</td> <td>7301h</td> </tr> <tr> <td>LM-H3P7D-96P-ASS0</td> <td>7401h</td> </tr> <tr> <td rowspan="9">LM-U2</td> <td>LM-U2PAB-05M-0SS0</td> <td rowspan="9">00B4h</td> <td>A201h</td> </tr> <tr> <td>LM-U2PAD-10M-0SS0</td> <td>A401h</td> </tr> <tr> <td>LM-U2PAF-15M-0SS0</td> <td>A601h</td> </tr> <tr> <td>LM-U2PBB-07M-1SS0</td> <td>B201h</td> </tr> <tr> <td>LM-U2PBD-15M-1SS0</td> <td>B401h</td> </tr> <tr> <td>LM-U2PBF-22M-1SS0</td> <td>2601h</td> </tr> <tr> <td>LM-U2P2B-40M-2SS0</td> <td>2201h</td> </tr> <tr> <td>LM-U2P2C-60M-2SS0</td> <td>2301h</td> </tr> <tr> <td>LM-U2P2D-80M-2SS0</td> <td>2401h</td> </tr> <tr> <td rowspan="8">LM-F</td> <td>LM-FP2B-06M-1SS0</td> <td rowspan="8">00B2h</td> <td>2201h</td> </tr> <tr> <td>LM-FP2D-12M-1SS0</td> <td>2401h</td> </tr> <tr> <td>LM-FP2F-18M-1SS0</td> <td>2601h</td> </tr> <tr> <td>LM-FP4B-12M-1SS0</td> <td>4201h</td> </tr> <tr> <td>LM-FP4D-24M-1SS0</td> <td>4401h</td> </tr> <tr> <td>LM-FP4F-36M-1SS0</td> <td>4601h</td> </tr> <tr> <td>LM-FP4H-48M-1SS0</td> <td>4801h</td> </tr> <tr> <td>LM-FP5H-60M-1SS0</td> <td>5801h</td> </tr> <tr> <td rowspan="7">LM-K2</td> <td>LM-K2P1A-01M-2SS1</td> <td rowspan="7">00B8h</td> <td>1101h</td> </tr> <tr> <td>LM-K2P1C-03M-2SS1</td> <td>1301h</td> </tr> <tr> <td>LM-K2P2A-02M-1SS1</td> <td>2101h</td> </tr> <tr> <td>LM-K2P2C-07M-1SS1</td> <td>2301h</td> </tr> <tr> <td>LM-K2P2E-12M-1SS1</td> <td>2501h</td> </tr> <tr> <td>LM-K2P3C-14M-1SS1</td> <td>3301h</td> </tr> <tr> <td>LM-K2P3E-24M-1SS1</td> <td>3501h</td> </tr> </tbody> </table>	Linear servo motor series	Servo motor model (primary side)	Parameter		[Pr. PA17] setting	[Pr. PA18] setting	LM-H3	LM-H3P2A-07P-BSS0	00BBh	2101h	LM-H3P3A-12P-CSS0	3101h	LM-H3P3B-24P-CSS0	3201h	LM-H3P3C-36P-CSS0	3301h	LM-H3P3D-48P-CSS0	3401h	LM-H3P7A-24P-ASS0	7101h	LM-H3P7B-48P-ASS0	7201h	LM-H3P7C-72P-ASS0	7301h	LM-H3P7D-96P-ASS0	7401h	LM-U2	LM-U2PAB-05M-0SS0	00B4h	A201h	LM-U2PAD-10M-0SS0	A401h	LM-U2PAF-15M-0SS0	A601h	LM-U2PBB-07M-1SS0	B201h	LM-U2PBD-15M-1SS0	B401h	LM-U2PBF-22M-1SS0	2601h	LM-U2P2B-40M-2SS0	2201h	LM-U2P2C-60M-2SS0	2301h	LM-U2P2D-80M-2SS0	2401h	LM-F	LM-FP2B-06M-1SS0	00B2h	2201h	LM-FP2D-12M-1SS0	2401h	LM-FP2F-18M-1SS0	2601h	LM-FP4B-12M-1SS0	4201h	LM-FP4D-24M-1SS0	4401h	LM-FP4F-36M-1SS0	4601h	LM-FP4H-48M-1SS0	4801h	LM-FP5H-60M-1SS0	5801h	LM-K2	LM-K2P1A-01M-2SS1	00B8h	1101h	LM-K2P1C-03M-2SS1	1301h	LM-K2P2A-02M-1SS1	2101h	LM-K2P2C-07M-1SS1	2301h	LM-K2P2E-12M-1SS1	2501h	LM-K2P3C-14M-1SS1	3301h	LM-K2P3E-24M-1SS1	3501h	0000h	Refer to Name and function column.
Linear servo motor series	Servo motor model (primary side)	Parameter																																																																																		
		[Pr. PA17] setting	[Pr. PA18] setting																																																																																	
LM-H3	LM-H3P2A-07P-BSS0	00BBh	2101h																																																																																	
	LM-H3P3A-12P-CSS0		3101h																																																																																	
	LM-H3P3B-24P-CSS0		3201h																																																																																	
	LM-H3P3C-36P-CSS0		3301h																																																																																	
	LM-H3P3D-48P-CSS0		3401h																																																																																	
	LM-H3P7A-24P-ASS0		7101h																																																																																	
	LM-H3P7B-48P-ASS0		7201h																																																																																	
	LM-H3P7C-72P-ASS0		7301h																																																																																	
	LM-H3P7D-96P-ASS0		7401h																																																																																	
LM-U2	LM-U2PAB-05M-0SS0	00B4h	A201h																																																																																	
	LM-U2PAD-10M-0SS0		A401h																																																																																	
	LM-U2PAF-15M-0SS0		A601h																																																																																	
	LM-U2PBB-07M-1SS0		B201h																																																																																	
	LM-U2PBD-15M-1SS0		B401h																																																																																	
	LM-U2PBF-22M-1SS0		2601h																																																																																	
	LM-U2P2B-40M-2SS0		2201h																																																																																	
	LM-U2P2C-60M-2SS0		2301h																																																																																	
	LM-U2P2D-80M-2SS0		2401h																																																																																	
LM-F	LM-FP2B-06M-1SS0	00B2h	2201h																																																																																	
	LM-FP2D-12M-1SS0		2401h																																																																																	
	LM-FP2F-18M-1SS0		2601h																																																																																	
	LM-FP4B-12M-1SS0		4201h																																																																																	
	LM-FP4D-24M-1SS0		4401h																																																																																	
	LM-FP4F-36M-1SS0		4601h																																																																																	
	LM-FP4H-48M-1SS0		4801h																																																																																	
	LM-FP5H-60M-1SS0		5801h																																																																																	
LM-K2	LM-K2P1A-01M-2SS1	00B8h	1101h																																																																																	
	LM-K2P1C-03M-2SS1		1301h																																																																																	
	LM-K2P2A-02M-1SS1		2101h																																																																																	
	LM-K2P2C-07M-1SS1		2301h																																																																																	
	LM-K2P2E-12M-1SS1		2501h																																																																																	
	LM-K2P3C-14M-1SS1		3301h																																																																																	
	LM-K2P3E-24M-1SS1		3501h																																																																																	
PA18	**MTY	<p>Servo motor type setting</p> <p>When you use a linear servo motor, select its model from [Pr. PA17] and [Pr. PA18]. Set this and [Pr. PA17] at a time.</p> <p>Refer to the table of [Pr. PA17] for settings.</p>	0000h	Refer to Name and function column of [Pr. PA17].																																																																																

5. PARAMETERS

No.	Symbol	Name and function	Initial value (unit)	Setting range				
PA19	*BLK	Parameter writing inhibit Select a reference range and writing range of the parameter. Refer to table 5.3 for settings.	00ABh	Refer to Name and function column.				
Table 5.3 [Pr. PA19] setting value and reading/writing range								
PA19	Setting operation	PA	PB	PC	PD	PE	PF	PL
Other than below	Reading	○						
	Writing	○						
000Ah	Reading	19のみ						
	Writing	19のみ						
000Bh	Reading	○	○	○				
	Writing	○	○	○				
000Ch	Reading	○	○	○	○			
	Writing	○	○	○	○			
000Fh	Reading	○	○	○	○	○		○
	Writing	○	○	○	○	○		○
00AAh	Reading	○	○	○	○	○	○	
	Writing	○	○	○	○	○	○	
00ABh (initial value)	Reading	○	○	○	○	○	○	○
	Writing	○	○	○	○	○	○	○
100Bh	Reading	○						
	Writing	Only 19						
100Ch	Reading	○	○	○	○			
	Writing	Only 19						
100Fh	Reading	○	○	○	○	○		○
	Writing	Only 19						
10AAh	Reading	○	○	○	○	○	○	
	Writing	Only 19						
10ABh	Reading	○	○	○	○	○	○	○
	Writing	Only 19						

5. PARAMETERS

No.	Symbol	Name and function	Initial value (unit)	Setting range															
PA20	*TDS	<p>Tough drive setting</p> <p>Alarms may not be avoided with the tough drive function depending on the situations of the power supply and load fluctuation.</p> <p>You can assign MTTR (During tough drive) to pins CN3-11 to CN3-13, CN3-24, and CN3-25 with [Pr. PD07] to [Pr. PD09].</p> <table border="1"> <thead> <tr> <th>Setting digit</th> <th>Explanation</th> <th>Initial value</th> </tr> </thead> <tbody> <tr> <td>___x</td> <td>For manufacturer setting</td> <td>0h</td> </tr> <tr> <td>__x_</td> <td>Vibration tough drive selection 0: Disabled 1: Enabled Selecting "1" enables to suppress vibrations by automatically changing setting values of [Pr. PB13 Machine resonance suppression filter 1] and [Pr. PB15 Machine resonance suppression filter 2] in case that the vibration exceed the value of the oscillation level set in [Pr. PF23]. Refer to section 7.3 for details.</td> <td>0h</td> </tr> <tr> <td>_x__</td> <td>Instantaneous power failure tough drive selection 0: Disabled 1: Enabled Selecting "1" enables to avoid generating [AL. 10 Undervoltage] using the electrical energy charged in the capacitor in case that an instantaneous power failure occurs during operation. Set the time of until [AL. 10 Undervoltage] occurs in [Pr. PF25 Instantaneous power failure tough drive - Detection time].</td> <td>0h</td> </tr> <tr> <td>x___</td> <td>For manufacturer setting</td> <td>0h</td> </tr> </tbody> </table>	Setting digit	Explanation	Initial value	___x	For manufacturer setting	0h	__x_	Vibration tough drive selection 0: Disabled 1: Enabled Selecting "1" enables to suppress vibrations by automatically changing setting values of [Pr. PB13 Machine resonance suppression filter 1] and [Pr. PB15 Machine resonance suppression filter 2] in case that the vibration exceed the value of the oscillation level set in [Pr. PF23]. Refer to section 7.3 for details.	0h	_x__	Instantaneous power failure tough drive selection 0: Disabled 1: Enabled Selecting "1" enables to avoid generating [AL. 10 Undervoltage] using the electrical energy charged in the capacitor in case that an instantaneous power failure occurs during operation. Set the time of until [AL. 10 Undervoltage] occurs in [Pr. PF25 Instantaneous power failure tough drive - Detection time].	0h	x___	For manufacturer setting	0h	Refer to Name and function column.	
Setting digit	Explanation	Initial value																	
___x	For manufacturer setting	0h																	
__x_	Vibration tough drive selection 0: Disabled 1: Enabled Selecting "1" enables to suppress vibrations by automatically changing setting values of [Pr. PB13 Machine resonance suppression filter 1] and [Pr. PB15 Machine resonance suppression filter 2] in case that the vibration exceed the value of the oscillation level set in [Pr. PF23]. Refer to section 7.3 for details.	0h																	
_x__	Instantaneous power failure tough drive selection 0: Disabled 1: Enabled Selecting "1" enables to avoid generating [AL. 10 Undervoltage] using the electrical energy charged in the capacitor in case that an instantaneous power failure occurs during operation. Set the time of until [AL. 10 Undervoltage] occurs in [Pr. PF25 Instantaneous power failure tough drive - Detection time].	0h																	
x___	For manufacturer setting	0h																	
PA21	*AOP3	<p>Function selection A-3</p> <table border="1"> <thead> <tr> <th>Setting digit</th> <th>Explanation</th> <th>Initial value</th> </tr> </thead> <tbody> <tr> <td>___x</td> <td>One-touch tuning function selection 0: Disabled 1: Enabled When the digit is "0", the one-touch tuning with MR Configurator2 will be disabled.</td> <td>1h</td> </tr> <tr> <td>__x_</td> <td>For manufacturer setting</td> <td>0h</td> </tr> <tr> <td>_x__</td> <td></td> <td>0h</td> </tr> <tr> <td>x___</td> <td></td> <td>0h</td> </tr> </tbody> </table>	Setting digit	Explanation	Initial value	___x	One-touch tuning function selection 0: Disabled 1: Enabled When the digit is "0", the one-touch tuning with MR Configurator2 will be disabled.	1h	__x_	For manufacturer setting	0h	_x__		0h	x___		0h	Refer to Name and function column.	
Setting digit	Explanation	Initial value																	
___x	One-touch tuning function selection 0: Disabled 1: Enabled When the digit is "0", the one-touch tuning with MR Configurator2 will be disabled.	1h																	
__x_	For manufacturer setting	0h																	
_x__		0h																	
x___		0h																	

5. PARAMETERS

No.	Symbol	Name and function	Initial value (unit)	Setting range													
PA23	DRAT	Drive recorder arbitrary alarm trigger setting <table border="1" data-bbox="347 405 1230 752"> <thead> <tr> <th>Setting digit</th> <th>Explanation</th> <th>Initial value</th> </tr> </thead> <tbody> <tr> <td>__ x x</td> <td> Alarm detail No. setting Set the digits when you execute the trigger with arbitrary alarm detail No. for the drive recorder function. When these digits are "0 0", only the arbitrary alarm No. setting will be enabled. </td> <td>00h</td> </tr> <tr> <td>x x __</td> <td> Alarm No. setting Set the digits when you execute the trigger with arbitrary alarm No. for the drive recorder function. When "0 0" are set, arbitrary alarm trigger of the drive recorder will be disabled. </td> <td>00h</td> </tr> </tbody> </table> <p>Setting example: To activate the drive recorder when [AL. 50 Overload 1] occurs, set "5 0 0 0". To activate the drive recorder when [AL. 50.3 Thermal overload error 4 during operation] occurs, set "5 0 0 3".</p>	Setting digit	Explanation	Initial value	__ x x	Alarm detail No. setting Set the digits when you execute the trigger with arbitrary alarm detail No. for the drive recorder function. When these digits are "0 0", only the arbitrary alarm No. setting will be enabled.	00h	x x __	Alarm No. setting Set the digits when you execute the trigger with arbitrary alarm No. for the drive recorder function. When "0 0" are set, arbitrary alarm trigger of the drive recorder will be disabled.	00h	Refer to Name and function column.					
Setting digit	Explanation	Initial value															
__ x x	Alarm detail No. setting Set the digits when you execute the trigger with arbitrary alarm detail No. for the drive recorder function. When these digits are "0 0", only the arbitrary alarm No. setting will be enabled.	00h															
x x __	Alarm No. setting Set the digits when you execute the trigger with arbitrary alarm No. for the drive recorder function. When "0 0" are set, arbitrary alarm trigger of the drive recorder will be disabled.	00h															
PA24	AOP4	Function selection A-4 <table border="1" data-bbox="347 983 1230 1541"> <thead> <tr> <th>Setting digit</th> <th>Explanation</th> <th>Initial value</th> </tr> </thead> <tbody> <tr> <td>___ x</td> <td> Vibration suppression mode selection 0: Standard mode 1: 3 inertia mode 2: Low response mode When two low resonance frequencies are generated, select "3 inertia mode (___ 1)". When the load to motor inertia ratio exceeds the recommended load to motor inertia ratio, select "Low response mode (___ 2)". When you select the standard mode or low response mode, "Vibration suppression control 2" is not available. When you select the 3 inertia mode, the feed forward gain is not available. Before changing the control mode with the controller during the 3 inertia mode or low response mode, stop the motor. </td> <td>0h</td> </tr> <tr> <td>__ x _</td> <td rowspan="3">For manufacturer setting</td> <td>0h</td> </tr> <tr> <td>_ x __</td> <td>0h</td> </tr> <tr> <td>x ___</td> <td>0h</td> </tr> </tbody> </table>	Setting digit	Explanation	Initial value	___ x	Vibration suppression mode selection 0: Standard mode 1: 3 inertia mode 2: Low response mode When two low resonance frequencies are generated, select "3 inertia mode (___ 1)". When the load to motor inertia ratio exceeds the recommended load to motor inertia ratio, select "Low response mode (___ 2)". When you select the standard mode or low response mode, "Vibration suppression control 2" is not available. When you select the 3 inertia mode, the feed forward gain is not available. Before changing the control mode with the controller during the 3 inertia mode or low response mode, stop the motor.	0h	__ x _	For manufacturer setting	0h	_ x __	0h	x ___	0h	Refer to Name and function column.	
Setting digit	Explanation	Initial value															
___ x	Vibration suppression mode selection 0: Standard mode 1: 3 inertia mode 2: Low response mode When two low resonance frequencies are generated, select "3 inertia mode (___ 1)". When the load to motor inertia ratio exceeds the recommended load to motor inertia ratio, select "Low response mode (___ 2)". When you select the standard mode or low response mode, "Vibration suppression control 2" is not available. When you select the 3 inertia mode, the feed forward gain is not available. Before changing the control mode with the controller during the 3 inertia mode or low response mode, stop the motor.	0h															
__ x _	For manufacturer setting	0h															
_ x __		0h															
x ___		0h															

5. PARAMETERS

5.2.2 Gain/filter setting parameters ([Pr. PB__])

No.	Symbol	Name and function	Initial value (unit)	Setting range														
PB01	FILT	Adaptive tuning mode (adaptive filter II) Set the adaptive filter tuning. <table border="1" data-bbox="347 465 1230 797"> <thead> <tr> <th>Setting digit</th> <th>Explanation</th> <th>Initial value</th> </tr> </thead> <tbody> <tr> <td>___x</td> <td> Filter tuning mode selection Select the adjustment mode of the machine resonance suppression filter 1. Refer to section 7.1.2 for details. 0: Disabled 1: Automatic setting 2: Manual setting </td> <td>0h</td> </tr> <tr> <td>__x_</td> <td rowspan="3">For manufacturer setting</td> <td>0h</td> </tr> <tr> <td>_x__</td> <td>0h</td> </tr> <tr> <td>x___</td> <td>0h</td> </tr> </tbody> </table>	Setting digit	Explanation	Initial value	___x	Filter tuning mode selection Select the adjustment mode of the machine resonance suppression filter 1. Refer to section 7.1.2 for details. 0: Disabled 1: Automatic setting 2: Manual setting	0h	__x_	For manufacturer setting	0h	_x__	0h	x___	0h	Refer to Name and function column.		
Setting digit	Explanation	Initial value																
___x	Filter tuning mode selection Select the adjustment mode of the machine resonance suppression filter 1. Refer to section 7.1.2 for details. 0: Disabled 1: Automatic setting 2: Manual setting	0h																
__x_	For manufacturer setting	0h																
_x__		0h																
x___		0h																
PB02	VRFT	Vibration suppression control tuning mode (advanced vibration suppression control II) This is used to set the vibration suppression control tuning. Refer to section 7.1.5 for details. <table border="1" data-bbox="347 913 1230 1391"> <thead> <tr> <th>Setting digit</th> <th>Explanation</th> <th>Initial value</th> </tr> </thead> <tbody> <tr> <td>___x</td> <td> Vibration suppression control 1 tuning mode selection Select the tuning mode of the vibration suppression control 1. 0: Disabled 1: Automatic setting 2: Manual setting </td> <td>0h</td> </tr> <tr> <td>__x_</td> <td> Vibration suppression control 2 tuning mode selection Select the tuning mode of the vibration suppression control 2. To enable the digit, select "3 inertia mode (_ __ 1)" of "Vibration suppression mode selection" in [Pr. PA24 Function selection A-4]. 0: Disabled 1: Automatic setting 2: Manual setting </td> <td>0h</td> </tr> <tr> <td>_x__</td> <td rowspan="2">For manufacturer setting</td> <td>0h</td> </tr> <tr> <td>x___</td> <td>0h</td> </tr> </tbody> </table>	Setting digit	Explanation	Initial value	___x	Vibration suppression control 1 tuning mode selection Select the tuning mode of the vibration suppression control 1. 0: Disabled 1: Automatic setting 2: Manual setting	0h	__x_	Vibration suppression control 2 tuning mode selection Select the tuning mode of the vibration suppression control 2. To enable the digit, select "3 inertia mode (_ __ 1)" of "Vibration suppression mode selection" in [Pr. PA24 Function selection A-4]. 0: Disabled 1: Automatic setting 2: Manual setting	0h	_x__	For manufacturer setting	0h	x___	0h	Refer to Name and function column.	
Setting digit	Explanation	Initial value																
___x	Vibration suppression control 1 tuning mode selection Select the tuning mode of the vibration suppression control 1. 0: Disabled 1: Automatic setting 2: Manual setting	0h																
__x_	Vibration suppression control 2 tuning mode selection Select the tuning mode of the vibration suppression control 2. To enable the digit, select "3 inertia mode (_ __ 1)" of "Vibration suppression mode selection" in [Pr. PA24 Function selection A-4]. 0: Disabled 1: Automatic setting 2: Manual setting	0h																
_x__	For manufacturer setting	0h																
x___		0h																
PB03	TFBGN	Torque feedback loop gain This is used to set a torque feedback loop gain in the continuous operation to torque control mode. Decreasing the setting value will also decrease a collision load during continuous operation to torque control mode. Setting a value less than 6 rad/s will be 6 rad/s.	18000 [rad/s]	0 to 18000														
PB04	FFC	Feed forward gain Set the feed forward gain. When the setting is 100%, the droop pulses during operation at constant speed are nearly zero. However, sudden acceleration/deceleration will increase the overshoot. As a guideline, when the feed forward gain setting is 100%, set 1 s or more as the acceleration time constant up to the rated speed.	0 [%]	0 to 100														

5. PARAMETERS

No.	Symbol	Name and function	Initial value (unit)	Setting range										
PB06	GD2	<p>Load to motor inertia ratio/load to motor mass ratio This is used to set the load to motor inertia ratio or load to motor mass ratio. The setting of the parameter will be the automatic setting or manual setting depending on the [Pr. PA08] setting. Refer to the following table for details. When the parameter is automatic setting, the value will vary between 0.00 and 100.00.</p> <table border="1"> <thead> <tr> <th>Pr.PA08</th> <th>This parameter</th> </tr> </thead> <tbody> <tr> <td>___ 0 (2 gain adjustment mode 1 (interpolation mode))</td> <td rowspan="2">Automatic setting</td> </tr> <tr> <td>___ 1: (Auto tuning mode 1)</td> </tr> <tr> <td>___ 2: (Auto tuning mode 2)</td> <td rowspan="3">Manual setting</td> </tr> <tr> <td>___ 3 (Manual mode)</td> </tr> <tr> <td>___ 4: (2 gain adjustment mode 2)</td> </tr> </tbody> </table>	Pr.PA08	This parameter	___ 0 (2 gain adjustment mode 1 (interpolation mode))	Automatic setting	___ 1: (Auto tuning mode 1)	___ 2: (Auto tuning mode 2)	Manual setting	___ 3 (Manual mode)	___ 4: (2 gain adjustment mode 2)	7.00 Multiplier (×1)	0.00 to 300.00	
Pr.PA08	This parameter													
___ 0 (2 gain adjustment mode 1 (interpolation mode))	Automatic setting													
___ 1: (Auto tuning mode 1)														
___ 2: (Auto tuning mode 2)	Manual setting													
___ 3 (Manual mode)														
___ 4: (2 gain adjustment mode 2)														
PB07	PG1	<p>Model loop gain Set the response gain up to the target position. Increasing the setting value will also increase the response level to the position command but will be liable to generate vibration and/or noise. The setting of the parameter will be the automatic setting or manual setting depending on the [Pr. PA08] setting. Refer to the following table for details.</p> <table border="1"> <thead> <tr> <th>Pr.PA08</th> <th>This parameter</th> </tr> </thead> <tbody> <tr> <td>___ 0 (2 gain adjustment mode 1 (interpolation mode))</td> <td>Manual setting</td> </tr> <tr> <td>___ 1: (Auto tuning mode 1)</td> <td rowspan="2">Automatic setting</td> </tr> <tr> <td>___ 2: (Auto tuning mode 2)</td> </tr> <tr> <td>___ 3 (Manual mode)</td> <td rowspan="2">Manual setting</td> </tr> <tr> <td>___ 4: (2 gain adjustment mode 2)</td> </tr> </tbody> </table>	Pr.PA08	This parameter	___ 0 (2 gain adjustment mode 1 (interpolation mode))	Manual setting	___ 1: (Auto tuning mode 1)	Automatic setting	___ 2: (Auto tuning mode 2)	___ 3 (Manual mode)	Manual setting	___ 4: (2 gain adjustment mode 2)	15.0 [rad/s]	1.0 to 2000.0
Pr.PA08	This parameter													
___ 0 (2 gain adjustment mode 1 (interpolation mode))	Manual setting													
___ 1: (Auto tuning mode 1)	Automatic setting													
___ 2: (Auto tuning mode 2)														
___ 3 (Manual mode)	Manual setting													
___ 4: (2 gain adjustment mode 2)														
PB08	PG2	<p>Position loop gain This is used to set the gain of the position loop. Set this parameter to increase the position response to level load disturbance. Increasing the setting value will also increase the response level to the load disturbance but will be liable to generate vibration and/or noise. The setting of the parameter will be the automatic setting or manual setting depending on the [Pr. PA08] setting. Refer to the following table for details.</p> <table border="1"> <thead> <tr> <th>Pr.PA08</th> <th>This parameter</th> </tr> </thead> <tbody> <tr> <td>___ 0 (2 gain adjustment mode 1 (interpolation mode))</td> <td rowspan="2">Automatic setting</td> </tr> <tr> <td>___ 1: (Auto tuning mode 1)</td> </tr> <tr> <td>___ 2: (Auto tuning mode 2)</td> <td rowspan="3">Manual setting</td> </tr> <tr> <td>___ 3 (Manual mode)</td> </tr> <tr> <td>___ 4: (2 gain adjustment mode 2)</td> </tr> </tbody> </table>	Pr.PA08	This parameter	___ 0 (2 gain adjustment mode 1 (interpolation mode))	Automatic setting	___ 1: (Auto tuning mode 1)	___ 2: (Auto tuning mode 2)	Manual setting	___ 3 (Manual mode)	___ 4: (2 gain adjustment mode 2)	37.0 [rad/s]	1.0 to 2000.0	
Pr.PA08	This parameter													
___ 0 (2 gain adjustment mode 1 (interpolation mode))	Automatic setting													
___ 1: (Auto tuning mode 1)														
___ 2: (Auto tuning mode 2)	Manual setting													
___ 3 (Manual mode)														
___ 4: (2 gain adjustment mode 2)														
PB09	VG2	<p>Speed loop gain This is used to set the gain of the speed loop. Set this parameter when vibration occurs on machines of low rigidity or large backlash. Increasing the setting value will also increase the response level but will be liable to generate vibration and/or noise. The setting of the parameter will be the automatic setting or manual setting depending on the [Pr. PA08] setting. Refer to the table of [Pr. PB08] for details.</p>	823 [rad/s]	20 to 65535										
PB10	VIC	<p>Speed integral compensation This is used to set the integral time constant of the speed loop. Decreasing the setting value will increase the response level but will be liable to generate vibration and/or noise. The setting of the parameter will be the automatic setting or manual setting depending on the [Pr. PA08] setting. Refer to the table of [Pr. PB08] for details.</p>	33.7 [ms]	0.1 to 1000.0										

5. PARAMETERS

No.	Symbol	Name and function	Initial value (unit)	Setting range														
PB11	VDC	Speed differential compensation This is used to set the differential compensation. To enable the parameter, select "Continuous PID control enabled (_ _ 3 _)" of "PI-PID switching control selection" in [Pr. PB24].	980	0 to 1000														
PB12	OVA	Overshoot amount compensation This is used to set a viscous friction torque or thrust to rated torque in percentage unit at servo motor rated speed or linear servo motor rated speed. When the response level is low or when the torque/thrust is limited, the efficiency of the parameter may be lower.	0 [%]	0 to 100														
PB13	NH1	Machine resonance suppression filter 1 Set the notch frequency of the machine resonance suppression filter 1. When you select "Automatic setting (_ _ _ 1)" of "Filter tuning mode selection" in [Pr. PB01], this parameter will be adjusted automatically. When you select "Manual setting (_ _ _ 2)" of "Filter tuning mode selection" in [Pr. PB01], the setting value will be enabled.	4500 [Hz]	10 to 4500														
PB14	NHQ1	Notch shape selection 1 Set the shape of the machine resonance suppression filter 1. When you select "Automatic setting (_ _ _ 1)" of "Filter tuning mode selection" in [Pr. PB01], this parameter will be adjusted automatically. Set manually for the manual setting. <table border="1" data-bbox="347 920 1230 1346"> <thead> <tr> <th>Setting digit</th> <th>Explanation</th> <th>Initial value</th> </tr> </thead> <tbody> <tr> <td>_ _ _ x</td> <td>For manufacturer setting</td> <td>0h</td> </tr> <tr> <td>_ _ x _</td> <td>Notch depth selection 0: -40 dB 1: -14 dB 2: -8 dB 3: -4 dB</td> <td>0h</td> </tr> <tr> <td>_ x _ _</td> <td>Notch width selection 0: $\alpha = 2$ 1: $\alpha = 3$ 2: $\alpha = 4$ 3: $\alpha = 5$</td> <td>0h</td> </tr> <tr> <td>x _ _ _</td> <td>For manufacturer setting</td> <td>0h</td> </tr> </tbody> </table>	Setting digit	Explanation	Initial value	_ _ _ x	For manufacturer setting	0h	_ _ x _	Notch depth selection 0: -40 dB 1: -14 dB 2: -8 dB 3: -4 dB	0h	_ x _ _	Notch width selection 0: $\alpha = 2$ 1: $\alpha = 3$ 2: $\alpha = 4$ 3: $\alpha = 5$	0h	x _ _ _	For manufacturer setting	0h	Refer to Name and function column.
Setting digit	Explanation	Initial value																
_ _ _ x	For manufacturer setting	0h																
_ _ x _	Notch depth selection 0: -40 dB 1: -14 dB 2: -8 dB 3: -4 dB	0h																
_ x _ _	Notch width selection 0: $\alpha = 2$ 1: $\alpha = 3$ 2: $\alpha = 4$ 3: $\alpha = 5$	0h																
x _ _ _	For manufacturer setting	0h																
PB15	NH2	Machine resonance suppression filter 2 Set the notch frequency of the machine resonance suppression filter 2. To enable the setting value, select "Enabled (_ _ _ 1)" of "Machine resonance suppression filter 2 selection" in [Pr. PB16].	4500 [Hz]	10 to 4500														

5. PARAMETERS

No.	Symbol	Name and function	Initial value (unit)	Setting range															
PB16	NHQ2	<p>Notch shape selection 2 Set the shape of the machine resonance suppression filter 2.</p> <table border="1"> <thead> <tr> <th>Setting digit</th> <th>Explanation</th> <th>Initial value</th> </tr> </thead> <tbody> <tr> <td>___x</td> <td>Machine resonance suppression filter 2 selection 0: Disabled 1: Enabled</td> <td>0h</td> </tr> <tr> <td>__x_</td> <td>Notch depth selection 0: -40 dB 1: -14 dB 2: -8 dB 3: -4 dB</td> <td>0h</td> </tr> <tr> <td>_x__</td> <td>Notch width selection 0: $\alpha = 2$ 1: $\alpha = 3$ 2: $\alpha = 4$ 3: $\alpha = 5$</td> <td>0h</td> </tr> <tr> <td>x___</td> <td>For manufacturer setting</td> <td>0h</td> </tr> </tbody> </table>	Setting digit	Explanation	Initial value	___x	Machine resonance suppression filter 2 selection 0: Disabled 1: Enabled	0h	__x_	Notch depth selection 0: -40 dB 1: -14 dB 2: -8 dB 3: -4 dB	0h	_x__	Notch width selection 0: $\alpha = 2$ 1: $\alpha = 3$ 2: $\alpha = 4$ 3: $\alpha = 5$	0h	x___	For manufacturer setting	0h	Refer to Name and function column.	
Setting digit	Explanation	Initial value																	
___x	Machine resonance suppression filter 2 selection 0: Disabled 1: Enabled	0h																	
__x_	Notch depth selection 0: -40 dB 1: -14 dB 2: -8 dB 3: -4 dB	0h																	
_x__	Notch width selection 0: $\alpha = 2$ 1: $\alpha = 3$ 2: $\alpha = 4$ 3: $\alpha = 5$	0h																	
x___	For manufacturer setting	0h																	
PB17	NHF	<p>Shaft resonance suppression filter This is used for setting the shaft resonance suppression filter. This is used to suppress a low-frequency machine vibration. When you select "Automatic setting (___0)" of "Shaft resonance suppression filter selection" in [Pr. PB23], the value will be calculated automatically from the servo motor you use and load to motor inertia ratio/load to motor mass ratio. Set manually for "Manual setting (___1)". When "Shaft resonance suppression filter selection" is "Disabled (___2)" in [Pr. PB23], the setting value of this parameter will be disabled. When you select "Enabled (___1)" of "Machine resonance suppression filter 4 selection" in [Pr. PB49], the shaft resonance suppression filter is not available.</p> <table border="1"> <thead> <tr> <th>Setting digit</th> <th>Explanation</th> <th>Initial value</th> </tr> </thead> <tbody> <tr> <td>__xx</td> <td>Shaft resonance suppression filter setting frequency selection This is used for setting the shaft resonance suppression filter. Refer to table 5.4 for settings. Set the value closest to the frequency you need.</td> <td>00h</td> </tr> <tr> <td>_x__</td> <td>Notch depth selection 0: -40 dB 1: -14 dB 2: -8 dB 3: -4 dB</td> <td>0h</td> </tr> <tr> <td>x___</td> <td>For manufacturer setting</td> <td>0h</td> </tr> </tbody> </table>	Setting digit	Explanation	Initial value	__xx	Shaft resonance suppression filter setting frequency selection This is used for setting the shaft resonance suppression filter. Refer to table 5.4 for settings. Set the value closest to the frequency you need.	00h	_x__	Notch depth selection 0: -40 dB 1: -14 dB 2: -8 dB 3: -4 dB	0h	x___	For manufacturer setting	0h	Refer to Name and function column.				
Setting digit	Explanation	Initial value																	
__xx	Shaft resonance suppression filter setting frequency selection This is used for setting the shaft resonance suppression filter. Refer to table 5.4 for settings. Set the value closest to the frequency you need.	00h																	
_x__	Notch depth selection 0: -40 dB 1: -14 dB 2: -8 dB 3: -4 dB	0h																	
x___	For manufacturer setting	0h																	

5. PARAMETERS

No.	Symbol	Name and function	Initial value (unit)	Setting range																																																																				
PB17	NHF	<p>Table 5.4 Shaft resonance suppression filter setting frequency selection</p> <table border="1"> <thead> <tr> <th>Setting value</th> <th>Frequency [Hz]</th> <th>Setting value</th> <th>Frequency [Hz]</th> </tr> </thead> <tbody> <tr><td>00</td><td>Disabled</td><td>10</td><td>562</td></tr> <tr><td>01</td><td>Disabled</td><td>11</td><td>529</td></tr> <tr><td>02</td><td>4500</td><td>12</td><td>500</td></tr> <tr><td>03</td><td>3000</td><td>13</td><td>473</td></tr> <tr><td>04</td><td>2250</td><td>14</td><td>450</td></tr> <tr><td>05</td><td>1800</td><td>15</td><td>428</td></tr> <tr><td>06</td><td>1500</td><td>16</td><td>409</td></tr> <tr><td>07</td><td>1285</td><td>17</td><td>391</td></tr> <tr><td>08</td><td>1125</td><td>18</td><td>375</td></tr> <tr><td>09</td><td>1000</td><td>19</td><td>360</td></tr> <tr><td>0A</td><td>900</td><td>1A</td><td>346</td></tr> <tr><td>0B</td><td>818</td><td>1B</td><td>333</td></tr> <tr><td>0C</td><td>750</td><td>1C</td><td>321</td></tr> <tr><td>0D</td><td>692</td><td>1D</td><td>310</td></tr> <tr><td>0E</td><td>642</td><td>1E</td><td>300</td></tr> <tr><td>0F</td><td>600</td><td>1F</td><td>290</td></tr> </tbody> </table>	Setting value	Frequency [Hz]	Setting value	Frequency [Hz]	00	Disabled	10	562	01	Disabled	11	529	02	4500	12	500	03	3000	13	473	04	2250	14	450	05	1800	15	428	06	1500	16	409	07	1285	17	391	08	1125	18	375	09	1000	19	360	0A	900	1A	346	0B	818	1B	333	0C	750	1C	321	0D	692	1D	310	0E	642	1E	300	0F	600	1F	290	Refer to Name and function column.	
Setting value	Frequency [Hz]	Setting value	Frequency [Hz]																																																																					
00	Disabled	10	562																																																																					
01	Disabled	11	529																																																																					
02	4500	12	500																																																																					
03	3000	13	473																																																																					
04	2250	14	450																																																																					
05	1800	15	428																																																																					
06	1500	16	409																																																																					
07	1285	17	391																																																																					
08	1125	18	375																																																																					
09	1000	19	360																																																																					
0A	900	1A	346																																																																					
0B	818	1B	333																																																																					
0C	750	1C	321																																																																					
0D	692	1D	310																																																																					
0E	642	1E	300																																																																					
0F	600	1F	290																																																																					
PB18	LPF	<p>Low-pass filter setting Set the low-pass filter. The following shows a relation of a required parameter to this parameter.</p> <table border="1"> <thead> <tr> <th>[Pr. PB23]</th> <th>[Pr. PB18]</th> </tr> </thead> <tbody> <tr> <td>__ 0 __ (Initial value)</td> <td>Automatic setting</td> </tr> <tr> <td>__ 1 __</td> <td>Setting value enabled</td> </tr> <tr> <td>__ 2 __</td> <td>Setting value disabled</td> </tr> </tbody> </table>	[Pr. PB23]	[Pr. PB18]	__ 0 __ (Initial value)	Automatic setting	__ 1 __	Setting value enabled	__ 2 __	Setting value disabled	3141 [rad/s]	100 to 18000																																																												
[Pr. PB23]	[Pr. PB18]																																																																							
__ 0 __ (Initial value)	Automatic setting																																																																							
__ 1 __	Setting value enabled																																																																							
__ 2 __	Setting value disabled																																																																							
PB19	VRF11	<p>Vibration suppression control 1 - Vibration frequency Set the vibration frequency for vibration suppression control 1 to suppress low-frequency machine vibration. When "Vibration suppression control 1 tuning mode selection" is "Automatic setting (___ 1)" in [Pr. PB02], this parameter will be set automatically. Set manually for "Manual setting (___ 2)". Refer to section 7.1.5 for details.</p>	100.0 [Hz]	0.1 to 300.0																																																																				
PB20	VRF12	<p>Vibration suppression control 1 - Resonance frequency Set the resonance frequency for vibration suppression control 1 to suppress low-frequency machine vibration. When "Vibration suppression control 1 tuning mode selection" is "Automatic setting (___ 1)" in [Pr. PB02], this parameter will be set automatically. Set manually for "Manual setting (___ 2)". Refer to section 7.1.5 for details.</p>	100.0 [Hz]	0.1 to 300.0																																																																				
PB21	VRF13	<p>Vibration suppression control 1 - Vibration frequency damping Set a damping of the vibration frequency for vibration suppression control 1 to suppress low-frequency machine vibration. When "Vibration suppression control 1 tuning mode selection" is "Automatic setting (___ 1)" in [Pr. PB02], this parameter will be set automatically. Set manually for "Manual setting (___ 2)". Refer to section 7.1.5 for details.</p>	0.00	0.00 to 0.30																																																																				
PB22	VRF14	<p>Vibration suppression control 1 - Resonance frequency damping Set a damping of the resonance frequency for vibration suppression control 1 to suppress low-frequency machine vibration. When "Vibration suppression control 1 tuning mode selection" is "Automatic setting (___ 1)" in [Pr. PB02], this parameter will be set automatically. Set manually for "Manual setting (___ 2)". Refer to section 7.1.5 for details.</p>	0.00	0.00 to 0.30																																																																				

5. PARAMETERS

No.	Symbol	Name and function	Initial value (unit)	Setting range															
PB23	VFBF	Low-pass filter selection Select the shaft resonance suppression filter and low-pass filter. <table border="1" data-bbox="422 398 1230 853"> <thead> <tr> <th>Setting digit</th> <th>Explanation</th> <th>Initial value</th> </tr> </thead> <tbody> <tr> <td>___x</td> <td> Shaft resonance suppression filter selection 0: Automatic setting 1: Manual setting 2: Disabled When you select "Enabled (___1)" of "Machine resonance suppression filter 4 selection" in [Pr. PB49], the shaft resonance suppression filter is not available. </td> <td>0h</td> </tr> <tr> <td>__x_</td> <td> Low-pass filter selection 0: Automatic setting 1: Manual setting 2: Disabled </td> <td>0h</td> </tr> <tr> <td>_x__</td> <td>For manufacturer setting</td> <td>0h</td> </tr> <tr> <td>x___</td> <td></td> <td>0h</td> </tr> </tbody> </table>	Setting digit	Explanation	Initial value	___x	Shaft resonance suppression filter selection 0: Automatic setting 1: Manual setting 2: Disabled When you select "Enabled (___1)" of "Machine resonance suppression filter 4 selection" in [Pr. PB49], the shaft resonance suppression filter is not available.	0h	__x_	Low-pass filter selection 0: Automatic setting 1: Manual setting 2: Disabled	0h	_x__	For manufacturer setting	0h	x___		0h	Refer to Name and function column.	
Setting digit	Explanation	Initial value																	
___x	Shaft resonance suppression filter selection 0: Automatic setting 1: Manual setting 2: Disabled When you select "Enabled (___1)" of "Machine resonance suppression filter 4 selection" in [Pr. PB49], the shaft resonance suppression filter is not available.	0h																	
__x_	Low-pass filter selection 0: Automatic setting 1: Manual setting 2: Disabled	0h																	
_x__	For manufacturer setting	0h																	
x___		0h																	
PB24	*MVS	Slight vibration suppression control Select the slight vibration suppression control and PI-PID switching control. <table border="1" data-bbox="422 965 1230 1440"> <thead> <tr> <th>Setting digit</th> <th>Explanation</th> <th>Initial value</th> </tr> </thead> <tbody> <tr> <td>___x</td> <td> Slight vibration suppression control selection 0: Disabled 1: Enabled To enable the slight vibration suppression control, select "Manual mode (___3)" of "Gain adjustment mode selection" in [Pr. PA08]. Slight vibration suppression control cannot be used in the speed control mode. </td> <td>0h</td> </tr> <tr> <td>__x_</td> <td> PI-PID switching control selection 0: PI control enabled (Switching to PID control is possible with commands of controller.) 3: Continuous PID control enabled </td> <td>0h</td> </tr> <tr> <td>_x__</td> <td>For manufacturer setting</td> <td>0h</td> </tr> <tr> <td>x___</td> <td></td> <td>0h</td> </tr> </tbody> </table>	Setting digit	Explanation	Initial value	___x	Slight vibration suppression control selection 0: Disabled 1: Enabled To enable the slight vibration suppression control, select "Manual mode (___3)" of "Gain adjustment mode selection" in [Pr. PA08]. Slight vibration suppression control cannot be used in the speed control mode.	0h	__x_	PI-PID switching control selection 0: PI control enabled (Switching to PID control is possible with commands of controller.) 3: Continuous PID control enabled	0h	_x__	For manufacturer setting	0h	x___		0h	Refer to Name and function column.	
Setting digit	Explanation	Initial value																	
___x	Slight vibration suppression control selection 0: Disabled 1: Enabled To enable the slight vibration suppression control, select "Manual mode (___3)" of "Gain adjustment mode selection" in [Pr. PA08]. Slight vibration suppression control cannot be used in the speed control mode.	0h																	
__x_	PI-PID switching control selection 0: PI control enabled (Switching to PID control is possible with commands of controller.) 3: Continuous PID control enabled	0h																	
_x__	For manufacturer setting	0h																	
x___		0h																	

5. PARAMETERS

No.	Symbol	Name and function	Initial value (unit)	Setting range														
PB26	*CDP	Gain switching function Select the gain switching condition. Set conditions to enable the gain switching values set in [Pr. PB29] to [Pr. PB36] and [Pr. PB56] to [Pr. PB60]. <table border="1" data-bbox="347 461 1230 909"> <thead> <tr> <th>Setting digit</th> <th>Explanation</th> <th>Initial value</th> </tr> </thead> <tbody> <tr> <td>___x</td> <td>Gain switching selection 0: Disabled 1: Control command from controller is enabled 2: Command frequency 3: Droop pulses 4: Servo motor speed/linear servo motor speed</td> <td>0h</td> </tr> <tr> <td>__x_</td> <td>Gain switching condition selection 0: Gain after switching is enabled with gain switching condition or more 1: Gain after switching is enabled with gain switching condition or less</td> <td>0h</td> </tr> <tr> <td>_x__</td> <td rowspan="2">For manufacturer setting</td> <td>0h</td> </tr> <tr> <td>x___</td> <td>0h</td> </tr> </tbody> </table>	Setting digit	Explanation	Initial value	___x	Gain switching selection 0: Disabled 1: Control command from controller is enabled 2: Command frequency 3: Droop pulses 4: Servo motor speed/linear servo motor speed	0h	__x_	Gain switching condition selection 0: Gain after switching is enabled with gain switching condition or more 1: Gain after switching is enabled with gain switching condition or less	0h	_x__	For manufacturer setting	0h	x___	0h	Refer to Name and function column.	
Setting digit	Explanation	Initial value																
___x	Gain switching selection 0: Disabled 1: Control command from controller is enabled 2: Command frequency 3: Droop pulses 4: Servo motor speed/linear servo motor speed	0h																
__x_	Gain switching condition selection 0: Gain after switching is enabled with gain switching condition or more 1: Gain after switching is enabled with gain switching condition or less	0h																
_x__	For manufacturer setting	0h																
x___		0h																
PB27	CDL	Gain switching condition This is used to set the value of gain switching (command frequency, droop pulses, and servo motor speed/linear servo motor speed) selected in [Pr. PB26]. The set value unit differs depending on the switching condition item. (Refer to section 7.2.3) The unit "r/min" will be "mm/s" for linear servo motors.	10 [kpps]/ [pulse]/ [r/min]	0 to 65535														
PB28	CDT	Gain switching time constant This is used to set the time constant at which the gains will change in response to the conditions set in [Pr. PB26] and [Pr. PB27].	1 [ms]	0 to 100														
PB29	GD2B	Load to motor inertia ratio/load to motor mass ratio after gain switching This is used to set the load to motor inertia ratio/load to motor mass ratio when gain switching is enabled. This parameter is enabled only when you select "Manual mode (___3)" of "Gain adjustment mode selection" in [Pr. PA08].	7.00 Multiplier (×1)	0.00 to 300.00														
PB30	PG2B	Position loop gain after gain switching Set the position loop gain when the gain switching is enabled. When you set a value less than 1.0 rad/s, the value will be the same as [Pr. PB08]. This parameter is enabled only when you select "Manual mode (___3)" of "Gain adjustment mode selection" in [Pr. PA08].	0.0 [rad/s]	0.0 to 2000.0														
PB31	VG2B	Speed loop gain after gain switching Set the speed loop gain when the gain switching is enabled. When you set a value less than 20 rad/s, the value will be the same as [Pr. PB09]. This parameter is enabled only when you select "Manual mode (___3)" of "Gain adjustment mode selection" in [Pr. PA08].	0 [rad/s]	0 to 65535														
PB32	VICB	Speed integral compensation after gain switching Set the speed integral compensation when the gain changing is valid. When you set a value less than 0.1 ms, the value will be the same as [Pr. PB10]. This parameter is enabled only when you select "Manual mode (___3)" of "Gain adjustment mode selection" in [Pr. PA08].	0.0 [ms]	0.0 to 5000.0														

5. PARAMETERS

No.	Symbol	Name and function	Initial value (unit)	Setting range
PB33	VRF11B	<p>Vibration suppression control 1 - Vibration frequency after gain switching</p> <p>Set the vibration frequency for vibration suppression control 1 when the gain switching is enabled.</p> <p>When you set a value less than 0.1 Hz, the value will be the same as [Pr. PB19].</p> <p>This parameter will be enabled only when the following conditions are fulfilled.</p> <ul style="list-style-type: none"> • "Gain adjustment mode selection" in [Pr. PA08] is "Manual mode (_ _ _ 3)". • "Vibration suppression control 1 tuning mode selection" in [Pr. PB02] is "Manual setting (_ _ _ 2)". • "Gain switching selection" in [Pr. PB26] is "Control command from controller is enabled (_ _ _ 1)". <p>Switching during driving may cause a shock. Be sure to switch them after the servo motor stops.</p>	0.0 [Hz]	0.0 to 300.0
PB34	VRF12B	<p>Vibration suppression control 1 - Resonance frequency after gain switching</p> <p>Set the resonance frequency for vibration suppression control 1 when the gain switching is enabled.</p> <p>When you set a value less than 0.1 Hz, the value will be the same as [Pr. PB20].</p> <p>This parameter will be enabled only when the following conditions are fulfilled.</p> <ul style="list-style-type: none"> • "Gain adjustment mode selection" in [Pr. PA08] is "Manual mode (_ _ _ 3)". • "Vibration suppression control 1 tuning mode selection" in [Pr. PB02] is "Manual setting (_ _ _ 2)". • "Gain switching selection" in [Pr. PB26] is "Control command from controller is enabled (_ _ _ 1)". <p>Switching during driving may cause a shock. Be sure to switch them after the servo motor stops.</p>	0.0 [Hz]	0.0 to 300.0
PB35	VRF13B	<p>Vibration suppression control 1 - Vibration frequency damping after gain switching</p> <p>Set a damping of the vibration frequency for vibration suppression control 1 when the gain switching is enabled.</p> <p>This parameter will be enabled only when the following conditions are fulfilled.</p> <ul style="list-style-type: none"> • "Gain adjustment mode selection" in [Pr. PA08] is "Manual mode (_ _ _ 3)". • "Vibration suppression control 1 tuning mode selection" in [Pr. PB02] is "Manual setting (_ _ _ 2)". • "Gain switching selection" in [Pr. PB26] is "Control command from controller is enabled (_ _ _ 1)". <p>Switching during driving may cause a shock. Be sure to switch them after the servo motor stops.</p>	0.00	0.00 to 0.30
PB36	VRF14B	<p>Vibration suppression control 1 - Resonance frequency damping after gain switching</p> <p>Set a damping of the resonance frequency for vibration suppression control 1 when the gain switching is enabled.</p> <p>This parameter will be enabled only when the following conditions are fulfilled.</p> <ul style="list-style-type: none"> • "Gain adjustment mode selection" in [Pr. PA08] is "Manual mode (_ _ _ 3)". • "Vibration suppression control 1 tuning mode selection" in [Pr. PB02] is "Manual setting (_ _ _ 2)". • "Gain switching selection" in [Pr. PB26] is "Control command from controller is enabled (_ _ _ 1)". <p>Switching during driving may cause a shock. Be sure to switch them after the servo motor stops.</p>	0.00	0.00 to 0.30

5. PARAMETERS

No.	Symbol	Name and function	Initial value (unit)	Setting range																																																																																																																																																																																																																		
PB45	CNHF	Command notch filter Set the command notch filter. <table border="1" style="margin-top: 10px;"> <thead> <tr> <th>Setting digit</th> <th>Explanation</th> <th>Initial value</th> </tr> </thead> <tbody> <tr> <td>__ x x</td> <td>Command notch filter setting frequency selection Refer to table 5.5 for the relation of setting values to frequency.</td> <td>00h</td> </tr> <tr> <td>_ x _ _</td> <td>Notch depth selection Refer to table 5.6 for details.</td> <td>0h</td> </tr> <tr> <td>x _ _ _</td> <td>For manufacturer setting</td> <td>0h</td> </tr> </tbody> </table> Table 5.5 Command notch filter setting frequency selection <table border="1" style="margin-top: 10px;"> <thead> <tr> <th>Setting</th> <th>Frequency [Hz]</th> <th>Setting</th> <th>Frequency [Hz]</th> <th>Setting</th> <th>Frequency [Hz]</th> </tr> </thead> <tbody> <tr><td>00</td><td>Disabled</td><td>20</td><td>70</td><td>40</td><td>17.6</td></tr> <tr><td>01</td><td>2250</td><td>21</td><td>66</td><td>41</td><td>16.5</td></tr> <tr><td>02</td><td>1125</td><td>22</td><td>62</td><td>42</td><td>15.6</td></tr> <tr><td>03</td><td>750</td><td>23</td><td>59</td><td>43</td><td>14.8</td></tr> <tr><td>04</td><td>562</td><td>24</td><td>56</td><td>44</td><td>14.1</td></tr> <tr><td>05</td><td>450</td><td>25</td><td>53</td><td>45</td><td>13.4</td></tr> <tr><td>06</td><td>375</td><td>26</td><td>51</td><td>46</td><td>12.8</td></tr> <tr><td>07</td><td>321</td><td>27</td><td>48</td><td>47</td><td>12.2</td></tr> <tr><td>08</td><td>281</td><td>28</td><td>46</td><td>48</td><td>11.7</td></tr> <tr><td>09</td><td>250</td><td>29</td><td>45</td><td>49</td><td>11.3</td></tr> <tr><td>0A</td><td>225</td><td>2A</td><td>43</td><td>4A</td><td>10.8</td></tr> <tr><td>0B</td><td>204</td><td>2B</td><td>41</td><td>4B</td><td>10.4</td></tr> <tr><td>0C</td><td>187</td><td>2C</td><td>40</td><td>4C</td><td>10</td></tr> <tr><td>0D</td><td>173</td><td>2D</td><td>38</td><td>4D</td><td>9.7</td></tr> <tr><td>0E</td><td>160</td><td>2E</td><td>37</td><td>4E</td><td>9.4</td></tr> <tr><td>0F</td><td>150</td><td>2F</td><td>36</td><td>4F</td><td>9.1</td></tr> <tr><td>10</td><td>140</td><td>30</td><td>35.2</td><td>50</td><td>8.8</td></tr> <tr><td>11</td><td>132</td><td>31</td><td>33.1</td><td>51</td><td>8.3</td></tr> <tr><td>12</td><td>125</td><td>32</td><td>31.3</td><td>52</td><td>7.8</td></tr> <tr><td>13</td><td>118</td><td>33</td><td>29.6</td><td>53</td><td>7.4</td></tr> <tr><td>14</td><td>112</td><td>34</td><td>28.1</td><td>54</td><td>7.0</td></tr> <tr><td>15</td><td>107</td><td>35</td><td>26.8</td><td>55</td><td>6.7</td></tr> <tr><td>16</td><td>102</td><td>36</td><td>25.6</td><td>56</td><td>6.4</td></tr> <tr><td>17</td><td>97</td><td>37</td><td>24.5</td><td>57</td><td>6.1</td></tr> <tr><td>18</td><td>93</td><td>38</td><td>23.4</td><td>58</td><td>5.9</td></tr> <tr><td>19</td><td>90</td><td>39</td><td>22.5</td><td>59</td><td>5.6</td></tr> <tr><td>1A</td><td>86</td><td>3A</td><td>21.6</td><td>5A</td><td>5.4</td></tr> <tr><td>1B</td><td>83</td><td>3B</td><td>20.8</td><td>5B</td><td>5.2</td></tr> <tr><td>1C</td><td>80</td><td>3C</td><td>20.1</td><td>5C</td><td>5.0</td></tr> <tr><td>1D</td><td>77</td><td>3D</td><td>19.4</td><td>5D</td><td>4.9</td></tr> <tr><td>1E</td><td>75</td><td>3E</td><td>18.8</td><td>5E</td><td>4.7</td></tr> <tr><td>1F</td><td>72</td><td>3F</td><td>18.2</td><td>5F</td><td>4.5</td></tr> </tbody> </table>	Setting digit	Explanation	Initial value	__ x x	Command notch filter setting frequency selection Refer to table 5.5 for the relation of setting values to frequency.	00h	_ x _ _	Notch depth selection Refer to table 5.6 for details.	0h	x _ _ _	For manufacturer setting	0h	Setting	Frequency [Hz]	Setting	Frequency [Hz]	Setting	Frequency [Hz]	00	Disabled	20	70	40	17.6	01	2250	21	66	41	16.5	02	1125	22	62	42	15.6	03	750	23	59	43	14.8	04	562	24	56	44	14.1	05	450	25	53	45	13.4	06	375	26	51	46	12.8	07	321	27	48	47	12.2	08	281	28	46	48	11.7	09	250	29	45	49	11.3	0A	225	2A	43	4A	10.8	0B	204	2B	41	4B	10.4	0C	187	2C	40	4C	10	0D	173	2D	38	4D	9.7	0E	160	2E	37	4E	9.4	0F	150	2F	36	4F	9.1	10	140	30	35.2	50	8.8	11	132	31	33.1	51	8.3	12	125	32	31.3	52	7.8	13	118	33	29.6	53	7.4	14	112	34	28.1	54	7.0	15	107	35	26.8	55	6.7	16	102	36	25.6	56	6.4	17	97	37	24.5	57	6.1	18	93	38	23.4	58	5.9	19	90	39	22.5	59	5.6	1A	86	3A	21.6	5A	5.4	1B	83	3B	20.8	5B	5.2	1C	80	3C	20.1	5C	5.0	1D	77	3D	19.4	5D	4.9	1E	75	3E	18.8	5E	4.7	1F	72	3F	18.2	5F	4.5	Refer to Name and function column.	
Setting digit	Explanation	Initial value																																																																																																																																																																																																																				
__ x x	Command notch filter setting frequency selection Refer to table 5.5 for the relation of setting values to frequency.	00h																																																																																																																																																																																																																				
_ x _ _	Notch depth selection Refer to table 5.6 for details.	0h																																																																																																																																																																																																																				
x _ _ _	For manufacturer setting	0h																																																																																																																																																																																																																				
Setting	Frequency [Hz]	Setting	Frequency [Hz]	Setting	Frequency [Hz]																																																																																																																																																																																																																	
00	Disabled	20	70	40	17.6																																																																																																																																																																																																																	
01	2250	21	66	41	16.5																																																																																																																																																																																																																	
02	1125	22	62	42	15.6																																																																																																																																																																																																																	
03	750	23	59	43	14.8																																																																																																																																																																																																																	
04	562	24	56	44	14.1																																																																																																																																																																																																																	
05	450	25	53	45	13.4																																																																																																																																																																																																																	
06	375	26	51	46	12.8																																																																																																																																																																																																																	
07	321	27	48	47	12.2																																																																																																																																																																																																																	
08	281	28	46	48	11.7																																																																																																																																																																																																																	
09	250	29	45	49	11.3																																																																																																																																																																																																																	
0A	225	2A	43	4A	10.8																																																																																																																																																																																																																	
0B	204	2B	41	4B	10.4																																																																																																																																																																																																																	
0C	187	2C	40	4C	10																																																																																																																																																																																																																	
0D	173	2D	38	4D	9.7																																																																																																																																																																																																																	
0E	160	2E	37	4E	9.4																																																																																																																																																																																																																	
0F	150	2F	36	4F	9.1																																																																																																																																																																																																																	
10	140	30	35.2	50	8.8																																																																																																																																																																																																																	
11	132	31	33.1	51	8.3																																																																																																																																																																																																																	
12	125	32	31.3	52	7.8																																																																																																																																																																																																																	
13	118	33	29.6	53	7.4																																																																																																																																																																																																																	
14	112	34	28.1	54	7.0																																																																																																																																																																																																																	
15	107	35	26.8	55	6.7																																																																																																																																																																																																																	
16	102	36	25.6	56	6.4																																																																																																																																																																																																																	
17	97	37	24.5	57	6.1																																																																																																																																																																																																																	
18	93	38	23.4	58	5.9																																																																																																																																																																																																																	
19	90	39	22.5	59	5.6																																																																																																																																																																																																																	
1A	86	3A	21.6	5A	5.4																																																																																																																																																																																																																	
1B	83	3B	20.8	5B	5.2																																																																																																																																																																																																																	
1C	80	3C	20.1	5C	5.0																																																																																																																																																																																																																	
1D	77	3D	19.4	5D	4.9																																																																																																																																																																																																																	
1E	75	3E	18.8	5E	4.7																																																																																																																																																																																																																	
1F	72	3F	18.2	5F	4.5																																																																																																																																																																																																																	

5. PARAMETERS

No.	Symbol	Name and function	Initial value (unit)	Setting range																																				
PB45	CNHF	<p>Table 5.6 Notch depth selection</p> <table border="1"> <thead> <tr> <th>Setting</th> <th>Depth [dB]</th> <th>Setting</th> <th>Depth [dB]</th> </tr> </thead> <tbody> <tr> <td>0</td> <td>-40.0</td> <td>8</td> <td>-6.0</td> </tr> <tr> <td>1</td> <td>-24.1</td> <td>9</td> <td>-5.0</td> </tr> <tr> <td>2</td> <td>-18.1</td> <td>A</td> <td>-4.1</td> </tr> <tr> <td>3</td> <td>-14.5</td> <td>B</td> <td>-3.3</td> </tr> <tr> <td>4</td> <td>-12.0</td> <td>C</td> <td>-2.5</td> </tr> <tr> <td>5</td> <td>-10.1</td> <td>D</td> <td>-1.8</td> </tr> <tr> <td>6</td> <td>-8.5</td> <td>E</td> <td>-1.2</td> </tr> <tr> <td>7</td> <td>-7.2</td> <td>F</td> <td>-0.6</td> </tr> </tbody> </table>	Setting	Depth [dB]	Setting	Depth [dB]	0	-40.0	8	-6.0	1	-24.1	9	-5.0	2	-18.1	A	-4.1	3	-14.5	B	-3.3	4	-12.0	C	-2.5	5	-10.1	D	-1.8	6	-8.5	E	-1.2	7	-7.2	F	-0.6	Refer to Name and function column.	
Setting	Depth [dB]	Setting	Depth [dB]																																					
0	-40.0	8	-6.0																																					
1	-24.1	9	-5.0																																					
2	-18.1	A	-4.1																																					
3	-14.5	B	-3.3																																					
4	-12.0	C	-2.5																																					
5	-10.1	D	-1.8																																					
6	-8.5	E	-1.2																																					
7	-7.2	F	-0.6																																					
PB46	NH3	<p>Machine resonance suppression filter 3</p> <p>Set the notch frequency of the machine resonance suppression filter 3.</p> <p>To enable the setting value, select "Enabled (___ 1)" of "Machine resonance suppression filter 3 selection" in [Pr. PB47].</p>	4500 [Hz]	10 to 4500																																				
PB47	NHQ3	<p>Notch shape selection 3</p> <p>Set the shape of the machine resonance suppression filter 3.</p> <table border="1"> <thead> <tr> <th>Setting digit</th> <th>Explanation</th> <th>Initial value</th> </tr> </thead> <tbody> <tr> <td>___ x</td> <td>Machine resonance suppression filter 3 selection 0: Disabled 1: Enabled</td> <td>0h</td> </tr> <tr> <td>__ x _</td> <td>Notch depth selection 0: -40 dB 1: -14 dB 2: -8 dB 3: -4 dB</td> <td>0h</td> </tr> <tr> <td>_ x __</td> <td>Notch width selection 0: $\alpha = 2$ 1: $\alpha = 3$ 2: $\alpha = 4$ 3: $\alpha = 5$</td> <td>0h</td> </tr> <tr> <td>x ___</td> <td>For manufacturer setting</td> <td>0h</td> </tr> </tbody> </table>	Setting digit	Explanation	Initial value	___ x	Machine resonance suppression filter 3 selection 0: Disabled 1: Enabled	0h	__ x _	Notch depth selection 0: -40 dB 1: -14 dB 2: -8 dB 3: -4 dB	0h	_ x __	Notch width selection 0: $\alpha = 2$ 1: $\alpha = 3$ 2: $\alpha = 4$ 3: $\alpha = 5$	0h	x ___	For manufacturer setting	0h	Refer to Name and function column.																						
Setting digit	Explanation	Initial value																																						
___ x	Machine resonance suppression filter 3 selection 0: Disabled 1: Enabled	0h																																						
__ x _	Notch depth selection 0: -40 dB 1: -14 dB 2: -8 dB 3: -4 dB	0h																																						
_ x __	Notch width selection 0: $\alpha = 2$ 1: $\alpha = 3$ 2: $\alpha = 4$ 3: $\alpha = 5$	0h																																						
x ___	For manufacturer setting	0h																																						
PB48	NH4	<p>Machine resonance suppression filter 4</p> <p>Set the notch frequency of the machine resonance suppression filter 4.</p> <p>To enable the setting value, select "Enabled (___ 1)" of "Machine resonance suppression filter 4 selection" in [Pr. PB49].</p>	4500 [Hz]	10 to 4500																																				

5. PARAMETERS

No.	Symbol	Name and function	Initial value (unit)	Setting range															
PB49	NHQ4	<p>Notch shape selection 4 Set the shape of the machine resonance suppression filter 4.</p> <table border="1"> <thead> <tr> <th>Setting digit</th> <th>Explanation</th> <th>Initial value</th> </tr> </thead> <tbody> <tr> <td>___x</td> <td>Machine resonance suppression filter 4 selection 0: Disabled 1: Enabled When you select "Enabled" of this digit, [Pr. PB17 Shaft resonance suppression filter] is not available.</td> <td>0h</td> </tr> <tr> <td>__x_</td> <td>Notch depth selection 0: -40 dB 1: -14 dB 2: -8 dB 3: -4 dB</td> <td>0h</td> </tr> <tr> <td>_x__</td> <td>Notch width selection 0: $\alpha = 2$ 1: $\alpha = 3$ 2: $\alpha = 4$ 3: $\alpha = 5$</td> <td>0h</td> </tr> <tr> <td>x___</td> <td>For manufacturer setting</td> <td>0h</td> </tr> </tbody> </table>	Setting digit	Explanation	Initial value	___x	Machine resonance suppression filter 4 selection 0: Disabled 1: Enabled When you select "Enabled" of this digit, [Pr. PB17 Shaft resonance suppression filter] is not available.	0h	__x_	Notch depth selection 0: -40 dB 1: -14 dB 2: -8 dB 3: -4 dB	0h	_x__	Notch width selection 0: $\alpha = 2$ 1: $\alpha = 3$ 2: $\alpha = 4$ 3: $\alpha = 5$	0h	x___	For manufacturer setting	0h	Refer to Name and function column.	
Setting digit	Explanation	Initial value																	
___x	Machine resonance suppression filter 4 selection 0: Disabled 1: Enabled When you select "Enabled" of this digit, [Pr. PB17 Shaft resonance suppression filter] is not available.	0h																	
__x_	Notch depth selection 0: -40 dB 1: -14 dB 2: -8 dB 3: -4 dB	0h																	
_x__	Notch width selection 0: $\alpha = 2$ 1: $\alpha = 3$ 2: $\alpha = 4$ 3: $\alpha = 5$	0h																	
x___	For manufacturer setting	0h																	
PB50	NH5	<p>Machine resonance suppression filter 5 Set the notch frequency of the machine resonance suppression filter 5. To enable the setting value, select "Enabled (___1)" of "Machine resonance suppression filter 5 selection" in [Pr. PB51].</p>	4500 [Hz]	10 to 4500															
PB51	NHQ5	<p>Notch shape selection 5 Set the shape of the machine resonance suppression filter 5. When you select "Enabled (___1)" of "Robust filter selection" in [Pr. PE41], the machine resonance suppression filter 5 is not available.</p> <table border="1"> <thead> <tr> <th>Setting digit</th> <th>Explanation</th> <th>Initial value</th> </tr> </thead> <tbody> <tr> <td>___x</td> <td>Machine resonance suppression filter 5 selection 0: Disabled 1: Enabled</td> <td>0h</td> </tr> <tr> <td>__x_</td> <td>Notch depth selection 0: -40 dB 1: -14 dB 2: -8 dB 3: -4 dB</td> <td>0h</td> </tr> <tr> <td>_x__</td> <td>Notch width selection 0: $\alpha = 2$ 1: $\alpha = 3$ 2: $\alpha = 4$ 3: $\alpha = 5$</td> <td>0h</td> </tr> <tr> <td>x___</td> <td>For manufacturer setting</td> <td>0h</td> </tr> </tbody> </table>	Setting digit	Explanation	Initial value	___x	Machine resonance suppression filter 5 selection 0: Disabled 1: Enabled	0h	__x_	Notch depth selection 0: -40 dB 1: -14 dB 2: -8 dB 3: -4 dB	0h	_x__	Notch width selection 0: $\alpha = 2$ 1: $\alpha = 3$ 2: $\alpha = 4$ 3: $\alpha = 5$	0h	x___	For manufacturer setting	0h	Refer to Name and function column.	
Setting digit	Explanation	Initial value																	
___x	Machine resonance suppression filter 5 selection 0: Disabled 1: Enabled	0h																	
__x_	Notch depth selection 0: -40 dB 1: -14 dB 2: -8 dB 3: -4 dB	0h																	
_x__	Notch width selection 0: $\alpha = 2$ 1: $\alpha = 3$ 2: $\alpha = 4$ 3: $\alpha = 5$	0h																	
x___	For manufacturer setting	0h																	
PB52	VRF21	<p>Vibration suppression control 2 - Vibration frequency Set the vibration frequency for vibration suppression control 2 to suppress low-frequency machine vibration. To enable this, select "3 inertia mode (___1)" of "Vibration suppression mode selection" in [Pr. PA24]. When "Vibration suppression control 2 tuning mode selection" is "Automatic setting (___1)" in [Pr. PB02], this parameter will be set automatically. Set manually for "Manual setting (___2)".</p>	100.0 [Hz]	0.1 to 300.0															

5. PARAMETERS

No.	Symbol	Name and function	Initial value (unit)	Setting range
PB53	VRF22	<p>Vibration suppression control 2 - Resonance frequency</p> <p>Set the resonance frequency for vibration suppression control 2 to suppress low-frequency machine vibration.</p> <p>To enable this, select "3 inertia mode (_ _ _ 1)" of "Vibration suppression mode selection" in [Pr. PA24].</p> <p>When "Vibration suppression control 2 tuning mode selection" is "Automatic setting (_ _ 1 _)" in [Pr. PB02], this parameter will be set automatically. Set manually for "Manual setting (_ _ 2 _)".</p>	100.0 [Hz]	0.1 to 300.0
PB54	VRF23	<p>Vibration suppression control 2 - Vibration frequency damping</p> <p>Set a damping of the vibration frequency for vibration suppression control 2 to suppress low-frequency machine vibration.</p> <p>To enable this, select "3 inertia mode (_ _ _ 1)" of "Vibration suppression mode selection" in [Pr. PA24].</p> <p>When "Vibration suppression control 2 tuning mode selection" is "Automatic setting (_ _ 1 _)" in [Pr. PB02], this parameter will be set automatically. Set manually for "Manual setting (_ _ 2 _)".</p>	0.00	0.00 to 0.30
PB55	VRF24	<p>Vibration suppression control 2 - Resonance frequency damping</p> <p>Set a damping of the resonance frequency for vibration suppression control 2 to suppress low-frequency machine vibration.</p> <p>To enable this, select "3 inertia mode (_ _ _ 1)" of "Vibration suppression mode selection" in [Pr. PA24].</p> <p>When "Vibration suppression control 2 tuning mode selection" is "Automatic setting (_ _ 1 _)" in [Pr. PB02], this parameter will be set automatically. Set manually for "Manual setting (_ _ 2 _)".</p>	0.00	0.00 to 0.30
PB56	VRF21B	<p>Vibration suppression control 2 - Vibration frequency after gain switching</p> <p>Set the vibration frequency for vibration suppression control 2 when the gain switching is enabled.</p> <p>To enable this, select "3 inertia mode (_ _ _ 1)" of "Vibration suppression mode selection" in [Pr. PA24].</p> <p>This parameter will be enabled only when the following conditions are fulfilled.</p> <ul style="list-style-type: none"> • "Gain adjustment mode selection" in [Pr. PA08] is "Manual mode (_ _ _ 3)". • "Vibration suppression control 2 tuning mode selection" in [Pr. PB02] is "Manual setting (_ _ 2 _)". • "Gain switching selection" in [Pr. PB26] is "Control command from controller is enabled (_ _ _ 1)". <p>Switching during driving may cause a shock. Be sure to switch them after the servo motor stops.</p>	0.0 [Hz]	0.0 to 300.0
PB57	VRF22B	<p>Vibration suppression control 2 - Resonance frequency after gain switching</p> <p>Set the resonance frequency for vibration suppression control 2 when the gain switching is enabled.</p> <p>To enable this, select "3 inertia mode (_ _ _ 1)" of "Vibration suppression mode selection" in [Pr. PA24].</p> <p>This parameter will be enabled only when the following conditions are fulfilled.</p> <ul style="list-style-type: none"> • "Gain adjustment mode selection" in [Pr. PA08] is "Manual mode (_ _ _ 3)". • "Vibration suppression control 2 tuning mode selection" in [Pr. PB02] is "Manual setting (_ _ 2 _)". • "Gain switching selection" in [Pr. PB26] is "Control command from controller is enabled (_ _ _ 1)". <p>Switching during driving may cause a shock. Be sure to switch them after the servo motor stops.</p>	0.0 [Hz]	0.0 to 300.0

5. PARAMETERS

No.	Symbol	Name and function	Initial value (unit)	Setting range
PB58	VRF23B	<p>Vibration suppression control 2 - Vibration frequency damping after gain switching</p> <p>Set a damping of the vibration frequency for vibration suppression control 2 when the gain switching is enabled.</p> <p>To enable this, select "3 inertia mode (_ _ _ 1)" of "Vibration suppression mode selection" in [Pr. PA24].</p> <p>This parameter will be enabled only when the following conditions are fulfilled.</p> <ul style="list-style-type: none"> • "Gain adjustment mode selection" in [Pr. PA08] is "Manual mode (_ _ _ 3)". • "Vibration suppression control 2 tuning mode selection" in [Pr. PB02] is "Manual setting (_ _ 2 _)". • "Gain switching selection" in [Pr. PB26] is "Control command from controller is enabled (_ _ _ 1)". <p>Switching during driving may cause a shock. Be sure to switch them after the servo motor stops.</p>	0.00	0.00 to 0.30
PB59	VRF24B	<p>Vibration suppression control 2 - Resonance frequency damping after gain switching</p> <p>Set a damping of the resonance frequency for vibration suppression control 2 when the gain switching is enabled.</p> <p>To enable this, select "3 inertia mode (_ _ _ 1)" of "Vibration suppression mode selection" in [Pr. PA24].</p> <p>This parameter will be enabled only when the following conditions are fulfilled.</p> <ul style="list-style-type: none"> • "Gain adjustment mode selection" in [Pr. PA08] is "Manual mode (_ _ _ 3)". • "Vibration suppression control 2 tuning mode selection" in [Pr. PB02] is "Manual setting (_ _ 2 _)". • "Gain switching selection" in [Pr. PB26] is "Control command from controller is enabled (_ _ _ 1)". <p>Switching during driving may cause a shock. Be sure to switch them after the servo motor stops.</p>	0.00	0.00 to 0.30
PB60	PG1B	<p>Model loop gain after gain switching</p> <p>Set the model loop gain when the gain switching is enabled.</p> <p>When you set a value less than 1.0 rad/s, the value will be the same as [Pr. PB07].</p> <p>This parameter will be enabled only when the following conditions are fulfilled.</p> <ul style="list-style-type: none"> • "Gain adjustment mode selection" in [Pr. PA08] is "Manual mode (_ _ _ 3)". • "Gain switching selection" in [Pr. PB26] is "Control command from controller is enabled (_ _ _ 1)". <p>Switching during driving may cause a shock. Be sure to switch them after the servo motor stops.</p>	0.0 [rad/s]	0.0 to 2000.0

5. PARAMETERS

5.2.3 Extension setting parameters ([Pr. PC__])

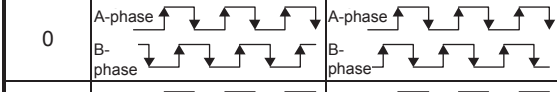
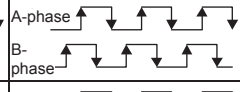
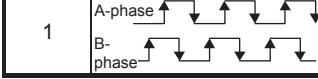
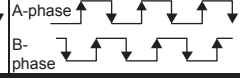
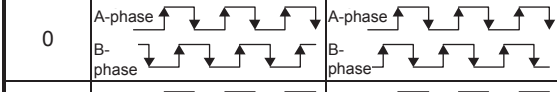
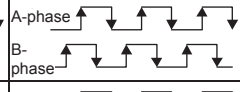
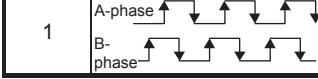
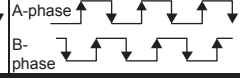
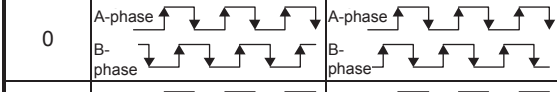
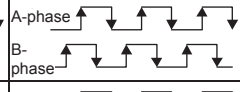
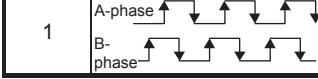
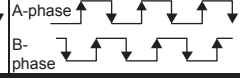
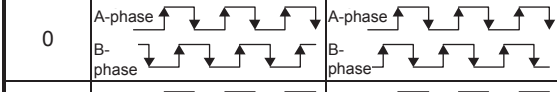
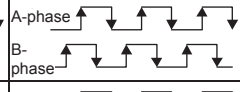
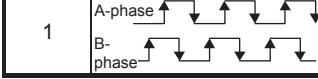
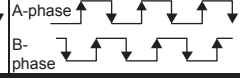
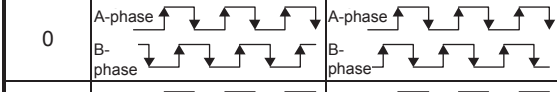
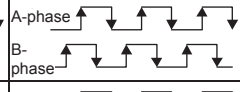
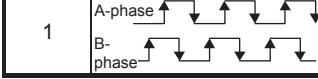
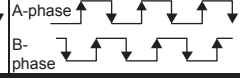
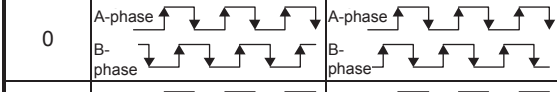
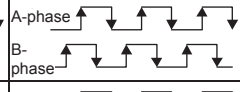
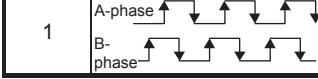
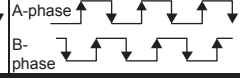
No.	Symbol	Name and function	Initial value (unit)	Setting range																										
PC01	ERZ	Error excessive alarm level Set an error excessive alarm level. Set this per rev. for rotary servo motors and direct drive motors. Set this per mm for linear servo motors. However, setting 0 will be "3 rev" for rotary servo motors and direct drive motors. It will be "100 mm" for linear servo motors. Not Setting can be changed in [Pr. PC06]. e.	0 [rev]/ [mm] (Note)	0 to 1000																										
PC02	MBR	Electromagnetic brake sequence output This is used to set the delay time between MBR (Electromagnetic brake interlock) and the base drive circuit is shut-off.	0 [ms]	0 to 1000																										
PC03	*ENRS	Encoder output pulse selection This is used to select the encoder pulse direction and encoder output pulse setting.	Refer to Name and function column.																											
		<table border="1"> <thead> <tr> <th>Setting digit</th> <th>Explanation</th> <th>Initial value</th> </tr> </thead> <tbody> <tr> <td>___x</td> <td> Encoder output pulse phase selection 0: Increasing A-phase 90° in CCW or positive direction 1: Increasing A-phase 90° in CW or negative direction <table border="1"> <thead> <tr> <th rowspan="2">Setting value</th> <th colspan="2">Servo motor rotation direction</th> </tr> <tr> <th>CCW</th> <th>CW</th> </tr> </thead> <tbody> <tr> <td>0</td> <td>  </td> <td>  </td> </tr> <tr> <td>1</td> <td>  </td> <td>  </td> </tr> </tbody> </table> </td> <td>0h</td> </tr> <tr> <td>__x_</td> <td> Encoder output pulse setting selection 0: Output pulse setting 1: Division ratio setting 3: A/B-phase pulse electronic gear setting For linear servo motors, selecting "0" will output as division ratio setting because the output pulse setting is not available. </td> <td>0h</td> </tr> <tr> <td>_x__</td> <td> Selection of the encoders for encoder output pulse This is used for selecting an encoder for servo amplifier output. 0: Servo motor encoder 1: Load-side encoder This is only for the fully closed loop system. If "1" is set other than in the fully closed loop system, [AL. 37 Parameter error] will occur. </td> <td>0h</td> </tr> <tr> <td>x___</td> <td>For manufacturer setting</td> <td>0h</td> </tr> </tbody> </table>			Setting digit	Explanation	Initial value	___x	Encoder output pulse phase selection 0: Increasing A-phase 90° in CCW or positive direction 1: Increasing A-phase 90° in CW or negative direction <table border="1"> <thead> <tr> <th rowspan="2">Setting value</th> <th colspan="2">Servo motor rotation direction</th> </tr> <tr> <th>CCW</th> <th>CW</th> </tr> </thead> <tbody> <tr> <td>0</td> <td>  </td> <td>  </td> </tr> <tr> <td>1</td> <td>  </td> <td>  </td> </tr> </tbody> </table>	Setting value	Servo motor rotation direction		CCW	CW	0			1			0h	__x_	Encoder output pulse setting selection 0: Output pulse setting 1: Division ratio setting 3: A/B-phase pulse electronic gear setting For linear servo motors, selecting "0" will output as division ratio setting because the output pulse setting is not available.	0h	_x__	Selection of the encoders for encoder output pulse This is used for selecting an encoder for servo amplifier output. 0: Servo motor encoder 1: Load-side encoder This is only for the fully closed loop system. If "1" is set other than in the fully closed loop system, [AL. 37 Parameter error] will occur.	0h	x___	For manufacturer setting	0h
Setting digit	Explanation	Initial value																												
___x	Encoder output pulse phase selection 0: Increasing A-phase 90° in CCW or positive direction 1: Increasing A-phase 90° in CW or negative direction <table border="1"> <thead> <tr> <th rowspan="2">Setting value</th> <th colspan="2">Servo motor rotation direction</th> </tr> <tr> <th>CCW</th> <th>CW</th> </tr> </thead> <tbody> <tr> <td>0</td> <td>  </td> <td>  </td> </tr> <tr> <td>1</td> <td>  </td> <td>  </td> </tr> </tbody> </table>	Setting value			Servo motor rotation direction		CCW	CW	0			1			0h															
Setting value	Servo motor rotation direction																													
	CCW	CW																												
0																														
1																														
__x_	Encoder output pulse setting selection 0: Output pulse setting 1: Division ratio setting 3: A/B-phase pulse electronic gear setting For linear servo motors, selecting "0" will output as division ratio setting because the output pulse setting is not available.	0h																												
_x__	Selection of the encoders for encoder output pulse This is used for selecting an encoder for servo amplifier output. 0: Servo motor encoder 1: Load-side encoder This is only for the fully closed loop system. If "1" is set other than in the fully closed loop system, [AL. 37 Parameter error] will occur.	0h																												
x___	For manufacturer setting	0h																												

5. PARAMETERS

No.	Symbol	Name and function	Initial value (unit)	Setting range													
PC04	**COP1	Function selection C-1 Select the encoder cable communication method selection. <table border="1" data-bbox="347 398 1230 707"> <thead> <tr> <th>Setting digit</th> <th>Explanation</th> <th>Initial value</th> </tr> </thead> <tbody> <tr> <td>___x</td> <td rowspan="3">For manufacturer setting</td> <td>0h</td> </tr> <tr> <td>__x_</td> <td>0h</td> </tr> <tr> <td>_x__</td> <td>0h</td> </tr> <tr> <td>x___</td> <td>Encoder cable communication method selection 0: Two-wire type 1: Four-wire type Incorrect setting will result in [AL. 16 Encoder initial communication error 1].</td> <td>0h</td> </tr> </tbody> </table>	Setting digit	Explanation	Initial value	___x	For manufacturer setting	0h	__x_	0h	_x__	0h	x___	Encoder cable communication method selection 0: Two-wire type 1: Four-wire type Incorrect setting will result in [AL. 16 Encoder initial communication error 1].	0h	Refer to Name and function column.	
Setting digit	Explanation	Initial value															
___x	For manufacturer setting	0h															
__x_		0h															
_x__		0h															
x___	Encoder cable communication method selection 0: Two-wire type 1: Four-wire type Incorrect setting will result in [AL. 16 Encoder initial communication error 1].	0h															
PC05	**COP2	Function selection C-2 This is used to select the motor-less operation. <table border="1" data-bbox="347 819 1230 1070"> <thead> <tr> <th>Setting digit</th> <th>Explanation</th> <th>Initial value</th> </tr> </thead> <tbody> <tr> <td>___x</td> <td>Motor-less operation selection 0: Disabled 1: Enabled</td> <td>0h</td> </tr> <tr> <td>__x_</td> <td rowspan="3">For manufacturer setting</td> <td>0h</td> </tr> <tr> <td>_x__</td> <td>0h</td> </tr> <tr> <td>x___</td> <td>0h</td> </tr> </tbody> </table>	Setting digit	Explanation	Initial value	___x	Motor-less operation selection 0: Disabled 1: Enabled	0h	__x_	For manufacturer setting	0h	_x__	0h	x___	0h	Refer to Name and function column.	
Setting digit	Explanation	Initial value															
___x	Motor-less operation selection 0: Disabled 1: Enabled	0h															
__x_	For manufacturer setting	0h															
_x__		0h															
x___		0h															
PC06	*COP3	Function selection C-3 Select the error excessive alarm level setting for [Pr. PC01]. The parameter is not available in the speed control mode and torque control mode. <table border="1" data-bbox="347 1205 1230 1514"> <thead> <tr> <th>Setting digit</th> <th>Explanation</th> <th>Initial value</th> </tr> </thead> <tbody> <tr> <td>___x</td> <td rowspan="3">For manufacturer setting</td> <td>0h</td> </tr> <tr> <td>__x_</td> <td>0h</td> </tr> <tr> <td>_x__</td> <td>0h</td> </tr> <tr> <td>x___</td> <td>Error excessive alarm level unit selection 0: Per rev or mm 1: Per 0.1 rev or 0.1 mm 2: Per 0.01 rev or 0.01 mm 3: Per 0.001 rev or 0.001 mm</td> <td>0h</td> </tr> </tbody> </table>	Setting digit	Explanation	Initial value	___x	For manufacturer setting	0h	__x_	0h	_x__	0h	x___	Error excessive alarm level unit selection 0: Per rev or mm 1: Per 0.1 rev or 0.1 mm 2: Per 0.01 rev or 0.01 mm 3: Per 0.001 rev or 0.001 mm	0h	Refer to Name and function column.	
Setting digit	Explanation	Initial value															
___x	For manufacturer setting	0h															
__x_		0h															
_x__		0h															
x___	Error excessive alarm level unit selection 0: Per rev or mm 1: Per 0.1 rev or 0.1 mm 2: Per 0.01 rev or 0.01 mm 3: Per 0.001 rev or 0.001 mm	0h															
PC07	ZSP	Zero speed Used to set the output range of ZSP (Zero speed detection). ZSP (Zero speed detection) has hysteresis of 20 r/min or 20 mm/s.	50 [r/min]/ [mm/s]	0 to 10000													
PC08	OSL	Overspeed alarm detection level This is used to set an overspeed alarm detection level. When you set a value more than "(linear) servo motor maximum speed × 120%", the set value will be clamped. When you set "0", the value of "(linear) servo motor maximum speed × 120%" will be set.	0 [r/min]/ [mm/s]	0 to 20000													

5. PARAMETERS

No.	Symbol	Name and function	Initial value (unit)	Setting range																																																																																																																																																				
PC09	MOD1	Analog monitor 1 output Used to selection the signal provided to MO1 (Analog monitor 1) output. Refer to app. 13 (3) for detection point of output selection.		Refer to Name and function column.																																																																																																																																																				
		<table border="1"> <thead> <tr> <th>Setting digit</th> <th>Explanation</th> <th>Initial value</th> </tr> </thead> <tbody> <tr> <td>__ x x</td> <td>Analog monitor 1 output selection Refer to table 5.7 for settings.</td> <td>00h</td> </tr> <tr> <td>_ x _ _</td> <td>For manufacturer setting</td> <td>0h</td> </tr> <tr> <td>x _ _ _</td> <td></td> <td>0h</td> </tr> </tbody> </table>	Setting digit	Explanation	Initial value	__ x x	Analog monitor 1 output selection Refer to table 5.7 for settings.	00h	_ x _ _	For manufacturer setting	0h	x _ _ _		0h																																																																																																																																										
Setting digit	Explanation	Initial value																																																																																																																																																						
__ x x	Analog monitor 1 output selection Refer to table 5.7 for settings.	00h																																																																																																																																																						
_ x _ _	For manufacturer setting	0h																																																																																																																																																						
x _ _ _		0h																																																																																																																																																						
PC09	MOD1	Table 5.7 Analog monitor setting value		Refer to Name and function column.																																																																																																																																																				
		<table border="1"> <thead> <tr> <th rowspan="2">Setting value</th> <th rowspan="2">Item</th> <th colspan="4">Operation mode (Note)</th> </tr> <tr> <th>Standard</th> <th>Full.</th> <th>Lin.</th> <th>D.D.</th> </tr> </thead> <tbody> <tr> <td>00</td> <td>(Linear) servo motor speed (± 8 V/max. speed)</td> <td>○</td> <td>○</td> <td>○</td> <td>○</td> </tr> <tr> <td>01</td> <td>Torque or thrust (± 8 V/max. torque or max. thrust)</td> <td>○</td> <td>○</td> <td>○</td> <td>○</td> </tr> <tr> <td>02</td> <td>(Linear) servo motor speed (+8V/max. speed)</td> <td>○</td> <td>○</td> <td>○</td> <td>○</td> </tr> <tr> <td>03</td> <td>Torque or thrust (+8V/max. torque or max. thrust)</td> <td>○</td> <td>○</td> <td>○</td> <td>○</td> </tr> <tr> <td>04</td> <td>Current command (± 8 V/max. current command)</td> <td>○</td> <td>○</td> <td>○</td> <td>○</td> </tr> <tr> <td>05</td> <td>Speed command (± 8 V/max. speed)</td> <td>○</td> <td>○</td> <td>○</td> <td>○</td> </tr> <tr> <td>06</td> <td>Servo motor-side droop pulses (± 10 V/100 pulses)</td> <td>○</td> <td>○</td> <td>○</td> <td>○</td> </tr> <tr> <td>07</td> <td>Servo motor-side droop pulses (± 10 V/1000 pulses)</td> <td>○</td> <td>○</td> <td>○</td> <td>○</td> </tr> <tr> <td>08</td> <td>Servo motor-side droop pulses (± 10 V/10000 pulses)</td> <td>○</td> <td>○</td> <td>○</td> <td>○</td> </tr> <tr> <td>09</td> <td>Servo motor-side droop pulses (± 10 V/100000 pulses)</td> <td>○</td> <td>○</td> <td>○</td> <td>○</td> </tr> <tr> <td>0A</td> <td>Feedback position (± 10 V/1 Mpulses)</td> <td>○</td> <td>○</td> <td>○</td> <td>○</td> </tr> <tr> <td>0B</td> <td>Feedback position (± 10 V/10 Mpulses)</td> <td>○</td> <td>○</td> <td>○</td> <td>○</td> </tr> <tr> <td>0C</td> <td>Feedback position (± 10 V/100 Mpulses)</td> <td>○</td> <td>○</td> <td>○</td> <td>○</td> </tr> <tr> <td>0D</td> <td>Bus voltage (+8 V/400 V, 200 V amplifiers)</td> <td>○</td> <td>○</td> <td>○</td> <td>○</td> </tr> <tr> <td>0E</td> <td>Speed command 2 (± 8 V/max. speed)</td> <td>○</td> <td>○</td> <td>○</td> <td>○</td> </tr> <tr> <td>10</td> <td>Load-side droop pulses (± 10 V/100 pulses)</td> <td>○</td> <td>○</td> <td>○</td> <td>○</td> </tr> <tr> <td>11</td> <td>Load-side droop pulses (± 10 V/1000 pulses)</td> <td>○</td> <td>○</td> <td>○</td> <td>○</td> </tr> <tr> <td>12</td> <td>Load-side droop pulses (± 10 V/10000 pulses)</td> <td>○</td> <td>○</td> <td>○</td> <td>○</td> </tr> <tr> <td>13</td> <td>Load-side droop pulses (± 10 V/100000 pulses)</td> <td>○</td> <td>○</td> <td>○</td> <td>○</td> </tr> <tr> <td>14</td> <td>Load-side droop pulses (± 10 V/1 Mpulses)</td> <td>○</td> <td>○</td> <td>○</td> <td>○</td> </tr> <tr> <td>15</td> <td>Servo motor-side/load-side position deviation (± 10 V/100000 pulses)</td> <td>○</td> <td>○</td> <td>○</td> <td>○</td> </tr> <tr> <td>16</td> <td>Servo motor-side/load-side speed deviation (± 8 V/max. speed)</td> <td>○</td> <td>○</td> <td>○</td> <td>○</td> </tr> <tr> <td>17</td> <td>Encoder inside temperature (± 10 V/± 128 °C)</td> <td>○</td> <td>○</td> <td>○</td> <td>○</td> </tr> </tbody> </table>	Setting value	Item	Operation mode (Note)				Standard	Full.	Lin.	D.D.	00	(Linear) servo motor speed (± 8 V/max. speed)	○	○	○	○	01	Torque or thrust (± 8 V/max. torque or max. thrust)	○	○	○	○	02	(Linear) servo motor speed (+8V/max. speed)	○	○	○	○	03	Torque or thrust (+8V/max. torque or max. thrust)	○	○	○	○	04	Current command (± 8 V/max. current command)	○	○	○	○	05	Speed command (± 8 V/max. speed)	○	○	○	○	06	Servo motor-side droop pulses (± 10 V/100 pulses)	○	○	○	○	07	Servo motor-side droop pulses (± 10 V/1000 pulses)	○	○	○	○	08	Servo motor-side droop pulses (± 10 V/10000 pulses)	○	○	○	○	09	Servo motor-side droop pulses (± 10 V/100000 pulses)	○	○	○	○	0A	Feedback position (± 10 V/1 Mpulses)	○	○	○	○	0B	Feedback position (± 10 V/10 Mpulses)	○	○	○	○	0C	Feedback position (± 10 V/100 Mpulses)	○	○	○	○	0D	Bus voltage (+8 V/400 V, 200 V amplifiers)	○	○	○	○	0E	Speed command 2 (± 8 V/max. speed)	○	○	○	○	10	Load-side droop pulses (± 10 V/100 pulses)	○	○	○	○	11	Load-side droop pulses (± 10 V/1000 pulses)	○	○	○	○	12	Load-side droop pulses (± 10 V/10000 pulses)	○	○	○	○	13	Load-side droop pulses (± 10 V/100000 pulses)	○	○	○	○	14	Load-side droop pulses (± 10 V/1 Mpulses)	○	○	○	○	15	Servo motor-side/load-side position deviation (± 10 V/100000 pulses)	○	○	○	○	16	Servo motor-side/load-side speed deviation (± 8 V/max. speed)	○	○	○	○	17	Encoder inside temperature (± 10 V/ ± 128 °C)	○	○	○	○		
Setting value	Item	Operation mode (Note)																																																																																																																																																						
		Standard	Full.	Lin.	D.D.																																																																																																																																																			
00	(Linear) servo motor speed (± 8 V/max. speed)	○	○	○	○																																																																																																																																																			
01	Torque or thrust (± 8 V/max. torque or max. thrust)	○	○	○	○																																																																																																																																																			
02	(Linear) servo motor speed (+8V/max. speed)	○	○	○	○																																																																																																																																																			
03	Torque or thrust (+8V/max. torque or max. thrust)	○	○	○	○																																																																																																																																																			
04	Current command (± 8 V/max. current command)	○	○	○	○																																																																																																																																																			
05	Speed command (± 8 V/max. speed)	○	○	○	○																																																																																																																																																			
06	Servo motor-side droop pulses (± 10 V/100 pulses)	○	○	○	○																																																																																																																																																			
07	Servo motor-side droop pulses (± 10 V/1000 pulses)	○	○	○	○																																																																																																																																																			
08	Servo motor-side droop pulses (± 10 V/10000 pulses)	○	○	○	○																																																																																																																																																			
09	Servo motor-side droop pulses (± 10 V/100000 pulses)	○	○	○	○																																																																																																																																																			
0A	Feedback position (± 10 V/1 Mpulses)	○	○	○	○																																																																																																																																																			
0B	Feedback position (± 10 V/10 Mpulses)	○	○	○	○																																																																																																																																																			
0C	Feedback position (± 10 V/100 Mpulses)	○	○	○	○																																																																																																																																																			
0D	Bus voltage (+8 V/400 V, 200 V amplifiers)	○	○	○	○																																																																																																																																																			
0E	Speed command 2 (± 8 V/max. speed)	○	○	○	○																																																																																																																																																			
10	Load-side droop pulses (± 10 V/100 pulses)	○	○	○	○																																																																																																																																																			
11	Load-side droop pulses (± 10 V/1000 pulses)	○	○	○	○																																																																																																																																																			
12	Load-side droop pulses (± 10 V/10000 pulses)	○	○	○	○																																																																																																																																																			
13	Load-side droop pulses (± 10 V/100000 pulses)	○	○	○	○																																																																																																																																																			
14	Load-side droop pulses (± 10 V/1 Mpulses)	○	○	○	○																																																																																																																																																			
15	Servo motor-side/load-side position deviation (± 10 V/100000 pulses)	○	○	○	○																																																																																																																																																			
16	Servo motor-side/load-side speed deviation (± 8 V/max. speed)	○	○	○	○																																																																																																																																																			
17	Encoder inside temperature (± 10 V/ ± 128 °C)	○	○	○	○																																																																																																																																																			
		Note. Items with ○ are available for each operation mode. Norm.: Normal (semi closed loop system) use of the rotary servo motor Full.: Fully closed loop system use of the rotary servo motor Lin.: Linear servo motor use. D.D.: Direct drive (D.D.) motor use.																																																																																																																																																						

5. PARAMETERS

No.	Symbol	Name and function	Initial value (unit)	Setting range													
PC10	MOD2	Analog monitor 2 output Used to selection the signal provided to MO2 (Analog monitor 2) output. Refer to app. 13 (3) for detection point of output selection. <table border="1" data-bbox="347 421 1230 611"> <thead> <tr> <th>Setting digit</th> <th>Explanation</th> <th>Initial value</th> </tr> </thead> <tbody> <tr> <td>--x x</td> <td>Analog monitor 2 output selection Refer to [Pr. PC09] for settings.</td> <td>01h</td> </tr> <tr> <td>_x _</td> <td rowspan="2">For manufacturer setting</td> <td>0h</td> </tr> <tr> <td>x _ _</td> <td>0h</td> </tr> </tbody> </table>	Setting digit	Explanation	Initial value	--x x	Analog monitor 2 output selection Refer to [Pr. PC09] for settings.	01h	_x _	For manufacturer setting	0h	x _ _	0h	Refer to Name and function column.			
Setting digit	Explanation	Initial value															
--x x	Analog monitor 2 output selection Refer to [Pr. PC09] for settings.	01h															
_x _	For manufacturer setting	0h															
x _ _		0h															
PC11	MO1	Analog monitor 1 offset This is used to set the offset voltage of MO1 (Analog monitor 1).	0 [mV]	-999 to 999													
PC12	MO2	Analog monitor 2 offset This is used to set the offset voltage of MO2 (Analog monitor 2).	0 [mV]	-999 to 999													
PC13	MOSDL	Analog monitor - Feedback position output standard data - Low Set a monitor output standard position (lower 4 digits) for the feedback position for when selecting "Feedback position" for MO1 (Analog monitor 1) and MO2 (Analog monitor 2). Monitor output standard position = [Pr. PC14] setting × 10000 + [Pr. PC13] setting	0 [pulse]	-9999 to 9999													
PC14	MOSDH	Analog monitor - Feedback position output standard data - High Set a monitor output standard position (higher 4 digits) for the feedback position for when selecting "Feedback position" for MO1 (Analog monitor 1) and MO2 (Analog monitor 2). Monitor output standard position = [Pr. PC14] setting × 10000 + [Pr. PC13] setting	0 [10000 pulses]	-9999 to 9999													
PC17	**COP4	Function selection C-4 This is used to select a home position setting condition. <table border="1" data-bbox="347 1081 1230 1330"> <thead> <tr> <th>Setting digit</th> <th>Explanation</th> <th>Initial value</th> </tr> </thead> <tbody> <tr> <td>___x</td> <td>Selection of home position setting condition 0: Need to pass servo motor Z-phase after power on 1: Not need to pass servo motor Z-phase after power on</td> <td>0h</td> </tr> <tr> <td>__x_</td> <td rowspan="3">For manufacturer setting</td> <td>0h</td> </tr> <tr> <td>_x__</td> <td>0h</td> </tr> <tr> <td>x___</td> <td>0h</td> </tr> </tbody> </table>	Setting digit	Explanation	Initial value	___x	Selection of home position setting condition 0: Need to pass servo motor Z-phase after power on 1: Not need to pass servo motor Z-phase after power on	0h	__x_	For manufacturer setting	0h	_x__	0h	x___	0h	Refer to Name and function column.	
Setting digit	Explanation	Initial value															
___x	Selection of home position setting condition 0: Need to pass servo motor Z-phase after power on 1: Not need to pass servo motor Z-phase after power on	0h															
__x_	For manufacturer setting	0h															
_x__		0h															
x___		0h															
PC18	*COP5	Function selection C-5 This is used to select an occurring condition of [AL. E9 Main circuit off warning]. <table border="1" data-bbox="347 1447 1230 1695"> <thead> <tr> <th>Setting digit</th> <th>Explanation</th> <th>Initial value</th> </tr> </thead> <tbody> <tr> <td>___x</td> <td rowspan="3">For manufacturer setting</td> <td>0h</td> </tr> <tr> <td>__x_</td> <td>0h</td> </tr> <tr> <td>_x__</td> <td>0h</td> </tr> <tr> <td>x___</td> <td>[AL. E9 Main circuit off warning] selection 0: Detection with ready-on and servo-on command 1: Detection with servo-on command</td> <td>0h</td> </tr> </tbody> </table>	Setting digit	Explanation	Initial value	___x	For manufacturer setting	0h	__x_	0h	_x__	0h	x___	[AL. E9 Main circuit off warning] selection 0: Detection with ready-on and servo-on command 1: Detection with servo-on command	0h	Refer to Name and function column.	
Setting digit	Explanation	Initial value															
___x	For manufacturer setting	0h															
__x_		0h															
_x__		0h															
x___	[AL. E9 Main circuit off warning] selection 0: Detection with ready-on and servo-on command 1: Detection with servo-on command	0h															

5. PARAMETERS

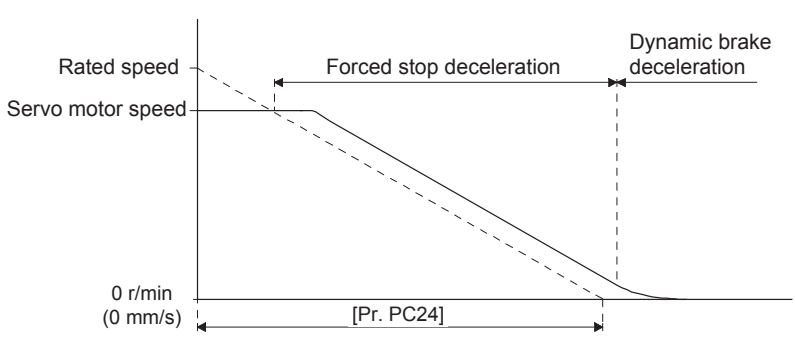
No.	Symbol	Name and function	Initial value (unit)	Setting range													
PC20	*COP7	<p>Function selection C-7 This is used to select an undervoltage alarm detection method.</p> <table border="1"> <thead> <tr> <th>Setting digit</th> <th>Explanation</th> <th>Initial value</th> </tr> </thead> <tbody> <tr> <td>___x</td> <td>Undervoltage alarm detection method selection When you use FR-RC, FR-CV, or FR-BU2, select "Method 2 (___1)". 0: Method 1 1: Method 2</td> <td>0h</td> </tr> <tr> <td>__x_</td> <td rowspan="3">For manufacturer setting</td> <td>0h</td> </tr> <tr> <td>_x__</td> <td>0h</td> </tr> <tr> <td>x___</td> <td>0h</td> </tr> </tbody> </table>	Setting digit	Explanation	Initial value	___x	Undervoltage alarm detection method selection When you use FR-RC, FR-CV, or FR-BU2, select "Method 2 (___1)". 0: Method 1 1: Method 2	0h	__x_	For manufacturer setting	0h	_x__	0h	x___	0h	Refer to Name and function column.	
Setting digit	Explanation	Initial value															
___x	Undervoltage alarm detection method selection When you use FR-RC, FR-CV, or FR-BU2, select "Method 2 (___1)". 0: Method 1 1: Method 2	0h															
__x_	For manufacturer setting	0h															
_x__		0h															
x___		0h															
PC21	*BPS	<p>Alarm history clear Used to clear the alarm history.</p> <table border="1"> <thead> <tr> <th>Setting digit</th> <th>Explanation</th> <th>Initial value</th> </tr> </thead> <tbody> <tr> <td>___x</td> <td>Alarm history clear selection 0: Disabled 1: Enabled When you select "Enabled", the alarm history will be cleared at next power-on. After the alarm history is cleared, the setting is automatically disabled.</td> <td>0h</td> </tr> <tr> <td>__x_</td> <td rowspan="3">For manufacturer setting</td> <td>0h</td> </tr> <tr> <td>_x__</td> <td>0h</td> </tr> <tr> <td>x___</td> <td>0h</td> </tr> </tbody> </table>	Setting digit	Explanation	Initial value	___x	Alarm history clear selection 0: Disabled 1: Enabled When you select "Enabled", the alarm history will be cleared at next power-on. After the alarm history is cleared, the setting is automatically disabled.	0h	__x_	For manufacturer setting	0h	_x__	0h	x___	0h	Refer to Name and function column.	
Setting digit	Explanation	Initial value															
___x	Alarm history clear selection 0: Disabled 1: Enabled When you select "Enabled", the alarm history will be cleared at next power-on. After the alarm history is cleared, the setting is automatically disabled.	0h															
__x_	For manufacturer setting	0h															
_x__		0h															
x___		0h															
PC24	RSBR	<p>Forced stop deceleration time constant This is used to set deceleration time constant when you use the forced stop deceleration function. Set the time per ms from the rated speed to 0 r/min or 0 mm/s.</p>  <p>[Precautions]</p> <ul style="list-style-type: none"> • If the servo motor torque is saturated at the maximum torque during forced stop deceleration because the set time is too short, the time to stop will be longer than the set time constant. • [AL. 50 Overload alarm 1] or [AL. 51 Overload alarm 2] may occur during forced stop deceleration, depending on the set value. • After an alarm that leads to a forced stop deceleration, if an alarm that does not lead to a forced stop deceleration occurs or if the control circuit power supply is cut, dynamic braking will start regardless of the deceleration time constant setting. • Set a longer time than deceleration time at quick stop of the controller. If a shorter time is set, [AL 52 Error excessive] may occur. 	100 [ms]	0 to 20000													

5. PARAMETERS

No.	Symbol	Name and function	Initial value (unit)	Setting range													
PC27	**COP9	Function selection C-9 This is used to select a polarity of the linear encoder or load-side encoder. <table border="1" data-bbox="347 398 1230 703"> <thead> <tr> <th>Setting digit</th> <th>Explanation</th> <th>Initial value</th> </tr> </thead> <tbody> <tr> <td>___ x</td> <td>Selection of encoder pulse count polarity 0: Encoder pulse increasing direction in the servo motor CCW or positive direction 1: Encoder pulse decreasing direction in the servo motor CCW or positive direction</td> <td>0h</td> </tr> <tr> <td>__ x _</td> <td rowspan="3">For manufacturer setting</td> <td>0h</td> </tr> <tr> <td>_ x _ _</td> <td>0h</td> </tr> <tr> <td>x _ _ _</td> <td>0h</td> </tr> </tbody> </table>	Setting digit	Explanation	Initial value	___ x	Selection of encoder pulse count polarity 0: Encoder pulse increasing direction in the servo motor CCW or positive direction 1: Encoder pulse decreasing direction in the servo motor CCW or positive direction	0h	__ x _	For manufacturer setting	0h	_ x _ _	0h	x _ _ _	0h	Refer to Name and function column.	
Setting digit	Explanation	Initial value															
___ x	Selection of encoder pulse count polarity 0: Encoder pulse increasing direction in the servo motor CCW or positive direction 1: Encoder pulse decreasing direction in the servo motor CCW or positive direction	0h															
__ x _	For manufacturer setting	0h															
_ x _ _		0h															
x _ _ _		0h															
PC29	*COPB	Function Selection C-B This is used to select the POL reflection at torque control. <table border="1" data-bbox="347 815 1230 1066"> <thead> <tr> <th>Setting digit</th> <th>Explanation</th> <th>Initial value</th> </tr> </thead> <tbody> <tr> <td>___ x</td> <td rowspan="3">For manufacturer setting</td> <td>0h</td> </tr> <tr> <td>__ x _</td> <td>0h</td> </tr> <tr> <td>_ x _ _</td> <td>0h</td> </tr> <tr> <td>x _ _ _</td> <td>POL reflection selection at torque control 0: Enabled 1: Disabled</td> <td>0h</td> </tr> </tbody> </table>	Setting digit	Explanation	Initial value	___ x	For manufacturer setting	0h	__ x _	0h	_ x _ _	0h	x _ _ _	POL reflection selection at torque control 0: Enabled 1: Disabled	0h	Refer to Name and function column.	
Setting digit	Explanation	Initial value															
___ x	For manufacturer setting	0h															
__ x _		0h															
_ x _ _		0h															
x _ _ _	POL reflection selection at torque control 0: Enabled 1: Disabled	0h															
PC31	RSUP1	Vertical axis freefall prevention compensation amount Set the compensation amount of the vertical axis freefall prevention function. Set it per servo motor rotation amount. When a positive value is set, compensation is performed to the address increasing direction. When a negative value is set, compensation is performed to the address decreasing direction. The vertical axis freefall prevention function is performed when all of the following conditions are met. <ol style="list-style-type: none"> 1) Position control mode 2) The value of the parameter is other than "0". 3) The forced stop deceleration function is enabled. 4) Alarm occurs or EM2 turns off when the (linear) servo motor speed is zero speed or less. 5) MBR (Electromagnetic brake interlock) was enabled in [Pr. PD07] to [Pr. PD09], and the base circuit shut-off delay time was set in [Pr. PC16]. 	0 [0.0001 rev]/ [0.01mm]	-25000 to 25000													

5. PARAMETERS

5.2.4 I/O setting parameters ([Pr. PD_ _])

No.	Symbol	Name and function	Initial value (unit)	Setting range																													
PD02	*DIA2	Input signal automatic on selection 2	Refer to Name and function column.																														
<table border="1"> <thead> <tr> <th colspan="2">Setting digit</th> <th rowspan="2">Explanation</th> <th rowspan="2">Initial value</th> </tr> <tr> <th>HEX.</th> <th>BIN.</th> </tr> </thead> <tbody> <tr> <td>___x</td> <td>___x</td> <td>FLS (Upper stroke limit) selection 0: Disabled 1: Enabled</td> <td rowspan="4">0h</td> </tr> <tr> <td></td> <td>__x_</td> <td>RLS (Lower stroke limit) selection 0: Disabled 1: Enabled</td> </tr> <tr> <td></td> <td>_x__</td> <td>For manufacturer setting</td> </tr> <tr> <td></td> <td>x___</td> <td>For manufacturer setting</td> </tr> <tr> <td></td> <td>__x_</td> <td rowspan="3">For manufacturer setting</td> <td>0h</td> </tr> <tr> <td></td> <td>_x__</td> <td>0h</td> </tr> <tr> <td></td> <td>x___</td> <td>0h</td> </tr> </tbody> </table>					Setting digit		Explanation	Initial value	HEX.	BIN.	___x	___x	FLS (Upper stroke limit) selection 0: Disabled 1: Enabled	0h		__x_	RLS (Lower stroke limit) selection 0: Disabled 1: Enabled		_x__	For manufacturer setting		x___	For manufacturer setting		__x_	For manufacturer setting	0h		_x__	0h		x___	0h
Setting digit		Explanation			Initial value																												
HEX.	BIN.																																
___x	___x	FLS (Upper stroke limit) selection 0: Disabled 1: Enabled			0h																												
	__x_	RLS (Lower stroke limit) selection 0: Disabled 1: Enabled																															
	_x__	For manufacturer setting																															
	x___	For manufacturer setting																															
	__x_	For manufacturer setting	0h																														
	_x__		0h																														
	x___		0h																														
PD07	*DO1	Output device selection 1 You can assign any output device to the CN3-13 pin.	Refer to Name and function column.																														
<table border="1"> <thead> <tr> <th>Setting digit</th> <th>Explanation</th> <th>Initial value</th> </tr> </thead> <tbody> <tr> <td>__xx</td> <td>Device selection Refer to table 5.8 for settings.</td> <td>05h</td> </tr> <tr> <td>_x__</td> <td>For manufacturer setting</td> <td>0h</td> </tr> <tr> <td>x___</td> <td></td> <td>0h</td> </tr> </tbody> </table>					Setting digit	Explanation	Initial value	__xx	Device selection Refer to table 5.8 for settings.	05h	_x__	For manufacturer setting	0h	x___		0h																	
Setting digit	Explanation	Initial value																															
__xx	Device selection Refer to table 5.8 for settings.	05h																															
_x__	For manufacturer setting	0h																															
x___		0h																															
<p style="text-align: center;">Table 5.8 Selectable output devices</p> <table border="1"> <thead> <tr> <th>Setting value</th> <th>Output device</th> </tr> </thead> <tbody> <tr><td>00</td><td>Always off</td></tr> <tr><td>02</td><td>RD (Ready)</td></tr> <tr><td>03</td><td>ALM (Malfunction)</td></tr> <tr><td>04</td><td>INP (In-position)</td></tr> <tr><td>05</td><td>MBR (Electromagnetic brake interlock)</td></tr> <tr><td>07</td><td>TLC (Limiting torque)</td></tr> <tr><td>08</td><td>WNG (Warning)</td></tr> <tr><td>09</td><td>BWNG (Battery warning)</td></tr> <tr><td>0A</td><td>SA (Speed reached)</td></tr> <tr><td>0C</td><td>ZSP (Zero speed detection)</td></tr> <tr><td>0F</td><td>CDPS (Variable gain selection)</td></tr> <tr><td>11</td><td>ABSV (Absolute position undetermined)</td></tr> <tr><td>17</td><td>MTTR (During tough drive)</td></tr> </tbody> </table>			Setting value	Output device	00	Always off	02	RD (Ready)	03	ALM (Malfunction)	04	INP (In-position)	05	MBR (Electromagnetic brake interlock)	07	TLC (Limiting torque)	08	WNG (Warning)	09	BWNG (Battery warning)	0A	SA (Speed reached)	0C	ZSP (Zero speed detection)	0F	CDPS (Variable gain selection)	11	ABSV (Absolute position undetermined)	17	MTTR (During tough drive)			
Setting value	Output device																																
00	Always off																																
02	RD (Ready)																																
03	ALM (Malfunction)																																
04	INP (In-position)																																
05	MBR (Electromagnetic brake interlock)																																
07	TLC (Limiting torque)																																
08	WNG (Warning)																																
09	BWNG (Battery warning)																																
0A	SA (Speed reached)																																
0C	ZSP (Zero speed detection)																																
0F	CDPS (Variable gain selection)																																
11	ABSV (Absolute position undetermined)																																
17	MTTR (During tough drive)																																

5. PARAMETERS

No.	Symbol	Name and function	Initial value (unit)	Setting range													
PD08	*DO2	Output device selection 2 You can assign any output device to the CN3-9 pin. INP (In-position) is assigned in the initial setting. The devices that can be assigned and the setting method are the same as in [Pr. PD07]. <table border="1" data-bbox="347 454 1230 640"> <thead> <tr> <th>Setting digit</th> <th>Explanation</th> <th>Initial value</th> </tr> </thead> <tbody> <tr> <td>__ x x</td> <td>Device selection Refer to table 5.8 in [Pr. PD07] for settings.</td> <td>04h</td> </tr> <tr> <td>_ x _ _</td> <td>For manufacturer setting</td> <td>0h</td> </tr> <tr> <td>X _ _ _</td> <td></td> <td>0h</td> </tr> </tbody> </table>	Setting digit	Explanation	Initial value	__ x x	Device selection Refer to table 5.8 in [Pr. PD07] for settings.	04h	_ x _ _	For manufacturer setting	0h	X _ _ _		0h	Refer to Name and function column.		
Setting digit	Explanation	Initial value															
__ x x	Device selection Refer to table 5.8 in [Pr. PD07] for settings.	04h															
_ x _ _	For manufacturer setting	0h															
X _ _ _		0h															
PD09	*DO3	Output device selection 3 You can assign any output device to the CN3-15 pin. ALM (Malfunction) is assigned in the initial setting. The devices that can be assigned and the setting method are the same as in [Pr. PD07]. <table border="1" data-bbox="347 808 1230 994"> <thead> <tr> <th>Setting digit</th> <th>Explanation</th> <th>Initial value</th> </tr> </thead> <tbody> <tr> <td>__ x x</td> <td>Device selection Refer to table 5.8 in [Pr. PD07] for settings.</td> <td>03h</td> </tr> <tr> <td>_ x _ _</td> <td>For manufacturer setting</td> <td>0h</td> </tr> <tr> <td>x _ _ _</td> <td></td> <td>0h</td> </tr> </tbody> </table>	Setting digit	Explanation	Initial value	__ x x	Device selection Refer to table 5.8 in [Pr. PD07] for settings.	03h	_ x _ _	For manufacturer setting	0h	x _ _ _		0h	Refer to Name and function column.		
Setting digit	Explanation	Initial value															
__ x x	Device selection Refer to table 5.8 in [Pr. PD07] for settings.	03h															
_ x _ _	For manufacturer setting	0h															
x _ _ _		0h															
PD12	*DOP1	Function selection D-1 <table border="1" data-bbox="347 1115 1230 1391"> <thead> <tr> <th>Setting digit</th> <th>Explanation</th> <th>Initial value</th> </tr> </thead> <tbody> <tr> <td>__ _ x</td> <td rowspan="3">For manufacturer setting</td> <td>0h</td> </tr> <tr> <td>__ x _</td> <td>0h</td> </tr> <tr> <td>_ x _ _</td> <td>0h</td> </tr> <tr> <td>x _ _ _</td> <td>Servo motor thermistor enabled/disabled selection 0: Enabled 1: Disabled For servo motors without thermistor, the setting will be disabled.</td> <td>0h</td> </tr> </tbody> </table>	Setting digit	Explanation	Initial value	__ _ x	For manufacturer setting	0h	__ x _	0h	_ x _ _	0h	x _ _ _	Servo motor thermistor enabled/disabled selection 0: Enabled 1: Disabled For servo motors without thermistor, the setting will be disabled.	0h	Refer to Name and function column.	
Setting digit	Explanation	Initial value															
__ _ x	For manufacturer setting	0h															
__ x _		0h															
_ x _ _		0h															
x _ _ _	Servo motor thermistor enabled/disabled selection 0: Enabled 1: Disabled For servo motors without thermistor, the setting will be disabled.	0h															

5. PARAMETERS

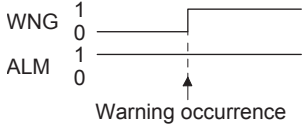
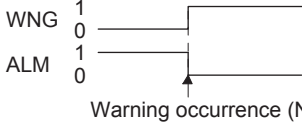
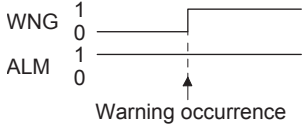
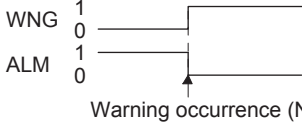
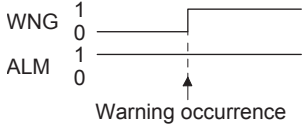
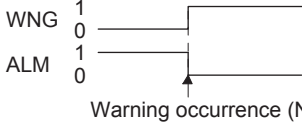
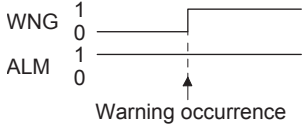
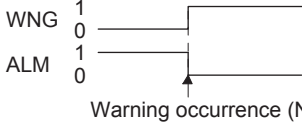
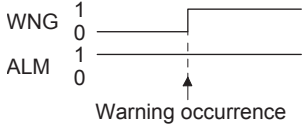
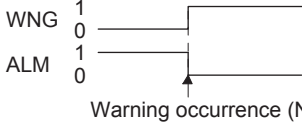
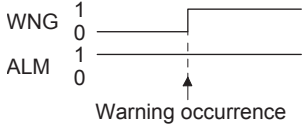
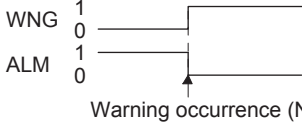
No.	Symbol	Name and function	Initial value (unit)	Setting range																							
PD14	*DOP3	Function selection D-3	Refer to Name and function column.																								
		<table border="1"> <thead> <tr> <th>Setting digit</th> <th>Explanation</th> <th>Initial value</th> </tr> </thead> <tbody> <tr> <td>___x</td> <td>For manufacturer setting</td> <td>0h</td> </tr> <tr> <td>__x_</td> <td>Selection of output device at warning occurrence Select WNG (Warning) and ALM (Malfunction) output status at warning occurrence. Servo amplifier output</td> <td>0h</td> </tr> <tr> <td></td> <td> <table border="1"> <thead> <tr> <th>Setting value</th> <th>(Note 1) Device status</th> </tr> </thead> <tbody> <tr> <td>0</td> <td>  <p>WNG 1 0 ALM 1 0 Warning occurrence</p> </td> </tr> <tr> <td>1</td> <td>  <p>WNG 1 0 ALM 1 0 Warning occurrence (Note 2)</p> </td> </tr> </tbody> </table> <p>Note 1.0: Off 1: On 2. Although ALM is turned off upon occurrence of the warning, the forced stop deceleration is performed.</p> </td> </tr> <tr> <td>_x__</td> <td>For manufacturer setting</td> <td>0h</td> </tr> <tr> <td>x___</td> <td></td> <td>0h</td> </tr> </tbody> </table>	Setting digit	Explanation	Initial value	___x	For manufacturer setting	0h	__x_	Selection of output device at warning occurrence Select WNG (Warning) and ALM (Malfunction) output status at warning occurrence. Servo amplifier output	0h		<table border="1"> <thead> <tr> <th>Setting value</th> <th>(Note 1) Device status</th> </tr> </thead> <tbody> <tr> <td>0</td> <td>  <p>WNG 1 0 ALM 1 0 Warning occurrence</p> </td> </tr> <tr> <td>1</td> <td>  <p>WNG 1 0 ALM 1 0 Warning occurrence (Note 2)</p> </td> </tr> </tbody> </table> <p>Note 1.0: Off 1: On 2. Although ALM is turned off upon occurrence of the warning, the forced stop deceleration is performed.</p>	Setting value	(Note 1) Device status	0	 <p>WNG 1 0 ALM 1 0 Warning occurrence</p>	1	 <p>WNG 1 0 ALM 1 0 Warning occurrence (Note 2)</p>	_x__	For manufacturer setting	0h	x___		0h		
Setting digit	Explanation	Initial value																									
___x	For manufacturer setting	0h																									
__x_	Selection of output device at warning occurrence Select WNG (Warning) and ALM (Malfunction) output status at warning occurrence. Servo amplifier output	0h																									
	<table border="1"> <thead> <tr> <th>Setting value</th> <th>(Note 1) Device status</th> </tr> </thead> <tbody> <tr> <td>0</td> <td>  <p>WNG 1 0 ALM 1 0 Warning occurrence</p> </td> </tr> <tr> <td>1</td> <td>  <p>WNG 1 0 ALM 1 0 Warning occurrence (Note 2)</p> </td> </tr> </tbody> </table> <p>Note 1.0: Off 1: On 2. Although ALM is turned off upon occurrence of the warning, the forced stop deceleration is performed.</p>	Setting value	(Note 1) Device status	0	 <p>WNG 1 0 ALM 1 0 Warning occurrence</p>	1	 <p>WNG 1 0 ALM 1 0 Warning occurrence (Note 2)</p>																				
Setting value	(Note 1) Device status																										
0	 <p>WNG 1 0 ALM 1 0 Warning occurrence</p>																										
1	 <p>WNG 1 0 ALM 1 0 Warning occurrence (Note 2)</p>																										
_x__	For manufacturer setting	0h																									
x___		0h																									

5. PARAMETERS

5.2.5 Extension setting 2 parameters ([Pr. PE_ _])

No.	Symbol	Name and function	Initial value (unit)	Setting range																					
PE01	**FCT1	Fully closed loop function selection 1 <table border="1"> <thead> <tr> <th>Setting digit</th> <th>Explanation</th> <th>Initial value</th> </tr> </thead> <tbody> <tr> <td>___x</td> <td> Fully closed loop function selection 0: Always enabled 1: Switching with the control command of controller (switching semi./full.) <table border="1"> <thead> <tr> <th>Switching with the control command of controller</th> <th>Control system</th> </tr> </thead> <tbody> <tr> <td>Off</td> <td>Semi closed loop control</td> </tr> <tr> <td>On</td> <td>Fully closed loop control</td> </tr> </tbody> </table> To enable the digit, select "Fully closed loop control mode (_ _ 1 _)" of "operation mode selection" in [Pr. PA01]. </td> <td>0h</td> </tr> <tr> <td>__x_</td> <td>For manufacturer setting</td> <td>0h</td> </tr> <tr> <td>_x__</td> <td></td> <td>0h</td> </tr> <tr> <td>x___</td> <td></td> <td>0h</td> </tr> </tbody> </table>	Setting digit	Explanation	Initial value	___x	Fully closed loop function selection 0: Always enabled 1: Switching with the control command of controller (switching semi./full.) <table border="1"> <thead> <tr> <th>Switching with the control command of controller</th> <th>Control system</th> </tr> </thead> <tbody> <tr> <td>Off</td> <td>Semi closed loop control</td> </tr> <tr> <td>On</td> <td>Fully closed loop control</td> </tr> </tbody> </table> To enable the digit, select "Fully closed loop control mode (_ _ 1 _)" of "operation mode selection" in [Pr. PA01].	Switching with the control command of controller	Control system	Off	Semi closed loop control	On	Fully closed loop control	0h	__x_	For manufacturer setting	0h	_x__		0h	x___		0h	Refer to Name and function column.	
Setting digit	Explanation	Initial value																							
___x	Fully closed loop function selection 0: Always enabled 1: Switching with the control command of controller (switching semi./full.) <table border="1"> <thead> <tr> <th>Switching with the control command of controller</th> <th>Control system</th> </tr> </thead> <tbody> <tr> <td>Off</td> <td>Semi closed loop control</td> </tr> <tr> <td>On</td> <td>Fully closed loop control</td> </tr> </tbody> </table> To enable the digit, select "Fully closed loop control mode (_ _ 1 _)" of "operation mode selection" in [Pr. PA01].	Switching with the control command of controller	Control system	Off	Semi closed loop control	On	Fully closed loop control	0h																	
Switching with the control command of controller	Control system																								
Off	Semi closed loop control																								
On	Fully closed loop control																								
__x_	For manufacturer setting	0h																							
_x__		0h																							
x___		0h																							
PE03	*FCT2	Fully closed loop function selection 2 <table border="1"> <thead> <tr> <th>Setting digit</th> <th>Explanation</th> <th>Initial value</th> </tr> </thead> <tbody> <tr> <td>___x</td> <td> Fully closed loop control error detection function selection 0: Disabled 1: Speed deviation error detection 2: Position deviation error detection 3: Speed deviation error/position deviation error detection </td> <td>3h</td> </tr> <tr> <td>__x_</td> <td> Position deviation error detection system selection 0: Continuous detection system 1: Detection system at stop (detected with command set to "0") </td> <td>0h</td> </tr> <tr> <td>_x__</td> <td>For manufacturer setting</td> <td>0h</td> </tr> <tr> <td>x___</td> <td> Fully closed loop control error reset selection 0: Reset disabled (reset by powering off/on enabled) 1: Reset enabled </td> <td>0h</td> </tr> </tbody> </table>	Setting digit	Explanation	Initial value	___x	Fully closed loop control error detection function selection 0: Disabled 1: Speed deviation error detection 2: Position deviation error detection 3: Speed deviation error/position deviation error detection	3h	__x_	Position deviation error detection system selection 0: Continuous detection system 1: Detection system at stop (detected with command set to "0")	0h	_x__	For manufacturer setting	0h	x___	Fully closed loop control error reset selection 0: Reset disabled (reset by powering off/on enabled) 1: Reset enabled	0h	Refer to Name and function column.							
Setting digit	Explanation	Initial value																							
___x	Fully closed loop control error detection function selection 0: Disabled 1: Speed deviation error detection 2: Position deviation error detection 3: Speed deviation error/position deviation error detection	3h																							
__x_	Position deviation error detection system selection 0: Continuous detection system 1: Detection system at stop (detected with command set to "0")	0h																							
_x__	For manufacturer setting	0h																							
x___	Fully closed loop control error reset selection 0: Reset disabled (reset by powering off/on enabled) 1: Reset enabled	0h																							
PE04	**FBN	Fully closed loop control - Feedback pulse electronic gear 1 - Numerator This is used to set a numerator of electronic gear for the servo motor encoder pulse at the fully closed loop control. Set the electronic gear so that the number of servo motor encoder pulses for one servo motor revolution is converted to the resolution of the load-side encoder.	1	1 to 65535																					
PE05	**FBD	Fully closed loop control - Feedback pulse electronic gear 1 - Denominator This is used to set a denominator of electronic gear for the servo motor encoder pulse at the fully closed loop control. Set the electronic gear so that the number of servo motor encoder pulses for one servo motor revolution is converted to the resolution of the load-side encoder.	1	1 to 65535																					
PE06	BC1	Fully closed loop control - Speed deviation error detection level This is used to set [AL. 42.2 Servo control error by speed deviation] of the fully closed loop control error detection. When the speed deviation between the servo motor encoder and load-side encoder becomes larger than the setting value, the alarm will occur.	400 r/min	1 to 50000																					

5. PARAMETERS

No.	Symbol	Name and function	Initial value (unit)	Setting range															
PE07	BC2	Fully closed loop control - Position deviation error detection level This is used to set [AL. 42.1 Servo control error by position deviation] of the fully closed loop control error detection. When the position deviation between the servo motor encoder and load-side encoder becomes larger than the setting value, the alarm will occur.	100 [kpulse]	1 to 20000															
PE08	DUF	Fully closed loop dual feedback filter This is used to set a dual feedback filter band.	10 [rad/s]	0 to 4500															
PE10	FCT3	Fully closed loop function selection 3 <table border="1" data-bbox="347 607 1230 1025"> <thead> <tr> <th>Setting digit</th> <th>Explanation</th> <th>Initial value</th> </tr> </thead> <tbody> <tr> <td>___ x</td> <td>For manufacturer setting</td> <td>0h</td> </tr> <tr> <td>__ x _</td> <td>Fully closed loop control - Position deviation error detection level - Unit selection 0: 1 kpulse unit 1: 1 pulse unit</td> <td>0h</td> </tr> <tr> <td>_ x __</td> <td>Droop pulse monitor selection for controller display 0: Servo motor encoder 1: Load-side encoder 2: Deviation between the servo motor and load side</td> <td>0h</td> </tr> <tr> <td>x ___</td> <td>Cumulative feedback pulses monitor selection for controller display 0: Servo motor encoder 1: Load-side encoder</td> <td>0h</td> </tr> </tbody> </table>	Setting digit	Explanation	Initial value	___ x	For manufacturer setting	0h	__ x _	Fully closed loop control - Position deviation error detection level - Unit selection 0: 1 kpulse unit 1: 1 pulse unit	0h	_ x __	Droop pulse monitor selection for controller display 0: Servo motor encoder 1: Load-side encoder 2: Deviation between the servo motor and load side	0h	x ___	Cumulative feedback pulses monitor selection for controller display 0: Servo motor encoder 1: Load-side encoder	0h	Refer to Name and function column.	
Setting digit	Explanation	Initial value																	
___ x	For manufacturer setting	0h																	
__ x _	Fully closed loop control - Position deviation error detection level - Unit selection 0: 1 kpulse unit 1: 1 pulse unit	0h																	
_ x __	Droop pulse monitor selection for controller display 0: Servo motor encoder 1: Load-side encoder 2: Deviation between the servo motor and load side	0h																	
x ___	Cumulative feedback pulses monitor selection for controller display 0: Servo motor encoder 1: Load-side encoder	0h																	
PE34	**FBN2	Fully closed loop control - Feedback pulse electronic gear 2 - Numerator This is used to set a numerator of electronic gear for the servo motor encoder pulse at the fully closed loop control. Set the electronic gear so that the number of servo motor encoder pulses for one servo motor revolution is converted to the resolution of the load-side encoder. Refer to section 16.3.1 (3) for details.	1	1 to 65535															
PE35	**FBD2	Fully closed loop control - Feedback pulse electronic gear 2 - Denominator This is used to set a denominator of electronic gear for the servo motor encoder pulse at the fully closed loop control. Set the electronic gear so that the number of servo motor encoder pulses for one servo motor revolution is converted to the resolution of the load-side encoder. Refer to section 16.3.1 (3) for details.	1	1 to 65535															
PE41	EOP3	Function selection E-3 <table border="1" data-bbox="347 1491 1230 1794"> <thead> <tr> <th>Setting digit</th> <th>Explanation</th> <th>Initial value</th> </tr> </thead> <tbody> <tr> <td>___ x</td> <td>Robust filter selection 0: Disabled 1: Enabled When you select "Enabled" of this digit, the machine resonance suppression filter 5 set in [Pr. PB51] is not available.</td> <td>0h</td> </tr> <tr> <td>__ x _</td> <td rowspan="3">For manufacturer setting</td> <td>0h</td> </tr> <tr> <td>_ x __</td> <td>0h</td> </tr> <tr> <td>x ___</td> <td>0h</td> </tr> </tbody> </table>	Setting digit	Explanation	Initial value	___ x	Robust filter selection 0: Disabled 1: Enabled When you select "Enabled" of this digit, the machine resonance suppression filter 5 set in [Pr. PB51] is not available.	0h	__ x _	For manufacturer setting	0h	_ x __	0h	x ___	0h	Refer to Name and function column.			
Setting digit	Explanation	Initial value																	
___ x	Robust filter selection 0: Disabled 1: Enabled When you select "Enabled" of this digit, the machine resonance suppression filter 5 set in [Pr. PB51] is not available.	0h																	
__ x _	For manufacturer setting	0h																	
_ x __		0h																	
x ___		0h																	

5. PARAMETERS

5.2.6 Extension setting 3 parameters ([Pr. PF__ _])

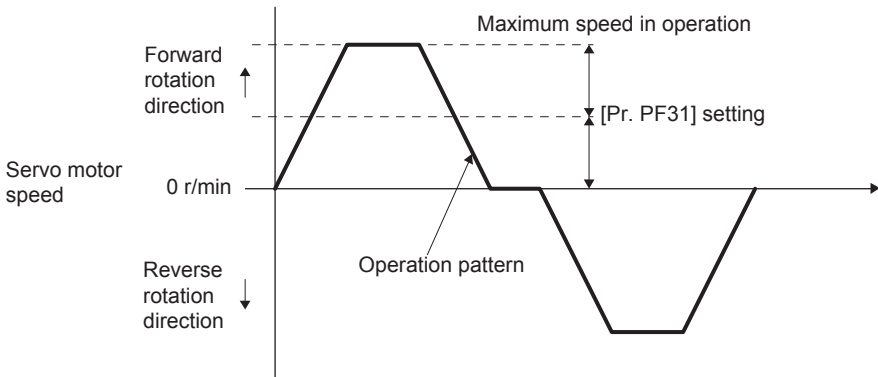
No.	Symbol	Name and function	Initial value (unit)	Setting range													
PF21	DRT	<p>Drive recorder switching time setting</p> <p>This is used to set a drive recorder switching time.</p> <p>When a USB communication is cut during using a graph function, the function will be changed to the drive recorder function after the setting time of this parameter.</p> <p>When a value from "1" to "32767" is set, it will switch after the setting value.</p> <p>However, when "0" is set, it will switch after 600 seconds.</p> <p>When "-1" is set, the drive recorder function is disabled.</p>	0 [s]	-1 to 32767													
PF23	OSCL1	<p>Vibration tough drive - Oscillation detection level</p> <p>This is used to set a filter readjustment sensitivity of [Pr. PB13 Machine resonance suppression filter 1] and [Pr. PB15 Machine resonance suppression filter 2] while the vibration tough drive is enabled.</p> <p>Example: When you set "50" to the parameter, the filter will be readjusted at the time of 50% or more oscillation level.</p>	50 [%]	0 to 100													
PF24	*OSCL2	<p>Vibration tough drive function selection</p> <table border="1" style="width: 100%; border-collapse: collapse;"> <thead> <tr> <th style="width: 15%;">Setting digit</th> <th style="width: 60%;">Explanation</th> <th style="width: 25%;">Initial value</th> </tr> </thead> <tbody> <tr> <td style="text-align: center;">_ _ _ x</td> <td> <p>Oscillation detection alarm selection</p> <p>0: [AL. 54 Oscillation detection] will occur at oscillation detection.</p> <p>1: [AL. F3.1 Oscillation detection warning] will occur at oscillation detection.</p> <p>2: Oscillation detection function disabled</p> <p>Select alarm or warning when a oscillation continues at a filter readjustment sensitivity level of [Pr. PF23].</p> <p>The digit is continuously enabled regardless of the vibration tough drive in [Pr. PA20].</p> </td> <td style="text-align: center;">0h</td> </tr> <tr> <td style="text-align: center;">_ _ x _</td> <td rowspan="3" style="text-align: center;">For manufacturer setting</td> <td style="text-align: center;">0h</td> </tr> <tr> <td style="text-align: center;">_ x _ _</td> <td style="text-align: center;">0h</td> </tr> <tr> <td style="text-align: center;">x _ _ _</td> <td style="text-align: center;">0h</td> </tr> </tbody> </table>	Setting digit	Explanation	Initial value	_ _ _ x	<p>Oscillation detection alarm selection</p> <p>0: [AL. 54 Oscillation detection] will occur at oscillation detection.</p> <p>1: [AL. F3.1 Oscillation detection warning] will occur at oscillation detection.</p> <p>2: Oscillation detection function disabled</p> <p>Select alarm or warning when a oscillation continues at a filter readjustment sensitivity level of [Pr. PF23].</p> <p>The digit is continuously enabled regardless of the vibration tough drive in [Pr. PA20].</p>	0h	_ _ x _	For manufacturer setting	0h	_ x _ _	0h	x _ _ _	0h	Refer to Name and function column.	
Setting digit	Explanation	Initial value															
_ _ _ x	<p>Oscillation detection alarm selection</p> <p>0: [AL. 54 Oscillation detection] will occur at oscillation detection.</p> <p>1: [AL. F3.1 Oscillation detection warning] will occur at oscillation detection.</p> <p>2: Oscillation detection function disabled</p> <p>Select alarm or warning when a oscillation continues at a filter readjustment sensitivity level of [Pr. PF23].</p> <p>The digit is continuously enabled regardless of the vibration tough drive in [Pr. PA20].</p>	0h															
_ _ x _	For manufacturer setting	0h															
_ x _ _		0h															
x _ _ _		0h															
PF25	CVAT	<p>Instantaneous power failure tough drive - Detection time</p> <p>Set the time of the [AL. 10.1 Voltage drop in the control power] occurrence.</p> <p>To disable the parameter, select "Disabled (_ 0 _)" of "Instantaneous power failure tough drive selection" in [Pr. PA20].</p>	200 [ms]	30 to 200													
PF31	FRIC	<p>Machine diagnosis function - Friction judgement speed</p> <p>Set a motor speed to divide a friction estimation area into high and low for the friction estimation process of the machine diagnosis.</p> <p>However, setting "0" will be the value half of the rated speed.</p> <p>When your operation pattern is under rated speed, we recommend that you set half value to the maximum speed with this.</p> <div style="text-align: center;">  </div>	0 [r/min]	0 to Permissible speed													

5. PARAMETERS

5.2.7 Linear servo motor/DD motor setting parameters ([Pr. PL_ _])

No.	Symbol	Name and function	Initial value (unit)	Setting range															
PL01	**LIT1	<p>Linear servo motor/DD motor function selection 1 Select a magnetic pole detection timing of the linear servo motor/DD motor and stop interval of the home position returning.</p> <table border="1"> <thead> <tr> <th>Setting digit</th> <th>Explanation</th> <th>Initial value</th> </tr> </thead> <tbody> <tr> <td>___x</td> <td> Linear servo motor/DD motor magnetic pole detection selection The setting value "0" will be enabled only with absolute position linear encoders. 0: Magnetic pole detection disabled 1: Magnetic pole detection at first servo-on 5: Magnetic pole detection at every servo-on </td> <td>1h</td> </tr> <tr> <td>__x_</td> <td>For manufacturer setting</td> <td>0h</td> </tr> <tr> <td>_x__</td> <td> Stop interval selection at the home position return Set a stop interval of the home position returning. The digit is enabled only for linear servo motors. 0: 2^{13} (= 8192) pulses 1: 2^{17} (= 131072) pulses 2: 2^{18} (= 262144) pulses 3: 2^{20} (= 1048576) pulses 4: 2^{22} (= 4194304) pulses 5: 2^{24} (= 16777216) pulses 6: 2^{26} (= 67108864) pulses </td> <td>3h</td> </tr> <tr> <td>x___</td> <td>For manufacturer setting</td> <td>0h</td> </tr> </tbody> </table>	Setting digit	Explanation	Initial value	___x	Linear servo motor/DD motor magnetic pole detection selection The setting value "0" will be enabled only with absolute position linear encoders. 0: Magnetic pole detection disabled 1: Magnetic pole detection at first servo-on 5: Magnetic pole detection at every servo-on	1h	__x_	For manufacturer setting	0h	_x__	Stop interval selection at the home position return Set a stop interval of the home position returning. The digit is enabled only for linear servo motors. 0: 2^{13} (= 8192) pulses 1: 2^{17} (= 131072) pulses 2: 2^{18} (= 262144) pulses 3: 2^{20} (= 1048576) pulses 4: 2^{22} (= 4194304) pulses 5: 2^{24} (= 16777216) pulses 6: 2^{26} (= 67108864) pulses	3h	x___	For manufacturer setting	0h	Refer to Name and function column.	
Setting digit	Explanation	Initial value																	
___x	Linear servo motor/DD motor magnetic pole detection selection The setting value "0" will be enabled only with absolute position linear encoders. 0: Magnetic pole detection disabled 1: Magnetic pole detection at first servo-on 5: Magnetic pole detection at every servo-on	1h																	
__x_	For manufacturer setting	0h																	
_x__	Stop interval selection at the home position return Set a stop interval of the home position returning. The digit is enabled only for linear servo motors. 0: 2^{13} (= 8192) pulses 1: 2^{17} (= 131072) pulses 2: 2^{18} (= 262144) pulses 3: 2^{20} (= 1048576) pulses 4: 2^{22} (= 4194304) pulses 5: 2^{24} (= 16777216) pulses 6: 2^{26} (= 67108864) pulses	3h																	
x___	For manufacturer setting	0h																	
PL02	**LIM	<p>Linear encoder resolution - Numerator Set a linear encoder resolution per μm in [Pr. PL02] and [Pr. PL03]. Set the numerator in [Pr. PL02]. This is enabled only for linear servo motors.</p>	1000 [μm]	1 to 65535															
PL03	**LID	<p>Linear encoder resolution - Denominator Set a linear encoder resolution per μm in [Pr. PL02] and [Pr. PL03]. Set the denominator in [Pr. PL03]. This is enabled only for linear servo motors.</p>	1000 [μm]	1 to 65535															

5. PARAMETERS

No.	Symbol	Name and function	Initial value (unit)	Setting range																																												
PL04	*LIT2	<p>Linear servo motor/DD motor function selection 2</p> <p>This is used to select a detection function and detection controller reset condition of [AL. 42 Servo control error].</p> <table border="1"> <thead> <tr> <th>Setting digit</th> <th>Explanation</th> <th>Initial value</th> </tr> </thead> <tbody> <tr> <td>___ x</td> <td>[AL. 42 Servo control error] detection function selection Refer to the following table.</td> <td>3h</td> </tr> <tr> <td></td> <td> <table border="1"> <thead> <tr> <th>Setting value</th> <th>Torque/thrust deviation error</th> <th>Speed deviation error</th> <th>Position deviation error</th> </tr> </thead> <tbody> <tr> <td>0</td> <td rowspan="3">Disabled</td> <td rowspan="2">Disabled</td> <td>Disabled</td> </tr> <tr> <td>1</td> <td>Enabled</td> </tr> <tr> <td>2</td> <td rowspan="2">Enabled</td> <td>Disabled</td> </tr> <tr> <td>3</td> <td>Enabled</td> </tr> <tr> <td>4</td> <td rowspan="4">Enabled</td> <td rowspan="2">Disabled</td> <td>Disabled</td> </tr> <tr> <td>5</td> <td>Enabled</td> </tr> <tr> <td>6</td> <td rowspan="2">Enabled</td> <td>Disabled</td> </tr> <tr> <td>7</td> <td>Enabled</td> </tr> </tbody> </table> </td> <td></td> </tr> <tr> <td>__ x _</td> <td>For manufacturer setting</td> <td>0h</td> </tr> <tr> <td>_ x _ _</td> <td></td> <td>0h</td> </tr> <tr> <td>x _ _ _</td> <td>[AL. 42 Servo control error] detection function controller reset condition selection 0: Reset disabled (reset by powering off/on enabled) 1: Reset enabled</td> <td>0h</td> </tr> </tbody> </table>	Setting digit	Explanation	Initial value	___ x	[AL. 42 Servo control error] detection function selection Refer to the following table.	3h		<table border="1"> <thead> <tr> <th>Setting value</th> <th>Torque/thrust deviation error</th> <th>Speed deviation error</th> <th>Position deviation error</th> </tr> </thead> <tbody> <tr> <td>0</td> <td rowspan="3">Disabled</td> <td rowspan="2">Disabled</td> <td>Disabled</td> </tr> <tr> <td>1</td> <td>Enabled</td> </tr> <tr> <td>2</td> <td rowspan="2">Enabled</td> <td>Disabled</td> </tr> <tr> <td>3</td> <td>Enabled</td> </tr> <tr> <td>4</td> <td rowspan="4">Enabled</td> <td rowspan="2">Disabled</td> <td>Disabled</td> </tr> <tr> <td>5</td> <td>Enabled</td> </tr> <tr> <td>6</td> <td rowspan="2">Enabled</td> <td>Disabled</td> </tr> <tr> <td>7</td> <td>Enabled</td> </tr> </tbody> </table>	Setting value	Torque/thrust deviation error	Speed deviation error	Position deviation error	0	Disabled	Disabled	Disabled	1	Enabled	2	Enabled	Disabled	3	Enabled	4	Enabled	Disabled	Disabled	5	Enabled	6	Enabled	Disabled	7	Enabled		__ x _	For manufacturer setting	0h	_ x _ _		0h	x _ _ _	[AL. 42 Servo control error] detection function controller reset condition selection 0: Reset disabled (reset by powering off/on enabled) 1: Reset enabled	0h	Refer to Name and function column.	
Setting digit	Explanation	Initial value																																														
___ x	[AL. 42 Servo control error] detection function selection Refer to the following table.	3h																																														
	<table border="1"> <thead> <tr> <th>Setting value</th> <th>Torque/thrust deviation error</th> <th>Speed deviation error</th> <th>Position deviation error</th> </tr> </thead> <tbody> <tr> <td>0</td> <td rowspan="3">Disabled</td> <td rowspan="2">Disabled</td> <td>Disabled</td> </tr> <tr> <td>1</td> <td>Enabled</td> </tr> <tr> <td>2</td> <td rowspan="2">Enabled</td> <td>Disabled</td> </tr> <tr> <td>3</td> <td>Enabled</td> </tr> <tr> <td>4</td> <td rowspan="4">Enabled</td> <td rowspan="2">Disabled</td> <td>Disabled</td> </tr> <tr> <td>5</td> <td>Enabled</td> </tr> <tr> <td>6</td> <td rowspan="2">Enabled</td> <td>Disabled</td> </tr> <tr> <td>7</td> <td>Enabled</td> </tr> </tbody> </table>	Setting value	Torque/thrust deviation error	Speed deviation error	Position deviation error	0	Disabled	Disabled	Disabled	1	Enabled	2	Enabled	Disabled	3	Enabled	4	Enabled	Disabled	Disabled	5	Enabled	6	Enabled	Disabled	7		Enabled																				
Setting value	Torque/thrust deviation error	Speed deviation error	Position deviation error																																													
0	Disabled	Disabled	Disabled																																													
1			Enabled																																													
2		Enabled	Disabled																																													
3	Enabled																																															
4	Enabled	Disabled	Disabled																																													
5			Enabled																																													
6		Enabled	Disabled																																													
7			Enabled																																													
__ x _	For manufacturer setting	0h																																														
_ x _ _		0h																																														
x _ _ _	[AL. 42 Servo control error] detection function controller reset condition selection 0: Reset disabled (reset by powering off/on enabled) 1: Reset enabled	0h																																														
PL05	LB1	<p>Position deviation error detection level</p> <p>This is used to set the position deviation error detection level of the servo control error detection.</p> <p>When the deviation between a model feedback position and actual feedback position is larger than the setting value, [AL. 42 Servo control error] will occur.</p> <p>However, when "0" is set, the level vary depending on the operation mode in [Pr. PA01].</p> <p>Linear servo motor: 50 mm Direct drive motor: 0.09 rev</p>	0 [mm]/ [0.01rev]	0 to 1000																																												
PL06	LB2	<p>Speed deviation error detection level</p> <p>This is used to set the speed deviation error detection level of the servo control error detection.</p> <p>When the deviation between a model feedback speed and actual feedback speed is larger than the setting value, [AL. 42 Servo control error] will occur.</p> <p>However, when "0" is set, the level vary depending on the operation mode in [Pr. PA01].</p> <p>Linear servo motor: 1000 mm/s Direct drive motor: 100 r/min</p>	0 [mm/s]/ [r/min]	0 to 5000																																												
PL07	LB3	<p>Torque/thrust deviation error detection level</p> <p>This is used to set the torque/thrust deviation error detection level of the servo control error detection.</p> <p>When the deviation between a current command and current feedback is larger than the setting value, [AL. 42.3 Servo control error by torque/thrust deviation] will occur.</p>	100 [%]	0 to 1000																																												

5. PARAMETERS

No.	Symbol	Name and function	Initial value (unit)	Setting range																																						
PL08	*LIT3	Linear servo motor/DD motor function selection 3 <table border="1"> <thead> <tr> <th>Setting digit</th> <th>Explanation</th> <th>Initial value</th> </tr> </thead> <tbody> <tr> <td>___x</td> <td>Magnetic pole detection method selection 0: Position detection method 4: Minute position detection method</td> <td>0h</td> </tr> <tr> <td>__x_</td> <td>For manufacturer setting</td> <td>1h</td> </tr> <tr> <td>_x__</td> <td>Magnetic pole detection - Stroke limit enabled/disabled selection 0: Enabled 1: Disabled</td> <td>0h</td> </tr> <tr> <td>x___</td> <td>For manufacturer setting</td> <td>0h</td> </tr> </tbody> </table>	Setting digit	Explanation	Initial value	___x	Magnetic pole detection method selection 0: Position detection method 4: Minute position detection method	0h	__x_	For manufacturer setting	1h	_x__	Magnetic pole detection - Stroke limit enabled/disabled selection 0: Enabled 1: Disabled	0h	x___	For manufacturer setting	0h	Refer to Name and function column.																								
Setting digit	Explanation	Initial value																																								
___x	Magnetic pole detection method selection 0: Position detection method 4: Minute position detection method	0h																																								
__x_	For manufacturer setting	1h																																								
_x__	Magnetic pole detection - Stroke limit enabled/disabled selection 0: Enabled 1: Disabled	0h																																								
x___	For manufacturer setting	0h																																								
PL09	LPWM	Magnetic pole detection voltage level This is used to set a direct current exciting voltage level during the magnetic pole detection. If [AL. 32 Overcurrent], [AL. 50 Overload 1], or [AL. 51 Overload 2] occurs during the magnetic pole detection, decrease the setting value. If [AL. 27 Initial magnetic pole detection error] occurs during the magnetic pole detection, increase the setting value.	30 [%]	0 to 100																																						
PL17	LTSTS	Magnetic pole detection - Minute position detection method - Function selection To enable the parameter, select "Minute position detection method (___4)" in [Pr. PL08]. <table border="1"> <thead> <tr> <th>Setting digit</th> <th>Explanation</th> <th>Initial value</th> </tr> </thead> <tbody> <tr> <td>___x</td> <td>Response selection Set a response of the minute position detection method. When reducing a travel distance at the magnetic pole detection, increase the setting value. Refer to table 5.9 for settings.</td> <td>0h</td> </tr> <tr> <td>__x_</td> <td>Load to motor mass ratio/load to motor inertia ratio selection Select a load to mass of the linear servo motor primary-side ratio or load to mass of the direct drive motor inertia ratio used at the minute position detection method. Set a closest value to the actual load. Refer to table 5.10 for settings.</td> <td>0h</td> </tr> <tr> <td>_x__</td> <td>For manufacturer setting</td> <td>0h</td> </tr> <tr> <td>x___</td> <td>For manufacturer setting</td> <td>0h</td> </tr> </tbody> </table> <p>Table 5.9 Response of minute position detection method at magnetic pole detection</p> <table border="1"> <thead> <tr> <th>Setting value</th> <th>Response</th> <th>Setting value</th> <th>Response</th> </tr> </thead> <tbody> <tr> <td>0</td> <td rowspan="7" style="text-align: center;"> Low response ↑ ↓ Middle response </td> <td>8</td> <td rowspan="7" style="text-align: center;"> Middle response ↑ ↓ High response </td> </tr> <tr> <td>1</td> <td>9</td> </tr> <tr> <td>2</td> <td>A</td> </tr> <tr> <td>3</td> <td>B</td> </tr> <tr> <td>4</td> <td>C</td> </tr> <tr> <td>5</td> <td>D</td> </tr> <tr> <td>6</td> <td>E</td> </tr> <tr> <td>7</td> <td>F</td> <td></td> </tr> </tbody> </table>	Setting digit	Explanation	Initial value	___x	Response selection Set a response of the minute position detection method. When reducing a travel distance at the magnetic pole detection, increase the setting value. Refer to table 5.9 for settings.	0h	__x_	Load to motor mass ratio/load to motor inertia ratio selection Select a load to mass of the linear servo motor primary-side ratio or load to mass of the direct drive motor inertia ratio used at the minute position detection method. Set a closest value to the actual load. Refer to table 5.10 for settings.	0h	_x__	For manufacturer setting	0h	x___	For manufacturer setting	0h	Setting value	Response	Setting value	Response	0	Low response ↑ ↓ Middle response	8	Middle response ↑ ↓ High response	1	9	2	A	3	B	4	C	5	D	6	E	7	F		Refer to Name and function column.	
Setting digit	Explanation	Initial value																																								
___x	Response selection Set a response of the minute position detection method. When reducing a travel distance at the magnetic pole detection, increase the setting value. Refer to table 5.9 for settings.	0h																																								
__x_	Load to motor mass ratio/load to motor inertia ratio selection Select a load to mass of the linear servo motor primary-side ratio or load to mass of the direct drive motor inertia ratio used at the minute position detection method. Set a closest value to the actual load. Refer to table 5.10 for settings.	0h																																								
_x__	For manufacturer setting	0h																																								
x___	For manufacturer setting	0h																																								
Setting value	Response	Setting value	Response																																							
0	Low response ↑ ↓ Middle response	8	Middle response ↑ ↓ High response																																							
1		9																																								
2		A																																								
3		B																																								
4		C																																								
5		D																																								
6		E																																								
7	F																																									

5. PARAMETERS

No.	Symbol	Name and function	Initial value (unit)	Setting range																																				
PL17	LTSTS	<p>Table 5.10 Load to motor mass ratio/load to motor inertia ratio</p> <table border="1"> <thead> <tr> <th>Setting value</th> <th>Load to motor mass ratio/load to motor inertia ratio</th> <th>Setting value</th> <th>Load to motor mass ratio/load to motor inertia ratio</th> </tr> </thead> <tbody> <tr> <td>0</td> <td>10 times or less</td> <td>8</td> <td>80 times</td> </tr> <tr> <td>1</td> <td>10 times</td> <td>9</td> <td>90 times</td> </tr> <tr> <td>2</td> <td>20 times</td> <td>A</td> <td>100 times</td> </tr> <tr> <td>3</td> <td>30 times</td> <td>B</td> <td>110 times</td> </tr> <tr> <td>4</td> <td>40 times</td> <td>C</td> <td>120 times</td> </tr> <tr> <td>5</td> <td>50 times</td> <td>D</td> <td>130 times</td> </tr> <tr> <td>6</td> <td>60 times</td> <td>E</td> <td>140 times</td> </tr> <tr> <td>7</td> <td>70 times</td> <td>F</td> <td>150 times or more</td> </tr> </tbody> </table>	Setting value	Load to motor mass ratio/load to motor inertia ratio	Setting value	Load to motor mass ratio/load to motor inertia ratio	0	10 times or less	8	80 times	1	10 times	9	90 times	2	20 times	A	100 times	3	30 times	B	110 times	4	40 times	C	120 times	5	50 times	D	130 times	6	60 times	E	140 times	7	70 times	F	150 times or more	Refer to Name and function column.	
Setting value	Load to motor mass ratio/load to motor inertia ratio	Setting value	Load to motor mass ratio/load to motor inertia ratio																																					
0	10 times or less	8	80 times																																					
1	10 times	9	90 times																																					
2	20 times	A	100 times																																					
3	30 times	B	110 times																																					
4	40 times	C	120 times																																					
5	50 times	D	130 times																																					
6	60 times	E	140 times																																					
7	70 times	F	150 times or more																																					
PL18	IDLV	<p>Magnetic pole detection - Minute position detection method - Identification signal amplitude</p> <p>Set an identification signal amplitude used in the minute position detection method.</p> <p>This parameter is enabled only when the magnetic pole detection is the minute position detection method.</p> <p>However, setting "0" will be 100% amplitude.</p>	0 [%]	0 to 100																																				

6. NORMAL GAIN ADJUSTMENT

6. NORMAL GAIN ADJUSTMENT

POINT
<ul style="list-style-type: none"> ● In the torque control mode, you do not need to make gain adjustment. ● Before making gain adjustment, check that your machine is not being operated at maximum torque of the servo motor. If operated over maximum torque, the machine may vibrate and may operate unexpectedly. In addition, make gain adjustment with a safety margin considering characteristic differences of each machine. It is recommended that generated torque during operation is under 90% of the maximum torque of the servo motor. ● When you use a linear servo motor, replace the following left words to the right words. <ul style="list-style-type: none"> Load to motor inertia ratio → Load to motor mass ratio Torque [N·m] → Thrust [N] (Servo motor) speed [r/min] → (Linear servo motor) speed [mm/s]

6.1 Different adjustment methods

6.1.1 Adjustment on a single servo amplifier

The following table shows the gain adjustment modes that can be set on a single servo amplifier. For gain adjustment, first execute "Auto tuning mode 1". If you are not satisfied with the result of the adjustment, execute "Auto tuning mode 2" and "Manual mode" in this order.

(1) Gain adjustment mode explanation

Gain adjustment mode	[Pr. PA08] setting	Estimation of load to motor inertia ratio	Automatically set parameters	Manually set parameters
Auto tuning mode 1 (initial value)	0 0 0 1	Always estimated	GD2 ([Pr. PB06]) PG1 ([Pr. PB07]) PG2 ([Pr. PB08]) VG2 ([Pr. PB09]) VIC ([Pr. PB10])	RSP ([Pr. PA09])
Auto tuning mode 2	0 0 0 2	Fixed to [Pr. PB06] value	PG1 ([Pr. PB07]) PG2 ([Pr. PB08]) VG2 ([Pr. PB09]) VIC ([Pr. PB10])	GD2 ([Pr. PB06]) RSP ([Pr. PA09])
Manual mode	0 0 0 3			GD2 ([Pr. PB06]) PG1 ([Pr. PB07]) PG2 ([Pr. PB08]) VG2 ([Pr. PB09]) VIC ([Pr. PB10])
2 gain mode 1 (interpolation mode)	0 0 0 0	Always estimated	GD2 ([Pr. PB06]) PG2 ([Pr. PB08]) VG2 ([Pr. PB09]) VIC ([Pr. PB10])	PG1 ([Pr. PB07]) RSP ([Pr. PA09])
2 gain adjustment mode 2	0 0 0 4	Fixed to [Pr. PB06] value	PG2 ([Pr. PB08]) VG2 ([Pr. PB09]) VIC ([Pr. PB10])	GD2 ([Pr. PB06]) PG1 ([Pr. PB07]) RSP ([Pr. PA09])

6. NORMAL GAIN ADJUSTMENT

(2) Adjustment sequence and mode usage

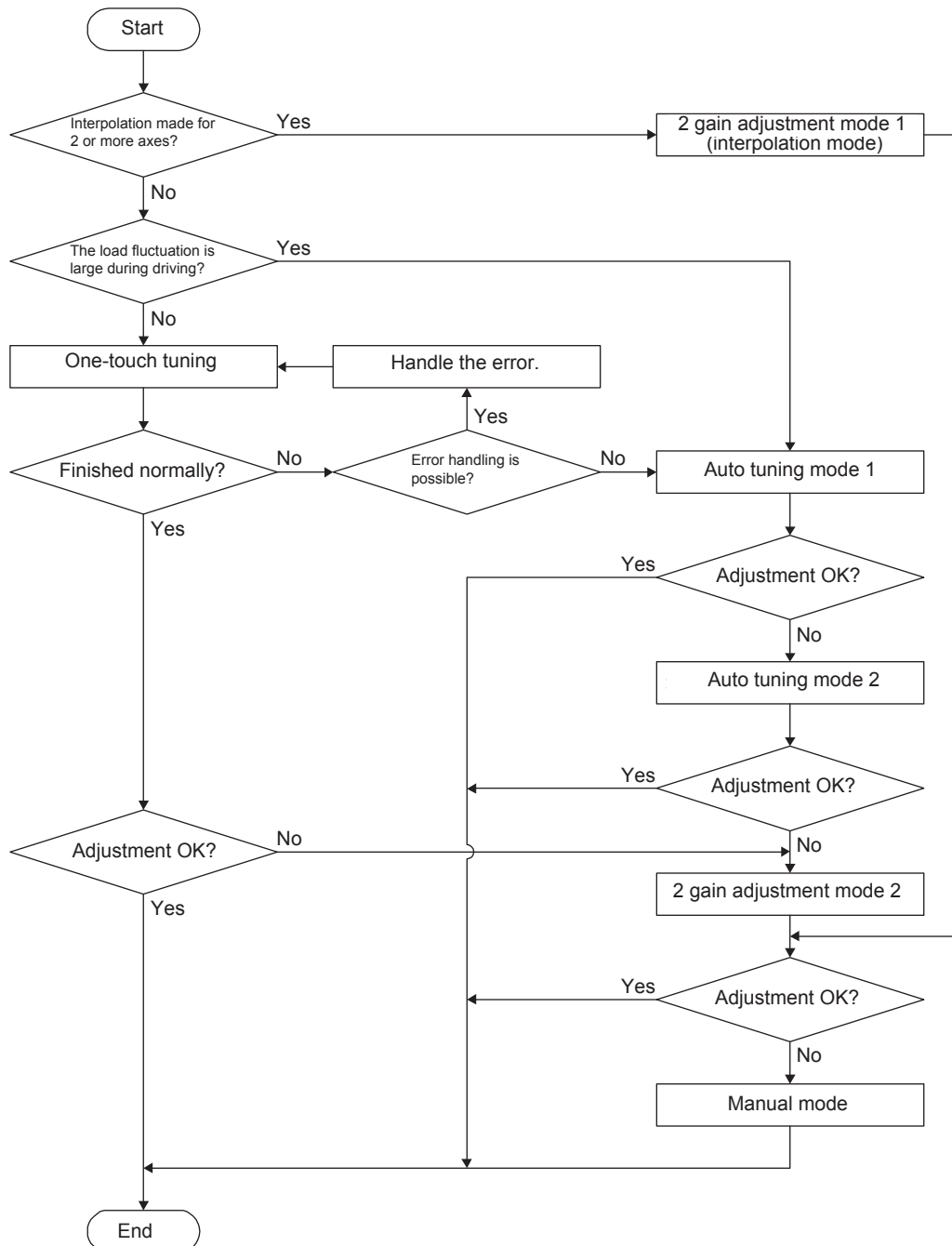

6.1.2 Adjustment using MR Configurator2

This section explains the functions and adjustment using the servo amplifier with MR Configurator2.

Function	Description	Adjustment
Machine analyzer	With the machine and servo motor coupled, the characteristic of the mechanical system can be measured by giving a random vibration command from a personal computer to the servo and measuring the machine response.	You can grasp the machine resonance frequency and determine the notch frequency of the machine resonance suppression filter.

6. NORMAL GAIN ADJUSTMENT

6.2 One-touch tuning

Connect Mr Configurator2 and open the one-touch tuning window, and you can use the function. The following parameters are set automatically with one-touch tuning.

Table 6.1 List of parameters automatically set with one-touch tuning

Parameter	Symbol	Name	Parameter	Symbol	Name
PA08	ATU	Auto tuning mode	PB16	NHQ2	Notch shape selection 2
PA09	RSP	Auto tuning response	PB18	LPF	Low-pass filter setting
PB01	FILT	Adaptive tuning mode (adaptive filter II)	PB19	VRF11	Vibration suppression control 1 - Vibration frequency
PB02	VRFT	Vibration suppression control tuning mode (advanced vibration suppression control II)	PB20	VRF12	Vibration suppression control 1 - Resonance frequency
PB06	GD2	Load to motor inertia ratio/load to motor mass ratio	PB21	VRF13	Vibration suppression control 1 - Vibration frequency damping setting
PB07	PG1	Model loop gain	PB22	VRF14	Vibration suppression control 1 - Resonance frequency damping setting
PB08	PG2	Position loop gain	PB23	VFBF	Low-pass filter selection
PB09	VG2	Speed loop gain	PB47	NHQ3	Notch shape selection 3
PB10	VIC	Speed integral compensation	PB48	NH4	Machine resonance suppression filter 4
PB12	OVA	Overshoot amount compensation	PB49	NHQ4	Notch shape selection 4
PB13	NH1	Machine resonance suppression filter 1	PB51	NHQ5	Notch shape selection 5
PB14	NHQ1	Notch shape selection 1	PE41	EOP3	Function selection E-3
PB15	NH2	Machine resonance suppression filter 2			

6.2.1 One-touch tuning flowchart

Make one-touch tuning as follows.

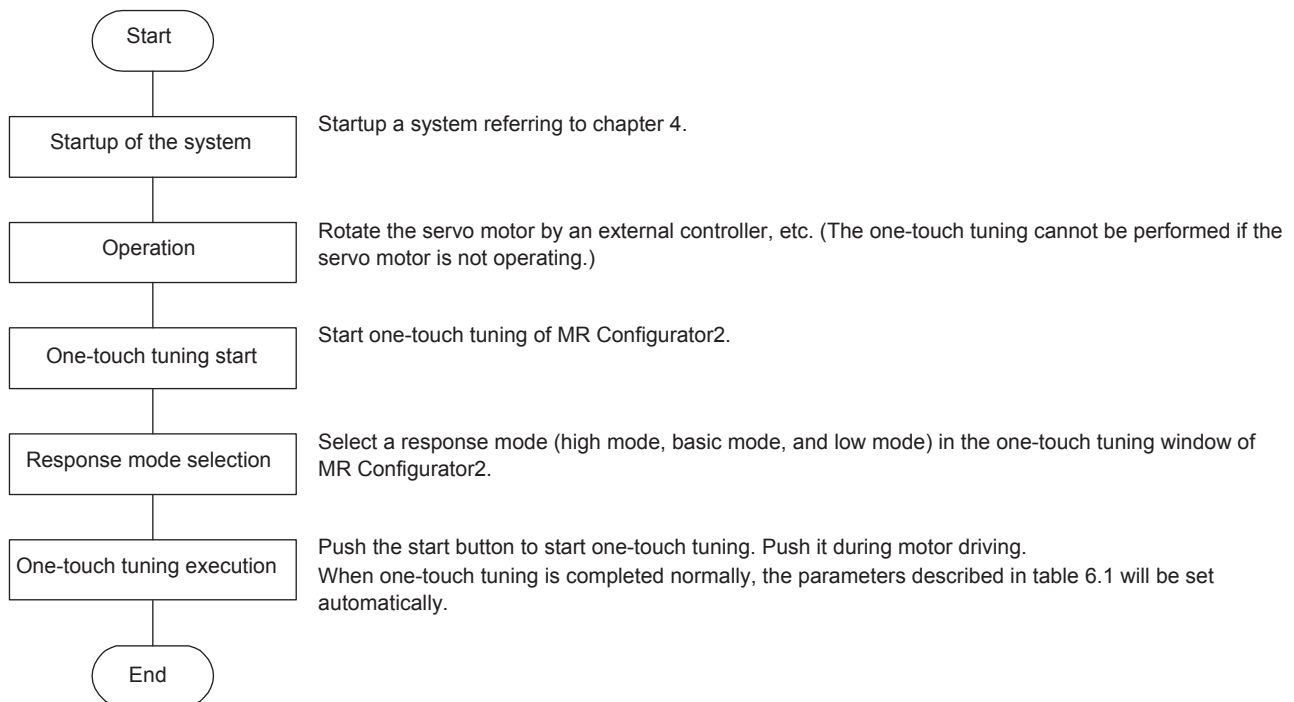

6. NORMAL GAIN ADJUSTMENT

6.2.2 Display transition and operation procedure of one-touch tuning

(1) Response mode selection

Select a response mode from 3 modes in the one-touch tuning window of MR Configurator2.

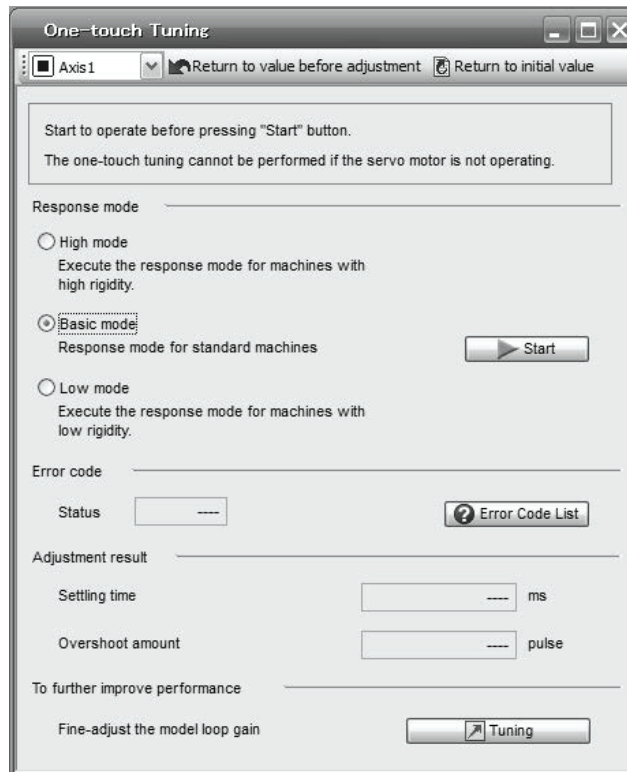

Response mode	Explanation
High mode	This mode is for high rigid system.
Basic mode	This mode is for normal system.
Low mode	This mode is for low rigid system.

Refer to the following table for selecting a response mode.

6. NORMAL GAIN ADJUSTMENT

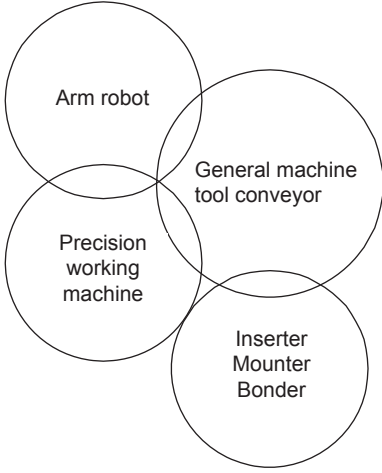
Response mode			Response	Machine characteristic
Low mode	Basic mode	High mode		Guideline of corresponding machine
↑ ↓	↑ ↓	↑ ↓	↑ ↓ Low response High response	 <p>Arm robot</p> <p>General machine tool conveyor</p> <p>Precision working machine</p> <p>Inserter Mounter Bonder</p>

6. NORMAL GAIN ADJUSTMENT

(2) One-touch tuning execution

After the response mode is selected in (1), pushing the start button during driving will start one-touch tuning. If the start button is pushed while the motor stops, "C 0 0 2" or "C 0 0 4" will be displayed at status in error code. (Refer to (4) in this section for error codes.)

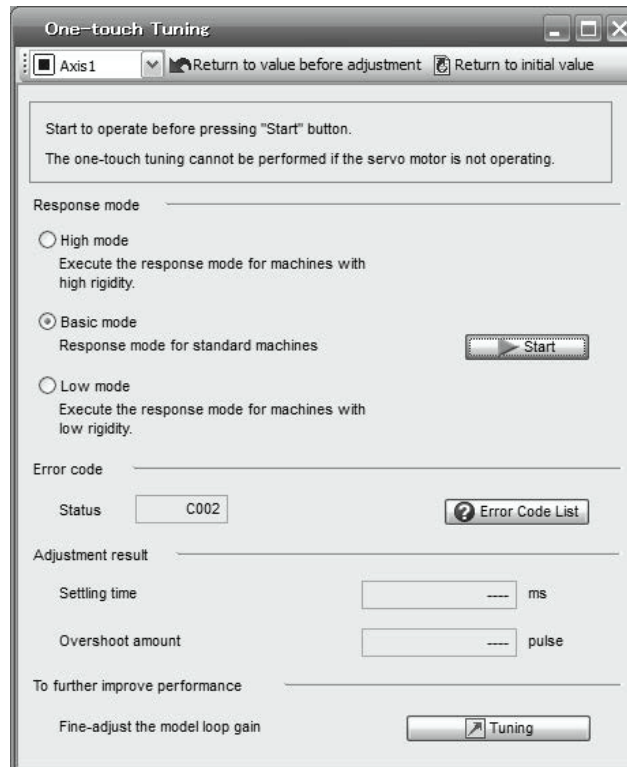

During processing of one-touch tuning, the status will be displayed in the progress window as follows. One-touch tuning will be finished at 100%.



Completing the one-touch tuning starts writing tuning parameters to the servo amplifier. "0 0 0 0" is displayed at status in error code. In addition, settling time and overshoot amount will be displayed in "Adjustment result" after adjustment.

6. NORMAL GAIN ADJUSTMENT

(3) One-touch tuning execution

During one-touch tuning, pushing the stop button stops one-touch tuning.

If the one-touch tuning is stopped, "C 0 0 0" will be displayed at status in error code.

(4) If an error occur

If a tuning error occurs during tuning, one-touch tuning will be forcibly terminated. With that, the following error code will be displayed in status. Check the cause of adjustment error.

Error code	Name	Description	Action
C000	Tuning canceled	The stop button was pushed during one-touch tuning.	
C001	Overshoot exceeded	The overshoot amount is larger than the value set in [Pr. PA10 In-position range].	Increase the in-position range.
C002	Servo-off during tuning	The one-touch tuning was attempted during servo-off.	Perform the one-touch tuning after servo-on.
C003	Control mode error	The one-touch tuning was attempted while the torque control mode was selected in the control modes.	Select the position control mode or speed control mode for the control mode from the controller, and then make one-touch tuning.
C004	Time-out	1. 1 cycle time during the operation has been over 30 s.	Set the 1 cycle time during the operation to 30 s or less.
		2. The command speed is low.	Set the servo motor speed to 100 r/min or higher.
		3. The operation interval of the continuous operation is short.	Maintain the operation interval during motor driving about 200 ms.
C005	Load to motor inertia ratio misestimated	1. The estimation of the load to motor inertia ratio at one-touch tuning was a failure.	Drive the motor with meeting conditions as follows. <ul style="list-style-type: none"> ▪ Time to reach 2000 r/min is the acceleration/deceleration time constant of 5 s or less. ▪ Speed is 150 r/min or higher. ▪ The load to motor inertia ratio is 100 times or less. ▪ The acceleration/deceleration torque is 10% or more of the rated torque.
		2. The load to motor inertia ratio was not estimated due to such as an oscillation.	Set to the auto tuning mode that does not estimate the load to motor inertia ratio as follows, and then execute the one-touch tuning. <ul style="list-style-type: none"> ▪ Select "Auto tuning mode 2 (_ _ _ 2)", "Manual mode (_ _ _ 3)", or "2 gain adjustment mode 2 (_ _ _ 4)" of "Gain adjustment mode selection" in [Pr. PA08]. ▪ Set [Pr. PB06 Load to motor inertia ratio/load to motor mass ratio] properly with manual setting.
C00F	One-touch tuning disabled	"One-touch tuning function selection" in [Pr. PA21] is "Disabled (_ _ _ 0)"	Select "Enabled (_ _ _ 1)".

(5) If an alarm occur

If an alarm occurs during tuning, one-touch tuning will be forcibly terminated.

(6) If a warning occur

If a warning which continue the motor driving occurs during the tuning, one-touch tuning will be continued. If a warning which does not continue the motor driving occurs during the tuning, one-touch tuning will be stopped.

6. NORMAL GAIN ADJUSTMENT

(7) Clearing one-touch tuning

You can clear the parameter values set with one-touch tuning.

Refer to table 6.1 for the parameters which you can clear.

Pushing "Return to before tuning" in the one-touch tuning window of MR Configurator2 enables to rewrite the parameter to the value before pushing the start button.

In addition, pushing "Return to initial value" in the one-touch tuning window enables to rewrite the parameter to the initial value.

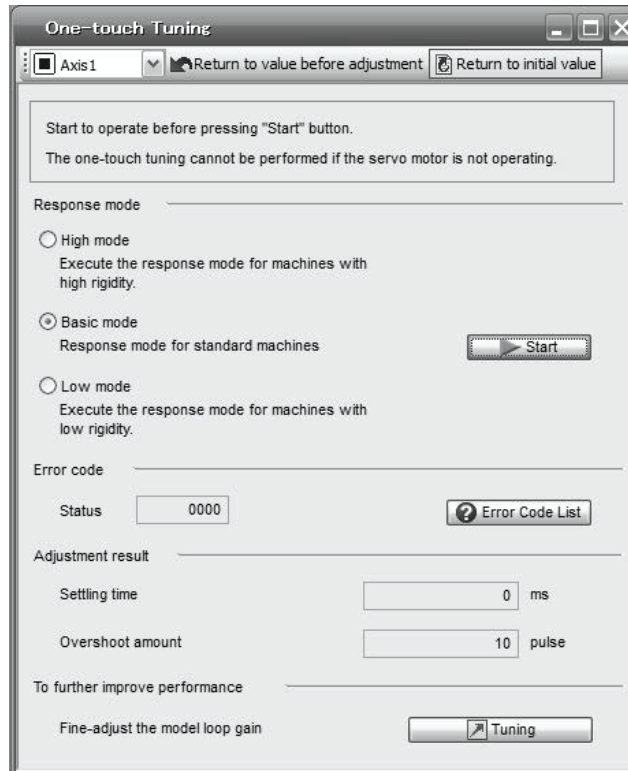

Clearing one-touch tuning is completed, the following window will be displayed. (returning to initial value)



6.2.3 Caution for one-touch tuning

- (1) The tuning is not available in the torque control mode.
- (2) The one-touch tuning cannot be executed while an alarm or warning which does not continue the motor driving is occurring.
- (3) The tuning is not available during the following test operation mode.
 - (a) Output signal (DO) forced output
 - (b) Motor-less operation

6. NORMAL GAIN ADJUSTMENT

6.3 Auto tuning

6.3.1 Auto tuning mode

The servo amplifier has a real-time auto tuning function which estimates the machine characteristic (load to motor inertia ratio) in real time and automatically sets the optimum gains according to that value. This function permits ease of gain adjustment of the servo amplifier.

(1) Auto tuning mode 1

The servo amplifier is factory-set to the auto tuning mode 1.

In this mode, the load to motor inertia ratio of a machine is always estimated to set the optimum gains automatically.

The following parameters are automatically adjusted in the auto tuning mode 1.

Parameter	Symbol	Name
PB06	GD2	Load to motor inertia ratio/load to motor mass ratio
PB07	PG1	Model loop gain
PB08	PG2	Position loop gain
PB09	VG2	Speed loop gain
PB10	VIC	Speed integral compensation

POINT
<ul style="list-style-type: none"> ● The auto tuning mode 1 may not be performed properly if all of the following conditions are not satisfied. <ul style="list-style-type: none"> ▪ Time to reach 2000 r/min is the acceleration/deceleration time constant of 5 s or less. ▪ Speed is 150 r/min or higher. ▪ The load to motor inertia ratio is 100 times or less. ▪ The acceleration/deceleration torque is 10% or more of the rated torque. ● Under operating conditions which will impose sudden disturbance torque during acceleration/deceleration or on a machine which is extremely loose, auto tuning may not function properly, either. In such cases, use the auto tuning mode 2 or manual mode to make gain adjustment.

(2) Auto tuning mode 2

Use the auto tuning mode 2 when proper gain adjustment cannot be made by auto tuning mode 1. Since the load to motor inertia ratio is not estimated in this mode, set the value of a correct load to motor inertia ratio in [Pr. PB06].

The following parameters are automatically adjusted in the auto tuning mode 2.

Parameter	Symbol	Name
PB07	PG1	Model loop gain
PB08	PG2	Position loop gain
PB09	VG2	Speed loop gain
PB10	VIC	Speed integral compensation

6. NORMAL GAIN ADJUSTMENT

6.3.2 Auto tuning mode basis

The block diagram of real-time auto tuning is shown below.

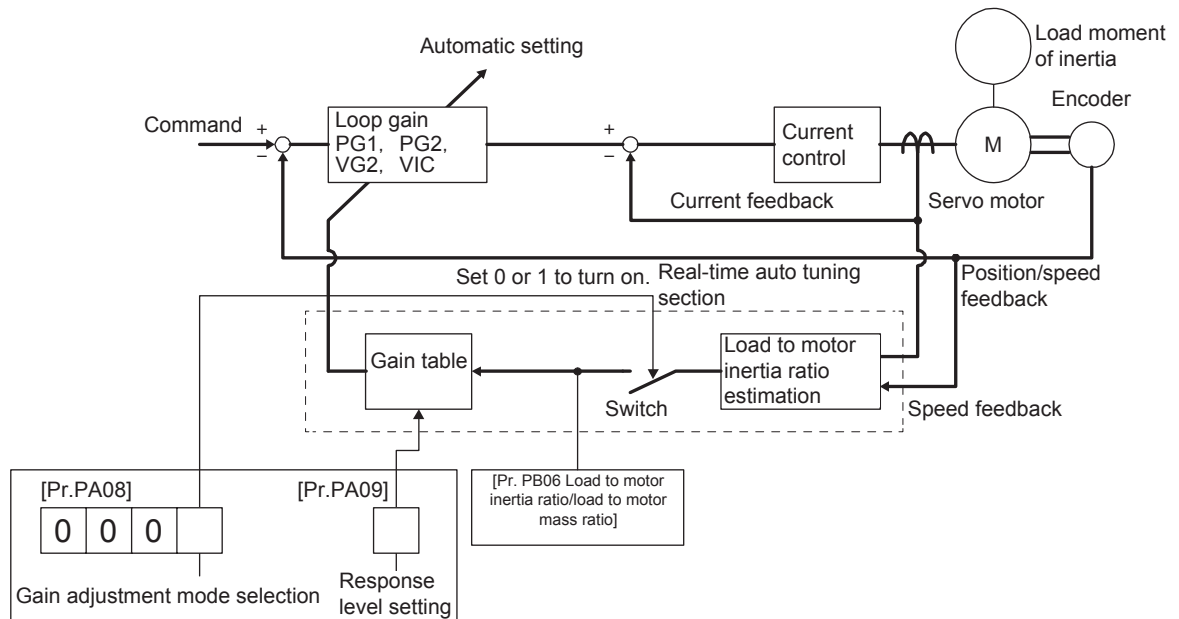

When a servo motor is accelerated/decelerated, the moment of inertia ratio estimation section always estimates the load to motor inertia ratio from the current and speed of the servo motor. The results of estimation are written to [Pr. PB06 Load to motor inertia ratio/load to motor mass ratio]. These results can be confirmed on the status display screen of the MR Configurator2.

If the value of the load to motor inertia ratio is already known or if estimation cannot be made properly, set "Gain adjustment mode selection" to "Auto tuning mode 2 (0 0 0 2)" in [Pr. PA08] to stop the estimation (turning off the switch in above diagram), and set the load to motor inertia ratio or load to motor mass ratio ([Pr. PB06]) manually.

From the preset load to motor inertia ratio [Pr. PB06] value and response [Pr. PA09], the optimum loop gains are automatically set on the basis of the internal gain table.

The auto tuning results are saved in the EEPROM of the servo amplifier every 60 minutes since power-on. At power-on, auto tuning is performed with the value of each loop gain saved in the EEPROM being used as an initial value.

POINT
<ul style="list-style-type: none"> ● If sudden disturbance torque is imposed during operation, the load to motor inertia ratio may be misestimated temporarily. In such a case, set "Gain adjustment mode selection" to "Auto tuning mode 2 (0 0 0 2)" in [Pr. PA08] and then set the correct load to motor inertia ratio in [Pr. PB06]. ● When any of the auto tuning mode 1 and auto tuning mode settings is changed to the manual mode 2 setting, the current loop gains and load to motor inertia ratio estimation value are saved in the EEPROM.

6. NORMAL GAIN ADJUSTMENT

6.3.3 Adjustment procedure by auto tuning

Since auto tuning is made valid before shipment from the factory, simply running the servo motor automatically sets the optimum gains that match the machine. Merely changing the response level setting value as required completes the adjustment. The adjustment procedure is as follows.

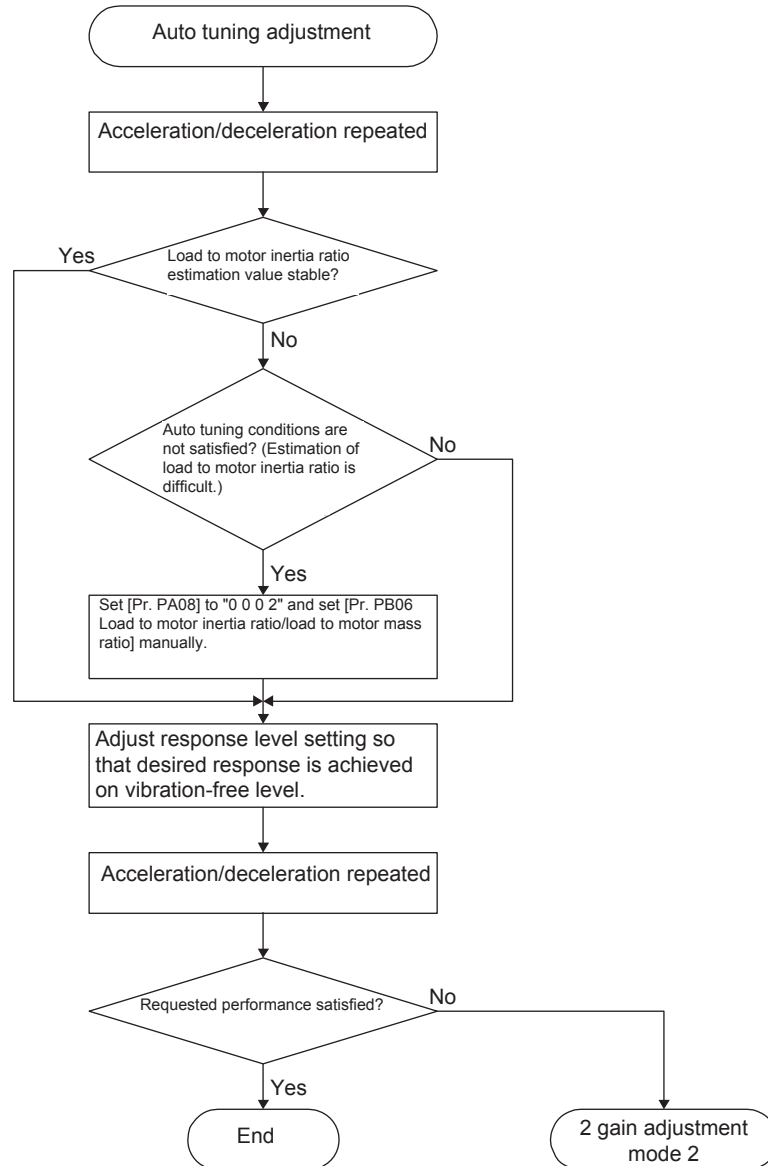

6. NORMAL GAIN ADJUSTMENT

6.3.4 Response level setting in auto tuning mode

Set the response of the whole servo system by [Pr. PA09]. As the response level setting is increased, the track ability and settling time for a command decreases, but a too high response level will generate vibration. Hence, make setting until desired response is obtained within the vibration-free range.

If the response level setting cannot be increased up to the desired response because of machine resonance beyond 100 Hz, filter tuning mode selection in [Pr. PB01] or machine resonance suppression filter in [Pr. PB13] to [Pr. PB16], [Pr. PB46] to [Pr. PB51] may be used to suppress machine resonance. Suppressing machine resonance may allow the response level setting to increase. Refer to section 7.2 and 7.3 for settings of the adaptive tuning mode and machine resonance suppression filter.

[Pr. PA09]

Setting value	Machine characteristic		Setting value	Machine characteristic	
	Response	Guideline for machine resonance frequency [Hz]		Response	Guideline for machine resonance frequency [Hz]
1	Low response ↑ ↓ Middle response	2.7	21	Middle response ↑ ↓ High response	67.1
2		3.6	22		75.6
3		4.9	23		85.2
4		6.6	24		95.9
5		10.0	25		108.0
6		11.3	26		121.7
7		12.7	27		137.1
8		14.3	28		154.4
9		16.1	29		173.9
10		18.1	30		195.9
11		20.4	31		220.6
12		23.0	32		248.5
13		25.9	33		279.9
14		29.2	34		315.3
15		32.9	35		355.1
16		37.0	36		400.0
17		41.7	37		446.6
18		47.0	38		501.2
19		52.9	39		571.5
20	Middle response	59.6	40		High response

6. NORMAL GAIN ADJUSTMENT

6.4 Manual mode

If you are not satisfied with the adjustment of auto tuning, you can make simple manual adjustment with three parameters.

POINT
<ul style="list-style-type: none"> ● If machine resonance occurs, filter tuning mode selection in [Pr. PB01] or machine resonance suppression filter in [Pr. PB13] to [Pr. PB16] and [Pr. PB46] to [Pr. PB51] may be used to suppress machine resonance. (Refer to section 7.2 to 7.3.)

(1) For speed control

(a) Parameter

The following parameters are used for gain adjustment.

Parameter	Symbol	Name
PB06	GD2	Load to motor inertia ratio/load to motor mass ratio
PB07	PG1	Model loop gain
PB09	VG2	Speed loop gain
PB10	VIC	Speed integral compensation

(b) Adjustment procedure

Step	Operation	Description
1	Brief-adjust with auto tuning. Refer to section 6.2.3.	
2	Change the setting of auto tuning to the manual mode ([Pr. PA08]: 0 0 0 3).	
3	Set the estimated value to the load to motor inertia ratio/load to motor mass ratio. (If the estimate value with auto tuning is correct, setting change is not required.)	
4	Set a slightly smaller value to the model loop gain Set a slightly larger value to the speed integral compensation.	
5	Increase the speed loop gain within the vibration- and unusual noise-free range, and return slightly if vibration takes place.	Increase the speed loop gain.
6	Decrease the speed integral compensation within the vibration-free range, and return slightly if vibration takes place.	Decrease the time constant of the speed integral compensation.
7	Increase the model loop gain, and return slightly if overshoot takes place.	Increase the model loop gain.
8	If the gains cannot be increased due to mechanical system resonance or the like and the desired response cannot be achieved, response may be increased by suppressing resonance with the adaptive tuning mode or machine resonance suppression filter and then executing steps 3 to 7.	Suppression of machine resonance Refer to section 7.2 and 7.3.
9	While checking the motor status, fine-adjust each gain.	Fine adjustment

6. NORMAL GAIN ADJUSTMENT

(c) Parameter adjustment

1) [Pr. PB09 Speed loop gain]

This parameter determines the response level of the speed control loop. Increasing this value enhances response but a too high value will make the mechanical system liable to vibrate. The actual response frequency of the speed loop is as indicated in the following expression.

$$\text{Speed loop response frequency [Hz]} = \frac{\text{Speed loop gain setting}}{(1 + \text{Load to motor inertia ratio}) \times 2\pi}$$

2) [Pr. PB10 Speed integral compensation]

To eliminate stationary deviation against a command, the speed control loop is under proportional integral control. For the speed integral compensation, set the time constant of this integral control. Increasing the setting lowers the response level. However, if the load to motor inertia ratio is large or the mechanical system has any vibratory element, the mechanical system is liable to vibrate unless the setting is increased to some degree. The guideline is as indicated in the following expression.

$$\geq \frac{\text{Speed integral compensation setting [ms]} \quad 2000 \sim 3000}{\text{Speed loop gain setting} / (1 + \text{Load to motor inertia ratio setting})}$$

3) [Pr. PB07 Model loop gain]

This parameter determines the response level to a speed command. Increasing the value improves track ability to a speed command, but a too high value will make overshoot liable to occur at settling.

$$\text{Model loop gain guideline} \leq \frac{\text{Speed loop gain setting}}{(1 + \text{Load to motor inertia ratio}) \times 2\pi} \times \left(\frac{1}{4} \sim \frac{1}{8} \right)$$

(2) For position control

(a) Parameter

The following parameters are used for gain adjustment.

Parameter	Symbol	Name
PB06	GD2	Load to motor inertia ratio/load to motor mass ratio
PB07	PG1	Model loop gain
PB08	PG2	Position loop gain
PB09	VG2	Speed loop gain
PB10	VIC	Speed integral compensation

6. NORMAL GAIN ADJUSTMENT

(b) Adjustment procedure

Step	Operation	Description
1	Brief-adjust with auto tuning. Refer to section 6.2.3.	
2	Change the setting of auto tuning to the manual mode ([Pr. PA08]: 0 0 0 3).	
3	Set the estimated value to the load to motor inertia ratio/load to motor mass ratio. (If the estimate value with auto tuning is correct, setting change is not required.)	
4	Set a slightly smaller value to the model loop gain and the position loop gain. Set a slightly larger value to the speed integral compensation.	
5	Increase the speed loop gain within the vibration- and unusual noise-free range, and return slightly if vibration takes place.	Increase the speed loop gain.
6	Decrease the speed integral compensation within the vibration-free range, and return slightly if vibration takes place.	Decrease the time constant of the speed integral compensation.
7	Increase the position loop gain, and return slightly if vibration takes place.	Increase the position loop gain.
8	Increase the model loop gain, and return slightly if overshoot takes place.	Increase the model loop gain.
9	If the gains cannot be increased due to mechanical system resonance or the like and the desired response cannot be achieved, response may be increased by suppressing resonance with the adaptive tuning mode or machine resonance suppression filter and then executing steps 3 to 8.	Suppression of machine resonance Refer to section 7.2 and 7.3.
10	While checking the settling characteristic and motor status, fine-adjust each gain.	Fine adjustment

(c) Parameter adjustment

1) [Pr. PB09 Speed loop gain]

This parameter determines the response level of the speed control loop. Increasing this value enhances response but a too high value will make the mechanical system liable to vibrate. The actual response frequency of the speed loop is as indicated in the following expression.

$$\text{Speed loop response frequency [Hz]} = \frac{\text{Speed loop gain setting}}{(1 + \text{Load to motor inertia ratio}) \times 2\pi}$$

2) [Pr. PB10 Speed integral compensation]

To eliminate stationary deviation against a command, the speed control loop is under proportional integral control. For the speed integral compensation, set the time constant of this integral control. Increasing the setting lowers the response level. However, if the load to motor inertia ratio is large or the mechanical system has any vibratory element, the mechanical system is liable to vibrate unless the setting is increased to some degree. The guideline is as indicated in the following expression.

$$\geq \frac{\text{Speed integral compensation setting [ms]} \quad 2000 \sim 3000}{\text{Speed loop gain setting}/(1 + \text{Load to motor inertia ratio setting})}$$

6. NORMAL GAIN ADJUSTMENT

3) [Pr. PB08 Position loop gain]

This parameter determines the response level to a disturbance to the position control loop. Increasing the value increases the response level to the disturbance, but a too high value will increase vibration of the mechanical system.

$$\text{Position loop gain guideline} \leq \frac{\text{Speed loop gain setting}}{(1 + \text{Load to motor inertia ratio}) \times 2\pi} \times \left(\frac{1}{4} \sim \frac{1}{8} \right)$$

4) [Pr. PB07 Model loop gain]

This parameter determines the response level to a position command. Increasing the value improves track ability to a position command, but a too high value will make overshoot liable to occur at settling.

$$\text{Model loop gain guideline} \leq \frac{\text{Speed loop gain setting}}{(1 + \text{Load to motor inertia ratio}) \times 2\pi} \times \left(\frac{1}{4} \sim \frac{1}{8} \right)$$

6. NORMAL GAIN ADJUSTMENT

6.5 2 gain adjustment mode

The 2 gain adjustment mode is used to match the position loop gains of the axes when performing the interpolation operation of servo motors of two or more axes for an X-Y table or the like. In this mode, manually set the model loop gain that determines command track ability. Other parameters for gain adjustment are set automatically.

(1) 2 gain adjustment mode 1 (interpolation mode)

The 2 gain adjustment mode 1 manually set the model loop gain that determines command track ability. The mode constantly estimates the load to motor inertia ratio, and automatically set other parameters for gain adjustment to optimum gains using auto tuning response.

The following parameters are used for 2 gain adjustment mode 1.

(a) Automatically adjusted parameter

The following parameters are automatically adjusted by auto tuning.

Parameter	Symbol	Name
PB06	GD2	Load to motor inertia ratio/load to motor mass ratio
PB08	PG2	Position loop gain
PB09	VG2	Speed loop gain
PB10	VIC	Speed integral compensation

(b) Manually adjusted parameter

The following parameters are adjustable manually.

Parameter	Symbol	Name
PA09	RSP	Auto tuning response
PB07	PG1	Model loop gain

(2) 2 gain adjustment mode 2

Use 2 gain adjustment mode 2 when proper gain adjustment cannot be made with 2 gain adjustment mode 1. Since the load to motor inertia ratio is not estimated in this mode, set the value of a proper load to motor inertia ratio in [Pr. PB06].

The following parameters are used for 2 gain adjustment mode 2.

(a) Automatically adjusted parameter

The following parameters are automatically adjusted by auto tuning.

Parameter	Symbol	Name
PB08	PG2	Position loop gain
PB09	VG2	Speed loop gain
PB10	VIC	Speed integral compensation

(b) Manually adjusted parameter

The following parameters are adjustable manually.

Parameter	Symbol	Name
PA09	RSP	Auto tuning response
PB06	GD2	Load to motor inertia ratio/load to motor mass ratio
PB07	PG1	Model loop gain

6. NORMAL GAIN ADJUSTMENT

(3) Adjustment procedure of 2 gain adjustment mode

POINT
<ul style="list-style-type: none"> ● Set the same value in [Pr. PB07 Model loop gain] for the axis used in 2 gain adjustment mode.

Step	Operation	Description
1	Set to the auto tuning mode.	Select the auto tuning mode 1.
2	During operation, increase the response level setting value in [Pr. PA09], and return the setting if vibration occurs.	Adjustment in auto tuning mode 1.
3	Check value of the model loop gain and the load to motor inertia ratio in advance.	Check the upper setting limits.
4	Set the 2 gain adjustment mode 1 ([Pr. PA08]: 0 0 0 0).	Select the 2 gain adjustment mode 1 (interpolation mode).
5	When the load to motor inertia ratio is different from the design value, select the 2 gain adjustment mode 2 ([Pr. PA08]: 0 0 0 4) and then set the load to motor inertia ratio manually in [Pr. PB06].	Check the load to motor inertia ratio.
6	Set the model loop gain of all the axes to be interpolated to the same value. At that time, adjust to the setting value of the axis, which has the smallest model loop gain.	Set position loop gain.
7	Considering the interpolation characteristic and motor status, fine-adjust the model loop gain and response level setting.	Fine adjustment

(4) Parameter adjustment

[Pr. PB07 Model loop gain]

This parameter determines the response level of the position control loop. Increasing the value improves track ability to a position command, but a too high value will make overshoot liable to occur at settling. The droop pulse value is determined by the following expression.

$$\text{Number of droop pulses [pulse]} = \frac{\text{Position command frequency [pulse/s]}}{\text{Model loop gain setting}}$$

Position command frequency differs depending on the operation mode.

Rotary servo motor and direct drive motor:

$$\text{Position command frequency} = \frac{\text{Speed [r/min]}}{60} \times \text{Encoder resolution (number of pulses per servo motor revolution)}$$

Linear servo motor:

$$\text{Position command frequency} = \text{Speed [mm/s]} \div \text{Encoder resolution (travel distance per pulse)}$$

7. SPECIAL ADJUSTMENT FUNCTIONS

7. SPECIAL ADJUSTMENT FUNCTIONS

POINT	
●	The functions given in this chapter need not be used normally. Use them if you are not satisfied with the machine status after making adjustment in the methods in chapter 6.
●	When you use a linear servo motor, replace the following left words to the right words.
Load to motor inertia ratio	→ Load to motor mass ratio
Torque [N•m]	→ Thrust [N]
(Servo motor) speed [r/min]	→ (Linear servo motor) speed [mm/s]

7.1 Filter setting

The following filters are available with MR-J4 servo amplifiers.

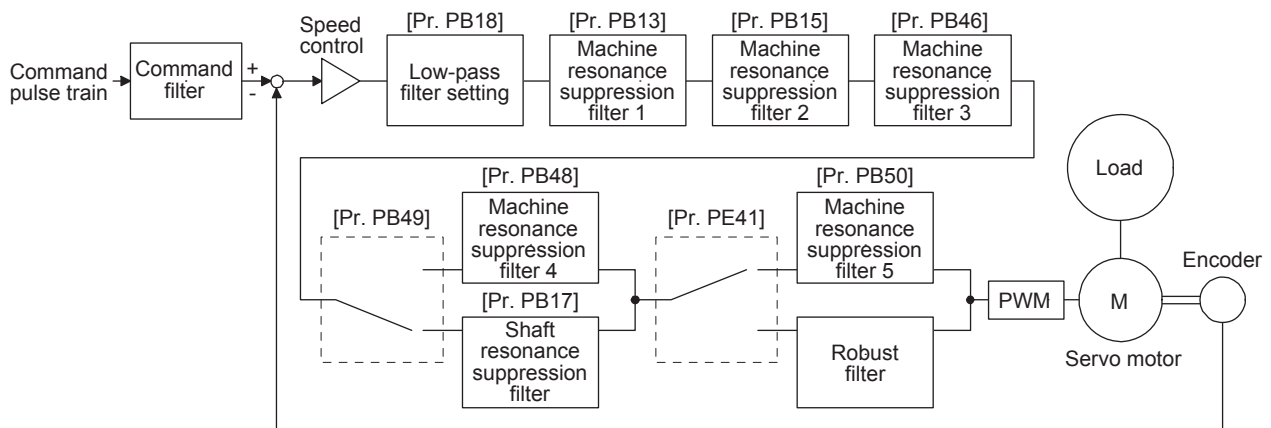

7.1.1 Machine resonance suppression filter

POINT	
●	The machine resonance suppression filter is a delay factor for the servo system. Therefore, vibration may increase if you set an incorrect resonance frequency or set notch characteristics too deep or too wide.
●	If the frequency of machine resonance is unknown, decrease the notch frequency from higher to lower ones in order. The optimum notch frequency is set at the point where vibration is minimal.
●	A deeper notch has a higher effect on machine resonance suppression but increases a phase delay and may increase vibration.
●	A deeper notch has a higher effect on machine resonance suppression but increases a phase delay and may increase vibration.
●	The machine characteristic can be grasped beforehand by the machine analyzer on MR Configurator2. This allows the required notch frequency and notch characteristics to be determined.

If a mechanical system has a natural resonance point, increasing the servo system response level may cause the mechanical system to produce resonance (vibration or unusual noise) at that resonance frequency. Using the machine resonance suppression filter and adaptive tuning can suppress the resonance of the mechanical system. The setting range is 10 Hz to 4500 Hz.

7. SPECIAL ADJUSTMENT FUNCTIONS

(1) Function

The machine resonance suppression filter is a filter function (notch filter) which decreases the gain of the specific frequency to suppress the resonance of the mechanical system. You can set the gain decreasing frequency (notch frequency), gain decreasing depth and width.

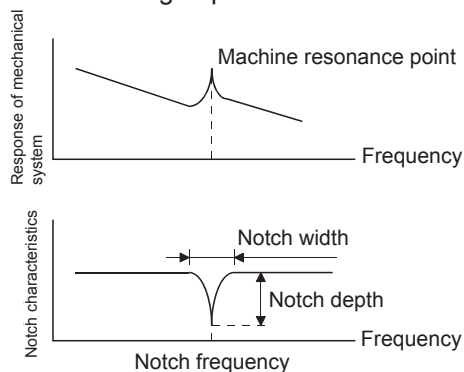

You can set five machine resonance suppression filters at most.

Filter	Setting parameter	Precaution	Parameter that is reset with vibration tough drive function	Parameter automatically adjusted with one-touch tuning
Machine resonance suppression filter 1	PB01/PB13/PB14	The filter can be set automatically with "Filter tuning mode selection" in [Pr. PB01].	PB13	PB01/PB13/PB14
Machine resonance suppression filter 2	PB15/PB16		PB15	PB15/PB16
Machine resonance suppression filter 3	PB46/PB47			PB47
Machine resonance suppression filter 4	PB48/PB49	Enabling the filter disables the shaft resonance suppression filter. The shaft resonance suppression filter is enabled for the initial setting.		PB48/PB49
Machine resonance suppression filter 5	PB50/PB51	The setting of this filter is disabled while you use the robust filter. The robust filter is disabled for the initial setting.		PB51

7. SPECIAL ADJUSTMENT FUNCTIONS

(2) Parameter

(a) Machine resonance suppression filter 1 ([Pr. PB13] and [Pr. PB14])

Set the notch frequency, notch depth and notch width of the machine resonance suppression filter 1 ([Pr. PB13] and [Pr. PB14])

When you select "Manual setting (_ _ _ 2)" of "Filter tuning mode selection" in [Pr. PB01], the setting of the machine resonance suppression filter 1 is enabled.

(b) Machine resonance suppression filter 2 ([Pr. PB15] and [Pr. PB16])

To use this filter, select "Enabled (_ _ _ 1)" of "Machine resonance suppression filter 2 selection" in [Pr. PB16].

How to set the machine resonance suppression filter 2 ([Pr. PB15] and [Pr. PB16]) is the same as for the machine resonance suppression filter 1 ([Pr. PB13] and [Pr. PB14]).

(c) Machine resonance suppression filter 3 ([Pr. PB46] and [Pr. PB47])

To use this filter, select "Enabled (_ _ _ 1)" of "Machine resonance suppression filter 3 selection" in [Pr. PB47].

How to set the machine resonance suppression filter 3 ([Pr. PB46] and [Pr. PB47]) is the same as for the machine resonance suppression filter 1 ([Pr. PB13] and [Pr. PB14]).

(d) Machine resonance suppression filter 4 ([Pr. PB48] and [Pr. PB49])

To use this filter, select "Enabled (_ _ _ 1)" of "Machine resonance suppression filter 4 selection" in [Pr. PB49]. However, enabling the machine resonance suppression filter 4 disables the shaft resonance suppression filter.

How to set the machine resonance suppression filter 4 ([Pr. PB48] and [Pr. PB49]) is the same as for the machine resonance suppression filter 1 ([Pr. PB13] and [Pr. PB14]).

(e) Machine resonance suppression filter 5 ([Pr. PB50] and [Pr. PB51])

To use this filter, select "Enabled (_ _ _ 1)" of "Machine resonance suppression filter 5 selection" in [Pr. PB51]. However, enabling the robust filter ([Pr. PE41: _ _ _ 1]) disables the machine resonance suppression filter 5.

How to set the machine resonance suppression filter 5 ([Pr. PB50] and [Pr. PB51]) is the same as for the machine resonance suppression filter 1 ([Pr. PB13] and [Pr. PB14]).

7. SPECIAL ADJUSTMENT FUNCTIONS

7.1.2 Adaptive filter II

POINT
<ul style="list-style-type: none"> ● The machine resonance frequency which adaptive filter II (adaptive tuning) can respond to is about 100 Hz to 2.25 kHz. As for the resonance frequency out of the range, set manually. ● When adaptive tuning is executed, vibration sound increases as an excitation signal is forcibly applied for several seconds. ● When adaptive tuning is executed, machine resonance is detected for a maximum of 10 seconds and a filter is generated. After filter generation, the adaptive tuning mode automatically shifts to the manual setting. ● Adaptive tuning generates the optimum filter with the currently set control gains. If vibration occurs when the response setting is increased, execute adaptive tuning again. ● During adaptive tuning, a filter having the best notch depth at the set control gain is generated. To allow a filter margin against machine resonance, increase the notch depth in the manual setting. ● Adaptive vibration suppression control may provide no effect on a mechanical system which has complex resonance characteristics.

(1) Function

Adaptive filter II (adaptive tuning) is a function in which the servo amplifier detects machine vibration for a predetermined period of time and sets the filter characteristics automatically to suppress mechanical system vibration. Since the filter characteristics (frequency, depth) are set automatically, you need not be conscious of the resonance frequency of a mechanical system.

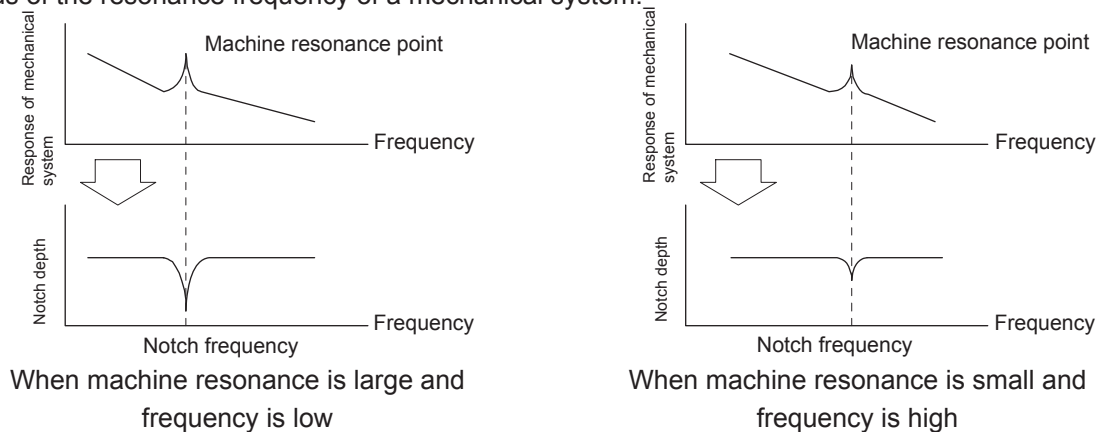

(2) Parameter

Select how to set the filter tuning in [Pr. PB01 Adaptive tuning mode (adaptive filter II)].

[Pr.PB01]
0 0 0

Filter tuning mode selection

Setting value	Filter tuning mode selection	Automatically set parameter
0	Disabled	
1	Automatic setting	PB13 · PB14
2	Manual setting	

7. SPECIAL ADJUSTMENT FUNCTIONS

(3) Adaptive tuning mode procedure

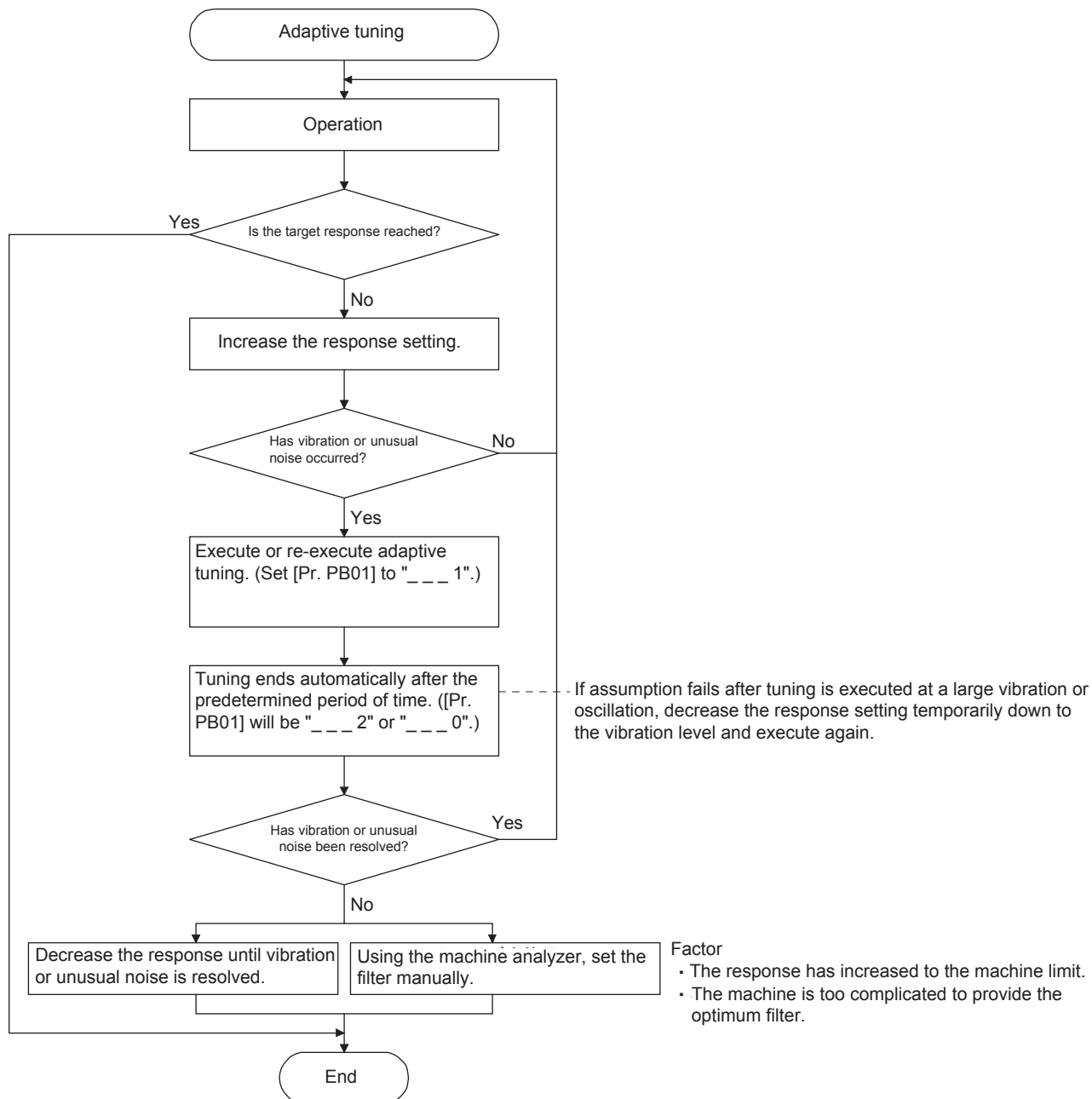

7. SPECIAL ADJUSTMENT FUNCTIONS

7.1.3 Shaft resonance suppression filter

(1) Function

When a load is mounted to the servo motor shaft, resonance by shaft torsion during driving may generate a mechanical vibration at high frequency. The shaft resonance suppression filter suppresses the vibration.

When you select "Automatic setting", the filter will be set automatically on the basis of the motor you use and the load to motor inertia ratio. The enabled setting increases the response of the servo amplifier for high resonance frequency.

(2) Parameter

Set "Shaft resonance suppression filter selection" in [Pr. PB23].

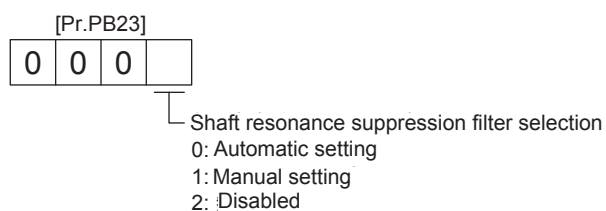

To set [Pr. PB17 Shaft resonance suppression filter] automatically, select "Automatic setting".

To set [Pr. PB17 Shaft resonance suppression filter] manually, select "Manual setting". The setting values are as follows.

Shaft resonance suppression filter setting frequency
selection

Setting value	Frequency [Hz]	Setting value	Frequency [Hz]
__ 0 0	Disabled	__ 1 0	562
__ 0 1	Disabled	__ 1 1	529
__ 0 2	4500	__ 1 2	500
__ 0 3	3000	__ 1 3	473
__ 0 4	2250	__ 1 4	450
__ 0 5	1800	__ 1 5	428
__ 0 6	1500	__ 1 6	409
__ 0 7	1285	__ 1 7	391
__ 0 8	1125	__ 1 8	375
__ 0 9	1000	__ 1 9	360
__ 0 A	900	__ 1 A	346
__ 0 B	818	__ 1 B	333
__ 0 C	750	__ 1 C	321
__ 0 D	692	__ 1 D	310
__ 0 E	642	__ 1 E	300
__ 0 F	600	__ 1 F	290

7. SPECIAL ADJUSTMENT FUNCTIONS

7.1.4 Low-pass filter

(1) Function

When a ball screw or the like is used, resonance of high frequency may occur as the response level of the servo system is increased. To prevent this, the low-pass filter is enabled for a torque command as a default. The filter frequency of the low-pass filter is automatically adjusted to the value in the following equation.

$$\text{Filter frequency ([rad/s])} = \frac{VG2}{1 + GD2} \times 10$$

To set [Pr. PB18] manually, select "Manual setting (_ _ 1 _)" of "Low-pass filter selection" in [Pr. PB23].

(2) Parameter

Set "Low-pass filter selection" in [Pr. PB23].

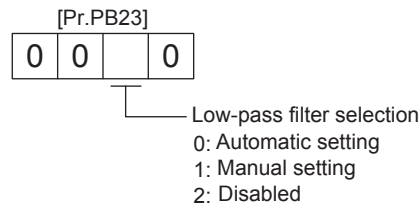

7.1.5 Advanced vibration suppression control II

POINT
<ul style="list-style-type: none"> ● The function is enabled when "Gain adjustment mode selection" in [Pr. PA08] is "Auto tuning mode 2 (_ _ _ 2)", "Manual mode (_ _ _ 3)", or "2 gain adjustment mode 2 (_ _ _ 4)". ● The machine resonance frequency supported in the vibration suppression control tuning mode is 1.0 Hz to 100.0 Hz. As for the vibration out of the range, set manually. ● Stop the servo motor before changing the vibration suppression control-related parameters. Otherwise, it may cause an unexpected operation. ● For positioning operation during execution of vibration suppression control tuning, provide a stop time to ensure a stop after vibration damping. ● Vibration suppression control tuning may not make normal estimation if the residual vibration at the servo motor side is small. ● Vibration suppression control tuning sets the optimum parameter with the currently set control gains. When the response setting is increased, set vibration suppression control tuning again. ● When using the vibration suppression control 2, set " _ _ _ 1" in [Pr. PA24].

7. SPECIAL ADJUSTMENT FUNCTIONS

(1) Function

Vibration suppression control is used to further suppress load-side vibration, such as work-side vibration and base shake. The servo motor-side operation is adjusted for positioning so that the machine does not vibrate.

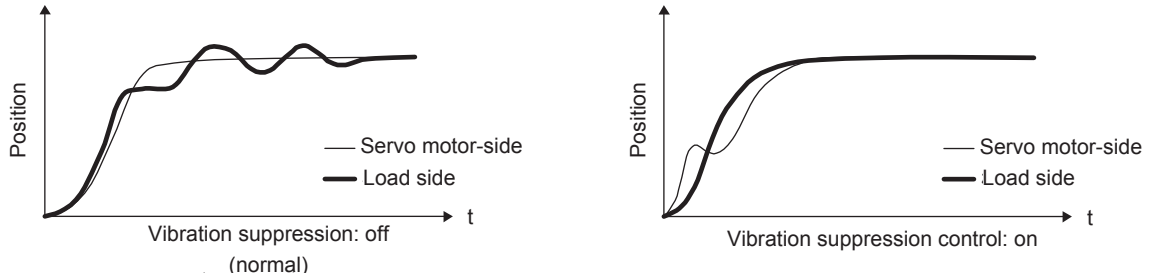

When the advanced vibration suppression control II ([Pr. PB02 Vibration suppression control tuning mode]) is executed, the vibration frequency at load side is automatically estimated to suppress machine side vibration two times at most.

In the vibration suppression control tuning mode, this mode shifts to the manual setting after the positioning operation is performed the predetermined number of times. For manual setting, adjust the vibration suppression control 1 with [Pr. PB19] to [Pr. PB22] and vibration suppression control 2 with [Pr. PB52] to [Pr. PB55].

(2) Parameter

Set [Pr. PB02 Vibration suppression control tuning mode (advanced vibration suppression control II)].

When you use a vibration suppression control, set "Vibration suppression control 1 tuning mode selection". When you use two vibration suppression controls, set "Vibration suppression control 2 tuning mode selection" in addition.

[Pr. PB02]
0 0

Vibration suppression control 1 tuning mode

Setting value	Vibration suppression control 1 tuning mode selection	Automatically set parameter
__ 0	Disabled	
__ 1	Automatic setting	PB19 · PB20 · PB21 · PB22
__ 2	Manual setting	

Vibration suppression control 2 tuning mode

Setting value	Vibration suppression control 2 tuning mode selection	Automatically set parameter
__ 0	Disabled	
__ 1	Automatic setting	PB52 · PB53 · PB54 · PB55
__ 2	Manual setting	

7. SPECIAL ADJUSTMENT FUNCTIONS

(3) Vibration suppression control tuning procedure

The following flow chart is for the vibration suppression control 1. For the vibration suppression control 2, set " __ 1 _ " in [Pr. PB02] to execute the vibration suppression control tuning.

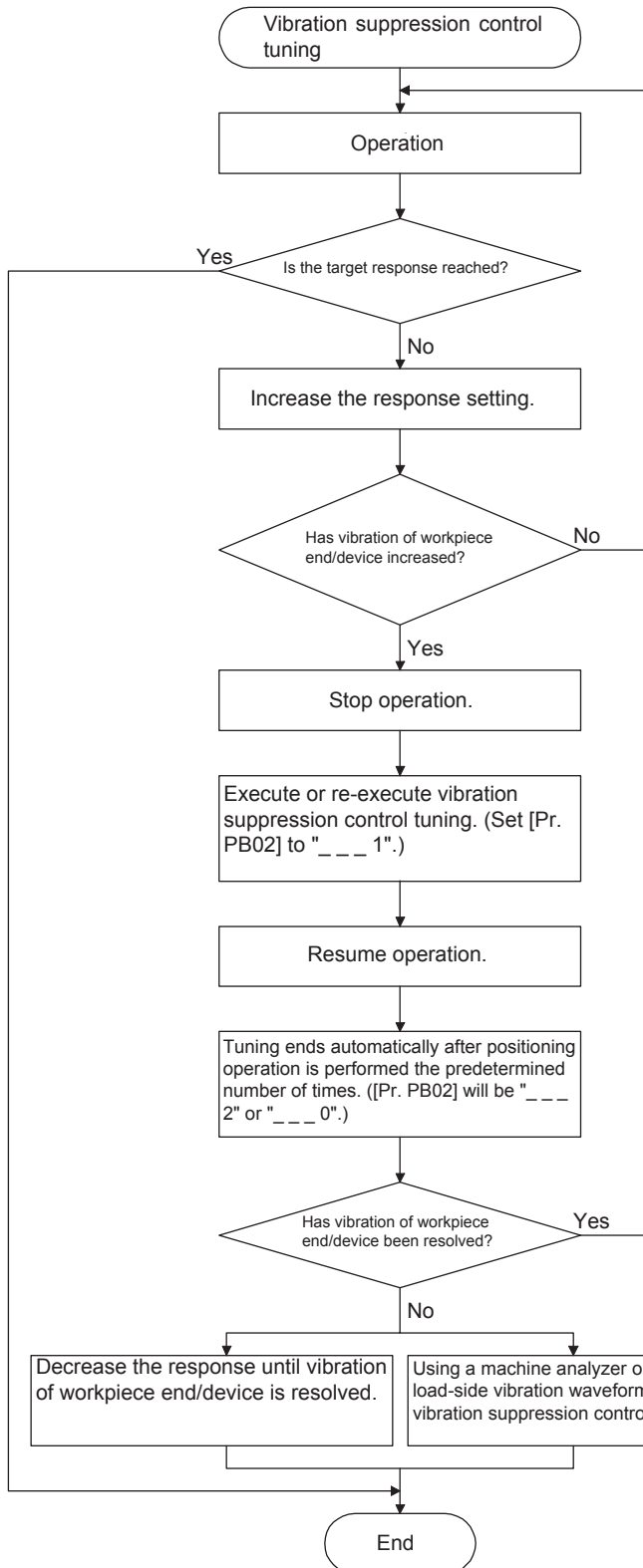

Factor

- Estimation cannot be made as load-side vibration has not been transmitted to the servo motor side.
- The response of the model loop gain has increased to the load-side vibration frequency (vibration suppression control limit).

7. SPECIAL ADJUSTMENT FUNCTIONS

(4) Vibration suppression control manual mode

POINT
<ul style="list-style-type: none"> ● When load-side vibration does not show up in servo motor-side vibration, the setting of the servo motor-side vibration frequency does not produce an effect. ● When the anti-resonance frequency and resonance frequency can be confirmed using the machine analyzer or external equipment, do not set the same value but set different values to improve the vibration suppression performance. ● A vibration suppression control effect is not produced if the relation between the [Pr. PB07 Model loop gain] value and vibration frequency is as follows. Vibration suppression control 1: $[\text{Pr. PB19}] < \frac{1}{2\pi} (0.9 \times [\text{Pr. PB07}])$ $[\text{Pr. PB20}] < \frac{1}{2\pi} (0.9 \times [\text{Pr. PB07}])$ Vibration suppression control 2: $[\text{Pr. PB52}] < 5.0 + 0.1 \times [\text{Pr. PB07}]$ $[\text{Pr. PB53}] < 5.0 + 0.1 \times [\text{Pr. PB07}]$

Measure work-side vibration and device shake with the machine analyzer or external measuring instrument, and set the following parameters to adjust vibration suppression control manually.

Setting item	Vibration suppression control 1	Vibration suppression control 2
Vibration suppression control – Vibration frequency	[Pr. PB19]	[Pr. PB52]
Vibration suppression control – Resonance frequency	[Pr. PB20]	[Pr. PB53]
Vibration suppression control – Vibration frequency damping setting	[Pr. PB21]	[Pr. PB54]
Vibration suppression control – Resonance frequency damping setting	[Pr. PB22]	[Pr. PB55]

Step 1 Select "Manual setting (_ _ _ 2)" of "Vibration suppression control 1 tuning mode selection" or "Manual setting (_ _ 2 _)" of "Vibration suppression control 2 tuning mode selection" in [Pr. PB02].

Step 2 Set "Vibration suppression control - Vibration frequency" and "Vibration suppression control - Resonance frequency" as follows.

7. SPECIAL ADJUSTMENT FUNCTIONS

- (a) When a vibration peak can be confirmed with machine analyzer using MR Configurator2, or external equipment.

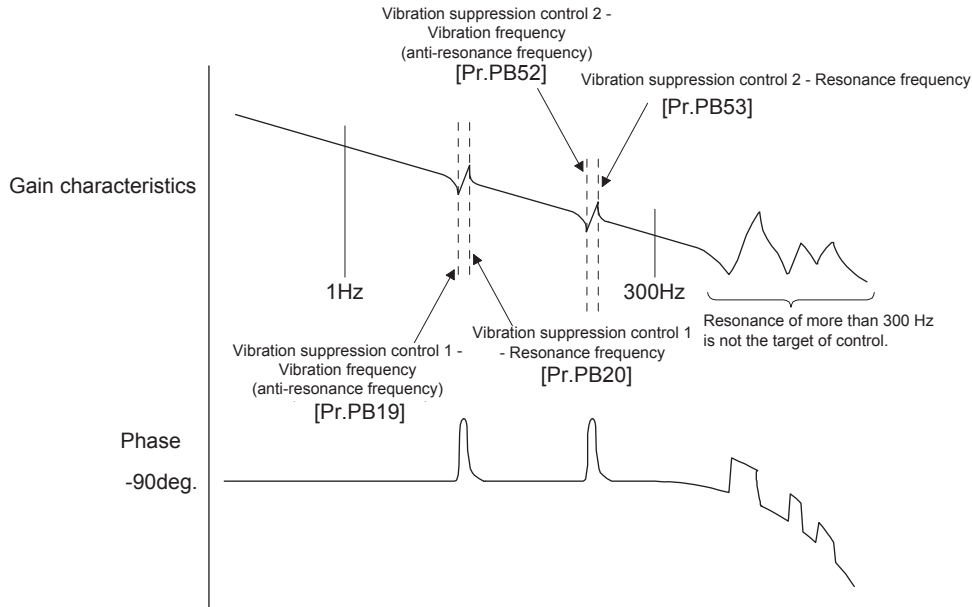

- (b) When vibration can be confirmed using monitor signal or external sensor

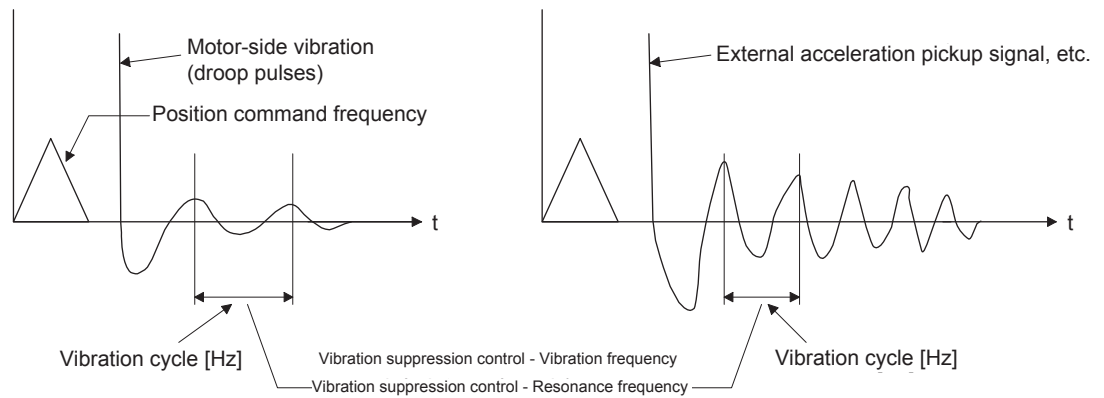

Set the same value.

- Step 3 Fine-adjust "Vibration suppression control - Vibration frequency damping setting" and "Vibration suppression control - Resonance frequency damping setting".

7. SPECIAL ADJUSTMENT FUNCTIONS

7.1.6 Command notch filter

POINT
<ul style="list-style-type: none"> ● By using the advanced vibration suppression control II and the command notch filter, the load-side vibration of three frequencies can be suppressed. ● The frequency range of machine vibration, which can be supported by the command notch filter, is between 4.5 Hz and 2250 Hz. Set a frequency close to the machine vibration frequency and within the range. ● When [Pr. PB45 Command notch filter] is changed during the positioning operation, the changed setting is not reflected. The setting is reflected approximately 150 ms after the servo motor stops (after servo-lock).

(1) Function

Command notch filter has a function that lowers the gain of the specified frequency contained in a position command. By lowering the gain, load-side vibration, such as work-side vibration and base shake, can be suppressed. Which frequency to lower the gain and how deep to lower the gain can be set.

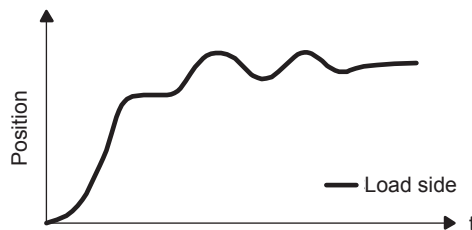

Command notch filter: disabled

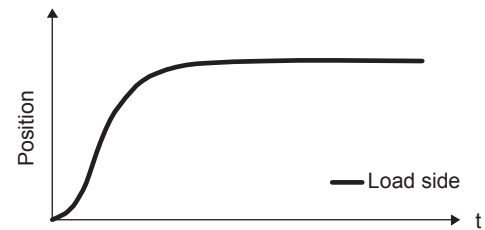

Command notch filter: enabled

7. SPECIAL ADJUSTMENT FUNCTIONS

(2) Parameter

Set [Pr. PB45 Command notch filter] as shown below. For the command notch filter setting frequency, set the closest value to the vibration frequency [Hz] at the load side.

[Pr.PB45]

0

Notch depth

Setting value	Depth [dB]
0	-40.0
1	-24.1
2	-18.1
3	-14.5
4	-12.0
5	-10.1
6	-8.5
7	-7.2
8	-6.0
9	-5.0
A	-4.1
B	-3.3
C	-2.5
D	-1.8
E	-1.2
F	-0.6

Control command from controller

Setting value	Frequency [Hz]	Setting value	Frequency [Hz]	Setting value	Frequency [Hz]
00	Disabled	20	70	40	17.6
01	2250	21	66	41	16.5
02	1125	22	62	42	15.6
03	750	23	59	43	14.8
04	562	24	56	44	14.1
05	450	25	53	45	13.4
06	375	26	51	46	12.8
07	321	27	48	47	12.2
08	281	28	46	48	11.7
09	250	29	45	49	11.3
0A	225	2A	43	4A	10.8
0B	204	2B	41	4B	10.4
0C	187	2C	40	4C	10.0
0D	173	2D	38	4D	9.7
0E	160	2E	37	4E	9.4
0F	150	2F	36	4F	9.1
10	140	30	35.2	50	8.8
11	132	31	33.1	51	8.3
12	125	32	31.3	52	7.8
13	118	33	29.6	53	7.4
14	112	34	28.1	54	7.0
15	107	35	26.8	55	6.7
16	102	36	25.6	56	6.4
17	97	37	24.5	57	6.1
18	93	38	23.4	58	5.9
19	90	39	22.5	59	5.6
1A	86	3A	21.6	5A	5.4
1B	83	3B	20.8	5B	5.2
1C	80	3C	20.1	5C	5.0
1D	77	3D	19.4	5D	4.9
1E	75	3E	18.8	5E	4.7
1F	72	3F	18.2	5F	4.5

7. SPECIAL ADJUSTMENT FUNCTIONS

7.2 Gain switching function

You can switch gains with the function. You can switch gains during rotation and during stop, and can use a control command from a controller to switch gains during operation.

7.2.1 Applications

The following shows when you use the function.

- (1) You want to increase the gains during servo-lock but decrease the gains to reduce noise during rotation.
- (2) You want to increase the gains during settling to shorten the stop settling time.
- (3) You want to change the gains using a control command from a controller to ensure stability of the servo system since the load to motor inertia ratio varies greatly during a stop (e.g. a large load is mounted on a carrier).

7. SPECIAL ADJUSTMENT FUNCTIONS

7.2.2 Function block diagram

The control gains, load to motor inertia ratio, and vibration suppression control settings are changed according to the conditions selected by [Pr. PB26 Gain switching function] and [Pr. PB27 Gain switching condition].

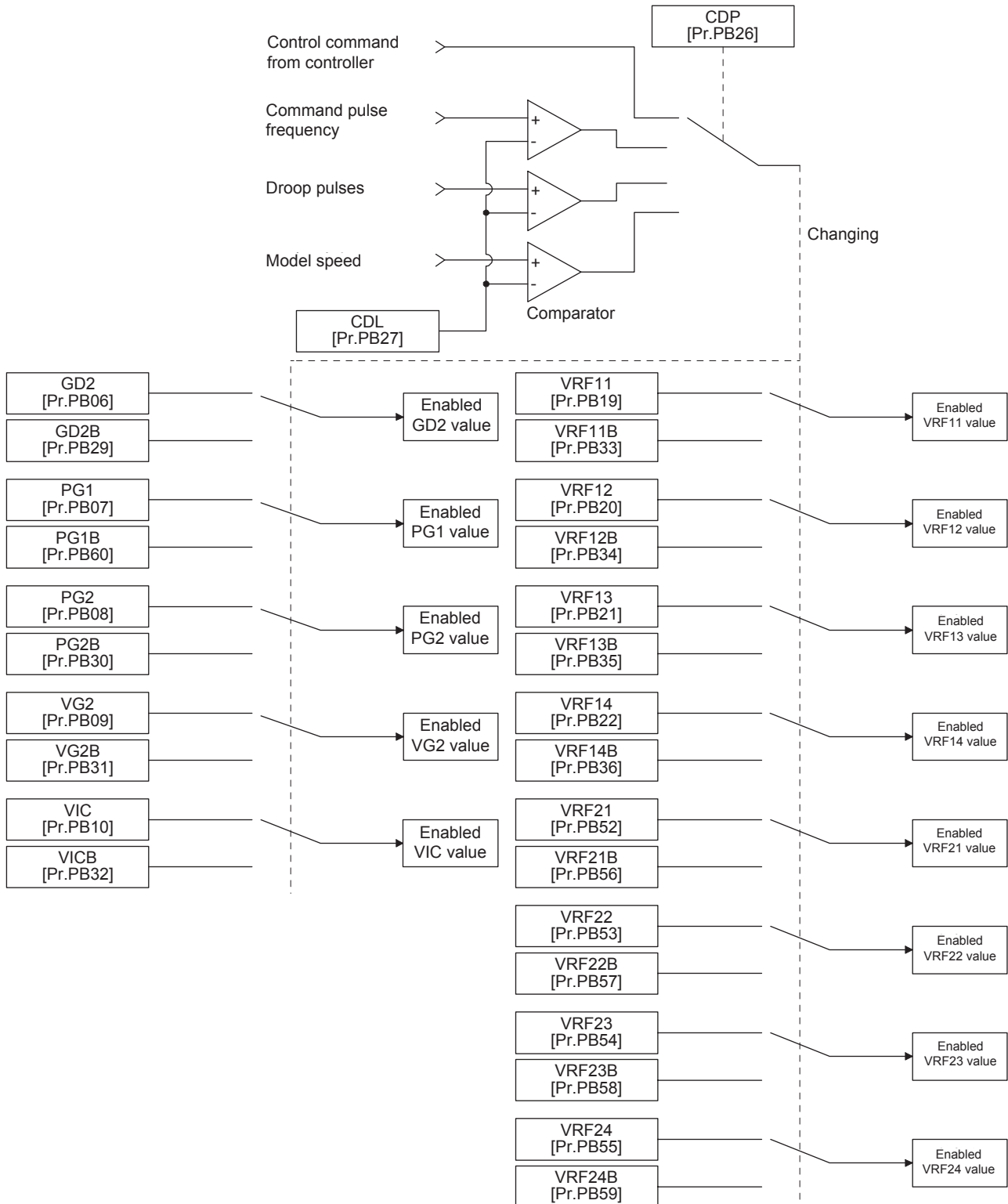

7. SPECIAL ADJUSTMENT FUNCTIONS

7.2.3 Parameter

When using the gain switching function, always select "Manual mode (_ _ _ 3)" of "Gain adjustment mode selection" in [Pr. PA08 Auto tuning mode]. The gain switching function cannot be used in the auto tuning mode.

(1) Variable gain operation setting parameter

Parameter	Symbol	Name	Unit	Description
PB26	CDP	Gain switching selection		Used to select the changing condition.
PB27	CDL	Gain switching condition	[kpps] /[pulse] /[r/min]	Used to set the changing condition values.
PB28	CDT	Gain switching time constant	[ms]	You can set the filter time constant for a gain change at changing.

(a) [Pr. PB26 Gain switching function]

Used to set the gain switching condition. Select the switching condition in the first digit and second digit.

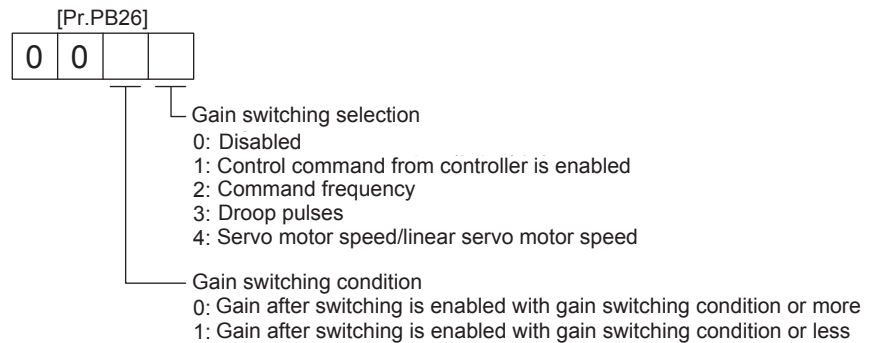

(b) [Pr. PB27 Gain switching condition]

Set a level to switch gains after you select "Command frequency", "Droop pulses", or "Servo motor speed/linear servo motor speed" in [Pr. PB26 Gain switching function].

The setting unit is as follows.

Gain switching condition	Unit
Command frequency	[kpps]
Droop pulses	[pulse]
Servo motor speed/linear servo motor speed	[r/min]/[mm/s]

(c) [Pr. PB28 Gain switching time constant]

You can set the primary delay filter to each gain at gain switching. This parameter is used to suppress shock given to the machine if the gain difference is large at gain switching, for example.

7. SPECIAL ADJUSTMENT FUNCTIONS

(2) Switchable gain parameter

Loop gain	Before switching			After switching		
	Parameter	Symbol	Name	Parameter	Symbol	Name
Load to motor inertia ratio/load to motor mass ratio	PB06	GD2	Load to motor inertia ratio/load to motor mass ratio	PB29	GD2B	Load to motor inertia ratio/load to motor mass ratio after gain switching
Model loop gain	PB07	PG1	Model loop gain	PB60	PG1B	Model loop gain after gain switching
Position loop gain	PB08	PG2	Position loop gain	PB30	PG2B	Position loop gain after gain switching
Speed loop gain	PB09	VG2	Speed loop gain	PB31	VG2B	Speed loop gain after gain switching
Speed integral compensation	PB10	VIC	Speed integral compensation	PB32	VICB	Speed integral compensation after gain switching
Vibration suppression control 1 - Vibration frequency	PB19	VRF11	Vibration suppression control 1 - Vibration frequency	PB33	VRF11B	Vibration suppression control 1 - Vibration frequency after gain switching
Vibration suppression control 1 - Resonance frequency	PB20	VRF12	Vibration suppression control 1 - Resonance frequency	PB34	VRF12B	Vibration suppression control 1 - Resonance frequency after gain switching
Vibration suppression control 1 - Vibration frequency damping setting	PB21	VRF13	Vibration suppression control 1 - Vibration frequency damping setting	PB35	VRF13B	Vibration suppression control 1 - Vibration frequency damping setting after gain switching
Vibration suppression control 1 - Resonance frequency damping setting	PB22	VRF14	Vibration suppression control 1 - Resonance frequency damping setting	PB36	VRF14B	Vibration suppression control 1 - Resonance frequency damping setting after gain switching
Vibration suppression control 2 - Vibration frequency	PB52	VRF21	Vibration suppression control 2 - Vibration frequency	PB56	VRF21B	Vibration suppression control 2 - Vibration frequency after gain switching
Vibration suppression control 2 - Resonance frequency	PB53	VRF22	Vibration suppression control 2 - Resonance frequency	PB57	VRF22B	Vibration suppression control 2 - Resonance frequency after gain switching
Vibration suppression control 2 - Vibration frequency damping setting	PB54	VRF23	Vibration suppression control 2 - Vibration frequency damping setting	PB58	VRF23B	Vibration suppression control 2 - Vibration frequency damping setting after gain switching
Vibration suppression control 2 - Resonance frequency damping setting	PB55	VRF24	Vibration suppression control 2 - Resonance frequency damping setting	PB59	VRF24B	Vibration suppression control 2 - Resonance frequency damping setting after gain switching

(a) [Pr. PB06] to [Pr. PB10]

These parameters are the same as in ordinary manual adjustment. Gain switching allows the values of load to motor inertia ratio/load to motor mass ratio, position loop gain, speed loop gain, and speed integral compensation to be switched.

(b) [Pr.PB19] to [Pr.PB22]/[Pr.PB52] to [Pr.PB55]

These parameters are the same as in ordinary manual adjustment. Executing gain switching while the servo motor stops, You can change vibration frequency, resonance frequency, vibration frequency damping setting, and resonance frequency damping setting.

7. SPECIAL ADJUSTMENT FUNCTIONS

- (c) [Pr. PB29 Load to motor inertia ratio/load to motor mass ratio after gain switching]
Set the load to motor inertia ratio or load to motor mass ratio after gain switching. If the load to motor inertia ratio does not change, set it to the same value as [Pr. PB06 Load to motor inertia ratio/load to motor mass ratio].
- (d) [Pr. PB30 Position loop gain after gain switching], [Pr. PB31 Speed loop gain after gain switching], and [Pr. PB32 Speed integral compensation after gain switching]
Set the values of after switching position loop gain, speed loop gain and speed integral compensation.
- (e) Vibration suppression control after gain switching ([Pr.PB33] to [Pr.PB36]/[Pr.PB56] to [Pr.PB59]), and [Pr. PB60 Model loop gain after gain switching]
The gain switching vibration suppression control and model loop gain are used only with control command from the controller.
You can switch the vibration frequency, resonance frequency, vibration frequency damping setting, resonance frequency damping setting, and model loop gain of the vibration suppression control 1 and vibration suppression control 2.

7. SPECIAL ADJUSTMENT FUNCTIONS

7.2.4 Gain switching procedure

This operation will be described by way of setting examples.

(1) When you choose switching by control command from the controller

(a) Setting

Parameter	Symbol	Name	Setting value	Unit
PB06	GD2	Load to motor inertia ratio/load to motor mass ratio	4.00	[Multiplier]
PB07	PG1	Model loop gain	100	[rad/s]
PB08	PG2	Position loop gain	120	[rad/s]
PB09	VG2	Speed loop gain	3000	[rad/s]
PB10	VIC	Speed integral compensation	20	[ms]
PB19	VRF11	Vibration suppression control 1 - Vibration frequency	50	[Hz]
PB20	VRF12	Vibration suppression control 1 - Resonance frequency	50	[Hz]
PB21	VRF13	Vibration suppression control 1 - Vibration frequency damping setting	0.20	
PB22	VRF14	Vibration suppression control 1 - Resonance frequency damping setting	0.20	
PB52	VRF21	Vibration suppression control 2 - Vibration frequency	20	[Hz]
PB53	VRF22	Vibration suppression control 2 - Resonance frequency	20	[Hz]
PB54	VRF23	Vibration suppression control 2 - Vibration frequency damping setting	0.10	
PB55	VRF24	Vibration suppression control 2 - Resonance frequency damping setting	0.10	
PB29	GD2B	Load to motor inertia ratio/load to motor mass ratio after gain switching	10.00	[Multiplier]
PB60	PG1B	Model loop gain after gain switching	50	[rad/s]
PB30	PG2B	Position loop gain after gain switching	84	[rad/s]
PB31	VG2B	Speed loop gain after gain switching	4000	[rad/s]
PB32	VICB	Speed integral compensation after gain switching	50	[ms]
PB26	CDP	Gain switching function	0001 (Switch by control command from the controller.)	
PB28	CDT	Gain switching time constant	100	[ms]
PB33	VRF11B	Vibration suppression control 1 - Vibration frequency after gain switching	60	[Hz]
PB34	VRF12B	Vibration suppression control 1 - Resonance frequency after gain switching	60	[Hz]
PB35	VRF13B	Vibration suppression control 1 - Vibration frequency damping setting after gain switching	0.15	
PB36	VRF14B	Vibration suppression control 1 - Resonance frequency damping setting after gain switching	0.15	
PB56	VRF21B	Vibration suppression control 2 - Vibration frequency after gain switching	30	[Hz]
PB57	VRF22B	Vibration suppression control 2 - Resonance frequency after gain switching	30	[Hz]
PB58	VRF23B	Vibration suppression control 2 - Vibration frequency damping setting after gain switching	0.05	
PB59	VRF24B	Vibration suppression control 2 - Resonance frequency damping setting after gain switching	0.05	

7. SPECIAL ADJUSTMENT FUNCTIONS

(b) Switching timing chart

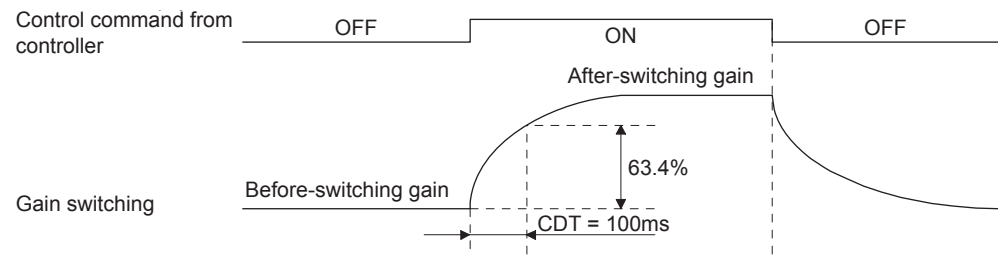

Model loop gain	100	→	50	→	100
Load to motor inertia ratio/load to motor mass ratio	4.00	→	10.00	→	4.00
Position loop gain	120	→	84	→	120
Speed loop gain	3000	→	4000	→	3000
Speed integral compensation	20	→	50	→	20
Vibration suppression control 1 - Vibration frequency	50	→	60	→	50
Vibration suppression control 1 - Resonance frequency	50	→	60	→	50
Vibration suppression control 1 - Vibration frequency damping setting	0.20	→	0.15	→	0.20
Vibration suppression control 1 - Resonance frequency damping setting	0.20	→	0.15	→	0.20
Vibration suppression control 2 - Vibration frequency	20	→	30	→	20
Vibration suppression control 2 - Resonance frequency	20	→	30	→	20
Vibration suppression control 2 - Vibration frequency damping setting	0.10	→	0.05	→	0.10
Vibration suppression control 2 - Resonance frequency damping setting	0.10	→	0.05	→	0.10

(2) When you choose switching by droop pulses

In this case, the vibration suppression control after gain switching and model loop gain after gain switching cannot be used.

(a) Setting

Parameter	Symbol	Name	Setting value	Unit
PB06	GD2	Load to motor inertia ratio/load to motor mass ratio	4.00	[Multiplier]
PB08	PG2	Position loop gain	120	[rad/s]
PB09	VG2	Speed loop gain	3000	[rad/s]
PB10	VIC	Speed integral compensation	20	[ms]
PB29	GD2B	Load to motor inertia ratio/load to motor mass ratio after gain switching	10.00	[Multiplier]
PB30	PG2B	Position loop gain after gain switching	84	[rad/s]
PB31	VG2B	Speed loop gain after gain switching	4000	[rad/s]
PB32	VICB	Speed integral compensation after gain switching	50	[ms]
PB26	CDP	Gain switching selection	0003 (switching by droop pulses)	
PB27	CDL	Gain switching condition	50	[pulse]
PB28	CDT	Gain switching time constant	100	[ms]

7. SPECIAL ADJUSTMENT FUNCTIONS

(b) Switching timing chart

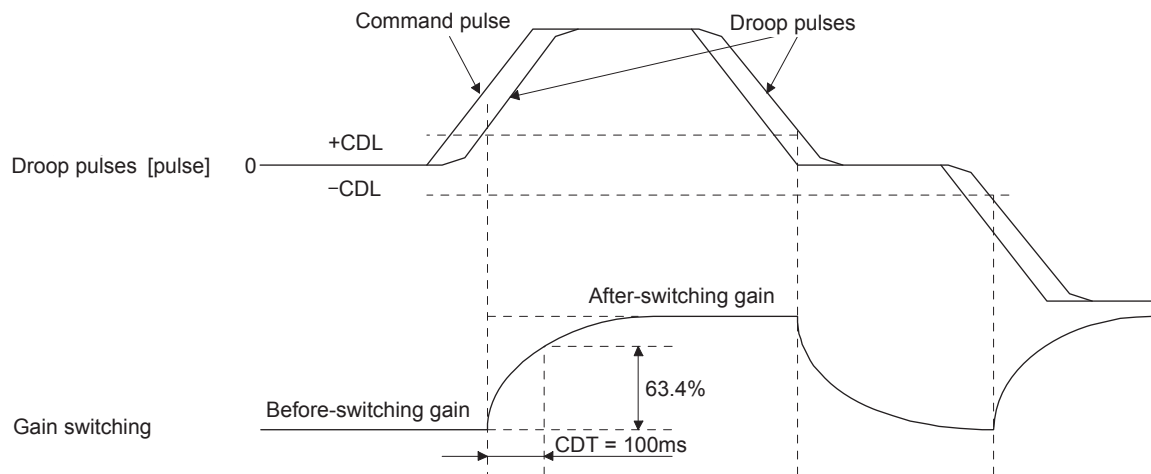

Load to motor inertia ratio/load to motor mass ratio	4.00	→	10.00	→	4.00	→	10.00
Position loop gain	120	→	84	→	120	→	84
Speed loop gain	3000	→	4000	→	3000	→	4000
Speed integral compensation	20	→	50	→	20	→	50

7. SPECIAL ADJUSTMENT FUNCTIONS

7.3 Tough drive function

POINT
<ul style="list-style-type: none"> ● Set enable/disable of the tough drive function with [Pr. PA20 Tough drive setting]. (Refer to section 5.2.1.)

This function makes the equipment continue operating even under the condition that an alarm occurs.

7.3.1 Vibration tough drive function

This function prevent from vibrating by resetting a filter instantaneously when machine resonance occurs due to varied vibration frequency caused machine aging.

To reset the machine resonance suppression filters with the function, [Pr. PB13 Machine resonance suppression filter 1] and [Pr. PB15 Machine resonance suppression filter 2] should be set in advance. Set [Pr. PB13] and [Pr. PB15] as follows.

(1) One-touch tuning execution (section 6.1)

(2) Manual setting (section 4.2.2)

The vibration tough drive function operates when a detected machine resonance frequency is within $\pm 30\%$ for a value set in [Pr. PB13 Machine resonance suppression filter 1] or [Pr. PB15 Machine resonance suppression filter 2].

To set a detection level of the function, set sensitivity in [Pr. PF23 Vibration tough drive - Oscillation detection level].

POINT
<ul style="list-style-type: none"> ● Resetting [Pr. PB13] and [Pr. PB15] by the vibration tough drive function is performed constantly. However, the number of write times to the EEPROM is limited to once per hour. ● The vibration tough drive function does not reset [Pr. PB46 Machine resonance suppression filter 3], [Pr. PB48 Machine resonance suppression filter 4], and [Pr. PB50 Machine resonance suppression filter 5].

7. SPECIAL ADJUSTMENT FUNCTIONS

The following shows the function block diagram of the vibration tough drive function.

The function detects machine resonance frequency and compare it with [Pr. PB13] and [Pr. PB15], and reset a machine resonance frequency of a parameter whose set value is closer.

Filter	Setting parameter	Precaution	Parameter that is reset with vibration tough drive function
Machine resonance suppression filter 1	PB01/PB13/PB14	The filter can be set automatically with "Filter tuning mode selection" in [Pr. PB01].	PB13
Machine resonance suppression filter 2	PB15/PB16		PB15
Machine resonance suppression filter 3	PB46/PB47		
Machine resonance suppression filter 4	PB48/PB49	Enabling the filter disables the shaft resonance suppression filter. The shaft resonance suppression filter is enabled for the initial setting.	
Machine resonance suppression filter 5	PB50/PB51	The setting of this filter is disabled while you use the robust filter. The robust filter is disabled for the initial setting.	

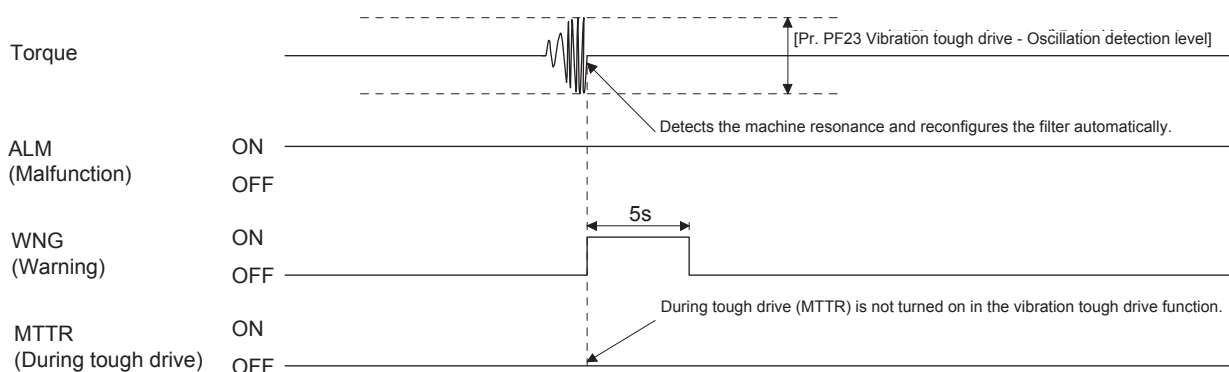
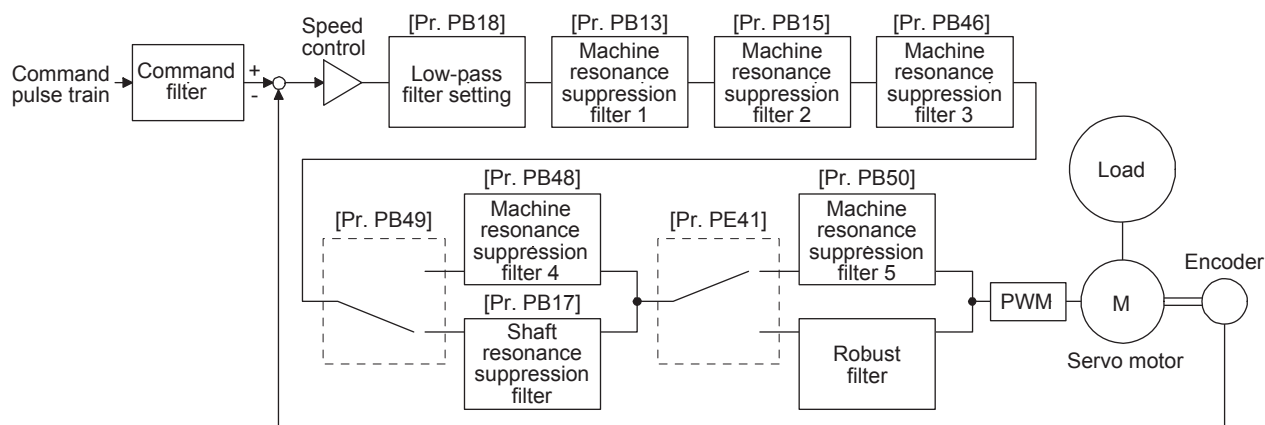

7. SPECIAL ADJUSTMENT FUNCTIONS

7.3.2 Instantaneous power failure tough drive function



CAUTION

- During the instantaneous power failure tough drive, the torque may be limited due to the load conditions or the set value of [Pr. PF25 Instantaneous power failure tough drive - Detection time].
- The immunity to instantaneous power failures is increased by the instantaneous power failure tough drive function. However, it is not compliant with the SEMI-F47 specification.

The instantaneous power failure tough drive function avoids [AL. 10 Undervoltage] even when an instantaneous power failure occurs during operation. When the instantaneous power failure tough drive activates, the function will increase the immunity to instantaneous power failures using the electrical energy charged in the capacitor in the servo amplifier and will change an alarm level of [AL. 10 Undervoltage] simultaneously. The [AL. 10.1 Voltage drop in the control power] detection time for the control circuit power supply can be changed by [Pr. PF25 Instantaneous power failure tough drive - Detection time]. In addition, [AL.10.2 Voltage drop in the main circuit power] detection level for the bus voltage is changed automatically.

POINT

- MBR (Electromagnetic brake interlock) will not turn off during the instantaneous power failure tough drive.
- When the load of instantaneous power failure is large, the undervoltage alarm ([AL. 10.2]) caused by the bus voltage drop may occur regardless of the set value of [Pr. PF25 Instantaneous power failure tough drive - Detection time].

7. SPECIAL ADJUSTMENT FUNCTIONS

- (1) Instantaneous power failure time of the control circuit power supply > [Pr. PF25 Instantaneous power failure tough drive - Detection time]

The alarm occurs when the instantaneous power failure time of the control circuit power supply exceeds [Pr. PF25 Instantaneous power failure tough drive - Detection time].

MTTR (During tough drive) turns on after detecting the instantaneous power failure.

MBR (Electromagnetic brake interlock) turns off when the alarm occurs.

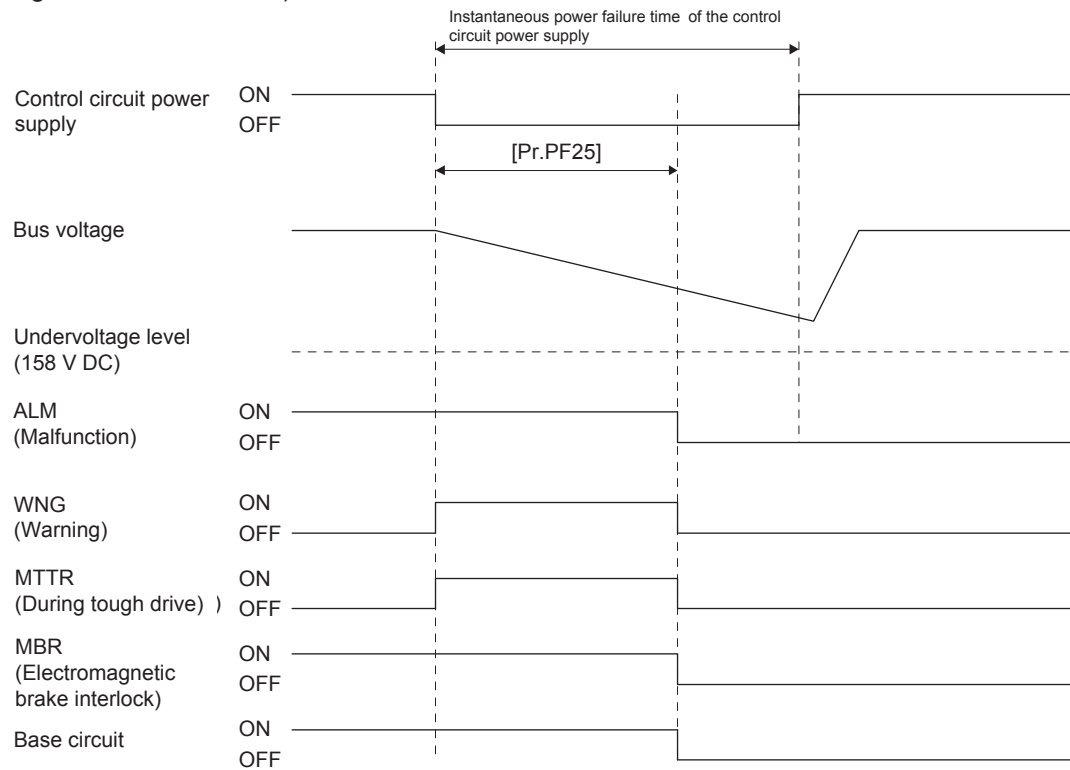

7. SPECIAL ADJUSTMENT FUNCTIONS

- (2) Instantaneous power failure time of the control circuit power supply < [Pr. PF25 Instantaneous power failure tough drive - Detection time]

Operation status differs depending on how bus voltage decrease.

- (a) When the bus voltage decrease lower than 158 V DC within the instantaneous power failure time of the control circuit power supply [AL. 10 Undervoltage] occurs when the bus voltage decrease lower than 158 V DC regardless of the enabled instantaneous power failure tough drive.

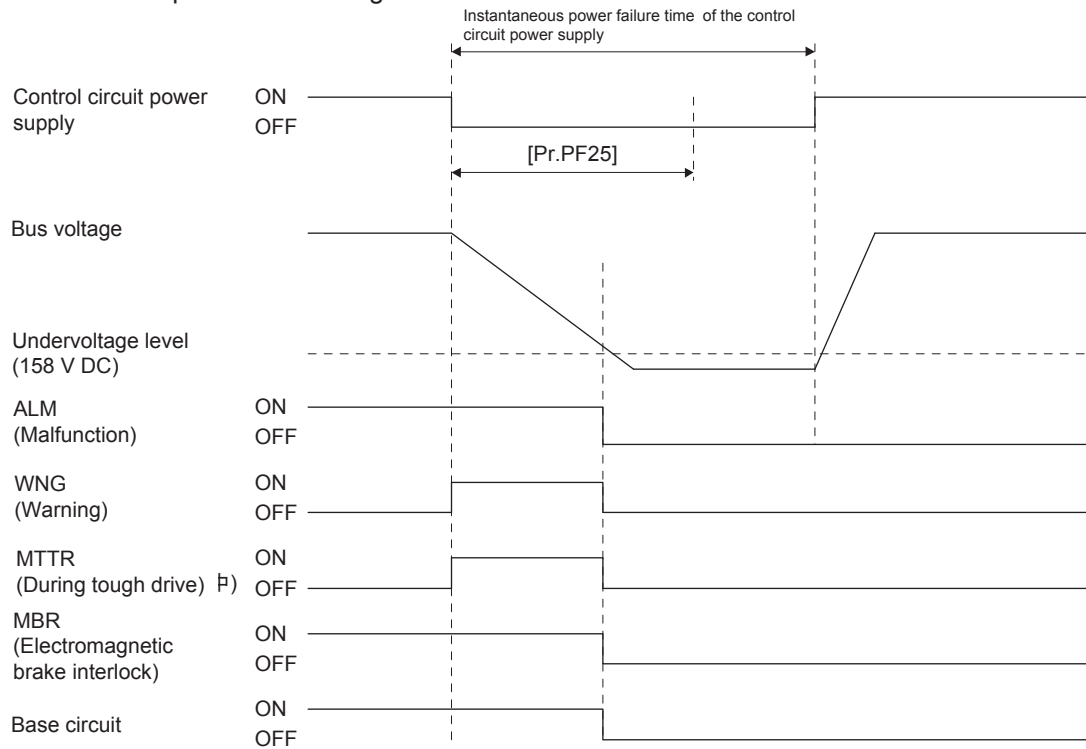

7. SPECIAL ADJUSTMENT FUNCTIONS

- (b) When the bus voltage does not decrease lower than 158 V DC within the instantaneous power failure time of the control circuit power supply

The operation continues without alarming.

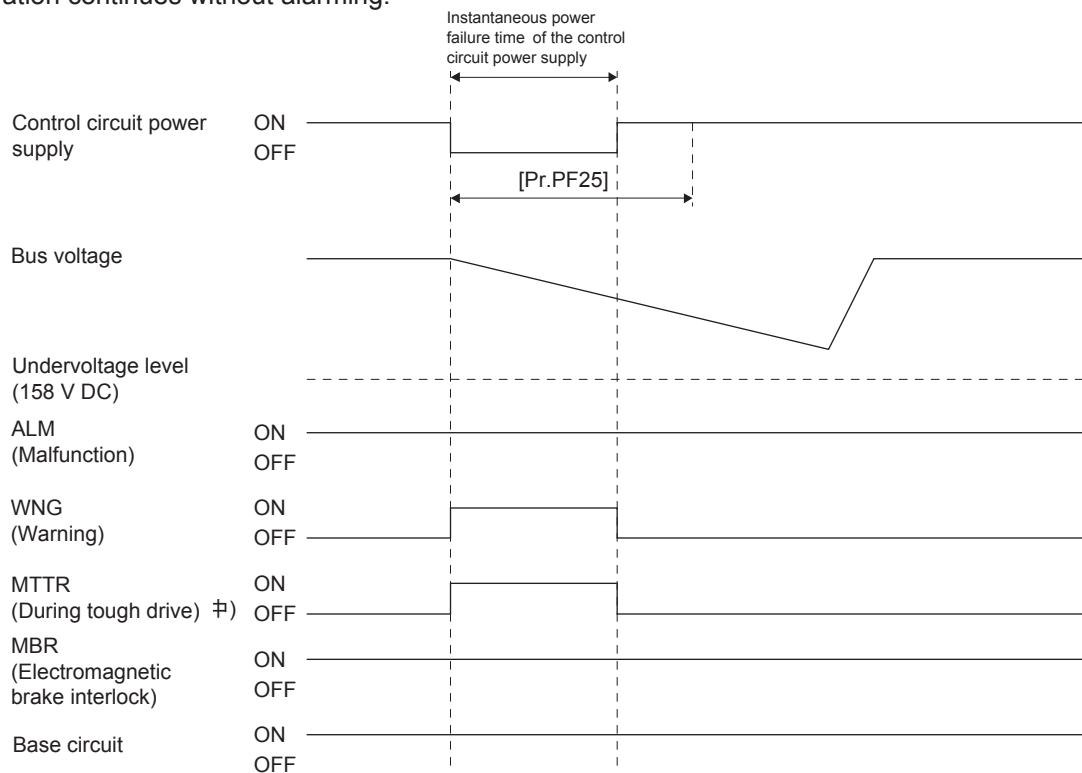

8. TROUBLESHOOTING

8. TROUBLESHOOTING

POINT

- Refer to MELSERVO-J4 Servo Amplifier Instruction Manual (Troubleshooting) for details of alarms and warnings.

8.1 Alarm and warning list

When an error occurs during operation, the corresponding alarm or warning is displayed. When the alarm or the warning occurs, refer to "MELSERVO-J4 Servo Amplifier Instruction Manual (Troubleshooting)" to remove the failure. When an alarm occurs, ALM will turn off.

After its cause has been removed, the alarm can be deactivated in any of the methods marked ○ in the alarm deactivation column in the following table. Warnings are automatically canceled after the cause of occurrence is removed.

For the alarms and warnings written "SD" in the stop method column, the axis stops with the dynamic brake after forced stop deceleration. For the alarms and warnings written "DB" in the stop method column, the axis stops with the dynamic brake without forced stop deceleration.

	No.	Name	Detail display	Detail name	Stop method (Note 4, 5)	Alarm reset			Operation mode		
						Error reset	CPU reset	Power off→on	Standard	Linear	DD
Alarm	10	Undervoltage	10.1	Voltage drop in the control power	DB	○	○	○	○	○	○
			10.2	Voltage drop in the main circuit power	SD	○	○	○	○	○	○
	12	Memory error 1 (RAM)	12.1	RAM error 1	DB	△	△	○	○	○	○
			12.2	RAM error 2	DB	△	△	○	○	○	○
			12.3	RAM error 3	DB	△	△	○	○	○	○
			12.4	RAM error 4	DB	△	△	○	○	○	○
			12.5	RAM error 5	DB	△	△	○	○	○	○
	13	Clock error	13.1	Clock error 1	DB	△	△	○	○	○	○
			13.2	Clock error 2	DB	△	△	○	○	○	○
	14	Control process error	14.1	Control process error 1	DB	△	△	○	○	○	○
			14.2	Control process error 2	DB	△	△	○	○	○	○
			14.3	Control process error 3	DB	△	△	○	○	○	○
			14.4	Control process error 4	DB	△	△	○	○	○	○
			14.5	Control process error 5	DB	△	△	○	○	○	○
			14.6	Control process error 6	DB	△	△	○	○	○	○
			14.7	Control process error 7	DB	△	△	○	○	○	○
			14.8	Control process error 8	DB	△	△	○	○	○	○
			14.9	Control process error 9	DB	△	△	○	○	○	○
			14.A	Control process error 10	DB	△	△	○	○	○	○
	15	Memory error 2 (EEP-ROM)	15.1	EEP-ROM error at power on	DB	△	△	○	○	○	○
15.2			EEP-ROM error during operation	DB	△	△	○	○	○	○	

8. TROUBLESHOOTING

	No.	Name	Detail display	Detail name	Stop method (Note 4, 5)	Alarm reset			Operation mode		
						Error reset	CPU reset	Power off→on	Standard	Linear	DD
Alarm	16	Encoder initial communication error 1	16.1	Encoder initial communication - Receive data error 1	DB	/	/	○	○	○	○
			16.2	Encoder initial communication - Receive data error 2	DB	/	/	○	○	○	○
			16.3	Encoder initial communication - Receive data error 3	DB	/	/	○	○	○	○
			16.5	Encoder initial communication - Transmission data error 1	DB	/	/	○	○	○	○
			16.6	Encoder initial communication - Transmission data error 2	DB	/	/	○	○	○	○
			16.7	Encoder initial communication - Transmission data error 3	DB	/	/	○	○	○	○
			16.A	Encoder initial communication - Process error 1	DB	/	/	○	○	/	○
			16.B	Encoder initial communication - Process error 2	DB	/	/	○	○	/	○
			16.C	Encoder initial communication - Process error 3	DB	/	/	○	○	/	○
			16.D	Encoder initial communication - Process error 4	DB	/	/	○	○	/	○
			16.E	Encoder initial communication - Process error 5	DB	/	/	○	○	/	○
			16.F	Encoder initial communication - Process error 6	DB	/	/	○	○	/	○
17	Board error	17.1	Board error 1	DB	/	/	○	○	○	○	
		17.3	Board error 2	DB	/	/	○	○	○	○	
		17.4	Board error 3	DB	/	/	○	○	○	○	
		17.5	Board error 4	DB	/	/	○	○	○	○	
		17.6	Board error 5	DB	/	/	○	○	○	○	
19	Memory error 3 (Flash-ROM)	19.1	Flash-ROM error 1	DB	/	/	○	○	○	○	
		19.2	Flash-ROM error 2	DB	/	/	○	○	○	○	
1A	Servo motor combination error	1A.1	Servo motor combination error	DB	/	/	○	○	○	○	
		1A.2	Servo motor control mode combination error	DB	/	/	○	○	○	○	
1E	Encoder initial communication error 2	1E.1	Encoder malfunction	DB	/	/	○	○	/	○	
1F	Encoder initial communication error 3	1F.1	Incompatible encoder	DB	/	/	○	○	○	○	
20	Encoder normal communication error 1	20.1	Encoder normal communication - Receive data error 1	DB	/	/	○	○	○	○	
		20.2	Encoder normal communication - Receive data error 2	DB	/	/	○	○	○	○	
		20.3	Encoder normal communication - Receive data error 3	DB	/	/	○	○	○	○	
		20.5	Encoder normal communication - Transmission data error 1	DB	/	/	○	○	○	○	
		20.6	Encoder normal communication - Transmission data error 2	DB	/	/	○	○	○	○	
		20.7	Encoder normal communication - Transmission data error 3	DB	/	/	○	○	○	○	
		20.9	Encoder normal communication - Receive data error 4	DB	/	/	○	○	○	○	
		20.A	Encoder normal communication - Receive data error 5	DB	/	/	○	○	○	○	

8. TROUBLESHOOTING

	No.	Name	Detail display	Detail name	Stop method (Note 4, 5)	Alarm reset			Operation mode		
						Error reset	CPU reset	Power off→on	Standard	Linear	DD
Alarm	21	Encoder normal communication error 2	21.1	Encoder error 1	DB	/	/	○	○	/	○
			21.2	Encoder data update error	DB	/	/	○	○	/	○
			21.3	Encoder data waveform error	DB	/	/	○	○	/	○
			21.4	Encoder non-signal error	DB	/	/	○	○	/	○
			21.5	Encoder hardware error 1	DB	/	/	○	○	/	○
			21.6	Encoder hardware error 2	DB	/	/	○	○	/	○
	24	Main circuit error	24.1	Ground fault detected at hardware detection circuit	DB	/	/	○	○	○	○
			24.2	Ground fault detected at software detection function	DB	○	○	○	○	○	○
	25	Absolute position erased	25.1	Servo motor encoder - Absolute position erased	DB	/	/	○	○	/	○
	27	Initial magnetic pole detection error	27.1	Magnetic pole detection - Abnormal termination	DB	/	/	○	/	○	○
			27.2	Magnetic pole detection - Time out error	DB	/	/	○	/	○	○
			27.3	Magnetic pole detection - Limit switch error	DB	/	/	○	/	○	○
			27.4	Magnetic pole detection - Estimated error	DB	/	/	○	/	○	○
			27.5	Magnetic pole detection - Position deviation error	DB	/	/	○	/	○	○
			27.6	Magnetic pole detection - Speed deviation error	DB	/	/	○	/	○	○
	28	Linear encoder error 2	28.1	Linear encoder - Environment error	DB	/	/	○	/	○	/
			28.2	Linear encoder - Environment error	DB	/	/	○	/	○	/
	2A	Linear encoder error 1	2A.1	Linear encoder error 1-1	DB	/	/	○	/	○	/
			2A.2	Linear encoder error 1-2	DB	/	/	○	/	○	/
			2A.3	Linear encoder error 1-3	DB	/	/	○	/	○	/
			2A.4	Linear encoder error 1-4	DB	/	/	○	/	○	/
			2A.5	Linear encoder error 1-5	DB	/	/	○	/	○	/
			2A.6	Linear encoder error 1-6	DB	/	/	○	/	○	/
			2A.7	Linear encoder error 1-7	DB	/	/	○	/	○	/
			2A.8	Linear encoder error 1-8	DB	/	/	○	/	○	/
	2B	Encoder counter error	2B.1	Encoder counter error 1	DB	/	/	○	/	/	○
			2B.2	Encoder counter error 2	DB	/	/	○	/	/	○
	30	Regenerative error (Note 1)	30.1	Regeneration heat error	DB	○ (Note 1)	○ (Note 1)	○ (Note 1)	○	○	○
			30.2	Regeneration signal error	DB	○ (Note 1)	○ (Note 1)	○ (Note 1)	○	○	○
			30.3	Regeneration feedback signal error	DB	○ (Note 1)	○ (Note 1)	○ (Note 1)	○	○	○
	31	Overspeed	31.1	Abnormal motor speed	SD	○	○	○	○	○	○
	32	Overcurrent	32.1	Overcurrent detected at hardware detection circuit (during operation)	DB	/	/	○	○	○	○
			32.2	Overcurrent detected at software detection function (during operation)	DB	○	○	○	○	○	○
			32.3	Overcurrent detected at hardware detection circuit (during a stop)	DB	/	/	○	○	○	○
			32.4	Overcurrent detected at software detection function (during a stop)	DB	○	○	○	○	○	○
	33	Overvoltage	33.1	Main circuit voltage error	DB	○	○	○	○	○	○
	34	SSCNET receive error 1	34.1	SSCNET receive data error	SD	○	○ (Note 2)	○	○	○	○
			34.2	SSCNET connector connection error	SD	○	○	○	○	○	○
			34.3	SSCNET communication data error	SD	○	○	○	○	○	○
			34.4	Hardware error signal detection	SD	○	○	○	○	○	○
35	Command frequency error	35.1	Command frequency error	SD	○	○	○	○	○	○	
36	SSCNET receive error 2	36.1	Continuous communication data error	SD	○	○	○	○	○	○	

8. TROUBLESHOOTING

	No.	Name	Detail display	Detail name	Stop method (Note 4, 5)	Alarm reset			Operation mode		
						Error reset	CPU reset	Power off → on	Standard	Linear	DD
Alarm	37	Parameter error	37.1	Parameter setting range error	DB	/	○	○	○	○	○
			37.2	Parameter combination error	DB	/	○	○	○	○	○
	3A	Inrush current suppression circuit error	3A.1	Inrush current suppression circuit error	DB	/	/	○	○	○	
	3E	Operation mode error	3E.1	Operation mode error	DB	/	/	○	○	○	
	42	Servo control error	42.1	Servo control error by position deviation	DB	○ (Note 3)	○ (Note 3)	○	/	○	○
			42.2	Servo control error by speed deviation	DB	○ (Note 3)	○ (Note 3)	○	/	○	○
			42.3	Servo control error by torque/thrust deviation	DB	○ (Note 3)	○ (Note 3)	○	/	○	○
	45	Main circuit device overheat (Note 1)	45.1	Main circuit device overheat error	SD	○ (Note 1)	○ (Note 1)	○ (Note 1)	○	○	○
	46	Servo motor overheat (Note 1)	46.1	Abnormal temperature of servo motor 1	SD	○ (Note 1)	○ (Note 1)	○ (Note 1)	○	/	○
			46.2	Abnormal temperature of servo motor 2	SD	○ (Note 1)	○ (Note 1)	○ (Note 1)	/	○	○
			46.3	Thermistor disconnected	SD	○ (Note 1)	○ (Note 1)	○ (Note 1)	○	○	○
			46.5	Abnormal temperature of servo motor 3	DB	○ (Note 1)	○ (Note 1)	○ (Note 1)	○	/	/
			46.6	Abnormal temperature of servo motor 4	DB	○ (Note 1)	○ (Note 1)	○ (Note 1)	○	/	/
	47	Cooling fan error	47.1	Cooling fan stop error	SD	/	/	○	○	○	○
			47.2	Cooling fan speed reduction error	SD	/	/	○	○	○	○
	50	Overload 1 (Note 1)	50.1	Thermal overload error 1 during operation	SD	○ (Note 1)	○ (Note 1)	○ (Note 1)	○	○	○
			50.2	Thermal overload error 2 during operation	SD	○ (Note 1)	○ (Note 1)	○ (Note 1)	○	○	○
			50.3	Thermal overload error 4 during operation	SD	○ (Note 1)	○ (Note 1)	○ (Note 1)	○	○	○
			50.4	Thermal overload error 1 during a stop	SD	○ (Note 1)	○ (Note 1)	○ (Note 1)	○	○	○
			50.5	Thermal overload error 2 during a stop	SD	○ (Note 1)	○ (Note 1)	○ (Note 1)	○	○	○
			50.6	Thermal overload error 4 during a stop	SD	○ (Note 1)	○ (Note 1)	○ (Note 1)	○	○	○
	51	Overload 2 (Note 1)	51.1	Thermal overload error 3 during operation	DB	○ (Note 1)	○ (Note 1)	○ (Note 1)	○	○	○
			51.2	Thermal overload error 3 during a stop	DB	○ (Note 1)	○ (Note 1)	○ (Note 1)	○	○	○
52	Error excessive	52.1	Excess droop pulse 1	SD	○	○	○	○	○	○	
		52.3	Excess droop pulse 2	SD	○	○	○	○	○	○	
		52.4	Error excessive during 0 torque limit	SD	○	○	○	○	○	○	
		52.5	Excess droop pulse 3	DB	○	○	○	○	○	○	

8. TROUBLESHOOTING

	No.	Name	Detail display	Detail name	Stop method (Note 4, 5)	Alarm reset			Operation mode		
						Error reset	CPU reset	Power off → on	Standard	Linear	DD
Alarm	54	Oscillation detection	54.1	Oscillation detection error	DB	○	○	○	○	○	○
	56	Forced stop error	56.2	Over speed during forced stop	DB	○	○	○	○	○	○
			56.3	Estimated distance over during forced stop	DB	○	○	○	○	○	○
	63	STO timing error	63.1	STO1 off	DB	○	○	○	○	○	○
			63.2	STO2 off	DB	○	○	○	○	○	○
	8A	USB communication time-out error	8A.1	USB communication time-out error	SD	○	○	○	○	○	○
	8E	USB communication error	8E.1	USB communication receive error	SD	○	○	○	○	○	○
			8E.2	USB communication checksum error	SD	○	○	○	○	○	○
			8E.3	USB communication character error	SD	○	○	○	○	○	○
			8E.4	USB communication command error	SD	○	○	○	○	○	○
			8E.5	USB communication data number error	SD	○	○	○	○	○	○
	888	Watchdog	88_	Watchdog	DB	○	○	○	○	○	○

Note 1. Leave for about 30 minutes of cooling time after removing the cause of occurrence.

2. In some controller communication status, the alarm factor may not be removed.

3. The alarm can be canceled by setting as follows:

- When a linear servo motor or a direct drive motor is used: set [Pr. PL04] to "1 _ _ _".

4. Stop method indicates as follows:

- DB: Stops with dynamic brake. (Coasts for the servo amplifier without dynamic brake.)
- SD: Decelerates to a stop

5. This is applicable when [Pr. PA04] is set to the initial value. The stop system of SD can be changed to DB using [Pr. PA04].

8. TROUBLESHOOTING

	No.	Name	Detail display	Detail name	Stop method (Note 2, 3)	Operation mode		
						Standard	Linear	DD
Warning	91	Servo amplifier overheat warning (Note 1)	91.1	Main circuit device overheat warning	-	○	○	○
	92	Battery cable disconnection warning	92.1	Encoder battery cable disconnection warning	-	○	△	○
			92.3	Battery degradation	-	○	△	○
	95	STO warning	95.1	STO1 off detection	DB	○	○	○
			95.2	STO2 off detection	DB	○	○	○
	96	Home position setting warning	96.1	In-position warning at home positioning	-	○	○	○
			96.2	Command input warning at home positioning	-	○	○	○
	9F	Battery warning	9F.1	Low battery	-	○	○	○
			9F.2	Battery degradation warning	-	○	△	○
	E0	Excessive regeneration warning (Note 1)	E0.1	Excessive regeneration warning	-	○	○	○
	E1	Overload warning 1 (Note 1)	E1.1	Thermal overload warning 1 during operation	-	○	○	○
			E1.2	Thermal overload warning 2 during operation	-	○	○	○
			E1.3	Thermal overload warning 3 during operation	-	○	○	○
			E1.4	Thermal overload warning 4 during operation	-	○	○	○
			E1.5	Thermal overload error 1 during a stop	-	○	○	○
			E1.6	Thermal overload error 2 during a stop	-	○	○	○
			E1.7	Thermal overload error 3 during a stop	-	○	○	○
			E1.8	Thermal overload error 4 during a stop	-	○	○	○
	E2	Servo motor overheat warning	E2.1	Servo motor temperature warning	-	○	○	○
	E3	Absolute position counter warning	E3.2	Encoder absolute positioning counter warning	-	○	△	○
			E3.5	Absolute position counter warning	-	○	△	○
	E4	Parameter warning	E4.1	Parameter setting range error warning	-	○	○	○
	E6	Servo forced stop warning	E6.1	Forced stop warning	SD	○	○	○
	E7	Controller forced stop warning	E7.1	Controller forced stop warning	SD	○	○	○
	E8	Cooling fan speed reduction warning	E8.1	Decreased cooling fan speed warning	-	○	○	○
	E9	Main circuit off warning	E9.1	Servo-on signal on during main circuit off	DB	○	○	○
			E9.2	Bus voltage drop during low speed operation	DB	○	○	○
			E9.3	Ready-on signal on during main circuit off	DB	○	○	○
EC	Overload warning 2 (Note 1)	EC.1	Overload warning 2	-	○	○	○	
ED	Output watt excess warning	ED.1	Output watt excess warning	-	○	○	○	
F0	Tough drive warning	F0.1	Instantaneous power failure tough drive warning	-	○	○	○	
		F0.3	Vibration tough drive warning	-	○	○	○	
F2	Drive recorder - Miswriting warning	F2.1	Drive recorder - Area writing time-out warning	-	○	○	○	
		F2.2	Drive recorder - Data miswriting warning	-	○	○	○	
F3	Oscillation detection warning	F3.1	Oscillation detection warning	-	○	○	○	

Note 1. Leave for about 30 minutes of cooling time after removing the cause of occurrence.

2. Stop method indicates as follows:

- DB: Stops with dynamic brake. (Coasts for the servo amplifier without dynamic brake.)
- SD: Decelerates to a stop

3. This is applicable when [Pr. PA04] is set to the initial value. The stop system of SD can be changed to DB using [Pr. PA04].

8. TROUBLESHOOTING

8.2 Troubleshooting at power on

When the servo system does not boot and system error occurs at power on of the servo system controller, improper boot of the servo amplifier might be the cause. Check the display of the servo amplifier, and take actions according to this section.

Display	Description	Cause	Checkpoint	Action
AA	Communication with the servo system controller has disconnected.	The power of the servo system controller was turned off.	Check the power of the servo system controller.	Switch on the power of the servo system controller.
		SSCNET III cable was disconnected.	"AA" is displayed in the corresponding axis and following axes.	Replace the SSCNET III cable of the corresponding axis.
			Check if the connectors (CNIA, CNIB) are unplugged.	Connect it correctly.
The power of the servo amplifier was turned off.	"AA" is displayed in the corresponding axis and following axes.	Check the power of the servo amplifier.		
		Replace the servo amplifier of the corresponding axis.		
AB	Initialization communication with the servo system controller has not completed.	The system has been in the test operation mode.	Check if the disabling control axis switch (SW2-2) is on.	Turn off the disabling control axis switch (SW2-2).
		The setting of the Axis No. is incorrect.	Check that the other servo amplifier is not assigned to the same axis No.	Set it correctly.
		Axis No. does not match with the axis No. set to the servo system controller.	Check the setting and axis No. of the servo system controller.	Set it correctly.
		Information about the servo series has not set in the simple motion module.	Check the value set in Servo series (Pr.100) in the simple motion module.	Set it correctly.
		Communication cycle does not match.	Check the communication cycle at the servo system controller side. When using 8 axes or less: 0.222 ms When using 16 axes or less: 0.444 ms When using 32 axes or less: 0.888 ms	Set it correctly.
		SSCNET III cable was disconnected.	"AB" is displayed in the corresponding axis and following axes.	Replace the SSCNET III cable of the corresponding axis.
			Check if the connectors (CNIA, CNIB) are unplugged.	Connect it correctly.
		The power of the servo amplifier was turned off.	"AB" is displayed in an axis and the following axes.	Check the power of the servo amplifier.
The servo amplifier is malfunctioning.	"AB" is displayed in an axis and the following axes.	Replace the servo amplifier of the corresponding axis.		
B##. (Note)	The system has been in the test operation mode.	Test operation mode has been active.	Test operation setting switch (SW2-1) is turned on.	Turn off the test operation setting switch (SW2-1).
off	Operation mode for manufacturer setting is set.	Operation mode for manufacturer setting is enabled.	Check if all of the control axis setting switches (SW2) are on.	Set the control axis setting switches (SW2) correctly.

Note. ## indicates axis No.

9. OUTLINE DRAWINGS

9. OUTLINE DRAWINGS

9.1 Servo amplifier

(1) MR-J4-10B•MR-J4-20B

[Unit: mm]

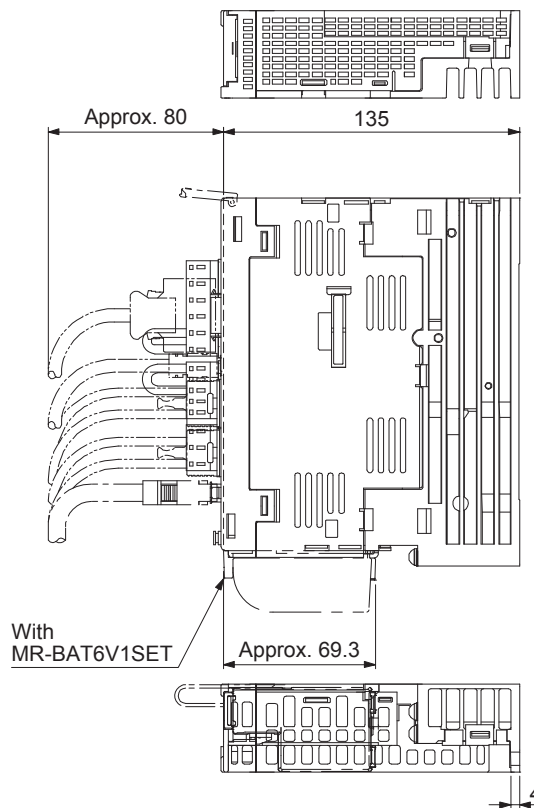
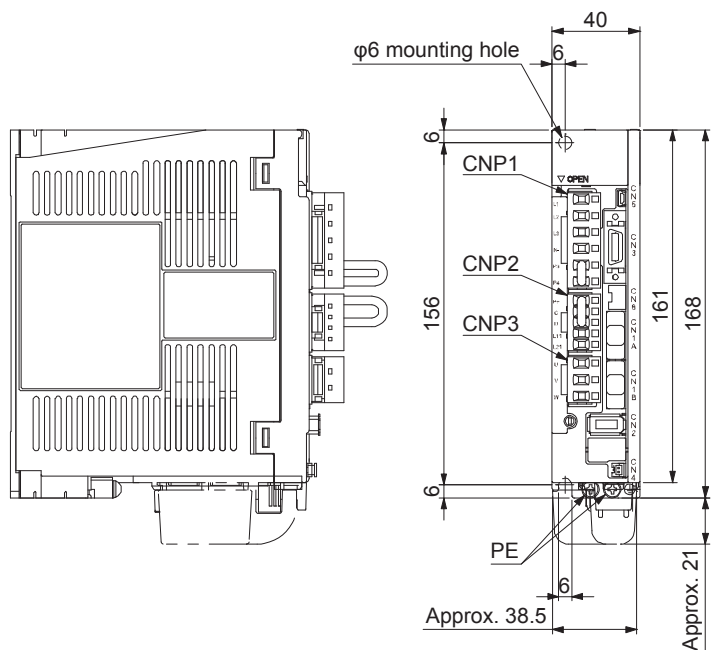

Mass: 0.8 [kg]

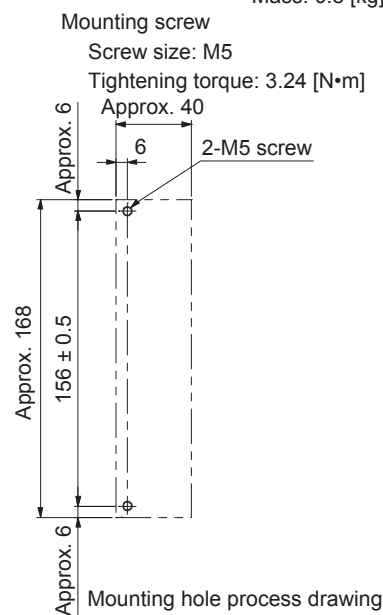
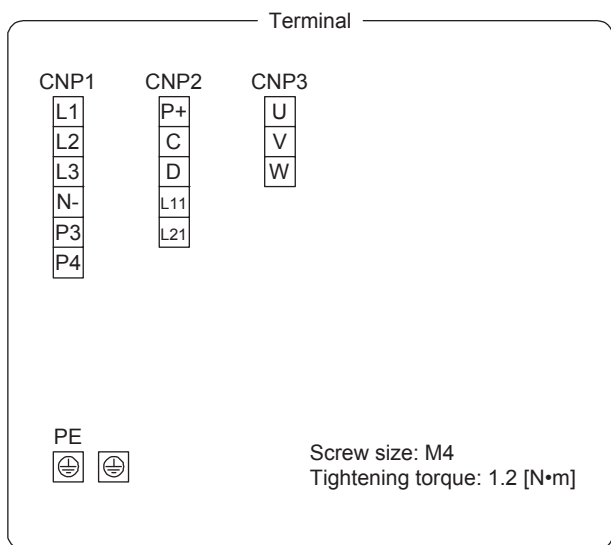

9. OUTLINE DRAWINGS

(2) MR-J4-40B•MR-J4-60B

[Unit: mm]

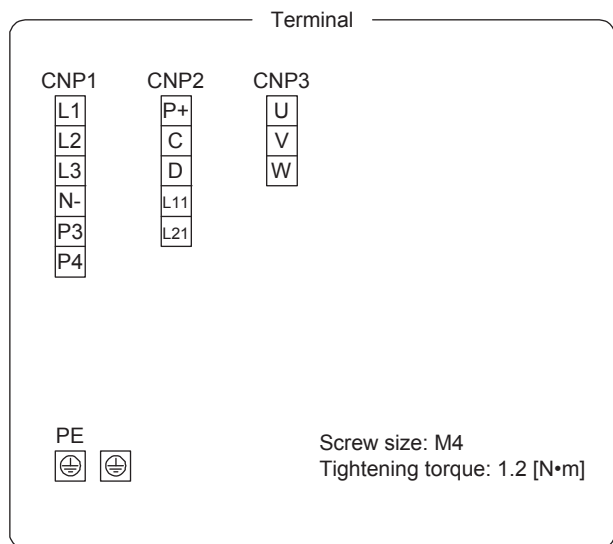
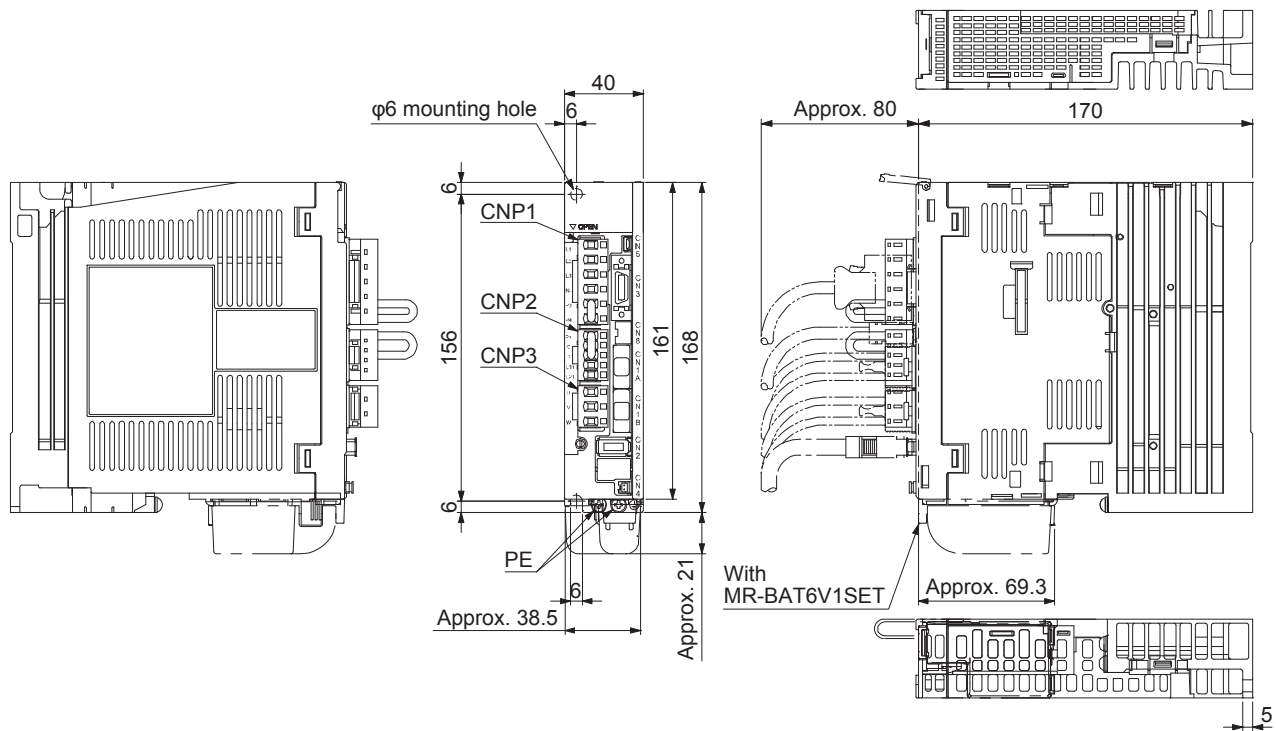

Mass: 1.0 [kg]
 Mounting screw
 Screw size: M5
 Tightening torque: 3.24 [N·m]

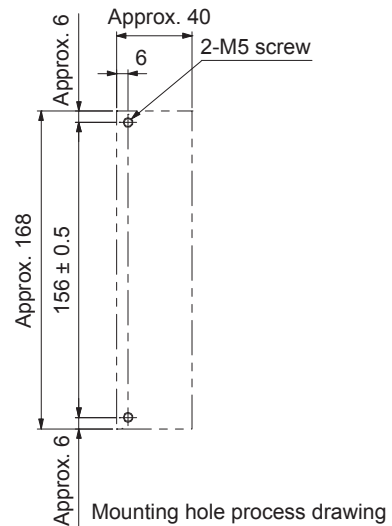

9. OUTLINE DRAWINGS

(3) MR-J4-70B•MR-J4-100B

[Unit: mm]

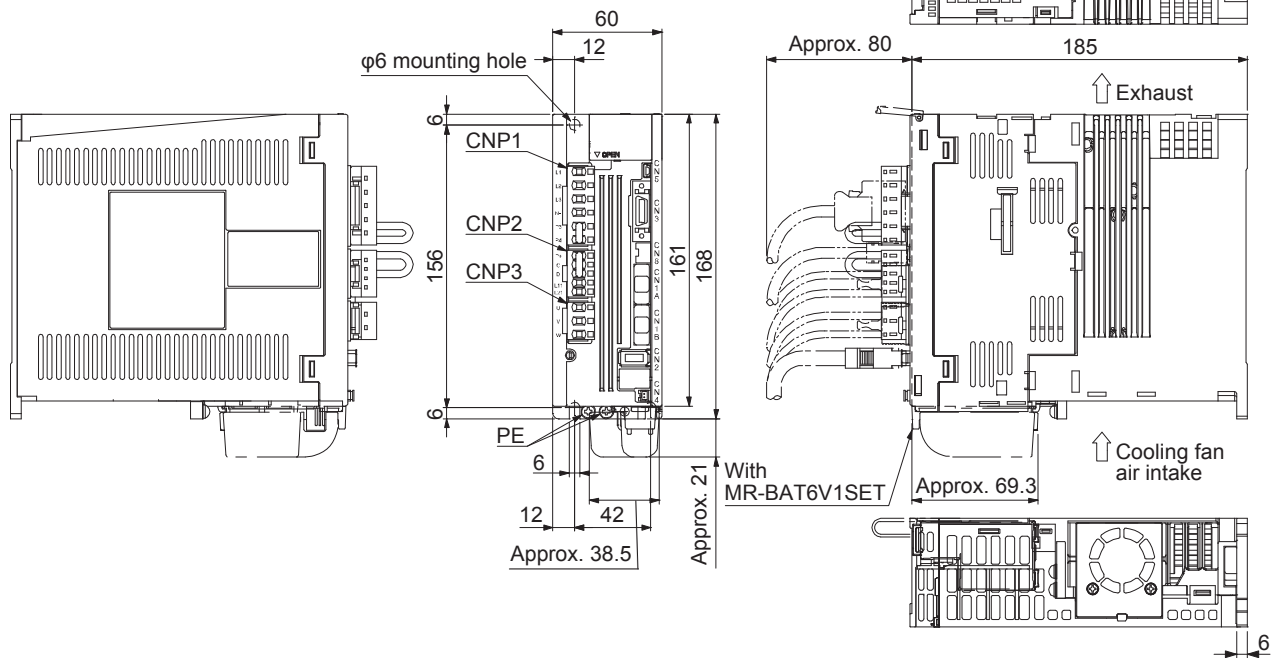

Mass: 1.4 [kg]

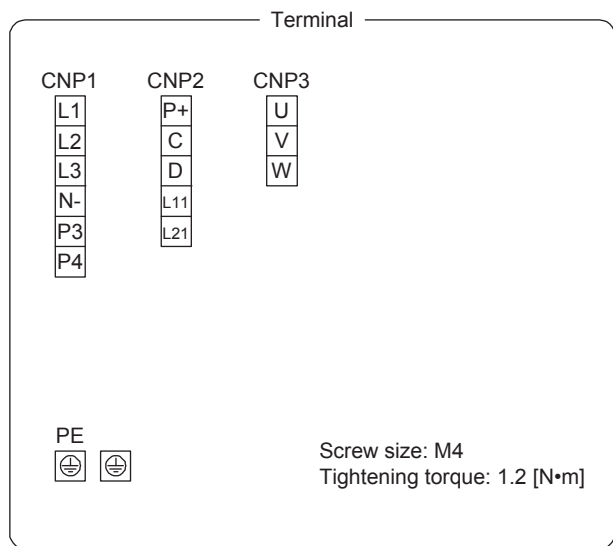

Mounting screw
Screw size: M5
Tightening torque: 3.24 [N·m]

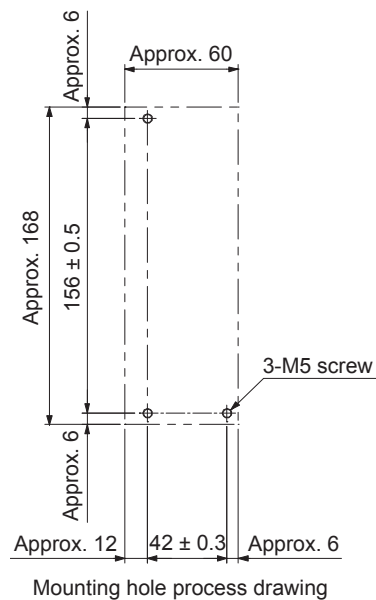

9. OUTLINE DRAWINGS

(4) MR-J4-200B

[Unit: mm]

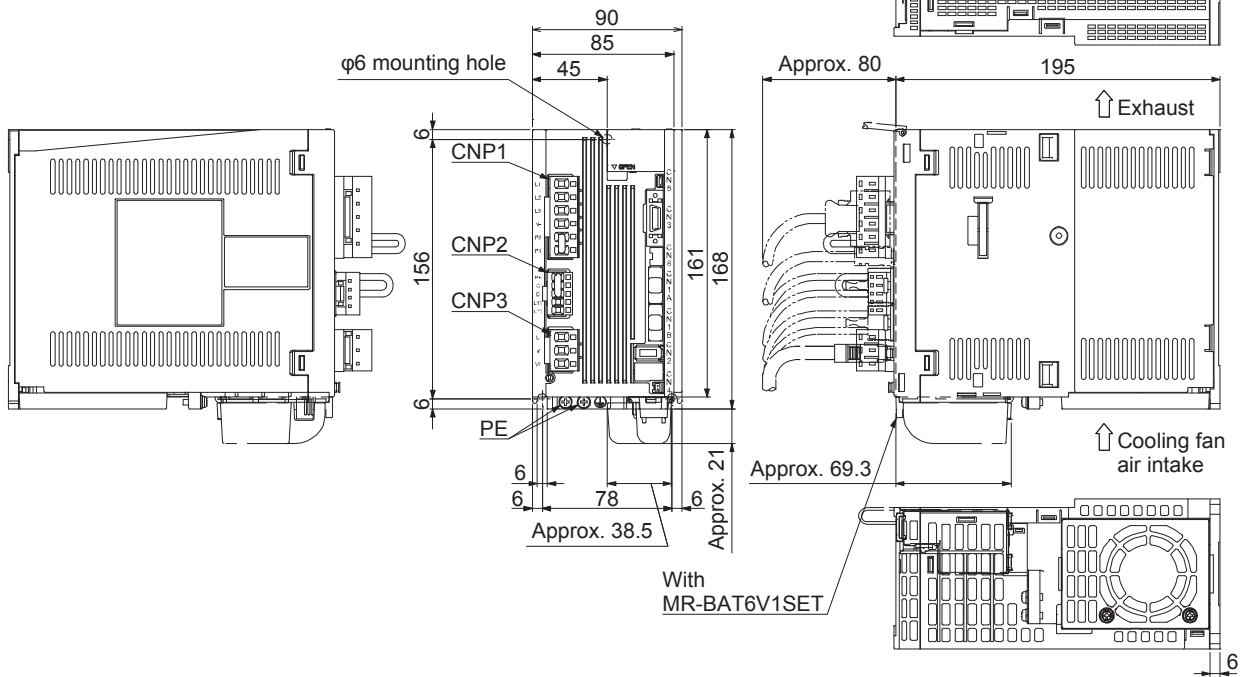

Mass: 2.1 [kg]

Mounting screw
Screw size: M5
Tightening torque: 3.24 [N·m]

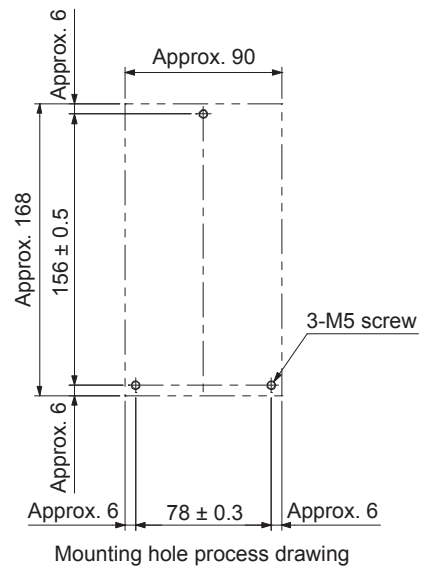
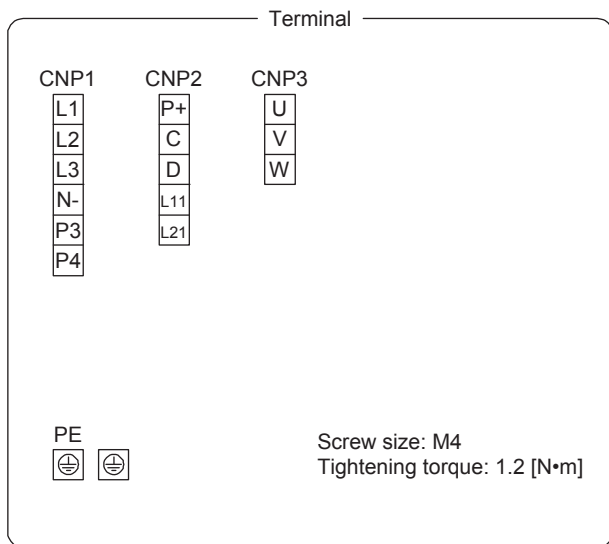

9. OUTLINE DRAWINGS

(5) MR-J4-350B

[Unit: mm]

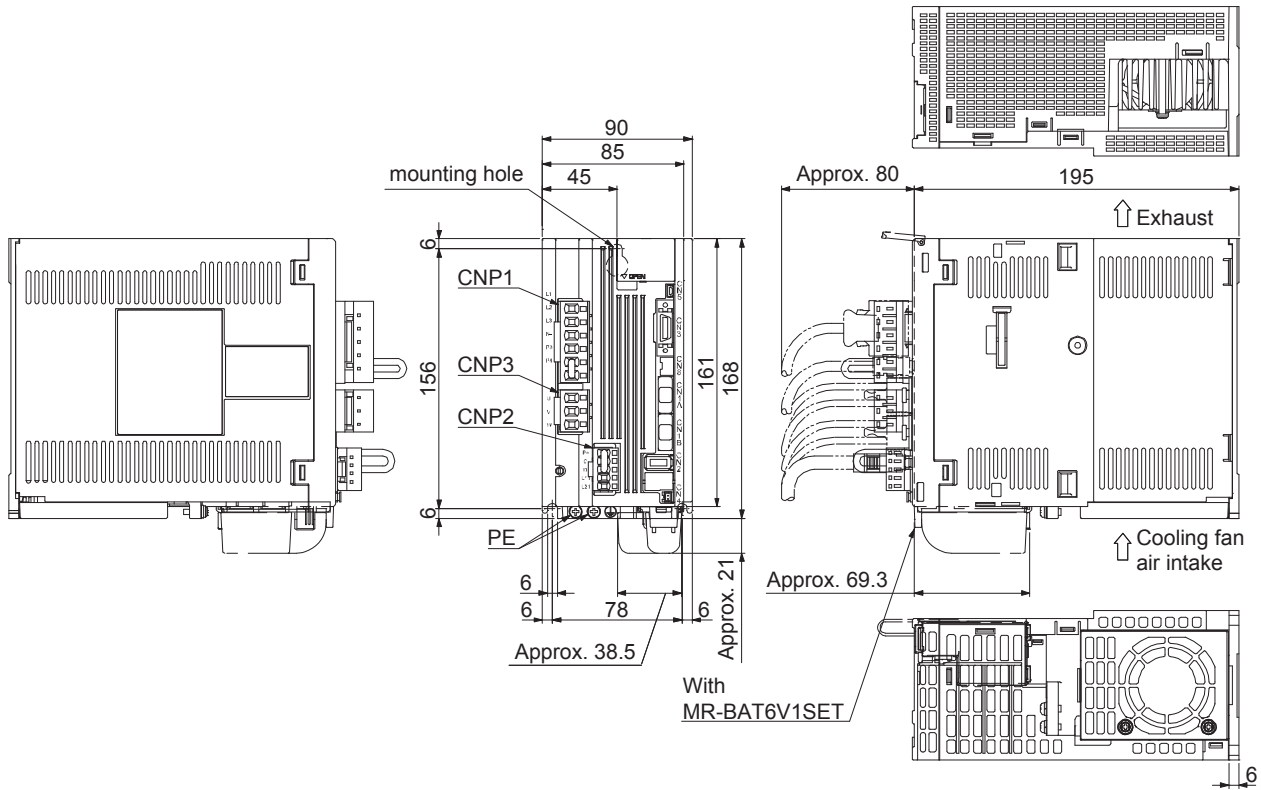

Mass: 2.3 [kg]

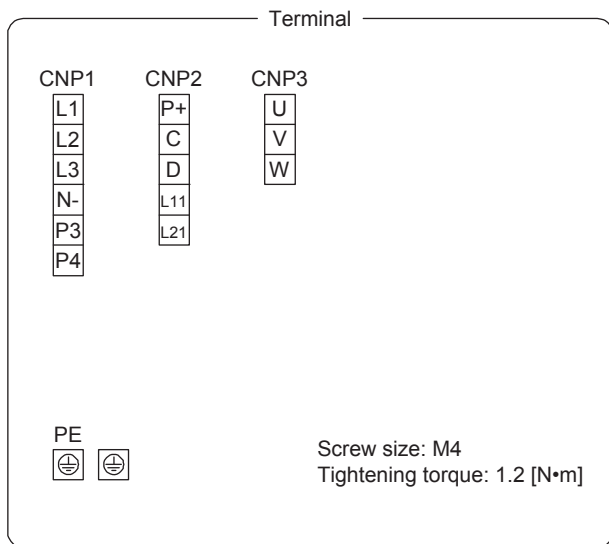

Mounting screw
Screw size: M5
Tightening torque: 3.24 [N·m]

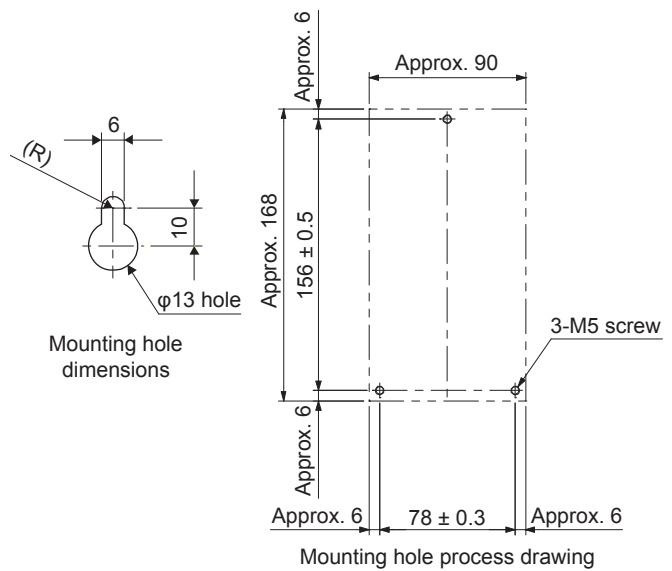

9. OUTLINE DRAWINGS

(6) MR-J4-500B

[Unit: mm]

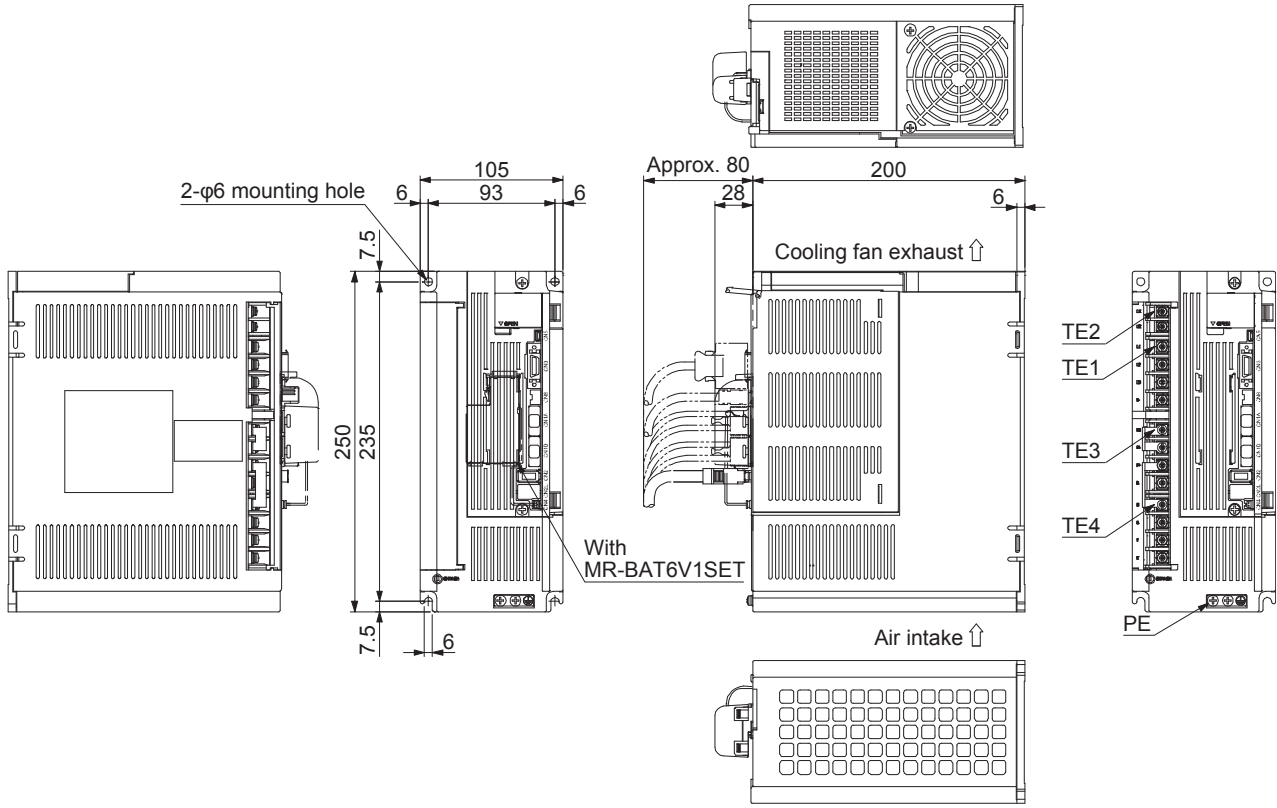

Mass: 4.6 [kg]

Terminal					
TE2	<table border="1"> <tr><td>L11</td></tr> <tr><td>L21</td></tr> </table> <p>TE2 Screw size: M3.5 Tightening torque: 0.8 [N•m]</p>	L11	L21		
L11					
L21					
TE1	<table border="1"> <tr><td>L1</td></tr> <tr><td>L2</td></tr> <tr><td>L3</td></tr> <tr><td>N-</td></tr> </table> <p>TE1 Screw size: M4 Tightening torque: 1.2 [N•m]</p>	L1	L2	L3	N-
L1					
L2					
L3					
N-					
TE3	<table border="1"> <tr><td>P3</td></tr> <tr><td>P4</td></tr> <tr><td>P+</td></tr> <tr><td>C</td></tr> </table> <p>TE3 Screw size: M4 Tightening torque: 1.2 [N•m]</p>	P3	P4	P+	C
P3					
P4					
P+					
C					
TE4	<table border="1"> <tr><td>D</td></tr> <tr><td>U</td></tr> <tr><td>V</td></tr> <tr><td>W</td></tr> </table> <p>TE4 Screw size: M4 Tightening torque: 1.2 [N•m]</p>	D	U	V	W
D					
U					
V					
W					
PE	<table border="1"> <tr><td>PE</td></tr> <tr><td>PE</td></tr> </table> <p>PE Screw size: M4 Tightening torque: 1.2 [N•m]</p>	PE	PE		
PE					
PE					

Mounting screw
Screw size: M5
Tightening torque: 3.24 [N•m]

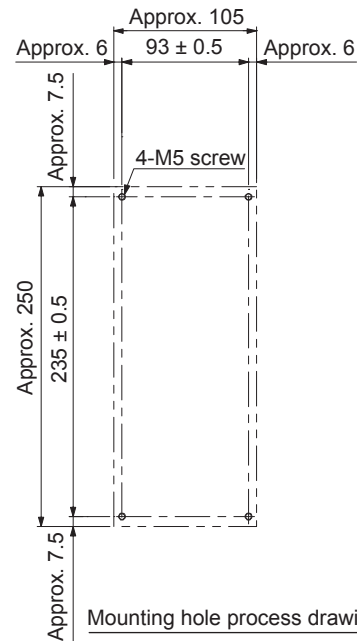

9. OUTLINE DRAWINGS

(7) MR-J4-700B

[Unit: mm]

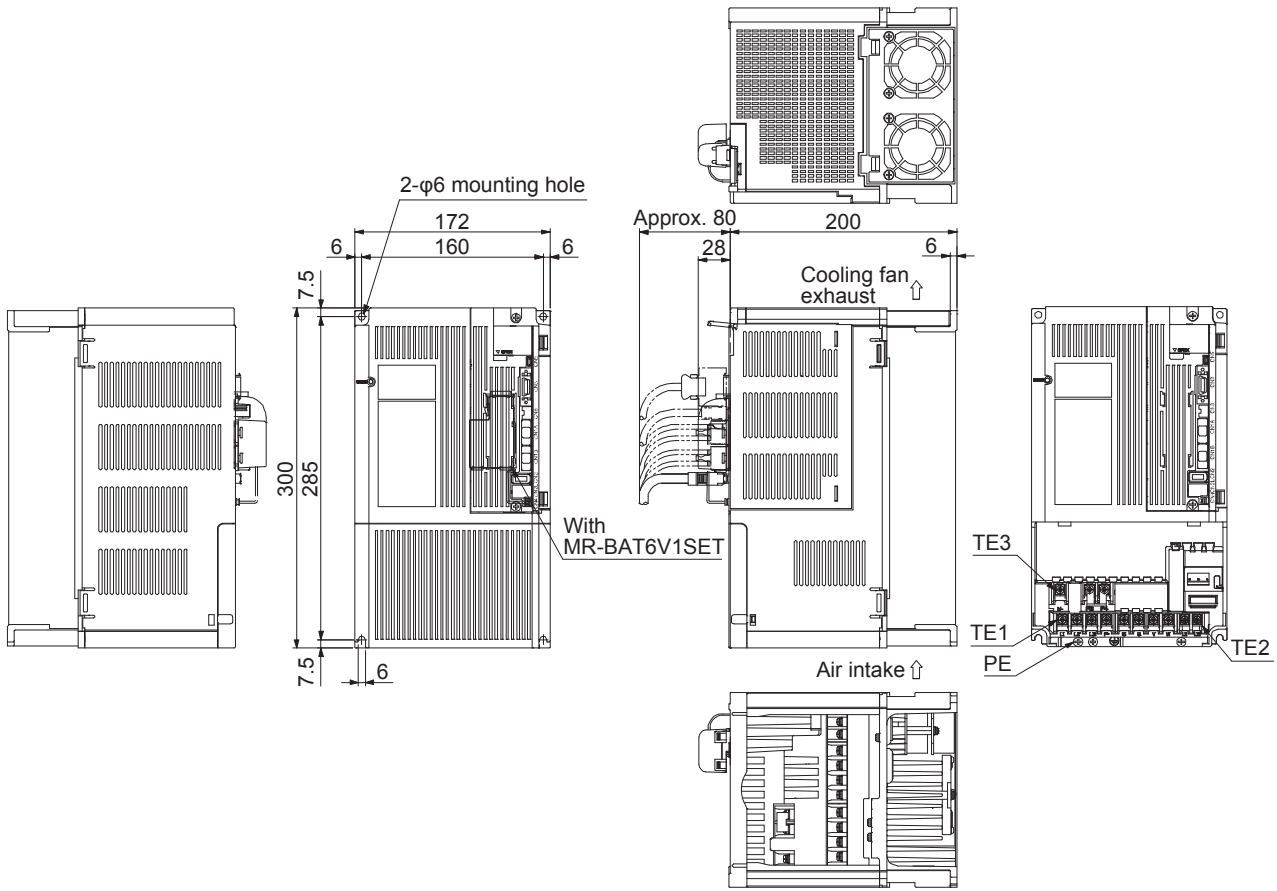

Mass: 6.2 [kg]

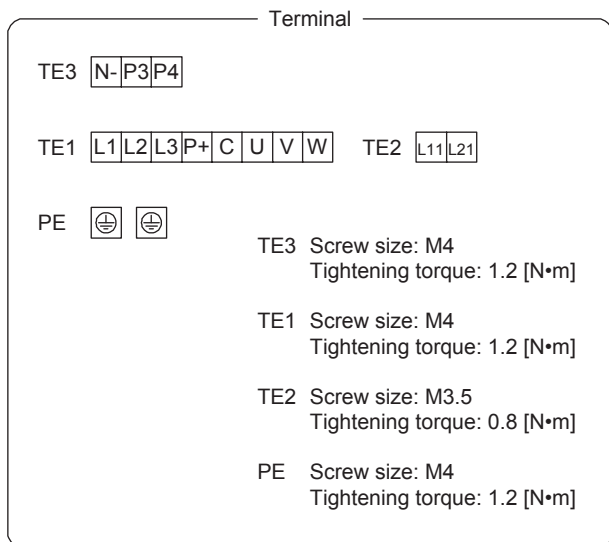

Mounting screw
Screw size: M5
Tightening torque: 3.24 [N•m]

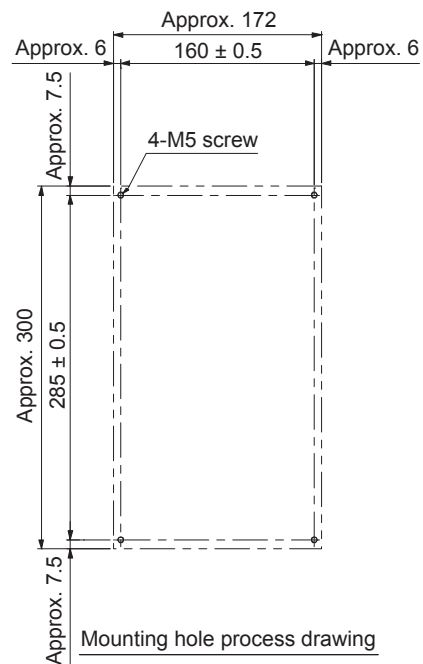

9. OUTLINE DRAWINGS

9.2 Connector

(1) CN1A•CN1B connector

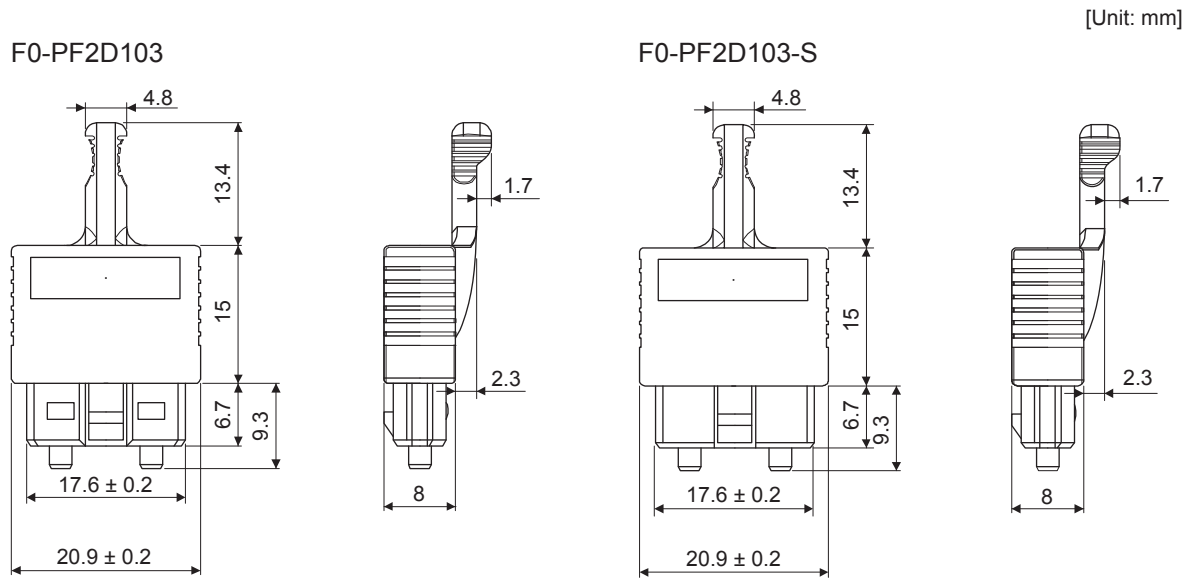

(2) Miniature delta ribbon (MDR) system (3M)

(a) One-touch lock type

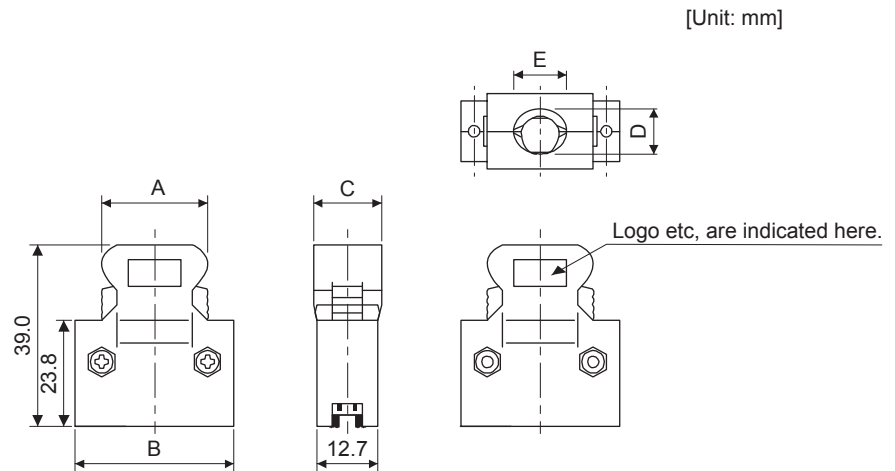

Connector	Shell kit	Each type of dimension				
		A	B	C	D	E
10120-3000PE	10320-52F0-008	22.0	33.3	14.0	10.0	12.0

9. OUTLINE DRAWINGS

- (b) Jack screw M2.6 type
This is not available as option.

[Unit: mm]

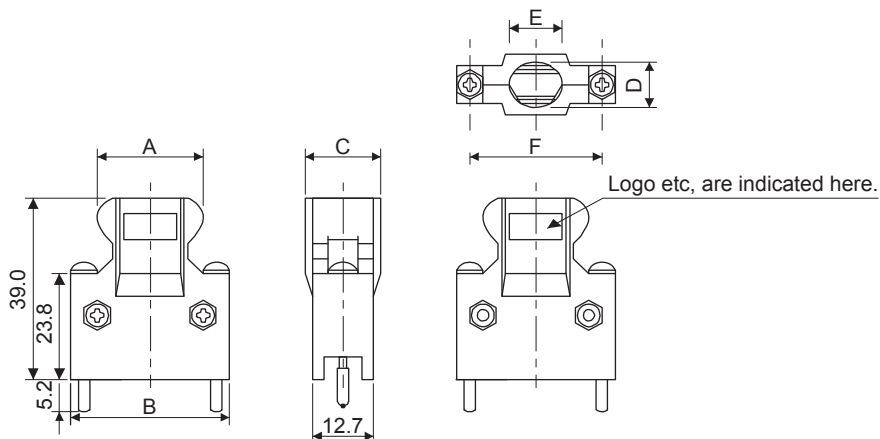

Connector	Shell kit	Each type of dimension					
		A	B	C	D	E	F
10120-3000PE	10320-52F0-008	22.0	33.3	14.0	10.0	12.0	27.4

- (3) SCR connector system (3M)
Receptacle: 36210-0100PL
Shell kit : 36310-3200-008

[Unit: mm]

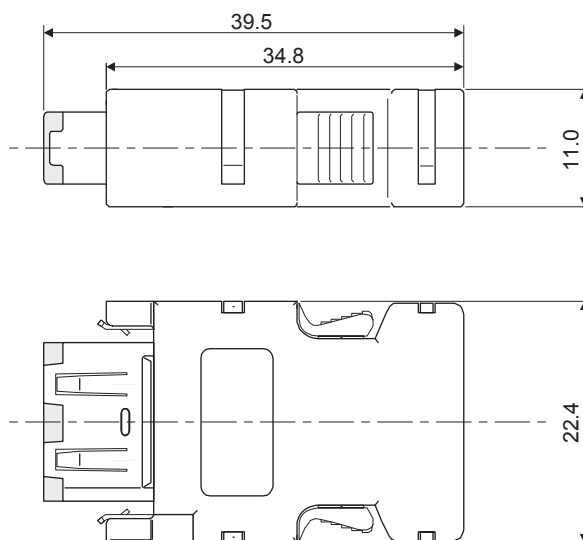

10. CHARACTERISTICS

10. CHARACTERISTICS

POINT
● For the characteristics of the linear servo motor and the direct drive motor, refer to sections 14.4 and 15.4.

10.1 Overload protection characteristics

An electronic thermal is built in the servo amplifier to protect the servo motor, servo amplifier and servo motor power wires from overloads.

[AL. 50 Overload 1] occurs if overload operation performed is above the electronic thermal protection curve shown in fig. 10.1 [AL. 51 Overload 2] occurs if the maximum current is applied continuously for several seconds due to machine collision, etc. Use the equipment on the left-hand side area of the continuous or broken line in the graph.

When unbalanced torque is generated, such as in a vertical lift machine, it is recommended that the unbalanced torque of the machine be kept at 70% or less of the motor's rated torque.

This servo amplifier has solid-state servo motor overload protection. (The servo motor overload current (full load current) is set on the basis of 120% rated current of the servo amplifier.)

10. CHARACTERISTICS

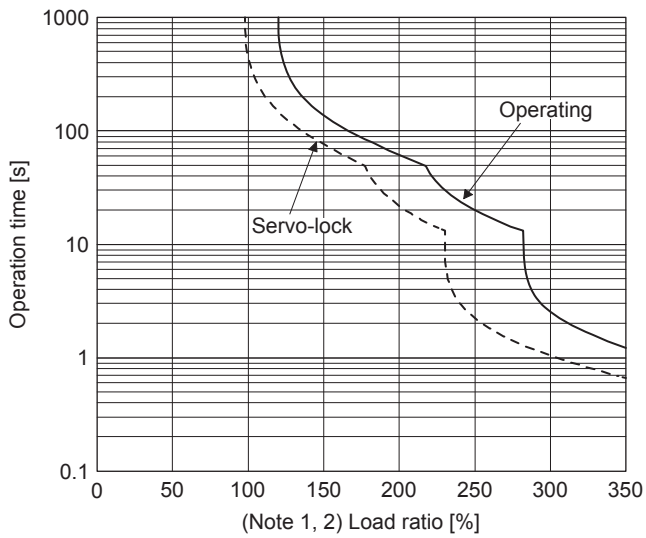

HG-KR053, HG-KR13
 HG-MR053, HG-MR13

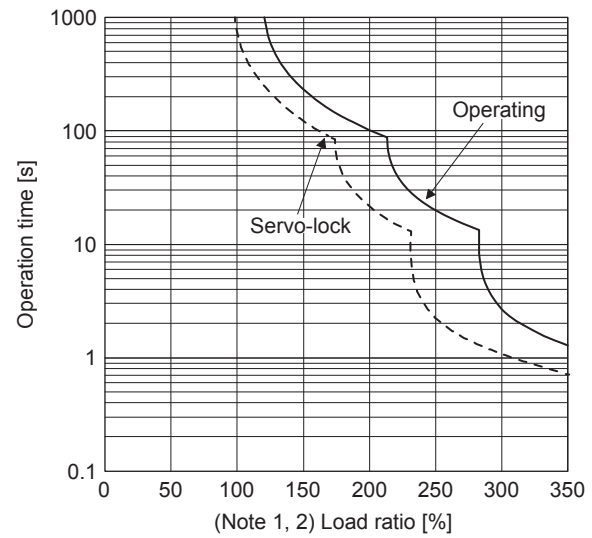

HG-KR23, HG-KR43, HG-KR73
 HG-MR23, HG-MR43, HG-MR73
 HG-SR51, HG-SR81, HG-SR52, HG-SR102

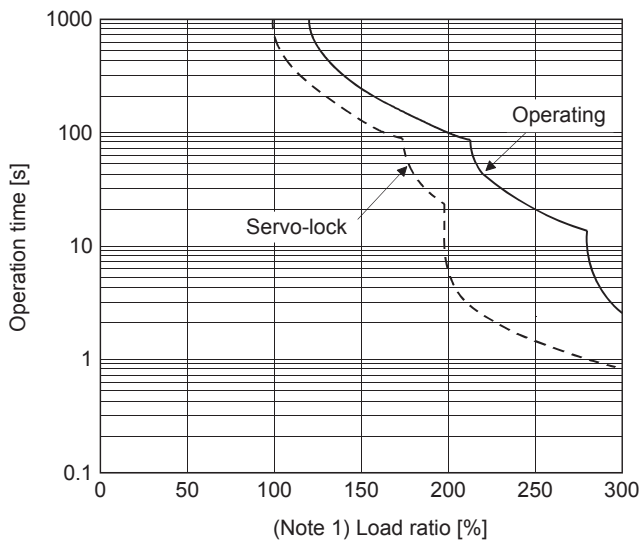

HG-SR121, HG-SR201, HG-SR152, HG-SR202,
 HG-SR301, HG-SR352

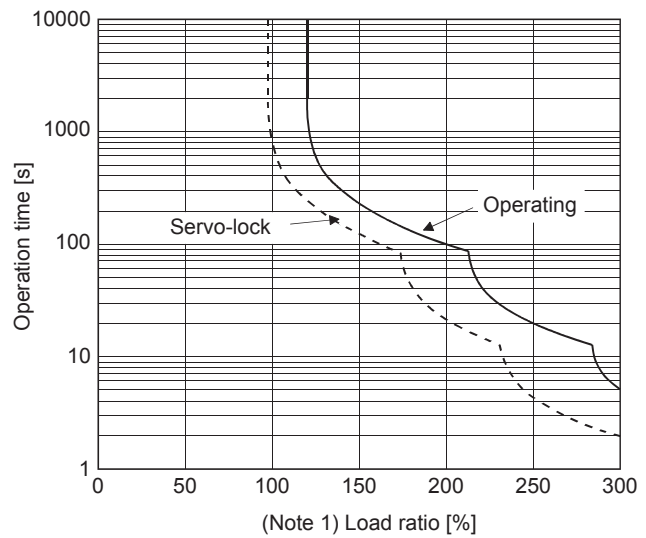

HG-SR421, HG-SR502, HG-SR702

- Note 1. If operation that generates torque more than 100% of the rating is performed with an abnormally high frequency in a servo motor stop status (servo-lock status) or in a 30 r/min or less low-speed operation status, the servo amplifier may malfunction regardless of the electronic thermal protection.
2. The load ratio ranging from 300 % to 350 % applies to the HG-KR servo motor.

Fig. 10.1 Electronic thermal protection characteristics

10. CHARACTERISTICS

10.2 Power supply capacity and generated loss

(1) Amount of heat generated by the servo amplifier

Table 10.1 indicates servo amplifiers' power supply capacities and losses generated under rated load. For thermal design of an enclosed type cabinet, use the values in the table in consideration for the worst operating conditions. The actual amount of generated heat will be intermediate between values at rated torque and servo-off according to the duty used during operation. When the servo motor is run at less than the rated speed, the power supply capacity will be smaller than the value in the table, but the servo amplifier's generated heat will not change.

Table 10.1 Power supply capacity and generated loss per servo motor at rated output

Servo amplifier	Servo motor	(Note 1) Power supply capacity [kVA]	(Note 2) Servo amplifier- generated heat [W]		Area required for heat dissipation [m ²]
			At rated output	With servo-off	
MR-J4-10B	HG-MR053	0.3	25	15	0.5
	HG-MR13	0.3	25	15	0.5
	HG-KR053/13	0.3	25	15	0.5
MR-J4-20B	HG-MR23	0.5	25	15	0.5
	HG-KR23	0.5	25	15	0.5
MR-J4-40B	HG-MR43	0.9	35	15	0.7
	HG-KR43	0.9	35	15	0.7
MR-J4-60B	HG-SR52	1.0	40	15	0.8
	HG-SR51	1.0	40	15	0.8
MR-J4-70B	HG-MR73	1.3	50	15	1.0
	HG-KR73	1.3	50	15	1.0
MR-J4-100B	HG-SR102	1.7	50	15	1.0
	HG-SR81	1.5	50	15	1.0
MR-J4-200B	HG-SR152	2.5	90	20	1.8
	HG-SR202	3.5	90	20	1.8
	HG-SR121	2.1	90	20	1.8
	HG-SR201	3.5	90	20	1.8
MR-J4-350B	HG-SR352	5.5	130	20	2.6
	HG-SR301	4.8	120	20	2.4
MR-J4-500B	HG-SR502	7.5	195	25	3.9
	HG-SR421	6.3	160	25	3.2
MR-J4-700B	HG-SR702	10	300	25	6.0

Note 1. Note that the power supply capacity will vary according to the power supply impedance. This value is applicable when the power factor improving AC reactor or power factor improving DC reactor are not used.

2. Heat generated during regeneration is not included in the servo amplifier-generated heat. To calculate heat generated by the regenerative option, refer to section 11.2.

10. CHARACTERISTICS

(2) Heat dissipation area for an enclosed type cabinet

The enclosed type cabinet (hereafter called the cabinet) which will contain the servo amplifier should be designed to ensure that its temperature rise is within +10 °C at the ambient temperature of 40 °C. (With an approximately 5 °C safety margin, the system should operate within a maximum 55 °C limit.) The necessary cabinet heat dissipation area can be calculated by equation 10.1.

$$A = \frac{P}{K \cdot \Delta T} \dots\dots\dots (10.1)$$

A : Heat dissipation area [m²]

P : Loss generated in the cabinet [W]

ΔT : Difference between internal and ambient temperatures [°C]

K : Heat dissipation coefficient [5 to 6]

When calculating the heat dissipation area with equation 10.1, assume that P is the sum of all losses generated in the cabinet. Refer to table 10.1 for heat generated by the servo amplifier. "A" indicates the effective area for heat dissipation, but if the cabinet is directly installed on an insulated wall, that extra amount must be added to the cabinet's surface area. The required heat dissipation area will vary with the conditions in the cabinet. If convection in the cabinet is poor and heat builds up, effective heat dissipation will not be possible. Therefore, arrangement of the equipment in the cabinet and the use of a cooling fan should be considered. Table 10.1 lists the cabinet dissipation area for each servo amplifier (guideline) when the servo amplifier is operated at the ambient temperature of 40 °C under rated load.

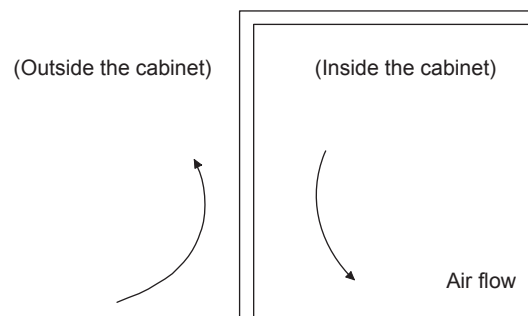

Fig. 10.2 Temperature distribution in an enclosed type cabinet

When air flows along the outer wall of the cabinet, effective heat exchange will be possible, because the temperature slope inside and outside the cabinet will be steeper.

10. CHARACTERISTICS

10.3 Dynamic brake characteristics

POINT
<ul style="list-style-type: none"> ● Do not use dynamic brake to stop in a normal operation as it is the function to stop in emergency. ● For a machine operating at the recommended load to motor inertia ratio or less, the estimated number of usage times of the dynamic brake is 1000 times while the machine decelerates from the rated speed to a stop once in 10 minutes. ● Be sure to make EM1 (Forced stop) valid after servo motor stops when using EM1 (Forced stop) frequently in other than emergency. ● Servo motors for MR-J4 may have the different coasting distance from that of the previous model.

10.3.1 Dynamic brake operation

(1) Calculation of coasting distance

Fig. 10.3 shows the pattern in which the servo motor comes to a stop when the dynamic brake is operated. Use equation 10.2 to calculate an approximate coasting distance to a stop. The dynamic brake time constant τ varies with the servo motor and machine operation speeds. (Refer to (2)(a), (b) of this section.)

A working part generally has a friction force. Therefore, actual coasting distance will be shorter than a maximum coasting distance calculated with the following equation.

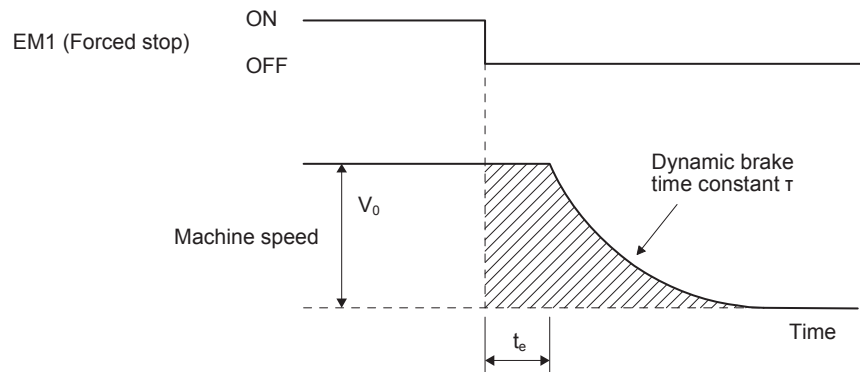

Fig. 10.3 Dynamic brake operation diagram

$$L_{\max} = \frac{V_0}{60} \cdot \left\{ t_e + \tau \left(1 + \frac{J_L}{J_M} \right) \right\} \dots \dots \dots (10.2)$$

- L_{\max} : Maximum coasting distance [mm]
- V_0 : Machine's fast feed speed [mm/min]
- J_M : Moment of inertia of the servo motor [kg·cm²]
- J_L : Load moment of inertia converted into equivalent value on servo motor shaft [kg·cm²]
- τ : Dynamic brake time constant [s]
- t_e : Delay time of control section [s]

For 7 kW or lower servo, there is internal relay delay time of about 10 ms.

10. CHARACTERISTICS

(2) Dynamic brake time constant

The following shows necessary dynamic brake time constant τ for equation 10.2.

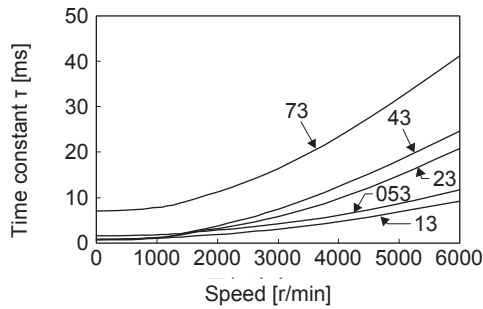

HG-MR series

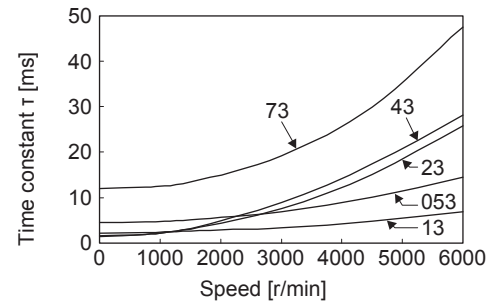

HG-KR series

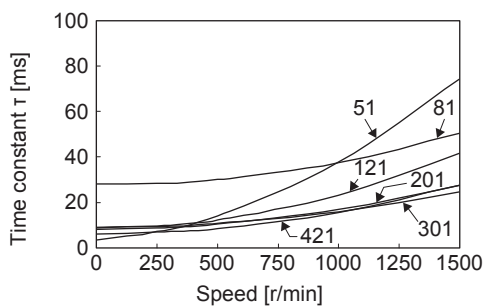

HG-SR1000 r/min series

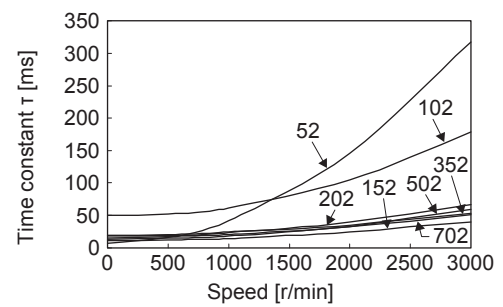

HG-SR2000 r/min series

10.3.2 Permissible load to motor inertia when the dynamic brake is used

Use the dynamic brake under the load to motor inertia ratio indicated in the following table. If the load inertia moment is higher than this value, the dynamic brake may burn. If the load to motor inertia ratio exceeds the indicated value, contact your local sales office.

The values of the permissible load to motor inertia ratio in the table are the values at the maximum rotation speed of the servo motor.

Servo amplifier	Servo motor			
	HG-KR_	HG-MR_	HG-SR_1	HG-SR_2
MR-J4-10B	30	HG-MR053: 35 HG-MR13: 32		
MR-J4-20B	30	32		
MR-J4-40B	30	32		
MR-J4-60B			30	30
MR-J4-70B	30	32		
MR-J4-100B			30	30
MR-J4-200B			30	21
MR-J4-350B			16	13 (Note)
MR-J4-500B			15	13 (Note)
MR-J4-700B				5 (Note)

Note. The permissible load to motor inertia ratio is 15 at the rated rotation speed.

10. CHARACTERISTICS

10.4 Cable bending life

The bending life of the cables is shown below. This graph calculated values. Since they are not guaranteed values, provide a little allowance for these values.

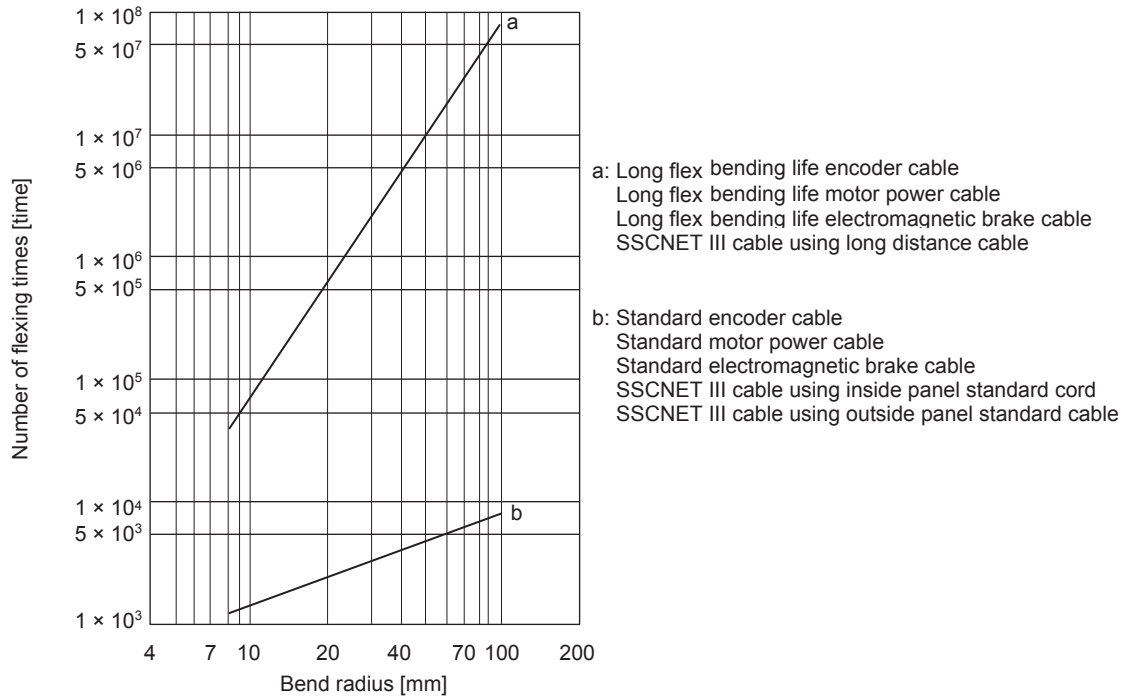

10.5 Inrush currents at power-on of main circuit and control circuit

The following table indicates the inrush currents (reference data) that will flow when 240 V AC is applied at the power supply capacity of 2500 kVA and the wiring length of 1 m.

Servo amplifier	Inrush currents (A_{0-P})	
	Main circuit power supply (L1, L2, and L3)	Control circuit power supply (L11 and L21)
MR-J4-10B, MR-J4-20B, MR-J4-40B, MR-J4-60B	30 A (attenuated to approx. 3 A in 20 ms)	20 A to 30 A (attenuated to approx. 1 A in 20 ms)
MR-J4-70B, MR-J4-100B	34 A (attenuated to approx. 7 A in 20 ms)	
MR-J4-200B, MR-J4-350B	113 A (attenuated to approx. 12 A in 20 ms)	
MR-J4-500B	42 A (attenuated to approx. 20 A in 20 ms)	34 A (attenuated to approx. 2 A in 20 ms)
MR-J4-700B	85 A (attenuated to approx. 20 A in 30 ms)	

Since large inrush currents flow in the power supplies, always use molded case circuit breakers and magnetic contactors. (Refer to section 11.10.)

When circuit protectors are used, it is recommended that the inertia delay type, which is not tripped by an inrush current, be used.

11. Options and peripheral devices

11. OPTIONS AND AUXILIARY EQUIPMENT

WARNING

- Before connecting any option or peripheral equipment, turn off the power and wait for 15 minutes or more until the charge lamp turns off. Then, confirm that the voltage between P+ and N- is safe with a voltage tester and others. Otherwise, an electric shock may occur. In addition, when confirming whether the charge lamp is off or not, always confirm it from the front of the servo amplifier.

Cautions

- Use the specified auxiliary equipment and options to prevent a malfunction or a fire.

11.1 Cable/connector sets

POINT

- IP rating indicated for cables and connectors is for a cable or connector alone. When the cables and connectors are used to connect the servo amplifier and servo motor, and if IP rating of the servo amplifier and servo motor are lower than that of the cable and connector, specifications of the servo amplifier and servo motor apply.







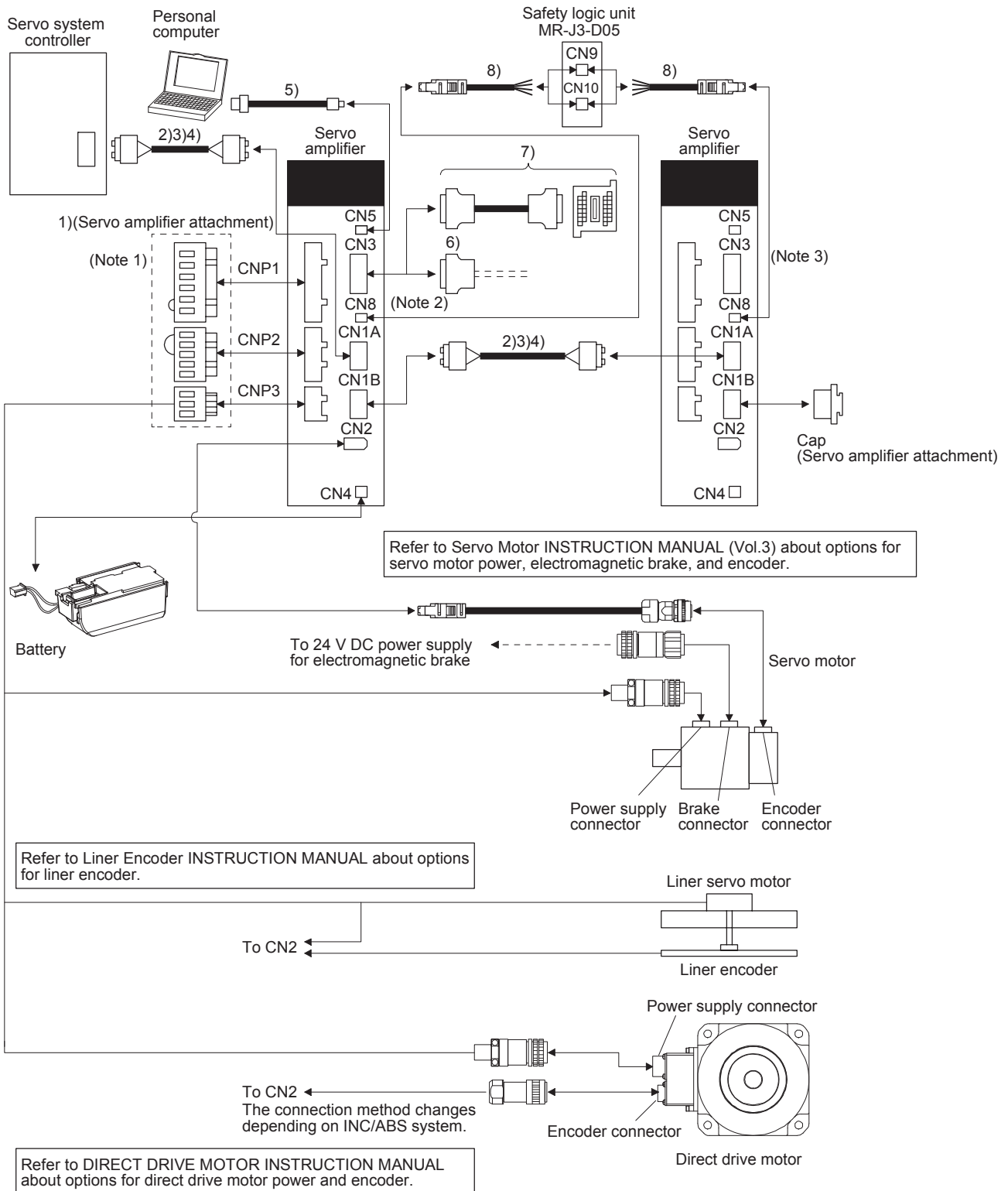

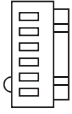

Purchase the cable and connector options indicated in this section.

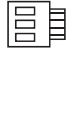
11. Options and peripheral devices

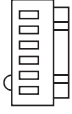

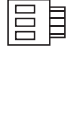
11.1.1 Combinations of cable/connector sets



11. Options and peripheral devices

No.	Name	Type	Description	Application		
1)	Servo amplifier power supply connector set		 <p>CNP1 Connector: 06JFAT-SAXGDK-H7.5 (JST) Applicable wire size: 0.8 mm² (AWG10) to 2.1 mm² (AWG 8) Insulator OD: to 3.9 mm</p>	 <p>CNP2 Connector: 05JFAT-SAXGDK-H5.0 (JST) (AWG 18 to 14)</p>	 <p>CNP3 Connector: 03JFAT-SAXGDK-H7.5 (JST)</p>  <p>Open tool J-FAT-OT (JST)</p>	Supplied with servo amplifiers of 1 kW or less
			 <p>CNP1 Connector: 06JFAT-SAXGFK-XL (JST) (For CNP1, CNP3) Applicable wire size: 1.25 mm² to 5.5 mm² (AWG 16 to 10) Insulator OD: to 4.7 mm</p>	 <p>CNP2 Connector: 05JFAT-SAXGDK-H5.0 (JST) CNP2 Applicable wire size: 0.8 mm² to 2.1 mm² (AWG 18 to 14) Insulator OD: to 3.9 mm</p>	 <p>CNP3 Connector: 03JFAT-SAXGFK-XL (JST)</p>  <p>Open tool quantity: 1 Model: J-FAT-OT-EXL (JST)</p>	Supplied with servo amplifiers of 2 kW
2)	SSCNET III cable	MR-J3BUS_M Cable length: 0.15 m to 3 m (Refer to section 11.1.3.)	Connector: PF-2D103 (JAE)	Connector: PF-2D103 (JAE)	Standard cord inside panel	
3)	SSCNET III cable	MR-J3BUS_M-A Cable length: 5 m to 20 m (Refer to section 11.1.3.)			Standard cable outside panel	
4)	SSCNET III cable	MR-J3BUS_M-B Cable length: 30 m to 50 m (Refer to section 11.1.3.)	Connector: CF-2D103-S (JAE)	Connector: CF-2D103-S (JAE)	Long-distance cable	
5)	USB cable	MR-J3USBCBL3M Cable length: 3 m	For CN5 connector mini-B connector (5 pins)	For personal computer connector A connector	For connection with PC-AT compatible personal computer	
6)	Connector set	MR-CCN1			Connector: 10120-3000PE Shell kit: 10320-52F0-008 (3M or equivalent)	
7)	Junction terminal block (recommended)		 <p>MR-J2HBUS_M</p> <p>PS7DW-20V14B-F (Yoshida Electric Industry)</p>		Junction terminal block PS7DW-20V14B-F is not option. For using the junction terminal block, option MR-J2HBUS_M is necessary. Refer to section 11.6 for details.	

11. Options and peripheral devices

No.	Name	Type	Description	Application
8)	STO cable	MR-D05UDL3M-B	Connector set: 2069250-1 (TE Connectivity) 	Connection cable for the CN8 connector
9)	Short-circuit connector			Supplied with servo amplifier

11.1.2 MR-D05UDL3M-B STO cable

This cable is for connecting an external device to the CN8 connector.

Cable model	Cable length	Application
MR-D05UDL3M-B	3 m	Connection cable for the CN8 connector

(1) Configuration diagram

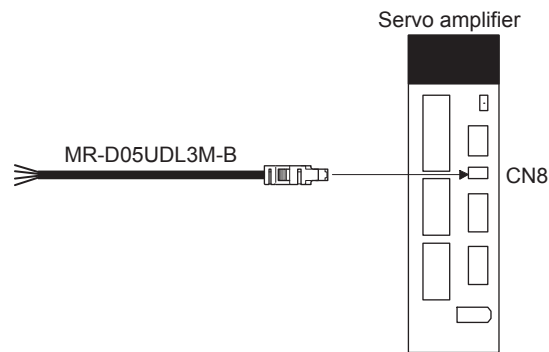

(2) Internal wiring diagram

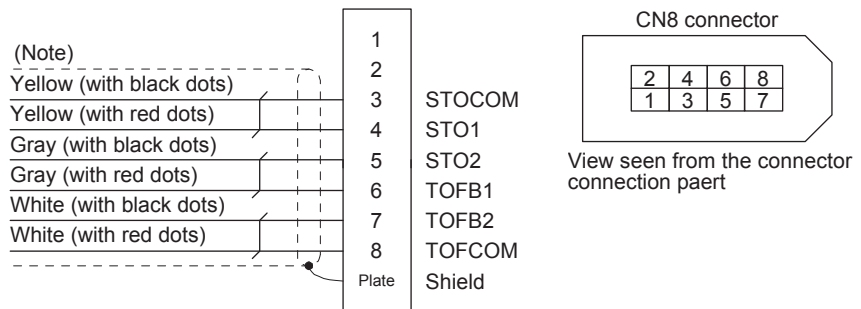

Note. Do not use the two core wires with orange sheath (with red or black dots).

11. Options and peripheral devices

11.1.3 SSCNET III cable

POINT
<ul style="list-style-type: none"> ● Do not look directly at the light generated from CN1A/CN1B connector of servo amplifier or the end of SSCNET III cable. The light can be a discomfort when it enters the eye. ● Refer to appendix.3 for long distance cable over 50 m and ultra-long bending life cable.

(1) Model explanations

The numerals in the Cable length field of the table are the symbols entered in the _ part of the cable model. Cables of which symbol exists are available.

Cable model	Cable length											Bending life	Application/remark
	0.15 m	0.3 m	0.5 m	1 m	3 m	5 m	10 m	20 m	30 m	40 m	50 m		
MR-J3BUS_M	015	03	05	1	3	/	/	/	/	/	/	Standard	Using inside panel standard cord
MR-J3BUS_M-A	/	/	/	/	/	5	10	20	/	/	/	Standard	Using outside panel standard cable
(Note) MR-J3BUS_M-B	/	/	/	/	/	/	/	/	30	40	50	Long bending life	Using long distance cable

Note. For cable of 30 m or less, contact your local sales office.

(2) Specifications

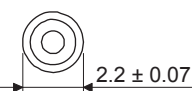
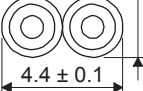
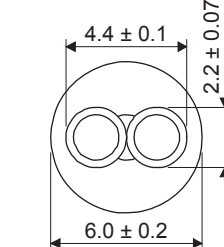
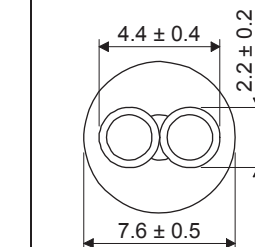
		Description			
SSCNET III cable model		MR-J3BUS_M		MR-J3BUS_M-A	MR-J3BUS_M-B
SSCNET III cable length		0.15 m	0.3 m to 3 m	5 m to 20 m	30 m to 50 m
Optical cable(cord)	Minimum bend radius	25 mm		Enforced covering cable: 50 mm Cord: 25 mm	Enforced covering cable: 50 mm Cord: 30 mm
	Tension strength	70 N	140 N	420 N (Enforced covering cable)	980 N (Enforced covering cable)
	Temperature range for use (Note)	-40 °C to 85 °C			-20 °C to 65 °C
	Ambience	Indoors (no direct sunlight)			
Appearance	[mm]				

Note. This temperature range for use is the value for optical cable (cord) only. Temperature condition for the connector is the same as that for servo amplifier.

11. Options and peripheral devices

(3) Dimensions

(a) MR-J3BUS015M

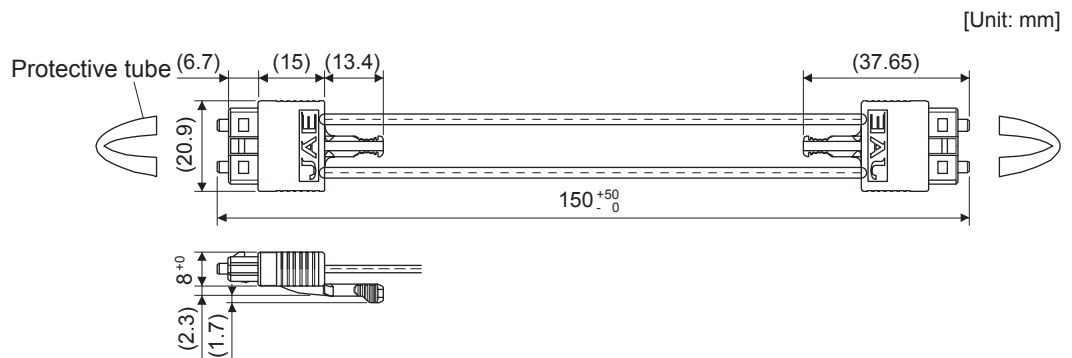

(b) MR-J3BUS03M to MR-J3BUS3M

Refer to the table shown in (1) of this section for cable length (L).

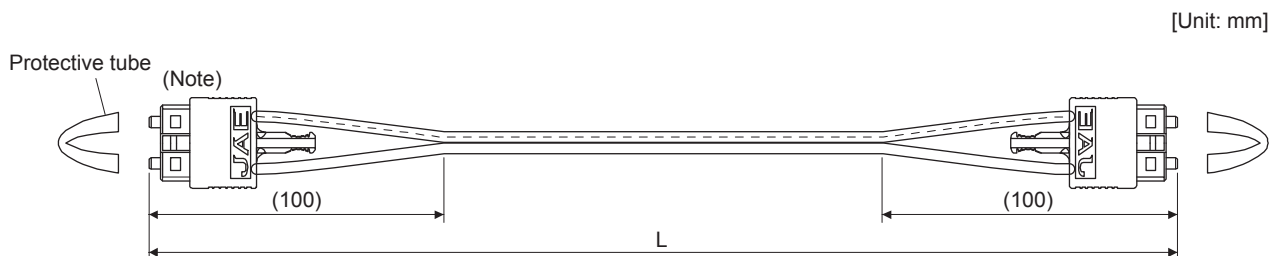

Note. Dimension of connector part is the same as that of MR-J3BUS015M.

(c) MR-J3BUS5M-A to MR-J3BUS20M-A/MR-J3BUS30M-B to MR-J3BUS50M-B

Refer to the table shown in (1) of this section for cable length (L).

SSCNET III cable	Variable dimensions	
	A	B
MR-J3BUS5M-A to MR-J3BUS20M-A	100	30
MR-J3BUS30M-B to MR-J3BUS50M-B	150	50

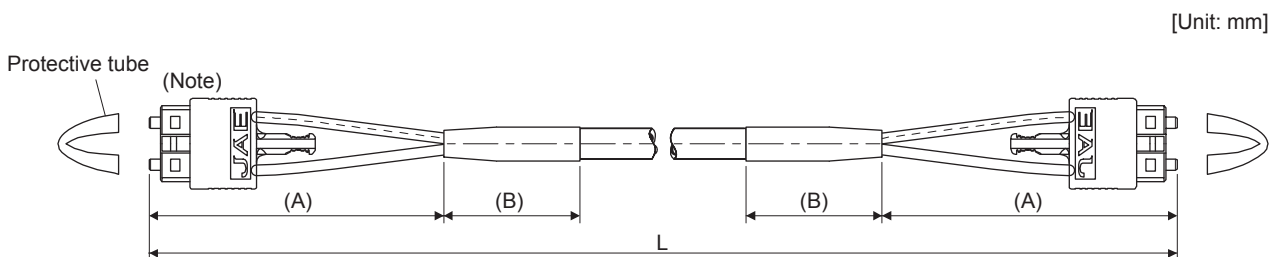

Note. Dimension of connector part is the same as that of MR-J3BUS015M.

11. Options and peripheral devices

11.2 Regenerative options



CAUTION

● Do not use servo amplifiers with regenerative options other than the combinations specified below. Otherwise, it may cause a fire.

11.2.1 Combination and regenerative power

The power values in the table are resistor-generated powers and not rated powers.

Servo amplifier	Regenerative Power [W]									
	Built-in regenerative resistor	MR-RB032 [40 Ω]	MR-RB12 [40 Ω]	MR-RB30 [13 Ω]	MR-RB3N [9 Ω]	MR-RB31 [6.7 Ω]	MR-RB32 [40 Ω]	(Note) MR-RB50 [13 Ω]	MR-RB5N [9 Ω]	(Note) MR-RB51 [6.7 Ω]
MR-J4-10B		30								
MR-J4-20B	10	30	100							
MR-J4-40B	10	30	100							
MR-J4-60B	10	30	100							
MR-J4-70B	20	30	100				300			
MR-J4-100B	20	30	100				300			
MR-J4-200B	100			300				500		
MR-J4-350B	100				300				500	
MR-J4-500B	130					300				500
MR-J4-700B	170					300				500

Note. Always install a cooling fan.

11. Options and peripheral devices

11.2.2 Selection of the regenerative option

(1) For rotary servo motor and direct drive motor

Use the following method when regeneration occurs continuously in vertical motion applications or when it is desired to make an in-depth selection of the regenerative option.

(a) Regenerative energy calculation

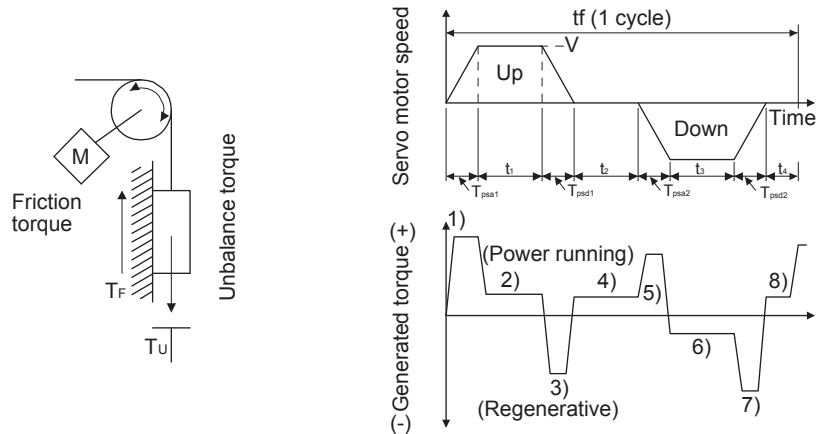

Formulas for calculating torque and energy in operation

Regenerative power	Torque applied to servo motor [N•m]	Energy E [J]
1)	$T_1 = \frac{(J_L + J_M) \cdot V}{9.55 \cdot 10^4} \cdot \frac{1}{t_{psa1}} + T_U + T_F$	$E_1 = \frac{0.1047}{2} \cdot V \cdot T_1 \cdot t_{psa1}$
2)	$T_2 = T_U + T_F$	$E_2 = 0.1047 \cdot V \cdot T_2 \cdot t_1$
3)	$T_3 = \frac{-(J_L + J_M) \cdot V}{9.55 \cdot 10^4} \cdot \frac{1}{t_{psa2}} + T_U + T_F$	$E_3 = \frac{0.1047}{2} \cdot V \cdot T_3 \cdot t_{psa2}$
4)	$T_4 = T_U$	$E_4 = 0$ (No regeneration)
5)	$T_5 = \frac{(J_L + J_M) \cdot V}{9.55 \cdot 10^4} \cdot \frac{1}{t_{psd2}} - T_U + T_F$	$E_5 = \frac{0.1047}{2} \cdot V \cdot T_5 \cdot t_{psd2}$
6)	$T_6 = -T_U + T_F$	$E_6 = 0.1047 \cdot V \cdot T_6 \cdot t_3$
7)	$T_7 = \frac{-(J_L + J_M) \cdot V}{9.55 \cdot 10^4} \cdot \frac{1}{t_{psd2}} - T_U + T_F$	$E_7 = \frac{0.1047}{2} \cdot V \cdot T_7 \cdot t_{psd2}$

From the calculation results in 1) to 8), find the absolute value (E_s) of the sum total of negative energies.

11. Options and peripheral devices

(b) Losses of servo motor and servo amplifier in regenerative mode

The following table lists the efficiencies and other data of the servo motor and servo amplifier in the regenerative mode.

Servo amplifier	Inverse efficiency [%]	Capacitor charging [J]	Servo amplifier	Inverse efficiency [%]	Capacitor charging [J]
MR-J4-10B	55	9	MR-J4-100B	85	18
MR-J4-20B	75	9	MR-J4-200B	85	36
MR-J4-40B	85	11	MR-J4-350B	85	40
MR-J4-60B	85	11	MR-J4-500B	90	45
MR-J4-70B	85	18	MR-J4-700B	90	70

Inverse efficiency (η): Efficiency including some efficiencies of the servo motor and servo amplifier when rated (regenerative) torque is generated at rated speed. Since the efficiency varies with the speed and generated torque, allow for about 10%.

Capacitor charging (E_c): Energy charged into the electrolytic capacitor in the servo amplifier

Subtract the capacitor charging from the result of multiplying the sum total of regenerative energies by the inverse efficiency to calculate the energy consumed by the regenerative option.

$$E_R [J] = \eta \cdot E_s - E_c$$

Calculate the power consumption of the regenerative option on the basis of single-cycle operation period t_f [s] to select the necessary regenerative option.

$$P_R [W] = E_R / t_f$$

11. Options and peripheral devices

(2) For linear servo motor

(a) Calculation of thrust and energy

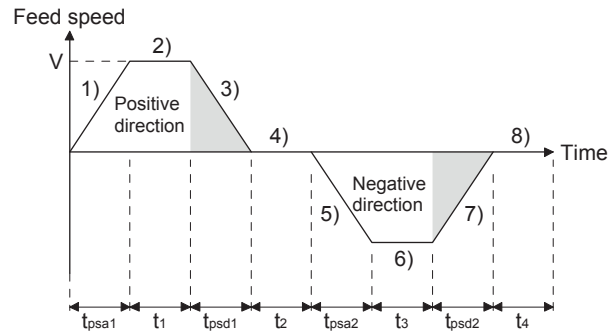
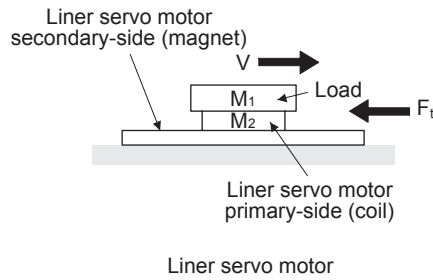

The following shows equations of the linear servo motor thrust and energy at the driving pattern above.

Section	Travel direction of linear servo motor	Energy E [J]
1)	$F_1 = (M_1 + M_2 \cdot V/t_{psa1} + F_t$	$E_1 = V/2 \cdot F_1 \cdot t_{psa1}$
2)	$F_2 = F_1$	$E_2 = V \cdot F_2 \cdot t_1$
3)	$F_3 = - (M_1 + M_2) \cdot V/t_{psd1} + F_t$	$E_3 = V/2 \cdot F_3 \cdot t_{psd1}$
4), 8)	$F_4, F_8 = 0$	$E_4, E_8 = 0$ (No regeneration)
5)	$F_5 = (M_1 + M_2) \cdot V/t_{psa2} + F_t$	$E_5 = V/2 \cdot F_5 \cdot t_{psa2}$
6)	$F_6 = F_t$	$E_6 = V \cdot F_6 \cdot t_3$
7)	$F_7 = - (M_1 + M_2) \cdot V/t_{psd2} + F_t$	$E_7 = V/2 \cdot F_7 \cdot t_{psd2}$

From the calculation results in 1) to 8), find the absolute value (E_s) of the sum total of negative energies.

(b) Losses of servo motor and servo amplifier in regenerative mode
Refer to this section (1) (b) for inverse efficiency and Capacitor charging.

(c) generative energy calculation

Subtract the capacitor charging from the result of multiplying the sum total of regenerative energies by the inverse efficiency to calculate the energy consumed by the regenerative resistor.

$$ER [J] = \eta \cdot E_s - E_c$$

From the total of ER's whose subtraction results are positive and a 1-cycle period, the power consumption of the regenerative option can be calculated with the following expression.

Power consumption PR [W] (total of positive ER's)/1-cycle operation period (tf)

Select the regenerative option from the PR value. Regenerative option is not required when the energy consumption is equal to or less than the built-in regenerative energy.

11. Options and peripheral devices

11.2.3 parameter setting

Set [Pr. PA02] according to the option to be used.

[Pr. PA02]

0	0		
---	---	--	--

Selection of regenerative option

00: Regenerative option is not used.

- For servo amplifier of 100 W, regenerative resistor is not used.
- For servo amplifier of 0.2 kW to 7 kW, built-in regenerative resistor is used.

01: FR-BU2/FR-RC/FR-CV

02: MR-RB032

03: MR-RB12

04: MR-RB32

05: MR-RB30

06: MR-RB50 (Cooling fan is required)

08: MR-RB31

09: MR-RB51 (Cooling fan is required)

0B: MR-RB3N

0C: MR-RB5N (Cooling fan is required)

11.2.4 Connection of regenerative option

POINT
<ul style="list-style-type: none"> ● When the MR-RB50, MR-RB51, or MR-RB5N is used, a cooling fan is required to cool it. The cooling fan should be prepared by the customer. ● For the sizes of wires used for wiring, refer to section 11.9.

The regenerative option generates heat of 100 °C higher than the ambient temperature. Fully consider heat dissipation, installation position, used wires, etc. to place the option. For wiring, use flame-resistant wires or make the wires flame-resistant and keep them away from the regenerative option. Always use twisted cables of max. 5 m length for connection with the servo amplifier.

11. Options and peripheral devices

(1) MR-J4-500B or less

Always remove the wiring from across P+ - D and fit the regenerative option across P+ - C. G3 and G4 are thermal sensor's terminals. Between G3 and G4 is opened when the regenerative option overheats abnormally.

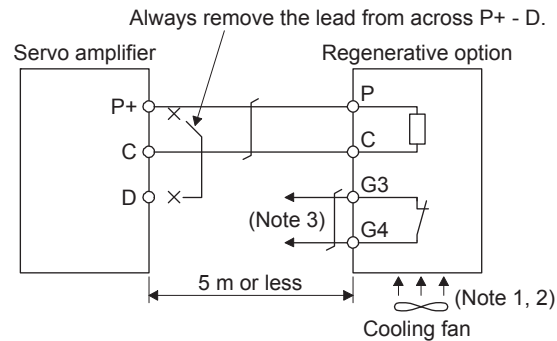

- Note 1. When using the MR-RB50 or MR-RB5N, forcibly cool it with a cooling fan (92 mm × 92 mm, minimum air flow: 1.0 m³/min).
- Note 2. When the ambient temperature is more than 55 °C and the regenerative load ratio is more than 60% in MR-RB30, MR-RB31, MR-RB32, or MR-RB3N, forcibly cool the air with a cooling fan (1.0 m³/min or more, 92 mm × 92 mm) A cooling fan is not required if the ambient temperature is 35 °C or less. (A cooling fan is required to cool it within the range shown in the slash in the following figure.)

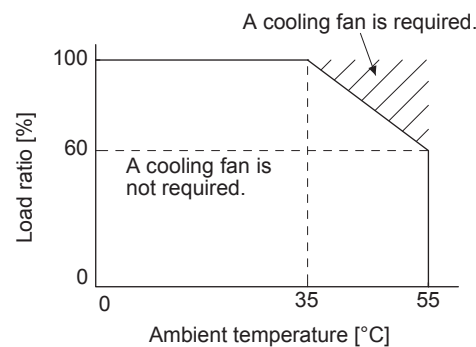

3. Make up a sequence which will switch off the magnetic contactor when abnormal heating occurs.

G3-G4 contact specifications

Maximum voltage: 120 V AC/DC

Maximum current: 0.5 A/4.8 V DC

Maximum capacity: 2.4 VA

11. Options and peripheral devices

(2) MR-J4-700B

Always remove the wiring (across P+ - C) of the servo amplifier built-in regenerative resistor and fit the regenerative option across P+ - C. G3 and G4 are thermal sensor's terminals. Between G3 and G4 is opened when the regenerative option overheats abnormally.

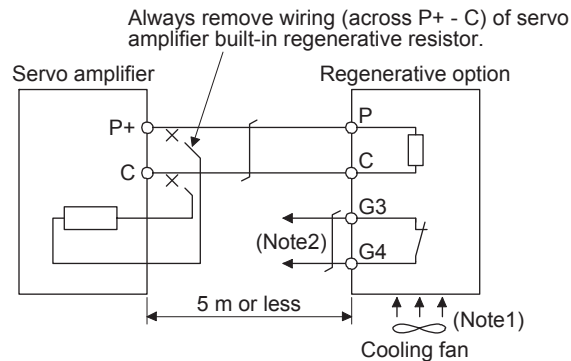

- Note 1. When using the MR-RB51, forcibly cool it with a cooling fan (92 mm × 92 mm, minimum air flow: 1.0 m³/min).
- Note 2. Make up a sequence which will switch off the magnetic contactor when abnormal heating occurs.
- G3-G4 contact specifications
- Maximum voltage: 120 V AC/DC
 - Maximum current: 0.5 A/4.8 V DC
 - Maximum capacity: 2.4 VA

When using the regenerative option, remove the servo amplifier's built-in regenerative resistor wires (across P+ - C), fit them back to back, and secure them to the frame with the accessory screw as shown below.

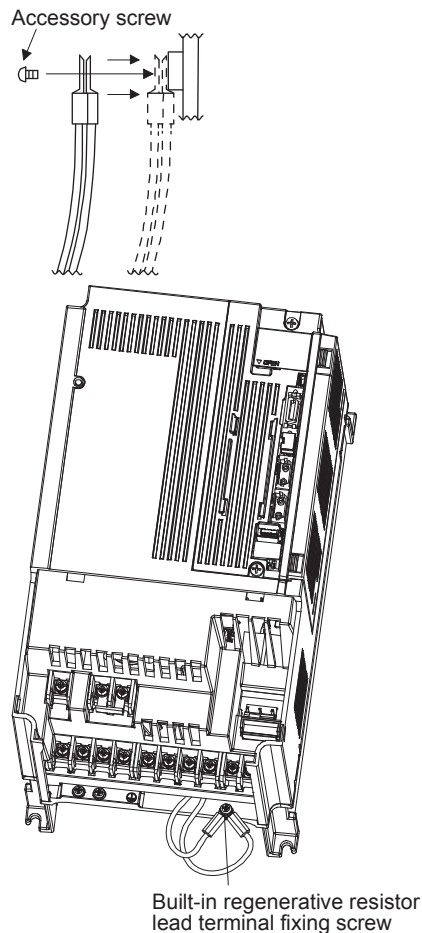

11. Options and peripheral devices

11.2.5 Dimensions

(1) MR-RB12

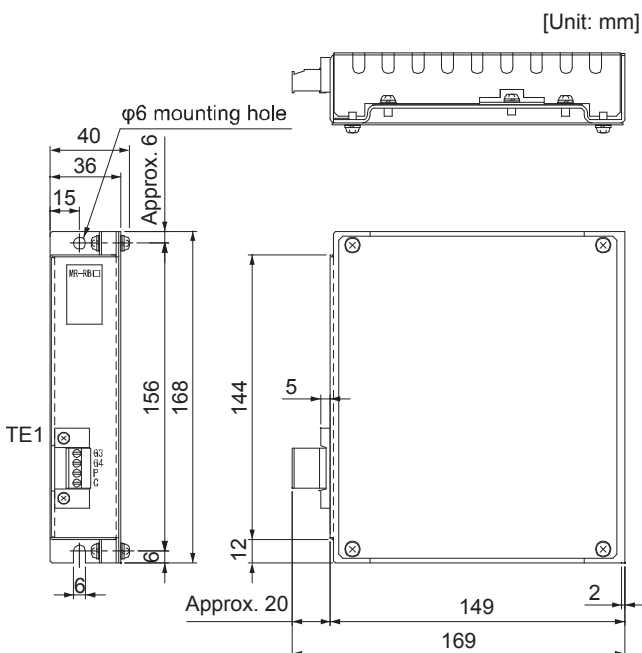

TE1 Terminal block

G3
G4
P
C

Applicable wire size: 0.2 mm² to 2.5 mm² (AWG 24 to 12)

Tightening torque: 0.5 to 0.6 [N•m]

Mounting screw

Screw size: M5

Tightening torque: 3.24 [N•m]

Mass: 1.1 [kg]

(2) MR-RB30/MR-RB31/MR-RB32/MR-RB3N

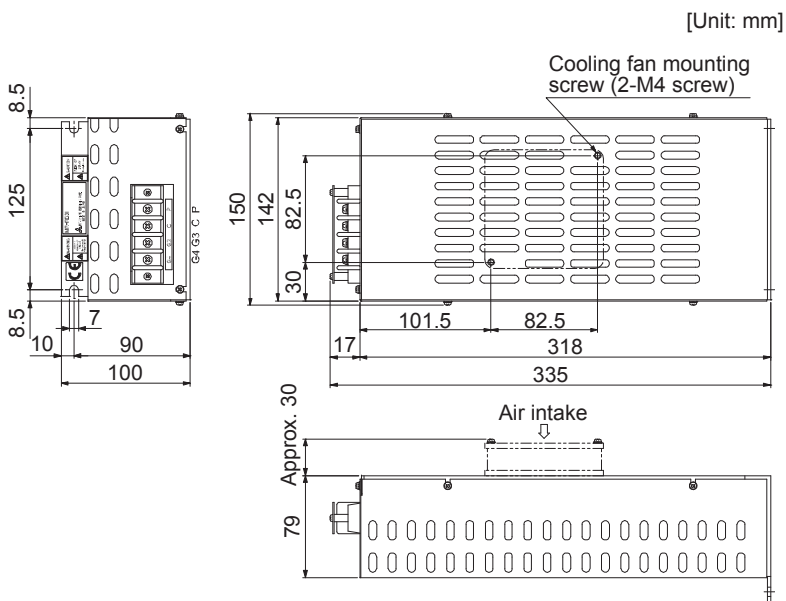

Terminal block

P
C
G3
G4

Screw size: M4

Tightening torque: 1.2 [N•m]

Mounting screw

Screw size: M6

Tightening torque: 5.4 [N•m]

Mass: 2.9 [kg]

11. Options and peripheral devices

(3) MR-RB50/MR-RB51/MR-RB5N

[Unit: mm]

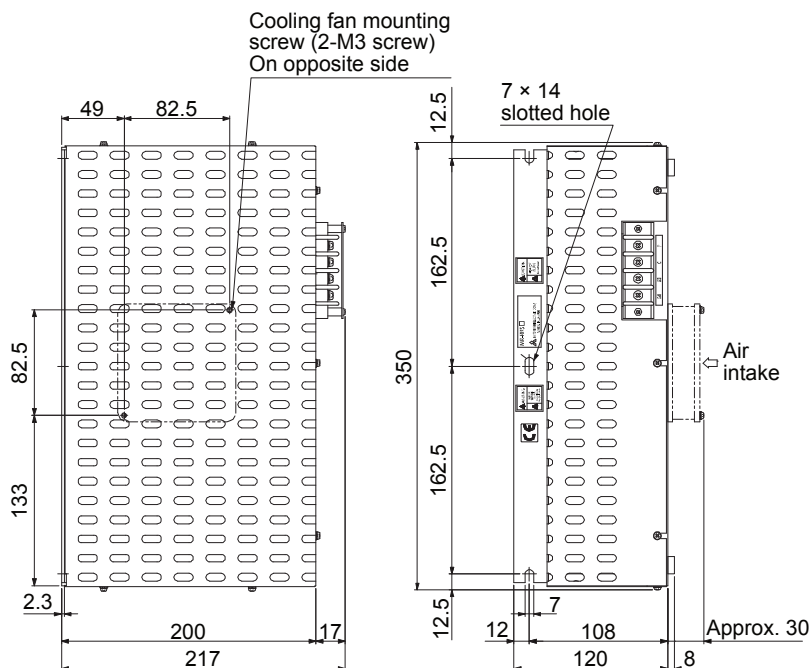

Terminal block

P
C
G3
G4

Screw size: M4
Tightening torque: 1.2 [N•m]

Mounting screw
Screw size: M6
Tightening torque: 5.4 [N•m]

Mass: 5.6 [kg]

(4) MR-RB032

[Unit: mm]

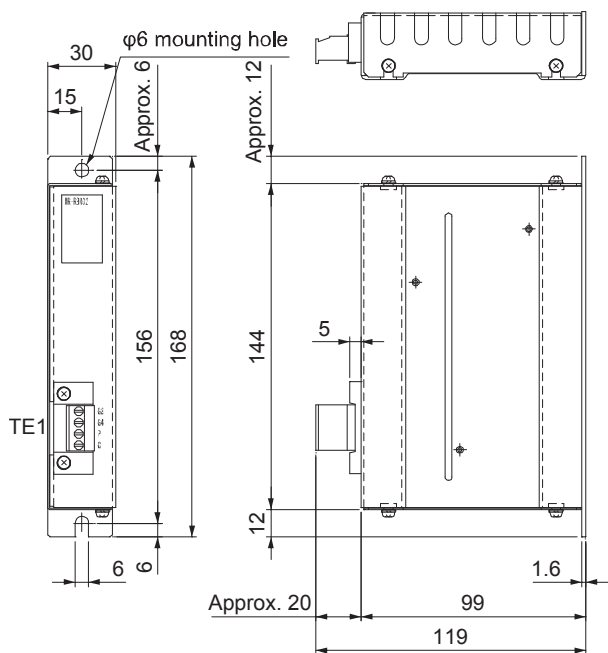

TE1 Terminal block

G3
G4
P
C

Applicable wire size: 0.2 mm² to 2.5 mm² (AWG 24 to 12)
Tightening torque: 0.5 to 0.6 [N•m]

Mounting screw
Screw size: M5
Tightening torque: 3.24 [N•m]

Mass: 0.5 [kg]

11. Options and peripheral devices

11.3 FR-BU2 Brake unit

POINT
<ul style="list-style-type: none"> ● When a brake unit and a resistor unit are installed horizontally or diagonally, the heat dissipation effect diminishes. Install them on a flat surface vertically. ● Temperature of the resistor unit case rises to higher than 100 °C. Keep cables and flammable materials away from the case. ● Ambient temperature condition of the brake unit is between -10 °C to 50 °C. Note that the condition is different from the ambient temperature condition of the servo amplifier (between 0 °C and 55 °C). ● Configure the circuit to shut down the power-supply with the alarm output of the brake unit and the resistor unit under abnormal condition. ● Use the brake unit with a combination indicated in section 11.3.1. ● For executing a continuous regenerative operation, use FR-RC power regenerative converter or FR-CV power regenerative common converter. ● Brake unit and regenerative options (Regenerative resistor) cannot be used simultaneously.

Connect the brake unit to the bus of the servo amplifier. As compared to the MR-RB regenerative option, the brake unit can return larger power. Use the brake unit when the regenerative option cannot provide sufficient regenerative capability.

When using the brake unit, set [Pr. PA02] of the servo amplifier to "_ _ 0 1".

When using the brake unit, always refer to the FR-BU2 Brake Unit Instruction Manual.

11.3.1 Selection

Use a combination of servo amplifier, brake unit and resistor unit listed below.

	Brake unit	Resistor unit	Number of connected units	Permissible continuous power [kW] [kW]	Resultant resistance [Ω]	Applicable servo amplifier
200 V class	FR-BU2-15K	FR-BR-15K	2(parallel)	1.98	4	MR-J4-500B MR-J4-700B
	FR-BU2-30K	FR-BR-30K	1	1.99	4	MR-J4-500B MR-J4-700B

11.3.2 Brake unit parameter setting

Whether a parameter can be changed or not is listed below.

Parameter		Change possible/ impossible	Remarks
No.	Name		
0	Brake mode switchover	Impossible	Do not change the parameter
1	Monitor display data selection	Possible	Refer to the FR-BU2-(H) Brake Unit Instruction Manual.
2	Input terminal function selection 1	Impossible	Do not change the parameter
3	Input terminal function selection 2		
77	Parameter write selection		
78	Cumulative energization time carrying-over times		
CLr	Parameter clear		
ECL	Alarm history clear		
C1	For manufacturer setting		

11. Options and peripheral devices

11.3.3 Connection example

POINT
<ul style="list-style-type: none"> ● EM2 is the same signal as EM1 in the torque control mode. ● Connecting PR terminal of the brake unit to P terminal of the servo amplifier results in brake unit malfunction. Always connect the PR terminal of the brake unit to the PR terminal of the resistor unit.

(1) Combination with FR-BR resistor unit

(a) When connecting a brake unit to a servo amplifier

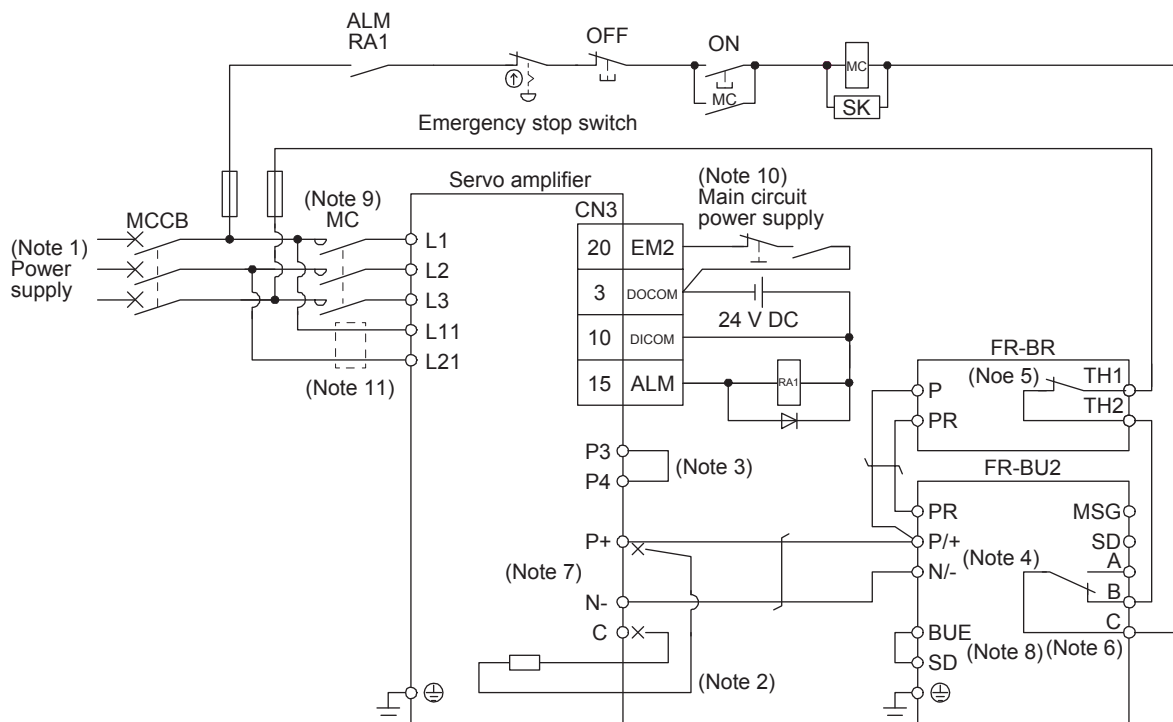

Note 1. For power supply specifications, refer to section 1.3.

Note 2. For the servo amplifier of 7 kW, always disconnect the lead wire of built-in regenerative resistor, which is connected to the P and C terminals.

Note 3. Always connect between P3 and P4 terminals. (factory-wired) Use either the power factor improving DC reactor or the power factor improving AC reactor. When using the power factor improving DC reactor, refer to section 11.11.

Note 4. Connect P/+ and N/- terminals of the brake unit to a correct destination. Incorrect connection results in servo amplifier and brake unit malfunction.

Note 5. Contact rating: 1b contact, 110 V AC_5 A/220 V AC_3 A

Normal condition: TH1-TH2 is conducting. Abnormal condition: TH1-TH2 is not conducting.

Note 6. Contact rating: 230 V AC_0.3 A/30 V DC_0.3 A

Normal condition: B-C is conducting/A-C is not conducting. Abnormal condition: B-C is not conducting/A-C is conducting.

Note 7. Do not connect more than one cable to each P+ to N- terminals of the servo amplifier.

Note 8. Always connect BUE and SD terminals. (factory-wired)

Note 9. Depending on the main circuit voltage and operation pattern, bus voltage decreases, and that may cause the forced stop deceleration to shift to the dynamic brake deceleration. When dynamic brake deceleration is not required, slow the time to turn off the magnetic contactor.

Note 10. Turn off EM2 when the main power circuit power supply is off.

Note 11. When wires used for L11 and L21 are thinner than wires used for L1, L2, and L3, use a molded case circuit breaker.

11. Options and peripheral devices

(b) When connecting two brake units to a servo amplifier

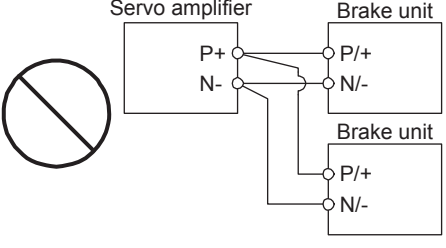
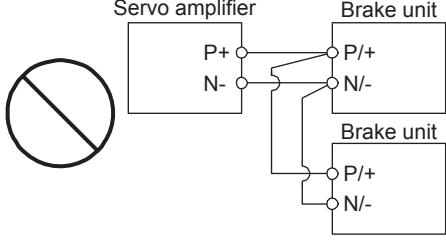
POINT	
<ul style="list-style-type: none"> ● To use brake units with a parallel connection, use two sets of FR-BU2 brake unit. Combination with other brake unit results in alarm occurrence or malfunction. ● Always connect the terminals for master/slave (MSG to MSG, SD to SD) between the two brake units. ● Do not connect the converter unit and brake units as below. Connect the cables with a terminal block to distribute as indicated in this section. 	
	
<p>Connecting two cables to P+ and N- terminals</p>	<p>Passing wiring</p>

11. Options and peripheral devices

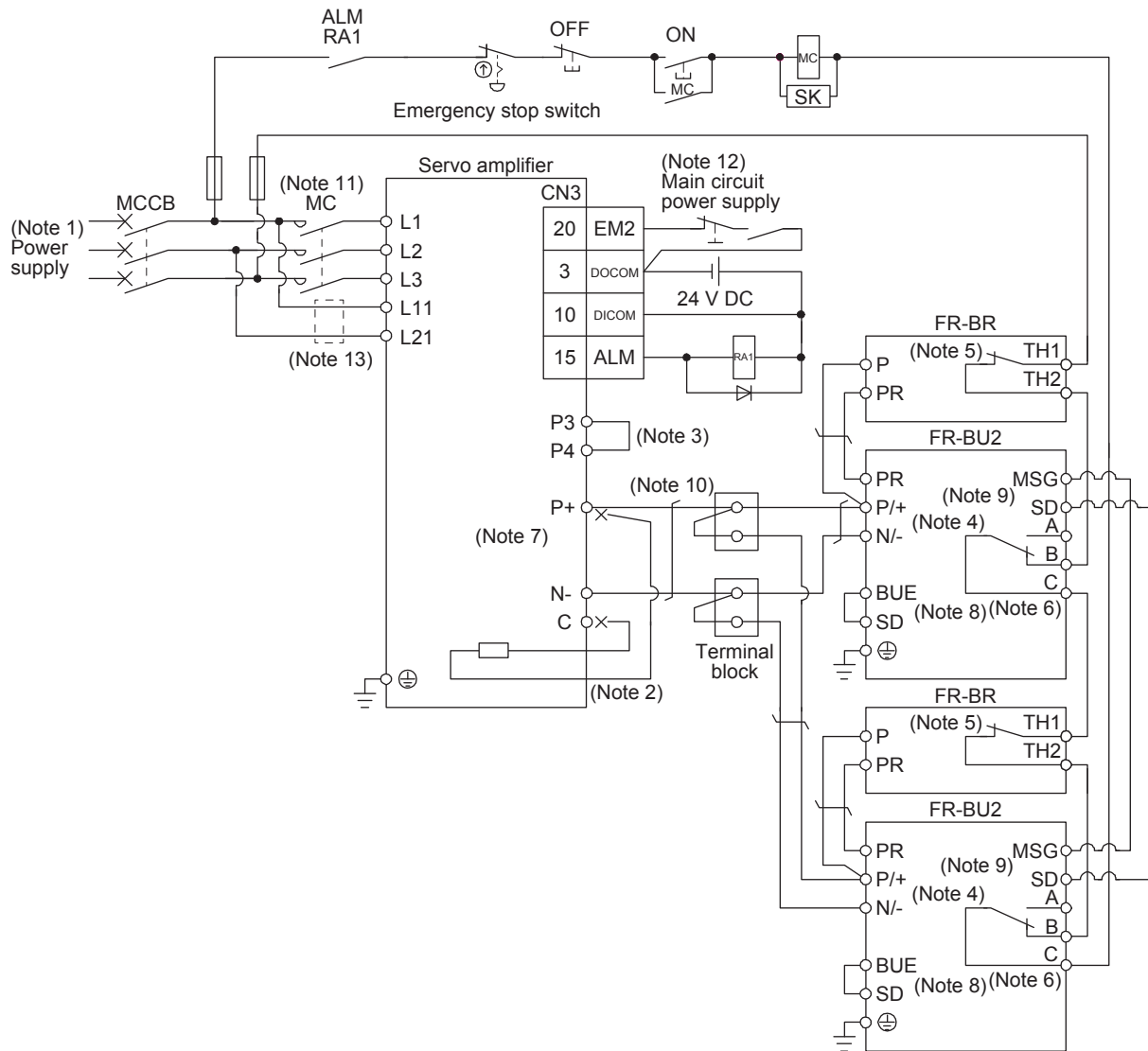

- Note
- For power supply specifications, refer to section 1.3.
 - For the servo amplifier of 7 kW, always disconnect the lead wire of built-in regenerative resistor, which is connected to the P+ and C terminals.
 - Always connect between P3 and P4 terminals. (factory-wired) Use either the power factor improving DC reactor or the power factor improving AC reactor. When using the power factor improving DC reactor, refer to section 11.11.
 - Connect P/+ and N/- terminals of the brake unit to a correct destination. Incorrect connection results in servo amplifier and brake unit malfunction.
 - Contact rating: 1b contact, 110 V AC_5 A/220 V AC_3 A
Normal condition: TH1-TH2 is conducting. Abnormal condition: TH1-TH2 is not conducting.
 - Contact rating: 230 V AC_0.3 A/30 V DC_0.3 A
Normal condition: B-C is conducting/A-C is not conducting. Abnormal condition: B-C is not conducting/A-C is conducting.
 - Do not connect more than one cable to each P+ to N- terminals of the servo amplifier.
 - Always connect BUE and SD terminals. (factory-wired)
 - Connect MSG and SD terminals of the brake unit to a correct destination. Incorrect connection results in servo amplifier and brake unit malfunction.
 - For the cable to connect the terminal block and the P+ and N- terminals of the servo amplifier, use the cable indicated in (3)(b) of this section.
 - Depending on the main circuit voltage and operation pattern, bus voltage decreases, and that may cause the forced stop deceleration to shift to the dynamic brake deceleration. When dynamic brake deceleration is not required, slow the time to turn off the magnetic contactor.
 - Turn off EM2 when the main power circuit power supply is off.
 - When wires used for L11 and L21 are thinner than wires used for L1, L2, and L3, use a molded case circuit breaker.

11. Options and peripheral devices

(2) Connection instructions

The cables between the servo amplifier and the brake unit, and between the resistor unit and the brake unit should be as short as possible. Always twist the cable longer than 5 m (twist five times or more per one meter). Even when the cable is twisted, the cable should be less than 10 m. Using cables longer than 5 m without twisting or twisted cables longer than 10 m, may result in the brake unit malfunction.

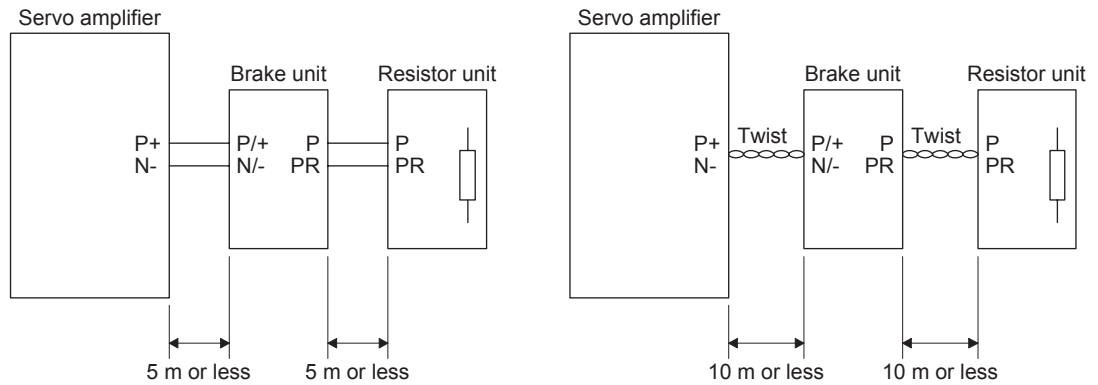

(3) Cables

(a) Cables for the brake unit

For the brake unit, HIV cable (600 V grade heat-resistant PVC insulated wire) is recommended.

1) Main circuit terminal

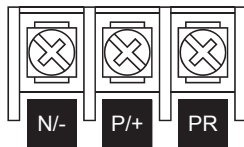

Terminal block

200 V class	Brake unit	Main circuit terminal screw size	Crimp terminal N/-, P/+, PR, ⊕	Tightening torque [N·m]	Wire size	
					N/-, P/+, PR, ⊕	
					HIV wire [mm ²]	AWG
	FR-BU2-15K	M4	5.5-4	1.5	3.5	12
	FR-BU2-30K	M5	5.5-5	2.5	5.5	10

11. Options and peripheral devices

2) Control circuit terminal

POINT

- Under tightening can cause a cable disconnection or malfunction. Over tightening can cause a short circuit or malfunction due to damage to the screw or the brake unit.



Terminal block

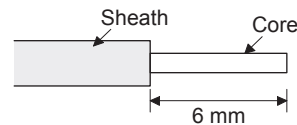

Wire the stripped cable after twisting to prevent the cable from becoming loose. In addition, do not solder it.

Screw size: M3

Tightening torque: 0.5 to 0.6 [N•m]

Wire size: 0.3 mm² to 0.75 mm²

Screw driver: Small flat-blade screwdriver

(Tip thickness: 0.4 mm/Tip width 2.5 mm)

- (b) Cables for connecting the servo amplifier and a distribution terminal block when connecting two sets of the brake unit

Brake unit	Wire size	
	HIV wire [mm ²]	AWG
FR-BU2-15K	8	8

(4) Crimp terminals for P+ and N- terminals of servo amplifier

(a) Recommended crimp terminals

POINT

- Make sure to use recommended crimp terminals or equivalent since some crimp terminals cannot be installed depending on the size.

Servo amplifier		Brake unit	Number of connected units	Crimp terminal (Manufacturer)	(Note 1) Applicable tool
200 V class	MR-J4-500B	FR-BU2-15K	1	FVD5.5-S4(JST)	a
			2	8-4NS(JST)(Note2)	b
	MR-J4-700B	FR-BU2-30K	1	FVD5.5-S4(JST)	a
			2	8-4NS(JST)(Note2)	b
		FR-BU2-30K	1	FVD5.5-S4(JST)	a

Note 1. Symbols in the applicable tool field indicate applicable tools in (4)(b) of this section.

2. Coat the crimping part with an insulation tube.

11. Options and peripheral devices

(b) Applicable tool

Symbol	Servo amplifier side crimp terminals		
	Crimp terminal	Applicable tool	Manufacturer
a	FVD5.5-S4 FVD5.5-6	YNT-1210S	JST
b	8-4NS	YHT-8S	

11.3.4 Dimensions

(1) FR-BU2 Brake unit

[Unit: mm]

FR-BU2-15K

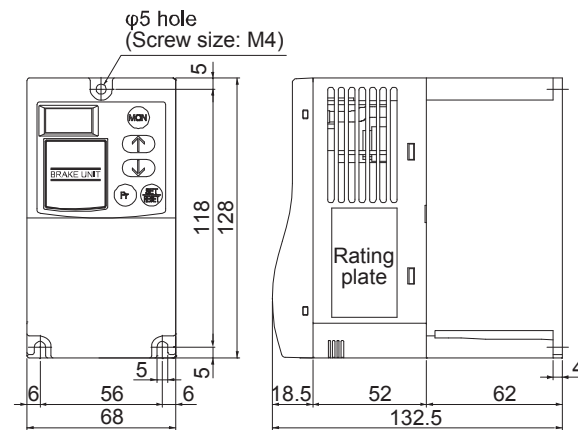

FR-BU2-30K

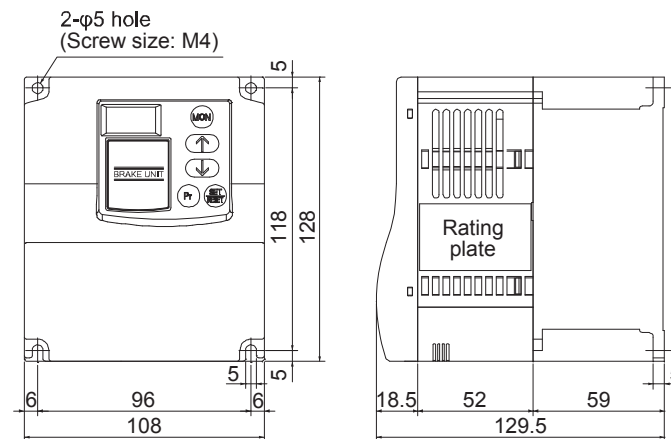

11. Options and peripheral devices

(2) FR-BR Resistor unit

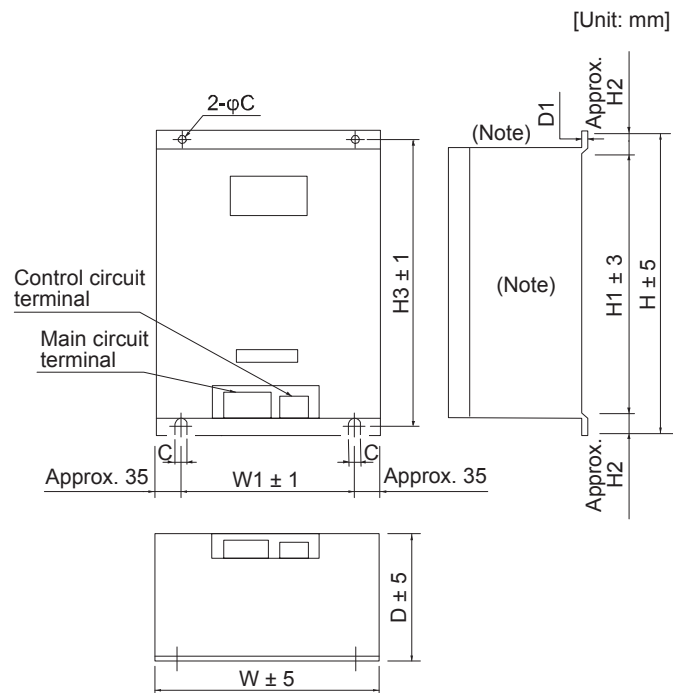

Note. Ventilation ports are provided on both sides and the top. The bottom is open.

	Resistor unit	W	W1	H	H1	H2	H3	D	D1	C	Approximate mass [kg]
200 V class	FR-BR-15K	170	100	450	410	20	432	220	3.2	6	15
	FR-BR-30K	340	270	600	560	20	582	220	4	10	30

11.4 FR-RC Power regenerative converter

POINT
● When using FR-RC, set [Pr. PA04] to "0 0 __" to enable EM1 (Forced stop 1).

When using the power regenerative converter, set "__ 0 1" in [Pr. PA02].

(1) Selection

The converters can continuously return 75% of the nominal regenerative power. They are applied to the servo amplifiers of the 5 kW to 7 kW.

Power regenerative converter	Nominal regenerative power [kW]	Servo amplifier
FR-RC-15K	15	MR-J4-500B
FR-RC-30K	30	MR-J4-700B

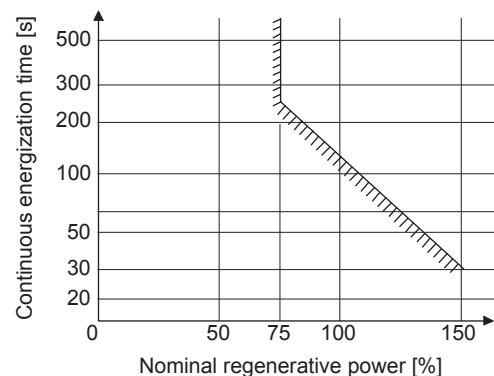

11. Options and peripheral devices

(2) Connection example

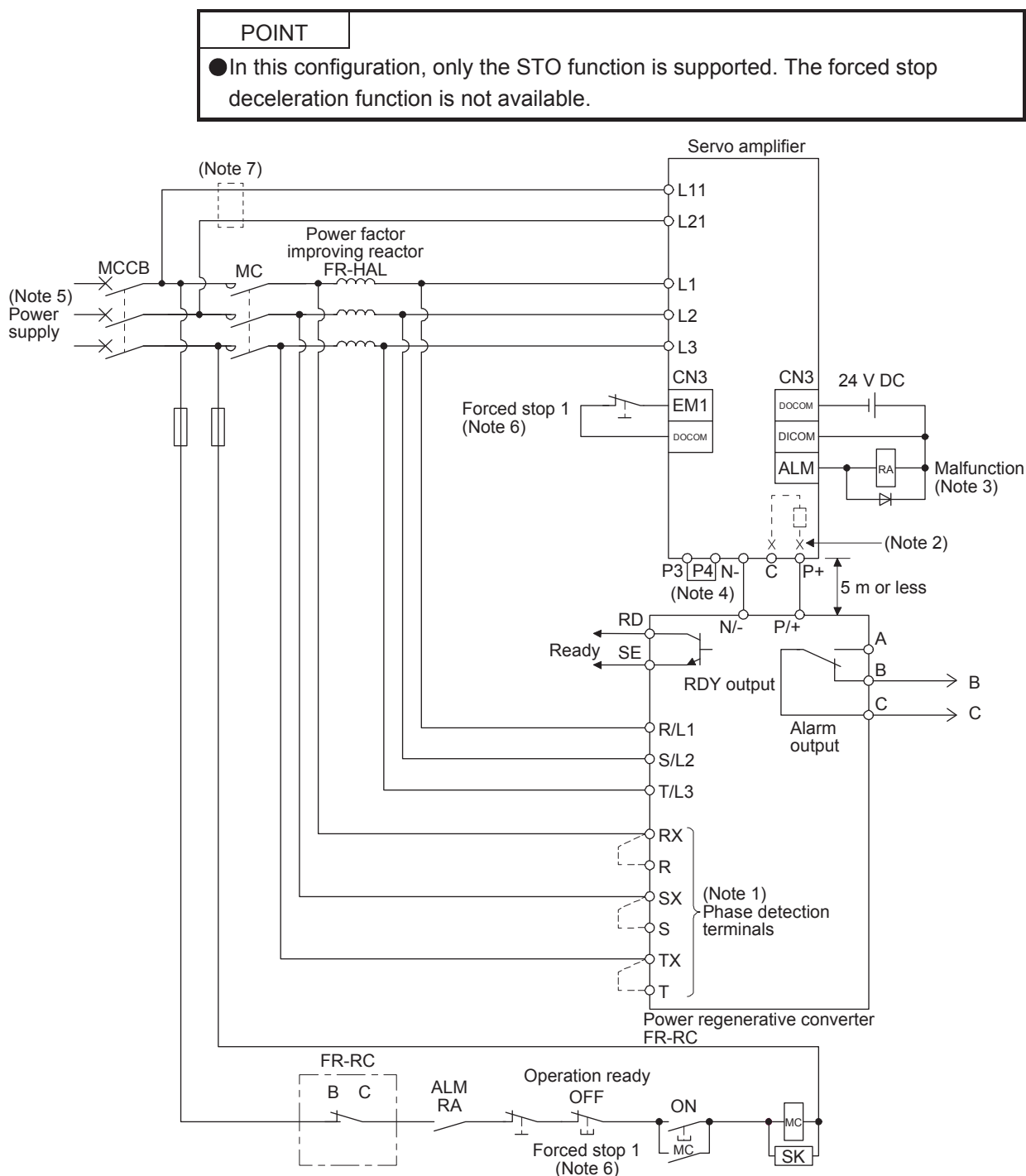

- Note
1. When not using the phase detection terminals, fit the jumpers across RX-R, SX-S and TX-T. If the jumpers remain removed, the FR-RC-(H) will not operate.
 2. For the servo amplifier of 7 kW, always disconnect the lead wire of built-in regenerative resistor, which is connected to the P+ and C terminals.
 3. If disabling ALM (Malfunction) output with the parameter, configure up the power supply circuit which switches off the magnetic contactor after detection of alarm occurrence on the controller side.
 4. Always connect between P3 and P4 terminals. (factory-wired) Use either the power factor improving DC reactor or the power factor improving AC reactor. When using the power factor improving DC reactor, refer to section 11.11.
 5. For power supply specifications, refer to section 1.3.
 6. Set [Pr. PA04] to "0 0 _ _" to enable EM1 (Forced stop 1). Configure up the circuit which shuts off main circuit power with external circuit at EM1 (Forced stop 1) off.
 7. When wires used for L11 and L21 are thinner than wires used for L1, L2, and L3, use a molded case circuit breaker.

11. Options and peripheral devices

(3) Dimensions

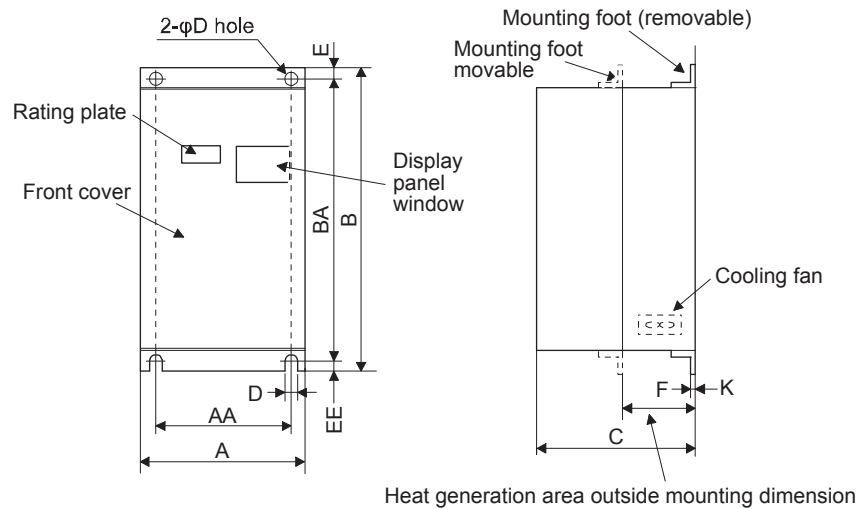

[Unit: mm]

Power regenerative converter	A	AA	B	BA	C	D	E	EE	K	F	Approximate mass [kg]
FR-RC-15K	270	200	450	432	195	10	10	8	3.2	87	19
FR-RC-30K	340	270	600	582	195	10	10	8	3.2	90	31

(4) Mounting hole machining dimensions

When the power regenerative converter is installed to an enclosed type cabinet, mount the heat generating area of the converter outside the box to provide heat generation measures. At this time, the mounting hole having the following dimensions is machined in the box.

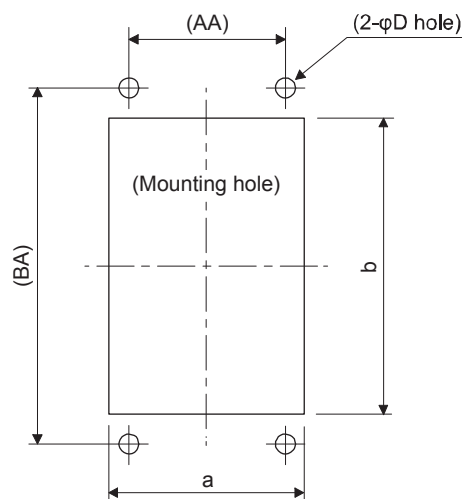

[Unit: mm]

Power regenerative converter	a	b	D	AA	BA
FR-RC-15K	260	412	10	200	432
FR-RC-30K	330	562	10	270	582

11. Options and peripheral devices

11.5 Power regenerative common converter

POINT
<ul style="list-style-type: none"> ● For details of the power regenerative common converter FR-CV, refer to the FR-CV-(H) Installation Guide (IB(NA)0600075). ● Do not supply power to the main circuit power supply terminals (L1, L2, and L3) of the servo amplifier. Doing so will fail the servo amplifier and FR-CV. ● Connect the DC power supply between the FR-CV and servo amplifier with correct polarity. Connection with incorrect polarity will fail the FR-CV and servo amplifier. ● Two or more FR-CV's cannot be installed to improve regeneration capability. Two or more FR-CV's cannot be connected to the same DC power supply line. ● When using FR-CV, set [Pr. PA04] to "0 0 __" to enable EM1 (Forced stop 1).

When using the power regenerative common converter, set [Pr. PA02] to "__ 0 1".

(1) Model

FR-CV-7.5K

Capacity

Symbol	Capacity [kW]
7.5K	7.5
11K	11
15K	15
22K	22
30K	30
37K	37
55K	55

(2) Selection

The power regenerative common converter FR-CV can be used for the servo amplifier of 200 V class with 750 W to 7 kW. The following shows the restrictions on using the FR-CV.

- (a) Up to six servo amplifiers can be connected to one FR-CV.
- (b) $\text{FR-CV capacity [W]} \geq \text{Total of rated capacities [W]} \times 2$ of servo amplifiers connected to FR-CV.
- (c) The total of used servo motor rated currents should be equal to or less than the applicable current [A] of the FR-CV.
- (d) Among the servo amplifiers connected to the FR-CV, the servo amplifier of the maximum capacity should be equal to or less than the maximum connectable capacity [W].

The following table lists the restrictions.

Item	FR-CV-__						
	7.5K	11K	15K	22K	30K	37K	55K
Maximum number of connected servo amplifiers	6						
Total of connectable servo amplifier capacities [kW]	3.75	5.5	7.5	11	15	18.5	27.5
Total of connectable servo motor rated currents [A]	33	46	61	90	115	145	215
Maximum servo amplifier capacity [kW]	3.5	5	7	11	15	15	22

11. Options and peripheral devices

When using the FR-CV, always install the dedicated stand-alone reactor (FR-CVL).

Power regenerative common converter	Dedicated stand-alone reactor
FR-CV-7.5K(-AT)	FR-CVL-7.5K
FR-CV-11K(-AT)	FR-CVL-11K
FR-CV-15K(-AT)	FR-CVL-15K
FR-CV-22K(-AT)	FR-CVL-22K
FR-CV-30K(-AT)	FR-CVL-30K
FR-CV-37K	FR-CVL-37K
FR-CV-55K	FR-CVL-55K

(3) Connection diagram

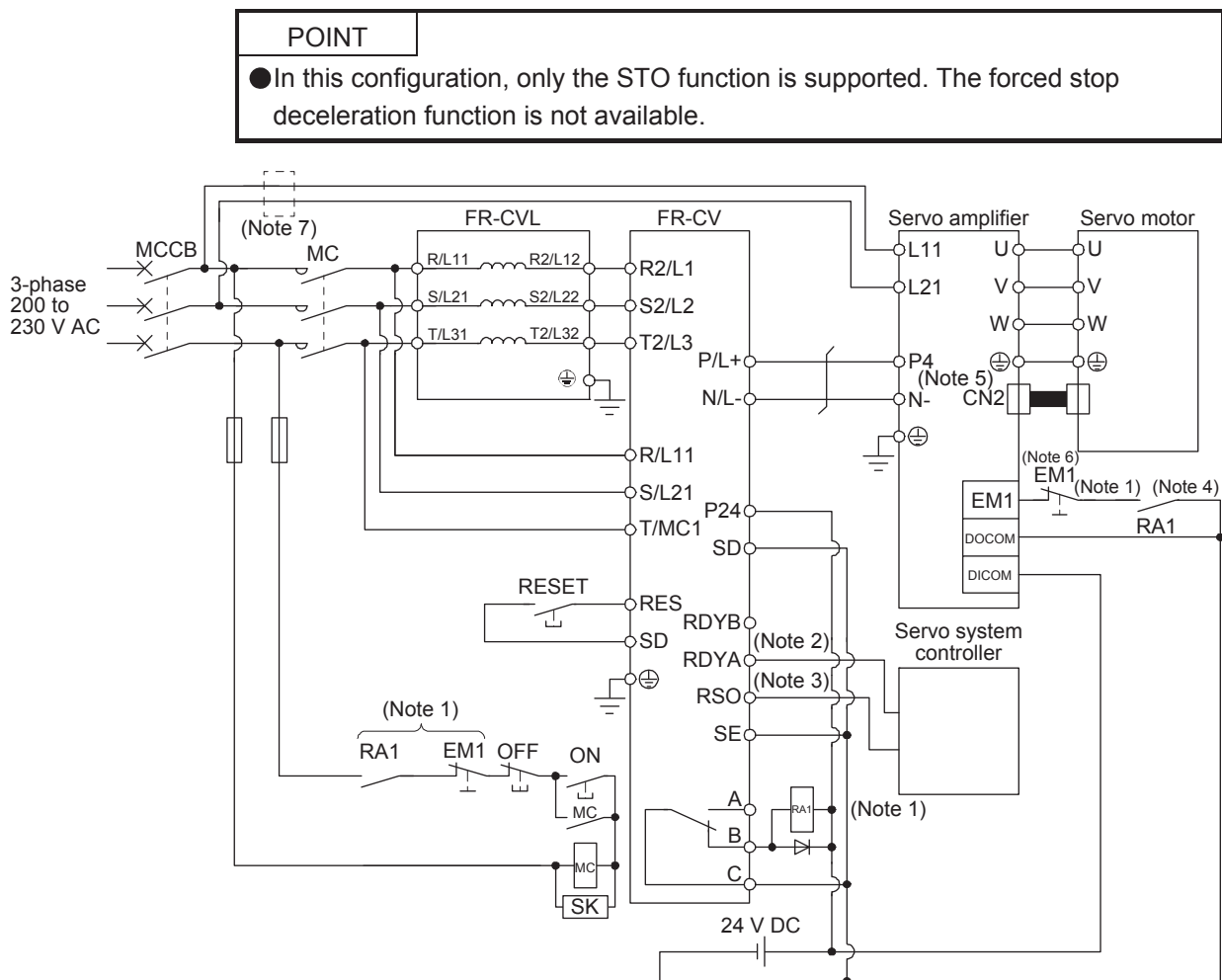

- Note 1. Configure a sequence that will shut off main circuit power at the follow cases.
- FR-CV or servo amplifier alarm occurs.
 - EM1 (forced stop 1) turns off.
2. For the servo amplifier, configure a sequence that will switch the servo-on after the FR-CV is ready.
3. For the FR-CV, the RSO signal turns off when it is put in a ready-to-operate status where the reset signal is input. Configure a sequence that will make the servo inoperative when the RSO signal is on.
4. Configure a sequence that will make a stop with the emergency stop input of the servo system controller if an alarm occurs in the FR-CV. When the servo system controller does not have an emergency stop input, use the forced stop input of the servo amplifier to make a stop as shown in the diagram.
5. When using the FR-CV, disconnect between P3 and P4 terminals.
6. Set [Pr. PA04] to "0 0 __" to enable EM1 (Forced stop 1).
7. When wires used for L11 and L21 are thinner than wires used for L1, L2, and L3, use a molded case circuit breaker.

11. Options and peripheral devices

(4) Selection example of wires used for wiring

POINT
<ul style="list-style-type: none"> ● Selection condition of wire size is as follows. <ul style="list-style-type: none"> Wire type: 600 V Polyvinyl chloride insulated wire (IV wire) Construction condition: One wire is constructed in the air

(a) Wire sizes

1) Across P - P4, N - N-

The following table indicates the connection wire sizes of the DC power supply (P4, N- terminals) between the FR-CV and servo amplifier.

Total of servo amplifier capacities [kW]	Wires [mm ²]
1 or less	2
2	3.5
5	5.5
7	8
11	14
15	22
22	50

2) Grounding

For grounding, use the wire of the size equal to or greater than that indicated in the following table, and make it as short as possible.

Power regenerative common converter	Grounding wire size [mm ²]
FR-CV-7.5K to FR-CV-15K	14
FR-CV-22K, FR-CV-30K	22
FR-CV-37K, FR-CV-55K	38

(b) Example of selecting the wire sizes

When connecting multiple servo amplifiers, always use junction terminals for wiring the servo amplifier terminals P4, N-. Also, connect the servo amplifiers in the order of larger to smaller capacities.

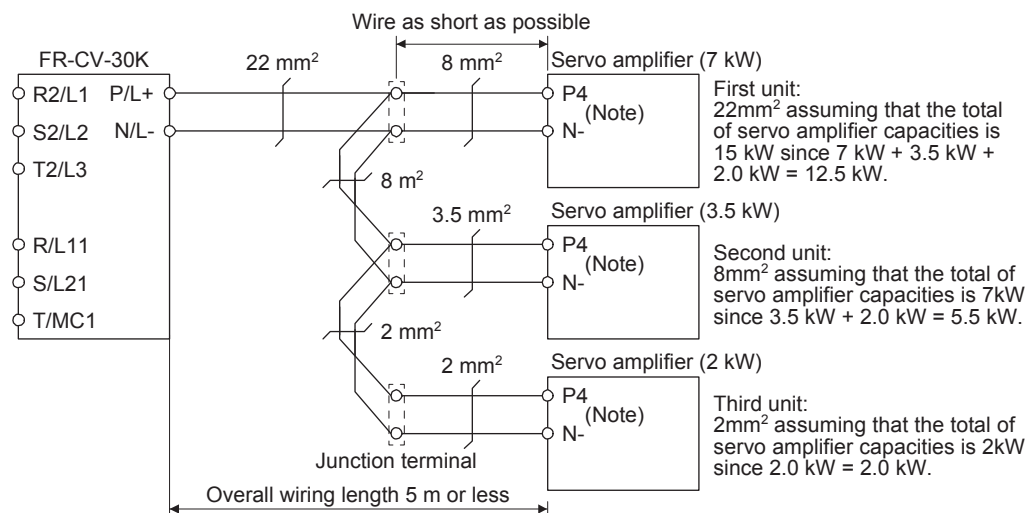

Note. When using the servo amplifier of 7 kW or less, make sure to disconnect the wiring of built-in regenerative resistor (5 kW or less: P4 and D, 7 kW: P4 and C).

11. Options and peripheral devices

(5) Other precautions

- (a) Always use the dedicated stand-alone reactor (FR-CVL) as the power factor improving reactor. Do not use the power factor improving AC reactor (FR-HAL) or Power factor improving DC reactor (FR-HEL).
- (b) The inputs/outputs (main circuits) of the FR-CV and servo amplifiers include high-frequency components and may provide electromagnetic wave interference to communication equipment (such as AM radios) used near them. In this case, interference can be reduced by installing the radio noise filter (FR-BIF) or line noise filter (FR-BSF01, FR-BLF).
- (c) The overall wiring length for connection of the DC power supply between the FR-CV and servo amplifiers should be 5 m or less, and the wiring must be twisted.

(6) Specifications

Power regenerative common converter FR-CV_		7.5K	11K	15K	22K	30K	37K	55K	
Item									
Total of connectable servo amplifier capacities	[kW]	3.75	5.5	7.5	11	15	18.5	27.5	
Maximum servo amplifier capacity	[kW]	3.5	5	7	11	15	15	22	
Output	Total of connectable servo motor rated currents	[A]	33	46	61	90	115	145	215
	Regenerative braking torque	Short-time rating	Total capacity of applicable servo motors, 300% torque, 60 s (Note 1)						
		Continuous rating	100% torque						
Power supply	Rated input AC voltage/frequency	3-phase 200 V AC to 220 V AC 50 Hz, 200 V AC to 230 V AC 60 Hz							
	Permissible AC voltage fluctuation	3-phase 170 V AC to 242 V AC 50 Hz, 170 V AC to 253 V AC 60 Hz							
	Permissible frequency fluctuation	± 5%							
	Power supply capacity (Note 2)	[kVA]	17	20	28	41	52	66	100
IP rating (JEM 1030), cooling method		Open type (IP00), forced cooling							
Environment	Ambient temperature	-10 °C to 50 °C (non-freezing)							
	Ambient humidity	90% RH or less (non-condensing)							
	Ambience	Indoors (no direct sunlight), free from corrosive gas, flammable gas, oil mist, dust, and dirt							
Altitude, vibration		1000 m or less above sea level, 5.9 m/s ² or less							
Molded case circuit breaker or leakage current breaker		30AF 30A	50AF 50A	100AF 75A	100AF 100A	225AF 125A	225AF 125A	225AF 175A	
Magnetic contactor		S-N20	S-N35	S-N50	S-N65	S-N95	S-N95	S-N125	

Note 1. This is the time when the protective function of the FR-CV is activated. The protective function of the servo amplifier is activated in the time indicated in section 10.1.

2. When connecting the capacity of connectable servo amplifier, specify the value of servo amplifier.

11. Options and peripheral devices

11.6 Junction terminal block PS7DW-20V14B-F (recommended)

(1) Usage

Always use the junction terminal block (PS7W-20V14B-F(YOSHIDA ELECTRIC INDUSTRY)) with the option cable (MR-J2HBUS_M) as a set. A connection example is shown below.

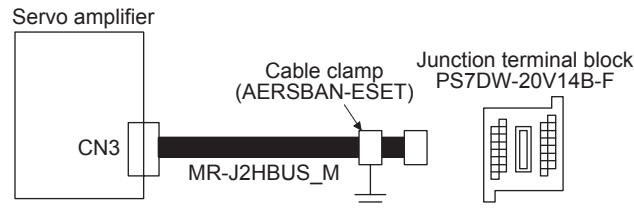

Ground the option cable on the junction terminal block side with the cable clamp fitting (AERSBAN-ESET). For the use of the cable clamp fitting, refer to section 11.14, (2)(c).

(2) Connection of MR-J2HBUS_M cable and junction terminal block

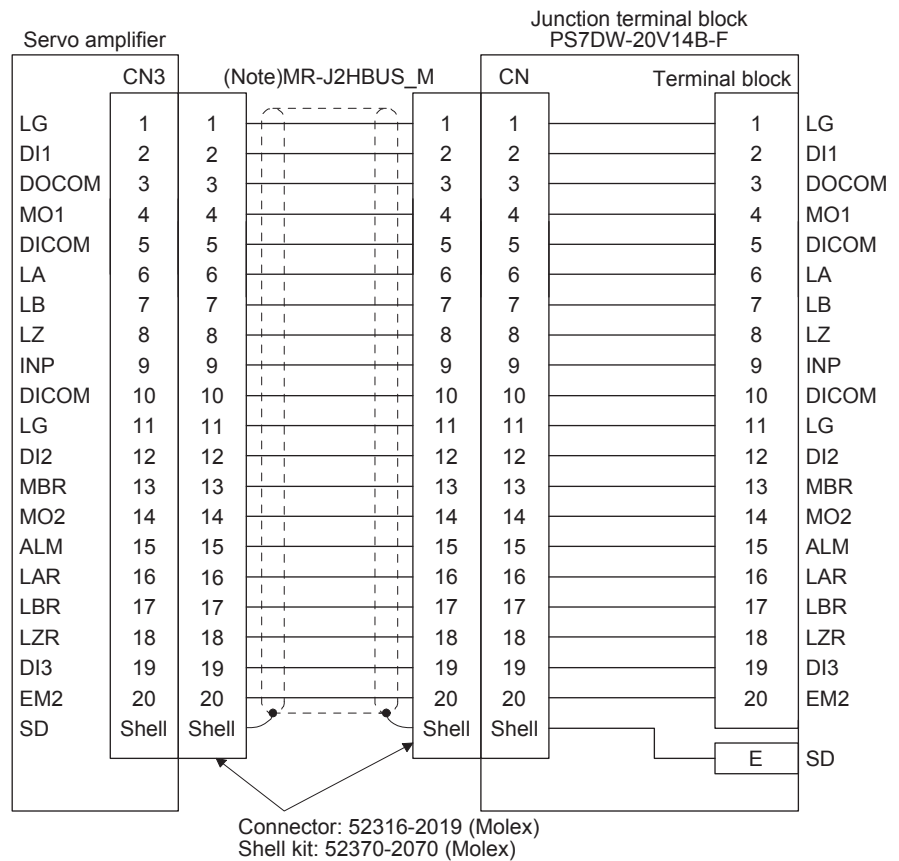

Note. Symbol indicating cable length is put in _.

05: 0.5 m

1: 1 m

5: 5 m

11. Options and peripheral devices

(3) Dimensions of junction terminal block

[Unit: mm]

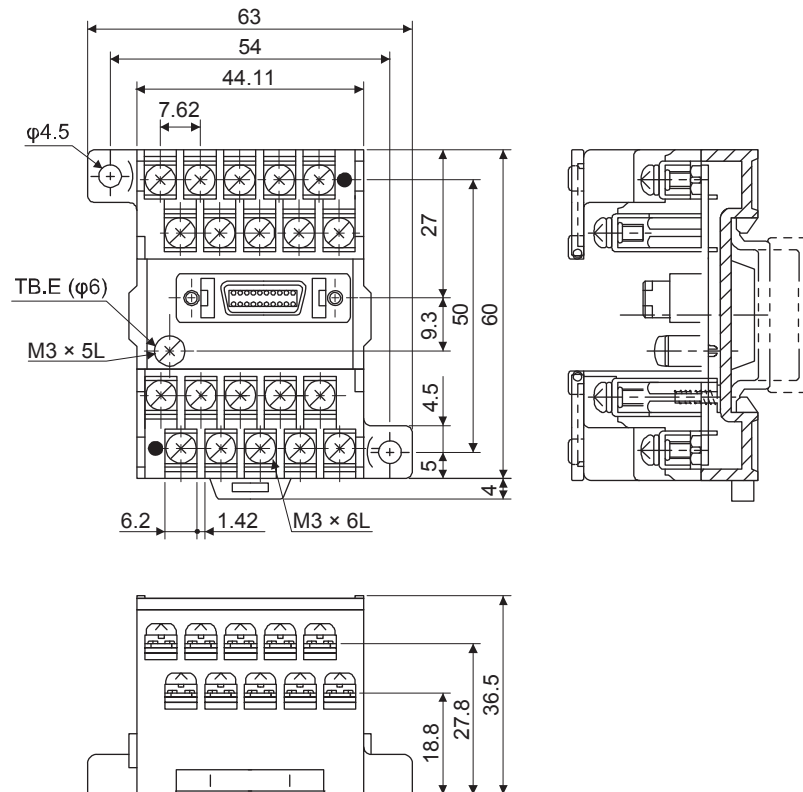

11.7 MR Configurator2

MR Configurator2 (SW1DNC-MRC2-E) uses the communication function of the servo amplifier to perform parameter setting changes, graph display, test operation, etc. on a personal computer.

(1) Specifications

Item	Description
Project	Project creation, reading, saving, or deleting, System setting, Print
Parameter	Parameter setting
Monitor	Batch display, Input/output monitor display, Graph, ABS data display
Diagnostic	Alarm display, Display of data that generated alarm, Drive recorder, Reason for rotation failure display, System structure display, Life assessment, Machine assessment, Fully closed loop diagnostics, Liner diagnostics
Test operation	Jog operation, Positioning operation, Motor-less operation (Note), DO forced output, Program operation, Test mode information
Adjustment	One-touch adjustment, Tuning, Machine analyzer
Others	Servo assistant, Update parameter setting range, Machine unit conversion display setting, Help display, Connection to MELFANSweb

Note. This function is available only with rotary servo motors and will be available with linear servo motors and direct drive motors in the future.

11. Options and peripheral devices

(2) System configuration

(a) Components

To use this software, the following components are required in addition to the servo amplifier and servo motor.

Equipment	(Note 1) Description	
(Note 2, 3, 4, 5) Personal computer	OS	Microsoft® Windows® 7 Ultimate [Service Pack none/1] Microsoft® Windows® 7 Enterprise [Service Pack none/1] Microsoft® Windows® 7 Professional [Service Pack none/1] Microsoft® Windows® 7 Home Premium [Service Pack none/1] Microsoft® Windows® 7 Starter [Service Pack none/1] Microsoft® Windows Vista® Home Basic [Service Pack none/1/2] Microsoft® Windows Vista® Home Premium [Service Pack none/1/2] Microsoft® Windows Vista® Business [Service Pack none/1/2] Microsoft® Windows Vista® Ultimate [Service Pack none/1/2] Microsoft® Windows Vista® Enterprise [Service Pack none/1/2] Microsoft® Windows® XP Professional [Service Pack 2/3] Microsoft® Windows® XP Home Edition [Service Pack 2/3] Microsoft® Windows® 2000 Professional [Service Pack 4]
	CPU	Desktop PC: Celeron® processor 2.8 GHz or more Laptop PC: Pentium® M processor 1.7 GHz or more
	Memory	512 MB or more (32 bit OS), 1 GB or more (64 bit OS)
	Hard Disk	1 GB or more of free space
	Communication interface	USB port
Browser	Internet Explorer 4.0 or more	
Display	One whose resolution is 1024 × 768 or more and that can provide a high color (16 bit) display. Connectable with the above personal computer.	
Keyboard	Connectable with the above personal computer.	
Mouse	Connectable with the above personal computer.	
Printer	Connectable with the above personal computer.	
USB cable	MR-J3USBCBL3M	

- Note
- Windows and Windows Vista are registered trademarks of Microsoft Corporation in the United States and/or other countries. Celeron and Pentium is the registered trademarks of Intel Corporation.
 - On some personal computers, MR Configurator2 may not run properly.
 - When Microsoft® Windows® 7, Microsoft® Windows Vista®, or Microsoft® Windows® XP is used, the follow functions cannot be used.
 - Windows Program Compatibility mode
 - Fast User Switching
 - Remote Desktop
 - Large Fonts Mode (Display property)
 - DPI settings other than 96 DPI (Display property)
 Moreover, only Windows® 7 corresponds to OS in 64 bits.
 - When Microsoft® Windows® 7 is used, the follow functions cannot be used.
 - Windows XP Mode
 - Windows touch
 - In Windows Vista® and Windows® 7, please use this software by the user more than the USER authority.

11. Options and peripheral devices

(b) Connection with servo amplifier

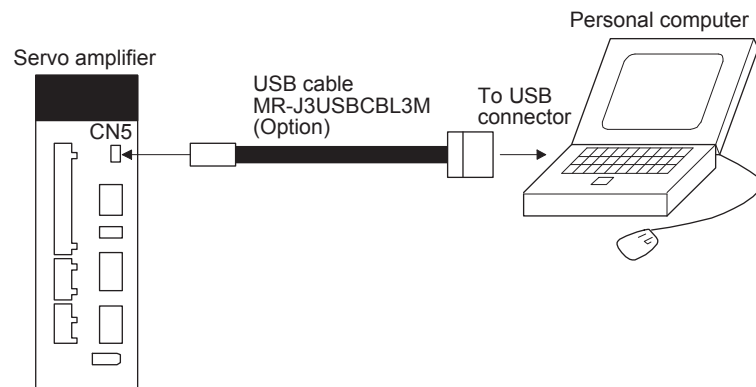

11.8 Battery

POINT

- Refer to appendix 7 and 8 for battery transportation and the new EU Battery Directive.

(1) Purpose of use for MR-BAT6V1SET

This battery is used to construct an absolute position detection system. Refer to section 12.3 for the fitting method, etc.

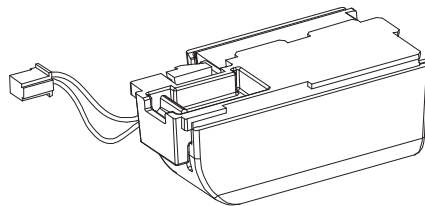

(2) Year and month when MR-BAT6V1SET is manufactured

The manufacturing years of MR-BAT6V1SET have been described to the rating plate put on a built-in MR-BAT6V1 battery.

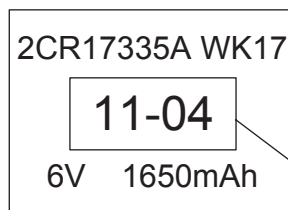

The year and month of manufacture

11. Options and peripheral devices

11.9 Selection example of wires

POINT
<ul style="list-style-type: none"> ● Refer to section 11.1.3 for SSCNET III cable. ● To comply with the UL/CSA standard, use the wires shown in appendix 9 for wiring. To comply with other standards, use a wire that is complied with each standard. ● Selection condition of wire size is as follows. Construction condition: One wire is constructed in the air Wire length: 30 m or less

The following diagram shows the wires used for wiring. Use the wires given in this section or equivalent.

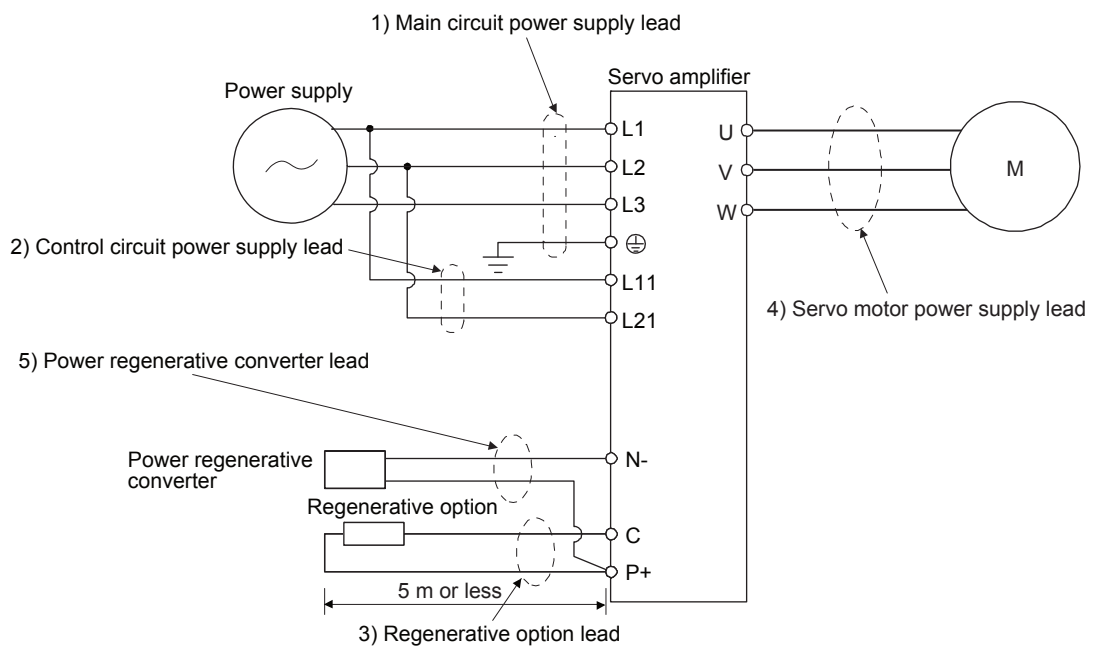

11. Options and peripheral devices

- (1) When using the 600 V Grade heat-resistant polyvinyl chloride insulated wire (HIV wire)
Selection example of wire size when using HIV wires is indicated below.

Table 11.1 Wire size selection example 1 (HIV wire)

Servo amplifier	Wires [mm ²]			
	1) L1/L2/L3⊕	2) L11/L21	3) P+/C	4) U/V/W/⊕ (Note 3)
MR-J4-10B	2 (AWG 14)	AWG 16 to 14 (Note 4)	2 (AWG 14)	AWG 18 to 14 (Note 4)
MR-J4-20B				
MR-J4-40B				
MR-J4-60B				
MR-J4-70B				
MR-J4-100B				
MR-J4-200B				
MR-J4-350B	3.5 (AWG 12)			1.3 to 5.3 (AWG 16 to 10)
MR-J4-500B (Note 2)	5.5 (AWG 10): a	1.25 (AWG 16): a 2 (AWG 14): d (Note 4)	2 (AWG 14): c	2 (AWG 14): c 3.5 (AWG 12): a 5.5 (AWG 10): a
MR-J4-700B (Note 2)	8 (AWG 8): b			2 (AWG 14): c 3.5 (AWG 12): a 5.5 (AWG 10): a 8 (AWG 8): b

- Note 1. Alphabets in the table indicate crimping tools. For crimp terminals and applicable tools, refer to (2) in this section.
2. To connect these models to a terminal block, be sure to use the screws that come with the terminal block.
3. This wire size is applicable wire size of servo amplifier connectors or terminals. For selecting cables, refer to each servo amplifier instruction manual.
4. Be sure to use 2 mm² wire when corresponding to EN standard.

Use wires 5) of the following sizes with the power regenerative converter (FR-RC).

Model	Wires [mm ²]
FR-RC-15K	14 (AWG 16)
FR-RC-30K	14 (AWG 16)
FR-RC-55K	22 (AWG 14)

- (2) Selection example of crimp terminals

The table below shows a selection example of crimp terminals for the servo amplifier terminal block.

Symbol	Servo amplifier side crimp terminals		
	(Note 2) Crimp terminals	Applicable tool	Manufacturer
a	FVD5.5-4	YNT-1210S	JST
(Note 1) b	8-4NS	YHT-8S	
c	FVD2-4	YNT-1614	
d	FVD2-M3		
e	FVD1.25-M3	YNT-2216	

- Note 1. Coat the crimping part with an insulation tube.
2. Some crimp terminals may not be mounted depending on the size. Make sure to use the recommended ones or equivalent ones.

11. Options and peripheral devices

11.10 Molded case circuit breakers, fuses, magnetic contactors

(1) For main circuit power supply

Always use one molded case circuit breaker and one magnetic contactor with one servo amplifier. When using a fuse instead of the molded case circuit breaker, use the one having the specifications given in this section.

Servo amplifier	Molded case circuit breaker (Note 1)		Fuse			Magnetic contactor (Note 2)
	Frame, rated current	Voltage AC [V]	Class	Current [A]	Voltage AC [V]	
MR-J4-10B	30 A frame 5 A	240	T	10	300	S-N10
MR-J4-20B						
MR-J4-40B						
MR-J4-60B	30 A frame 10 A			20		
MR-J4-70B						
MR-J4-100B	30 A frame 15 A			40		
MR-J4-200B						
MR-J4-350B	30 A frame 20 A			70		
MR-J4-500B	30 A frame 30 A			125		
MR-J4-700B	50 A frame 50 A			150		
	100 A frame 75 A					

- Note 1. To comply with the UL/CSA standard, use the wires shown in appendix 8 for wiring.
2. Use a magnetic contactor with an operation delay time (interval between current being applied to the coil until closure of contacts) of 80 ms or less.

(2) For control circuit power supply

If wires for L11 and L21 are slimmer than wires for L1, L2, and L3, use a molded case circuit breaker or fuse to protect the branch circuit.

Servo amplifier	Molded case circuit breaker (Note)		Fuse (Class T)		Fuse (Class K5)	
	Frame, rated current	Voltage AC [V]	Current [A]	Voltage AC [V]	Current [A]	Voltage AC [V]
MR-J4-10B	30 A frame 5 A	240	1	300	1	250
MR-J4-20B						
MR-J4-40B						
MR-J4-60B						
MR-J4-70B						
MR-J4-100B						
MR-J4-200B						
MR-J4-350B						
MR-J4-500B						
MR-J4-700B						

Note. To comply with the UL/CSA standard, use the wires shown in appendix 8 for wiring.

11.11 Power factor improving DC reactors

The following shows the advantages of using power factor improving DC reactor.

- It improves the power factor by increasing the form factor of the servo amplifier's input current.
- It decreases the power supply capacity.
- The input power factor is improved to be about 85%.
- As compared to the power factor improving AC reactor (FR-HAL), it decreases the loss.

When connecting the power factor improving DC reactor to the servo amplifier, always disconnect P3 and P4. If it remains connected, the effect of the power factor improving DC reactor is not produced.

When used, the power factor improving DC reactor generates heat. To release heat, therefore, leave a 10 cm or more clearance at each of the top and bottom, and a 5 cm or more clearance on each side.

11. Options and peripheral devices

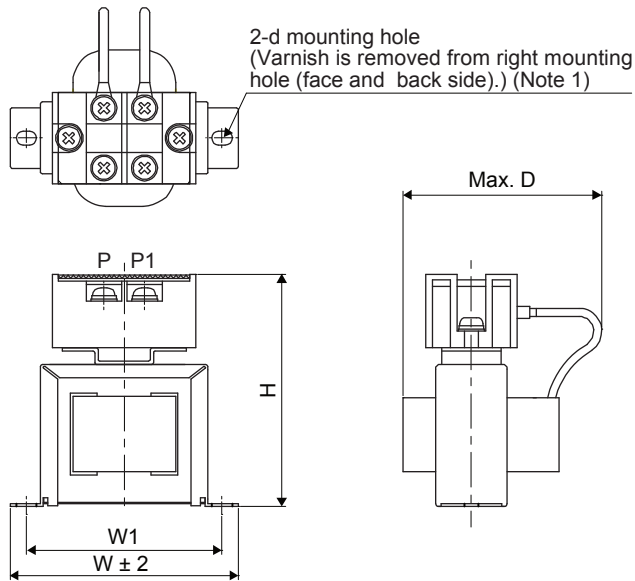

Fig. 11.1

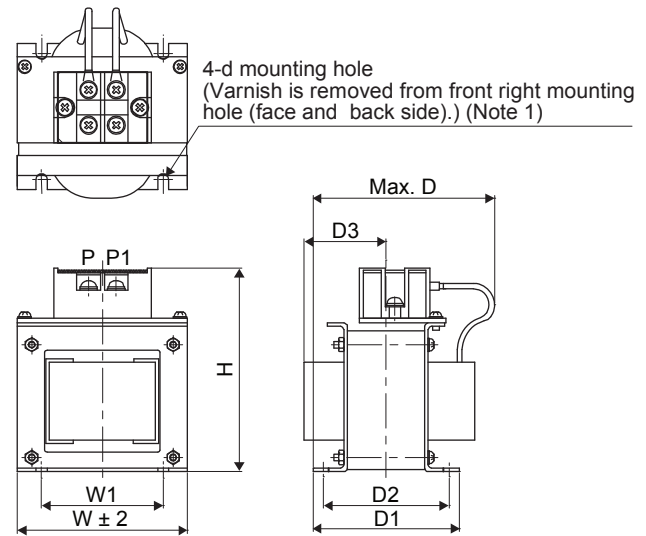
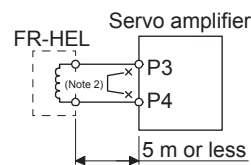

Fig. 11.2



Note 1. Use this hole for grounding.

Note 2. When using the Power factor improving DC reactor, remove the short bar across P3-P4.

Servo amplifier	Power factor improving DC reactor	Reference	Dimensions [mm]							Terminal screw size	Mass [kg]	Wire [mm ²] (Note 2)		
			W	W1	H	D (Note 1)	D1	D2	D3				d	
MR-J4-10B/MR-J4-20B	FR-HEL-0.4K	Fig. 11.1	70	60	71	61	/	21	/	M4	M4	0.4	2 (AWG 14)	
MR-J4-40B	FR-HEL-0.75K		85	74	81	61		21		M4	M4	0.5		
MR-J4-60B/MR-J4-70B	FR-HEL-1.5K		85	74	81	70		30		M4	M4	0.8		
MR-J4-100B	FR-HEL-2.2K		85	74	81	70		30		M4	M4	0.9		
MR-J4-200B	FR-HEL-3.7K	Fig. 11.2	77	55	92	82	66	57	37	M4	M4	1.5		
MR-J4-350B	FR-HEL-7.5K		86	60	113	98	81	72	43	M4	M5	2.5		3.5 (AWG 12)
MR-J4-500B	FR-HEL-11K		105	64	133	112	92	79	47	M6	M6	3.3		5.5 (AWG 10)
MR-J4-700B	FR-HEL-15K		105	64	133	115	97	84	48.5	M6	M6	4.1		8 (AWG 8)

Note 1. Maximum dimensions (The dimension varies depending on the bending degree of the input/output line.)

Note 2. Selection condition of wire size is as follows.

Wire type: 600 V Grade heat-resistant polyvinyl chloride insulated wire (HIV wire)

Construction condition: One wire is constructed in the air

11. Options and peripheral devices

11.12 Power factor improving AC reactors

The following shows the advantages of using power factor improving AC reactor.

- It improves the power factor by increasing the form factor of the servo amplifier's input current.
- It decreases the power supply capacity.
- The input power factor is improved to be about 80%.

When using power factor improving reactors for two servo amplifiers or more, be sure to connect a power factor improving reactor to each servo amplifier. If using only one power factor improving reactor, enough improvement effect of phase factor cannot be obtained unless all servo amplifiers are operated.

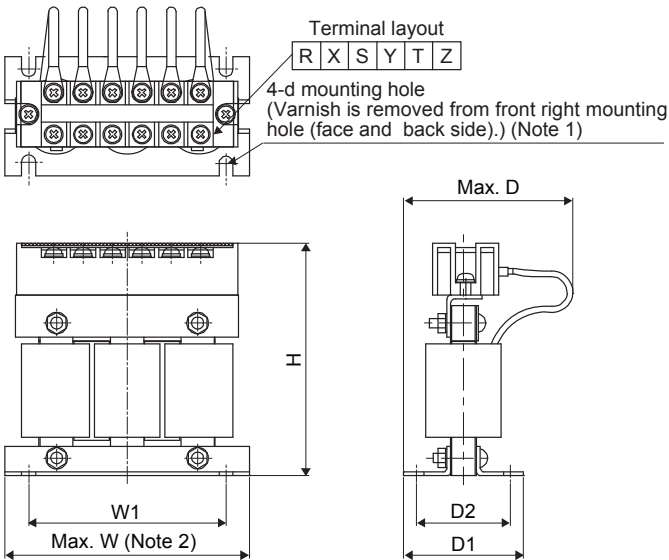
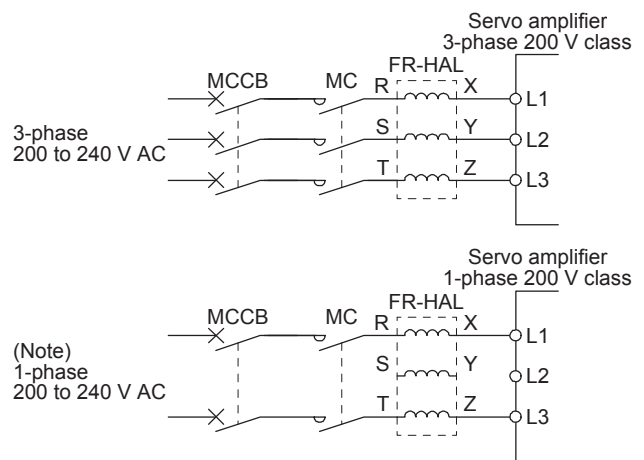

Fig. 11.3

- Note 1. Use this hole for grounding.
2. $W \pm 2$ for HR-HAL-0.4K to 1.5K.



- Note. For 1-phase 200 V AC to 240 V AC, connect the power supply to L1 and L3. Leave L2 open.

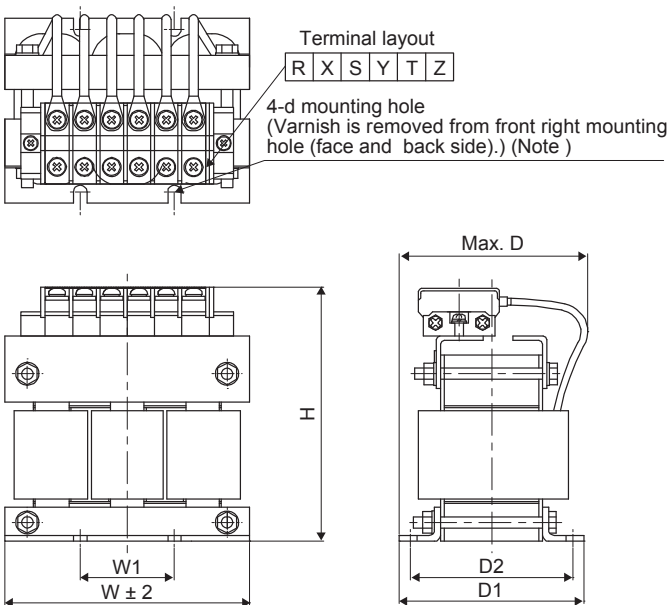

Fig. 11.4

- Note. Use this hole for grounding.

11. Options and peripheral devices

Servo amplifier	Power factor improving DC reactor	Reference	Dimensions [mm]							Terminal screw size	Mass [kg]
			W	W1	H	D (Note)	D1	D2	d		
MR-J4-10B/MR-J4-20B	FR-HAL-0.4K	Fig. 11.3	104	84	99	72	51	40	M5	M4	0.6
MR-J4-40B	FR-HAL-0.75K		104	84	99	74	56	44	M5	M4	0.8
MR-J4-60B/MR-J4-70B	FR-HAL-1.5K		104	84	99	77	61	50	M5	M4	1.1
MR-J4-100B	FR-HAL-2.2K		115 (Note)	40	115	77	71	57	M6	M4	1.5
MR-J4-200B	FR-HAL-3.7K		115 (Note)	40	115	83	81	67	M6	M4	2.2
MR-J4-350B	FR-HAL-7.5K	Fig. 11.4	130	50	135	100	98	86	M6	M5	4.2
MR-J4-500B	FR-HAL-11K		160	75	164	111	109	92	M6	M6	5.2
MR-J4-700B	FR-HAL-15K		160	75	167	126	124	107	M6	M6	7.0

Note. Maximum dimensions (The dimension varies depending on the bending degree of the input/output line.)

11.13 Relays (recommended)

The following relays should be used with the interfaces

Interface	Selection example
Digital input interface (DI-1) Relay used for digital input command signals	To prevent defective contacts, use a relay for small signal (twin contacts). (Ex.) Omron : type G2A, MY
Digital output interface (DO-1) Relay used for digital output signals	Small relay with 12 V DC or 24 V DC of rated current 40 mA or less (Ex.) Omron : type MY

11.14 Noise reduction techniques

Noises are classified into external noises which enter the servo amplifier to cause it to malfunction and those radiated by the servo amplifier to cause peripheral devices to malfunction. Since the servo amplifier is an electronic device which handles small signals, the following general noise reduction techniques are required. Also, the servo amplifier can be a source of noise as its outputs are chopped by high carrier frequencies. If peripheral devices malfunction due to noises produced by the servo amplifier, noise suppression measures must be taken. The measures will vary slightly with the routes of noise transmission.

(1) Noise reduction techniques

(a) General reduction techniques

- Avoid laying power lines (input and output cables) and signal cables side by side or do not bundle them together. Separate power lines from signal cables.
- Use a shielded twisted pair cable for connection with the encoder and for control signal transmission, and connect the external conductor of the cable to the SD terminal.
- Ground the servo amplifier, servo motor, etc. together at one point. (Refer to section 3.12.)

11. Options and peripheral devices

(b) Reduction techniques for external noises that cause the servo amplifier to malfunction

If there are noise sources (such as a magnetic contactor, an electromagnetic brake, and many relays which make a large amount of noise) near the servo amplifier and the servo amplifier may malfunction, the following countermeasures are required.

- Provide surge absorbers on the noise sources to suppress noises.
- Attach data line filters to the signal cables.
- Ground the shields of the encoder connecting cable and the control signal cables with cable clamp fittings.
- Although a surge absorber is built into the servo amplifier, to protect the servo amplifier and other equipment against large exogenous noise and lightning surge, attaching a varistor to the power input section of the equipment is recommended.

(c) Techniques for noises radiated by the servo amplifier that cause peripheral devices to malfunction

Noises produced by the servo amplifier are classified into those radiated from the cables connected to the servo amplifier and its main circuits (input and output circuits), those induced electromagnetically or statically by the signal cables of the peripheral devices located near the main circuit cables, and those transmitted through the power supply cables.

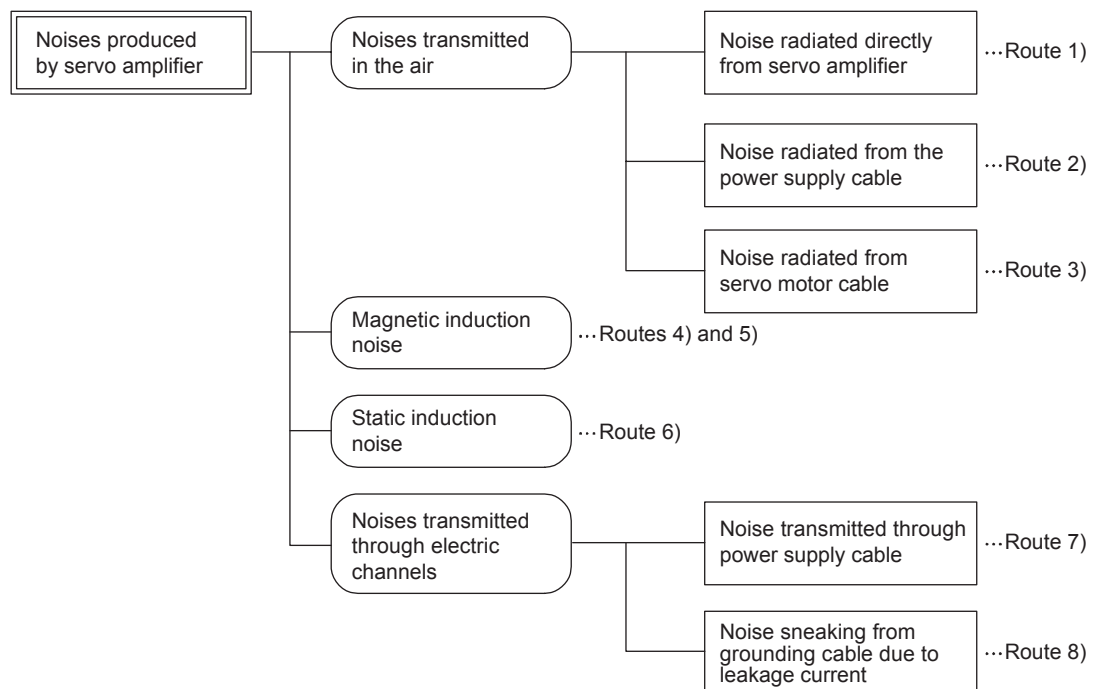

11. Options and peripheral devices

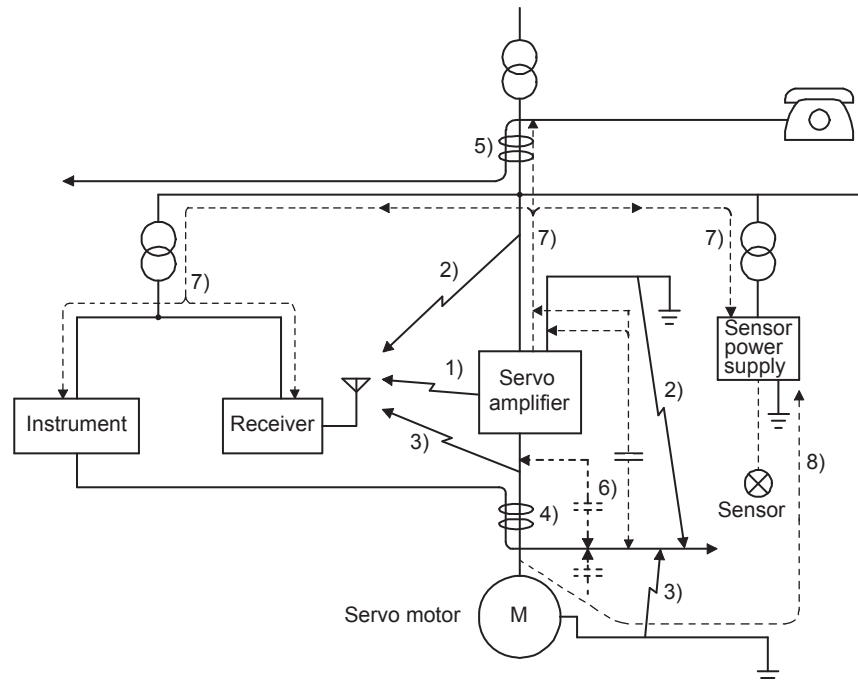

Noise transmission route	Suppression techniques
1)2)3)	<p>When measuring instruments, receivers, sensors, etc. which handle weak signals and may malfunction due to noise and/or their signal cables are contained in a cabinet together with the servo amplifier or run near the servo amplifier, such devices may malfunction due to noises transmitted through the air. The following techniques are required.</p> <ol style="list-style-type: none"> 1. Provide maximum clearance between easily affected devices and the servo amplifier. 2. Provide maximum clearance between easily affected signal cables and the I/O cables of the servo amplifier. 3. Avoid laying the power lines (Input cables of the servo amplifier) and signal cables side by side or bundling them together. 4. Insert a line noise filter to the I/O cables or a radio noise filter on the input line. 5. Use shielded wires for signal and power cables or put cables in separate metal conduits.
4)5)6)	<p>When the power lines and the signal cables are laid side by side or bundled together, magnetic induction noise and static induction noise will be transmitted through the signal cables and malfunction may occur. The following techniques are required.</p> <ol style="list-style-type: none"> 1. Provide maximum clearance between easily affected devices and the servo amplifier. 2. Provide maximum clearance between easily affected signal cables and the I/O cables of the servo amplifier. 3. Avoid laying the power lines (Input cables of the servo amplifier) and signal cables side by side or bundling them together. 4. Use shielded wires for signal and power cables or put cables in separate metal conduits.
7)	<p>When the power supply of peripheral devices is connected to the power supply of the servo amplifier system, noises produced by the servo amplifier may be transmitted back through the power supply cable and the devices may malfunction. The following techniques are required.</p> <ol style="list-style-type: none"> 1. Insert the radio noise filter (FR-BIF) on the power cables (Input cables) of the servo amplifier. 2. Insert the line noise filter (FR-BSF01/FR-BLF) on the power cables of the servo amplifier.
8)	<p>When the cables of peripheral devices are connected to the servo amplifier to make a closed loop circuit, leakage current may flow to malfunction the peripheral devices. If so, malfunction may be prevented by disconnecting the grounding cable of the peripheral device.</p>

11. Options and peripheral devices

(2) Noise reduction techniques

(a) Data line filter (recommended)

Noise can be prevented by installing a data line filter onto the encoder cable, etc.

For example, the ZCAT3035-1330 by TDK, the ESD-SR-250 by NEC TOKIN, and GRFC-13 by Kitagawa Industries are available as data line filters.

As a reference example, the impedance specifications of the ZCAT3035-1330 (TDK) are indicated below. This impedances are reference values and not guaranteed values.

Impedance [Ω]	
10 MHz to 100 MHz	100 MHz to 500 MHz
80	150

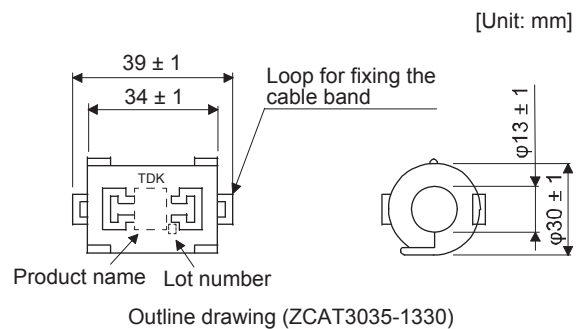

(b) Surge killer (recommended)

The recommended surge killer for installation to an AC relay, AC valve or the like near the servo amplifier is shown below. Use this product or equivalent.

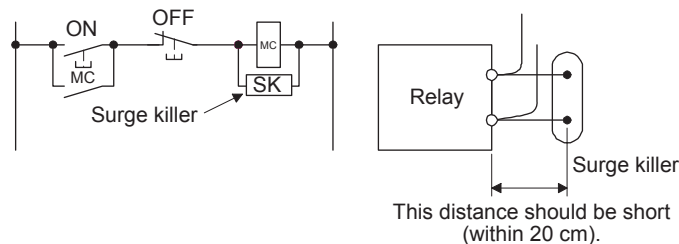

(Ex.) CR-50500 (OKAYA Electric Industries Co., Ltd.)

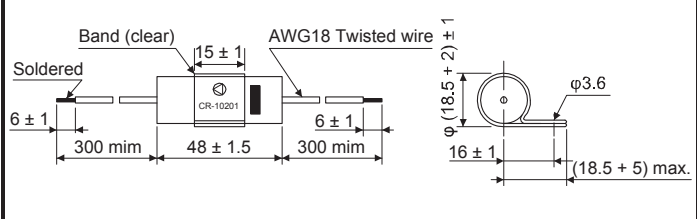
Rated voltage Voltage AC [V]	C [$\mu\text{F} \pm 20\%$]	R [$\Omega \pm 30\%$]	Test voltage	Dimensions
250	0.5	50 (1/2 W)	Between terminals: 625 V AC 50/60 Hz 60 s Between terminal and case: 2,000 V AC 50/60 Hz 60 s	

Note that a diode should be installed to a DC relay or the like.

Maximum voltage: Not less than 4 times the drive voltage of the relay or the like

Maximum current: Not less than twice the drive current of the relay or the like

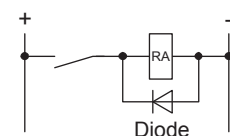

11. Options and peripheral devices

(c) Cable clamp fitting AERSBAN-_SET

Generally, the grounding of the shielded wire may only be connected to the connector's SD terminal. However, the effect can be increased by directly connecting the cable to an grounding plate as shown below.

Install the grounding plate near the servo amplifier for the encoder cable. Peel part of the cable sheath to expose the external conductor, and press that part against the grounding plate with the cable clamp. If the cable is thin, clamp several cables in a bunch.

The clamp comes as a set with the grounding plate.

[Unit: mm]

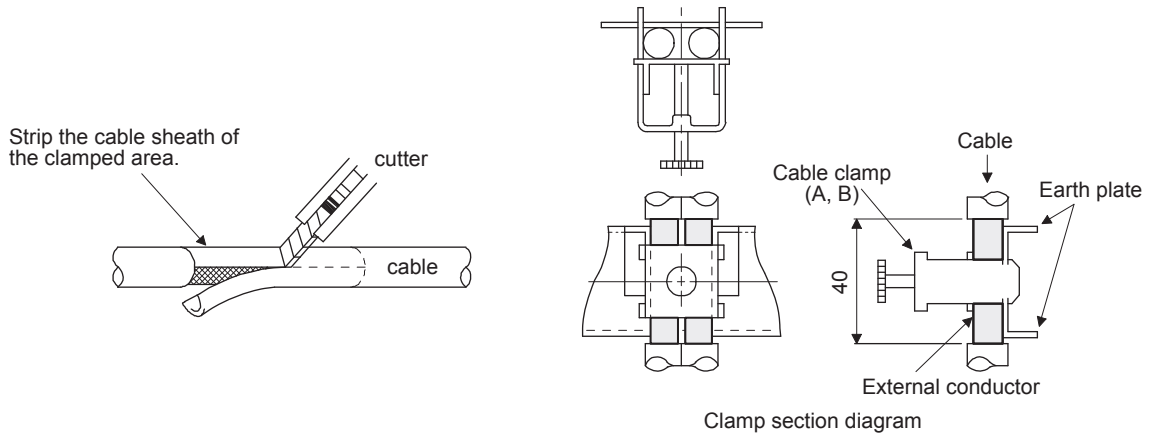

• Dimensions

[Unit: mm]

[Unit: mm]

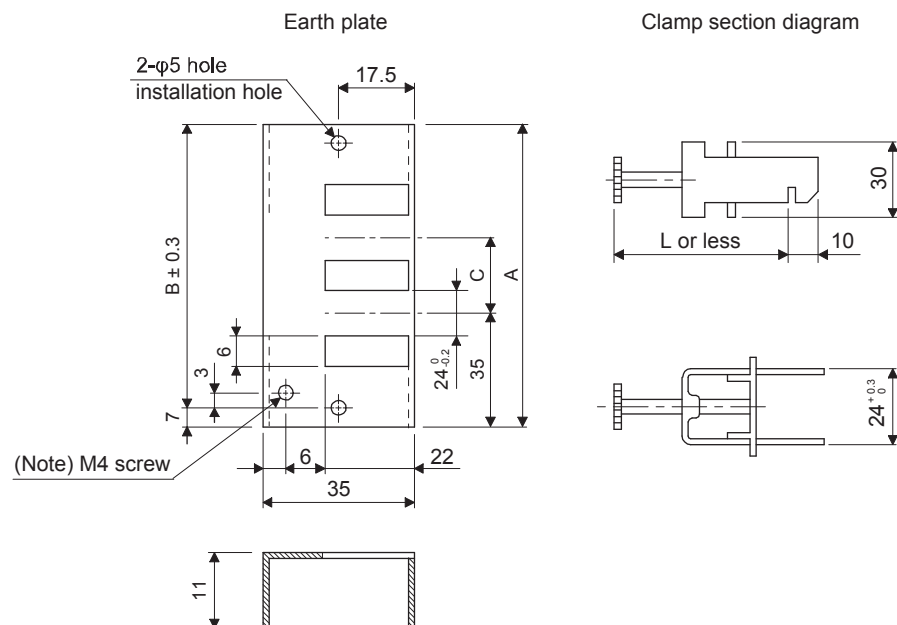

Note. Screw hole for grounding. Connect it to the grounding plate of the cabinet.

Model	A	B	C	Accessory fittings
AERSBAN-DSET	100	86	30	clamp A: 2 pcs.
AERSBAN-ESET	70	56		clamp B: 1 pc.

Clamp fitting	L
A	70
B	45

11. Options and peripheral devices

(d) Line noise filter (FR-BSF01/ FR-BLF)

This filter is effective in suppressing noises radiated from the power supply side and output side of the servo amplifier and also in suppressing high-frequency leakage current (0-phase current). It especially affects the noises between 0.5 MHz and 5 MHz band.

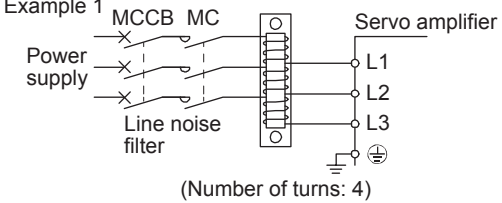
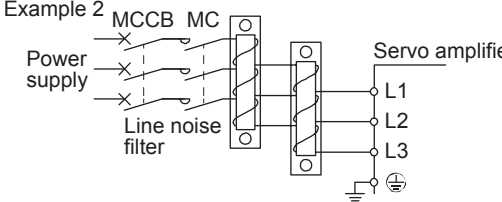
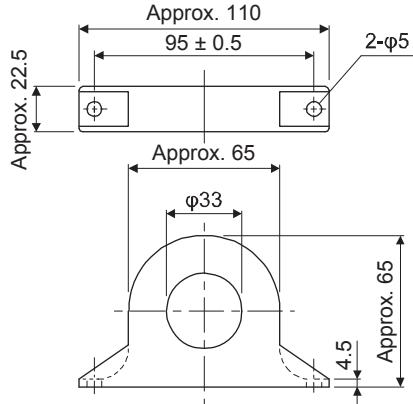
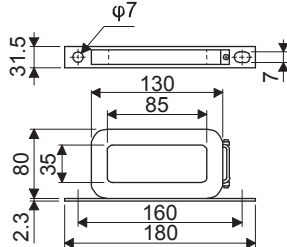
Connection diagram	Dimensions [Unit: mm]
<p>Use the line noise filters for wires of the main power supply (L1, L2, and L3) and of the servo motor power (U, V, and W). Pass each of the wires through the line noise filter an equal number of times in the same direction. For the main power supply, the effect of the filter rises as the number of passes increases, but generally four passes would be appropriate. For the servo motor power lines, passes must be four times or less. Do not pass the grounding wire through the filter, or the effect of the filter will drop. Wind the wires by passing through the filter to satisfy the required number of passes as shown in Example 1. If the wires are too thick to wind, use two or more filters to have the required number of passes as shown in Example 2.</p> <p>Place the line noise filters as close to the servo amplifier as possible for their best performance.</p> <p>Example 1</p>  <p>(Number of turns: 4)</p> <p>Example 2</p>  <p>Two filters are used (Total number of turns: 4)</p>	<p>FR-BSF01 (for wire size 3.5 mm² (AWG 12) or less)</p>  <p>FR-BLF (for wire size 5.5 mm² (AWG 10) or more)</p> 

11. Options and peripheral devices

(e) Radio noise filter (FR-BIF)

This filter is effective in suppressing noises radiated from the power supply side of the servo amplifier especially in 10 MHz and lower radio frequency bands. The FR-BIF is designed for the input only.

200 V class: FR-BIF

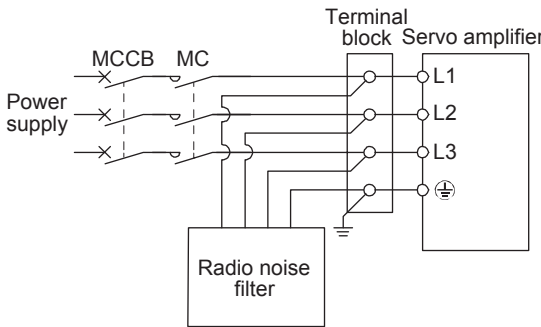
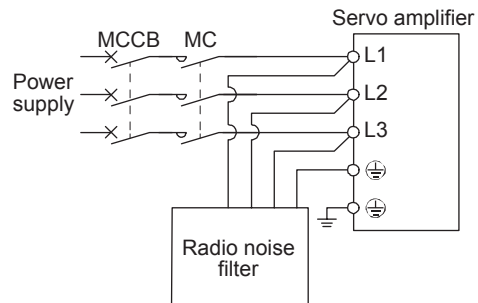
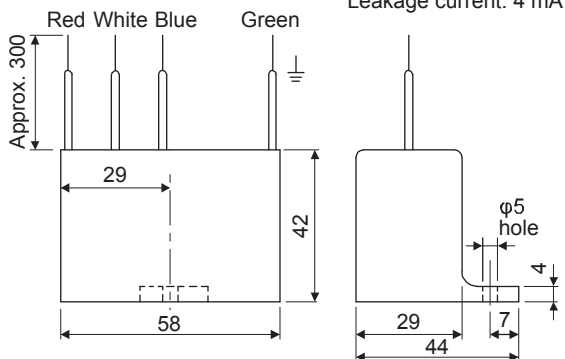
Connection diagram	Dimensions
<p>Make the connection cables as short as possible. Grounding is always required.</p> <p>When using the FR-BIF with a single-phase power supply, always insulate the wires that are not used for wiring.</p> <p>MR-J4-350B or less</p>  <p>Mr-J4B-500B or more</p> 	<p>Leakage current: 4 mA</p> 

11. Options and peripheral devices

(f) Varistor for input power supply (recommended)

Varistors are effective to prevent exogenous noise and lightning surge from entering the servo amplifier. When using a varistor, connect it between each phase of the input power supply of the equipment. For varistors, the TND20V-431K and TND20V-471K, manufactured by NIPPON CHEMI-CON, are recommended. For detailed specification and usage of the varistors, refer to the manufacturer catalog.

Power supply voltage	Varistor	Maximum rating					Maximum limit voltage		Static capacity (reference value)	Varistor voltage rating (range) V1 mA
		Permissible circuit voltage		Surge current immunity	Energy immunity	Rated pulse power	[A]	[V]		
		AC [Vrms]	DC [V]	8/20 μ s [A]	2 ms [J]	[W]			[pF]	[V]
200 V class	TND20V-431K	275	350	10000/1 time	195	1.0	100	710	1300	430 (387 to 473)
	TND20V-471K	300	385	7000/2 time	215			775	1200	470 (423 to 517)

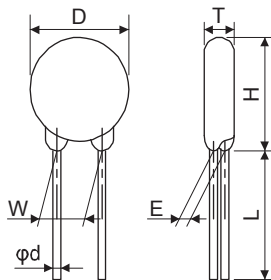

[Unit: mm]

Model	D Max.	H Max.	T Max.	E \pm 1.0	(Note) L min.	ϕ d \pm 0.05	W \pm 1.0
TND20V-431K	21.5	24.5	6.4	3.3	20	0.8	10.0
TND20V-471K			6.6	3.5			

Note. For special purpose items for lead length (L), contact the manufacturer.

11. Options and peripheral devices

11.15 Leakage current breaker

(1) Selection method

High-frequency chopper currents controlled by pulse width modulation flow in the AC servo circuits. Leakage currents containing harmonic contents are larger than those of the motor which is run with a commercial power supply.

Select a leakage current breaker according to the following formula, and ground the servo amplifier, servo motor, etc. securely.

To minimize leakage currents, make the input and output cables as short as possible, and make the grounding cable longer than 30 cm.

$$\text{Rated sensitivity current} \geq 10 \cdot \{I_{g1} + I_{gn} + I_{ga} + K \cdot (I_{g2} I_{gm})\} \text{ [mA]} \dots\dots\dots (11.1)$$

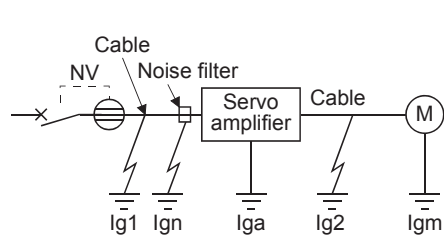

Leakage current breaker		K
Type	Mitsubishi products	
Models provided with harmonic and surge reduction techniques	NV-SP	1
	NV-SW	
	NV-CP	
	NV-CW	
	NV-HW	
General models	BV-C1	3
	NFB	
	NV-L	

I_{g1} Leakage current on the electric channel from the leakage current breaker to the input terminals of I_{g2} the servo amplifier (Found from Fig. 11.5.)

I_{gn} Leakage current on the electric channel from the output terminals of the servo amplifier to the servo I_{ga} motor (Found from Fig. 11.5.)

I_{gm} Leakage current when a filter is connected to the input side (4.4 mA per one FR-BIF)

Leakage current of the servo amplifier (Found from table 11.4.)

Leakage current of the servo motor (Found from table 11.3.)

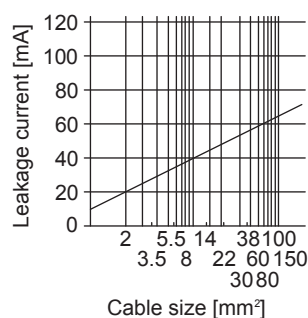

Fig.11.5 Leakage current example (I_{g1}, I_{g2}) for CV cable run in metal conduit

11. Options and peripheral devices

Table 11.3 Servo motor's leakage current example (Igm)

Servo motor power [kW]	Leakage current [mA]
0.05 to 1	0.1
2	0.2
3.5	0.3
5	0.5
7	0.7

Table 11.4 Servo amplifier's leakage current example (Iga)

Servo amplifier capacity [kW]	Leakage current [mA]
0.1 to 0.6	0.1
0.75 to 3.5	0.15
5 / 7	2

Table 11.5 Leakage circuit breaker selection example

Servo amplifier capacity [kW]	Rated sensitivity current of leakage circuit breaker [mA]
MR-J4-10B to MR-J4-350B	15
MR-J4-500B	30
MR-J4-700B	50

11. Options and peripheral devices

(2) Selection example

Indicated below is an example of selecting a leakage current breaker under the following conditions.

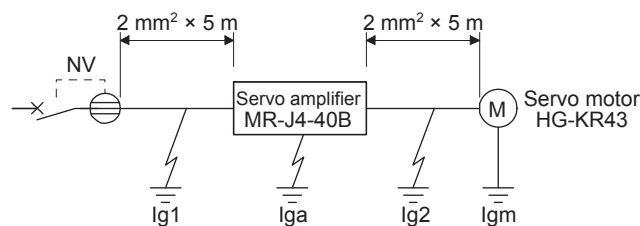

Use a leakage current breaker designed for suppressing harmonics/surges.

Find the terms of Equation (11.1) from the diagram.

$$I_{g1} = 20 \cdot \frac{5}{1000} = 0.1 \text{ [mA]}$$

$$I_{g2} = 20 \cdot \frac{5}{1000} = 0.1 \text{ [mA]}$$

$$I_{gn} = 0 \text{ (not used)}$$

$$I_{ga} = 0.1 \text{ [mA]}$$

$$I_{gm} = 0.1 \text{ [mA]}$$

Insert these values in Equation (11.1).

$$I_g \geq 10 \cdot \{0.1 + 0 + 0.1 + 1 \cdot (0.1 + 0.1)\} \\ \geq 4 \text{ [mA]}$$

According to the result of calculation, use a leakage current breaker having the rated sensitivity current (I_g) of 4.0 [mA] or more.

A leakage current breaker having I_g of 15 [mA] is used with the NV-SP/SW/CP/CW/HW series.

11. Options and peripheral devices

11.16 EMC filter (recommended)

It is recommended that one of the following filters be used to comply with EN standard's EMC directive. Some EMC filters have large in leakage current.

(1) Combination with the servo amplifier

Servo amplifier	Recommended filter (Soshin Electric)				Mass [kg]
	Model	Rated current [A]	Rated voltage [V AC]	Leakage current [mA]	
MR-J4-10B to MR-J4-100B	(Note) HF3010A-UN	10	Max. 250	5	3.5
MR-J4-200B/MR-J4-350B	(Note) HF3030A-UN	30			5.5
MR-J4-500B/MR-J4-700B	(Note) HF3040A-UN	40		6.5	6

Note. A surge protector is separately required to use any of these EMC filters.

(2) Connection example

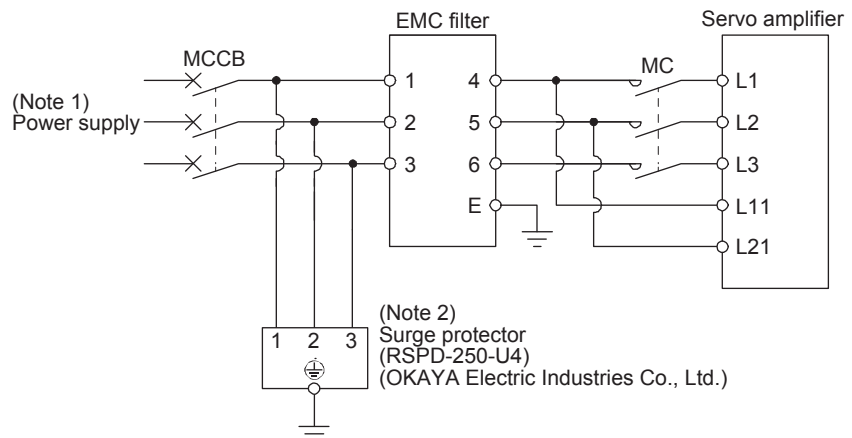

- Note 1. For 1-phase 200 V AC to 240 V AC, connect the power supply to L1 and L3. Leave L2 open.
2. The example is when a surge protector is connected.

11. Options and peripheral devices

(3) Dimensions

(a) EMC filter

HF3010A-UN

[Unit: mm]

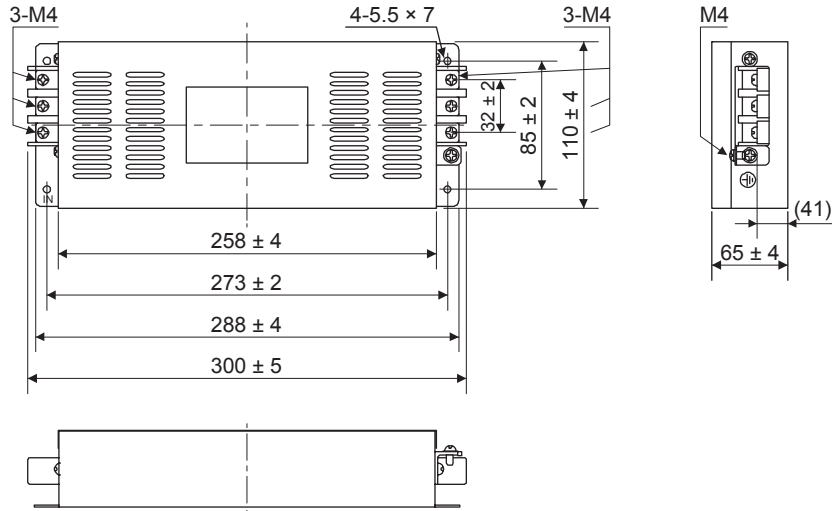

HF3030A-UN/HF-3040A-UN

[Unit: mm]

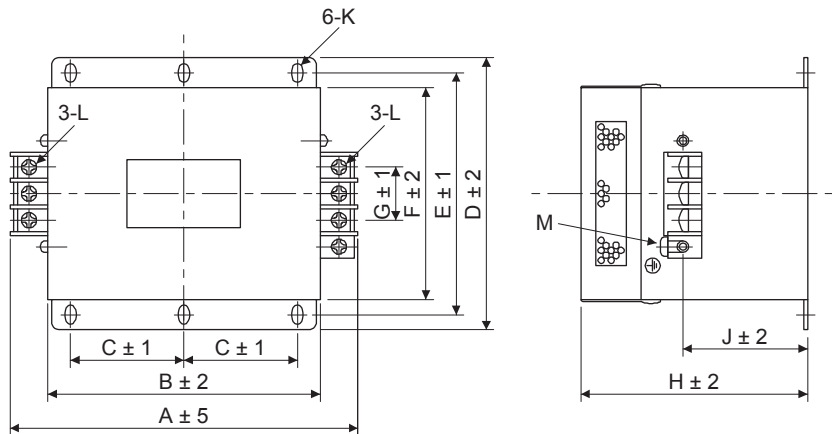

Model	Dimensions [mm]											
	A	B	C	D	E	F	G	H	J	K	L	M
HF3030A-UN	260	210	85	155	140	125	44	140	70	R3.25 Length 8	M5	M4
HF3040A-UN												

11. Options and peripheral devices

(b) Surge protector

RSPD-250-U4

[Unit: mm]

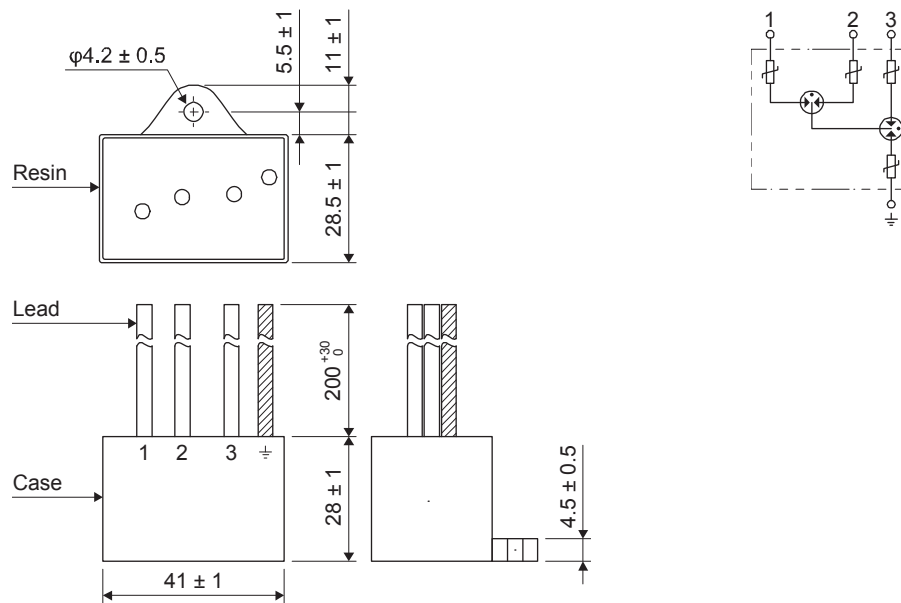

12. ABSOLUTE POSITION DETECTION SYSTEM

12. ABSOLUTE POSITION DETECTION SYSTEM



CAUTION

- If [AL. 25 Absolute position erased] or [AL. E3 Absolute position counter warning] has occurred, always perform home position setting again. Otherwise, it may cause an unexpected operation.
- Refer to appendix 2 and 3 for battery transportation and the new EU Battery Directive.
- If [AL. 25], [AL. 92], or [AL. 9F] occur due to such as short circuit of the battery, the MR-BAT6V1 battery can become hot. Use the MR-BAT6V1 battery with care to prevent getting burnt.

POINT

- Disconnecting the encoder cable will erase the absolute position data. After disconnecting the encoder cable, always execute home position setting and then positioning operation.

12.1 Features

For normal operation, as shown below, the encoder consists of a detector designed to detect a position within one revolution and a cumulative revolution counter designed to detect the number of revolutions. The absolute position detection system always detects the absolute position of the machine and keeps it battery-backed, independently of whether the servo system controller power is on or off. Therefore, once home position return is made at the time of machine installation, home position return is not needed when power is switched on thereafter.

Even at a power failure or a malfunction, the system can be easily restored.

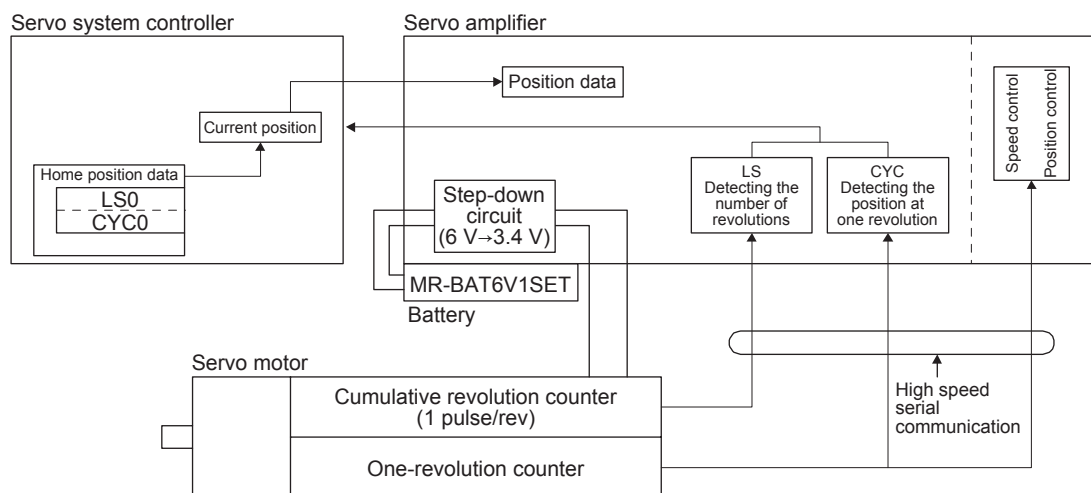

12. ABSOLUTE POSITION DETECTION SYSTEM

12.2 Specifications

(1) Specification list

Item		Description
System		Electronic battery backup type
Battery	Model	MR-BAT6V1SET
	Battery pack	2CR17335A (Primary lithium battery)
	Nominal voltage [V]	6
	Nominal capacity [mAh]	1650
	Storage temperature [°C]	0 to 55
	Operating temperature [°C]	0 to 55
	Amount of lithium metal [g]	1.2
	Mercury content	Less than 1 ppm
	Dangerous goods class	Inapplicable to Class 9 (Battery pack containing 2 g or less lithium)
	Operating humidity and storage humidity	90% RH or less (non-condensing)
	Mass [g]	34
Maximum revolution range		Home position ± 32767 rev.
(Note 1) Maximum speed at power failure [r/min]	Rotary servo motor	6000 (However, it is only when the acceleration time up to 6000 r/min is 0.2 s or longer.)
	Direct drive motor	500 (However, it is only when the acceleration time up to 500 r/min is 0.1 s or longer.)
(Note 2) Battery backup time	Rotary servo motor	Approximately 20,000 hours (equipment power supply: off, ambient temperature: 20 °C)
	Direct drive motor	Approximately 5,000 hours (equipment power supply: off, ambient temperature: 20 °C)
(Note 3) Battery life		5 years from date of manufacture

- Note 1. Maximum speed available when the shaft is rotated by external force at the time of power failure or the like.
- Note 2. The data-holding time using a battery of MR-BAT6V1SET on condition that the power supply of the servo amplifier is off. Replace the batteries within 3 years since the operation start whether the power supply of the servo amplifier is on/off. If the battery is used out of specification, [AL. 25 Absolute position erased] may occur.
- Note 3. Quality of battery degrades by the storage condition. The life of battery is 5 years from the production date regardless of the connection.

(2) Structure

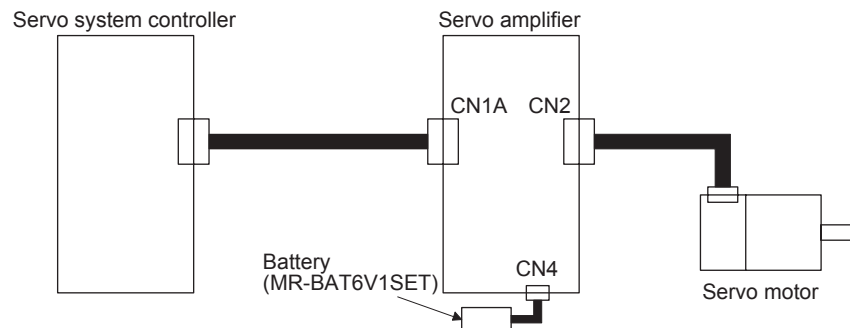

12. ABSOLUTE POSITION DETECTION SYSTEM

(3) Parameter setting

Set "___ 1" in [Pr. PA03] to make the absolute position detection system valid.

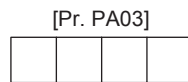

Absolute position detection system selection
 0: Used in incremental system
 1: Used in absolute position detection system

12.3 Battery replacement procedure

WARNING

- Before installing a battery, turn off the main circuit power and wait for 15 minutes or longer until the charge lamp turns off. Then, check the voltage between P+ and N- with a voltage tester or others. Otherwise, an electric shock may occur. In addition, when confirming whether the charge lamp is off or not, always confirm it from the front of the servo amplifier.

CAUTION

- The internal circuits of the servo amplifier may be damaged by static electricity. Always take the following precautions.
 - Ground human body and work bench.
 - Do not touch the conductive areas, such as connector pins and electrical parts, directly by hand.

POINT

- Replacing battery with the control circuit power off will erase the absolute position data.

Replace the battery with only the control circuit power on. Replacing battery with the control circuit power on will not erase the absolute position data.

Refer to section 12.4 for installation procedure of battery to the servo amplifier.

12. ABSOLUTE POSITION DETECTION SYSTEM

12.4 Battery installation and removal procedure

(1) Installation procedure

POINT

- For the servo amplifier with a battery holder on the bottom, it is not possible to wire for the earth with the battery installed. Insert the battery after executing the earth wiring of the servo amplifier.

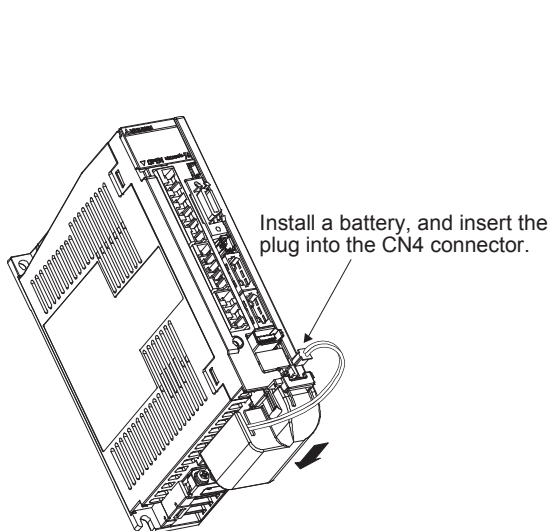

MR-J4-350B or smaller capacity models

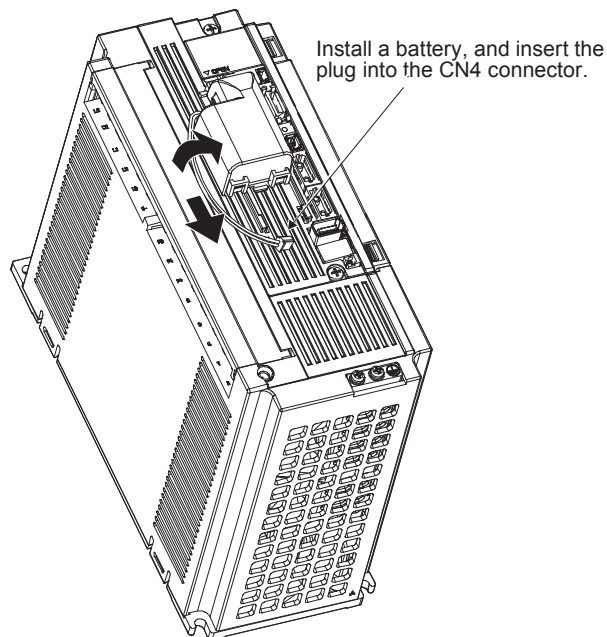

MR-J4-500B or larger capacity models

(2) Removal procedure



CAUTION

- Pulling out the connector of the MR-BAT6V1SET without the lock release lever pressed may damage the CN4 connector of the servo amplifier or the connector of the MR-BAT6V1SET.

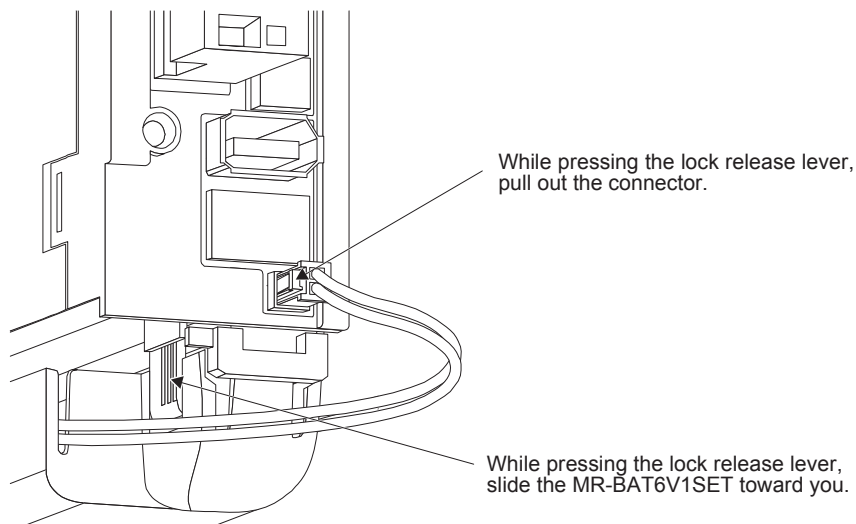

12. ABSOLUTE POSITION DETECTION SYSTEM

(3) Replacement procedure of the battery in the MR-BAT6V1SET

When the MR-BAT6V1SET reaches the end of its life, replace the MR-BAT6V1 battery in the MR-BAT6V1SET.

While pressing the locking part, open the cover.

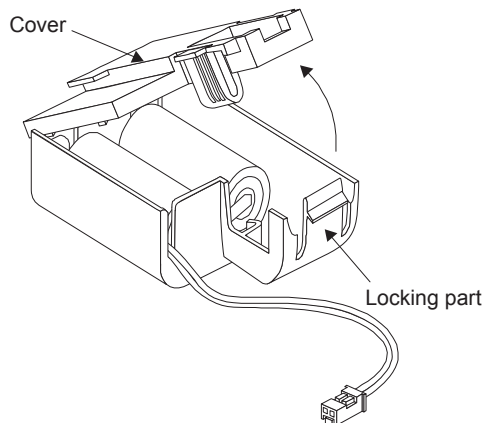

Replace the battery with a new MR-BAT6V1 battery.

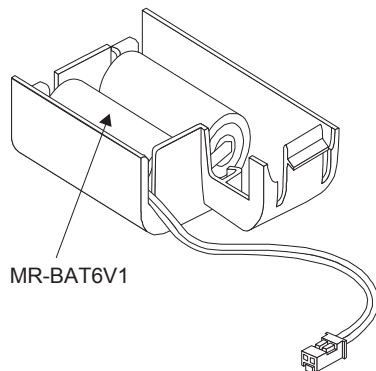

Press the cover until it is fixed with the projection of the locking part to close the cover.

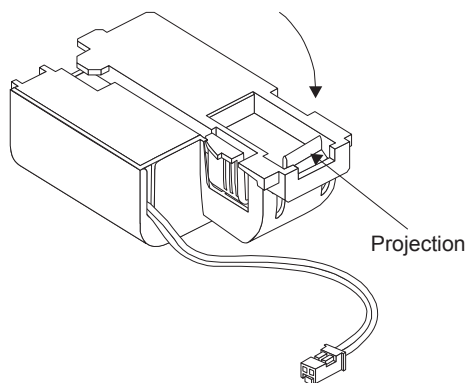

12. ABSOLUTE POSITION DETECTION SYSTEM

12.5 Confirmation of absolute position detection data

You can check the absolute position data with MR Configurator 2.

Choose "Diagnostics" and "Absolute Encoder Data" to open the absolute position data display screen.



13. USING STO FUNCTION

13. USING STO FUNCTION

POINT
● In the torque control mode, the forced stop deceleration function is not available.

13.1 Introduction

This section provides the cautions of the STO function.

13.1.1 Summary

This servo amplifier complies with the following safety standards.

- ISO/EN ISO 13849-1 category 3 PL d
- IEC/EN 61508 SIL 2
- IEC/EN 61800-5-2 SIL 2

13.1.2 Terms related to safety

The STO function shuts down energy to servo motors, thus removing torque. This function electronically cuts off power supply in the servo amplifier.

The purpose of this safety function is as follows.

- (1) Uncontrolled stop according to stop category 0 of IEC/EN 60204-1
- (2) Preventing unexpected start-up

13.1.3 Cautions

The following basic safety notes must be read carefully and fully in order to prevent injury to persons or damage to property.

Only qualified personnel are authorized to install, start-up, repair, or service the machines in which these components are installed.

They must be familiar with all applicable local regulations and laws in which machines with these components are installed, particularly the standards mentioned in this manual.

The staff responsible for this work must be given express permission from the company to perform start-up, programming, configuration, and maintenance of the machine in accordance with the safety standards.

 WARNING	● Improper installation of the safety related components or systems may cause improper operation in which safety is not assured, and may result in severe injuries or even death.
--	---

Protective Measures

- This servo amplifier satisfies the Safe Torque Off (STO) function described in IEC/EN 61800-5-2 by preventing the energy supply from the servo amplifier to the servo motor. If an external force acts upon the drive axis, additional safety measures, such as brakes or counterbalances must be used.

13. USING STO FUNCTION

13.1.4 Residual risks of the STO function

Machine manufacturers are responsible for all risk evaluations and all associated residual risks. Below are residual risks associated with the STO function. Mitsubishi is not liable for any damages or injuries caused by these risks.

- (1) The STO function disables energy supply to the servo motor by electrical shut-off. The function does not mechanically disconnect electricity from the motor. Therefore, it cannot prevent exposure to electric shock. To prevent an electric shock, install a magnetic contactor or a molded case circuit breaker to the main circuit power supply (L1, L2, and L3) of the servo amplifier.
- (2) The STO function disables energy supply to the servo motor by electrical shut-off. It does not guarantee the stop control or the deceleration control of the servo motor.
- (3) For proper installation, wiring, and adjustment, thoroughly read the manual of each individual safety related component.
- (4) In the safety circuit, use components that are confirmed safe or meet the required safety standards.
- (5) The STO function does not guarantee that the drive part of the servo motor will not rotate due to external or other forces.
- (6) Safety is not assured until safety-related components of the system are completely installed or adjusted.
- (7) When replacing this servo amplifier, confirm that the model name of servo amplifiers are exactly the same as those being replaced. Once installed, make sure to verify the performance of the safety functions before commissioning the system.
- (8) Perform all risk assessments to the machine or the whole system.
- (9) To prevent accumulation of malfunctions, perform malfunction checks at regular intervals based on the risk assessments of the machine or the system. Regardless of the system safety level, malfunction checks should be performed at least once per year.
- (10) If the upper and lower power module in the servo amplifier are shorted and damaged simultaneously, the servo motor may make a half revolution at a maximum. For a linear servo motor, the primary side will move a distance of pole pitch.
- (11) The STO input signals (STO1 and STO2) must be supplied from one power source. Otherwise, the STO function may not function properly due to a sneak current, failing to bring the STO shut-off state.
- (12) For the STO I/O signals of the STO function, supply power by using a safety extra low voltage (SELV) power supply with the reinforced insulation.

13. USING STO FUNCTION

13.1.5 Specifications

(1) Specifications

Item	Specifications
Safety function	STO (IEC/EN 61800-5-2)
Safety performance (Certification standards)	ISO/EN ISO 13849-1 category 3 PL d, IEC/EN 61508 SIL 2, EN 62061 SIL CL2, EN 61800-5-2 SIL 2
Mean time to dangerous failure (MTTFd) (available in the future)	100 years (Note)
Diagnostic converge (DC)	90% (Note)
Average probability of dangerous failures per hour (PFH) [1/h]	1.01×10^{-7} (Note)
Number of on/off F times of STO	1,000,000 times
CE marking	LVD: EN 61800-5-1 EMC: EN 61800-3 MD: EN ISO 13849-1, EN 61800-5-2, EN 62061

Note. This is the value required by safety standards.

(2) Function block diagram (STO function)

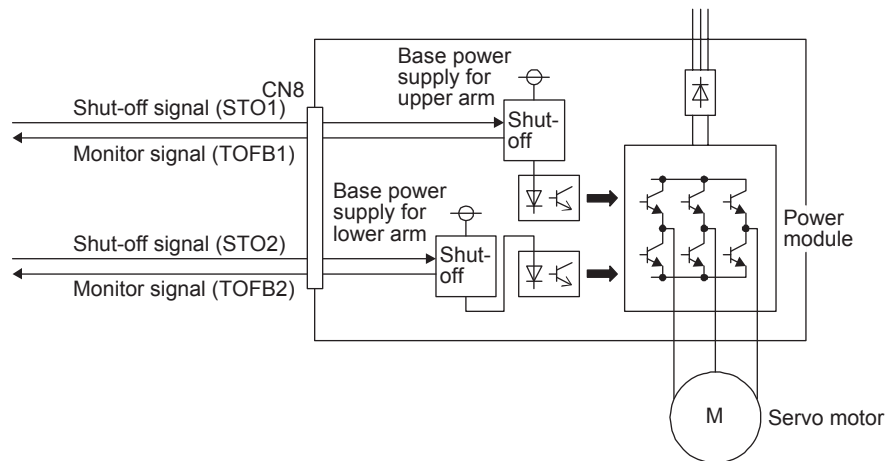

(3) Operation sequence (STO function)

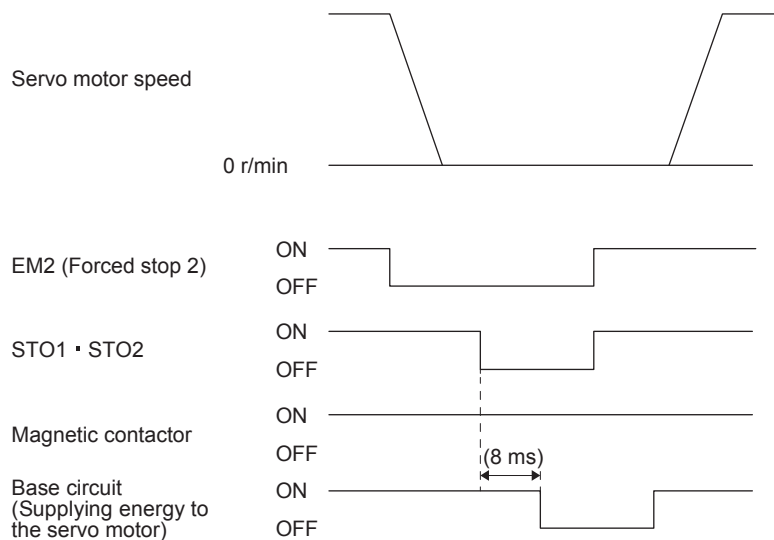

13. USING STO FUNCTION

13.1.6 Maintenance

This servo amplifier has alarms and warnings for maintenance that supports the Mitsubishi drive safety function. (Refer to chapter 8.)

13.2 STO I/O signal connector (CN8) and signal layouts

13.2.1 Pin assignment

POINT

- The pin configurations of the connectors are as viewed from the cable connector wiring section.

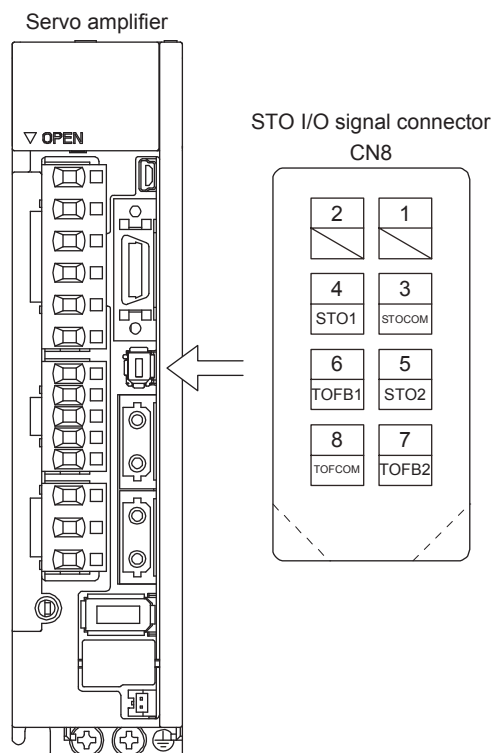

13. USING STO FUNCTION

13.2.2 Signal (device) explanations

(1) I/O device

Signal name	Connector pin No.	Description	I/O division
STOCOM	CN8-3	Common terminal for input signal of STO1 and STO2	DI-1
STO1	CN8-4	Inputs STO state 1. STO state (base shut-off): Open between STO1 and STOCOM. STO release state (in driving): Close between STO1 and STOCOM. Be sure to turn off STO1 after the servo motor stops by the servo-off state or with forced stop deceleration by turning off EM2 (Forced stop 2).	DI-1
STO2	CN8-5	Inputs STO state 2. STO state (base shut-off): Open between STO2 and STOCOM. STO release state (in driving): Close between STO2 and STOCOM. Be sure to turn off STO2 after the servo motor stops by the servo-off state or with forced stop deceleration by turning off EM2 (Forced stop 2).	DI-1
TOFCOM	CN8-8	Common terminal for monitor output signal in STO state	DO-1
TOFB1	CN8-6	Monitor output signal in STO1 state STO state (base shut-off): Between TOFB1 and TOFCOM is closed. STO release state (in driving): Between TOFB1 and TOFCOM is opened.	DO-1
TOFB2	CN8-7	Monitor output signal in STO2 state STO state (base shut-off): Between TOFB2 and TOFCOM is closed. STO release state (in driving): Between TOFB2 and TOFCOM is opened.	DO-1

(2) Signals and STO state

The following table shows the TOFB and STO states when the power is on in normal state and STO1 and STO2 are on (closed) or off (opened).

Input signal		State		
STO1	STO2	Between TOFB1 and TOFCOM (Monitoring STO1 state)	Between TOFB2 and TOFCOM (Monitoring STO2 state)	Between TOFB1 and TOFB2 (Monitoring STO state of servo amplifier)
OFF	OFF	ON: STO state (base circuit shut-off)	ON: STO state (base circuit shut-off)	ON: STO state (base circuit shut-off)
OFF	ON	ON: STO state (base circuit shut-off)	OFF: STO release state	ON: STO state (base circuit shut-off)
ON	OFF	OFF: STO release state	ON: STO state (base circuit shut-off)	ON: STO state (base circuit shut-off)
ON	ON	OFF: STO release state	OFF: STO release state	OFF: STO release state

(3) Test pulse of STO input signal

The test pulse off time is 1 ms or less.

13.2.3 How to pull out the STO cable

The following shows how to pull out the STO cable from the CN8 connector of the servo amplifier.

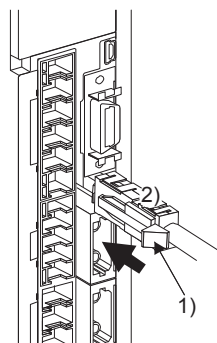

While pressing knob 1) of the STO cable plug in the direction of the arrow, pull out the plug 2).

13. USING STO FUNCTION

13.3 Connection example

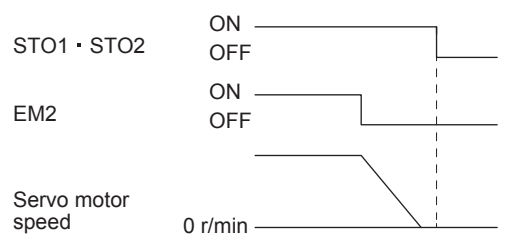
POINT	
●	Turn off STO (STO1 and STO2) after the servo motor stops by the servo off state or with forced stop deceleration by turning off EM2 (Forced stop 2). Configure an external sequence that has the timings shown as below using an external device such as the MR-J3-D05 safety logic unit.
	
●	If STO is turned off during operation, the servo motor is in dynamic brake stop (stop category 0), and [AL.63 STO timing error] will occur.

13.3.1 Connection example for CN8 connector

This servo amplifier is equipped with the connector (CN8) in accordance with the STO function. When this connector is used with a certified external safety relay, power to the motor can be safely removed and unexpected restart can be prevented. The safety relay used should meet the applicable safety standards and have forcibly guided or mirror contacts for the purpose of error detection.

In addition, the MR-J3-D05 safety logic unit can be used instead of a safety relay for implementation of various safety standards. Refer to Appendix 7 for details.

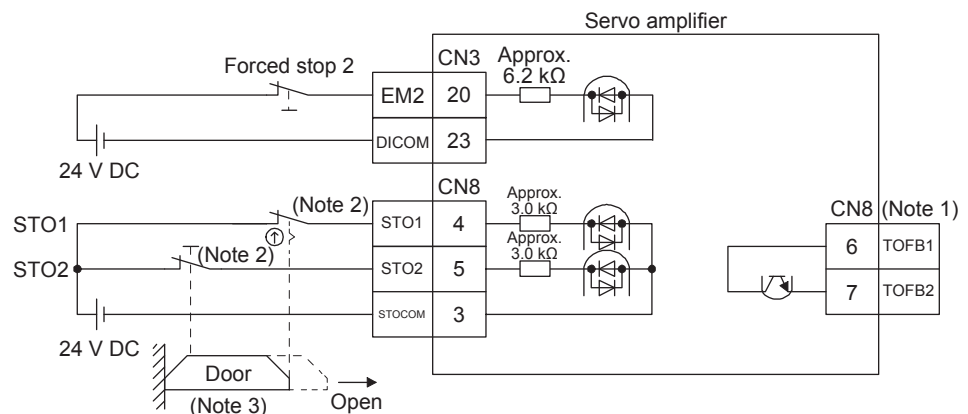

Note 1. By using TOFB, whether the servo is in the STO state can be confirmed. For connection examples, refer to section 13.3.2 to 13.3.4.

Note 2. When using the STO function, turn off STO1 and STO2 at the same time. Turn off STO1 and STO2 after the servo motor stops by the servo off state or with forced stop deceleration by turning off EM2 (Forced stop 2).

Note 3. Configure the interlock circuit so that the door is open after the servo motor is stopped.

13. USING STO FUNCTION

13.3.2 External I/O signal connection example using a MR-J3-D05 safety logic unit

POINT

- This connection is for the source interface. For the other I/O signals, refer to the connection examples in section 3.2.2.

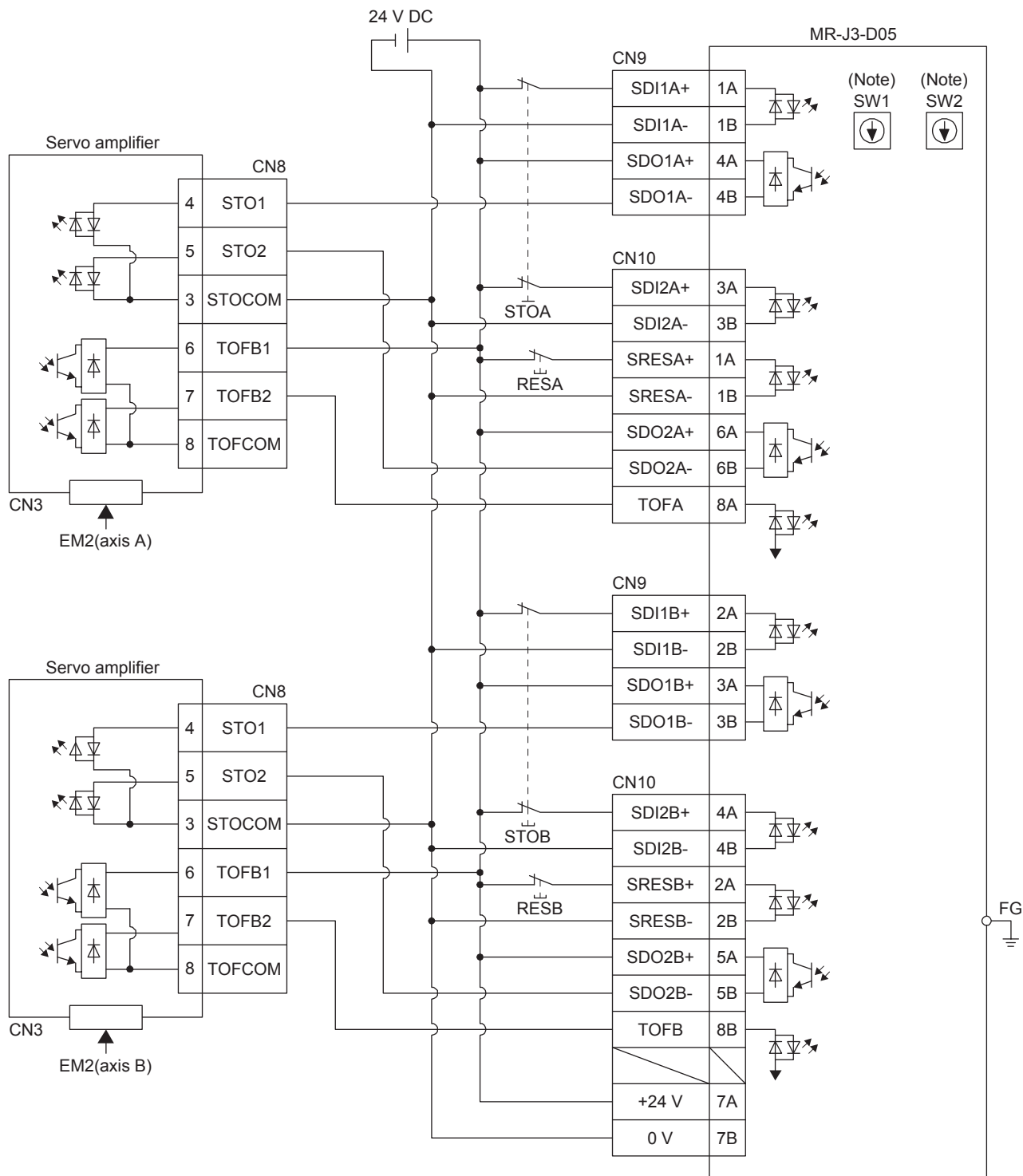

Note. Set the delay time of STO output with SW1 and SW2. These switches are located where denoted from the front panel.

13. USING STO FUNCTION

13.3.3 External I/O signal connection example using an external safety relay unit

POINT

- This connection is for the source interface. For the other I/O signals, refer to the connection examples in section 3.2.2.

This connection example complies with the requirement of ISO/EN ISO 13849-1 category 3 PL d. For details, refer to the safety relay module user's manual.

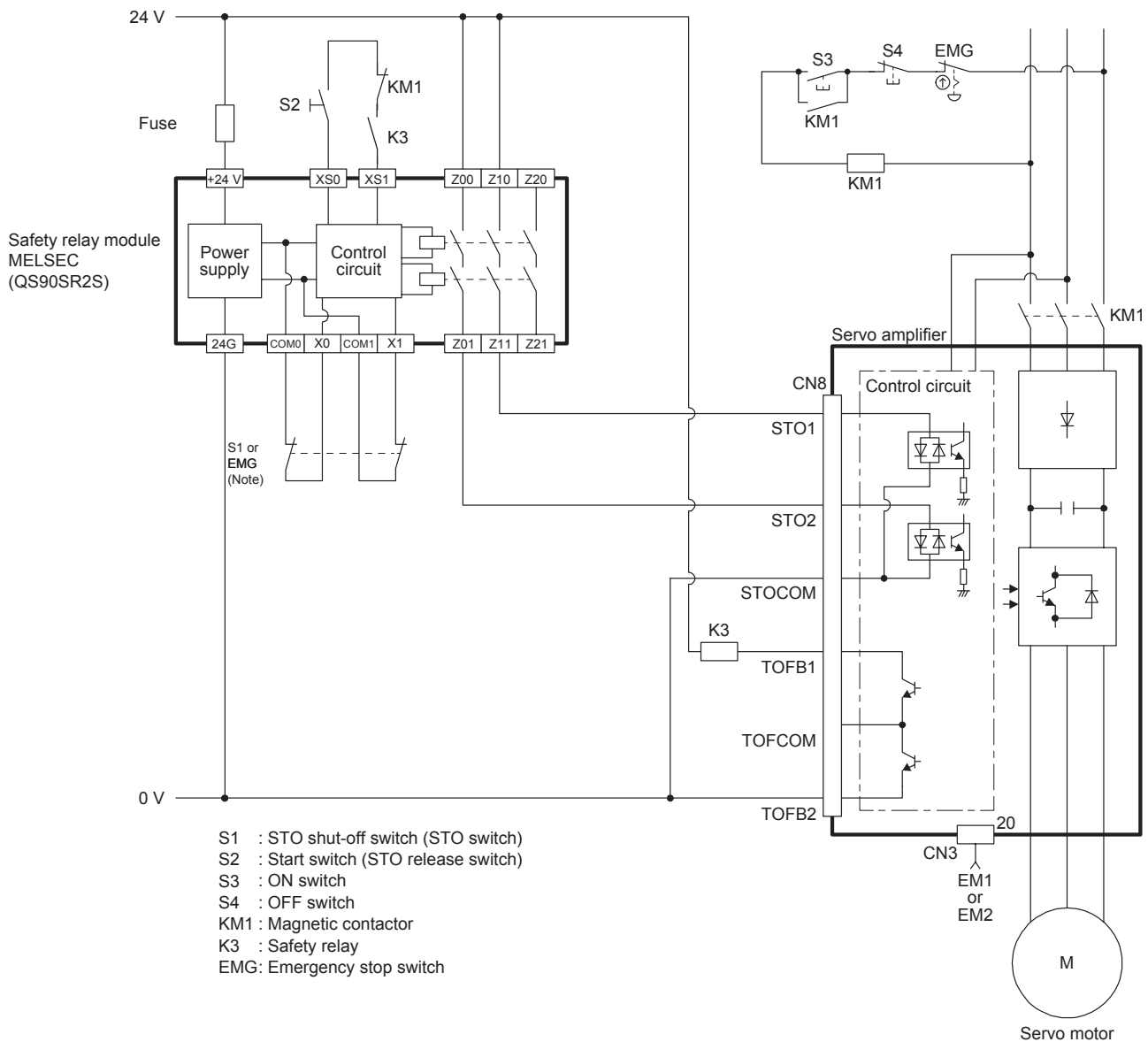

Note. To enable the STO function of the servo amplifier by using "Emergency switching off", change S1 to EMG. The stop category at this time is "0". If STO is turned off while the servo motor is rotating, [AL. 63 STO timing error] will occur.

13. USING STO FUNCTION

13.3.4 External I/O signal connection example using a motion controller

POINT
<ul style="list-style-type: none"> ● This connection is for the source interface. For the other I/O signals, refer to the connection examples in section 3.2.2. ● For MC-Y0B and PC-Y0B, design a ladder program to output MC-Y0B and PC-Y0B after the servo motor stops.

This connection diagram is an example of STO circuit configured with a servo amplifier and motion controller. Use the switch that complies with the requirement of ISO/EN ISO 13849-1 category 3 PL d as an emergency stop switch. This connection example complies with the requirement of ISO/EN ISO 13849-1 category 3 PL d. The following shows an example of I/O (X and Y) signal assignment of the motion controller safety signal module. For details, refer to the motion controller user's manual.

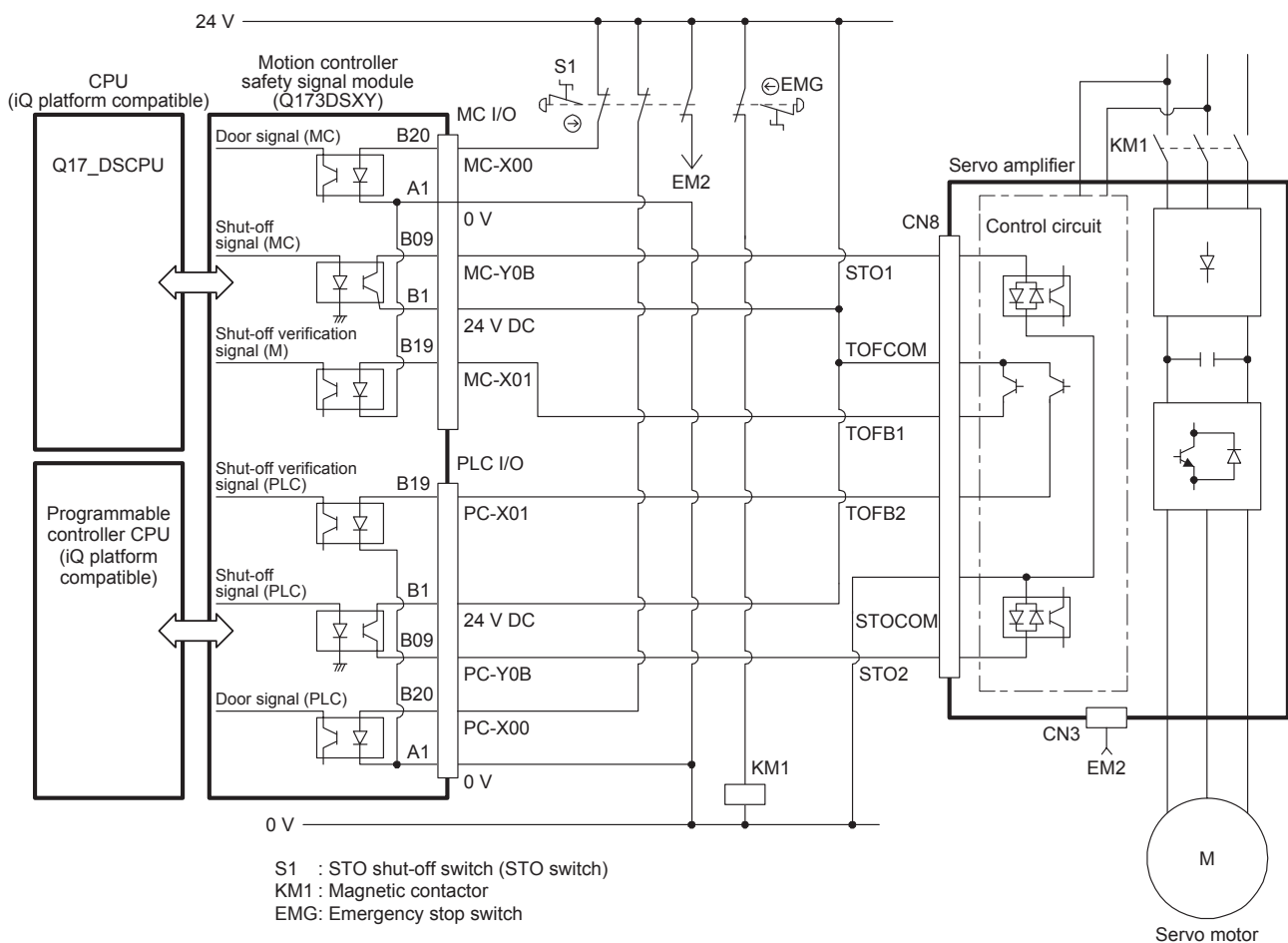

13. USING STO FUNCTION

13.4 Detailed description of interfaces

This section provides the details of the I/O signal interfaces (refer to the I/O division in the table) given in section 13.2. Refer to this section and make connection with the external device.

13.4.1 Sink I/O interface

(1) Digital input interface DI-1

Turn on/off the input signal with a relay or open collector transistor.

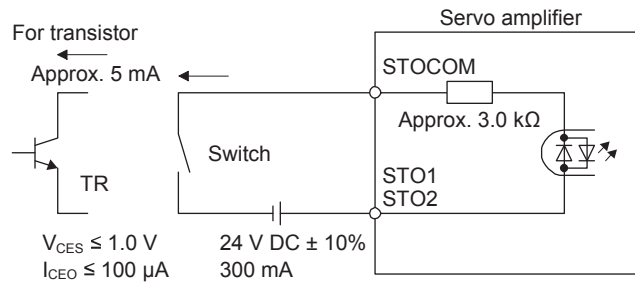

(2) Digital output interface DO-1

A lamp, relay or photocoupler can be driven. Install a diode (D) for an inductive load, or install an inrush current suppressing resistor (R) for a lamp load.

(Rated current: 40 mA or less, maximum current: 50 mA or less, inrush current: 100 mA or less) A maximum of 5.2 V voltage drop occurs in the servo amplifier.

(a) When outputting two STO states by using each TOFB

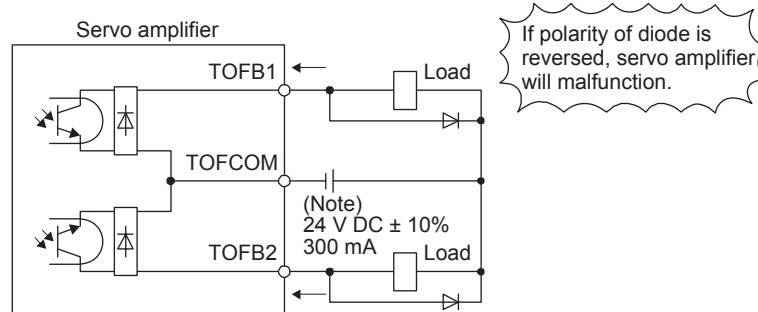

Note. If the voltage drop (maximum of 5.2 V) interferes with the relay operation, apply high voltage (maximum of 26.4 V) from external source.

(b) When outputting two STO states by using one TOFB

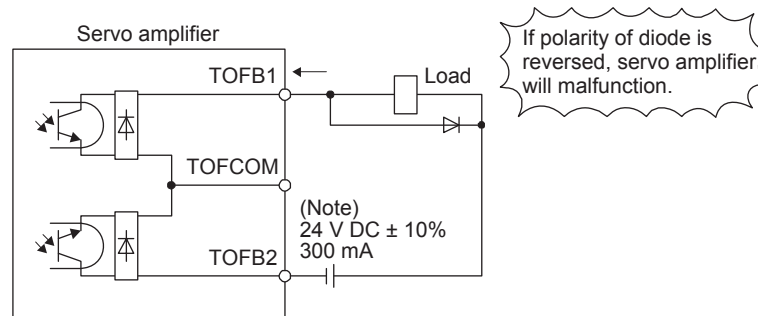

Note. If the voltage drop (maximum of 5.2 V) interferes with the relay operation, apply high voltage (maximum of 26.4 V) from external source.

13. USING STO FUNCTION

13.4.2 Source I/O interface

In this servo amplifier, source type I/O interfaces can be used. In this case, all DI-1 input signals and DO-1 output signals are of source type. Perform wiring according to the following interfaces.

(1) Digital input interface DI-1

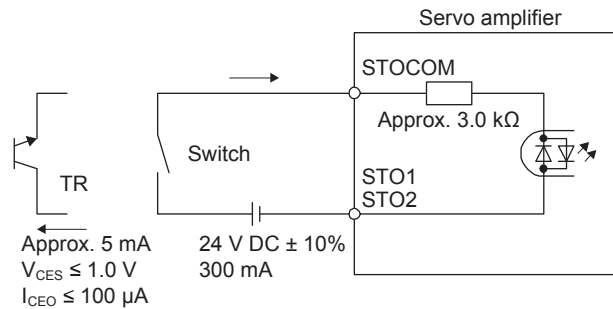

(2) Digital output interface DO-1

A maximum of 5.2 V voltage drop occurs in the servo amplifier.

(a) When outputting two STO states by using each TOFB

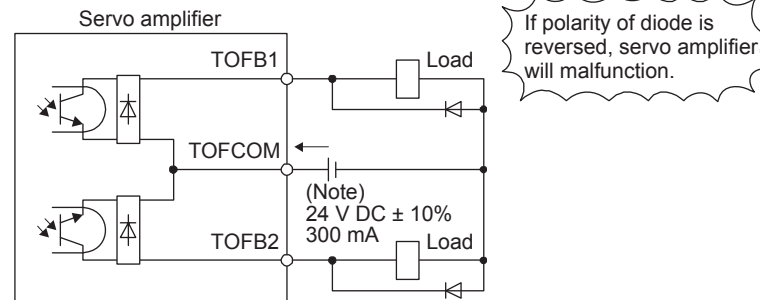

Note. If the voltage drop (maximum of 5.2 V) interferes with the relay operation, apply high voltage (maximum of 26.4 V) from external source.

(b) When outputting two STO states by using one TOFB

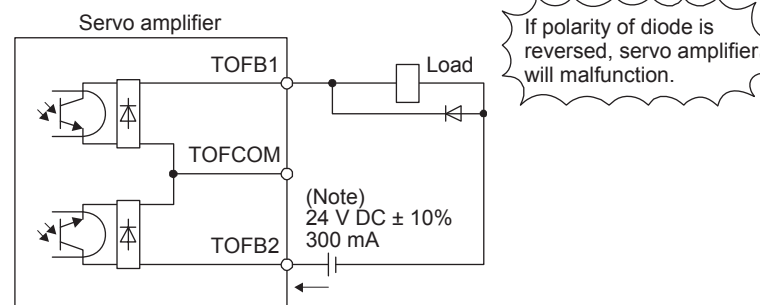

Note. If the voltage drop (maximum of 5.2 V) interferes with the relay operation, apply high voltage (maximum of 26.4 V) from external source.

14. USING A LINEAR SERVO MOTOR

14. USING A LINEAR SERVO MOTOR

 **WARNING** ●When using the linear servo motor, read the Linear Servo Motor Instruction Manual (SH(NA)030110) and the Linear Encoder Instruction Manual (SH(NA)030111).

14.1 Functions and configuration

14.1.1 Summary

The fields of semiconductor/LCD manufacturing systems, mounters, and others have strong demands for high accuracy, high speed, and efficiency. Therefore, the number of systems using a linear servo motor for a drive axis has been increasing. Since the linear servo system can obtain the characteristics of the high speed and the high acceleration/deceleration greater than the ball screw drive system. The linear servo system also does not have a ball screw wear which is a weak point in the ball screw drive system. This will extend the life of the equipment. In addition, since a response error due to backlash and friction does not occur, you can establish a high-accuracy system.

The following shows the differences between the linear servo motor and the rotary servo motor.

Category	Item	Differences		Remarks	
		Linear servo motor	Rotary servo motor		
External I/O signal	FLS (Upper stroke limit), RLS (Lower stroke limit)	Required (for magnetic pole detection)	Not required	Automatically turns on in the parameter setting.	
Motor pole adjustment	Magnetic pole detection	Required	Not required (default setting)	Automatically executed at the first servo-on after the power is turned on. For the absolute position linear encoder, [Pr. PL01] can disable the magnetic pole detection. The timing of the magnetic pole detection can be changed with [Pr. PL01]. (Refer to (2) (b) of 14.3.3.)	
Home position return	Reference home position	1048576 pulses unit (initial value)	One servo motor revolution unit	Home position return pitch can be changed with parameter setting. (Refer to section 14.3.3)	
Absolute position detection system	Absolute position encoder battery (MR-BAT6V1SET)	Not required	Required	The following alarms and warnings are not provided for the linear servo motor. <ul style="list-style-type: none"> • [AL. 25 Absolute position erased] • [AL. 92 Battery cable disconnection warning] • [AL. 9F Battery warning] • [AL. E3 Absolute position counter warning] 	
Auto tuning	Load to motor inertia ratio (J)	Load to motor mass ratio	Load to motor inertia ratio		
MR Configurator2 (SW1DNC-MRC2-J) (Software version 1.09K or later)	Motor speed (Data display and setting)	mm/s unit	r/min unit		
	Test operation function	Positioning operation	Supported	Supported	
		Motor-less operation	Supported	Supported	
		JOG operation	None	Supported	
Program operation		Supported	Supported		

14. USING A LINEAR SERVO MOTOR

14.1.2 Servo system with auxiliary equipment

CAUTION ● Connecting an inappropriate linear servo motor to the CNP3 and CN2 will cause an unexpected operation or an alarm.

POINT

- Equipment other than the servo amplifier and linear servo motor are optional or recommended products.
- When using the linear servo motor, set [Pr. PA01] to " _ _ 4 _".

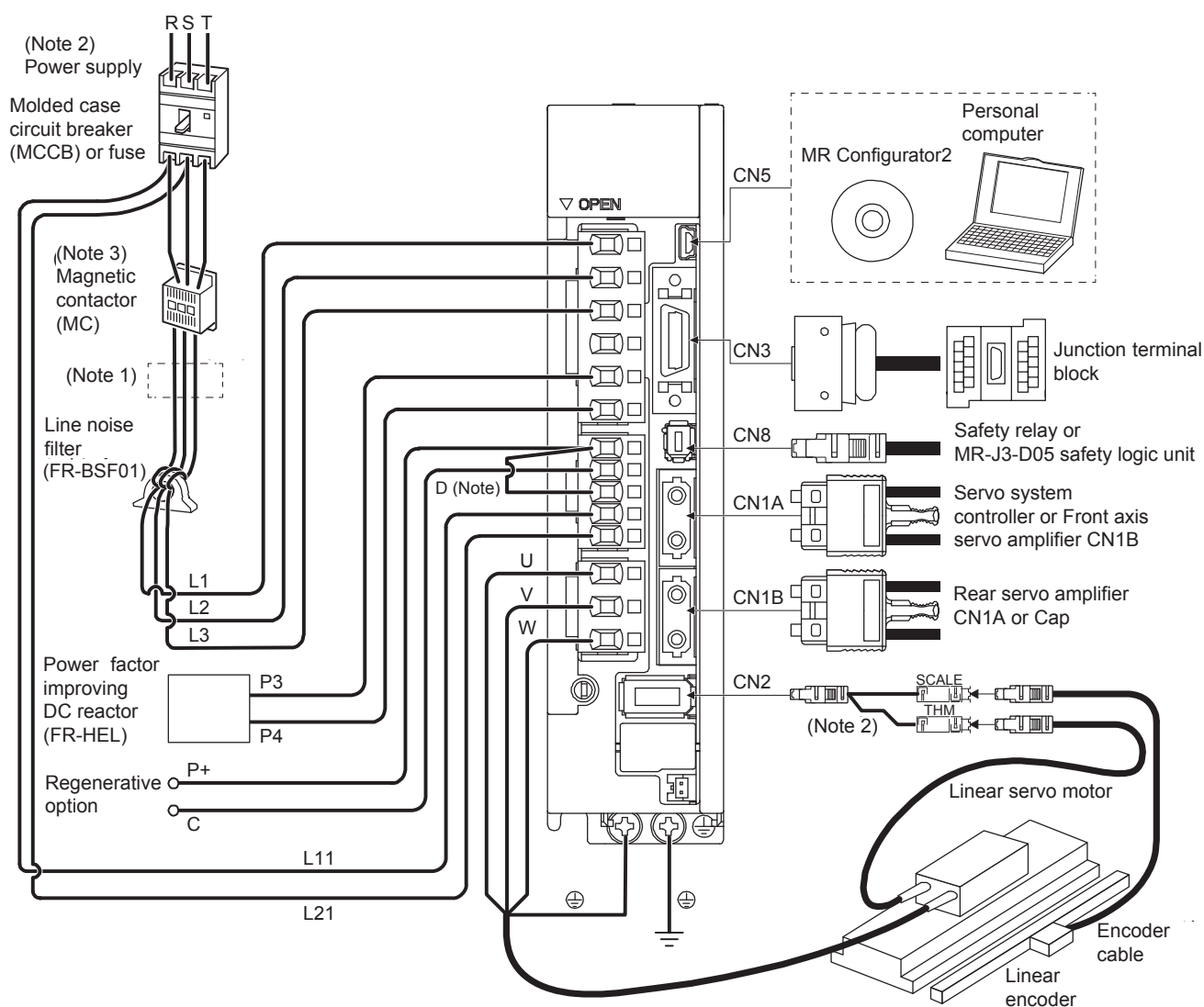

- Note 1. The power factor improving AC reactor can also be used. In this case, the power factor improving DC reactor cannot be used. When not using the power factor improving DC reactor, short P3 and P4.
- Note 2. A 1-phase 200 V AC to 240 V AC power supply may be used with the servo amplifier of MR-J4-70B or less. For 1-phase 200 V AC to 240 V AC, connect the power supply to L1 and L3. Leave L2 open. For power supply specifications, refer to section 1.3.
- Note 3. Depending on the main circuit voltage and operation pattern, bus voltage decreases, and that may cause the forced stop deceleration to shift to the dynamic brake deceleration. When dynamic brake deceleration is not required, slow the time to turn off the magnetic contactor.
- Note 4. For the branch cable, use the MR-J4THCBL03M (optional).
- Note 5. Always connect between P+ and D terminals. When using the regenerative option, refer to section 11.2.

14. USING A LINEAR SERVO MOTOR

14.2 Signals and wiring

! WARNING

- Any person who is involved in wiring should be fully competent to do the work.
- Before wiring, turn off the power and wait for 15 minutes or more until the charge lamp turns off. Then, confirm that the voltage between P+ and N- is safe with a voltage tester and others. Otherwise, an electric shock may occur. In addition, when confirming whether the charge lamp is off or not, always confirm it from the front of the servo amplifier.
- Ground the servo amplifier and the linear servo motor securely.
- Do not attempt to wire the servo amplifier and the linear servo motor until they have been installed. Otherwise, it may cause an electric shock.
- The cables should not be damaged, stressed, loaded, or pinched. Otherwise, it may cause an electric shock.
- To avoid an electric shock, insulate the connections of the power supply terminals.

- Wire the equipment correctly and securely. Otherwise, the linear servo motor may operate unexpectedly, resulting in injury.
- Connect cables to the correct terminals. Otherwise, a burst, damage, etc. may occur.
- Ensure that polarity (+/-) is correct. Otherwise, a burst, damage, etc. may occur.
- The surge absorbing diode installed to the DC relay for control output should be fitted in the specified direction. Otherwise, the emergency stop and other protective circuits may not operate.

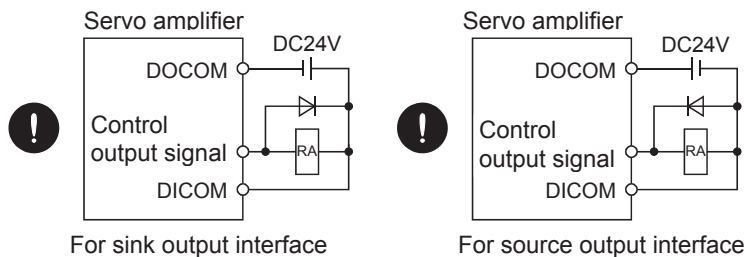

! CAUTION

- Use a noise filter, etc. to minimize the influence of electromagnetic interference. Electromagnetic interference may be given to the electronic equipment used near the servo amplifier.
- Do not install a power capacitor, surge killer or radio noise filter (FR-BIF option) with the power wire of the linear servo motor.
- When using the regenerative resistor, switch power off with the alarm signal. Otherwise, a transistor fault or the like may overheat the regenerative resistor, causing a fire.
- Connect the servo amplifier power output (U, V, and W) to the linear servo motor power input (U, V, and W) directly. Do not let a magnetic contactor, etc. intervene. Otherwise, it may cause a malfunction.

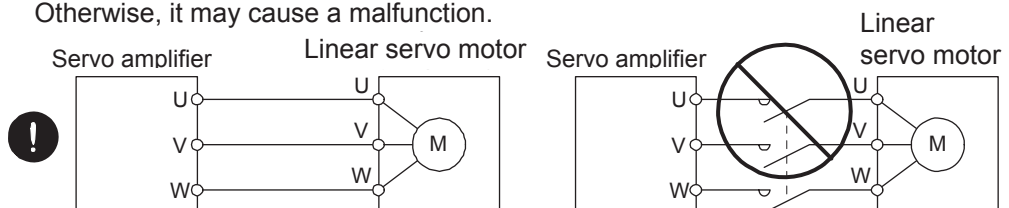

14. USING A LINEAR SERVO MOTOR

 CAUTION	<ul style="list-style-type: none"> ● Do not modify the equipment. ● The cables such as power wires deriving from the primary side cannot stand the long-term flexing action. Avoid the flexing action by fixing the cables to the moving part, etc. Also, use the cable that stands the long-term flexing action for the wiring to the servo amplifier.
--	---

This section does not describe the following items. For the items, refer to the corresponding sections below.

Item	Reference
Input power supply circuit	Section 3.1
Explanation of power supply system	Section 3.3
Signal (device) explanations	Section 3.5
Alarm occurrence timing chart	Section 3.7
Interfaces	Section 3.8
SSCNET III cable connection	Section 3.9
Grounding	Section 3.11
Switch setting and display of the servo amplifier	Section 4.3

14. USING A LINEAR SERVO MOTOR

14.3 Operation and functions

14.3.1 Startup

POINT
<ul style="list-style-type: none"> ● When using the linear servo motor, set [Pr. PA01] to " __ 4 _".

(1) Startup procedure

Start up the linear servo in the following procedure.

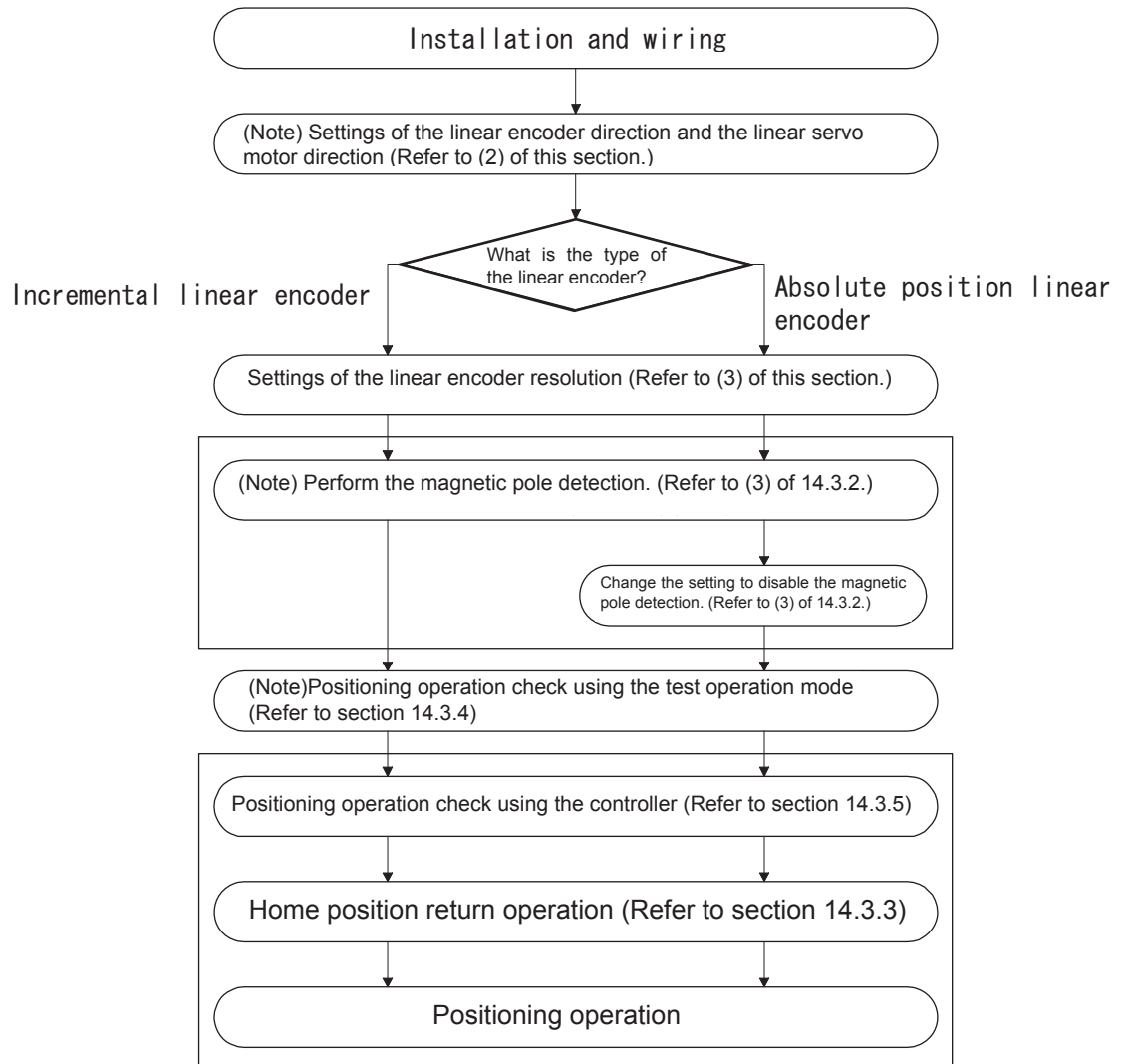

Note. Use MR Configurator2.

14. USING A LINEAR SERVO MOTOR

(2) Settings of the linear encoder direction and the linear servo motor direction

Set the first digit of [Pr. PC27] (Selection of encoder pulse count polarity) so that the positive direction of the linear servo motor matches with the increasing direction of the linear encoder feedback.

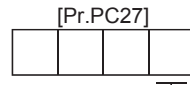

Selection of encoder pulse count polarity

Selection of encoder pulse count polarity

- 0: Linear servo motor positive direction and linear encoder increasing direction
- 1: Linear servo motor positive direction and linear encoder decreasing direction

(a) Parameter setting method

- 1) Confirm the positive direction of the linear servo motor. [Pr. PA14] determines the relation of the travel direction of the linear servo motor under commands as shown below.

[Pr. PA14] setting	Travel direction of linear servo motor	
	Address increasing command	Address decreasing command
0	Positive direction	Negative direction
1	Negative direction	Positive direction

The positive/negative directions of the linear servo motor are as follows.

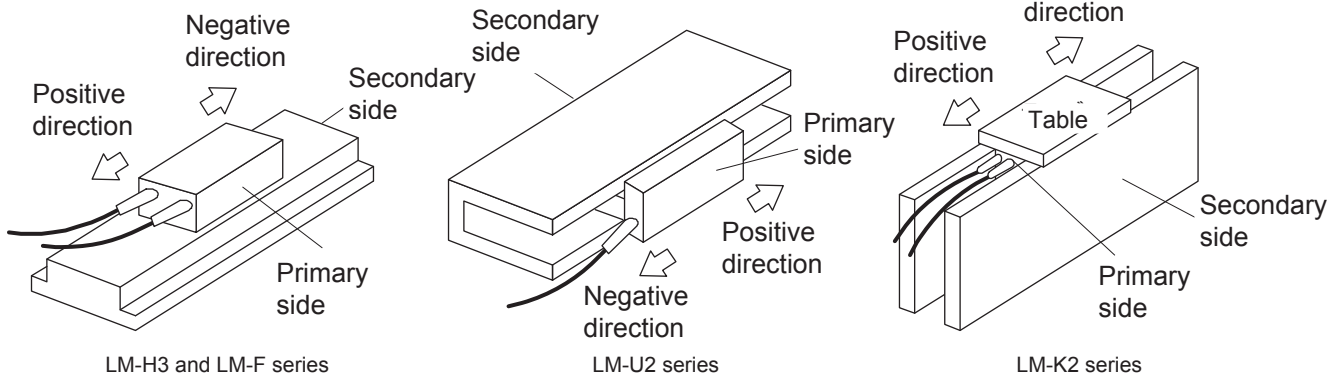

- 2) Confirm the increasing direction of the linear encoder.

- 3) If the positive direction of the linear servo motor matches with the increasing direction of the linear encoder, set [Pr. PC27] to "_ _ _ 0". If the positive direction of the linear servo motor does not match with the increasing direction of the linear encoder, set [Pr. PC27] to "_ _ _ 1".

(b) Confirmation method

Confirm the positive direction of the linear servo motor and the increasing direction of the linear encoder in the following procedure.

- 1) In servo-off status, move the linear servo motor in the positive direction manually.
- 2) Confirm the motor speed (in the positive and negative directions) at that time with MR Configurator2.
- 3) When [Pr. PC27] is set to "_ _ _ 0" and the positive direction of the linear servo motor matches with the increasing direction of the linear encoder, if the linear servo motor operates in the positive direction, the motor speed will be a positive value. If the positive direction of the linear servo motor does not match with the increasing direction of the linear encoder, the motor speed will be a negative value. When [Pr. PC27] is set to "_ _ _ 1" and the positive direction of the linear

14. USING A LINEAR SERVO MOTOR

servo motor matches with the increasing direction of the linear encoder, if the linear servo motor operates in the positive direction, the motor speed will be a negative value.

14. USING A LINEAR SERVO MOTOR

(3) Linear encoder resolution setting

Set the ratio of the electronic gear to the linear encoder resolution with [Pr. PL02 Linear encoder resolution numerator setting] and [Pr. PL03 Linear encoder resolution denominator setting].

POINT
● To enable the parameter value, cycle the power after setting.

(a) Parameter setting

Set the values that apply to the following equation.

$$\frac{[\text{Pr. PL02 Linear encoder resolution numerator setting}]}{[\text{Pr. PL03 Linear encoder resolution denominator setting}]} = \text{Linear encoder resolution } [\mu\text{m}]$$

(b) Parameter setting example

When the linear encoder resolution is 0.5 μm

$$\frac{[\text{Pr. PL02}]}{[\text{Pr. PL03}]} = \text{Linear encoder resolution} = 0.5 \mu\text{m} = \frac{1}{2}$$

The following shows the simplified chart for the setting values of [Pr. PL02] and [Pr. PL03].

		Linear encoder resolution [μm]							
		0.01	0.02	0.05	0.1	0.2	0.5	1.0	2.0
Setting value	[Pr. PL02]	1	1	1	1	1	1	1	2
	[Pr. PL03]	100	50	20	10	5	2	1	1

POINT
● If an incorrect value is set for [Pr. PL02] or [Pr. PL03], the linear servo motor may not operate properly, or [AL. 27] or [AL. 42] may occur at the positioning operation or the magnetic pole detection.

14.3.2 Magnetic pole detection

Before the positioning operation of the linear servo motor, make sure to perform the magnetic pole detection. When [Pr. PL01] is set to the initial value, perform the magnetic pole detection only at the first servo-on after the power is turned on.

The magnetic pole detection includes the following two methods. Each method has advantages and disadvantages. Select a magnetic pole detection method suitable for your usage.

The position detection method is selected in the initial setting.

Magnetic pole detection	Advantage	Disadvantage
Position detection method	<ol style="list-style-type: none"> The magnetic pole detection has a high degree of accuracy. The adjustment procedure at the magnetic pole detection is simple. 	<ol style="list-style-type: none"> The travel distance at the magnetic pole detection is large. For equipment with small friction, the initial magnetic pole detection error may occur.
Minute position detection method	<ol style="list-style-type: none"> The travel distance at the magnetic pole detection is small. Even for equipment with small friction, the magnetic pole detection is available. 	<ol style="list-style-type: none"> The adjustment procedure at the magnetic pole detection is complex. If a disturbance occurs during the magnetic pole detection, [AL. 27 Initial magnetic pole detection error] may occur.

14. USING A LINEAR SERVO MOTOR

(1) Magnetic pole detection method by using MR Configurator2

The following shows the magnetic pole detection procedure by using MR Configurator2.

(a) Magnetic pole detection by the position detection method

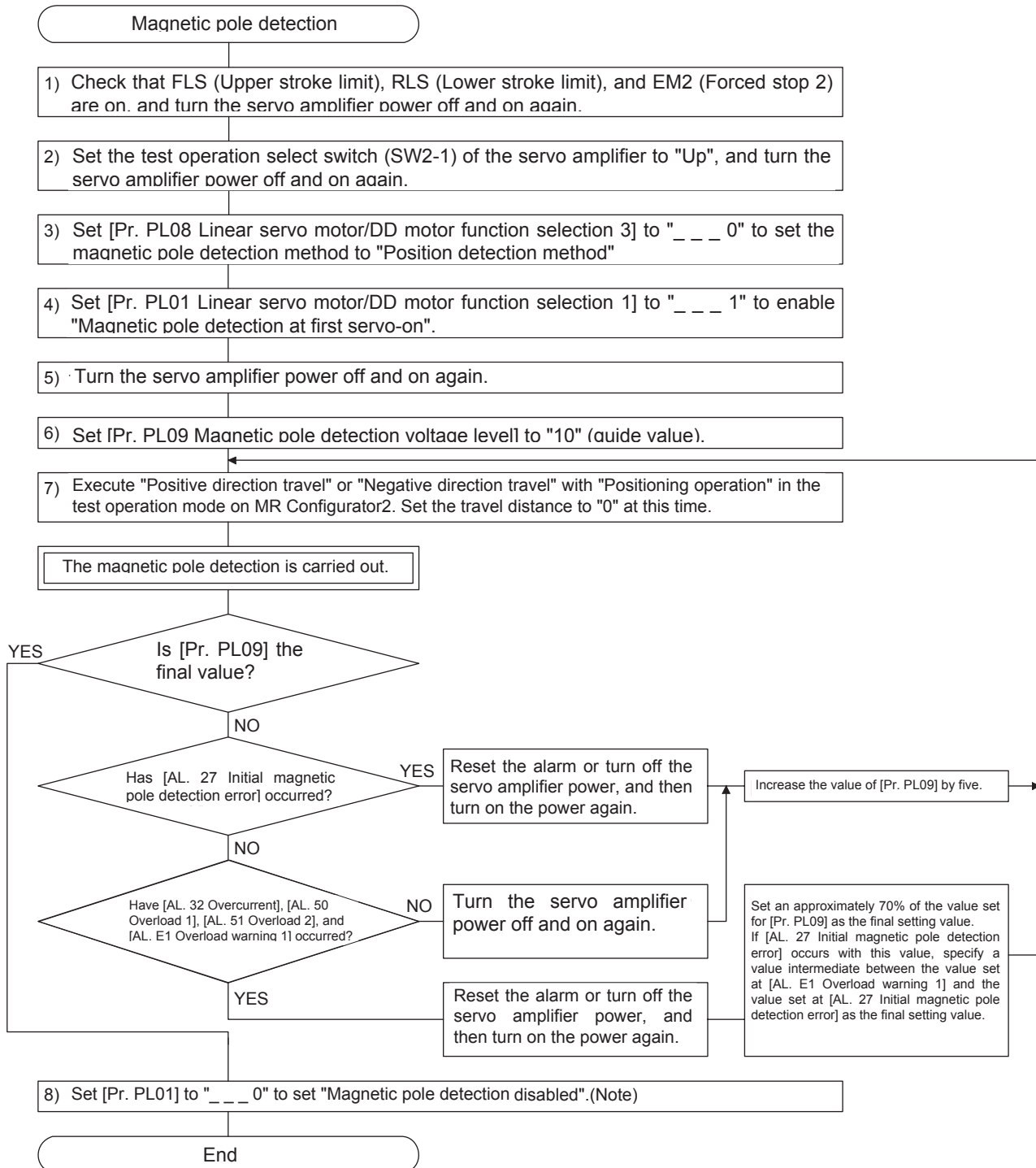

Note. When the linear encoder is an incremental type, the [Pr. PL01] setting is not required.

14. USING A LINEAR SERVO MOTOR

(b) Magnetic pole detection by the minute position detection method

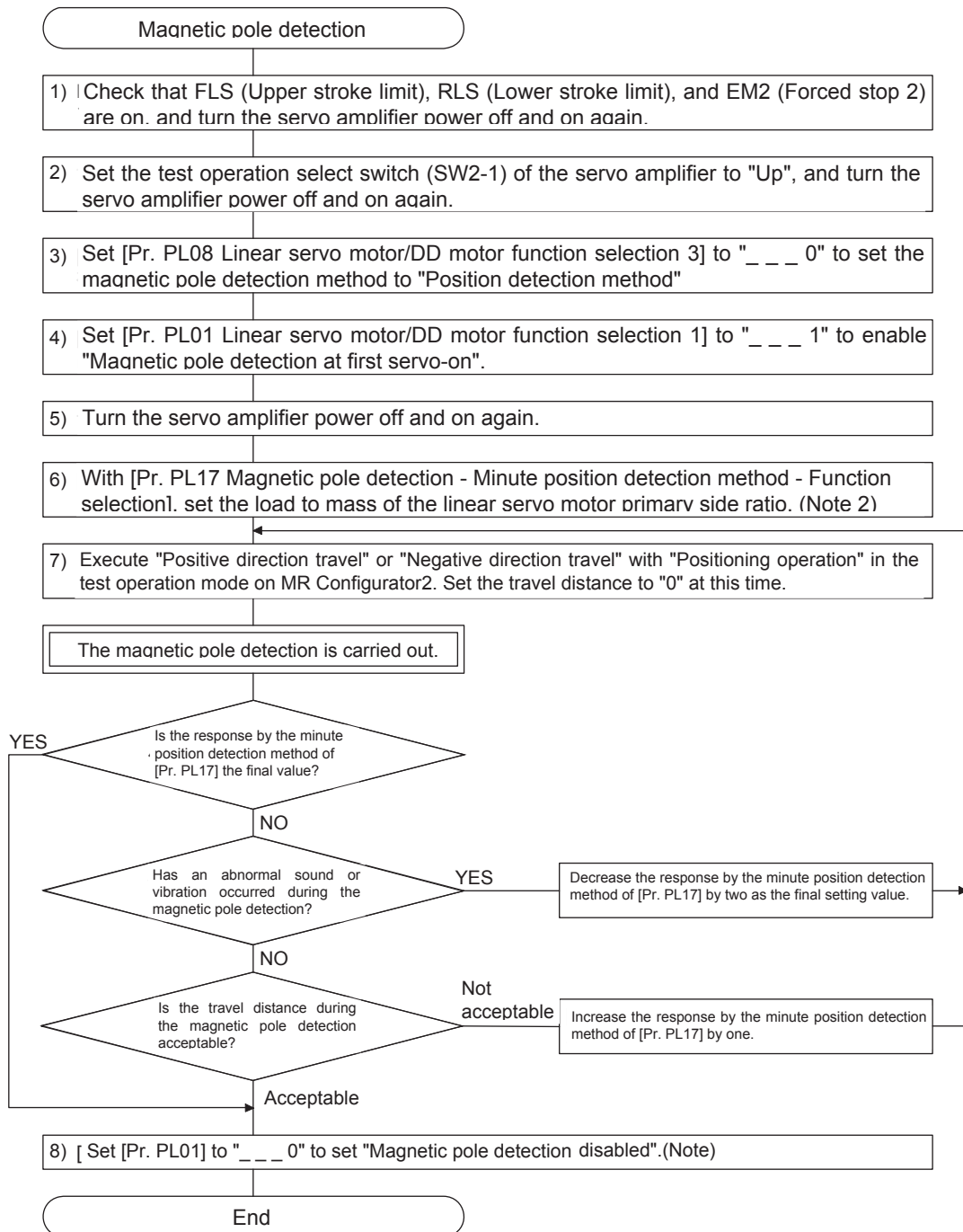

- Note
1. For the incremental system, the [Pr. PL01] setting is not required.
 2. If the load to primary-side linear servo motor mass ratio is unknown, perform the magnetic pole detection by the position detection method, and then perform the auto tuning to set an estimated value.
 3. For the magnetic pole detection by the minute position detection method, the maximum travel distance at the magnetic pole detection must be 0.5 mm or less. To shorten the travel distance, increase the response by the minute position detection method in [Pr. PL17].

14. USING A LINEAR SERVO MOTOR

- (c) State transition of the servo amplifier display (3-digit, 7-segment LED) at the magnetic pole detection
 When the magnetic pole detection with MR Configurator2 is normally executed, the servo amplifier display (3-digit, 7-segment LED) shows the state as below.

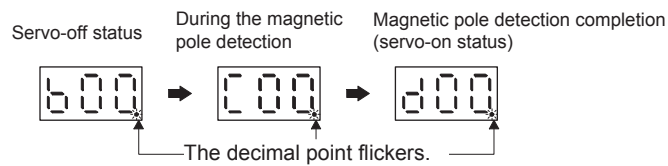

- (2) Preparation for the magnetic pole detection

POINT
<ul style="list-style-type: none"> ● When the test operation mode is selected with the test operation select switch (SW2-1), the SSCNET III/H communication for the servo amplifier in the test operation mode and the following servo amplifiers is blocked.

For the magnetic pole detection, use the test operation mode (positioning operation) of MR Configurator2. Turn off the servo amplifier power, and set the test operation select switch (SW2-1) as shown below. Turning on the power enables the test operation mode.

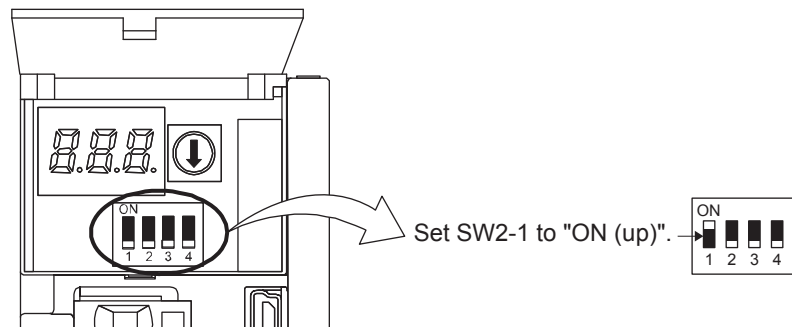

14. USING A LINEAR SERVO MOTOR

(3) Operation at the magnetic pole detection



WARNING

- Note that the magnetic pole detection automatically starts simultaneously with the turning-on of the servo-on command.



CAUTION

- If the magnetic pole detection is not executed properly, the linear servo motor may operate unexpectedly.

POINT

- Establish the machine configuration using FLS (Upper stroke limit) and RLS (Lower stroke limit). Otherwise, the machine may be damaged due to a collision.
- At the magnetic pole detection, whether the linear servo motor moves in the positive or negative direction is unpredictable.
- Depending on the setting value of [Pr. PL09 Magnetic pole detection voltage level], an overload, overcurrent, magnetic pole detection alarm, or others may occur.
- When performing the positioning operation from a controller, use the sequence which confirms the normal completion of the magnetic pole detection and the servo-on status, then outputs the positioning command. If the controller outputs the positioning command before RD (Ready) turns on, the command may not be accepted or a servo alarm may occur.
- After the magnetic pole detection, check the positioning accuracy with the test operation (positioning operation function) of MR Configurator2.
- When the absolute position linear encoder is used, if a gap is generated to the positional relation between the linear encoder and the linear servo motor, perform the magnetic pole detection again.
- The accuracy of the magnetic pole detection improves with no load.
- A servo alarm may occur when the linear encoder is not mounted properly, or when the linear encoder resolution setting ([Pr. PL02] and [Pr. PL03]) or the setting value of [Pr. PL09 Magnetic pole detection voltage level] is incorrect.
- For the machine that its friction becomes 30% or more of the continuous thrust, the linear servo motor may not operate properly after the magnetic pole detection.
- For the horizontal shaft of the machine that its unbalanced thrust becomes 20% or more of the continuous thrust, the linear servo motor may not operate properly after the magnetic pole detection.
- For the machine that multiple axes are connected like a tandem configuration, if you try to perform the magnetic pole detection simultaneously for multiple axes, the magnetic pole detection may not be executed. Perform the magnetic pole detection for each axis. At this time, set the axes that the magnetic pole detection is not performed for to servo-off.

14. USING A LINEAR SERVO MOTOR

(a) For the incremental linear encoder

POINT
<p>● When the incremental linear encoder is used, the magnetic pole detection is required when the power is turned on.</p>

For the incremental linear encoder, the magnetic pole detection is required every time the power is turned on. By turning on the servo-on command from the controller after the power-on, the magnetic pole detection is automatically carried out. Therefore, there is not need to set the parameter (first digit of [Pr. PL01]) for executing the magnetic pole detection.

1) Timing chart

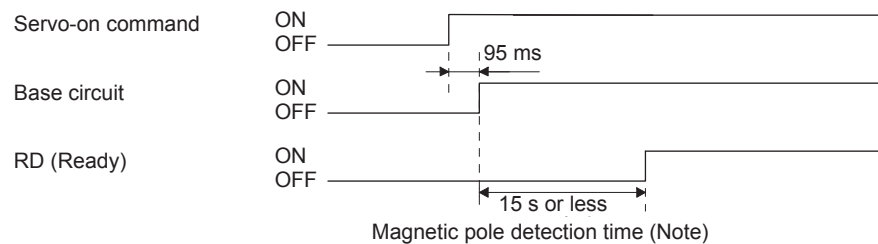

Note. The magnetic pole detection time indicates the operation time when FLS (Upper stroke limit) and RLS (Lower stroke limit) are on.

2) Linear servo motor movement (when FLS (Upper stroke limit) and RLS (Lower stroke limit) are on)

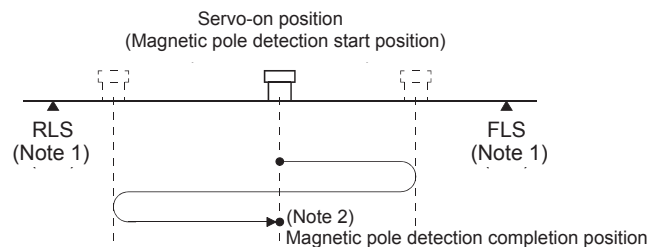

Note 1. When FLS (Upper stroke limit) or RLS (Lower stroke limit) turns off during the magnetic pole detection, the operation of the magnetic pole detection is carried on to the opposite direction. When both FLS and RLS are off, [AL. 27 Initial magnetic pole detection error] occurs.

The following shows the pitch against the magnetic pole.

Linear servo motor series	LM-H3 LM-F	LM-U2		LM-K2
		Medium thrust (Continuous thrust: Less than 400 N)	Large thrust (Continuous thrust: 400 N or more)	
Pitch against magnetic pole [mm]	48	30	60	48

14. USING A LINEAR SERVO MOTOR

- 3) Linear servo motor movement (when FLS (Upper stroke limit) or RLS (Lower stroke limit) is off)
 When FLS or RLS is off at servo-on, the magnetic pole detection is carried out as follows.

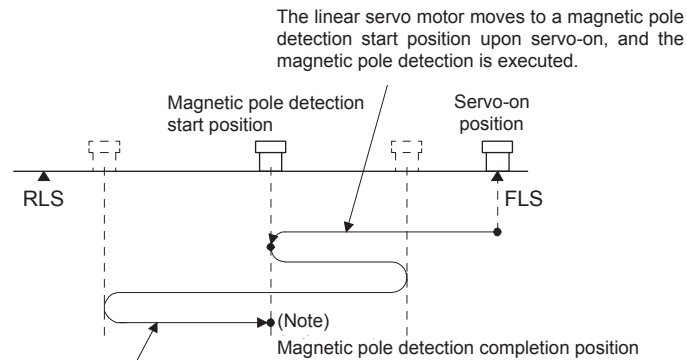

The linear servo motor reciprocates several times and returns to the magnetic pole detection start position to complete the magnetic pole detection and to go into the servo-lock status. At this time, there may be a gap, approximately a quarter of the pitch against magnetic pole, from the start position.

Note. For the pitch against magnetic pole, refer to (3) (a) 2) Note 2 of this section.

- (b) For the absolute position linear encoder

POINT
<ul style="list-style-type: none"> ● When the absolute position linear encoder is used, the magnetic pole detection is required when the power is turned on with the following timing. <ul style="list-style-type: none"> ▪ When the system is set up (at the first startup of equipment) ▪ After a servo amplifier is replaced ▪ After a linear servo motor (primary-side or secondary-side) is replaced ▪ After a linear encoder (scale or head) is replaced or its position is adjusted ● When the absolute position linear encoder is used, if a gap is generated to the positional relation between the linear encoder and the linear servo motor, perform the magnetic pole detection again.

Perform the magnetic pole detection in the following procedure.

- 1) Set [Pr. PL01 Linear servo motor/DD motor function selection 1] to "___ 1" (Magnetic pole detection at first servo-on).

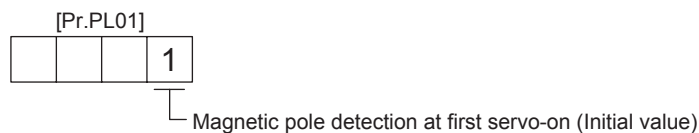

- 2) Execute the magnetic pole detection. (Refer to (3) (a) 1), 2) of this section.)
- 3) After the completion of the magnetic pole detection, change [Pr. PL01] to "___ 0" (Magnetic pole detection disabled).

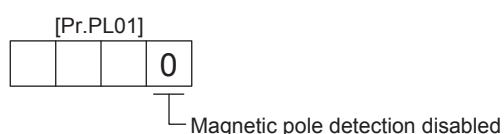

After the magnetic pole detection, by disabling the magnetic pole detection function with [Pr. PL01], the magnetic pole detection after each power-on is not required.

14. USING A LINEAR SERVO MOTOR

(4) Magnetic pole detection method setting

POINT
<ul style="list-style-type: none"> ● In the following cases, set the magnetic pole detection method to the minute position detection method. <ul style="list-style-type: none"> ▪ When a shorten travel distance at the magnetic pole detection is required ▪ When the magnetic pole detection by the position detection method is not completed

Set the magnetic pole detection method using the first digit of [Pr. PL08] (Magnetic pole detection method selection).

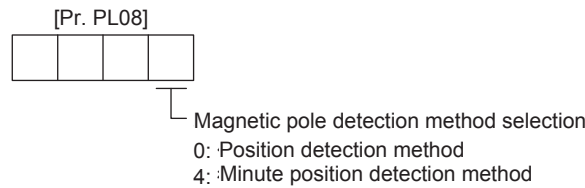

(5) Setting of the magnetic pole detection voltage level by the position detection method

For the magnetic pole detection by the position detection method, set the voltage level with [Pr. PL09 Magnetic pole detection voltage level]. For the magnetic pole detection by the minute position detection method, the voltage level setting is not required.

(a) Guideline of parameter settings

Set the parameters by referring to the following table.

Servo status	[Pr. PL09] setting (guide value)	Small ← Medium → Large (10 or less (initial value) 50 or more)	
	Thrust at operation		Small
Overload, overcurrent alarm		Seldom occurs	Frequently occurs
Magnetic pole detection alarm		Frequently occurs	Seldom occurs
Magnetic pole detection accuracy		Low	High

(b) Setting procedure

- 1) Perform the magnetic pole detection, and increase the setting value of [Pr. PL09 Magnetic pole detection voltage level] until [AL. 50 Overload 1], [AL. 51 Overload 2], [AL. 33 Overvoltage], [AL. E1 Overload warning 1], and [AL. EC Overload warning 2] occur. Increase the setting value by five as a guide value. When these alarms and warnings occur during the magnetic pole detection by using MR Configurator2, the test operation of MR Configurator2 automatically completes and the servo-off status is established.
- 2) Specify the setting value that is an approximately 70% of the value set when [AL. 50 Overload 1], [AL. 51 Overload 2], [AL. 33 Overvoltage], [AL. E1 Overload warning 1], and [AL. EC Overload warning 2] occurred as the final setting value. However, if [AL. 27 Initial magnetic pole detection error] occurs with this value, specify a value intermediate between the value set at [AL. 50 Overload 1], [AL. 51 Overload 2], [AL. 33 Overvoltage], [AL. E1 Overload warning 1], and [AL. EC Overload warning 2] and the value set at the magnetic pole detection alarm as the final setting value.
- 3) Perform the magnetic pole detection again with the final setting value.

14. USING A LINEAR SERVO MOTOR

(c) Setting example

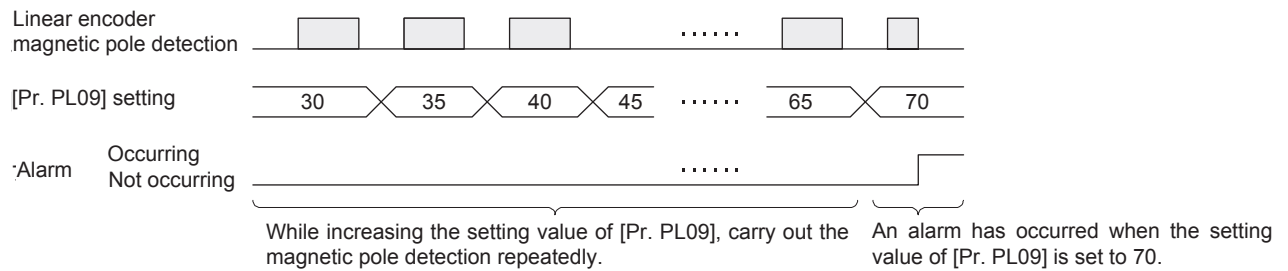

In this example, the final setting value of [Pr. PL09] is 49 (Setting value at the alarm occurrence = 70×0.7).

14.3.3 Home position return

POINT

- The incremental linear encoder and the absolute position linear encoder have different reference home positions at the home position return.

(1) Incremental linear encoder

CAUTION ● If the resolution or the stop interval (the third digit of [Pr. PL01]) of the linear encoder is large, it is very dangerous since the linear servo motor may crash into the stroke end.

(a) When the linear encoder home position (reference mark) exists in the home position return direction

When an incremental linear encoder is used, the home position is the position per 1048576 pulses (changeable with the third digit of [Pr. PL01]) with reference to the linear encoder home position (reference mark) passed through first after a home position return start. Change the setting value of [Pr. PL01] according to the linear encoder resolution.

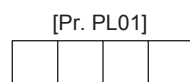

Stop interval setting at the home position return

Setting value	Stop interval [pulse]
0	8192
1	131072
2	262144
3	1048576 (initial value)
4	4194304
5	16777216
6	67108864

14. USING A LINEAR SERVO MOTOR

The following shows the relation between the stop interval at the home position return and the linear encoder resolution. For example, when the linear encoder resolution is 0.001 [μm] and the parameter for the stop interval at the home position return, [Pr.PL01], is set to "_ 5 _" (16777216 pulses), the stop interval is 16.777 [mm]. The value inside a bold box indicates the recommended stop interval for each linear encoder resolution.

[Unit: mm]

Pr. PL01	Linear encoder resolution [μm] Stop interval [pulse]	0.001	0.005	0.01	0.02	0.05	0.1	0.2	0.5	1	2
_ 0 _	8192	0.008	0.041	0.082	0.164	0.410	0.819	1.638	4.096	8.192	16.384
_ 1 _	131072	0.131	0.655	1.311	2.621	6.554	13.107	26.214	65.536	131.072	262.144
_ 2 _	262144	0.262	1.311	2.621	5.243	13.107	26.214	52.429	131.072	262.144	524.288
_ 3 _	1048576	1.049	5.243	10.486	20.972	52.429	104.858	209.715	524.288	1048.576	2097.152
_ 4 _	4194304	4.194	20.972	41.943	83.886	209.715	419.430	838.861	2097.152	4194.304	8388.608
_ 5 _	16777216	16.777	83.886	167.772	335.544	838.861	1677.722	3355.443	8388.608	16777.216	33554.432
_ 6 _	67108864	67.109	335.544	671.089	1342.177	3355.443	6710.886	13421.773	33554.432	67108.864	134217.728

In the case of a proximity dog type home position return, the nearest reference home position after proximity dog off is the home position.

Set one linear encoder home position in the full stroke, and set it in the position that can always be passed through after a home position return start. The encoder Z-phase pulse (LZ) cannot be used.

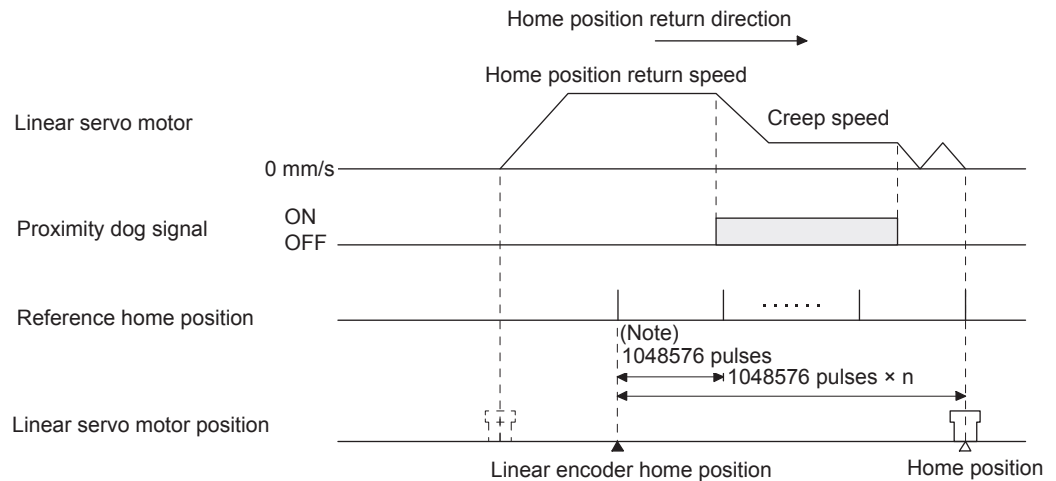

Note. Changeable with [Pr. PL01].

14. USING A LINEAR SERVO MOTOR

(b) When the linear encoder home position does not exist in the home position return direction

If the home position return is performed from the position where the linear encoder does not exist in the home position return direction, a home position return error occurs on the controller. The error contents differ according to the controller type. Move the linear servo motor to the stroke end on the opposite side of the home position return direction with the JOG operation from the controller and others, and then perform a home position return.

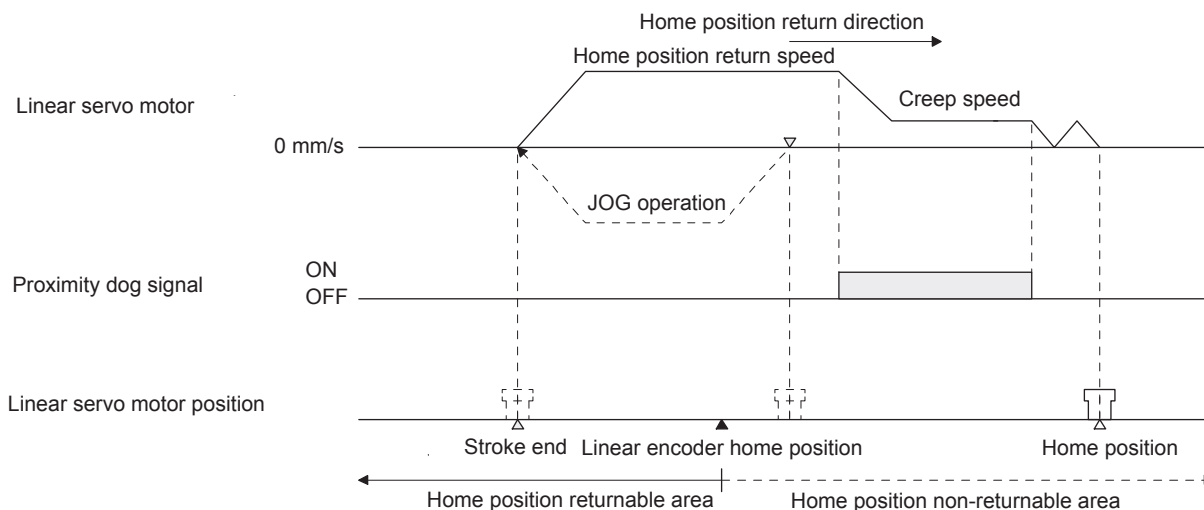

POINT

- To execute a home position return securely, start a home position return after moving the linear servo motor to the opposite stroke end with JOG operation from the controller and others.
- Change the third digit value of [Pr. PL01] according to the linear encoder resolution.

14. USING A LINEAR SERVO MOTOR

(2) Absolute position linear encoder

When an absolute linear encoder is used, the reference home position is the position per 1048576 pulses (changeable with the third digit of [Pr. PL01]) with reference to the linear encoder home position (absolute position data = 0).

In the case of a proximity dog type home position return, the nearest reference home position after proximity dog off is the home position. The linear encoder home position can be set in any position. The encoder Z-phase pulse (LZ) cannot be used.

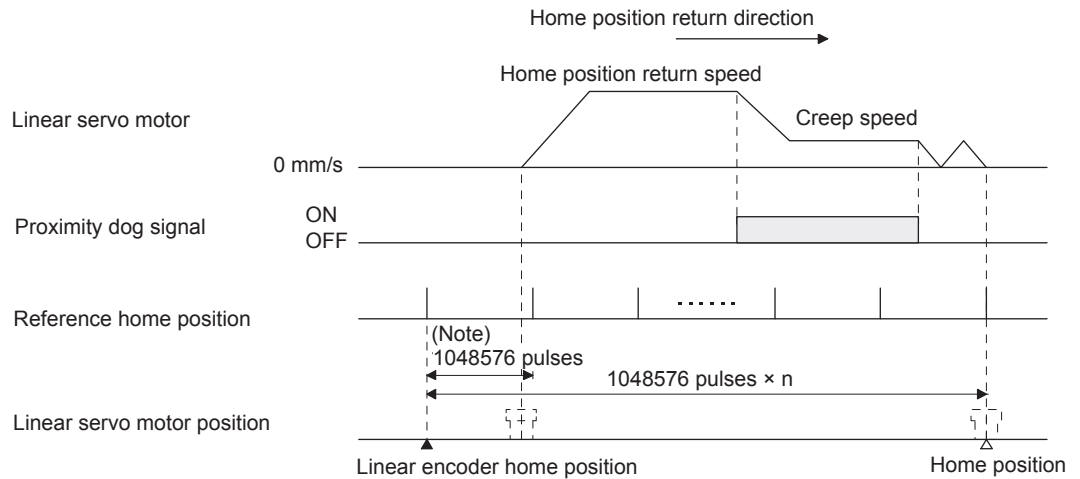

Note. Changeable with [Pr. PL01].

POINT	<ul style="list-style-type: none"> ● The data set type home position return can also be carried out.
-------	---

14. USING A LINEAR SERVO MOTOR

14.3.4 Test operation mode in MR Configurator2

 CAUTION	<ul style="list-style-type: none"> ● The test operation mode is designed for checking servo operation. It is not for checking machine operation. Do not use this mode with the machine. Always use the linear servo motor alone.
	<ul style="list-style-type: none"> ● If the servo motor operates abnormally, use EM2 (Forced stop 2) to stop it.

POINT
<ul style="list-style-type: none"> ● The content described in this section indicates the environment where the servo amplifier and a personal computer are directly connected. ● When the test operation mode is selected with the test operation select switch (SW2-1), the SSCNET III/H communication for the servo amplifier in the test operation mode and the following servo amplifiers is blocked.

By using a personal computer and MR Configurator2, you can execute the positioning operation, the output signal (DO) forced output, and the program operation without connecting the servo system controller.

(1) Test operation mode type

(a) Positioning operation

Positioning operation can be performed without using the servo system controller. Use this operation with the forced stop reset. This operation may be used independently of whether the servo is on or off and whether the servo system controller is connected or not.

Exercise control on the positioning operation screen of MR Configurator2.

1) Operation pattern

Item	Initial value	Setting range
Travel distance [pulse]	1048576	0 to 99999999
Speed [mm/s]	10	0 to Maximum speed
Acceleration/deceleration time constant [ms]	1000	0 to 50000
Repeat pattern	Positive direction travel → Negative direction travel	Positive direction travel → Negative direction travel Positive direction travel → Positive direction travel Negative direction travel → Positive direction travel Negative direction travel → Negative direction travel
Dwell time [s]	2.0	01 to 50.0
Number of repeats [time]	1	1 to 9999

2) Operation method

Operation	Screen control
Positive direction travel	Click the "Positive Direction Movement" button.
Negative direction travel	Click the "Reverse Direction Movement" button.
Pause	Click the "Pause" button.
Stop	Click the "Stop" button.
Forced stop	Click the "Forced stop" button.

(b) Output signal (DO) forced output

14. USING A LINEAR SERVO MOTOR

Output signals can be switched on/off forcibly independently of the servo status. This function is used for output signal wiring check, etc. Exercise control on the DO forced output screen of MR Configurator2.

(c) Program operation

Positioning operation can be performed in two or more operation patterns combined, without using the servo system controller. Use this operation with the forced stop reset. This operation may be used independently of whether the servo is on or off and whether the servo system controller is connected or not.

Exercise control on the program operation screen of MR Configurator2. For full information, refer to the MR Configurator2 Installation Guide.

Operation	Screen control
Start	Click the "Operation start" button.
Pause	Click the "Pause" button.
Stop	Click the "Stop" button.
Forced stop	Click the "Forced stop" button.

(2) Operation procedure

- 1) Turn off the power.
- 2) Turn "ON (up)" SW2-1.

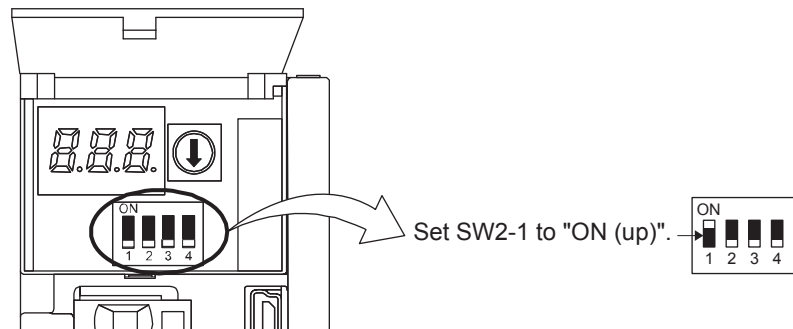

Turning "ON (up)" SW2-1 during power-on will not enable the test operation mode.

3) Turn on the servo amplifier.

When initialization is over, the display shows the following screen.

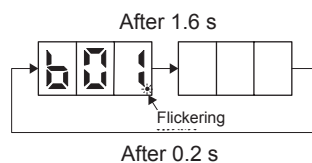

4) Start operation with the personal computer.

14. USING A LINEAR SERVO MOTOR

14.3.5 Operation from controller

The linear servo can be used with any of the following controllers.

Servo system controller	Model
Motion controller	Q17_DSCPU
Simple motion module	QD77MS_

(1) Operation method

For the system using the incremental linear encoder, the magnetic pole detection is automatically performed at the first servo-on after the power-on. For this reason, when performing the positioning operation, create the sequence which surely confirms the servo-on status as the inter lock condition of the positioning command.

Also, some parameter settings and the home position return type differ according to the controller type.

(2) Servo system controller setting

(a) Setting precautions

The following parameters will be enabled by turning the servo amplifier power off and on again after the controller writes the parameters to the servo amplifier.

Setting item				Set content	
				Motion controller Q17_DSCPU	Simple motion module QD77MS_
Command resolution				Linear encoder resolution unit	
Servo amplifier setting				MR-J4-B Linear	
Motor setting				Automatic setting	
Parameter	No.	(Note) Symbol	Name	Initial value	Set the items as required.
	PA01	**STY	Operation mode (Note 2)	1000h	
	PC01	ERZ	Error excessive alarm level	0	
	PC03	*ENRS	Encoder output pulse selection	0000h	
	PC27	**COP9	Function selection C-9	0000h	
	PL01	**LIT1	Linear servo motor/DD motor function selection 1	0301h	
	PL02	**LIM	Linear encoder resolution - Numerator	1000	
	PL03	**LID	Linear encoder resolution - Denominator	1000	
	PL04	*LIT2	Linear servo motor/DD motor function selection 2	0003h	
	PL05	LB1	Position deviation error detection level	0	
	PL06	LB2	Speed deviation error detection level	0	
	PL07	LB3	Torque/thrust deviation error detection level	100	
	PL08	*LIT3	Linear servo motor/DD motor function selection 3	0010h	
	PL09	LPWM	Magnetic pole detection voltage level	30	
	PL17	LTSTS	Magnetic pole detection - Minute position detection method - Function selection	0000h	
PL18	IDLV	Magnetic pole detection - Minute position detection method - Identification signal amplitude	0		
Positioning control parameter	Unit setting			mm	
	Number of pulses (AP) Travel distance (AL)			Refer to (2) (b) of this section.	

14. USING A LINEAR SERVO MOTOR

Note. The parameter whose symbol is preceded by * is enabled with the following conditions:

* : After setting the parameter, power off and on the servo amplifier or reset the controller.

** : After setting the parameter, cycle the power of the servo amplifier.

(b) Settings of the number of pulses (AP) and travel distance (AL)

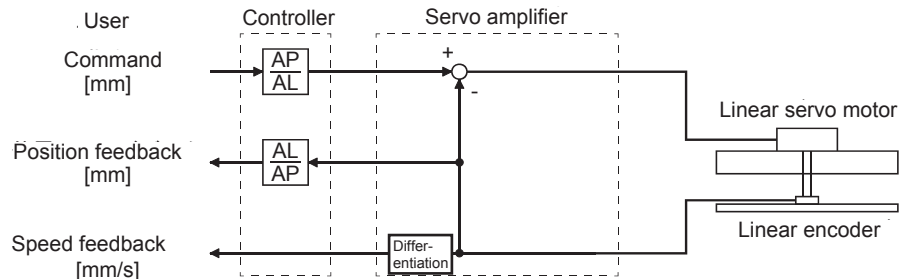

Calculate the number of pulses (AP) and travel distance (AL) of the linear encoder in the following conditions.

When the linear encoder resolution is 0.05 μm

$$\frac{\text{Number of pulses (AP)}}{\text{Travel distance (AL) } [\mu\text{m}]} = \frac{1}{0.05} = \frac{20}{1}$$

14.3.6 Function

(1) Linear servo control error detection function

POINT
<ul style="list-style-type: none"> ● For the linear servo control error detection function, the position and speed deviation error detections are enabled by default. ([Pr. PL04]: __ __ 3)

If the linear servo control gets unstable for some reasons, the linear servo motor may not operate properly. To detect this state and to stop operation, the linear servo control error detection function is used as a protective function.

The linear servo control error detection function has three different detection methods: the position deviation, speed deviation, and thrust deviation. An error is detected when each method is enabled with [Pr. PL04 Linear servo motor/DD motor function selection 2]. The detection level can be changed with [Pr. PL05], [Pr. PL06], and [Pr. PL07].

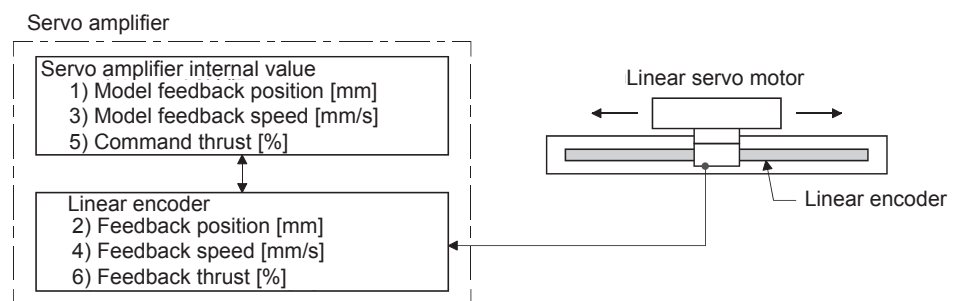
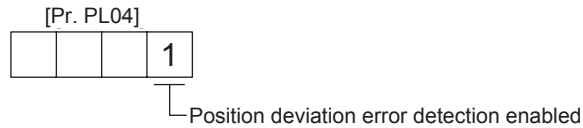

Figure 14.1 Outline of linear servo control error detection function

14. USING A LINEAR SERVO MOTOR

(a) Position deviation error detection

Set [Pr. PL04] to "___ 1" to enable the position deviation error detection.



When you compare the model feedback position (1)) and the feedback position (2)) in figure 14.1, if the deviation is more than the value of [Pr. PL05 Position deviation error detection level] (1 mm to 1000 mm), [AL. 42.1 Servo control error by position deviation] will occur and the linear servo motor will stop. The initial value of this detection level is 50 mm. Replace the set value as required.

(b) Speed deviation error detection

Set [Pr. PL04] to "___ 2" to enable the speed deviation error detection.

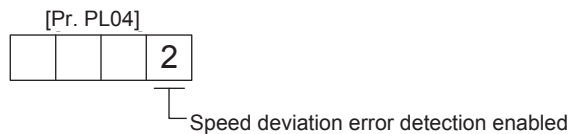

When you compare the model feedback speed (3)) and the feedback speed (4)) in figure 14.1, if the deviation is more than the value of [Pr. PL06 Speed deviation error detection level] (1 mm/s to 5000 mm/s), [AL. 42.2 Servo control error by speed deviation] will occur and the linear servo motor will stop. The initial value of this detection level is 1000 mm/s. Replace the set value as required.

(c) Thrust deviation error detection level

Set [Pr. PL04] to "___ 4" to enable the thrust deviation error detection.

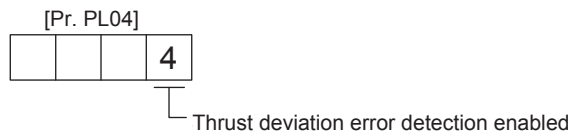

When you compare the command thrust (5)) and the feedback thrust (6)) in figure 14.1, if the deviation is more than the value of [Pr. PL07 Torque/thrust deviation error detection level] (1% to 1000%), [AL. 42.3 Servo control error by torque/thrust deviation] will occur and the linear servo motor will stop. The initial value of this detection level is 100%. Replace the set value as required.

(d) Detecting multiple deviation errors

When setting [Pr. PL04] as shown below, multiple deviation errors can be detected. For the error detection methods, refer to (1) (a), (b), (c) of this section.

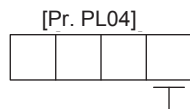

Setting value	Position deviation error detection	Speed deviation error detection	Thrust deviation error detection
1	○	—	—
2	—	○	—
3	○	○	—
4	—	—	○
5	○	—	○
6	—	○	○
7	○	○	○

14. USING A LINEAR SERVO MOTOR

(2) Auto tuning function

The auto tuning function during the linear servo operation is the same as that of the rotary servo motor. However, the calculation method of the load to motor mass ratio (J ratio) differs. The load to motor mass ratio (J ratio) on the linear servo is calculated by dividing the load mass by the mass of the linear servo motor primary side.

Example) Mass of linear servo motor primary side = 2 kg
 Load mass (excluding the mass of the linear servo motor primary side) = 4 kg
 Mass ratio = $4/2 = 2$ times

For the parameters set by the auto tuning function, refer to chapter 6.

POINT
<ul style="list-style-type: none"> ● The auto tuning mode 1 may not be performed properly if the following conditions are not satisfied. <ul style="list-style-type: none"> ▪ Time to reach 2000 mm/s is the acceleration/deceleration time constant of 5 s or less. ▪ The linear servo motor speed is 150 mm/s or higher. ▪ The load to mass of the linear servo motor primary-side ratio is 100 times or less. ▪ The acceleration/deceleration thrust is 10% or less of the continuous thrust.

(3) Machine analyzer function

POINT
<ul style="list-style-type: none"> ● Make sure to perform the machine analyzer function after the magnetic pole detection. If the magnetic pole detection is not performed, the machine analyze function may not operate properly. ● The stop position at the completion of the machine analyzer function can be any position.

14.3.7 Absolute position detection system

When the linear servo is used in the absolute position detection system, an absolute position linear encoder is required. The linear encoder backs up the absolute position data. Therefore, the encoder battery MR-BAT6V1SET need not be installed to the servo amplifier. Additionally, [AL. 25 Absolute position erased], [AL. 92 Battery cable disconnection warning], [AL. 9F Battery warning], and [AL. E3 Absolute position counter warning] are not provided for the linear servo motor.

14. USING A LINEAR SERVO MOTOR

14.4 Characteristics

14.4.1 Overload protection characteristics

An electronic thermal is built in the servo amplifier to protect the linear servo motor, servo amplifier and linear servo motor power wires from overloads.

[AL. 50 Overload 1] occurs if overload operation performed is above the electronic thermal protection curve shown in fig. 14.2. [AL. 51 Overload 2] occurs if the maximum current is applied continuously for several seconds due to machine collision, etc. Use the equipment on the left-hand side area of the continuous or broken line in the graph.

This servo amplifier has solid-state linear servo motor overload protection. (The servo motor overload current (full load current) is set on the basis of 120% rated current of the servo amplifier.)

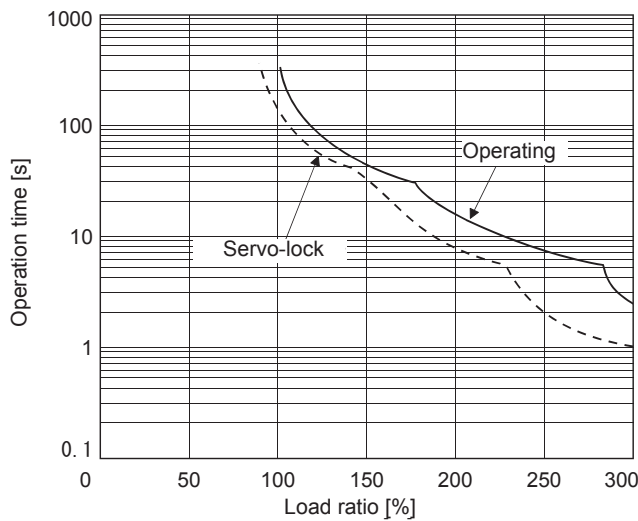

a. LM-H3 series
LM-K2 series

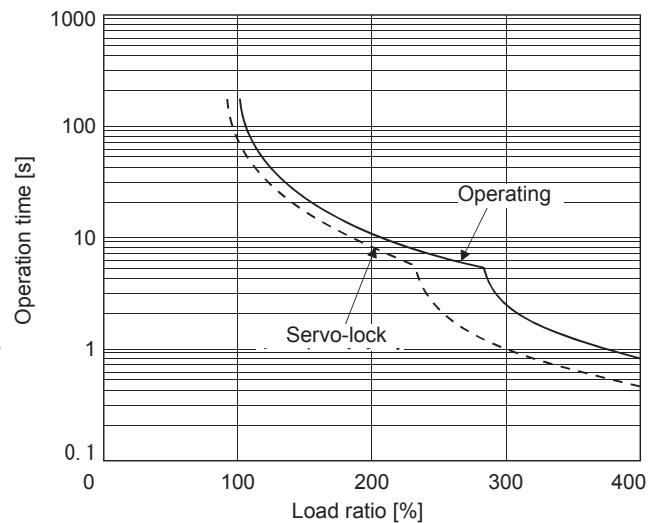

b. LM-U2 series

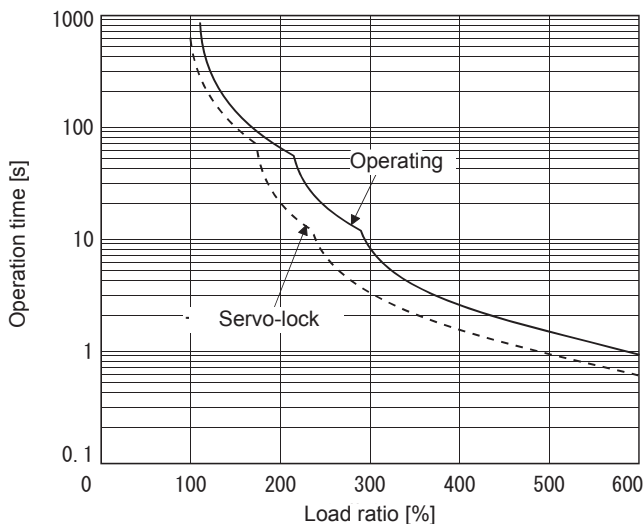

c. LM-F (natural cooling)

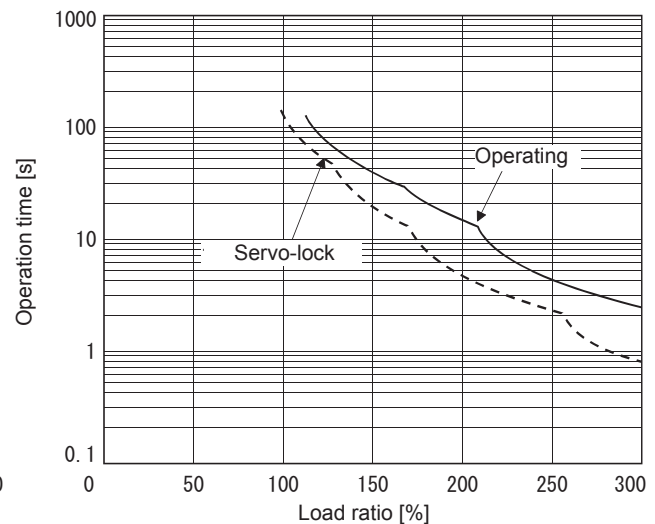

d. LM-F (liquid cooling)

Fig. 14.2 Electronic thermal protection characteristics

14. USING A LINEAR SERVO MOTOR

14.4.2 Power supply capacity and generated loss

Table 14.1 indicates servo amplifiers' power supply capacities and losses generated under rated load. For thermal design of an enclosed type cabinet, use the values in the table in consideration for the worst operating conditions. The actual amount of generated heat will be intermediate between values at rated torque and servo-off according to the duty used during operation. When the linear servo motor is run at less than the rated speed, the power supply capacity will be smaller than the value in the table, but the servo amplifier's generated heat will not change.

Mounting a heat sink outside of the cabinet enables to reduce heat in the cabinet and design a compact enclosed type cabinet.

Table 14.1 Power supply capacity and generated loss per linear servo motor at rated output

Linear servo motor	Servo amplifier	Power supply capacity [kVA] (Note 1)	Servo amplifier-generated heat [W] (Note 2)		Area required for heat dissipation [m ²]
			At rated output	With servo-off	
LM-H3P2A-07P-BSS0	MR-J4-40B	0.9	35	15	0.7
LM-H3P3A-12P-CSS0		0.9	35	15	0.7
LM-H3P3B-24P-CSS0	MR-J4-70B	1.3	50	15	1.0
LM-H3P3C-36P-CSS0		1.9	75	15	1.5
LM-H3P3D-48P-CSS0	MR-J4-200B	3.5	90	20	1.8
LM-H3P7A-24P-ASS0	MR-J4-70B	1.3	50	15	1.0
LM-H3P7B-48P-ASS0	MR-J4-200B	3.5	90	20	1.8
LM-H3P7C-72P-ASS0		3.8	100	20	1.1
LM-H3P7D-96P-ASS0	MR-J4-350B	5.5	130	20	2.7
LM-U2PAB-05M-0SS0	MR-J4-20B	0.5	25	15	0.5
LM-U2PAD-10M-0SS0	MR-J4-40B	0.9	35	15	0.7
LM-U2PAF-15M-0SS0		0.9	35	15	0.7
LM-U2PBB-07M-1SS0	MR-J4-20B	0.5	25	15	0.5
LM-U2PBD-15M-1SS0	MR-J4-60B	1.0	40	15	0.8
LM-U2PBF-22M-1SS0	MR-J4-70B	1.3	50	15	1.0
LM-U2P2B-40M-2SS0	MR-J4-200B	3.5	90	20	1.8
LM-U2P2C-60M-2SS0	MR-J4-350B	5.5	130	20	2.7
LM-U2P2D-80M-2SS0	MR-J4-500B	7.5	195	25	3.9
LM-FP2B-06M-1SS0	MR-J4-200B	3.5	90	20	1.8
LM-FP2D-12M-1SS0	MR-J4-500B	7.5	195	25	3.9
LM-FP2F-18M-1SS0	MR-J4-700B	10	300	25	6.0
LM-FP4B-12M-1SS0	MR-J4-500B	7.5	195	25	3.9
LM-FP4D-24M-1SS0	MR-J4-700B	10	300	25	6.0
LM-K2P1A-01M-2SS1	MR-J4-40B	0.9	35	15	0.7
LM-K2P1C-03M-2SS1	MR-J4-200B	3.5	90	20	1.8
LM-K2P2A-02M-1SS1	MR-J4-70B	1.3	50	15	1.0
LM-K2P2C-07M-1SS1	MR-J4-350B	5.5	130	20	2.7
LM-K2P2E-12M-1SS1	MR-J4-500B	7.5	195	25	3.9
LM-K2P3C-14M-1SS1	MR-J4-350B	5.5	130	20	2.7
LM-K2P3E-24M-1SS1	MR-J4-500B	7.5	195	25	3.9

Note 1. Note that the power supply capacity will vary according to the power supply impedance. This value is applicable when the power factor improving AC reactor or power factor improving DC reactor are not used.

2. Heat generated during regeneration is not included in the servo amplifier-generated heat. To calculate heat generated by the regenerative option, refer to section 11.2.

14. USING A LINEAR SERVO MOTOR

14.4.3 Dynamic brake characteristics

POINT
<ul style="list-style-type: none"> ● Do not use dynamic brake to stop in a normal operation as it is the function to stop in emergency. ● For a machine operating at the recommended load to motor mass ratio or less, the estimated number of usage times of the dynamic brake is 1000 times while the machine decelerates from the rated speed to a stop once in 10 minutes. ● Be sure to enable EM1 (Forced stop 1) after the linear servo motor stops when using EM1 (Forced stop 1) frequently in other than emergency.

The approximate coasting distance from when the dynamic break is activated until when the linear servo motor stops can be calculated with the equation below.

$$L_{max} = V_0 \cdot (0.03 + M \cdot (A + B \cdot V_0^2))$$

- L_{max} : Coasting distance of the machine [m]
 V_0 : Speed when the brake is activated [m/s]
 M : Full mass of the moving part [kg]
 A : Coefficient (Refer to the following tables.)
 B : Coefficient (Refer to the following tables.)

Linear servo motor	Coefficient A	Coefficient B
LM-H3P2A-07P-BSS0	7.15E-03	2.94E-03
LM-H3P3A-12P-CSS0	2.81E-03	1.47E-03
LM-H3P3B-24P-CSS0	7.69E-03	2.27E-04
LM-H3P3C-36P-CSS0	7.22E-03	1.13E-04
LM-H3P3D-48P-CSS0	1.02E-03	2.54E-04
LM-H3P7A-24P-ASS0	7.69E-03	2.14E-04
LM-H3P7B-48P-ASS0	9.14E-04	2.59E-04
LM-H3P7C-72P-ASS0	7.19E-04	1.47E-04
LM-H3P7D-96P-ASS0	6.18E-04	9.59E-05

Linear servo motor	Coefficient A	Coefficient B
LM-U2PAB-05M-0SS0	5.72×10^{-2}	1.72×10^{-4}
LM-U2PAD-10M-0SS0	2.82×10^{-2}	8.60×10^{-5}
LM-U2PAF-15M-0SS0	1.87×10^{-2}	5.93×10^{-5}
LM-U2PBB-07M-1SS0	3.13×10^{-2}	1.04×10^{-4}
LM-U2PBD-15M-1SS0	1.56×10^{-2}	5.18×10^{-5}
LM-U2PBF-22M-1SS0	4.58×10^{-2}	1.33×10^{-5}
LM-U2P2B-40M-2SS0	1.47×10^{-3}	1.27×10^{-5}
LM-U2P2C-60M-2SS0	1.07×10^{-3}	7.66×10^{-6}
LM-U2P2D-80M-2SS0	9.14×10^{-4}	5.38×10^{-6}

Linear servo motor	Coefficient A	Coefficient B
LM-FP2B-06M-1SS0	8.96×10^{-4}	1.19×10^{-3}
LM-FP2D-12M-1SS0	5.55×10^{-4}	4.81×10^{-4}
LM-FP2F-18M-1SS0	4.41×10^{-4}	2.69×10^{-4}
LM-FP4B-12M-1SS0	5.02×10^{-4}	4.36×10^{-4}
LM-FP4D-24M-1SS0	3.55×10^{-4}	1.54×10^{-4}
LM-FP4F-36M-1SS0	1.79×10^{-4}	1.36×10^{-4}
LM-FP4H-48M-1SS0	1.15×10^{-4}	1.19×10^{-4}
LM-FP5H-60M-1SS0	1.95×10^{-4}	4.00×10^{-5}

Linear servo motor	Coefficient A	Coefficient B
LM-K2P1A-01M-2SS1	5.36×10^{-3}	6.56×10^{-3}
LM-K2P1C-03M-2SS1	1.17×10^{-3}	3.75×10^{-4}
LM-K2P2A-02M-1SS1	2.49×10^{-2}	1.02×10^{-3}
LM-K2P2C-07M-1SS1	6.85×10^{-4}	2.80×10^{-4}
LM-K2P2E-12M-1SS1	5.53×10^{-4}	1.14×10^{-4}
LM-K2P3C-14M-1SS1	2.92×10^{-4}	1.16×10^{-4}
LM-K2P3E-24M-1SS1	2.53×10^{-4}	5.52×10^{-5}

CAUTION

- The coasting distance is a theoretically calculated value which ignores the running load such as friction. The calculated value is considered to be longer than the actual distance. However, if an enough breaking distance is not obtained, the linear servo motor may crash into the stroke end, which is very dangerous. Install the anti-crash mechanism such as an air brake or an electric/mechanical stopper such as a shock absorber to reduce the shock of moving parts. No linear servo motor with an electromagnetic brake is available.

14. USING A LINEAR SERVO MOTOR

14.4.4 Permissible load to motor mass ratio when the dynamic brake is used

Use the dynamic brake under the load to motor mass ratio indicated in the following table. If the load to motor mass ratio is higher than this value, the dynamic brake may burn. If there is a possibility that the load inertia moment may exceed the value, contact your local sales office.

The values of the permissible load to motor mass ratio in the table are the values when the linear servo motor is used at the maximum speed.

Linear servo motor		Servo amplifier							
		MR-J4-							
		20_	40_	60_	70_	200_	350_	500_	700_
LM-H3 series	LM-H3P2A-07P-BSS0		35						
	LM-H3P3A-12P-CSS0		35						
	LM-H3P3B-24P-CSS0				35				
	LM-H3P3C-36P-CSS0				35				
	LM-H3P3D-48P-CSS0					35			
	LM-H3P7A-24P-ASS0				35				
	LM-H3P7B-48P-ASS0					35			
	LM-H3P7C-72P-ASS0					35			
	LM-H3P7D-96P-ASS0						35		
LM-U2 series	LM-U2PAB-05M-0SS0	30							
	LM-U2PAD-10M-0SS0		30						
	LM-U2PAF-15M-0SS0		30						
	LM-U2PBB-07M-1SS0	30							
	LM-U2PBD-15M-1SS0			30					
	LM-U2PBF-22M-1SS0				30				
	LM-U2P2B-40M-2SS0					30			
	LM-U2P2C-60M-2SS0						30		
	LM-U2P2D-80M-2SS0							30	
LM-F series	LM-FP2B-06M-1SS0					15			
	LM-FP2D-12M-1SS0							15	
	LM-FP2F-18M-1SS0								15
	LM-FP4B-12M-1SS0							15	
	LM-FP4D-24M-1SS0								15
LM-K2 series	LM-K2P1A-01M-2SS1		30						
	LM-K2P1C-03M-2SS1					30			
	LM-K2P2A-02M-1SS1				30				
	LM-K2P2C-07M-1SS1						30		
	LM-K2P2E-12M-1SS1							30	
	LM-K2P3C-14M-1SS1						30		
	LM-K2P3E-24M-1SS1							30	

15. USING A DIRECT DRIVE MOTOR

15. USING A DIRECT DRIVE MOTOR



CAUTION

● When using the direct drive motor, read the Direct Drive Motor Instruction Manual (SH(NA)030112).

15.1 Functions and configuration

15.1.1 Summary

The fields of semiconductor/LCD manufacturing systems, mounters, and others have strong demands for high accuracy and efficiency. Therefore, the number of systems using a direct drive motor for a drive axis has been increasing. The direct drive servo system includes the following features.

(1) Performance

- (a) The direct drive servo system ensures the high-rigidity and the high-torque. A high-resolution encoder enables the high-accuracy control.
- (b) The high-resolution encoder contributes to the high-accuracy indexing.
- (c) Since transmission mechanism is no longer required, no backlash occurs. In addition, the settling time is reduced, and the high-frequency operation is enabled.
- (d) Since transmission mechanism is no longer required, the direct drive motor does not deteriorate with time.

(2) Mechanism

- (a) The motor's low profile design contributes to compact moving part of the machine and a low center of gravity for enhanced equipment stability.
- (b) The motor has an inner rotor with hollow shaft which enables cables and pipes to be passed through.
- (c) Lubrication and the maintenance due to abrasion are not required.

The following shows the differences between the direct drive motor and the rotary servo motor.

Category	Item	Differences		Remarks
		Direct drive motor	Rotary servo motor	
External I/O signal	FLS (Upper stroke limit), RLS (Lower stroke limit)	Required (for magnetic pole detection)	Not required	Automatically turns on in the parameter setting.
Motor pole adjustment	Magnetic pole detection	Required	Not required (default setting)	Automatically executed at the first servo-on after the power is turned on. For the absolute position detection system, [Pr. PL01] can disable the magnetic pole detection. (Refer to (3) (a) of section 15.3.2.)
Absolute position detection system	Absolute position encoder battery (MR-BAT6V1SET)	Required	Required	
	Absolute position storage unit (MR-BTAS01)	Required	Not required	

15. USING A DIRECT DRIVE MOTOR

15.1.2 Servo system with auxiliary equipment

CAUTION ● Connecting an inappropriate servo motor to the CNP3_ and CN2_ will cause an unexpected operation or an alarm.

POINT

- Equipment other than the servo amplifier and direct drive motor are optional or recommended products.
- When using the direct drive motor, set [Pr. PA01] to " _ _ 6 _ ".

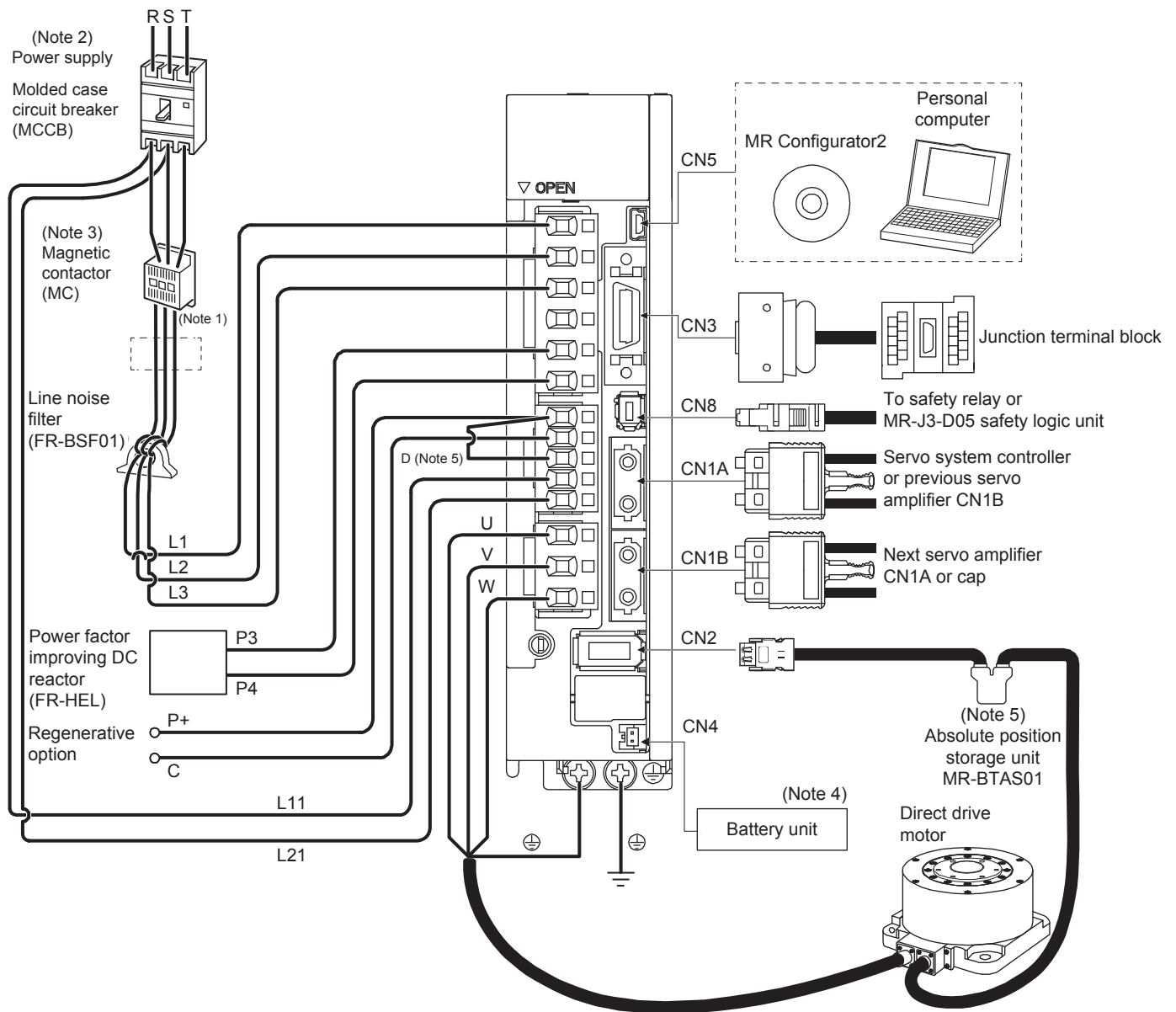

15. USING A DIRECT DRIVE MOTOR

- Note
1. The power factor improving AC reactor can also be used. In this case, the power factor improving DC reactor cannot be used. When not using the power factor improving DC reactor, short P3 and P4.
 2. A 1-phase 200 V AC to 240 V AC power supply may be used with the servo amplifier of MR-J4-70B or less. For 1-phase 200 V AC to 240 V AC, connect the power supply to L1 and L3. Leave L2 open. For the power supply specifications, refer to section 1.3.
 3. Depending on the main circuit voltage and operation pattern, bus voltage decreases, and that may cause the forced stop deceleration to shift to the dynamic brake deceleration. When dynamic brake deceleration is not required, slow the time to turn off the magnetic contactor.
 4. The battery unit (MR-BAT6V1SET) is used for the absolute position detection system. (Refer to chapter 12.)
 5. Always connect P+ and D. When using the regenerative option, refer to section 11.2.
 6. The absolute position storage unit is used for the absolute position detection system.

15.2 Signals and wiring



WARNING

- Any person who is involved in wiring should be fully competent to do the work.
- Before wiring, turn off the power and wait for 15 minutes or more until the charge lamp turns off. Then, confirm that the voltage between P+ and N- is safe with a voltage tester and others. Otherwise, an electric shock may occur. In addition, when confirming whether the charge lamp is off or not, always confirm it from the front of the servo amplifier.
- Ground the servo amplifier and the direct drive motor securely.
- Do not attempt to wire the servo amplifier and the direct drive motor until they have been installed. Otherwise, it may cause an electric shock.
- The cables should not be damaged, stressed, loaded, or pinched. Otherwise, it may cause an electric shock.
- To avoid an electric shock, insulate the connections of the power supply terminals.



CAUTION

- Wire the equipment correctly and securely. Otherwise, the direct drive motor may operate unexpectedly, resulting in injury.
- Connect cables to the correct terminals. Otherwise, a burst, damage, etc. may occur.
- Ensure that polarity (+/-) is correct. Otherwise, a burst, damage, etc. may occur.
- The surge absorbing diode installed to the DC relay for control output should be fitted in the specified direction. Otherwise, the emergency stop and other protective circuits may not operate.

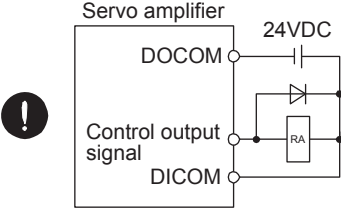

For sink output interface

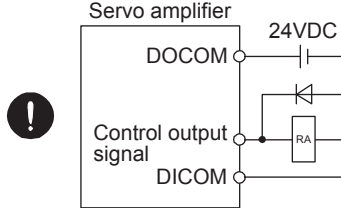

For source output interface

- Use a noise filter, etc. to minimize the influence of electromagnetic interference. Electromagnetic interference may be given to the electronic equipment used near the servo amplifier.
- Do not install a power capacitor, surge killer, or radio noise filter (FR-BIF option) with the power wire of the direct drive motor.

15. USING A DIRECT DRIVE MOTOR

- When using the regenerative resistor, switch power off with the alarm signal. Otherwise, a transistor fault or the like may overheat the regenerative resistor, causing a fire.
- Do not modify the equipment.
- During power-on, do not open or close the power line of the direct drive motor. Otherwise, it may cause a malfunction.
- Connect the servo amplifier power output (U, V, and W) to the power input of the direct drive motor (U, V, and W) directly. Do not let a magnetic contactor, etc. intervene. Otherwise, it may cause a malfunction.

! CAUTION

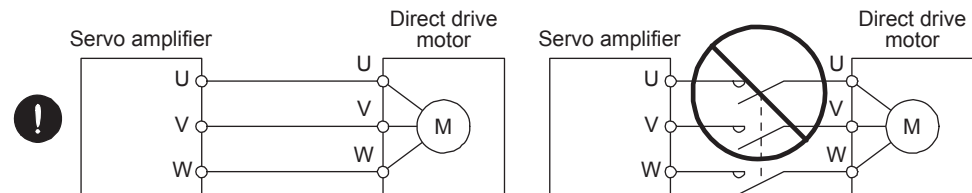

This section does not describe the following items. For the items, refer to the corresponding sections below.

Item	Reference
Input power supply circuit	Section 3.1
Explanation of power supply system	Section 3.3
Signal (device) explanations	Section 3.5
Alarm occurrence timing chart	Section 3.7
Interfaces	Section 3.8
SSCNET III cable connection	Section 3.9
Grounding	Section 3.11
Switch setting and display of the servo amplifier	Section 4.3

15.3 Operation and functions

POINT

- When using the direct drive motor, set [Pr. PA01] to "__ 6 __".
- For the test operation, refer to section 4.4.
- The Z-phase pulse of the direct drive motor must be turned on after power-on. When the machine configuration does not allow one or more revolution of the direct drive motor, install the direct drive motor so that the Z-phase pulse can be turned on.

15. USING A DIRECT DRIVE MOTOR

15.3.1 Startup procedure

Start up the direct drive servo in the following procedure.

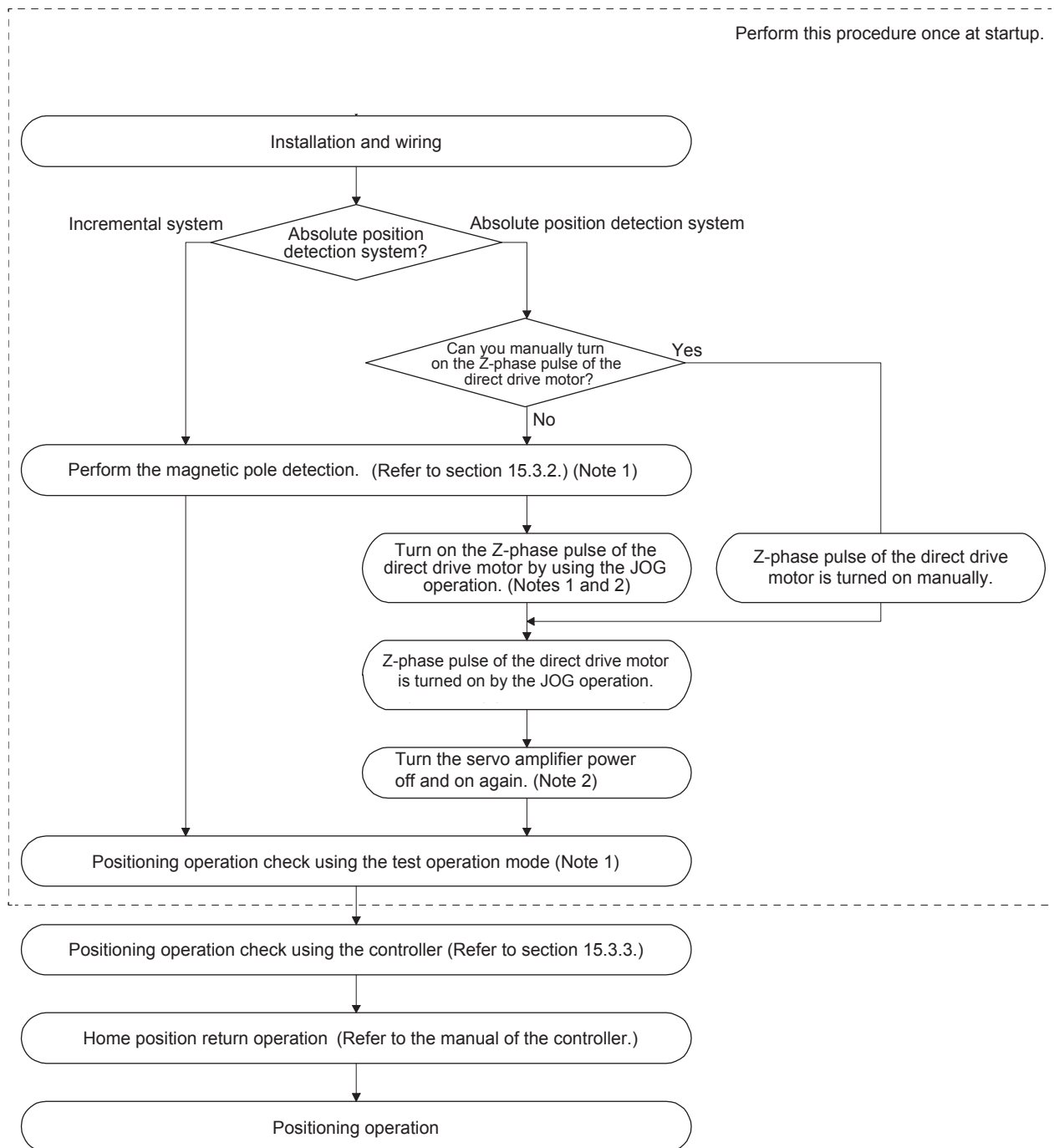

Note 1. Use MR Configurator2.

- For the absolute position detection system, always turn on the Z-phase pulse of the direct drive motor while the servo amplifier power is on, and then turn the servo amplifier power supply off and on again. By turning off and on the power supply, the absolute position becomes confirmed. Without this operation, the absolute position will not be regained properly, and a warning will occur at the controller.

- If the Z-phase pulse of the direct drive motor can be turned on manually, the Z-phase pulse does not have to be turned on by the magnetic pole detection or the JOG operation.

For this operation, always connect the direct drive motor encoder and the servo amplifier, and turn on only the control power supply of the servo amplifier (L11 and L21) (turn off the main circuit power supply L1, L2, and L3). Perform this operation by considering the safety.

15. USING A DIRECT DRIVE MOTOR

15.3.2 Magnetic pole detection

POINT
<ul style="list-style-type: none">● The magnetic pole detection is not required for the configured absolute position detection system where the Z-phase pulse of the direct drive motor can be turned on manually. For this operation, always connect the direct drive motor encoder and the servo amplifier and turn on the control power supply of the servo amplifier. Perform this operation by considering the safety.

Before the positioning operation of the direct drive motor, make sure to perform the magnetic pole detection. Before starting up the equipment, perform the test operation (positioning operation) of MR Configurator2.

15. USING A DIRECT DRIVE MOTOR

(1) Magnetic pole detection method by using MR Configurator2

The following shows the magnetic pole detection procedure by using MR Configurator2.

(a) Magnetic pole detection by the position detection method

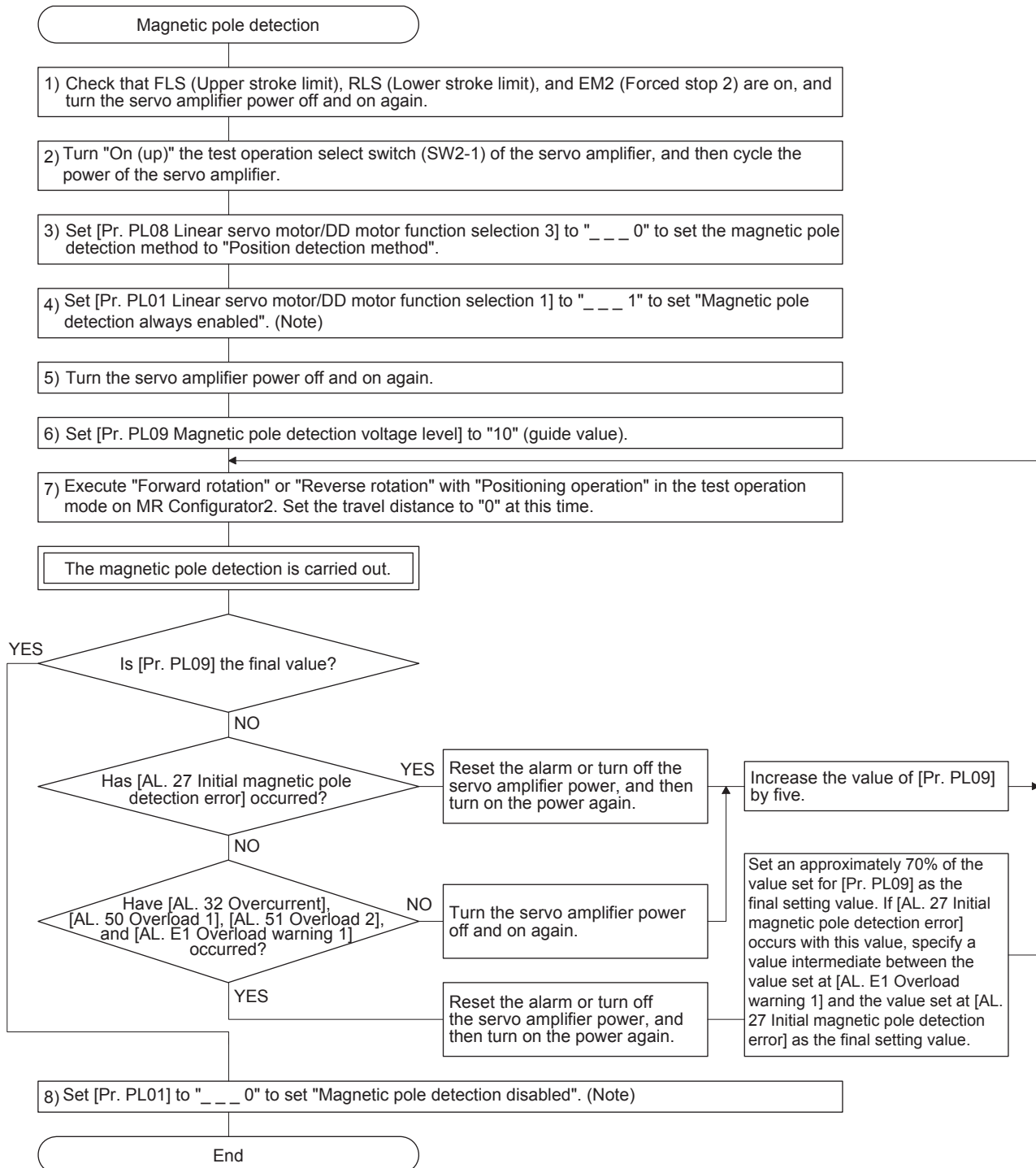

Note. For the incremental system, the [Pr. PL01] setting is not required.

15. USING A DIRECT DRIVE MOTOR

(b) Magnetic pole detection by the minute position detection method

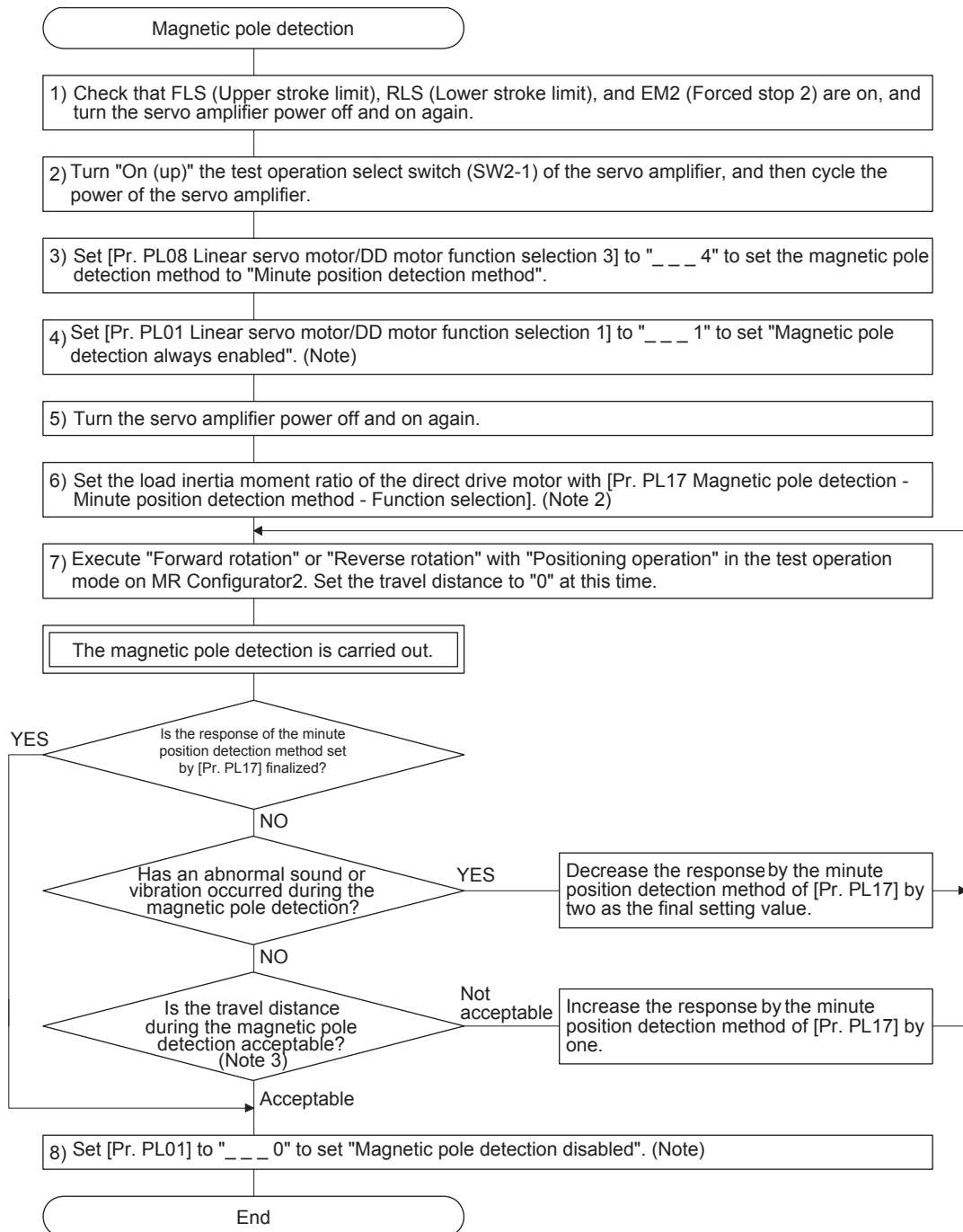

- Note 1. For the incremental system, the [Pr. PL01] setting is not required.
- Note 2. If the load to direct drive motor inertia ratio is unknown, perform the magnetic pole detection by the position detection method, and then perform the auto tuning to set an estimated value.
- Note 3. For the magnetic pole detection by the minute position detection method, the maximum rotation angle at the magnetic pole detection must be five degrees or less. To shorten the travel distance, increase the response by the minute position detection method in [Pr. PL17].

15. USING A DIRECT DRIVE MOTOR

- (c) State transition of the servo amplifier display (3-digit, 7-segment LED) at the magnetic pole detection
 When the magnetic pole detection with MR Configurator2 is normally executed, the servo amplifier display (3-digit, 7-segment LED) shows the state as below.

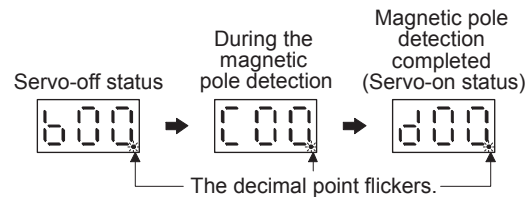

- (2) Preparation for the magnetic pole detection

POINT
<ul style="list-style-type: none"> ● When the test operation mode is selected with the test operation select switch (SW2-1), the SSCNET III/H communication for the servo amplifier in the test operation mode and the following servo amplifiers is blocked.

For the magnetic pole detection, use the test operation mode (positioning operation) of MR Configurator2. Turn off the servo amplifier power, and set the test operation select switch (SW2-1) and the disabling control axis switch (SW2-2, SW2-3, and SW2-4) as shown below. Turning on the power enables the test operation mode.

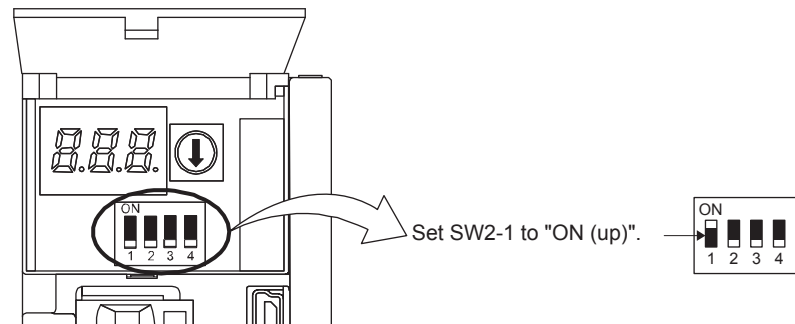

15. USING A DIRECT DRIVE MOTOR

(3) Operation at the magnetic pole detection

WARNING ● Note that the magnetic pole detection automatically starts simultaneously with the turning-on of the servo-on command.

CAUTION ● If the magnetic pole detection is not executed properly, the direct drive motor may operate unexpectedly.

POINT

- Establish the machine configuration using FLS (Upper stroke limit) and RLS (Lower stroke limit). Otherwise, the machine may be damaged due to a collision.
- At the magnetic pole detection, whether the motor rotates in the forward or reverse direction is unpredictable.
- Depending on the setting value of [Pr. PL09 Magnetic pole detection voltage level], an overload, overcurrent, magnetic pole detection alarm, or others may occur.
- When performing the positioning operation from a controller, use the sequence which confirms the normal completion of the magnetic pole detection and the servo-on status, then outputs the positioning command. If the controller outputs the positioning command before RD (Ready) turns on, the command may not be accepted or a servo alarm may occur.
- After the magnetic pole detection, check the positioning accuracy with the test operation (positioning operation function) of MR Configurator2.
- The accuracy of the magnetic pole detection improves with no load.

(a) Incremental system

POINT

- When the motor is used in the incremental system, the magnetic pole detection is required when the power is turned on.

For the incremental system, the magnetic pole detection is required every time the power is turned on. By turning on the servo-on command from the controller after the power-on, the magnetic pole detection is automatically carried out. Therefore, there is not need to set the parameter (first digit of [Pr. PL01]) for executing the magnetic pole detection.

1) Timing chart

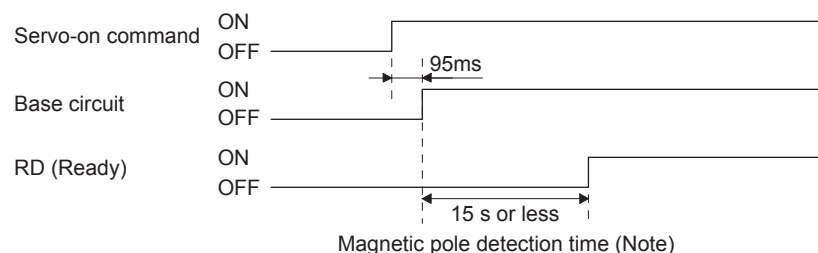

Note. The magnetic pole detection time indicates the operation time when FLS (Upper stroke limit) and RLS (Lower stroke limit) are on.

15. USING A DIRECT DRIVE MOTOR

2) Direct drive motor movement (when FLS and RLS are on)

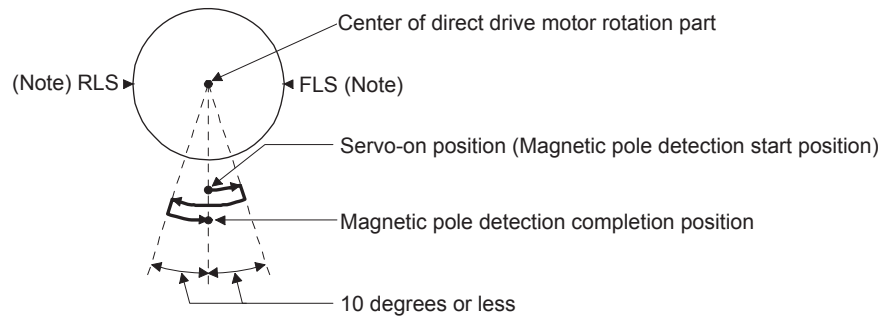

Note. When the stroke limit (FLS or RLS) turns off during the magnetic pole detection, the magnetic pole detection is carried on to the opposite direction. When FLS and RLS are off, [AL. 27 Initial magnetic pole detection error] occurs.

3) Direct drive motor movement (when FLS or RLS is off)

When FLS or RLS is off at servo-on, the magnetic pole detection is carried out as follows.

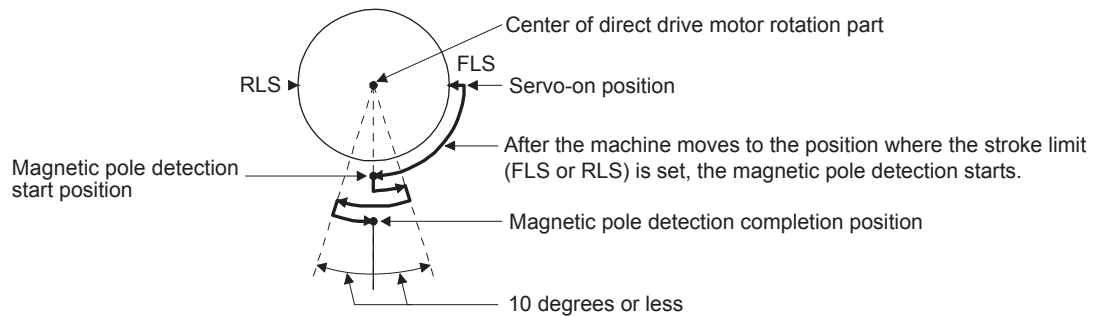

(b) Absolute position detection system

POINT
<ul style="list-style-type: none"> ● When the absolute position detection system is used, the magnetic pole detection is required when the power is turned on with the following timing. <ul style="list-style-type: none"> ▪ When the Z-phase pulse of the direct drive motor is not turned on at the system setup (When the Z-phase pulse of the direct drive motor can be turned on manually, the magnetic pole detection is not required.) ▪ After a direct drive motor is replaced ▪ When [AL. 25 Absolute position erased] has occurred ● Turn on the Z-phase pulse in JOG operation after the magnetic pole detection.

Perform the magnetic pole detection in the following procedure.

- 1) Set [Pr. PL01 Linear servo motor/DD motor function selection 1] to "___ 1" (Magnetic pole detection at first servo-on).

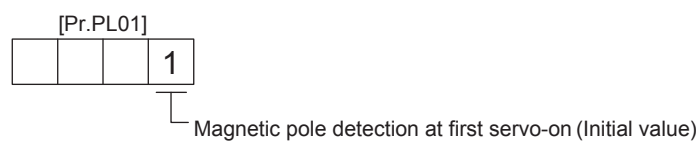

15. USING A DIRECT DRIVE MOTOR

- 2) Execute the magnetic pole detection. (Refer to (2) (a) 1), 2) of this section.)
- 3) After the completion of the magnetic pole detection, change [Pr. PL01] to "_ _ _ 0" (Magnetic pole detection enabled).

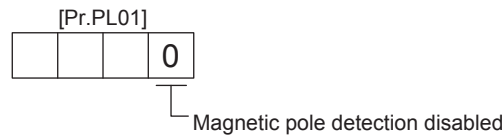

After the magnetic pole detection, by turning on the Z-phase pulse in JOG operation and by disabling the magnetic pole detection function with [Pr. PL01], the magnetic pole detection after each power-on is not required.

(4) Magnetic pole detection method setting

Set the magnetic pole detection method using the first digit of [Pr. PL08] (Magnetic pole detection method selection).

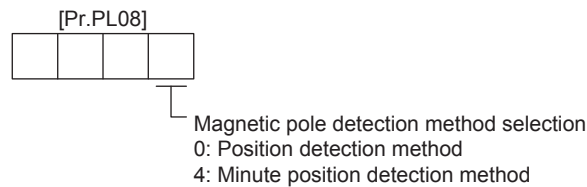

(5) Setting of the magnetic pole detection voltage level by the position detection method

For the magnetic pole detection by the position detection method, set the voltage level with [Pr. PL09 Magnetic pole detection voltage level]. For the magnetic pole detection by the minute position detection method, the voltage level setting is not required.

(a) Guideline of parameter settings

Set the parameters by referring to the following table.

[Pr. PL09] setting (Guide value)	Small ← Medium → Large (10 or less (initial value) 50 or more)	
Servo status		
Torques required for operation	Small	Large
Overload, overcurrent alarm	Not frequently occurs	Frequently occurs
Magnetic pole detection alarm	Frequently occurs	Not frequently occurs
Magnetic pole detection accuracy	Low	High

(b) Setting procedure

- 1) Perform the magnetic pole detection, and increase the setting value of [Pr. PL09 Magnetic pole detection voltage level] until [AL. 50 Overload 1], [AL. 51 Overload 2], [AL. E1 Overload warning 1], and [AL. EC Overload warning 2] occur. Increase the setting value by five as a guide value. When these alarms and warnings occur during the magnetic pole detection by using MR Configurator2, the test operation of MR Configurator2 automatically completes and the servo-off status is established.
- 2) Specify the setting value that is an approximately 70% of the value set when [AL. 50 Overload 1], [AL. 51 Overload 2], [AL. E1 Overload warning 1], and [AL. EC Overload warning 2] occurred as the final setting value. However, if [AL. 27 Initial magnetic pole detection error] occurs with this value, specify a value intermediate between the value set at [AL. 50 Overload 1], [AL. 51 Overload 2], [AL. E1 Overload warning 1], or [AL. EC Overload warning 2] and the value set at the magnetic pole detection alarm as the final setting value.

15. USING A DIRECT DRIVE MOTOR

3) Perform the magnetic pole detection again with the final setting value.

(c) Setting example

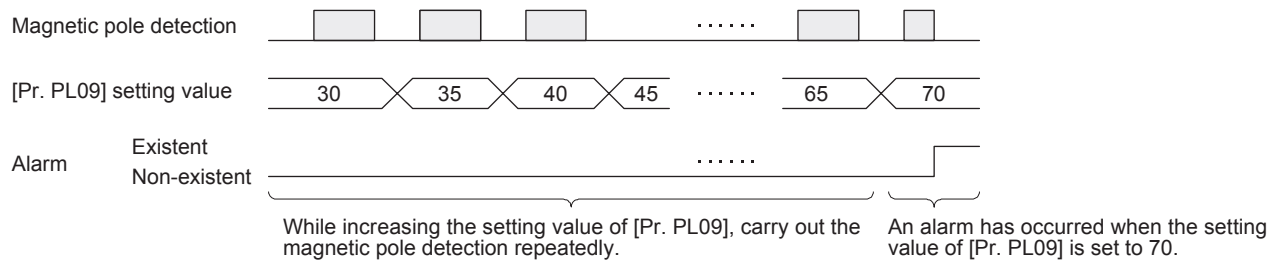

In this example, the final setting value of [Pr. PL09] is 49 (Setting value at the alarm occurrence = 70×0.7).

15.3.3 Operation from controller

To configure the absolute position detection system by using the direct drive motor, the battery unit (MR-BAT6V1SET) and the absolute position storage unit MR-BTAS01 are required.

(1) Operation method

For the incremental system, the magnetic pole detection is automatically performed at the first servo-on after the power-on. For this reason, when performing the positioning operation, create the sequence which surely confirms the servo-on status as the inter lock condition of the positioning command.

Also, some parameter settings and the home position return differ according to the controller type.

15. USING A DIRECT DRIVE MOTOR

(2) Servo system controller setting

The following parameters will be valid by turning the servo amplifier power off and on again after the controller writes the parameters to the servo amplifier.

Setting item				Setting	
				Motion controller Q17_DSCPU	Simple motion module QD77MS_
Amplifier setting				MR-J4-B DD	
Motor setting				Automatic setting	
No.	(Note) Symbol	Name	Initial value	Set the items as required.	
PA01	**STY	Operation mode	1000h		
PC01	*ERZ	Error excessive alarm level	0		
PC03	*ENRS	Encoder output pulse selection	0000h		
PL01	**LIT1	Linear servo motor/DD motor function selection 1	0301h		
PL04	*LIT2	Linear servo motor/DD motor function selection 2	0003h		
PL05	LB1	Position deviation error detection level	0		
PL06	LB2	Speed deviation error detection level	0		
PL07	LB3	Torque/thrust deviation error detection level	100		
PL08	*LIT3	Linear servo motor/DD motor function selection 3	0010h		
PL09	LPWM	Magnetic pole detection voltage level	30		
PL17	LTSTS	Magnetic pole detection - Minute position detection method - Function selection	0000h		
PL18	IDLV	Magnetic pole detection - Minute position detection method - Identification signal amplitude	0		

Note. The parameter whose symbol is preceded by * is enabled with the following conditions:

* : After setting the parameter, power off and on the servo amplifier or reset the controller.

** : After setting the parameter, power off and on the servo amplifier.

15. USING A DIRECT DRIVE MOTOR

15.3.4 Function

(1) Servo control error detection function

POINT
<p>● For the servo control error detection function, the position and speed deviation error detections are enabled by default. ([Pr. PL04]: ___ 3)</p>

If the servo control gets unstable for some reasons, the direct drive motor may not operate properly. To detect this state and to stop operation, the servo control error detection function is used as a protective function.

The servo control error detection function has three different detection methods: the position deviation, speed deviation, and torque deviation. An error is detected when each method is enabled with [Pr. PL04 Linear servo motor/DD motor function selection 2]. The detection level can be changed with [Pr. PL05], [Pr. PL06], and [Pr. PL07].

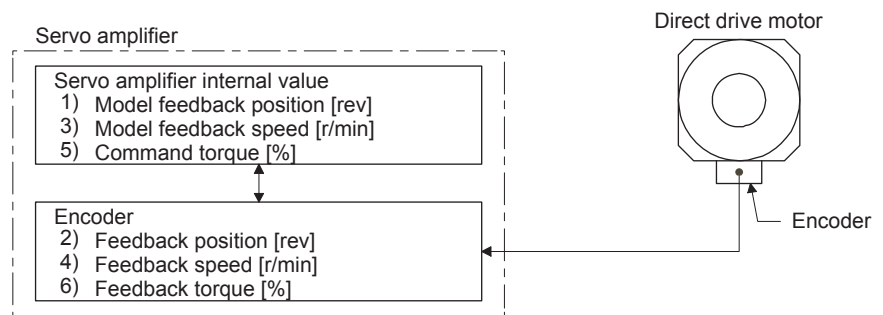
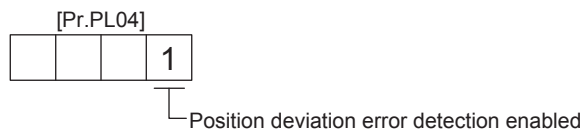

Figure 15.1 Outline of servo control error detection function

(a) Position deviation error detection

Set [Pr. PL04] to "___ 1" to enable the position deviation error detection.



When you compare the model feedback position (1)) and the feedback position (2)) in figure 15.1, if the deviation is more than the value of [Pr. PL05 Position deviation error detection level] (1 rev to 1000 rev), [AL. 42.1 Servo control error by position deviation] will occur and the linear servo motor will stop. The initial value of this detection level is 0.09 rev. Replace the set value as required.

(b) Speed deviation error detection

Set [Pr. PL04] to "___ 2" to enable the speed deviation error detection.

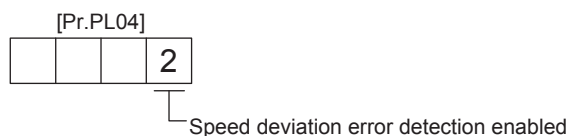

When you compare the model feedback speed (3)) and the feedback speed (4)) in figure 15.1, if the deviation is more than the value of [Pr. PL06 Speed deviation error detection level] (1 r/min to 2000 r/min), [AL. 42 Servo control error] will occur and the linear servo motor will stop. The initial value of this detection level is 100 r/min. Replace the set value as required.

15. USING A DIRECT DRIVE MOTOR

(c) Torque deviation error detection level

Set [Pr. PL04] to "___4" to enable the torque deviation error detection.

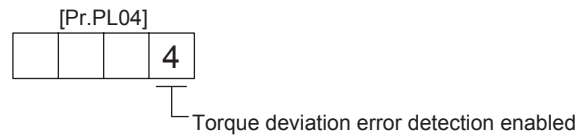

When you compare the command torque (5) and the feedback torque (6) in figure 15.1, if the deviation is more than the value of [Pr. PL07 Torque/thrust deviation error detection level] (1% to 1000%), [AL. 42 Servo control error] will occur and the linear servo motor will stop. The initial value of this detection level is 100%. Replace the set value as required.

(d) Detecting multiple deviation errors

When setting [Pr. PL04] as shown below, multiple deviation errors can be detected. For the error detection methods, refer to (1) (a), (b), (c) of this section.

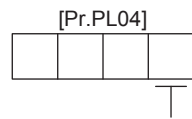

Setting value	Position deviation error detection	Speed deviation error detection	Torque deviation error detection
1	○	○	○
2	○	○	○
3	○	○	○
4	○	○	○
5	○	○	○
6	○	○	○
7	○	○	○

15.4 Characteristics

15.4.1 Overload protection characteristics

An electronic thermal is built in the servo amplifier to protect the servo amplifier, the direct drive motor, and direct drive motor power wires from overloads.

[AL. 50 Overload 1] occurs if overload operation performed is above the electronic thermal protection curve shown in Fig. 15.2. [AL. 51 Overload 2] occurs if the maximum current is applied continuously for several seconds due to machine collision, etc. Use the equipment on the left-hand side area of the continuous or broken line in the graph.

When unbalanced torque is generated, such as in a vertical lift machine, it is recommended that the unbalanced torque of the machine be kept at 70% or less of the motor's rated torque.

This servo amplifier has solid-state direct drive motor overload protection for each axis. (The direct drive motor overload current (full load current) is set on the basis of 120% rated current of the servo amplifier.)

15. USING A DIRECT DRIVE MOTOR

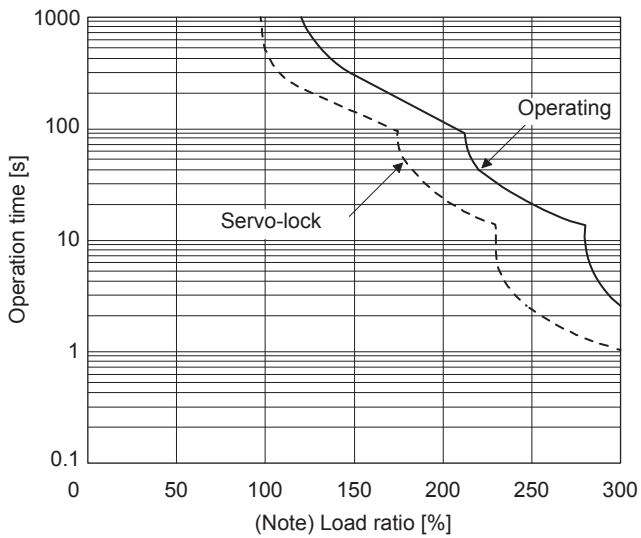

TM-RFM002C20, TM-RFM004C20,
 TM-RFM006C20, TM-RFM006E20,
 TM-RFM012E20, TM-RFM018E20,
 TM-RFM012G20, TM-RFM040J10

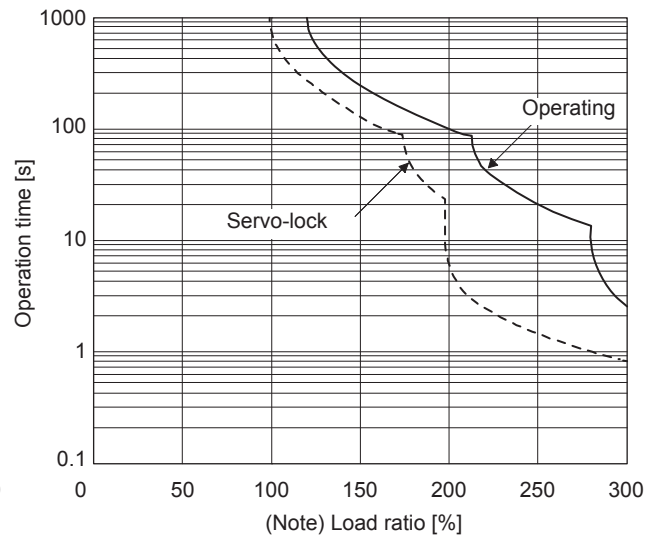

TM-RFM048G20, TM-RFM072G20,
 TM-RFM120J10

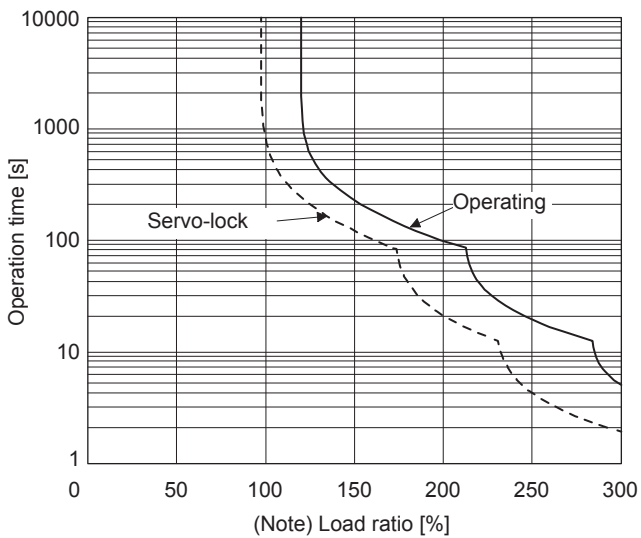

TM-RFM240J10

Note. If operation that generates torque more than 100% of the rating is performed with an abnormally high frequency in a direct drive motor stop status (servo-lock status) or in a 30 r/min or less low-speed operation status, the servo amplifier may malfunction regardless of the electronic thermal protection.

Fig. 15.2 Electronic thermal protection characteristics

15. USING A DIRECT DRIVE MOTOR

15.4.2 Power supply capacity and generated loss

Table 15.1 indicates servo amplifiers' power supply capacities and losses generated under rated load. For thermal design of an enclosed type cabinet, use the values in the table in consideration for the worst operating conditions. The actual amount of generated heat will be intermediate between values at rated torque and servo-off according to the duty used during operation. When the servo motor is run at less than the rated speed, the power supply capacity will be smaller than the value in the table, but the servo amplifier's generated heat will not change.

Table 15.1 Power supply capacity and generated loss per direct drive motor at rated output

Servo motor	Power supply capacity [kVA]	Servo amplifier-generated heat [W]		Area required for heat dissipation [m ²]
		At rated output	With servo-off	
TM-RFM002C20	0.25	25	15	0.5
TM-RFM004C20	0.38	35	15	0.7
TM-RFM006C20	0.53	40	15	0.8
TM-RFM006E20	0.46	40	15	0.8
TM-RFM012E20	0.81	50	15	1.0
TM-RFM018E20	1.3	50	15	1.0
TM-RFM012G20	0.71	50	15	1.0
TM-RFM048G20	2.7	90	20	1.8
TM-RFM072G20	3.8	110	20	2.2
TM-RFM040J10	1.2	50	15	1.0
TM-RFM120J10	3.4	90	20	1.8
TM-RFM240J10	6.6	160	25	3.2

15.4.3 Dynamic brake characteristics

POINT
<ul style="list-style-type: none"> ● Do not use dynamic brake to stop in a normal operation as it is the function to stop in emergency. ● For a machine operating at the recommended load to motor inertia ratio or less, the estimated number of usage times of the dynamic brake is 1000 times while the machine decelerates from the rated speed to a stop once in 10 minutes. ● Be sure to enable EM1 (Forced stop 1) after the direct drive motor stops when using EM1 (Forced stop 1) frequently in other than emergency.

15. USING A DIRECT DRIVE MOTOR

(1) Dynamic brake operation

(a) Calculation of coasting distance

Fig. 15.3 shows the pattern in which the servo motor comes to a stop when the dynamic brake is operated. Use equation 15.1 to calculate an approximate coasting distance to a stop. The dynamic brake time constant τ varies with the direct drive motor and machine operation speeds. (Refer to (1) (b) of this section.)

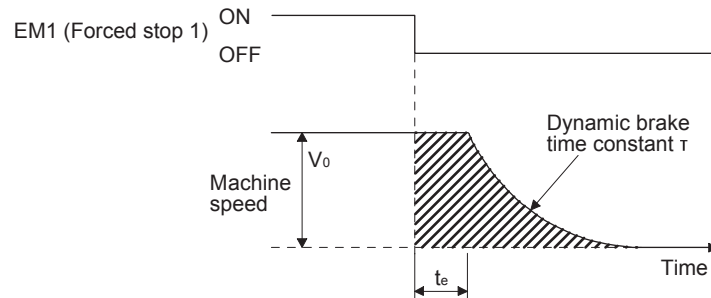

Fig. 15.3 Dynamic brake operation diagram

$$L_{\max} = \frac{V_0}{60} \cdot \left\{ t_e + T \left(1 + \frac{J_L}{J_M} \right) \right\} \dots \dots \dots (15.1)$$

- | | | |
|------------|--|-----------------------|
| L_{\max} | : Maximum coasting distance | [mm] |
| V_0 | : Machine's fast feed speed | [mm/min] |
| J_M | : Moment of inertia of direct drive motor | [kg·cm ²] |
| J_L | : Load moment of inertia converted into equivalent value on direct drive motor rotor | [kg·cm ²] |
| τ | : Dynamic brake time constant | [s] |
| t_e | : Delay time of control section | [s] |
- There is internal relay delay time of about 10 ms.

15. USING A DIRECT DRIVE MOTOR

(b) Dynamic brake time constant

The following shows necessary dynamic brake time constant τ for equation 15.1.

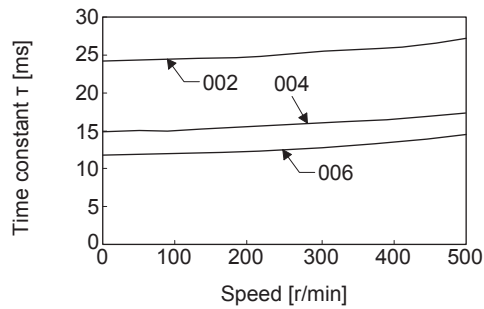

TM-RFM_C20

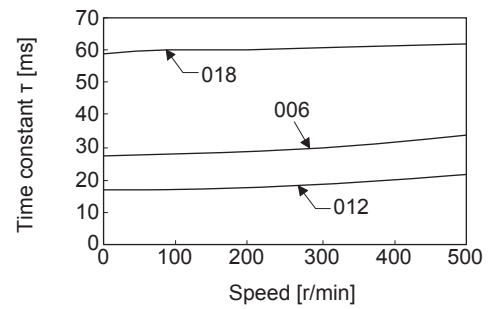

TM-RFM_E20

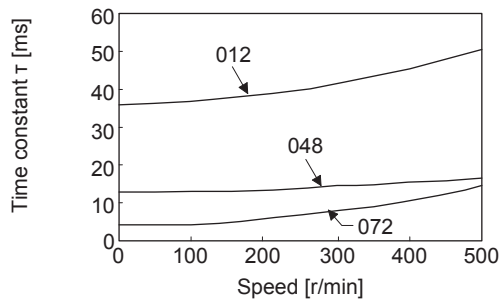

TM-RFM_G20

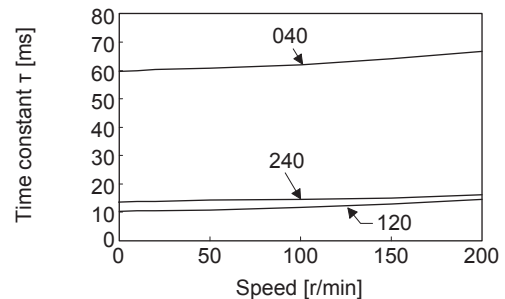

TM-RFM_J10

(2) Permissible load to motor inertia ratio when the dynamic brake is used

Use the dynamic brake under the load to motor inertia ratio indicated in the following table. If the load inertia moment is higher than this value, the dynamic brake may burn. If the load to motor inertia ratio exceeds the indicated value, contact your local sales office.

The values of the permissible load to motor inertia ratio in the table are the values at the maximum rotation speed of the direct drive motor.

The value in the parenthesis shows the value at the rated speed of the direct drive motor.

Direct drive motor	Servo amplifier						
	MR-J4-20_	MR-J4-40_	MR-J4-60_	MR-J4-70_	MR-J4-100_	MR-J4-350_	MR-J4-500_
TM-RFM002C20	100 (300)	100 (300)	100 (300)	/	/	/	/
TM-RFM004C20	100 (300)	100 (300)	100 (300)				
TM-RFM006C20	100 (300)	100 (300)	100 (300)				
TM-RFM006E20	/	/	100 (300)	100 (300)	100 (300)	/	/
TM-RFM012E20			100 (300)	100 (300)	100 (300)		
TM-RFM018E20			100 (300)	100 (300)	100 (300)		
TM-RFM012G20	/	/	/	50 (300)	/	50 (300)	/
TM-RFM048G20				50 (300)		50 (300)	
TM-RFM072G20				50 (300)		50 (300)	
TM-RFM040J10	/	/	/	50 (200)	/	50 (200)	50 (200)
TM-RFM120J10				50 (200)		50 (200)	
TM-RFM240J10				50 (200)		50 (200)	
TM-RFM240J10				50 (200)		50 (200)	

16. FULLY CLOSED LOOP SYSTEM (available in the future)

The following table shows the functions of each control mode.

Control	Description	
Semi closed loop control	Feature	Position is controlled according to the servo motor-side data.
	Advantage	Since this control is insusceptible to machine influence (such as machine resonance), the gains of the servo amplifier can be raised and the settling time shortened.
	Disadvantage	If the servo motor side is at a stop, the side may be vibrating or the load-side accuracy not obtained.
Dual feedback control	Feature	Position is controlled according to the servo motor-side data and load-side data.
	Advantage	Control is performed according to the servo motor-side data during operation, and according to the load side-data at a stop in sequence to raise the gains during operation and shorten the settling time. A stop is made with the load-side accuracy.
Fully closed loop control	Feature	Position is controlled according to the load-side data.
	Advantage	The load-side accuracy is obtained not only at a stop but also during operation.
	Disadvantage	Since this control is susceptible to machine resonance or other influences, the gains of the servo amplifier may not rise.

16. FULLY CLOSED LOOP SYSTEM (available in the future)

16.1.2 Selecting procedure of control mode

(1) Control mode configuration

In this servo, a semi closed loop system or fully closed loop system can be selected as a control system. In addition, on the fully closed loop system, the semi closed loop control, fully closed loop control and dual feedback control can be selected by the [Pr. PE08] settings.

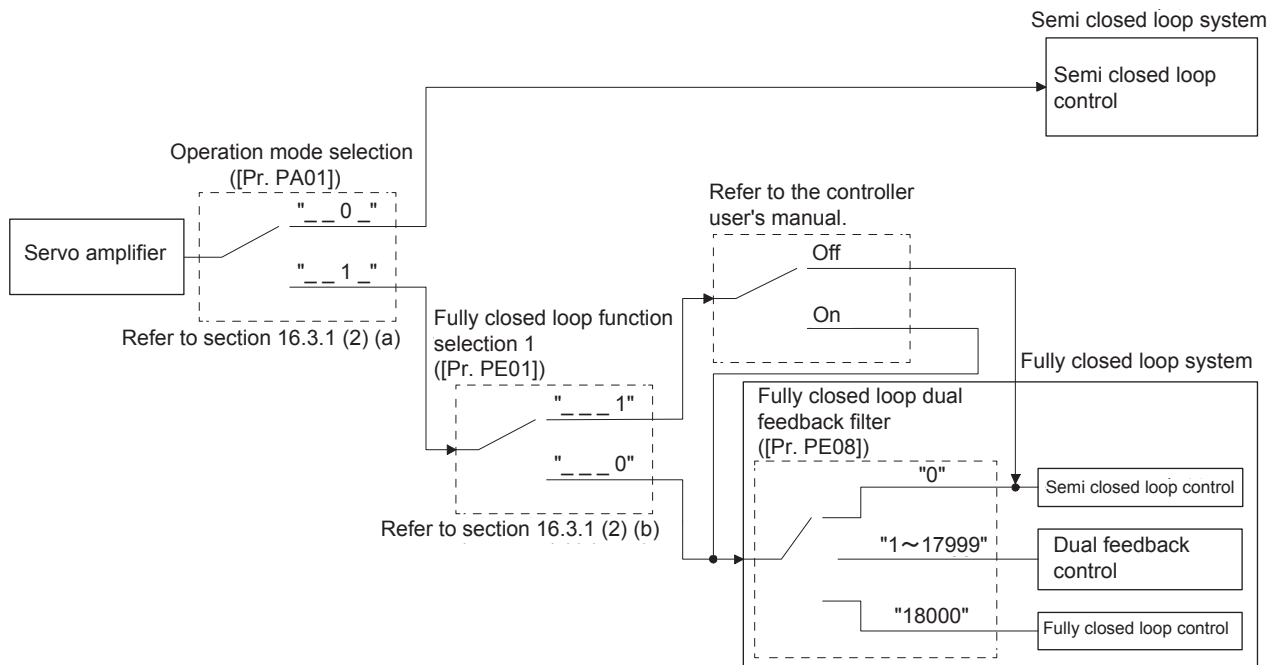

(2) Dual feedback filter equivalent block diagram

A dual feedback filter equivalent block diagram on the dual feedback control is shown below.

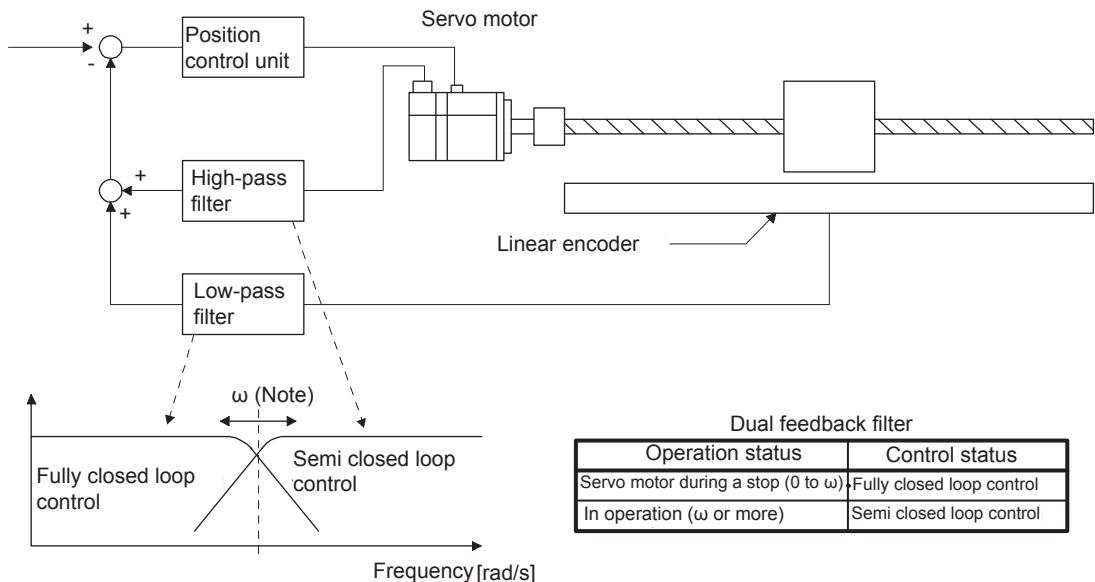

Dual feedback filter	
Operation status	Control status
Servo motor during a stop (0 to ω)	Fully closed loop control
In operation (ω or more)	Semi closed loop control

Note. " ω " (a dual feedback filter band) is set by [Pr. PE08].

16. FULLY CLOSED LOOP SYSTEM (available in the future)

16.1.3 System configuration

(1) For a linear encoder

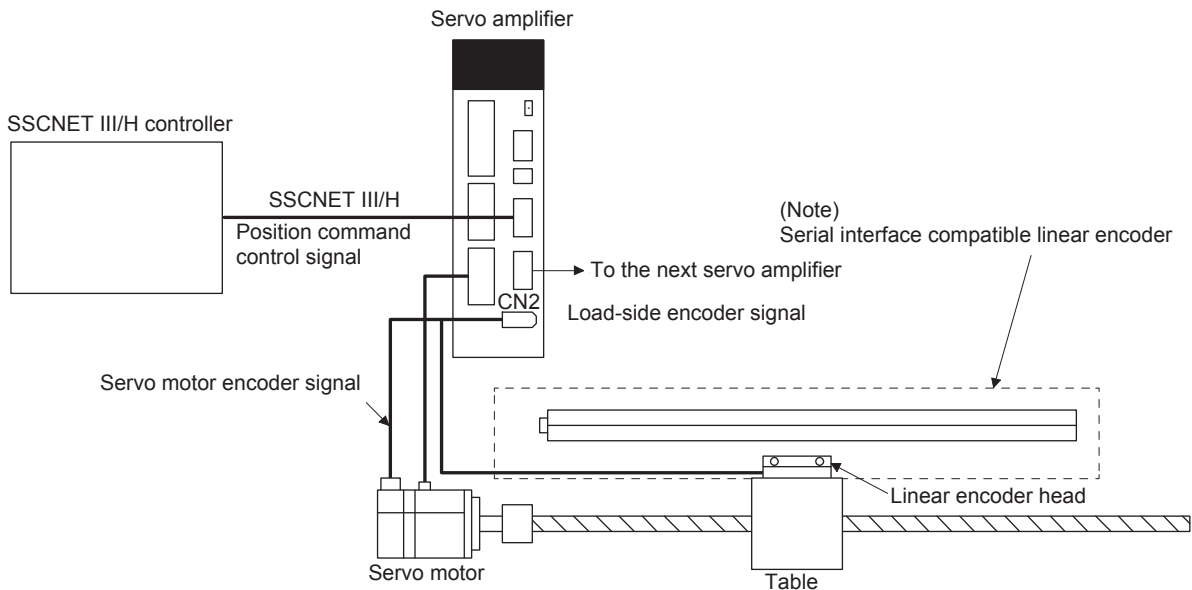

Note. Applicable for the absolute position detection system when an absolute position linear encoder is used.
In that case, a battery (MR-BAT6V1SET) is not required.

(2) For a rotary encoder

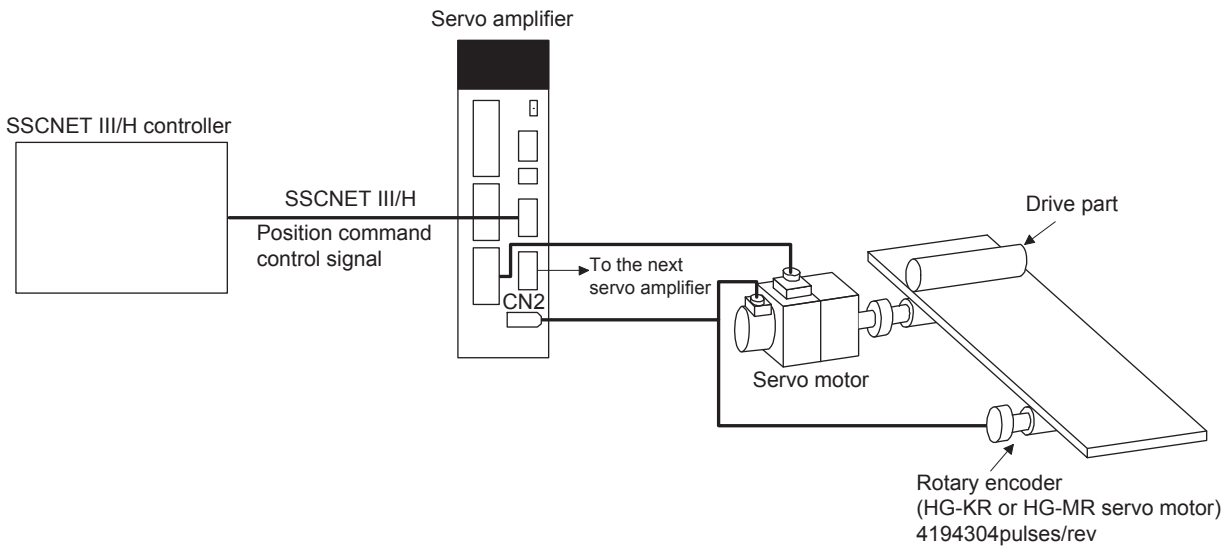

16. FULLY CLOSED LOOP SYSTEM (available in the future)

16.2 Load-side encoder

POINT
<ul style="list-style-type: none"> ● Always use the load-side encoder cable introduced in this section. Using other products may cause a malfunction. ● For details of the load-side encoder specifications, performance and assurance, contact each encoder manufacturer.

16.2.1 LINEAR ENCODER

Linear encoder type	Manufacturer	Model	Communication method
Absolute type	Magnescape	SR77 SR87	Two-wire type
	Mitutoyo	AT343A AT543A-SC AT545A-SC ST741A ST742A ST743A ST744A	Two-wire type
	Renishaw	RESOLUTE RL40M	Two-wire type
Incremental type	Magnescape	SR75 SR85 SL710 + PL101-RM/RHM	Two-wire type
	Renishaw	RGH26P RGH26Q	Two-wire type

16.2.2 Rotary encoder

When a rotary encoder is used for the load-side encoder, use HG-KR or HG-MR servo motor as an encoder. Use a two-wire type encoder cable. Do not use MR-EKCBL30M-L, MR-EKCBL30M-H, MR-EKCBL40M-H, or MR-EKCBL50M-H as they are four-wire type.

16.2.3 Configuration diagram of encoder cable

Configuration diagram for servo amplifier and load-side encoder is shown below. Cables used vary, depending on the load-side encoder.

(1) Linear encoder

Refer to Linear Encoder Instruction Manual for encoder cables for linear encoder.

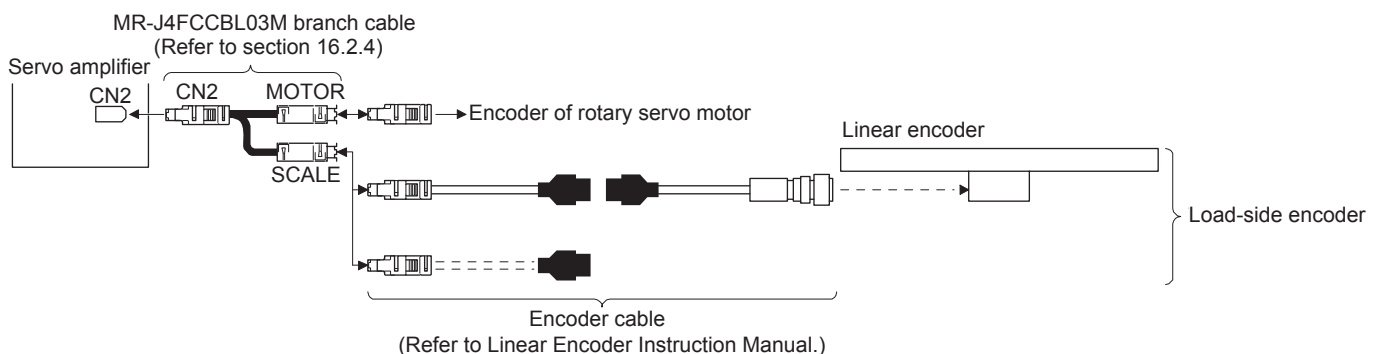

16. FULLY CLOSED LOOP SYSTEM (available in the future)

(2) Rotary encoder

Refer to Linear Encoder Instruction Manual for encoder cables for rotary encoder.

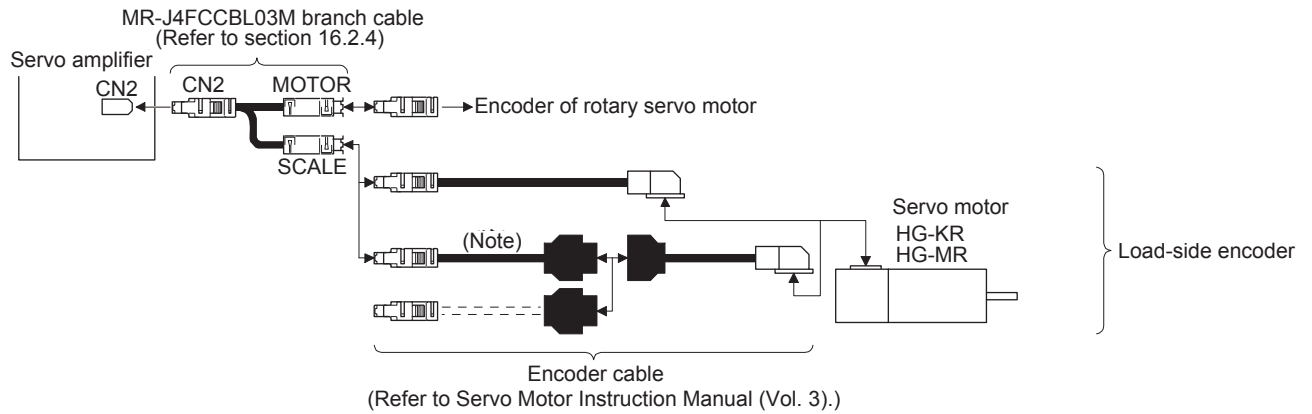

Note. Use a two-wire type encoder cable. A four-wire type linear encoder cable cannot be used.

16. FULLY CLOSED LOOP SYSTEM (available in the future)

16.2.4 MR-J4FCCBL03M branch cable

Use MR-J4FCCBL03M branch cable to connect the rotary encoder and the load-side encoder to CN2 connector.

When fabricating the branch cable using MR-J3THMCN2 connector set, refer to Linear Encoder Instruction Manual.

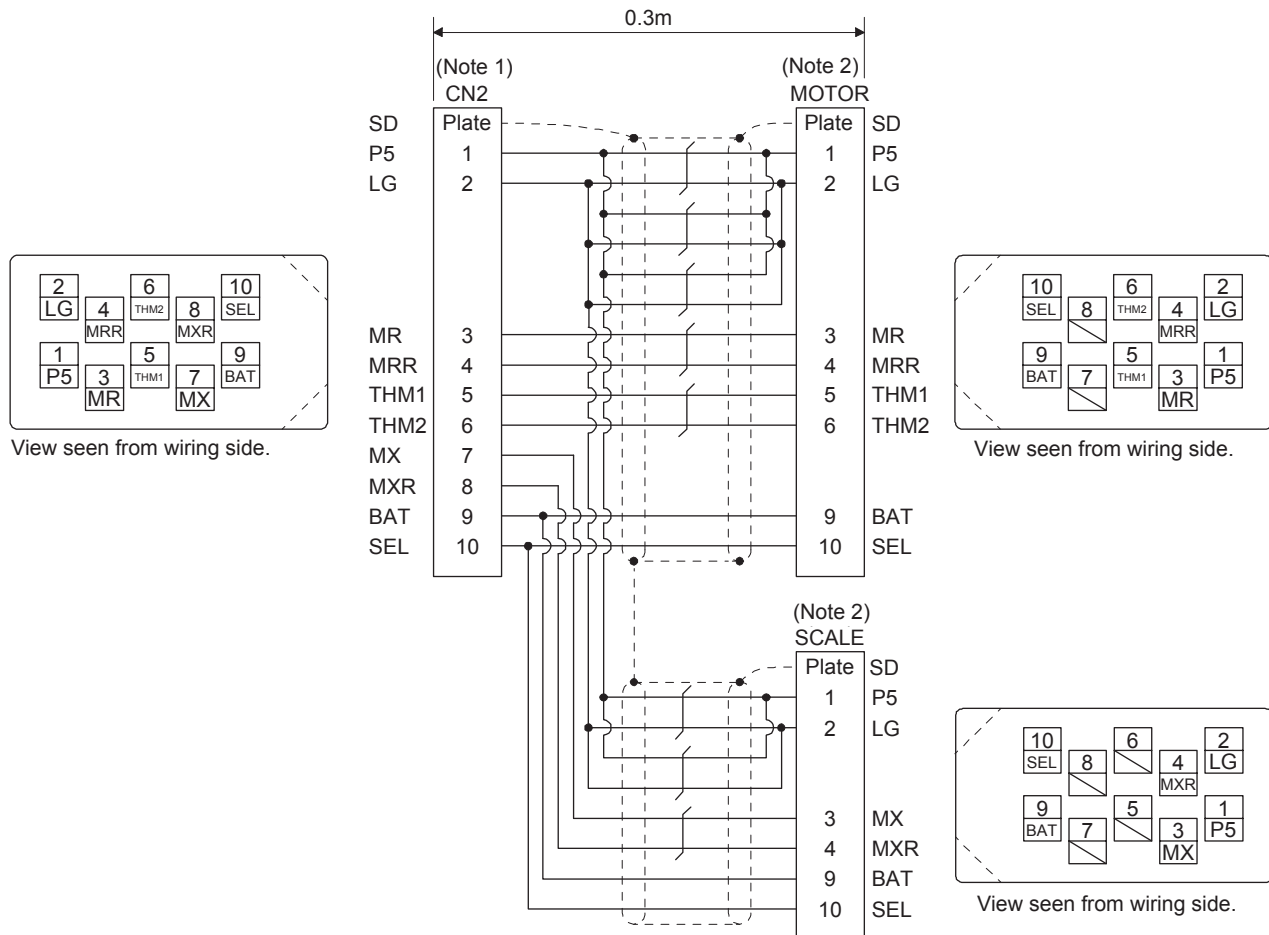

- Note 1. Receptacle: 36210-0100PL, shell kit: 36310-3200-008 (3M)
2. Plug: 36110-3000FD, shell kit: 36310-F200-008 (3M)

16. FULLY CLOSED LOOP SYSTEM (available in the future)

16.3 Operation and functions

16.3.1 Startup

(1) Startup procedure

Start up the fully closed loop system in the following procedure.

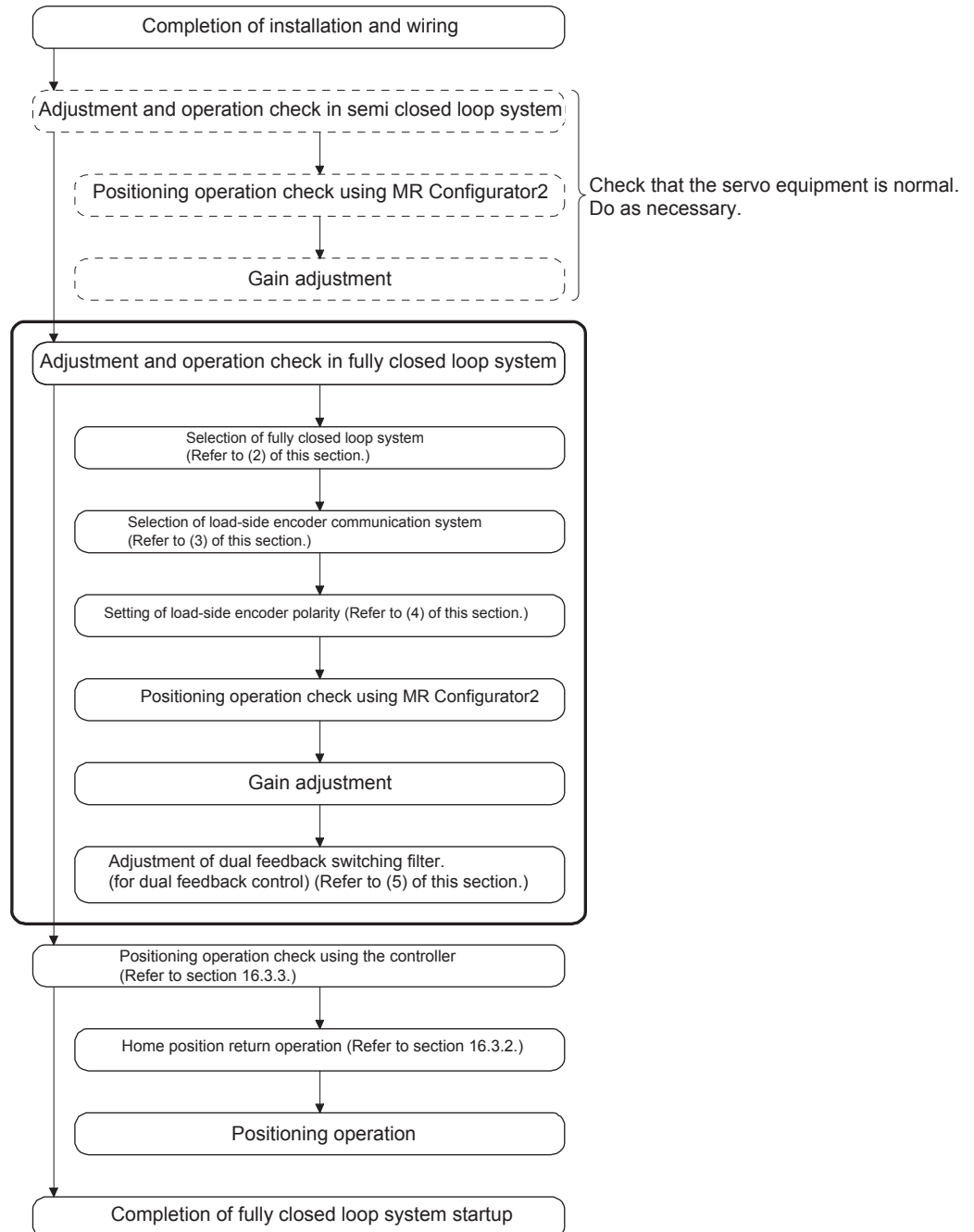

16. FULLY CLOSED LOOP SYSTEM (available in the future)

(2) Selection of fully closed loop system

By setting [Pr. PA01], [Pr. PE01] and the control command of controller, the control method can be selected as shown in the following table.

[Pr. PA01]	[Pr. PE01]	Semi closed loop control/ fully closed loop control selection command	Command unit	Control System	Absolute position detection system
"_ _ 0 _" Semi closed loop system (standard control mode)			Servo motor encoder unit	Semi closed loop control	○
"_ _ 1 _" Fully closed loop system (fully closed loop control mode)			Load-side encoder unit	Dual feedback control (fully closed loop control)	○(Note)
	"_ _ _ 0"	Off		Semi closed loop control	×
	"_ _ _ 1"	On		Dual feedback control (fully closed loop control)	×

Note. Applicable when the load-side encoder is set as the absolute position encoder.

(1) Operation mode selection

Select a operation mode.

[Pr. PA01]
0 0 0

Operation mode selection

Setting value	Operation mode	Control unit
0	Semi closed loop system (Standard control mode)	Servo motor-side resolution unit
1	Fully closed loop system (Fully closed loop control mode)	Load-side encoder resolution unit

(b) Semi closed loop control/fully closed loop control selection

Select the semi closed loop control/fully closed loop control.

[Pr. PE01]
0 0 0

Fully closed loop control selection

0: Always enabled

1: Switching using the control command of controller (switching between semi closed/fully closed)

Selection using the control command of controller	Control method
Off	Semi closed loop control
On	Fully closed loop control

When the control mode selection in [Pr. PA01] is set to "_ _ 1 _" (fully closed loop system), this setting is enabled.

16. FULLY CLOSED LOOP SYSTEM (available in the future)

(3) Setting of feedback pulse electronic gear

POINT
<p>● If an incorrect value is set in the feedback pulse electronic gear ([Pr. PE04], [Pr. PE05], [Pr. PE34], and [Pr. PE35]), [AL. 37 Parameter error] and an abnormal operation may occur. Also, it may cause [AL. 42.1 Servo control error by position deviation] during the positioning operation.</p>

The numerator ([Pr. PE04] and [Pr. PE34]) and denominator ([Pr. PE05] and [Pr. PE35]) of the electronic gear are set to the servo motor-side encoder pulse. Set the electronic gear so that the number of servo motor encoder pulses per servo motor revolution is converted to the number of load-side encoder pulses. The relational expression is shown below.

$$\frac{[\text{Pr. PE04}] \times [\text{Pr. PE34}]}{[\text{Pr. PE05}] \times [\text{Pr. PE35}]} = \frac{\text{Number of motor encoder pulses per servo motor revolution}}{\text{Number of load side encoder pulses per servo motor revolution}}$$

Select the load-side encoder so that the number of load-side encoder pulses per servo motor revolution is within the following range.

$$4096(2^{12}) \leq \text{Number of load-side encoder pulses per servo motor revolution} \leq 67108864 (2^{26})$$

(a) When the servo motor is directly coupled with a ball screw and the linear encoder resolution is 0.05 μm

Conditions

Servo motor resolution: 4194304 pulses/rev

Servo motor reduction ratio: 1/11

Ball screw lead: 20 mm

Linear encoder resolution: 0.05 μm

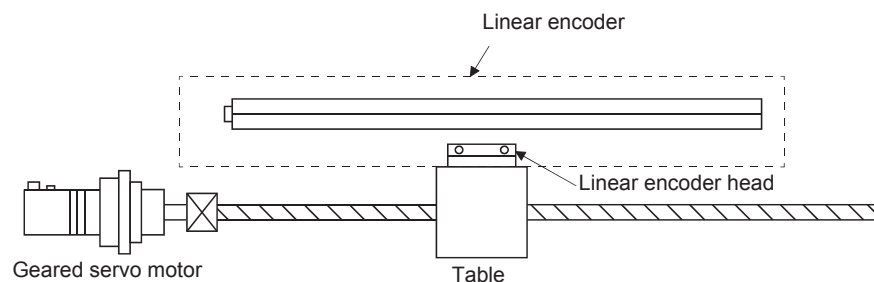

Calculate the number of linear encoder pulses per ball screw revolution.

Number of linear encoder pulses per ball screw revolution

= Ball screw lead/linear encoder resolution

= 20 mm/0.05 μm = 400000 pulses

$$\frac{1) [\text{Pr. PE04}] \times 2) [\text{Pr. PE34}]}{3) [\text{Pr. PE05}] \times 4) [\text{Pr. PE35}]} = \frac{400000}{4194304} \times \frac{1}{11} = \frac{1) 3125}{3) 32768} \times \frac{2) 1}{4) 11}$$

16. FULLY CLOSED LOOP SYSTEM (available in the future)

(b) Setting example when using the rotary encoder for the load-side encoder of roll feeder

Conditions

Servo motor resolution: 4194304 pulses/rev

Pulley diameter on the servo motor side: 30 mm

Pulley diameter on the rotary encoder side: 20 mm

Rotary encoder resolution: 4194304 pulse/rev

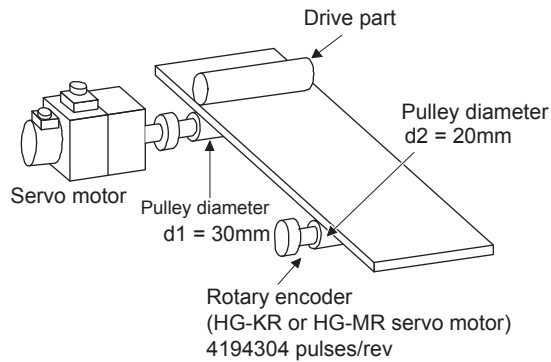

When the pulley diameters or reduction ratios differ, consider that in calculation.

$$\frac{1) [\text{Pr.PE04}] \times 2) [\text{Pr.PE34}]}{3) [\text{Pr.PE05}] \times 4) [\text{Pr.PE35}]} = \frac{4194304 \times 30}{4194304 \times 20} = \frac{1) 1}{3) 1} \times \frac{2) 3}{4) 2}$$

16. FULLY CLOSED LOOP SYSTEM (available in the future)

(4) Confirmation of load-side encoder position data

Check the load-side encoder mounting and parameter settings for any problems.

POINT
<ul style="list-style-type: none"> ● Depending on the check items, MR Configurator2 may be used. Refer to section 16.3.6 for the data displayed on the MR Configurator2.

When checking the following items, the fully closed loop control mode must be set. For the setting of control mode, refer to (2) in this section.

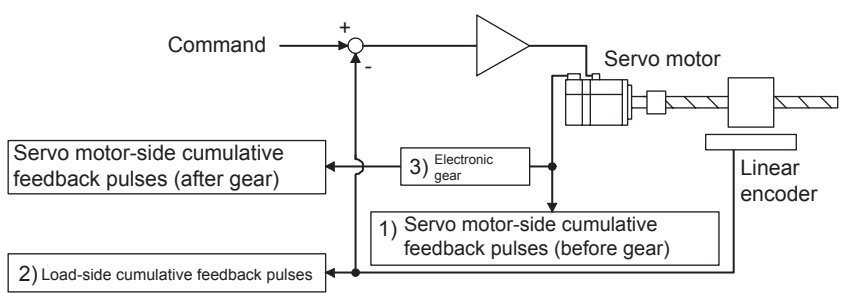
No.	Check item	Confirmation method and description
1	Read of load-side encoder position data	With the load-side encoder in a normal state (mounting, connection, etc.), the load-side cumulative feedback pulses value is counted normally when the load-side encoder is moved.
2	Read of load-side encoder scale home position (reference mark, Z-phase)	With the home position (reference mark, or Z-phase) of the load-side encoder in a normal condition (mounting, connection, etc.), the value of load-side encoder information 1 is cleared to 0 when the home position (reference mark, or Z-phase) is passed through by moving the load-side encoder.
3	Confirmation of load-side encoder feedback direction (Setting of load-side encoder polarity)	Confirm that the directions of the cumulative feedback pulses of servo motor encoder (after gear) and the load-side cumulative feedback pulses are matched by moving the device (load-side encoder) manually in the servo-off status. If mismatched, reverse the polarity.
4	Setting of load-side encoder electronic gear	<p>When the servo motor and load-side encoder operate synchronously, the servo motor-side cumulative feedback pulses (after gear) and load-side cumulative feedback pulses are matched and increased.</p> <p>If mismatched, review the setting of fully closed loop control feedback electronic gear ([Pr. PE04], [Pr. PE05], [Pr. PE34], and [Pr. PE35]) with the following method.</p> <ol style="list-style-type: none"> 1) Check the servo motor-side cumulative feedback pulses (before gear). 2) Check the load-side cumulative feedback pulses. 3) Check that the ratio of above 1) and 2) has been that of the feedback electronic gear. 

16. FULLY CLOSED LOOP SYSTEM (available in the future)

(5) Setting of fully closed loop dual feedback filter

With the initial value (setting = 10) set in [Pr. PE08 Fully closed loop dual feedback filter the dual feedback filter], make gain adjustment by auto tuning, etc. as in semi closed loop control. While observing the servo operation waveform with the graph function, etc. of MR Configurator2, adjust the dual feedback filter.

The dual feedback filter operates as described below depending on the setting.

[Pr. PE08] setting	Control mode	Vibration	Settling time
0	Semi closed loop		
1 to 17999	Dual feedback	Not frequently occurs to Frequently occurs	Long time to Short time
18000	Fully closed loop		

Increasing the dual feedback filter setting shortens the settling time, but increases servo motor vibration since the motor is more likely to be influenced by the load-side encoder vibration. The maximum setting of the dual feedback filter should be less than half of the PG2 setting.

Reduction of settling time: Increase the dual feedback filter setting.

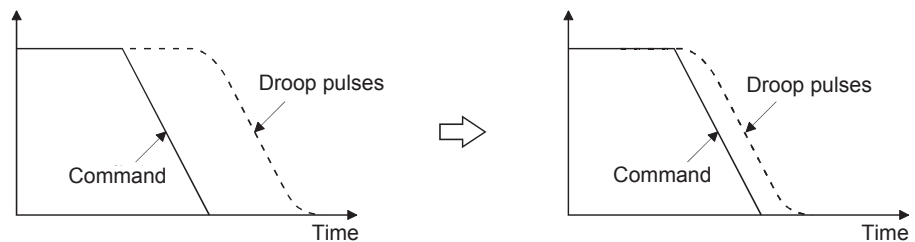

Suppression of vibration: Decrease the dual feedback filter setting.

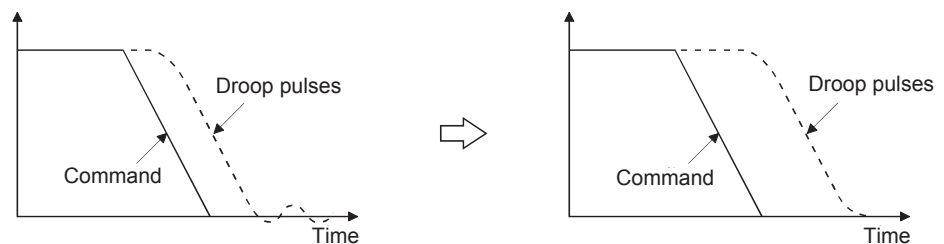

16. FULLY CLOSED LOOP SYSTEM (available in the future)

16.3.2 Home position return

(1) General instruction

Home position return is all performed according to the load-side encoder feedback data, independently of the load-side encoder type. It is irrelevant to the Z-phase position of the servo motor encoder. In the case of a home position return using a dog signal, the scale home position (reference mark) must be passed through when an incremental type linear encoder is used, or the Z-phase be passed through when a rotary encoder is used, during a period from a home position return start until the dog signal turns off.

(2) Load-side encoder types and home position return methods

(a) About proximity dog type home position return using absolute type linear encoder

When an absolute type linear encoder is used, the home position reference position is the position per servo motor revolution to the linear encoder home position (absolute position data = 0). In the case of a proximity dog type home position return, the nearest position after proximity dog off is the home position.

The linear encoder home position may be set in any position.

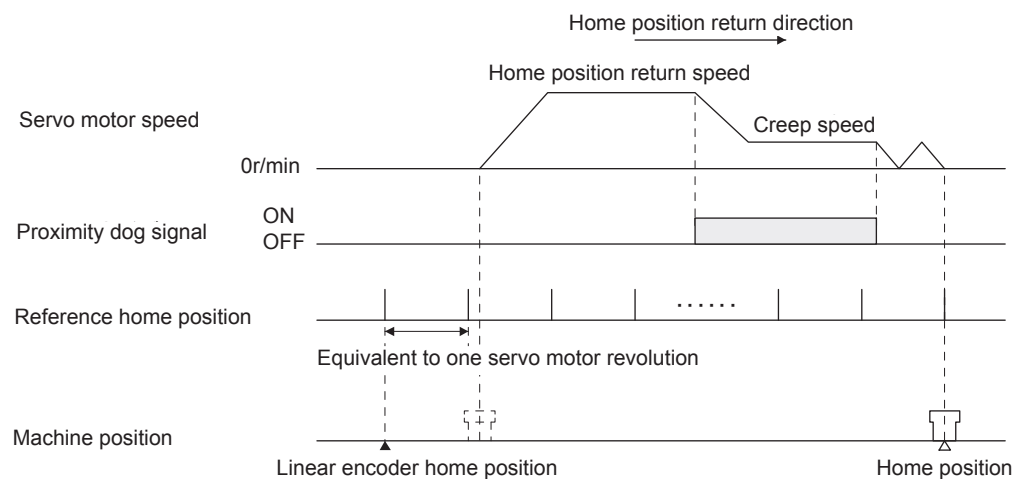

16. FULLY CLOSED LOOP SYSTEM (available in the future)

(b) About proximity dog type home position return using incremental linear encoder

- 1) When the linear encoder home position (reference mark) exists in the home position return direction

When an incremental linear encoder is used, the home position is the position per servo motor revolution to the linear encoder home position (reference mark) passed through first after a home position return start.

In the case of a proximity dog type home position return, the nearest position after proximity dog off is the home position.

Set one linear encoder home position in the full stroke, and set it in the position that can always be passed through after a home position return start.

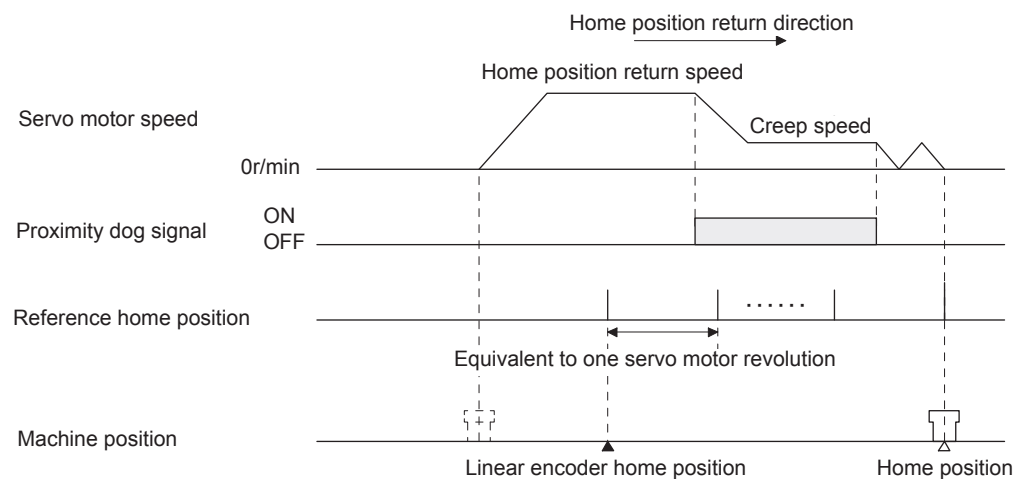

- 2) When the linear encoder home position does not exist in the home position return direction

If the home position return is performed from the position where the linear encoder home position (reference mark) does not exist, a home position return error occurs on the controller side. The error contents differ according to the controller type. When starting a home position return at the position where the linear encoder home position (reference mark) does not exist in the home position return direction, move the axis up to the stroke end on the side opposite to the home position return direction by JOG operation, etc. of the controller once, then make a home position return.

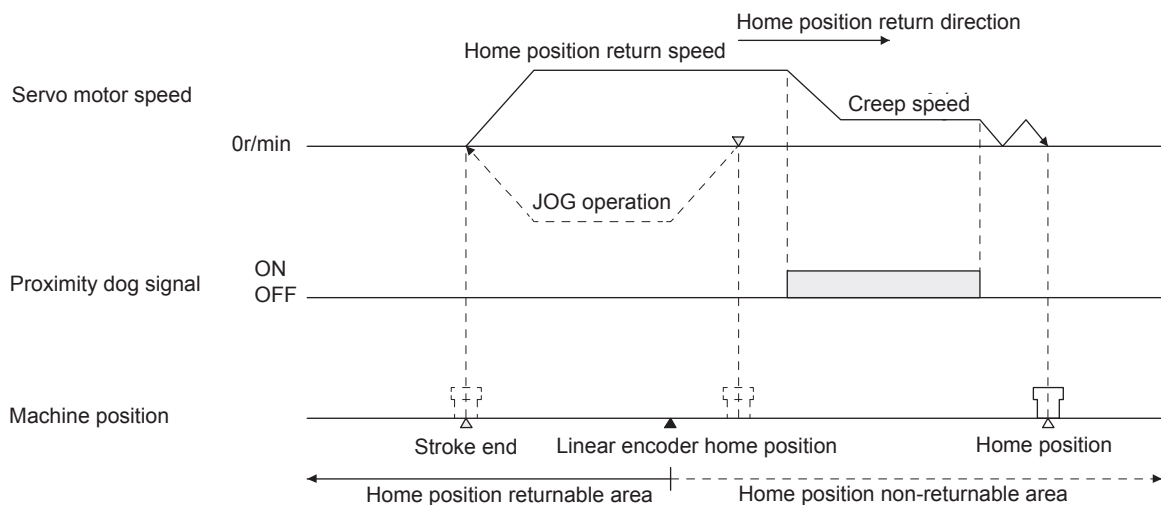

16. FULLY CLOSED LOOP SYSTEM (available in the future)

POINT

- To execute a home position return securely, start a home position return after moving the axis to the opposite stroke end by jog operation, etc. of the controller.
- A home position return cannot be made if the incremental linear encoder does not have a linear encoder home position (reference mark). Always provide a linear encoder home position (reference mark). (one place in the fully stroke)

- (c) About dog type home position return when using the rotary encoder of a serial communication servo motor

The home position for when using the rotary encoder of a serial communication servo motor for the load-side encoder is at the load-side Z-phase position.

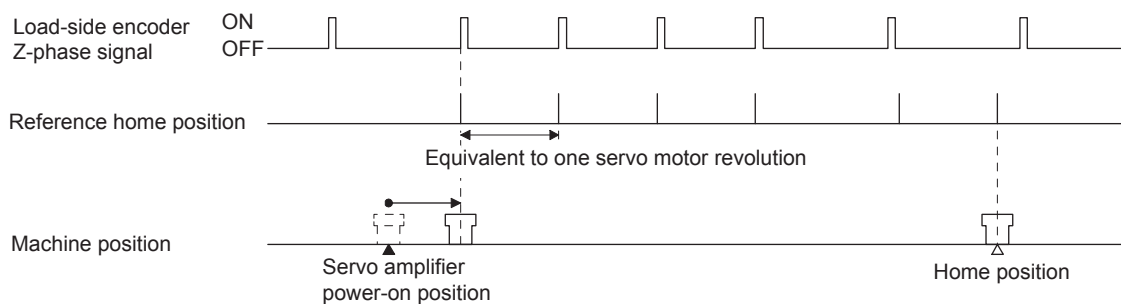

- (b) About data setting type (Common to all load-side encoders)

In the data setting type home position return method, pass through a scale home position (reference mark) and the Z-phase signal of the rotary encoder, and then make a home position return.

When the machine has no distance of one servo motor encoder revolution until the Z-phase of the rotary encoder is passed through, a home position return can be made by changing the home position setting condition selection in [Pr. PC17] if the home position is not yet passed through.

16. FULLY CLOSED LOOP SYSTEM (available in the future)

16.3.3 Operation from controller

The fully closed loop control compatible servo amplifier can be used with any of the following controllers.

Category	Model	Remarks
Motion controller	Q17nDSCPU	Speed control (II) instructions (VVF and VVR) cannot be used.
Simple motion module	QD77MS_	

An absolute type linear encoder is necessary to configure an absolute position detection system under fully closed loop control using a linear encoder. In this case, the encoder battery (MR-BAT6V1SET) need not be installed to the servo amplifier. When an rotary encoder is used, an absolute position detection system can be configured by installing the encoder battery (MR-BAT6V1SET) to the servo amplifier. In this case, the battery life will be shorter because the power consumption is increased as the power is supplied to the two encoders of motor side and load side.

(1) Operation from controller

Positioning operation from the controller is basically performed like the semi closed loop control.

(2) Servo system controller setting

When using fully closed loop system, make the following setting.

[[Pr.PA01], [Pr.PC17], [Pr.PE01], [Pr.PE03] to [Pr.PE05], [Pr.PE34] and [Pr.PE35] are written to the servo amplifier and then are enabled using any of the methods indicated by in Parameter valid conditions. [Pr. PE06] to [Pr. PE08] are enabled at setting regardless of the valid conditions.

Setting item		Parameter valid conditions		Settings	
		Controller reset	Power supply Off→on	Motion controller	Simple motion module
				Q17nDSCPU	QD77MS_
Command resolution				Load-side encoder resolution unit	
Servo parameter	MR-J4-B fully closed loop servo amplifier setting			MR-J4-B fully closed loop control	
	Motor setting			Automatic setting	
	Home position setting condition selection ([Pr. PC17])	<input type="radio"/>	<input type="radio"/>	Set the items as required.	
	Fully closed loop selection ([Pr. PA01] and [Pr. PE01])	<input checked="" type="radio"/>	<input type="radio"/>		
	Fully closed loop selection 2 ([Pr. PE03])	<input type="radio"/>	<input type="radio"/>		
	Fully closed loop control error detection speed deviation error detection level ([Pr. PE06])	Valid at setting regardless of the valid conditions			
	Fully closed loop control error detection position deviation error detection level ([Pr. PE07])				
	Fully closed loop electronic gear numerator ([Pr. PE04] and [Pr. PE34])	<input checked="" type="radio"/>	<input type="radio"/>		
	Fully closed loop electronic gear denominator ([Pr. PE05] and [Pr. PE35])	<input checked="" type="radio"/>	<input type="radio"/>		
Fully closed loop dual feedback filter ([Pr. PE08])	Valid at setting regardless of the valid conditions				
Positioning control parameter	Unit setting	mm/inch/degree/pulse			
	Number of pulses per revolution (AP) Travel distance per revolution (AL)	For the setting methods, refer to (2) (a), (b) in this section.			

16. FULLY CLOSED LOOP SYSTEM (available in the future)

(a) When using a linear encoder (unit setting: mm)

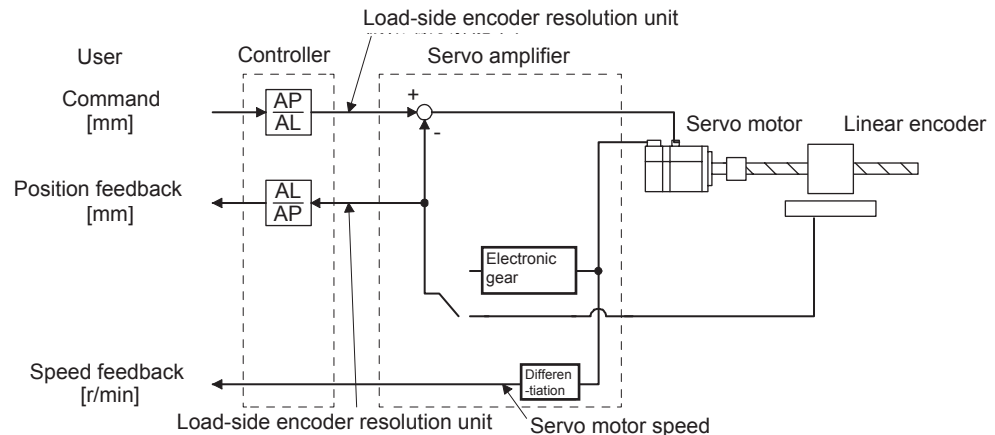

Calculate the number of pulses (AP) and travel distance (AL) of the linear encoder per ball screw revolution in the following conditions.

Ball screw lead: 20 mm

Linear encoder resolution: 0.05 μm

Number of linear encoder pulses (AP) per ball screw revolution

$$= \text{Ball screw lead/linear encoder resolution} = 20 \text{ mm}/0.05 \mu\text{m} = 400000 \text{ pulses}$$

$$\frac{\text{Number of pulses per revolution [pulse] (AP)}}{\text{Travel distance per revolution } [\mu\text{m}] \text{ (AL)}} = \frac{400000 \text{ pulses}}{20 \text{ mm}} = \frac{400000}{20000}$$

(b) When using a rotary encoder (unit setting: deg)

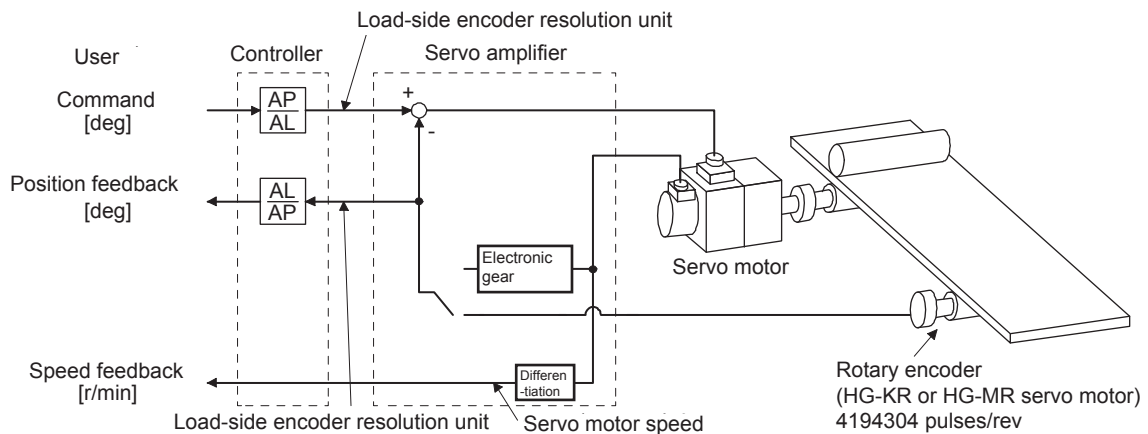

Calculate the number of pulses (AP) and travel distance (AL) of the rotary encoder per servo motor revolution in the following conditions.

Resolution of rotary encoder = Load-side resolution: 4194304 pulses/rev

$$\frac{\text{Number of pulses per revolution [pulse] (AP)}}{\text{Travel distance per revolution [deg] (AL)}} = \frac{4194304 \text{ pulses}}{360 \text{ deg}} = \frac{524288}{45}$$

16. FULLY CLOSED LOOP SYSTEM (available in the future)

16.3.4 Fully closed loop control error detection functions

If fully closed loop control becomes unstable for some reason, the speed at servo motor side may increase abnormally. The fully closed loop control error detection function is a protective function designed to pre-detect it and stop operation.

The fully closed loop control error detection function has two different detection methods, speed deviation and position deviation, and errors are detected only when the corresponding functions are enabled by setting [Pr. PE03 Fully closed loop function selection 2].

The detection level setting can be changed using [Pr. PE06] and [Pr. PE07].

(1) Parameter

The fully closed loop control error detection function is selected.

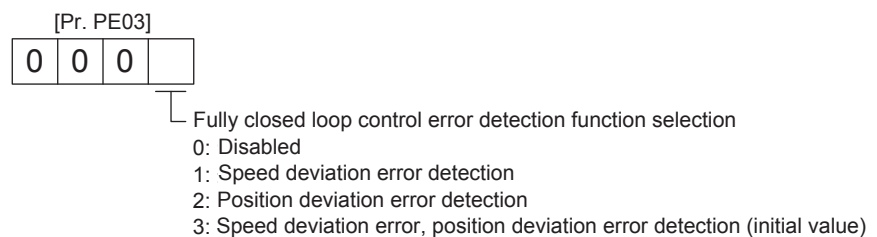

(2) Fully closed loop control error detection functions

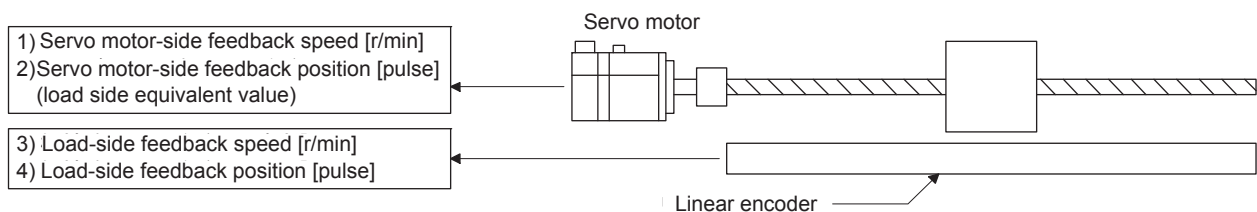

(a) Speed deviation error detection

Set [Pr. PE03] to "___ 1" to enable the speed deviation error detection.

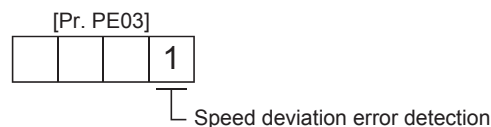

The function compares the servo motor-side feedback speed (1)) and load-side feedback speed (3)). If the deviation is not less than the set value (1 r/min to the permissible speed) of [Pr. PE06 Fully closed loop control speed deviation error detection level], the function generates [AL. 42.2 Servo control error by speed deviation] and stops. The initial value of [Pr. PE06] is 400 r/min. Change the set value as required.

16. FULLY CLOSED LOOP SYSTEM (available in the future)

(b) Position deviation error detection

Set [Pr. PE03] to "___2" to enable the position deviation error detection.



Comparing the servo motor-side feedback position (2)) and load-side feedback position (4)), if the deviation is not less than the set value (1 kpulses to 20000 kpulses) of [Pr. PE07 Fully closed loop control position deviation error detection level], the function generates [AL. 42 42.1 Servo control error by position deviation] and stops. The initial value of [Pr. PE07] is 100 kpulses. Change the set value as required.

(c) Detecting multiple deviation errors

When setting [Pr. PE03] as shown below, multiple deviation errors can be detected. For the error detection method, refer to (2) (a), (b) in this section.

[Pr. PE03]

--	--	--	--

Setting value	Speed deviation error detection	Position deviation error detection
1	<input type="radio"/>	<input type="radio"/>
2	<input type="radio"/>	<input type="radio"/>
3	<input type="radio"/>	<input type="radio"/>

(3) Test operation mode

Test operation mode is enabled by MR Configurator2.

For details on the test operation mode, refer to section 4.5.

Function	Item	Usability	Remarks
Test operation mode	JOG operation	<input type="radio"/>	It drives in the load-side encoder resolution unit
	Positioning operation	<input type="radio"/>	The fully closed loop system is operated in the load-side encoder resolution unit.
	Program operation	<input type="radio"/>	For details, refer to section 4.5.1 (1) (c).
	Output signal (DO) forced output	<input type="radio"/>	Refer to section 4.5.1 (1) (b).
	Motor-less operation	<input type="radio"/>	Refer to section 4.5.2.

16. FULLY CLOSED LOOP SYSTEM (available in the future)

16.3.5 Absolute position detection system under fully closed loop system

An absolute type linear encoder is necessary to configure an absolute position detection system under fully closed loop control using a linear encoder. In this case, the encoder battery (MR-BAT6V1SET) need not be installed to the servo amplifier. When a rotary encoder is used, an absolute position detection system can be configured by installing the encoder battery (MR-BAT6V1SET) to the servo amplifier. In this case, the battery life will be shorter because the power consumption is increased as the power is supplied to the two encoders of motor side and load side.

For the absolute position detection system with linear encoder, the restrictions mentioned in this section apply. Enable the absolute position detection system with [Pr. PA03 Absolute position detection system] and use this servo within the following restrictions.

(1) Using conditions

- (a) Use an absolute type linear encoder with the load-side encoder.
- (b) Select Always fully closed loop ([Pr. PA01] = __ 1 __ and [Pr. PE01] = ___ 0).

(2) Absolute position detection range using encoder

Encoder type	Absolute position detection enabled range
Linear encoder (Serial Interface)	Movable distance range of scale (within 32-bit absolute position data)

(3) Alarm detection

The absolute position-related alarm ([AL. 25]) and warnings (AL. 92) and [AL. 9F]) are not detected.

16. FULLY CLOSED LOOP SYSTEM (available in the future)

16.3.6 About MR Configurator 2

Using MR Configurator2 can confirm if the parameter setting is normal or if the servo motor and the load-side encoder operate properly.

This section explains the fully closed diagnosis screen.

Click "Monitor start" to constantly read the monitor display items from the servo amplifier.

Then, click "Monitor stop" to stop reading. Click "Parameter read" to read the parameter items from the servo amplifier, and then click "Parameter write" to write them.

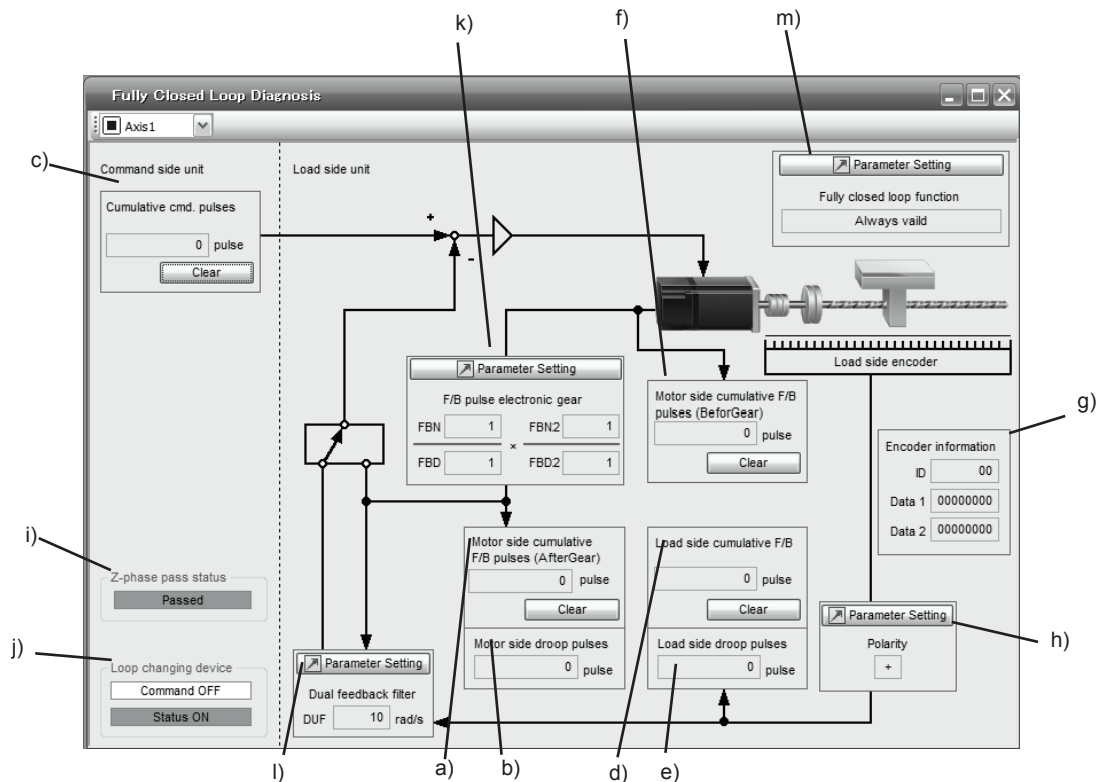

Symbol	Name	Explanation	Unit
a)	Motor side cumu. feedback pulses (after gear)	Feedback pulses from the servo motor encoder are counted and displayed. (load-side encoder unit) When the set value exceeds 999999999, it starts with 0. Click "Clear" to reset the value to 0. The "-" symbol is indicated for reverse.	pulse
b)	Motor side droop pulses	Droop pulses of the deviation counter between a servo motor-side position and a command are displayed. The "-" symbol is indicated for reverse.	pulse
C	Cumu. Com. pulses	Position command input pulses are counted and displayed. Click "Clear" to reset the value to 0. The "-" symbol is indicated for reverse command.	pulse
d)	Load side cumu. feedback pulses	Feedback pulses from the load-side encoder are counted and displayed. When the set value exceeds 999999999, it starts with 0. Click "Clear" to reset the value to 0. The "-" symbol is indicated for reverse.	pulse
E	Load side droop pulses	Droop pulses of the deviation counter between a load-side position and a command are displayed. The "-" symbol is indicated for reverse.	pulse

16. FULLY CLOSED LOOP SYSTEM (available in the future)

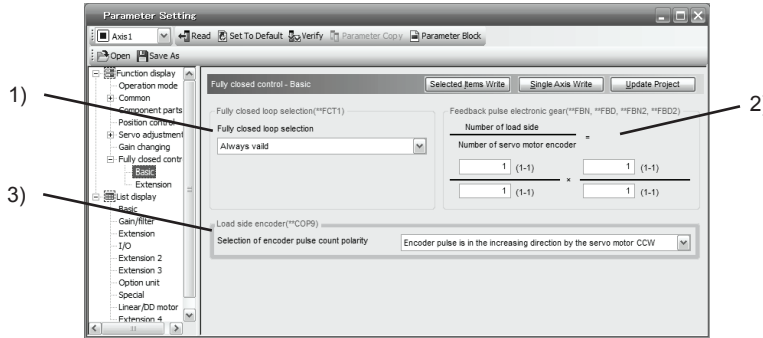
Symbol	Name	Explanation	Unit
f)	Motor side cumu. feedback pulses (before gear)	Feedback pulses from the servo motor encoder are counted and displayed. (Servo motor encoder unit) When the set value exceeds 999999999, it starts with 0. Click "Clear" to reset the value to 0. The "-" symbol is indicated for reverse.	pulse
g)	Encoder information	The load-side encoder information is displayed. The display contents differ depending on the load-side encoder type. <ul style="list-style-type: none"> • ID: The ID No. of the load-side encoder is displayed. • Data 1: For the incremental type linear encoder, the counter from powering on is displayed. For the absolute position type linear encoder, the absolute position data is displayed. • Data 2: For the incremental type linear encoder, the distance (number of pulses) from the reference mark (Z-phase) is displayed. For the absolute position type linear encoder, "00000000" is displayed. 	
h)	Polarity	For address increasing direction in the servo motor CCW, it is indicated as "+" and for address decreasing direction in the servo motor CCW, as "-".	
i)	Z phase pass status	If the fully closed loop system is "Invalid", the Z-phase pass status of the servo motor encoder is displayed. If the fully closed loop system is "Valid" or "Semi closed loop control/fully closed loop control switching", the Z-phase pass status of the load-side encoder is displayed.	
j)	Fully closed loop changing device	Only if the fully closed loop system is "Semi closed loop control/fully closed loop control switching", the device is displayed. The state of the semi closed loop control/fully closed loop control switching bit and the inside state during selection are displayed.	
k)	Parameter (Feedback pulse electronic gear)	The feedback pulse electronic gears ([Pr. PE04], [Pr. PE05], [Pr. PE34], and [Pr. PE35]) are displayed/set for servo motor encoder pulses in this parameter. (Refer to section 16.3.1 (3).)	
l)	Parameter (Dual feedback filter)	The band of [Pr. PE08 Fully closed loop dual feedback filter] is displayed/set in this parameter.	
m)	Parameter (fully closed loop selection)	The parameter for the fully closed loop control is displayed or set. Click "Parameter setting" button to display the "Fully closed loop control - Basic setting" window. <div style="text-align: center;">  </div> <ol style="list-style-type: none"> 1) Fully closed loop selection ([Pr. PE01]) "Always valid" or "Switching with the control command of controller" is selected here. 2) Fully closed loop feedback pulse electronic gear ([Pr. PE04], [Pr. PE05], [Pr. PE34], [Pr. PE35]) Setting of feedback pulse electronic gear 3) Selection of encoder pulse count polarity ([Pr. PC27]) Polarity of the load-side encoder information is selected. 	

APPENDIX

App. 1 Auxiliary equipment manufacturer (for reference)

Names given in the table are as of January 2012.

Manufacturer	Reference
JST	J.S.T. Mfg. Co., Ltd.
Junkosha	Purchase from Toa Electric Industry Co. Ltd., Nagoya Branch
3M	3M
Soshin Electric	Soshin Electric Co., Ltd.
TE Connectivity	TE Connectivity
Molex	Molex

App. 2 Handling of AC servo amplifier batteries for the United Nations Recommendations on the Transport of Dangerous Goods

United Nations Recommendations on the Transport of Dangerous Goods Rev. 15 (hereinafter Recommendations of the United Nations) has been issued. To reflect this, transport regulations for lithium metal batteries are partially revised in the Technical Instruction (ICAO-TI) by the International Civil Aviation Organization (ICAO) and the International Maritime Dangerous Goods Code (IMDG Code) by the International Maritime Organization (IMO).

To comply the instruction and code, we have modified the indication on the package for general-purpose AC servo batteries.

The above change will not affect the function and performance of the product.

(1) Target model

(a) Battery (cell)

Model	Option model
ER6	MR-J3BAT
ER17330	MR-BAT, A6BAT

(b) Battery unit (assembled)

Model	Option model
ER17330	MR-J2M-BT
CR17335A	MR-BAT6V1
	MR-BAT6V1SET

(2) Purpose

Safer transportation of lithium metal batteries.

(3) Change in regulations

The following points are changed for lithium metal batteries transportation by sea or air due to Recommendations of the United Nations Rev. 15 and ICAO-TI 2009-2010 edition. For lithium metal batteries, cells are classified as UN3090, and batteries contained in or packed with equipment are classified as UN3091.

(a) A package containing 24 cells or 12 batteries or less that are not contained in equipment are no longer exempt from the following: attachment of a handling label, submission of the Shipper's Declaration for Dangerous Goods, and a 1.2 m drop test.

(b) A battery handling label (size: 120 mm × 110 mm) is required. Emergency telephone number must be filled out in the additional handling information of the Shipper's Declaration for Dangerous Goods.

APPENDIX

(c) New handling label design containing battery illustration must be used. (only air transportation)



Figure. Example of Mitsubishi Label with Battery Illustration

(4) Action taken by Mitsubishi

The following caution will be added to the packages of the target batteries.

"Containing lithium metal battery. Regulations apply for transportation."

(5) Transportation precaution for customers

For sea or air transportation, attaching the handling label (figure) and the Shipper's Declaration for Dangerous Goods are required to the package of a Mitsubishi cell or battery. In addition, attaching them to the outer package containing several packages of Mitsubishi cells or batteries are also required. Please attach the documentations in the specified design to the packages and the outer packages.

APPENDIX

App. 3 Symbol for the new EU Battery Directive

Symbol for the new EU Battery Directive (2006/66/EC) that is plastered to general-purpose AC servo battery is explained here.



Note. This symbol mark is for EU countries only.

This symbol mark is according to the directive 2006/66/EC Article 20 Information for end-users and Annex II. Your MITSUBISHI ELECTRIC product is designed and manufactured with high quality materials and components which can be recycled and/or reused.

This symbol means that batteries and accumulators, at their end-of-life, should be disposed of separately from your household waste.

If a chemical symbol is printed beneath the symbol shown above, this chemical symbol means that the battery or accumulator contains a heavy metal at a certain concentration.

This will be indicated as follows.

Hg: mercury (0.0005%), Cd: cadmium (0.002%), Pb: lead (0.004%)

In the European Union there are separate collection systems for used batteries and accumulators. Please, dispose of batteries and accumulators correctly at your local community waste collection/recycling centre. Please, help us to conserve the environment we live in!

App. 4 Compliance with the CE marking

This servo amplifier is designed to comply with EN61800-3 and EN61800-5-1 standard.

App. 4.1 What is CE marking?

The CE marking is mandatory and must be affixed to specific products placed on the European Union. When a product conforms to the requirements, the CE marking must be affixed to the product. The CE marking also applies to machines and equipment incorporating servos.

(1) EMC directive

The EMC directive applies to the servo units alone. This servo is designed to comply with the EMC directive. The EMC directive also applies to machines and equipment incorporating servos. This requires the EMC filters to be used with machines and equipment incorporating servos to comply with the EMC directive.

(2) Low voltage directive

The low voltage directive also applies to servo units alone. This servo is designed to comply with the low voltage directive.

APPENDIX

(3) Machinery directive

The MR-J4 series servo amplifiers comply with the safety component laid down in the Machinery directive.

Do not allow using the machine until the machine in which this servo amplifier is mounted is declared to comply with the machinery directive.

4.2 For compliance

Be sure to perform an appearance inspection of every unit before installation. In addition, have a final performance inspection on the entire machine/system, and keep the inspection record.

(1) Servo amplifiers and servo motors used

Use servo amplifiers and servo motors which standard product.

Servo amplifier : MR-J4-10B, MR-J4-20B, MR-J4-40B, MR-J4-60B, MR-J4-70B, MR-J4-100B,
MR-J4-200B, MR-J4-350B, MR-J4-500B, MR-J4-700B

Servo motor : HG-MR_, HG-KR_, HG-SR_

(2) Structure

To comply with the CE marking, configure each equipment as follows.

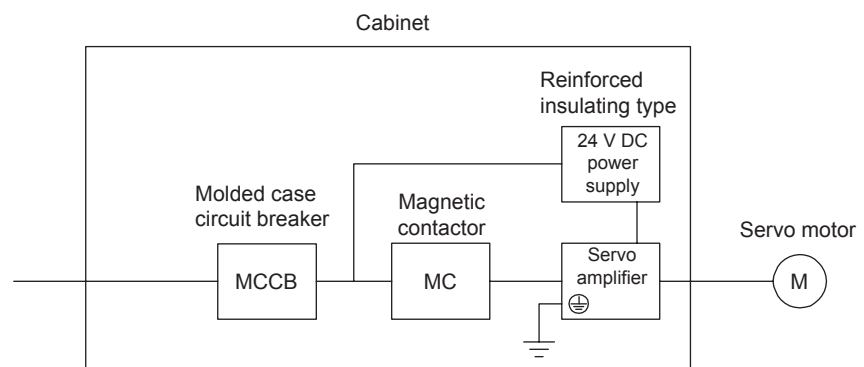

(3) Environment

(a) Operate the servo amplifier at pollution degree 2 or 1 set forth in EN 61800-5-1. For this purpose, install the servo amplifier in a cabinet which is protected against water, oil, carbon, dust, dirt, etc. (IP54).

(b) Use the equipment under the following environment.

Item		Environment
(Note 1) Ambient temperature	Operation	(Note 2) 0 °C to 55 °C (non-freezing)
	Storage/transportation	-20 °C to 65 °C (non-freezing)
Ambient humidity	Operation/storage/transportation	90% RH or less (non-condensing)
Altitude	Operation/storage	1000 m or shorter
	Transportation	10000 m or shorter

Note 1. Ambient temperature is the internal temperature of the cabinet.

2. The servo amplifier of under 3.5 kW for 200 V class can be mounted closely. In this case, keep the ambient temperature within 0 °C to 45 °C or use the servo amplifier with 75% or less of the effective load ratio.

APPENDIX

(4) Power supply

- (a) This servo amplifier can be supplied from star-connected supply with earthed neutral point of overvoltage category III set forth in EN 61800-5-1. However, when you use the neutral point of 400 V system for single phase supply, a reinforced insulating transformer is required in the power input section.
- (b) The control circuit provides safe separation to the main circuit in the servo amplifier. For the interface power supply, use an external 24 V DC power supply with reinforced insulation on I/O terminals.

(5) Grounding

- (a) To prevent an electric shock, always connect the protective earth (PE) terminal (marked \oplus) of the servo amplifier to the protective earth (PE) of the cabinet.
- (b) Do not connect two grounding cables to the same protective earth (PE) terminal. Always connect cables to the terminals one-to-one.



- (c) If using a leakage circuit breaker, always ground the protective earth (PE) terminal of the servo amplifier to prevent an electric shock.

(6) Wiring

- (a) The wires to be connected to the terminal block of the servo amplifier must have crimp terminals provided with insulating tubes to prevent contact with adjacent terminals.

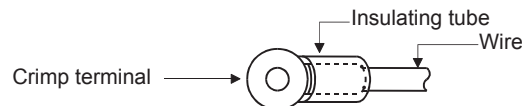

- (b) Use the servo motor-side power connector which complies with EN. The EN compliant power connector sets are available from us as options.
- (c) The servo amplifier must be installed in the metal cabinet.

(7) Peripheral devices/options

- (a) Use the molded case circuit breaker and magnetic contactor models which are EN-compliant products given in the MR-J4 Series Servo Amplifier Instruction Manual. Use a leakage current device (RCD) of type B as necessary. When it is not used, provide insulation between the servo amplifier and other device by double insulation or reinforced insulation, or install a transformer between the main power supply and the servo amplifier. Refer to App. 5 (8) for molded case circuit breakers and fuses.
- (b) The sizes of the wires given in the MR-J4 Series Servo Amplifier Instruction Manual meet the following conditions. For use in any other conditions, follow table 6 and Annex D of EN 60204-1.
 - Ambient temperature: 40 °C
 - Insulator: PVC (polyvinyl chloride)
 - Route the wires on wall surface or open cable tray.
- (c) Use shielded wires for I/O power wires.
- (d) Use EMC filters of HF3000A-UN series manufactured by Soshin Electric.

APPENDIX

(e) Use the surge protector of RSPD-250-U4 manufactured by Okaya Electric Industries.

(8) Performing EMC tests

When EMC tests are run on a machine and device into which the servo amplifier has been installed, it must conform to the electromagnetic compatibility (immunity/emission) standards after it has satisfied the operating environment/electrical equipment specifications.

For EMC directive conforming methods about servo amplifiers, refer to the EMC Installation Guidelines (IB(NA)67310).

(9) Short Circuit Current Rating (SCCR)

We confirmed in the short-circuit test that this servo amplifier is suitable for use in a circuit rated at 100 kA RMS or less, and maximum voltage 500 V.

(10) Configuration diagram

Refer to App. 5 (9) for configuration diagram.

App. 5 Compliance with UL/CSA standard

This servo amplifier is designed to comply with UL 508C and CSA C22.2 No.14 standard.

For the situation of safety certification, contact your local sales office.

(1) Servo amplifiers and servo motors used

Use servo amplifiers and servo motors which standard product.

Servo amplifier	Servo motor		
	HG-MR	HG-KR	HG-SR
MR-J4-10B	053/13	053/13	
MR-J4-20B	23	23	
MR-J4-40B	43	43	
MR-J4-60B			51/52
MR-J4-70B	73	73	
MR-J4-100B			81/102
MR-J4-200B			121/152/201/202
MR-J4-350B			301/352
MR-J4-500B			421/502
MR-J4-700B			702

APPENDIX

(2) Installation

The MR-J4 series have been approved as the products which have been installed in a cabinet. The minimum cabinet size is based on 150% of each MR-J4 combination. And also, design the cabinet so that the ambient temperature in the cabinet is 55 °C or less.

The servo amplifier must be installed in the metal cabinet.

To ensure safety, do not touch the charging section for 15 minutes after power-off.

Item		Environment
(Note 1) Ambient temperature	Operation	(Note 2) 0 °C to 55 °C (non-freezing)
	Storage/transportation	-20 °C to 65 °C (non-freezing)
Ambient humidity	Operation/storage/transportation	90% RH or less (non-condensing)
Altitude	Operation/storage	1000 m or shorter
	Transportation	10000 m or shorter

Note 1. Ambient temperature is the internal temperature of the cabinet.

2. The servo amplifier of under 3.5 kW for 200 V class can be mounted closely. In this case, keep the ambient temperature within 0 °C to 45 °C or use the servo amplifier with 75% or less of the effective load ratio.

(3) Short Circuit Current Rating (SCCR)

We confirmed in the short-circuit test that this servo amplifier is suitable for use in a circuit rated at 100 kA RMS or less, and maximum voltage 500 V.

(4) Overload protection characteristics

Servo amplifier MR-J4 series has solid-state servo motor overload protection. (It is set on the basis (full load current) of 120% rated current of the servo amplifier.)

(5) Selection example of wires

To comply with the UL/CSA standard, use UL-approved copper wires rated at 75 °C for wiring.

The following table shows the wire sizes [AWG] and the crimp terminal symbols rated at 75 °C.

Servo amplifier	(Note 2) Wires [AWG]			
	L1/L2/L3/⊕	L11/L21	P+/C/D	U/V/W
MR-J4-10B/MR-J4-20B MR-J4-40B/MR-J4-60B MR-J4-70B/MR-J4-100B	14	14	14	(Note 3)
MR-J4-200B	12			
MR-J4-350B	10			
(Note 1) MR-J4-500B	8: a	14: c	14: c	
(Note 1) MR-J4-700B	8: b		12: a	

Note 1. To connect these models to a terminal block, be sure to use the screws that come with the terminal block.

2. Alphabets in the table indicate crimping tools. Refer to the following table for the crimp terminals and crimping tools.

3. The wire size depends on the servo motor characteristics.

APPENDIX

Table: Recommended crimp terminals

Symbol	Servo amplifier side crimp terminals		Manufacturer
	(Note 2) Crimp terminals	Applicable tool	
a	FVD5.5-4	YNT-1210S	JST
(Note 1) b	8-4NS	YHT-8S	
c	FVD2-4	YNT-1614	

- Note 1. Coat the crimping part with an insulation tube.
2. Always use recommended crimp terminals or equivalent since some crimp terminals cannot be installed depending on the size.

(6) Tightening torque of each terminal

Servo amplifier	Tightening torque [N•m]															
	L1	L2	L3	N-	P3	P4	P+	C	D	L11	L21	U	V	W	PE	
MR-J4-10B/MR-J4-20B MR-J4-40B/MR-J4-60B MR-J4-70B/MR-J4-100B MR-J4-200B/ MR-J4-350B	1.2															
MR-J4-500B	1.2								0.8		1.2					
MR-J4-700B	1.2								0.8		1.2					

(7) About wiring protection

For installation in United States, branch circuit protection must be provided, in accordance with the National Electrical Code and any applicable local codes.

For installation in Canada, branch circuit protection must be provided, in accordance with the Canada Electrical Code and any applicable provincial codes.

(8) Options and peripheral devices

Use the UL/CSA standard-compliant products.

Use the molded case circuit breaker (UL489 Listed MCCB) or a Class T fuse indicated in the table below.

Servo amplifier	Molded case circuit breaker		Fuse	
	Current	Voltage AC [V]	Current [A]	Voltage AC [V]
MR-J4-10B	50 A frame 5 A	240	10	300
MR-J4-20B				
MR-J4-40B				
MR-J4-60B				
MR-J4-70B	50 A frame 10 A		15	
MR-J4-100B	50 A frame 20 A		40	
MR-J4-200B	50 A frame 30 A		60	
MR-J4-350B	50 A frame 40 A		80	
MR-J4-500B	50 A frame 50 A		100	
MR-J4-700B				

APPENDIX

(9) Configuration diagram

Representative configuration diagram example to conform to the UL/CSA standard is shown below. The grounding wiring is excluded from the figure configuration.

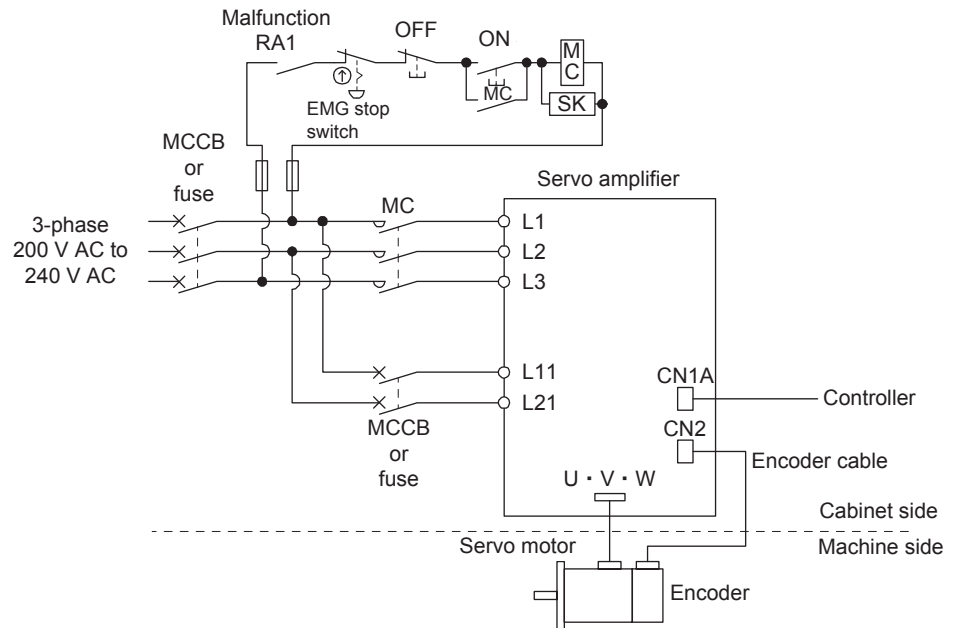

(10) Power supply

The control circuit provides safe separation to the main circuit in the servo amplifier.

	Connector/terminal
Main circuit	CNP1/CNP2/CNP3/TE1/TE2/TE3/TE4
Control circuit	CN1A/CN1B/CN2/CN3/CN4/CN5/CN8

(11) UL/CSA standard certification mark on products

The following mark shows UL/CSA standard certification of MR-J4 multi-axis servo amplifiers.

Mark	Certification Body	Remarks
	TUV Rheinland of North America Inc. Independent public testing institution in North America National recognized testing laboratory (NRTL)	NRTL listing mark (UL 508C)

App. 6 Compliance with KC mark

For the situation of compliance, contact your local sales office.

When you use the products in South Korea, note the following.

이 기기는 업무용 (A 급) 전자파적합기기로서 판 매자 또는 사용자는 이 점을 주의하시기 바라며, 가정외의 지역에서 사용하는 것을 목적으로 합니다.

(The product is for business use (Class A) and meets the electromagnetic compatibility requirements. The seller and the user must note the above point, and use the product in a place except for home.)

APPENDIX

App. 7 MR-J3-D05 Safety logic unit

App. 7.1 Contents of the package

Open packing, and confirm the content of packing.

Contents	Quantity
MR-J3-D05 Safety logic unit	1
Connector for CN9 1-1871940-4 (TE Connectivity)	1
Connector for CN10 1-1871940-8 (TE Connectivity)	1
MR-J3-D05 Installation Guide	1

App. 7.2 Terms related to safety

App. 7.2.1 Stop function for IEC/EN 61800-5-2

(1) STO function (Refer to IEC/EN 61800-5-2: 2007 4.2.2.2 STO.)

This function is integrated into the MR-J4 series servo amplifiers.

The STO function shuts down energy to servo motors, thus removing torque. This function electronically cuts off power supply in servo amplifiers for MR-J4 series servo amplifiers.

The purpose of this safety function is as follows.

- 1) Uncontrolled stop according to stop category 0 of IEC/EN 60204-1
- 2) Preventing unexpected start-up

(2) SS1 function (Refer to IEC 61800-5-2: 2007 4.2.2.3C Safe stop 1 temporal delay.)

SS1 is a function which initiates the STO function when the previously set delay time has passed after the servo motor starts decelerating. The delay time can be set with MR-J3-D05 safety logic unit.

The purpose of this safety function is as follows. This function is available by using a MR-J4 series servo amplifier with MR-J3-D05.

- Controlled stop according to stop category 1 of IEC/EN 60204-1

App. 7.2.2 Emergency operation for IEC/EN 60204-1

(1) Emergency stop (Refer to IEC/EN 60204-1: 2005 9.2.5.4.2 Emergency Stop.)

Emergency stop must override all other functions and actuation in all operation modes. Power to the machine driving part which may cause a hazardous state must be either removed immediately (stop category 0) or must be controlled to stop such hazardous state as soon as possible (stop category 1). Restart must not be allowed even after the cause of the emergency state has been removed.

(2) Emergency switching off (Refer to IEC/EN 60204-1: 2005 9.2.5.4.3 Emergency Switching OFF.)

Removal of input power to driving device to remove electrical risk and to meet above mentioned safety standards.

APPENDIX

App. 7.3 Cautions

The following basic safety notes must be read carefully and fully in order to prevent injury to persons or damage to property.

Only qualified personnel are authorized to install, start-up, repair or service the machines in which these components are installed.

They must be familiar with all applicable local safety regulations and laws in which machines with these components are installed, particularly the standards and guidelines mentioned in this Instruction Manual and the requirements mentioned in ISO/EN ISO 13849-1, IEC/EN 61508, IEC/EN 61800-5-2, and IEC/EN 60204-1.

The staff responsible for this work must be given express permission from the company to perform start-up, programming, configuration, and maintenance of the machine in accordance with the safety standards.



WARNING

● Improper installation of the safety related components or systems may cause improper operation in which safety is not assured, and may result in severe injuries or even death.

Protective Measures

- As described in IEC/EN 61800-5-2, the Safe Torque Off (STO) function only prevents the servo amplifier from supplying energy to the servo motor. Therefore, if an external force acts upon the drive axis, additional safety measures, such as brakes or counter-weights must be used.

App. 7.4 Residual risk

Machine manufacturers are responsible for all risk evaluations and all associated residual risks. Below are residual risks associated with the STO/EMG function. Mitsubishi is not liable for any damages or injuries caused by the residual risks.

- (1) The SS1 function only guarantees the delay time before STO/EMG is engaged. Proper setting of this delay time is the full responsibility of the company and/or individuals responsible for installation and commissioning of the safety related system. The system, as a whole, must pass safety standards certification.
- (2) When the SS1 delay time is shorter than the required servo motor deceleration time, if the forced stop function is malfunctioning, or if STO/EMG is engaged while the servo motor is still rotating; the servo motor will stop with the dynamic brake or freewheeling.
- (3) For proper installation, wiring, and adjustment, thoroughly read the manual of each individual safety related component.
- (4) Be sure that all safety related switches, relays, sensors, etc., meet the required safety standards. The Mitsubishi Electric safety related components mentioned in this manual are certified by Certification Body as meeting the requirements of ISO/EN ISO 13849-1 Category 3, PL d and IEC/EN 61508 SIL 2.
- (5) Safety is not assured until safety-related components of the system are completely installed or adjusted.
- (6) When replacing a servo amplifier etc. or MR-J3-D05 safety logic unit, confirm that the new equipment is exactly the same as those being replaced. Once installed, be sure to verify the performance of the safety functions before commissioning the system.

APPENDIX

- (7) Perform all risk assessments and safety level certification to the machine or the system as a whole. It is recommended that a Certification Body final safety certification of the system be used.
- (8) To prevent accumulation of multiple malfunctions, perform a malfunction check at regular intervals as deemed necessary by the applicable safety standard. Regardless of the system safety level, malfunction checks should be performed at least once per year.
- (9) If the upper and lower power module in the servo amplifier are shorted and damaged simultaneously, the servo motor may make a half revolution at a maximum. For a linear servo motor, the primary side will move a distance of pole pitch.

App. 7.5 Block diagram and timing chart

(1) Function block diagram

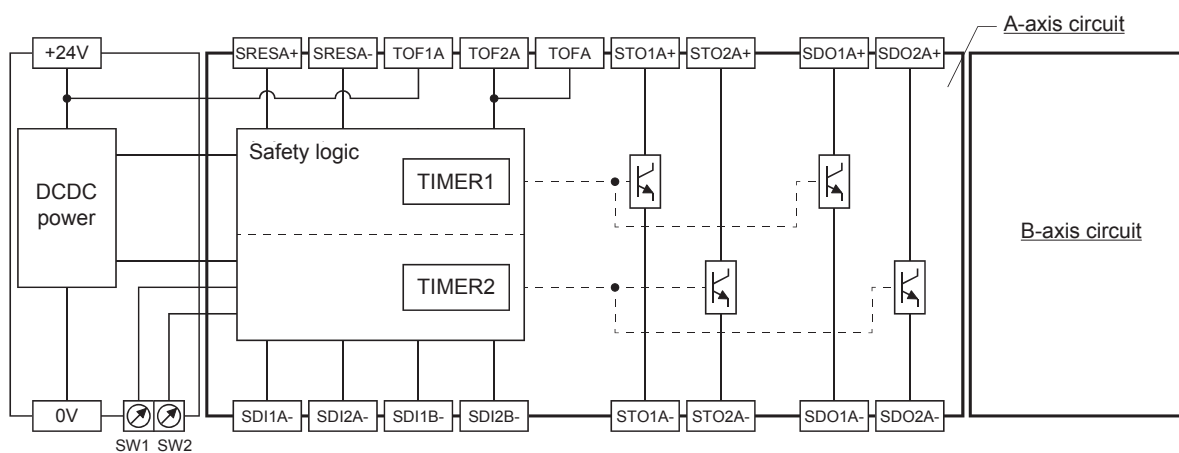

(2) Operation sequence

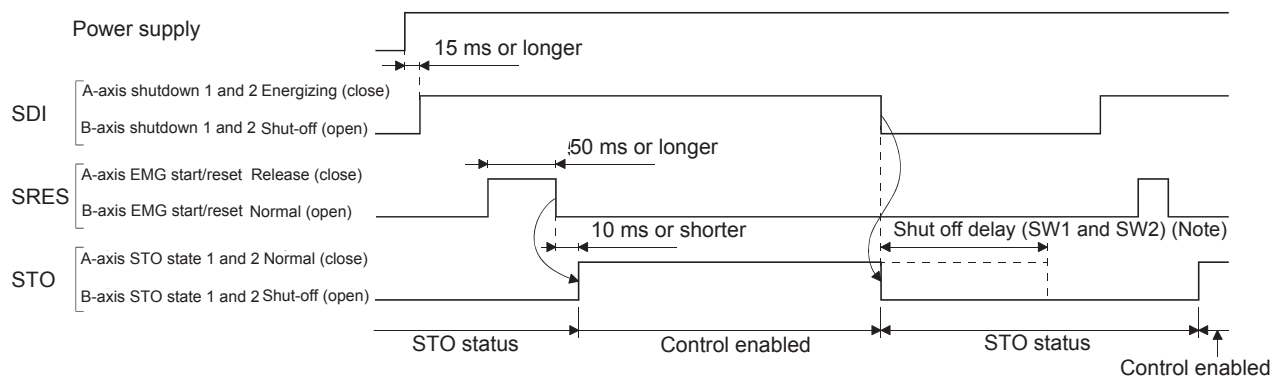

Note. Refer to App. 7.10.

APPENDIX

App. 7.6 Maintenance and disposal

MR-J3-D05 safety logic unit is equipped with LED displays to check errors for maintenance.
Please dispose this unit according to your local laws and regulations.

App. 7.7 Functions and configuration

App. 7.7.1 Introduction

The safety logic unit MR-J3-D05 has two systems in which the each system has SS1 function (delay time) and output of STO function.

APPENDIX

App. 7.7.2 Specifications

Safety logic unit model		MR-J3-D05
Control circuit power supply	Voltage	24 V DC
	Permissible voltage fluctuation	24 V DC \pm 10%
	Power supply capacity [A]	0.5 (Note 1,2)
Compatible system		2 systems (A-axis, B-axis independent)
Shut-off input		4 points (2 point \times 2 systems) SDI_: (source/sink compatible) (Note 3)
Shut-off release input		2 points (1 point \times 2 systems) SRES_: (source/sink compatible) (Note 3)
Feedback input		2 points (1 point \times 2 systems) TOF_: (source compatible) (Note 3)
Input type		Photocoupler insulation, 24 V DC (external supply), internal limited resistance 5.4 k Ω
Shut-off output		8 points (4 point \times 2 systems) STO_: (source compatible) (Note 3) SDO_: (source/sink compatible) (Note 3)
Output method		Photocoupler insulation, open-collector type Permissible current: 40 mA/1 output, Inrush current: 100 mA/1 output
Delay time setting		A-axis: Select from 0 s, 1.4 s, 2.8 s, 5.6 s, 9.8 s, or 30.8 s. B-axis: Select from 0 s, 1.4 s, 2.8 s, 9.8 s, or 30.8 s. Accuracy: \pm 2%
Safety function		STO, SS1 (IEC/EN 61800-5-2) EMG STOP, EMG OFF IEC/EN 60204-1)
Safety performance	Standards certified by CB	EN ISO 13849-1 category 3 PL d, EN 61508 SIL 2, EN 62061 SIL CL 2, and EN 61800-5-2 SIL 2
	Response performance (when delay time is set to 0s)	10 ms or less (STO input off \rightarrow shut-off output off)
	Test pulse input (STO) (Note 4)	Test pulse interval: 1 Hz to 25 Hz Test pulse off time: Up to 1 ms
	Mean time to dangerous failure (MTTFd)	516 years
	Diagnosis converge (DC avg)	93.1%
	Average probability of dangerous failures per hour (PFH)	4.75×10^{-9} [1/h]
Compliance to standards	CE marking	LVD: EN 61800-5-1 EMC: EN 61800-3 MD: EN ISO 13849-1, EN 61800-5-2, EN 62061
Structure		Natural-cooling, open (IP rating: IP 00)
Environment	Ambient temperature	0 °C to 55 °C (non-freezing), storage: -20 °C to 65 °C (non-freezing)
	Ambient humidity	90% RH or less (non-condensing), storage: 90% RH or less (non-condensing)
	Ambience	Indoors (no direct sunlight), free from corrosive gas, flammable gas, oil mist, dust, and dirt
	Altitude	Max. 1000 m above sea level
	Vibration	5.9 m/s ² or less at 10 Hz to 55 Hz (directions of X, Y and Z axes)
Mass [kg]		0.2 (including CN9 and CN10 connectors)

Note 1. Inrush current of approximately 1.5 A flows instantaneously when turning the control circuit power supply on. Select an

2. appropriate capacity of power supply considering the inrush current.

3. Power-on duration of the safety logic unit is 100,000 times.

4. _ : in signal name indicates a number or axis name.

This function diagnoses malfunction of contacts including an external circuit by shortly turning off signals from a controller to the servo amplifier at a constant period while input signals of the servo amplifier are on.

APPENDIX

App. 7.7.3 When using MR-J3-D05 with a MR-J4 series servo amplifier

(1) System configuration diagram

POINT
● The STO cable (MR-D05UDL-M) for MR-J3 series is not available.

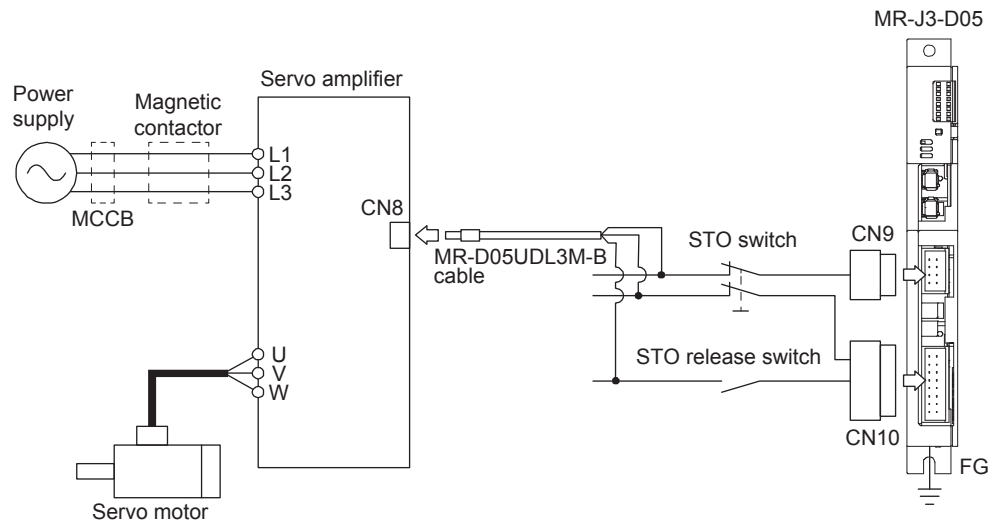

APPENDIX

(2) Connection example

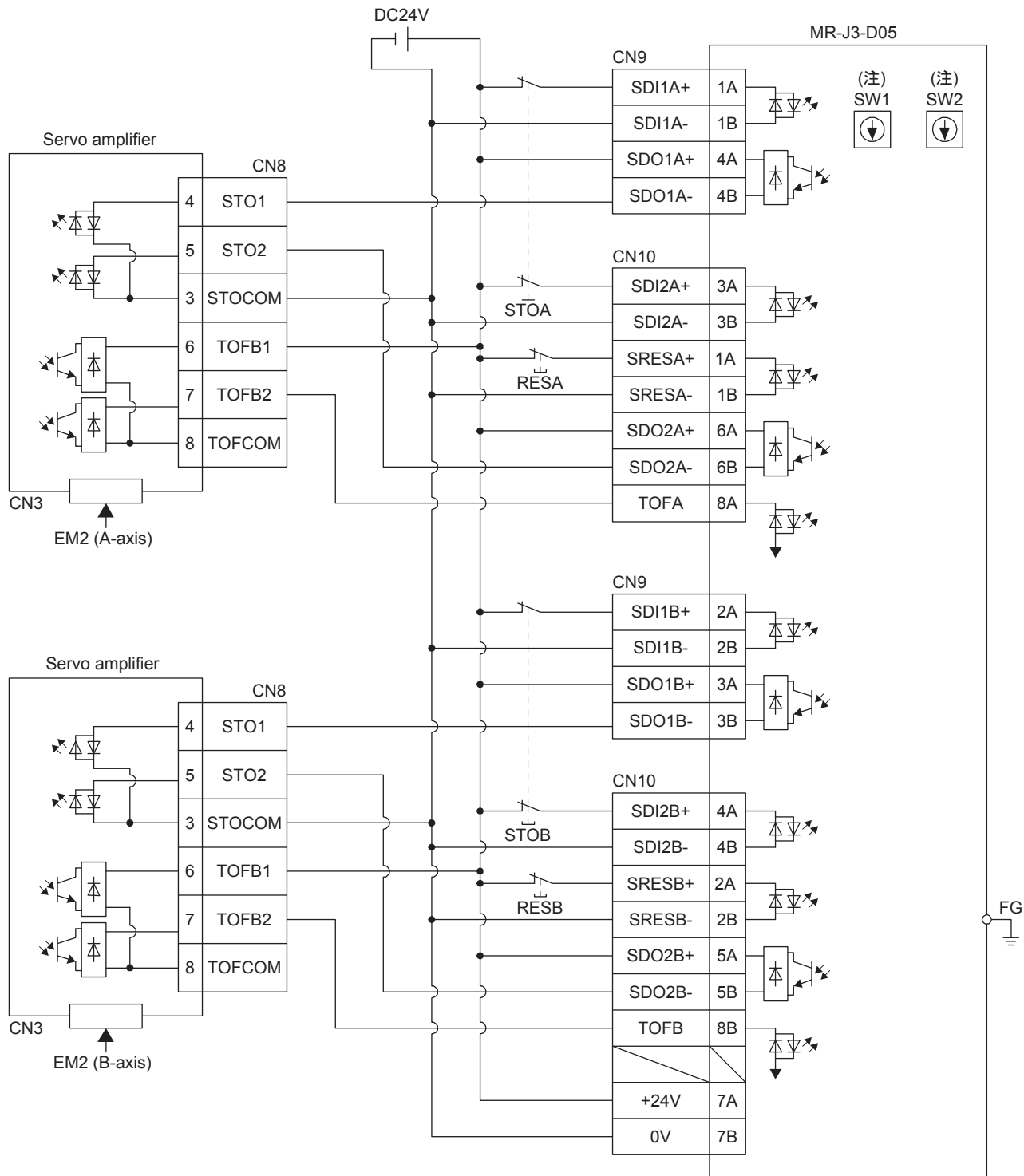

Note. Set the delay time of STO output with SW1 and SW2. These switches are located where denoted from the front panel.

APPENDIX

(3) Description of signal and function

The following table lists which operation, the forced stop deceleration or the dynamic brake, will function for each signal input or power-off.

Input signal to MR-J4 series servo amplifier	Signal logic	Definition	Forced stop deceleration ○: operates ×: does not operate	Remarks
EM2	Normally closed contact opens	Decelerating to stop signal	○	Unlike the decelerating to stop signal, RES and SON are prioritized.
STO1	Normally closed contact opens	STO1 shut-off signal	-	
STO2	Normally closed contact opens	STO2 shut-off signal	-	
LSP	Normally closed contact opens	Stroke end +	○	
LSN	Normally closed contact opens	Stroke end -	○	
Reset command	Normally open contact closes	Alarm reset	-	
Servo-on command	Normally open contact opens	Servo-off	-	
Servo amplifier Control circuit power supply shut-off			×	Decelerating to stop starts with dynamic brake after control circuit power supply shut-off is detected.
Servo amplifier Main circuit power supply shut-off			○	Deceleration to stop starts at the detection voltage of [AL. 10 Undervoltage], and the dynamic brake starts at 80% of the detection voltage.

(4) Basic operation example

The following shows when you use MR-J3-D05 with a MR-J4 series servo amplifier.

The switching of STOA is output to CN8A and usually is input to the MR-J4 series servo amplifier.

The switching of STOB is output to CN8B and usually is input to the MR-J4 series servo amplifier.

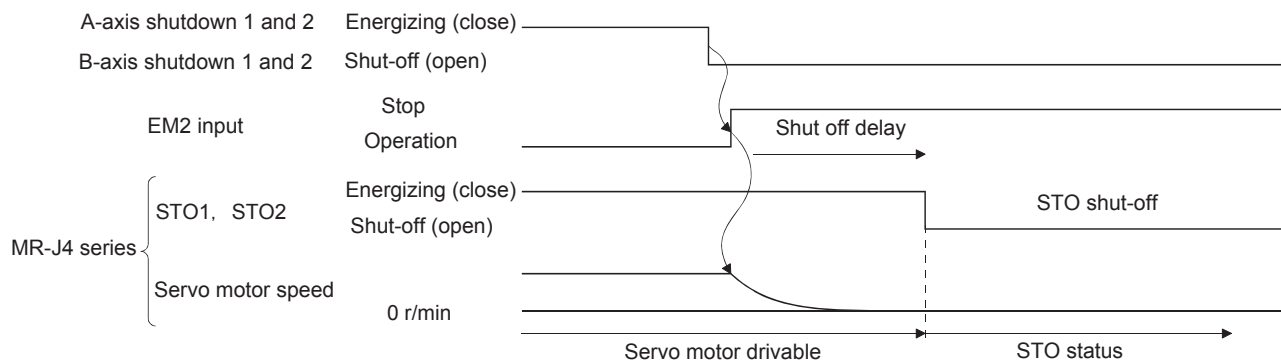

APPENDIX

App. 7.8 Signal

App. 7.8.1 Connector/pin assignment

(1) CN8A

Device	Symbol	Pin No.	Function/application	(Note) I/O
A-axis STO1	STO1A- STO1A+	4	Outputs STO1 to A-axis driving device.	O
		1	Outputs the same signal as A-axis STO2. STO state (base shutdown): Between STO1A+ and STO1A- is opened. STO release state (in driving): Between STO1A+ and STO1A- is closed.	
A-axis STO2	STO2A- STO2A+	5	Outputs STO2 to A-axis driving device.	O
		6	Outputs the same signal as A-axis STO1. STO state (base shutdown): Between STO2A+ and STO2A- is opened. STO release state (in driving): Between STO2A+ and STO2A- is closed.	
A-axis STO state	TOF2A TOF1A	7	Inputs STO state of A-axis driving device.	I
		8	STO state (base shutdown): Open between TOF2A and TOF1A. STO release state (in driving): Close between TOF2A and TOF1A.	

Note. Exclusive interface for MR-J4 series servo amplifiers.

(2) CN8B

Device	Symbol	Pin No.	Function/application	(Note) I/O
B-axis STO1	STO1B- STO1B+	1	Outputs STO1 to B-axis driving device.	O
		4	Outputs the same signal as B-axis STO2. STO state (base shutdown): Between STO1B+ and STO1B- is opened. STO release state (in driving): Between STO1B+ and STO1B- is closed.	
B-axis STO2	STO2B- STO2B+	5	Outputs STO2 to B-axis driving device.	O
		6	Outputs the same signal as B-axis STO1. STO state (base shutdown): Between STO2B+ and STO2B- is opened. STO release state (in driving): Between STO2B+ and STO2B- is closed.	
B-axis STO state	TOF2B TOF1B	7	Inputs STO state of B-axis driving device.	I
		8	STO state (base shutdown): Open between TOF2B and TOF1B. STO release state (in driving): Close between TOF2B and TOF1B.	

Note. Exclusive interface for MR-J4 series servo amplifiers.

(3) CN9

Device	Symbol	Pin No.	Function/application	I/O division
A-axis shutdown 1	SDI1A+ SDI1A-	1A	Connect this device to a safety switch for A-axis driving device.	DI-1
		1B	Input the same signal as A-axis shutdown 2. STO state (base shutdown): Open between SDI1A+ and SDI1A-. STO release state (in driving): Close between SDI1A+ and SDI1A-.	
B-axis shutdown 1	SDI1B+ SDI1B-	2A	Connect this device to a safety switch for B-axis driving device.	DI-1
		2B	Input the same signal as B-axis shutdown 2. STO state (base shutdown): Open between SDI1B+ and SDI1B-. STO release state (in driving): Close between SDI1B+ and SDI1B-.	
A-axis SDO1	SDO1A+ SDO1A-	4A	Outputs STO1 to A-axis driving device.	DO-1
		4B	Outputs the same signal as A-axis SDO2. STO state (base shutdown): Between SDO1A+ and SDO1A- is opened. STO release state (in driving): Between SDO1A+ and SDO1A- is closed.	
B-axis SDO1	SDO1B+ SDO1B-	3A	Outputs STO1 to B-axis driving device.	DO-1
		3B	Outputs the same signal as B-axis SDO2. STO state (base shutdown): Between SDO1B+ and SDO1B- is opened. STO release state (in driving): Between SDO1B+ and SDO1B- is closed.	

APPENDIX

(4) CN10

Device	Symbol	Pin No.	Function/application	I/O division
A-axis shutdown 2	SDI2A+ SDI2A-	3A 3B	Connect this device to a safety switch for A-axis driving device. Input the same signal as A-axis shutdown 1. STO state (base shutdown): Open between SDI2A+ and SDI2A-. STO release state (in driving): Close between SDI2A+ and SDI2A-.	DI-1
B-axis shutdown 2	SDI2B+ SDI2B-	4A 4B	Connect this device to a safety switch for B-axis driving device. Input the same signal as B-axis shutdown 1. STO state (base shutdown): Open between SDI2B+ and SDI2B-. STO release state (in driving): Close between SDI2B+ and SDI2B-.	DI-1
A-axis EMG start/reset	SRESA+ SRESA-	1A 1B	Signal for releasing STO state (base shutdown) on A-axis driving device. Releases STO state (base shutdown) on A-axis driving device by switching between SRESA+ and SRESA- from on (connected) to off (opened).	DI-1
B-axis EMG start/reset	SRESB+ SRESB-	2A 2B	Signal for releasing STO state (base shutdown) on B-axis driving device. Releases STO state (base shutdown) on B-axis driving device by switching between SRESB+ and SRESB- from on (connected) to off (opened).	DI-1
A-axis SDO2	SDO2A+ SDO2A-	6A 6B	Outputs STO2 to A-axis driving device. Outputs the same signal as A-axis STO1. STO state (base shutdown): Between SDO2A+ and SDO2A- is opened. STO release state (in driving): Between SDO2A+ and SDO2A- is closed.	DO-1
B-axis SDO2	SDO2B+ SDO2B-	5A 5B	Outputs STO2 to B-axis driving device. Outputs the same signal as B-axis SDO1. STO state (base shutdown): Between SDO2B+ and SDO2B- is opened. STO release state (in driving): Between SDO2B+ and SDO2B- is closed.	DO-1
Control circuit power supply	+24V	7A	Connect + side of 24 V DC.	
Control circuit power GND	0V	7B	Connect - side of 24 V DC.	
A-axis STO state	TOFA	8A	TOFA is internally connected with TOF2A.	
B-axis STO state	TOFB	8B	TOFB is internally connected with TOF2B.	

App. 7.8.2 Interfaces

(1) Sink I/O interface (CN9, CN10 connector)

(a) Digital input interface DI-1

Turn on/off the input signal with a relay or open-collector transistor.

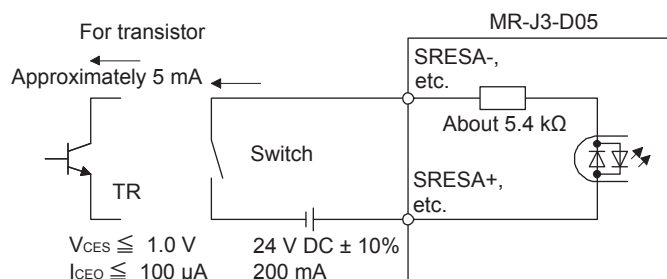

APPENDIX

(b) Digital output interface DO-1

A lamp, relay or photocoupler can be driven. Install a diode (D) for an inductive load, or install an inrush current suppressing resistor (R) for a lamp load. (Rated current: 40 mA or less, maximum current: 50 mA or less, inrush current: 100 mA or less) A maximum of 2.6 V voltage drop occurs in the MR-J3-D05.

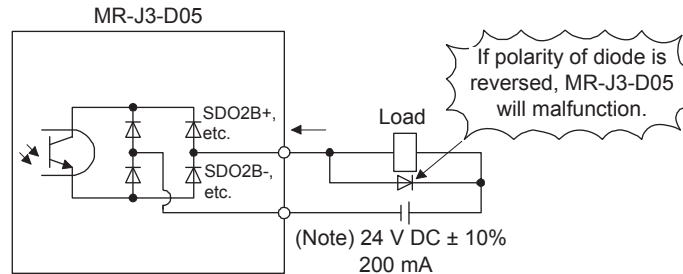

Note. If the voltage drop (maximum of 2.6 V) interferes with the relay operation, apply high voltage (maximum of 26.4 V) from external source.

(2) Source I/O interfaces (CN9, CN10 connector)

In this servo amplifier, source type I/O interfaces can be used. In this case, all DI-1 input signals and DO-1 output signals are of source type. Perform wiring according to the following interfaces.

(a) Digital input interface DI-1

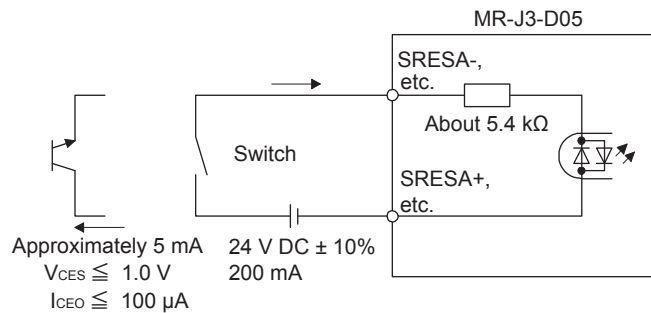

(b) Digital output interface DO-1

A maximum of 2.6 V voltage drop occurs in the servo amplifier.

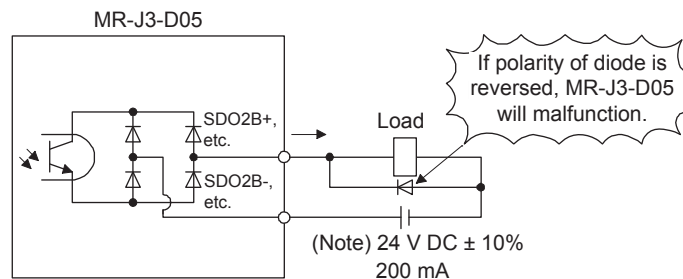

Note. If the voltage drop (maximum of 2.6 V) interferes with the relay operation, apply high voltage (maximum of 26.4 V) from external source.

APPENDIX

App. 7.8.3 Wiring CN9 and CN10 connectors

Handle with the tool with care when connecting wires.

(1) Wire strip

(a) Use wires with size of AWG 24 to 20 (0.22 mm^2 to 0.5 mm^2) (recommended electric wire: UL1007) and strip the wires to make the stripped length $7.0 \text{ mm} \pm 0.3 \text{ mm}$. Confirm the stripped length with gauge, etc. before using the wires.

(b) If the stripped wires are bent, feazed or too thick due to twisting too much, fix the wires by twisting lightly, etc. Then, confirm the stripped length before using the wires. Do not use excessively deformed wires.

(c) Smooth out the wire surface and stripped insulator surface.

(2) Connecting wires

Before connecting wires, be sure to pull out the receptacle assembly from the header connector. If wires are connected with inserted connector, the connector and the printed board may malfunction.

(a) Using extraction tool (1891348-1 or 2040798-1)

1) Dimensions and mass

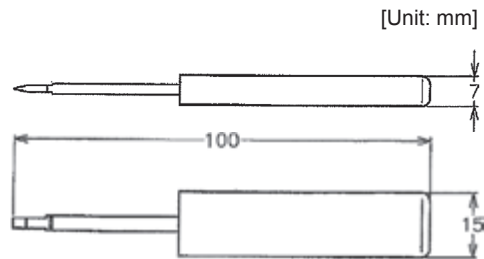

Mass : Approx. 20 g

APPENDIX

2) Connecting wires

a) Confirm the model number of the housing, contact and tool to be used.

b) Insert the tool diagonally into the receptacle assembly.



c) Insert the tool until it hits the surface of the receptacle assembly. At this stage, the tool is vertical to the receptacle assembly.

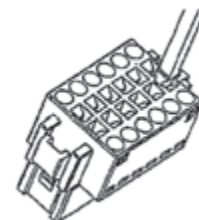

d) Insert wires in the wiring hole till the end. The wires should be slightly twisted in advance to prevent it from being feazed.

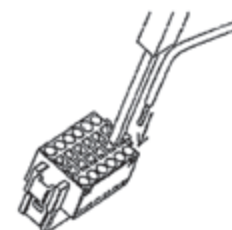

It is easy to insert the wire if the wire is inserted diagonally while twisting the tool.

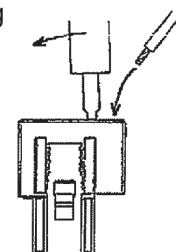

e) Remove the tool.

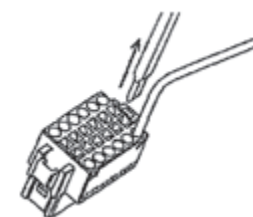

APPENDIX

(b) Using a screwdriver

To avoid damaging housings and springs when wiring with screwdriver, do not put excessive force. Be cautious when connecting.

1) Adjusting screw driver

Diameter: 2.3 mm \pm 0.05 mm
 Length: 120 mm or less
 Width: 2.3 mm, Blade thickness: 0.25 mm
 Angle in tip of the blade: 18 ± 1 degrees

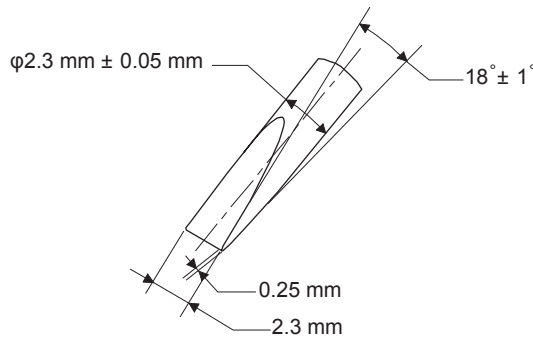

Screwdriver diameter: ϕ 2.3 mm

Diameter: 2.5 mm \pm 0.05 mm
 Length: 120 mm or less
 Width: 2.5 mm, Blade thickness: 0.3 mm
 Angle in tip of the blade: 12 ± 1 degrees

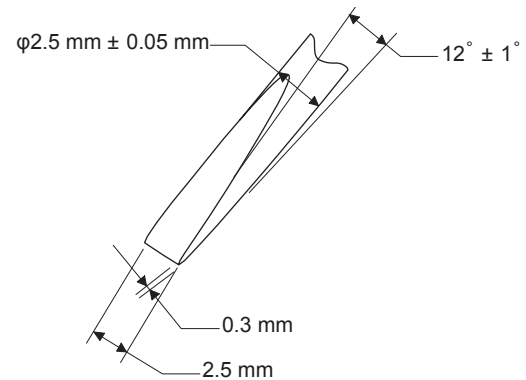

Screwdriver diameter: ϕ 2.5 mm

2) Connecting wires

- a) Insert a screwdriver in the front slot a little diagonally, and depress the spring. While depressing the spring, insert the wires until they hit the end. Note that the housing and spring may be damaged if the screwdriver is inserted strongly. Never insert the screwdriver in the wire hole. Otherwise, the connector will be damaged.
- b) Pull the screwdriver out while pressing the wires. Connecting wires is completed.
- c) Pull the wire lightly to confirm that the wire is surely connected.
- d) To remove the wires, depress the spring by the screwdriver in the same way as connecting wires, and then pull the wires out.

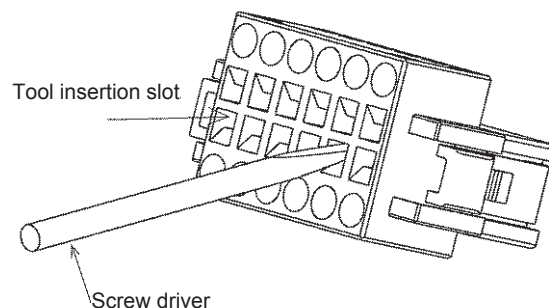

APPENDIX

(3) Connector insertion

Insert the connector all the way straight until you hear or feel clicking. When removing the connector, depress the lock part completely before pulling out. If the connector is pulled out without depressing the lock part completely, the housing, contact and/or wires may be damaged.

(4) Compatible wire

Compatible wire size is listed below.

Wire size	
mm ²	AWG
0.22	24
0.34	22
0.50	20

(5) Others

(a) Fix a wire tie at least distance of "A" × 1.5 away from the end of the connector.

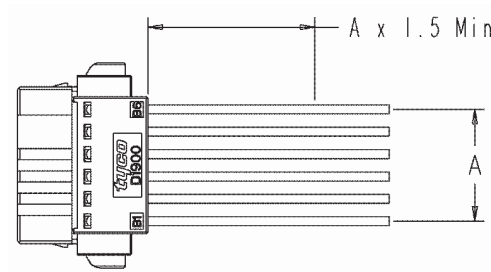

(b) Be sure that wires are not pulled excessively when the connector is inserted.

App. 7.8.4 Wiring FG

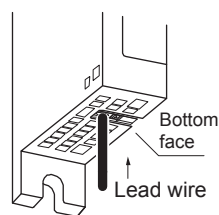

Wire range

Single wire: ϕ 0.4 mm to 1.2 mm (AWG 26 to AWG 16)

Stranded wire: 0.2 mm² to 1.25 mm² (AWG 24 to AWG 16),
wire ϕ 0.18 mm or more

APPENDIX

App. 7.9 LED display

I/O status, malfunction and power on/off are displayed with LED for each A-axis and B-axis.

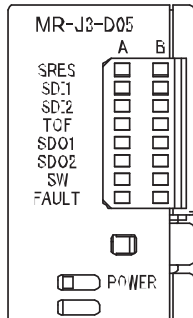

LED	Definition	LED	
		Column A	Column B
SRES	Monitor LED for start/reset Off: The start/reset is off. (The switch contact is opened.) On: The start/reset is on. (The switch contact is closed.)	A-axis	B-axis
SDI1	Monitor LED for shut-off 1 Off: The shut-off 1 is off. (The switch contact is closed.) On: The shut-off 1 is on. (The switch contact is opened.)		
SDI2	Monitor LED for shut-off 2 Off: The shut-off 2 is off. (The switch contact is closed.) On: The shut-off 2 is on. (The switch contact is opened.)		
TOF	Monitor LED for STO state Off: Not in STO state On: In STO state		
SDO1	Monitor LED for SDO1 Off: Not in STO state On: In STO state		
SDO2	Monitor LED for SDO2 Off: Not in STO state On: In STO state		
SW	Monitor LED for confirming shutdown delay setting Off: The settings of SW1 and SW2 do not match. On: The settings of SW1 and SW2 match.		
FAULT	FAULT LED Off: Normal operation (STO monitoring state) On: Fault has occurred.		
POWER	Power Off: Power is not supplied to MR-J3-D05. On: Power is being supplied to MR-J3-D05.		

App. 7.10 Rotary switch setting

Rotary switch is used to shut off the power after control stop by SS1 function.

Set the delay time for STO output after STO shut off switch is pressed. Set same setting for SW1 and SW2, and set the rotary switch setting according to the delay time in the table below.

Setting cannot be changed while power is on. Notify users that setting cannot be changed by putting a seal or by another method so that end users will not change the setting after the shipment.

0 to F in the following table is the set value of the rotary switches (SW1 and SW2).

Rotary switch setting and delay time at A/B-axis [s]

		B-axis					
		0 s	1.4 s	2.8 s	5.6 s	9.8 s	30.8 s
A-axis	0 s	0	1	2	-	3	4
	1.4 s		-	5	-	6	7
	2.8 s			8	-	9	A
	5.6 s				-	B	C
	9.8 s					D	E
	30.8 s						F

APPENDIX

App. 7.11 Troubleshooting

When power is not supplied or FAULT LED turns on, refer the following table and take the appropriate action.

Event	Definition	Cause	Action
Power is not supplied.	Power LED does not turn on although power is supplied.	1. 24 V DC power supply is malfunctioning.	Replace the 24 V DC power supply.
		2. Wires between MR-J3-D05 and 24 V DC power supply are disconnected or are in contact with other wires.	Check the wiring.
		3. MR-J3-D05 is malfunctioning.	Replace the MR-J3-D05.
FAULT LED is on.	FAULT LED of A-axis or B-axis is on, and will not turn off.	1. The delay time settings are not matched.	Check the settings of the rotary switch.
		2. Switch input error	Check the wiring or sequence of the input signals.
		3. TOF signal error	Check the connection with the servo amplifier.
		4. MR-J3-D05 is malfunctioning.	Replace the MR-J3-D05.

App. 7.12 Dimensions

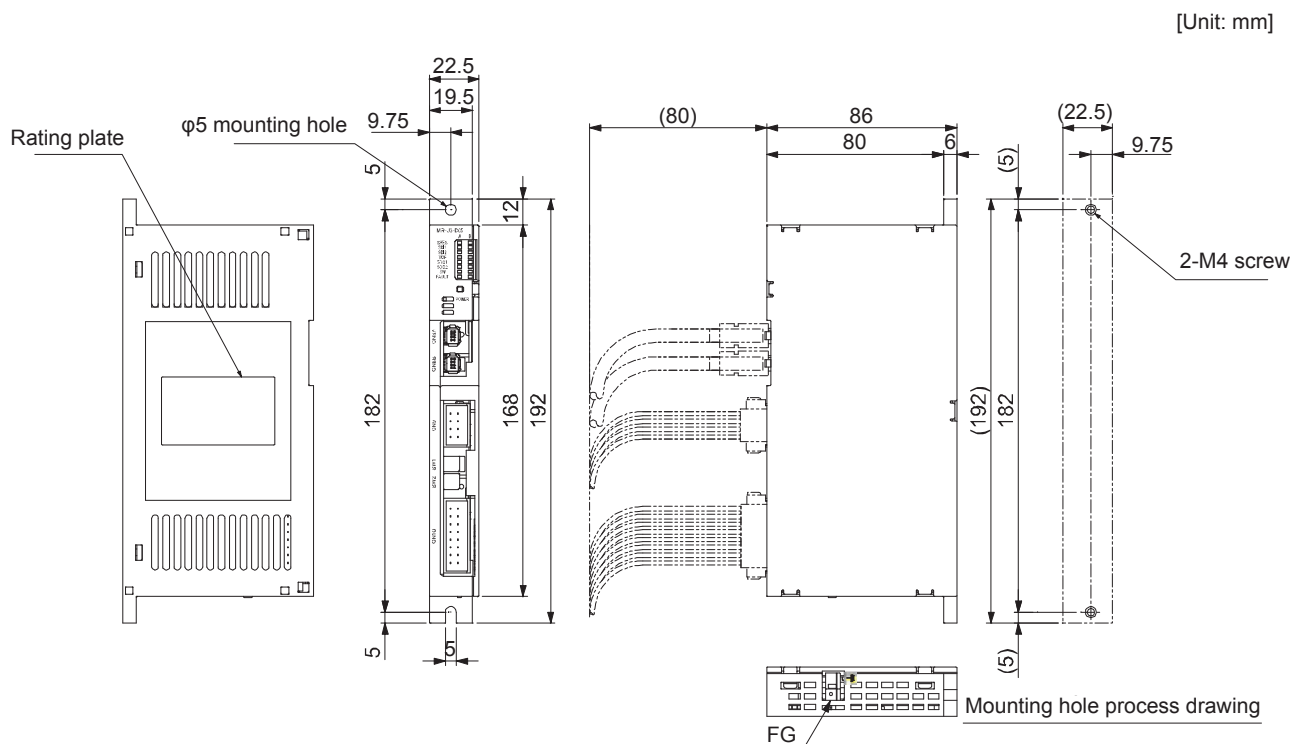

Mounting screw
Screw size: M4
Tightening torque: 1.2 N•m

Mass: 0.2 [kg]

APPENDIX

App. 7.13 Installation

Follow the instructions in this chapter and install MR-J3-D05 in the specified direction. Leave clearances between MR-J3-D05 and other equipment including the cabinet.

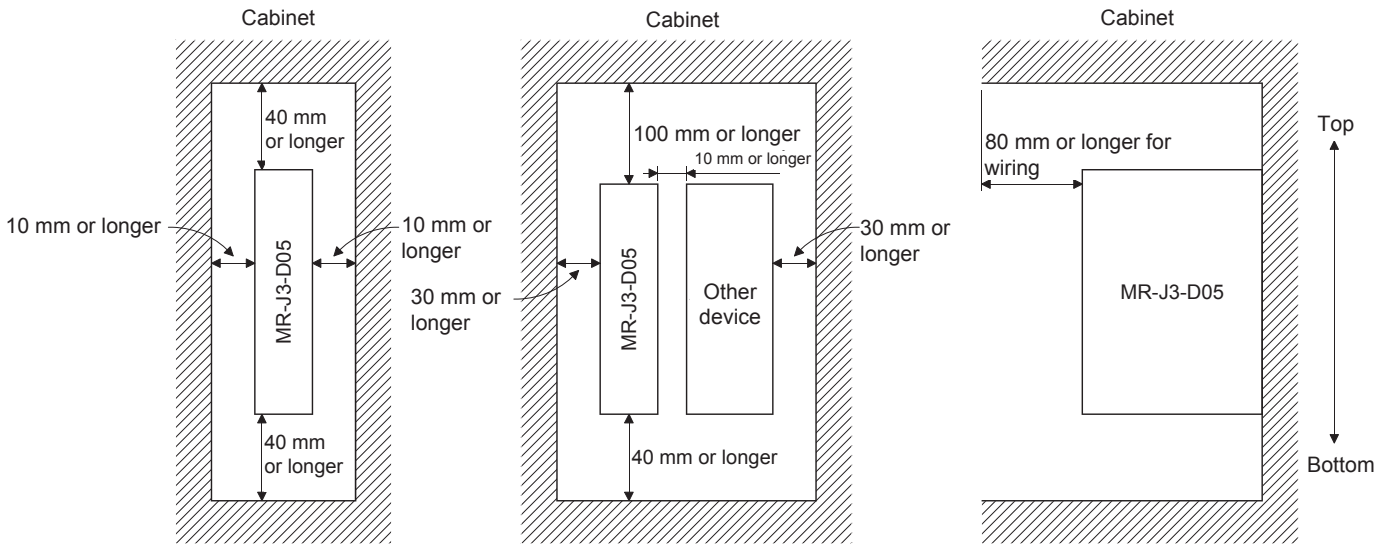

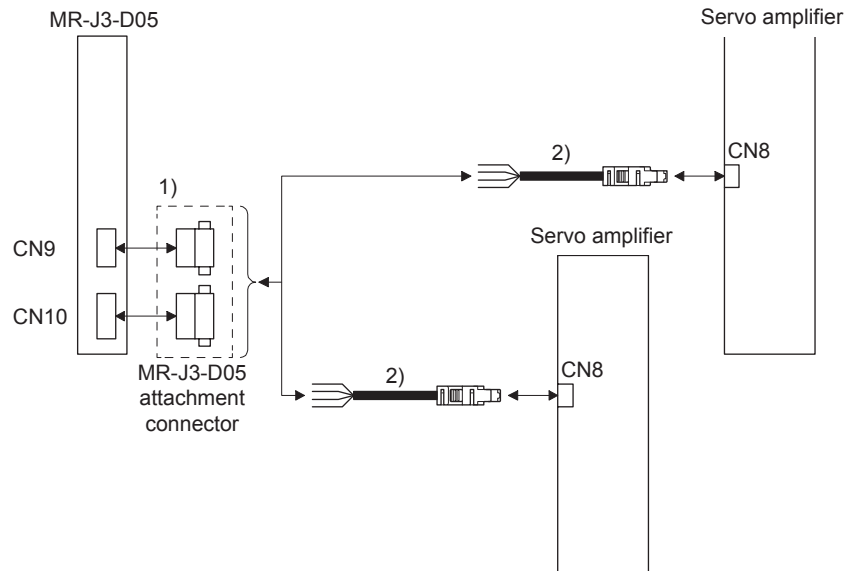

App. 7.14 Combinations of cable/connector

POINT
● The STO cable (MR-D05UDL-M) for MR-J3 series is not available.



APPENDIX

No.	Product	Model	Description
1)	Connector	MR-J3-D05 attachment connector	<div style="display: flex; justify-content: space-around; align-items: center;">   </div> Connector for CN9: 1-1871940-4 (TE Connectivity) Connector for CN10: 1-1871940-8 (TE Connectivity)
2)	STO cable	MR- D05UDL3M-B Cable length: 0.3/1/3 m	Connector set: 2069250-1 (TE Connectivity) 

COMPLIANCE WITH THE MACHINERY DIRECTIVES

The MR-J3-D05 complies with the safety components laid down in the directive 2006/42/EC (Machinery).

APPENDIX

App. 8 EC declaration of conformity

The MR-J3-D05 safety logic unit complies with the safety component laid down in the Machinery directive.



ZERTIFIKAT CERTIFICATE

Nr./No. 968/EL 612.00/09

Prüfgegenstand Product tested	Safety Logic Module for usage in combination with MR-J3-cS Servo Drives	Inhaber Holder	Mitsubishi Electric Corporation Nagoya Works 1-14 Yada-Minami 5-chome, Higashi-ku Nagoya 461-8670 Japan
Typbezeichnung Type designation	MR-J3-D05	Verwendungszweck Intended application	Drive Applications STO / SS1 acc. to EN 61800-5-2 Safe Stop / Safe Off Stop Category 0 / Stop Category 1 acc. to EN 60204-1
Prüfgrundlagen Codes and standards forming the basis of testing	EN ISO 13849-1:2008 EN 62061:2005 EN 61800-5-2:2007 EN 61800-5-1:2007	EN 61800-3:2004 EN 60204-1:2005 EN 50178:1997 EN 61506-1 to -7:2000-2002	
Prüfungsergebnis Test results	The MR-J3-D05 Safety Logic Module in combination with the MR-J3 series servo drives is suitable for the basic safety functions "STO" and "SS1" (Type C) according to EN 61800-5-2 as well as "Safe Stop" (Stop category 0 and Stop category 1) and "Safe Off" according to EN 60204-1. It can be used within safety related applications up to Safety Category 3 / PL d and SIL 2 / SIL CL 2 according to EN ISO 13849-1 and EN 62061.		
Besondere Bedingungen Specific requirements	For a safe usage of the product the instructions in the user documentation must be observed. For "Safe Off" two suitable additional magnetic contactors must be used additionally.		

Der Prüfbericht-Nr.: 968/EL 612.00/09 vom 21.04.2009 ist Bestandteil dieses Zertifikates.
Dieses Zertifikat ist nur gültig für Erzeugnisse, die mit dem Prüfgegenstand übereinstimmen. Es wird ungültig bei jeglicher Änderung der Prüfgrundlagen für den angegebenen Verwendungszweck.

The test report-no.: 968/EL 612.00/09 dated 2009-04-21 is an integral part of this certificate.
This certificate is valid only for products which are identical with the product tested. It becomes invalid at any change of the codes and standards forming the basis of testing for the intended application.

TÜV Rheinland Industrie Service GmbH
Geschäftsfeld ASI
Automation, Software and Informationstechnologie
Am Grauen Stein, 51106 Köln
Postfach 91 09 51, 51101 Köln



Dipl.-Ing. Heinz Gall

2009-04-21
Datum/Date

Firmenstempel/Company stamp

Dipl.-Ing. Heinz Gall

APPENDIX

App. 9 How to replace servo amplifier without magnetic pole detection



CAUTION

● Be sure to write the magnetic pole information of the servo amplifier before the replacement to the servo amplifier after the replacement. If the information before and after replacement are not the same, the servo motor may operate unexpectedly.

When replacing the servo amplifier, carry out the magnetic pole detection again. If the magnetic pole detection cannot be performed unavoidably, write the magnetic pole information from the servo amplifier before the replacement to the one after the replacement using MR Configurator2.

(1) Procedures

- (a) Read the magnetic pole information of the servo amplifier before the replacement.
- (b) Write the read magnetic pole information to the servo amplifier after the replacement.
- (c) Perform the test operation with the torque limit for ensuring the safety, and confirm that there is no trouble.

(2) Migration method of the magnetic pole information

(a) How to read the magnetic pole information from the servo amplifier before the replacement

- 1) Open the project in MR Configurator2, select "MR-J4-B" for model, and select "Linear" for operation mode.
- 2) Check that the personal computer is connected with the servo amplifier, and select "Diagnosis" and then "Linear diagnosis".
- 3) Click the "Magnetic pole information" button (1) in figure) to open the magnetic pole information window.
- 4) Click "Read All" of the magnetic pole information window. (2) in figure)
- 5) Confirm the data 1 and data 2 (3) in figure) of the magnetic pole information window and take notes.

(b) How to write the magnetic pole information to the servo amplifier after the replacement

- 1) Open the project in MR Configurator2, select "MR-J4-B" for model, and select "Linear" for operation mode.
- 2) Check that the personal computer is connected with the servo amplifier, and select "Diagnosis" and then "Linear diagnosis".
- 3) Click the "Magnetic pole information" button (1) in figure) to open the magnetic pole information window.
- 4) Input the value of the magnetic pole information taken notes to the data 1 and data 2 (3) in figure) of the magnetic pole information window.
- 5) Click "Write All" (4) in figure) of the magnetic pole information window.
- 6) Cycle the power of the servo amplifier.

APPENDIX

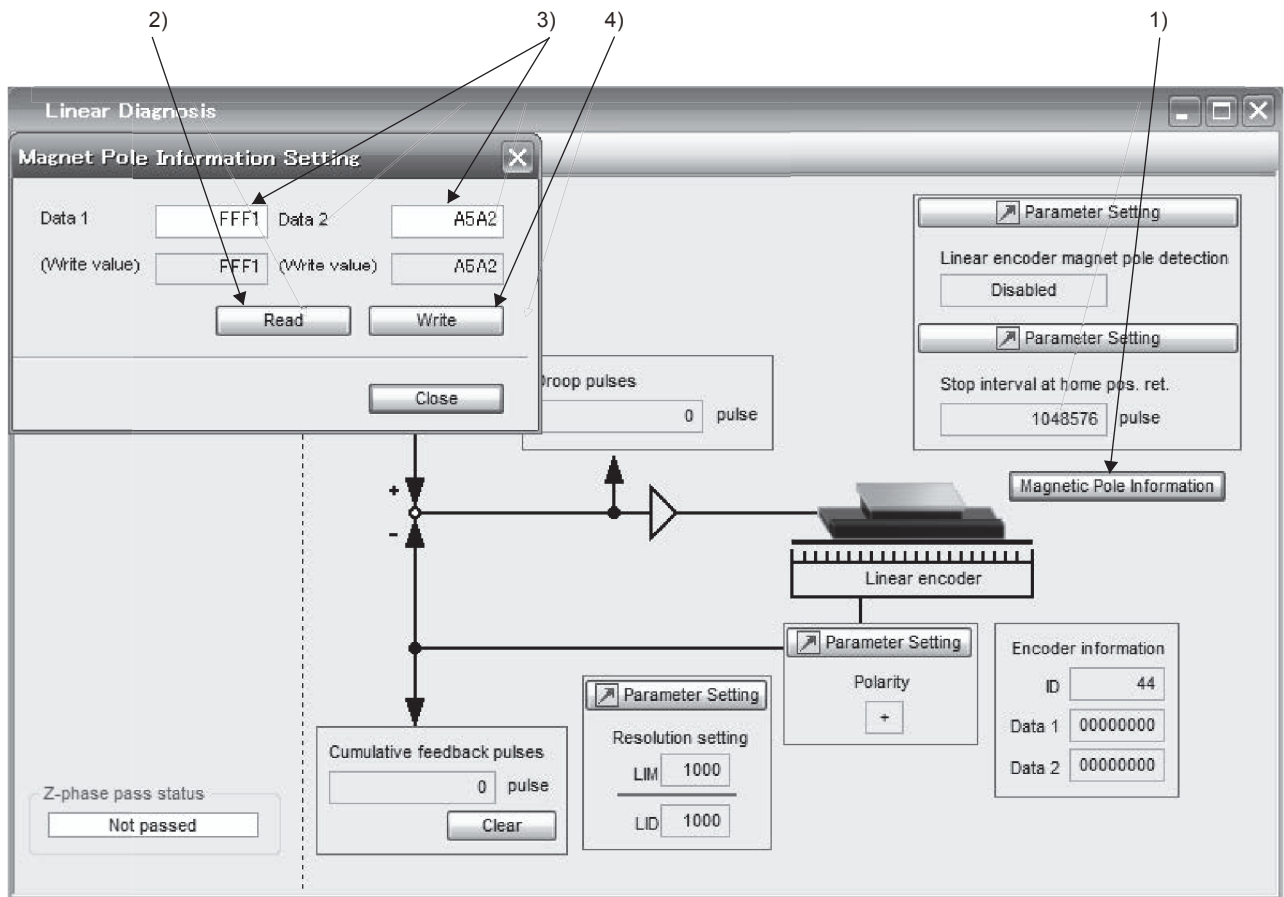

App. 10 Two-wire type encoder cable for HG-MR/HG-KR

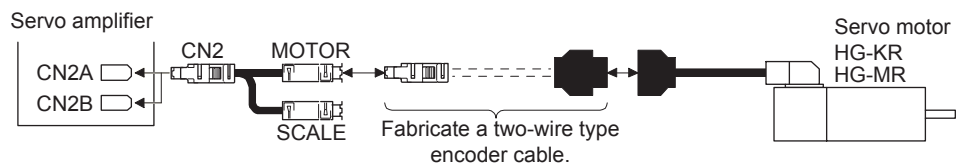

Use a two-wire type encoder cable for the fully closed loop control (available in the future).
For MR-EKCBL_M_ encoder cables for HG-MR and HG-KR, up to 20 m cables are two-wire type.
Therefore, when you need a longer encoder cable of two-wire type than 20 m, fabricate one using MR-ECNM connector set. Use the internal wiring diagram in the section to fabricate a cable up to 50 m.

App. 10.1 Configuration diagram

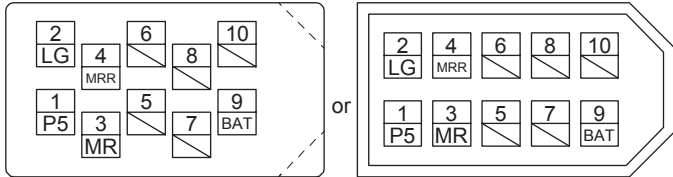

APPENDIX

App. 10.2 Connector set

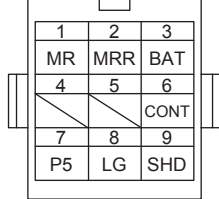
Connector set	1) Servo amplifier-side connector	2) Servo motor-side connector
MR-ECNM	Receptacle: 36210-0100PL Shell kit: 36310-3200-008 (3M)	Connector set: 54599-1019 (Molex)
	 <p>(Note) View seen from wiring side. (Note) View seen from wiring side.</p>	Housing: 1-172161-9 Connector pin: 170359-1 (TE Connectivity or equivalent) Cable clamp: MTI-0002 (Toa Electric Industry)
	<p>Note.  Keep open the pins shown with . Especially, pin 10 is provided for manufacturer adjustment. If it is connected with any other pin, the servo amplifier cannot operate normally.</p>	 <p>View seen from wiring side.</p>

App. 10.3 Internal wiring diagram

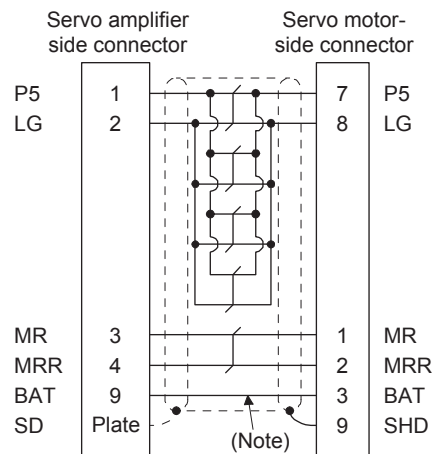

Note. Always make connection for use in an absolute position detection system. Wiring is not necessary for use in an incremental system.

APPENDIX

App. 11 SSCNET III cable (SC-J3BUS_M-C) manufactured by Mitsubishi Electric System & Service

POINT
<ul style="list-style-type: none"> ● For the details of the SSCNET III cables, contact your local sales office. ● Do not look directly at the light generated from CN1A/CN1B connector of servo amplifier or the end of SSCNET III cable. The light can be a discomfort when it enters the eye.

The cable is available per 1 m up to 100 m. The number of the length (1 to 100) will be in the underscore in the cable model.

Cable model	Cable length	Bending life	Application/remark
	1 m to 100 m		
SC-J3BUS_M-C	1 to 100	Ultra-long bending life	Using long distance cable

App.12 Analog monitor

The servo status can be output to two channels in terms of voltage.

(1) Setting

Change the following digits of [Pr. PC09] and [Pr. PC10].

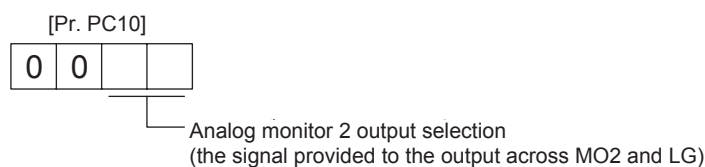
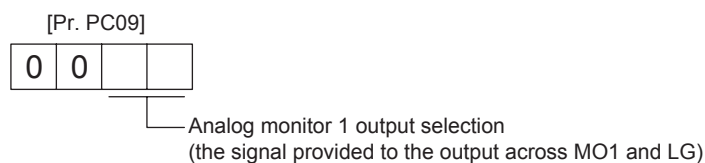

[Pr. PC11] and [Pr. PC12] can be used to set the offset voltages to the analog output voltages. Setting value is -999 mV to 999 mV.

Parameter	Description	Setting range [mV]
PC11	This is used to set the offset voltage of MO1 (Analog monitor 1).	-999 to 999
PC12	This is used to set the offset voltage of MO2 (Analog monitor 2).	

APPENDIX

(2) Setting

POINT
<p>● When you use a linear servo motor, replace the following left words to the right words.</p> <p>(servo motor) speed [r/min] → (linear servo motor) speed [mm/s]</p> <p>CCW direction → Positive direction</p> <p>CW direction → Negative direction</p> <p>Torque [N•m] → Thrust [N]</p>

The servo amplifier is factory-set to output the servo motor speed to MO1 (Analog monitor 1) and the torque to MO2 (Analog monitor 2). The setting can be changed as listed below by setting the [Pr. PC09] and [Pr. PC10] value.

Refer to (3) for the detection point.

Setting value	Output item	Description	Setting value	Output item	Description
00	Servo motor speed		01	Torque	
02	Servo motor speed		03	Torque	
04	Current command		05	Speed command	
06	Servo motor-side droop pulses (Note 1, 4, 6, 7) (±10 V/100 pulses)		07	Servo motor-side droop pulses (Note 1, 4, 6, 7) (±10 V/1000 pulses)	
08	Servo motor-side droop pulses (Note 1, 4, 6, 7) (±10 V/10000 pulses)		09	Servo motor-side droop pulses (Note 1, 4, 6, 7) (±10 V/100000 pulses)	

APPENDIX

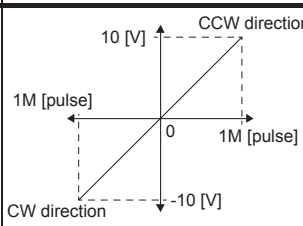
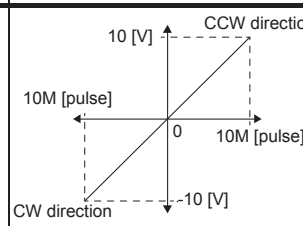
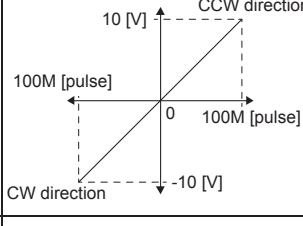
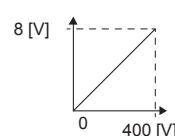
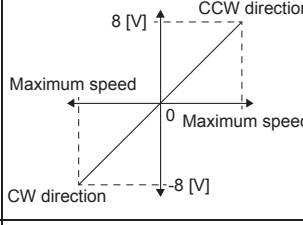
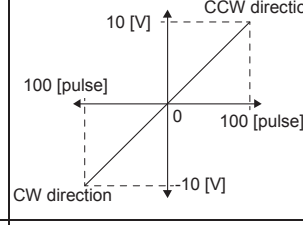
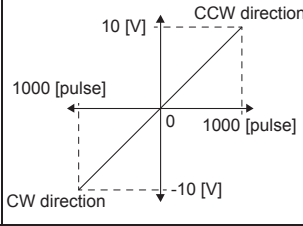
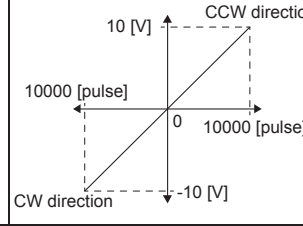
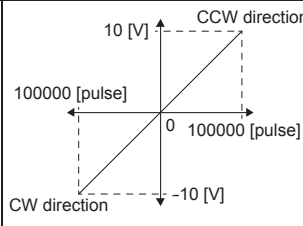
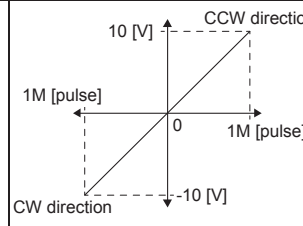
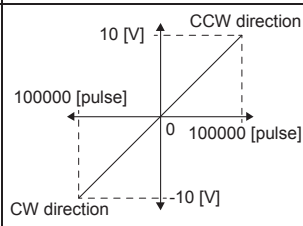
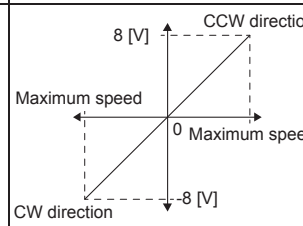
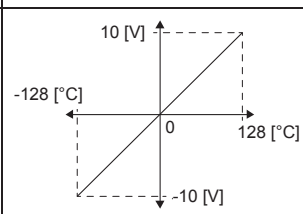
Setting value	Output item	Description	Setting value	Output item	Description
0A	Feedback position (Note 1, 2, 4) (± 10 V/1 Mpulse)		0B	Feedback position (Note 1, 2, 4) (± 10 V/10 Mpulse)	
0C	Feedback position (Note 1, 2, 4) (± 10 V/100 Mpulse)		0D	Bus voltage (Note 3)	
0E	Speed command 2 (Note 4, 5)		10	Load-side droop pulses (Note 4, 6, 7) (± 10 V/100 pulses)	
11	Load-side droop pulses (Note 4, 6, 7) (± 10 V/1000 pulses)		12	Load-side droop pulses (Note 4, 6, 7) (± 10 V/10000 pulses)	
13	Load-side droop pulses (Note 4, 6, 7) (± 10 V/100000 pulses)		14	Load-side droop pulses (Note 4, 6, 7) (± 10 V/1 Mpulses)	
15	Motor-side/load-side position deviation (Note 4, 6, 7) (± 10 V/100000 pulses)		16	Servo motor-side/load-side speed deviation	
17	Encoder inside temperature (± 10 V/ ± 128 °C)				

APPENDIX

Note 1. Encoder pulse unit.

2. Available in position control mode
3. For 400 V class servo amplifier, the bus voltage becomes +8 V/800 V.
4. This cannot be used in the torque control mode.
5. This can be used with MR Configurator2 with software version 1.02C or later.
6. This cannot be used in the speed control mode.
7. Output in the load-side encoder unit for the fully closed loop control. Output in the servo motor encoder unit for the semi closed loop control.

(3) Analog monitor block diagram

(a) Semi closed loop control

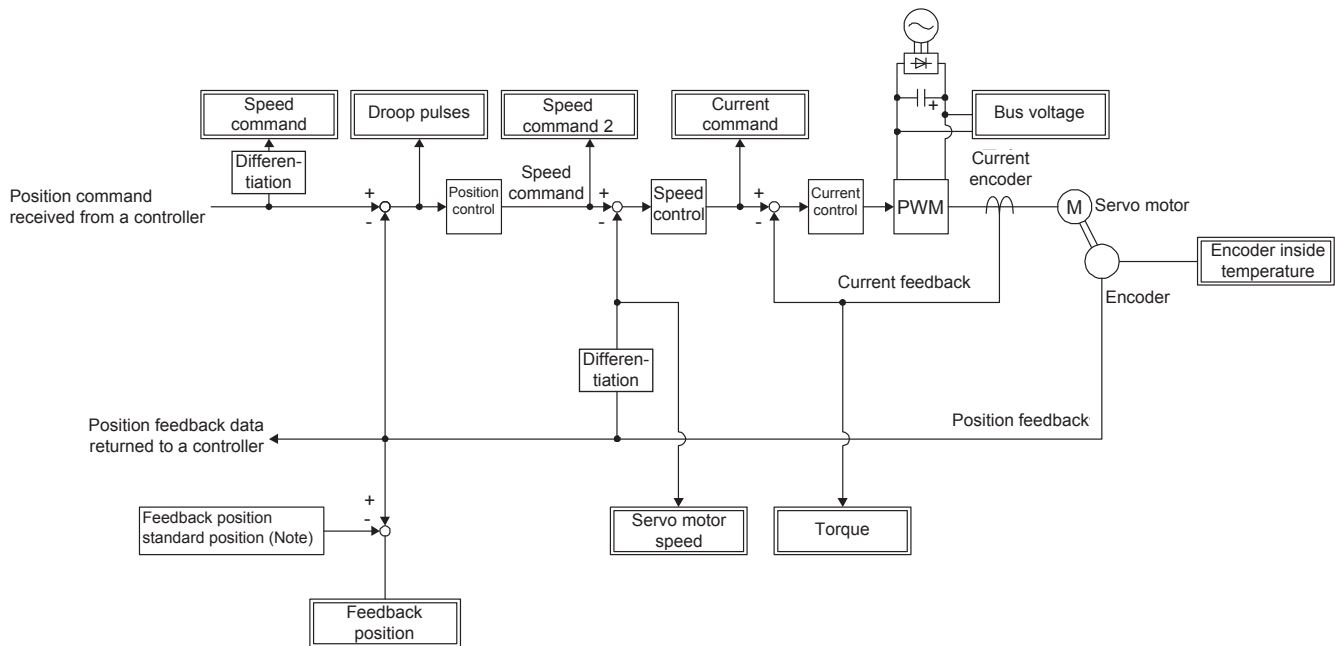

Note. The feedback position is output based on the position data passed between servo system controller and servo amplifier. [Pr. PC13] and [Pr. PC14] can set up the standard position of feedback position that is output to analog monitor in order to adjust the output range of feedback position. The setting range is between -9999 pulses and 9999 pulses.

$$\text{Standard position of feedback position} = [\text{Pr. PC14}] \text{ setting value} \times 10000 + [\text{Pr. PC13}] \text{ setting value}$$

Parameter	Description	Setting range
PC13	Sets the lower-order four digits of the standard position of feedback position	-9999 to 9999 [pulse]
PC14	Sets the higher-order four digits of the standard position of feedback position	-9999 to 9999 [10000 pulses]

APPENDIX

(b) Fully closed loop control (Available in the future.)

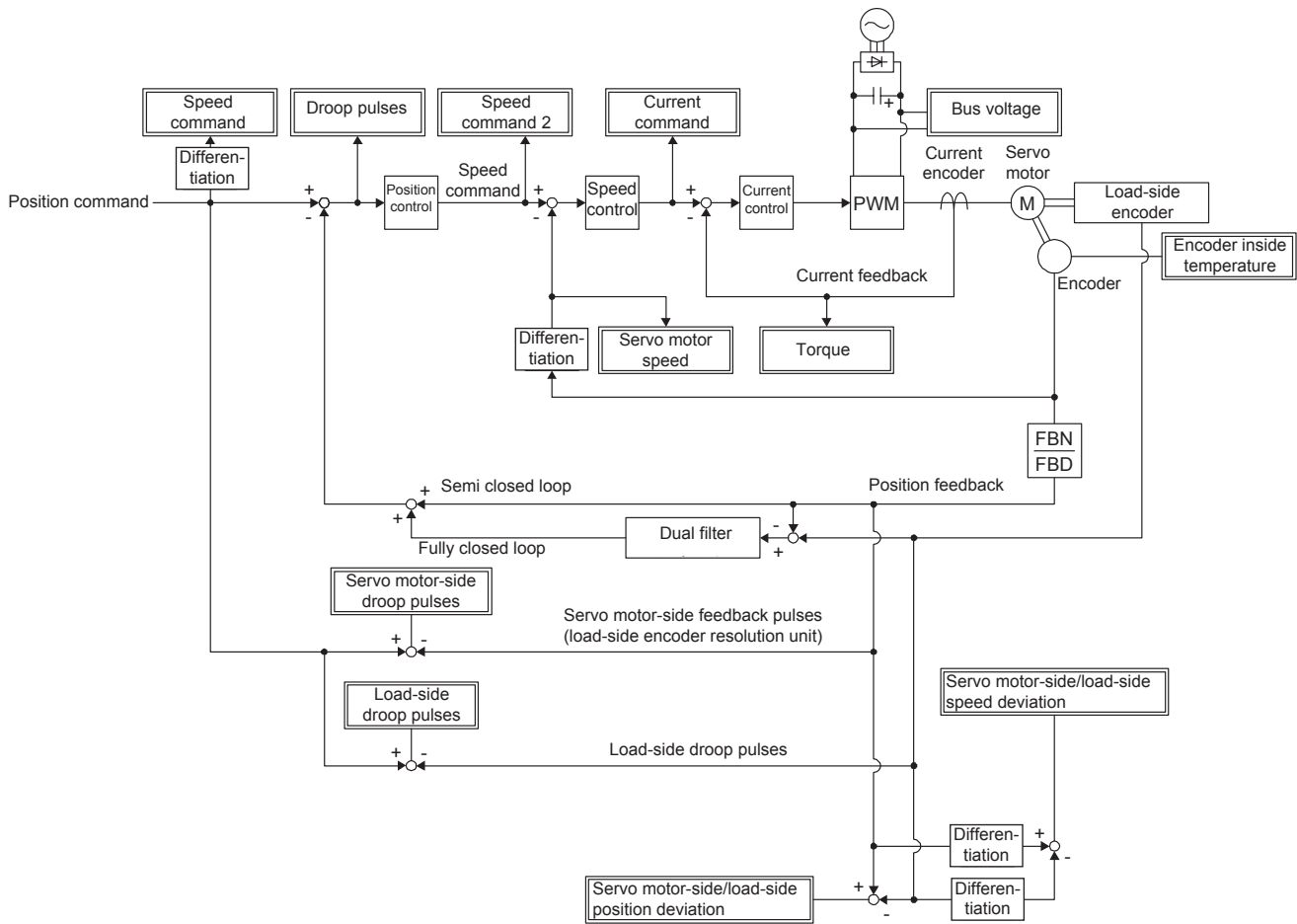

Country/Region	Sales office	Tel/Fax
USA	Mitsubishi Electric Automation Inc. 500 Corporate Woods Parkway, Vernon Hills, IL 60061, USA	Tel : +1-847-478-2100 Fax : +1-847-478-0327
Germany	Mitsubishi Electric Europe B.V. German Branch Gothaer Strasse 8, D-40880 Ratingen, Germany	Tel : +49-2102-486-0 Fax : +49-2102-486-1120
Italy	Mitsubishi Electric Europe B.V. Italian Branch Viale Colleoni 7 1-20041 Agrate Brianza (Milano), Italy	Tel : +39-39-60531 Fax : +39-39-6053312
China	Mitsubishi Electric Automation (China) Ltd. 4F Zhi Fu Plazz, No. 80 Xin Chang Road Shanghai 200003, China	Tel : +86-21-6120-0808 Fax : +86-21-6121-2444
Taiwan	Setsuyo Enterprise Co., Ltd. 6F, No.105 Wu-Kung 3rd Rd, Wu-Ku Hsiang, Taipei Hsine, Taiwan	Tel : +886-2-2299-2499 Fax : +886-2-2299-2509
Korea	Mitsubishi Electric Automation Korea Co., Ltd. 3F, 1480-6, Gayang-dong, Gangseo-gu, Seoul 157-200, Korea	Tel : +82-2-3660-9552 Fax : +82-2-3664-8372
Singapore	Mitsubishi Electric Asia Pte, Ltd. 307 Alexandra Road #05-01/02, Mitsubishi Electric Building Singapore 159943	Tel : +65-6470-2460 Fax : +65-6476-7439

Warranty

1. Warranty period and coverage

We will repair any failure or defect hereinafter referred to as "failure" in our FA equipment hereinafter referred to as the "Product" arisen during warranty period at no charge due to causes for which we are responsible through the distributor from which you purchased the Product or our service provider. However, we will charge the actual cost of dispatching our engineer for an on-site repair work on request by customer in Japan or overseas countries. We are not responsible for any on-site readjustment and/or trial run that may be required after a defective unit are repaired or replaced.

[Term]

The term of warranty for Product is twelve (12) months after your purchase or delivery of the Product to a place designated by you or eighteen (18) months from the date of manufacture whichever comes first ("Warranty Period"). Warranty period for repaired Product cannot exceed beyond the original warranty period before any repair work.

[Limitations]

- (1) You are requested to conduct an initial failure diagnosis by yourself, as a general rule.
It can also be carried out by us or our service company upon your request and the actual cost will be charged. However, it will not be charged if we are responsible for the cause of the failure.
- (2) This limited warranty applies only when the condition, method, environment, etc. of use are in compliance with the terms and conditions and instructions that are set forth in the instruction manual and user manual for the Product and the caution label affixed to the Product.
- (3) Even during the term of warranty, the repair cost will be charged on you in the following cases;
 - (i) a failure caused by your improper storing or handling, carelessness or negligence, etc., and a failure caused by your hardware or software problem
 - (ii) a failure caused by any alteration, etc. to the Product made on your side without our approval
 - (iii) a failure which may be regarded as avoidable, if your equipment in which the Product is incorporated is equipped with a safety device required by applicable laws and has any function or structure considered to be indispensable according to a common sense in the industry
 - (iv) a failure which may be regarded as avoidable if consumable parts designated in the instruction manual, etc. are duly maintained and replaced
 - (v) any replacement of consumable parts (battery, fan, smoothing capacitor, etc.)
 - (vi) a failure caused by external factors such as inevitable accidents, including without limitation fire and abnormal fluctuation of voltage, and acts of God, including without limitation earthquake, lightning and natural disasters
 - (vii) a failure generated by an unforeseeable cause with a scientific technology that was not available at the time of the shipment of the Product from our company
 - (viii) any other failures which we are not responsible for or which you acknowledge we are not responsible for

2. Term of warranty after the stop of production

- (1) We may accept the repair at charge for another seven (7) years after the production of the product is discontinued. The announcement of the stop of production for each model can be seen in our Sales and Service, etc.
- (2) Please note that the Product (including its spare parts) cannot be ordered after its stop of production.

3. Service in overseas countries

Our regional FA Center in overseas countries will accept the repair work of the Product. However, the terms and conditions of the repair work may differ depending on each FA Center. Please ask your local FA center for details.

4. Exclusion of responsibility for compensation against loss of opportunity, secondary loss, etc.

Whether under or after the term of warranty, we assume no responsibility for any damages arisen from causes for which we are not responsible, any losses of opportunity and/or profit incurred by you due to a failure of the Product, any damages, secondary damages or compensation for accidents arisen under a specific circumstance that are foreseen or unforeseen by our company, any damages to products other than the Product, and also compensation for any replacement work, readjustment, start-up test run of local machines and the Product and any other operations conducted by you.

5. Change of Product specifications

Specifications listed in our catalogs, manuals or technical documents may be changed without notice.

6. Application and use of the Product

- (1) For the use of our General-Purpose AC Servo, its applications should be those that may not result in a serious damage even if any failure or malfunction occurs in General-Purpose AC Servo, and a backup or fail-safe function should operate on an external system to General-Purpose AC Servo when any failure or malfunction occurs.
- (2) Our General-Purpose AC Servo is designed and manufactured as a general purpose product for use at general industries. Therefore, applications substantially influential on the public interest for such as atomic power plants and other power plants of electric power companies, and also which require a special quality assurance system, including applications for railway companies and government or public offices are not recommended, and we assume no responsibility for any failure caused by these applications when used.
In addition, applications which may be substantially influential to human lives or properties for such as airlines, medical treatments, railway service, incineration and fuel systems, man-operated material handling equipment, entertainment machines, safety machines, etc. are not recommended, and we assume no responsibility for any failure caused by these applications when used.
We will review the acceptability of the abovementioned applications, if you agree not to require a specific quality for a specific application. Please contact us for consultation.



General-Purpose AC Servo

MITSUBISHI SERVO AMPLIFIERS & MOTORS
MELSERVO-J4

SSCNET III/H Interface AC Servo
MODEL

MR-J4- B

SERVO AMPLIFIER
INSTRUCTION MANUAL

MITSUBISHI MELSERVO-J4 MR-J4- B SERVO AMPLIFIER INSTRUCTION MANUAL

MODEL	MR-J4-B INSTRUCTIONMANUAL
MODEL CODE	1CW805

MITSUBISHI ELECTRIC CORPORATION

HEAD OFFICE : TOKYO BLDG MARUNOUCHI TOKYO 100-8310

www.nicsanat.com

021-87700210





HEADQUARTERS

MITSUBISHI ELECTRIC EUROPE B.V. **EUROPE**
German Branch
Gothaer Straße 8
D-40880 Ratingen
Phone: +49 (0)2102 / 486-0
Fax: +49 (0)2102 / 486-1120

MITSUBISHI ELECTRIC EUROPE B.V.-org.sl. **CZECH REP.**
Czech Branch
Avenir Business Park, Radlická 714/113a
CZ-158 00 Praha 5
Phone: +420 - 251 551 470
Fax: +420 - 251-551-471

MITSUBISHI ELECTRIC EUROPE B.V. **FRANCE**
French Branch
25, Boulevard des Bouvets
F-92741 Nanterre Cedex
Phone: +33 (0)1 / 55 68 55 68
Fax: +33 (0)1 / 55 68 57 57

MITSUBISHI ELECTRIC EUROPE B.V. **IRELAND**
Irish Branch
Westgate Business Park, Ballymount
IRL-Dublin 24
Phone: +353 (0)1 4198800
Fax: +353 (0)1 4198890

MITSUBISHI ELECTRIC EUROPE B.V. **ITALY**
Italian Branch
Viale Colleoni 7
I-20041 Agrate Brianza (MB)
Phone: +39 039 / 60 53 1
Fax: +39 039 / 60 53 312

MITSUBISHI ELECTRIC EUROPE B.V. **POLAND**
Poland Branch
Krakowska 50
PL-32-083 Balice
Phone: +48 (0)12 / 630 47 00
Fax: +48 (0)12 / 630 47 01

MITSUBISHI ELECTRIC EUROPE B.V. **RUSSIA**
52, bid. 3 Kosmodamienskaya nab 8 floor
RU-115054 Moscow
Phone: +7 495 721-2070
Fax: +7 495 721-2071

MITSUBISHI ELECTRIC EUROPE B.V. **SPAIN**
Spanish Branch
Carretera de Rubí 76-80
E-08190 Sant Cugat del Vallés (Barcelona)
Phone: 902 131121 // +34 935653131
Fax: +34 935891579

MITSUBISHI ELECTRIC EUROPE B.V. **UK**
UK Branch
Travellers Lane
UK-Hatfield, Herts. AL10 8XB
Phone: +44 (0)1707 / 27 61 00
Fax: +44 (0)1707 / 27 86 95

MITSUBISHI ELECTRIC CORPORATION **JAPAN**
Office Tower "Z" 14 F
8-12,1 chome, Harumi Chuo-Ku
Tokyo 104-6212
Phone: +81 3 622 160 60
Fax: +81 3 622 160 75

MITSUBISHI ELECTRIC AUTOMATION, Inc. **USA**
500 Corporate Woods Parkway
Vernon Hills, IL 60061
Phone: +1 847 478 21 00
Fax: +1 847 478 22 53

EUROPEAN REPRESENTATIVES

GEVA **AUSTRIA**
Wiener Straße 89
AT-2500 Baden
Phone: +43 (0)2252 / 85 55 20
Fax: +43 (0)2252 / 488 60

TECHNIKON **BELARUS**
Oktyabrskaya 19, Off. 705
BY-220030 Minsk
Phone: +375 (0)17 / 210 46 26
Fax: +375 (0)17 / 210 46 26

ESCO DRIVES & AUTOMATION **BELGIUM**
Culliganlaan 3
BE-1831 Diegem
Phone: +32 (0)2 / 717 64 30
Fax: +32 (0)2 / 717 64 31

Koning & Hartman b.v. **BELGIUM**
Woluwelaan 31
BE-1800 Vilvoorde
Phone: +32 (0)2 / 257 02 40
Fax: +32 (0)2 / 257 02 49

INEA RBT d.o.o. **BOSNIA AND HERZEGOVINA**
Aleja Lipa 56
BA-71000 Sarajevo
Phone: +387 (0)33 / 921 164
Fax: +387 (0)33 / 524 539

AKHNATON **BULGARIA**
4, Andrei Ljapchev Blvd., PO Box 21
BG-1756 Sofia
Phone: +359 (0)2 / 817 6000
Fax: +359 (0)2 / 97 44 06 1

INEA RBT d.o.o. **CROATIA**
Losinjska 4 a
HR-10000 Zagreb
Phone: +385 (0)1 / 36 940 - 01 / -02 / -03
Fax: +385 (0)1 / 36 940 - 03

AutoCont C.S. s.r.o. **CZECH REPUBLIC**
Technologická 374/6
CZ-708 00 Ostrava-Pustkovce
Phone: +420 595 691 150
Fax: +420 595 691 199

Beijer Electronics A/S **DENMARK**
Lykkegårdsvej 17
DK-4000 Roskilde
Phone: +45 (0)46 / 75 76 66
Fax: +45 (0)46 / 75 56 26

Beijer Electronics Eesti OÜ **ESTONIA**
Pärnu mnt.160i
EE-11317 Tallinn
Phone: +372 (0)6 / 51 81 40
Fax: +372 (0)6 / 51 81 49

Beijer Electronics OY **FINLAND**
Peltoie 37
FIN-28400 Ulvila
Phone: +358 (0)207 / 463 540
Fax: +358 (0)207 / 463 541

UTEKO **GREECE**
5, Mavrogenou Str.
GR-18542 Piraeus
Phone: +30 211 / 1206 900
Fax: +30 211 / 1206 999

MELTRADE Kft. **HUNGARY**
Fertő utca 14.
HU-1107 Budapest
Phone: +36 (0)1 / 431-9726
Fax: +36 (0)1 / 431-9727

Beijer Electronics SIA **LATVIA**
Ritausmas iela 23
LV-1058 Riga
Phone: +371 (0)784 / 2280
Fax: +371 (0)784 / 2281

Beijer Electronics UAB **LITHUANIA**
Savanoriu Pr. 187
LT-02300 Vilnius
Phone: +370 (0)5 / 232 3101
Fax: +370 (0)5 / 232 2980

EUROPEAN REPRESENTATIVES

ALFATRADA Ltd. **MALTA**
99, Paola Hill
Malta- Paola PLA 1702
Phone: +356 (0)21 / 697 816
Fax: +356 (0)21 / 697 817

INTEHSIS srl **MOLDOVA**
bld. Traian 23/1
MD-2060 Kishinev
Phone: +373 (0)22 / 66 4242
Fax: +373 (0)22 / 66 4280

HIFLEX AUTOM.TECHNIEK B.V. **NETHERLANDS**
Wolweverstraat 22
NL-2984 CD Ridderkerk
Phone: +31 (0)180 - 46 60 04
Fax: +31 (0)180 - 44 23 55

Koning & Hartman b.v. **NETHERLANDS**
Haarlerbergweg 21-23
NL-1101 CH Amsterdam
Phone: +31 (0)20 / 587 76 00
Fax: +31 (0)20 / 587 76 05

Beijer Electronics AS **NORWAY**
Postboks 487
NO-3002 Drammen
Phone: +47 (0)32 / 24 30 00
Fax: +47 (0)32 / 84 85 77

Fonseca S.A. **PORTUGAL**
R. João Francisco do Casal 87/89
PT - 3801-997 Aveiro, Esgueira
Phone: +351 (0)234 / 303 900
Fax: +351 (0)234 / 303 910

Sirius Trading & Services srl **ROMANIA**
Aleea Lacul Morii Nr. 3
RO-060841 Bucuresti, Sector 6
Phone: +40 (0)21 / 430 40 06
Fax: +40 (0)21 / 430 40 02

INEA SR d.o.o. **SERBIA**
Izletnicka 10
SER-113000 Smederevo
Phone: +381 (0)26 / 615 401
Fax: +381 (0)26 / 615 401

SIMAP s.r.o. **SLOVAKIA**
Jána Derku 1671
SK-911 01 Trenčín
Phone: +421 (0)32 743 04 72
Fax: +421 (0)32 743 75 20

PROCONT, spol. s r.o. Prešov **SLOVAKIA**
Kúpeľná 1/A
SK-080 01 Prešov
Phone: +421 (0)51 7580 611
Fax: +421 (0)51 7580 650

INEA RBT d.o.o. **SLOVENIA**
Stegne 11
SI-1000 Ljubljana
Phone: +386 (0)1 / 513 8116
Fax: +386 (0)1 / 513 8170

Beijer Electronics AB **SWEDEN**
Box 426
SE-20124 Malmö
Phone: +46 (0)40 / 35 86 00
Fax: +46 (0)40 / 93 23 01

Omni Ray AG **SWITZERLAND**
Im Schörl 5
CH-8600 Dübendorf
Phone: +41 (0)44 / 802 28 80
Fax: +41 (0)44 / 802 28 28

GTS **TURKEY**
Bayraktar Bulvarı Nutuk Sok. No:5
TR-34775 Yukarı Dudullu-Ümraniye-İSTANBUL
Phone: +90 (0)216 526 39 90
Fax: +90 (0)216 526 3995

CSC Automation Ltd. **UKRAINE**
4-B, M. Raskovoyi St.
UA-02660 Kiev
Phone: +380 (0)44 / 494 33 55
Fax: +380 (0)44 / 494-33-66

Systemgroup **UKRAINE**
2 M. Krivonosy St.
UA-03680 Kiev
Phone: +380 (0)44 / 490 92 29
Fax: +380 (0)44 / 248 88 68

EURASIAN REPRESENTATIVES

TOO Kazpromavtomatika **KAZAKHSTAN**
Ul. Zhambyla 28
KAZ-100017 Karaganda
Phone: +7 7212 / 50 10 00
Fax: +7 7212 / 50 11 50

MIDDLE EAST REPRESENTATIVE

SHERF Motion Techn. Ltd. **ISRAEL**
Rehov Hamerkava 19
IL-58851 Holon
Phone: +972 (0)3 / 559 54 62
Fax: +972 (0)3 / 556 01 82

CEG INTERNATIONAL **LEBANON**
Cebaco Center/Block A Autostrade DORA
Lebanon - Beirut
Phone: +961 (0)1 / 240 430
Fax: +961 (0)1 / 240 438

AFRICAN REPRESENTATIVE

CBI Ltd. **SOUTH AFRICA**
Private Bag 2016
ZA-1600 Isando
Phone: +27 (0)11 / 977 0770
Fax: +27 (0)11 / 977 0761