

www.nicsanat.com

021-87700210

NIC SANAT

نیک صنعت



EDB/EDC Series

All Digital AC Servo Systems



ISO9001

ESTUN
Drive your success

www.nicsanat.com

021-87700210



Company Profile

As NO.1 Servo brand in China, Estun Automation is devoted to R&D, manufacturing and sales of high-end products in the realm of motion control. Estun Automation has a completely self-owned IPR technology of AC servo systems which are widely applied in CNC machines, textile machines, packaging machines, printing machines, wood processing machines and other automatization production lines. Till now, Estun Automation has an established long-term strategic partnership with many prestigious and professional sales agents and has become the first cooperation option for many machine manufacturers at home and abroad.



NanJing City

Nanjing is the capital of Jiangsu Province and a modern city in China, with a history more than 6,000 years old. If we were to think of Jiangsu as a country, it would be ranked 40th in regards to GDP in the world.

05

EDB/EDC Series All Digital AC Servo

08

EDB/EDC Series Servo Drive

12

EMJ Series Servo Motor

16

EMG Series Servo Motor

20

EML Series Servo Motor

24

Mounting Dimension of Motor & Drive

25

Typical Connection Example



GuLou Square

As the biggest square in Nanjing, Gulou Square lies in the downtown city accompanied with a 455,000 square meters garden. The Town's people love gathering around the square to rest, talk or exercise.

EDB Series Servo Drive



With a power range from 750w to 5Kw, the EDB series is designed to meet various general purpose applications. Mature servo software control technology and hardware design leads to high performance. Features include high overload capacity, auto disturbance rejection, control flexibility, single axis positioning, a windows-based software and RS422/485 communications.

EDC Series Servo Drive



The EDC series is designed for lower cost applications with step and direction control. Composing software by C language ensures high responsiveness. A palm operator is necessary to set, change or monitor the parameters. The EDC series has 8-node build-in positioning points, a windows-based software and RS232/Canopen communication.

High Responsiveness

- The Responding performance has been greatly improved with new functions like current forward-feed control, acceleration forward-feed control and speed observer.
- Updated with control mode switch function, effectively reduce overshoot and adjustment time by setting appropriate switch function.

EDB/EDC

Series All Digital AC Servo System

High Overload Capacity

EDB/EDC servo drive utilizes a larger capacity industrial grade intelligent power modules (IPM) than a normal servo with the same power capacity. Therefore, they have stronger overload capacity, higher disturbance rejection capacity and larger startup torque. The servo drives assure three times overload capacity for types below 1.5Kw and 2.5 times above 2Kw at rated speed.

Auto Disturbance Rejection

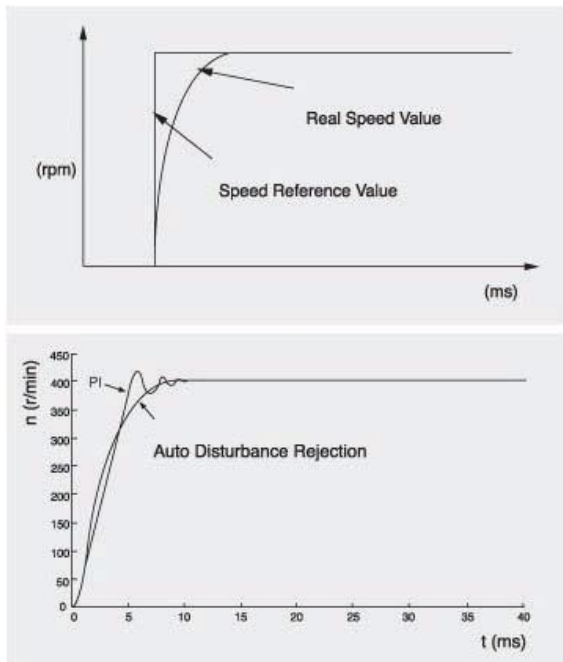

The most updated high speed DSP is used to meet the control requirements of high speed, high precision servo. With its auto disturbance rejection control and speed observation control algorithm, combined with compensation servo delay's forward-feedback control, reference smoothing technique, the servo drives have much better dynamic features and stabilities than those with conventional PI control. Servo's real fast response, high precision, high speed and high stability are realized. In addition, being equipped with automatic inertia identification, it makes adjustment operations easier.

Communication Interface

Standard CAN bus interfaces are available in EDC series servo which makes it easy to get integrated into a distributed control system. Based on Modbus Protocols of RS485 or RS232 interfaces, the host can be connected up to 32 servos for network control & the transmission distance can reach 1200 meter in maximum (if RS485 interface be used). Besides, the host can also communicate with PLC, DCS, intelligent instruments, touch screen and so on for centralized monitor.

Flexible switching

Position control, speed control and torque control are combined all in one in EDB servo drives. It's available to switch dynamically among different control modes and operation is more convenient and flexible.

Windows-based ESview Computer Software

With special window-based computer software, the following functions are achieved:

➤ **Parameter management**

Fast and convenient operations to all parameters are available, such as editing, transmission, comparison and initialization.

➤ **Monitoring**

Real time monitoring of all I/O signals, alarm of the present and history record, and system status etc.

➤ **Real time sampling**

Real time sampling the curves of speed and torque facilitates the adjustment and analysis.

➤ **Adjusting**

Fast adjustment of gains is available. Sample test is available when there is no position or speed reference input.

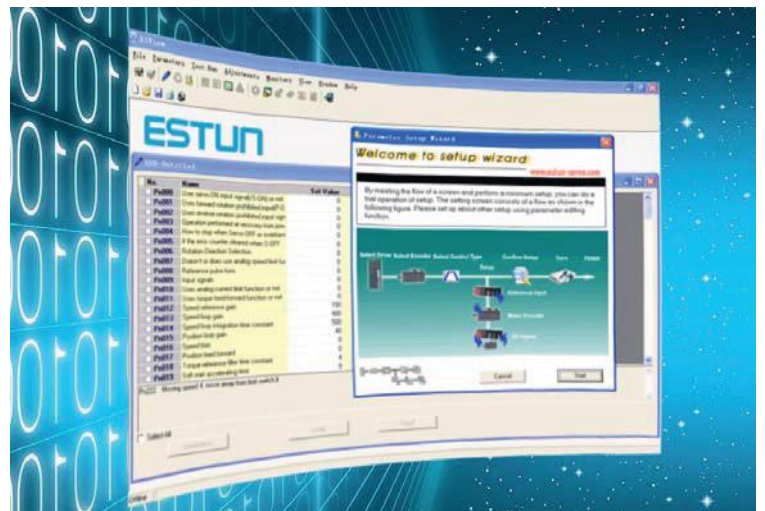

Single Axis Positioning Function

The 16-node single axis positioning function is built inside the servo drives, and a touch screen can be connected directly to the RS-232 interface on the servo drives. Thus the costs is lower since an intermediate PLC unit is eliminated. With the touch screen, users may easily program every node's position, speed, acceleration, deceleration time, latency time, start point and stop point, moreover, the above info can be transmitted to the servo drive via RS-232 interface. Users may select to program absolute values or incremental values and select cycle run or not. Users may also use a reference point search function and program the go and back speed for reference point search and it's also available to use external signals for step changes. Users may develop their own application programs to meet different demands on different occasions.



EDB/EDC

Series Servo Drive

Features

- FFT Analysis to control the vibration
- Dynamical change of electronic gear
- Inertia detection and speed forward-feedback function
- Superior reliability

Model Specification Description

EDC-08

A

P

E

EDC Servo Drive

Rated Power

Power voltage

Control Style

Design Sequence

Sign	Specification
02	200W
04	400W
08	750W

Sign	Specification
A	200VAC

Sign	Specification
P	Position Control

Sign	Specification
E	Design Sequence

EDB-10

A

M

A

EDB Servo Drive

Rated Power

Power voltage

Control Style

Design Sequence

Sign	Specification
08	750W
10	1KW
15	1.5KW
20	2KW
30	3KW
50	5KW

Sign	Specification
A	200VAC

Sign	Specification
P	Position Control
M	Position, speed, torque control

Sign	Specification
A	Design Sequence

Model Comparison Table

Servo Motors			EDC/EDB series Servo Drives			
Series			Capacity	Model	Single phase 190~245Vac	Three phase 190~245Vac
Medium Inertia	Small Capacity	EMJ 3000r/min	200w	EMJ-02APA	EDC-02APE	
			400w	EMJ-04APA	EDC-04APE	
			750w	EMJ-08APA	EDC-08APE EDB-08A□A	EDB-08 A□A
			1000W	EMJ-10APA	EDB-10A□A	EDB-10A□A
	Medium Capacity	EMG 2000r/min	1.0kW	EMG-10A□	EDB-10A□A	EDB-10A□A
			1.5kW	EMG-15A□	EDB-15A□A	EDB-15A□A
			2.0kW	EMG-20A□		EDB-20A□A
			3.0kW	EMG-30A□		EDB-30A□A
			5.0kW	EMG-50A□		EDB-50A□A
			EML 1000r/min	1.0kW	EML-10A□	
		2.0kW		EML-20A□		EDB-20A□A
		3.0kW		EML-30A□		EDB-30A□A
		4.0kW		EML-40A□		EDB-50A□A

Cable Models

Servo Drive	Servo Motor	Power Cable Model	Encoder Cable Model	Communication Cable Model	Palm Operator
EDC-02APE	EMJ-02APA				
EDC-04APE	EMJ-04APA	CDM-JB18	CMP-JB26	CSC-CC24A	OP-01A
EDC-08APE	EMJ-08APA				
EDB-08A□□	EMJ-08APA	BDM-JB18	BMP-JB24		
EDB-10A□□	EMJ-10APA				
EDB-10A□□	EMG-10APA	BDM-GA16			
EDB-15A□□	EMG-15APA	BDM-GA14			
EDB-20A□□	EMG-20APA	BDM-GD12			
EDB-30A□□	EMG-30APA		BMP-GA24	BSC-CC24A	-
EDB-50A□□	EMG-50APA				
EDB-10A□□	EML-10APA	BDM-GA16			
EDB-20A□□	EML-20APA	BDM-GD14			
EDB-30A□□	EML-30APA	BDM-GD12			
EDB-50A□□	EML-40APA				

Technical Specification of Servo Drives

Servo Drive Model		EDB Series	EDC Series	
Basic Data	Power Supply	Single/Three Phase AC220V+10-15%,50/60HZ	single Phase AC220V+10-15%,50/60HZ	
	Control Mode	SVPWM	SVPWM	
	Feedback	8 Cores(Wire saving) Incremental Encoder(2500P/R)	8 Cores(Wire saving) Incremental Encoder(2500P/R)	
	Working Condition	Operating/Storage Temperature	0 to +55°C/-20 to +85°C	0 to +55°C/-20 to +85°C
		Operating/Storage Humidity	90% RH or less(no condensation)	90% RH or less(no condensation)
		Shock/Vibration Resistance	4.9m/s ² / 19.6m/s ²	4.9m/s ² / 19.6m/s ²
	Structure	Base-mounted	Base-mounted	
Speed Control Range	1: 5000	1: 5000		
Speed Control Mode	Speed Regulation	Load Regulation	0 to 100% load:±0.01% max	—
		Voltage Regulation	Rated voltage±10%: 0%(at rated speed)	—
		Temperature Regulation	25±25°C:±0.1% max. (at rated speed)	—
	Frequency Characteristics with workload		300HZ(JL<=JM)	300HZ(JL<=JM)
	Software Startup Time setting		0-10s(Set Acceleration and Deceleration Individually)	—
	Speed Ref.Input	Reference Voltage	±10V DC	—
		Input Resistance	40kΩ	—
		Loop Time Constant	47μs	—
	Torque Ref.Input	Reference Voltage	±10V DC	—
		Input Resistance	40kΩ	—
		Loop Time Constant	47μs	—
Node Speed Reference	Reverse Rotation Direction Selection	Use P-CON Signal	—	
	Speed Selection	Use FWD/REV current limit signal (select speed 1-3),when both not OFF, select Stop or other control mode	—	
Position Control Mode	Reference Pulse	Type	SIGN+PULSE Train, Sin. Pulse Phase A and Phase B, CCW+CW Pulse Train	SIGN+PULSE Train, Sin. Pulse Phase A and Phase B, CCW+CW Pulse Train
		Pulse Buffer	Line Driving(+5V Level).Open Collector	Line Driving(+5V Level).Open Collector
		Pulse Frequency	Maxi.500Kpps(Difference) /200Kpps(Collector)	Maxi.500Kpps(Difference) /200Kpps(Collector)

Technical Specification of Servo Drives

Servo Drive Model		EDB Series	EDC Series	
Position Control Mode	Control Signal	clear	Clear	
	Offset Setting	0-300r/min(Set Resolution as 1r/min)	—	
	Feed Forward Compensation	0-100%(Set Resolution as 1%)	—	
	In position Error Setting	0-500 Reference Unit(Set resolution as 1 reference unit)	—	
I/O Signals	Position Output	Output Signal	Phase A, Phase B and Phase C; Line Driving Output	
		Dividing Ratio	(1-2500)/2500	
	Sequence Control Input		Servo ON, Proportional Control or Control Mode Switch, Forward Run Prohibited, Reverse Run Prohibited, Alarm Reset, FWD Torque External Limit, REV Torque External Limit, Zero Clamp Signal	Servo On, Alarm Reset, Error Counter, Clear Signal, Zero Clamp Signal
	Sequence Control Output		Servo Alarm, Servo Ready, Positioning Complete(Speed Coincidence), Brake Release, Limiting Torque, Motor Run Detection	Servo Alarm, Positioning Complete(Speed Coincidence), Brake Release, Limiting Torque
Built-in Function	COM Function		With RS485 interface for communication. With host controller's special software, parameter setting, run operation and status display can be done in Windows mode. Compatible with Modbus com protocol and CANopen protocol.	With RS485 interface for communication. With host controller's special software, parameter setting, run operation and status display can be done in Windows mode. Compatible with Modbus com protocol and CANopen protocol.
	LED Display		Charge, Power, Five 7-segment LEDs and 4 Pushbuttons(Digital Operation Panel)	Charge, Power & ALM Indicator, Five 7 Segment Tube(On Handheld Operator)
	Braking		Dynamic Brake, Overtravel Protection	Dynamic Brake
	Protection		Overcurrent, Overload, Overspeed, Under Voltage, Overvoltage, Encoder Error, Parameter Error, etc.	IPM Power Module Error, Overload, Overspeed, Voltage Error, Position Error, Counter Overflow, Encoder Disconnected, Parameter Damaged, etc.
	Regeneration Treatment Function		Built in Regenerative Resistance	—
	Other		Zero Clamp, 16 internal Position Nodes.	—

EMJ

Series Servo Motor

Features

- Medium inertia
- Peak torque up to 300% of rated torque
- Various models (200w~1000w, with brake, etc.,)
- Run at speed of up to 4500r/min
- Equipped with wire-saving encoder(2500P/R)

Applications

- SMM(surface mounting machine)
- PCB puncher machine
- Robot arm
- Handing machine
- Foodstuff processing machine
- Textile machine



Model Specification Description

EMJ-08

A

P

A

1

1

EMJ Model
Servo Motor

Rated Power		Power Voltage		Encoder		Design Sequence		Shaft End		Optional Parts	
Sign	Spec.	Sign	Spec.	Sign	Spec.	Sign	Spec.	Sign	Spec.	Sign	Spec.
2	200W	A	200Vac	P	2500P/R	A	Design Sequence	1	Flat, without keys	1	None
4	400W									2	With Oil Seal
8	750W							2	Flat, with keys, with screw thread	3	With brake (DC24V)
10	1000W									4	With oil seal, with brake (DC24V)

Rated Value and Specifications

Voltage		200VAC			
Servo motor type	EMJ-	02A	04A	08A	10A
Rated output power	W	200	400	750	1000
Rated torque	N.m	0.64	1.27	2.40	3.18
Instantaneous peak torque	N.m	1.92	3.82	7.16	9.55
Rated current	Arms	1.3	2.7	4.0	5.3
Instantaneous peak current	Arms	3.9	8.1	12.0	15.9
Rated rotated speed	min ⁻¹	3000			
The highest rotated speed	min ⁻¹	4500			
Rotator rotated inertia	x10 ⁻⁴ kg/m ²	0.19(0.23)	0.31(0.35)	1.35(1.47)	1.74(1.87)
Encoder	Standard	Incremental wire-saving type: 2500P/R			
Heat endurance level		F			
Environment temperature		0 to +40°C (Non-iced)			
Environment humidity		20 to 80% RH (No dew)			
Protection method		All-closed, self-cool, IP65 (Except output shaft and connector)			
Anti-vibration performance		49m/s ²			

(Note): The values in parentheses are for servo motors with holding brakes.

Torque-Speed Feature

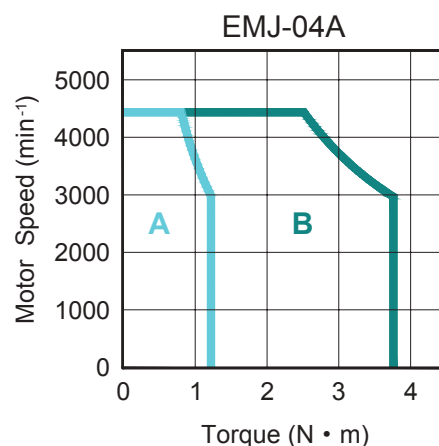
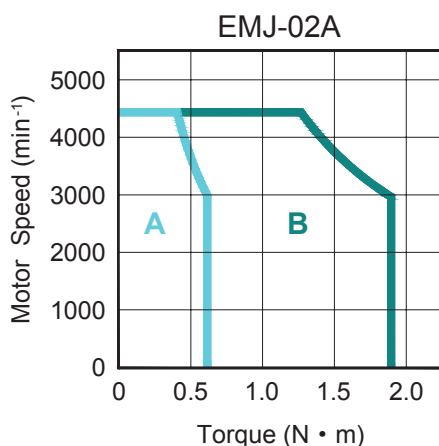

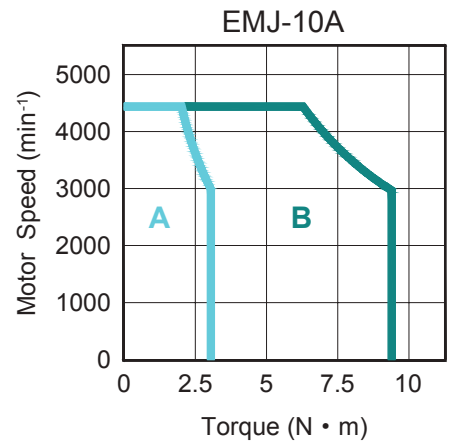
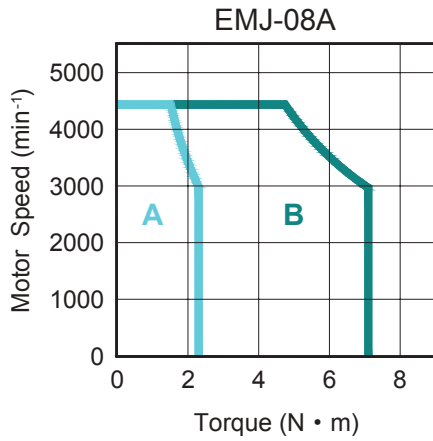

A: Continuous Working Area B: Repeatable Working Area

Dimension

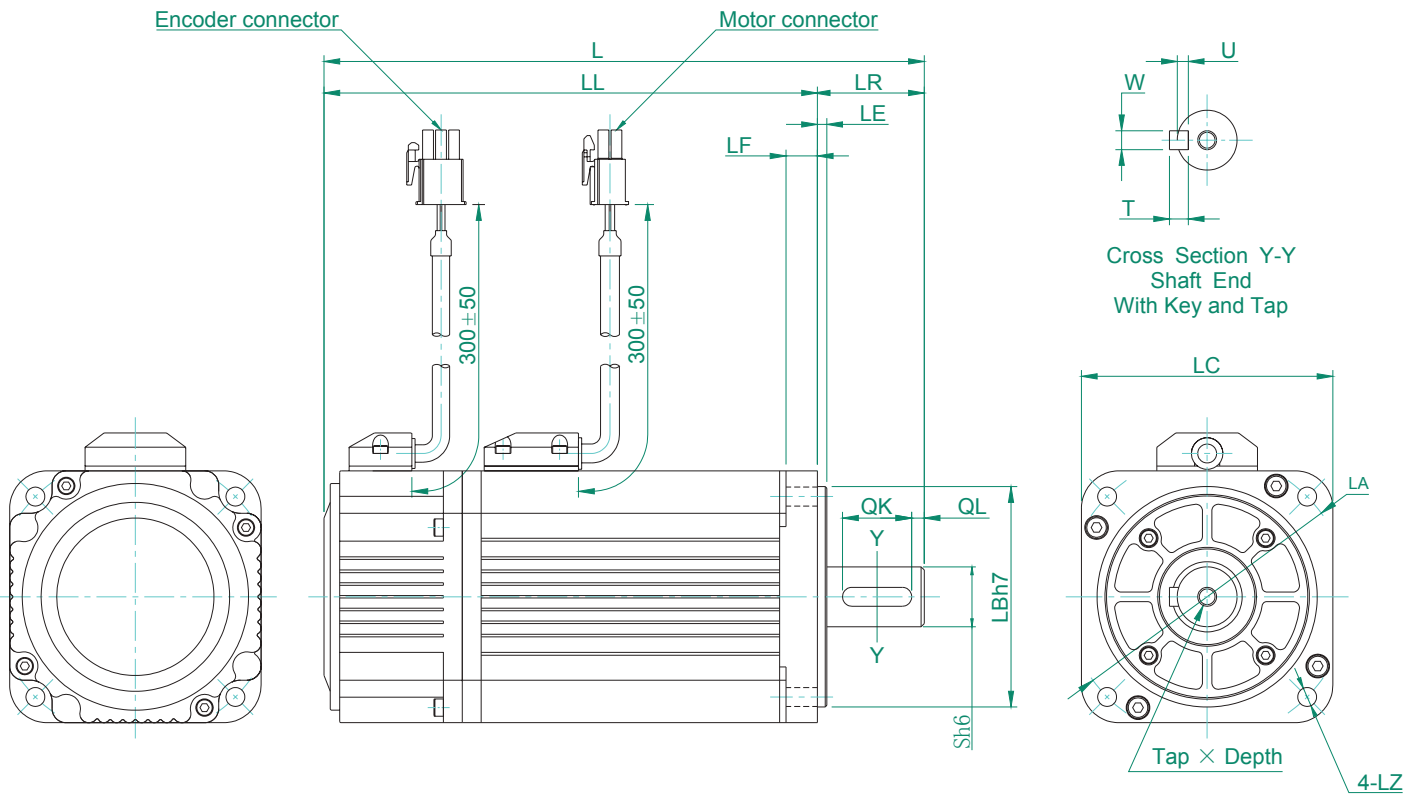

Model EMJ-	L	LL	Flange face							S	Tap×Depth	Key				
			LR	LE	LF	LC	LA	LB	LZ			QK	QL	W	T	U
02A	140(180)	110(150)	30	3	6	60	70	50	5.5	14	M5x10L	16	4	5	5	3
04A	160(200)	130(170)	30	3	6	60	70	50	5.5	14	M5x10L	16	4	5	5	3
08A	178(221)	143(186)	35	3	9	80	90	70	6	19	M6x15L	22	4	6	6	3.5
10A	198(241)	163(206)	35	3	9	80	90	70	6	19	M6x15L	22	4	6	6	3.5

Note: The dimension in parentheses is for servo motors with holding brake.



➤ Motor connector specification

- Plug: 172167-1 (AMP)
- Pin: 170360-1 (AMP)

Pin No.	Signal	Color
1	U phase	Red
2	V phase	Blue
3	W phase	White
4	FG	Green/yellow



➤ Encoder connector specification

- Plug: 172169-1 (AMP)
- Pin: 170359-3 (AMP)

Pin No.	Signal	Color
1	A+	Blue
2	B+	Green
3	C+	Yellow
4	A-	Blue/Black
5	B-	Green/Black
6	C-	Yellow/Black
7	PG5V	Red
8	PG0V	Black
9	FG	Shield



➤ Brake Connector Specifications

- Plug: 172165-1(AMP)
- Pin: 170360-1(AMP)

Pin No.	Signal	Color
1	B1	Blue
2	B2	White

EMG

Series Servo Motor

Features

- Be used to drive the feed shaft of various machine
- Various products (1.0KW ~5.0KW, with brake etc.)
- Equipped with wire-saving encoder(2500P/R)
- Standard configuration is IP65

Applications

- Machine tools
- Handling machine
- Foodstuff processing machine
- Textile machine



Model Specification Description

EMG-10 A P A 1 1

EMG Model Servo Motor

Rated Power		Power Voltage		Encoder		Design Sequence		Shaft End		Optional Parts	
Sign	Spec.	Sign	Spec.	Sign	Spec.	Sign	Spec.	Sign	Spec.	Sign	Spec.
10	1.0KW	A	200Vac	P	2500P/R	A	Design Sequence	1	Flat, without keys	1	None
15	1.5KW							2	Flat, with keys, with screw thread	2	With Oil Seal
20	2.0KW									3	With brake (DC24V)
30	3.0KW									4	With oil seal, with brake (DC24V)
50	5.0KW										

Rated Value and Specifications

Voltage		200VAC				
Motor type	EMG-	10A	15A	20A	30A	50A
Rated output power	kW	1.0	1.5	2.0	3.0	5.0
Rated torque	N.m	4.78	7.16	9.55	14.3	23.9
Instantaneous peak torque	N.m	14.3	21.5	28.7	43	71.6
Rated current	Arms	6.0	9.0	12.0	18.0	28
Instantaneous peak current	Arms	18.0	27.0	36.0	54.0	84
Rated rotated speed	min ⁻¹	2000				
Peak rotated speed	min ⁻¹	3000				
Rotator rotated inertia	x10 ⁻⁴ kg/m ²	10(10.6)	14.5(15.1)	19.0(19.6)	41.3(44.5)	65.7(68.9)
Feedback unit	Standard	Incremental cable-saved type: 2500P/R				
Heat-endurance level		F				
Environment humidity temperature		0 to +40°C (Non-iced)				
Environment humidity		20 to 80% RH (No dew)				
Protection method		All-closed, Self-cooled, IP65 (Except output shaft and connector)				
Anti-vibration performance		24.5m/s ²				

(Note): The values in parentheses are for servo motors with holding brakes.

Torque-Speed Feature

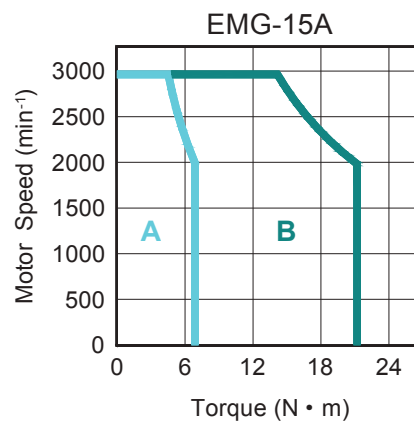
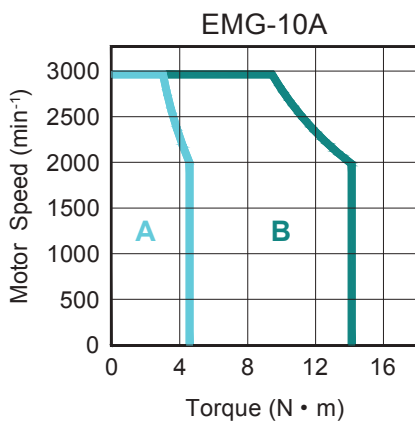

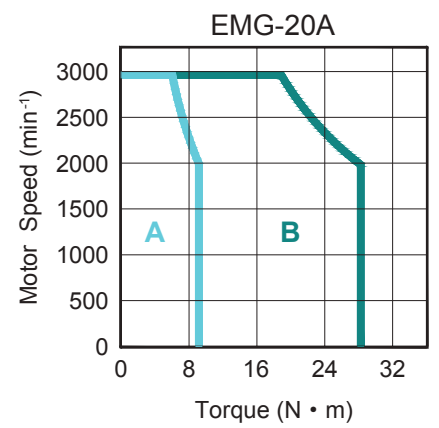
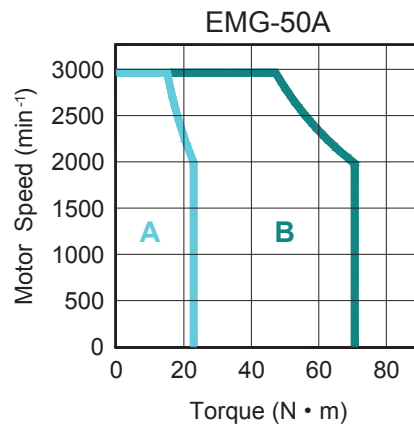
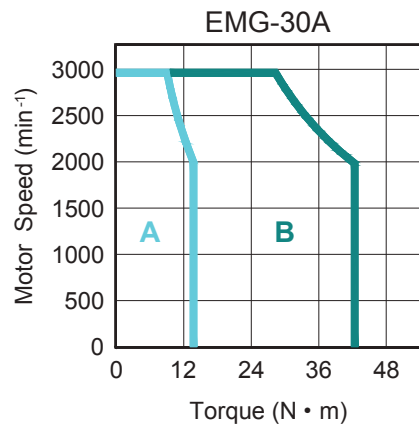

A: Continuous Working Area B: Repeatable Working Area

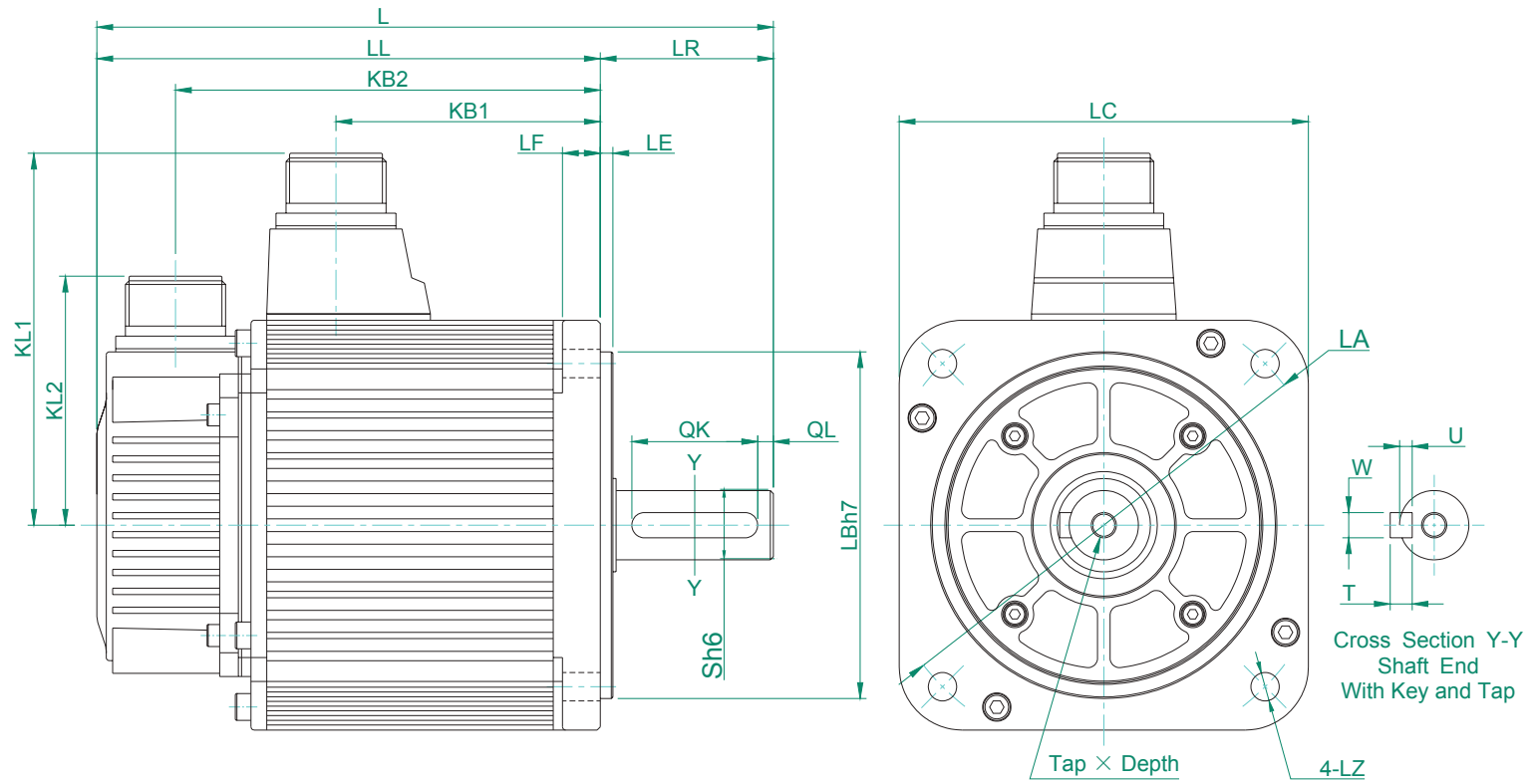

Model EMG-	L	LL	KB1	KB2	KL1	KL2	Flange face						S	Tap×Depth	Key					
							LR	LE	LF	LC	LA	LB			LZ	QK	QL	W	T	U
10A	215	160	84	135	118	79	55	4	12	130	145	110	9	22	M6x20L	40	5	8	7	4
15A	240	185	109	160	118	79	55	4	12	130	145	110	9	22	M6x20L	40	5	8	7	4
20A	265	210	134	185	118	79	55	4	12	130	145	110	9	22	M6x20L	40	5	8	7	4
30A	307	228	143	203	140	79	79	3.2	18	180	200	114.3	13.5	35	M8x16L	55	6	10	8	5
50A	347	268	183	243	140	79	79	3.2	18	180	200	114.3	13.5	35	M8x16L	55	6	10	8	5



➤ Motor connector specification

- Plug: MS3108B20-4S(LC=130), MS3108B22-22S(LC=180)
- Receptacle: MS3102A20-4P(LC=130),MS3102A22-22P(LC=180)
- Cable Clamp: MS3057-12A

Pin No.	Signal
A	U phase
B	V phase
C	W phase
D	FG



➤ Encoder connector specification

- Plug: MS3108B20-29S
- Receptacle: MS3102A20-29P
- Cable Clamp: MS3057-12A

Pin No.	Signal	Color
A	A+	Blue
B	A -	Blue/Black
C	B+	Green/Black
D	B -	Green
E	C+	Yellow
F	C -	Yellow/Black
G	PG0V	Black
H	PG5V	Red
J	FG	Shield



➤ Brake Connector Specifications

- Plug: MS3106A10SL-3S
- Receptacle: MS3102A10SL-3P
- Cable Clamp: MS3057-4A

Pin No.	Signal
A	B1
B	B2
C	-

EML

Series Servo Motor

Features

- Be used to drive the feed shaft of various machine
- Various products(1.0KW ~4.0KW, with brake etc.)
- Equipped with wire-saving encoder(2500P/R)
- Standard configuration is IP65

Applications

- Machine tools
- Handling machine
- Foodstuff processing machine
- Textile machine



Model Specification Description

EML-10 A P A 1 1

EML Model
Servo Motor

Rated Power		Power Voltage		Encoder		Design Sequence		Shaft End		Optional Parts	
Sign	Spec.	Sign	Spec.	Sign	Spec.	Sign	Spec.	Sign	Spec.	Sign	Spec.
10	1.0KW	A	200Vac	P	2500P/R	A	Design Sequence	1	Flat, without keys	1	None
20	2.0KW							2	Flat, with keys, with screw thread	2	With Oil Seal
30	3.0KW									3	With brake (DC24V)
40	4.0KW									4	With oil seal, with brake (DC24V)

Rated Value and Specifications

Voltage		200VAC			
Servo motor type	EML -	10A	20A	30A	40A
Rated output power	kW	1.0	2.0	3.0	4.0
Rated torque	N.m	9.55	19.1	28.7	38.2
Instantaneous peak torque	N.m	28.7	57.3	86.0	114.6
Rated current	Arms	6.0	12.0	18.0	24.0
Instantaneous peak current	Arms	18.0	36.0	54.0	72.0
Rated rotated speed	min ⁻¹	1000			
The highest rotated speed	min ⁻¹	1500			
Rotator rotated inertia	x10 ⁻⁴ kg /m ²	19(19.6)	53.5(56.7)	77.8(81.0)	102.2(105.4)
Feedback unit	Standard	Incremental cable-saved type : 2500P/R			
Heat endurance level		F			
Environment temperature		0 to + 40 C (Non-iced)			
Environment humidity		20 to 80% RH (No dew)			
Protection method		All-closed , self-cool , IP65 (Except output shaft and connector)			
Anti-vibration performance		24.5m /s ²			

(Note): The values in parentheses are for servo motors with holding brakes.

Torque-Speed Feature

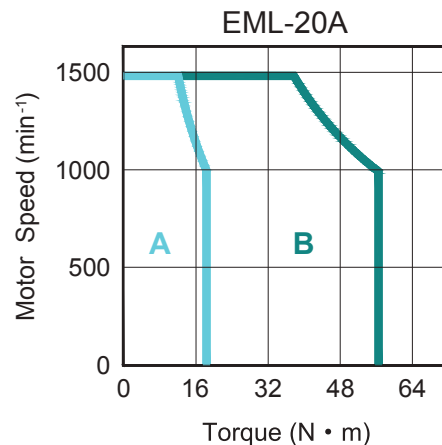
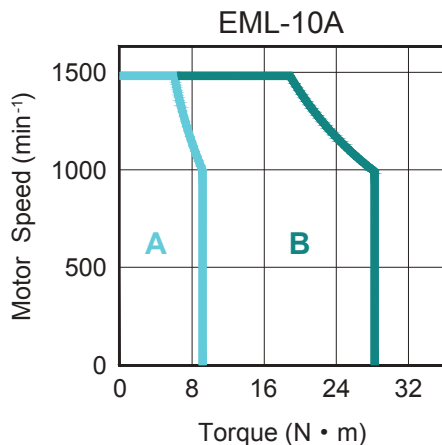

www.nicsanat.com
021-87700210



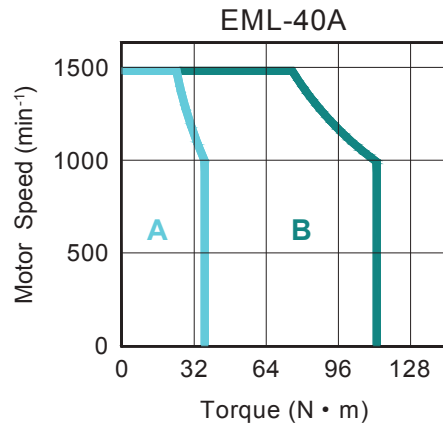
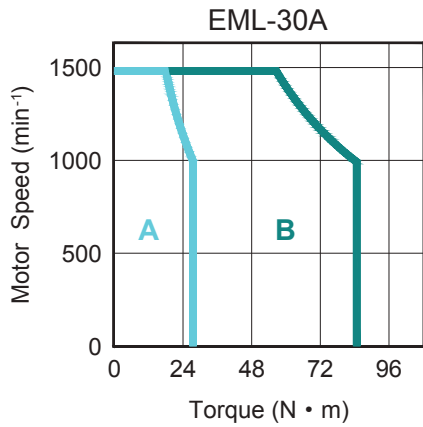

A: Continuous Working Area B: Repeatable Working Area

Dimension

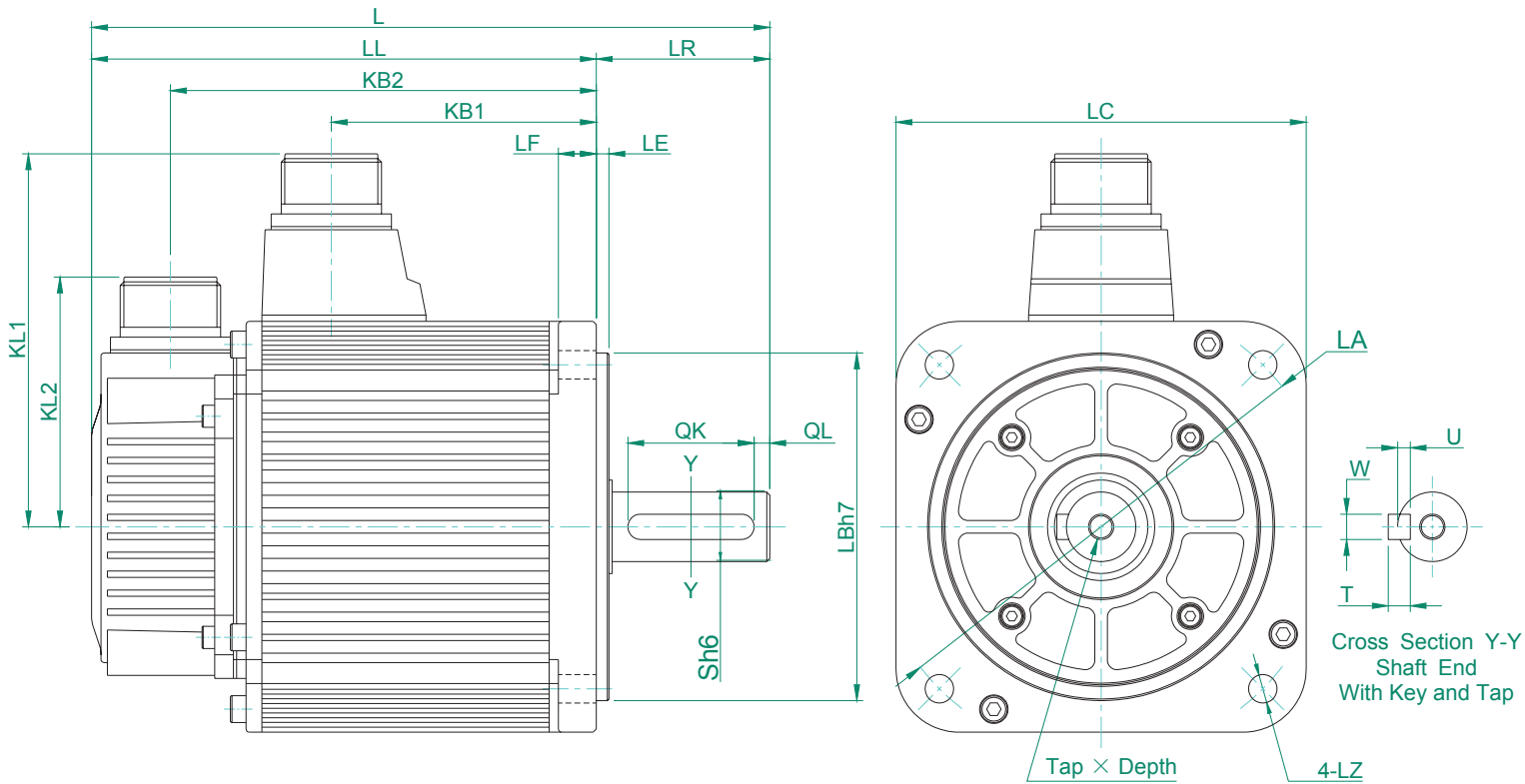

Model EML-	L	LL	KB1	KB2	KL1	KL2	Flange face						S	Tap×De pth	key					
							LR	LE	LF	LC	LA	LB			LZ	QK	QL	W	T	U
10A	265	210	134	185	118	79	55	4	12	130	145	110	9	22	M6x20 L	40	5	8	7	4
20A	332	253	168	228	140	79	79	3.2	18	180	200	114	13.5	35	M8x16 L	55	6	10	8	5
30A	372	293	208	268	140	79	79	3.2	18	180	200	114	13.5	35	M8x16 L	55	6	10	8	5
40A	412	333	248	308	140	79	79	3.2	18	180	200	114	13.5	35	M8x16 L	55	6	10	8	5



➤ Motor connector specification

- Plug: MS3108B20-4S(LC=130), MS3108B22-22S(LC=180)
- Receptacle: MS3102A20-4P (LC=130),MS3102A22-22P(LC=180)
- Cable Clamp: MS3057-12A

Pin No.	Signal
A	U phase
B	V phase
C	W phase
D	FG



➤ Encoder connector specification

- Plug: MS3108B20-29S
- Receptacle: MS3102A20-29P
- Cable Clamp: MS3057-12A

Pin No.	Signal	Color
A	A+	Blue
B	A -	Blue/Black
C	B+	Green/Black
D	B -	Green
E	C+	Yellow
F	C -	Yellow/Black
G	PG0V	Black
H	PG5V	Red
J	FG	Shield



➤ Brake Connector Specifications

- Plug: MS3106A10SL-3S
- Receptacle: MS3102A10SL-3P
- Cable Clamp: MS3057-4A

Pin No.	Signal
A	B1
B	B2
C	-

EDB/EDC

Typical Connection Example

Typical Connection Example of EDC Servo

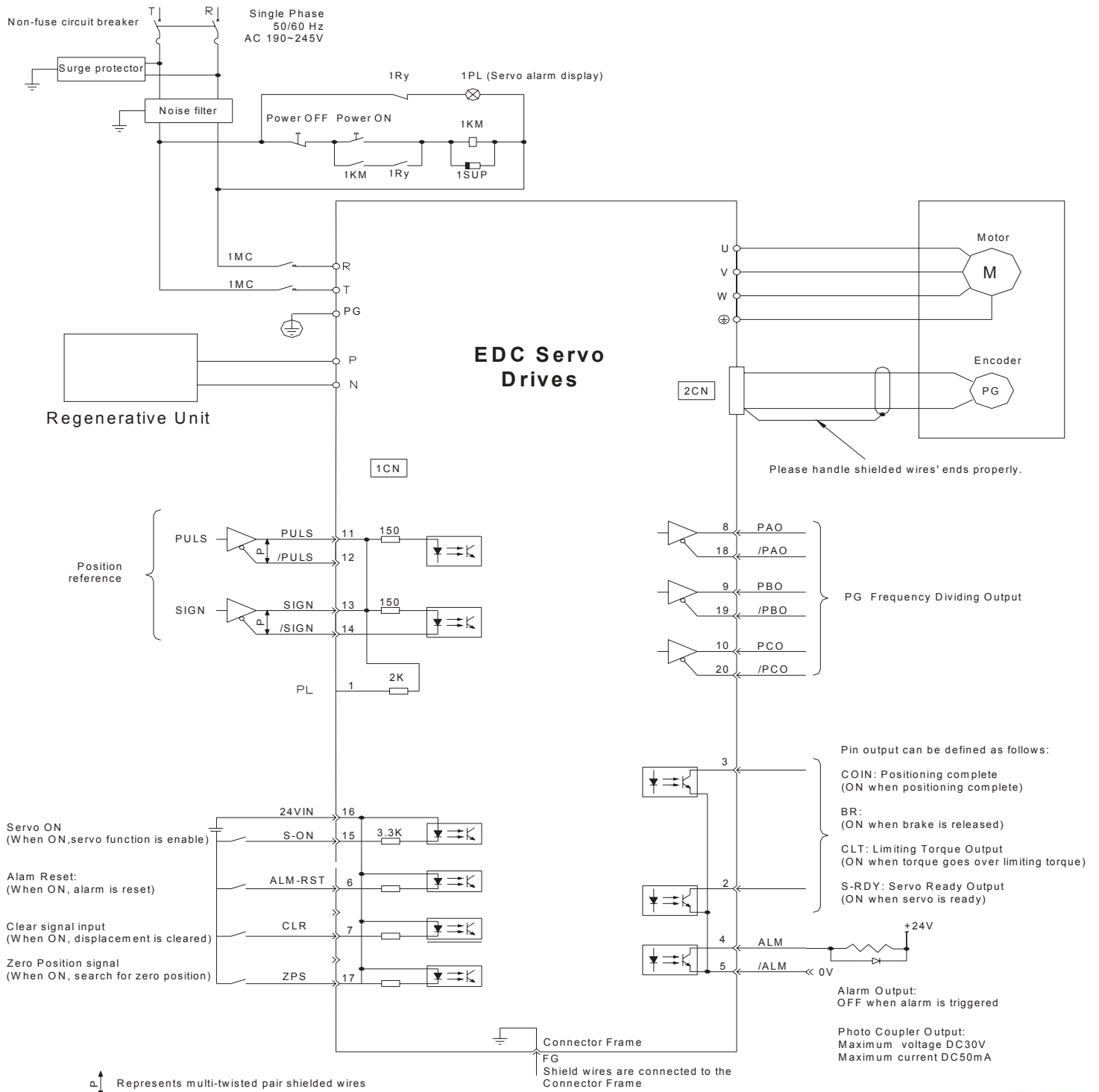

Typical Connection Example of EDB Servo

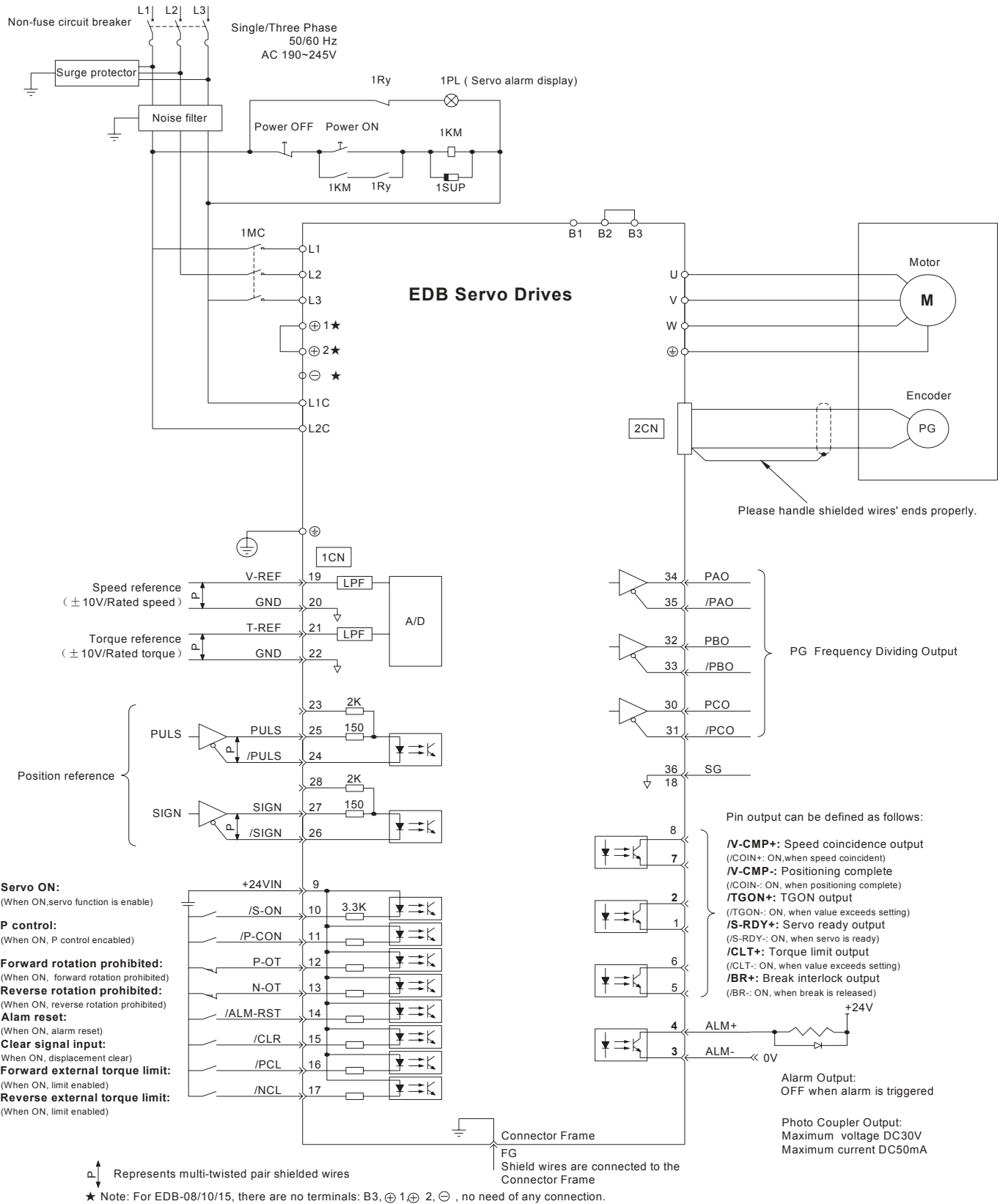

Vision

Enjoy your life from Automation!



Estun's Brochures and Technical Guidance

- ES2009-C Estun Sales Agent Training Course
- ES2009-D Estun Servo Parameter Adjustment Guidance
- ES2009-E Second Electronic Gear
- ES2009-F Speed Forward-Feedback Function
- ES2010-C Estun Servo Motor Selection Principle
- ES2011-A Estun Outline
- ES2011-B Motor Outline
- ES2011-A EDB/EDC Series Product Brochure**
- ES2011-B ProNet Series Product Brochure

ESTUN

Estun Automation Technology Co., Ltd.

Add.: 155 Jiangjun Road, Jiangning Development Zone,
Nanjing 211100, P.R.China

Tel: +86-25-52785915 Fax: +86-25-52785576

Website: <http://www.estun.cn>

Email: export@estun.com